

**PASSENGER  
CARS  
&  
LIGHT DUTY  
TRUCKS**

**UNIT REPAIR  
MANUAL  
(OVERHAUL)**



**1981 CHEVROLET**

**1981  
UNIT REPAIR (OVERHAUL)  
MANUAL  
covering  
IMPALA, CAPRICE, MALIBU,  
MONTE CARLO,  
CAMARO  
and  
LIGHT DUTY TRUCKS  
(SERIES 10-30)**

**FOREWORD**

This manual includes procedures involved in disassembly and assembly of major components of 1981 Impala, Caprice, Malibu, Monte Carlo, Camaro and Light Duty Trucks. Information on diagnosis, maintenance and adjustments, minor service operations, and removal and installation for these components is contained in either the 1981 Passenger Car or the Light Duty Truck Service Manuals.

The Section Index on the contents page enables the user to quickly locate any desired section. At the beginning of each section containing more than one major subject is a Table of Contents, which gives the page number on which each major subject begins. An index is placed at the beginning of each major subject within the section.

Summaries of Special Tools, when required, are found at the end of major sections.

When reference is made in this manual to a brand name, number, or specific tool, an equivalent product may be used in place of the recommended item.

The manual should be kept in a handy place for ready reference. If properly used, it will enable the technician to better serve the owners of Chevrolet built vehicles.

All information, illustrations and specifications contained in this literature are based on the latest product information available at the time of publication approval. The right is reserved to make changes at any time without notice.

**CHEVROLET MOTOR DIVISION**

General Motors Corporation  
DETROIT, MICHIGAN

## **IMPORTANT SAFETY NOTICE**

Proper service and repair is important to the safe, reliable operation of all motor vehicles. The service procedures recommended by Chevrolet and described in this service manual are effective methods of performing service operations. Some of these service operations require the use of tools specially designed for the purpose. The special tools should be used when and as recommended.

It is important to note that this manual contains various CAUTIONS, and NOTICES which should be carefully read in order to minimize the risk of personal injury to service personnel or the possibility that improper service methods will be followed which may damage the vehicle. It also is important to understand that these CAUTIONS and NOTICES are not exhaustive. Chevrolet could not possibly know, evaluate and advise the service trade of all conceivable ways in which service might be done or of the possible hazardous consequences of each way. Consequently, Chevrolet has not undertaken any such broad evaluation. Accordingly, anyone who uses a service procedure or tool which is not recommended by Chevrolet must first satisfy himself thoroughly that neither his safety nor the vehicle will be jeopardized by the service method he selects.

Classiccarlibrary.com

# 1981 UNIT REPAIR (OVERHAUL) MANUAL

### CAUTION

*This vehicle contains some parts dimensioned in the metric system as well as in the customary system. Some fasteners are metric and are very close in dimension to familiar customary fasteners in the inch system. It is important to note that, during any vehicle maintenance procedures, replacement fasteners must have the same measurements and strength as those removed, whether metric or customary. (Numbers on the heads of metric bolts and on surfaces of metric nuts indicate their strength. Customary bolts use radial lines for this purpose, while most customary nuts do not have strength markings.) Mismatched or incorrect fasteners can result in vehicle damage or malfunction, or possibly personal injury. Therefore, fasteners removed from the vehicle should be saved for re-use in the same locations whenever possible. Where the fasteners are not satisfactory for re-use, care should be taken to select a replacement that matches the original. For information and assistance, see your Authorized dealer.*

SECTION INDEX	
SECTION	NAME
<b>1D</b>	AIR CONDITIONING COMPRESSOR
<b>3B</b>	STEERING
<b>4B</b>	REAR AXLE
<b>4C</b>	FRONT WHEEL DRIVE
<b>5</b>	BRAKES
<b>7A</b>	AUTOMATIC TRANSMISSION
<b>7B</b>	MANUAL TRANSMISSION
<b>7C</b>	CLUTCH
<b>7E</b>	TRANSFER CASE
<b>10</b>	METRIC AND FASTENER INFORMATION

classicalibrary.com

# SECTION 1D

## AIR CONDITIONING COMPRESSOR OVERHAUL

For Compressor REMOVAL AND INSTALLATION, see Air Conditioning Section. For DISCHARGING, ADDING OIL, EVACUATING AND CHARGING PROCEDURES FOR C.C.O.T. A/C SYSTEMS, see Air Conditioning Section.

### CONTENTS OF THIS SECTION

Minor Repair Procedures for the A-6 Compressor .....	1D-2
A-6 Compressor Clutch Plate and Hub Assembly .....	1D-2
A-6 Compressor Pulley and Bearing Assy.....	1D-5
A-6 Compressor Pulley Bearing .....	1D-6
A-6 Compressor Clutch Coil and Housing Assembly .....	1D-7
Major A-6 Compressor Repair Procedures.....	1D-8
A-6 Compressor Shaft Seal .....	1D-8
Seal Leak Detection.....	1D-10
A-6 Compressor Pressure Relief Valve.....	1D-11
A-6 Compressor Cylinder and Shaft Assembly .....	1D-13
Removal.....	1D-13
Disassembly.....	1D-13
Gaging Operation.....	1D-14
A-6 Teflon Piston Ring Replacement.....	1D-18
Assembly .....	1D-18
Re-Install.....	1D-21
Minor Repair Procedures for the R-4 Compressor .....	1D-25
R-4 Compressor Clutch Plate and Hub Assy.....	1D-25
R-4 Compressor Clutch Rotor and/or Bearing.....	1D-25
Replace Rotor and Bearing Assembly (On Car) .....	1D-25
Replace Rotor and Bearing Assembly (On Bench) .....	1D-25
R-4 Compressor Clutch Coil and /or Pulley Rim .....	1D-30
R-4 Compressor Inertia Ring Installation.....	1D-31
Major R-4 Compressor Repair Procedures.....	1D-33
R-4 Compressor Shaft Seal .....	1D-33
Seal Leak Detection.....	1D-33
R-4 Compressor Shaft Seal Replacement (On Car).....	1D-34
R-4 Compressor Shaft Seal Replacement (Off Car) .....	1D-35
R-4 Compressor Pressure Relief Valve.....	1D-35
R-4 Compressor Front Head and/or O-Ring .....	1D-35
R-4 Compressor Thrust and Belleville Washers.....	1D-37
R-4 Compressor Main Bearing.....	1D-38
R-4 Compressor Shell and/or O-Rings.....	1D-38
R-4 Compressor Discharge Valve Plate and/or Retainer .....	1D-40
R-4 Compressor Cylinder and Shaft Assy. ....	1D-40
A-6 and R-4 Comp. Leak Testing (External and Internal) .....	1D-41

For all practical purposes, all vehicles make use of the same air conditioning 4 and 6-cylinder compressors. Actual differences between compressors are found in their mounting brackets, pulleys, connector assemblies and compressor capacities, none of which will affect the following Overhaul Procedures.

When servicing the compressor, it is essential that steps be taken to prevent dirt or foreign material from getting on or into the compressor parts and system during disassembly

or reassembly of the compressor. Clean tools and clean work area are very important for proper service. The compressor connection areas and the exterior of the compressor should be cleaned off as much as possible prior to any "on car" repairs or removal of the compressor for workbench service. The parts must be kept clean at all times and any parts to be reassembled should be cleaned with trichloroethane, naphtha, stoddard solvent, kerosene or equivalent solvent

## 1D-2 AIR CONDITIONING COMPRESSOR OVERHAUL

and dried off with dry air. When necessary to use a cloth on any part, it should be of a non-lint producing type.

Although certain service operations can be performed without completely removing the compressor from the vehicle, the operations described herein are based on bench over-haul with the compressor removed from the vehicle. They have been prepared in sequence in order of accessibility of the components. Pad fender/skirt and secure compressor near top of fender skirt with wire, rope, etc. when performing on-car service.

When an A-6 or R-4 compressor is removed from the vehicle for servicing, the amount of oil remaining in the compressor should be drained and measured. This oil should then be discarded and new 525 viscosity refrigerant oil

added to the compressor (See Fig. 1D-1, and "C.C.O.T. Refrigerant Oil Distribution" in the Air Conditioning section).

Should an A-6 compressor, it's compressor shaft seal or any other component ever be removed for servicing because it was determined to be the cause of excessive signs of oil leakage in the A/C system, then the oil in the A-6 compressor must be drained, measured and replaced according to "C.C.O.T. Refrigerant Oil Distribution" in the Air Conditioning section to determine oil loss. The accumulator in this A-6 system then must also be removed - oil drained - measured, etc. according to same section.

**NOTICE:** To avoid possible damage do not kink or place excessive tension on refrigerant lines or hoses.

# MINOR REPAIR PROCEDURES FOR THE A-6 COMPRESSOR

**THE FOLLOWING OPERATIONS TO THE A-6 COMPRESSOR CLUTCH PLATE AND HUB, PULLEY AND BEARING, AND COIL AND HOUSING ARE COVERED AS "MINOR" BECAUSE THEY MAY BE PERFORMED WITHOUT FIRST PURGING THE SYSTEM OR REMOVING THE COMPRESSOR from the vehicle.**

The Compressor Shaft Seal assembly and Pressure Relief Valve may also be serviced without removing the compressor from the vehicle but these operations are covered later in this section as "Major Repair Procedures" because the system must first be purged of Refrigerant-12.

Illustrations used in describing these operations show the compressor removed from the vehicle only to more clearly illustrate the various operations.



Fig. 1D-1 A-6 Compressor

When servicing the compressor, remove only the necessary components that preliminary diagnosis indicates

are in need of service. Refer to the AIR CONDITIONING section and Fig. 1D-2 and Fig. 1D-3 for information relative to parts nomenclature and location.

Removal and installation of external compressor components and disassembly and assembly of internal components must be performed on a clean workbench. **The work area, tools, and parts must be kept clean at all times.** Parts Tray J 9402 (Fig. 1D-33) should be used for all A-6 internal compressor parts being removed, as well as for replacement parts.

## A-6 COMPRESSOR CLUTCH PLATE AND HUB ASSEMBLY

### Remove

1. Place Holding Fixture J 9396 in a vise and clamp the compressor in the Holding Fixture.
2. Keep clutch hub from turning with Clutch Hub Holder J 25030 or J 9403, and remove locknut from end of shaft using Thin Wall Socket J 9399 (Fig. 1D-3).

**NOTICE:** To avoid internal damage to the compressor, **DO NOT DRIVE OR POUND** on the Clutch Plate and Hub assembly **OR** on the end of the shaft. If proper tools to remove and replace clutch parts are not used, it is possible to disturb the position of the axial plate (keyed to the main shaft), resulting in compressor damage and seal leakage due to shifting of the crankshaft.

3. Thread Clutch Plate and Hub assembly Remover J 9401 into hub. Hold body of Remover with a wrench and tighten center screw to remove Clutch Plate and Hub assembly (Fig. 1D-4).
4. Remove square drive key from shaft or drive plate hub.
5. Inspect driven plate for cracks or stresses in the drive surface. Do not replace driven plate for a scoring condition (Fig. 1D-5).





## 1D-4 AIR CONDITIONING COMPRESSOR OVERHAUL

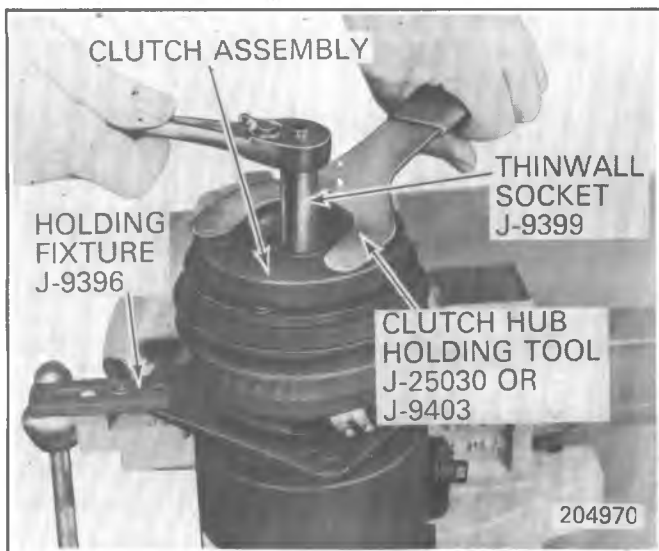

Fig. 1D-3 Removing A-6 Shaft Lock Nut

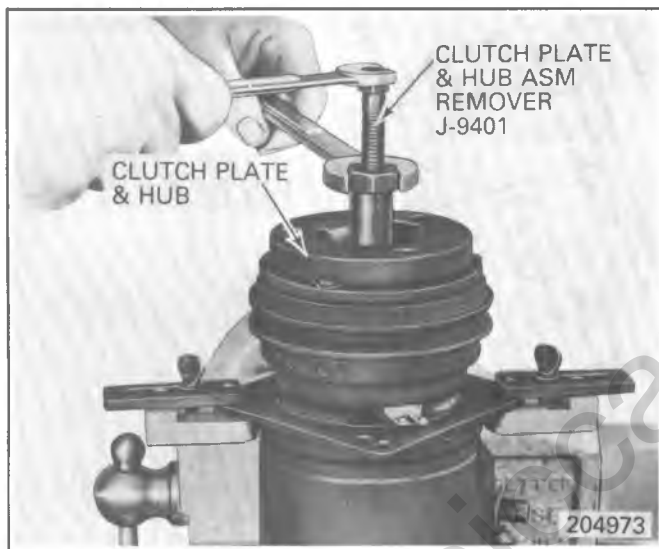

Fig. 1D-4 Removing A-6 Clutch Plate and Hub Asm.

If the frictional surface shows signs of damage due to excessive heat, the Clutch Plate and Hub and Pulley and Bearing should be replaced. Check further for the underlying cause of the damage (i.e. low coil voltage, coil should draw 3.2 amps at 12 volts) binding of the compressor internal mechanism (cylinder and shaft assembly), clutch air gap too wide (see Fig. 1D-8), broken drive plate to hub asm. springs, etc.

### Replace

1. Insert the square drive key into the hub of driven plate; allow it to project approximately 4.8mm (3/16") out of the keyway. The key has a slight curve for interference fit into hub keyway.
2. Line up the key in the hub with keyway in the shaft (Fig. 1D-6).
3. Install the Drive Plate Installer J 9480-1 as illustrated. This Installer has a left hand thread on the body (Fig. 1D-7).
4. Press the driven plate onto the shaft until there is approximately 2.4mm (3/32") space between the frictional

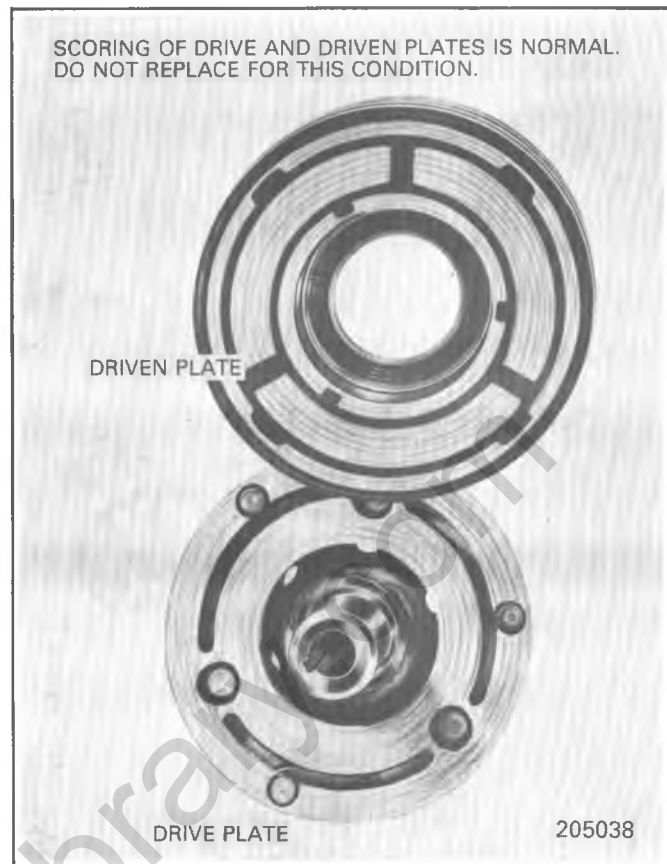

Fig. 1D-5 A-6 Clutch Driven Plate and Drive Plate

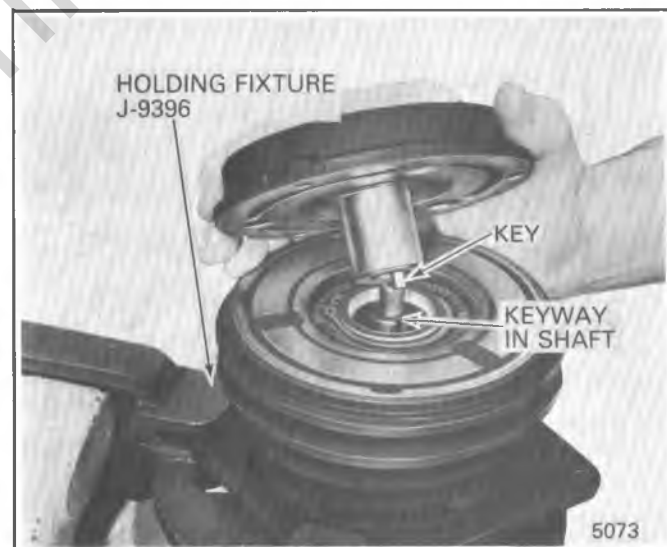

Fig. 1D-6 Aligning A-6 Drive Plate Key

faces of the Clutch Drive Plate and Pulley. Make certain key remains in place when pressing hub on shaft.

A zero thrust race is approximately 2.4mm (3/32") thick and may be used to roughly gage this operation. Use Clutch Hub Holder J 25030 or J 9403 to hold Clutch Plate and Hub if necessary.

6. Using Thin-Wall Socket J 9399 and Clutch Hub Holder J 25030 or J 9403 to install a new shaft locknut. Tighten the nut to 19 to 35 N·m (14-26 lb.ft.) torque. Air gap between the frictional faces should now be .6 to 1.4mm (.022" to .057") (Fig. 1D-8). If not, check for mispositioned key or shaft.

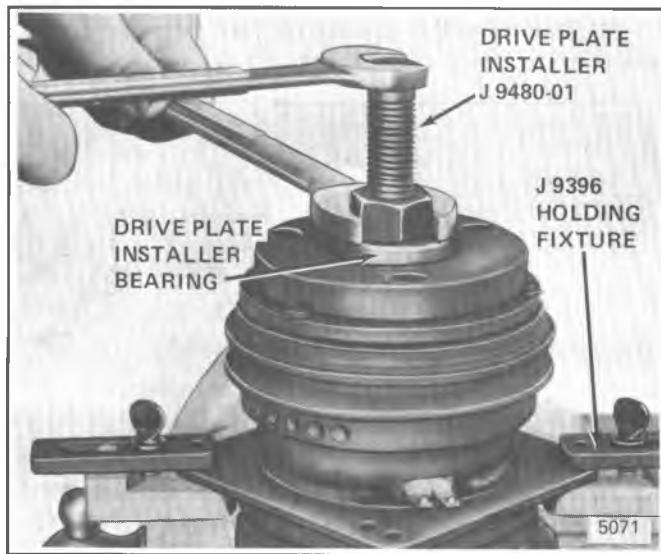

Fig. 1D-7 Installing A-6 Drive Plate

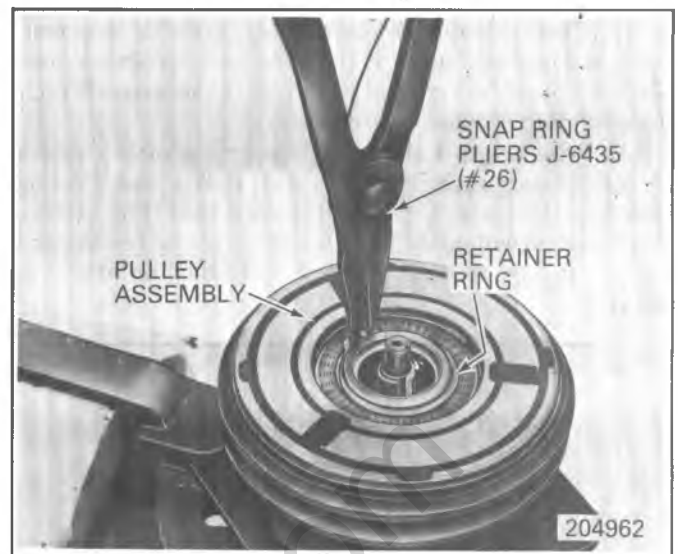

Fig. 1D-9 Removing A-6 Pulley Retainer Ring



Fig. 1D-8 Checking A-6 Air Gap

7. The pulley should now rotate freely.

8. Operate the refrigeration system in the MAX A/C control selector (mode) lever position and warm engine (off fast idle) speed at 2000 RPM. Rapidly cycle the compressor clutch by turning the A/C control selector (mode) lever from OFF-to-MAX at least 15 times at approximately one second intervals to burnish the mating parts of the clutch.

## A-6 COMPRESSOR PULLEY AND BEARING ASSEMBLY

### Remove

1. Remove Clutch Plate and Hub assembly as described in "A-6 Compressor Clutch Plate and Hub Asm." Removal procedure.
2. Remove pulley retainer ring, using Snap-Ring Pliers J 6435, Fig. 1D-9.
3. Pry out absorbent sleeve retainer, and remove absorbent sleeve from compressor neck.
4. Place Puller Pilot J 9395 over end of compressor shaft.

**NOTICE:** It is important that Puller Pilot J 9395 be used to prevent internal damage to compressor when removing pulley. Under no circumstances should puller be used directly against threaded end of shaft.

5. Remove Pulley and Bearing Assembly, using Pulley Puller J 8433 (Fig. 1D-10).



Fig. 1D-10 Removing A-6 Pulley and Bearing Asm.

### Inspection

Check the appearance of the Pulley and Bearing assembly (see Fig. 1D-5). The frictional surfaces of the Pulley and Bearing assembly should be cleaned with trichloroethane, naphtha, stoddard solvent, kerosene or equivalent solvent before reinstallation.

### Replace

1. If original Pulley and Bearing assembly is to be reinstalled, wipe frictional surface of pulley clean. If frictional surface of pulley shows any indication of damage due to overheating, the Pulley and Bearing assembly should be replaced.

## 1D-6 AIR CONDITIONING COMPRESSOR OVERHAUL

2. Check bearing for brinelling, excessive looseness, noise, and lubricant leakage. If any of these conditions exist, bearing should be replaced. See "A-6 Compressor Pulley Bearing" Replacement procedure.

3. Press or tap Pulley and Bearing assembly on neck of compressor until it seats, using Pulley and Bearing Installer J 9481 with Universal Handle J 8092 (Fig. 1D-11). The Installer will apply force to inner race of bearing and prevent damage to bearing if tool is installed on handle as shown.



Fig. 1D-11 Installing A-6 Pulley and Bearing Asm.

4. Check pulley for binding or roughness. Pulley should rotate freely.

5. Install retainer ring, using Snap Ring Pliers J 6435.

6. Install absorbent sleeve retainer in neck of compressor. Using sleeve from Seal Seat Remover-Installer J 9393, install retainer so that outer edge is recessed .8mm (1/32") from compressor neck face.

7. Install Clutch Plate and Hub assembly as described in "A-6 Compressor Clutch Plate and Hub Asm." Replacement procedure.

### A-6 COMPRESSOR PULLEY BEARING

#### Remove

1. Remove Clutch Plate and Hub assembly as described in "A-6 Compressor Clutch Plate and Hub Asm." Removal procedure.

2. Remove Pulley and Bearing assembly as described in "A-6 Compressor Pulley and Bearing Asm." Removal procedure.

3. Remove pulley bearing retainer ring with a small screwdriver or pointed tool (Fig. 1D-12).

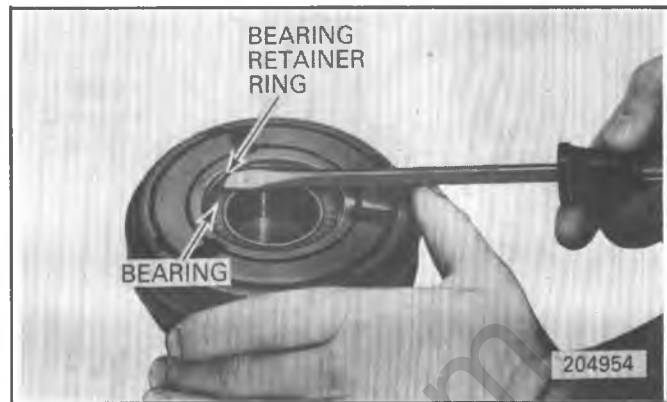

Fig. 1D-12 Removing A-6 Pulley and Bearing Retainer Ring

4. Place Pulley and Bearing assembly on inverted Support Block J 21352 and, using Pulley Bearing Remover J 9398 with Universal Handle J 8092, drive Bearing assembly out of pulley (Fig. 1D-13).



Fig. 1D-13 Removing Bearing From A-6 Pulley Asm.

#### Replace

1. Install new bearing in pulley using Pulley and Bearing Installer J 9481 with Universal Handle J 8092 (Fig. 1D-14). The Installer will apply the force to the outer race of the bearing when tool is used as shown.

**NOTICE:** Do not clean new bearing assembly with any type of solvent. Bearing is supplied with correct lubricant when assembled and requires no other lubricant at any time.

2. Install bearing retainer ring, making certain that it is properly seated in ring groove.

3. Install Pulley and Bearing assembly as described in "A-6 Compressor Pulley and Bearing Asm." Replacement procedure.

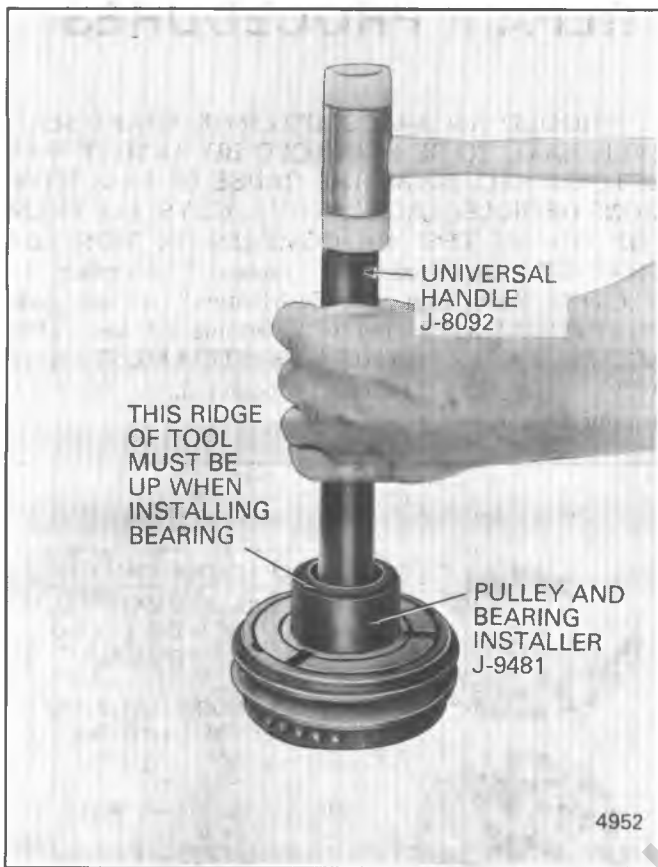

Fig. 1D-14 Installing Bearing on A-6 Pulley

4. Install Clutch Plate and Hub assembly as described in "A-6 Compressor Clutch Plate and Hub Asm." Replacement procedure.

### A-6 COMPRESSOR CLUTCH COIL AND HOUSING ASSEMBLY

#### Remove

1. Remove Clutch Plate and Hub assembly as described in "Compressor Clutch Plate and Hub Asm." Removal procedure.
2. Remove Pulley and Bearing assembly as described in "A-6 Compressor Pulley and Bearing Asm." Removal procedure. Note position of terminals on coil housing and scribe location on compressor front head casting.
3. Remove coil housing retaining ring, using Snap-Ring Pliers J 6435 (Fig. 1D-15).
4. Lift Coil and Housing assembly off compressor front head.

#### Replace

1. Position coil and housing assembly on compressor front head casting so that electrical terminals line up with marks previously scribed on compressor (Fig. 1D-16).

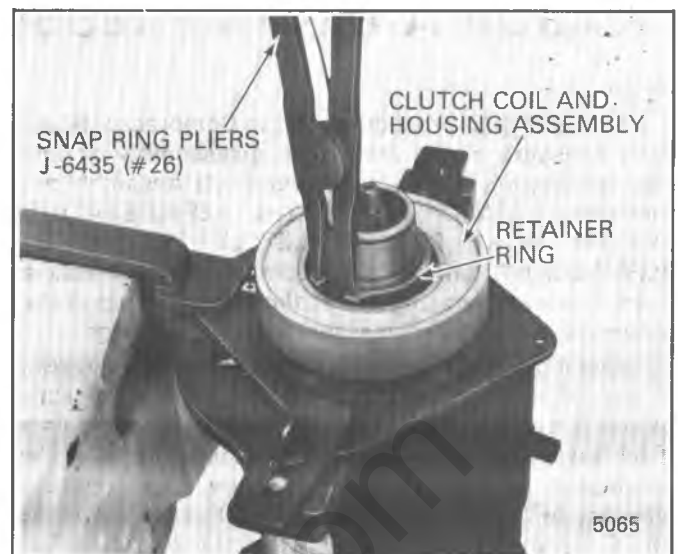

Fig. 1D-15 Removing A-6 Coil Housing Retainer Ring

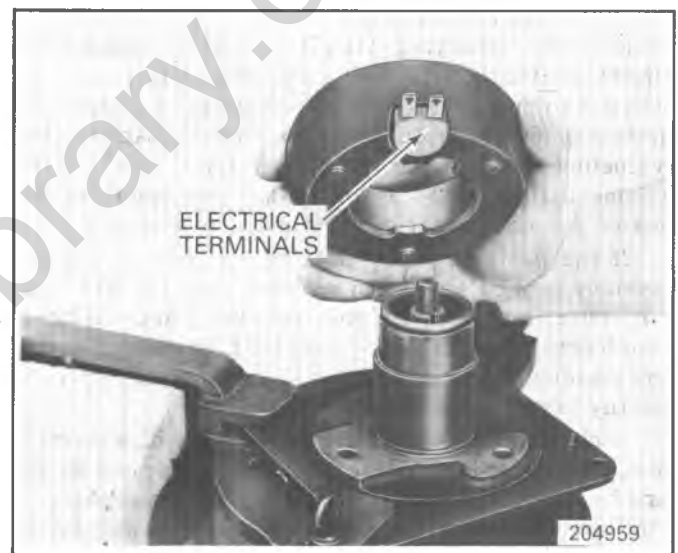

Fig. 1D-16 Installing A-6 Coil Housing

2. Align locating extrusions on coil housing with holes in front head casting.
3. Install coil housing retaining ring with flat side of ring facing coil, using Snap-Ring Pliers J 6435.
4. Install Pulley and Bearing assembly as described in "A-6 Compressor Pulley and Bearing Asm." Replacement procedure.
5. Install Clutch Plate and Hub assembly as described in "A-6 Compressor Clutch Plate and Hub Asm." Replacement procedure.

## MAJOR A-6 COMPRESSOR REPAIR PROCEDURES

Service repair procedures to the Compressor Shaft Seal, Pressure Relief Valve, or disassembly of the Internal Compressor Cylinder and Shaft Assembly are considered "MAJOR" SINCE THE REFRIGERATION SYSTEM MUST BE COMPLETELY PURGED OF REFRIGERANT before proceeding and/or because major internal operating and sealing components of the compressor are being disassembled and serviced.

Should an A-6 compressor, its compressor shaft seal, or any other component ever be removed for servicing because it was determined to be the cause of excessive signs of oil leakage in the A-6 A/C system, then the oil in the compressor must be drained, measured and replaced according to "C.C.O.T. Refrigerant Oil Distribution" in the Air Conditioning section to determine oil loss. The accumulator in this A-6 system must then also be removed - oil drained - measured, etc. according to same section.

When replacing the shaft seal assembly (Fig. 1D-17), pressure relief valve (Fig. 1D-23), even if the compressor remains on the vehicle during the operation, it will be necessary to purge the system of refrigerant as outlined in the Air Conditioning section (see "Discharging, Adding Oil, Evacuating and Charging Procedures for C.C.O.T. A/C Systems"). The same holds true for any disassembly of the internal A-6 compressor cylinder and shaft assembly.

If the A-6 Compressor Internal Cylinder and Shaft Assembly is to be serviced or replaced, then the oil in the compressor must be drained, measured and replaced according to "C.C.O.T. Refrigerant Oil Distribution" in the Air Conditioning section to determine addition of proper oil quantity to new assembly.

A clean workbench, preferably covered with a sheet of clean paper, orderliness in the work area and a place for all parts being removed and replaced is of great importance, as is the use of the proper, clean service tools. Any attempt to use make-shift or inadequate equipment may result in damage and/or improper compressor operation.

These procedures are based on the use of the proper service tools and the condition that an adequate stock of service parts is available. All parts required for servicing the internal compressor are protected by a preservation process and packaged in a manner which will eliminate the necessity of cleaning, washing or flushing of the parts. The parts can be used in the internal assembly just as they are removed from the service package.

Piston shoe discs and shaft thrust races will be identified by "number" on the parts themselves for reference to determine their size and dimension (see Fig. 1D-41).

### A-6 COMPRESSOR SHAFT SEAL

#### SEAL LEAK DETECTION

A SHAFT SEAL SHOULD NOT BE CHANGED BECAUSE OF AN OIL-LINE ON THE HOOD INSULATOR. The Seal is designed to seep some oil for lubrication purposes. Only change a Shaft Seal when a leak is detected by evidence of oil sprayed in LARGE AMOUNTS and then only after actual refrigerant leakage is determined by testing with a Leak Detector J 23400.

SHOULD AN A-6 COMPRESSOR SHAFT SEAL EVER HAVE TO BE REPLACED BECAUSE IT WAS DETERMINED TO BE THE CAUSE OF EXCESSIVE SIGNS OF OIL LEAKAGE IN THE A/C SYSTEM, THEN THE OIL IN THE A-6 COMPRESSOR MUST BE DRAINED, measured and replaced according to "C.C.O.T. Refrigerant Oil Distribution" in the AIR CONDITIONING section to determine oil loss. THE ACCUMULATOR IN THIS A-6 SYSTEM MUST THEN ALSO be removed - oil drained - measured, etc. according to same section.

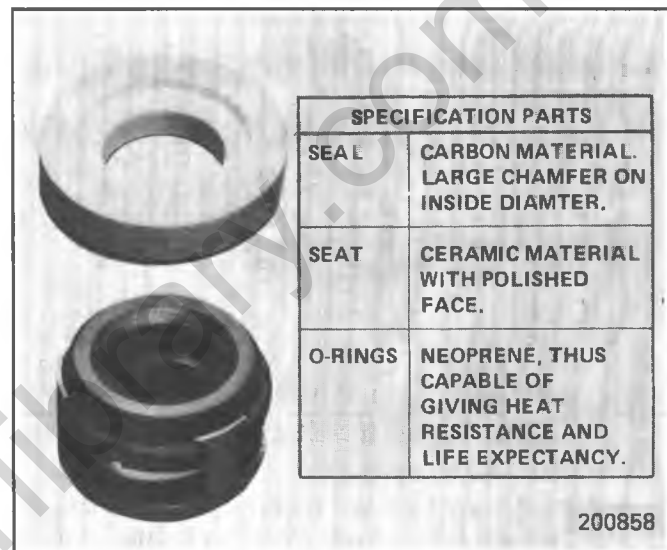

Fig. 1D-17 Specification A-6 and R-4 Compressor Shaft Seal Kit

#### Remove

1. "Discharge the Refrigerant System" according to the discharging, adding oil, evacuating and charging procedures for C.C.O.T. A/C systems in the Air Conditioning section.

2. Remove the clutch plate and hub assembly and shaft key as described in "A-6 Compressor Clutch Plate and Hub Asm." removal procedure.

3. Pry out the sleeve retainer and remove the absorbent sleeve. Remove the shaft seal seat retaining ring, using Snap-Ring Pliers J 5403. See Fig. 1D-18.

4. Thoroughly clean inside of compressor neck area surrounding the shaft, the exposed portion of the seal seat and the shaft itself. This is absolutely necessary to prevent any dirt or foreign material from getting into compressor.

5. Place Seal Protector J 22974 over the end of the shaft to prevent chipping the ceramic seat. Fully engage the knurled tangs of Seal Seat Remover-Installer J 23128 into the recessed portion of the seal seat by turning the handle clockwise. Remove the Seal Seat from the compressor with a rotary-pulling motion (Fig. 1D-19). Discard the Seat.

Do not tighten the handle with a wrench or pliers; however, the handle must be hand-tightened securely to remove the Seat.

6. With Seal Protector J 22974 still over the end of the shaft, set Seal Remover-Installer J 9392 down over shaft

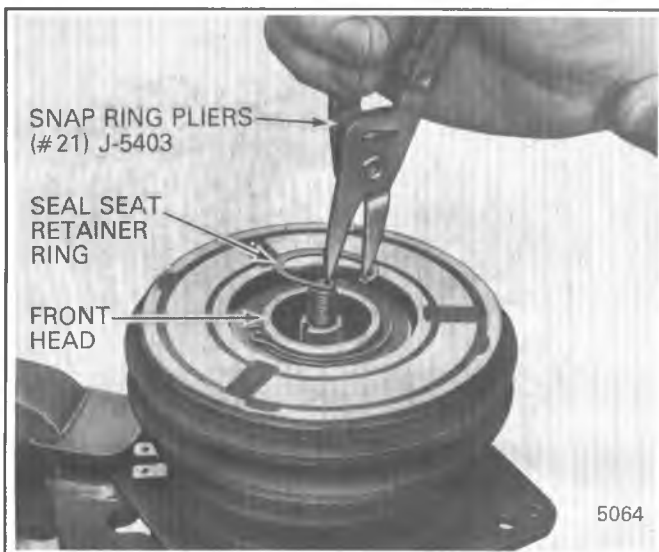

Fig. 1D-18 Removing or Installing A-6 Shaft Seal Seat Retaining Ring



Fig. 1D-20 Replacing A-6 Seal and O-Ring

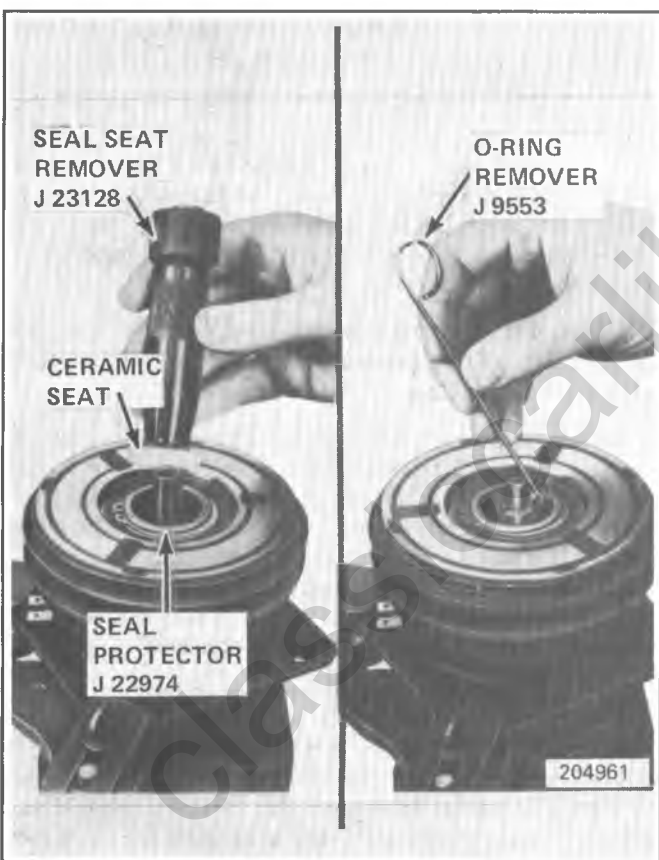

Fig. 1D-19 Removing A-6 Shaft Seal Seat and O-Ring

end, turning clockwise, while pressing down, to engage Remover tangs with the tabs on the Seal assembly. Then lift the Shaft Seal assembly out (see Fig. 1D-20). Discard the Seal.

7. Remove and discard the seal seat O-ring from the compressor neck, using O-Ring Remover J 9533 (see Fig. 1D-19).

8. Recheck the shaft and inside of the compressor neck for dirt or foreign material and be sure these areas are perfectly clean before installing new parts.

### Inspection

Seals should not be reused. Always use a new seal kit on rebuild (see Fig. 1D-17). Be extremely careful that the face of the Seal to be installed is not scratched or damaged in any way. Make sure that the Seal Seat and Seal are free of lint and dirt that could damage the seal surface or prevent sealing.

### Replace

1. Coat the new seal seat O-ring in clean 525 viscosity refrigerant oil and assemble onto O-Ring Installer J 21508 (see Fig. 1B-20).

2. Insert the O-Ring Installer J 21508 completely down into the compressor neck until the Installer "bottoms." Lower the movable slide of the O-Ring Installer to release the O-ring into the seal seat O-ring lower groove. (The compressor neck top groove is for the shaft seal seal retainer ring.) Rotate the Installer to seat the O-ring and remove Installer (See Fig. 1D-21).

3. Dip the O-ring and seal face of the new Seal assembly into clean 525 viscosity refrigerant oil. Carefully mount the Seal assembly to Seal Installer J 9392 by engaging the tabs of the Seal with the tangs of the Installer (Fig. 1D-20).

4. Place Seal Protector J 22974 (Fig. 1D-20) over end of compressor shaft and carefully slide the new Seal assembly down onto the shaft. Gently twist the Installer J 9392 CLOCK-WISE, while pushing the seal assembly down the shaft until the Seal assembly engages the flats on the shaft and is seated in place. Disengage the Installer by pressing downward and twisting counter-clockwise.

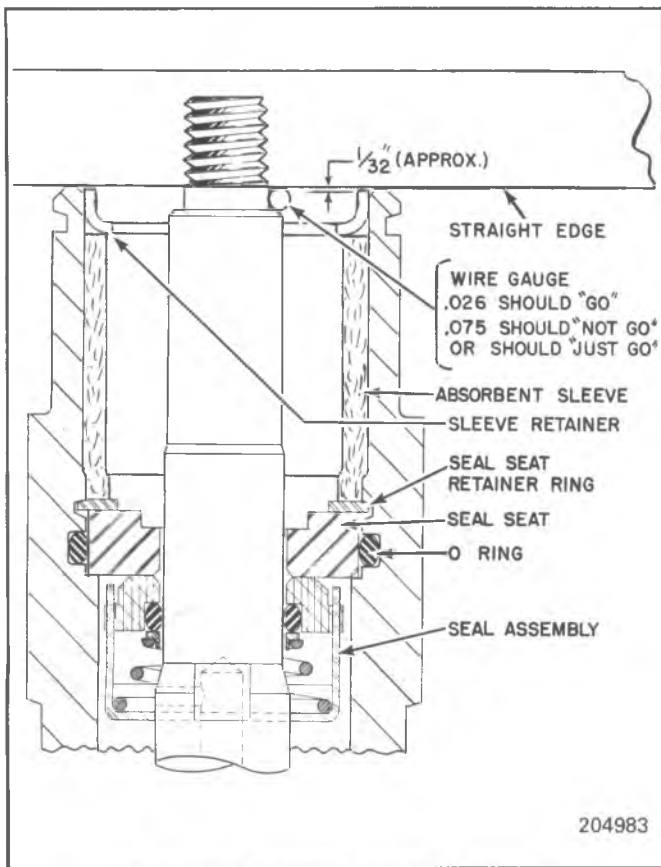

Fig. 1D-21 A-6 Compressor Shaft and Seal

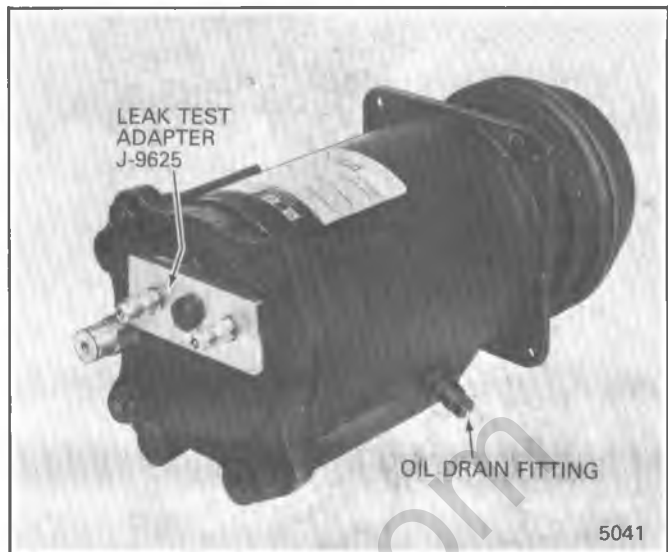

Fig. 1D-22 Leak Testing A-6 Compressor

or similar instrument, carefully spread the sleeve until the ends of the sleeve butt at the top vertical centerline.

10. Position the new metal sleeve retainer so that its flange face will be against the front end of the sleeve. The sleeve from seal seat remove installer tool J 9393 may be used to install the retainer. Press and tap with a mallet, setting the retainer and sleeve into place (retainer should be recessed approximately .8mm (1/32") from the face of the compressor neck). (See Fig. 1D-21.)

11. Reinstall the Clutch Plate and Hub assembly as described in "A-6 Compressor Clutch Plate and Hub Asm." Replacement procedure.

Some compressor shaft seal leaks may be the result of mispositioning of the axial plate on the compressor shaft. The mispositioning of the axial plate may be caused by improper procedures used during pulley and driven plate removal, pounding, collisions or dropping the compressor. If the axial plate is mispositioned, the carbon face of the shaft seal assembly may not contact the seal seat and the rear thrust races and bearing may be damaged.

To check for proper positioning of the axial plate on the shaft, remove the clutch driven plate and measure the distance between the front head extension and the flat shoulder on the shaft as shown in Fig. 1D-21. To measure this distance, use a wire gage (the clearance should be between .7 and 1.9mm (.026" and .075")). If the shaft has been pushed back in the axial plate (measurement greater than 1.9mm (.075")), disassemble the compressor and replace the shaft and axial plate assembly rear thrust races and thrust bearing.

If there also appears to be too much or insufficient air gap between the drive and driven plates, dislocation of the shaft should be suspected. If the carbon seal is not seating against the seal seat, it will not be possible to completely "Evacuate the System" as outlined under discharging, adding oil, evacuating and charging procedures for C.C.O.T. A/C systems in the Air Conditioning section.

12. "Add Oil, Evacuate and Charge System" (see discharging, adding oil, evacuating and charging procedures for C.C.O.T. A/C systems in the air conditioning section).

5. Attach the ceramic Seal Seat to the Seal Seat Remover and Installer J 23128 and dip the ceramic Seat in clean 525 viscosity refrigerant oil to coat the seal face and outer surface. Carefully install the Seat over the compressor shaft end and Seal Protector J 22974 and push the Seat into place with a rotary motion. Take care not to dislodge the seat O-ring. However, be sure Seal Seat makes a good seal with O-ring. Remove Installer J 23128 and Seal Protector J 22974 (Fig. 1D-19).

6. Install the new seal seat retainer ring with its flat side against the Seal Seat, using Snap-Ring Pliers J 5403. See Fig. 1D-18. Use the sleeve from Seal Seat Remove-Installer J 9393 to press in on the seal seat retainer ring so that it snaps into its groove.

7. Install Compressor Leak Test Fixture J 9625 (Fig. 1D-22) on rear head of compressor and connect gage charging lines or pressurize suction side (low-pressure side) of compressor on vehicle with Refrigerant-12 vapor to equalize pressure to the drum pressure. Temporarily install the shaft nut and, with compressor in horizontal position and oil sump down, rotate the compressor shaft in normal direction of rotation several times by hand then leak test the Seal. Correct any leak found. Remove, discard and later replace the shaft nut.

8. Remove any excess oil, resulting from installing the new seal parts, from the shaft and inside the compressor neck.

9. Install the new absorbent sleeve by rolling the material into a cylinder, overlapping the ends, and then slipping the sleeve into the compressor neck with the overlap towards the top of the compressor. With a small screwdriver



## A-6 COMPRESSOR PRESSURE RELIEF VALVE

When necessary to replace the Pressure Relief Valve located in the compressor rear head casting (Fig. 1D-23), the valve assembly should be removed after purging the system of refrigerant. A new valve and O-ring coated with 525 viscosity refrigerant oil should be installed (see discharging, adding oil, evacuating and charging procedures for C.C.O.T. A/C systems in the air conditioning section).



Fig. 1D-23 A-6 High Pressure Relief Valve

## A-6 COMPRESSOR INTERNAL MECHANISM (CYLINDER AND SHAFT ASM.)

Service operations to the A-6 compressor Rear Head or Internal Mechanism (Cylinder and Shaft) of the compressor should be performed with the system purged of refrigerant according to the discharging, adding oil, evacuating and charging procedures for C.C.O.T. A/C systems in the Air Conditioning section. The compressor must also be removed from the vehicle to insure that the necessary degree of cleanliness may be maintained. Additionally, "Compressor Clutch Plate and Hub, Pulley and Bearing, Clutch Coil and Housing and Shaft Seal" Removal procedures, as described earlier in the OVERHAUL section, all are to have been followed. Clean hands, clean tools and a clean bench, preferably covered with clean paper, are of extreme importance.

An inspection should be made of the Internal Mechanism (Cylinder and Shaft) assembly to determine if any service operations should be performed. A detailed inspection of parts should be made to determine if it is necessary to replace them.

### Removal

1. Before proceeding with disassembly, wipe exterior surface of compressor clean.
2. All oil in compressor should be drained and measured. Assist draining by positioning compressor with

oil drain plug down. Record the amount of oil drained from the compressor (See "C.C.O.T. Refrigerant Oil Distribution" in the Air Conditioning section).

3. Invert compressor and Holding Fixture J 9396, with front end of compressor shaft up, suction - discharge ports now facing downward (Fig. 1D-24).

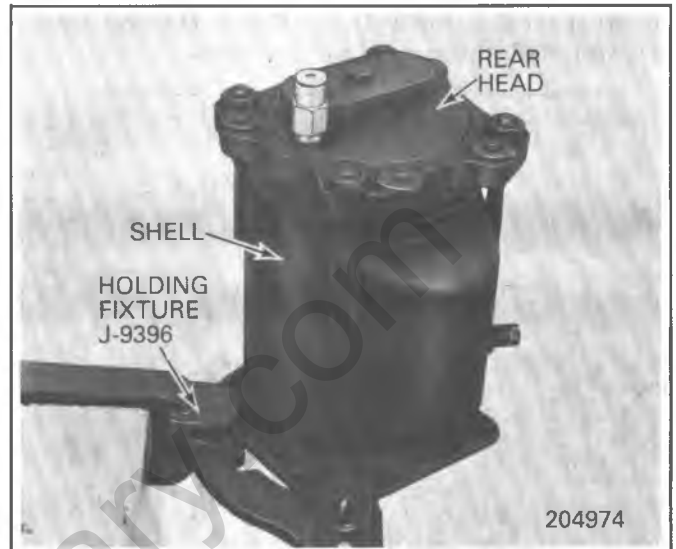

Fig. 1D-24 A-6 Compressor Installed in Holding Fixture

Additional oil may drain from the compressor at this time. All oil must be drained into a container so that total amount can be measured. (SEE STEP 2 ABOVE.) A liquid measuring cup may be used for this purpose. Drained oil should then be discarded.

4. Remove four locknuts from threaded studs on compressor shell and remove rear head. Tap uniformly around rear head if head is binding (Fig. 1D-24).

5. Wipe excess oil from all sealing surfaces on rear head casting webs, and examine sealing surfaces (Fig. 1D-25). If any damage is observed, the Rear Head should be replaced.

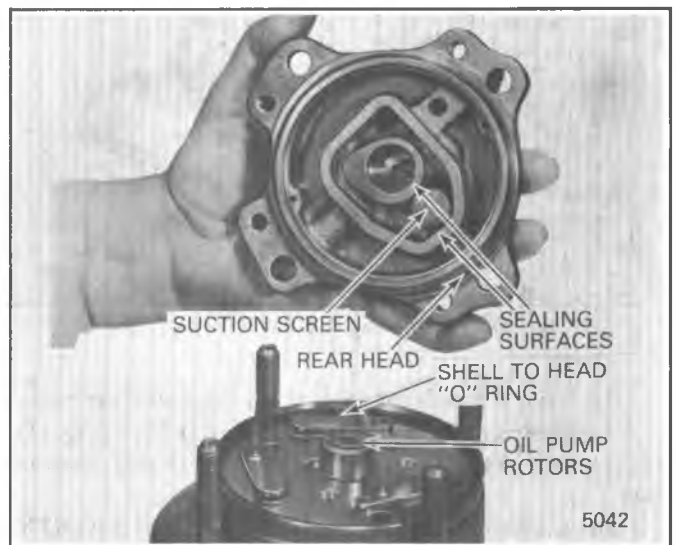

Fig. 1D-25 A-6 Rear Head Removal

6. Remove Suction Screen and examine for any damage or contamination. Clean or replace if necessary.

## 1D-12 AIR CONDITIONING COMPRESSOR OVERHAUL

7. Make an identifying mark on exposed face of inner and outer Oil Pump Gears and then remove gears. Identifying marks are to assure that gears, if re-used, will be installed in identical position.

8. Remove and discard rear head to shell O-ring.

9. Carefully remove Rear Discharge Valve Plate assembly. Use two small screwdrivers under reed retainers to pry up on assembly (Fig. 1D-26). Do not position screwdrivers between reeds and reed seats.

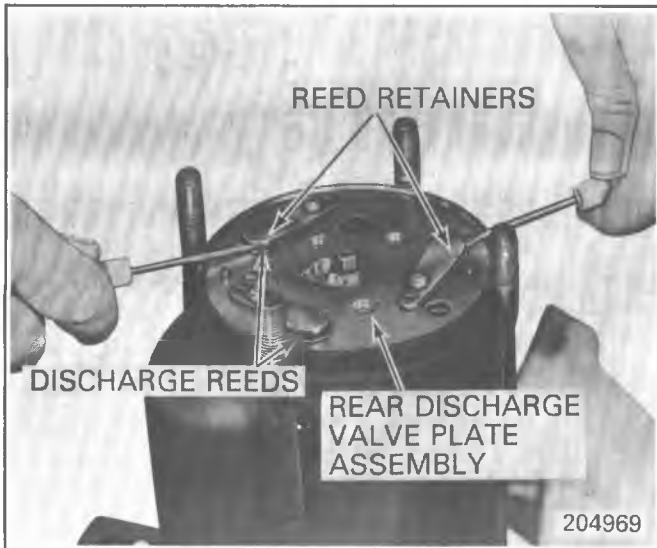

Fig. 1D-26 Removing A-6 Rear Discharge Valve Plate

10. Examine Valve Reeds and Seats. Replace entire assembly if any reeds or seats are damaged.

11. Using two small screwdrivers, carefully remove Rear Suction Reed (Fig. 1D-27). Do not pry up on horseshoe-shaped reed valves.

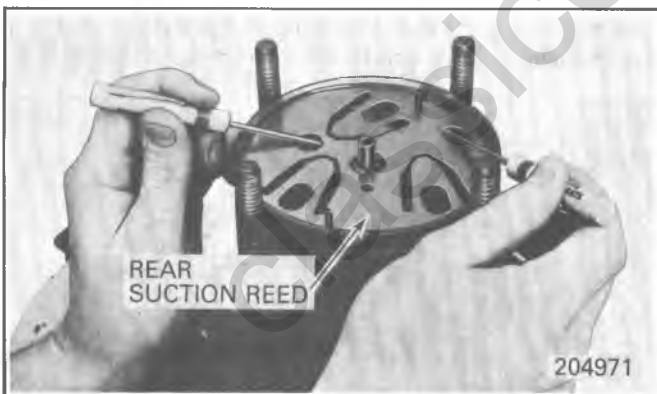

Fig. 1D-27 Removing A-6 Rear Suction Reed

12. Examine reeds for damage, and replace if necessary.

13. Using Oil Pick-Up Tube Remover J 5139 (Fig. 1D-28), remove Oil Pick-Up Tube. Remove O-ring from oil inlet.

14. Loosen compressor from Holding Fixture J 9396, place Internal Cylinder and Shaft Assembly Support Block J 21352 over oil pump end of shaft and, while holding Support Block in position with one hand, lift compressor from Holding Fixture with other hand. Invert compressor (shaft will now be facing upward) and position on bench with Internal Assembly Support Block resting on bench.



Fig. 1D-28 Removing A-6 Oil Pick-Up Tube

15. Lift Front Head and Compressor Shell Assembly up, leaving Internal Cylinder and Shaft Assembly resting on Internal Assembly Support Block.

**NOTICE:** To prevent damage to shaft, DO NOT TAP ON END OF COMPRESSOR SHAFT to remove Internal Cylinder and Shaft Assembly. If Internal Assembly will not slide out of compressor shell, tap on Front Head with a plastic hammer.

16. Rest compressor shell on its side and push Front Head assembly through Compressor Shell, being careful not to damage sealing areas on inner side of front head. Discard O-ring.

It may be necessary to tap on outside of front head, using a plastic hammer, to overcome friction of O-ring seal between front head and compressor shell.

17. Wipe excess oil from sealing surfaces on front head casting webs and examine sealing surface. If any surface damage is observed, the head should be replaced.

18. Remove Front Discharge Valve Plate assembly and Front Suction Reed Plate. Examine reeds and seats. Replace necessary parts.

19. Remove Suction Cross-Over Cover by prying with screwdriver between cylinder casting and cover (Fig. 1D-29).

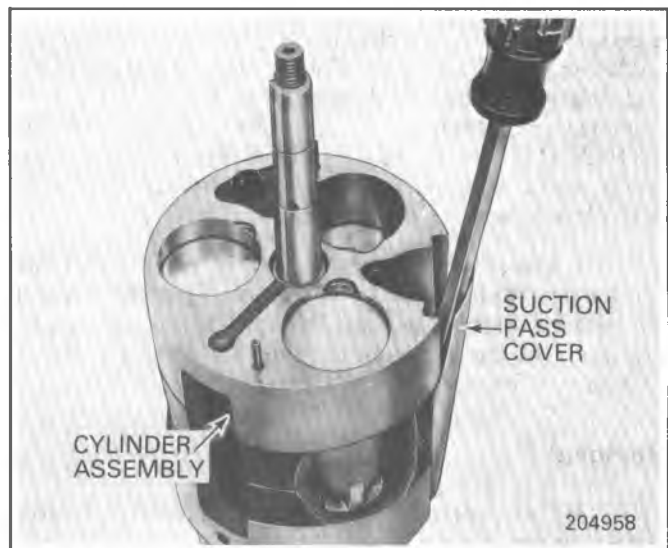

Fig. 1D-29 Removing A-6 Suction Cross-Over Cover

20. Examine Internal Cylinder and Shaft Assembly for any obvious damage. If Internal Assembly has sustained major damage, due to loss of refrigerant or oil, it may be necessary to use the Service Internal Cylinder and Shaft Assembly rather than replace individual parts.

## A-6 COMPRESSOR INTERNAL CYLINDER AND SHAFT ASM

### Disassembly

Use Parts Tray J 9402 (Fig. 1D-33) to retain compressor parts during disassembly.

1. Remove Internal Cylinder and Shaft Assembly from compressor as described in "A-6 Compressor Internal Mechanism (Cylinder and Shaft Asm.)" Removal procedure.

2. Identify by pencil mark, or some other suitable means, each piston numbering them as 1, 2 and 3 (Fig. 1D-30).

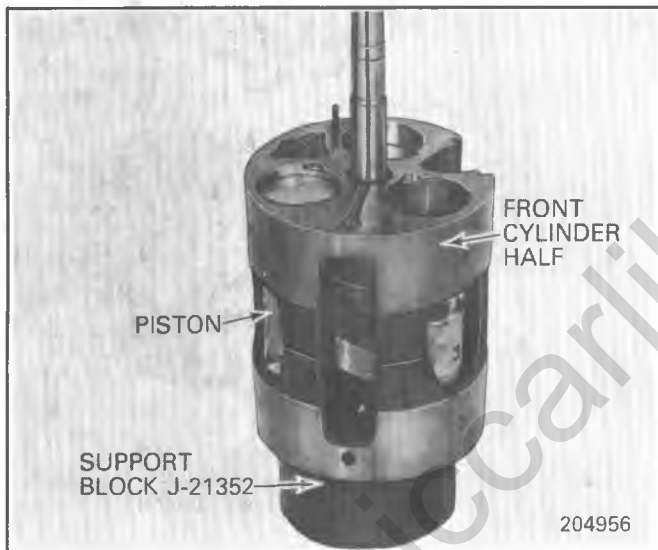

Fig. 1D-30 Numbering A-6 Piston and Cylinder Bores

Number the piston bores in the front cylinder half in like manner, so that pistons can be replaced in their original locations.

3. Separate cylinder halves, using a wood block and mallet (Fig. 1D-31). Make certain that discharge cross-over tube does not contact axial plate when separating cylinder halves (a new Service Discharge Cross-Over Tube will be installed later - see Step 5 of Internal Cylinder and Shaft Assembly procedure).

**NOTICE: UNDER NO CIRCUMSTANCES SHOULD SHAFT BE STRUCK AT EITHER END in an effort to separate upper and lower cylinder halves because the shaft and the axial plate could be damaged.**

4. Carefully remove the Rear Half of the cylinder from the pistons and set the Front Cylinder Half, with the piston, shaft and axial plate in Compressing Fixture J 9397.

5. Pull up on compressor shaft and remove piston previously identified as No. 1, with balls and shoe discs, from axial plate.

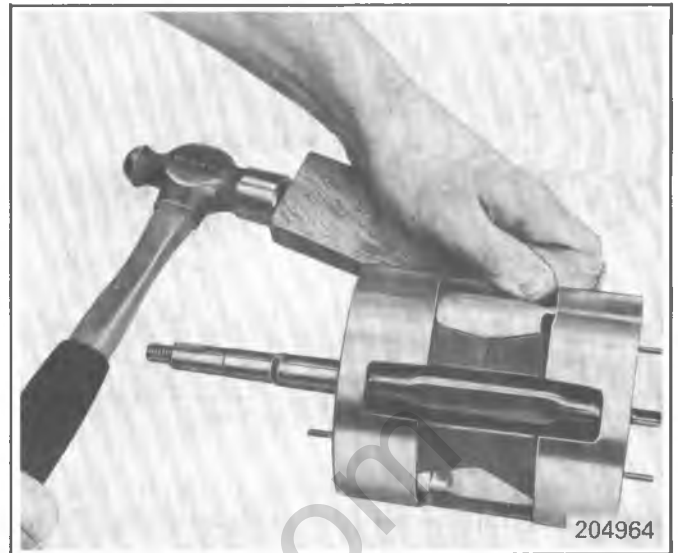

Fig. 1D-31 Separating A-6 Cylinder Halves

a. Inspect the Teflon piston rings for nicks, cuts or metal particles imbedded in exposed ring surface and replace the piston rings as required if either condition exists. See "A-6 Teflon Piston Ring" Replacement procedure.

6. Remove and discard the piston shoe discs.

7. Remove and examine piston balls, and if satisfactory for re-use, place balls in No. 1 compartment of Parts Tray J 9402 (Fig. 1D-33).

8. Place piston in No. 1 compartment of Parts Tray J 9402, with notch in casting web at front end of piston (Fig. 1D-32) into the dimpled groove of Parts Tray compartment.

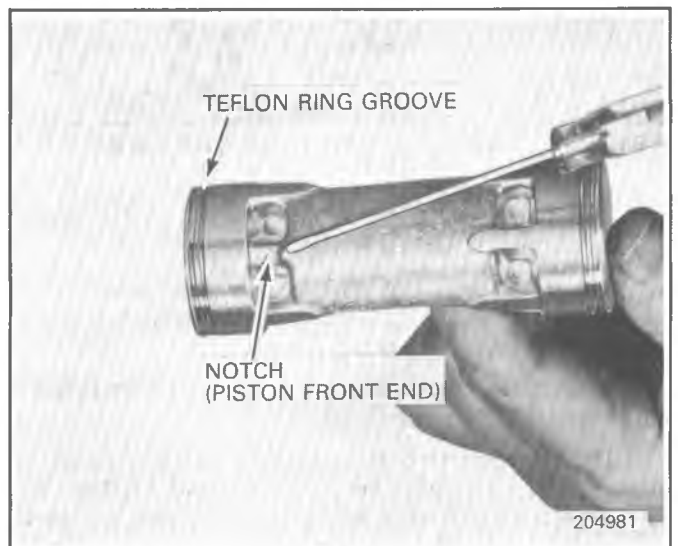

Fig. 1D-32 Notch Identifying Front End of A-6 Piston

9. Repeat Steps 5 through 9 for Pistons No. 2 and No. 3.

10. Remove rear combination of thrust races and thrust bearing from shaft. Discard races and bearing.

11. Remove shaft assembly from front cylinder half. If the Discharge Cross-Over Tube remained in the front cylinder half, it may be necessary to bend discharge cross-over tube slightly in order to remove shaft.

## 1D-14 AIR CONDITIONING COMPRESSOR OVERHAUL

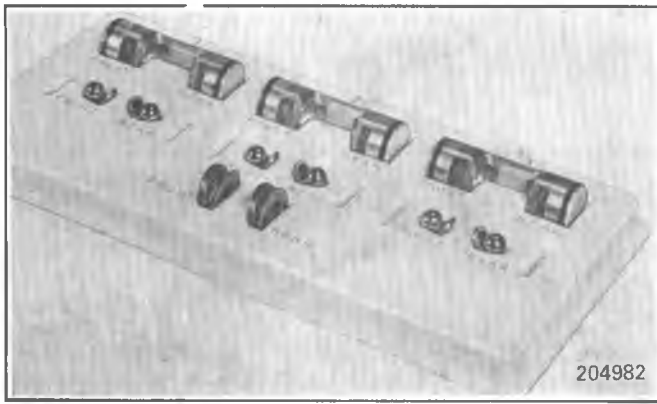

Fig. 1D-33 A-6 Parts Tray

12. Remove front combination of thrust races and bearing from shaft. Discard races and bearing (Fig. 1D-34).

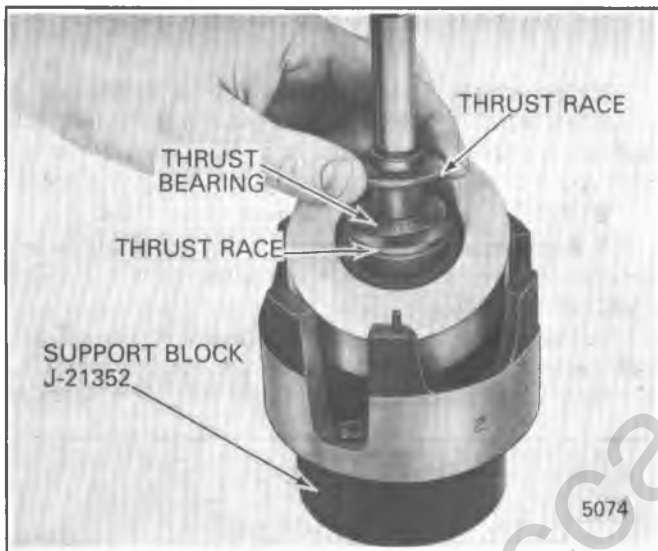

Fig. 1D-34 Removing A-6 Front Thrust Races and Bearings

13. Examine surface of Axial Plate and Shaft. Replace as an assembly, if necessary.

A certain amount of shoe disc wear on axial plate is normal, as well as some markings indicating load of needle bearings on shaft.

14. Remove Discharge Cross-Over Tube from cylinder half, using self-clamping pliers.

This is necessary only on original factory equipment, as ends of the tube are swaged into cylinder halves. The discharge cross-over tube in Internal Cylinder and Shaft Assemblies that have been previously serviced have an O-ring and bushing at each end of the tube, and can be easily removed by hand (see Fig. 1D-53).

15. Examine piston bores and needle bearings in front and rear cylinder halves. Replace front and rear cylinders if any cylinder bore is deeply scored or damaged.

16. Needle bearings may be removed if necessary by driving them out with special Thin-Wall Socket J 9399. Insert socket in hub end (inner side) of cylinder head and drive bearing out.

To install needle bearing, place cylinder half on Support Block J 21352, and insert bearing in end of cylinder head

with bearing identification marks up. Use Needle Bearing Installer J 9432 and drive bearing into cylinder head (Fig. 1D-35 until Installer "bottoms" on the cylinder face.

Two different width needle bearings are used in Production compressors - a 13mm (1/2") size and a 16mm (5/8") size. The bearings are interchangeable. Service replacement bearings are all 12.7mm (1/2").



Fig. 1D-35 Installing A-6 Needle Bearing

17. Wash all parts to be re-used with trichloroethane, naphtha, stoddard solvent, kerosene, or a similar solvent. Air-dry parts using a source of clean, dry air.

A-6 compressor internal components may be identified by referring to Fig. 1D-2.

### A-6 COMPRESSOR INTERNAL CYLINDER AND SHAFT ASM

#### Gaging Operation

1. Install Compressing Fixture J 9397 on Holding Fixture J 9396 in vise. Place front cylinder half in Compressing Fixture, flat side down. Front cylinder half has long slot extending out from shaft hole. "Legs" of front cylinder half will be pointed upward.

2. Secure from Service parts stock four zero thrust races, two thrust bearings and three zero shoe discs.

3. Now install a zero thrust race, then one thrust bearing, and a second zero thrust race onto front end of compressor shaft.

4. Insert threaded end of axial shaft through needle bearing in front cylinder half, and allow thrust race and bearing assembly (race-bearing-race) to rest on hub of cylinder.

5. Now install a zero thrust race on rear end of compressor axial shaft (Fig. 1D-36), so that it rests on hub of axial plate. Then add one thrust bearing and a second zero thrust race onto shaft.

At this point, both front end and rear end of axial shaft will have a stack-up of one zero race-one bearing-one zero race.

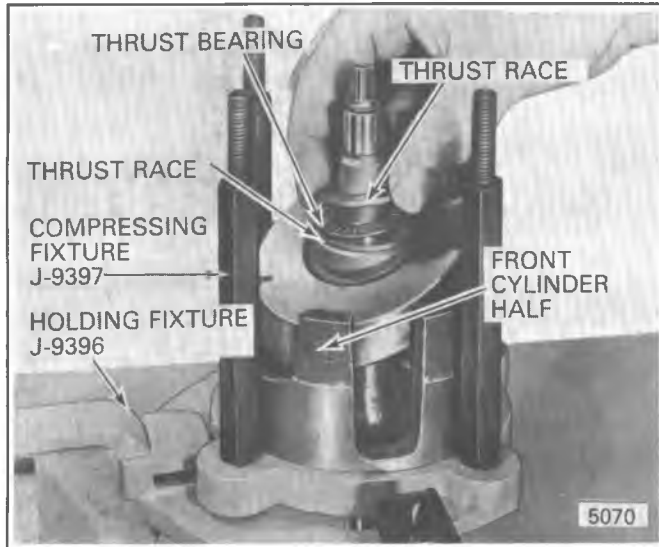

Fig. 1D-36 Installing A-6 Rear Thrust Races and Bearings

6. Lubricate ball pockets of the No. 1 Piston with 525 viscosity refrigerant oil and place a ball in each socket. Use balls previously removed if they were considered acceptable for re-use.

7. Lubricate cavity of a zero shoe disc with 525 viscosity refrigerant oil and place shoe disc over ball in front end of piston (Fig. 1D-37). Front end of piston has an identifying notch in casting web (Fig. 1D-32).

**NOTICE:** Exercise care in handling the Piston and Ring Assembly, particularly during assembly into and removal from the cylinder bores to prevent damage to the Teflon piston rings.

Shoe discs should not be installed on rear of piston during following "Gaging" operation.

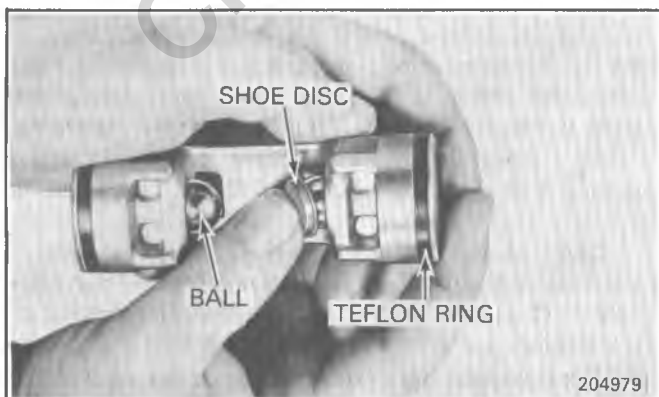

Fig. 1D-37 Installing A-6 Front Shoe Disc

8. Rotate shaft and axial plate until high point of axial plate is over the No. 1 Piston cylinder bore.

9. Lift the axial shaft assembly up a little out of front cylinder half and hold front thrust race and bearing assembly ("zero" race-bearing-"zero" race) against axial plate hub.

10. Position No. 1 Piston over No. 1 cylinder bore (notched end of piston being on bottom and piston straddling axial plate) and lower the shaft to allow No. 1 Piston to drop into its bore (Fig. 1D-38). If ball and shoe will not remain in front socket of piston during assembly use a light smear of petrolatum on the piston and shoe ball socket surfaces.

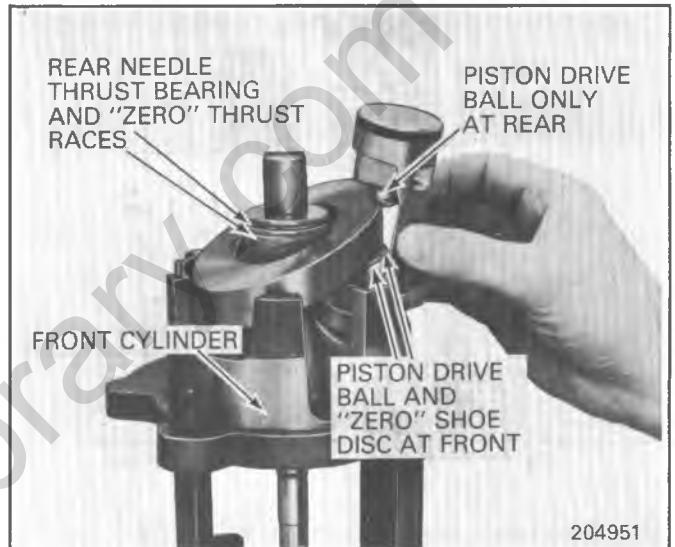

Fig. 1D-38 Installing A-6 Piston During Gaging Operation

11. Repeat Steps 6 through 10 for Pistons No. 2 and No. 3.

12. Now install rear cylinder half onto pistons, aligning cylinder with discharge cross-over tube hole in front cylinder half.

Tap into place using a plastic mallet or piece of clean wood and hammer (Fig. 1D-39).

13. Position discharge cross-over tube opening between a pair of Compressing Fixture J 9397 bolts to permit access for feeler gage.

14. Install top plate on Compressing Fixture J 9397. Tighten nuts to 20 N·m (15 lb. ft.) torque using a 0-60 N·m (0-25 lb.ft.) torque wrench.

### Gaging Procedure (Steps 15 thru 18)

The gaging operations which follow have been worked out on a simple basis to establish and provide necessary running tolerances. Two gaging procedures are necessary.

The first is made to choose the proper size shoe discs to provide, at each piston, a .04 to .06mm (.0016" to .0024") total preload between the seats and the axial plate at the tightest place through the 360-degree rotation of the axial plate. The bronze shoe discs are provided in .01mm (.0005") variations, including a basic ZERO shoe.

The second, performed at the rear shaft thrust race and bearing stack-up, is designed to obtain .06 to .08mm (.0025" to .0030") preload between the hub surfaces of the axial plate and the front and rear hubs of the cylinder. A total



Fig. 1D-39 Assembling A-6 Cylinder Halves

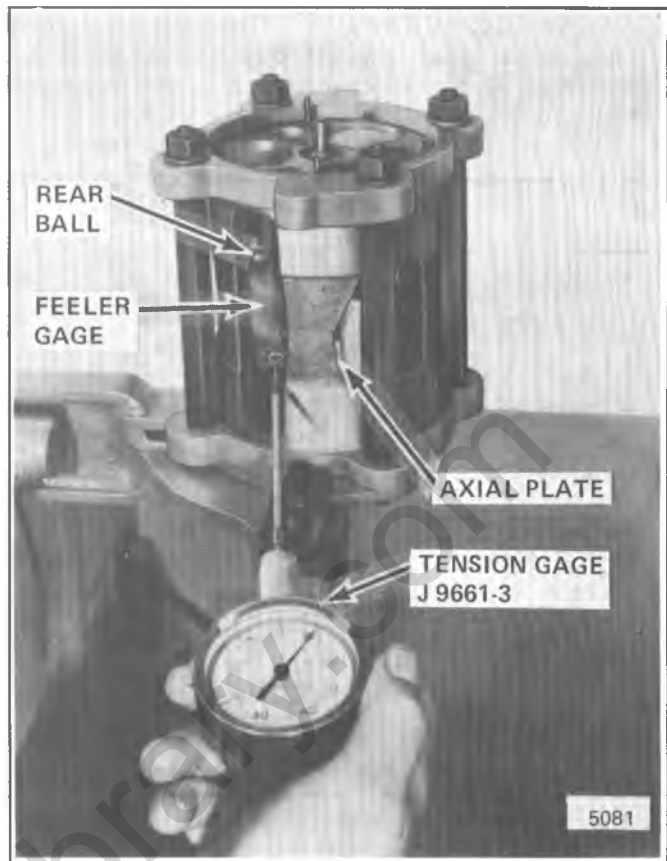

Fig. 1D-40 Gaging A-6 Rear Piston Ball

of 14 steel thrust races, including a basic ZERO race, are provided in increments of .01mm (.0005") thickness to provide the required fit.

Feeler and Tension Gage Set J 9564-01 or J 9661-01 may be used for gaging proper shoe disc size. Feeler Gage Set J 9564-01 or Dial Indicator Set J 8001 may be used to determine proper thrust race size.

Proper selection of thrust races and ball seats is of extreme importance.

15. Measure clearance between rear ball of No. 1 Piston and axial plate, in following manner:

a. Select a suitable combination of well-oiled Feeler Gage leaves to fit snugly between ball and axial plate.

b. Attach Tension Gage J 9661-3 to the feeler gage. A distributor point checking scale or Spring Scale J 544 may be used.

c. Pull on Spring Scale to slide Feeler Gage stock out from between ball and axial plate, and note reading on Spring Scale as Feeler Gage is removed (Fig. 1D-40). Reading should be between 4 and 8 ounces.

d. If reading in Step "c" above is under 4 OR over 8 ounces, reduce or increase thickness of Feeler Gage leaves and repeat Steps a. through c. above until a reading of 4 to 8 ounces is obtained. Record the clearance between ball and axial plate that results in the desired 4 to 8 ounce pull on Spring Scale.

16. Now rotate shaft 120° and repeat Step 15 between this same No. 1 Piston Rear Ball and axial plate. Record this measurement.

If shaft is hard to rotate, install shaft nut onto shaft and turn shaft with wrench.

17. Rotate shaft another 120° and again repeat Step 15 between these same parts and record measurements.

18. Select a "numbered" shoe disc corresponding to minimum feeler gage reading recorded in the three checks just made above. (See example in Fig. 1D-42). Place the selected shoe discs in Parts Tray J 9402 compartment corresponding to Piston No. 1 and Rear Ball pocket position.

Shoe discs are provided in .01mm (.0005") (one-half thousandths) variations. There are a total of 11 sizes available for field servicing. All shoe discs are marked with the shoe size, which corresponds to the last three digits of the piece part number. (See Shoe Disc Size Chart in Fig. 1D-41.)

Once a proper selection of the shoe has been made, the matched combination of shoe disc to rear ball and spherical cavity in piston must be kept in proper relationship during disassembly after Gaging operation, and during final assembly into the Internal Cylinder and Shaft Assembly.

19. Repeat in detail the same Gaging Procedure outlined in Steps 15 through 18 for Piston No. 2 and No. 3.

20A. Mount Dial Indicator J 8001 on edge of Compressing Fixture J 9397 with Clamp J 8001-1 and Sleeve J 8001-2 (Fig. 1D-43). Position Dial Indicator on rear end of axial shaft and adjust to "zero."

From bottom, apply full hand-force at end of shaft a few times before reading clearance. This will help squeeze the oil out from/between mating parts. Now push upward again and record measurement. Dial Indicator increments are .03mm (.001"); therefore, reading must be estimated to nearest .01mm (.0005").

SHOE DISC			THRUST BEARING RACE		
PART NO. ENDING IN	IDENTIFICATION STAMP	MIN. FEELER GAGE READING	PART NO. ENDING IN	IDENTIFICATION STAMP	DIAL INDICATOR READING
000	0	.0000	000	0	.0000
175	17-1/2	.0175	050	5	.0050
180	18	.0180	055	5-1/2	.0055
185	18-1/2	.0185	060	6	.0060
190	19	.0190	065	6-1/2	.0065
195	19-1/2	.0195	070	7	.0070
200	20	.0200	075	7-1/2	.0075
205	20-1/2	.0205	080	8	.0080
210	21	.0210	085	8-1/2	.0085
215	21-1/2	.0215	090	9	.0090
220	22	.0220	095	9-1/2	.0095
			100	10	.0100
			105	10-1/2	.0105
			110	11	.0110
			115	11-1/2	.0115
			120	12	.0120

200913

Fig. 1D-41 Available A-6 Service Shoes and Thrust Races

	POSITION 1	POSITION 2	POSITION 3	SELECT AND USE SHOE NO.
PISTON NO. 1	.019"	.0195"	.019"	19
PISTON NO. 2	.020"	.020"	.020"	20
PISTON NO. 3	.021"	.021"	.022"	21

200914

Fig. 1D-42 Selection of Proper A-6 Shoe Disc

20B. An alternate method of selecting a proper race is to use Gage Set J 9661-01 selecting a suitable feeler gage leaf until the result is a 4 to 8 ounce pull on the scale between the rear thrust bearing and upper (which also happens to be the outer rear) thrust race (Fig. 1D-44). If the pull is just less than 4 ounces, add .01mm (.0005") to the thickness of the feeler stock used to measure the clearance. If the pull on the scale reads just over 8 ounces, then subtract .01mm (.0005") from the thickness of the feeler stock.

21. For either method used, select a thrust race with a "number" corresponding to two (2) full sizes larger than Dial Indicator or Feeler Gage measurement of the amount of end play shown. (If measurement is .17mm (.007"), select a No.9 or 090 race.)

Place thrust race in right-hand slot at bottom center of parts tray J 9402.

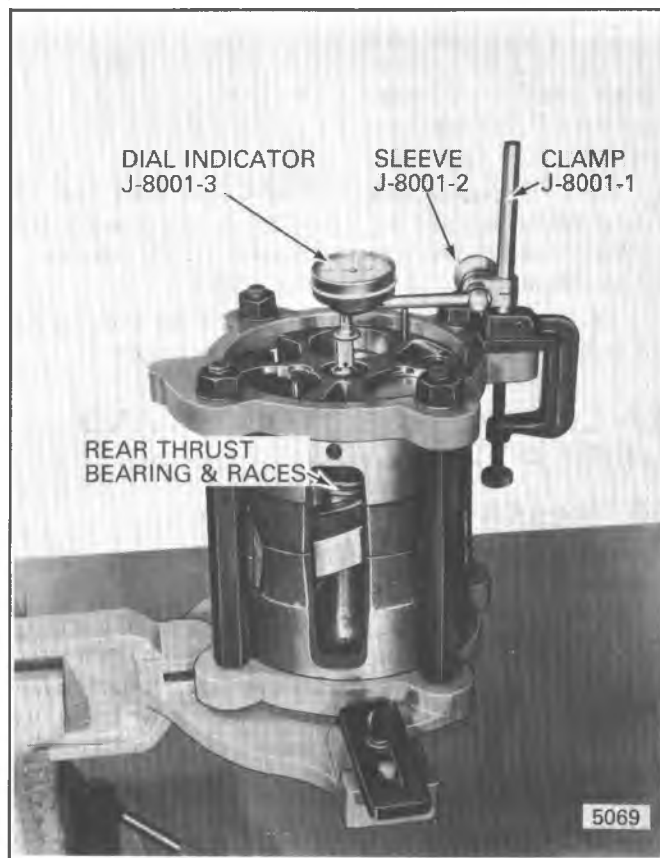

Fig. 1D-43 Gaging A-6 Rear Thrust Race

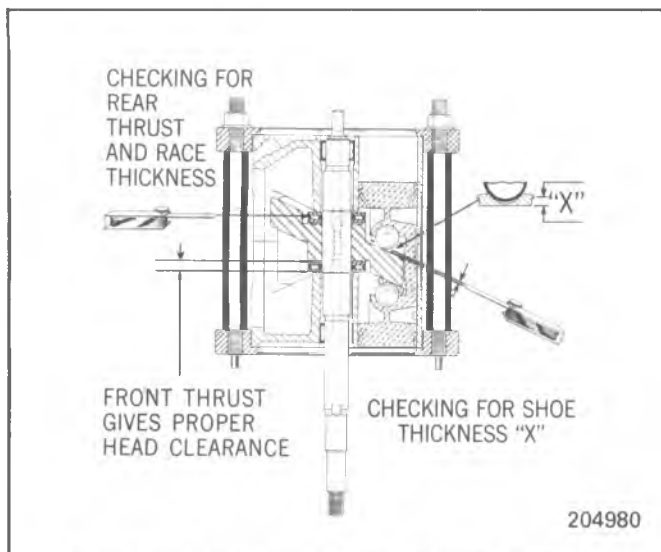

Fig. 1D-44 Checking A-6 Piston and Shaft End Play

Fifteen (15) thrust races are provided in increments of .01mm (.0005") (one-half thousandths) thickness and one ZERO gage thickness, providing a total of 16 sizes available for field service. The thrust race "number" also corresponds to the last three digits of the piece part number. See Thrust Race Size Chart in Fig. 1D-41.

22. Remove nuts from top plate of Compressing Fixture J 9397, and remove top plate.

23. Separate cylinder halves while unit is in Fixture. It may be necessary to use a wooden block and mallet.

24. Remove Rear Cylinder Half and carefully remove one piston at a time from axial plate and front cylinder half. Do not lose the relationship of the front ball and shoe disc and rear ball. Transfer each piston, ball and shoe disc to its proper place in Parts Tray J 9402.

25. Now remove rear outer zero thrust race (it will be on top) from shaft and install the thrust race just selected in Steps 20 and 21 that is presently setting in the right-hand slot at bottom center of Parts Tray J 9402.

The removed zero thrust race may be put aside for re-use in additional Gaging or rebuilding operations.

## A-6 COMPRESSOR CYLINDER AND SHAFT ASSEMBLY

### A-6 Teflon Piston Ring Replacement

The Teflon piston ring installing, sizing and gaging tools are shown in Fig. 1D-45.

1. Remove the old piston rings by carefully slicing through the ring with a knife or sharp instrument, holding the blade almost flat with the piston surface. Be careful not to damage the aluminum piston or piston groove in cutting to remove the ring. Exercise personal care in cutting the piston ring for removal to prevent injury.

2. Clean the piston and piston ring grooves with trichloroethane, naphtha, stoddard solvent, kerosene or equivalent solvent and blow the piston dry with DRY air.

3. Set the piston on-end on a clean, flat surface and install the Ring Installer Guide J 24608-2 on the end of the piston (Fig. 1D-46).

4. Install a Teflon ring on the Ring Installer Guide J 24605-2 as shown in Fig. 1D-47, with the dished or dull-side down and glossy-side up.

5. Push the Ring Installer J 24608-5 down over the Installer Guide J 24608-2 to install the Teflon ring in the piston ring groove (Fig. 1D-47). If the Teflon ring is slightly off position in the ring groove, it can be positioned into place by fingernail or blunt-edged tool that will not damage the piston.

The Ring Installer J 24608-5 will retain the Installer Guide J 24608-2 internally when the Teflon ring is installed on the piston. Remove the Installer Guide from the Ring Installer and do not store the installer guide in the ring installer, as the Ring Installer Segment Retainer O-Ring J 24608-3 will be stretched and possibly weakened during storage. This could result in the O-Ring J 24608-3 not holding the Ring Installer segments tight enough to the Installer Guide J 24608-2 to properly install the Teflon ring on the piston.

6. Lubricate the piston ring area with 525 viscosity refrigerant oil and rotate the Piston and Ring Assembly into the Ring Sizer J 24608-6 at a slight angle (Fig. 1D-48). Rotate the piston, while pushing inward, until the piston is inserted against the center stop of the Ring Sizer J 23608-6.

**NOTICE:** DO NOT push the Piston and Ring Assembly into the Ring Sizer J 24608-6 without proper positioning and rotating as described above, as the ends of the needle bearings of the Ring Sizer may damage the end of the piston.

7. Rotate the Piston and Ring Assembly in the Ring Sizer J 24608-6 several complete turns, until the Assembly rotates relatively free in the Ring Sizer (Fig. 1D-48).

8. Remove the Piston and Ring Assembly, wipe the end of the piston and ring area with a clean cloth and then push the Piston and Ring Assembly into the Ring Gage J 24608-1 (Fig. 1D-49). The piston should go through the Ring Gage with a 2 to 8 lb. force or less without lubrication. If not, repeat Steps 6 and 7.

9. Repeat the procedure for the opposite end of the piston (Fig. 1D-50).

**NOTICE:** DO NOT lay the piston down on a dirty surface where dirt or metal chips might come into contact and become imbedded in the Teflon ring surface.

10. Lubricate both ends of the piston with 525 viscosity refrigerant oil before inserting the piston into the cylinder bore.

**NOTICE:** Reasonable care should be exercised in installing the piston into the cylinder bore to prevent damage to the Teflon ring.

## A-6 COMPRESSOR INTERNAL CYLINDER AND SHAFT ASM.

### Assembly

After properly performing the "Gaging Procedure," choosing the correct shoe discs and thrust races, and





Fig. 1D-45 A-6 Teflon Piston Ring Installing, Sizing and Gaging Tools



Fig. 1D-46 A-6 Teflon Piston Ring Positioned on Ring Installer Guide

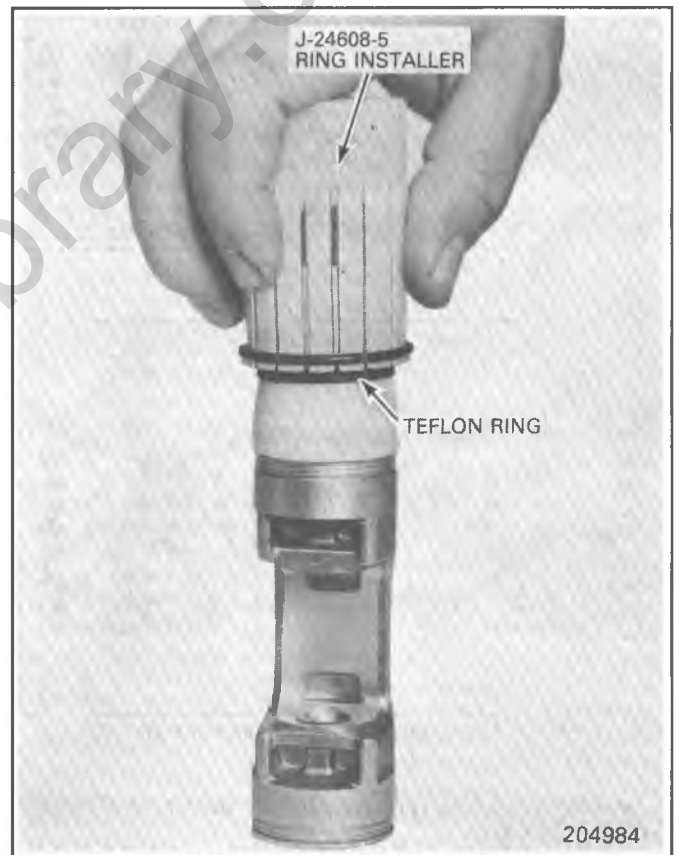

Fig. 1D-47 Installing A-6 Teflon Piston Ring

installing any needed Teflon piston rings, the cylinder assembly may now be reassembled. Be sure to install all new seals and O-rings. All are included in the compressor O-Ring Service Kit.

Assembly procedure is as follows:

1. Support the front half of the cylinder assembly on Compressing Fixture J 9397. Install the shaft and axial plate, threaded end down, with its front bearing race pack (ZERO race-bearing-ZERO race), if this was not already done at the end of the "Gaging Procedure." Install rear bearing race pack (ZERO race-bearing-NUMBERED race).

2. Apply a light smear of petroleum jelly to the shoe discs and piston ball sockets and install all balls and shoe discs in their proper place in the piston assembly.

3. Rotate the axial plate so that the high point is above cylinder bore No. 1.

- a. Carefully assemble Piston No. 1, complete with ball and "zero" shoe disc on the front and ball and "numbered" shoe disc on the rear, over the axial plate.

- b. Hold front thrust bearing pack tightly against axial plate hub while lifting shaft and axial plate to install piston asm.

## 1D-20 AIR CONDITIONING COMPRESSOR OVERHAUL

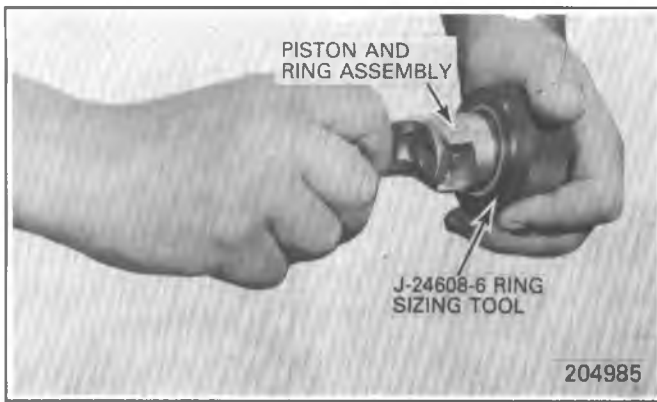

Fig. 1D-48 Turning A-6 Piston and Ring Asm. Into Ring Sizing Tool

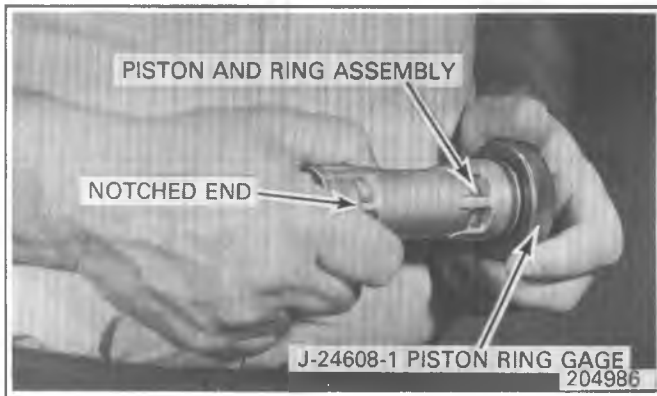

Fig. 1D-49 Gaging A-6 Piston Ring Size

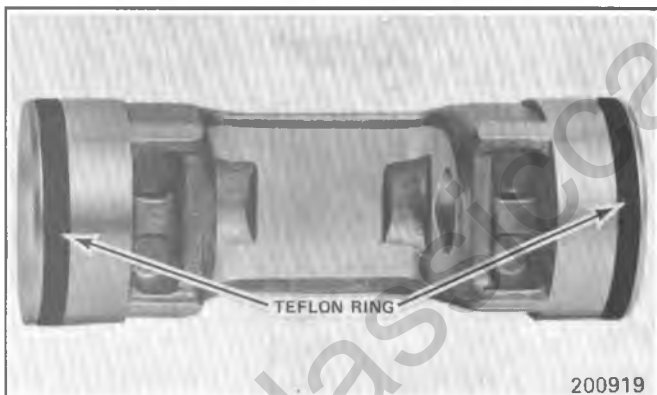

Fig. 1D-50 A-6 Teflon Piston Ring Installed in Piston Groove

c. Insert the Piston Assembly into the Front Cylinder Half (Fig. 1D-51).

4. Repeat this operation for Pistons No. 2 and No. 3 (Fig. 1D-52).

5. Without installing any O-rings or bushings, assemble one end of the new Service Discharge Cross-Over Tube into the hole in the front cylinder half (Figs. 1D-53 and 1D-54).

Be sure the flattened portion of this tube faces the inside of the compressor to allow for axial plate clearance (Fig. 1D-54).

6. Now rotate the shaft to position the pistons in a stair-step arrangement; then carefully place the Rear Cylinder Half over the shaft and start the pistons into the cylinder bore (Fig. 1D-55).

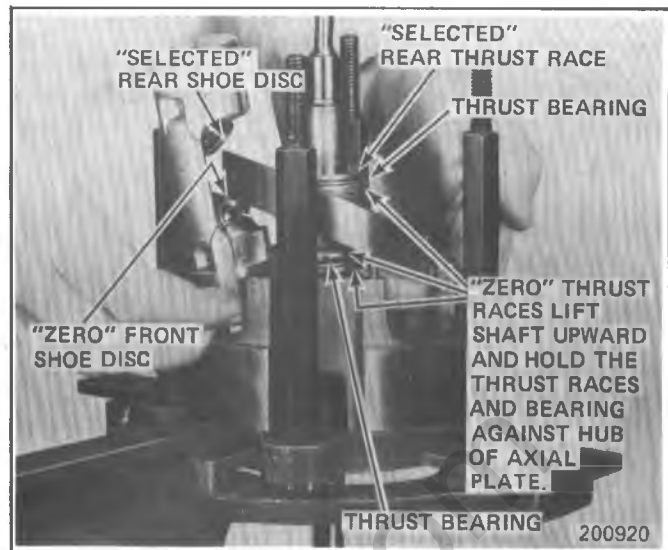

Fig. 1D-51 Installing 1st A-6 Piston Assembly Into Front Cylinder Half

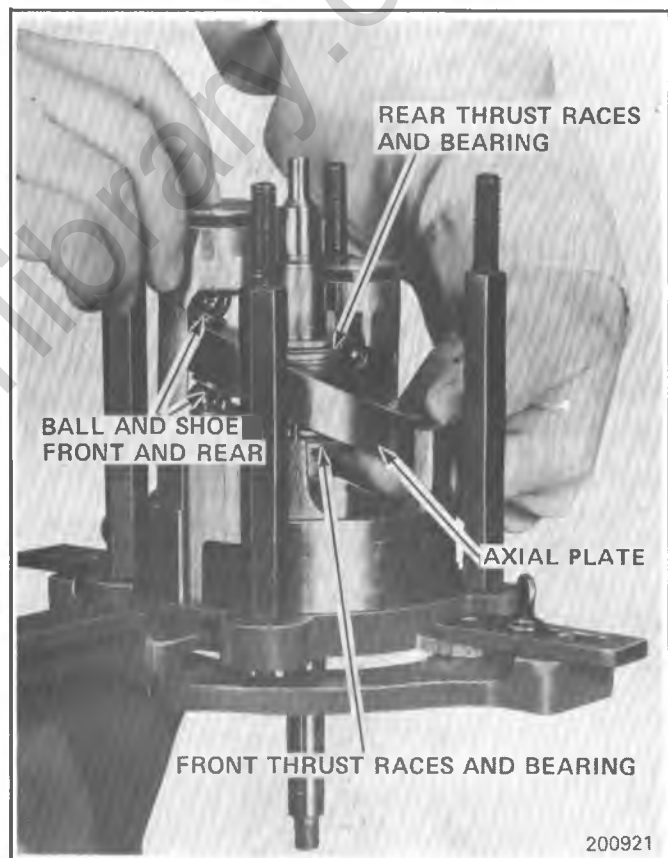

Fig. 1D-52 Installing 2nd A-6 Piston

7. When all three Piston and Ring assemblies are in their respective cylinders, align the end of the discharge cross-over tube with the hole in the rear half of the cylinder.

8. When all parts are in proper alignment, tap with a clean wooden block and mallet to seat the rear half of the cylinder over the locating dowel pins. If necessary, clamp the cylinder in Compressing Fixture J 9397, to complete drawing the cylinder halves together.

9. Generously lubricate all moving parts with clean 525 viscosity refrigerant oil and check for free rotation of the parts.

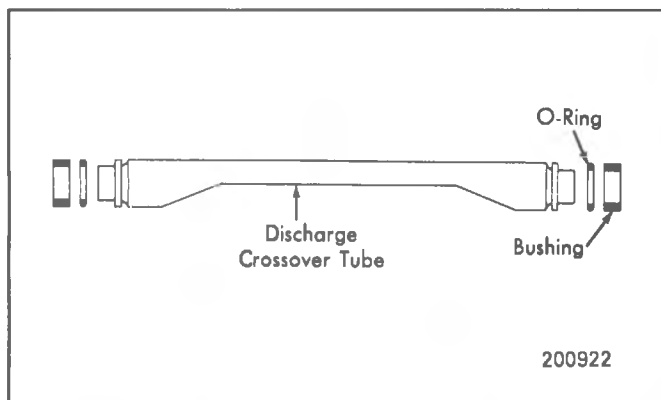

Fig. 1D-53 Service-type A-6 Discharge Cross-Over Tube

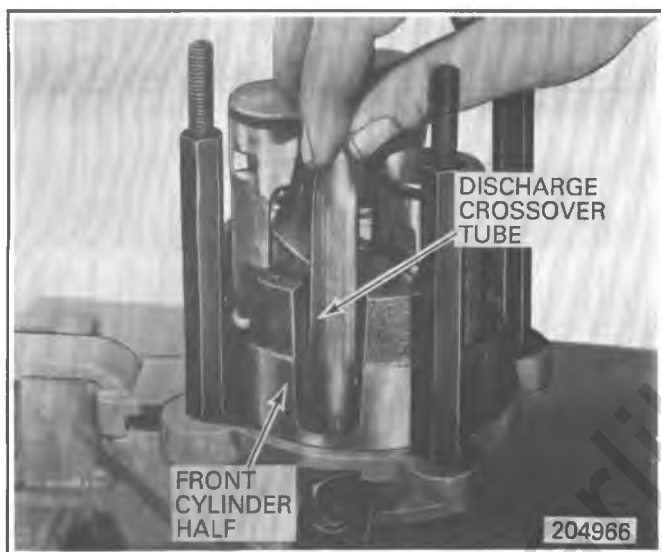

Fig. 1D-54 Installing A-6 Discharge Cross-over Tube

10. Replace the Suction Cross-Over Cover (Fig. 1D-56). Compress the cover as shown to start it into the slot, and then press or carefully tap it in until flush on both ends.

## A-6 COMPRESSOR INTERNAL CYLINDER AND SHAFT ASM

### Re-Install

1. Place Internal Cylinder and Shaft Assembly on Internal Assembly Support Block J 21352, with rear-end of shaft in Support Block hole.

2. Now install new O-ring and bushing in front-end of discharge cross-over tube (Fig. 1D-57). The O-ring and bushing are Service parts only for Internal Cylinder and Shaft Assemblies that have been disassembled in the field (Also see Fig. 1D-53).

3. Install new dowel pins in front cylinder half, if previously removed.

4. Install Front Suction Reed Plate on front cylinder half. Align with dowel pins, suction ports, oil return slot, and discharge cross-over tube (Fig. 1D-58).

5. Install Front Discharge Valve Plate assembly (it has a large diameter hole in the center), aligning holes with dowel pins and proper openings in front suction reed plate (Fig. 1D-59 and Fig. 1D-60).

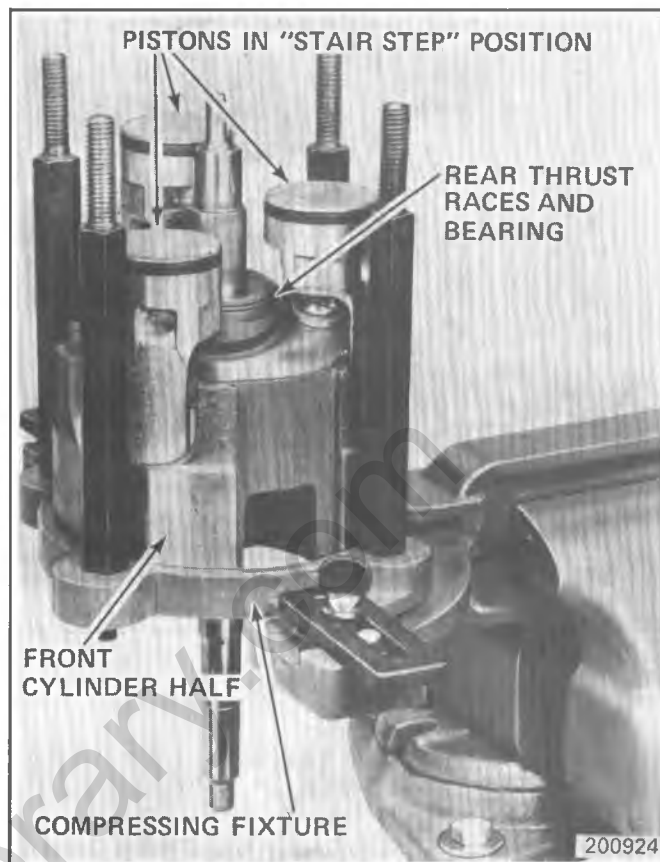

Fig. 1D-55 A-6 Pistons Positioned in Stair-Step Arrangement

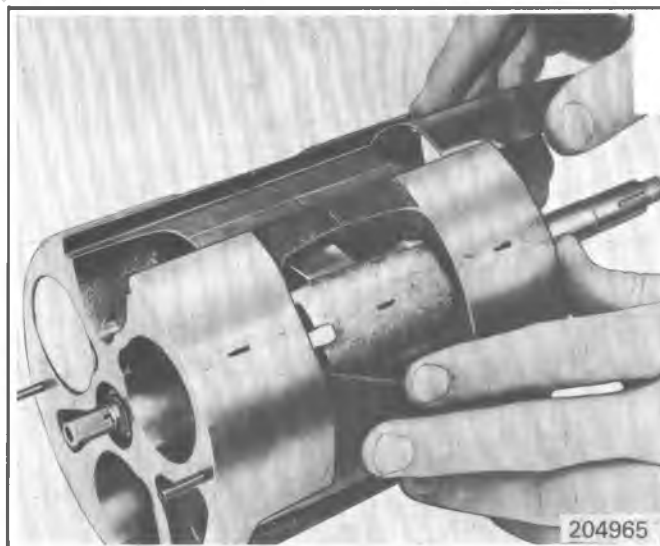

Fig. 1D-56 Installing A-6 Suction Cross-over Cover

6. Coat sealing surfaces on webs of compressor front head casting with clean 525 viscosity refrigerant oil.

7. Determine exact position of Front Head casting in relation to dowel pins on Internal Cylinder and Shaft Assembly. Mark position of dowel pins on sides of Front Head assembly and on sides of Internal Cylinder and Shaft Assembly with a grease pencil. Carefully lower Front Head casting into position (Fig. 1D-61), making certain that sealing area around center bore of head assembly does not contact shaft as head assembly is lowered. Do not rotate head assembly to line up with dowel pins, as the sealing areas would then contact the reed retainers.

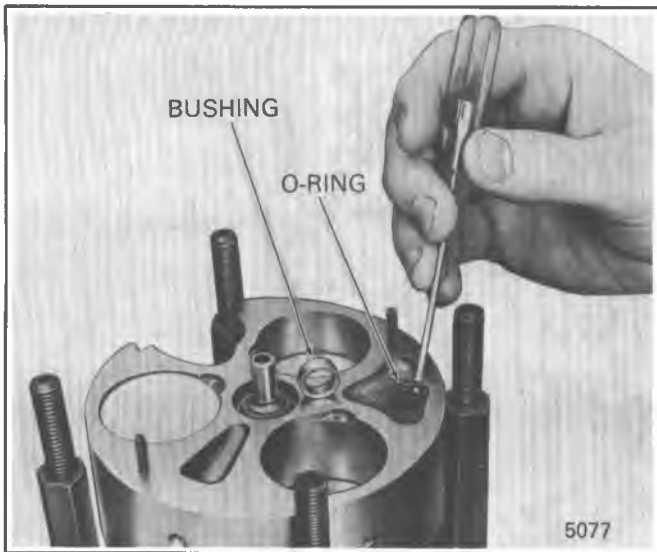

Fig. 1D-57 Installing O-Ring On A-6 Discharge Cross-Over Tube

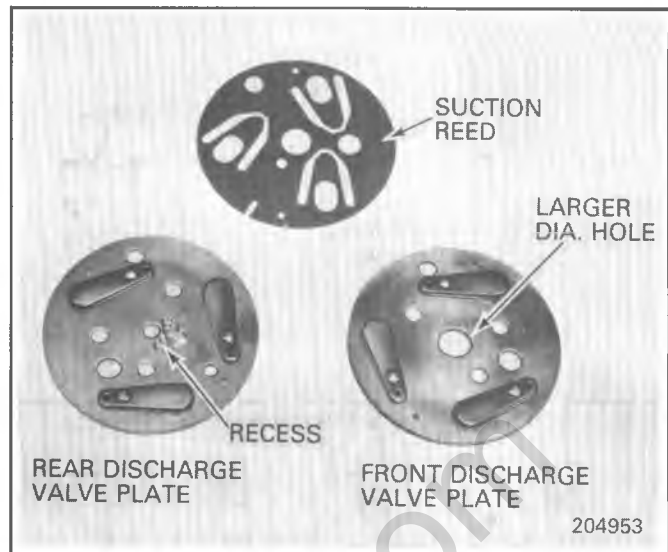

Fig. 1D-60 Front and Rear A-6 Discharge Valve Plates

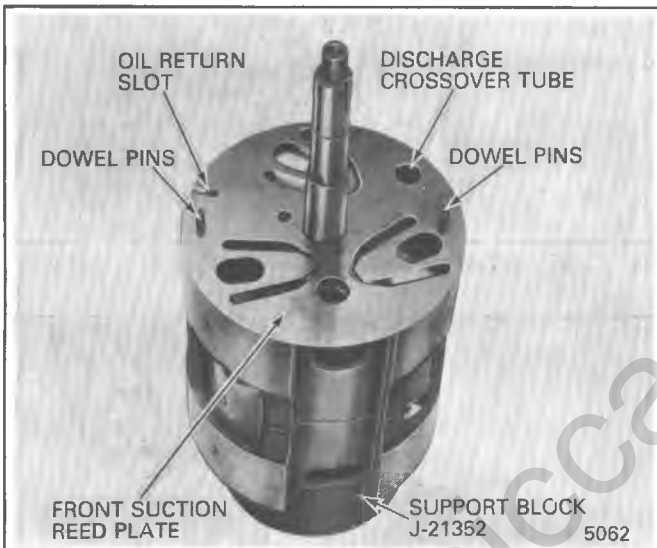

Fig. 1D-58 Installing A-6 Front Suction Reed



Fig. 1D-61 Installing A-6 Front Head Casting

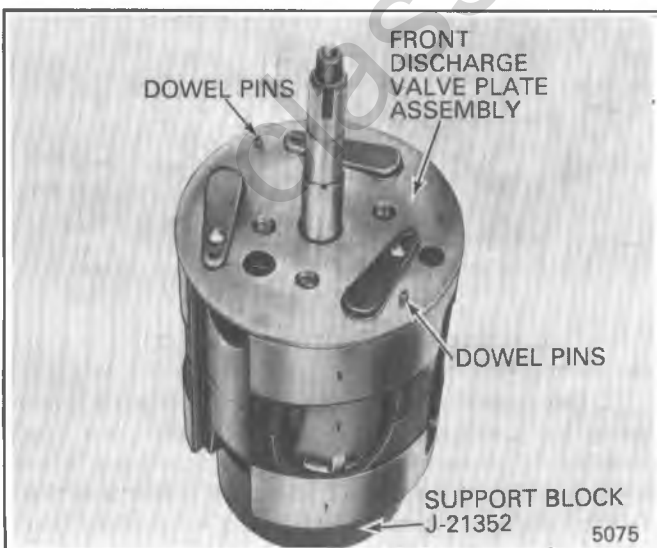

Fig. 1D-59 Installing A-6 Front Discharge Valve Plate

8. Generously lubricate new O-ring and angled groove at lower edge of front head casting with 525 viscosity refrigerant oil and install new O-ring into groove (Fig. 1D-62).

9. Coat inside machined surfaces of compressor shell with 525 viscosity refrigerant oil and position shell on Internal Cylinder and Shaft Assembly, resting on J21352 support block.

10. Using flat-side of a small screwdriver, gently position O-ring in around circumference of Internal Cylinder and Shaft Assembly until Compressor Shell slides down over Internal Cylinder and Shaft Assembly. As shell



Fig. 1D-62 A-6 Front Head O-Ring Installed



Fig. 1D-63 Installing A-6 Compressor Shell

slides down, line up oil sump with oil intake tube hole (Fig. 1D-63).

11. Holding Support Block J 21352 with one hand, invert Internal Cylinder and Shaft Assembly and place back into Holding Fixture J9396 with front end of shaft now facing downward. Remove Support Block.

12. Install new dowel pins in rear cylinder half, if previously removed.

13. Install new O-ring in oil pick-up tube cavity.

14. Lubricate Oil Pick-Up Tube with 525 viscosity refrigerant oil and install into cavity, rotating compressor mechanism to align tube with hole in shell baffle (Fig. 1D-64).

15. Now install new O-ring and bushing on rear-end of discharge cross-over tube (See Fig. 1D-53).

16. Install Rear Suction Reed over dowel pins, with slot towards sump.

17. Install Rear Discharge Valve Plate assembly over dowel pins, with reed retainers UP.

18. Position Inner Oil Pump Gear over shaft with previously applied identification mark UP.

19. Position Outer Oil Pump Gear over inner gear with previously applied identification mark up and, when standing facing oil sump, position outer gear so that it meshes with inner gear at the 9-o'clock position. The resulting cavity between gear teeth is then at 3-o'clock position (Fig. 1D-65).

20. Generously oil Rear Discharge Valve Plate assembly with 525 viscosity refrigerant oil around outer edge where large diameter O-ring will be placed. Oil the valve reeds, pump gears, and area where sealing surface will contact Rear Discharge Valve Plate.



Fig. 1D-64 Installing A-6 Oil Pick-up Tube

21. Using the 525 oil, lubricate new head to-shell O-ring and install on rear discharge valve plate, in contact with shell (Fig. 1D-66).

22. Install Suction Screen in rear head casting, using care not to damage screen.

23. Coat sealing surface on webs of compressor rear head casting with 525 viscosity refrigerant oil.

24. Install Rear Head assembly over studs on compressor shell. The two lower threaded compressor mounting holes should be in alignment with the compressor sump.

Make certain that suction screen does not drop out of place when lowering rear head into position (Fig. 1D-67).

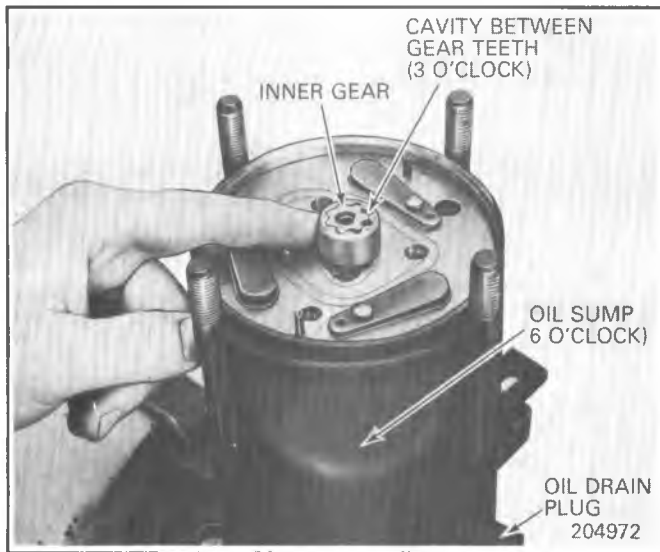

Fig. 1D-65 Positioning A-6 Oil Pump Gears

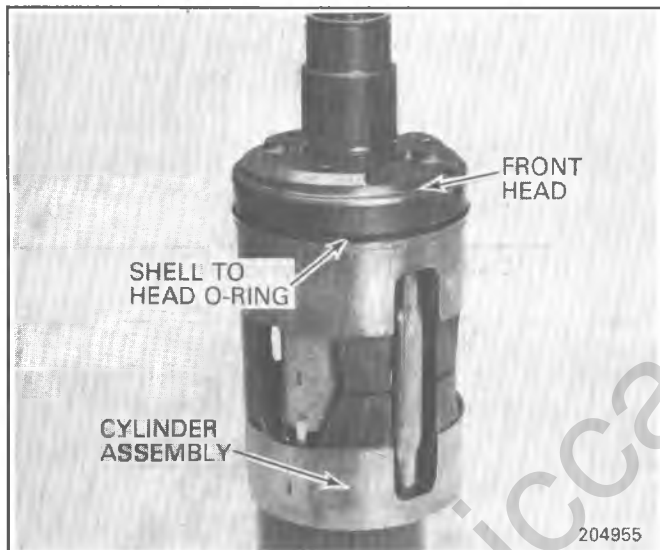

Fig. 1D-66 A-6 Shell-To-Front Head O-Ring Installation

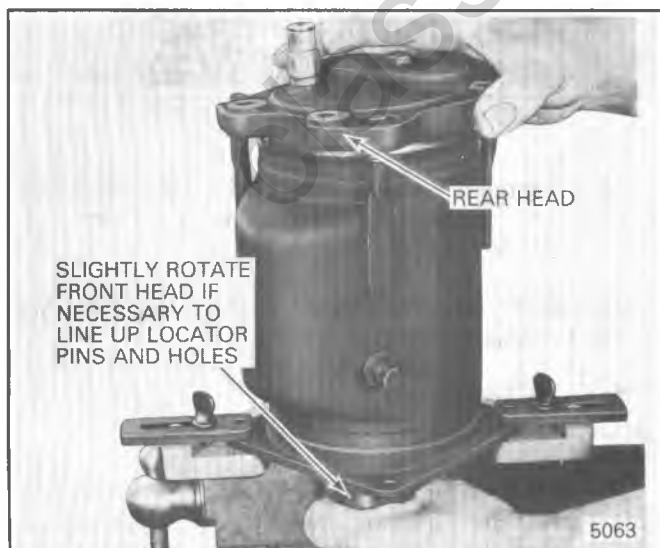

Fig. 1D-67 Installing A-6 Rear Head

If Rear Head assembly will not slide down over dowels in Internal Cylinder and Shaft Assembly, twist Front Head assembly back-and-forth very slightly by-hand until Rear Head drops over dowel pins (Fig. 1D-67).

25. Install nuts on threaded shell studs and tighten evenly to 34 N·m (25 lb. ft.) torque using a 0-60 N·m (0-50 lb. ft.) torque wrench.

26. Invert compressor in Holding Fixture and install compressor Shaft Seal as described in "A-6 Compressor Shaft Seal" Replacement procedure.

27. Install compressor Clutch Coil and Housing assembly as described in "A-6 Compressor Clutch Coil and Housing Asm." Replacement procedure.

28. Install compressor Pulley and Bearing assembly as described in "A-6 Compressor Pulley and Bearing" Replacement procedure.

29. Install compressor Clutch Plate and Hub assembly as described in "A-6 Compressor Clutch Plate and Hub Asm." Replacement procedure.

30. Add required amount of 525 viscosity refrigerant oil (see "C.C.O.T. Refrigerant Oil Distribution" in the Air Conditioning section).

31. Check for external and internal leaks as described in the following "A-6 Compressor Leak Testing" procedure found at the end of this over-haul section.

32. "Evacuate and charge the refrigerant system" according to the Discharging, Adding Oil, Evacuating and Charging Procedures for C.C.O.T. A/C Systems in the Air Conditioning section.

## MINOR REPAIR PROCEDURES FOR THE R-4 COMPRESSOR

THE FOLLOWING OPERATIONS TO THE R-4 COMPRESSOR CLUTCH PLATE AND HUB, ROTOR AND BEARING, AND COIL & PULLEY RIM ARE COVERED AS "MINOR" BECAUSE THEY MAY BE PERFORMED WITHOUT FIRST PURGING THE SYSTEM OR REMOVING THE COMPRESSOR FROM THE VEHICLE.

The Compressor Shaft Seal assembly, and Pressure Relief Valve may also be serviced WITHOUT REMOVING THE COMPRESSOR from the vehicle but these operations are covered later in this section as "Major Repair Procedures" because the system MUST FIRST BE PURGED of Refrigerant-12.

Illustrations used in describing these operations show the compressor removed from the vehicle only to more clearly illustrate the various operations.



Fig. 1D-68 R-4 Compressor

When servicing the compressor, remove only the necessary components that preliminary diagnosis indicates are in need of service. Refer to the AIR CONDITIONING section and Fig. 1D-69 and Fig. 1D-70 for information relative to parts nomenclature and location.

Removal and installation of external compressor components and disassembly and assembly of internal components must be performed on a clean workbench. The work area, tools and parts must be kept clean at all times.

### R-4 COMPRESSOR CLUTCH PLATE AND HUB ASM.

#### Remove

1. If compressor is on the car, loosen compressor mounting brackets, disconnect the compressor drive belt and reposition the compressor for access, if necessary.

If compressor has been removed from the car, attach the compressor to Holding Fixture J 25008-1, and clamp the Holding Fixture in a vise (Fig. 1D-71).

- Compressor mounting holes are metric. Use proper metric bolts with holding fixture J 25008-1.

2. Keep the clutch hub from turning with the Clutch Hub Holding Tool J 25030, remove, and discard the shaft nut, using Thin Wall Socket J 9399, Fig. 1D-72.

3. Thread the Clutch Plate and Hub Assembly Remover J 9401, into the hub. Hold the body of the Remover with a wrench and turn the center screw into the Remover body to remove the Clutch Plate and Hub assembly (Fig. 1D-73).

4. Remove the shaft key.

#### Replace

1. Install the shaft key into the hub key groove (Fig. 1D-74). Allow the key to project approximately 4.8mm (3/16") out of the keyway.

The shaft key is curved slightly to provide an interference fit in the shaft key groove of the hub.

2. Be sure the frictional surface of the clutch plate and the clutch rotor are clean before installing the Clutch Plate and Hub assembly.

3. Align the shaft key with the shaft keyway and place the Clutch Plate and Hub assembly onto the compressor shaft.

**NOTICE:** To avoid internal damage to the compressor, do not drive or pound on the clutch hub or shaft.

4. Install the Clutch Plate and Hub Installer J 9480-01 as illustrated in Fig. 1D-75.

5. Hold the hex portion of the Installer Body J 9480-1 with a wrench and tighten the center screw to press the hub onto the shaft until there is a .5mm - 1.0mm (.020"-.040") inch air gap between the frictional surfaces of the clutch plate and clutch rotor.

6. Install a new shaft nut with the small diameter boss of the nut against the crankshaft shoulder, using Thin Wall Socket J 9399. Hold the Clutch Plate and Hub assembly with Clutch Hub Holding Tool J 25030, and tighten to 14 N·m (10 lb. ft.) torque, using a 0-60 N·m (0-25 pounds) torque wrench.

7. If operation is performed with compressor on car, connect drive belt, tighten mounting brackets and adjust belt tension.

### R-4 COMPRESSOR CLUTCH ROTOR AND/OR BEARING

#### Remove

1. Remove the Clutch Plate and Hub assembly as described in "R-4 Compressor Clutch Plate & Hub Asm." Removal procedure.

2. Remove Rotor and Bearing assembly retaining ring, using Snap Ring Pliers J 6083, Fig. 1D-76. Mark the location of the clutch coil terminals.

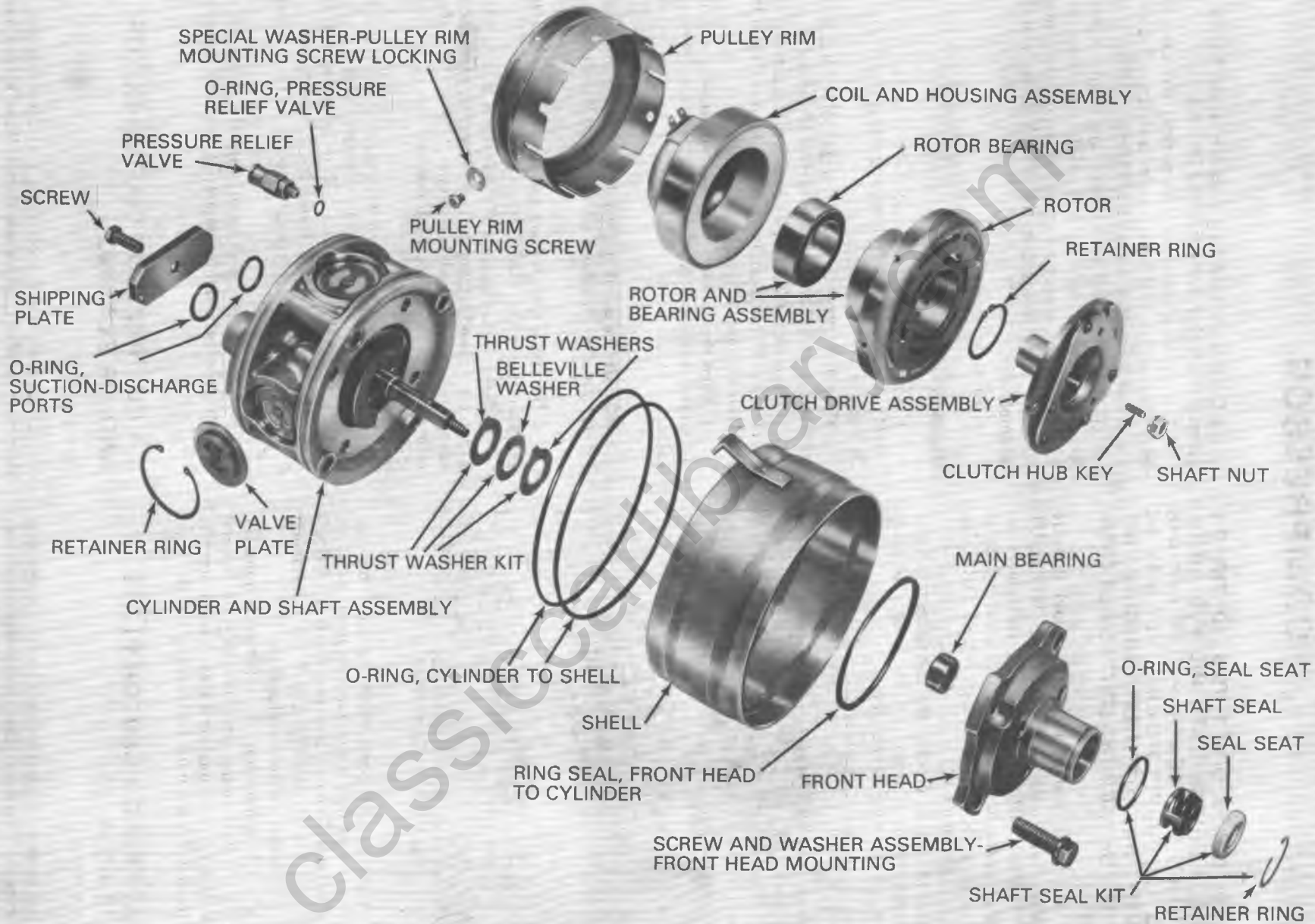

Fig. 1D-69 Exploded View of R-4 Compressor



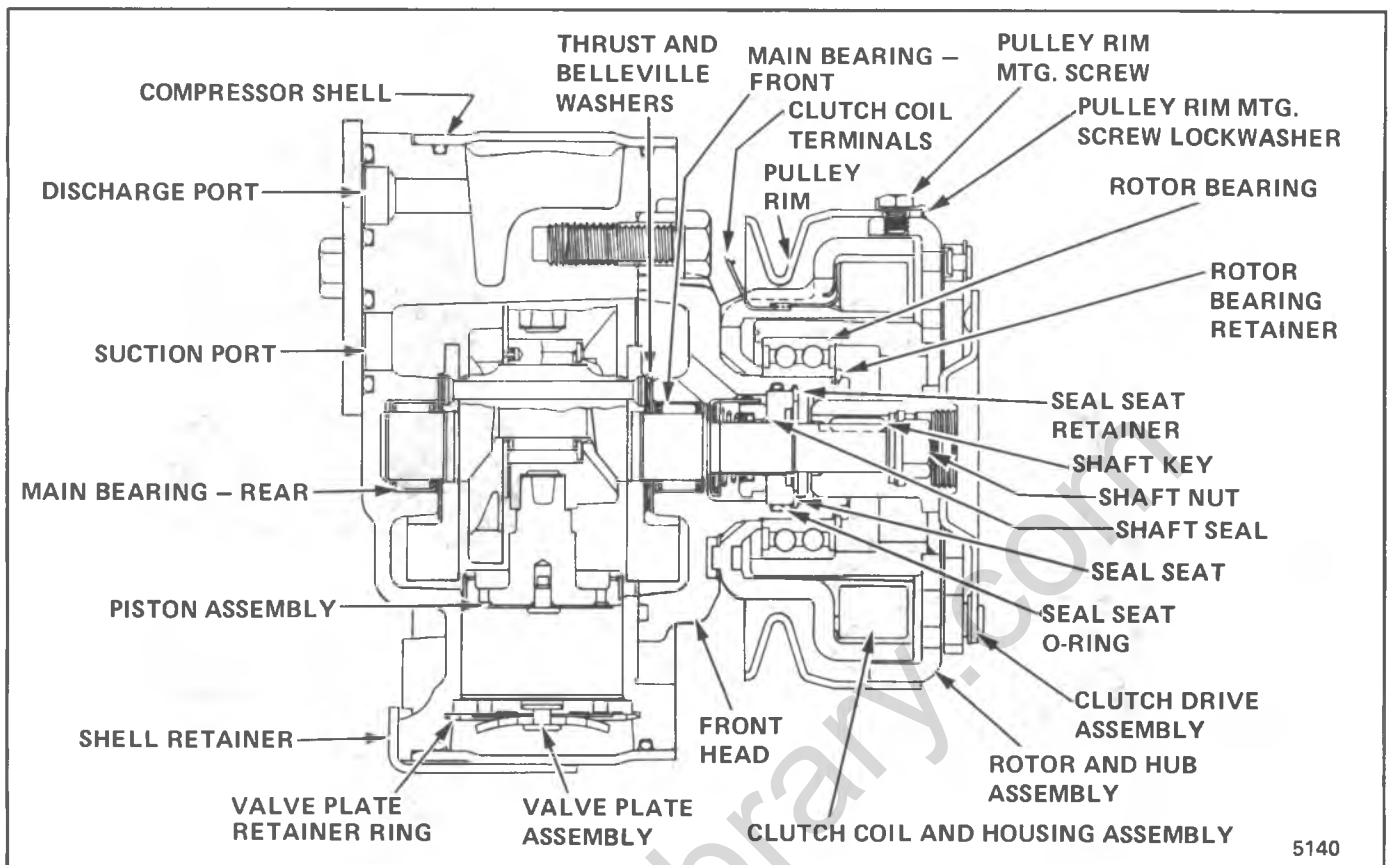

Fig. 1D-70 R-4 Compressor Cross Section

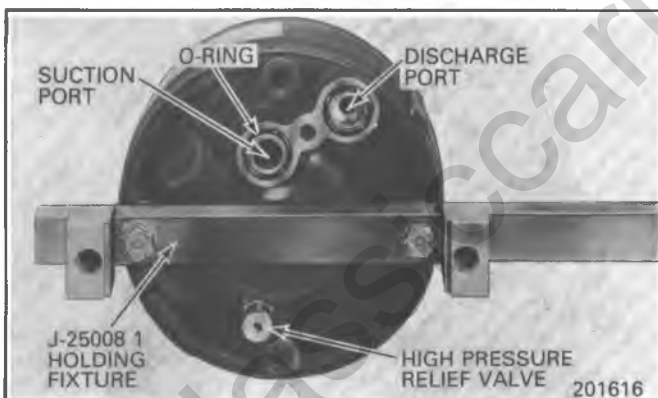

Fig. 1D-71 R-4 In Holding Fixture

If only the Clutch Rotor and/or Rotor Bearing are to be replaced, bend the lockwashers away from the pulley rim mounting screws (see Fig. 1D-77), and remove the six mounting screws and special lock washers before proceeding with Step 3. Discard the lock washers.

3. Install Rotor and Bearing Puller J 25031-2 down into the rotor until the Puller arms engage the recessed edge of the rotor hub. Hold the Puller and arms in place and tighten the Puller screw against the Puller Guide to remove the Clutch Rotor and Bearing assembly (Fig. 1D-77 and 1D-78), being careful not to drop the Puller Guide.

4. If the pulley rim mounting screws and washers were removed in Step 2, only the Clutch Rotor and Bearing assembly will be removed for replacement. The Clutch Coil and Housing assembly is pressed onto the Front Head of the compressor with a press fit and will not be removed unless the pulley rim mounting screws are left securely in

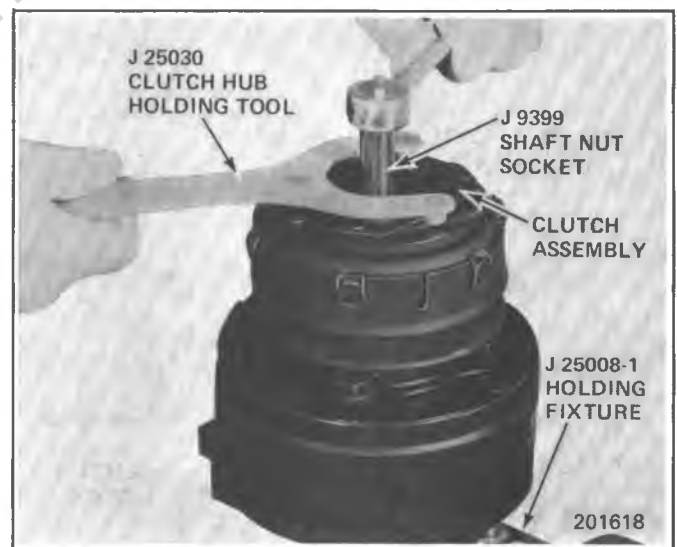

Fig. 1D-72 Removing R-4 Shaft Nut

place and the pulley rim pulls the Coil and Housing assembly off with the total Clutch Rotor and Pulley Rim Assembly.

5. Place the Rotor and Bearing assembly on blocks as shown in Fig. 1D-79. Drive the bearing out of the rotor hub with Rotor Bearing Remover J 9398.

It is not necessary to remove the staking at the rear of the rotor hub to remove the bearing however, it will be necessary to file away the old stake metal for proper clearance for the new bearing to be installed into the rotor bore or bearing may be damaged (see Fig. 1D-80).

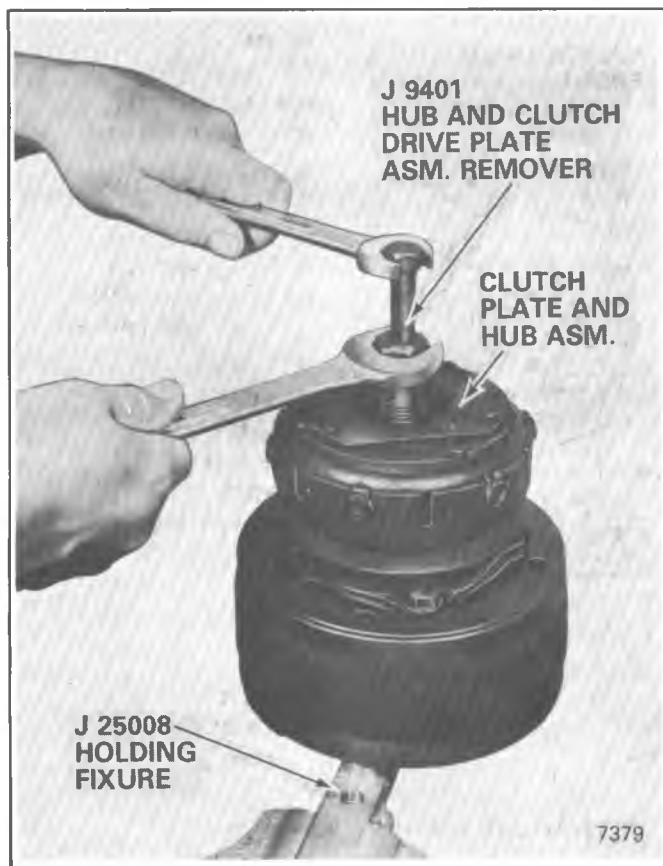

Fig. 1D-73 R-4 Clutch Plate & Hub Asm. Removal

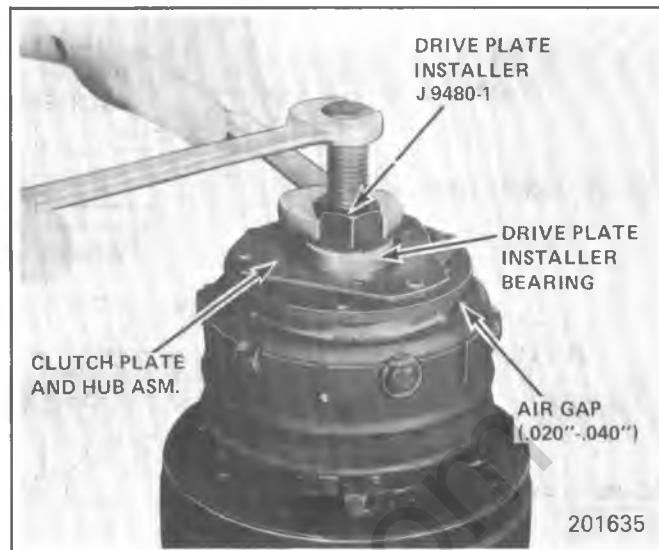

Fig. 1D-75 Installing R-4 Clutch Plate & Hub Asm.

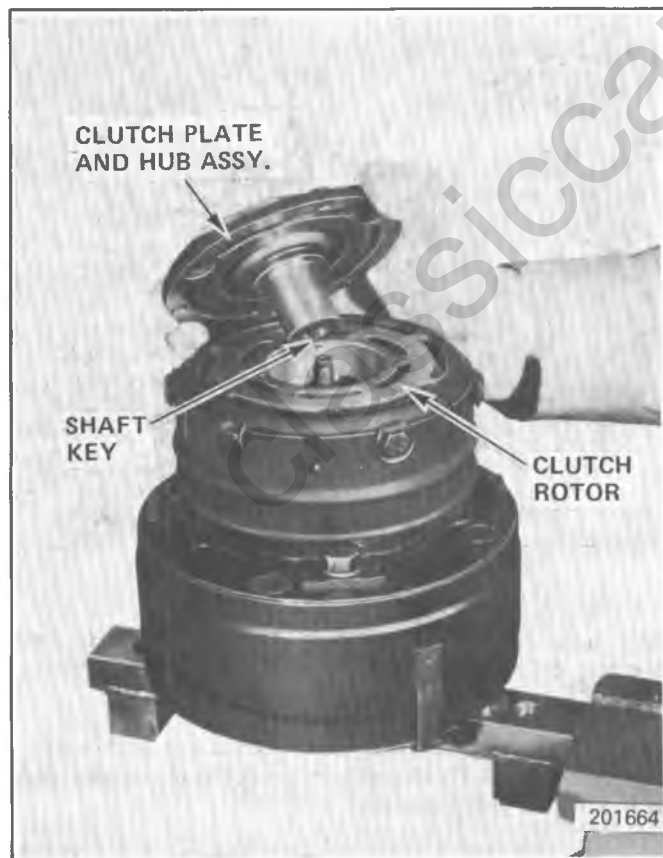

Fig. 1D-74 Installing R-4 Shaft Key

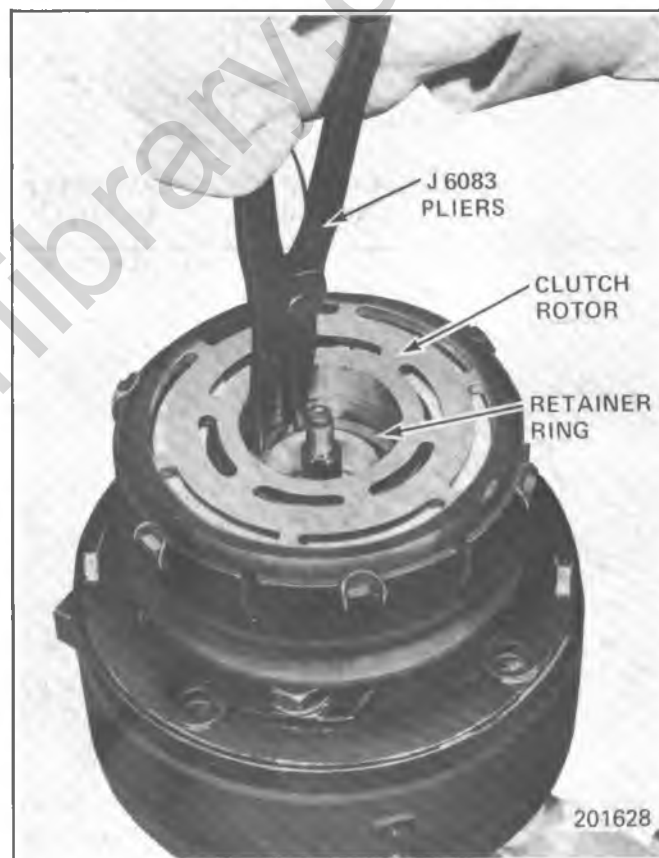

Fig. 1D-76 Removing R-4 Rotor & Bearing Asm. Retainer Ring

### Replace

1. Place the Rotor and Hub assembly face down on a clean, flat and firm surface.

2. Align the new bearing squarely with the hub bore and using Pulley and Bearing Installer J 9481 with Universal Handle J 8092, drive the bearing fully into the hub (Fig. 1D-81). The Installer will apply force to the outer race of the bearing if used as shown.

3. Using a center punch with a 45° angle point, stake 1.1 - 1.4mm (0.45"-.055" deep) the bearing in three places



Fig. 1D-77 Installing R-4 Rotor & Bearing Puller Guide



Fig. 1D-78 Removing R-4 Clutch Rotor Asm.

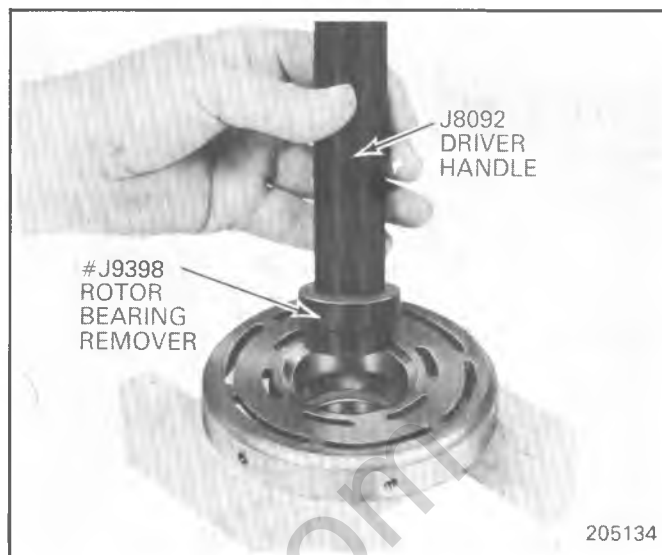

Fig. 1D-79 R-4 Clutch Rotor Bearing Removal

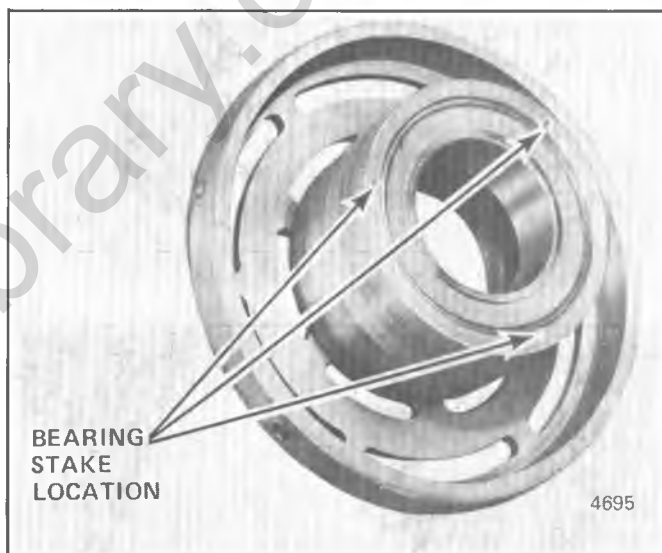

Fig. 1D-80 R-4 Rotor & Bearing Asm.

120° apart as shown in Fig. 1D-80, but do not stake too deeply to avoid distorting the outer race of the bearing.

4. Replace rotor & bearing asm. (on car)

A. Position the Rotor and Bearing assembly on the front head.

B. With Rotor & Bearing Installer J 26271 (without driver handle) in position and Rotor and Bearing assembly aligned with the Front Head as shown in (Fig. 1D-82), drive the assembly part way onto the head (Fig. 1D-82).

C. Plug clutch coil connector onto Clutch Coil.

D. Position the Clutch Coil so the 3 locating tabs will align with the holes in the head and continue to drive the Rotor and Bearing assembly onto the front head.

E. Install the retainer ring (Fig. 1D-76).

F. Reassemble the Clutch Plate and Hub with the shaft key onto the shaft with Installer J 9480-1 until .5 - 1.0mm (.020" to .040") air gap is obtained.

G. Install shaft lock nut. Torque to 14 N·m (10 lb. ft.).

4. Replace rotor & bearing asm. (on bench).

Reassemble the Rotor and Bearing assembly to the front head of the compressor using Rotor & Bearing



Fig. 1D-81 Installing R-4 Clutch Rotor Bearing

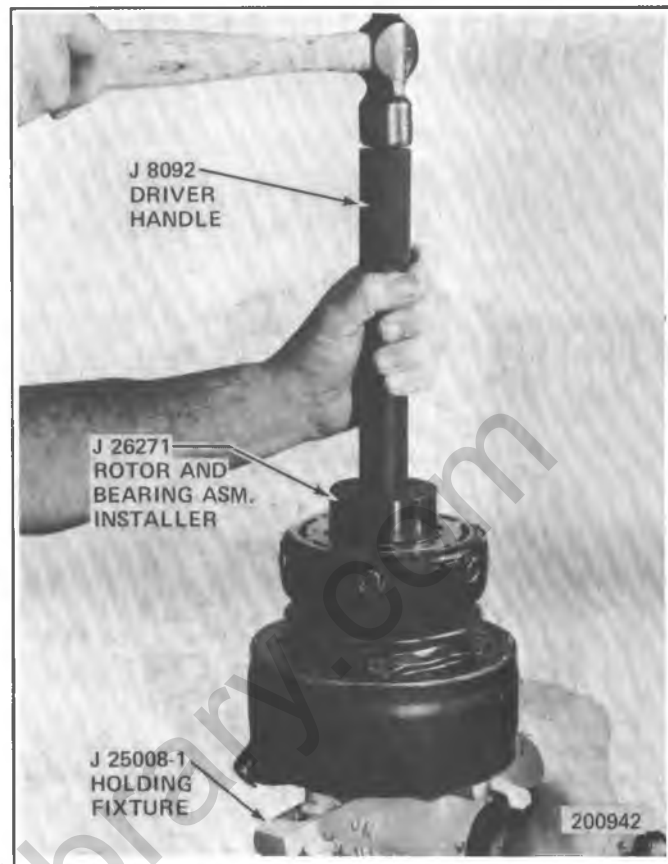

Fig. 1D-83 Installing R-4 Rotor & Bearing Asm. (On Bench)

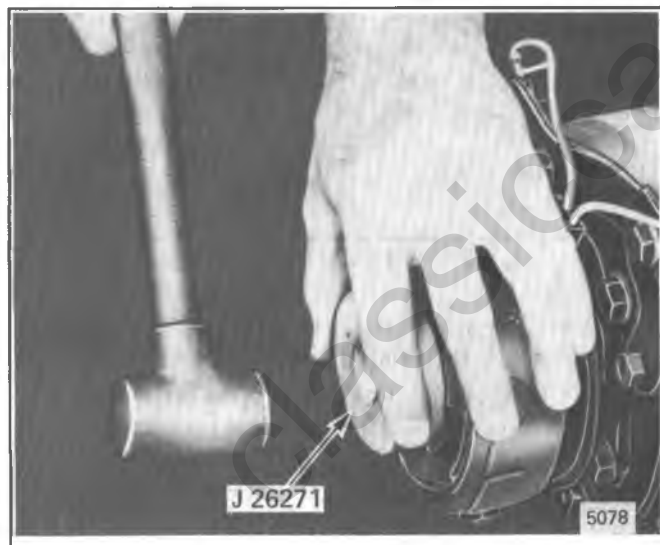

Fig. 1D-82 Installing R-4 Rotor and Bearing Asm. (On Car)

Installer J 26271. With Installer assembled to the Universal Handle J 8092, as shown in Fig. 1D-83, force will be applied to the inner race of the bearing and the face of the rotor when installing the assembly onto the front head of the compressor.

5. Install rotor and bearing assembly retainer ring, using Snap Ring Pliers J 6083 (see Fig. 1D-76).

6. Apply sealer (Loctite RC-75, Loctite 601 or equivalent) to threads of pulley rim mounting screws. Install screws and new special lock washers but do not torque the screws.

7. Rotate the pulley rim and rotor to insure that pulley rim is rotating "in-line." If pulley rim is distorted (does not rotate in-line) adjust or replace pulley rim.

8. Tighten pulley rim mounting screws to 11 N·m (100 inch-pounds) torque and lock screw heads in place by bending special lock washers (Fig. 1D-83), similar to original crimp and lock bends on washers.

9. Reinstall Clutch Plate and Hub assembly as described in "R-4 Compressor Clutch Plate and Hub" Replacement procedures.

## R-4 COMPRESSOR CLUTCH COIL AND/OR PULLEY RIM

- If original pulley rim was equipped with an inertia ring, either bolted or welded on, or if a ring is to be added, refer to inertia ring installation following.

### Remove

1. Perform Steps 1 through 4 of "R-4 Compressor Clutch Rotor and/or Bearing" Removal procedure but do not loosen or remove the pulley rim mounting screws until the Clutch Rotor, Coil and Pulley Rim assembly have been removed from the Front Head. Be careful not to drop the Puller Guide J 25031-1 when removing the assembly.

2. Remove the pulley rim mounting screws and special lock washers. Discard the lock washers and screws.

3. Slide the pulley rim off the Rotor and Hub assembly. The Pulley Rim and the Clutch Coil (Fig. 1D-84) are replaceable at this point.

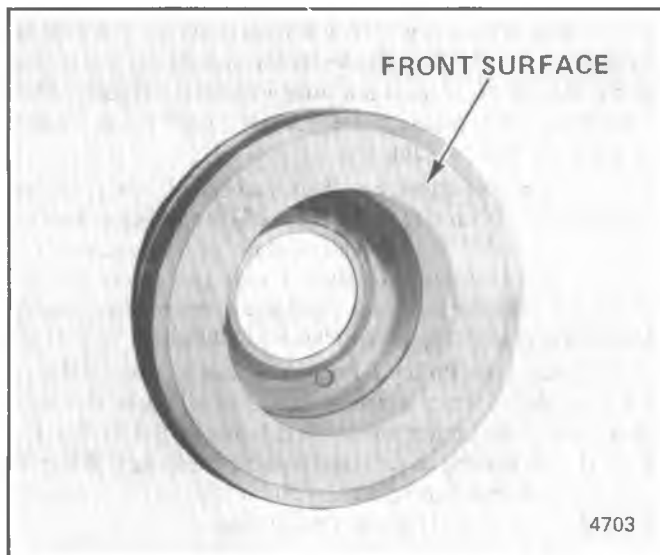

Fig. 1D-84 R-4 Clutch Coil Asm.

### Replace

1. Assemble the Clutch Coil, Pulley Rim and the Clutch Rotor and Bearing assembly as shown in Fig. 1D-85. Use new screws and special lock washers and apply sealer (Loctite RC-75, Loctite 601, or equivalent) to screw threads but do not lock the screws in place.

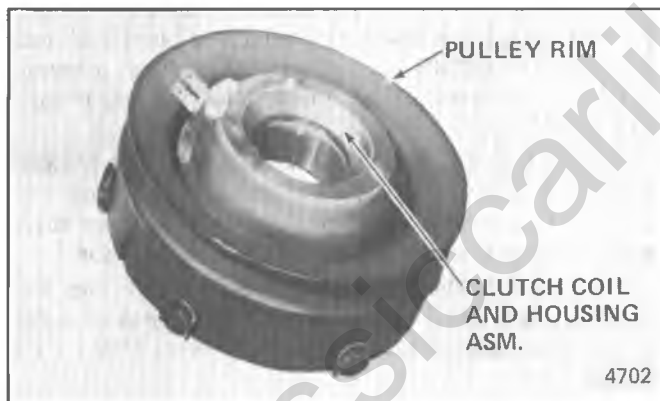

Fig. 1D-85 Assembling R-4 Clutch Coil, Pulley Rim and Rotor & Bearing

2. Place the assembly on the neck of the Front Head and seat into place using Rotor & Bearing Installer J 26271 (Fig. 1D-83).

Before fully seating the assembly on the Front Head, be sure the clutch coil terminals are in the proper location in relation to the compressor and that the three protrusions on the rear of the clutch coil align with the locator holes in the Front Head.

3. Install the rotor and bearing assembly retaining ring and reassemble the Clutch Plate and Hub assembly as described in "R-4 Compressor Clutch Plate and Hub Asm." Replacement procedure. Check to see that the clutch plate to clutch rotor air gap is .5 - 1.0mm (.020 - .040) inches.

Rotate the Pulley Rim and Rotor to be sure the Pulley Rim is rotating "in-line" and adjust or replace as required.

4. Tighten the pulley rim mounting screws to 11 N·m (100 inch-pounds) torque and lock the screw heads in place by bending lock washers (Fig. 1D-83), similar to original crimp and lock bends on washers.

## R-4 COMPRESSOR INERTIA RING INSTALLATION

R-4 compressors will be built with one of three conditions:

1) No Inertia Ring installed - no installation is required unless directed by a diagnostic procedure. If a ring is to be added, use Procedure I.

2) A bolted - on Inertia Ring is installed - replace using Procedure I. All new screws, washers, and Loctite 601 (or equivalent) must be used.

3) A welded - on Inertia Ring is installed - replace using Procedure II.

### Procedure I

1. Loosen the compressor drive belt and rotate the compressor pulley as required to locate one screw and lock washer mounted through a "mounting hole" of the Pulley Rim, Figure 1D-86, rather than a "mounting notch" screw location. Do not remove the drive belt unless necessary. For identification purposes, washers locked over the edge of the Pulley Rim at the "mounting hole" locations will not usually dimple down in the center like the indentation of the lockover at a "mounting notch" screw location.

2. Remove the three mounting screws and lockwashers at the pulley rim "mounting hole" locations. (The pulley rim "mounting holes" are located 120° apart radially around the rim or every other mounting screw location.) Do not remove the screws in the "mounting notches."

3. Temporarily make a trial fit of the Inertia Ring to the Pulley Rim. If any portion of the sheer edge of the Pulley Rim prevents the installation of the Inertia Ring, the raised edge may be filed off to remove the excess metal and facilitate installation. Do not use undue force or cock the ring in assembling the Inertia Ring in place over the Pulley Rim that could cause ring distortion or stress.

4. Assemble the Inertia Ring onto the Pulley Rim, being careful to align the inertia ring mounting holes with the mounting holes in the pulley rim. If the Inertia Ring must be rotated on the Pulley Rim for centering the mounting holes and cannot be shifted by hand, use a drift punch or blunt tool and a hammer to carefully tap the Inertia Ring at a clearance notch, Figure 1D-87, to move the ring into position.

5. Install a special lockwasher onto each 6.4mm-28 x 13.5mm (1/4"-28 X 17/32") mounting screw.

6. Apply Loctite 601 (or equivalent sealer) to the screw threads of each mounting screw and threads of the mounting holes in the Clutch Rotor. Wet the threads thoroughly to ensure complete thread coverage.

7. Install the screws into the mounting holes and tighten finger-tight. Torque each screw to 11 N·m (100 in. lbs.) torque.

8. Lock the three screws in place by flattening the special washer against two sides of the hex head screw using vise grip pliers and one portion of the lockwasher bent down over the edge of the inertia ring slot, Fig. 1D-87. Do not move the screw heads from the torqued position. Locking of the screws must be similar to the production forming of the lockwasher in order to effectively retain the screw.

9. Retighten the compressor drive belt to proper belt tension.

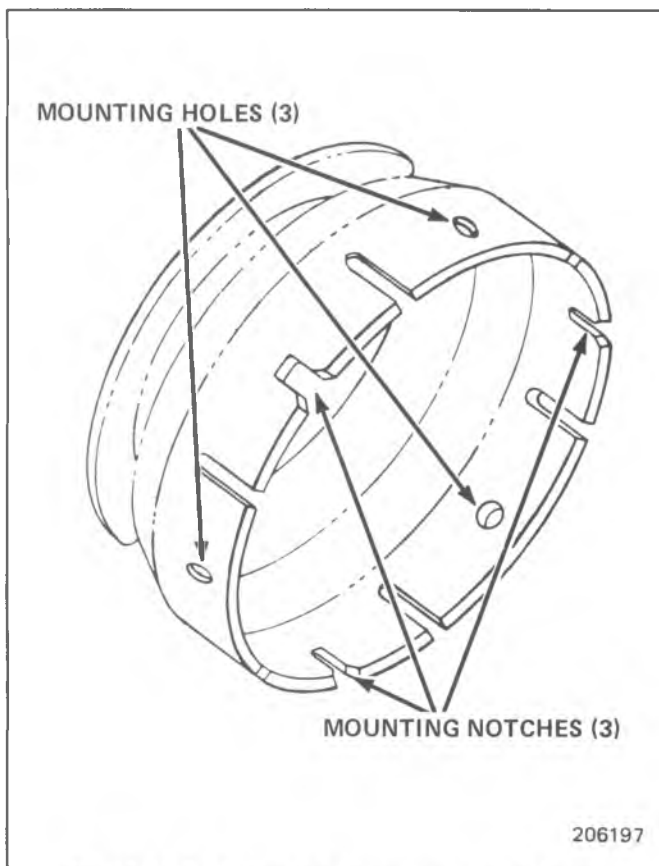

Fig. 1D-86 R-4 Pulley Rim Mounting Location Detail

10. Check compressor and system operation.

● If "mounting notch" screws must be replaced for any reason, the screws should be torqued into place 11 N·m (100 in. lbs.) torque using Loctite 601 (or equivalent sealer) on the threads and locked into place similar to the original locking method.

## Procedure II

### INERTIA RING AND PULLEY RIM WELDED ASSEMBLY - REPLACEMENT (NEW PULLEY RIM AND INERTIA RING KIT REQUIRED)

1. Loosen the compressor mounting bracket and remove the compressor drive belt.

2. Remove the Clutch Hub and Drive Plate assembly as described in "R-4 Compressor Clutch Plate and Hub Asm." Removal procedure.

3. To remove as an assembly, perform Steps 1 through 4 of "R-4 Compressor Clutch Rotor and/or Bearing" Removal procedures but do not loosen or remove the pulley rim mounting screws, so as to remove the Clutch Rotor and Bearing, Clutch Coil, Pulley Rim and Inertia Ring as a total assembly. Be careful not to drop the Puller Guide J 25031 when removing the assembly.

4. Remove all six pulley rim mounting screws and lockwashers from the assembly and discard.

5. Separate the Pulley Rim and Inertia Ring assembly away from the Rotor and Bearing assembly.

6. Inspect the drive surfaces of the Rotor and Drive Plate to be sure they are still in good condition. Replace as required.

7. Assemble a new Pulley Rim over the Clutch Coil and mount the Pulley Rim to the Rotor and Bearing assembly, using the short notch mounting locations, Figure 1D-86. The mounting notches are located 120° apart radially around the Pulley Rim.

8. Assemble three new lockwashers on the three new 6.4mm-28 x 13.5mm (1/4-28 X 5/16") mounting screws and apply Loctite 601 (or equivalent sealer) to the entire thread surface of the mounting screws and the mounting hole threads in the Rotor. Assemble the three screws into the short notch mounting hole locations and tighten finger tight.

9. Align the Pulley Rim so that the bottom of the rim notches touch the mounting screws at all three mounting locations. Also center the drilled holes in the Pulley Rim with the remaining mounting holes in the Rotor. When the rim is positioned properly, tighten the three mounting screws to 11 N·m (100 in. lbs.) torque.

10. Temporarily make a trial fit of the Inertia Ring to the Pulley Rim. If any portion of the sheer edge of the Pulley Rim prevents the installation of the Inertia Ring, the raised edge may be filed off to remove the excess metal and facilitate installation. Do not use undue force or cock the ring in assembling the Inertia Ring in place over the Pulley Rim that could cause ring distortion or stress.

11. Assemble the Inertia Ring onto the Pulley Rim being careful to align the Inertia Ring mounting holes with the mounting holes in the Pulley Rim. If the Inertia Ring cannot be moved by hand and must be rotated for centering the mounting holes, use a drift punch or blunt tool and a hammer to carefully tap at one of the large clearance notches in the inertia ring to rotate the ring into position, Fig. 1D-87.

12. Install the special lock washers onto the 13mm-28 x 13.5mm (1/4-28 X 17/32") mounting screws and apply Loctite 601 (or equivalent sealer) to the total screw thread and the threads of the mounting holes in the rotor.

13. Install the screw and washers into the rotor mounting holes and tighten finger tight. When all screws are in place, torque each screw to 11 N·m (100 in. lbs.) torque.

14. Using Rotor and Bearing assembly Installer J-26271 and Universal Handle J-8092, install the Pulley, Clutch Coil, Rotor and Bearing assembly onto the Front Head of the compressor. Be sure to locate the clutch coil terminals in the proper position.

15. Spin the Rotor and Pulley assembly to ascertain that the pulley runs "in line." If not, the mounting screws will have to be loosened and the parts aligned.

16. When all screws are torqued in place, lock all mounting screws in position by flattening the special washer against two opposite sides of the hex head screw, using vise-grip pliers. Form a portion of the lock washer down over the pulley rim or over the Inertia Ring slot to secure the screws in place. Do not move the screw heads from the torqued position. See Fig. 1D-87.

17. Install the Clutch Hub and Drive Plate as described in "R-4 Compressor Clutch Plate and Hub Asm." Replacement procedures.

18. Install the compressor drive belt and adjust for proper tension.

19. Operate the air conditioning system to check for proper operation.

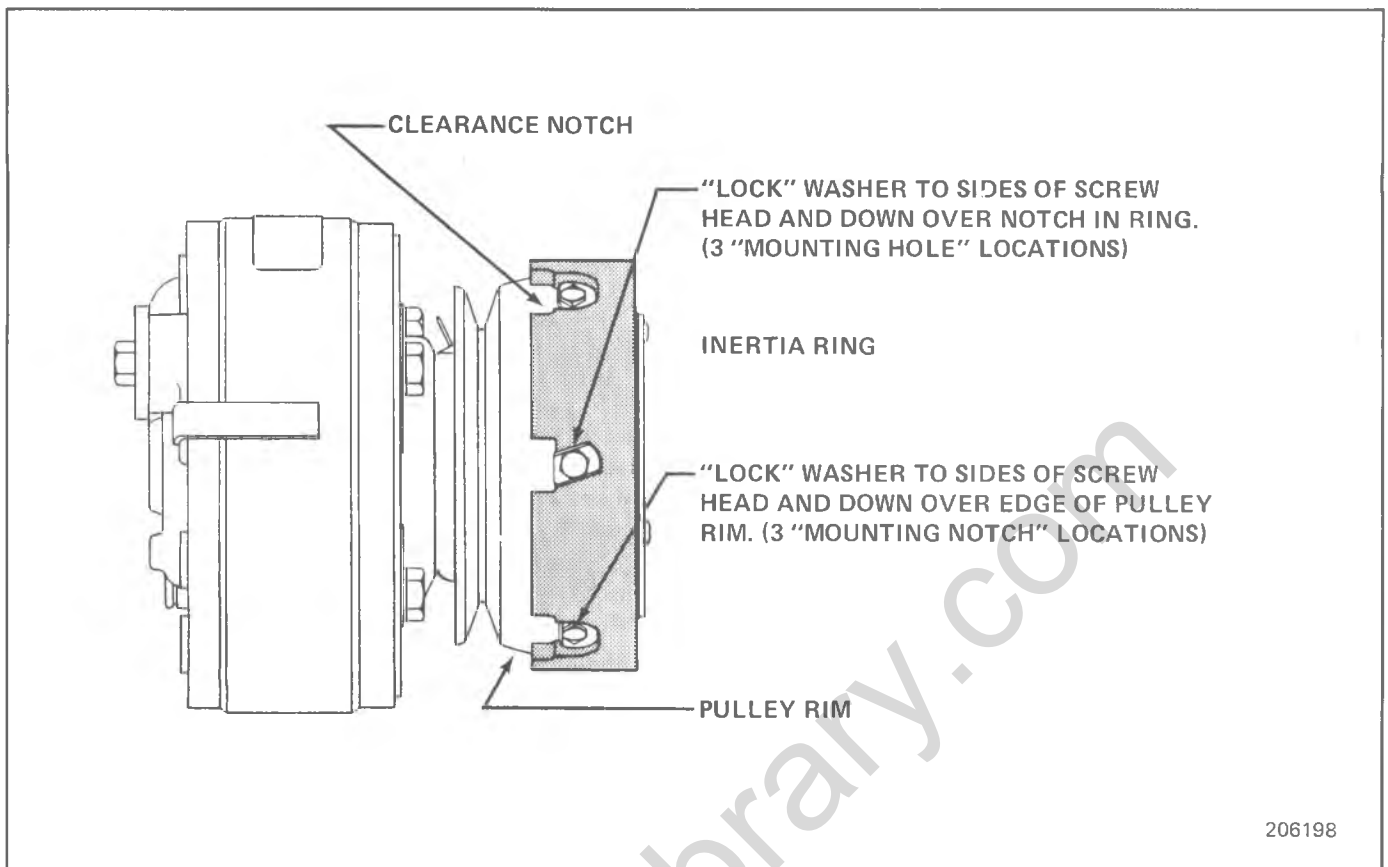

Fig. 1D-87 R-4 Pulley Rim and Inertia Ring Mounting Detail

## MAJOR R-4 COMPRESSOR REPAIR PROCEDURES

Service repair procedures to the Compressor Shaft Seal, Pressure Relief Valve, or disassembly of the Internal Compressor Cylinder and Shaft Assembly are considered "MAJOR" SINCE THE REFRIGERATION SYSTEM MUST BE COMPLETELY PURGED OF REFRIGERANT before proceeding and/or because major internal operating and sealing components of the compressor are being disassembled and serviced.

When replacing the shaft seal assembly (see Fig. 1D-17) or pressure relief valve (see Fig. 1D-69) even if the compressor remains on the vehicle during the operation, it will be necessary to purge the system of refrigerant (see Section 1B). Other than clutch repair procedures, the same holds true for any disassembly of the compressor.

If the compressor shell, front head or cylinder and shaft assembly are to be serviced or replaced, the oil in the compressor must be drained, measured and replaced. (See Section 1B) to determine addition of proper oil quantity to new assembly.

A clean workbench, preferably covered with a sheet of clean paper, orderliness in the work area and a place for all parts being removed and replaced is of great importance, as is the use of the proper, clean service tools.

**NOTICE:** Any attempt to use make-shift or inadequate equipment may result in damage and/or improper compressor operation.

All parts required for servicing the internal compressor are protected by a preservation process and packaged in a manner which will eliminate the necessity of cleaning, washing or flushing of the parts. The parts can be used in the internal assembly just as they are removed from the service package.

### R-4 COMPRESSOR SHAFT SEAL

#### Seal Leak Detection

A shaft seal should not be changed because of an oil-line on the hood insulator. The Seal is designed to seep some oil for lubrication purposes. Only change a Shaft Seal when a leak is detected by evidence of oil sprayed in large amounts and then only after actual refrigerant leakage is found by using an approved leak Detector such as J 23400 or equivalent.

Should an R-4 compressor shaft seal ever have to be replaced, the accumulator in this R-4 system must also be removed from the vehicle. The oil in the accumulator then must be drained, measured and replaced according to the directions in Section 1B to determine oil loss.

#### Remove (On Car)

1. "Discharge the Refrigerant System" according to the direction in Section 1B.
2. Loosen and reposition compressor in mounting brackets, if necessary.

## 1D-34 AIR CONDITIONING COMPRESSOR OVERHAUL

3. Remove Clutch Plate and Hub assembly from compressor as described in Minor Repairs.

4. Remove the shaft seal seat retainer ring, using Snap Ring Pliers J 5403.

5. Thoroughly clean inside of compressor neck area surrounding the shaft, the exposed portion of the seal seat and the shaft itself. Any dirt or foreign material getting into compressor may cause damage.

6. Place Seal Protector J 22974 over the end of the shaft to prevent chipping the ceramic seat. Fully engage the knurled tangs of Seal Seat Remover-Installer J 23128 into the recessed portion of the seal seat by turning the handle clockwise. Remove the Seal Seat from the compressor with a rotary-pulling motion (Fig. 1B-88). Discard the Seat. The handle must be hand-tightened securely. Do not use a wrench or plier.

7. With Seal Protector J 22974 still over the end of the shaft, set Seal Remover-Installer J 9392 down onto shaft end, turning clockwise, while pressing down to engage Remover tangs with the tabs on the Seal assembly. Then lift the Shaft Seal assembly out (see Fig. 1B-89). Discard the Seal.

8. Remove and discard the seal seat O-ring from the compressor, neck using O-Ring Remover J 9553 (Fig. 1D-89).

9. Recheck the shaft and inside of the compressor neck for dirt or foreign material and be sure these areas are perfectly clean before installing new parts.

### Inspection

Seals should not be re-used. Always use a new specification service seal kit on rebuild (see Fig. 1D-17). Be extremely careful that the face of the Seal to be installed is not scratched or damaged in any way. Make sure that the Seal Seat and Seal are free of lint and dirt that could damage the seal surface or prevent sealing.

### Replace (On Car)

1. Dip the new seal seat O-ring in clean 525 viscosity refrigerant oil and assemble onto O-Ring Installer J 21508 (see Fig. 1D-89).

2. Insert the O-Ring Installer J 21508 completely down into the compressor neck until the Installer "bottoms." Lower the moveable slide of the O-Ring Installer to release

the O-Ring into the seal seat O-ring lower groove. (The compressor neck top groove is for the shaft seal retainer ring.) Rotate the Installer to seat the O-ring and remove the Installer.

3. Dip the O-Ring and seal face of the new Seal assembly into clean 525 viscosity refrigerant oil. Carefully mount the Seal assembly to Seal Installer J 9392 by engaging the tabs of the seal with the tangs of the Installer (Fig. 1D-89).

4. Place Seal Protector J 22974 over end of compressor shaft and slide the new Seal assembly onto the shaft. Twist the Installer J 9392 clock-wise, while pushing the Seal assembly down the shaft until the Seal assembly engages the flats on the shaft and is seated in place. Disengage the Installer by pressing downward and twisting counterclockwise.

5. Attach the ceramic Seal Seat to the Seal Seat Remover and Installer J 23128 and dip the ceramic Seal in clean 525 viscosity refrigerant oil to coat the seal face and outer surface. Install the Seat over the compressor shaft and J 22974 Seal Protector and push the Seat into place with a rotary motion (Fig. 1D-88). Take care not to dislodge the seat O-ring. Be sure Seal Seat makes a good seal with O-ring. Remove Installer J 23128 and Seal Protector J 22974.

6. Install the new seal seat retainer ring with its flat side against the Seal Seat, using Snap-Ring Pliers J 5403. See Fig. 1D-90. Use the sleeve from Seal Seat Remover-Installer J 9393 to press in on the seal seat retainer ring so that it snaps into its groove.

7. For Leak Test, pressurize suction side (low-pressure side) of compressor on vehicle with Refrigerant-12 vapor to equalize pressure to the drum pressure. Temporarily install the shaft nut and, with compressor in horizontal position, rotate the compressor shaft in normal direction of rotation several times by hand. Leak test the Seal and correct any leak found. Remove, discard and later replace the shaft nut.

8. Remove any excess oil, resulting from installing the new seal parts, from the shaft and inside the compressor neck.

9. Install the Clutch Plate and Hub assembly as described in minor repair procedures.

10. Re-install compressor belt and tighten bracketry.

11. Evacuate and Charge the Refrigerant System according to directions in Section 1B.

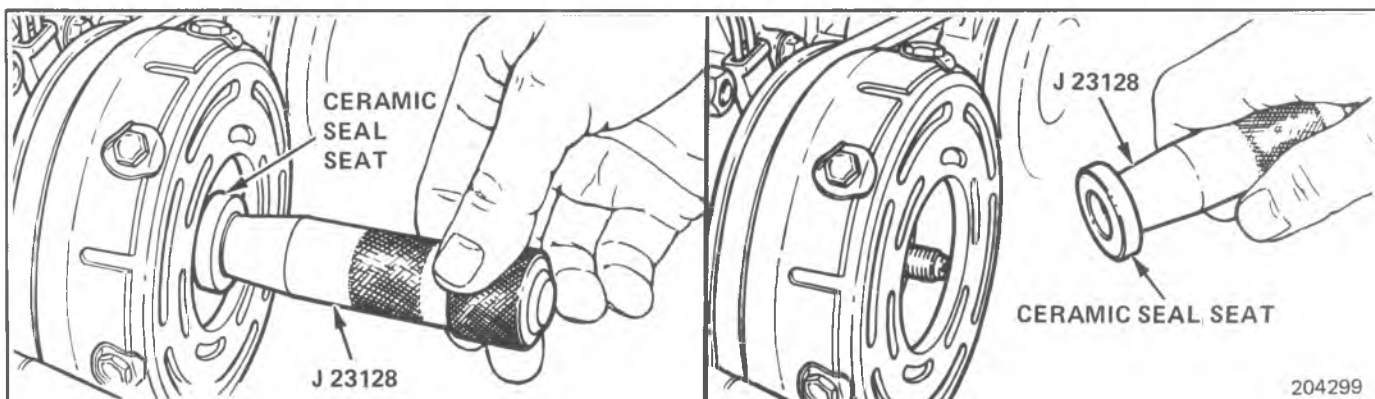

Fig. 1D-88 Removing and Installing R-4 Ceramic Seal Seat (On Car)



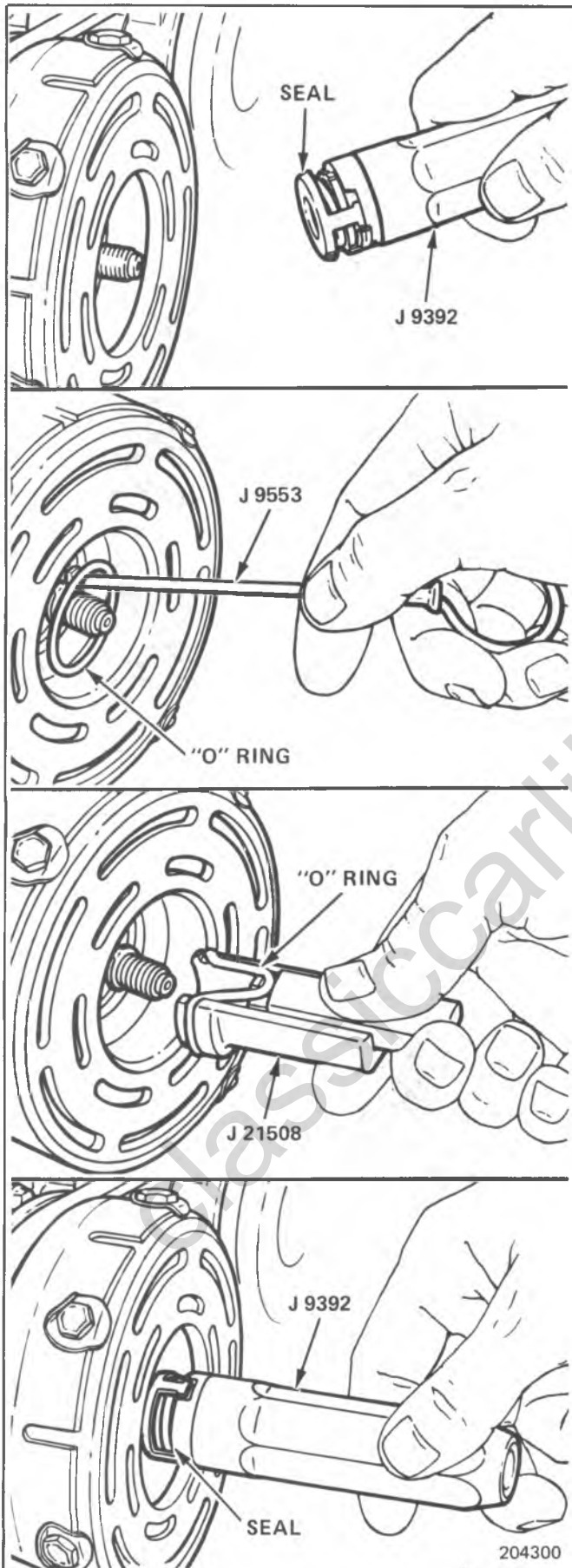

Fig. 1D-89 Removing and Installing R-4 Seal and O-Ring (On-Car)

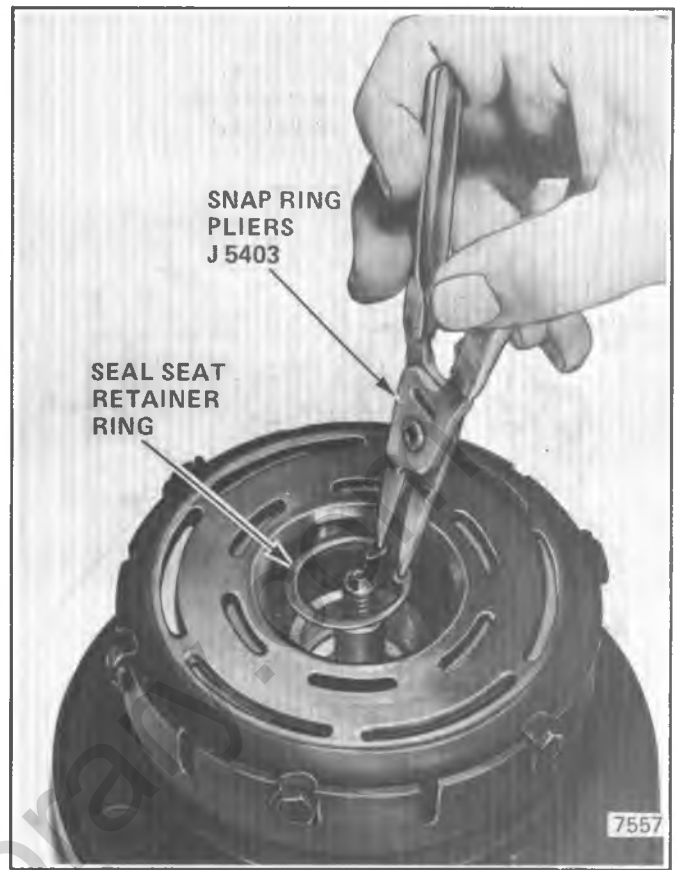

Fig. 1D-90 Removing or Installing R-4 Shaft Seal Seat Retaining Ring

### R-4 COMPRESSOR SHAFT SEAL REPLACEMENT (OFF CAR)

1. Follow applicable on-car procedures.
2. To Leak Test, install leak Test Fixture J 9625 (Fig. 1D-94) on rear head of compressor and connect gage charging lines, or pressurize suction side (low pressure side) of compressor on car with Refrigerant-12 vapor to equalize pressure to the drum pressure. Temporarily install the shaft nut and, with compressor in horizontal position and using a wrench rotate the compressor shaft in normal direction of rotation several times by hand. Leak test the seal and correct any leak found. Remove, discard, and later replace with a new shaft nut.
3. See Figs. 1D-91, 1D-92 and 1D-93.

### R-4 COMPRESSOR PRESSURE RELIEF VALVE

The Pressure Relief Valve, located in the compressor rear head casting (Fig. 1D-69), should only be replaced after purging the system of refrigerant. A new valve and O-ring coated with 525 viscosity refrigerant oil should be installed.

### R-4 COMPRESSOR FRONT HEAD AND/OR O-RING

#### Remove

1. "Discharge the Refrigerant System" according to the directions in Section 1B.
2. Perform steps 1 through 4 of "R-4 Compressor Clutch Rotor and/or Bearing" Removal procedure but do



Fig. 1D-91 Removing & Installing R-4 Seal Seat (Off Car)



Fig. 1D-93 Installing R-4 Seal Seat O-Ring(Off Car)



Fig. 1D-92 Removing & Installing R-4 Seal (Off Car)



Fig. 1D-94 Compressor Leak Testing Fixture

not loosen or remove the pulley rim mounting screws so as to remove the Clutch Rotor and Bearing, Clutch Coil and Pulley Rim as a total assembly. Be careful not to drop the Puller Guide J 25031, when removing the assembly.

3. Remove and discard the Shaft Seal parts as described in "R-4 Compressor Shaft Seal" Removal procedure.

4. Remove the four front head mounting screws (Fig. 1D-95) and remove the Front Head assembly (Fig. 1D-96).

5. Remove and discard the front head O-ring.

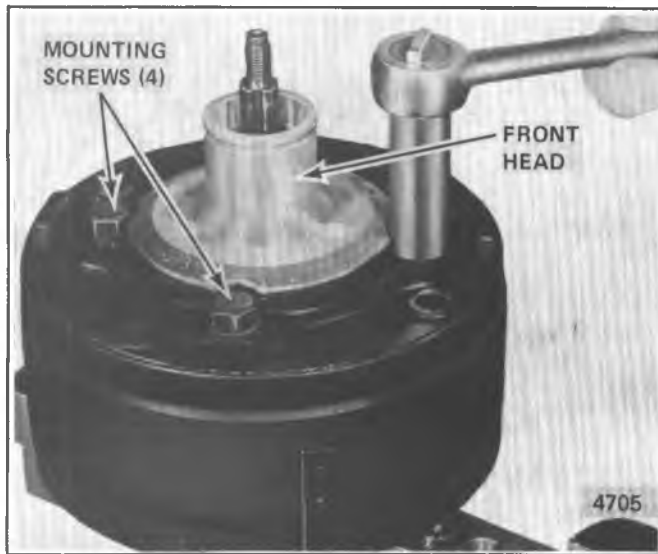

Fig. 1D-95 Removing R-4 Front Head Mounting Screws

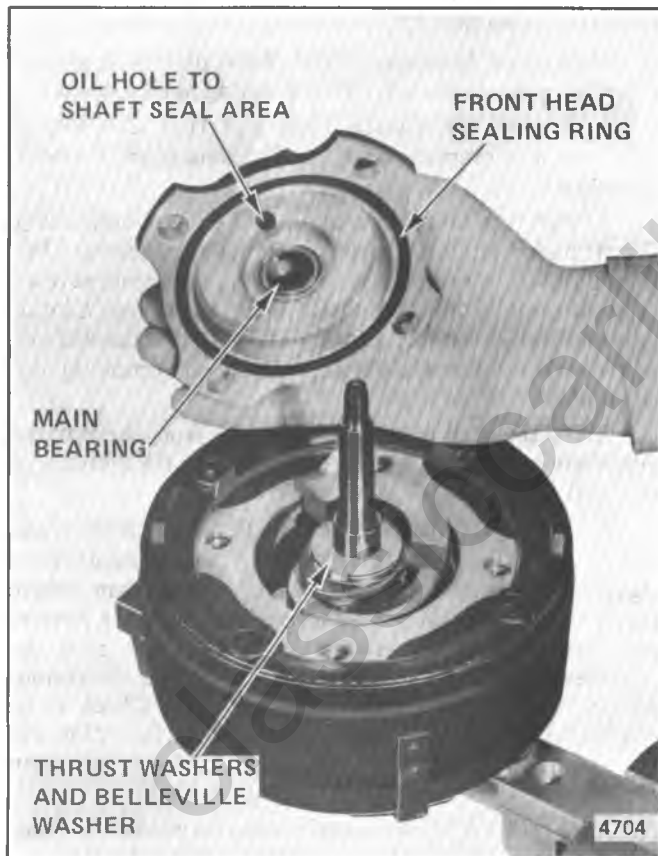

Fig. 1D-96 Removing R-4 Front Head Asm.

**Replace**

1. Check the Front Head and compressor cylinder area for any dirt, lint, etc. and clean, if necessary. Install a new Service thrust washer kit, if required, as described in "R-4 Compressor Thrust and Belleville Washers" Removal and Replacement procedures.

2. Dip the new front head O-ring in clean 525 viscosity refrigerant oil and install in the seal groove on the front head (Fig. 1D-96).

3. Position the oil hole in the Front Head to be "up" when assembled to the compressor cylinder to correspond

with the "up" position of the compressor. Install the Front Head and tighten the front head mounting screws to 27 N·m (20 lb. ft.) torque.

4. Install new specification Service Shaft Seal kit (Fig. 1D-17) as described in "R-4 Compressor Shaft Seal" Replacement procedure.

5. Install the Clutch Rotor and Bearing assembly, Clutch Coil and Pulley Rim assembly to the Front Head, using Rotor and Bearing Installer J 26271 (Fig. 1D-83).

Before fully seating the assembly onto the Front Head, be sure the clutch coil terminals are in the proper location in relation to the compressor and that the three protrusions on the rear of the clutch coil align with the locator holes in the Front Head.

6. Install the rotor and bearing assembly retainer ring and reassemble the Clutch Plate and Hub assembly as described in "R-4 Compressor Clutch Plate and Hub" Replacement procedure. Check to see that the clutch plate to clutch rotor gap is .5 - 1.0mm (.020 - .040) inches.

7. "Evacuate and Charge the Refrigerant System" according to the directions in Section 1B.

**R-4 COMPRESSOR THRUST AND BELLEVILLE WASHERS**

**Remove and Replace**

1. "Discharge the Refrigerant System" according to the directions in Section 1B.

2. Remove the Front Head assembly as described in "Front Head" Removal procedure. Remove and discard the front head O-ring seal.

3. Remove the two thrust washers and one belleville washer from the compressor shaft. Note the assembled position of the washers.

4. Install a new thrust washer on the compressor shaft with the thrust washer tang pointing "up" (Fig. 1D-97).

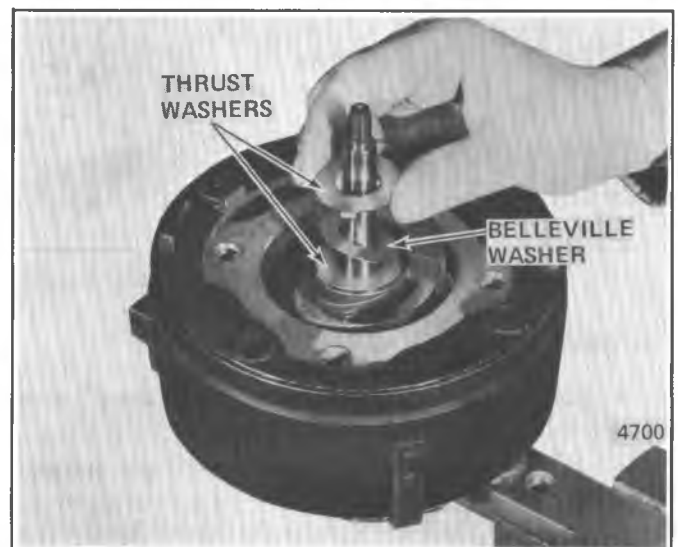

Fig. 1D-97 Replacing R-4 Thrust and Belleville Washers

5. Install the new belleville washer on the shaft with the high center of the washer "up."

6. Install the remaining thrust washer on the shaft with the tang pointing "down" (Fig. 1D-97).

7. Lubricate the three washers with clean 525 viscosity refrigerant oil and assemble the Front Head and new O-ring onto the compressor as described in "R-4 Compressor Front Head" Replacement procedure.

## R-4 COMPRESSOR MAIN BEARING

### Remove

1. "Discharge the Refrigerant System" according to the direction in Section 1B.
2. Remove the Front Head assembly as described in "Front Head" Removal procedure. Discard front head O-ring.
3. Place the Front Head assembly on two blocks, as shown in Fig. 1D-98, and use Main Bearing Remover J 24896 to drive the Main Bearing out of the Front Head.

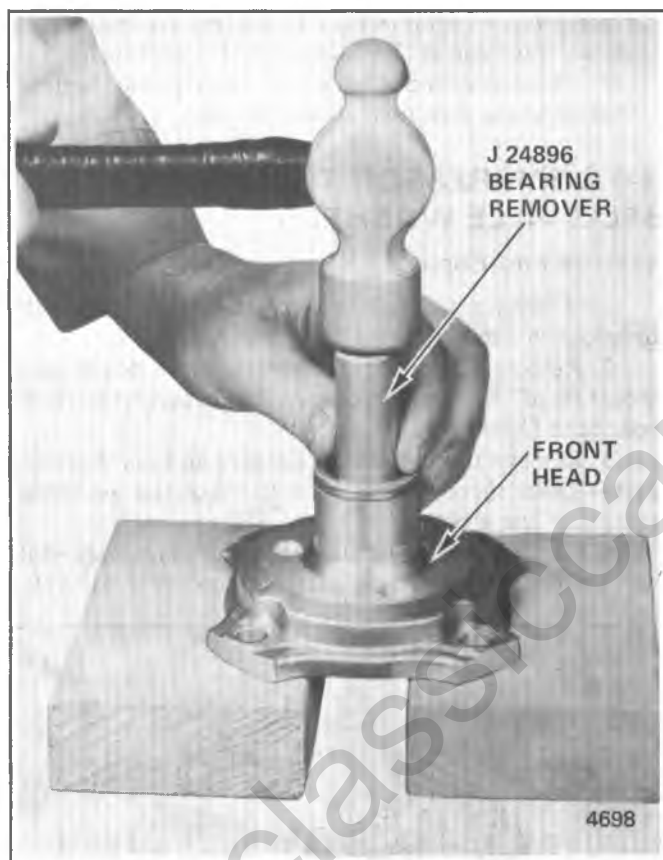

Fig. 1D-98 Removing R-4 Main Bearing

### Replace

1. Place the Front Head "with neck-end down" on a flat, solid surface.
2. Align the new Main Bearing and the Bearing Installer J 24895 squarely with the bearing bore of the Front Head and drive the bearing into the Front Head. The Installer J 24895 must seat against the Front Head to insert the bearing to the proper clearance depth (see Fig. 1D-99).
3. Assemble the Front Head to the cylinder, using a new O-ring as described in "R-4 Compressor Front Head" Replacement procedure.
4. "Evacuate and Charge the Refrigerant System" according to the directions in Section 1B.

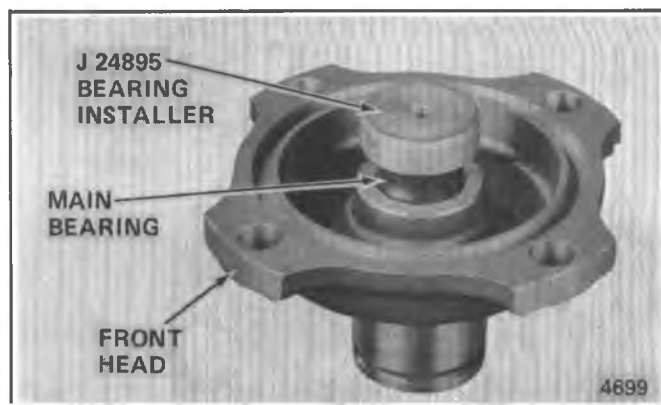

Fig. 1D-99 Installing R-4 Main Bearing

## R-4 COMPRESSOR SHELL AND/OR O-RINGS

### Remove

1. "Discharge the Refrigerant System" according to the directions in Section 1B.
2. Thoroughly clean exterior of compressor to prevent dirt from getting into compressor during shell removal.
3. Remove the Clutch Plate and Hub assembly as described in "Compressor Clutch Plate and Hub" Removal procedures.
4. Perform Steps 1 through 4 of "R-4 Compressor Clutch Rotor and/or Bearing" Removal procedure but do not loosen or remove the pulley rim mounting screws so as to remove the Clutch Rotor and Bearing, Clutch Coil and Pulley Rim as a total assembly. Be careful not to drop the Puller Guide J 25031 when removing the assembly.
5. Pry the shell retaining strap away from the cylinder and position the strap high enough to clear the cylinder as the Shell is removed (Fig. 1D-100).
6. Remove Compressor Holding Fixture J 25008-1, and reverse Holding Fixture with step block protrusions engaging the compressor Shell. Install the medium-length metric thread mounting bolts through the Holding Fixture and thread them finger-tight on both sides into the compressor cylinder until the step of the fixture protrusions contact the compressor Shell (Fig. 1D-101). Check to be sure the step protrusions do not overlap the cylinder but will pass both sides. Allow compressor to cool to room temperature before removing compressor shell.
7. Alternately tighten each bolt approximately 1/4 turn to push the Shell free of the O-rings on the cylinder.

If one screw appears to require more force to turn than the other, immediately turn the other screw to bring the screw threading sequence in-step or the Shell will be cocked and made more difficult to remove. Normal removal does not require much force on the wrench if the screws are kept in-step while turning. The Shell can be removed by hand as soon as the Shell is free of the shell to cylinder O-rings. Do not turn the screws any further than necessary to release the Shell.

8. Remove the compressor Shell and remove the Holding Fixture J 25008-1 from the compressor. Reverse the Holding Fixture to again hold the compressor by the opposite side, using the short-length screws with metric threads.

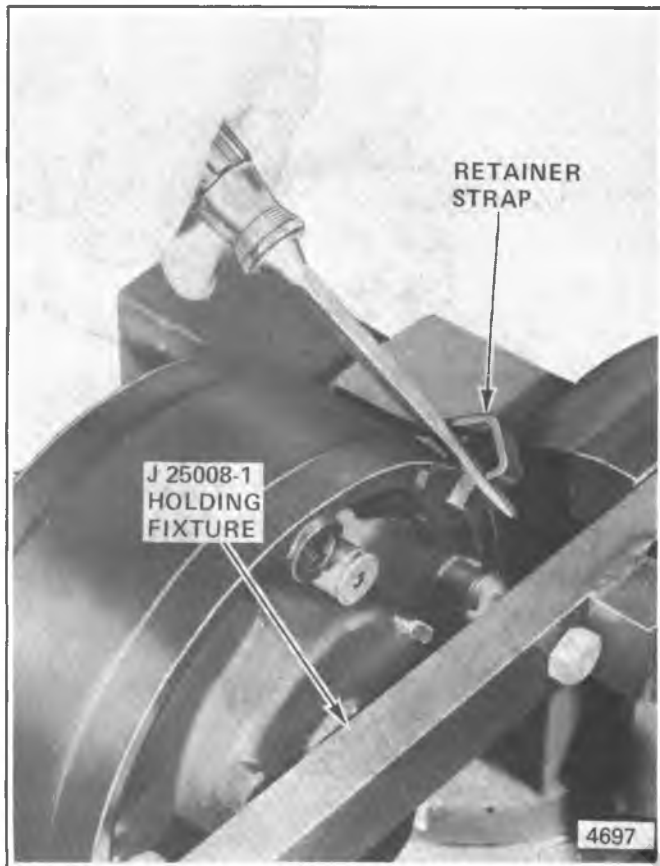

Fig. 1D-100 Releasing R-4 Shell Retaining Strap

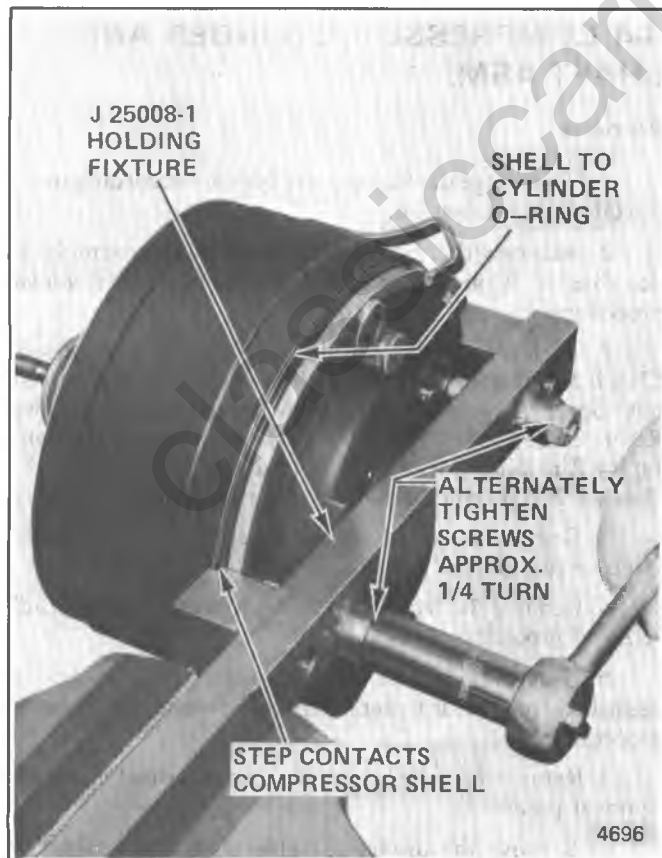

Fig. 1D-101 Removing R-4 Shell

9. Remove and discard both cylinder to Shell O-rings.

**Replace**

1. Check the compressor cylinder assembly and interior of the compressor Shell to be sure they are free of lint, dirt, etc.

2. Dip a new cylinder-to-shell O-ring in clean 525 viscosity refrigerant oil and install in the rear O-ring groove of the cylinder. Be careful in moving the O-ring across the cylinder surface to prevent damaging the O-ring.

3. Dip the remaining cylinder-to-shell O-ring in the 525 oil and install it in the front O-ring groove of the cylinder.

4. Also coat inner O-ring surface of compressor Shell with oil. Place the compressor Shell on the cylinder and rotate the retaining strap to its original location.

5. Attach the Shell Installing Fixture J 25008-2 to the Holding Fixture J 25008-1, using the long-bolts and plate washers of the set. Align the step projections of the Installing Fixture J 25008-2, to contact the compressor Shell evenly on both sides.

6. Push the compressor shell as close to the O-ring, Fig. 1D-102, as possible by hand and check for equal alignment of the shell around the cylinder. Tighten the Fixture screws finger tight.

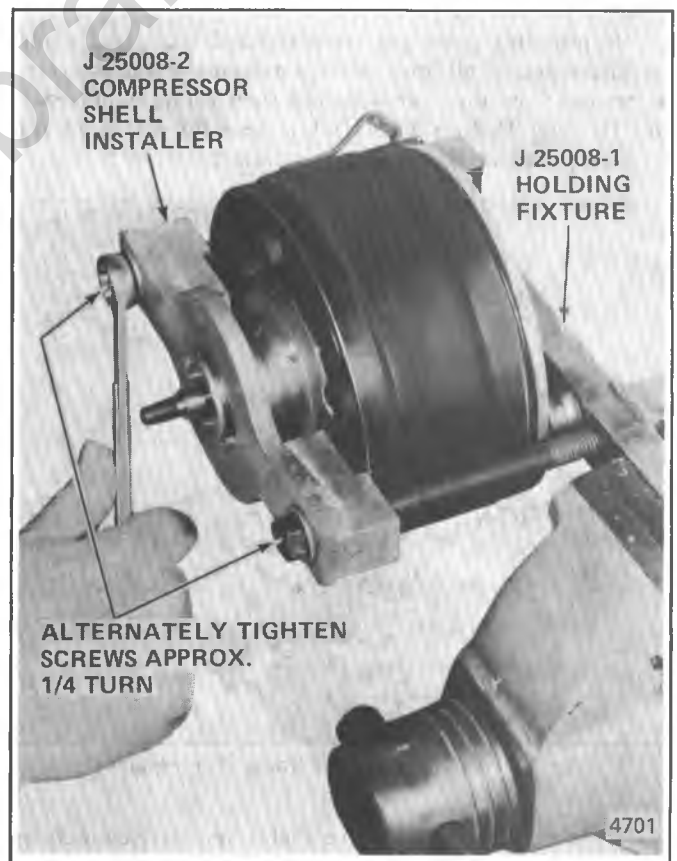

Fig. 1D-102 Installing R-4 Shell

7. Alternately tighten each bolt approximately 1/4 turn to push the compressor Shell over the O-rings and back against the shell stop flange at the rear of the compressor cylinder.

If one screw appears to require more force to turn than the other, immediately turn the other screw to bring the screw threading sequence in-step or the Shell will be cocked

## 1D-40 AIR CONDITIONING COMPRESSOR OVERHAUL

and made more difficult to install. Normal installation does not require much force on the wrench if the screws are kept in-step while turning.

8. When the Shell is seated against the stops, bend the shell retaining strap down into place by tapping gently with a hammer. Remove the Shell Installing Fixture J 25008-2.

9. Re-install Clutch Rotor and Bearing Asm., Clutch Coil and Pulley Rim as an assembly with Installer J 26271 (Fig. 1D-76), and the Clutch Plate and Hub Assembly with Installer J 9480-01 (Fig. 1D-75).

10. "Evacuate and Charge the Refrigerant System" according to the directions in Section 1B.

### R-4 COMPRESSOR DISCHARGE VALVE PLATE AND/OR RETAINER

#### Remove and Replace

1. "Discharge the Refrigerant System" according to the directions in Section 1B.

2. Perform Steps 1 through 9 of "R-4 Compressor Shell and/or O-Rings" Removal procedure.

3. Remove valve plate retainer ring, using Internal Snap Ring Pliers J 4245, Fig. 1D-103. Remove Compressor Discharge Valve Plate (Fig. 1D-104) for valve plate replacement and/or piston inspection.

Repeat this operation for additional valve plates and retainers. If all four valve plates and retainers are to be removed, remove two sets and then rotate compressor and Holding Fixture J 25008-1 in vise for access to the remaining two valve plates and retainers.

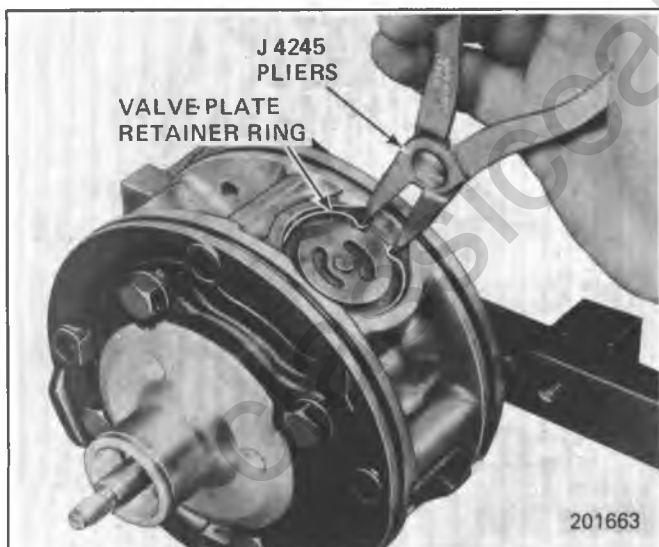

Fig. 1D-103 Replacing R-4 Valve Plate Retainer

4. Install Discharge Valve Plates and/or Retainers as shown in Figs. 1D-103 and 1D-104. Reposition compressor and Holding Fixture in vise as necessary for access.

5. Re-install compressor Shell as described in "R-4 Compressor Shell and/or O-Rings" Replacement procedures.

6. "Evacuate and Charge the Refrigerant System" according to the directions in Section 1B.

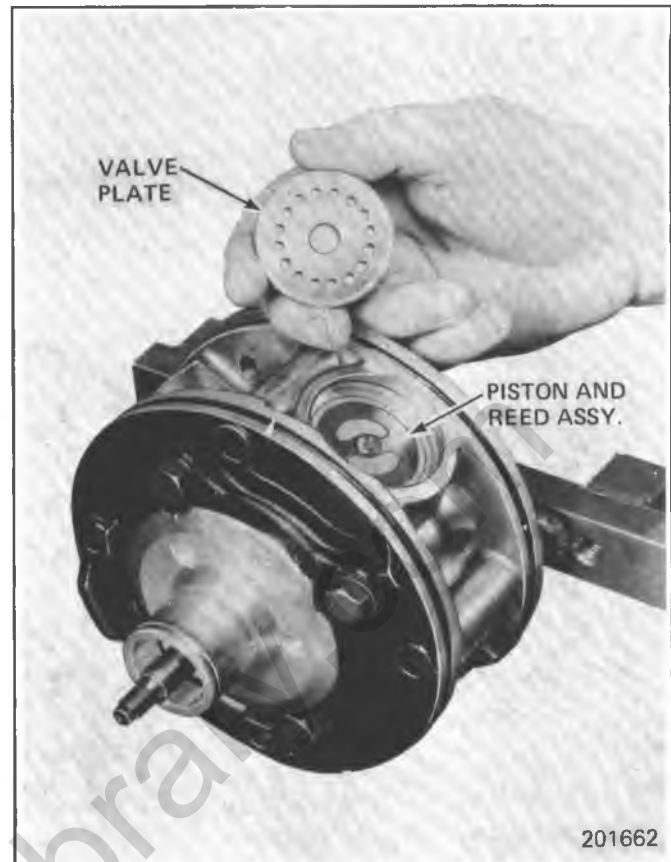

Fig. 1D-104 Replacing R-4 Discharge Valve Plate

### R-4 COMPRESSOR CYLINDER AND SHAFT ASM.

#### Remove

1. "Discharge the Refrigerant System" according to the directions in Section 1B.

2. Remove the Clutch Plate and Hub assembly as described in "Compressor Clutch Plate and Hub" Removal procedure.

3. Perform Steps 1 through 4 of "R-4 Compressor Clutch Rotor and/or Bearing" Removal procedure but do not loosen or remove the pulley rim mounting screws. Remove the Clutch Rotor and Bearing, Clutch Coil and Pulley Rim as an assembly. Be careful not to drop the Puller Guide J 25031, when removing the assembly.

4. Remove the shaft seal as described in "shaft seal" removal procedure.

5. Remove the front head as described in "front head" removal procedure.

6. Remove the thrust and belleville washers as described in "thrust and belleville washers" removal procedures.

7. Remove the compressor shell as described in "shell" removal procedure.

8. Remove the discharge valve plate and retainer as described in "discharge valve plate and/or retainer" removal procedure.

9. Remove the high pressure relief valve as described in "high pressure relief valve" removal procedure.

**Replace**

1. Replace above parts in opposite order.
2. "Evacuate and Charge the Refrigerant System" according to the directions in Section 1B.

## **A-6 AND R-4 COMPRESSOR LEAK TESTING (EXTERNAL AND INTERNAL)**

**Bench-Check Procedure**

1. Install Test Plate J 9625 on Rear Head of compressor.

2. Attach center hose of Manifold Gage Set on Charging Station to a refrigerant drum standing in an upright position and open valve on drum.

3. Connect Charging Station high and low pressure lines to corresponding fittings on Test Plate J 9625, using J 5420 Gage Adapters if hoses are not equipped with valve depressors.

- Suction port (low-side) of compressor has large internal opening. Discharge port (hi-side) has smaller internal opening into compressor.

4. Open low pressure control, high pressure control and refrigerant control on Charging Station to allow refrigerant vapor to flow into compressor.

5. Using a Leak Detector, check for leaks at Pressure Relief Valve, compressor Shell to cylinder, compressor front head seal, and compressor Shaft Seal. After checking, shut off low pressure control and high pressure control on Charging Station.

6. If an external leak is present, perform the necessary corrective measures and recheck for leaks to make certain the leak has been corrected.

7. Loosen the Manifold Gage hose connections to the Gage Adapters J 5420 connected to the low and high sides and allow the vapor pressure to release from the compressor.

8. Disconnect both Gage Adapters J 5420 from the Test Plate J 9625.

9. Rotate the complete compressor assembly (not the crankshaft or drive plate hub) slowly several turns to distribute oil to all cylinder and piston areas.

10. Install a shaft nut on the compressor crankshaft if the drive plate and clutch assembly are not installed.

11. Using a box-end wrench or socket and handle, rotate the compressor crankshaft or clutch drive plate on the crankshaft several turns to ensure piston assembly to cylinder wall lubrication.

12. Connect the Charging Station high pressure line or a high pressure gage and Gage Adapter J 5420 to the Test Plate J 9625 high side connector.

13. Attach an Adapter J 5420 to the suction or low pressure port of the Test Plate J 9625 to open the schrader-type valve.

Oil will drain out of the compressor suction port adapter if the compressor is positioned with the suction port downward.

14. Attach the compressor to the Holding Fixture J 25008-1 using metric mounting screws for the (R-4 compressor), and J 9396 Holding Fixture for the (A-6 compressor). Clamp the compressor Holding Fixture in a vise so that the compressor can be manually turned with a wrench.

15. Using a wrench, rotate the compressor crankshaft or drive plate hub 10-complete revolutions at a speed of approximately one-revolution per second.

Turning the compressor at less than one-revolution per second can result in a lower pump-up pressure and disqualify a good pumping compressor.

16. Observe the reading on HIGH pressure gage at the completion of the tenth revolution of the compressor. The pressure reading for a good pumping compressor should be 344.75 kPa (50 P.S.I.) or above for the R-4 and 413.7 kPa (60 P.S.I.) or above for the A-6 compressor. A pressure reading of less than 310.275 kPa (45 p.s.i.) for the R-4 or 344.75 kPa (50 p.s.i.) for the A-6 would indicate one or more suction and/or discharge valves leaking, an internal leak, or an inoperative valve and the compressor should be disassembled and checked for cause of leak. Repair as needed, reassemble and repeat the pump-up test. Externally leak test.

17. When the pressure pump-up test is completed, release the air pressure from the HIGH side and remove the Gage Adapters J 5420 and Test Plate J 9625.

18. On the R-4 compressor, tilt the compressor so that the compressor suction and discharge ports are down. Drain the oil from the compressor.

On the A-6 compressor, remove oil charge screw and drain the oil sump.

19. Allow the compressor to drain for 10 minutes, then charge with the proper amount of oil. The oil may be poured into the suction port.

If further assembly or processing is required, a shipping plate or Test Plate J 9625 should be installed to keep out air, dirt and moisture until the compressor is installed.

1D-42 AIR CONDITIONING COMPRESSOR OVERHAUL

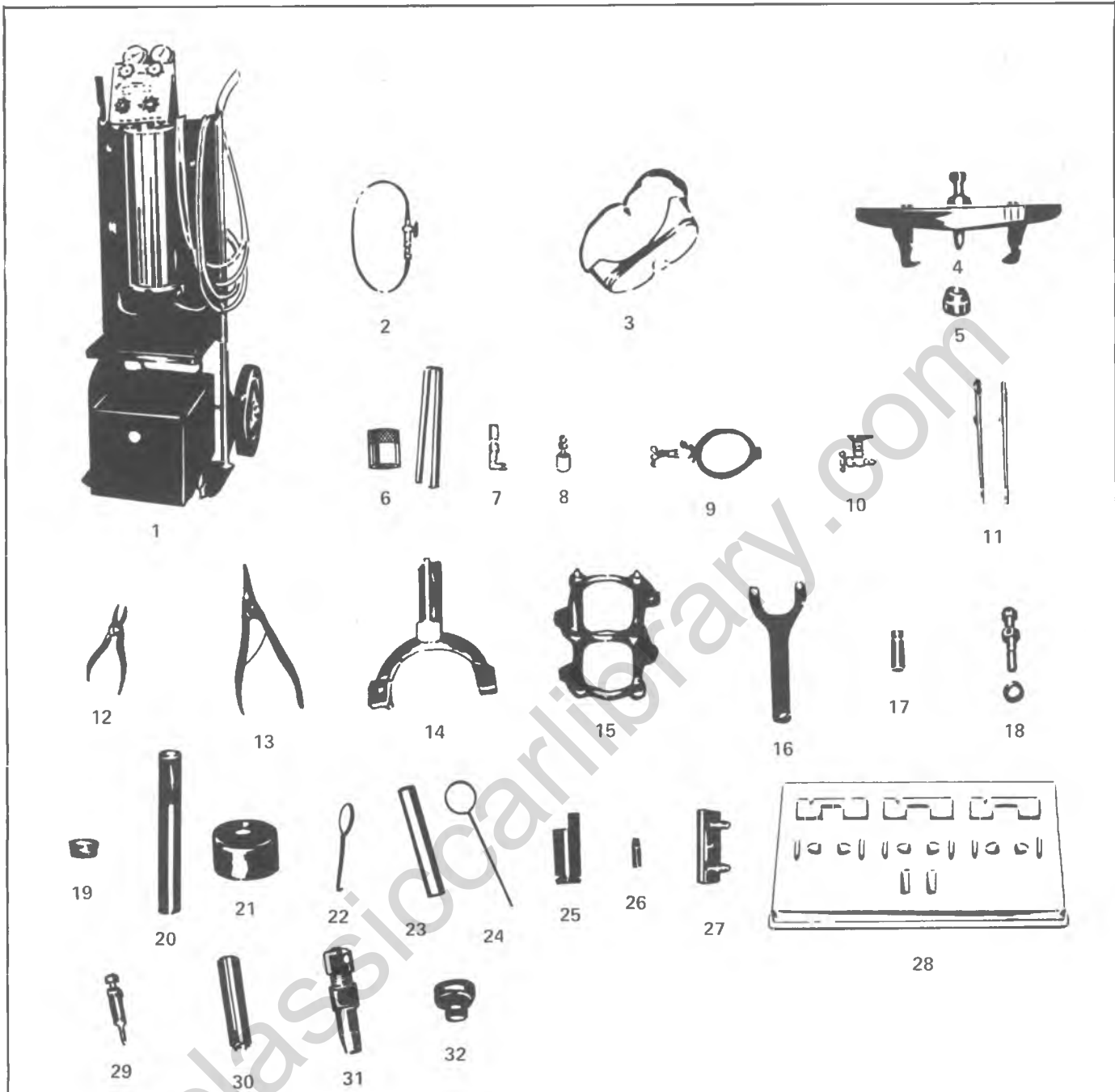

1.	J 23500	Charging Station	12.	J 5403	No. 21 Snap Ring Pliers	23.	J 9432	Needle Bearing Installer
2.	J 24095	Oil Inducer	13.	J 6435	No. 26 Snap Ring Pliers	24.	J 9553-01	Seal Seat 'O' Ring Remover
3.	J 5453	Goggles	14.	J 9396	Compressor Holding Fixture	25.	J 21508	Seal Seat 'O' Ring Installer
4.	J 8433	Puller	15.	J 9397	Compressing Fixture	26.	J 22974	Shaft Seal Protector
5.	J 9395	Puller Pilot	16.	J 25030	Clutch Hub Holding Tool	27.	J 9625	Pressure Test Connector
6.	J 9393-1	Seal Seat Remover + Installer	17.	J 9399	9/16" Thin Wall Socket	28.	J 9402	Parts Tray
	J 9393-2		18.	J 9401	Hub and Drive Plate Assembly Installer	29.	J 9480-01	Hub and Drive Plate Assembly Remover
7.	J 9459 — 7/16" — 20	90° Gauge Line	19.	J 9398	Pulley Bearing Remover	30.	J 9392	Seal Remover — Installer
	J 25499 — 3/8" — 24	Adapter	20.	J 8092	Handle	31.	J 23128	Seal Seat Remover — Installer
8.	J 5420 — 7/16" — 20	Straight Gauge Line	21.	J 21352	Internal Assembly Support Block	32.	J 9481	Pulley Bearing and Pulley Installer
	J 25498 — 3/8" — 24	Adapter	22.	J 5139	Oil Pickup Tube Remover			
9.	J 23595	Refrigerant Can Valve (Side-Tap)						
10.	J 6271-01	Refrigerant Can Valve (Top-Tap)						
11.	J 5421-02	Pocket Thermometers (2)						

Fig. 1D-105 Special Tools, A/C Refrigerant System and A-6 Compressor



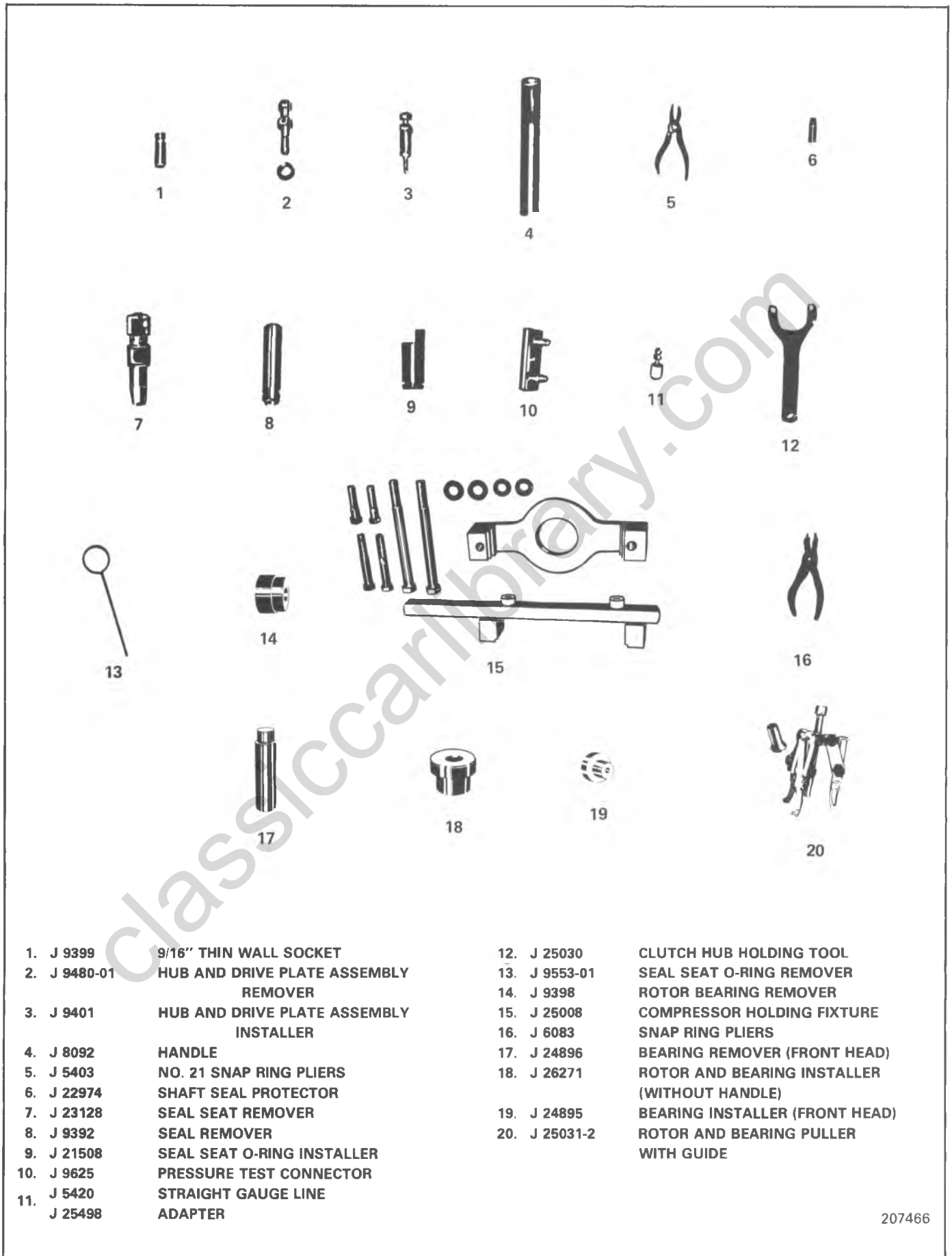

- |              |  |               |  |
|--------------|--|---------------|--|
| 1. J 9399    | 9/16" THIN WALL SOCKET                 | 12. J 25030   | CLUTCH HUB HOLDING TOOL                      |
| 2. J 9480-01 | HUB AND DRIVE PLATE ASSEMBLY REMOVER   | 13. J 9553-01 | SEAL SEAT O-RING REMOVER                     |
| 3. J 9401    | HUB AND DRIVE PLATE ASSEMBLY INSTALLER | 14. J 9398    | ROTOR BEARING REMOVER                        |
| 4. J 8092    | HANDLE                                 | 15. J 25008   | COMPRESSOR HOLDING FIXTURE                   |
| 5. J 5403    | NO. 21 SNAP RING PLIERS                | 16. J 6083    | SNAP RING PLIERS                             |
| 6. J 22974   | SHAFT SEAL PROTECTOR                   | 17. J 24896   | BEARING REMOVER (FRONT HEAD)                 |
| 7. J 23128   | SEAL SEAT REMOVER                      | 18. J 26271   | ROTOR AND BEARING INSTALLER (WITHOUT HANDLE) |
| 8. J 9392    | SEAL REMOVER                           | 19. J 24895   | BEARING INSTALLER (FRONT HEAD)               |
| 9. J 21508   | SEAL SEAT O-RING INSTALLER             | 20. J 25031-2 | ROTOR AND BEARING PULLER WITH GUIDE          |
| 10. J 9625   | PRESSURE TEST CONNECTOR                |               |  |
| 11. J 5420   | STRAIGHT GAUGE LINE                    |               |  |
| 11. J 25498  | ADAPTER                                |               |  |

Fig. 1D-106 Special Tools, R-4 Compressor.

classiccarylbrary.com

## SECTION 3B STEERING

### CONTENTS OF THIS SECTION

Manual Steering Gear.....	3B-1
Power Steering Pump .....	3B-5
Integral Power Steering Gear.....	3B-8
Special Tools .....	3B-19

### MANUAL STEERING GEARS

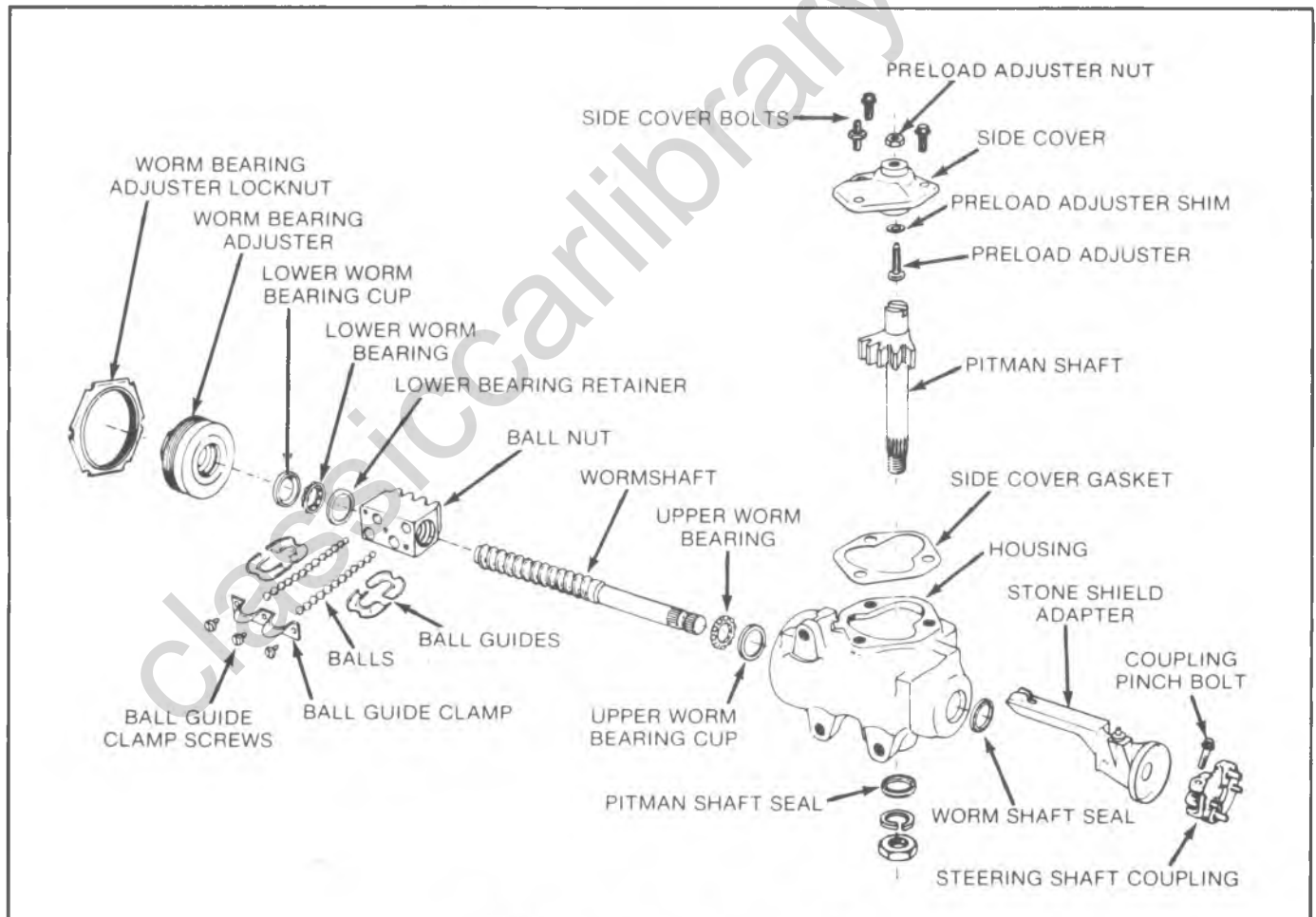
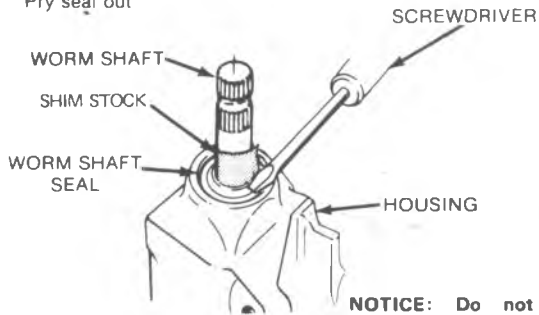

Fig. 3B2-1—Manual Gear, Exploded View

**1. REMOVE AND INSTALL WORM SHAFT SEAL-GEAR ASSEMBLED**

**REMOVE**

1. Wrap 0.1 mm to 0.2 mm (.005" to .008") shim stock around shaft and insert between shaft and seal. Pry seal out.



**INSTALL**

1. Install parts as shown.

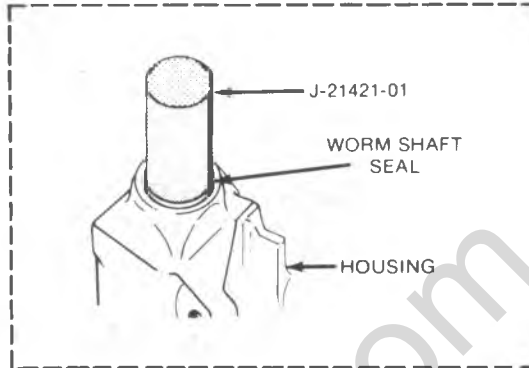

Install seal

**NOTICE:** Do not turn steering wheel hard against "stops" when linkage is disconnected, as damaged to the ends of ball guides may occur.

**2. REMOVE AND INSTALL PITMAN SHAFT AND SIDE COVER**

**REMOVE**

1. Center steering gear.
2. Remove parts as shown.

**INSTALL**

1. Before installing turn preload adjuster screw counter-clockwise until it bottoms, then back screw off one half turn.
2. Install parts as shown.

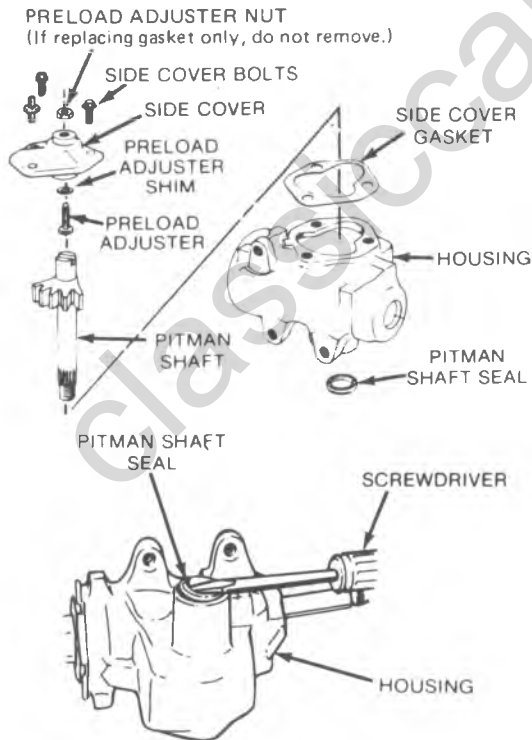

Checking end clearance

If clearance is greater than .05 mm (.002") a steering gear lash adjuster kit is available

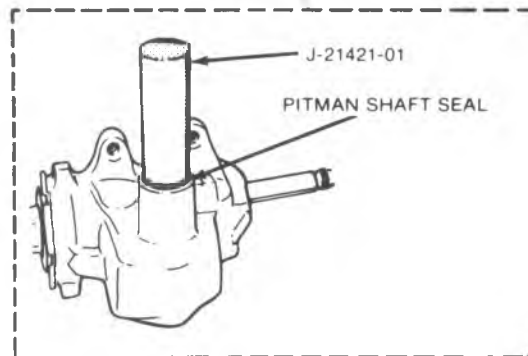
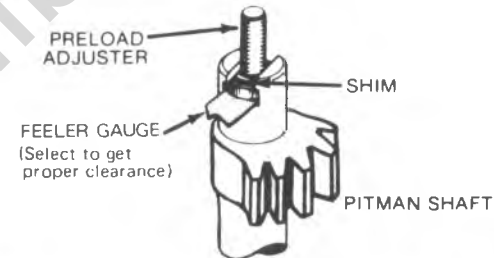

Install seal

**LUBRICATION**

The steering gear requires 3118 kg (11 oz.) of lubricant GM4673M or equivalent

Fig. 3B2-2-Manual Gear Overhaul, Chart A

### 3. REMOVE AND INSTALL WORMSHAFT AND BALL NUT

**REMOVE** **INSTALL**

1. Loosen lock nut. Use punch against edge of slot
2. Remove parts as shown

**NOTICE:** Use care that the ball nut does not run down to either end of the worm. Damage may be done to the ends of the ball guides if the ball nut is allowed to rotate until stopped at the end of the worm.

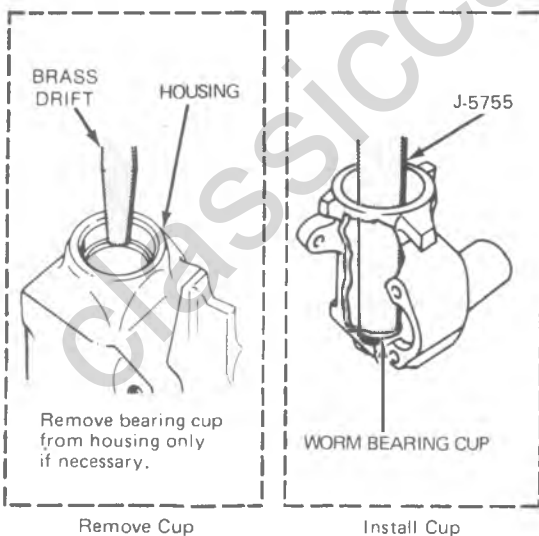
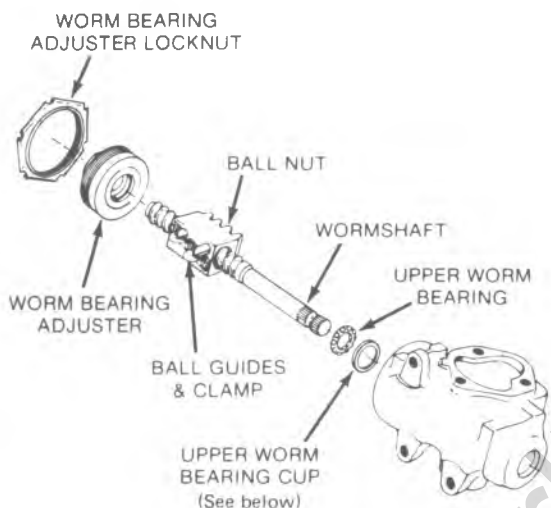

### 4. DISASSEMBLE AND ASSEMBLE WORM BEARING ADJUSTER

**DISASSEMBLE** **ASSEMBLE**

1. Pry lower bearing retainer out with screwdriver.
2. Remove cup using J-5822 puller and slide hammer.



### 5. DISASSEMBLE AND ASSEMBLE WORMSHAFT AND BALL NUT

**DISASSEMBLE** **ASSEMBLE**

1. Disassemble parts as shown
2. Clean and inspect all parts for excessive wear

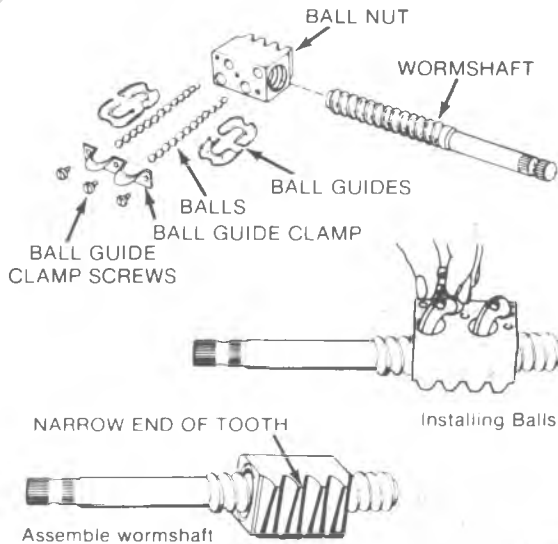

Dimension A—Measure land between ball grooves

Dim A		Balls per circuit
mm	in	
1.0	0.04	25
2.5	0.10	27
5.0	0.20	27

WORMSHAFT

Fig A

Fig. 3B2-3—Manual Gear Overhaul, Chart B

**6. ADJUST WORM BEARING PRELOAD**

- 1 Tighten worm bearing adjuster until it bottoms then loosen one-quarter turn.
- 2 Carefully turn the wormshaft all the way to end of travel then turn back one-half turn.
- 3 Tighten adjuster plug until torque wrench reads 0.6 to 1.0 N m (5 to 8 in lbs).
- 4 Tighten locknut using punch against edge of slot.

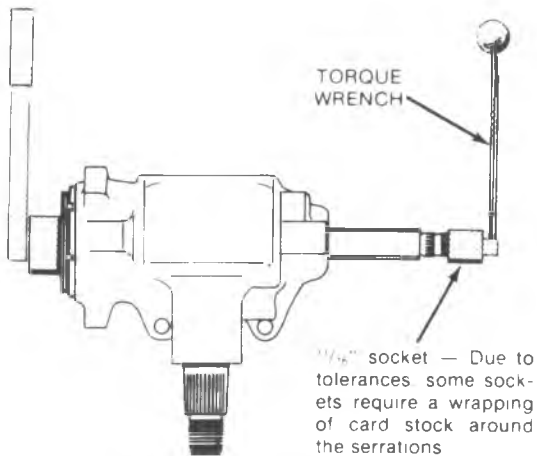

**7. ADJUST "OVER CENTER" PRELOAD**

A. Back off preload adjuster until it stops, then turn it in one full turn.



With gear at center of travel, check torque to turn stub shaft (reading #1).

B Turn adjuster in until torque to turn stub shaft is 0.5 to 1.2 N m (4 to 10 in lbs) more than reading #1.



Torque adjuster lock nut to 34 N m (25 ft lbs). Prevent adjuster screw from turning while torquing lock nut.

**ADJUSTMENT SPECIFICATIONS – MANUAL STEERING**

ADJUSTMENT	TORQUE TO TURN WORM SHAFT	
Worm Bearing	0.6-1.0 N·m	5-8 In. Lbs.
Over Center Preload	0.5-1.2 N·m	4-10 In. Lbs. in excess of Worm Bearing Preload.
Total Steering Gear Preload	1.8 N·m	16 In. Lbs. Maximum

**RECOMMENDED TORQUE SPECIFICATIONS**

MANUAL STEERING GEAR	N·m	FT. LB.
Gear to Frame Bolts	95	70
Pitman Shaft Nut	251	185
Side Cover Bolts	40	30
Pitman Shaft Adjusting Screw Locknut	34	25
Coupling Flange To Gear Pinch Bolt	40	30
Coupling Clamp Nut (Starfire)	70	50
Clamp To Ball Nut Screw	5.5	4

**TOOLS**



J-21421-01



J-5755



J-5822

- J-21421-01 Seal Installer
- J-5755 Worm Bearing Cup Installer
- J-5822 Worm Bearing Adjuster Cup Puller

Fig. 3B2-4--Manual Gear Overhaul, Chart C

## POWER STEERING PUMP

**NOTICE:** If when overhauling a power steering gear or pump, broken components or foreign material are encountered, the remaining components of the entire hydraulic system should be disassembled, inspected, thoroughly cleaned and flushed before servicing is completed, or damage to the other components may occur.

classiccarlibrary.com

1. REMOVE AND INSTALL DRIVE SHAFT SEAL WITHOUT DISASSEMBLING THE PUMP.

- |   |   |
|---|---|
| <p><b>REMOVE</b></p> <ol style="list-style-type: none"> <li>1. PROTECT DRIVE SHAFT WITH SHIM STOCK.</li> <li>2. USE CHISEL TO CUT SEAL AND REMOVE.</li> </ol> | <p><b>INSTALL</b></p> <ol style="list-style-type: none"> <li>1. COAT DRIVE SHAFT SEAL WITH HYDRAULIC PUMP FLUID. REFER TO INSET FOR DRIVE SHAFT SEAL INSTALLATION.</li> </ol> |
|---|---|

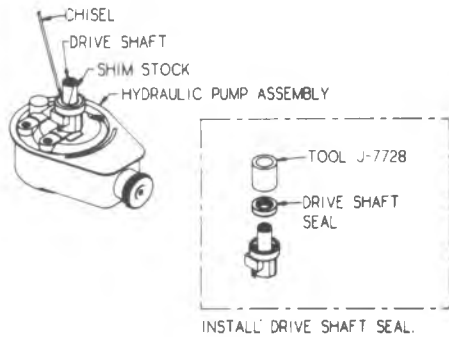

2. REMOVE AND INSTALL PUMP RESERVOIR ASSEMBLY

- |  |   |
|--|---|
| <p><b>REMOVE</b></p> <ol style="list-style-type: none"> <li>1. DRAIN OIL FROM RESERVOIR ASSEMBLY BEFORE REMOVAL.</li> <li>2. REMOVE PARTS AS SHOWN.</li> </ol> | <p><b>INSTALL</b></p> <ol style="list-style-type: none"> <li>1. USE ALL NEW SEALS AND LUBRICATE WITH POWER STEERING FLUID BEFORE INSTALLATION.</li> <li>2. INSTALL PARTS AS SHOWN.</li> </ol> |
|--|---|

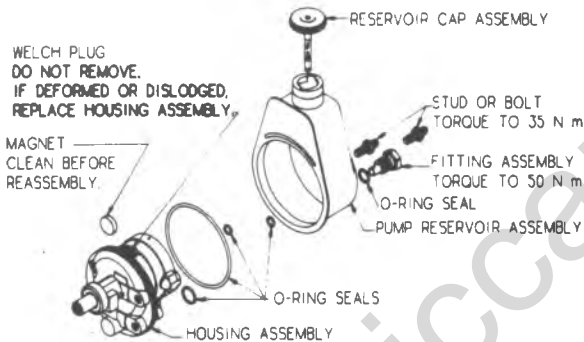

3. REMOVE AND INSTALL END PLATE.

- |  |   |
|--|---|
| <p><b>REMOVE</b></p> <ol style="list-style-type: none"> <li>1. REFER TO INSET FOR RETAINING RING REMOVAL.</li> </ol> | <p><b>INSTALL</b></p> <ol style="list-style-type: none"> <li>1. LUBRICATE END PLATE AND RETAINING RING. INSTALL PARTS AS SHOWN. REFER TO INSET FOR POSITIONING OF RETAINING RING IN HOUSING.</li> </ol> |
|--|---|

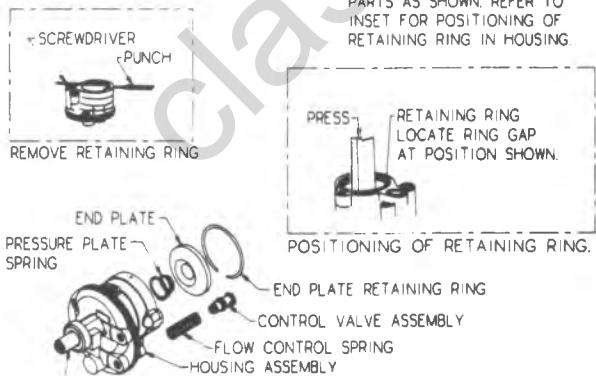

NOTICE: BEFORE PROCEEDING, EXAMINE THIS PART OF THE DRIVE SHAFT. IF IT IS CORRODED, CLEAN WITH CROCUS CLOTH BEFORE REMOVING. THIS WILL PREVENT DAMAGE TO THE SHAFT BUSHING WHICH MIGHT REQUIRE REPLACEMENT OF THE ENTIRE HOUSING.

4. REMOVE AND INSTALL ROTATING GROUP.

- |  |  |
|--|--|
| <p><b>REMOVE</b></p> <ol style="list-style-type: none"> <li>1. USING A RUBBER Mallet, TAP LIGHTLY ON DRIVE SHAFT UNTIL PRESSURE PLATE IS FREE.</li> <li>2. REMOVE RETAINING RING FROM DRIVE SHAFT AND DISCARD. REMOVE PARTS AS SHOWN.</li> </ol> | <p><b>INSTALL</b></p> <ol style="list-style-type: none"> <li>1. INSTALL PARTS AS SHOWN ON DRIVE SHAFT. INSTALL NEW RETAINING RING ON DRIVE SHAFT AND INSTALL IN PUMP HOUSING.</li> <li>2. REFER TO INSET FOR POSITIONING OF PUMP RING IN HOUSING.</li> </ol> |
|--|--|

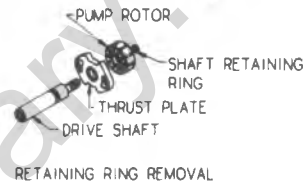
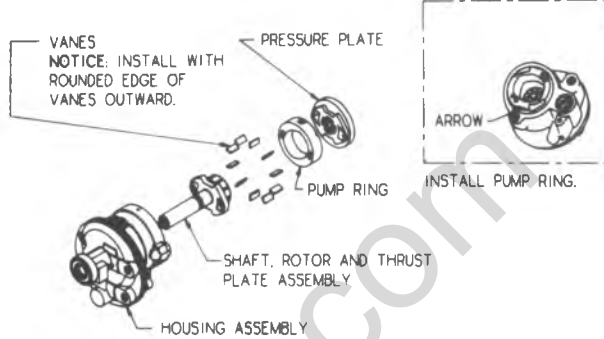

5. REMOVE AND INSTALL DRIVE SHAFT AND O-RING SEALS.

- |  |   |
|--|---|
| <p><b>REMOVE</b></p> <ol style="list-style-type: none"> <li>1. REMOVE PARTS AS SHOWN.</li> </ol> | <p><b>INSTALL</b></p> <ol style="list-style-type: none"> <li>1. REFER TO THE INSET FOR DRIVE SHAFT SEAL INSTALLATION. USE ALL NEW SEALS AND LUBRICATE SEALS WITH POWER STEERING FLUID BEFORE INSTALLATION.</li> <li>2. INSTALL PARTS AS SHOWN.</li> </ol> |
|--|---|

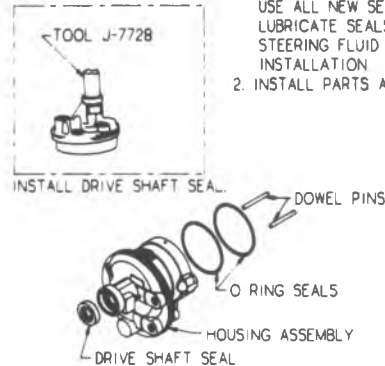

Fig. 3B3-1—Power Steering Pump (Overhaul)



## POWER STEERING GEAR (605 MODEL)

### GENERAL DESCRIPTION

This Integral Power Steering Gear has a control valve which directs oil to either side of the rack piston. The rack piston converts hydraulic power into mechanical force. This force is transmitted to the mating pitman shaft teeth, through the pitman shaft to the steering linkage.

This is a small design steering gear. To determine this gear from our large steering gear see difference in side cover below.

Whenever a part which forms a sealing surface for an "O" ring seal is removed, the "O" ring seal should also be removed and replaced with a new seal. Whenever one of the Pitman shaft or stub shaft seals are removed all adjacent seals should be removed and replaced with new seals. Lubricate all new seals with power steering fluid to ease assembly.

Round side cover — held in place with retaining ring



(605 MODEL)

**Key No. Part Name**

- 1 - HOUSING, STEERING GEAR
- 2 - RETAINER, STRG. COUPLING SHIELD
- 3 - BEARING ASSY., NEEDLE (STUB SHAFT)
- 4 - SEAL, STUB SHAFT
- 5 - SEAL, STUB SHAFT DUST
- 6 - RING, RETAINING (STUB SHAFT SEAL)
- 7 - BEARING ASSY., NEEDLE (PITMAN SHAFT)
- 8 - SEAL, PITMAN SHAFT
- 9 - WASHER, SEAL BACK-UP (PITMAN SHAFT)
- 10 - SEAL, PITMAN SHAFT DUST
- 11 - RING, RETAINING (PITMAN SHAFT SEAL)
- 12 - WASHER, LOCK (PITMAN SHAFT)
- 13 - NUT, PITMAN ARM
- 14 - BEARING ASSY., RACE & UPPER
- 15 - RING, VALVE BODY (3)
- 16 - SEAL, "O" RING (VALVE BODY) (3)
- 17 - BODY ASSY., VALVE
- 18 - SEAL, "O" RING (DAMPNER)
- 19 - SPOOL, VALVE

**Key No. Part Name**

- 20 - SHAFT ASSY., STUB
- 21 - SEAL, "O" RING (SHAFT TO WORM)
- 22 - WORM ASSY., PIN & STRG.
- 23 - RING, RETAINING (SHAFT TO WORM)
- 24 - RING, RACK PISTON
- 25 - SEAL, "O" RING (RACK PISTON)
- 26 - RACK-PISTON-NUT
- 27 - BEARING ASSY., SUPPORT & LWR. THR.
- 28 - SEAL, "O" RING (ADJUSTER PLUG)
- 29 - PLUG, ADJUSTER
- 30 - NUT, ADJUSTER LOCK
- 31 - SPRING, SIDE COVER
- 32 - SEAL, "O" RING (SIDE COVER)
- 33 - GEAR ASSY., PITMAN SHAFT
- 34 - COVER, ASSY., HOUSING SIDE
- 35 - RING, RETAINING (SIDE COVER)
- 36 - NUT, PRELOAD ADJUSTER SEALING
- 37 - CONNECTOR, INVERTED FLARE (2)

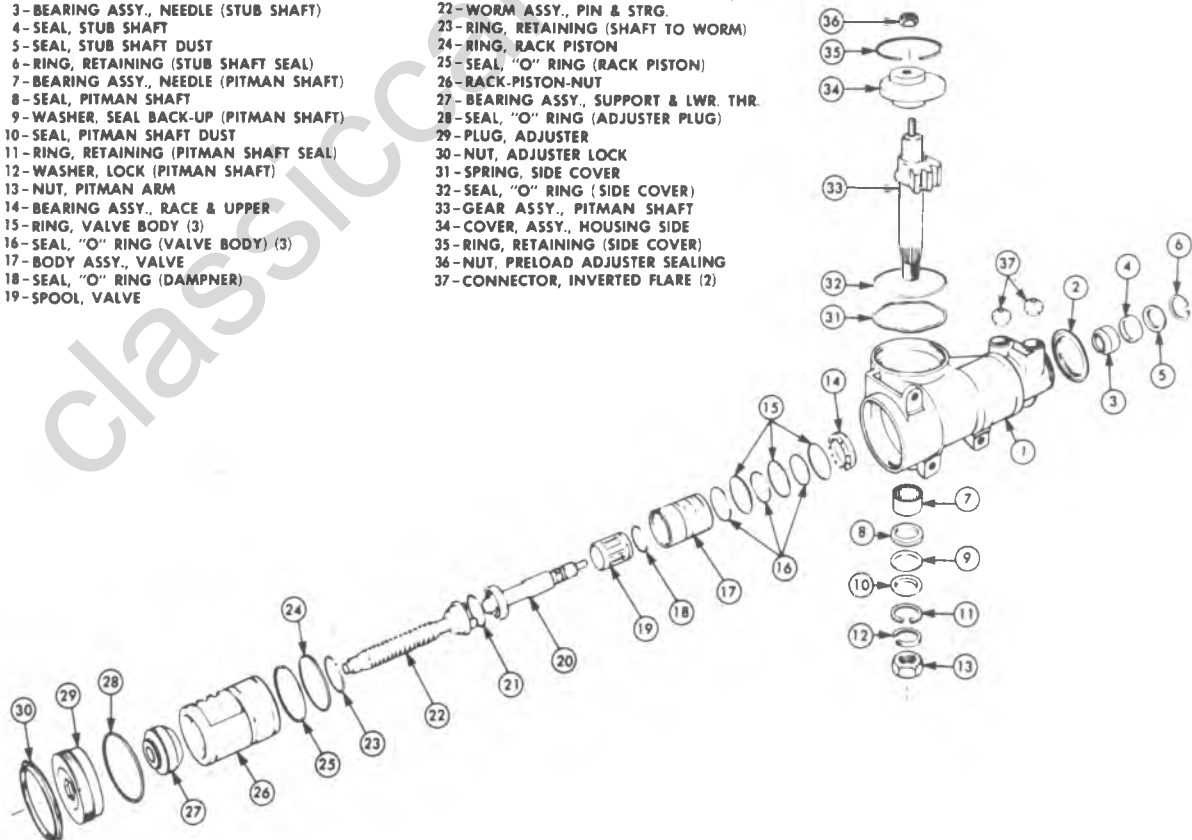

Fig. 3B3-1C—Overhaul 605 Gear, Chart A

### 1. REMOVE AND INSTALL PITMAN SHAFT SEALS IN CAR

**REMOVE**

1. Clean exposed end of pitman shaft and end of housing after removing arm.
2. Remove retaining ring.
3. Start engine and turn wheels fully to the right to force seals and washer out.
4. Turn off engine.
5. Inspect housing and shaft.

**PITMAN SHAFT** — Inspect seal surface for roughness and pitting

**INSTALL**

1. Install parts as shown

**HOUSING ASSEMBLY**  
Inspect for burrs.

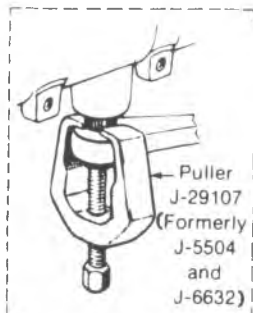
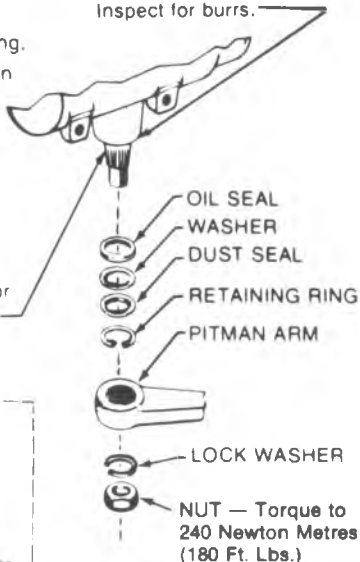

Remove Pitman Arm

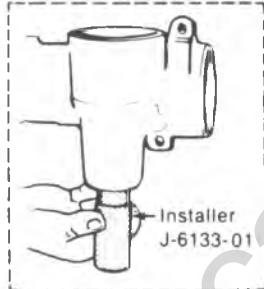

Install Seals

### 2. REMOVE AND INSTALL STUB SHAFT SEALS WITHOUT DISASSEMBLING GEAR

**REMOVE**

1. Remove retaining ring and dust seal. Take care not to scratch shaft.
2. Wrap 0.1mm to 0.2mm (.005" to .008") shim stock around shaft and insert between shaft and sealing lip until it bottoms. Pry seal out \*

**INSTALL**

1. Install stub shaft seal. Liberally coat top of seal with anhydrous calcium grease.
2. Install dust seal just deep enough to clear retaining ring groove, then install retaining ring.

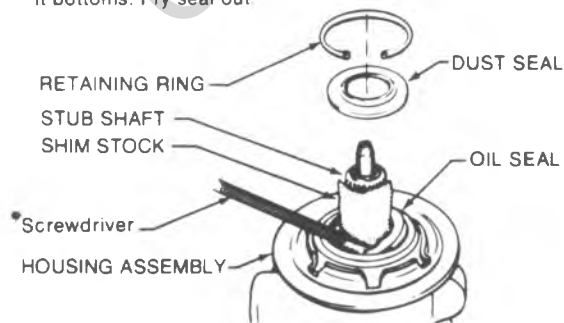

### 3. REMOVE AND INSTALL PITMAN SHAFT AND SIDE COVER

**REMOVE**

1. If pitman shaft and side cover are to be separated, remove preload adjuster nut. IT IS A LEFT HAND THREAD.
2. Rotate stub shaft to center gear, then remove parts as shown. Tap on thread end of pitman shaft with plastic hammer.

**INSTALL**

1. Install parts as shown. Use new retaining ring, make sure that open end of retaining ring is approx. 13mm (1/2") from access hole.
2. Side cover must be depressed to install retaining ring. (SEE BELOW)\*

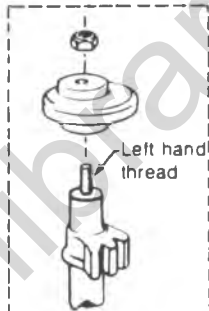
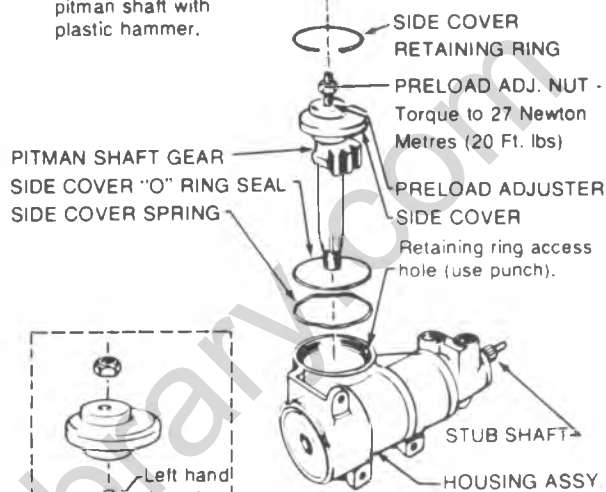

Separate pitman shaft from side cover if required.

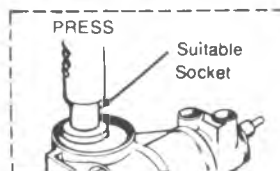

PRESS

Suitable Socket

\* Depress side cover

### 4. REMOVE AND INSTALL LOWER BEARING AND ADJUSTER

**REMOVE**

1. Loosen lock nut. Use punch against edge of one slot.
2. Remove parts as shown
3. Inspect lower thrust bearing assembly.

**INSTALL**

1. Install parts as shown.
2. Adjust thrust bearing preload (see adjustment procedure) before tightening lock nut

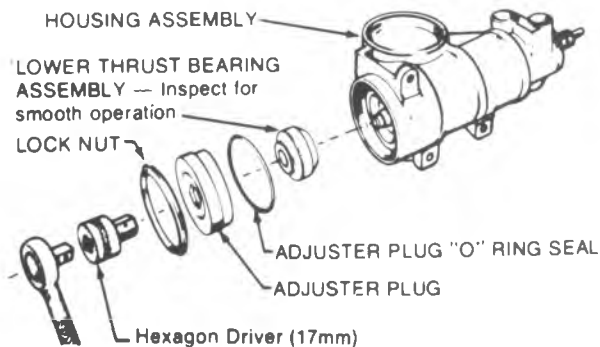

Fig. 3B3-2C--Overhaul 605 Gear, Chart B

### 5. REMOVE AND INSTALL RACK PISTON AND VALVE ASSEMBLY

**REMOVE**

1. Remove parts as shown. Push on stub shaft. **DO NOT** remove upper bearing assembly (see stub shaft seal removal)

**INSTALL**

1. Install parts as shown. Make sure rack piston teeth are positioned toward side cover opening.

### 6. REMOVE AND INSTALL VALVE AND WORM ASSEMBLY FROM RACK PISTON

**REMOVE**

1. Unscrew valve and worm from rack.
2. Remove teflon ring and rack piston "O" ring from rack piston.

**INSTALL**

1. Install "O" ring and teflon ring as shown.
2. Screw worm and valve into rack piston. See procedure below.

**VALVE AND WORM ASSEMBLY**  
\* To ease assembly, soak teflon rings in warm water.

**A. Assemble worm and valve to rack piston**

a. Hold rack teeth and worm drive pin in relation shown with light pressure to hold worm thread against piston.

b. Turn worm and valve counterclockwise slowly until one "Click" is felt.

c. Turn worm and valve clockwise to complete assembly

**B. Check relation of stub shaft and rack piston**

a. Screw worm and valve into rack piston until valve face and rack piston face are flush.

b. With rack piston in position shown, flats on stub shaft and piston are to be parallel. If not parallel, disassemble and repeat "A." above.

### 7. REMOVE AND INSTALL VALVE ASSEMBLY FROM WORM ASSEMBLY

**REMOVE**

1. Remove parts as shown.

**INSTALL**

1. Install parts as shown. See below.

Assemble worm to valve

RETAINING RING — Install with "curved in end" on same side as access hole.

### 8. DISASSEMBLE AND ASSEMBLE VALVE

**DISASSEMBLE**

1. Disassemble parts as shown.

**ASSEMBLE**

2. Assemble parts as shown.

\* To ease assembly, soak teflon rings in warm water.

**A. Loosen shaft cap**

**B. Remove and install stub shaft.**

Pull cap out approx. 6 mm (1/4")

**C. Remove and install spool**

Rotate while removing or installing

**D. Engage stub shaft**

Fig. 3B3-3C—Overhaul 605 Gear, Chart C

**9. REMOVE AND INSTALL STUB SHAFT SEALS AND BEARINGS**

**REMOVE**

1. Clean end of housing to prevent dirt from entering gear.
2. Remove parts as shown, being careful not to score housing bore.
3. Remove stub shaft needle bearing and upper thrust bearing if required. Put a finger into the stub shaft cavity and hook it onto the upper thrust bearing race. Turn the race while pulling up. If bearing operation is smooth, it does not need removal. Check the stub shaft needle bearing for smoothness. If O.K., do not remove.

**INSTALL**

1. If removed, install new stub shaft needle bearing. Bottom tool on housing counterbore.
- NOTICE:** SERVICE thrust bearing DOES NOT SNAP ON needle bearing. If removed, install as shown below.
2. Install stub shaft seal. Liberally coat top of seal with anhydrous calcium grease.
  3. Install dust seal just deep enough to clear retaining ring groove, then install retaining ring.

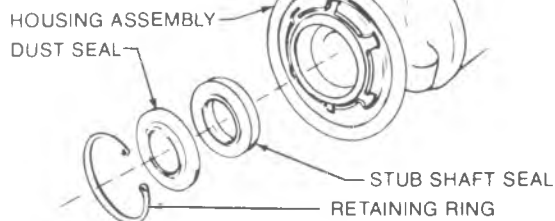

**A Remove bearings**

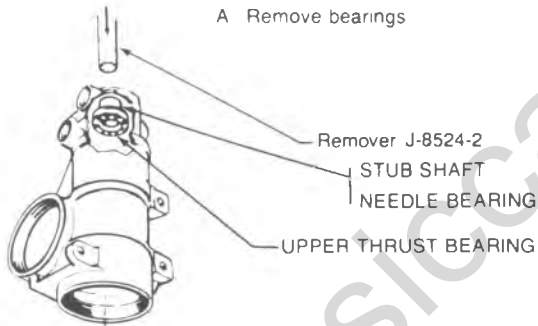

**B Install bearings**

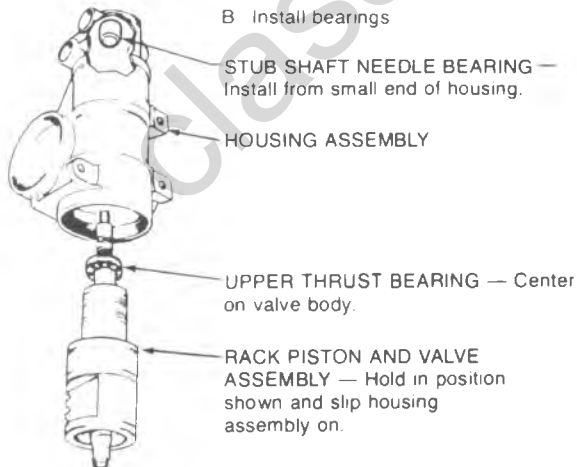

**10. REMOVE AND INSTALL PITMAN SHAFT SEALS AND BEARING**

**REMOVE**

1. Clean end of housing thoroughly to prevent dirt from entering and be extremely careful not to score the housing bore.
2. Remove retaining ring with snap ring pliers J-4245.
3. Using screw driver, pry seals and washer from bore.

**INSTALL**

1. Bottom oil seal in counterbore. Install washer. Coat seal lip and washer face with anhydrous calcium grease.
2. Install remaining parts as shown.

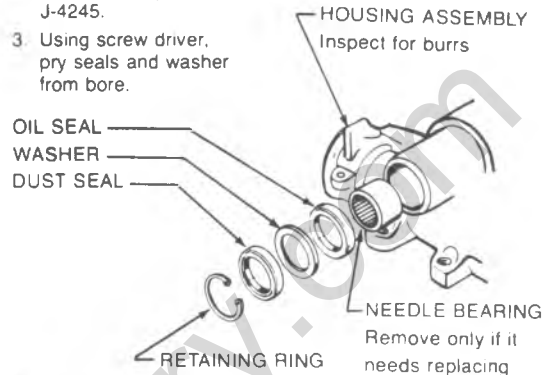

Remove and install bearing (not necessary unless bearing is to be replaced).

**11. REMOVE AND INSTALL CONNECTORS**

**REMOVE**

1. Remove parts as shown.

**INSTALL**

1. Install parts as shown.

**NOTICE:** Some models will not use these connectors.

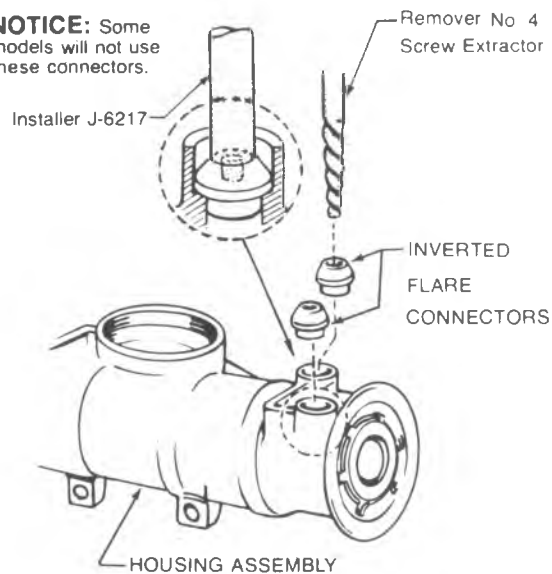
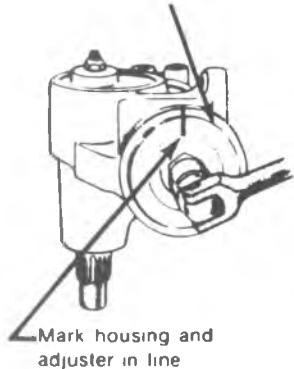

Fig. 3B3-4C—Overhaul 605 Gear, Chart D

### 12. ADJUST WORM BEARING PRELOAD

A Tighten adjuster plug until it bottoms (use 17mm hex. driver). Torque to approx. 40 Newton meters (30 ft. lbs.)



B Measure 13mm (1/2") counter-clockwise and mark housing only

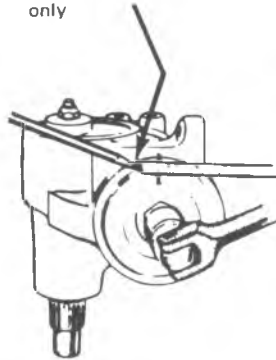

C Turn adjuster back until mark lines up with second mark on housing

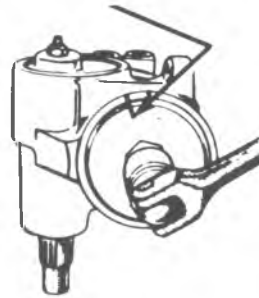

D Tighten lock nut. Use punch in notch

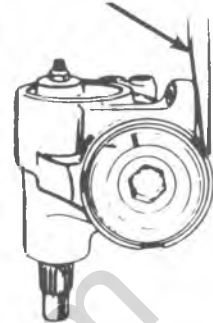

### 13. ADJUST "OVER CENTER" PRELOAD

A. Whenever a power steering gear requires adjustment, the gear should be drained of hydraulic fluid.



To drain the fluid, position the assembly with hydraulic line ports pointing downward over a container and cycle the rack-piston-nut from stop to stop three or four times.

B. When a unit has been disassembled for any reason, the side cover must be firmly seated against its retaining ring before any adjustment is attempted.

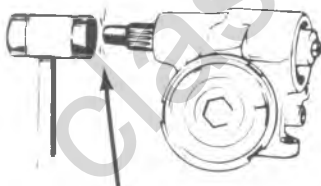

To seat the side cover, tap on the end of the pitman shaft with a soft hammer.

C. Back off preload adjuster (LEFT HAND THREAD) until it stops, then turn it in one full turn.

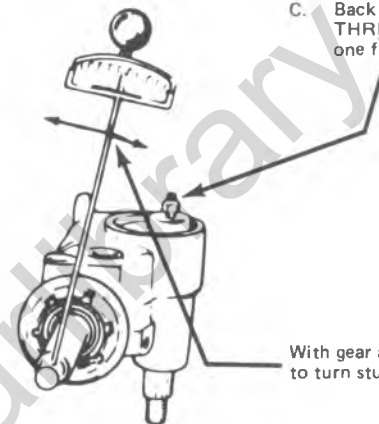

With gear at center of travel, check torque to turn stub shaft (reading No. 1)

D. Turn adjuster in until torque to turn stub shaft is 0.6 to 1.2 Newton meters (6 to 10 in. lbs.) more than reading No. 1.

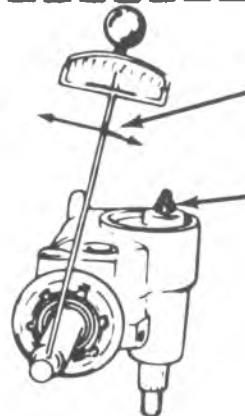

Torque adjuster lock nut to 27 Newton meters (20 ft. lbs.) Prevent adjuster screw from turning while torquing lock nut.

### SPECIAL TOOLS

J-4245	— Snap Ring Pliers	J-8058	— 0-125 Newton-meter Torque Wrench (0-50 foot-pounds)
J-29107	— Pitman Arm Puller	J-8810	— Pitman Shaft Bearing Remover And Installer
J-6133-01	— Pitman Shaft Seal Installer	J-25323	— Power Steering Analyzer
J-6217	— Connector Seat Installer		
J-7754	— 0-5 Newton-meter Torque Wrench (0-25 inch-pounds)		

Fig. 3B3-5C—Overhaul 605 Gear, Chart E

### POWER STEERING GEAR (800 MODEL)

#### GENERAL DESCRIPTION

These Integral Power Steering Gears have a control valve which directs oil to either side of the rack piston. The rack piston converts hydraulic power into mechanical force. This force is transmitted to the mating pitman shaft teeth, through the pitman shaft to the steering linkage.

The model 800 incorporates a recirculating ball system in which steel balls act as a rolling thread between a steering worm-shaft and the rack-piston. The model 605 uses an acme thread on the worm which mates with an acme thread in the rack-piston.

Repair procedures for these two models are different. Note the side cover differences in the sketch below.

Whenever a part which forms a sealing surface for an "O" ring is removed, the "O" ring seal should also be removed and replaced with a new seal. Whenever one of the Pitman shaft or stub shaft seals are removed all adjacent seals should be removed and replaced with new seals. Lubricate all new seals with power steering fluid to ease assembly.

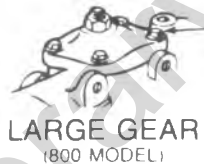

Rectangular side cover held in place with four bolts

Key No.	Part Name	Key No.	Part Name	Key No.	Part Name
1	HOUSING, STEERING GEAR	19	PLUG ADJUSTER	37	SCREW ASSY, LOCKWASHER & (2)
2	RACE, THRUST BEARING (WORM)	20	BEARING, NEEDLE	38	PLUG RACK PISTON
3	BEARING ASSY, ROLLER THRUST (WORM)	21	SEAL, STUB SHAFT	39	SEAL, "O" RING (RACK PISTON)
4	RACE, THRUST BEARING (WORM)	22	SEAL, STUB SHAFT DUST	40	RING, RACK PISTON
5	WORM, STEERING	23	RING, RETAINING	41	SEAL, "O" RING (HOUSING END PLUG)
6	SEAL, "O" RING (STUB SHAFT)	24	NUT, ADJUSTER PLUG LOCK	42	PLUG HOUSING END
7	SHAFT, STUB	25	BEARING ASSY, NEEDLE (PITMAN SHAFT)	43	RING, RETAINING (HOUSING END PLUG)
8	SPOOL, VALVE	26	SEAL, PITMAN SHAFT (SINGLE LIP)	44	GEAR ASSY, PITMAN SHAFT
9	SEAL, "O" RING (SPOOL)	27	WASHER, SEAL BACK-UP (PITMAN SHAFT)	45	SEAL ASSY, GASKET
10	BODY, VALVE	28	SEAL, PITMAN SHAFT (DOUBLE LIP)	46	COVER ASSY, HOUSING SIDE
11	RING, VALVE BODY (3)	29	WASHER, SEAL BACK-UP (PITMAN SHAFT)	47	BOLT, HEX HEAD (SIDE COVER) (4)
12	SEAL, "O" RING (VALVE BODY) (3)	30	RING, RETAINING (PITMAN SHAFT SEAL)	48	NUT, LASH ADJUSTER
13	RETAINER, BEARING (ADJUSTER)	31	WASHER, PITMAN SHAFT LOCK	49	SPRING CHECK VALVE
14	SPACER, THRUST BEARING	32	NUT, PITMAN SHAFT	50	POPPET CHECK VALVE
15	RACE, UPPER THRUST BEARING (SMALL)	33	NUT, RACK PISTON	51	CONNECTOR INVERTED FLARE
16	BEARING, UPPER THRUST	34	BALL	52	CONNECTOR INVERTED FLARE
17	RACE, UPPER THRUST BEARING (LARGE)	35	GUIDE, BALL RETURN (2)		
18	SEAL, "O" RING (ADJUSTER)	36	CLAMP, BALL RETURN GUIDE		

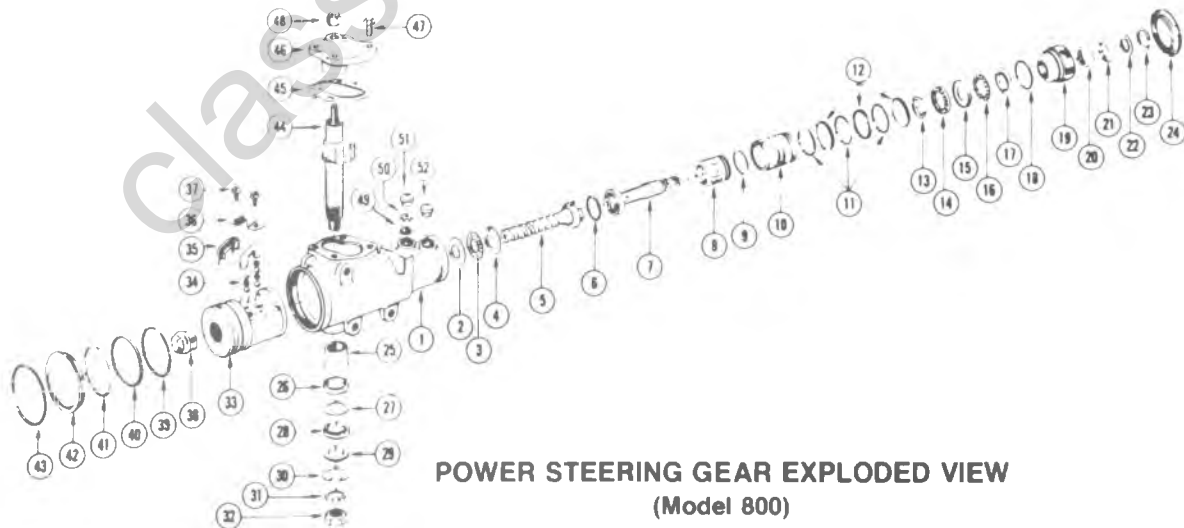

POWER STEERING GEAR EXPLODED VIEW (Model 800)

Fig. 3B3-6C—Overhaul 800 and 808 Gears. Chart A

- | Key No. | Part Name                           |
|---------|-------------------------------------|
| 1       | HOUSING, STEERING GEAR              |
| 2       | RACE, THRUST BEARING (WORM)         |
| 3       | BEARING ASSY., ROLLER THRUST (WORM) |
| 4       | RACE, THRUST BEARING (WORM)         |
| 5       | WORM, STEERING                      |
| 6       | SEAL, "O" RING (STUB SHAFT)         |
| 7       | SHAFT, STUB                         |
| 8       | SPOOL, VALVE                        |
| 9       | SEAL, "O" RING (SPOOL)              |
| 10      | BODY, VALVE                         |
| 11      | RING, VALVE BODY (3)                |
| 12      | SEAL, "O" RING (VALVE BODY) (3)     |
| 13      | RETAINER, BEARING (ADJUSTER)        |
| 14      | SPACER, THRUST BEARING              |
| 15      | RACE, UPPER THRUST BEARING (SMALL)  |
| 16      | BEARING, UPPER THRUST               |
| 17      | RACE, UPPER THRUST BEARING (LARGE)  |
| 18      | SEAL, "O" RING (ADJUSTER)           |

- | Key No. | Part Name                            |
|---------|--------------------------------------|
| 19      | PLUG, ADJUSTER                       |
| 20      | BEARING, NEEDLE                      |
| 21      | SEAL, STUB SHAFT                     |
| 22      | SEAL, STUB SHAFT DUST                |
| 23      | RING, RETAINING                      |
| 24      | NUT, ADJUSTER PLUG LOCK              |
| 25      | BEARING ASSY., NEEDLE (PITMAN SHAFT) |
| 26      | SEAL, PITMAN SHAFT (SINGLE LIP)      |
| 27      | WASHER, SEAL BACK-UP (PITMAN SHAFT)  |
| 28      | SEAL, PITMAN SHAFT (DOUBLE LIP)      |
| 29      | WASHER, SEAL BACK-UP (PITMAN SHAFT)  |
| 30      | RING, RETAINING (PITMAN SHAFT SEAL)  |
| 31      | WASHER, PITMAN SHAFT LOCK            |
| 32      | NUT, PITMAN SHAFT                    |
| 33      | NUT, RACK PISTON                     |
| 34      | BALL                                 |
| 35      | GUIDE, BALL RETURN (2)               |
| 36      | CLAMP, BALL RETURN GUIDE             |

- | Key No. | Part Name                          |
|---------|------------------------------------|
| 37      | SCREW ASSY., LOCKWASHER & (2)      |
| 38      | PLUG, RACK PISTON                  |
| 39      | SEAL, "O" RING (RACK PISTON)       |
| 40      | RING, RACK PISTON                  |
| 41      | SEAL, "O" RING (HOUSING END PLUG)  |
| 42      | PLUG, HOUSING END                  |
| 43      | RING, RETAINING (HOUSING END PLUG) |
| 44      | GEAR ASSY., PITMAN SHAFT           |
| 45      | SEAL ASSY., GASKET                 |
| 46      | COVER ASSY., HOUSING SIDE          |
| 47      | BOLT, HEX. HEAD (SIDE COVER) (4)   |
| 48      | NUT, LASH ADJUSTER                 |
| 49      | SPRING, CHECK VALVE                |
| 50      | POPPET, CHECK VALVE                |
| 51      | CONNECTOR, INVERTED FLARE          |
| 52      | CONNECTOR, INVERTED FLARE          |
| 53      | BOLT, COUPLING PINCH               |
| 54      | COUPLING, STEERING SHAFT           |



USED ON SOME MODELS

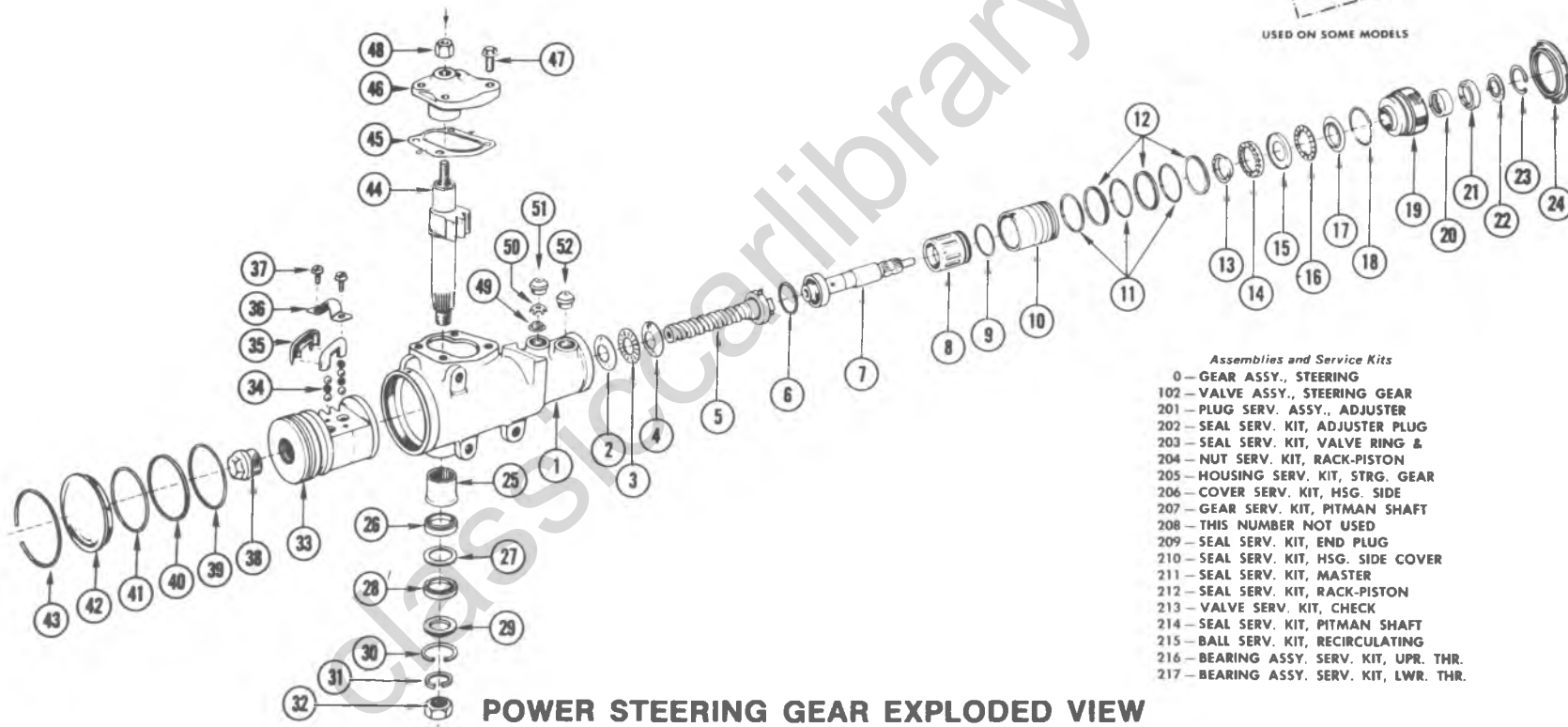

POWER STEERING GEAR EXPLODED VIEW

- Assemblies and Service Kits*
- 0 — GEAR ASSY., STEERING
  - 102 — VALVE ASSY., STEERING GEAR
  - 201 — PLUG SERV. ASSY., ADJUSTER
  - 202 — SEAL SERV. KIT, ADJUSTER PLUG
  - 203 — SEAL SERV. KIT, VALVE RING &
  - 204 — NUT SERV. KIT, RACK-PISTON
  - 205 — HOUSING SERV. KIT, STRG. GEAR
  - 206 — COVER SERV. KIT, HSG. SIDE
  - 207 — GEAR SERV. KIT, PITMAN SHAFT
  - 208 — THIS NUMBER NOT USED
  - 209 — SEAL SERV. KIT, END PLUG
  - 210 — SEAL SERV. KIT, HSG. SIDE COVER
  - 211 — SEAL SERV. KIT, MASTER
  - 212 — SEAL SERV. KIT, RACK-PISTON
  - 213 — VALVE SERV. KIT, CHECK
  - 214 — SEAL SERV. KIT, PITMAN SHAFT
  - 215 — BALL SERV. KIT, RECIRCULATING
  - 216 — BEARING ASSY. SERV. KIT, UPR. THR.
  - 217 — BEARING ASSY. SERV. KIT, LWR. THR.

Fig. 3B3-7C-Overhaul 800 and 808 Gears, Chart B

**1. REMOVE AND INSTALL PITMAN SHAFT SEALS IN CAR**

**REMOVE**

1. Clean exposed end of pitman shaft and end of housing after removing pitman arm.
2. Remove retaining ring with snap ring pliers J-4245.
3. Start engine and turn wheels fully to the left to force seals and washer out.
4. Turn off engine.
5. Inspect housing and shaft.

**PITMAN SHAFT**  
Inspect seal surface for roughness and pitting

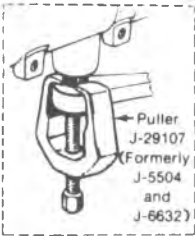

**INSTALL**

1. Install parts as shown.

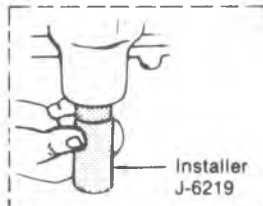
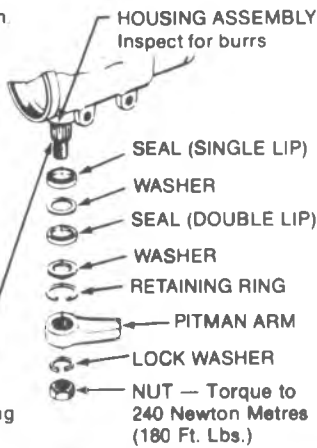

Remove Pitman Arm

Install Seals

**2. REMOVE AND INSTALL PITMAN SHAFT AND SIDE COVER**

**REMOVE**

1. If pitman shaft and side cover are to be separated, remove preload adjuster nut.
2. Rotate stub shaft to center gear, then remove parts as shown.



**INSTALL**

1. If removed, install gasket seal by bending tabs around cover edges.
2. Install parts as shown.

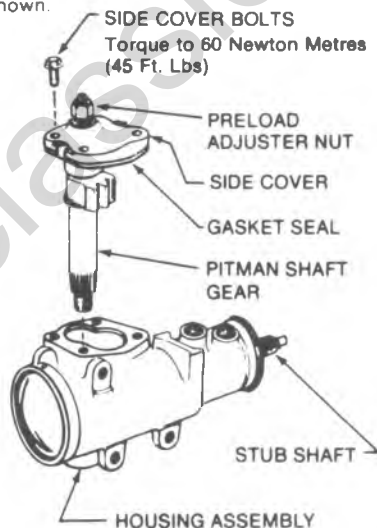

Separate pitman shaft and gasket seal from side cover if required.

**3. REMOVE AND INSTALL HOUSING END PLUG**

**REMOVE**

1. Remove parts as shown.

**INSTALL**

1. Install parts as shown. Open end of retaining ring to be approx. 25 mm (1 inch) from access hole.

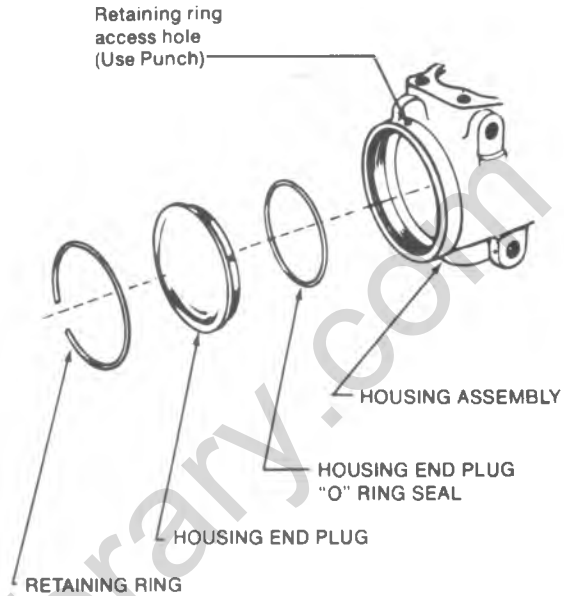

**4. REMOVE AND INSTALL RACK PISTON**

**REMOVE**

1. Remove parts as shown.
- When installing rack, care should be taken not to cut teflon seal, rack piston seal compressor J-7576 or J-8947 may be used to compress seal.

**INSTALL**

1. Install parts as shown.

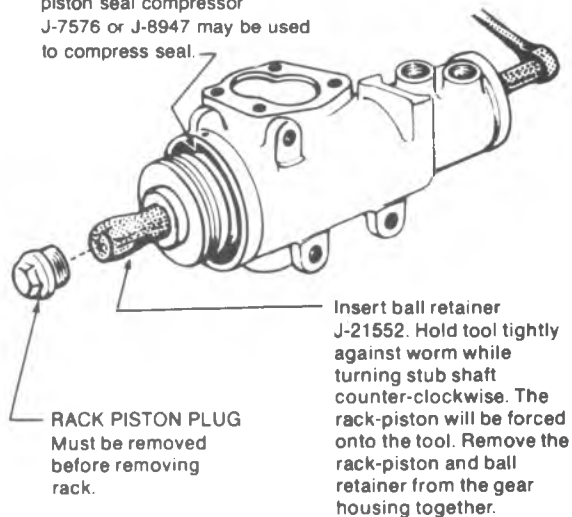

Fig. 3B3-8C--Overhaul 800 and 808 Gears, Chart C



**5. REMOVE AND INSTALL ADJUSTER PLUG ASSEMBLY**

**REMOVE**

1. Loosen lock nut. Use punch against edge of slots.
2. Remove adjuster plug using spanner wrench J-7624.

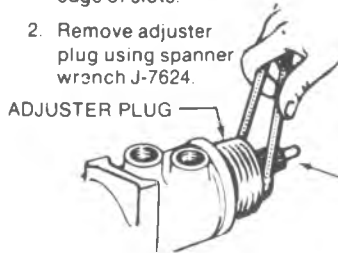

**INSTALL**

1. Install parts as shown.



**NOTICE:** When installing adjuster plug care should be taken not to cut seals.

**6. DISASSEMBLE AND ASSEMBLE ADJUSTER PLUG ASSEMBLY**

**DISASSEMBLE**

1. Disassemble parts as shown.

**ASSEMBLE**

1. Assemble parts as shown.

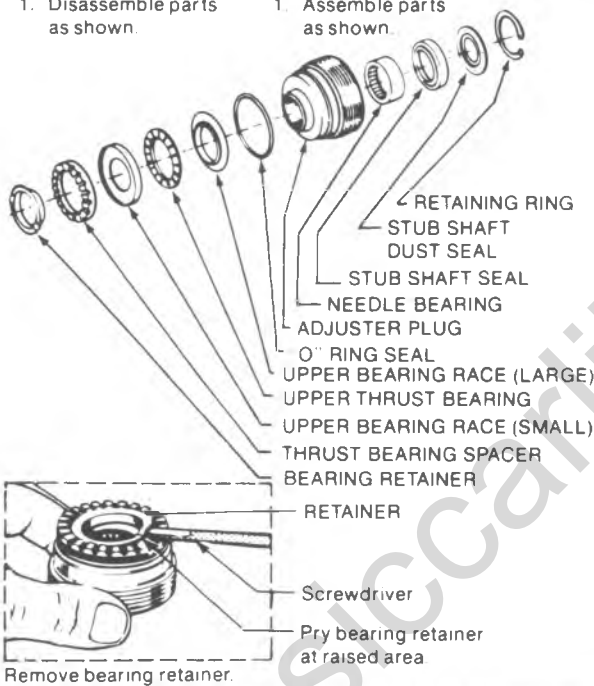

Remove bearing retainer.

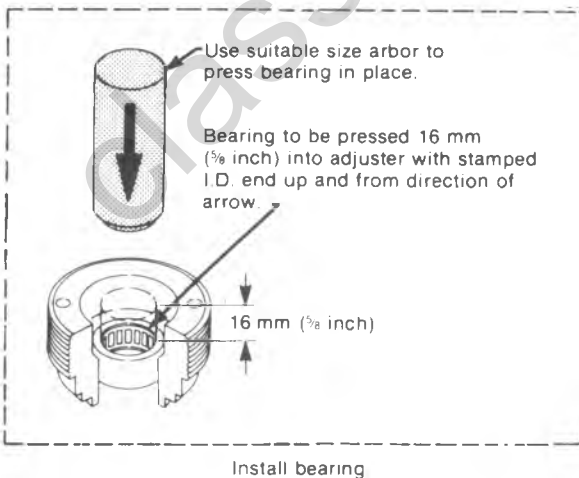

Install bearing

**7. REMOVE AND INSTALL BEARING, WORM, AND VALVE ASSEMBLY**

**REMOVE**

1. Grasp stub shaft and remove valve and worm assembly as a unit.

Separate the valve from the worm. Note how the pin in the worm fits the slot in the valve.

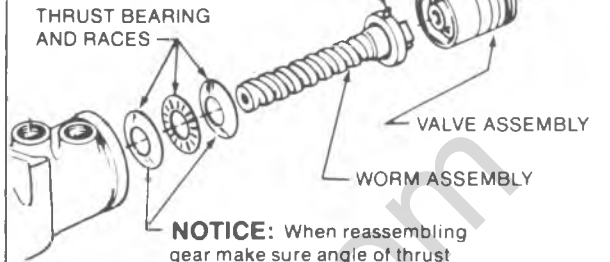

**NOTICE:** When reassembling gear make sure angle of thrust races are as shown.

**INSTALL**

1. Install parts as shown.

**8. DISASSEMBLE AND ASSEMBLE VALVE**

**DISASSEMBLE**

1. Disassemble parts as shown.

**ASSEMBLE**

1. Assemble parts as shown.

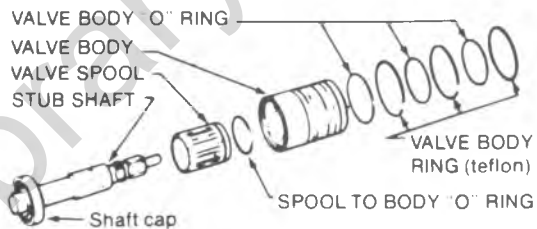

**A. Loosen shaft cap**



**B. Remove and install stub shaft**

Pull cap out approx. 6 mm (1/4")

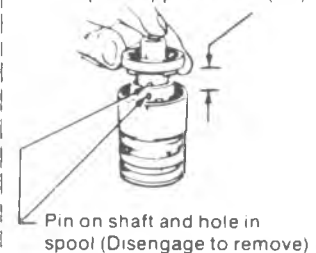

**C. Remove and install spool**

Rotate while removing or installing



Lubricate spool and body with power steering fluid.

**D. Engage stub shaft**



Fig. 3B3-9C--Overhaul 800 and 808 Gears, Chart D

**9. DISASSEMBLE AND ASSEMBLE RACK PISTON**

**DISASSEMBLE**

1. Disassemble parts as shown.
2. Clean and inspect all parts for excessive wear.

**ASSEMBLE**

1. Assemble parts as shown.

**NOTICE:** The black balls are smaller than the silver balls. The black and silver balls must be installed alternately into the rack-piston and return guide to maintain rack piston to worm gear preload.

**TEFLON SEAL AND "O" RING—**  
If replaced lubricate new seal and "O" ring with power steering fluid.

Turn worm until worm groove is aligned with the lower ball return guide hole.

**WORM—**Slide all the way into the rack-piston.

Before assembling rack in housing, ball retainer J-21552 must be inserted into rack to allow removal of worm.

Lubricate balls with power steering fluid. Install balls, through ball return guide hole, while rotating worm counterclockwise.

**GUIDE—**Alternately install remainder of balls and retain with grease at each end of guide.

**CLAMP**

**SCREW—**Tighten to 5 Newton Metres (4 Ft. Lbs.)

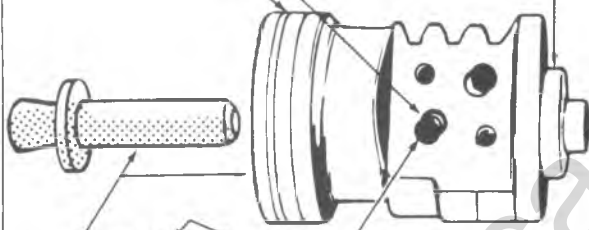

**10. REMOVE AND INSTALL PITMAN SHAFT SEALS AND BEARING**

**REMOVE**

1. Clean end of housing thoroughly to prevent dirt from entering and be extremely careful not to score the housing bore.
2. Remove retaining ring with snap ring pliers J-4245.
3. Using screw driver, pry seals and washers from bore.

**INSTALL**

1. Coat seal lip and washer face with anhydrous calcium grease.
2. Install parts as shown.

**HOUSING ASSEMBLY**  
Inspect for burrs.

**PITMAN SHAFT SEAL (SINGLE LIP)**

**PITMAN SHAFT SEAL (DOUBLE LIP)**

**RETAINING RING**

**SEAL BACK UP WASHER**

**NEEDLE BEARING**  
Remove only if it needs replacing.

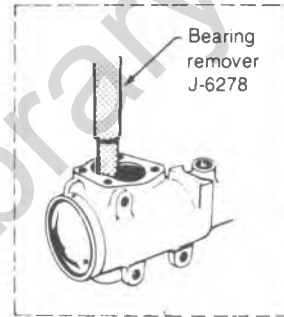
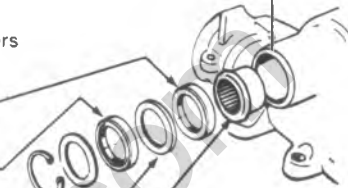

Removing bearing

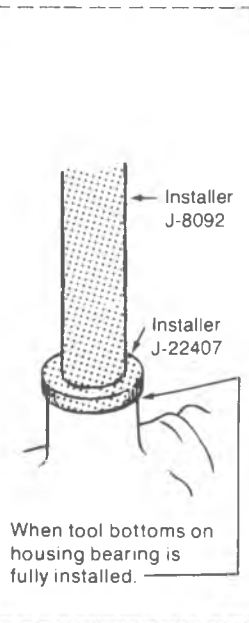

Install Pitman shaft bearing

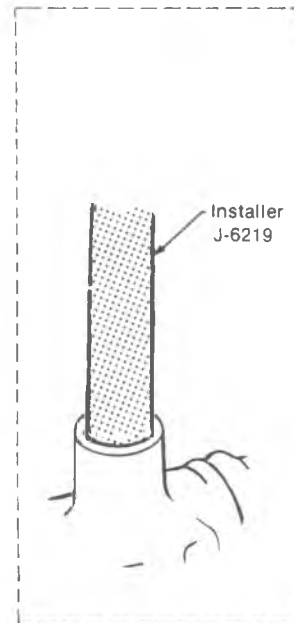

Install Pitman shaft seals

Fig. 3B3-10C—Overhaul 800 and 808 Gears, Chart E

**11. REMOVE AND INSTALL CHECK VALVE**

**REMOVE**

1. Remove parts as shown.

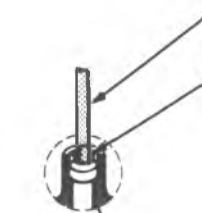

With small screwdriver, pry check valve from housing.  
Care should be taken not to damage threads when prying on edge of housing.

Remove check valve.

**INSTALL**

1. Install parts as shown.



Using a piece of 3/8 tubing, 4 inches long, carefully drive the check valve into the housing.

Install check valve.

**12. ADJUST THRUST BEARING PRELOAD**

A. Using spanner wrench J-7624, tighten adjuster plug until thrust bearing is firmly bottomed, 27 Newton Metres (20 Ft. Lbs.)

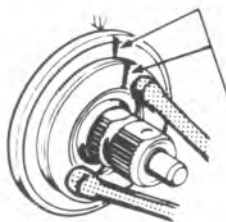

Mark housing and face of adjuster plug.

B.

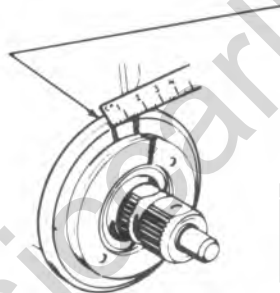

Measure back counterclockwise 13 mm (1/2") and place a second mark on housing.

C.

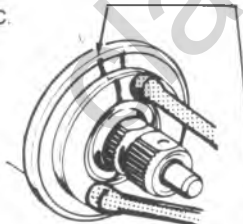

Turn adjuster counterclockwise until mark on face of adjuster plug lines up with second mark on housing.

D.

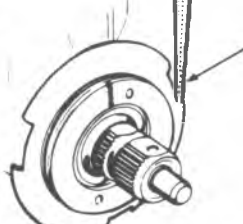

Using punch in notch tighten lock nut securely. Hold adjuster plug to maintain alignment of the marks.

**13. PITMAN SHAFT "OVER-CENTER" SECTOR ADJUSTMENT**

A.

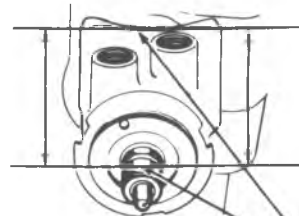

When gear is on center flat on stub shaft is normally on same side as, and parallel with, side cover.

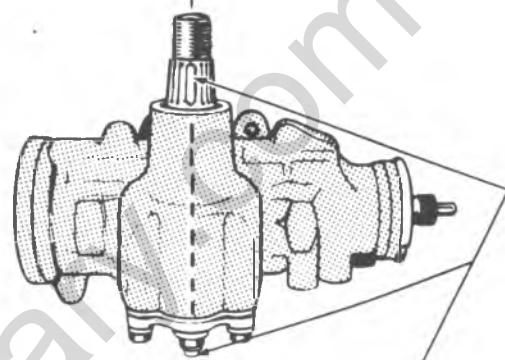

The block tooth on the Pitman shaft is in line with the over-center preload adjuster.

B. Back off preload adjuster until it stops, then turn it in one full turn.



With gear at center of travel, check torque to turn stub shaft (reading #1).

C. Turn adjuster in until torque to turn stub shaft is 0.6 to 1.2 Newton Metres (6 to 10 in. Lbs.) more than reading #1.



Torque adjuster lock nut to 27 Newton Metres (20 Ft. Lbs.)

Prevent adjuster screw from turning while torquing lock nut.

Fig. 3B3-11C—Overhaul 800 and 808 Gears, Chart F

**GENERAL SPECIFICATIONS**

**LUBRICATION**

Lubricant . . . . . Power Steering Fluid No. 1050017 or equivalent

**ADJUSTMENTS**

Valve Assembly and Seal Drag . . . . . 0.1 to 0.4 N•m (1 to 4 in. lbs.)  
 Thrust Bearing Pre-load . . . . . 0.3 to 0.4 N•m (3 to 4 in. lbs.) in excess of valve assembly and seal drag.  
 Overcenter Adjustment . . . . . 0.4 to 3.0 N•m (4 to 8 in. lbs.) (new gear) 0.4 to 0.5 N•m (or 4 to 5 in. lbs.) (used gear)  
 in excess of combined thrust bearing pre-load.

Adjustment of the steering gear in the car is not recommended because of the difficulty encountered in adjusting the worm thrust bearing preload and the confusing effects of the hydraulic fluid in the gear. Since a gear adjustment is made only as a correction and not as a periodic adjustment, it is better to take the extra time and make the adjustment correctly the first time.

Since a handling stability complaint can be caused by improperly adjusted worm thrust bearings as well as an improper gear over-center adjustment, it is necessary that the steering gear assembly be removed from the car and both thrust bearing and over-center preload be checked and corrected as necessary. An in-car check of the steering gear will not show a thrust bearing adjustment error.

**TORQUE SPECIFICATIONS**

**POWER STEERING PUMP**

	N•m	FT. LBS.
Reservoir Bolt . . . . .	48	35
Flow Control Fitting . . . . .	48	35
Pressure Hose . . . . .	27	20

**GENERAL SPECIFICATIONS**

**POWER STEERING**

**LUBRICATION**

Lubricant . . . . . Power Steering Fluid No. 1050017 or equivalent  
 Capacity (Exc. Diesel) - Complete System . . . . . 1-1/4 Liters 1-1/4 Qts.  
 Capacity (Diesel) - Complete System . . . . . 1-3/4 Liters 1-3/4 Qts.  
 Capacity - Pump Only . . . . . 1/2 Liter 1/2 Qt.

**STEERING GEAR**

**RECOMMENDED TORQUE SPECIFICATIONS**

	NEWTON METERS	FOOT-POUNDS
Gear to Frame Bolts . . . . .	110	80
High Pressure Line Fitting (At Gear) . . . . .	27	20
Oil Return Line Fitting (At Gear) . . . . .	27	20
Adjusting Screw Locknut . . . . .	27	20
Side Cover Bolts . . . . .	60	45
Adjuster Plug Locknut . . . . .	110	80
Coupling Flange Nuts . . . . .	27	20
Return Guide Clamp Screws . . . . .	5	4
Rack-Piston Plug . . . . .	100	75
Pitman Shaft Nut . . . . .	240	185
Coupling Flange Bolt . . . . .	40	30

Fig. 3B3-12C—Overhaul 800 and 808 Gears, Chart G

POWER STEERING PUMP



J-25033

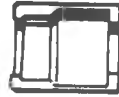

BT-7515

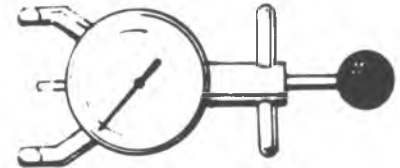

BT-7002-3  
J-23600



J-25034



J-7132-2

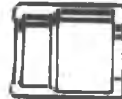

J-22616

POWER STEERING GEAR



J-6221



J-7576  
J-8947

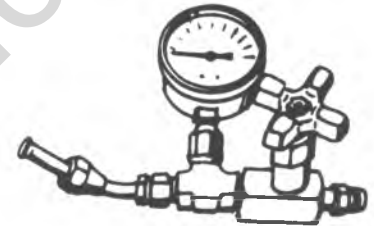

J-5176-01



J-21552

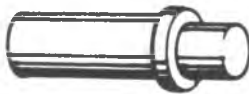

J-5188



J-6222



J-6217

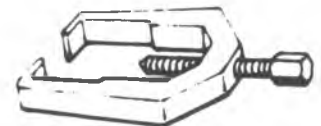

J-29107  
OR  
J-24319-01



J-7624



J-6278



J-22407

- J-5176-01 Pressure Testing Manifold
- J-5188 End Cover Seal and Needle Bearing Installer
- J-6217 Hose Connector Installer
- J-6221 Bearing Installer
- J-6222 End Cover Seal Protector (Used for Installing Adjuster Plug)
- J-6278 Pitman Shaft Bearing Remover and Installer
- J-6278-2 Adapter (Used with J-6278 for Installing Pitman Shaft Seals and Bearing)
- BT-7002-3 Belt Tension Gage
- J-21552 Ball Retainer
- J-7624 Spanner Wrench
- J-7624 Spanner Wrench

- J-7576 Rack-Piston Teflon Ring Compressor
- J-7624 Spanner Wrench
- J-8947 Rack-Piston Teflon Ring Compressor
- J-21552 Ball Retainer
- J-24319-01 Puller
- J-22407 Pitman Bearing Installer
- J-22616 Seal Protector
- J-23600 Belt Tension Gage
- J-25033 Power Steering Pump Pulley Installer
- J-25034 Power Steering Pump Pulley Remover
- J-29107 Pitman Arm Puller

Fig. 3B3-13C--Special Tools

classicalibrary.com

# SECTION 4B

## REAR AXLE DIFFERENTIAL CARRIER

### 8-1/2 AND 8-7/8" 9 1/2" RING GEAR

#### INDEX

Differential Case.....	4B-1	Bearing Replacement .....	4B-8
Removal and Disassembly.....	4B-1	Setting Pinion Depth .....	4B-8
Inspection .....	4B-1	Installation and Adjustment.....	4B-10
Side Bearing Replacement .....	4B-1	Checks and Adjustments .....	4B-11
Ring Gear Replacement .....	4B-2	Pinion Bearing Preload.....	4B-11
Installation and Adjustment.....	4B-3	Side Bearing Preload .....	4B-11
Drive Pinion .....	4B-7	Pinion Depth and Backlash.....	4B-11
Removal .....	4B-7		

## GENERAL INFORMATION

### AXLE IDENTIFICATION

The rear axle codes are located as follows:

#### 10 Series

The code is stamped on top of the right axle tube, 3" to 5" outboard of the carrier.

#### 20-30 Series

The code is stamped on the top of the right axle tube, 6" to 8" outboard of the carrier.

#### Dana Axles

Dana rear axles used in Light Duty Trucks will be stamped with the Dana part number and production code indicating the month, day, year, shift and production line on which the axles were assembled.

### DIFFERENTIAL CASE

#### Removal and Disassembly

Before proceeding with following steps, it is advisable to check the existing ring gear to pinion backlash as described under "Checks and Adjustments". This will indicate gear or bearing wear or an error in backlash or pinion depth setting which will help in determining cause of axle noise. Backlash should be recorded so that if same gears are reused, they may be reinstalled at original lash to avoid changing gear tooth contact.

1. Remove screw that retains differential pinion shaft, and remove pinion shaft.
2. Remove rear axle shafts as outlined in the Service Manual.
3. Roll out the differential pinions and thrust washers, then remove side gears and thrust washers. Mark pinions and side gears so that they can be reassembled in original position.

4. Mark the bearing caps and housing for reassembly in same position. Loosen bearing cap bolts. Tap surface of bearing caps to loosen.

**NOTICE:** Do not attempt to pry caps off as this may damage machined face of caps.

5. Using a pry bar as shown in figure 2B, pry differential case out of carrier. Exercise caution in prying on carrier so that gasket sealing surface is not damaged. If the bearings are preloaded, the case will suddenly fall free when it is pried past a certain point; therefore, make sure case is properly supported to prevent damage. The bearing caps may be loosely installed, as shown in Figure 2B, to prevent case from falling.
6. Place left and right bearing cups with bearing caps so that they may be reinstalled in original positions. Place shims with appropriate cups.

#### Inspection

1. Clean all parts in cleaning solvent; inspect all bearing cups, races and rollers for scoring, chipping or evidence of excessive wear.
2. Inspect axle shaft and side gear splines for evidence of excessive wear.
3. Inspect hypoid ring gear and pinion teeth for possible scoring, cracking or chipping.
4. Inspect differential case, pinions side gears, thrust washers and pinion shaft for cracks, scoring, spalling or excessive wear.
5. Check fit of differential side gears in case.

#### Differential Bearing Replacement

1. Install Tool J-22888 and Adapter Plug J-8107-4, J-8107-3 for the 9 1/2" ring gear, assuring puller legs are fitted securely in notches in case and against bearing cone, as shown in figure 3B.
2. Tighten puller screw to remove bearing.

# TRUCK REAR AXLE IDENTIFICATION

All rear axles used in Chevrolets are stamped with a prefix code designating the axle ratio and vehicle identification, build date, axle source, and shift code.

## CHEVROLET AXLE EXAMPLE:

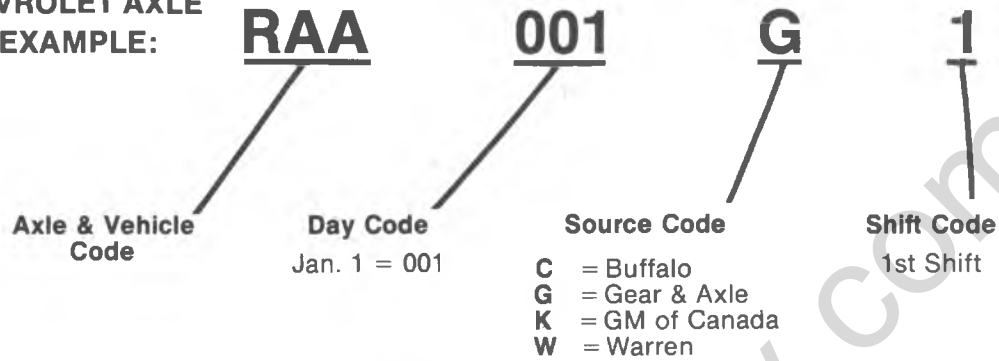

## DANA AXLE EXAMPLE:

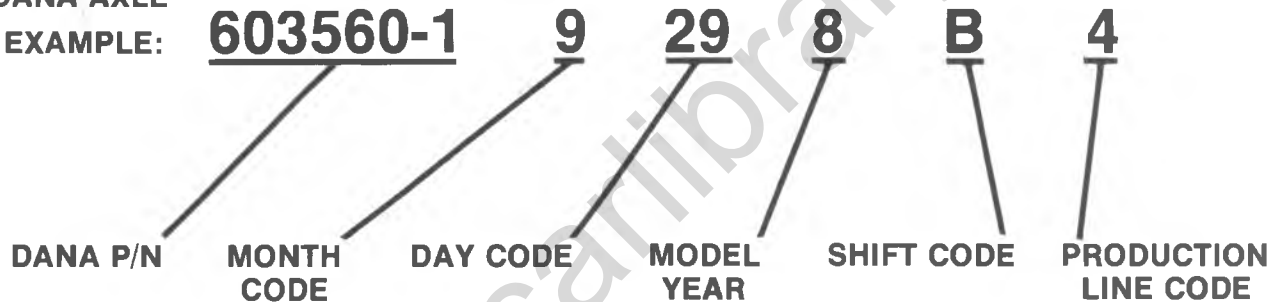

The Dana Part number and build date are stamped on the rear surface of the right hand axle tube. In addition, the three digit axle code appears on a strip of tape attached to the outboard end of the axle tube.

- Place new bearing on hub with thick side of inner race toward case and drive into place, using J-22175 for 8-7/8" or J-22761 for 8-1/2" or J-29710 for the 9 1/2" ring gear and Driver Handle J-8092, as shown in figure 4B.
- Before bearing installation on opposite hub, support differential case on Adapter Plug J-8107-4 or J-8107-3. This allows differential case to rest on adapter instead of bearing cage. See figure 4B. Install remaining bearing as instructed in step 3.
- Remove any nicks or imbedded dirt from case flange surface which mates with ring gear. Clean all surfaces.
- Liberally coat the differential case pilot with hypoid lubricant. Pre-align ring gear and differential case bolt holes, and press on adaptor plug J-8107-4 to initially start ring gear on case pilot, as shown in figure 5B.
- Start all ring gear bolts during initial assembly to maintain bolt hole adlignment. Draw up all bolts evenly, using a criss-cross pattern to avoid cocking the gear on the case.
- Insure that the gear is seated firmly against the case, then torque the bolts to 105 ft. lbs. for the 9 1/2" ring gear. 60 ft. lbs.

### Ring Gear or Differential Case Replacement

- Remove the ring gear bolts and, using a soft drift and a hammer, tap ring gear off the case.

**NOTICE:** Do not attempt to pry ring gear from case. To do so may damage machined surfaces.



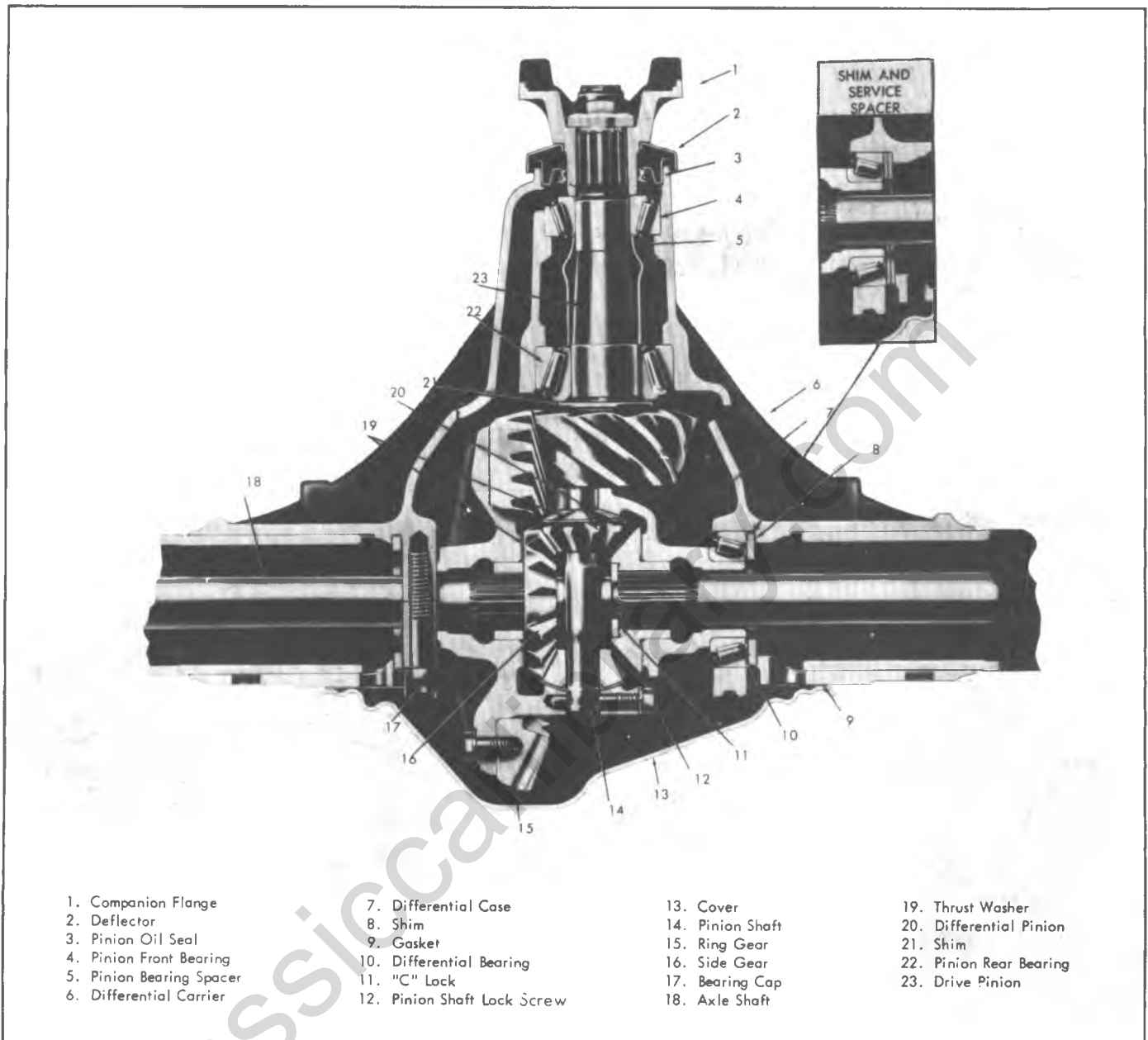

- |                          |                             |                  |                         |
|--------------------------|-----------------------------|------------------|-------------------------|
| 1. Companion Flange      | 7. Differential Case        | 13. Cover        | 19. Thrust Washer       |
| 2. Deflector             | 8. Shim                     | 14. Pinion Shaft | 20. Differential Pinion |
| 3. Pinion Oil Seal       | 9. Gasket                   | 15. Ring Gear    | 21. Shim                |
| 4. Pinion Front Bearing  | 10. Differential Bearing    | 16. Side Gear    | 22. Pinion Rear Bearing |
| 5. Pinion Bearing Spacer | 11. "C" Lock                | 17. Bearing Cap  | 23. Drive Pinion        |
| 6. Differential Carrier  | 12. Pinion Shaft Lock Screw | 18. Axle Shaft   |                         |

Fig. 1B--Cross Section of Differential

**Reassembly**

1. Install thrust washers and side gears into case. If original parts are being reused, replace in original positions.
2. Position pinions and thrust washers through loading hole in case 180° apart so they engage side gears.
3. Rotate gears until the differential pinion bores and the case shaft holes are aligned.
4. Install pinion shaft and lock screw. It is not necessary to torque lock screw until axle shafts are installed.
5. Differential may be installed in carrier now, or after service is performed on the drive pinion.

**Installation and Adjustment (8 1/2" and 8 7/8" ring gear)**

1. Check condition of bearing, bearing cups, cup seat in carrier and carrier caps to make sure that they are free from nicks, burrs and foreign material.

2. Lubricate bearings with axle lubricant; position cups on proper bearing, then install differential assembly in carrier and support the assembly to prevent it from falling.
3. Install strap J-22779-6 on left bearing by tightening bearing bolts alternately and evenly to snug fit.
4. With the ring gear tight against the pinion gear (.000" to .001" backlash), insert gaging Tool J-22779 between the left bearing cup and carrier housing as shown in figure 6B.
5. While oscillating tool, turn adjusting nut clockwise until a noticeable drag is produced.
6. Tighten lock bolt on side of tool.
7. Between the right bearing and carrier, install Service Spacer A (.170"), Service Shim B and Feeler Gage C. Thickness of Feeler Gage must be sufficient to produce

#### 4B-4 REAR AXLE DIFFERENTIAL

a slight "drag" when moved between carrier and Service Shim.

8. Now measure the above dimensions as shown in figure 7B.

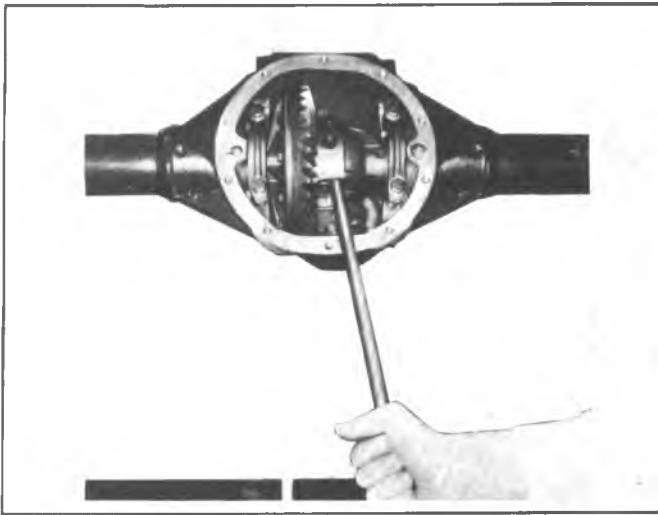

Fig. 2B--Differential Case Removal

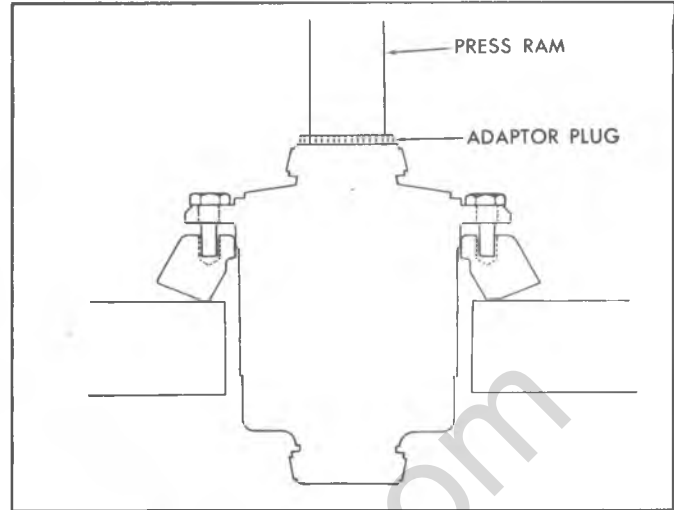

Fig. 5B--Ring Gear-to-Case Installation

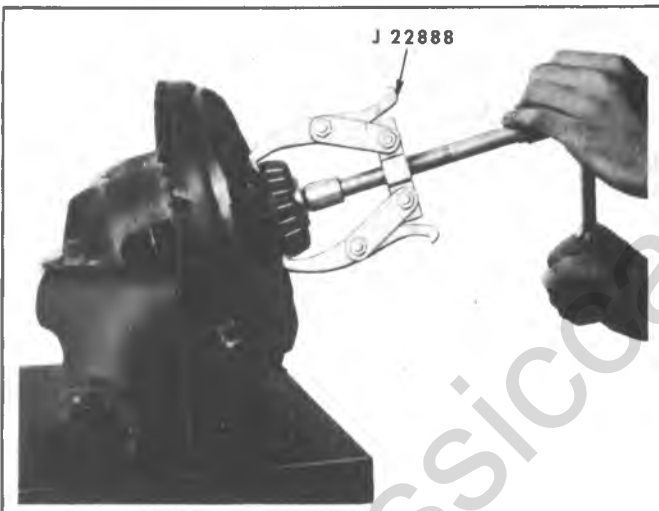

Fig. 3B--Differential Bearing Removal

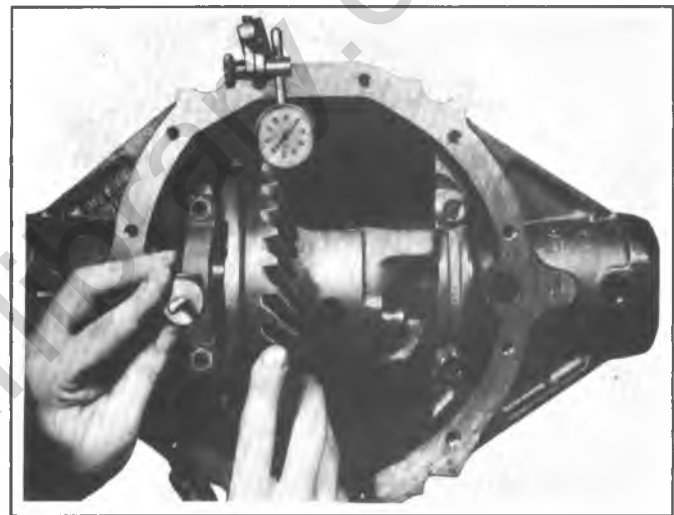

Fig. 6B--Installing Gaging Tool

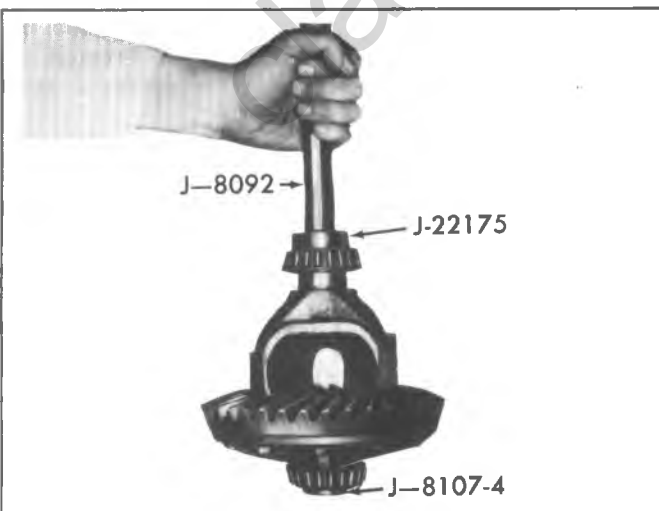

Fig. 4B--Differential Bearing Installation

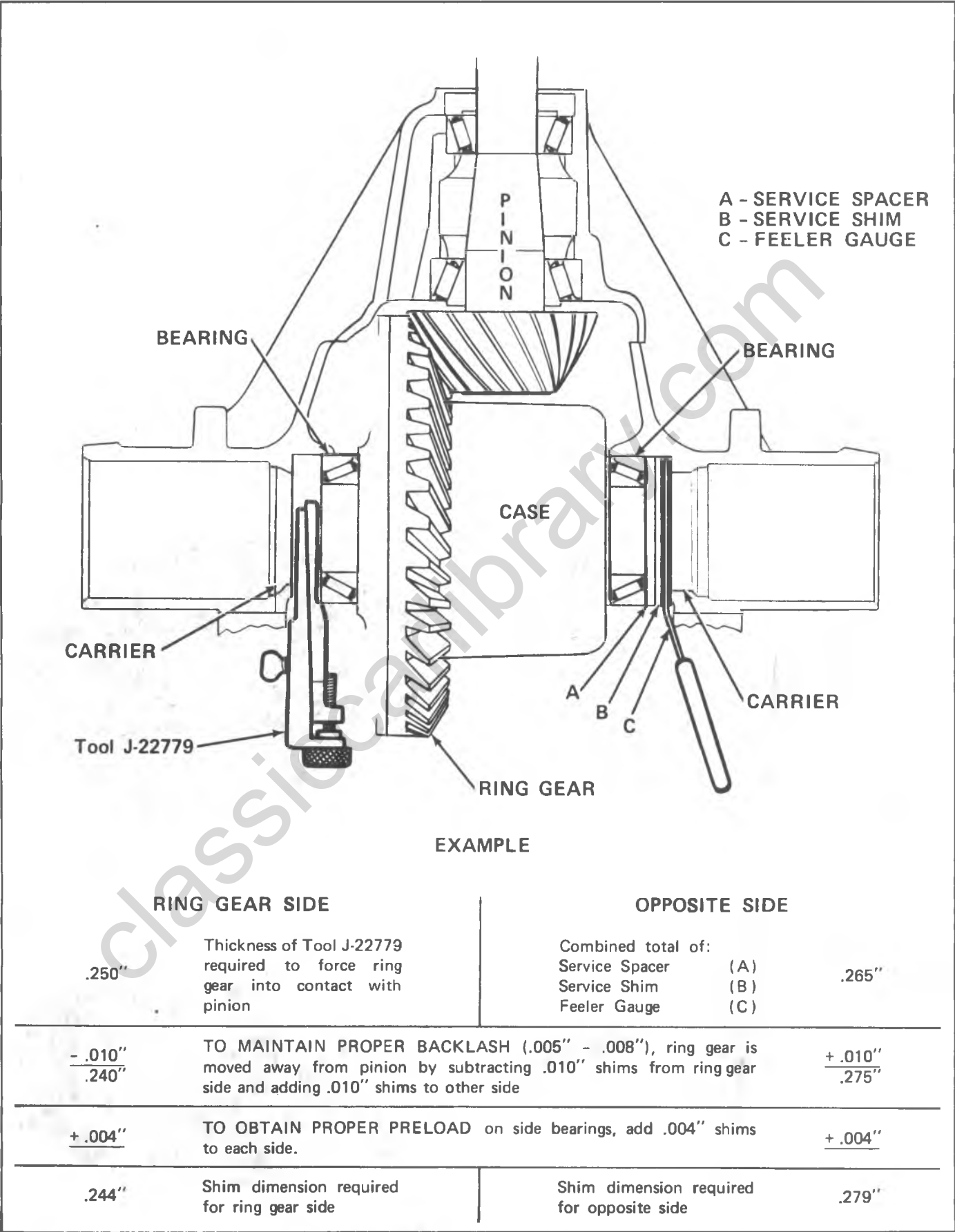

Fig. 7B--Determining Side Bearing Shim Requirements

- a. Using a micrometer as in figure 8B, measure the thickness of J-22779 in a minimum of three places and average these readings. Record the result.
  - b. Add together the dimensions of the Service Shim, Service Spacer and Feeler Gage. Record the result.
9. Use the sample procedure in figure 7B to determine the proper thickness for each shim pack.
- NOTICE:** Production preloading of the differential bearings is accomplished by the use of cast iron preload shim. These shims cannot be used when rebuilding the carrier as they may break when tapped into place.
10. Install left shim first, then wedge right shim between bearing cup and spacer. Position shim so that chamfered side is outward or next to spacer. If shim does not have sufficient chamfer or lead around O.D. to allow easy installation without scraping spacer, file or grind chamfer before installing.
11. If difficulty is encountered in installing shim, partially remove case and slide case and shim into position. Tap shim into position, using a soft faced hammer, while rotating differential case with free hand as shown in figure 9B.



Fig. 8B--Measuring Gage Plate Thickness



Fig. 9B--Installing Differential Shim

12. Install bearing caps in original position and torque to 60 ft. lbs.
- At this point, the differential side bearings are properly preloaded. If any adjustments are required in later procedures, make sure the preload remains as established in step 9. If backlash is changed in later steps, be sure the **total** thickness of the two shim packs does not change.
13. Mount a dial indicator on the carrier and check the backlash between the ring gear and pinion, as shown in figure 10B. The backlash should be within the range of 0.005"-0.008". Check gear lash at four different equally spaced positions around the gear. Variation in readings should not exceed .001". Position the dial indicator so that indicator button is perpendicular to tooth angle and in line with gear rotation.
14. If variation in backlash readings exceeds .002"; measure ring gear and case runout as shown in figure 11B. Gear runout should not exceed .003"; should runout exceed this limit, check ring gear and case for deformation and/or foreign matter between case and gear.

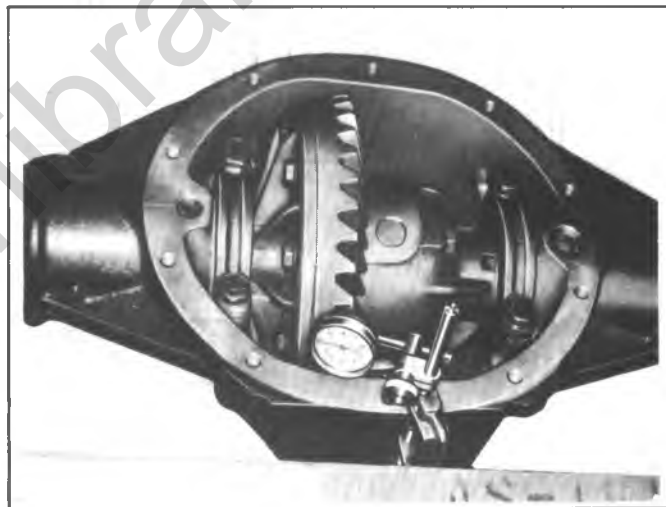

Fig. 10B--Checking Ring Gear Backlash

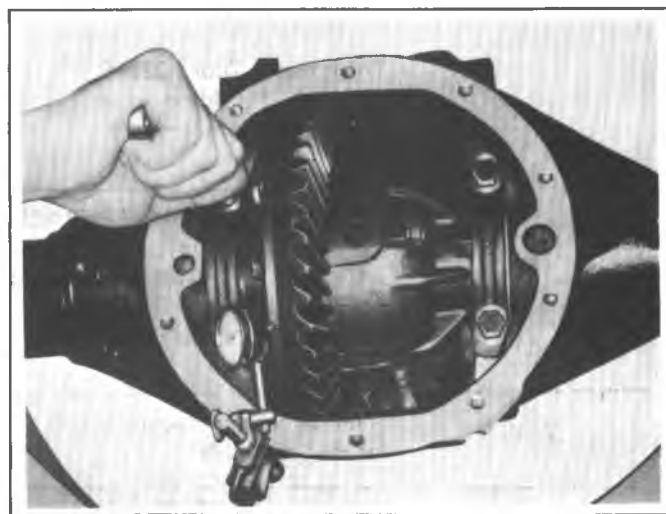

Fig. 11B--Checking Ring Gear Runout

15. If gear lash is not within limits, correct by decreasing shim thickness on one side and increasing thickness of other shim **the same amount**. Total shim thickness must be maintained at all times to maintain proper preload.
16. Backlash changes approximately .002" for each .003" change in shim dimensions.  
If backlash exceeds .008", increase the shim thickness on the ring gear side, while decreasing the shim thickness on the opposite side **an equal amount**. If backlash is less than .005", decrease the shim thickness on the ring gear side, while increasing the shim thickness on the opposite side **an equal amount**.

**Differential Backlash Adjustment (9 1/2" Ring Gear)**

1. Place bearing cups over side bearings and lift the differential assembly into the carrier.
2. Install bearing shim.
3. Push case towards bearing shim side of carrier.
4. Tighten adjusting nut using tool J-24429 and rotate pinion to seat bearings as shown in Fig. 12B.
5. Back adjusting nut off and install bearing cups loosely.
6. Turn adjusting nut until initial contact and index 3 additional slots.
7. Install bearing caps to 80 N·m (70 ft. lbs.).
8. Install locking retainers into holes and attach fingers to bearing cap loosely.
9. At this time, the differential bearings are properly preloaded. If any additional adjustment is required, make sure that the preload remains established.
10. Mount a dial indicator on the housing as shown in Fig. 13B and measure backlash between the ring gear and pinion. Backlash should be .075 mm - .25 mm (.003 - .010) with .125 mm - .20 mm (.005 - .008) preferred.
11. If reading is too high, increase bearing shim size. If reading is too low, decrease bearing shim size.
12. Torque locking retainer to 30 N·m (20 ft. lbs.).  
A service spacer 4.34 mm (.171) thick is available. Service shims are available from 1.278 - 2.256 mm (0.50 - .088) in increments of .050 mm (.002). Pinion shims are available from .5080 - .9398 mm (.020 - .037) in increments of .025 mm (.001).

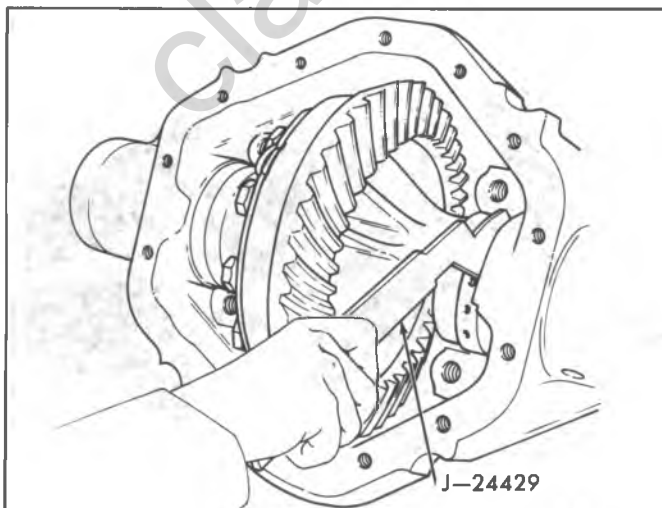

Fig. 12B--Loosening Adjusting Nut

**DRIVE PINION**

**Removal**

1. Remove differential as previously outlined.
2. Check torque required to rotate drive pinion, as described under "Drive Pinion - Installation and Adjustment". If there is no preload reading, check for looseness of pinion assembly by shaking (push-pull) the companion flange. Looseness indicates the need for bearing replacement.
3. Install Holder J-8614-11 on flange by using two bolts with flat washers, as shown in figure 14B. Position J-8614-11 on flange so that the four notches are toward the flange.
4. Remove pinion nut and washer.
5. Thread end of J-8614-3 into small O.D. end of J-8614-2. Then with J-8614-11 installed as in step 3, insert J-8614-2 into J-8614-11 and turn it 1/8 of a turn to locked position. Remove flange by turning J-8614-3 while holding J-8614-11 as shown in figure 15B.
6. To remove the drive pinion, first thread the original pinion nut half way on the pinion, for thread protection.

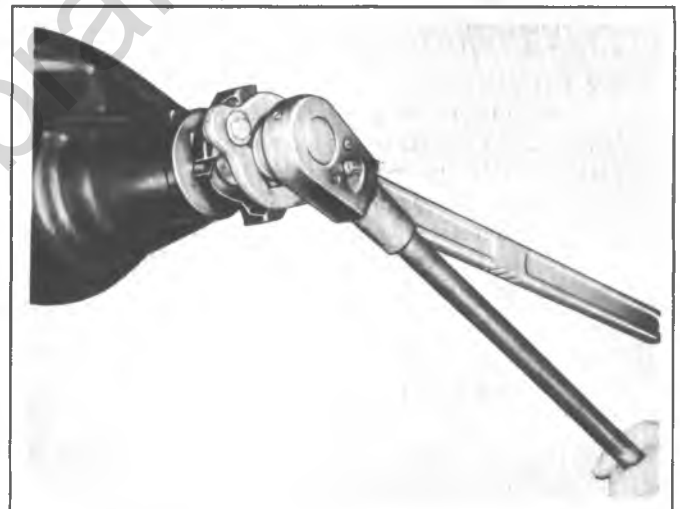

Fig. 14B--Drive Pinion Nut Removal



Fig. 15B--Drive Pinion Flange Removal

7. Place the differential cover temporarily back onto the housing, using two screws. This will prevent the pinion from falling to the floor during removal.
8. Tap the end of the pinion nut with a large hammer and a soft drift, as shown in figure 16B.  
Care must be taken not to damage pinion bearings while removing pinion from carrier. Inspect bearings and cups for damage and replace if needed.
9. Remove the pinion oil seal and the front pinion bearing. Remove the cover and retrieve the drive pinion from the housing. Discard the pinion oil seal, nut, and collapsible spacer. Use a new oil seal, nut and spacer on reassembly.

**Bearing Removal and Cup Replacement**

1. If front pinion bearing is to be replaced, drive outer race from carrier using a drift in slots provided for this purpose. Tap alternately on opposite sides of the bearing cup to avoid cocking.
2. If rear pinion bearing is to be replaced drive outer race from carrier using a drift in slots provided for this purpose.
3. Remove rear pinion bearing from pinion shaft using press plate J-8612 for 8-1/2" ring gear and J-22912 for 8-7/8" J-22912-01 for 9 1/2" ring gear as shown in Figure 17B.

Tighten nuts on tool until plates are under the bearing inner race. Then set the tool on a press. Make sure the plates straddle the opening on the press. Do not position bolts across the opening. To do so may bend the bolts when pressure is applied. Press bearing from pinion. Record the thickness of shim removed from between bearing and pinion head.

4. Inspect carrier pinion bearing bores and shoulders for nicks. Remove as necessary. Clean the bores and the installation tools.
5. Lubricate both bearing cups with liberal amounts of hypoid lubricant.
6. Install the rear cup, with the large end against the bore shoulder, using Installer J-8608 for 8-1/2" ring gear

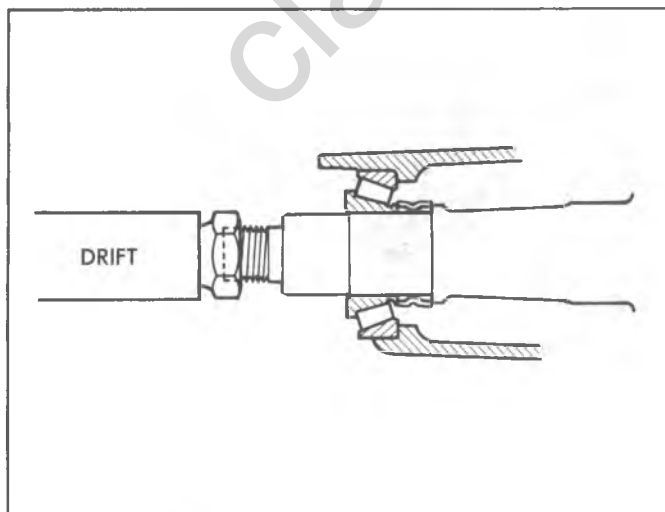

Fig. 16B--Removing Drive Pinion



Fig. 17B--Removing Drive Pinion Rear Bearing and J-0270-14 for the 8-7/8" ring gear or J-22306 for the 9 1/2" ring gear as shown in figure 18B.

7. Install the front cup, with the large end against the bore shoulder, using Installer J-8611-01 for the 8-1/2" ring gear or J-7137 for the 8-7/8" ring gear or J-7818 for the 9 1/2" ring gear as shown in figure 19B.
8. Check both bores to make sure cups are fully seated.

**Setting Pinion Depth and Installing Pinion Bearings**

If the original ring gear and pinion and the pinion rear bearing assembly are to be reinstalled, the original shim thickness may be used.

Ring and pinion gear sets are matched in a special test machine which permits adjustment of pinion depth in ring gear until a point is reached where best operation and proper tooth contact under load is obtained. At this point, the setting of the pinion with reference to the centerline of the ring gear is indicated by the machine. This setting may vary slightly from the design or "nominal" setting due to allowable variation in machining the parts. When a pinion is found having a plus or minus reading recorded in thousandths on the rear face of the pinion, this indicates that the

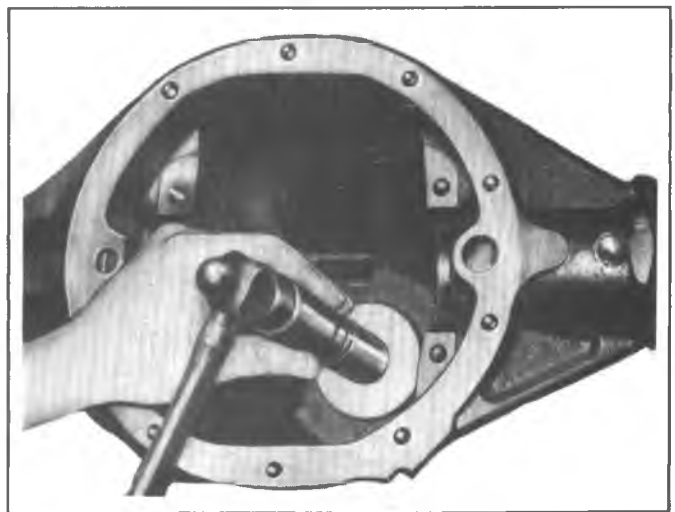

Fig. 18B--Installing Pinion Rear Bearing Cup

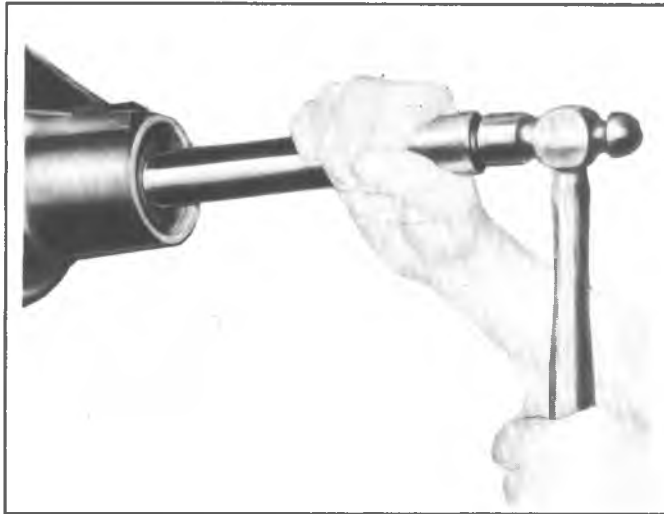

Fig. 19B--Installing Pinion Front Bearing Cup

pinion during testing was found to have best tooth contact at a position varying from design or nominal depth.

In order to compensate for all of the allowable machining variables, a procedure of gaging the carrier and shimming the pinion has been developed. After gaging a carrier, the assembler must install the appropriate shim between the drive pinion shoulder and rear bearing so that pinion depth can be adjusted to the required position for best tooth contact in each axle assembly.

Proper pinion depth is determined with Pinion Setting Gage J-21777-01.

1. Clean the housing assembly and all gage parts to insure accurate measurements.
2. Lubricate front and rear pinion bearings which will be used in final assembly and position them in their respective races in the carrier.
3. Use cloverleaf gage plate J-21777-29 for 8-1/2" ring gear or J-21777-36 for 8-7/8" ring gear or J-21777-85 for 9 1/2" ring gear mounted on preload stud J-21777-43 insert stud through rear bearing and pilot J-21777-35, or J-21777-8 for the 9 1/2" ring gear. and through front bearing and pilot J-21777-42. Install the hex nut until snug and rotate the bearings to make sure they are properly seated. See figure 20B for illustration of proper positioning.
4. Hold the preload stud stationary with a wrench on the flats and tighten hex nut. Tighten until 20 in. lbs. of torque are required to rotate the bearings, as shown in figure 21B.
5. Mount the side bearing discs J-21777-45 or J-21777-86 on the ends of arbor J-21777-1, using the step of the disc that corresponds to the bore of the carrier.
6. Place the arbor and plunger assembly into the carrier, being sure the side bearing discs are seated properly.
7. Install the bearing caps finger tight to hold the discs from movement.
8. Position dial indicator J-8001 on the mounting post of the arbor with the contact button resting on the top surface of the plunger.

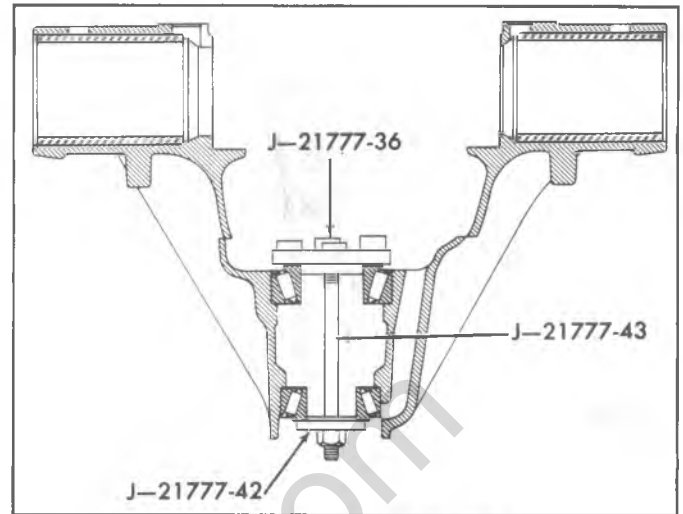

Fig. 20B--Gage Plate Installed

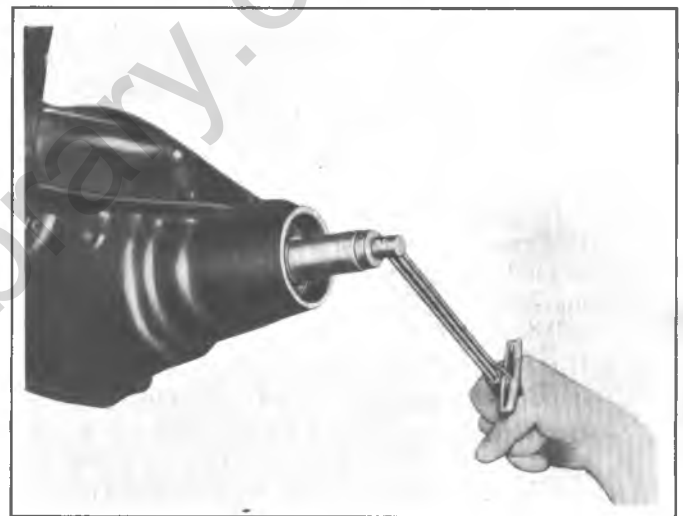

Fig. 21B--Measuring Rotating Torque

9. Preload the dial indicator one-half revolution, and tighten in this position.
10. Select the button on the gage plate or gage block that corresponds to the ring gear size and rotate the plate until the plunger rests directly upon that button.
11. Rock the plunger rod slowly back and forth across the button until the dial indicator reads the greatest deflection. At this point, set the dial indicator to zero. Tools will now be positioned as shown in figure 22B. It is important to use a dial indicator correctly when determining pinion depth requirements. Be sure to record the number indicated by the indicator needle; do not record the amount of travel of the needle. After "zeroing" the dial indicator on the highest point of deflection on the gauge plate, the indicator probe is swung off the gauge plate, allowing the needle to move. The number which the needle points toward is the correct shim thickness required for a nominal pinion. See figure 23B.
12. Repeat the rocking action of the plunger several times to verify the setting.
13. Once the zero reading is obtained, swing the plunger until it is removed from the gaging plate button.

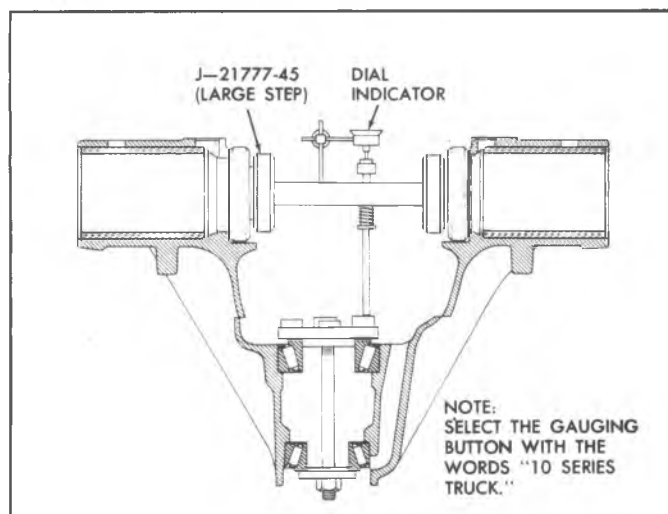

Fig. 22B--Gaging Tools Installed in Carrier

The dial indicator will now read the required pinion shim thickness for a "nominal" pinion. Record this figure.

14. Check the rear face of the drive pinion being installed for a pinion code number. This number indicates the necessary alteration of the pinion shim thickness as determined in step 13.
  - a. If the pinion is stamped with a plus (+) number, **add** that many thousandths to the indicator reading. For example, if indicator reading is .019, and pinion is marked (+2), the correct depth shim for installation will be  $.019 + .002 = .021$  inch.
  - b. If the pinion has no plus (+) or minus (-), use the indicator reading as the correct shim thickness.
  - c. If the pinion is stamped with a minus (-) number, **subtract** that many thousandths from the indicator reading. For example, if the indicator reading is .031, and pinion is marked (-3), the correct depth shim for installation will be  $.031 - .003 = .028$  inch.
15. Remove bearing caps and depth gaging tools from carrier.
16. Position the shim selected in step 14 on the pinion shaft against pinion head.
17. Lubricate the rear pinion bearing with liberal amounts of hypoid lubricant and install rear bearing. Use J-8609-01 for the 8-1/2" ring gear or J-5590 for the 8-7/8" ring gear or J-6547 for the 9 1/2" ring gear, as shown in figure 24B.

### Installation and Adjustment

1. Lubricate the front bearing with liberal amounts of hypoid lubricant, and place into outer cup.
2. For 8-7/8" ring gear position seal in bore and place gage plate J-22804-2 over seal and against flange. Gage plate insures proper seating of seal in carrier bore. See figure 25B. Use J-23911 to press seal into bore until gage plate is flush with the carrier shoulder and seal flange. Turn gage plate 180°; seal must be square in carrier to seal properly.  
For 8-1/2" ring gear place a new seal into position in carrier bore. Tap lightly with a protective plate and a hammer until seal flange seats against carrier.

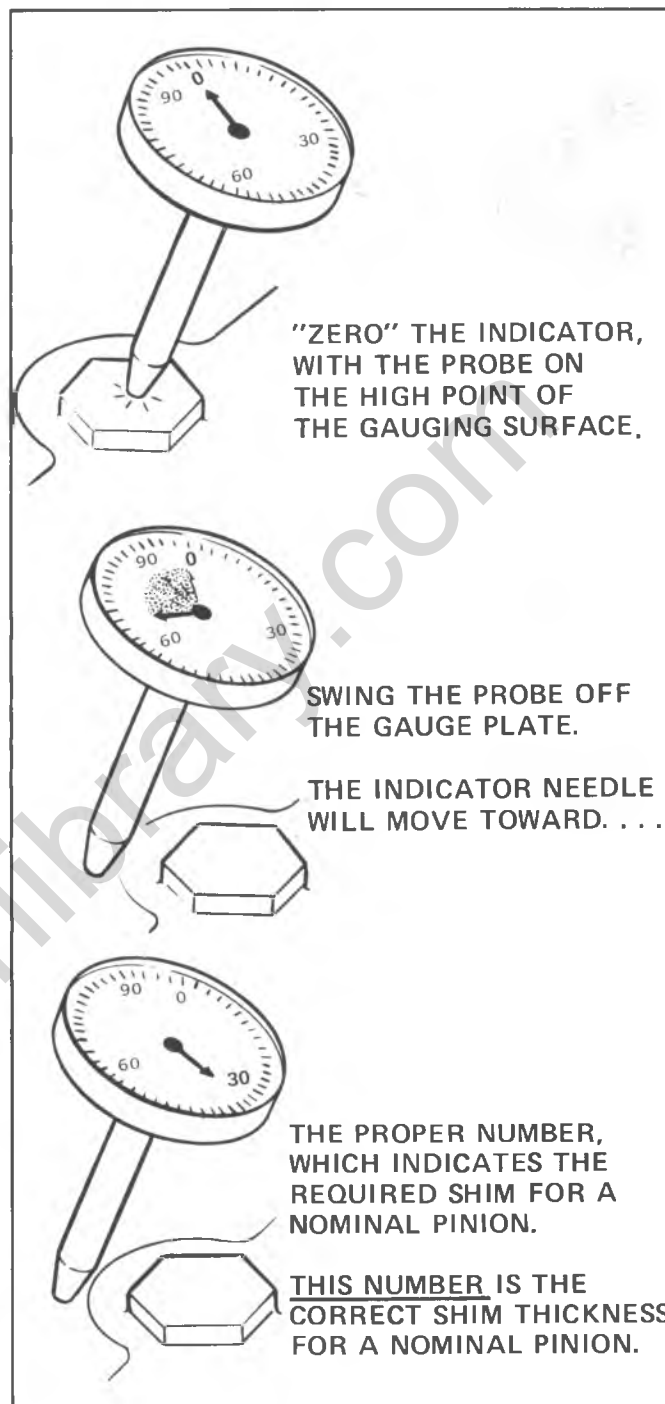

Fig. 23B--Use of Dial Indicator

For 9-1/2" ring gear use tool J-22388 pinion seal installer.

3. Coat lips of pinion oil seal and seal surface of pinion flange with hypoid lubricant.
4. Install a new pinion bearing spacer onto drive pinion.
5. Place drive pinion into position, and mount a suitable thick washer or sheet metal plate over the pinion stem. Install the original pinion nut and tighten sufficiently to draw pinion through the front bearing far enough to leave threads exposed when the companion flange is placed into position. Remove the washer and install the companion flange, using J-8614-11.





Fig. 24B--Installing Rear Bearing

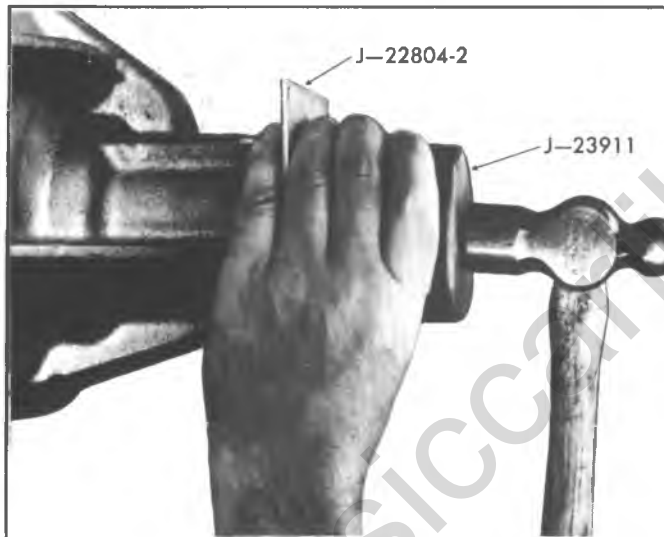

Fig. 25B--Installing Pinion Oil Seal

6. Tighten nut until all end play is removed from drive pinion.

When no further end play is detectable, and when Holder J-8614-11 will no longer pivot freely as pinion is rotated, preload specifications are being neared. Further tightening should be done only after nut and washer installation and preload has been checked.

7. While observing the preceding caution, carefully set preload drag at 20-25 inch pounds on new bearings, or 10-15 inch pounds on reused bearings. Use an inch-pound torque wrench such as J-5853 as shown in figure 24B, to measure the rotating torque.

After torque has been checked, final tightening should be done very carefully. For example, if when checking, torque was found to be 5 inch-pounds, additional tightening of the pinion nut as little as 1/8 turn can add 5 additional inch pounds drag. Therefore, the pinion nut should be further tightened only a little at a time and torque should be checked after each slight amount of tightening. Exceeding torque specifications may

compress the collapsible spacer too far and require its replacement.

8. Rotate the pinion several times to assure that bearings have been seated. Check preload again. If drag has been reduced, re-set preload to specifications.

## CHECKS AND ADJUSTMENTS

Four adjustments are essential for proper operation of the differential and its related parts. These adjustments are a) Pinion Bearing Preload, b) Side Bearing Preload, c) Pinion Depth and d) Ring Gear-to-Pinion Backlash.

Pinion Bearing Preload is set to specifications in step 7 of "Drive Pinion Installation and Adjustment".

Side Bearing Preload is set to specifications in step 9 of "Differential Case-Installation and Adjustment".

Following service to the Differential Case or to the Drive Pinion and Ring Gear, a Gear Tooth Contact Pattern Check **must be made to verify the accuracy of the work in setting the pinion depth and the ring gear-to-pinion backlash.**

## Gear Tooth Contact Pattern Check

Prior to final assembly of the differential, a Gear Tooth Contact Pattern Check is necessary to verify the correct relationship between ring gear and drive pinion. Gear sets which are not positioned properly may be noisy, or have short life or both. With a pattern check, the most desirable contact between ring gear and drive pinion for low noise level and long life can be assured.

## Gear Tooth Nomenclature

The side of the ring gear tooth which curves outward, or is convex, is referred to as the "drive" side. The concave side is the "coast" side. The end of the tooth nearest center of ring gear is referred to as the "toe" end. The end of the tooth farthest away from center is the "heel" end. Toe end of tooth is smaller than heel end. See figure 27B.

## Test

1. Wipe oil out of carrier and carefully clean each tooth of ring gear.
2. Use gear marking compound and apply this mixture sparingly to all ring gear teeth using a medium stiff



Fig. 26B--Measuring Rotating Torque

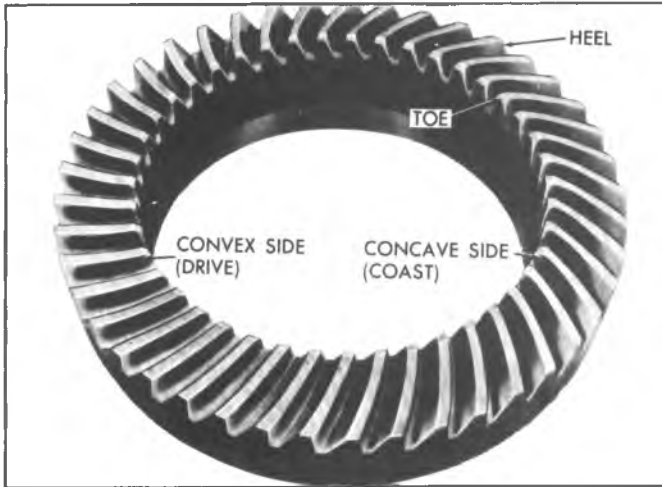

Fig. 27B--Gear Tooth Nomenclature

brush. When properly used, the area of pinion tooth contact will be visible when hand load is applied.

3. Tighten bearing cap bolts to 55 lb. ft.
4. Expand brake shoes until a torque of 20-30 lb. ft. is required to turn the pinion. A test made without loading the gears will not give a satisfactory pattern. Turn companion flange with wrench so that ring gear rotates one full revolution then reverse rotation so that ring gear rotates one revolution in opposite direction. Excessive turning of ring gear is not recommended.
5. Observe pattern on ring gear teeth and compare with Figure 28B.

**Adjustments Affecting Tooth Contact**

Two adjustments can be made which will affect tooth contact pattern. These are backlash and position of drive pinion in carrier. The effects of bearing preloads are not readily apparent on hand loaded teeth pattern tests; however, these adjustments should be within specifications before proceeding with backlash and drive pinion adjustments.

It may be necessary to adjust both pinion depth and backlash to obtain the correct pattern.

The position of the drive pinion is adjusted by increasing or decreasing the shim thickness between the pinion head and inner race of rear bearing.

The shim is used in the differential to compensate for manufacturing tolerances. Increasing shim thickness will move the pinion closer to centerline of the ring gear. Decreasing shim thickness will move pinion farther away from centerline of the ring gear.

Backlash is adjusted by means of the side bearing adjusting shims which moves the entire case and ring gear assembly closer to, or farther from the drive pinion. (The adjusting shims are also used to set side bearing preload). To increase backlash, increase right shim and decrease left shim an equal amount. To decrease backlash, decrease right shim and increase left shim an equal amount.

The important thing to note is that the contact pattern is centrally located up and down on the face of the ring gear teeth.

**SERIES 20-30 TRUCK DIFFERENTIAL  
10-1/2" RING GEAR**

**INDEX**

Differential Case .....	4B-12	Pinion Bearing Preload.....	4B-17
Removal.....	4B-12	Side Bearing Preload .....	4B-17
Side Bearing Replacement.....	4B-13	Pinion Depth and Backlash.....	4B-18
Ring Gear Replacement .....	4B-14	Gear Tooth Contact Pattern Check.....	4B-18
Disassembly and Reassembly .....	4B-14		
Installation and Adjustment.....	4B-15		
Drive Pinion.....	4B-15		
Removal.....	4B-15		
Disassembly.....	4B-15		
Inspection .....	4B-16		
Reassembly.....	4B-16		
Installation and Adjustment.....	4B-17		
Checks and Adjustments.....	4B-17		

**DIFFERENTIAL CASE**

**Removal**

1. Mount axle assembly in a bench vise or holding fixture.
2. Remove cover bolts and cover, as seen in figure 2E, and allow lubricant to drain into pan.

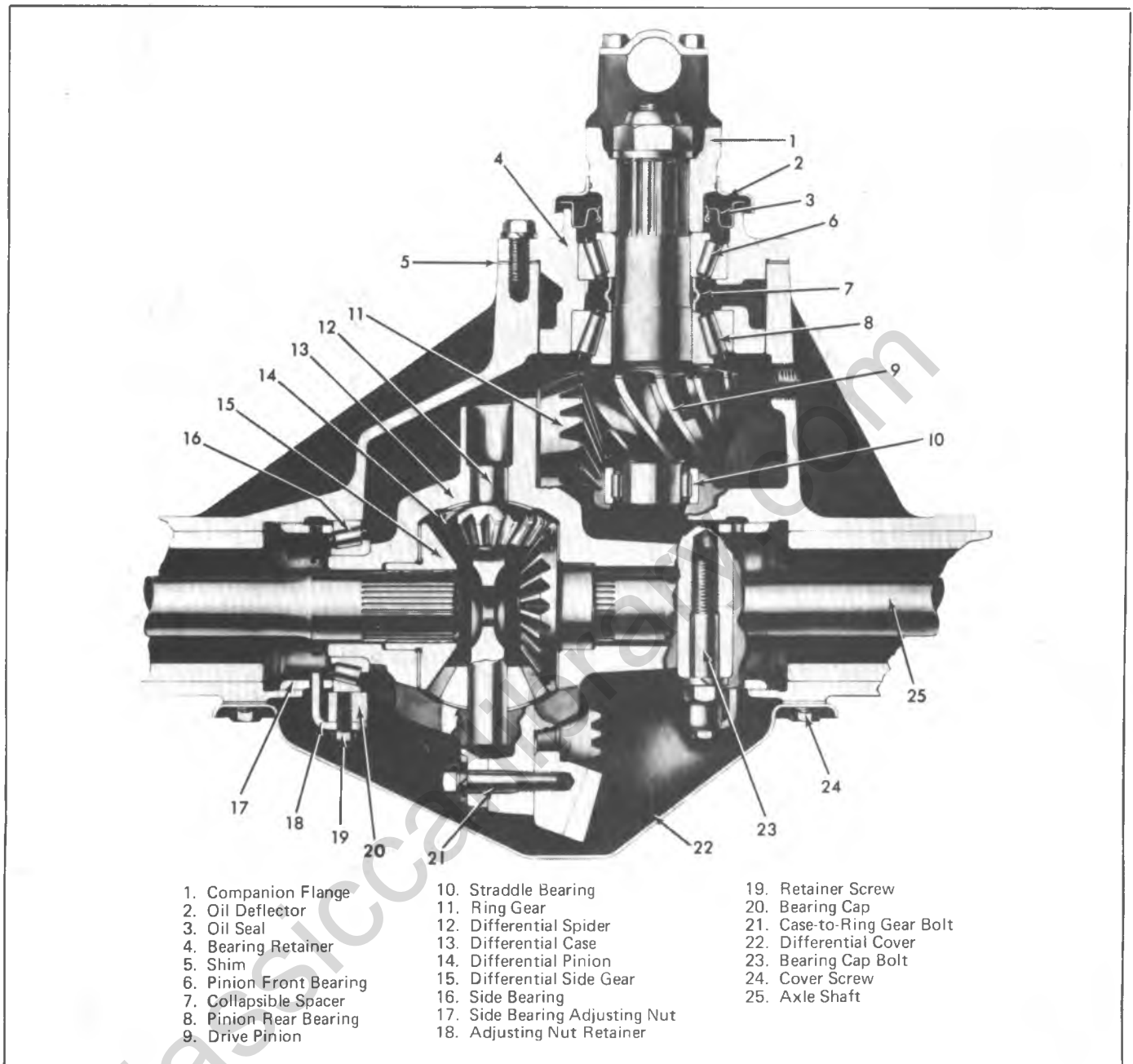

Fig. 1E—Cross Section of Truck Differential with 10 1/2" Ring Gear

3. Remove axle shafts as outlined in Truck Service Manual.

Before proceeding with following steps, it is advisable to check the existing ring gear to pinion backlash as described in Step 9 of "Differential Case - Installation." This will indicate gear or bearing wear or an error in backlash or pinion depth setting which will help in determining cause of axle noise. Backlash should be recorded so that if same gears are reused, then may be reinstalled at original lash to avoid changing gear tooth contact.

4. Remove adjusting nut lock retainers from bearing caps.

5. Mark bearing caps for reinstallation in the same position, and remove caps.

6. Loosen side bearing adjusting nuts, using J-24429 as shown in figure 3E.

7. Remove differential from carrier.

### Side Bearing Replacement

1. Install bearing puller J-8107 onto one side bearing, with puller screw centered on pilot plug as shown in figure 4E. Be sure to install puller fingers into notches of case, in order to pull on inner race only.

2. Tighten puller screw, while rotating bearing to insure that bearing cage is not being distorted.

3. Remove the other bearing in the same manner.

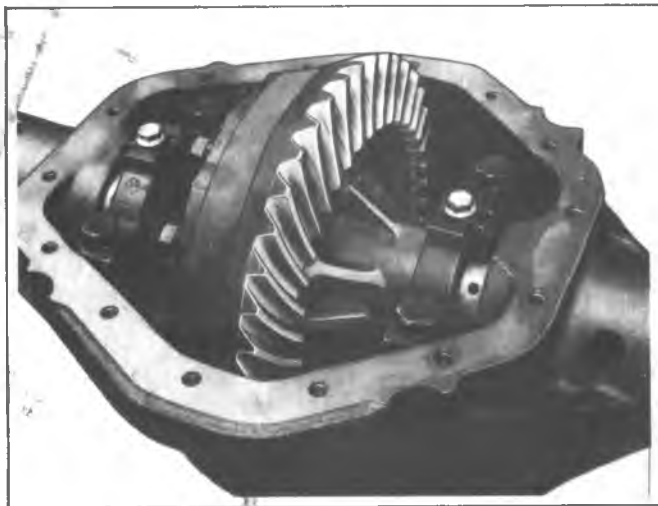

Fig. 2E—Cover Removed from Carrier



Fig. 4E—Differential Bearing Removal

4. Inspect bearings and hub for nicks, burrs or evidence of abnormal wear.

5. To install bearings, place bearing onto hub, and use driver handle J-8092 and bearing installer J-24430 to drive bearing onto hub until it seats against the shoulder.

6. When installing the second bearing, support case on pilot plug as shown in figure 5E to prevent damage to first bearing installed.

#### Ring Gear Replacement

1. Remove the ring gear bolts and lock washers, and use a soft faced hammer to tap the ring gear from the case.
2. Place new ring gear into position on case and install lock washers and bolts.
3. Torque bolts alternately to specifications.

#### Disassembly of Case

1. Mark the case and cover halves with a scribe line for reassembly in the same position.
2. With ring gear removed, separate case and cover.
3. Remove the internal parts and keep separated so they may be installed in the same relative positions.

#### Inspection

1. Inspect the differential gears, pinions, thrust washers, spider and all mating surfaces for evidence of abnormal wear.
2. Clean all parts thoroughly in suitable solvent.
3. Replace parts as necessary.

#### Reassembly of Differential

1. Lubricate internal parts with hypoid gear lubricant.
2. Place differential pinions and thrust washers onto spider.
3. Assemble differential gears and washers to case and cover.
4. Assemble differential case and cover making sure scribe marks align.
5. Install ring gear and attaching bolts and lockwashers and torque alternately to specifications.

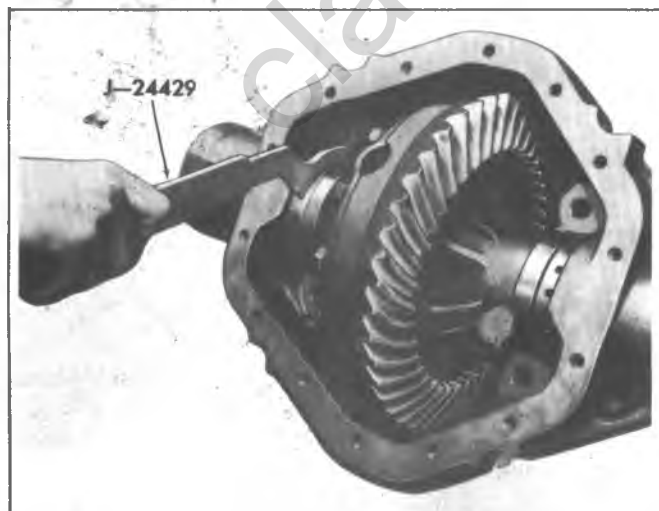

Fig. 3E—Loosening Adjusting Nuts



Fig. 5E—Differential Bearing Installation

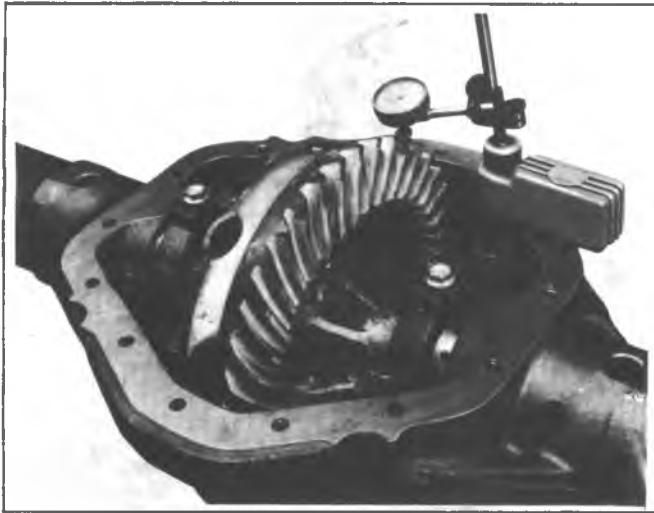

Fig. 6E--Measuring Backlash

6. The differential may be installed into the carrier at this point, or may be installed after servicing the drive pinion.

### Installation and Adjustment

1. Place bearing cups over side bearings and lift the differential assembly into the carrier. Install bearing caps, making sure marked caps are installed in original positions. Secure the cap bolts snugly.

2. Loosen the right side adjusting nut and tighten the left side nut, using J-24429 as shown in figure 3E, until the ring gear contacts the drive pinion. Do not force the gears into contact so as to bind them. At this point, zero lash is obtained.

3. Back off the left adjusting nut approximately two slots. Install locking fingers into holes and fasten fingers to bearing cap.

4. Tighten right adjusting nut firmly to force the case into solid contact with the left adjusting nut.

5. Loosen right adjusting nut until it is free from its bearing, then retighten until it contacts the bearing.

6. Tighten right adjusting nut approximately two slots if used bearings are being installed, or three slots if new bearings are being installed.

7. Install locking retainer into holes and attach fingers to bearing cap.

8. Torque bearing cap bolts to specifications. At this point the differential bearings are properly preloaded. If any additional adjustments are required in the following procedures, make sure that the preload remains as established. If one adjusting nut is loosened, the other nut must be tightened **an equal amount** to maintain this preload.

9. Mount a dial indicator on the housing and measure the backlash between the ring gear and pinion. Backlash should be from .003" to .012" with .005" to .008" preferred. Refer to figure 6E.

If backlash is more than .012", loosen the right adjusting nut one slot and tighten left adjusting nut one slot. If backlash is less than .003", loosen the left adjusting nut one slot and tighten the right adjusting nut one slot.



Fig. 7E--Removing Retainer Bolts

### DRIVE PINION ASSEMBLY

#### Removal

1. Remove differential as previously outlined.

2. Check pinion bearing preload as described under "Drive Pinion - Reassembly". Record the result. If there is no preload reading, check for looseness of pinion assembly by shaking the companion flange. Looseness indicates the need for bearing replacement.

3. Remove the pinion bearing retainer bolts from the housing as shown in figure 7E.

4. Remove the pinion and bearing retainer assembly. It may be necessary to rap on the pilot end of the pinion to assist the assembly from the carrier.

5. Record the thickness of the shims removed from between the bearing retainer flange and the carrier housing.

#### Disassembly

1. Clamp the pinion assembly in vise.

2. Install Holder J-8614-11 on flange by using two bolts with flat washers, as shown in figure 8E. Position J-8614-11 on flange so that the four notches are toward the flange.

3. Use a suitable sized socket to remove the pinion nut and washer. Discard the pinion nut and use a new one upon reassembly.

4. Thread end of J-8614-3 into small O.D. end of J-8614-2. Then with J-8614-11 installed as a step 2, insert J-8614-2 into J-8614-11 and turn it 1/8 of a turn to locked position. Remove flange by turning J-8614-3 while holding J-8614-11 as shown in figure 9E.

5. Support the bearing retainer as shown in figure 10E and press out the drive pinion. Do not allow drive pinion to fall onto the floor.

6. Separate the pinion flange, the oil seal, the front bearing and the bearing retainer. The oil seal may have to be driven from the bearing retainer if it is being replaced.

7. Drive the pinion front and rear bearing cups from the bearing retainer, using a drift.

8. To remove the rear bearing, use J-22912 as shown in figure 11E.

9. Drive the pinion straddle bearing from the carrier housing, using a drift as shown in figure 12E.

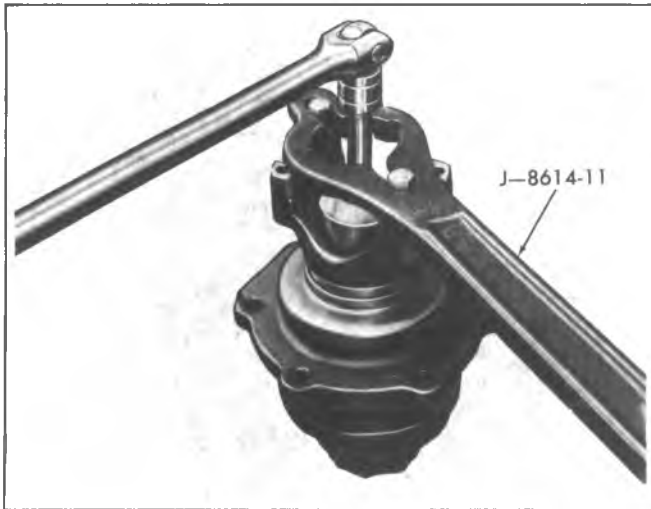

Fig. 8E—Removing Pinion Nut

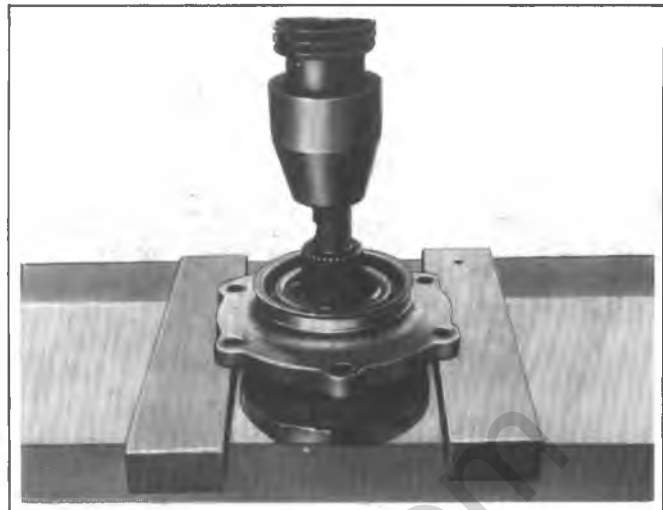

Fig. 10E—Pressing Drive Pinion from Bearing Retainer

### Inspection

1. Clean all parts in a suitable solvent and dry with air.
2. Inspect the drive pinion for chipped, cracked or excessively worn teeth and inspect the splines for wear.
3. Inspect the bearings for worn or pitted rollers or races. Inspect the pinion flange splines for wear.
4. Inspect the bearing retainer for cracks, imperfections, corrosion, pits and grooves.
5. Replace parts as required.

### Reassembly

1. Lubricate all parts with hypoid lubricant.
2. Press pinion rear bearing onto drive pinion as shown in figure 13E, using J-24433.
3. Install the front end rear pinion bearing cups into the bearing retainer, using driver handle J-8092 on J-8608 for the front cup, and on J-24432 for the rear cup.
4. Install the pinion straddle bearing into the carrier housing, using driver handle J-8092 and installer J-23322, as shown in figure 14E.

5. Place bearing retainer, with cups in position, onto the drive pinion. Install a new collapsible spacer into position.

6. Press front bearing onto drive pinion.

7. Lubricate the oil seal lips with a lithium-base extreme pressure lubricant, and install the seal in the retainer bore. Use J-24434 with driver handle J-8092. Press the seal into the bore until it seats against internal shoulder.

8. Install pinion flange and oil deflector onto the splines, then install lock washer and new pinion nut.

9. Clamp the pinion flange into a vise. Install J-8614-11 as in figure 8E. Tighten the nut to achieve proper bearing preload.

a. Proper preload is attained when rotational torque required to rotate the pinion is 25-35 in. lbs. for new bearings, or 5-15 in. lbs. for used bearings.

b. Tighten pinion nut to approximately 350 ft. lbs., then take a torque reading as shown in figure 15E, using J-5853.

c. Continue tightening pinion nut in small increments until proper preload is attained.

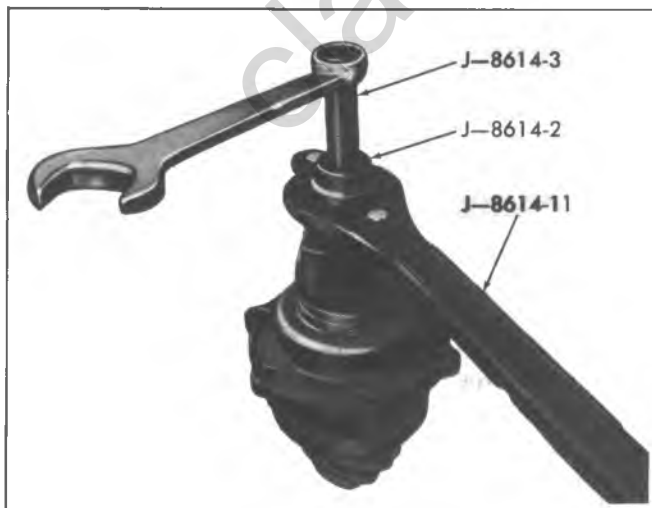

Fig. 9E—Removing Flange

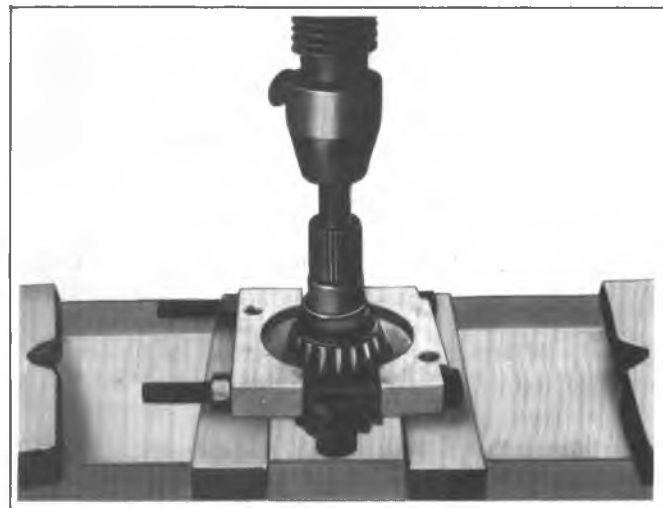

Fig. 11E—Removing Pinion Rear Bearing

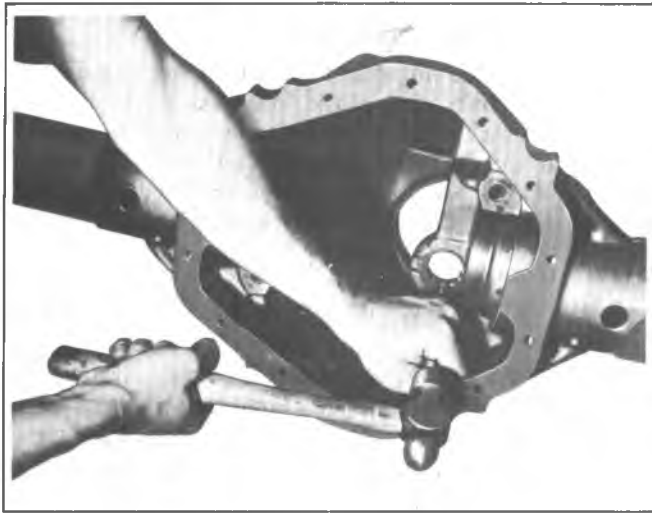

Fig. 12E--Removing Straddle Bearing

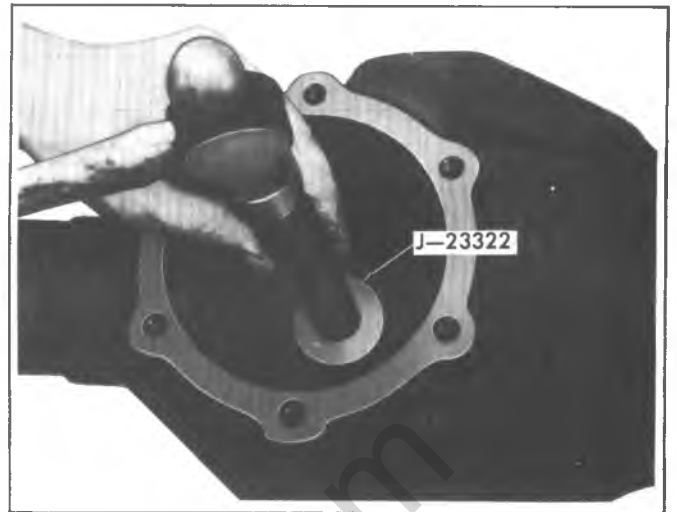

Fig. 14E--Installing Straddle Bearing

**NOTICE:** Over-tightening of pinion nut may collapse spacer too much, requiring its replacement.

### Installation and Adjustment

1. Examine the head of the drive pinion for a pinion depth code number.

2. Compare the depth code number with the number on the original pinion. Use the following chart to select the proper shim for preliminary setting of pinion depth.

3. Refer to the thickness of the shim recorded earlier in Pinion Removal procedures. Increase or decrease the shim dimension as indicated by the chart in figure 16E.

a. For example, if original shim measured .014 inch, original code was -1 and new code is +2, the correct shim would be .014 inch plus .003 = .017 inch.

b. If original shim was .012 inch, original code +2, and new code is -2, the correct shim would be .012 minus .004 = .008 inch.

4. Place the pinion shim as determined in step 3 onto the carrier housing, making sure the bolt holes align with those of carrier, and that the mating surfaces are clean and

free from foreign material.

5. Place the pinion retainer assembly into position, and align bolt holes to carrier. Install retaining bolts and tighten in a crosswise manner. Torque to specifications.

6. Following dirve pinion service, a Contact Pattern Check must be made.

### CHECK AND ADJUSTMENTS

Four adjustments are essential for proper operation of the differential and its related parts. These adjustments are a) Pinion Bearing Preload, b) Side Bearing Preload, c) Pinion Depth and d) Ring Gear-to-Pinion Backlash.

Pinion Bearing Preload is set to specifications in step 9 of "Drive Pinion Reassembly".

Side Bearing Preload is set to specifications in step 6 of "Differential Case-Installation and Adjustment".

Following service to the Differential assembly or to the Drive Pinion, the Pinion Depth and Ring-Gear-to-Pinion Backlash **must** be checked, using a Gear Tooth Contact Pattern Check as outlined below.

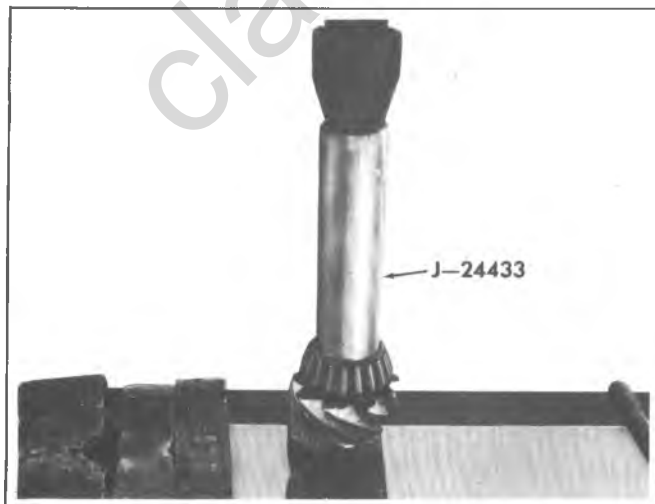

Fig. 13E--Installing Pinion Rear Bearing

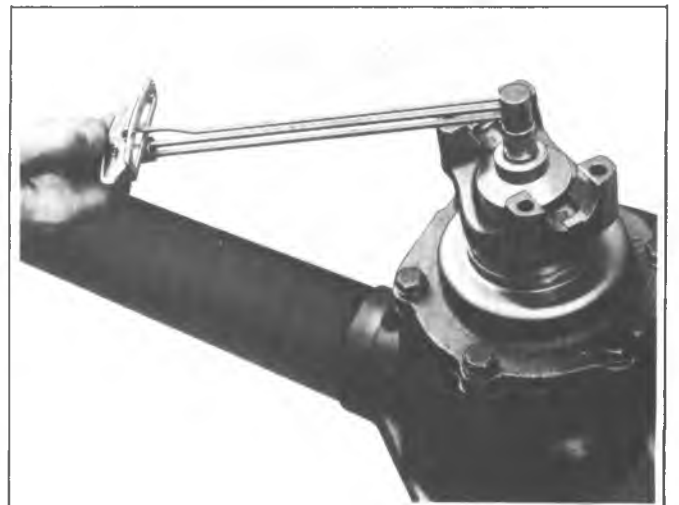

Fig. 15E--Measuring Rotating Torque

		CODE NUMBER ON ORIGINAL PINION				
		+2	+1	0	-1	-2
CODE NUMBER ON SERVICE PINION	+2	-	ADD .001	ADD .002	ADD .003	ADD .004
	+1	SUBT. .001	-	ADD .001	ADD .002	ADD .003
	0	SUBT. .002	SUBT. .001	-	ADD .001	ADD .002
	-1	SUBT. .003	SUBT. .002	SUBT. .001	-	ADD .001
	-2	SUBT. .004	SUBT. .003	SUBT. .002	SUBT. .001	-

Fig. 16E—Pinion Depth Codes

### Gear Tooth Contact Pattern Check

Prior to final assembly of the differential, a Gear Tooth Contact Pattern Check is necessary to verify the correct relationship between ring gear and drive pinion. Gear sets which are not positioned properly may be noisy, or have short life, or both. With a pattern check, the most desirable contact between ring gear and drive pinion for low noise level and long life can be assured.

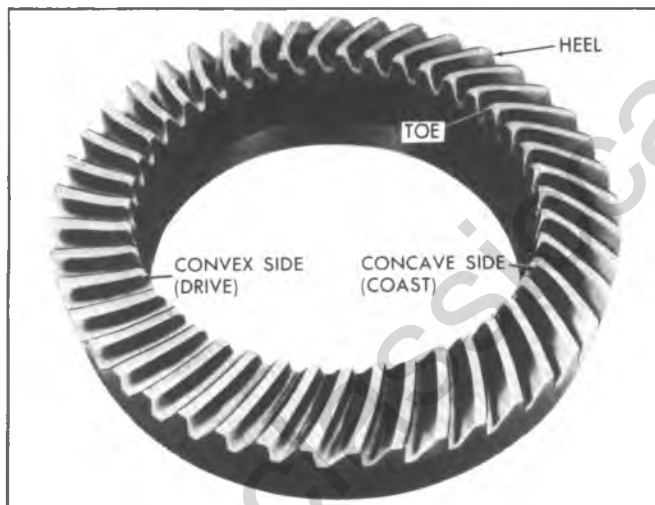

Fig. 17E—Gear Tooth Nomenclature

### Gear Tooth Nomenclature

The side of the ring gear tooth which curves outward, or is convex, is referred to as the "drive" side. The concave side is the "coast" side. The end of the tooth nearest center of ring gear is referred to as the "toe-in" end. The end of the tooth farthest away from center is the "heel" end. Toe end of tooth is smaller than heel end. See Figure 17E.

### Pattern Check

1. Wipe oil out of carrier and carefully clean each tooth of ring gear.
2. Use gear marking compound and apply this mixture to ring gear teeth. When properly applied, the area of tooth contact will be clearly visible after load is applied.
3. Tighten bearing cap bolts to specifications.
4. Apply load to gears by expanding brake shoes or by wrapping a heavy rag around the companion flange to resist rotation.

A test made without loading the gears will not give a satisfactory pattern. Turn companion flange with wrench so that ring gear rotates one full revolution then reverse rotation so that ring gear rotates one revolution in opposite direction. Excessive turning of ring gear is not recommended.

5. Observe pattern on ring gear teeth and compare with figure 18E. Make adjustments as outlined below.
6. The important thing to achieve in the pattern check and subsequent adjustments is to locate the contact pattern centrally on the face of the ring gear teeth.

### Pinion Depth Adjustment

1. The pinion depth shim may be replaced as necessary to place the drive pinion at the correct depth. See figure 18E.
2. Depth shims are available from .006 inch to .024 inch, in increments of .001 inch.

### Backlash Adjustment

1. Remove locking retainers from side bearing adjusting nuts.
2. Move adjusting nuts **an equal amount** in or out to achieve proper backlash.
  - a. To increase backlash, loosen the left adjusting nut and tighten the right adjusting nut **an equal amount**.
  - b. To decrease backlash, loosen the right adjusting nut and tighten the left adjusting nut **an equal amount**.



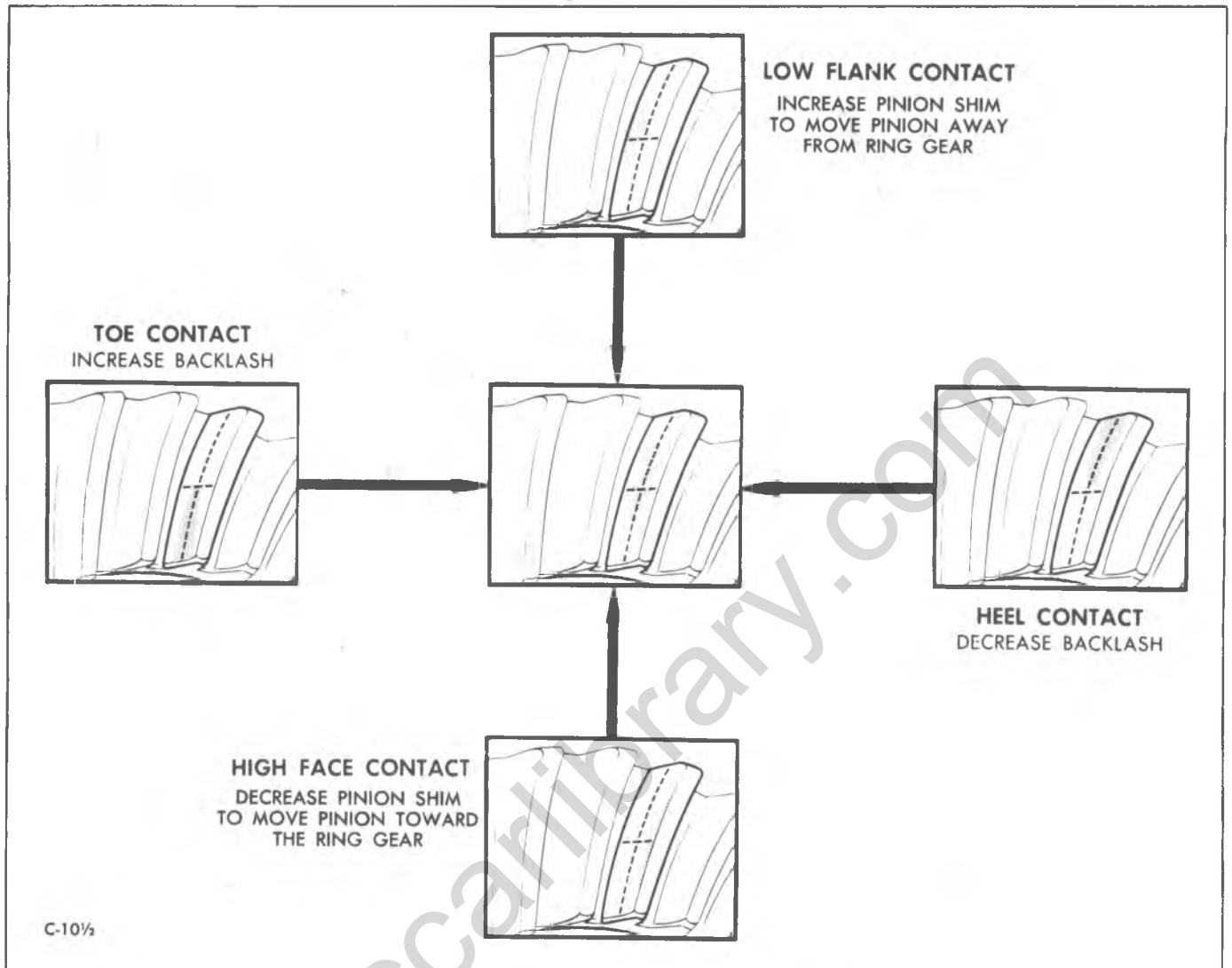

Fig. 18E—Gear Teeth Contact Pattern Check

## DANA DIFFERENTIALS 10-1/2. RING GEAR

### INDEX

Differential Case - Removal and Disassembly.....	4B-20
Drive Pinion - Removal and Disassembly.....	4B-21
Differential Case - Reassembly.....	4B-22
Shim Requirements - Gaging Procedures.....	4B-22
Drive Pinion - Assembly and Installation.....	4B-23
Differential Case - Installation and Adjustment.....	4B-24
Checks and Adjustments.....	4B-25

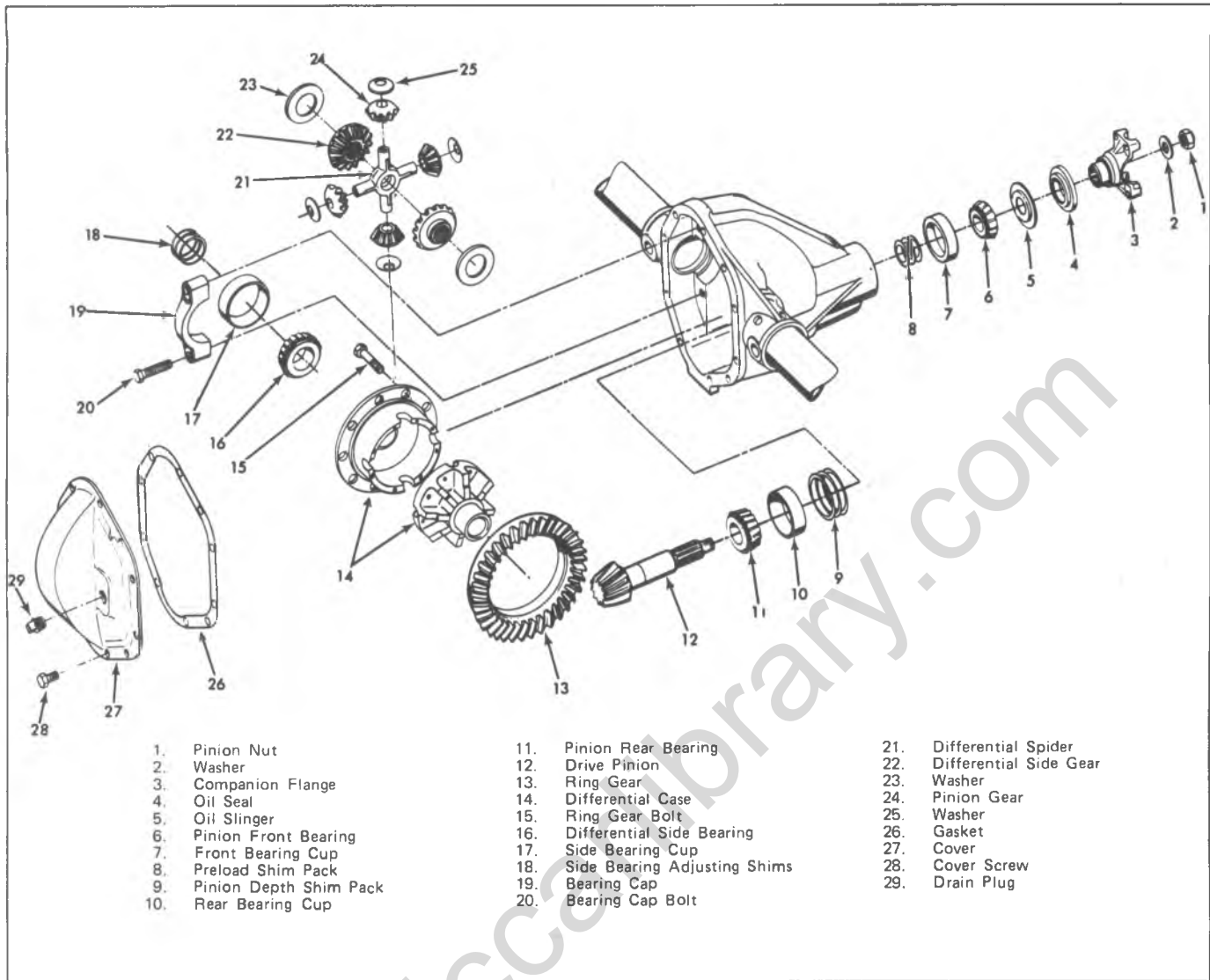

Fig. 1F -Dana Differential with 10-1/2" Ring Gear - Exploded View

**GENERAL DESCRIPTION**

This Dana Spicer axle is similar in design to other Salisbury type axles with the following exceptions:

1. In order to remove the differential case, the carrier must be spread.

2. The drive pinion assembly incorporates an inner and outer bearing shim. The inner shim is used to maintain proper pinion depth. The outer shim is used to maintain proper preload on the pinion bearing.

**DIFFERENTIAL CASE**

**Removal**

1. Place vehicle on hoist with rear axle hanging free.
2. Remove wheel and tire assemblies.
3. The axle shafts are full-floating type with flanged outer end of shaft attached to wheel hub by studs and nuts. Wheel is supported by tapered roller bearings at outer end of axle housing.

- a. Remove axle shaft to hub attaching nuts.
- b. Rap on axle shaft to loosen shaft from hub and remove shafts.

4. Remove plug in carrier and drain lubricant.
5. Remove cap screws and lock washers attaching cover to carrier. Remove cover and gasket.
6. Mark one side of carrier and matching cap for reassembly in the same position. Remove bearing caps.
7. Using spreader tool J-24385, and a dial indicator as shown in figure 2F, spread carrier a maximum of .015 inch.

**NOTICE:** Do not exceed this dimension, as carrier may be permanently damaged.

8. Remove the dial indicator and use a prybar to remove the differential case from the carrier. Record the

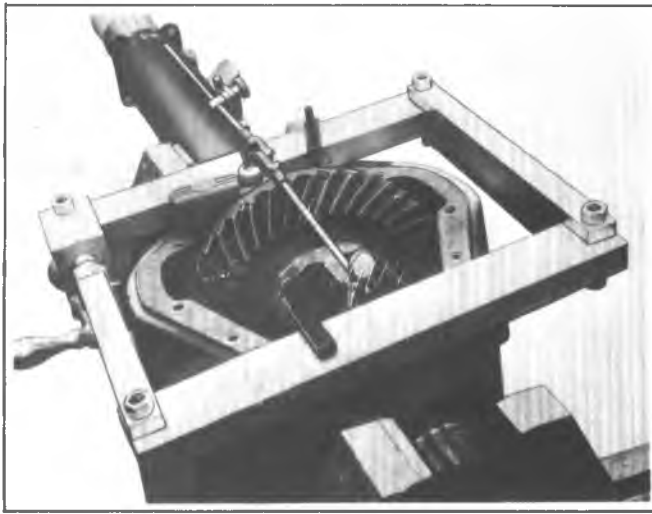

Fig. 2F--Spreading the Carrier

dimensions and location of the side bearing shims. Remove the spreader tool.

### Disassembly

1. Remove differential side bearings by placing J-22912 under bearings and supporting plates on a press bed. Apply force to pilot plug J-8107-3 to drive the case from the bearing.

Use care not to damage case hubs with tool J-22912.

2. Remove the ring gear bolts and the ring gear. Tap the ring gear with a soft-faced hammer to free it from the case.

3. Scribe both case halves for reassembly in same position.

4. Remove bolts holding case halves together, as shown in figure 3F.

5. Tap lightly on top half of case to free it from the bottom half. Remove top half of case.

6. Lift out all internal parts.



Fig. 3F--Separating Case Halves

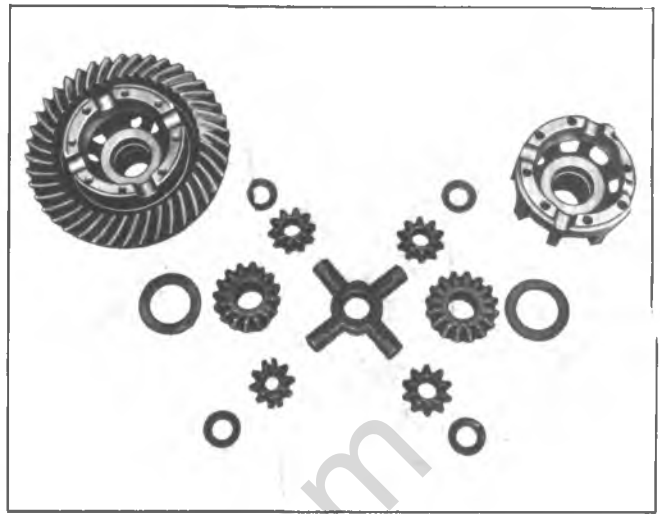

Fig. 4F--Internal Parts Inspection

### Inspection

1. Clean all gears and bearings in solvent. Inspect cups, races and rollers for scoring, chipping or evidence of excessive wear.

2. Inspect ring gear teeth and machined surfaces. Examine fit of internal gears.

3. Inspect pinion cross-shaft.

4. Replace parts as required.

### DRIVE PINION

#### Removal and Disassembly

1. Remove differential as previously outlined.

2. Check pinion bearing preload as described under "Drive Pinion - Installation and Adjustment." If there is no preload reading, check for looseness of pinion assembly by shaking the companion flange. Looseness indicates the need for bearing replacement.

3. Install Holder J-8614-11 on flange by using two bolts with flat washers, as shown in figure 5F. Position J-8614-11 on flange so that the four notches are toward the flange.

4. Remove pinion nut and washer. Discard pinion nut and use a new one upon reassembly.

5. Thread end of J-8614-3 into small O.D. end of J-8614-2. Then with J-8614-11 installed as in step 3, insert J-8614-2 into J-8614-11 and turn it 1/8 of a turn to locked position. Remove flange by turning J-8614-3 while holding J-8614-22 as shown in figure 6F.

6. Remove drive pinion from carrier. It may be necessary to tap on the pinion with a soft faced hammer.

7. With a long drift tap on inner race of outer pinion bearing, to remove pinion oil seal, slinger, gasket, outer pinion cone and roller and shim pack. Tag shim pack for reassembly.

8. Should inspection indicate necessity, pinion bearing cups can be removed from carrier using a long drift and hammer. Remove shims and oil slinger which are located behind the inner bearing cup. Tag shims for reassembly.

9. Remove rear pinion bearing using J-22912, and an arbor press.

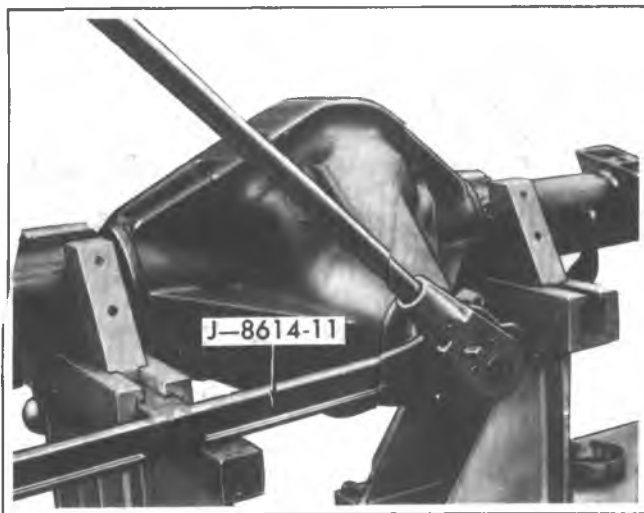

Fig. 5F—Removing Pinion Nut

**Inspection**

1. Clean all gears and bearings in cleaning solvent and inspect all bearing cups, races and rollers for scoring, chipping or evidence of excessive wear. On pinion bearing rollers, inspect large end of rollers for wear. This is where wear is most evident on tapered roller bearings.
2. Inspect pinion splines and flange splines for evidence of excessive wear.
3. Inspect ring gear and pinion teeth for possible scoring, cracking or chipping.
4. Inspect differential case for cracks or scores or side gears, thrust washers, and pinion thrust faces.
5. Check fit of differential side gears in case.
6. Check fit of side gears and axle shaft splines.
7. Inspect differential pinion shaft and spacer for scoring or evidence of excessive wear.

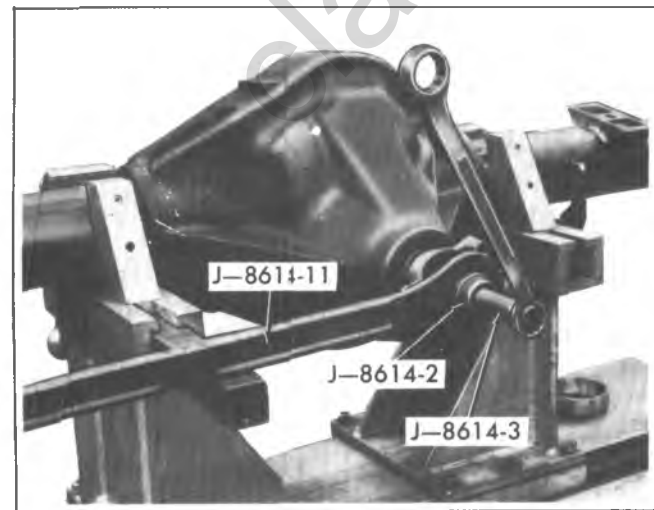

Fig. 6F—Removing Companion Flange

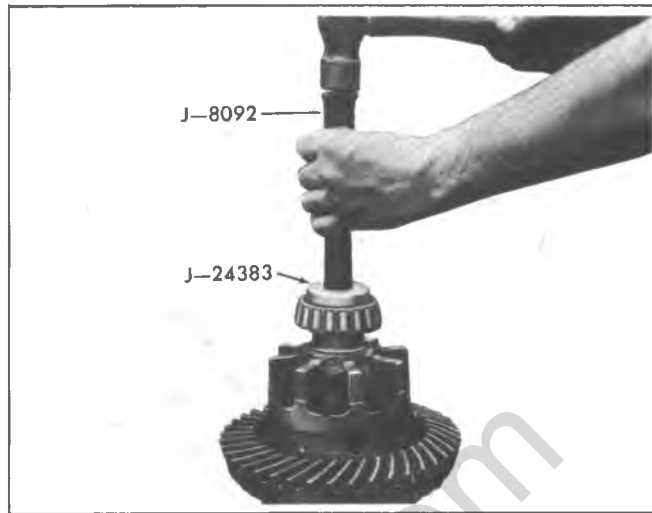

Fig. 7F—Installing Side Bearing

**DIFFERENTIAL CASE**

**Reassembly**

1. Assemble new washers to side gears. Apply a small amount of hypoid lubricant on the side gear hubs.
2. Assemble pinion gears and new washers onto cross shaft.
3. Place side gears, pinion gears, cross shaft and washers into flanged half of case.
4. Assemble top half of case to bottom half, making sure scribe marks are aligned.
5. Assemble body bolts finger tight. Then tighten bolts alternately to specifications.
6. Install ring gear to differential case.
7. Install ring gear-to-case bolts finger tight, then tighten alternately to specifications.
8. Place side bearing into position and install, using tools J-8092 and bearing installer J-24383 as shown in figure 7F.
9. Install bearing on opposite side in the same manner. Be sure to support differential case on pilot plug J-8107-3.

**SHIM REQUIREMENTS - GAGING PROCEDURES**

**Side Bearing Shims**

1. With the pinion removed from the carrier, place the bearing cups over the side bearings, and install the differential case into the carrier.
2. Place the shim which was originally installed on the ring gear side into its original position.
3. Install the bearing caps lightly in their marked positions. Tighten the caps just enough to keep the bearings in place.
4. Mount a dial indicator on the carrier with the tip of the indicator on the back face of the ring gear.
5. Position two screwdrivers between the bearing shim and carrier on the ring gear side of the case. Pull on the screwdrivers and force the differential case as far as possible away from the dial indicator.
6. With force still applied, set the indicator dial to "zero", being sure the probe is still in contact with the ring



Fig. 8F -Screwdrivers Against Case

gear.

7. Reposition the screwdrivers to the opposite side of the differential case as shown in figure 8F.

8. Pull on the screwdrivers and force the differential case back toward the dial indicator. Repeat several times until the same indicator reading is obtained.

9. To the dial indicator reading, add the thickness of the shim. Record the result, as this figure will be used during determination of side bearing shim requirements.

**Pinion Shims**

Ring gears and pinions are supplied in matched sets only. Matching numbers on both pinion and ring gear are etched for verification. If a new gear set is being used, verify the numbers of each pinion and ring gear before proceeding with assembly.

On the rear face of each pinion there is etched a plus (+) number, a minus (-) number, or a zero (0) number, which indicates the best running position for each particular

gear set. This dimension is controlled by the shimming behind the inner bearing cup. Whenever baffles or oil slingers are used, they become a part of the adjusting shim pack.

For example: if a pinion is etched +3, this pinion would require .003" less shims than a pinion etched "0". This means by removing shims, the mounting distance of the pinion is increased by .003" which is just what a + etching indicates. 3 Or if a pinion is etched -3, we would want to add .003" more shims than would be required if the pinions were etched "0". By adding .003" shims, the mounting distance of the pinion was decreased .003" which is just what a -3 etching indicated. Refer to figure 10F.

If the old ring and pinion set is to be reused, measure the old shim pack and build a new shim pack to this same dimension. If baffle is in the axle assembly, it is considered as part of the shim pack.

To change the pinion adjustment, shims are available in thicknesses of .003", .005" and .010".

If baffle or slinger is bent or mutilated, it should be replaced.

Measure each shim separately with a micrometer and add together to get total shim pack thickness from original build up.

If a new gear set is being used, notice the plus or minus etching on both the old and new pinion, and adjust the thickness of the old shim pack to compensate for the difference of these two figures.

For example: If the old pinion reads (+2) and the pinion is (-2), add .004" shims to the original shim pack.

**DRIVE PINION**

**Assembly and Installation**

1. Determine the correct pinion depth shim by using the chart in figure 9F.

Old Pinion Marking	New Pinion Marking								
	- 4	- 3	- 2	- 1	0	+ 1	+ 2	+ 3	+ 4
+ 4	+ 0.008	+ 0.007	+ 0.006	+ 0.005	+ 0.004	+ 0.003	+ 0.002	+ 0.001	0
+ 3	+ 0.007	+ 0.006	+ 0.005	+ 0.004	+ 0.003	+ 0.002	+ 0.001	0	- 0.001
+ 2	+ 0.006	+ 0.005	+ 0.004	+ 0.003	+ 0.002	+ 0.001	0	- 0.001	- 0.002
+ 1	+ 0.005	+ 0.004	+ 0.003	+ 0.002	+ 0.001	0	- 0.001	- 0.002	- 0.003
0	+ 0.004	+ 0.003	+ 0.002	+ 0.001	0	- 0.001	- 0.002	- 0.003	- 0.004
- 1	+ 0.003	+ 0.002	+ 0.001	0	- 0.001	- 0.002	- 0.003	- 0.004	- 0.005
- 2	+ 0.002	+ 0.001	0	- 0.001	- 0.002	- 0.003	- 0.004	- 0.005	- 0.006
- 3	+ 0.001	0	- 0.001	- 0.002	- 0.003	- 0.004	- 0.005	- 0.006	- 0.007
- 4	0	- 0.001	- 0.002	- 0.003	- 0.004	- 0.005	- 0.006	- 0.007	- 0.008

Fig. 9F-Dana Pinion Code Chart



Fig. 10F—Pinion Code Location

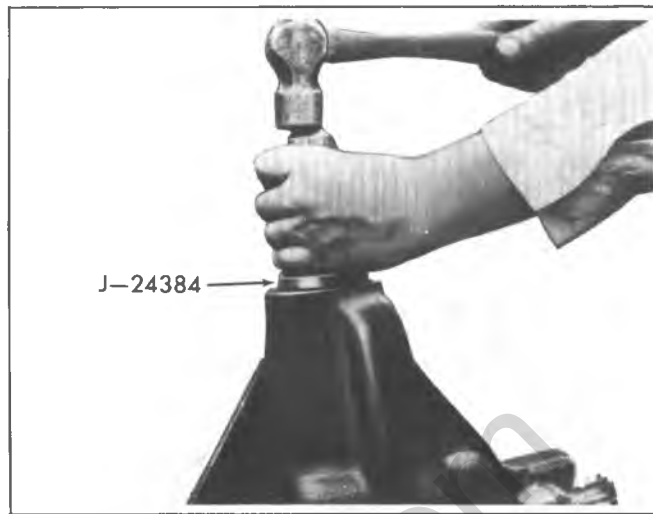

Fig. 11F—Installing Pinion Oil Seal

2. Install the pinion depth shim in rear cup bore.
3. Install rear bearing cup by using driver handle J-8092 and installer J-24381.
4. To the outer shim pack (for setting preload) add or remove an equal amount as was added or removed from the inner shim pack.
5. Install outer cup in carrier bore, using installer J-7818 with Drive Handle J-8092.
6. Press rear pinion bearing onto pinion shaft, using installer J-24433.
7. Install drive pinion and bearing into the differential carrier.
8. Install preload shims and front pinion bearing. Do not install oil seal at this time.
9. Install flange and holding bar J-8614-11 as shown in "Drive Pinion - Removal".
10. Install washer and nut onto pinion shaft. Torque nut to 250 lbs. ft.
11. Remove holding bar and with an inch pound torque wrench measure rotating torque. Rotating torque should be 10 to 20 in. lbs. with original bearings or 20 to 40 in. lb. with new bearings.  
Torque reading to start shaft turning must be disregarded.
12. If torque requirements (preload) are not to specifications, adjust shim pack as necessary.
  - a. To increase preload, decrease the thickness of preload shims.
  - b. To decrease preload, increase the thickness of preload shims.
13. When bearing preload meets specifications, remove nut, washer and flange from pinion shaft.
14. Install new pinion oil seal into housing as shown in figure 11F, using J-24384.
15. Install flange, washer and nut. Using holder bar J-8614-11, torque nut to 250 lbs. ft.

## DIFFERENTIAL CASE

### Installation and Adjustment

1. Place the differential case, with side bearings and cups installed, into position in the carrier.
2. Select the smallest of the original shims as a "gaging shim" and place it between the bearing cup and the carrier on the ring gear side of the case.
3. Install bearing caps and bearing screws finger tight. Make sure bearing caps are in correct marked position.
4. Mount a dial indicator on the ring gear side of the carrier, with the indicator probe in contact with the back face of the ring gear.
5. Position two screwdrivers between the bearing cup and the carrier on the side opposite the ring gear.
6. Pull on the screwdrivers and force the differential case as far as possible toward the indicator. With force still applied, set the dial indicator to zero.
7. Reposition the screwdrivers on the ring gear side of the case. Force the ring gear into mesh with the drive pinion and observe the dial indicator. Repeat this operation several times until the same reading is obtained.
8. Add the indicator reading to the "gaging" shim thickness to determine the correct shim dimension for installation on the ring gear side of the case.  
For example, if the gaging shim was .155 inch, and the indicator reading in step 7 was .017 inch, the correct shim would be  $.155 + .017 = .172$  inch.
9. Remove the "gaging" shim and install the correct size shim into position between the bearing cup and the carrier on the ring gear side of the case.
10. To determine the correct dimension for the remaining shim, first refer to the dimension obtained in step 8 of "Gaging Procedures—Side Bearing Shims". From that figure, subtract the size of the shim installed in step 9 above; then add .006 inch for preload and backlash.  
For example, if the reading in step 8 was .329 inch, and the shim just installed on the ring gear side of the case was .172 inch, the correct shim dimension would be  $.329 - .172 = .157 + .006 = .163$  inch.

11. Spread the differential carrier as shown in figure 2F.

12. Assemble the shim determined in step 10 into place between the bearing cup and the carrier.

13. Remove the spreader and the dial indicator.

14. Install the bearing caps in marked positions and torque cap screws to specifications.

15. Install dial indicator and check ring gear backlash at four equally spaced points around the ring gear. Backlash must be held to .004" to .009" and must not vary more than .002" between positions checked.

16. Whenever backlash is not within limits, differential bearing shim pack should be corrected to bring backlash within limits.

a. Low backlash is corrected by decreasing the shim on the ring gear side and increasing the opposite side shim **an equal amount**.

b. High backlash is corrected by increasing the shim on the ring gear side and decreasing the opposite side shim **an equal amount**.

17. Check gear tooth contact, as described in "Gear Tooth Contact Pattern Check".

18. Using a new gasket, install housing cover and torque bolts to specifications.

19. Reinstall the rear universal joint, and torque "U" bolt nuts to specifications.

20. Install axles into carrier and axle flange over hub studs.

21. Torque hub stud nuts to specifications.

22. Fill differential with lubricant.

23. Install wheel and tire assembly.

### CHECKS AND ADJUSTMENTS

Four adjustments are essential for proper operation of the differential and its related parts. These adjustments are a) Pinion Bearing Preload, b) Side Bearing Preload, c) Pinion Depth and d) Ring Gear-to-Pinion Backlash.

Pinion Bearing Preload is set to specifications in step 12 of "Drive Pinion - Assembly and Installation". Side Bearing Preload is set to specifications in step 10 of "Differential Case - Installation and Adjustment". Following service to the Differential Case or to the Drive Pinion and Ring Gear, a Gear Tooth Contact Pattern Check **must** be made, to verify the accuracy of the work in setting the pinion depth and the ring gear-to-pinion backlash.

### GEAR TOOTH CONTACT PATTERN CHECK

Prior to final assembly of the differential, a Gear Tooth Contact Pattern Check is necessary to verify the correct relationship between ring gear and drive pinion. Gear sets which are not positioned properly may be noisy, or have short life or both. With pattern check, the most desirable contact between ring gear and drive pinion for low noise level and long life can be assured.

### Gear Tooth Nomenclature

The side of the ring gear tooth which curves outward, or is convex, is referred to as the "drive" side. The concave side is the "coast" side. The end of the tooth nearest center of ring gear is referred to as the "toe end." The end of the tooth farthest away from center is the "heel" end. Toe end of tooth is smaller than heel end. See figure 12F.

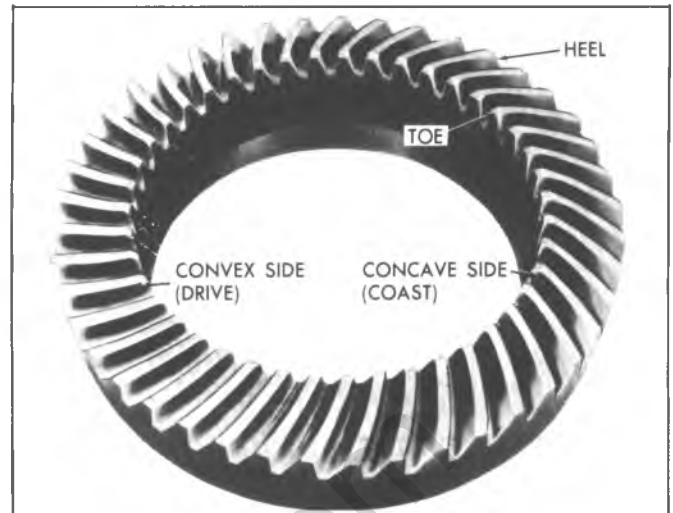

Fig. 12F—Gear Tooth Nomenclature

### Test

1. Wipe oil out of carrier and carefully clean each tooth of ring gear.

2. Use gear marking compound and apply this mixture sparingly to all ring gear teeth using a medium stiff brush. When properly used, the area of pinion tooth contact will be visible when hand load is applied.

3. Tighten bearing cap bolts to specifications.

4. Apply load to gears by expanding brake shoes or by wrapping a heavy rag around the companion flange to resist rotation.

A test made without loading the gears will not give a satisfactory pattern. Turn companion flange with wrench so that ring gear rotates one full revolution then reverse rotation so that ring gear rotates one revolution in opposite direction. Excessive turning of ring gear is not recommended.

5. Observe pattern on ring gear teeth and compare with figure 13F. Make adjustments as necessary.

6. The important thing to achieve in the pattern check and subsequent adjustments is to locate the contact pattern centrally on the face of the ring gear teeth.

### Adjustments Affecting Tooth Contact

Two adjustments can be made which will affect tooth contact pattern. These adjustments are backlash and position of drive pinion in carrier. The effects of bearing preloads are not readily apparent on hand loaded teeth pattern tests; however, these adjustments should be within specifications before proceeding with backlash and drive pinion adjustments.

It may be necessary to adjust both pinion depth and backlash to obtain the correct pattern.

The position of the drive pinion is adjusted by increasing or decreasing the shim thickness of the inner shim, located between the rear bearing cup and the carrier housing. Increasing the shim thickness will move the pinion closer to centerline of the ring gear. Decreasing shim thickness will move pinion farther away from centerline of the ring gear.

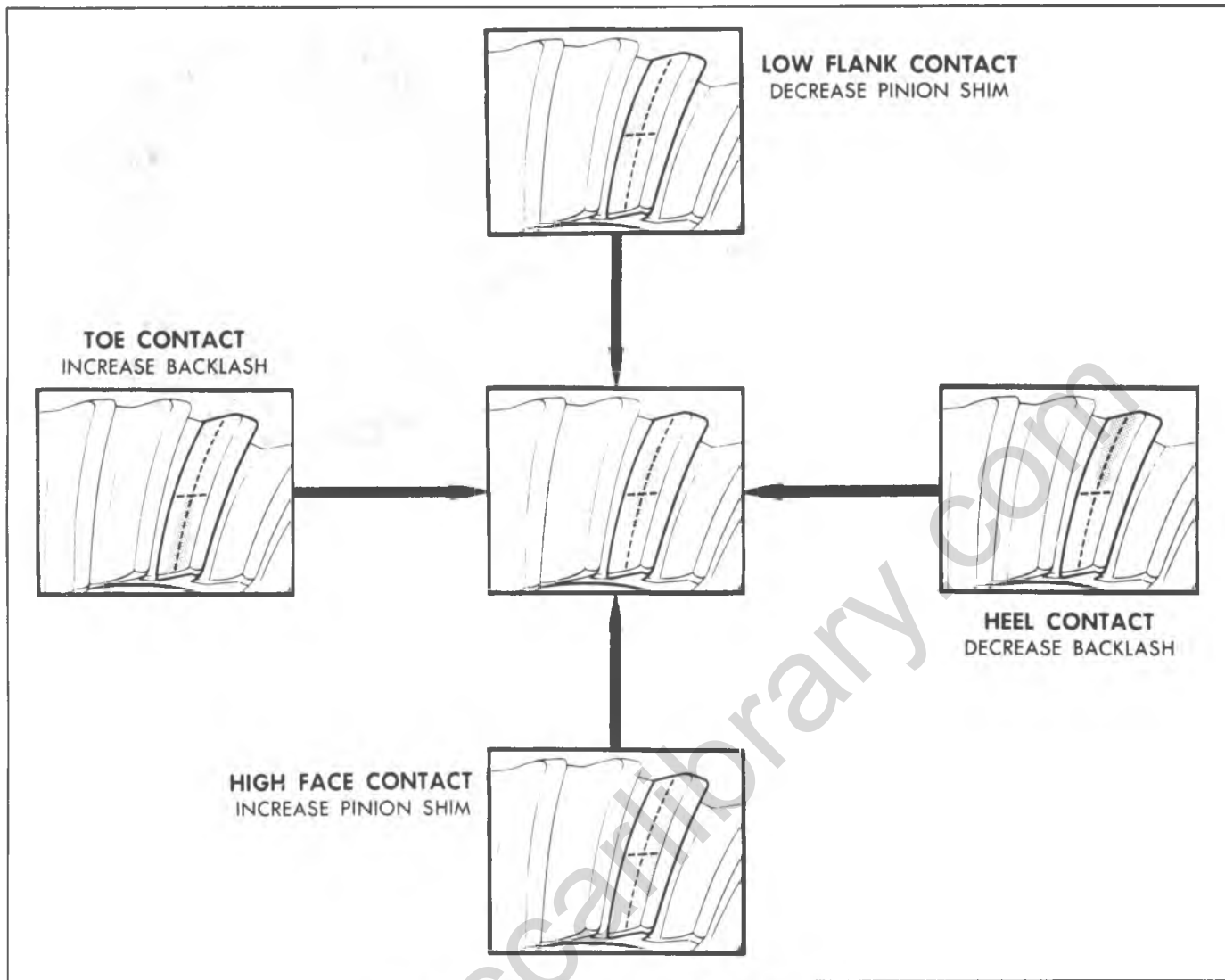

Fig. 13F—Gear Teeth Contact Pattern Check

Backlash is adjusted by means of the side bearing adjusting shims which moves the entire case and ring gear assembly closer to, or farther from the drive pinion. (The adjusting shims are also used to set side bearing preload). To increase backlash, increase right shim and decrease left

shim **an equal amount**. To decrease backlash, decrease right shim and increase left shim **an equal amount**.

## DANA 9-3/4. RING GEAR

### INDEX

General Description .....	4B-27
Differential Case-Removal and Disassembly .....	4B-27
Drive Pinion-Removal and Disassembly .....	4B-28
Differential Case-Reassembly .....	4B-29
Drive Pinion-Installation and Adjustment .....	4B-29
Differential Case-Installation and Adjustment .....	4B-30



**GENERAL DESCRIPTION**

This Dana Spicer axle is similar in design to other Salisbury type axles with the following exceptions:

1. The differential side bearing shims are located between the side bearing cone and roller assembly and the differential case. See figure 14F. These bearings are of the tapered roller design and are preloaded. In order to remove the differential case the carrier must be spread.

2. The pinion assembly incorporates an inner and outer bearing shim. The inner shim is used to maintain proper pinion depth. The outer shim is used to maintain proper preload on the pinion bearing.

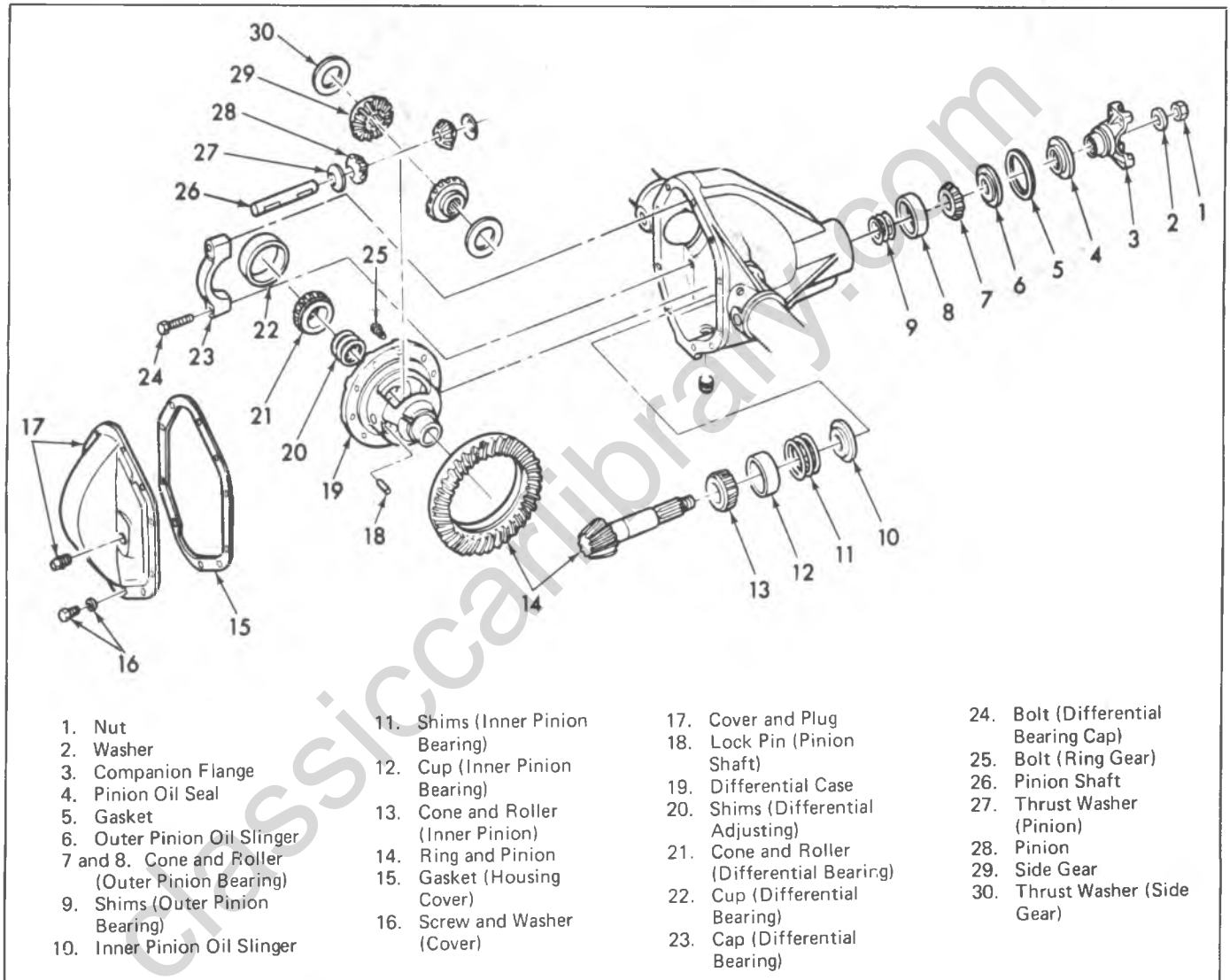

Fig. 14F—Dana Differential With 9-3/4" Ring Gear - Exploded View

**DIFFERENTIAL CASE**

**Removal**

1. Place vehicle on hoist with rear axle hanging free.
2. Remove wheel and tire assemblies.
3. The axle shafts are full-floating type with flanged outer end of shaft attached to wheel hub by studs and nuts. Wheel is supported by tapered roller bearings at outer end of axle housing.
  - a. Remove axle shaft to hub attaching nuts.
  - b. Rap on axle shaft to loosen shaft from hub and remove shafts.

4. Remove plug in carrier and drain lubricant.
5. Remove cap screws and lock washers attaching cover to carrier. Remove cover and gasket.
6. Mark one side of carrier and matching cap for reassembly. Remove cap screws attaching bearing caps to carrier.
7. Using spreader Tool J-24385 and dial indicator as shown in figure 15F, spread carrier a maximum of .020".

**NOTICE:** Do not exceed this dimension as carrier may be permanently damaged.

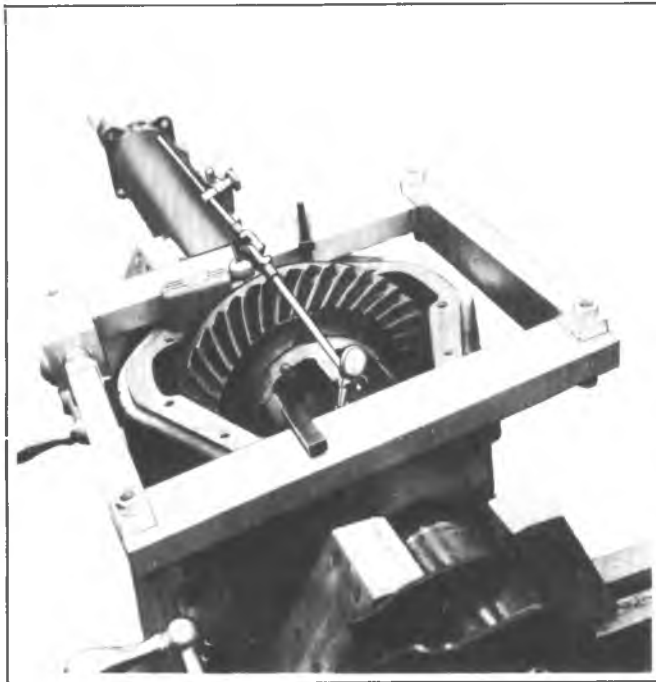

Fig. 15F--Tool J-24385 Mounted on Carrier

8. Remove dial indicator and with the use of a pry bar remove differential case from carrier. Remove spreader.

**Disassembly**

1. Remove differential bearing cups and identify with a tag for reassembly.
2. Place differential in vise and drive out pinion shaft lock pin.
3. Remove differential bearing cone and roller using Puller J-22888, with Plug J-8107-3, as in figure 16F. Tag cone and rollers for assembly.

If ring gear and pinion are to be reassembled, note position of shims and replace accordingly.

4. Remove spacer, pinion shaft, pinions, side gears and thrust washers from differential case.
5. Remove screws attaching ring gear to differential case. Remove gear.

**DRIVE PINION**

**Removal**

1. Separate rear universal joint, tape trunnion bearings to joint, position propeller shaft to one side and tie propeller shaft to frame side rail.
2. Using Holding Bar J-8614-11, attached to pinion shaft flange, remove self-locking nut and washer from pinion shaft.
3. Install Tool J-8614-2, and 3 into holding bar as shown in figure 17F and remove flange from drive pinion. Remove drive pinion from carrier.
4. With a long drift, tap on inner race of outer pinion bearing to remove pinion oil seal, slinger, gasket, outer pinion cone and roller and shim pack. Tag shim pack for reassembly.
5. Should inspection indicate necessity, pinion bearing cups can be removed from carrier using long drift and hammer. Remove shims and oil slinger which are located behind the inner bearing cup. Tag shims for reassembly.

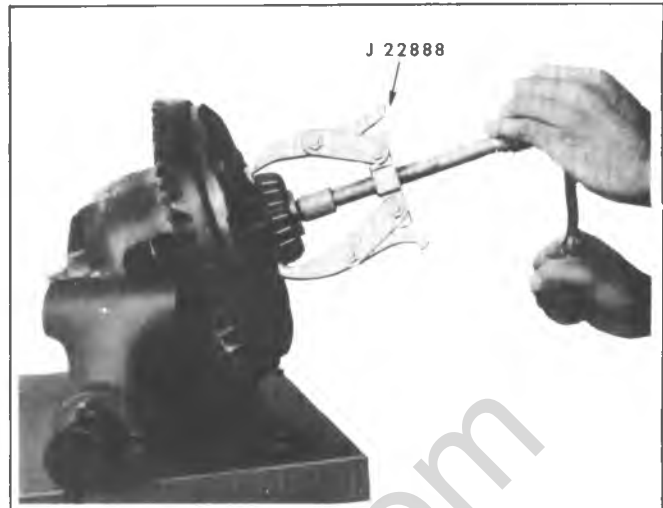

Fig. 16F--Removing Differential Side Bearings

6. Remove inner pinion cone and roller using Tool J-22912, installed as shown in Figure 18F, and press pinion from bearing.

**Inspection**

1. Clean all gears and bearings in cleaning solvent and inspect all bearing cups, races and rollers for scoring, chipping or evidence of excessive wear. On pinion bearing rollers, inspect large end of rollers for wear. This is where wear is most evident on tapered roller bearings.

The pinion bearings are of the tapered type, and the natural wear pattern is a frosted condition with occasional slight scratches on races or rollers. This does not indicate a defective bearing.

2. Inspect pinion splines and flange splines for evidence of excessive wear.
3. Inspect ring gear and pinion teeth for possible scoring, cracking or chipping.
4. Inspect differential case for cracks or scores. Inspect side gears, thrust washers, and pinion thrust faces.

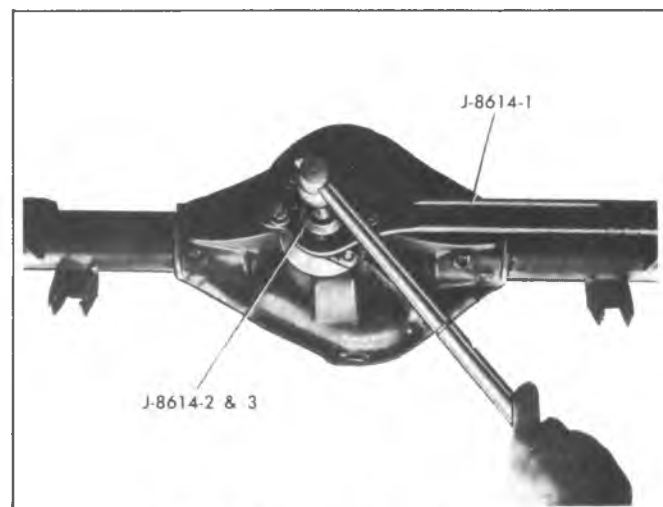

Fig. 17F--Removing Pinion Flange

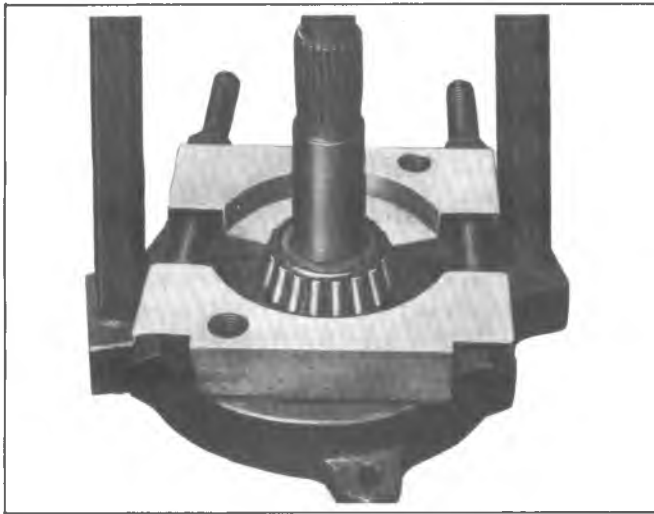

Fig. 18F--Removing Inner Pinion Bearing Cone and Roller

5. Check fit of differential side gears in case.
6. Check fit of side gears and axle shaft splines.
7. Inspect differential pinion shaft and spacer for scoring or evidence of excessive wear.

**DIFFERENTIAL CASE**

**Reassembly**

1. Position differential side gears and new thrust washers in differential case.
2. Position differential pinions and new thrust washers in differential case. Align pinions with holes in differential case.
3. Install pinion shaft in differential case. Align hole in shaft with hole in case, then install lock pin. Peen hole to prevent pin dropping out of case.
4. Position ring gear to case, then install cap screws. Tighten cap screws evenly and alternately to specifications.
5. With an arbor press, press differential side bearings onto case using Tool J-21051. Do not install shims at this time.

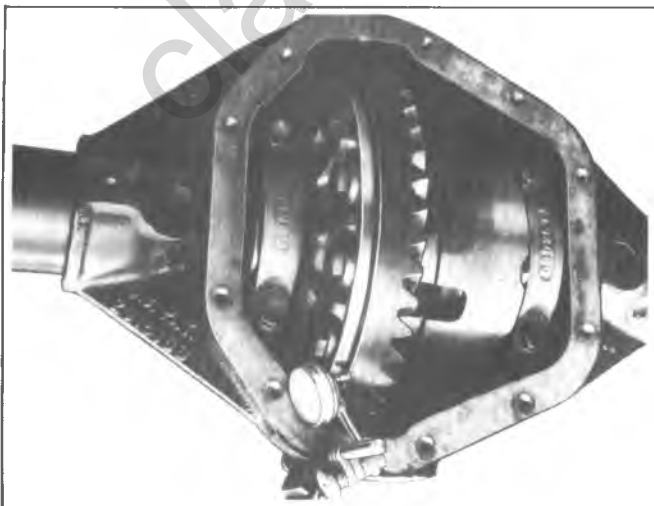

Fig. 19F--Checking Runout

6. Place differential case in carrier and install bearing caps. Care should be taken to install caps in original position. Use mark placed on caps and carrier at removal. Tighten caps just enough to keep bearing caps in place.

7. Install dial indicator on carrier with indicator button contacting back of ring gear, as in figure 19F. Rotate differential case and check for runout. If runout is greater than .002", the assembly should be removed and the ring gear removed from the case. Again install differential case and check runout at differential case flange.

8. Should runout of case flange be greater than .002" the defect is probably due to , bearings or differential case, and should be corrected before proceeding further.

9. Position two screwdrivers between bearing cup and carrier on opposite side of ring gear (away from dial indicator side). Pull on screwdrivers and force differential case as far as possible toward the dial indicator. Rock the ring gear to set the bearings. With force still applied, set indicator at "O".

10. Reposition screwdrivers between bearing cup and carrier on ring gear side. Pull on screwdrivers and force differential case as far as possible toward center of carrier. Record the indicator reading. This will be the total amount of shims needed (less preload) for setting backlash later during assembly.

11. Remove differential from carrier.

**DRIVE PINION**

**Installation and Adjustment of Depth and Preload**

Ring gears and pinions are supplied in matched sets only. Matching numbers on both pinion and ring gear are etched for verification. If a new gear set is being used, verify the numbers of each pinion and ring gear before proceeding with assembly.

On the button end of each pinion there is etched a plus (+) number, a minus (-) number, or a zero (0) number, which indicates the best running position for each particular gear set. This dimension is controlled by the shimming behind the inner bearing cup. Whenever baffles or oil slingers are used, they become a part of the adjusting shim pack.

For example: If a pinion is etched +3, this pinion would require .003" less shims than a pinion etched "0". This means by removing shims, the mounting distance of the pinion is increased by .003" which is just what a + etching indicates. 3 Or if a pinion is etched -3, we would want to add .003" more shims than would be required if the pinions were etched "0". By adding .003" shims, the mounting distance of the pinion was decreased .003" which is just what a -3 etching indicated. See figure 20F.

If the old ring and pinion set is to be reused, measure the old shim pack and build a new shim pack to this same dimension. If baffle is in the axle assembly, it is considered as part of the shim pack.

To change the pinion adjustment, shims are available in thicknesses of .003", .005" and .010".

If baffle or slinger is bent or mutilated, it should be replaced.

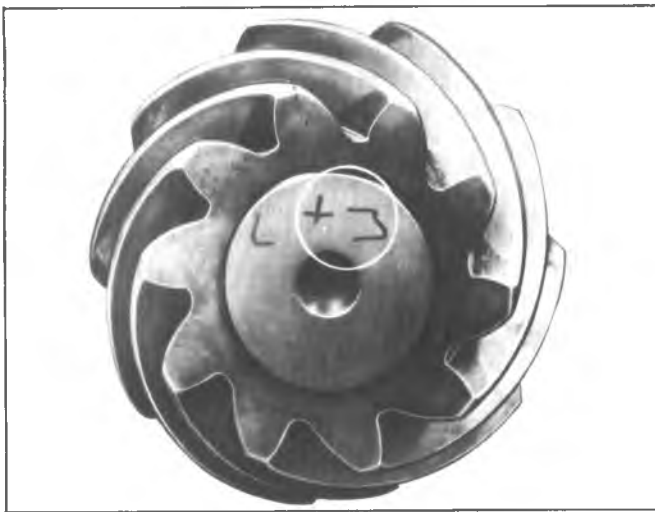

Fig. 20F—Marking From Nominal on Pinion

Measure each shim separately with a micrometer and add together to get total shim pack thickness from original build up.

If a new gear set is being used, notice the plus or minus etching on both the old and new pinion, and adjust the thickness of the old shim pack to compensate for the difference of these two figures.

For example: If the old pinion reads (+2) and the new pinion is (-2), add .004" shims to the original shim pack.

1. Determine proper inner shim pack (for setting pinion depth) by using chart in figure 21F.

2. Install inner shim pack and oil slinger in inner cup bore and drive inner cup into position using Tool J-21059 used with J-8092.

3. To the outer shim pack (for setting preload) add or remove an equal amount as was added or removed from the inner shim pack.

4. Install outer cup in carrier bore, using installer J-7818 with Drive Handle J-8092 as shown in figure 22F.

5. Press inner pinion bearing cone and roller onto pinion shaft using Installer J-9772 on arbor press as shown in figure 23F.

6. Install drive pinion and inner bearing cone and roller assembly in differential carrier.

7. Install shims and outer pinion cone and roller on pinion shaft using Tool J-5590 and companion flange to press bearing onto pinion, as in figure 24F.

8. Install flange holding bar and install washer and nut on pinion shaft. Torque nut to 255 ft. lbs.

9. Remove holding bar and with an inch pound torque wrench measure rotating torque. Rotating torque should be 10 to 20 in. lbs. with original bearings or 20 to 40 in. lb. with new bearings.

Torque reading to start shaft turning must be disregarded.

10. If torque requirements (preload) are not to specifications, adjust shim pack as necessary. Increase the outer shim pack to reduce rotation torque. Decrease shim pack to increase rotating torque.

11. Remove nut, washer and flange from pinion shaft.

12. Install oil slinger, gasket and using Tool J-22804 install oil seal.

13. Install flange, washer and nut. Torque nut to specifications.

## DIFFERENTIAL CASE

### Preload and Adjustment

1. Place differential assembly (with pinion assembled) into housing. Install bearing caps in their proper position and tighten screws just enough to hold the bearing cups in place.

2. Install dial indicator on carrier with indicator button contacting back of ring gear, as in figure 19F.

3. Place two screwdrivers between bearing cup and housing on ring gear side of case, and pry ring gear into mesh with pinion gear as far as it will go. Rock ring gear to allow bearings to seat and gears to mesh. With force still applied, set indicator to "0".

4. Reposition screw drivers on opposite side of ring gear and pry ring gear as far as it will go. Now take an indicator reading. Repeat until the same reading is obtained every time. This reading will be the necessary amount of shims between the differential case and differential bearing on the ring side gear. Remove differential bearing from the ring side and assemble proper amount of shims. Reassemble bearing.

5. Remove the differential bearing from the opposite side of ring gear. To determine the amount of shims needed here, use the following method.

a. Subtract the size of shim pack just installed on ring gear side of case from the reading obtained and recorded in step 10 of Differential Case-Reassembly.

b. To this figure, add an additional .015" shims to compensate for preload and backlash.

Example: If reading in step 10 of Differential Case-Reassembly was .085", and the shims installed on ring gear side of case was .055", the correct amount of shim will be  $.085" - .055" + .015" = .045"$ .

6. Install shims as indicated in step 5, (which will give the proper bearing preload and backlash) and install side bearing.

### Installation

1. Spread differential carrier, using spreader as shown in figure 15F.

2. Install differential bearing outer races in their correct location, then install differential case into carrier.

3. Install differential bearing caps in the correct location as indicated by marks made at disassembly. Install cap screws finger tight. Rotate differential assembly and rap on case with a soft faced hammer to ensure proper seating of case in carrier.

4. Remove spreader and torque cap bolts to specifications.

5. Install dial indicator and check ring gear backlash at four equally spaced points around the ring gear. Backlash must be held to .004" to .009" and must not vary more than .002" between positions checked.

6. Whenever backlash is not within limits, differential bearing shim pack should be corrected to bring backlash within limits.

Old Pinion Marking	New Pinion Marking								
	- 4	- 3	- 2	- 1	0	+ 1	+ 2	+ 3	+ 4
+ 4	+ 0.008	+ 0.007	+ 0.006	+ 0.005	+ 0.004	+ 0.003	+ 0.002	+ 0.001	0
+ 3	+ 0.007	+ 0.006	+ 0.005	+ 0.004	+ 0.003	+ 0.002	+ 0.001	0	- 0.001
+ 2	+ 0.006	+ 0.005	+ 0.004	+ 0.003	+ 0.002	+ 0.001	0	- 0.001	- 0.002
+ 1	+ 0.005	+ 0.004	+ 0.003	+ 0.002	+ 0.001	0	- 0.001	- 0.002	- 0.003
0	+ 0.004	+ 0.003	+ 0.002	+ 0.001	0	- 0.001	- 0.002	- 0.003	- 0.004
- 1	+ 0.003	+ 0.002	+ 0.001	0	- 0.001	- 0.002	- 0.003	- 0.004	- 0.005
- 2	+ 0.002	+ 0.001	0	- 0.001	- 0.002	- 0.003	- 0.004	- 0.005	- 0.006
- 3	+ 0.001	0	- 0.001	- 0.002	- 0.003	- 0.004	- 0.005	- 0.006	- 0.007
- 4	0	- 0.001	- 0.002	- 0.003	- 0.004	- 0.005	- 0.006	- 0.007	- 0.008

Fig. 21F--Dana Pinion Code Chart

7. Check gear tooth contact, as described earlier in "Dana 10-1/2" Ring Gear" section, under "Gear Tooth Contact Pattern Check". Refer to figure 25F.

8. Using a new gasket, install housing cover and torque bolts to specifications.

9. Reinstall the rear universal joint, and torque "U" bolt nuts to specifications.

10. Install axles into carrier and axle flange over hub studs. Torque hub stud nuts to specifications.

11. Fill differential with lubricant.

12. Install wheel and tire assembly.

**CAUTION: See Caution on page 1 of this section regarding the fasteners referred to in the above steps.**

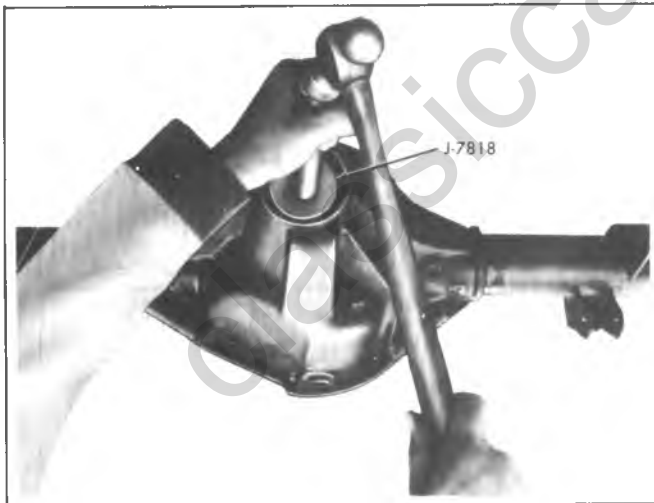

Fig. 22F--Installing Outer Pinion Bearing Cup

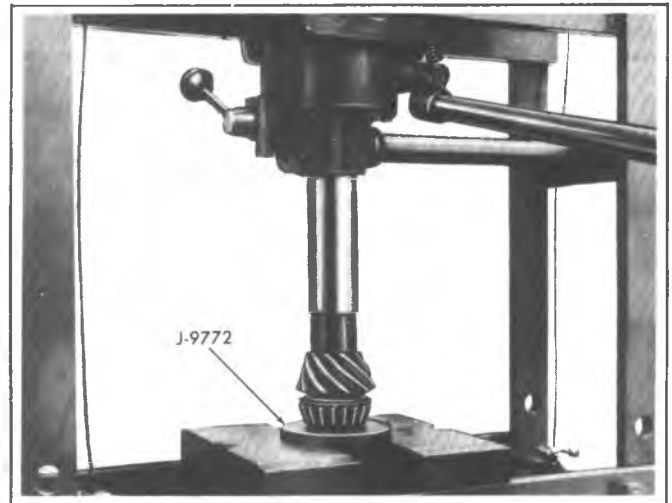

Fig. 23F--Installing Inner Pinion Cone and Roller

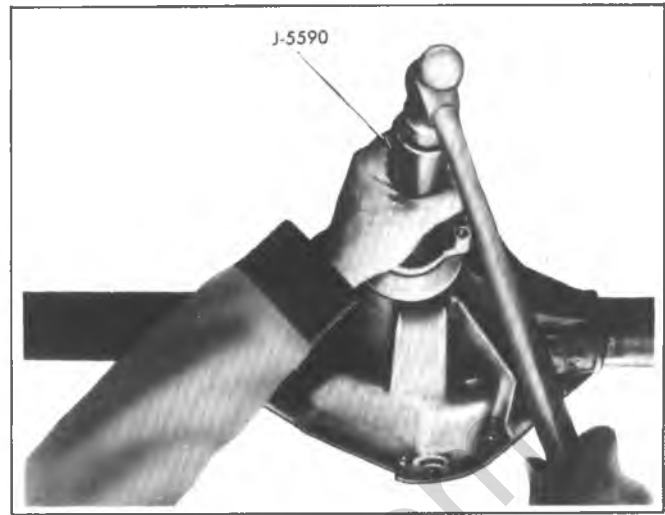

Fig. 24F--Installing Pinion Flange

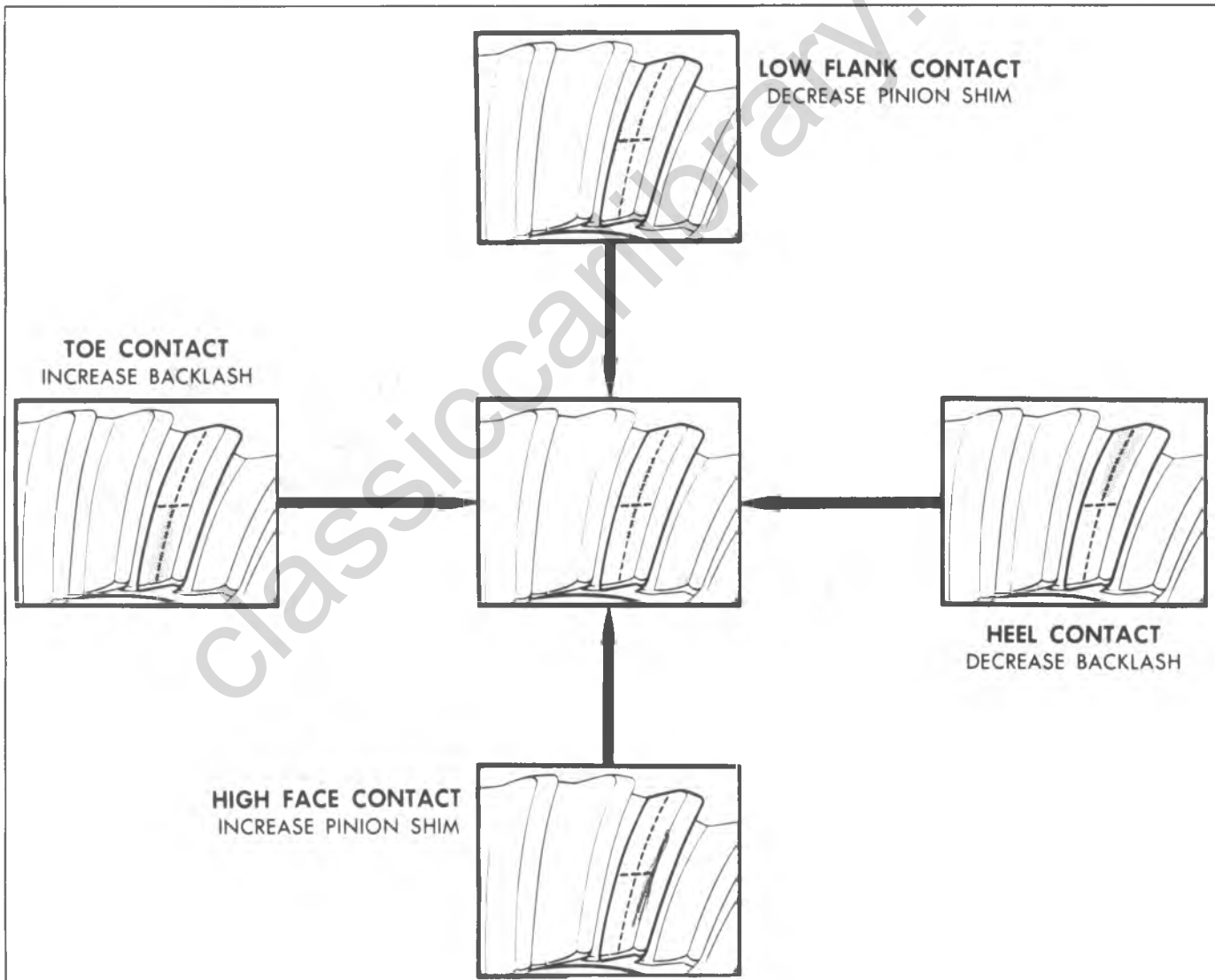

Fig. 25F--Gear Teeth Contact Pattern Check

# TRUCK DIFFERENTIAL 12-1/4" RING GEAR

## INDEX

Case and Drive Pinion.....	4B-34	Ring Gear Replacement .....	4B-36
Removal.....	4B-34	Differential Bearing Replacement .....	4B-36
Disassembly .....	4B-34	Differential Reassembly .....	4B-36
Repairs.....	4B-35	Reassembly .....	4B-37
Pinion Disassembly .....	4B-35	Ring Gear and Pinion Adjustmnet.....	4B-37
Pinion Inspection .....	4B-35	Backlash and Preload Adjustment .....	4B-37
Pinion Reassembly .....	4B-35	Ring Gear Thrust Pad Adjustment .....	4B-37
Differential Disassembly .....	4B-36	Installation.....	4B-37
Differential Inspection .....	4B-36		

classiccarlibrary.com

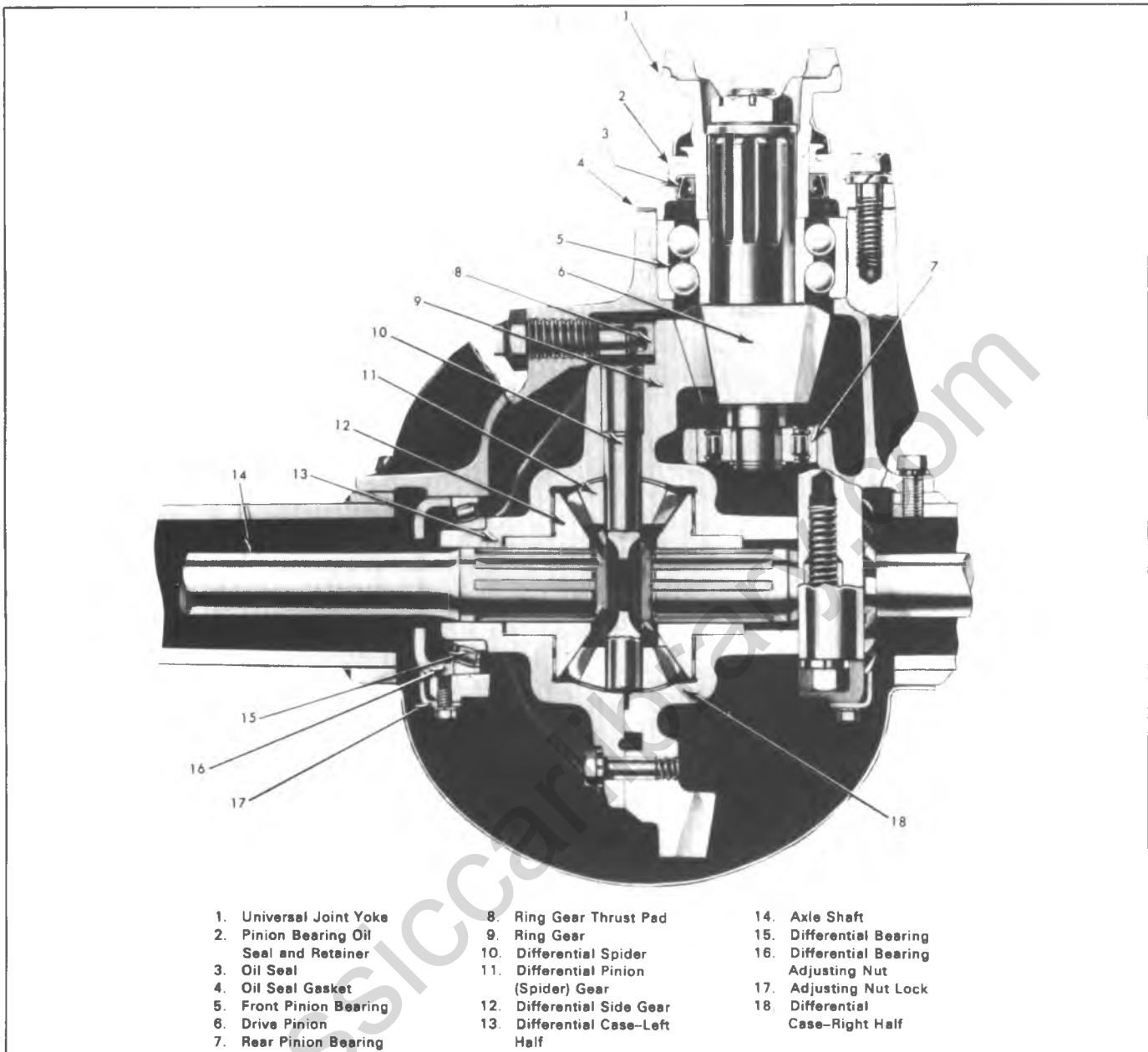

Cross Section of Truck Differential With 12-1/4" Ring Gear

## CASE AND DRIVE PINION

### Removal

1. Drain lubricant from differential, remove axle shaft as outlined in Truck Service Manual. See "Axle Shaft Removal".

2. Remove two trunnion bearing "U" bolts from the rear yoke and split the rear universal joint. The bearings can be left on the trunnion and held in place with tape.

3. Swing propeller shaft to one side and tie to the frame side rail.

4. Remove bolts and lock washers which retain the carrier assembly to the axle housing. Support the differential housing with a floor jack and roll it from under truck.

### Disassembly

1. Mount carrier assembly in a bench vise or holding fixture.

2. Loosen ring gear thrust pad locknut and remove thrust pad.

3. Remove differential adjusting nut locks and bearing cap bolts and lock washers.

4. Mark bearing caps and carrier for reassembly in same position. Remove bearing caps and adjusting nuts by tapping on bosses of caps with a soft faced hammer until caps are free from dowels.

**NOTICE:** Do not attempt to pry cap off as this may damage machined face of cap.



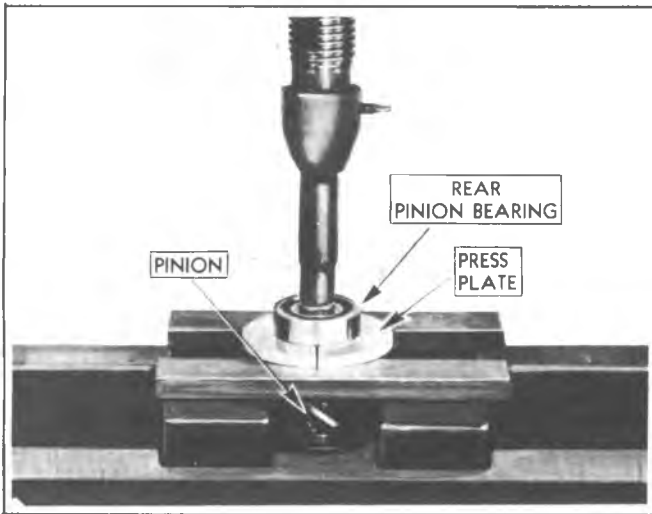

Fig. 2G—Pinion Rear Bearing Removal

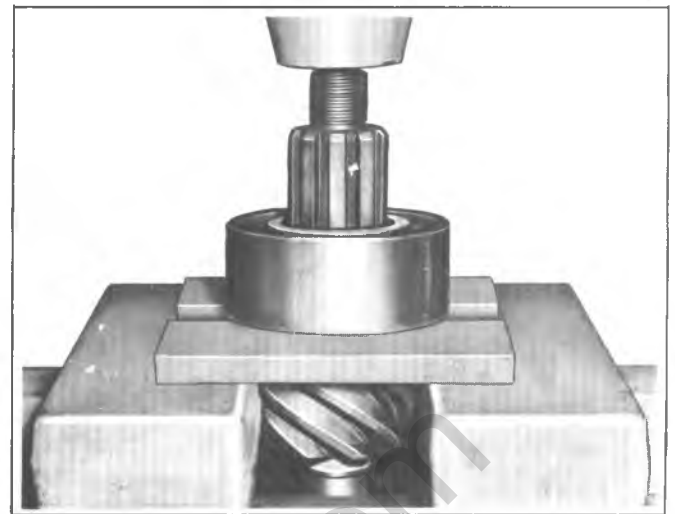

Fig. 3G—Drive Pinion Front Bearing Removal

5. Remove differential and ring gear assembly from the carrier. Exercise care that differential bearing outer races are not dropped while removing assembly from carrier.
6. Remove the bolts which attach the pinion bearing retainer to the carrier.
7. Remove the pinion and bearing assembly from the carrier. It may be necessary to drive this unit from carrier. Use brass drift against pilot end of pinion.

## Repairs

### Pinion Disassembly

1. Clamp pinion drive flange in bench vise.
2. Remove cotter pin, nut and washer from end of pinion.
3. Remove drive flange and bearing retainer assembly from pinion.
4. Drive oil seal from retainer. Discard seal as new parts should be used at assembly.
5. Remove pinion rear bearing snap ring and press bearing from pinion, using Tool J-1453, as shown in figure 2G.

6. Position drive pinion in an arbor press so that the bearing is supported by two pieces of flat steel stock as shown in figure 3G. Place flat stock parallel to each other and against pinion so as to pick up a large area of bearing outer race. Press pinion from bearing making sure pinion is supported to prevent damage when removed from bearing.

### Pinion Inspection

1. Wash all parts in cleaning solvent.
2. Inspect pinion for scored, cracked, chipped or worn teeth.
3. Inspect splines on pinion shaft for excessive wear.
4. Inspect pinion bearing assemblies for roughness, defects or excessive wear.

### Pinion Reassembly

1. Pack the cavity between the pinion oil seal lips with a lithium-base EP lubricant to provide initial lubrication and to aid in inserting pinion flange.

2. Press the oil seal into the retainer. Position seal lips toward the pinion bearing, using Tool J-22281 as shown in figure 4G.

3. Install the pinion rear bearing assembly on pinion shaft making sure that chamfered side of inner race seats against shoulder on pinion shaft. Then install pinion bearing lock ring using Tool J-1364 as shown in figure 5G.

4. To install pinion front bearing, position the one-piece double row ball bearing on pinion shaft, so that extended portion of inner race is toward pinion head. Then, using a suitable length of 2 inch pipe, press bearing onto shaft until it seats against the pinion head.

When pressing bearing on pinion, exercise care to prevent damage to ground surface of pilot.

5. Slide oil seal retainer on pinion shaft, then tap drive flange onto pinion splines.

6. Clamp drive flange in a bench vise and install flange washer and nut. Torque to specifications and install cotter pin without backing off on nut.



Fig. 4G—Pinion Oil Seal Installation

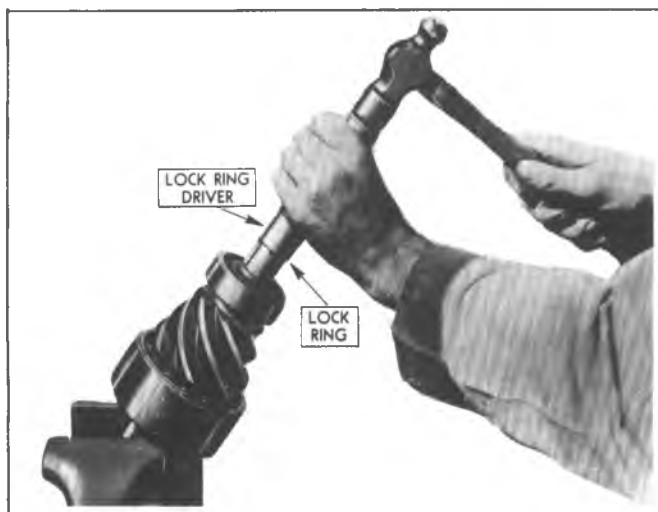

Fig. 5G-Pinion Rear Bearing Lock Ring Installation

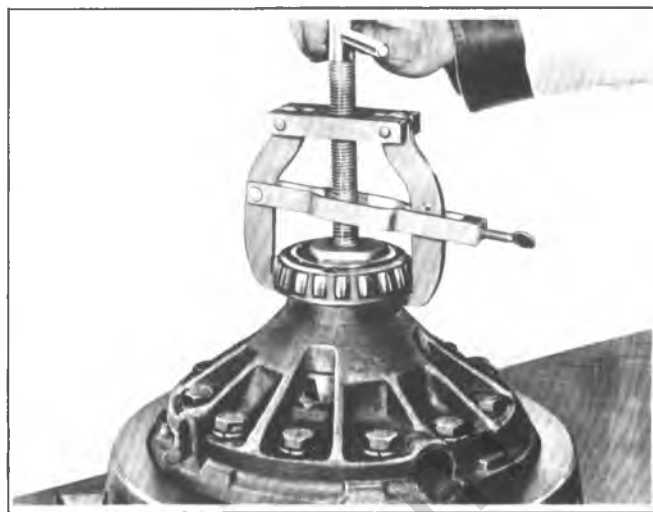

Fig. 7G-Differential Bearing Removal

### Differential Disassembly

1. Check differential case to make sure that the two halves are marked so they may be reassembled in same relation. See figure 6G.
2. Remove bolts holding case and cover together. Ring gear is mounted on the case.
3. Separate cover from case and remove differential side gears and thrust washers, pinion gears with thrust washers and differential spider.

### Differential Inspection

1. Wash all parts thoroughly in cleaning solvent.
2. Inspect ring gear for chipped, scored or worn teeth.
3. Check radial clearance between differential side gears and differential case, also fit of differential pinions on spider.
4. Inspect spider arms for wear and distortion.
5. Inspect splines and teeth of differential side gears and pinions for chipping or excessive wear.
6. Check thrust washers for wear and replace if even slight wear is indicated.

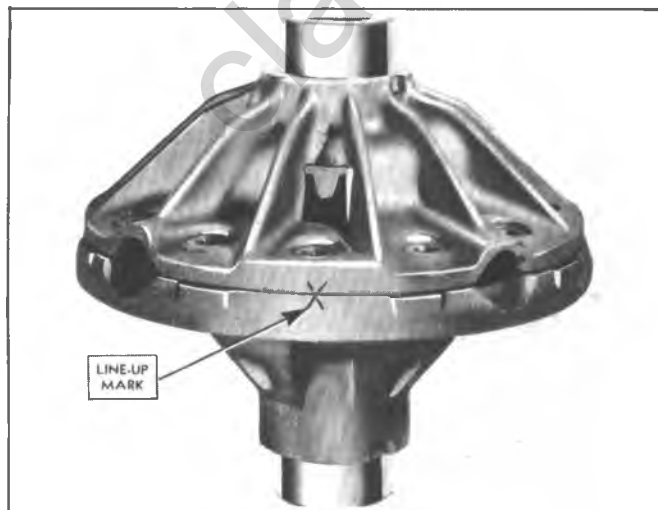

Fig. 6G-Differential Case Line-Up Marks

7. Check differential side bearings and cups for broken races, discoloration or roughness.
8. Inspect differential case for cracks or distortion.

### Ring Gear Replacement

1. Remove ring gear from case by tapping the back of the gear with a soft faced hammer.
2. Inspect ring gear pilot case flange and back of ring gear for dirt or burrs.
3. Install two guide pins (made from cap screws with heads cut off and ends slotted) to new gear diametrically opposite each other.
4. Start guide pins through case flange and tap ring gear on case.

### Differential Bearing Replacement

1. Install Tool J-8107 making sure puller legs are fitted securely in notches in case and tighten retaining yoke as shown in figure 7G.
2. Tighten puller screw to remove bearing.
3. Place new bearing on hub with thick side of inner race toward case and install bearing using J-1488 as shown in figure 8G.

The side bearing tool is counterbored and has pilot to assure proper installation and seating of bearing.

### Differential Reassembly

1. Lubricate differential side gears, pinions and thrust washers.
2. Place differential pinions and thrust washers on spider.
3. Assemble side gears and pinions and thrust washers to left half of differential case.
4. Assemble right half of case to left half being sure to line up marks on the two halves.
5. Install differential to-ring bolts and lock washers and tighten evenly - until ring gear is flush with case flange.
6. Remove two guide pins and install remaining two bolts. Torque all bolts alternately and evenly to specifications.



Fig. 8G--Differential Bearing Installation

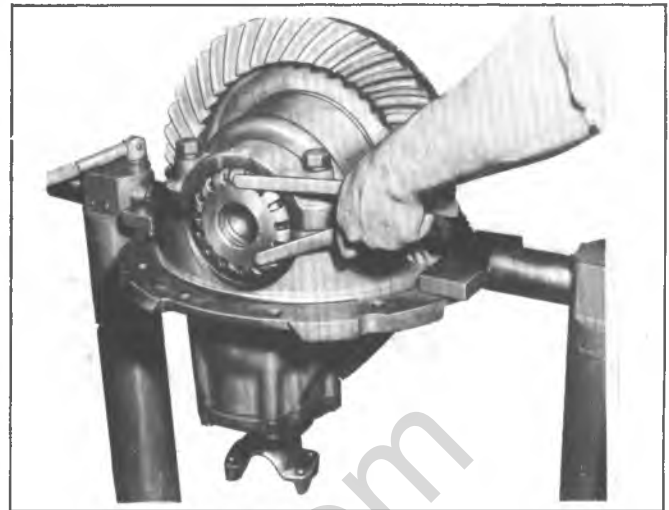

Fig. 9G--Backlash and Preload Adjustment

### Reassembly

1. Place new pinion bearing retainer gasket on the retainer and install pinion assembly in carrier.

**NOTICE:** The pinion assembly should be pressed into the carrier to prevent the possibility of damaging the shims.

2. Install pinion bearing retainer bolts and lock washers and torque bolts to specifications.
3. Lubricate differential bearing rollers with engine oil and place outer races over them.
4. Install differential assembly in carrier and install adjusting nuts. Carefully slide adjusting nuts alongside the bearings so that threads on nuts fit into threads in carrier.
5. Install differential bearing caps making sure the marks on the caps line up with the marks on the carrier.
6. Install bearing cap bolts and lock washers and tighten until lock washers just flatten out.

### Backlash and Preload Adjustment

1. With differential bearing cap bolts loosened just enough to permit turning the bearing adjustment nuts with Tool J-0972, remove all lash between ring gear and pinion. See figure 9G.
  2. Back off left hand adjusting nut one to two notches to a locking position.
  3. Tighten right hand adjusting nut firmly to force differential in solid contact with left hand adjusting nut.
  4. Back off right hand adjusting nut until free of bearing; then retighten snugly against bearing.
  5. Tighten right hand nut from one to two additional notches to a locking position.
- This method of adjustment provides for proper preload of bearings.
6. Mount a dial indicator on the carrier and check the backlash between ring gear and pinion as shown in figure 10G. Backlash should be from .003" to .012" (.005" to .008" preferred).

If backlash is more than .012 inch, loosen the right hand adjusting nut one notch and tighten left hand adjusting nut one notch. If backlash is less than .003 inch, loosen the

left hand adjusting nut one notch and tighten right hand nut one notch.

7. Tighten bearing cap bolts to specifications.
8. Install side bearing adjusting nut locks and torque to specifications.

### Ring Gear Thrust Pad Adjustment

1. Inspect bronze tip of thrust pad and if worn install a new one.
2. Install thrust pad and tighten screw until bronze tip engages back face of ring gear while rotating gear.
3. Back off screw one-twelfth (1/12) turn and tighten locknut to specifications. See figure 11G.

Make sure screw does not turn during locking process. This adjustment provides .005 in. to .007 in. clearance between thrust pad and ring gear face.

### Installation

1. Clean out axle housing and cover and place new gasket over axle housing.
2. Assemble differential carrier to axle housing, install lockwashers and bolts and tighten securely.

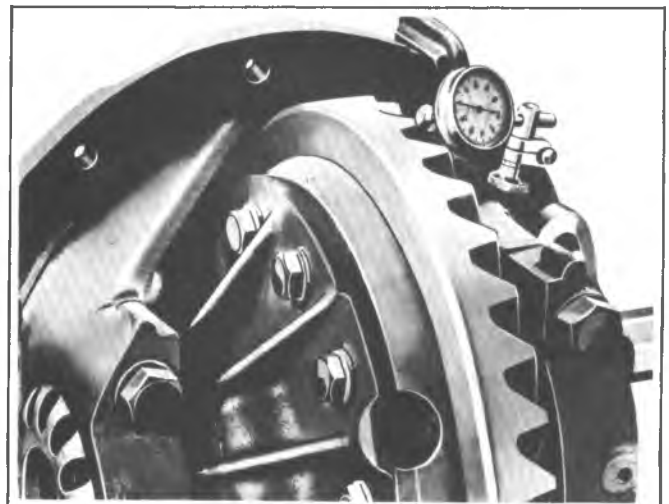

Fig. 10G--Checking Backlash

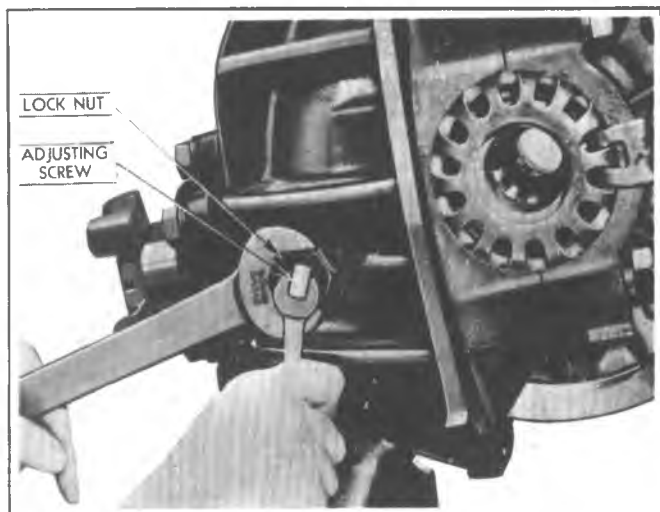

Fig. 11G-Ring Gear Thrust Pad Adjustment

3. Replace axle housing inspection cover, if removed, using new gasket.

4. Assemble rear universal joint.

**NOTICE:** This propeller shaft to pinion flange fastener is an important attaching part in that it could affect the performance of vital components and systems, and/or could result in major repair expense. It must be replaced with one of the same part number or with an equivalent part if replacement becomes necessary. Do not use a replacement part of lesser quality or substitute design. Torque values must be used as specified during reassembly to assure proper retention of this part.

5. Install axle shafts as outlined in applicable axle installation procedure in Service Manual.

6. Fill axle with lubricant to a level even with bottom of filler hole. See Section 0 in the Truck Service Manual for proper lubricant.

## LIMITED SLIP DIFFERENTIAL UNITS

### INDEX

Eaton Limited Slip.....	4B-39	Power-Lok Differential.....	4B-46
Disassembly.....	4B-39	Disassembly.....	4B-46
Inspection.....	4B-40	Inspection.....	4B-46
Reassembly.....	4B-40	Assembly.....	4B-47
Chevrolet Limited Slip.....	4B-42	Testing Procedure.....	4B-47
Disassembly.....	4B-42	Eaton Positive Locking Differentials	
Inspection.....	4B-42	1/2 Ton and 3/4 Ton Units.....	4B-48
Reassembly.....	4B-42	Description.....	4B-48
Borg Warner (Cone Type).....	4B-44	Disassembly.....	4B-51
Description.....	4B-44	Inspection.....	4B-51
Disassembly.....	4B-44	Cam/Clutch Service.....	4B-51
Inspection.....	4B-45	Reassembly.....	4B-52
Assembly.....	4B-45		

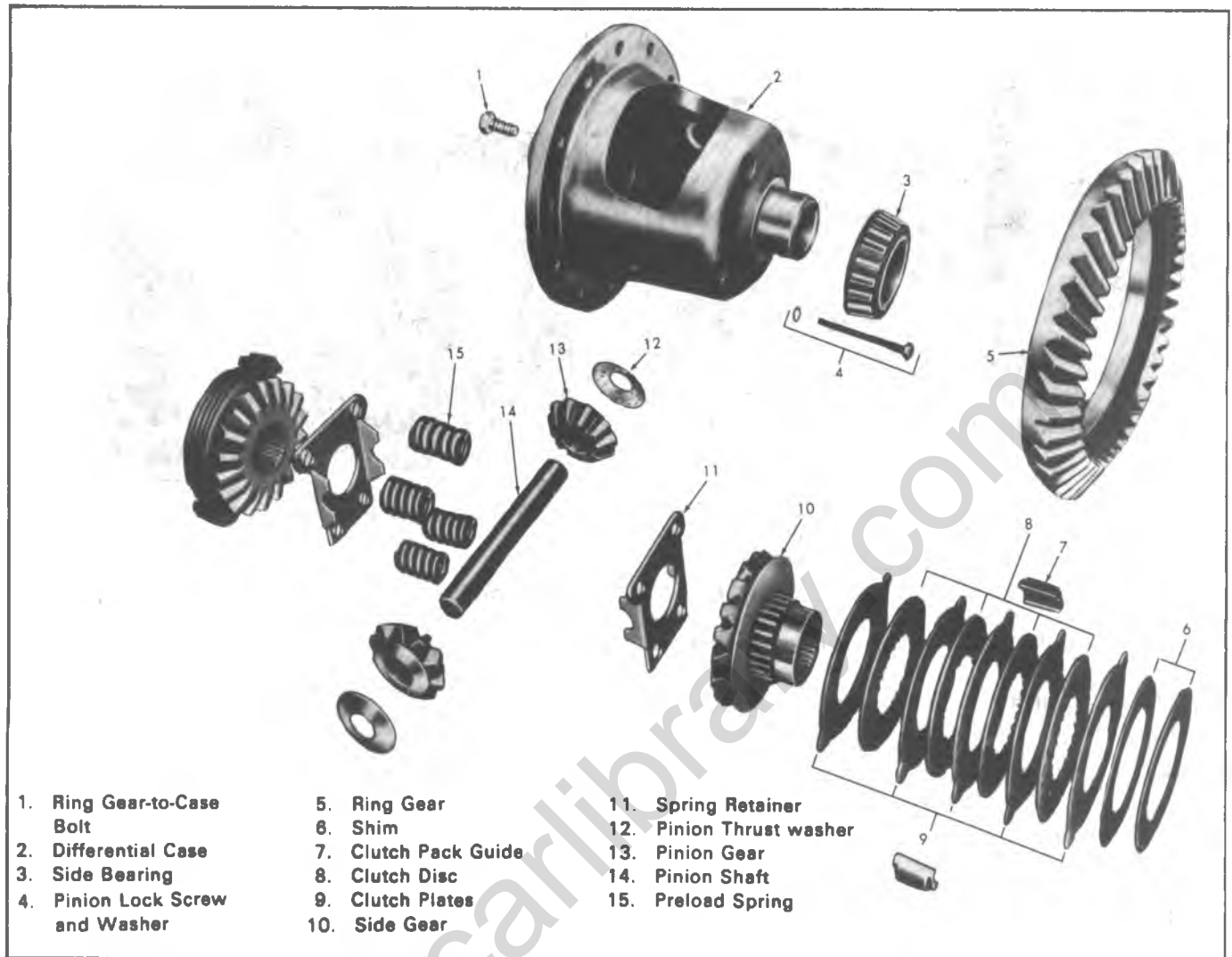

Fig. 1D-Eaton Limited Slip Exploded View

## EATON LIMITED SLIP - FIGURE 1D

### Disassembly

1. Remove ring gear and side bearings following the procedures established for the conventional differential unit.

2. Remove the preload spring retainer and springs by tapping on the spring retainer through the observation hole in the case. See figure 2D. Drive the spring retainer from the case sufficiently to allow insertion of a 1/4 inch bolt in each of the two front springs. Secure each bolt with a nut as in figure 3D.

4. After installing the retaining bolts, continue to drive spring retainer from the case until enough of the retainer is exposed to permit installation of bar stock and "C" clamp

as shown in figure 5D. Center the bar stock over the axle shaft hole in the spring retainer, then compress "C" clamp sufficiently to permit withdrawal of spring pack.

5. Position spring pack in vise and remove 1/4 inch bolts. Alternately relieve "C" clamp pressure and vise pressure until spring compression is relieved. See figure 6D.

6. For Truck Models, roll out the differential pinions and thrust washers.

For Passenger models, pinion gears can be removed by rotating them in one direction only. Using figure 7D as a reference, rotate differential case clockwise to remove the first gear, then rotate case counter-clockwise to remove the second gear. To remove second gear, it may

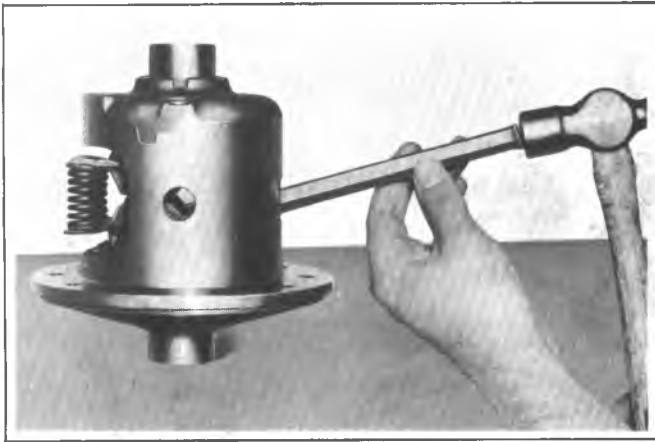

Fig. 2D-Removing Preload Spring Pack (Typical)

be necessary to assist pinion gear upon its seat by prying on gear through observation holes on case. Mark pinions and side gears for reassembly in original position.

7. Remove side gear, clutch pack, shims and guides from case. Tap the assembly from the case, using a brass drift as shown in figure 8D. Repeat removal on opposite gear.

8. Separate clutch pack assembly from side gear. Retain clutch pack assembly with original side gear.

**Inspection**

1. Check clutch plates and discs for excessive wear and signs of overheating.

Clutch plates and discs are not serviced separately. If replacement is required, clutch pack must be replaced as an assembly.

2. Inspect preload springs for distortion and other defects.

3. Compress springs and determine if they are capable of properly preloading the clutch pack, replace springs that are weak or questionable.

4. Examine spring retainer for alignment between the retainer halves and for excessive wear at spring seats.

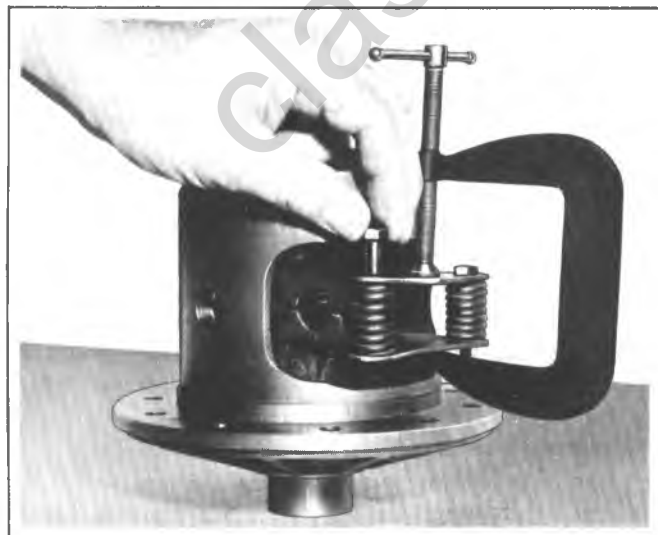

Fig. 3D-Installing Bolts to Retain Springs

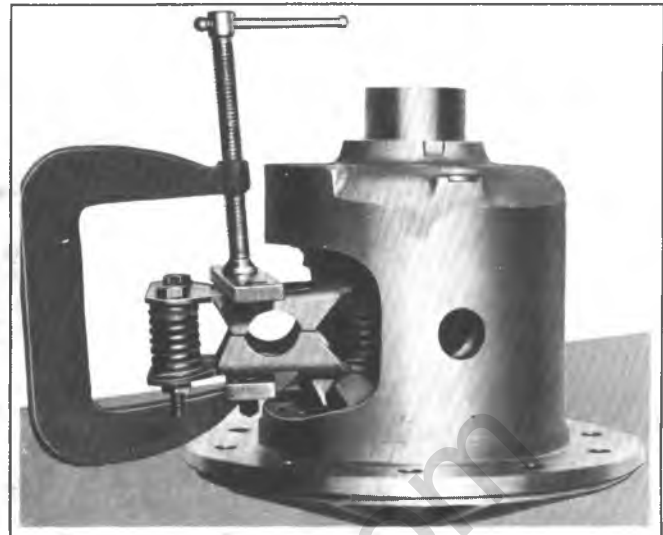

Fig. 5D-C-Clamp and Bar Stock Installed for Spring Removal

**Reassembly**

1. Lubricate clutch plates and discs with special limited slip lubricant.

2. Alternately position clutch plate and clutch disc on side gear, beginning and ending with clutch plate, until assembly of clutch pack is complete. See figure 9D.

3. Install clutch pack guides on the clutch plate lugs. Make sure that the clutch disc lugs engage with side gear teeth.

4. Select shims of equal thickness as those removed from the case, or if old shims are suitable, reinstall them over the side gear hub.

5. Lubricate and assemble opposite side gear as above.

6. Install one side gear, clutch pack assembly and shim(s) in the differential case.

7. Position pinion gears and thrust washers on side gears. Install pinion shaft through case and gears.

8. Install dial indicator in case so that contact button rests against pinion gear as shown in figure 10D.

9. Compress clutch pack, using a screwdriver as shown in figure 11D. Move the pinion gear to obtain tooth

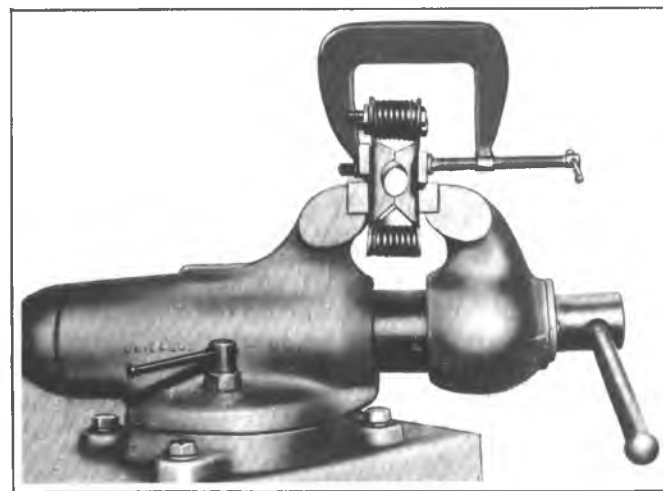

Fig. 6D-Removing Preload Springs from Pack

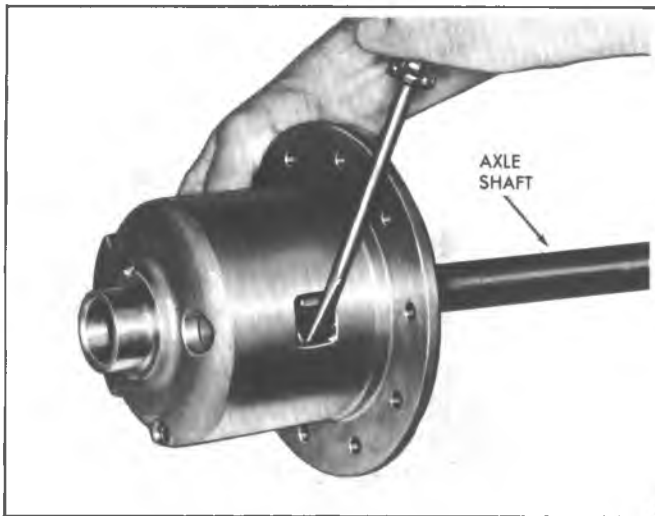

Fig. 7D--Removing Differential Pinion Gears

clearance.

10. Tooth clearance should be .001" to .008". If required, change shims to obtain proper tooth clearance.

11. Remove side gear assembly and repeat tooth clearance procedure for other side gear on opposite side of case.

12. Remove pinion shaft, gears and thrust washers.

13. Install remaining side gear, clutch pack assembly and shims in case.

14. Install pinion gears and thrust washers. Installation of pinion gears can be performed by reversing the pinion gear removal procedure.

15. **For all except Corvette**, assemble springs in spring retainer and clamp assembly in vise. Install "C" clamp and bar stock on spring retainer then install a 1/4 inch bolt and nut in each front spring. See figure 11D.

16. Position spring pack between side gears and remove bar stock and "C" clamp.

17. **On Corvette** install Tool J-22311 to compress clutch pack, secure pack with 1/4" bolts as shown in figure 12D. Partially install pack then remove bolts and complete pack installation. Remove tool.



Fig. 8D--Removing Side Gear

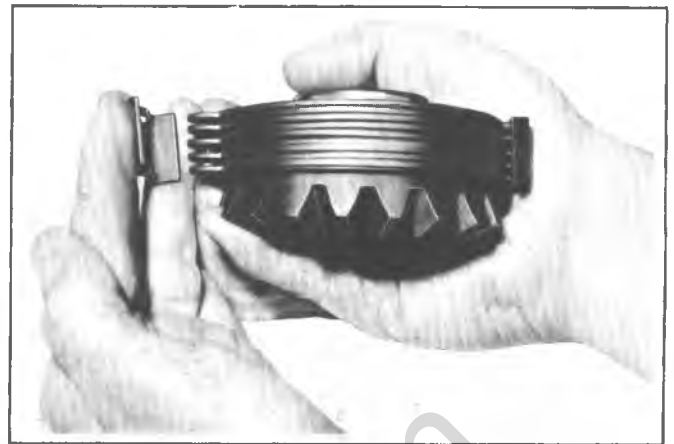

Fig. 9D--Assembling Clutch Pack

18. Drive spring pack into side gears sufficiently to retain front springs, then remove 1/4 inch bolts from springs. Drive spring pack into position. See figure 13D.

19. Install the pinion shaft and lock screw to retain side gears until axle shafts are installed.

20. Check alignment of spring retainer with side gears. Slight movement of the spring pack can be made if necessary.

21. Install side bearings and ring gear to case using procedure outlined for the conventional differential.

22. Place differential in carrier and adjust bearings and backlash as outlined for the conventional differential.

23. Check operation of unit as follows:

a. Raise rear of vehicle until rear wheels are off the ground, and remove one wheel and tire assembly.

b. Attach Adapter J-5748 to axle shaft flange and install a 1/2-13 bolt into adapter, shown in figure 14D.

c. With wheel and tire assembly still on vehicle held firmly to prevent turning, measure torque required to rotate opposite axle shaft with a 0-150 lb. torque wrench attached to J-5748. Torque required to rotate axle shaft should be no less than 40 ft. lbs.

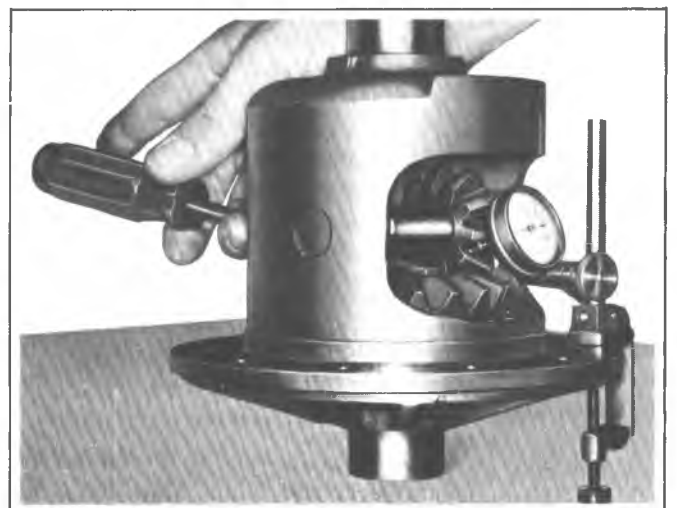

Fig. 10D--Measuring Pinion Gear Tooth Clearance

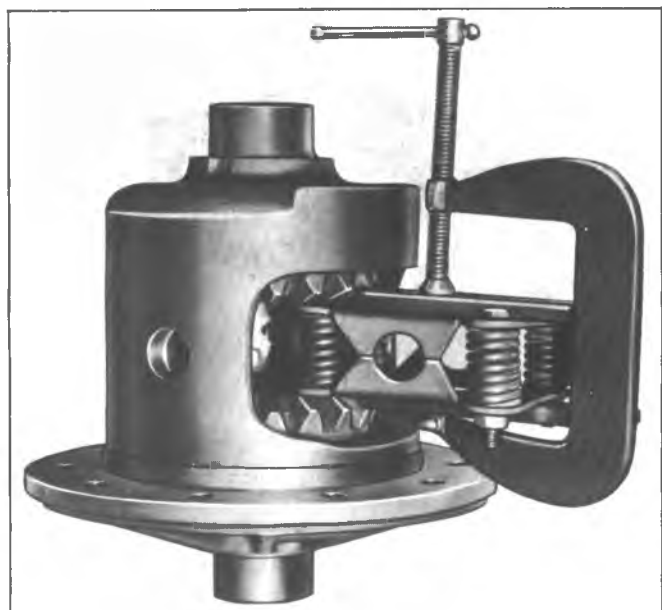

Fig. 11D--Spring Pack Compressed for Installation

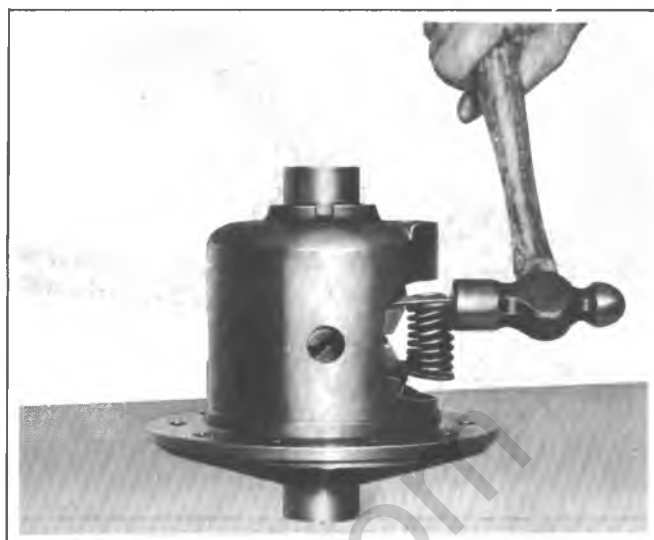

Fig. 13D--Installing Spring Pack



Fig. 12D--Installing Spring Pack Compression Tool (Corvette)

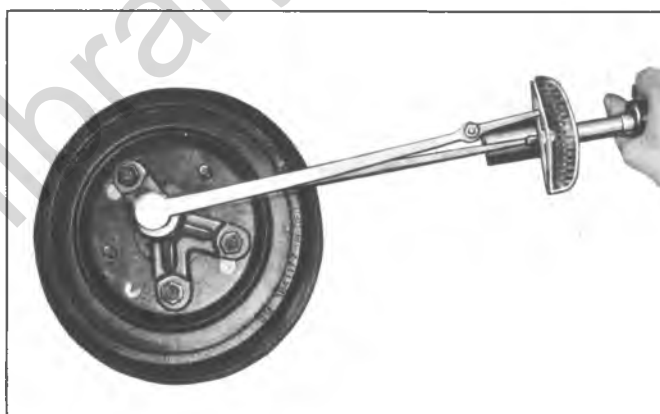

Fig. 14D--Measuring Positraction Rotating Torque

## CHEVROLET LIMITED SLIP - FIGURE 15D

### Disassembly

1. Remove ring gear and side bearings following the procedures established for the conventional differential unit. Remove pinion shaft.
2. Using a wide, blunt instrument such as a drift or block of wood, drive the preload spring from the case.
3. Support an axle shaft in a vise, and slide the case into the shaft; then turn the case to remove both pinions and thrust washers.
4. Remove the case from the axle shaft and remove both side gears, clutch packs and shims. Mark the gears, clutch packs and shims for reinstallation in same positions.

### Inspection

Check the clutch plates and discs for wear and signs of overheating. Check the condition of the preload spring. Check the gear teeth for signs of wear. Replace parts as needed. Clean all parts to be used for assembly.

The force required to compress the preload spring to 1-5/16 inches should be  $300 \pm 30$  lbs.

### Reassembly

1. Lubricate the clutch discs and plates with limited slip lubricant.
2. Alternately position clutch plates and discs on a side gear, beginning and ending with a clutch plate.
3. Position the side gear, clutch pack and original shim into the case.



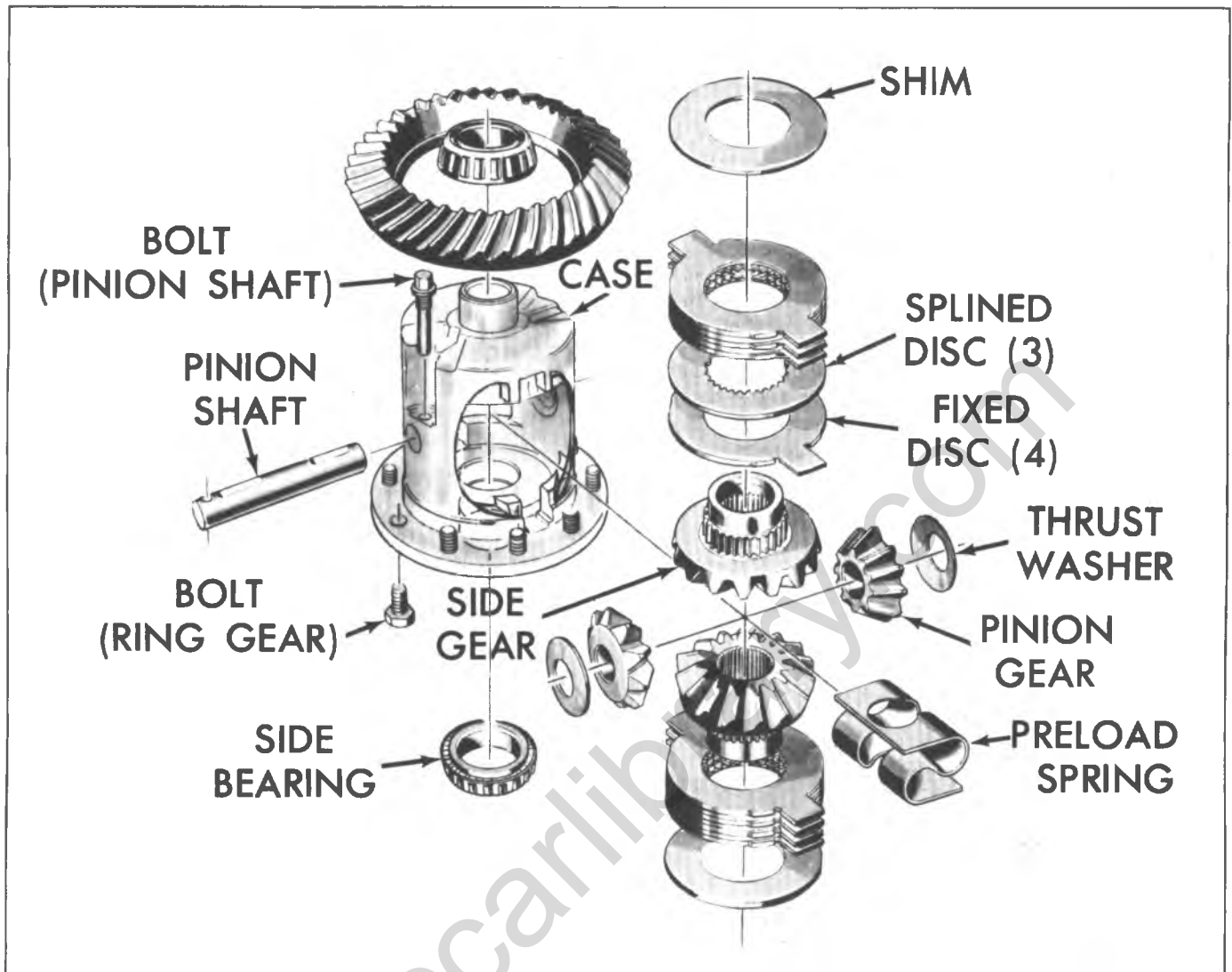

Fig. 15D—Chevrolet Limited Slip - Exploded

4. Install both pinion gears and thrust washers into the case, and install pinion shaft.

5. Place the case onto an axle shaft supported in a vise.

6. Insert a screwdriver between the pinion shaft and the face of the side gear. Force the screwdriver in until the clutch pack is compressed.

7. Check the backlash between side gear and pinion gears. If backlash does not fall into the range of .005" to .008", adjust the shim dimension as required. Increasing shim thickness will decrease backlash; to increase backlash, decrease the thickness of the shim.

Service shims are available from .070" to .122" in increments of .004".

8. Remove the pinion shaft, pinion gears, side gear, clutch pack and shim from the case.

9. Install the opposite gear, clutch pack and original shim into the opposite side of the case. Place both pinion gears, and thrust washers into position, and install the pinion shaft.

10. Follow the procedure in steps 5, 6 and 7 to determine the proper shim dimension.

11. When the proper shims have been determined to achieve .005" to .008" backlash between both pinion gears and both side gears, install shims, clutch packs and side gears into case.

12. Mount the case onto the axle shaft locked in a vise. Place both pinions and thrust washers into position-180°-apart-and carefully "roll in" by turning the case on the shaft.

A large "C" clamp may be used to apply slight compression against pinion gears to aid the "rolling in" procedure.

13. Tap the preload spring into place with a hammer.

14. Install the pinion shaft and lock screw.

15. Install the side bearings and ring gear using the procedure outlined for conventional units.

16. Place the differential unit in the carrier and adjust ring gear and pinion backlash, and gear tooth pattern.

## BORG WARNER (CONE TYPE)

### DESCRIPTION

The limited slip differential can be identified by a tag attached to the lower right section of axle cover. It is designed to direct the major driving force to the wheel with greater traction, thereby reducing the possibility of the car becoming stuck while driving under adverse conditions.

All rear axle parts of vehicles equipped with the limited slip differential are interchangeable with those equipped with the conventional differential, except for the case assembly. It is similar in all respects to the conventional case assembly, with the addition of cone clutches splined to each side gear.

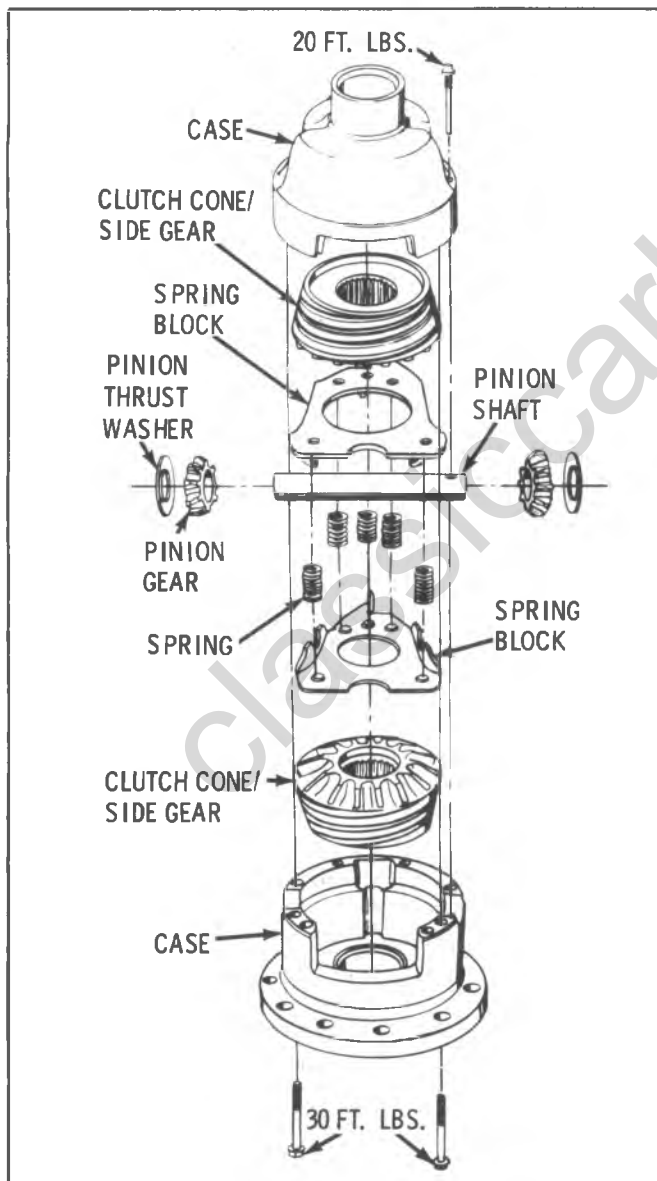

Fig. 4B-16D--Limited Slip (Cone Type)

### LUBRICATION

The differential should be checked for leaks and level every oil change. Maintain level to within 3/8" of the filler plug opening.

If necessary to add lubricant, use only lubricant No. 1052271 or equivalent.

### SERVICE PROCEDURES

Rear axle service procedures are the same for the limited slip as for the conventional differential, except for servicing the case assembly.

If the case, clutch cone/side gears, or pinion gears are damaged, it is necessary to replace case assembly.

Never raise one wheel and run the engine with the transmission in gear. The driving force to the wheel on the floor will cause the vehicle to move. Do not use "on the vehicle" type wheel balancers on the rear wheels, unless both wheels are off the floor.

### Differential Case

#### Disassemble

1. Before disassembling differential case, inspect differential side bearings for visible damage of rollers and outer races.
2. Place one outer race onto its matched inner race and roller assembly and turn slowly, applying hand load.
3. If bearing outer race turns smoothly and no visible damage is found, bearing can be reused.
4. Repeat above operation with other race and matched bearing and check for smoothness.

Both side bearings and their outer races are matched parts. If either bearing is to be replaced, its matching outer race must also be replaced.

5. Inspect fit of inner races on case hubs by prying against shoulders at puller recesses. Bearing inner races must be tight on case hubs.

If either bearing is loose on case, entire case must be replaced.

6. If bearing inspection indicates that bearings should be replaced, remove side bearings by using tools as shown in the 1979 Service Manual.

7. If removing ring gear, clamp case in vise so jaws are 90° to pinion shaft holes and remove ten ring gear retaining bolts.

8. Partially install two bolts on opposite sides of ring gear.

9. Remove ring gear from case by alternately tapping on bolts.

Do not pry between case and ring gear.

10. Remove differential case half attaching bolts.

11. Lift cap half of case from flange half. Remove clutch cone/side gears, spring blocks, preload springs, pinion gears and shaft.

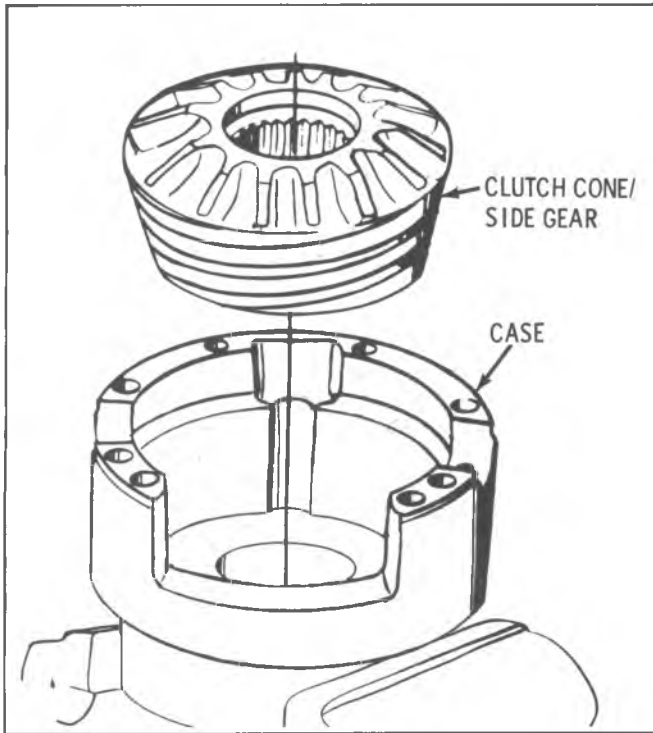

Fig. 4B-17D--Cone-Gear Position

Be certain that each clutch cone/side gear and pinion gear are marked so they can be installed in their original location.

**Cleaning and Inspection**

1. Make certain all parts are absolutely clean and dry.
2. Inspect pinion shaft, pinion and side gears, brake cone surfaces and corresponding cone seats in case. The cone seats in case should be smooth and free of any excessive scoring. Slight grooves or scratches, indicating passage of foreign material, are permissible and normal. The land surface on the heavy spirals of male cones will duplicate case surface condition. If case or clutch cone/side gear are damaged, it is necessary to replace case assembly. All other parts are serviceable.

**Assembly**

1. Install proper cone/gear assembly, seating it into position in cap half of case. (Fig. 4B-17D).

Be certain that each cone/gear is installed in proper case half, since tapers and surfaces become matched and their positions should not be changed.

2. Place one spring block in position over gear face, in alignment with pinion gear shaft grooves. Install pinion shaft, pinion gears and thrust washers into cap half or differential case in such a manner that pinion shaft retaining dowel can be inserted through pinion gear shaft into differential case. This prevents pinion shaft from sliding out and causing damage to carrier. (Fig. 4B-18D).

Be certain that pinion gears are installed in their original locations.

3. Insert five springs into spring block that is already installed into case, then place second spring block over springs. (Fig. 4B-19D).

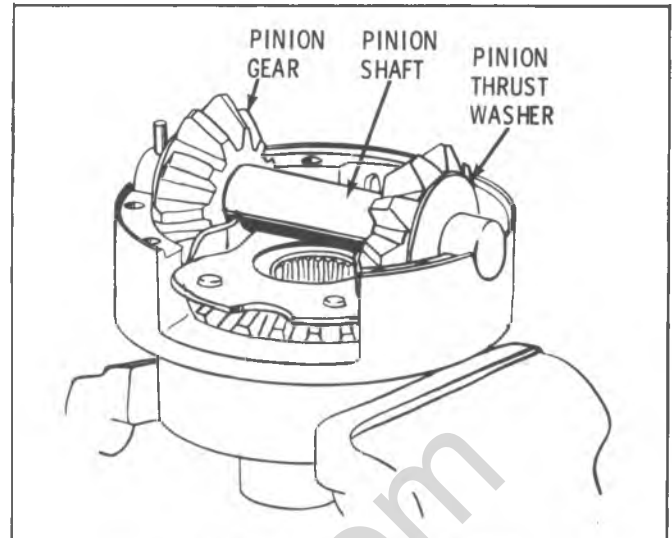

Fig. 4B-18D--Pinion Shaft Position

4. Install second cone/gear assembly face down on spring block so that gear will mesh with pinion gears.

5. Install flange half of differential case over cone, insert case bolts finger tight. (Fig. 4B-20D).

6. Tighten bolts one turn at a time in sequence shown in Fig. 4B-21D. Then torque case bolts to 30 ft. lbs.

7. If side bearings were removed, lubricate outer bearing surfaces and press on bearings as shown in the Service Manual.

8. After making sure that matching surfaces are clean and free of burrs, position ring gear on case so holes are in line.

9. Lubricate NEW attaching bolts with clean engine oil and install.

10. Pull ring gear onto case by alternately tightening bolts around case. When all bolts are snug, tighten bolts evenly and alternately across diameter to 120 ft. lbs. torque. Do not use hammer to force ring gear on case.

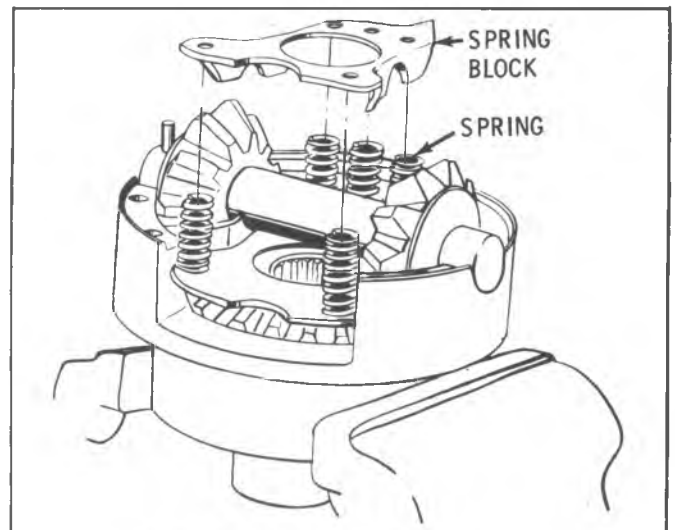

Fig. 4B-19D--Spring and Spring Block

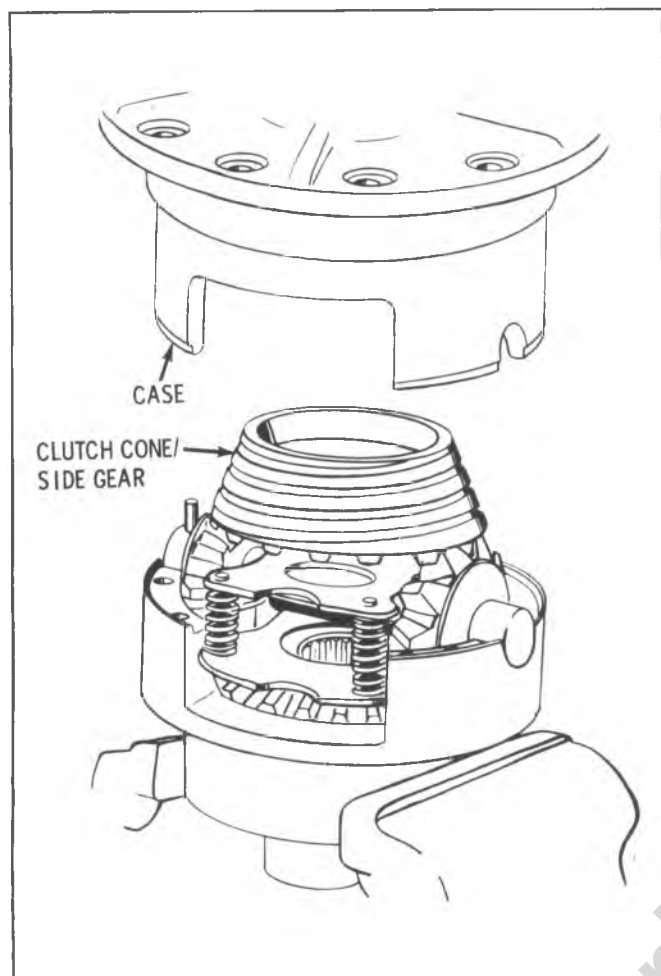

Fig. 4B-20D-Case-Cone Installation

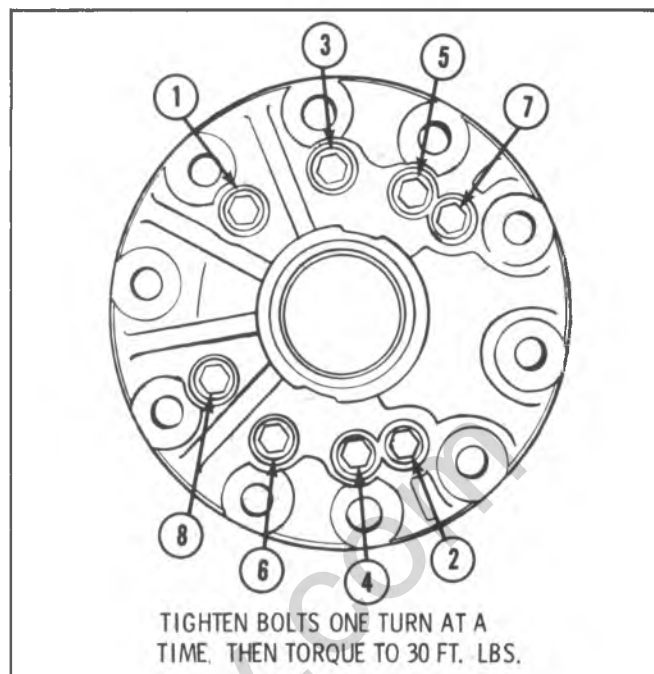

Fig. 4B-21D-Bolt Torque Sequence

11. Install unit into axle carrier following instructions given for Standard Differential.

## POWER-LOK DIFFERENTIAL

The Power-Lok differential shown in figure 22D is a unit which is installed as optional equipment in place of the standard differential. The locking differential permits the major driving force to be transmitted to the wheel with better traction. This means that the vehicle can be operated on ice, snow, sand or under other adverse conditions with a minimum amount of slippage through one wheel.

### Disassembly

1. Remove differential bearing cups and tag for reassembly reference.
2. Remove differential bearing cones, using Puller Tool J-22888.
3. Tag each bearing cone and shim for reassembly reference, as they should be replaced in their original locations.
4. Scribe mark on both halves of differential so they can be reassembled in their original locations.
5. Remove eight bolts attaching two halves of case together.

6. Separate plain half of differential case from flanged half.

7. Remove five plates and discs from side gear ring.

A series of clutch plates and dished (Belleville) friction plates on each side of differential side gears transmits drive from differential case to axle shafts. Carefully observe the order in which the plates are used, since they must be replaced in the same order. Refer to figure 22D.

8. Remove side gear ring and side gear.

9. Remove two cross shafts and pinion gears.

10. Remove side gear, side gear ring, and five plates and discs from the opposite side. Observe the order in which the plates are used.

### Inspection

1. Inspect cross shafts and pinions for scoring, wear, pitting, etc. If the center lands of either cross shaft show signs of wear, examine ends of axle shafts to determine if the axle shaft is rubbing against cross shaft. This rubbing condition may cause a whine or howl that is similar to a pinion bearing noise, at 40 to 50 MPH. This condition can

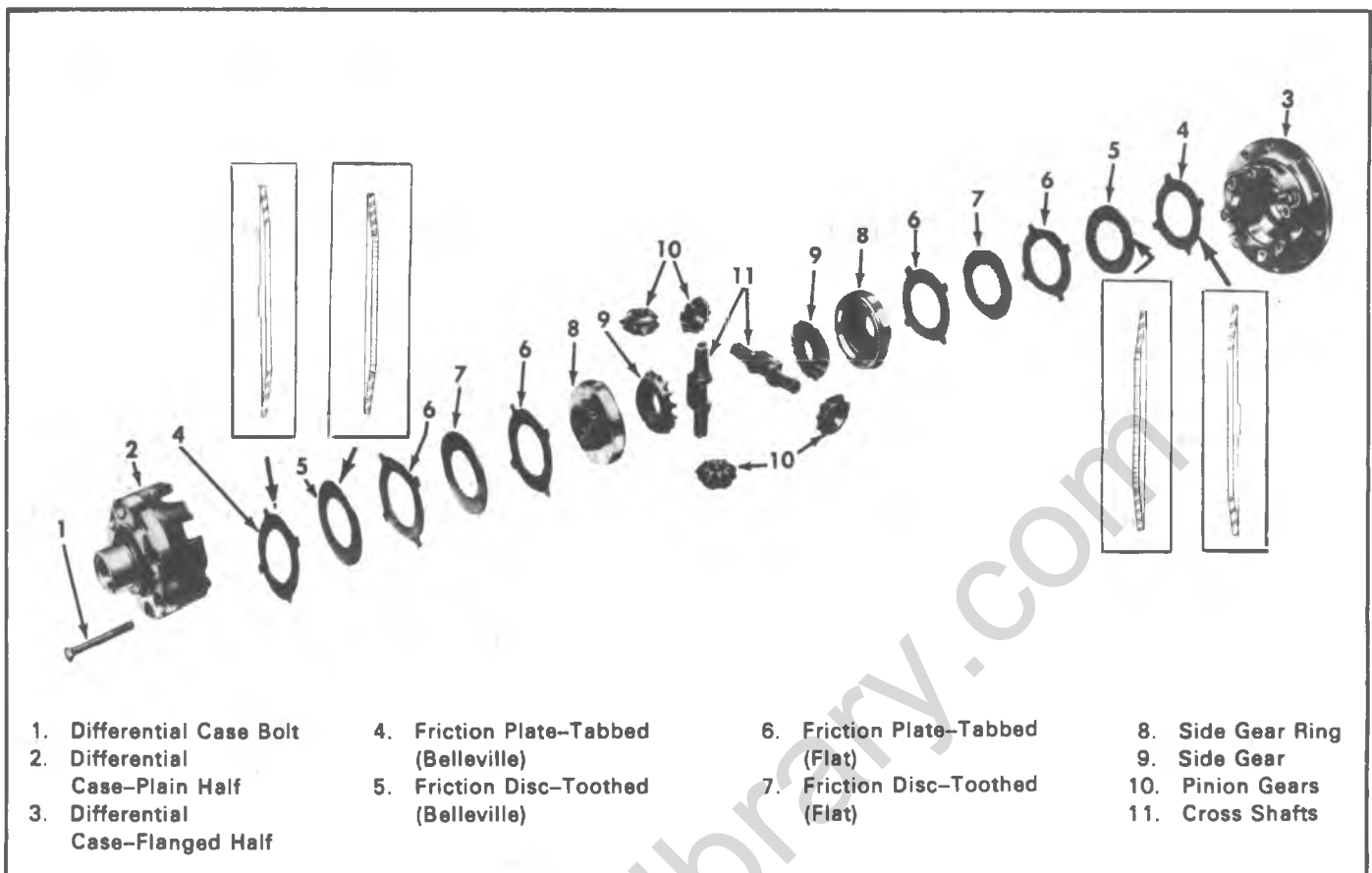

Fig. 22D—Power-Lok Differential

be corrected by grinding 1/32" off the end of the axle shaft.

2. Inspect clutch discs and plates for wear, cracked, or distorted condition.

3. Inspect side gear rings, side gears, and differential cases for worn, cracked, or distorted condition that would render these parts unfit for further services.

### Assembly

During assembly operations, all parts should be kept clean and free of dirt or other foreign material. As each part is assembled in its proper position, it is necessary that it be lightly coated with the correct lubricant.

1. Place tabbed Belleville friction plate (4) in flanged differential case, being extremely careful that convex (bulged) side is toward the side gear. See figure 22D.

2. Assemble remaining plates and discs to splines of side gear ring, being sure they are assembled in the same order of removal. The convex (bulged) side of the Belleville friction disc (5) should be toward the side gear and it should nest into the Belleville friction plate (4).

3. Place assembled side gear ring with plates and discs in flanged half of differential case.

4. Install side gear and cross shafts with pinions.

5. In the order listed install the following: (1) side gear, (2) side gear ring, (3) flat plate with tabs, (4) flat disc with teeth, (5) flat plate with tabs, (6) Belleville disc with convex (bulged) side up, or toward side gear, (7) Belleville plate, with convex (bulged) side up, or side toward gear.

6. Position plain half of differential case over previously assembled parts with scribe markings on both halves of case in alignment.

7. Install differential case bolts, but do not tighten at this time.

8. Before tightening bolts, use axle shafts and align splines of the side gear and side gear ring, on each side. Tighten bolts evenly and alternately. Remove axle shafts.

9. Observe if Power-Lok components have been assembled properly. Each pinion cross shaft can be tight on its ramp or if there is clearance it should be only a few thousandths, and it should be equal at all four cross shaft ends.

### Testing Procedure

The Power-Lok can be effectively tested for correct operation by placing one rear wheel on good dry pavement and the other on ice, snow, mud, gravel, grease, etc.

It can easily be determined whether or not the non-slipping wheel is providing pulling power. The procedure should then be repeated with the opposite wheels on the dry and slippery surfaces.

The above testing procedure is a rough test that can be made by the owner of the vehicle. However, if it is suspected that the unit is not operating properly, it can be checked by the following procedure.

Be sure the transmission is in neutral. Raise one wheel off the floor and place a block in the front and rear of the opposite wheel. Remove the hub cap and install a special tool across two wheel studs. Apply a torque wrench to

special tool. Disregard breakaway torque and observe only the torque required to continuously turn the wheel smoothly.

If the torque reading is less than 40 foot-pounds or more than 200 ft. lbs., the unit should be disassembled and the necessary repairs made.

## EATON POSITIVE LOCKING DIFFERENTIAL

### DESCRIPTION

Trucks equipped with locking differentials use one of the Eaton locking units in Figure 4B-1H, 2H. These differentials provide true differential action and also incorporates a speed sensitive device which automatically and positively locks both rear wheels together if either wheel should spin excessively during slow vehicle operation.

Locking is accomplished through the use of a flyweight governor mechanism, cam system, and multi-disc clutch. The flyweights on the governor mechanism move outward to engage a latching bracket whenever the wheel-to-wheel speed varies by approximately 100 rpm or more. This action retards a cam which, in turn, compresses a multi-disc clutch locking one side gear to the case. At wheel-to-wheel

differentials of less than approximately 100 rpm, the unit operates as a standard or open differential.

At vehicle speeds above approximately 20 mph (32 km/h), the latching bracket overcomes a spring preload and swings away from the flyweights. At this vehicle speed or greater, the differential will not lock as the added traction is not necessary.

### Service Test Procedure

1. Place the Truck on a frame-contact hoist, allowing free rotation of the rear wheels.
2. Raise hoist until wheels clear floor. Holding one wheel stationary, slowly rotate other wheel approximately 1/2 revolution per second, in both the forward and reverse

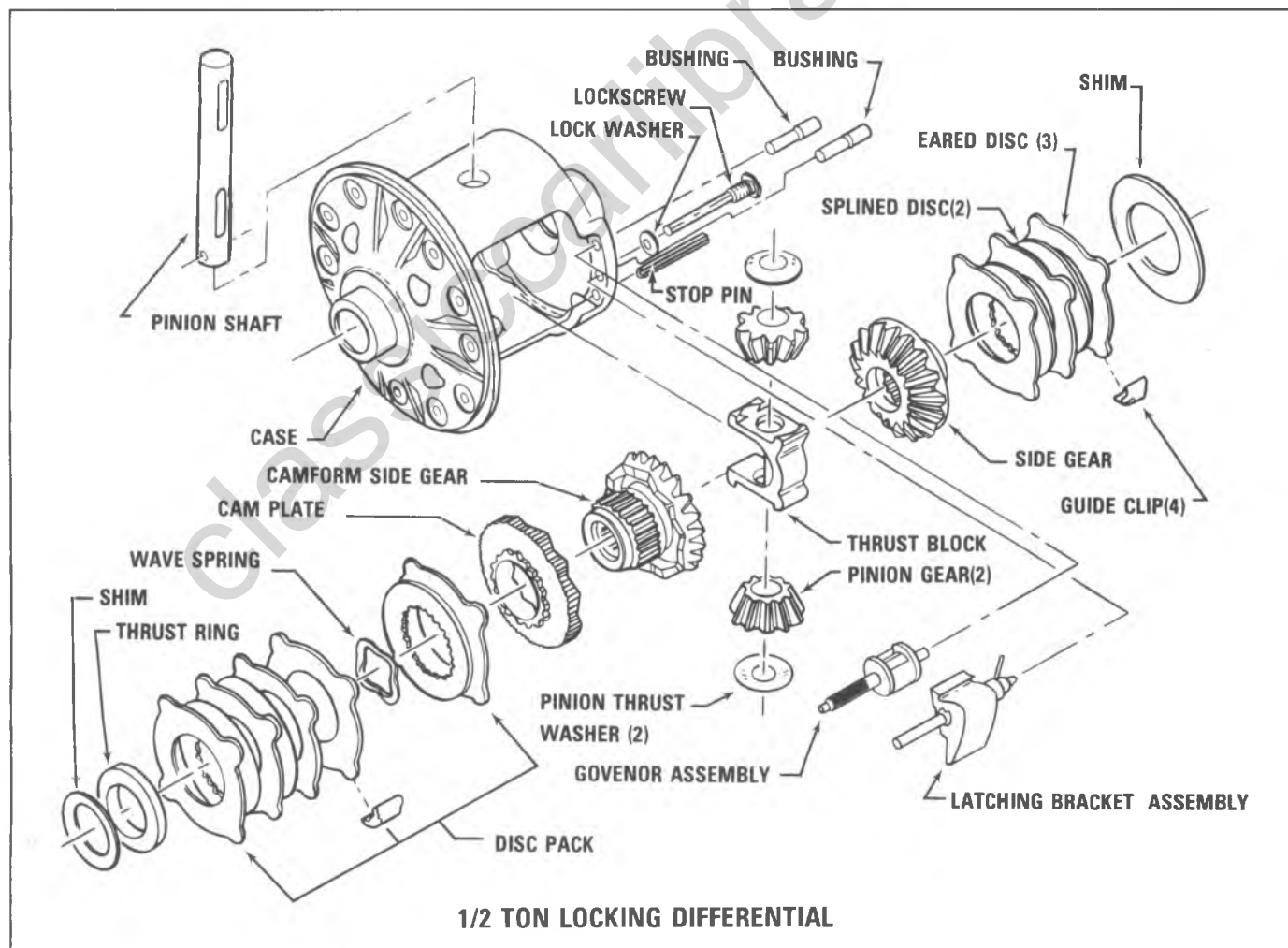

Fig. 4B-1H--1/2 Ton Unit

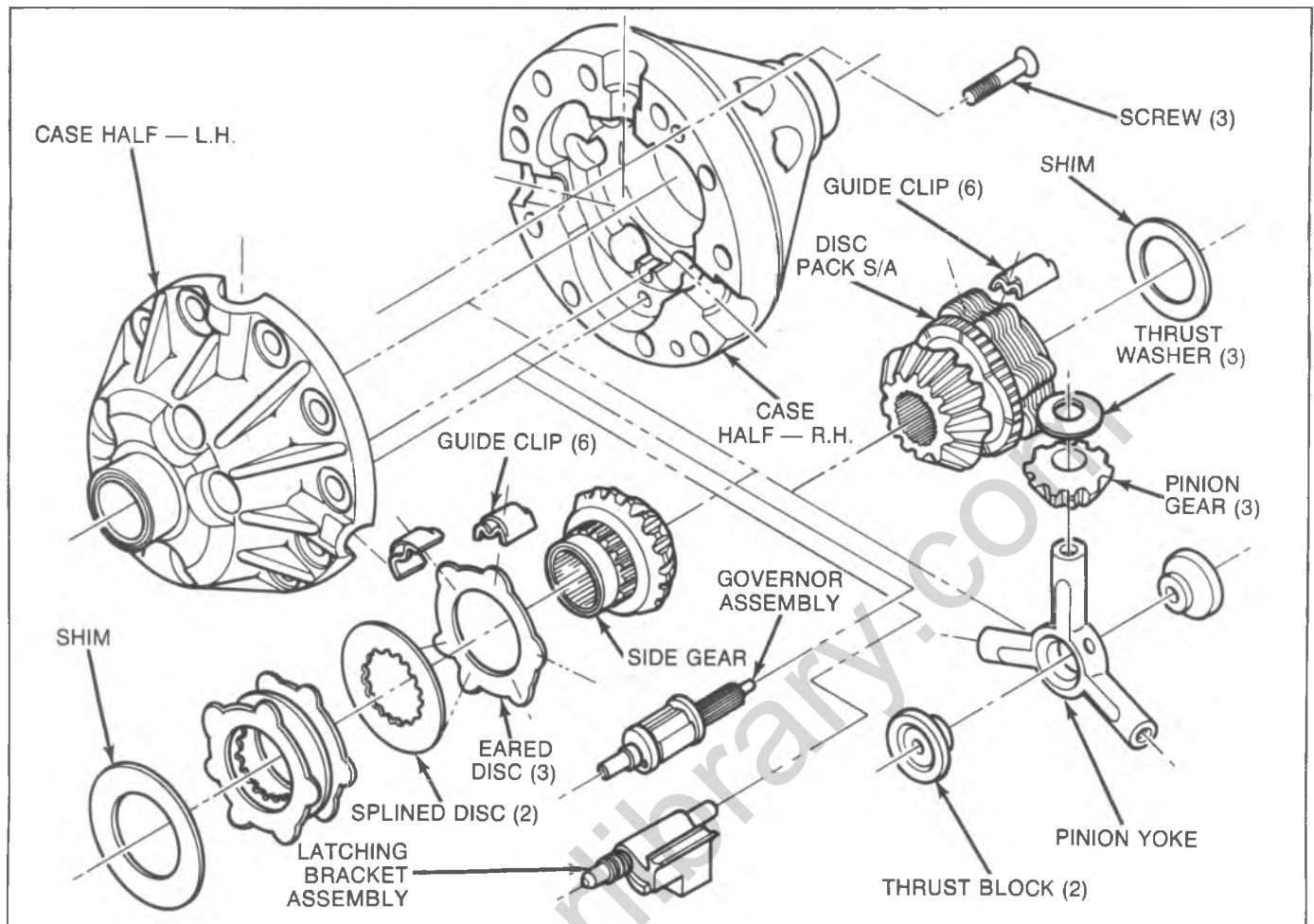

Fig. 4B-2H-3/4 Ton Unit

directions. Wheel should rotate freely. If both wheels attempt to turn together, the differential is locking and is defective.

Rapid wheel rotation will cause a properly operating differential to lock and both wheels will rotate in the same direction.

3. Raise hoist to maximum height with one person in vehicle.

4. Start engine making sure that carburetor is set to provide a low idle speed of 600-800 rpm.

5. Place transmission in drive range and apply brakes. With manual transmission, depress clutch and place transmission in first gear.

6. Lock one rear wheel by pulling one parking brake cable from under the vehicle.

7. With engine at low idle, slowly release brakes. With manual transmission, slowly engage clutch.

8. Locked rear wheel will remain stationary and free wheel will begin turning. It is important that brakes or clutch be released slowly enough to start the free wheel turning and allow the free wheel to gradually increase in speed. As speed of the free wheel is increased, the differential will lock causing the rotating wheel to stop or both wheels to turn at the same speed. The engine may stall if equipped with a manual transmission. It may be necessary to accelerate engine until approximately 10 mph is indicated

on vehicle speedometer to cause differential lock. If indicated speed can be increased beyond 20 mph (32 km/h) without causing differential lock, the unit is not functioning properly.

Rapid release of brakes or clutch, or rapid acceleration of engine will invalidate test.

9. Lock opposite rear wheel and repeat procedure. The following chart provides guidelines for diagnosis and repair of differential complaints

### OVERHAUL PROCEDURES 8-7/8 RING GEAR AXLE 1/2 TON TRUCKS

Due to critical internal clearance dimensions, differential side gears and case cannot be serviced separately. If any side gear or case damage is found, the entire differential must be replaced.

Internal clearances are such that shims, reaction block, and thrust rings should not be replaced unnecessarily even if slight wear indications are present. If shims, reaction block, or thrust ring must be replaced due to damage, correct measurement and replacement procedures must be followed. Failure to do so may disturb critical clearances and could result in differential complaints.

DIFFERENTIAL DIAGNOSIS

Complaint	Possible Cause	Correction
Does not lock:	A. Little or no spring preload on the latching bracket.	A. Replace governor assembly and latching bracket.
	B. Flyweights on governor assembly stuck closed.	B. Replace governor assembly and latching bracket.
	C. Broken Drive teeth on governor and/or cam gear assembly.	C. Replace cam plate, governor assembly and latching bracket.
	D. Broken clutch plates in cam gear assembly.	D. Replace clutch plates and wave spring.
Locks in turns:	A. Governor assembly tight in case.	A. Free up governor assembly.
	B. Broken or weak governor flyweight spring.	B. Replace governor assembly and latching bracket.
	C. Flyweight in governor assembly stuck open.	C. Replace governor assembly and latching bracket.
	D. Broken cam plate and/or governor drive teeth.	D. Replace cam plate, governor assembly and latching bracket.
Noisy:		
NOTE:	In addition to normal axle noise (see section on standard differential), the locking differential exhibits some clutch noise upon engagement and disengagement.	
	A. Broken clutch plates.	A. Replace clutch plates and wave spring.
	B. Broken reaction block.	B. Replace reaction block.* Check closely for other damage. Replace entire unit if housing, side gear, or pinion gears are damaged.
	C. Broken differential gears.	C. Replace entire unit.

\*Reaction blocks must be replaced with blocks of identical thickness.

Fig. 4B-3H-Diagnosis Chart



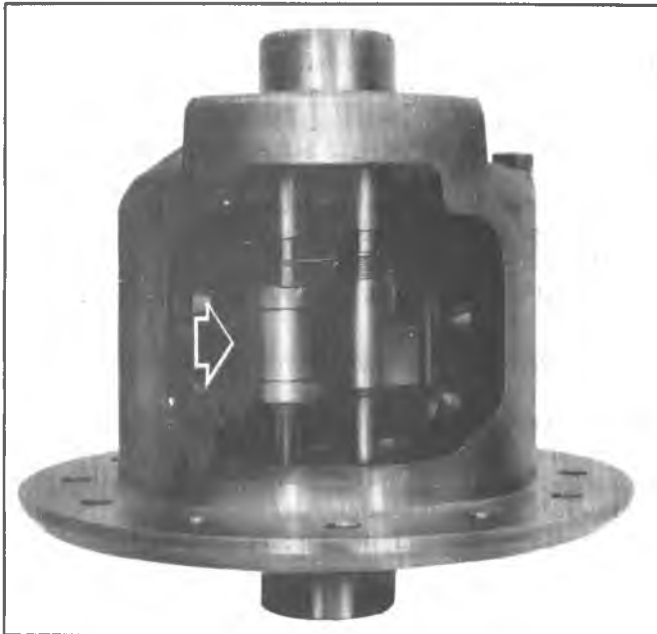

Fig. 4B-4H-Governor and Latching Bracket

Internal components can be inspected through the windows of the differential housing.

If the governor assembly and latching bracket are the only items to be replaced, proceed only through step No. 2 of the disassembly procedure. To install new governor and latching bracket, begin at step No. 6 of the reassembly procedure.

### Disassembly

1. Note position of governor and latching bracket assembly, Figure 4B-4H. Remove ring gear and side bearings following procedures established for the standard differential.



Fig. 4B-5H-Bearing Puller J-26252

2. Using bushing puller tool No. J-26252, remove governor assembly and latching bracket by pulling the retaining bushings as shown in Figure 4B-5H. Pull the latching bracket spring out of the way while pulling the governor assembly bushing to prevent damage. Remove the stop pin by driving through the case with a drive pin punch.

3. Remove lock screw and pinion shaft, and roll out differential pinion gears.

4. Remove thrust block and pinion thrust washers.

5. Remove cam gear, disc pack assembly and disc pack guide clips.

6. Remove bell disc pack assembly and shim.

### Inspection

1. Clean all parts with solvent. Inspect all bearing for chipping or evidence of excessive wear. Replace parts as needed.

2. Inspect all differential components for excessive wear and breakage. Replace parts as needed. The following are serviceable components for this differential:

- Governor assembly and latching bracket with spring and stop pin.
- Cam plate.
- Clutch disc pack with guides (flange end only).
- Pinion cross-shaft.
- Pinion gears.
- Pinion thrust washers.
- Reaction block (6 sizes).
- Thrust ring.
- Flange end shim (5 sizes).

Attempts to service other components may disturb critical clearances and could result in differential complaints.

If reaction block or flange end shim must be replaced, the original pieces must be carefully measured for thickness and replaced with a piece of the same size.

### CAM/CLUTCH SERVICE

#### Disassembly

If cam plate or clutch discs must be replaced, the cam gear sub-assembly must be serviced as follows:

1. Measure and record overall length of gear assembly (front face of gear to back side of thrust ring, include shim). This dimension will be needed to reassembly unit if thrust ring is replaced. **DO NOT REPLACE THRUST RING UNLESS NECESSARY.** If ring is excessively worn or scored, check bore in case for scoring. If bore is scored, replace entire differential.

2. With gear hub end up, compress disc pack and install jaws of split ring bearing remover (J-22912) between the thrust ring and the top eared disc. Bevel side of bearing remover should face up toward thrust ring.

3. Place cam gear assembly with bearing remover attached in an arbor press supporting the bearing remover on both sides.

4. Install a 1-1/2" to 1-3/4" diameter plug similar to (J-8107-4) on gear hub. Press against plug with ram of press to remove thrust ring. Keep all components in the proper order, Figure 4B-6H.

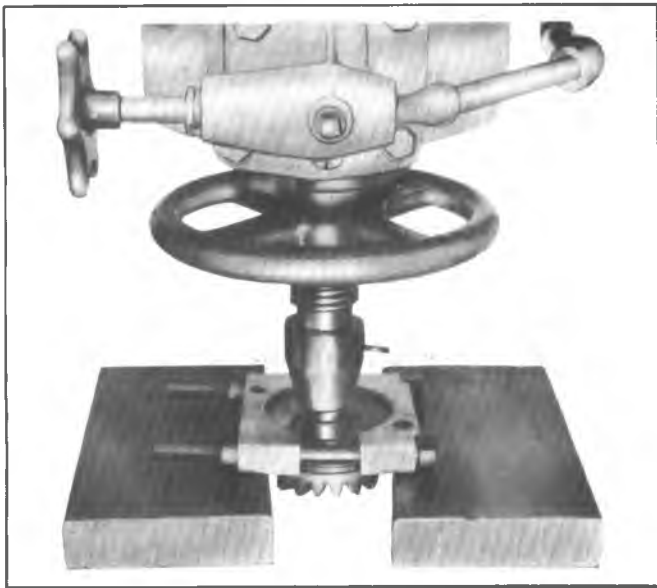

Fig. 4B-6H--Bearing Remover J-22912

### Reassembly

Replace cam plate and wave spring or clutch discs as necessary and reassemble as follows: See Fig. 4B-1H.

1. Place gear on bench with hub end up.
2. Assemble cam plate with cam form down to mate with cam form on gear.
3. Assemble onto cam plate: (2) eared discs, (1) splined disc, and (1) wave spring alternately as shown.
4. Assemble on to gear hub (2) splined discs and (3) eared discs alternately as shown. Begin and end with an eared disc.
5. Locate cam gear assembly in arbor press with hub end up. Place thrust ring on gear hub and press to shoulder making sure that ring is square with hub.

Compress disc pack by pushing down on the discs to keep the splined discs from becoming wedged between the thrust ring and gear shoulder while pressing the sub-assembly together. Completed sub-assembly should be checked for proper disc sequence. Also, make sure the first splined disc (large spline) is properly located on the cam plate.

### Reassembly

1. Install (4) clutch pack guide clips on the ears of the cam gear clutch pack using grease for retention.
2. Install cam gear assembly and original shim in flange end of case. If a new thrust ring has been pressed on the cam gear, reshimming may be necessary. Measure the overall length of the new cam gear assembly, including the shim and compare to the dimension obtained in Step A of cam gear service section. If the length of the new assembly varies by more than .003" larger or smaller than the original dimension, reshimming will be necessary. Select a shim which will result in a reading closest to the original.

**NOTICE:** Incorrect shimming will disturb critical clearance dimensions and may result in differential failure.

3. Lock an axle shaft in vise, in a vertical position. Mount the differential case over the end of the axle shaft engaging the spline of the side gear with the shaft. Grease the two pinion gear thrust washers and locate them in their proper position. Assemble on to bell end gear hub (2) splined discs and (3) eared discs alternately as shown. Begin and end with an eared disc. Install (4) small clutch pack guide clips on the ears of the bell end clutch pack using grease for retention. Install in case with original shim.

Original shim must be used to maintain proper clearance dimensions.

4. Insert one pinion gear through the small window opening in the case while at the same time inserting the reaction block and other pinion gear through the large window opening. Rotate the two pinion gears and thrust block 90° so as to position the reaction block with the open side towards the small window opening in the case. Be sure the two pinion gears and thrust washers are in their proper location.

**NOTICE:** Reaction block must be replaced with a block of the identical thickness. Incorrect block thickness will disturb critical clearance dimensions and may result in differential failure.

5. Install shaft and lock screw.
6. Insert governor assembly and latching bracket into case, Figure 4B-4H. Place straight end of latching bracket spring over and to the outside of the engagement shaft to preload the latching bracket against the governor assembly. Press bushing and 1/4" stop pin into case. Press bushing for governor assembly into case to give .004 to .020 shaft end play. Press bushing for latching bracket into case to remove end play. A 3/8 diameter plug or socket will aid in pressing the bushings into the housing. Press stop pin flush with top of case.

For the latching bracket use bushing with the tapered hole. The bushing for the governor assembly has a straight hole.

7. Install ring gear and side bearings using the procedure outlined for conventional differentials.

8. Place differential unit in carrier and adjust ring gear and pinion backlash and gear tooth pattern as outlined in the conventional differential section.

9. Check operation as outlined in the Service Test Procedure.

**NOTICE:** Use standard differential lubricant. Do not use lubricant designed for "Limited Slip" differentials, or damage may result.

## 10-1/2" RING GEAR AXLE 3/4 TON AND 1-TON TRUCKS

**NOTICE:** Due to critical internal clearance dimensions, differential side gears and case cannot be serviced separately. If any side gear or case damage is found, the entire differential must be replaced.



Fig. 4B-7H--3/4 Ton Unit

Internal clearances are such that shims, reaction blocks, and thrust ring should not be replaced unnecessarily even if slight wear indications are present. If shims, reaction blocks, or thrust ring must be replaced due to damage, correct measurement and replacement procedures must be followed. Failure to do so may disturb critical clearances and could result in differential complaints.

### Disassembly

1. Remove ring gear and side bearings following procedures established for the standard differential.
2. Remove (3) screws on front face of ring gear flange.
3. Set unit on right side case half and gently pry apart at yoke hole locations Fig. 4B-7H.
4. Remove left side case half. To prevent side gear from falling out, hold thumb against inside of gear hub while separating case halves.



Fig. 4B-8H--3/4 Ton Assembly

5. Inspect components for damage. If the governor assembly and latching bracket are the only items to be replaced, remove and proceed to Step 7 of reassembly procedure. Pry under pinion yoke and remove and proceed with detailed inspection if further damage is observed.

### Inspection

1. Clean all parts with solvent. Inspect all bearings for chipping or evidence of excessive wear. Replace parts as needed.

2. Inspect all differential components for excessive wear and breakage. Replace parts as needed. **THE FOLLOWING ARE SERVICEABLE COMPONENTS FOR THIS DIFFERENTIAL.**

- Governor assembly and latching bracket with spring.
- Cam Plate.
- Clutch disc pack with wave spring and guide clips.
- Pinion yoke.
- Pinion gears.
- Pinion thrust washers.
- Reaction blocks (4 sizes).
- Thrust ring.
- Right side shim (4 sizes).
- Left side guide clips.

Attempts to service other components will disturb critical clearances and may result in differential failure. If reaction blocks or right side shim must be replaced, the original pieces must be carefully measured for thickness and replaced with a piece of the same size.

### CAM/CLUTCH SERVICE

#### Disassembly

If cam plate or clutch discs must be replaced, the cam gear sub-assembly must be serviced as follows: Refer to Figure 4B-9H.

1. Measure and record overall length of gear assembly (front face of gear to back side of thrust ring, include shim). This dimension will be needed to reassemble unit if thrust ring is replaced. **DO NOT REPLACE THRUST RING UNLESS NECESSARY**. If ring is excessively worn or scored, check bore in case for scoring. If bore is scored, replace entire differential.

2. With gear hub end up, compress disc pack and install jaws of split ring bearing removed (J-22912) between the thrust ring and the top eared disc. Bevel side of bearing remover should face up toward thrust ring.

3. Place cam gear assembly with bearing remover attached in an arbor press supporting the bearing remover on both sides.

4. Install a 1-1/2" to 1-3/4" diameter plug (J-8107-4) on gear hub. Press against plug with ram of press to remove thrust ring. Keep all components in the proper order.

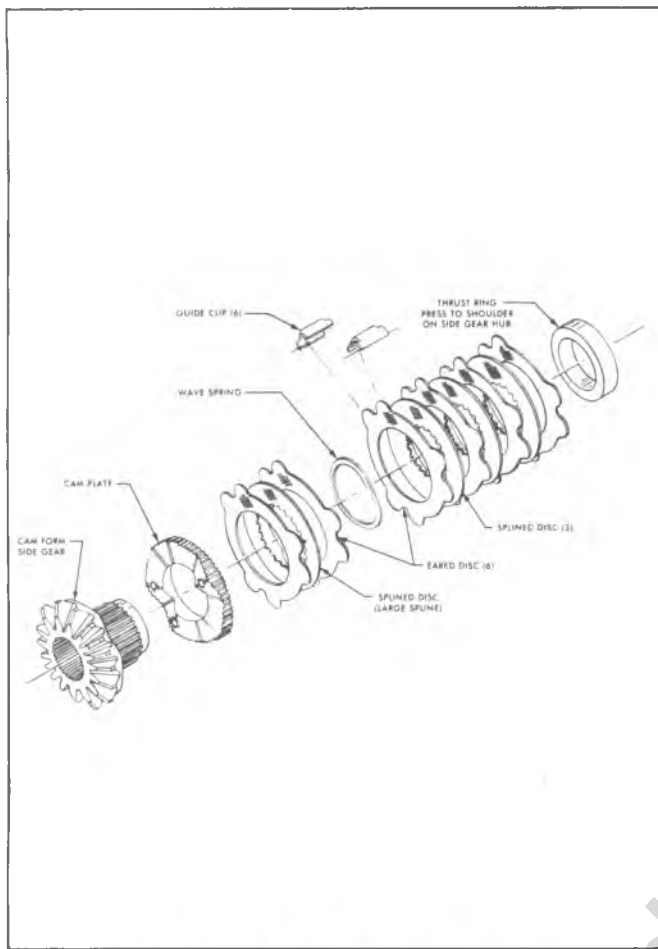

Fig. 4B-9H—Cam Plate and Clutch Discs

### Reassembly

Replace cam plate and/or clutch discs as necessary and reassemble as follows:

1. Place gear on bench with hub end up.
2. Assemble cam plate with cam form down to mate with cam form on gear.
3. Assemble onto cam plate (2) eared discs, (1) splined disc, and (1) : wave spring alternately as shown, Fig. 4B-9H.
4. Assemble onto gear hub: (4) eared discs and (3) splined discs alternately as shown. Begin and end with an eared disc.
5. Locate cam gear assembly in arbor press with hub end up. Place thrust ring on gear hub and press to shoulder making sure that ring is square with hub.

Compress disc pack by pushing down on the discs to keep the splined discs from becoming wedged between the thrust ring and gear shoulder while pressing the sub-assembly together. Completed sub-assembly should be checked for proper disc sequence. Also, make sure the first splined disc (large spline) is properly located on the cam plate.

### Reassembly

1. Install (6) clutch pack guide clips on the ears of the cam gear clutch pack using grease for retention.

2. Install cam gear assembly and original shim in right side case half. If a new thrust ring has been pressed on the cam gear, reshimming may be necessary. Measure the overall length of the new cam gear assembly, including the shim and compare to the dimension obtained in Step A of cam gear service section. If the length of the new assembly varies by more than .003" larger or smaller than the original dimension, reshimming will be necessary. Select a shim which will result in a reading closest to the original.

**NOTICE:** Incorrect shimming will disturb critical clearance dimensions and may result in differential failure.

3. Install right side reaction block on gear face with button side of block facing up. Use original block unless severely scored or worn. If new block is used, determine face-to-face thickness of original block with calipers and replace with a service block of the same thickness.

**NOTICE:** Incorrect block thickness will disturb critical clearances and may result in differential failure.

4. Preassemble pinions and pinion thrust washers on pinion yoke. Index yoke to proper position and install in housing with center over button end of reaction block. A light tap on the yoke may be needed to seat it in the housing.

5. Install left side reaction block on the yoke with flange side up. Use original block unless severely scored or worn. If new block is used, determine face-to-face thickness of original block with calipers and replace with a service block of the same thickness.

**NOTICE:** Right and left side reaction blocks may not be the same thickness. If blocks are broken or cannot be accurately measured for thickness, the entire differential must be replaced. Incorrect block thickness will disturb critical clearances and may result in differential failure.

6. Install governor assembly and latching barcket in their respective locations. Place straight end of latching bracket spring over and to the outside of the governor shaft to preload the latching bracket against the governor assembly.

7. Install the original (3) eared and (2) splined clutch plates on the left side gear alternately, starting and ending with an eared disc.

**NOTICE:** Original discs must be used. Attempts to install other than original discs will disturb critical clearances and may result in differential failure.

8. Install (6) clutch pack guide clips on the left side disc pack assembly using grease for retention.

9. Install original shim in left side case half.

Original shim must be used. Attempts to install other than original shim will disturb critical clearances and may result in differential failure. Slight polishing or scuffing on discs and shims is normal.

10. Remove disc pack from side gear and carefully lower disc pack assembly into left side case half. Make sure car guide clips are in their proper position.

11. Install side gear in left side case half. Rotate gear to engage spline with splines on discs.

12. Being careful not to dislodge side gear assembly (hold thumb on inside of side gear spline), lower the left hand case assembly onto the right hand case. Index left hand case so holes in housing will line up for the governor assembly and latching bracket shafts.

13. Turn entire unit over and install three (3) screws.

14. Lock an axle shaft in a vise in a vertical position. Install differential assembly on axle shaft engaging the spline of the axle with a side gear. Rotate unit slowly. A short shaft held in pinion yoke hole will aid in rotating. The unit should turn smoothly without binding or locking up.

Differential will lock if turned rapidly--50 rpm or greater.

15. Install ring gear and side bearings using the procedure outlined for conventional differentials.

16. Place differential unit in carrier and adjust ring gear to pinion backlash and gear tooth pattern as outlined in the conventional differential section.

**NOTICE:** Use standards differential lubricant. DO NOT use lubricants specifically designed for "limited slip differentials".

classiccarlibrary.com

## SPECIAL TOOLS

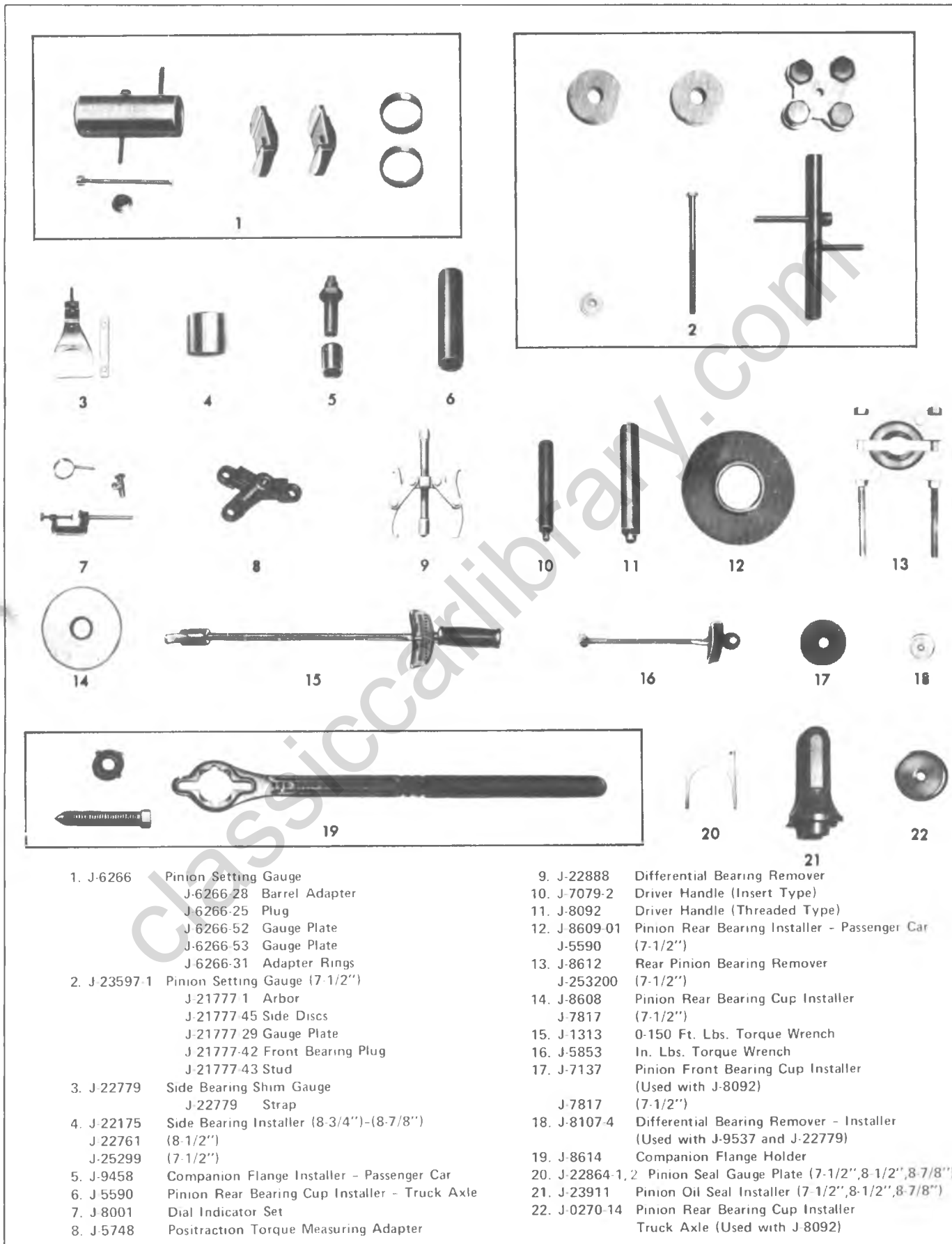

- |              |  |                  |  |
|--------------|--|------------------|--|
| 1. J-6266    | Pinion Setting Gauge                           | 9. J-22888       | Differential Bearing Remover                       |
|              | J-6266-28 Barrel Adapter                       | 10. J-7079-2     | Driver Handle (Insert Type)                        |
|              | J-6266-25 Plug                                 | 11. J-8092       | Driver Handle (Threaded Type)                      |
|              | J-6266-52 Gauge Plate                          | 12. J-8609-01    | Pinion Rear Bearing Installer - Passenger Car      |
|              | J-6266-53 Gauge Plate                          | J-5590           | (7-1/2")   |
|              | J-6266-31 Adapter Rings                        | 13. J-8612       | Rear Pinion Bearing Remover                        |
| 2. J-23597-1 | Pinion Setting Gauge (7-1/2")                  | J-253200         | (7-1/2")   |
|              | J-21777-1 Arbor                                | 14. J-8608       | Pinion Rear Bearing Cup Installer                  |
|              | J-21777-45 Side Discs                          | J-7817           | (7-1/2")   |
|              | J-21777-29 Gauge Plate                         | 15. J-1313       | 0-150 Ft. Lbs. Torque Wrench                       |
|              | J-21777-42 Front Bearing Plug                  | 16. J-5853       | In. Lbs. Torque Wrench                             |
|              | J-21777-43 Stud                                | 17. J-7137       | Pinion Front Bearing Cup Installer                 |
| 3. J-22779   | Side Bearing Shim Gauge                        | J-7817           | (Used with J-8092)                                 |
|              | J-22779 Strap                                  |                  | (7-1/2")   |
| 4. J-22175   | Side Bearing Installer (8-3/4")-(8-7/8")       | 18. J-8107-4     | Differential Bearing Remover - Installer           |
| J-22761      | (8-1/2")                                       |                  | (Used with J-9537 and J-22779)                     |
| J-25299      | (7-1/2")                                       | 19. J-8614       | Companion Flange Holder                            |
| 5. J-9458    | Companion Flange Installer - Passenger Car     | 20. J-22864-1, 2 | Pinion Seal Gauge Plate (7-1/2", 8-1/2", 8-7/8")   |
| 6. J-5590    | Pinion Rear Bearing Cup Installer - Truck Axle | 21. J-23911      | Pinion Oil Seal Installer (7-1/2", 8-1/2", 8-7/8") |
| 7. J-8001    | Dial Indicator Set                             | 22. J-0270-14    | Pinion Rear Bearing Cup Installer                  |
| 8. J-5748    | Positraction Torque Measuring Adapter          |                  | Truck Axle (Used with J-8092)                      |

Fig. 1T--Special Tools - 8-1/2" and 8-7/8" Ring Gear Differentials

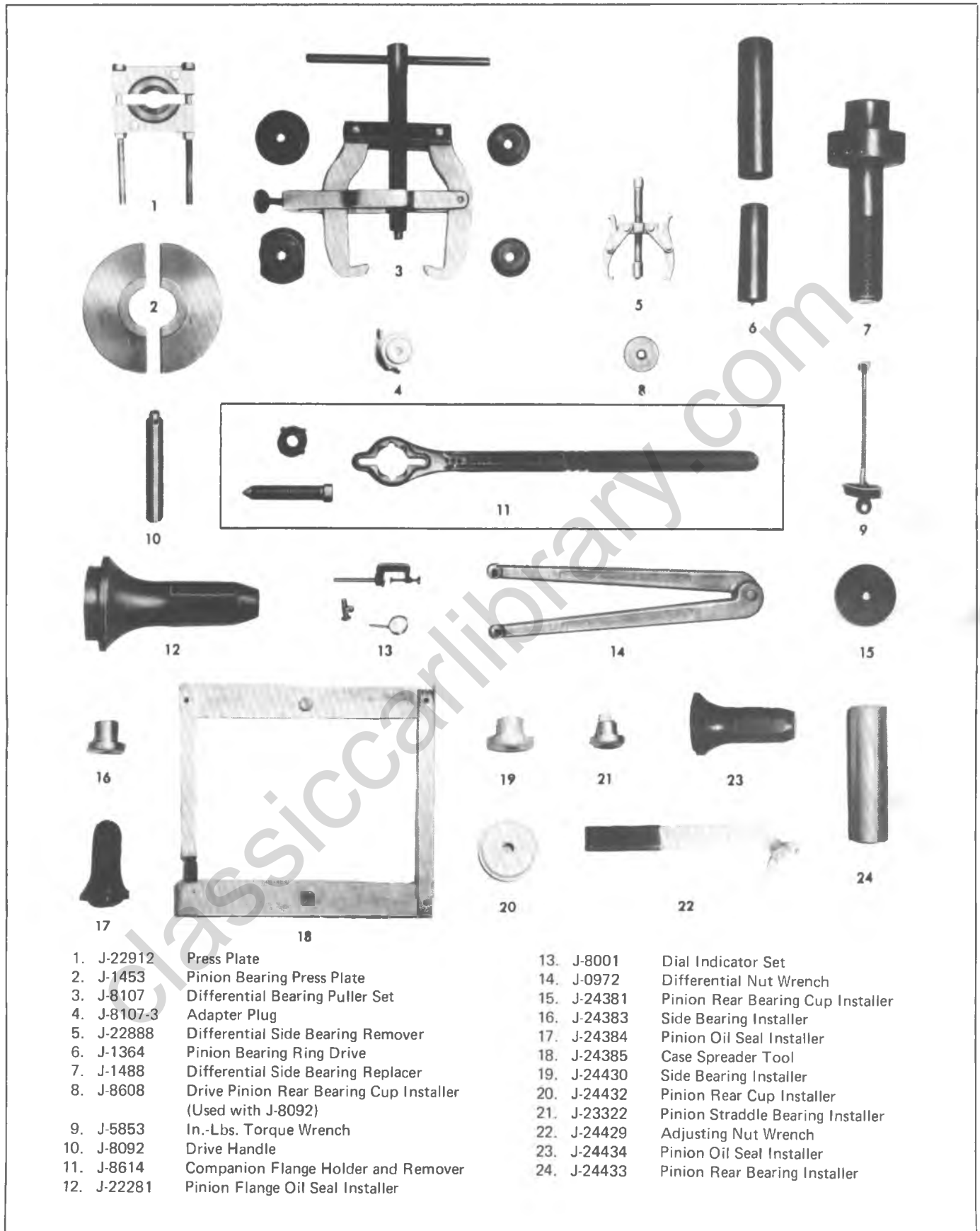

- |             |   |             |                                   |
|-------------|---|-------------|-----------------------------------|
| 1. J-22912  | Press Plate   | 13. J-8001  | Dial Indicator Set                |
| 2. J-1453   | Pinion Bearing Press Plate                                    | 14. J-0972  | Differential Nut Wrench           |
| 3. J-8107   | Differential Bearing Puller Set                               | 15. J-24381 | Pinion Rear Bearing Cup Installer |
| 4. J-8107-3 | Adapter Plug  | 16. J-24383 | Side Bearing Installer            |
| 5. J-22888  | Differential Side Bearing Remover                             | 17. J-24384 | Pinion Oil Seal Installer         |
| 6. J-1364   | Pinion Bearing Ring Drive                                     | 18. J-24385 | Case Spreader Tool                |
| 7. J-1488   | Differential Side Bearing Replacer                            | 19. J-24430 | Side Bearing Installer            |
| 8. J-8608   | Drive Pinion Rear Bearing Cup Installer<br>(Used with J-8092) | 20. J-24432 | Pinion Rear Cup Installer         |
| 9. J-5853   | In.-Lbs. Torque Wrench  | 21. J-23322 | Pinion Straddle Bearing Installer |
| 10. J-8092  | Drive Handle  | 22. J-24429 | Adjusting Nut Wrench              |
| 11. J-8614  | Companion Flange Holder and Remover                           | 23. J-24434 | Pinion Oil Seal Installer         |
| 12. J-22281 | Pinion Flange Oil Seal Installer                              | 24. J-24433 | Pinion Rear Bearing Installer     |

Fig. 2T--Special Tools 10-1/2" and 12-1/4" Ring Gear Differentials

classiccarylbrary.com



## SECTION 4C

# FRONT AXLE DIFFERENTIAL

### (4-WHEEL DRIVE)

#### CONTENTS

Front Axle Differential.....	4C-1	Reassembly .....	4C-6
General Information.....	4C-1	Drive Pinion.....	4C-6
Differential Case.....	4C-1	Installation and Adjustment .....	4C-6
Removal .....	4C-1	Differential Case.....	4C-6
Oil Seal Replacement.....	4C-5	Preload and Adjustment.....	4C-7
Disassembly .....	4C-5	Installation.....	4C-8
Drive Pinion.....	4C-5	Gear Tooth Contact Pattern Check.....	4C-8
Removal .....	4C-5	Gear Tooth Nomenclature .....	4C-8
Inspection.....	4C-5	Test .....	4C-8
Differential Case.....	4C-6	Adjustments.....	4C-8
		Special Tools.....	4C-10

### GENERAL INFORMATION

K10-20 Models use a Chevrolet style front axle, which incorporates an 8-1/2" ring gear. The K-30 axle is a Dana (60 series) which incorporates a 9-3/4" ring gear.

The differential procedures in this section pertain to Dana model axles only. Procedures for the Chevrolet 8-1/2" model are the same as covered previously in Section 4B of this manual.

#### Axle Shaft

##### Removal

1. Siphon master cylinder.
2. Raise vehicle.
3. Remove wheel and tire.
4. Remove caliper.
5. Remove hub lock mechanism.
6. Remove gears and snap rings.
7. Remove rotor.
8. Remove inner bearing and seal.
9. Remove spindle and backing plate.
10. Remove axle shaft.

##### Installation

Prior to installation, the following items should be checked.

- a. Lube spindle bearing.
- b. Clean, inspect and repack inner and outer wheel bearing.
- c. Clean hub and spindle and lube spindle.
1. Install seal and thrust washer on axle shaft.
2. Install axle shaft into axle housing.
3. Install spindle.
4. Install splash shield. Torque nuts to specifications.
5. Install rotor and adjust wheel bearings.
6. Install gears and snap rings.

7. Install hub lock mechanism.
8. Install caliper.
9. Install tire and wheel.
10. Lower vehicle.
11. Add fluid and check brake operation.

#### FRONT AXLE DIFFERENTIAL

##### Differential Case (Dana-Models)

##### Removal (On Vehicle ) Fig. 4C-1

1. Raise the vehicle on a hoist. (Twin Post Hoist under axle).



Fig. 4C-1--Removing Differential Case On Vehicle

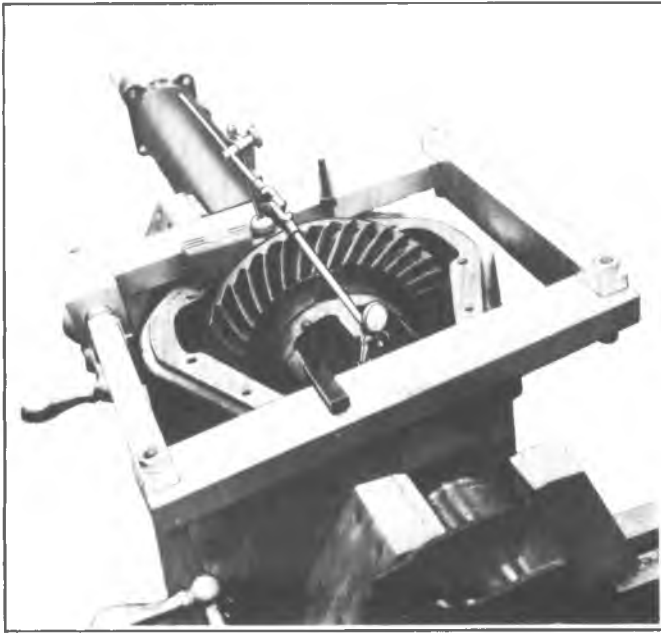

Fig. 4C-2--Spreading Case With J-24385

2. Place jack stands under right hand and left hand frame rails.
3. Disconnect the right shock absorber at the axle.
4. Remove the U-bolt nuts.
5. Disconnect the tie rod at the right hand knuckle.
6. Place a jack stand under the right steering knuckle.
7. Lower the axle on stand, remove U-bolts and move spring aside.

**NOTICE:** Care should be taken so as not to stretch and damage the brake hose.

8. Turn stabilizer bar to spring plate attaching plate bolt and rotate the spring plate to provide clearance for the spreader tool, J-24385.  
If front axle assembly is removed from vehicle, mount assembly in suitable holding fixture.
9. Remove axle shafts as outlined in Axle Shaft Removal, Truck Service Manual.
10. Remove cover attaching bolts and lock washers and the metal tag secured by one of the attaching bolts. Remove cover and gasket.  
The tag shows the number of teeth on pinion and drive gear.
11. Remove differential side bearing caps, making sure they are marked for reassembly in the same position.
12. Position Spreader Tool J-24385 so the two dowels on tool fit into recesses in carrier, install two hold down bolts and install a dial indicator at one end of opening in carrier to indicate width of opening, (Fig. 4C-1 and 4C-2).
13. Expand spreader tool to spread carrier a maximum of .020".  
**NOTICE:** Do not attempt to remove differential without using the spreader tool. Do not expand carrier more than .020 in. or it may be damaged and take a permanent set.
14. Remove dial indicator and, using a pry bar, lift out differential assembly. Remove and tag bearing cups so they may be reinstalled in their original positions. Relieve pressure on spreader tool and remove tool.

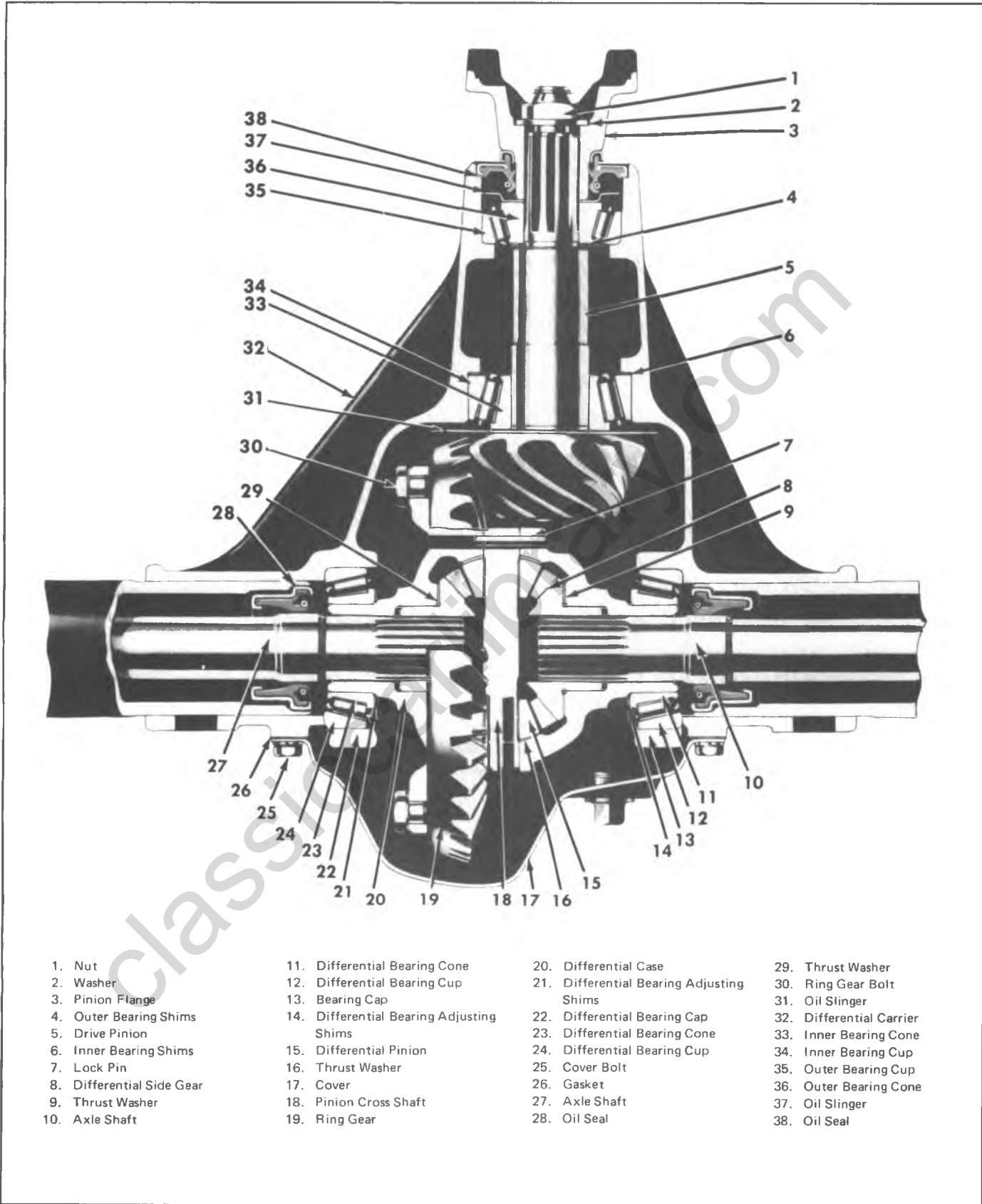

Fig. 4C-3--Front Axle Differential Assembly



## Oil Seal Replacement

The axle shaft inner oil seals are located just outboard of the differential bearings, item 28 Fig. 4C-3. They can be replaced only after the differential is removed from the carrier, using tool J-28648.

## Disassembly

1. Remove bearing cups from differential case and identify for reassembly.
2. Remove bearing cones from case, using puller J-22888 and correct plug (fig. 4C-5) and remove shims from case. Identify all parts so they may be reassembled in their original location.
3. Drive the pinion shaft lock pin out of case.
4. Remove ring gear bolts from case and separate ring gear from case.
5. Remove pinion shaft, pinions, side gears and thrust washers from case.

## DRIVE PINION

### Removal

1. Using Holding Bar J-8614-1, attached to pinion shaft flange, remove self-locking nut and washer from pinion shaft.
2. Install Tool J-8614-2, and 3 into holding bar as shown in Figure 4C-6 and remove flange from drive pinion. Remove drive pinion from carrier.
3. With a long drift, tap on inner race of outer pinion bearing to remove pinion oil seal, slinger gasket, outer pinion cone and roller and shim pack. Tag shim pack for reassembly.
4. Should inspection indicate necessity, pinion earring cups can be removed from carrier using a long drift and hammer. Remove shims and oil slinger which are located behind the inner bearing cup. Tag shims for reassembly.
5. Remove inner pinion cone and roller using Tool J-22912, installed as shown in Figure 4C-7, and press pinion from bearing.

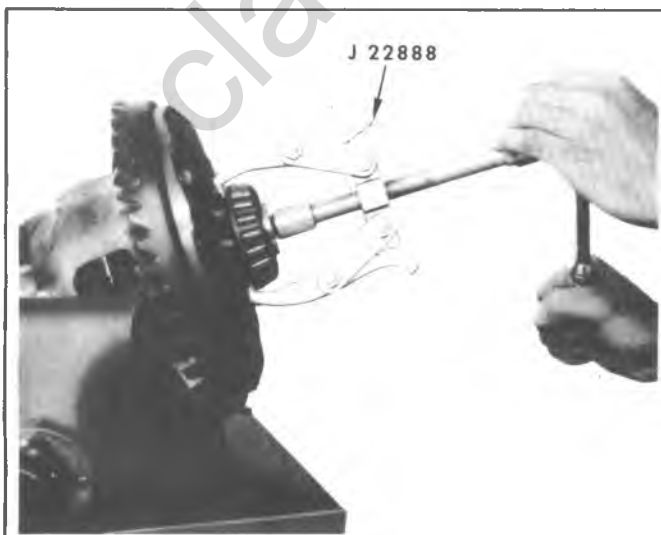

Fig. 4C-5--Removing Side Bearing

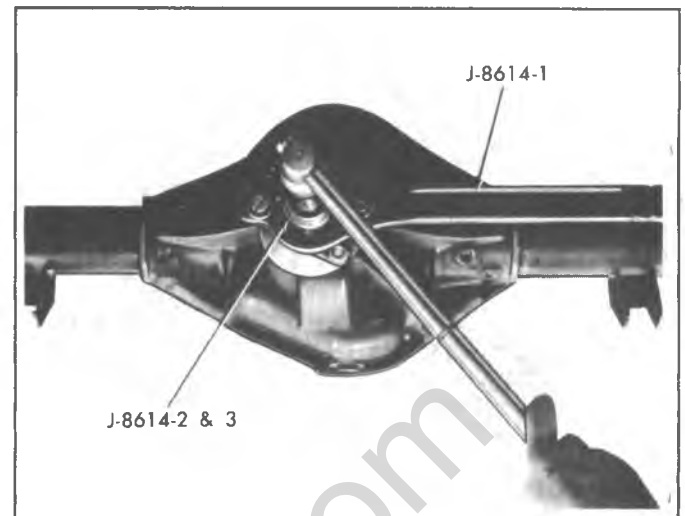

Fig. 4C-6--Removing Pinion Flange

### Inspection

1. Clean all gears and bearings in cleaning solvent and inspect all bearing cups, races and rollers for scoring chipping or evidence of excessive wear. On pinion bearing rollers, inspect large end of rollers for wear. This is where wear is most evident on tapered roller bearings.  
The pinion bearings are of the tapered type, and the natural wear pattern is a frosted condition with occasional slight scratches on races or rollers. This does not indicate a defective bearing.
2. Inspect pinion splines and flange splines for evidence of excessive wear.
3. Inspect ring gear and pinion teeth for possible scoring cracking or chipping.
4. Inspect differential case for cracks or scores or side gears, thrust washers, and pinion thrust faces.
5. Check fit of differential side gears in case.
6. Check fit of side gears and axle shaft splines.
7. Inspect differential pinion shaft and spacer for scoring or evidence of excessive wear.

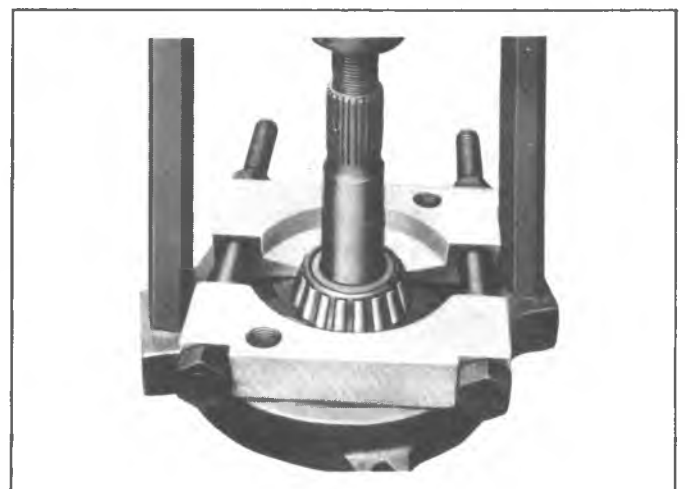

Fig. 4C-7--Removing Inner Pinion Bearing Cone and Roller

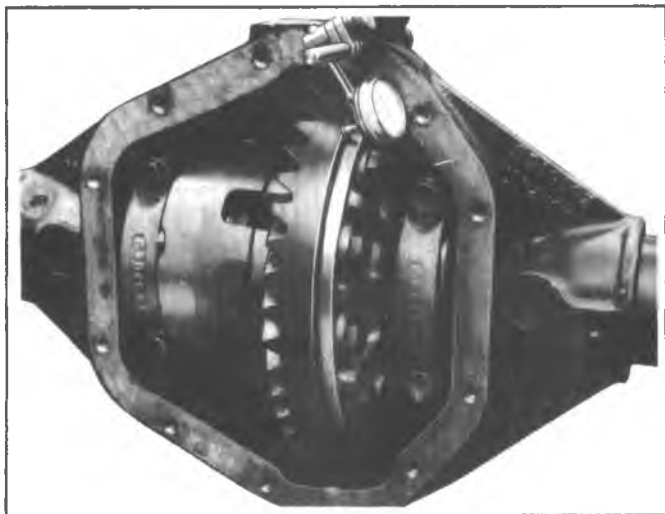

Fig. 4C-8--Checking Runout

## DIFFERENTIAL CASE

### Reassembly

1. Position differential side gears and new thrust washers in differential case.
2. Position differential pinions and new thrust washers in differential case. Align pinions with holes in differential case.
3. Install pinion shaft in differential case. Align hole in shaft with hole in case, then install lock pin. Peen hole to prevent pin dropping out of case.
4. Position ring gear to case, then install cap screws. Tighten cap screws evenly and alternately to specifications.
5. With an arbor press, press differential side bearings onto case using Tool J-22175. Do not install shims at this time.
6. Place differential case in carrier and install bearing caps. Care should be taken to install caps in original position. Use mark placed on caps and carrier at removal. Tighten caps just enough to keep bearing caps in place.
7. Install dial indicator on carrier with indicator button contacting back of ring gear (Fig. 4C-8). Rotate differential case and check for runout. If runout is greater than .002", the assembly should be removed and the ring gear removed from case. Again install differential case and check runout at differential case flange.
8. Should runout of case flange be greater than .002", the defect is probably due to bearings or differential case, and should be corrected before proceeding further.
9. Position two screwdrivers between bearing cup and carrier on opposite side of ring gear (away from dial indicator side). Pull on screwdrivers and force differential case as far as possible toward the dial indicator. Rock the ring gear to set the bearings. With force still applied, set indicator at "0".
10. Reposition screwdrivers between bearing cup and carrier on ring gear side. Pull on screwdrivers and force differential case as far as possible toward center of carrier. Repeat several times until the same reading is obtained. Record the indicator reading. This will be the

total amount of shims needed (less preload) for setting backlash later during assembly.

11. Remove differential from carrier.

## DRIVE PINION

### Installation and Adjustment of Depth and Preload

Ring gears and pinions are supplied in matched sets only. Matching numbers on both pinion and ring gear are etched for verification. If a new gear set is being used, verify the numbers of each pinion and ring before proceeding with assembly.

On the button end of each pinion there is etched a plus + number, a minus - number, or a zero(0) number, which indicates the best running position for each particular gear set. This dimension is controlled by the shimming behind the inner bearing cup. Whenever baffles or oil slingers are used, they become a part of the adjusting shim pack.

For example: If a pinion is etched +3, this pinion would require .003" less shims than a pinion etched "0". This means by removing shims, the mounting distance of the pinion is increased by .003" which is just what a +3 etching indicates. Or if a pinion is etched -3, we would want to add .003" more shims than would be required if the pinions were etched "0". By adding .003" shims, the mounting distance of the pinion was decreased .003" which is just what a -3 etching indicated.

If the old ring and pinion set is to be reused measure the old shim pack and build a new shim pack to this same dimension. If baffle is in the axle assembly, it is considered as part of the shim pack.

To change the pinion adjustment, shims are available in thicknesses of .003", .005" and .010".

If baffle or slinger is bent or mutilated, it should be replaced.

Measure each shim separately with a micrometer and add together to get total shim pack thickness from original build up.

If a new gear set is being used, notice the plus or minus etching on both the old and new pinion, and adjust the thickness of the old shim pack to compensate for the difference of these two figures.

For example: If the old pinion reads +2 and the new pinion is -2, add .004" shims to the original shim pack.

1. Determine proper inner shim pack (for setting pinion depth) by using chart (Fig. 4C-9).
2. Install inner shim pack and oil slinger in inner cup bore and drive inner cup into position using Tool J-21059 used with J-8092.
3. To the outer shim pack (for setting preload) add or remove an equal amount as was added or removed from the inner shim pack.
4. Install outer cup in carrier bore, using installer J-7818 with Drive Handle J-8092.
5. Press inner pinion bearing cone and roller onto pinion shaft using Installer J-9772 on arbor press as shown in Figure 4C-10.
6. Install drive pinion and inner bearing cone and roller assembly in differential carrier.

Old Pinion Marking	New Pinion Marking								
	- 4	- 3	- 2	- 1	0	+ 1	+ 2	+ 3	+ 4
+ 4	+ 0.008	+ 0.007	+ 0.006	+ 0.005	+ 0.004	+ 0.003	+ 0.002	+ 0.001	0
+ 3	+ 0.007	+ 0.006	+ 0.005	+ 0.004	+ 0.003	+ 0.002	+ 0.001	0	- 0.001
+ 2	+ 0.006	+ 0.005	+ 0.004	+ 0.003	+ 0.002	+ 0.001	0	- 0.001	- 0.002
+ 1	+ 0.005	+ 0.004	+ 0.003	+ 0.002	+ 0.001	0	- 0.001	- 0.002	- 0.003
0	+ 0.004	+ 0.003	+ 0.002	+ 0.001	0	- 0.001	- 0.002	- 0.003	- 0.004
- 1	+ 0.003	+ 0.002	+ 0.001	0	- 0.001	- 0.002	- 0.003	- 0.004	- 0.005
- 2	+ 0.002	+ 0.001	0	- 0.001	- 0.002	- 0.003	- 0.004	- 0.005	- 0.006
- 3	+ 0.001	0	- 0.001	- 0.002	- 0.003	- 0.004	- 0.005	- 0.006	- 0.007
- 4	0	- 0.001	- 0.002	- 0.003	- 0.004	- 0.005	- 0.006	- 0.007	- 0.008

Fig. 4C-9--Drive Pinion Shim Chart

- Install shims and outer pinion cone and roller on pinion shaft using Tool J-5590 and companion flange to press bearing onto pinion (Fig. 4C-11).
- Install flange holding bar and install washer and nut on pinion shaft. Torque nut to 255 ft. lbs.
- Remove holding bar and with an inch pound torque wrench measure rotating torque. Rotating torque should be 10 to 20 in. lbs. with original bearings or 20 to 40 in. lb. with new bearings. Torque reading to start shaft turning must be disregarded.
- If torque requirements (preload) are not to specifications, adjust shim pack as necessary. Increase the outer shim pack to reduce rotation torque. Decrease shim pack to increase rotating torque.
- Remove nut, washer and flange from pinion shaft.
- Install oil slinger, gasket and using Tool J-22804 install oil seal.
- Install flange, washer and nut. Torque nut to specifications.

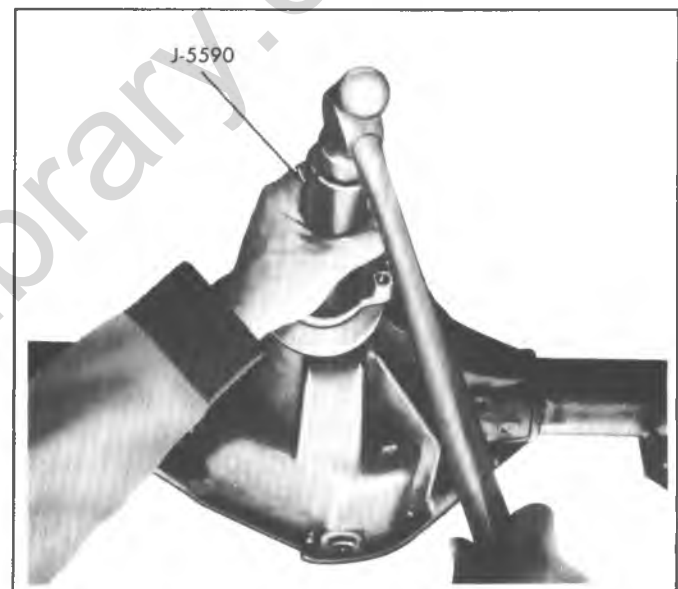

Fig. 4C-11--Installing Pinion Flange

## DIFFERENTIAL CASE

### Preload and Adjustment

- Place differential assembly (with pinion assembled) into housing. Install bearing caps in their proper

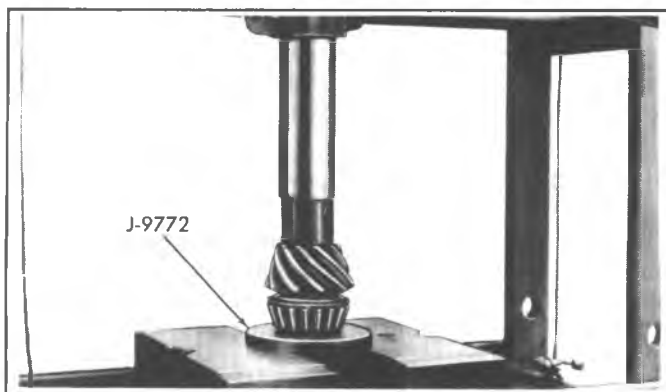

Fig. 4C-10--Installing Inner Pinion Core and Roller

position and tighten screws just enough to hold the bearing cups in place.

- Install dial indicator on carrier with indicator button contacting back of ring gear (Fig. 4C-8).
- Place two screwdrivers between bearing cup and housing on ring gear side of case, and pry ring gear into mesh with pinion gear as far as it will go. Rock ring gear to allow bearings to seat and gears to mesh. With force still applied, set indicator to "0".
- Reposition screw drivers on opposite side of ring gear and pry ring gear as far as it will go. Now take and indicator reading. Repeat until the same reading is obtained every time. This reading will be the necessary amount of shims between the differential case and differential bearing on the ring gear side. Remove differential bearing from the ring gear side and assemble proper amount of shims. Reassemble bearing.
- Remove the differential bearing from the opposite side of ring gear. To determine the amount of shims needed here, use the following method.

- a. Subtract the size of shim pack just installed on ring gear side of case from the reading obtained and recorded in step 10 of Differential Case Reassembly.
  - b. To this figure, add an additional .015" shims to compensate for preload and backlash.  
Example: If reading in step 10 of Differential Case-Reassembly was .085" and the shims installed on ring gear side of case was .055", the correct amount of shim will be  $.085" - .055" + .015" = .045"$ .
6. Install shims as indicated in step 5, (which will give the proper bearing preload and backlash) and install side bearing.

#### Installation

1. Spread differential carrier, using spreader as shown in Figure 4C-1 and 4C-2.
2. Install differential bearing cups in their correct locations then install differential case into carrier.
3. Install differential bearing caps in the correct location as indicated by marks made at disassembly. Install cap screws finger tight. Rotate differential assembly and rap on case with a soft-faced hammer to ensure proper seating of case in carrier.
4. Remove spreader and torque cap bolts to specifications.
5. Install dial indicator and check ring gear backlash at four equally spaced points around the ring gear. Backlash must be held to .004" to .009" and must not vary more than .002" between positions checked.
6. Whenever backlash is not within limits, differential bearing shim pack should be corrected to bring backlash within limits.
7. Check gear tooth contact as described in "Gear Tooth Contact Pattern Check".
8. After a successful pattern check, install housing cover using a new gasket.
9. Install axle shafts and install axle assembly into vehicle (See Service Manual).
10. Fill with recommended lubricant, lower vehicle to floor and road test vehicle.

#### GEAR TOOTH CONTACT PATTERN CHECK

Prior to final assembly of the differential, a Gear Tooth Contact Pattern Check is necessary to verify the correct relationship between ring gear and drive pinion. Gear sets which are not positioned properly may be noisy, or have short life, or both. With a pattern check, the most desirable contact between ring gear and drive pinion for low noise level and long life can be assured.

#### Gear Tooth Nomenclature

The side of the ring gear tooth which curves outward, or is convex, is referred to as the "drive" side. The concave side is the "coast" side. The end of the tooth nearest center of ring gear is referred to as the "toe" end. The end of the tooth farthest away from center is the "heel" end. Toe end of tooth is smaller than heel end. See Figure 4C-12.

#### Test

1. Wipe oil out of carrier and carefully clean each tooth of ring gear.
2. Use gear marking compound and apply this mixture sparingly to all ring gear teeth using a medium stiff

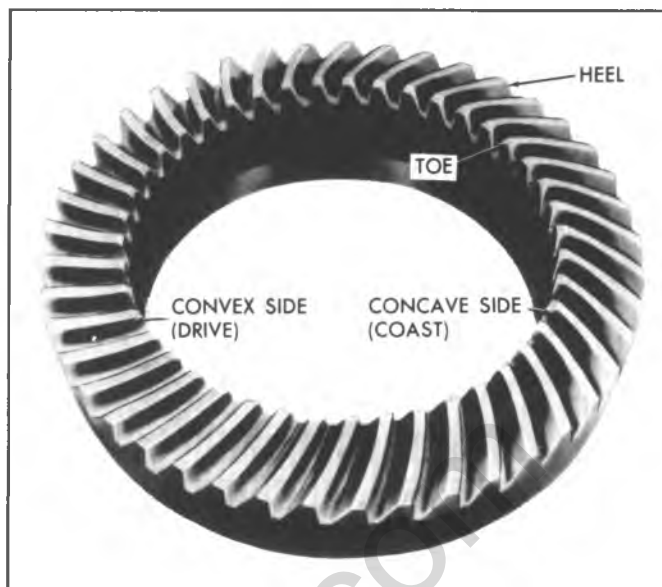

Fig. 4C-12--Gear Tooth Nomenclature

brush. When properly used, the area of pinion tooth contact will be visible when hand load is applied.

3. Tighten bearing cap bolts to 55 lb. ft.
4. Apply a load until a torque of 40-50 lb. ft. is required to turn the pinion.  
A test made without loading the gears will not give a satisfactory pattern. Turn companion flange with wrench so that ring gear rotates one full revolution then reverse rotation so that ring gear rotates one revolution in opposite direction. Excessive turning of ring gear is not recommended.
5. Observe pattern on ring gear teeth and compare with Figure 4C-13.

#### Adjustments Affecting Tooth Contact

Two adjustments can be made which will affect tooth contact pattern. These are backlash and position of drive pinion in carrier. The effects of bearing preloads are not readily apparent on hand loaded teeth pattern tests: however, these adjustments should be within specifications before proceeding with backlash and drive pinion adjustments.

It may be necessary to adjust both pinion depth and backlash to obtain the correct pattern.

The position of the drive pinion is adjusted by increasing or decreasing the shim thickness between the pinion head and inner race of rear bearing. The shim is used in the differential to compensate for manufacturing tolerances. Increasing shim thickness will move the pinion closer to centerline of the ring gear. Decreasing shim thickness will move pinion farther away from centerline of the ring gear.

Backlash is adjusted by means of the side bearing adjusting shims which moves the entire case and ring gear assembly closer to, or farther from the drive pinion. (The adjusting shims are also used to set side bearing preload). To increase backlash, increase right shim and decrease left shim an equal amount. To decrease backlash decrease right shim and increase left shim an equal amount.

The important thing to note is that the contact pattern is centrally located up and down on the face of the ring gear teeth.



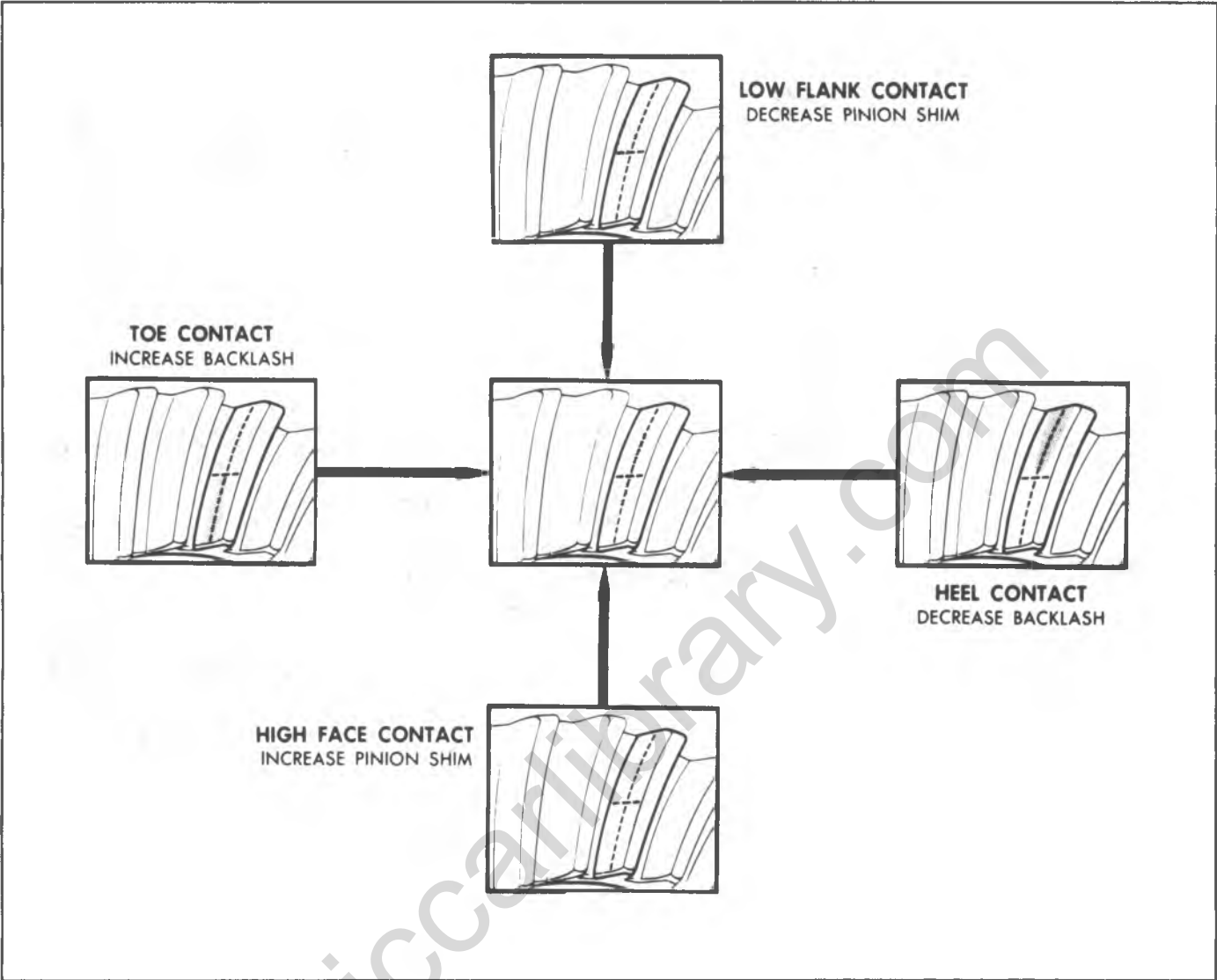

Fig. 4C-13--Gear Tooth Pattern Contact Pattern

classiccarrlibrary.com

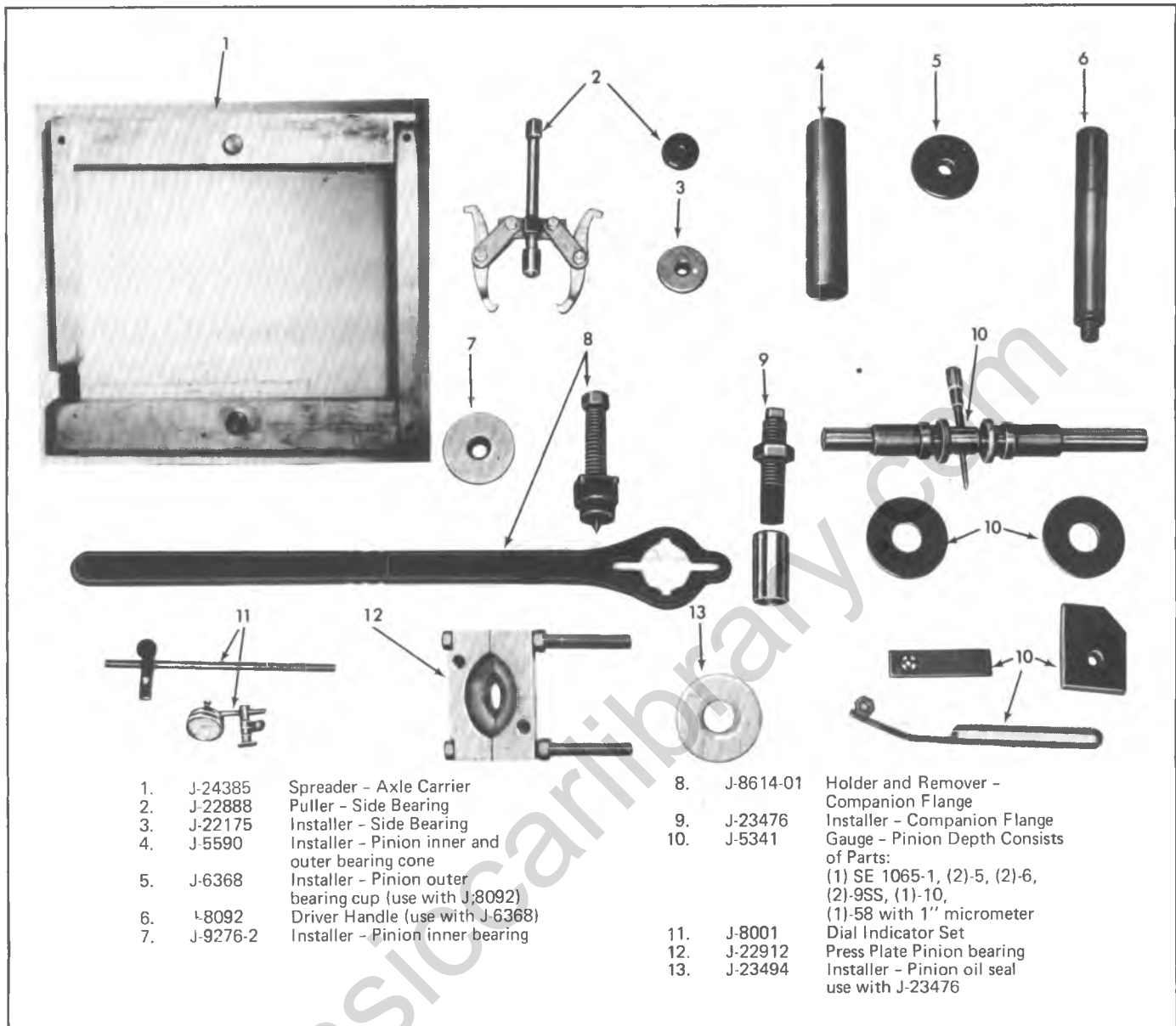

Fig. 4C-14--Special Tools Chart 4C-A

## SECTION 5

# BRAKES

The following notice applies to one or more steps in the assembly procedure of components in this portion of the manual as indicated at appropriate locations by the terminology "See Notice on page 1 of this section".

**NOTICE:** This fastener is an important attaching part in that it could affect the performance of vital components and systems, and/or could result in major repair expense. It must be replaced with one of the same part number or with an equivalent part if replacement becomes necessary. Do not use a replacement part of lesser quality or substitute design. Torque values must be used as specified during reassembly to assure proper retention of this part.

### CONTENTS

Delco Tandem Power Brake Unit .....	5-1
Bendix Tandem Power Brake Unit .....	5-7
Delco Single Diaphragm Power Brake Unit .....	5-13
Bendix Single Diaphragm Power Brake Unit .....	5-18
Bendix Hydro-Boost Power Unit .....	5-22
Bendix Hydro-Boost II Power Unit .....	5-28

## DELCO TANDEM POWER BRAKE UNIT

### UNIT REPAIR

#### GENERAL DESCRIPTION

This booster is a tandem vacuum suspended unit. In a normal operating mode, with the service brakes in the released position, a tandem vacuum suspended booster operates with vacuum on both sides of its diaphragms. When the brakes are applied, air at atmospheric pressure is admitted to one side of each diaphragm to provide the power assist.

**NOTICE:** To prevent damage to brake parts, use all components included in repair kits to service this booster. Lubricate rubber parts with silicone grease provided in kits. Torque values specified are for dry, unlubricated fasteners.

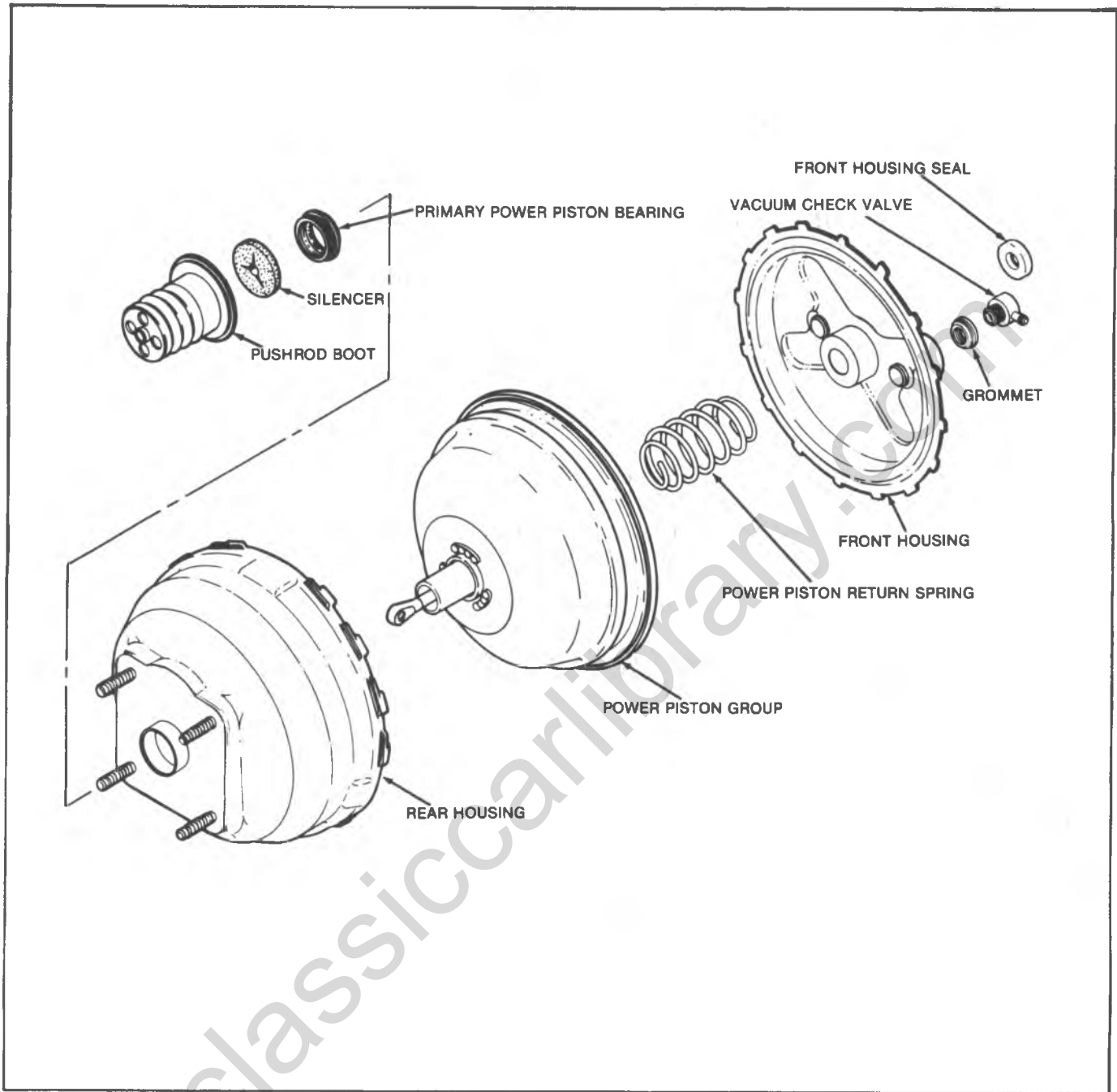

Fig. 5-1A--Booster Assembly Exploded

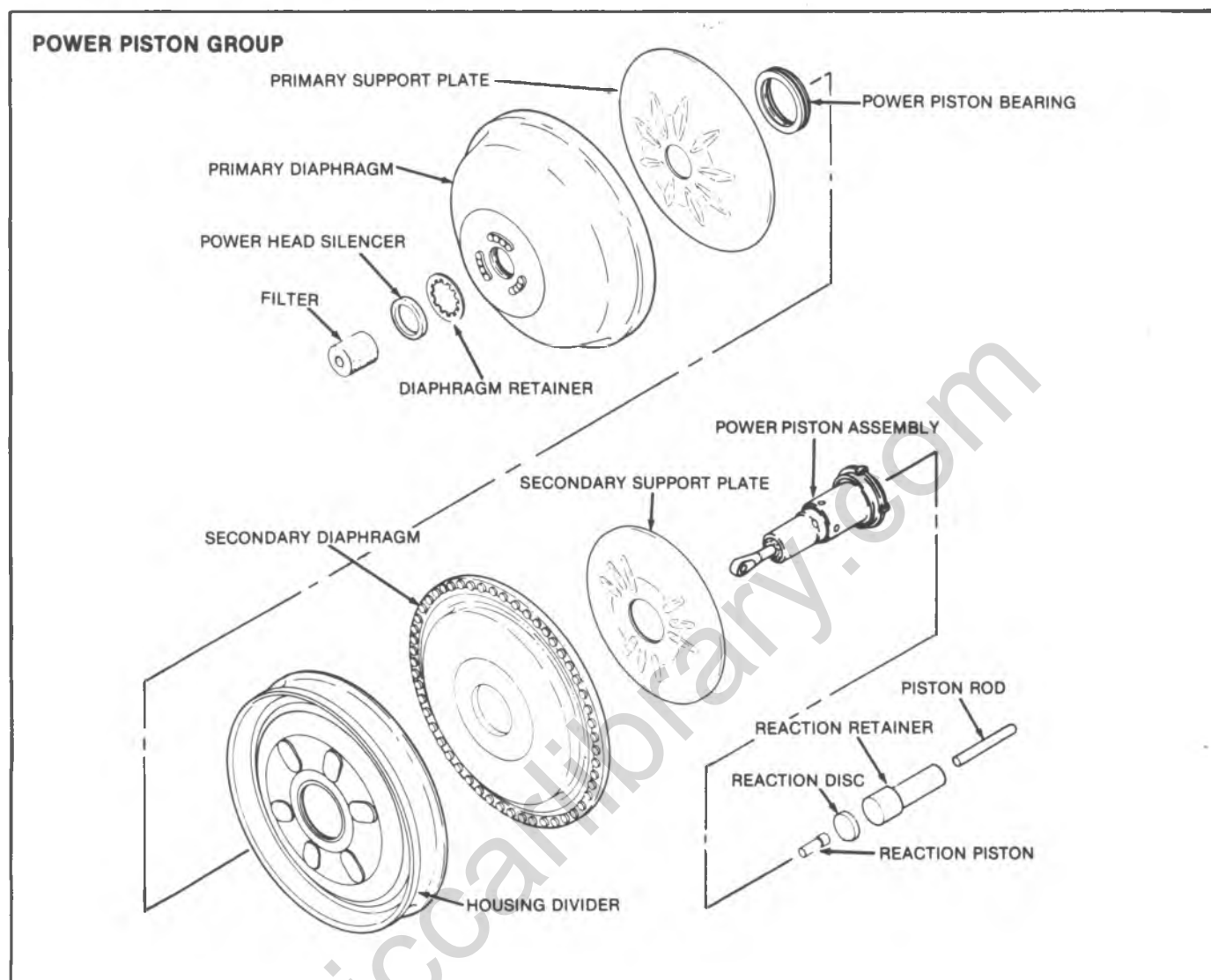

Fig. 5-2A--Power Piston Group

**1. REMOVE AND INSTALL BOOSTER.**

**REMOVE**

1. Disconnect master cylinder from booster and disconnect booster pushrod as shown.
2. Remove attaching nuts and remove booster as shown.

**INSTALL**

SEE NOTICE ON PAGE 5-1 OF THIS SECTION.

1. Install booster to cowl as shown. Torque attaching nuts to 30-45 N-m (22-33 ft-lb).
2. Connect booster pushrod.
3. Install master cylinder on booster and torque attaching nuts to 30-45 N-m (22-33 ft-lb).

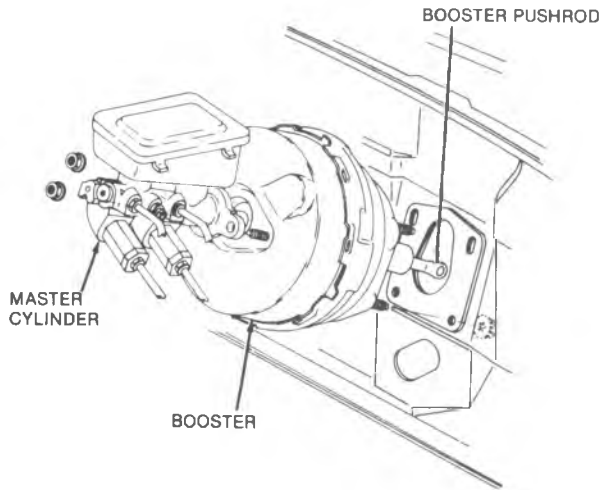

**2. REMOVE AND INSTALL EXTERIOR COMPONENTS.**

**REMOVE**

1. Remove parts as shown.

**INSTALL**

1. Lubricate inside and outside diameters of grommet and front housing seal.
2. Install parts as shown.

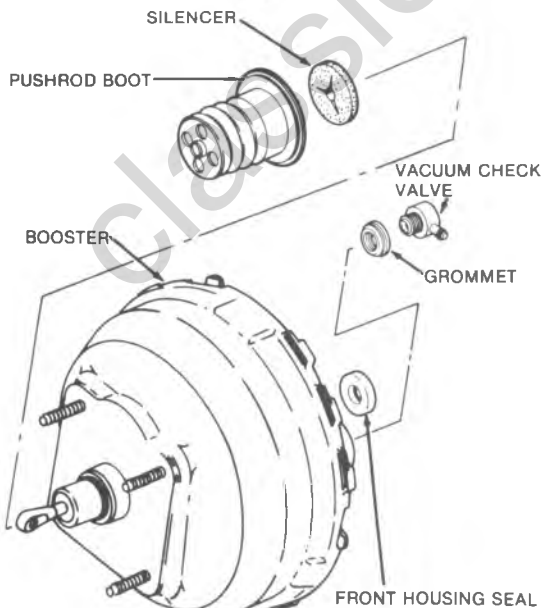

**3. UNLOCKING AND LOCKING BOOSTER**

**DISASSEMBLE**

1. Unlock booster as shown in A and disassemble booster as shown.

**ASSEMBLE**

1. Assemble parts as shown.
2. Lock housing as shown in A.
3. Stake housing as shown in B.

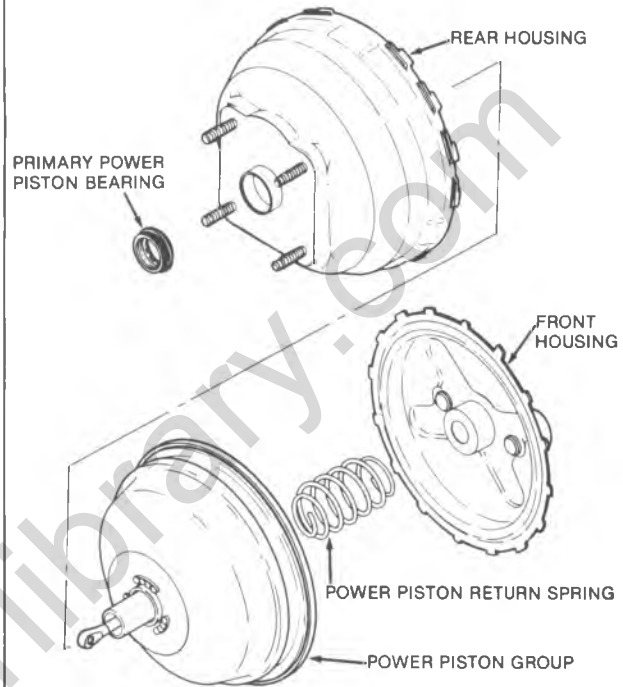

**A.**

**UNLOCKING BOOSTER**

1. Scribe a mark on front and rear housings to facilitate assembly.
2. Press down on tool J-9504 and turn counterclockwise to unlock housing.

**LOCKING BOOSTER**

1. Align scribe marks.
2. Press down on tool J-9504 and turn clockwise to lock front and rear housings. Assembly can be facilitated by connecting a vacuum source to the booster.

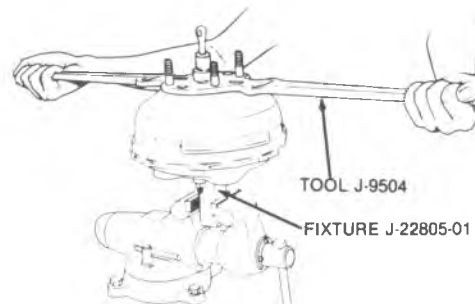

Fig. 5-3A--Service

**3. (CONT)**

**B.**

**STAKING**

1. Stake housing as shown after locking.
2. Do not stake a tab that has been previously staked.

STAKE

STAKE AT TWO TABS 180° APART

UNSTAKED TAB

STAKE

STAKING TAB SOCKET WITH SCREW DRIVER

**4. DISASSEMBLY AND ASSEMBLY OF POWER PISTON GROUP.**

DISASSEMBLE	ASSEMBLE
1. Remove piston rod, reaction retainer, and power head silencer.	1. Lubricate inside diameter of secondary diaphragm lip and fit in secondary support plate.
2. Grasp assembly at outside edge of divider and diaphragms. Hold with pushrod down against a hard surface. Use a slight force of impact to dislodge diaphragm retainer.	2. Install secondary diaphragm and support plate as shown in A.
3. Remove parts as shown.	3. Lubricate inside diameter of secondary power piston bearing and install in housing divider as shown, flat surface of bearing on same side as 6 raised lugs on divider.
	4. Install secondary power piston and divider as shown in B.
	5. Lubricate inside diameter of primary diaphragm lip and fit in primary support plate.
	6. Install primary diaphragm and support plate as shown in C.
	7. Install diaphragm retainer and seat as shown in D.

**4. (CONT)**

PRIMARY DIAPHRAGM

DIAPHRAGM RETAINER

POWER HEAD SILENCER

HOUSING DIVIDER

SECONDARY POWER PISTON BEARING

PRIMARY SUPPORT PLATE

SECONDARY SUPPORT PLATE

SECONDARY DIAPHRAGM

PUSHROD

REACTION RETAINER

PISTON ROD

POWER PISTON ASSEMBLY

Fig. 5-4A--Service

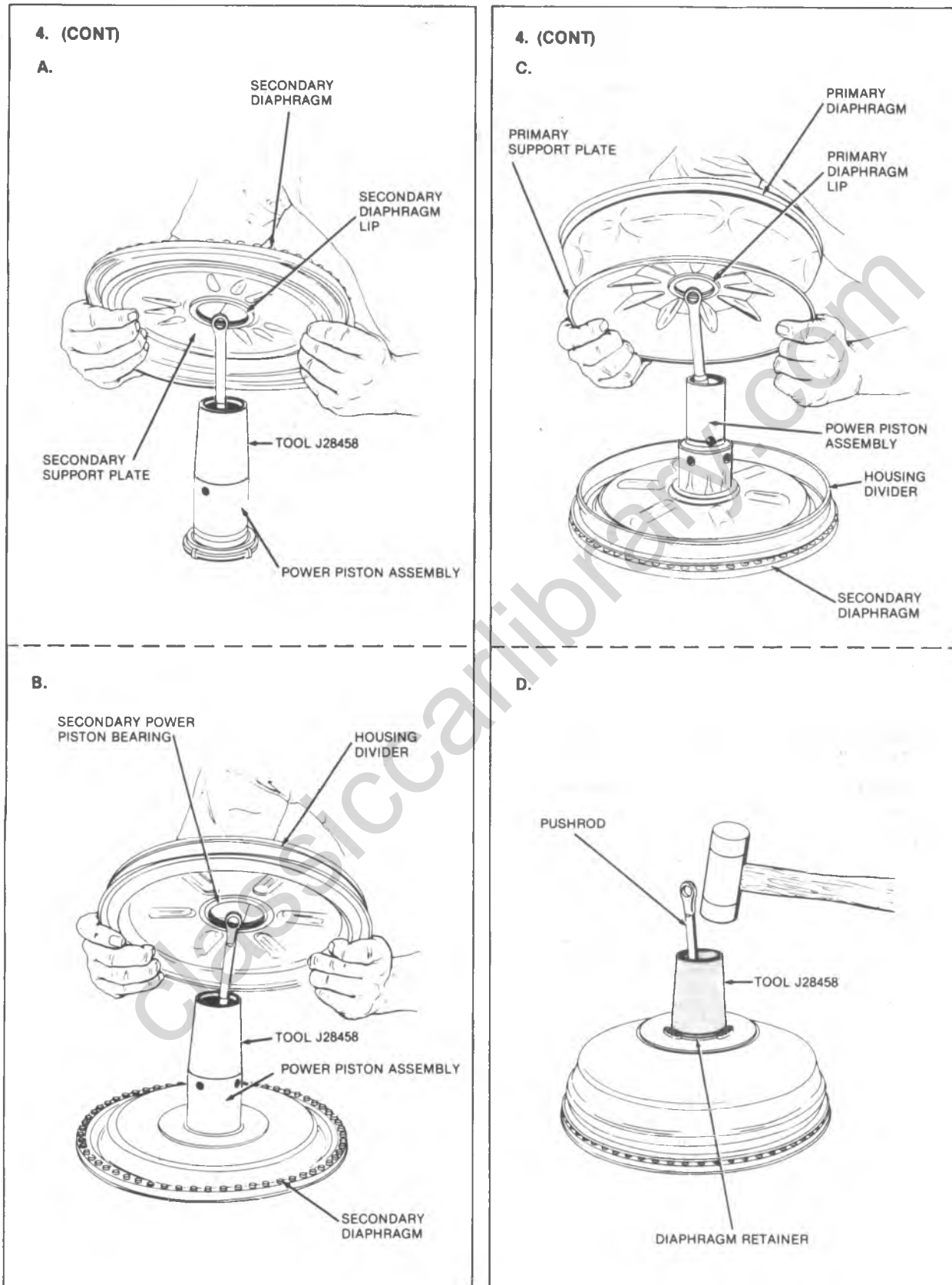

Fig. 5-5A--Service



## 5. GAGING PROCEDURE

### GAGING

1. After assembly of booster, position gage over piston rod as shown.
2. If piston rod height is not within GO-NO-GO limits of gage, procure and use a service-adjustable piston rod to obtain correct height.

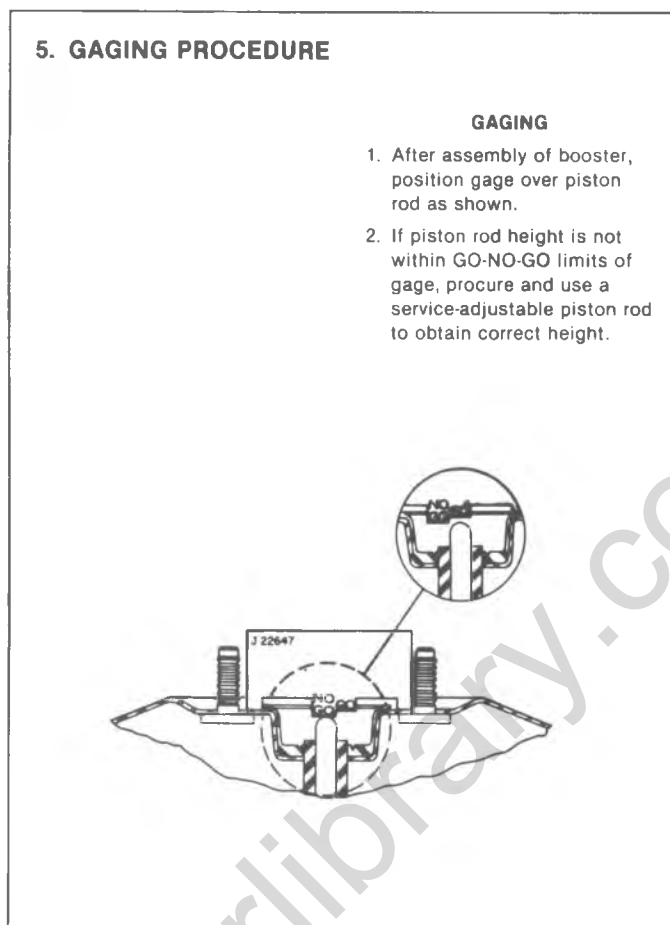

Fig. 5-6A--Gaging Procedure

# BENDIX TANDEM POWER BRAKE UNIT

## UNIT REPAIR

### Disassembly

1. Scribe a line across the front and rear housings to facilitate reassembly.
2. Carefully remove hydraulic push rod and seal and slide seal from rod.
3. Remove vacuum check valve and grommet.
4. Remove dust boot and silencer from operating valve rod.
5. Remove dust guard retainer, dust guard and silencers from rear plate hub with an awl. Then reinstall steel retainer on hub.
6. Squirt denatured alcohol down the operating valve rod to lubricate rubber grommet in the valve plunger.
7. Position two small blocks of wood on either side of air valve rod and install end of air valve rod in vise, leaving just enough clearance to position two (2) open end wrenches between the vise and retainer on hub of rear plate.
8. Using the wrench nearest the vise as a pry, force the air valve off the ball end of the rod. DO NOT damage the plastic hub or allow vacuum cylinder to fall to the floor (fig. 5-1B and 5-2B).

9. The edge of the rear housing contains twelve (12) lances. Four (4) of these lances (one in each quadrant)

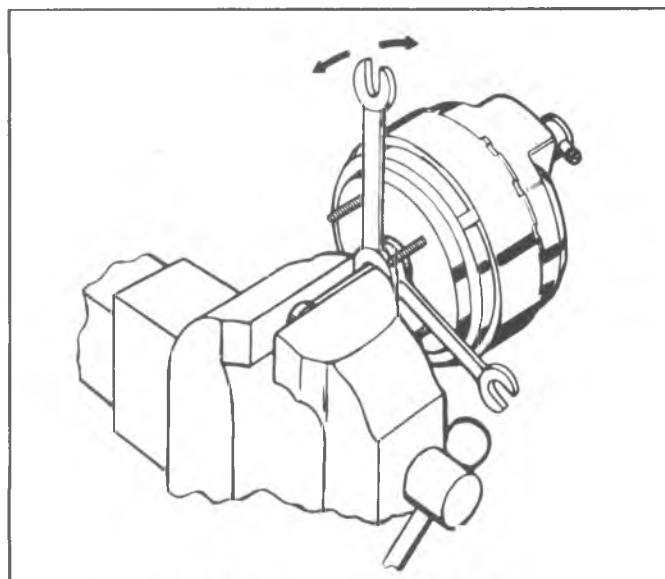

Fig. 5-1B--Removing Air Valve Rod

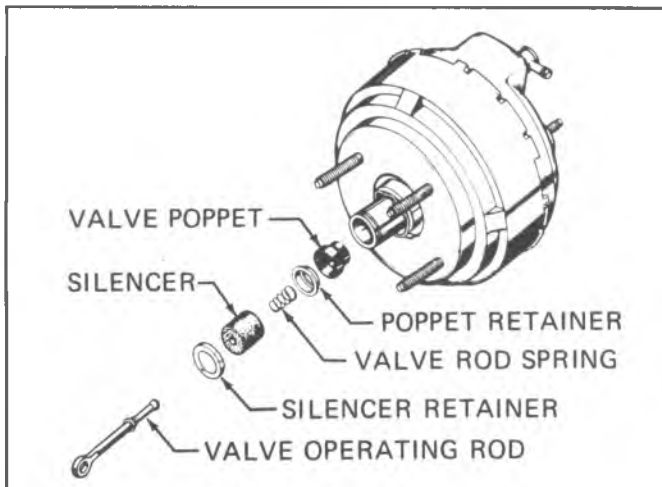

Fig. 5-2B--Air Valve Rod Assembly

are deeper than the other lances. The metal that forms the four (4) deep lances must be partially straightened so that the lances will clear the cutouts in the front housing. If the metal tabs that form the deep lances break during straightening, the housing must be replaced (fig. 5-3B).

10. Remove the hydraulic push rod and vacuum seal from the front housing.
11. Attach base of Holding Fixture J-22805 to front housing with nuts and washers and draw down tight to eliminate bending or damage to studs.
12. Place power unit with Holding Fixture J-22805 in an arbor press with rear housing up and secure to plate of press by a suitable means of holding Tool J-22805 (fig. 5-4B). By using a 1-1/2" open end wrench on Tool J-22805 and allowing unit to turn against back of arbor press, press will hold unit from turning.

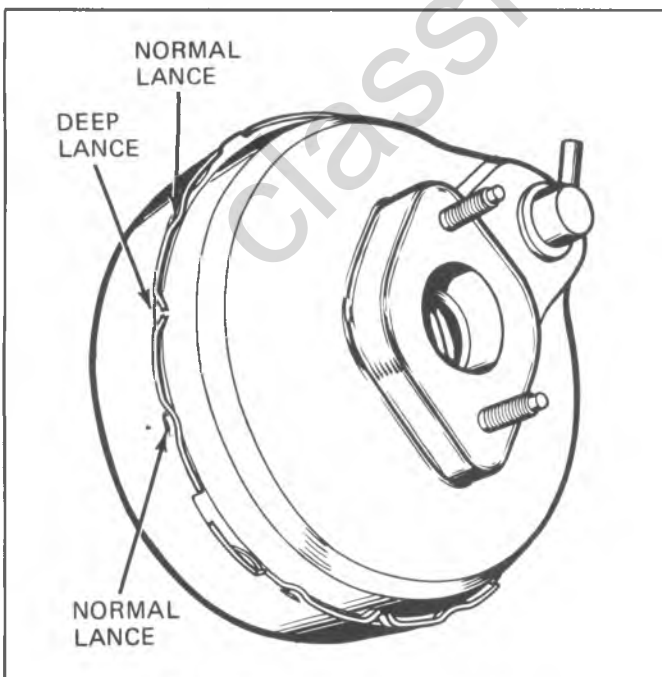

Fig. 5-3B--Lances in Rear Housing

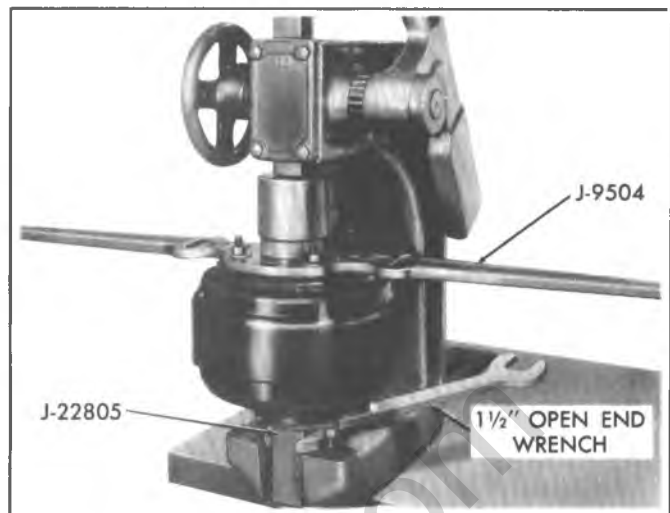

Fig. 5-4B--Holding and Separating Housings Using J-22805 and J-9504 in Arbor Press

13. Place Spanner Wrench J-9504 over studs on rear shell (fig. 5-4B). Use three washers and nuts to attach wrench to housing. Use a suitable piece of pipe of approximately two inches I.D. and approximately three inches in length. Place over plastic diaphragm plate hub. Place a piece of flat stock steel over end of pipe and press rear housing down far enough to relieve tension of diaphragm rubber lip and spring.
  14. Rotate spanner bar counterclockwise until the lances in the edge of the rear housing are aligned with the cutouts in the front housing. Considerable effort may be required to rotate the front housing.
- CAUTION:**The diaphragm return spring is compressed in the power section and expands as the pressure on the housings is removed. If the housings do not separate when the screw has been turned slightly to reduce the pressure, tap the housings with a rubber hammer to break the bond.
15. Slowly release press to permit the two housings to separate.
  16. Continue to release press until diaphragm spring tension has been removed.
  17. Remove the front housing and return spring.
  18. Remove three nuts and washers from Spanner Wrench and separate wrench and rear housing.
  19. Remove Holding Fixture J-22805 from front housing.
  20. Work edges of front diaphragm from under lances of rear housing and remove complete vacuum assembly from rear housing, using care not to damage rear housing seal. Bosses on center plate must be aligned with cutouts in rear housing to remove the assembly.
  21. Wet the rear diaphragm retainer with denatured alcohol and remove the retainer using fingers only.
  22. Clamp Tool J-22839 in a vise. Place the diaphragm and plate assembly on the tool with the tool seated in the hex opening in the front plate.
  23. Twist the rear diaphragm plate counterclockwise, using hand leverage on the outer edge of the plate. It may be necessary to use a 1" x 1-3/16" x 8" wood strip as a

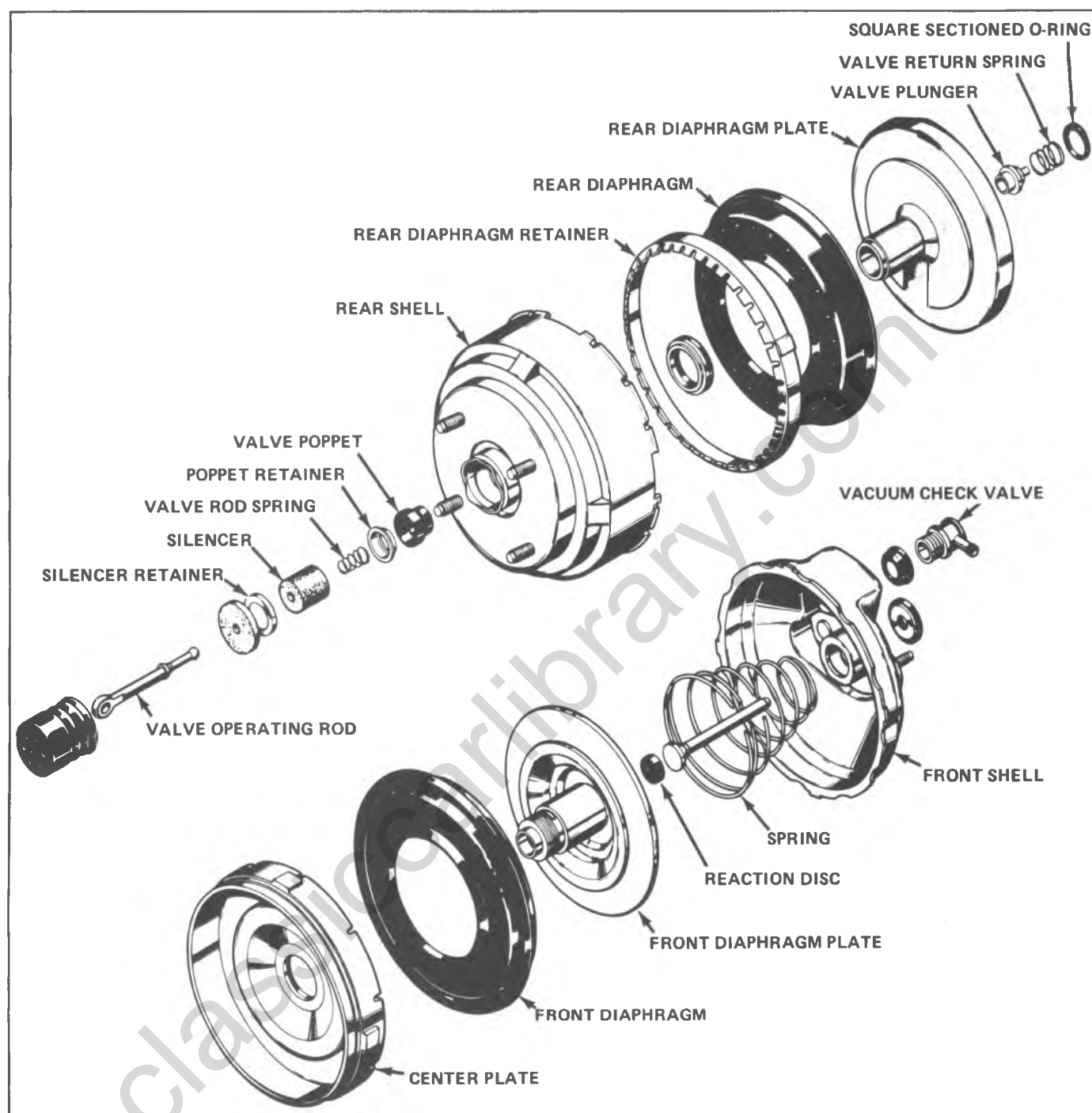

Fig. 5-5B--Diaphragm and Plates

- lever in cover slot on outside circumference of rear plate.
24. After the two (2) plates have been loosened, remove the plates from Tool J-22839 and place on a bench with the front plate down. Unscrew the rear plate completely and carefully lift it off the front plate hub, grasping the air valve plunger and valve return spring as the parts are separated (fig. 5-5B).
  25. Remove the square ring seal from the shoulder of the front diaphragm plate hub.
  26. Remove the reaction disc from inside the front diaphragm plate hub. Carefully slide the center plate off the hub of the front plate.
  27. Remove the diaphragms from the plates.
  28. Use a blunt punch or 1-1/4" socket to drive seal from rear housing (figs. 5-6B and 5-7B).

### Cleaning

All parts to be reused should be washed in denatured alcohol or brake fluid. Dry the parts with compressed air and place them on clean paper or lint free cloth.

Small rust spots inside the shells may be removed with crocus cloth or fine emery cloth. Be sure to clean thoroughly after using any abrasive.



Fig. 5-6B--Removing Rear Seal

Inspect all parts and replace any that are damaged or show excessive wear.

### Assembly

1. Press the new bearing and seal into the cavity in the rear housing using Tool J-22677 (fig. 5-8B). The flat rubber surface of the seal should be  $5/16$ " below the flat, inside surface of the rear housing.
2. Install reaction disc in hub of front plate with small tip toward hole. Use rounded rod to seat disc.
3. Mount Tool J-22839 in vise.
4. Install front diaphragm on front plate. Long fold of diaphragm must be facing down.
5. Install Tool J-22733 over threads on front plate hub (fig. 5-9B).
6. Apply a light film of silicone lubricant to front plate hub and to seal in center plate, then guide center plate, seal first, onto the front plate hub, being careful not to damage center plate seal. Remove Seal Protector J-22733.

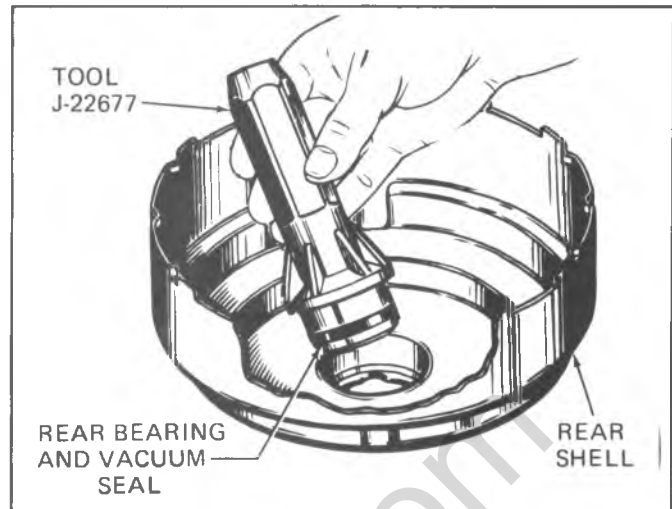

Fig. 5-8B--Installing Rear Bearing and Vacuum Seal

7. Apply a light coat of silicone lubricant to bearing surfaces of air valve plunger, being careful not to apply lubricant to rubber grommet inside plunger. Install square ring seal on shoulder of front plate hub and install valve plunger return spring and plunger in base of front plate hub (fig. 5-10B).
8. Set rear plate over hub of front plate, and using hands only, screw plate on hub, making sure that valve and spring are properly aligned. Hand torque plates to 150 in. lbs. Check travel of valve plunger with index finger.
9. Assemble rear diaphragm to rear plate and place lip of diaphragm in groove in rear plate. Install diaphragm retainer over rear diaphragm and lip of center plate. Using fingers, press retainer until it seats on shoulder of center plate (fig. 5-11B).
10. Apply talcum powder to inside wall of rear housing and silicone lubricant to the scalloped cutouts of front housing and to seal in rear housing. Assemble diaphragm and plate assembly into rear housing by carefully guiding rear plate hub through seal in rear housing. Bosses on center plate must be aligned between lances in rear housing for reassembly. Work

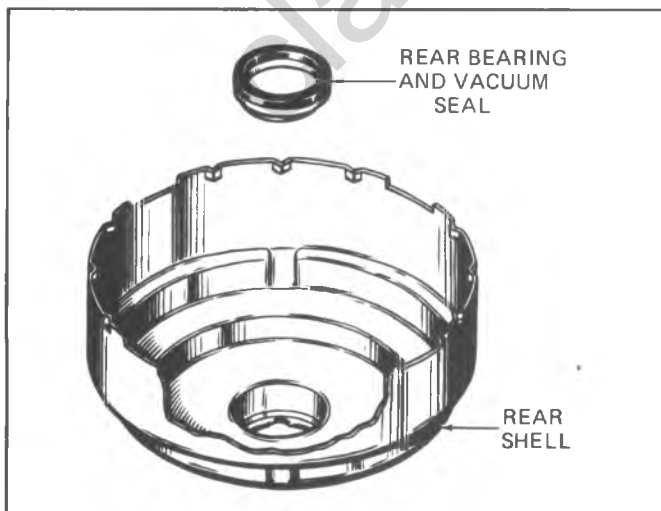

Fig. 5-7B--Rear Bearing and Rear Shell

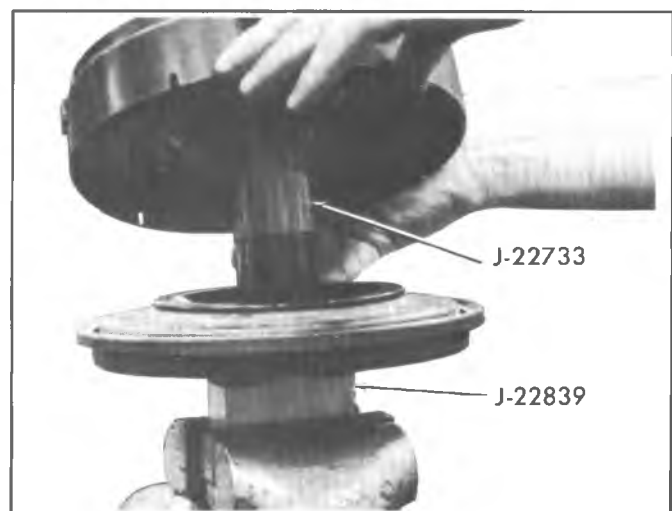

Fig. 5-9B--Seal Protector J-22733 Installed



Fig. 5-10B--Installing Air Valve Plunger

outer rim of front diaphragm into rear housing with screwdriver blade so that it is under lances in housing.

11. Attach base of Holding Fixture J-22805 to front housing with nuts and washers and draw down tight to eliminate bending or damage to studs.
12. Secure front housing and Holding Fixture J-22805 on arbor press plate by a suitable means (fig. 5-4B).
13. Place Spanner Wrench J-9504 over studs on rear housing. Use three washers and nuts to attach wrench to housing. Place a suitable piece of pipe (approximately two inch I.D. and approximately three inches in length) over plastic diaphragm plate hub. Place a piece of flat stock steel over end of pipe.
14. Install diaphragm return spring so that small end of spring is against front housing.
15. Place rear housing over front housing, and align scribe marks.



Fig. 5-11B--Installing Rear Diaphragm Retainer

16. Rotate spanner wrench clockwise until housings are locked together. Bend tabs of the four deep lances back to their original position.
17. Remove three nuts and lock washers securing rear housing to spanner wrench.
18. Remove Holding Fixture J-22805 from front housing by removing two nuts and washers.
19. Wet poppet valve with denatured alcohol and assemble in rear plate hub, small end first. Wet poppet retainer with denatured alcohol and assemble with shoulder inside poppet. Assemble retainer, filters and silencer over ridge on rod and return spring over ball end of operating valve rod. Wet grommet in valve plunger with denatured alcohol and guide air valve rod into valve plunger. Tap end of operating valve rod with plastic hammer to lock ball in grommet. Press filters and silencers into hub and install retainer on hub.
20. Assemble silencer in dust boot, wet dust boot opening with denatured alcohol and assemble over operating valve rod and over flange of rear housing.
21. Install **new** check valve and grommet
22. Apply silicone lubricant to piston end of hydraulic push rod and insert in cavity in front plate. Twist rod to eliminate air bubbles at reaction disc. Assemble seal over push rod and press into recess in front housing.

#### Piston Rod Gauging

1. Place the power head assembly in a padded vise (front housing up); *Do not clamp tight.*
2. Remove the front housing seal to assure that no vacuum is in the power head while gaging.
3. Insert the master cylinder piston rod, flat end first, into the piston rod retainer.
4. Press down on the master cylinder piston rod (with approximately a 40-50 pound load) to be sure it is properly seated.
5. Place Gage J-22647 over the piston rod in a position which will allow the gage to be slipped to the left or right without contacting the studs (fig. 5-12B).
6. The center section of the gage has two levels. The piston rod should always contact the longer section (lower

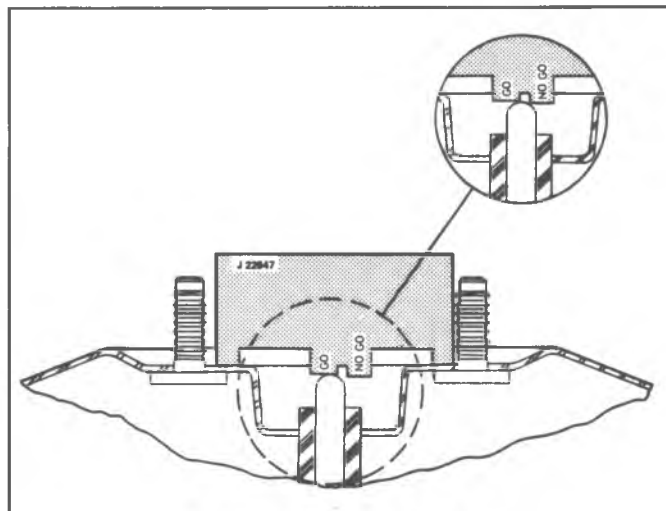

Fig. 5-12B Gaging Piston Rod

level) of the gage. The piston rod should **never** contact the shorter section (higher level) of the gage. Move gage from side to side to check piston rod height.

7. Any variation beyond these two limits must be compensated for by obtaining the service adjustable piston rod

and adjusting the self-locking screw to meet the gaging specifications.

8. Wipe a thin film of silicone lubricant on the I.D. of the front housing seal and position seal in the depression in the housing.

classiccarlibrary.com

# DELCO SINGLE DIAPHRAGM POWER BRAKE UNIT

## UNIT REPAIR

### GENERAL DESCRIPTION

This booster is a 240mm, single diaphragm vacuum suspended unit. In a normal operating mode, with the service brakes in the released position, a vacuum suspended booster operates with vacuum on both sides of its diaphragm. When the brakes are applied, air at atmospheric pressure is admitted to one side of the diaphragm to provide the power assist.

**NOTICE:** To prevent damage to brake parts, use all components included in repair kits to service this booster. Lubricate rubber parts with silicone grease provided in kits. Torque values specified are for dry, unlubricated fasteners.

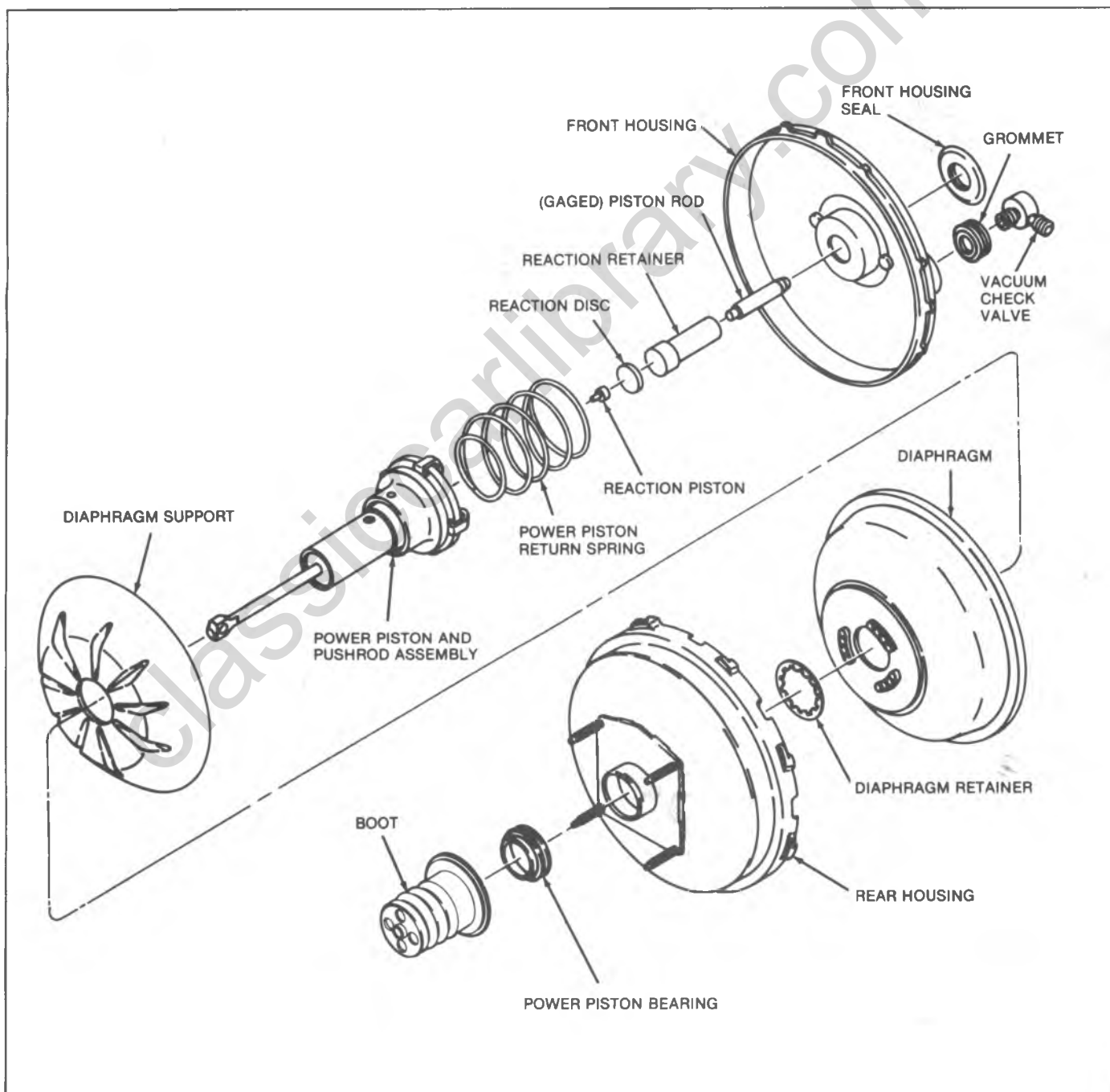

Fig. 5-1C--Booster Assembly Exploded

**1. REMOVE AND INSTALL BOOSTER.**

**REMOVE**

1. Disconnect master cylinder from booster and disconnect booster pushrod as shown.
2. Remove attaching nuts and remove booster as shown.

**INSTALL**

SEE NOTICE ON PAGE 5-1 OF THIS SECTION.

1. Install booster to cowl as shown. Torque attaching nuts to 30-45 N-m (22-33 ft-lb).
2. Connect booster pushrod.
3. Install master cylinder on booster and torque attaching nuts to 30-45 N-m (22-33 ft-lb).

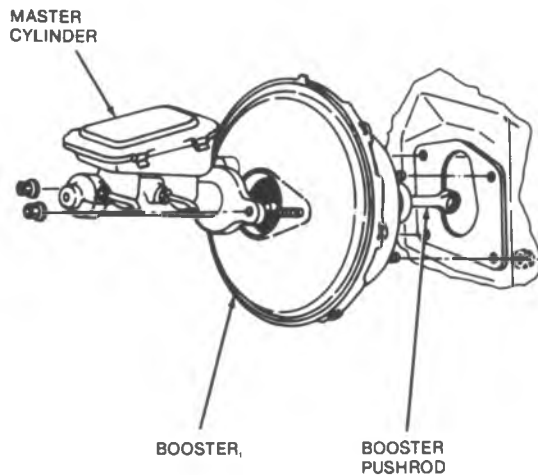

**3. UNLOCKING AND LOCKING BOOSTER**

**DISASSEMBLE**

1. Unlock booster as shown in A and disassemble booster as shown.

**ASSEMBLE**

1. Assemble parts as shown. Make sure white coil on return spring is flush against housing.
2. Lock housing as shown in A, following.
3. Stake housing as shown in B, following.

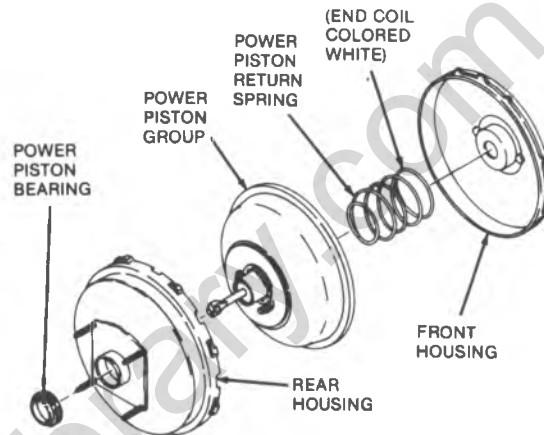

**2. REMOVE AND INSTALL EXTERIOR COMPONENTS.**

**REMOVE**

1. Remove parts as shown.

**INSTALL**

1. Lubricate inside and outside diameters of grommet and front housing seal.
2. Install parts as shown.

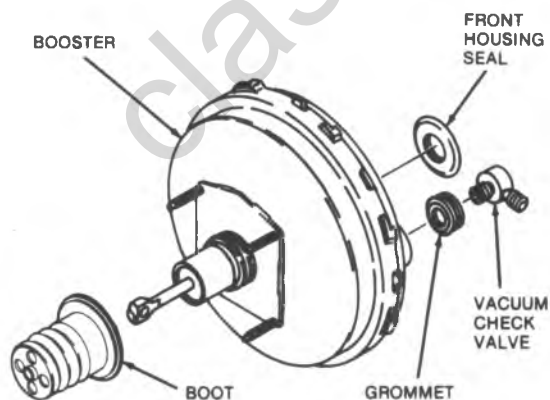

**A.**

**UNLOCKING BOOSTER**

1. Scribe a mark on front and rear housings to facilitate assembly.
2. Press down on tool J-9504 and turn counterclockwise to unlock housing.

**LOCKING BOOSTER**

1. Align scribe marks.
2. Press down on tool J-9504 and turn clockwise to lock front and rear housings. Assembly can be facilitated by connecting a vacuum source to the booster.

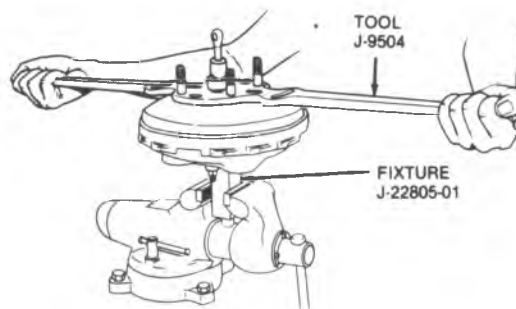

Fig. 5-2C--Service



**3. (CONT)**

**B.**

**STAKING**

1. Stake housing as shown after locking.
2. Do not stake a tab that has been previously staked.

STAKING TAB SOCKET WITH SCREW DRIVER

**4. DISASSEMBLY AND ASSEMBLY OF POWER PISTON GROUP.**

<p style="text-align: center;"><b>DISASSEMBLE</b></p> <ol style="list-style-type: none"> <li>1. Remove piston rod and reaction retainer.</li> </ol> <p><b>CAUTION:</b> Use care not to damage power piston assembly when removing reaction disc as described in the following step. Reaction disc must be replaced.</p> <ol style="list-style-type: none"> <li>2. Use an awl, ice pick or similar tool to remove reaction disc. Then, remove reaction piston.</li> <li>3. Grasp assembly at outside edge of diaphragm support and diaphragm. Hold with pushrod down against a hard surface. Use a slight force or impact to dislodge diaphragm retainer.</li> <li>4. Remove only parts shown. Do not disassemble power piston and pushrod assembly.</li> </ol>	<p style="text-align: center;"><b>ASSEMBLE</b></p> <ol style="list-style-type: none"> <li>1. Lubricate inside diameter of diaphragm lip and fit in diaphragm support.</li> <li>2. Install diaphragm and support as shown in A, following.</li> <li>3. Install new diaphragm retainer and seat as shown in B, following.</li> <li>4. Install reaction piston, new reaction disc, reaction retainer and piston rod.</li> </ol>
--	--

**4. (CONT)**

**A.**

POWER PISTON AND PUSHROD ASSEMBLY

Fig. 5-3C--Service

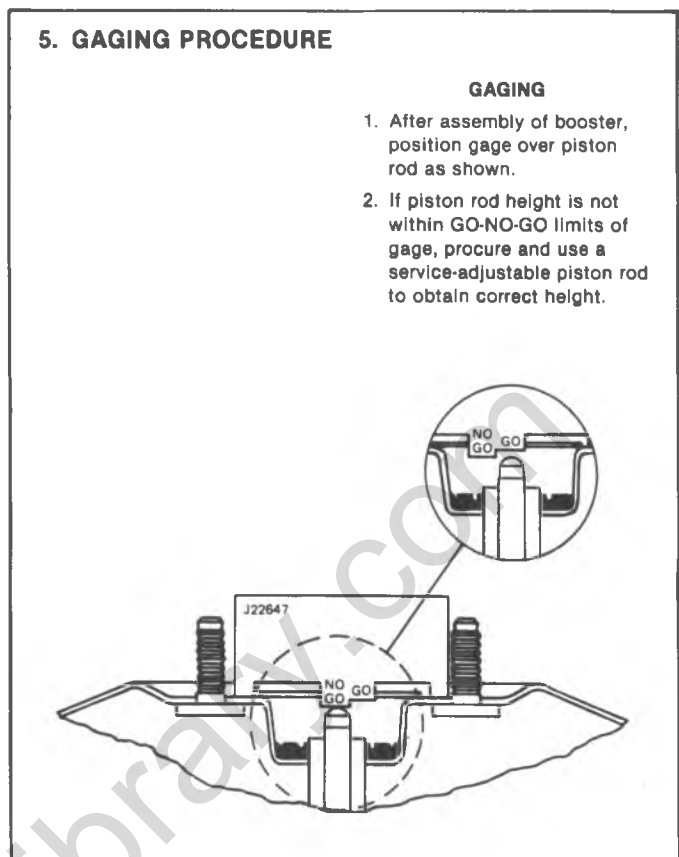
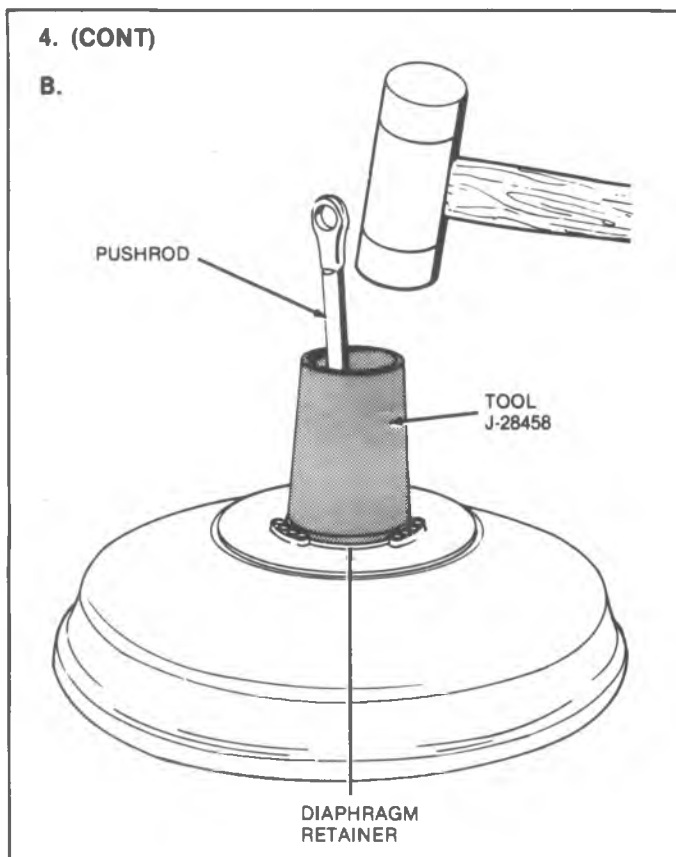

Fig. 5-4C--Service

## INSPECTION CHART

Part	Inspect For	Corrective Action
Power Piston and Support Plate and Reaction Retainer	1. Cracks, distortion, chipping, damaged lever seats, pitted or rough holes.	1. Clean up or replace.
	2. Worn seal surfaces (tubes).	2. Replace
	3. Rough or uneven floating valve seat.	3. Replace
	4. Open passages and flow holes.	4. Clean
Reaction Levers or Plates	1. Cracks, distortion, tears and heavy wear.	1. Replace
Floating Control Valve	1. Deterioration of rubber or warped valve face.	1. Replace
Air Valve - Push Rod Assembly	1. Air valve: scratches, dents, distortion, or corrosion of I.D. or O.D. All seats to be smooth and free of nicks and dents.	1. Do not repair - Replace.
	2. Push rod must move freely in air valve, but must not pull out.	2. If worn, replace air valve - push rod assembly.
Front and Rear Housings	1. Scratches, scores, pits, dents, or other damage affecting rolling or sealing of diaphragm or other seals.	1. Replace, unless easily repaired
	2. Cracks, damage at ears, damaged threads on studs.	2. Replace, unless easily repaired
	3. Bent or nicked locking lugs.	3. Replace, unless easily repaired
	4. Loose studs.	4. Replace or repair.
Air Filters	1. Dirty	1. Replace

# BENDIX SINGLE DIAPHRAGM POWER BRAKE UNIT

## UNIT REPAIR

### Disassembly (Figs. 5-1D and 5-2D)

1. Scribe a line across front and rear housings to facilitate reassembly.
2. Remove the front housing seal (fig. 5-2D); pulling the piston rod from the front housing will also remove the seal assembly. Remove the piston rod.
3. Attach base of Holding Fixture J-22805 to front housing with nuts and washers and draw down tight to eliminate bending or damage to studs. Clamp base in bench vise with power section up (fig. 5-1A).

**NOTICE:** Be sure to align tool so that the check valve in the front housing is not damaged.

4. Loosen locknut and remove push rod clevis and locknut, if so equipped.
5. Remove the mounting bracket from the rear housing, if so equipped.
6. Remove the dust boot retainer, dust boot and silencer from the diaphragm plate extension.
7. The edge of the rear housing contains twelve lances. Four of these lances (one in each quadrant) are deeper than the other lances (fig. 5-3D). The metal that forms

the four deep lances must be partially straightened so that the lances will clear the cutouts in the front housing. If the metal tabs that form the deep lances crack or break during straightening, the housing must be replaced.

8. Place Spanner Wrench J-9504 over studs on rear housing and attach with nuts and washers. Draw nuts down tight to eliminate bending or damaging of studs (fig. 5-2A).
9. Press down on Spanner Wrench J-9504 and rotate the rear housing clockwise to separate the two housings. If the rear housing cannot be readily loosened, tap the rear housing lightly with plastic hammer.
10. Remove Tool J-9504 from the rear housing.

**NOTICE:** Care must be exercised not to damage or loosen studs in the rear housing. Also, take care that no pressure is brought to bear on plastic diaphragm plate tension.

11. Lift the rear housing assembly from the unit.

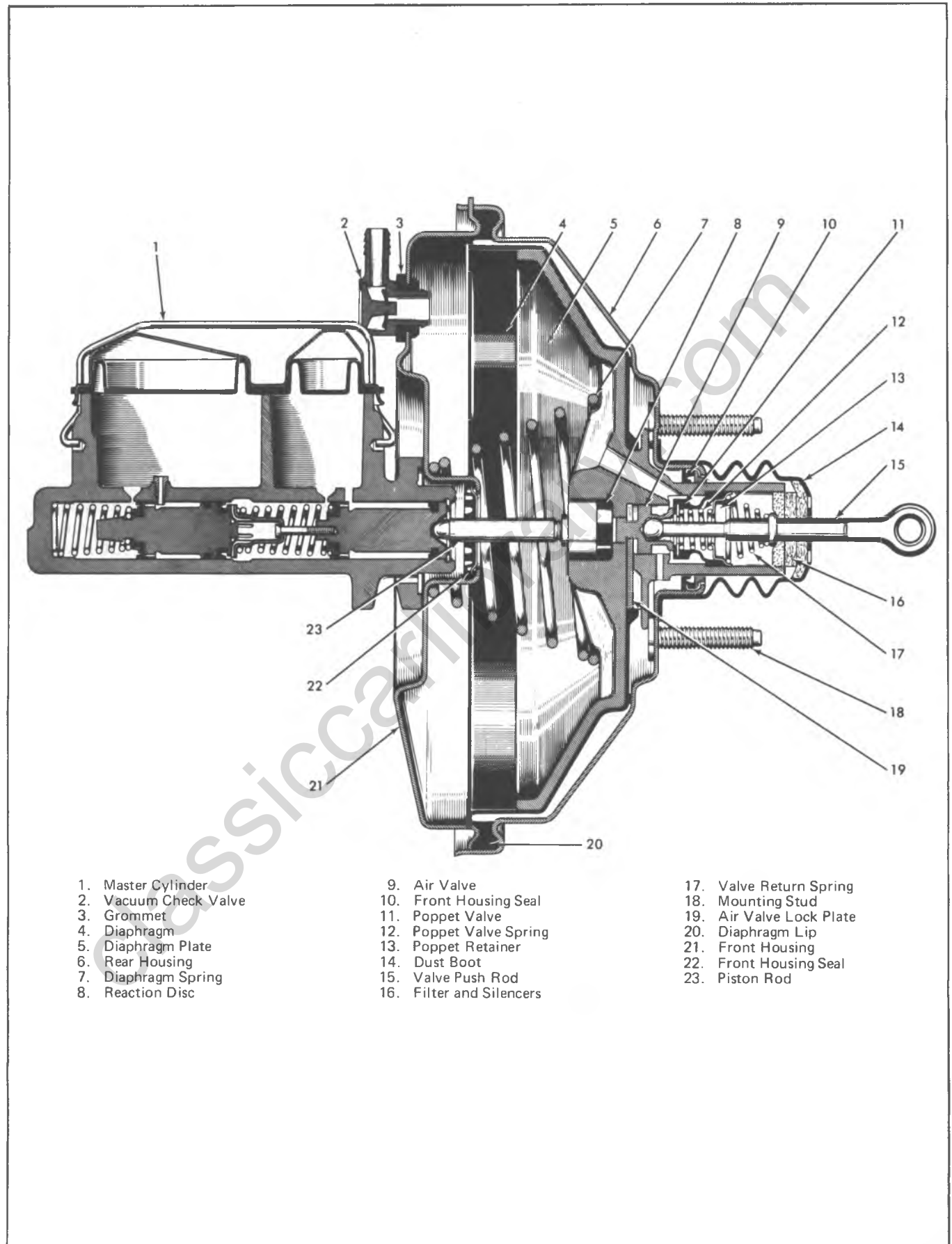

1. Master Cylinder
2. Vacuum Check Valve
3. Grommet
4. Diaphragm
5. Diaphragm Plate
6. Rear Housing
7. Diaphragm Spring
8. Reaction Disc

9. Air Valve
10. Front Housing Seal
11. Poppet Valve
12. Poppet Valve Spring
13. Poppet Retainer
14. Dust Boot
15. Valve Push Rod
16. Filter and Silencers

17. Valve Return Spring
18. Mounting Stud
19. Air Valve Lock Plate
20. Diaphragm Lip
21. Front Housing
22. Front Housing Seal
23. Piston Rod

Fig. 5-1D--Bendix Single Diaphragm Unit (Typical)

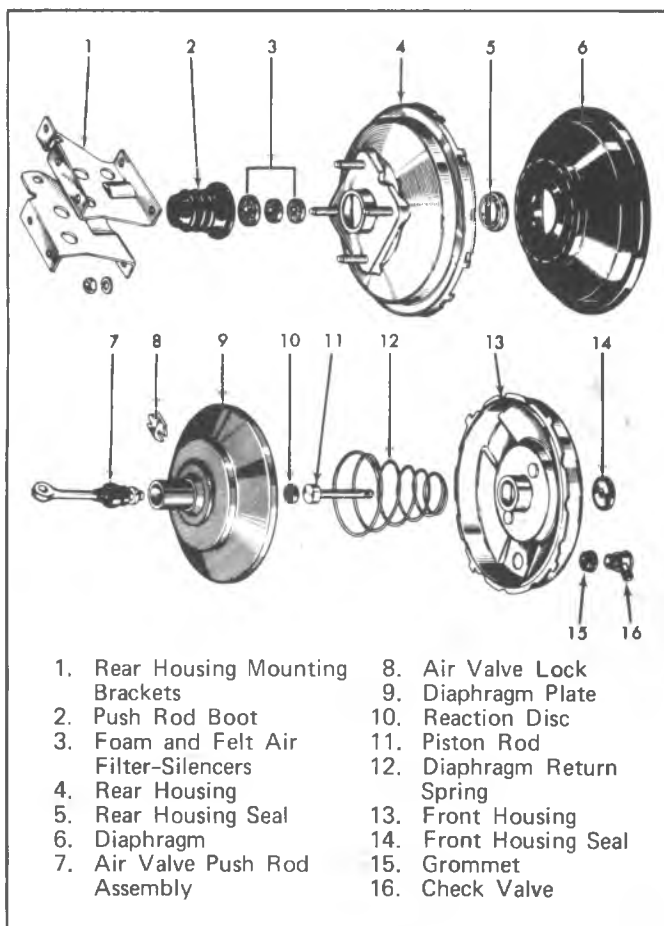

Fig. 5-2D--Bendix Power Booster Components (Typical)

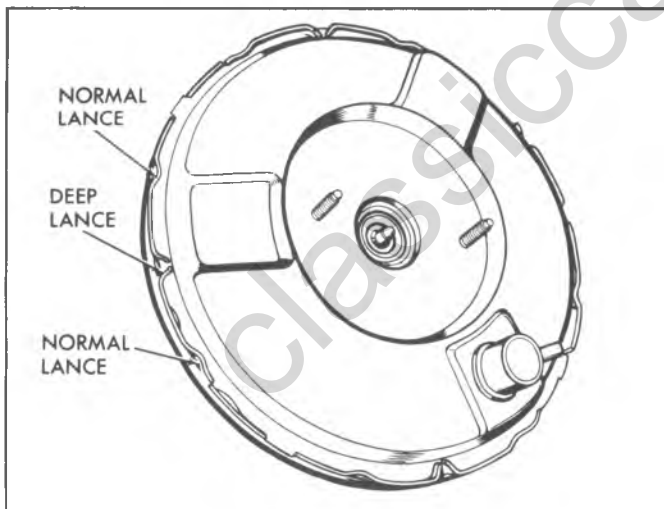

Fig. 5-3D--Lances in Rear Housing

### Rear Housing Group

1. Remove the air filter element from location within the diaphragm plate extension.

**NOTICE:** To prevent chipping of the plastic diaphragm plate, exercise extreme caution when removing the air filter retainer. Use a small screwdriver or other suitable tool, and pry at several peripheral locations until the retainer is freed.

2. Separate the diaphragm plate assembly from the rear housing and lay the rear housing aside.
3. Disassemble diaphragm plate assembly (fig. 5-2D).
  - a. Remove rolling diaphragm from the groove in the diaphragm plate hub.

**NOTICE:** Care should be used in handling the diaphragm of the diaphragm plate assembly. The diaphragm should be protected from grease, oil, foreign matter and from nicks, scratches and gouges.

- b. Hold the diaphragm plate so that the push rod is in its normal (horizontal) installed position, depress the push rod slightly (approximately 1/16 inch), and rotate piston so the air valve lock will fall from its location in the diaphragm plate hub. Remove the air valve-push rod assembly from the diaphragm plate. Remove the reaction disc from its location in the diaphragm plate bore (insert the piston rod or other suitable tool through diaphragm plate extension and push disc from its seat). Exercise care so as not to chip surface of passages in the diaphragm plate. Perform Step 4 only if seal is defective and a new seal is available. Do not reuse seal once it has been removed from the unit.

4. Support outer surface of rear housing on blocks of wood or other suitable material (stud side up) and drive out seal with a punch or a thin blade screwdriver. Discard seal.

### Front Housing Group

1. Remove check valve from grommet and then remove grommet from front housing; discard valve and grommet.
2. Remove front housing and holding fixture from vise; then remove holding fixture from front housing.

## Cleaning

Use clean brake fluid to thoroughly clean all reusable brake parts. Immerse in the cleaning fluid and brush metal parts with hair brush to remove foreign matter. Blow out all passages, orifices and valve holes. Air dry and place cleaned parts on clean paper or lint free clean cloth. If slight rust is found inside either the front or rear half housing assemblies, polish clean with crocus cloth or fine emery paper, washing clean afterwards. Dirt is the major cause of trouble and wear in service. Be sure to keep parts clean until re-assembly. Re-wash at re-assembly if there is any occasion to doubt cleanliness--such as parts dropped or left exposed for eight hours or longer.

**NOTICE:** If there is any suspicion of contamination or any evidence of corrosion, completely flush the vehicle hydraulic brake system. Failure to clean the hydraulic brake system can result in early repetition of trouble. Use of gasoline kerosene, anti-freeze, alcohol or any other cleaner, with even a trace of mineral oil, will damage rubber parts.

## Inspecting Rubber Parts

Wipe fluid from the rubber parts and carefully inspect each rubber part for cuts nicks or other damage. These parts are the key to the control of fluid or air flow, if the unit is in for overhaul, or if there is any question as to the serviceability of rubber parts, REPLACE them.

## Inspecting Metal Parts

**BADLY DAMAGED ITEMS, OR THOSE WHICH WOULD TAKE EXTENSIVE WORK OR TIME TO REPAIR, SHOULD BE REPLACED.** In case of doubt, install new parts. Do not rely on the brake unit being overhauled at an early or proper interval. New parts will provide more satisfactory service, even if the brake unit is allowed to go beyond the desired overhaul period.

## Assembly (Figs. 5-1D and 5-2D)

1. Be careful during the rebuild procedure that no grease or mineral oil comes in contact with the rubber parts of the power brake unit.
2. Lubricate power head parts, as outlined below, with silicone lubricant provided in the service repair kit.

### Front Housing Group

1. Install new check valve grommet in front housing with beveled edge of grommet inside of housing. Dip new check valve in clean denatured alcohol and install in grommet--check valve stem is to be outside of housing.
2. Position and secure Holding Fixture J-22805 to mounting studs, and place tool and front housing in a vise. Be sure to align tool so that check valve is not damaged. If either or both of the housings are replaced, make sure alignment marks are transferred to the new housing.

### Rear Housing Group

1. Place rear housing on a block of wood, stud side down, and position housing seal in center hole. Use Tool J-22677 (fig. 5-4D) to seat seal in recess of rear

housing. Tool bottoms against housing when seal is in place.

2. Assemble diaphragm plate assembly (see fig. 5-2D).
  - a. Apply silicone lubricant to outside diameter of diaphragm plate and extension, to bearing surfaces of air valve and to outer edge of valve poppet. Insert air valve and push rod assembly in extension of diaphragm plate.  
The air valve, poppet valve and push rod are serviced as an assembly; a complete unit must be installed if there is damage to any of the component parts.
  - b. Depress the push rod slightly and install the air valve lock. Make sure the lock indexes and retains the air valve.
  - c. Install the rolling diaphragm in the groove of diaphragm plate.
  - d. Apply silicone lubricant to surface of reaction disc and position disc in center bore of diaphragm plate. Use piston rod to seat disc in bore. Make sure disc is fully seated before removing piston rod. If reaction disc is not fully seated, it will result in an erroneous push rod height adjustment.
3. Apply silicone lubricant to I.D. of rear housing seal and diaphragm bead contact surface of rear housing. Install diaphragm plate assembly in rear housing.
4. Place air filter element over push rod and into diaphragm plate extension. Install filter retainer.

## Final Assembly

1. Attach base of Holding Fixture J-22805 to front housing with nuts and washers and draw down tight to eliminate bending or damage to studs. Clamp base in bench vise with power section up (fig. 5-1A).

**NOTICE:** Be sure to align tool so that the check valve in the front housing is not damaged.

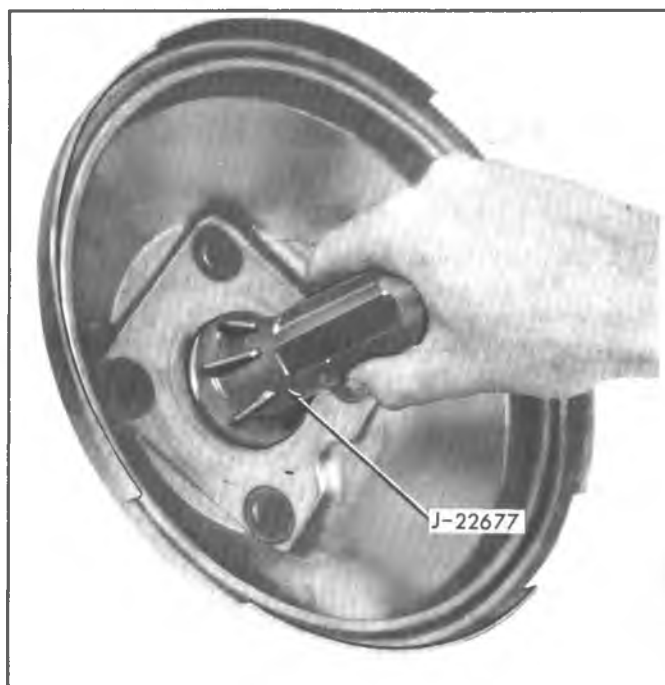

Fig. 5-4D--Installing Rear Housing Seal

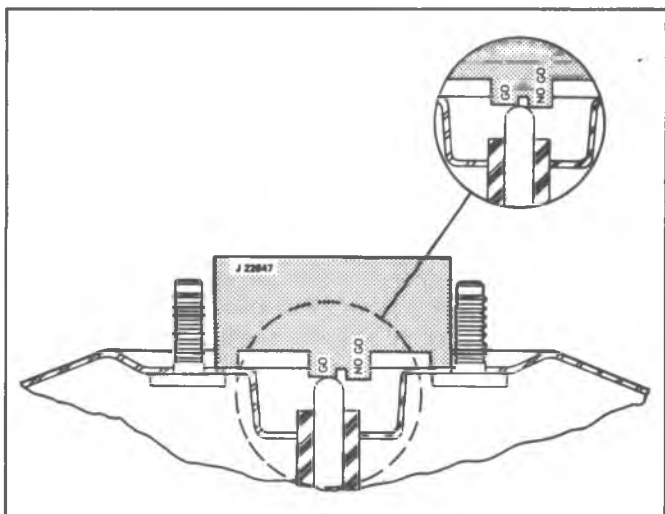

Fig. 5-5D--Gaging Piston Rod

- Place Spanner Wrench J-9504 over studs on rear housing and attach with nuts and washers. Draw nuts down tight to eliminate bending or damaging of studs.
- Place diaphragm plate return spring in front housing and position rear housing assembly on front housing (small end of spring downward). Position rear housing so that when housings are locked, scribe marks on front and rear housings will be in alignment.
- Press down on Spanner Wrench J-9504 and rotate the rear housing counterclockwise to assemble the two housings.

**NOTICE:** Bend lances in on the rear housing. If the tangs crack or break during this operation it will be necessary to replace that half of the housing.

- Remove Tool J-9504 from the rear shell.
- Install air silencers over push rod end and then install push rod boot. Install boot retainer.
- Clevis Type Push Rod** - Install locknut and push rod clevis.

- Install mounting bracket to the rear shell, if so equipped.

**NOTICE:** See "Notice" on Page 1 of this section.

- Remove power cylinder from vise and remove Holding Fixture J-22805.
- Apply silicone lubricant sparingly to the piston rod, keeping lubricant away from rounded end of rod. Guide piston rod into center bore of the diaphragm plate until it is fully seated against reaction disc.
- Install front housing seal. Press seal into front housing until seal is bottomed in recess of housing.

### Gaging

- Place the power head assembly in a padded vise (front housing up). *Do not clamp tight.*
- Remove the front housing seal to assure that no vacuum is in the power head while gaging.
- Insert the master cylinder piston rod, flat end first, into the piston rod retainer.
- Press down on the master cylinder piston rod (with approximately a 40-50 pound load) to be sure it is properly seated.
- Place Gage J-22647 over the piston rod in a position which will allow the gage to be slipped to the left or right without contacting the studs (fig. 5-5D).
- The center section of the gage has two levels. The piston rod should always contact the longer section (lower level) of the gage. The piston rod should *never* contact the shorter section (higher level) of the gage. Move gage from side to side to check piston rod height.
- Any variation beyond these two limits must be compensated for by obtaining the service adjustable piston rod and adjusting the self-locking screw to meet the gaging specifications.
- Wipe a thin film of silicone lubricant on the I.D. of the front housing seal and position seal in the depression in the housing.

tu

## BENDIX HYDRAULIC BRAKE BOOSTER (HYDRO-BOOST)

### UNIT REPAIR

**CAUTION:** The accumulator contains compressed gas. Always use proper tools and follow recommended procedures or personal injury may result. Do not apply heat to accumulator. Do not attempt to repair an inoperative accumulator, always replace with a new accumulator. Dispose of an inoperative accumulator by drilling a 1/16" diameter hole through the end of the accumulator can opposite the "O" ring.

The Bendix Hydraulic Brake Booster utilizes the hydraulic pressure supplied by the power steering pump to provide power assist for brake applications. The dual master cylinder is mounted to the output push rod end of the booster.

The procedures below include removal of the mounting bracket even though it is not necessary to remove the bracket for overhaul of the internal assembly.

#### Disassembly (Fig. 5-1E)

- Secure the booster in a vise (bracket end up) and use a hammer and chisel to cut the bracket nut that secures the mounting bracket to the power section (cut the nut at the open slot in the threaded portion of the housing). Be careful to avoid damage to the threads on the booster hub. Spread the nut and remove it from the power section. Then remove the mounting bracket.
- Remove the pedal rod boot (if equipped) by pulling it off over the pedal rod eyelet.
- Place Tool J-24569 around the pedal rod and resting on the input rod end as shown in Figure 5-2E.



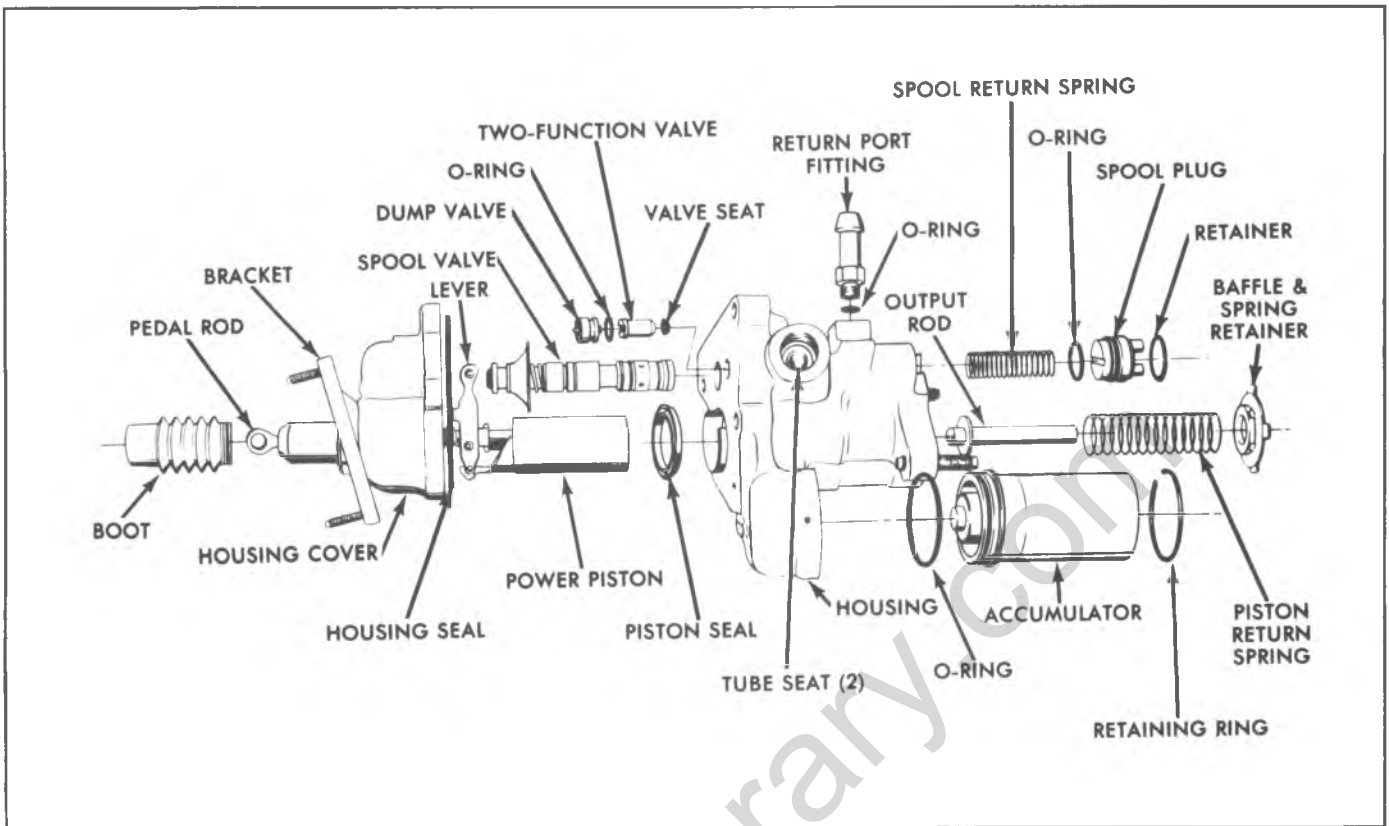

Fig. 5-1E--Bendix Hydro-Boost Explode--Typical

4. Place a punch (or similar tool) through the pedal rod from the lower side of Tool J-24569. Push the punch on through to rest on the higher side of the tool. Lift up on the punch to shear the pedal rod retainer; remove the pedal rod.
5. Remove the remnants of the rubber grommet from the groove near the end of the pedal rod and from the groove inside the input rod end.
6. With a small screwdriver, pry the plastic guide out of the output push rod retainer. Disengage the tabs of the spring retainer from the ledge inside the opening near the master cylinder mounting flange of the booster. Remove the retainer, the piston return spring and output rod from the opening (fig. 5-3E).
7. Place the booster cover in a vise equipped with soft jawed devices. Remove the five screws that secure the booster housing to the cover.
8. Remove the booster assembly from the vise and while holding the unit over a pan, separate the cover from the housing. Remove the "figure eight" seal from the housing cover; discard the seal.
9. Remove the input rod and piston assembly, the spool assembly and spool spring from the booster housing.

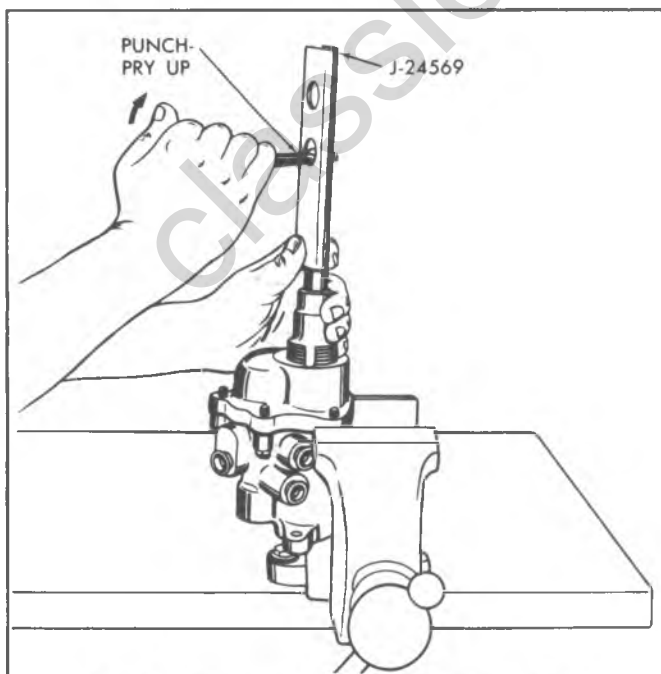

Fig. 5-2E--Removing Booster Pedal Rod (Typical)

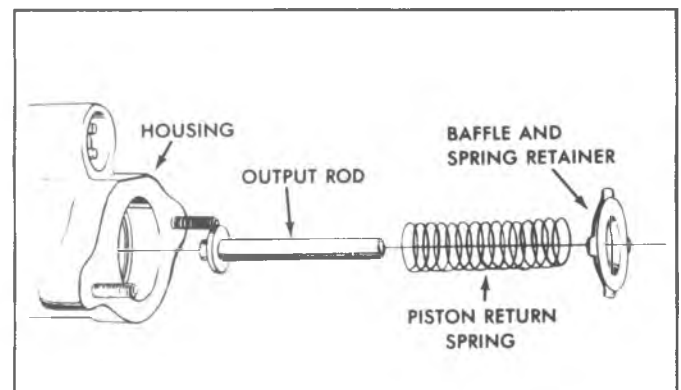

Fig. 5-3E--Output Rod, Spring and Retainer

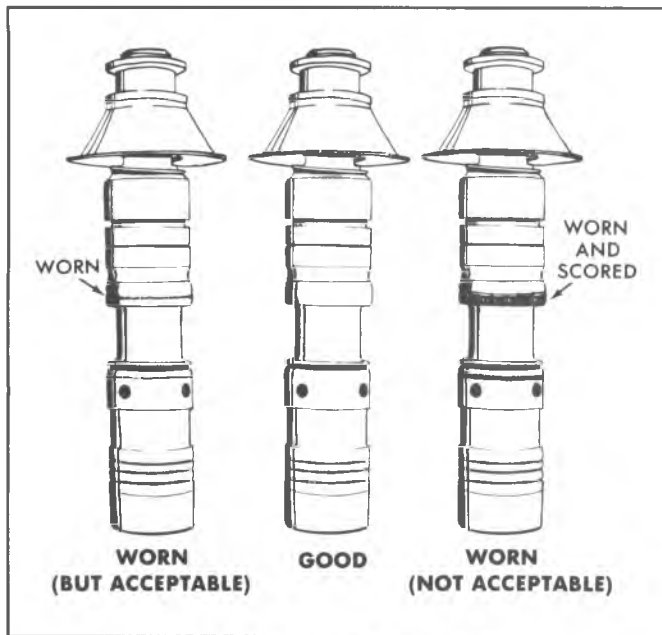

Fig. 5-4E--Spool Valve Inspection

Compare spool valve condition to Figure 5-4E. If spool valve is defective, the complete unit must be replaced.

10. Inspect power piston. If scratches big enough to be felt with a fingernail are present, the input rod and piston must be replaced.
11. Remove the input rod seals from the input rod end, and the piston seal from the piston bore in the housing; discard the seals.
12. Place the accumulator retaining cap Tool J-26889 over the master cylinder stud and install the nut as shown in Figure 5-6E.
13. Using Tool J-22269-01 or a large "C" clamp (6" minimum), depress the accumulator. Insert a punch into the hole in the housing and remove retaining ring with a small screwdriver, (fig. 5-6E).
14. Slowly back off the clamp until tension on the accumulator is released; remove accumulator and "O" ring.
15. If accumulator valve was determined to be faulty, remove valve using a small diameter wire tool (fig. 5-5E). Remove the dump valve by catching the tool

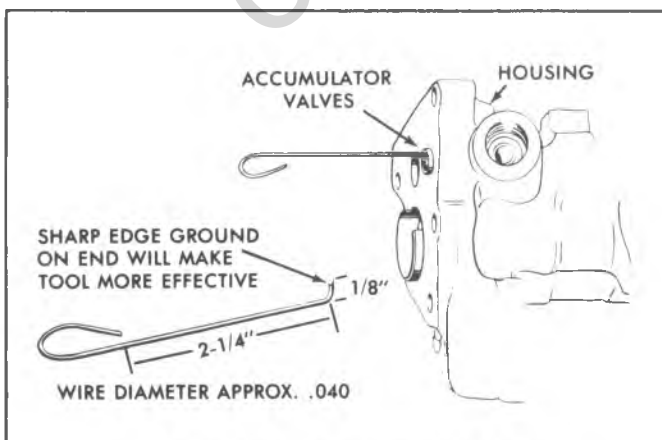

Fig. 5-5E--Removing Accumulator Valves

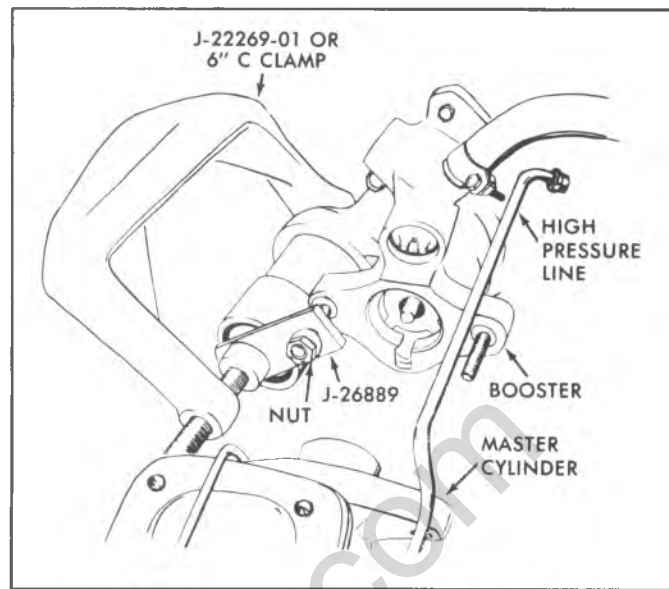

Fig. 5-6E--Compressing Accumulator With J-26889

under the pin guide near the center of the valve, then remove two function valves and seat (fig. 5-8E).

16. Return hose fitting "O" ring can be removed if leaking.
17. Push spool valve plug in and use a small screwdriver to remove retaining ring (Fig. 5-9E).
18. Remove spool valve plug and "O" ring.
19. Remove the tube seats using No. 4 easy-out as shown in Figure 5-10E.

### Cleaning and Inspection

**NOTICE:** Be sure to keep parts clean until reassembly. Wash at reassembly if there are any parts dropped or left exposed for eight hours or longer. Lubricate all seals and metal friction points with power steering fluid. Whenever the booster is disassembled and all

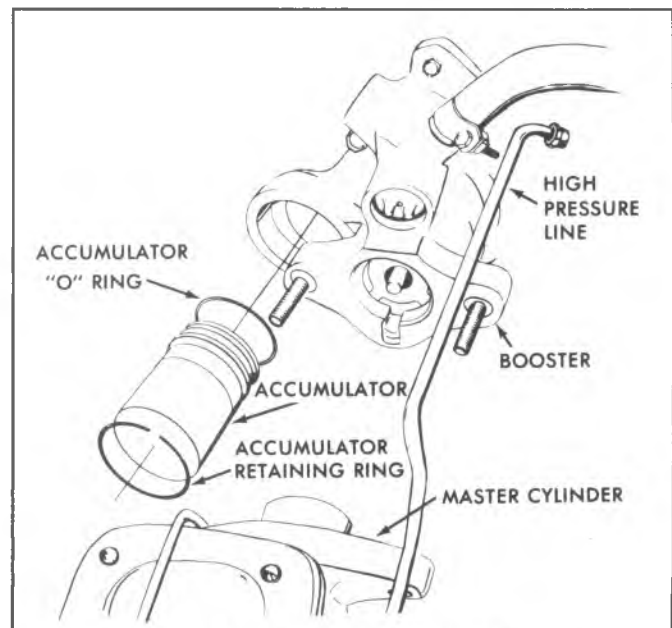

Fig. 5-7E--Accumulator Installation

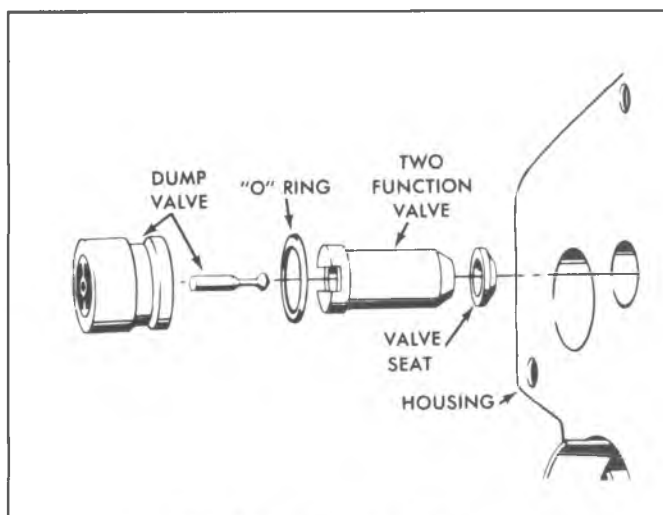

Fig. 5-8E--Accumulator Valves

disturbed seals and damaged tube inserts should be replaced. All of these parts are included in a kit. If any

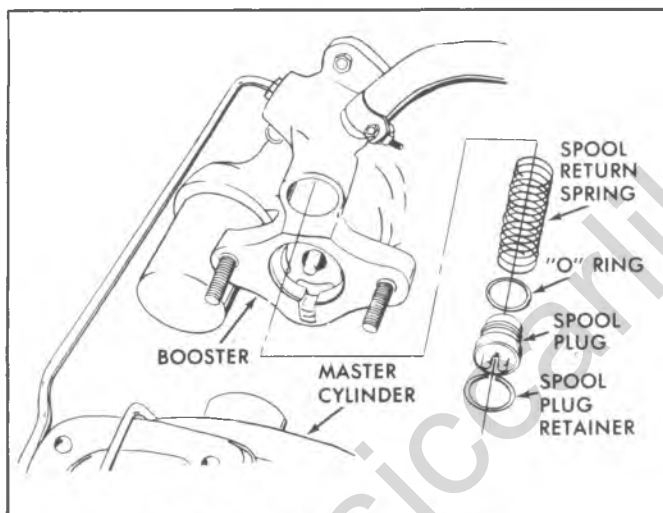

Fig. 5-9E--Spool Valve Plug Removal

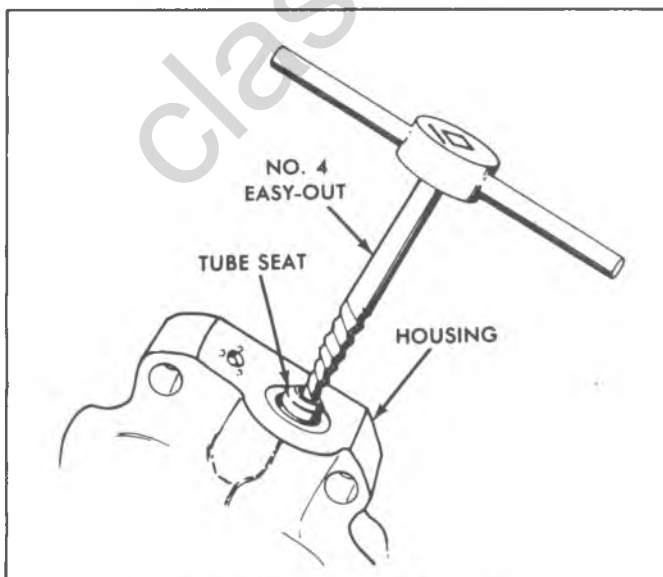

Fig. 5-10E--Removing Tube Seat

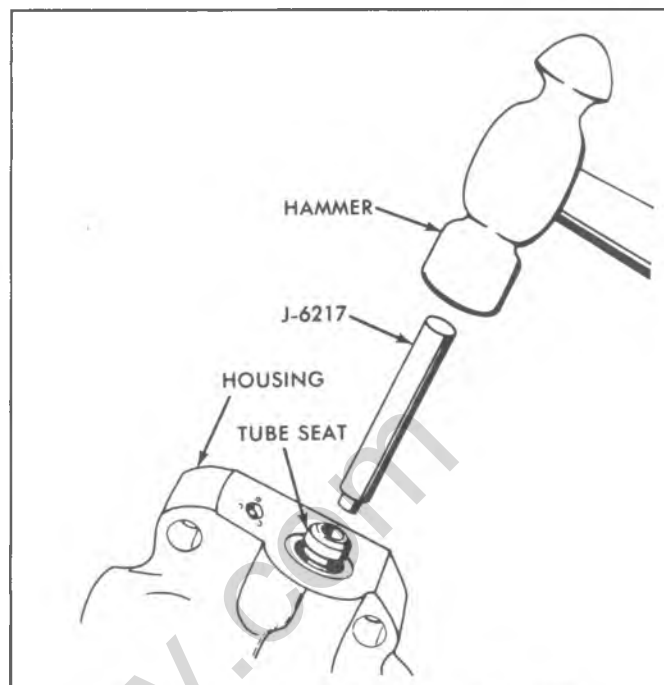

Fig. 5-11E--Installing Tube Seat Using J-6217

of the accumulator valve components are damaged or lost, replace all the valve components.

1. Clean all metal parts in a suitable solvent. Be careful to avoid losing small parts.
2. Inspect the valve spool and the valve spool bore in the housing for corrosion, nicks, scoring or other damage. Discoloration of the spool or bore, particularly in the grooves, is not harmful and is no cause for replacement.
3. If the valve spool or the valve spool bore has nicks or scoring that can be felt with a fingernail, particularly on the lands, the entire booster should be replaced as an assembly.

The clearance between the spool valve and the spool valve bore of the housing assembly is important. Because of this, the valve spool valve and the housing assembly make up a selective assembly. The spool valve is selected to match the spool valve bore.

4. Inspect the piston for scratches, nicks, etc. If scratches on the outside diameter can be felt with a fingernail, the input rod and piston must be replaced.

### Assembly

1. Install tube seat with Tool J-6217 as shown in Figure 5-11E.
2. Install "O" ring and spool valve plug (fig. 5-9E).
3. Push spool valve plug in and install retaining ring.
4. Coat the piston bore and the piston seal with clean power steering fluid, and assemble the **NEW** seal in the bore. The lip of the seal must be toward the rear (away from the master cylinder mounting flange). Be sure the seal is fully seated in the housing.
5. Lubricate the input rod end, **NEW** input rod seals and Seal Installer with clean power steering fluid. Slide the seals on the tool with the lip of the cups toward the open end of the tool (fig. 5-12E).

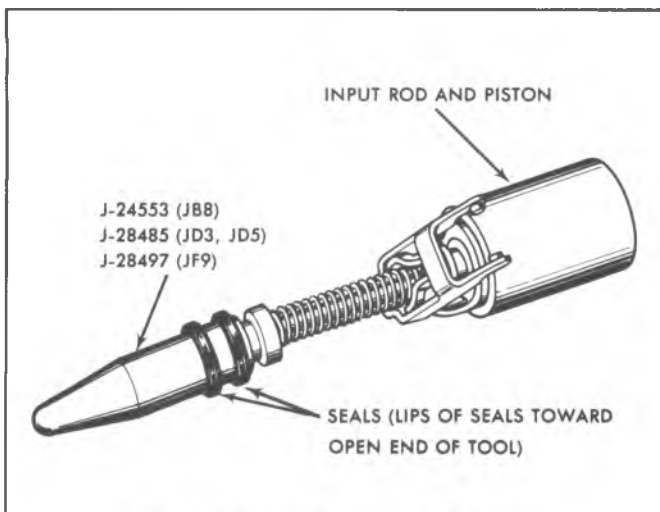

Fig. 5-12E--Installing Input Rod Seals

6. Slide the tool over the input rod end and down to the second groove; then slide the forward seal off the tool and into the groove. Assemble the other seal in the first groove. Be sure that both seals are fully seated. Only one seal is used on JD3 and JD5 applications.
7. The piston counterbore on JF9 applications is of a different diameter than on JB8. Remove the pilot portion of Tool J-24551.
8. Lubricate the piston and Piston Installing Tool with clean power steering fluid. Hold the large end of the tool against the piston (fig. 5-13E), and slide the tool and piston into the piston bore and through the piston seal. Remove piston installing tool.
9. If removed, install return hose fitting with new "O" ring.
10. If accumulator valve was removed, install new seat into the valve bore. The seat can be forced to the bottom by installing the two function valve (fig. 5-8E). Make certain the check valve seat is cup side up when in bore.
11. If removed, insert new dump valve over the two function valve making certain that the dump valve plunger is held in place until installation is complete.

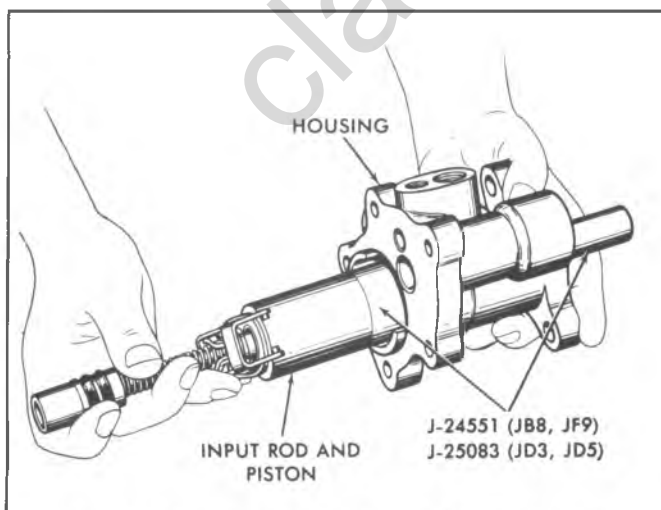

Fig. 5-13E--Installing Input Rod and Piston Assembly into Booster (Typical)

12. Insert spool valve spring and spool valve assembly into bore in housing. Extend power piston lever to accept sleeve on spool valve, then slide lever pins into slot in sleeve.
13. Position a **NEW** "figure eight" seal in the groove in the housing cover. Then join the booster housing and cover and secure with five screws. Tighten the screws to 20 ft. lbs.

**NOTICE:** See "Notice" on Page 1 of this section.

14. Install output rod, spring and new spring retainer.
15. Secure new baffle and spring retainer using Piston Installing Tool or 7/8" socket as shown in Figure 5-14E.
16. Using clean power steering fluid, lubricate accumulator seal. Install seal and accumulator in housing and then place the retaining ring over the accumulator (fig. 5-7E). Place Tool J-26889 over accumulator.
17. Using Tool J-22269-01 or a large "C" clamp (6" minimum) depress the accumulator making certain that the accumulator is compressed straight (fig. 5-6E).
18. Snap the retaining ring into the housing groove by pushing it down all the way around with a small screwdriver.
19. Remove Tool J-22269-01 or "C" clamp and retaining cap Tool J-26889.

**NOTICE:** Carefully check to make sure the retaining ring was completely installed properly.

20. Position the mounting bracket on the booster. The tab on the inside diameter of the large hole in the bracket should fit into a slot in the threaded portion of the booster hub.
21. Install the **NEW** bracket nut with the staking groove outward on the threaded hub of the booster. Using Tool J-24554 and a torque wrench (fig. 5-15E), tighten the nut to 110 ft. lbs.

**NOTICE:** See "Notice" on Page 1 of this section.

22. Use a hammer and a small punch inserted into the staking groove of the nut, at the slot in the booster hub (fig. 5-16E), to stake the nut in place. Be sure that the outer thread of the nut is upset.
23. Assemble a boot (if used) on the pedal rod. Then assemble a **NEW** grommet in the groove near the end of the pedal rod.
24. Moisten the grommet with water (to ease assembly), and insert the grommet end of the pedal rod into the

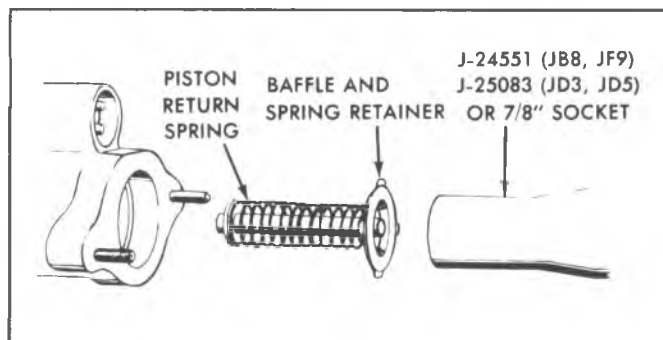

Fig. 5-14E--Installing Baffle and Spring Retainer

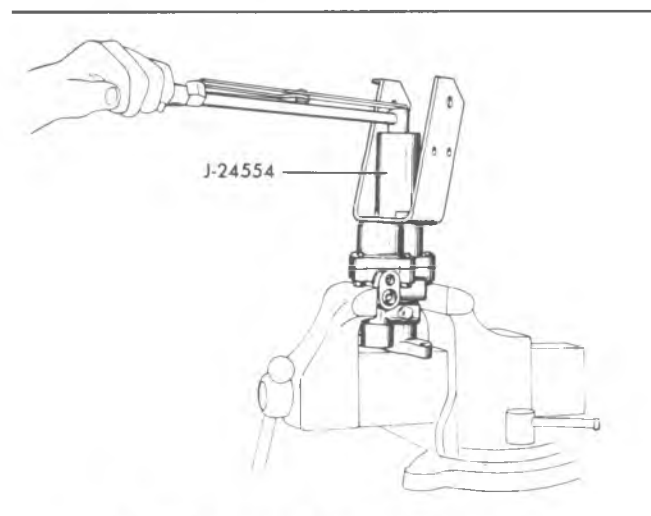

Fig. 5-15E--Installing Mounting Bracket Nut

input rod end of the booster housing. Push on the end of the pedal rod to seat the grommet in the groove inside the housing. When the grommet is fully seated, the pedal rod will rotate freely with no binding.

25. Slide the boot on the pedal rod and assemble the large end of the boot onto the hub of the power section.

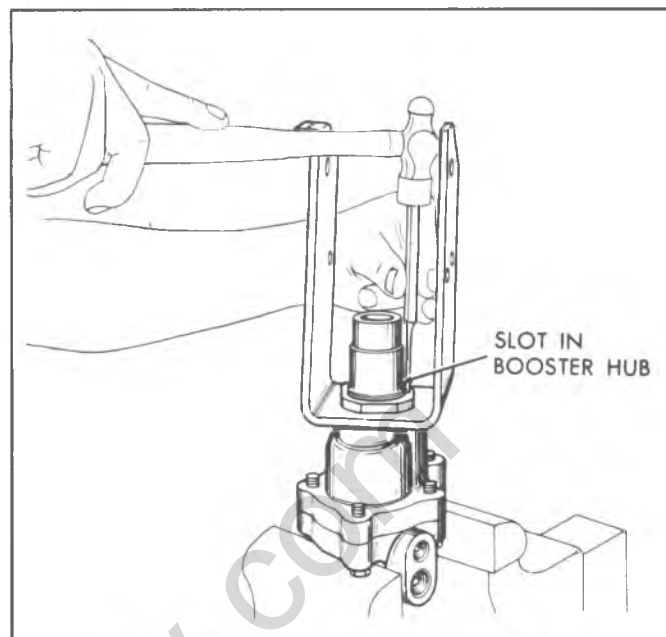

Fig. 5-16E--Staking Mounting Bracket Nut

classiccarrlibrary.com

# BENDIX HYDRAULIC BRAKE BOOSTER (HYDRO-BOOST II)

## UNIT REPAIR

### 1. Remove And Install Spool Valve Plug And Seal In Car.

#### REMOVE

1. Turn engine "OFF" and pump brake pedal 4 or 5 times to deplete accumulator.
2. Remove parts as shown.

#### INSTALL

1. Install parts as shown.
2. Fill and bleed system. Refer to Hydro-Boost II bleeding procedure.

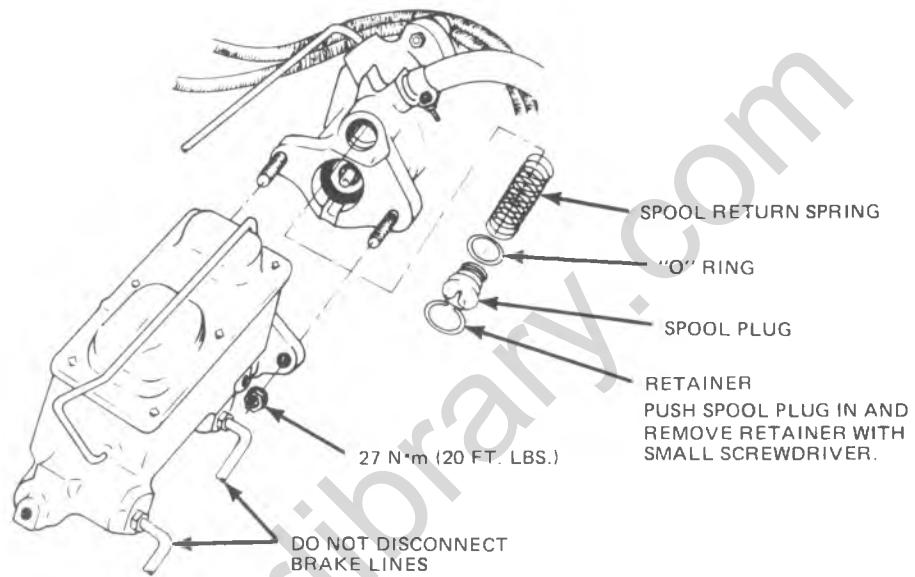

### 2. Remove And Install Hydro-Boost II.

#### REMOVE

NOTICE: Power steering fluid and brake fluid cannot be mixed. If brake seals contact steering fluid or steering seals contact brake fluid, damage will result.

1. Turn engine "OFF" and pump brake pedal 4 or 5 times to deplete accumulator.
2. Remove parts as shown.

#### INSTALL

1. Install parts as shown.
2. Fill and bleed system. Refer to Hydro-Boost II bleeding procedure.

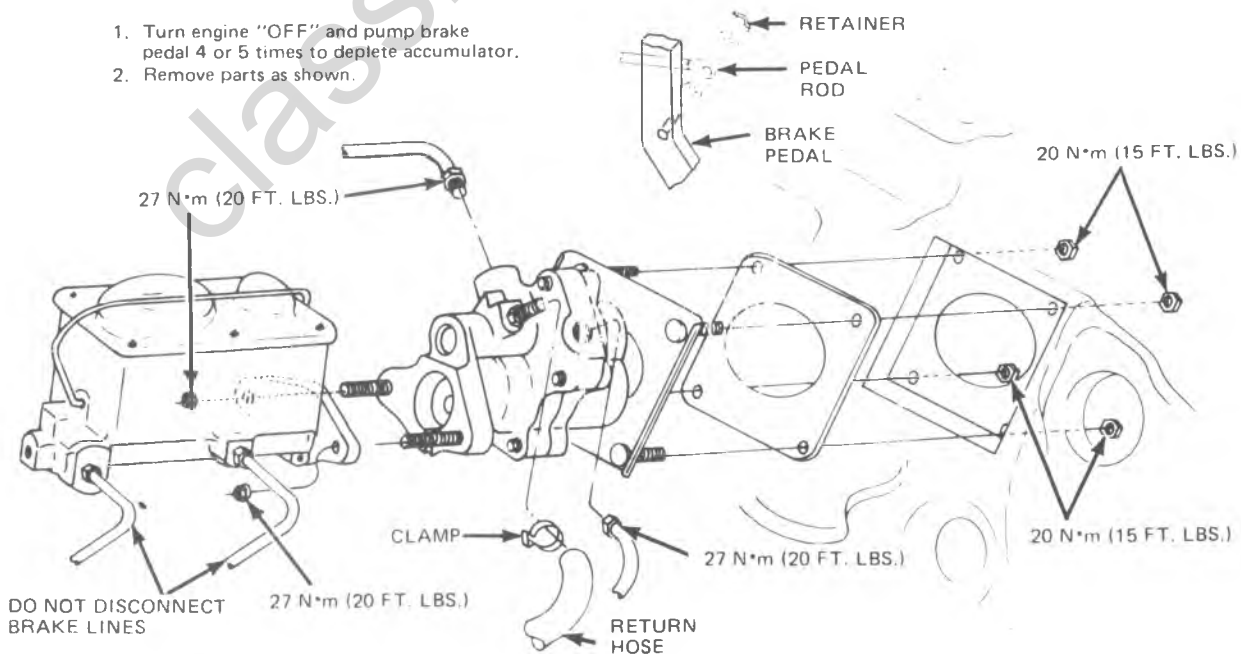

3. Remove And Install Bracket.

REMOVE

1. Cut nut with chisel.
2. Remove parts as shown.

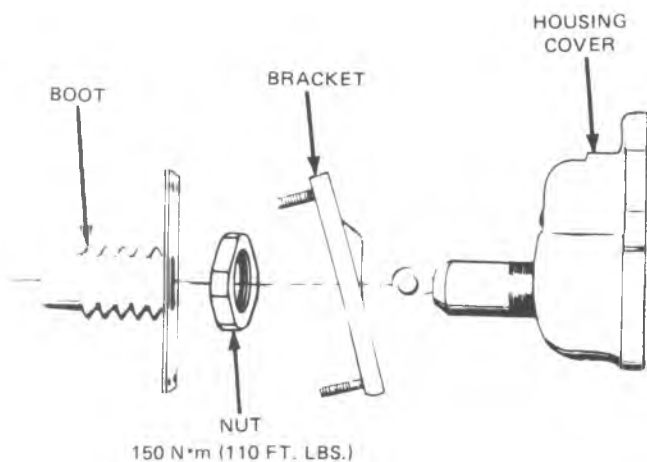

INSTALL

1. Install parts as shown.

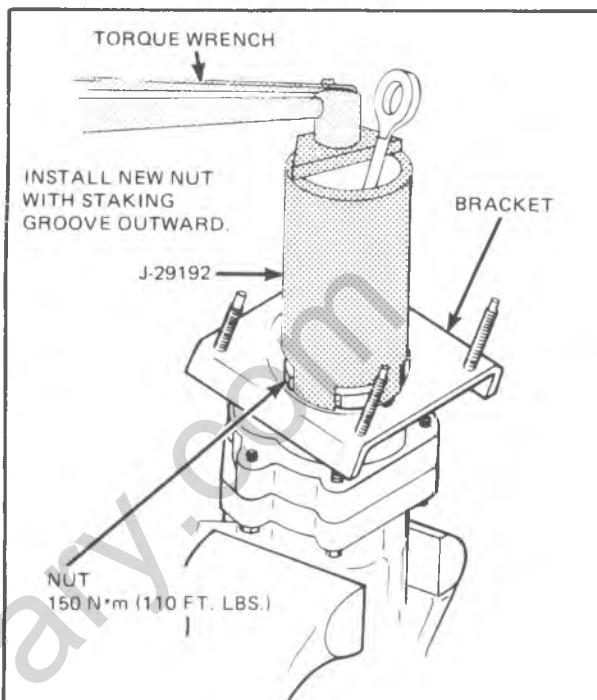

TORQUE NUT WITH TOOL J-29192

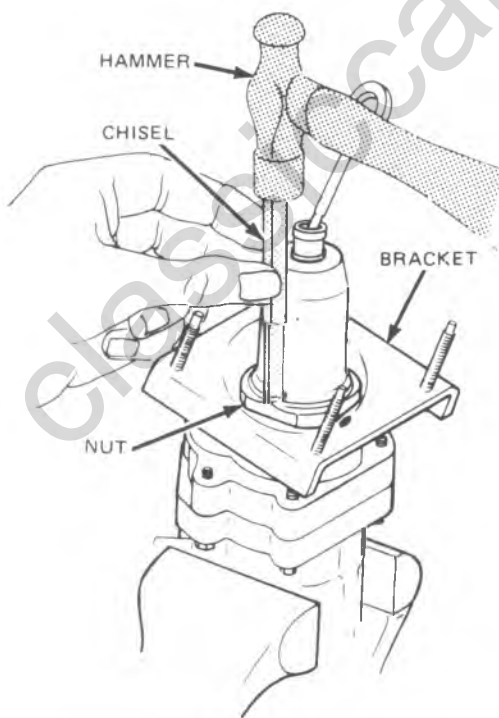

CUTTING NUT TO REMOVE BRACKET

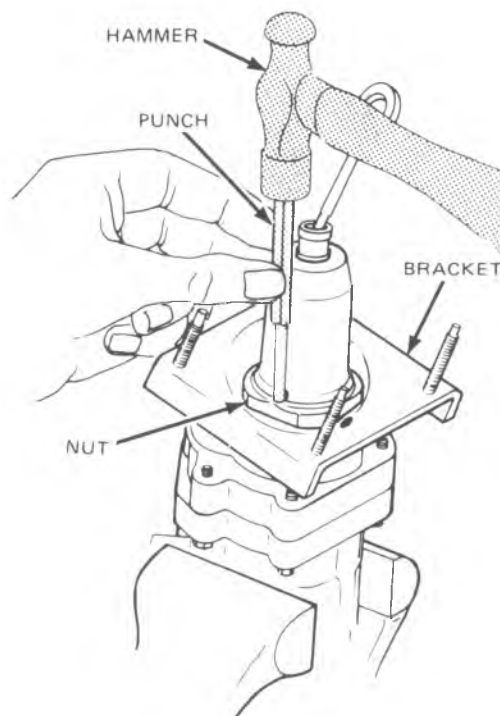

STAKING BRACKET NUT

4. Remove And Install Spool Valve, Power Piston/Accumulator And Seal.

REMOVE

1. Remove parts as shown.
2. If removing spool valve plug refer to Remove and Install Spool Valve Plug In Car.

INSTALL

1. Install parts as shown.
2. If installing spool valve plug refer to Remove And Install Spool Valve Plug In Car.

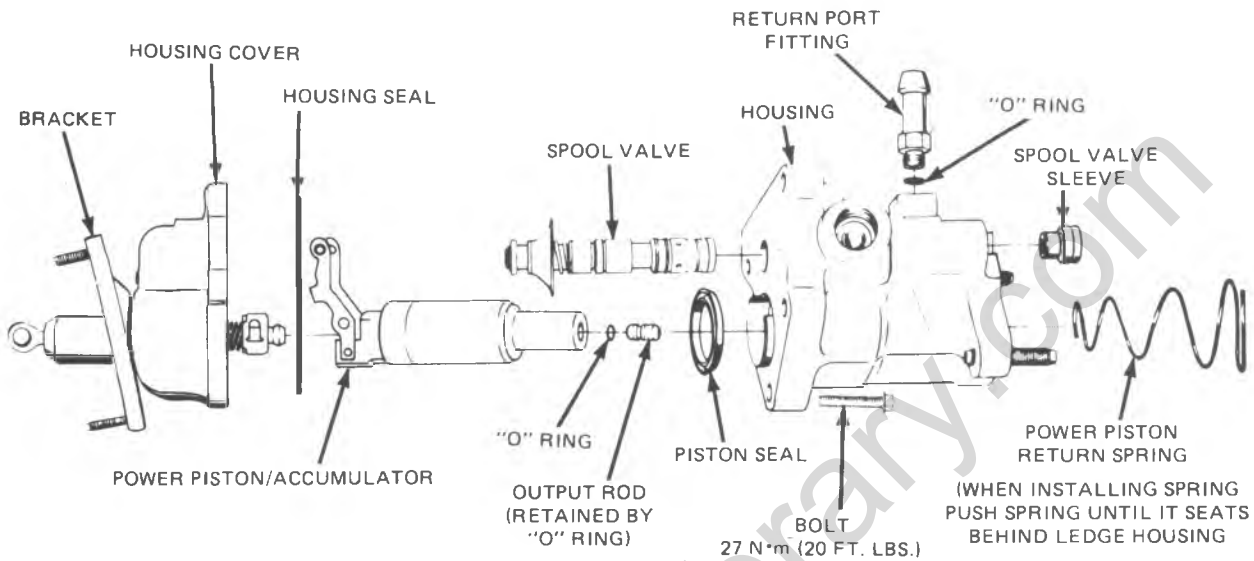

POWER PISTON/ACCUMULATOR SPRING

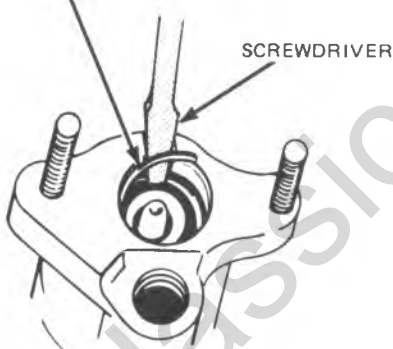

REMOVE POWER PISTON/ACCUMULATOR SPRING

CLEAN GROOVE BOTTOM BEFORE INSTALLING SEAL

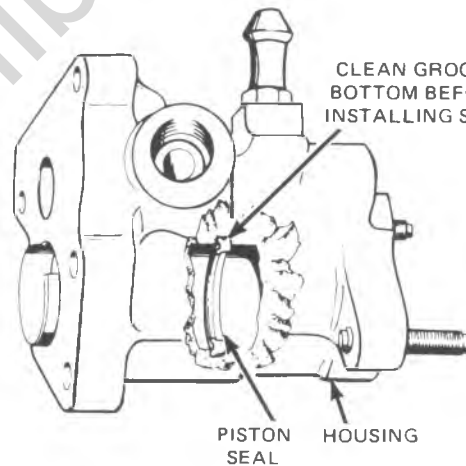

INSTALL POWER PISTON/ACCUMULATOR SEAL

BE SURE SPOOL VALVE IS ENGAGE

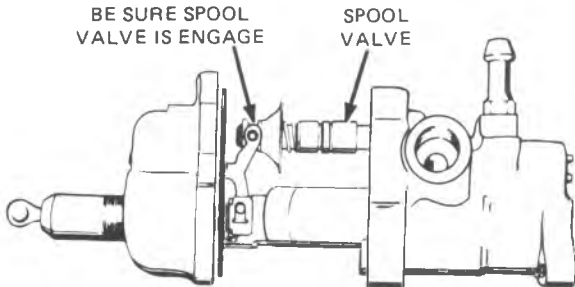

INSTALL SPOOL VALVE

WHEN REPLACING POWER PISTON/ACCUMULATOR DRILL A 1/8" HOLE BEFORE DISPOSING

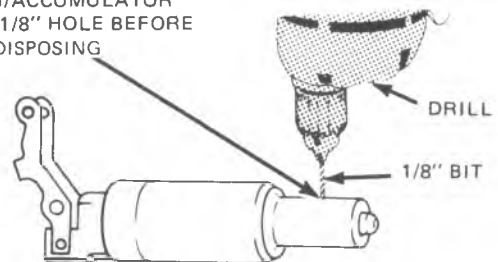

DISPOSE POWER PISTON/ACCUMULATOR



## Special Tools

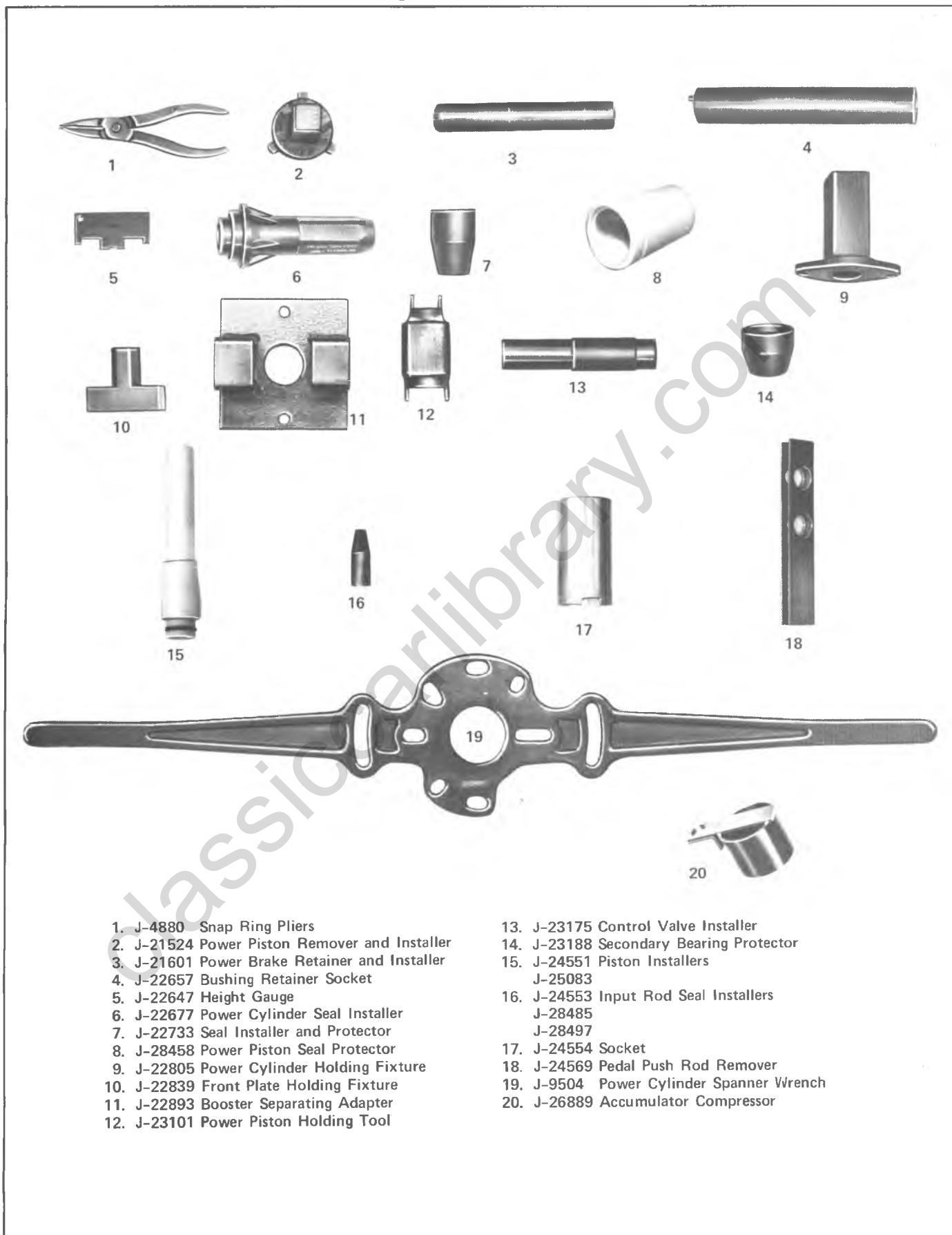

- |   |   |
|---|---|
| 1. J-4880 Snap Ring Pliers                    | 13. J-23175 Control Valve Installer                         |
| 2. J-21524 Power Piston Remover and Installer | 14. J-23188 Secondary Bearing Protector                     |
| 3. J-21601 Power Brake Retainer and Installer | 15. J-24551 Piston Installers<br>J-25083                    |
| 4. J-22657 Bushing Retainer Socket            | 16. J-24553 Input Rod Seal Installers<br>J-28485<br>J-28497 |
| 5. J-22647 Height Gauge                       | 17. J-24554 Socket  |
| 6. J-22677 Power Cylinder Seal Installer      | 18. J-24569 Pedal Push Rod Remover                          |
| 7. J-22733 Seal Installer and Protector       | 19. J-9504 Power Cylinder Spanner Wrench                    |
| 8. J-28458 Power Piston Seal Protector        | 20. J-26889 Accumulator Compressor                          |
| 9. J-22805 Power Cylinder Holding Fixture     |   |
| 10. J-22839 Front Plate Holding Fixture       |   |
| 11. J-22893 Booster Separating Adapter        |   |
| 12. J-23101 Power Piston Holding Tool         |   |

classiccarylbrary.com

## SECTION 7A

# AUTOMATIC TRANSMISSION UNIT REPAIR (OVERHAUL)

## CONTENTS

200 Automatic Transmission W/TCC .....	7A1-1
200 4R Automatic Transmission W/TCC.....	7A6-1
250C Automatic Transmission .....	7A5-1
350 Automatic Transmission W/TCC .....	7A3-1
400 Automatic Transmission .....	(400)7A-1

## 200 AUTOMATIC TRANSMISSION W/TCC

General Description.....	7A1-1
Diagnosis Maintenance and Adjustments.....	7A1-2
Unit Repair .....	7A1-5
Specifications.....	7A1-58

### GENERAL DESCRIPTION

The 200 Automatic transmission is a fully automatic unit consisting primarily of a 3-element hydraulic torque converter with the addition of a converter clutch and a compound planetary gear set. Three multiple-disc clutches, a roller clutch and a band provide friction elements required to obtain the desired function of the compound planetary gear set.

The torque converter couples the engine to the planetary gears through oil and provides hydraulic torque multiplication when required. The compound planetary gear set produces three forward speeds and reverse.

The 3-element torque converter consists of a pump or driving member, a turbine or driven member, and a stator assembly. The stator is mounted on a one-way roller clutch which will allow the stator to turn clockwise but not counterclockwise.

The torque converter housing is filled with oil and is attached to the engine crankshaft by a flex plate and always rotates at engine speed. The converter pump is an integral part of the converter housing, therefore the pump blades,

rotating at engine speed, set the oil within the converter into motion and direct it to the turbine, causing the turbine to rotate.

As the oil passes through the turbine it is traveling in such a direction that if it were not redirected by the stator it would hit the rear of the converter pump blades and impede its pumping action. At low turbine speeds, the oil is re-directed by the stator to the converter pump in such a manner that it actually assists the converter pump to deliver power or multiply engine torque.

As turbine speed increases, the direction of the oil leaving the turbine changes and flows against the rear side of the stator vanes in a clockwise direction. Since the stator is now impeding the smooth flow of oil, its roller clutch releases and it revolves freely on its shaft. Once the stator becomes inactive, there is no further multiplication of engine torque within the converter. The converter clutch is splined to the turbine assembly, and when operated, applies against the converter cover providing a mechanical direct drive coupling of the engine to the planetary gears.

A hydraulic system pressurized by a gear type pump provides the working pressure required to operate the friction elements and automatic controls.

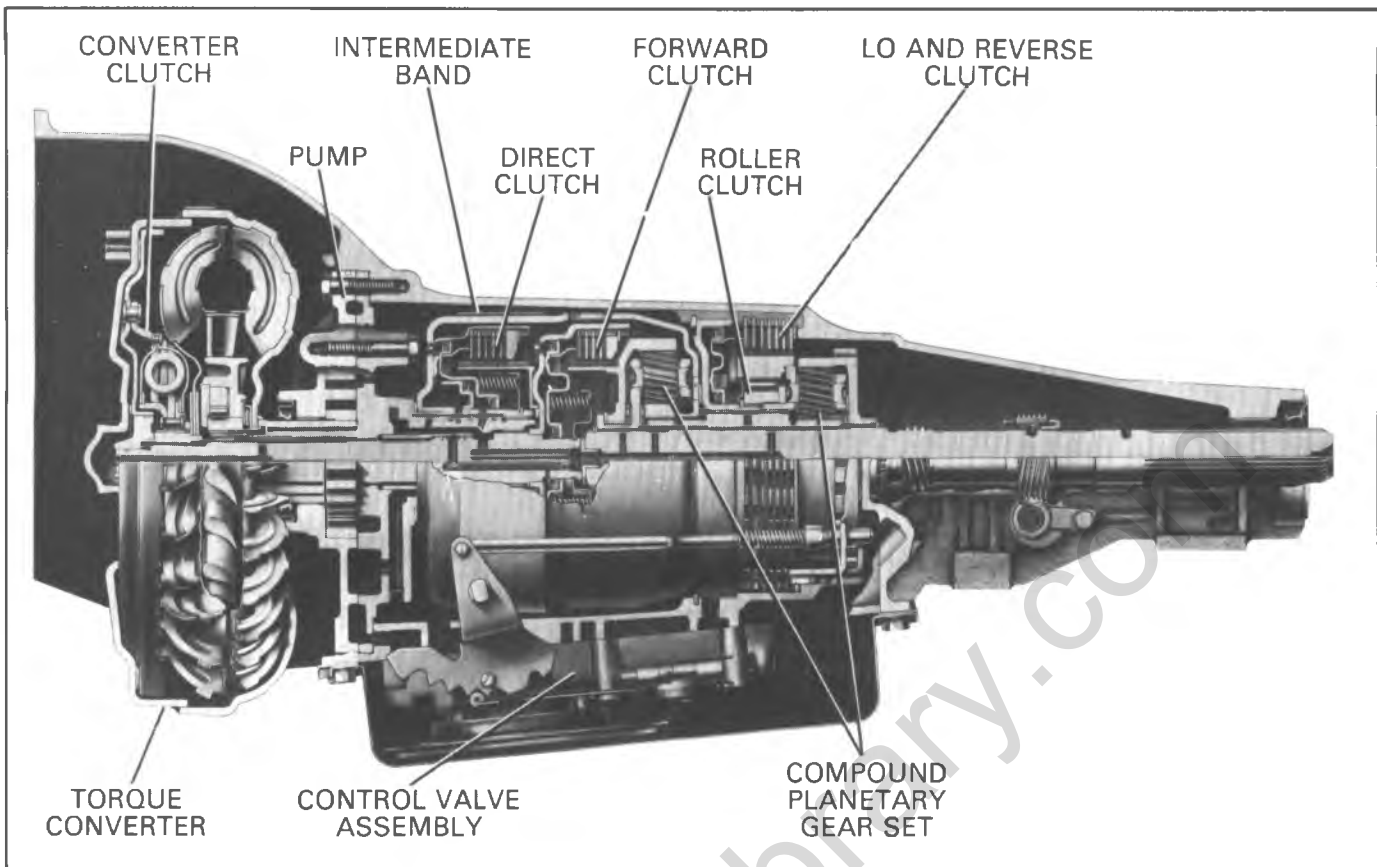

Figure 7A1-1 Cut Away View - 200 Automatic Transmission

## DIAGNOSIS MAINTENANCE AND ADJUSTMENTS

Approximately 3.3 litres (7 pints) of fluid are required to refill transmission after the oil pan has been drained. The fluid capacity of the 200 transmission and converter assembly is approximately 8.9 litres (19 pints) but correct level is determined by mark on the dipstick rather than by amount added. Use only DEXRON® II number automatic transmission fluid or its equivalent.

### OIL PRESSURE CHECKS

1. Connect an oil pressure gage to the line pressure tap. Compare with oil pressure chart, Fig. 7A1-2.
2. Connect a tachometer to the engine.

### NO DRIVE IN DRIVE RANGE (INSTALL PRESSURE GAGE)

1. **Low oil level.**
  - a. Incorrect level.
  - b. External leaks.
2. **Manual Linkage**
  - a. Maladjusted.
3. **Low oil pressure.**
  - a. Plugged or restricted oil screen.
  - b. Oil screen gasket off location.
  - c. Pump assembly - pressure regulator.
  - d. Pump drive gear - tangs damaged by converter.

e. Case - porosity in intake bore.

#### 4. Forward clutch:

- a. Forward clutch does not apply - piston cracked, seals missing, damaged; clutch plates burned; snap ring out of groove.
- b. Forward clutch oil seal rings missing or damaged on turbine shaft; leak in feed circuits; pump to case gasket mispositioned or damaged.
- c. Clutch housing ball check stuck or missing.
- d. Cup plug leaking or missing in the rear of the turbine shaft in the clutch apply passage.
- e. Wrong forward clutch piston assembly or wrong number of clutch plates.
- f. Feed orifice plugged in turbine shaft.

#### 5. Roller Clutch

- a. Springs missing in the roller clutch.
- b. Rollers galled or missing.

### HIGH OR LOW OIL PRESSURE (REFER TO OIL PRESSURE CHECKS)

1. **Throttle Valve Cable**
  - a. Misadjusted, binding, unhooked or broken.
2. **Throttle Valve Assembly or No. 1 Ball Check missing or leaking.**
  - a. Throttle lever and bracket assembly binding, unhooked or mispositioned.
  - b. Throttle valve or plunger valve binding.
  - c. Shift T.V. valve binding.
  - d. No. 1 check ball missing or leaking.

1981 200 AUTOMATIC TRANSMISSION OIL PRESSURES					
<sup>1</sup> NOTICE: TOTAL RUNNING TIME FOR THIS COMBINATION NOT TO EXCEED (2) MINUTES, AND BRAKES MUST BE APPLIED AT ALL TIMES.					
<sup>2</sup> NOTE: FULL T.V. REVERSE LINE PRESSURE TO BE CHECKED AT 2,000 R.P.M.					
Model	Range	Normal Oil Pressure At Minimum T.V.		Normal Oil Pressure At Full T.V.	
		KPA	P.S.I.	KPA	P.S.I.
CN, CX, CY CC, OW, PE, CE, PD, PF, PG BZ, AS, OT	Park at 1000 rpm	401-439 458-511 523-586	58-64 66-74 76-85	No T.V. pressure in Park. Line pressure is the same as Park at minimum T.V.	
CX CY BZ CN CC CE, PD, PE, PF, PG, OW OT, AS	<sup>1, 2</sup> Reverse at 1000 rpm	740-998 740-998 861-1144 937-1431 938-1404 993-1499 1058-1578	107-145 107-145 125-166 136-208 136-204 144-217 153-229	1159-1474 1113-1421 1280-1620 1356-1578 1303-1458 1413-1821 1359-1924	168-214 161-206 186-235 197-229 189-211 205-264 197-279
CN, CX CY CC OW, PD, PE, PF, PG, CE OT, AS BZ	<sup>1</sup> Drive and Neutral at 1000 rpm	401-474 401-474 456-546 458-542 523-621 523-621	58-69 58-69 66-79 66-79 76-90 76-90	821-915 775-862 833-939 877-938 824-932 942-1062	119-133 112-125 121-136 127-143 120-135 137-154
CX CY CN CC OT, AS PD, PE, PF, OW, CE PZ	<sup>1</sup> Intermediate at 1000 rpm	653-769 653-769 742-893 848-1015 864-1040 894-1067 959-1146	95-112 95-112 108-130 123-147 125-151 130-155 139-166	821-915 775-862 821-915 848-1015 864-1040 894-1067 959-1146	119-133 112-125 119-133 123-147 125-151 130-155 139-166
CX, CY CN CC OT, AS PD, PE, PF, OW, CE PZ	<sup>1</sup> Lo at 1000 rpm	653-769 742-893 848-1015 864-1040 894-1067 959-1146	95-112 108-130 123-147 125-151 130-155 139-166	653-769 742-893 848-1015 864-1040 894-1067 959-1146	95-112 108-130 123-147 125-151 130-155 139-166

Figure 7A1-2 Oil Pressure Chart

**3. Pressure Regulator Valve and Spring.**

- Valve binding.
- Wrong spring - check pressures.
- Oil pressure control orifice in pump cover plugged, causing high oil pressure.
- Pressure regulator bore plug leaking.

**4. Manual Valve**

- Unhooked manual valve.

**5. Intermediate Boost Valve**

- Valve binding - pressures will be incorrect in intermediate and low ranges only.
- Orifice in spacer plate at end of valve plugged.

**6. Reverse Boost Valve**

- Valve binding - pressures will be incorrect in reverse only.
- Orifice in spacer plate at end of valve plugged.

**1-2 SHIFT - FULL THROTTLE ONLY****1. Throttle Valve Cable**

- Binding, unhooked or broken.
- Misadjusted.

**2. Throttle Lever and Bracket Assembly**

- Binding or unhooked.

**3. T.V Exhaust Ball Lifter or No. 5 Ball**

- Binding, mispositioned or unhooked. (Allowing No. 5 ball to seat causes full T.V. pressure regardless of throttle valve position.)

**4. Throttle Valve and Plunger**

- Binding

**5. Control Valve Assembly**

- Valve body gaskets leaking, damaged, incorrectly installed.

**6. Case Assembly**

- Porosity.

**FIRST SPEED ONLY, NO. 1-2 SHIFT****1. Governor and Governor Feed Passages**

- Plugged governor oil feed orifice in spacer plate.
- Plugged orifice in spacer plate that feeds governor oil to the shift valves.
- Governor ball or balls missing in governor assembly.
- Inner governor cover rubber "O" ring seal missing or leaking. (If the outer governor cover "O" ring seal leaks, an external leak will be present along with no upshifts.)
- Governor shaft seal missing or damaged.
- Governor driven gear stripped.
- Governor weights binding on pin.

**2. Control Valve Assembly**

- 1-2 shift valve or 1-2 throttle valve stuck in downshift position.

**3. Case**

- Porosity in case channels or undrilled 2nd speed feed holes.
- Excessive leakage between case bore and intermediate band apply ring.
- Intermediate band anchor pin missing or unhooked from band.
- Broken or missing band.

**4. Intermediate Servo Assembly**

- a. Servo to cover oil seal ring missing or damaged.
- b. Porosity in servo cover or piston.
- c. Wrong intermediate band apply pin.
- d. Incorrect usage of cover and piston.

**FIRST AND SECOND SPEEDS ONLY,  
NO. 2-3 SHIFT**

**1. Control Valve Assembly and Spacer Plate**

- a. 2-3 shift valve or 2-3 throttle valve stuck in the downshift position.
- b. Direct clutch feed orifice in spacer plate plugged.
- c. Valve body gaskets leaking, damaged or incorrectly installed.

**2. Case**

- a. Porosity in case channels

**3. Pump**

- a. Channels in pump plugged or leaking.
- b. Pump to case gasket off location.
- c. Rear oil seal ring on pump cover leaking or missing.

**4. Direct Clutch**

- a. Oil seals missing or damaged on piston.
- b. Direct clutch piston or housing cracked.
- c. Direct clutch plates damaged or missing.
- d. Direct clutch backing plate snap ring out of groove.

**5. Intermediate Servo Assembly (Direct Clutch Accumulator Oil Passages).**

- a. Servo to case oil seal ring broken or missing on intermediate servo piston.
- b. Exhaust hole in case between servo piston seal rings plugged or undrilled.

**DRIVE IN NEUTRAL**

**1. Manual Linkage**

- a. Misadjusted or disconnected.

**2. Forward Clutch**

- a. Clutch does not release.

**3. Pump**

- a. Cross leakage in pump passages.

**4. Case**

- a. Cross leakage to forward clutch passages.

**NO DRIVE IN REVERSE OR SLIPS IN REVERSE (INSTALL PRESSURE GAGE)**

**1. Throttle Valve Cable binding or misadjusted.**

**2. Manual Linkage misadjusted.**

**3. Throttle valve binding.**

**4. Shift T.V. valve binding in valve body bore.**

**5. Reverse boost valve binding in valve body bore.**

**6. Low overrun clutch valve binding in valve body bore. (Line pressure readings will be normal.)**

**7. Reverse Clutch**

- a. Piston cracked, broken or missing seals. Clutch plates burned.

- b. Wrong selective spacer ring.

**8. Direct Clutch Passages**

- a. Porosity in case passages.

- b. Pump - case to pump gasket mispositioned or damaged.

- c. Pump channels cross feeding, leaking or restricted.

- d. Pump cover oil seal rings damaged or missing.

- e. Piston or housing cracked.

- f. Piston seals cut or missing.

- g. Housing ball check stuck, leaking or missing.

- h. Plates burned.

- i. Incorrect piston.

- j. Orifices plugged in spacer plate.

- k. Intermediate servo to case oil seal ring cut or missing.

**SLIPS 1-2 SHIFT**

**1. Low Oil Level.**

- a. Correct oil level.

**2. Spacer Plate and Gaskets.**

- a. Second speed feed orifice partially blocked.

- b. Gaskets damaged or mispositioned.

**3. 1-2 Accumulator Valve.**

- a. Valve sticking in valve body causing low 1-2 accumulator pressure.

- b. Weak or missing spring.

**4. 1-2 accumulator piston.**

- a. Seal leaking, spring broken or missing.

- b. Leak between piston and pin.

**5. Intermediate Band Apply Pin.**

- a. Wrong selection of apply pin.

- b. Excessive leakage between apply pin and case.

**6. Intermediate Servo Assembly**

- a. Porosity in piston.

- b. Cover to servo oil seal ring damaged or missing.

- c. Incorrect usage of cover and piston.

**7. Throttle valve cable not properly adjusted.**

- 8. Throttle valve binding, causing low T.V. pressure.**

**9. Shift T.V. valve binding.**

**10. Intermediate band worn or burned.**

**11. Case porosity in 2nd clutch passages.**

**ROUGH 1-2 SHIFT**

**1. Throttle Valve Cable**

- a. Not adjusted properly

- b. Binding

**2. Throttle Valve**

- a. T.V. plunger binding.

- b. Throttle valve binding.

**3. Shift T.V. Valve binding.**

**4. 1-2 Accumulator Valve binding.**

**5. Intermediate Servo Assembly**

- a. Wrong apply pin.

- b. Servo piston to case oil seal ring damaged or missing.

**6. 1-2 Accumulator**

- a. Oil ring damaged.

- b. Piston stuck.

- c. Broken or missing spring.

- d. Bore damaged.

**SLIPS 2-3 SHIFT**

1. **Oil Level Low**
  - a. Correct oil level.
2. **Throttle valve cable not adjusted properly.**
3. **Throttle valve binding.**
4. **Spacer Plate and Gaskets**
  - a. Direct clutch orifice partially blocked in spacer plate.
  - b. Gaskets mispositioned or damaged.
5. **Intermediate Servo Assembly**
  - a. Servo to case oil seal ring damaged.
6. **Direct Clutch Feed**
  - a. Porosity in direct clutch feed channels in case.
  - b. Pump to case gasket mispositioned or damaged.
  - c. Pump channels cross feeding, leaking or restricted.
  - d. Pump cover oil seal rings damaged or missing.
  - e. Direct clutch piston or housing cracked.
  - f. Piston seals cut or missing.
  - g. Direct clutch plates burned.

**ROUGH 2-3 SHIFT**

1. **Throttle valve cable mispositioned or missing.**
2. **Throttle Valve and Plunger**
  - a. T.V. plunger binding.
  - b. Throttle valve binding.
3. **Shift T.V. valve binding.**
4. **Intermediate Servo Assembly**
  - a. Exhaust hole undrilled or plugged between intermediate servo piston seals, not allowing intermediate servo piston to complete its stroke.
5. **Direct Clutch Exhaust Valve Ball Check No. 4 missing or mispositioned.**

**NO ENGINE BRAKING IN L2 RANGE - 2ND GEAR**

1. **Intermediate boost valve binding in valve body.**
2. **Intermediate Rev. Ball Check (No. 3 Ball) mispositioned or missing.**
3. **Shift T.V. Ball Check (No. 1 Ball) mispositioned or missing.**
4. **Intermediate Servo Assembly**
  - a. Servo to cover oil seal ring missing or damaged.
5. **Intermediate Band**
  - a. Off anchor pin.
  - b. Broken or burned.

**NO ENGINE BRAKING IN L1 RANGE - 1ST GEAR**

1. **Low overrun clutch valve binding in valve body.**
2. **Low-Reverse Clutch Assembly**
3. **No reverse should also be a complaint with any of the following conditions.**
  - a. Piston seals broken or missing.
  - b. Porosity in piston or housing.
  - c. Clutch housing snap ring out of case.
  - d. Cup plug or rubber seal missing or damaged between case and low reverse clutch housing.

**NO PART THROTTLE DOWNSHIFT (INSTALL PRESSURE GAGE)**

1. **Throttle plunger bushing passages not open.**
2. **2-3 throttle valve bushing passages not open.**
3. **Valve body gaskets mispositioned or damaged.**
4. **Spacer plate hole plugged or undrilled.**
5. **Throttle valve cable improperly set.**
6. **Shift T.V. valve binding.**
7. **Throttle valve binding.**

**LOW OR HIGH SHIFT POINTS (INSTALL PRESSURE GAGE)**

1. **Throttle valve cable binding or disconnected.**
2. **Throttle valve binding.**
3. **Shift T.V. valve binding.**
4. **T.V. Shift Ball, (No. 1 ball) missing or mispositioned.**
5. **Throttle valve plunger binding.**
6. **1-2 or 2-3 throttle valves binding in bushings.**
7. **Valve body gaskets mispositioned or damaged.**
8. **Pressure regulator valve binding.**
9. **T.V. Exhaust Ball (No. 5) and lifter mispositioned, unhooked or missing.**
10. **Throttle Lever and Bracket Assembly**
  - a. Binding, unhooked or loose at mounting valve body bolt.
  - b. Not positioned at the throttle valve plunger bushing pin locator.
11. **Governor shaft to cover seal ring broken or missing.**
12. **Governor Cover "O" Rings broken or missing.**
  - a. The outer ring will leak externally and the inner ring internally.
13. **Case porosity.**
14. **Missing pump body check ball - 2-3 only.**

**WON'T HOLD IN PARK**

1. **Manual linkage misadjusted.**
2. **Internal linkage**
  - a. Park pawl binding in case.
  - b. Actuator rod or plunger damaged.
  - c. Parking pawl broken.
  - d. Parking bracket loose or damaged.
3. **Inside Detent Lever and Pin Assembly**
  - a. Nut loose.
  - b. Hole in lever worn or damaged.
4. **Manual Detent Roller and Spring Assembly**
  - a. Bolt loose that holds roller assembly to valve body.
  - b. Pin or roller damaged or mispositioned or missing.

**UNIT REPAIR****Removal of Converter**

1. With transmission in cradle of portable jack, remove J-21366 and then converter assembly by pulling straight out.
2. Installing Holding Fixture, J-8763-02 on transmission and place into Holding Fixture, J-3289-20,

# PARK (WITH GASOLINE ENGINE)

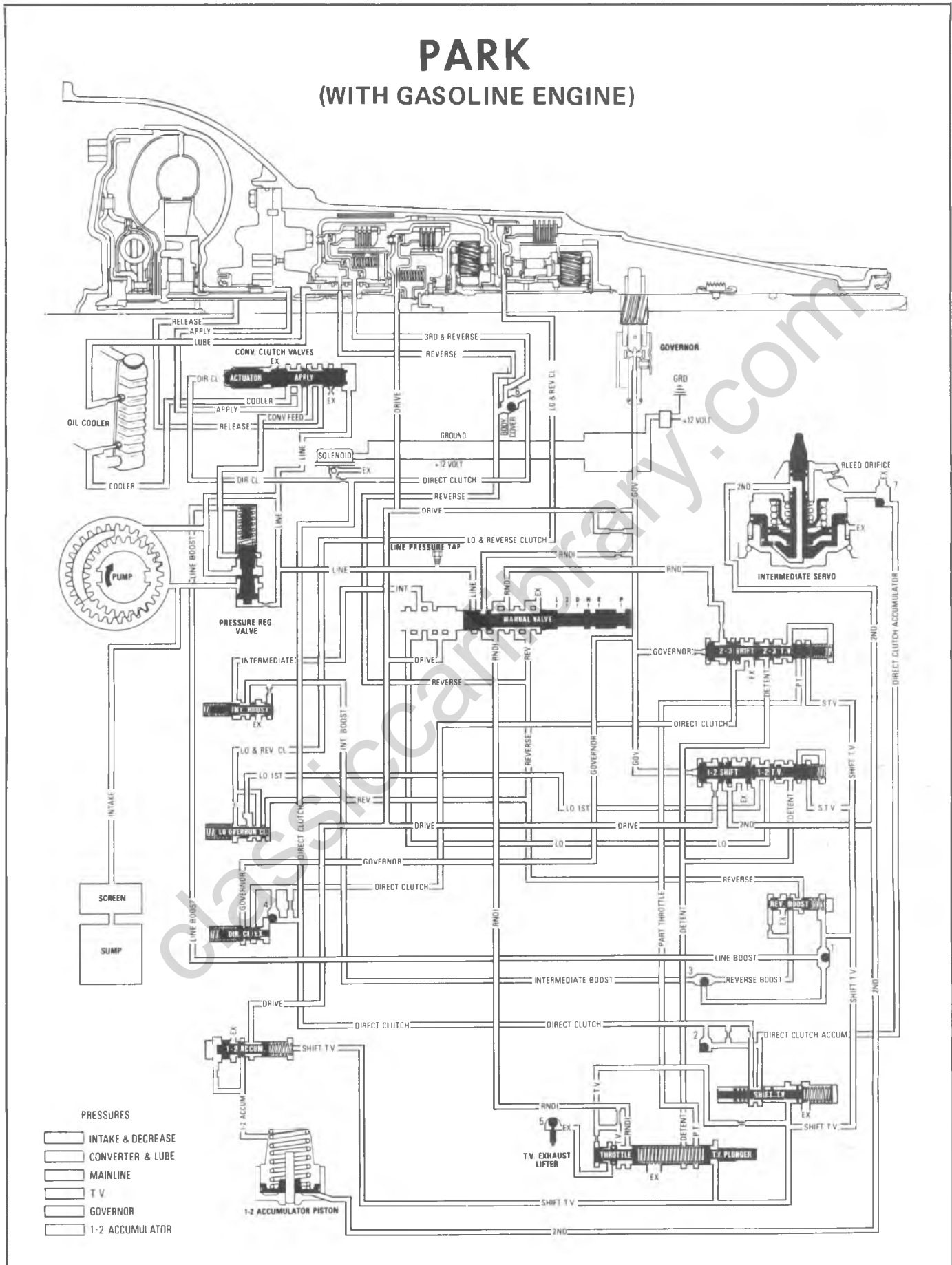

Figure 7A1-3 Park (Gas)



# PARK (WITH DIESEL ENGINE)

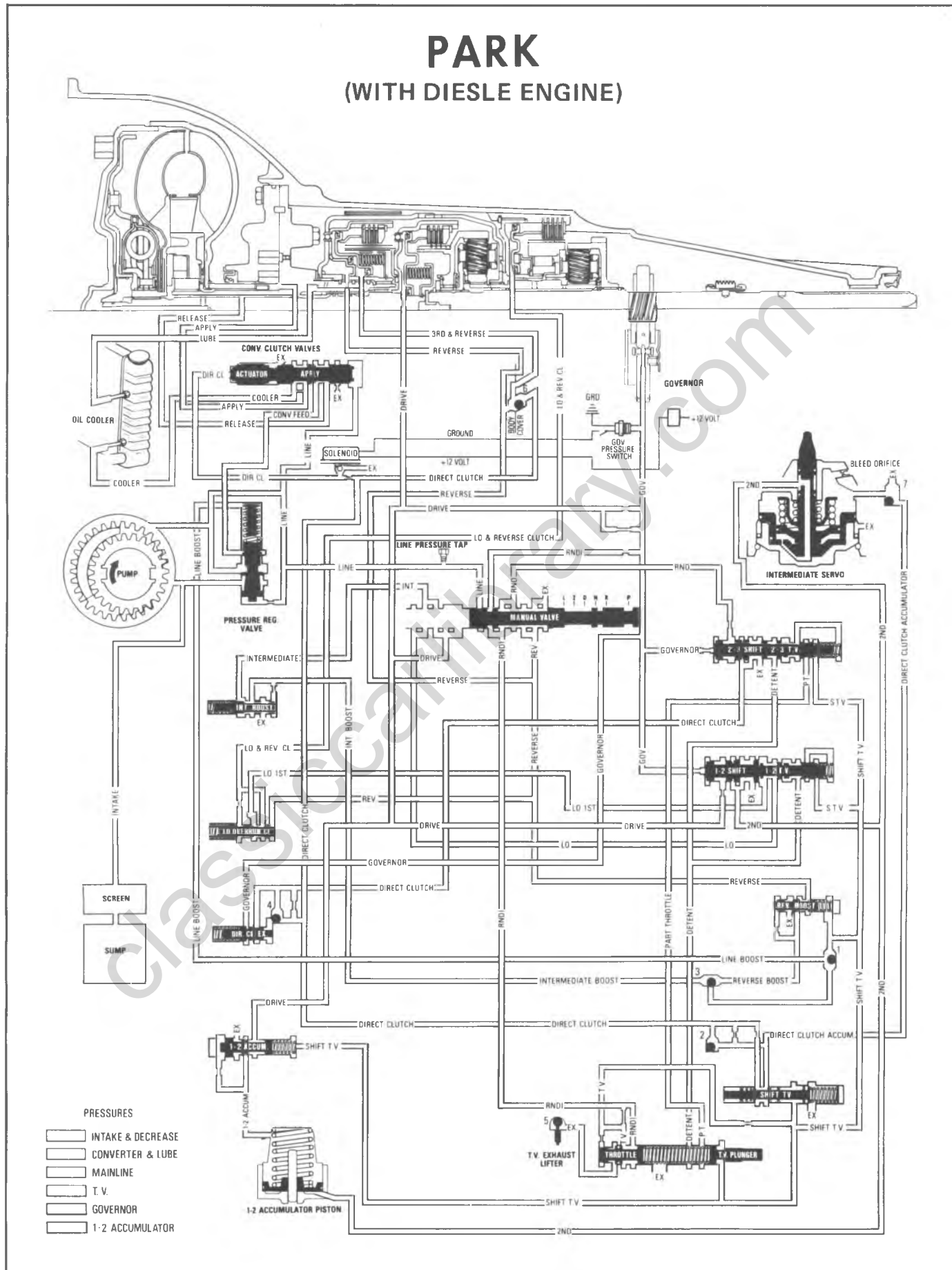

Figure 7A1-4 Park (Diesel)

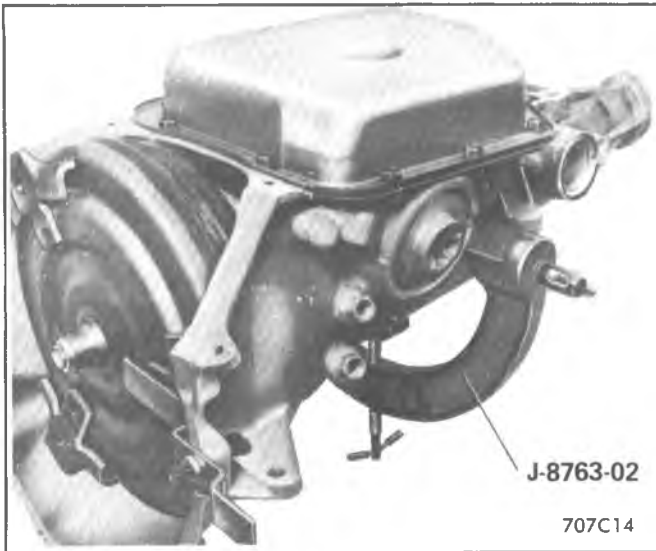

Figure 7A1-6 Transmission in Holding Fixture

with manual shaft facing bench and oil pan side up. (Figure 7A1-6). Do not over torque fixture holding screw.

## SEALS

If any Teflon seal rings are damaged (distorted, cut, scored, etc.), or do not rotate freely in their groove, and replacement is necessary, proceed as follows:

1. Remove and discard old angle cut seal rings; full circle rings must be cut off.
2. Inspect seal ring groove for burrs or damage.
3. When installing angle cut seal rings, do not over-stretch. Make sure cut ends are in same relation as cut. (Figure 7A1-7). Also, make sure rings are seated in the grooves to prevent damage to the rings during reassembly of mating part over rings. Retain with petrolatum.



Figure 7A1-7 Teflon Oil Seal Rings

4. New angle cut or full circle teflon seal rings may appear to be distorted after being installed. Once exposed to normal transmission oil temperatures, the new seal rings will return to their normal shape and fit freely in their bores.

5. The seal rings allow for a free fit in their bores after operation. The free fit of the rings in their bores does not indicate leakage during operation.

## SNAP RINGS

Do not over expand snap rings when removing or installing.

## THRUST WASHER SURFACES

The thrust washers and thrust bearings will polish the surfaces they protect. This is not to be considered damaged part because of this condition.

## EXTERNAL PARTS

### Removal

1. Remove oil pan and gasket.
2. Remove oil screen and gasket. (Figure 7A1-8). The two oil screen attaching bolts are about 10mm (3/8") longer than the control valve assembly attaching bolts, and they are not interchangeable.
3. **Governor Pressure Switch (Diesel Torque Converter Clutch Model)**
  - a. Remove lead wire from pressure switch and wire clips.
  - b. Using a 1-1/16" oil sending unit socket, remove governor pressure switch. (Figure 7A1-10)
4. **Control Valve Assembly:**
  - a. Remove throttle lever and bracket assembly. (Figure 7A1-9). Do not bend throttle lever link. T.V. exhaust valve lifter and spring may separate from throttle lever and bracket assembly.
  - b. Remove manual detent roller and spring assembly. (Figure 7A1-11).
  - c. Remove remaining control valve assembly attaching bolts.

### Do not drop manual valve.

- d. Holding manual valve with finger, remove control valve assembly, spacer plate, and gaskets together, to prevent the dropping of 4 check balls, located in the control valve assembly. (Figure 7A1-12).
- e. Lay control valve assembly down with spacer plate side up.
5. Remove 1-2 accumulator spring. (Figure 7A1-13).
6. Remove 5th check ball located in case. (Figure 7A1-14).

### 7. Governor Assembly:

- a. Using small screwdriver, remove governor cover retaining ring. (Figure 7A1-15).
- b. Using pliers, remove governor cover and 2 seal rings; seal rings may be located in case. (Figure 7A1-16). Governor assembly may come out with cover.

c. Remove governor assembly and governor to case washer from case. It may be necessary to rotate output shaft counterclockwise while removing the governor. Do not use any type of pliers to remove assembly.

### 8. Electrical Connector:

- a. Compress fingers on electrical connector sleeve and withdraw. (Figure 7A1-17)

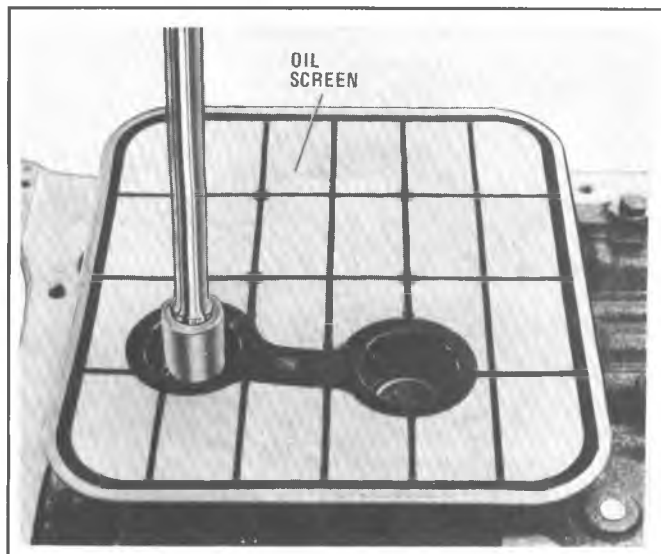

Figure 7A1-8 Removing Oil Screen

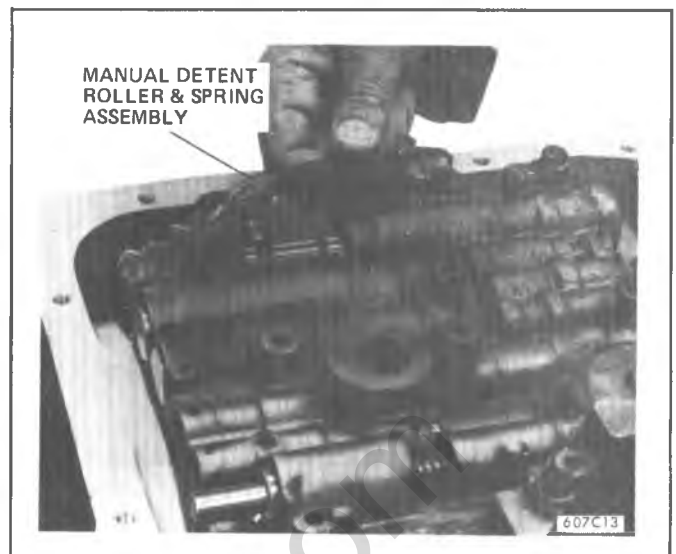

Figure 7A1-11 Removing Manual Detent Roller and Spring Assembly

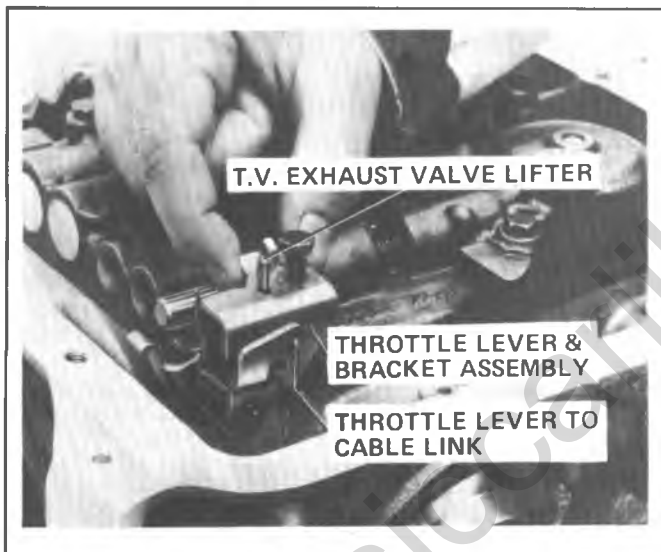

Figure 7A1-9 Removing Throttle Valve and Bracket Assembly

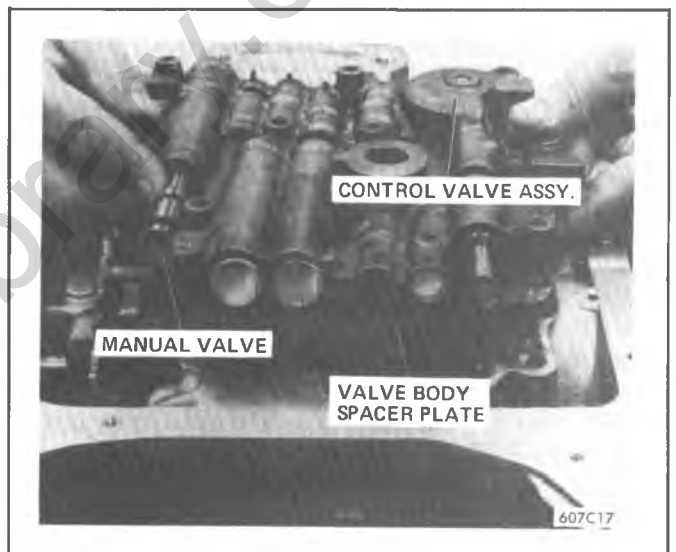

Figure 7A1-12 Removing Control Valve Assembly from Case



Figure 7A1-10 Removing Governor Pressure Switch (Diesel)

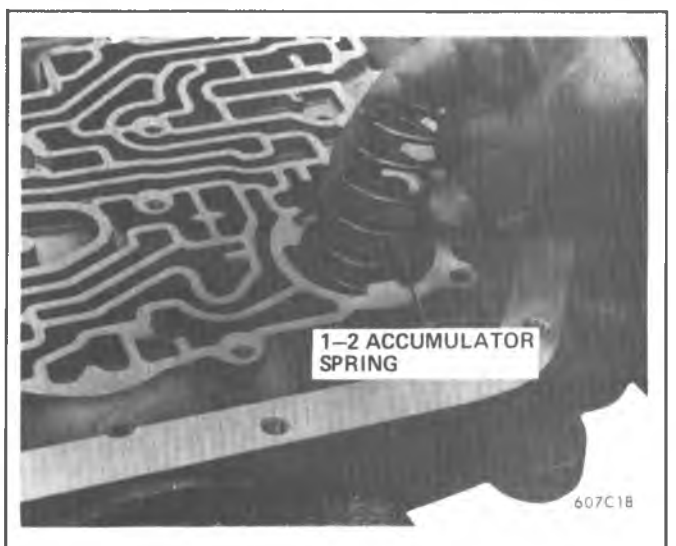

Figure 7A1-13 Removing 1-2 Accumulator Spring

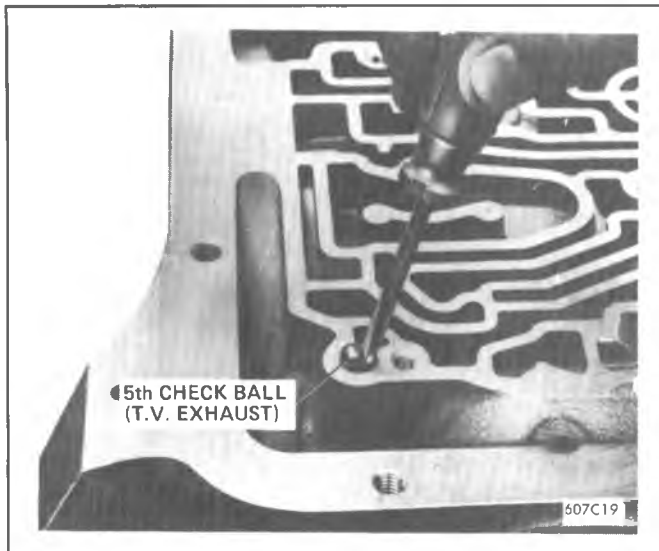

Figure 7A1-14 Removing 5th Check Ball

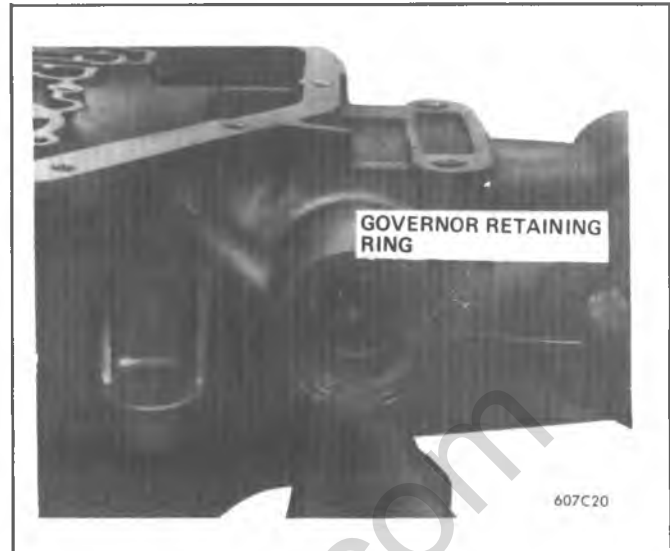

Figure 7A1-15 Removing Governor Cover Retaining Ring

b. Remove solenoid connector from electrical connector. (Figure 7A1-18)

**9. Intermediate Servo Assembly:**

a. Using two oil pan bolts, install J-28653 on case to depress servo cover. (Figure 7A1-19).

b. Using small screwdriver, remove intermediate servo cover retaining ring. Figure 7A1-19.

c. Remove Tool J-28653.

d. Using pliers, remove intermediate servo cover and seal ring; cover seal ring may be located in case.

e. Remove intermediate servo piston and band apply pin assembly. Figure 7A1-20.

**10. Check for proper intermediate band apply pin as follows:**

a. Install J-25014-2 in intermediate servo bore and retain with intermediate servo cover retaining ring aligning ring with gap at case slot. (Figure 7A1-21).

b. Install pin J-25014-1 into J-25014-2. (Figure 7A1-21). Make sure the tapered pin end is properly located against the band apply lug. Also, make sure the band anchor pin is properly located in the case and band anchor lug.

c. Install dial indicator J-8001 and position dial indicator point (Figure 7A1-21) on top of J-25014-2 zero post and set dial indicator to zero. Seat J-25014-2 squarely against the servo retaining snap ring.

d. Align stepped side of pin J-25014-1 with torquing arm of J-25014-2. Arm must stop against step of pin J-25014-1. If band selection pin does not register between the high and low limits, look for possible problem with the intermediate band, direct clutch or case.

e. Apply 12 N·m (100 lb. in.) of torque to hex nut on side of gage. Slide dial indicator over pin J-25014-1. (Figure 7A1-22). Read dial indicator and see chart Figure 7A1-23 for proper size. (Dial indicator travel is reversed, making the indicator readings backwards. On an indicator that ranges from 0-100, a .5mm (.020") travel will read 2mm (.080"), a 1.5mm (.060") travel will read 1mm (.040"). The identification ring is located on the band end of the pin.)

f. Remove tools J-25014-2 and J-25014-1.

11. Inspect the 3rd accumulator check valve for the following conditions: missing check ball, check ball binding or stuck in tube, oil feed slot in tube missing or restricted,

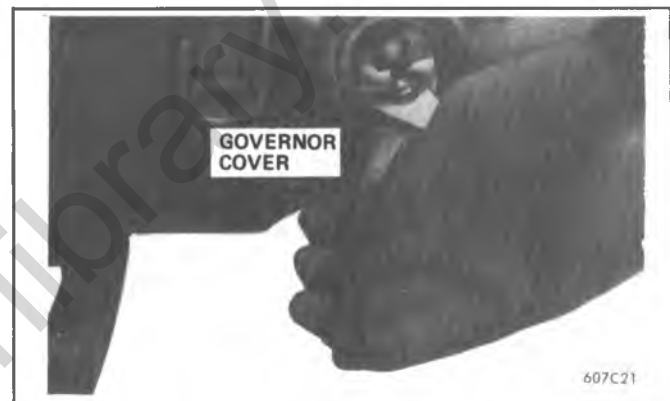

Figure 7A1-16 Removing Governor Cover

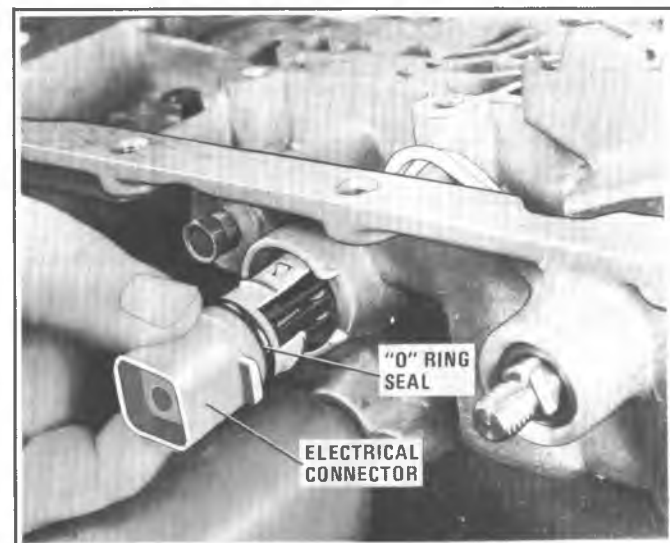

Figure 7A1-17 Removing Electrical Connector from Case

improperly assembled, loose fitting or not fully seated in case and damaged or missing. (Figure 24).

If the 3rd accumulator check valve assembly requires replacement, perform the following:

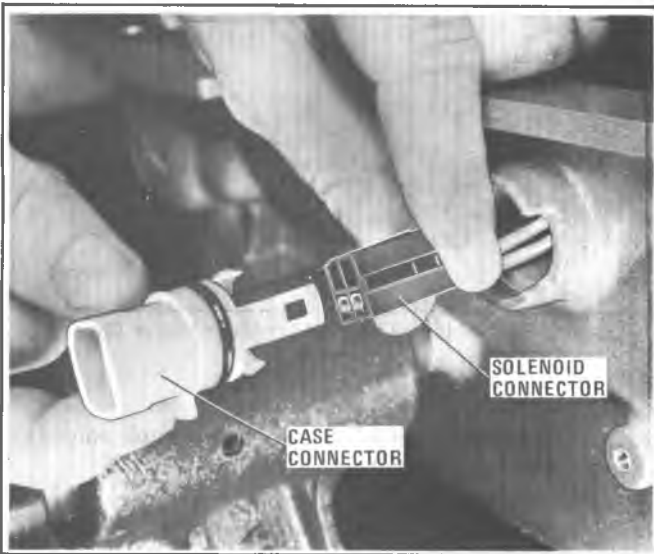

Figure 7A1-18 Removing Solenoid Connector from Case Connector



Figure 7A1-19 Removing Intermediate Servo Retaining Ring

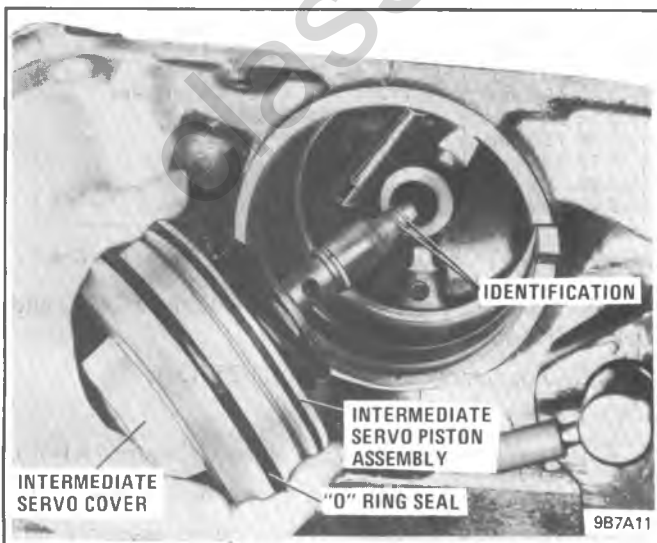

Figure 7A1-20 Removing Intermediate Servo

a. Using a No. 4 easy out, remove the check valve assembly from the case by turning and pulling straight out. (Figure 25)

b. Install new check valve assembly, small end first, into case. Position the oil feed slot in tube so it faces the servo cover.

c. Using a 9.5mm (3/8") diameter metal rod and hammer, drive check valve assembly until it is flush or below the surface of the 3rd accumulator case hole. (Figure 26)

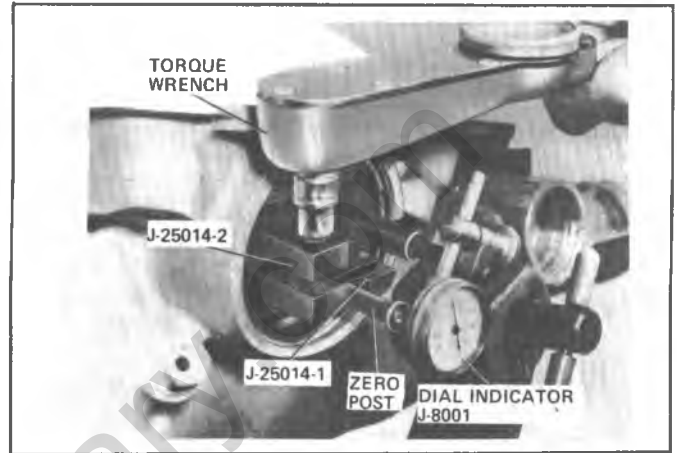

Figure 7A1-21 Intermediate Band Apply Pin Tools

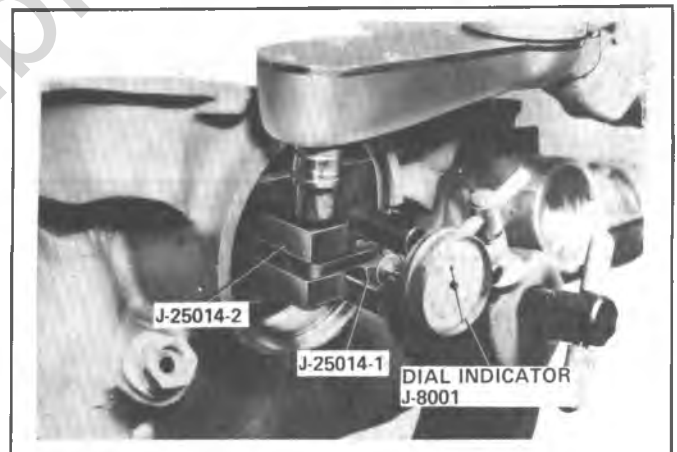

Figure 7A1-22 Checking for Proper Intermediate Band Apply Pin

INTERMEDIATE BAND APPLY PIN SELECTION CHART

DIAL INDICATOR TRAVEL	APPLY PIN IDENTIFICATION
.0 - .72mm (.0 - .029")	1 Ring
.72mm - 1.44mm (.029"-.057")	2 Rings
1.44mm - 2.16mm (.057"-.086")	3 Rings
2.16mm - 2.88mm (.086"-.114")	Wide Band

9B7A6

Figure 7A1-23 Intermediate Band Apply Pin Selector Chart

FRONT UNIT PARTS

Removal

1. Check front unit end play as follows: (Figure 7A1-28).

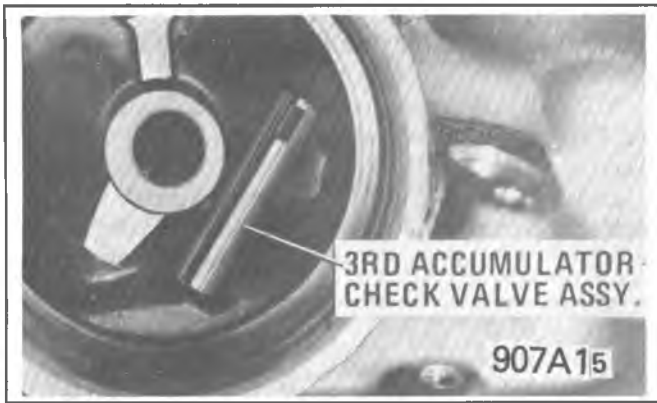

Figure 7A1-24 3rd Accumulator Check Valve Assembly



Figure 7A1-25 Removing 3rd Accumulator Check Valve Assy.



Figure 7A1-26 Installing 3rd Accumulator Check Valve Assy.

a. Install J-25013-1 sleeve on output shaft first; then bolt J-25013-5 on end of case. (Figure 7A1-27).

b. Turn transmission to vertical position, pump side up.

c. Remove pump to case bolt and washer and install 278mm (11") long bolt and locking nut as shown. (Figure 7A1-29).

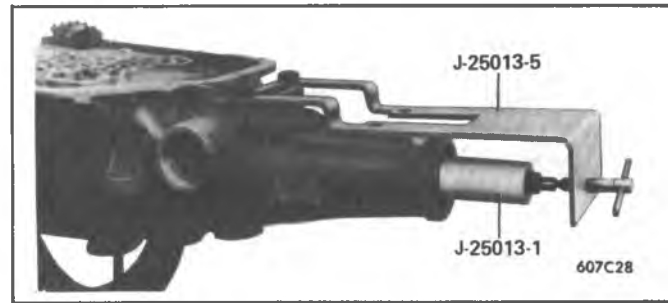

Figure 7A1-27 Installing Tools on Rear End of Case

d. Push turbine shaft downward.

e. Install J-25022 on J-24773 tool and secure on end of turbine shaft. (Figure 7A1-29).

f. Mount dial indicator and clamp assembly on bolt, positioning indicator point against cap nut of J-24773. (Figure 7A1-29)

g. Move output shaft upward by turning the adjusting screw on J-25013-5 until the white or scribed line on sleeve J-25013-1 begins to disappear (Figure 7A1-27), then set dial indicator to zero.

h. Pull J-24773 on turbine shaft upward and read end play. Front unit end play should be 0.56mm-1.30mm (.022"-.051").

Selective washer controlling this end play is located between the output shaft and turbine shaft. If more or less washer thickness is required to bring end play within specifications, select proper washer from the front unit end play washer thickness chart.

FRONT UNIT END PLAY WASHER THICKNESS CHART		
THICKNESS		IDENTIFICATION Number and/or Color
1.66-1.77 mm	(0.065"-0.070")	1 - —
1.79-1.90 mm	(0.070"-0.075")	2 - —
1.92-2.03 mm	(0.076"-0.080")	3 - Black
2.05-2.16 mm	(0.081"-0.085")	4 - Light Green
2.18-2.29 mm	(0.086"-0.090")	5 - Scarlet
2.31-2.42 mm	(0.091"-0.095")	6 - Purple
2.44-2.55 mm	(0.096"-0.100")	7 - Cocoa Brown
2.57-2.68 mm	(0.101"-0.106")	8 - Orange
2.70-2.81 mm	(0.106"-0.111")	9 - Yellow
2.83-2.94 mm	(0.111"-0.116")	10 - Light Blue
2.96-3.07 mm	(0.117"-0.121")	11 - —
3.09-3.20 mm	(0.122"-0.126")	12 - —
3.22-3.33 mm	(0.127"-0.131")	13 - Pink
3.35-3.46 mm	(0.132"-0.136")	14 - Green
3.48-3.59 mm	(0.137"-0.141")	15 - Gray 907A4

Figure 7A1-28 Front Unit End Play Washer Thickness Chart

i. Remove dial indicator, clamp assembly, J-24773 and J-25022. (Figure 7A1-29).

j. Do not remove J-25013-5 or J-25013-1.

2. Pump:

a. If necessary remove pump oil seal. (Figure 7A1-30).

b. Remove remaining pump to case bolts and washers.

c. Using J-24773 tool, remove pump assembly and pump to case gasket. (Figure 7A1-31).

3. Forward and Direct Clutch:

a. Grasp turbine shaft and remove direct and forward clutch assemblies. (Figure 7A1-32).

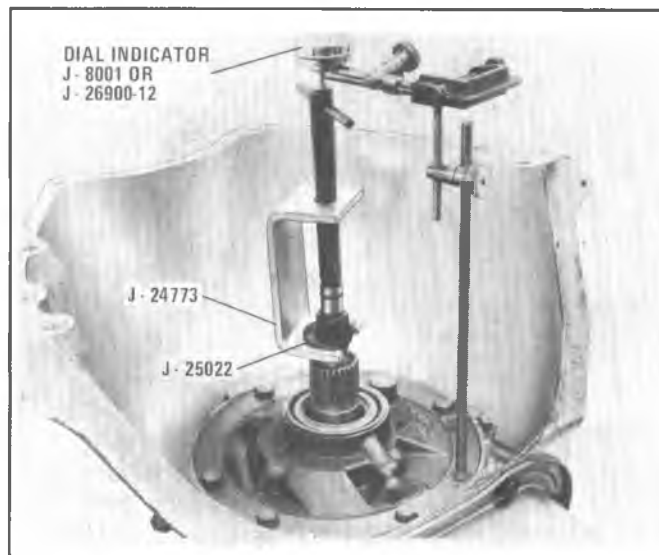

Figure 7A1-29 Checking Front Unit End Play

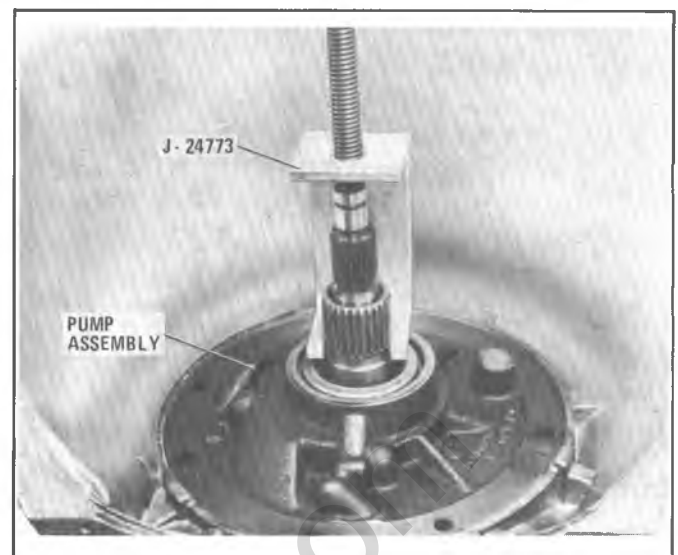

Figure 7A1-31 Removing Pump Assembly

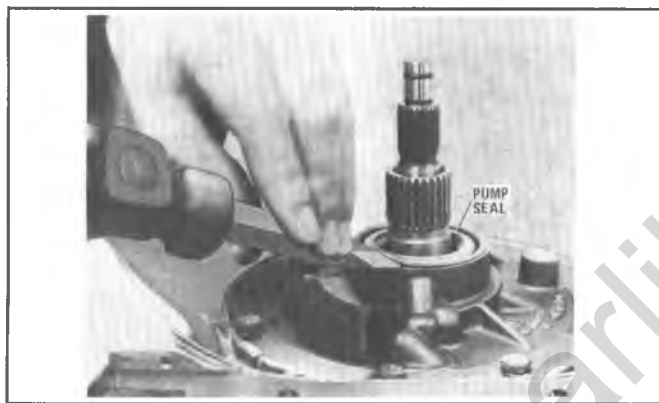

Figure 7A1-30 - Removing Pump Seal

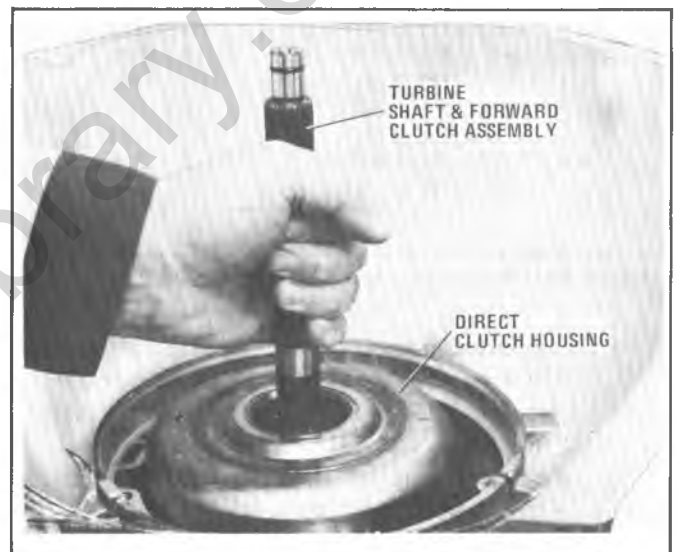

Figure 7A1-32 Removing Forward and Direct Clutch Assemblies

b. Lift direct clutch assembly off forward clutch assembly. (The direct-to-forward clutch thrust washer may stick to the end of the direct clutch housing when it is removed from the forward clutch housing.)

4. Remove intermediate band assembly. (Figure 7A1-33).

5. Remove band anchor pin. (Figure 7A1-34).

## FRONT GEAR PARTS

### Removal

1. Remove output shaft to turbine shaft front selective washer. (Figure 7A1-36). (This washer may be stuck to the end of the turbine shaft.)

2. Check Rear Unit end play as follows:

a. Loosen J-25013-5 adjusting screw on output shaft and push output shaft downward. (Figure 7A1-37).

b. Install gage clamp on case as shown. (Figure 7A1-38).

c. Install dial indicator J-8001 and plunger extension J-7057. Position extension against end of output shaft and set dial indicator to zero. (Figure 7A1-38).

d. Move output shaft upward by turning adjusting screw on J-25013-5 until the white or scribed line on sleeve J-25013 begins to disappear; then read end play. (Rear unit end play should be 0.10-0.64mm (.004"-.025").



Figure 7A1-33 Removing Intermediate Band Assembly

Selective washer controlling this end play is located between the front internal gear thrust washer and output shaft snap ring. If more or less washer thickness is required to bring end play within specifications, select proper washer from the rear unit end play washer thickness chart.

## 7A1-14 200 AUTOMATIC TRANSMISSION

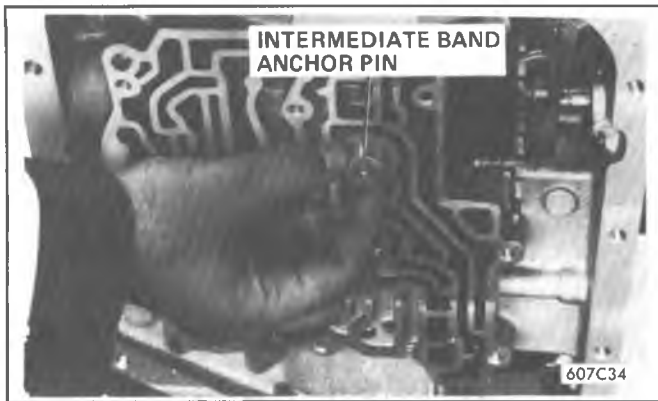

Figure 7A1-34 Removing Intermediate Band Anchor Pin

THICKNESS		IDENTIFICATION
		Number and/or Color
2.90-3.01mm	(0.114"-0.119")	1 - Orange
3.08-3.19mm	(0.121"-0.126")	2 - White
3.26-3.37mm	(0.128"-0.133")	3 - Yellow
3.44-3.55mm	(0.135"-0.140")	4 - Blue
3.62-3.73mm	(0.143"-0.147")	5 - Red
3.80-3.91mm	(0.150"-0.154")	6 - Brown
3.98-4.09mm	(0.157"-0.161")	7 - Green
4.16-4.27mm	(0.164"-0.168")	8 - Black
4.34-4.45mm	(0.171"-0.175")	9 - Purple

7B7A512

Figure 7A1-35 Rear Unit End Play Washer Thickness Chart

e. Remove dial indicator and clamp assembly. (Figure 7A1-38). Do not remove J-25013 tools. (Figure 7A1-37).

f. Tighten J-25013 adjusting screw on output shaft to remove snap ring.

3. Using snap ring pliers, remove output shaft to selective washer snap ring. (Figure 7A1-39).

#### 4. Front Internal Gear:

a. Remove front internal gear, rear selective washer and thrust washer. (Figure 7A1-39).

b. Remove rear selective washer and thrust washer from front internal gear.

5. Remove front carrier assembly and the front internal gear to front carrier roller bearing assembly. (Figure 7A1-40).

**The front sun gear to front carrier thrust bearing assembly may come out as the front carrier is removed.**

6. Remove front sun gear and front sun gear to front carrier thrust bearing assembly. (Figure 7A1-41). (This thrust bearing requires only one thrust race.)

#### 7. Input drum and rear sun gear assembly:

a. Remove input drum and rear sun gear. (Figure 7A1-42).

b. Remove the 4 tapered input drum to reverse clutch housing thrust washer from rear of input drum or from reverse clutch housing.

#### 8. Low and Reverse clutch housing assembly:

9. Grind approximately 20mm (3/4") from end of 6.3mm (No. 4) easy out or equivalent to remove cup plug.

a. Remove housing to case cup plug and seal by turning screw 2 or 3 turns and pulling straight out. (Figure 7A1-43).

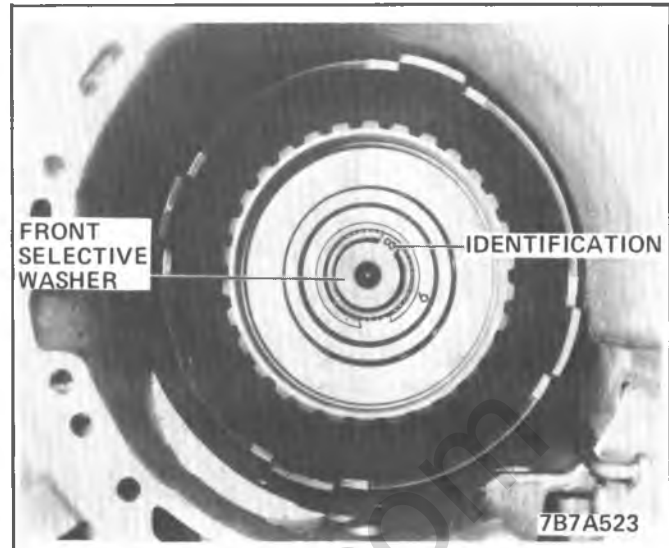

Figure 7A1-36 Location of Front Selective Washer



Figure 7A1-37 Installing Tools on Rear of Case

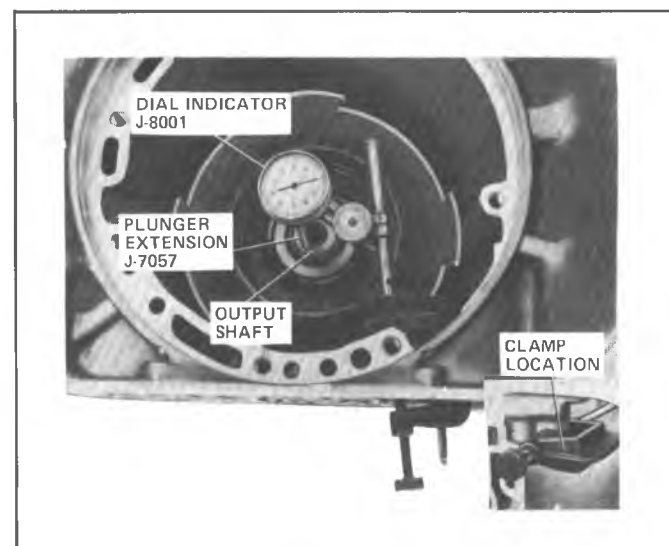

Figure 7A1-38 Checking Rear Unit End Play

b. Remove low and reverse clutch housing to case beveled snap ring. (Figure 7A1-44). (The flat side of the ring should have been against the low and reverse clutch housing with beveled side up.)



c. Using J-25012, remove low and reverse clutch housing assembly by moving J-25012 back and forth. (Figure 7A1-45).

d. Remove low and reverse clutch housing to case spacer ring. (Figure 7A1-46).

## REAR GEAR PARTS

### Removal

Make sure governor has been removed at this time.

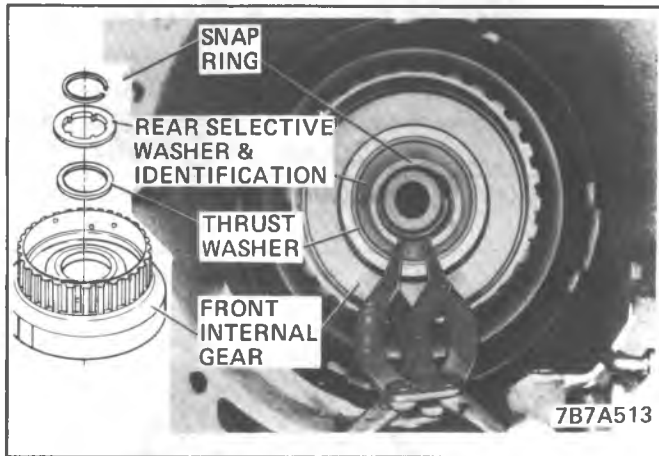

Figure 7A1-39 Removing Output Shaft to Selective Washer Snap Ring

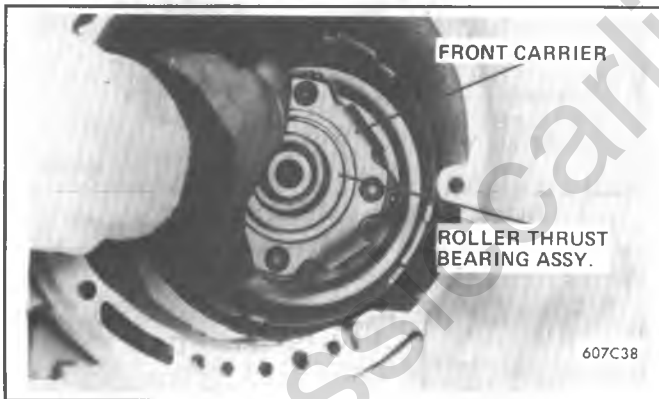

Figure 7A1-40 Removing Front Carrier and Roller Thrust Bearing

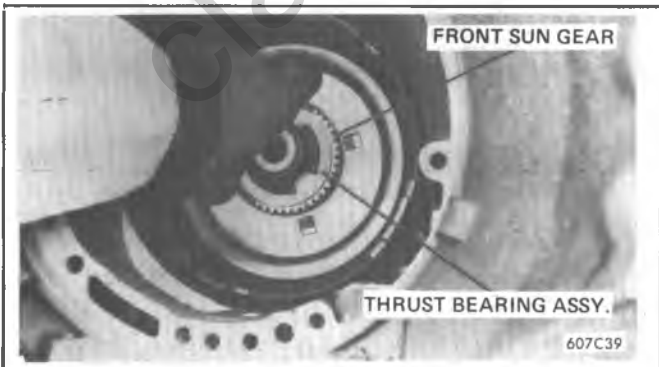

Figure 7A1-41 Removing Thrust Bearing Assembly and Front Sun Gear

1. Grasp output shaft and lift out remainder of rear unit parts and lay down in a horizontal position. (Figure 7A1-47).

2. Roller clutch and rear carrier assembly:

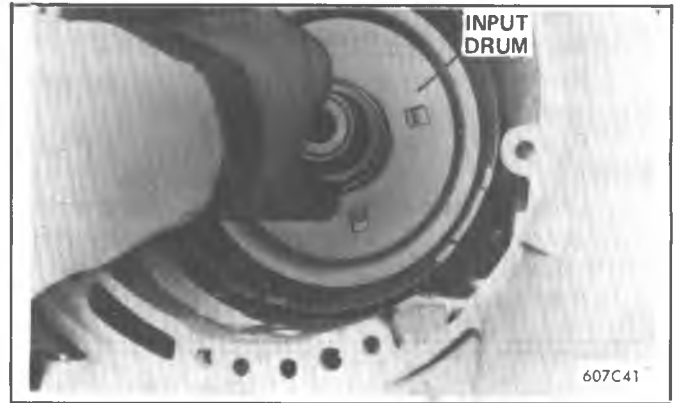

Figure 7A1-42 Removing Input Drum and Rear Sun Gear

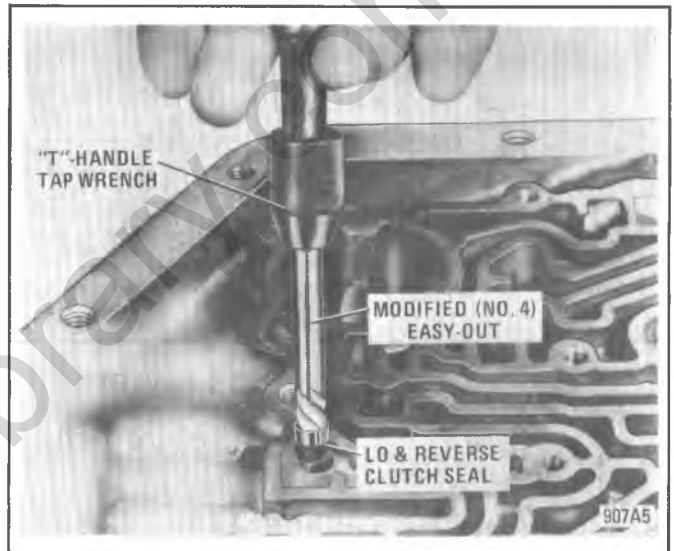

Figure 7A1-43 Removing Cup Plug and Seal Assembly

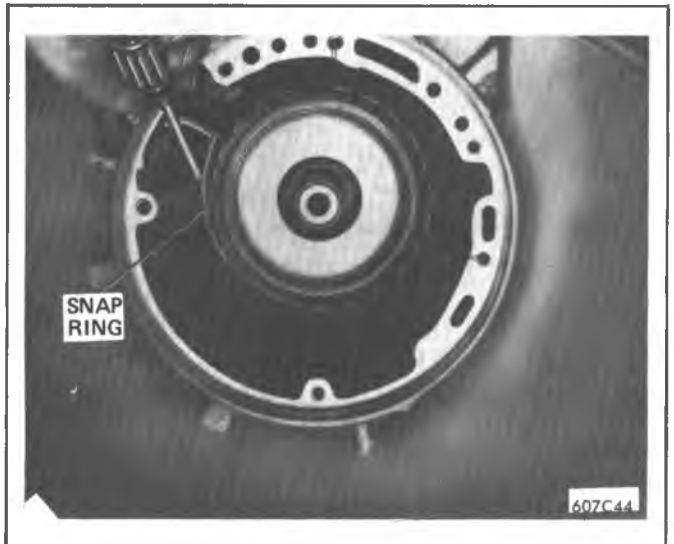

Figure 7A1-44 Removing Lo and Reverse Housing to Case Snap Ring

a. Remove roller clutch and rear carrier assembly off output shaft.

b. Remove the 4 tanged rear carrier to rear internal gear thrust washer off the end of the rear carrier, or inside the rear internal gear. (Figure 7A1-48).

## 7A1-16 200 AUTOMATIC TRANSMISSION

3. Remove lo and reverse clutch plates off output shaft.
4. Rear internal gear:
  - a. Remove rear internal gear to rear sun gear roller thrust bearing assembly off rear internal gear.
  - b. Remove rear internal gear off output shaft. (Figure 7A1-49).
5. Turn transmission to horizontal position and remove J-25013-5 and J-25013-1 tools from case. Turn transmission to vertical position with rear end up.
6. If necessary, remove rear oil seal. (Figure 7A1-50).



Figure 7A1-45 Removing Low and Reverse Clutch Housing

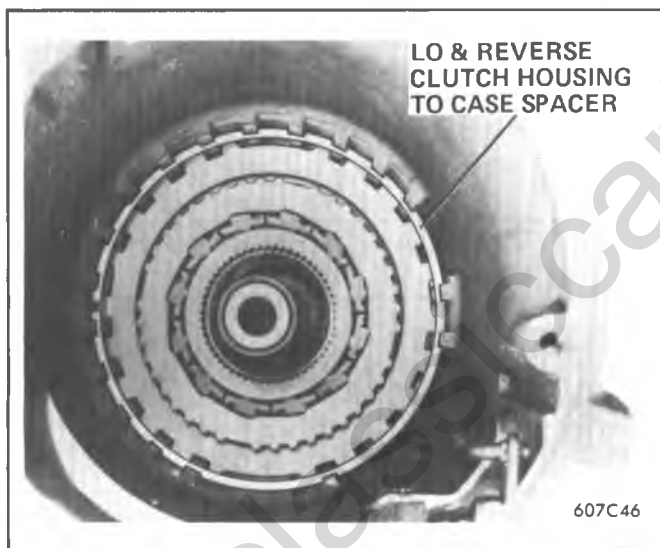

Figure 7A1-46 Proper Location of Low and Reverse Housing to Case Spacer

## MANUAL SHAFT AND PARKING PAWL PARTS (FIGURE 7A1-51)

### Removal

1. Turn transmission to horizontal position, oil pan side up.
2. If necessary, remove manual shaft and parking linkage as follows:
  - a. Remove hex nut which holds inside detent lever to manual shaft. (Figure 7A1-52).
  - b. Remove parking lock actuator rod and inside detent lever assembly.
  - c. Remove manual shaft retaining pin from case and slide manual shaft out. (Figure 7A1-53).

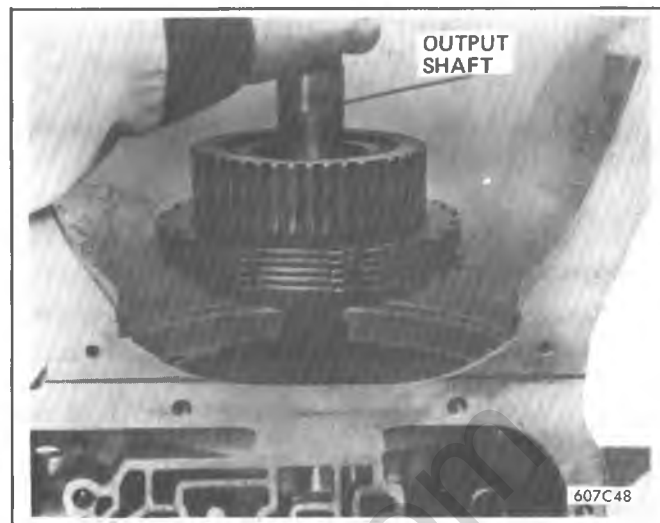

Figure 7A1-47 Removing Rear Unit Parts

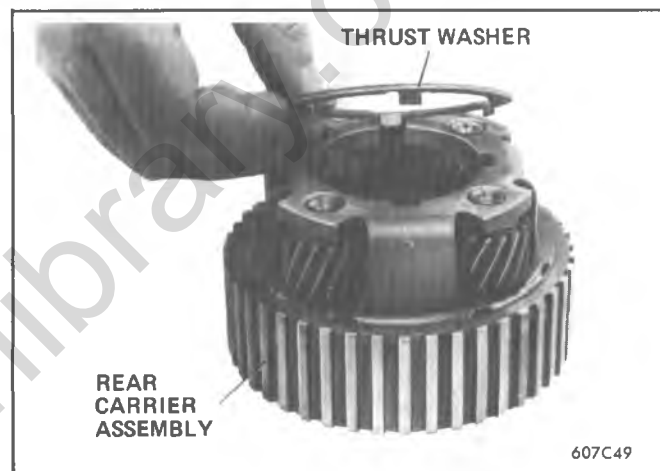

Figure 7A1-48 Removing Thrust Washer

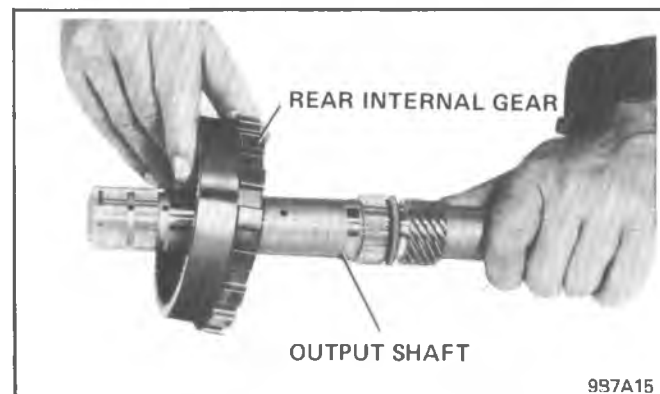

Figure 7A1-49 Removing Rear Internal Gear

- d. Inspect manual shaft to case seal for damage. If necessary, pry out manual shaft seal using screwdriver. (Figure 7A1-54).
- e. Remove parking lock bracket. (Figure 7A1-55).
- f. Remove parking lock pawl shaft retaining pin. (Figure 7A1-56).
- g. Grind approximately 20mm (3/4") from end of 6.3mm (No. 4) easy out and remove parking lock pawl cup plug. (Figure 7A1-57).
- h. Using a 4mm (No. 3) easy out, remove parking lock pawl shaft. (Figure 7A1-58).

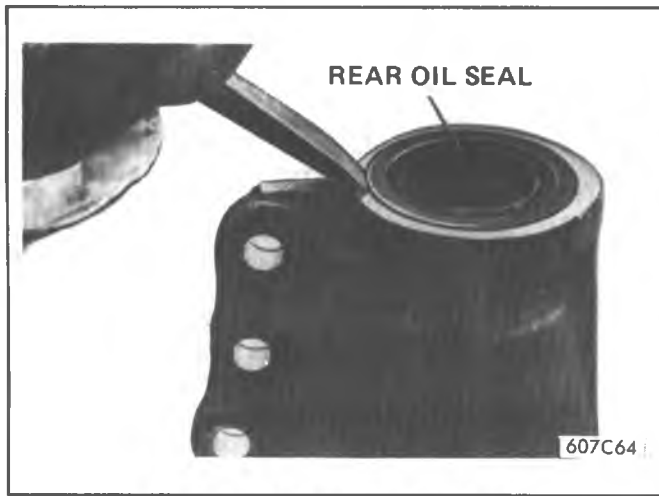

Figure 7A1-50 Removing Rear Oil Seal

i. Remove parking pawl and return spring.

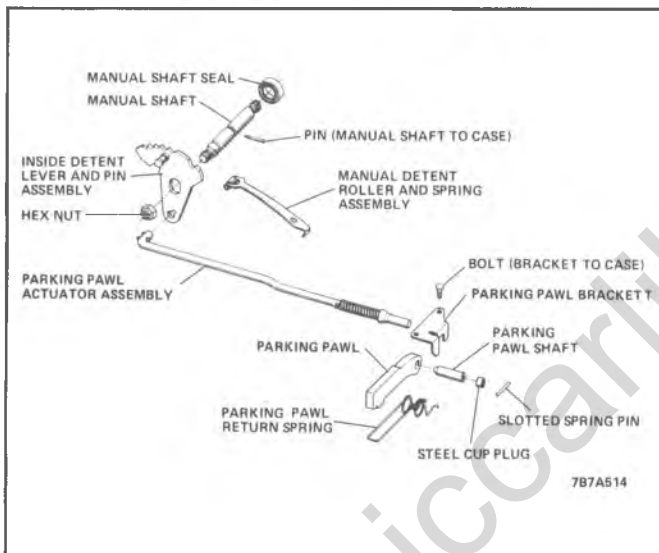

Figure 7A1-51 Manual Shaft and Parking Shaft Parts

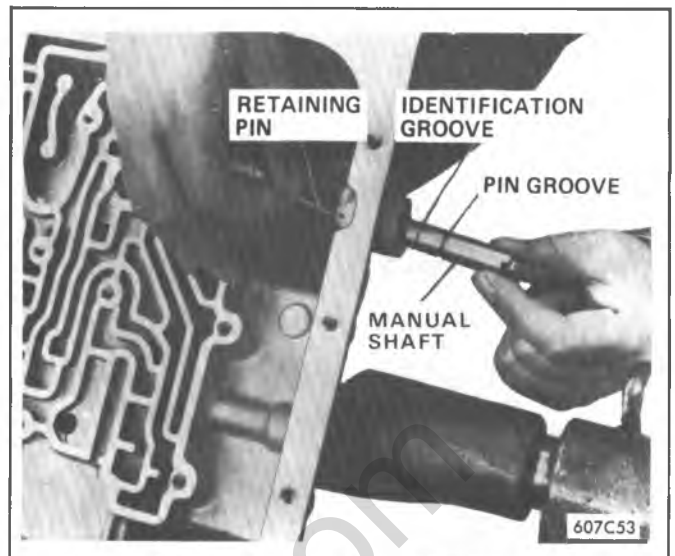

Figure 7A1-53 Removing Manual Shaft from Case



Figure 7A1-54 Removing Manual Shaft Seal From Case

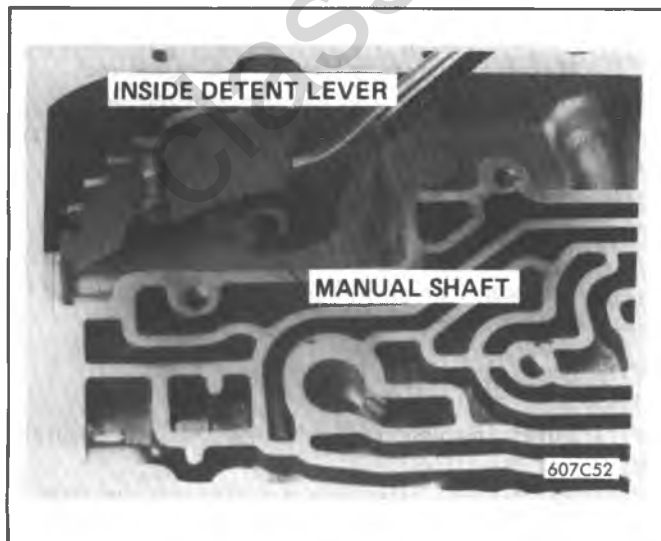

Figure 7A1-52 Removing Manual Shaft Nut

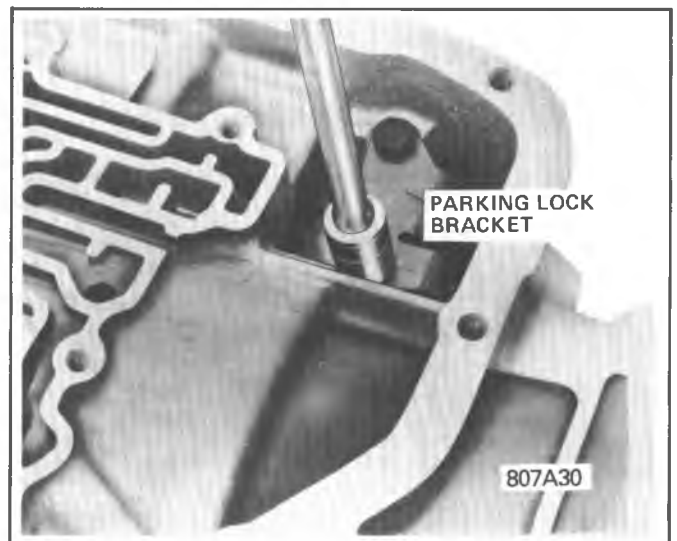

Figure 7A1-55 Removing Parking Pawl Bracket Bolt

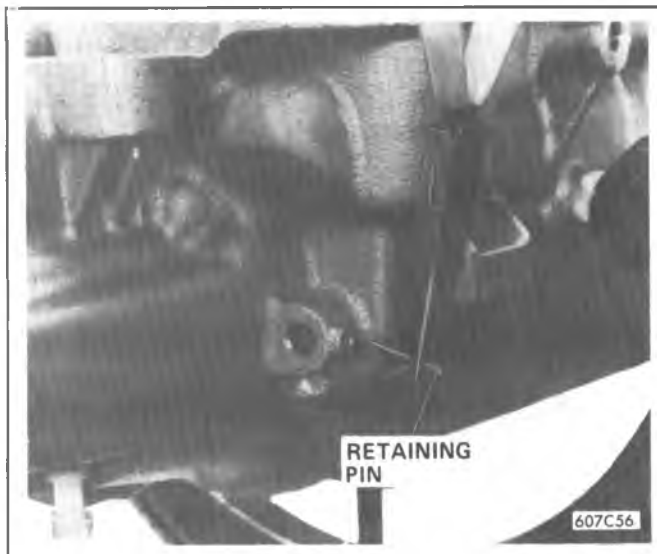

Figure 7A1-56 Removing Parking Pawl Shaft Pin

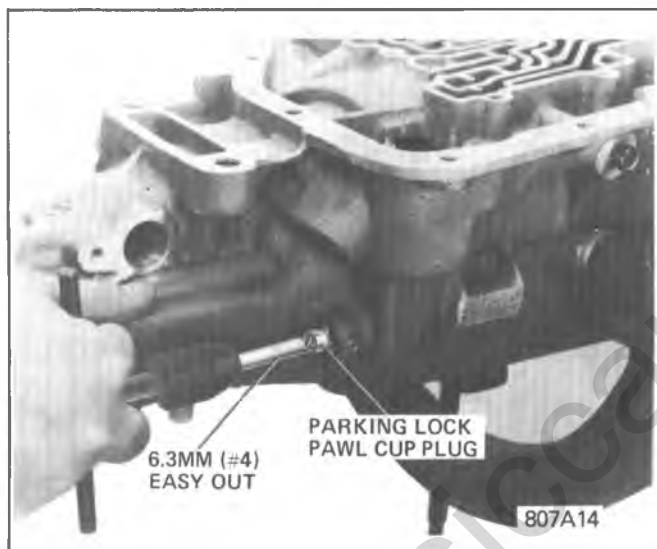

Figure 7A1-57 Removing Parking Pawl Shaft Cup Plug from Case

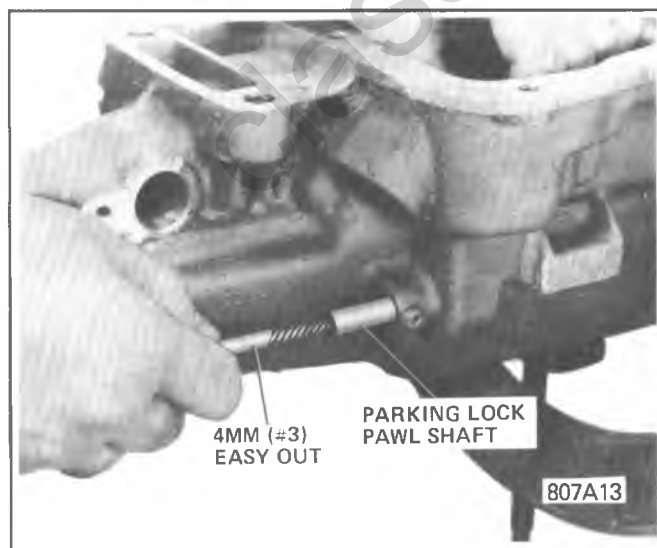

Figure 7A1-58 Removing Parking Pawl Shaft from Case

## TRANSMISSION INSPECTION AND REASSEMBLY

### INSPECTION OF CASE ASSEMBLY (FIGURES 7A1-59 AND 7A1-60)

1. Inspect case assembly for damage, cracks, porosity or interconnected oil passages. If case is porous, refer to porosity repair.
2. Inspect orifice plug in the intermediate servo bore. If the plug requires replacement, place the new plug, orifice end first, into plug hole in case. Drive plug flush to slightly below top of plug hole.
3. Inspect the exhaust vents for being opened.
4. Inspect reverse clutch lugs, governor bore, intermediate servo bore, speedometer bore and snap ring grooves for damage.
5. Inspect reverse clutch seal and intermediate band anchor pin bores for damage.
6. Inspect for damage or stripped bolt holes. If any threaded holes require heli-coils or equivalent, install these to renew the threads.
7. Turn transmission to vertical position, rear end up.
8. Inspect cooler line connectors for damage. Do not remove unless replacing.
9. Inspect case bushing for damage or scoring.
10. If removed, install a new oil seal, using J-21426. (Figure 7A1-61).
11. If removed, install cooler line connector(s); torque connector(s) to 24.0 N·m (18 lb. ft.). Using a commercial thread sealant on connector threads.

### MANUAL SHAFT AND PARKING PAWL PARTS (FIGURE 7A1-62)

#### Inspection

1. Align actuator rod tangs with hole in inside detent lever and separate.
2. Inspect parking lock actuator rod for damage, or broken retainer lugs.
3. Inspect parking lock actuator spring for damage.
4. Inspect actuator for free fit on actuator rod.
5. Inspect parking pawl for cracks or damage.
6. Inspect parking pawl return spring for deformed end or coils.
7. Inspect parking pawl shaft for damage.
8. Inspect parking lock bracket for cracks or wear.
9. Inspect inside detent lever for cracks or loose pin.
10. Inspect manual shaft for damaged threads and the flats for raised edges. File down any raised edges.

#### Reassembly

1. Turn transmission to horizontal position, oil pan side up.
2. If removed, install new manual shaft seal with lip facing inward into transmission case using a 13mm or (9/16") socket to seat seal. (Figure 7A1-63).
3. Install parking pawl and return spring with tooth toward inside of case and parking pawl return spring under pawl tooth with spring ends toward inside of case. (Figure 7A1-64). Make sure spring ends locate against case pad.

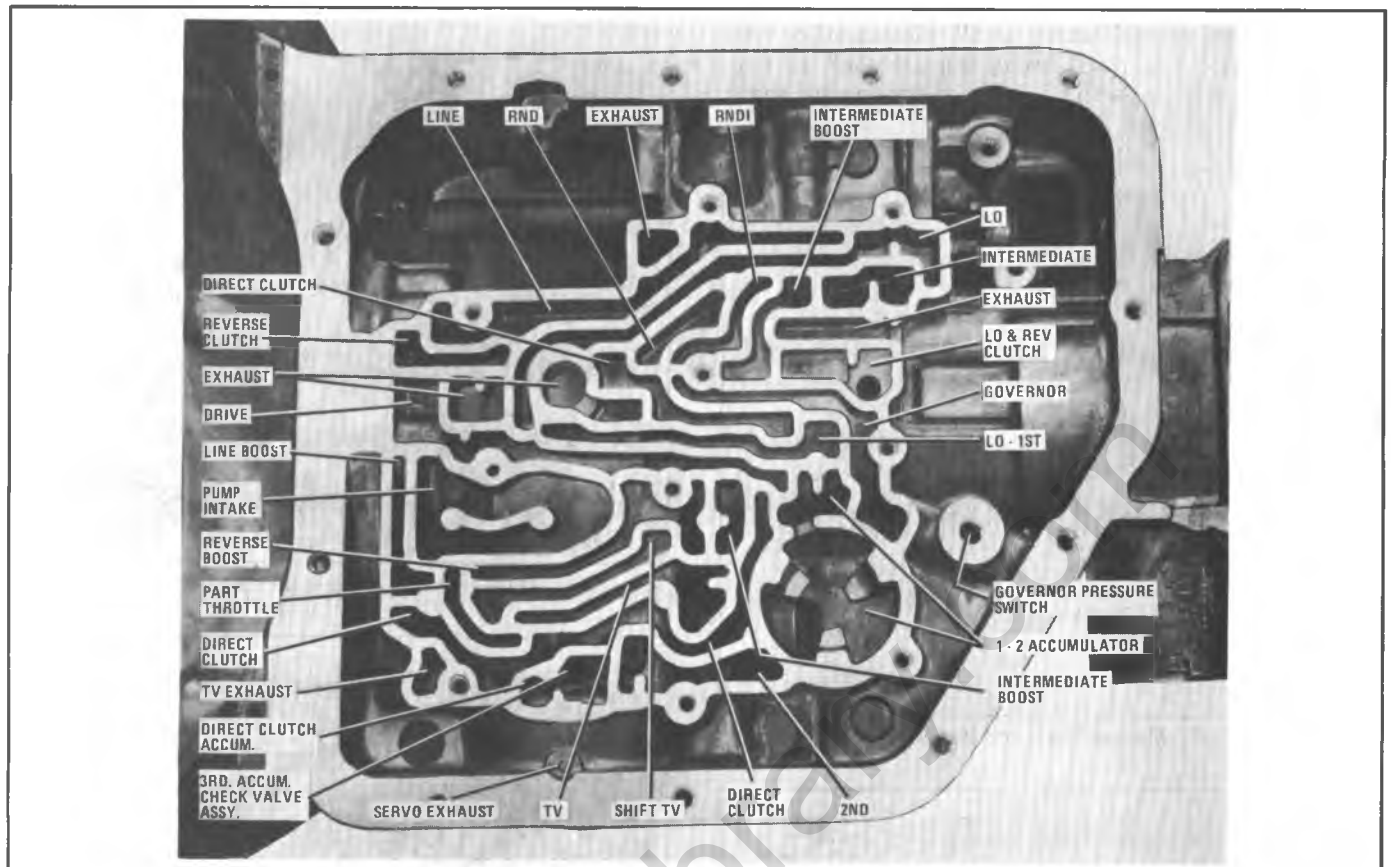

Figure 7A1-59 Oil Passages - Bottom of Case

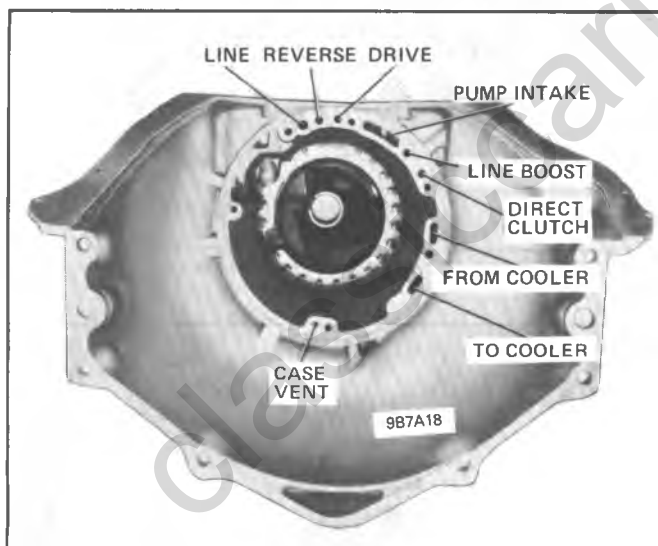

Figure 7A1-60 Oil Passages - Front of Case

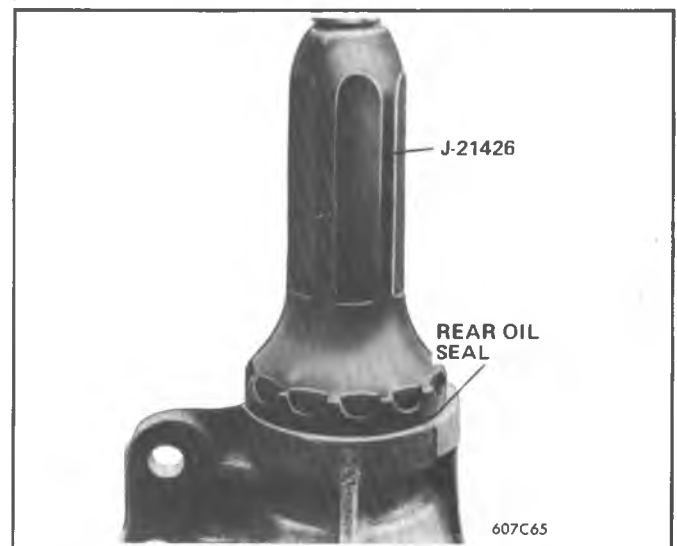

Figure 7A1-61 Installing Rear Oil Seal

4. Align parking pawl and return spring with case shaft bore.
5. Install parking pawl shaft, tapered end first.
6. Using 10mm (3/8") rod, install new parking pawl shaft cup plug, open end out, past retaining pin hole. (Figure 7A1-65).
7. Install parking pawl shaft retaining pin.
8. While holding the parking pawl toward center of transmission, install parking lock bracket. Torque bolts to 24 N·m (18 lb. ft.).

9. Install parking lock actuator rod into inside detent lever on pin side, locating lever between actuator rod tangs.

10. Install parking lock actuator rod and inside detent lever with detent lever pin toward center of transmission and actuator plunger between parking pawl and parking lock bracket. (Figure 7A1-66).

**NOTICE:** File any burrs or raised edges off the manual shaft that could damage the seal during installation of the shaft.

## 7A1-20 200 AUTOMATIC TRANSMISSION

11. Install manual shaft, small identification ring groove first, through case. Install manual shaft to case retaining pin, indexing with larger groove on manual shaft. (Figure 7A1-67).

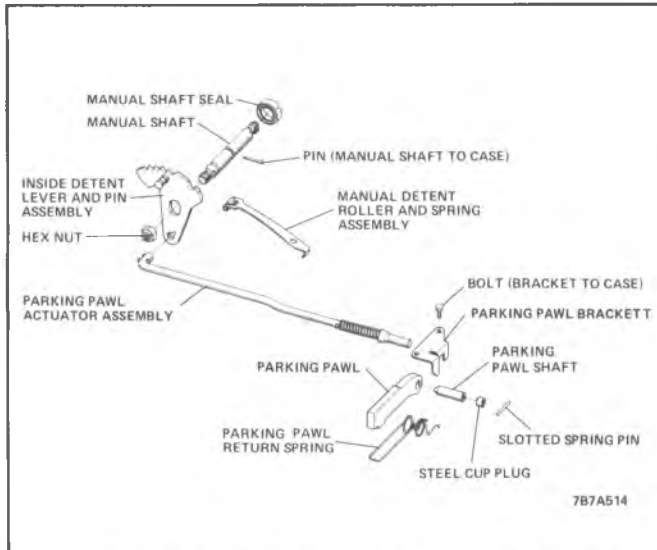

Figure 7A1-62 Manual Shaft and Parking Shaft Parts

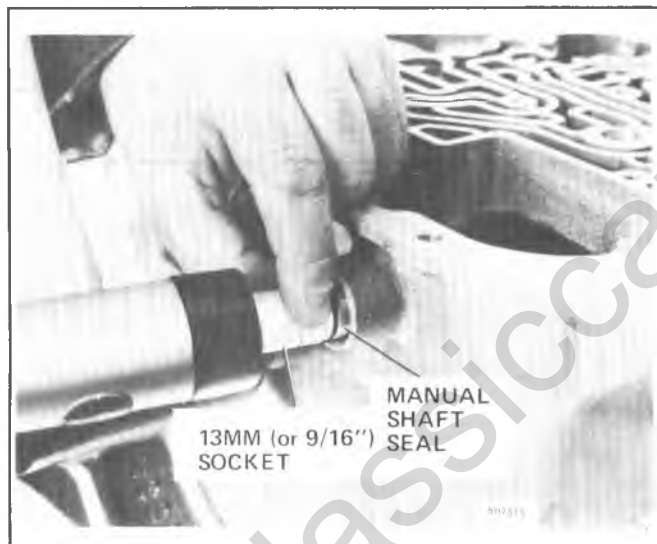

Figure 7A1-63 Installing Manual Shaft Seal Into Case

12. Aligning inside detent lever with flats on manual shaft, install inside detent lever on shaft.

13. Install hex nut on manual shaft and torque to 31 N·m (23 lb. ft.).

## REAR GEAR PARTS

### Output Shaft (Figure 7A1-71)

The service output shaft has one speedometer drive gear clip hole at the front speedometer gear location which is about 6.3mm (1/4") diameter and opposite this hole is another clip hole which is about 4.0mm (5/32"). The shaft also has the same size holes at the rear speedometer gear location.

1. Inspect journals and snap ring grooves for wear or damage.

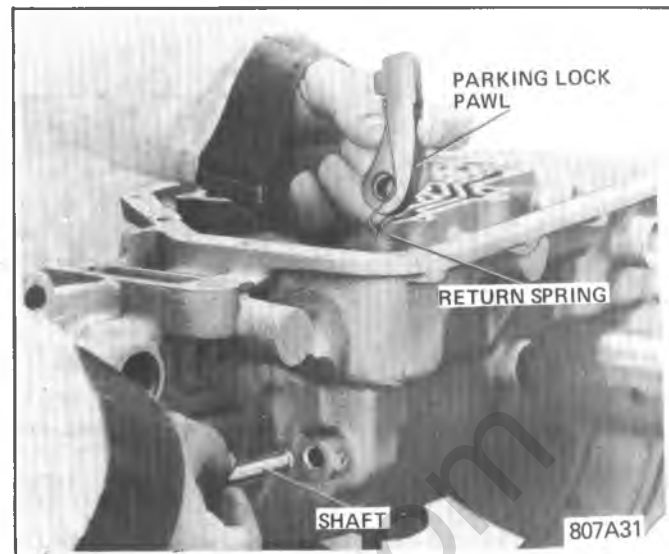

Figure 7A1-64 Installing Parking Pawl

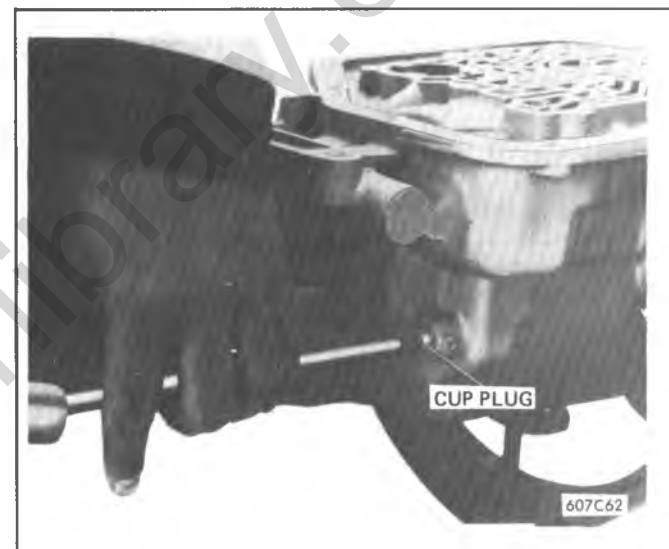

Figure 7A1-65 Installing Parking Pawl Cup Plug

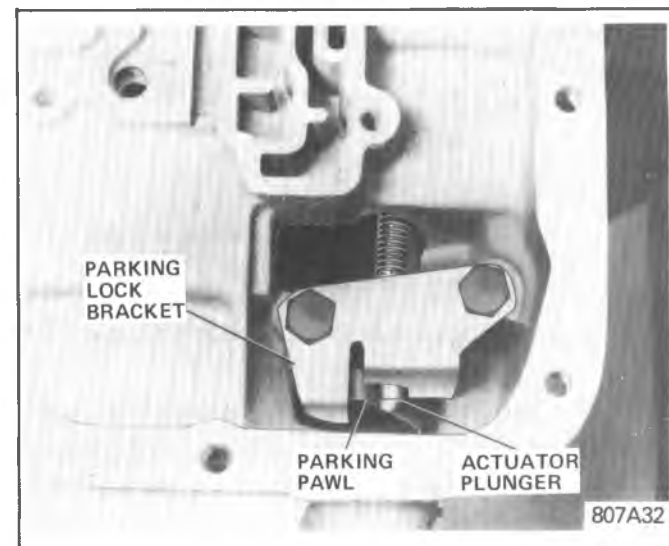

Figure 7A1-66 Installing Parking Pawl Rod

2. Inspect lubrication passages for being plugged or damaged.
3. Inspect splines for damage.
4. Inspect governor drive gear for rough or damaged teeth.
5. Inspect speedometer drive gear for rough or damaged teeth and also the clip for damage.
6. If necessary to replace speedometer drive gear, proceed as follows:
  - a. Depress speedometer drive gear clip.
  - b. Remove gear and clip, tapping gear lightly with plastic hammer.

**NOTICE:** Make sure speedometer drive gear is located so speedometer driven gear will mesh with it.

- c. Place speedometer drive gear clip with the tanged end in the correct hole in the output shaft (Figure 7A1-69).
- d. Align the slot of the speedometer drive gear with the clip and install the gear.

### Steel Speedometer Drive Gear

1. Install speedometer gear removing Tool J-21427-01 and suitable puller such as J-8433 on output shaft and remove speedometer drive gear. (Figure 7A1-70).
2. Place front end of shaft on block of wood to prevent damaging the front end.
3. Position speedometer gear, larger chamfered inside diameter first, over rear end of output shaft. (Figure 7A1-71).
4. Using Tool J-28578 drive gear to 156.15mm (6-5/32") from rear end of output shaft to rear face of gear.

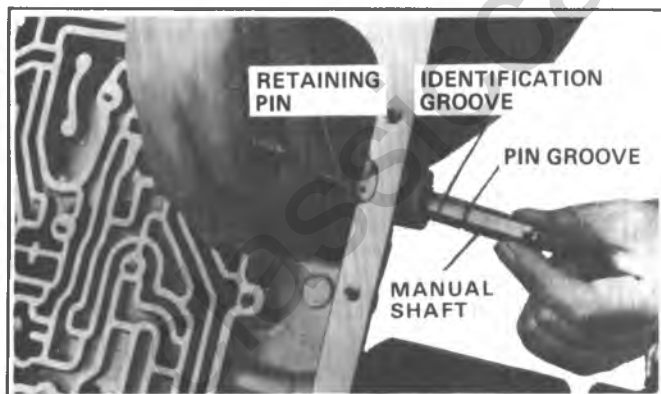

Figure 7A1-67 Installing Manual Shaft into Case

### Rear Internal Gear

1. Inspect rear internal gear, splines, teeth and bearing surface for wear, cracks or damage.
2. Inspect parking pawl lugs for cracks or damage.
3. Install rear internal gear, hub end first, on output shaft, as shown in Figure 7A1-73.
4. Thoroughly clean, air dry and inspect closely, the rear internal gear to rear sun gear roller thrust bearing assembly for pitted or rough conditions.
5. Install rear internal gear to rear sun gear roller thrust bearing assembly by placing the small diameter race over the output shaft. (Figure 7A1-72).

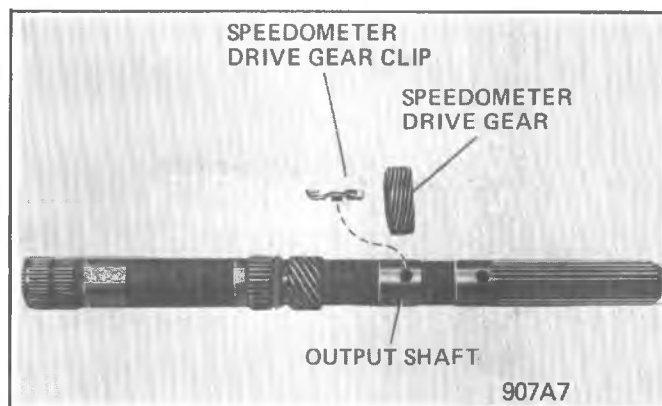

Figure 7A1-68 Output Shaft

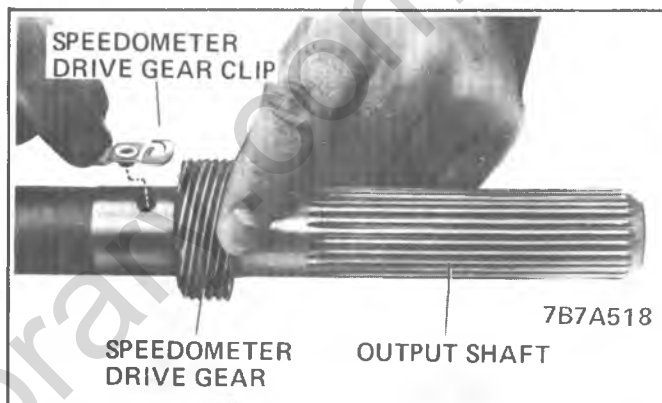

Figure 7A1-69 Installing Plastic Speedometer Driven Gear and Clip

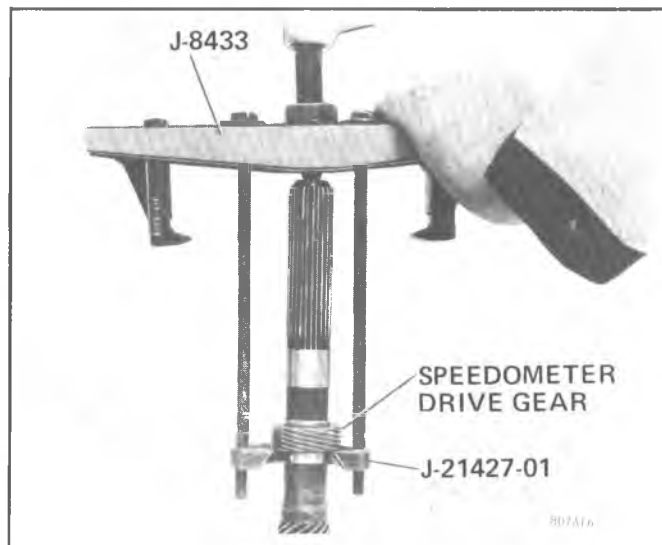

Figure 7A1-70 Removing Speedo Gear (Steel)

### Roller Clutch and Rear Carrier Assembly Inspection

1. Remove roller clutch race. Inspect race and spline for scoring or wear. (Figure 7A1-74).
2. Remove roller clutch assembly and inspect roller bearings, cage and springs for damage or wear. (Figure 7A1-74).
3. Remove and inspect rear carrier to roller clutch thrust washer for signs of scoring or excessive wear. (Figure 7A1-74).

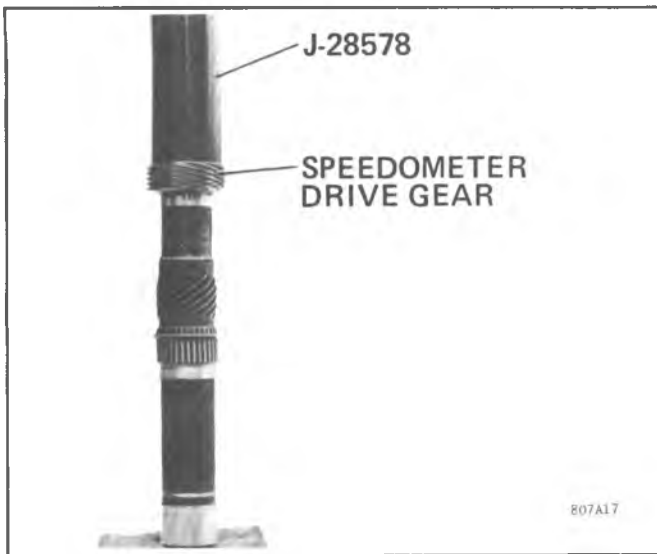

Figure 7A1-71 Installing Speedo Gear (Steel)

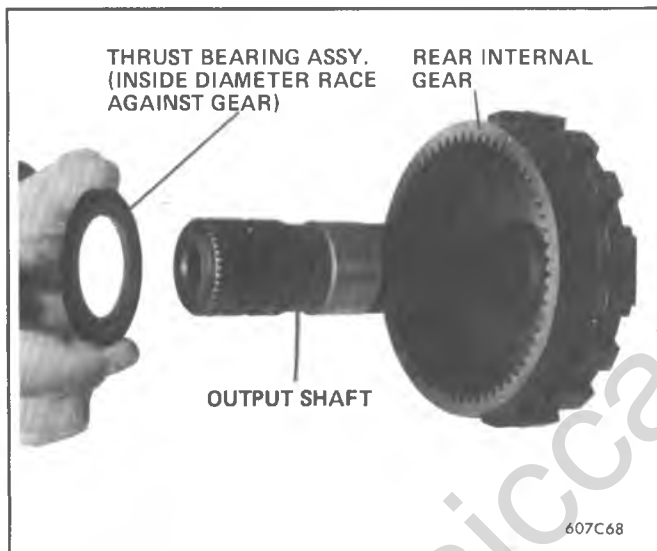

Figure 7A1-72 Installing Thrust Bearing Assembly

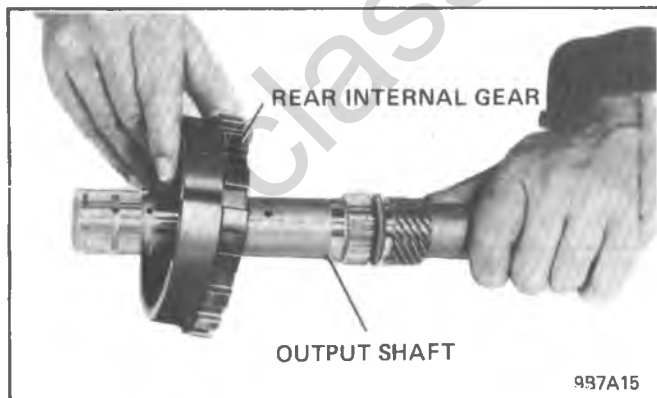

Figure 7A1-73 Installing Rear Internal Gear on Output Shaft

4. Inspect 4 tanged rear carrier to rear internal gear thrust washer for being scored or distorted tangs. (Figure 7A1-74)

5. Inspect rear carrier for damage. (Figure 7A1-74).

6. Inspect roller clutch cam ramps for damage.

7. Inspect bushing for damage or scoring.
8. Inspect planet pinions for damage, rough bearings or tilt.
9. Check pinion end play. Pinion end play should be 0.24-0.69mm (0.009"-0.027"). (Figure 7A1-75).

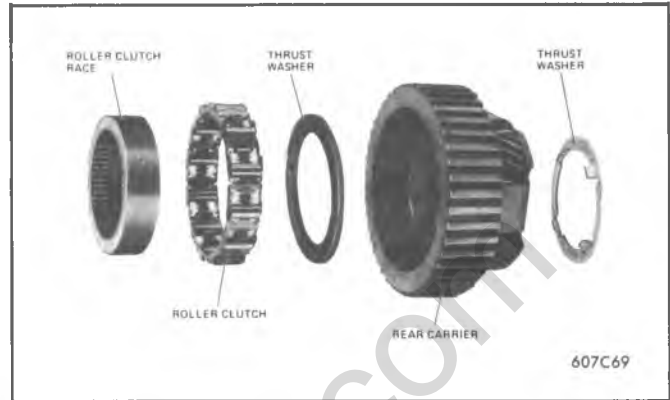

Figure 7A1-74 Roller Clutch and Rear Carrier - Exploded

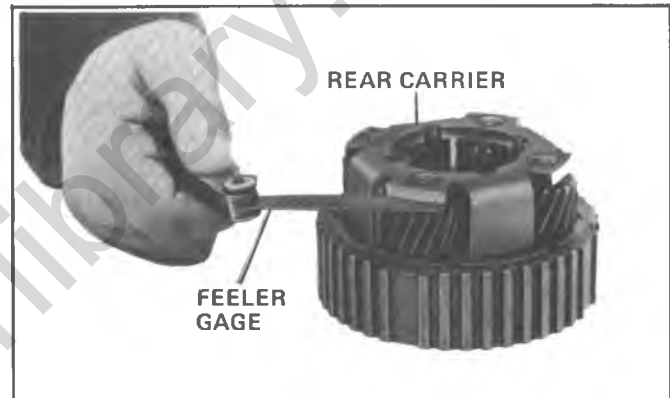

Figure 7A1-75 Checking Rear Carrier Pinion End Play

## Reassembly

1. Install roller clutch to rear carrier thrust washer. (Figure 7A1-76).
2. Install rollers that may have come out of roller clutch cage, by compressing the energizing spring with forefinger and inserting roller from outer edge. (Figure 7A1-77).
3. Install roller clutch assembly into roller clutch cam. (Figure 7A1-78).
4. Install roller clutch race, spline side out and rotate clutch race counterclockwise into position. (Figure 7A1-79).
5. Install 4 tanged rear carrier to rear internal gear thrust washer. Align tangs into slots of rear carrier and retain with petrolatum. (Figure 7A1-80).
6. Install roller clutch and rear carrier assembly into rear internal gear. (Figure 7A1-81).
7. Install J-25013-1, open end first, into rear end of case. Bolt J-25013-5 on end of case. (Figure 7A1-82).
8. Turn case to vertical position, pump end up.
9. Install rear unit parts into case and into J-25013-1 sleeve (Figure 7A1-83), indexing rear internal gear parking pawl lugs to pass by parking pawl tooth.
10. Using J-25013-5 adjusting screw (Figure 7A1-82) and looking through parking pawl case slot, adjust the height of the rear internal gear parking pawl lugs to align flush with the parking pawl tooth.





Figure 7A1-76 Installing Thrust Washer Into Rear Carrier

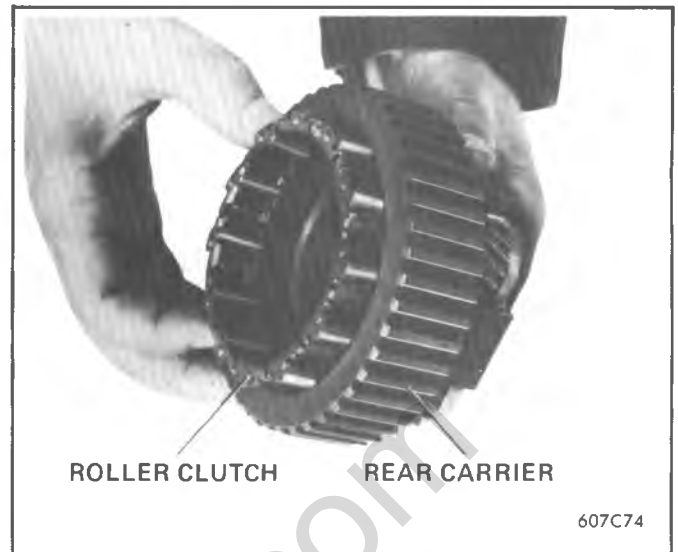

Figure 7A1-78 Installing Roller Clutch Into Rear Carrier

Make sure speedometer drive gear is visible through speedometer gear bore. If drive gear is not visible, it may be located on wrong journal of shaft.

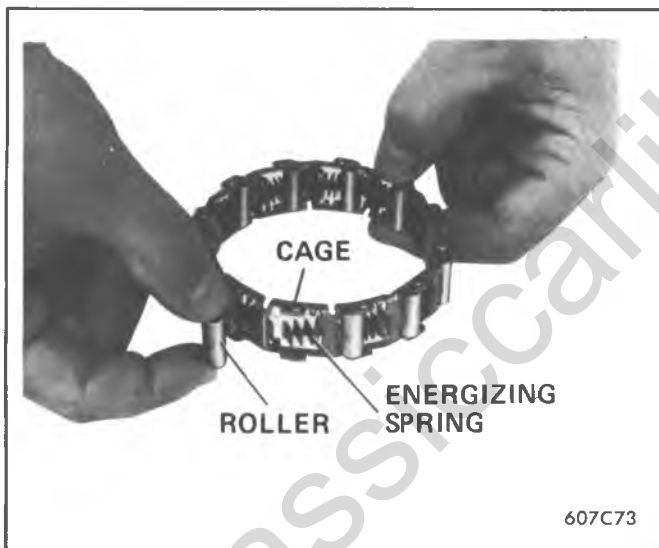

Figure 7A1-77 Installing Roller Into Cage



Figure 7A1-79 Installing Roller Clutch Race

## LOW AND REVERSE CLUTCH

### Inspection

Inspect low and reverse clutch composition-faced and steel clutch plates for signs of wear or burning.

### Low and Reverse Clutch Housing Assembly (Figure 7A1-85).

#### Disassembly

1. Compress low and reverse clutch spring retainer, remove snap ring and retainer and inspect for damage or distortion. (Figure 7A1-84).
2. Remove waved spring. (Figure 7A1-86).
3. Remove low and reverse clutch piston.
4. Remove outer and inner piston seals. (Figures 7A1-87 and 7A1-88).



Figure 7A1-80 Installing Thrust Washer

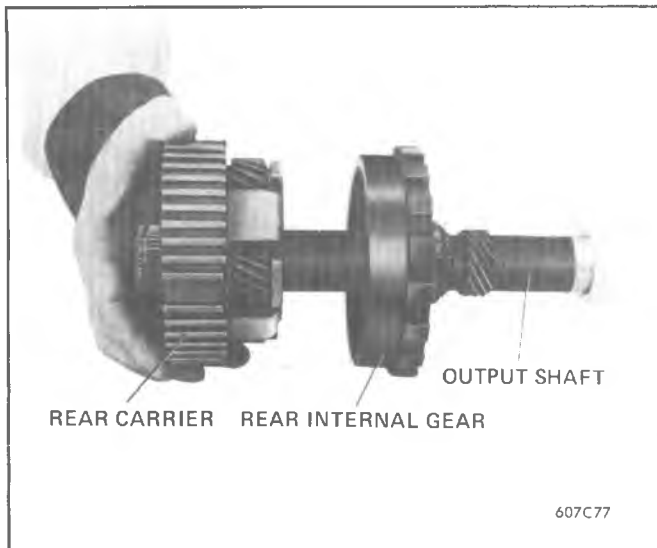

Figure 7A1-81 Installing Rear Carrier into Rear Internal Gear

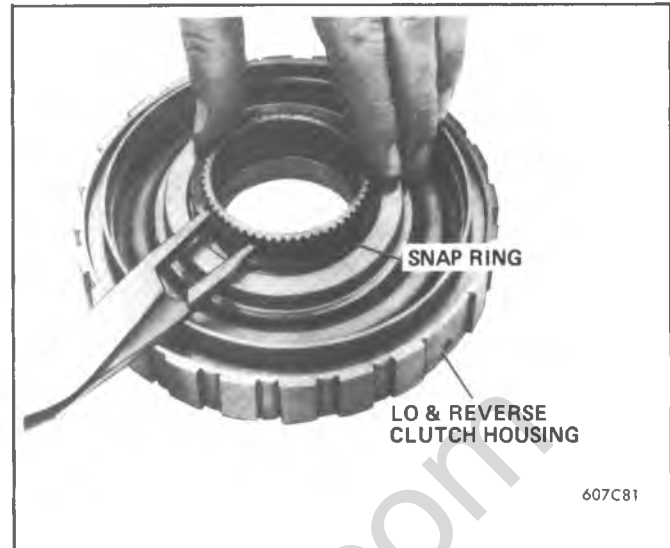

Figure 7A1-84 Removing Lo and Reverse Clutch Spring Retaining Snap Ring

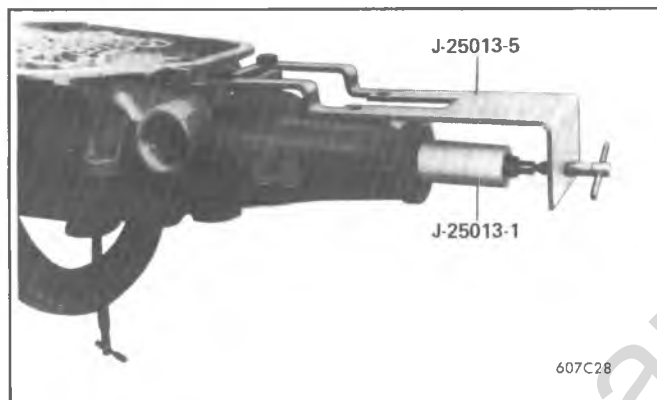

Figure 7A1-82 Installing Tools on Rear End of Case

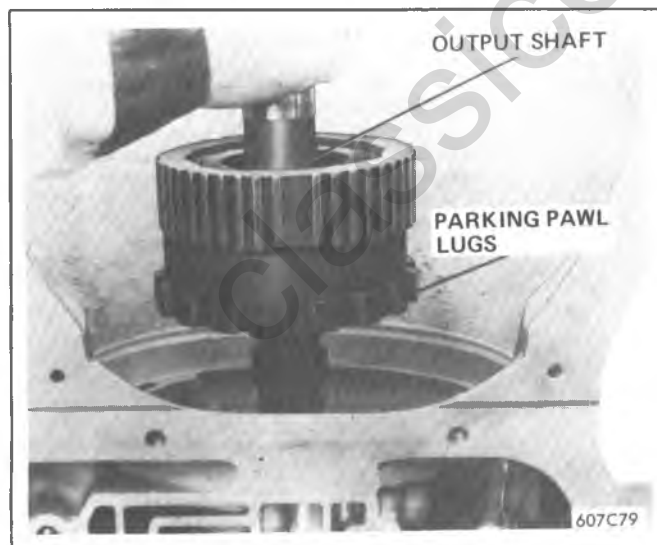

Figure 7A1-83 Installing Rear Unit Parts

5. Remove clutch apply ring.

### Inspection

1. Inspect lo and reverse clutch housing for damage, plugged feed hole.

2. Inspect lo and reverse clutch housing bushing for damage or scoring.
3. Inspect lo and reverse clutch splines and snap ring groove for damage or burrs. Remove any burrs on splines or snap ring groove.
4. Inspect lo and reverse clutch piston and clutch apply ring assembly for distortion, cracks or damage. (The apply ring is identified by a number located on the ring. See 200 clutch plate and apply ring usage chart for apply ring identification. Figure 7A1-93.)
5. Inspect lo and reverse clutch spring retainer for damage.
6. Inspect waved spring for damage.
7. Inspect lo and reverse clutch housing to case spacer ring for damage.

### Reassembly

1. Install clutch apply ring on lo and reverse clutch piston.
2. Install new outer and inner seals on piston with lips facing away from clutch apply ring side. (Figure 7A1-87 and 7A1-88).
3. Install seal protector J-25011.
  - a. Apply transmission fluid to all clutch seals before reassembly.
  - b. Flat screwdriver surface area must be smooth to prevent damaging outer seal.
4. Using flat edged small screwdriver, or Piston Installing tool (Figure 7A1-116) install lo and reverse clutch piston, while rotating and pushing down into place. (Figure 7A1-89).
5. Remove seal protector J-25011.
6. Install waved release spring. (Figure 7A1-90).
7. Install retainer, cupped faced down. (Figure 7A1-94).
8. Compress retainer and install snap ring. (Figure 7A1-94).

### Installation

1. Oil and install the lo and reverse clutch plates into the case, starting with a flat steel and alternating

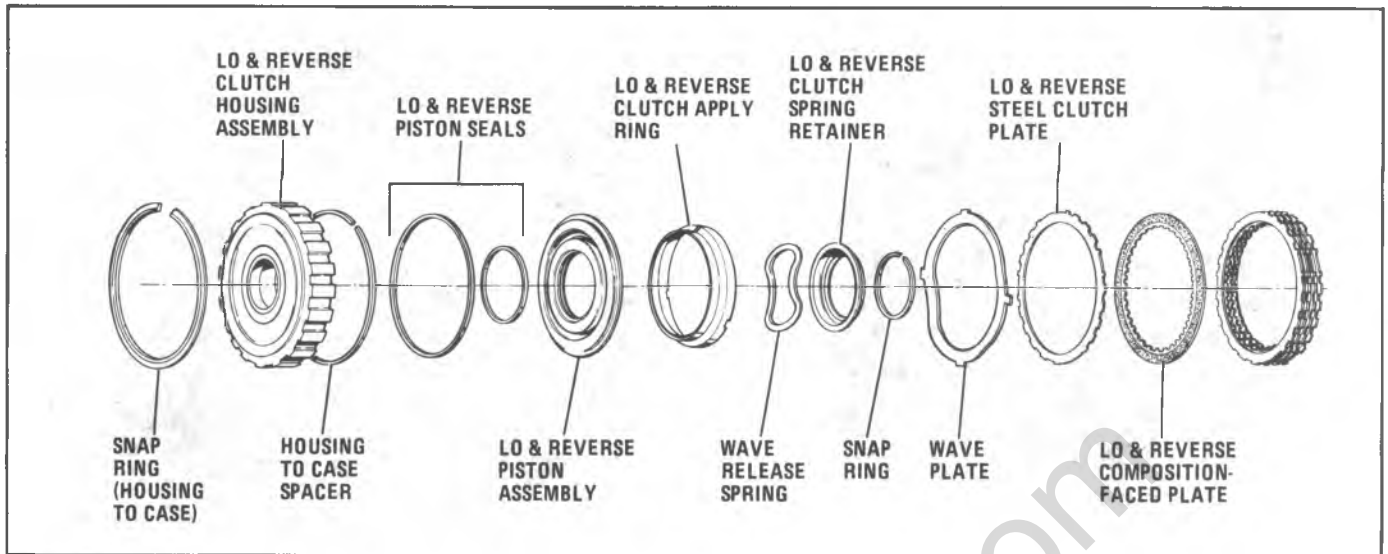

Figure 7A1-85 Lo and Reverse Clutch Housing - Exploded View



Figure 7A1-86 Removing Lo and Reverse Clutch Wave Release Spring.

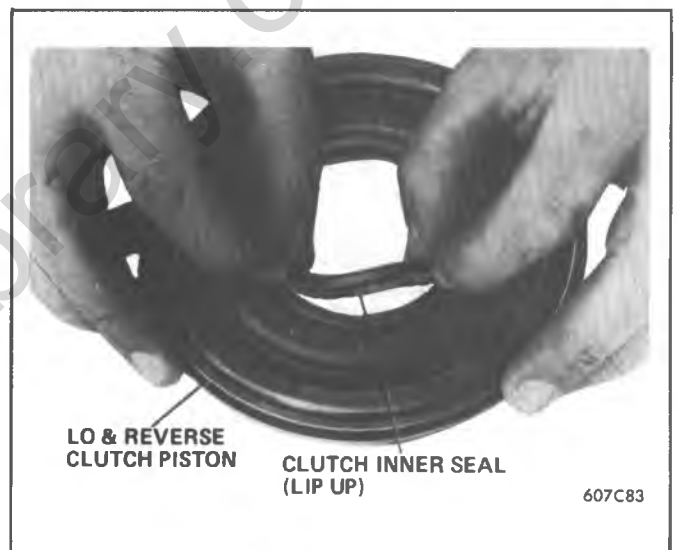

Figure 7A1-88 Removing or Installing Low and Reverse Clutch Inner Seal



Figure 7A1-87 - Removing or Installing Low and Reverse Clutch Outer Seal



Figure 7A1-89 Installing Lo and Reverse Clutch Piston



Figure 7A1-90 Installing Lo and Reverse Clutch Wave Release Spring



Figure 7A1-91 Installing Lo and Reverse Clutch Retaining Snap Ring

composition-faced and flat steel clutch plates. See Figure 7A1-93.

2. Install waved steel clutch plate.
3. Install low and reverse clutch housing to case spacer ring in case. (Figure 7A1-92).
4. Install low and reverse clutch housing assembly aligning reverse clutch housing feed hole to reverse clutch case feed passage, using J-25012. (Figure 7A1-94). If the low and reverse clutch housing does not seat past the case snap ring groove, proceed as follows:
  - a. Remove tool J-25012.
  - b. Using rear sun gear and input drum as a tool, install input drum and rear sun gear in case.
  - c. Rotate rear sun gear back and forth, tapping lightly with input drum, to align roller clutch race and low and reverse clutch hub splines. (Figure 7A1-95).
  - d. Remove tool (input drum and rear sun gear).
  - e. Loosen adjusting screw on J-25013-5 on output shaft to install snap ring.
  - f. Repeat the above steps if low and reverse clutch housing is not fully seated past case snap ring groove.

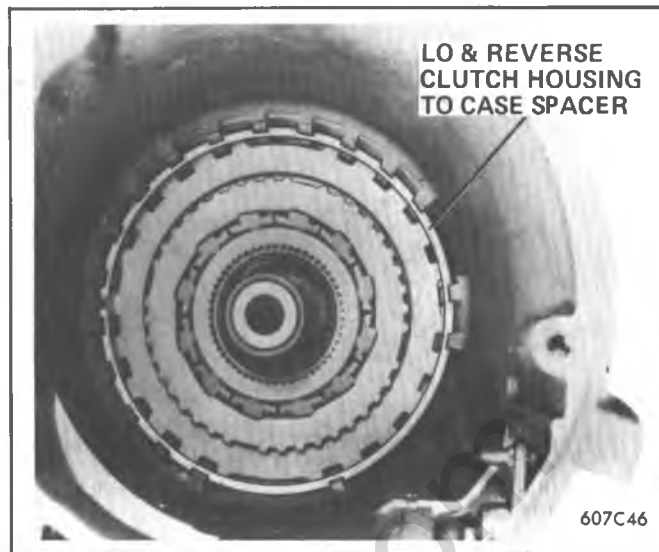

Figure 7A1-92 Proper Location of Low and Reverse Housing to Case Spacer

4. Install low and reverse clutch housing to case snap ring, flat side against clutch housing (beveled side up). Position snap ring gap on opposite side of parking pawl rod.

## FRONT GEAR PARTS

### Rear Sun Gear and Input Drum

#### Inspection

1. Inspect rear sun gear for cracks, splits, damage spline, worn gear or journals and plugged lubrication holes. (Figure 7A1-96).
2. Inspect rear sun gear bushing for damage or scoring.
3. If necessary, remove input drum to rear sun gear snap ring and remove sun gear from input drum.
4. Inspect input drum for damage. (Figure 7A1-96).
5. Inspect 4 tanged input drum to low and reverse clutch housing thrust washer for scoring or distorted tangs. (Figure 7A1-96).
6. If damaged, replace rear sun gear to input drum snap ring.

#### Reassembly

1. Install rear sun gear into input drum, spline side first, and retain with snap ring. (Figure 7A1-96).
2. Install 4 tanged thrust washer on input drum over sun gear end; align tangs into input drum and retain with petrolatum. (Figures 7A1-96 and 7A1-97).
3. Install rear sun gear and input drum assembly. (Figure 7A1-95).

### Front Sun Gear

1. Inspect front sun gear splines and teeth for damage or wear.
2. Inspect machined face for pitting, scoring or damage.
3. Install front sun gear face with the identification mark (a drill spot or groove) against input drum to rear sun gear snap ring. (Figure 7A1-99). See Figure 7A1-98 for identification marks.

200 CLUTCH PLATE AND APPLY RING USAGE CHART																		
1981 MODELS	DIRECT CLUTCH					FORWARD CLUTCH						LO & REVERSE CLUTCH						
	Flat Steel Plate		Comp. Faced Plate	Apply Ring		Waved Plate		Flat Steel Plate		Comp. Faced Plate	Apply Ring		Waved Plate		Flat Steel Plate	Comp. Faced Plate	Apply Ring	
	No.	Thick-ness	No.	I.D.	Width*	No.	Thick-ness	No.	Thick-ness	No.	I.D.	Width*	No.	Thick-ness	No.	No.	I.D.	Width*
CN,CY,CX	4	2.324 mm (.091")	4	1	16.99 mm (.663")	1	1.585 mm (.062")	2	1.969 mm (.077")	3	0	17.52 mm (.690")	1	1.969 mm (.077")	5	4	5	24.34 mm (.958")
BZ,HA,HZ, HK, OW	5	2.324 mm (.091")	5	9	12.5 mm (.492")	1	1.585 mm (.062")	3	1.969 mm (.077")	4	8	13.50 mm (.532")	1	1.969 mm (.077")	6	5	4	20.14 mm (.793")
HB,PF,PG,CE, HT,PD,PE,CC, OT,AS	5	2.324 mm (.091")	5	9	12.5 mm (.492")	1	1.585 mm (.062")	3	1.969 mm (.077")	4	8	13.50 mm (.532")	1	1.969 mm (.077")	7	6	3	15.94 mm (.628")

The direct, forward, and lo & reverse clutch flat steel clutch plates and the forward clutch waved steel plate should be identified by their thickness. The direct and forward production installed composition-faced clutch plates must not be interchanged. For service, direct and forward clutch use the same composition-faced plates.  
\*Measure the width of the clutch apply ring for positive identification.

Figure 7A1-93 Clutch Plate and Clutch Apply Ring Usage

4. Thoroughly clean, air dry and inspect front sun gear to front carrier thrust race and thrust bearing for pitted or rough conditions.

5. Install front sun gear to front carrier thrust bearing and race assembly with roller thrust bearing against the front sun gear. (Figure 7A1-100). (This thrust bearing requires only 1 thrust race.)



Figure 7A1-94 Installing Low and Reverse Clutch Housing

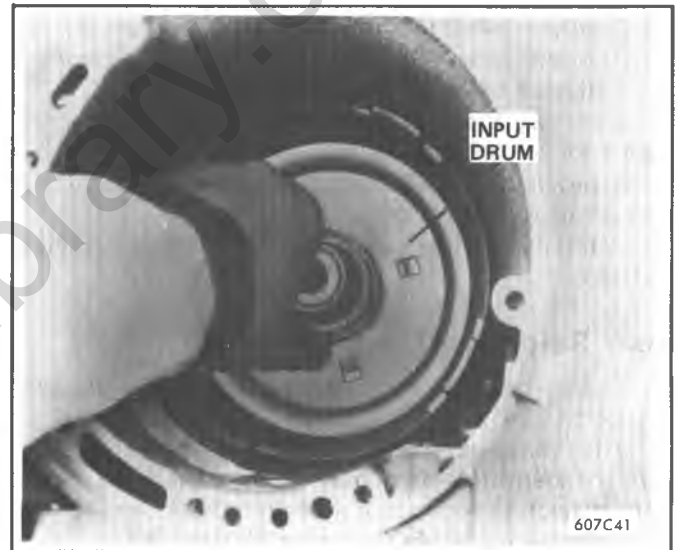

Figure 7A1-95 Installing Input Drum and Rear Sun Gear

## Front Carrier Assembly

### Inspection

1. Inspect front carrier for damage. (Figure 7A1-101).
2. Inspect pinions for damage, rough bearings or tilt.
3. Check pinion end play. Pinion end play should be 0.24mm-0.69mm (0.009"-.027"). (Figure 7A1-101).
4. Thoroughly clean, air dry and inspect closely, front carrier to front internal gear roller thrust bearing assembly for pitted or rough conditions.

### Reassembly

1. Install front carrier to front internal gear roller thrust bearing assembly by placing the smaller diameter race against carrier. Retain with petrolatum. (Figure 7A1-102).
2. Install front carrier and thrust bearing assembly. (Figure 7A1-104).

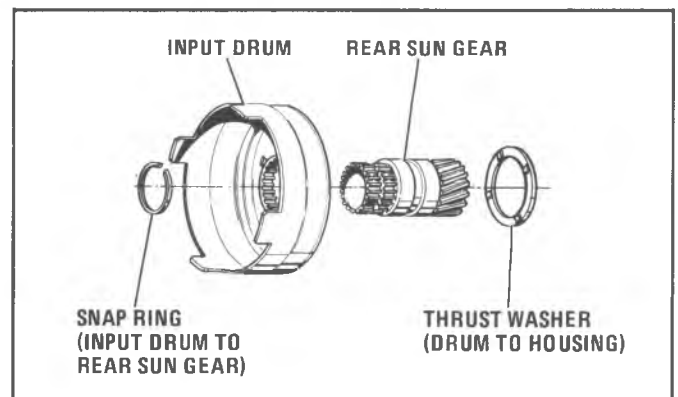

Figure 7A1-96 Rear Sun Gear and Input Drum

## Front Internal Gear and Thrust Washer (Figure 7A1-103)

1. Inspect forward clutch hub for worn splines and for lubrication holes.

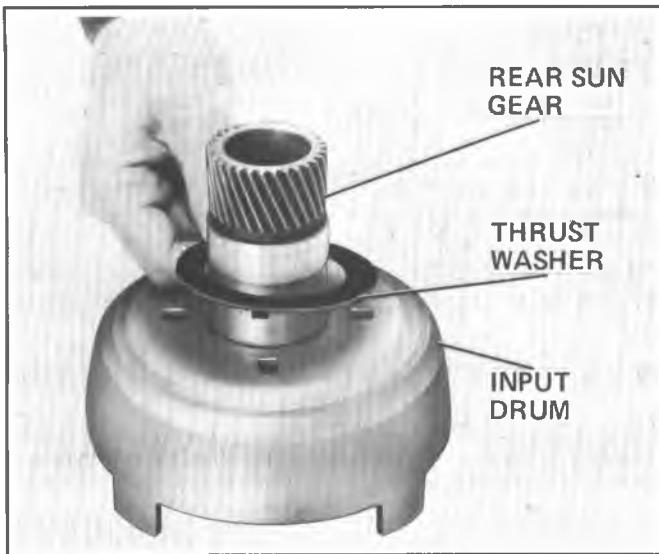

Figure 7A1-97 Installing Thrust Washer

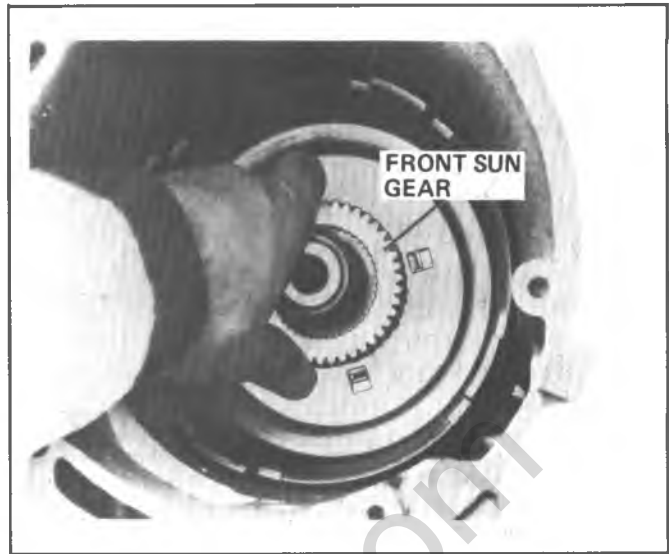

Figure 7A1-99 Installing Front Sun Gear

2. Inspect internal gear for cracks or damage.
3. Inspect gear teeth for excessive wear or damage.
4. Inspect bushing for damage or scoring.
5. Inspect thrust washer, front internal gear to selective washer for scoring or damage.
6. Install thrust washer on front internal gear and retain with petrolatum. (Figure 7A1-103).
7. Install front internal gear and thrust washer. (Figure 7A1-103).

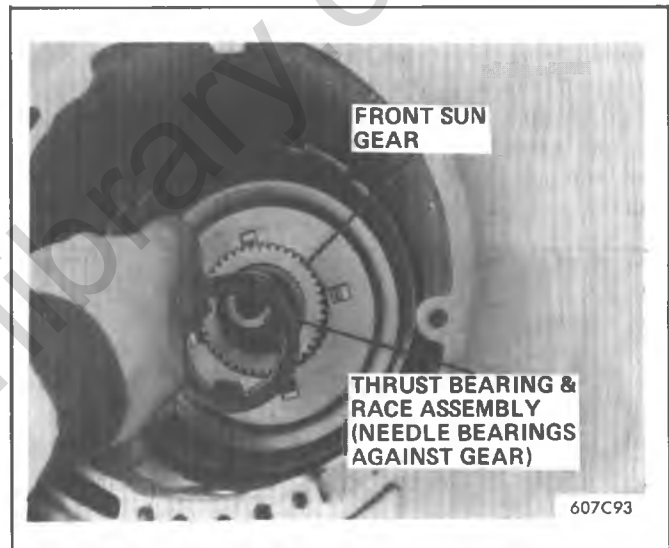

Figure 7A1-100 Installing Thrust Bearing Assembly Against Front Sun Gear

### Rear Selective Thrust Washer

1. Inspect selective washer for scoring or damage. (Figure 7A1-103).

The rear selective thrust washer must be installed with the identification number toward the front of the transmission to retain rear selective thrust washer i.d.

2. Install rear selective washer. (Figure 7A1-103).
3. Inspect output shaft to selective thrust washer snap ring for damage or distortion.

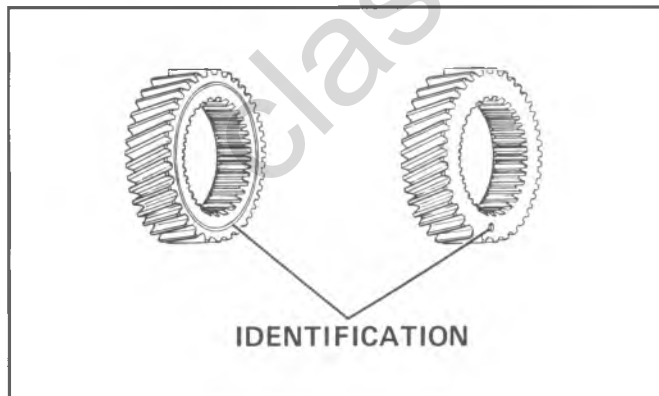

Figure 7A1-98 Front Sun Gear Identification

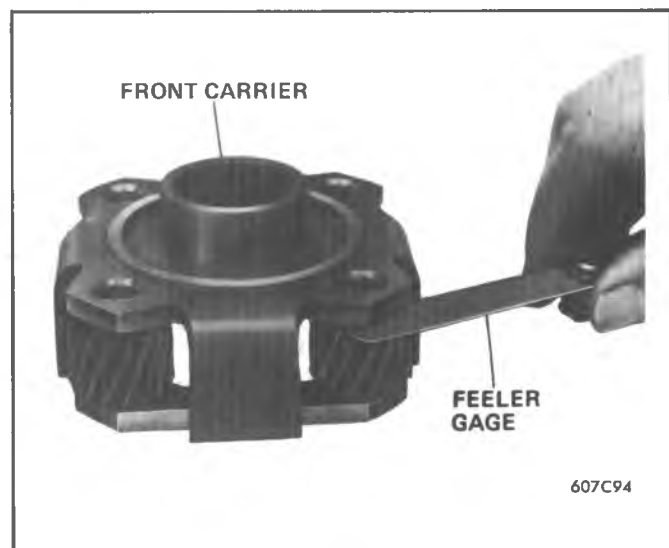

Figure 7A1-101 Checking Front Carrier Pinion End Play

Move output shaft upward by turning the adjusting screw on J-25013-5 to install output shaft to selective washer snap ring.

4. Install snap ring on output shaft. (Figure 7A1-106).

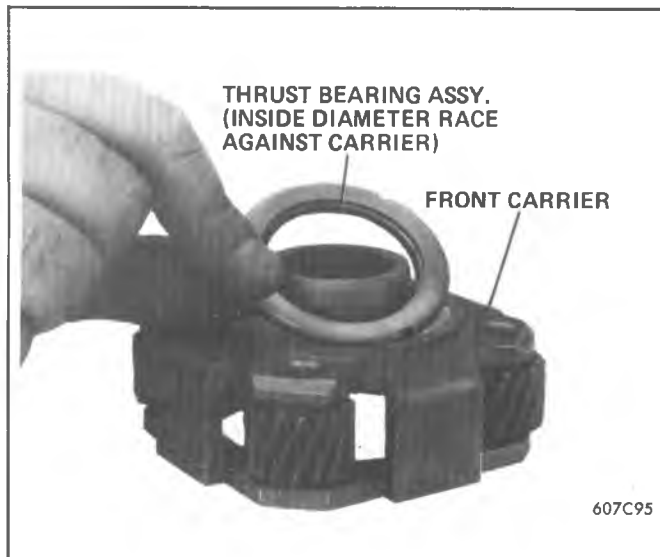

Figure 7A1-102 Installing Thrust Bearing Assembly Onto Front Carrier

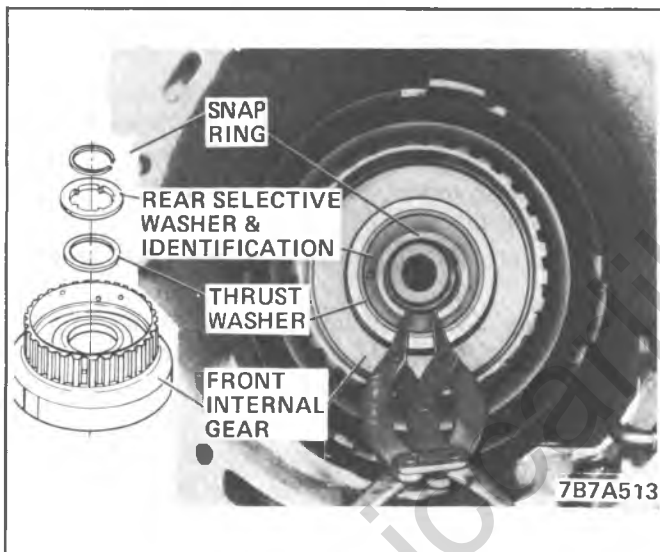

Figure 7A1-103 Installing Output Shaft to Selective Washer Snap Ring

Make sure snap ring is fully seated in output shaft groove.

### Checking Rear Unit End Play

1. Loosen J-25013-5 adjusting screw on output shaft and push output shaft downward. (Figure 7A1-106).  
Do not install clamp assembly on any machined case surfaces.
2. Install gage clamp on case as shown in Figure 7A1-107.
3. Install dial indicator J-8001 and plunger extension J-7057. Position extension against end of output shaft. Set dial indicator to zero. (Figure 7A1-108).
4. Move output shaft upward by turning the adjusting screw on J-25013-5 until the white or scribed line on sleeve J-25013-1 begins to disappear (Figure 7A1-106), and read end play. Rear unit end play should be 0.10-0.64mm (.004"-.025").
5. Selective washer controlling this end play is located between the front internal gear thrust washer and output shaft snap ring. If more or less washer thickness is required

to bring end play within specifications, select proper washer from the THICKNESS CHART.

6. Remove dial indicator and clamp assembly. (Figure 7A1-107).
7. Loosen J-25013-5 adjusting screw on output shaft.
8. Inspect output shaft to turbine shaft front selective thrust washer for damage or scoring.
9. Install output shaft to turbine shaft, front selective thrust washer, locating in output shaft and retain with petrolatum. (Figure 7A1-109).

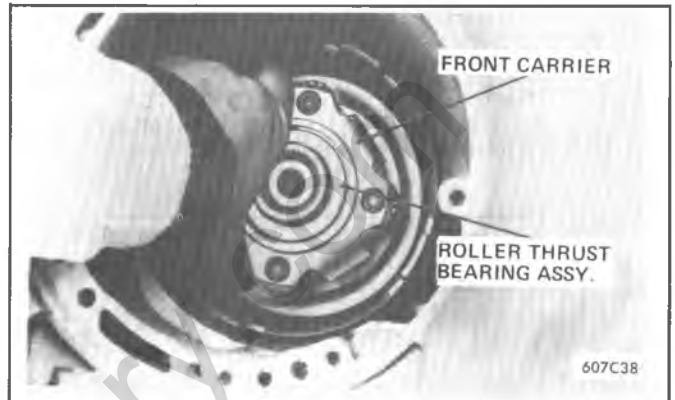

Figure 7A1-104 Installing Front Carrier and Roller Thrust Bearing

REAR UNIT END PLAY WASHER THICKNESS CHART	
THICKNESS	IDENTIFICATION
	Number and/or Color
2.90 - 3.01 mm (0.114" - 0.119")	1 - ORANGE
3.08 - 3.19 mm (0.121" - 0.126")	2 - WHITE
3.26 - 3.37 mm (0.126" - 0.133")	3 - YELLOW
3.44 - 3.55 mm (0.135" - 0.140")	4 - BLUE
3.62 - 3.73 mm (0.143" - 0.147")	5 - RED
3.80 - 3.91 mm (0.150" - 0.154")	6 - BROWN
3.98 - 4.09 mm (0.157" - 0.161")	7 - GREEN
4.16 - 4.27 mm (0.164" - 0.168")	8 - BLACK
4.34 - 4.45 mm (0.171" - 0.175")	9 - PURPLE

7B7A522

Figure 7A1-105 Rear Unit End Play Washer Thickness Chart

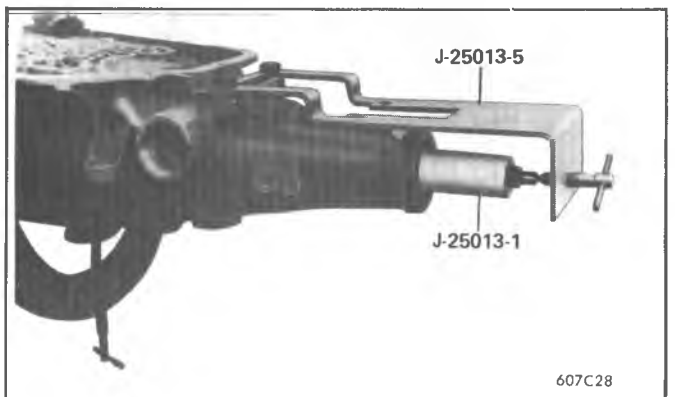

Figure 7A1-106 Installing Tools on Rear End of Case

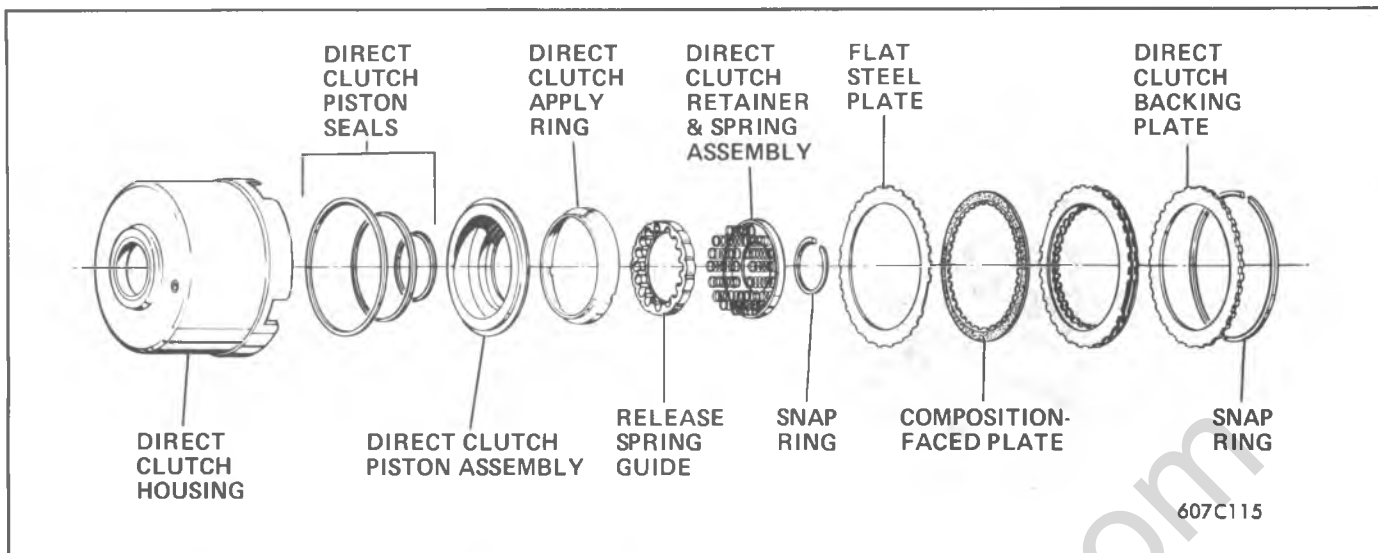

Figure 7A1-107 Direct Clutch Assembly - Exploded

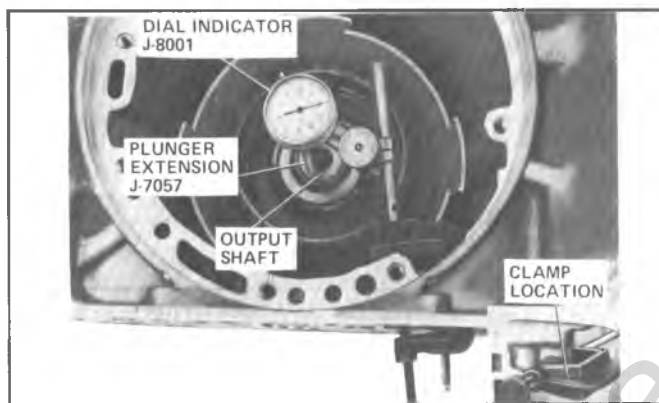

Figure 7A1-108 Checking Rear Unit End Play

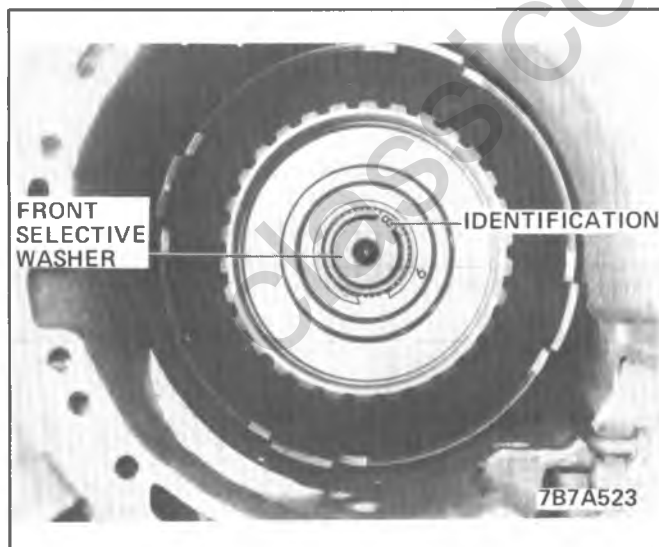

Figure 7A1-109 Location of Front Selective Washer

## FRONT UNIT PARTS

### Direct Clutch Housing Assembly

1. Remove snap ring. (Figure 7A1-110).

2. Remove the clutch backing plate from the direct clutch housing.

3. Remove the clutch plates from the direct clutch housing and keep them separated from the forward clutch plates. (See Clutch Plate Usage Chart, Figure 7A1-93).

4. Inspect composition-faced plates and steel clutch plates for wear or burning.

5. Inspect clutch backing plate for scoring or other damage.

6. Using J-23327, compress retainer and spring assembly (Figure 7A1-111), remove snap ring and inspect for damage or distortion.

7. Remove J-23327.

8. Remove retainer and spring assembly from housing.

9. Inspect release spring retainer for being collapsed.

10. Inspect release springs for being collapsed.

11. Remove release spring guide and inspect for damage.

12. Remove direct clutch piston.

13. Remove outer and inner seals from direct clutch piston. (Figures 7A1-112 and 7A1-113).

14. Do not remove the clutch apply ring from the piston unless the piston or apply ring requires replacement. See 200 Clutch Plate and Apply Ring Usage Chart for Apply Ring Identification.

15. Inspect direct clutch piston assembly for distortion, cracks, damage and check ball for free operation.

16. Remove center seal from direct clutch housing and discard. (Figure 7A1-114).

17. Inspect direct clutch housing for cracks, wear and open oil passages.

18. Check for free operation of check ball.

19. Inspect direct clutch housing snap ring grooves for damage.

20. Inspect direct clutch bushings for damage or scoring.

### Reassembly

1. Install clutch apply ring on piston.





Figure 7A1-110 Removing Direct Clutch Snap Ring

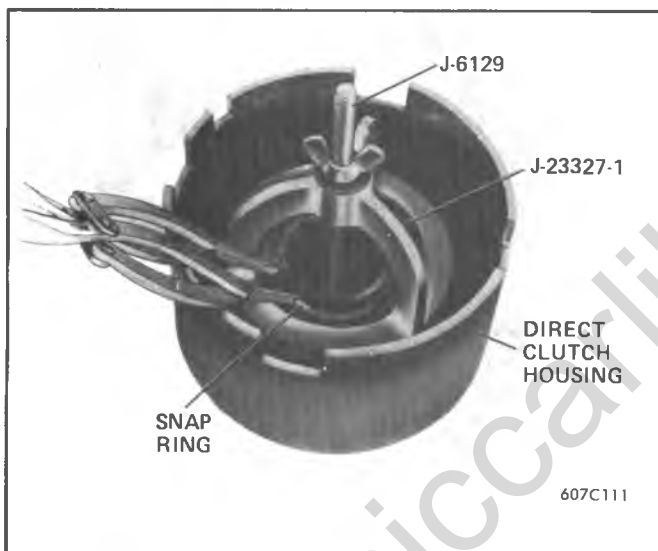

Figure 7A1-111 Removing Direct Clutch Inner Snap Ring

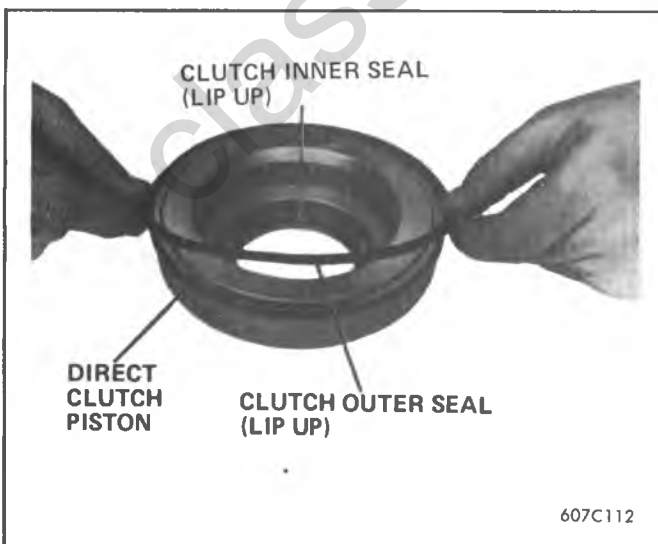

Figure 7A1-112 Removing Direct Clutch Piston Outer Seal

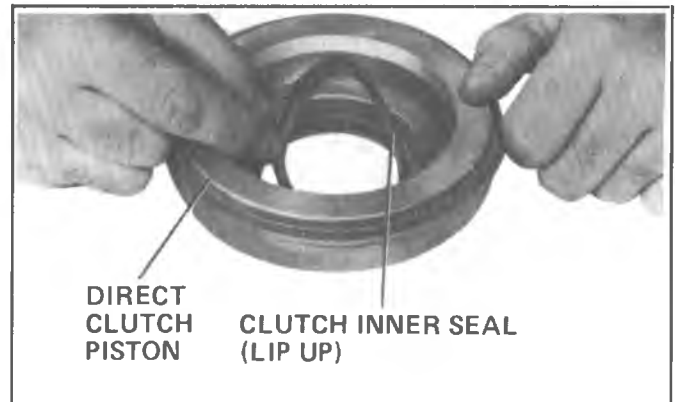

Figure 7A1-113 Removing Direct Clutch Piston Inner Seal

2. Install new inner and outer seals on piston with lips facing away from clutch apply ring side. (Figures 7A1-113 and 7A1-112).

3. Install new center seal on direct clutch housing with lip facing up. (Figure 7A1-114).

4. Install seal protector J-25010. (Figure 7A1-115).

**Use extreme care when installing direct clutch piston past larger direct clutch snap ring groove. Groove could cut outer seal on piston.**

5. Oil seals and install direct clutch piston. (Figure 7A1-115). To make the piston easier to install, insert tool between seal and housing; rotate tool around the housing to compress the lip of the seal, while pushing down slightly on the piston. See tool Figure 7A1-116 and tool being used on a forward clutch (Figure 7A1-126).

6. Remove seal protector J-25010.

7. Install release spring guide with the omitted rib over the check ball in the piston, as shown in Figure 7A1-117.

8. Install retainer and spring assembly.

**Retainer could locate in snap ring groove and forcing retainer to compress springs, could damage retainer plate when installing.**

9. Using J-23327 tool, compress retainer and spring assembly past the snap ring groove. Install the snap ring. (Figure 7A1-111). An arbor press and J-23327-1 can be used to compress the retainer and spring assembly.

10. Remove J-23327-1 and/or J-6129.

11. Oil and install the direct clutch plates into the direct clutch housing, starting with a flat steel and alternating composition-faced and flat steel clutch plates (See Figure 7A1-118 and Clutch Plate Usage Chart, Figure 7A1-93).

12. Install backing plate, chamfered side up.

13. Install snap ring. (Figure 7A1-110).

**Make sure composition clutch plates turn freely.**

### Forward Clutch Housing Assembly (Figure 7A1-122)

#### Inspection

1. Inspect teflon oil seals on turbine shaft for damage and free fit in grooves. Do not remove unless replacing.

2. Remove and inspect forward clutch to direct clutch thrust washer for damage. (Figure 7A1-120).

3. Place forward clutch down with turbine shaft through hole in work bench.

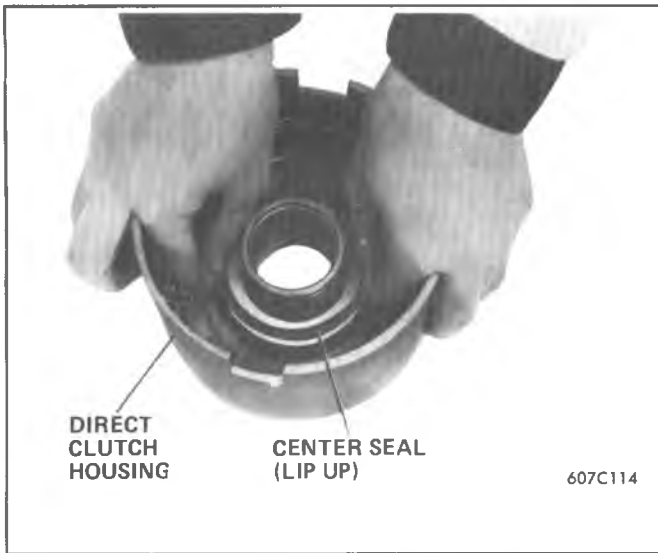

Figure 7A1-114 Removing Center Seal From Direct Clutch Housing

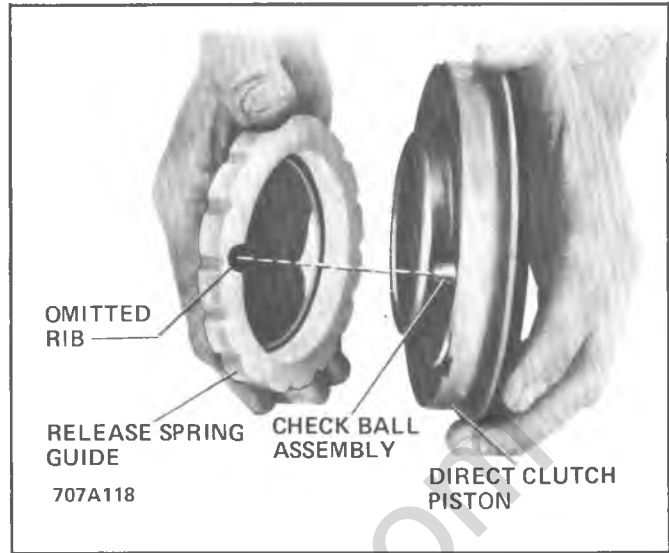

Figure 7A1-117 Installing Release Spring Guide

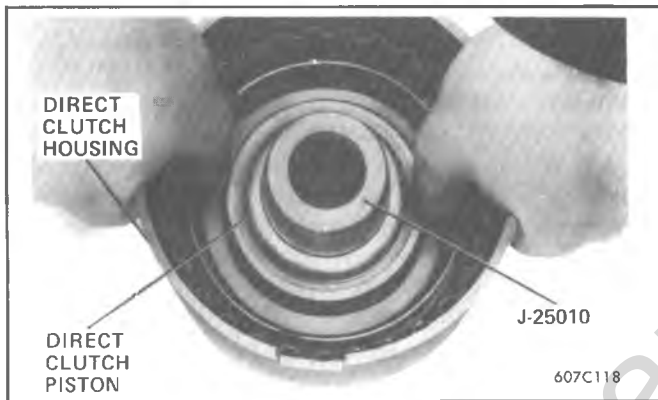

Figure 7A1-115 Installing Direct Clutch Piston

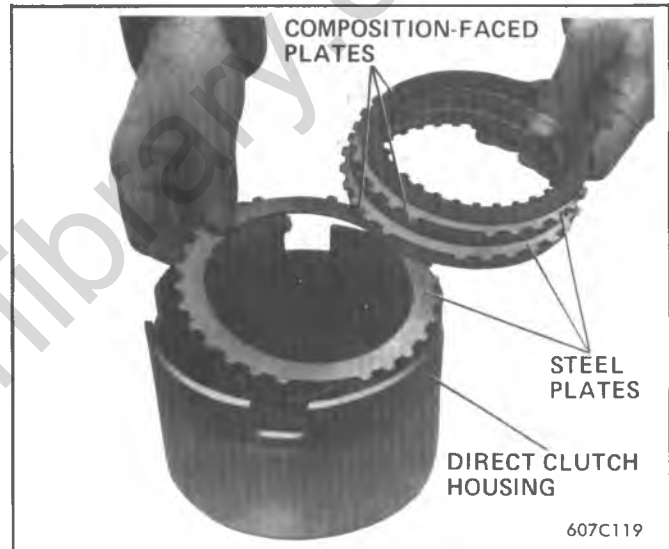

Figure 7A1-118 Installing Clutch Plates into Direct Clutch Housing

4. Remove snap ring and inspect for damage. (Figure 7A1-121).

5. Remove backing plate from the forward clutch housing.

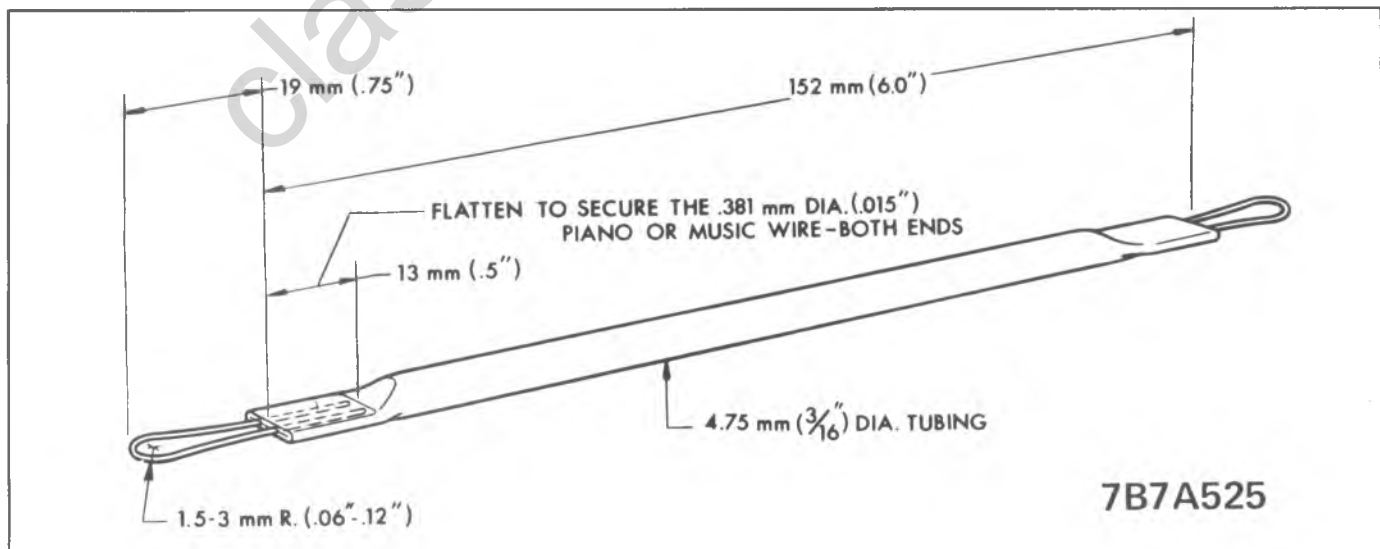

Figure 7A1-116 Piston Installing Tool

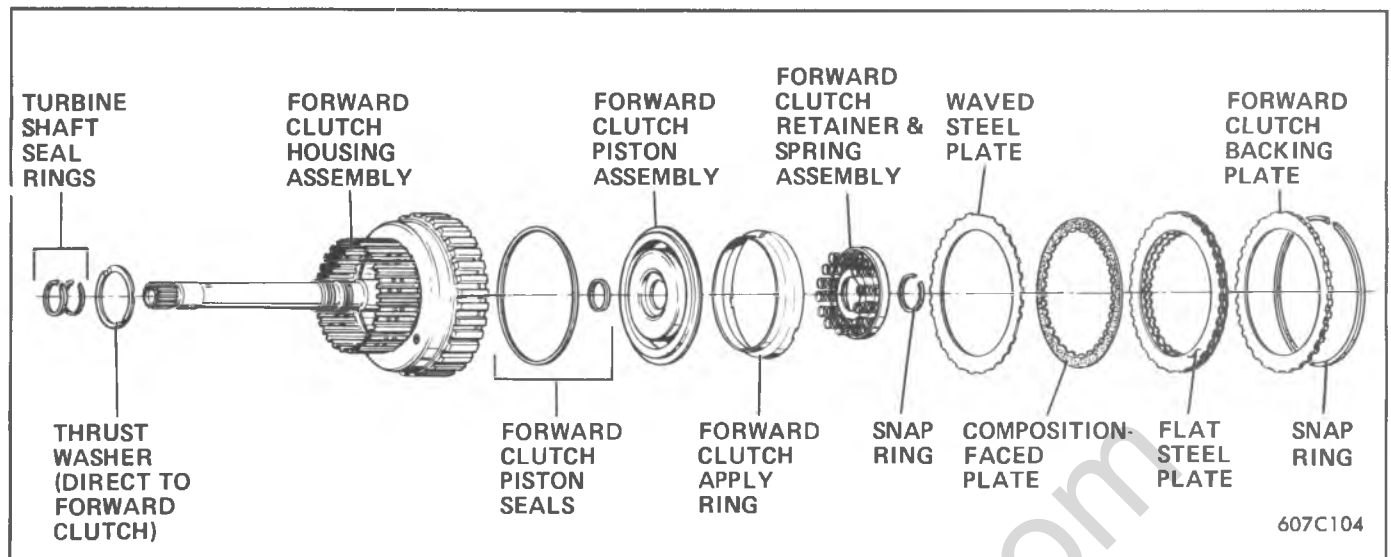

Figure 7A1-119 Forward Clutch Assembly - Exploded View

6. Remove the clutch plates from the forward clutch housing and keep them separated from the direct clutch plates. (See Clutch Plate Usage Chart, Figure 7A1-93).

7. Inspect composition-faced and steel clutch plates for signs of wear or burning.

8. Inspect backing plate for scratches or damage.

9. Using tools J-25018, J-25024 and J-23327-1 compress retainer and spring assembly and remove snap ring. (Figure 7A1-122). An arbor press and tools J-25018 and J-23327-1 can be used to compress the retainer and spring assembly.

10. Remove J-23327-1, J-2504 and J-25018.

11. Remove retainer and spring assembly from housing.

12. Inspect release spring retainer for distortion.

13. Inspect release springs for being collapsed.

14. Remove forward clutch piston.

15. Remove forward clutch outer and inner piston seals. (Figures 7A1-123 and 7A1-124).

16. Do not remove the clutch apply ring from the piston unless the piston or apply ring requires replacement.

17. Inspect the forward clutch piston and clutch apply ring assembly for cracks or damage.

**See 200 Clutch Plate and Apply Ring Usage Chart for Apply Ring Identification.**

18. Inspect forward clutch housing for cracks, opened oil passages or other damage.

19. Check for free operation of check ball.

20. Inspect forward clutch housing snap ring groove for damage or burrs.

21. Inspect turbine shaft for open oil passages on both ends of shaft and journals for damage.

22. Inspect cup plug for damage. If cup plug is damaged or missing, proceed as follows:

a. Use 4mm (No. 3) easy out or equivalent (grind to fit) and remove cup plug.

b. Install new cup plug to 1.0mm (.039") below surface.

### Reassembly

1. Install clutch apply ring on piston.

2. Install new outer and inner seals on piston with lips facing away from clutch apply ring side. (Figures 7A1-123 and 7A1-124).

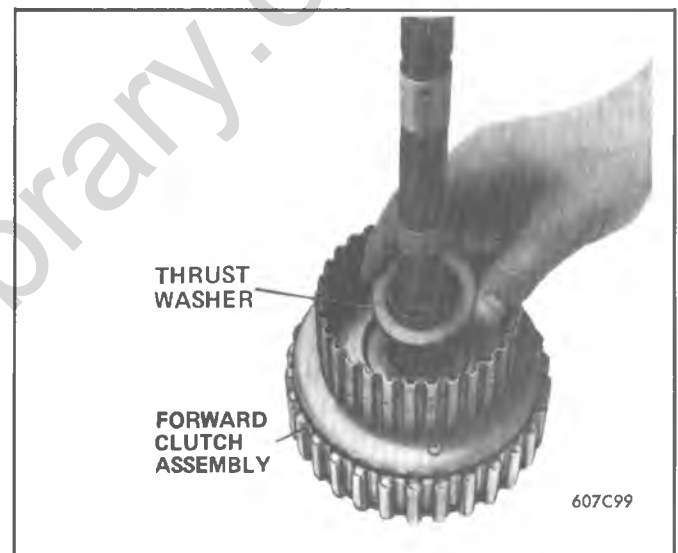

Figure 7A1-120 Removing Forward Clutch to Direct Clutch Thrust Washer

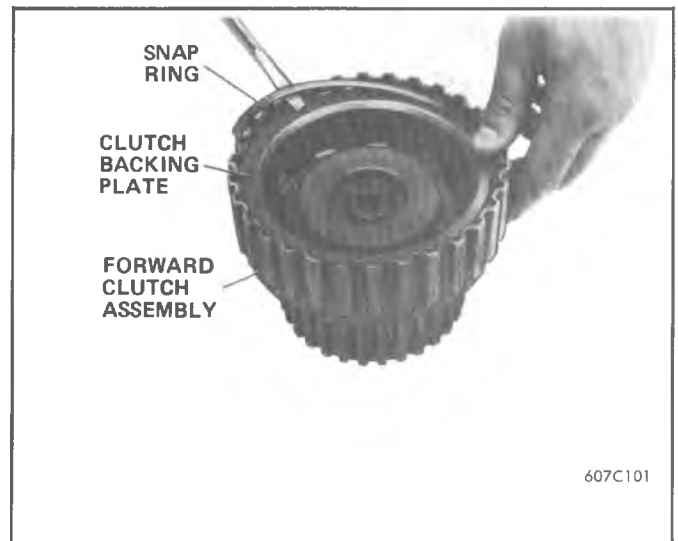

Figure 7A1-121 Removing Snap Ring from Forward Clutch Housing

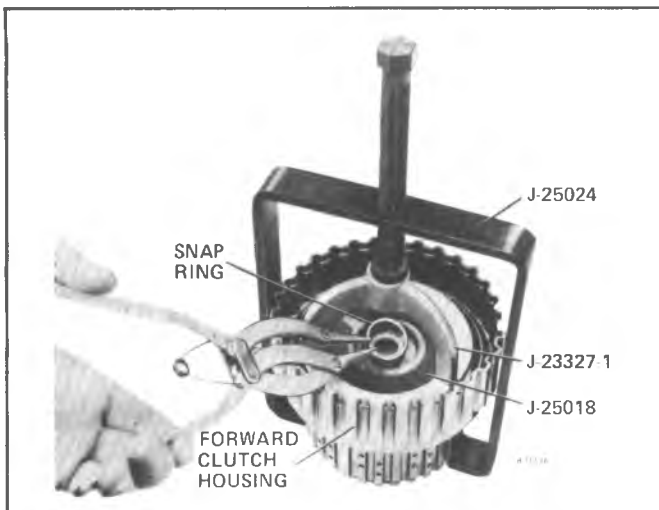

Figure 7A1-122 Removing Forward Clutch Release Spring Snap Ring



Figure 7A1-123 Removing or Installing Outer Piston Seal



Figure 7A1-124 Removing or Installing Inner Piston Seal

Use extreme care when installing forward clutch piston past large forward clutch snap ring groove. Groove could cut outer seal on piston.

3. Lubricate seals and install forward clutch piston. (Figure 7A1-126).

4. To make the piston easier to install, insert tool between the inner seal and shaft; rotate tool around the shaft to compress the lip of the seal, while pushing down slightly on the piston. Use the same procedure between the outer seal and the housing. Refer to Figure 7A1-126.

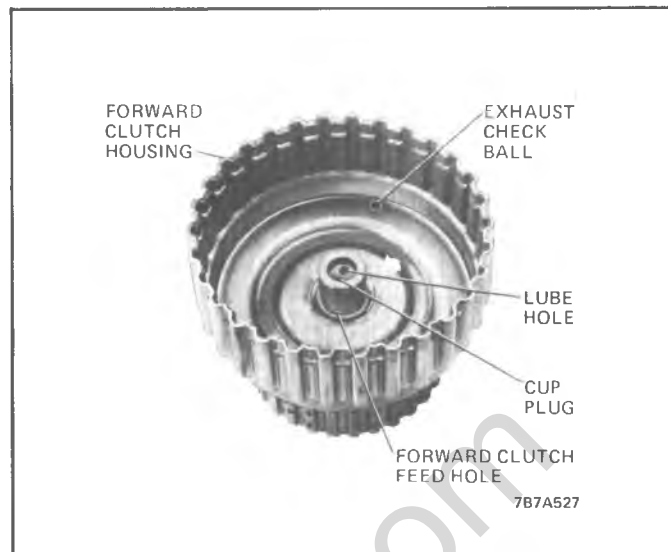

Figure 7A1-125 Forward Clutch Housing

5. Install retainer and spring assembly.

Retainer could locate is snap ring groove and forcing retainer to compress springs, could damage retainer plate.

6. Using J-23327-1, J-25024 and J-25018 adapter, compress retainer past snap ring groove and install snap ring (Figure 7A1-122). An arbor press and J-23327-1 and J-25018 can be used to compress the retainer and spring assembly.

7. Remove J-23327-1 and J-25018.

8. Oil and install the forward clutch plates into the forward clutch housing, starting with the waved steel plate and alternating composition-faced and flat steel clutch plates (See Figure 7A1-127 and Clutch Plate Usage Chart, Figure 7A1-93).

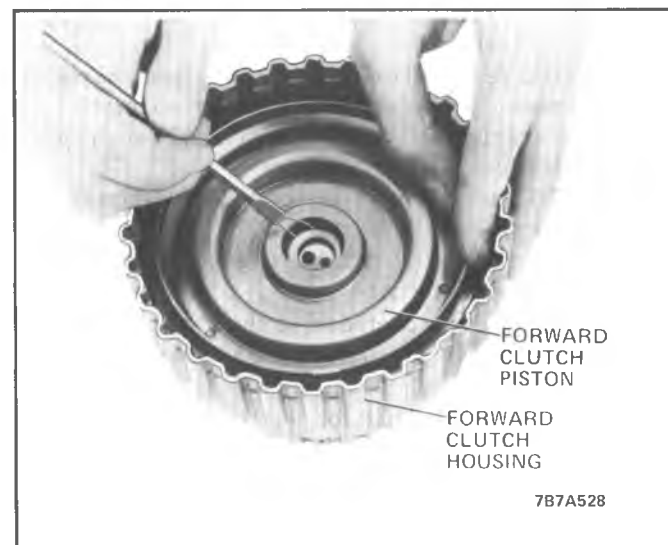

Figure 7A1-126 Installing Forward Clutch Piston

9. Install backing plate, chamfered side up.

10. Install snap ring. (Figure 7A1-121). Make sure composition clutch plates turn freely.

11. Install forward to direct clutch thrust washer and retain with petrolatum. (Figure 7A1-120).



Figure 7A1-127 Installing Clutch Plates Into Forward Clutch Housing

12. If removed, install new turbine shaft seal rings, making sure cut ends are assembled in the same relationship as cut and rings are seated in their groove (See Figure 7A1-128) for correct way to position cut ends.

### Intermediate Band Assembly

1. Inspect band for burning, flaking or damage.
2. Install intermediate band, locating band apply lug and anchor pin lug in case slots. (Figure 7A1-129).

### Forward and Direct Clutch Installation

1. Position direct clutch assembly, clutch plate end up, over hole in bench.

2. Align direct clutch composition-faced clutch plate teeth one above the other to make the forward clutch assembly easier to install.

3. Install forward clutch assembly, turbine shaft first, into direct clutch. Hold direct clutch housing and rotate forward clutch back and forth until the forward clutch is seated. (Figure 7A1-130).

4. When the forward clutch is seated, it will be approximately 15.8mm (5/8") from the tang end of the direct clutch housing to the end of the forward clutch drum, Figure 7A1-131).

5. Grasp direct and forward clutch assemblies to prevent their separation and position on bench, with the turbine shaft up.

6. Install J-25021 as shown in Figure 7A1-132.

7. Install direct and forward clutch assemblies, using J-25021, and rotate into position. (Figure 7A1-132). The direct clutch housing will be approximately 33.34mm (1-5/16") from the pump face in case when correctly seated. See Figure 7A1-133.

8. Remove J-25021.

### PUMP ASSEMBLY

#### Inspection

1. Remove pump to case seal ring and inspect groove for damage.



Figure 7A1-128 Teflon Oil Seal Rings

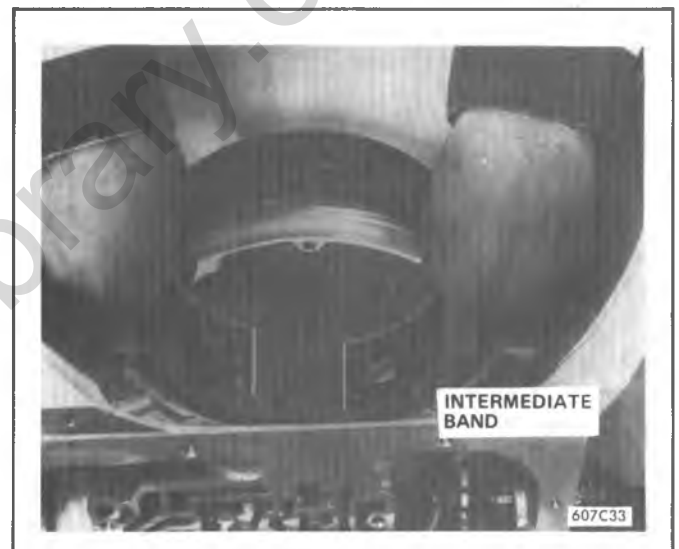

Figure 7A1-129 Installing Intermediate Band Assembly

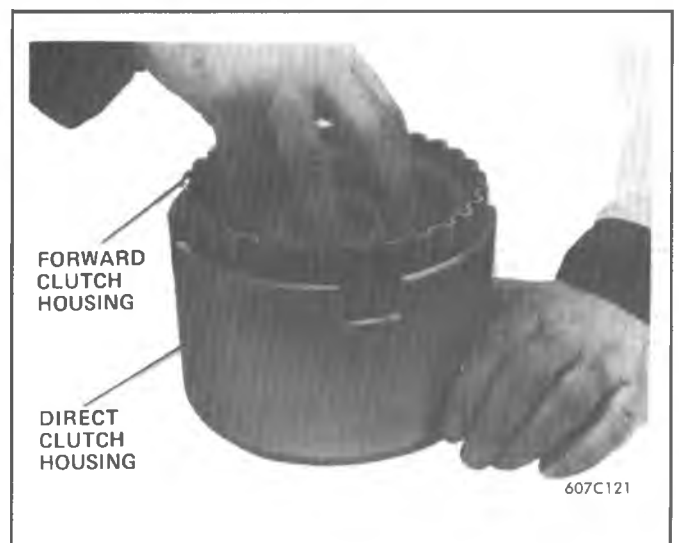

Figure 7A1-130 Installing Forward Clutch Assembly

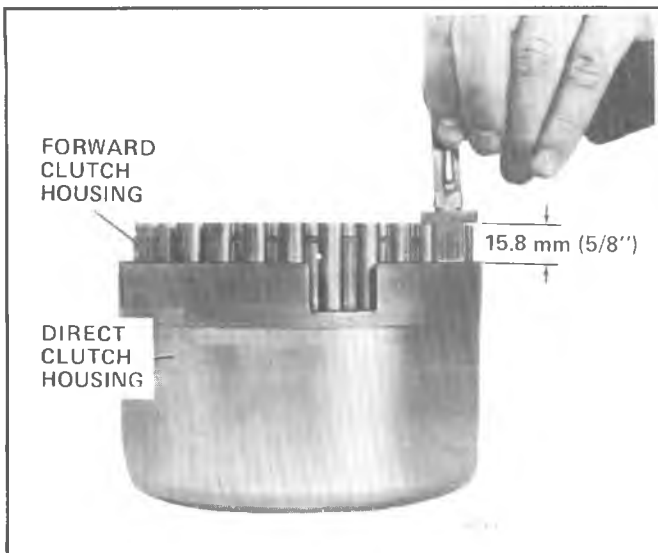

Figure 7A1-131 Forward Clutch Properly Seated in Direct Clutch

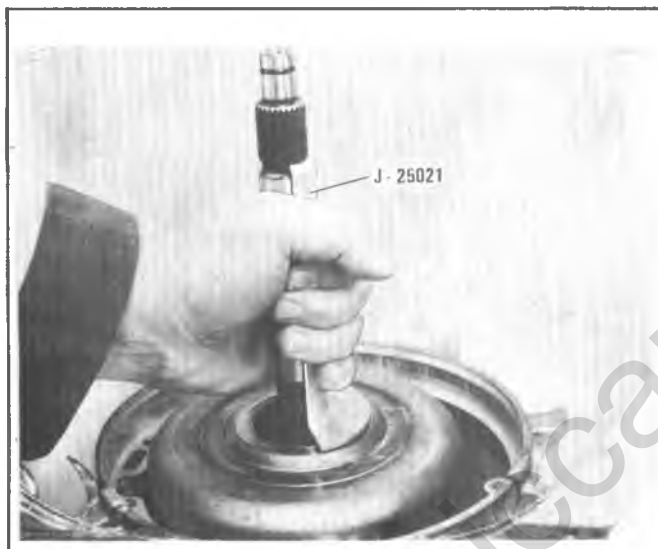

Figure 7A1-132 Installing Direct and Forward Clutch Assemblies

2. Place pump over hole in bench with pump cover side up.

3. Remove pump to direct clutch thrust washer and inspect for damage or wear. (Figure 7A1-135).

4. Inspect 3 oil ring seals for damage and free fit in grooves. Do not remove unless replacing. (Figure 7A1-134)

## CONVERTER CLUTCH SOLENOID

### Inspection

1. Remove solenoid assembly wires from wire clip.
2. Inspect solenoid assembly wires for loose connections and damaged or cut insulation.
3. Remove solenoid assembly attaching bolts. (Figure 7A1-137)
4. Remove solenoid assembly. (Figure 7A1-138)
5. Remove "O"-ring seal from solenoid assembly.
6. Inspect solenoid assembly ball check valve for nicks or damage.
7. Check for defective ball or ball seat;
  - a. Blow into ball seat with solenoid de-energized; air should pass through ball seat.
  - b. Noting polarity, energize solenoid with +12V.D.C. and blow into ball seat; air should **not** pass through ball seat.

**NOTICE:** Do not use compressed air to blow into ball seat. The use of compressed air may cause a false reading.

### Solenoid Diode Check

Solenoids should not be bench tested by touching the leads to an automotive battery. The internal diode will be destroyed by touching the negative terminal (black, marked with -) to the positive battery terminal and the positive terminal (red, marked +) to the negative battery terminal.

Diode used in solenoids may be checked using **ONLY** a **METER READING** or **SCALE-TYPE** ohm meter, set on the **X1 SCALE**. Electronic or digital-type meters, **CANNOT** be used because a false defective indication can be obtained.

Proper procedure is as follows:

- 1) Set the **SCALE-TYPE** or **METER-READING** ohm meter on the **X1 SCALE** and zero the needle.
- 2) Attach the **POSITIVE SOLENOID LEAD** (red, marked with +) to the **POSITIVE METER LEAD** and the **NEGATIVE SOLENOID LEAD** (black, marked -) to the **NEGATIVE METER LEAD**.
- 3) Reverse the solenoid lead attachment.

### METER READING

20 to 40 Ohms  
 (Depending on Solenoid Temperature)  
 0 Ohms  
 Open Circuit Reading  
 Lower reading than in Step 2  
 (Usually 2 to 15 ohms)  
 Same reading as in Step 2.

### CONCLUSION

Diode or coil is not shorted.  
 Diode or coil is shorted.  
 Coil is open.  
 Solenoid is OK  
 Diode is open.

## CONVERTER CLUTCH APPLY VALVES:

### Inspection

1. Remove the converter clutch valve bushing pin retainer. (Figure 7A1-139)
2. Remove the converter clutch valve bushing retaining pin. (Figure 7A1-140)
3. Remove the converter clutch valve bushing. (Figure 7A1-141)
4. Remove the apply and actuator valves. (Figure 7A1-142)
5. Inspect the apply and actuator valves for nicks or damage.
6. Inspect valves for free operation in bushing bore.

## PRESSURE REGULATOR

### Inspection

1. To prevent the pump from turning while removing the pressure regulator valve, place a bolt or screwdriver through a hole in the pump and bench. (Figure 7A1-136).
2. Using small screwdriver, push on bore plug, compressing pressure regulator spring; and using snap ring pliers, remove retaining ring. (Figure 7A1-136).
3. Release valve spring tension slowly and remove valve train.
4. Inspect pressure regulator valve for nicks or damage.
5. Inspect spring and guide for damage or distortion.
6. Inspect pressure regulator valve for free operation in bore.
7. Remove pump cover to pump body attaching bolts and separate pump cover from pump body. (Do not drop the check ball that is in the pump, as the pump body and pump cover are separated.)

## PUMP BODY

### Inspection

1. Remove the check ball 7.14mm (.281") from the pump body or pump cover and keep it separated from the five check balls 6.35mm (.250") used in the case and control valve assembly.
2. Remove drive and driven gear from pump body. (Figure 7A1-143).
3. Inspect drive and driven gears for scoring, galling or damage:
  - a. Driven gear identification marks should be against the pump body gear pocket. (See Figure 7A1-150 for identification.)
  - b. The drive gear has 1 identification mark on each drive tang (Figure 7A1-143). This side should be facing away from the pump body gear pocket.
4. Inspect drive and driven gear pocket and crescent for scoring or damage.
5. Inspect pump body face for nicks and overall flatness.
6. Inspect for open oil passages. (Figure 7A1-144).
7. Inspect for damaged bolt hole threads.
8. Inspect for open drainback hole. (See Figure 7A1-144 for location.)

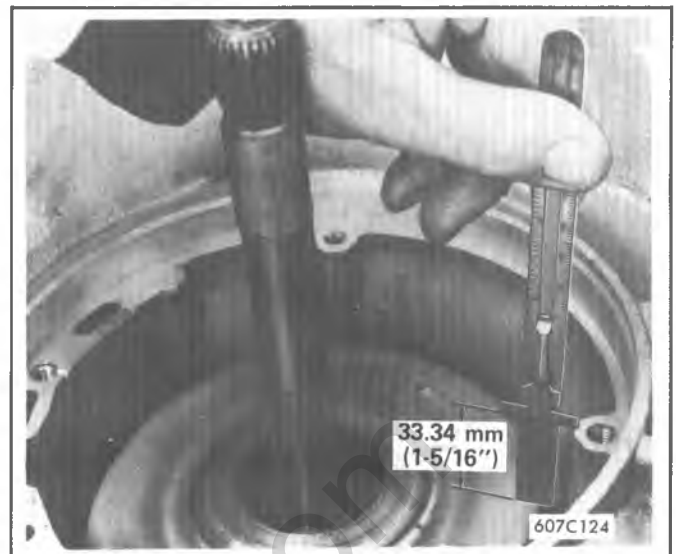

Figure 7A1-133 Direct and Forward Clutch Assemblies Properly Installed

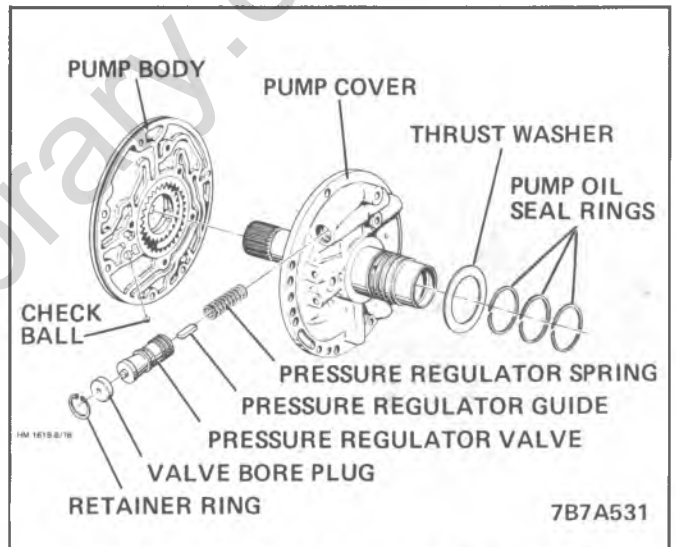

Figure 7A1-134 Pump Assembly - Exploded View

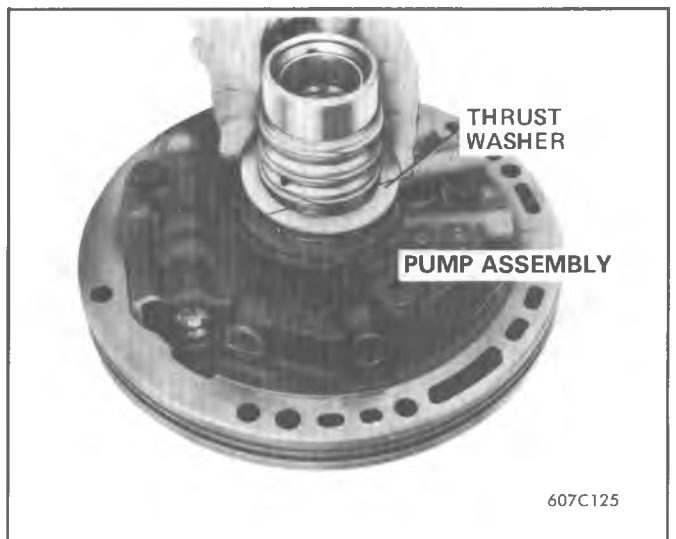

Figure 7A1-135 Removing Thrust Washer from Pump

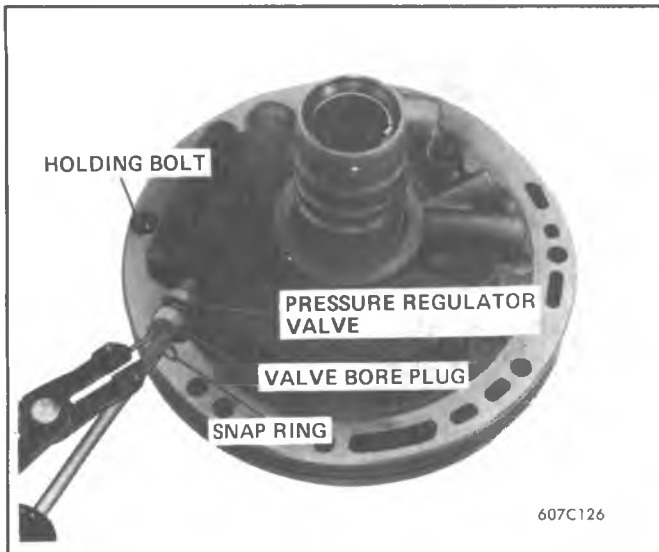

Figure 7A1-136 Removing Pressure Regulator Valve

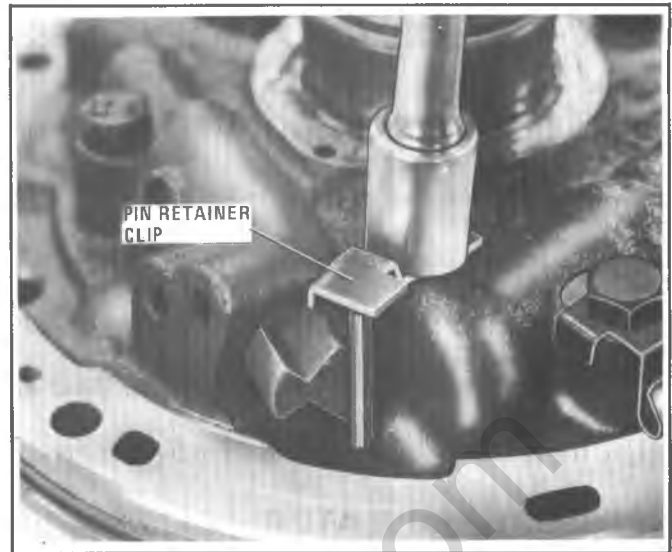

Figure 7A1-139 Removing Pin Retainer



Figure 7A1-137 Removing Solenoid Attaching Bolts

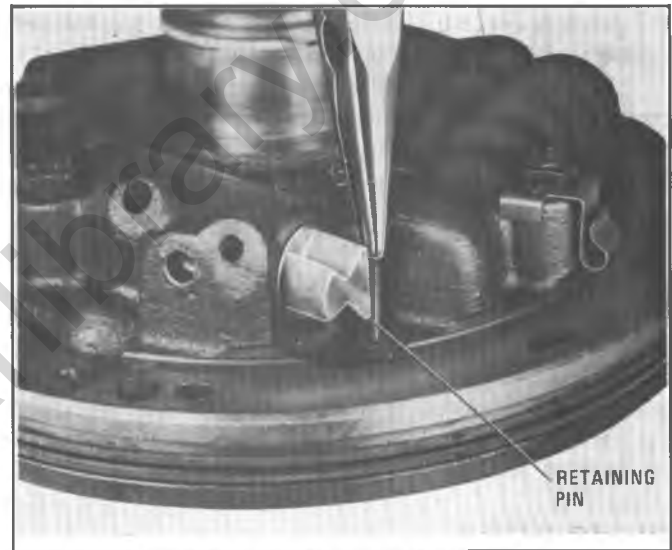

Figure 7A1-140 Removing Retaining Pin

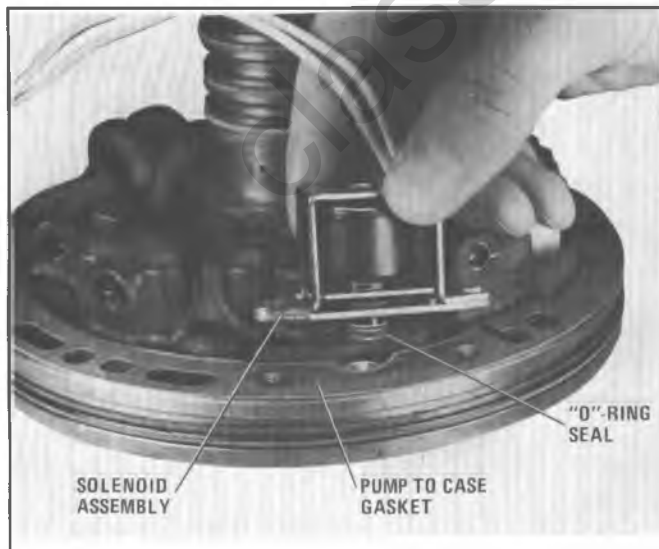

Figure 7A1-138 Removing Solenoid Assy.

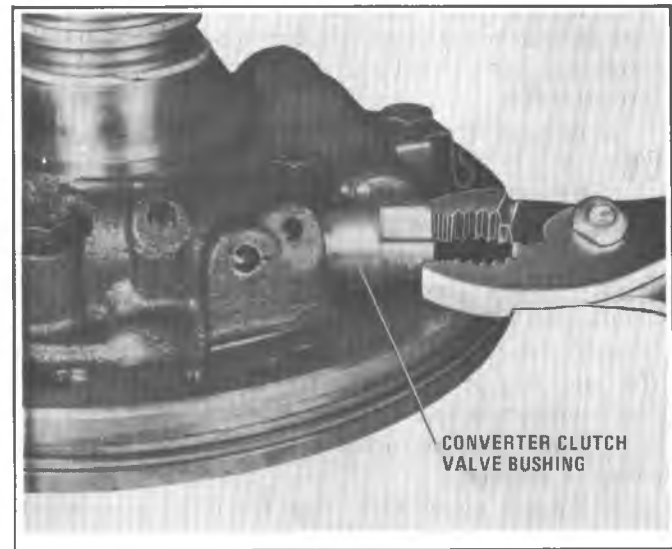

Figure 7A1-141 Removing Valve Bushing



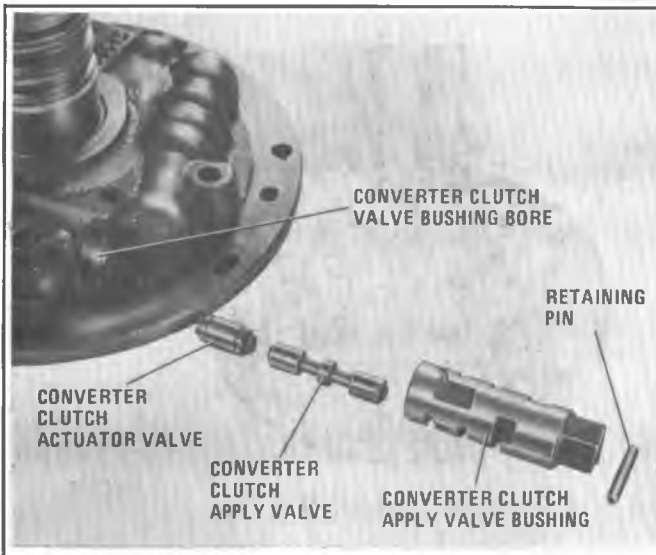

Figure 7A1-142 Converter Clutch Valves - Exploded View

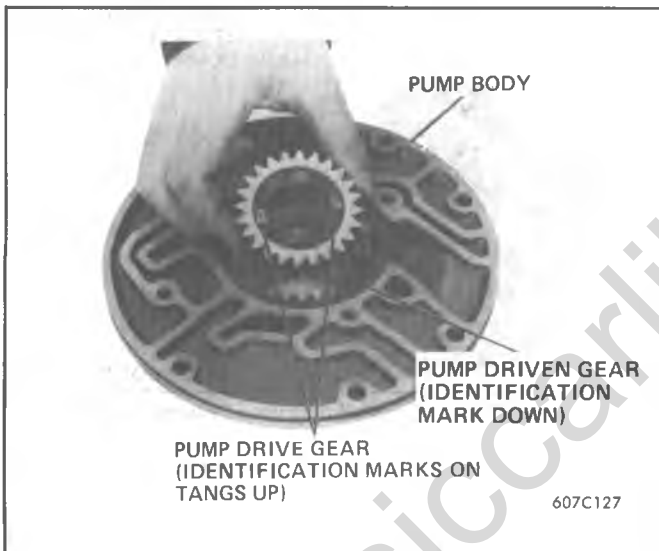

Figure 7A1-143 Removing Pump Drive Gear

9. Inspect bushing for scores or nicks.

9a. Grind about 12.7mm (1/2") from end of No. 4 easy out.

9b. Using the modified No. 4 easy out, remove cup plug. (Figure 7A1-145)

9c. Remove screen from pump body and clean. (Figure 7A1-146) Clean screen in clean solvent and air dry. Install screen in pump body.

9d. Install new cup plug, small diameter end first, into hole in pump body.

9e. Using a 7.9mm (5/16") diameter metal rod and hammer, drive cup plug until just below surface of hole. (Figure 7A1-147).

10. If removed, coat outside of seal body with non-hardening sealing compound; support pump body, oil seal side up, and using J-25016, install new pump body oil seal. (Figure 7A1-148).

11. Install driven pump gear with identification mark down against gear pocket of pump body. (Figure 7A1-149). (See Figure 7A1-144 for identification.)

12. Install drive gear with identification marks on drive tangs up. (Figure 7A1-143).

13. Pump body face to gear face clearance should be 0.020-0.055mm (.0007"-.0021"). (Figure 7A1-151).

14. Place the check ball into the check ball pocket in the pump body and retain it with petrolatum (See Figure 7A1-144 for ball location).

## PUMP COVER

### Inspection

1. Inspect for open oil passages. (Figures 7A1-152 and 7A1-153).

2. Inspect six (6) cup plugs. If a plug is missing, drive a new cup plug to .79mm (1/32") below top of hole, using a 6.35mm (1/4") diameter rod on the smaller plug and a 7.92mm (5/16") diameter rod on the five larger plugs. Stake top of hole two places, directly opposite each other, to retain plug.

3. Inspect pump cover face for nicks and overall flatness.

4. Inspect for chips in pressure regulator bore.

5. Inspect stator shaft for damaged splines or damaged bushings.

6. Insert orifice plug (See Figure 7A1-152). If the plug requires replacement, place new plug, orifice end first, into plug hole from the rough casting side. Drive the plug flush to .25mm (.010") below top of hole, rough casting side. Stake the top of hole two places to retain the plug.

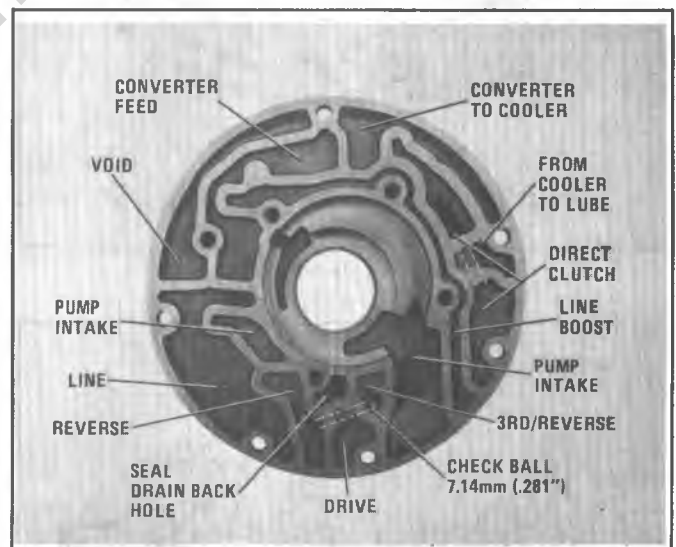

Figure 7A1-144 Pump Body Assembly

### Reassembly

1. Place pump body over hole in bench.

2. Assemble pump cover to pump body with attaching bolts, finger tight. (Leave pin retainer clip bolt out. Figure 7A1-139)

3. Align pump cover and pump body using J-25015 (Figure 7A1-154) and place bolt or screwdriver through pump to case bolt hole and bench.

4. Torque pump cover attaching bolts to 24 N·m (18 lb. ft.).

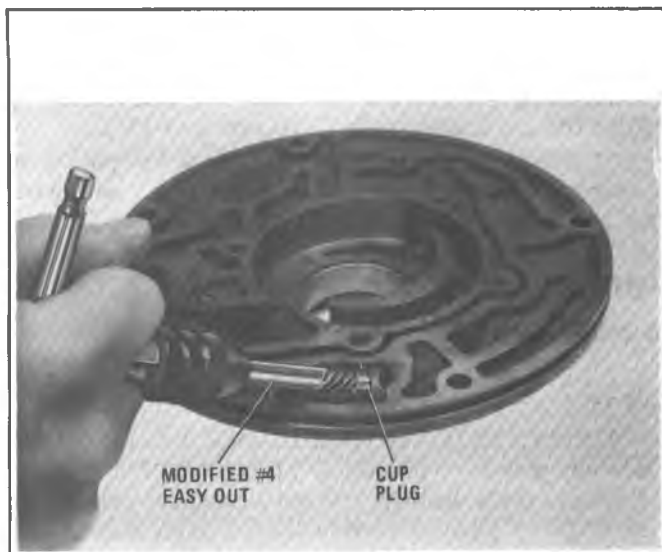

Figure 7A1-145 Removing Cup Plug

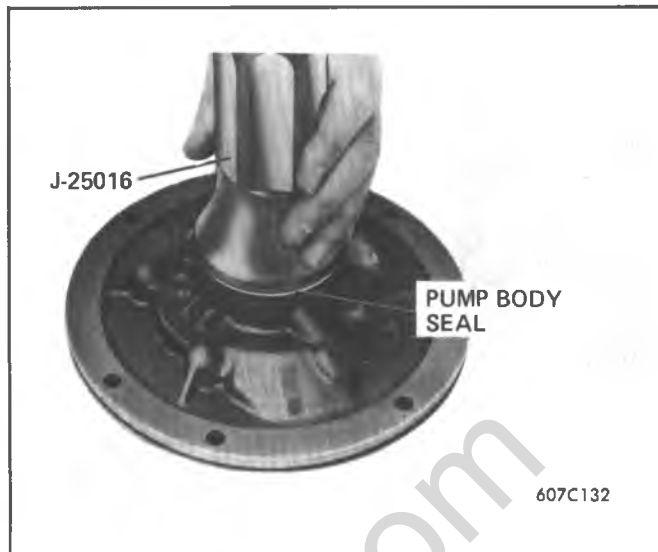

Figure 7A1-148 Installing Seal into Pump Body



Figure 7A1-146 Removing Screen

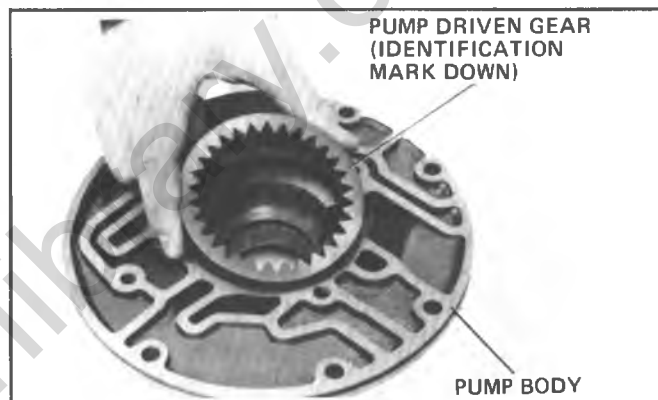

Figure 7A1-149 Installing Pump Driven Gear

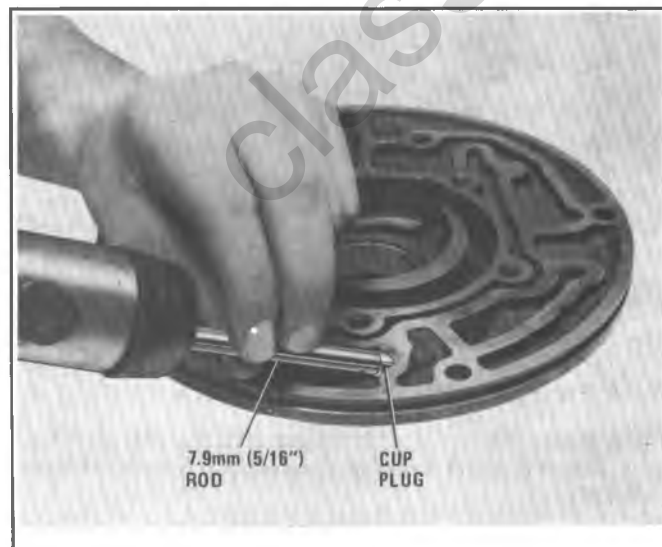

Figure 7A1-147 Installing Cup Plug

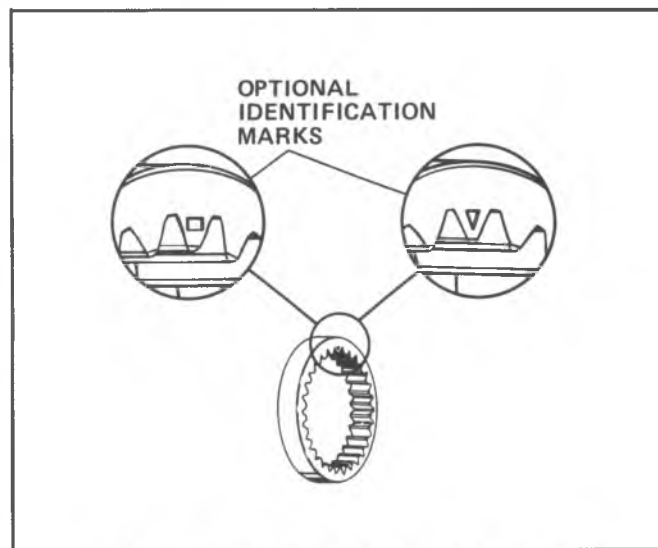

Figure 7A1-150 Pump Driven Gear Identification

5. Remove J-25015.

6. Install pressure regulator spring, guide, valve with stem end out, and bore plug, hole side out. (Figure 7A1-155).



Figure 7A1-151 Checking Pump Body-to-Gear End Clearance

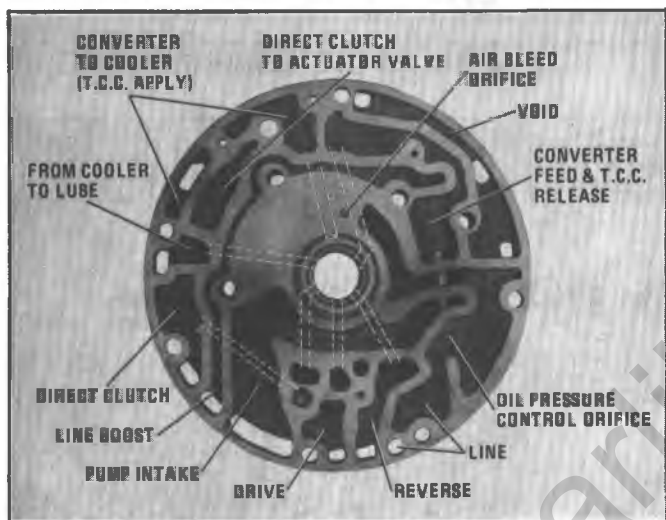

Figure 7A1-152 Pump Cover Assembly

7. Compress pressure regulator valve spring by pushing on bore plug with small screwdriver and install retaining ring. (Figure 7A1-156).

8. Install actuator valve into bushing bore of pump cover.

9. Install apply valve into apply valve bushing.

10. Install apply valve bushing into bore of pump cover (Figure 7A1-157).

11. Install apply valve bushing retaining pin (Figure 7A1-159).

12. Install pin retainer clip and bolt. (Figure 7A1-159). Torque bolt to 24 N·m (18 lb. ft.)

13. Install new pump to case gasket on pump and retain with petrolatum.

14. Lubricate with petrolatum and install new "O"-ring on solenoid assembly.

15. Install solenoid assembly onto pump. (Figure 7A1-160).

16. Install solenoid assembly attaching bolts and torque to 3.0-5.0 N·m (2-4 ft. lbs.)

17. Install solenoid assembly wires into wire clip.

18. If removed, install 3 new oil seal rings, making sure cut ends are assembled in the same relationship as cut. Also, make sure rings are seated in the grooves to prevent damage to the rings during reassembly of mating part over rings. Retain with petrolatum.

19. Install pump to case seal ring, chamfered side out, making sure the ring is not twisted.

20. Install pump to direct clutch thrust washer and retain with petrolatum. (Figure 7A1-161).

21. Remove holding bolt or screwdriver. (Figure 7A1-156).

22. Install new pump to case gasket on pump and retain with petrolatum.

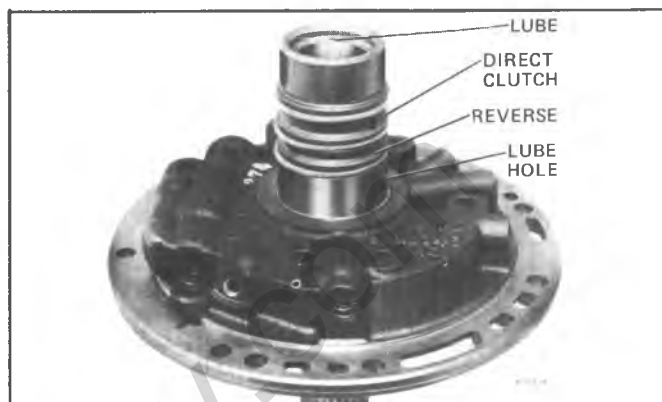

Figure 7A1-153 Pump Cover Oil Passages

23. Install 2 pump to case alignment pins in case as shown in Figure 7A1-162.

Before installing pump, make sure intermediate band anchor pin lug is aligned with band anchor pin hole in case.

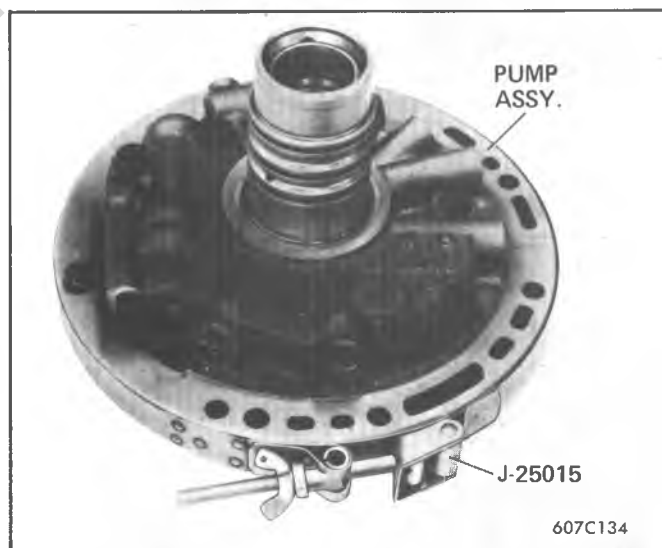

Figure 7A1-154 Aligning Pump Cover and Pump Body

23. Install pump assembly and finger start pump to case bolts and new washers, except one bolt hole (Figure 7A1-163) which will be used to make the front unit end play check.

**NOTICE:** If turbine shaft cannot be rotated as pump is being pulled into place, the forward or direct clutch housings have not been installed properly to index with all the clutch plates. This condition must be corrected before pump is pulled fully into place or damage to the direct clutch plates will result.

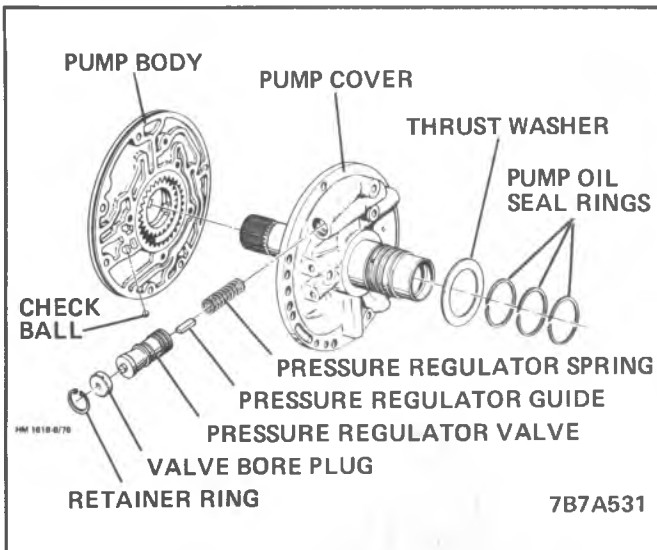

Figure 7A1-155 Pump Assembly - Exploded View



Figure 7A1-158 Install Retaining Pin

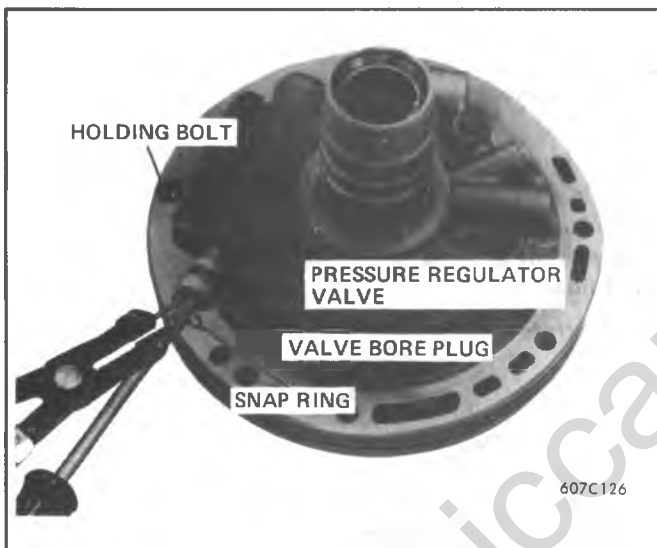

Figure 7A1-156 Installing Pressure Regulator Valve

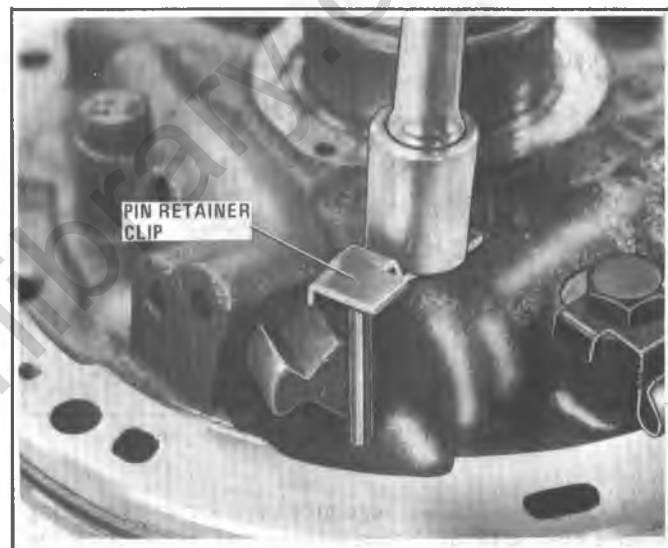

Figure 7A1-159 Install Pin Retainer

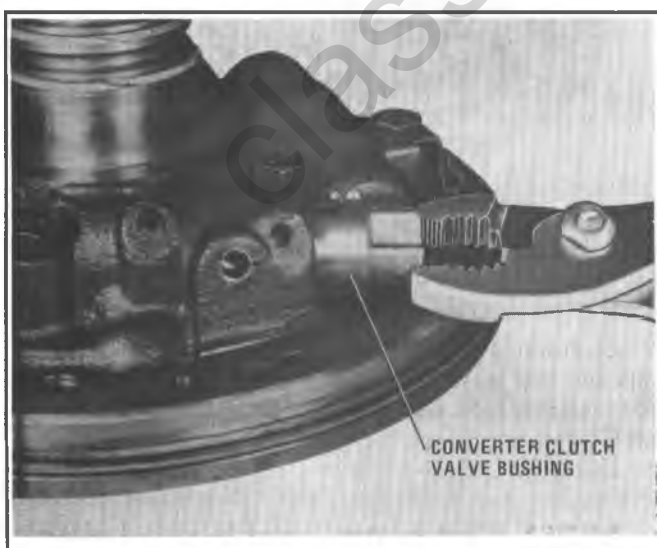

Figure 7A1-157 Install Apply Valve Bushing

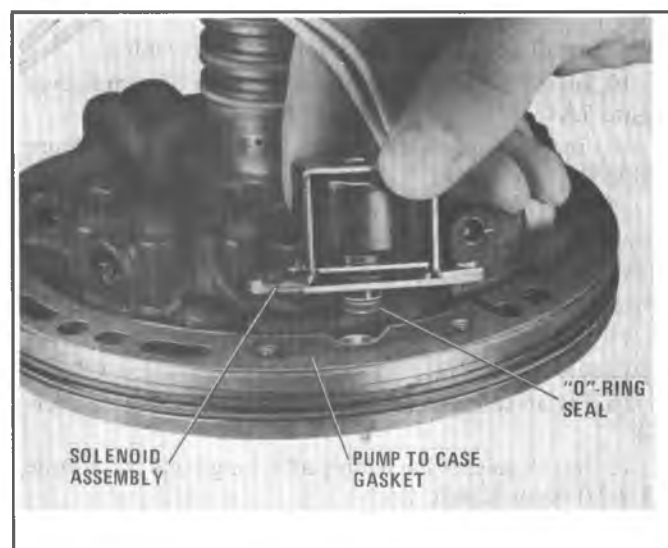

Figure 7A1-160 Install Solenoid Assembly

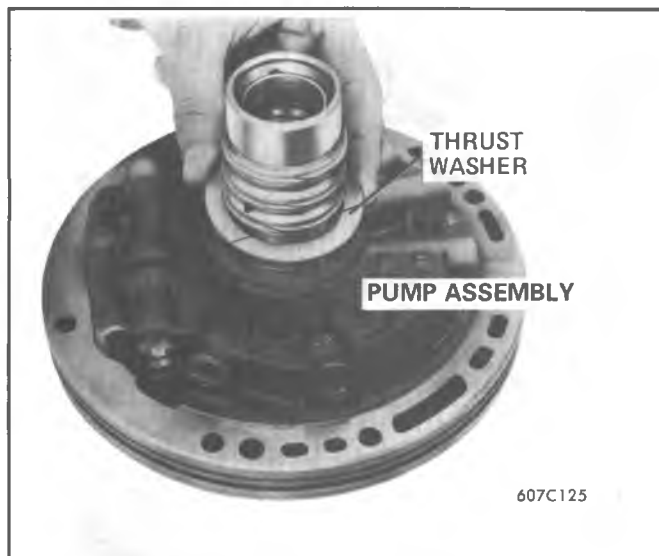

Figure 7A1-161 Installing Thrust Washer on Pump

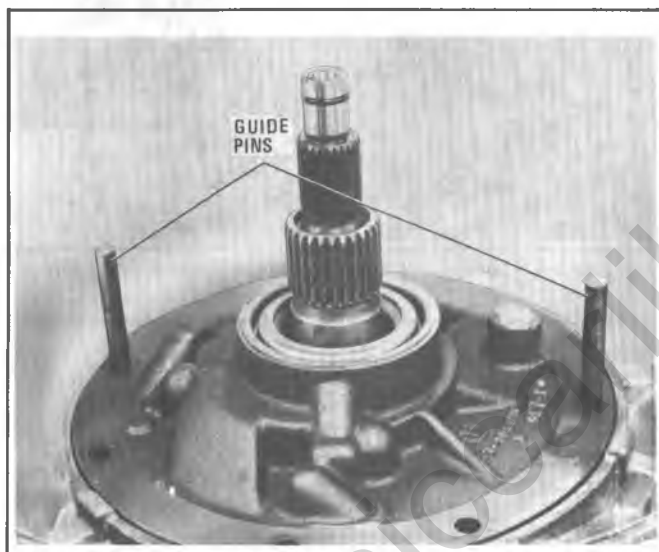

Figure 7A1-162 Installing Pump Assembly

24. Replace 2 alignment pins with 2 bolts and new washers.

25. Torque to case bolts to 24 N·m (18 lb. ft.).  
**Make sure turbine shaft rotates freely.**

### Check Front Unit End Play

1. Install 278mm (11") bolt and locking nut as shown in Figure 7A1-163.

2. Push turbine shaft downward.

3. Install J-25022 on J-24773 tool and locate on end of turbine shaft. (Figure 7A1-163).

4. Mount dial indicator on bolt and position indicator point against cap nut of J-24773.

5. Move output shaft forward by turning the adjusting screw on J-25013-5 until the white or scribed line on sleeve J-25013-1 begins to disappear, then set dial indicator to zero.

6. Pull turbine shaft upward, and read end play. Front unit end play should be 0.56mm-1.30mm (.022"-.051").

**Selective washer controlling this end play is located between the output shaft and turbine shaft. If more or less washer thickness is required to bring end**

**play within specifications, select proper washer from FRONT UNIT END PLAY WASHER THICKNESS CHART.**

7. Remove front unit end play checking tools.

8. Install remaining pump to case bolt and new washer, torquing bolt to 24 N·m (18 lb. ft.).

9. Remove J-25013-5 and J-25013-1 from rear end of transmission.

10. Turn transmission to horizontal position, oil pan side up.

## EXTERNAL PARTS

### Governor Assembly

#### Inspection

1. Inspect governor cover for damage, scored or worn bore or plugged oil passage.

2. Wash in cleaning solvent and blow out oil passage.

3. Inspect governor driven gear for nicks or damage.

4. Inspect governor shaft seal ring for cuts, damage and free fit in groove.

5. Inspect for free operation of governor weights.

6. Inspect for damaged, mispositioned, or tilted springs.

(All governors use two springs).

7. Inspect for presence of 2 check balls.

8. Inspect shaft for damage.

9. Inspect governor washer for damage.

10. If damaged, cut seal ring off governor shaft. **Do not damage governor shaft seal ring groove when removing seal.**

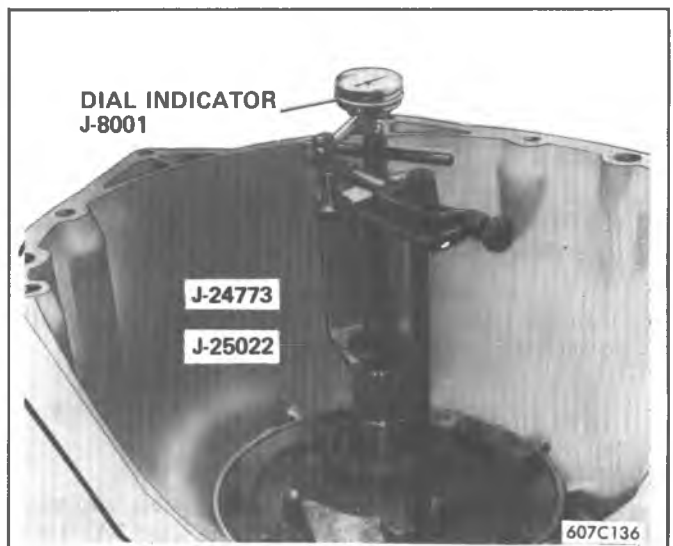

Figure 7A1-163 Checking Front Unit End Play

**CAUTION: Do not damage seal ring groove when removing seal.**

#### Installation

1. If removed, install new seal ring on shaft and place seal ring end into governor cover to size seal; lubricate with petrolatum.

2. Lubricate with petrolatum and install (2) two new seal rings on governor cover.

FRONT UNIT END PLAY WASHER THICKNESS CHART		
THICKNESS		IDENTIFICATION Number and/or Color
1.66-1.77 mm	(0.065"-0.070")	1 - —
1.79-1.90 mm	(0.070"-0.075")	2 - —
1.92-2.03 mm	(0.076"-0.080")	3 - Black
2.05-2.16 mm	(0.081"-0.085")	4 - Light Green
2.18-2.29 mm	(0.086"-0.090")	5 - Scarlet
2.31-2.42 mm	(0.091"-0.095")	6 - Purple
2.44-2.55 mm	(0.096"-0.100")	7 - Cocoa Brown
2.57-2.68 mm	(0.101"-0.106")	8 - Orange
2.70-2.81 mm	(0.106"-0.111")	9 - Yellow
2.83-2.94 mm	(0.111"-0.116")	10 - Light Blue
2.96-3.07 mm	(0.117"-0.121")	11 - —
3.09-3.20 mm	(0.122"-0.126")	12 - —
3.22-3.33 mm	(0.127"-0.131")	13 - Pink
3.35-3.46 mm	(0.132"-0.136")	14 - Green
3.48-3.59 mm	(0.137"-0.141")	15 - Gray

907A4

Figure 7A1-164 Front Unit End Play Washer Thickness Chart

**NOTICE:** The governor cover seal rings must be well lubricated with petrolatum to prevent damage or cutting of the rings. Also, make sure (2) two check balls are in the governor before installation.

3. Install governor assembly, seal ring end first, into cover.

**NOTICE:** Do not use any type of hammer to install governor assembly and cover into case. Damage to case, governor or cover could result.

4. Install governor and cover assembly, aligning governor shaft with shaft hole in case. (Figure 7A1-165). Rotate governor and cover assembly and output shaft slightly. The governor cover fits tight in the bore the last 1.5mm (1/16").

**NOTICE:** Governor shaft is not aligned with case hole, if retaining ring cannot be installed.

5. Install governor retaining ring. Align ring gap with an end showing in case slot.

### Intermediate Band Anchor Pin

1. Inspect anchor pin for damage.
2. Install anchor pin, stem end first, making sure stem locates in hole of intermediate band lug. (Figure 7A1-166).

### Intermediate Servo Piston Assembly

#### Inspection

1. Inspect pin oil seal rings for damage.
2. Inspect pin for damage and fit in case bore.
3. Inspect inner and outer piston seal rings for damage and free fit in ring grooves. Do not remove unless replacing.
4. Inspect spring.
5. Inspect intermediate servo cover and piston assembly for proper combination and usage. (See Figure 7A1-167).

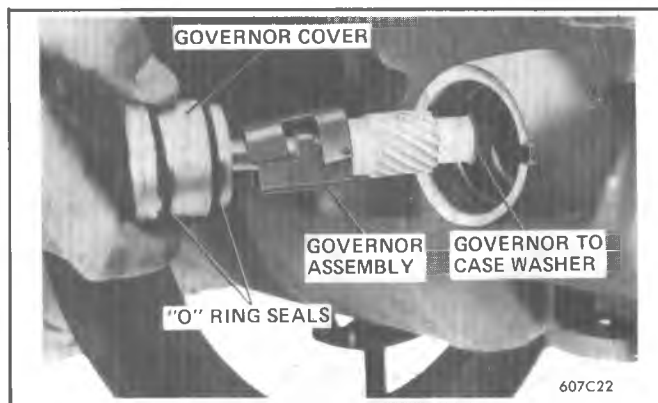

Figure 7A1-165 Installing Governor and Cover Assembly

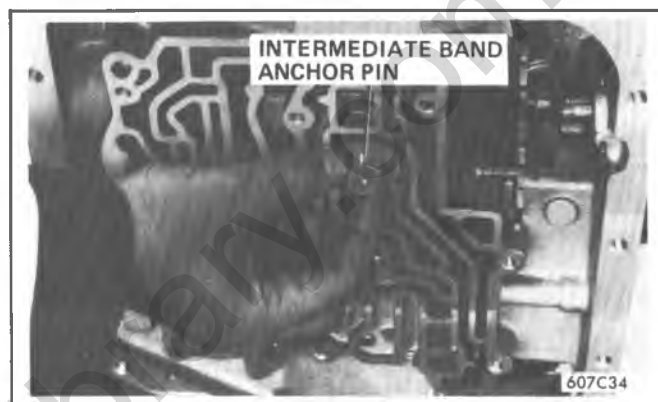

Figure 7A1-166 Installing Intermediate Band Anchor Pin

1981 THM 200 INTERMEDIATE SERVO COVER AND PISTON USAGE			
MODEL	SERVO COVER	OUTER PISTON I.D. BY CAST NO.	INNER PISTON I.D.
PD, PE	8632144	8633561	1 Step
CC, OT, AS	8632145	8633562	2 Steps
CK, CA, PF, OW, PG, CE	8632141	8633563	3 Steps
CN, CY, BZ, CX	8630569	8633564	Wide Band

Figure 7A1-167 Intermediate Servo Cover and Piston Usage

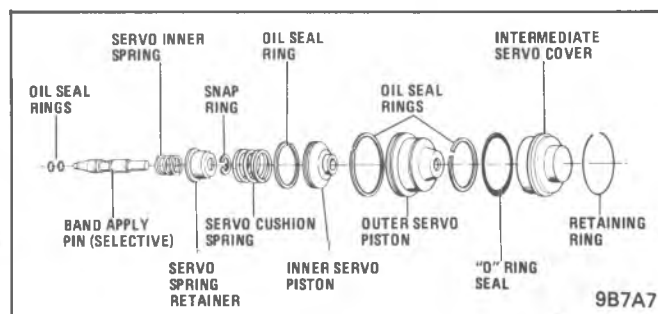

Figure 7A1-168 Intermediate Servo Piston - Exploded

6. Check for proper intermediate band apply pin as follows:

a. Install J-25014-2 in intermediate servo bore and retain with intermediate servo cover retaining ring, aligning ring with gap at case slot. (Figure 7A1-170).

b. Install pin J-25014-1 into J-25014-2. (Figure 7A1-170). Make sure the tapered pin end is properly located against the band apply lug. Also, make sure the band anchor pin is properly located in the case and band anchor lug.

c. Install dial indicator J-8001 and position dial indicator point (Figure 7A1-170) on top of J-25014-2 zero post and set dial indicator to zero. Make sure J-25014-2 gage plate is pulled backwards and seated squarely against the retaining ring.

d. Align stepped side of pin J-25014-1 with torquing arm of J-25014-2. Arm must stop against step of pin J-25014-1. If band selection pin does not register between the high and low limits, look for possible problem with the intermediate band, direct clutch or case.

e. Apply 12 N·m (100 lb. in.) of torque to hex nut on side of gage. Slide dial indicator over gage pin J-25014-1. (Figure 7A1-170). Read dial indicator and see Figure 7A1-169 for proper size. (Dial indicator travel is reversed, making the indicator readings backwards. On an indicator that ranges from 0-100, a .5mm (.020") travel will read 2mm (.080"), a 1.5mm (.060") travel will read 1mm (.040"). The identification ring is located on the band end of the pin.)

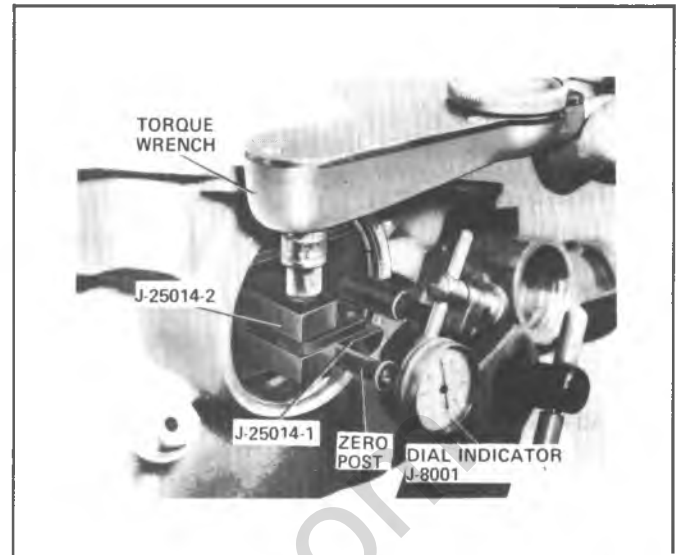

Figure 7A1-170 Intermediate Band Apply Pin Tools



Figure 7A1-171 Intermediate Band Apply Gages

INTERMEDIATE BAND APPLY PIN SELECTION CHART	
DIAL INDICATOR TRAVEL	APPLY PIN IDENTIFICATION
.0 - .72mm (.0 - .029")	1 Ring
.72mm - 1.44mm (.029"-.057")	2 Rings
1.44mm - 2.16mm (.057"-.086")	3 Rings
2.16mm - 2.88mm (.086"-.114")	Wide Band

9B7A6

Figure 7A1-169 Intermediate Band Apply Pin Chart

f. Remove retaining ring and band apply pin gages. If new apply pin or replacement of piston is required, proceed as follows:

**Disassembly**

1. Using small flat edge screwdriver, remove intermediate pin to retainer snap ring. (Figure 7A1-172)

2. Remove J-22269-01 and separate band apply pin; spring and washer from intermediate servo piston.

**Reassembly**

1. Install retainer on band apply pin.
2. Install snap ring on band apply pin. Figure 7A1-172.

3. Install band apply pin, retainer end first, through intermediate servo pistons, Figure 7A1-168.

4. If removed, install new intermediate servo piston, inner and outer seal rings. Make sure cut ends are assembled

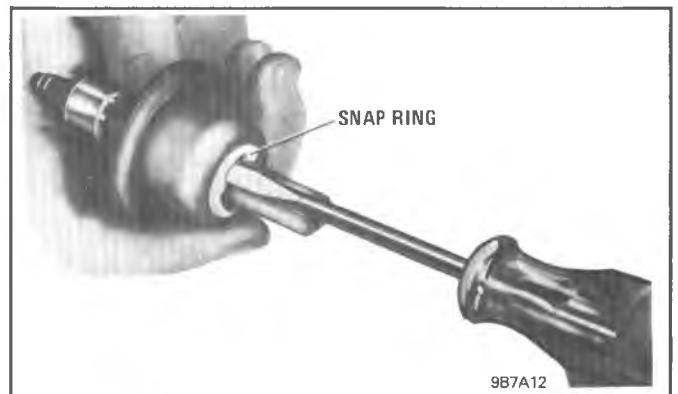

Figure 7A1-172 Removing Intermediate Servo Spring Retainer from Apply Pin

in the same relationship as cut, Figure 7A1-128. Make sure rings are seated in the grooves to prevent damage to the rings. Retain with petrolatum.

5. Lubricate with petrolatum and install new seal ring on intermediate servo cover.

**NOTICE:** The intermediate servo cover seal ring must be well lubricated with petrolatum to prevent damage or cutting of ring.

6. Install intermediate servo piston assembly into intermediate servo cover.

7. Install intermediate servo assembly into case, Figure 7A1-173. Make sure the tapered end of the band apply pin is properly located against the band apply lug.

8. Using two oil pan bolts, install J-28653 on case and depress servo cover, Figure 7A1-174.

9. Install servo cover retaining ring. Align ring gap with an end showing in case slot.

### Low and Reverse Clutch Housing to Case Cup Plug and Seal

1. Install new cup plug and seal assembly, with seal end first, into hole in case.

2. Using a 10 mm (3/8") diameter metal rod and hammer, drive cup plug and seal assembly until it seats against the Lo and Reverse clutch housing. Figure 7A1-176.

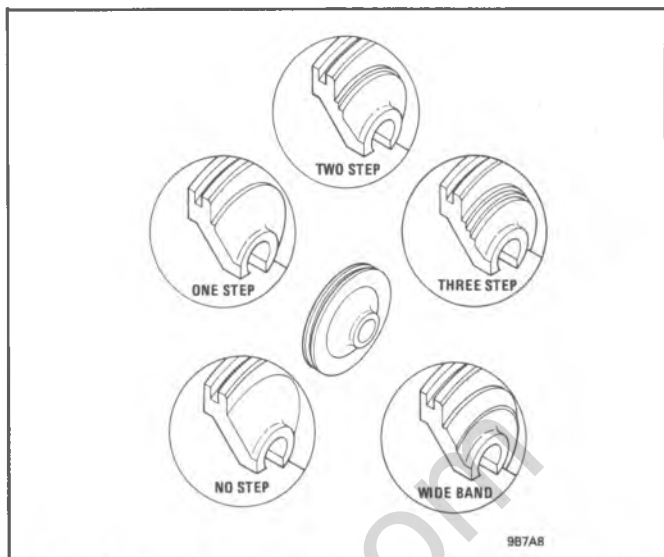

Figure 7A1-175 Steps on Intermediate Servo Inner Piston

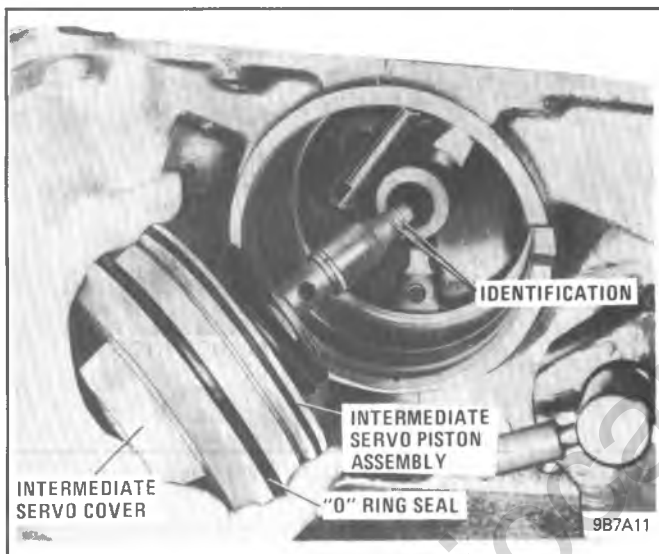

Figure 7A1-173 Installing Intermediate Servo Piston and Cover Assembly into Case

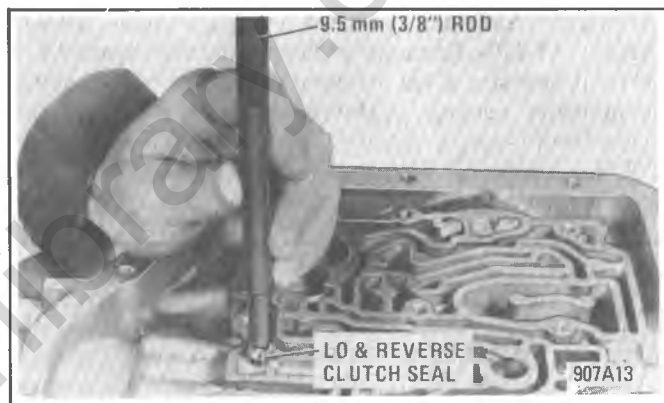

Figure 7A1-176 Installing Low and Reverse Clutch Housing to Case Cup Plug and Seal Assembly



Figure 7A1-174 Installing Intermediate Servo Cover Retaining Ring

### Electrical Connector

1. Lubricate with petrolatum and install new "O"-ring seal on the case connector.
2. Connect solenoid connector to case connector. (Figure 7A1-177)
3. Install electrical connector with lock tabs facing into case, positioning locator tab in notch on side of case. (Figure 7A1-178)

### Control Valve Assembly

#### Disassembly

As each valve train is removed, place the individual valve train in the order that it is removed and in a separate location relative to its position in the valve body. None of the valves, bushings or springs are interchangeable; some coiled pins are interchangeable. Remove all coiled pins by pushing through from the rough cast surface side of the control valve assembly, except the 2 pins which retain the throttle valve and throttle valve plunger.

1. Remove the 4 check balls.
2. Position control valve assembly as shown in Figure 7A1-179.
3. Remove 1-2 accumulator piston.



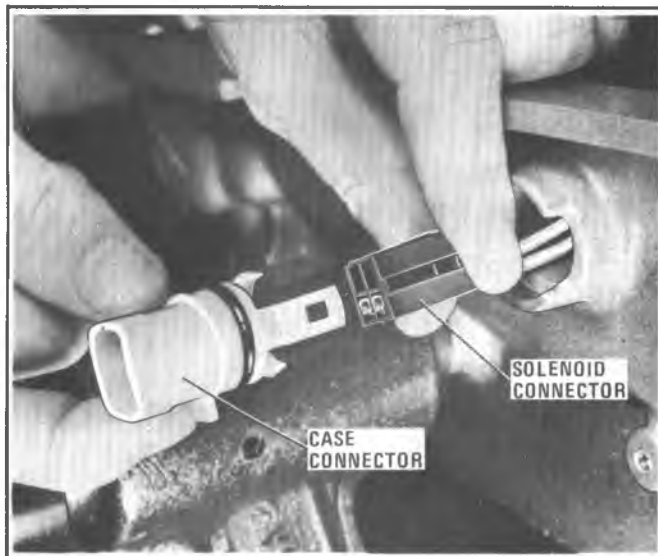

Figure 7A1-177 Installing Solenoid Connector to Case Connector

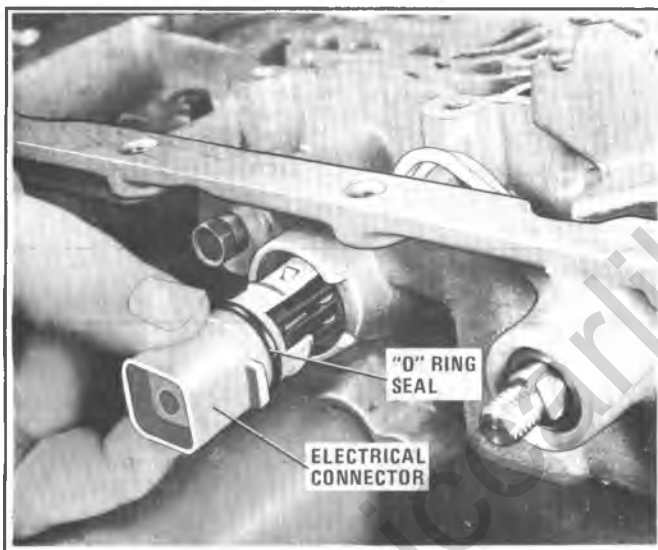

Figure 7A1-178 Installing Electrical Connector

4. Remove manual valve from upper valve bore.

Some of the coiled pins in the control valve assembly have pressure against them. Therefore, hold a shop towel over the bore while removing the pin, to prevent possibly losing a bore plug, spring, etc.

5. Remove coiled pin from upper right bore. Remove 2-3 throttle valve bushing, 2-3 throttle valve spring, 2-3 throttle valve and 2-3 shift valve. (The 2-3 throttle valve spring and 2-3 throttle valve may be inside the 2-3 throttle valve bushing.)

6. From next bore down, remove coiled pin. Remove 1-2 throttle valve bushing, 1-2 throttle valve spring, 1-2 throttle valve and 1-2 shift valve.

The 1-2 throttle valve spring and the 1-2 throttle valve may be inside the 1-2 throttle valve bushing.

7. From next bore down, remove coiled pin and bore plug. Remove reverse boost spring and reverse boost valve.

8. Check the operation of the shift T.V. valve in the next bore down, by moving the valve against the spring. If it is necessary to remove the valve, proceed as follows: (Figures 7A1-180 and 7A1-181).

a. Remove coiled pin and place valve body on shop towel with rough casting surface up.

b. Using needle nose pliers, compress the shift T.V. spring by pushing on the shift T.V. valve; hold valve with small screwdriver. (Figure 7A1-180).

c. Place 6.3mm (1/4") rod, 9.5mm (3/8") long, against the end of the shift T.V. valve.

d. Prying on end of the rod with a large screwdriver, remove small screwdriver and remove shift T.V. plug, shift T.V. spring and shift T.V. valve (Figure 7A1-181).

e. Discard shift T.V. plug and remove 6.3mm (1/4") rod from shift T.V. bore.

9. From next bore down, remove outer coiled pin. Remove the throttle valve plunger, bushing and throttle valve spring. Using a 1.5mm (1/16") allen wrench with ground sides to fit inside the pin, remove the inner coiled pin. (Figure 7A1-182). Remove the throttle valve.

10. From upper left bore, remove coiled pin, intermediate boost spring and intermediate boost valve.

11. From next bore down, remove coiled pin, low overrun clutch spring and low overrun clutch valve.

12. From next bore down, remove coiled pin, direct clutch exhaust spring and direct clutch exhaust valve.

13. From next bore down, remove coiled pin, valve bore plug, 1-2 accumulator valve and 1-2 accumulator valve spring.

### Inspection

1. Wash control valve body, valves, springs, and other parts in clean solvent and air dry.
2. Inspect 1-2 accumulator piston for damage.
3. Inspect 1-2 accumulator piston seal for damage and free fitting groove. Do not remove seal unless replacing.
4. Inspect valve for scoring, cracks and free movement in their bores.
5. Inspect bushings for cracks or scored bores.
6. Inspect valve body for cracks damage or scored bores.
7. Inspect springs for distortion or collapsed coils.
8. Inspect bore plugs for damage.

### Reassembly

Install all flared coiled pins (zinc coated) flare end out, and from the machined face of the control valve assembly. Install the two (2) tapered coiled pins (black finish) that retain the throttle valve bushing, tapered end first. Coiled pins do not fit flush on rough casting face. Make sure that all coil pins are flush at machined face.

1. Position control valve body as shown in Figure 7A1-179.
2. Install into lower left bore, 1-2 accumulator spring, 1-2 accumulator valve, smaller stem end out. Install bore plug, hole out, and coiled pin.
3. In next bore up, install direct clutch exhaust valve, longer stem end out, direct clutch exhaust spring and coiled pin.
4. In next bore up, install low overrun clutch valve, longer stem end out, low overrun clutch spring and coiled pin.

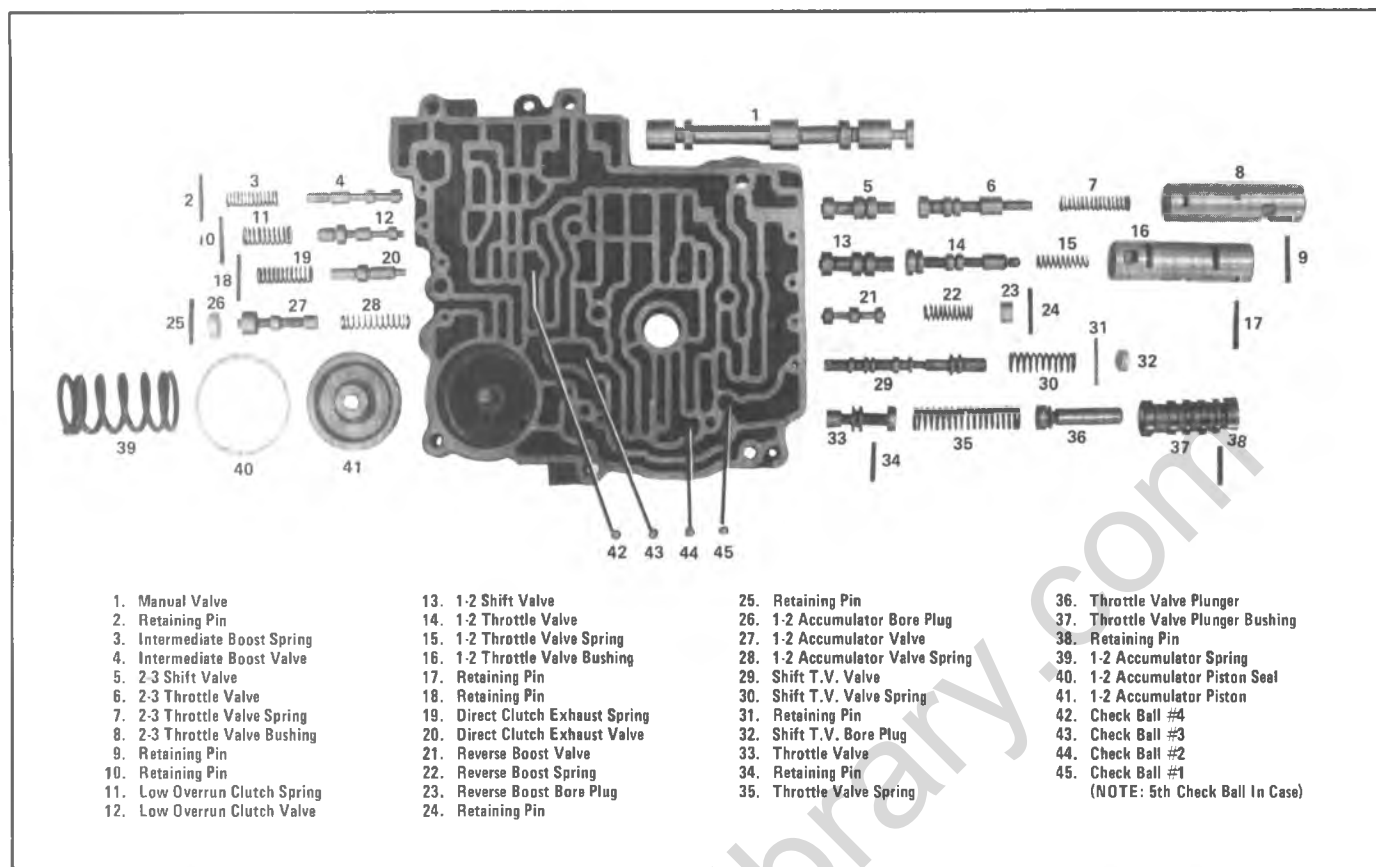

Figure 7A1-179 Control Valve Assembly - Exploded View

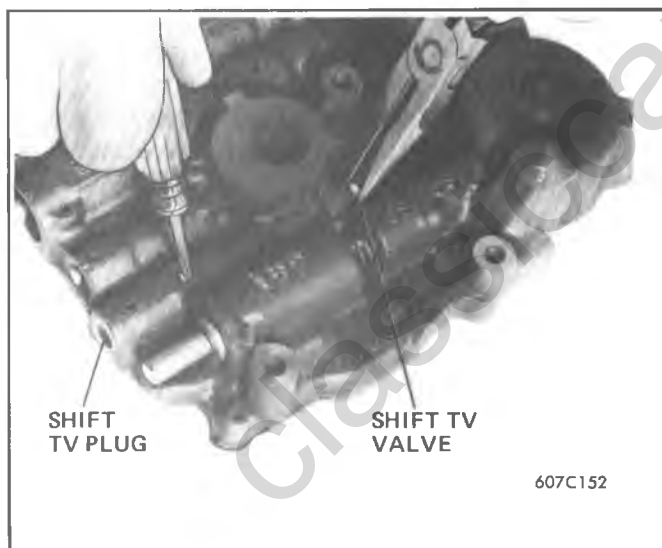

Figure 7A1-180 Removing Shift T.V. Plug

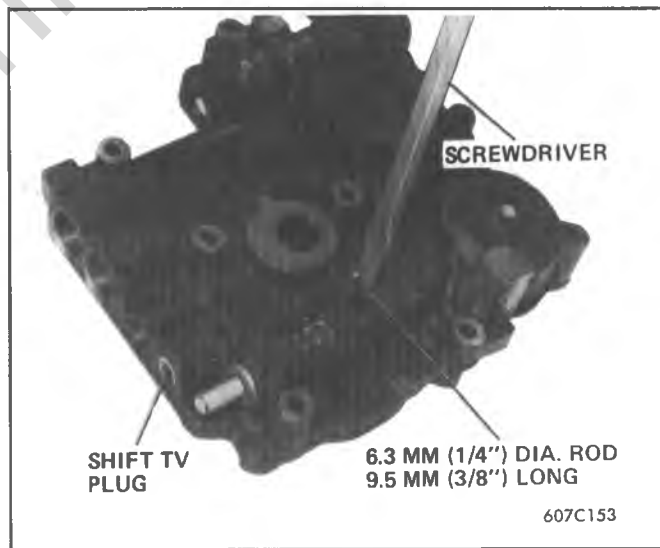

Figure 7A1-181 Removing Shift T.V. Plug

5. In next bore up, install intermediate boost valve, longer stem end out, intermediate boost spring and coiled pin.

6. In lower right bore, install throttle valve, smaller outside diameter land first, making sure valve is seated at the bottom of the bore. Install inner coiled pin between the lands of this valve. (Figure 7A1-182). Install the shift T.V. spring into the bore. Install the throttle valve plunger, stem end first, into the throttle valve plunger bushing and install these 2 parts into the bore, valve end first. Install outer coiled pin from rough cast surface side, aligning pin with slot in bushing.

7. In next bore up, if removed, install shift T.V. valve, larger outside diameter stem end out, shift T.V. spring and coiled pin. Then, using plastic hammer, install new shift T.V. plug flush with rough casting surface.

8. In next bore up, install reverse boost valve, stem end out, reverse boost spring. Install bore plug, hole side out and coiled pin.

9. In next bore up, install 1-2 shift valve, longer stem end out, making sure valve is seated at the bottom of the bore. Install 1-2 throttle valve spring into the 1-2 throttle valve bushing and 1-2 throttle valve, stem end first, into the bushing. Install these 3 parts, valve end first, into the bore,



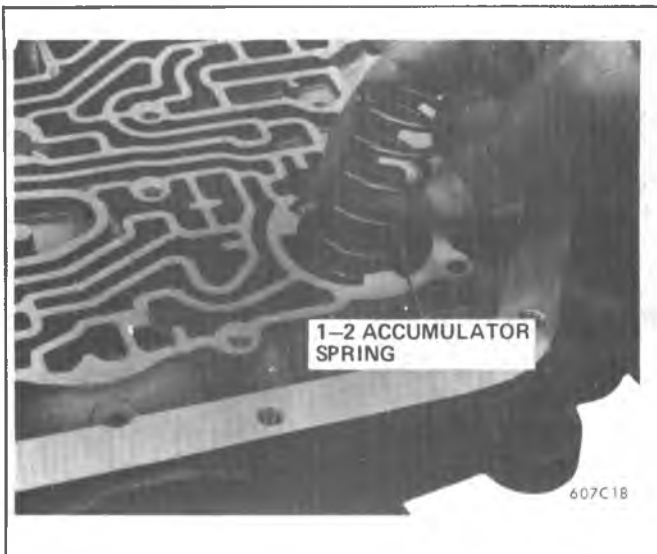

Figure 7A1-186 Installing 1-2 Accumulator Spring

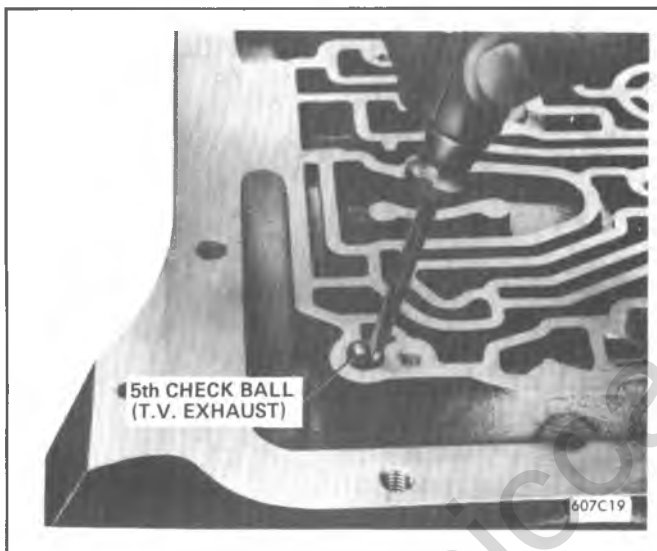

Figure 7A1-187 Installing 5th Check Ball



Figure 7A1-188 Installing Governor Pressure Switch (Diesel Model)

plate; and install these parts, aligning the manual valve with the detent lever pin (Figure 7A1-190). (Make sure check balls, 1-2 accumulator piston and manual valve do not fall out.)

11. Start control valve assembly to case attaching bolts, except the throttle lever and bracket assembly and the oil screen attaching bolts.

**The (2) oil screen attaching bolts are about 10mm (3/8") longer than the control valve assembly attaching bolts, and they are not interchangeable.**

12. Inspect inside manual detent roller and spring assembly for damage.

13. Remove guide pins and replace with bolts and inside manual detent roller and spring assembly, locating the tang in the control valve, and the roller on the inside detent lever. (Figure 7A1-191).

14. Throttle lever and bracket assembly.

a. Inspect throttle lever and bracket assembly for damage. (Figure 7A1-192).

b. If removed, install spring on top of lifter. Then place lifter and spring into throttle bracket. (Figure 7A1-192).

c. Install link on throttle lever making sure link is hooked as shown. (Figure 7A1-192).

d. Install throttle lever and bracket assembly, location slot in bracket with coiled pin, aligning lifter through valve body hole and link through T.V. linkage case bore. Retain with bolt. (Figure 7A1-193).

15. Torque all control valve assembly to case attaching bolts to 15 N·m (11 lb. ft.).

### Oil Screen

1. Thoroughly clean, air dry and inspect oil screen assembly.

2. Install new oil screen gasket on screen and retain with petrolatum.

3. Install oil screen assembly and attaching bolts. (Figure 7A1-194). Torque bolts to 15 N·m (11 lb. ft.).

### GOVERNOR PRESSURE SWITCH

1. Install governor pressure switch using a 1-1/16" oil sending unit socket. Torque to 7-14 N·m (5-10 ft. lbs.) Figure 7A1-188.

2. Connect long solenoid lead wire to governor pressure switch terminal.

3. Press solenoid lead wires into wire clips.

### Oil Pan

1. Clean and inspect oil pan for damage.

2. Install new oil pan to case gasket on case.

3. Install oil pan and retaining bolts. Torque bolts to 16 N·m (12 lb. ft.).

### Speedometer Driven Gear

#### Inspection

1. Remove speedometer driven gear from housing and inspect gear for damage.

2. Inspect housing for damage and "O" ring for damage or cuts.

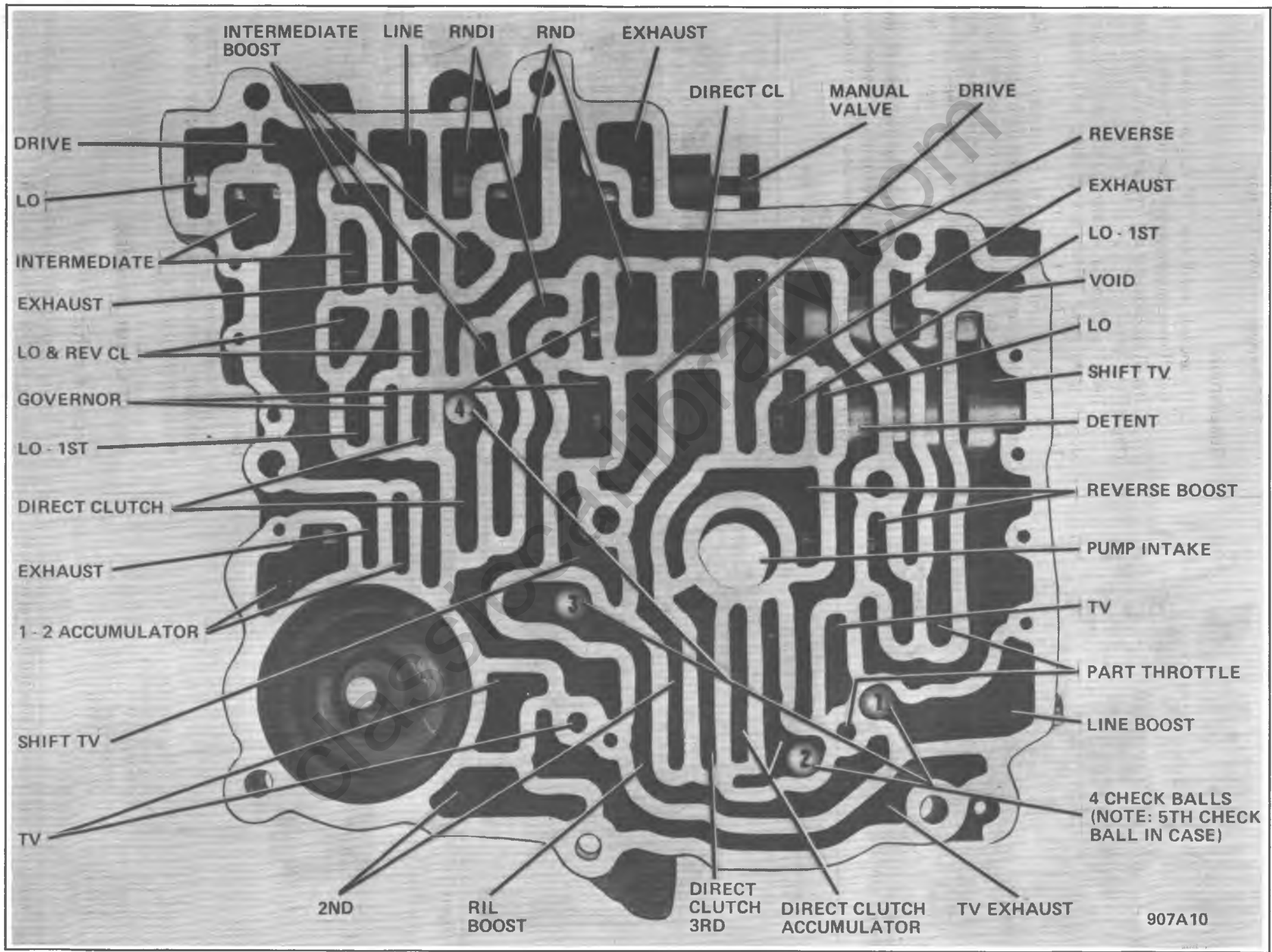

Figure 7A1-189 Control Valve Assembly with Four Check Ball Locations

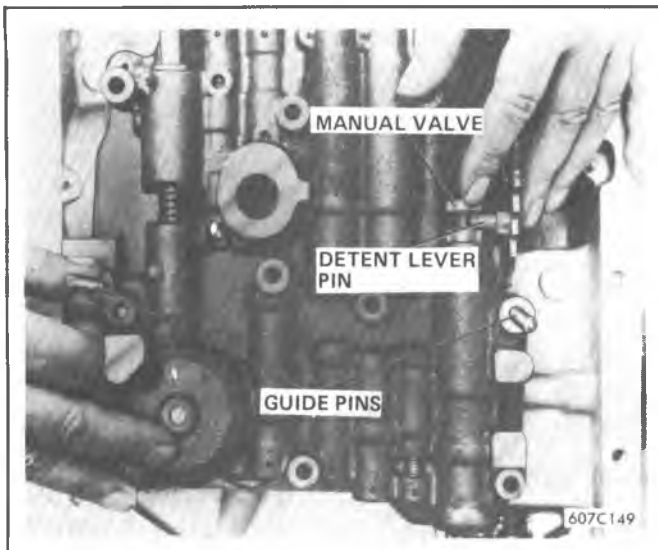

Figure 7A1-190 Installing Control Valve Assembly using Guide Pins

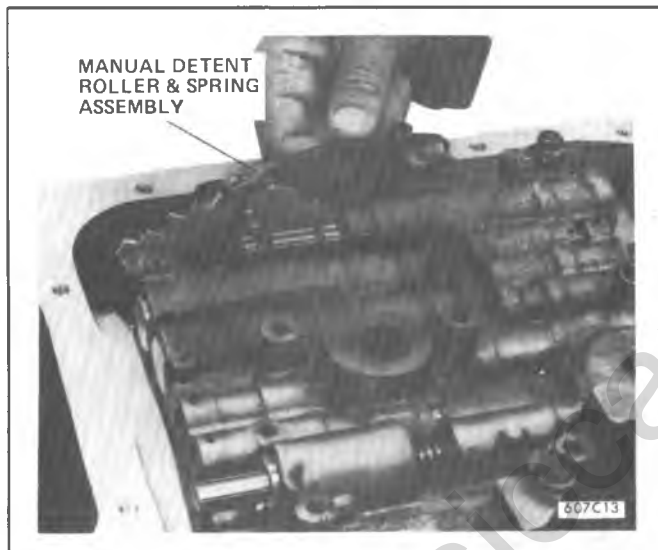

Figure 7A1-191 Installing Manual Detent Roller and Spring Assembly

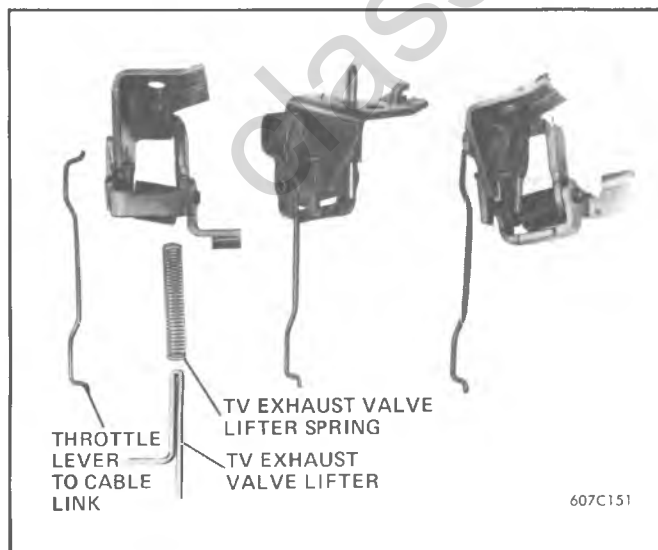

Figure 7A1-192 Throttle Lever and Bracket Assembly

3. If damaged, remove "O" ring.

### Reassembly

1. If removed, install new "O" ring on housing.
2. Install speedometer driven gear into housing.
3. Install speedometer driven gear assembly into case. (Figure 7A1-195).
4. Install speedometer retainer and attaching bolt, align slot in speedometer driven gear housing with retainer. Torque bolt to 12 N·m (8 lb. ft.).
5. Place transmission in cradle or transmission jack. Remove holding fixture, J-8763-02 from transmission.
6. Install the converter assembly into the pump assembly, making sure that the converter hub drive slots are fully engaged with the pump drive gear tangs and the converter installed fully towards the rear of the transmission.

The converter will be properly installed if the distance is 25.4mm (1.00") minimum between the engine mounting face of the case and the front face of the converter cover drive lugs.

7. Retain converter with J-21366.

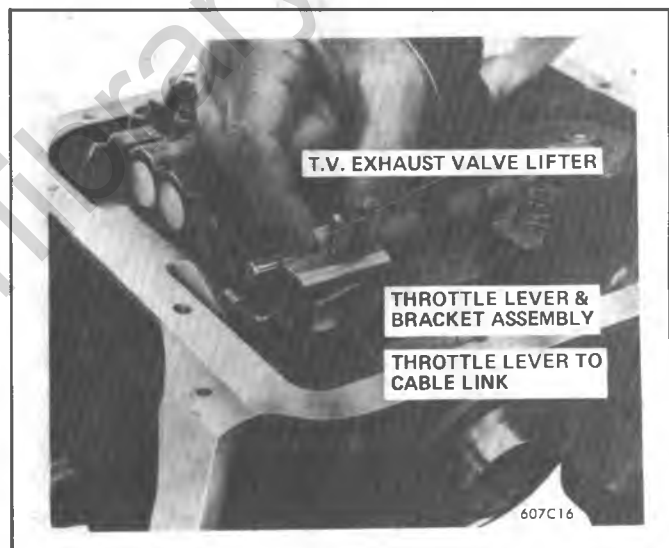

Figure 7A1-193 Installing Throttle Valve and Bracket Assembly

### BUSHING REPLACEMENT PROCEDURE

During disassembly and inspection of the transmission, if a bushing is galled, scored or excessively worn, the bushing should be replaced.

The replacement bushings used for field service are of high quality with close tolerances to fit, and do not require boring or reaming after installation.

### Pump Cover Bushing

#### Front Bushing:

Using Tool J-24036 with Slide Hammer, J-7004-1, removing bushing (Figure 7A1-196).

Using Tool J-25019-2 with Driver Handle J-8092, drive or press new bushing, Part No. 8628915, into place until tool bottoms (Figure 7A1-197).

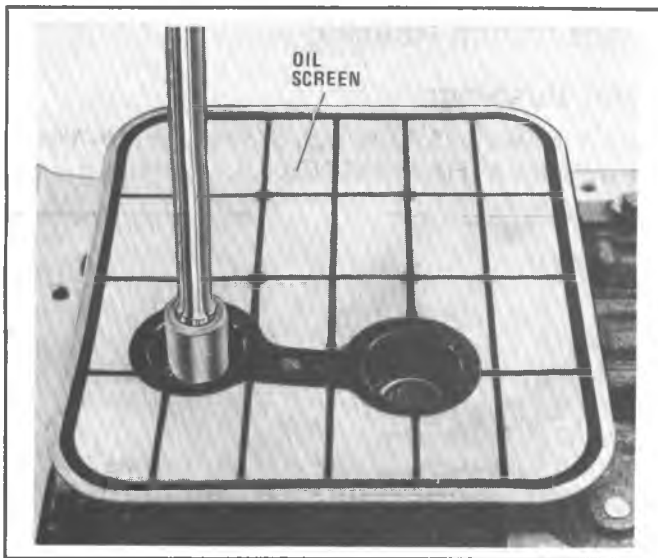

Figure 7A1-194 Installing Oil Screen

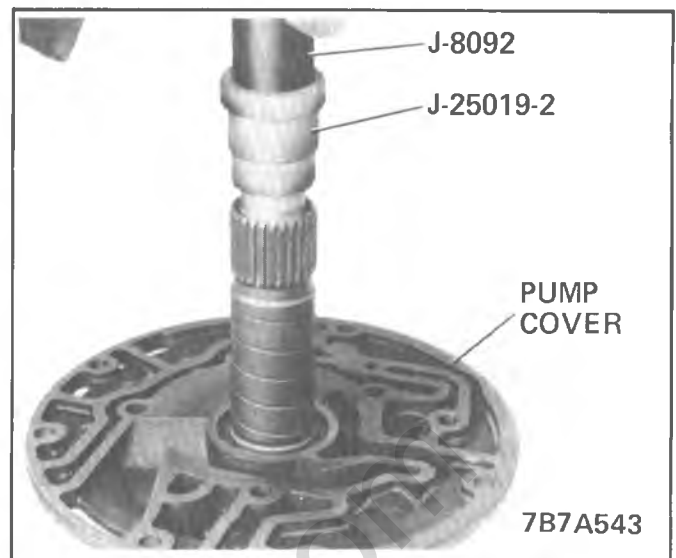

Figure 7A1-197 Installing Pump Cover Bushing - Front

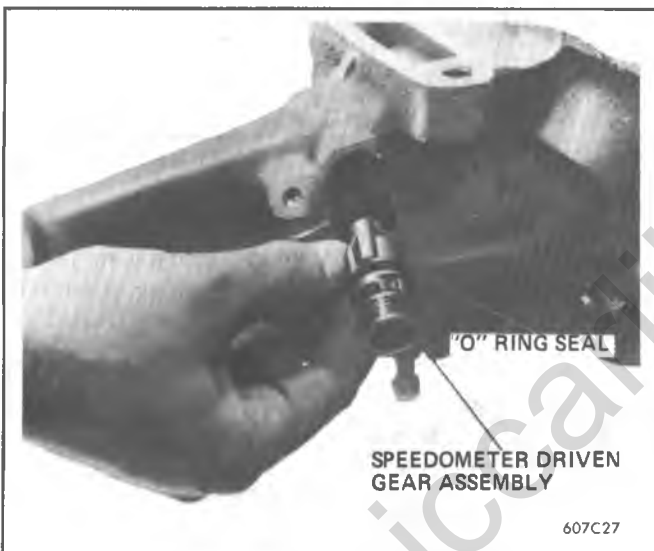

Figure 7A1-195 Removing and Installing Speedometer Driven Gear - Typical

### Rear Bushing

Using Tool J-25019-14 with Slide Hammer J-7004-1, remove bushing (Figure 7A1-198).

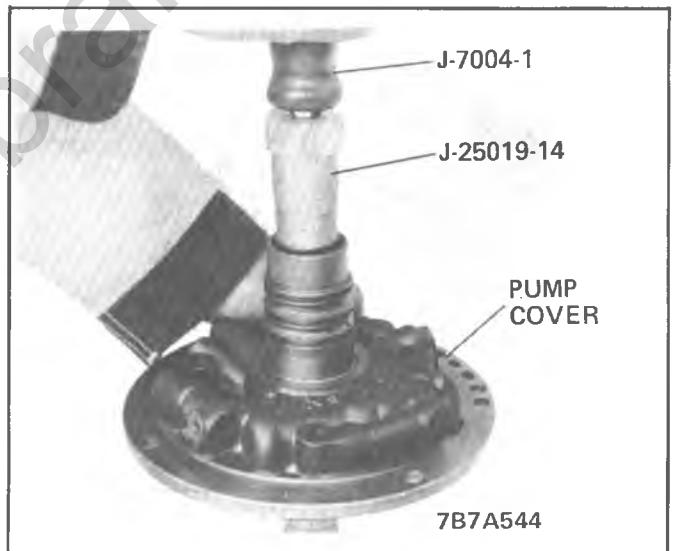

Figure 7A1-198 Removing Pump Cover Bushing - Rear

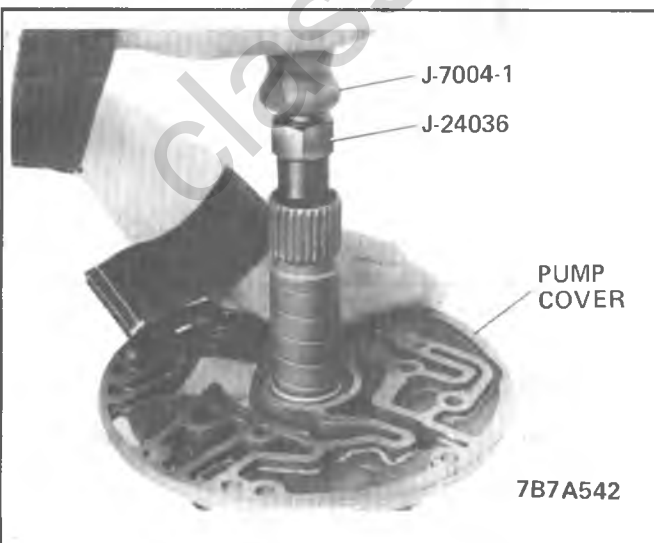

Figure 7A1-196 Removing Pump Cover Bushing - Front

Using Tool J-25019-6 with Driver Handle J-8092, drive or press new bushing, Part No. 8628916, until tool bottoms (Figure 7A1-199).

### Pump Body Bushing

Place pump body with the machined face down, on two blocks of wood, to prevent damaging the machined surface (Figure 7A1-200).

Using Tool J-25019-4 with Drive Handle J-8092, remove bushing (Figure 7A1-200).

Using Tool J-25019-12 with Driver Handle J-8092, drive or press new bushing, Part No. 8628913, into place until tool bottoms (Figure 7A1-201).

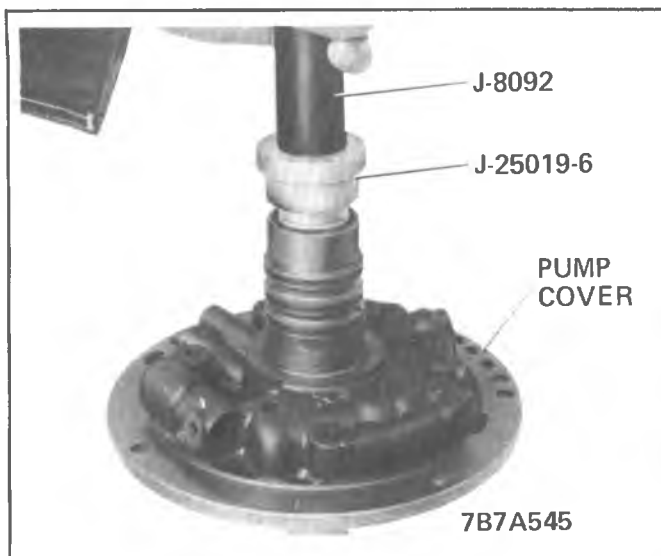

Figure 7A1-199 Installing Pump Cover Bushing - Rear

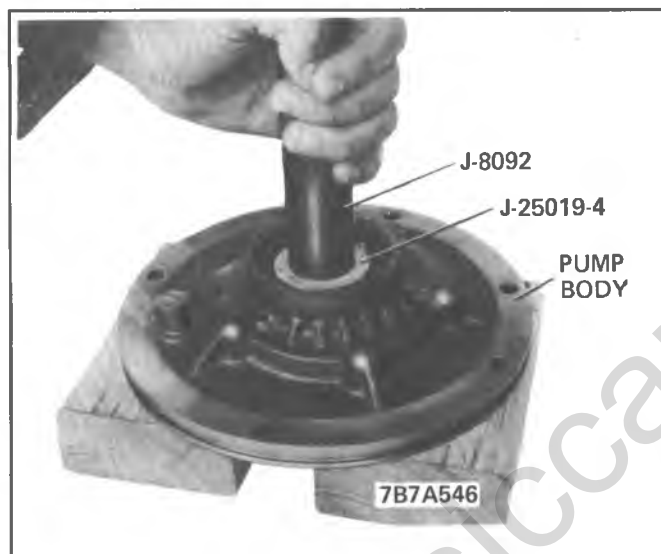

Figure 7A1-200 Removing Pump Bushing

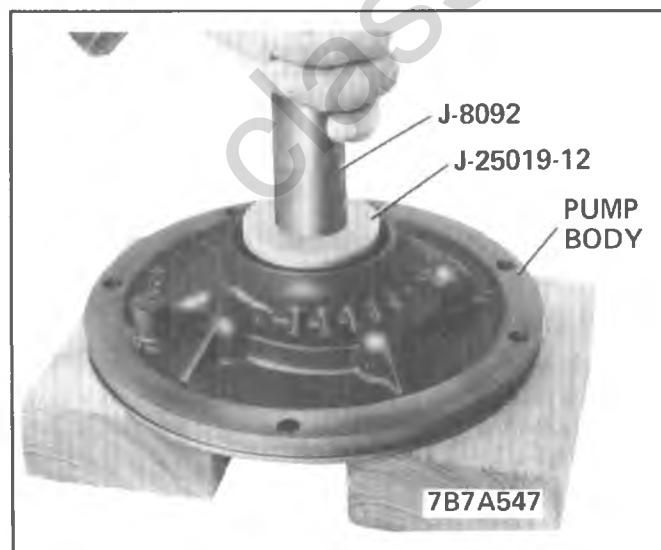

Figure 7A1-201 Installing Pump Body Bushing

## Direct Clutch Housing

### Front Bushing:

Using Tool J-25019-16 with Slide Hammer J-7004-1, remove bushing (Figure 7A1-202).

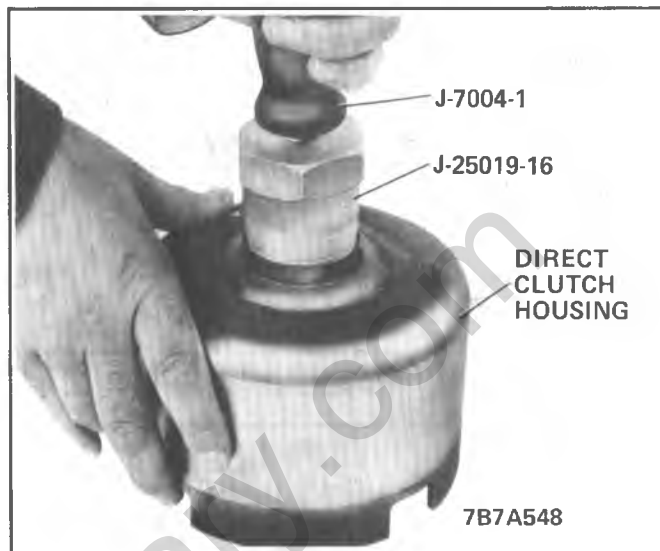

Figure 7A1-202 Removing Direct Clutch Housing Bushing - Front

Place bushing, chamfered inside diameter end first, over Tool J-25019-9. Using Tool J-25019-9 with Driver Handle J-8092, drive or press new bushing, Part No. 8628918, into place until tool bottoms (Figure 7A1-203).

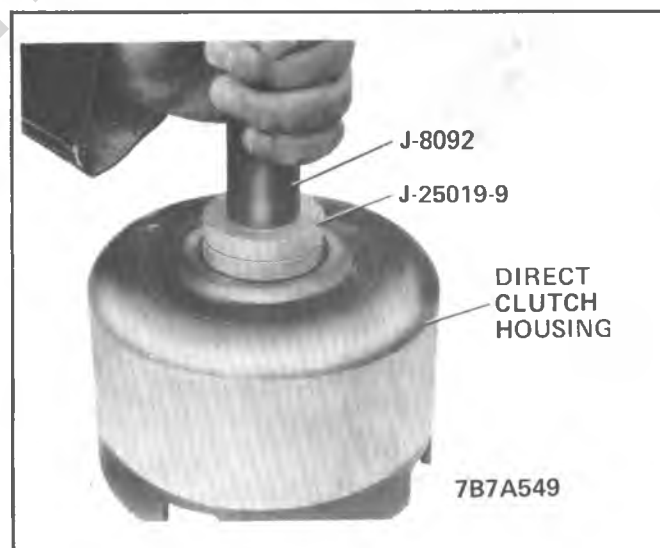

Figure 7A1-203 Installing Direct Clutch Housing Bushing - Front

### Rear Bushing:

Place direct clutch housing with the thrust washer face down on a block of wood to prevent damaging the thrust washer surface (Figure 7A1-204).

Using Tool J-25019-4 with Driver Handle J-8092, remove bushing (Figure 7A1-204).

Using Tool J-25019-6 with Driver Handle J-8092, drive or press new bushing, Part No. 8628917, into place until tool bottoms (Figure 7A1-205).



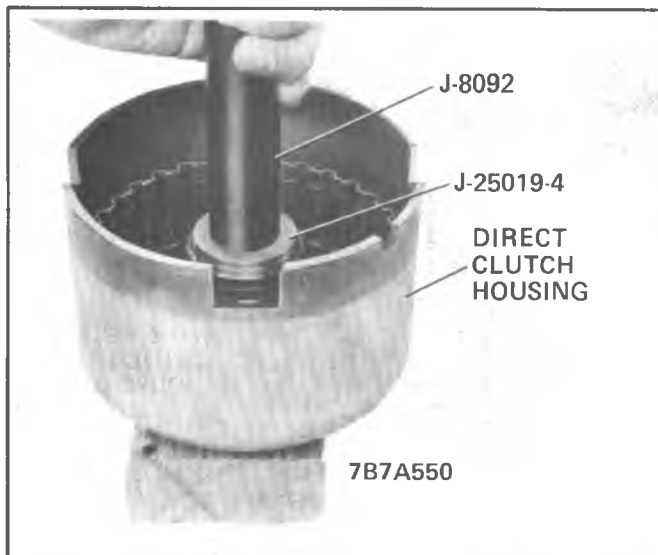

Figure 7A1-204 Removing Direct Clutch Housing Bushing - Rear

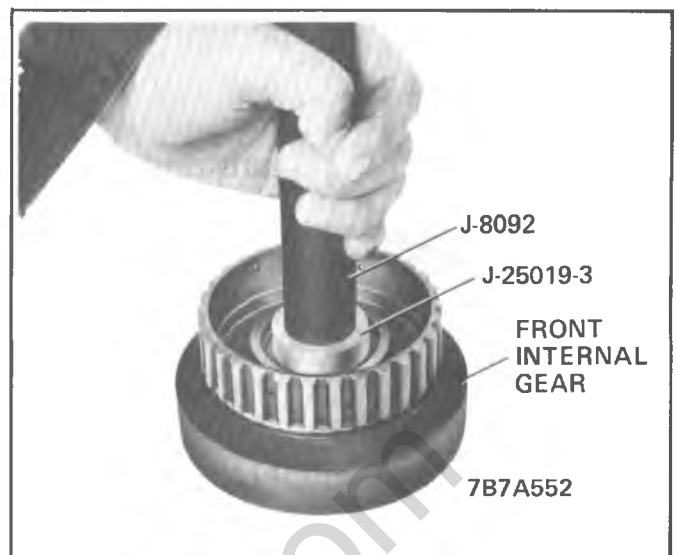

Figure 7A1-206 Removing Front Internal Gear Bushing

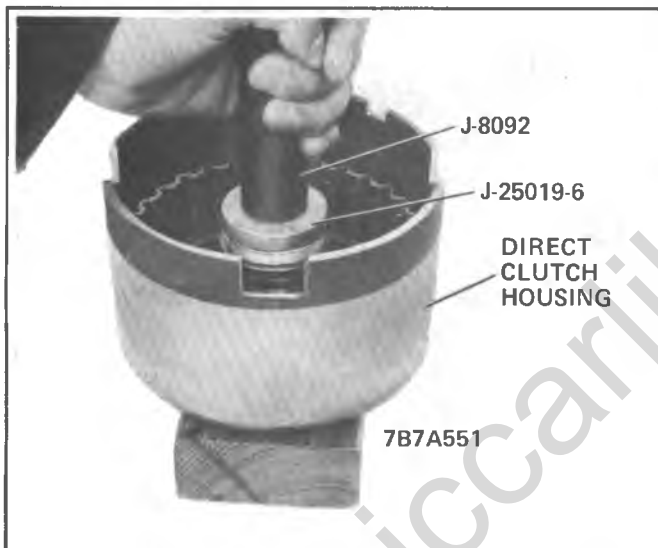

Figure 7A1-205 Installing Direct Clutch Housing Bushing - Rear

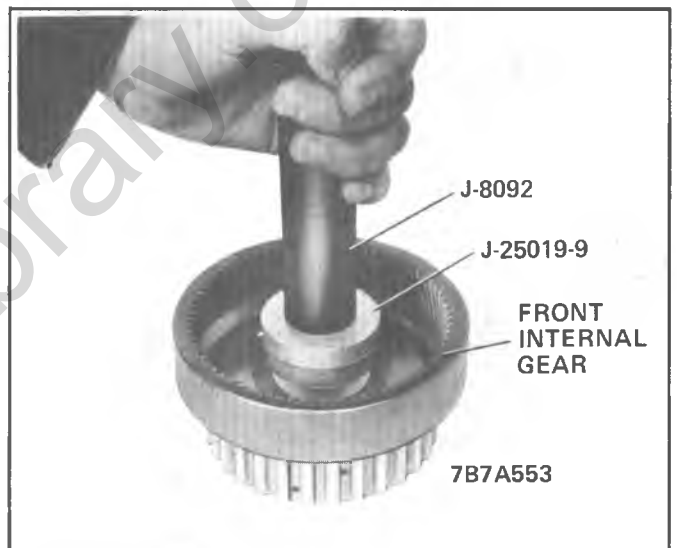

Figure 7A1-207 Installing Front Internal Gear Bushing

### Front Internal Gear Bushing

Using Tool J-25019-3 with Driver Handle J-8092, remove bushing (Figure 7A1-206).

Using Tool J-25019-9 with Driver Handle J-8092, drive or press new bushing, Part No. 8628925, into place until tool bottoms (Figure 7A1-207).

### Rear Sun Gear

Using Tool J-25019-14 with Slide Hammer J-7004-1, remove bushing. (Figure 7A1-208).

Place rear sun gear with gear side down on block of wood to prevent damaging the gear (Figure 7A1-209).

Using Tool J-25019-2 with Driver Handle J-8092, drive or press new bushing, Part No. 8628928, into place until tool bottoms. (Figure 7A1-209).

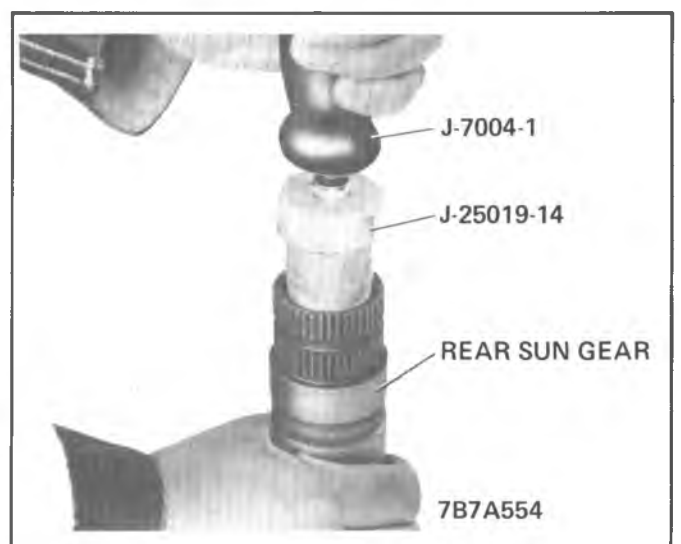

Figure 7A1-208 Removing Rear Sun Gear Bushing

### Lo and Reverse Clutch Housing Bushing

Using Tool J-25019-16 with Slide Hammer J-7004-1, remove bushing (Figure 7A1-210).

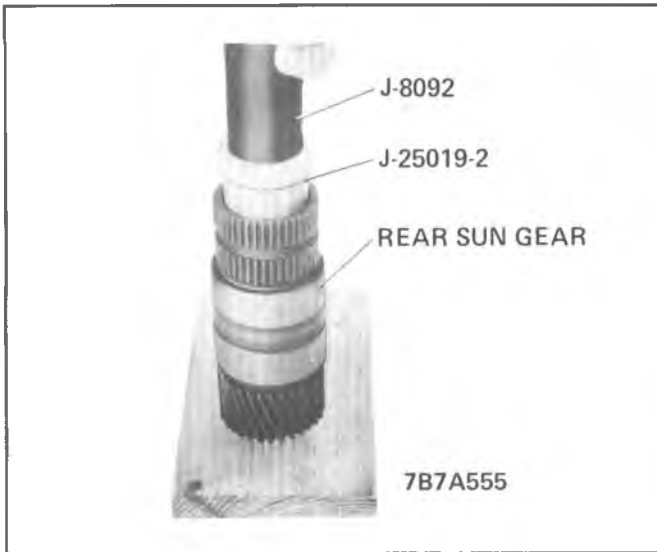

Figure 7A1-209 Installing Rear Sun Gear Bushing

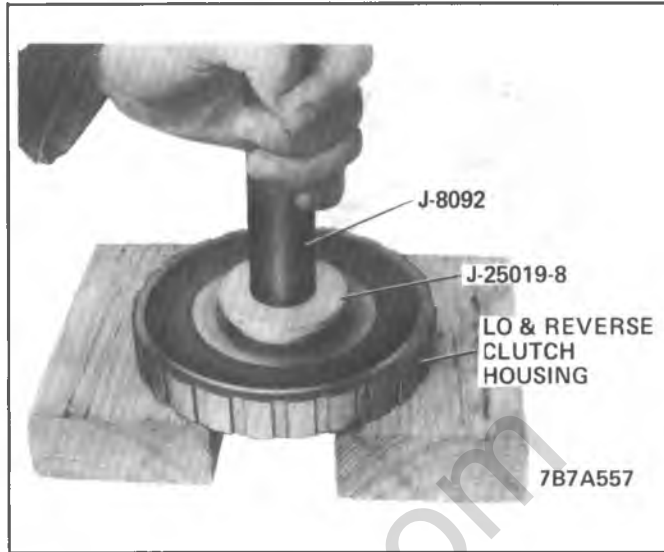

Figure 7A1-211 Installing Lo and Reverse Clutch Housing Bushing



Figure 7A1-210 Removing Lo and Reverse Clutch Housing Bushing



Figure 7A1-212 Removing Rear Carrier Bushing

Place lo and reverse clutch housing with splined hub between two blocks of wood to prevent damaging the splines (Figure 7A1-211).

Using Tool J-25019-8 with Driver Handle J-8092, drive or press new bushing, Part No. 8628929, into place until tool bottoms (Figure 7A1-211).

### Rear Carrier Bushing

Using Tool J-25019-16 with Slide Hammer J-7004-1, remove bushing (Figure 7A1-212).

Using Tool J-25019-7 with Driver Handle J-8092, drive or press new bushing, Part No. 8628947, into place until tool bottoms. (Figure 7A1-213).

### Case Bushing

Using Tool J-21424-9 with Driver Handle J-8092, remove bushing (Figure 7A1-214).

Using Tool J-21424-9 with Driver Handle J-8092, drive or press new bushing, Part No. 6261109, to a distance of

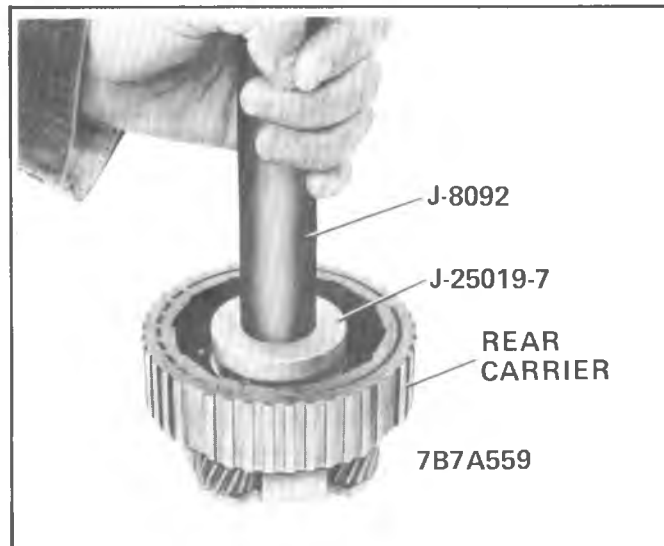

Figure 7A1-213 Installing Rear Carrier Bushing

approximately 17.3mm (or 11/16") between rear end of the bushing and rear end of the case (Figure 7A1-214).

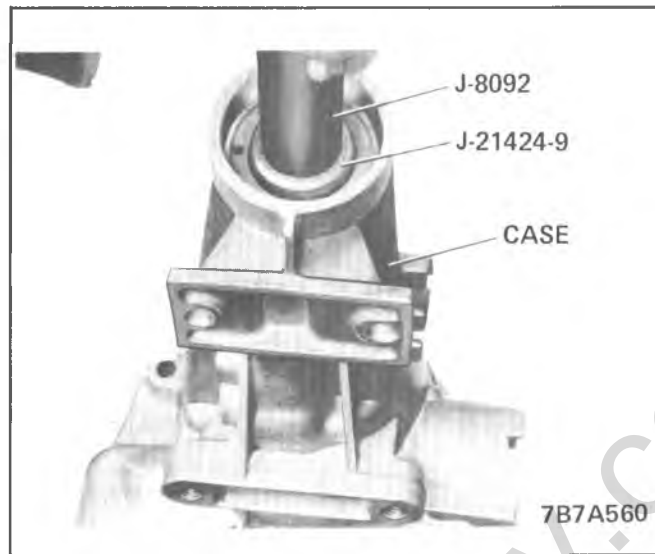

Figure 7A1-214 Removing or Installing Case Bushing

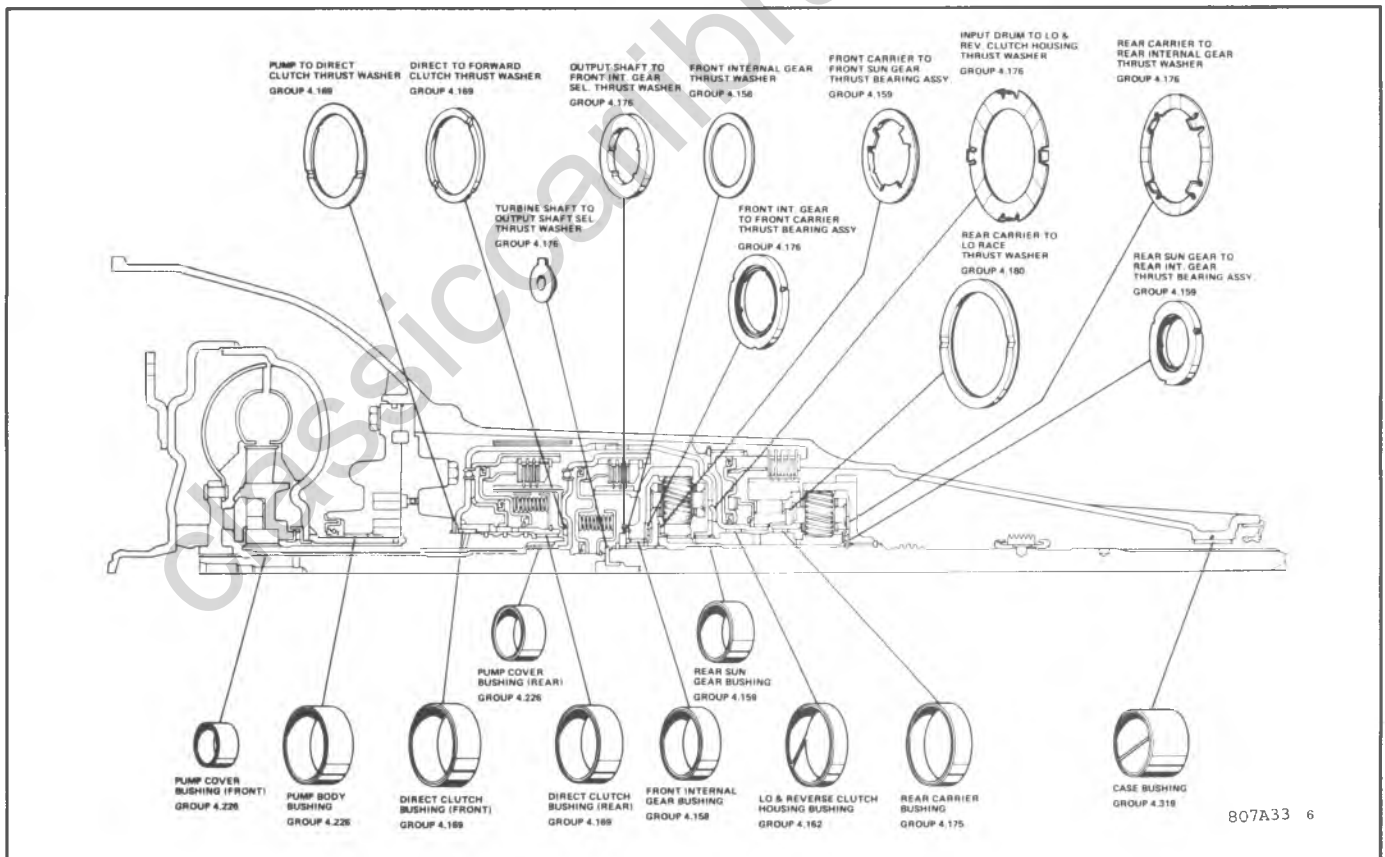

Figure 7A1-215 Thrust Washer and Bushing Locations

## TORQUE SPECIFICATIONS

DESCRIPTION OF USAGE	QUANTITY	SIZE	TORQUE ASSEMBLY
Pump Body To Pump Cover	5	M8 x 1.25 x 45	20.0 - 27.0 Nm (15-20 ft.-lbs.)
Pump Assembly To Case	6	M8 x 1.25 x 35	20.0 - 27.0 Nm (15-20 ft.-lbs.)
Parking Lock Bracket To Case	2	M8 x 1.25 x 20	20.0 - 27.0 Nm (15-20 ft.-lbs.)
Transmission Oil Pan To Case	11	M8 x 1.25 x 16	14.0 - 18.0 Nm (10-13 ft.-lbs.)
Manual Shaft to Inside Detent Lever	1	M10 x 1.5	27.0 - 34.0 Nm (20-25 ft.-lbs.)
Cooler Connector-Brass	2	1/4 - 18 NPSF	35.0 - 40.0 Nm (26-30 ft.-lbs.)
Line Pressure - Take-Off	1	1/8 - 27 NPTF	7.0 - 14.0 Nm (5-10 ft.-lbs.)
Throttle Lever, Link and Bracket To Case	1	M6.3 x 1.0 x 45	13.0 - 17.0 Nm (9-12 ft.-lbs.)
Control Valve Assembly To Case	7	M6.3 x 1.0 x 45	13.0 - 17.0 Nm (9-12 ft.-lbs.)
Oil Screen To Case	2	M6.3 x 1.0 x 55	13.0 - 17.0 Nm (9-12 ft.-lbs.)
Speedometer Driven Gear Retainer To Case	1	M6.3 x 1.0	8.0 - 14.0 Nm (6-10 ft.-lbs.)
Governor Pressure Switch	1	1/8 - 27 NPTF	7.0 - 14.0 Nm (5-10 ft.-lbs.)
Solenoid Assembly To Pump	2	M5 x .8 x 12.0	3.0 - 5.0 Nm (2-4 ft.-lbs.)

Figure 7A1-216 Torque Specifications Chart



- |              |  |               |                                   |
|--------------|--|---------------|-----------------------------------|
| 1. J25015    | Oil Pump Body and Cover Alignment Band                 | 14. J25022    | End-Play Checking Fixture Adapter |
| 2. J25016    | Front Oil Pump Seal Installer                          | 15. J-23327   | Clutch Spring Compressor          |
| 3. J25020-01 | Converter Stator and Turbine End-Play Checking Fixture | 16. J22269-01 | Direct Clutch Spring Compressor   |
| 4. J25023    | Reverse Clutch Selective Shim Group                    | 17. J21426    | Rear Oil Seal Installer           |
| 5. J25012    | Reverse Clutch Housing Installer and Remover           | 18. J25024    | Forward Clutch Spring Compressor  |
| 6. J25018    | Forward Clutch Spring Compressor                       | 19. J21427-01 | Speedo Gear Puller                |
| 7. J25019    | Bushing Service Set                                    | 20. J24773    | Gaging Fixture                    |
| 8. J25014    | Intermediate Band Apply Pin Gauge                      | 21. J8092     | Driver Handle                     |
| 9. J25021    | Turbine Shaft and Direct Clutch Installer              | 22. J7004     | Slide Hammer                      |
| 10. J25025   | Alignment Pin and Stud Set                             | 23. J8001     | Dial Indicator Set                |
| 11. J25013   | Output Shaft and Rear Unit Support Fixture             | 24. J8433     | Puller                            |
| 12. J25010   | Direct Clutch Seal Protector                           | 25. J8763-02  | Holding Fixture and Base          |
| 13. J25011   | Reverse Clutch Seal Protector                          | J3289-20      |                                   |

B3974 907A12

907A12

Figure 7A1-217 Special Tools

classicalibrary.com

# SECTION 7A3

## AUTOMATIC 350C AND 350 TRANSMISSION

### CONTENTS

#### GENERAL DESCRIPTION

Trouble Diagnosis ..... 7A3-2

#### UNIT REPAIR

Transmission Disassembly ..... 7A3-9

Removal of Extension, Speedometer

Driven Gear Oil Pan and Screen..... 7A3-13

Removal of Valve Body and Linkage ..... 7A3-13

Removal of Oil Pump and Internal

Case Components ..... 7A3-17

Valve Body

Disassembly..... 7A3-33

Inspection..... 7A3-35

Reassembly..... 7A3-35

Auxiliary Valve Body T.C.C. Models

250-C Section

Disassembly..... 7A5-14

Inspection..... 7A5-14

Reassembly..... 7A5-15

Oil Pump

Disassembly..... 7A3-21

Inspection..... 7A3-22

Reassembly..... 7A3-23

Direct Clutch

Disassembly..... 7A3-24

Inspection..... 7A3-25

Reassembly..... 7A3-28

Forward Clutch

Disassembly..... 7A3-28

Inspection..... 7A3-31

Reassembly..... 7A3-32

Sun Gear and Sun Gear Drive Shell

Disassembly..... 7A3-32

Inspection..... 7A3-32

Reassembly..... 7A3-33

Low and Reverse Clutch

Disassembly..... 7A3-33

Inspection..... 7A3-33

Reassembly..... 7A3-33

Servo Assembly

Disassembly..... 7A3-14

Inspection..... 7A3-14

Reassembly..... 7A3-17

Governor Assembly (250-C Section)

Disassembly..... 7A5-23

Inspection..... 7A5-23

Governor, Driven Gear Replacement ..... 7A5-23

Reassembly..... 7A5-24

Transmission Reassembly ..... 7A3-36

#### GENERAL DESCRIPTION

The 350 automatic transmission, is a fully automatic unit consisting primarily of 3-element hydraulic torque converter and two planetary gear sets. Four multiple-disc clutches, two roller clutches, and an intermediate overrun band provide the friction elements required to obtain the desired function of the two planetary gear sets.

A hydraulic system pressurized by a gear type pump provides the working pressure required to operate the friction elements and automatic controls.

External control connections to the transmission are:

1. Manual Linkage - To select the desired operating range.

2. Engine Vacuum - To operate the vacuum modulator.

3. Cable Control - To operate the detent valve.

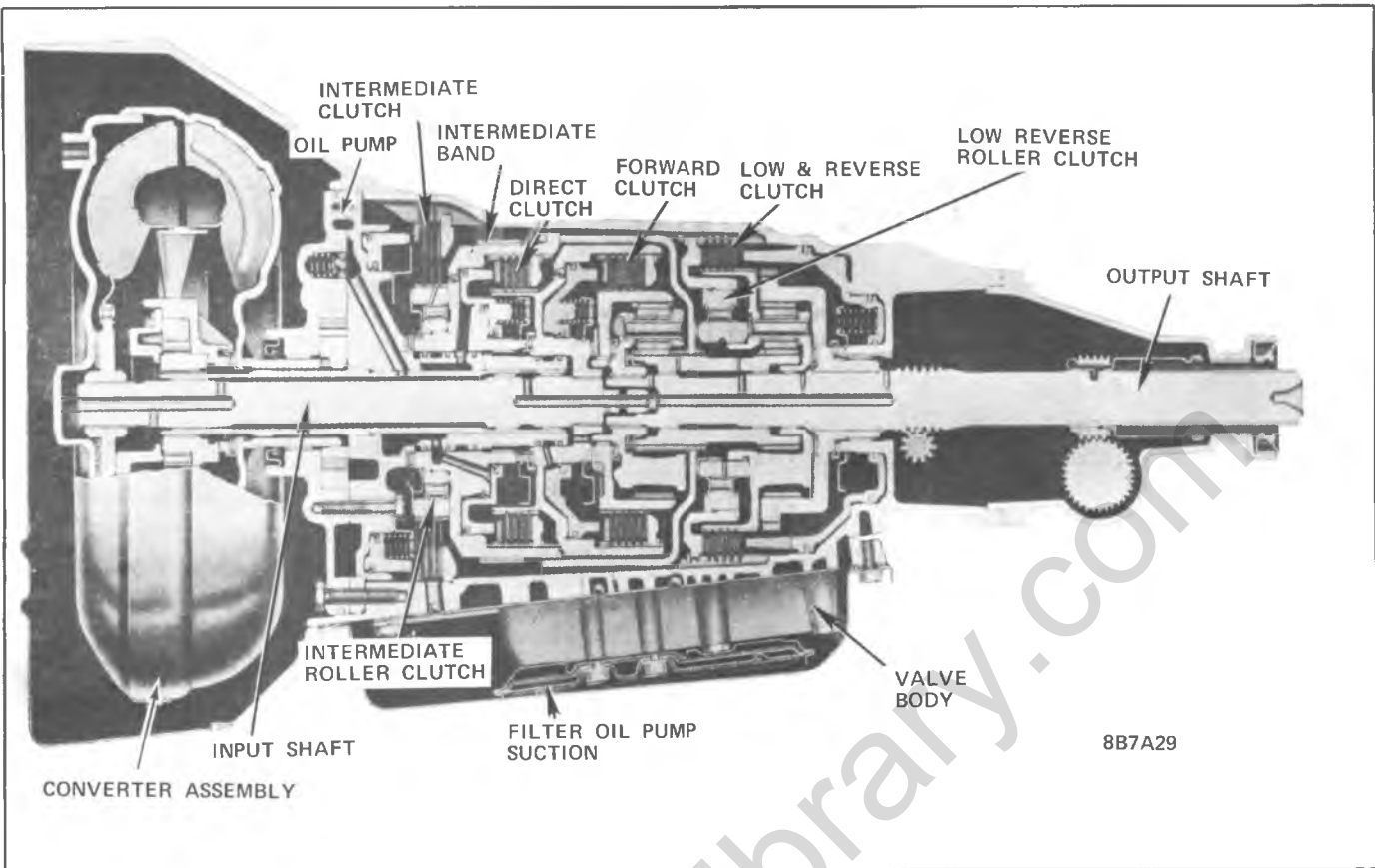

Figure 7A3-1 350 Automatic Transmission

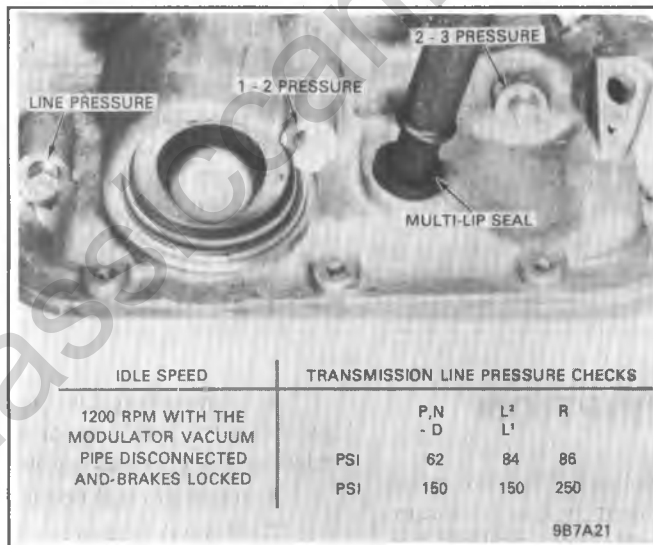

Figure 7A3-2 Line Pressure Chart

## 350 TROUBLE DIAGNOSIS CHART

Condition	Possible Cause	Correction
No drive in drive range - (install pressure gage).	1. Low oil level.	1. Correct level - check for external leaks or vacuum modulator (leaking diaphragm will evacuate oil from unit).



	<ul style="list-style-type: none"> <li>2. Manual Linkage adjustment.</li> <li>3. Low oil pressure.</li> <li>4. Control valve assembly.</li> <li>5. Forward clutch.</li> <li>6. Roller clutch assembly.</li> </ul>	<ul style="list-style-type: none"> <li>2. See Manual linkage. Adjustment in the 400 section.</li> <li>3a. Filter assembly - blocked.</li> <li>b. Pump assembly - pressure regulator, pump drive gear - tangs damaged by converter.</li> <li>c. Case - porosity in intake bore.</li> <li>4. Manual valve disconnected from inner lever.</li> <li>5a. Forward clutch does not apply - piston cracked; seals missing, damaged; clutch plates burned.</li> <li>b. Pump feed circuit to forward clutch oil seal rings missing or broken on pump cover; leak in feed circuits; pump to case gasket mispositioned or damaged. Clutch drum ball check stuck or missing.</li> <li>6. Broken spring or damaged cage.</li> </ul>
Oil pressure high low	<ul style="list-style-type: none"> <li>1. High oil pressure.</li> <li>2. Low oil pressure.</li> </ul>	<ul style="list-style-type: none"> <li>1a. Vacuum line or fittings leaking.</li> <li>b. Vacuum modulator.</li> <li>c. Modulator valve.</li> <li>d. Pressure regulator.</li> <li>e. Oil pump.</li> <li>2a. Vacuum line or fittings obstructed.</li> <li>b. Vacuum modulator.</li> <li>c. Modulator valve.</li> <li>d. Pressure regulator.</li> <li>e. Governor.</li> <li>f. Oil pump.</li> </ul>
1-2 shift - full throttle only.	<ul style="list-style-type: none"> <li>1. Detent valve</li> <li>2. Vacuum leak.</li> <li>3. Control valve assembly.</li> <li>4. Case assembly.</li> </ul>	<ul style="list-style-type: none"> <li>1. Sticking or linkage misadjusted.</li> <li>2. Vacuum line or fittings leaking.</li> <li>3a. Valve body gaskets - leaking, damaged, incorrectly installed.</li> <li>b. Detent valve train stuck.</li> <li>c. 1-2 valve stuck.</li> <li>4. Porosity.</li> </ul>
First speed only - no 1-2 shift.	<ul style="list-style-type: none"> <li>1. Governor assembly.</li> </ul>	<ul style="list-style-type: none"> <li>1a. Governor valve sticking.</li> <li>b. Driven gear loose, damaged or worn (check for pin in case and length of pin showing); also,</li> </ul>

	<ul style="list-style-type: none"> <li>2. Control valve assembly.</li> <li>3. Case</li> <li>4. Intermediate clutch.</li> </ul>	<p>check output shaft drive gear for nicks or rough finish, if driven gear shows damage..</p> <ul style="list-style-type: none"> <li>2a. 1-2 shift valve train stuck closed.</li> <li>b. Governor feed channels blocked.</li> <li>c. Valve body gaskets - leaking, damaged, incorrectly installed.</li> <li>3a. Porosity between channels.</li> <li>b. Governor feed channel blocked, governor bore scored or worn, allowing cross pressure leak.</li> <li>4a. Clutch piston seals - missing, improperly assembled, cut.</li> <li>b. Intermediate roller clutch.</li> </ul> <p>Broken spring or damaged cage.</p>
First and second speeds only, no 2-3 shift.	<ul style="list-style-type: none"> <li>1. Control valve assembly.</li> <li>2. Direct clutch.</li> </ul>	<ul style="list-style-type: none"> <li>1a. 2-3 shift train stuck.</li> <li>b. Valve body gaskets - leaking, damaged, incorrectly installed.</li> <li>2a. Pump hub - direct clutch oil seal rings - broken, missing.</li> <li>b. Clutch piston seals - missing, improperly assembled, cut, piston ball check stuck or missing.</li> </ul>
Drive in "Neutral".	<ul style="list-style-type: none"> <li>1. Manual linkage.</li> <li>2. Forward clutch.</li> </ul>	<ul style="list-style-type: none"> <li>1. Misadjusted</li> <li>2. Clutch does not release - (this condition will also cause "No Reverse").</li> </ul>
No motion in "Reverse", or slips in "Reverse" - (install pressure gage).	<ul style="list-style-type: none"> <li>1. Low oil level.</li> <li>2. Manual linkage.</li> <li>3. Oil pressure.</li> </ul>	<ul style="list-style-type: none"> <li>1. Add oil.</li> <li>2. Misadjusted. Refer to Adjustment area in the 400 section.</li> <li>3a. Modulator valve stuck.</li> <li>b. Modulator and reverse boost valve stuck.</li> <li>c. Pump hub - direct clutch oil seal rings broken, missing.</li> <li>d. Direct clutch piston seal cut or missing.</li> <li>e. Low and reverse clutch</li> </ul>

- |                                   |  |
|-----------------------------------|--|
| <p>4. Control valve assembly.</p> | <p>piston seal cut or missing.<br/>f. No. 1 check ball missing.</p> <p>4a. Valve body gaskets - leaking, damaged, incorrectly installed (other malfunctions may also be indicated).<br/>b. 2-3 valve train stuck in upshifted position. This will also cause 1-3 upshift in drive range.<br/>c. 1-2 valve train stuck in upshifted position.</p> |
| <p>5. Intermediate servo.</p>     | <p>5a. Piston or pin stuck so intermediate overrun band is applied.</p>  |
| <p>6. Low and reverse clutch.</p> | <p>6. Piston out or seal damaged or missing.</p>   |
| <p>7. Direct clutch.</p>          | <p>7a. Outer seal damaged or missing.<br/>b. Clutch plates burned - may be caused by stuck ball check in piston.</p>   |
| <p>8. Forward clutch.</p>         | <p>8. Clutch does not release (will also cause "Drive" in "Neutral").</p>  |

Slips in all ranges, slips on take-off - (install pressure gage).

- |                                    |   |
|------------------------------------|---|
| <p>1. Oil level low.</p>           | <p>1. Add oil.</p>  |
| <p>2. Oil pressure.</p>            | <p>2a. Vacuum modulator inoperative.<br/>b. Vacuum modulator valve sticking.<br/>c. Filter assembly - plugged or leaks.</p> |
| <p>3. Case</p>                     | <p>3a. Pressure regulator valve stuck.<br/>b. Pump to case gasket damaged or incorrectly installed.</p>                     |
| <p>4. Forward clutch slipping.</p> | <p>4. Cross leaks, porosity.</p>  |

Slips 1-2 shift - (install pressure gage).

- |                                |  |
|--------------------------------|--|
| <p>1. Oil level low.</p>       | <p>1. Add oil.</p>   |
| <p>2. Oil pressure.</p>        | <p>2a. Vacuum modulator assembly inoperative.<br/>b. Modulator valve sticking.<br/>c. Pump pressure regulator valve.</p> |
| <p>3. 2-3 accumulator.</p>     | <p>3. Oil ring damaged or missing.</p>   |
| <p>4. 1-2 accumulator.</p>     | <p>4. Oil ring missing or damaged, case bore damaged.</p>  |
| <p>5. Pump to case gasket.</p> | <p>5. Mispositioned</p>  |

## 7A3-6 350 AUTOMATIC TRANSMISSION

	<ul style="list-style-type: none"> <li>6. Case</li> <li>7. Intermediate clutch.</li> </ul>	<ul style="list-style-type: none"> <li>6. Porosity between channels.</li> <li>7. Piston seals missing or damaged; clutch plates burned.</li> </ul>
Rough 1-2 shift - (install pressure gage).	<ul style="list-style-type: none"> <li>1. Oil pressure.</li> <li>2. Case</li> <li>3. 1-2 accumulator assembly.</li> </ul>	<ul style="list-style-type: none"> <li>1a. Vacuum modulator - check for loose fittings, restrictions in line.</li> <li>b. Modulator valve stuck.</li> <li>c. Valve body - regulator or boost valve stuck.</li> <li>d. Pump to case gasket - off location or damaged.</li> <li>2. Porosity between channels.</li> <li>3a. Oil rings damaged.</li> <li>b. Piston stuck.</li> <li>c. Broken or missing spring.</li> <li>d. Bore damaged.</li> <li>e. Check accumulator feed hole in valve body plate.</li> </ul>
Slips 2-3 shift - (install pressure gage).	<ul style="list-style-type: none"> <li>1. Oil level low.</li> <li>2. Oil pressure low.</li> <li>3. Case</li> <li>4. Direct clutch.</li> </ul>	<ul style="list-style-type: none"> <li>1. Add oil.</li> <li>2a. Modulator assembly.</li> <li>b. Modulator valve.</li> <li>c. Pump pressure regulator valve or boost valve; pump to case gasket off location.</li> <li>3. Porosity</li> <li>4. Piston seals leaking, or ball check leak.</li> </ul>
Rough 2-3 shift - (install pressure gage).	<ul style="list-style-type: none"> <li>1. Oil pressure high</li> <li>2. 2-3 accumulator assembly.</li> </ul>	<ul style="list-style-type: none"> <li>1a. Vacuum leak.</li> <li>b. Modulator valve sticking.</li> <li>c. Valve body - pressure regulator or boost valve inoperative.</li> <li>2a. 2-3 accumulator spring missing, broken.</li> <li>b. Accumulator piston stuck.</li> </ul>
No engine braking - L2 - 2nd gear.	<ul style="list-style-type: none"> <li>1. Intermediate servo and 2-3 accumulator.</li> <li>2. Intermediate overrun band.</li> <li>3. Oil pressure low.</li> </ul>	<ul style="list-style-type: none"> <li>1a. Servo or accumulator oil rings or bores leaking.</li> <li>b. Servo piston stuck.</li> <li>2. Intermediate overrun band broken, burned (check for cause).</li> <li>3. Pressure regulator and/or boost valve stuck.</li> </ul>
No engine braking - L-1 - 1st gear.	<ul style="list-style-type: none"> <li>1. Manual low control valve assembly.</li> <li>2. Oil pressure low.</li> <li>3. Low and reverse clutch.</li> </ul>	<ul style="list-style-type: none"> <li>1. Stuck</li> <li>2. Pressure regulator and/or boost valve stuck.</li> <li>3. Piston inner seal damaged or missing.</li> </ul>

No part throttle downshift - (install pressure gage).	<ol style="list-style-type: none"> <li>1. Oil pressure.</li> <li>2. Detent valve and linkage.</li> <li>3. 2-3 shift valve.</li> </ol>	<ol style="list-style-type: none"> <li>1. Vacuum modulator assembly, modulator valve, pressure regulator valve train (other malfunctions may also be noticed).</li> <li>2. Sticks or disconnected or broken.</li> <li>3. Stuck</li> </ol>
No detent downshifts.	<ol style="list-style-type: none"> <li>1. Control valve assembly.</li> <li>2. Detent valve and linkage.</li> </ol>	<ol style="list-style-type: none"> <li>1. 2-3 valve stuck.</li> <li>2. Sticks or disconnected or broken.</li> </ol>
Low or high shift points - (install pressure gage).	<ol style="list-style-type: none"> <li>1. Oil pressure.</li> <li>2. Governor</li> <li>3. Detent valve and linkage.</li> <li>4. Control valve assembly.</li> <li>5. Case</li> </ol>	<ol style="list-style-type: none"> <li>1a. Engine vacuum - check at transmission end of the modulator pipe.</li> <li>b. Vacuum modulator assembly vacuum line connections at engine and transmission, modulator valve, pressure regulator valve train.               <ol style="list-style-type: none"> <li>2a. Valve sticking.</li> <li>b. Feed holes restricted or leaking, pipes damaged or mispositioned.</li> <li>c. Feed line plugged.</li> </ol> </li> <li>3. Stuck open. (Will cause late shifts).</li> <li>4a. 2-3 valve train sticking.</li> <li>b. 1-2 shift valve train sticking.</li> <li>5. Porosity</li> </ol>
Won't hold in "Park".	<ol style="list-style-type: none"> <li>1. Manual linkage.</li> <li>2. Internal linkage.</li> </ol>	<ol style="list-style-type: none"> <li>1. Misadjusted               <ol style="list-style-type: none"> <li>2a. Parking brake lever and actuator assembly. Check for chamfer on actuator rod sleeve.</li> <li>b. Parking pawl broken or inoperative.</li> </ol> </li> </ol>
Locks up in manual low (usually hot only).	<ol style="list-style-type: none"> <li>1. Converter pressure leaking into direct clutch thru stator shaft.</li> <li>2. Direct clutch.</li> <li>3. Lo and Reverse Clutch.</li> </ol>	<ol style="list-style-type: none"> <li>1. Check stator shaft index.</li> <li>2a. Direct clutch bore undersize or piston oversize.</li> <li>b. Direct clutch feed hole shy small chamber.</li> <li>3. Lo and Reverse Clutch piston center seal missing or cut.</li> </ol>
Second gear start or slips second gear only.	<ol style="list-style-type: none"> <li>1. Intermediate clutch.</li> </ol>	<ol style="list-style-type: none"> <li>1. Wrong number of clutch plates or wrong piston.</li> </ol>

## 7A3-8 350 AUTOMATIC TRANSMISSION

---

Locks up in reverse (usually hot only).	<ol style="list-style-type: none"><li>1. Forward clutch.</li><li>2. Direct clutch.</li></ol>	<ol style="list-style-type: none"><li>1. Bore undersize or piston oversize.</li><li>2. Direct clutch feeding forward clutch thru stator shaft. (check stator shaft index).</li></ol>
Locks in reverse from park to reverse only.	<ol style="list-style-type: none"><li>1. Parking pawl.</li></ol>	<ol style="list-style-type: none"><li>1. Parking pawl staying in due to a burr on leading edge.</li></ol>
Cold morning reverse no drive till engine warms up.	<ol style="list-style-type: none"><li>1. Pressure regulator bore or sleeve tight.</li></ol>	<ol style="list-style-type: none"><li>1. Remove and repair.</li></ol>
Shifts cold but not warm.	<ol style="list-style-type: none"><li>1. Governor assembly.</li></ol>	<ol style="list-style-type: none"><li>1. Nylon gear roll pin shy.</li></ol>
No drive-but has manual low.	<ol style="list-style-type: none"><li>1. Low &amp; reverse roller clutch.</li></ol>	<ol style="list-style-type: none"><li>1. Low &amp; reverse roller clutch installed backwards.</li></ol>
No 1-2 shift-makes 1-3 shift and 3-1 shift, but has all shifts manually.	<ol style="list-style-type: none"><li>1. Intermediate roller clutch.</li></ol>	<ol style="list-style-type: none"><li>1. Intermediate roller clutch not locking.</li></ol>
Governor nylon gear stripped 360°.	<ol style="list-style-type: none"><li>1. Case pin.</li><li>2. Output shaft.</li></ol>	<ol style="list-style-type: none"><li>1. Governor case pin missing.</li><li>2. Output shaft rough or worn.</li></ol>
Governor gear stripped one sided.	<ol style="list-style-type: none"><li>1. Governor sizing in bore.</li></ol>	<ol style="list-style-type: none"><li>1. Repair or replace as necessary.</li></ol>
Slow reverse (cold only).	<ol style="list-style-type: none"><li>1. Low oil level.</li></ol>	<ol style="list-style-type: none"><li>1. Adjust oil level.</li></ol>
Harsh 1-2 shift.	<ol style="list-style-type: none"><li>1. 1-2 accumulator.</li></ol>	<ol style="list-style-type: none"><li>1a. Piston or spring.</li><li>b. Accumulator feed hole in valve body plate.</li></ol>
Slow reverse (hot only).	<ol style="list-style-type: none"><li>1. Valve body.</li><li>2. Shift selector lever.</li></ol>	<ol style="list-style-type: none"><li>1a. Leaking valve body support plate.</li><li>2a. Bent or S-hook hole off location.</li><li>b. S-hook bent.</li><li>c. Detent roller spring hole off location.</li><li>d. Manual valve S-hook hole off location.</li></ol>

---

---

## REMOVAL OF CONVERTER HOLDING TOOL J-21366, CONVERTER, VACUUM MODULATOR

The following disassembly information covers both the 350 and 350C converter clutch type transmission. Please note the differences called out in the text and figures. Converter clutch models are identified by the initials TCC (Torque Converter Clutch).

## UNIT REPAIR

### TRANSMISSION ASSEMBLY — REMOVAL AND INSTALLATION

#### Removal

1. Disconnect detent cable.

**NOTICE:** H series also remove mounting bracket.

2. Raise car on hoist.
3. H series only remove exhaust crossover pipe.
4. Remove flywheel inspection cover.
5. Remove flywheel to converter bolts and mark for reassembly in same position.
6. A, B and C series remove catalytic converter and bracket. X and H series remove bracket only.
7. Remove propeller shaft, and mark for reassembly in same position. H series also disconnect torque arm and mount from transmission extension housing.
8. Remove rear transmission mounting pad bolts.
9. Using a transmission jack raise transmission and remove crossmember support and mount.
10. Lower transmission leaving jack still holding full support of transmission at lowest position.
11. Disconnect shift linkage and speedo cable.
12. Disconnect vacuum modulator line, detent cable, and cooler lines.
13. Remove transmission to engine block mounting bolts, and filler pipe.
14. Move transmission rearward, and lower away from car using Tool J-21366 to hold converter in place.

#### Installation

The installation of the transmission is the reverse of removal except for the following reminder steps.

1. Torque transmission to engine block mounting bolts to (47 N•m) 30 lb. ft.
2. Install propeller shaft in original position.
3. Connect converter and flywheel in original position, and torque bolts to (41 N•m) 30 lb. ft.
4. Lower car and if transmission was disassembled add 6 pints of transmission fluid (10 pints if converter was replaced) through the filler tube.
5. With manual control lever in park position, start engine, **DO NOT RACE ENGINE**, apply service brake and move selector lever through each range.
6. With selector lever in park, engine running, check fluid level.
7. Add additional fluid to bring level between the two small dimples located below the add mark on the dipstick. This is the correct reading at room temperature approximately 65° to 85°F (18° to 29°C).

### PRELIMINARY INSTRUCTIONS

1. Before starting disassembly of the transmission is should be thoroughly cleaned externally to avoid getting dirt inside.
2. Place transmission on a CLEAN work bench and use CLEAN tools during disassembly. Provide clean storage space for parts and units removed from transmission.
3. The transmission contains parts which are ground and highly polished, therefore, parts should be kept separated to avoid nicking and burring surfaces.
4. When disassembling transmission carefully inspect all gaskets at times of removal. The imprint of parts on both sides of an old gasket will show whether a good seal was obtained. A poor imprint indicates a possible source of oil leakage due to gasket condition, looseness of bolts, or uneven surfaces of parts.
5. None of the parts require forcing when disassembling or assembling transmission. Use a rawhide or plastic mallet to separate tight fitting cases — do not use a hard hammer.





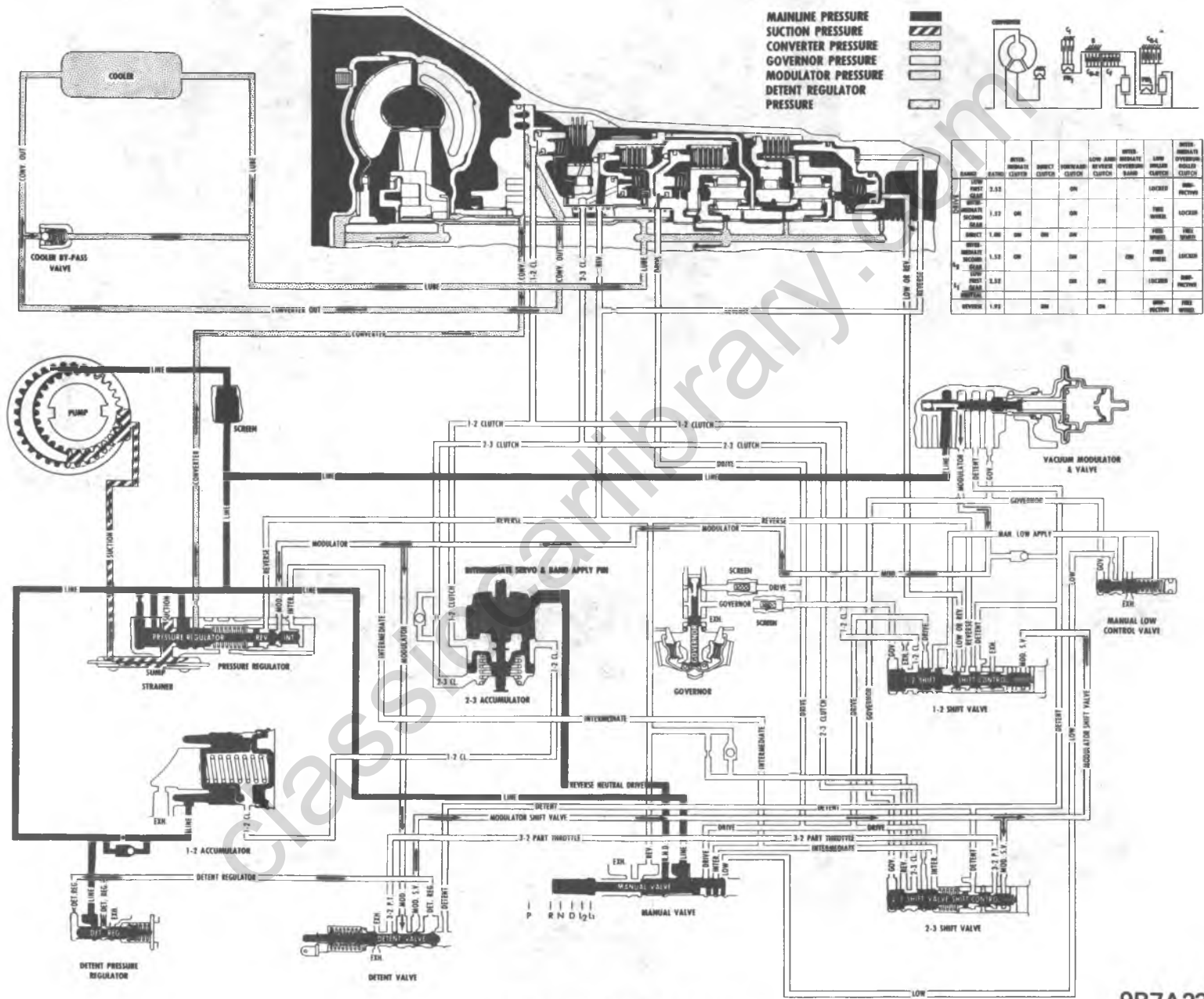

NEUTRAL—ENGINE RUNNING

9B7A23A

Figure 7A3-25A Neutral - Engine Running

### Removal of Converter

1. Place transmission in Fixture J-8763. Do not overtighten. See Figure 7A3-27.

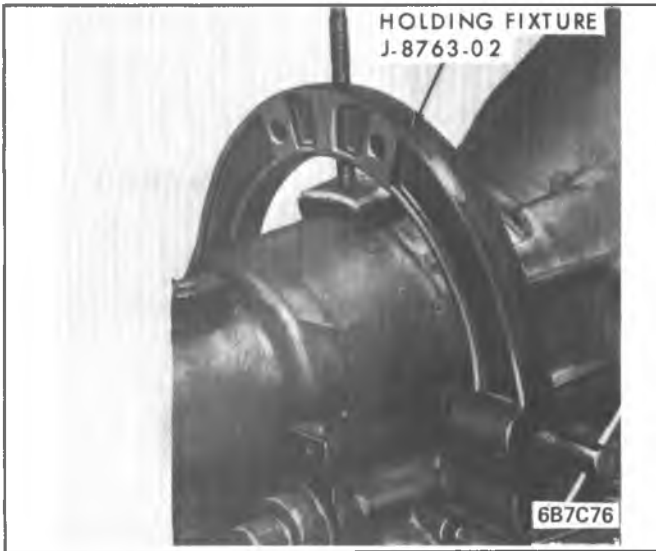

Figure 7A3-27 Transmission Holding Fixture

2. Remove converter Holding Tool J-21366. See Figure 7A3-28.

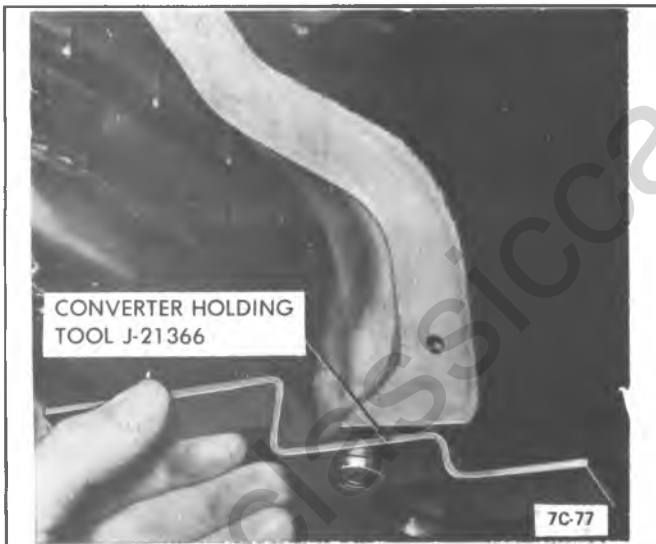

Figure 7A3-28 Converter Holding Fixture

3. With transmission in Holding Fixture J-8763, remove torque converter assembly. See Figure 7A3-29. On TCC models it may be necessary to pry the converter with a screwdriver due to a suction condition caused by the input shaft "O" ring.



Figure 7A3-29 Torque Converter Removal

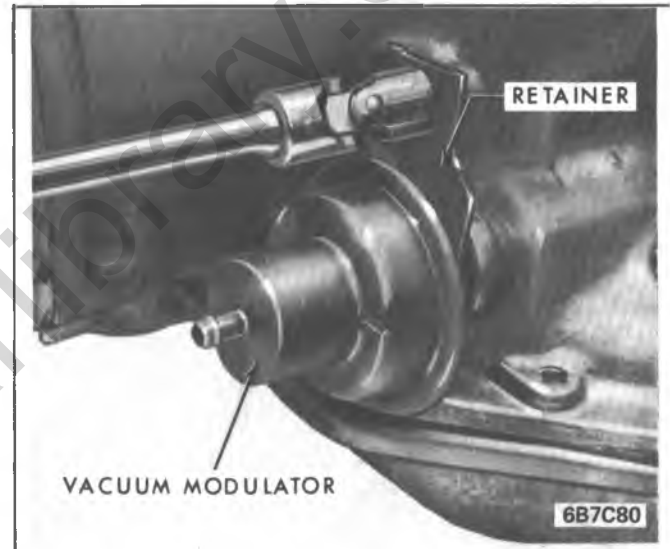

Figure 7A3-30 Removal of Modulator Retainer

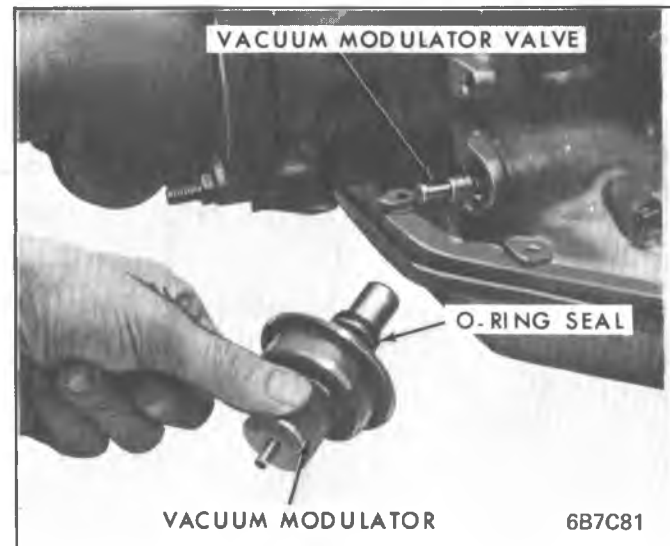

Figure 7A3-31 Vacuum Modulator

### Removal of Vacuum Modulator

1. Remove modulator assembly attaching bolt and retainer. See Figure 7A3-30.

2. Remove vacuum modulator assembly "O" ring seal and modulator valve from case. See Figure 7A3-31.

## REMOVAL OF EXTENSION HOUSING AND LIP SEAL

### Removal of Extension Housing

1. Remove bolt retainer and speedometer driven gear from side of extension housing and remove four (4) extension housing to case attaching bolts. See Figure 7A3-32.
2. Remove speedometer drive gear and retaining clip.

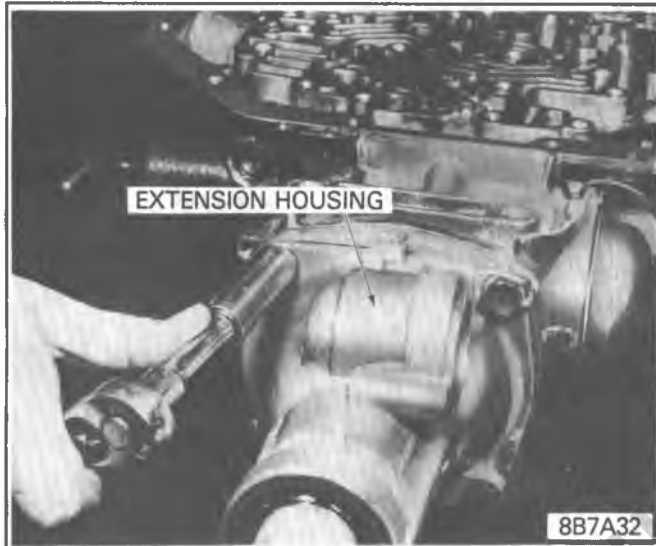

Figure 7A3-32 Extension Housing Removal

### Removal of Extension Housing Seal

1. Remove extension housing to case oil seal. See Figure 7A3-33.

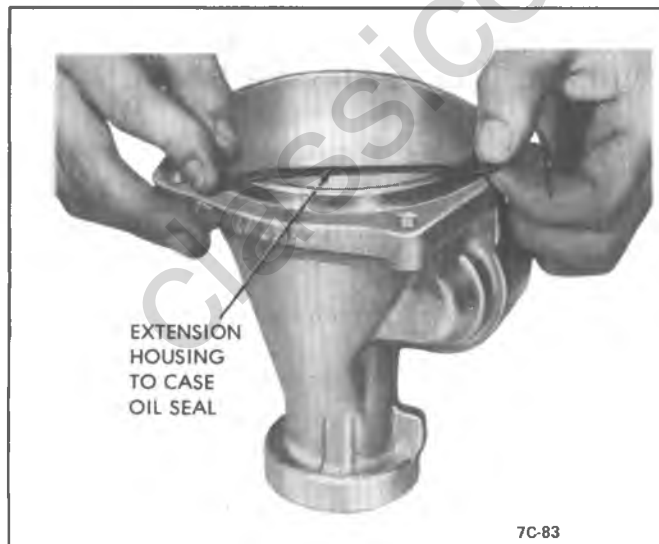

Figure 7A3-33 Extension Housing Square Cut Oil Seal

### Removal of Extension Housing Lip Seal

1. Remove extension housing lip seal using screwdriver. See Figure 7A3-34.

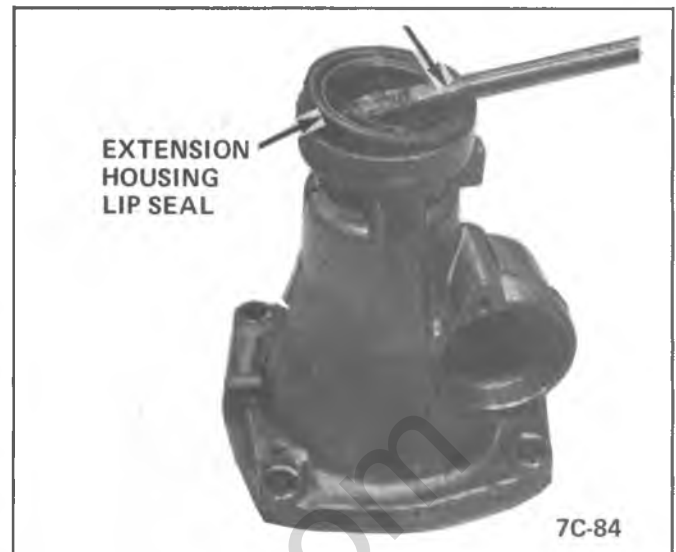

Figure 7A3-34 Removing Extension Housing Lip Seal Removal

### Installation of Extension Housing Lip Seal

1. Install extension housing lip seal using Installer J-21426. See Figure 7A3-35.

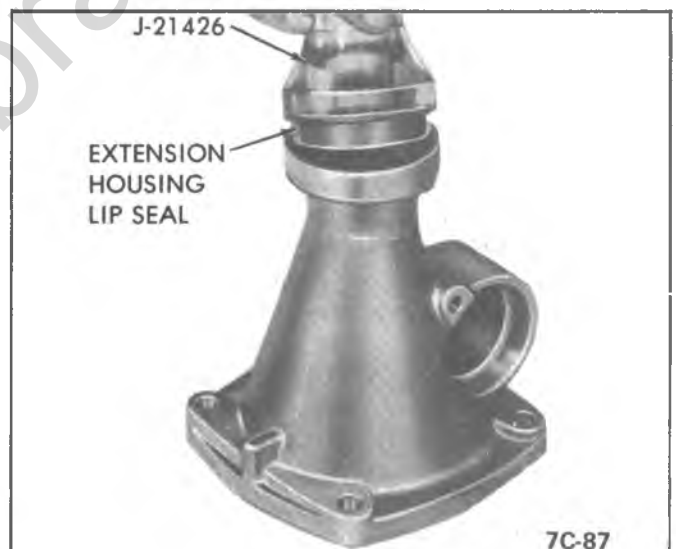

Figure 7A3-35 Installing Extension Housing Lip Seal Installation

## REMOVAL OF VALVE BODY, GOVERNOR, SCREEN, AND CHECK BALLS

1. Remove oil pan and pan gasket.
2. Remove filter assembly and filter gasket.

### Removal of Valve Body

1. Remove detent roller and spring assembly from valve body. See Figure 7A3-35A.
2. Remove actuator pin from detent control link and remove control wire.
3. TCC Models, disconnect solenoid wires. Remove pressure switch only if replacement is necessary.

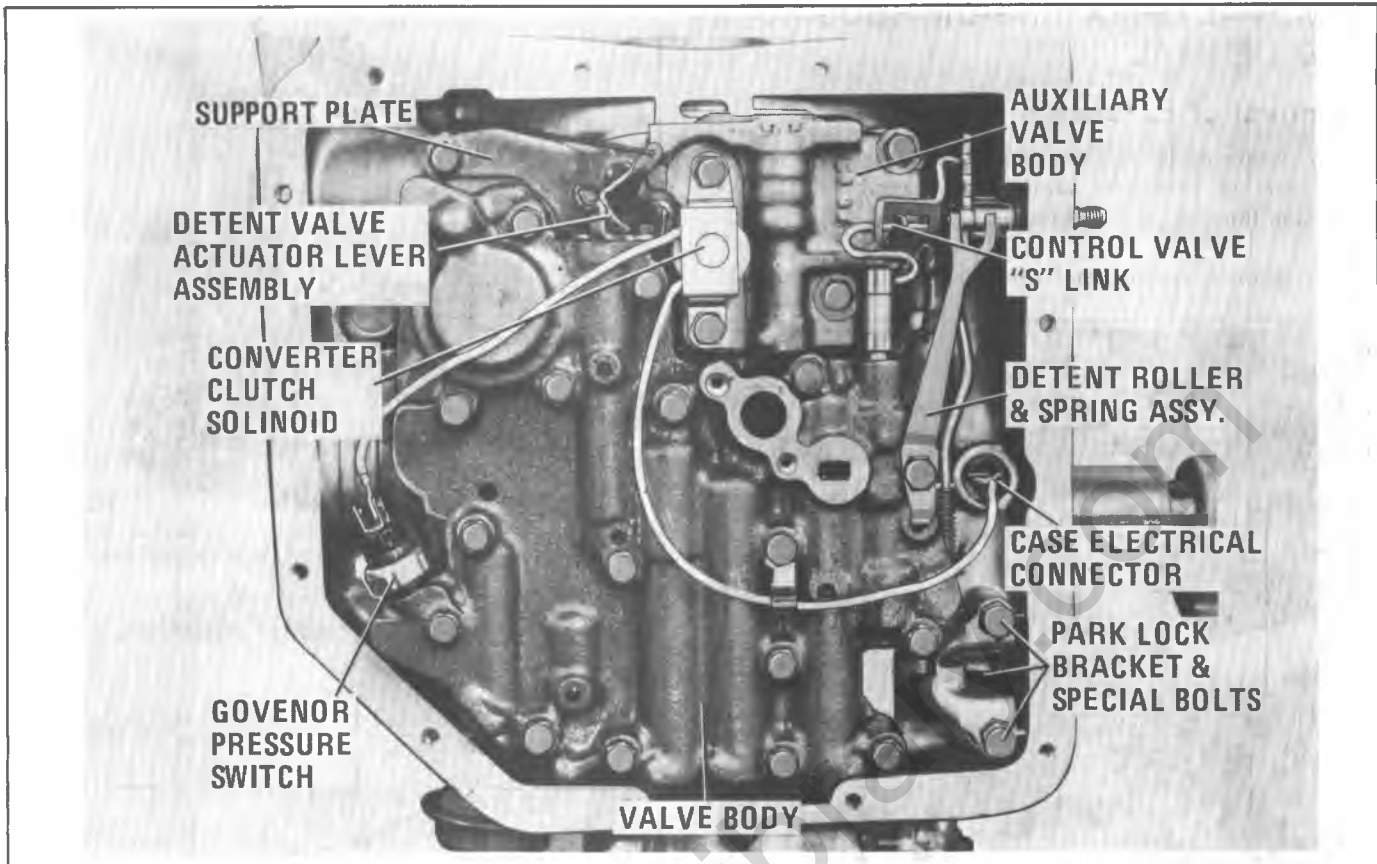

Figure 7A3-35A Valve Body and Related Components

Refer to Figure 7A3-36 for specific wiring diagrams for the various 350C Transmission models. The model code stamped is in the right side of the bell housing.

4. TCC Models, remove solenoid attaching bolts and solenoid. Inspect solenoid wires for loose connections and cut or worn insulator.

The spacer plate to valve body has a gasket with a yellow ink stripe. The yellow ink stripe is necessary for identification purposes. The gasket is almost identical to the spacer plate to case gasket.

5. Remove manual shaft retaining clip with (Figure 7A3-42) screwdriver and slide manual shaft outward. This will allow the manual valve "S" link to be removed.

6. Remove valve body attaching bolts and valve body.

7. TCC Models - remove auxiliary valve body attaching bolts and auxiliary valve body. (Figure 7A3-37A)

8. Remove support plate attaching bolts and support plate.

9. Remove spacer plate and gaskets.

10. Remove four check balls from case face. TCC Models - remove 5 check balls. Note locations of check balls.

11. Remove park lock bracket and special bolts. Figure 7A3-35A.

### Removal of Pressure Screen

1. Remove oil pump pressure screen from oil pump pressure hole in case, and clean. See Figure 7A3-40.

2. Remove governor screen from case and clean. See Figure 7A3-41.

### Removal of Case Electrical Connector

1. Remove case electrical connector and "O" ring by depressing tabs.

### REMOVAL OF MANUAL SHAFT, INNER, LEVER, PARKING PAWL, AND

#### Removal of Range Selector Inner Lever

If removal of internal manual linkage is required proceed as follows:

1. Remove manual control valve link retainer from range selector inner lever.

3. Remove jam nut holding range selector inner lever to manual shaft.

4. Remove manual shaft from case. Remove range selector inner lever and parking pawl actuating rod.

5. Remove manual shaft to case lip seal, if necessary. See Figure 7A3-43.

6. Remove parking pawl shaft retaining plug stake marks.

Remove retaining plug, parking pawl shaft, parking pawl, and disengaging spring. See Figure 7A3-45.

### Removal of Intermediate Servo Piston

1. Remove intermediate servo piston, washer, spring seat, and apply pin. See Figure 7A3-46.

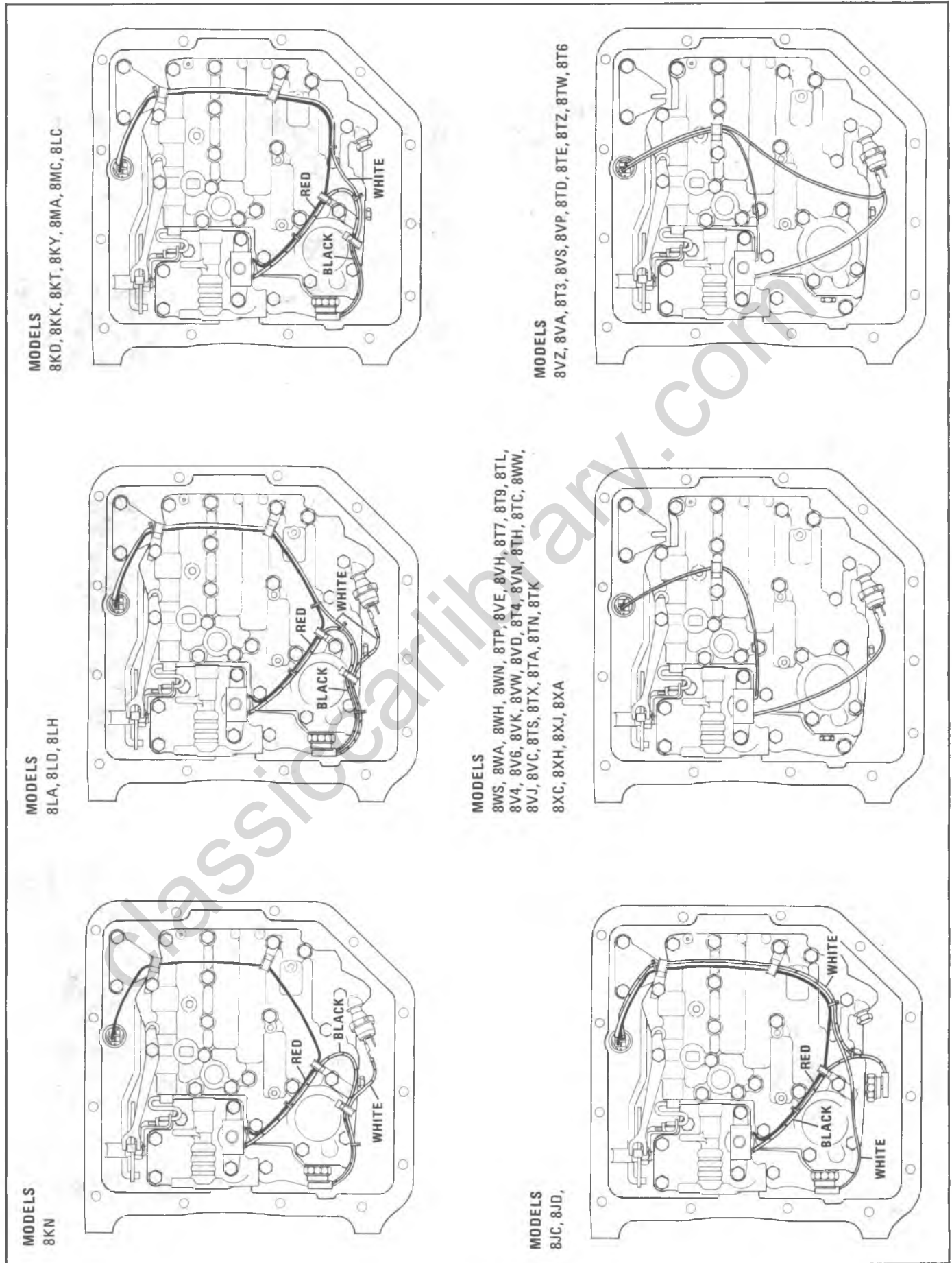

**MODELS**

8KD, 8KK, 8KT, 8KY, 8MA, 8MC, 8LC

**MODELS**

8LA, 8LD, 8LH

**MODELS**

8KN

**MODELS**

8VZ, 8VA, 8T3, 8VS, 8VP, 8TD, 8TE, 8TZ, 8TW, 8T6

**MODELS**

8WS, 8WA, 8WH, 8WN, 8TP, 8VE, 8VH, 8T7, 8T9, 8TL, 8V4, 8V6, 8VK, 8VW, 8VD, 8T4, 8VN, 8TH, 8TC, 8WW, 8VJ, 8VC, 8TS, 8TX, 8TA, 8TN, 8TK

**MODELS**

8XC, 8XH, 8XJ, 8XA

Figure 7A3-36 T.C.C. Wiring Diagrams

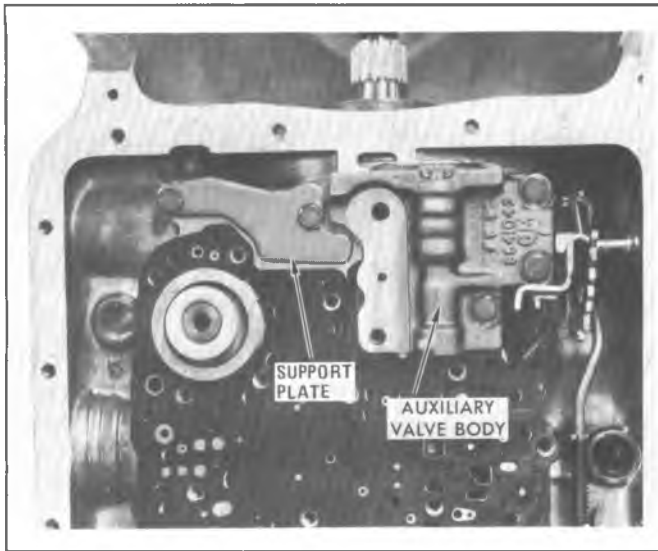

Figure 7A3-37A Auxiliary Valve Body and Support Plate

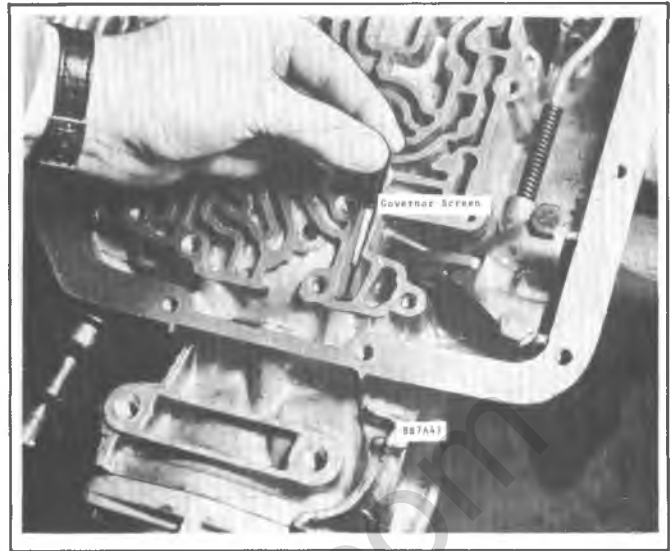

Figure 7A3-41 Removing Governor Feed Screen

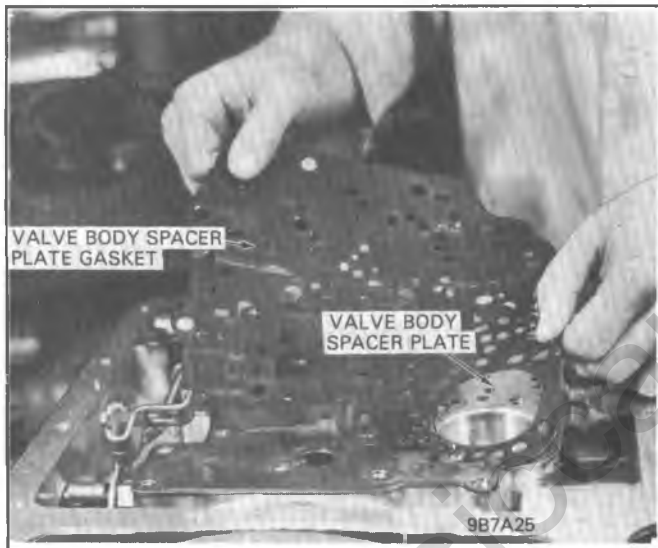

Figure 7A3-38 Valve Body and Spacer Plate Gasket

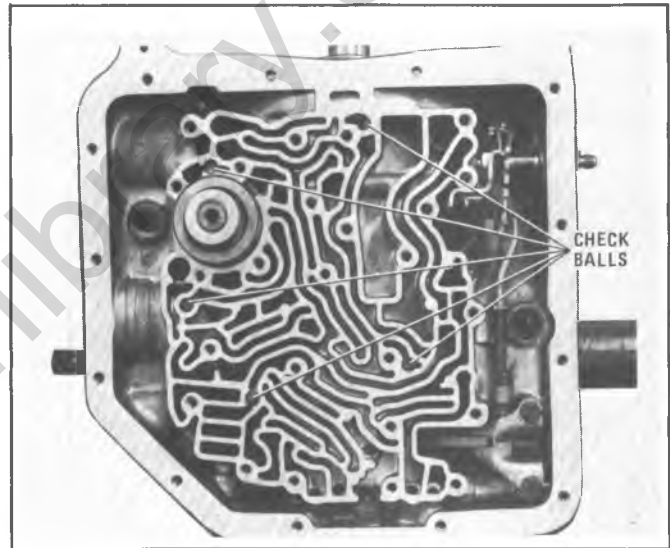

Figure 7A3-41A T.C.C. Check Ball Locations

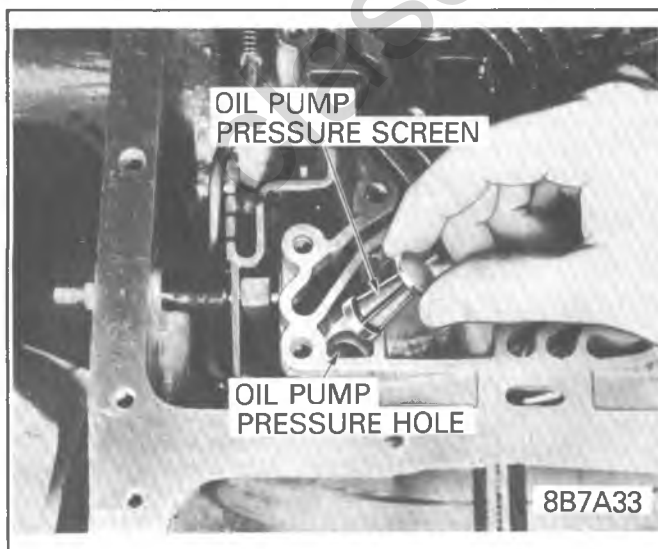

Figure 7A3-40 Pump Screen Removal

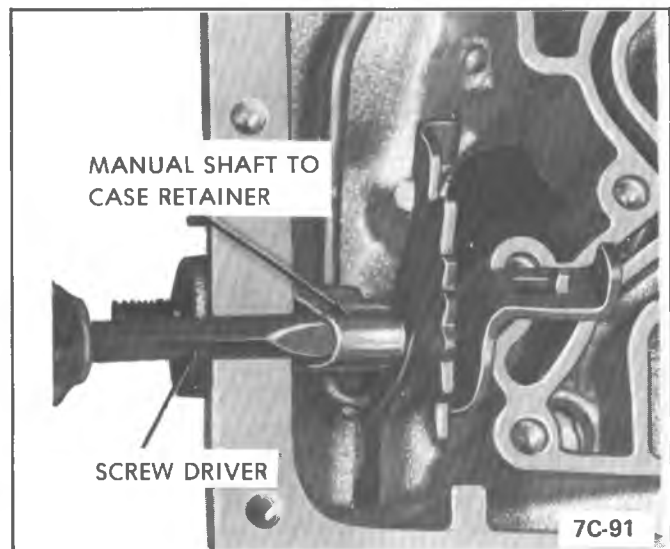

Figure 7A3-42 Removing Manual Shaft Retainer

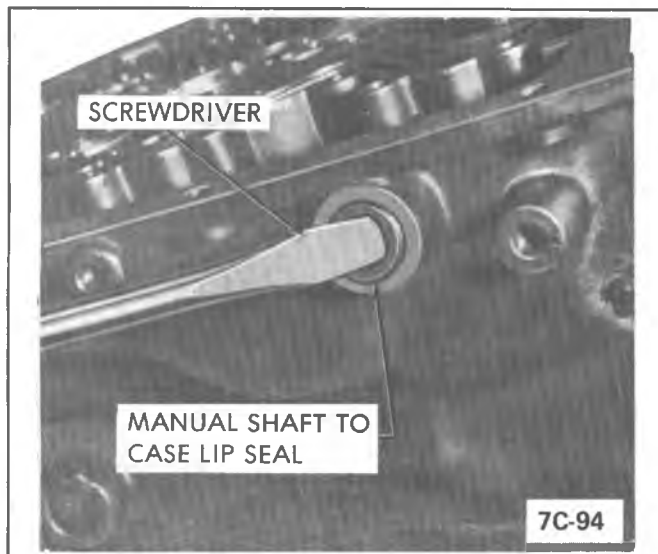

Figure 7A3-43 Removing Manual Shaft Lip Seal

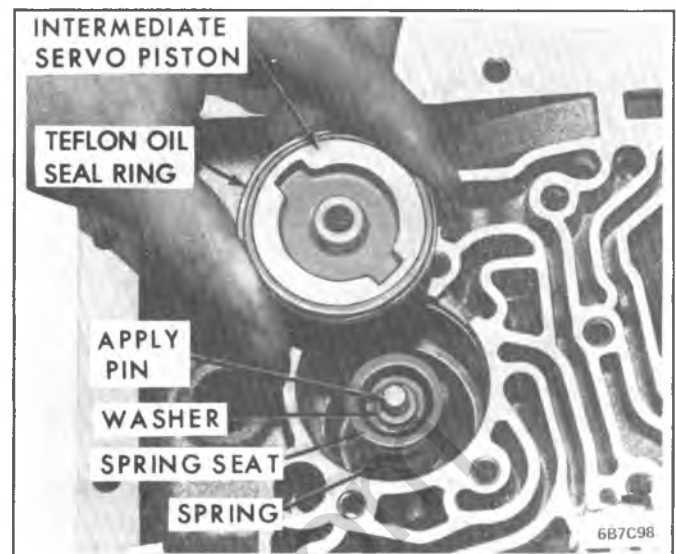

Figure 7A3-46 Intermediate Servo Assembly



Figure 7A3-45 Park Pawl

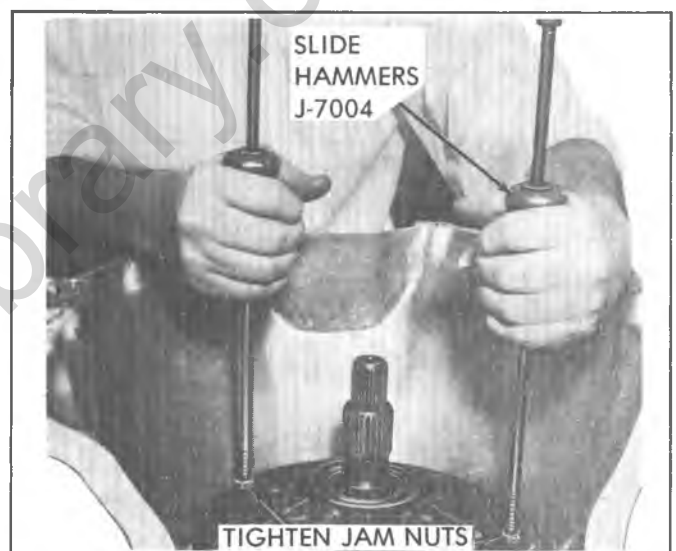

Figure 7A3-47 Pump Removal

2. If the piston seal needs replacing, the piston assembly will have to be replaced. This is due to a plastic grooved piston that is not serviceable. (Piston and Seal are one assembly).

## REMOVAL OF PUMP ASSEMBLY

### Removal of Oil Pump Assembly

1. Remove eight (8) pump attaching bolts with washer type seals.
2. Install two (2) threaded slide hammers J-7004 into threaded holes in pump body. Tighten jam nuts and remove pump assembly from case. See Figure 7A3-47.
3. Remove pump assembly to case gasket.

### Removal of Intermediate Clutch Cushion Spring, Intermediate Clutch Plates and Intermediate Overrun Brake Band

1. Remove intermediate clutch cushion spring.

2. Remove the intermediate clutch faced plates and the steel separator plates. See Figure 7A3-48 and one wave spring.

3. Inspect condition of the lined and steel plates. Do not diagnose a lined drive plate by color.

A. Dry lined plates with compressed air and inspect the lined surfaces for:

1. Pitting and flaking
2. Wear
3. Glazing
4. Cracking
5. Charring
6. Chips or metal particles imbedded in lining

If a lined drive plate exhibits any of the above conditions, replacement is required.

B. Wipe steel plates dry and check for heat discoloration. If the surface is smooth and an even color smear is indicated, the plates should be reused. If severe heat spot discoloration or surface scuffing is indicated, the plates must be replaced.

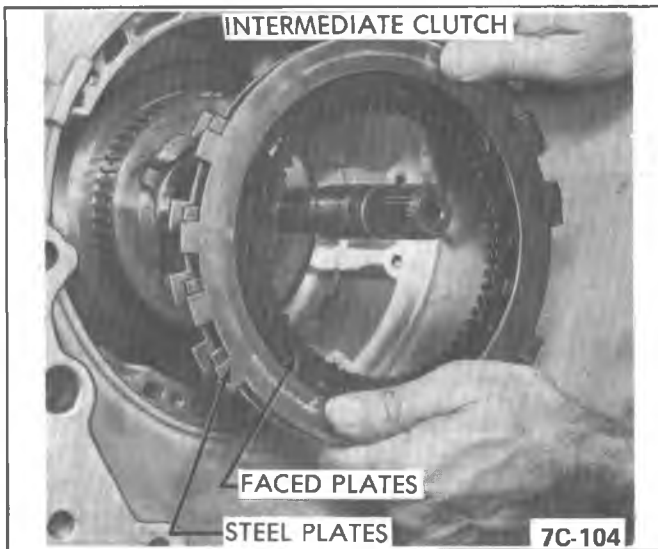

Figure 7A3-48 Intermediate Clutch Plate Removal

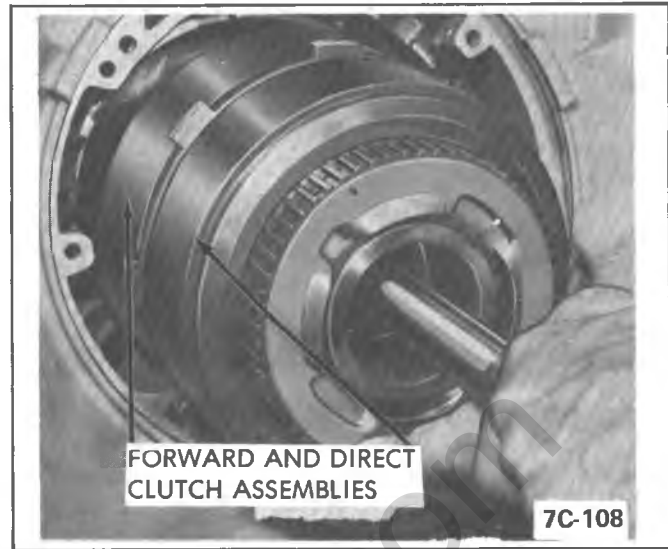

Figure 7A3-50 Removing Forward and Direct Clutch Assemblies

4. Remove intermediate clutch pressure plate.
5. Remove intermediate overrun brake band. See Figure 7A3-49.

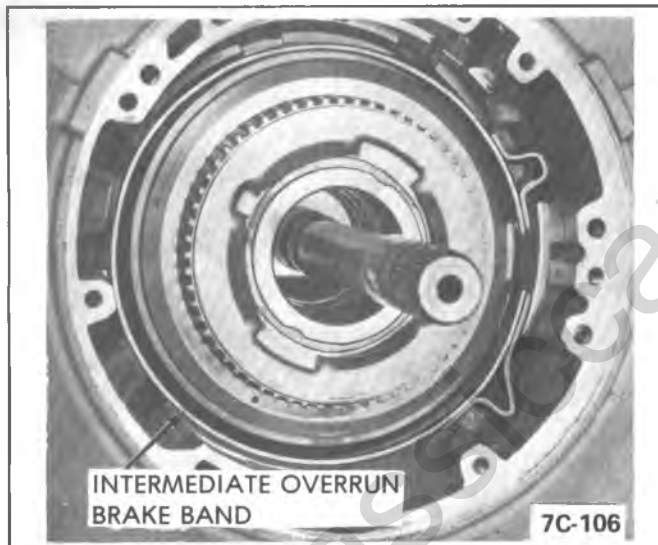

Figure 7A3-49 Intermediate Overrun Brake Band

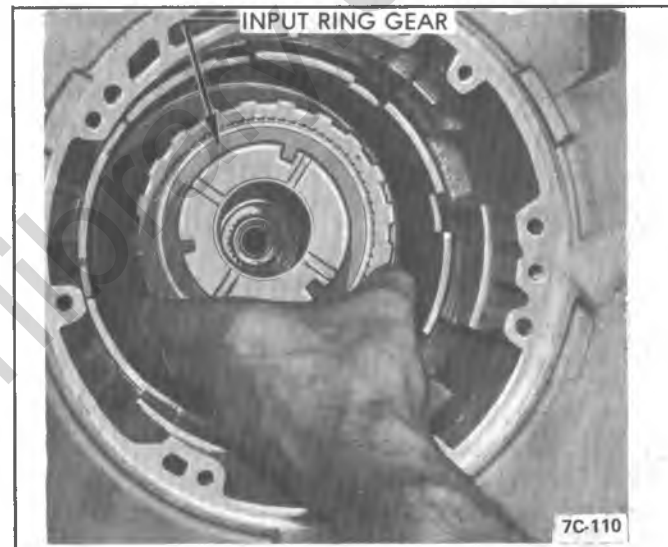

Figure 7A3-51 Removing Input Ring Gear

### REMOVAL OF DIRECT AND FORWARD CLUTCH ASSEMBLIES, INPUT RING GEAR, AND OUTPUT CARRIER

#### Removal of Direct and Forward Clutch Assemblies

1. Remove direct and forward clutch assemblies from case. See Figure 7A3-50.

#### Removal of Input Ring Gear

1. Remove forward clutch housing to input ring gear front thrust washer. Inspect for excessive wear or scoring.
2. Remove input ring gear. See Figure 7A3-51.

#### Removal of Output Carrier Assembly

1. Remove input ring gear to output carrier needle thrust bearing.
2. Remove output carrier to output shaft snap ring. See Figure 7A3-52.
3. Remove output carrier assembly.

### REMOVAL OF SUN GEAR DRIVE SHELL, LOW AND REVERSE CLUTCH SUPPORT ASSEMBLY, LOW AND REVERSE CLUTCH PLATES AND REACTION CARRIER

#### Removal of Sun Gear Drive Shell Assembly

1. Remove sun gear drive shell assembly. See Figure 7A3-53.



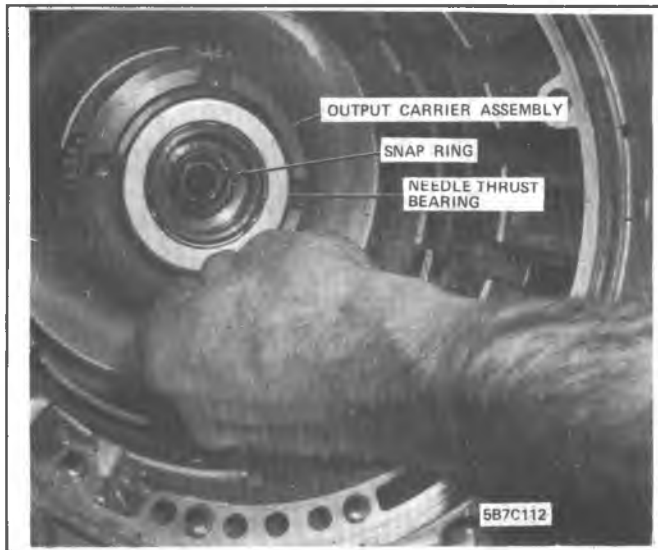

Figure 7A3-52 Removing Input Carrier

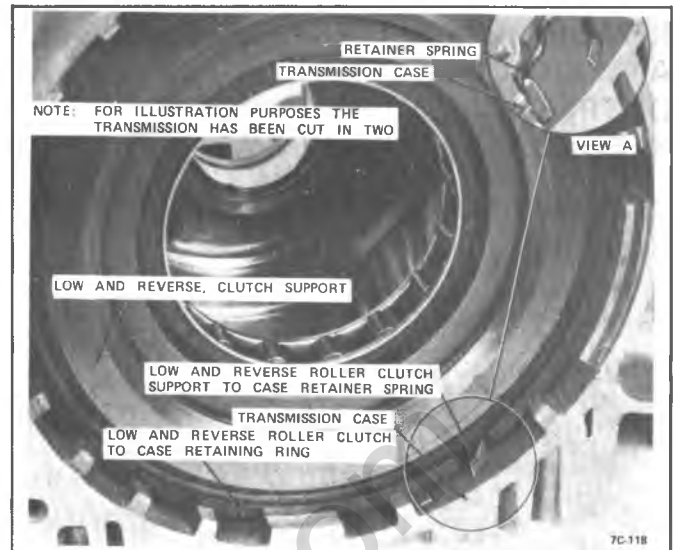

Figure 7A3-54 Retainer Position

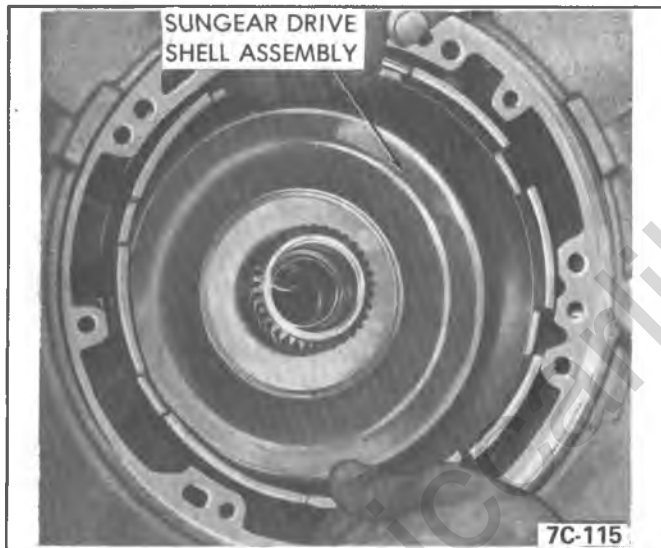

Figure 7A3-53 Removing Drive Shell Assembly

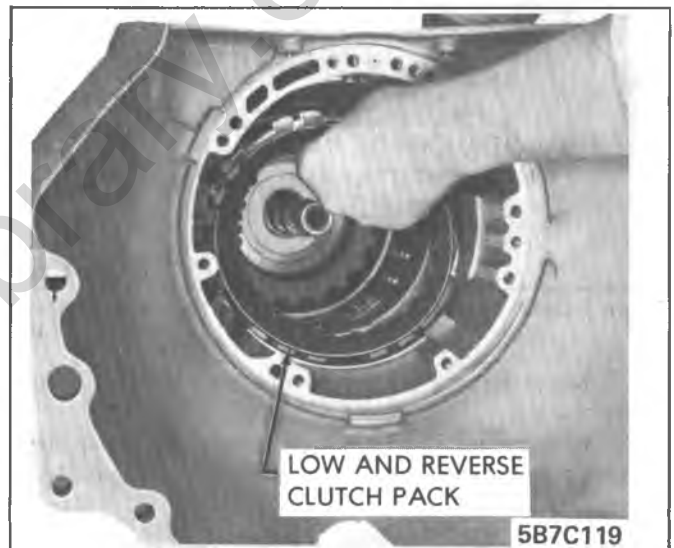

Figure 7A3-55 Lo and Reverse Clutch Removal

### Removal of Low and Reverse Clutch Support Assembly

1. Remove low and reverse roller clutch support to case retaining ring. See Figure 7A3-54.
2. Grasp output shaft and pull up until low and reverse roller clutch and support assembly clear low and reverse clutch support retainer spring and remove support assembly.
3. Remove low and reverse clutch support retainer spring. See Figure 7A3-54.

### Removal of Low and Reverse Clutch Plates

1. Remove the low and reverse clutch faced plates and the steel separator plates. See Figure 7A3-55.

### Removal of Reaction Carrier Assembly

1. Remove reaction carrier assembly from output ring gear and shaft assembly. See Figure 7A3-56.

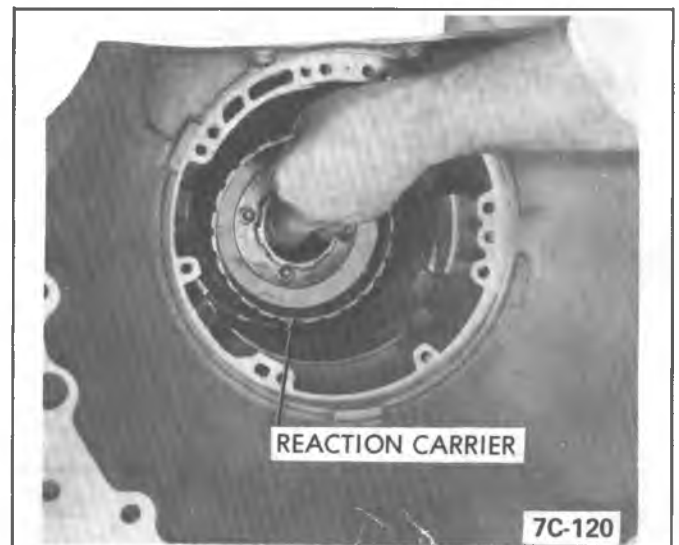

Figure 7A3-56 Reaction Carrier Removal

## REMOVAL OF OUTPUT RING GEAR AND SHAFT ASSEMBLY, AND OUTPUT RING GEAR TO CASE NEEDLE BEARING ASSEMBLY

### Removal of Output Ring Gear and Shaft Assembly

1. Remove output ring gear and shaft assembly from case. See Figure 7A3-57.

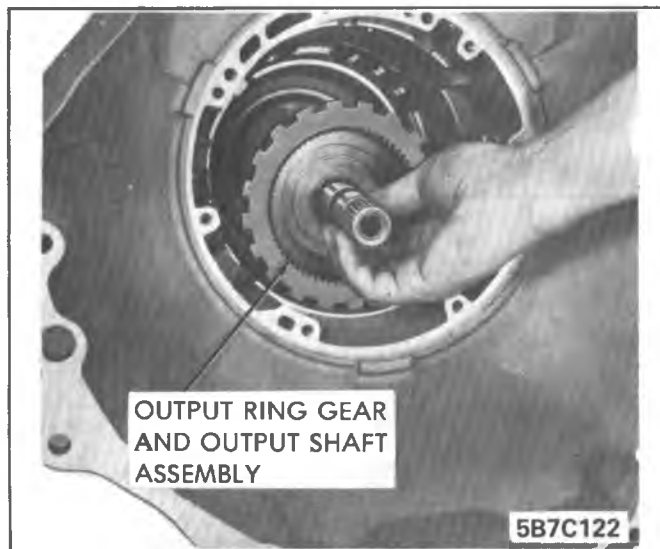

Figure 7A3-57 Output Ring Gear and Shaft Assembly Removal

2. Remove reaction carrier to output ring gear needle thrust bearing.

3. Remove output ring gear to output shaft snap ring. Remove output ring gear from output shaft. See Figure 7A3-58.

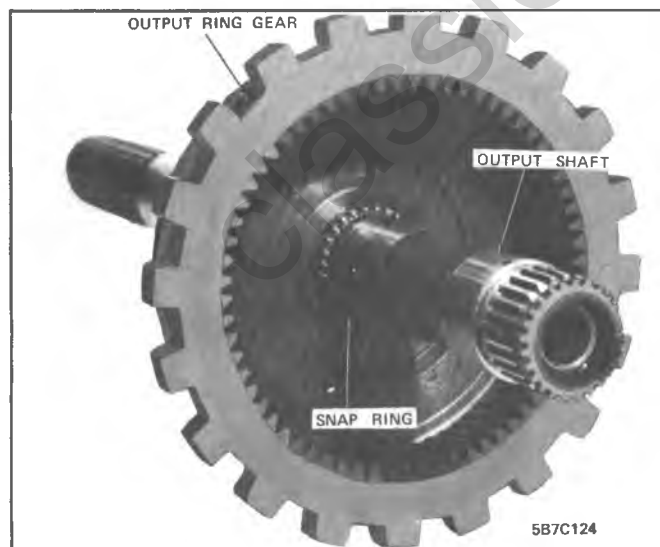

Figure 7A3-58 Output Ring Gear Snap Ring

4. Remove output ring gear to case needle bearing. See Figure 7A3-59.

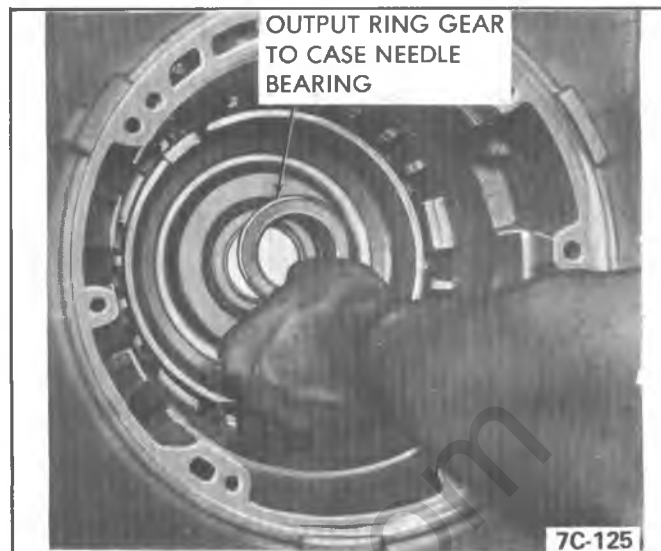

Figure 7A3-59 Removal of Needle Bearing

### Removal of Low and Reverse Clutch Piston

1. Using Tool J-23327 compress low and reverse clutch piston spring retainer and remove piston retaining ring, and spring retainer with springs. See Figure 7A3-60.

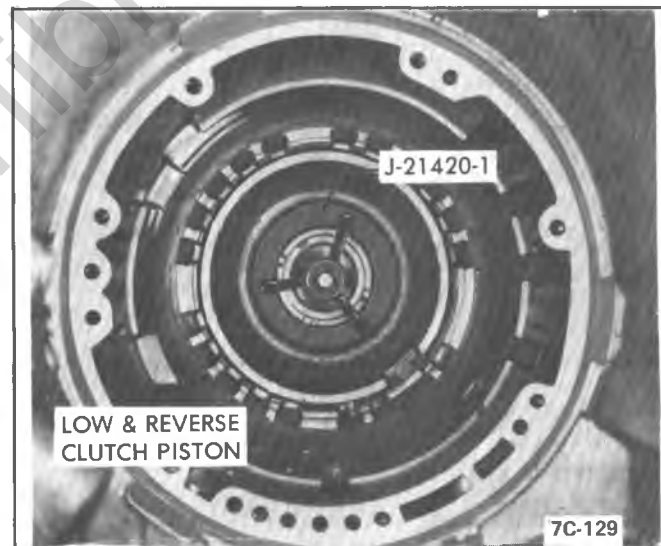

Figure 7A3-60 Remove Lo and Reverse Piston Snap Ring

2. Remove low and reverse clutch piston assembly. Aid removal with the use of compressed air in passage shown. See Figure 7A3-61.

### Removal of Low and Reverse Clutch Piston Seals

1. Remove low and reverse clutch piston outer seal.

2. Remove low and reverse clutch piston center and inner seal. See Figure 7A3-62.

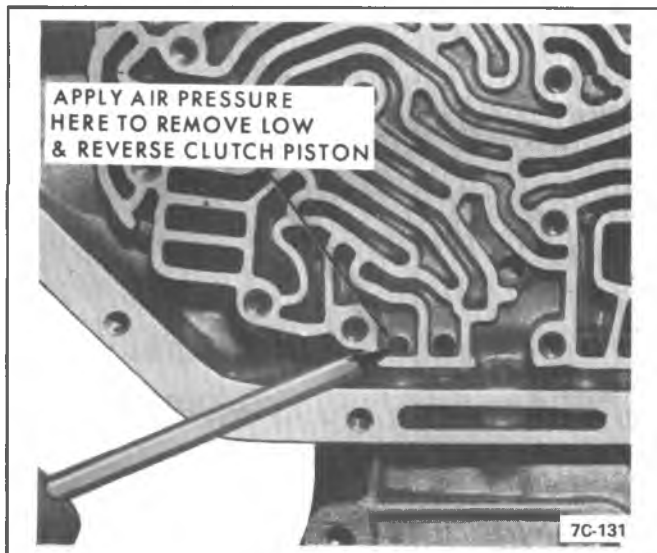

Figure 7A3-61 Location for Air Pressure



Figure 7A3-63 Removal of 1-2 Accumulator Cover

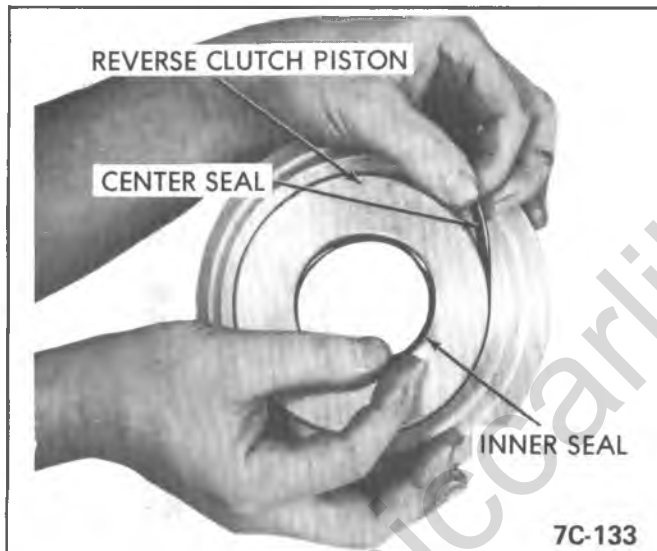

Figure 7A3-62 Piston Seal Removal

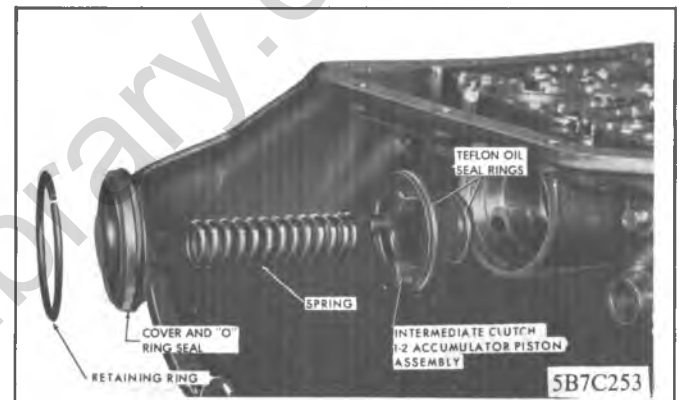

Figure 7A3-64 Intermediate Clutch 1-2 Accumulator

replacement of one or the other of the two rings is necessary, the piston assembly will have to be replaced. See Figure 7A3-64. (Piston and Seal are one assembly).

## REMOVAL AND INSTALLATION OF INTERMEDIATE CLUTCH 1 - 2 ACCUMULATOR

Removal and installation of intermediate clutch 1 - 2 accumulator can be done without removal of transmission from car. See On Car Service.

### Removal of Intermediate Clutch 1-2 Accumulator Piston

1. Install Tool J-23069 to compress intermediate clutch 1-2 accumulator cover and remove retaining ring. See Figure 7A3-63.
2. Remove intermediate clutch 1-2 accumulator piston cover and "O" ring seal from case. See Figure 7A3-64.
3. Remove intermediate clutch 1-2 accumulator piston spring. See Figure 7A3-64.
4. Remove intermediate clutch 1-2 accumulator piston assembly. *Inspect the inner and outer teflon oil seal rings for wearing or scoring. DO NOT REMOVE THESE TWO RINGS UNLESS THEY ARE DAMAGED.* If

### Installation of Intermediate Clutch 1-2 Accumulator Piston

1. Install intermediate clutch 1-2 accumulator piston assembly and spring. See Figure 7A3-64.
2. Place new "O" ring seal on intermediate clutch 1-2 accumulator piston cover, and install cover into case. See Figure 7A3-64.
3. Install J-23069 tool and compress intermediate clutch 1-2 accumulator cover and install retaining ring. See Figure 7A3-63.

## DISASSEMBLY AND REASSEMBLY OF OIL PUMP ASSEMBLY

### Disassembly of Oil Pump Assembly

1. Place assembly through hole in bench. Remove five (5) pump cover to body attaching bolts. See Figure 7A3-65.
2. Remove intermediate clutch return spring seat retainer with springs and the intermediate clutch piston assembly. See Figure 7A3-66.

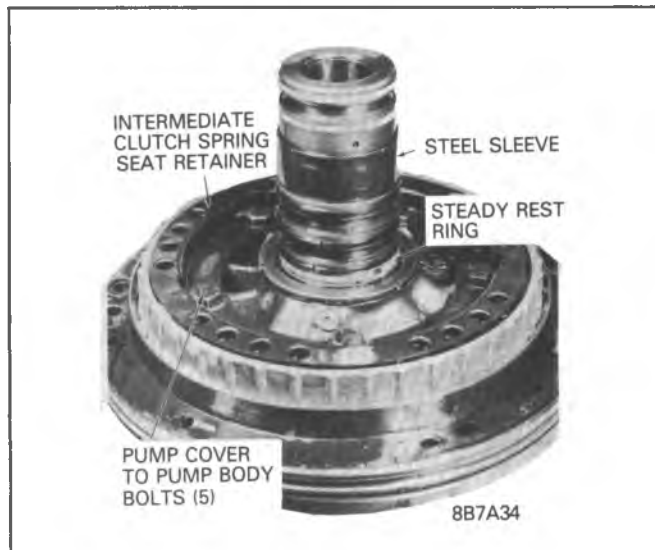

Figure 7A3-65 Intermediate Clutch Piston Removal

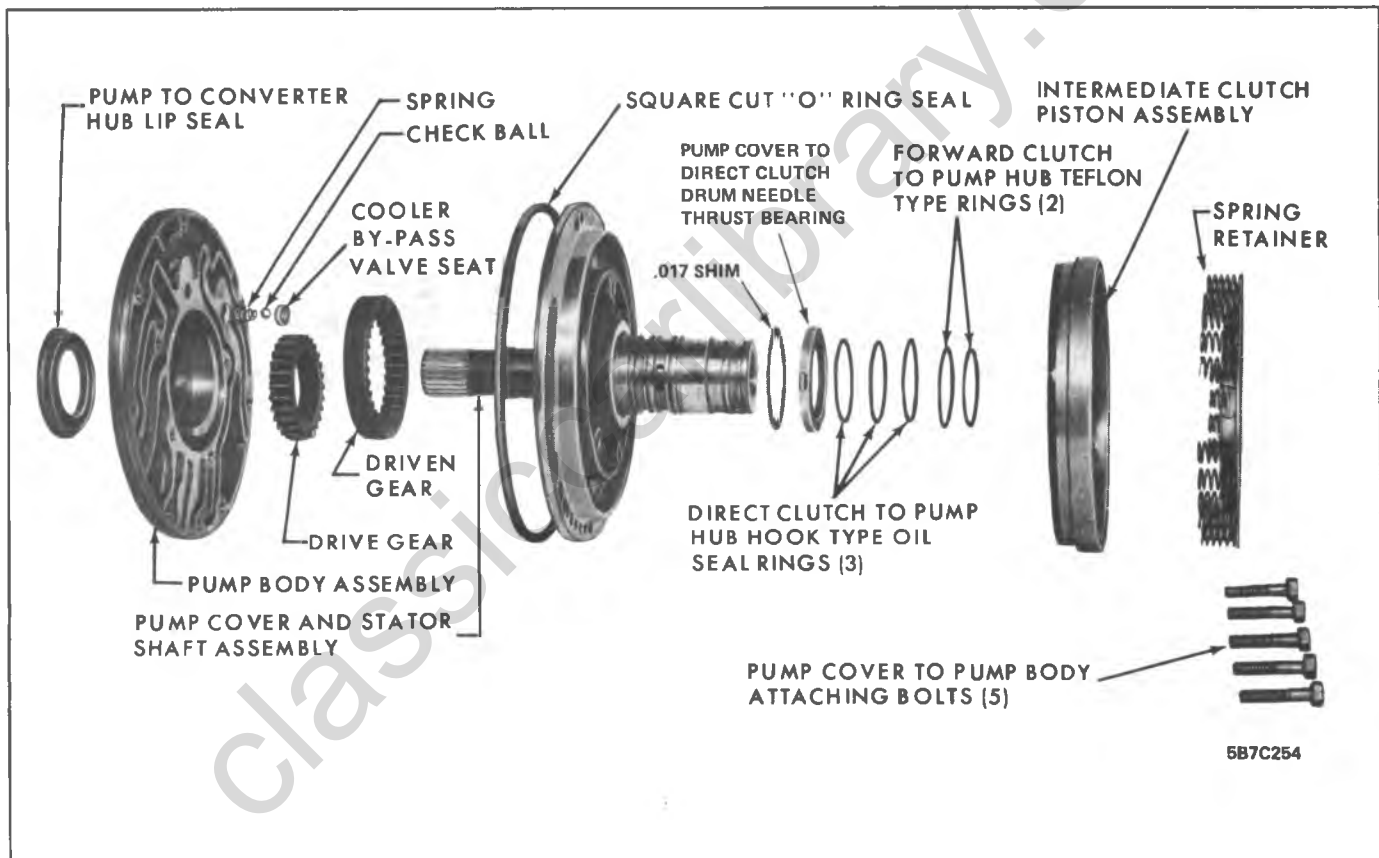

Figure 7A3-66 Oil Pump Assembly - Exploded View

3. Remove intermediate clutch piston inner and outer seals. See Figure 7A3-67.

4. Remove three (3) direct clutch to pump hub oil rings. Remove pump cover to direct clutch drum needle thrust bearing. Inspect the two (2) forward clutch to pump hub teflon oil seal rings, (some rings will be solid, new type rings will be scarf cut for easier assembly with no expander ring behind) but do not remove them unless they are damaged. If replacement is necessary, use two metal hook type service replacement rings. See Figure 7A3-66.

5. Check steady rest ring, if cut or frozen in bore remove and replace with the same color ring.

Steady rest rings come in four colors, yellow, green, white and purple. The different colors compensate for groove depth. Always replace this ring with the same color ring.

6. Remove pump cover and stator shaft assembly from pump body. See Figure 7A3-68.

6. Remove pump drive gear and driven gear from pump body. Inspect pump gears and cover for wear or scoring. See Figure 7A3-69.

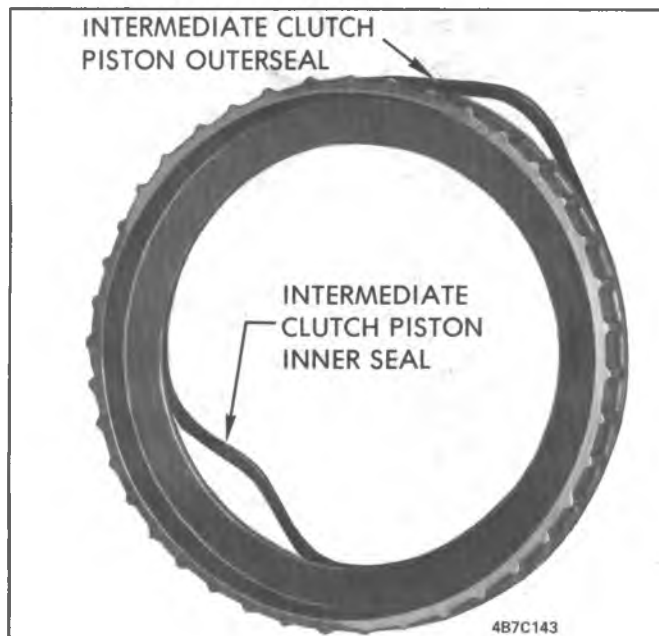

Figure 7A3-67 Intermediate Clutch Piston Seals



Figure 7A3-68 Pump Cover Removal

The pump body assembly should be replaced only if the drive and/or driven gears are broken or galled, pump body galled, uneven machined surfaces or pump body to case seal ring groove damaged, or the pump seal drain back hole is un-drilled.

7. Fill cooler by-pass passage with grease and insert Tool J-23134 and force by-pass valve seat, check ball, and spring from pump body. See Figure 7A3-70.

8. Remove pump outside diameter to case square cut "O" ring seal. See Figure 7A3-71.

9. Remove pump body to converter hub lip seal, if necessary. See Figure 7A3-72.

10. Place pump on wood blocks so surface finish is not damaged and install pump to converter hub lip seal using Seal Driver J-21359. See Figure 7A3-73.

Make certain lip seal is not turned or nicked.

### Reassembly of Oil Pump Assembly

1. Install pump drive gear and driven gear. Drive gear has off-set tangs, assemble with tang face up to prevent damage to converter. See Figure 7A3-69.

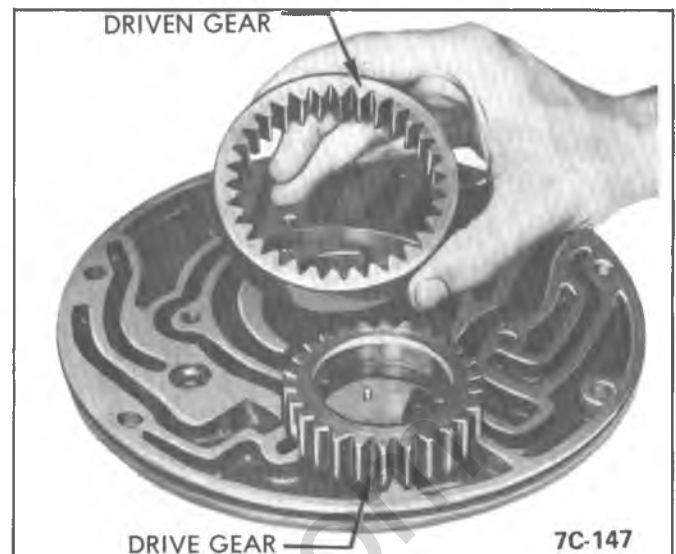

Figure 7A3-69 Oil Pump Gears

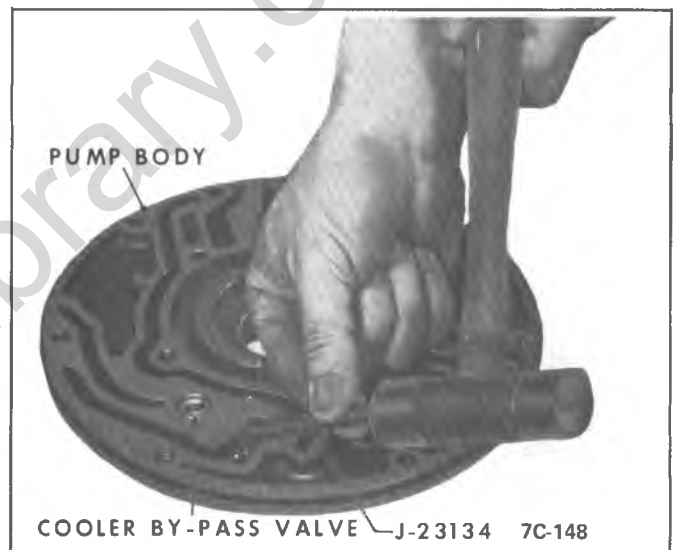

Figure 7A3-70 Cooler By-Pass Valve

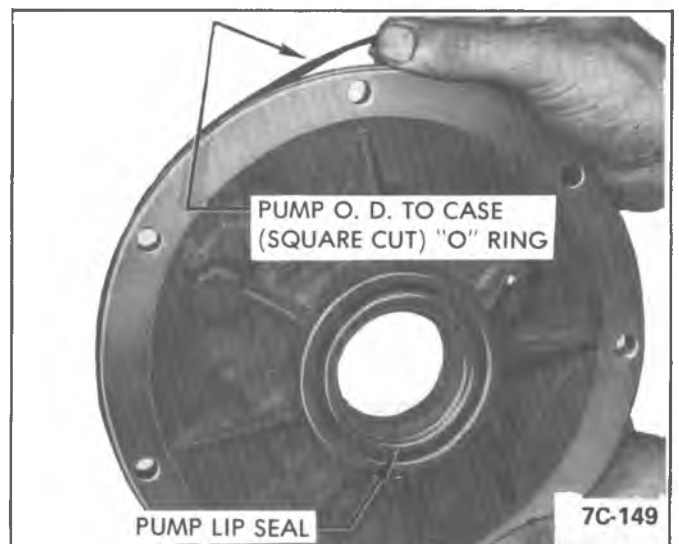

Figure 7A3-71 Square Cut Pump Seal

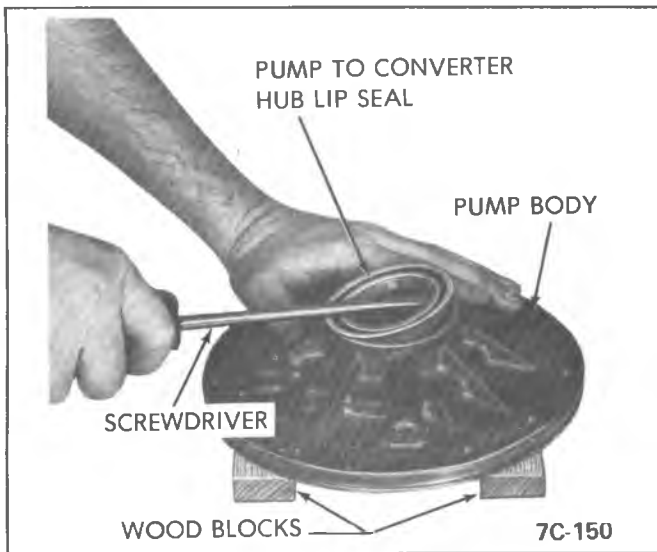

Figure 7A3-72 Converter Seal Removal



Figure 7A3-74 Installing Cooler By-Pass

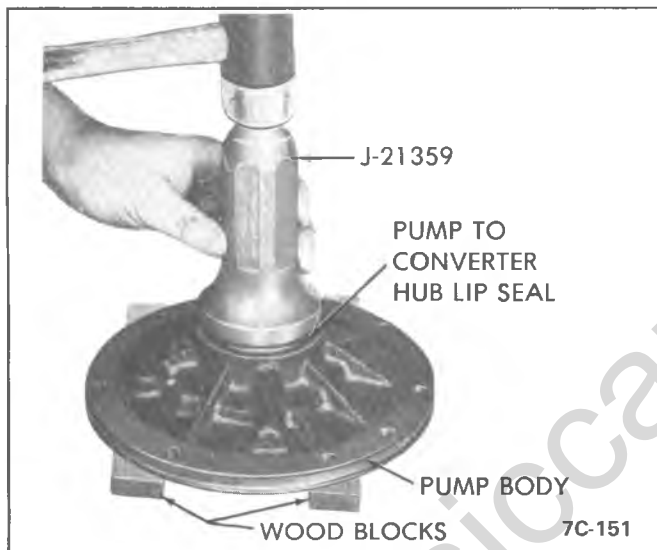

Figure 7A3-73 Converter Seal Removal

2. Install cooler by-pass spring, check ball and seat. Using Tool J-23112, press seat into bore until top of seat is flush with face of pump body. See Figure 7A3-74.

3. Assemble pump cover to pump body. See Figure 7A3-68.

4. Install intermediate clutch piston new inner and outer seals. See Figure 7A3-67.

5. Install intermediate clutch piston assembly into pump cover with J-26744-A.

6. Install spring retainer and install five (5) attaching bolts, finger tight. See Figures 7A3-66 and 7A3-65.

7. Place pump aligning strap, J-21368 over pump body and cover and tighten.

8. Tighten attaching bolts. Torque to 18 ft.lbs. (24 N·m).

9. Install pump outside diameter to case (square cut) "O" ring seal. See Figure 7A3-71. Use new square cut "O" ring seal.

10. Install three (3) direct clutch to pump hub scarf cut oil seal rings. Inspect two (2) forward clutch to pump hub

oil seal rings, (some rings will be solid, new type rings will be scarf cut for easier assembly with no expander ring behind) for service if rings require replacement use hook type cast iron rings. See Figure 7A3

11. Check three (3) pump cover hub lube holes. Make certain they are not restricted. See Figure 7A3-75.



Figure 7A3-75 Lube Hole Location

## DISASSEMBLY AND REASSEMBLY OF DIRECT CLUTCH

*Refer to specifications in rear of this section to determine the required amount of lined and steel clutch plates to use with specific transmission model and engine combination. When replacing piston assembly specific part number must be used.*

### Disassembly of Direct Clutch

1. Remove intermediate overrun clutch front retainer ring and retainer. See Figure 7A3-76.

2. Remove intermediate clutch overrun outer race. See Figure 7A3-77.

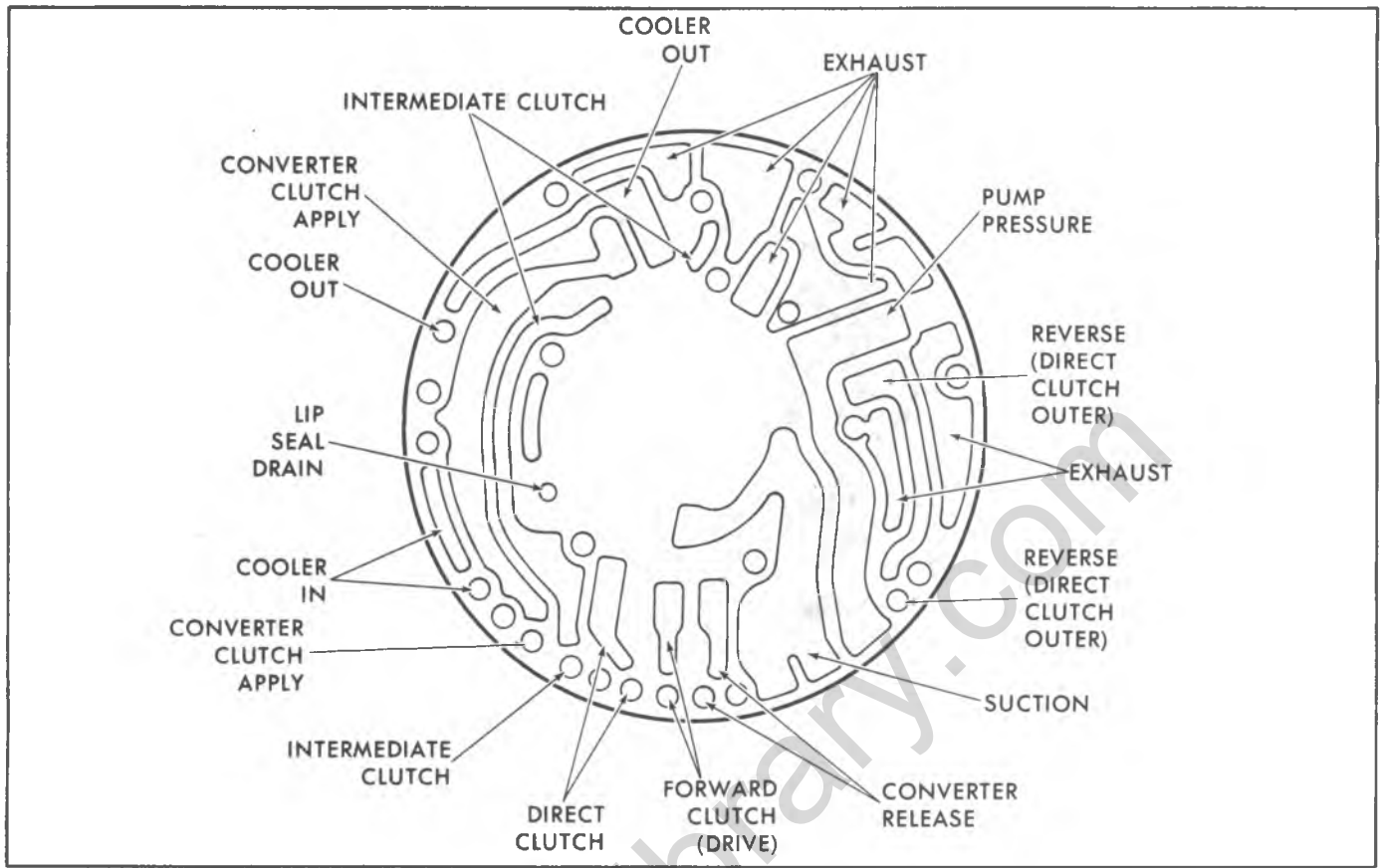

Figure 7A3-75A Identification of Oil Channels in Pump Cover and Stator Shaft Face

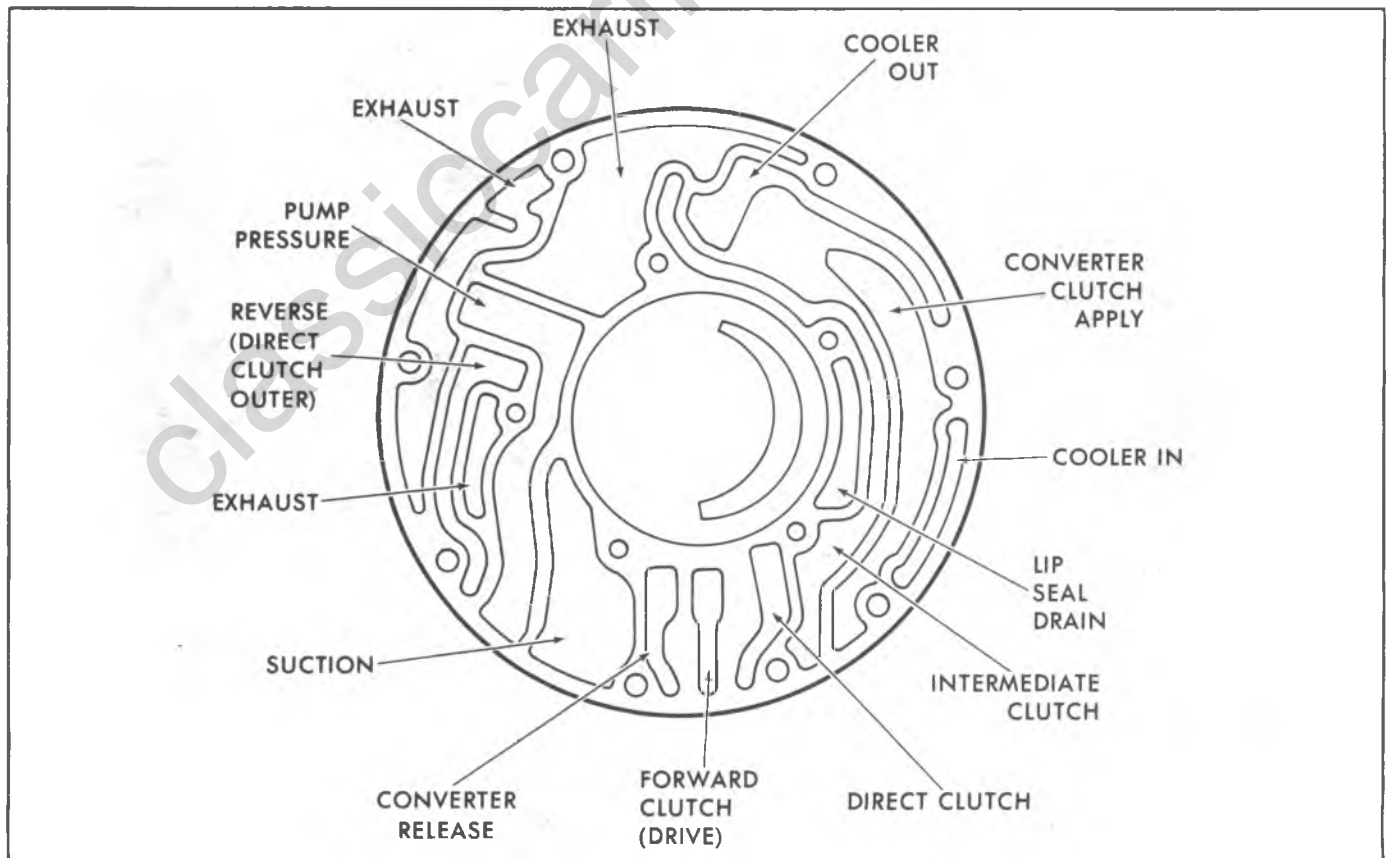

Figure 7A3-75B Identification of Oil Channels in Pump Body Front Face

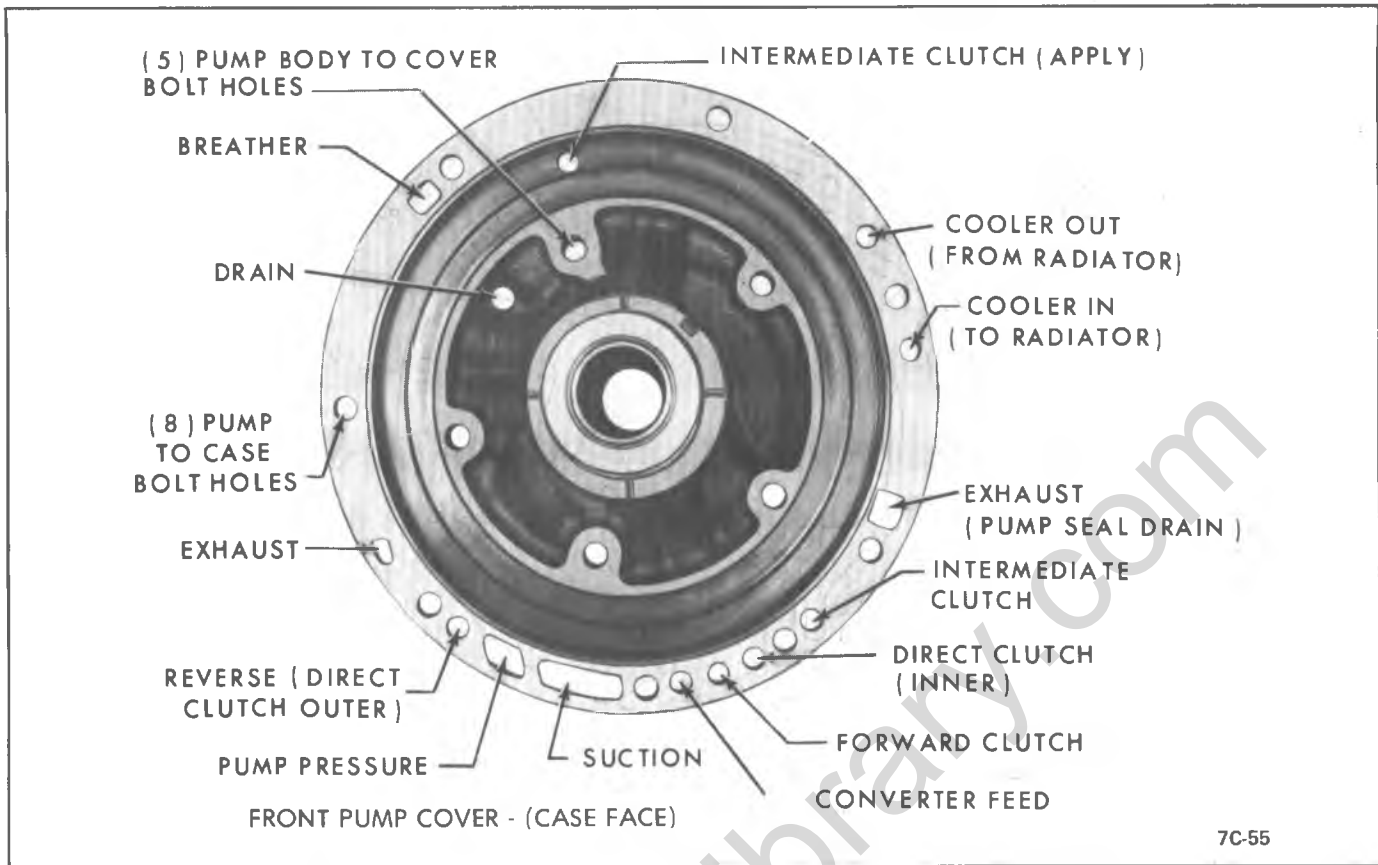

Figure 7A3-75C Identification of Oil Channels in Pump Cover Rear Face

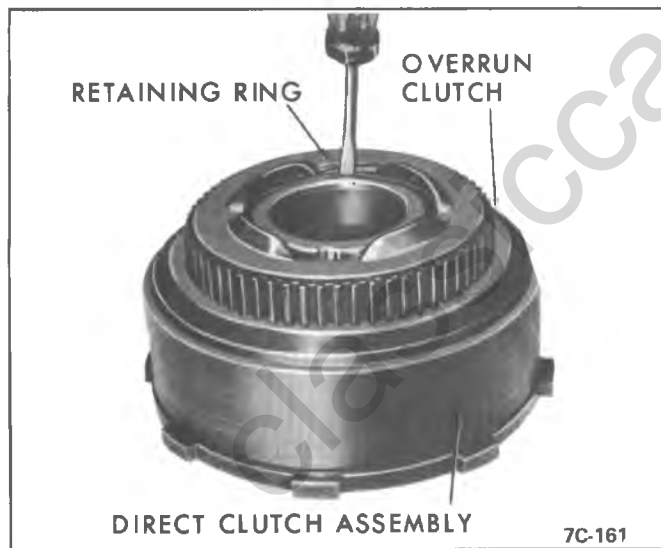

Figure 7A3-76 Overrun Clutch Retaining Ring



Figure 7A3-77 Roller Clutch Outer Race

3. Remove intermediate overrun roller clutch assembly. See Figure 7A3-78.

4. Remove direct clutch drum to forward clutch housing needle roller bearing. See Figure 7A3-79.

5. Remove direct clutch pressure plate to clutch drum retaining ring and pressure plate. See Figure 7A3-80.

6. Remove lined and steel plates from direct clutch housing. See Figure 7A3-81 and one cushion spring.

7. Inspect condition of lined and steel plates. *Do not diagnose a lined drive plate by color.*

8. Remove direct clutch piston return spring seat retaining ring and spring seat by using Tools J- 2590-3, J- 2590-5, and snap ring pliers. See Figure 7A3-82.

9. Remove spring retainer, springs and piston. See Figure 7A3-83.

10. Inspect the return springs. Evidence of extreme heat or burning in the area of the clutch may have caused the springs to take a heat set and would justify replacement of the springs.

11. Remove direct clutch piston inner and outer seals. See Figure 7A3-84.



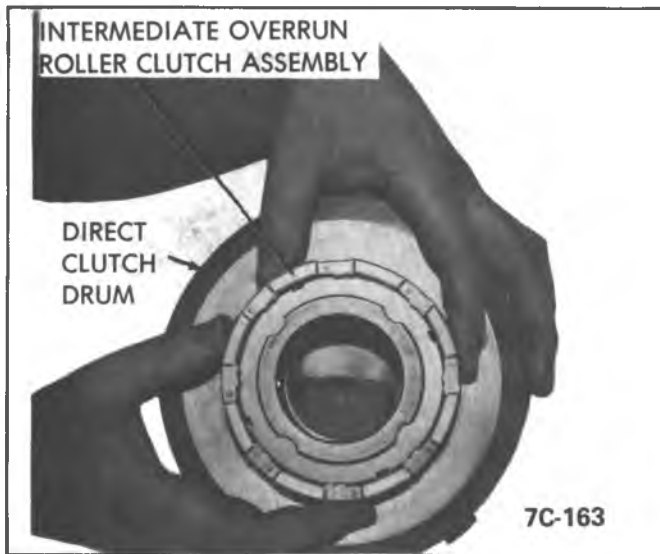

Figure 7A3-78 Removing Roller Clutch Outer Race

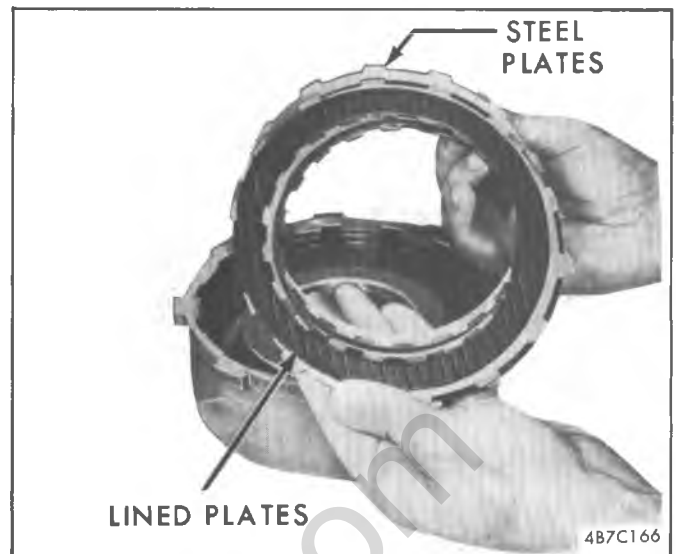

Figure 7A3-81 Clutch Plates



Figure 7A3-79 Needle Bearing Assembly

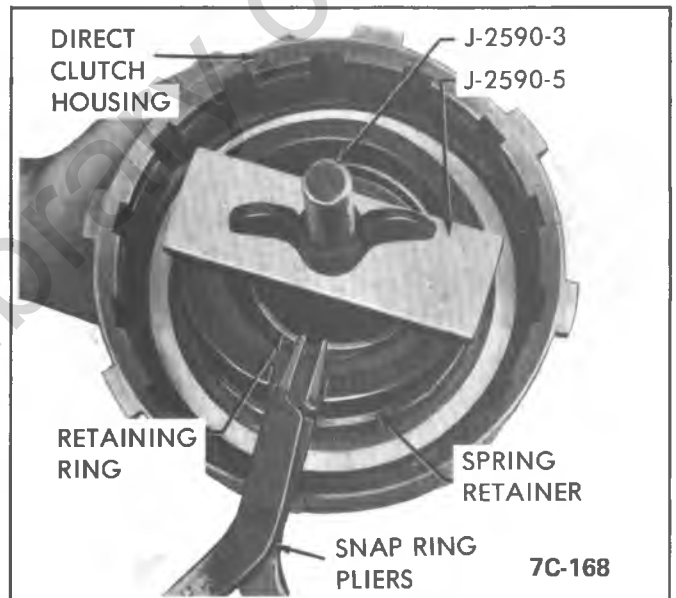

Figure 7A3-82 Piston Snap Ring Removal

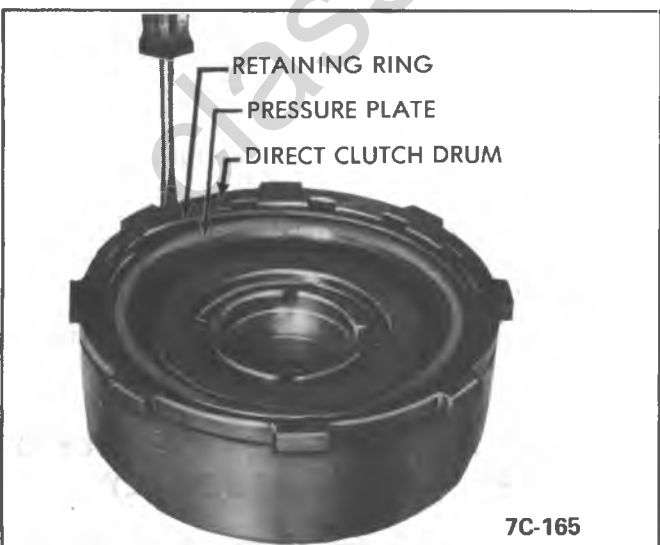

Figure 7A3-80 Disassembly of Direct Clutch

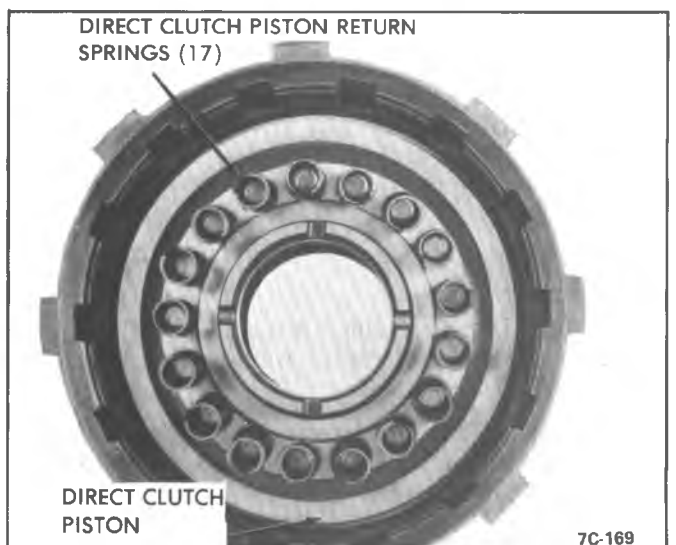

Figure 7A3-83 Install Piston Return Springs

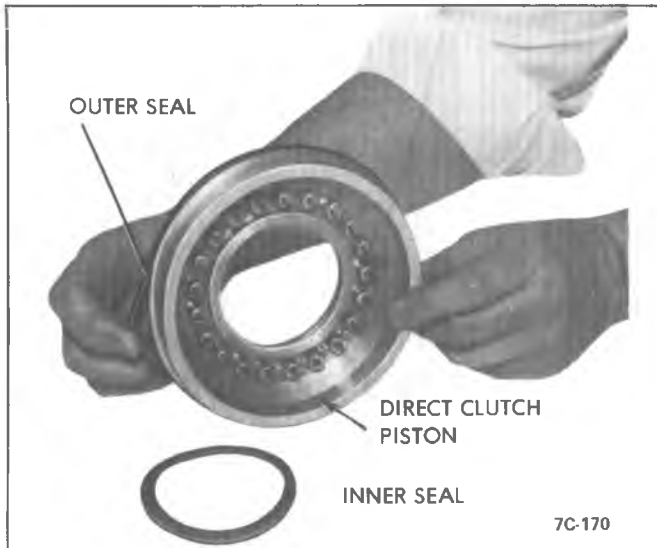

Figure 7A3-84 Install Piston Seals

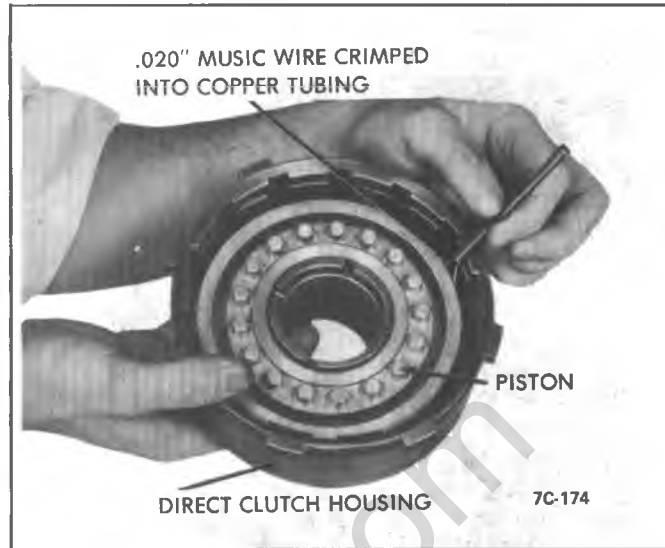

Figure 7A3-86 Install Piston

12. Remove direct clutch piston center seal. See Figure 7A3-85.

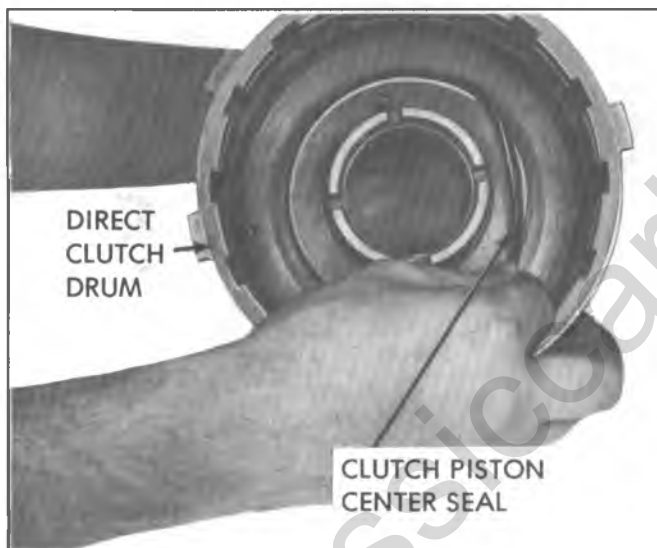

Figure 7A3-85 Install Center Seal

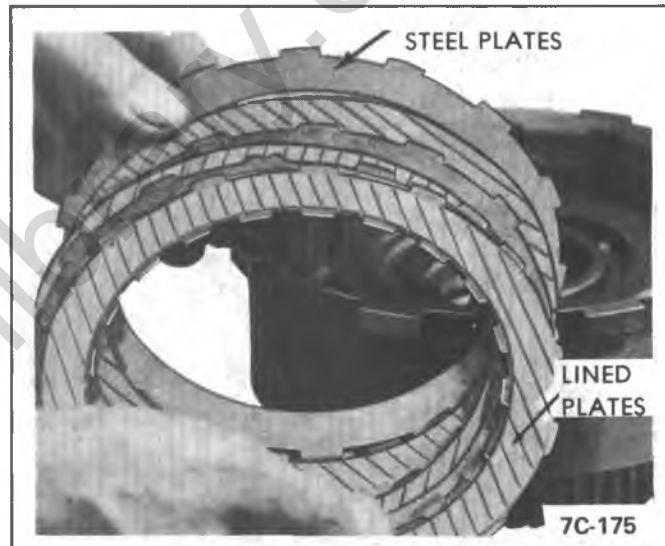

Figure 7A3-87 Install Clutch Plates

### Reassembly of Direct Clutch

1. Install new direct clutch piston outer seal and inner seal. See Figure 7A3-84.
2. Install new direct clutch piston center seal. See Figure 7A3-85.
3. Install the direct clutch piston into housing with the aid of a piece of .020" music wire crimped into copper tubing. See Figure 7A3-86.
4. Install spring retainer and springs. Compress spring retainer and install retaining ring, using Tools J-2590-3 and J-2590-5. See Figure 7A3-82.
5. Lubricate with transmission fluid and install faced plates and steel separator plates starting with a steel plate and alternating steel and faced. See Figure 7A3-87.
6. Install direct clutch pressure plate and retaining ring. See Figure 7A3-80.

7. Install intermediate overrun roller clutch assembly. See Figure 7A3-89. Roller clutch assembly must be assembled with four (4) holes up (toward front of transmission).

8. Install intermediate clutch overrun outer race. See Figure 7A3-89.

When the intermediate overrun clutch outer race is installed, it should free wheel in the counterclockwise direction only.

9. Install intermediate overrun clutch retainer, and retaining ring. See Figure 7A3-89.

### DISASSEMBLY AND REASSEMBLY OF FORWARD CLUTCH ASSEMBLY

Refer to specifications in rear of this section to determine the required amount of lined and steel clutch plates to use with specific transmission model and engine combination. When replacing piston assembly specific part number must be used.

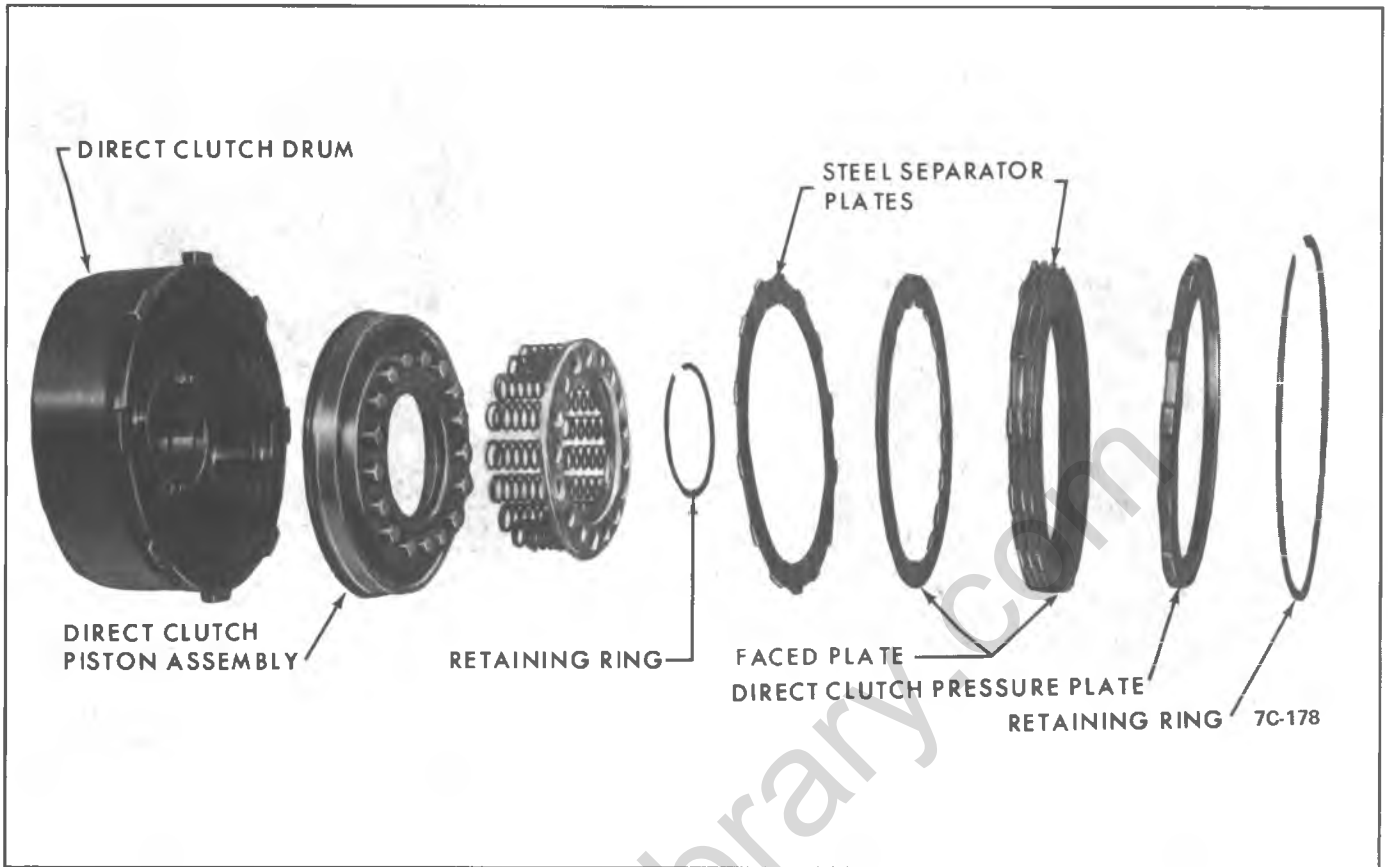

Figure 7A3-88 Direct Clutch Assembly - Exploded View

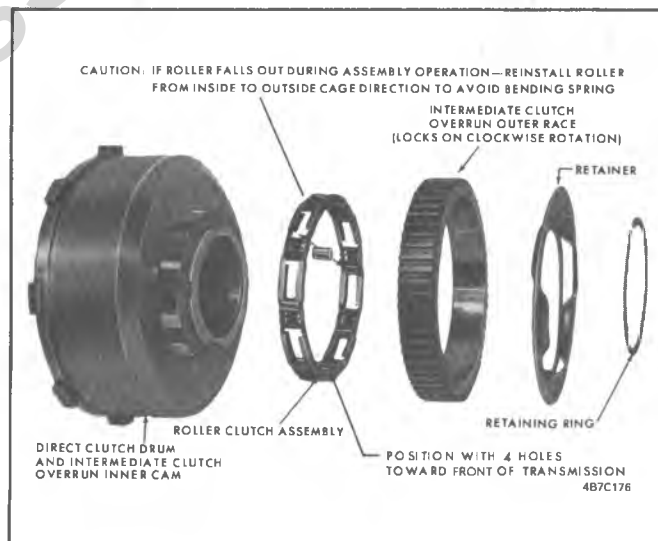

Figure 7A3-89 Intermediate Overrun Roller Clutch Assembly

## Disassembly of Forward Clutch

1. Remove forward clutch drum to pressure plate retaining ring. Remove forward clutch pressure plate. See Figure 7A3-90.

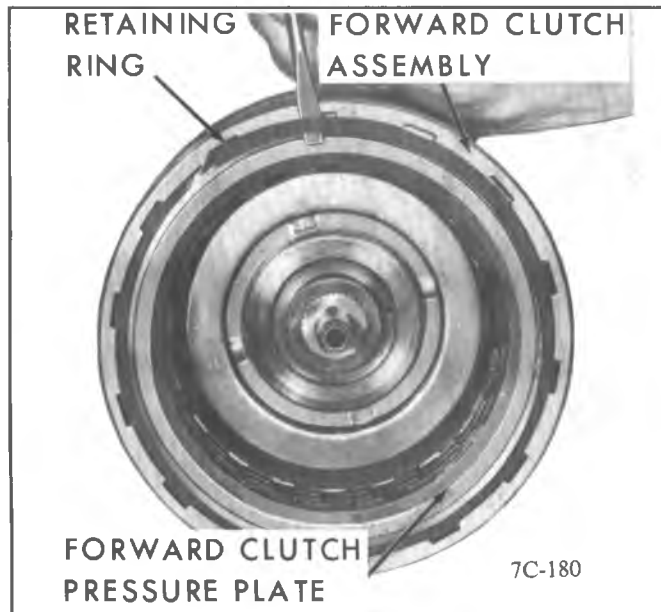

Figure 7A3-90 Forward Clutch Retaining Ring

2. Remove forward clutch housing faced plates, steel plates, and cushion spring. See Figure 7A3-91.

3. Inspect condition of lined and steel plates. *Do not diagnose a lined drive plate by color.*

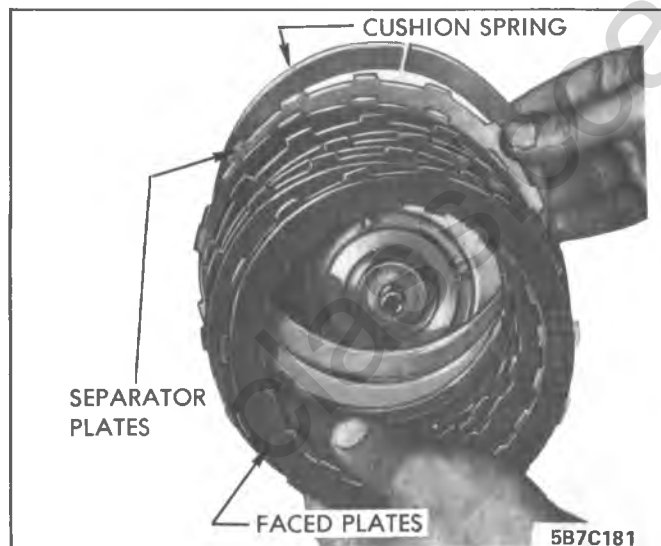

Figure 7A3-91 Forward Clutch Plates

4. Remove spring retainer and springs by compressing with a ram press. See Figure 7A3-92.

5. Inspect the return springs. Evidence of extreme heat or burning in the area of the clutch may have caused the springs to take a heat set and would justify replacement of the springs.

6. Remove forward clutch piston assembly. See Figure 7A3-94.

7. Remove forward clutch piston inner and outer seals. See Figure 7A3-95.

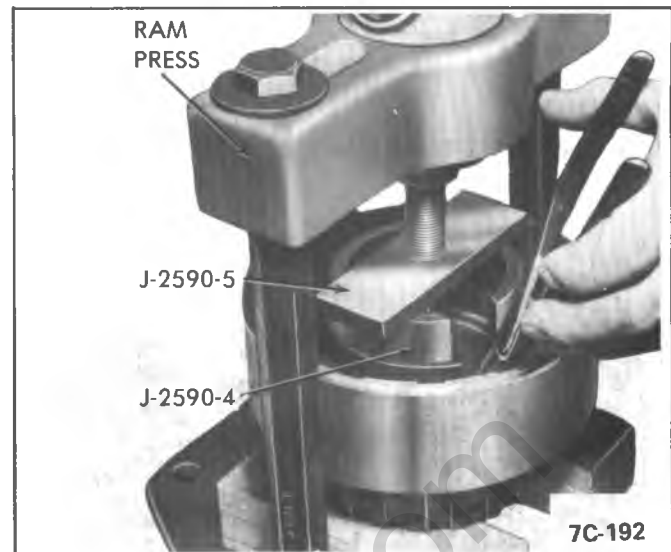

Figure 7A3-92 Forward Clutch Piston Snap Ring Removal

8. Make certain forward clutch ball check exhaust is free of dirt, etc. See Figure 7A3-96.

9. If the input shaft is scored excessively (Figure 7A3-97) it may be replaced using the following procedure.

a. Using wood blocks for support press input shaft out of forward clutch housing.

b. Taking care support forward clutch housing on rear thrust washer surface and press input shaft into housing until it is properly seated.

**NOTICE:** When pressing the input shaft into the forward clutch housing, care must be taken not to place excessive force on the pilot end of the input shaft as damage may result.

c. Runout at rear thrust washer surface should be no more than .005.

## INPUT SHAFT SEAL REMOVAL AND INSTALLATION

1. Inspect the input shaft seal ring for damage. If the seal is cut or otherwise damaged, it must be replaced. Some scoring and/or scuffing of the shaft is normal. Figure 7A3-97.

2. Remove seal with a sharp pointed knife by inserting under the seal and cutting, making sure not to damage the seal land area.

3. Install new seal using Tool J-28553 and a 9/16" box end wrench.

4. Position J-28553 with dowel peg inserted in end of shaft until taper fits down onto shaft.

5. Slide seal partially down taper of tool by hand.

6. Position 9/16" box end wrench over end of J-28553 and quickly push seal down taper and onto shaft and into groove. See Figure 7A3-98.

*Do not leave seal on untapered or middle of tool as this will stretch the seal excessively.*

7. The seal must now be sized. Dip end of input shaft into automatic transmission fluid to lubricate seal and shaft, slowly insert end of shaft with seal into output shaft three times before final assembly.

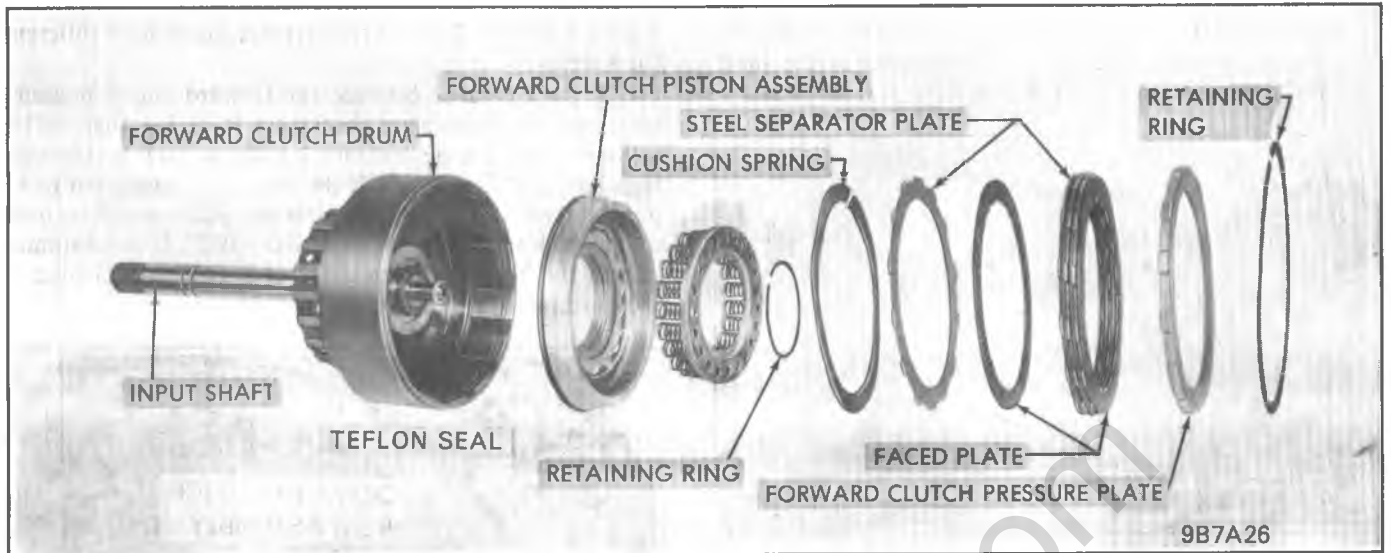

Figure 7A3-93 Forward Clutch Assembly Exploded View

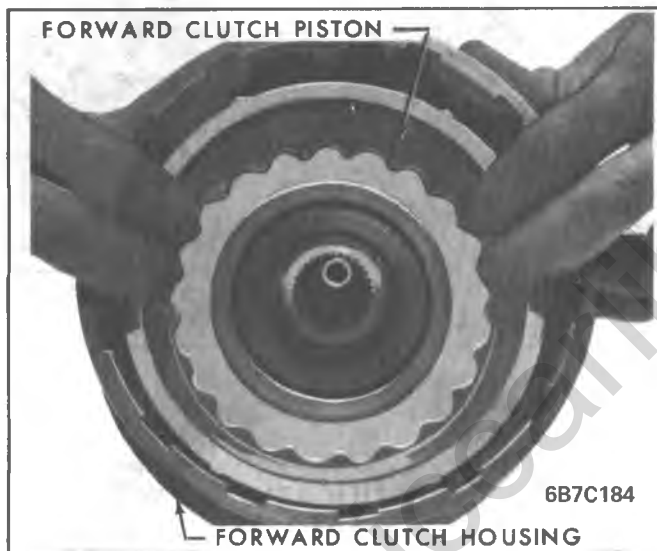

Figure 7A3-94 Forward Clutch Piston Removal

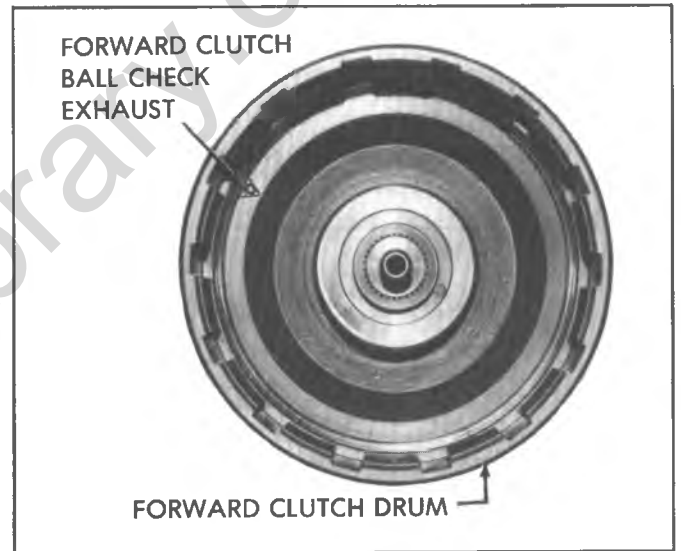

Figure 7A3-96 Ball Exhaust Location

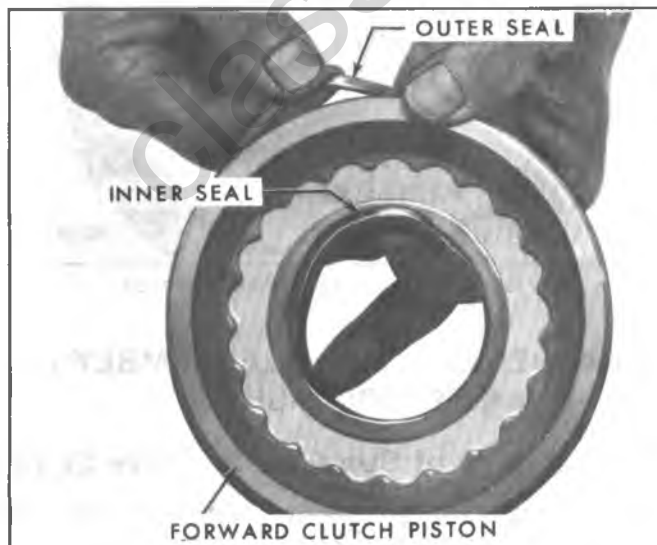

Figure 7A3-95 Piston Seal Removal

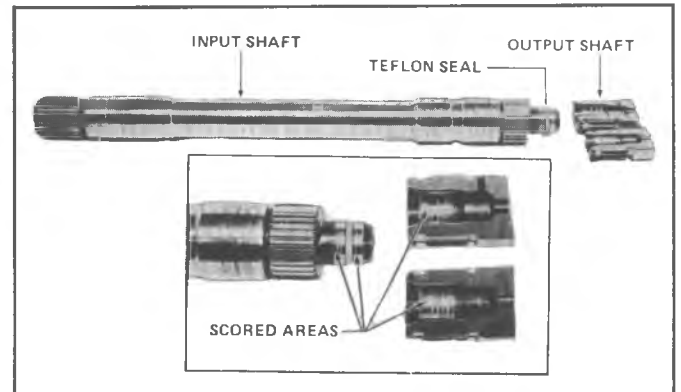

Figure 7A3-97 Normal Scuffing and Scoring

8. Check that the seal has not been cut and is free in the groove.

**NOTICE:** All service input shafts will be provided with the seal design incorporated, therefore when replacing an input shaft with a bronze bushing between input and

output shaft, the bronze bushing must be removed from the output shaft and the inside diameter of the shaft polished to accept the new seal.

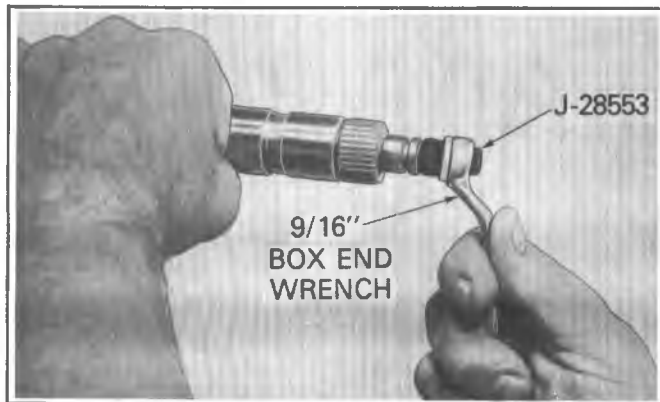

Figure 7A3-98 Installing Input Shaft Seal

Figure 7A3-101. These three pressure plates have different thicknesses.

If the clearance between the forward clutch pressure plate and the faced plate checks out to be less than .011", a thinner pressure plate should be used to have a clearance between .011" and .082". If the clearance checks out to be greater than .082", a thicker pressure plate should be used to have a clearance between .011" and .082". If the clearance checks out to be between .011" and .082", no change of pressure plate is necessary.

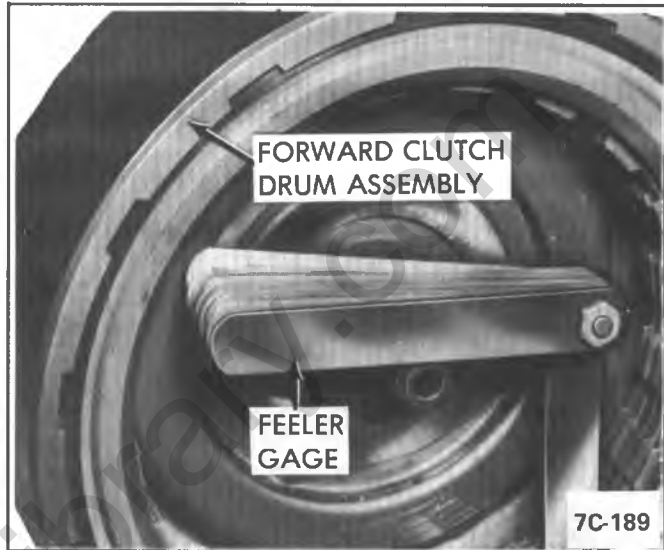

Figure 7A3-100 Checking Pressure Plate Clearance

### Reassembly of Forward Clutch Assembly

1. Install the forward clutch inner piston seal and outer piston seal. See Figure 7A3-91.
2. Install the forward clutch piston assembly using a thin feeler gage. See Figure 7A3-99.

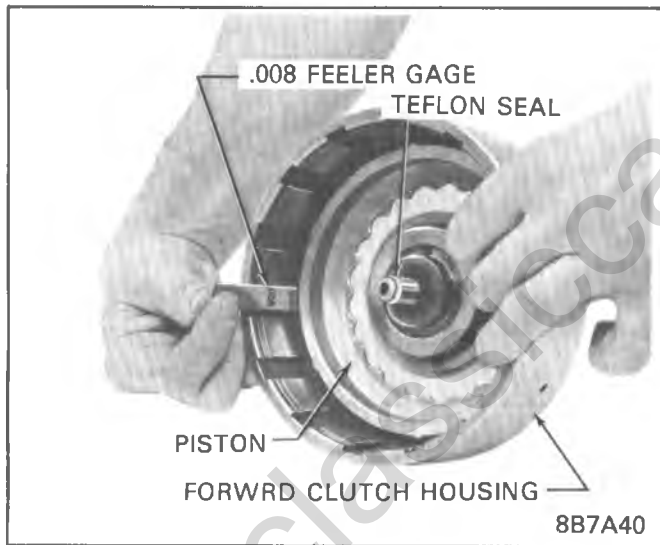

Figure 7A3-99 Installing Clutch Piston

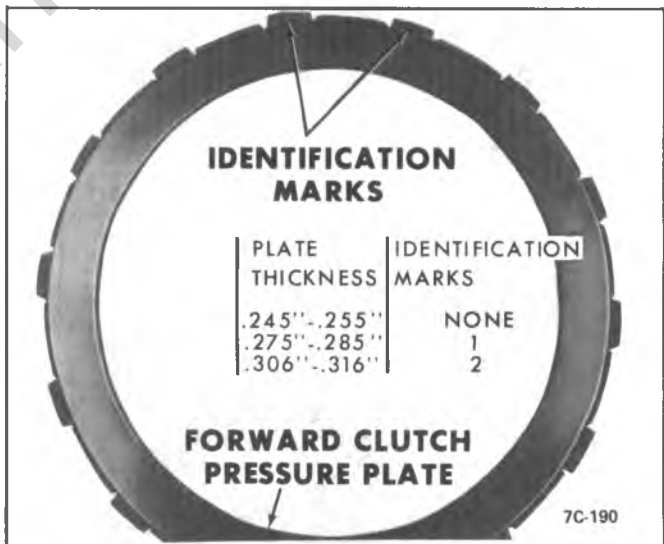

Figure 7A3-101 Pressure Plate Selection

3. Install spring retainer and springs. Compress spring retainer with an arbor press or ram press. See Figure 7A3-92.

4. Lubricate with transmission fluid and install cushion spring, faced plates and steel separator plates, starting with the cushion spring and alternating steel and faced. See Figure 7A3-93.

5. Install forward clutch pressure plate and retaining ring. Using a feeler gage check clearance between forward clutch pressure plate and faced plate. See Figure 7A3-100.

The specifications for this transmission call for a clearance of no less than .011" and no greater than .082". There are three pressure plates available which are identified by tangs adjacent to the source identification mark. See

### DISASSEMBLY AND REASSEMBLY OF SUN GEAR TO DRIVE SHELL

#### Disassembly of Sun Gear to Drive Shell

1. Remove sun gear to sun gear drive shell rear retaining ring. See Figure 7A3-102.
2. Remove sun gear to drive shell flat rear thrust washer. See Figure 7A3-103.
3. Remove front retaining ring from sun gear. See Figure 7A3-104.

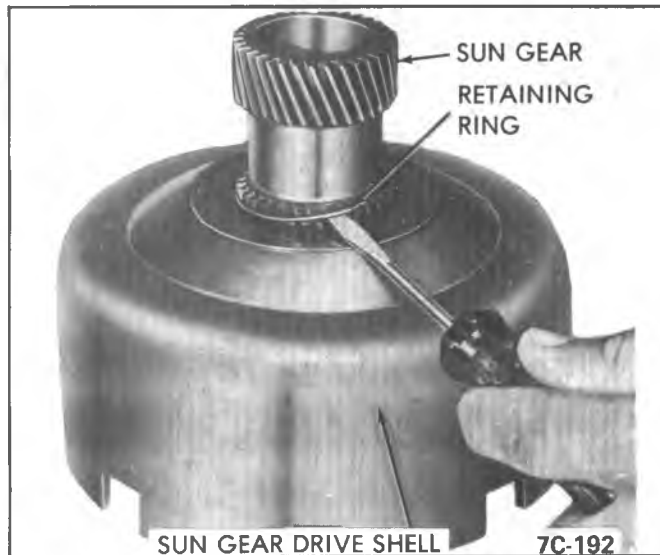

Figure 7A3-102 Sun Gear Retaining Ring Removal

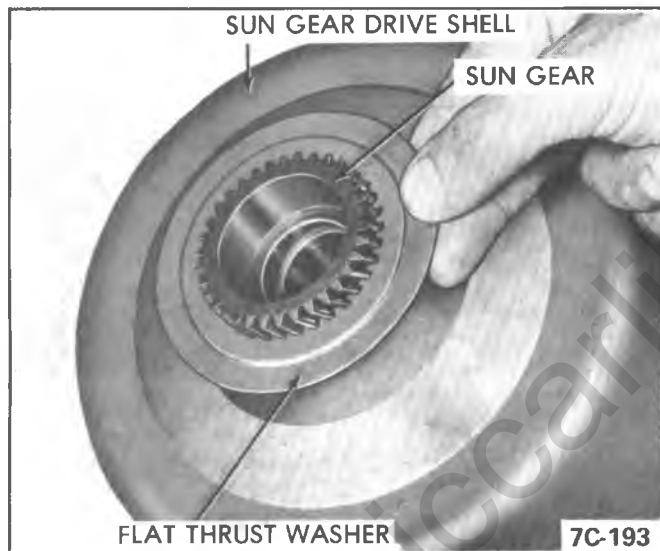

Figure 7A3-103 Sun Gear Drive Shell Flat Washer

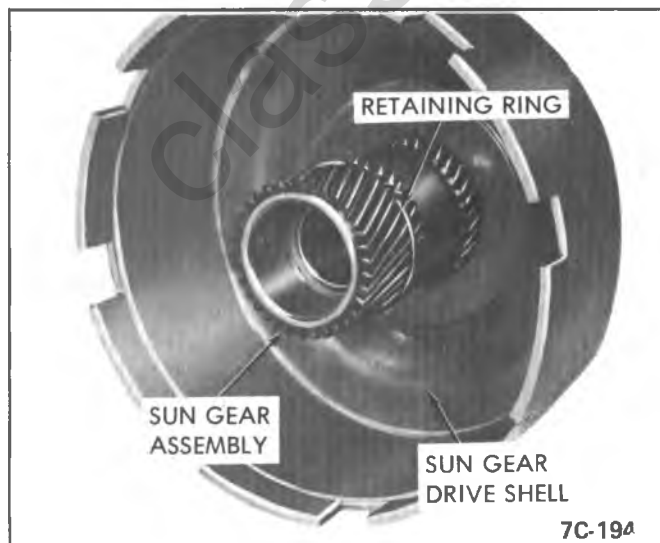

Figure 7A3-104 Front Retaining Ring Removal

### Reassembly of Sun Gear to Drive Shell

1. Install sun gear to drive shell front retaining ring, and install into drive shell. See Figure 7A3-104. Use a new ring and do not overstress when installing.
2. Install sun gear to drive shell flat thrust washer. See Figure 7A3-103.
3. Install sun gear to sun gear drive shell rear retaining ring. See Figure 7A3-102. Use a new ring and do not overstress when installing.

### DISASSEMBLY AND REASSEMBLY OF LOW AND REVERSE ROLLER CLUTCH ASSEMBLY

#### Disassembly of Low and Reverse Roller Clutch Assembly (Refer to Figure 7A3-105)

1. Remove low and reverse clutch to sun gear shell thrust washer.
2. Remove low and reverse overrun clutch inner race.
3. Remove low and reverse roller clutch retaining ring.
4. Remove low and reverse roller clutch assembly and visually inspect the rollers for wearing and scoring and check for any springs that may be collapsed.

#### Reassembly of Low and Reverse Roller Clutch Assembly

1. Install low and reverse roller clutch assembly to inner race. See Figure 7A3-106. The inner race should free wheel in the clockwise direction only.
2. Install low and reverse overrun roller clutch assembly and inner race into the low and reverse clutch support. See Figure 7A3-107. Assemble with four (4) holes down or to rear of transmission.
3. Install low and reverse clutch to cam retaining ring. See Figure 7A3-108.
4. Install low and reverse clutch to sun gear drive shell thrust washer. See Figure 7A3-105.

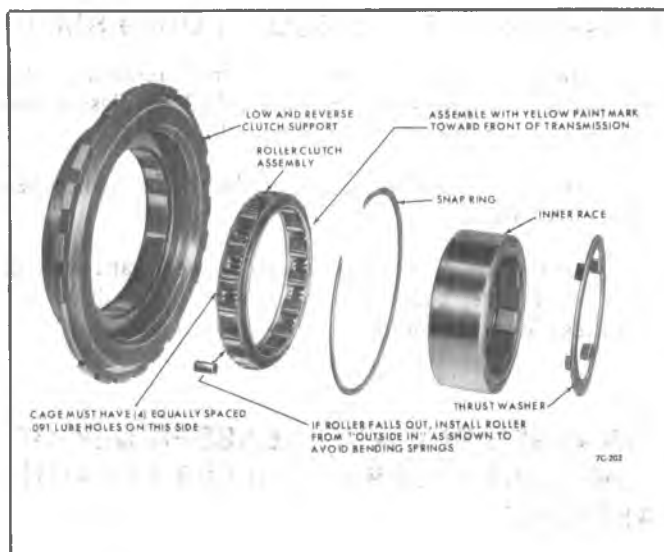

Figure 7A3-105 Low and Reverse Clutch Support and Overrun Roller Clutch Assembly

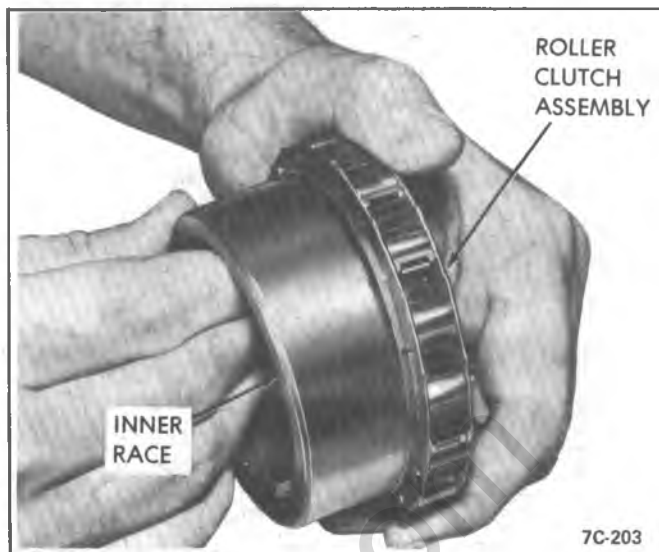

Figure 7A3-106 Checking Roller Clutch

## VALVE BODY DISASSEMBLY, INSPECTION AND REASSEMBLY

### Disassembly of Valve Body (Refer to Figure 7A3-110)

Transmission need not be removed from car to perform the following operations.

1. Position valve body assembly with cored face up.
2. Remove manual valve from lower left hand bore (J).
3. From lower right hand bore (A) remove the pressure regulator valve train retaining pin, boost valve sleeve, intermediate boost valve, reverse and modulator boost valve, pressure regulator valve spring, and the pressure regulator valve.
4. From the next bore (B), remove the 2-3 shift valve train retaining pin, sleeve, control valve spring, 2-3 shift control valve, shift valve spring, and the 2-3 shift valve.
5. From the next bore (C), remove the 1-2 shift valve train retaining pin, sleeve, shift control valve spring, 1-2 shift control valve, and the 1-2 shift valve.
6. From the next bore (E), remove retaining pin, plug, manual low control valve spring, and the manual low control valve.
7. From the next bore (F), remove the retaining pin, spring, seat, and the detent regulator valve.
8. Install Tool J-22269, on direct clutch 2-3 accumulator piston and remove retaining "E" ring. (G) See Figure 7A3-111.

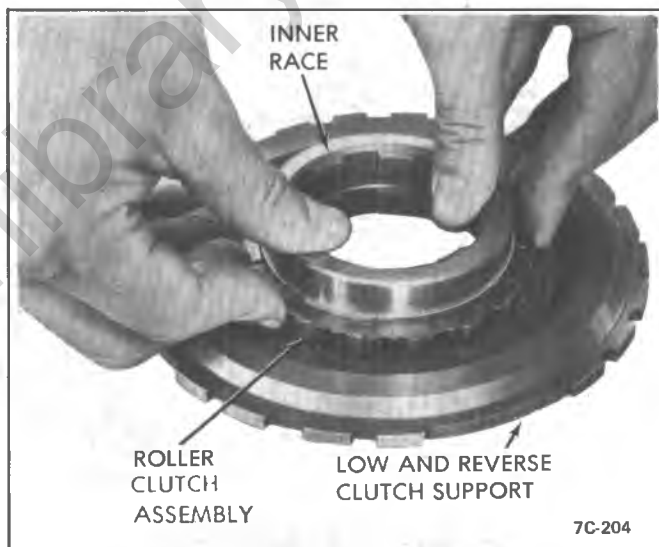

Figure 7A3-107 Install Roller Clutch Inner Race

9. Remove direct clutch 2-3 accumulator piston, and spring. (G) If the piston seal needs replacing the piston assembly will have to be replaced. (Piston and Seal are one assembly).

10. From the next bore down (D) from the direct clutch accumulator, remove the detent actuating lever bracket bolt, bracket, actuating lever and retaining pin, stop, spring retainer, seat, outer spring, inner spring, washer and the detent valve. Use care when handling valve body assembly as valve body sleeve retaining pins may fall out.



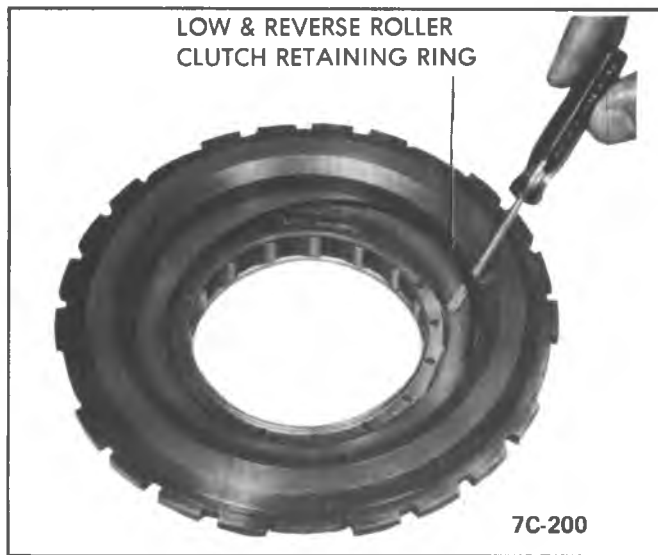

Figure 7A3-108 Install Roller Clutch Retaining Ring

### Valve Body Inspection

1. Inspect all valves for scoring, cracks and free movement in their respective bores.
2. Inspect valve body for cracks, scored bores, interconnected oil passages and flatness of mounting face.
3. Check all springs for distortion or collapsed coils.

### Reassembly of Valve Body

1. Install direct clutch accumulator piston spring and piston into valve body.
2. Install J-22269 and J-24675 (installs piston evenly) on direct clutch 2-3 accumulator piston and compress spring and piston and secure with retaining ring. See Figure 7A3-111. Align piston and oil seal ring when entering bore.
3. Install the detent valve, washer, outer spring, inner spring, spring seat, and spring retainer. Install detent valve stop and detent valve actuating bracket. Torque bolt to 52 lb. in. Assemble detent actuating lever with retaining pin.
4. Install the pressure regulator valve, spring, reverse and modulator boost valve, intermediate boost valve, boost valve sleeve and retaining pin.
5. In the next bore up, install 2-3 shift valve, shift valve spring, 2-3 shift control valve, shift control valve spring, shift control valve sleeve and retaining pin.
6. In the next bore up, install the 1-2 shift valve, 1-2 shift control valve, control valve spring, control valve sleeve and retaining pin.
7. In the next bore up, install the manual low control valve, spring, plug and retaining pin.
8. In the top right hand bore, install the detent regulator valve, spring seat, spring and retaining pin.

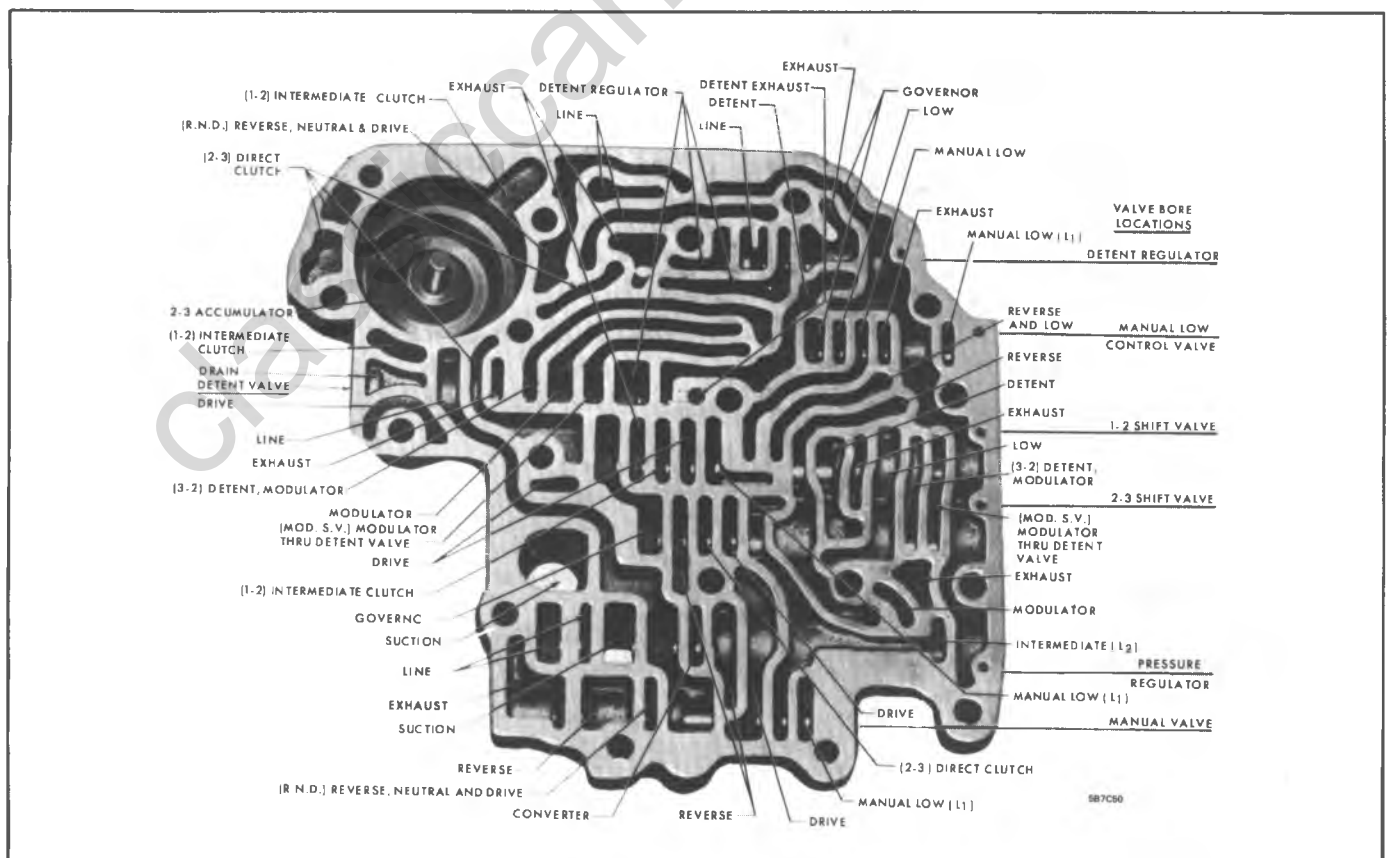

Figure 7A3-109 Identification of Oil Channels in Valve Body

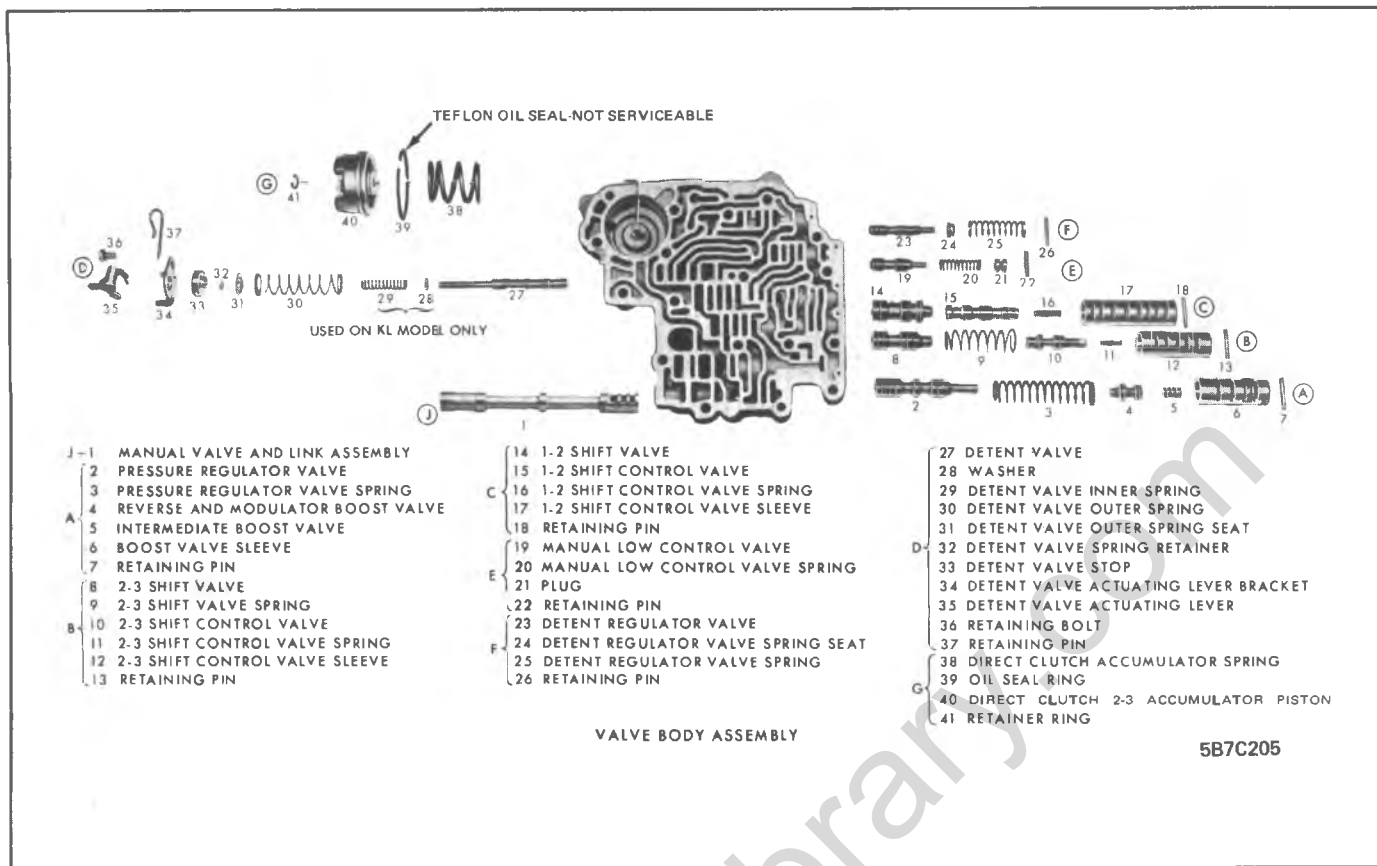

Figure 7A3-110 Valve Body - Exploded

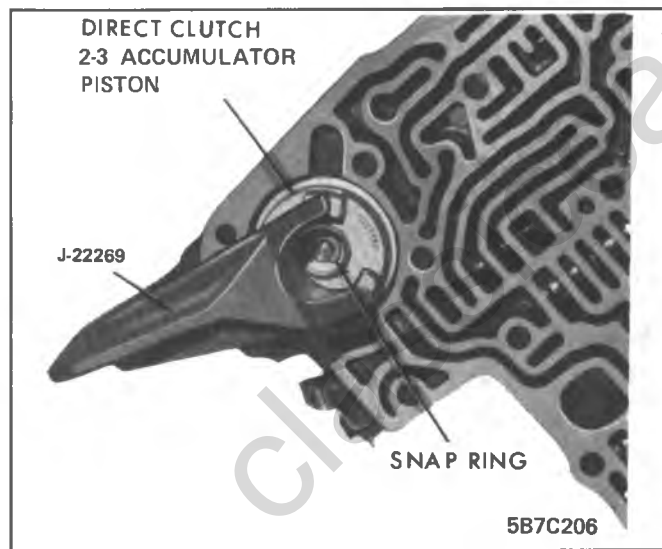

Figure 7A3-111 Removing 2-3 Accumulator

## REASSEMBLY OF TRANSMISSION

### General Instructions

1. Before starting to assemble the transmission make certain that all parts are *absolutely clean*. Keep hands and tools clean to avoid getting dirt into assembly. If work is stopped before assembly is completed cover all openings with clean cloths.

2. When reassembling it is important that all thrust washer surfaces be given an initial lubrication. Bushings should be lubricated with transmission fluid. Thrust

washers should be lubricated on both surfaces with petrolatum before installation.

3. Use care to avoid making nicks or burrs on parts, particularly on surfaces where gaskets are used.

4. It is extremely important to tighten all parts evenly and in proper sequence, to avoid distortion of parts and leakage at gaskets and other joints. *Use a reliable torque wrench to tighten all bolts and nuts to specified torque and in the specified sequence.*

### Installation of Low and Reverse Clutch Piston

1. Install low and reverse clutch piston outer seal. See Figure 7A3-112.

2. Install low and reverse clutch piston center and inner seal. See Figure 7A3-113.

3. Install low and reverse clutch piston assembly with notch in piston installed adjacent to parking pawl. See Figure 7A3-114.

4. Position piston return seat and springs. Place snap ring on return seat so that ring may be easily installed when seat is compressed with Tool J-21420.

5. Using tool J-21420-1 compress return seat so spring retainer retaining ring may be installed with snap ring pliers. See Figure 7A3-115.

As spring retainer is compressed make certain inner edge of retainer does not hang up on snap ring groove.

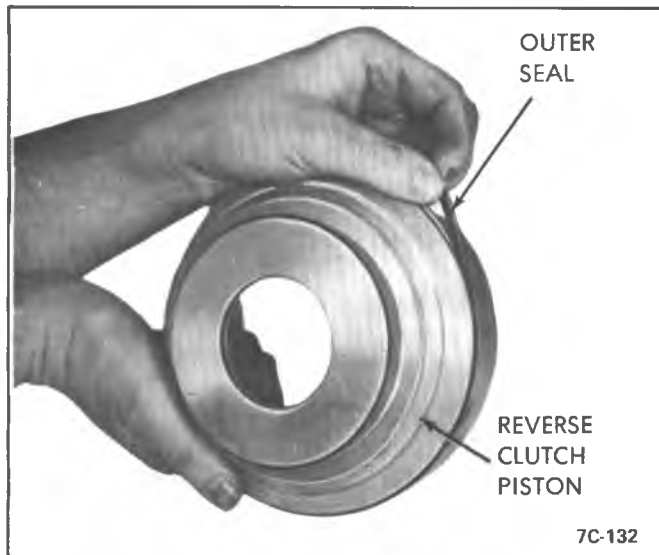

Figure 7A3-112 Installation of Outer Seal

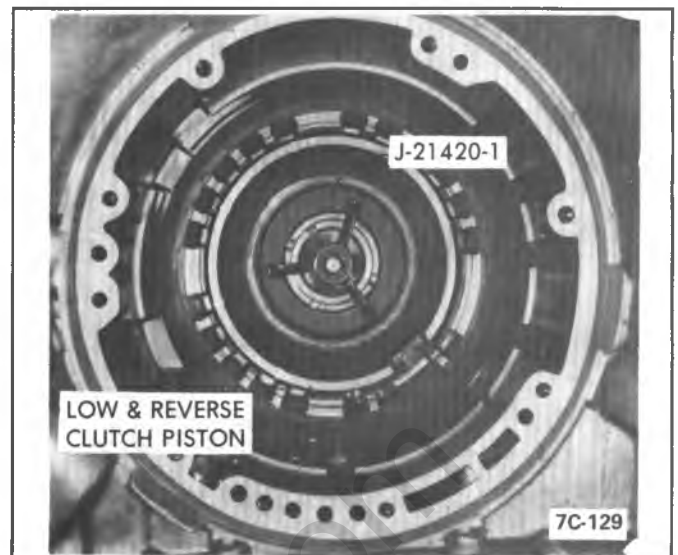

Figure 7A3-115 Low and Reverse Piston Snap Ring

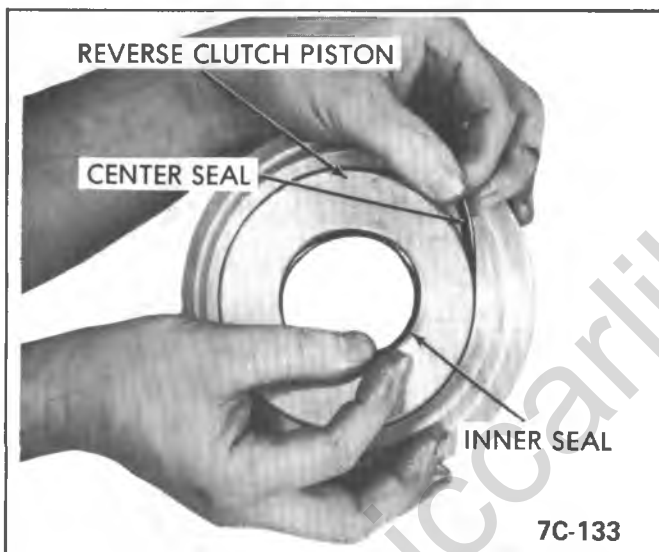

Figure 7A3-113 Installation of Inner and Center Seal

### Installing Output Shaft and Reaction Carrier

1. Install output ring gear to output shaft and output ring gear to output shaft snap ring. See Figure 7A3-116.

**DO NOT OVER STRESS SNAP RING ON ASSEMBLY. ALWAYS USE NEW RING ON REASSEMBLY.**

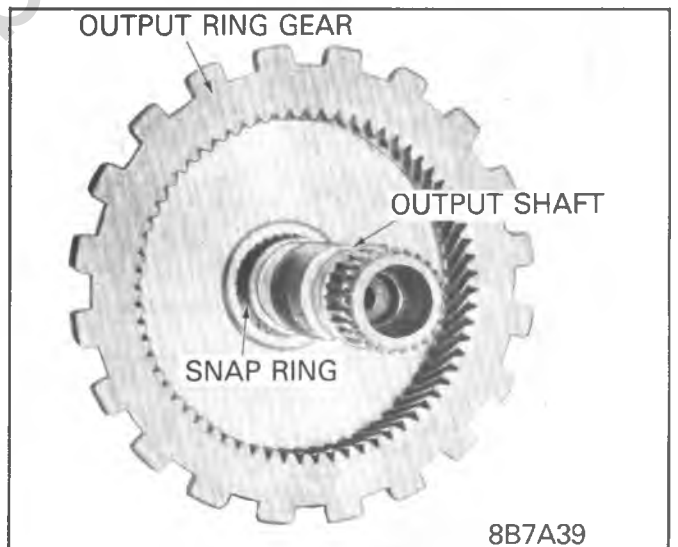

Figure 7A3-116 Output Ring Gear and Shaft Assembly

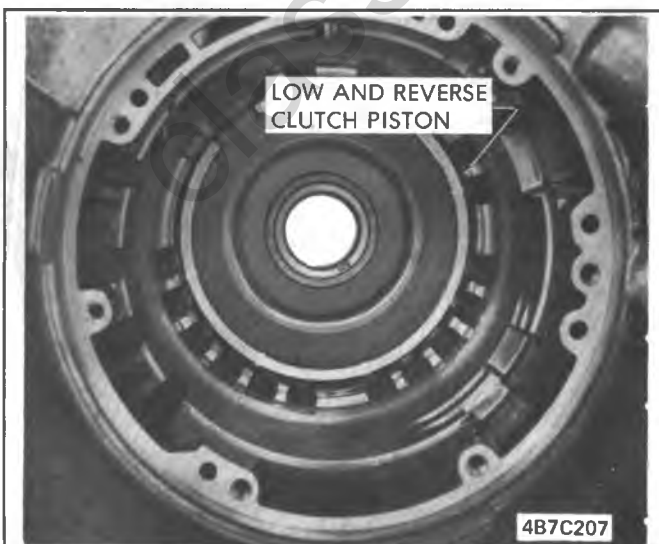

Figure 7A3-114 Installation of Low and Reverse Piston

2. Install reaction carrier to output ring gear needle thrust bearing with lip side face up. See Figure 7A3-117.

3. Install output ring gear to case needle bearing assembly. See Figure 7A3-118. Lip on inner race of bearing **MUST** point toward rear of transmission.

4. Install reaction carrier assembly into output ring gear and shaft assembly. See Figure 7A3-119.

5. Install output shaft and reaction carrier assembly into case.

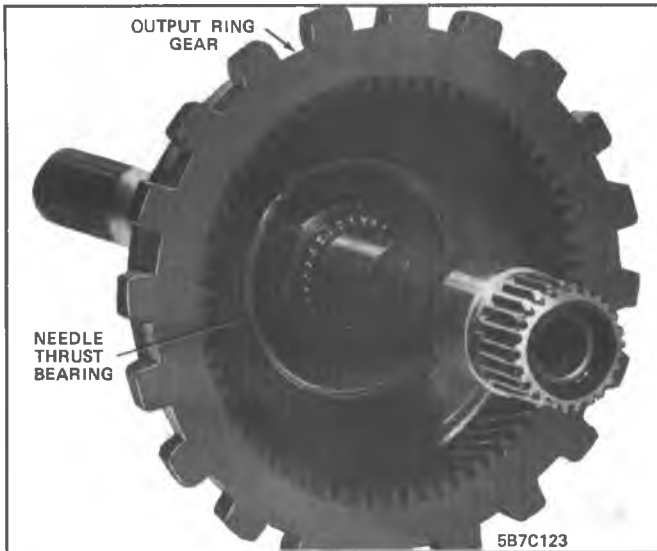

Figure 7A3-117 Needle Bearing Assembly

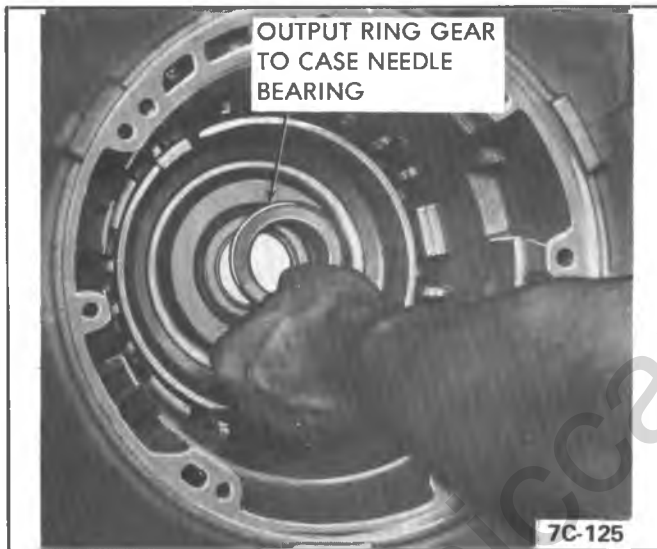

Figure 7A3-118 Needle Bearing Assembly

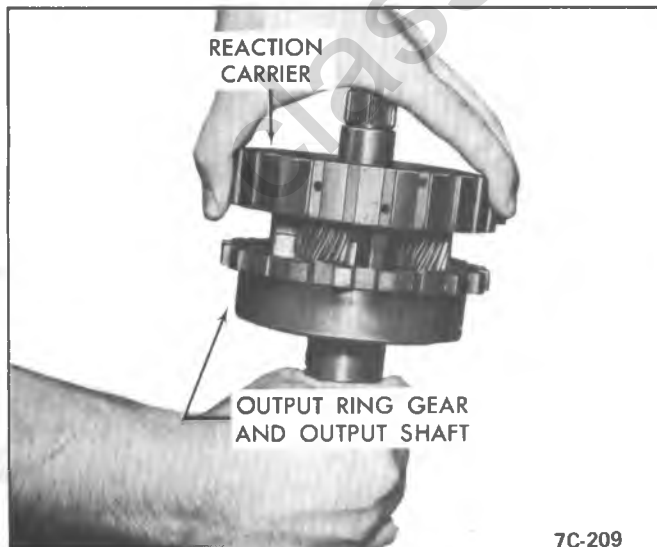

Figure 7A3-119 Installing Reaction Carrier

## Installing Low and Reverse Clutch Plates

**NOTICE:** Refer to specifications in rear of this section to determine the required amount of lined and steel clutch plates to use with specific transmission model and engine combination. When replacing piston assembly specific part number must be used.

1. Oil and install low and reverse clutch steel separator plates and faced plates, starting with a steel plate and alternating with faced plates. See Figure 7A3-120.

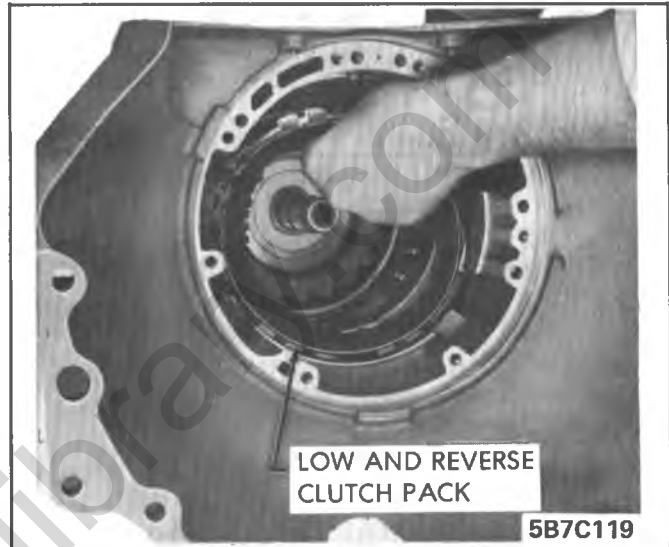

Figure 7A3-120 Installing Low and Reverse Clutch Plates

2. Install low and reverse clutch support retainer spring. See Figure 7A3-121.

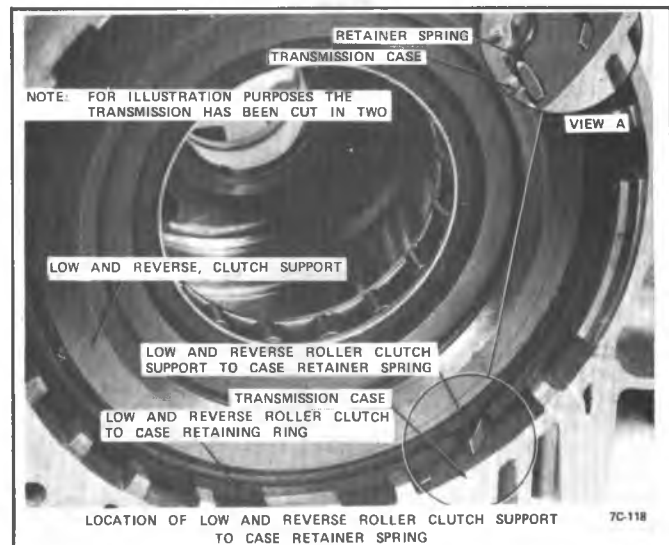

Figure 7A3-121 Retainer Location

3. Install low and reverse clutch support assembly pushing firmly until support assembly is seated past top of low and reverse clutch support retainer spring so retaining ring can be installed. See Figure 7A3-122.

Make certain the splines on inner race of the roller clutch align with splines on reaction carrier.

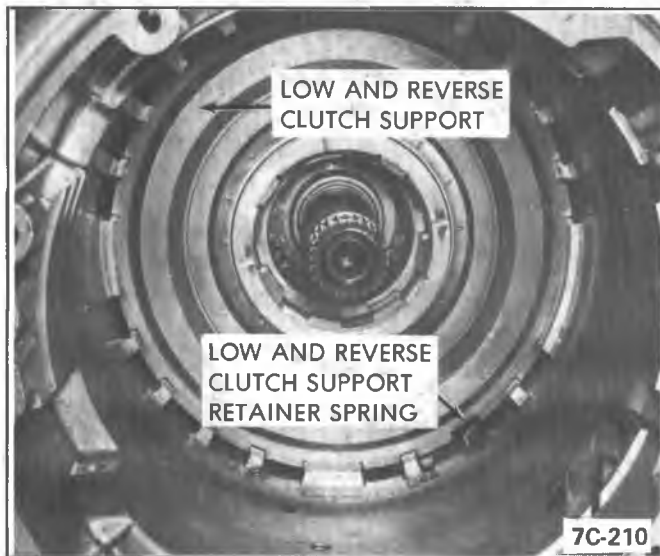

Figure 7A3-122 Low and Reverse Clutch Support

4. Install low and reverse clutch support to case retaining ring. See Figure 7A3-121.

### Installing Sun Gear Drive Shell Assembly

1. Install low and reverse clutch support inner race to sun gear drive shell thrust washer and install sun gear drive shell assembly. See Figure 7A3-123.

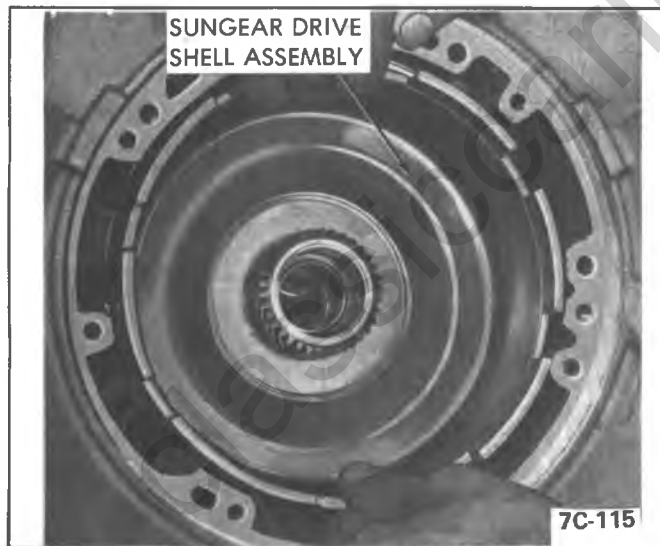

Figure 7A3-123 Sun Gear Drive Shell Assembly

### Installing Output Carrier Assembly

1. Install output carrier assembly. See Figure 7A3-124.
2. Install input ring gear to output carrier needle thrust bearing lip side face down. See Figure 7A3-125.
3. Install output carrier to output shaft snap ring.  
Use new snap ring and do not over stress on installing. See Figure 7A3-125.

### Installing Input Ring Gear

1. Install input ring gear. See Figure 7A3-126.

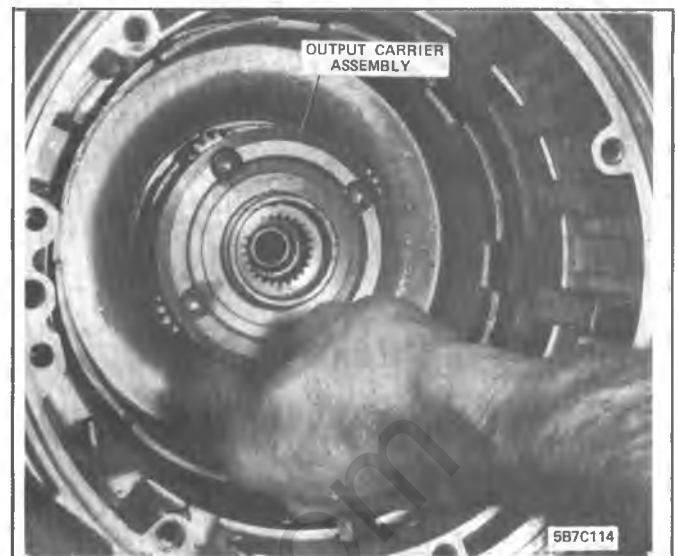

Figure 7A3-124 Install Output Carrier

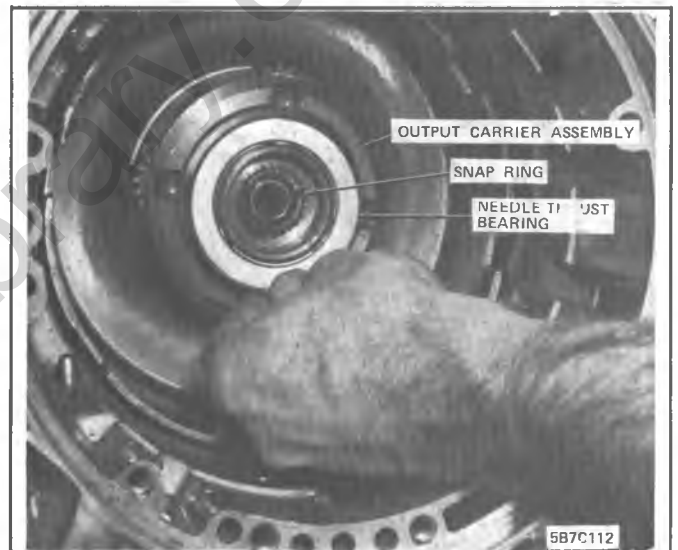

Figure 7A3-125 Output Carrier Needle Bearing

2. Install forward clutch housing to input ring gear front thrust washer. See Figure 7A3-120. Washer has three (3) tangs.

### Installing Direct and Forward Clutch Assemblies

1. Install direct clutch drum to forward clutch housing needle roller bearing. See Figure 7A3-127.
2. Install direct clutch assembly to forward clutch assembly. Install assemblies into case making certain forward clutch faced plates are positioned over input ring gear and the tangs on direct clutch housing are installed into slots on the sun gear drive shell. See Figure 7A3-128.

### Installing Intermediate Clutch Overrun Brake Band

1. Install intermediate clutch overrun brake band. See Figure 7A3-129.

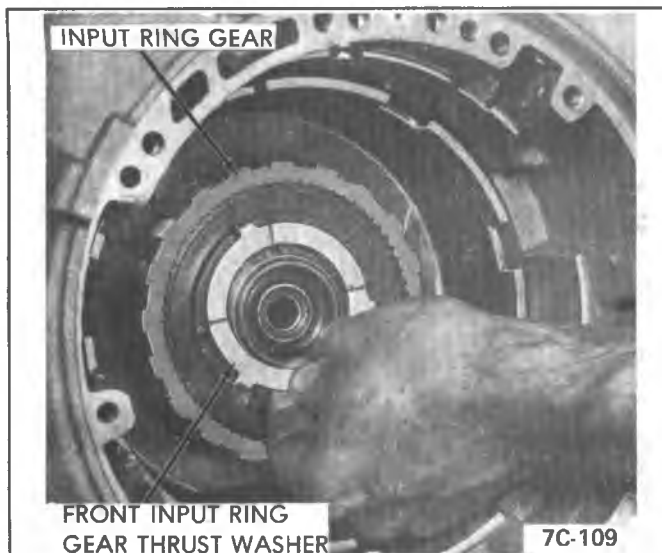

Figure 7A3-126 Input Ring Gear Thrust Washer

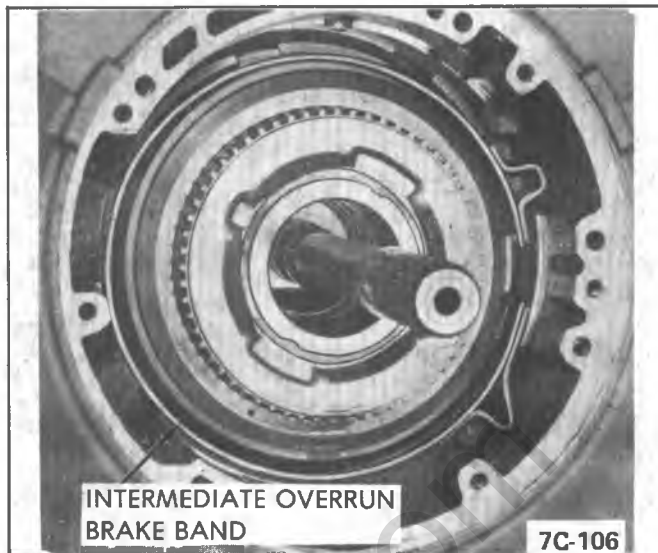

Figure 7A3-129 Install Intermediate Band



Figure 7A3-127 Forward Clutch Needle Bearing

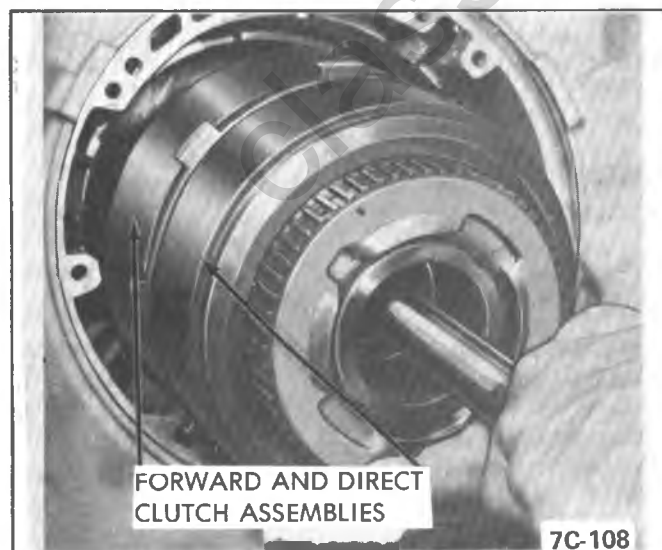

Figure 7A3-128 Install Forward and Direct Clutch Assembly

### Installing Intermediate Clutch Pressure Plate, Clutch Plates, and Cushion Spring

**NOTICE:** Refer to specifications in rear of this section to determine the required amount of lined and steel clutch plates to use with specific transmission model and engine. When replacing piston assembly specific part number must be used.

1. Install intermediate clutch pressure plate. See Figure 7A3-130.

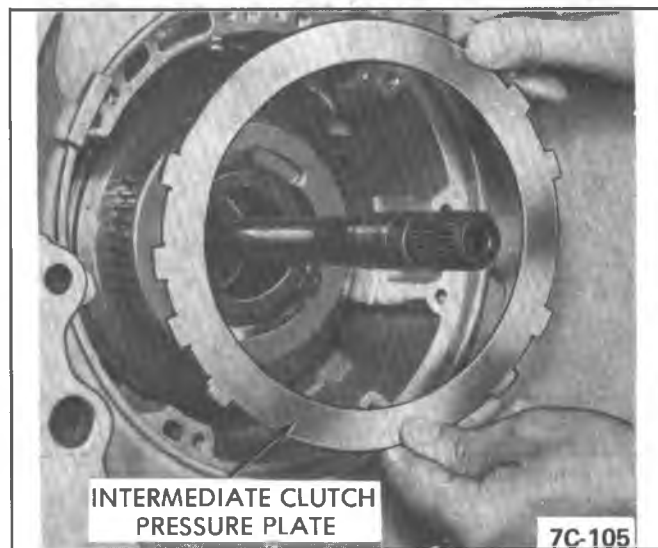

Figure 7A3-130 Intermediate Clutch Pressure Plate

2. Oil and install lined and steel intermediate clutch plates, starting with a lined plate and alternating steel and lined. See Figure 7A3-131.

3. Install intermediate clutch cushion spring. See Figure 7A3-132.

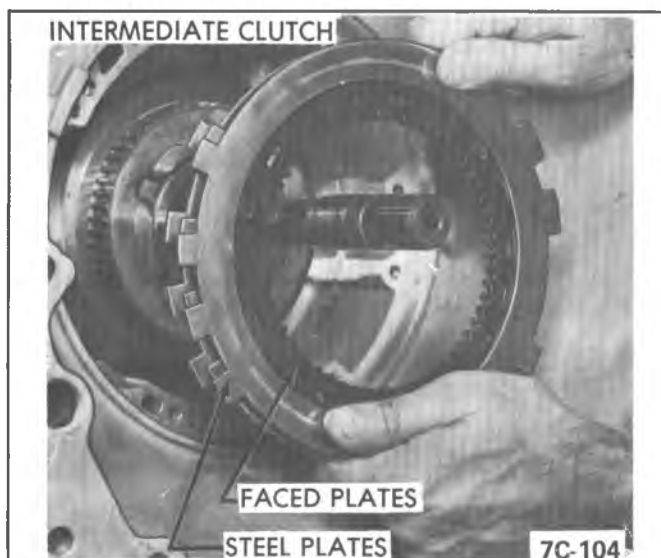

Figure 7A3-131 Intermediate Clutch Plates

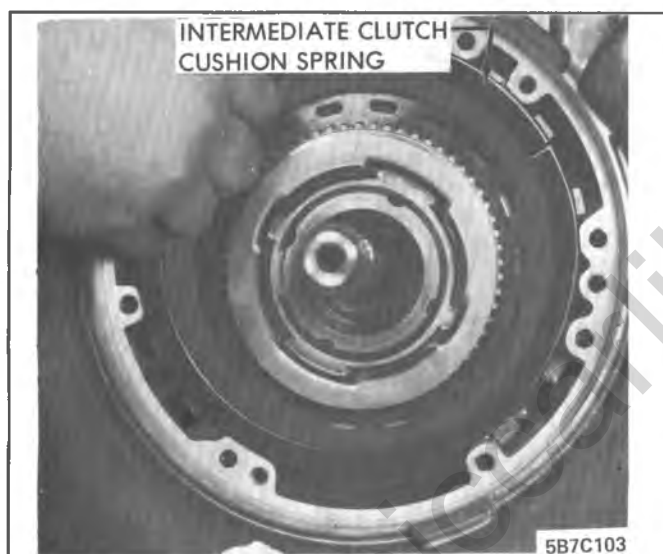

Figure 7A3-132 Intermediate Clutch Cushion Spring

### Installing Oil Pump Assembly

1. Install original amount of .017 shims, and needle thrust bearing lip side face down on pump cover hub. Before installation apply petrolatum to both sides of shim and bearing. See Figure 7A3-133.

2. Install new pump assembly to case gasket. See Figure 7A3-134. Before installing pump lubricate case bore.

3. Install guide pins into case. Install pump assembly into case, remove guide pins and install pump to case bolts. Using new washer type seals tighten alternately to 20 ft. lbs. (27 N·m) torque. See Figure 7A3-135.

4. If input shaft cannot be rotated as the pump is being pulled into place, the direct and forward clutch housings have not been properly installed to index the faced plates with their respective parts. This condition must be corrected before the pump is pulled into place.

5. Checking direct clutch to oil pump clearance, attach slide hammer bolt to threaded hole in oil pump. See Figure 7A3-136. With flat of hand on end of input shaft move shaft rearward. Install Dial Indicator Set J-8001 on rod and "O" dial indicator on end of input shaft. Push on end of output

shaft to move shaft forward, the reading obtained should be between .010 and .044. If the reading is incorrect remove pump assembly and install zero, one, or two .017 shims to obtain correct reading. See Figure 7A3-133.

### Installing Speedometer Drive Gear

1. Place speedometer drive gear retaining clip into hole in output shaft. See Figure 7A3-137.

2. Align slot in speedometer drive gear with retaining clip and install. See Figure 7A3-137.

### Installing Extension Housing

1. Install extension housing to case square cut "O" - ring seal. See Figure 7A3-138.

2. Attach extension housing to case using attaching bolts. Torque to 35 ft.lbs. (47 N·m).

3. Install speedometer driven gear, retainer and bolt. Torque bolt to 12 ft.lbs. (16 N·m).

### Installing Parking Pawl and Actuating Rod

If internal linkage was removed proceed as follows:

1. Install parking pawl, tooth toward the inside of case. See Figure 7A3-139.

2. Install parking pawl shaft into case through disengaging spring. Install disengaging spring on parking pawl and slide shaft through parking pawl. See Figure 7A3-140.

3. Install parking pawl shaft retainer plug. Drive into case using a 3/8" dia. rod, until retainer plug is flush to .010" below face of case. Stake plug in three (3) places to retain plug in case. See Figure 7A3-141.

4. Install park lock bracket, torque bolts to 29 ft.lbs. (39 N·m). See Figure 7A3-142.

5. Install actuating rod under the park lock bracket, and parking pawl. See Figure 7A3-143.

### Installing Manual Shaft and Range Selector Inner Lever

1. If a new manual shaft to case lip seal is necessary, use a 7/8" diameter rod and seat flush with case. See Figure 7A3-144.

2. Install manual shaft through case and range selector inner lever.

3. Install retaining jam nut on manual shaft. Torque jam nut to 30 ft.lbs. (40 N·m). See Figure 7A3-145. Install manual shaft to case retainer.

### Installing Intermediate Servo Piston, Check Balls, Oil Pump Pressure Screen and Governor Feed Screens

1. Install park lock bracket and special bolts.

2. Install intermediate servo piston, apply pin, spring seat. See Figure 7A3-146.

3. Install four (4) check balls into correct transmission case pockets. See Figure 7A3-148. If number one (1) check

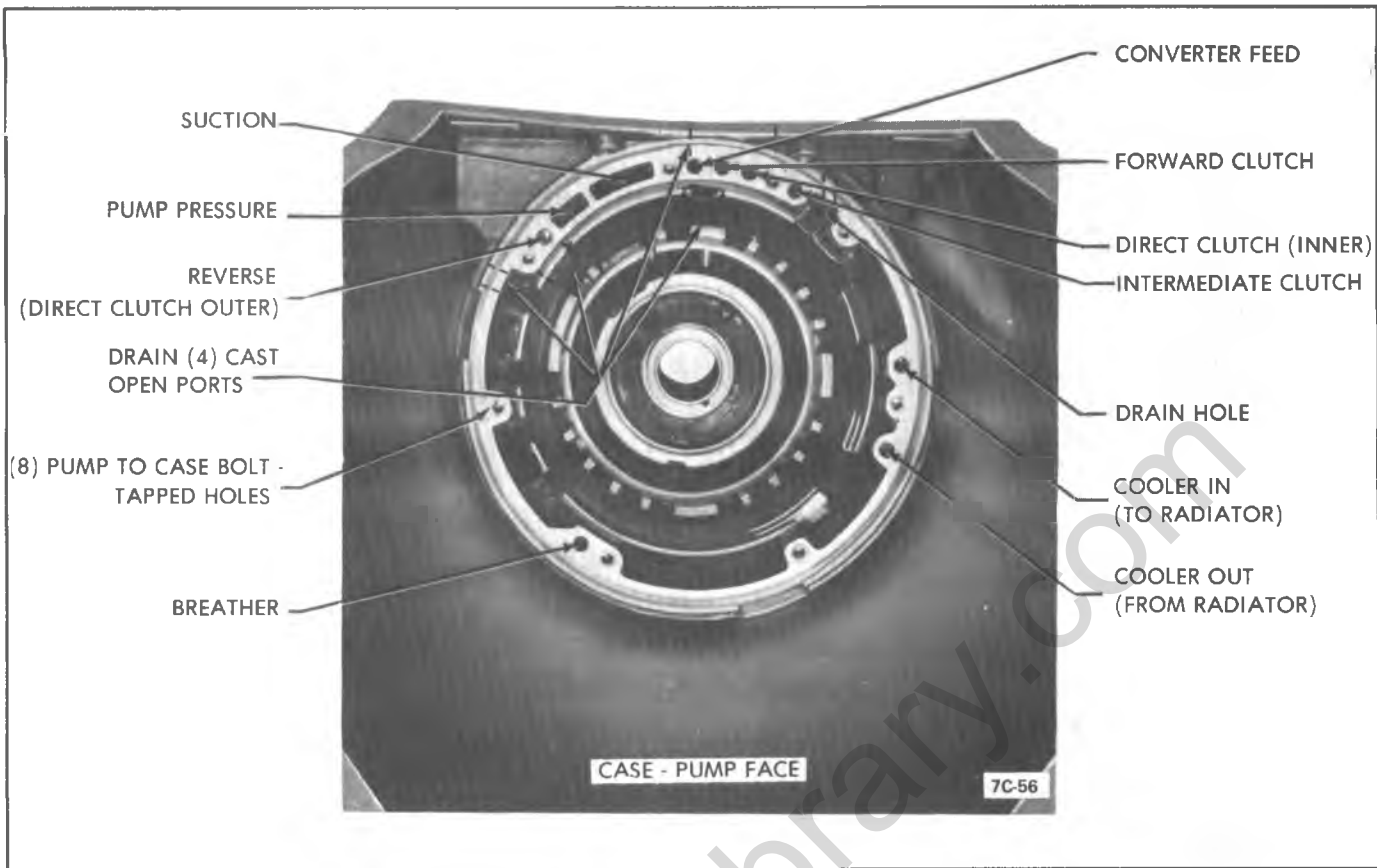

Figure 7A3-132A Case - Pump Identification of Oil Channels

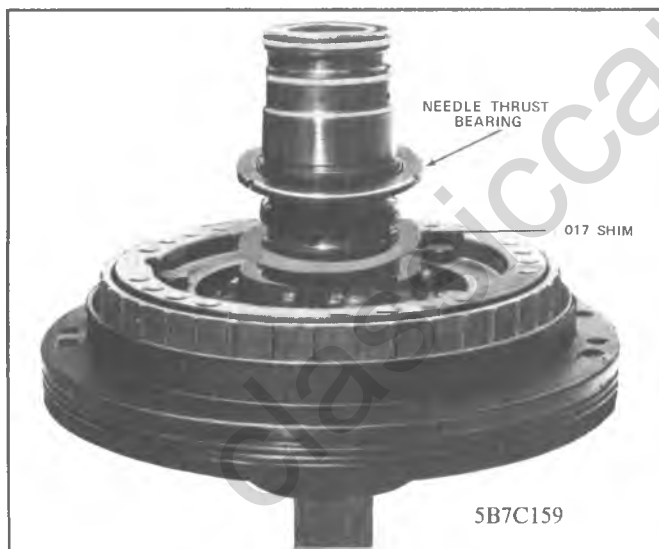

Figure 7A3-133 Pump Shim and Needle Bearing

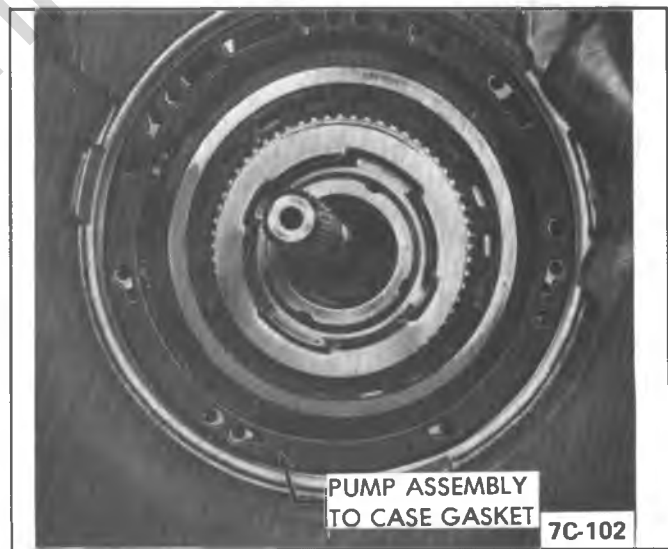

Figure 7A3-134 Pump Gasket

ball is omitted or incorrectly placed, transmission failure will result due to minimum line pressure. TCC Models - Install 5 check balls. Figure 7A3-146A

4. Install oil pump pressure screen in the oil pump pressure hole in case. Open end of screen must be installed toward case face. See Figure 7A3-149. (*Clean before installing*).

5. Install governor screen in the case. See Figure 7A3-150. (*Clean before installing*).

6. TCC Models - If removed, install case electrical connector with new "O" ring seal.

### Installing Valve Body, Detent Roller and Spring Assembly, and Filter

1. Install valve body spacer plate to case gasket, valve body spacer plate and spacer plate to valve body gasket. (This gasket has a yellow ink stripe for identification purposes.) See Figure 7A3-152.

2. Install spacer support plate. Torque bolts to 13 ft.lbs. (18 N·m). See Figure 7A3-153.

3. TCC Models - Install auxiliary valve body, torque bolts to 13 ft. lbs.



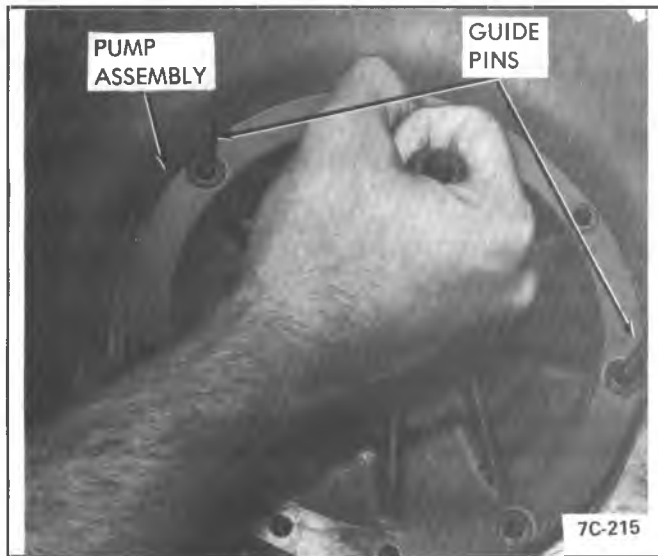

Figure 7A3-135 Installing Pump



Figure 7A3-138 Extension Oil Seal

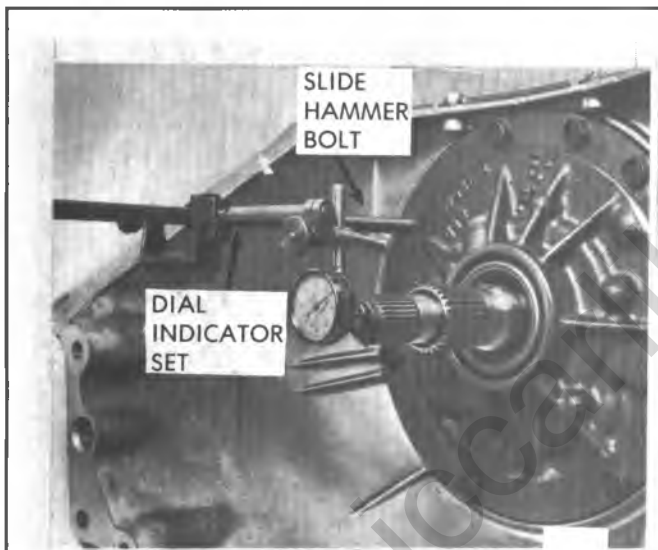

Figure 7A3-136 Checking End-Play



Figure 7A3-139 Install Parking Pawl

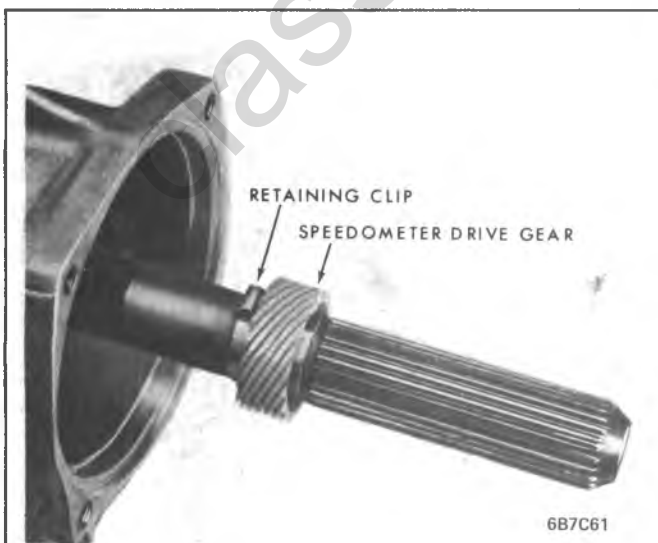

Figure 7A3-137 Speedo Gear and Clip

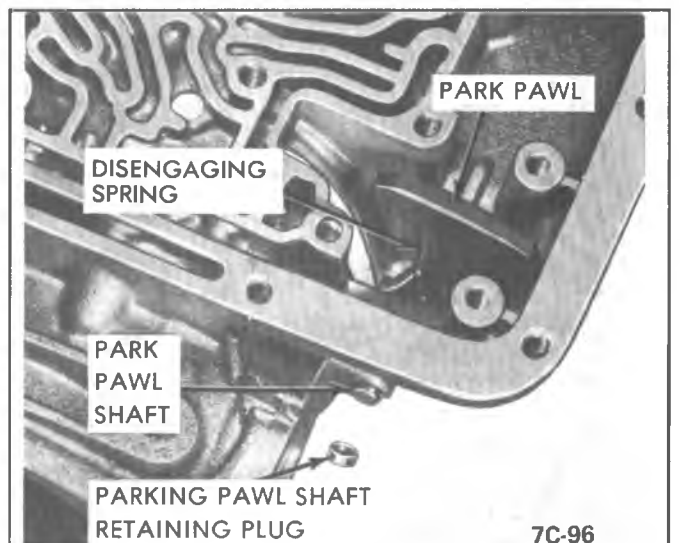

Figure 7A3-140 Parking Pawl Shaft and Retaining Plug

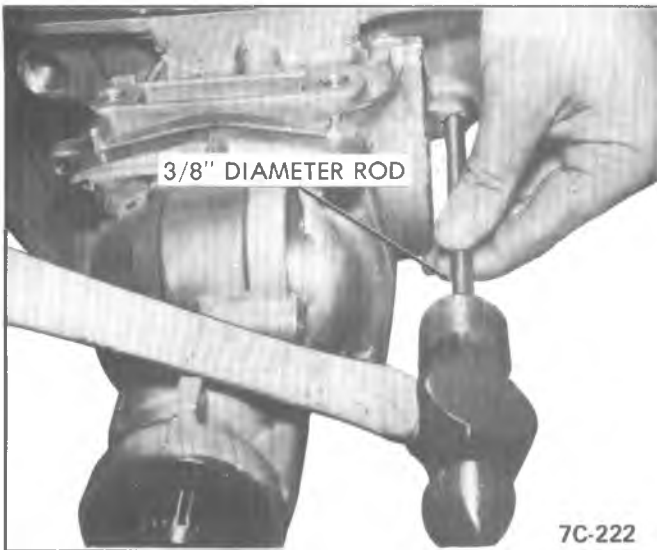

Figure 7A3-141 Install Retaining Plug

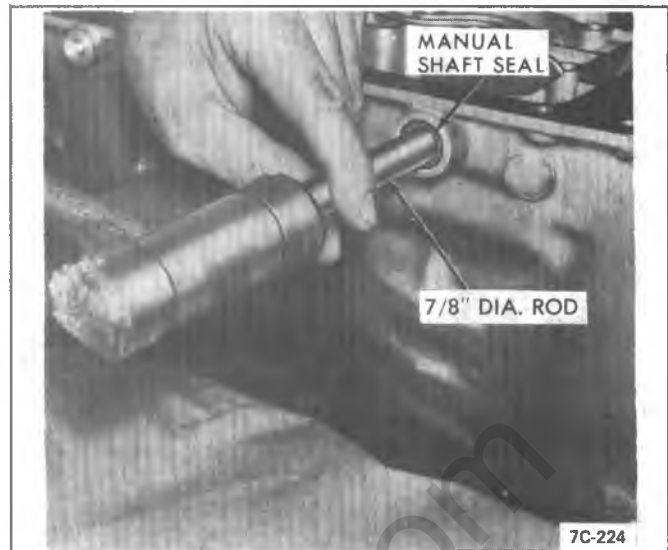

Figure 7A3-144 Seal Installation

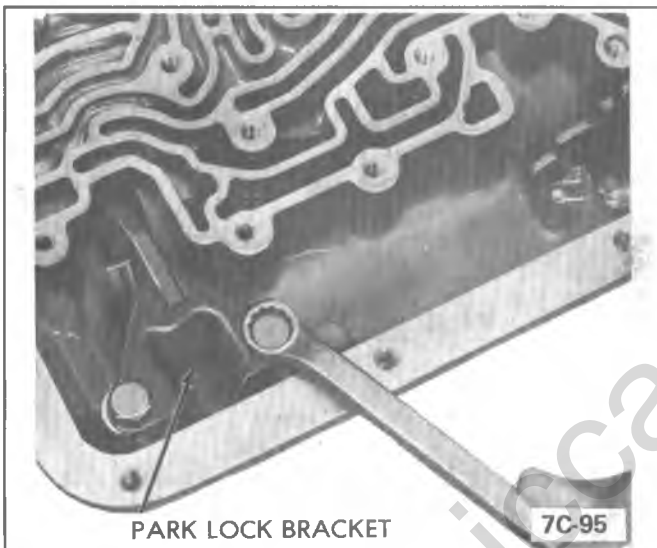

Figure 7A3-142 Install Park Lock Bracket

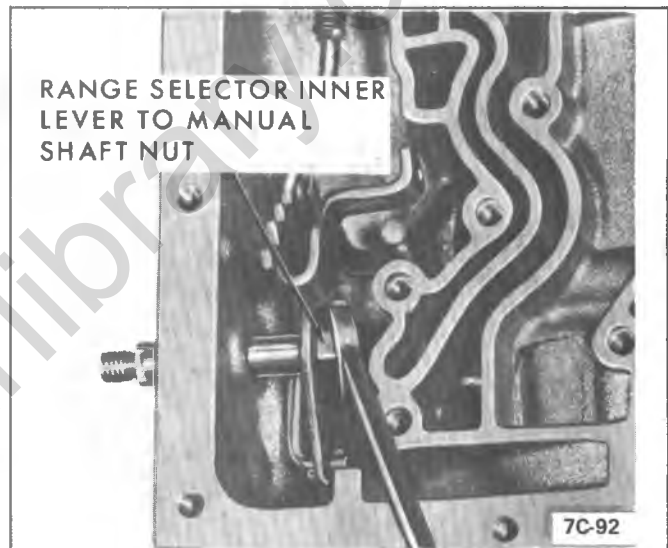

Figure 7A3-145 Manual Shaft Nut

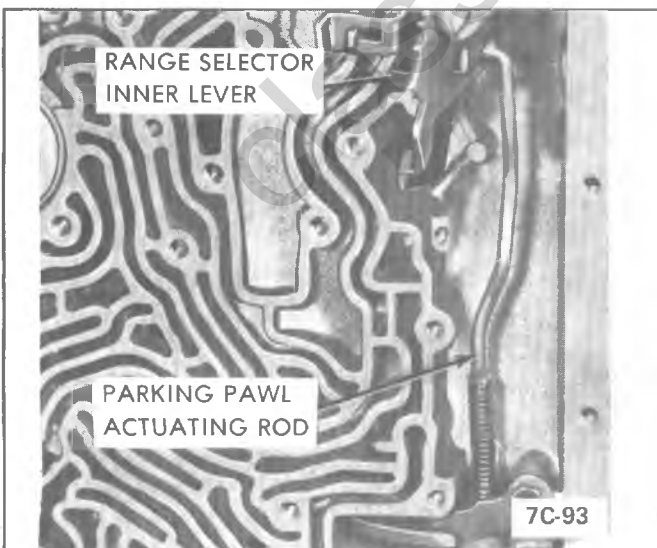

Figure 7A3-143 Actuating Rod

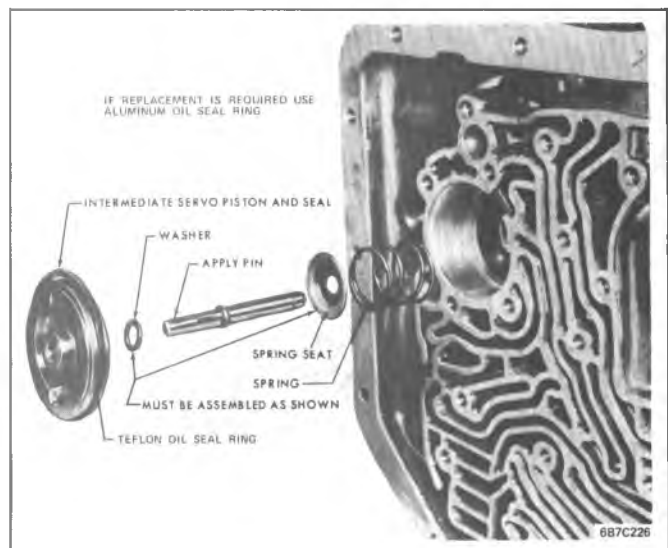

Figure 7A3-146 Intermediate Servo Assembly - Exploded View

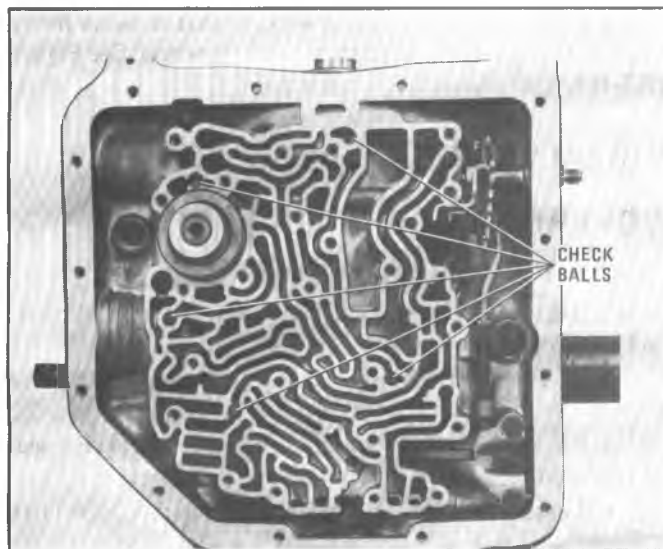

Figure 7A3-146A Check Ball Locations

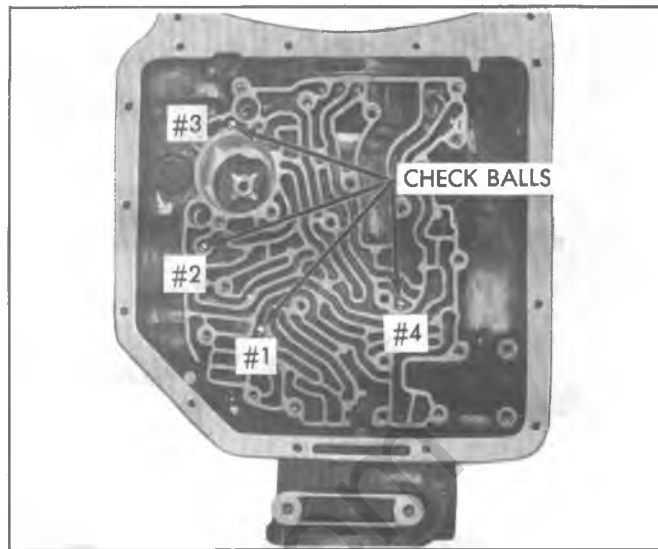

Figure 7A3-148 Check Ball Locations (Non-Converter Clutch)

4. Install valve body. Connect manual control valve link to range selector inner lever. Install manual shaft retaining clip. Torque bolts in random sequence to 13 ft.lbs. leaving bolt loose for detent roller and spring assembly. See Figure 7A3-155. When handling valve body assembly do not touch sleeves as retainer pins may fall into transmission.

5. Install detent roller and spring assembly to valve body. See Figure 7A3-156.

6. Install detent control valve wire to detent valve actuating lever, then attach lever to valve body.

7. TCC Models - Install solenoid and connect wires (if removed, install governor pressure switch).

8. Install filter and gasket assembly. See Figure 7A3-157. Install filter and gasket exactly as shown. Always replace filter when foreign material is found to be present.

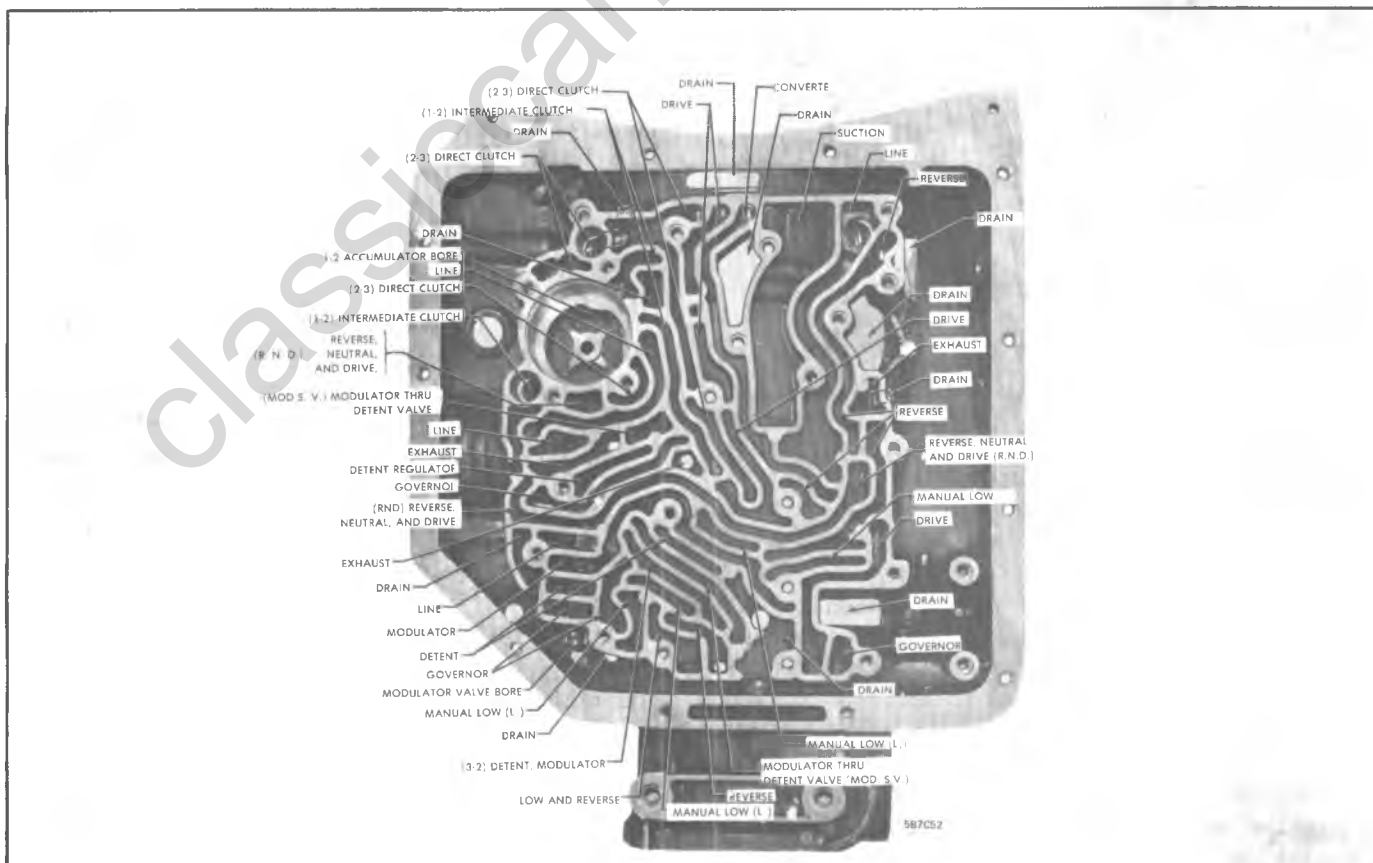

Figure 7A3-147 Identification of Oil Channels in Case Face

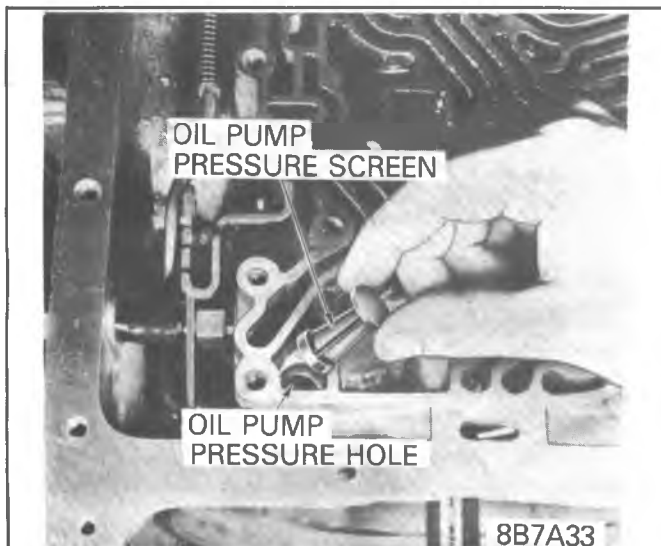

Figure 7A3-149 Pump Screen



Figure 7A3-150 Installing Governor Feed Screen

## Installing Oil Pan, Governor, and Modulator Valve

1. Install new bottom pan gasket and bottom pan. See Figure 7A3-158.

2. Install governor assembly, uniformly apply Loctite Cup Plug Sealant #2 or equivalent to governor cover O.D. and install by gently tapping into place with a plastic or rawhide hammer. Figure 7A3-159. If cover is damaged it must be replaced.

3. Install vacuum modulator valve and modulator. See Figure 7A3-160. Lubricate "O" ring seal to prevent damage, install retaining clip, and torque bolt to 12 ft. lbs. (16 N·m).

## Install Converter

1. Install converter, making sure that the converter hub engages the drive lugs inside the pump gear. If they don't engage, a low mileage pump failure will occur.

2. Make sure that the converter hasn't bound up the pump gear inside the transmission.

3. Check the converter to be sure that it turns freely and is able to move forward to meet the flywheel. See Figure 7A3-161.

## INSTALLATION OF BUSHINGS

### GOVERNOR BUSHING

1. Remove transmission from car.  
2. Remove the output shaft, valve body, support plate, and governor from the case.

3. Assemble transmission case in fixture J-8763 and mount in a vise. See Figure 7A3-162.

4. Clean off excess stock from the governor o-ring seal to case mating surface. See Figure 7A3-163.

5. Loosely bolt the drill bushing fixture J-22976-11 to the case.

6. Place the alignment arbor J-122976-13 into the drill bushing fixture and down into the governor bore until it bottoms on the dowel pin. See Figure 7A3-164.

7. Torque the bolts on the drill bushing fixture 10 ft. lbs. (13 N·m). *Do not over torque and strip the threads.* The alignment arbor should be able to rotate freely after the bolts are properly torqued. If the alignment arbor cannot be rotated by hand, recheck the work performed in step 4.

8. Remove the alignment arbor.

9. Using reamer J-122976-9 and drive ratchet, *hand ream* the governor bore using the following procedure: ( *Hand Ream Only* )

a. Oil the reamer, drill bushing, and governor bore.

b. Use 7 lbs. of feeding force on the reamer. See Figure 7A3-165.

c. *After each 10 revolutions* remove the reamer and dip it into a cup full of transmission oil. This will clean the chips from the reamer and lubricate it. See Figure 7A3-166.

d. When the reamer reaches the end of the bore, continue reaming the bore until the reamer bottoms out on the dowel pin in the case. *At this point, rotate the reamer 10 complete revolutions.*

e. Remove the reamer using a clockwise rotation and 7-10 lbs. force upward.

Pulling the reamer out without rotating it may score the bore causing a leak between the case and the bushing.

10. Remove the drill bushing fixture from the case.

11. Thoroughly clean the chips from the case, visually check the governor feed holes to insure that they are free from chips.

12. Install the bushing using the following procedure:

a. Note the two (2) notches at one end of the bushing.

b. Position the notches so that one notch is toward the front of the case and the other is toward the bottom of the case. See Figure 7A3-167.

c. Use J-122976-13 alignment arbor and bushing installer to drive the bushing into the case. See Figure 7A3-168. A brass hammer should be used to strike the hardened steel bushing installer tool.

d. Drive the bushing until it is flush with the top of the bore and seated properly in the case. See Figure 7A3-169.

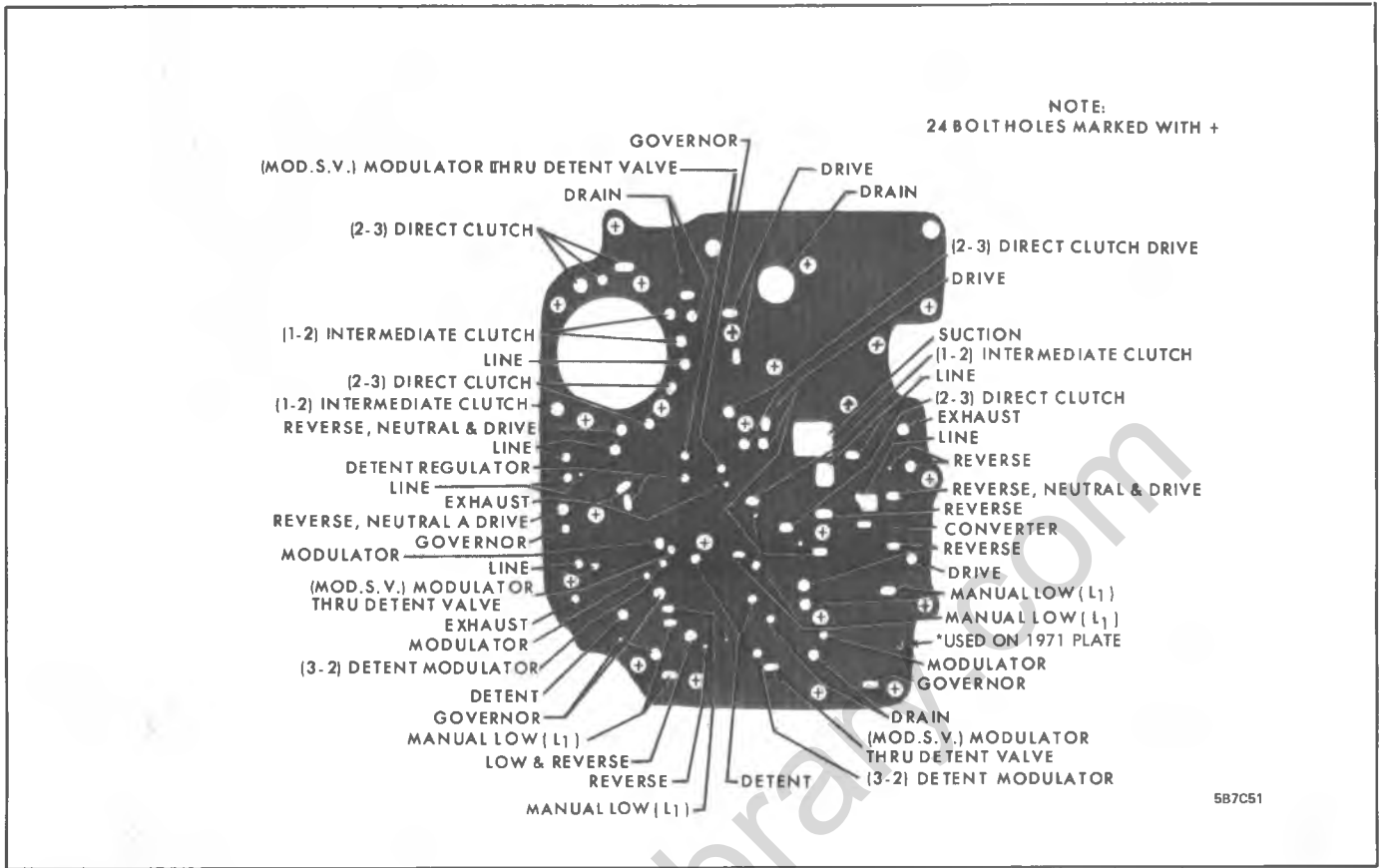

Figure 7A3-151 Valve Body Spacer Plate - (Typical)

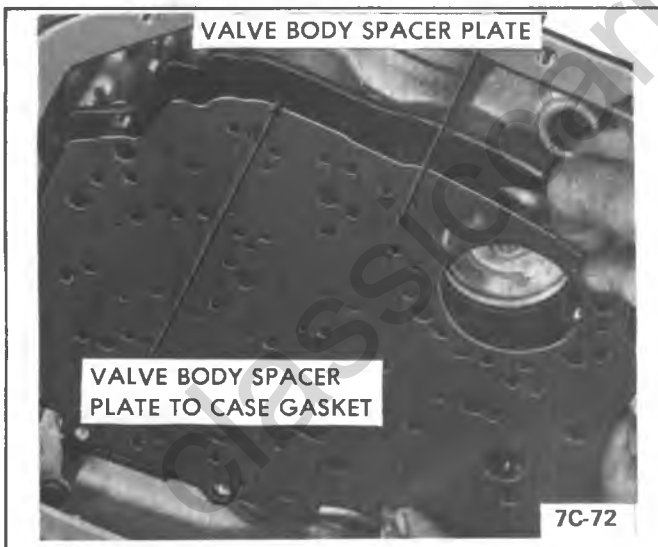

Figure 7A3-152 Spacer Plate and Gaskets

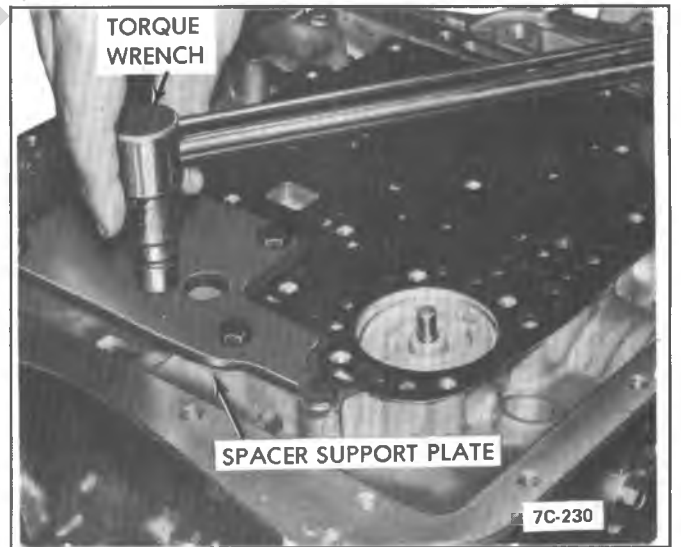

Figure 7A3-153 Support Plate

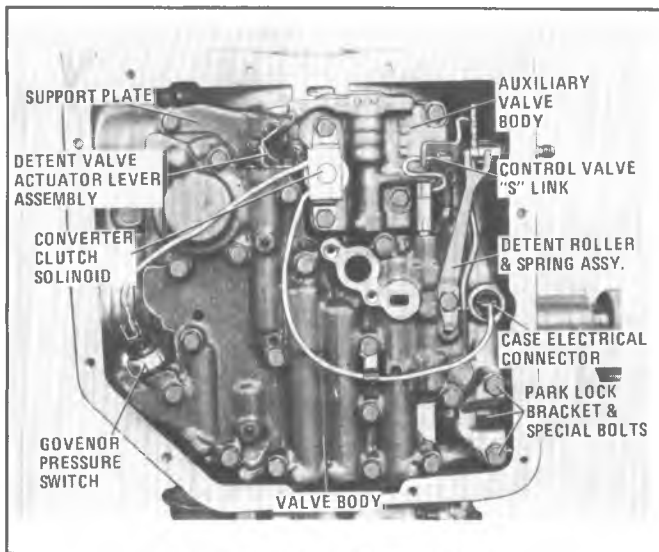

Figure 7A3-153A T.C.C. Models

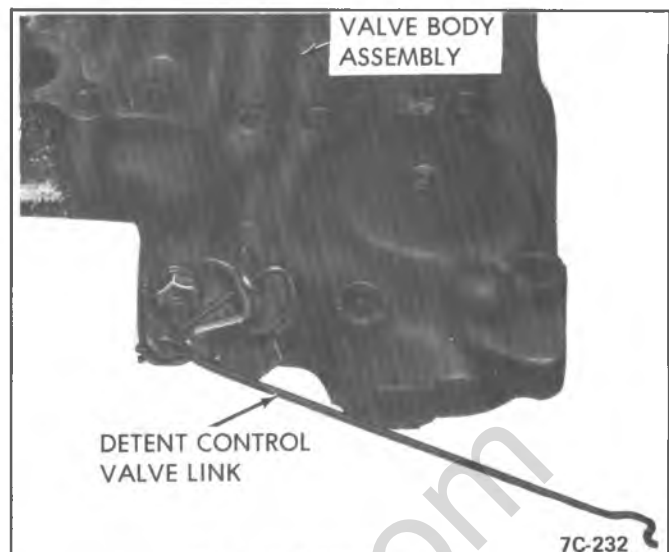

Figure 7A3-154 Detent Link



Figure 7A3-155 Manual Valve Link

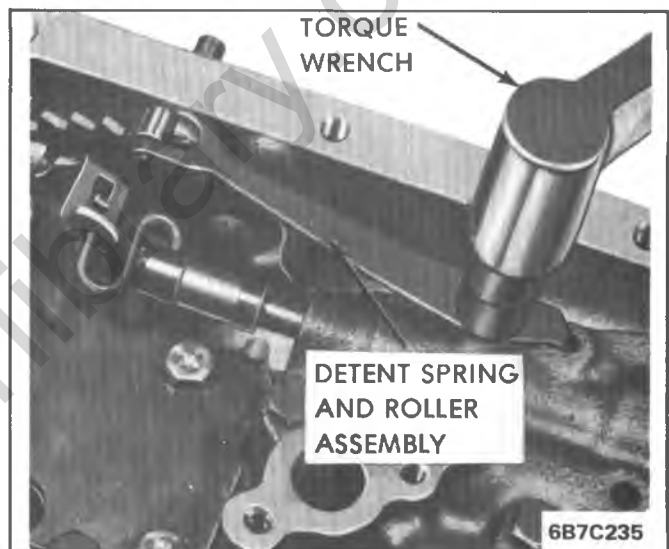

Figure 7A3-156 Detent Spring and Roller



Figure 7A3-157 Oil Filter



Figure 7A3-158 Install Oil Pan

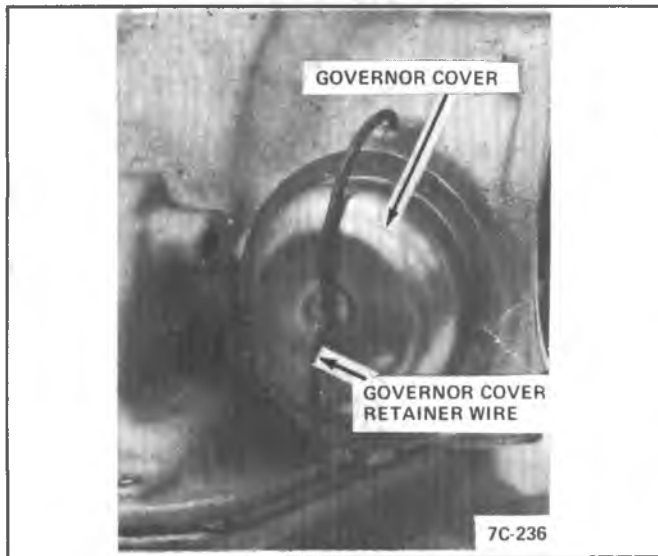

Figure 7A3-159 Governor Cover

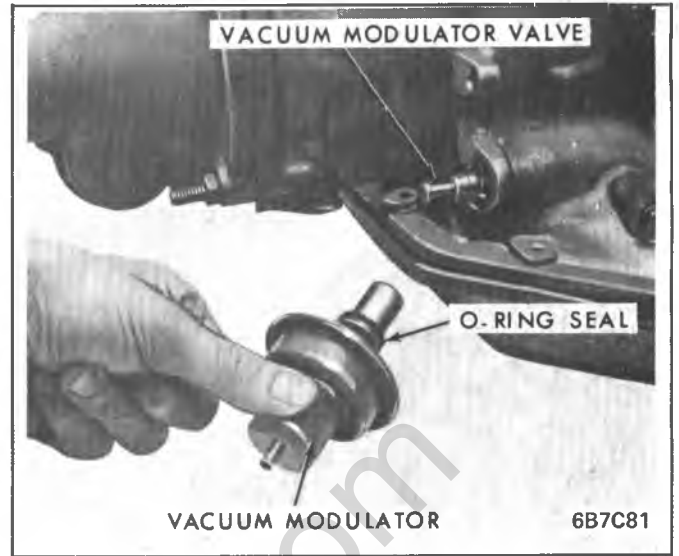

Figure 7A3-160 Install Modulator

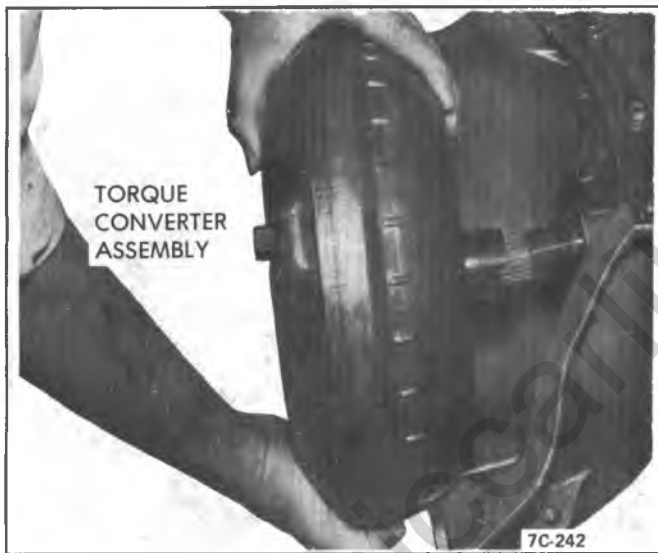

Figure 7A3-161 Install Torque Converter

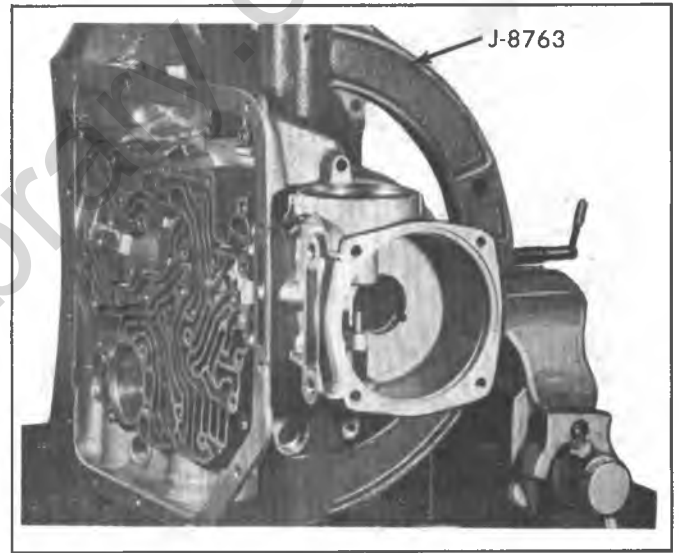

Figure 7A3-162 Case in Holding Fixture

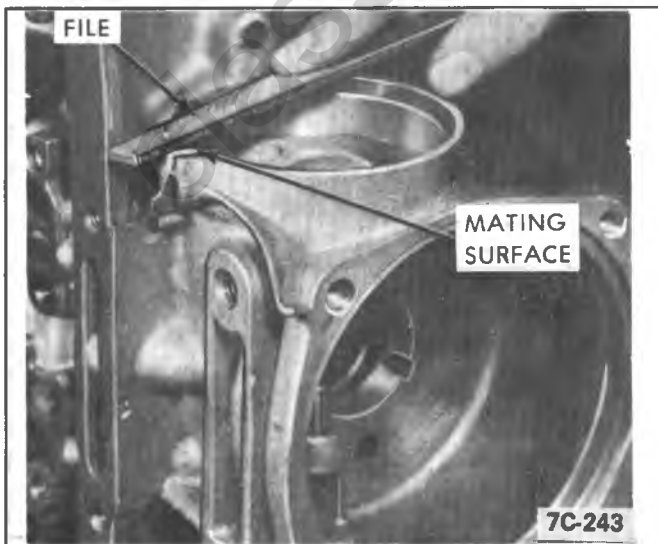

Figure 7A3-163 Removing Excess Material From Governor Surface

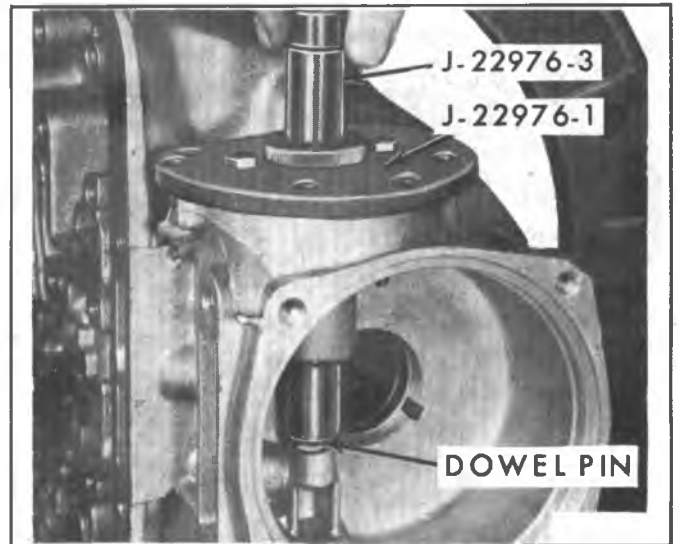

Figure 7A3-164

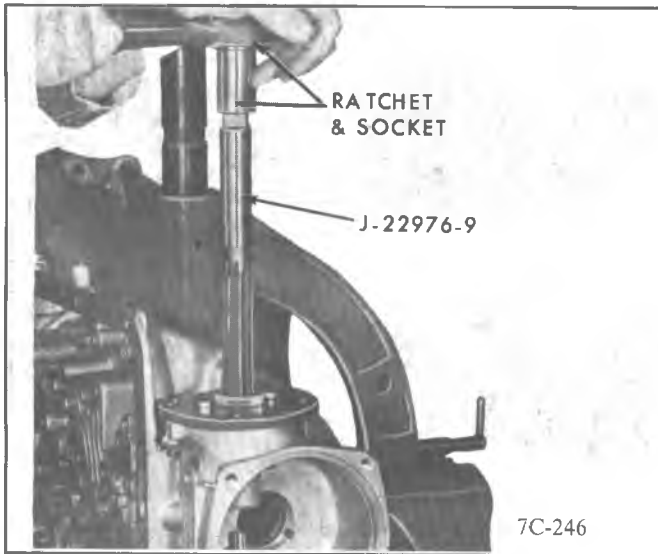

Figure 7A3-165 Reamer

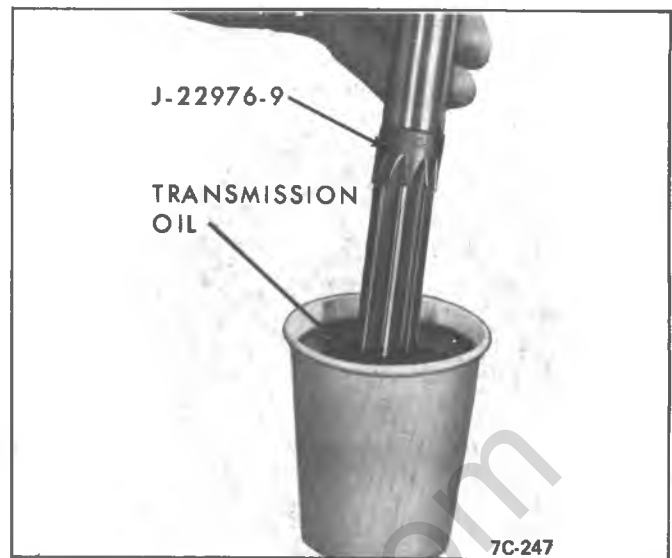

Figure 7A3-166

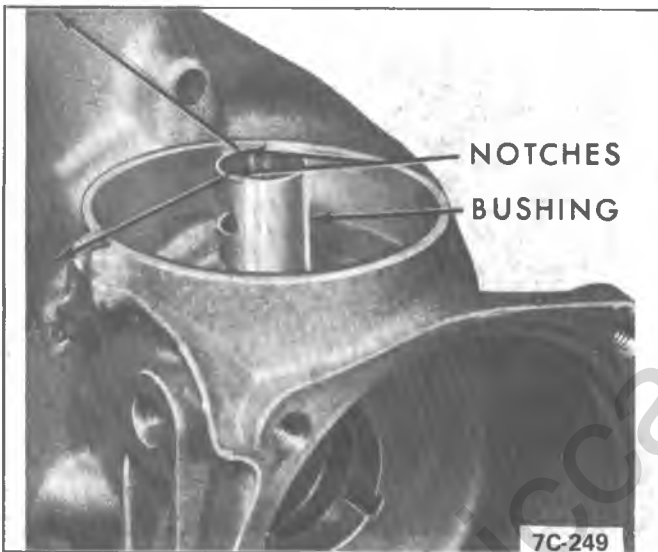

Figure 7A3-167 Position Notches



Figure 7A3-168 Bushing Installer

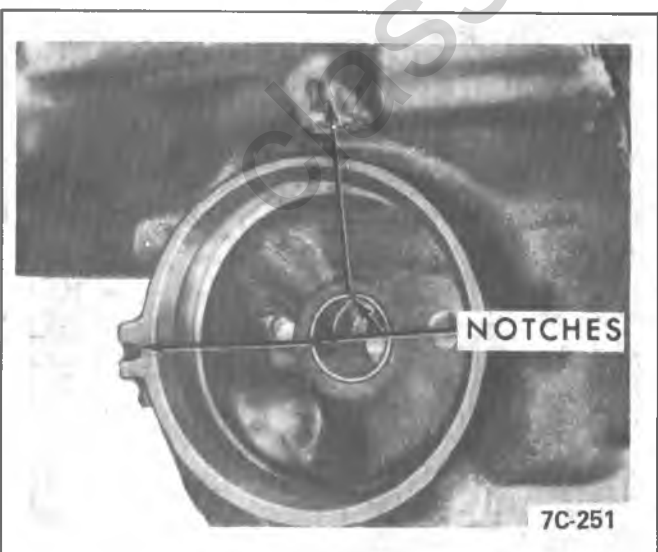

Figure 7A3-169 Bushing Properly Seated

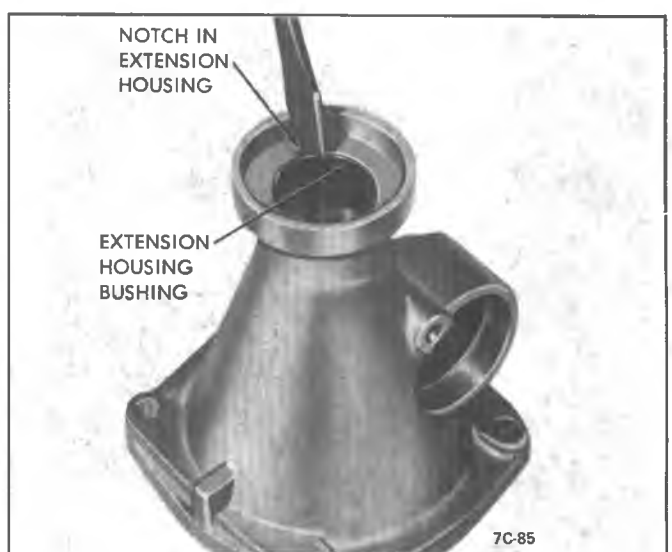

Figure 7A3-170 Collapsing Bushing



13. Oil a new governor and insert it into the installed bushing. The governor should spin freely. If slight honing on the bushing is necessary, use crocus or fine emery cloth and move in a circular one-way direction only.

### Removal of Extension Housing Bushing

1. Remove extension housing bushing using screwdriver to collapse bushing. See Figure 7A3-170.

### Installation of Extension Housing Bushing

1. Install extension housing bushing using drive handle J-8092 and Bushing Tool J-121424-9. See Figure 7A3-171.

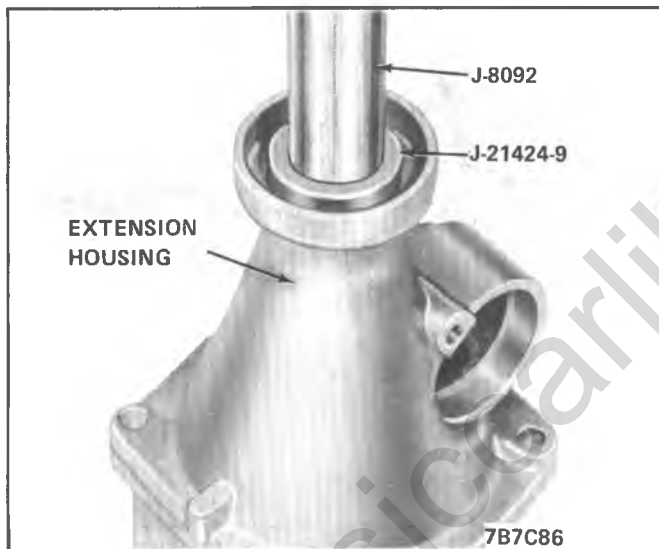

Figure 7A3-171 Installing Extension Housing Bushing

### Replacing Input Ring Gear Bushing

1. Inspect bushing for wear or galling. If replacement is necessary, proceed as follows:

a. Thread Tool J-123062-15 on Drive Handle J-8092, and remove bushing from ring gear. See Figure 7A3-172.

b. Using Tool J-123062-15, press in new bushing .050" to .060" from inner surface of hub. See Figure 7A3-172.

### Replacing Reaction Carrier Bushing

1. Inspect reaction carrier bushing for wear or galling. If replacement is necessary, proceed as follows:

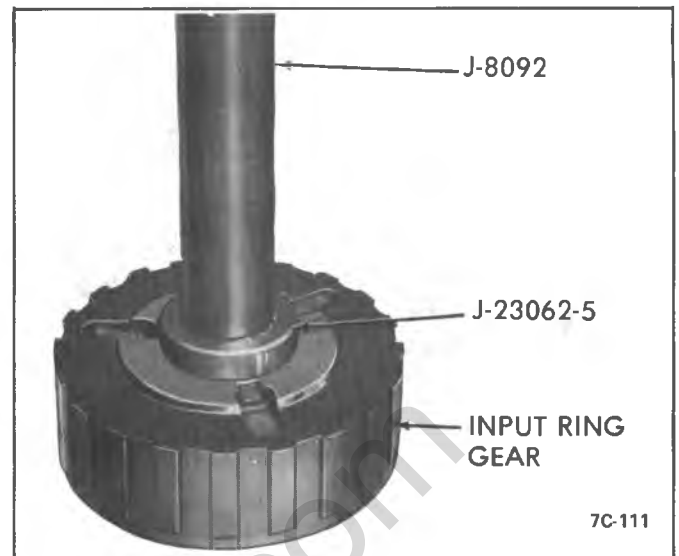

Figure 7A3-172 Reaction Carrier Bushing Removal

a. Thread Tool J-123062-13 on Drive Handle J-8092 and remove bushing. See Figure 7A3-173.

b. Using Tool J-123062-13, press in new bushing flush to .010" from inner surface of hub. See Figure 7A3-173.

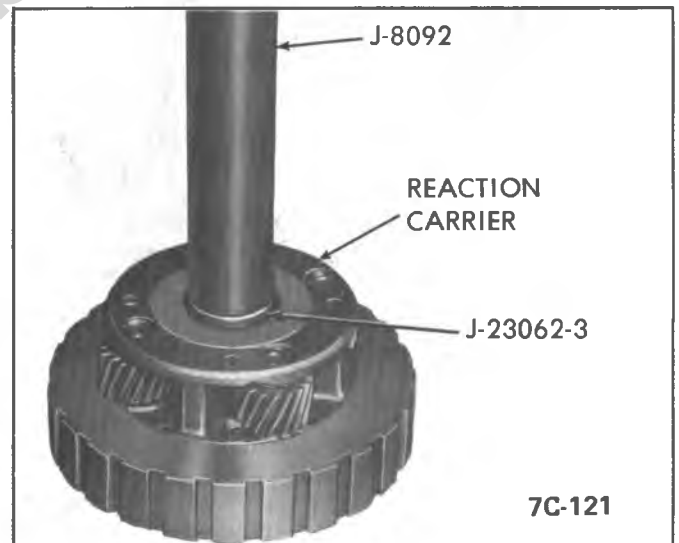

Figure 7A3-173 Reaction Carrier Bushing Installation

### Replacing Case Bushing

1. Inspect case bushing for nicks, scoring or excessive wear. If damaged, remove as follows: Assemble Tool J-123062-116 on Drive Handle J-8092. Place Tool J-123062-8 into back of case, insert assembly of drive handle J-8092 and Tool J-123062-116 into Tool J-123062-8 and remove bushing. See Figure 7A3-174.

2. Using Tool J-123062-11 and Drive Handle J-8092, press bushing to 1/5" below chamfered edge of case. Make

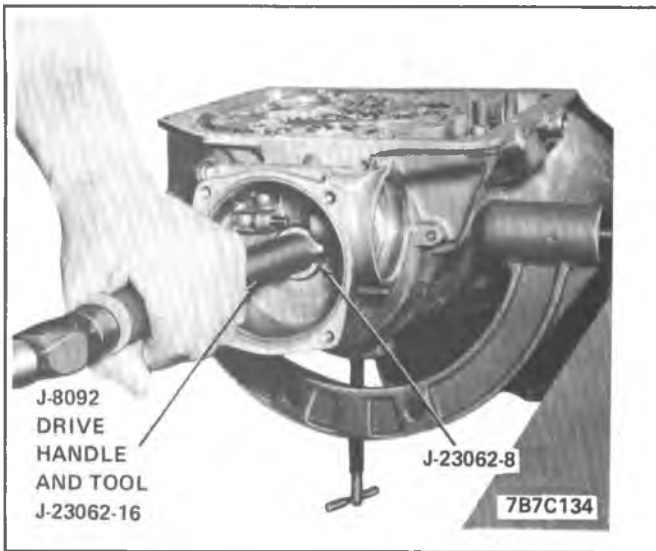

Figure 7A3-174 Removing Case Bushing

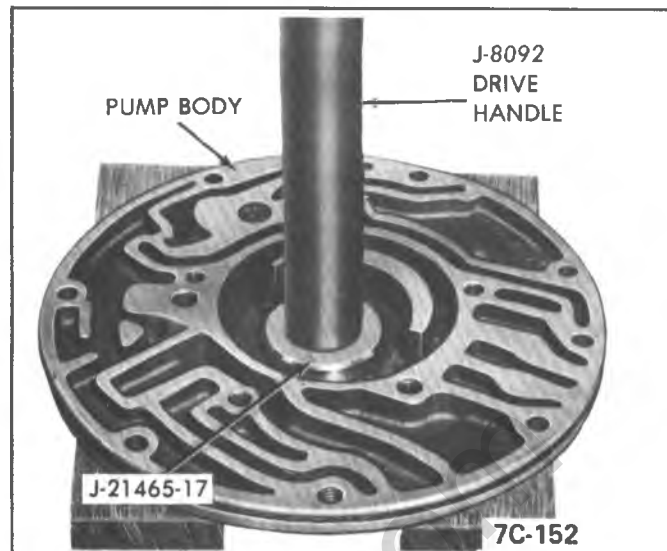

Figure 7A3-176 Pump Bushing Removal

certain split in bushing is opposite notch in case. See Figure 7A3-175.

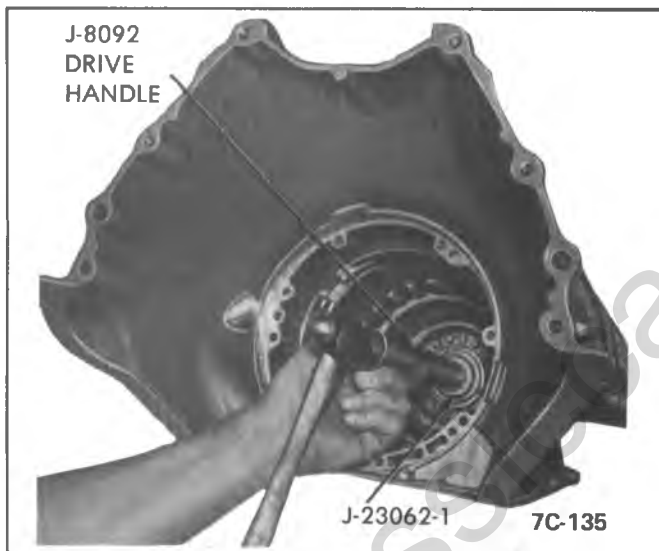

Figure 7A3-175 Installing Case Bushing

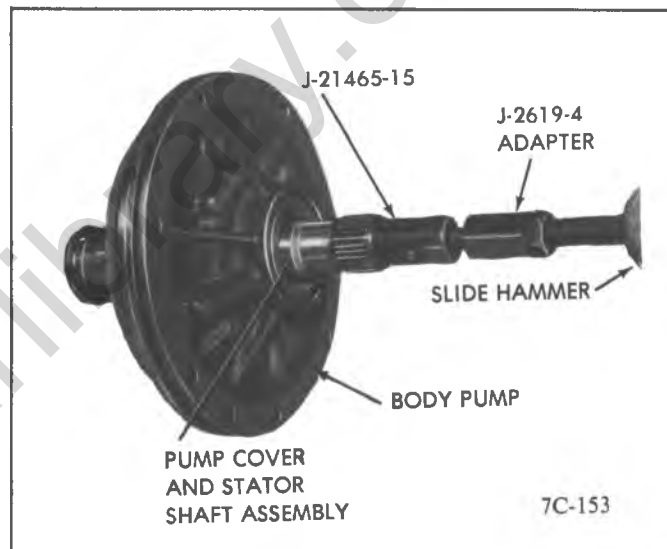

Figure 7A3-177 Remove Front Stator Bushing

## Replacing Pump Body Bushing

1. Check oil pump bushing for nicks, severe scoring or wear. If bushing replacement is necessary, remove as follows: Support pump on wood blocks. Use Tool J-121465-117 and Drive Handle J-8092 to press bushing out of pump body. To install new oil pump bushing, use Tool J-121465-117 and Drive Handle J-8092 and press bushing into pump body from gear pocket face until it is flush to .010" below opposite face. (Front pump seal side). See Figure 7A3-176.

## Replacing Front Stator Shaft Bushing

1. Check front stator shaft bushing for nicks, severe scoring or wear. If bushing replacement is necessary, remove as follows: Assemble bushing remover J-121465-115 to adapter J-12619-14. Assemble this assembly into slide hammer J-12619. Clamp slide hammer into vise. Grasp stator shaft and remove bushing. See Figure 7A3-177.

2. Install front stator shaft bushing as follows: Support pump assembly on J-121424-17 before installing bushing. Install bushing into the front end of stator shaft. Using installer J-121424-17 and Drive Handle J-8092, tap bushing into shaft 1/4 inch below top of stator shaft. See Figure 7A3-178. Extreme care must be taken so bushing is not driven past shoulder.

## Replacing Rear Stator Shaft Bushings

1. If replacement at lower rear stator shaft bushing is required, proceed as follows: Thread Tool J-121465-115 into stator shaft lower rear bushing. Thread slide hammer J-12619 into remover. Clamp slide hammer into vise. Grasp stator shaft and remove bushing. See Figure 7A3-179. If upper rear stator shaft bushing is required, repeat above procedure.

2. Using Tool J-123062-12, press upper rear stator shaft bushing to 1-11/32 inch below top surface of oil pump delivery sleeve. See Figure 7A3-180.

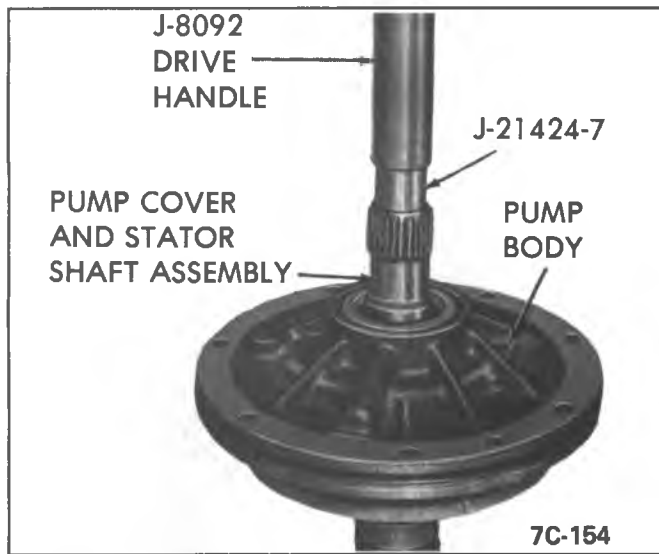

Figure 7A3-178 Install Front Stator Shaft Bushing

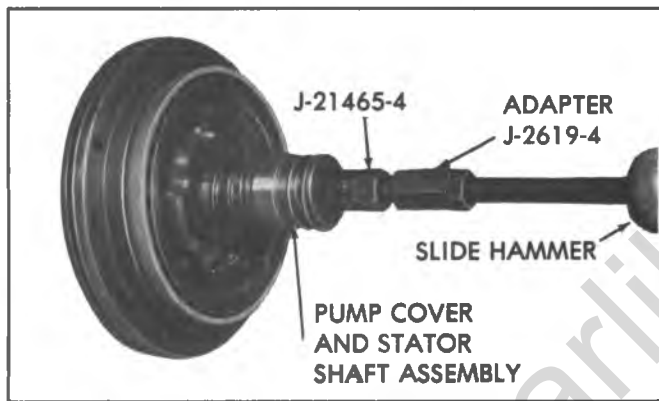

Figure 7A3-179 Remove Rear Stator Bushing

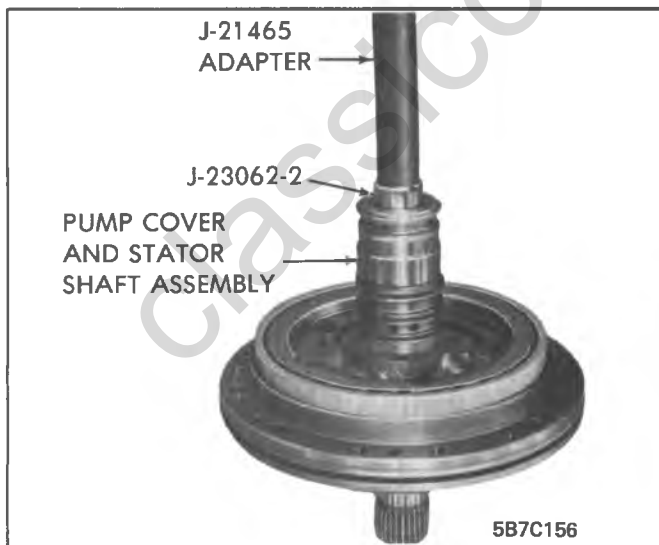

Figure 7A3-180 Install Rear Stator Bushing

3. Using Tool J-123062-12, press lower rear stator shaft bushing flush to .010" below chamfer on oil pump delivery sleeve.

### Replacing Direct Clutch Bushing

1. If bushing replacement is necessary, use Tool J-123062-110 and Drive Handle J-18092 and remove the bushing. See Figure 7A3-181.

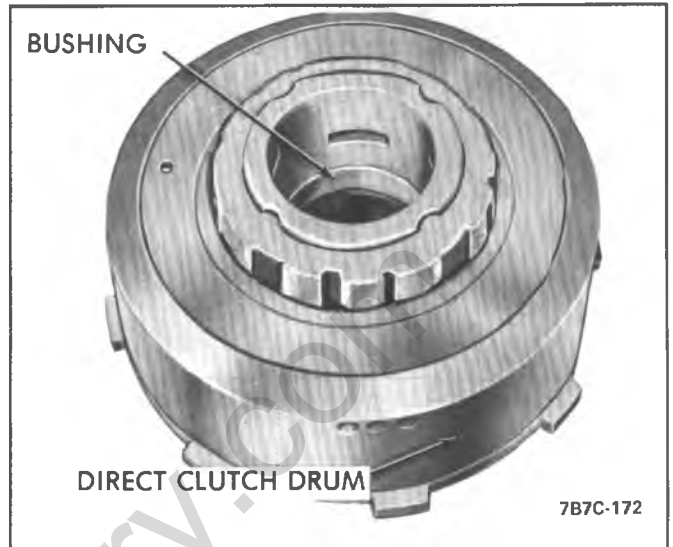

Figure 7A3-181 Removing Direct Clutch Bushing

2. Install direct clutch bushing using Tool J-123062-14, Drive Handle J-18092, and install .010" below slot in retainer hub. See Figure 7A3-182.

**NOTICE:** The direct clutch housing with the aluminum bushing can be used only with the cast iron pump cover. The housing with the bronze bushing can be used either with the steel sleeve pump cover or the cast iron pump cover.

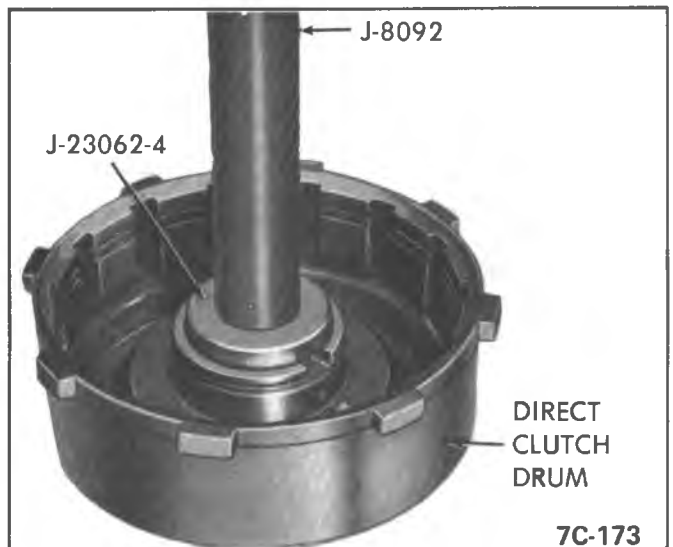

Figure 7A3-182 Install Direct Clutch Bushing

### Replacing Sun Gear Bushing

1. If replacement of sun gear bushings is necessary, use Tool J-123062-13 and Drive Handle J-18092 and drive both bushings out through sun gear. See Figure 7A3-183.

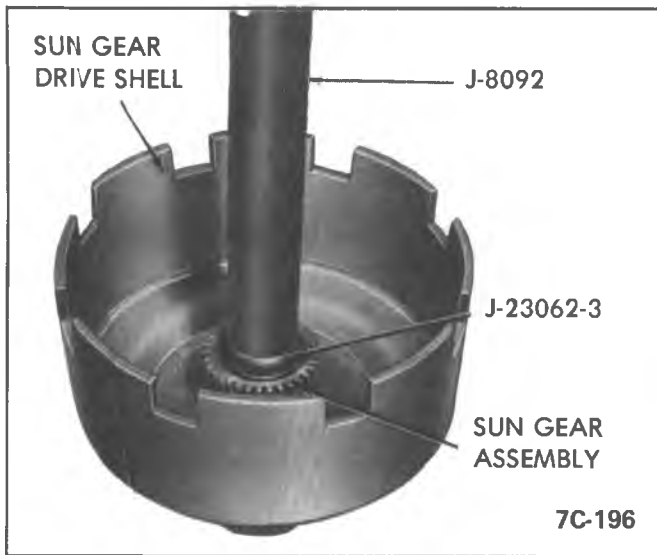

Figure 7A3-183 Install Sun Gear Bushing

2. Install sun gear bushings using Tool J-123062-13 and Drive Handle J-18092 and install flush to .010" below counter bores. See Figure 7A3-183.

**Transmission Identification Number**

A production day and shift built number, transmission model and model year are stamped on the governor cover. See Figure 7A3-184. Since the production day built number

and model number furnishes the key to construction and interchangeability of parts in each transmission, they should be used when selecting replacement parts as listed in the master parts list. The model number and day built number should always be furnished *on product reports, warranty document forms, and all correspondence with factory concerning a particular transmission.*



Figure 7A3-184 Production Code

**TORQUE SPECIFICATIONS**

Location	Thread	Torque ft.lbs.
Oil Pan to Transmission Case	5/16-18	13
Pump Assembly to Transmission Case	5/16-18	20
Vacuum Modulator Retainer to Case	5/16-18	12
Valve Body Assembly to Case	5/16-18	13
Oil Channel Support Plate to Case	5/16-18	13
Pump Body to Pump Cover	5/16-18	15
Parking Lock Bracket to Case	5/16-18	29
Extension Housing to Case	3/8-16	35
Inside Shift Nut	3/8-16	30
External Test Plugs to Case	1/8-27	8
Transmission Mount to Transmission	M10-1.5	48 N·m (35 ft. lbs.)
Speedo sleeve retainer on Extension Housing	M6.0-1.0	17 N·m (150 lb. in.)
Detent Cable to Case	M6.0-1.0	8.5 N·m (75 lb. in.)
Nut on End of Selector Lever Shaft	M10-1.5	27 N·m (20 ft. lbs.)
Converter to Flywheel	M10-1.5	45 N·m (35 ft. lbs.)

**AUTOMATIC 350/350C TRANSMISSION CLUTCH PLATE USAGE**

TRANSMISSION I.D. CODE	SPEEDOMETER DRIVE GEAR		INTERMEDIATE CLUTCH			DIRECT CLUTCH			FORWARD CLUTCH			LOW AND RESERVE CLUTCH		
	Number of Teeth	Gear Color	No. of Faced Plates	No. of Steel Plates	Clutch Piston Thickness	No. of Faced Plates	No. of Steel Plates	Clutch Piston Thickness	No. of Faced Plates	No. of Steel Plates	Clutch Piston Thickness	No. of Faced Plates	No. of Steel Plates	Clutch Piston Thickness
8TA	—	—	3	3	.992	4	4	.833	4	4	1.405	4	4	3.106
8TJ	—	—	3	3	.992	4	4	.833	4	4	1.405	5	5	2.921
8T2, 8T9, 8TH 8TN & 8TW	—	—	3	3	.992	4	4	.833	5	5	1.223	5	5	2.921
8T6, 8TC, 8TS, 8TX, 8VC, 8VL, 8YJ & 8VN	8	Green	3	3	.992	4	4	.833	4	4	1.405	4	4	3.106
8XK	8	Green	3	3	.992	4	4	.833	5	5	1.223	5	5	2.921
8T3, 8T4, 8T7, 8TD, 8TE, 8TL 8TP, 8V4, 8V6, 8VA, 8VD, 8VE, & 8VH	9	Orange	3	3	.992	4	4	.833	5	5	1.223	5	5	2.921
8VK, 8VP, 8VS, 8YW, 8V2, 8WE & 8WJ	9	Orange	3	3	.992	4	4	.833	5	5	1.223	5	5	2.921
8WA, 8WC, 8WD, 8WH, 8WN, 8WT & 8W2	10	Purple	3	3	.992	4	4	.833	4	4	1.405	4	4	3.106
8WP	10	Purple	2	2	1.184	3	3	1.014	4	4	1.405	4	4	3.106
JD	9	Orange	3	3	.992	4	4	.833	5	5	1.223	5	5	2.921
JC	17	Red	3	3	.992	4	4	.833	5	5	1.223	5	5	2.921
KD, KN & KY	17	Red	2	2	1.184	3	3	1.001	4	4	1.391	4	4	3.106
KT & MC	18	Blue	3	3	.992	4	4	.833	5	5	1.223	5	5	2.921
KK & LC	19	Yellow	2	2	1.184	3	3	1.001	4	4	1.391	4	4	3.106
LA	19	Yellow	3	3	.992	4	4	.833	5	5	1.223	5	5	2.921
LB	19	Yellow	3	3	.992	4	4	.833	4	4	1.391	4	4	3.106
LD	19	Yellow	3	3	.992	4	4	.833	5	5	1.223	5	5	2.921
MA	20	Brown	3	3	.992	4	4	.833	5	5	1.223	5	5	2.921

Figure 7A3-185

ESSENTIAL TOOLS — THM350C & THM250C











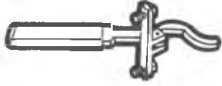
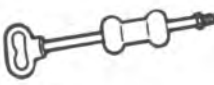

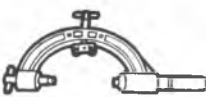







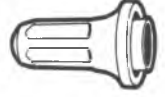

	J 2590-02 Clutch Spring Compressor		J 23069 Accumulator Cover Remover & Installer
	J 2619-A Slide Hammer (5/8" x 18" with 1/4" x 13 Adapter)		J 26744 Piston Seal Installer
	J 8763-02 Holding Fixture (Use with J3289-20)		J 22974 Seal Protector
	J 3289-20 Holding Fixture Base (Use with J 8763-02)		J 23327 Clutch Spring Compressor
	J 7004-1 Slide Hammers-Pair (3/4" x 16 Thread)		J 22269-01 Servo Remover-THM250 Direct Clutch Accumulator Remover & Installer
	J 8092 Driver Handle		J 24367 Band Adjuster-THM250C
	J 21359 Oil Pump Seal Installer		J 23062-01 Bushing Service Tool Set (use with J 8092)
	J 21426 Extension Housing Seal Installer		J 21424-7 Stator Shaft Bushing Installer (Front) (use with J 8098)
	J 21366 Converter Holding Strap		J 21424-9 Extension Housing Bushing Remover & Installer (use with J 8098)
	J 21369-B Converter Leak Test Fixture		J 22976 Governor Bore Bushing Installation Tool Set (use with J 8092)
	J 23134 Pump Check Valve Seat Remover		J 21465-13 Driver Handle Extension (J 8092)
	J 23112 Pump Check Valve Seat Remover		J 21465-15 Stator Shaft Bushing Remover (J 8092)
	J 24466 Modulator Checking Tool		J 21465-17 Converter Hub & Extension Housing Bushing Remover & Installer (Use with J 8092)
	J 26507 Low & Reverse Clutch Support Remover		J 9534-01 Output Shaft Bushing Remover

Figure 7A3-189 Special Tools

# AUTOMATIC 250 C TRANSMISSION

## CONTENTS

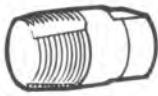
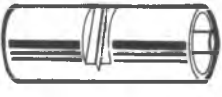
### GENERAL DESCRIPTION AND BAND ADJUSTMENT

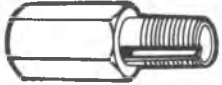
Intermediate Band Adjustment ..... 7A5-2

### DIAGNOSIS

#### UNIT REPAIR

7A5-3

Transmission Disassembly ..... 7A5-7

Removal of Extension, Speedometer

Driven Gear, Oil Pan and Screen..... 7A5-8

Removal of Valve Body and Linkage ..... 7A5-9

Removal of Oil Pump and Internal

Case Components ..... 7A5-10

Valve Body

Disassembly..... 7A5-13

Inspection..... 7A5-14

Reassembly..... 7A5-14

Auxiliary Valve Body

Disassembly..... 7A5-14

Inspection..... 7A5-14

Reassembly..... 7A5-15

Oil Pump

Disassembly..... 7A5-15

Inspection..... 7A5-15

Reassembly..... 7A5-16

Direct Clutch

Disassembly..... 7A5-17

Inspection..... 7A5-17

Reassembly..... 7A5-18

Forward Clutch

Disassembly..... 7A5-19

Inspection..... 7A5-20

Reassembly..... 7A5-20

Sun Gear and Sun Gear Drive Shell

Disassembly..... 7A5-21

Inspection..... 7A5-21

Reassembly..... 7A5-21

Low and Reverse Clutch

Disassembly..... 7A5-21

Inspection..... 7A5-22

Reassembly..... 7A5-22

Servo Assembly

Disassembly..... 7A5-22

Inspection..... 7A5-23

Reassembly..... 7A5-23

Governor Assembly

Disassembly..... 7A5-23

Inspection..... 7A5-23

Governor, Driven Gear Replacement..... 7A5-23

Reassembly..... 7A5-24

Transmission Reassembly..... 7A5-24

Clutch Plate Usage..... 7A5-30

## GENERAL DESCRIPTION

The 250C transmission (Figure 7A5-1) is a fully automatic unit consisting primarily of a three (3)-element hydraulic torque converter and two planetary gear sets. Three (3) multiple-disc clutches, one roller clutch, and an adjustable intermediate band provide friction elements required to obtain desired function of two planetary gear sets.

The three (3)-element torque converter consists of a pump, turbine, a stator assembly, with the addition of a converter clutch. Stator is mounted on a one way roller clutch which will allow stator to turn clockwise, but not counterclockwise. References to clockwise and counterclockwise are determined by looking toward rear of vehicle.

The torque converter is of welded construction and is serviced as a complete assembly. The unit is filled with hydraulic fluid and is attached to the engine crankshaft by a flywheel, thus always rotates at engine speed. Converter pump is an integral part of converter housing, therefore, pump blades, rotating at engine speed, set fluid within converter into motion and direct it to turbine, causing turbine to rotate.

As fluid passes throughout turbine it is traveling in such a direction that if it were not redirected by stator it would hit the rear of the converter pump blades and impede its

pumping action. So at low turbine speeds, fluid is redirected by stator to converter pump in such a manner that it actually assists converter pump to deliver power, or multiply engine torque.

As turbine speed increases, the direction of fluid leaving turbine changes and flows against rear side of stator vanes in a clockwise direction. Since stator is now impeding the smooth flow of fluid, its roller clutch releases and it revolves freely on its shaft. Once stator becomes inactive, there is no further multiplication of engine torque within converter.

At this point, converter is merely acting as a fluid coupling as both converter pump and turbine are being driven at approximately the same speed.

The torque converter clutch is an internal mechanism (with a friction material attached to the front plate) splined to the turbine assembly, and when operated applies against the converter cover. This provides a mechanical direct drive coupling of the engine to the planetary gears. By applying the converter clutch, slippage is eliminated, resulting in improved fuel economy and reduced fluid operating temperatures.

A hydraulic system pressurized by a gear type pump provides working pressure required to operate friction elements and automatic controls.

## 7A5-2 AUTOMATIC TRANSMISSION (250C)

External control connections to transmission are:

- Transmission Control Cable - To select desired operating range.
- Engine Vacuum - To operate vacuum modulator.
- Cable Control - To operate detent valve.
- Electrical connector to operate the converter clutch.

A vacuum modulator is used to automatically sense any change in torque input to transmission. Vacuum modulator transmits this signal to pressure regulator, which controls line pressure, so that all torque requirements of transmission are met and smooth shifts are obtained at all throttle openings.

Detent valve is activated by a cable that is connected to accelerator level assembly. When throttle is half open, valve is actuated causing throttle downshift at speeds below approximately 40 mph (64 km/h). When the throttle is fully open the detent valve is actuated causing transmission to down shift from 3-1 at speeds below approximately 40 mph (56 km/h), and from 3-2 below approximately 70 mph (105 km/h).

## INTERMEDIATE BAND ADJUSTMENT

Intermediate band adjustment should be performed every 60,000 (96,000 km) miles or sooner, as necessary if operating performance indicates intermediate band slippage.

1. Position selector lever in NEUTRAL (N) and raise vehicle on hoist.

2. Using Special Tool J-24367 in position over adjusting screw and locknut on right side of transmission, loosen locknut 1/2 turn and hold tool in this position.

3. With a torque wrench attached on special tool, tighten adjusting screw to 30 in. lb. and back-off 3 complete turns. Use mark on special tool as indicator.

4. With torque wrench held in position on special tool, tighten locknut 15 ft. lb.

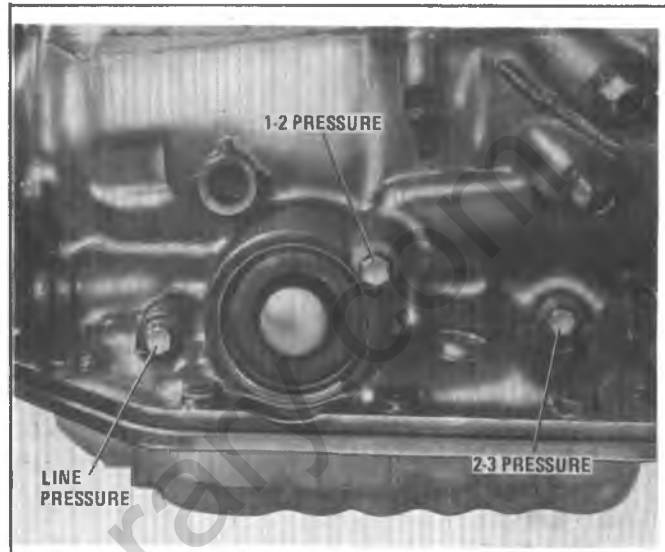

Figure 7A5-3 Pressure Tap Location

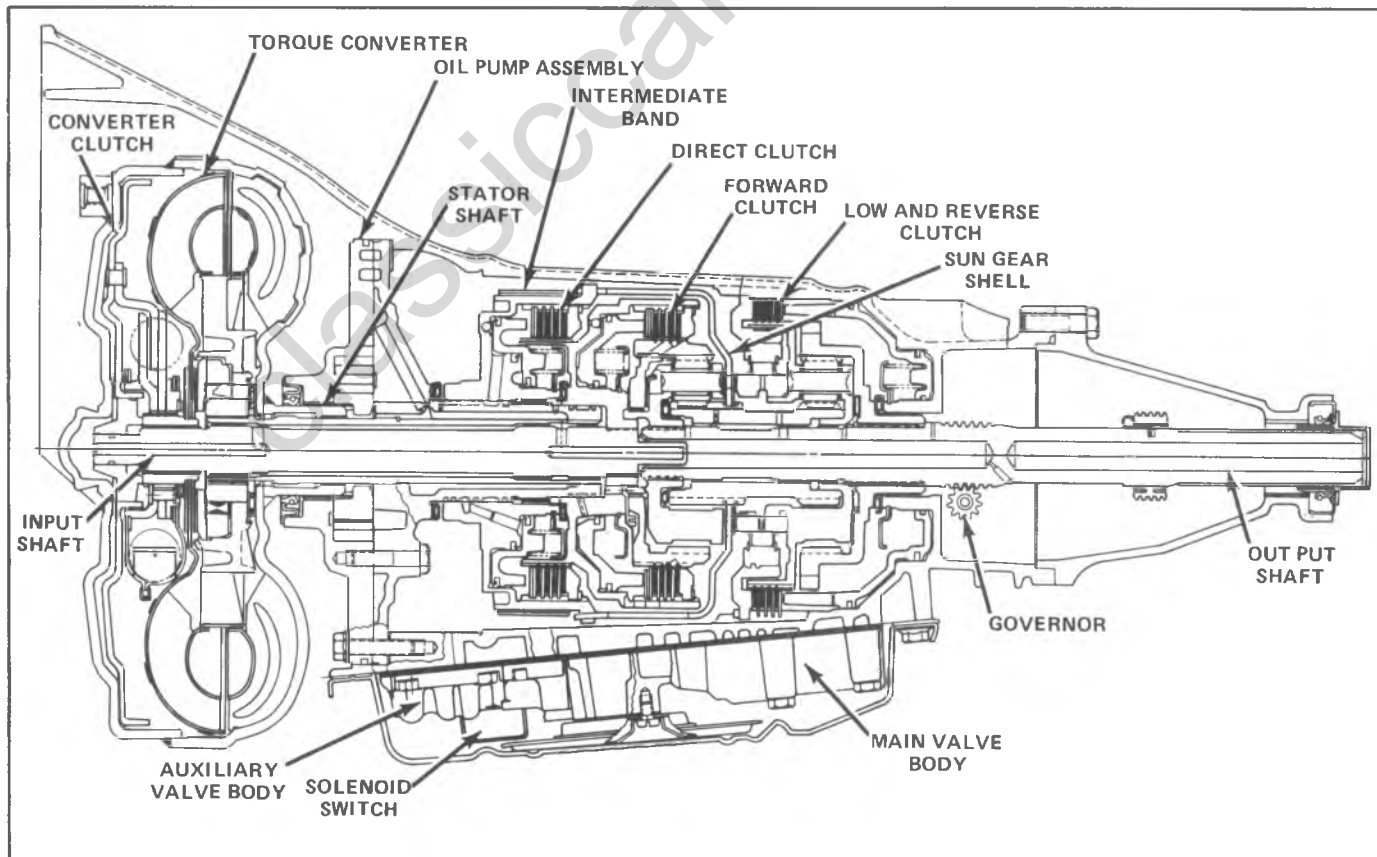

Figure 7A5-1 250C Sectional View



## **TROUBLE DIAGNOSIS**

Refer to Diagnosis Chart to determine a possible cause of a transmission problem.

Additional diagnosis of a malfunction is as follows:

### **No Drive in Drive Range**

(Install pressure gage)

- Low Fluid Level - correct level and check for external leaks or defective vacuum modulator (leaking diaphragm will evacuate fluid from unit).

- Manual Linkage - misadjusted, correct alignment to manual lever shift quadrant is essential.

- Low Fluid Pressure - refer to **LOW LINE PRESSURE**.

- Forward Clutch

- a. Forward clutch does not apply - piston cracked; (refer to **BURNED CLUTCH PLATES**, Section 7A.

- b. Pump feed circuit-to-forward clutch oil seal rings missing or broken on pump cover; leak in feed circuits, pump-to-case gasket mispositioned or damaged; clutch drum ball check stud or missing.

- Low and Reverse Roller Clutch Assembly - broken spring, damaged cage or installed backwards.

### **High or Low Fluid Pressure**

(Refer to **FLUID PRESSURE CHECKS**)

#### **High Line Pressure**

- Vacuum Leak:

- a. Vacuum line disconnected.

- b. Leak in line from engine to modulator.

- c. Improper engine vacuum.

- d. Leak in vacuum-operated accessory (hoses, vacuum advance, etc.)

- Modulator:

- a. Stuck modulator valve.

- b. Water in modulator.

- c. Damaged, not operating properly.

- Detent System - detent valve or cable stuck in detent position.

- Valve Body:

- a. Pressure regulator and/or boost valve stuck.

- b. Boost valve sleeve broken or defective.

- c. Incorrect pressure regulator valve spring.

#### **Low Line Pressure**

- Low transmission fluid level.

- Defective vacuum modulator assembly.

- Strainer Assembly:

- a. Blocked or restricted.

- b. Gasket omitted or damaged.

- Oil Pump:

- a. Gear clearance, damaged, worn, gear installed backwards.

- b. Pump-to-case gasket mispositioned.

- c. Defective pump body and/or cover.

- Valve Body:

- a. Pressure regulator or boost valve stuck.

- b. Pressure regulator valve spring, too weak.

- Internal Circuit Leaks:

- a. Forward clutch leak (pressure low in Drive range, pressure normal in Neutral and Reverse).

1. Check pump oil seal rings.

2. Check forward clutch seals.

- b. Direct clutch leak (pressure low in Reverse, pressure normal in other ranges).

1. Check direct clutch outer seal.

2. Check 1-2 accumulator piston and ring for damage or missing.

- Case Assembly - check ball missing from cored passages in case face.

#### **1-2 Shift-Full Throttle Only**

- Detent Valve - sticking or linkage misadjusted.

- Vacuum Leak - vacuum line or fittings leaking.

- Control Valve Assembly:

- a. Valve body gaskets-leaking, damaged or incorrectly installed.

- b. Detent valve train stuck.

- c. 1-2 valve stuck closed (in downshifted position).

- Case Assembly - refer to case porosity repair.

#### **First Speed Only No 1-2 Shift**

- Detent (downshift) cable - binding.

- Governor Assembly:

- a. Governor valve sticking.

- b. Driven gear loose, damaged or worn (check for pin in case and length of pin showing; also, check output shaft drive gear for nicks or rough finish if driven gear shows damage).

- Control Valve Assembly:

- a. Valve body gaskets - leaking, damaged or incorrectly installed.

- b. Governor feed channels blocked.

- c. 1-2 shift valve train stuck closed (in downshifted position).

- Intermediate Band:

- a. Servo piston seals - missing, improperly installed or broken.

- b. Band improperly adjusted - screw loose.

- c. Servo apply rod broken.

- Case:

- a. Porosity between channels.

- b. Governor feed channel blocked; governor bore scored or worn, allowing cross pressure leak.

#### **First and Second Speeds Only No 2-3 Shift**

- Control Valve Assembly:

- a. Valve body gaskets - leaking, damaged or incorrectly installed.

- b. 2-3 shift valve train stuck closed (in downshifted position).

- Direct Clutch:

- a. Pump hub - direct clutch oil seal rings - broken or missing.

- b. Clutch piston seals - missing, improperly assembled or cut.

## 7A5-4 AUTOMATIC TRANSMISSION (250C)

c. Clutch plates burned (Refer to BURNED CLUTCH PLATES).

### No First Speed-Starts in Second Speed

(Locks up to L Range)

Intermediate Band:

- Band adjustment too tight.
- 1-2 shift valve stuck in upshifted position.

### Drive in Neutral

● Manual Linkage - misadjusted, (correct alignment in manual lever shaft quadrant is essential).

● Internal Linkage - manual valve disconnected or end broken.

● Oil Pump - line pressure leaking into forward clutch apply passage.

● Forward Clutch - incorrect clutch plate usage or burned clutches (Refer to BURNED CLUTCH PLATES).

### No Motion in Reverse or Slips in Reverse

(Install pressure gage)

● Low Fluid Level - add fluid.

● Manual Linkage - misadjusted (correct alignment in manual lever shift quadrant is essential).

● Low Oil Pressure - refer to LOW LINE PRESSURE above.

● Control Valve Assembly:

a. Valve body gaskets - leaking, damaged or incorrectly installed.

b. 2-3 shift valve train stuck open (in upshifted position).

● Intermediate Servo - piston or pin stuck so intermediate band is applied.

● Low and Reverse Clutch - piston outer seal damaged or missing.

● Direct Clutch:

a. Outer seal damaged or missing.

b. Clutch plates burned (Refer to BURNED CLUTCH PLATES).

● Forward Clutch - clutch does not release (will cause DRIVE (D) in NEUTRAL (N)).

### Slips in All Ranges or Slips on Start

Install pressure gage

● Low Fluid Level - add fluid.

● Low Fluid Pressure - Refer to LOW LINE PRESSURE.

● Forward Clutch:

a. Clutch plates burned (Refer to BURNED CLUTCH PLATES below).

b. Pump cover oil seal rings broken or worn.

● Case - cross leaks or porosity.

### Slipping 1-2 Shift

Install pressure gage

● Low Fluid Level - add fluid.

● Low Fluid Pressure - Refer to LOW LINE PRESSURE.

● 1-2 Accumulator - oil ring damaged, missing or case bore damaged.

● Pump-to-Case Gasket - mispositioned or damaged.

● Intermediate Band:

a. Piston seals damaged or missing.

b. Intermediate Band burned (Refer to BURNED INTERMEDIATE BAND).

● Case - porosity between channels.

● Improper Intermediate Band adjustment.

### Slipping 2-3 Shift

(Install pressure gage)

● Low Fluid Level - add fluid.

● Low Oil Pressure - refer to LOW LINE PRESSURE.

● Direct Clutch:

a. Piston seals leaks, damaged or missing.

b. Clutch plates burned (Refer to BURNED CLUTCH PLATES).

c. Inspect for proper number and type of clutch plates.

● Case - refer to case porosity repair.

### Rough 1-2 Shift

(Install pressure gage)

● High Fluid Pressure - refer to HIGH LINE PRESSURE above.

● 1-2 Accumulator:

a. Oil rings damaged.

b. Piston stuck.

c. Broken or improper spring.

d. Bore damaged.

● Case:

a. Check for correct number and location of check balls.

b. Porosity between channels.

● Intermediate Band:

a. Improper adjustment.

b. Improper or broken servo spring.

### Rough 2-3 Shift

(Install pressure gage)

● High Fluid Pressure - Refer to HIGH LINE PRESSURE.

● 2-3 Accumulator:

a. Oil ring damaged.

b. Piston stuck.

c. Broken or missing spring.

d. Piston bore damaged.

### No Engine Braking in I

(Install pressure gage)

● Low Fluid Pressure - pressure regulator and/or boost valve stuck.

● Intermediate Servo:

a. Servo oil rings or bores leaking or damaged.

b. Servo piston stuck or cocked.

● Intermediate Band - intermediate band broken or burned (look for cause), not engaged on servo pin or improper adjustment.

### No Engine Braking in L

(Install pressure gage)





- Low Fluid Pressure - pressure regulator and/or boost valves stuck.
- Manual Low Control Valve Assembly - stuck.
- Low and Reverse Clutch - piston inner seal damaged or missing.

**No Part Throttle Downshift**

(Install pressure gage)

- Fluid pressure - vacuum modulator assembly, modulator valve or pressure regulator valve train (other malfunctions may also be noticed).
- Detent Valve and Linkage - sticks, disconnected or broken.
- 2-3 shift valve - stuck.

**No Detent (Wide Open Throttle) Downshift**

Detent cable or retainer not adjusted properly.

- Detent cable disconnected at transmission or throttle linkage.
- Valve Body:
  - a. Detent valve sticks.
  - b. Detent regulator valve sticks.
  - c. Incorrect spacer plate or gasket.

**High or Low Shift Points**

(Install pressure gage)

- Fluid Pressure:
  - a. Engine Vacuum - check at transmission end of modulator pipe.
  - b. Check vacuum line connections at engine and transmission.
  - c. Vacuum modulator assembly and valve and pressure regulator valve train.
- Governor:
  - a. Valve sticking.
  - b. Feed holes restricted or leaking.
- Detent Valve and Linkage - stuck open (will cause high shift points).
- Control Valve Assembly:
  - a. 1-2 shift valve train sticking.
  - b. 2-3 shift valve train sticking.
- Case - refer to case porosity repair.

**Won't Hold in Park(P)**

- Manual Linkage - misadjusted (correct alignment in manual lever shift quadrant is essential).
- Internal Linkage:

- a. Inner lever and actuating rod assembly - defective or improperly installed.
- b. Parking pawl - broken or inoperative.
- c. Parking lock bracket loose, burred or rough edges or incorrectly installed.
- d. Parking pawl disengaging spring missing, broken or incorrectly hooked.

**Transmission Noisy**

**NOTICE:** Before checking transmission, make certain that noise is not coming from water pump, generator power steering, etc. These components can be isolated by removing proper belt and running engine not more than two minutes at one time.

**Park(P), Neutral(N) and all Driving Ranges**

- Pump Cavitation:
  - a. Fluid level.
  - b. Plugged or restricted strainer.
  - c. Strainer-to-valve body gasket damaged.
  - d. Porosity in valve body intake area.
  - e. Water in fluid.
  - f. Porosity or voids at transmission case (pump face) intake port.
  - g. Pump-to-case gasket off location.
- Pump Assembly:
  - a. Gears damaged.
  - b. Driving gear assembled backwards.
  - c. Crescent interference.
  - d. Oil seal rings damaged or worn.
- Converter:
  - a. Loosen flexplate-to-converter bolts.
  - b. Converter damage.
  - c. Water in fluid (causes whine).

**First, Second and/or Reverse Gear**

Planetary Gear Set:

- Gears or thrust bearings damaged.
- Input or output ring gear damaged.

**During Acceleration-Any Gear**

- Transmission grounded to underbody.
- Motor mounts loose or broken.

**Squeal at Low Vehicle Speed**

Speedometer driven gear shaft seal - requires lubrication or replacement.

**TRANSMISSION DISASSEMBLY AND REASSEMBLY**

**TRANSMISSION DISASSEMBLY**

1. Install Holding Fixture J-8763-01 on transmission and place into Holding Tool base J-3289-14 with converter facing up.

Cleanliness is an important factor in the overhaul of a transmission. Before attempting any disassembly operation,

exterior of case should be thoroughly cleaned and prevent the possibility of dirt entering the transmission internal mechanism. During disassembly, all parts should be thoroughly cleaned in cleaning fluid and then air dried. Wiping cloths or rags should not be used to dry parts.

2. With transmission in holding fixture remove torque converter assembly. In some cases it may be necessary to

## 7A5-8 AUTOMATIC TRANSMISSION (250C)

pry the converter from the transmission due to a suction caused by the "O" ring seal on the input shaft.

3. Remove vacuum modulator assembly attaching bolt and retainer.

4. Remove vacuum modulator assembly, "O" ring seal, and modulator valve from case.

### Removal of Extension, Speedometer Driven Gear, Governor, Oil Pump Screen

1. Remove four extension housing to case attaching bolts.

2. Remove extension housing from case and remove square cut "O" ring seal from extension housing.

3. Remove extension housing lip seal using screw driver if replacement is necessary.

4. Remove speedometer gear and retaining clip.

5. Remove governor cover retainer with a screw driver.

6. Using a screw driver and hammer, gently tap along governor cover lip, remove governor cover and "O" ring seal (Figure 7A5-15). Discard seal. Do not pry screwdriver between case and and governor cover - case damage may result.

7. Remove governor assembly from case and check governor bore and governor sleeve for scoring.

8. Remove oil pan attaching bolt, oil pan, and gasket.

9. Remove oil pump screen (strainer) and gasket from valve body.



Figure 7A5-15 Governor Cover and "O" Ring Seal

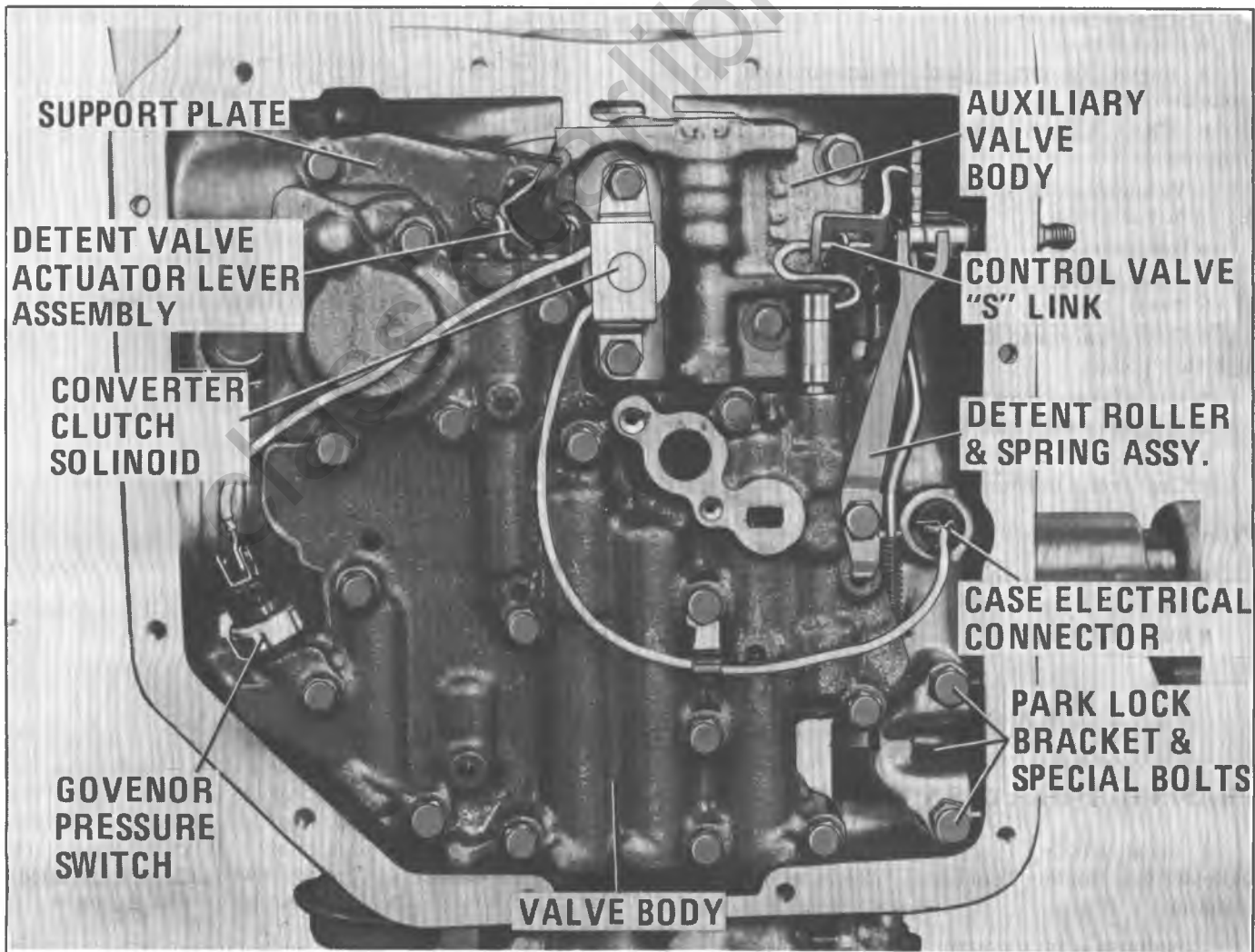

Figure 7A5-14 Valve Body, Detent Roller, Park Bracket and T.C.C. Components - Typical

### Removal of Valve Body and Linkage

1. Remove detent roller and spring assembly from valve body. (Figure 7A5-14)

2. Remove actuator pin from detent actuator valve lever and remove control wire (Figure 7A5-14).

3. Disconnect wires from case connector and remove solenoid. If replacement is required remove governor pressure switch. Inspect solenoid wires for loose connections or cut insulation. (Figure 7A5-14)

4. Remove manual shaft retainer clip with screwdriver and slide manual shaft outward to disconnect manual valve link. Remove link.

5. Remove valve body attaching bolts and valve body.

The intermediate servo can not be removed until the band has been removed.

6. Remove auxiliary valve body and support plate attaching bolts. Remove auxiliary valve body and support plate.

7. Remove spacer plate and gaskets.

8. Remove five (5) check balls from case, note locations. (Figure 7A5-18)

9. Remove oil pump screen and clean.

10. Remove governor feed screen from case and clean.

11. Remove park lock special attaching bolts and (Figure 7A5-14) park lock. If it becomes necessary to remove the internal linkage proceed as follows.

a. Loosen nut holding range selector inner lever to manual shaft. Pull on manual shaft and remove nut. Remove manual shaft and nut.

b. Remove range selector lever parking pawl actuator

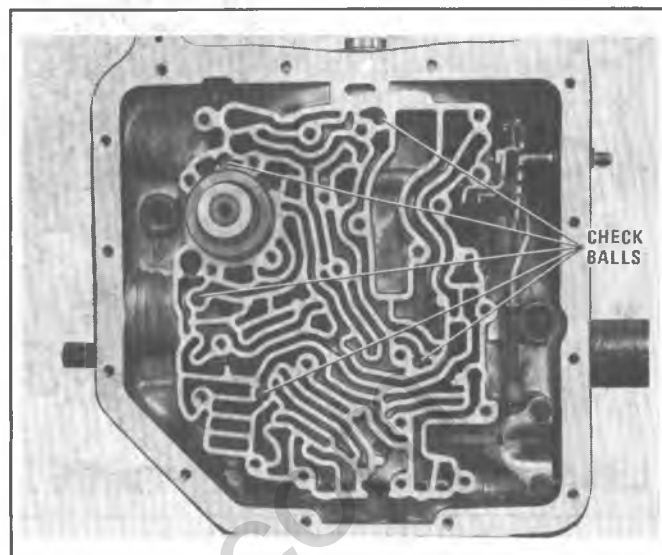

Figure 7A5-18 Check Ball Locations

rod from case. Disassemble inner lever from parking pawl actuator rod (Figure 7A5-21).

c. Remove manual shaft to case lip seal replace if required.

d. Remove parking pawl disengaging spring (Figure 7A5-22).

e. Remove parking pawl shaft retaining plug, parking pawl shaft, and parking pawl (Figure 7A5-22) if replacement is required.

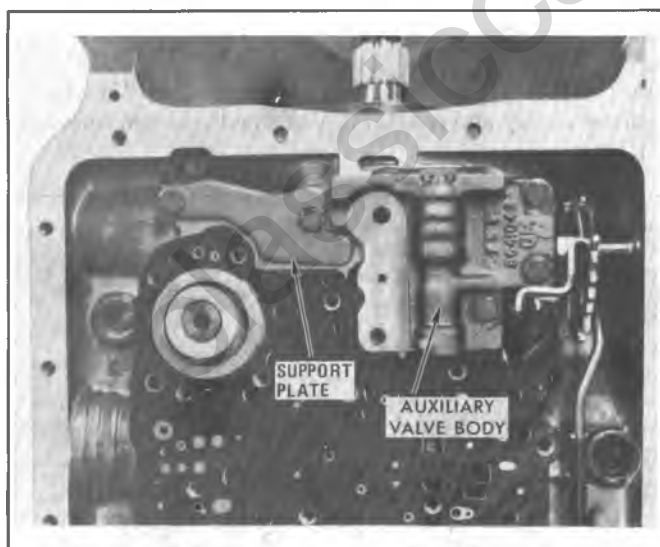

Figure 7A5-17 Auxiliary Valve Body and Support Plate

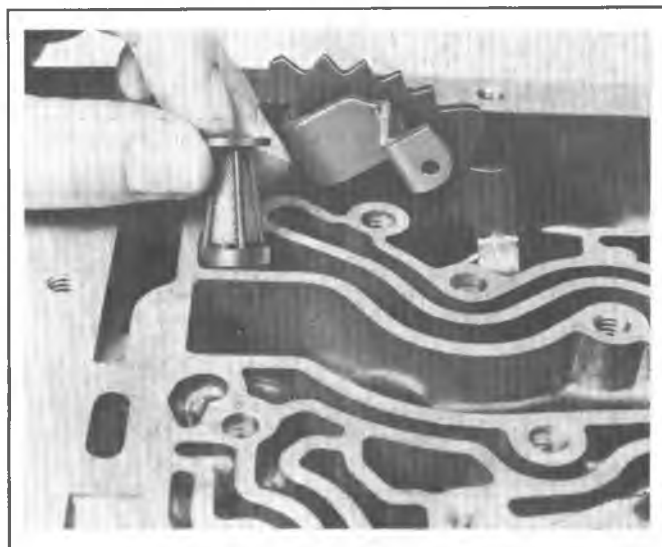

Figure 7A5-19 Oil Pump Screen

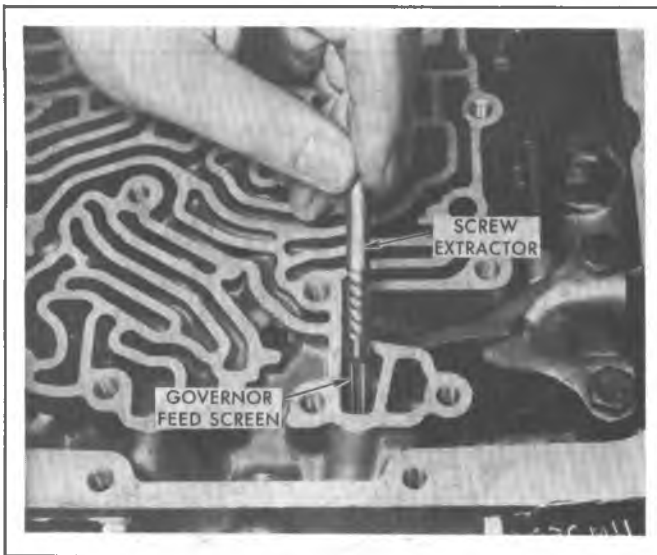

Figure 7A5-20 Governor Feed Screen

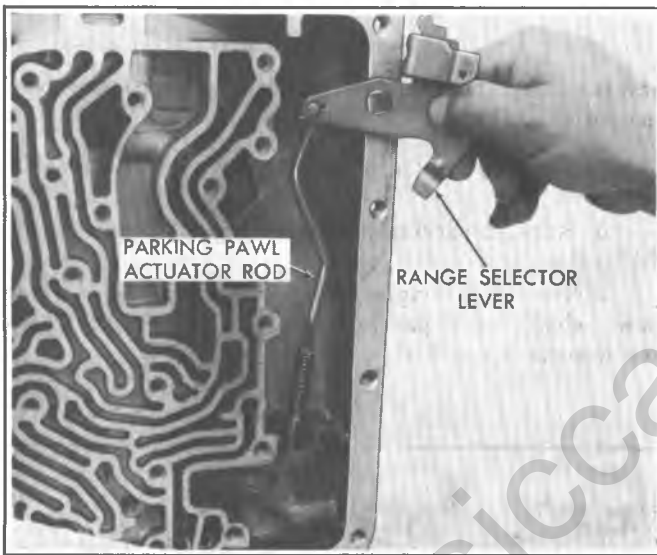

Figure 7A5-21 Removal of Actuator and Range Selector

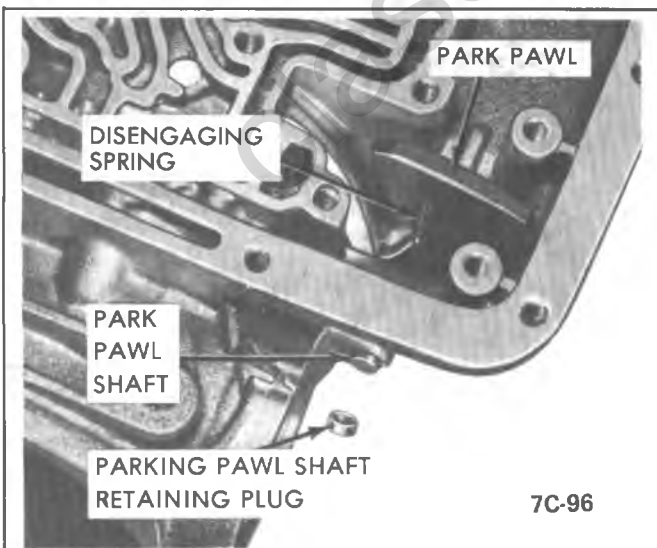

Figure 7A5-22 Park Pawl Removal

The parking pawl shafts retaining clip may be removed by using a bolt extractor.

12. Remove case electrical connector by compressing tabs on sleeve.

### Removal of Oil Pump and Internal Case Components

1. Remove eight (8) pump attaching bolts with washer type seals.

2. Install two (2) threaded slide hammers J-7004 into \*threaded holes in pump body and remove pump assembly from case (Figure 7A5-23).



Figure 7A5-23 Pump Removal

3. Loosen nut and intermediate band anchor bolt (Figure 7A5-24).

4. Remove direct and forward clutch assemblies and intermediate band from case (Figure 7A5-25). Refer to disassembly and reassembly of the direct and forward clutches.

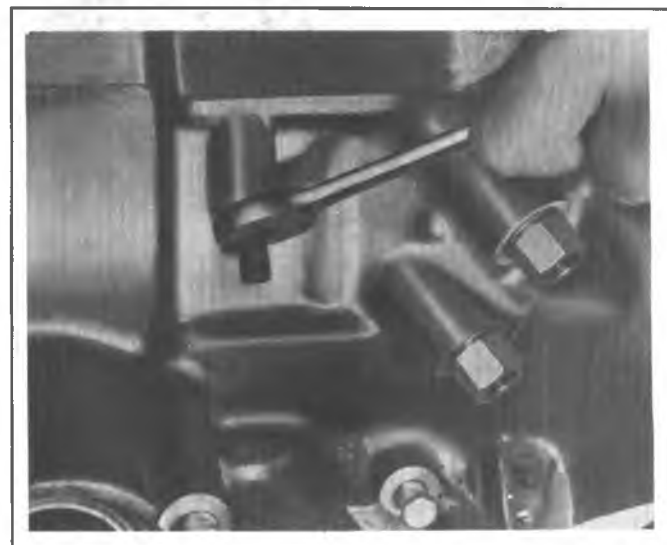

Figure 7A5-24 Intermediate Band Anchor Bolt



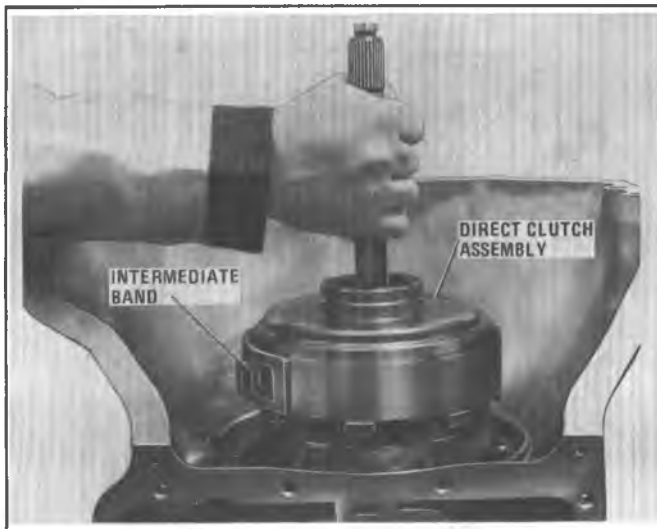

Figure 7A5-25 Removing Forward and Direct Clutch Assemblies and Intermediate Band

5. Remove intermediate servo, cushion spring, and washer from case from input ring gear.
6. Remove thrust washer (Figure 7A5-27). Washer has 3 tangs.
7. Remove input ring gear.
8. Remove output carrier to output shaft snap ring (Figure 7A5-28).
9. Remove input ring gear rear (output carrier) thrust washer (Figure 7A5-29).
10. Remove output carrier assembly (Figure 7A5-29).
11. Remove sun gear drive shell assembly (Figure 7A5-30).
12. Remove low and reverse roller clutch support to case retaining ring (Figure 7A5-31).
13. Remove low and reverse clutch support and race assembly and anti-clunk spring (clutch retainer spring).
14. Remove reaction carrier assembly, output ring gear, shaft assembly, and clutch plates from case. (Figure 7A5-35).

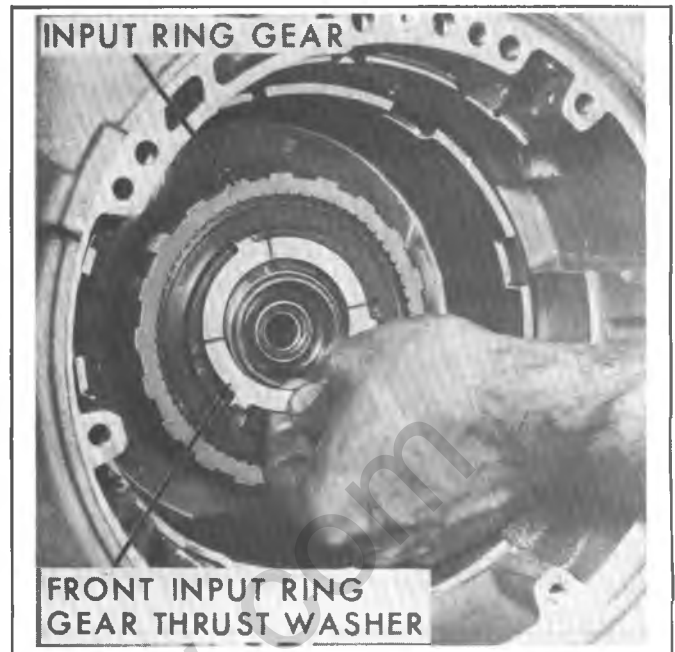

Figure 7A5-27 Input Ring Gear & Thrust Washer Removal

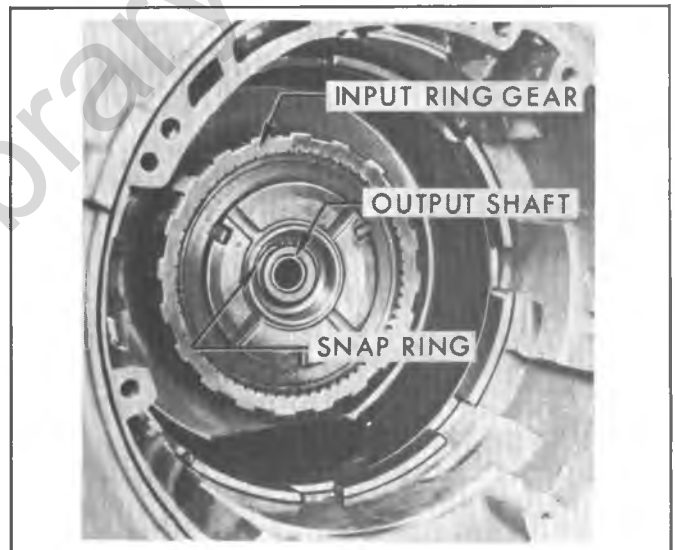

Figure 7A5-28 Output Shaft Snap Ring

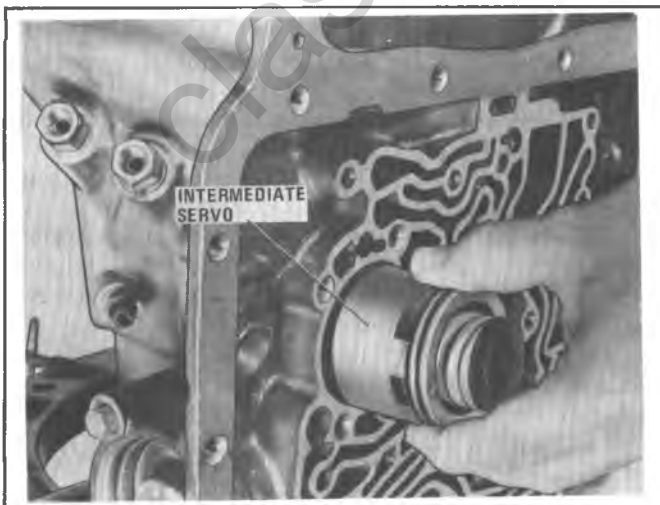

Figure 7A5-26 Intermediate Servo Removal

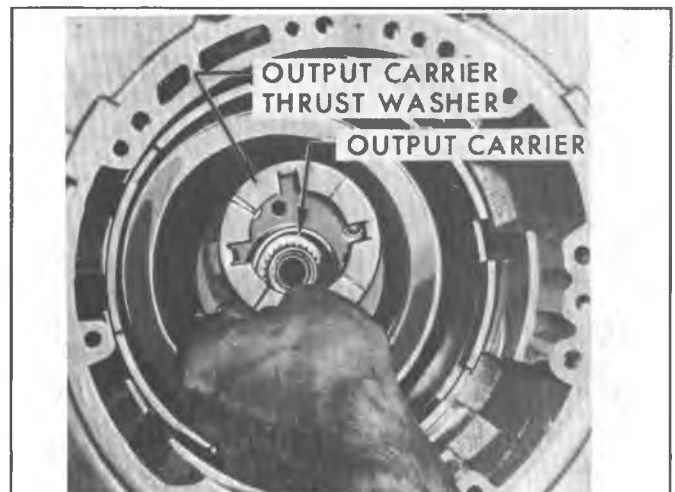

Figure 7A5-29 Output Carrier and Thrust Washer Removal



Figure 7A5-30 Sun Gear Drive Shell Removal

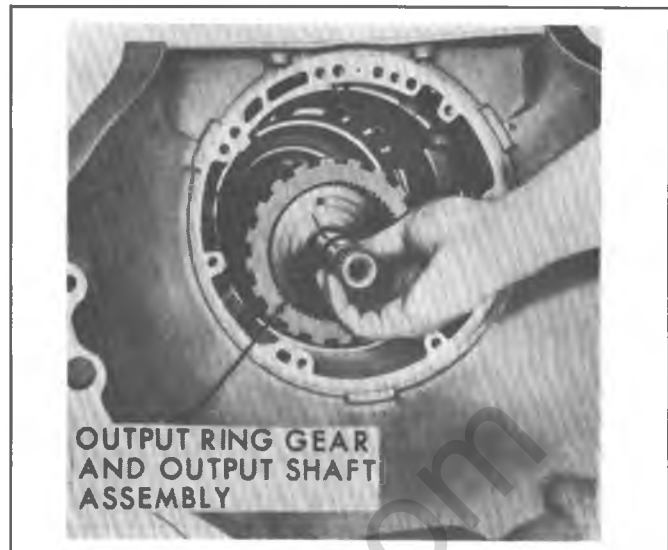

Figure 7A5-33 Output Shaft and Ring Gear Removal

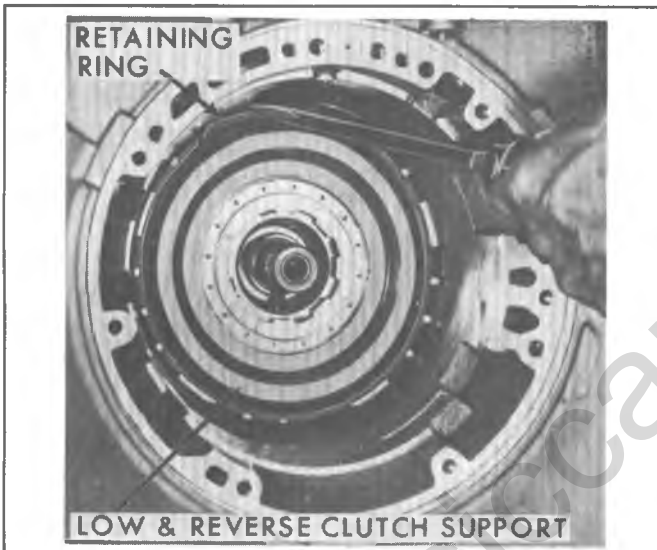

Figure 7A5-31 Low & Reverse Clutch Support Retaining Ring



Figure 7A5-34 Low & Reverse Clutch Plate Removal



Figure 7A5-32 Anti-Clunk Spring

15. Remove reaction carrier assembly from output ring gear and shaft assembly.

16. Remove reaction carrier to output ring gear needle bearing (Figure 7A5-35).

17. Remove output ring gear to case needle bearing assembly (Figure 7A5-36).

18. Compress low and reverse clutch piston spring retainer using Tool J-23327 and remove piston retaining ring, spring retainer (Figure 7A5-37) and springs. Inspect springs for heat distortion.

19. Remove low and reverse clutch piston assembly by applying compressed air in passage shown on Figure 7A5-38.

20. Remove low and reverse clutch piston outer seal (Figure 7A5-40).

21. Remove low and reverse clutch piston center and inner seal (Figure 7A5-39).

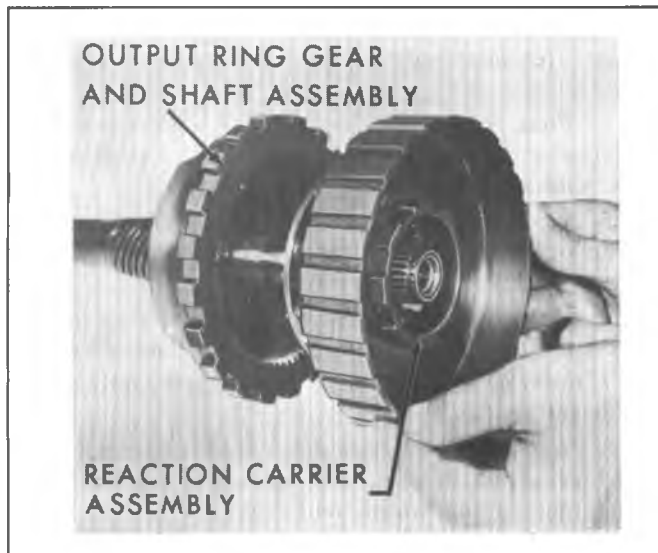

Figure 7A5-35 Removing Output Carrier Assembly



Figure 7A5-38 Removing Low & Reverse Piston



Figure 7A5-36 Output Ring Gear To Case Needle Bearing

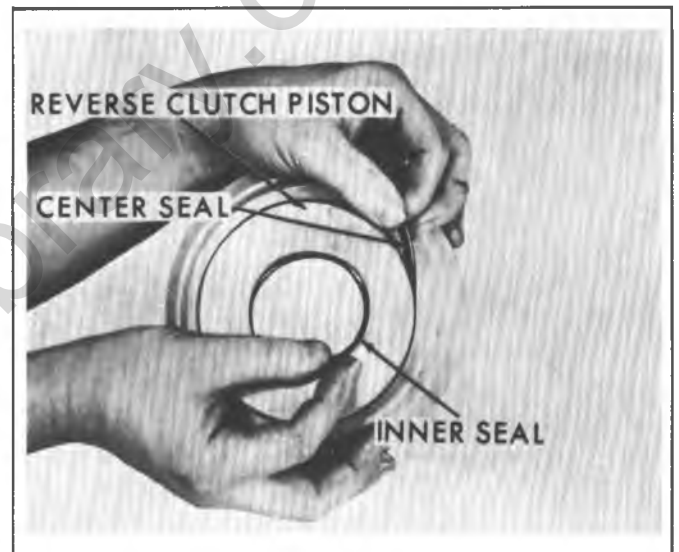

Figure 7A5-39 Low & Reverse Center & Inner Seals

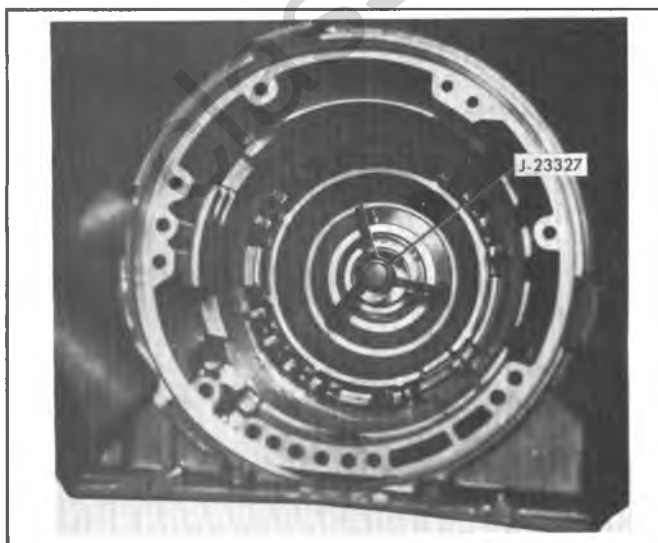

Figure 7A5-37 Tool J-23327

22. Install Tool J-23069 to compress 1-2 accumulator piston cover and remove retaining ring (Figure 7A5-41).

23. Remove 1-2 accumulator piston cover. Remove "O" ring seal from case.

24. Remove 1-2 accumulator piston spring.

25. Remove 1-2 accumulator piston assembly. Refer to Figure 7A5-42.

Remove inner and outer scarf cut teflon oil seal rings only if replacement is required.

### Valve Body (Figure 7A5-43)

#### Disassembly

1. Position valve body assembly with cored faced up and direct clutch accumulator piston pocket positioned as shown in Figure 7A5-38D.

2. Remove manual valve from lower left hand bore.

3. From lower right hand bore remove pressure regulator valve train retaining pin, boost valve sleeve,

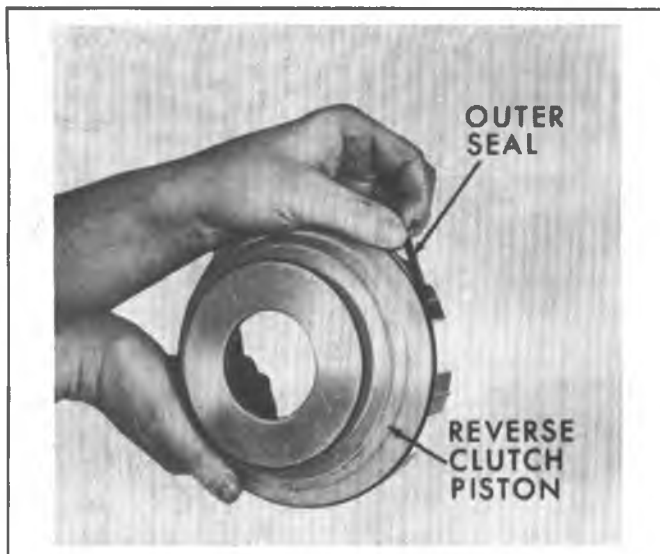

Figure 7A5-40 Removing Low & Reverse Piston Outer Seal

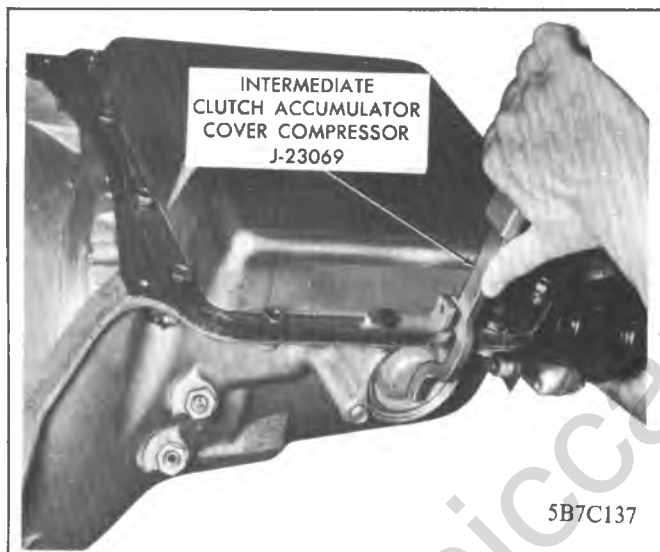

Figure 7A5-41 1-2 Accumulator Removal



Figure 7A5-42 1-2 Accumulator-Exploded View

intermediate boost valve, reverse and modulator boost valve, pressure regulator valve spring, and pressure regulator valve.

4. From next bore, remove 2-3 shift valve train retaining pin, sleeve, control valve spring 2-3 shaft control valve, shift valve spring, and 2-3 shift valve.

5. From next bore, remove the 1-2 shift valve train retaining pin, sleeve, shift control valve spring, 1-2 shift control valve, and 1-2 shift valve.

6. From next bore, remove retaining pin, plug, manual low control valve spring, and manual low control valve.

7. From next bore, remove retaining pin, spring, seat, and detent regulator valve.

8. From bore on opposite side, remove detent actuating lever bracket bolt, bracket, stop, spring retainer, seat, outer spring, inner spring, washer and detent valve.

### Inspection

1. Inspect all valves for scoring, cracks and free movement in their respective bores.
2. Inspect valve body for cracks, scored bores, interconnected oil passages and flatness of mounting face.
3. Check all springs for distortion or collapsed coils.

### Reassembly

1. Install detent valve, washer, outer spring, inner spring, spring seat, and spring retainer. Install detent valve stop and detent valve actuating bracket. Torque bolt to 52 in. lb. (58 N·m)
2. Install pressure regulator valve, spring, reverse and modulator boost valve, intermediate boost valve, boost valve sleeve and retaining pin.
3. In next bore up, install 2-3 shift control valve, shift control valve spring, shift control valve sleeve and retaining pin.
4. In next bore up, install 1-2 shift valve 1-2 shift control valve, control valve spring, control valve sleeve and retaining pin.
5. In next bore up, install manual low control valve, spring, plug and retaining pin.
6. In top right hand bore, install detent regulator valve, spring seat, spring and retaining pin.

### Auxiliary Valve Body (Figure 7A5-44 TCC Model)

#### Disassembly

1. Position valve body assembly core face up.
2. From bore remove retaining pin, seat, spring, and converter clutch apply valve.

#### Inspection

1. Inspect apply valve for scoring, cracks, and free movement in bore.
2. Inspect valve body for cracks, scored bores, interconnected oil passage, and flatness of mounting face.
3. Check spring for distortion.

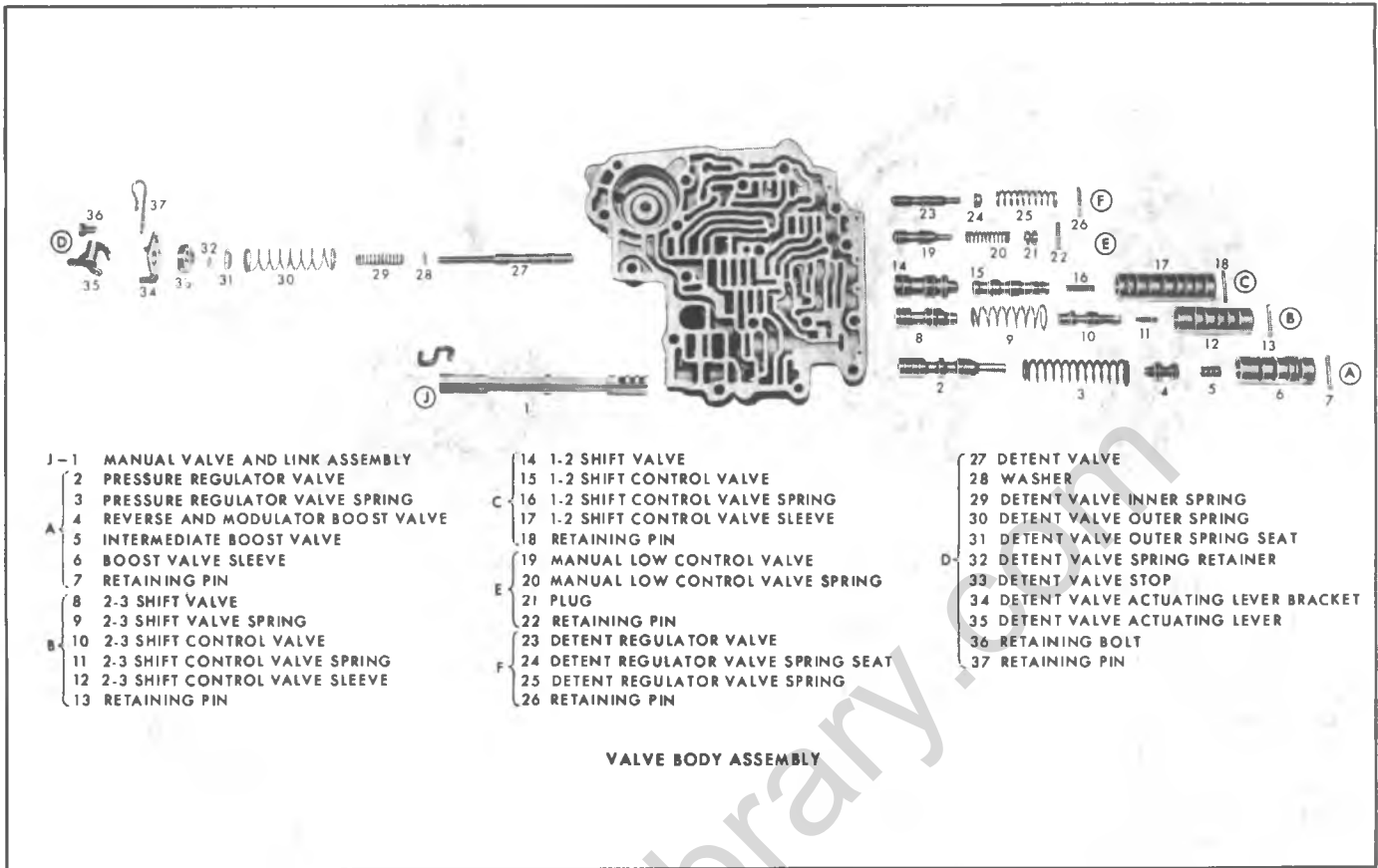

Figure 7A5-43 Valve Body Exploded View

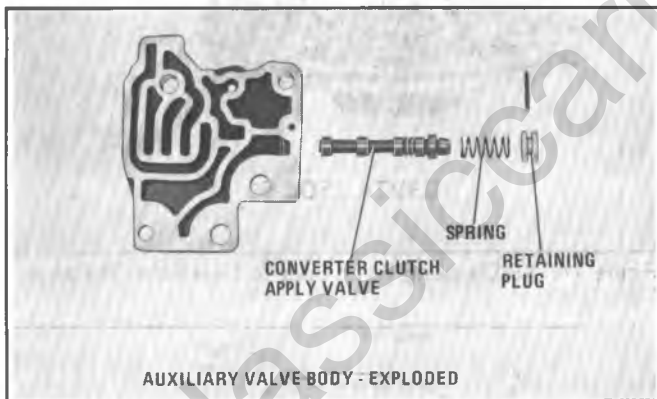

Figure 7A5-44

**Reassembly**

1. Install apply valve, spring, seat and retaining pin.

**Oil Pump**

**Disassembly**

1. Place pump cover and stator shaft assembly through hole in bench.
2. Remove pump cover to body attaching bolts.
3. If damaged remove two (2) forward clutch to pump hub scarf cut oil seal rings and three(3) direct clutch to pump hub oil rings. Do not remove unless replacement is required. (Figure 7A5-45)
4. Check steady rest ring, if cut or frozen in bore remove and replace.

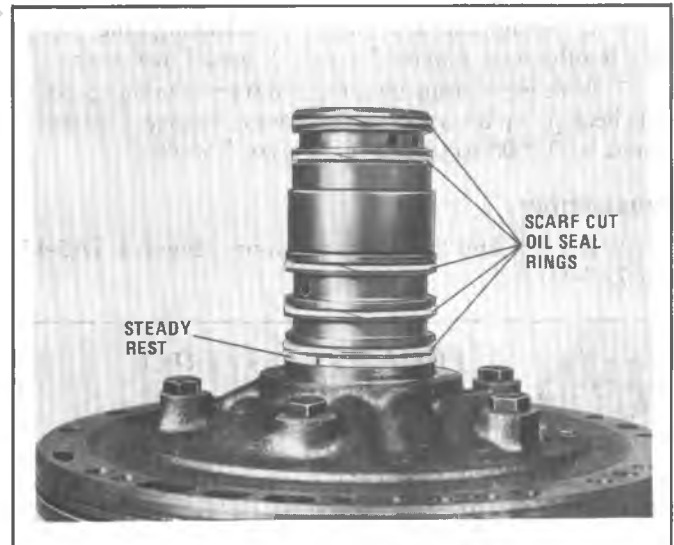

Figure 7A5-45 Pump Tower

5. Remove pump cover and stator shaft assembly from pump body (Figure 7A5-45).
6. Remove pump drive gear and driven gear. Note position of gears so that they may be reassembled properly.
7. Remove pump outside diameter to case (square cut) "O" ring seal.

**Inspection**

1. Wash all parts in cleaning solvent and blow out all oil passages. DO NOT USE CLOTH OR PAPER TO DRY PARTS - AIR DRY PARTS ONLY.



Figure 7A5-46 Pump Gear Identification

2. Inspect pump gears for nicks or damage.
3. Inspect body and cover faces for nicks or scoring. Inspect cover hub O.D. for nicks or burrs which might damage clutch drum bushing journal.
4. Inspect body bushing for galling or scoring. Check clearance between body bushing and converter pump hub. Maximum clearance is 0.005 in. If bushing is damaged, oil pump body should be replaced.
5. Inspect converter housing hub O.D. for nicks or burrs which might damage pump seal or bushing. Repair or replace as necessary.
6. If hub lip seal is damaged or is leaking (and pump body is otherwise suitable for reuse), install new seal.
7. With parts clean and dry, pump gears in pump body and check pump body face to gear face clearance. Clearance should be 0.0005 to 0.0015 in. (Figure 7A5-49).

**Reassembly**

1. Replace hub lip seal as necessary (Figures. 7A5-47 and 7A5-48).

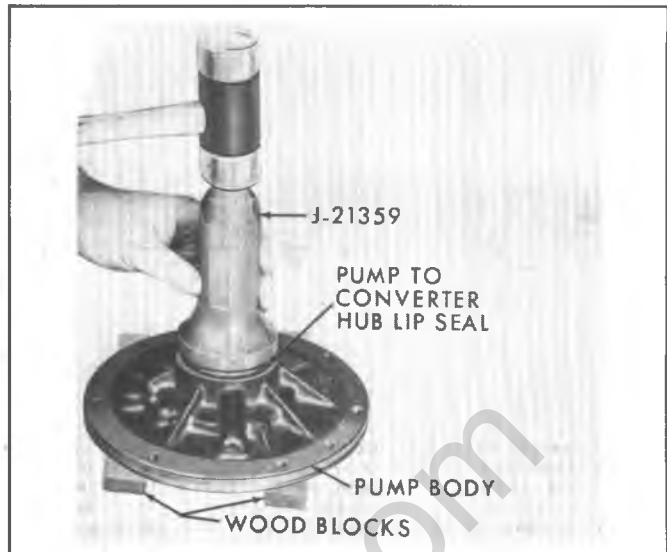

Figure 7A5-48 Installing Hub Lip Seal



Figure 7A5-49 Checking Pump Body to Gear Face Clearance

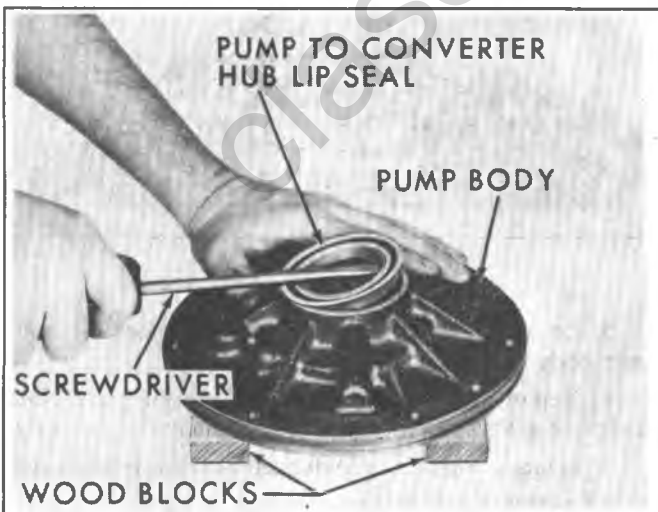

Figure 7A5-47 Removing Pump to Converter Hub Lip Seal

2. To replace seal place pump body on wood blocks and pry out seal. Coat outer diameter of new seal with a nonhardening sealer and seal using seal installer J-21359 to seat full in counterbore.

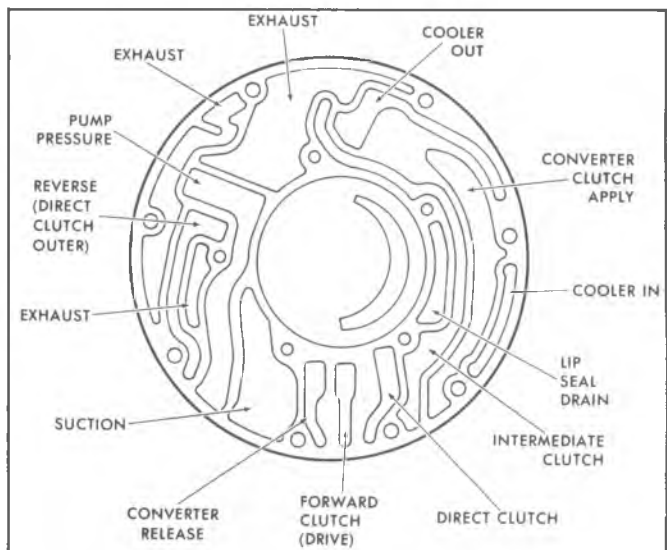

Figure 7A5-50 Pump Body Oil Passages

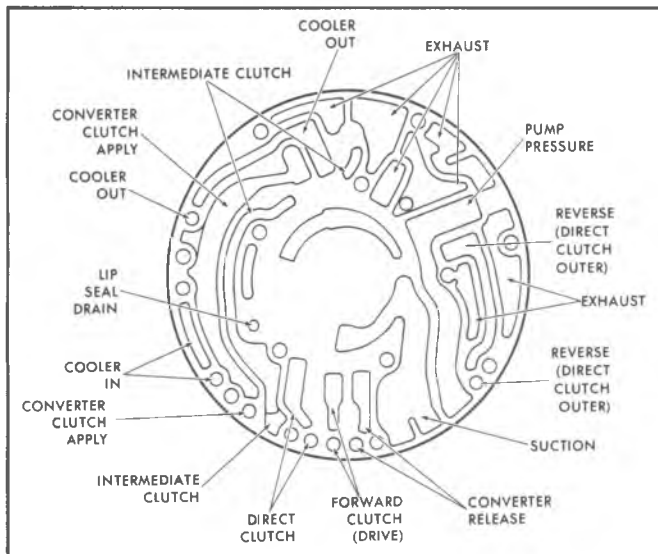

Figure 7A5-51 Pump Cover Oil Passages

3. Install pump drive gear and driven gear (Figure 7A5-46).
4. Install direct clutch drum housing to pump cover needle bearing over pump cover delivery sleeve.
5. If removed install three (3) direct clutch to pump hub oil seal rings. Install two(2) forward clutch to pump hub oil seal rings. (Figure 7A5-45)

Check pump cover and body oil passages to make sure they are not restricted (Figs. 7A5-50 and 7A5-51).

6. Install new pump outside diameter to case (square cut) "O" ring seal.
7. Align pump body to cover and install five(5) attaching bolts. Tighten bolts to 18 ft. lb. (24 N·m)

## Direct Clutch

### Disassembly

1. Remove direct clutch pressure plate to clutch drum retaining ring and pressure plate.

2. Remove lined drive plates and steel driven plates (Figure 7A5-54) and cushion spring.
3. Using Compressor Tool J-23327-1, remove direct clutch piston spring retainer, and springs. (Figure 7A5-52).
4. Remove direct clutch piston assembly.
5. Remove direct clutch piston outer seal and inner seal (Figure 7A5-56).
6. Remove direct clutch piston center seal on drum (Figure 7A5-57).

### Inspection

1. Inspect drive and driven clutch plates for signs of burning, scoring or wear.
2. Inspect piston return springs for collapsed coils or signs of heat distortion.
3. Inspect piston for cracks.
4. Inspect clutch housing for wear, scoring, open oil passages and proper operation of ball check.

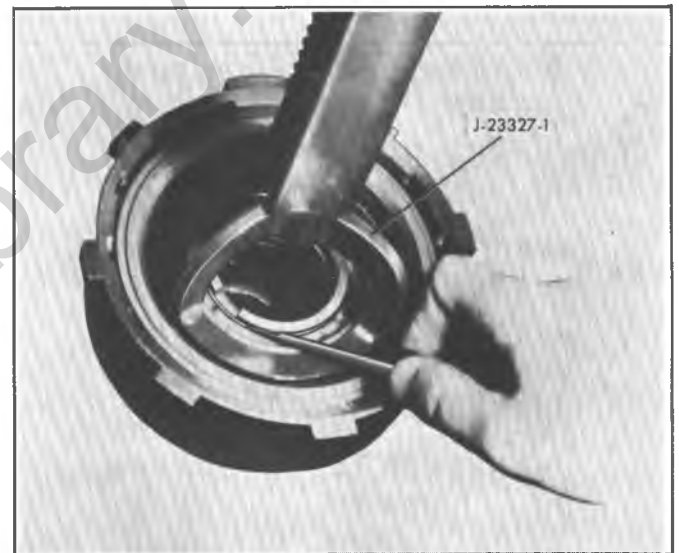

Figure 7A5-52 Removing Direct Clutch Retaining Ring

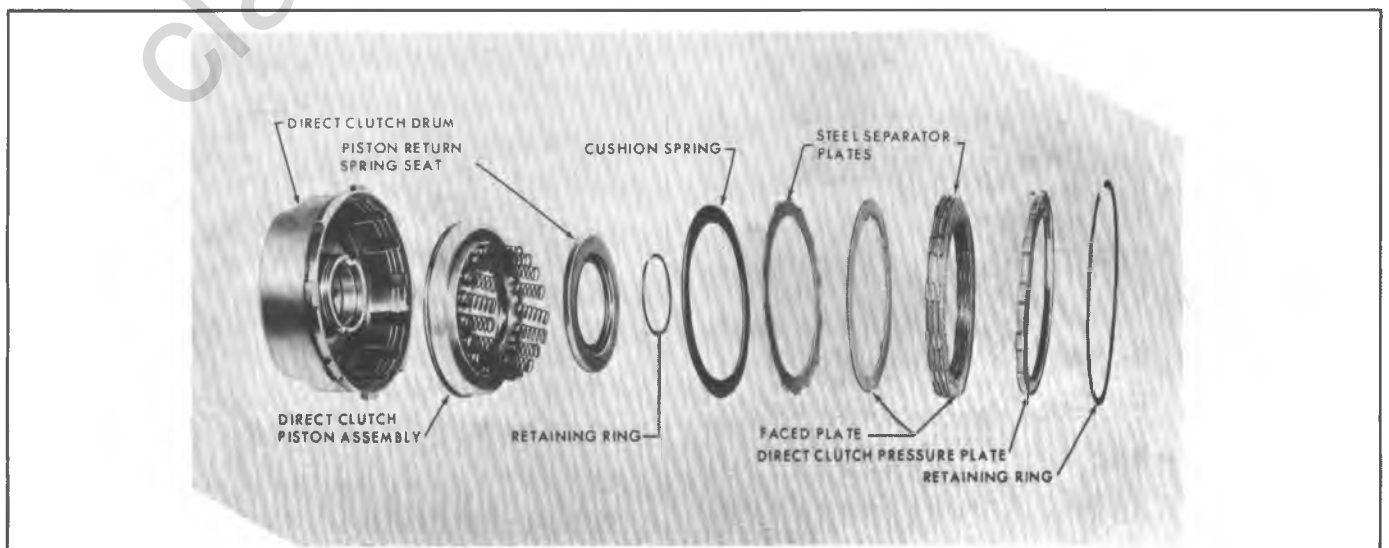

Figure 7A5-53 Direct Clutch Assembly-Exploded View

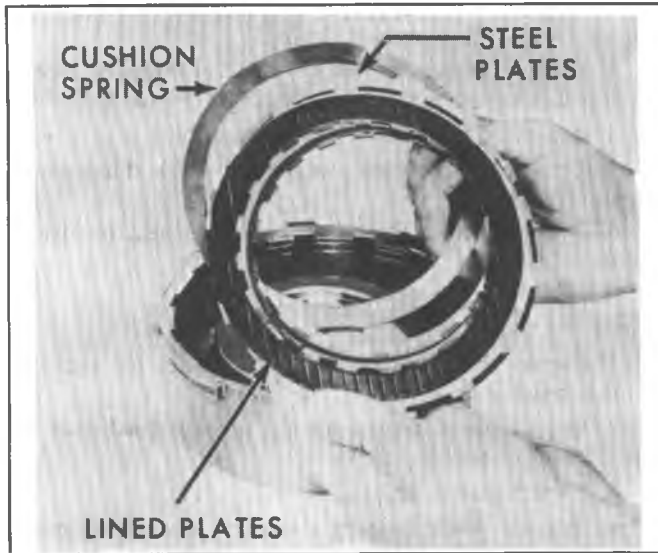

Figure 7A5-54 Removing Face Plates and Steel Separator Plates

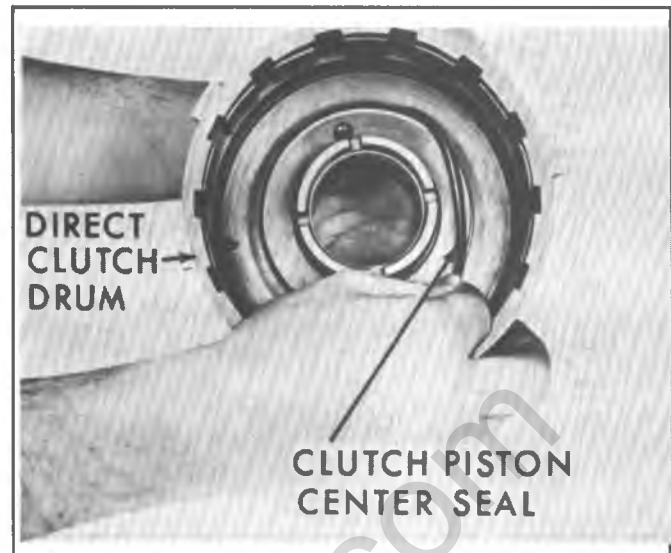

Figure 7A5-57 Removing Direct Clutch Piston Center Seal on Drum



Figure 7A5-55 Direct Clutch Retainer & Seat

### Reassembly

1. Install new direct clutch piston outer seal and inner seal.
2. Install new direct clutch piston center seal on drum with lip facing upward.
3. Install direct clutch piston into housing with aid of a feeler gage or a piece of 0.020 in. piano wire crimped into copper tubing (Figure 7A5-58).
4. Install clutch return coil springs and retainer.
5. Install piston return spring seat. Compress spring seat with Tool J-23327 and install retaining ring (Figure 7A5-59).
6. Lubricate with transmission fluid and install cushion spring, face plates and steel separator plates, alternating steel and faced plates.
7. Install retaining ring and pressure plate.

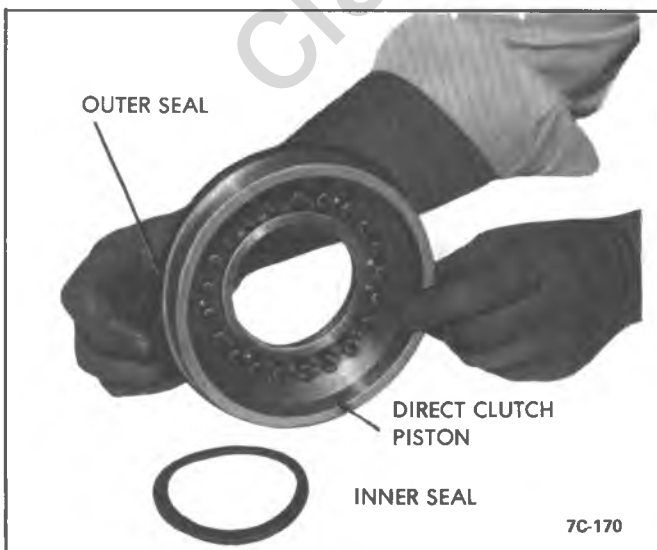

Figure 7A5-56 Removing Direct Clutch Outer and Inner Seals

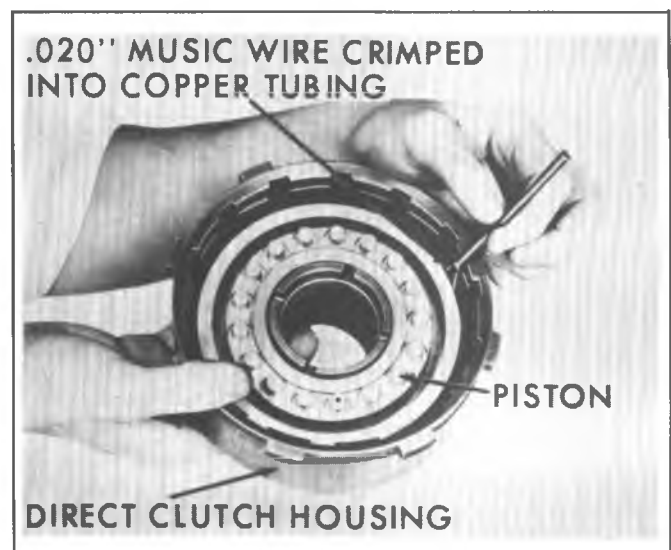

Figure 7A5-58 Installing Direct Clutch Piston



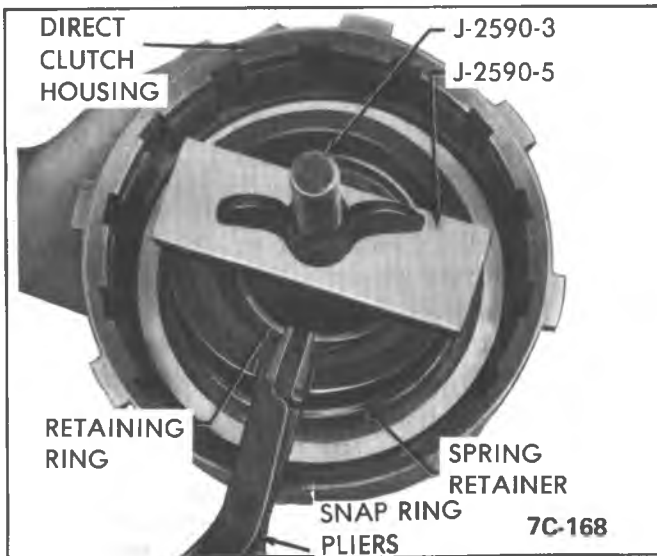

Figure 7A5-59 Installing Direct Clutch Piston Return Spring Seat



Figure 7A5-61 Direct Clutch Drum to Forward Clutch

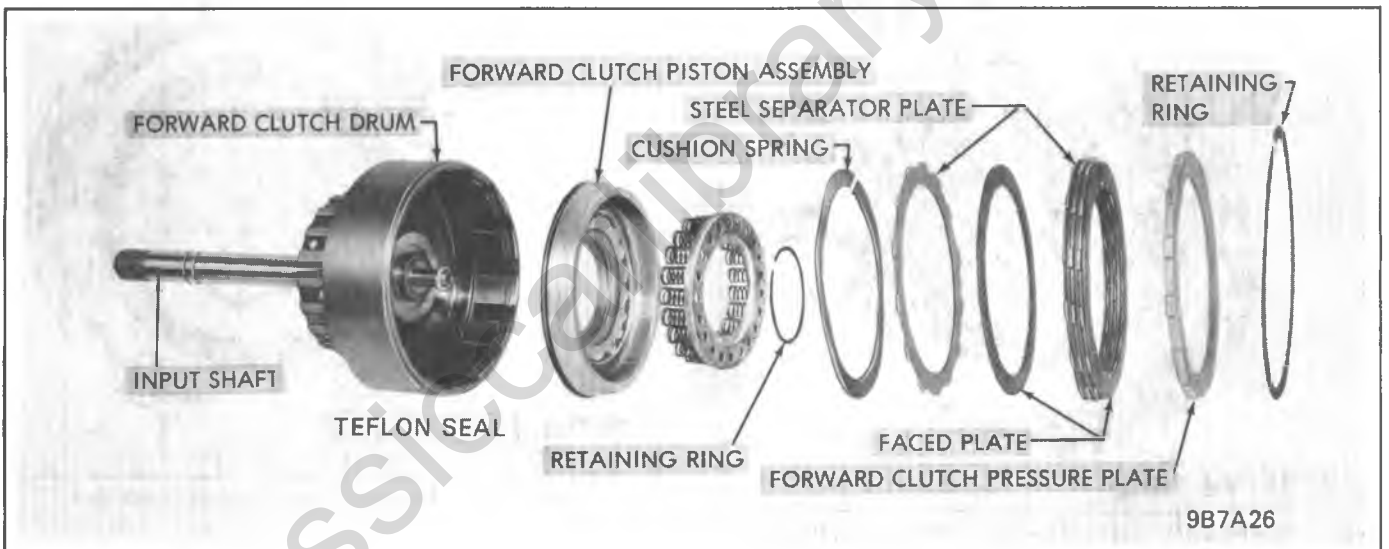

Figure 7A5-60 Forward Clutch Exploded

## Forward Clutch (Figure 7A5-60)

### Disassembly

1. Remove direct clutch drum to forward clutch housing needle bearing (Figure 7A5-61).

#### Housing Needle Bearings

2. Remove forward clutch retaining ring and pressure plate (Figure 7A5-62).

3. Remove face plates, steel separator plates and cushion spring (Figure 7A5-63).

4. Using Tool J-23327-1, compress retainer and remove forward clutch drum to pressure plate retaining ring (Figure 7A5-64).

5. Remove piston return seat, spring retainer and springs.

6. Remove forward clutch piston assembly.

7. Remove the forward clutch inner and outer piston seals (Figure 7A5-65).

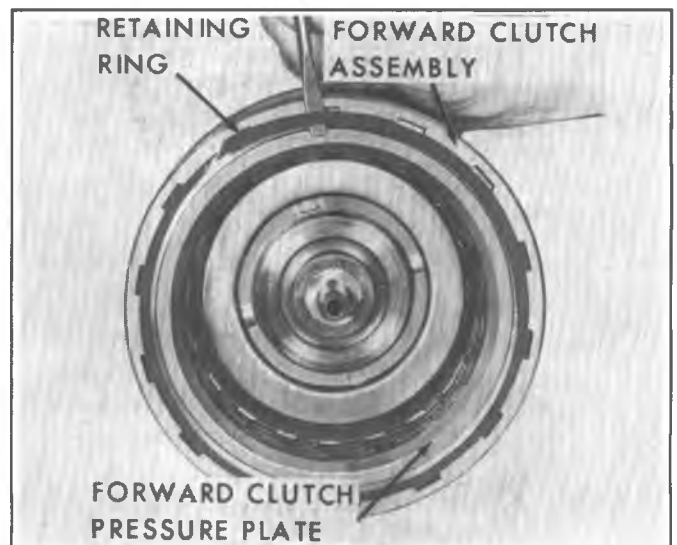

Figure 7A5-62 Removing Forward Clutch Retaining Ring and Pressure Plate

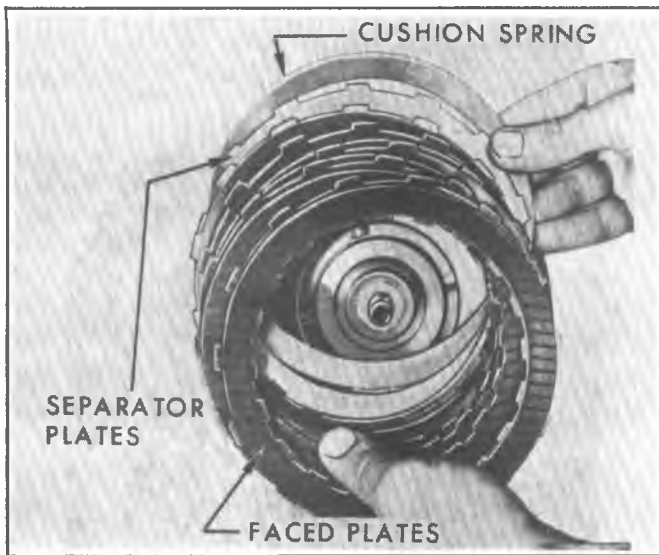

Figure 7A5-63 Removing Forward Clutch Plates



Figure 7A5-64 Compressing Forward Clutch Spring Retaining Seat

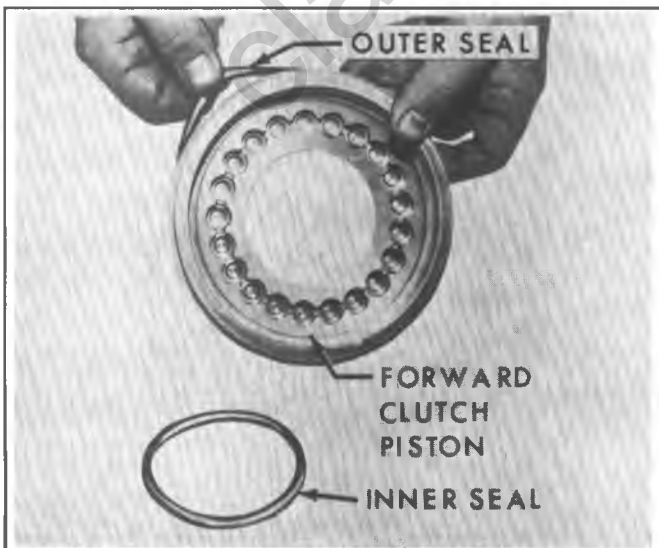

Figure 7A5-65 Removing Forward Clutch Piston Inner and Outer Seals

### Inspection

1. Inspect drive and driven clutch plates for signs of burning, scoring or wear.
2. Inspect piston return springs for collapsed coils or signs of heat distortion.
3. Inspect piston for cracks.
4. Inspect clutch housing for wear, scoring, open oil passages and free operation of exhaust check (Figure 7A5-66).
5. Inspect output shaft.
  - a. Inspect for open lubrication passages at each end.
  - b. Inspect splines for damage.
  - c. Inspect ground bushing journals for damage.

Input shaft and clutch housing are serviced separately. Make certain that the center of the forward clutch housing is properly supported when removing the input shaft.

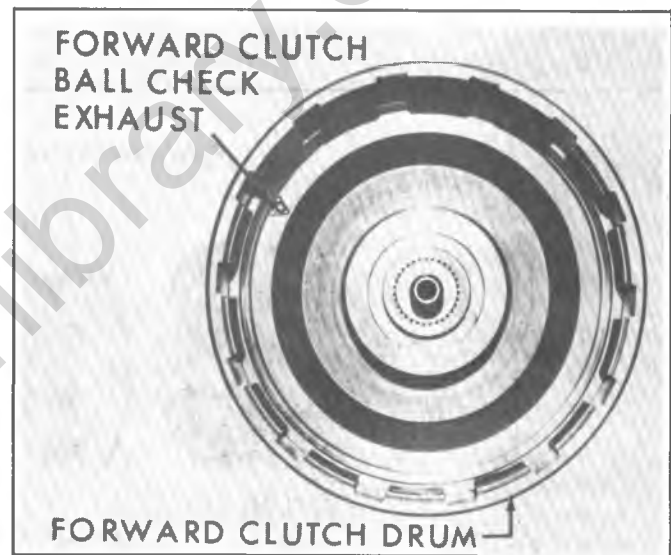

Figure 7A5-66 Forward Clutch Exhaust Check Ball

### Reassembly

1. Install new forward clutch inner piston seal and outer piston seal.
2. Install the forward clutch piston assembly (with the aid of a feeler gage or piece of 0.020 in. piano wire crimped into copper tubing (Figure 7A5-67).
3. Install clutch return coil springs and retainer.
4. Install spring retainer. Compress spring retainer and install retaining ring using Tool J-23327 as shown on Figure 7A5-64).
5. Lubricate with transmission fluid and install cushion spring face plates and steel separator plates, starting with the cushion spring and alternating steel and faced.
6. Install forward clutch pressure plate (selective fit and retaining ring). Using chart (Figure 7A5-68) select the correct pressure plate (dimension C), measure distance from the top of clutch pack to the top of clutch drum (dimension A). Measure distance from the lower edge of the notch on the inner surface of the drum to the end of the drum (dimension B). Subtract B from A to get dimension C.



Figure 7A5-67 Installing Forward Clutch Piston

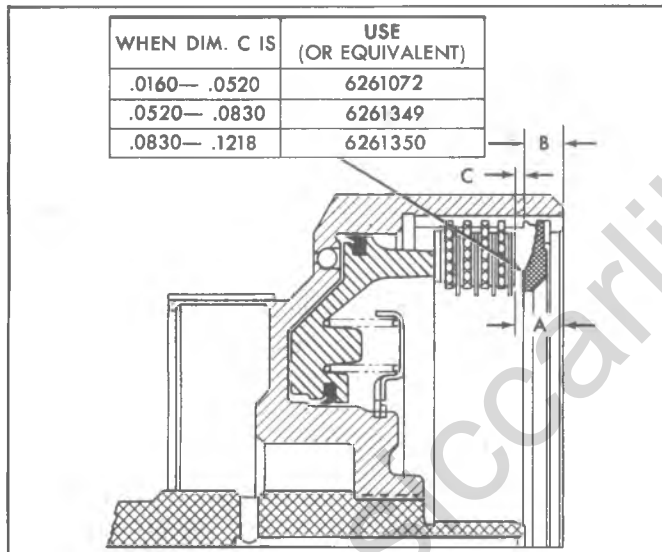

Figure 7A5-68 Determining Selective Fit for Forward Clutch Pressure Plate

## Sun Gear and Sun Gear Drive Shell (Figure 7A5-69)

### Disassembly

1. Remove sun gear to sun gear drive shell rear retaining ring (Figure 7A5-70).
2. Remove sun gear to drive shell flat rear steel thrust washer (Figure 7A5-71).
3. Remove sun gear assembly from drive shell.
4. Remove sun gear to drive shell front retaining ring.
5. If bushing is to be replaced, refer to Figure 7A5-71). Rear Steel Thrust Washer

### Inspection

Check gear and sun gear shell for damage or wear.

### Reassembly

1. Install new sun gear to drive shell front retaining ring.

2. Install sun gear assembly into drive shell.
3. Install sun gear to drive shell flat steel thrust washer.
4. Install new sun gear to sun gear drive shell retaining ring.

Do not stress front and rear retaining rings at installation.



Figure 7A5-70 Removing Sun Gear Drive Shell Rear Retaining Ring

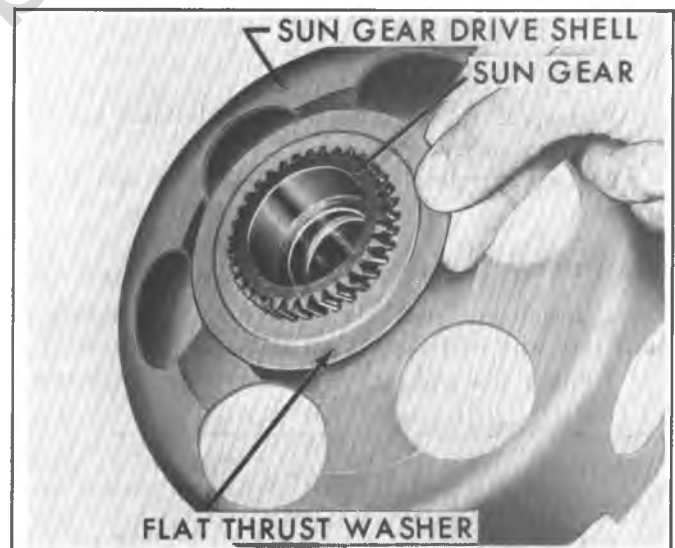

Figure 7A5-71 Removing Sun Gear to Drive Shell

## Low and Reverse Clutch Support (Figure 7A5-72)

### Disassembly

1. Remove low and reverse clutch to sun gear shell thrust washer.
2. Remove low and reverse overrun clutch inner race from support (Figure 7A5-73).
3. Remove low and reverse clutch roller clutch retaining ring (Figure 7A5-74).
4. Remove low and reverse roller clutch assembly. (Figure 7A5-75)

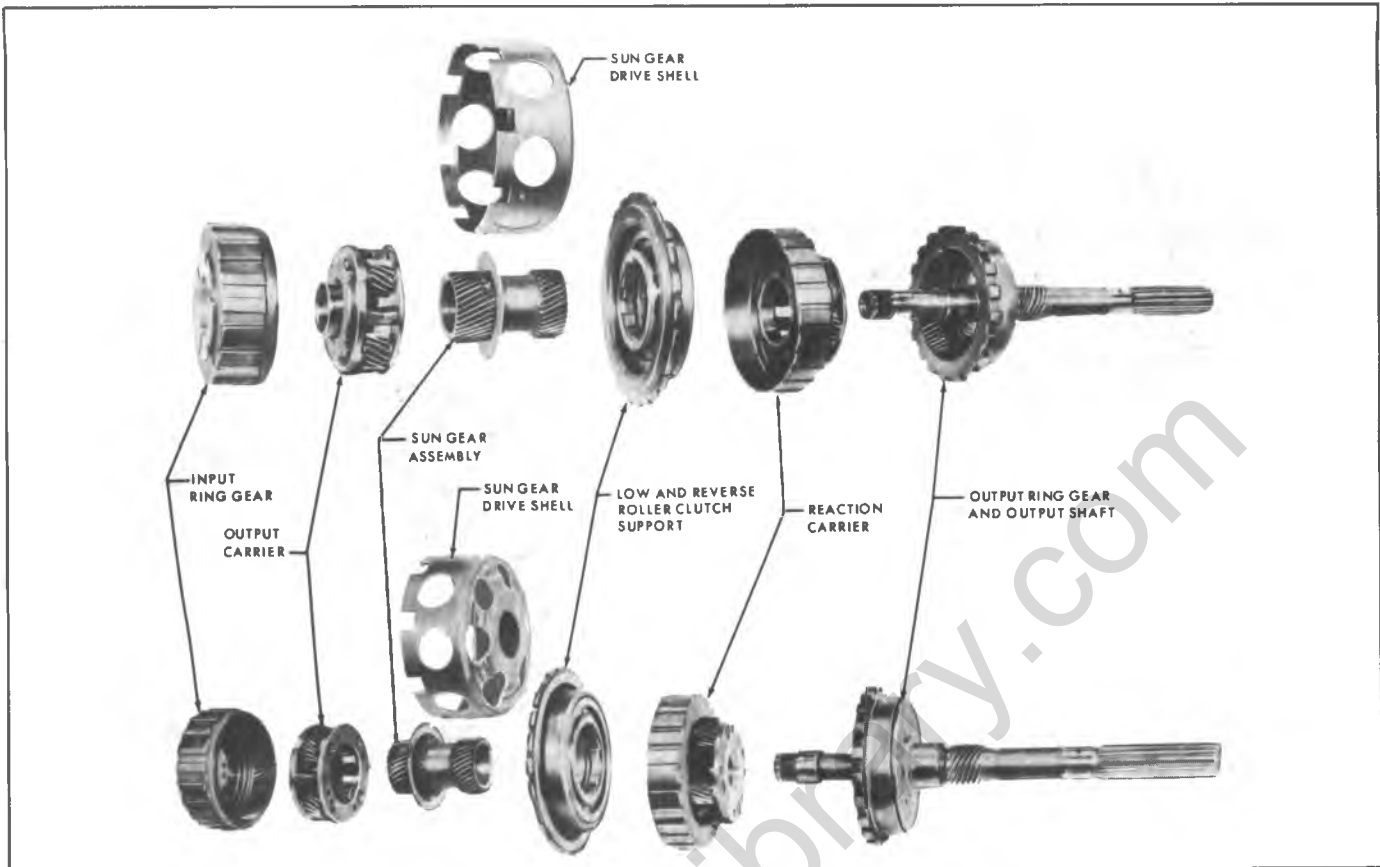

Figure 7A5-69 Planetary Gear Train-Exploded View

**Inspection**

1. Inspect roller clutch inner and outer race for scratches and indentations.
2. Inspect rollers for wear and roller springs for distortion.

**Reassembly**

1. Install low and reverse roller clutch assembly to outer race with oil holes toward rear of transmission.
2. Install low and reverse overrun clutch inner race.

3. Install low and reverse clutch to cam retaining ring.

Low and reverse overrun clutch inner race should free wheel in the clockwise direction only.

**INTERMEDIATE SERVO**

Place tool J-22269 in a vise and place the intermediate servo in tool J-22269 (Figure 7A5-77). Compress the servo piston enough to allow removal of the "E" ring retainer. Remove the apply piston, spring, and pilot. Place a socket behind servo retainer as shown in Figure 7A5-78 and

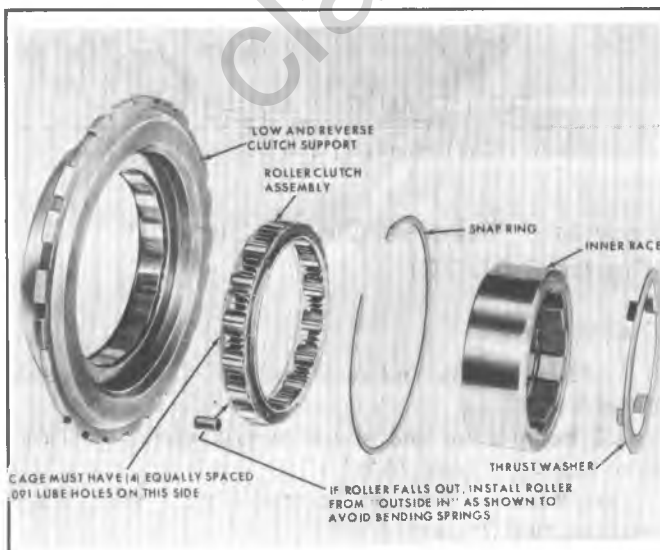

Figure 7A5-72 Low and Reverse Roller Clutch Assembly-Exploded

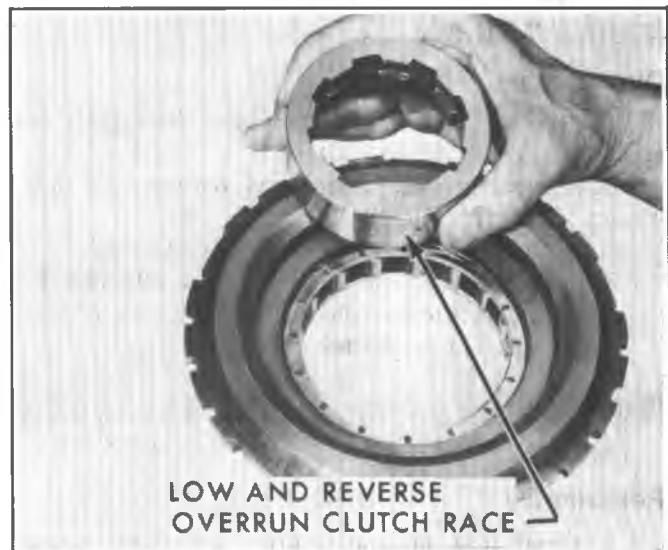

Figure 7A5-73 Removing Inner Race

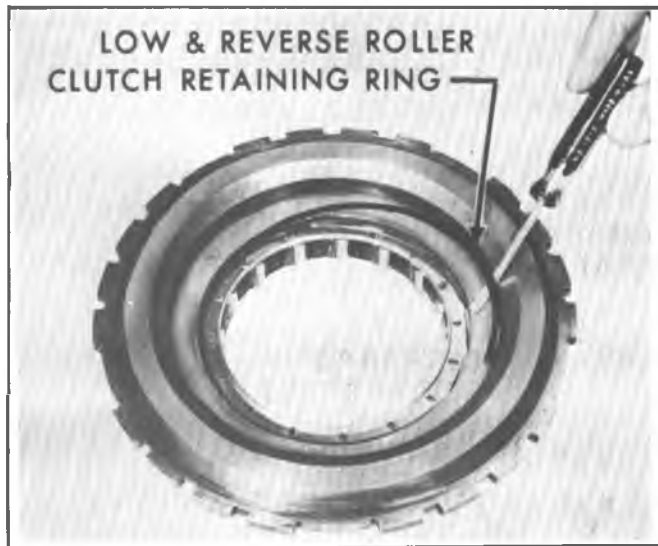

Figure 7A5-74 Retaining Ring Removal

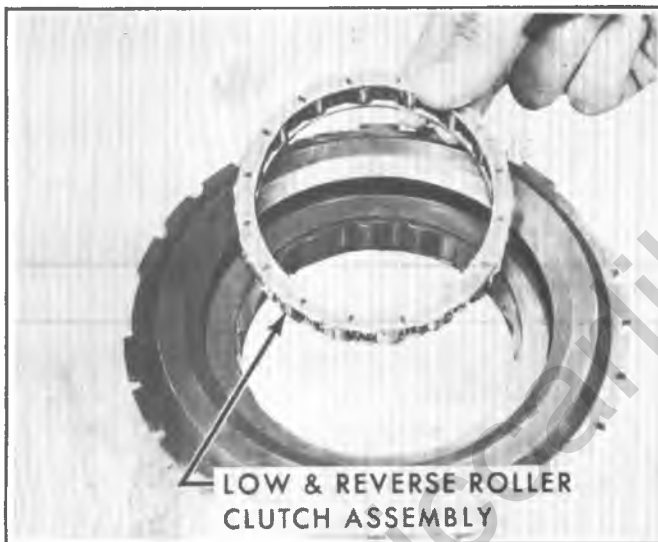

Figure 7A5-75 Roller Clutch Assembly

compress cushion piston to allow removal of "E" ring retainer. Inspect (Figure 7A5-76) oil seal rings on pistons. Remove **only** if replacement is required. Inspect servo rod seal, replace if necessary.

Reassemble, making sure that the apply piston oil seal is properly installed into the pilot piston.

### **Governor Assembly**

All components of governor assembly, with exception of driven gear, are a select fit and each assembly is calibrated. The governor, including driven gear, is serviced as a complete assembly. The driven gear can be serviced separately.

It is necessary to disassemble governor assembly in order to replace driven gear. Disassembly may also be necessary due to improper operation. In such cases, proceed as follows:

### **Disassembly**

1. Cut off one end of each governor weight pin and remove pins, governor thrust cap, governor weights,

and springs. Governor weights are interchangeable from side to side and need not be identified (Figure 7A5-70B).

2. Remove governor valve from governor sleeve. Be careful not to damage valve.

3. Perform following inspections and replace governor driven gear, if necessary.

### **Inspection**

1. Wash all parts in cleaning solvent, air dry and blow out all passages.

2. Inspect governor sleeve for nicks, burrs, scoring or galling.

3. Check governor sleeve for free operation in bore of transmission case.

4. Inspect governor valve for nicks, burrs, scoring or galling.

5. Check governor valve for free operation in bore of governor sleeve.

6. Inspect governor driven gear for nicks, burrs, or damage.

7. Check governor driven gear for looseness on governor sleeve.

8. Inspect governor weight springs for distortion or damage.

9. Check governor weights for free operation in their retainers.

10. Check valve opening at entry and exhaust (0.020 in. minimum).

### **Governor Driven Gear Replacement**

To facilitate governor repair in the field, a governor driven gear and replacement pins are available for service use. The service package contains a nylon driven gear, two governor weight retaining pins and one governor gear retainer split pin. Replacement of gear must be performed with care in the following manner:

1. Drive out governor gear retaining split pin using small punch.

2. Support governor on 3/16 in. (4.7mm) plates installed in exhaust slots of governor sleeve, place in arbor press, and with a long punch, press gear out of sleeve.

3. Carefully clean governor sleeve of chips that remain from original gear installation.

4. Support governor on 3/16 in. (4.7mm) plates installed in exhaust slots of sleeve, position new gear in sleeve and, with a suitable socket, press gear into sleeve until nearly seated. Carefully remove any chips that may have shaved off gear hub and press gear in until it bottoms on shoulder.

5. A new pin hole must be drilled through sleeve and gear. Locate hole position 90 degrees from existing hole, center punch and then, while supporting governor in press, drill new hole through sleeve and gear using a standard (1/8 in.) drill.

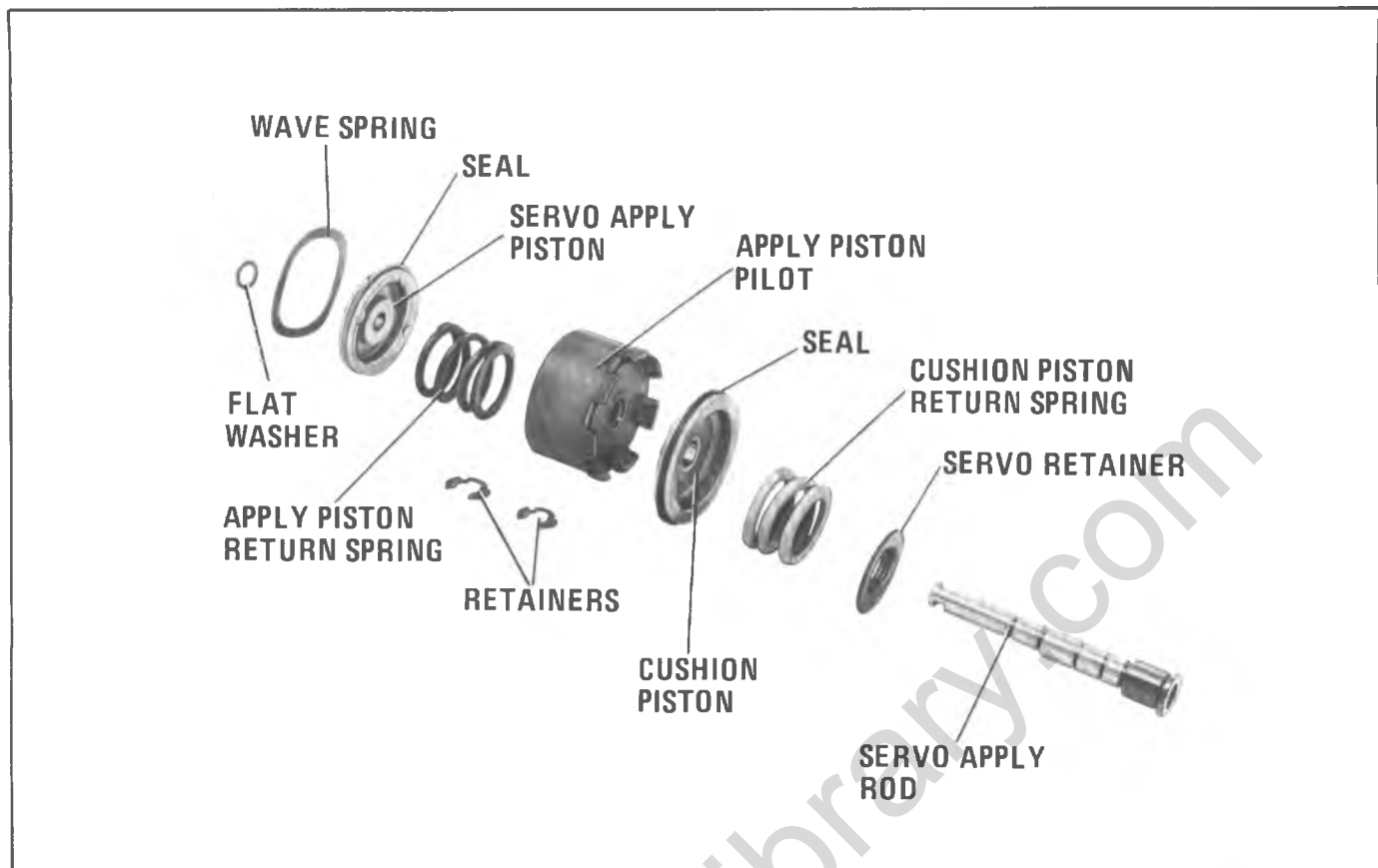

Figure 7A5-76 Intermediate Servo-Exploded View

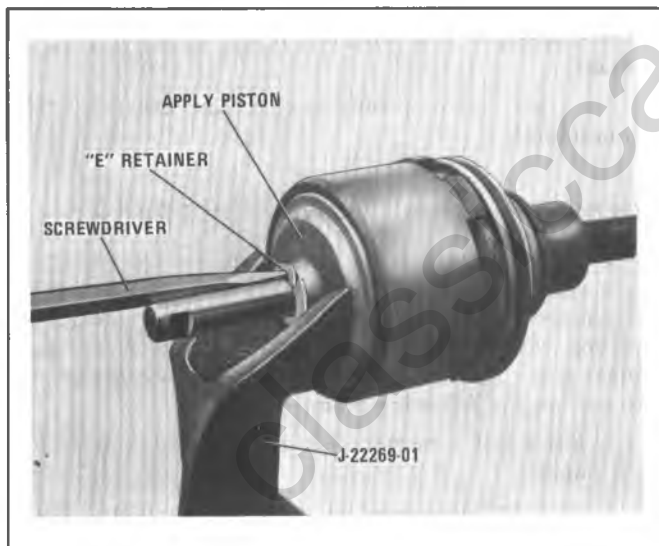

Figure 7A5-77 Servo Apply Piston Retainer Removal

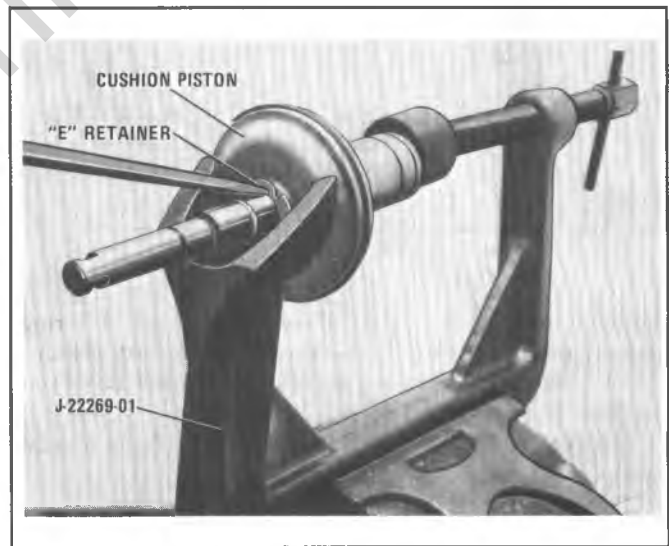

Figure 7A5-78 Servo Cushion Piston Retainer Removal

6. Install split retaining pin.
7. Wash governor assembly thoroughly to remove any chips that may have collected.

**Reassembly**

1. Install governor valve in bore of sleeve, large land end first.
2. Install governor weights and springs, and thrust cap on governor sleeve.
3. Align pin holes in thrust cap, governor weight assemblies and governor sleeve, and install new pins. Crimp both ends of pins to prevent them from falling out.

4. Check governor weight assemblies for free operation on pins.
5. Check governor valve for free movement in governor sleeve.

**TRANSMISSION REASSEMBLY**  
**Transmission Internal Components**

1. Install low and reverse clutch piston assembly, be sure to index piston lug into slot in case and seat piston fully.

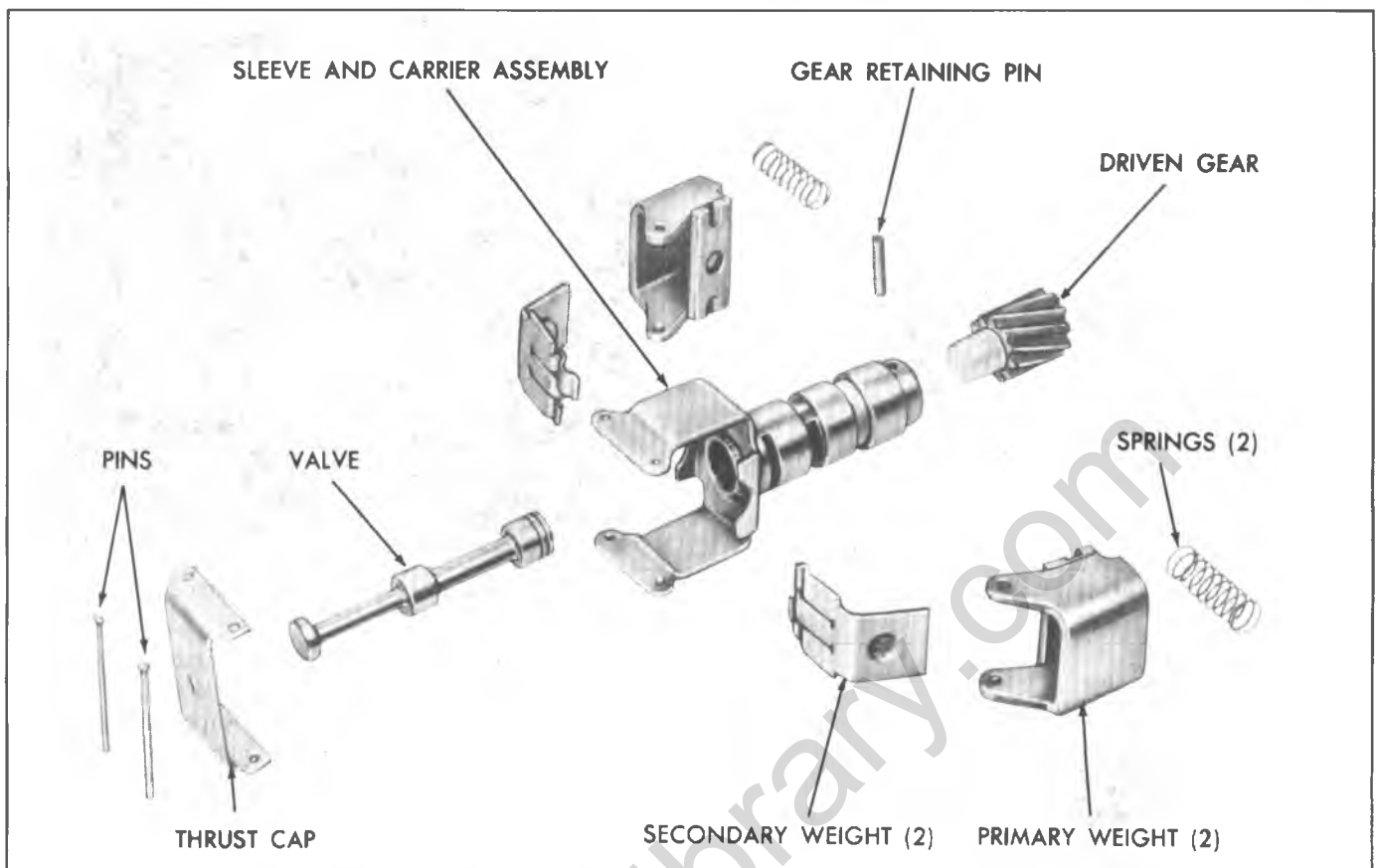

Figure 7A5-79 Governor Assembly

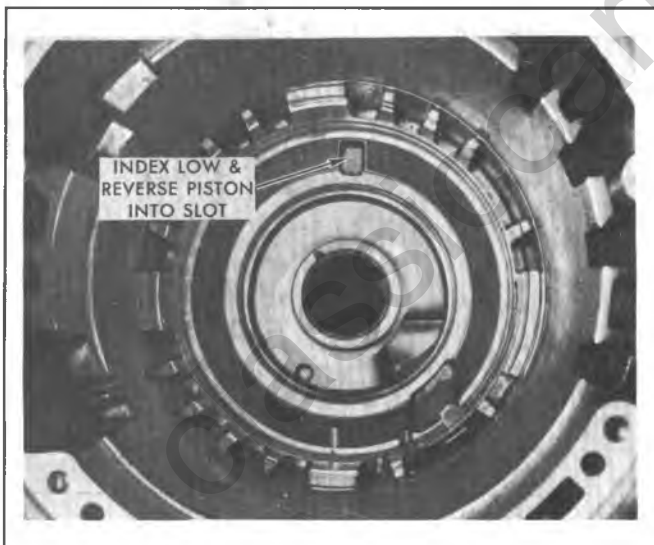

Figure 7A5-80 Low & Reverse Piston Indexing Slot

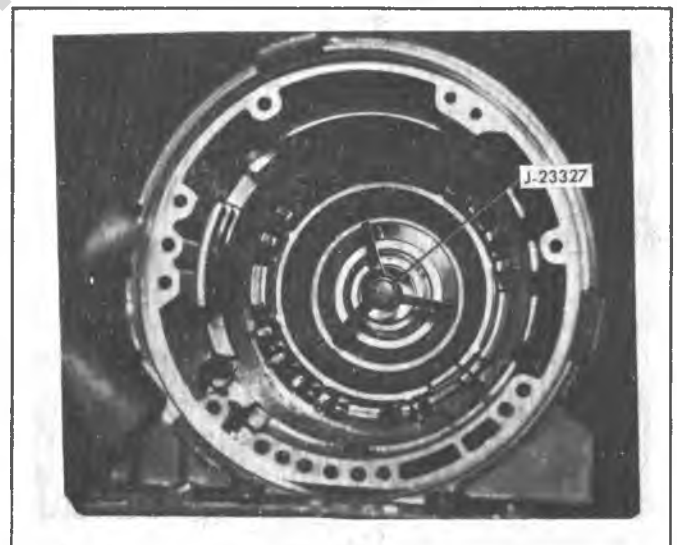

Figure 7A5-81 Installing Low & Reverse Piston

2. Install piston return spring and retainer assembly. Using tool J-23327.

3. Install spring retainer and retaining ring. Using Tool J-23327, compress return seat so spring retainer retaining ring may be installed. Install output ring gear rear thrust bearing in case.

4. Install output ring gear on output shaft.

5. Install reaction carrier to output ring gear bearing into output ring gear support, tanged race (black side) up.

6. Install output shaft assembly into case.

7. Install reaction carrier assembly into output ring gear and shaft assembly.

8. Lubricate and install low reverse clutch steel reaction plates and face plates, starting with a steel plate and alternating with face plates. Install low and reverse clutch support retainer spring (anti-clunk) spring.

Notch in steel separator plates should be placed toward bottom of case.

9. Install low and reverse clutch support assembly. (Figure 7A5-85)

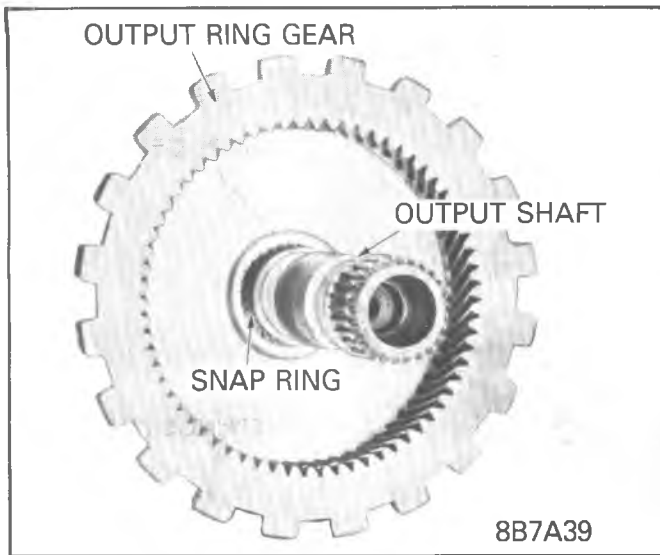

Figure 7A5-82 Ring Gear Installed

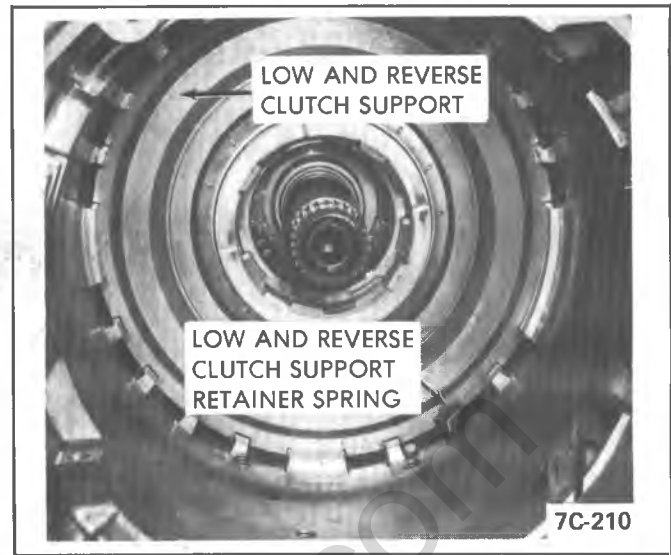

Figure 7A5-85 Low & Reverse Clutch Support

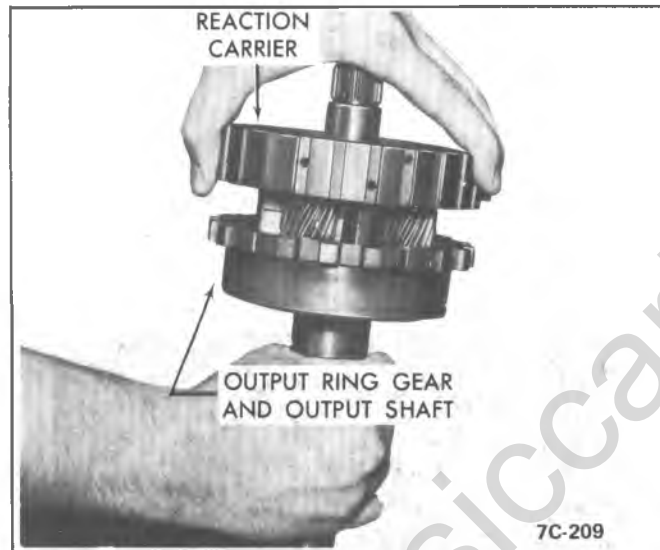

Figure 7A5-83 Reaction Carrier

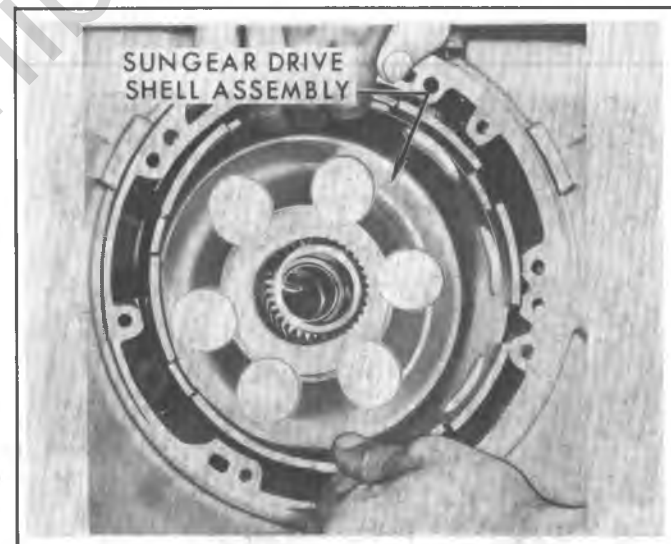

Figure 7A5-86 Sun Gear Drive Shell



Figure 7A5-84 Anti Clunk Spring Piston

Make certain the splines on inner race of the roller clutch align with splines on reaction carrier.

10. Install low and reverse clutch support to case snap ring with anti-clunk spring between gap.

11. Install sun gear thrust washer onto roller clutch race.

12. Install sun gear drive shell assembly.

13. Install output carrier assembly.

14. Install input ring gear rear thrust washer.

15. Install input ring gear to output shaft snap ring.

16. Install input ring gear.

**NOTICE:** Do not over stress snap ring, damage may occur.

17. Install input gear front thrust washer.

18. Install needle bearing to forward clutch assembly.

19. Install direct clutch assembly, to forward clutch assembly.



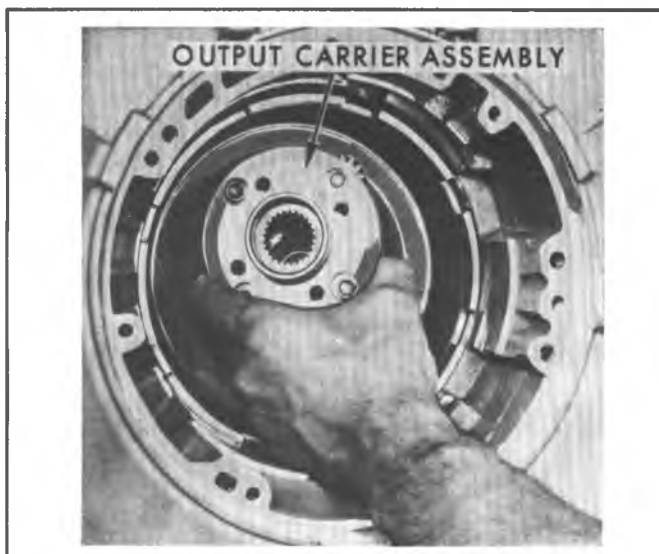

Figure 7A5-87 Output Carrier

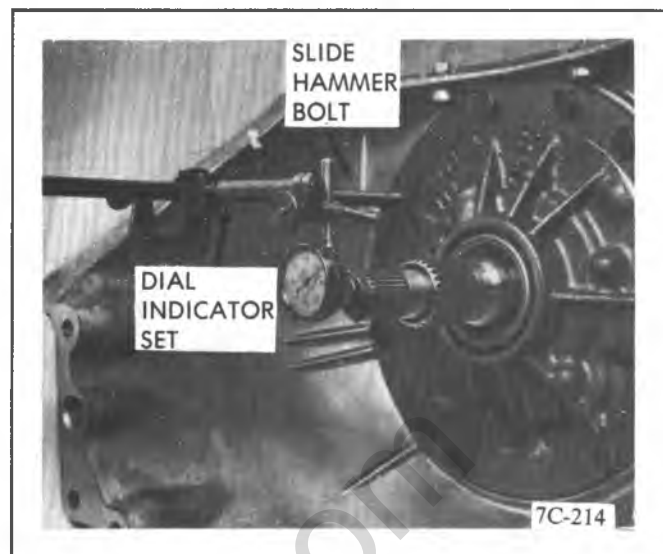

Figure 7A5-89 Dial Indicator For End Play Check

20. Install direct and forward clutch assemblies into case.

Make certain the tangs on direct clutch housing are installed into slots in the sun gear drive shell.

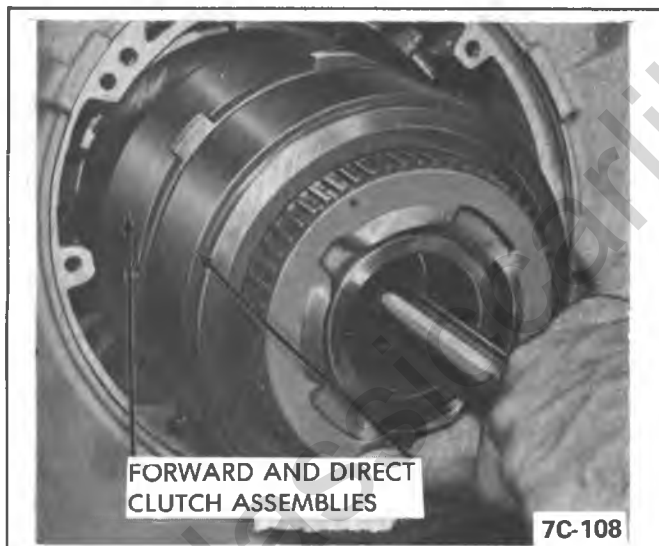

Figure 7A5-88 Installing Direct and Forward Clutches

21. Install cushion spring into intermediate servo bore and retain with petrolatum, install intermediate servo. (Be sure washer is in place on servo rod).

22. Install intermediate band. Make sure band ends are properly located on adjusting screw and servo rod ends. Turn adjusting screw into case until end of screw is against band lug. Align slotted band end on notched end of servo rod.

23. Check for proper thickness of selective fit shim between oil pump cover and direct clutch assembly, proceed as follows:

a. Install original number of shims found during disassembly, oil pump gasket and using guide studs from J-3387 set, install oil pump. Install two pump to case bolts.

b. Install dial indicator as shown in Figure 7A5-80B. Zero indicator.

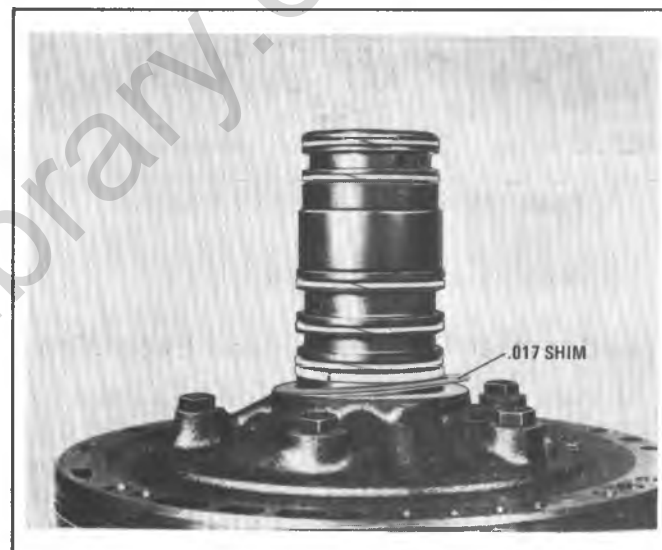

Figure 7A5-89A Pump Shim

c. Lift up on transmission output shaft and observe total indicator movement.

d. Indicator reading should be between 0.010 to 0.044 in. If end play is within the specified limits install pump. If the end play is not within the specified limits add or remove shims to correct this condition.

**NOTICE:** Do not use more than two (2) shims. If incorrect end play can not be corrected with two (2) shims, excessive wear or unproper oil pump assembly is indicated.

24. Install new pump assembly to case gasket.

25. Install new pump assembly square cut oil seal ring.

26. Install guide pins into case.

27. Install pump assembly into case. Install attaching bolts with washer seals.

**NOTICE:** If input shaft cannot be rotated as the pump is being pulled into place, direct and forward clutch housings have not been properly installed to index faced

## 7A5-28 AUTOMATIC TRANSMISSION (250C)

plates with their respective parts. This condition must be corrected before pump is pulled into place.

28. After pump assembly is completely installed, adjust intermediate band. Tighten adjusting screw to 30 in. lb. 33 N·m) and then back-off 3 complete turns. While holding screw in position, tighten locknut to 15 ft. lb.

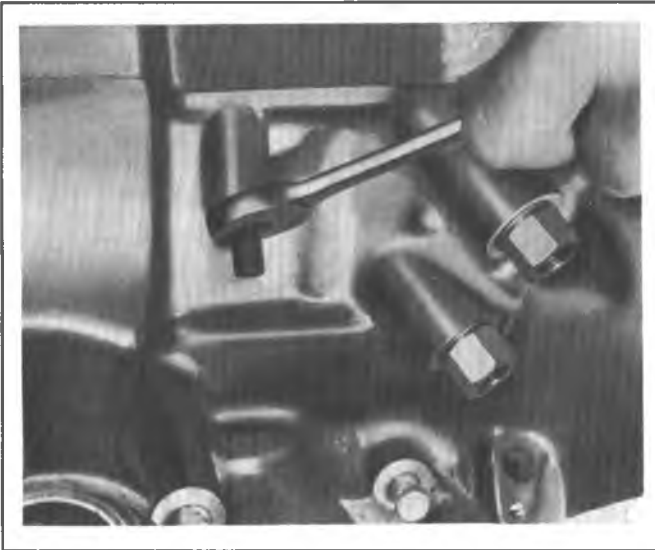

Figure 7A5-90 Intermediate Band Adjustment

29. Install new "O" ring seal on input shaft.

### Speedometer Drive Gear and Extension

1. Place speedometer drive gear retaining clip into hole in output shaft.

2. Align slot in speedometer drive gear with retaining clip and install. If installation is difficult **carefully** heat speedometer gear with heat lamp or other suitable method and install.

3. Install extension housing to case square cut "O" ring seal.

4. Attach extension housing to case. Torque to 25 ft. lb. If necessary, install a new extension housing seal using Seal Installer J-21426 (Figure 7A5-91).

### Manual Linkage

If manual linkage has been removed proceed as follows:

1. If necessary, install a new manual shaft to case lip seal using 3/4 in. diameter rod, seat seal in case. Make certain that seal is fully seated to the bottom of the manual shaft bore.

2. Install parking pawl, tooth toward the inside of case, into case.

3. Install parking pawl shaft into case and through parking pawl.

4. Install parking pawl shaft retainer plug. Drive into case using a 3/8 in. (9.5mm) dia. rod, until retainer plug is 0.130 in. to 1.170 in. below face of case, then stake in three places.

5. Install parking pawl disengaging spring, square end hooked on pawl.

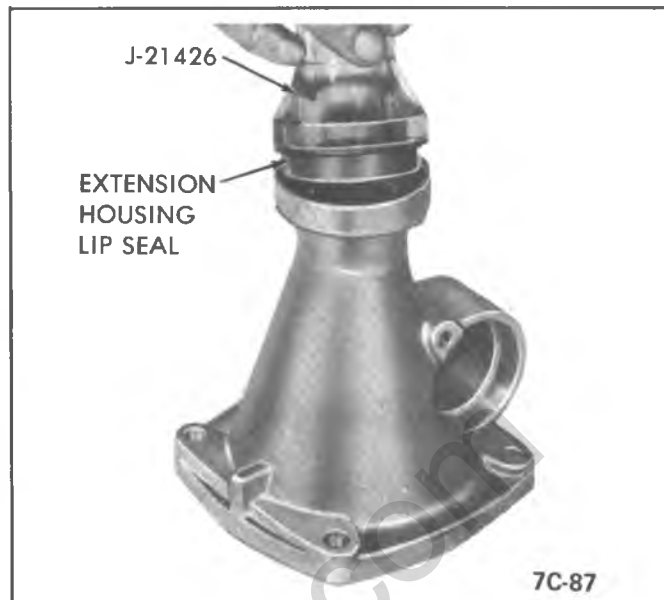

Figure 7A5-91 Installing Extension Housing Lip Seal



Figure 7A5-92 Parking Pawl

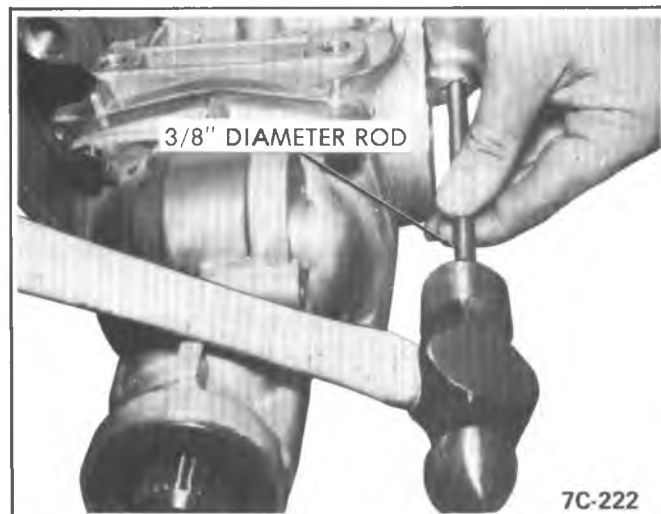

Figure 7A5-93 Parking Pawl Shaft

6. Install park lock bracket, using 2 special bolts (GM 300M, 6 marks on head) and torque bolts to 29 ft. lb. (39N·m) (Figure 7A5-94).

7. Install range selector inner lever to parking pawl actuator rod.

8. Install actuating rod under the park lock bracket and parking pawl.

9. Install manual shaft through case and range selector inner lever.

10. Install retaining nut on manual shaft. Torque to 30 ft. lb. (40 N·m)

**Valve Body, Auxiliary Valve Body, AND Solenoid**

1. Install park lock bracket and special bolts.

2. Install oil pump pressure screen and governor feed screen.

3. If removed, install case electrical connector with new "O" ring seal.

4. Install five (5) check balls into proper transmission case pockets.

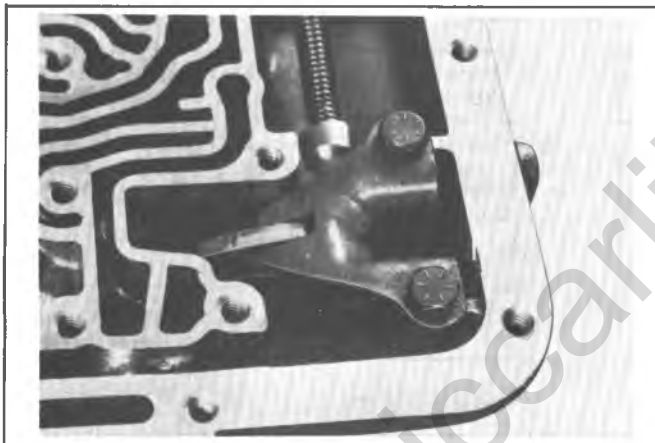

Figure 7A5-94 Park Lock Bracket Special Bolt Identification

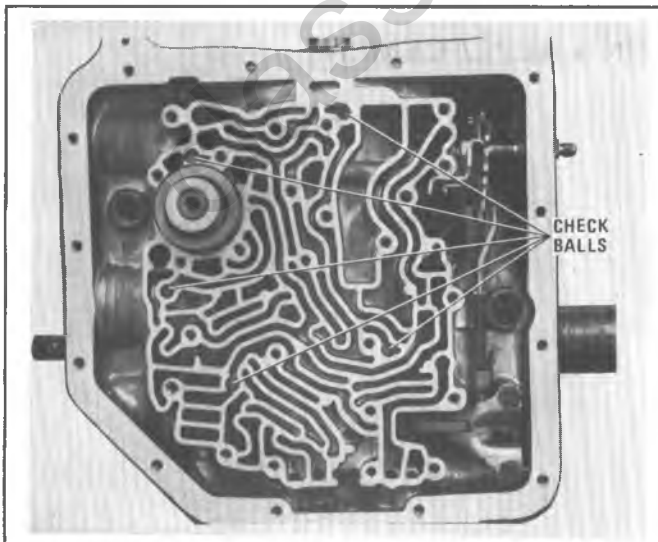

Figure 7A5-95 Check Ball Locations

- 5. Install valve body spacer plate and gaskets.
- 6. Install auxiliary valve body and support plate.

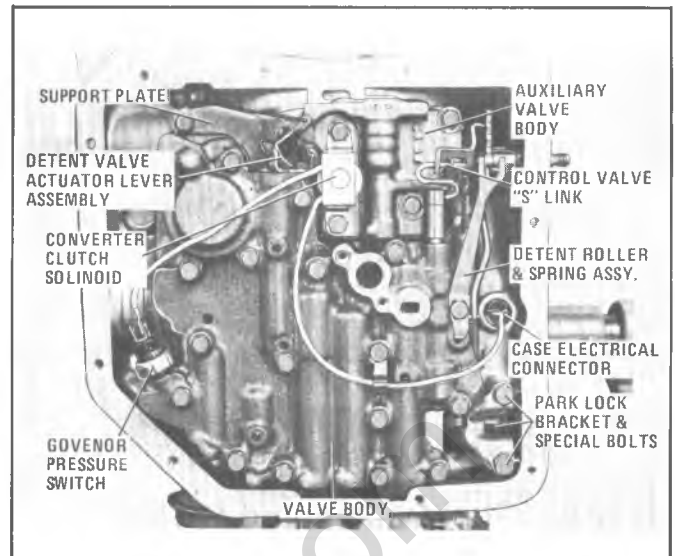

Figure 7A5-96 Valve Body Linkage and TCC Components

7. Install valve body. Torque bolts to 130 in. lb. (143 N·m in a random sequence.

8. Install manual valve to range selector link. Install manual shaft retainer.

9. Connect detent control valve wire to detent valve actuating lever, then attach lever to valve body.

10. Install solenoid and connect wires. If removed install governor pressure switch.

11. Install detent roller and spring assembly to valve body.

12. Align lube holes in suction screen and valve body and install screen gasket and screen.

Be sure lube holes in screen match up with those in valve body.

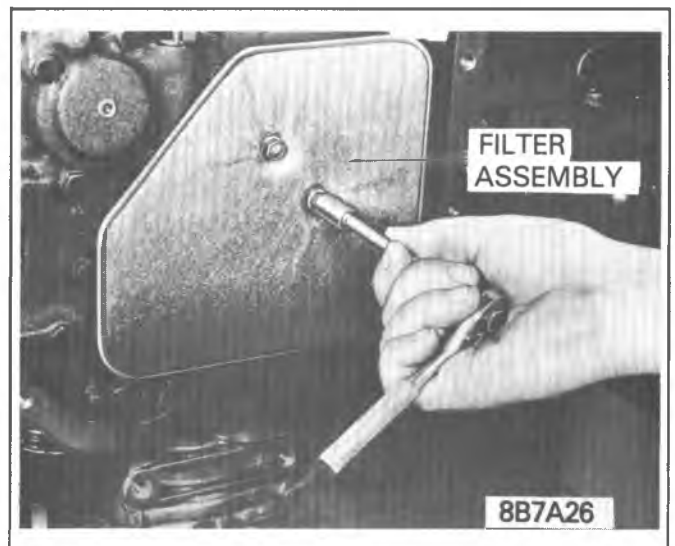

Figure 7A5-97 Filter Assembly

**Governor and Vacuum Modulator**

1. Install governor assembly, "O" ring and cover seal. Install retainer wire.

2. Install vacuum modulator valve.

3. Install vacuum modulator and retainer clip. Torque bolts to 130 in. lb. (143 N·m).

### 1-2 Accumulator

1. Install 1-2 accumulator piston assembly.
2. Install accumulator spring.
3. Install new "O" ring seal in groove in case before installing cover.
4. Install 1-2 accumulator cover and retaining ring.

### Electrical Connector

1. Lubricate with petrolatum and install new 'O'-ring seal on the case connector.
2. Install electrical connector with tabs facing into the case.
3. Connect solenoid wire to electrical connector.

### Transmission Oil Pan and Gasket

Install new gasket and oil pan.

AUTOMATIC 250C TRANSMISSION											
TRANSMISSION I.D. CODE	SPEEDOMETER DRIVE GEAR		DIRECT CLUTCH			FORWARD CLUTCH			LOW AND REVERSE CLUTCH		
	Number of Teeth	Gear Color	No. of Faced Plates	No. of Steel Plates	Clutch Piston Thickness	No. of Faced Plates	No. of Steel Plates	Clutch Plate Thickness	No. of Faced Plates	No. of Steel Plates	Clutch Piston Thickness
8XC, 8XP 8XS, 8XX	10	Purple	3	3	.926	4	4	1.445	4	4	3.146
8XA, 8XH, 8XJ, 8XK, 8X7	10	Purple	4	4	.755	4	4	1.445	4	4	3.146

Figure 7A3-98

**REFER TO 350 SECTION FOR TORQUE  
SPECIFICATIONS, BUSHING REPLACEMENT  
AND SPECIAL TOOLS**

# SECTION 7A6

# AUTOMATIC 200-4R TRANSMISSION

## CONTENTS

GENERAL DESCRIPTION .....	7A6-1
DIAGNOSIS .....	7A6-1
UNIT REPAIR .....	7A6-9

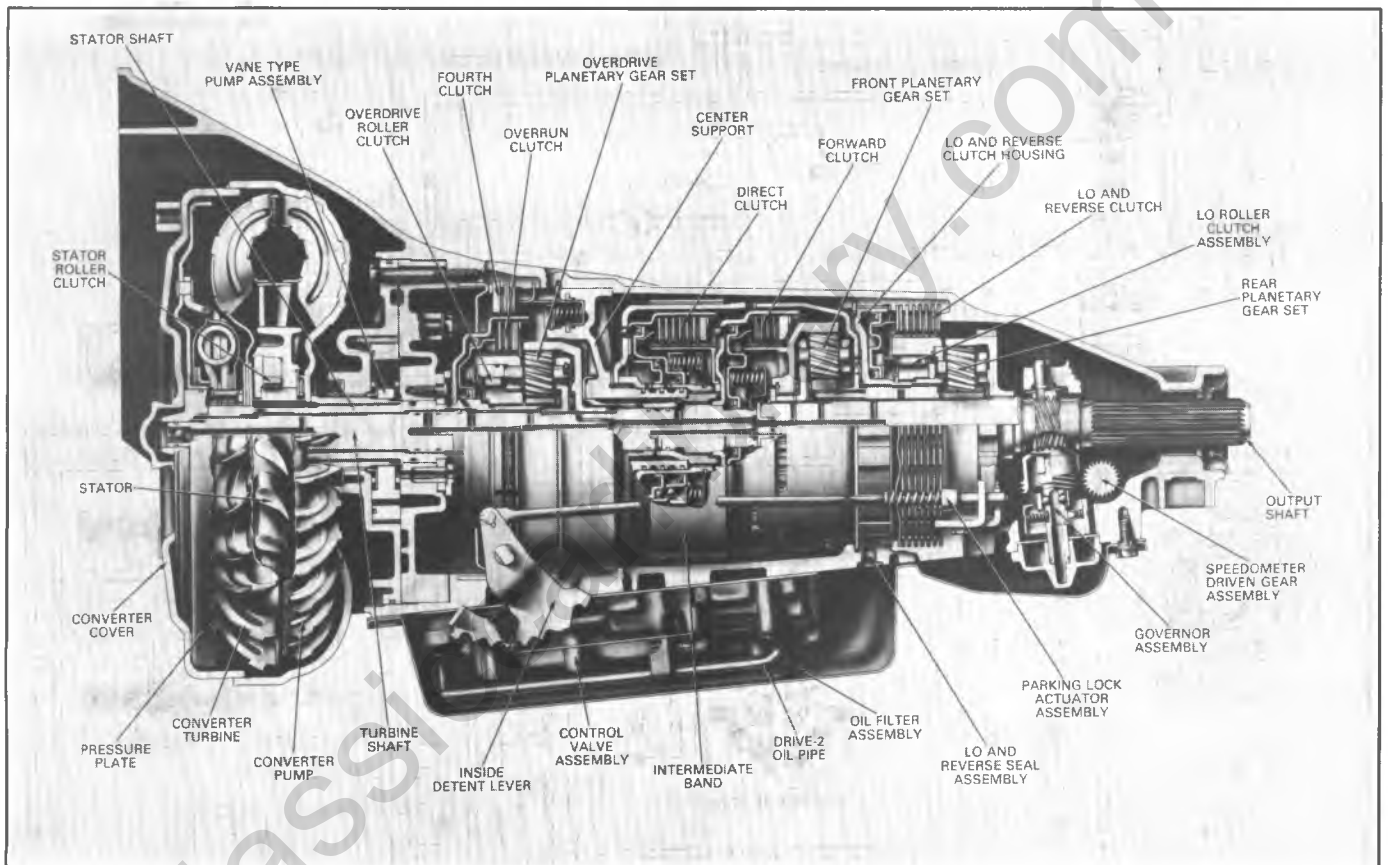

Figure 7A6-1 Cut Away View - 200-4R Transmission

### GENERAL DESCRIPTION

The Model 200-4R Automatic transmission is a fully automatic unit consisting primarily of a 3-element hydraulic torque converter with the addition of a converter clutch, a compound planetary gear set and an overdrive unit. Five multiple-disc clutches, two roller clutches and a band provide the friction elements required to obtain the desired function of the compound planetary gear set and the overdrive unit.

The torque converter smoothly couples the engine to the overdrive unit and planetary gears through oil and hydraulically provides additional torque multiplication when required. The combination of the compound planetary gear set and the overdrive unit provides four forward ratios and one reverse. Changing of the gear ratios is fully automatic in relation to vehicle speed and engine torque.

Vehicle speed and engine torque signals are constantly fed to the transmission to provide the proper gear ratios for maximum efficiency and performance at all throttle openings.

A hydraulic system pressurized by a variable capacity vane type pump provides the working pressure required to operate the friction elements and automatic controls.

### DIAGNOSIS

#### POSSIBLE POINTS OF OIL LEAK

- 1. Transmission Oil Pan Leak.**
  - a. Attaching bolts not correctly torqued.
  - b. Improperly installed or damaged pan gasket.
  - c. Oil pan gasket mounting face not flat.
- 2. Case Leak**



# PRELIMINARY CHECK PROCEDURE

- CHECK TRANSMISSION OIL LEVEL
- CHECK AND ADJUST T.V. CABLE
- CHECK OUTSIDE MANUAL LINKAGE AND CORRECT
- CHECK ENGINE TUNE
- INSTALL OIL PRESSURE GAGE
- CONNECT TACHOMETER TO ENGINE

CHECK OIL PRESSURES IN THE FOLLOWING MANNER:

### Minimum T.V. Line Pressure Check

Set the T.V. cable to specification; and with the brakes applied, take the line pressure readings in the ranges and at the engine r.p.m.'s indicated in the chart below.

### Full T.V. Line Pressure Check

Full T.V. line pressure readings are obtained by tying or holding the T.V. cable to the full extent of its travel; and with the brakes applied, take the line pressure readings in the ranges and at the engine r.p.m.'s indicated in the chart below.

**\*NOTICE** Total running time for this combination not to exceed 2 minutes.

**CAUTION** Brakes must be applied at all times.

1981 200-4R AUTOMATIC TRANSMISSION OIL PRESSURE					
MODEL	RANGE	NORMAL OIL PRESSURE AT MINIMUM T.V.		NORMAL OIL PRESSURE AT FULL T.V.	
		kPa	P.S.I.	kPa	P.S.I.
BM, BY, EG, OG, CU, PH	Park and Neutral at 1000 RPM	385 - 440	55 - 65	830 - 990	120 - 145
		385 - 440	55 - 65	945 - 115	140 - 165
BM, BY, EG, OG, CU, PH	*Reverse at 1000 RPM	675 - 775	100 - 110	1460 - 1730	210 - 250
		675 - 775	100 - 110	1165 - 1970	240 - 285
BM, BY, EG, OG, CU, PH	*Drive and Manual Third at 1000 RPM	385 - 440	55 - 65	830 - 990	120 - 145
		385 - 440	55 - 65	945 - 115	140 - 165
BM, BY, EG, OG, CU, PH	*Manual Second and Lo at 1000 RPM	900 - 1035	130 - 150	900 - 1030	130 - 150
		900 - 1035	130 - 150	900 - 1030	130 - 150

Line pressure is basically controlled by pump output and the pressure regulator valve. In addition, line pressure is boosted in Reverse, Second and Lo by the reverse boost valve.

Also, in the Neutral, Drive, Intermediate and Reverse positions of the selector lever, the line pressure should increase with throttle opening because of the T.V. system. The T.V. system is controlled by the T.V. cable, the throttle lever and bracket assembly and the T.V. link, as well as the control valve assembly.

Figure 7A6-3 Oil Pressure Chart

a. Filler pipe multi lip seal damaged or missing; misposition of filler pipe bracket to engine "loading" one side of seal.

b. T.V. cable multi lip seal missing, damaged or improperly installed.

c. Rear seal assembly damaged or improperly installed.

d. Speedometer driven gear "O" ring damaged.

e. Manual shaft lip seal damaged or improperly installed.

f. Line pressure tap plug.

g. Fourth clutch pressure tap plug.

h. Vent pipe.

i. Porous casting.

j. Intermediate servo "O" rings damaged.

### 3. Leak at Front of Transmission.

a. Front pump seal leaks.

● Seal lip cut. Check converter hub for nicks, etc.

●● Bushing moved forward and damaged.

●●● Garter spring missing from seal.

b. Front pump attaching bolts loose or bolt seal damaged or missing.

c. Front pump housing "O" ring damaged or cut.

d. Converter leak in weld area.

e. Porous casting (pump or case).

### 4. Oil comes out Vent Pipe.

a. Transmission over-filled.

b. Water in oil.

c. Foreign matter between pump and case or between pump cover and body.

d. Case porous; front pump cover mounting face shy of stock near breather.

e. Pump to case gasket mispositioned.

f. Incorrect dipstick.

g. Pump shy of stock on mounting faces, porous casting, breather hole plugged in pump cover.

## NO DRIVE IN DRIVE RANGE (INSTALL PRESSURE GAGE)

### 1. Low oil level:

a. Incorrect level.

b. External leaks.

### 2. Manual Linkage:

a. Misadjusted.

### 3. Low oil pressure:

a. Plugged or restricted oil filter.

b. Cut or missing oil filter "O" ring seals.

c. Pump assembly - pressure regulator stuck.

d. Pump rotor - tangs damaged by converter.

e. Porosity in oil filter to pump intake bore.

### 4. Overdrive Unit:

a. Springs missing in the roller clutch.

b. Rollers galled or missing.

### 5. Forward Clutch.

a. Forward clutch does not apply - piston cracked, seals missing, damaged; clutch plates burned; snap ring out of groove.

b. Forward clutch oil seal rings missing or damaged on turbine shaft; leak in feed circuits; pump to case gasket mispositioned or damaged.

c. Clutch housing ball check stuck or missing.

d. Cup plug leaking or missing in the rear of the forward clutch shaft in the clutch apply passage.

### 6. Lo and Reverse Roller Clutch:

a. Springs missing in the roller clutch.

b. Rollers galled or missing.

## HIGH OR LOW OIL PRESSURE (REFER TO OIL PRESSURE CHECKS)

### 1. Throttle Valve Cable:

a. Misadjusted, binding, unhooked, broken, or wrong link.

### 2. Throttle Valve Assembly damaged or leaking:

a. Throttle lever and bracket assembly binding, unhooked or mispositioned.

b. Throttle valve or plunger valve binding.

### 3. Pressure Regulator Valve:

a. Valve binding.

### 4. T.V. Boost Valve:

a. Valve binding.

b. Wrong valve - causing low oil pressure only.

### 5. Reverse Boost Valve:

a. Valve binding.

### 6. Manual Valve:

a. Unhooked manual valve.

b. Mispositioned manual valve.

### 7. Pressure Relief Valve:

a. Ball missing.

b. Spring damaged.

### 8. Pump:

a. Slide stuck.

b. Pump slide seal damaged or missing.

c. Decrease air bleed orifice missing or damaged - causing high oil pressure.

d. Decrease air bleed orifice plugged - causing low oil pressure.

### 9. T.V. Limit Valve:

a. Valve binding.

### 10. Line Bias Valve:

a. Valve binding in open position - causing high oil pressure.

b. Valve binding in closed position - causing low oil pressure.

**The control valve assembly spacer plate and case should be closely inspected for correct orifices and passages.**

## 1-2 SHIFT - FULL THROTTLE ONLY

### 1. Throttle Valve Cable:

a. Binding, unhooked or broken.

b. Misadjusted.

### 2. Throttle Lever and Bracket Assembly:

a. Binding or unhooked.

3. T.V. Exhaust Ball Lifter or #5 Ball:



- a. Binding, mispositioned or unhooked.

**Allowing #5 ball to seal causes full T.V. pressure regardless of throttle valve position.**

**4. Throttle Valve and Plunger:**

- a. Binding.

**5. Control Valve Assembly:**

- a. Valve body gaskets leaking, damaged, incorrectly installed.

**6. Case Assembly:**

- a. Porosity.

**FIRST SPEED ONLY, NO 1-2 SHIFT**

**1. Governor and Governor Feed Passages.**

- a. Plugged governor oil feed orifice in spacer plate.
- b. Governor ball or balls missing in governor assembly.
- c. Inner governor cover rubber "O" ring seal missing or leaking.
- d. Governor shaft seal missing or damaged.
- e. Governor driven gear stripped.
- f. Governor weights binding on pin.
- g. Governor driven gear not engaged with governor shaft.

**2. Control Valve Assembly**

- a. 1-2 shift, Lo 1st/Detent, or 1-2 throttle valve stuck in downshift position.

- b. Spacer plate gaskets in wrong position.

**3. Case**

- a. Porosity in case channels or undrilled 2nd oil feed hole.

- b. Excessive leakage between case bore and intermediate band apply rings.

- c. Intermediate band anchor pin missing or unhooked from band.

- d. Broken or missing band.

**4. Intermediate Servo Assembly.**

- a. Servo cover oil seal ring missing.
- b. Porosity in servo; cover, inner piston or outer piston.
- c. Wrong intermediate band apply pin.
- d. Incorrect usage of cover and piston.

**5. 1-2 Accumulator.**

- a. 1-2 accumulator housing bolts loose.
- b. 1-2 accumulator housing face damaged.
- c. Missing or damaged accumulator plate.

**FIRST AND SECOND SPEEDS ONLY, NO 2-3 SHIFT**

**1. Control Valve Assembly and Spacer Plate.**

- a. 2-3 shift valve or 2-3 throttle valve stuck in the downshift position.

- b. Valve body gaskets leaking, damaged or incorrectly installed.

- c. Reverse/3rd check ball not seating, damaged or missing.

**2. Case.**

- a. Porosity in case channels.

**3. Center Support.**

- a. Direct clutch feed passage in the center support plugged or not drilled through.

- b. Steel oil seal rings on center support damaged.

**4. Direct Clutch.**

- a. Inner oil seal ring missing or damaged on piston.

- b. Center oil seal ring missing or damaged on direct clutch hub.

- c. Check ball and/or retainer damaged or missing from direct clutch piston.

- d. Direct clutch piston or housing damaged or missing.

- e. Direct clutch plates damaged or missing.

- f. Direct clutch backing plate snap ring out of groove.

- g. Release spring guide mislocated, preventing piston check ball from seating in retainer.

**5. Intermediate Servo Assembly (Third Clutch Accumulator Oil Passages).**

- a. Servo to case oil seal ring broken or missing on intermediate servo piston.

- b. Intermediate servo and/or capsule missing or damaged.

- c. Exhaust hole in case between servo piston seal rings plugged or undrilled.

- d. Bleed orifice cup plug missing from intermediate servo pocket in case.

**NO DRIVE IN REVERSE OR SLIPS IN REVERSE (INSTALL PRESSURE GAGE).**

- 1. Throttle Valve Cable binding or misadjusted.

- 2. Manual Linkage misadjusted.

- 3. Throttle Valve binding.

- 4. T.V. Limit Valve binding.

- 5. Line Bias Valve binding.

- 6. Reverse Boost Valve binding in pressure regulator bore.

- 7. Reverse/3rd or Lo/Reverse Check Ball missing or seat in spacer plate damaged.

**8. Reverse Clutch**

- a. Piston cracked, or missing inner or outer seals. Clutch plates burned.

- b. Reverse oil seal in case missing or damaged.

- c. Missing clutch plate or wave plate.

**9. Center Support**

- a. Center support attaching bolts loose or missing.

- b. Passages blocked or not drilled.

- c. Porosity.

**10. Direct Clutch Housing.**

- a. Piston or housing cracked.

- b. Inner or outer piston seal missing or damaged.

- c. Check ball in either the direct clutch housing or the piston missing or damaged.

- d. Plates burned.

- 11. Lo/Reverse Overrun Clutch Orifice in spacer plate plugged.

**DRIVE IN NEUTRAL**

**1. Manual Linkage.**

- a. Misadjusted or disconnected.

**2. Forward Clutch.**

- a. Clutch does not release.

- b. Exhaust check ball sticking.

c. Plates burned together.

**3. Case.**

a. Cross leakage to forward clutch passage (D4).

**SLIPS 1-2 SHIFT**

**1. Low Oil Level.**

a. Correct oil level.

**2. Spacer Plate and Gaskets.**

a. Gaskets damaged or incorrectly installed.

**3. Accumulator Valve.**

a. Valve sticking in valve body causing low 1-2 accumulator pressure.

b. Weak or missing spring.

**4. 1-2 Accumulator Piston.**

a. Seal leaking, spring broken or missing.

b. Leak between piston and pin.

c. 1-2 accumulator piston binding.

d. 1-2 accumulator piston bore damaged.

**5. Intermediate Band Apply Pin.**

Wrong selection of apply pin.

b. Excessive leakage between apply pin and case.

c. Apply pin feed hole not completely drilled.

**6. Intermediate Servo Assembly.**

a. Porosity in piston.

b. Cover to servo oil seal ring damaged or missing.

c. Leak between servo apply pin and case.

**7. Throttle Valve Cable not properly adjusted.**

**8. Throttle Valve binding, causing low T.V. pressure.**

**9. T.V. Limit Valve binding.**

**10. Line Bias Valve sticking, causing low line pressure.**

**11. Intermediate Band worn or burned.**

**12. Case porosity in 2nd clutch passage.**

**ROUGH 1-2 SHIFT**

**1. Throttle Valve Cable.**

a. Not adjusted properly.

b. Binding.

**2. Throttle Valve or T.V. Plunger**

a. Binding.

**3. T.V. Limit Valve binding.**

**4. Accumulator Valve binding.**

**5. Line Bias Valve binding.**

**6. Intermediate Servo Assembly.**

a. Wrong selection apply pin.

b. Servo piston to case oil seal ring damaged or missing.

c. Bleed cup plug missing in case.

**7. 1-2 Accumulator.**

a. Oil ring damaged.

b. Piston stuck.

c. Broken or missing spring.

d. Bore damaged.

**8. 1-2 Shift Check Ball #8 missing or sticking.**

**SLIPS 2-3 SHIFT**

**1. Oil Level Low.**

a. Correct oil level.

**2. Throttle Valve Cable not adjusted properly.**

**3. Throttle Valve binding.**

**4. Spacer Plate and Gaskets.**

a. Direct clutch orifice partially blocked in spacer plate.

b. Gaskets mispositioned or damaged.

**5. Intermediate Servo Assembly.**

a. Servo to case oil seal ring damaged or missing.

b. Piston or servo bore damaged.

c. Intermediate servo orifice bleed cup plug in case missing.

d. Porosity in the case in the servo bore area.

**6. Direct Clutch Feed.**

a. Porosity in direct clutch feed channels in case.

b. Case to support bolts not tight causing leakage.

c. Direct clutch piston or housing cracked.

d. Piston seals cut or missing.

e. Direct clutch plates burned.

f. Check ball in piston and/or housing missing, damaged or leaking.

g. Check ball capsule damaged.

h. Release spring guide mislocated preventing check ball from seating in piston.

**7. Center Support.**

a. Channels cross feeding, leaking or restricted.

b. Oil seal rings damaged or missing.

**ROUGH 2-3 SHIFT**

**1. Throttle Valve Cable mispositioned or missing.**

**2. Throttle Valve and Plunger.**

a. T.V. plunger binding.

b. Throttle valve binding.

**3. T.V. Limit Valve binding.**

**4. Intermediate Servo Assembly.**

a. Exhaust hole undrilled or plugged between intermediate servo piston seals, not allowing intermediate servo piston to complete its stroke.

**5. 3-2 Exhaust Check Ball #4 missing or mispositioned.**

**6. 3rd Accumulator Check Ball #2 missing or mispositioned.**

**SLIPS 3-4 SHIFT**

**1. Low Oil Level**

**2. Control Valve Assembly and Spacer Plate.**

a. Gaskets or spacer plate damaged or incorrectly installed.

b. Accumulator valve sticking causing low 3-4 accumulator pressure.

c. Weak or missing accumulator valve spring.

**3. 3-4 Accumulator.**

a. Piston stuck.

b. Bore damaged.

c. Oil ring damaged.

**4. Center Support.**

a. Porosity.

b. Center support attaching bolts loose.

- c. Fourth clutch piston surface damaged.
- d. Fourth clutch piston seals damaged.
- e. Proper plate usage, See Clutch Plate Usage Chart (Figure 7A6-107).

f. Fourth clutch plates burned.

**5. Case.**

- a. Porosity.
- b. 1-2 accumulator housing bolts loose.
- c. 3-4 accumulator piston seal damaged.
- d. 3-4 accumulator leaking between the piston and pin.
- e. 3-4 accumulator bore damaged.

**ROUGH 3-4 SHIFT**

**1. Throttle Valve Cable mispositioned or missing.**

**2. Throttle Valve and Plunger.**

- a. T.V. plunger binding.
- b. Throttle valve binding.

**3. T.V. Limit Valve binding.**

**4. 3-4 Accumulator.**

- a. Piston stuck.
- b. Bore damaged.
- 5. Fourth Clutch Piston binding.

**NO CONVERTER CLUTCH APPLY**

**1. Electrical Problem.**

a. 12 volts must be supplied to the solenoid for it to engage.

- b. Defective solenoid.
- c. Damaged electrical connector.
- d. Defective pressure switch.
- e. Wire grounded.

**2. Control Valve Assembly and Spacer Plate.**

a. Converter clutch shift valve or throttle valve stuck.

**3. Pump Assembly.**

- a. Orifice plugged for converter signal oil in pump.
- b. "O" ring damaged or missing on solenoid.
- c. Orificed cup plug missing in oil cooler passage in pump.
- d. Pump to case gasket damaged or mispositioned.
- e. Converter clutch apply valve stuck.
- f. Cup plug missing from apply passage.

**ROUGH CONVERTER CLUTCH APPLY**

**1. Converter Clutch Pressure Plate Damaged.**

**2. Check Ball in end of turbine shaft damaged or missing.**

**NO CONVERTER CLUTCH RELEASE**

**1. Converter Clutch Apply Valve Stuck.**

**2. Damaged Converter.**

**3. Cup Plug in release passage missing in pump.**

**4. Seal on end of turbine shaft missing or damaged.**

**5. Hole not drilled through in turbine shaft.**

**FIRST, SECOND AND THIRD SPEED ONLY, NO 3-4 SHIFT (INSTALL PRESSURE GAGE TO FOURTH CLUTCH PRESSURE TAP)**

**1. Control Valve Assembly and Spacer Plate.**

- a. 3-4 shift valve or 3-4 throttle valve stuck.
- b. Orifice in spacer plate plugged.

**2. Center Support.**

- a. Oil passages plugged or not drilled.
- b. Center support attaching bolts loose or missing.
- c. Fourth clutch piston cracked or damaged.
- d. Fourth clutch piston seals damaged, missing or improperly assembled.

e. Proper plate usage, See Clutch Plate Usage Chart (Figure 7A6-107).

- f. Fourth clutch plates burned.
- g. Overrun clutch plates binding.

**3. Case.**

- a. Porosity.
- b. Orificed cup plug missing in 3-4 accumulator passage in case.
- c. Leakage between accumulator piston and pin.
- d. 3-4 accumulator bore damaged.

**NO ENGINE BRAKING IN MANUAL LO - 1ST GEAR**

**1. Control Valve Assembly and Spacer Plate.**

- a. Manual linkage misadjusted.
- b. D-3 orifice in spacer plate plugged.
- c. Valve body gaskets leaking, damaged or incorrectly installed.

d. D-2 oil pipe leaking or out of position.

e. Lo overrun clutch valve binding in valve body.

f. Lo/Reverse check ball (#10) mispositioned or missing.

g. Lo/Detent check ball (#9) mispositioned or missing.

h. Lo/Reverse overrun clutch orifice in spacer plate plugged.

i. PT/D-3 check ball (#3) mispositioned or missing.

**2. Turbine Shaft and Overrun Clutch.**

**No manual 3rd or 2nd should also be a complaint with the following:**

a. D-3 oil passage not drilled or plugged in turbine shaft.

b. D-3 oil passage not drilled through in overrun clutch hub.

c. Oil seals missing or damaged in the overrun clutch piston.

d. Overrun clutches burned.

e. Overrun clutch backing plate snap ring out of groove.

**3. Case.**

a. Porosity.

**4. Lo/Reverse Clutch Assembly.**

**No reverse should also be a complaint with any of the following conditions:**

a. Piston seals broken or missing.

- b. Clutch housing snap ring out of case.
- c. Piston or housing cracked or porous.
- d. Cup plug or rubber seal missing or damaged between case and lo/reverse clutch housing.

### NO ENGINE BRAKING IN MANUAL 2ND - 2ND GEAR

1. **Control Valve Assembly and Spacer Plate.**
  - a. Manual linkage misadjusted.
  - b. Valve body gaskets leaking, damaged, or incorrectly installed.
  - c. D-2 oil pipe leaking or out of position.
  - d. D-3 orifice in spacer plate plugged.
  - e. PT/D-3 check ball (#3) mispositioned or missing.
2. **Case.**
  - a. Porosity.
3. **Intermediate Servo Assembly.**
  - a. Servo cover to case oil seal ring missing or damaged.
4. **Intermediate Band.**
  - a. Off anchor pin.
  - b. Broken or burned.
5. **Turbine Shaft and Overrun Clutch.**
  - a. D-3 oil passage not drilled through in overrun clutch hub.
  - b. Oil seals missing or damaged in the overrun clutch piston.
  - c. D-3 oil hole not drilled or plugged in turbine shaft.
  - d. Overrun clutches burned.
  - e. Overrun clutch backing plate snap ring out of groove.

### NO ENGINE BRAKING IN MANUAL 3RD - 3RD GEAR

1. **Control Valve Assembly and Spacer Plate.**
  - a. Manual linkage misadjusted.
  - b. D-3 orifice in spacer plate plugged.
  - c. Valve body gaskets leaking, damaged, or incorrectly installed.
  - d. PT/D-3 check ball (#3) mispositioned or missing.
2. **Turbine Shaft and Overrun Clutch.**
  - a. D-3 oil passage not drilled or plugged in turbine shaft.
  - b. D-3 oil hole not drilled through in overrun clutch hub.
  - c. Oil seals missing or damaged in the overrun clutch piston.
  - d. Overrun clutches burned.
  - e. Overrun clutch backing plate snap ring out of groove.

### WILL NOT HOLD IN PARK

1. **Manual Linkage misadjusted.**
2. **Internal linkage.**
  - a. Parking pawl binding in case.
  - b. Actuator rod, spring, or plunger damaged.
  - c. Parking pawl broken.
  - d. Parking bracket loose or damaged.
  - e. Manual shaft to case pin missing or mispositioned.
3. **Inside Detent Lever and Pin Assembly.**

- a. Nut loose.
  - b. Hole in lever worn or damaged.
4. **Manual Detent Roller and Spring Assembly.**
    - a. Bolt loose that holds roller assembly to valve body.
    - b. Pin or roller damaged, mispositioned or missing.

### NO PART THROTTLE DOWNSHIFTS (INSTALL PRESSURE GAGE)

1. Throttle Valve binding.
2. T.V. Limit Valve Binding.
3. Spacer Plate hole plugged or undrilled.
4. Valve Body Gaskets mispositioned or damaged.
5. T.V. Modulator Downshift Valve stuck.
6. Throttle Valve Cable improperly set.

### NO PART THROTTLE 4-3 DOWNSHIFT (ON SELECTED MODELS WITH A P.T. PASSAGE IN THE THROTTLE PLUNGER BUSHING)

1. Throttle Plunger Bushing passages not open.
2. 3-4 Throttle Valve Bushing passages not open.
3. PT/D-3 Check Ball (# 3) mispositioned or missing.
4. Valve Body Gaskets mispositioned or damaged.
5. Throttle Valve Cable improperly set.
6. T.V. Limit Valve binding.

### LOW OR HIGH SHIFT POINTS (INSTALL PRESSURE GAGE TO LINE PRESSURE TAP)

1. Throttle Valve Cable binding or misadjusted.
2. T.V. Limit Valve binding.
3. Throttle Valve binding.
4. T.V. Modulator Upshift Valve binding.
5. T.V. Modulator Downshift Valve binding.
6. Valve Body Gaskets mispositioned, leaking or damaged.
7. Throttle Valve Plunger binding.
8. 1-2, 2-3 or 3-4 Throttle Valves binding in bushings.
9. Pressure Regulator Valve binding.
10. T.V. Exhaust Ball (#5) and Lifter mispositioned, unhooked or missing.
11. Throttle Lever and Bracket Assembly.
  - a. Binding, unhooked or loose at mounting valve body bolt.
  - b. Not positioned at the throttle valve plunger bushing pin locator.
12. Governor Shaft to Cover Seal Ring broken or missing.
13. Governor Cover Gasket broken or missing.
14. Case porosity.

## UNIT REPAIR

### Removal of Converter

1. With transmission in cradle of portable jack, remove J-12366 and then converter assembly by pulling straight out.

2. Install Holding Fixture, J-8763-02, on transmission and place into Holding Fixture, J-3289-20, with manual shaft facing bench and oil pan side up (Figure 7A6-4).

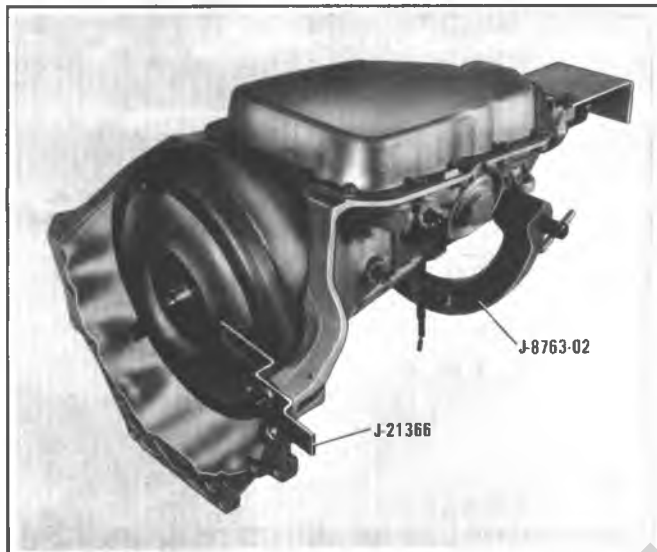

Figure 7A6-4 Transmission in Holding Fixture

**Do not over torque fixture holding screw.**

**Cleanliness is an important factor in the overhaul of the transmission. Before attempting any disassembly operation the exterior of the transmission should be thoroughly cleaned to prevent the possibility of dirt entering the transmission internal mechanism. During inspection and re-assembly, all parts should be thoroughly cleaned with cleaning fluid and then air dried. Wiping cloths or rags should not be used to dry parts.**

**Do not use solvents on neoprene seals, composition faced clutch plates, or thrust washers.**

### SEALS

If any seal rings are damaged (distorted, cut, scored, etc.) or do not rotate freely in their groove, and replacement is necessary, do the following:

#### Teflon Oil Seal Rings

1. Remove old angle cut seal rings; full circle rings must be cut off.

2. Inspect seal ring groove for burrs or damage.

3. When installing angle cut seal rings, do not over stretch. Make sure cut ends are in same relation as cut (Figure 7A6-5). Also, make sure rings are seated in the grooves to prevent damage to the rings during reassembly of mating part over rings. Retain with petrolatum.

4. New angle cut or full circle oil seal rings may appear to be distorted after being installed. Once exposed to normal transmission oil temperatures, the new seal rings will return to their normal shape and fit freely in their bores.

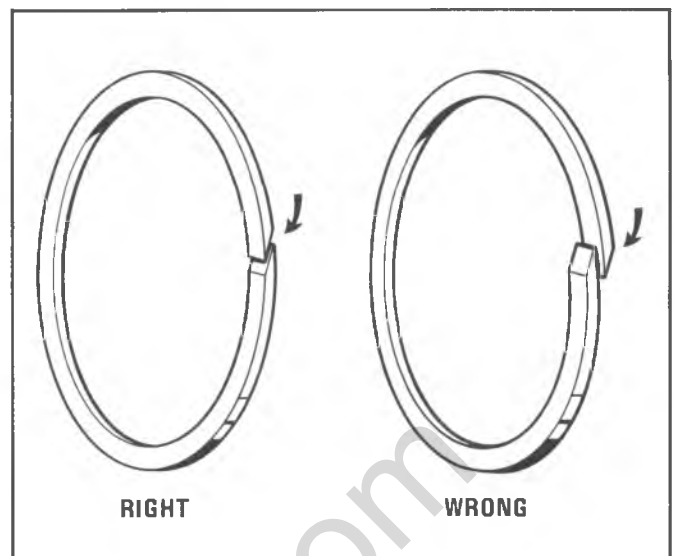

Figure 7A6-5 Teflon Oil Seal Rings

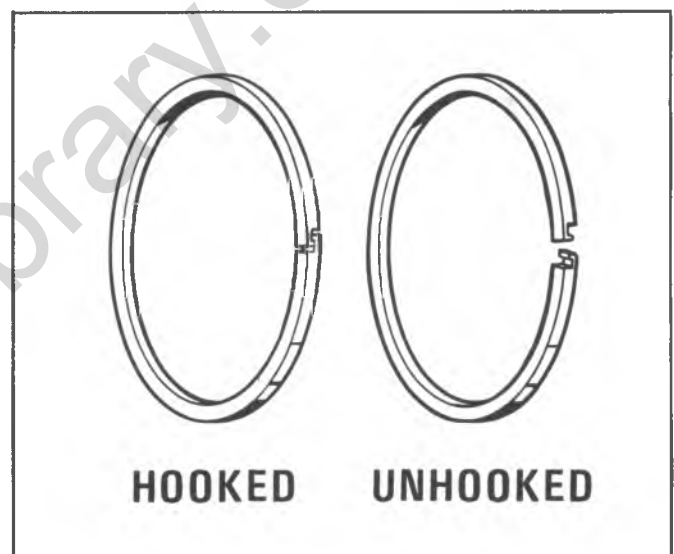

Figure 7A6-6 Cast Iron Oil Seal Rings

#### Cast Iron Oil Seal Rings

The 200-4R also uses cast iron, hook seal rings on the center support. When installing these rings, the ends must overlap and hook one in the other. Make sure the ends are flush with each other when hooked (Figure 7A6-6).

The oil seal rings allow for a free fit in their bores after operation. The free fit of the rings in their bores does not indicate leakage during operation.

### SNAP RINGS

Do not over expand snap rings when removing or installing.

### THRUST WASHER SURFACES

The thrust washers and thrust bearings will polish the surfaces they protect. This is not to be considered a damaged part because of this condition.

## EXTERNAL PARTS

## Removal

1. Rotate transmission to horizontal position, oil pan side up.
2. Remove oil pan and gasket.
3. Remove oil filter intake pipe and "O" rings (Figure 7A6-7), "O" rings may be located in pump bore.

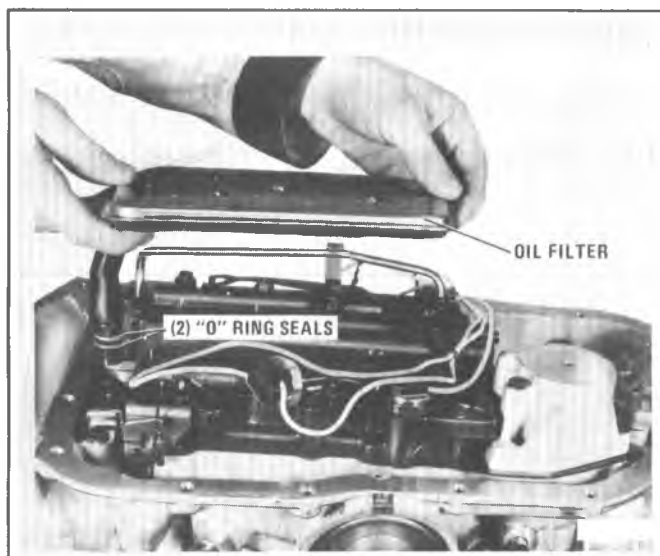

Figure 7A6-7 Removing Oil Filter

4. Disconnect wire leads at electrical connector located in case (Figure 7A6-8) and pressure switches on control valve assembly.

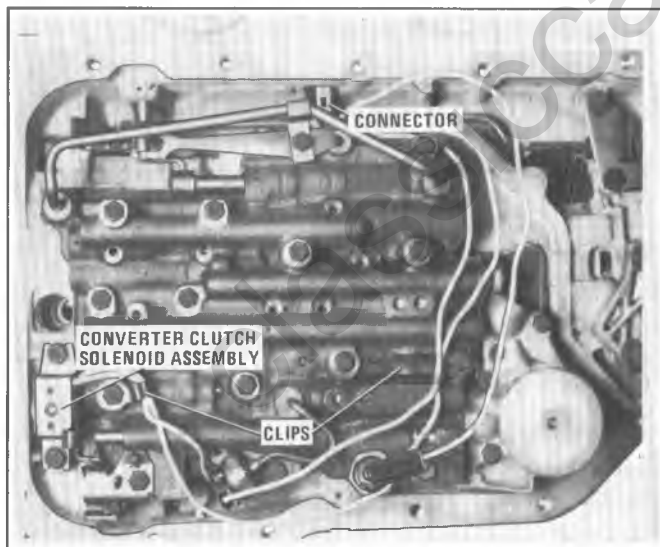

Figure 7A6-8 Removing Solenoid Wires and Pressure Switches

5. Withdraw electrical connector and "O" ring seal from case (Figure 7A6-9). Use a 19 mm (3/4") box wrench to compress the connector tangs.

6. Remove solenoid assembly attaching bolts, clips and solenoid. (Figure 7A6-10).

## 7. Control Valve Assembly:

- a. Remove throttle lever and bracket assembly (Figure 7A6-11). Do not bend throttle lever link. The T.V. exhaust

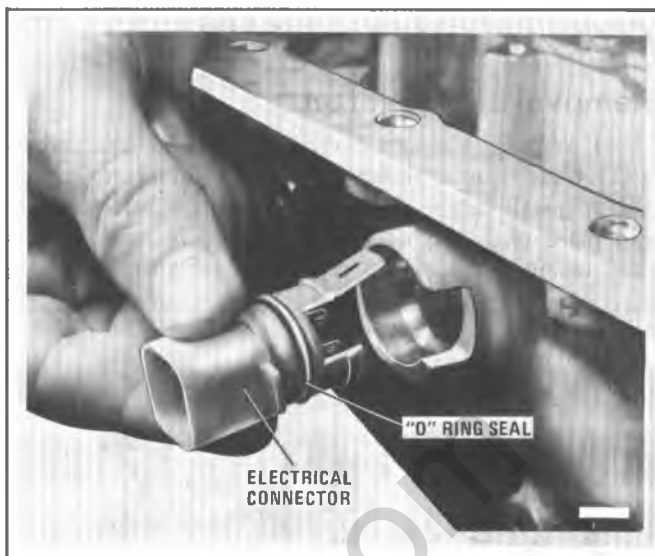

Figure 7A6-9 Removing Electrical Connector

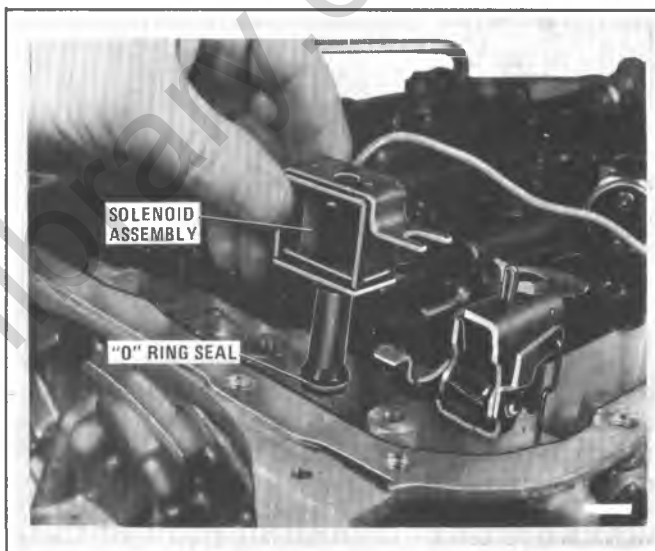

Figure 7A6-10 Removing Solenoid Assembly

valve lifter and spring may separate from the throttle lever and bracket assembly.

- b. Remove manual detent roller and spring assembly, signal oil pipe retaining clip and signal oil pipe (Figure 7A6-12).

- c. Remove the 4-3 pressure switch and retaining bolt.

- d. Remove remaining control valve assembly attaching bolts.

**NOTICE:** Do not drop manual valve. Damage to valve may occur.

- e. Holding manual valve in bore with finger, remove control valve assembly. Care must be taken as three (3) check balls will be exposed on top of the spacer plate to valve body gasket. Remove the three (3) exposed check balls (Figure 7A6-13).

- f. Lay the control valve assembly down with spacer plate side up.

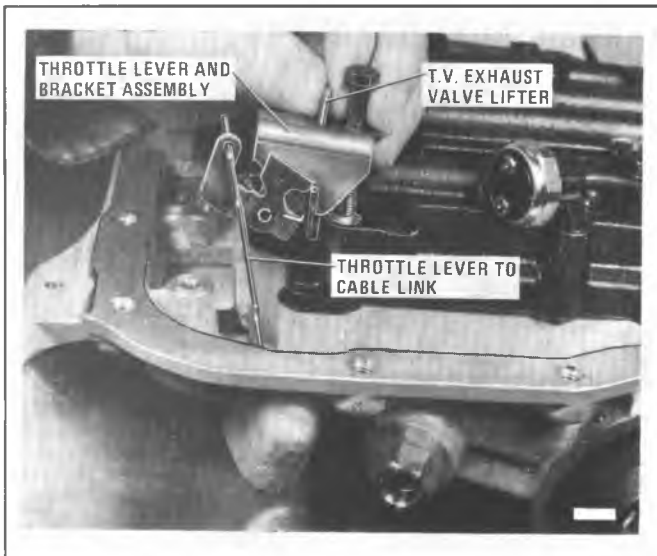

Figure 7A6-11 Removing Throttle Valve and Bracket Assembly

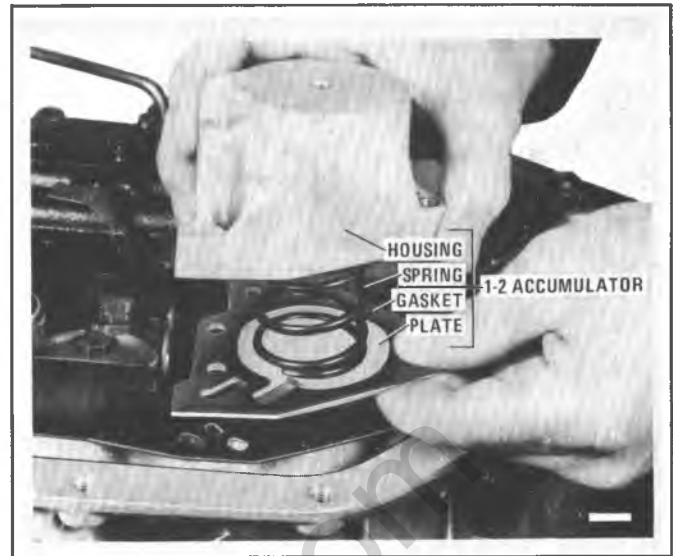

Figure 7A6-14 Removing 1-2 Accumulator Assembly

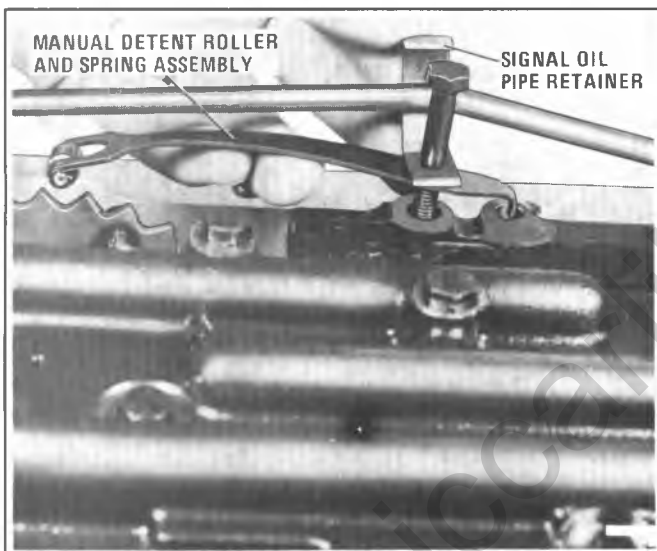

Figure 7A6-12 Removing Manual Detent Roller and Spring Assembly

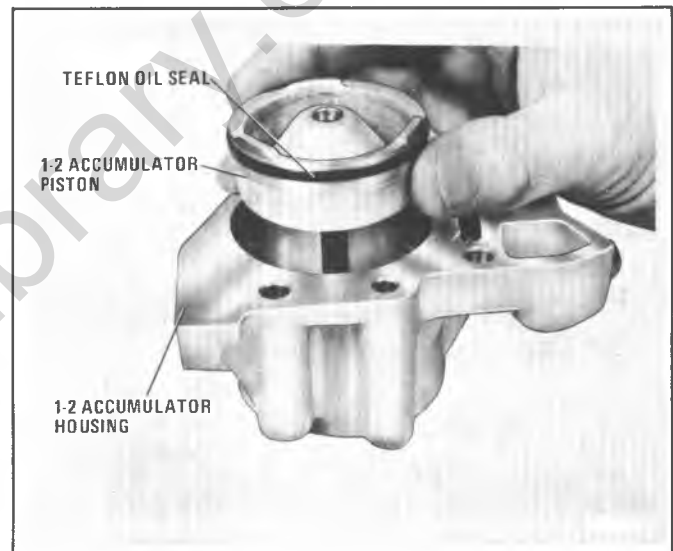

Figure 7A6-15 Removing 1-2 Accumulator Piston from Housing

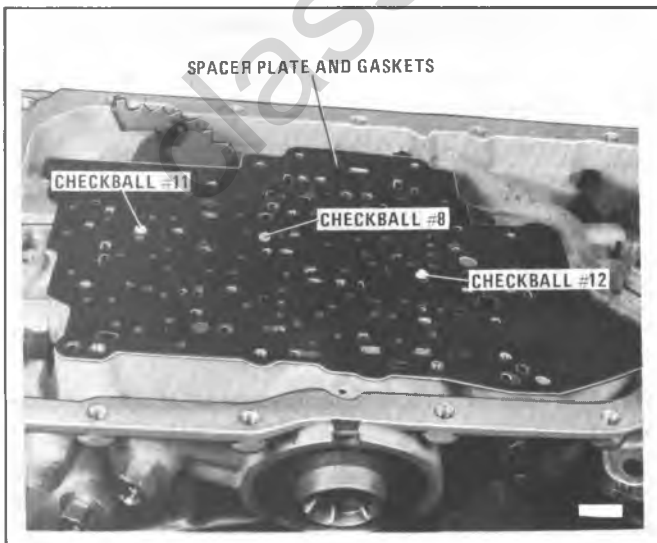

Figure 7A6-13 Location of Check Balls on Spacer Plate and Gasket

9. Remove 1-2 accumulator housing attaching bolts, accumulator housing, spring, gasket and plate (Figure 7A6-14).

a. Remove 1-2 accumulator piston from housing (Figure 7A6-15).

b. It may be necessary to apply low air pressure (approximately 3 psi) to orifice in accumulator housing passage to remove 1-2 accumulator piston.

10. Remove control valve assembly gaskets and spacer plate (Figure 7A6-16).

11. Remove 3-4 accumulator spring, piston and pin from case (Figure 7A6-17).

a. It may be necessary to apply low air pressure (approximately 3 psi) to orifice in case core passage to remove 3-4 accumulator piston (Figure 7A6-18).

12. Remove eight (8) check balls from core passages in case (Figure 7A6-19).

13. Governor assembly:

a. Remove governor cover attaching bolts, governor cover and gasket (Figure 7A6-20).

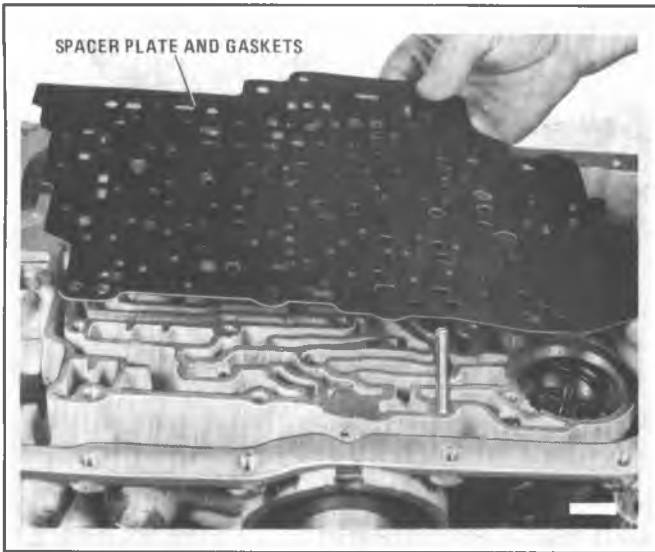

Figure 7A6-16 Removing Control Valve Assembly Gaskets and Spacer Plate



Figure 7A6-19 Removing Check Balls from Case

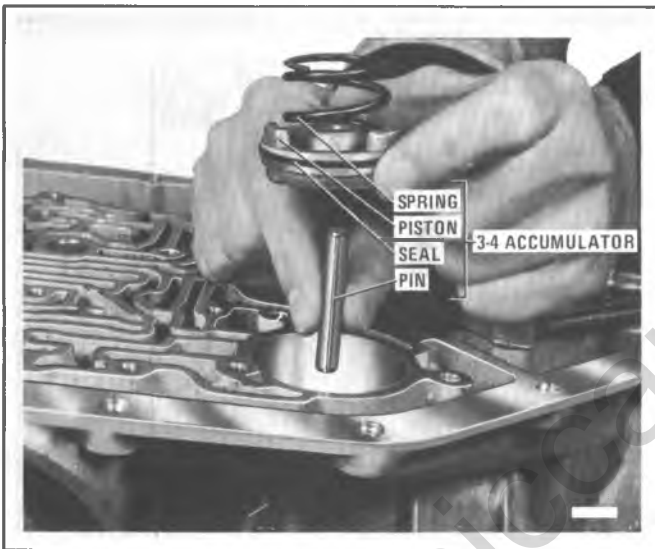

Figure 7A6-17 Removing 3-4 Accumulator Assembly

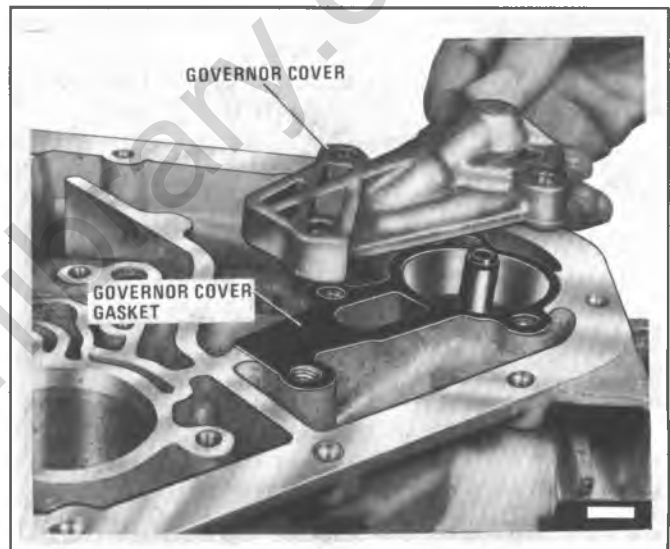

Figure 7A6-20 Removing Governor Cover

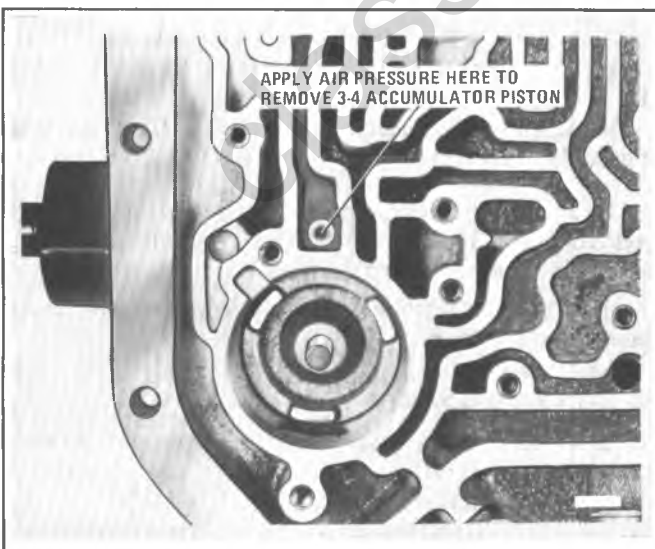

Figure 7A6-18 Removing 3-4 Accumulator Piston

b. Remove governor assembly from case (Figure 7A6-21). It may be necessary to rotate output shaft counterclockwise while removing the governor. Do not use any type of pliers to remove governor assembly.

14. Intermediate Servo Assembly:

a. Using small screwdriver, remove intermediate servo cover retaining ring (Figure 7A6-22).

b. Remove intermediate servo cover and discard seal ring (Figure 7A6-23). Cover seal ring may be located in case.

c. Remove intermediate servo piston and band apply pin assembly (Figure 7A6-24).

15. Check for proper intermediate band apply pin as follows:

a. Install J-25014-2 in intermediate servo bore and retain with intermediate servo cover retaining ring, aligning ring with gap at case slot (Figure 7A6-25).

b. Install pin J-25014-1 into J-24014-2. Make sure the tapered pin end is properly located against the band apply lug. Also, make sure the band anchor pin is properly located in the case and band anchor lug. (Figure 7A6-25).



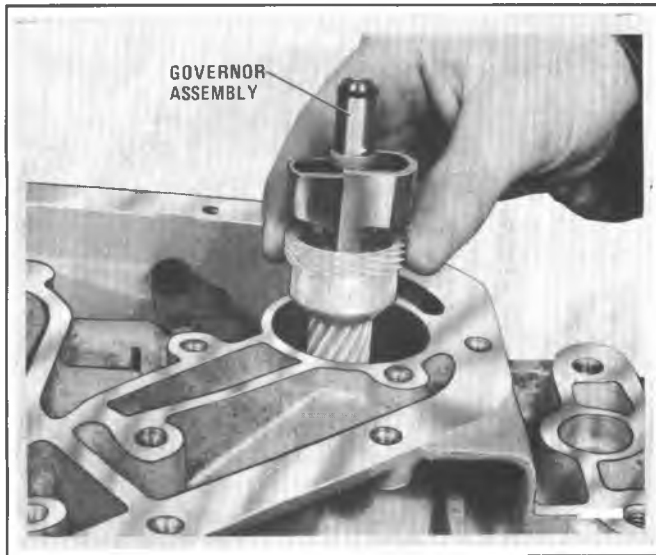

Figure 7A6-21 Removing Governor Assembly from Case

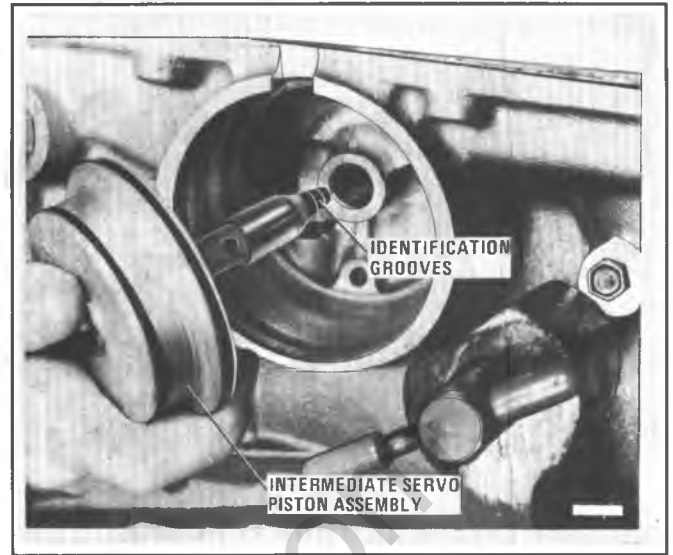

Figure 7A6-24 Removing Intermediate Servo

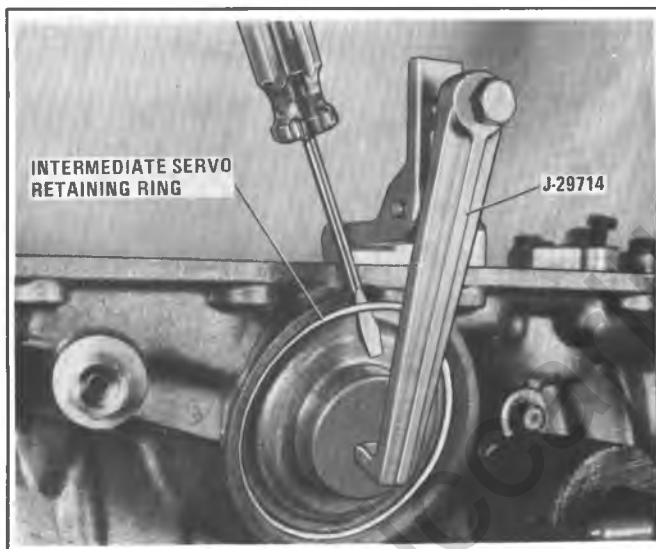

Figure 7A6-22 Removing Intermediate Servo Retaining Ring



Figure 7A6-25 Intermediate Band Apply Pin Tools

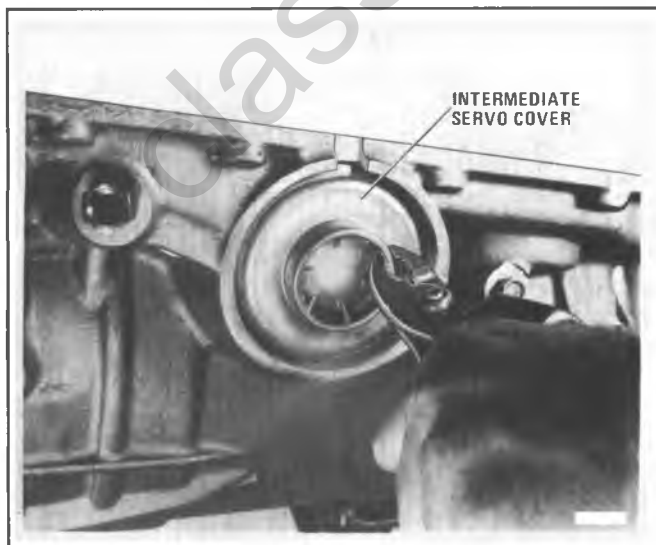

Figure 7A6-23 Removing Intermediate Servo Cover

c. Install dial indicator J-8001 and position dial indicator point (Figure 7A6-25) on top of J-25014-2 post and set dial indicator to zero.

**J-25014-2 must be seated squarely against the servo retaining snap ring.**

d. Align stepped side of pin J-25014-1 with torquing arm of J-25014-1.

**If band selection pin does not register between the high and low limits, look for possible problem with the intermediate band, direct clutch housing or case.**

e. Apply 12 N·m (100 in. lbs.) of torque to hex nut on side of gage. Slide dial indicator over pin J-25014-1 (Figure 7A6-26). Read dial indicator and see chart for proper size (Figure 7A6-27).

Dial indicator travel is reversed, making the indicator readings backwards. On an indicator that ranges from 0-100, a .5 mm (.020") travel will read 2 mm (.080"). A 1.5 mm (.060") travel will read 1 mm (.040"). The identification groove is located on the band end of the pin.

f. Remove tools J-25014-2 and J-25014-1.

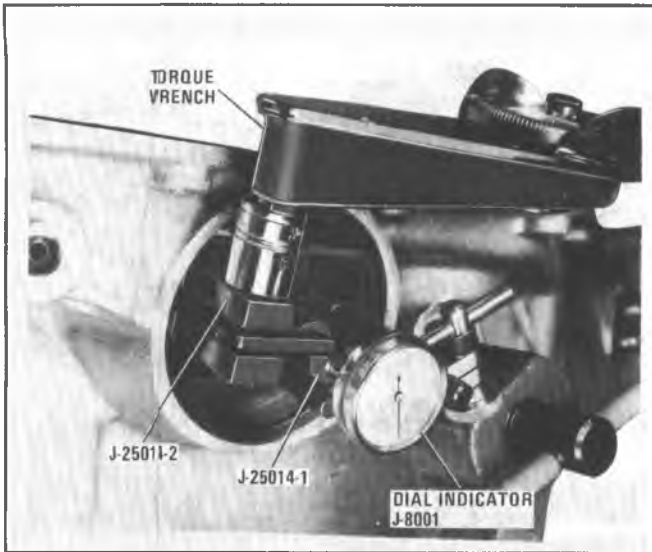

Figure 7A6-26 Checking for Proper Intermediate Band Apply Pin

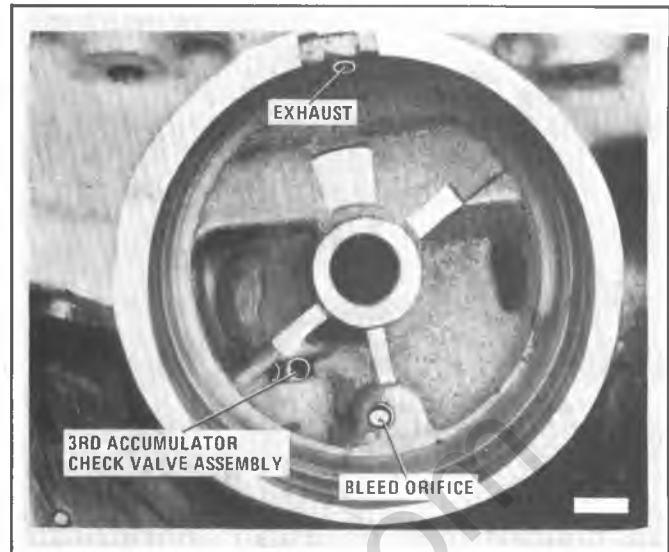

Figure 7A6-28 3rd Accumulator Check Valve Assembly

**INTERMEDIATE BAND APPLY PIN SELECTION CHART**

DIAL INDICATOR TRAVEL	APPLY PIN IDENTIFICATION
.0- .72mm (.0 - .029")	1 Groove
.72mm-1.44mm (.029"-.057")	2 Grooves
1.44mm-2.16mm (.057"-.086")	3 Grooves
2.16mm-2.88mm (.086"-.114")	None

Figure 7A6-27 Intermediate Band Apply Pin Selector Chart

16. Inspect the 3rd accumulator check valve for the following conditions: missing check ball, check ball binding or stuck in tube, oil feed slot in tube missing or restricted, improperly assembled, loose fitting or not fully seated in case and damaged or missing. (Figure 7A6-28)

If the 3rd accumulator check valve assembly requires replacement, perform the following:

- a. Using a 6.3 mm (#4) easy out, remove the check valve assembly from the case by turning and pulling straight out. (Figure 7A6-29)
- b. Install new check valve assembly, small end first, into case. Position the oil feed slot in tube so it faces the servo cover.
- c. Using a 9.5 mm (3/8") diameter metal rod and hammer, drive check valve assembly until it is seated in the 3rd accumulator case hole. (Figure 7A6-30).

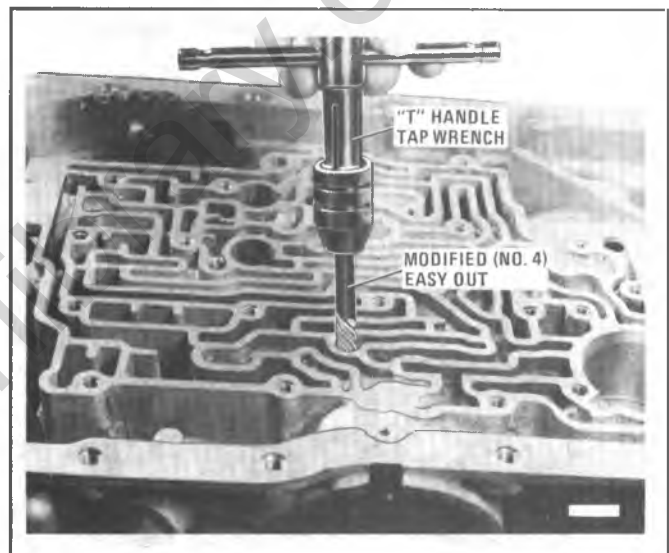

Figure 7A6-29 Removing 3rd Accumulator Check Valve Assembly

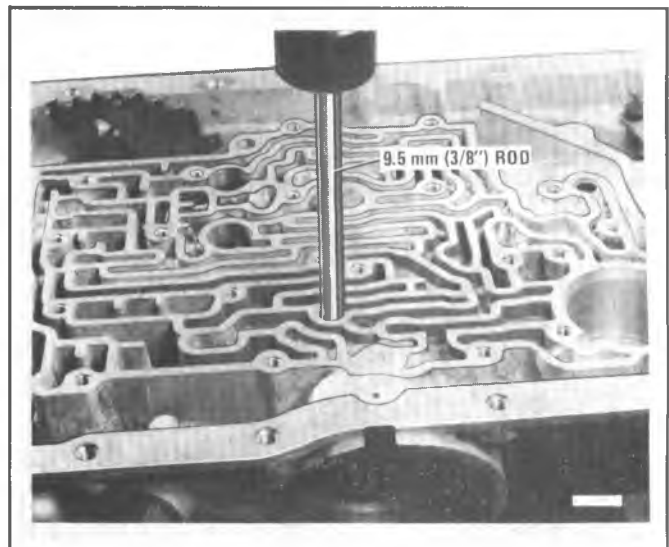

Figure 7A6-30 Installing 3rd Accumulator Check Valve Assembly

**OVERDRIVE UNIT PARTS**

**Removal**

1. Check overdrive unit end play as follows: (Figure 7A6-31)
  - a. Install J-25013-1 on sleeve on output shaft first; then bolt J-29312-1 on end of case. (Figure 7A6-32).
  - b. Turn transmission to vertical position, pump side up.

**OVERDRIVE UNIT END PLAY WASHER THICKNESS CHART**

THICKNESS		IDENTIFICATION NUMBER AND/OR COLOR
4.25 - 4.36 mm	(0.167" - 0.171")	0 - Scarlet
4.36 - 4.48 mm	(0.172" - 0.176")	1 - White
4.49 - 4.60 mm	(0.177" - 0.180")	2 - Cocoa Brown
4.61 - 4.72 mm	(0.181" - 0.185")	3 - Gray
4.73 - 4.84 mm	(0.186" - 0.190")	4 - Yellow
4.85 - 4.96 mm	(0.191" - 0.195")	5 - Light Blue
4.97 - 5.08 mm	(0.196" - 0.200")	6 - Purple
5.09 - 5.20 mm	(0.201" - 0.204")	7 - Orange
5.21 - 5.32 mm	(0.205" - 0.209")	8 - Green

Figure 7A6-31 Overdrive Unit End Play Washer Thickness Chart

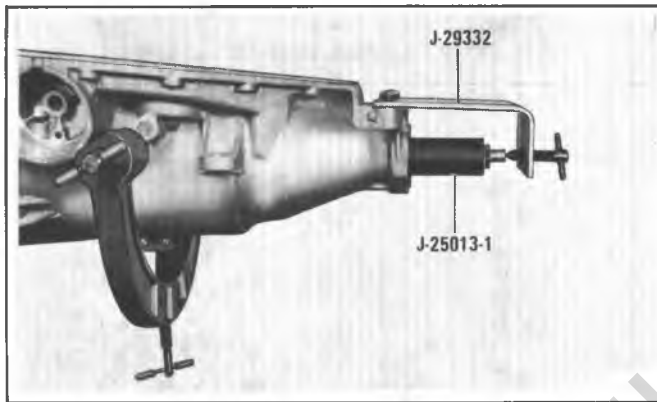

Figure 7A6-32 Installing Tools on Rear End of Case

c. Remove pump to case bolt and washer and install 278 mm (11") long bolt and locking nut as shown (Figure 7A6-33).

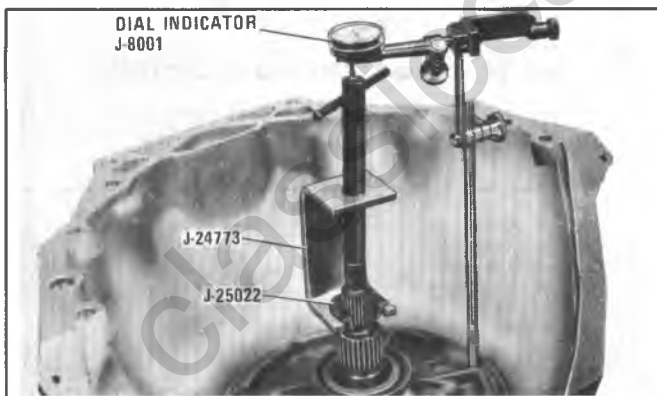

Figure 7A6-33 Checking Overdrive Unit End Play

d. Install J-25022 on J-24773-5 tool and secure on end of turbine shaft (Figure 7A6-33).

e. Mount dial indicator and clamp assembly on bolt, positioning indicator point cap nut on top of J-24773-5 (Figure 7A6-33).

f. Lift up on J-24773-5 with approximately 3 lbs. of upward force and while holding, set dial indicator to zero (MAINTAIN UPWARD FORCE).

The above procedure must be performed to eliminate the tolerance difference between the turbine shaft snap ring and the overdrive carrier.

g. With the dial indicator at zero, increase force to approximately 20 lbs. and read dial indicator. Overdrive unit end play should be 0.10 - 0.81 mm (.004 - .027").

Selective thrust washer controlling this end play is located between the pump cover and overrun clutch housing. If more or less washer thickness is required to bring end play within specification, select proper washer from the following chart (Figure 7A6-31).

h. Remove dial indicator, clamp assembly, J-24773-5 and J-25022 (Figure 7A6-33).

**2. Pump:**

a. If necessary, remove pump oil seal (Figure 7A6-34).

b. Remove remaining pump to case bolts and washers.

c. Using J-24773-5 tool, remove pump assembly, pump to case gasket (Figure 7A6-35).

d. Remove oil deflector plate (Figure 7A6-36).

**3. Fourth clutch assembly:**

a. Remove fourth clutch plate to case snap ring (Figure 7A6-37).

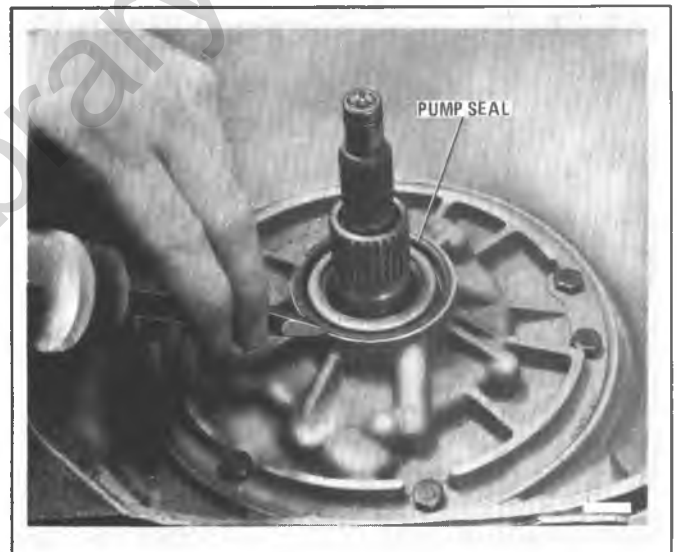

Figure 7A6-34 Removing Pump Seal

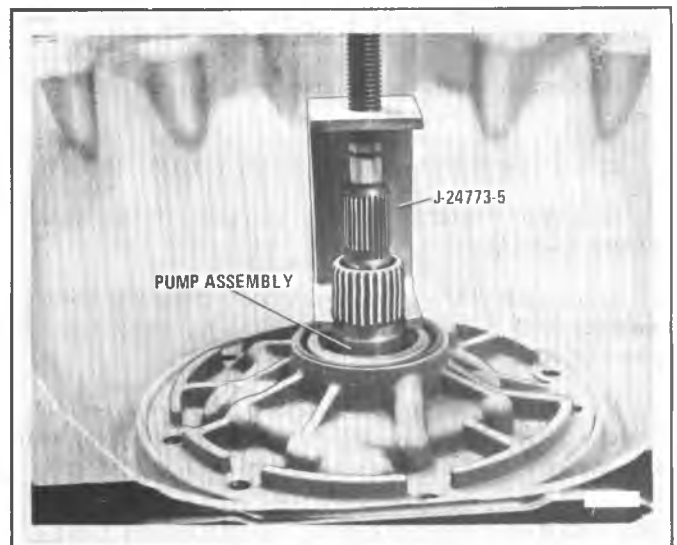

Figure 7A6-35 Removing Pump Assembly

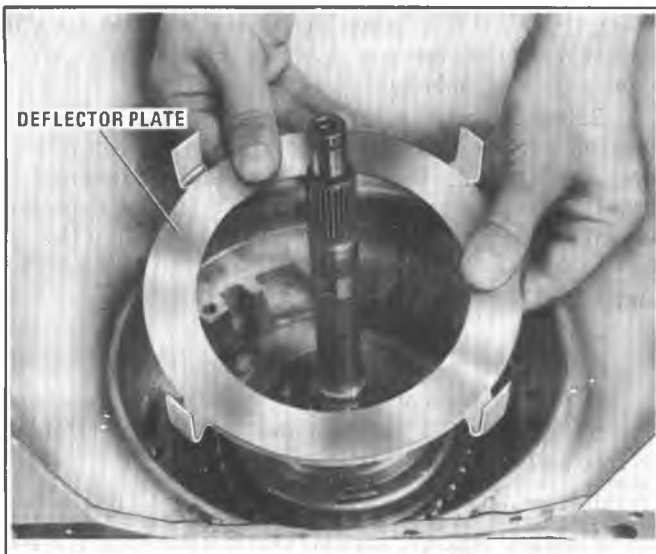

Figure 7A6-36 Removing Oil Deflector Plate

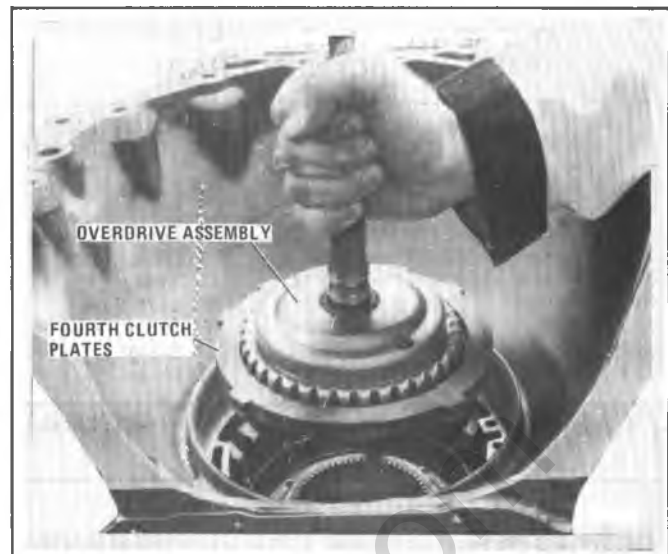

Figure 7A6-38 Removing Overdrive Assembly and Fourth Clutches

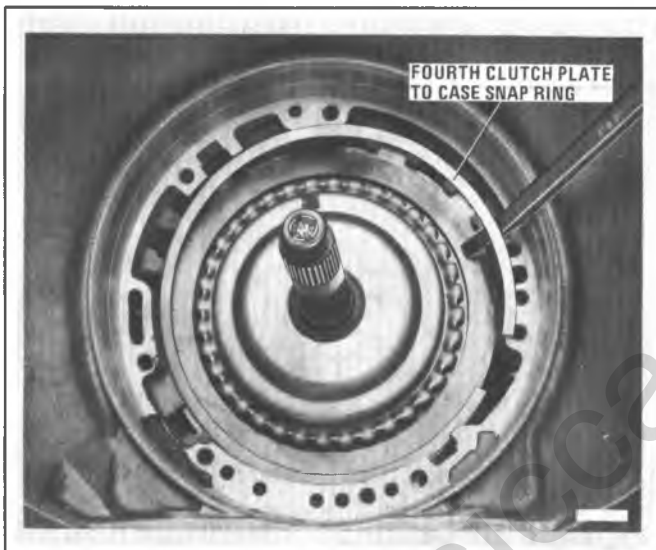

Figure 7A6-37 Removing Fourth Clutch Snap Ring

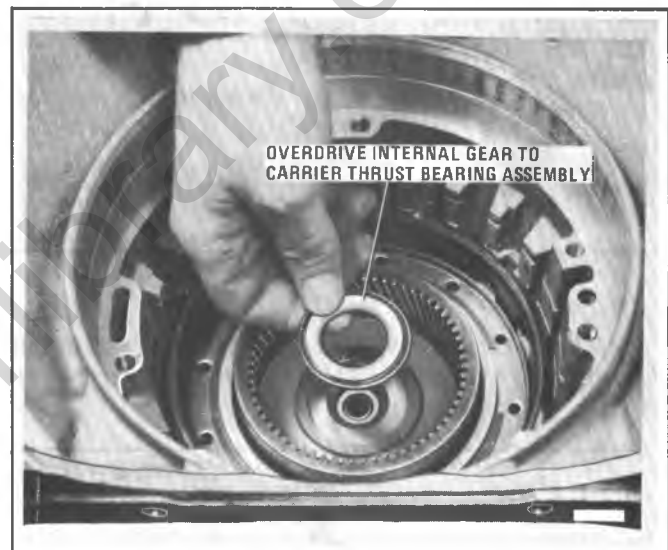

Figure 7A6-39 Removing Overdrive Internal Gear to Carrier Thrust Washer

b. Grasp turbine shaft and lift out overdrive assembly and fourth clutch plates (Figure 7A6-38).

c. Remove fourth clutch plates off overdrive assembly and one remaining steel plate out of case.

d. Remove overdrive internal gear to carrier thrust washer (Figure 7A6-39).

e. Remove overdrive internal gear (Figure 7A6-40).

f. Remove internal gear to support thrust washer (Figure 7A6-41).

g. Install J-29334-1 on fourth clutch spring and retainer assembly and J-29334-4 on case housing using two (2) governor cover bolts (Figure 7A6-42).

h. Compress fourth clutch spring and retainer assembly; then remove support to fourth clutch spring and retainer assembly (Figure 7A6-43).

i. Remove J-29334-1 and J-29334-4

j. Remove fourth clutch piston (Figure 7A6-44).

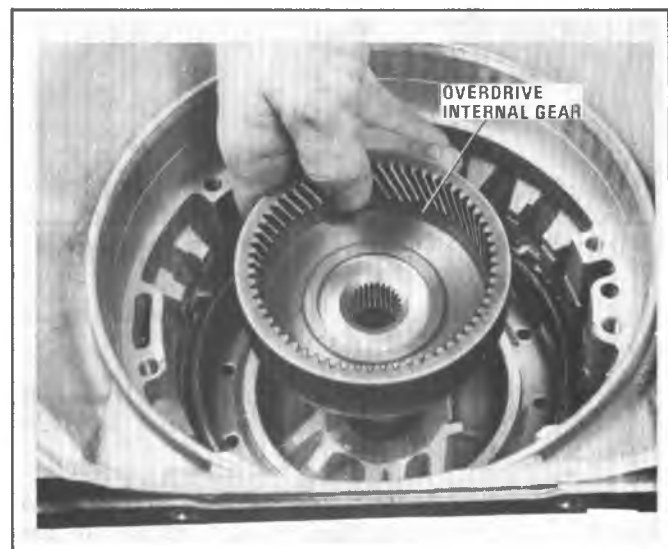

Figure 7A6-40 Removing Overdrive Internal Gear



Figure 7A6-41 Removing Overdrive Internal Gear to Support Thrust Washer

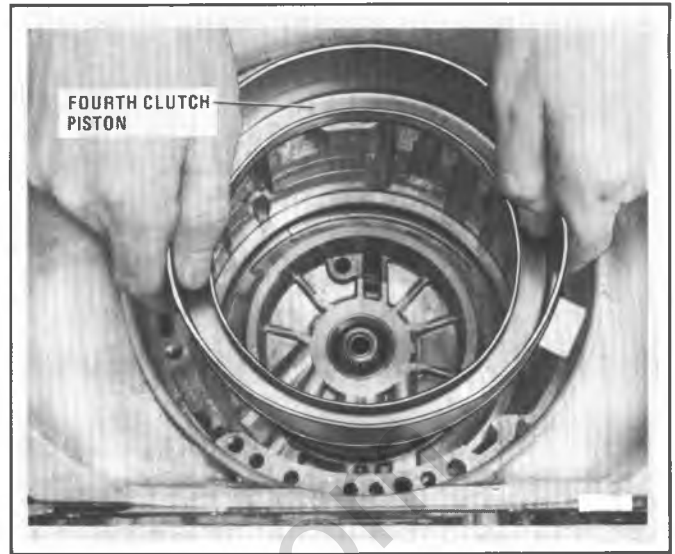

Figure 7A6-44 Removing Fourth Clutch Piston

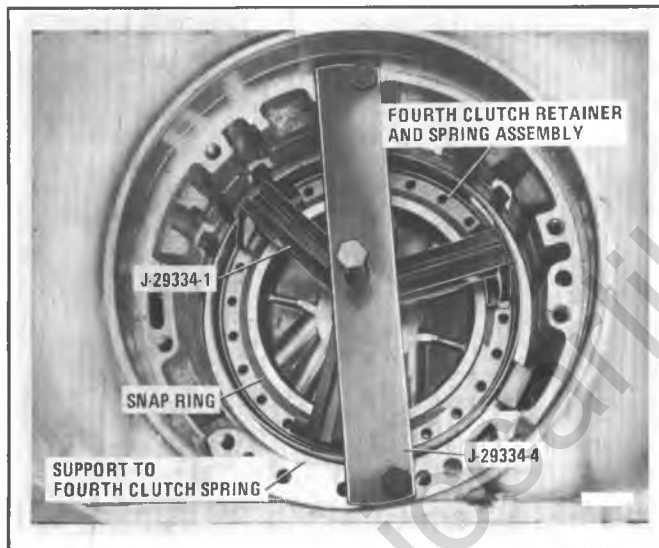

Figure 7A6-42 Installing Tools on Fourth Clutch Spring and Retainer Assembly

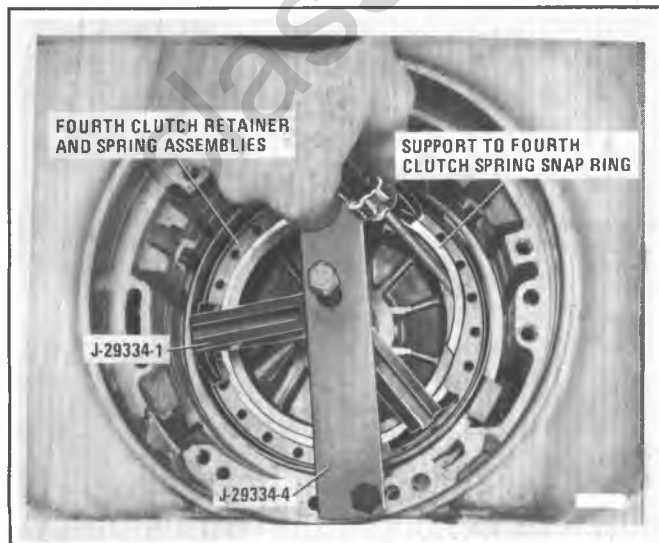

Figure 7A6-43 Removing Fourth Clutch Snap Ring and Spring and Retainer Assembly

**FRONT UNIT END PLAY WASHER THICKNESS CHART**

THICKNESS		IDENTIFICATION NUMBER AND/OR COLOR
1.66 - 1.77 mm	(0.065" - 0.070")	1 - —
1.79 - 1.90 mm	(0.070" - 0.075")	2 - —
1.92 - 2.03 mm	(0.076" - 0.080")	3 - Black
2.05 - 2.16 mm	(0.081" - 0.085")	4 - Light Green
2.18 - 2.29 mm	(0.086" - 0.090")	5 - Scarlet
2.31 - 2.42 mm	(0.091" - 0.095")	6 - Purple
2.44 - 2.55 mm	(0.096" - 0.100")	7 - Cocoa Brown
2.57 - 2.68 mm	(0.101" - 0.106")	8 - Orange
2.70 - 2.81 mm	(0.106" - 0.111")	9 - Yellow
2.83 - 2.94 mm	(0.111" - 0.116")	10 - Light Blue
2.96 - 3.07 mm	(0.117" - 0.121")	11 - —
3.09 - 3.20 mm	(0.122" - 0.126")	12 - —
3.22 - 3.33 mm	(0.127" - 0.131")	13 - Pink
3.35 - 3.46 mm	(0.132" - 0.136")	14 - Green
3.48 - 3.59 mm	(0.137" - 0.141")	15 - Gray

Figure 7A6-45 Front Unit End Play Washer Thickness Chart

**FRONT UNIT PARTS**

**Removal**

1. Check front unit end play as follows: (Figure 7A6-45).
  - a. Push forward clutch shaft downward.
  - b. Install J-29337 in end of forward clutch shaft (Figure 7A6-46).
  - c. Mount dial indicator and clamp assembly on bolt, positioning indicator point on top of J-29337 (Figure 7A6-46).
  - d. Move output shaft upward by turning the adjusting screw on J-29332-1 until the white or scribed line on sleeve J-25013-1 begins to disappear (Figure 7A6-47), then set dial indicator to zero.
  - e. Pull J-29337 upward and read end play. Front unit end play should be 0.56 mm-1.30 mm (.022-.051").

Selective washer controlling this end play is located between the output shaft and forward clutch shaft. If more or less washer thickness is required to

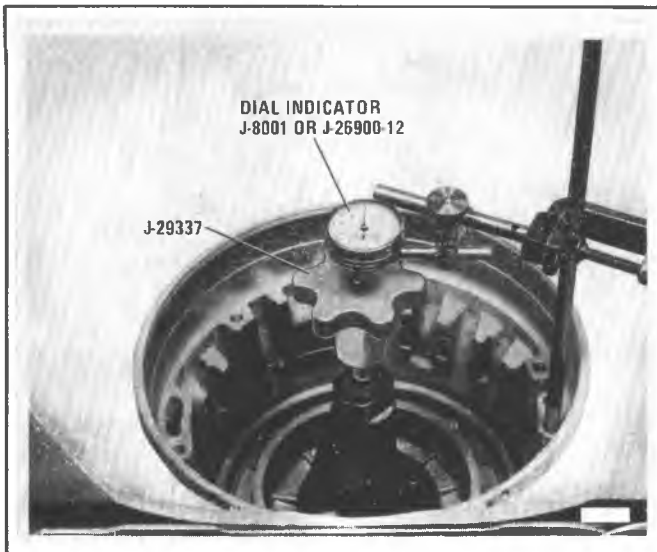

Figure 7A6-46 Installing Tool in Forward Clutch Shaft and Checking Front Unit End Play

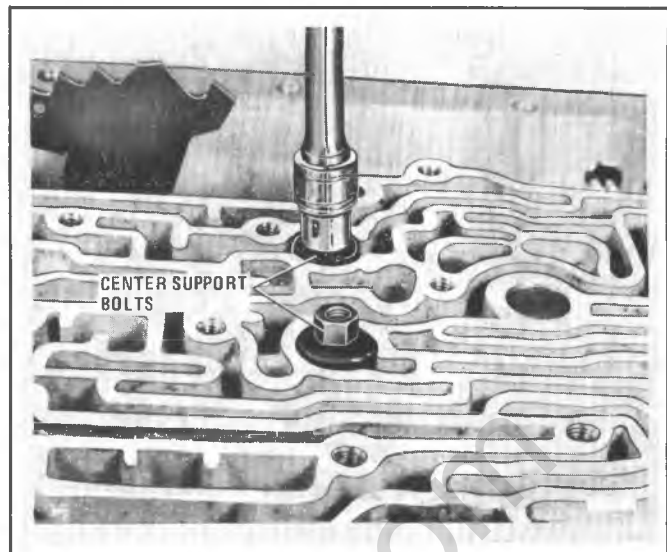

Figure 7A6-48 Removing Center Support Bolts



Figure 7A6-47 Tools on Rear End of Case

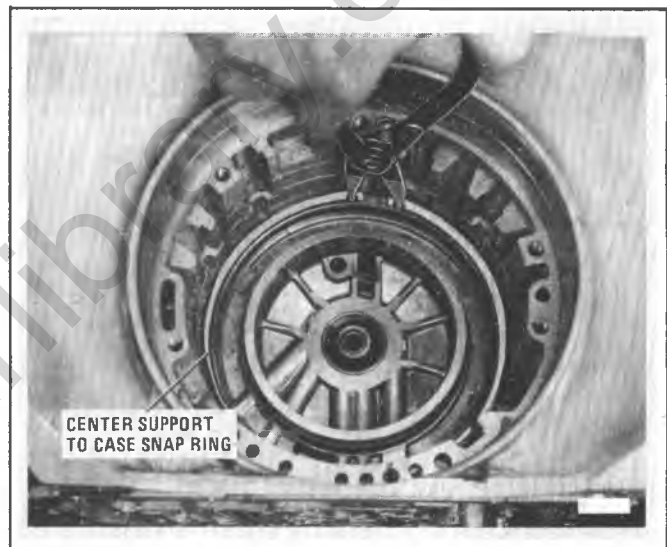

Figure 7A6-49 Removing Center Support to Case Snap Ring

bring end play within specifications, select proper washer from chart (Figure 7A6-45).

- f. Remove dial indicator, clamp assembly and J-29337.
- g. Do not remove J-29332-1 or J-25013-1.
2. Center support
  - a. Remove (2) two center support to case screws with a 10 mm socket (Figure 7A6-48).
  - b. Remove center support to case beveled snap ring (Figure 7A6-49).
  - c. Install J-29334-1 on center support. Retain in place using center support to fourth clutch spring snap ring (Figure 7A6-50).
  - d. Using J-29334-1 with slide hammer J-7004, remove center support (Figure 7A6-50).

**Make sure that center support bolts on control valve assembly side have been removed.**

e. Remove support to direct clutch thrust washer (Figure 7A6-51). Thrust washer may be stuck to the back of the direct clutch.

3. Forward and Direct Clutch:
  - a. Install J-29337 in end of forward clutch shaft (Figure 7A6-46).
  - b. Grasp J-29337, and remove direct and forward clutch assemblies (Figure 7A6-52).

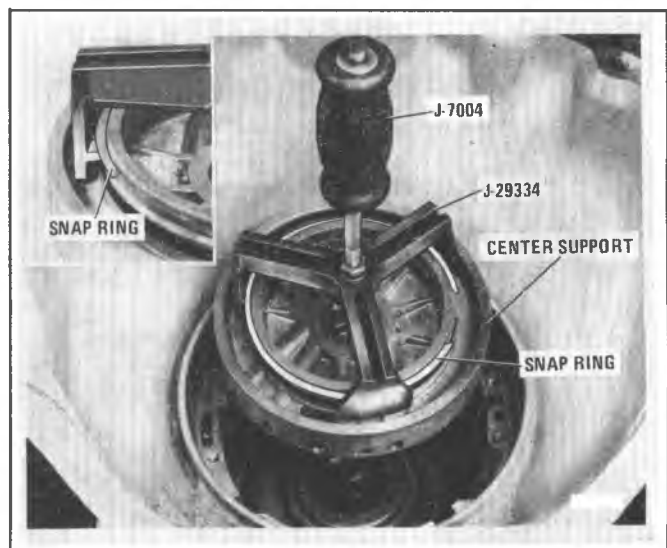

Figure 7A6-50 Removing Center Support with Tools



Figure 7A6-51 Removing Support to Direct Clutch Thrust Washer



Figure 7A6-53 Removing Intermediate Band Assembly

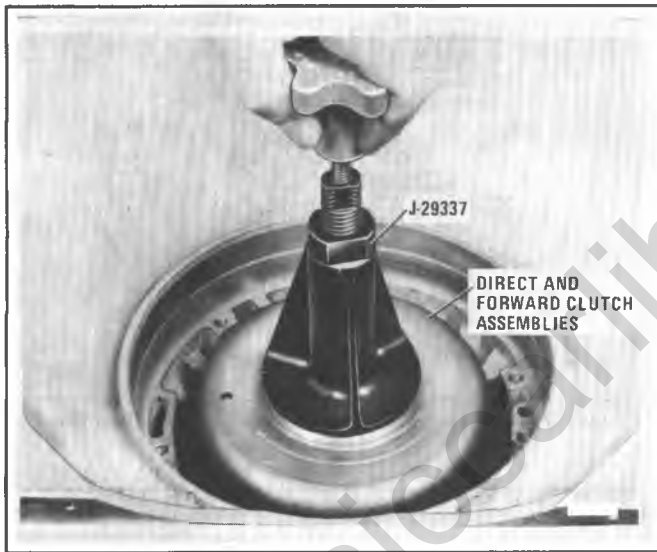

Figure 7A6-52 Removing Forward and Direct Clutch Assemblies

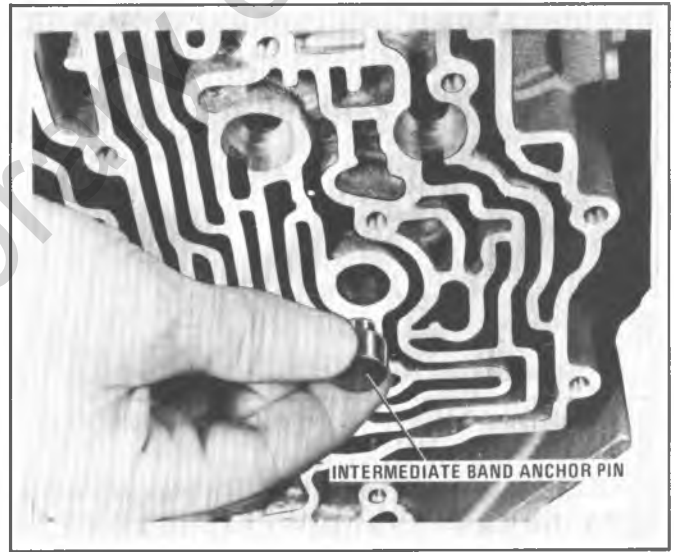

Figure 7A6-54 Removing Intermediate Band Anchor Pin

c. Lift direct clutch assembly off forward clutch assembly.

The direct to forward clutch thrust washer may stick to the end of the direct clutch housing when it is removed from the forward clutch housing.

4. Remove intermediate band assembly (Figure 7A6-53).

5. Remove band anchor pin (Figure 7A6-54).

## FRONT GEAR PARTS

### Removal

1. Remove output shaft to forward clutch shaft front selective washer. (Figure 7A6-55)

This washer may be stuck to the end of the forward clutch shaft.

2. Check rear unit end play as follows:

a. Loosen J-29332-1 adjusting screw on output shaft and push output shaft downward (Figure 7A6-56).

b. Install gage clamp on case as shown (Figure 7A6-57).

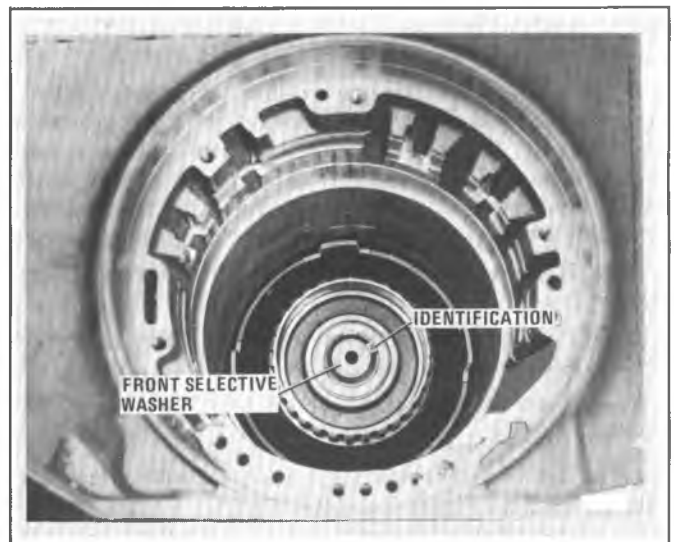

Figure 7A6-55 Location of Front Selective Washer



Figure 7A6-56 Installing Tools on Rear of Case

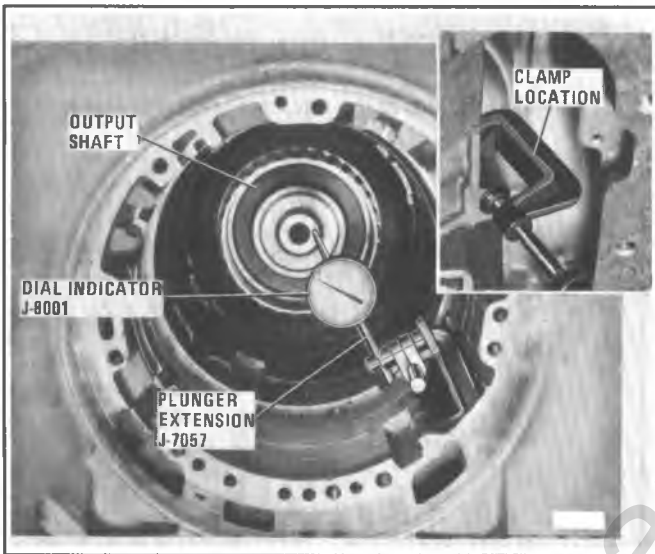

Figure 7A6-57 Installing Tools on Forward Clutch Shaft

c. Install dial indicator J-8001 and plunger extension J-7057. Position extension against end of output shaft and set dial indicator to zero (Figure 7A6-57).

d. Move output shaft upward by turning adjusting screw on J-29332-1 until the white or scribed line on sleeve J-25013 begins to disappear; then read end play. (Rear unit end play should be 0.10-0.64 mm (.004"-.025").

**Selective washer controlling this end play is located between the front internal gear thrust washer and output shaft front ring. If more or less washer thickness is required to bring end play within specifications, select proper washer from the Rear Unit End Play Washer Thickness Chart. (Figure 7A6-58).**

e. Remove dial indicator and clamp assembly. (Figure 7A6-57).

Do not remove J-25013 or J-29332-1. (Figure 7A6-56).

3. Using snap ring pliers, remove output shaft to selective washer snap ring (Figure 7A6-59).

4. Front Internal Gear:

a. Remove front internal gear, rear selective washer and thrust washer (Figure 7A6-59).

b. Remove rear selective washer and thrust washer from front internal gear.

5. Remove front carrier assembly and the front internal gear to front carrier thrust bearing assembly. (Figure 7A6-60).

**REAR UNIT END PLAY WASHER THICKNESS CHART**

THICKNESS		IDENTIFICATION NUMBER AND/OR COLOR
2.463 - 2.590 mm	(0.097" - 0.102")	0 - —
2.90 - 3.01 mm	(0.114" - 0.119")	1 - Orange
3.08 - 3.19 mm	(0.121" - 0.126")	2 - White
3.26 - 3.37 mm	(0.128" - 0.133")	3 - Yellow
3.44 - 3.55 mm	(0.135" - 0.140")	4 - Blue
3.62 - 3.73 mm	(0.143" - 0.147")	5 - Red
3.80 - 3.91 mm	(0.150" - 0.154")	6 - Brown
3.98 - 4.09 mm	(0.157" - 0.161")	7 - Green
4.16 - 4.27 mm	(0.164" - 0.168")	8 - Black
4.34 - 4.45 mm	(0.171" - 0.175")	9 - Purple

Figure 7A6-58 Rear Unit End Play Washer Thickness Chart

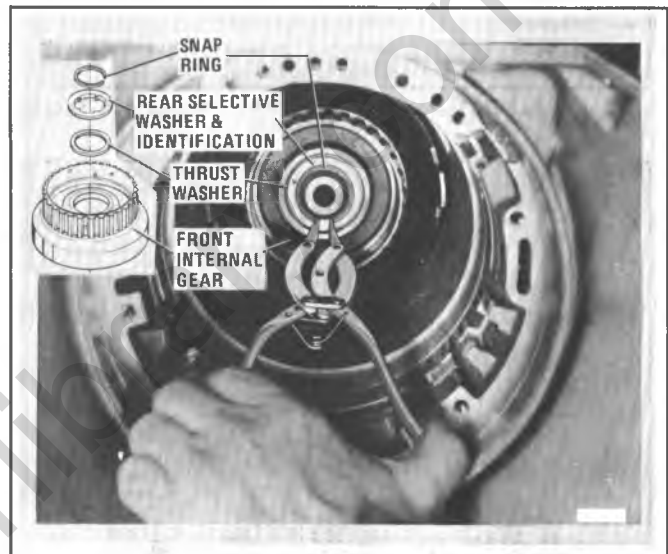

Figure 7A6-59 Removing Output Shaft to Selective Washer Snap Ring

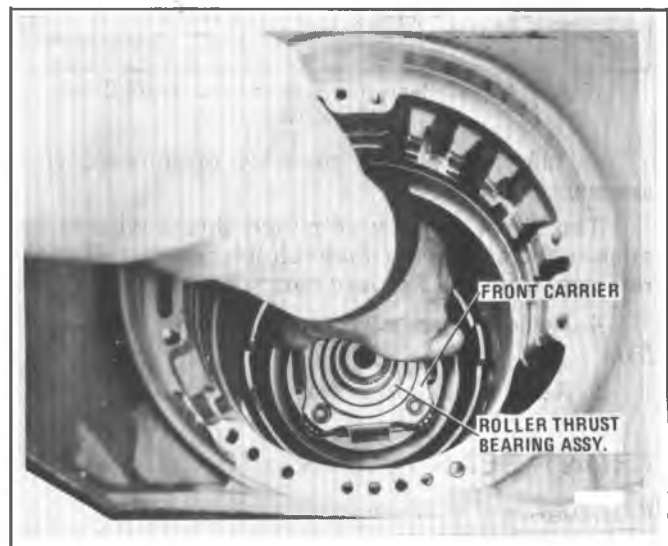

Figure 7A6-60 Removing Front Carrier and Roller Thrust Bearing

**The front sun gear to front carrier thrust bearing assembly and race may come out as the front carrier is removed.**

6. Remove front sun gear and front sun gear to front carrier thrust bearing assembly. (Figure 7A6-61).



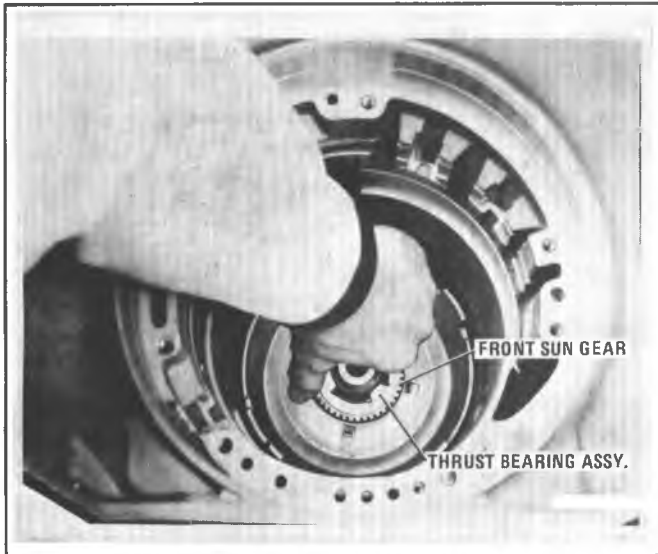

Figure 7A6-61 Removing Thrust Bearing Assembly and Front Sun Gear

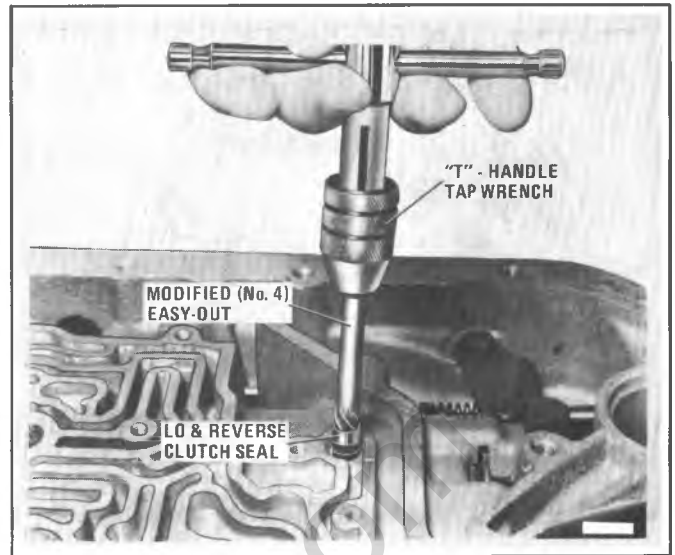

Figure 7A6-63 Removing Cup Plug and Seal Assembly

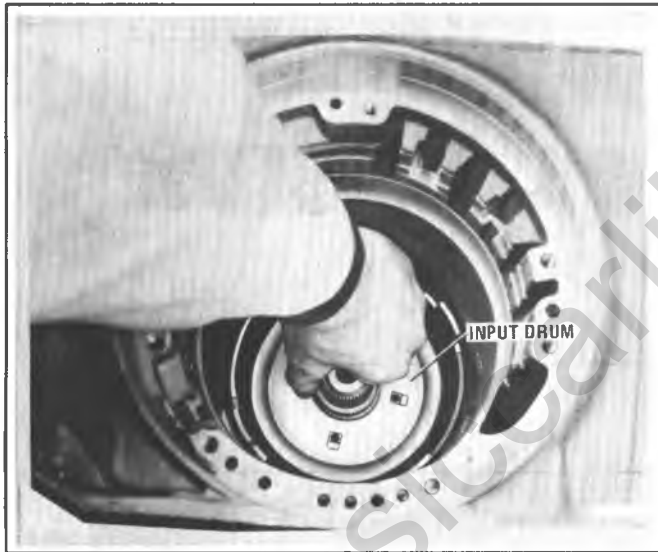

Figure 7A6-62 Removing Input Drum and Rear Sun Gear

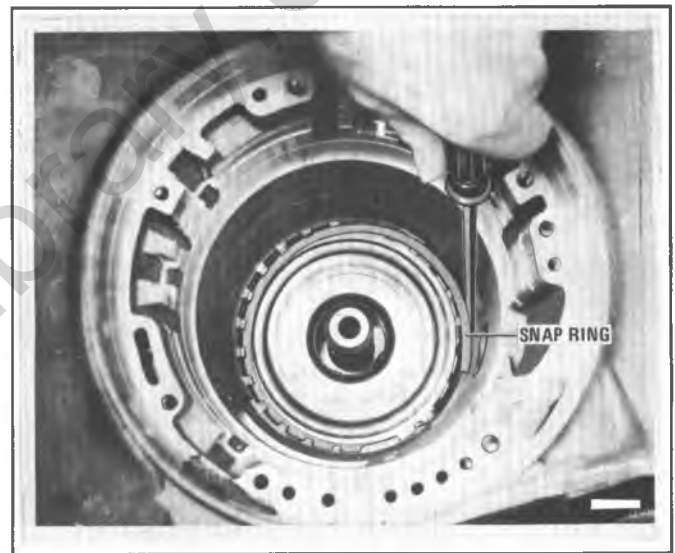

Figure 7A6-64 Removing Lo and Reverse Housing to Case Snap Ring

**This thrust bearing requires only one thrust race.**

7. Input drum and rear sun gear assembly:

a. Remove input drum and rear sun gear (Figure 7A6-62).

b. Remove the 4 tanged input drum to reverse clutch housing thrust washer from rear of input drum or from reverse clutch housing.

8. Lo and Reverse clutch housing assembly:

a. Grind approximately 20 mm (3/4") from end of 6.3 mm (#4) easy out to remove cup plug. Remove housing to case cup plug assembly by turning easy out 2 or 3 turns and pulling straight out. Do not reuse plug and seal assembly (Figure 7A6-63).

b. Remove lo and reverse clutch housing to case beveled snap ring (Figure 7A6-64).

**The flat side of the ring should have been against the lo and reverse clutch housing with beveled side up (Figure 7A6-64).**

c. Using J-25012, remove lo and reverse clutch housing assembly by moving J-25012 back and forth (Figure 7A6-65).

d. Remove lo and reverse clutch housing to case spacer ring (Figure 7A6-66).

## REAR GEAR PARTS

### Removal

**Make sure governor has been removed at this time.**

1. Grasp output shaft and lift out remainder of rear unit parts and lay down in a horizontal position (Figure 7A6-67).

2. Roller clutch and rear carrier assembly:

a. Remove roller clutch and rear carrier assembly off output shaft.

b. Remove the 4 tanged rear carrier to rear internal gear thrust washer off the end of the rear carrier, or inside the rear internal gear (Figure 7A6-68).

3. Remove lo and reverse clutch plates off output shaft.

4. Rear internal gear:

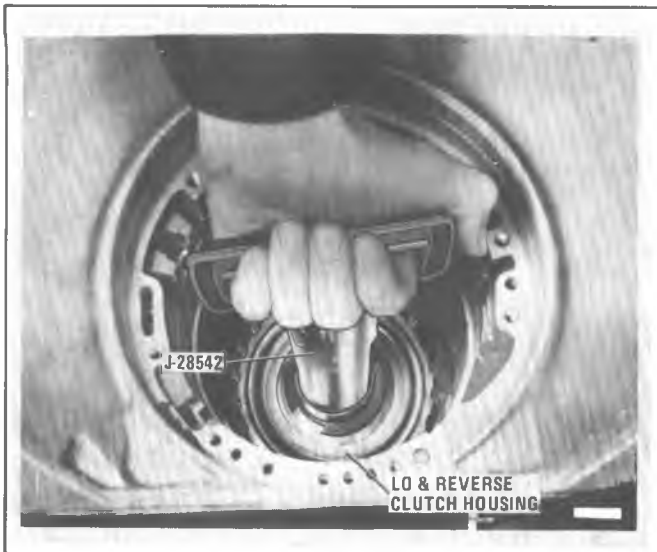

Figure 7A6-65 Removing Lo and Reverse Clutch Housing

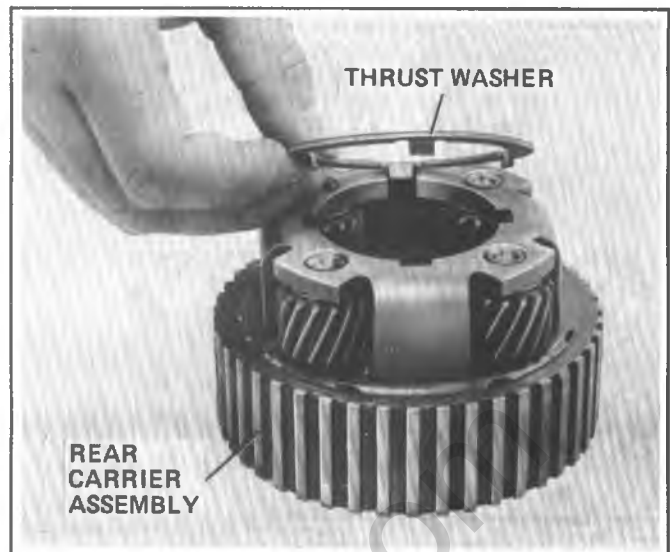

Figure 7A6-68 Removing Thrust Washer

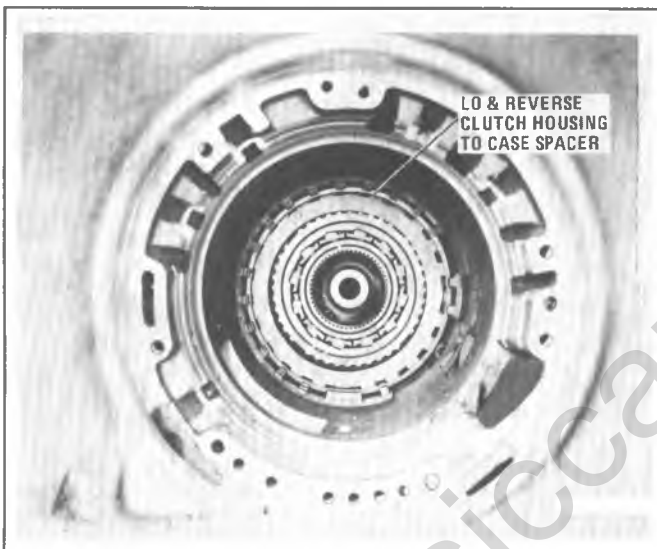

Figure 7A6-66 Proper Location of Lo and Reverse Housing to Case Spacer

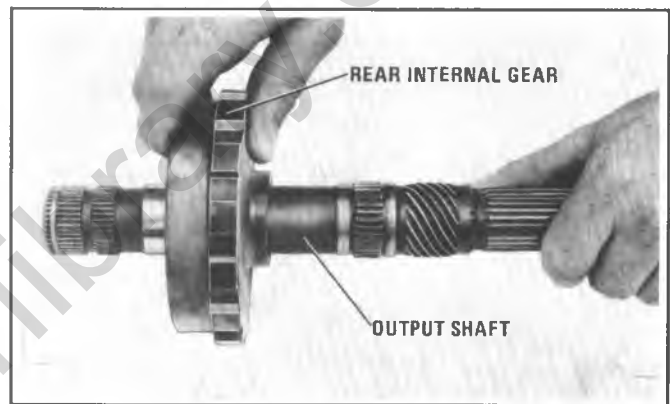

Figure 7A6-69 Removing Rear Internal Gear

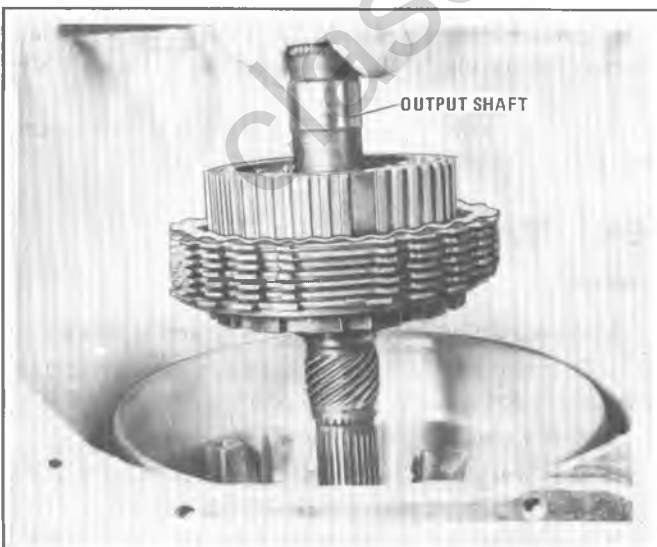

Figure 7A6-67 Removing Rear Unit Parts



Figure 7A6-70 Removing Rear Oil Seal

- a. Remove rear internal gear to rear sun gear thrust bearing assembly off rear internal gear.
- b. Remove rear internal gear off output shaft (Figure 7A6-69).
5. Turn transmission to horizontal position and remove J-25013-1 and J-29332-1 tools from case. Turn transmission to vertical position with rear end up.
6. If necessary, remove rear oil seal (Figure 7A6-70).

## MANUAL SHAFT AND PARKING PAWL PARTS (FIGURE 7A6-71)

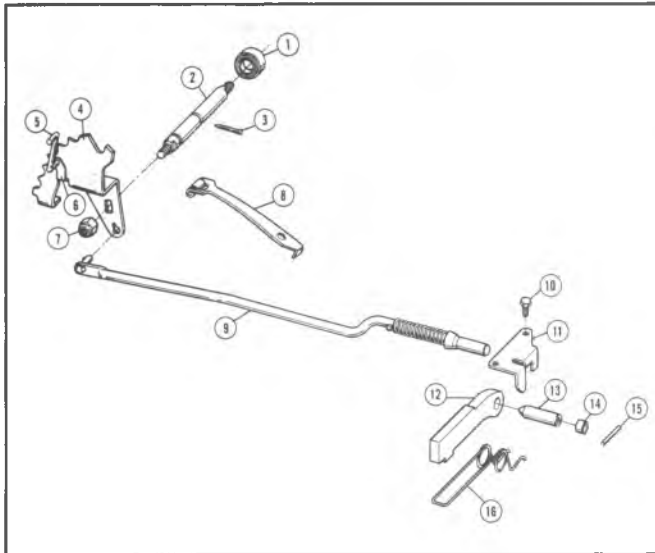

Figure 7A6-71 Manual Shaft and Parking Shaft Parts

### Removal

1. Turn transmission to horizontal position, oil pan side up.
2. If necessary, remove manual shaft and parking linkage as follows:
  - a. Remove hex nut which holds inside detent lever to manual shaft (Figure 7A6-72).

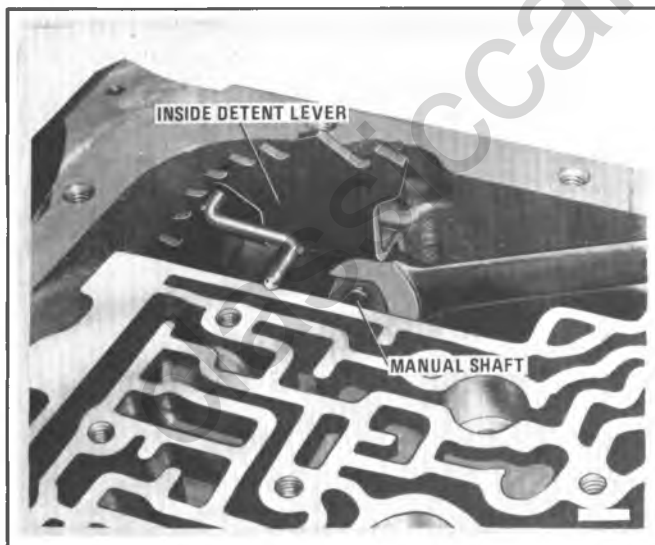

Figure 7A6-72 Removing Manual Shaft Nut

- b. Remove parking lock actuator rod and inside detent lever assembly.
  - c. Remove manual shaft retaining pin from case and slide manual shaft out (Figure 7A6-73).
  - d. Inspect manual shaft to case seal for damage. If necessary, pry out manual shaft seal using screwdriver (Figure 7A6-74).
  - e. Remove parking lock bracket (Figure 7A6-75).

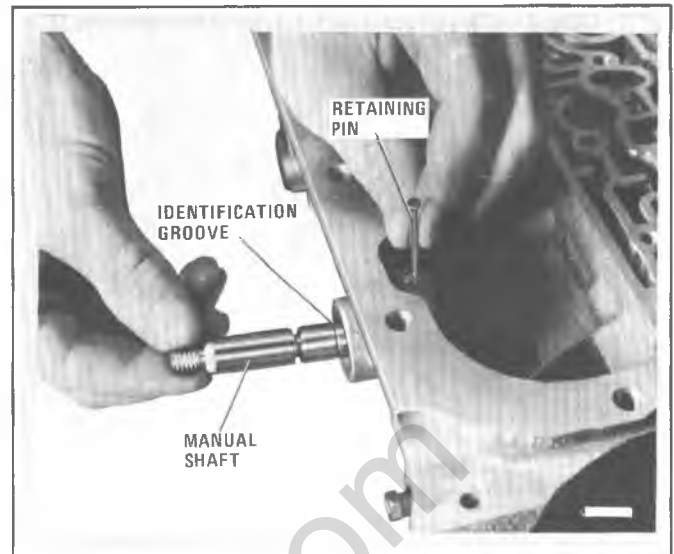

Figure 7A6-73 Removing Manual Shaft from Case

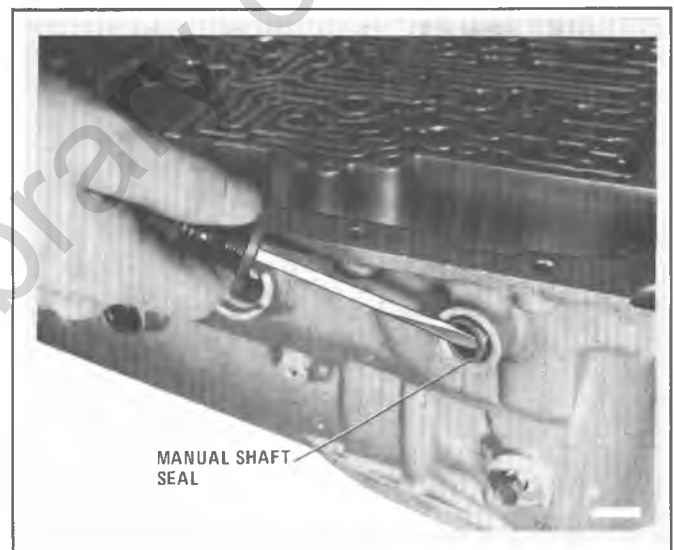

Figure 7A6-74 Removing Manual Shaft Seal from Case

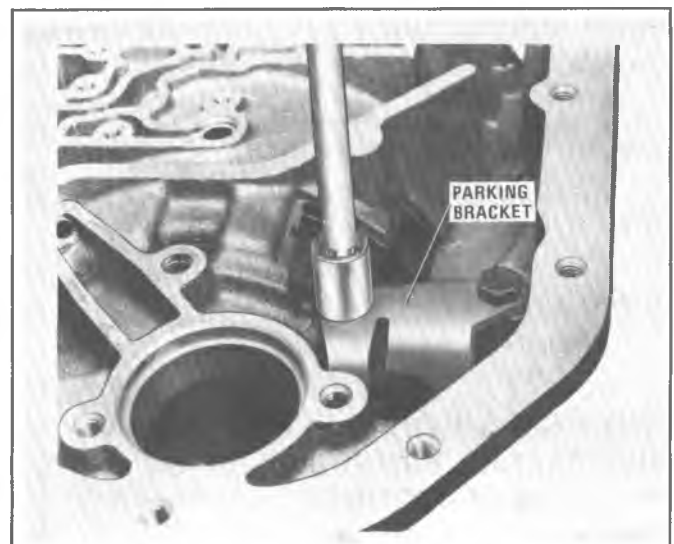

Figure 7A6-75 Removing Parking Pawl Bracket Bolt



Figure 7A6-76 Removing Parking Pawl Shaft Pin

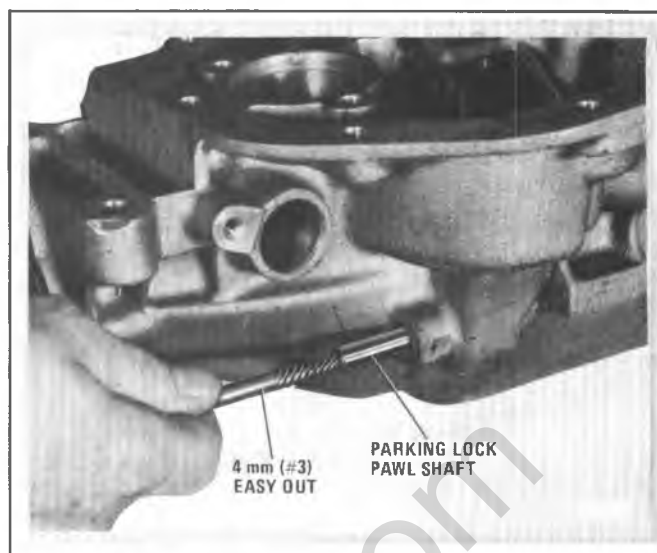

Figure 7A6-78 Removing Parking Pawl Shaft from Case

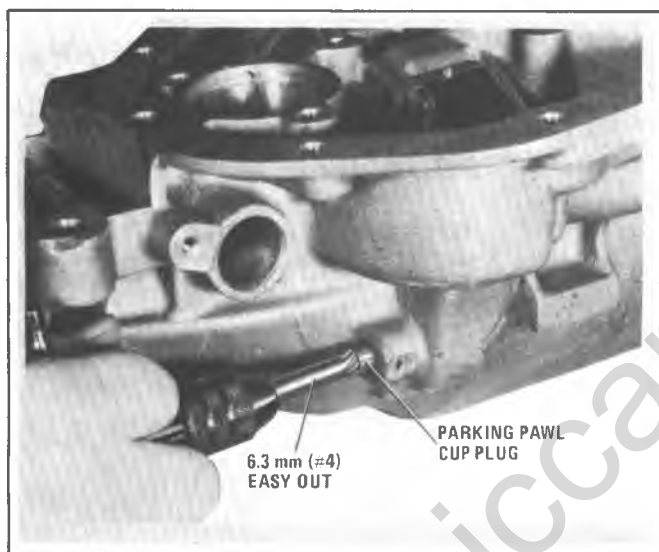

Figure 7A6-77 Removing Parking Pawl Shaft Cup Plug from Case

f. Remove parking lock pawl shaft retaining pin (Figure 7A6-76).

g. Using 6.3 mm (#4) easy out, remove parking lock pawl cup plug (Figure 7A6-77).

Grind approximately 20 mm (3/4") from the end 6.3 mm (#4) easy out to remove cup plug.

h. Using 4 mm (#3) easy out, remove parking pawl shaft (Figure 7A6-78).

i. Remove parking pawl and return spring.

## TRANSMISSION INSPECTION AND REASSEMBLY INSPECTION OF CASE ASSEMBLY (FIGURES 7A6-79 AND 7A6-80)

1. Inspect case assembly for damage, cracks, porosity or interconnected oil passages. If case is porous, refer to porosity repair.

2. Inspect orifice plug in the intermediate servo bore. If the plug requires replacement, place the new plug, orifice end first, flush to slightly below top of plug hole.

3. Inspect the exhaust passages for being open.

4. Inspect reverse clutch lugs, governor bore, intermediate servo bore, speedometer bore and snap ring grooves for damage.

5. Inspect reverse clutch seal and intermediate band anchor pin bores for damage.

6. Inspect for damage or stripped bolt holes. If any threaded holes require heli-coils or equivalent, install these to renew the threads.

7. Turn transmission to vertical position, rear end up.

8. Inspect cooler line connectors for damage. Do not remove unless replacing.

9. Inspect case bushing for damage or scoring.

10. If removed, install a new oil seal, using J-21426 (Figure 7A6-81).

11. If removed, install cooler line connector(s) using a commercial thread sealant on connector threads. Torque connector(s) to 27.0 N·m (20 ft. lbs.).

## MANUAL SHAFT AND PARKING PAWL PARTS (FIGURE 7A6-82).

### Inspection

1. Align actuator rod tangs with hole in inside detent lever and separate.

2. Inspect parking actuator rod for damage, or broken retainer lugs.

3. Inspect parking actuator spring for damage.

4. Inspect actuator for free fit on actuator rod.

5. Inspect parking pawl for cracks or damage.

6. Inspect parking pawl return spring for deformed end or coils.

7. Inspect parking pawl shaft for damage.

8. Inspect parking bracket for cracks or wear.

9. Inspect inside detent lever for cracks or loose pin.

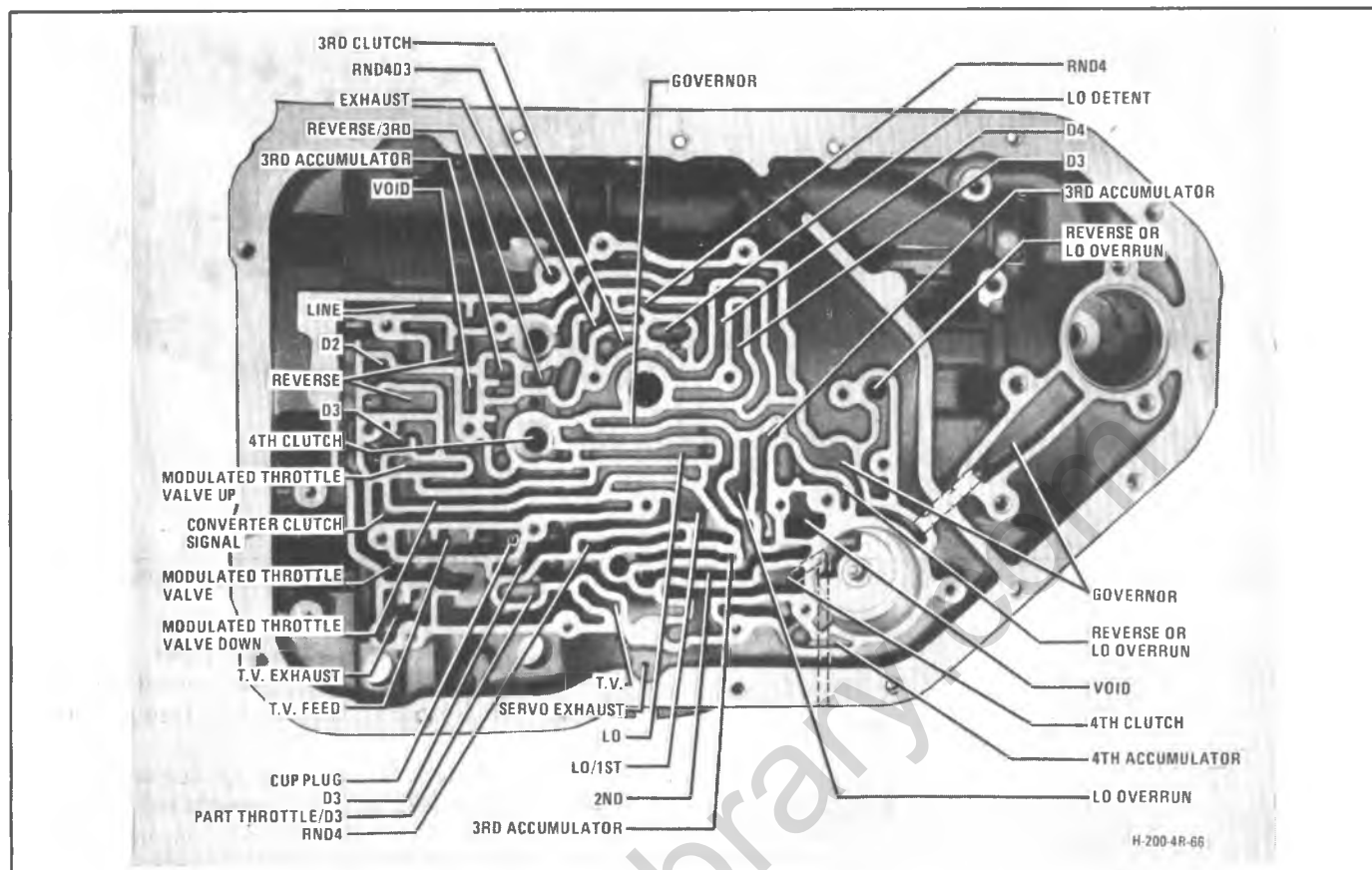

Figure 7A6-79 Oil Passages - Bottom of Case

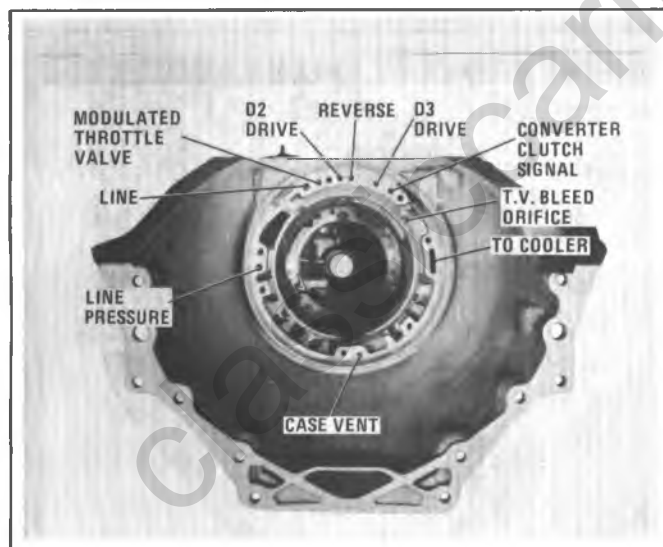

Figure 7A6-80 Oil Passages - Front of Case

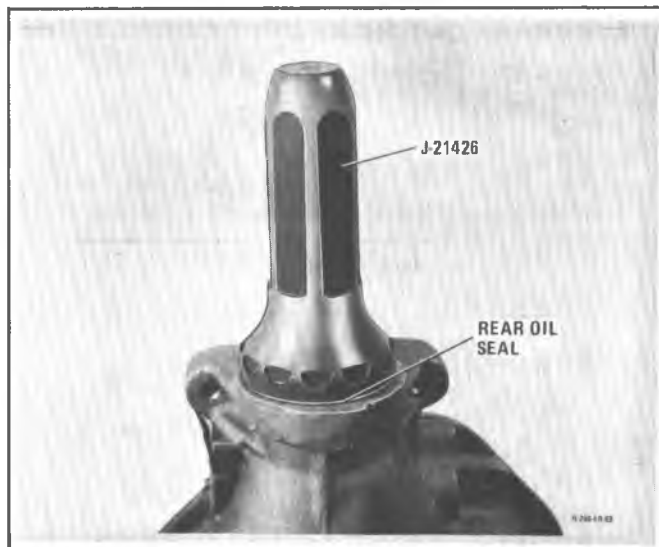

Figure 7A6-81 Installing Rear Oil Seal

10. Inspect manual shaft for damaged threads and the flats for raised edges. File down any raised edges.

**Reassembly**

1. Turn transmission to horizontal position, oil pan side up.

2. If removed, install new manual shaft seal with lip facing inward into transmission case using a 13 mm (9/16") socket to seat seal (Figure 7A6-83).

3. Install parking pawl and return spring with tooth toward inside of case and parking pawl return spring under pawl tooth with spring ends toward inside of case (Figure 7A6-84). Make sure spring ends locate against case pad.

4. Align parking pawl and return spring with case shaft bore.

5. Install parking pawl shaft, tapered end first.

6. Using 10 mm (3/8") rod, install new parking pawl shaft cup plug, open end out, past retaining pin hole (Figure 7A6-85).

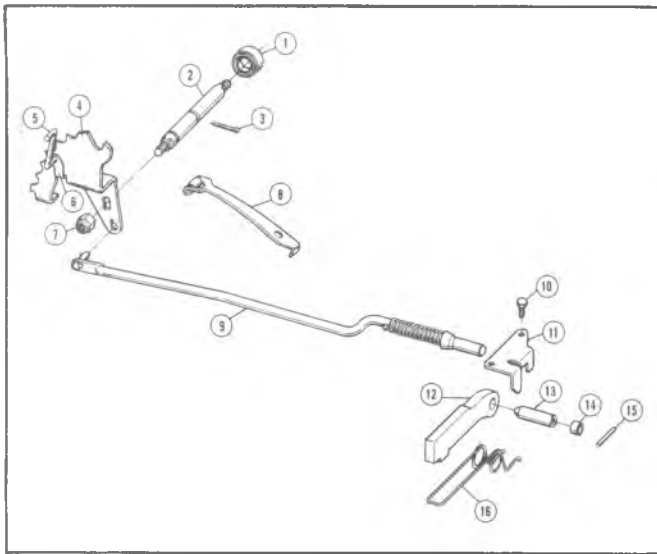

Figure 7A6-82 Manual Shaft and Parking Shaft Parts



Figure 7A6-85 Installing Parking Pawl Cup Plug

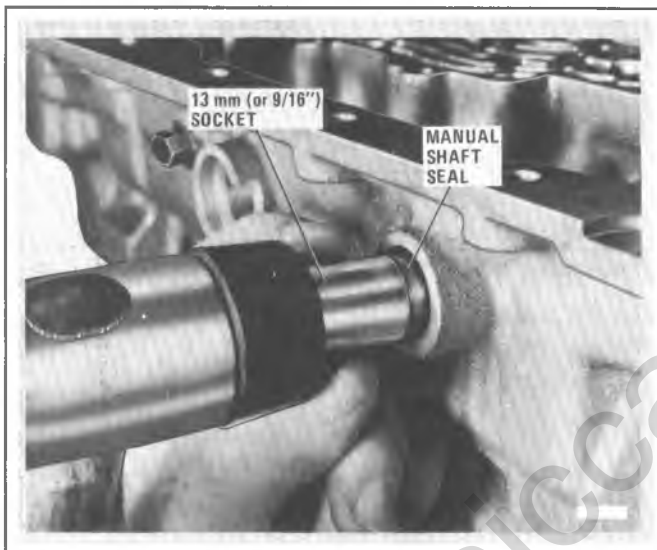

Figure 7A6-83 Installing Manual Shaft Seal into Case

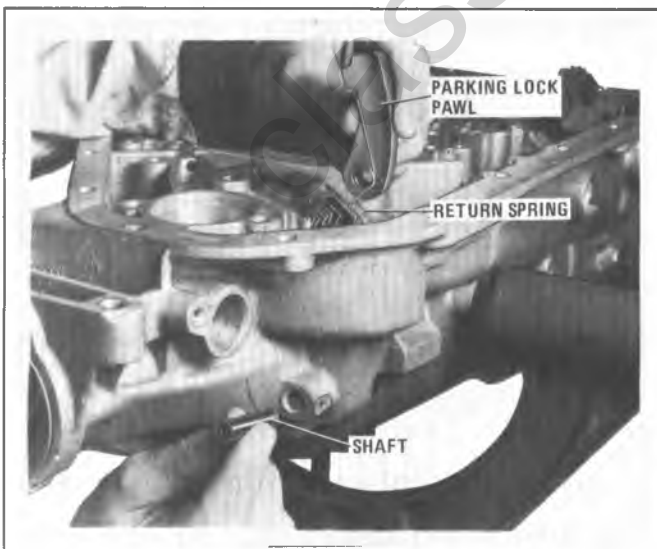

Figure 7A6-84 Installing Parking Pawl

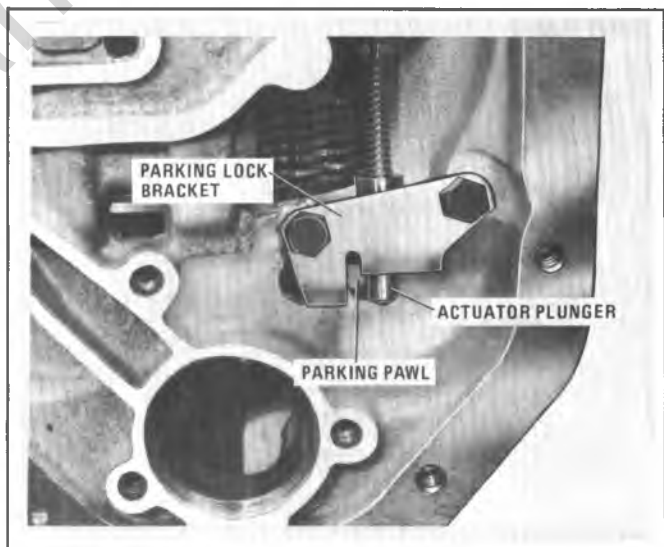

Figure 7A6-86 Installing Parking Pawl Rod

7. Install parking pawl shaft retaining pin.
8. While holding the parking pawl toward center of transmission, install parking lock bracket. Torque bolts to 24 N·m (18 ft. lbs.).
9. Install parking actuator rod into inside detent lever on pin side, locating lever between actuator rod tangs.
10. Install parking actuator rod and inside detent lever with detent lever pin toward center of transmission and actuator plunger between parking pawl and parking lock bracket (Figure 7A6-86).

**File any burrs or raised edges off the manual shaft that could damage the seal during installation of the shaft.**

11. Install manual shaft, small identification ring groove first, through case (Figure 7A6-87).
12. Aligning inside detent lever with flats on manual shaft, install inside detent lever on shaft.
13. Install hex nut on manual shaft and torque to 31 N·m (23 ft. lbs.).

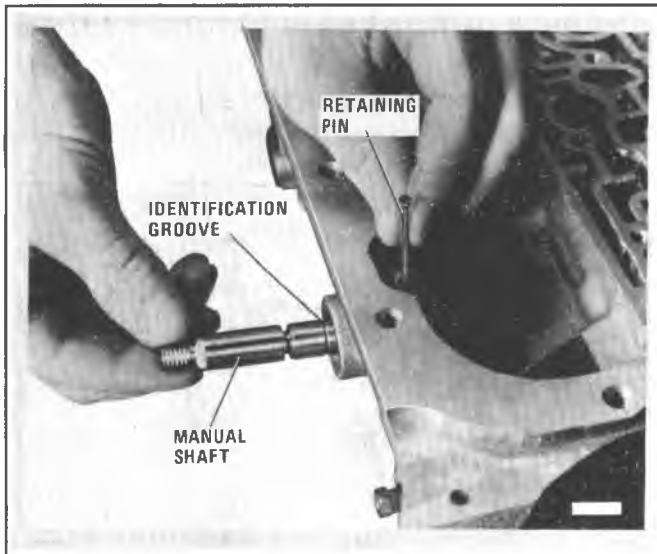

Figure 7A6-87 Installing Manual Shaft Into Case

14. Install manual shaft to case retaining pin, indexing with larger groove on manual shaft (Figure 7A6-87).

## REAR GEAR PARTS

### Output Shaft (Figure 7A6-88)

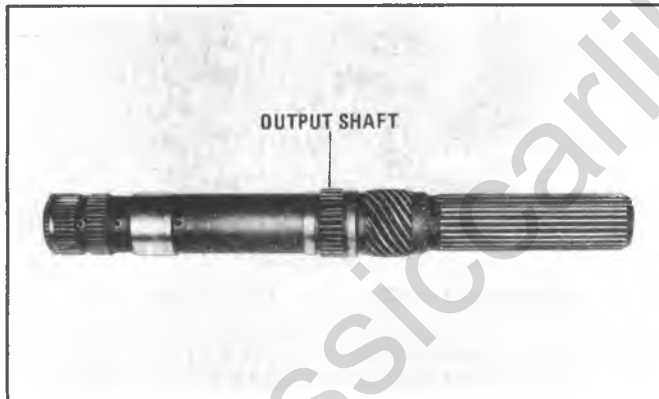

Figure 7A6-88 Output Shaft

1. Inspect journals and snap ring groove for wear or damage.
2. Inspect lubrication passages for being plugged or damaged.
3. Inspect splines for damage.
4. Inspect governor drive gear for rough or damaged teeth.

### Rear Internal Gear

1. Inspect rear internal gear splines, teeth and bearing surface for wear, cracks or damage.
2. Inspect parking pawl lugs for cracks or damage.
3. Install rear internal gear, hub end first, on output shaft as shown in Figure 7A6-89.
4. Thoroughly clean, air dry and inspect closely, the rear internal gear to rear sun gear thrust bearing assembly for pitted or rough conditions.

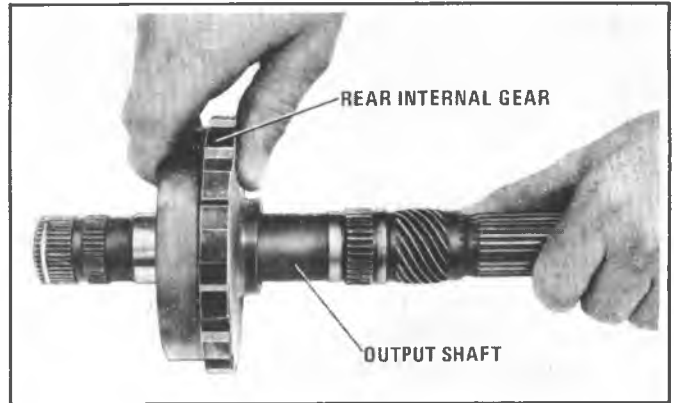

Figure 7A6-89 Installing Rear Internal Gear on Output Shaft

5. Install rear internal gear to rear sun gear thrust bearing assembly by placing the small diameter race over the output shaft (Figure 7A6-90).

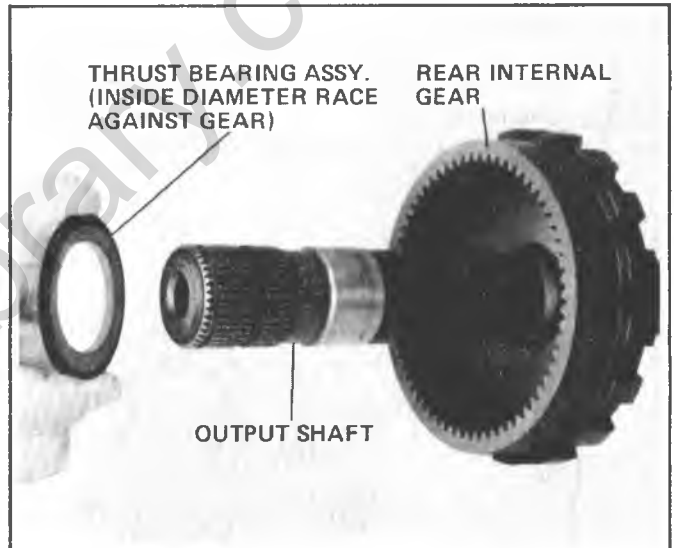

Figure 7A6-90 Installing Thrust Bearing Assembly

### Roller Clutch and Rear Carrier Assembly Inspection

1. Remove roller clutch race. Inspect race and spline for scoring or wear (Figure 7A6-91).

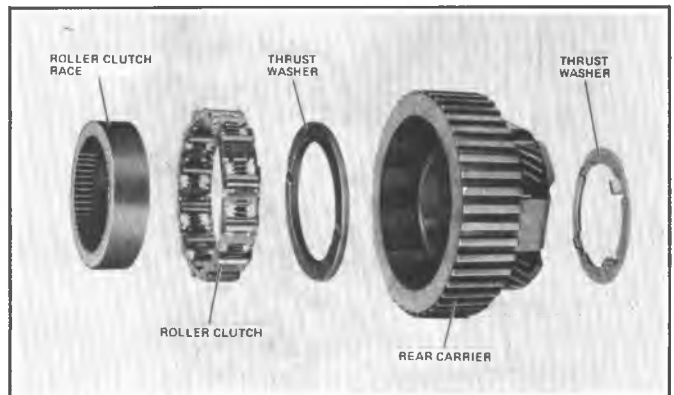

Figure 7A6-91 Roller Clutch and Rear Carrier - Exploded

## 7A6-28 AUTOMATIC 200-4R TRANSMISSION

2. Remove roller clutch assembly and inspect roller bearings, cage and springs for damage or wear (Figure 7A6-91).

3. Remove and inspect rear carrier to clutch thrust washer for signs of scoring or excessive wear (Figure 7A6-91).

4. Inspect 4 tanged rear carrier to rear internal gear thrust washers for being scored or distorted tangs (Figure 7A6-91).

5. Inspect rear carrier for damage (Figure 7A6-91).

6. Inspect roller clutch cam ramps for damage.

7. Inspect bushing for damage or scoring.

8. Inspect planet pinions for damage, rough bearings or tilt.

9. Check pinion end play. Pinion end play should be .024-0.60 mm (.009"-.024"). (Figure 7A6-92).

### Reassembly

1. Install roller clutch to rear carrier thrust washer (Figure 7A6-93).

2. Install rollers that may have come out of roller clutch cage, by compressing the energizing spring with forefinger and inserting roller from outer edge (Figure 7A6-94).

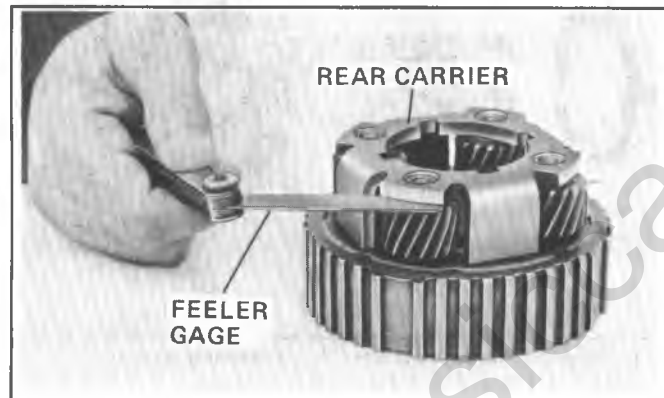

Figure 7A6-92 Checking Rear Carrier Pinion End Play



Figure 7A6-93 Installing Thrust Washer Into Rear Carrier

3. Install roller clutch assembly into roller clutch cam (Figure 7A6-95).

4. Install roller clutch race, spline side out and rotate clutch race counterclockwise into position (Figure 7A6-96).

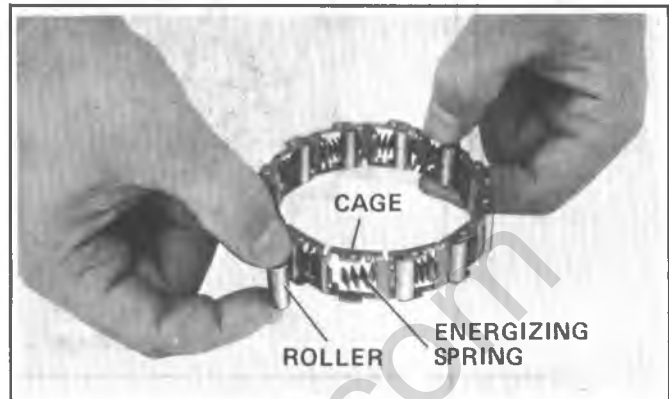

Figure 7A6-94 Installing Roller Into Case

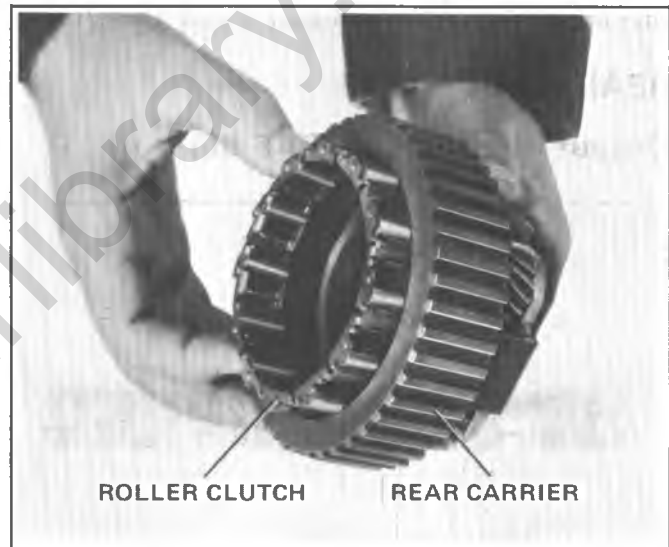

Figure 7A6-95 Installing Roller Clutch Into Rear Carrier

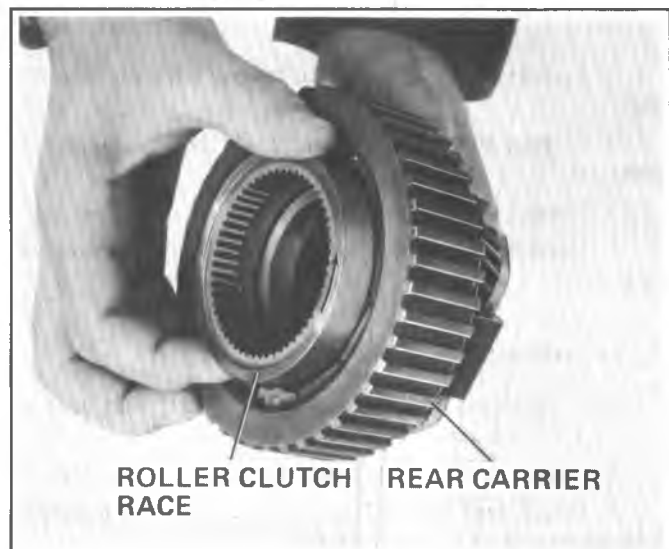

Figure 7A6-96 Installing Roller Clutch Race



5. Install 4 tanged rear carrier to rear internal gear thrust washer. Align tangs into slots of rear carrier and retain with petrolatum (Figure 7A6-97).

6. Install roller clutch and rear carrier assembly into rear internal gear (Figure 7A6-98).

7. If removed install J-25013 open end first, into rear end of case. Bolt J-29332-1 on end of case (Figure 7A6-99).



Figure 7A6-97 Installing Thrust Washer

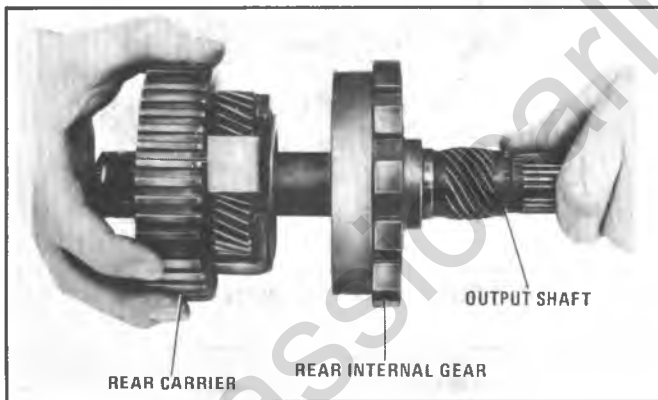

Figure 7A6-98 Installing Rear Carrier Into Rear Internal Gear



Figure 7A6-99 Installing Tools on Rear End of Case

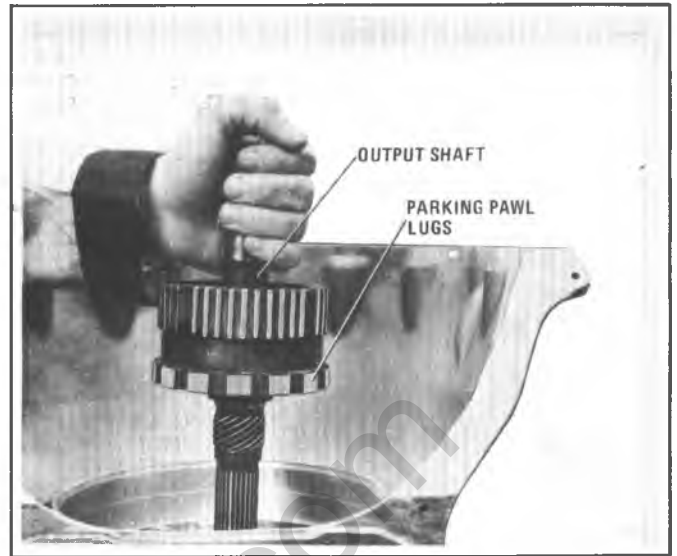

Figure 7A6-100 Installing Rear Unit Parts

8. Turn case to vertical position, pump end up.

9. Install rear unit parts into case and into J-25013-1 sleeve (Figure 7A6-100), indexing rear internal gear parking pawl lugs to pass by parking pawl tooth.

10. Using adjusting screw (Figure 7A6-99) and looking through parking pawl case slot, adjust the height of the rear internal gear parking pawl lugs to align flush with the parking pawl tooth.

## LO AND REVERSE CLUTCH

### Inspection

Inspect lo and reverse clutch composition-faced, steel clutch plates and wave plate for signs of wear or burning.

### Lo and Reverse Clutch Housing Assembly (Figure 7A6-101)

### Disassembly

1. Compress lo and reverse clutch spring retainer, remove snap ring and retainer and inspect for damage or distortion (Figure 7A6-102).

2. Remove waved spring (Figure 7A6-103).

3. Remove lo and reverse clutch piston.

4. Remove outer and inner piston seals (Figure 7A6-104 and 105).

5. Remove clutch apply ring.

### Inspection

1. Inspect lo and reverse clutch housing for damage or plugged feed hole.

2. Inspect lo and reverse clutch housing bushing for damage or scoring.

3. Inspect lo and reverse clutch splines and snap ring groove for damage or burrs. Remove any burrs on splines or snap ring groove.

4. Inspect lo and reverse clutch piston and clutch apply ring assembly for distortion, cracks or damage.

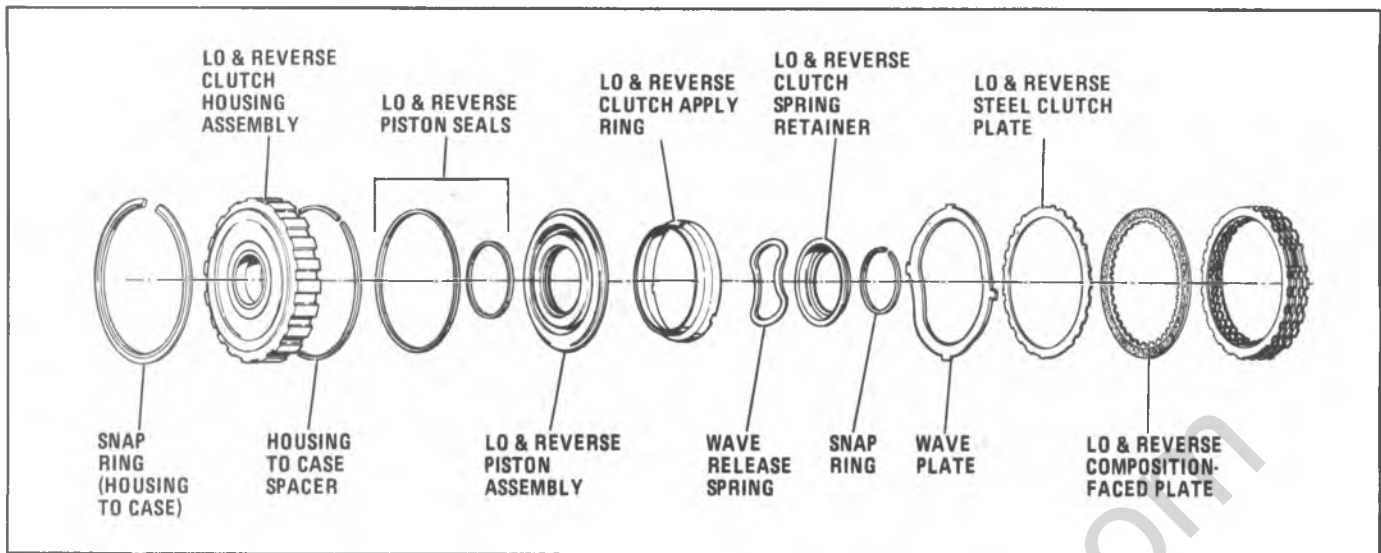

Figure 7A6-101 Lo and Reverse Clutch Housing - Exploded View

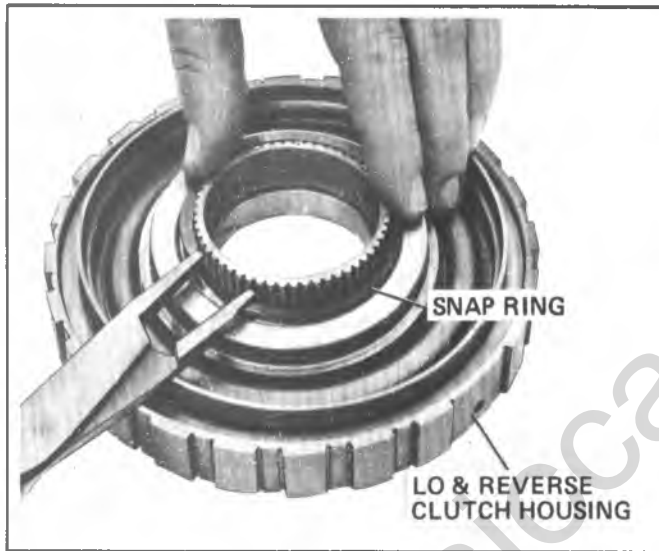

Figure 7A6-102 Removing Lo and Reverse Clutch Spring Retaining Snap Ring

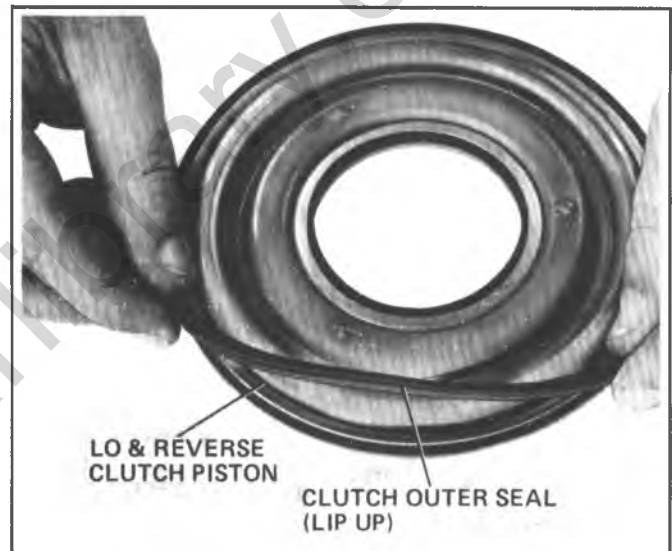

Figure 7A6-104 Removing Lo and Reverse Clutch Outer Seal



Figure 7A6-103 Removing Lo and Reverse Clutch Wave Release Spring



Figure 7A6-105 Removing Lo and Reverse Clutch Inner Seal

5. Inspect lo and reverse clutch spring retainer for damage.
6. Inspect waved spring for damage.
7. Inspect lo and reverse clutch housing to case spacer ring for damage.

**Reassembly**

1. Install clutch apply ring on lo and reverse clutch piston.
  2. Install new outer and inner seals on piston with lips facing away from clutch apply ring side (Figure 7A6-104 and 106).
  3. Install seal protector J-25011.
- Apply transmission fluid to all clutch seals before reassembly.**

4. Using a smooth flat edged small screwdriver or piston installing tool (Figure 7A6-135), install lo and reverse clutch piston, while rotating pushing down into place (Figure 7A6-106).



Figure 7A6-106 Installing Lo and Reverse Clutch Piston

5. Remove seal protector J-25011.
6. Install waved release spring (Figure 7A6-103).
7. Install retainer, cupped faced down (Figure 7A6-102).
8. Compress retainer and install snap ring (Figure 7A6-102).

**Installation**

1. Oil and install the lo and reverse clutch plates into case starting with a flat steel and alternating composition-faced and flat steel clutch plates. Next, install the waved steel plate on top of the last flat steel. (See Figure 7A6-101 and 107.)

2. Install lo and reverse clutch housing to case spacer ring in case (Figure 7A6-108).

3. Install lo and reverse clutch housing assembly aligning reverse clutch housing feed hole to reverse clutch case feed passage, using J-28542 (Figure 7A6-109). If the lo and reverse clutch housing does not seat past the case snap ring groove, proceed as follows:

**200-4R CLUTCH PLATE AND APPLY RING USAGE CHART**

MODEL	OVERRUN CLUTCH		FOURTH CLUTCH			DIRECT CLUTCH					
	FLAT STEEL PLATE	COMP. FACED PLATE	FLAT STEEL PLATE	COMP. FACED PLATE	FLAT STEEL PLATE	COMP. FACED PLATE	APPLY RING				
	No.	Thick-ness	No.	No.	Thick-ness	No.	No.	Thick-ness	No.	I.D.	Width
BM, EG, OG, CU, PH	2	1.969mm (.077")	2	3	1.969mm (.077")	2	6	2.324mm (.091")	6	9	12.5mm (.492")

FORWARD CLUTCH					LO & REV. CLUTCH								
WAVE PLATE	FLAT STEEL PLATE	COMP. FACED PLATE	APPLY RING	WAVE PLATE	FLAT STEEL PLATE	COMP. FACED PLATE	APPLY RING						
No.	Thick-ness	No.	I.D.	Width	No.	Thick-ness	No.	Thick-ness	No.	I.D.	Width		
1	1.585mm (.062")	3	1.969mm (.077")	4	8	12.5mm (.492")	1	1.969mm (.077")	7	1.969mm (.077")	6	0	13.13mm (.516")

Figure 7A6-107 Clutch Plate and Clutch Apply Ring Usage Chart

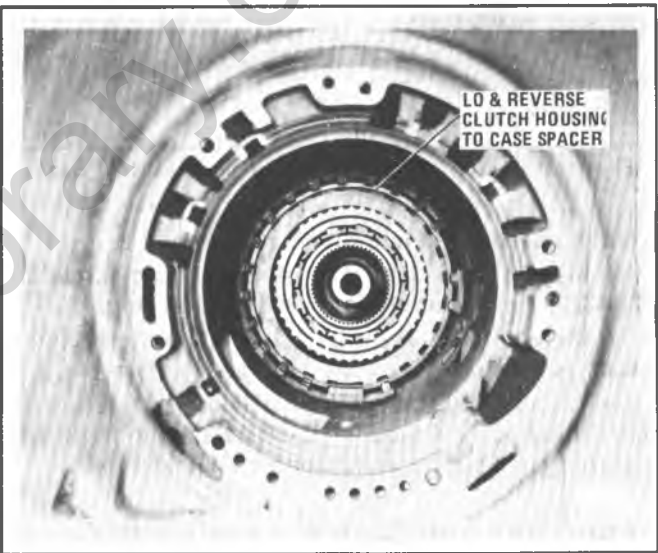

Figure 7A6-108 Proper Location of Lo and Reverse Housing to Case Spacer



Figure 7A6-109 Installing Lo and Reverse Clutch

- a. Remove tool J-28542.
- b. Using rear sun gear and input drum as a tool, install input drum and rear sun gear in case.
- c. Rotate rear sun gear back and forth, tapping lightly with input drum to align roller clutch race and lo and reverse clutch hub splines (Figure 7A6-110).

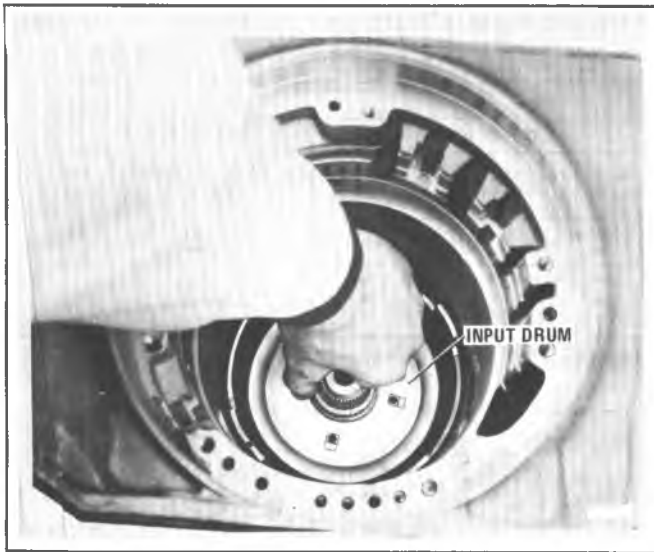

Figure 7A6-110 Installing Input Drum and Rear Sun Gear

- d. Remove tool (input drum and rear sun gear).
- It may be necessary to loosen adjusting screw on J-29332-1 on output shaft to install snap ring.
- e. Repeat the above steps if lo and reverse clutch housing is not fully seated past case snap ring groove.
  4. Install lo and reverse clutch housing to case snap ring, flat side against housing (beveled side up). Position snap ring gap on opposite side of parking pawl rod.

### Lo and Reverse Clutch Housing to Case Cup Plug and Seal (Figure 7A6-111)

1. Install new cup plug and seal assembly, with seal end first, into hole in case.
2. Using a 10 mm (3/8") diameter metal rod and hammer, drive cup plug and seal assembly until it seats against the lo and reverse clutch housing. (Figure 7A6-111)

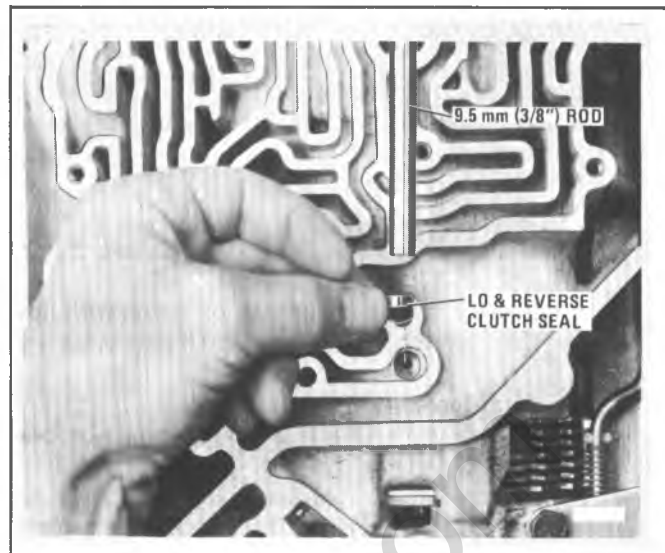

Figure 7A6-111 Installing Lo and Reverse Clutch Housing to Case Cup Plug and Seal

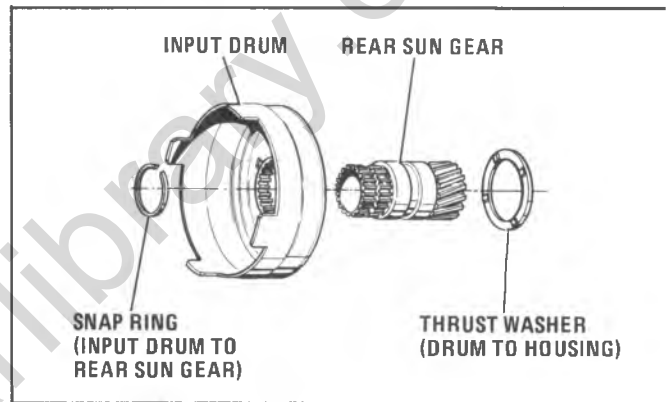

Figure 7A6-112 Rear Sun Gear and Input Drum

6. If damaged, replace rear sun gear to input drum snap ring.

### Reassembly

1. Install rear sun gear into input drum, spline side first, and retain with snap ring (Figure 7A6-112).
2. Install 4 tanged thrust washer on input drum over sun gear end; align tangs into input drum and retain with petrolatum (Figures 7A6-112 and 113).
3. Install rear sun gear and input drum assembly (Figure 7A6-110).

## FRONT GEAR PARTS

### Rear Sun Gear and Input Drum (Figure 7A6-112)

#### Inspection

1. Inspect rear sun gear for cracks, splits, damaged spline, worn gear or journals and plugged lubrication holes (Figure 7A6-112).
2. Inspect rear sun gear bushing for damage or scoring.
3. If necessary, remove input drum to rear sun gear snap ring and remove sun gear from input drum.
4. Inspect input drum for damage (Figure 7A6-112).
5. Inspect 4 tanged input drum to lo and reverse clutch housing thrust washer for scoring or distorted tangs (Figure 7A6-112).

### Front Sun Gear

1. Inspect front sun gear splines and teeth for damage or wear.
2. Inspect machined face for pitting, scoring or damage.
3. Install front sun gear face with the identification mark (groove) against input drum to rear sun gear snap ring (Figure 7A6-114). See Figure 7A6-115 for identification marks.
4. Thoroughly clean, air dry and inspect front sun gear to front carrier thrust race and thrust bearing for pitted or rough conditions.

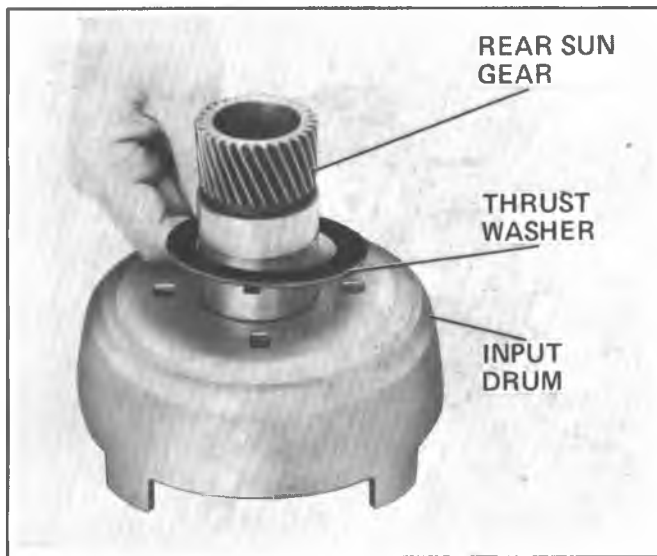

Figure 7A6-113 Installing Thrust Washer

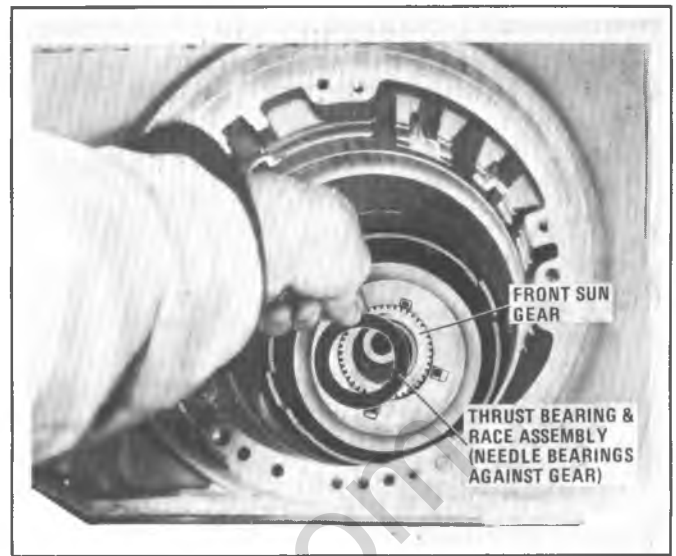

Figure 7A6-116 Installing Thrust Bearing Assembly Against Front Sun Gear

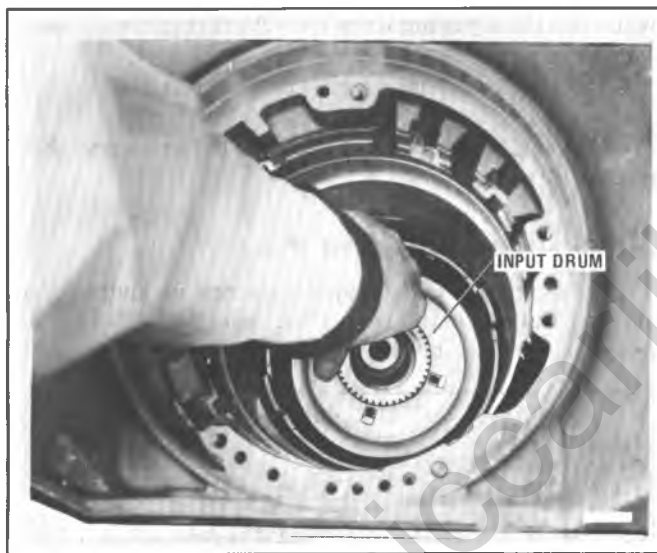

Figure 7A6-114 Installing Front Sun Gear

### Front Carrier Assembly

#### Inspection

1. Inspect front carrier for damage (Figure 7A6-117).

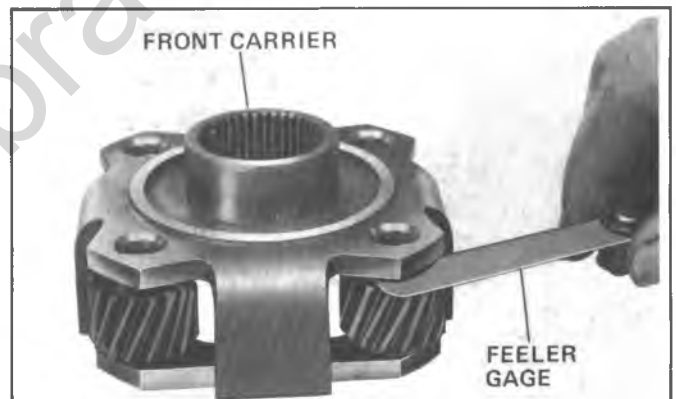

Figure 7A6-117 Checking Front Carrier Pinion End Play

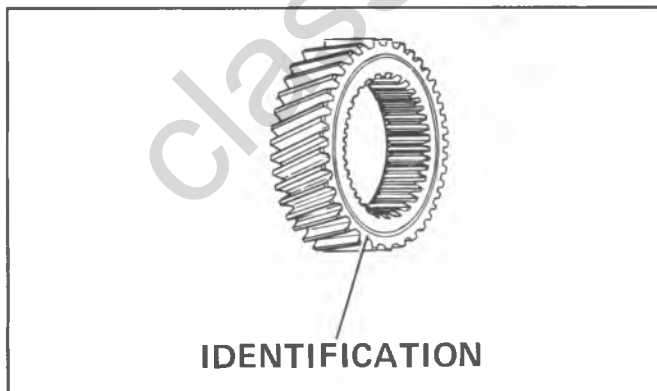

Figure 7A6-115 Front Sun Gear Identification

2. Inspect pinions for damage, rough bearings or tilt.
3. Check pinion end play. Pinion end play should be 0.24-.060 mm (.009"-.024") (Figure 7A6-117).

4. Thoroughly clean, air dry and inspect closely, front carrier to front internal gear thrust bearing assembly for pitted or rough conditions.

#### Reassembly

1. Install front carrier to front internal gear thrust bearing assembly by placing the smaller diameter race against the carrier. Retain with petrolatum (Figure 7A6-118).

2. Install front carrier and thrust bearing assembly (Figure 7A6-119).

5. Install front sun gear to front carrier thrust bearing and race assembly with thrust bearing against the front sun gear (Figure 7A6-116).

### Front Internal Gear and Selective Thrust Washer (Figure 7A6-120)

1. Inspect forward clutch hub for worn splines and for lubrication holes.

**This thrust bearing requires only 1 thrust race.**



Figure 7A6-118 Installing Thrust Bearing Assembly Onto Front Carrier

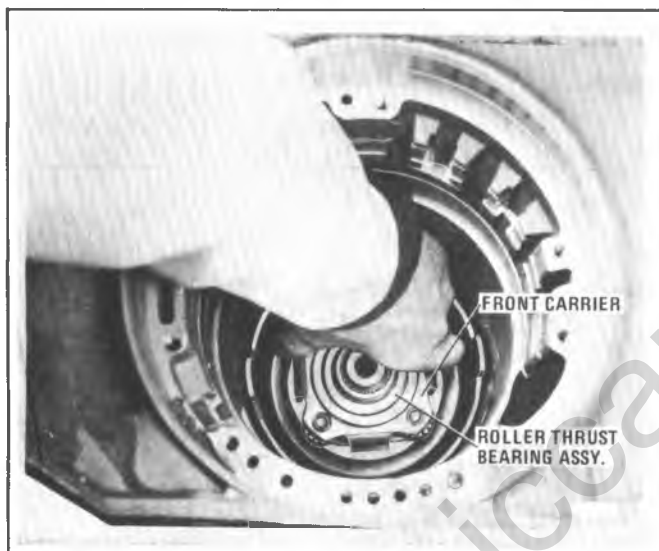

Figure 7A6-119 Installing Front Carrier and Roller Thrust Bearing

2. Inspect internal gear for cracks or damage.
3. Inspect gear teeth for excessive wear or damage.
4. Inspect bushing for damage or scoring.
5. Inspect thrust washer (front internal gear to selective washer) for scoring or damage.
6. Install thrust washer on front internal gear and retain with petrolatum (Figure 7A6-120).
7. Install front internal gear and thrust washer (Figure 7A6-120).

### Rear Selective Thrust Washer

1. Inspect selective washer for scoring or damage.  
**To retain rear selective thrust washer I.D., the rear selective thrust washer must be installed with the identification number toward the front of the transmission.**
  2. Install rear selective washer (Figure 7A6-120).
  3. Inspect output shaft to selective thrust washer snap ring for damage or distortion. Move output shaft upward

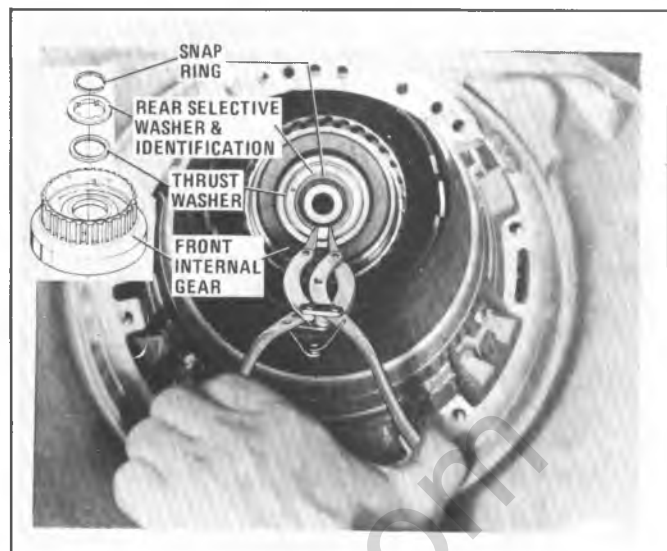

Figure 7A6-120 Installing Output Shaft to Selective Washer Snap Ring

by turning the adjusting screw on J-29332-1 to install output shaft to selective washer snap ring.

4. Install wide snap ring on output shaft (Figure 7A6-120).

**Make sure snap ring is fully seated in output shaft groove.**

### Check Rear Unit End Play

1. Loosen J-29332-1 adjusting screw on output shaft and push output shaft downward (Figure 7A6-121). Do not install clamp assembly on any machined case surfaces.

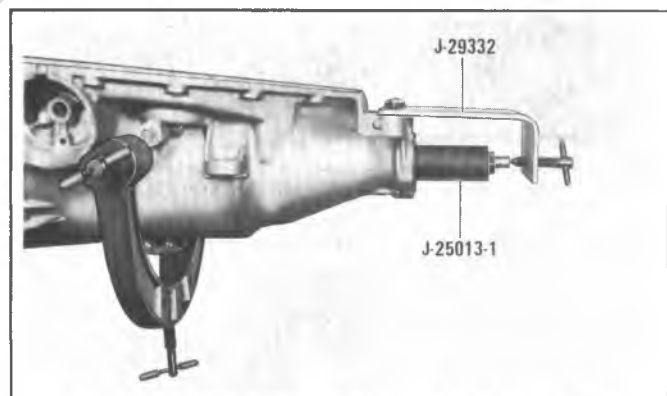

Figure 7A6-121 Installing Tools on Rear End of Case

2. Install gage clamp on case as shown (Figure 7A6-122).
3. Install dial indicator J-8001 and plunger extension J-7057. Position extension against end of output shaft and set dial indicator to zero (Figure 7A6-122).
4. Move output shaft upward by turning adjusting screw on J-29332-1 until the white or scribed line on sleeve J-25013 begins to disappear (Figure 7A6-121), and read end play. Rear unit end play should be 0.10-0.64 mm (.004"-.025").

**Selective washer controlling this play is located between the front internal gear thrust washer and output shaft snap ring. If more or less washer thickness**

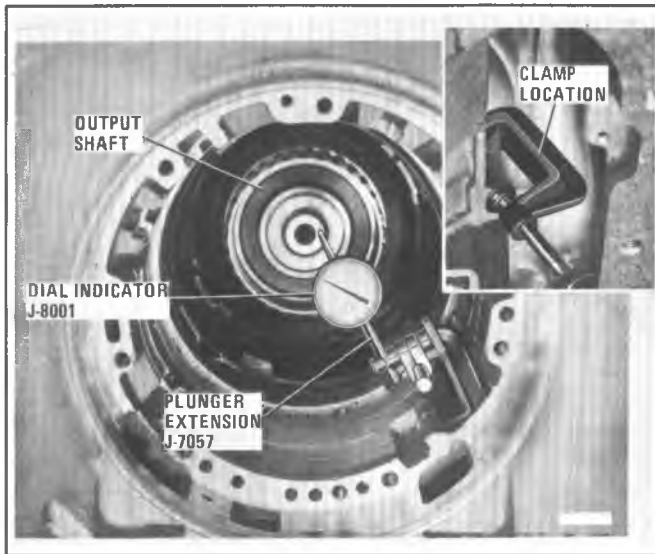

Figure 7A6-122 Checking Rear Unit End Play

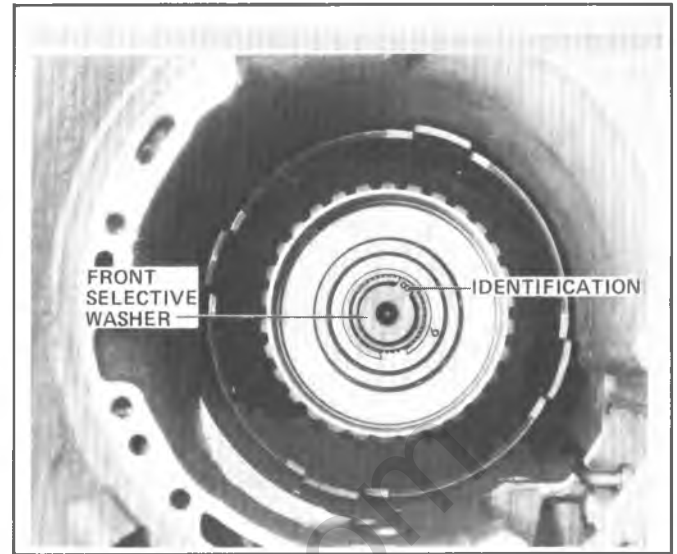

Figure 7A6-124 Location of Front Selective Washer

is required to bring end play within specifications, select proper washer from the Rear Unit End Play Washer Thickness Chart (Figure 7A6-123).

REAR UNIT END PLAY WASHER THICKNESS CHART		
THICKNESS		IDENTIFICATION NUMBER AND/OR COLOR
2.463 - 2.590 mm	(0.097" - 0.102")	0 - —
2.90 - 3.01 mm	(0.114" - 0.119")	1 - Orange
3.08 - 3.19 mm	(0.121" - 0.126")	2 - White
3.26 - 3.37 mm	(0.128" - 0.133")	3 - Yellow
3.44 - 3.55 mm	(0.135" - 0.140")	4 - Blue
3.62 - 3.73 mm	(0.143" - 0.147")	5 - Red
3.80 - 3.91 mm	(0.150" - 0.154")	6 - Brown
3.98 - 4.09 mm	(0.157" - 0.161")	7 - Green
4.16 - 4.27 mm	(0.164" - 0.168")	8 - Black
4.34 - 4.45 mm	(0.171" - 0.175")	9 - Purple

Figure 7A6-123 Rear Unit End Play Washer Thickness Chart

5. Remove dial indicator and clamp assembly (Figure 7A6-122).
6. Loosen J-29332-1 adjusting screw on output shaft.
7. Inspect output shaft to forward clutch shaft front selective thrust washer for damage or scoring.
8. Install output shaft to forward clutch shaft front selective thrust washer, locating in output shaft and retain with petrolatum (Figure 7A6-124).

## FRONT UNIT PARTS

### Direct Clutch Assembly (Figure 7A6-125)

1. Remove snap ring (Figure 7A6-126).
2. Remove the clutch backing plate from the direct clutch housing.
3. Remove the clutch plates from the direct clutch housing and keep them separated from the forward clutch plates (See Clutch Plate Usage Chart, Figure 7A6-107).
4. Inspect composition-faced plates and steel clutch plates for wear or burning.

5. Inspect clutch backing plate for scoring or other damage.
6. Using J-23327, compress retainer and spring assembly (Figure 7A6-127), remove snap ring and inspect for damage or distortion.
7. Remove J-23327.
8. Remove retainer and spring assembly from housing.
9. Inspect release spring retainer for being collapsed.
10. Inspect release springs for being collapsed.
11. Remove release spring guide and inspect for damage.
12. Remove direct clutch piston.
13. Remove outer and inner seals from direct clutch piston. (Figures 7A6-128 and 129).
14. Do not remove the clutch apply ring from the piston unless the piston or apply ring requires replacement.

**See 200-4R Clutch Plate and Clutch Apply Ring Usage Chart for Apply Ring Identification, (Figure 7A6-107).**

15. Inspect direct clutch piston assembly for distortion, cracks, or other damage.
16. Check for free operation of check ball in the direct clutch housing and direct clutch piston. If damaged, replace the check ball assembly in the following manner:
  - a. Remove the check ball assembly, using a 10 mm (3/8") diameter rod as a punch.
  - b. Place new check ball assembly in check ball hole. Using a 10 mm (3/8") diameter rod, drive check ball down until it bottoms.
17. Remove center seal from direct clutch housing (Figure 7A6-130).
18. Inspect direct clutch housing for cracks, wear and open oil passages.
19. Check for free operation of check balls.
20. Inspect direct clutch housing snap ring grooves for damage.
21. Inspect direct clutch bushings for damage or scoring.

### Reassembly

1. Install clutch apply ring on piston.

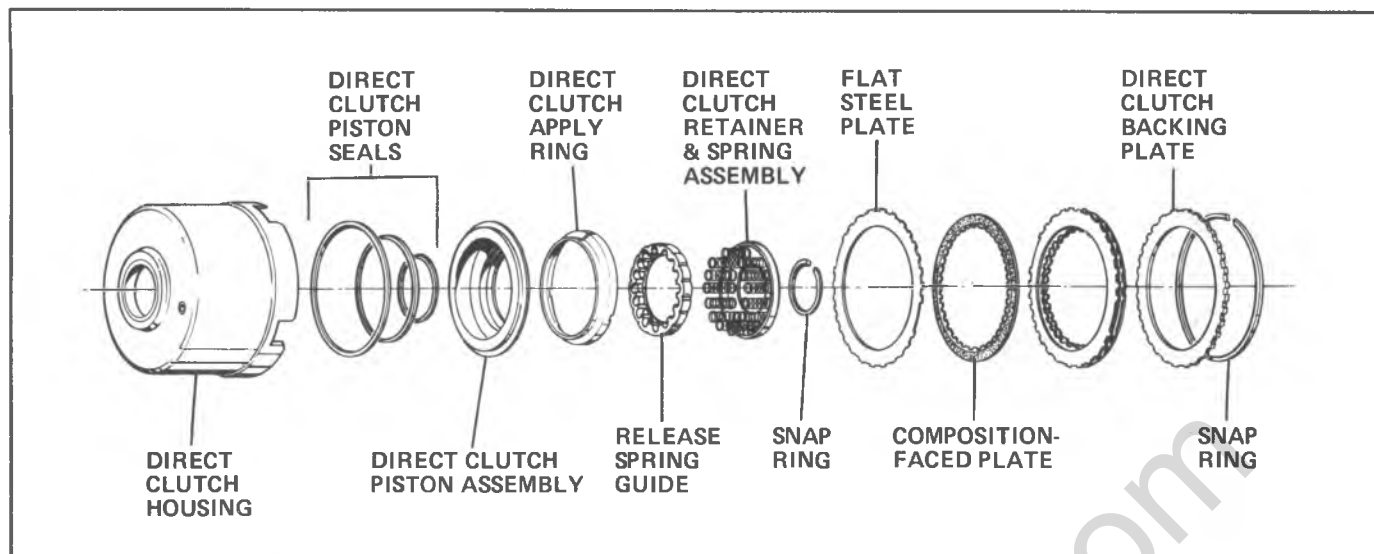

Figure 7A6-125 Direct Clutch Assembly - Exploded

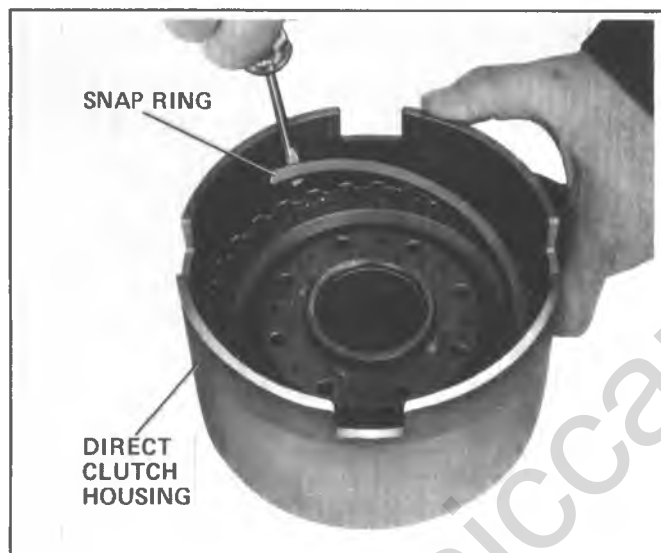

Figure 7A6-126 Removing Direct Clutch Snap Ring

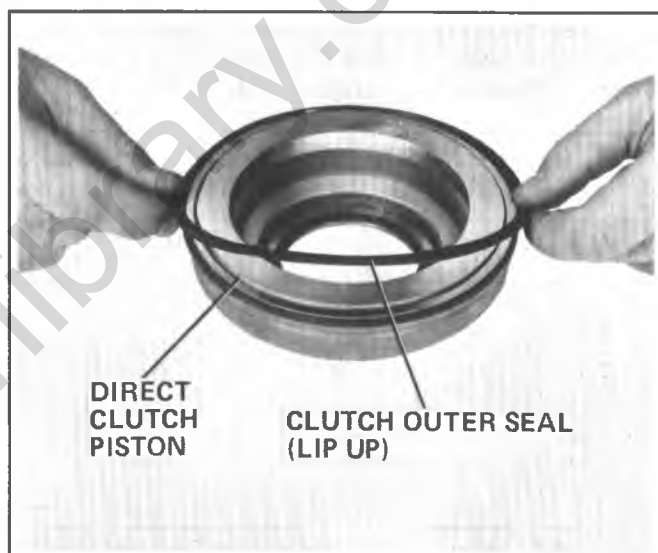

Figure 7A6-128 Removing or Installing Direct Clutch Piston Outer Seal

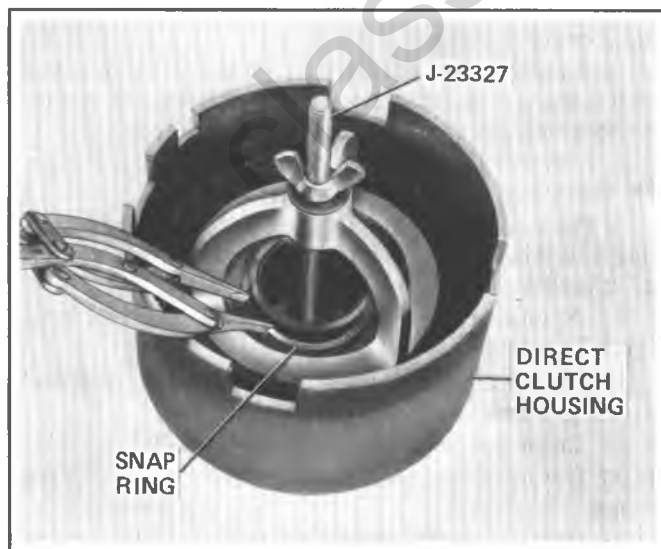

Figure 7A6-127 Removing Direct Clutch Inner Snap Ring

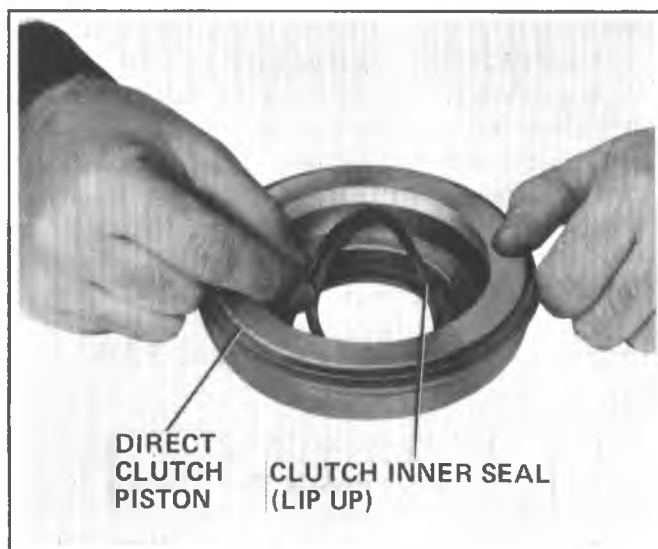

Figure 7A6-129 Removing or Installing Direct Clutch Piston Inner Seal





Figure 7A6-130 Removing or Installing Center Seal on Direct Clutch Housing

2. Install new outer and inner seals on piston with lips facing away from clutch apply ring side (Figures 7A6-128 and 129).
3. Install new center seal on direct clutch housing with lip facing up (Figure 7A6-130).
4. Install seal protector J-25010 (Figure 7A6-131).

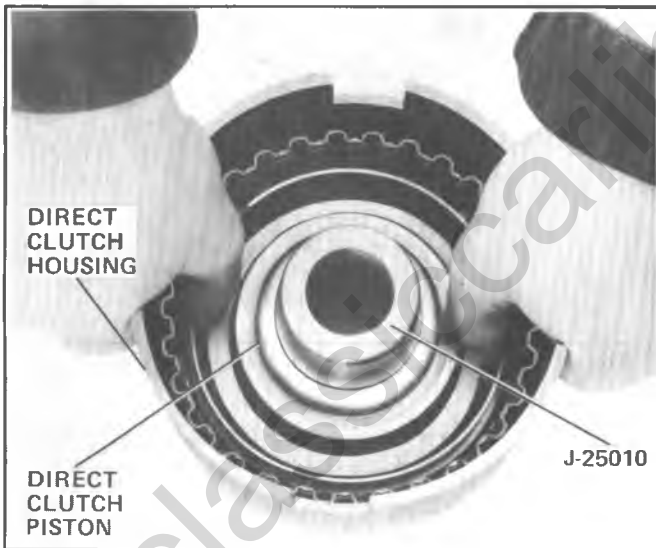

Figure 7A6-131 Installing Direct Clutch Piston

**NOTICE:** Use care when installing direct clutch piston past larger direct clutch snap ring groove. Groove could cut outer seal on piston.

5. Oil the seals and install direct clutch piston (Figure 7A6-131).

To make the piston easier to install, insert tool between seal and housing; rotate tool around the housing to compress the lip of the seal while pushing down slightly on the piston. See tool, Figure 7A6-132 and tool being used on a forward clutch piston (Figure 7A6-133).

6. Remove seal protector J-25010.

7. Install release spring guide with the omitted rib over the check ball in the piston as shown in Figure 7A6-134.
8. Install retainer and spring assembly.

**NOTICE:** Retainer could catch in the snap ring groove. Forcing the retainer to compress the springs while in this groove could damage the retainer plate.

9. Using J-23327 tool, compress retainer and spring assembly past the snap ring groove. Install the snap ring (Figure 7A6-127). An arbor press and J-23327 can be used to compress the retainer and spring assembly.
  10. Remove J-23327 and/or J-6129.
  11. Oil and install the direct clutch plates into the direct clutch housing, starting with a flat steel and alternating composition-faced and flat steel clutch plates (See Figure 7A6-135 and Clutch Plate Usage Chart, Figure 7A6-107).
  12. Install backing plate, micro finish down.
  13. Install snap ring (Figure 7A6-126).
- Make sure composition clutch plates turn freely.**
14. Set direct clutch assembly aside.

### Forward Clutch Housing Assembly (Figure 7A6-139)

#### Inspection

1. Inspect teflon oil seals on forward clutch shaft for damage and free fit in grooves. Do not remove unless replacing.
2. Remove and inspect forward clutch to direct clutch thrust washer for damage (Figure 7A6-137)
3. Place forward clutch down with forward clutch shaft through hole in work bench.
4. Remove snap ring and inspect for damage (Figure 7A6-138).
5. Remove backing plate from the forward clutch housing.
6. Remove the clutch plates from the forward clutch housing and keep them separated from the direct clutch plates (See Clutch Plate Usage Chart, Figure 7A6-107).
7. Inspect composition-faced and steel clutch plates for signs of wear or burning.
8. Inspect backing plate for scratches or damage.
9. Using tools J-25018, J-25024 and J-23327-1 compress retainer and spring assembly and remove snap ring (Figure 7A6-139). An arbor press and tools J-25018 and J-23327-1 can be used to compress the retainer and spring assembly.
10. Remove J-23327-1, J-25024 and J-25018.
11. Remove retainer and spring assembly from housing.
12. Inspect release spring retainer for distortion.
13. Inspect release springs for being collapsed.
14. Remove forward clutch piston.
15. Remove forward clutch outer and inner piston seals (Figures 7A6-140 and 141).
16. Do not remove the clutch apply ring from the piston unless the piston or apply ring requires replacement.
17. Inspect the forward clutch piston and clutch apply ring assembly for cracks or damage.

**See the 200-4R Clutch Plate and Apply Ring Usage Chart for apply ring identification, (Figure 7A6-107).**

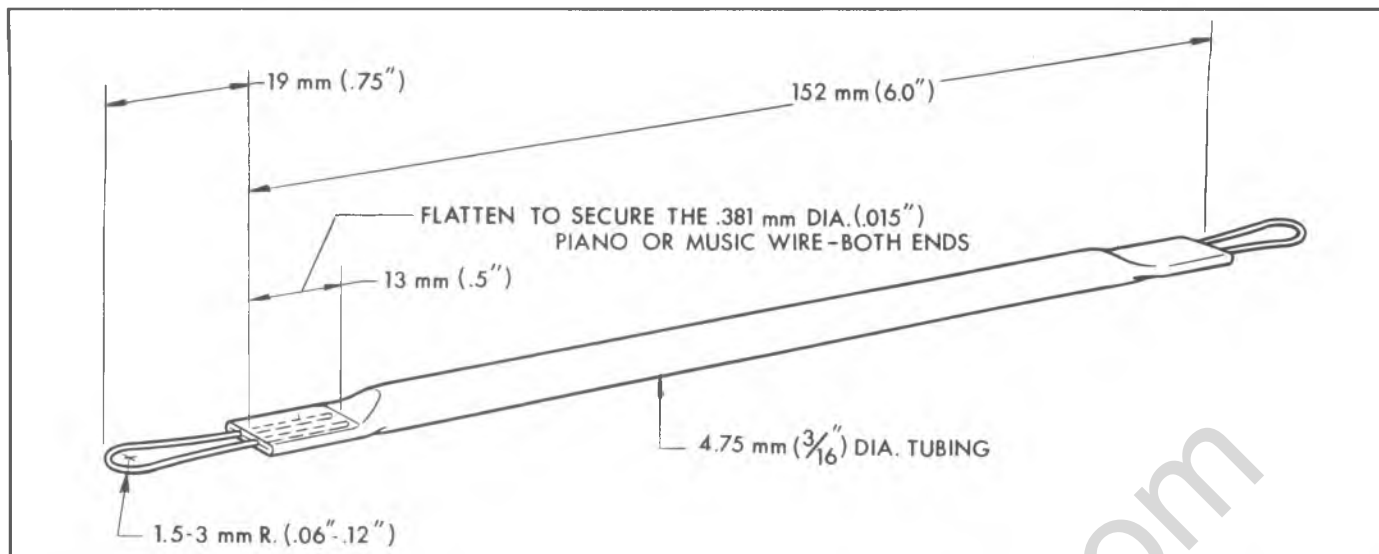

Figure 7A6-132 Piston Installing Tool

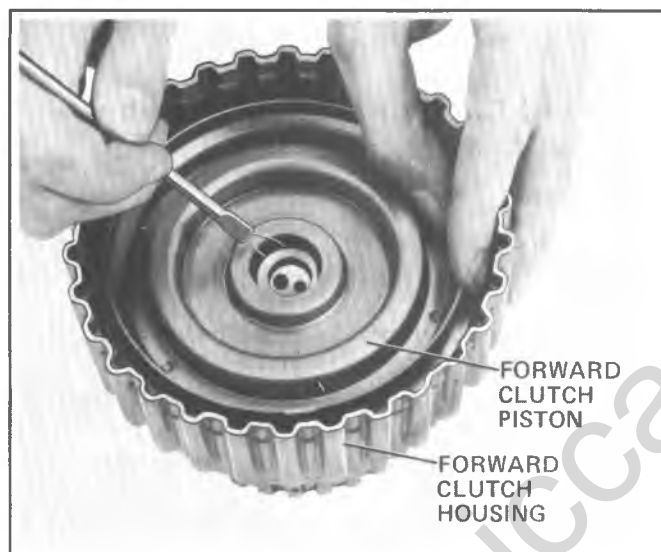

Figure 7A6-133 Installing Direct Clutch Piston

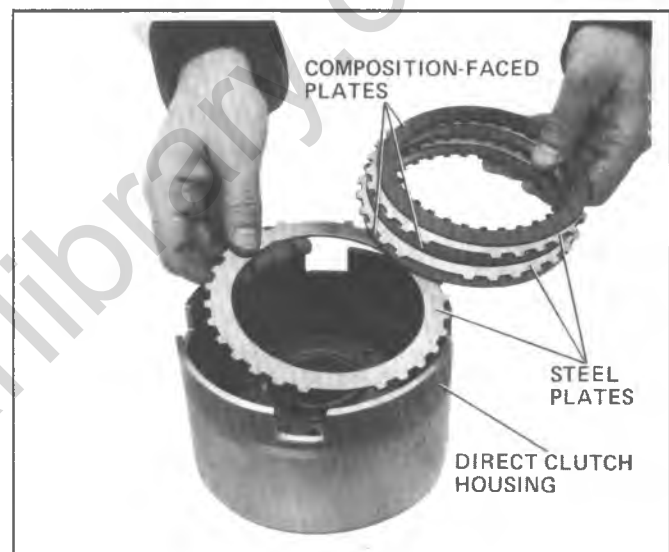

Figure 7A6-135 Installing Clutch Plates into Direct Clutch Housing

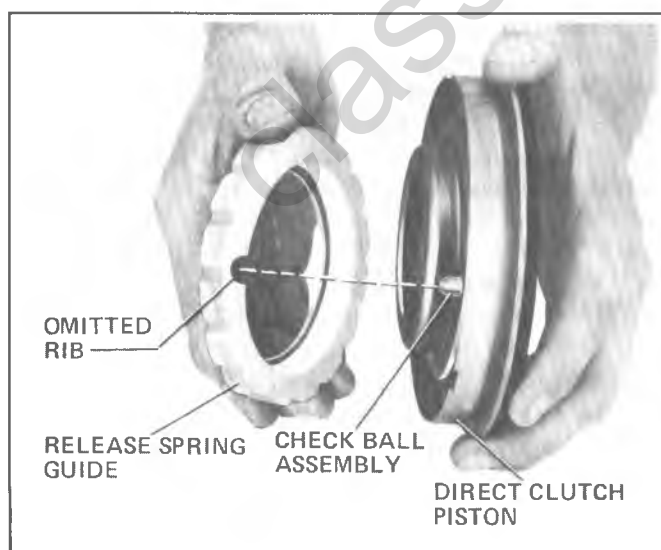

Figure 7A6-134 Installing Release Spring Guide

18. Inspect forward clutch housing for cracks, opened oil passages or other damage.

19. Check for free operation of check ball in forward clutch housing. If damaged, replace the check ball assembly as follows:

a. Remove the check ball assembly, using a 10 mm (3/8") diameter rod as a punch.

b. Place new check ball assembly in check ball hole. Using a 10 mm (3/8") diameter rod, drive check ball down until it bottoms.

20. Inspect forward clutch housing snap ring groove for damage or burrs.

21. Inspect forward clutch shaft for open oil passages on both ends of shaft and journals for damage.

22. Inspect cup plug for damage (Figure 7A6-142). If cup plug is damaged or missing, proceed as follows:

a. Use 4 mm (#3) easy out (grind to fit) and remove cup plug.

b. Install new cup plug to 1.0 mm (.039") below surface.

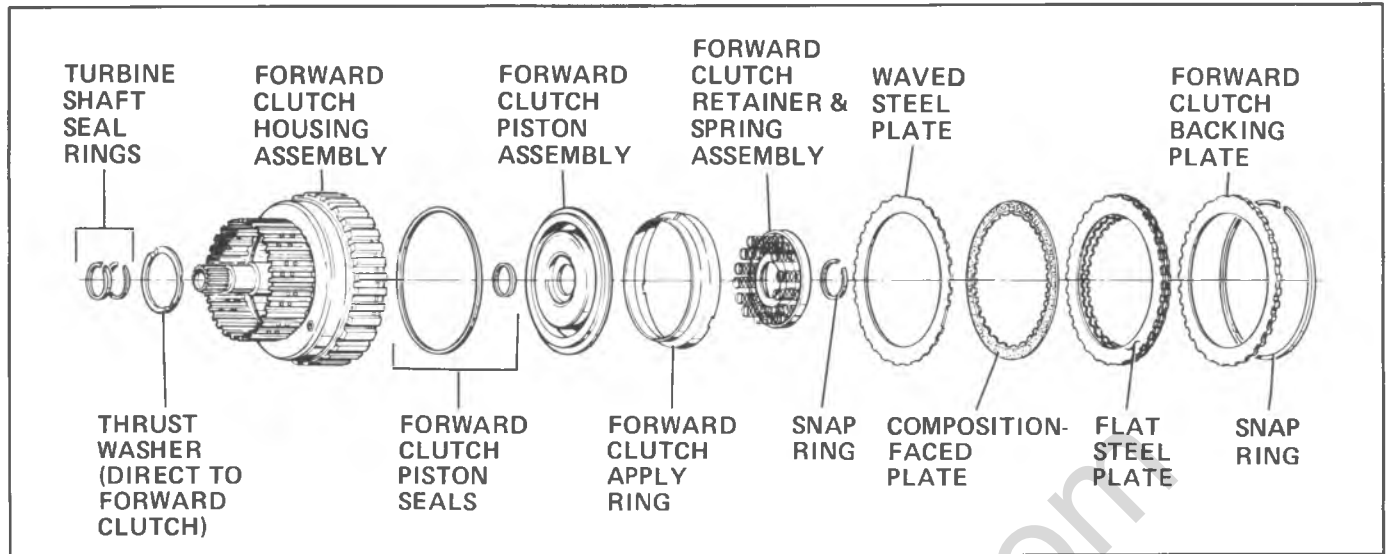

Figure 7A6-136 Forward Clutch Assembly - Exploded View

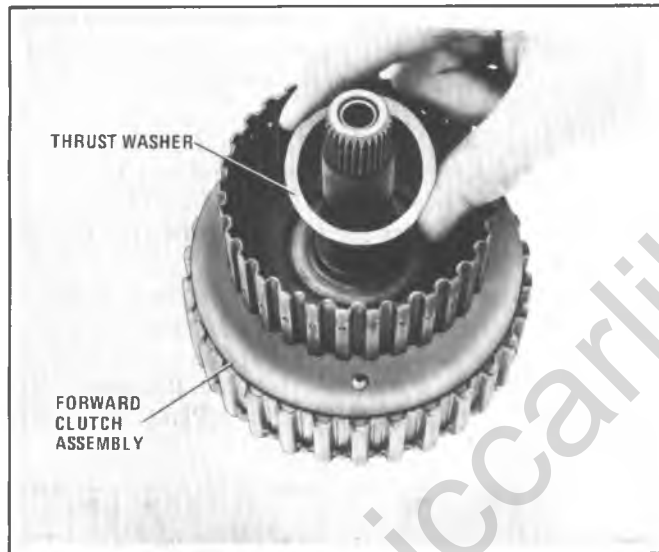

Figure 7A6-137 Removing Forward Clutch to Direct Clutch Thrust Washer

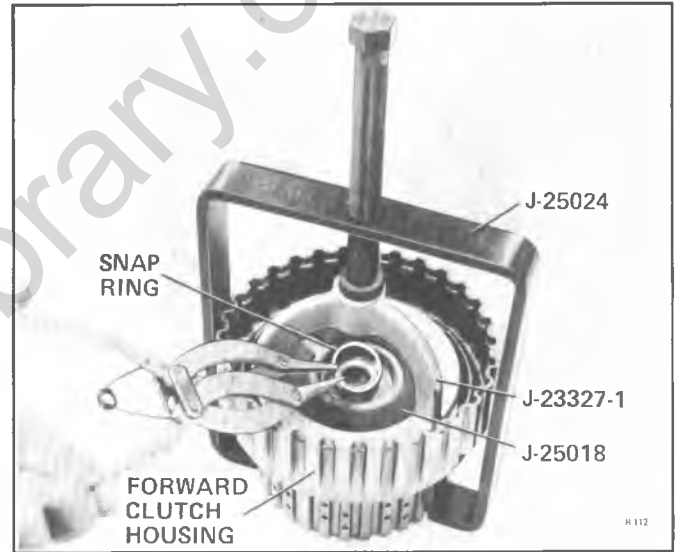

Figure 7A6-139 Removing Forward Clutch Release Spring Snap Ring

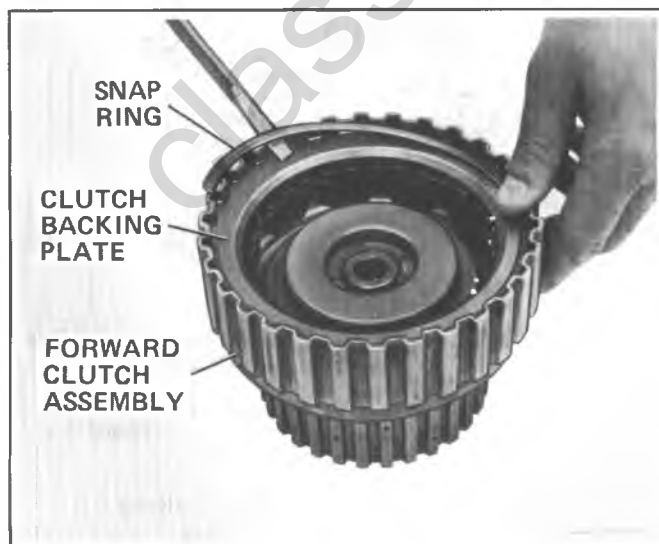

Figure 7A6-138 Removing Snap Ring from Forward Clutch Housing

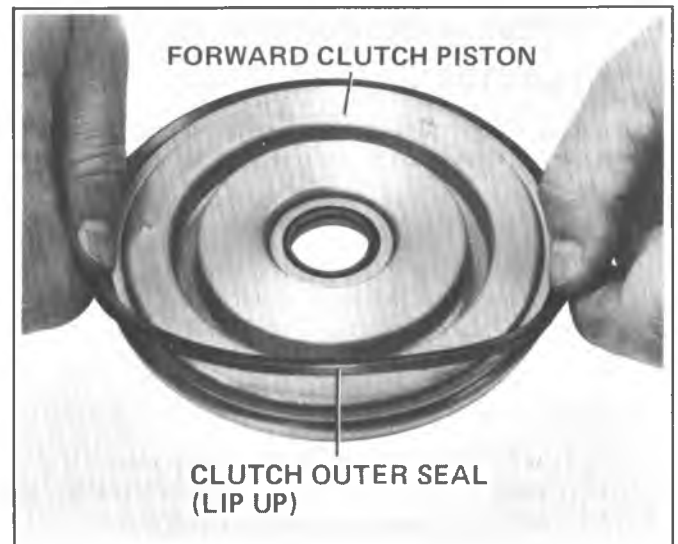

Figure 7A6-140 Removing or Installing Outer Piston Seal



Figure 7A6-141 Removing or Installing Inner Piston Seal

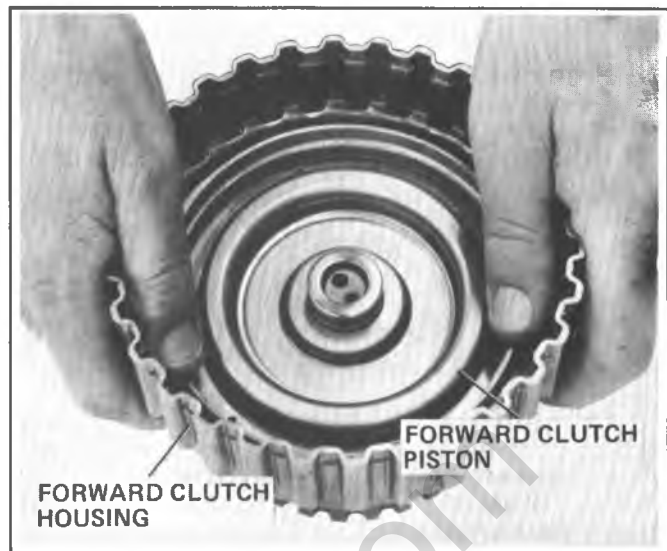

Figure 7A6-143 Installing Forward Clutch Piston

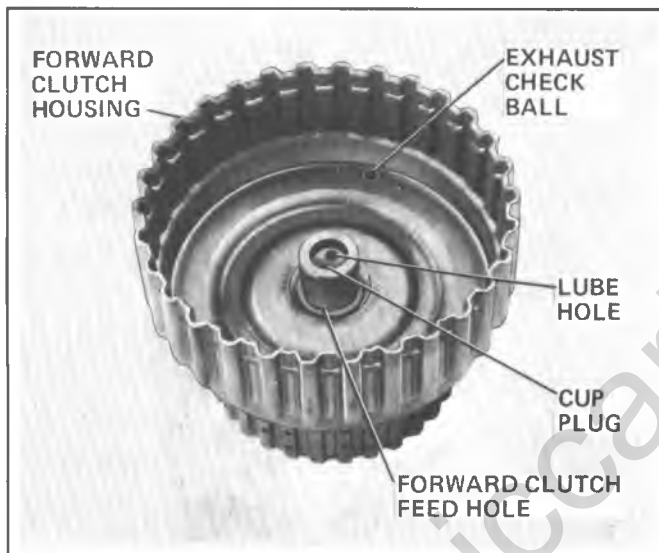

Figure 7A6-142 Forward Clutch Housing

**Reassembly**

1. Install clutch apply ring on piston.
2. Install new outer and inner seals on piston with lips facing away from clutch apply ring side. (Figures 7A6-140 and 141).

**NOTICE:** Use care when installing forward clutch piston past large forward clutch snap ring groove. Groove could cut outer seal on piston.

3. Lubricate seals and install forward clutch piston.

To make the piston easier to install, insert tool J-26744-A between the inner seal and shaft; rotate tool around the shaft to compress the lip of the seal, while pushing down slightly on the piston. Use the same procedure between the outer seal and the housing. Refer to Figure 7A6-143.

4. Install retainer and spring assembly.

**NOTICE:** Retainer could catch in the snap ring groove. Forcing the retainer to compress the springs while in this groove could damage the retainer plate.

5. Using J-23327-1, J-25024 and J-25018-4 adapter, compress retainer past snap ring groove and install snap ring. An arbor press and J-23327-1 and J-25018 can be used to compress the retainer and spring assembly (Figure 7A6-139).

6. Remove J-23327-1, J-25018-4 and/or J-25018.

7. Oil and install the forward clutch plates into the forward clutch housing, starting with the waved steel plate and alternating composition-faced and flat steel clutch plates (See Figure 7A6-144 and Clutch Plate Usage Chart, Figure 7A6-107).



Figure 7A6-144 Installing Clutch Plates Into Forward Clutch Housing

8. Install backing plate, micro finish down.

9. Install snap ring (Figure 7A6-138).

**Make sure composition clutch plates turn freely.**

10. Install forward to direct clutch thrust washer and retain with petrolatum (Figure 7A6-137).

11. If removed, install new forward clutch shaft seal rings, making sure cut ends are assembled in the same relationship as cut and rings are seated in their groove and retain with petrolatum (See Figure 7A6-145 for correct way to position cut ends).

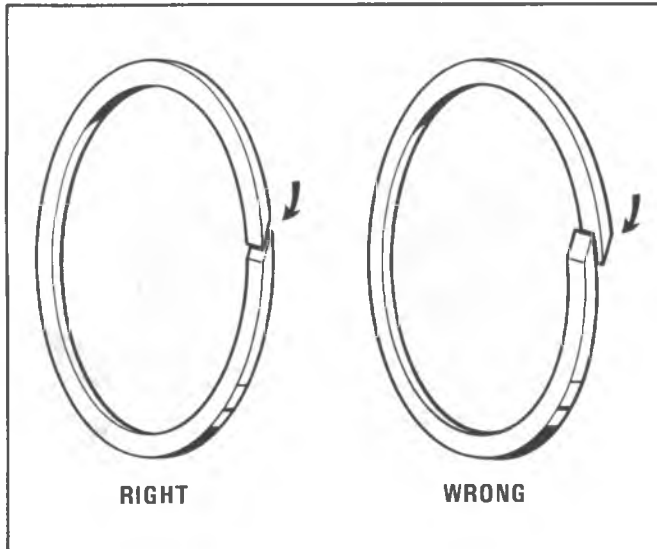

Figure 7A6-145 Teflon Oil Seal Rings

### Intermediate Band Assembly

1. Inspect band for burning, flaking or damage.
2. Install intermediate band, locating band apply lug and anchor pin lug in case slots (Figure 7A6-145).
3. Install band anchor pin (Figure 7A6-147).



Figure 7A6-146 Installing Intermediate Band Assembly

### Forward and Direct Clutch

#### Installation

1. Position direct clutch assembly, clutch plate end up, over hole in bench.

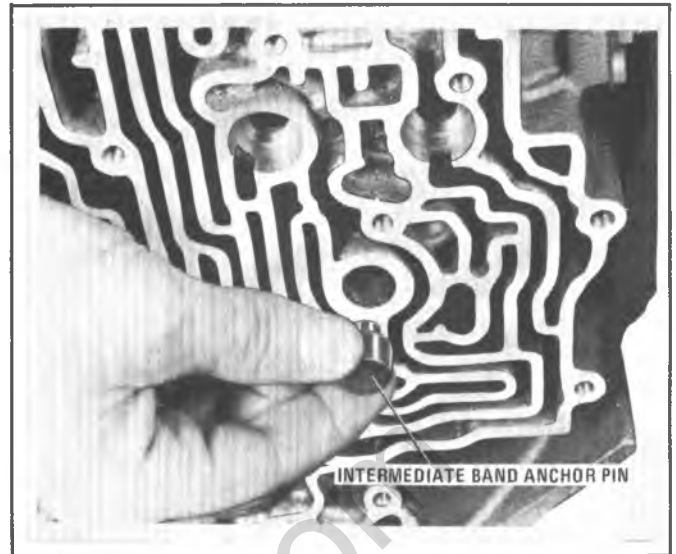

Figure 7A6-147 Installing Band Anchor Pin

Align direct clutch composition-faced clutch plate teeth one above the other to make the forward clutch assembly easier to install.

2. Install forward clutch assembly, shaft first, into direct clutch. Hold direct clutch housing and rotate forward clutch back and forth until the forward clutch is seated (Figure 7A6-148).

When the forward clutch is seated, it will be approximately 15.8 mm (5/8") from the tang end of the direct clutch housing to the end of the forward clutch drum, (Figure 7A6-149).

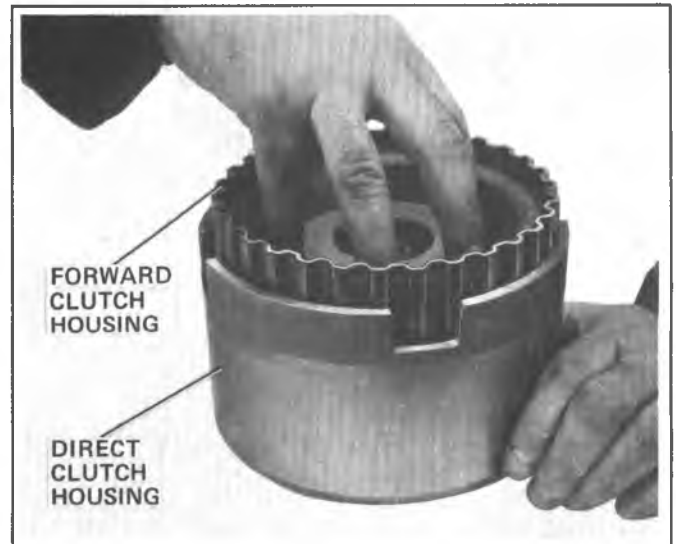

Figure 7A6-148 Installing Forward Clutch Assembly

3. Grasp direct and forward clutch assemblies to prevent their separation and position on bench, with the forward clutch shaft up.

4. Install J-29337 as shown in (Figure 7A6-150).

5. Install direct and forward clutch assemblies using J-29337 and rotate into position (Figure 7A6-150).

The direct clutch housing will be approximately 105 mm (4 1/8") from the pump face in case when correctly seated (see Figure 7A6-151).

6. Remove J-29337.

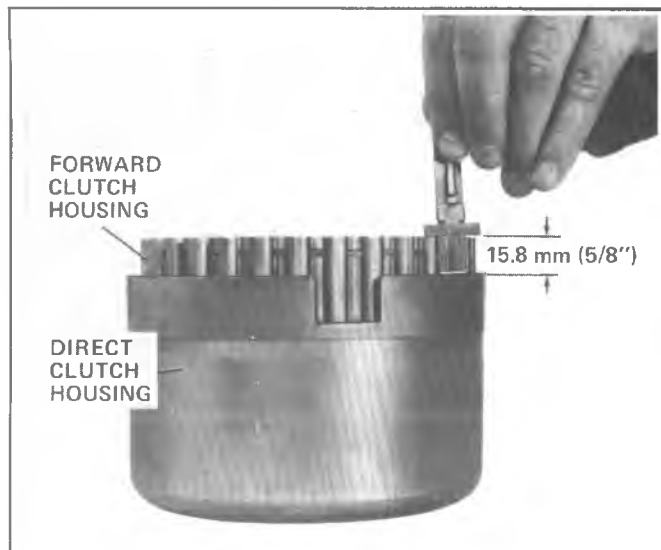

Figure 7A6-149 Forward Clutch Properly Seated in Direct Clutch

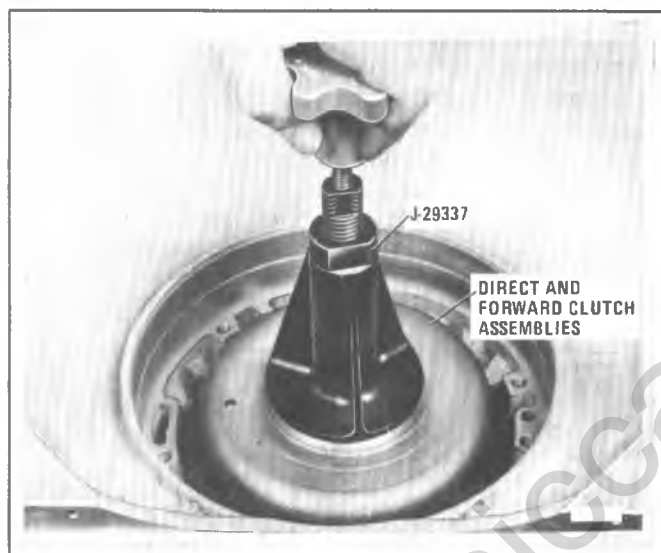

Figure 7A6-150 Installing Direct and Forward Clutch Assemblies

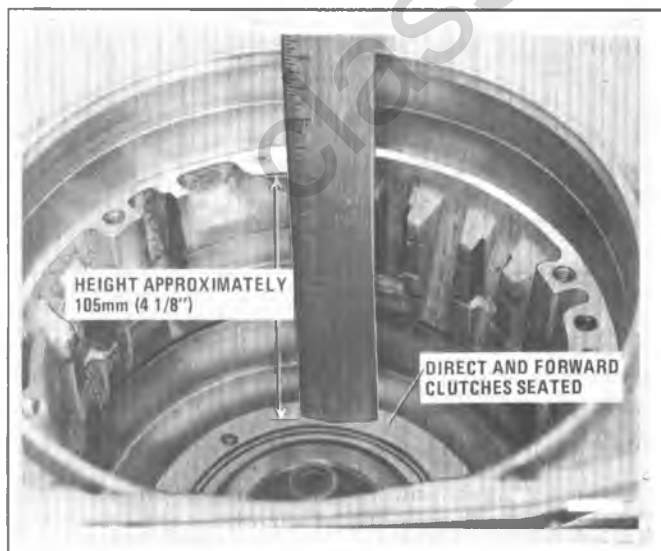

Figure 7A6-151 Direct and Forward Clutch Assemblies Properly Installed

## CENTER SUPPORT

### Disassembly

1. Remove fourth clutch inner and outer seals (Figures 7A6-152 and 153).



Figure 7A6-152 Removing Fourth Clutch Inner Seal

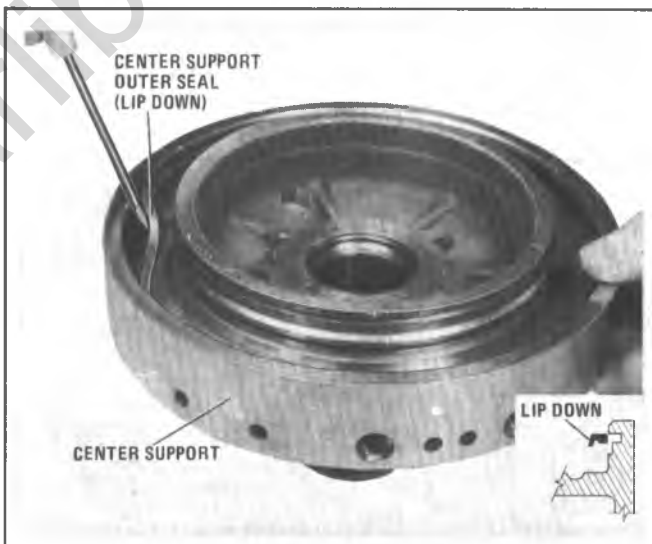

Figure 7A6-153 Removing Fourth Clutch Outer Seal

2. Check condition of cast iron oil rings then remove from center support if necessary (Figure 7A6-154).

### Inspection

1. Inspect bushings for scoring, wear or galling.
2. Check oil ring grooves and oil rings for nicks or other damages.
3. Air check oil passages to be sure they are open and are not interconnected.
4. Inspect the piston sealing surfaces for scratches.
5. Inspect the support for cracks or porosity.

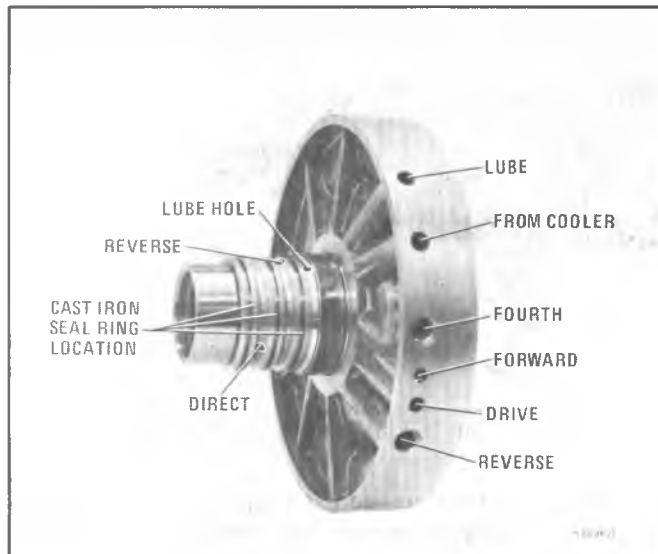

Figure 7A6-154 Location of Cast Iron Seals on Center Support

6. Inspect support for burrs or raised edges. If present, remove with fine stone or fine abrasive paper.

**Reassembly**

If removed, install the cast iron oil seal rings on the center support (Figure 7A6-154).

**NOTICE:** When installing cast iron oil seal rings, make sure the ends overlap and interlock. Make sure ends are flush with each other when interlocked (Figure 7A6-155), and oil seal rings are seated in ring grooves to prevent damage to rings during reassembly of mating parts over rings. Apply petrolatum to oil seal rings.

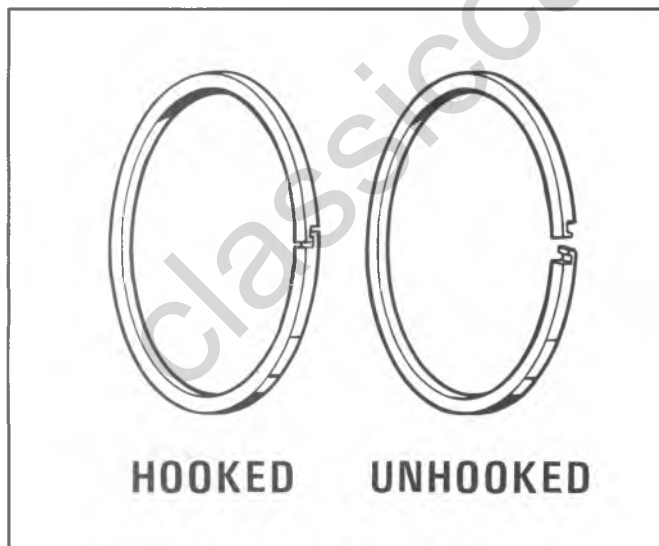

Figure 7A6-155 Cast Iron Oil Seal Rings

2. Install center support to direct clutch thrust washer (Figure 7A6-156).

3. Visually align center support with case bolt holes and install center support (Figure 7A6-157).

4. Install two (2) center support to case retaining bolts with a 10 mm socket (Figure 7A6-158). Do not tighten or torque.



Figure 7A6-156 Installing Center Support to Direct Clutch Thrust Washer



Figure 7A6-157 Installing Center Support

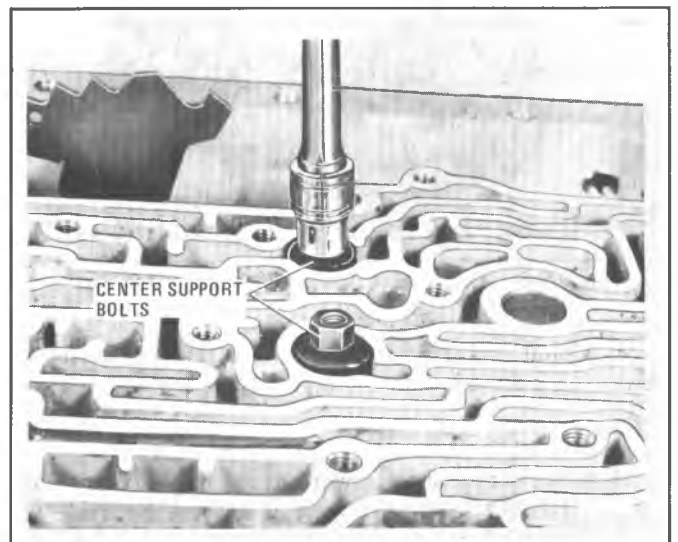

Figure 7A6-158 Installing Center Support Retaining Bolts



Figure 7A6-159 Installing Center Support Snap Ring

5. Install center support to case snap ring with beveled side up (Figure 7A6-159).

6. Torque center support retaining bolts to 24 N·m (18 lbs.) (Figure 7A6-158).

**Check Front Unit Play (Figure 7A6-160)**

a. Push forward clutch shaft downward.

b. Install J-29337 in end of forward clutch shaft (Figure 7A6-160).



Figure 7A6-160 Installing Tool in Forward Clutch Shaft

c. Mount dial indicator and clamp assembly on bolt, positioning indicator point on top of J-29337 (Figure 7A6-160).

d. Move output shaft upward by turning the adjusting screw on J-29332-1 until the white or scribed line on sleeve J-25013-1 begins to disappear (Figure 7A6-161), then set dial indicator to zero.

e. Pull J-29337 upward and read end play. Front unit end play should be 0.56 mm-1.30 mm (.022"-.051").



Figure 7A6-161 Tools on Rear End of Case

Selective washer controlling this end play is located between the output shaft and forward clutch shaft. If more or less washer thickness is required to bring end play within specifications, select proper washer from chart (Figure 7A6-162).

FRONT UNIT END PLAY WASHER THICKNESS CHART		
THICKNESS		IDENTIFICATION NUMBER AND/OR COLOR
1.66 - 1.77 mm	(0.065" - 0.070")	1 - —
1.79 - 1.90 mm	(0.070" - 0.075")	2 - —
1.92 - 2.03 mm	(0.076" - 0.080")	3 - Black
2.05 - 2.16 mm	(0.081" - 0.085")	4 - Light Green
2.18 - 2.29 mm	(0.086" - 0.090")	5 - Scarlet
2.31 - 2.42 mm	(0.091" - 0.095")	6 - Purple
2.44 - 2.55 mm	(0.096" - 0.100")	7 - Cocoa Brown
2.57 - 2.68 mm	(0.101" - 0.106")	8 - Orange
2.70 - 2.81 mm	(0.106" - 0.111")	9 - Yellow
2.83 - 2.94 mm	(0.111" - 0.116")	10 - Light Blue
2.96 - 3.07 mm	(0.117" - 0.121")	11 - —
3.09 - 3.20 mm	(0.122" - 0.126")	12 - —
3.22 - 3.33 mm	(0.127" - 0.131")	13 - Pink
3.35 - 3.46 mm	(0.132" - 0.136")	14 - Green
3.48 - 3.59 mm	(0.137" - 0.141")	15 - Gray

Figure 7A6-162 Front Unit End Play Washer Thickness Chart

f. Remove dial indicator, clamp assembly and J-29337.

**OVERDRIVE UNIT PARTS**

**Fourth Clutch Assembly**

**Inspection**

1. Inspect snap rings for damage.
2. Inspect fourth clutch piston for cracks or damage.
3. Inspect release spring and retainer assembly for distortion or damage.
4. Inspect composition-faced and steel clutch plates for signs of wear or burning.
5. Inspect backing plate for scratches or damage.

**Reassembly**

1. Install fourth clutch outer and inner seals on center support with lips facing down (Figure 7A6-163 and Figure 7A6-164). Apply petrolatum.

The center support inner seal is identified by a white stripe.



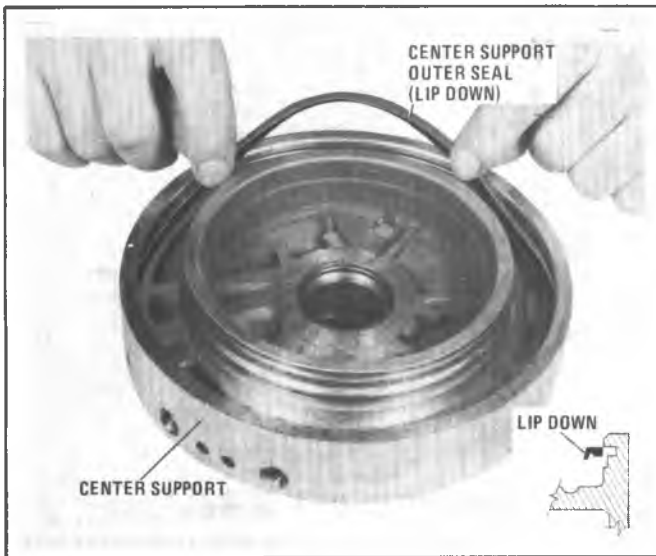

Figure 7A6-163 Installing Fourth Clutch Outer Seal

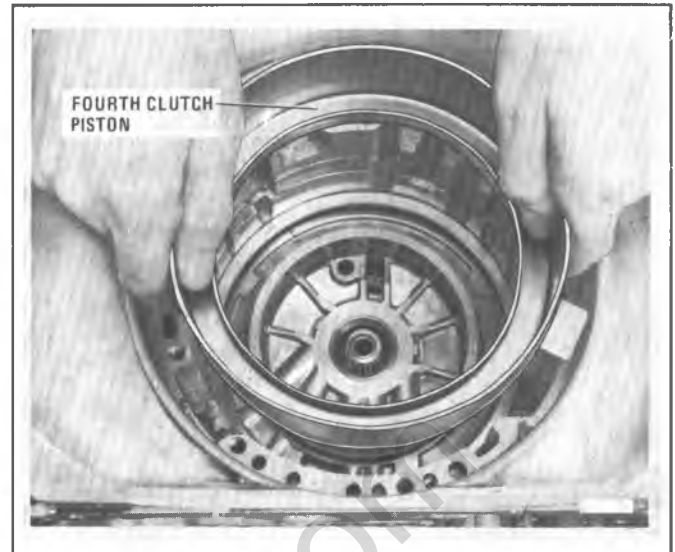

Figure 7A6-165 Installing Fourth Clutch Piston

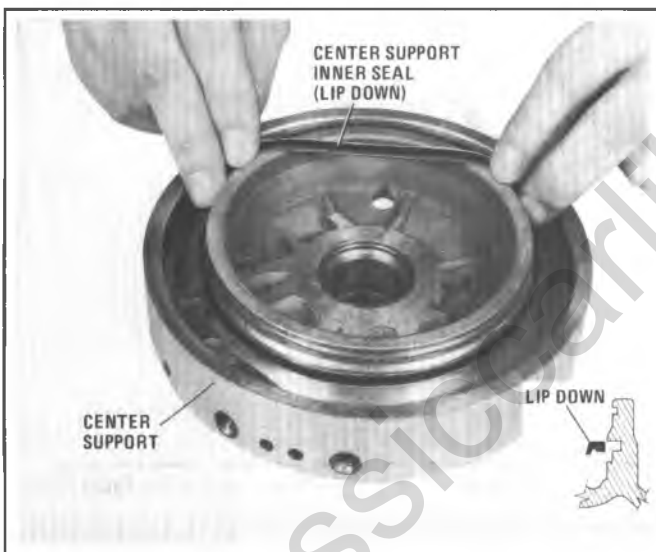

Figure 7A6-164 Installing Fourth Clutch Inner Seal

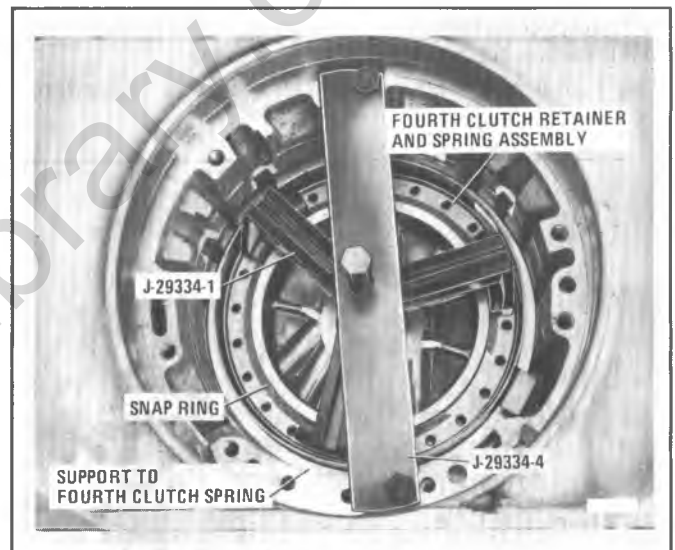

Figure 7A6-166 Installing Tools on Fourth Clutch Spring Assembly and Case

2. Install fourth clutch piston, aligning piston tab with wide case spline (Figure 7A6-165).
3. Install fourth clutch spring and retainer assembly on piston.
4. Install J-29334-1 on fourth clutch spring and retainer assembly (Figure 7A6-166).
5. Install J-29334-4 on case housing using two (2) governor cover to case bolts (Figure 7A6-166).
6. Compress fourth clutch spring and retainer assembly and install support to fourth clutch spring snap ring (Figure 7A6-167).

### Overdrive Internal Gear

1. Thoroughly clean, air dry and inspect closely, the internal gear to support thrust washer.
2. Install internal gear to support thrust washer by placing tangs down (Figure 7A6-168).

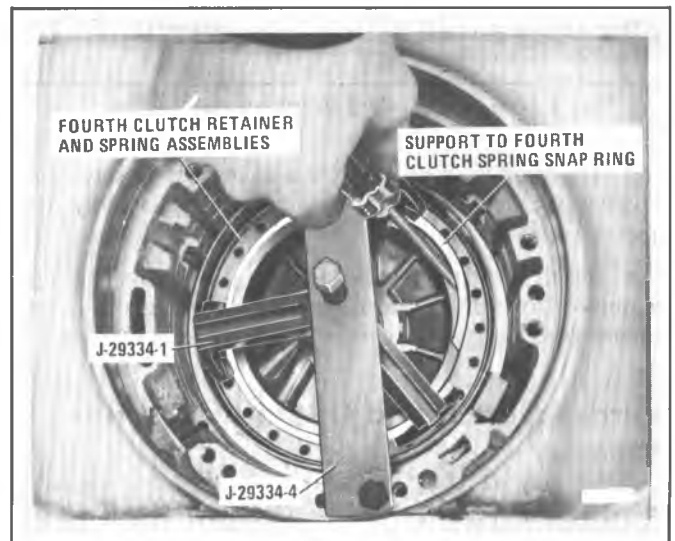

Figure 7A6-167 Installing Fourth Clutch Snap Ring



Figure 7A6-168 Installing Overdrive Internal Gear to Center Support Thrust Washer

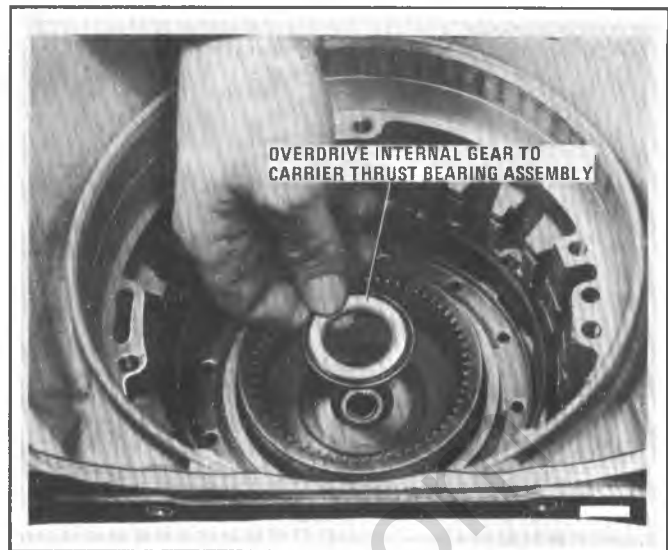

Figure 7A6-170 Installing Overdrive Carrier to Sun Gear Thrust Washer

3. Inspect overdrive internal gear, splines, teeth and bearing surface for wear, cracks, or damage.
4. Install rear internal gear hub end first, on forward clutch shaft as shown (Figure 7A6-169).

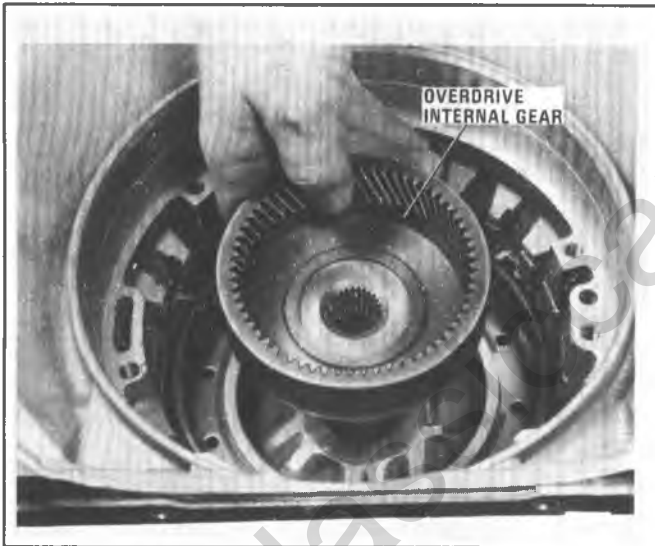

Figure 7A6-169 Installing Overdrive Internal Gear



Figure 7A6-171 Removing Turbine Shaft to Carrier Snap Ring

end of the shaft with a rubber mallet to disengage shaft from overdrive carrier splines.

3. Remove overdrive carrier assembly from overrun clutch assembly (Figure 7A6-173).
4. Remove overdrive sun gear from overrun clutch assembly (Figure 7A6-174).

### Overrun Clutch Assembly

1. Remove overrun clutch snap ring with screwdriver (Figure 7A6-175).
2. Remove the overrun clutch backing plate from the overrun clutch housing.
3. Remove the clutch plates from the overrun clutch housing and keep them separated from other plate assemblies (Figure 7A6-176).
4. Inspect composition faced plates and steel clutch plates for wear or burning.
5. Remove overrun clutch hub snap ring with snap ring pliers (Figure 7A6-177).

### Overrun Clutch and Overdrive Carrier Assembly

#### Disassembly

1. Remove snap ring from turbine shaft (Figure 7A6-171).
2. Remove turbine shaft from overdrive carrier assembly (Figure 7A6-172). It may be necessary to tap the

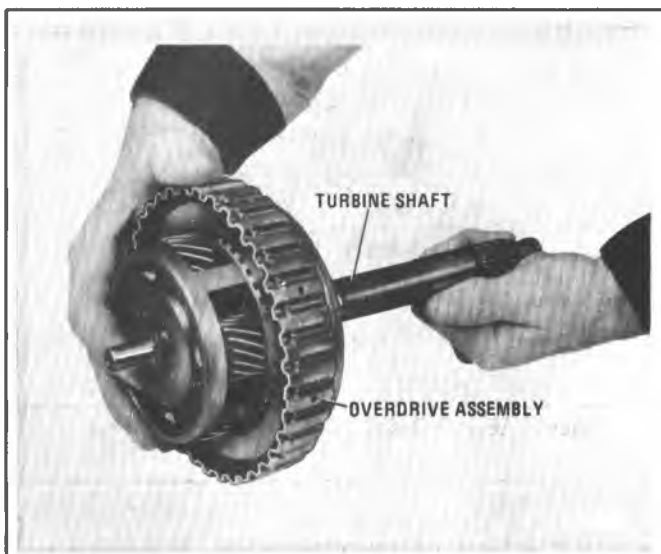

Figure 7A6-172 Removing Turbine Shaft from Carrier



Figure 7A6-175 Removing Overrun Clutch Snap Ring



Figure 7A6-173 Removing Overdrive Carrier



Figure 7A6-176 Removing Overrun Clutches



Figure 7A6-174 Removing Overdrive Sun Gear

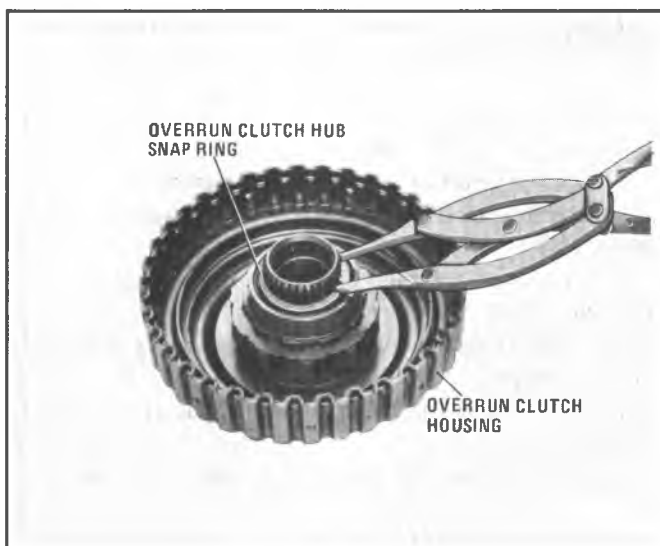

Figure 7A6-177 Removing Overrun Clutch Hub Snap Ring



Figure 7A6-178 Removing Overdrive Roller Clutch Cam Assembly

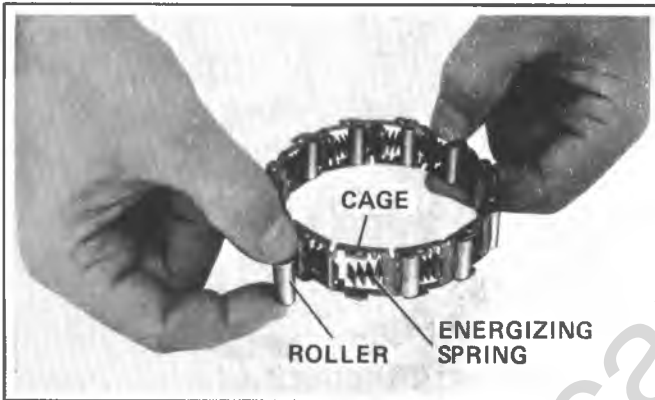

Figure 7A6-179 Roller Clutch Assembly

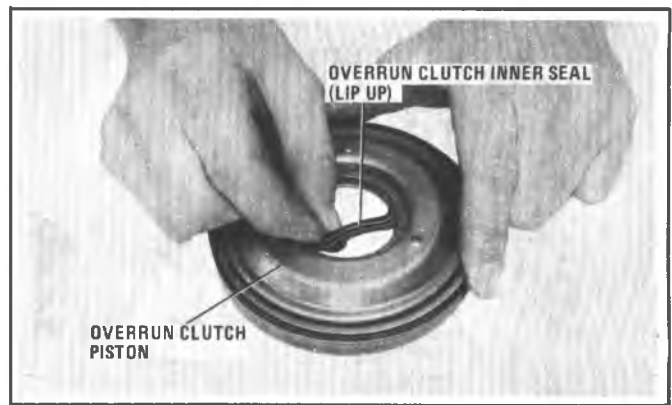

Figure 7A6-180 Overrun Clutch Piston Inner Seal



Figure 7A6-181 Overrun Clutch Piston Outer Seal

6. Remove overdrive roller clutch cam assembly, and inspect roller clutch cam ramps for damage (Figure 7A6-178).

7. Remove roller clutch assembly and inspect roller bearings, cage and springs for damage or wear (Figure 7A6-179).

8. Remove retainer and wave spring assembly from housing and inspect for damage.

9. Remove overrun clutch piston assembly.

10. Remove inner and outer seal from overrun clutch piston (Figure 7A6-180 and 181).

11. Inspect overrun clutch piston assembly for distortion, cracks and damage.

12. Inspect overrun clutch housing for cracks, wear and open oil passages.

13. Inspect overrun clutch housing snap ring grooves for damage.

14. Inspect overrun clutch bushing for damage or scoring.

**Reassembly**

1. Install new inner and outer seals on piston with lips facing away from clutch apply ring side (Figure 7A6-180 and 7A6-181).

2. Install seal protector J-29335 (Figure 7A6-181).
3. Oil the seals and install overrun clutch piston. To make the piston easier to install, insert piston installing tool (Figure 7A6-132) between seal and housing; rotate tool around the housing to compress the lip (Figure 7A6-182) of the seal, while pushing down slightly on the piston.

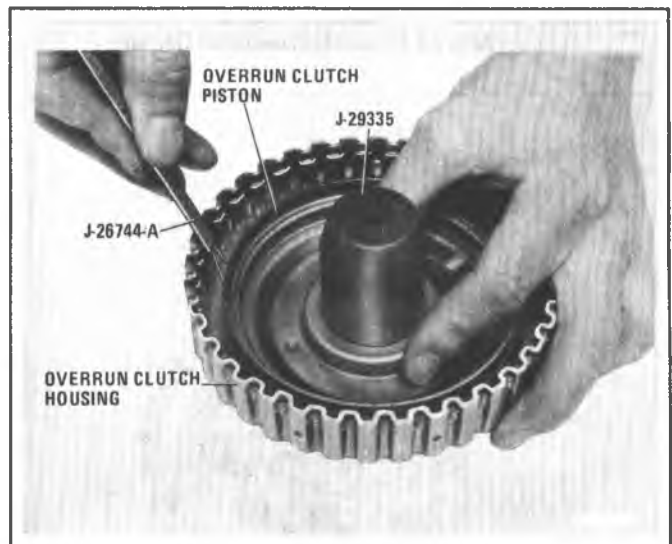

Figure 7A6-182 Installing Overrun Clutch Piston Using Tools

4. Remove seal protector J-29335 (Figure 7A6-182).

5. Install overrun clutch waved release spring (Figure 7A6-183).



Figure 7A6-183 Installing Overrun Clutch Waved Release Spring



Figure 7A6-184 Installing Overrun Clutch Waved Spring Retainer

6. Install overrun clutch waved spring retainer, cupped face down (Figure 7A6-184).

7. Install roller clutch cam on roller clutch assembly. The locating tangs on the roller clutch must set on the roller clutch cam (Figure 7A6-185).

8. Install roller clutch assembly on the overrun clutch hub (Figure 7A6-178).

9. Compress the retainer by pushing down on the roller clutch assembly and install narrow snap ring (Figure 7A6-177).

10. Oil and install the overrun clutch plates into the overrun clutch housing, starting with a flat steel and alternating composition-faced and flat steel clutch plates (See Figure 7A6-176 and Clutch Plate Usage Chart, Figure 7A6-107).

11. Install backing plate, chamfered side up.

12. Install snap ring (Figure 7A6-175). Make sure composition clutch plates turn freely.



Figure 7A6-185 Installing Overrun Roller Clutch Cam

### Overdrive Carrier

1. Inspect locating splines for damage.
2. Inspect roller clutch race for scratches or wear.
3. Inspect carrier housing for cracks and wear.
4. Inspect pinions for damage, rough bearings or tilt.
5. Check pinion end play (Figure 7A6-186). Pinion end play should be 0.24 mm - 0.60 mm (0.009" - .024").

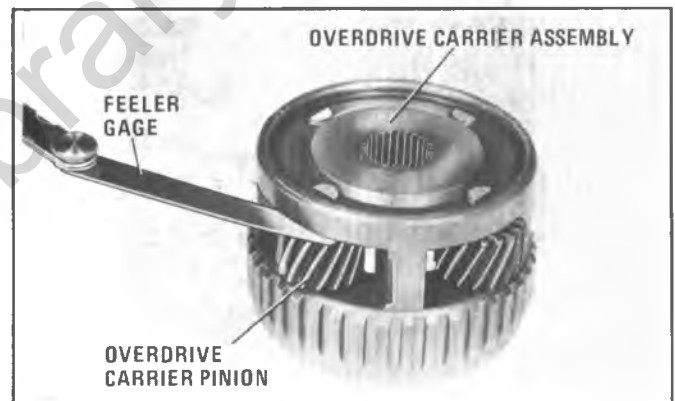

Figure 7A6-186 Checking Overdrive Carrier Pinion End Play

6. Remove overdrive carrier snap ring (Figure 7A6-187).

7. Using pliers, remove overdrive pinion pins (Figure 7A6-188).

8. Remove the pinions, thrust washer and roller needle bearings.

9. Inspect the pinion pocket thrust faces for burrs and remove if present.

10. Remove overdrive sun gear to overdrive carrier thrust bearing assembly (Figure 7A6-189).

11. Thoroughly clean, air dry and closely inspect the thrust bearing assembly for pitting or rough conditions.

12. Install thrust bearing assembly by placing the small diameter race down (Figure 7A6-189). Hold in place with petrolatum or equivalent.

13. Install 19 needle bearings into each pinion, thumb lock needle bearings to hold them in place (Figure 7A6-190).

14. Place a bronze and steel thrust washer on each side so steel washer is against pinion. Hold them in place with petrolatum or equivalent (Figure 7A6-191).

15. Place the pinion assembly in position in the carrier and use a pilot shaft to align parts in place (Figure 7A6-192).

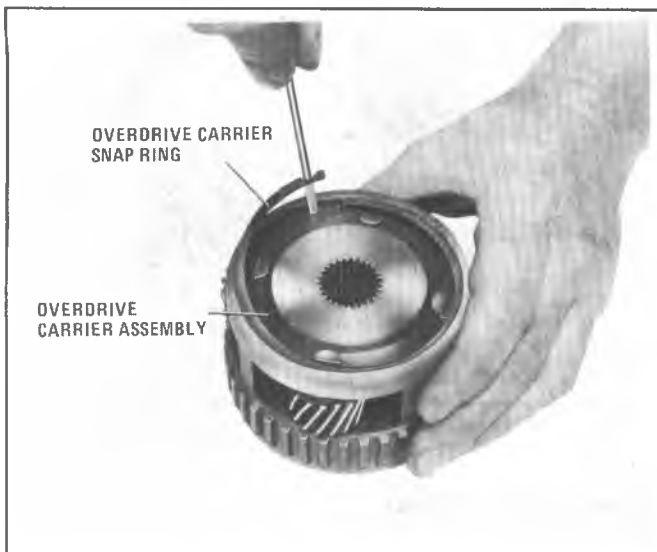

Figure 7A6-187 Removing Overdrive Carrier Snap Ring

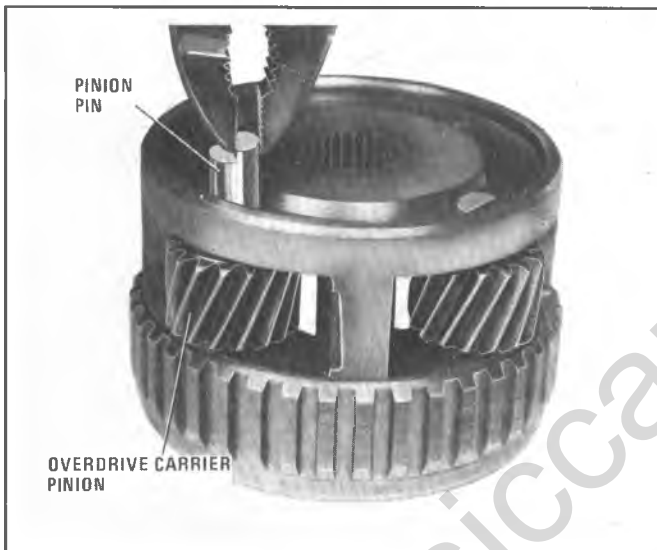

Figure 7A6-188 Removing Overdrive Pinion Pins

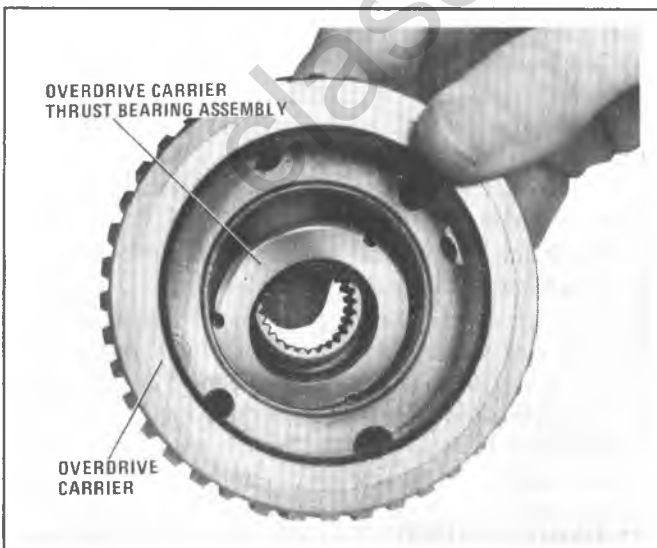

Figure 7A6-189 Removing or Installing Overdrive Carrier Thrust Bearing Assembly

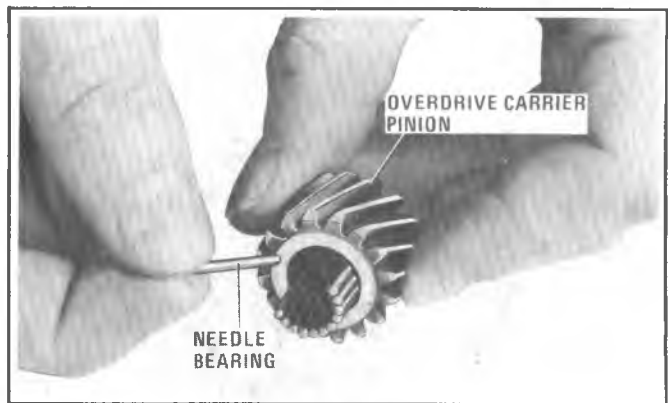

Figure 7A6-190 Installing Needle Bearing into Overdrive Pinions

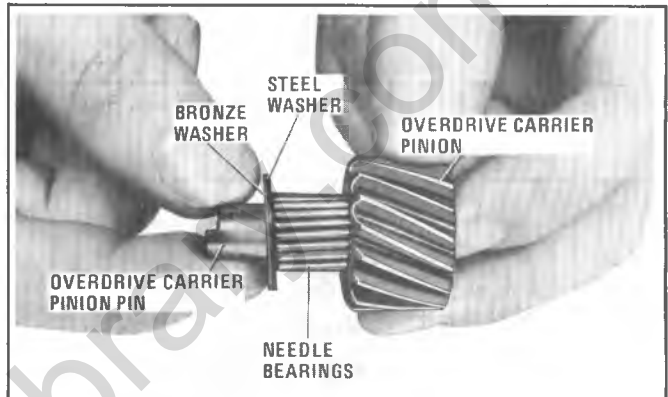

Figure 7A6-191 Installing Bronze and Steel Thrust Washer on Pinion Pin

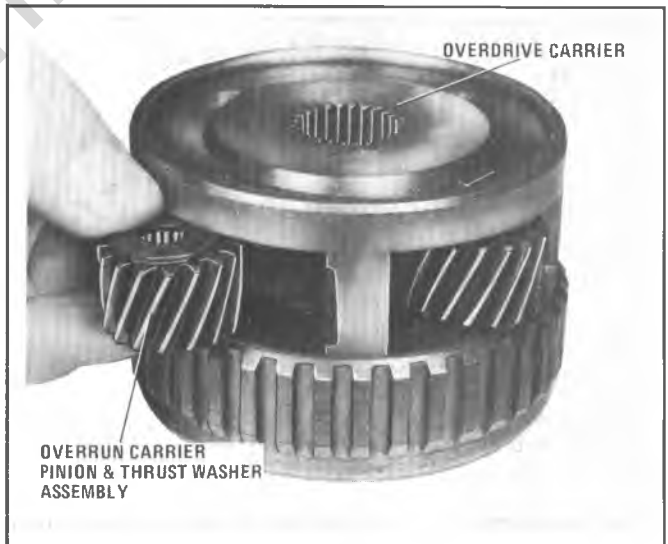

Figure 7A6-192 Installing Pinion Assembly into Carrier

16. Push pinion pin into place while rotating pinion from the side.

17. Install overdrive carrier snap ring to retain pinion pins (Figure 7A6-187).

### Turbine Shaft

1. Inspect teflon oil seals on turbine shaft for damage and free fit in grooves. Do not remove unless replacing.
2. Inspect snap ring for damage.

3. Inspect journals and snap ring grooves for wear or damage.
4. Inspect turbine shaft for open oil passages on both ends of shaft and journals for damage (Figure 7A6-193).

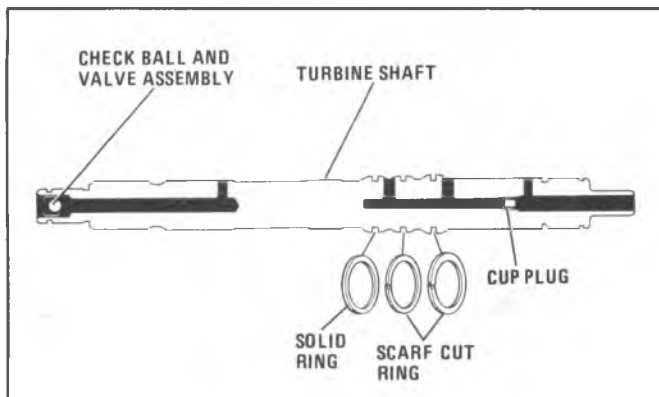

Figure 7A6-193 Turbine Shaft - Exploded

5. Check for free operation of check ball in end of turbine shaft (Figure 7A6-193). If damaged perform the following:

- a. Straighten the tangs of the retainer and check valve assembly capsule and remove the check ball (Figure 7A6-194).



Figure 7A6-194 Removing the Check Ball from Capsule

- b. Using a No. 4 easy out, remove the check valve retainer from the turbine shaft by turning and pulling straight out (Figure 7A6-195).
- c. Install the new check valve assembly, check valve seat first, into the turbine shaft (Figure 7A6-196).
- d. Using a 9.5 mm (3/8") diameter metal rod and hammer, drive retainer and check valve assembly until it is 3 mm (1/8") below the top surface of the turbine shaft (Figure 7A6-196).

6. Inspect cup plug for damage (Figure 7A6-193).

**Reassembly**

1. Install overdrive sun gear on overrun clutch hub with groove up. (Figure 7A6-174).

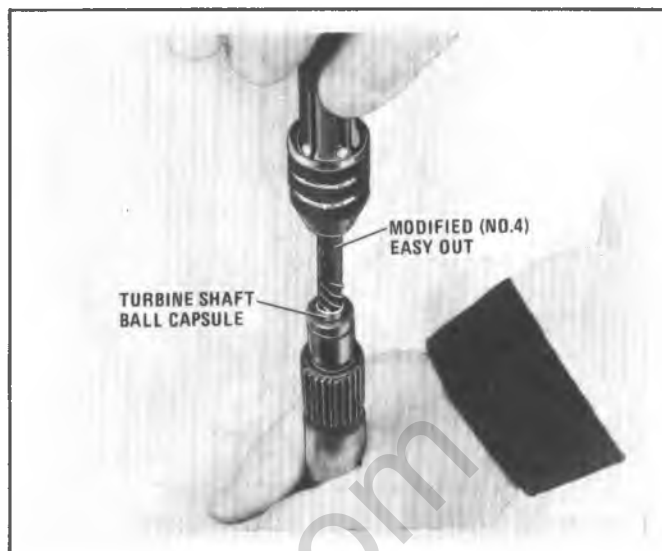

Figure 7A6-195 Removing the Check Valve Retainer from the Turbine Shaft

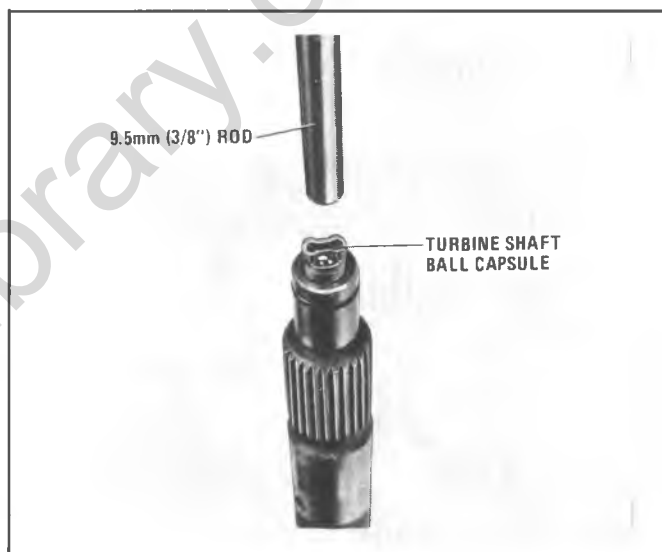

Figure 7A6-196 Installing Retainer and Check Valve Assembly in Turbine Shaft

2. Center the clutches in overrun clutch housing.
3. Grasp overdrive carrier assembly by the pinion side and install in overrun clutch (Figure 7A6-173). It may be necessary to turn overdrive carrier assembly counterclockwise to seat it.
4. Position overrun clutch and overdrive carrier assembly, (overrun clutch up) over hole in bench.
5. Install turbine shaft, ring grooved spline first (Figure 7A6-172).
6. Turn assembly sideways and install new turbine shaft snap ring (Figure 7A6-171).

**NOTICE:** A new turbine shaft snap ring must be installed as damage to unit may occur if old snap ring is used.

7. Grasp turbine shaft and install overdrive unit, and rotate into position (Figure 7A6-197).



Figure 7A6-197 Installing Overdrive Unit

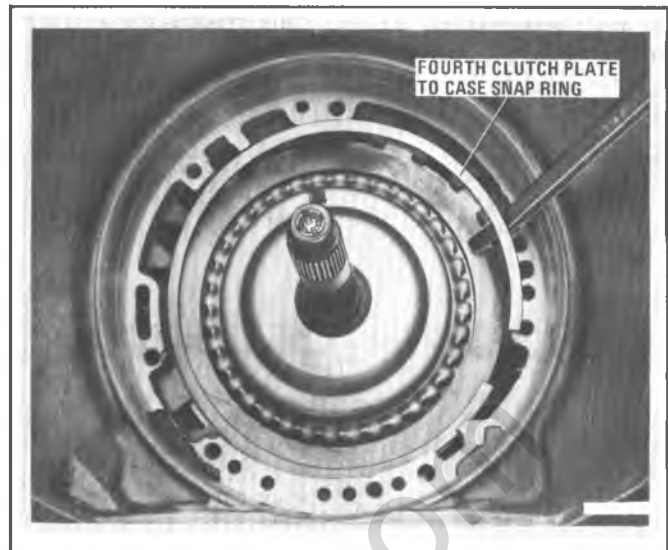

Figure 7A6-199 Installing Fourth Clutch to Case Snap Ring

8. Oil and install the fourth clutch plates into case. Refer to Figure 7A6-198 and Clutch Plate Usage Chart Figure 7A6-107.

**NOTICE:** Note the order of the plates. The center has two steel plates together. The thick plate is on top. Incorrect sequence will cause damage to unit.

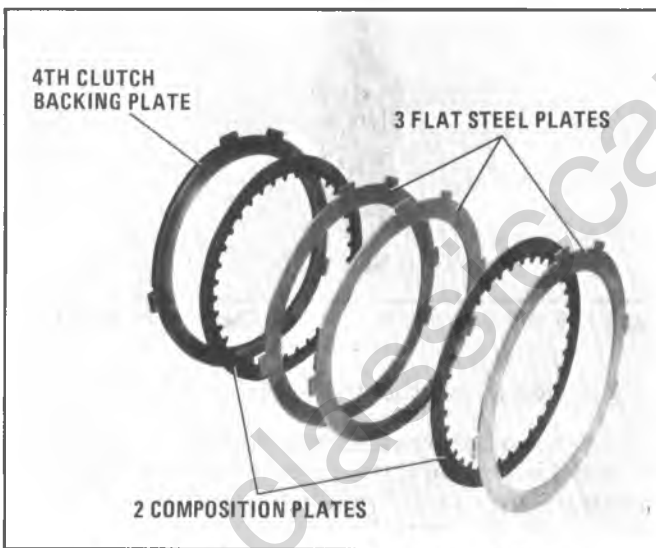

Figure 7A6-198 Installing Fourth Clutch Plates

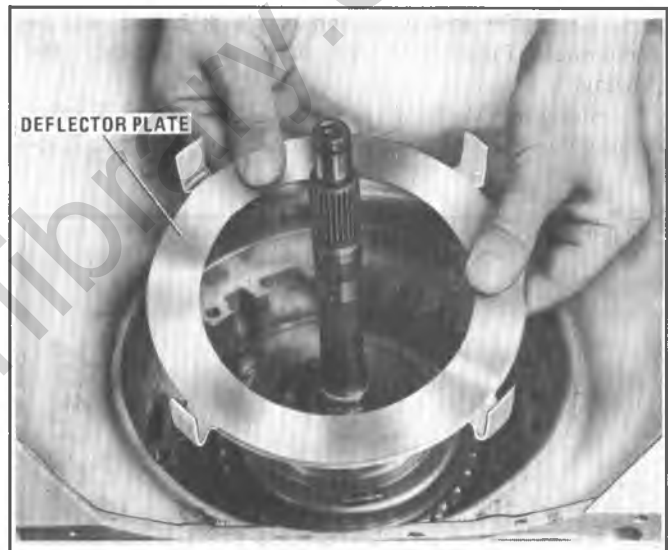

Figure 7A6-200 Installing Oil Deflector Plate

9. Install snap ring (Figure 7A6-199). Make sure composition clutch plates turn freely.

10. Install oil deflector plate with tangs facing up (Figure 7A6-200).

### PUMP ASSEMBLY (FIGURE 7A6-201)

#### Inspection

1. Remove pump to case seal ring and inspect groove for damage.

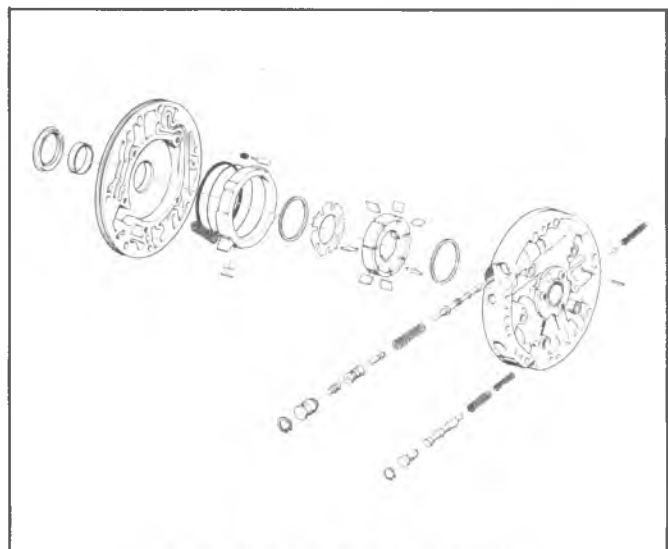

Figure 7A6-201 Pump - Exploded



2. Place pump over hole in bench with pump cover side up.
3. Remove pump cover to pump body attaching bolts and separate pump cover from pump body.
4. Remove stator shaft to overrun selective thrust washer and inspect for damage or wear (Figure 7A6-202).

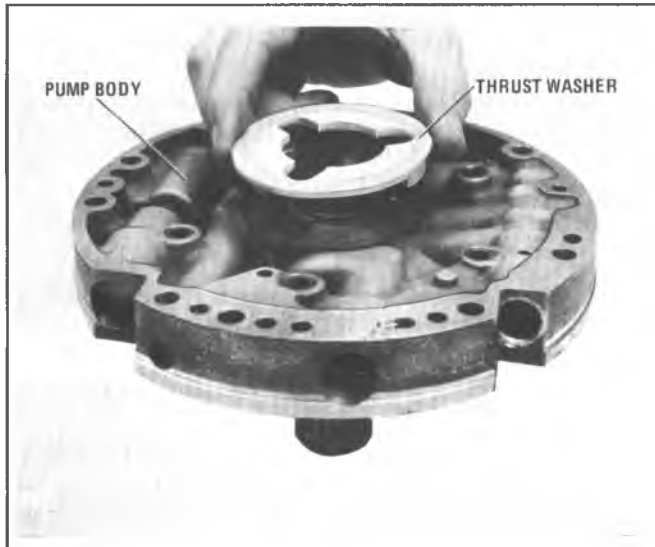

Figure 7A6-202 Removing Stator Shaft to Overrun Selective Washer

### **Pump Cover, Pressure Regulator, T.V. And Reverse Boost Assembly Inspection**

1. To prevent the pump from turning while removing the pressure regulator valve, place a bolt or screwdriver through a hole in the pump and bench (Figure 7A6-203).

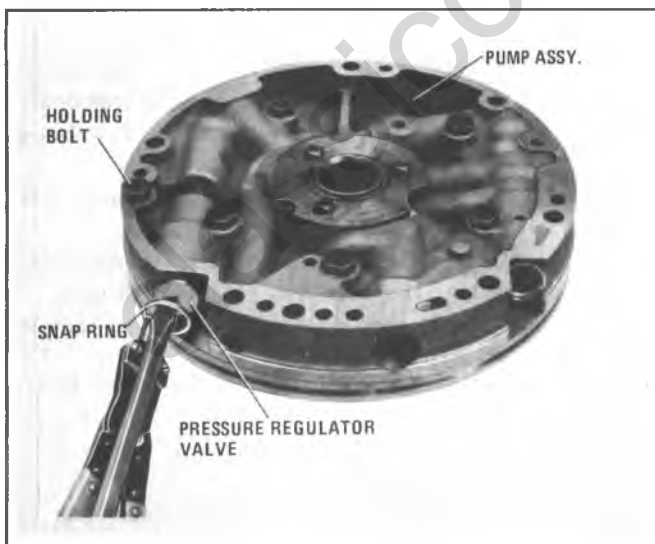

Figure 7A6-203 Removing Pressure Regulator Valve Snap Ring

2. Using a small screwdriver, push on the T.V. boost bushing, compressing the pressure regulator spring; and using snap ring pliers, remove the retaining snap ring (Figure 7A6-203).
3. Release the valve spring tension slowly and remove valve train.

4. Inspect the T.V. boost valve for nicks or damage.
5. Inspect the T.V. boost valve for free operation in T.V. boost bushing.
6. Inspect the reverse boost valve for nicks or damage.
7. Inspect the reverse boost valve for free operation in reverse boost bushing.
8. Inspect the T.V. and reverse boost bushings for free operation in pump cover bore.
9. Inspect the spring for damage or distortion.
10. Inspect the pressure regulator valve for nicks or damage.
11. Inspect the pressure regulator valve for free operation in pump cover bore.
12. Reverse the above procedure for installation.

### **Converter Clutch Valve Inspection**

1. Using a small screwdriver, push on the converter clutch stop valve, compressing the converter clutch valve spring; and using a snap ring pliers, remove the retaining snap ring (Figure 7A6-204).

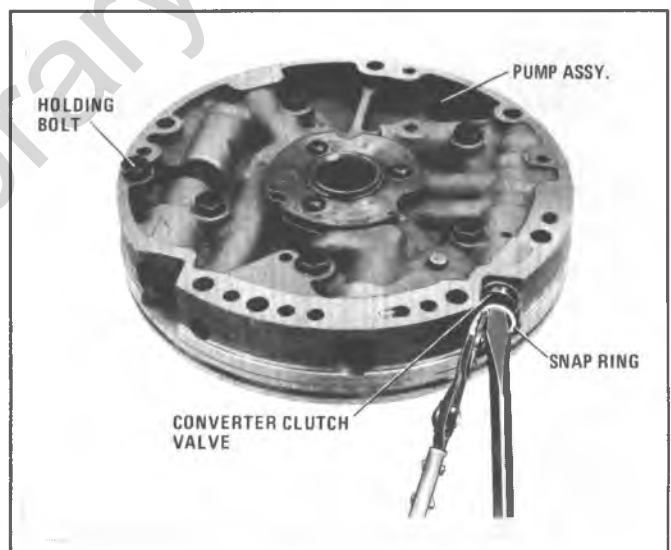

Figure 7A6-204 Removing Converter Clutch Valve Snap Ring

2. Release the valve spring tension slowly and remove stop valve and converter clutch valve.
3. Inspect the stop valve and converter clutch valve for nicks or damage.
4. Inspect the valves for free operation in pump cover bore.
5. Inspect the spring for damage or distortion.
6. Reverse the above procedure for installation.

### **Pressure Relief Valve Inspection**

1. Using a punch remove pressure relief spring retaining sleeve (Figure 7A6-205).
2. Remove the pressure relief spring and ball and inspect for damage or distortion.
3. Reverse the above procedures for installation.



Figure 7A6-205 Removing Pressure Relief Spring Retaining Sleeve

## Stator Shaft and Flange Assembly

### Inspection

1. Inspect the stator shaft and flange assembly for damaged splines or damaged bushing; inspect for damaged or missing orifice cup plug in dowel pin; do not remove unless damaged.

**Stator shaft and flange assembly is pressed into and removed with the pump body. Do not remove them unless it is necessary.**

### Disassembly

1. If replacement of the stator shaft and flange assembly is required, proceed as follows:

- a. Remove the stator shaft and flange assembly attaching screws using J-25359-3.
- b. Using a press, press the stator shaft until it is removed from the pump cover bore (Figure 7A6-206).

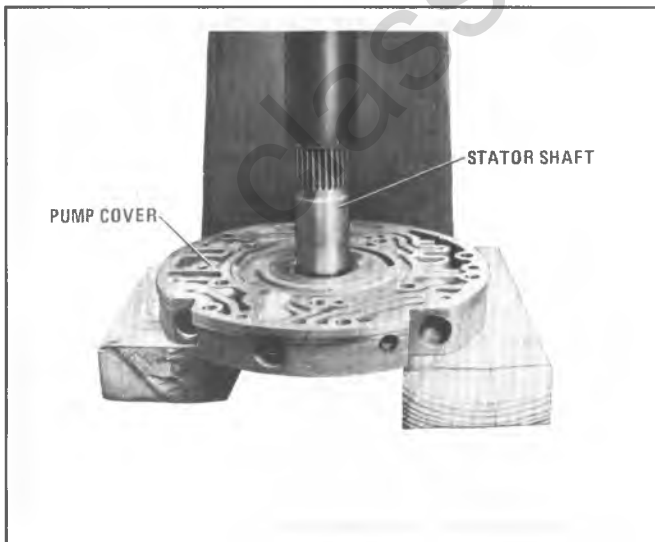

Figure 7A6-206 Removing Stator Shaft and Flange Assembly

When pressing the stator shaft out of the pump body bore, avoid damaging or distorting the stator shaft.

### Reassembly

1. Align dowel pin of stator shaft with hole in pump cover.
2. Using a press, press the stator until it is seated on the pump cover.
3. Install the stator shaft and flange assembly attaching screws using J-25359-3 and torque to 12 N·m (9 ft. lbs.).

## Pump Body

### Disassembly

1. Using a small screwdriver remove pump slide spring. **CAUTION: Spring is under high pressure. Place shop towel over spring to help prevent spring from flying out and causing personal injury.**
2. Remove the pump slide, slide to wear plate oil seal and back up "O" ring seal, rotor, rotor guide, seven vanes and two vane rings, pump slide seal support and seal (Figure 7A6-190).
3. Remove the pivot slide pin and spring (Figure 7A6-211).

### Inspection

1. Wash the pump body, springs, pump slide, pump rotor, vanes, vane rings and rotor guide. Do not put the pump seals into the solvent.
2. Inspect the pump pocket and pump body for damage or scoring.
3. Inspect the pump body bushing for wear or scoring.
4. Inspect the springs for damage or distortion.
5. Inspect the pump slide for damage, cracks or wear.
6. Inspect the pump rotor for damage, cracks or wear.
7. Inspect the pump vanes and vane rings for damage, cracks or wear.
8. Inspect pump body face for nicks and overall flatness.
9. Inspect for open oil passages (Figure 7A6-207).
10. Inspect for damaged bolt holes and threads.
11. If seal was removed, coat outside of seal body with non-hardening sealing compound; support pump body oil seal side up, and using J-25016, install new pump body oil seal (Figure 7A6-208).

### Reassembly

1. Turn the pump body so the pump pocket side is up.
2. Install the slide "O" ring seal and slide to wear plate oil seal in the pump. Retain with petrolatum (Figure 7A6-209).
3. Install the pump slide into pump pocket with seal side down (Figure 7A6-210).
4. Install the pump slide seal support and pump slide seal. Retain with petrolatum. Make sure the slide seal is located properly (Figure 7A6-210).
5. Install the pivot pin spring and pivot slide pin (Figure 7A6-211).

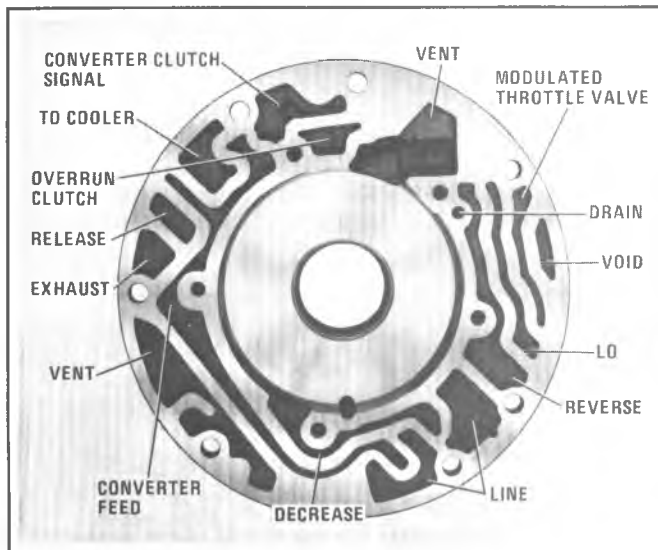

Figure 7A6-207 Pump Body Assembly

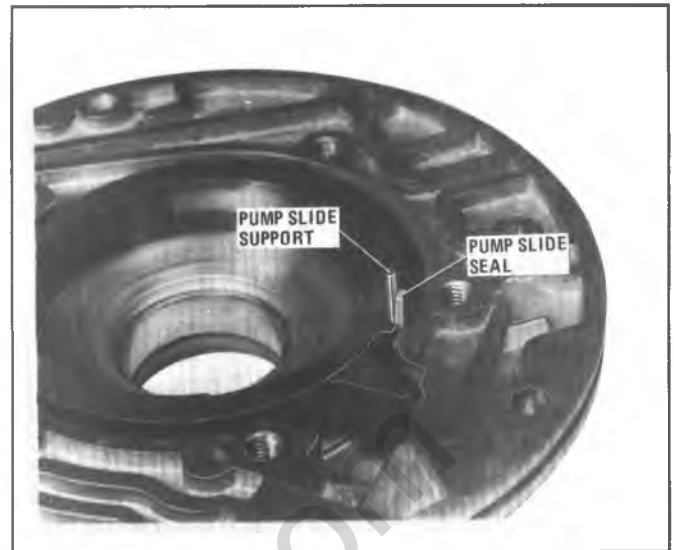

Figure 7A6-210 Installing Slide Seal and Support

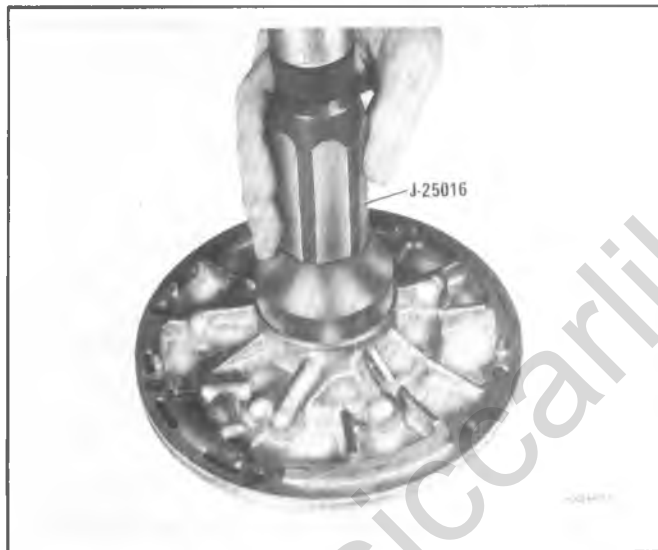

Figure 7A6-208 Installing Seal into Pump Body

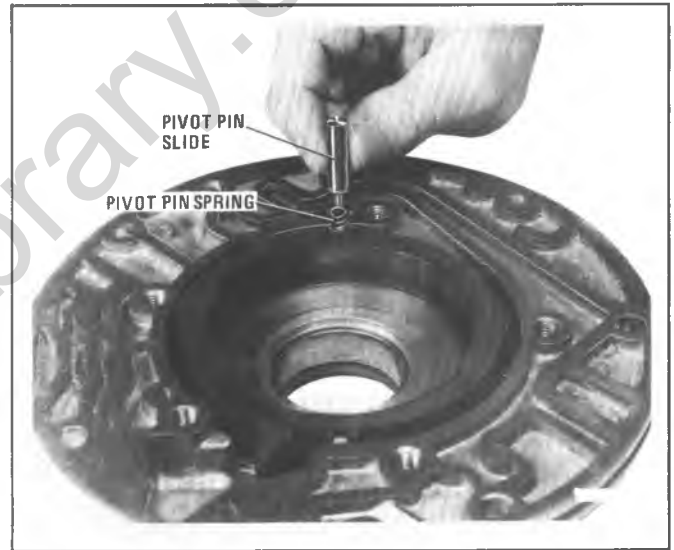

Figure 7A6-211 Installing Pivot Pin and Spring

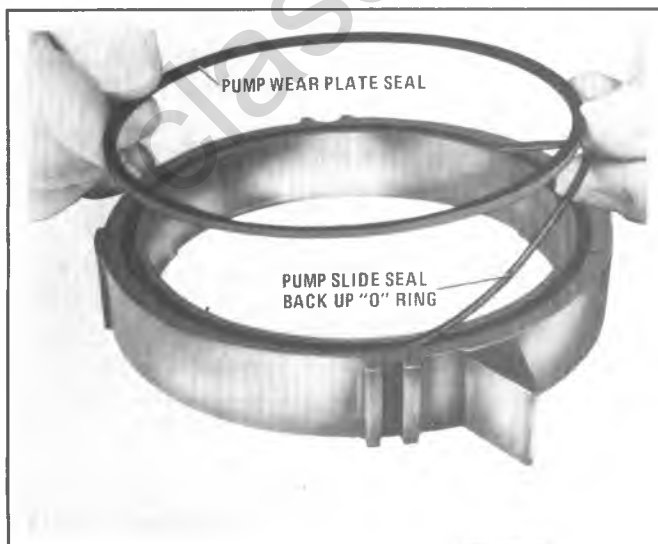

Figure 7A6-209 Installing Slide Seal

6. Install a vane ring in the pump pocket (Figure 7A6-201).
7. Install the rotor guide in the pump rotor (Figure 7A6-201).
8. Install the pump rotor into the pump pocket. Center and seat pump rotor on rotor guide so rotor is flush with pump slide (Figure 7A6-201).
9. Install seven vanes into the pump. Make sure the vane pattern is installed against the vane ring.
10. Install the top vane ring.
11. Install the pump slide spring (Figure 7A6-201).

## Pump Cover

### Inspection

1. Inspect for open oil passages (Figure 7A6-212).
2. Inspect four cup plugs. If a plug is missing, drive a new cup plug to .79 mm (1/32") below the top of hole, using a 7.14 mm (9/32") diameter rod on the two smaller plugs, a 7.97 mm (5/16") rod on the line to case cup plug and a 11.11 mm (7/16") diameter rod on the large plug. Stake top

## 7A6-56 AUTOMATIC 200-4R TRANSMISSION

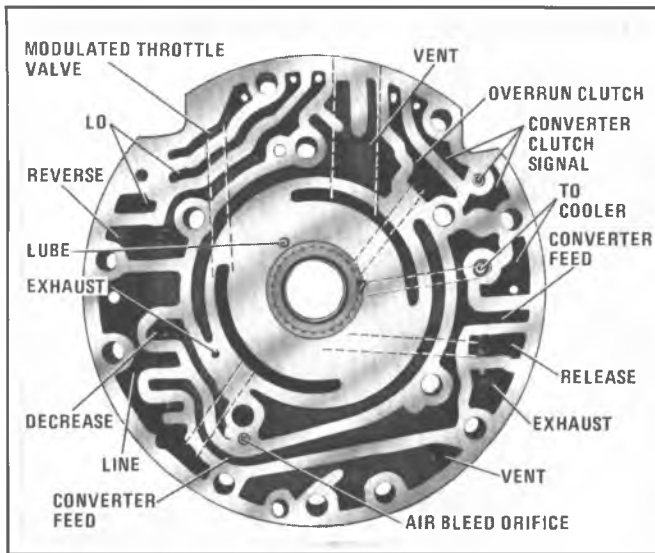

Figure 7A6-212 Pump Cover Assembly

of hole two places, directly opposite each other, to retain plug.

3. Inspect pump cover face for nicks and overall flatness.

4. Inspect for chips in pressure regulator, pressure relief and converter clutch bores.

5. Inspect orifice plugs (Figure 7A6-212). If the plugs required replacement, place new plug, orifice end first, into plug hole from the rough casting side. Drive the plug flush to .25 mm (.10") below top of hole, rough casting side. Stake the top of hole two places to retain the plug.

### Reassembly

1. Place the pump body over hole in bench.

2. Assemble the pump cover to pump body with attaching bolts, finger tight.

3. Align the pump cover and pump body using J-25015 (Figure 7A6-213) and place bolt or screwdriver through pump to case bolt hole and bench.

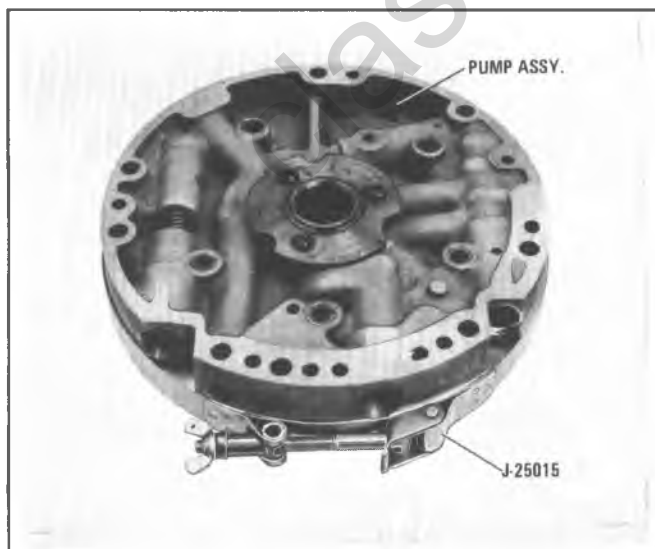

Figure 7A6-213 Aligning Pump Cover and Pump Body

4. Torque the pump cover attaching bolts to 24 N·m (18 ft. lbs.).

5. Remove J-25015.

6. Install the pump to case "O" ring seal, chamfered side out, making sure the seal is not twisted.

7. Install the stator shaft flange to overrun clutch selective thrust washer. Retain with petrolatum (Figure 7A6-214).

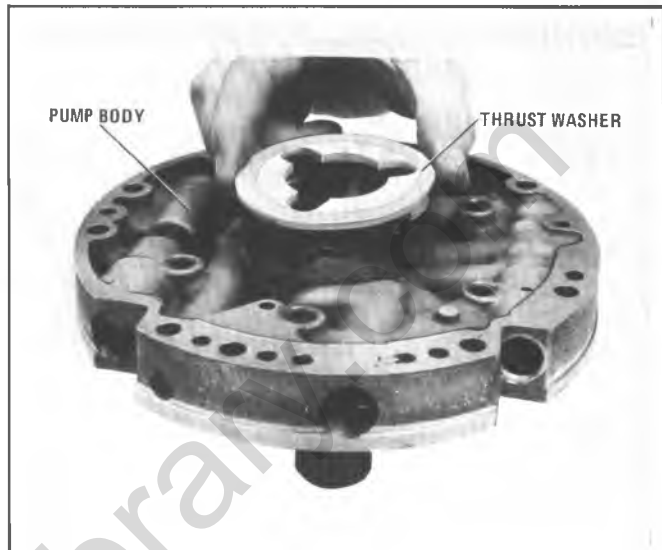

Figure 7A6-214 Installing Stator Shaft Flange to Overrun Clutch Selective Thrust Washer

8. Remove the holding bolt or screwdriver.

9. Install the new pump to case gasket on pump and retain with petrolatum.

10. Install 2 pump to case alignment pins in case as shown in (Figure 7A6-215).

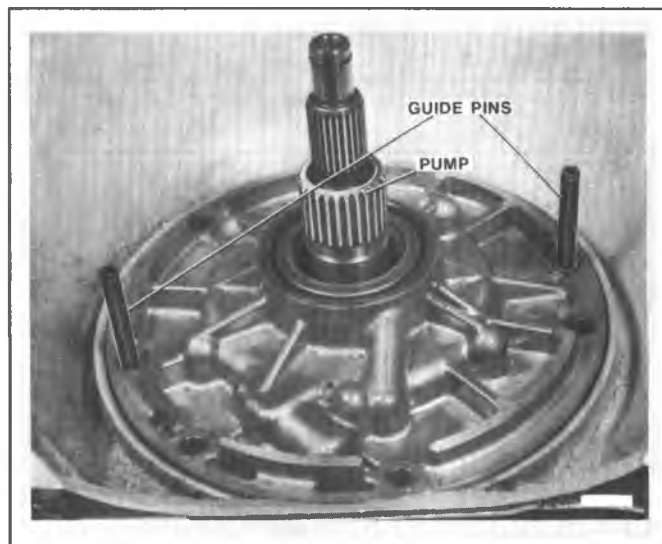

Figure 7A6-215 Installing Pump Assembly

11. Install pump assembly. Finger start pump to case bolts and new washers, except on bolt hole (Figure 7A6-214) which will be used to make the overdrive unit end play check.

12. Replace 2 alignment pins with 2 bolts and new washers.

13. Torque pump to case bolts to 24 N·m (18 ft. lbs.).  
Make sure turbine shaft rotates freely.

**Check Overdrive Unit End Play (Figure 7A6-216)**

OVERDRIVE UNIT END PLAY WASHER THICKNESS CHART		
THICKNESS		IDENTIFICATION NUMBER AND/OR COLOR
4.25 - 4.36 mm	(0.167" - 0.171")	0 - Scarlet
4.36 - 4.48 mm	(0.172" - 0.176")	1 - White
4.49 - 4.60 mm	(0.177" - 0.180")	2 - Cocoa Brown
4.61 - 4.72 mm	(0.181" - 0.185")	3 - Gray
4.73 - 4.84 mm	(0.186" - 0.190")	4 - Yellow
4.85 - 4.96 mm	(0.191" - 0.195")	5 - Light Blue
4.97 - 5.08 mm	(0.196" - 0.200")	6 - Purple
5.09 - 5.20 mm	(0.201" - 0.204")	7 - Orange
5.21 - 5.32 mm	(0.205" - 0.209")	8 - Green

Figure 7A6-216 Overdrive Unit End Play Washer Thickness Chart

1. Install 278 mm (11") bolt and locking nut as shown in Figure 7A6-217.

- a. Install J-25022 on J-24773-5 tool and secure on end of turbine shaft (Figure 7A6-217).

- b. Mount dial indicator and clamp assembly on bolt, positioning indicator point cap nut on top of J-24773-5 (Figure 7A6-217).

- c. Lift up on J-24773-5 with approximately 3 lbs. of upward force and while holding, set dial indicator to zero (MAINTAIN UPWARD FORCE).

**NOTICE:** The above procedure must be performed to eliminate the tolerance difference between the turbine shaft snap ring and the overdrive carrier. Incorrect selective washer selection will cause damage to transmission.

- d. With the dial indicator at zero, increase force to approximately 20 lbs. and read dial indicator. Overdrive unit end play should be 0.10 - 0.81 mm (.004 - .027").

Selective washer controlling this end play is located between the pump and the overrun clutch housing. If more or less washer thickness is required to bring end play within specifications, select proper washer from the OVERDRIVE UNIT END PLAY WASHER THICKNESS CHART.

- e. Remove overdrive unit end play checking tools.
- f. Install remaining pump to case bolts and new washer, torquing bolts to 24 N·m (18 ft. lbs.).
- g. Remove J-29332-1 and J-25013-5 from rear end of transmission.
- h. Turn transmission to horizontal position, oil pan side up.

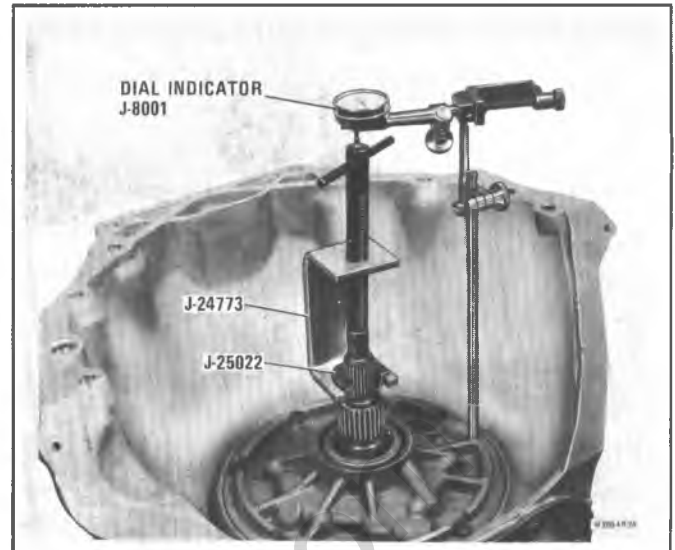

Figure 7A6-217 Checking Overdrive Unit End Play

**EXTERNAL PARTS**

**Governor Assembly**

**Inspection**

1. Inspect governor cover for damage, scored or worn bore, or plugged oil passage.
2. Wash in cleaning solvent and blow out oil passage.
3. Inspect governor driven gear for nicks or damage. If replacement is necessary perform the following:

- a. Using a small screwdriver remove the governor gear retaining ring then remove the thrust washer and driven gear.

**Care must be taken after removing governor driven gear to keep governor in vertical position to retain the governor weight pin in its holding position.**

- b. For installation reverse the above procedure.
4. Inspect governor shaft seal ring for cuts, damage and free fit in groove.
5. Inspect for free operation of governor weights. Weights must operate freely and independently of each other.
6. Inspect governor spring for damage and correct installation.
7. Inspect for presence of 2 check balls.
8. Inspect shaft for damage.
9. Inspect governor washer for damage.
10. If seal is damaged, cut seal ring off governor shaft.

**Do not damage seal ring groove when removing seal.**

**Installation**

1. If removed, install new seal ring; lubricate with petrolatum.
2. Install governor assembly into case (Figure 7A6-218).
3. Install governor cover and retaining bolts, torque bolts to 24 N·m (18 ft. lbs.).

**Make sure the governor shaft is piloted in the governor cover before torquing the retaining bolts.**

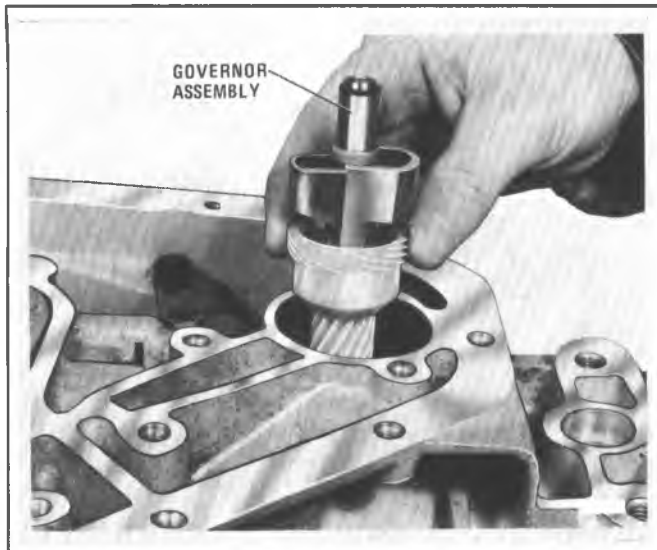

Figure 7A6-218 Installing Governor Assembly

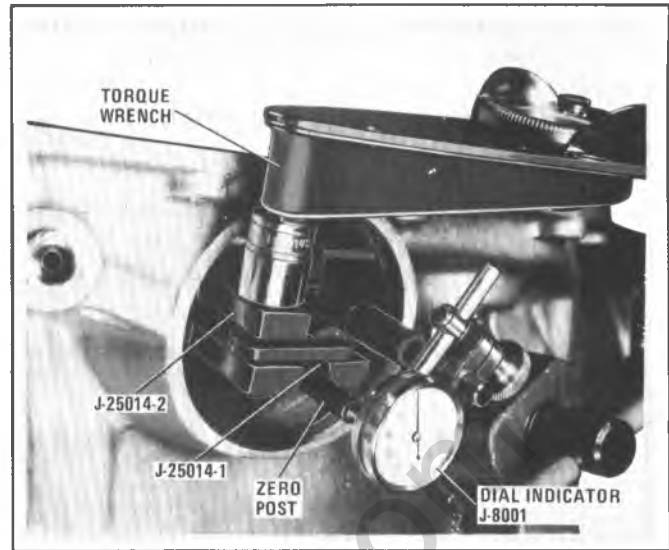

Figure 7A6-220 Intermediate Band Apply Pin Tools

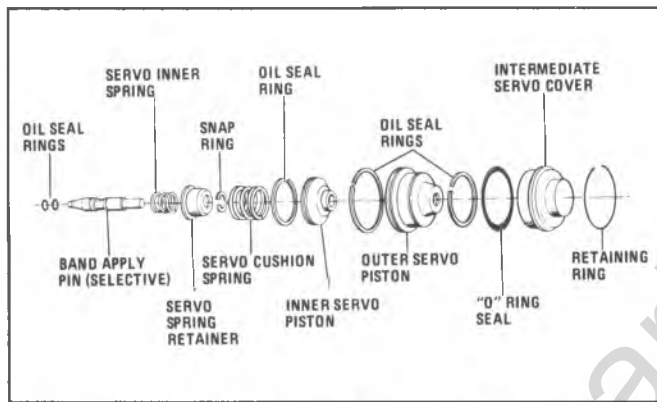

Figure 7A6-219 Intermediate Servo Piston - Exploded View

## Intermediate Servo Piston Assembly (Figure 7A6-219)

### Inspection

1. Inspect pin oil seal rings for damage.
2. Inspect pin for damage and fit in case bore.
3. Inspect inner and outer piston seal rings for damage and free fit in ring grooves. Do not remove unless replacing.
4. Inspect spring.
5. Check for proper intermediate band apply pin as follows:

a. Install J-25014-2 in intermediate servo bore and retain with intermediate servo cover retaining ring, aligning ring with gap at case slot (Figure 7A6-220).

b. Install pin J-25014-1 into J-25014-1 (Figure 7A6-220).

**NOTICE:** Make sure the tapered pin end is properly located against the band apply lug. Also, make sure the band anchor pin is properly located in the case and band anchor lug. If not, damage to the transmission will occur.

c. Install dial indicator J-8001 and position dial indicator point (Figure 7A6-220) on top of J-25014-2, zero post and set dial indicator to zero.

d. Align stepped side of pin J-25014-1 with torquing arm of J-25014-2. Arm must stop against step of pin J-25014-1.

If band selection pin does not register between the high and low limits, look for possible problem with the intermediate band, direct clutch or case.

Make sure J-25014-2 gage plate is pulled backwards and seated squarely against the retaining ring.

e. Apply 12 N·m (100 in. lbs.) of torque to hex nut on side of gage. Slide dial indicator over gage pin J-25014-1 (Figure 7A6-221). Read dial indicator and see chart for proper size (Figure 7A6-222).

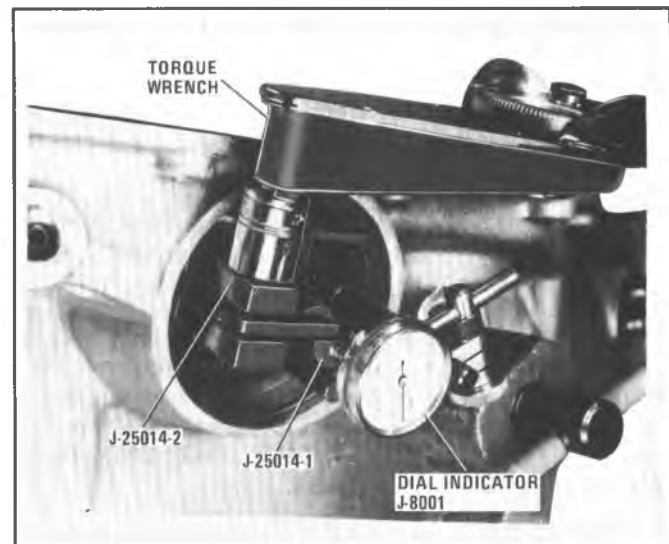

Figure 7A6-221 Checking for Proper Intermediate Band Apply Pin

Dial indicator travel is reversed making the indicator readings backwards. On an indicator that ranges from 0-100, a .5 mm (.020") travel will read 2 mm (.080"), a 1.5 mm (.060") travel will read 1 mm

INTERMEDIATE BAND APPLY PIN SELECTION CHART	
DIAL INDICATOR TRAVEL	APPLY PIN IDENTIFICATION
.0- .72mm (.0-.029")	1 Groove
.72mm-1.44mm (.029"-.057")	2 Grooves
1.44mm-2.16mm (.057"-.086")	3 Grooves
2.16mm-2.88mm (.086"-.114")	None

Figure 7A6-222 Intermediate Band Apply Pin Chart

(.040"). The identification ring is located on the band end of the pin.

f. Remove retaining ring and band apply gages. If new apply pin or replacement of piston is required, proceed as follows:

**Disassembly**

1. Using small flat edge screwdriver, remove intermediate pin to retainer snap ring.
2. Remove J-22269-01 and separate band apply pin, spring and washer from intermediate servo piston.

**Reassembly**

1. Install retainer on band apply pin (Figure 7A6-223).

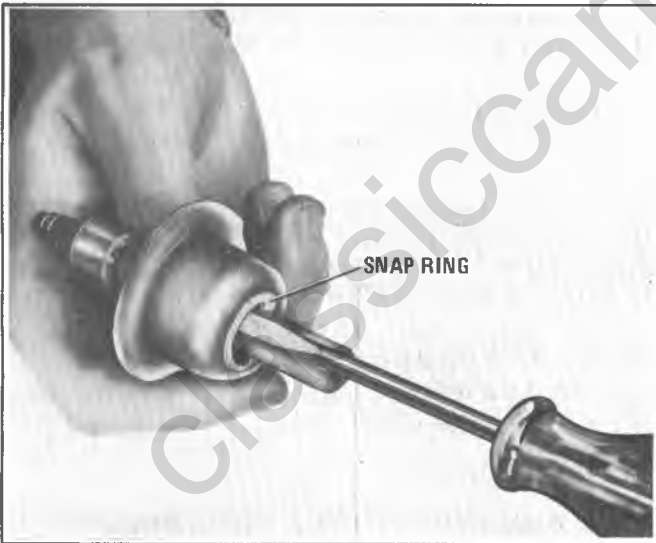

Figure 7A6-223 Installing Intermediate Servo Spring Retainer on Apply Pin

2. Install snap ring on band apply pin (Figure 7A6-223).

3. Install band apply pin, retainer end first, through intermediate servo pistons, Figure 7A6-224.

4. If removed, install new intermediate servo piston inner and outer seal rings. Make sure cut ends are assembled in the same relationship as cut (Figure 7A6-155). Make sure rings are seated in the grooves to prevent damage to the rings. Retain with petrolatum.

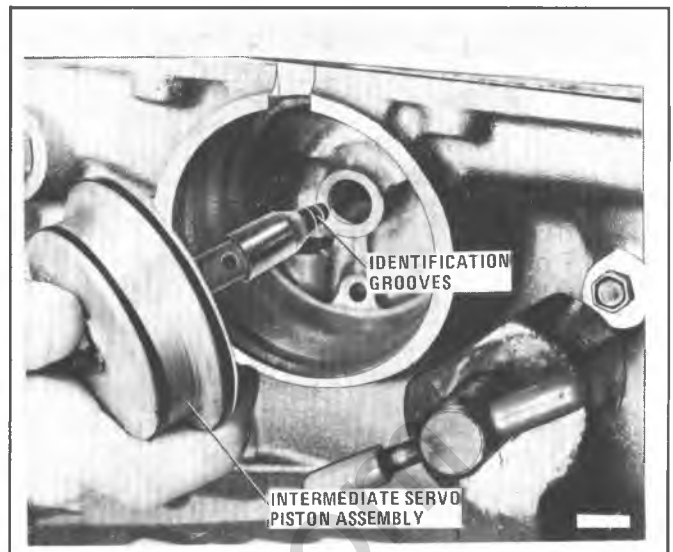

Figure 7A6-224 Installing Intermediate Servo Piston and Cover Assembly into Case

5. Lubricate with petrolatum and install new seal ring on intermediate servo cover.

**NOTICE:** The intermediate servo cover seal rings must be well lubricated with petrolatum to prevent damage or cutting of ring.

6. Install intermediate servo piston assembly into intermediate servo cover.
7. Install intermediate servo assembly into case, (Figure 7A6-224). Make sure the tapered end of the band apply pin is properly located against the band apply lug.

**NOTICE:** The intermediate servo cover seal rings must be well lubricated with petrolatum to prevent damage or cutting of ring.

Install servo cover retaining ring. Align ring gap with an end showing in case slot.

**NOTICE:** Make sure the tapered end of the band apply pin is properly located against the band apply lug. If not, damage to the transmission will occur.

**ELECTRICAL CONNECTOR**

1. Lubricate with petrolatum and install new "O" ring seal on the case connector.
2. Install electrical connector with lock tabs facing into case, positioning locator tab in notch on side of case. (Figure 7A6-225).

**Control Valve Assembly (Figure 7A6-226)**

**Disassembly**

As each valve train is removed, place the individual valve train in the order that it is removed and in a separate location relative to its position in the valve

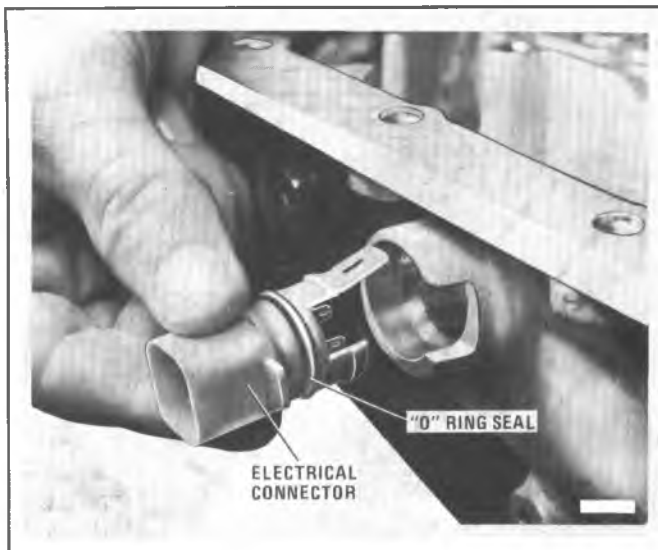

Figure 7A6-225 Installing Electrical Connector

body. None of the valves, bushings or springs are interchangeable; some roll pins are interchangeable. Remove all roll pins and spring retaining sleeve by pushing through from the rough case surface side of the control valve pump assembly, except for the blind hole roll pins.

1. Lay the control valve assembly machined face up, with the manual valve at the top as shown in Figure 7A6-226.
2. Remove the 3 check balls if still intact.
3. Remove manual valve from upper bore.

**NOTICE:** Some of the roll pins in the control valve assembly have pressure against them. Hold a shop towel over the bore while removing the pin, to help prevent possibly losing a bore plug, spring, etc.

4. Remove roll pin from upper left bore. Remove 2-3 throttle valve bushing, 2-3 throttle valve spring, 2-3 throttle valve and 2-3 shift valve. The 2-3 throttle valve spring and 2-3 throttle valve may be inside the 2-3 throttle valve bushing.
5. From the next bore down, remove the roll pin. Remove the converter clutch throttle bushing, converter clutch throttle valve spring, converter clutch throttle valve, and converter clutch shift valve. The converter clutch throttle valve spring and the converter clutch throttle valve may be inside the converter clutch throttle bushing.
6. From the next bore down, remove the outer roll pin. Remove the 1-2 throttle valve bushing, 1-2 throttle valve spring, 1-2 throttle valve and lo 1st/detent valve: The 1-2 throttle valve spring and the 1-2 throttle valve may be inside the 1-2 throttle valve bushing. Remove the inner roll pin. Remove the lo 1st/detent valve bushing and 1-2 shift valve.
7. From the next bore down, remove the outer spring retaining sleeve.

**NOTICE:** This spring is under a load. Cover the open end of the bore to prevent loss of spring.

- a. Remove bore plug, 4-3 control valve and 4-3 control valve spring.
- From the same bore, remove the inner spring retaining sleeve.

**NOTICE:** This spring is under a load. Cover the open end of the bore to prevent loss of spring.

- a. Remove the lo/overrun clutch valve spring and lo/overrun clutch valve.
8. From the next bore down, remove the roll pin. Remove the 3-4 throttle valve bushing, 3-4 throttle valve spring, 3-4 throttle valve and 3-4 shift valve. The 3-4 throttle valve and spring may be inside the 3-4 throttle valve bushing.
9. From the last bore down, remove the roll pin and bore plug. Remove the accumulator valve bushing, accumulator valve and accumulator spring. The accumulator spring and accumulator valve may be inside the accumulator bushing.
10. From the upper right bore, remove roll pin, valve bore plug, line bias valve and line bias valve spring.
11. From the next bore down, remove the roll pin, 3-2 control valve spring and 3-2 control valve.
12. From the next bore down, remove the roll pin, valve bore plug, T.V. modulator upshift valve and T.V. modulator upshift valve spring.
13. From the next bore down, remove the roll pin, valve bore plug, T.V. modulator downshift valve and T.V. modulator downshift valve spring.
14. From the next bore down, remove spring retaining sleeve, T.V. limit valve spring and T.V. limit valve.

**NOTICE:** This sleeve is under a load. Cover the open end of the bore to prevent loss of spring.

15. From the last bore, remove the outer roll pin from the rough casting side, the throttle valve plunger bushing, throttle valve plunger and throttle valve spring. Remove the inner roll pin as follows (Figure 7A6-227).
  - a. Grind a taper to one end of a #49 drill.
  - b. Lightly tap the tapered end into the roll pin.
  - c. Pull the drill and coil pin out.
  - d. Remove the throttle valve.

### Inspection

1. Wash control valve body, valves, springs, and other parts in clean solvent and air dry.
2. Inspect valves for scoring, cracks and free movement in their bores.
3. Inspect bushings for cracks or scored bores.
4. Inspect valve body for cracks, damage or scored bores.
5. Inspect springs for distortion or collapsed coils.
6. Inspect bore plugs for damage.

**NOTICE:** Install all flared coiled pins (zinc coated), flared end out, and from the machined face of the control valve assembly. Install the two (2) tapered coiled pins (black finish) that retain the throttle valve and throttle valve bushing, tapered end first. Coiled



Figure 7A6-226 Control Valve Assembly - Exploded View

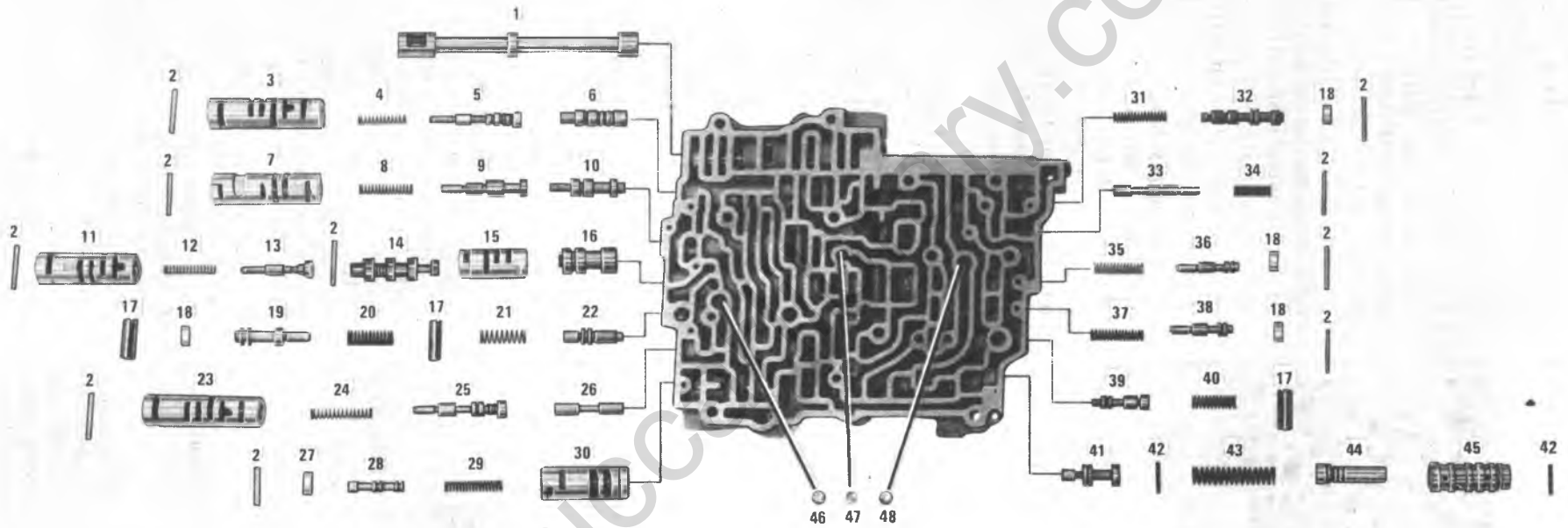

1. MANUAL VALVE
2. RETAINING COILED PIN (Zinc)
3. 2-3 THROTTLE VALVE BUSHING
4. 2-3 THROTTLE VALVE SPRING
5. 2-3 THROTTLE VALVE
6. 2-3 SHIFT VALVE
7. CONVERTER CLUTCH THROTTLE BUSHING
8. CONVERTER CLUTCH THROTTLE VALVE SPRING
9. CONVERTER CLUTCH THROTTLE VALVE
10. CONVERTER CLUTCH SHIFT VALVE
11. 1-2 THROTTLE VALVE BUSHING
12. 1-2 THROTTLE VALVE SPRING
13. 1-2 THROTTLE VALVE
14. LO 1ST/DETENT VALVE
15. LO 1ST/DETENT VALVE BUSHING
16. 1-2 SHIFT VALVE

17. SPRING RETAINING SLEEVE
18. VALVE BORE PLUG [12.50mm (.500 in.)]
19. LO/OVERRUN CLUTCH VALVE
20. LO/OVERRUN CLUTCH VALVE SPRING
21. 4-3 CONTROL VALVE SPRING
22. 4-3 CONTROL VALVE
23. 3-4 THROTTLE VALVE BUSHING
24. 3-4 THROTTLE VALVE SPRING
25. 3-4 THROTTLE VALVE
26. 3-4 SHIFT VALVE
27. VALVE BORE PLUG [14.27mm (.560 in.)]
28. ACCUMULATOR VALVE
29. ACCUMULATOR VALVE SPRING
30. ACCUMULATOR VALVE BUSHING
31. LINE BIAS VALVE SPRING
32. LINE BIAS VALVE

33. 3-2 CONTROL VALVE
34. 3-2 CONTROL VALVE SPRING
35. T.V. MODULATOR UPSHIFT VALVE SPRING
36. T.V. MODULATOR UPSHIFT VALVE
37. T.V. MODULATOR DOWNSHIFT VALVE SPRING
38. T.V. MODULATOR DOWNSHIFT VALVE
39. T.V. LIMIT VALVE
40. T.V. LIMIT VALVE SPRING
41. THROTTLE VALVE
42. RETAINING COILED PIN (Black)
43. THROTTLE VALVE SPRING
44. THROTTLE VALVE PLUNGER
45. THROTTLE VALVE PLUNGER BUSHING
46. #11 D3
47. #8 1-2 SHIFT VALVE
48. #12 LO 1ST

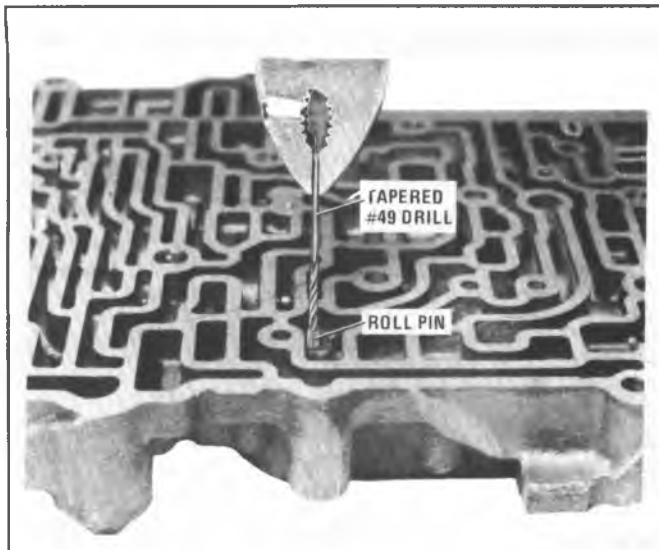

Figure 7A6-227 Removing Blind Hole Roll Pin With Tapered #49 Drill

pins do not fit flush on rough casting face. Make sure that all coiled pins are flush at machined face or damage to the transmission will occur.

7. Inspect the fourth clutch pressure switch for damage. If necessary replace pressure switch using a 24 mm socket (Figure 7A6-228).

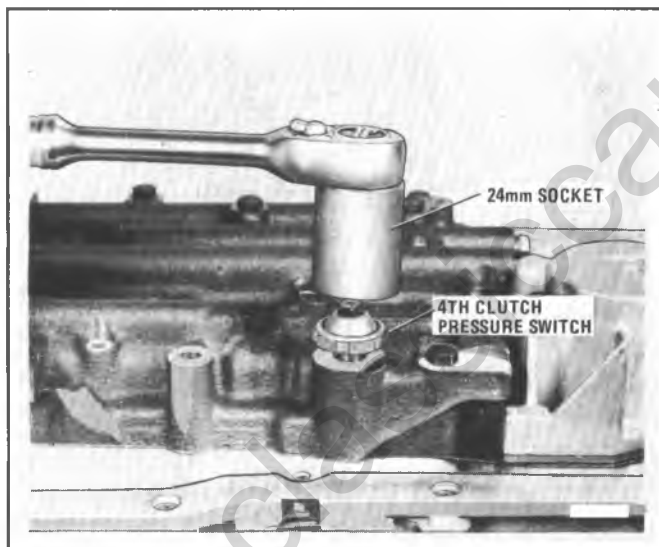

Figure 7A6-228 Fourth Clutch Pressure Switch

## Reassembly

1. Position control valve body as shown in Figure 7A6-228.

2. Install into lower right bore, throttle valve, smaller outside diameter land first, make sure valve is seated at the bottom of the bore. Install inner roll pin between the lands of this valve. Install the T.V. spring into the bore. Install the throttle valve plunger, stem end first, into the throttle valve plunger bushing and install these two parts into the bore, valve end first. Install outer roll pin from rough cast surface side, aligning pin with slot in bushing.

3. In the next bore up, install T.V. limit valve, stem end first. Install the T.V. limit valve spring. Compress the T.V. limit valve spring and install the spring retaining sleeve from the machined face. Make sure the sleeve is level with or below the machined surface.

4. In the next bore up, install T.V. modulator downshift valve spring then install the T.V. modulator downshift valve, smaller chamfered stem end first. Install bore plug, hole out, and roll pin.

5. In the next bore up, install T.V. modulator upshift valve spring then install the T.V. modulator upshift valve, smaller chamfered stem end first. Install bore plug, hole out, and roll pin.

6. In the next bore up, install 3-2 control valve, smaller stem end out. Install 3-2 control valve spring and roll pin.

7. In the next bore up, install line bias valve spring then install the line bias valve, smaller stem end first. Install bore plug, hole out, and roll pin.

8. In the lower left bore, install accumulator bushing into bore, aligning the pin slot in line with the pin hole in control valve assembly. Install accumulator spring then accumulator valve, smaller end first. Next, install bore plug, hole out, and roll pin.

9. In the next bore up, install 3-4 shift valve, chamfered end first. Install the 3-4 throttle valve spring into the 3-4 throttle valve bushing. Next, install the 3-4 throttle valve, stem end first into the 3-4 bushing. Install the 3-4 throttle valve and bushing into the bore, making sure the pin slot is aligned with the pin hole in the control valve assembly. Install the roll pin.

10. In the next bore up, install lo/overrun clutch valve, smaller end first. Next, install the lo/overrun clutch valve spring; compress the spring and install the spring retaining sleeve from the machined face. Make sure the sleeve is level with or below the machined surface. Install the 4-3 control valve spring and 4-3 control valve smaller stemmed end first. Install bore plug, hole out and retaining sleeve from the machined face. Make sure the sleeve is level with or below the machined surface.

11. In the next bore up, install the 1-2 shift valve, small stem outward. Install the 1-2 shift valve bushing, small I.D. first and aligning pin hole in bushing with the inner pin hole in the control valve assembly. Install the inner roll pin. Next, install low 1st/detent valve long stem end out. Install the 1-2 throttle valve spring into the 1-2 throttle valve bushing and the 1-2 throttle valve, stem end first, into the bore, aligning the bushing so the outer pin can be installed in the pin slot. Install the outer roll pin.

12. In the next bore up, install the converter clutch shift valve, short stemmed end first. Next, install the converter clutch throttle valve spring into the converter clutch throttle bushing and the converter clutch throttle valve, stem end first, into the bushing. Install these three parts, valve end first, into the bore, aligning the bushing so the pin can be installed in the pin slot. Install the roll pin.

13. In the next bore up, install the 2-3 shift valve, large end first. Next, install the 2-3 throttle valve spring into the 2-3 throttle valve bushing and the 2-3 throttle valve, stem end first, into the bushing. Install these three parts, valve end first, into the bore, aligning the bushing so the pin can be installed in the pin slot. Install the roll pin.

14. Install manual valve with the inside detent lever pin hole first.

### Case Assembly

1. Inspect 3-4 accumulator spring, piston and pin for damage.
2. Install a new teflon seal on the 3-4 accumulator piston.
3. Install 3-4 accumulator pin in case.
4. Install 3-4 accumulator piston and spring in case (Figure 7A6-229).

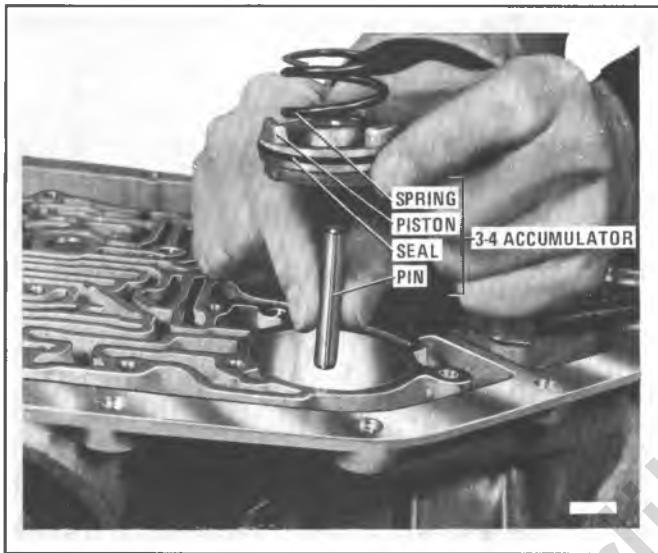

Figure 7A6-229 Installing 3-4 Accumulator Assembly in Case

5. Install eight (8) check balls in the locations shown in Figure 7A6-230.
6. Install two guides as shown in Figure 7A6-232.
7. Install the spacer plate to case gasket marked "C" on the case (Figure 7A6-231).
8. Install the spacer plate (Figure 7A6-233).
9. Install the control valve assembly to spacer plate gasket marked "VB" on the spacer plate (Figure 7A6-233).
10. Inspect the 1-2 accumulator housing, spring, piston and plate for damage.
11. Install the 1-2 accumulator plate and gasket as shown in Figure 7A6-234.
12. Install the 1-2 accumulator spring on plate (Figure 7A6-234).
13. Install a new teflon seal on the 1-2 accumulator piston Figure 7A6-235).
14. Install the 1-2 accumulator piston in the 1-2 accumulator housing with the dome up (Figure 7A6-235).
15. Install the 1-2 accumulator assembly (Figure 7A6-234).
16. Install the five attaching bolts and torque to 12 N·m (8 ft. lb.)

17. Install three (3) check balls in control valve assembly, retain with petrolatum (Figure 7A6-226).

18. Remove both guide pins.

19. Install the control valve assembly making sure to align the manual valve with the detent lever (Figure 7A6-236).

**NOTICE: It is possible during reassembly to position the manual valve too far into the valve body and still connect the selective lever link to it, which will then prevent the valve body from fitting properly onto the transmission case (Figure 7A6-237).**

### Assembly

20. Start control valve assembly to case attaching bolts, except the throttle lever and bracket assembly and the inside manual detent roller and spring assembly and clip retaining bolts (Figure 7A6-238).

21. Install the signal oil pipe in the control valve assembly.

22. Inspect inside manual detent roller and spring assembly for damage.

23. Install the inside manual detent roller and spring assembly, locating the tang in the control valve, and the roller on the inside detent lever. (Figure 7A6-239).

24. Throttle lever and bracket assembly.

a. Inspect throttle lever and bracket assembly for damage (Figure 7A6-240).

b. If removed, install spring on top of lifter, then lifter spring first into throttle bracket (Figure 7A6-240).

c. Install link on throttle lever making sure link is hooked as shown (Figure 7A6-240).

d. Install throttle lever and bracket assembly, locating slot in bracket with roll pin, aligning lifter through valve body hole and link through T.V. linkage case bore. Retain with bolt (Figure 7A6-241).

25. Install the 4-3 pressure switch (locating pipe in hole) and bolt (Figure 7A6-238).

### Filter Assembly

1. Install the filter intake pipe "O" ring on intake pipe (Figure 7A6-242) and add petrolatum.

2. Install filter in pump bore and position as shown in Figure 7A6-242.

3. Install pan using new gasket. Torque attaching bolts to 16 N·m (12 ft. lbs.).

### Install Converter

1. Install converter, making sure that the converter hub engages the drive lugs inside the pump rotor. If they do not engage, a low mileage pump failure will occur.

2. Make sure that the converter has not bound up the pump rotor inside the transmission.

3. Check the converter to be sure that it turns freely and is able to move forward to meet the flywheel.

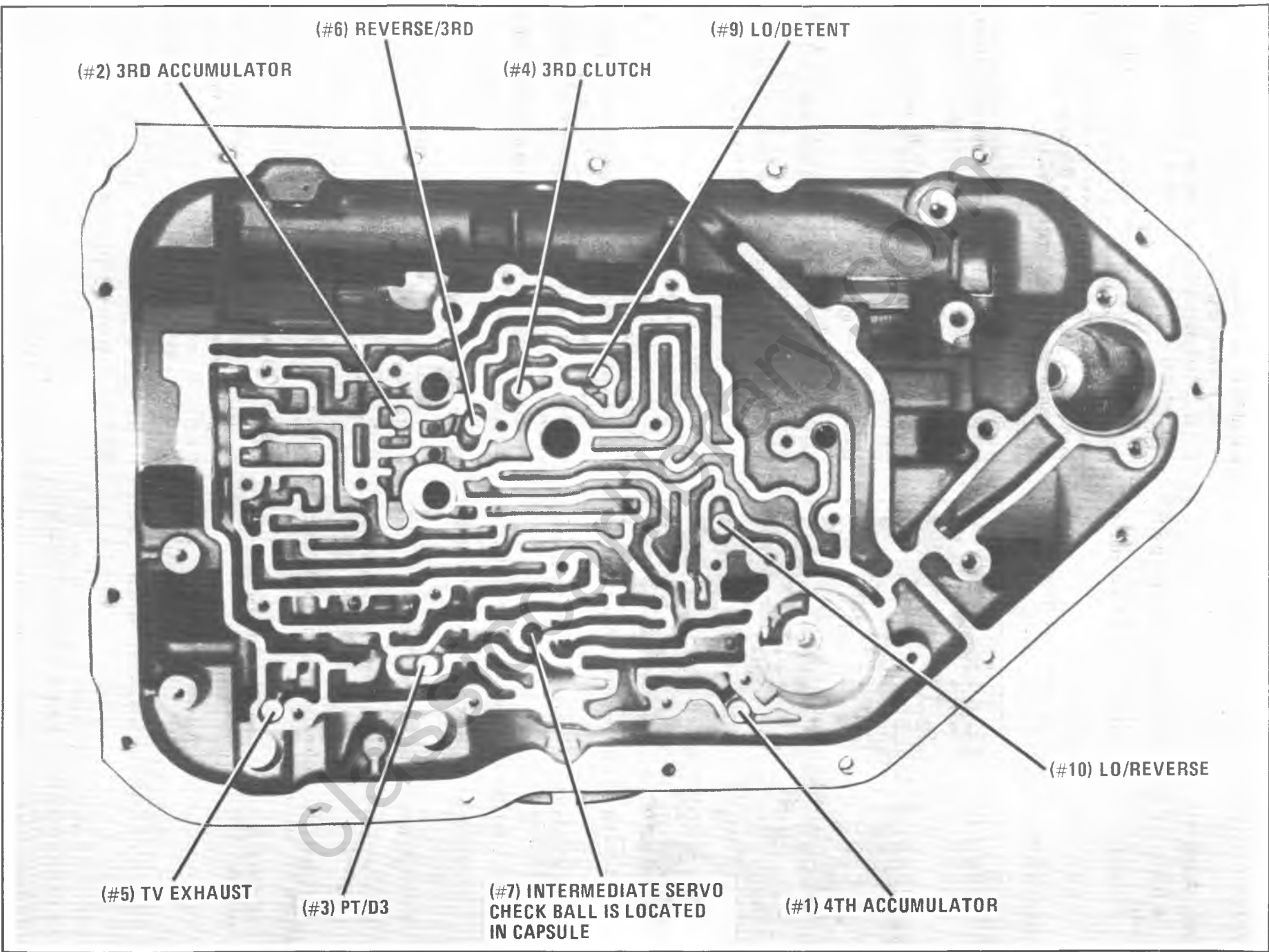

Figure 7A6-230 Check Ball Location in Bottom of Case



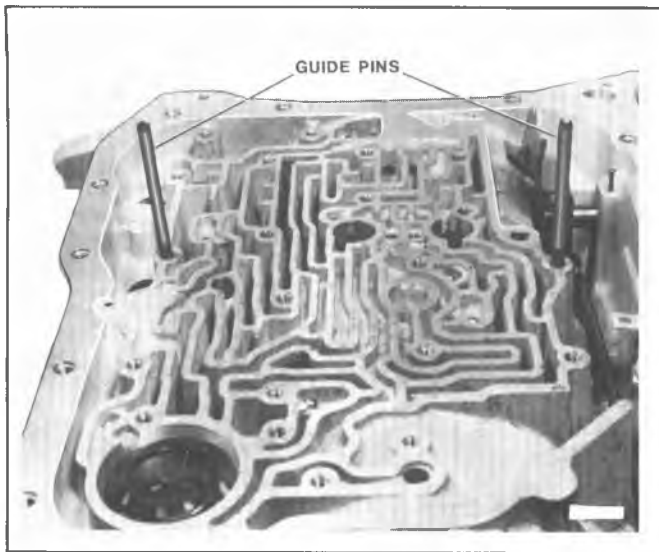

Figure 7A6-232 Installing Guide Pins in Case

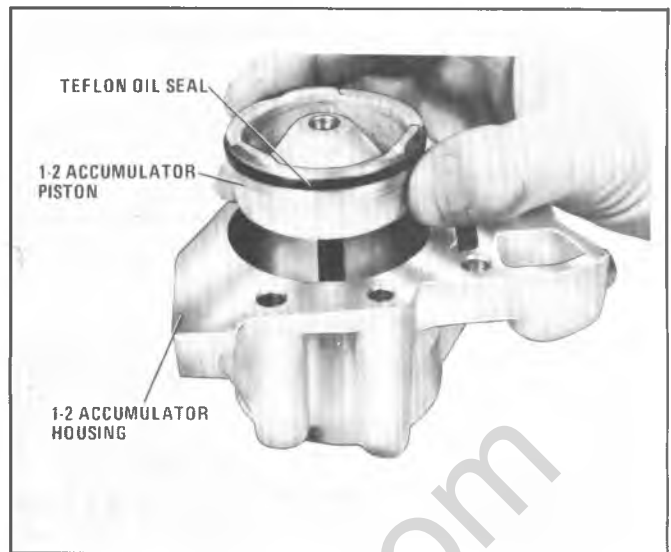

Figure 7A6-235 Installing 1-2 Accumulator Piston in Housing

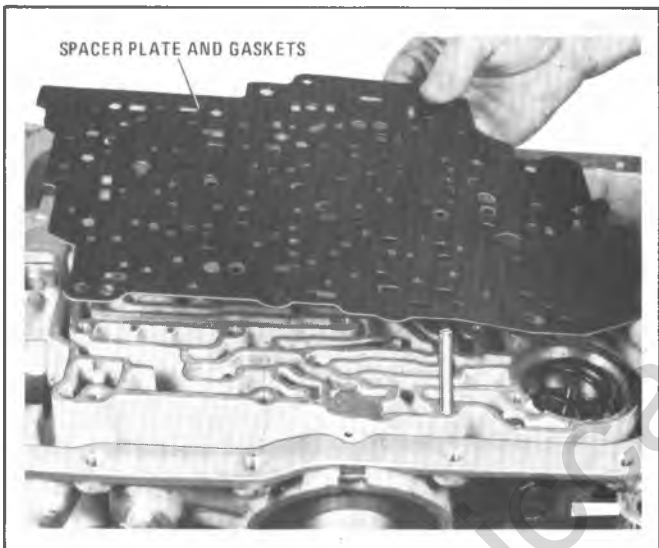

Figure 7A6-233 Installing Control Valve Assembly Spacer Plate and Gaskets

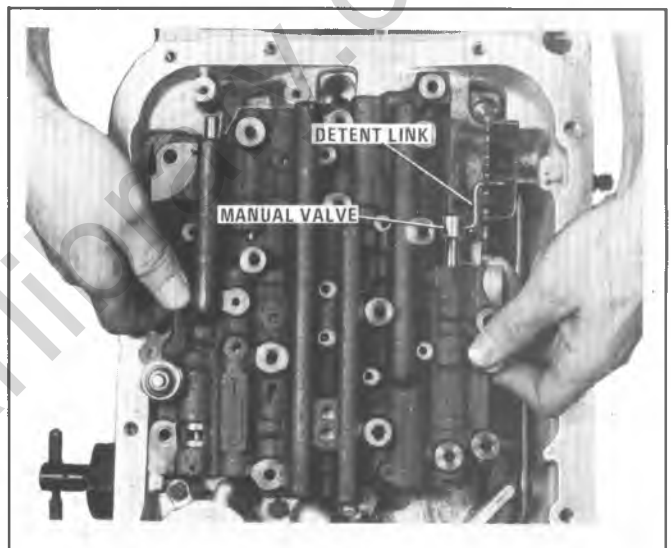

Figure 7A6-236 Installing Control Valve Assembly

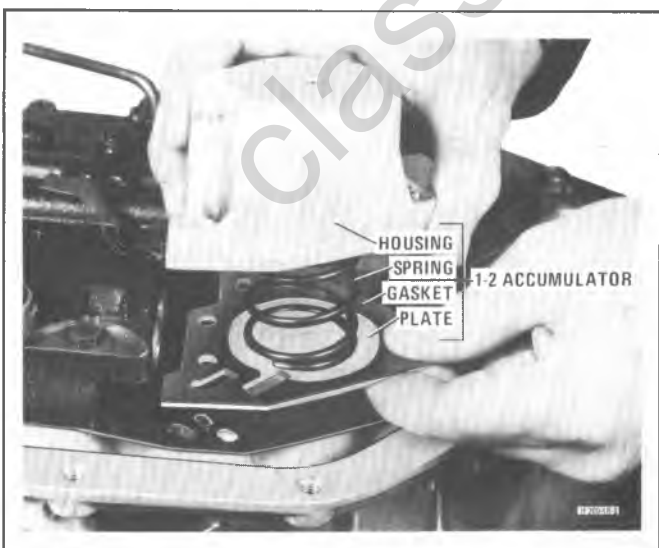

Figure 7A6-234 Installing 1-2 Accumulator Assembly

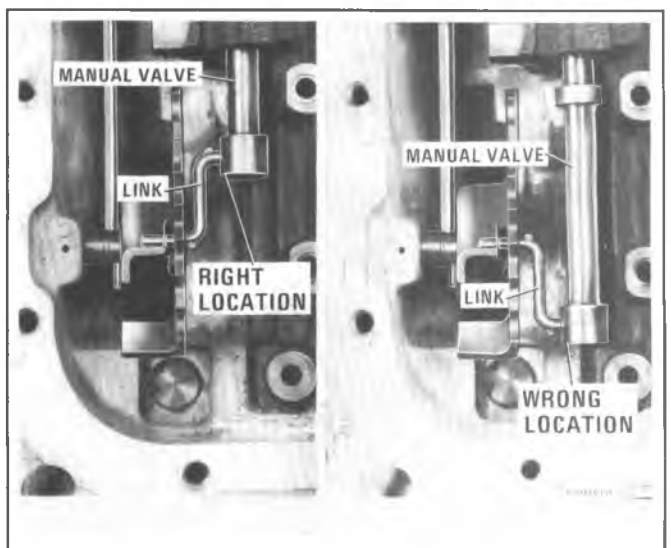

Figure 7A6-237 Proper Location of Manual Valve and Selective Lever Link in Control Valve

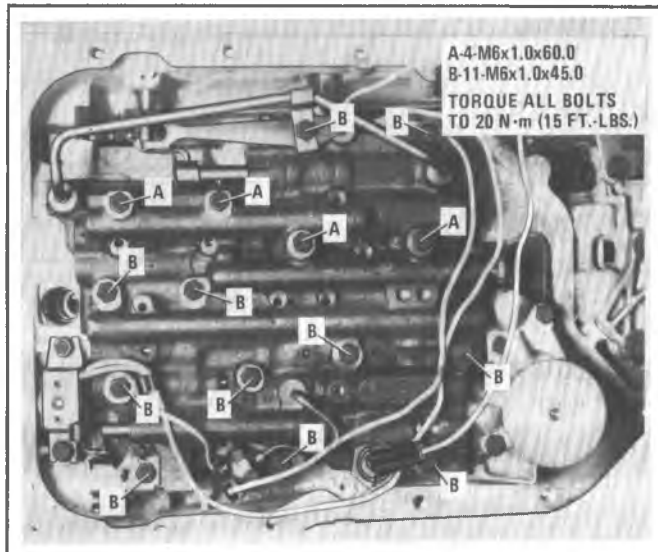

Figure 7A6-238 Control Valve Assembly Bolt Location

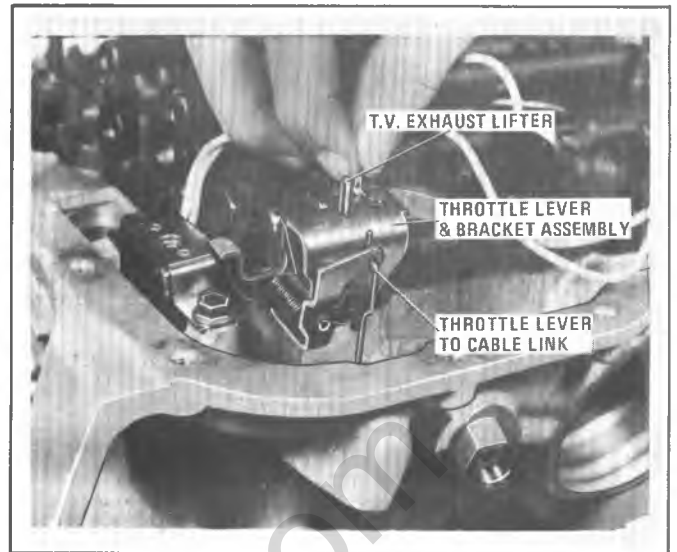

Figure 7A6-241 Installing Throttle Valve and Bracket Assembly

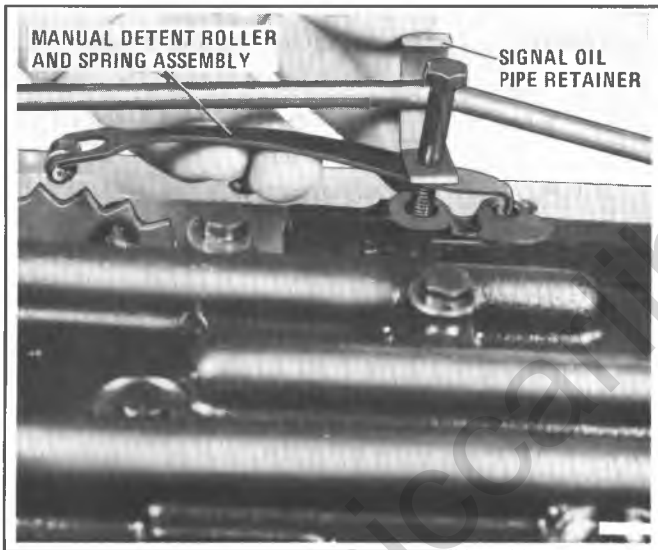

Figure 7A6-239 Installing Detent Roller Assembly

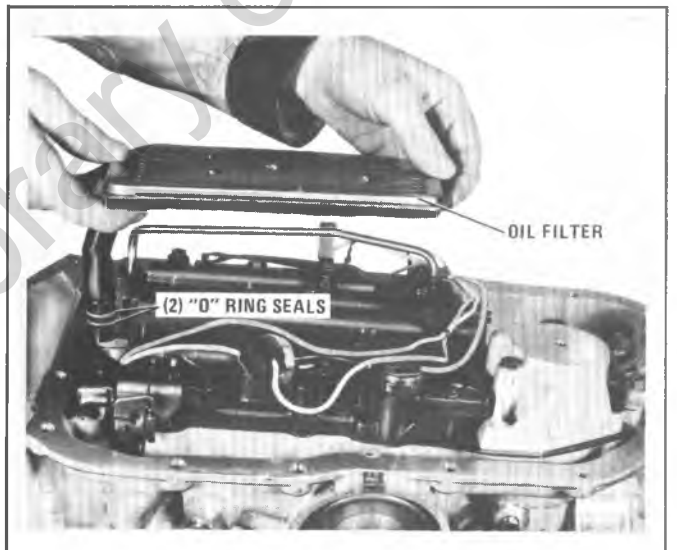

Figure 7A6-242 Installing Filter Assembly

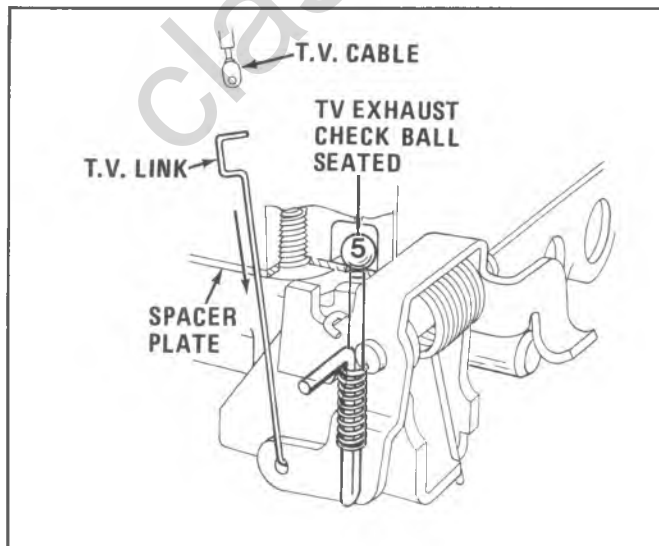

Figure 7A6-240 Throttle Lever and Bracket Assembly

**7A6-68 AUTOMATIC 200-4R TRANSMISSION**

REQUIRED SPECIAL TOOLS			
TOOL NO.	NAME	TOOL NO.	NAME
J-29332	Output Shaft Loading Fixture Adapter	J-25015	Oil Pump Body and Cover Alignment Band
J-25013-1	Rear Unit Support	J-25016	Front Oil Pump Seal Installer
J-24773-5	Oil Pump Remover Screw	J-25018-A	Forward Clutch Spring Compressor Adapter
J-24773-1	Oil Pump Remover and End Play Checking Fixture	J-25022	Oil Pump End-Play Checking Fixture Adapter
J-29334	Fourth Clutch Compressor and Center Support Remover	J-25024	Forward Clutch Spring Compressor
J-29335	Inner Overrun Clutch Piston Seal Protector	J-25025-A	Alignment Pin and Stud Set
J-29337	Forward and Direct Clutch Unit Fixture	J-28542	Reverse Clutch Housing Installer and Remover
J-8763-02	Holding Fixture and Base	J-29060	Torque Converter Clutch End-Play Fixture
J-3289-20		J-7004	Slide Hammer
J-25359-3	#27 Torx Bit	J-8001	Dial Indicator Set
J-26744-A	Seal Installer	or	
J-21426	Rear Oil Seal Installer	J-26900-12	Dial Indicator Set
J-23327	Clutch Spring Compressor	J-8092	Driver Handle
J-25010	Direct Clutch Seal Protector		
J-25011	Reverse Clutch Seal Protector		
J-25014	Intermediate Band Apply Pin Gage		

Figure 7A6-243 Required Tool List

STANDARD TOOLS	
<p>Speed Handle Wrench, 3/8" Drive                      10mm, 13mm and 24mm Sockets, 3/8" Drive                      Small Flat Edge Screwdriver and Long Flat Edge Screwdriver                      Plastic or Rubber Hammer                      No. 4 Easy Out or Equivalent                      "T" Handle Tap Wrench                      3mm (1/8"), 5mm (3/16") and 6.4mm (1/4") Punch</p>	<p>Feeler Gage from 0.04mm - 2.40mm                      Expanding Type Snap Ring Pliers                      Contracting Type Snap Ring Pliers                      Needle Nose Pliers                      Newton Meter (Inch Pound and Foot Pound)                      Torque Wrench                      #49 Drill                      300mm (12") Scale Pliers</p>

Figure 7A6-244 Standard Tool List



## TORQUE SPECIFICATIONS

Description Of Usage	Quantity	Size	Torque Assembly
Line Pressure Take-Off and Direct Clutch Pressure Take-Off	2	1/8-27 NPTF	7.0-14.0 N•m (5-10 ft.-lbs.)
Cooler Connector	2	1/4-18 NPSF	35.0-40.0 N•m (26-30 ft.-lbs.)
Valve Body Assembly to Case	15	M6 x 1.0	10.0-14.0 N•m (7-10 ft.-lbs.)
Speedo Retainer to Case	1	M6 x 1.0	10.0-14.0 N•m (7-10 ft.-lbs.)
Pump Body to Pump Cover	5	M8 x 1.25	20.0-27.0 N•m (15-20 ft.-lbs.)
Pump Assembly to Case	7	M8 x 1.25	20.0-27.0 N•m (15-20 ft.-lbs.)
Parking Lock Bracket to Case	2	M8 x 1.25	20.0-27.0 N•m (15-20 ft.-lbs.)
Transmission Oil Pan to Case	16	M8 x 1.25	14.0-18.0 N•m (10-13 ft.-lbs.)
Manual Shaft to Inside Detent Lever (Nut)	1	M10 x 1.5	27.0-34.0 N•m (20-25 ft.-lbs.)
Stator Shaft to Pump Cover	3	M6 x 1.0	10.0-14.0 N•m (7-10 ft.-lbs.)
Case to Center Support	2	M10 x 1.5	20.0-27.0 N•m (15-20 ft.-lbs.)
Solenoid to Case	2	M6 x 1.0	10.0-14.0 N•m (7-10 ft.-lbs.)
Pressure Switch	1	1/8-27 NPTF	7.0-14.0 N•m (5-10 ft.-lbs.)
Accumulator Housing to Case	5	M6 x 1.0	10.0-14.0 N•m (7-10 ft.-lbs.)
Governor Cover to Case	4	M8 x 1.25	20.0-27.0 N•m (15-20 ft.-lbs.)

H-200-4R-173

Figure 7A6-245 Torque Specifications

classiccarylbrary.com

## SECTION 7A

## 400 AUTOMATIC TRANSMISSION

## INDEX

Transmission Disassembly and Reassembly .....	7A-3	Output Shaft, Rear Internal Gear, Sun Gear and Shaft .....	7A-41
Disassembly of Major Units .....	7A-3	Sun Gear Shaft Bushing-Front .....	7A-41
Governor, Speedometer Driven Gear, Pan, Filter and Intake Pipe .....	7A-3	Sun Gear Shaft Bushing-Rear .....	7A-41
Control Valve Assembly, Solenoid Connector, Governor Pipes and Detent Spring .....	7A-4	Main Shaft Inspection .....	7A-41
Rear Servo, Valve Body Spacer, Gasket and Front Servo .....	7A-5	Front and Rear Bands Inspection .....	7A-41
Rear Band Apply Pin Selection .....	7A-6	Case Extension .....	7A-41
Manual Linkage .....	7A-7	Modulator and Valve .....	7A-42
Rear Oil Seal and Case Extension .....	7A-9	Manual and Parking Linkage Inspection .....	7A-42
Front Unit End Play Checking Procedure .....	7A-9	Case Assembly Inspection .....	7A-42
Oil Pump and Internal Case Components .....	7A-10	Case Assembly Bushing .....	7A-44
Rear End Play Checking Procedure .....	7A-11	Converter Inspection .....	7A-44
Gear Unit Assembly .....	7A-13	Converter End Clearance Check .....	7A-44
Speedometer Drive Gear .....	7A-15	Assembly of Rear Unit .....	7A-45
Governor Assembly .....	7A-16	Assembly of Units to Transmission Case .....	7A-48
Driven Gear Replacement .....	7A-17	Install Manual Linkage .....	7A-51
Front Servo Parts Inspection .....	7A-18	Rear Extension Assembly .....	7A-52
Rear Servo Parts Service .....	7A-18	Check Balls, Front Servo, Spacer and Solenoid ...	7A-53
Control Valve Service .....	7A-19	Rear Servo Assembly .....	7A-55
Oil Pump Service .....	7A-22	Control Valve Assembly and Governor Pipes .....	7A-56
Forward Clutch Service .....	7A-25	Filter and Intake Pipe .....	7A-56
Direct Clutch and Intermediate Roller Service .....	7A-31	Modulator Valve and Vacuum Modulator .....	7A-57
Center Support Service .....	7A-35	Governor .....	7A-57
Reaction Carrier, Roller Clutch and Output Carrier Assembly .....	7A-40	Speedometer Driven Gear .....	7A-57
Pinion Replacement .....	7A-40	Converter Assembly-Installation .....	7A-57
		Specifications .....	7A-58
		Special Tools .....	7A-59

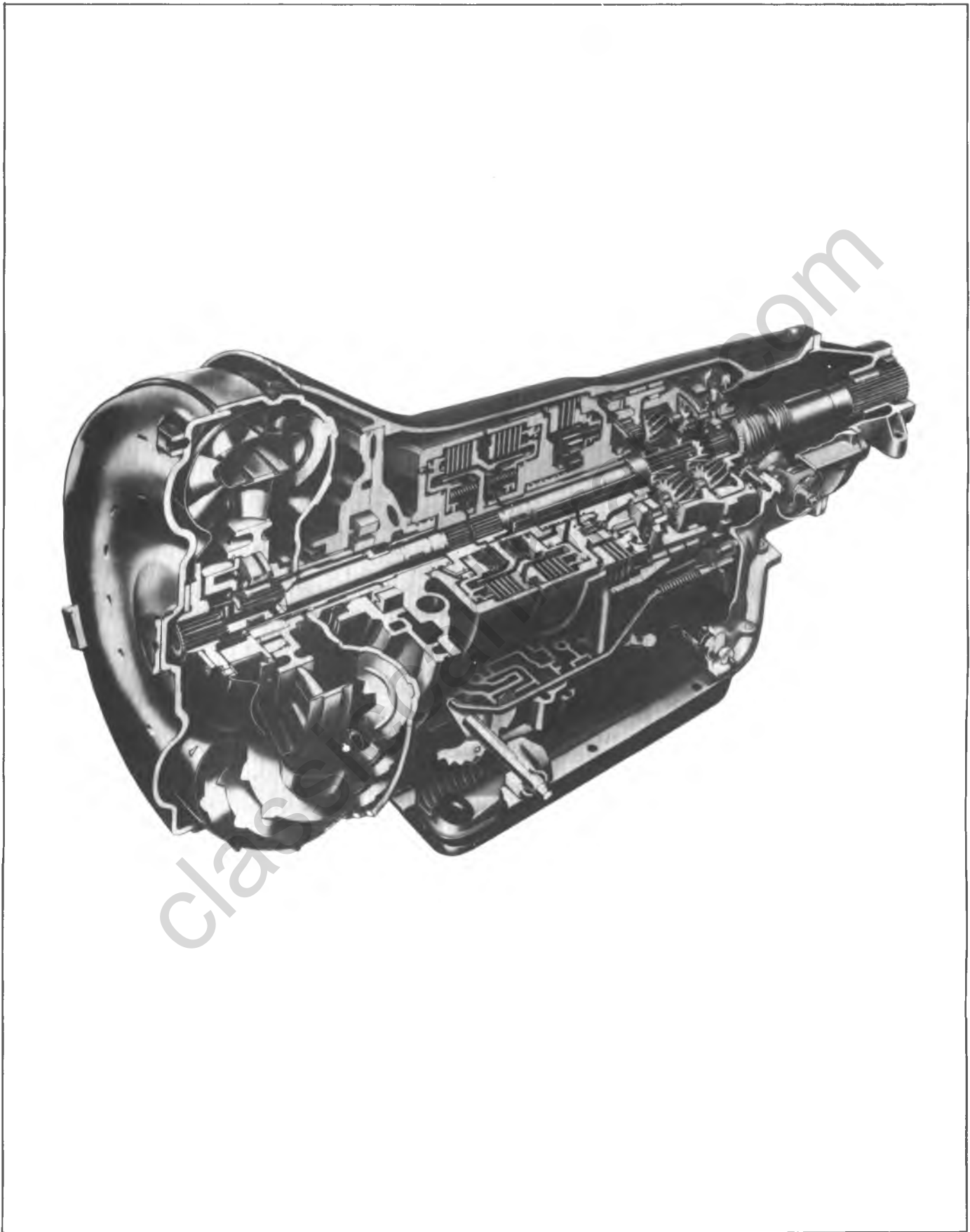

Fig. 7A-1C-400 Automatic Transmission, Side Cross Section--Typical

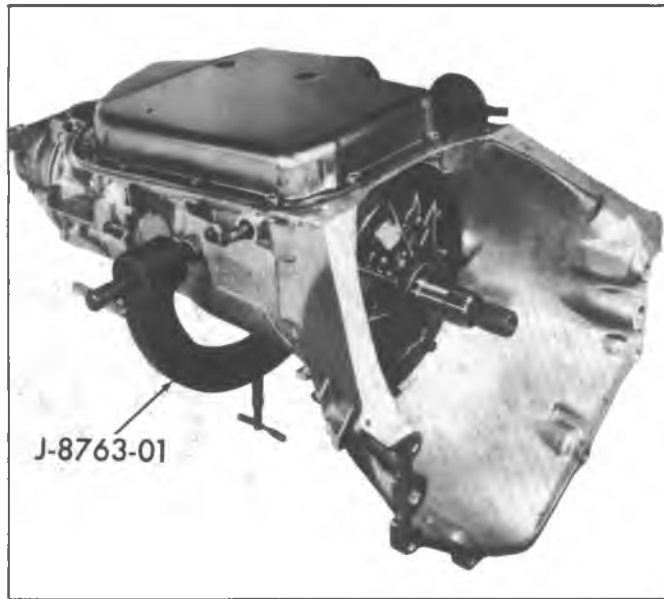

Fig. 7A-2C--Transmission in Holding Fixture

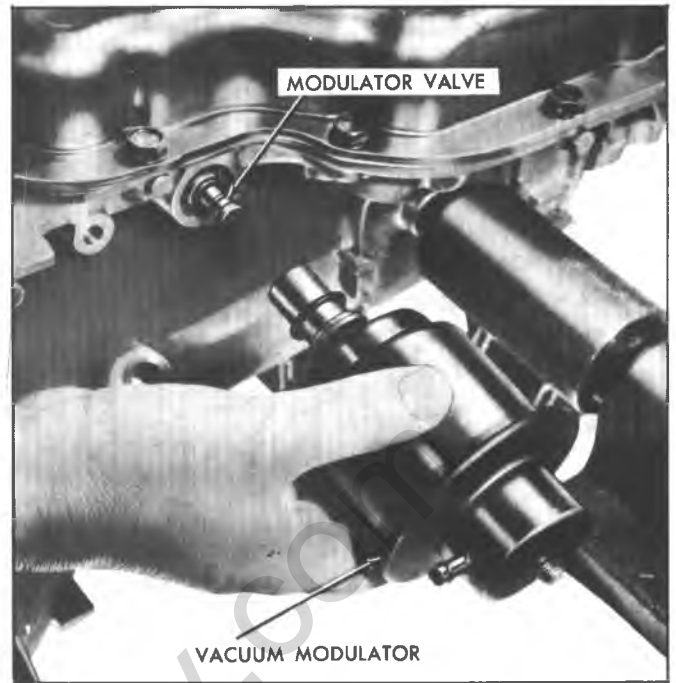

Fig. 7A-4C--Removing Vacuum Modulator and Valve

### DISASSEMBLY OF MAJOR UNITS

1. With transmission in cradle on portable jack, remove converter assembly by pulling straight out. Converter contains a large amount of oil.

2. Install holding Fixture J-8763-01 on transmission so that modulator assembly will be located on side of holding fixture nearest bench (Fig 7A-2C). Do not over-torque holding screw. This will bind center support.

3. Install fixture and transmission into holding Tool Base J-3289-14 with bottom pan facing up (Fig. 7A-2C).

4. Remove modulator assembly attaching screw and retainer (Fig. 7A-3C).

5. Remove vacuum modulator assembly and "O" ring seal from case (Fig. 7A-4C). Discard "O" ring.

6. Remove modulator valve from transmission case (Fig. 7A-4C).

### Removal of Governor, Speedometer Driven Gear, Pan, Filter and Intake Pipe

1. Remove attaching screws, governor cover and gasket (Fig. 7A-5C). Discard gasket.

2. Withdraw governor assembly from case.



Fig. 7A-3C--Removing Modulator Retainer

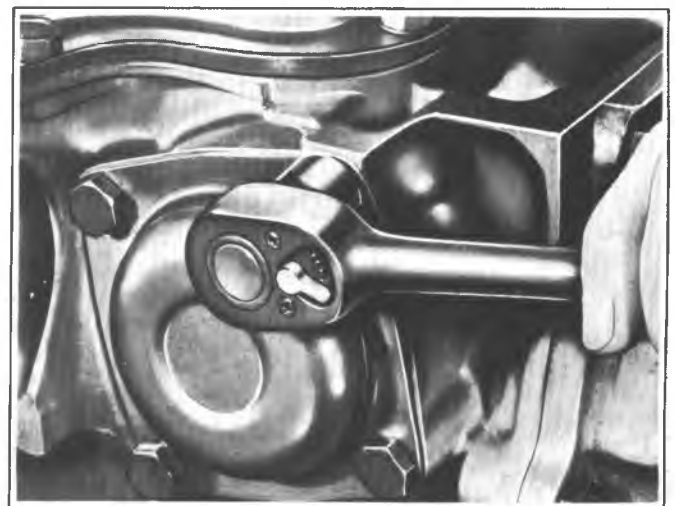

Fig. 7A-5C--Removing Governor Cover Attaching Screws

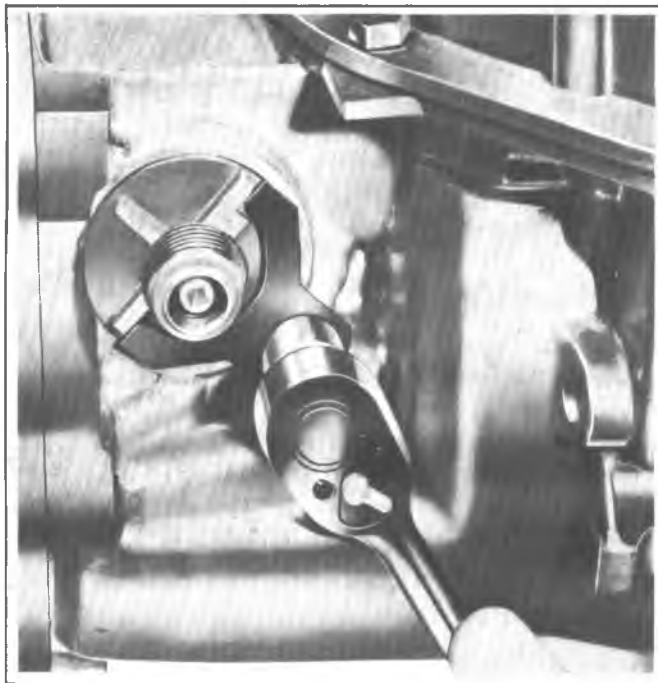

Fig. 7A-6C--Removing Speedometer Driven Gear Retainer

3. Remove speedometer driven gear attaching screw and retainer (Fig. 7A-6C).
4. Withdraw speedometer driven gear assembly from case.
5. Remove bottom pan attaching screws, bottom pan and bottom pan gasket. Discard gasket.
6. Remove the filter retainer bolt (Fig. 7A-7C).
7. Remove filter and intake pipe assembly from case (Fig. 7A-8C) and discard filter.
8. Remove intake pipe to case "O" ring seal from intake pipe or case and discard.

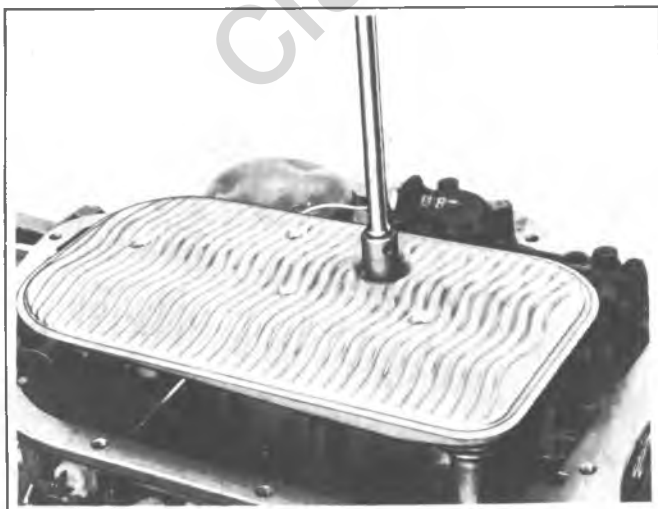

Fig. 7A-7C--Removing Filter Retainer Bolt

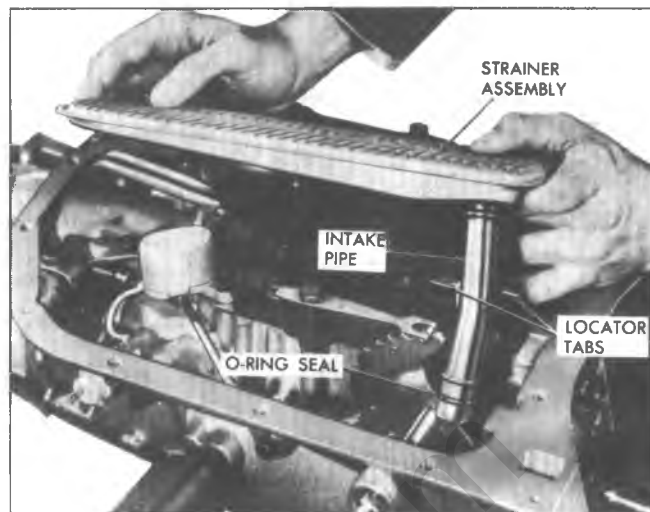

Fig. 7A-8C--Removing Filter Assembly and "O" Ring

### Removal of Control Valve Assembly, Solenoid Connector, Governor Pipes, Governor Screen Assembly, and Detent Spring Assembly

1. Remove control valve body attaching screws and detent roller and spring assembly (Fig. 7A-9C). Do not remove solenoid attaching screws.

**NOTICE:** If transmission is in the vehicle, the front servo parts may drop out as the control valve assembly is removed.

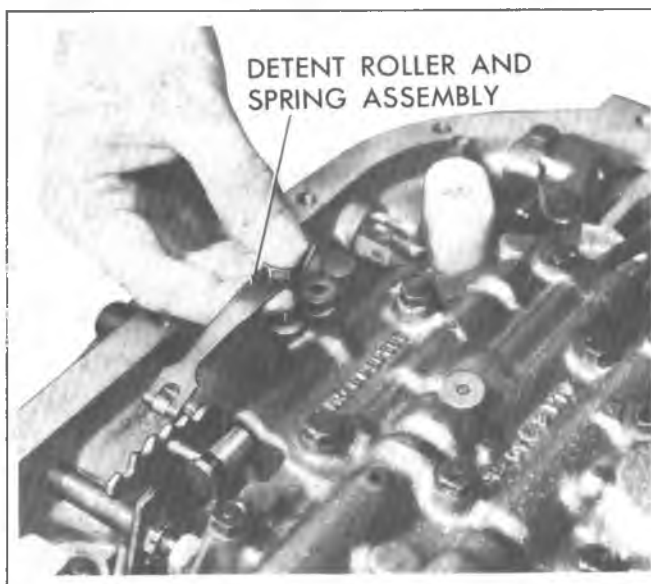

Fig. 7A-9C--Removing Detent Roller and Spring Assembly

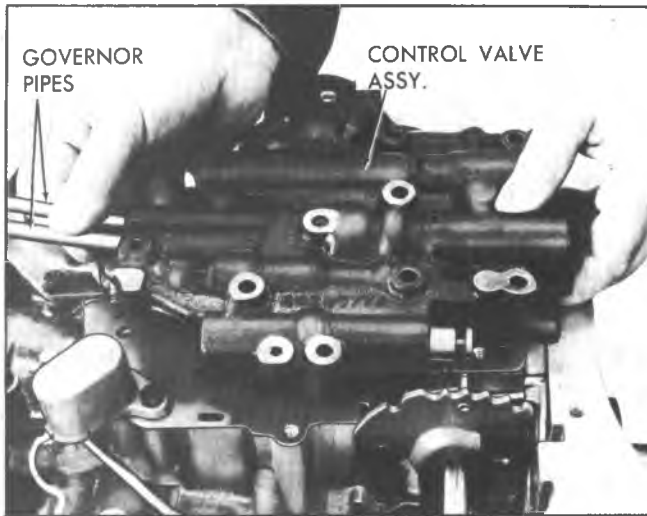

Fig. 7A-10C--Removing Control Valve Assembly and Governor Pipes from Case

2. Remove control valve assembly and governor pipes (Fig. 7A-10C). Do not drop manual valve.
3. Remove governor screen assembly from governor feed pipe hole in the case or from end of governor feed pipe (Fig. 7A-11C). Clean governor screen in clean solvent and air dry.
4. Remove governor pipes from control valve assembly.
5. Disconnect solenoid lead wire from connector terminal (Fig. 7A-12C).

### Removal of Rear Servo, Valve Body Spacer, Gasket and Front Servo

1. Remove rear servo cover attaching screws, servo cover and gasket. Discard gasket (Fig. 7A-13C).
2. Remove rear servo assembly from case (Fig. 7A-14C).
3. Remove rear servo accumulator spring.
4. Make band apply pin selection check to determine possible cause of malfunction (Fig. 7A-15C).

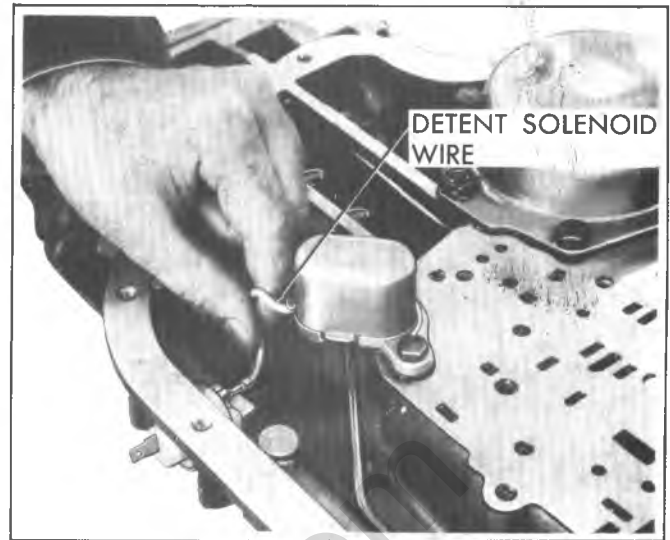

Fig. 7A-12C--Disconnecting Detent Solenoid Wire

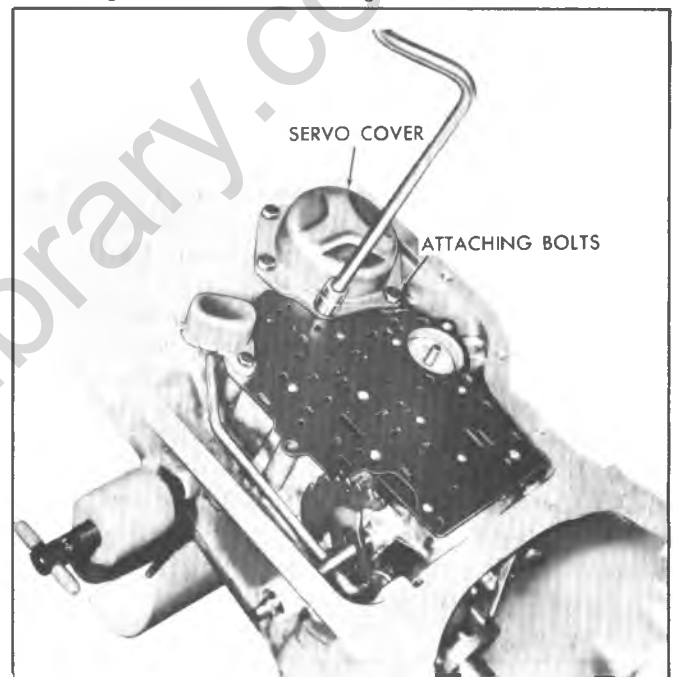

Fig. 7A-13C--Removing Rear Servo Cover Attaching Bolts

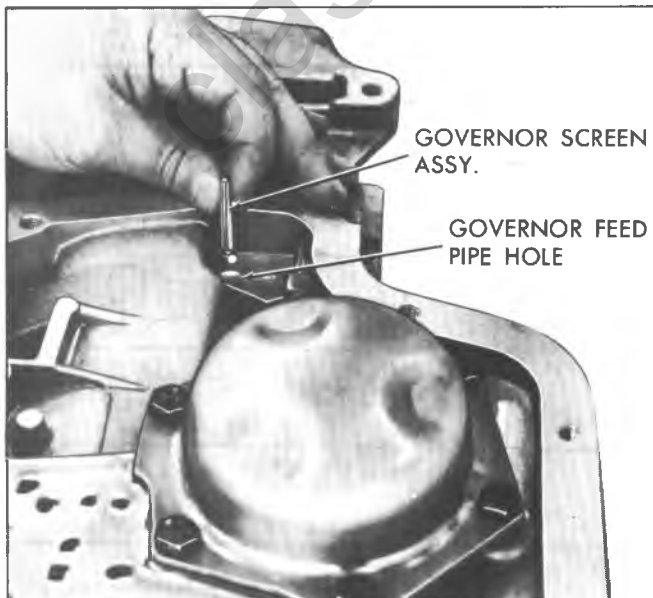

Fig. 7A-11C--Removing Governor Screen Assembly

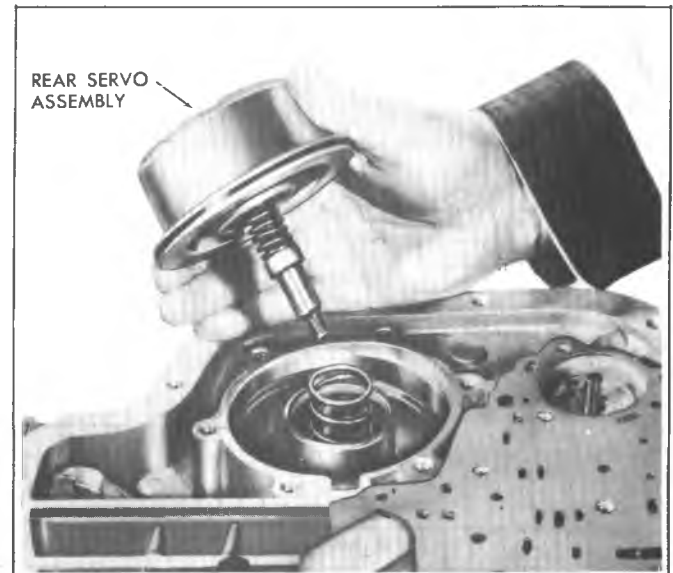

Fig. 7A-14C--Removing Rear Servo Assembly

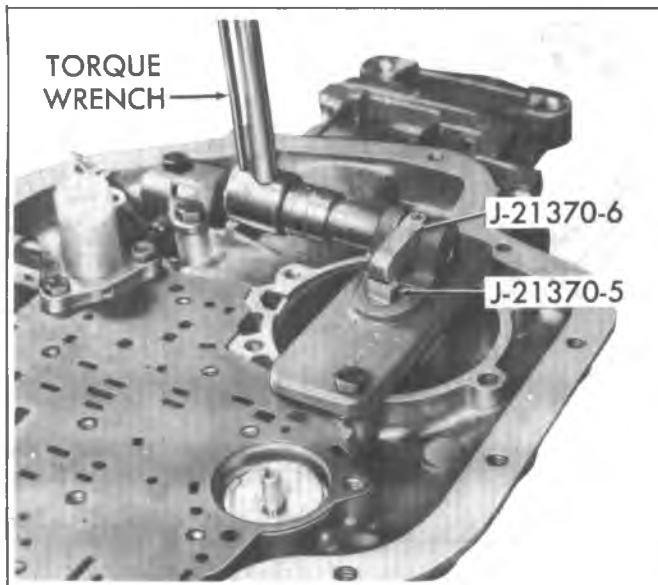

Fig. 7A-15C--Checking Rear Band Apply Pin, Except Models CD and CL

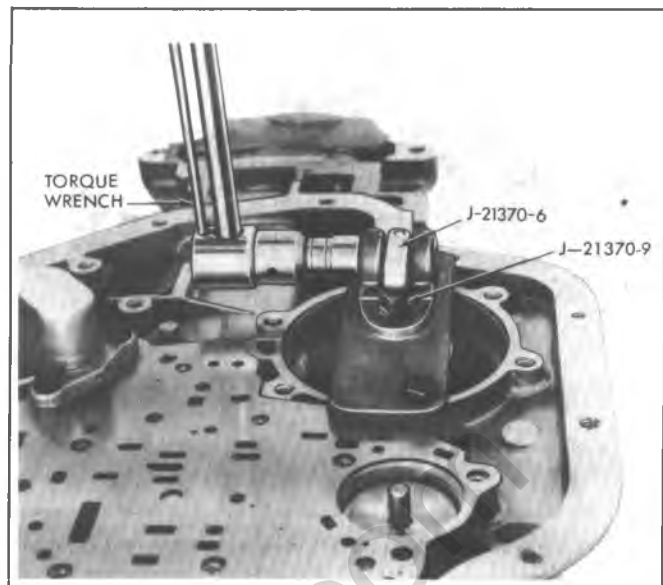

Fig. 7A-16C--Checking Rear Band Apply Pin, Models CD and CL

**Rear Band Apply Pin Selection (All Models Except CD and CL)**

a. Attach band apply pin selection Gage J-21370-5 and J-21370-6 to transmission case with attaching screws checking to make certain the gage pin does not bind in servo pin hole (Fig. 7A-15C).

b. Apply 25 ft. lb. torque and select proper pin to be used during assembly of transmission. Selecting proper length pin is equivalent to adjusting band. The band lug end of each selective apply pin bears identification in the form of one, two or three rings.

c. If both steps of J-21370-5 are below the gage surface, the long pin, identified by 3 rings, should be used.

d. If the gage surface is between the steps, the medium pin, identified by 2 rings, should be used.

e. If both steps are above the gage surface, the short pin, identified by 1 ring, should be used.

**Rear Band Apply Pin Selection (Models CD and CL)**

There are six selective pins identified as shown in Figure 7A-17C. Selecting proper pin is equivalent to adjusting band.

a. Attach band apply pin selection gage (J-21370-9 and J-21370-6), to transmission case (lever pivot pin to rear) with rear servo cover attaching screws.

GAGING STEPS LOCATED ON THREE SIDES OF TOOL J-21370-9		PART NO.	PIN IDENTIFICATION
	C LONGEST PIN	THIS STEP: USE PIN NO. 8627195	
		THIS STEP: SIDES B TO C USE PIN NO. 8627194	
	B	THIS STEP: USE PIN NO. 8624141	
		THIS STEP: SIDES A TO B USE PIN NO. 8627193	
	A	THIS STEP: USE PIN NO. 8624140	
	LOWER STEP SHORTEST PIN	LOWER STEP: USE PIN NO. 8627192	

Note: The Identification Rings are .030" and .100" wide.

Fig. 7A-17C--Rear Band Apply Pin Identification





Fig. 7A-18C--Removing Detent Solenoid and Gasket

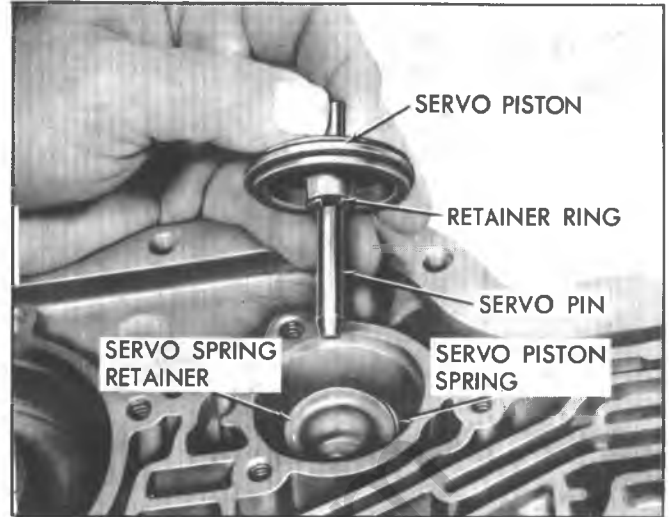

Fig. 7A-20C--Removing Front Servo Piston, Retainer Ring, and Pin

b. Attach tool attaching screws finger tight and check freeness of selective pin. Torque attaching screws to 15 foot-pounds and recheck pin to make certain it does not bind.

c. Apply 25 foot-pounds torque to the lever on Tool J-21370-6 (Fig. 7A-16C). Selection of the proper rear band apply pin is determined by the relation of the flat on Tool J-21370-9 to the flat machined area around the hole on Tool J-21370-6.

d. Before removing gaging tool make note of the proper band apply pin to be used during assembly of the transmission as determined by the six selective pins identified as shown in Fig. 7A-17C. If the transmission is in the vehicle, be careful when the detent solenoid is removed as it prevents the spacer plate and gasket and check balls from dropping down.

5. Remove detent solenoid attaching screws, detent solenoid and gasket (Fig. 7A-18C).

6. Withdraw electrical connector and "O" ring seal (Fig. 7A-19C).

7. Remove control valve assembly spacer plate and gasket.

8. Remove six (6) check balls from cored passages in transmission case. Mark location of balls for aid in reassembly.

9. Remove front servo piston, retainer ring, washer, pin, spring retainer and spring from transmission case (Fig. 7A-20C).

### Remove Manual Linkage

1. Unthread jam nut holding detent lever to manual shaft. (Model CD transmission does not have parking lock mechanism).

2. Remove manual shaft retaining pin from case (Fig. 7A-21C).

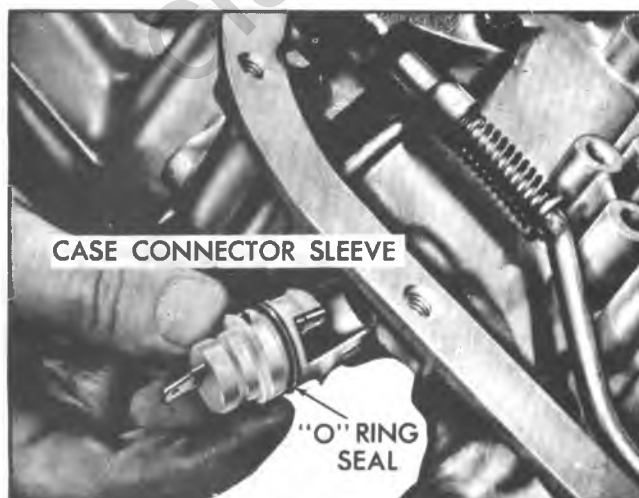

Fig. 7A-19C--Removing Electrical Connector and "O" Ring Seal

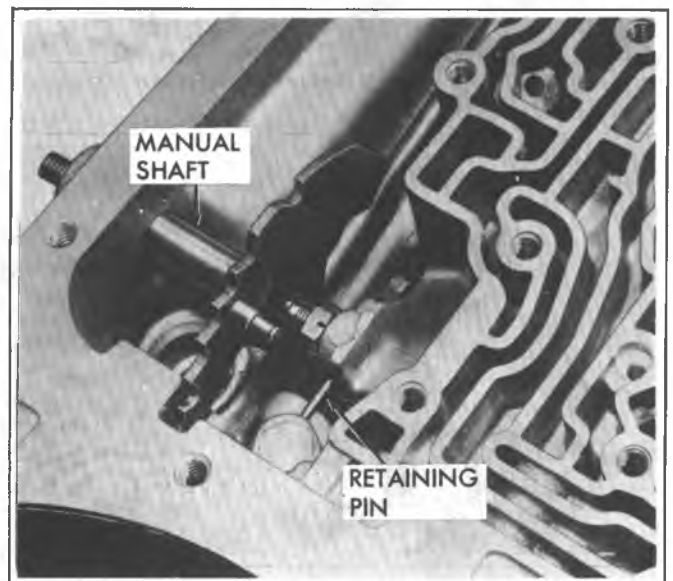

Fig. 7A-21C--Removing Manual Shaft Retaining Pin from Case

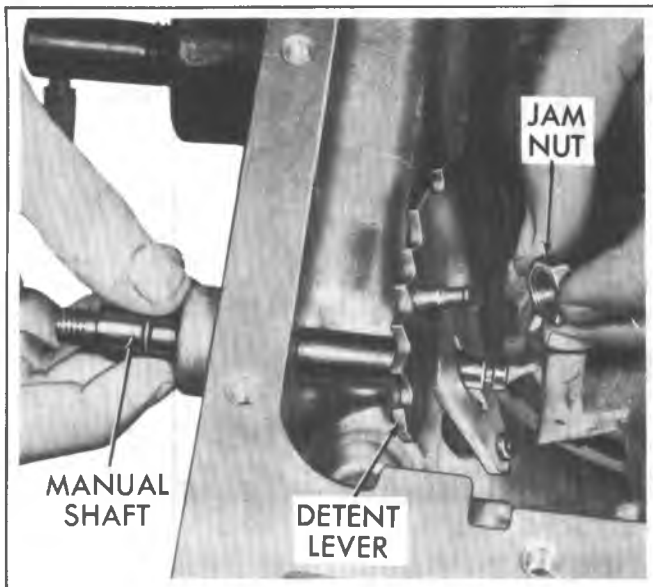

Fig. 7A-22C--Removing Detent Lever and Jam Nut from Manual Shaft

3. Remove manual shaft and jam nut from case (Fig. 7A-22C). Do not lose jam nut as it becomes free from manual shaft.

4. Remove parking actuator rod and detent lever assembly.

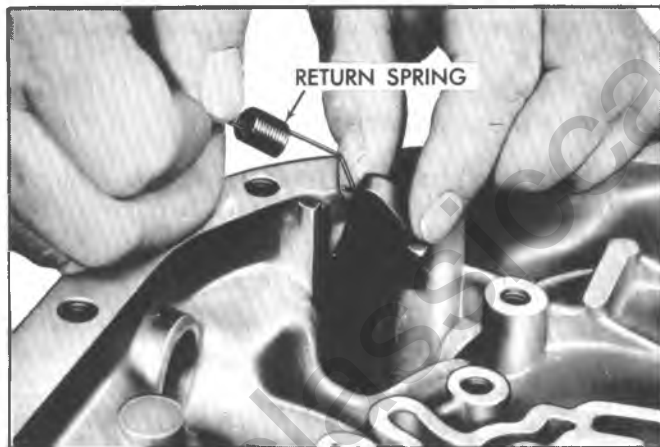

Fig. 7A-24C--Removing Parking Pawl Return Spring



Fig. 7A-23C--Removing Parking Bracket

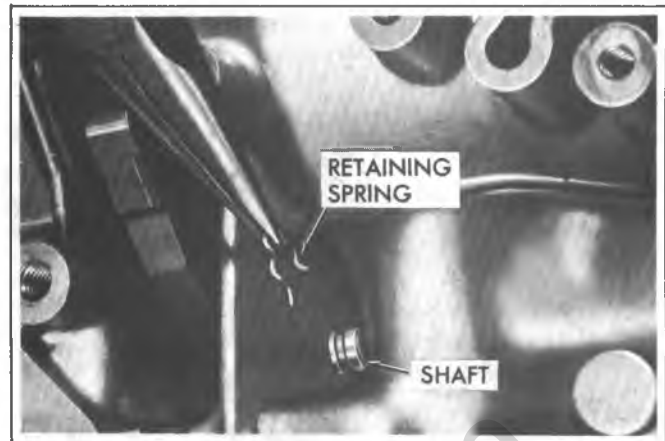

Fig. 7A-25C--Removing Parking Shaft Retaining Spring

5. Remove attaching screws and parking bracket (Fig. 7A-23C).

6. Remove parking pawl return spring (Fig. 7A-24C).

The following steps are to be completed only if 1 or more of the parts involved require replacement.

7. Remove parking pawl shaft retainer (Fig. 7A-25C).

8. Remove parking pawl shaft cup plug by inserting a screwdriver, between the parking pawl shaft and the case rib, and prying outwards (Fig. 7A-26C).

9. Remove parking pawl shaft and parking pawl (Fig. 7A-26C).

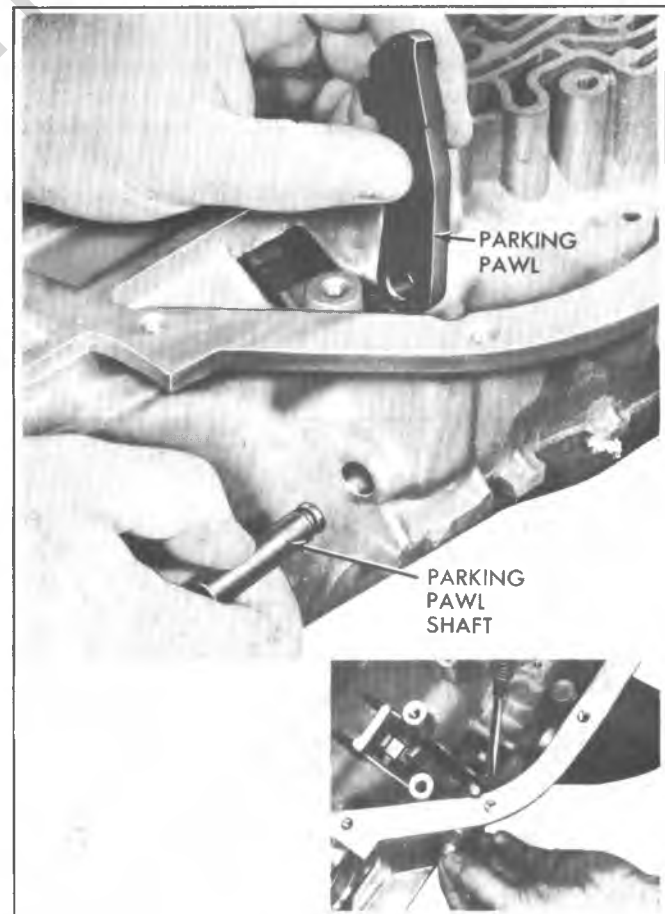

Fig. 7A-26C--Removing Parking Pawl, Shaft and Cup Plug

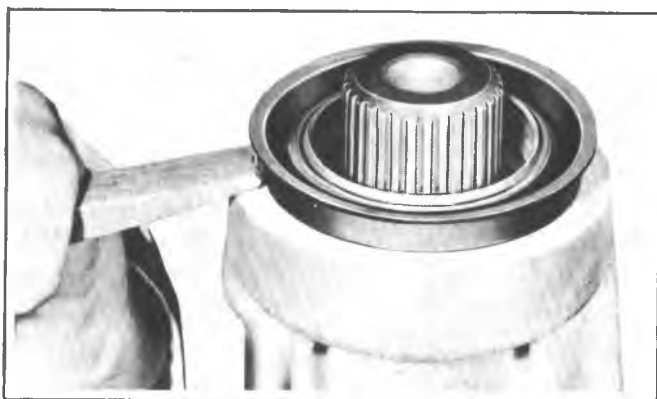

Fig. 7A-27C--Removing Rear Oil Seal from Case Extension

### Removal of Rear Oil Seal and Case Extension and Front Unit End Play Check

1. If necessary to replace, pry rear oil seal from case extension (Fig. 7A-27C).
2. Remove case extension to case attaching bolts.
3. Remove case extension to case gasket (Fig. 7A-28C).
4. Make front unit end play check as follows (Fig. 7A-29C):
  - a. Remove one front pump attaching bolt, and bolt washer. (See Fig. 7A-29C for location).
  - b. Install a 3/8"-16 threaded slide hammer bolt or J-9539, into bolt hole.
  - c. Mount a dial indicator on rod and index indicator to register with end of turbine shaft.

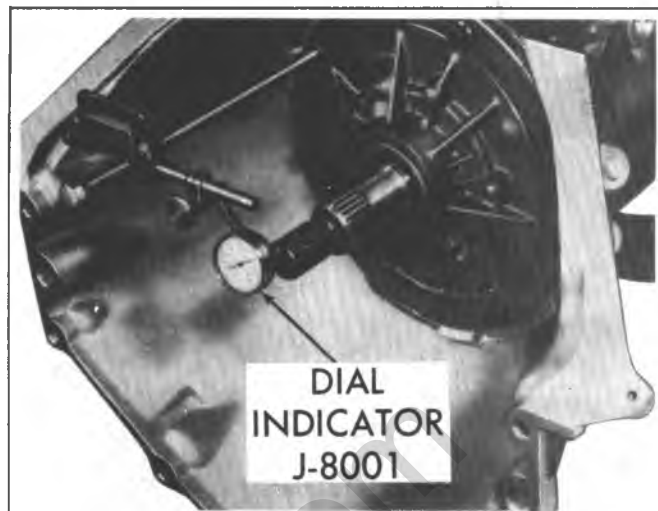

Fig. 7A-29C--Checking Front Unit End Play

- d. Push on turbine shaft rearward.
- e. Push output shaft forward.
- f. Set dial indicator to Zero.
- g. Pull turbine shaft forward.

Read resulting travel or end play. Should be .003"-.024".

Selective washer controlling this end play is the washer located between pump cover and forward clutch housing. If more or less washer thickness is required to bring end play within specifications, select proper washer from the chart shown in Fig. 7A-30C. An oil soaked washer may tend to discolor, so it will be necessary to measure washer for its actual thickness.

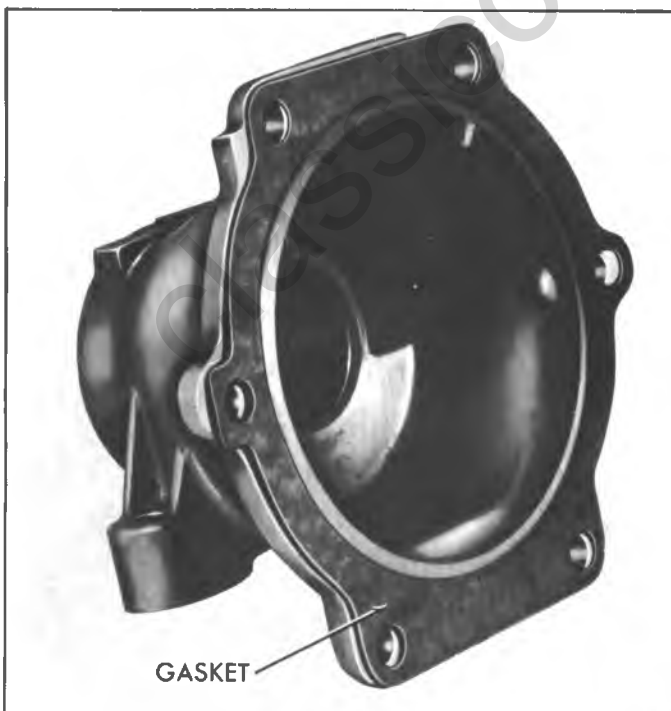

Fig. 7A-28C--Case Extension and Gasket

FRONT END WASHER THICKNESS		
Thickness	Number	Color
.060 - .064	- 0 -	Yellow
.071 - .075	- 1 -	Blue
.082 - .086	- 2 -	Red
.093 - .097	- 3 -	Brown
.104 - .108	- 4 -	Green
.115 - .119	- 5 -	Black
.126 - .130	- 6 -	Purple

Fig. 7A-30C--Front End Washer Selection Chart

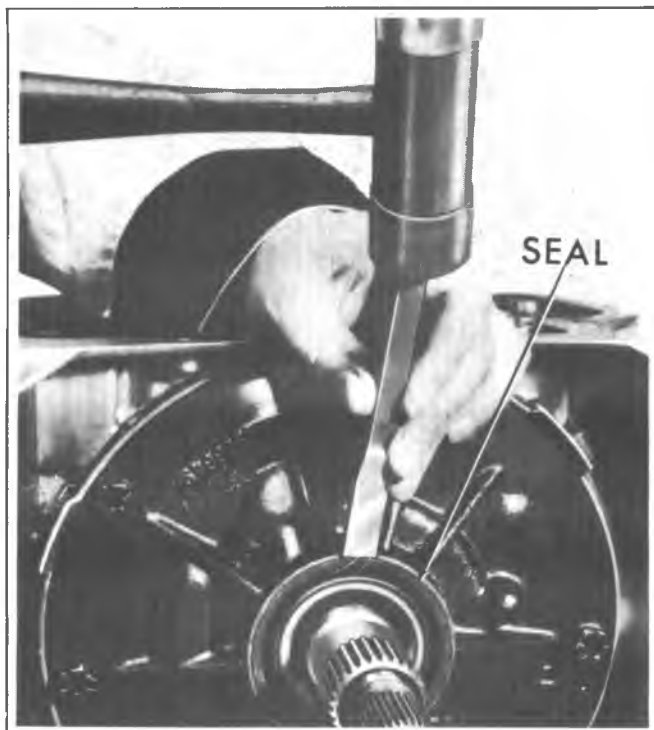

Fig. 7A-31C--Removing Front Seal

### Oil Pump and Internal Case Components Removal

1. If necessary to replace, pry front seal from pump (Fig. 7A-31C).
2. Remove pump attaching bolts.



Fig. 7A-32C--Removing Pump Assembly

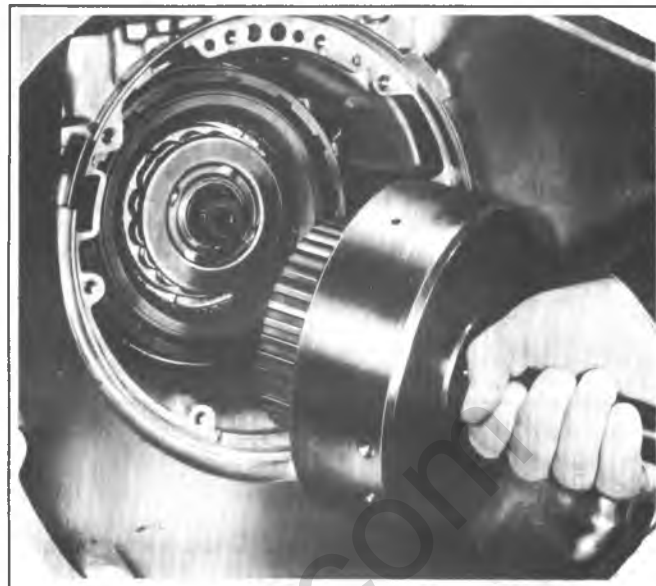

Fig. 7A-33C--Removing Forward Clutch Assembly and Turbine Shaft

3. Install two 3/8"-16 threaded slide hammer bolts, J-9539 with weights J-6585-01, into bolt holes in pump body and remove pump assembly from case (Fig. 7A-32C). (See illustration for location of threaded holes.)
4. Remove and discard pump to case seal and gasket.
5. Remove forward clutch assembly and turbine shaft from transmission (Fig. 7A-33C).
6. Remove forward clutch hub to direct clutch housing thrust washer, if it did not come out with forward clutch housing assembly.
7. Remove direct clutch assembly (Fig. 7A-34C).

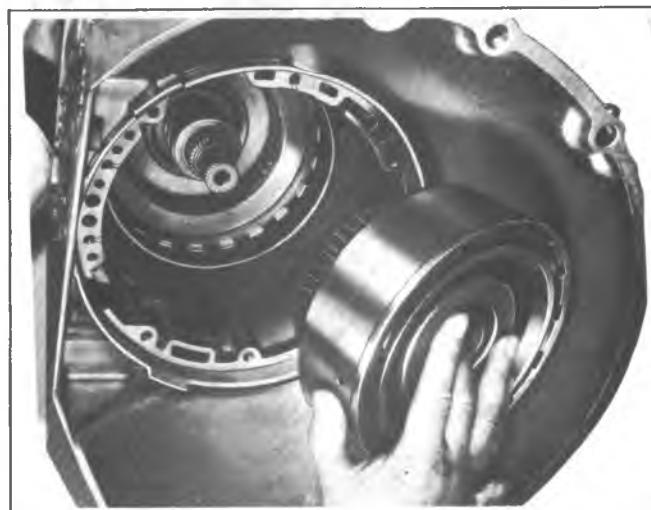

Fig. 7A-34C--Removing Direct Clutch Assembly

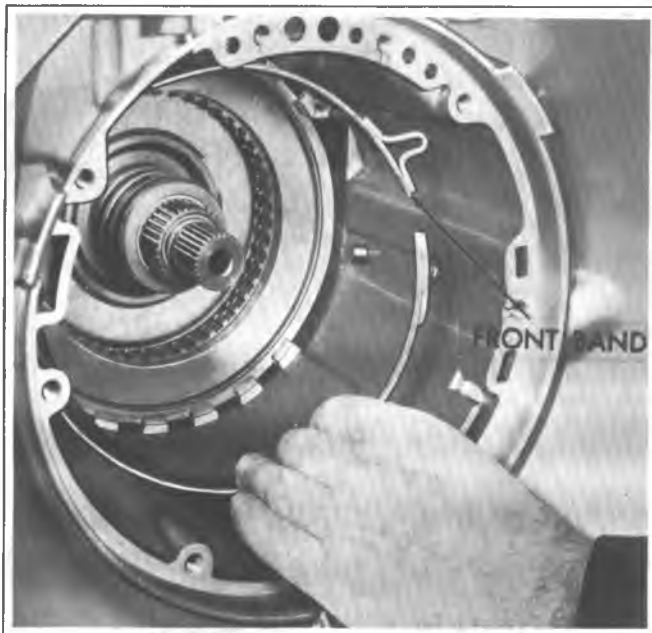

Fig. 7A-35C--Removing Front Band

8. Remove front band assembly (Fig. 7A-35C).
9. Remove sun gear shaft (Fig. 7A-36C).

**Check Rear End Play as Follows (Fig. 7A-37C)**

- a. Install J-9539 or a 3/8"-16 threaded bolt into an extension housing attaching bolt hole (Fig. 7A-37C).
- b. Mount a dial indicator on bolt and index with end of output shaft.
- c. Move output shaft in and out to read end play. End play should be from .007"-.019". Selective washer controlling this end play is a steel washer having 3 lugs that is located between output shaft thrust washer and rear face of transmission case.

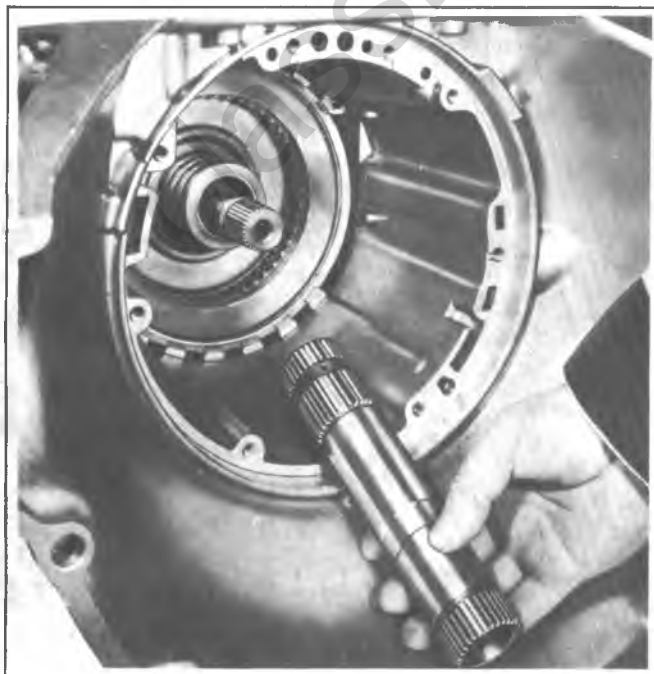

Fig. 7A-36C--Removing Sun Gear Shaft

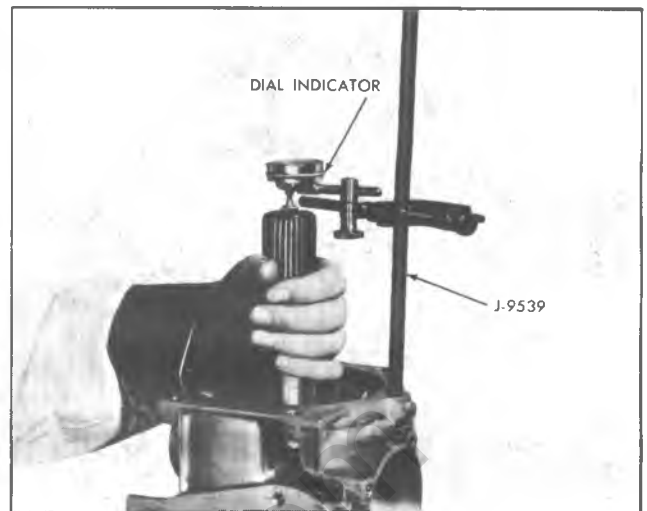

Fig. 7A-37C--Checking Rear Unit End Play

**REAR END WASHER THICKNESS**

Thickness	Identification
.074 - .078	None . . . . . 1
.082 - .086	1 Tab Side . . . . . 2
.090 - .094	2 Tab Side . . . . . 3
.098 - .102	1 Tab O.D. . . . . . 4
.106 - .110	2 Tabs O.D. . . . . . 5
.114 - .118	3 Tabs O.D. . . . . . 6

Fig. 7A-38C--Rear End Washer Thickness Chart

If a different washer thickness is required to bring end play within specification, it can be selected from the chart shown in Fig. 7A-38C.

10. Remove center support to case bolt (Fig. 7A-39C), using a 3/8" 12-point thin wall deep socket.

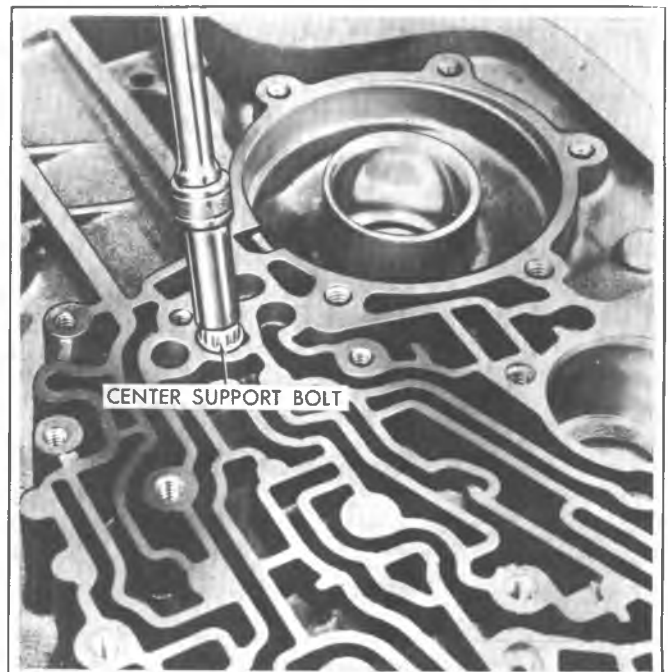

Fig. 7A-39C--Removing Center Support Bolt

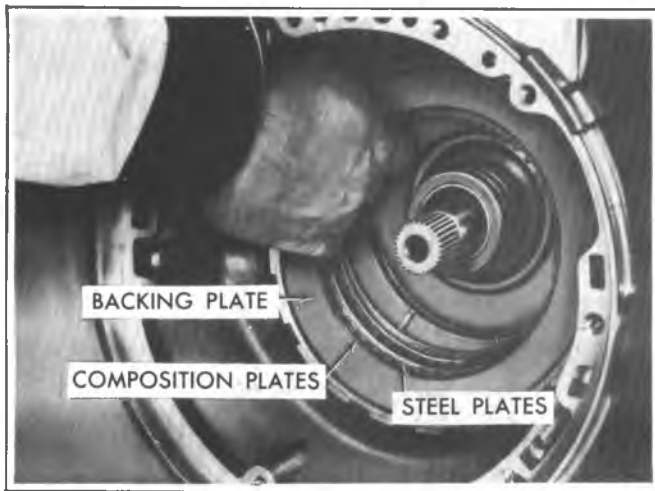

Fig. 7A-40C--Removing Intermediate Backing Plate and Clutch Plates

11. Remove intermediate clutch backing plate to case snap ring.

12. Remove intermediate clutch backing plate, as shown in Fig. 7A-40C.

13. Remove intermediate clutch plates.

a. (All except CB, CL and CD models) Remove three (3) composition, two (2) steel clutch plates and one waved steel plate.

b. (CB, CL and CD models) Remove three (3) composition, and three (3) steel clutch plates.

14. Remove center support to case retaining snap ring (Fig. 7A-41C).

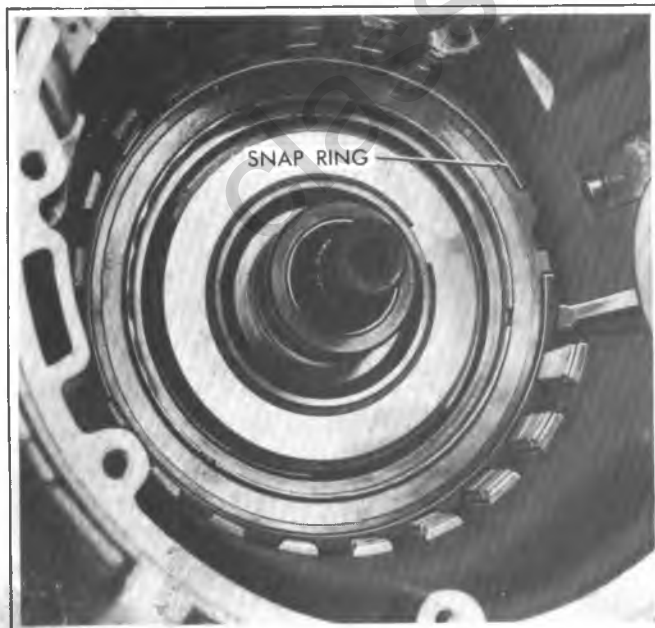

Fig. 7A-41C--Removing Center Support to Case Retaining Snap Ring

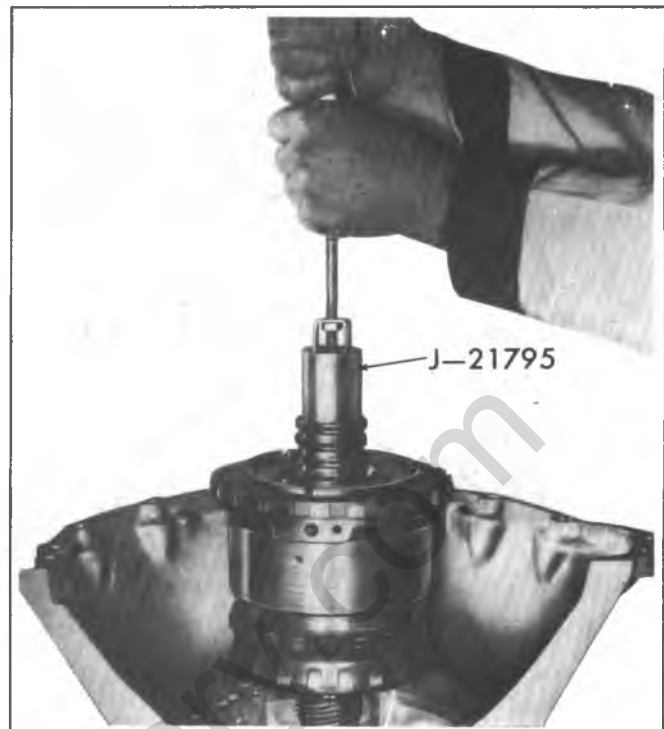

Fig. 7A-42C--Removing Center Support and Gear Unit from Case

15. Remove entire gear unit assembly by lifting with gear assembly installing and removing Holding Tool J-21795 with J-9539 slide hammer (Fig. 7A-42C).

16. Remove shaft to case thrust washer from rear of output shaft or inside case.

17. Place gear unit assembly, with output shaft facing down through hole in work bench.

18. Remove rear unit selective washer from transmission case (Fig. 7A-43C).



Fig. 7A-43C--Removing Selective Washer



Fig. 7A-44C--Removing Center Support to Case Spacer



Fig. 7A-46C--Removing Center Support Assembly

19. Remove center support to case spacer (Fig. 7A-44C).
20. Remove rear band assembly (Fig. 7A-45C).

**Disassembly of Gear Unit Assembly**

CL Model (spur gears) disassembly procedure is identical as illustrated.

1. Remove center support assembly (Fig. 7A-46C).

2. Remove center support to reaction carrier thrust washer (Fig. 7A-47C).

3. Remove center support to sun gear races and thrust bearing. One race may have been removed with center support.

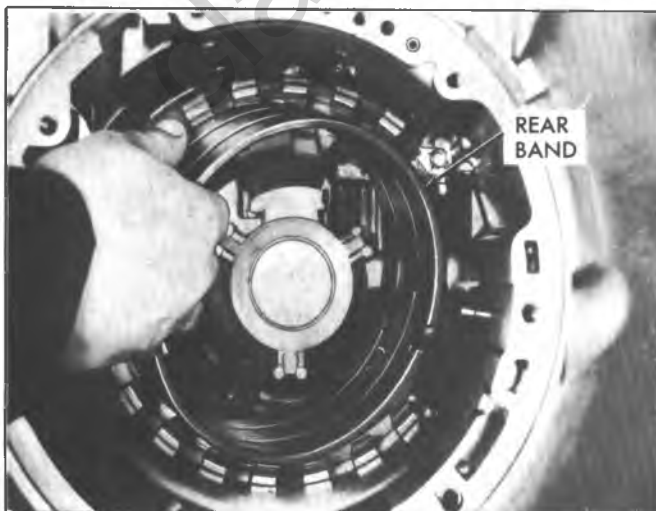

Fig. 7A-45C--Removing Rear Band

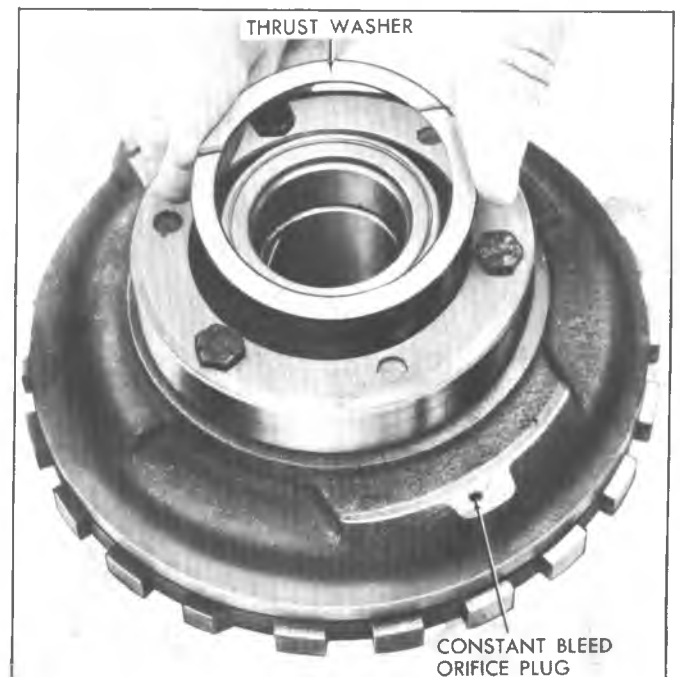

Fig. 7A-47C--Removing Center Support Thrust Washer

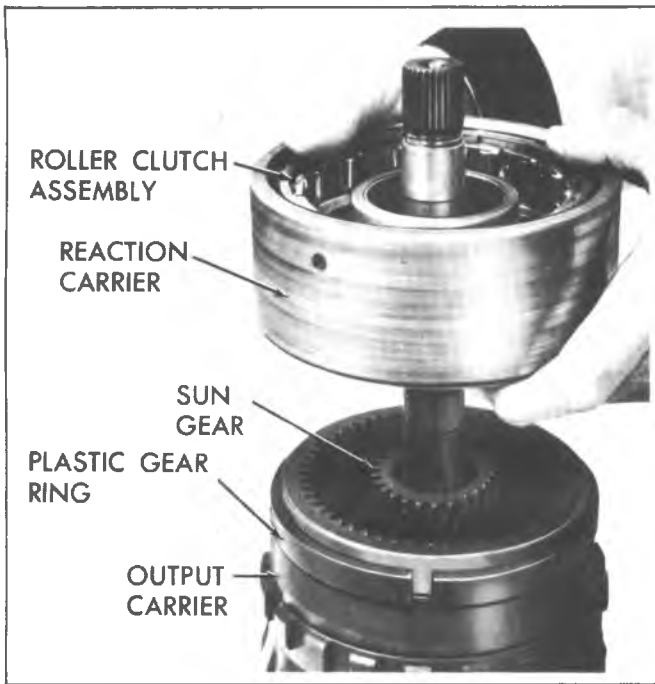

Fig. 7A-48C--Removing Reaction Carrier and Roller Clutch from Output Carrier

4. Remove reaction carrier and roller clutch assembly (Fig. 7A-48C). Lift roller clutch assembly out of carrier.
5. Remove front internal gear ring from output carrier assembly.
6. Remove sun gear (Fig. 7A-49C).
7. Remove reaction carrier to output carrier thrust washer.
8. Turn assembly over and place main shaft through hole in work bench.



Fig. 7A-49C--Removing Sun Gear

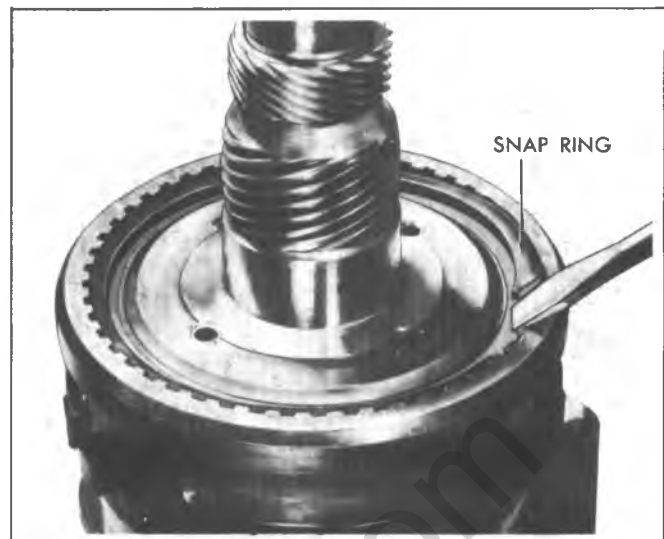

Fig. 7A-50C--Removing Output Shaft to Carrier Snap Ring

9. Remove "O" ring from output shaft of models that use an "O" ring.
10. Remove output shaft to output carrier snap ring (Fig. 7A-50C).
11. Remove output shaft.
12. Remove output shaft to rear internal gear thrust bearing and two (2) races.
13. Remove rear internal gear and mainshaft (Fig. 7A-51C). Do not drop bearings.



Fig. 7A-51C--Removing Rear Internal Gear and Mainshaft



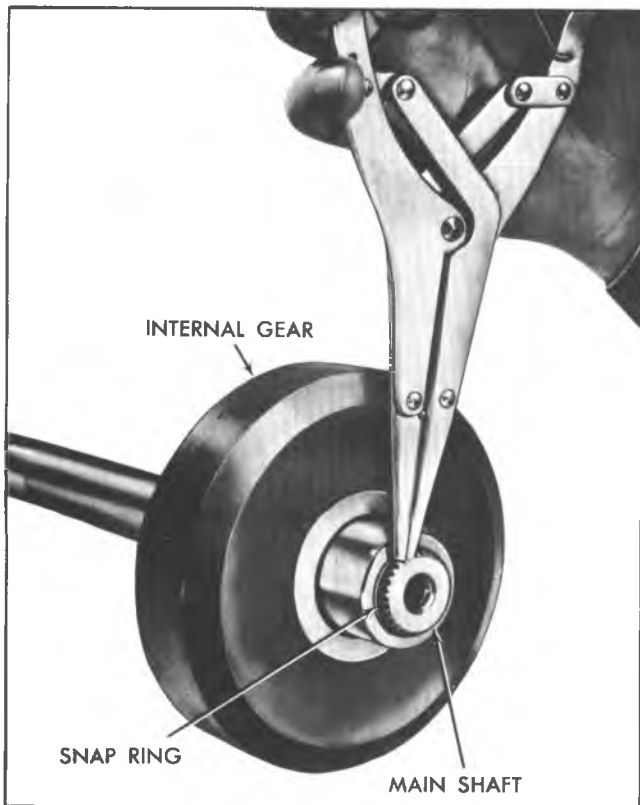

Fig. 7A-52C--Removing Rear Internal Gear to Main Shaft Snap Ring

14. Remove rear internal gear to sun gear thrust bearing and two (2) races.
15. If necessary, remove rear internal gear to mainshaft snap ring, to remove mainshaft (Fig. 7A-52C).

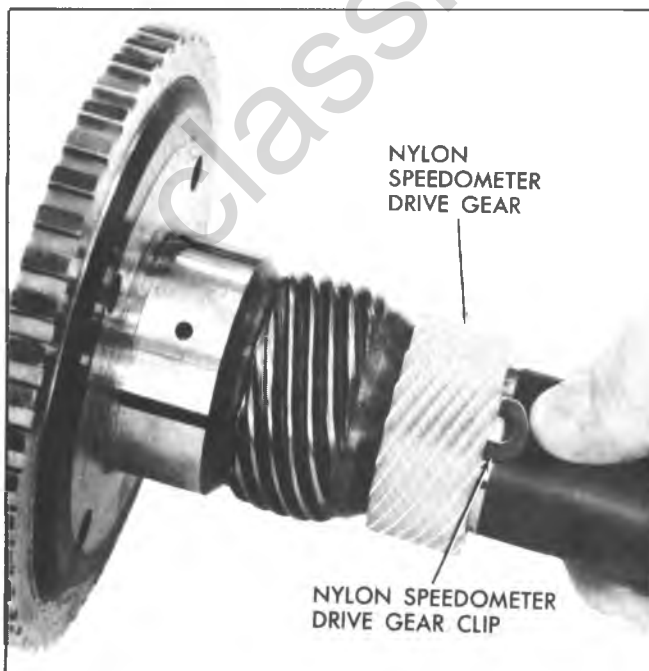

Fig. 7A-53C--Removing Nylon Speedometer Drive Gear

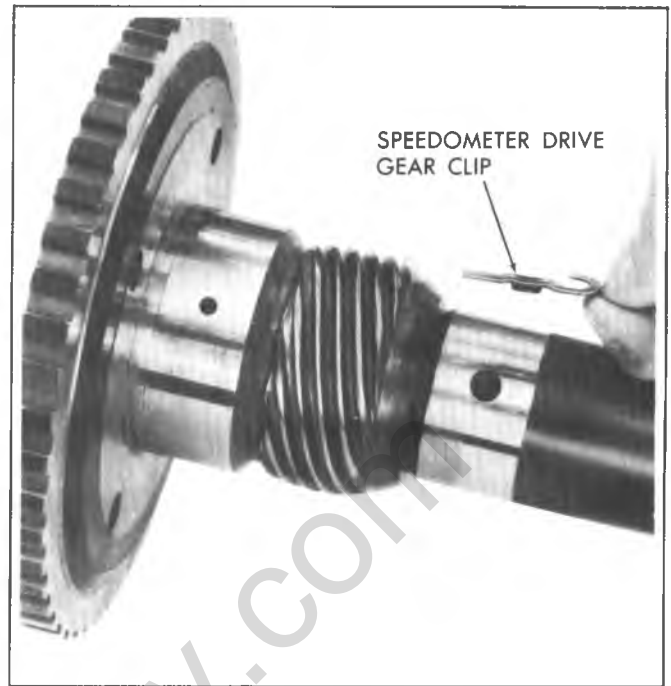

Fig. 7A-54C--Installing Speedometer Drive Gear Clip

### Speedometer Drive Gear Replacement

If removal and installation or replacement of the speedometer drive gear is necessary, proceed as follows:

#### Nylon Speedometer Drive Gear

1. Depress clip and slide speedometer drive gear off output shaft (Fig. 7A-53C).
2. To install, place clip (square end toward flange of shaft) into hole in output shaft (Fig. 7A-54C). Align slot in speedometer drive gear with clip and install gear.

The nylon speedometer drive gear is installed at the factory only. ALL service replacement speedometer drive gears are STEEL. When replacing the nylon speedometer drive gear with a steel gear, discard the retaining clip and refer to Step "2" of steel speedometer drive gear installation. Models CA, CF and CG do not have a speedometer drive gear.

#### Steel Speedometer Drive Gear

1. Install speedometer drive gear remover Tool J-21427-01 and J-9539 bolts with J-8105 or suitable puller on



Fig. 7A-55C--Removing Steel Speedometer Drive Gear

output shaft, and remove speedometer drive gear (fig. 7A-55C).

2. Install new steel speedometer drive gear and drive to location 5-21/32" below end of output shaft for all models. (Fig. 7A-56C).

### GOVERNOR ASSEMBLY

All components of governor assembly, with exception of driven gear, are a select fit and each assembly is calibrated. The governor, including the driven gear, is

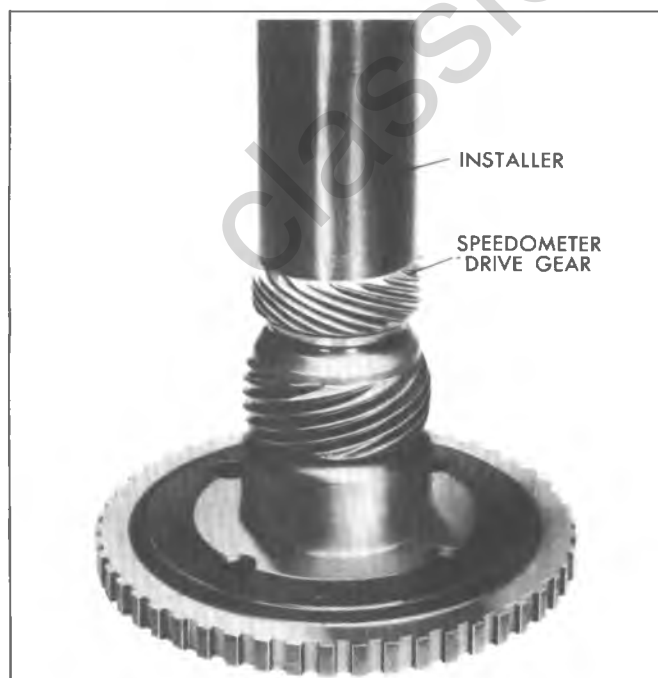

Fig. 7A-56C--Installing Steel Speedometer Drive Gear

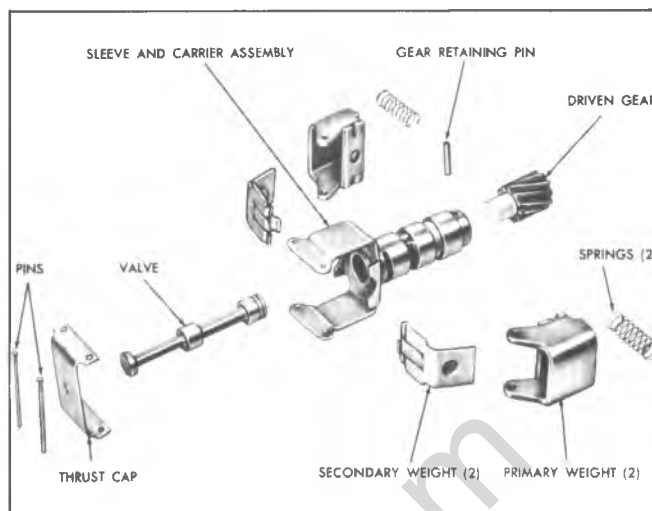

Fig. 7A-57C--Governor--Exploded

serviced as a complete assembly. However, the driven gear can also be serviced separately.

It is necessary to disassemble governor assembly in order to replace driven gear. Disassembly may also be necessary due to foreign material causing improper operation. In such cases, proceed as follows:

### Disassembly

1. Cut off one end of each governor weight pin and remove pins, governor thrust cap, governor weights, and springs. Governor weights are interchangeable from side to side and need not be identified. (Fig. 7A-57C).
2. Remove governor valve from governor sleeve. Be careful not to damage valve.
3. Perform following inspections and replace governor driven gear, if necessary.

### Inspection

1. Wash all parts in cleaning solvent, air dry and blow out all passages.
2. Inspect governor sleeve for nicks, burrs, scoring or galling.
3. Check governor sleeve for free operation in bore of transmission case.
4. Inspect governor valve for nicks, burrs, scoring or galling.
5. Check governor valve for free operation in bore of governor sleeve.
6. Inspect governor driven gear for nicks, burrs, or damage.
7. Check governor driven gear for looseness on governor sleeve.
8. Inspect governor weight springs for distortion or damage.
9. Check governor weights for free operation in their retainers.

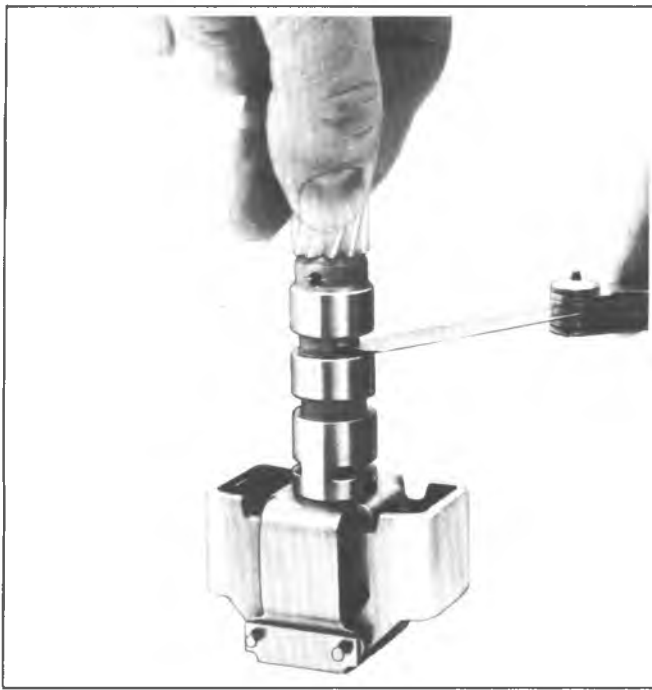

Fig. 7A-58C--Checking Valve Opening With Weights Outward

10. Check valve operating at entry (.020" minimum) with a feeler gage, holding governor as shown with governor weights extended completely outward (Fig. 7A-58C).

11. Check valve opening at exhaust (.020" minimum) with a feeler gage, holding governor as shown with governor weights completely inward (Fig. 7A-59C).

### Governor Driven Gear Replacement

To facilitate governor repair in the field, a governor driven gear and replacement pins are available for service use. The service package contains a nylon driven gear, two governor weight retaining pins and one governor gear retainer split pin. Replacement of gear must be performed



Fig. 7A-59C--Checking Valve Opening With Weight Inward



Fig. 7A-60C--Removing Governor Gear Retaining Pin

with care in the following manner:

1. Drive out governor gear retaining split pin using small punch (Fig. 7A-60C).

2. Support governor on 7/64 inch plates installed in exhaust slots of governor sleeve, place in arbor press, and with a long punch, press gear out of sleeve.

3. Carefully clean governor sleeve of chips that remain from original gear installation.

4. Support governor on 7/64 inch plates installed in exhaust slots of sleeve, position new gear in sleeve and, with a suitable socket, press gear into sleeve until nearly seated. Carefully remove any chips that may have shaved off gear hub and press gear in until it bottoms on shoulder.

5. A new pin hole must be drilled through sleeve and gear. Locate hole position 90 degrees from existing hole, center punch and then, while supporting governor in press, drill new hole through sleeve and gear using a standard (1/8 inch) drill.

6. Install split retaining pin.

7. Wash governor assembly thoroughly to remove any chips that may have collected.

### Assembly

1. Install governor valve in bore of governor sleeve, large end first.

2. Install governor weights and springs, and thrust cap on governor sleeve.

3. Align pin holes in thrust cap, governor weight assemblies and governor sleeve, and install new pins. Crimp both ends of pins to prevent them from falling out.

4. Check governor weight assemblies for free operation on pins.

5. Check governor valve for free movement in governor sleeve.

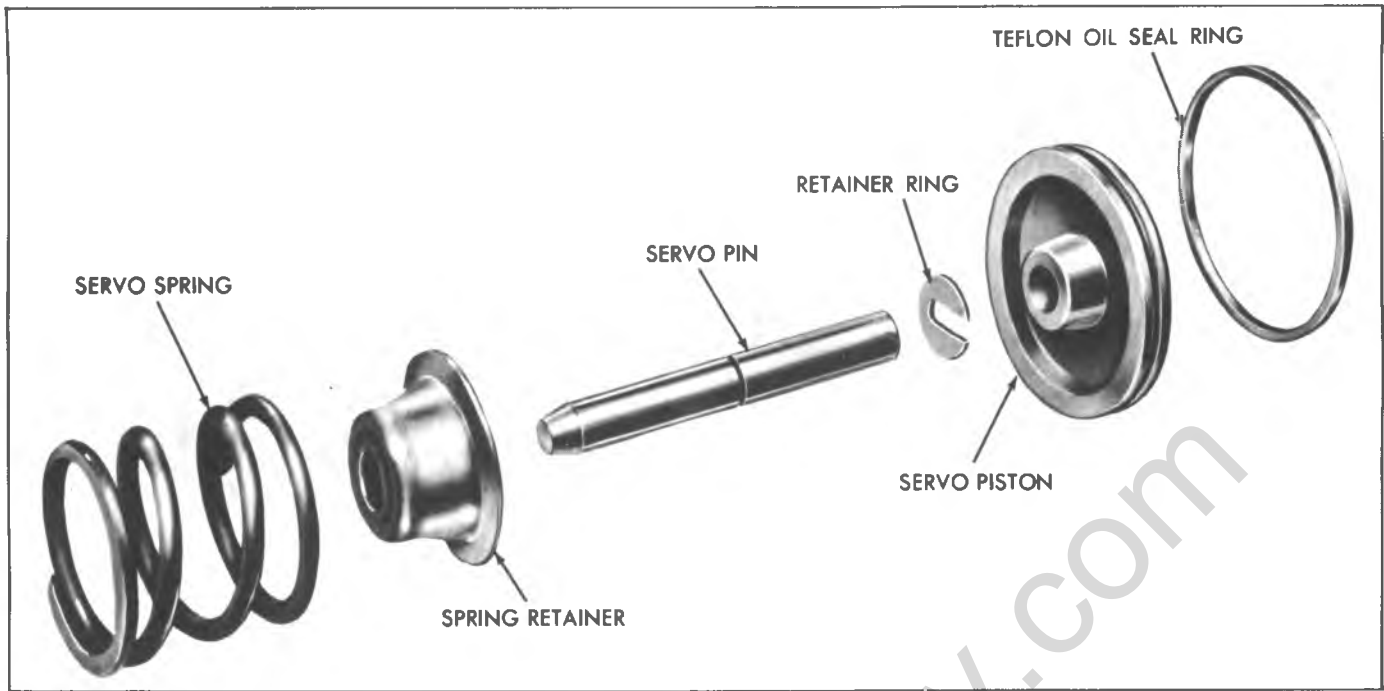

Fig. 7A-61C--Front Servo Assembly--Exploded View

### Front Servo Parts Inspection

See Fig. 7A-61C. Do not remove the teflon oil seal ring from the front servo piston unless the oil seal ring requires replacement. For service, the oil seal ring is aluminum.

1. Inspect servo pin for damage.
2. Inspect piston and oil ring for damage.
3. Check fit of servo pin in piston and case bore.

### Rear Servo Assembly

#### Disassembly

1. Remove rear accumulator piston from rear servo piston (Fig. 7A-62C-A).
2. Remove "E" ring retaining rear servo piston to servo pin (Fig. 7A-63C).



Fig. 7A-62C--Removing Rear Accumulator Piston from Rear Servo Piston

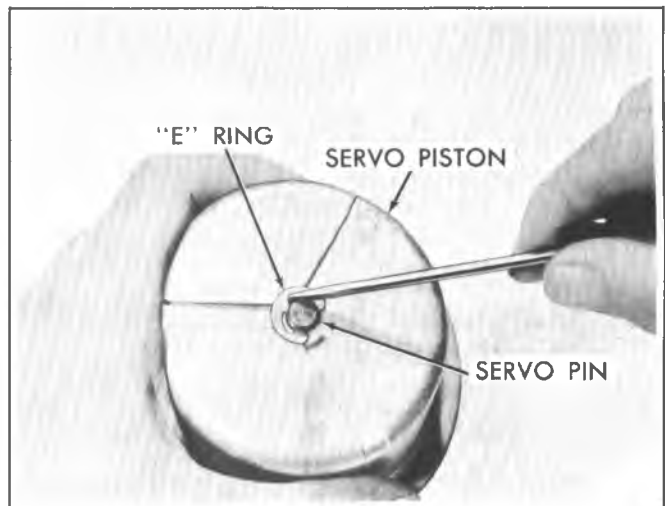

Fig. 7A-63C--Removing Retaining "E" Ring from Rear Servo Pin

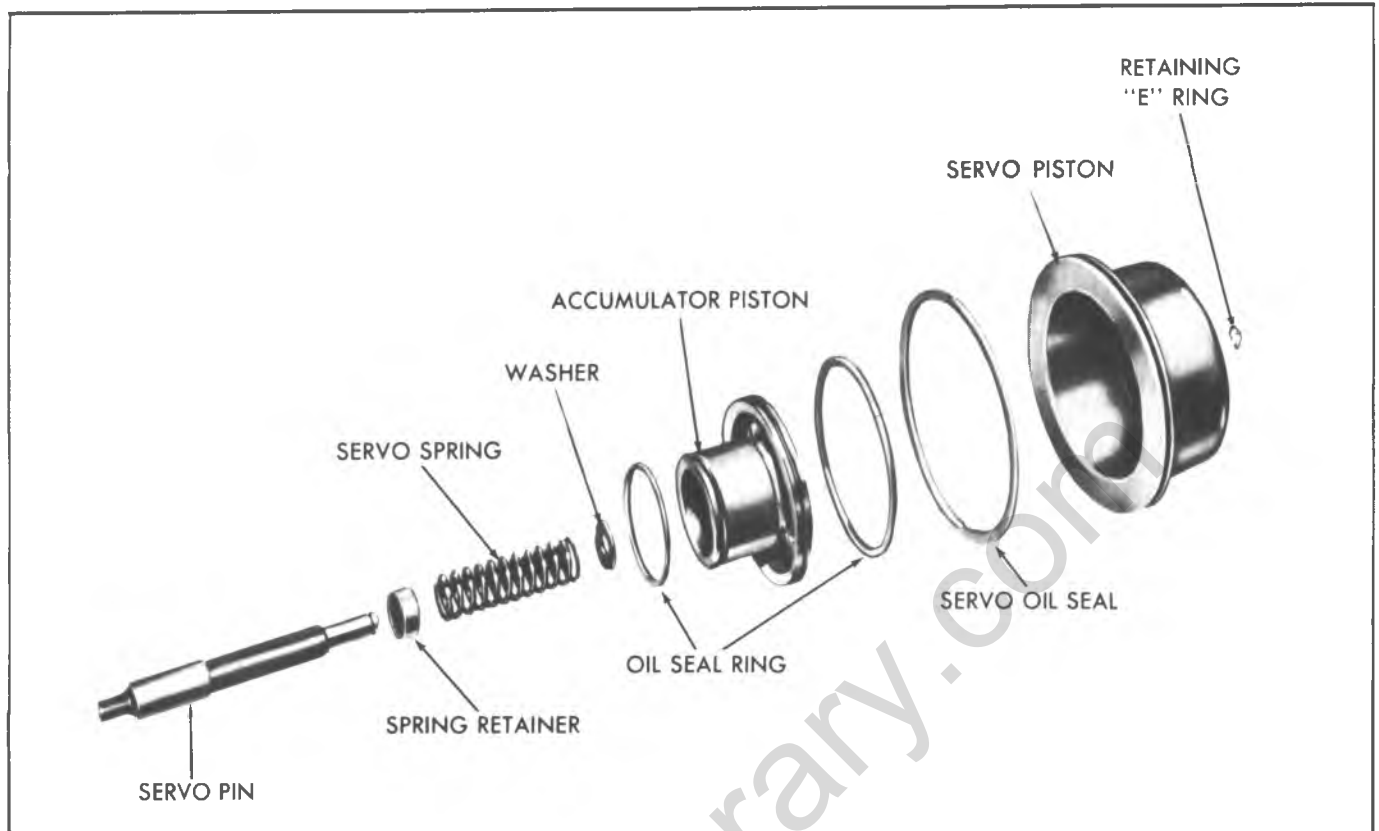

Fig. 7A-64C--Rear Servo and Accumulator Assembly--Exploded View

3. Remove rear servo piston and seal from servo pin (Fig. 7A-64C). (Exploded view.)
4. Remove washer, spring, and spring retainer.

**Inspection**

**NOTICE:** See Fig. 7A-64C. Do not remove the teflon oil seal rings from the rear accumulator piston, unless the oil seal rings require replacement. If the teflon inner oil seal ring (small diameter) requires replacement, for service, use the aluminum oil seal ring.

The rear accumulator piston, large diameter ring groove depth, is machined shallower to take the large teflon oil seal ring. If this ring requires replacement use only the teflon oil seal ring.

1. Inspect freedom of accumulator rings in piston grooves.
2. Inspect fit of servo pin in servo piston in case bore.
3. Inspect servo pin for scores or cracks.
4. Inspect accumulator and servo pistons for scoring, cracks or porosity.

**Assembly**

1. Install spring retainer cup side down, spring and washer on servo pin.
2. Install servo pin, retainer, spring and washer, into bore of servo piston and secure with "E" ring.
3. Install oil seal ring on servo piston, if removed.
4. Install outer and inner oil rings on accumulator piston, if removed, and assemble into bore of servo piston.

**CONTROL VALVE, DISASSEMBLY, INSPECTION AND RE-ASSEMBLY (Fig. 7A-67C)**

**Disassembly**

1. Position control valve assembly with cored face up and accumulator pocket nearest operator.
2. Remove manual valve from upper bore.
3. Install Special Tools J-22269 and J-24675, on accumulator piston and remove retaining ring (Fig. 7A-65C).

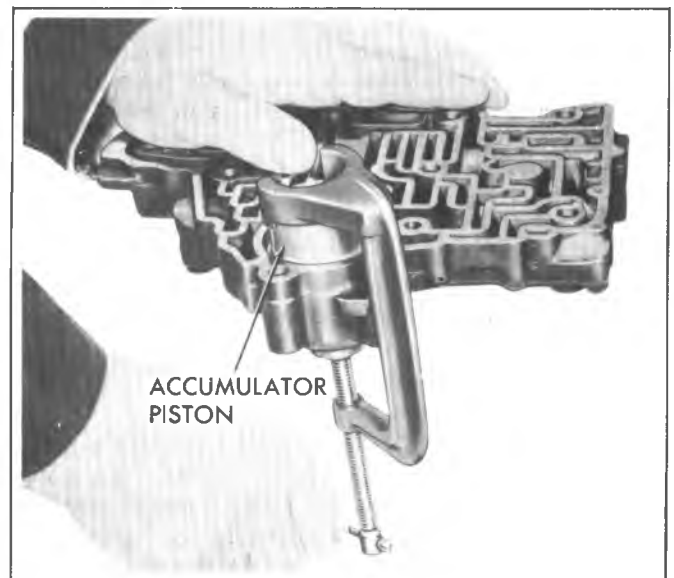

Fig. 7A-65C--Installing Compressor Tool to Front Accumulator Piston

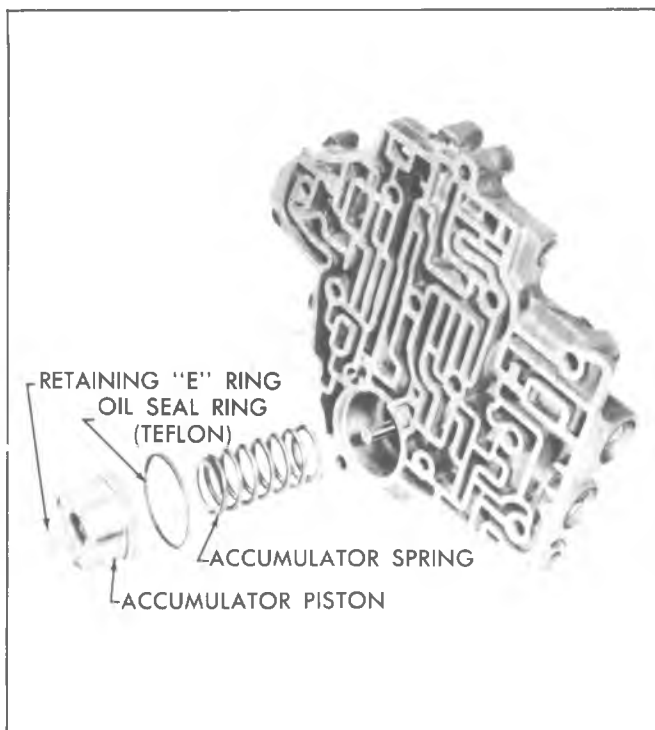

Fig. 7A-66C—Front Accumulator Assembly - Exploded View

4. Remove front accumulator piston and spring (Fig. 7A-66C).

5. On the right side adjacent to the manual valve, remove the 1-2 valve train as follows:

a. (Models CG, CJ and CP) Remove retaining pin, 1-2 modulator bushing, 1-2 valve spring, 1-2 modulator valve, and 1-2 shift valve.

b. (All other models) Remove retaining pin, 1-2 modulator bushing, 1-2 regulator valve, 1-2 regulator spring, 1-2 detent valve and 1-2 shift valve.

6. From next bore down, remove retaining pin, 2-3 shift valve spring, 2-3 modulator valve bushing, 2-3 modulator valve, 3-2 intermediate spring, and 2-3 shift valve.

Model CZ does not use a 2-3 shift valve spring.

7. From next bore down remove retaining pin, bore plug, spring, spacer, and 3-2 valve.

8. At other end of assembly, top bore, remove retaining pin and bore plug, detent valve, detent regulator valve, spring and spacer.

9. From the next bore down, remove the 1-2 accumulator valve train as follows:

a. (Model CP, CZ, and CK) Remove the grooved retaining pin, bore plug, 1-2 accumulator valve and spring.

b. (Models CB, CD, CJ, and CL) Remove the grooved retaining pin, bore plug, 1-2 accumulator valve.

c. (Models CF, CH, CG, CM, CT and CW) Remove the grooved retaining pin, bore plug, 1-2 accumulator secondary spring and 1-2 accumulator valve.

## Inspection

**NOTICE:** See Fig. 7A-66C. Do not remove the teflon oil seal ring from the front accumulator piston unless the oil seal ring requires replacement. For service, the oil seal ring is cast iron.

1. Inspect all valves for scoring, cracks and free movement in their respective bores.
2. Inspect bushings for cracks, scratches or distortion.
3. Inspect body for cracks, or scored bores.
4. Check all springs for distortion or collapsed coils.
5. Inspect accumulator piston and oil seal ring for damage.

## Reassembly

1. Install front accumulator spring and piston into valve body.

2. Install Special Tools J-22269 and J-24675 and compress spring and piston and secure with retaining "E" ring.

3. Install the 1-2 accumulator valve train into the lower left hand bore as follows:

a. (Model CZ, CK and CP) Install the 1-2 accumulator spring and 1-2 accumulator valve, stem end out, into bore. Place the bore plug into valve bore and install grooved retaining pin from the cast surface side of the valve body, with the grooves entering the pin hole last. Tap pin with a hammer until flush with cast surface of valve body.

b. (Models CB, CD, CJ, and CL) Install 1-2 accumulator valve stem end out, into bore. Place bore plug into valve bore and install grooved retaining pin from cast surface side of the valve body, with the groove entering the pin holes last. Tap pin with a hammer until flush with cast surface of valve body.

c. (Models CF, CG, CH, CM and CT) Install the 1-2 accumulator valve, stem end out, and 1-2 accumulator secondary spring. Install the bore plug and compress spring until grooved retaining pin can be inserted from the cast surface side of the valve body. Install retaining pin with the grooved end entering the pin hole last and tap in place until flush with cast surface of the valve body.

4. In next bore up, install detent spring and spacer. Compress spring and secure with small screwdriver (Fig. 7A-68C).

5. Install detent regulator valve, wide land first.

6. Install detent valve, narrow land first.

7. Install bore plug (hole out), depress spring by pressing in on plug, install retaining pin, and remove screwdriver.

8. In lower right hand bore, install 3-2 valve.

9. Install 3-2 spring, spacer, bore plug (hole out) and retaining pin.

10. In next bore up, install the 2-3 shift valve, open end out, into the bore and install 3-2 intermediate spring.

11. Install 2-3 modulator valve into bushing and install both parts into valve body bore.

12. Install 2-3 valve spring and retaining pin. Model CZ does not use a 2-3 shift valve spring.

13. In next bore up, install 1-2 valve, stem end out.

14. Install parts as follows:

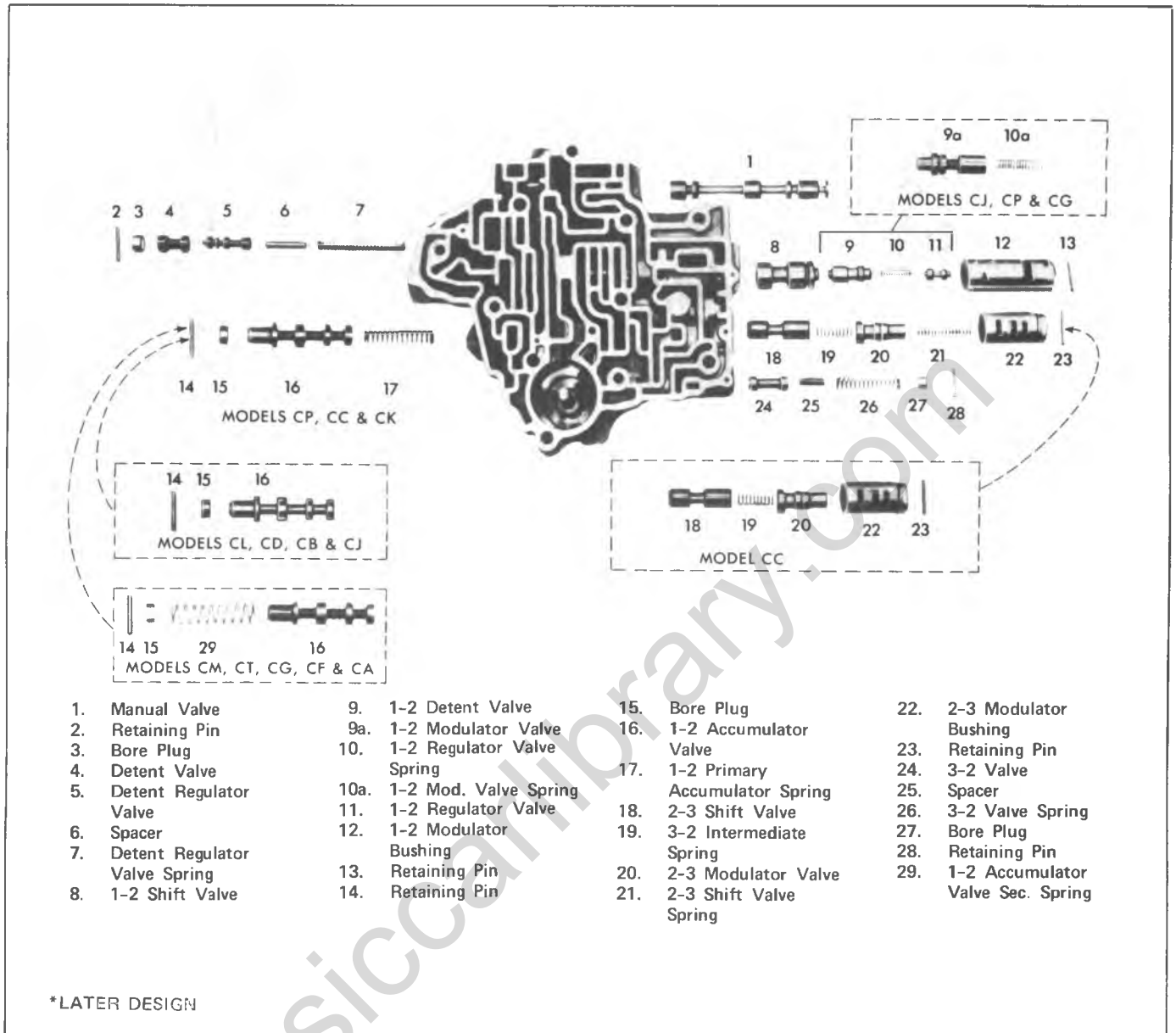

Fig. 7A-67C--Control Valve Assembly--Exploded View

a. (Models CG, CJ and CP) Install the 1-2 valve spring and 1-2 modulator valve into the 1-2 modulator bushing, aligning the spring in the bore of the modulator valve. Install parts into the valve body bore.

b. (All other models) Install the 1-2 regulator valve, regulator spring and 1-2 detent valve open hole first into the 1-2 modulator bushing, aligning the spring in the bore of the detent valve.

15. Compress bushing against spring and install retaining pin.

16. Install manual valve with detent pin groove to the right.

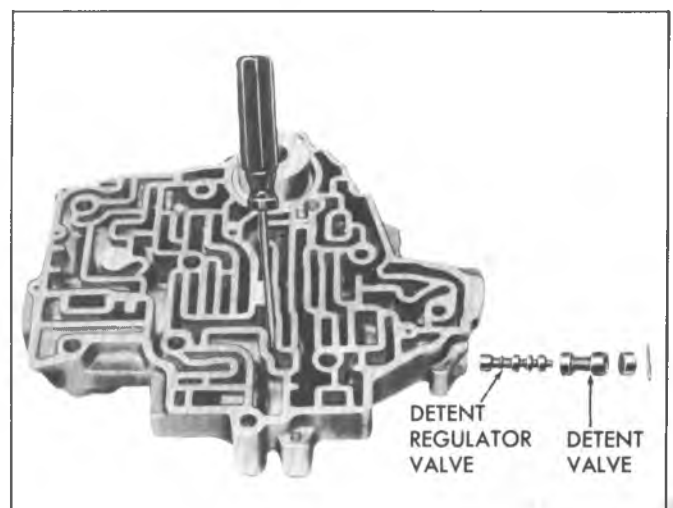

Fig. 7A-68C--Installing Detent Regulator Valve and Detent Valve

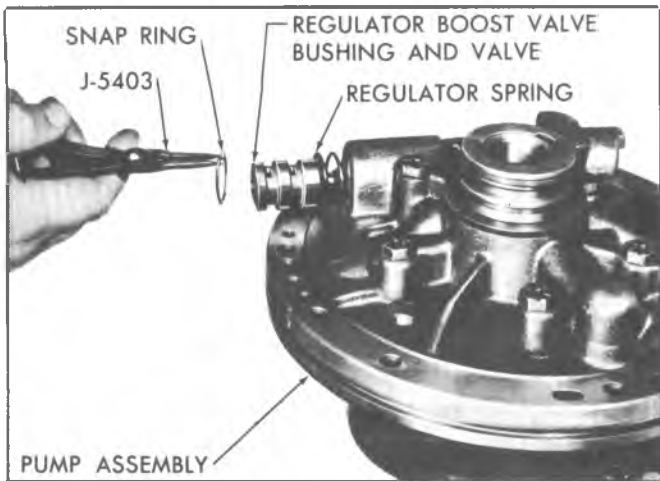

Fig. 7A-69C--Removing Pump Regulator Valve Snap Ring

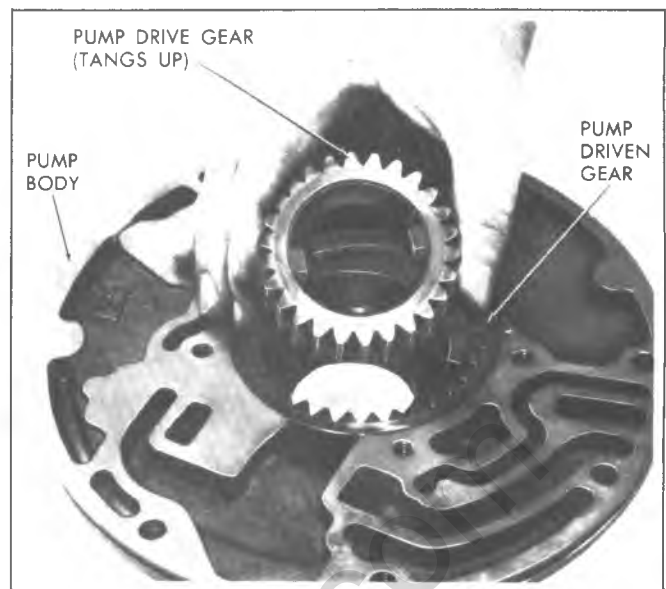

Fig. 7A-71C--Installing Pressure Regulator Retaining Pin and Bore Plug

## Oil Pump Disassembly, Inspection and Assembly

### Disassembly

1. Place oil pump assembly in hole in bench or holding fixture, J-6116 with J-21364 adapter.
2. Compress regulator boost valve bushing against pressure regulator spring and remove snap ring, using J-5403 pliers (Fig. 7A-69C).
3. Remove regulator boost valve bushing and valve.
4. Remove pressure regulator spring.
5. Remove regulator valve, spring retainer and spacer(s), if present (Fig. 7A-70C).
6. Remove pump cover to body attaching bolts.

7. Remove pump cover from body.
8. Remove retaining pin and bore plug from pressure regulator bore (Fig. 7A-71C).
9. Remove hook type oil rings from pump cover.
10. Remove pump to forward clutch housing selective washer.
11. Mark drive and driven gears for reassembly in same position and remove from the pump body. See Fig. 7A-72C.

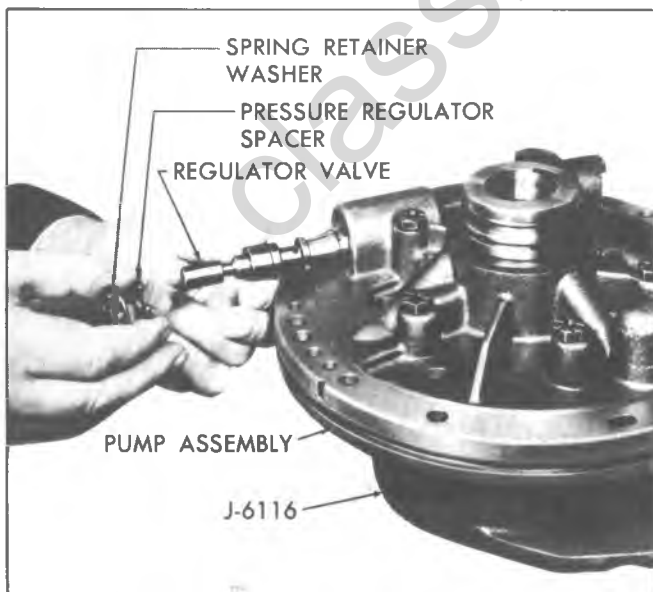

Fig. 7A-70C--Removing Pressure Regulator Valve

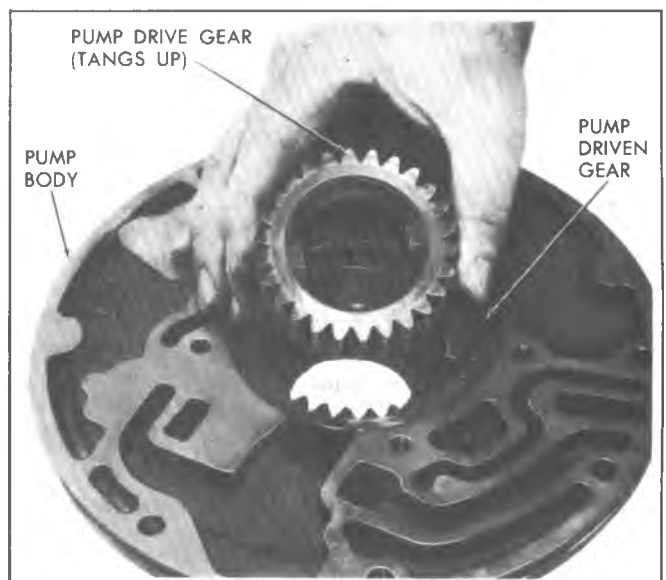

Fig. 7A-72C--Installing Pump Drive Gear



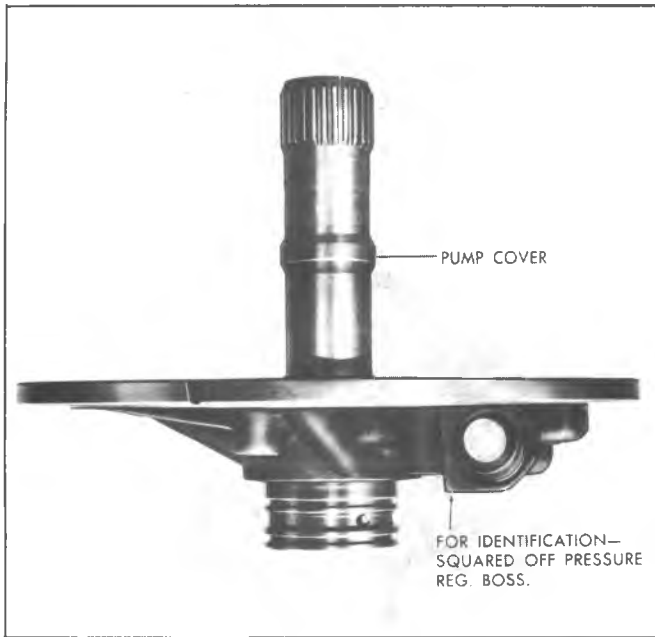

Fig. 7A-73C--Pressure Regulator Valve Identification

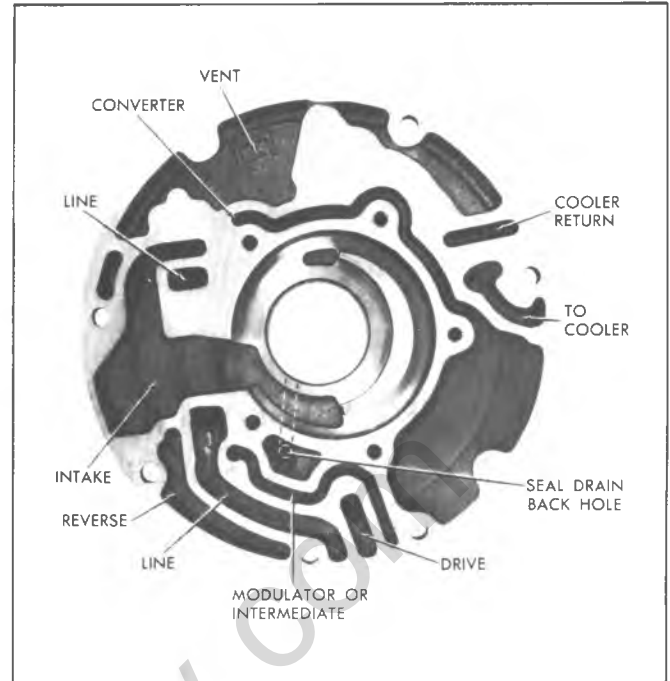

Fig. 7A-75C--Pump Body Oil Passages

### Inspection of Pump Body and Pump Cover

**NOTICE:** A solid type pressure regulator valve must only be used in a pump cover with a squared off pressure regulator boss. See Fig. 7A-73C. A pressure regulator valve with oil holes and orifice cup plug may be used to service either type pump cover.

1. Inspect drive and driven gear pocket and crescent for scoring, galling or other damage.
2. Place pump gears in pump body and check pump body face to gear face clearance (should be .0008" - .0035") (Fig. 7A-74C).
3. Check face of pump body for scores or nicks.
4. Check oil passages (Fig. 7A-75C).
5. Check for damaged cover bolt attaching threads.
6. Check for overall flatness of pump body face.



Fig. 7A-74C--Checking Pump Body Face to Gear Face Clearance

7. Check bushing for scores or nicks. If replacement is necessary, proceed as follows:

- a. Using Tool J-21465-17 and driver Handle J-8092 remove bushing.
- b. From front side of pump, using J-21465-17 and driver Handle J-8092 install new bushing flush to .010" below gear pocket face.
8. Inspect pump attaching bolt seats for damage, replace if necessary.
9. Inspect pump cover face for overall flatness.
10. Check for scores or chips in pressure regulator bore.
11. Check that all passages are open and not interconnected (Fig. 7A-76C).

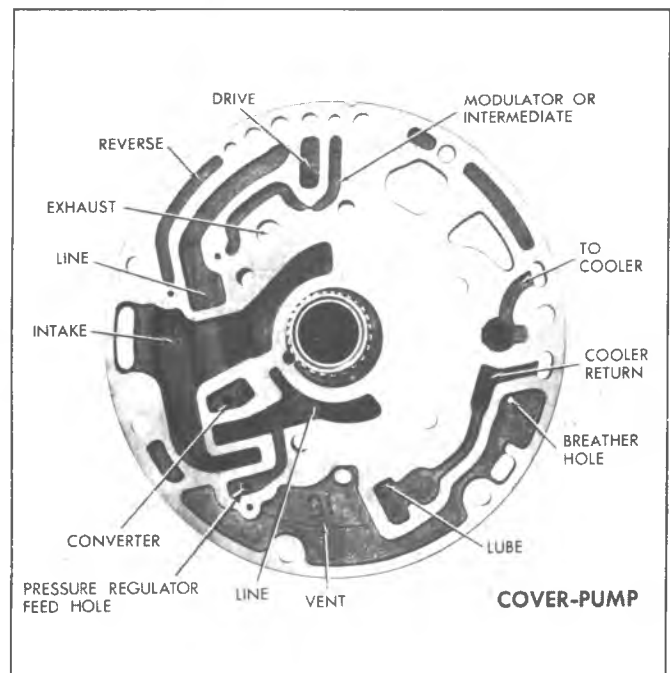

Fig. 7A-76C--Pump Cover Oil Passages

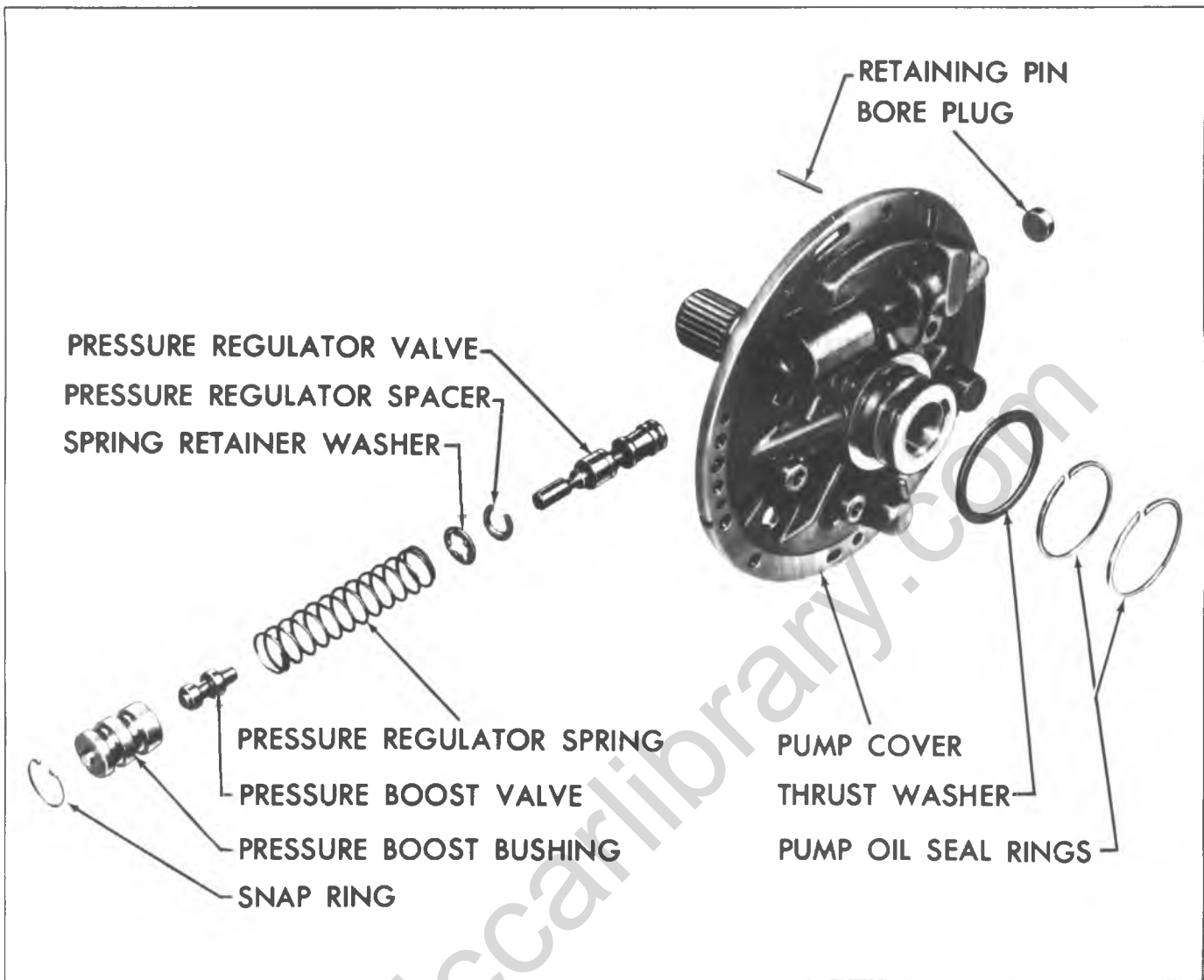

Fig. 7A-77C--Pump Cover--Exploded View

12. Check for scoring or damage at pump gear face.
13. Inspect stator shaft for damaged splines, or scored bushings. If replacement of bushing is necessary proceed as follows:

**Front**

- a. With pump cover and stator shaft properly supported, using Tool J-21465-15, with slide hammer tool J-2619, and adapter Tool J-2619-4 remove bushing.
- b. Using Tool J-21465-3 with Driver Handle J-8092 press or drive replacement bushing into place until tool bottoms.

**Rear**

- c. With pump and stator shaft properly supported, using Tool J-21465-15, with slide hammer Tool J-2619 and adapter tool J-2619-4, remove bushing.
- d. Using Tool J-21465-2 with Driver Handle J-8092, pressor drive replacement bushing into place until tool bottoms.

14. Inspect oil ring grooves for damage or wear.
15. Inspect selective washer thrust face for wear or damage.
16. Inspect pressure regulator and boost valve for free operation in their respective bores.
17. Inspect pump cover for open 1/8" breather hole (Fig. 7A-76C).

**Assembly**

1. Install drive and driven pump gears with alignment marks up into pump body (Fig. 7A-72C) drive gear tangs up.
2. Protect stator shaft and install pump cover in vise.
3. Install spacer(s) if used, retainer and spring, into pressure regulator bore (Fig. 7A-77C).
4. Install pressure regulator valve from opposite end of bore, stem end first.

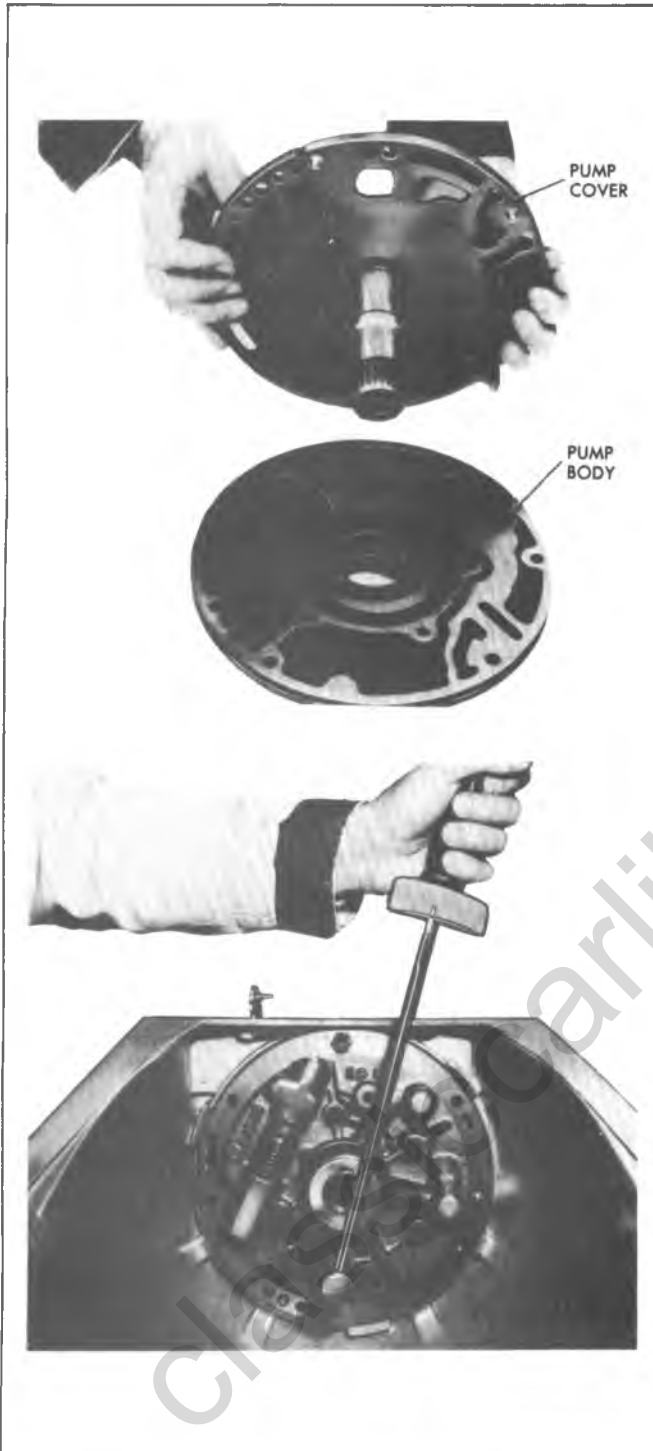

Fig. 7A-78C--Aligning and Installing Pump Cover to Pump Body

5. Install boost valve into bushing, stem end out, and install both parts into pump cover by compressing bushing against spring.

6. Install retaining snap ring.

7. Install pressure regulator valve bore plug and retaining pin into opposite end of bore.

8. Install previously selected front unit selective thrust washer over pump cover delivery sleeve.

9. Install two (2) hook type oil seal rings.

10. Assemble pump cover to pump body with attaching bolts (Fig. 7A-78C). Leave bolts one turn loose at this time.

11. To align the pump body and cover, place the pump assembly, less rubber seal ring, upside down into the pump bore of the case (Fig. 7A-78C).

12. Tighten pump cover bolts to 18 foot pounds. Remove pump assembly from case bore.

13. Install pump to case "O" ring seal.

**FORWARD CLUTCH DISASSEMBLY, INSPECTION AND ASSEMBLY**

See Clutch Chart, Fig. 7A-79C, for details of clutch components by specific model designations.

1981  
CLUTCH APPLICATION CHART  
THM 400

MODEL	FORWARD CLUTCH				DIRECT CLUTCH				INTERMEDIATE CLUTCH		
	FLAT STEEL PLATES		NO. OF WAVED STEEL PLATES	NO. OF COMPOSITION PLATES	NO. OF FLAT STEEL PLATES	NO. OF WAVED STEEL PLATES	NO. OF COMPOSITION PLATES	NO. OF FLAT STEEL PLATES	NO. OF WAVED STEEL PLATES	NO. OF COMPOSITION PLATES	
	NO.	THICKNESS									
FM, FA, FJ, FP, FN, FH, FY, FF, FW, FB, FD	4	.0775"	1	4	4	0		5	2	1	3
FL	5	.0915"	0	5	6	0	6		3	0	*3
FV	4	.0775"	1	5	5	6	0		3	0	*3
FQ, FT, FR	4	.0775"	1	5	4	1		5	2	1	3

\* MODELS FL & FV HAVE INTERMEDIATE CLUTCH PLATES WHICH ARE DIFFERENT THAN OTHER MODELS. REFER TO THE PARTS CATALOG FOR CORRECT USAGE.

Fig. 7A-79C--Clutch Chart, Component Details

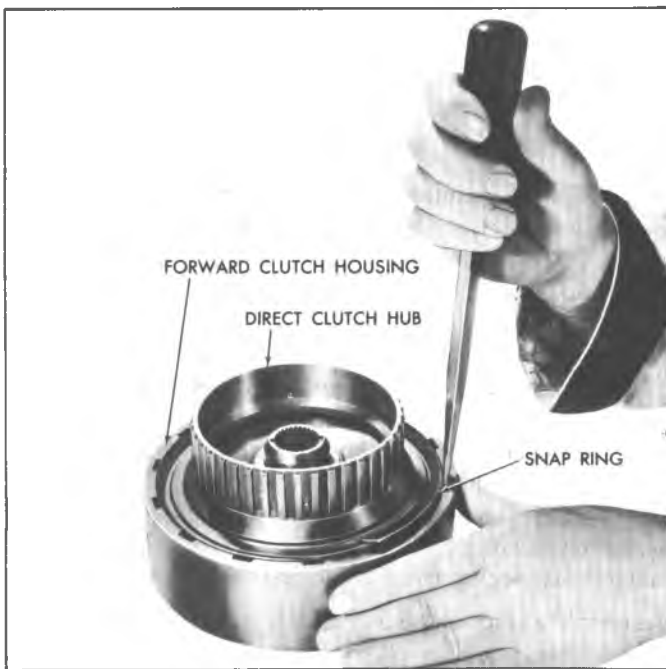

Fig. 7A-80C--Removing Forward Clutch Housing to Direct Clutch Hub Snap Ring

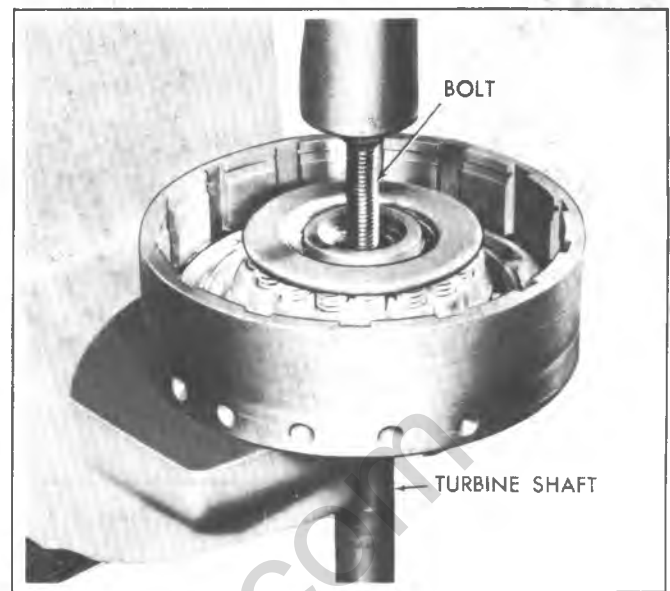

Fig. 7A-82C--Removing Turbine Shaft from Forward Clutch Housing

**Disassembly**

1. Place forward clutch assembly with turbine shaft through hole in bench or Holding Fixture J-6116, and remove forward clutch housing to direct clutch hub snap ring (Fig. 7A-80C).
2. Remove direct clutch hub.
3. Remove forward clutch hub and thrust washers (Fig. 7A-81C).
4. Remove composition, steel clutch plates, and waved steel plate. Models CL and CD do not use a waved steel plate.

5. If necessary place forward clutch and turbine shaft in arbor press and remove turbine shaft (Fig. 7A-82C).

6. Using J-4670 clutch spring compressor in arbor press with Adapter J-21664, compress spring retainer and remove snap ring (Fig. 7A-83C).

7. Remove spring retainer and sixteen (16) clutch release springs. Keep springs separate from direct clutch release springs.

8. Remove forward clutch piston.

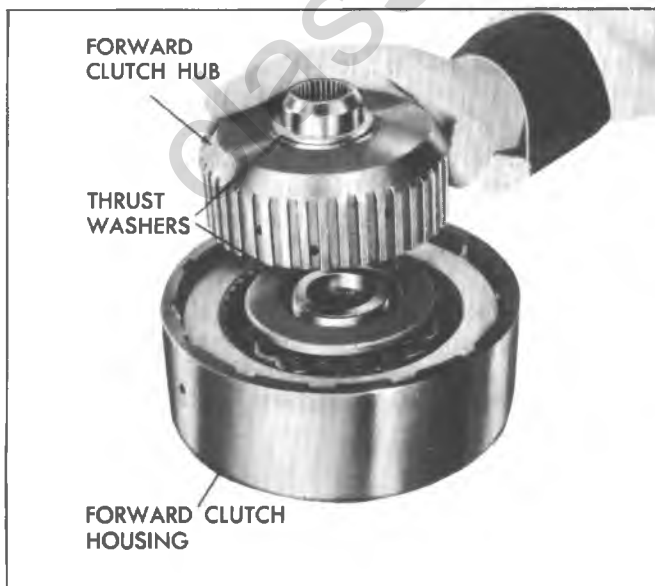

Fig. 7A-81C--Removing Forward Clutch Hub and Thrust Washers

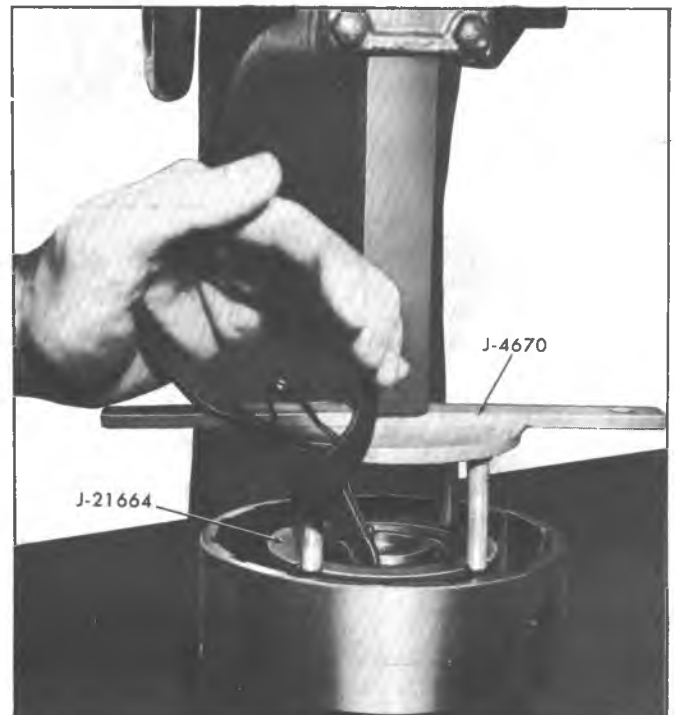

Fig. 7A-83C--Removing Forward Clutch Spring Retaining Snap Ring



Fig. 7A-84C--Removing Forward Clutch Piston Outer Seal

9. Remove inner and outer clutch piston seals (Fig. 7A-84C).

10. Remove center piston seal from forward clutch housing (Fig. 7A-85C).

### Inspection

1. Inspect composition-faced and steel clutch plates for signs of burning, scoring or wear.

2. Inspect sixteen (16) springs for collapsed coils or signs of distortion.

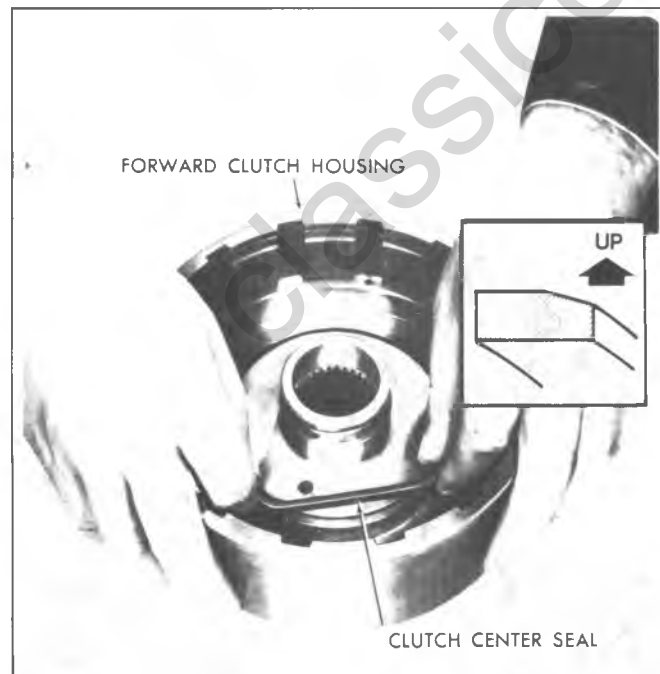

Fig. 7A-85C--Removing Forward Clutch Center Seal

3. Inspect clutch hubs for worn splines, proper lubrication holes or scored thrust faces.

4. Inspect piston for cracks.

5. Inspect clutch housing for wear, scoring, open oil passages and free operation of ball check.

6. Inspect turbine shaft.

a. Inspect for open lubrication passages at each end.

b. Inspect splines for damage.

c. Inspect ground bushing journals for damage.

d. Inspect shaft for cracks or distortion.

Turbine shaft and clutch housing are serviced separately. Shaft may be removed from housing by using a suitable size socket in an arbor press (Fig. 7A-82C).

### Assembly (Fig. 7A-86C)

**NOTICE:** The forward and direct clutch pistons have identical inside and outside diameters. It is possible to reverse the pistons during reassembly, therefore, care should be exercised to make certain the proper piston be installed in the clutch assemblies, as shown in Figure 7A-102C.

1. Place new inner and outer oil seals on clutch piston, lips face away from spring pockets (Fig. 7A-84C).

2. Place a new center seal on clutch housing, as shown in Fig. 7A-85C. Apply automatic transmission oil to all seals and clutch plates.

3. Place seal protector Tool J-21362, over clutch hub and install outer clutch piston seal Protector J-21409, into clutch drum and install piston, rotating piston on drum until seated (Fig. 7A-87C).

4. Install sixteen (16) clutch release springs into pockets in piston.

5. Place spring retainer and snap ring on springs.

6. Compress springs in arbor press, using clutch compressor Tools J-4670 and J-21664, install snap ring.

7. If removed, install turbine shaft in forward clutch housing, using arbor press.

8. Install forward clutch hub washers on forward clutch hub. Retain with petrolatum.

9. Place forward clutch hub into forward clutch housing.

10. Oil and install the composition plates, flat steel plates and waved steel clutch plate (with "U" notches), starting with waved steel and then alternating composition and steel clutch plates, as shown in Fig. 7A-88C. Models CD and CL do not use a waved steel clutch plate.

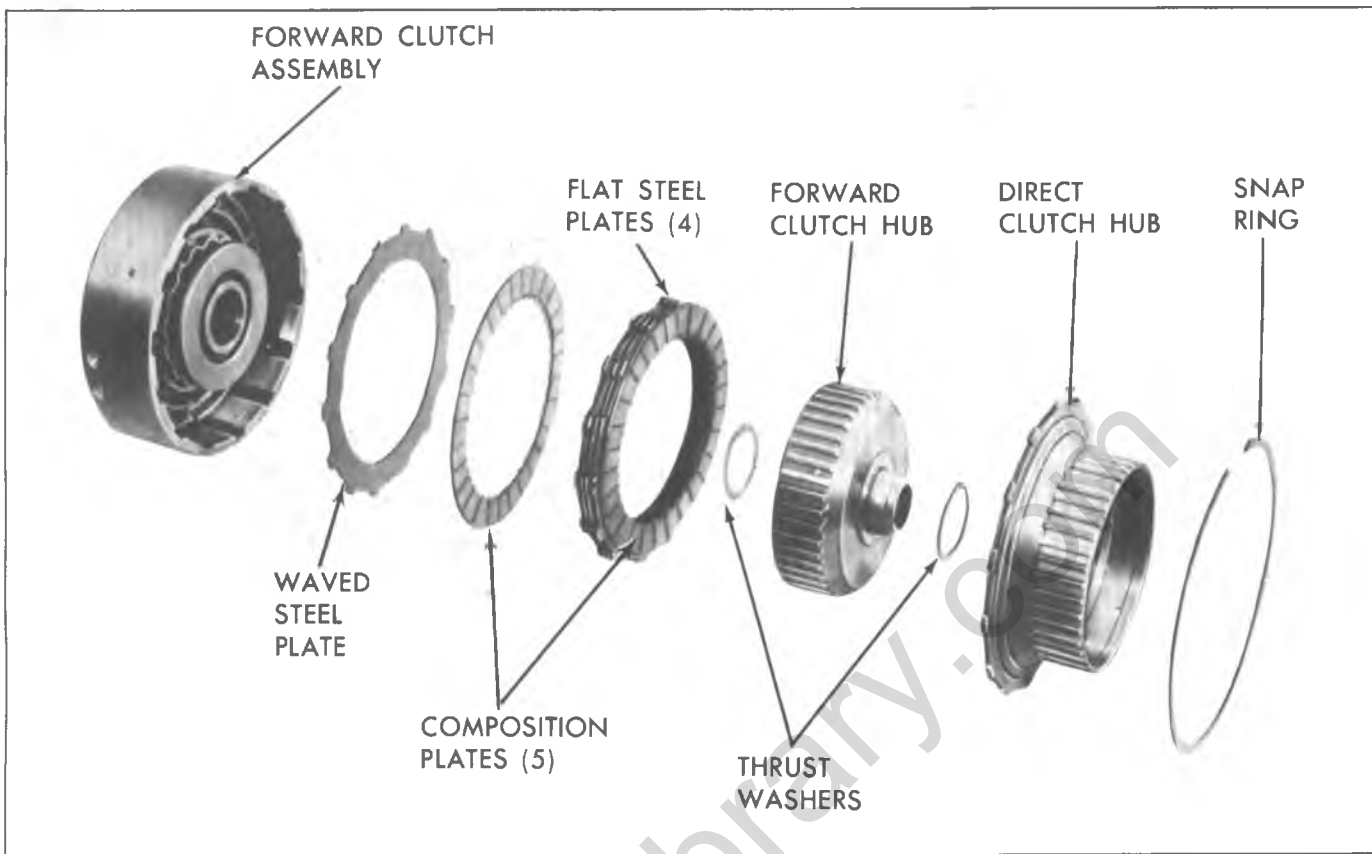

Fig. 7A-86C--Forward Clutch Assembly--Exploded View

**NOTICE:** Do not confuse the flat steel clutch plate (plate with "V" notch) with the waved steel clutch plate (plate with "U" notch), or damage may occur.

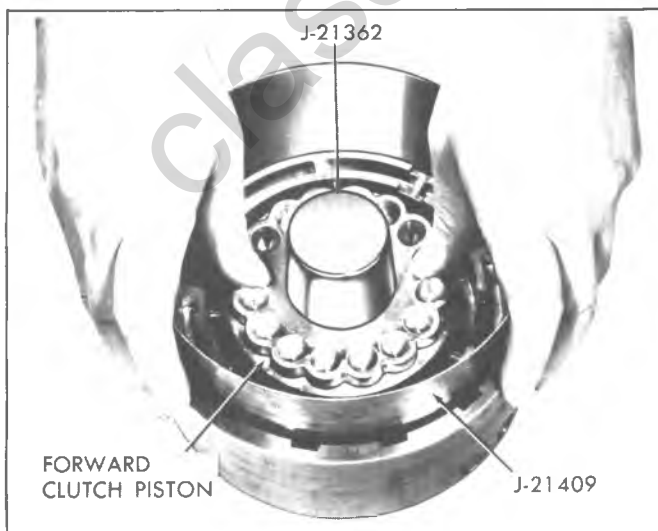

Fig. 7A-87C--Installing Forward Clutch Piston

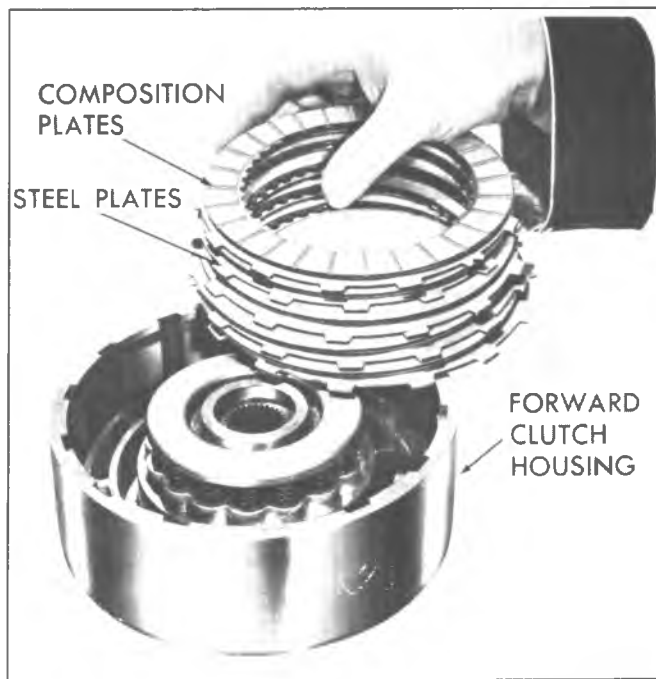

Fig. 7A-88C--Installing Forward Clutch Composition and Steel Plates



Fig. 7A-89C--Installing Forward Clutch Housing to Direct Clutch Hub Snap Ring

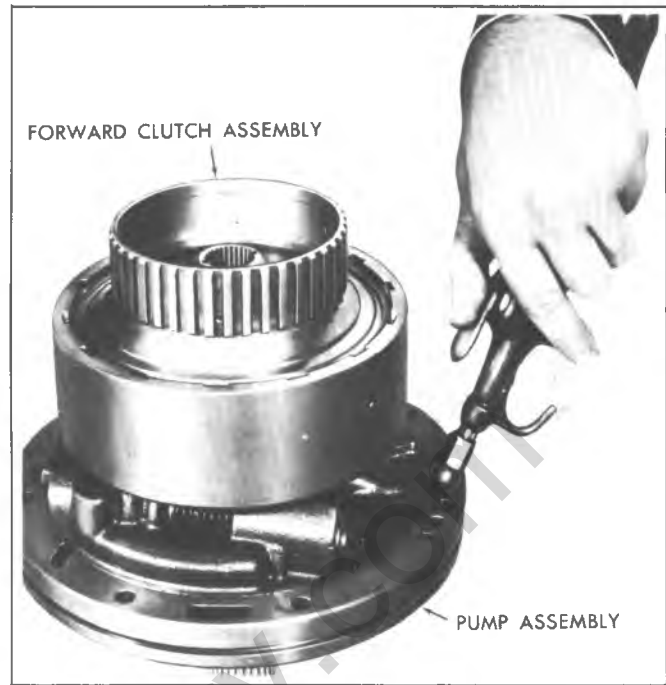

Fig. 7A-90C--Air Checking Forward Clutch Assembly

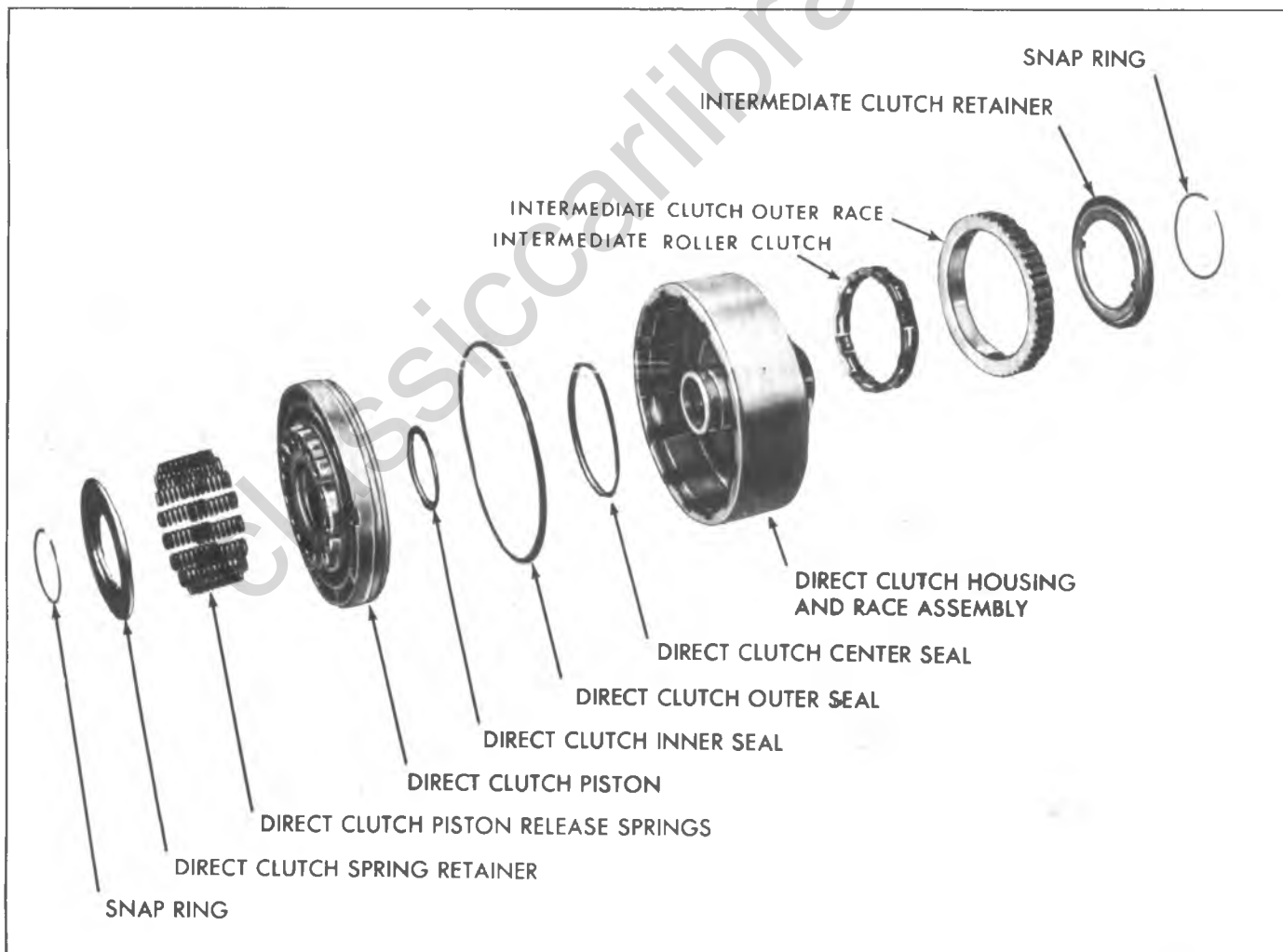

Fig. 7A-91C--Direct Clutch and Intermediate Roller Assembly



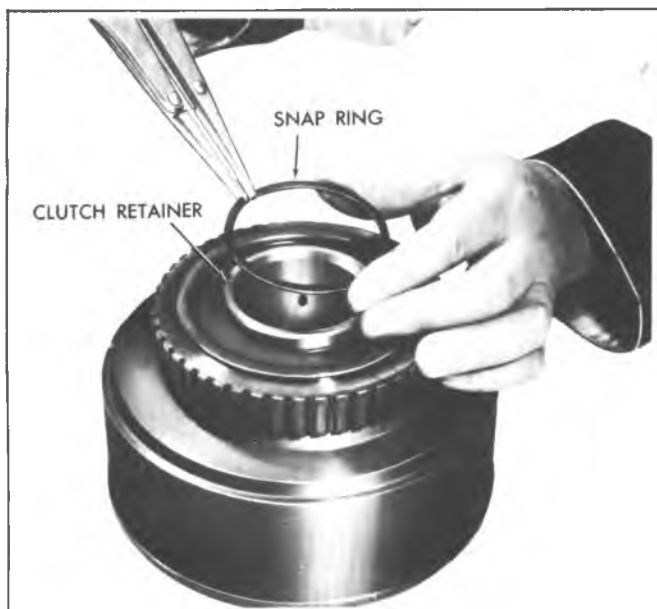

Fig. 7A-92C--Removing Intermediate Clutch Retainer Snap Ring

11. Install direct clutch hub and retaining snap ring (Fig. 7A-89C).
12. Place forward clutch housing on pump delivery sleeve and air check clutch operation (7A-90C).

**DIRECT CLUTCH AND INTERMEDIATE ROLLER DISASSEMBLY, INSPECTION AND ASSEMBLY**

Refer to Fig. 7A-79C.

**Disassembly (Fig. 7A-91C)**

1. Remove intermediate roller assembly retainer snap ring and retainer (Fig. 7A-92C).
2. Remove roller outer race and roller assembly.
3. Turn unit over and remove backing plate to direct clutch housing snap ring (Fig. 7A-93C).

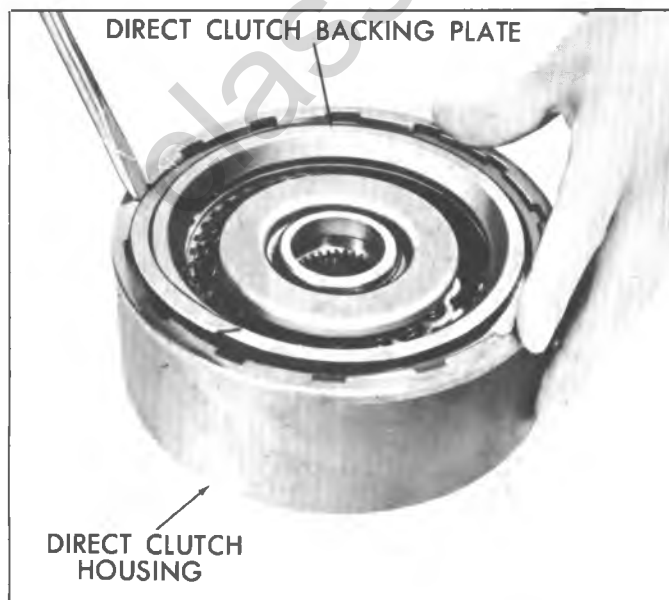

Fig. 7A-93C--Removing Direct Clutch Backing Plate Snap Ring



Fig. 7A-94C--Removing or Installing Direct Clutch Snap Ring

4. Remove direct clutch backing plate, composition plates, and steel clutch plates.
5. Using clutch compressor Tool J-4670 and J-21664, compress spring retainer in arbor press and remove snap ring (Fig. 7A-94C).
6. Remove retainer and fourteen (14) piston release springs. Keep springs separate from forward clutch release springs.
7. Remove direct clutch piston (Fig. 7A-95C).
8. Remove outer seal from piston.
9. Remove inner seal from piston.
10. Remove center piston seal from direct clutch housing.

**Inspection**

1. Inspect roller assembly for popped or loose rollers.
2. Inspect inner cam and outer race for scratches or wear.

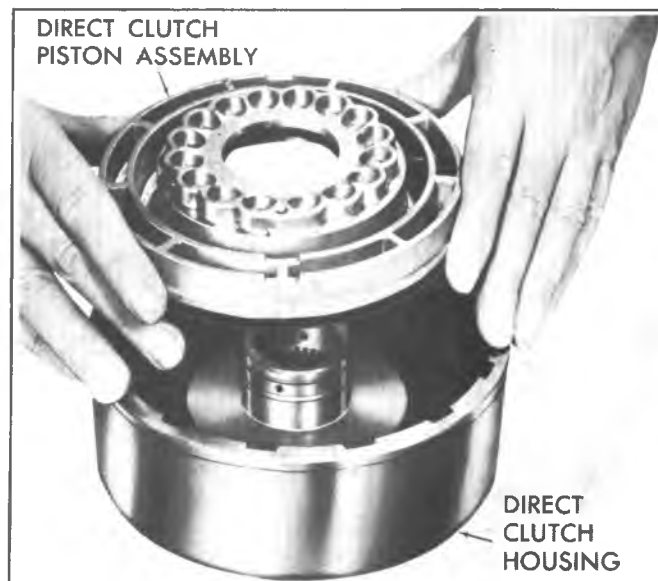

Fig. 7A-95C--Removing Direct Clutch Piston Assembly

3. Inspect clutch housing for cracks, wear, proper opening of oil passages or wear on clutch plate drive lugs.
4. Inspect composition-faces and steel clutch plates for sign of wear or burning.
5. Inspect backing plate for scratches or other damage.
6. Inspect clutch piston for cracks.
7. Inspect fourteen (14) release springs for collapsed coils or signs of distortion. The 14 direct clutch release springs are not serviced. If one or more of these springs require replacement, discard all of them and install the 16 service direct clutch release springs.
8. Inspect housing for free operation of check ball.

### Assembly

The forward and direct clutch pistons have identical inside and outside diameters. It is possible to reverse the pistons during reassembly, therefore, care should be exercised to make certain the proper piston be installed in the clutch assemblies, as shown in Figure 7A-102C.

1. Install a new inner clutch piston seal on piston with lip facing away from spring pockets (Fig. 7A-96C).
2. Install a new outer clutch piston seal with lip facing away from spring pockets (Fig. 7A-97C).
3. Install a new center seal on clutch housing with lip of seal facing up (Fig. 7A-98C). Apply automatic transmission oil to all seals and clutch plates before installation.

**NOTICE:** The direct clutch housing for models CB, CD and CL use the 6 plate clutch assembly. This housing can be identified by the elimination of the inside diameter chamfer on the clutch plate end and/or

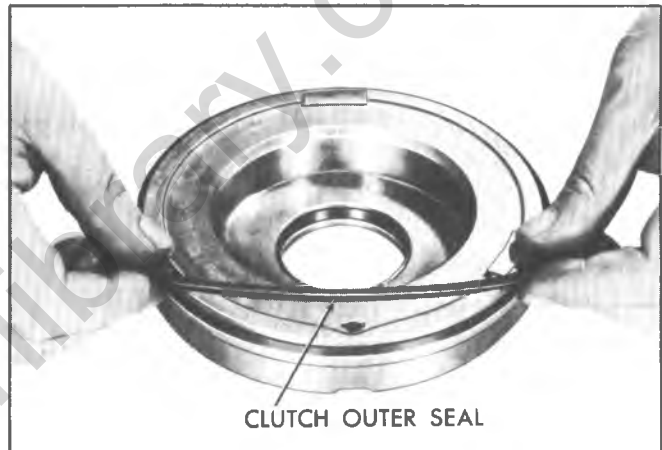

Fig. 7A-97C--Installing Direct Clutch Outer Seal

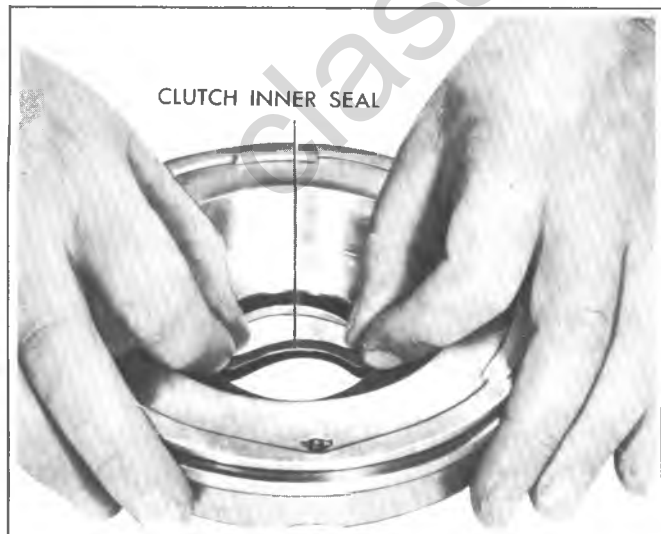

Fig. 7A-96C--Installing Direct Clutch Inner Seal

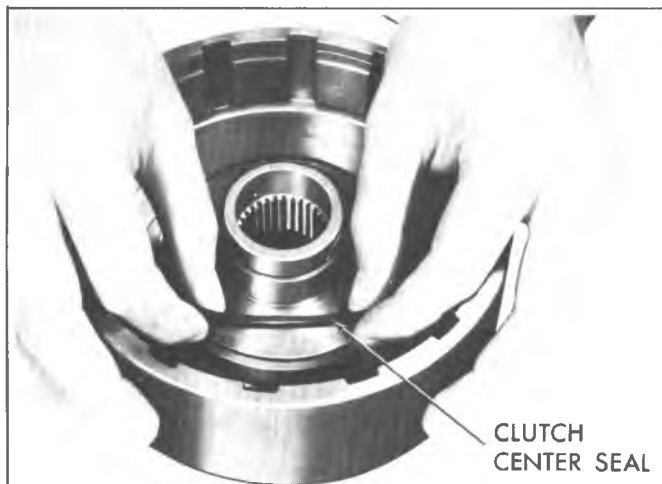

Fig. 7A-98C--Installing Direct Clutch Center Seal

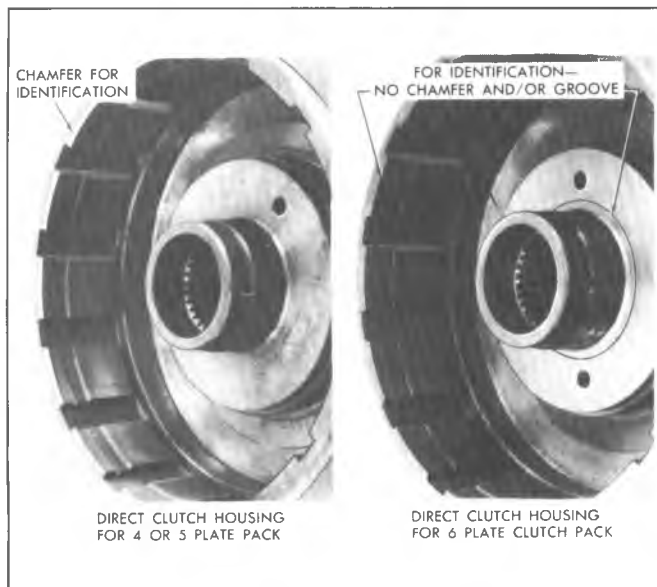

Fig. 7A-99C--Direct Clutch Housing Identification

a groove in the face at the base of the tower (Fig. 7A-99C). Should replacement of the direct clutch housing become necessary, extreme care must be taken in obtaining the correct part for the model involved.

Production built transmissions use a direct clutch housing with a check ball (See Fig. 7A-100C). If the housing requires replacement and the replacement housing does not contain a check ball, replace the direct clutch piston with the service piston which has a check ball (Models CB, CD and CL service piston has 2 check balls). **EITHER THE DIRECT CLUTCH HOUSING AND/OR THE PISTON MUST CONTAIN A CHECK BALL(S).**

4. Place seal protectors, Tools J-21362 Inner, J-21409 Outer, over hub and clutch housing and install clutch piston, with a rotating motion (Fig. 7A-101C).

5. Install fourteen (14) springs into piston leaving two pockets diagonally opposite with no springs.

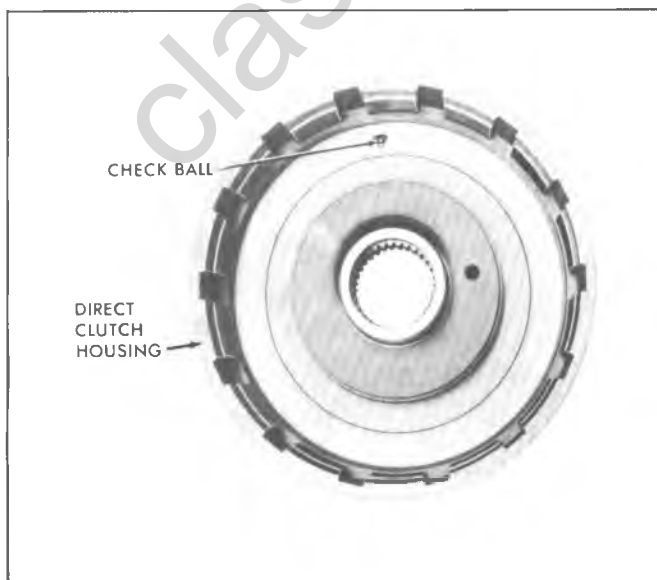

Fig. 7A-100C--Direct Clutch Housing with Check Ball

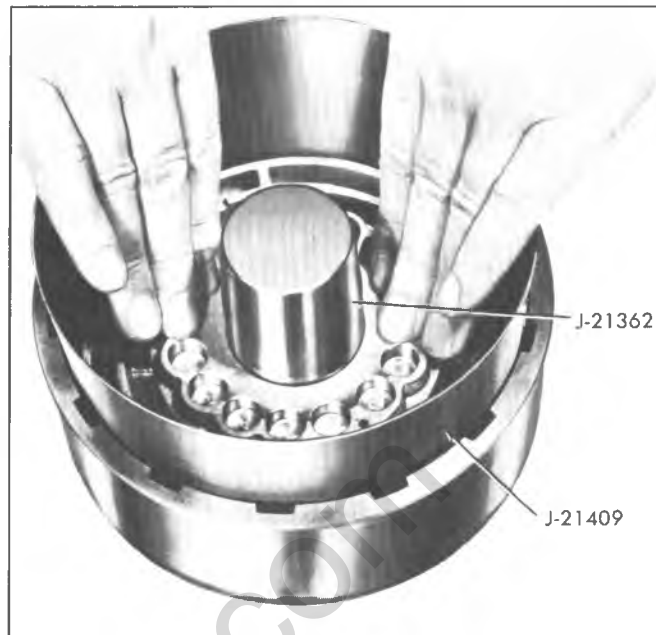

Fig. 7A-101C--Installing Direct Clutch Piston

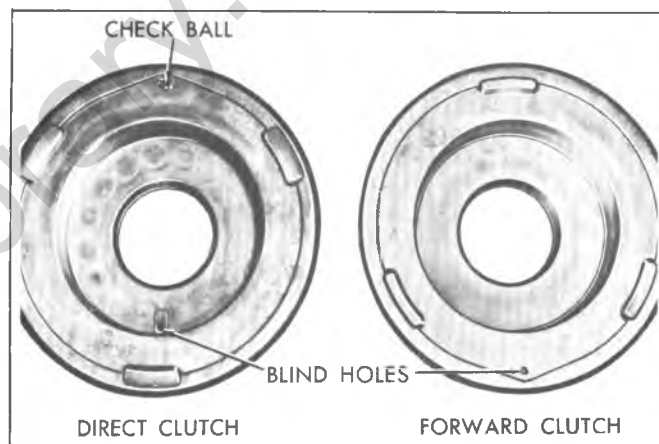

Fig. 7A-102C--Forward and Direct Clutch Piston Identification

6. Place spring retainer and snap ring on retainer.

7. Using an arbor press and Tool J-4670, with J-21664, compress springs and install snap ring (Fig. 7A-94C):

8. Install direct clutch plates. See Fig. 7A-103C.

a. For model CZ, start with one (1) waved steel plate,

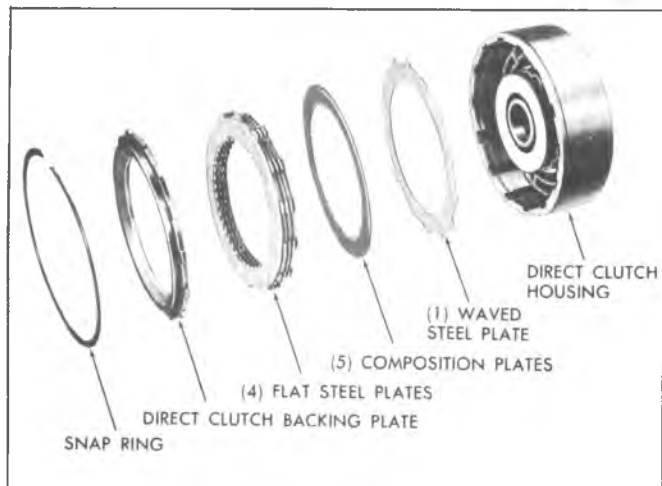

Fig. 7A-103C--Direct Clutch Assembly Exploded

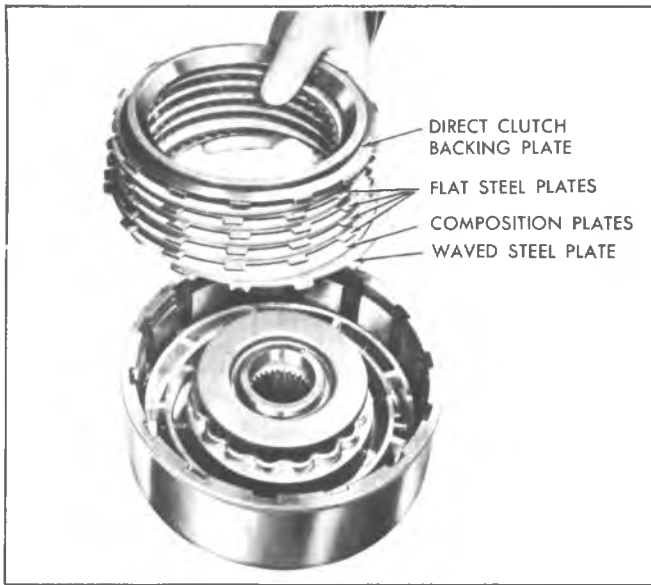

Fig. 7A-104C--Install Direct Clutch Backing Plate, Composition Plates, and Steel Plates

followed alternately by four (4) composition plates and three (3) flat steel plates. (Fig. 7A-104C).

b. (Models CB, CD and CL) Oil and install six (6) composition and six (6) flat steel plates, starting with a flat steel plate and alternating composition and flat steel clutch plates.

9. Install clutch backing plate.

10. Install backing plate retaining snap ring (Fig. 7A-105C). Install rollers that may have come out of the roller cage by compressing the energizing spring with forefinger and inserting the roller from the outer side.

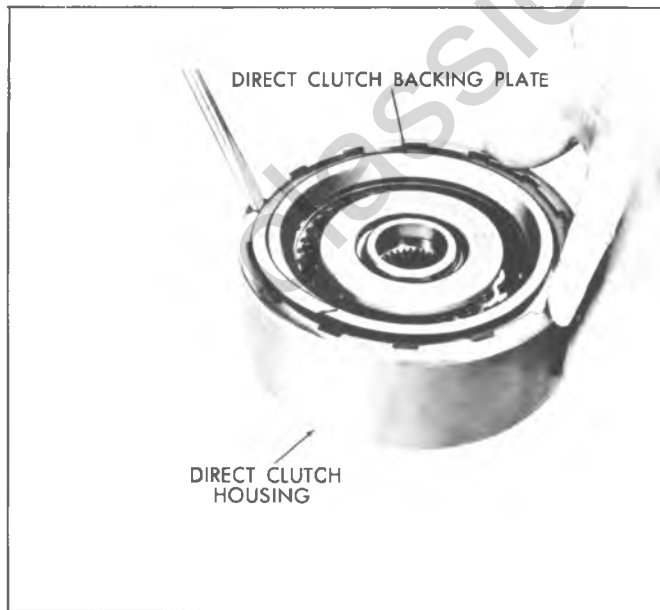

Fig. 7A-105C--Installing Direct Clutch Housing to Backing Plate Snap Ring

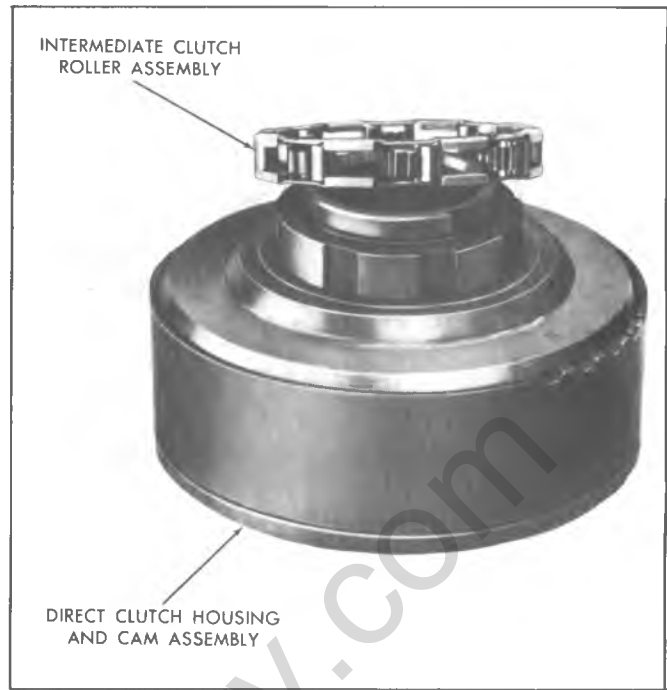

Fig. 7A-106C--Installing Intermediate Clutch Roller Assembly

11. Turn unit over and install the intermediate clutch roller assembly onto the intermediate clutch inner cam (fig. 7A-106C).

12. Install the intermediate clutch outer race with a clockwise turning motion (fig. 7A-107C).

Intermediate roller clutch is not released for the CB, CD and CL models. The sprag assembly is released for these models. Outer race should not turn counter-clockwise after installation. (See Figure 7A-108C).

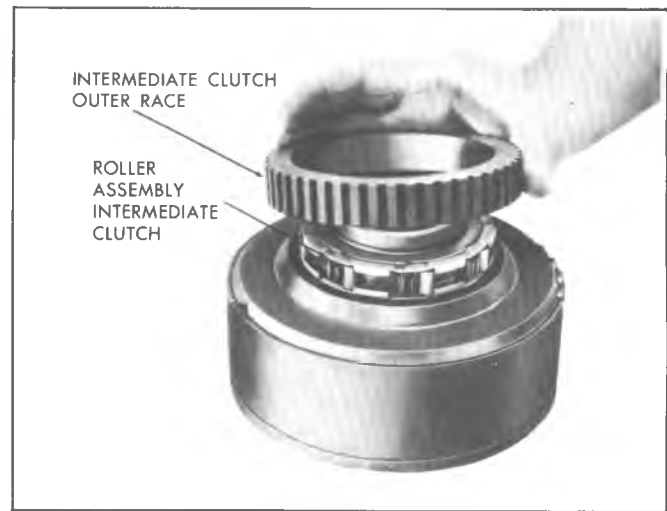

Fig. 7A-107C--Installing Intermediate Clutch Outer Race to Direct Clutch

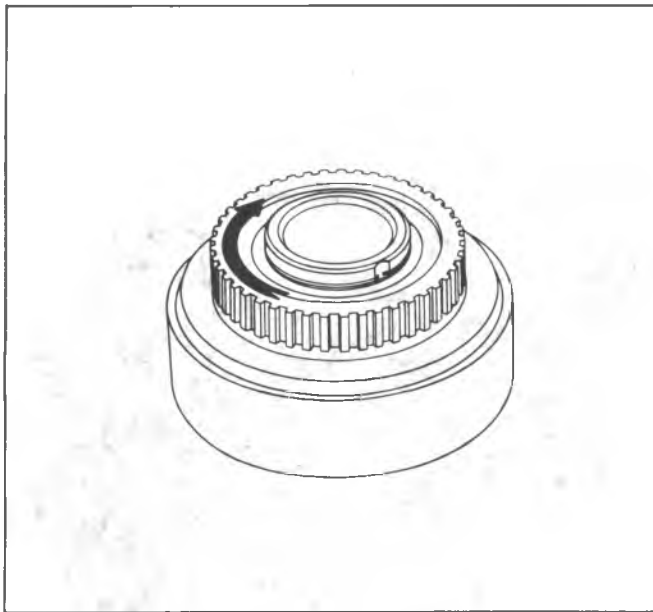

Fig. 7A-108C--Intermediate Roller Clutch Rotation

13. Install intermediate clutch retainer and snap ring (Fig. 7A-109C and 7A-110C).

14. Place direct clutch assembly over center support and air check operation of direct clutch (Fig. 7A-111C).

If air is applied through reverse passage, (right oil feed hole) it will escape from direct clutch passage (left oil feed hole). This is considered normal. Apply air through left oil feed hole to actuate piston and move direct clutch plates.

**DISASSEMBLY, INSPECTION AND RE-ASSEMBLY OF CENTER SUPPORT**

**Disassembly**

1. Remove four (4) oil seal rings from the center support (Fig. 7A-112C).

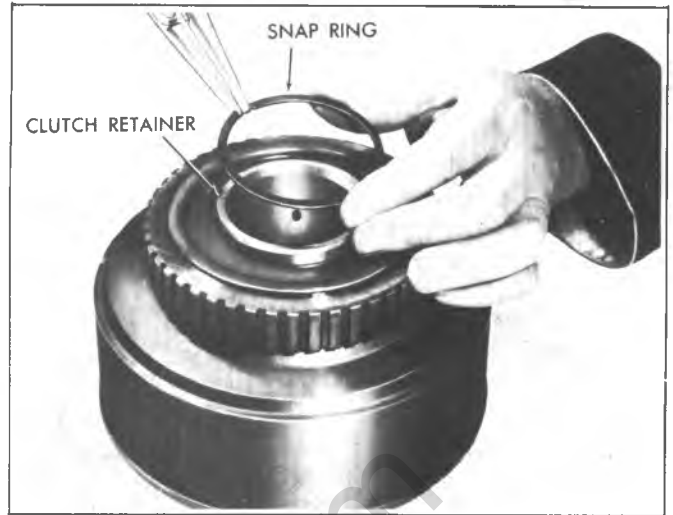

Fig. 7A-110C--Installing Intermediate Clutch Retainer Snap Ring



Fig. 7A-111C--Air Checking Direct Clutch Assembly



Fig. 7A-109C--Installing Intermediate Clutch Retainer

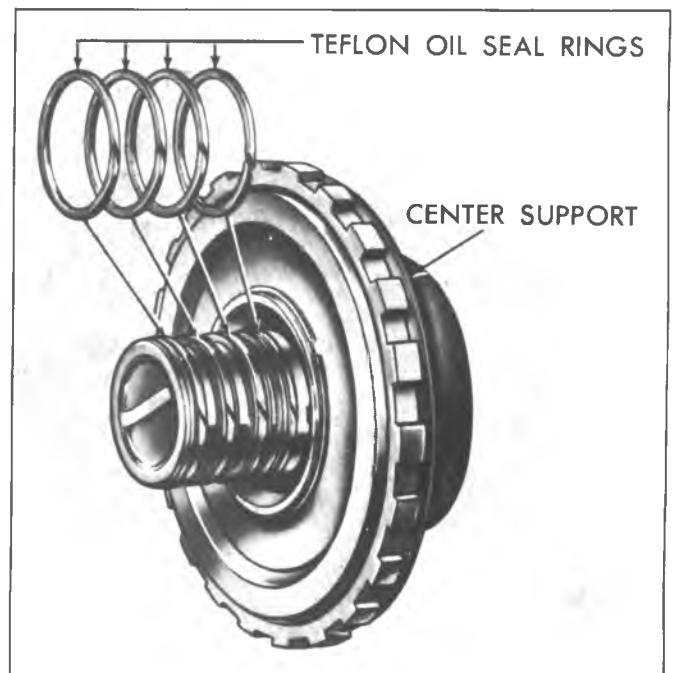

Fig. 7A-112C--Center Support and Oil Seal Rings

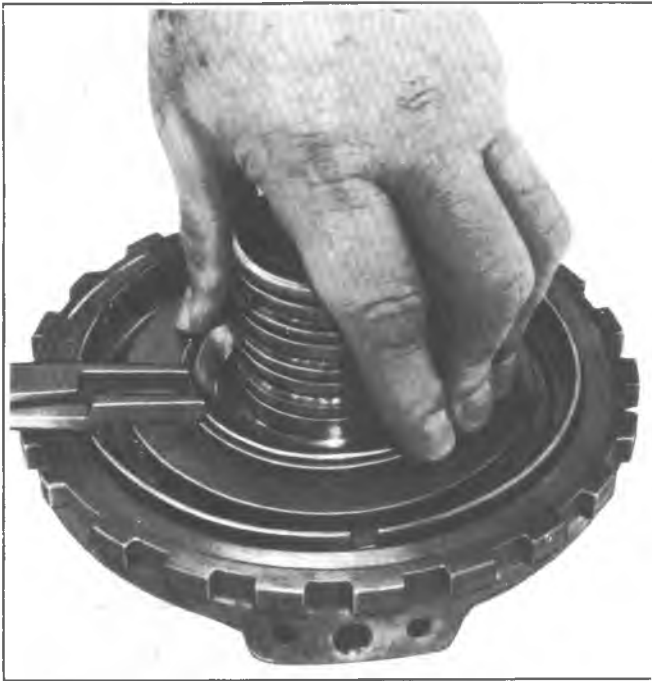

Fig. 7A-113C--Removing Intermediate Clutch Piston Snap Ring

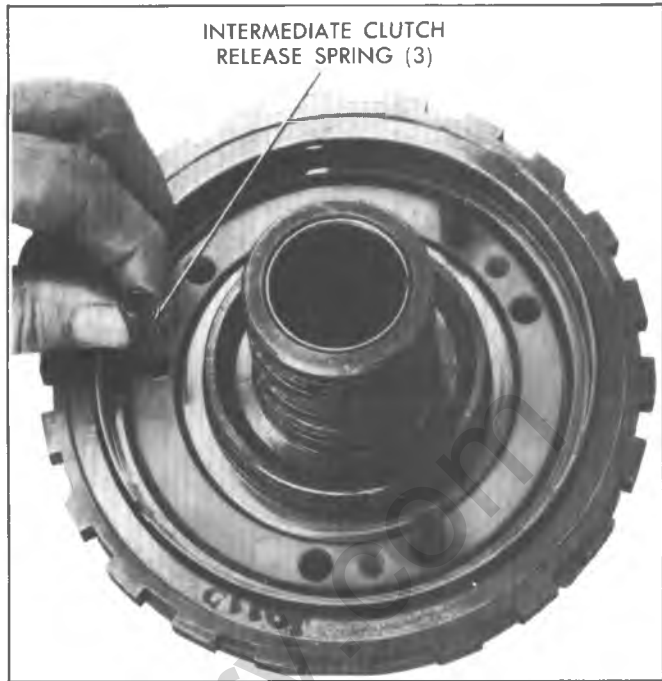

Fig. 7A-115C--Removing Clutch Release Springs

2. Compress spring retainer and remove snap ring (7A-113C).

3. Remove spring retainer (Fig. 7A-114C) and three (3) clutch release springs (Fig. 7A-115C).

4. Remove intermediate clutch spring guide (Fig. 7A-116C).

5. Remove intermediate clutch piston (Fig. 7A-117C).

6. Remove inner and outer piston seal. Do not remove three (3) screws retaining roller clutch inner race to center support.

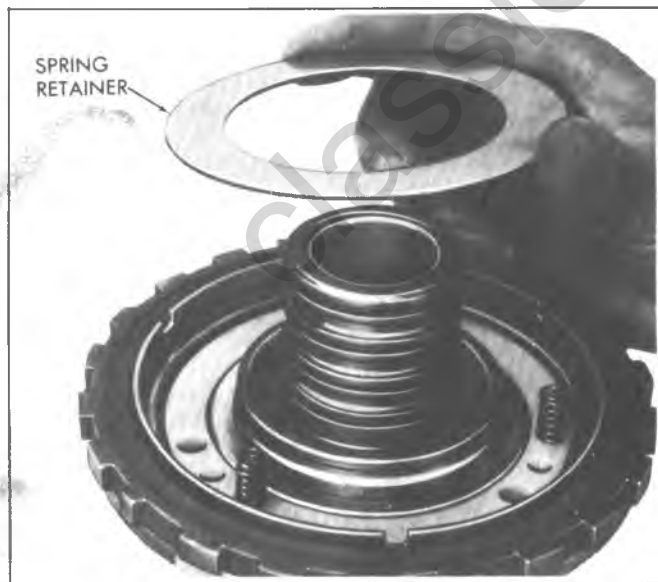

Fig. 7A-114C--Removing Spring Retainer

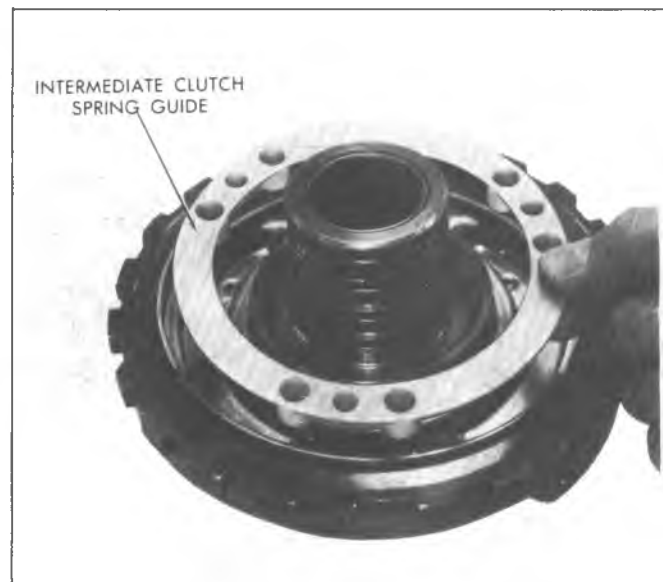

Fig. 7A-116C--Removing Intermediate Clutch Spring Guide



Fig. 7A-117C--Removing Intermediate Clutch Piston

**Inspection (Fig. 7A-118C)**

1. Inspect roller clutch inner race for scratches or indentations. Be sure lubrication hole is open. Be sure constant bleed plug orifice, (approx. .020 dia.), is open (Fig. 7A-47C).
2. Inspect bushing for scoring, wear or galling. If replacement is necessary, proceed as follows:
  - a. Using Tool J-21465-6 with Driver Handle J-8092 remove bushing.
  - b. From front side of center support, align elongated slot in the bushing with drilled hole in the oil delivery sleeve closest to the piston. Using Tool J-21465-6 and Driver Handle J-8092, drive bushing squarely into the bore until the bushing is flush to .010" below top of oil delivery sleeve.
3. Check oil ring grooves and oil rings for damage.
4. Air check oil passages to be sure they are not interconnected.
5. Inspect piston sealing surfaces for scratches.
6. Inspect piston seal grooves for nicks or other damage.
7. Inspect piston for cracks.
8. Inspect release springs for distortion.
9. Inspect support to case for burrs or raised edges. If present, remove with a stone or fine sandpaper.

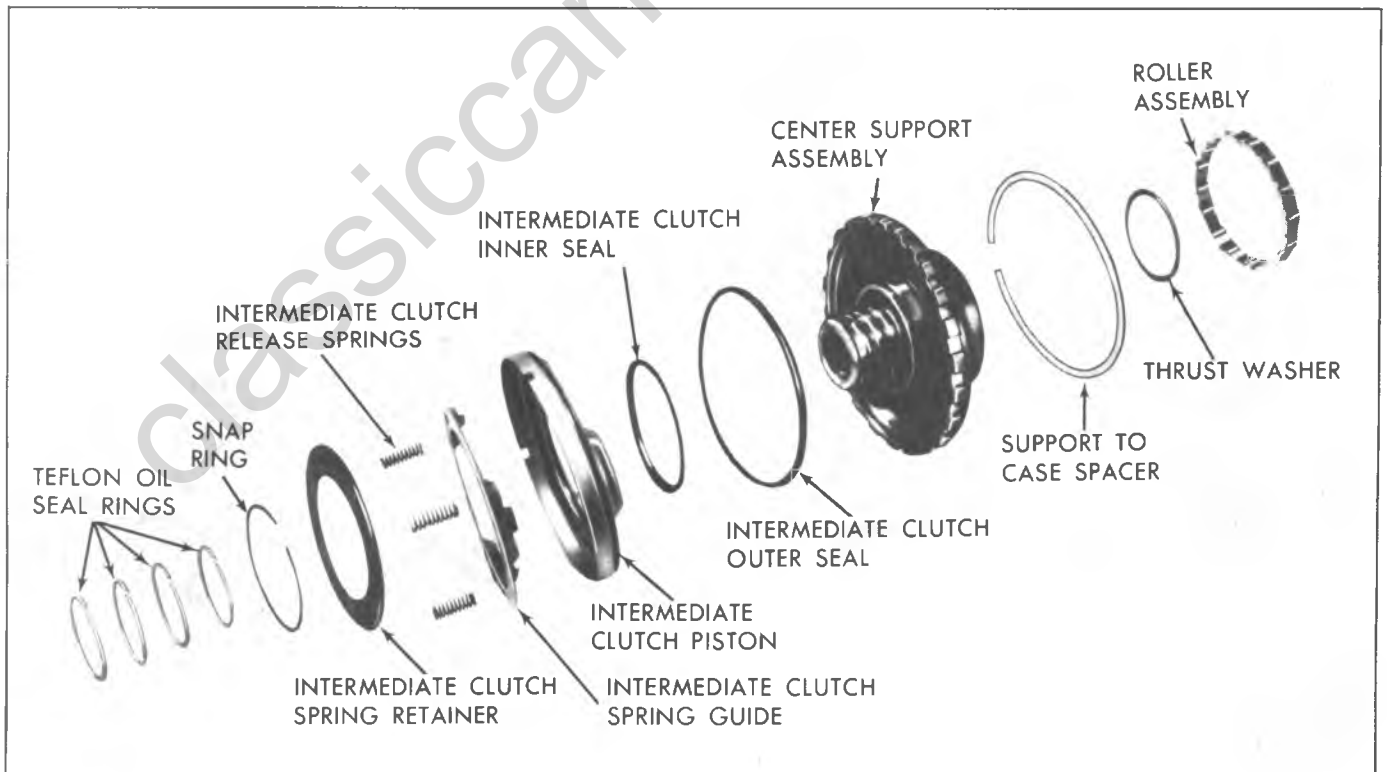

Fig. 7A-118C--Center Support Assembly--Exploded View

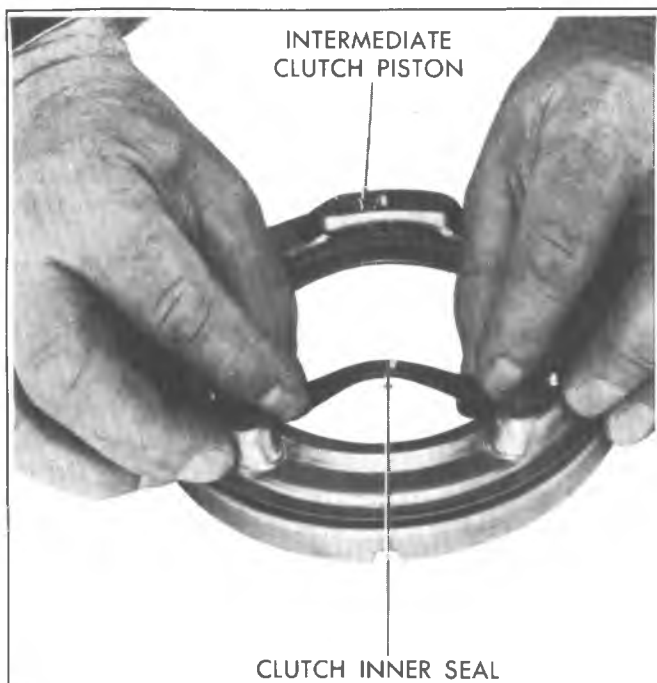

Fig. 7A-119C--Installing Intermediate Clutch Inner Seal

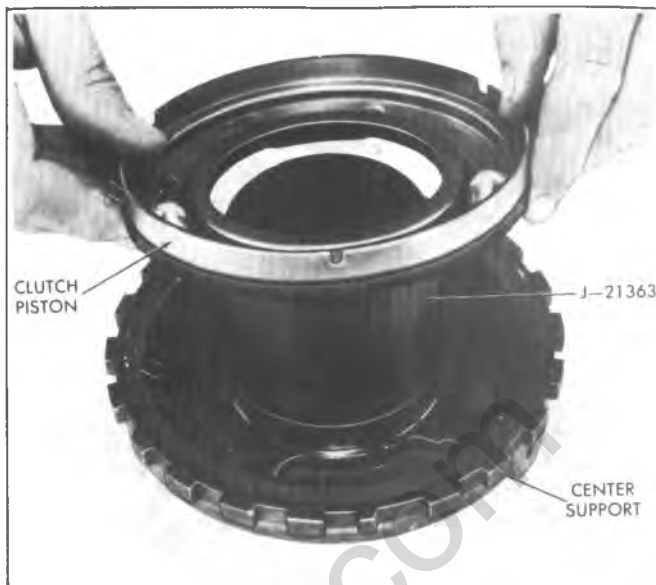

Fig. 7A-121C--Installing Intermediate Clutch Piston

### Assembly

1. Lubricate and install new inner and outer seals on piston with lip of seal facing away from spring pocket (Fig. 7A-119C and 7A-120C).

2. Install inner seal protector, Tool J-21363, on center support hub, install piston, indexing spring pockets of piston into cored areas of the center support (Fig. 7A-121C).

3. Install intermediate clutch spring guide (Fig. 7A-122C).



Fig. 7A-120C--Installing Intermediate Clutch Outer Seal

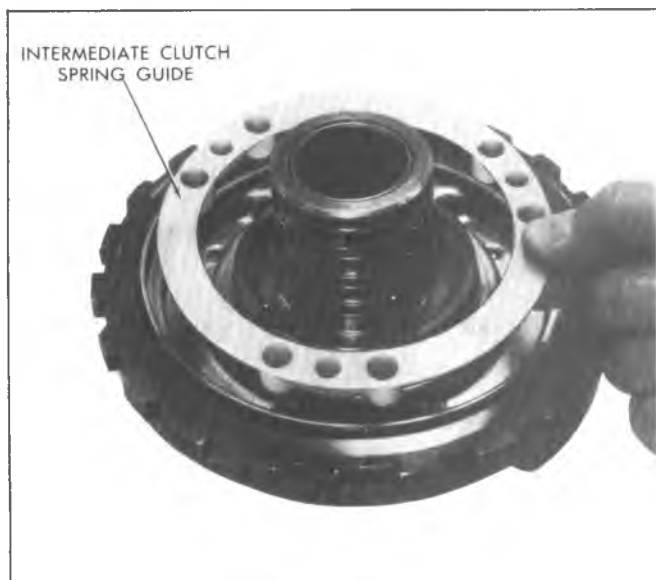

Fig. 7A-122C--Installing Intermediate Clutch Spring Guide





Fig. 7A-123C--Installing Intermediate Clutch Release Springs

4. Install three (3) release springs into holes of spring guide. Space equally during assembly (Fig. 7A-123C).
5. Place spring retainer and snap ring over springs.

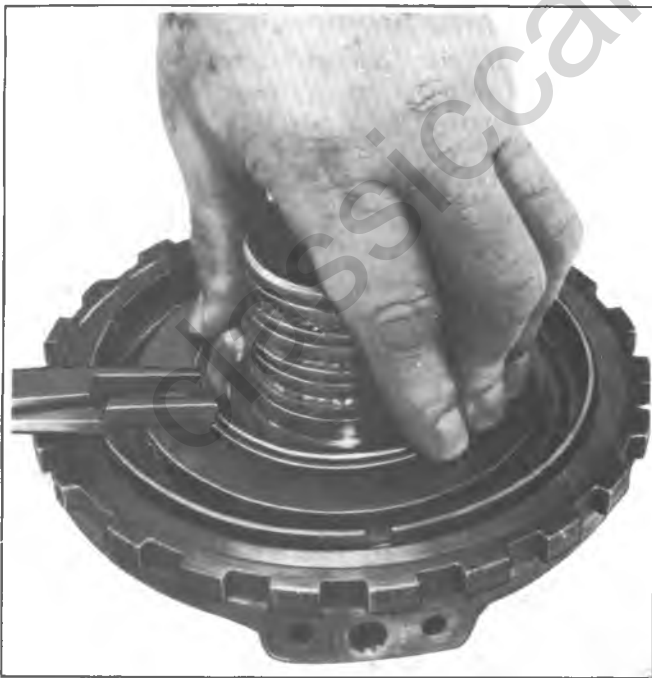

Fig. 7A-124C--Installing Intermediate Clutch Piston Snap Ring



Fig. 7A-125C--Teflon Rings

6. Compress springs and install snap ring (Fig. 7A-124C).
7. Install four (4) oil seal rings on the center support. When installing teflon oil seal rings, make sure slit ends are assembled in same relation as cut (Fig. 7A-125C). Also, make sure oil seal rings are seated in ring grooves to prevent damage to rings during re-assembly of mating parts over rings. Retain with petrolatum.
8. Air check operation of intermediate clutch piston (Fig. 7A-126C).



Fig. 7A-126C--Air Checking Intermediate Clutch Piston

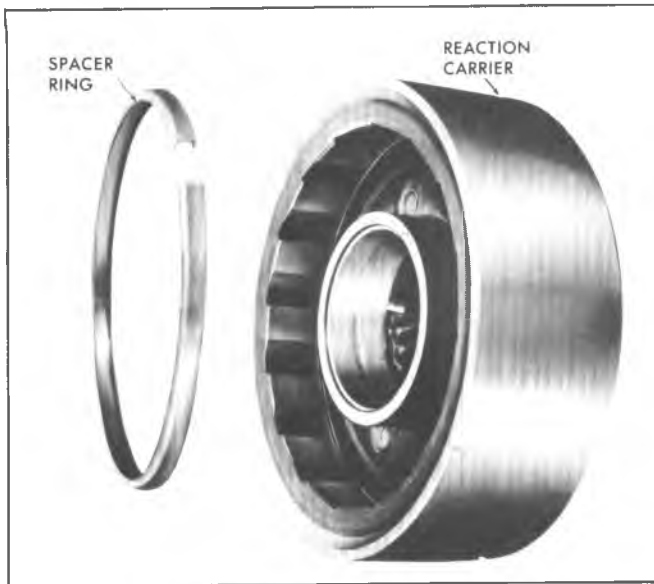

Fig. 7A-127C--Inspecting Spacer Ring

### Inspection of Reaction Carrier, Roller Clutch, and Output Carrier Assembly

1. If the reaction carrier has a spacer ring in an undercut at the bottom of the roller cam ramps, inspect it for damage (Fig. 7A-127C).



Fig. 7A-128C--Checking Pinions End Play

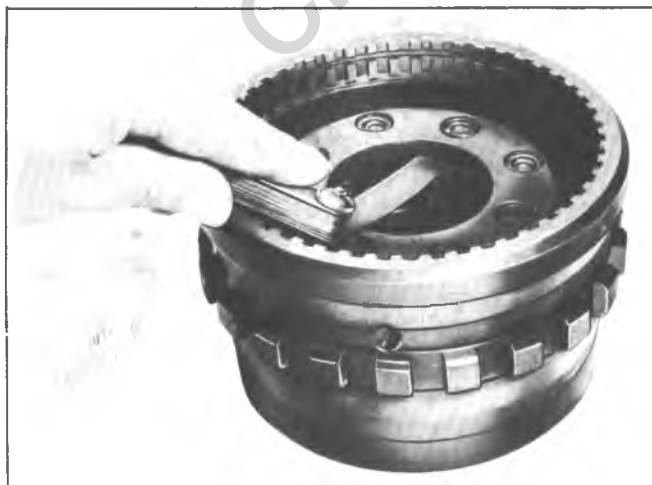

Fig. 7A-129C--Checking Output Carrier Pinion End Play

The reaction carrier with the undercut and spacer ring is used optionally and interchangeably with the reaction carrier which does not have an undercut and spacer ring.

2. Inspect band surface on reaction carrier for signs of burning or scoring.

3. Inspect roller clutch outer race for scoring or wear.

4. Inspect thrust washer surfaces for signs of scoring or wear.

5. Inspect bushing for damage. If bushing is damaged, reaction carrier must be replaced.

6. Inspect reaction carrier pinions for damage, rough bearings, or excessive tilt.

7. Check pinion end play. Pinion end play should be .009"-.024" (Fig. 7A-128C).

8. Inspect roller clutch for damaged rollers.

9. Inspect roller clutch cage and springs for damage.

10. Inspect front internal gear (output carrier) for damaged teeth.

11. Inspect output carrier pinions for damage, rough bearings or excessive tilt.

12. Check pinion end play. Pinion end play should be .009"-.024" (Fig. 7A-129C).

13. Inspect parking pawl lugs for cracks or damage.

14. Inspect output locating splines for damage.

15. Inspect front internal gear ring for flaking (Fig. 7A-49C).

### Pinion Replacement Procedure

1. Support carrier assembly on its front face.

2. Using a 1/2 inch diameter drill, remove stake marks from the end of the pinion pin, or pins, to be replaced. This will reduce the probability of cracking the carrier when pinion pins are pressed out. Do not allow drill to remove any stock from the carrier.

3. Using a tapered punch, drive or press pinion pins out of carrier (Fig. 7A-130C).

4. Remove pinions, thrust washers and roller needle bearing.

5. Inspect pinion pocket thrust faces for burrs and remove if present.

6. Install eighteen (18) needle bearings into each pinion



Fig. 7A-130C--Removing Planet Pinion Pin

using petrolatum to hold bearings in place. Use pinion pin as guide (Fig. 7A-131C).

7. Place a bronze and steel washer on each side of pinion so steel washer is against pinion, hold them in place with petrolatum.

8. Place pinion assembly in position in carrier and install a pilot shaft through rear face of assembly to hold parts in place.

9. Drive a new pinion pin into place while rotating pinion from front, being sure that headed end is flush or below face of carrier (Fig. 7A-132C).

10. Place a large punch in a bench vise to be used as an anvil while staking opposite end of pinion pin in three places. Both ends of pinion pins must lie below face of carrier or interference may occur.

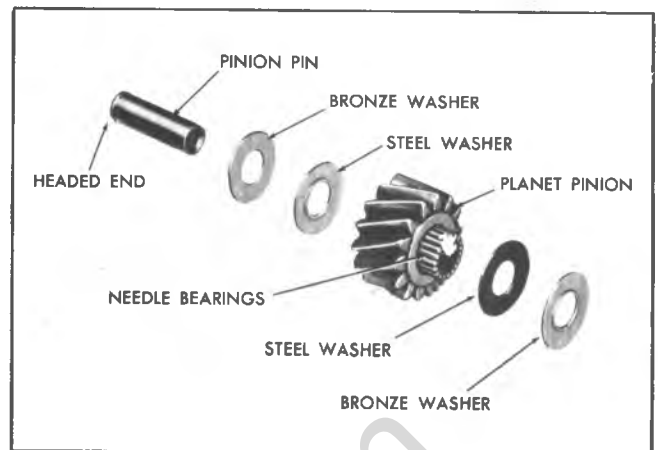

Fig. 7A-131C--Planet Pinion Assembly--Exploded View

## OUTPUT SHAFT, REAR INTERNAL GEAR, SUN GEAR AND SHAFT

### Output Shaft

1. Inspect bushing for wear or galling. If replacement is necessary, proceed as follows:

a. Thread Tool J-21465-16 into bushing and using Slide Hammer J-2619, remove bushing.

b. Using Tool J-21465-1 with drive handle J-8092, install bushing into place until tool bottoms.

2. Inspect bearing and thrust washer surfaces for damage.

3. Inspect governor drive gear for rough or damaged teeth.

4. Inspect splines for damage.

5. Inspect drive lugs for damage.

6. Inspect speedometer drive gear.

### Inspection of Rear Internal Gear

1. Inspect gear teeth for damage or wear.

2. Inspect splines for damage.

3. Inspect gear for cracks.

### Inspection of Sun Gear

1. Inspect gear teeth for damage or wear.

2. Inspect splines for damage.

3. Be sure oil lubrication hole is open.

### Inspection of Sun Gear Shaft

1. Inspect shaft for cracks or splits.

2. Inspect splines for damage.

3. Inspect bushings for scoring or galling. If necessary to replace, proceed as follows:

## SUN GEAR SHAFT BUSHING-FRONT AND REAR

### Remove

With sun gear shaft properly supported, using Tool J-21465-15, with slide hammer and Adapter J-2619, remove bushing.

### Replace

Using Tool J-21465-5 with Driver Handle J-8092 press or drive replacement bushing into place until tool bottoms.

### INSPECTION OF MAIN SHAFT

1. Inspect shaft for cracks or distortion.

2. Inspect splines for damage.

3. Inspect ground bushing journals for damage.

4. Inspect snap ring groove for damage.

5. Make sure that lubrication holes are open.

**NOTICE:** If replacement of mainshaft is required, make sure that the orifice cup plug in the service mainshaft is removed.

### INSPECTION OF FRONT AND REAR BANDS, SUPPORT TO CASE SPACER

1. Inspect lining for cracks, flaking, burning, or looseness.

2. Inspect bands for cracks or distortion.

3. Inspect end for damage at anchor lugs or apply lugs.

4. Inspect support to case spacer for burrs or raised edges, if present remove with stone or fine abrasive.

### INSPECTION OF CASE EXTENSION - ALL EXCEPT CL MODEL

1. Inspect bushing for excessive wear or damage. If replacement is necessary, remove rear seal and with



Fig. 7A-132C--Installing Planet Pinion Pin

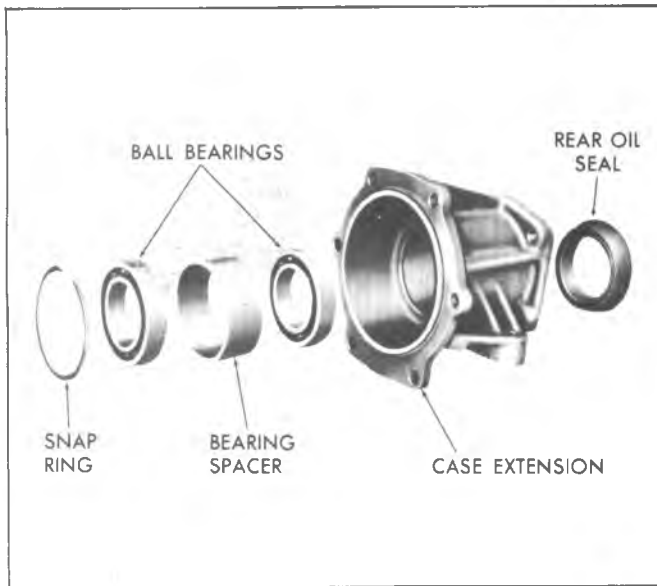

Fig. 7A-133C--Model CL Case Extension

extension housing properly supported, remove bushing as follows:

a. With rear seal removed, position case extension on bench, with seal end up. Assemble remover J-21465-17 on handle J-8092, and drive out bushing with lead or brass hammer.

b. Using tool J-21465-17, with Driver Handle J-8092, drive or press replacement bushing into place, flush to .010 below oil seal counter bore area. Stake bushing, using tool J-21465-10. Stake marks to be in bushing lubrication grooves.

2. Inspect gasket mounting face for damage.
3. Inspect housing for cracks or porosity.
4. Be sure rear seal drain back port is not obstructed.

### INSPECTION OF CASE EXTENSION-

#### CL MODEL (FIG. 7A-133C)

1. Inspect seal (case extension to case) groove for damage.
2. Inspect for cracks, or porosity.
3. Inspect dowel pin in rear face for damage.

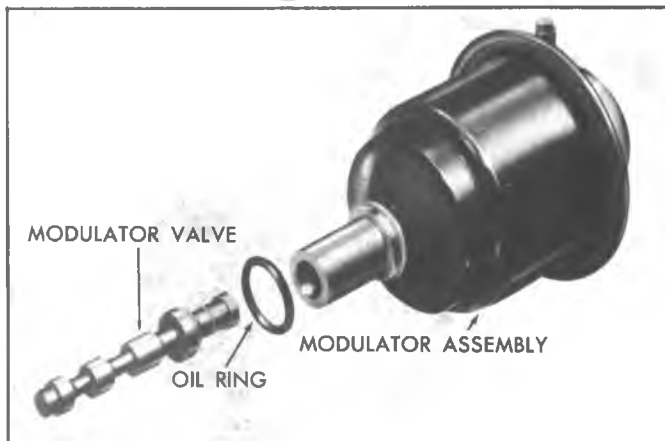

Fig. 7A-134C--Modulator Assembly and Valve

4. Inspect oil seal for damage. If replacement is required, proceed as follows:

a. Pry oil seal from extension.

b. Apply non-hardening sealer to outside of new oil seal, and install oil seal into case extension using tool (J-24057) (see Fig. 7A-171C).

5. Inspect ball bearing assemblies. If they are damaged, or if they require cleaning, proceed as follows:

a. Remove rear seal.

b. Remove snap ring.

c. Remove ball bearings and bearing spacer, using a brass rod on the outside race of bearing. An arbor press can be used if tool to press bearing out is located on outer race of bearing. DO NOT locate against inner race or balls.

d. Install ball bearing assembly and spacer, bearing first.

e. Install ball bearing assembly and snap ring.

f. Install new rear oil seal.

### INSPECTION OF MODULATOR AND VALVE

1. Inspect modulator assembly for any signs of bending or distortion (Fig. 7A-134C).

2. Inspect "O" ring seal seat for damage.

3. Apply suction to vacuum tube and check for diaphragm leaks.

4. Check modulator bellows as outlined in Section 7 of Service Manual (modulator plunger is under pressure - 16 lbs.). If bellows is damaged plunger will have very little pressure.

5. Inspect modulator valve for nicks or damage.

6. Check freeness of valve operation in case bore.

### INSPECTION OF MANUAL AND PARKING LINKAGE

1. Inspect parking actuator rod for cracks, or broken spring retainer lugs (Fig. 7A-135C).

2. Inspect actuator spring for damage.

3. Inspect actuator for free fit on actuator rod.

4. Inspect parking pawl for cracks or wear.

5. Inspect manual shaft for damaged threads, rough oil surface or loose lever.

6. Inspect inside detent lever for cracks or a loose pin.

7. Inspect parking pawl shaft if removed for damaged retainer groove.

8. Inspect parking pawl return spring for deformed coils or end.

9. Inspect parking bracket for cracks or wear.

10. Inspect detent roller and spring assembly.

### INSPECTION OF CASE ASSEMBLY (FIGS. 7A-136C AND 7A-137C)

If the case assembly requires replacement, make sure the center support-to-case spacer is removed from the old case and reinstalled in the new case.

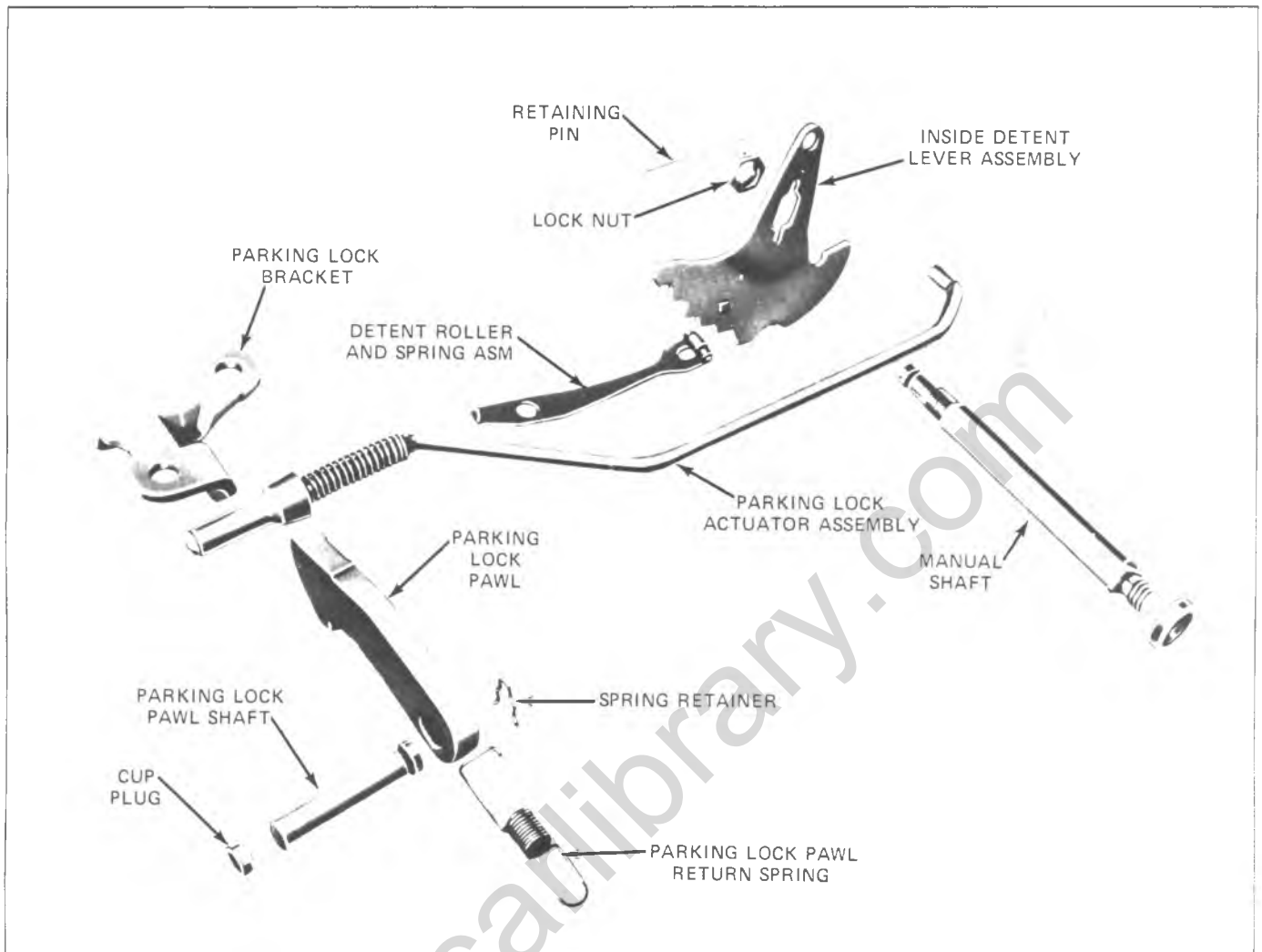

Fig. 7A-135C--Manual and Parking Linkage--Exploded View

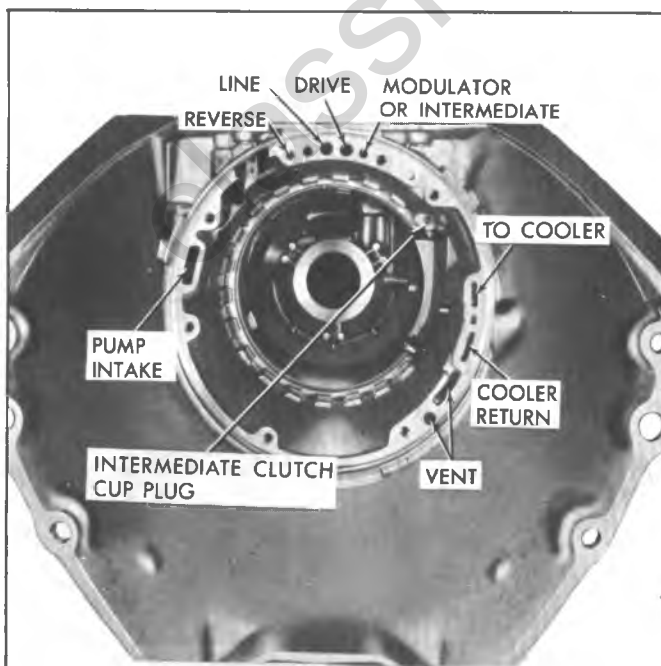

Fig. 7A-136C--Case-Front View Passage Identification

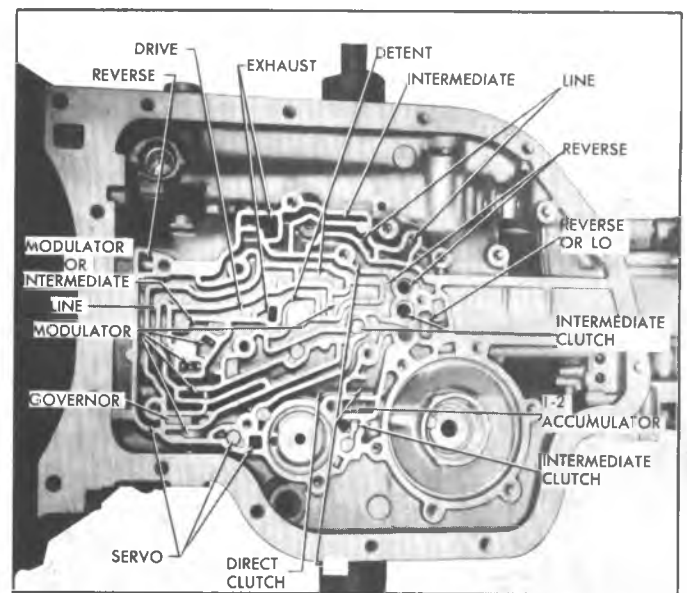

Fig. 7A-137C--Inspect Transmission Case

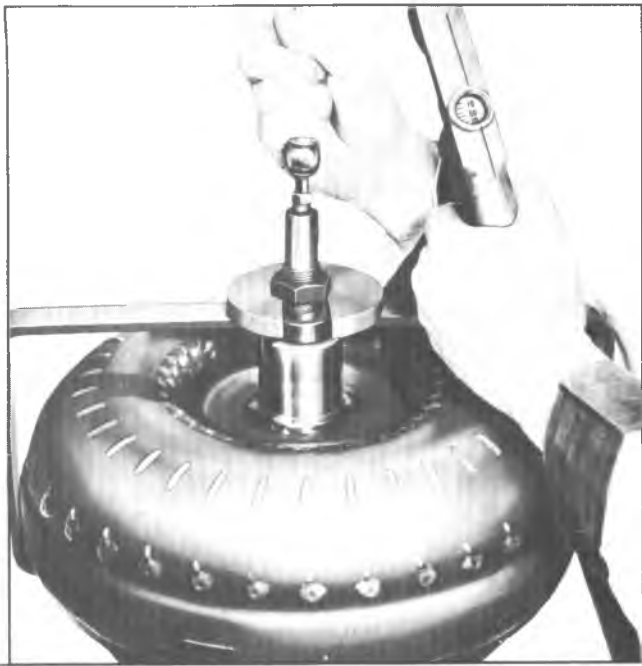

Fig. 7A-138C--Air Checking Converter

1. Inspect case assembly for cracks, porosity or interconnected passages.
2. Check for good retention of band anchor pins.
3. Inspect all threaded holes for thread damage.
4. On model CL inspect studs for thread damage, and make sure they are tight.

The two (2) studs at 9 o'clock and 11 o'clock (when viewed from the rear of case and transmission in vehicle) are approximately 1/4" longer than the other four (4) studs. These two longer studs are required to accommodate the parking brake actuating cable bracket.

5. Inspect intermediate clutch driven plate lugs for damage or brinelling.

If the case assembly requires replacement, remove the nameplate from the old case and re-install it on the new case, using the truss head nameplate attaching screw that is serviced with the case.

6. Inspect snap ring grooves for damage.
7. Inspect bore for governor assembly for scratches or scoring.
8. Inspect modulator valve bore for scoring or damage.
9. Inspect cup plug inside case for good staking and sealing.
10. Inspect case bushing. If necessary to replace, proceed as follows:

### Case Bushing

#### Remove

With case properly supported, using tool J-21465-8, with Driver Handle J-8092, remove bushing.

#### Replace

Using tool J-21465-8 adaptor ring J-21465-9, Driver Handle J-8092, and extension J-21465-13, with lube passage facing front of transmission case, drive replacement bushing into case until .040 to .055 above selective washer face. Stake bushing with tool J-21465-10. Stake marks to be in bushing lubrication grooves.

### INSPECTION OF CONVERTER

1. Check converter for leaks as follows (Fig. 7A-138C):
  - a. Install Tool J-21369 and tighten.
  - b. Apply 80 psi air pressure to tool.
  - c. Submerge in water and check for leaks.
2. Check converter hub surfaces for signs of scoring or wear.

### Converter End Clearance Check (Figs. 7A-139C and 7A-140C)

1. Fully release collet end of Tool J-21371-8.
2. Install collet end of Tool J-21371-8 into converter

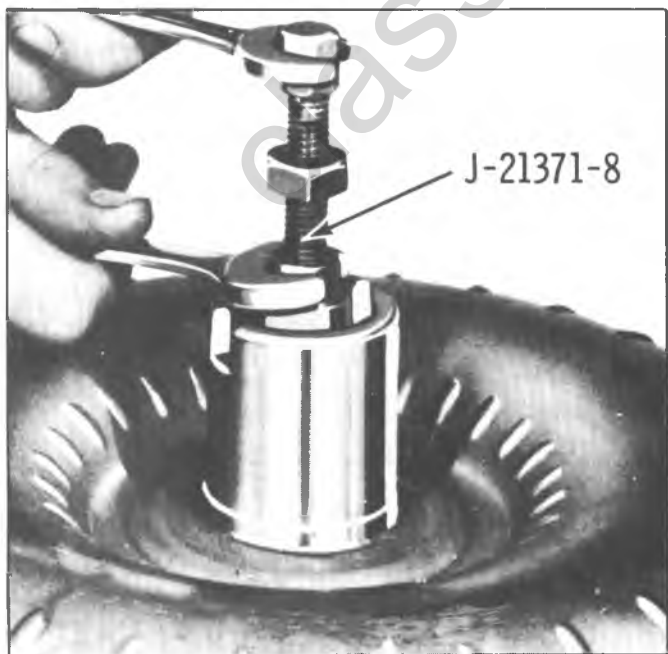

Fig. 7A-139C--Loosening Collet on Tool J-21571-8

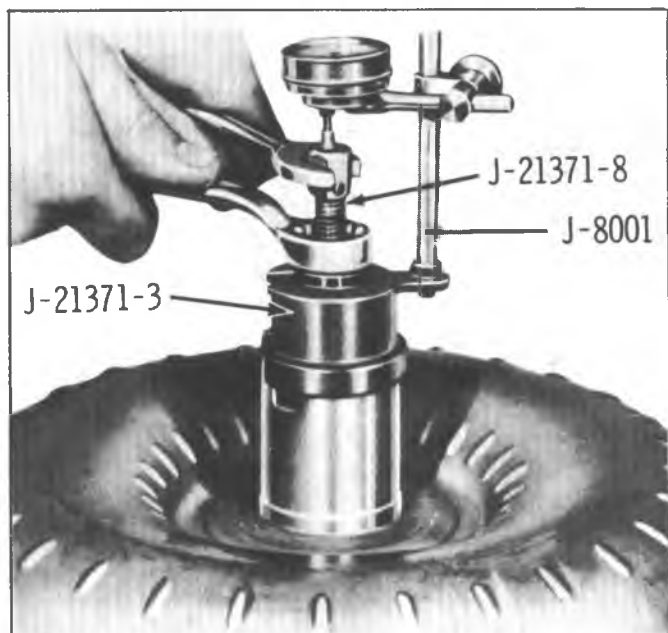

Fig. 7A-140C--Checking Converter End Clearance

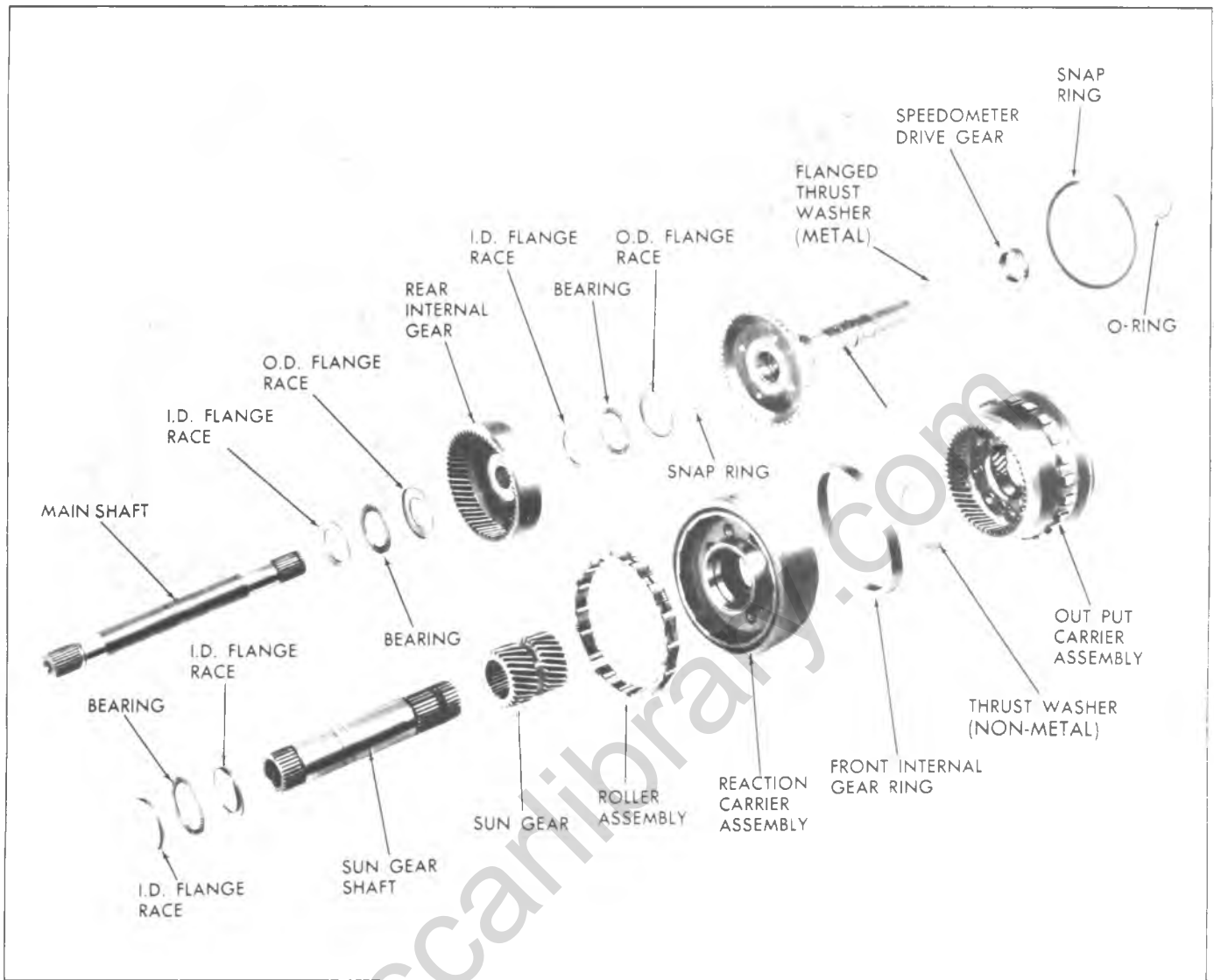

Fig. 7A-141C--Gear Unit Assembly--Exploded View

hub until it bottoms; then tighten cap nut to 5 lb. ft. (Fig. 7A-139C).

3. Install Tool J-21371-3 and tighten hex nut to 3 lb. ft. (Fig. 7A-140C).

4. Install Dial Indicator J-8001 and set it at "zero", while its plunger rests on the cap nut of Tool J-21371-8.

5. Loosen hex nut while holding cap nut stationary. With the hex nut loosened and holding Tool J-21371-3 firmly against the converter hub, the reading obtained on the dial indicator will be the converter end clearance. End clearance should be less than .050". If the end clearance is .050" or greater, the converter must be replaced.

**ASSEMBLY OF REAR UNIT (FIG 7A-141C)**

1. Install rear internal gear on end of main shaft.
2. Install rear internal gear retaining snap ring (Fig. 7A-142C).
3. Install sun gear to internal gear thrust races and bearings against inner face of rear internal gear as follows, and retain with petrolatum.

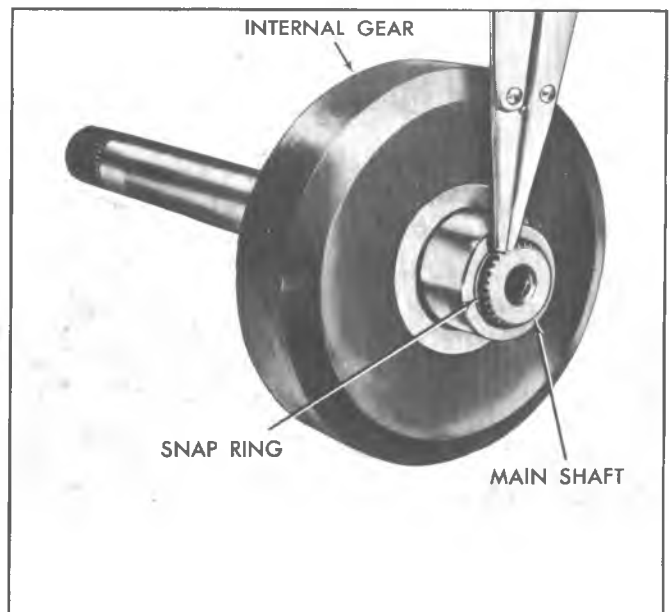

Fig. 7A-142C--Installing Rear Internal Gear Snap Ring

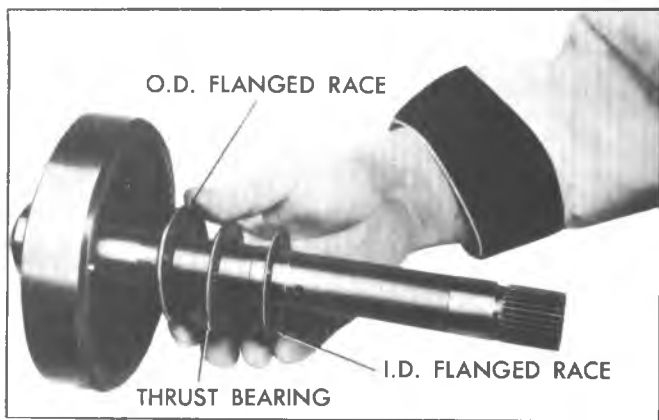

Fig. 7A-143C--Installing Rear Internal Gear to Sun Gear Bearing and Races

- a. Place large race against internal gear with outer flange facing forward or up (Fig. 7A-153C).
- b. Place thrust bearing against race.
- c. Place small race against bearing with inner flange facing into bearing or down.

4. Install output carrier over mainshaft so that pinions mesh with rear internal gear.

5. Place above portion of "build-up" through hole in bench so that mainshaft hangs downward.

6. Install rear internal gear to output shaft thrust races and bearings as follows and retain with petrolatum (Fig. 7A-144C).



Fig. 7A-144C--Installing Rear Internal Gear to Output Shaft Bearing and Races



Fig. 7A-145C--Installing Output Shaft

- a. Place small diameter race against internal gear with center flange facing up.
- b. Place bearing on race.
- c. Place second race on bearing with outer flange cupped over bearing.

7. Install output shaft into output carrier assembly (Fig. 7A-145C).

8. Install output shaft to output carrier snap ring.

9. Install "O" ring on output shaft of models that use an "O" ring.

Models CB, CD, CF, CG and CH do not use an output shaft "O" ring.

10. Turn assembly over and support so that output shaft hangs downward.

11. Install reaction carrier to output carrier metal or non-metal thrust washer with tabs facing down in pockets of output carrier and retain with petrolatum. The production built transmissions use a non-metal washer here. However, the service replacement washer is made of metal.

12. Install sun gear I.D. splines with chamfer down.



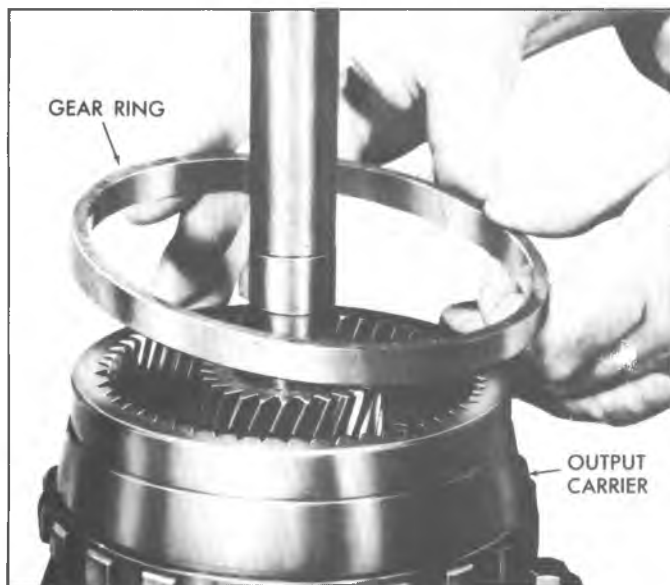

Fig. 7A-146C--Installing Front Internal Gear Ring to Output Carrier

13. Install front internal gear ring over output carrier (Fig. 7A-146C).

14. Install sun gear shaft with long splined end down.

15. Install reaction carrier (Fig. 7A-147C).



Fig. 7A-147C--Installing Reaction Carrier

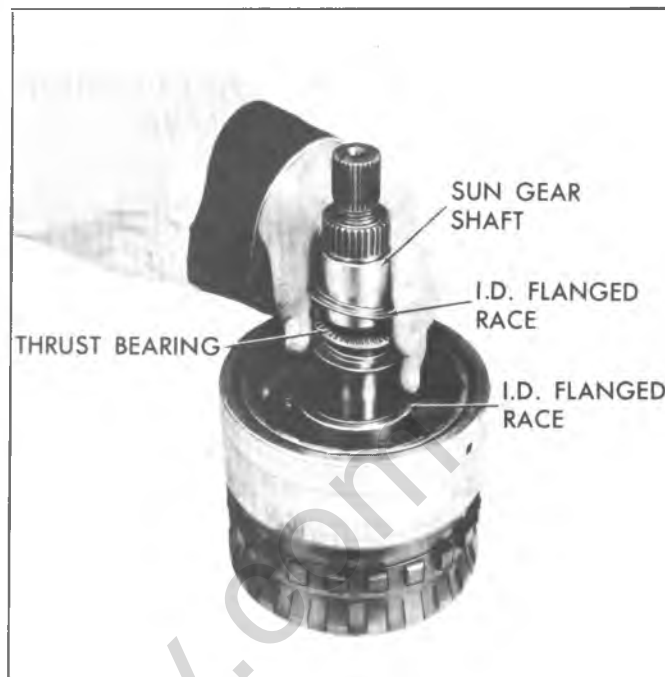

Fig. 7A-148C--Installing Center Support to Sun Gear Thrust Bearing and Races

**NOTICE:** When a new output carrier and/or reaction carrier is being installed and if the front internal gear ring prevents assembly of the carriers, replace the front internal gear ring with the SERVICE ring.

16. Install center support to sun gear thrust races and bearings as follows: (Retain with petrolatum).

a. Install large race, center flange up over sun gear shaft.

b. Install thrust bearing against race.

c. Install second race, center flange up (Fig. 7A-148C).

17. Install rollers that may have come out of the roller clutch cage, by compressing the energizing spring with forefinger and inserting roller from the outer edge (Fig. 7A-149C).



Fig. 7A-149C--Installing Roller into Roller Clutch Cage

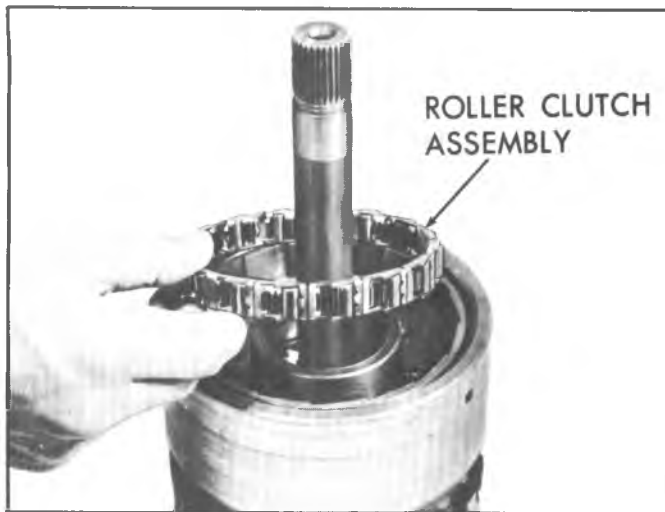

Fig. 7A-150C--Installing Roller Clutch to Reaction Carrier

18. Install roller clutch assembly (Fig. 7A-150C) into reaction carrier.

19. Install center support to reaction carrier thrust washer into recess in center support. Retain with petrolatum (Fig. 7A-47C).

20. Install center support into roller clutch in reaction carrier (Fig. 7A-151C). With reaction carrier held, center support should only turn counter-clockwise after installation. See Fig. 7A-152C for check of roller clutch.

21. Install J-21795 on gear unit assembly to hold units in place.

22. Install output shaft to case thrust washer tabs in pockets (Fig. 7A-152C), and retain with petrolatum. This must be a metal washer.

### ASSEMBLY OF UNITS TO TRANSMISSION CASE

The first three steps can be omitted if the parts involved were not removed on disassembly.

1. Install parking pawl tooth toward inside of case, and parking pawl shaft (Fig. 7A-154C).

2. Install parking pawl shaft retainer clip (Fig. 7A-155C).

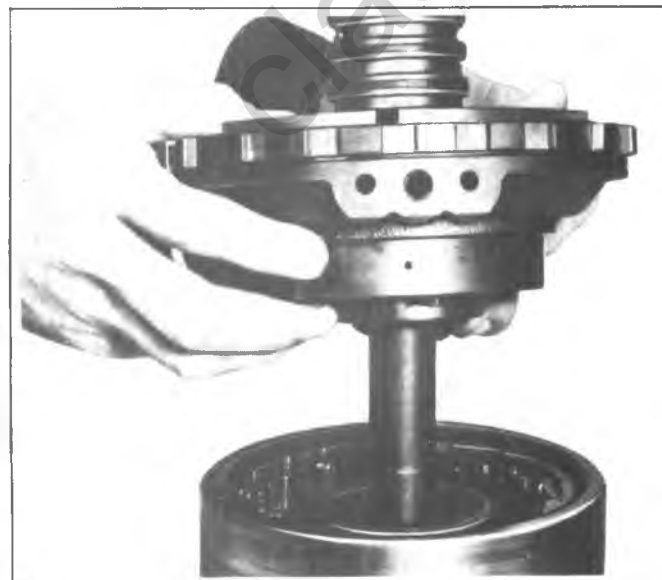

Fig. 7A-151C--Installing Center Support to Reaction Carrier

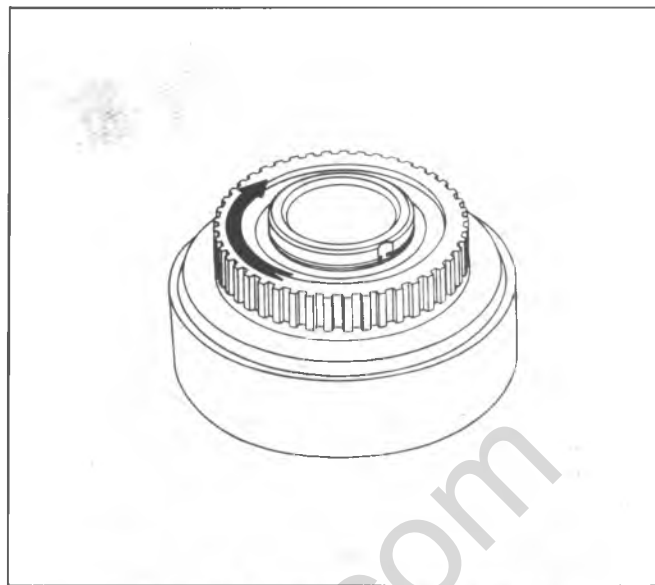

Fig. 7A-152C--Checking Roller Clutch Rotation

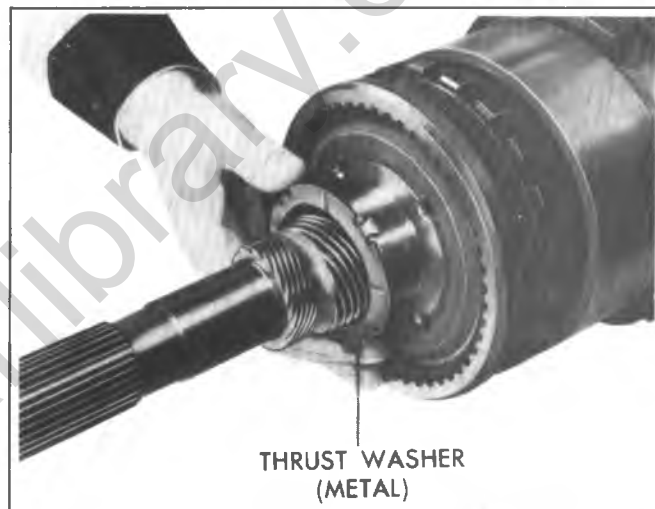

Fig. 7A-153C--Installing Case to Output Shaft Thrust Washer



Fig. 7A-154C--Installing Parking Pawl Shaft Cup Plug

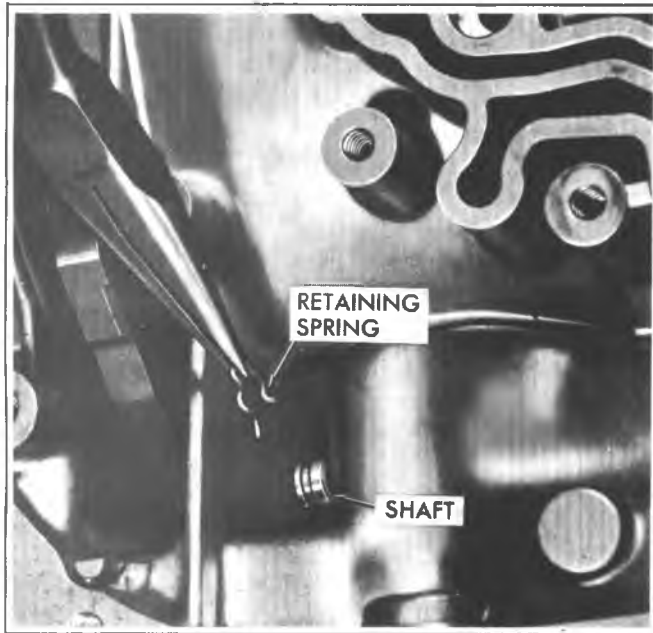

Fig. 7A-155C--Installing Parking Shaft Retaining Spring



Fig. 7A-157C--Installing Center Support to Case Spacer

3. Install parking pawl shaft cup plug and drive into the case, using a 3/8 dia. rod, until the parking pawl shaft bottoms on the case rib (Fig. 7A-154C).

4. Install parking pawl return spring, square end hooked on pawl and other end on case.

5. Install parking bracket with guides over parking pawl using two attaching bolts, torque to 18 ft. lbs.

6. Install rear band assembly so that two lugs index with two anchor pins. Check to make sure band is seated on lugs (Fig. 7A-156C).

7. Install the center support to case spacer against the shoulder at the bottom of case splines and the gap located adjacent to the band anchor pin (Fig. 7A-157C).

Do not confuse this spacer (.040" thick and both sides flat) with either the center support to case snap ring (one side beveled) or the intermediate clutch backing plate to case snap ring (.093" thick and both sides flat).

8. Install proper rear selective washer (proper washer determined by previous end play check) into slots provided inside rear of transmission case.

9. Install complete gear unit assembly into case, using Tool J-21795 (Fig. 7A-158C).

10. Install center support to case retaining snap ring with bevel side up (flat surface against the center support)



Fig. 7A-156C--Installing Rear Band

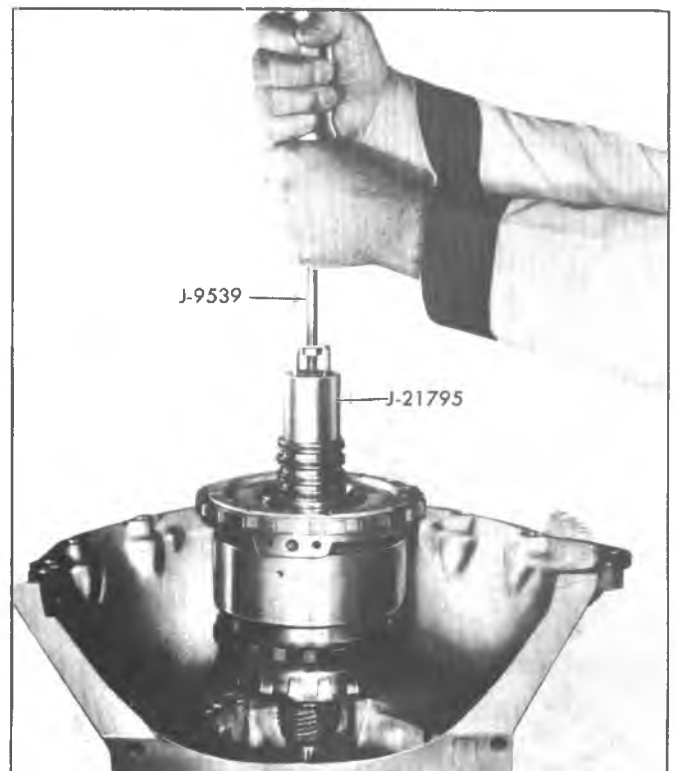

Fig. 7A-158C--Installing Center Support and Gear Unit

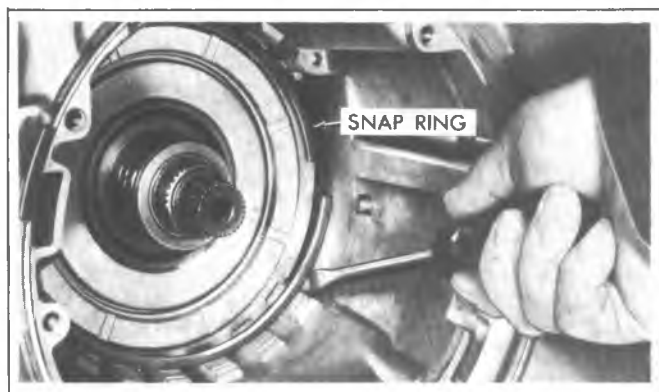

Fig. 7A-159C--Installing Center Support to Case Snap Ring

and locating gap adjacent to band anchor pin. Make certain ring is properly seated in case (Fig. 7A-159C).

11. Install case to center support bolt by placing the center support locating tool into the case direct clutch passage, with the handle of the tool pointing to the right as viewed from the front of the transmission and parallel to the bell housing mounting face. Apply pressure downward on the tool handle which will tend to rotate the center support counterclockwise as viewed from the front of the transmission. While holding the center support firmly, counterclockwise against the case splines, torque the case to center support bolt to 20-25 ft. lbs., using a 3/8" 12-point thin wall deep socket (Fig. 7A-160C).

**NOTICE:** When using the locating tool, care should be taken not to raise burrs on the case valve body mounting face.

12. Install intermediate clutch plates.

a. (All models except CB, CD and CL) Lubricate with transmission oil two (2) flat steel and one (1) waved steel plates and three (3) composition-faced intermediate clutch plates and install, starting with waved steel plate and alternating composition-faced and flat steel plates (Fig. 7A-161C).

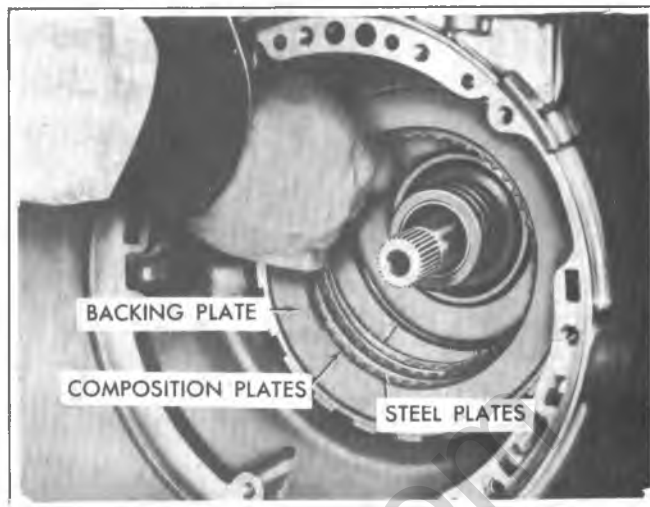

Fig. 7A-161C--Installing Intermediate Backing Plate and Clutch Plates

b. (Models CB, CD and CL) Lubricate with transmission oil three (3) flat steel and three (3) composition-faced intermediate clutch plates and install, starting with flat steel and alternating composition-faced and flat steel plates (Fig. 7A-161C).

The models CB, CD and CL intermediate composition-faced plates are different from the other models. Refer to parts catalog for correct usage.

13. Install intermediate clutch backing plate, ridge up (Fig. 7A-161C).

14. Install intermediate clutch backing plate to case snap ring, locating gap opposite band anchor pin. Both sides of this snap ring are flat, and it is .093" thick.

15. Check rear end play as follows:

a. Install a 3/8"-16 bolt or J-9539, into an extension housing attaching bolt hole (Fig. 7A-37C).

b. Mount a dial indicator on a rod and index with end of output shaft.

c. Move output shaft in and out to read end play. End play should be from .007"-.019". The selective washer controlling this end play is a steel washer having 3 lugs that is located between thrust washer and rear face of transmission case.

If a different washer thickness is required to bring end play within specifications, it can be selected from the chart shown in Fig. 7A-162C.

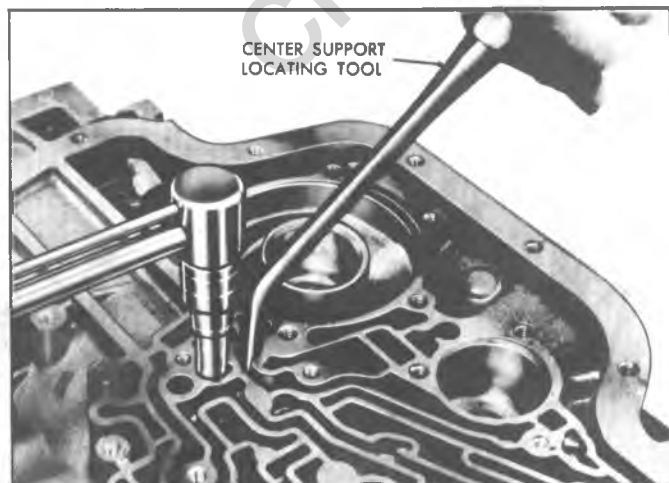

Fig. 7A-160C--Installing Center Support Bolt

**REAR END WASHER THICKNESS**

Thickness	Identification
.074 - .078	None . . . . . 1
.082 - .086	1 Tab Side . . . . . 2
.090 - .094	2 Tab Side . . . . . 3
.098 - .102	1 Tab O.D. . . . . . 4
.106 - .110	2 Tabs O.D. . . . . . 5
.114 - .118	3 Tabs O.D. . . . . . 6

Fig. 7A-162C--Rear End Washer Selection Chart

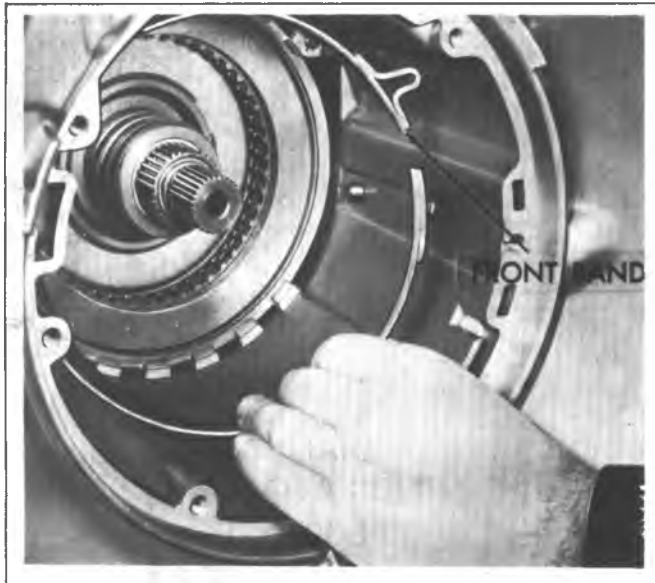

Fig. 7A-163C--Installing Front Band

16. Install front band with anchor hole placed over band anchor pin and apply lug facing servo hole (Fig. 7A-163C).

**Install Manual Linkage**

- a. Install a new manual shaft seal into transmission case using a 3/4 diameter rod to seat seal.
- b. If removed, insert actuator rod into manual detent lever from side opposite pin.
- c. Install actuator rod plunger under parking bracket over parking pawl.
- d. Install manual shaft through case and detent lever (Fig. 7A-164C).

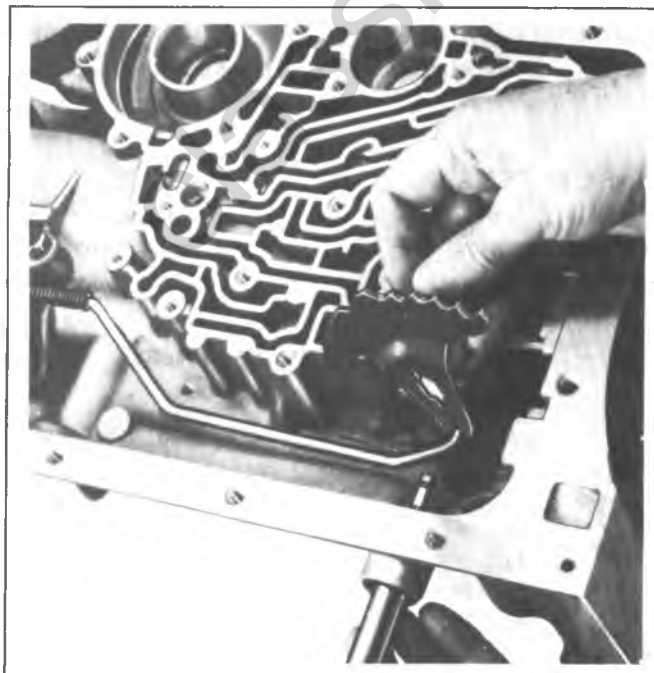

Fig. 7A-164C--Installing Manual Shaft to Case

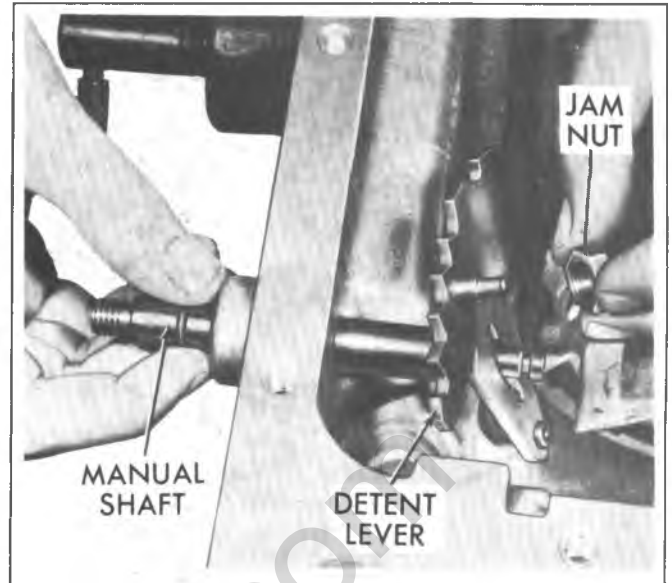

Fig. 7A-165C--Installing Detent Lever and Jam Nut to Manual Shaft

- e. Install detent jam nut on manual shaft, and tighten to 18 ft. lbs. (Fig. 7A-165C).
- f. Install retaining pin indexing with groove in manual shaft. Rotate transmission to vertical position and remove J-21795.

17. With converter end of transmission up, carefully install direct clutch and intermediate roller assembly. It will be necessary to shake and slightly twist housing to allow roller outer race to index with composition plates. Housing hub will bottom on sun gear shaft (Fig. 7A-166C).

First visually line up the intermediate clutch drive lugs, one above the other to help engagement of housing hub splines. It also may be helpful to remove the direct clutch plates while installing housing.

18. Install forward clutch hub to direct clutch housing thrust washer on forward clutch hub, if not already installed. Retain with petrolatum.

19. Install forward clutch assembly and turbine shaft; indexing direct clutch hub so end of mainshaft will bottom on end of forward clutch hub. When forward clutch is

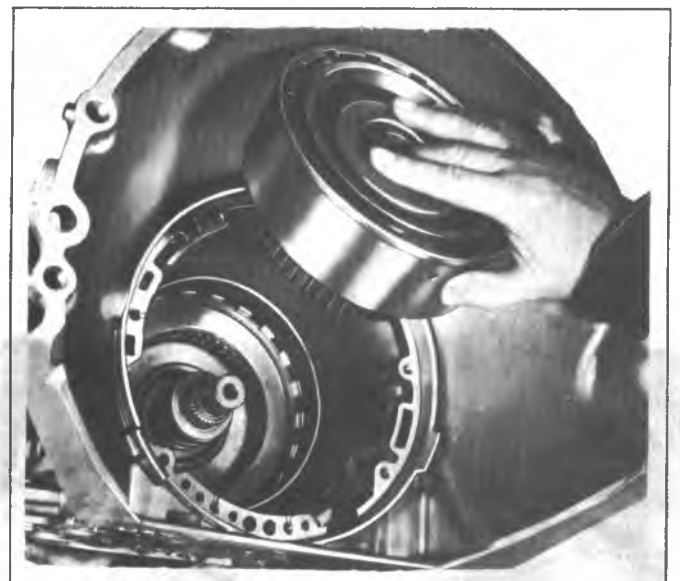

Fig. 7A-166C--Installing Direct Clutch Assembly

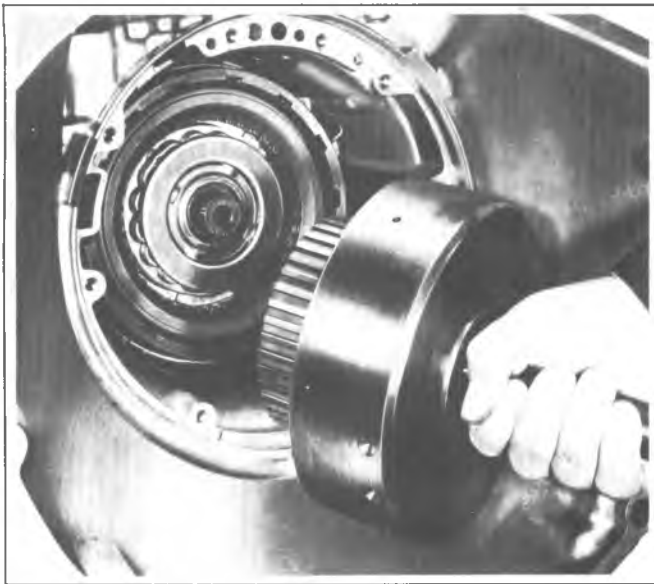

Fig. 7A-167C--Installing Forward Clutch Assembly and Turbine Shaft

seated it will be approximately 1-1/4" from pump face in case (Fig. 7A-167C).

20. Install pump assembly and gasket.

**NOTICE:** If turbine shaft cannot be rotated as pump is being pulled into place, forward or direct clutch housing have not been properly installed to index with all clutch plates. This condition must be corrected before pump is pulled fully into place.

21. Install all but one pump attaching bolts and seals. Torque to 18 ft. lbs. (See Figure 7A-169C for location of omitted bolt.)

22. If necessary to install a new front seal, use a non-hardening sealer on outside of seal body; and using Tool J-21359, drive seal in place (Fig. 7A-168C).



Fig. 7A-168C--Installing Pump Seal

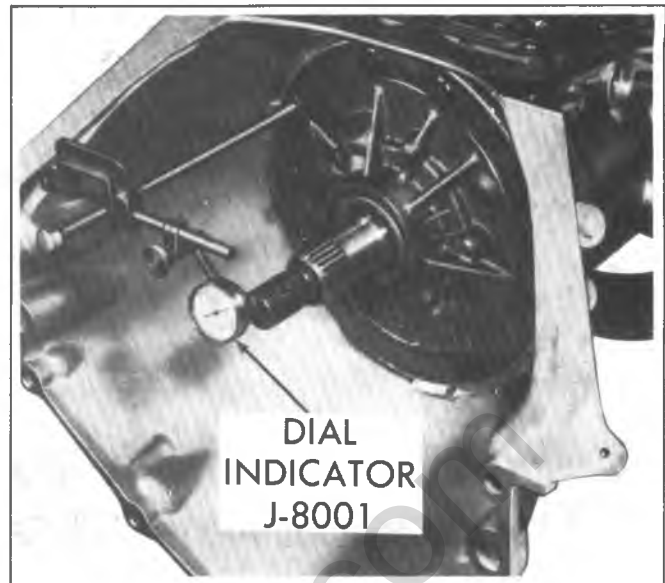

Fig. 7A-169C--Checking Front Unit End Play

23. Check front unit end play as follows (Fig. 7A-169C).

- a. Install a 3/8"-16 threaded bolt or a Slide Hammer Bolt J-9539 into bolt hole in pump.
- b. Mount a dial indicator on rod and index indicator to register with end of turbine shaft.
- c. Push turbine shaft rearward.
- d. Push output shaft forward.
- e. Set dial indicator to zero.
- f. Pull turbine shaft forward.

Read resulting travel or end play which should be .003"-.024". Selective washer controlling this end play is located between pump cover and forward clutch housing. If more or less washer thickness is required to bring end play within specifications, select proper washer from the chart in Fig. 7A-170C.

An oil soaked washer may tend to discolor. It will be necessary to measure washer for its actual thickness.

24. Install remaining front pump attaching bolt and seal. Torque 18 ft. lbs.

### CASE EXTENSION ASSEMBLY

1. Install new case extension housing to case gasket on extension housing. Model CL uses a seal between the extension housing and case extension.

FRONT END WASHER THICKNESS		
Thickness	Number	Color
.060 - .064	- 0 -	Yellow
.071 - .075	- 1 -	Blue
.082 - .086	- 2 -	Red
.093 - .097	- 3 -	Brown
.104 - .108	- 4 -	Green
.115 - .119	- 5 -	Black
.126 - .130	- 6 -	Purple

Fig. 7A-170C--Front End Washer Selection Chart

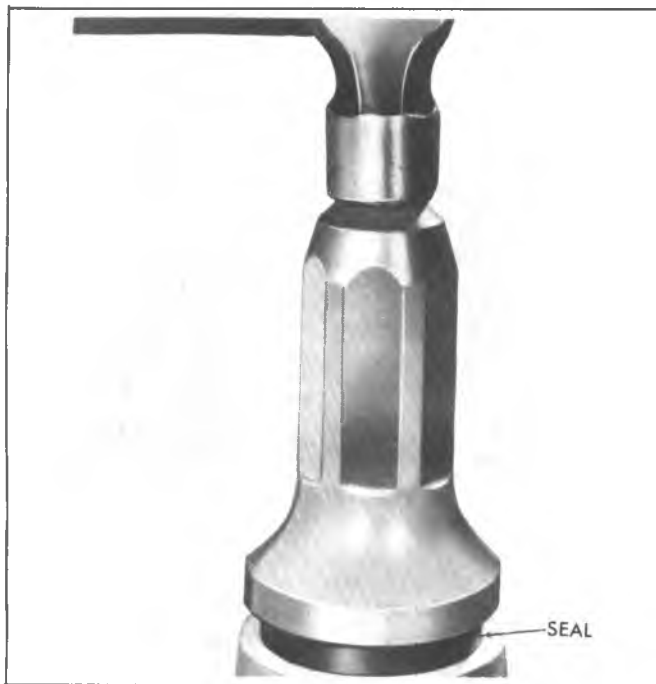

Fig. 7A-171C--Installing Extension Oil Seal (Typical)

2. Attach extension housing to case using attaching bolts and/or studs. Torque bolts to 20-25 ft. lbs.

3. If necessary, install a new seal as follows:

a. (All except CL Models) use a non-hardening sealer on outside of seal body; and using Tool J-21359, drive seal in place (Fig. 7A-171C).

b. (Model CL) use a non-hardening sealer on outside of seal body; and using Tool J-24057 drive seal in place (Fig. 7A-171C).

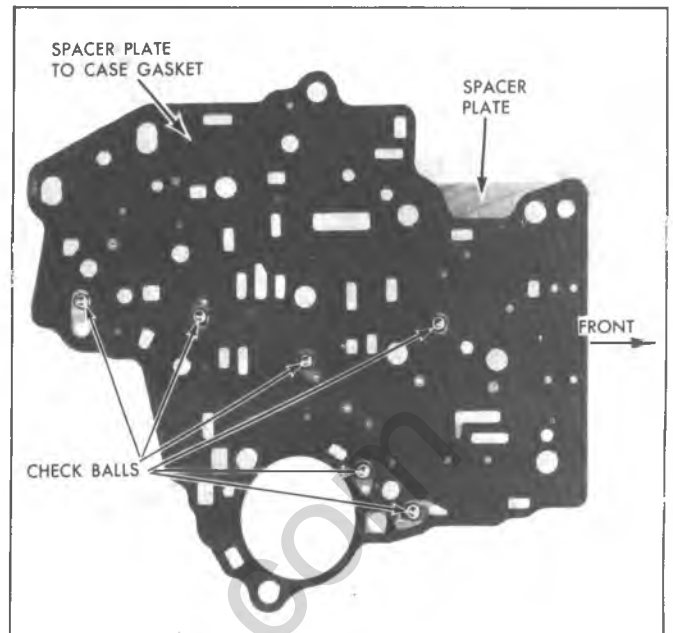

Fig. 7A-173C--Location of Check Balls--In Vehicle Installation

### Installation of Check Balls, Control Valve Spacer Plate and Gasket,

#### Detent Solenoid, Front Servo Assembly, and Electrical Connector

1. Install two control valve assembly attaching bolts with heads cut off as guide pins as shown in figure 7A-183C.

2. Install six (6) check balls into ball seat pockets in transmission case. Figure 7A-172C. If transmission is in the vehicle, install check balls into ball seat pockets on spacer plate (Fig. 7A-173C).

3. Install control valve spacer plate-to-case gasket (gasket with extension for detent solenoid and a "C" near front servo location) (Fig. 7A-174C).

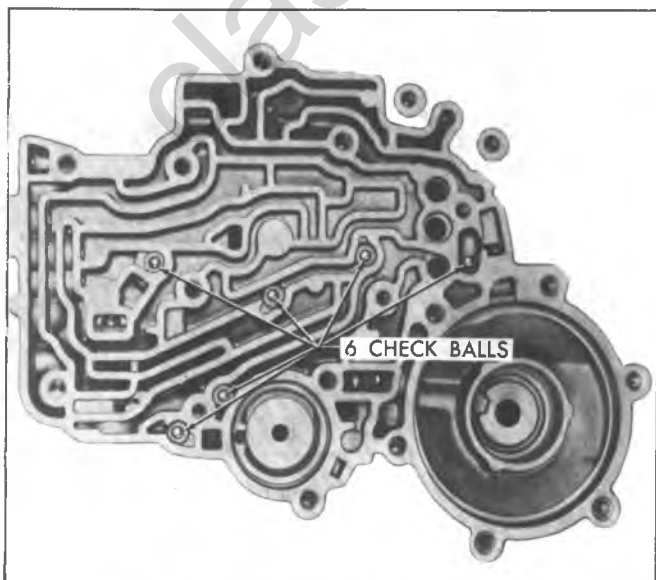

Fig. 7A-172C--Location of Check Balls

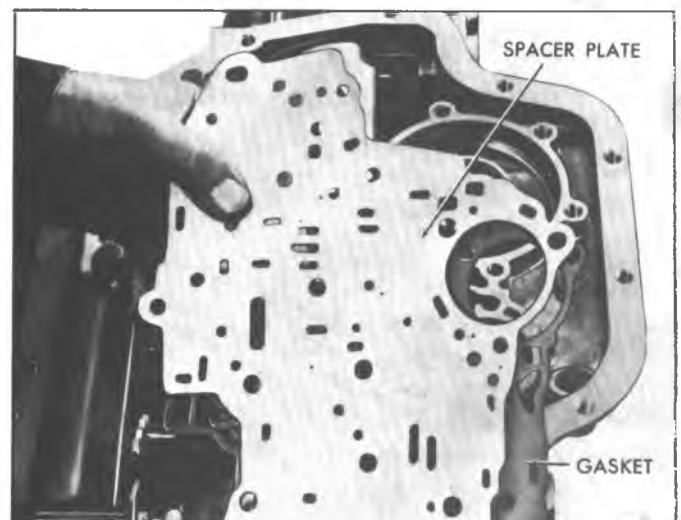

Fig. 7A-174C--Installing Control Valve Assembly Spacer Plate and Gasket

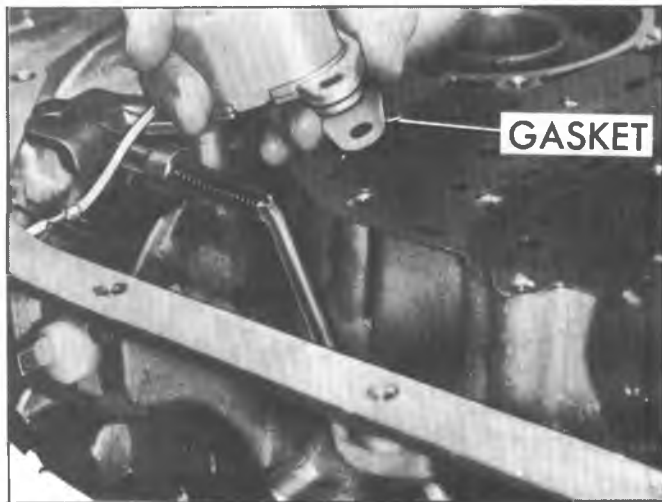

Fig. 7A-175C--Installing Detent Solenoid and Gasket

4. Install control valve spacer plate and control valve to spacer plate gasket (gasket identified with a "VB" near front servo).

5. Install detent solenoid gasket.

6. Install detent solenoid assembly with connector facing outer edge of case (Fig. 7A-175C). Do not tighten bolts at this time.

7. Install front servo spring and spring retainer into transmission case.

8. Install retainer pins in front servo pin groove and install pin into case so that tapered end contacts band. Make certain retainer ring is installed in servo pin groove.

9. Install seal ring on servo piston, if removed, and install on servo pin with flat side of piston positioned toward bottom pan. (Figure 7A-176C).

The teflon ring allows the front servo piston to slide very freely in the case. The free fit of the ring in the bore is a normal characteristic and does not indicate leakage

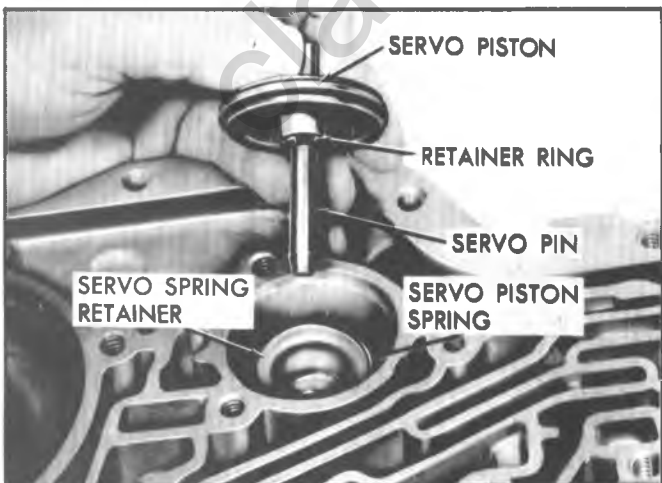

Fig. 7A-176C--Installing Front Servo Piston, Washer, and Pin

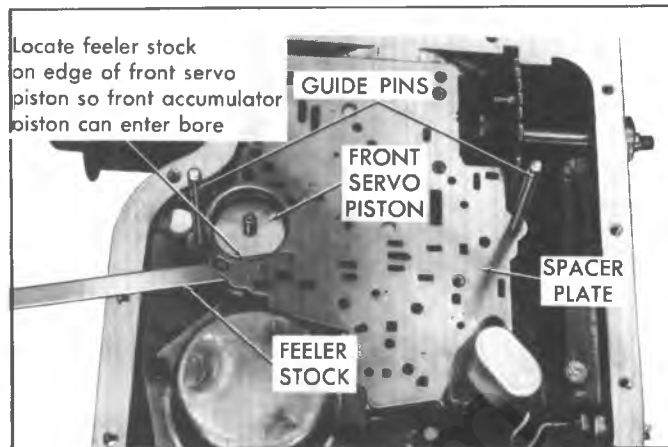

Fig. 7A-177C--Front Servo Group--In Vehicle Installation

during operation. The teflon ring should only be replaced if it shows damage or if evidence of leakage during operation exists.

If transmission is in the vehicle, assemble front servo group as shown in Figure 7A-61C and install this group of parts into front servo bore in case and hold. Slip a length of straight, clean feeler gage or shim stock (about .020") between spacer plate and front servo piston to temporarily retain front servo group. Figure 7A-177C.

10. Install "O" ring seal on electrical connector.

11. Lubricate and install electrical connector with lock tabs facing into case, positioning locator tab in notch on side of case (Fig. 7A-178C).

12. Install detent wire to electrical connector (Fig. 7A-12C).



Fig. 7A-178C--Installing Electrical Connector and "O" Ring Seal



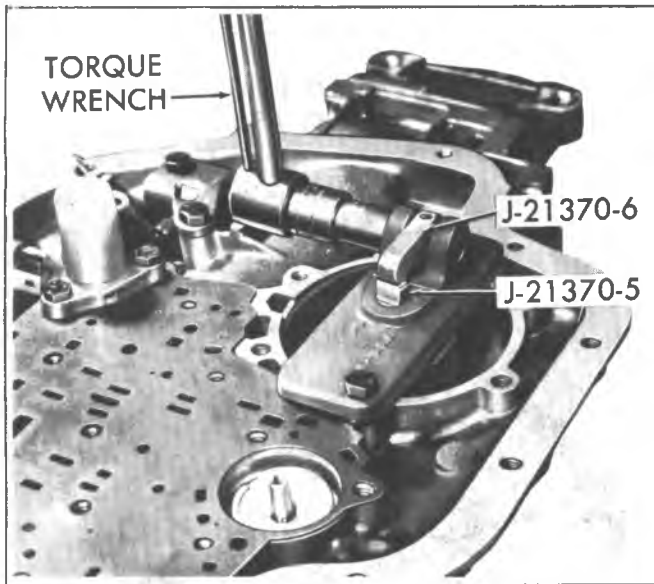

Fig. 7A-179C--Checking Rear Band Pin

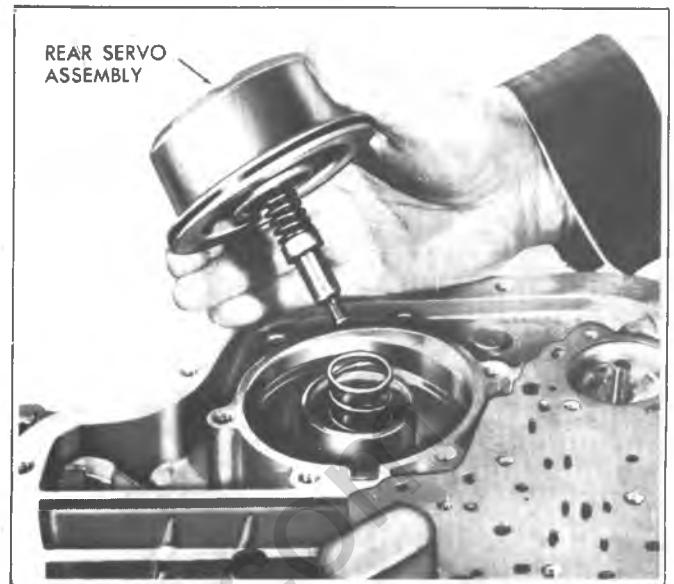

Fig. 7A-181C--Installing Rear Servo Assembly

### Installation of Rear Servo Assembly

1. Check rear servo band apply pin. (Fig. 7A-179C).
  - a. Attach band apply pin selection Gage J-21370-6 and J-21370-5 to transmission case (lever pivot pin to rear) with attaching screws.

Attach tool attaching screws finger tight and check freeness of selective pin. Torque attaching screws to 15 ft. lbs. and recheck pin to make certain it does not bind.

- b. Apply 25 ft. lb. torque and select proper servo pin to be used from scale on tool.

Selecting proper length pin is equivalent to adjusting band. The band lug end of each selective apply pin bears identification in the form of one, two, or three rings.

There are three selective pins identified as follows:

1. If both steps are below the gage surface, the long pin, identified by 3 rings, should be used.

2. If the gage surface is between the steps, the medium pin, identified by 2 rings, should be used.

If both steps are above the gage surface, the short pin, identified by 1 ring, should be used.

3. Install rear accumulator spring into case (Fig. 7A-180C).

4. Lubricate and install rear servo assembly into case (Fig. 7A-181C).

5. Install rear servo gasket and cover (Fig. 7A-182C).

6. Install attaching screws. Torque bolts to 15-20 ft. lbs.



Fig. 7A-180C--Installing Rear Accumulator Spring



Fig. 7A-182C--Installing Rear Servo Cover and Gasket

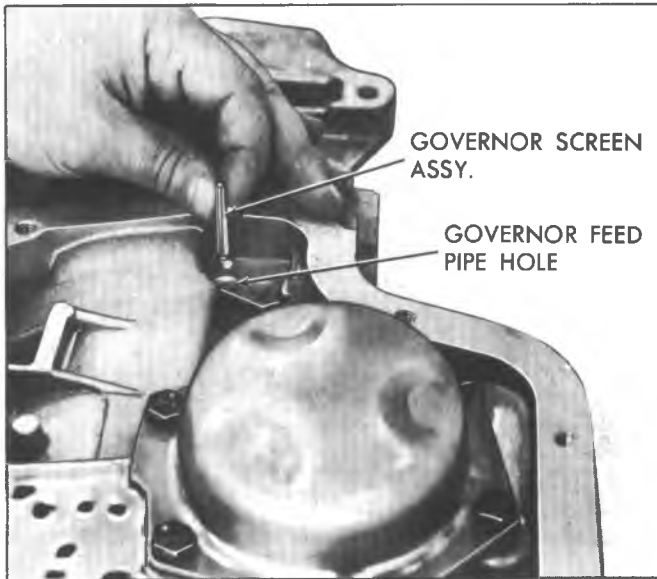

Fig. 7A-183C--Installing Governor Screen Assembly

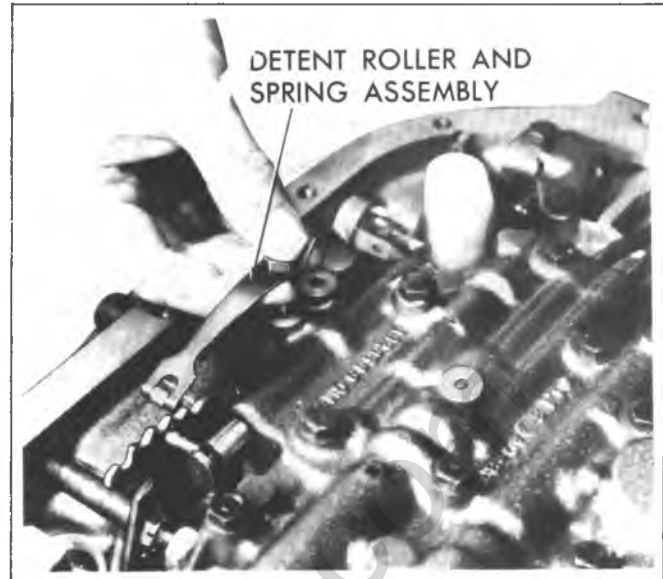

Fig. 7A-185C--Installing Detent Roller and Spring Assembly

### INSTALLATION OF CONTROL VALVE ASSEMBLY, GOVERNOR PIPES AND GOVERNOR SCREEN ASSEMBLY

1. Install governor pipes on control valve assembly. Governor pipes are interchangeable.
2. Install governor screen assembly, open end first, into governor feed pipe hole in case (hole nearest the center of the transmission) (Fig. 7A-183C).

If transmission is in vehicle, before installing the control valve assembly and governor pipes as outlined in Step 3 below, insert the governor screen, closed end first, into governor feed pipe. (This pipe locates in the governor feed pipe hole in the case nearest the center of the transmission). See Figure 7A-183C).

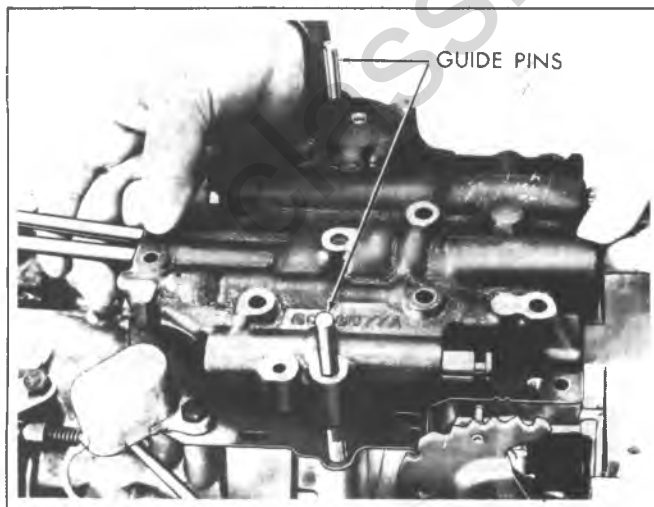

Fig. 7A-184C--Installing Control Valve Assembly and Governor Pipes

3. Install control valve assembly and governor pipes on transmission, while carefully aligning the governor feed pipe over the governor screen (Fig. 7A-184C). Make certain gasket and spacer do not become mispositioned.

Check manual valve to make sure it is indexed properly with pin on detent lever and check governor pipes to make certain they are properly seated in case holes.

4. Start control valve assembly attaching bolts. If transmission is in the vehicle, remove feeler stock before tightening any control valve bolts.
5. Remove guide pins and install detent roller and spring assembly and remaining bolts (Fig. 7A-185C).

### INSTALLATION OF FILTER AND INTAKE PIPE

1. Install case to intake pipe "O" ring seal on intake pipe and assemble into filter assembly.
2. Install filter and intake pipe assembly (Fig. 7A-8C). It is recommended that the filter be replaced, rather than cleaned, whenever the transmission is disassembled.
3. Install filter retainer bolt (Fig. 7A-7C).
4. Install new bottom pan gasket and bottom pan, with attaching screws. Torque to 12 ft. lbs.

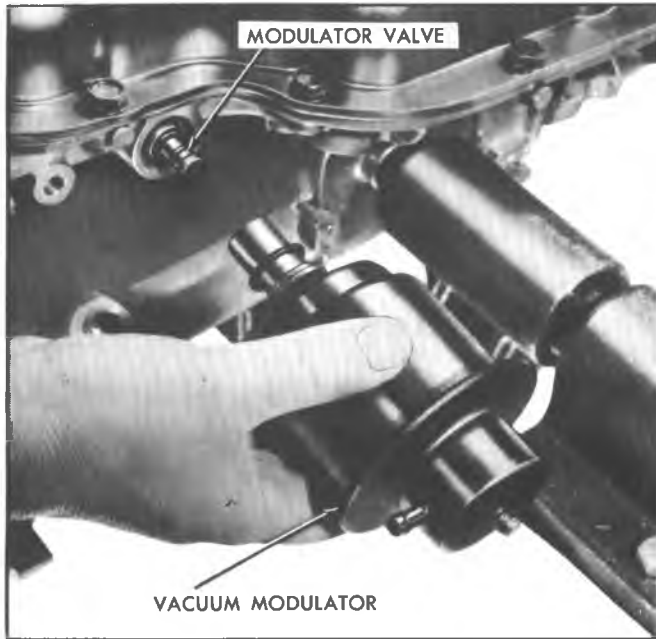

Fig. 7A-186C--Installing Vacuum Modulator and Valve

**INSTALLATION OF MODULATOR VALVE AND VACUUM MODULATOR**

1. Install modulator valve into case, stem end out (Fig. 7A-186C).
2. Install "O" ring seal on vacuum modulator.
3. Install vacuum modulator into case.

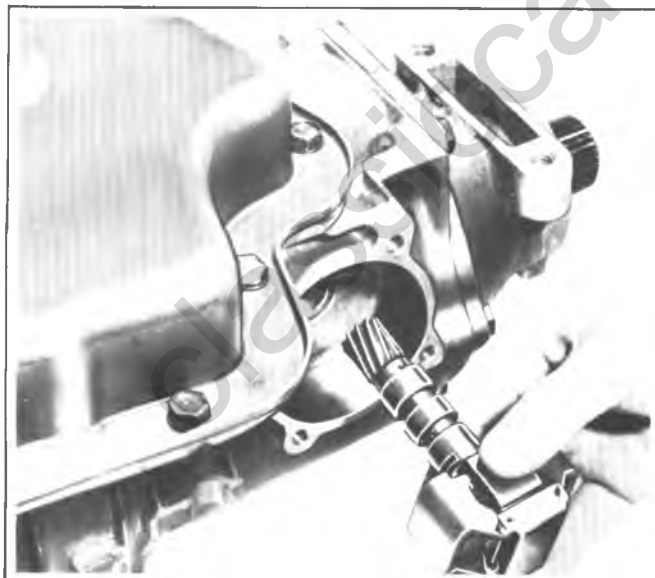

Fig. 7A-187C--Installing Governor Assembly

Models CB, CK and CZ use a modulator that is different than the modulator used on the other models. Refer to parts catalog book for correct usage.

4. Install modulator retainer and attaching bolt. Torque bolt 18 ft. lbs.

**INSTALLATION OF GOVERNOR ASSEMBLY**

1. Install governor assembly into case (Fig. 7A-187C).
2. Attach governor cover and gasket with four (4) attaching bolts. Torque bolts to 18 ft. lbs.

**INSTALLATION OF SPEEDOMETER DRIVEN GEAR ASSEMBLY**

1. Install speedometer driven gear assembly (Fig. 7A-188C).
2. Install speedometer driven gear retainer and attaching bolt.

**INSTALL CONVERTER ASSEMBLY**

With the transmission in cradle or portable jack, install the converter assembly into the pump assembly making certain that the converter hub drive slots are fully engaged with the pump drive gear tangs and the converter installed fully towards the rear of the transmission.

The converter used in the CB, CD, CF, CL, CM and CT models has six (6) mounting lugs.

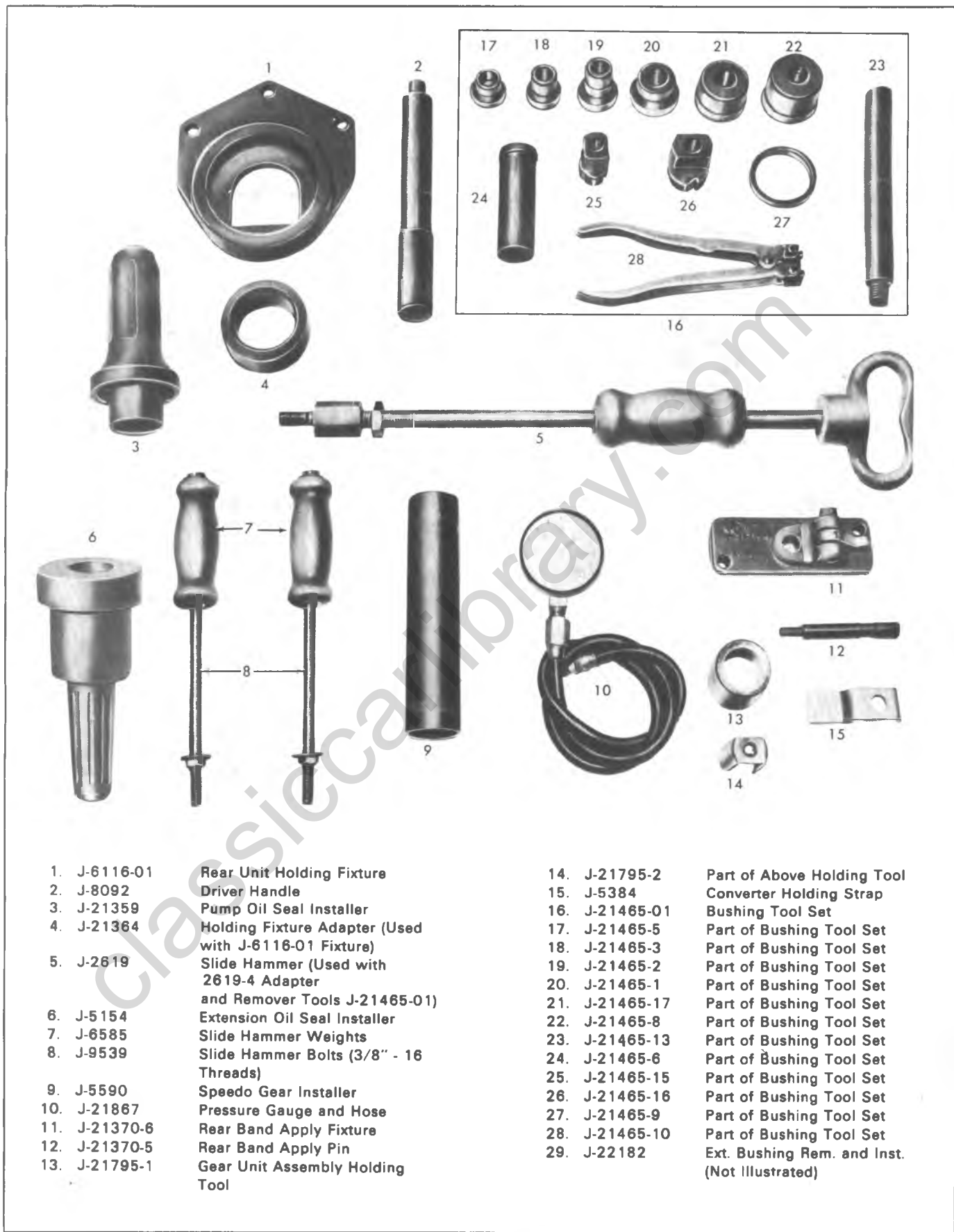

Fig. 7A-188C--Installing Speedometer Driven Gear and Sleeve

# SPECIFICATIONS

## TORQUE SPECIFICATIONS

Pump Cover Bolts . . . . .	18 ft. lbs.
Parking Pawl Bracket Bolts . . . . .	18 ft. lbs.
Center Support Bolt . . . . .	23 ft. lbs.
Pump to Case Attaching Bolts . . . . .	18 ft. lbs.
Extension Housing to Case Attaching Bolts . . . . .	23 ft. lbs.
Rear Servo Cover Bolts . . . . .	18 ft. lbs.
Detent Solenoid Bolts . . . . .	7 ft. lbs.
Control Valve Body Bolts . . . . .	8 ft. lbs.
Bottom Pan Attaching Screws . . . . .	12 ft. lbs.
Modulator Retainer Bolt . . . . .	18 ft. lbs.
Governor Cover Bolts . . . . .	18 ft. lbs.
Manual Lever to Manual Shaft Nut . . . . .	8 ft. lbs.
Manual Shaft to Inside Detent Lever . . . . .	18 ft. lbs.
Linkage Swivel Clamp Nut . . . . .	43 ft. lbs.
Converter Dust Shield Screws . . . . .	93 ft. lbs.
Transmission to Engine Mounting Bolts . . . . .	35 ft. lbs.
Converter to Flywheel Bolts . . . . .	32 ft. lbs.
Rear Mount to Transmission Bolts . . . . .	40 ft. lbs.
Rear Mount to Crossmember Bolt . . . . .	40 ft. lbs.
Crossmember Mounting Bolts . . . . .	25 ft. lbs.
Line Pressure Take-Off Plug . . . . .	13 ft. lbs.
Strainer Retainer Bolt . . . . .	10 ft. lbs.
Oil Cooler Pipe Connectors to Transmission	
Case . . . . .	28 ft. lbs.
Oil Cooler Pipe to Connector . . . . .	10 ft. lbs.
Gearshift Bracket to Frame . . . . .	15 ft. lbs.
Gearshift Shaft to Swivel . . . . .	20 ft. lbs.
Manual Shaft to Bracket . . . . .	20 ft. lbs.
Downshift Switch to Bracket . . . . .	30 in. lbs.



- |               |  |                |   |
|---------------|--|----------------|---|
| 1. J-6116-01  | Rear Unit Holding Fixture  | 14. J-21795-2  | Part of Above Holding Tool                    |
| 2. J-8092     | Driver Handle  | 15. J-5384     | Converter Holding Strap                       |
| 3. J-21359    | Pump Oil Seal Installer  | 16. J-21465-01 | Bushing Tool Set                              |
| 4. J-21364    | Holding Fixture Adapter (Used with J-6116-01 Fixture)                | 17. J-21465-5  | Part of Bushing Tool Set                      |
| 5. J-2619     | Slide Hammer (Used with 2619-4 Adapter and Remover Tools J-21465-01) | 18. J-21465-3  | Part of Bushing Tool Set                      |
| 6. J-5154     | Extension Oil Seal Installer   | 19. J-21465-2  | Part of Bushing Tool Set                      |
| 7. J-6585     | Slide Hammer Weights   | 20. J-21465-1  | Part of Bushing Tool Set                      |
| 8. J-9539     | Slide Hammer Bolts (3/8" - 16 Threads)                               | 21. J-21465-17 | Part of Bushing Tool Set                      |
| 9. J-5590     | Speedo Gear Installer  | 22. J-21465-8  | Part of Bushing Tool Set                      |
| 10. J-21867   | Pressure Gauge and Hose  | 23. J-21465-13 | Part of Bushing Tool Set                      |
| 11. J-21370-6 | Rear Band Apply Fixture  | 24. J-21465-6  | Part of Bushing Tool Set                      |
| 12. J-21370-5 | Rear Band Apply Pin  | 25. J-21465-15 | Part of Bushing Tool Set                      |
| 13. J-21795-1 | Gear Unit Assembly Holding Tool                                      | 26. J-21465-16 | Part of Bushing Tool Set                      |
|               |  | 27. J-21465-9  | Part of Bushing Tool Set                      |
|               |  | 28. J-21465-10 | Part of Bushing Tool Set                      |
|               |  | 29. J-22182    | Ext. Bushing Rem. and Inst. (Not Illustrated) |

Fig. 7A-1ST-- 400 Special Tools

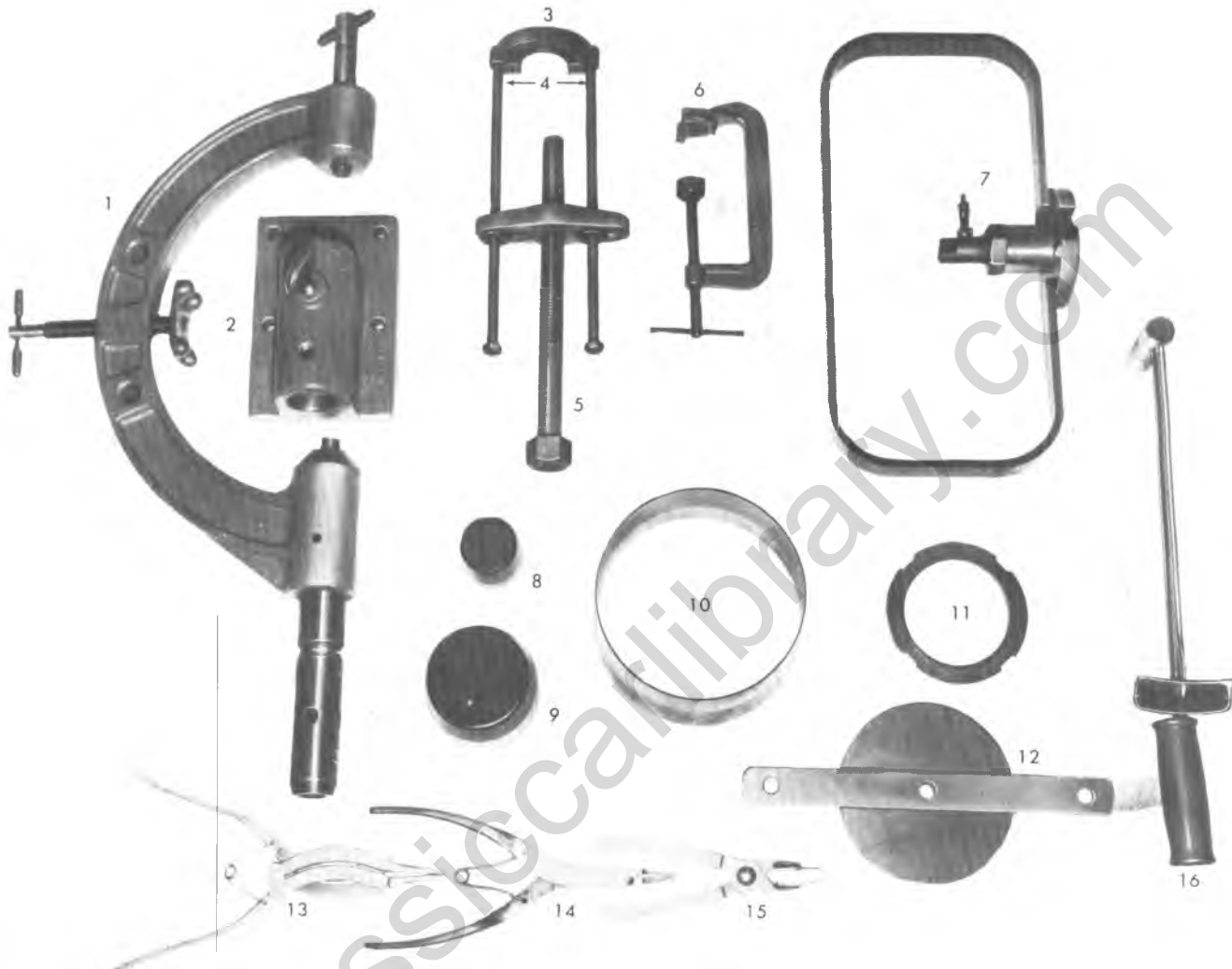

- |               |  |                 |   |
|---------------|--|-----------------|---|
| 1. J-8763     | Transmission Holding Fixture                       | 11. J-21664     | Clutch Spring Compressor Adapter Ring             |
| 2. J-3289-14  | Holding Fixture Base                               | 12. J-4670      | Clutch Spring Compressor                          |
| 3. J-21427-1  | Speedo Gear Remover                                | 13. J-8059      | Snap Ring Pliers                                  |
| 4. J-9539     | Side Hammer Bolts (3/8" - 16 Threads)              | 14. J-5586      | Snap Ring Pliers                                  |
| 5. J-8105     | Speedo Gear Remover Puller                         | 15. J-5403      | Snap Ring Pliers                                  |
| 6. J-22269-01 | Accumulator Piston Remover and Installer           | 16. J-1313      | Torque Wrench 0-140 Ft. Lbs.                      |
| 7. J-21369    | Converter Pressure Check Fixture                   | Not Illustrated | Pressure Regulator Valve Compressor               |
| 8. J-21362    | Seal Protector - Forward and Direct Clutch - Inner | J-24684         | Accumulator Piston Adapter (Used with J-22269-01) |
| 9. J-21363    | Seal Protector - Intermediate Clutch - Inner       | J-24675         |   |
| 10. J-21409   | Seal Protector - Forward Clutch - Outer            |                 |   |

Fig. 7A-2ST--400 Special Tools

## SECTION 7B

# MANUAL TRANSMISSION

### CONTENTS

3-Speed 76mm Transmission.....	7B-1	4-Speed 89mm Transmission .....	7B-35
3-Speed 77mm Transmission.....	7B-9	4-Speed 117mm Transmission.....	7B-44
4-Speed 76mm Transmission.....	7B-17	Specifications .....	7B-57
4-Speed 83mm Transmission.....	7B-25	Special Tools .....	7B-58

## 3-SPEED 76MM TRANSMISSION

### INDEX

Disassembly of Transmission .....	7B-1	Repairs.....	7B-4
Disassembly of Mainshaft .....	7B-1	Clutch Keys and Spring .....	7B-4
Cleaning and Inspection .....	7B-1	Extension Oil Seal or Bushing .....	7B-4
Transmission Case .....	7B-1	Clutch Bearing Retainer Oil Seal.....	7B-4
Front and Rear Bearings.....	7B-3	Assembly of Mainshaft.....	7B-5
Bearing Rollers.....	7B-3	Assembly of Transmission.....	7B-6
Gears.....	7B-3	Specifications.....	7B-48
Reverse Idler Gear Bushing.....	7B-3	Special Tools.....	7B-49

### DISASSEMBLY OF TRANSMISSION (FIG 7B-1A)

1. Remove side cover attaching bolts and side cover assembly.
2. Remove drive gear bearing retainer and gasket.
3. Remove drive gear bearing-to-gear stem snap ring, then remove clutch gear bearing by pulling outward on clutch gear until a screwdriver or other suitable tool can be inserted between bearing large snap ring and case to complete removal (Fig. 7B-2A). The clutch gear bearing is a slip fit on the gear and into the case bore. (This provides clearance for removal of clutch gear and mainshaft assembly.)
4. Remove speedometer driven gear from extension.
5. Remove extension to case attaching bolts.
6. Remove the reverse idler shaft "E" ring (Fig. 7B-3A).
7. Remove drive gear, mainshaft and extension assembly together through the rear case opening. Remove drive gear, needle bearings and synchronizer ring from mainshaft assembly.
8. Using snap ring pliers, expand the snap ring in the extension which retains the mainshaft rear bearing (Fig. 7B-4A) and remove the extension.
9. Using J-22246 at the front of the countershaft, drive the shaft and its woodruff key out the rear of the case (Fig. 7B-5A). Tool J-22246 will now hold the roller bearings in position within the countergear bore. Remove the gear, bearings and thrust washers.

10. Use a long drift or punch through the front bearing case bore and drive the reverse idler shaft and woodruff key through the rear of the case (Fig. 7B-6A).

### DISASSEMBLY OF MAINSHAFT

1. Using snap ring pliers, remove the 2nd and 3rd speed sliding clutch hub snap ring from mainshaft and remove clutch assembly, second speed blocker ring and second speed gear from front of mainshaft. See Fig. 7B-7A.
2. Depress speedometer retaining clip and slide or tap gear from mainshaft.
3. Remove rear bearing snap ring from mainshaft groove. See Fig. 7B-8A.
4. Support reverse gear with press plates and press on rear of mainshaft to remove reverse gear, thrust washer, spring washer, rear bearing, and snap ring from rear of mainshaft. See Fig. 7B-9A.
5. Remove the 1st and Reverse sliding clutch hub snap ring from the mainshaft and remove the clutch assembly, 1st speed blocker ring and first speed gear from rear of the mainshaft.

Under certain tolerance conditions, it may be necessary to press the synchronizer hub and gear from the mainshaft.

### CLEANING AND INSPECTION

#### Transmission Case

1. Wash the transmission thoroughly inside and outside with cleaning solvent, then inspect the case for cracks.
2. Check the front and rear faces for burrs, and if present, dress them off with a fine mill file.

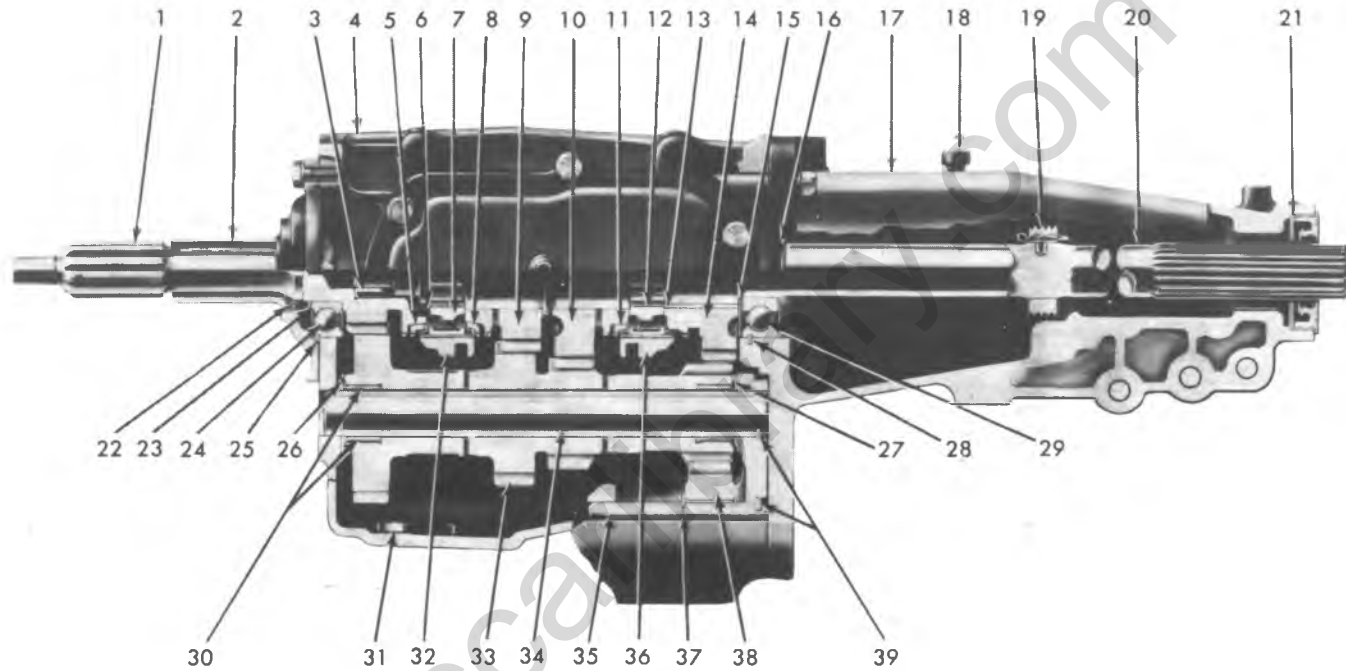

Fig. 7B-1A-3-Speed 76mm Transmission Cross-Section

- |                           |  |                                     |                                    |                             |
|---------------------------|--|-------------------------------------|------------------------------------|-----------------------------|
| 1. Clutch Gear            | 10. 1st Speed Gear                         | 16. Snap Ring-Bearing to Mainshaft  | 24. Clutch Gear Bearing            | 31. Magnet                  |
| 2. Bearing Retainer       | 11. 1st Speed Blocker Ring                 | 17. Extension                       | 25. Snap Ring-Bearing to Case      | 32. 2-3 Synch. Sleeve       |
| 3. Pilot Bearings         | 12. 1st Speed Synch. Hub                   | 18. Vent                            | 26. Thrust Washer-Front            | 33. Countergear             |
| 4. Case                   | 13. 1st Speed Synch. Snap Ring             | 19. Speedometer Drive Gear and Clip | 27. Thrust Washer-Rear             | 34. Counter Shaft           |
| 5. 3rd Speed Blocker Ring | 14. Reverse Gear                           | 20. Mainshaft                       | 28. Snap Ring-Bearing to Extension | 35. Reverse Idler Shaft     |
| 6. 2-3 Synch. Snap Ring   | 15. Reverse Gear Thrust and Spring Washers | 21. Rear Oil Seal                   | 29. Rear Bearing                   | 36. 1st Speed Synch. Sleeve |
| 7. 2-3 Synch. Hub         |  | 22. Retainer Oil Seal               | 30. Countergear Roller Bearings    | 37. "E" Ring                |
| 8. 2nd Speed Blocker Ring |  | 23. Snap Ring-Bearing to Gear       |                                    | 38. Reverse Idler Gear      |
| 9. 2nd Speed Gear         |  |                                     |                                    | 39. Woodruff Keys           |





Fig. 7B-2A--Removing Clutch Gear Bearing Retaining Ring

3. Check bearing bores in case and, if damaged, replace case.

### Front and Rear Bearings

1. Wash the front and rear ball bearings thoroughly in a cleaning solvent.
2. Blow out bearings with compressed air.

**NOTICE:** Do not allow the bearings to spin, turn them slowly by hand. Spinning bearings may damage the race and balls.

3. Make sure bearings are clean, then lubricate with light engine oil and check them for roughness by slowly turning the race by hand.

### Bearing Rollers

All clutch gear and counter gear bearing rollers should be inspected closely and replaced if they show wear. Inspect counter shaft and reverse idler shaft at the same time, replace if necessary. Replace all worn washers.

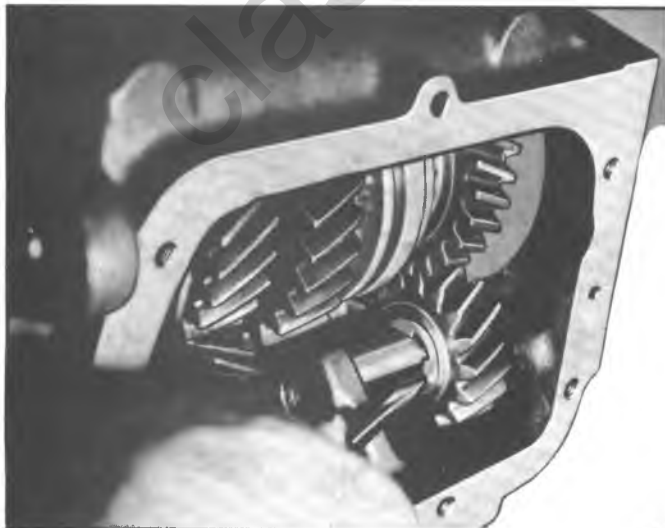

Fig. 7B-3A--Removing Reverse Idler Shaft "E" Ring



Fig. 7B-4A--Removing Rear Extension From Main Shaft

### Gears

1. Inspect all gears for excessive wear, chips or cracks and replace any that are worn or damaged.
2. Inspect reverse gear bushing and if worn or damaged replace the entire gear. Reverse gear bushing is not serviced separately.
3. Check both clutch sleeves to see that they slide freely on their hubs.

### Reverse Idler Gear Bushing

The bushing used in the idler gear is pressed into the gear and finished bored in place. This insures the positive alignment of the bushing and shaft as well as proper meshing of the gears. Because of the high degree of accuracy to which these parts are machined, the bushing is not serviced separately.



Fig. 7B-5A--Removing Counter Gear Shaft

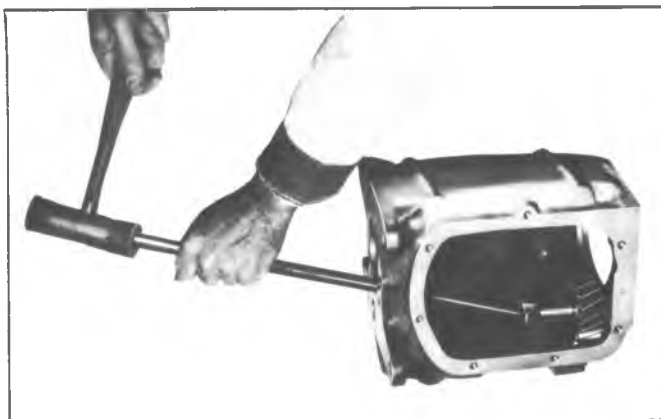

Fig. 7B-6A--Removing Reverse Idler Shaft



Fig. 7B-8A--Removing Rear Bearing Retaining Ring

## REPAIRS

### Clutch Keys and Springs

#### Replacement

The clutch hubs and sliding sleeves are a selected assembly and should be kept together as originally assembled, but the keys and two springs may be replaced if worn or broken.

1. Mark hub and sleeve so that they can be matched upon reassembly.

2. Push the hub from the sliding sleeve, the keys and the springs may be easily removed.

3. Place the three keys and two springs in position (one on each side of hub) so all three keys are engaged by both springs (Fig. 7B-10A). The tanged end of each synchronizer spring should be installed into different key cavities on either side. Slide the sleeve onto the hub aligning the marks made before disassembly.

A groove around the outside of the synchronizer hub identifies the end that must be opposite the fork slot in the sleeve when assembled. This groove indicates the end of the hub with a greater recess depth.



Fig. 7B-7A--Removing 2nd-3rd Clutch Hub Retaining Ring

### Extension Oil Seal or Bushing

If bushing in rear of extension requires replacement, remove seal and use Tool J-5778 to drive bushing into extension housing (Fig. 7B-11A). Using the same tool, drive new bushing in from the rear. Coat I.D. of bushing and seal with transmission lubricant, then install new oil seal using Tool J-21426 or J-5154 (Fig. 7B-12A).

### Clutch Bearing Retainer Oil Seal

If the lip seal in the reatiner needs replacement; pry the old seal out (Fig. 7B-13A) and replace with a new seal using Installer Tool J-23096, or similar tool, until seal seats in its bore (Fig. 7B-14A).

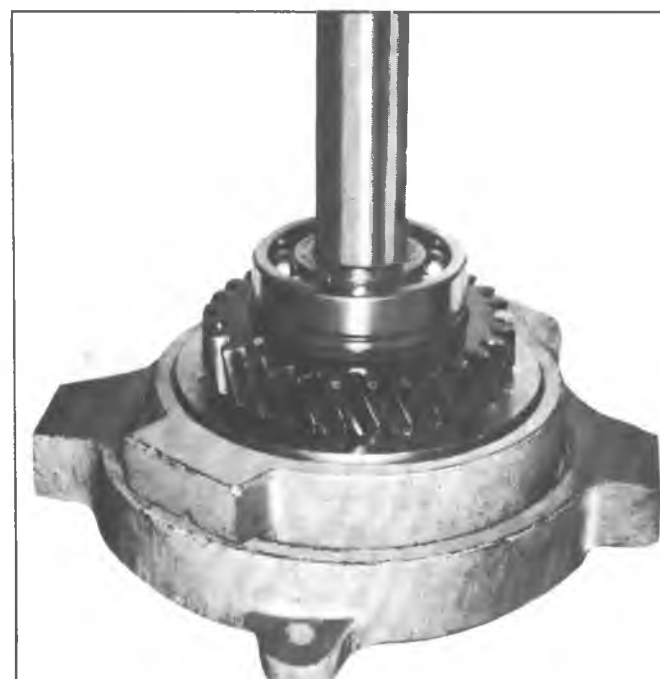

Fig. 7B-9A--Removing Rear Bearing From Mainshaft

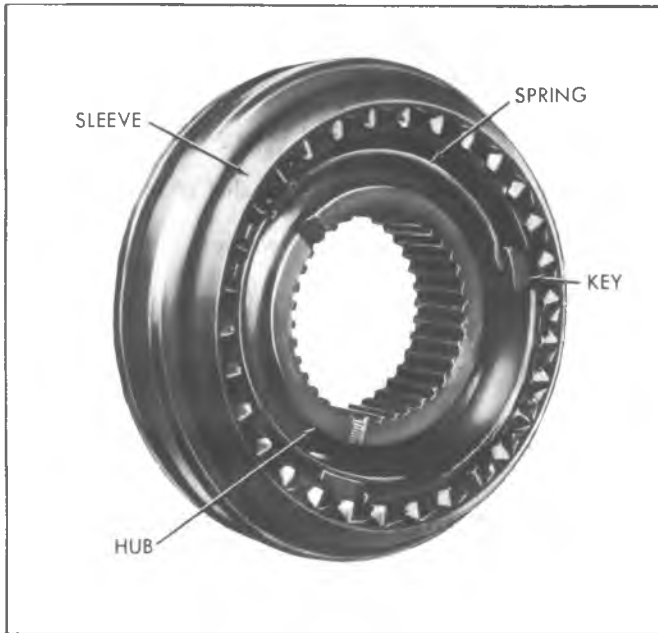

Fig. 7B-10A—Synchronizer Assembly

**ASSEMBLY OF MAINSHAFT (FIG. 7B-15A)**

Turn the front of the mainshaft upward. Install the following components of the mainshaft:

1. Install the second speed gear with clutching teeth upward; the rear face of the gear will butt against the flange on the mainshaft.
2. Install a blocking ring with clutching teeth downward over the synchronizing surface of the second speed gear. All three blocker rings used in this transmission are identical.
3. Install the second and third synchronizer assembly with the fork slot downward; press it onto splines on the mainshaft until it bottoms out. Both synchronizer assemblies used in this transmission are identical. (If sleeve

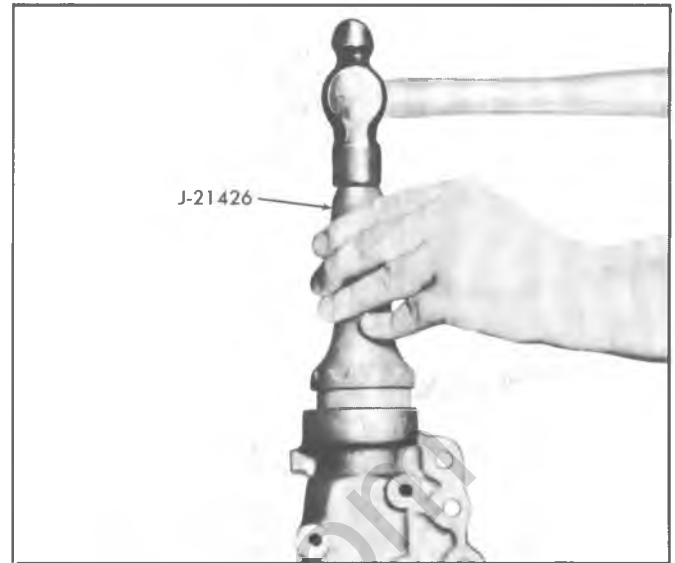

Fig. 7B-12A—Installing Rear Extension Seal

becomes removed from 2-3 hub; notches on hub O.D. face forward end of mainshaft.) Be sure the notches of the blocker ring align with the keys of the synchronizer assembly.

4. Install snap ring retaining synchronizer hub to mainshaft. Both synchronizer snap rings are identical. Turn the rear of the mainshaft upward. Install the following components on the mainshaft:
5. Install the first speed gear with clutching teeth upward; the front face of the gear will butt against the flange on the mainshaft.
6. Install a blocker ring with clutching teeth downward over synchronizing surface of the first speed gear.
7. Install the first and reverse synchronizer assembly with fork slot downward; push it onto splines on the mainshaft.

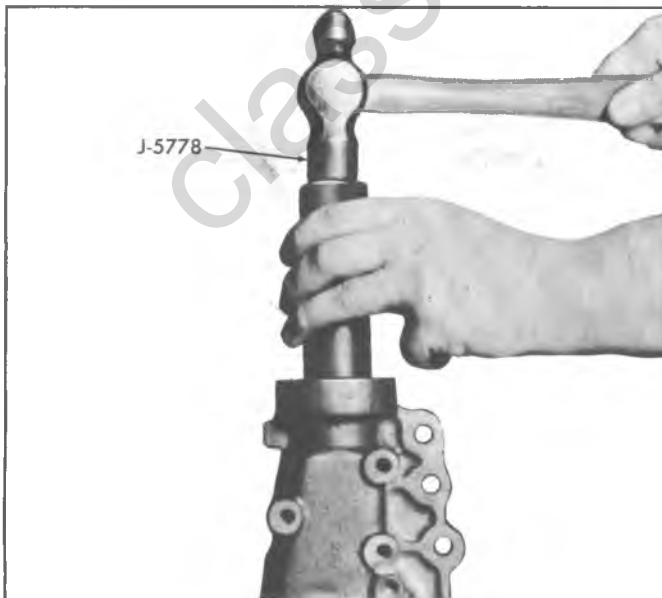

Fig. 7B-11A—Removing or Installing Rear Extension Bushing

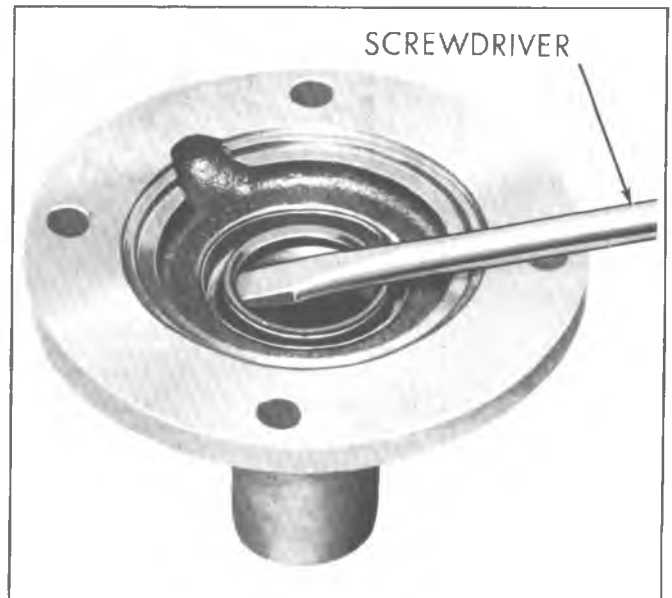

Fig. 7B-13A—Removing Drive Gear Bearing Retainer Seal

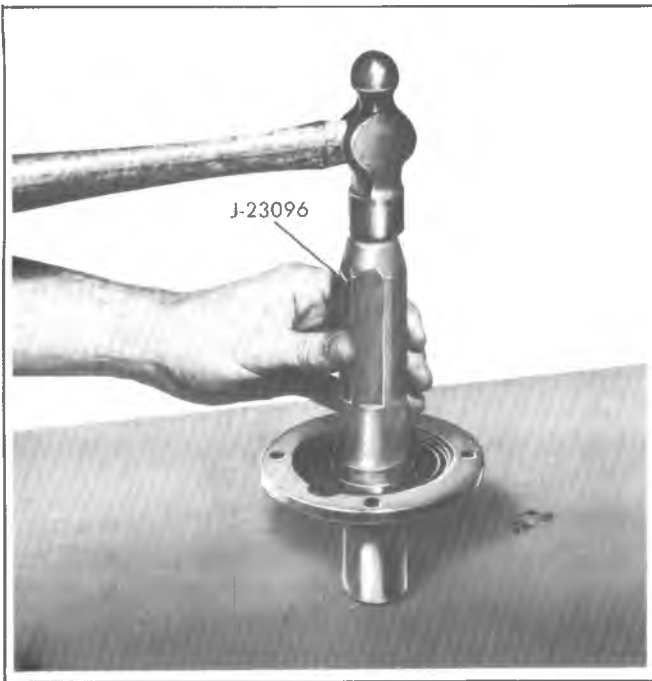

Fig. 7B-14A--Installing Clutch Gear Bearing Retainer Seal

8. Install synchronizer hub to mainshaft snap ring. Be sure the notches of the blocker ring align with the keys of the synchronizer assembly.

9. Install reverse gear with clutching teeth downward.

10. Install reverse gear thrust washer (steel).

11. Install reverse gear spring washer.

12. Install rear ball bearing with snap ring slot downward; press onto mainshaft.

13. Install rear bearing to mainshaft snap ring.

14. Install speedometer drive gear and retaining clip.

**ASSEMBLY OF TRANSMISSION (FIG. 7B-18A)**

1. Using Tool J-22246 load a row of roller bearings (27) and a bearing thrust washer at each end of the countergear. Use heavy grease to hold them in place (Fig. 7B-16A).

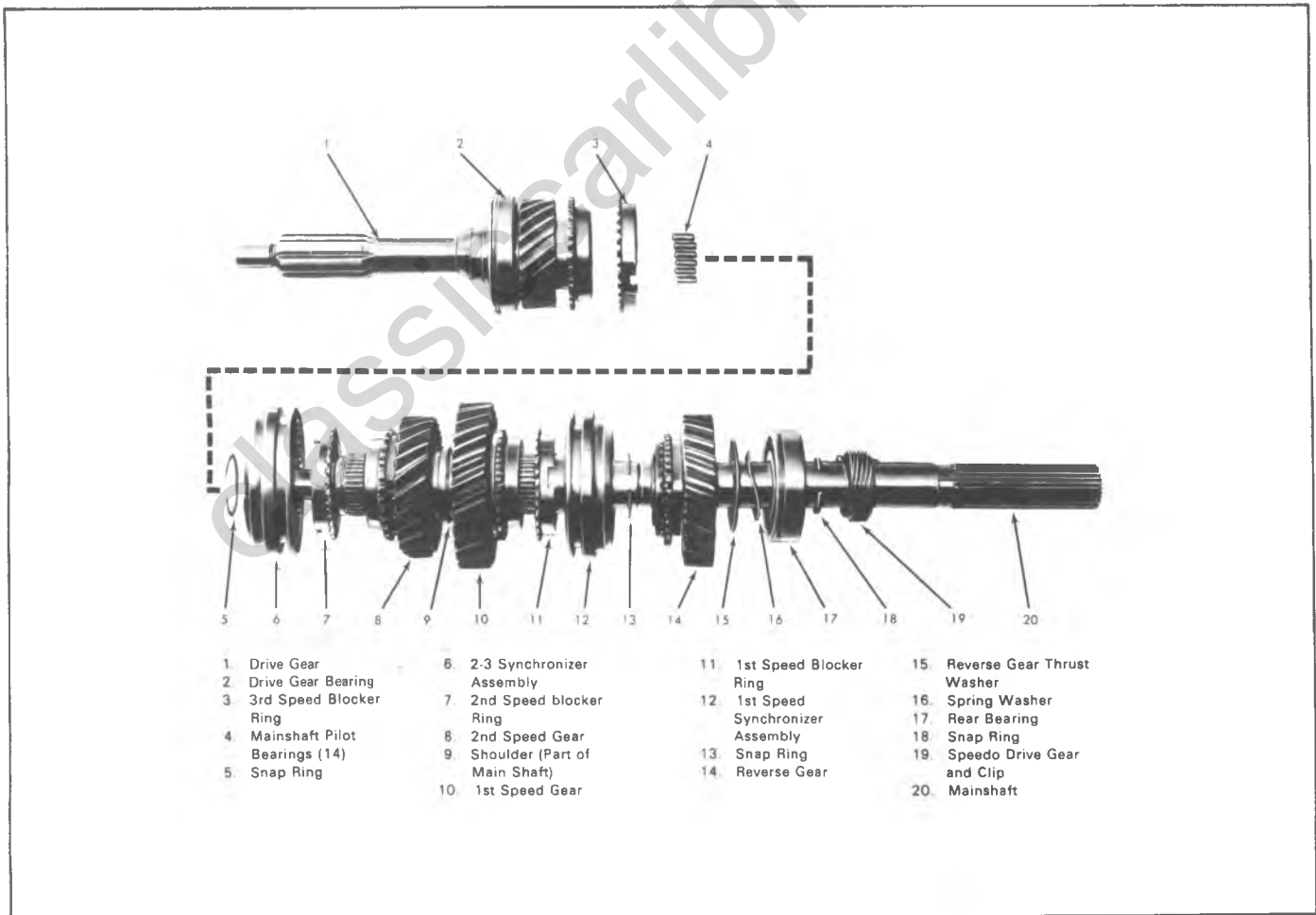

Fig. 7B-15A--Clutch Gear and Mainshaft Assembly

2. Place countergear assembly through case rear opening along with a tanged thrust washer (tang away from gear) at each end and install countergear shaft and woodruff key from rear of case. Be sure countershaft picks up both thrust washers and that the tangs are aligned with their notches in the case.

3. Install reverse idler gear and shaft with its woodruff key from the rear of case. Do not install idler shaft "E" ring yet.

4. Using snap ring pliers, expand the snap ring in the extension and assemble extension over rear of mainshaft and onto rear bearing. Seat snap ring in rear bearing groove (Fig. 7B-4A).

5. Load the mainshaft pilot bearings (14) into the clutch gear cavity and assemble the 3rd speed blocker ring onto the clutch gear clutching surface with its teeth toward the gear.

6. Pilot the clutch gear, pilot bearings and 3rd speed blocker ring assembly over the front of the mainshaft assembly. Do not assemble bearing to gear yet. Be sure the notches in the blocker ring align with the keys in the 2-3 synchronizer assembly.

7. Place extension to case gasket at rear of case holding in place with grease and, from the rear of case, assemble the clutch gear, mainshaft and extension to case as an assembly.

8. Install extension to case retaining bolts.

9. Install front bearing outer snap ring to bearing and position bearing over stem of clutch gear and into front case bore.

10. Install snap ring to clutch gear stem, and clutch gear bearing retainer and gasket to case.

The retainer oil return hole should be at the bottom.

11. Install reverse idler gear retainer "E" ring to shaft.

12. Shift synchronizer sleeves to neutral positions and install cover, gasket and fork assembly to case. Be sure forks align with their synchronizer sleeve grooves.

13. Install speedometer driven gear in extension.

14. Tighten all bolts to specified torque.

15. Rotate clutch gear shaft and shift transmission to free rotation in all gears.

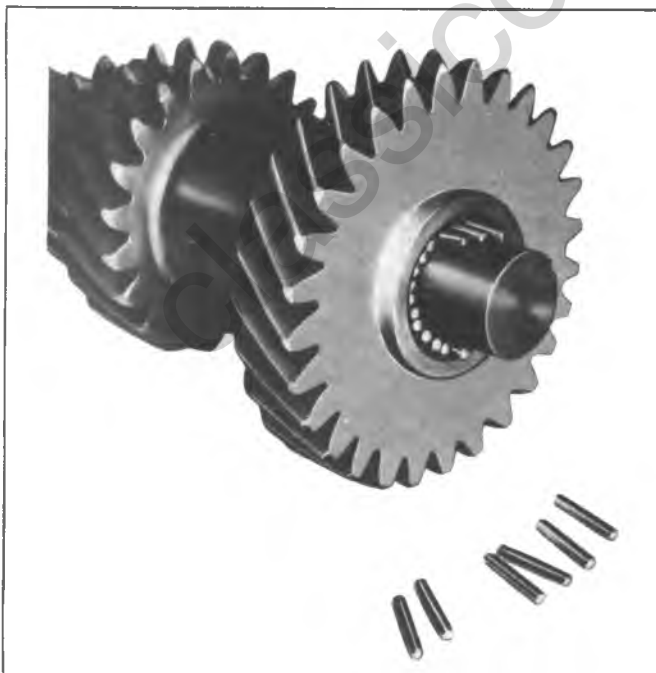
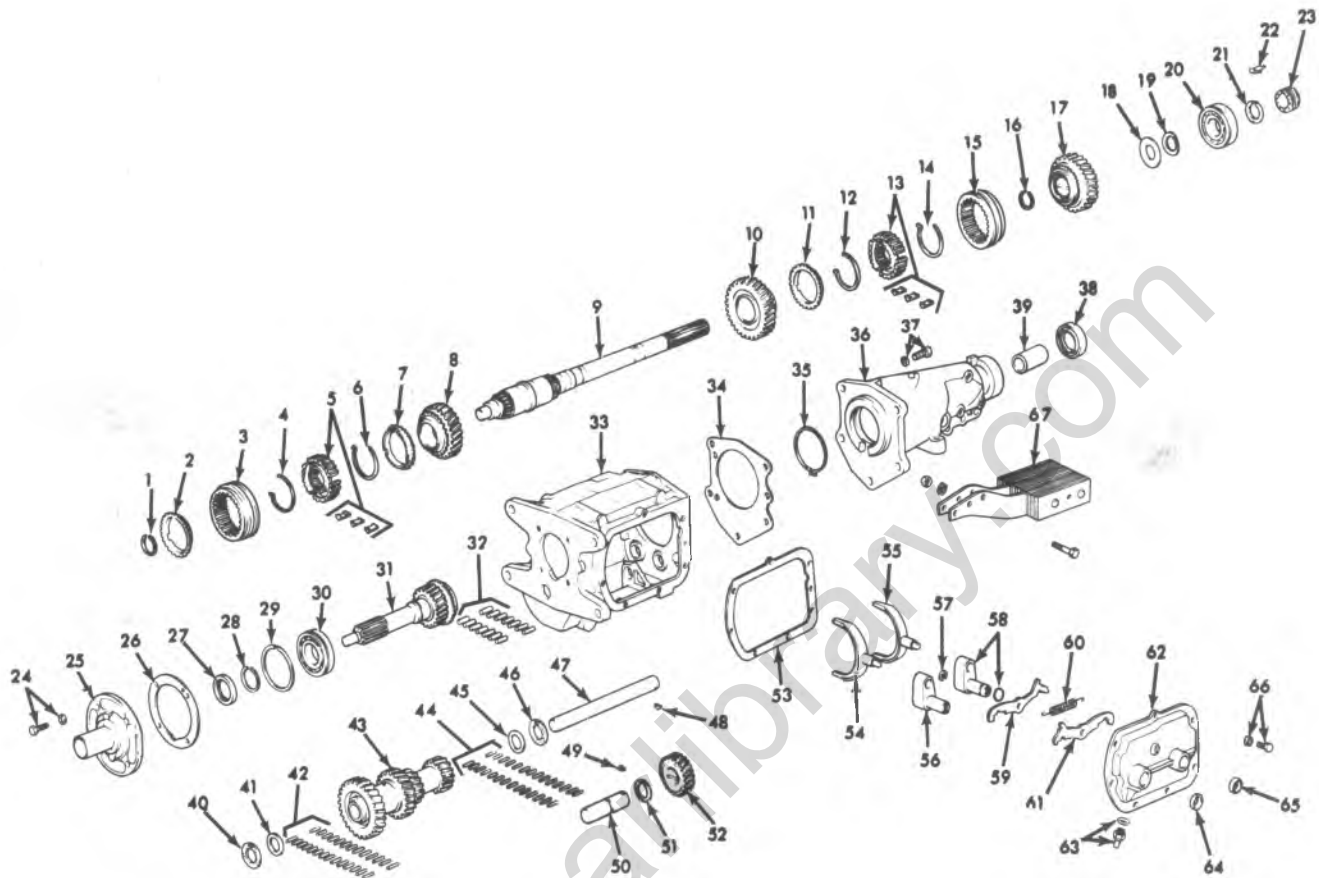

Fig. 7B-16A--Loading Countergear



Fig. 7B-17A--Loading Pilot Bearings



- |  |   |  |
|--|---|--|
| <ul style="list-style-type: none"> <li>1. Snap Ring</li> <li>2. Synchronizer Ring</li> <li>3. 2-3 Synchronizer Sleeve</li> <li>4. Synchronizer Key Spring</li> <li>5. Synchronizer Hub and Keys</li> <li>6. Synchronizer Key Spring</li> <li>7. Synchronizer Ring</li> <li>8. Second Gear</li> <li>9. Main Shaft</li> <li>10. First Gear</li> <li>11. Synchronizer Ring</li> <li>12. Synchronizer Key Spring</li> <li>13. Synchronizer Hub and Keys</li> <li>14. Synchronizer Key Spring</li> <li>15. 1-2 Synchronizer Sleeve</li> <li>16. Snap Ring</li> <li>17. Reverse Gear</li> <li>18. Thrust Washer</li> <li>19. Waved Washer</li> <li>20. Rear Bearing</li> <li>21. Snap Ring</li> <li>22. Speedometer Gear Clip</li> <li>23. Speedometer Drive Gear</li> </ul> | <ul style="list-style-type: none"> <li>24. Bearing Retainer Bolts and Washers (4)</li> <li>25. Front Bearing Retainer</li> <li>26. Bearing Retainer Gasket</li> <li>27. Bearing Retainer Oil Seal</li> <li>28. Snap Ring</li> <li>29. Bearing Snap Ring</li> <li>30. Front Bearing</li> <li>31. Drive Gear</li> <li>32. Pilot Bearings</li> <li>33. Case</li> <li>34. Extension to Case Gasket</li> <li>35. Rear Bearing to Extension Retaining Ring</li> <li>36. Rear Extension</li> <li>37. Extension to Case Retaining Bolts and Washers</li> <li>38. Rear Extension Bushing</li> <li>39. Rear Seal</li> <li>40. Thrust Washer</li> <li>41. Spacer</li> <li>42. Countergear Shaft Bearings</li> <li>43. Countergear</li> <li>44. Countergear Shaft Bearings</li> <li>45. Spacer</li> </ul> | <ul style="list-style-type: none"> <li>46. Thrust Washer</li> <li>47. Countergear Shaft</li> <li>48. Countergear Shaft Key</li> <li>49. Idler Shaft Key</li> <li>50. Reverse Idler Shaft</li> <li>51. Snap Ring</li> <li>52. Reverse Idler Gear</li> <li>53. Side Cover Gasket</li> <li>54. 2-3 Shift Fork</li> <li>55. 1-Rev Shift Fork</li> <li>56. 2-3 Shifter Shaft</li> <li>57. Retaining "E" Ring</li> <li>58. 1-Rev Shifter Shaft with "O" Ring</li> <li>59. 2-3 Detent Cam</li> <li>60. Detent Cam Spring</li> <li>61. 1-Rev Detent Cam</li> <li>62. Shift Cover</li> <li>63. TCS Switch and Gasket</li> <li>64. Shifter Shaft Seal</li> <li>65. Shifter Shaft Seal</li> <li>66. Shift Cover Bolts and Washers</li> <li>67. Damper Assembly</li> </ul> |
|--|---|--|

Fig. 7B-18A-3-Speed, 76mm, Transmission Exploded View

## 3 SPEED 77MM TRANSMISSION

### INDEX

Overhaul Operations.....	7B-9	Repairs.....	7B-14
Transmission Disassembly.....	7B-9	Synchronizer Keys and Spring.....	7B-14
Mainshaft Disassembly.....	7B-12	Extension Oil Seal or Bushing.....	7B-14
Cleaning and Inspection.....	7B-12	Clutch Bearing Retainer Oil Seal.....	7B-14
Transmission Case.....	7B-12	Mainshaft Assembly.....	7B-14
Front and Rear Bearings.....	7B-13	Transmission Assembly.....	7B-15
Roller Bearings.....	7B-13		
Gears.....	7B-13		

### TRANSMISSION DISASSEMBLY

1. Remove lower extension housing bolt and drain transmission (Fig. 7B-3B).

2. Remove top cover and gasket from case.

3. Remove long spring that retains the detent plug in the case (Fig. 7B-4B). Remove the detent plug with a small magnet.

4. Remove extension housing and gasket.

5. Press down on speedometer gear retainer and remove speedometer drive gear and retainer from output shaft.

6. Remove fill plug from right side of case (Fig. 7B-3B). Working through the plug opening drive out countergear roll pin with a 3/16 inch pin punch that has been chamfered slightly.

Do not attempt to retrieve pin at this time. Pin can easily be retrieved after output shaft assembly is removed.

7. Insert dummy shaft tool J-25232 into bore at front of case, tap lightly on tool to push countershaft out rear of case (Fig. 7B-5B). With countershaft removed, allow countergear to lie at bottom of case.

8. Punch alignment mark in front bearing retainer and transmission case to ensure correct assembly and remove front bearing retainer and gasket (Fig. 7B-6B).

9. Remove large locating snap ring from front bearing and smaller snap ring from clutch gear shaft.

10. Remove clutch shaft front bearing using tool J-6654-01 and tool J-8433-1 (Fig. 7B-7B).

It may be necessary to alternate the tightening of the bolts between tools J-6654-01 and J-8433-1 to remove the front bearing.

11. Remove large locating snap ring from rear bearing and smaller retaining snap ring from output shaft.

It may be necessary to place a screwdriver or a piece of bar stock between the case and the first-reverse sleeve and gear assembly. This will hold the output shaft assembly in place while removing the rear bearing.

12. Remove rear bearing from output shaft using tool J-8157-01 (Fig. 7B-8B).

13. Remove set screw from First-Reverse shifter fork and slide shift rail out rear of case.

14. Shift First-Reverse sleeve and gear all the way forward and rotate First-Reverse shifter fork upward and out of case. Remove First-Reverse Detent plug from case.

15. Shift Second-Third Shifter fork rearward to gain access to setscrew, remove setscrew, rotate shift rail 90° with pliers to clear bottom detent plug and remove interlock plug with magnet (Fig. 7B-9B).

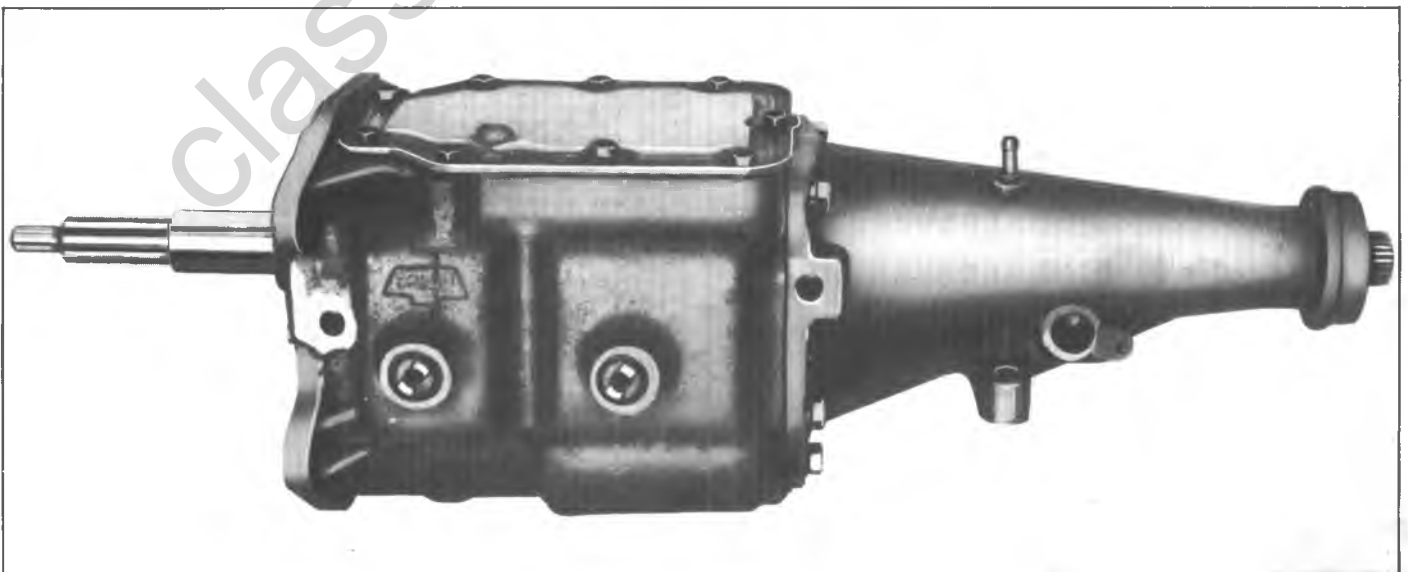
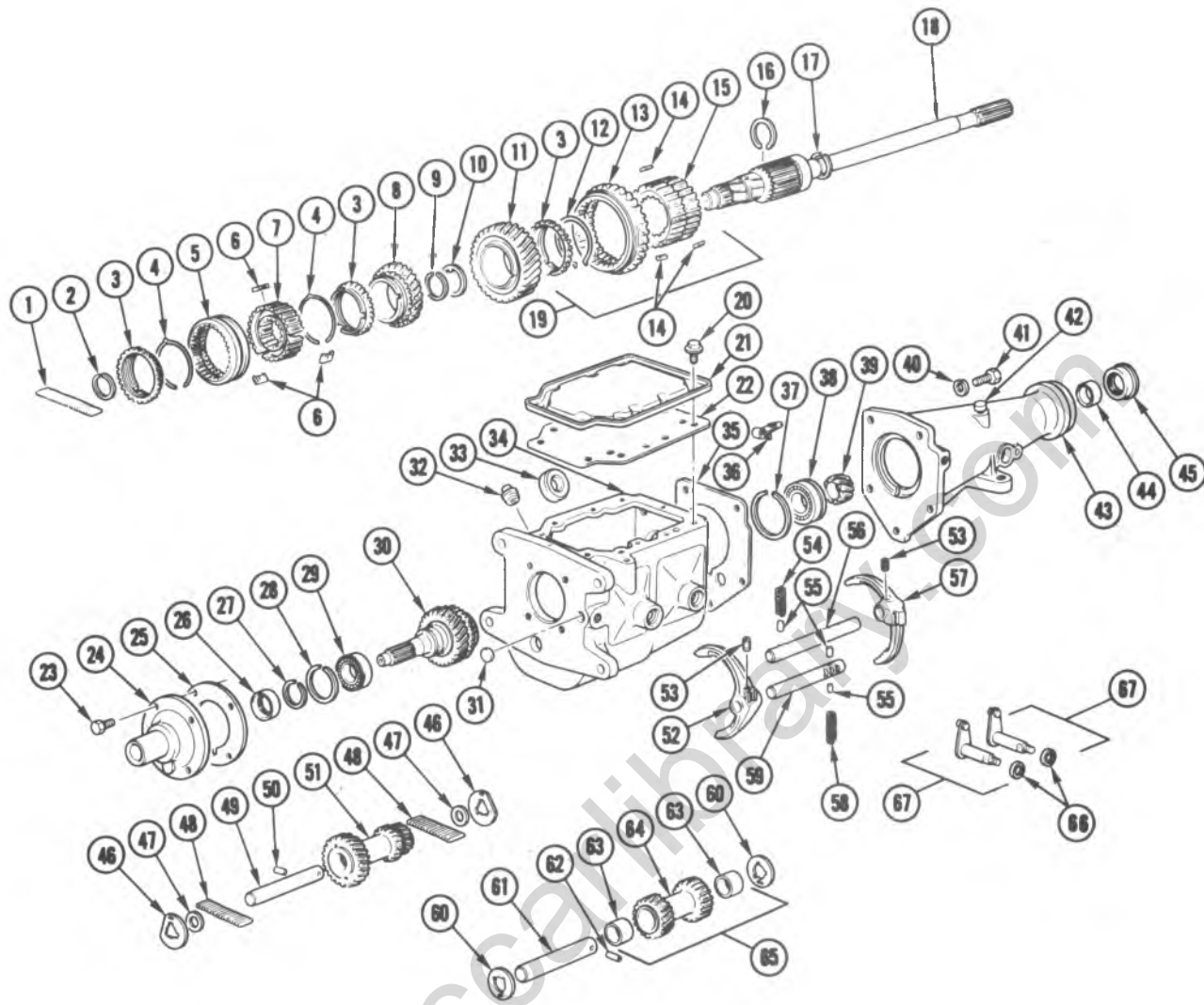

Fig. 7B-1B-3-Speed 77mm Transmission



- |  |  |
|--|--|
| 1. MAINSHAFT ROLLER BEARINGS                     | 36. EXTENSION HOUSING TO CASE GASKET           |
| 2. 2ND & 3RD SYNCHRONIZER RETAINING RING         | 37. SPEEDOMETER DRIVER GEAR RETAINING CLIP     |
| 3. SYNCHRONIZER BLOCKER RINGS                    | 38. TRANSMISSION REAR BEARING LOCK RING        |
| 4. 2ND & 3RD SYNCHRONIZER SPRING                 | 39. MAINSHAFT BEARING ASSEMBLY                 |
| 5. 2ND & 3RD SYNCHRONIZER SLEEVE                 | 40. SPEEDOMETER DRIVE GEAR                     |
| 6. 2ND & 3RD SYNCHRONIZER KEYS                   | 41. EXTENSION TO CASE WASHER                   |
| 7. 2ND & 3RD SYNCHRONIZER HUB                    | 42. EXTENSION TO CASE BOLT                     |
| 8. SECOND SPEED GEAR                             | 43. TRANSMISSION EXTENSION VENTILATOR ASSEMBLY |
| 9. 1ST SPEED GEAR RETAINING RING                 | 44. EXTENSION HOUSING ASSEMBLY                 |
| 10. 1ST SPEED GEAR TABBED WASHER                 | 45. EXTENSION HOUSING BUSHING                  |
| 11. 1ST SPEED GEAR                               | 46. EXTENSION HOUSING OIL SEAL ASSEMBLY        |
| 12. REVERSE SYNCHRONIZER SPRING                  | 47. COUNTERGEAR THRUST WASHER                  |
| 13. 1ST & REVERSE SYNCHRONIZER SLEEVE & GEAR     | 48. COUNTERGEAR SPACER                         |
| 14. REVERSE SYNCHRONIZER KEYS                    | 49. COUNTERGEAR ROLLET BEARINGS                |
| 15. 1ST & REVERSE SYNCHRONIZER HUB               | 50. COUNTERGEAR SHAFT                          |
| 16. 1ST & REVERSE SYNCHRONIZER RETAINING RING    | 51. COUNTERGEAR SPRING PIN                     |
| 17. REAR BEARING RETAINING RING                  | 52. COUNTERGEAR                                |
| 18. TRANSMISSION MAINSHAFT                       | 53. 2ND & 3RD SHIFTER FORK                     |
| 19. REVERSE SYNCHRONIZER ASSEMBLY                | 54. SHIFTER LOCKING SCREW                      |
| 20. ACCESS COVER BOLTS                           | 55. 1ST & 2ND SHIFTER INTERLOCK SPRING         |
| 21. ACCESS COVER                                 | 56. SHIFTER INTERLOCK PIN                      |
| 22. ACCESS COVER GASKET                          | 57. 1ST & REVERSE SHIFTER RAIL                 |
| 23. BEARING RETAINER - TO CASE BOLTS             | 58. 1ST & REVERSE SHIFTER FORK                 |
| 24. BEARING RETAINER - CLUTCH GEAR               | 59. 2ND & 3RD SHIFTER INTERLOCK SPRING         |
| 25. GASKET - CLUTCH GEAR BEARING RETAINER        | 60. 2ND & 3RD SHIFTER RAIL                     |
| 26. SEAL ASSEMBLY - CLUTCH GEAR BEARING RETAINER | 61. REVERSE IDLER GEAR THRUST WASHER           |
| 27. CLUTCH GEAR BEARING RETAINING RING           | 62. REVERSE IDLER GEAR SHAFT                   |
| 28. CLUTCH GEAR BEARING LOCK RING                | 63. SPRING PIN IDLER GEAR SHAFT                |
| 29. CLUTCH GEAR BEARING ASSEMBLY                 | 64. REVERSE IDLER GEAR BUSHING                 |
| 30. CLUTCH GEAR                                  | 65. REVERSE IDLER GEAR                         |
| 31. EXPANSION PLUG                               | 66. REVERSE IDLER GEAR ASSEMBLY                |
| 32. FILLER PLUG                                  | 67. SEAL TRANSMISSION SHIFTER                  |
| 33. TRANSMISSION CASE MAGNET                     |  |
| 34. CASE   |  |

Fig. 7B-2B—Exploded View - 3 Speed 77mm Transmission



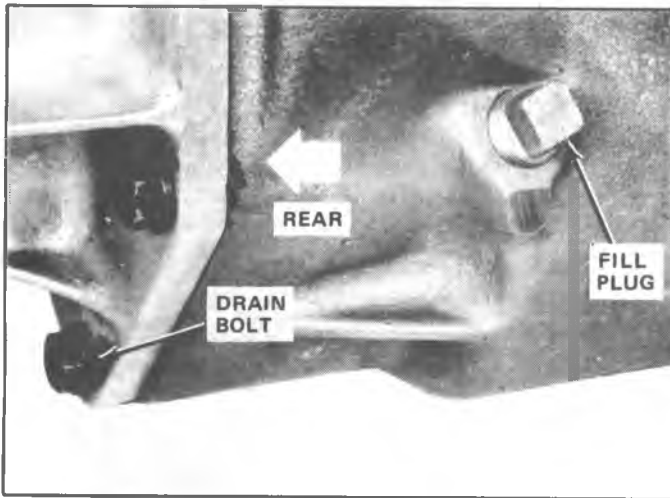

Fig. 7B-3B-Drain Transmission

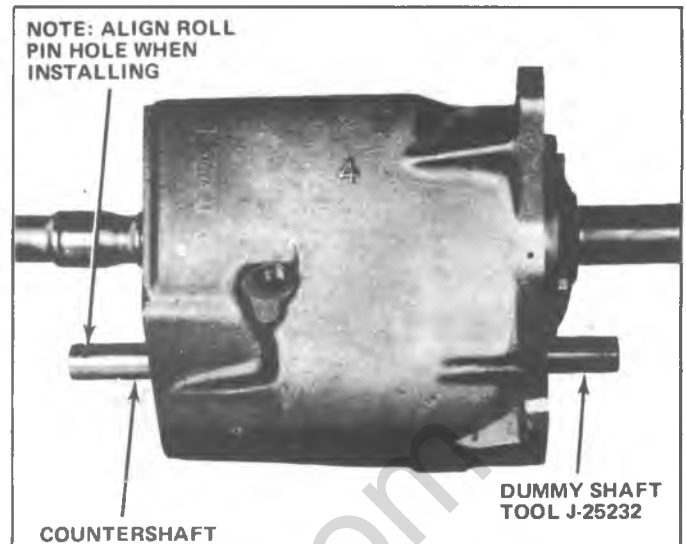

Fig. 7B-5B-Removing Countershaft

16. Using a long thin punch (1/4 inch diameter or less) insert through access hole in rear case to drive out shift rail and expansion plug located in shift rail bore at front of case.

17. Rotate second-third shifter fork upward and out of case.

18. Remove the bottom detent plug and short detent spring from case.

19. Separate clutch gear from output shaft and remove output shaft assembly (Fig. 7B-10B); tilt spline end of shaft downward and lift gear end upward and out of case.

First and reverse sleeve and gear must pass through notch at right rear end of case.

20. Remove clutch gear through top of case.

21. Remove both shifter fork shafts (Fig. 7B-11B).

22. Remove countergear (with tool in place), thrust washers and roll pin.

23. Remove reverse idler gear and thrust washers by tapping shaft with hammer until end of idler gear shaft (end with roll pin) clears counterbore in rear of case and remove shaft (Fig. 7B-12B).

24. From the bottom of the case retrieve, clutch shaft roller bearing or countergear needle bearing that may have fallen into case during disassembly.

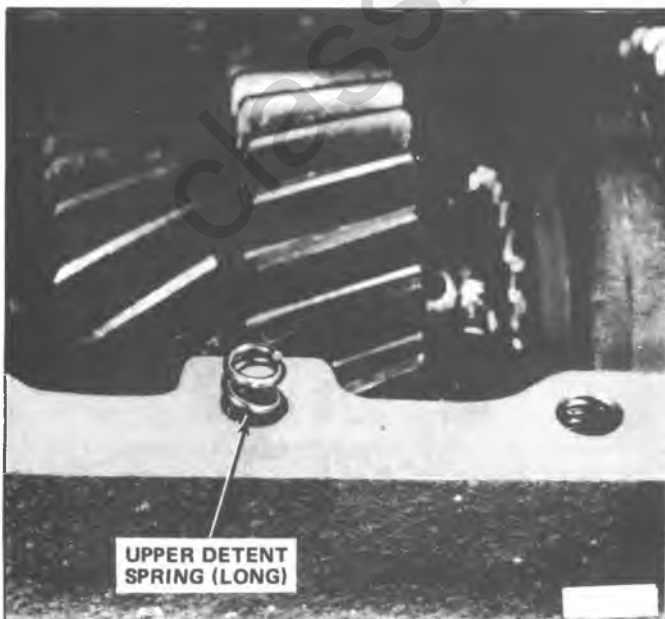

Fig. 7B-4B-Location of Upper Detent Spring

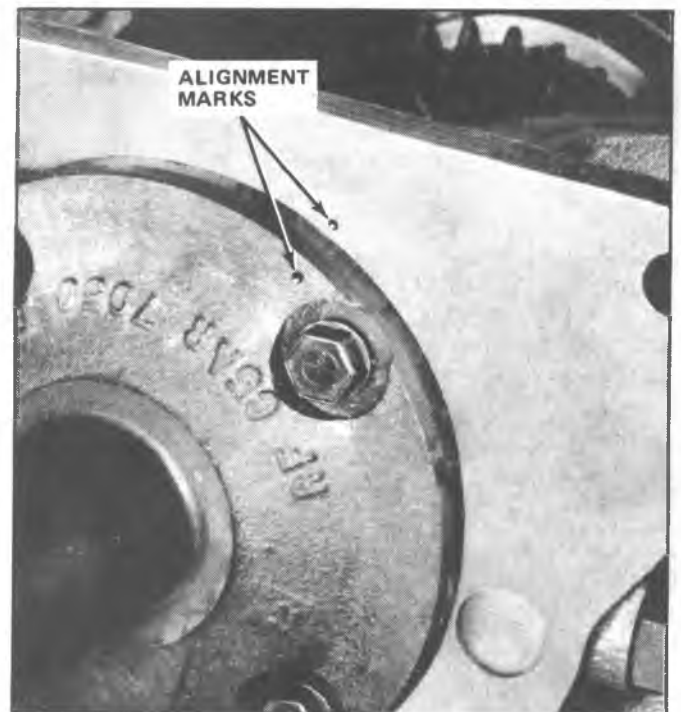

Fig. 7B-6B-Removing Front Bearing Retainer

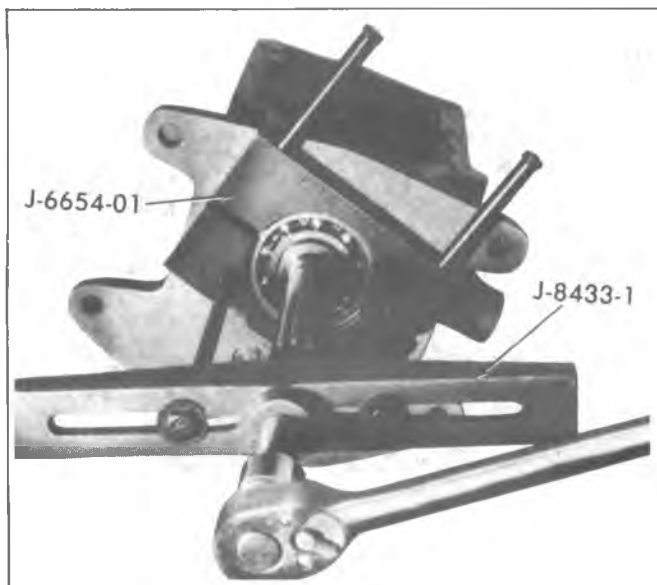

Fig. 7B-7B-Removing Front Bearing

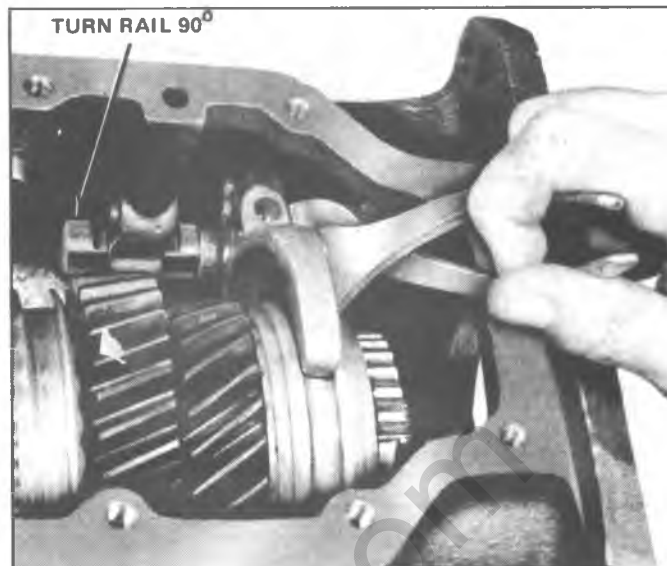

Fig. 7B-9B-Rotating Shift Rail

### MAINSHAFT DISASSEMBLY

1. Remove snap ring from front of output shaft and remove Second-Third synchronizer assembly and second gear. Mark hub and sleeve for correct assembly.

2. Remove snap ring and tabbed thrust washer from shaft and remove first gear and blocking ring.

3. Remove First-Reverse hub retaining snap ring. Observe position of spring and keys before removal, also, mark hub and sleeve for correct assembly.

4. Remove sleeve and gear, spring and three keys from hub (Fig. 7B-13B).

5. Using an arbor press, remove hub from output shaft.

### CLEANING AND INSPECTION

#### Transmission Case

1. Wash the transmission thoroughly inside and outside with cleaning solvent, then inspect the case for cracks.

2. Check the front and rear faces for burrs, and if present, dress them off with a fine mill file.

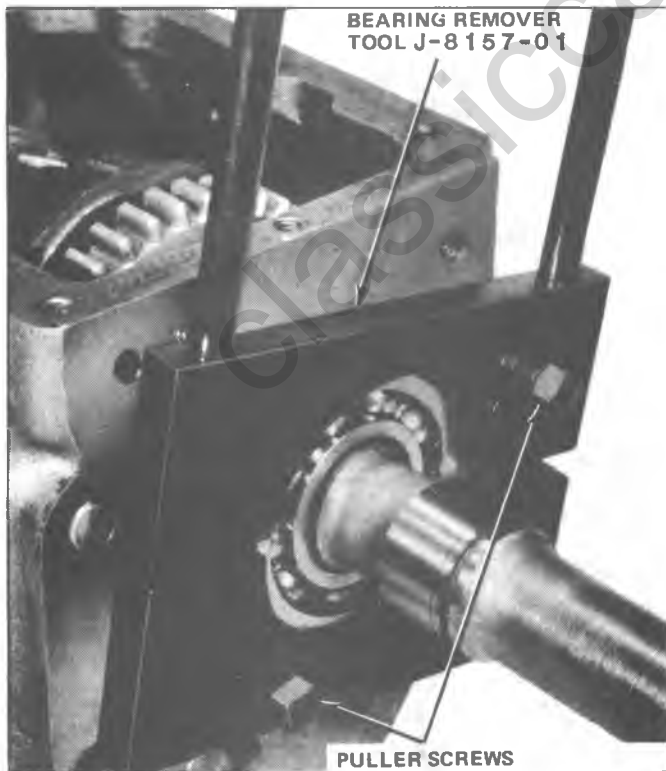

Fig. 7B-8B-Removing Rear Bearing



Fig. 7B-10B-Removing Output Shaft Assembly

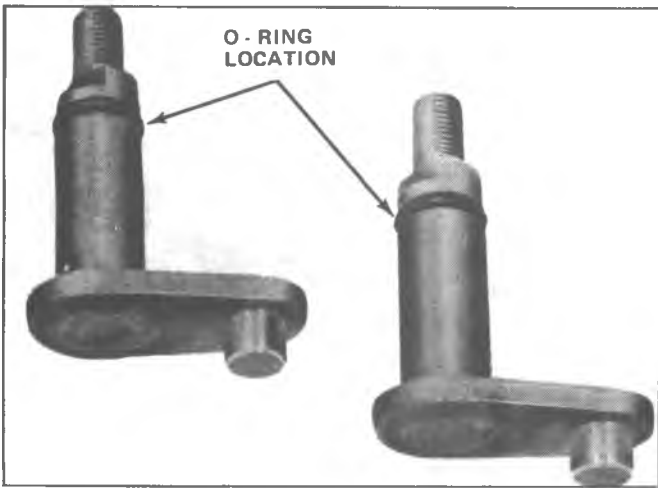

Fig. 7B-11B—Shift Fork Shafts

**Front and Rear Bearings**

1. Wash the front and rear ball bearings thoroughly in a cleaning solvent.
2. Blow out bearings with compressed air.

**NOTICE:** Do not allow the bearings to spin, turn them slowly by hand. Spinning bearings may damage the race and balls.

3. Make sure bearings are clean, then lubricate with light engine oil and check them for roughness by slowly turning the race by hand.

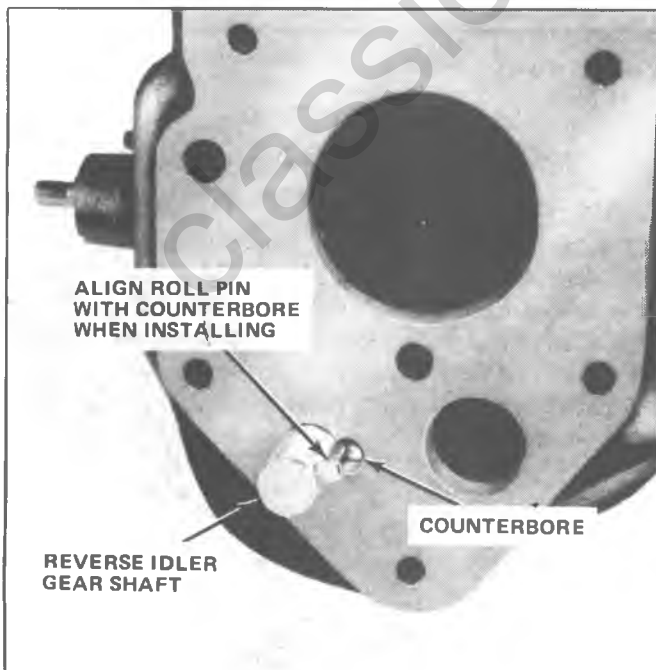

Fig. 7B-12B—Removing Reverse Idler Gear Shaft

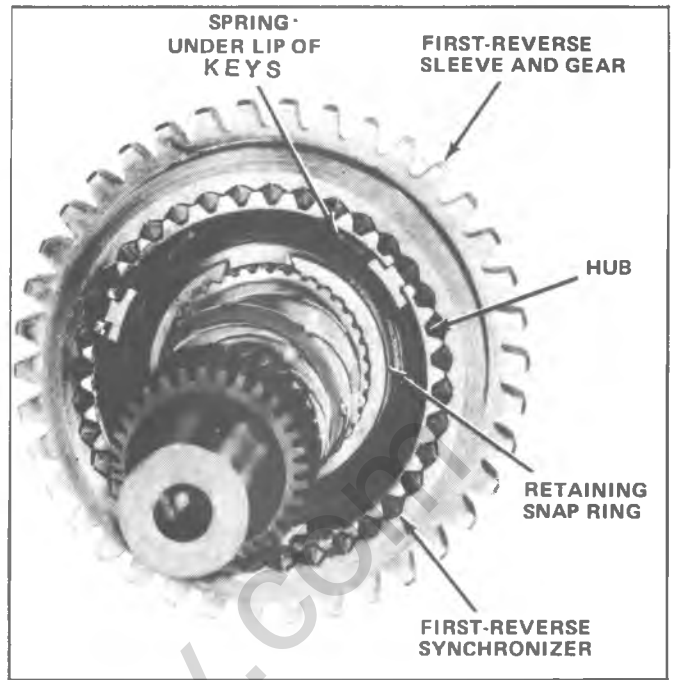

Fig. 7B-13B—First-Reverse Synchronizer Hub

**Bearing Rollers**

All clutch gear and countergear bearing rollers should be inspected closely and replaced if they show wear. Inspect countershaft and reverse idler shaft at the same time, replace if necessary. Replace all worn washers.

**Gears**

1. Inspect all gears for excessive wear, chips, or cracks and replace any that are worn or damaged.

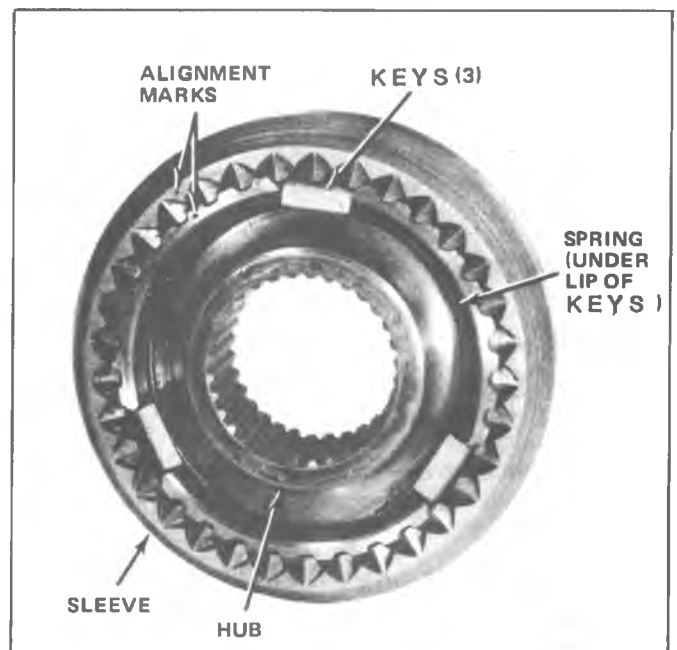

Fig. 7B-14B—Second-Third Synchronizer Assembly

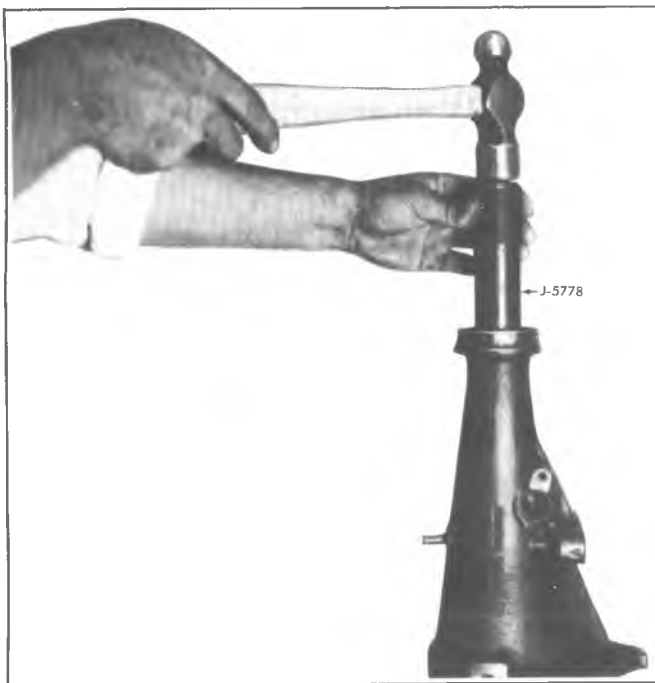

Fig. 7B-15B—Installing Extension Housing Bushing

2. Check both clutch sleeves to see that they slide freely on their hubs.

## REPAIRS

### Synchronizer Keys and Spring

#### Replacement

1. Mark hub and sleeve so they can be matched upon reassembly.

2. Push the hub from the sliding sleeve, the keys and the springs may be easily removed.

3. Install one spring into second-third hub. Be sure spring covers all three key slots in hub. Align second-third sleeve to hub using marks made during disassembly, and start sleeve onto hub.

4. Place the three keys into hub slots and on top of spring, then push sleeve fully onto hub to engage keys in sleeve (Fig. 7B-14B).

5. Install remaining spring in exact same position as first spring. Ends of both spring must cover same slots in hub and not be staggered. Keys have small lip on each end. When correctly installed, this lip will fit over spring (Fig. 7B-14B).

### Extension Oil Seal or Bushing

If bushing in rear of extension requires replacement, remove seal and use Tool J-5778 to drive bushing into extension housing (Fig. 7B-15B). Using the same tool, drive new bushing in from the rear. Coat I.D. of bushing and seal with transmission lubricant, then install new oil seal using Tool J-5154 (Fig. 7B-16B).

### Clutch Bearing Retainer Oil Seal

If the lip seal in the retainer needs replacement; pry the old seal out and replace with a new seal using Installer Tool J-25233, or similar tool, until seal seats in its bore (Fig. 7B-17B).



Fig. 7B-16B—Installing Extension Housing Seal

## ASSEMBLY OF MAINSHAFT

1. Install First-Reverse synchronizer hub on output shaft splines by hand. Slotted end of hub should face front of shaft. Use an arbor press to complete hub installation on shaft and install retaining snap ring (in most rearward groove).

**NOTICE:** DO NOT attempt to drive hub onto shaft with hammer. Hammer blows could damage hub and splines.

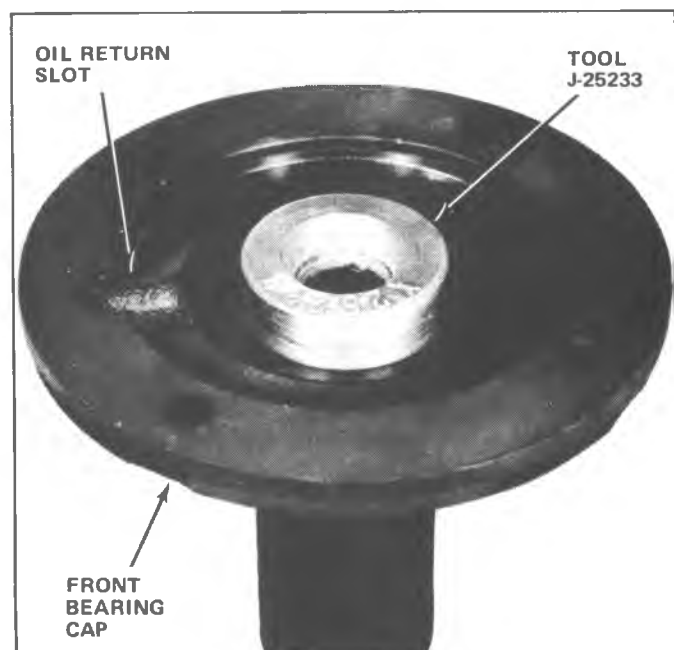
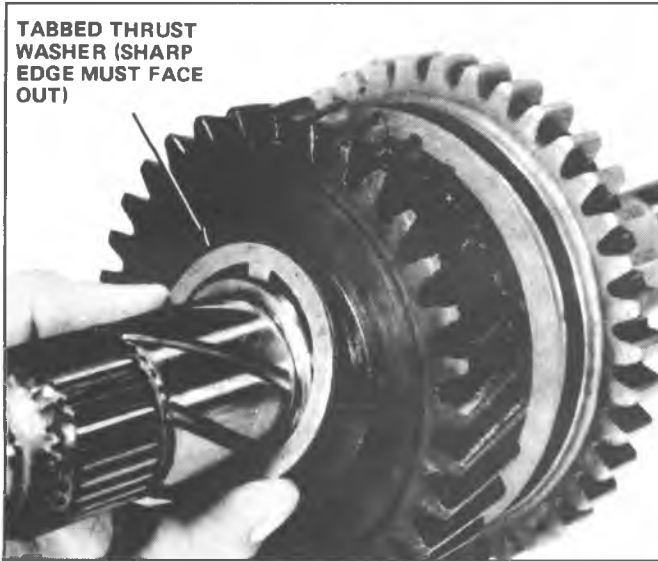

Fig. 7B-17B—Installing Clutch Bearing Retainer Seal



TABBED THRUST WASHER (SHARP EDGE MUST FACE OUT)

Fig. 7B-18B—Installing Tabbed Thrust Washer

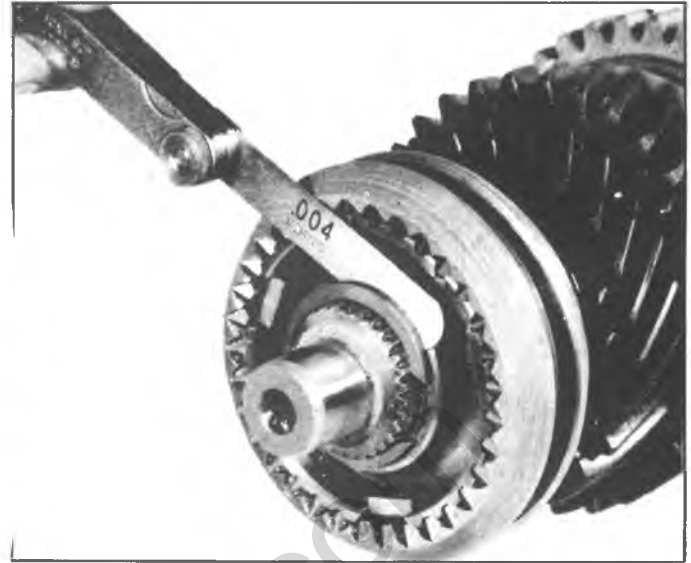

Fig. 7B-20B—Measuring Output Shaft End Play

2. Install First-Reverse sleeve and gear half-way onto hub with gear end of sleeve facing rear of shaft. Index sleeve to hub with marks made during disassembly.

3. Install spring in First-Reverse hub. (Make sure spring is bottomed in hub and covers all three key slots.) Position three synchronizer keys in hub, with small ends in hub slots and large ends inside hub. Push keys fully into hub so they seat on spring. Then slide First-Reverse sleeve and gear over keys until the keys engage in the synchronizer sleeve (Fig. 7B-13B).

4. Place first gear blocking ring on tapered surface of gear. Install First gear on output shaft. Rotate gear until notches in blocking ring engages keys in First-Reverse hub.

5. Install tabbed thrust washer (sharp edge facing out) and retaining snap ring on output shaft (Fig. 7B-18B).

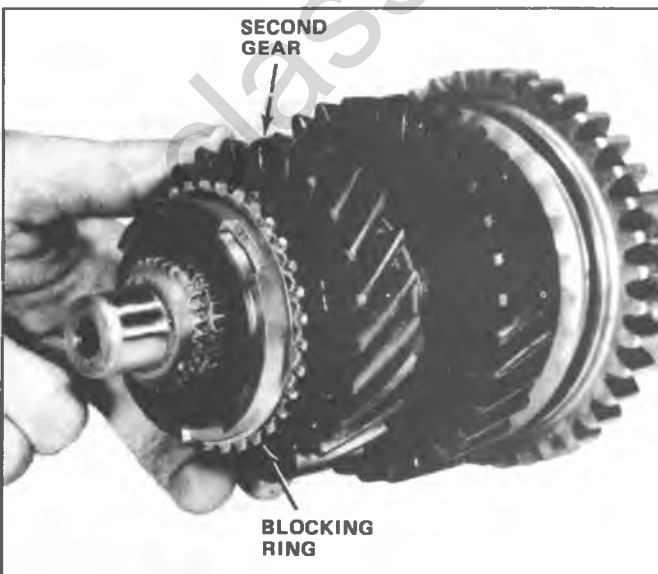

Fig. 7B-19B—Installing Second Gear

6. Place second gear blocking ring on tapered surface of gear and install second gear on output shaft with tapered surface of gear facing front of output shaft (Fig. 7B-19B).

7. Install Second-Third synchronizer assembly with flat portion of synchronizer hub facing rearward on output shaft. Rotate Second gear until notches in blocking ring engages keys in Second-Third synchronizer assembly. It may be necessary to tap synchronizer with a plastic hammer to ease assembly.

8. Install retaining snap ring on output shaft and measure end play between snap ring and Second-Third synchronizer hub with feeler gauge (Fig. 7B-20B). End play should be 0.004 to 0.0014 inch. If end play exceeds 0.014 inch, replace thrust washer and all snap rings on output shaft assembly.

### ASSEMBLY OF TRANSMISSION

1. Coat transmission case reverse idler gear thrust washer surfaces with vaseline (or equivalent) and position thrust washer in case. Be sure to engage locating tabs on thrust washers in locating slots in case.

2. Install reverse idler gear with helical cut gear towards front of case. Align gear bore, thrust washers, case bores, and install reverse idler gear shaft from rear of case. Be sure to align and seat roll pin in shaft into counterbore in rear of case.

3. Measure reverse idler gear end play by inserting feeler gauge between thrust washer and gear. End play should be 0.004 to 0.018 inch. If end play exceeds 0.018 inch, remove idler gear and replace thrust washer.

4. Install shaft tool J-25232 in bore of countergear and load a row of needle bearing (25) in each end of gear. Use heavy grease or equivalent to hold them in place. Install one needle bearing retainer on each end of gear.

5. Position countergear thrust washer in case, use vaseline or equivalent to hold washers in place. Be sure to engage locating tabs on thrust washer in locating slots in case.

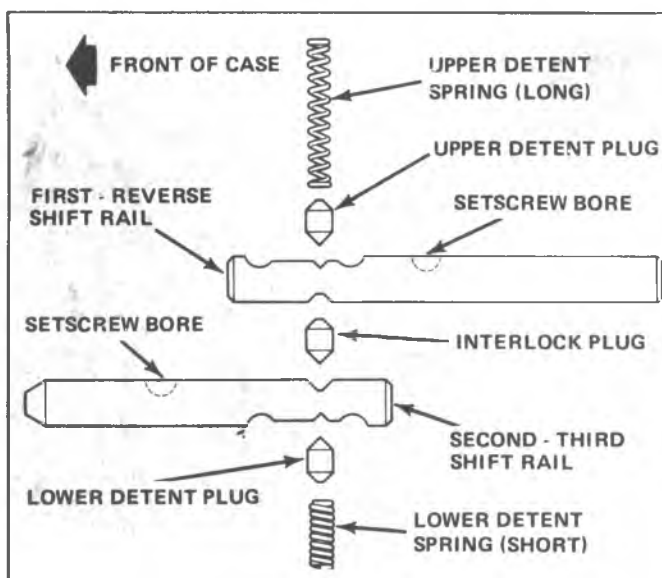

Fig. 7B-21B—Installation Sequence - Detent Plugs and Springs

6. Insert countershaft into bore at rear of case just far enough to hold rear thrust washer from being displaced when the countergear is installed.

7. Align bore in countergear with countershaft and front thrust washer, then start countershaft into countergear. Before countershaft is completely installed make sure that roll pin hole in countershaft is aligned with hole in case. When holes are aligned, tap countershaft into place, remove tool J-25232 (Fig. 7B-5B).

8. Measure countershaft end play by inserting feeler gauge between thrust washer and countergear. End play should be 0.004 to 0.018 inch. If end play exceeds 0.018 inch, remove gear and replace thrust washers.

9. After correct end play has been obtained, install roll pin in case.

10. Lower shorter detent spring in detent bore in case (Fig. 7B-21B). Allow spring to drop into place at bottom of Second-Third shift rail bore. Insert lower detent plug in detent bore on top of spring.

11. Install shifter fork shafts in their case bores with the pivot lug facing up. Shifter fork shafts are interchangeable.

12. Install (15) roller bearings in clutch shaft bore. Use vaseline (or equivalent) to hold bearings in place.

**NOTICE:** Do not use chassis grease or a similar "heavy" grease in clutch shaft bore. Heavy grease could plug the lubricant holes in the shaft and prevent proper lubrication of the roller bearing.

13. Install blocking ring on clutch gear and place clutch gear through top of case and position in front case bore.

14. Install output shaft assembly in case. Be sure First-Reverse sleeve and gear is in Neutral (centered) position on hub so gear end of sleeve will clear notch in top of case when output shaft assembly is installed.

15. Assemble the clutch gear to the output shaft.

16. Move Second-Third sleeve rearward to Second gear position and position Second-Third shifter fork in groove

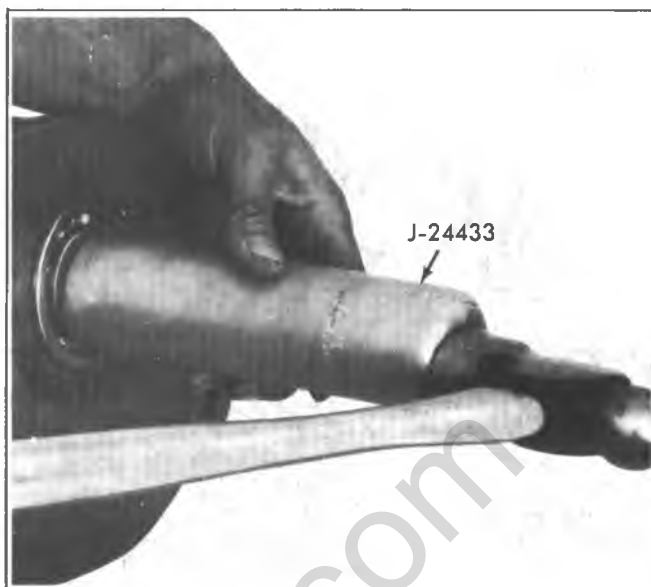

Fig. 7B-22B—Installing Front Bearing

of sleeve. Be sure setscrew hold in shifter fork is facing up. Second-Third fork is the smaller of the two shifter forks.

17. Engage Second-Third shifter fork in shifter fork shaft and insert Second-Third shift rail through front case bore and into shifter fork. Tapered end of rail faces front of case.

18. Turn shift rail until detent notches in rail face bottom of case. Insert a phillips screwdriver in detent bore to depress lower detent plug and push shift rail into rear bore. Move rail inward until detent plug engages forward notch in shift rail (second gear position).

19. Secure fork to rail with setscrew and move second-third synchronizer to Neutral (centered) position.

20. Install interlock plug in detent bore. With Second-Third synchronizer in Neutral position, top of plug will be slightly below surface of First-Reverse shift rail bore.

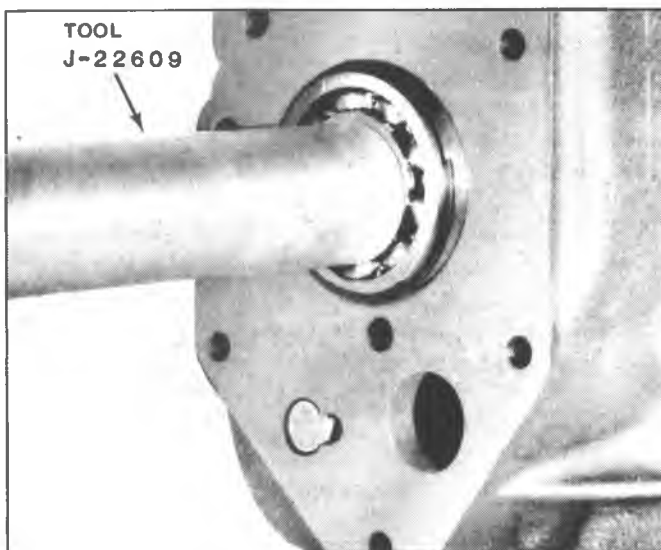

Fig. 7B-23B—Installing Rear Bearing

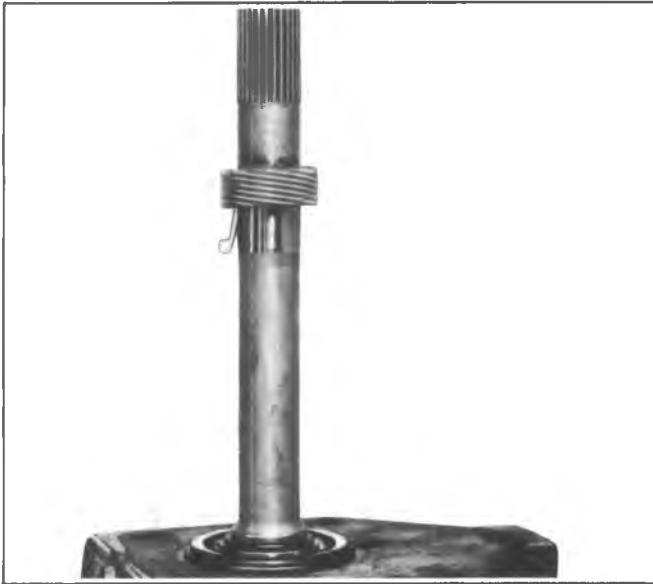

Fig. 7B-24B—Installing Speedometer Retainer and Gear

21. Move first reverse synchronizer forward to first gear position. Place First-Reverse shifter fork in groove of sleeve. Be sure setscrew hole in fork is facing up. Rotate fork into position in case, engage fork in shifter fork shaft, and insert First-Reverse shift rail through rear case bore and shifter fork.

22. Turn shift rail until detent notches in rail face upward. Move rail inward until setscrew hole in fork and setscrew bore in shift rail are aligned. Secure fork to rail with setscrew and place First Reverse sleeve and gear into Neutral (centered) position (Fig. 7B-20B).

23. Install large snap ring on front bearing.

24. Install front bearing on clutch gear shaft by hand drive bearing on clutch gear shaft using tool J-24433 (Fig. 7B-22B).

25. Install smaller snap ring on clutch gear shaft.

26. Position bearing retainer gasket on case. Be sure cut-out in gasket is aligned with oil return hole in case.

27. Install front bearing retainer and tighten attaching bolts to 30 to 36 foot-pounds of torque. Be sure to index cap to case with alignment marks, and that oil return slot in cap is aligned with oil return hole in case.

28. Install large snap ring on rear bearing.

29. Install rear bearing on output shaft by hand. Drive bearing onto shaft and into case with tool J-22609, make sure snap ring groove is facing rear of shaft (Fig. 7B-23B).

30. Install smaller snap ring on output shaft to hold rear bearing in place.

31. Engage speedometer gear retainer in hole provided in output shaft, with retainer loop forward, slide speedometer gear over output shaft and into position (Fig. 7B-24B).

32. Position extension housing gasket on case and install extension housing to case. Tighten bolts to 42 to 50 foot pounds torque.

33. Install expansion plug in Second-Third shift rail bore in front of case. Be sure plug is fully seated in bore and is approximately 1/16 inch below front face of case.

34. Install upper detent plug in detent bore, then install long detent spring on top of plug. Install transmission fill plug and tighten 10 to 20 foot pounds torque.

35. Install top cover and gasket on case and secure with attaching bolts. Tighten bolts 20 to 25 foot pounds torque.

## 4-SPEED 76MM TRANSMISSION

### INDEX

Disassembly of Transmission .....	7B-17
Disassembly of Mainshaft .....	7B-19
Cleaning and Inspection .....	7B-19
Transmission Case .....	7B-19
Bearings .....	7B-19
Gears and Bushings .....	7B-20

Repairs .....	7B-20
Clutch Keys and Springs Replacement .....	7B-20
Extension Oil Seal or Bushing .....	7B-21
Clutch Bearing Retainer Oil Seal .....	7B-21
Assembly of Mainshaft .....	7B-21
Assembly of Transmission .....	7B-22

### DISASSEMBLY OF TRANSMISSION (Fig. 7B-1J)

1. Remove side cover attaching bolts and remove side cover assembly.

2. Remove clutch gear bearing retainer bolts, retainer and gasket.

3. Remove clutch gear bearing to gear stem snap ring, then remove clutch gear bearing by pulling outward on clutch gear until a screwdriver or other suitable tool can be inserted between bearing, large snap ring and case to complete removal (Fig. 7B-2J). The clutch gear bearing is a slip fit on the gear and into the case bore. This provides clearance for removal of clutch gear and mainshaft assembly.

4. Remove extension to case attaching bolts.

5. Remove clutch gear, mainshaft and extension assembly together through the rear case opening (Fig. 7B-3J).

6. Using snap ring pliers, expand the snap ring in the extension which retains the mainshaft rear bearing (Fig. 7B-4J) and remove the extension.

7. Using J-22246 at the front of the countershaft, drive the shaft and its woodruff key out the rear of the case. Tool J-22246 will now hold the roller bearings in position within the counter gear bore. Remove the gear and bearings (Fig. 7B-5J).

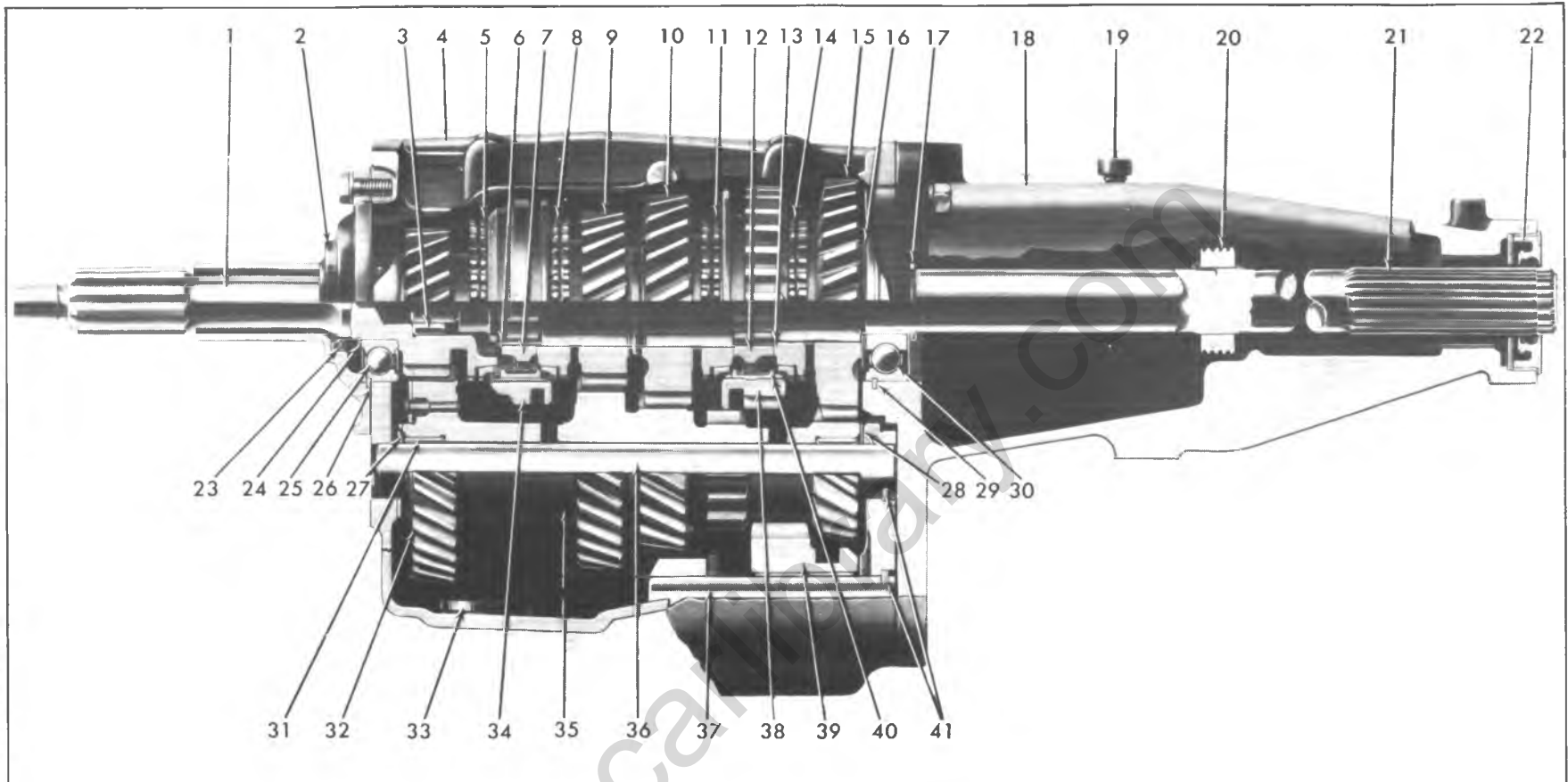

Fig. 7B-1J-4-Speed 76mm Transmission Cross Section

- |                           |  |                                     |                                    |  |
|---------------------------|--|-------------------------------------|------------------------------------|--|
| 1. Drive Gear             | 11. 2nd Speed Blocker Ring                 | 18. Extension                       | 27. Thrust Washer-Front            | 35. Countergear Assembly                     |
| 2. Bearing Retainer       | 12. 1-2 Speed Synch. Hub                   | 19. Vent                            | 28. Thrust Washer-Rear             | 36. Counter Shaft                            |
| 3. Pilot Bearings         | 13. 1-2 Speed Synch. Snap Ring             | 20. Speedometer Drive Gear and Clip | 29. Snap Ring-Bearing to Extension | 37. Reverse Idler Shaft                      |
| 4. Case                   | 14. 1st Speed Blocker Ring                 | 21. Mainshaft                       | 30. Rear Bearing                   | 38. 1-2 Speed Synch. Sleeve and Reverse Gear |
| 5. 4th Speed Blocker Ring | 15. First Gear                             | 22. Rear Oil Seal                   | 31. Countergear Roller Bearings    | 39. Reverse Idler Gear (Sliding)             |
| 6. 4-3 Synch. Snap Ring   | 16. Reverse Gear Thrust and Spring Washers | 23. Retainer Oil Seal               | 32. Anti-Lash Plate Assembly       | 40. Clutch Key                               |
| 7. 4-3 Synch. Hub         | 17. Snap Ring-Bearing to Mainshaft         | 24. Snap Ring-Bearing to Gear       | 33. Magnet                         | 41. Woodruff Key                             |
| 8. 3rd Speed Blocker Ring |  | 25. Drive Gear Bearing              | 34. 4-3 Synch. Sleeve              |  |
| 9. 3rd Speed Gear         |  | 26. Snap Ring-Bearing to Case       |                                    |  |
| 10. 2nd Speed Gear        |  |                                     |                                    |  |



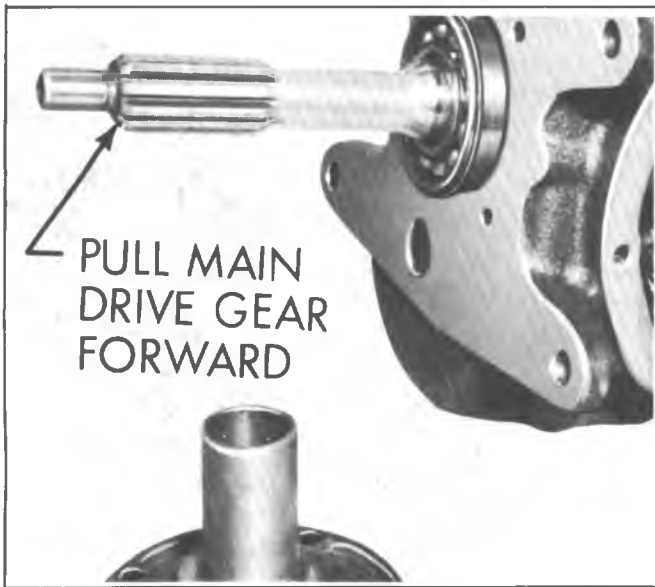

Fig. 7B-2J—Removing Clutch Gear Bearing

8. Remove reverse idler gear stop ring. Use a long drift or punch through the front bearing case bore and drive the reverse idler shaft and woodruff key through the rear of the case (Fig. 7B-6J).

**DISASSEMBLY OF MAINSHAFT**

1. Using snap ring pliers, remove the 3rd and 4th speed sliding clutch hub snap ring from mainshaft and remove clutch assembly, third gear blocker ring and third speed gear from front of mainshaft (Fig. 7B-7J).
2. Depress speedometer retaining clip and slide gear from mainshaft.
3. Remove rear bearing snap ring from mainshaft groove (Fig. 7B-8J).
4. Support first gear with press plates and press on rear of mainshaft to remove first gear, thrust washer, spring washer and rear bearing from rear of mainshaft (Fig. 7B-9J).
5. Remove the 1st and 2nd sliding clutch hub snap ring from the mainshaft and remove the clutch assembly, 2nd speed blocker ring and 2nd speed gear from the rear of the



Fig. 7B-3J—Removing Clutch Gear and Mainshaft

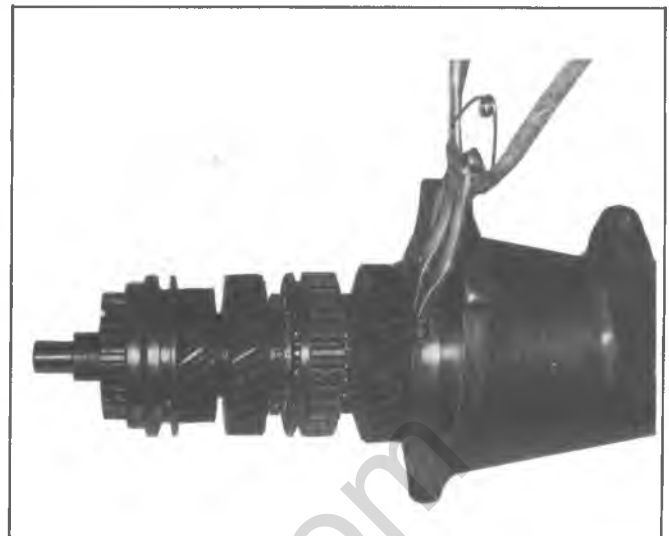

Fig. 7B-4J—Removing Extension to Rear Bearing Snap Ring

mainshaft (Fig. 7B-10J).

**CLEANING AND INSPECTION**

**Transmission Case**

1. Wash the transmission thoroughly inside and outside with cleaning solvent, then inspect the case for cracks.
2. Check the front and rear faces for burrs, and if present, dress them off with a fine mill file.

**Front and Rear Bearings**

1. Wash the front and rear ball bearings thoroughly in a cleaning solvent.
2. Blow out bearings with compressed air.

**NOTICE:** Do not allow the bearings to spin, turn them slowly by hand. Spinning bearings may damage the race and balls.

3. Make sure bearings are clean, then lubricate with light engine oil and check them for roughness by slowly turning the race by hand.

**Bearing Rollers**

All clutch gear and countergear bearing rollers should be inspected closely and replaced if they show wear. Inspect counter shaft and reverse idler shaft at the same time, replace if necessary. Replace all worn washers.



Fig. 7B-5J—Removing Countershaft

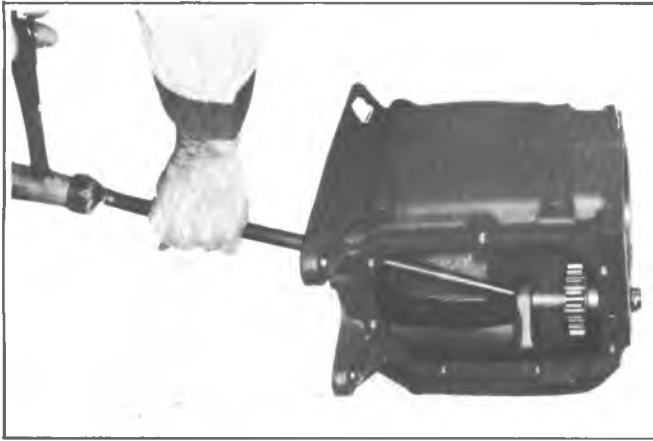

Fig. 7B-6J—Removing Reverse Idler Gear Shaft



Fig. 7B-8J—Rear Bearing to Mainshaft Snap Ring

## Gears

1. Inspect all gears for excessive wear, chips, or cracks and replace any that are worn or damaged.
2. Check both clutch sleeves to see that they slide freely on their hubs.

## Reverse Idler Gear Bushings

The bushing used in the idler gear is pressed into the gear and finish bored in place. This insures the positive alignment of the bushing and shaft as well as proper meshing of the gears. Because of the high degree of accuracy to which these parts are machined, the bushing is not serviced separately.

## REPAIRS

### Clutch Keys and Springs

The clutch hubs and sliding sleeves are a selected assembly and should be kept together as originally assembled, but the keys and two springs may be replaced if worn or broken.



Fig. 7B-7J—Removing 3rd and 4th Synchronizer Snap Ring

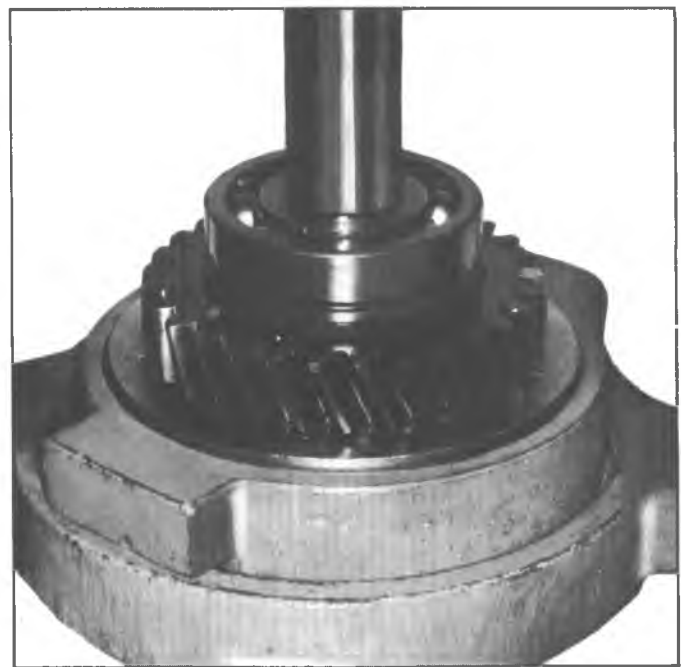

Fig. 7B-9J—Removing Rear Bearing and 1st Speed Gear

1. Mark hub and sleeve so they can be matched upon reassembly.
2. Push the hub from the sliding sleeve, the keys and the springs may be easily removed.
3. Place the three keys and two springs in position (one on each side of hub), so all three keys are engaged by both springs (Fig. 7B-11J). The tanged end of each synchronizer spring should be installed into different key cavities on either side. Slide the sleeve onto the hub aligning the marks made before disassembly.

A groove around the outside of the synchronizer hub identifies the end that must be opposite the fork slot in the sleeve when assembled, for the 3-4 synchronizer. However,

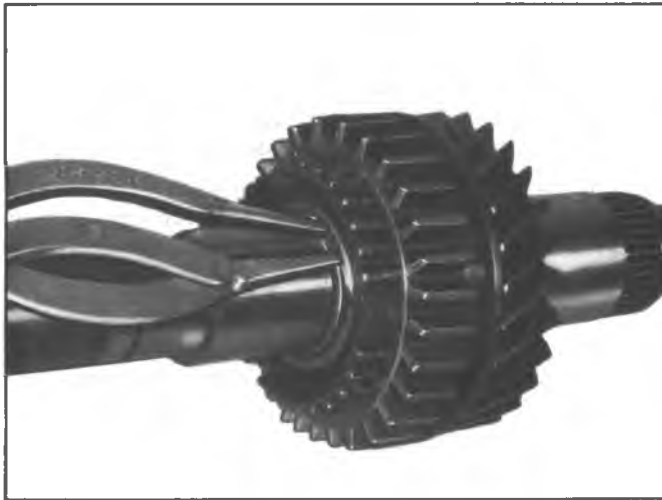

Fig. 7B-10J-Removing 1st and 2nd Synchronizer Snap Ring

for the 1-2 synchronizer, the groove is at the same end as the fork slot. This groove indicates the end of the hub with a greater recess depth.

### Extension Oil Seal or Bushing

If bushing in rear of extension requires replacement, remove seal and use Tool J-5778 to drive bushing into extension housing (Fig. 7B-12J). Using the same tool, drive new bushing in from the rear. Coat I.D. of bushing and seal with transmission lubricant, then install new oil seal using Tool J-5154 (Fig. 7B-13J).

### Clutch Gear Bearing Retainer Oil Seal

If the lip seal in the retainer needs replacement; pry the oil seal out and replace with a new seal using Tool J-23096 until seal seats in its bore (Figs. 7B-14J and 7B-15J).

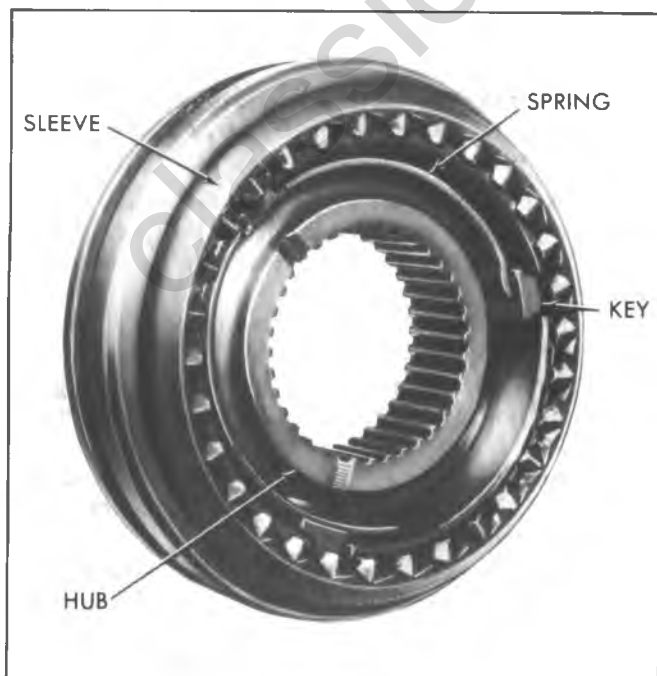

Fig. 7B-11J-3-4 Synchronizer Assembly

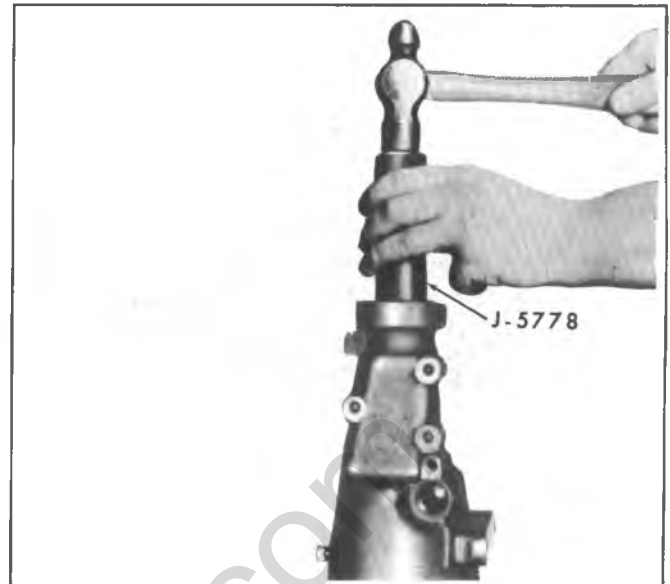

Fig. 7B-12J-Extension Bushing Replacement

Lip of seal must face rear of bearing retainer.

### ASSEMBLY OF MAINSHAFT (Fig. 7B-16J)

Turn the front of the mainshaft upward. Install the following components on the mainshaft:

1. Install the third speed gear with clutching teeth upward; the rear face of the gear will butt against the flange on the mainshaft.
2. Install a blocking ring with clutching teeth downward over the synchronizing surface of the third speed gear. All four blocker rings used in this transmission are identical.
3. Install the 3rd and 4th synchronizer assembly with the fork slot downward on the mainshaft until it bottoms out against flange. Be sure the notches of the blocker ring align with the keys at the synchronizer assembly.

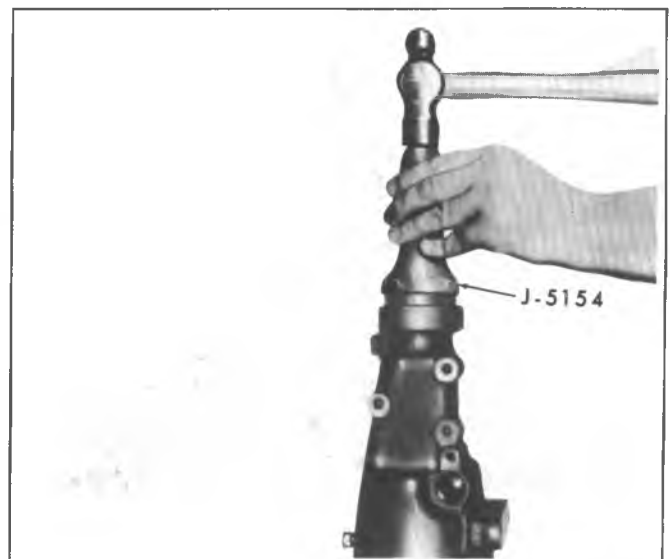

Fig. 7B-13J-Installing Extension Oil Seal



Fig. 7B-14J—Removing Bearing Retainer Oil Seal

4. Install synchronizer hub to mainshaft snap ring (Fig. 7B-7J). Both synchronizer snap rings are identical. Turn the rear of the mainshaft upward. Install the following components on the mainshaft:

5. Install the second speed gear with clutching teeth upward; the front face of the gear will butt against the flange on the mainshaft.

6. Install a blocker ring with clutching teeth downward over synchronizing surface of the second speed gear.

7. Install the first and second synchronizer assembly with fork slot downwards.



Fig. 7B-15J—Installing Bearing Retainer Oil Seal

8. Install synchronizer hub to mainshaft snap ring (Fig. 7B-10J).

9. Install a blocker ring with notches downward so they align with the keys of the 1-2 synchronizer assembly.

10. Install first gear with clutching teeth downward.

11. Install first gear thrust washer (steel). Be sure the notches of the blocker ring align with the keys of the synchronizer assembly.

12. Install first gear spring washer.

13. Install rear ball bearing with snap ring slot downward; press onto mainshaft (Fig. 7B-17J).

14. Install rear bearing to mainshaft snap ring (Fig. 7B-8J).

15. Install speedometer drive gear and clip.

This completes the assembly of the mainshaft.

#### ASSEMBLY OF TRANSMISSION (Fig. 7B-18J)

1. Using Tool J-22246 load a row of roller bearings (27) and a bearing thrust washer at each end of the countergear. Use heavy grease to hold them in place (Fig. 7B-19J).

2. Place countergear assembly through case rear opening along with a tanged thrust washer (tang away from gear) at each end and install countergear shaft and woodruff key from rear of case.

Be sure countershaft picks up both thrust washers and that the tangs are aligned with their notches in the case.

3. Install reverse idler gear and shaft with its woodruff key from the rear of case.

4. Using snap ring pliers, expand the snap ring in the extension and assembly extension over rear of mainshaft and onto rear bearing. Seat snap ring in rear bearing groove (Fig. 7B-4J).

5. Load the mainshaft pilot bearings (14) into the clutch gear cavity and assemble the 4th speed blocker ring onto the clutch gear clutching surface with its clutching teeth toward the gear (Fig. 7B-20J).

6. Pilot the clutch gear, pilot bearings and 4th speed blocker ring assembly over the front of the mainshaft assembly. Do not assemble bearing to gear yet.

**CAUTION: Be sure the notches in the blocker ring align with the keys in the 3-4 synchronizer assembly.**

7. Place extension to case gasket at rear of case holding in place with grease and, from the rear of the case, assemble the clutch gear, mainshaft and extension to case as an assembly.

8. Install extension to case retaining bolts. Using seal cement on bottom bolt only.

9. Install front bearing outer snap ring to bearing and position bearing over stem of drive gear and into front case bore.

10. Install snap ring to drive gear stem, and drive gear bearing retainer and gasket to case. The retainer oil return hole should be at the bottom.

11. Shift synchronizer sleeves to neutral positions and install cover, gasket and fork assembly to case. Be sure forks align with their synchronizer sleeve grooves.

12. Tighten all bolts to specified torque.

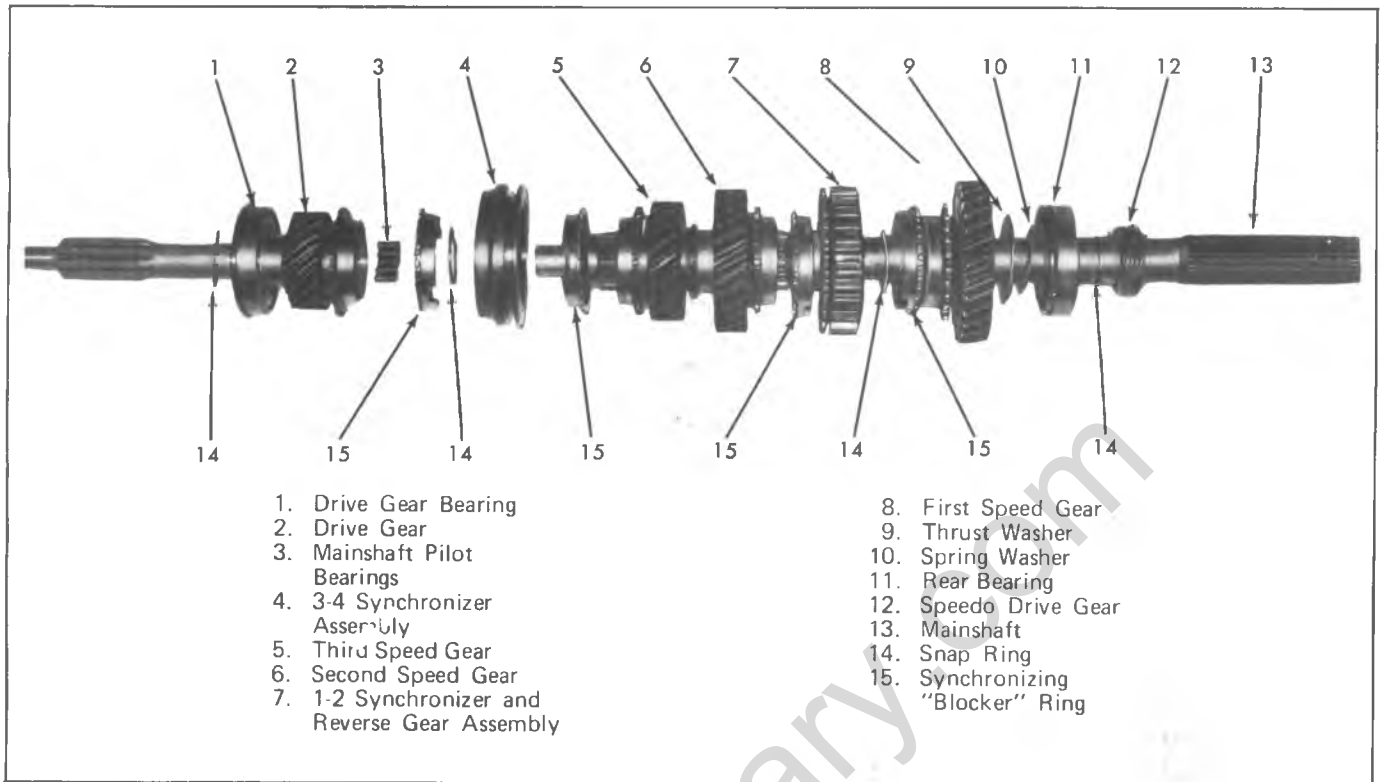

Fig. 7B-16J-Clutch Gear and Mainshaft Details

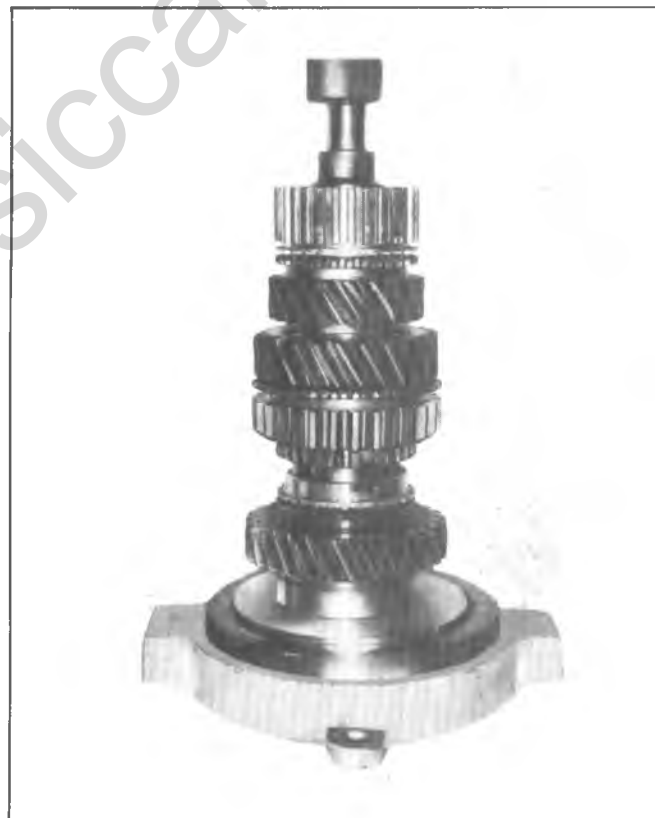

Fig. 7B-17J-Installing Rear Bearing

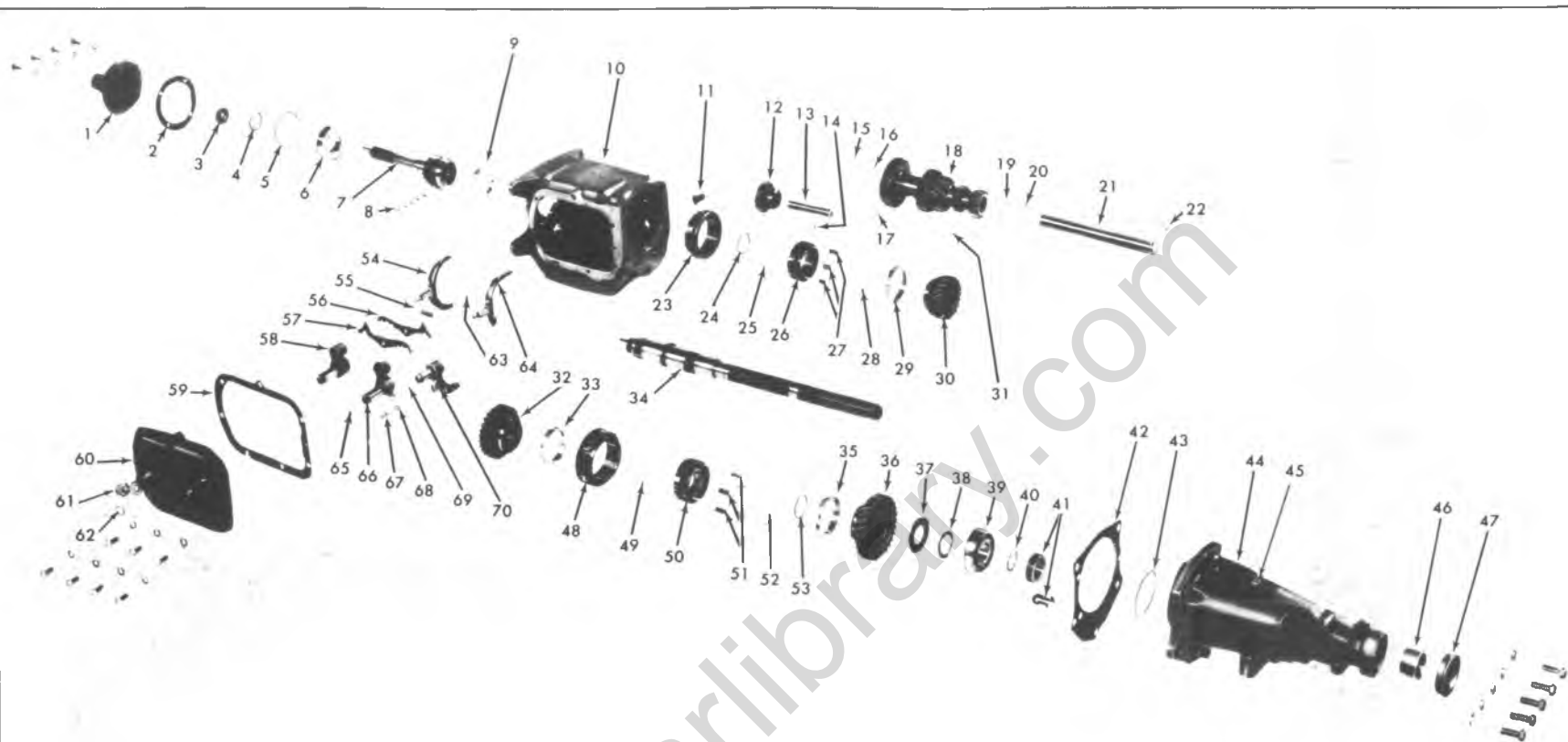

Fig. 7B-18J-4-Speed 76mm Transmission-Exploded View

- |                               |                              |                                |  |                                    |
|-------------------------------|------------------------------|--------------------------------|--|------------------------------------|
| 1. Bearing Retainer           | 15. Thrust Washer-Front Gear | 29. 3rd Speed Blocker Ring     | 42. Gasket-Extension to Case                 | 55. Detent Spring                  |
| 2. Gasket-Retainer to Case    | 16. Needle Retainer Washer   | 30. 3rd Speed Gear             | 43. Snap Ring-Extension to Rear Bearing      | 56. 3-4 Detent Cam                 |
| 3. Oil Seal                   | 17. Needle Bearings          | 31. Needle Bearings            | 44. Extension                                | 57. 1-2 Detent Cam                 |
| 4. Snap Ring-Bearing to Shaft | 18. Countergear              | 32. Second Speed Gear Ring     | 45. Vent                                     | 58. 3-4 Shifter Shaft              |
| 5. Snap Ring-Bearing to Case  | 19. Needle Retainer Washer   | 33. 2nd Speed Blocker Ring     | 46. Bushing                                  | 59. Gasket-Cover to Case           |
| 6. Drive Gear Bearing         | 20. Thrust Washer-Rear Gear  | 34. Mainshaft                  | 47. Oil Seal                                 | 60. Cover                          |
| 7. Drive Gear                 | 21. Countershaft             | 35. 1st Speed Blocker Ring     | 48. 1-2 Synchronizer Sleeve and Reverse Gear | 61. TCS Switch and Gasket          |
| 8. Mainshaft Pilot Bearings   | 22. Woodruff Key             | 36. First Speed Gear           | 49. Key Retainer                             | 62. Lipseal                        |
| 9. 4th Speed Blocker Ring     | 23. Synchronizer Sleeve      | 37. Thrust Washer              | 50. 1-2 Synchronizer Hub                     | 63. Detent Cam Retainer            |
| 10. Case                      | 24. Snap Ring-Hub to Shaft   | 38. Wave Washer                | 51. Clutch Keys                              | 64. 1-2 Shift Fork                 |
| 11. Filler Plug               | 25. Key Retainer             | 39. Rear Bearing               | 52. Key Retainer                             | 65. "O" Ring                       |
| 12. Reverse Idler Gear        | 26. 3-4 Synchronizer Hub     | 40. Snap Ring-Bearing to Shaft | 53. Snap Ring-Hub to Shaft                   | 66. 1-2 Shift Shaft                |
| 13. Reverse Idler Shaft       | 27. Clutch Keys              | 41. Speedo Drive Gear and Clip | 54. 3-4 Shift Fork                           | 67. Spring                         |
| 14. Woodruff Key              | 28. Key Retainer             |                                |  | 68. Ball                           |
|                               |                              |                                |  | 69. "O" Ring                       |
|                               |                              |                                |  | 70. Reverse Shifter Shaft and Fork |

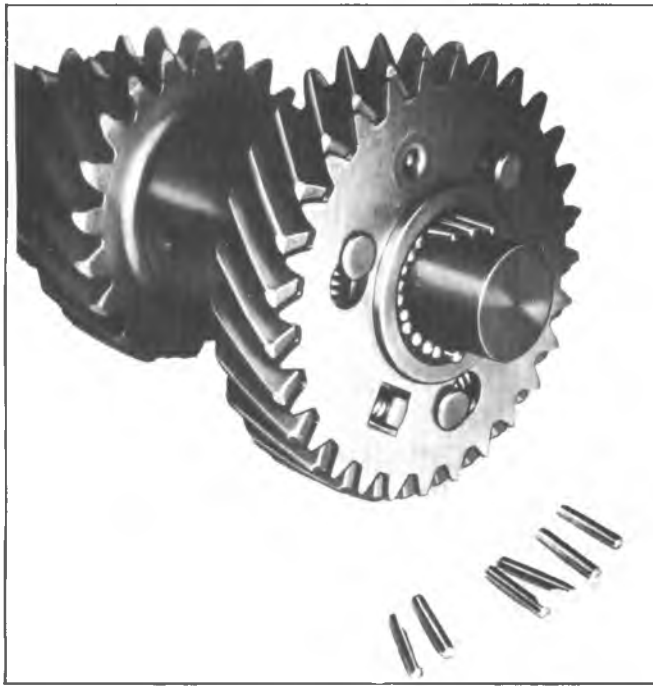

Fig. 7B-19J--Loading Countergear Bearing



Fig. 7B-20J--Loading Mainshaft Bearings

## 4-SPEED 83MM TRANSMISSION

### INDEX

Disassembly of Transmission .....	7B-25	Extension Oil Seal and/or Bushing Replacement ..	7B-29
Disassembly of Mainshaft .....	7B-28	Drive Gear Bearing Retainer Oil.....	7B-30
Cleaning and Inspection .....	7B-28	Reverse Shifter Shaft and/or Seal Replacement ...	7B-30
Transmission Case .....	7B-28	Reverse Idler Shaft Replacement.....	7B-31
Bearing Rollers and Spacers.....	7B-28	Transmission Side Cover .....	7B-32
Gears .....	7B-29	Assembly of Countergear .....	7B-32
Front and Rear Bearings.....	7B-29	Checking Countergear End Play.....	7B-32
Repairs.....	7B-29	Assembly of Mainshaft.....	7B-32
Clutch Keys and Springs Replacement .....	7B-29	Assembly of Transmission.....	7B-33

### DISASSEMBLY OF TRANSMISSION

Sectional and exploded view of the transmission are provided in Figures 7B-1K and 7B-2K to assist in the disassembly of the transmission.

1. Thoroughly clean the exterior of the transmission assembly.
2. Shift transmission into second gear, remove drain plug from lower right of case and drain lubricant from transmission.
3. Remove nine (9) shift cover attaching bolts, cover assembly and gasket. Remove both shift forks.
4. Remove four (4) drive gear bearing retainer bolts, retainer and gasket from front of transmission.
5. Remove lock pin from reverse shifter lever boss (Fig. 7B-3K) and pull shifter shaft partially out to disengage the reverse shifter fork from the reverse gear.
6. Remove five (5) rear extension attaching bolts, tap extension rearward with a soft hammer to start removal.

Slide extension rearward until reverse idler shaft is clear of reverse idler gears. Then rotate extension to the left to free shift fork from collar of reverse gear and remove the case extension. Remove and discard gasket.

7. Remove speedometer gear outer snap ring (Fig. 7B-4K). Tap or slide speedometer gear from mainshaft, then remove second snap ring.
8. Slide the reverse gear from the mainshaft (Fig. 7B-5K), and slide the rear portion of the reverse idler gear from the transmission case.
9. Remove four (4) front bearing retainer bolts, gasket, and front bearing retainer from case.
10. Remove front bearing snap ring selective fit snap ring and spacer washer.
11. Using Tool J-6654-01, remove front main drive gear bearing from transmission case (Fig. 7B-6K).
12. Remove the rear retainer lock bolt.

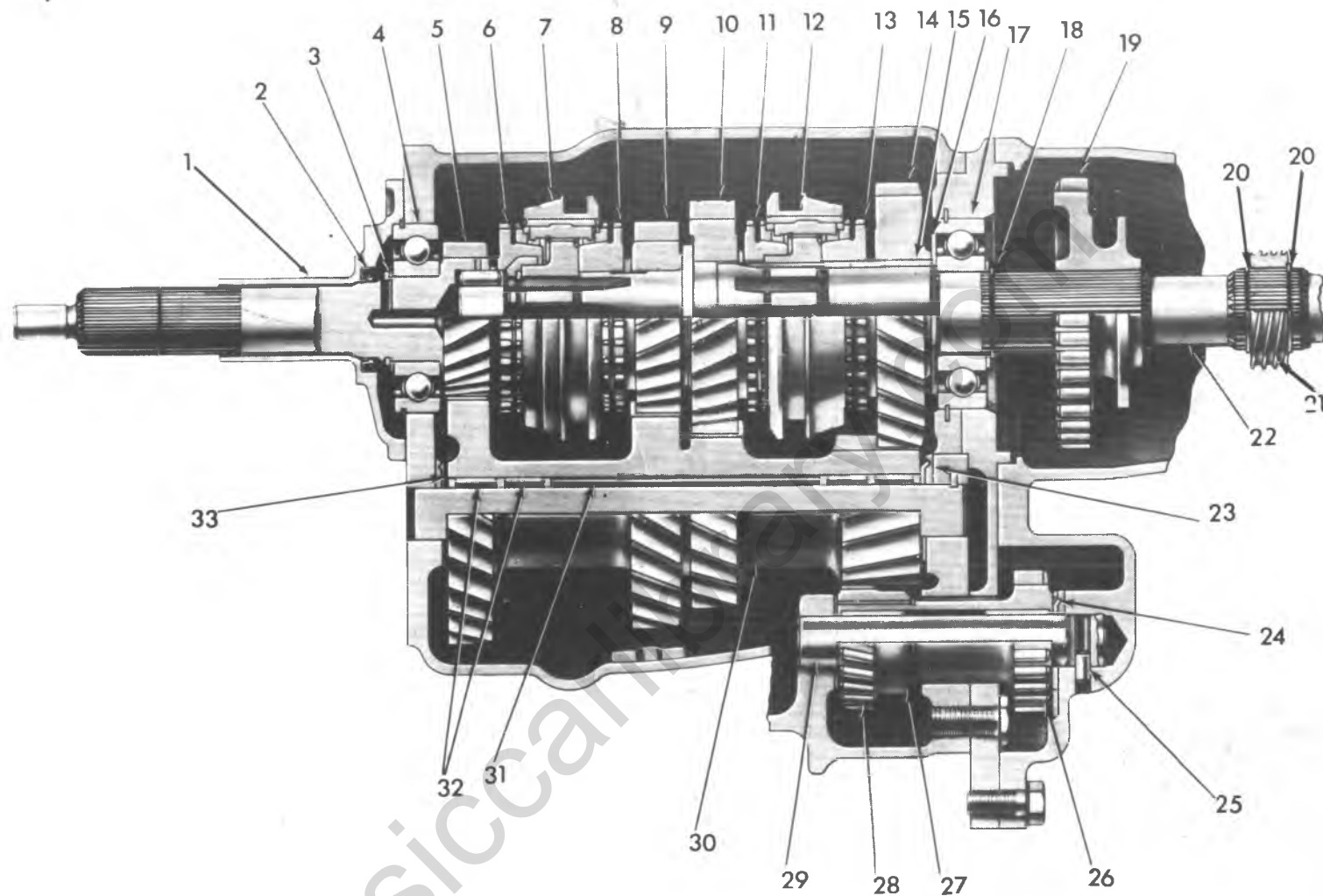
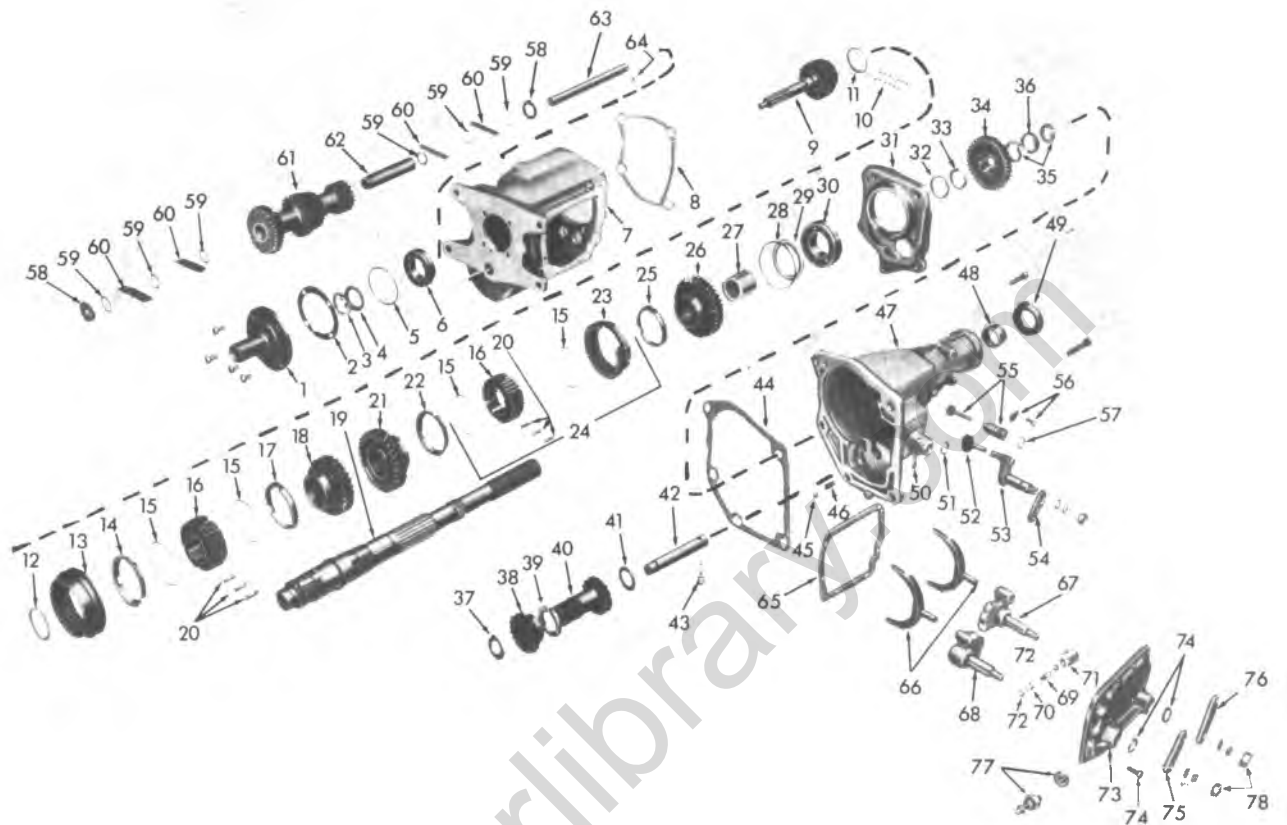

Fig. 7B-1K-Sectional View of 4-Speed 83mm Transmission

- |                                |                                 |                                |
|--------------------------------|---------------------------------|--------------------------------|
| 1 Clutch Gear Bearing Retainer | 12 1st & 2nd Speed Clutch Assy. | 23 Thrust Washer               |
| 2 Retainer Lip Seal            | 13 1st Speed Synochronizer Ring | 24 Thrust Washer               |
| 3 Snap Ring and Washer         | 14 1st Speed Gear               | 25 Idler Shaft Roll Pin        |
| 4 Clutch Gear Bearing          | 15 1st Speed Gear Bushing       | 26 Rear Idler Gear             |
| 5 Clutch Gear                  | 16 Spacer                       | 27 Spacer                      |
| 6 4th Speed Synchronizer Ring  | 17 Rear Main Bearing            | 28 Front Idler Gear            |
| 7 3rd & 4th Speed Clutch Assy. | 18 Snap Ring and Washer         | 29 Reverse Idler Shaft         |
| 8 3rd Speed Synchronizer Ring  | 19 Reverse Gear                 | 30 Countergear                 |
| 9 3rd Speed Gear               | 20 Snap Rings                   | 31 Countergear Sleeve          |
| 10 2nd Speed Gear              | 21 Speedometer Gear             | 32 Countergear Bearing Rollers |
| 11 2nd Speed Synchronizer Ring | 22 Mainshaft                    | 33 Thrust Washers              |





- |  |  |  |  |
|--|--|--|--|
| 1. Bearing Retainer                              | 23. First and Second Speed Clutch Sliding Sleeve | 44. Rear Bearing Retainer To Case Extension Gasket | 63. Countershaft   |
| 2. Gasket  | 24. First and Second Speed Clutch Assembly       | 45. Reverse Shifter Shaft Detent Ball              | 64. Countershaft Woodruff Key                                  |
| 3. Selective Fit Snap Ring                       | 25. First Speed Gear Synchronizing Ring          | 46. Reverse Shifter Shaft Ball Detent Spring       | 65. Gasket   |
| 4. Spacer Washer                                 | 26. First Speed Gear                             | 47. Case Extension                                 | 66. Forward Speed Shift Forks                                  |
| 5. Bearing Snap Ring                             | 27. First Speed Gear Sleeve                      | 48. Extension Bushing                              | 67. First and Second Speed Gear Shifter Shaft and Detent Plate |
| 6. Main Drive Gear Bearing                       | 28. Rear Bearing Snap Ring                       | 49. Rear Oil Seal                                  | 68. Third and Fourth Speed Gear Shifter Shaft and Detent Plate |
| 7. Transmission Case                             | 29. Thrust Washer                                | 50. Reverse Shifter Shaft Lock Pin                 | 69. Poppet Spring  |
| 8. Rear Bearing Retainer Gasket                  | 30. Rear Bearing                                 | 51. Reverse Shifter Shaft "O" Ring Seal            | 70. Interlock Pin  |
| 9. Main Drive Gear                               | 31. Rear Bearing Retainer                        | 52. Reverse Shift Fork                             | 71. Interlock Sleeve   |
| 10. Bearing Rollers (16)                         | 32. Washer                                       | 53. Reverse Shifter Shaft and Detent Plate         | 72. Detent Balls   |
| 11. Washer                                       | 33. Selective Fit Snap Ring                      | 54. Reverse Shifter Lever                          | 73. Transmission Side Cover                                    |
| 12. Snap Ring                                    | 34. Reverse Gear                                 | 55. Speedometer Driven Gear and Fitting            | 74. Lip Seals  |
| 13. Third and Fourth Speed Clutch Sliding Sleeve | 35. Snap Ring                                    | 56. Retainer and Bolt                              | 75. Third and Fourth Speed Shifter Lever                       |
| 14. Fourth Speed Gear Synchronizing Ring         | 36. Speedometer Drive Gear                       | 57. "O" Ring Seal                                  | 76. First and Second Speed Shifter Lever                       |
| 15. Clutch Key Spring                            | 37. Reverse Idler Front Thrust Washer (Flat)     | 58. Washer (Tanged)                                | 77. T.C.S. Switch and Gasket                                   |
| 16. Clutch Hub                                   | 38. Reverse Idler Gear (Front)                   | 59. Spacer (.050")                                 | 78. Lever Attaching Nuts                                       |
| 17. Third Speed Gear Synchronizing Ring          | 39. Snap Ring                                    | 60. Bearing Rollers (28)                           |  |
| 18. Third Speed Gear                             | 40. Reverse Idler Gear (Rear)                    | 61. Countergear                                    |  |
| 19. Mainshaft                                    | 41. Thrust Washer (Tanged)                       | 62. Countergear Roller Spacer                      |  |
| 20. Clutch Keys (3)                              | 42. Reverse Idler Shaft                          |  |  |
| 21. Second Speed Gear                            | 43. Reverse Idler Shaft Lock Pin and Welch Plug  |  |  |
| 22. Second Speed Gear Synchronizing Ring         |  |  |  |

Fig. 7B-2K—Exploded View of 4-Speed 83mm Transmission

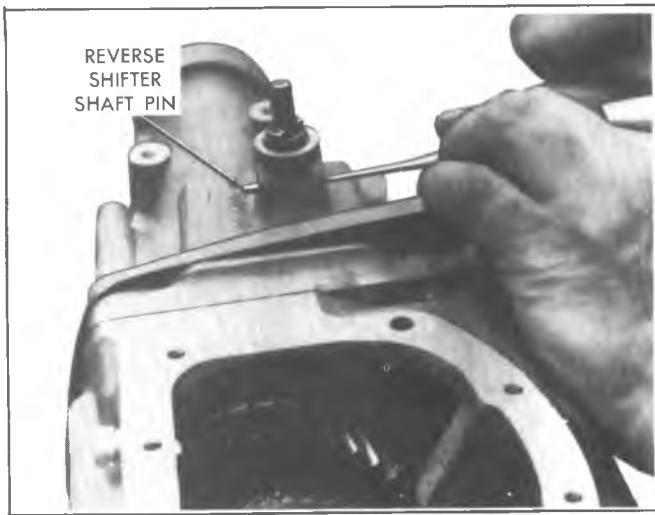

Fig. 7B-3K-Removing Reverse Shifter Shaft Lock Pin

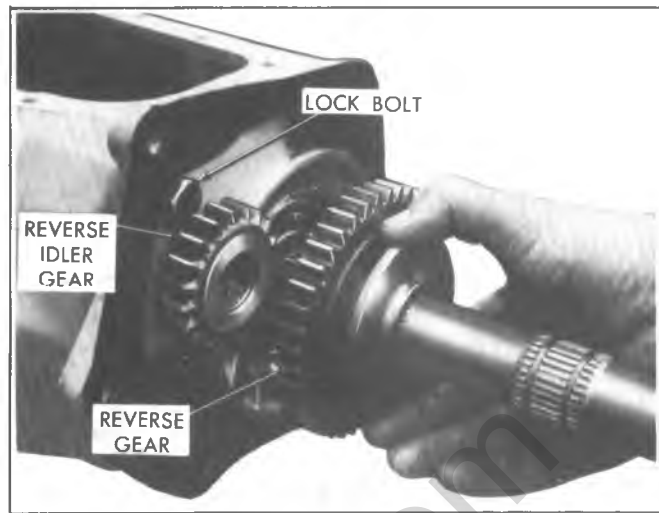

Fig. 7B-5K-Removing Reverse Gear

13. Shift first-second and third-fourth clutch sliding sleeves forward to permit adequate clearance for mainshaft removal. Remove mainshaft and rear bearing retainer assembly from the transmission case.

14. Remove front reverse idler gear and thrust washer from case. Gear teeth face toward front of transmission.

15. Using a dummy shaft J-24658 drive countergear shaft out of countergear (Fig. 7B-7K) and remove countergear and tanged thrust washers from case. Check bottom of case for pilot bearings or other loose components.

**DISASSEMBLY OF MAINSHAFT (Fig. 7B-8K)**

1. Using snap ring pliers, remove 3-4 clutch assembly retaining ring at front of mainshaft (Fig. 7B-9K). Slide washer, synchronizer and clutch assembly, synchronizer ring 3rd speed gear from mainshaft.

2. Spread rear bearing retainer snap ring (Fig. 7B-10K) and slide retainer from mainshaft.

3. Remove rear bearing-to-mainshaft snap ring (Fig. 7B-11K).

4. Support mainshaft under 2nd gear and press mainshaft from rear bearing, 1st gear and sleeve, 1-2 clutch

and synchronizer assembly, and the second gear (Fig. 7B-12K).

**CLEANING AND INSPECTION**

**Transmission Case**

1. Wash the transmission thoroughly inside and outside with cleaning solvent, then inspect the case for cracks.

2. Check the front and rear faces for burrs, and if present, dress them off with a fine mill file.

3. Make sure bearings are clean, then lubricate with light engine oil and check them for roughness by slowly turning the race by hand.

**Roller Bearings and Spacers**

All main drive gear and countergear bearing rollers should be inspected closely and replaced if they show wear. Inspect countershaft and reverse idler shaft at the same time, replace if necessary. Replace all worn spacers.

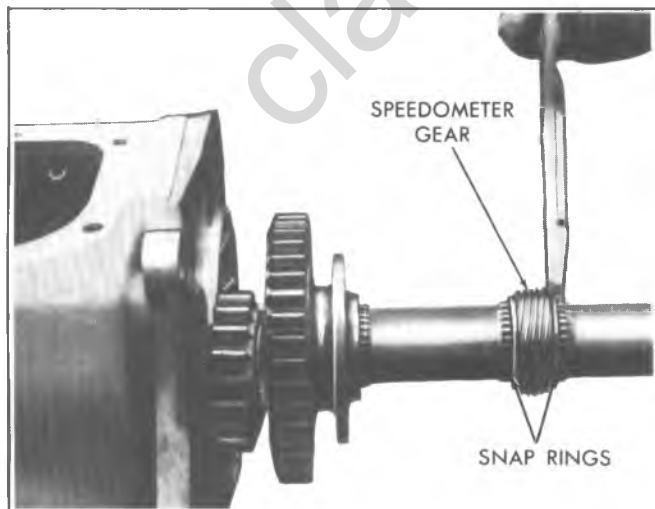

Fig. 7B-4K-Speedometer Gear and Retaining Rings

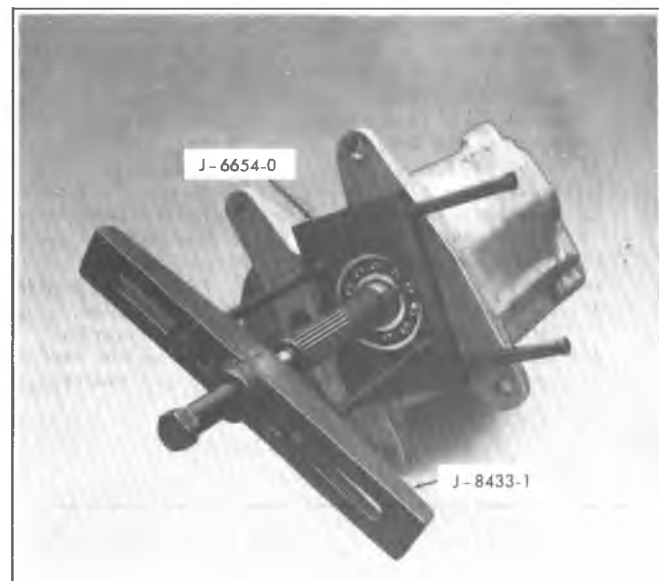

Fig. 7B-6K-Removing Main Drive Gear Bearing

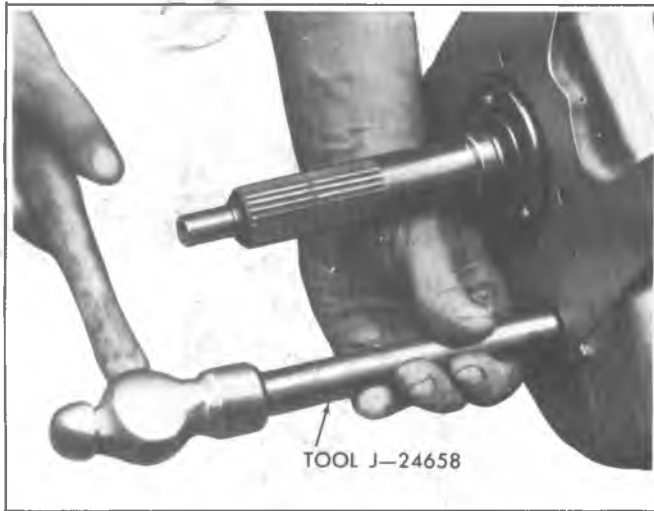

Fig. 7B-7K—Removing Countergear Shaft

**Gears**

1. Inspect all gears for excessive wear, chips or cracks and replace any that are worn or damaged.
2. Inspect reverse gear bushing and if worn or damaged replace the entire gear (reverse gear bushing is not serviced separately).
3. Check both clutch sleeves to see that they slide freely on their hubs.

**Front and Rear Bearings**

1. Wash the front and rear ball bearings thoroughly in a cleaning solvent.

2. Blow out bearings with compressed air.

**NOTICE:** Do not allow the bearings to spin. Turn them slowly by hand. Spinning bearings may damage the race and balls.

**REPAIRS**

**Synchronizer Keys and Springs**

**Replacement**

The synchronizer hubs and sliding sleeves are a selected assembly and should be kept together as originally assembled, but the keys and two springs may be replaced if worn or broken.

1. If relation of hub and sleeve are not already marked, mark for assembly purposes.
2. Push the hub from the sliding sleeve; the keys will fall free and the springs may be easily removed.
3. Place the two springs in position (one on each side of hub), so all three keys are engaged by both springs (Fig. 7B-13K).

Place the keys in position and while holding them in place, slide the sleeve onto the hub, aligning the marks made before disassembly.

**Extension Oil Seal and/or**

**Bushing Replacement**

1. Pry seal from rear of extension.
2. Remove bushing using Tool J-21465-17 with Handle J-8092. Drive bushing from rear of extension housing (Fig. 7B-14K).
3. Using a new bushing and Tool J-21465-17 with Handle J-8092, press bushing into extension from rear of extension.

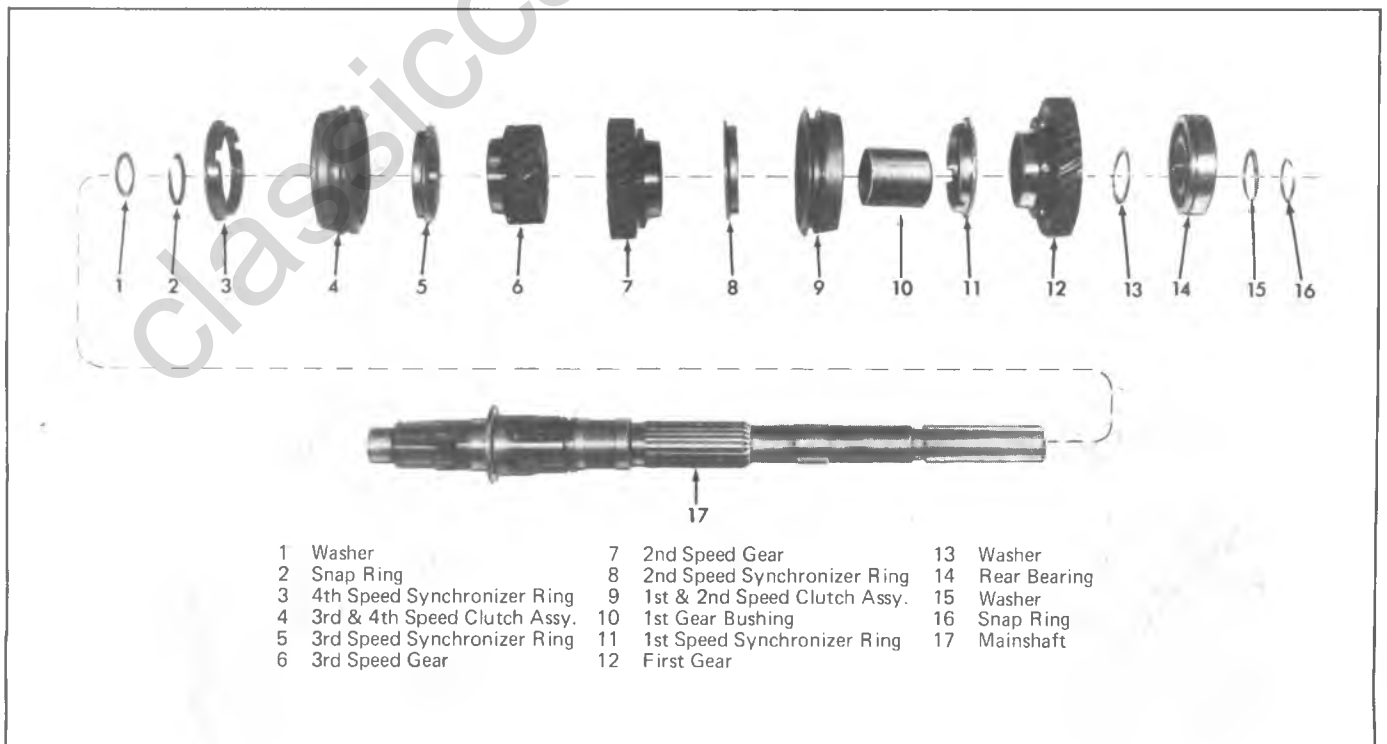

Fig. 7B-8K—Mainshaft Assembly Components



Fig. 7B-9K—Removing 3-4 Clutch Assembly Retainer

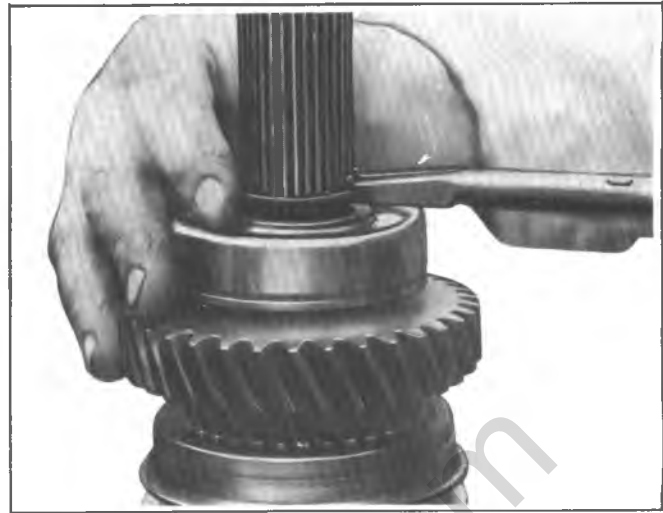

Fig. 7B-11K—Removing Rear Bearing Snap Ring

4. Coat I.D. of bushing and seal with transmission lubricant. Install new seal using Tool J-21359 (Fig. 7B-15K).

**Drive Gear Bearing Retainer Oil**

**Seal Replacement**

1. Pry out old seal.
2. Using a new seal, install new seal into retainer using Tool J-21359 until it bottoms in bore (Fig. 7B-16K). Lubricate I.D. of seal with transmission lubricant.

**Reverse Shifter Shaft and/or**

**Seal Replacement**

1. With case extension removed from transmission the reverse shifter shaft lock pin will already be removed. (see Step 5 under Transmission Disassembly).
2. Remove shift fork.
3. Carefully drive shifter shaft into case extension, allowing ball detent to drop into case. Remove shaft and ball detent spring. Remove "O" ring seal from shaft.

4. Place ball detent spring into detent spring hole and start reverse shifter shaft into hole in boss.

5. Place detent ball on spring and while holding ball down, push the shifter shaft into place and turn until the ball drops into place in detent on the shaft detent plate.

6. Install "O" ring seal on shaft.

7. Install shift fork. Do not drive the shifter shaft lock pin into place until the extension has been installed on the transmission case.

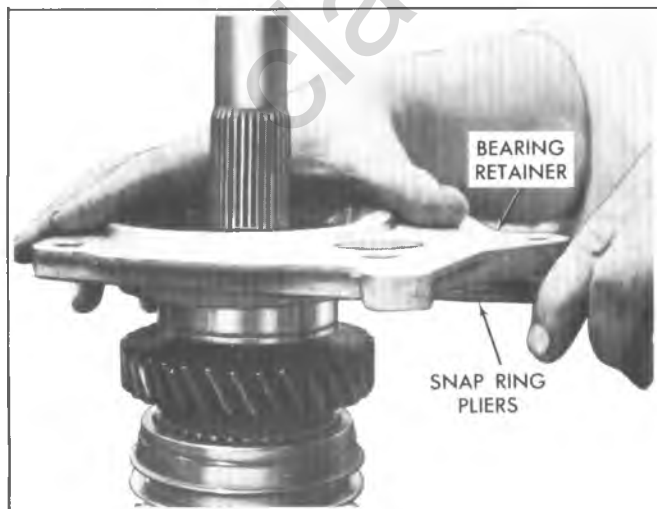

Fig. 7B-10K—Removing Rear Bearing Retainer

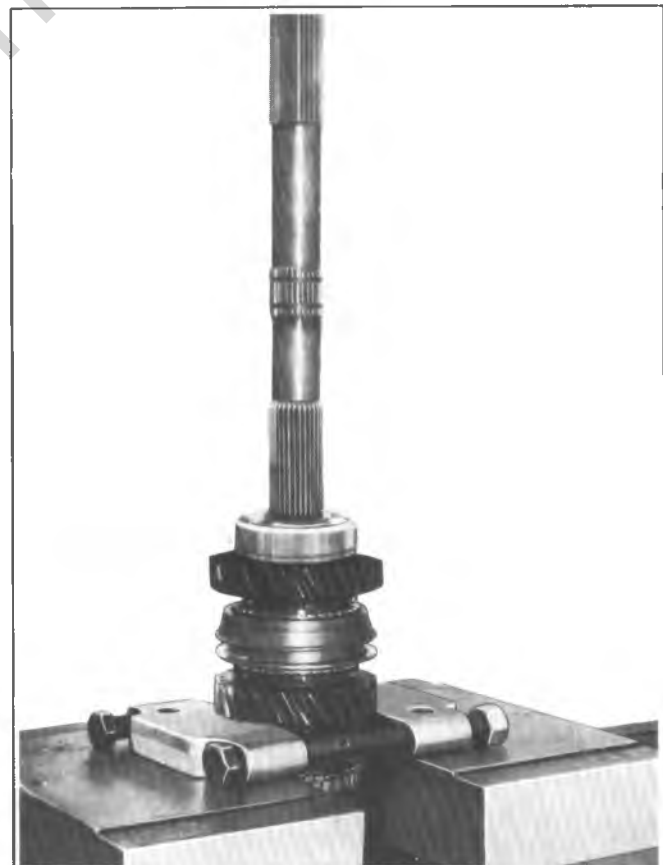

Fig. 7B-12K—Pressing Rear Bearing From Mainshaft

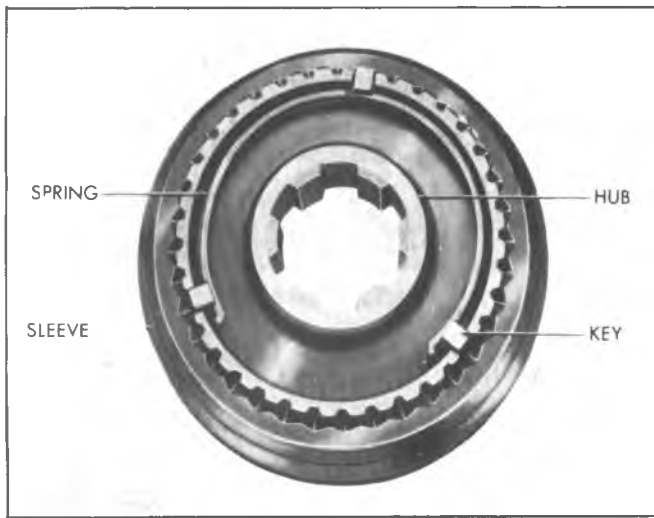

Fig. 7B-13K-Synchronizer Assembly

**Reverse Idler Shaft**

**Replacement**

1. Place a small punch into hole in extension's reverse idler shaft boss and drive the welch plug and pin into the shaft (Fig. 7B-17K) until the shaft can be pulled from rear extension.
2. Insert new idler shaft into extension until hole in shaft lines up with hole in boss.

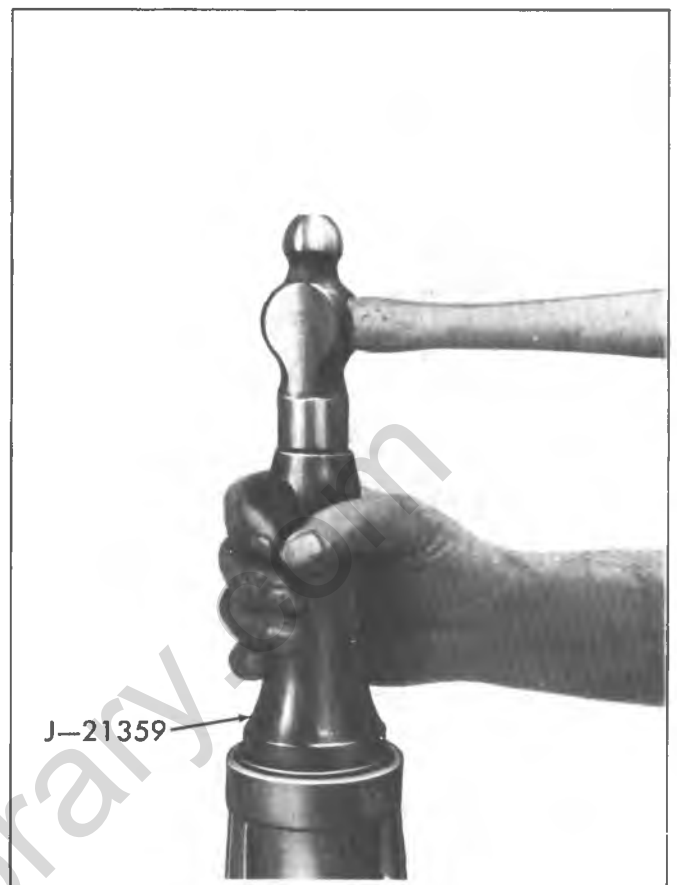

Fig. 7B-15K-Installing Rear Extension Seal

3. Insert roller pin in transmission boss opening and drive the pin into the extension until the shaft is securely locked in place. Install new welch plug, with sealer, in boss opening.



Fig. 7B-14K-Removing Rear Extension Bushing

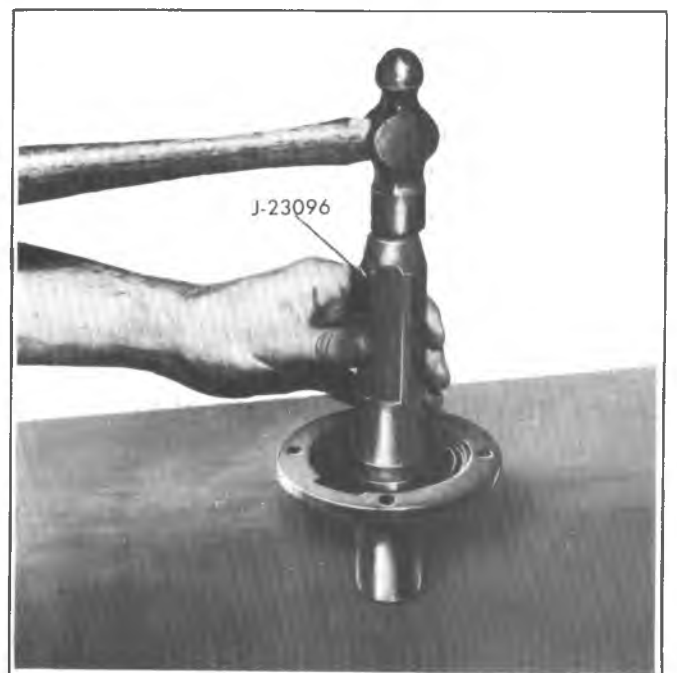

Fig. 7B-16K-Installing Drive Gear Bearing Retainer Seal

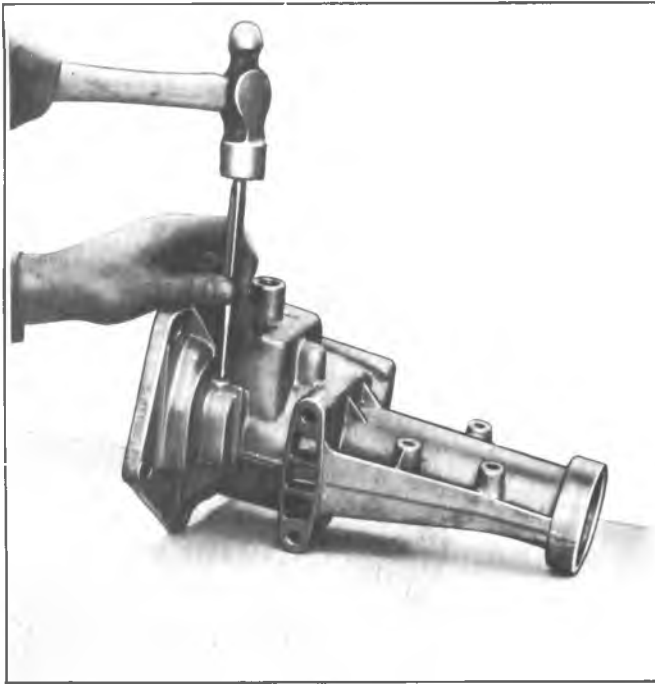

Fig. 7B-17K—Removing Reverse Idler Shaft Roll Pin

### Transmission Side Cover

Although service of the side cover is covered here, the transmission does not have to be removed to perform these operations. To remove the side cover on-the-vehicle, simply drain the transmission, disconnect the 1st/2nd cross shaft and 3rd/4th linkage and remove the attaching bolts.

1. Remove the outer shifter lever nuts and lockwasher and pull levers from shafts.
2. Carefully push the shifter shafts into cover, allowing the detent balls to fall free, then remove both shifter shafts.
3. Remove interlock sleeve, interlock pin and poppet spring.
4. Replace necessary parts (Fig. 7B-18K) and assembly by reversing Steps 1-3.

### ASSEMBLY OF COUNTERGEAR

1. Install roller spacer in counter gear (if removed).
2. Using heavy grease to retain rollers, install spacer, rollers, spacer, rollers, and spacer in either end of counter gear. Repeat in other end of counter gear (Fig. 7B-19K).
3. Insert a dummy shaft or loading Tool J-24658 into counter gear.

### CHECKING COUNTERGEAR END PLAY

1. Rest the transmission case on its side with the side cover opening toward the assembler. Put counter gear tanged thrust washers in place, retaining them with heavy grease, making sure the tangs are resting in the notches of the case.
2. Set counter gear in place in bottom of transmission case, making sure that tanged thrust washers are not knocked out of place.
3. Position the transmission case resting on its front face.

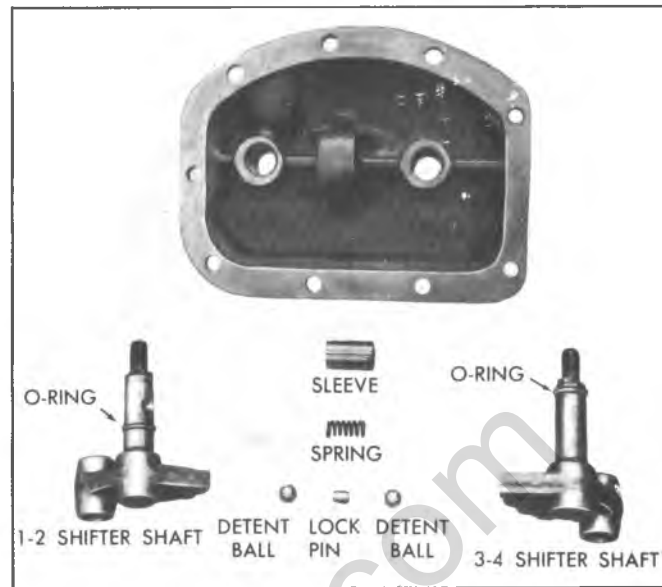

Fig. 7B-18K—Shift Cover Assembly

4. Lubricate and insert counter gear (pushing loading Tool J-24658 out front of case) until woodruff key slot is in its relative installed position (do not install key).

5. Attach a dial indicator as shown in Fig. 7B-20K and check end play of the counter gear. If end play is greater than .025", a new thrust washers must be installed.

### ASSEMBLY OF MAINSHAFT

1. From rear of mainshaft, assemble the 2nd speed gear (with hub of gear toward rear of shaft).
2. Install 1st-2nd synchronizer clutch assembly (sliding clutch sleeve taper toward rear, hub to front) on the mainshaft together with a synchronizer ring on both sides of the clutch assemblies.
3. Position the 1st gear sleeve on the shaft and press the sleeve onto the mainshaft until the 2nd gear, clutch assembly and sleeve bottom against the shoulder of the mainshaft (Fig. 7B-21K).

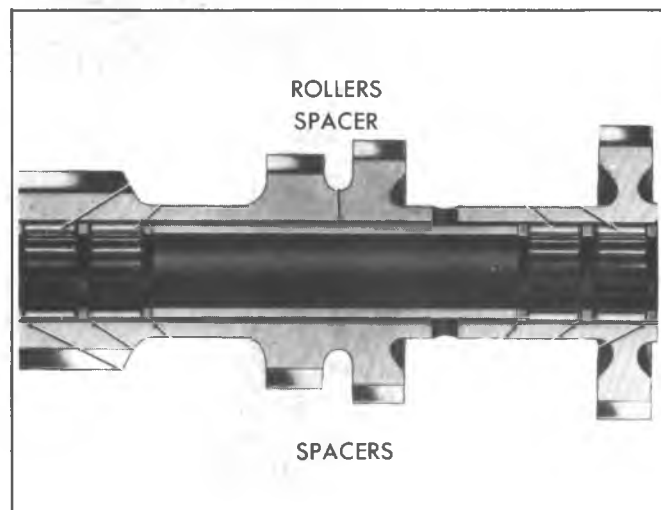

Fig. 7B-19K—Counter gear Cross Section



Fig. 7B-20K--Checking Countergear End Play

4. Install 1st speed gear (with hub toward front) and supporting inner race, press the rear bearing onto the mainshaft with the snap ring groove toward front of the transmission (Fig. 7B-22K).

5. Install spacer and new correct selective fit (thickest that will assemble) snap ring in mainshaft behind rear bearing.

6. Install the 3rd speed gear (hub to front of transmission) and the 3rd speed gear synchronizing ring (notches to front of transmission).

7. Install the 3rd and 4th speed gear clutch assembly (hub and sliding sleeve) with taper toward the front making sure that the keys in the hub correspond to the notches in the 3rd speed gear synchronizing ring.

8. Install new selective fit snap ring (thickest that will install) in the groove in mainshaft in front of the 3rd and 4th speed clutch assembly.

9. Install the rear bearing retainer over end of mainshaft. Spread the snap ring to drop around the rear

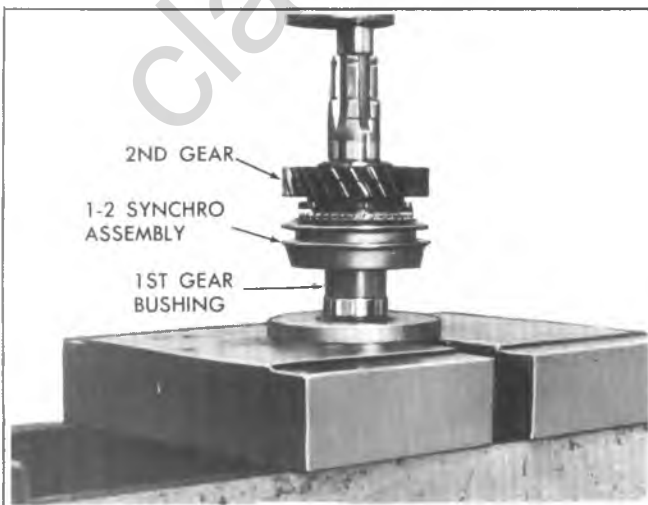

Fig. 7B-21K--Installing 1st Gear Sleeve

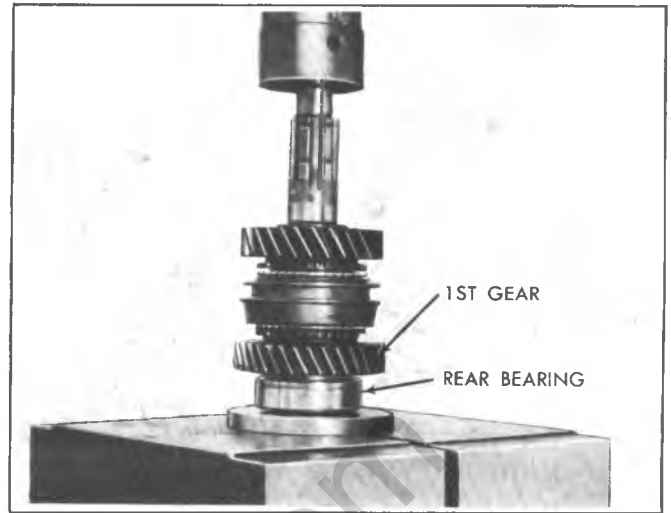

Fig. 7B-22K--Installing Rear Bearing

bearing. Release snap ring when it aligns with groove in rear bearing.

10. Install the reverse gear (shift collar to rear).

11. Install a snap ring, the speedometer drive gear and a second snap ring, onto the mainshaft.

### ASSEMBLY OF TRANSMISSION

1. Place the transmission case on its side with the shift cover opening toward the assembler. Position the countergear tanged washers in place, using a heavy grease to retain them.

**NOTICE:** Be sure the tangs are in the notches of the thrust face.

2. Install the countergear in the case, aligning the bore of the countergear with the case opening. With the thrust washers in place, slide the loading tool to the front of the case and install the countergear shaft from the rear of the case. Install the woodruff key and tap shaft into gear until shaft is flush with rear face of transmission case.

3. Install front reverse idler gear (teeth forward) and thrust washer in case. Use a heavy grease to hold thrust washer in position.

4. Using a heavy grease install sixteen (16) roller bearings and washer into main drive gear. Mate main drive gear with mainshaft assembly. Position 3rd-4th clutch sliding sleeve forward. This will provide clearance for installation as well as hold the assembly together.

5. Position new rear bearing retainer to case extension gasket on rear of case. Install mainshaft and drive gear assembly into case.

6. Align rear bearing retainer with transmission case. Install retainer to case locating pin and retainer locking bolt. Torque to recommended specifications.

7. Place bearing snap ring on front main bearing. Position front main bearing to case opening and with a hollow shaft, or tool J-5590, tap bearing into case (Fig. 7B-23K). Install spacer washer and selective fit snap ring to secure main drive bearing.

8. Install front bearing retainer and gasket. Apply sealer to bolts and torque to recommended specification.

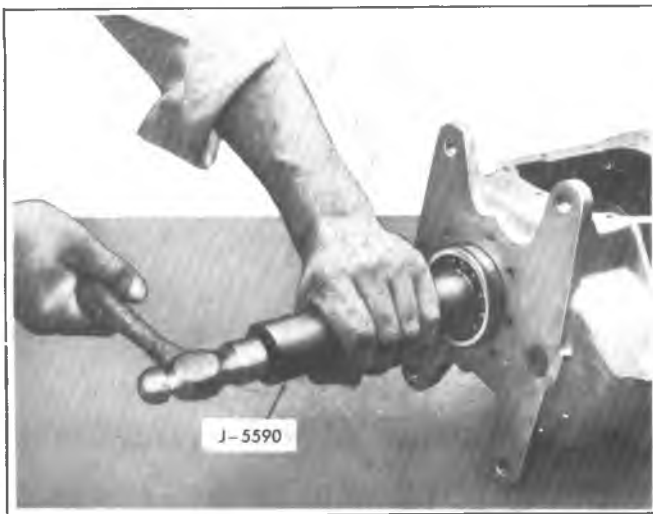

Fig. 7B-23K—Installing Front Main Bearing

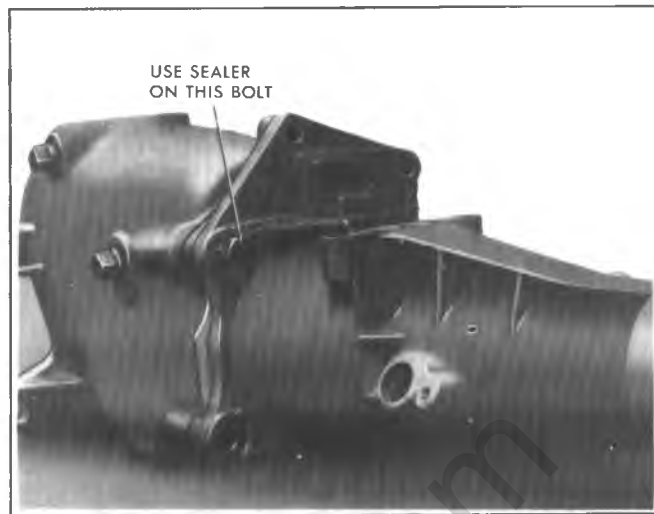

Fig. 7B-24K—Extension Bolt

9. Install rear reverse idler gear engaging the splines with the portion of the gear within the case.

10. Place new rear bearing retainer to case extension gasket into position on rear face of bearing retainer. Slide reverse gear on shaft. Install speedometer gear and two selective fit snap rings.

11. Install idler shaft into extension until hole in shaft lines up with hole in boss. Insert reverse idler shaft lock pin in transmission boss opening and drive the pin into the extension until the shaft is securely locked in place. Install new welch plug, with sealer, in boss opening.

12. Install reverse shifter shaft and detent plate into extension. Locate reverse shift fork in reverse shifter shaft. Use a heavy grease to hold reverse shift fork in position.

Be sure reverse shifter shaft "O" ring is placed on reverse shifter shaft after the shaft has been installed in the extension housing.

13. Install tanged thrust washer on reverse idler shaft with tang of washer in notch of idler thrust face of extension.

14. Place the 1st-2nd speed and 3rd-4th speed clutch sliding sleeve in neutral position. Pull reverse shift shaft partially out of extension and reverse shift fork as far

forward in as possible. Start the extension onto the mainshaft while pushing in on the shifter shaft to engage the shift fork with the reverse gear shift collar. When the fork engages, rotate the shifter shaft to move the reverse gear rearward permitting the extension to mate against the transmission case.

15. Install reverse shifter shaft lock pin.

16. Install rear extension housing-to-case bolts. Install rear extension to rear bearing retainer bolts (short bolts). Torque all bolts to recommended specification.

**NOTICE:** It is essential that sealer be used on the extension bolt as indicated in Fig. 7B-24K.

17. Position 1st-2nd speed clutch sliding sleeve into 2nd gear and 3rd-4th speed clutch sliding sleeve into neutral. Position forward shift forks in sliding sleeves.

18. Position 1st-2nd speed gear shifter shaft and detent plate into 2nd gear position and using a sealer, install cover gasket and side cover assembly to transmission.

19. Check operation of transmission.



## 4-SPEED 89MM TRANSMISSION

### CONTENTS

Disassembly of Transmission .....	7B-35	Clutch Keys and Springs Replacement .....	7B-40
Disassembly of Mainshaft .....	7B-38	Extension Oil Seal and/or Bushing Replacement ....	7B-41
Cleaning and Inspection .....	7B-40	Drive Gear Bearing Retainer Oil .....	7B-41
Transmission Case .....	7B-40	Transmission Side Cover .....	7B-41
Bearing Rollers and Spacers .....	7B-40	Assembly of Countergear .....	7B-42
Gears .....	7B-40	Assembly of Drive Gear .....	7B-42
Front and Rear Bearings .....	7B-40	Assembly of Mainshaft .....	7B-42
Repairs .....	7B-40	Assembly of Transmission .....	7B-42

### DISASSEMBLY OF TRANSMISSION

1. Thoroughly clean the exterior of the transmission assembly.
2. Remove drain plug and drain lubricant from transmission.
3. Shift transmission into neutral position. Remove reverse shift lever, side cover bolts, side cover and shift forks. Refer to Fig. 1R. Remove reverse detent spring and ball from base in side of case.
4. Remove extension housing bolts and rotate the extension on the output shaft to expose the rear of the countershaft. Clearance has been provided on the extension flange to enable one bolt to be reinstalled to hold the extension in the inverted position to gain access for the countershaft removal. Refer to Fig. 3R.
5. With a centerpunch or drill, make a hole the countershaft expansion plug at the front of the case.
6. Using this hole, push the countershaft rearward until the woodruff key is exposed. Remove key and push the countershaft forward against the expansion plug. Using a brass drift, tap the countershaft forward until the plug is driven out of the case.
7. Using tool J-29793 at the front of the countershaft, drive the shaft out the rear of the case. Tool J-29793 will now hold the roller bearings in position within the gear bore. Lower countershaft gear to bottom of case.
8. Rotate the extension housing back to its normal position.
9. Remove drive gear bearing retainer bolts and slide retainer and gasket off the gear assembly.
10. Using a brass drift, tap the gear and bearing assembly forward and remove through front of case. Replacement of the drive gear or bearing require no further disassembly of the transmission. Replace the failed part and reassemble the transmission.
11. Slide third and overdrive (O/D) synchronizer sleeve slightly forward, slide reverse idler gear to center of its shaft, then using a soft faced hammer, tap on extension housing in a rearward direction. Slide housing and mainshaft assembly out and away from case. Refer to Fig. 4R.

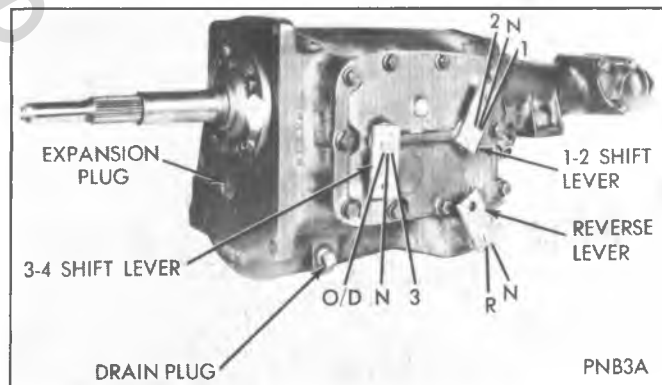

Fig. 1R--Transmission Shift Levers

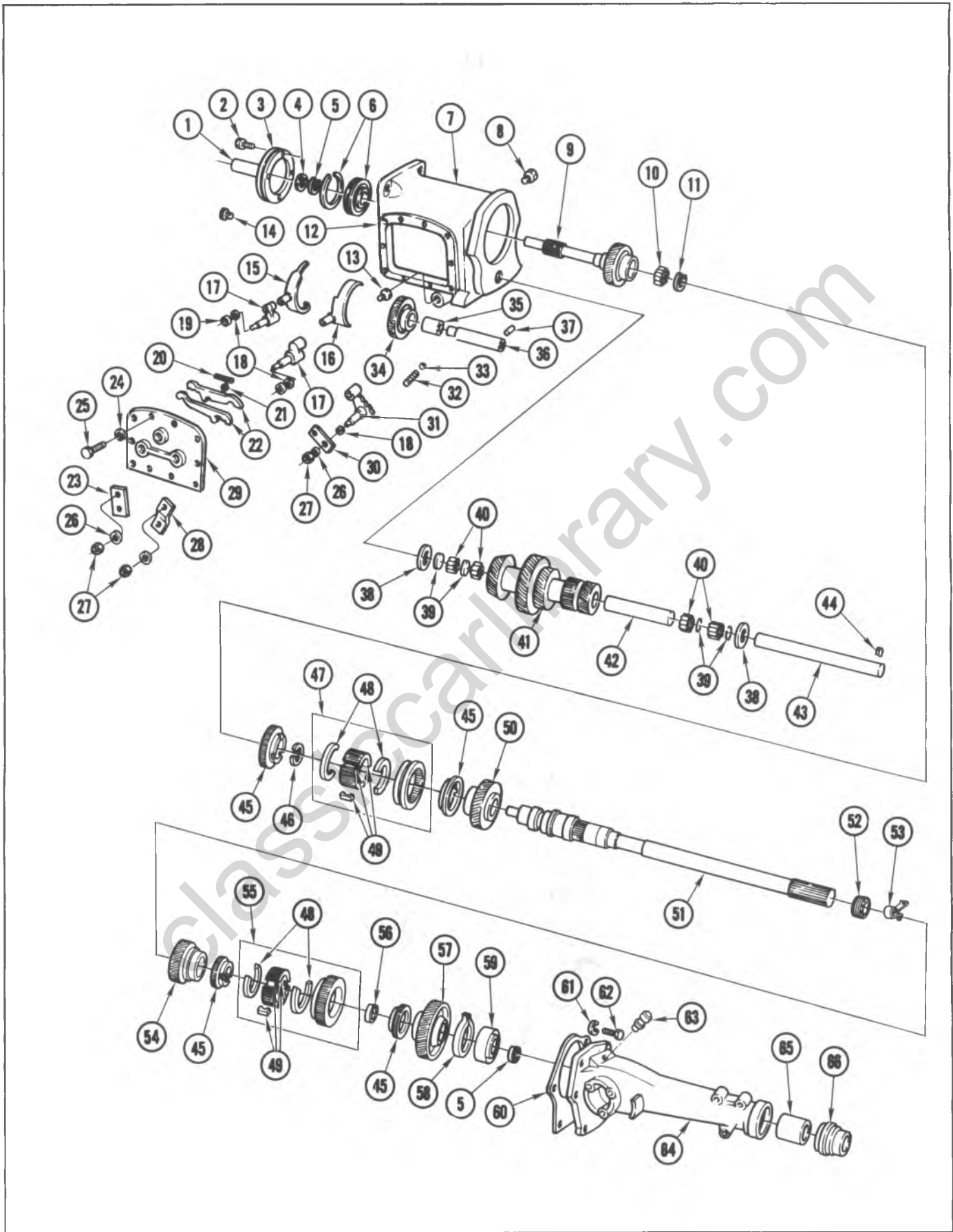

Fig. 2R--Exploded View 89mm 4-Speed

- |   |   |
|---|---|
| 1. RETAINER, CLUTCH GEAR BEARING            | 34. GEAR, REVERSE IDLER                 |
| 2. BOLT                                     | 35. BUSHING, REVERSE IDLER GEAR         |
| 3. GASKET, CLUTCH GEAR BEARING RETAINER     | 36. SHAFT, REVERSE IDLER                |
| 4. SEAL, CLUTCH GEAR BEARING OIL            | 37. KEY, REVERSE IDLER SHAFT            |
| 5. RING, MAIN DRIVE GEAR SNAP               | 38. WASHER, CLUTCH COUNTER GEAR THRUST  |
| 6. BEARING, W/SNAP RING, MAIN DRIVE GEAR    | 39. SPACER, CLUTCH COUNTER GEAR BEARING |
| 7. CASE, TRANS                              | 40. BEARING, COUNTER GEAR ROLLERS       |
| 8. PLUG, SQ HD, FILLER                      | 41. GEAR, COUNTER                       |
| 9. GEAR, CLUTCH                             | 42. SPACER, CLUTCH COUNTER GEAR BEARING |
| 10. BEARING, MAINSHAFT ROLLERS              | 43. SHAFT, COUNTER GEAR                 |
| 11. RING, PILOT BEARING SNAP                | 44. KEY, COUNTER GEAR                   |
| 12. GASKET, CONTROL LEVER HOUSING           | 45. RING, SYN BLOCKING                  |
| 13. PLUG, DRAIN                             | 46. RING, SYN 3RD & 4TH SNAP            |
| 14. PLUG, EXPANSION                         | 47. SYNCHRONIZER ASM, TRANS 3RD & 4TH   |
| 15. FORK, SHIFT 3RD & 4TH                   | 48. SPRING, FORWARD CLUTCH KEY          |
| 16. FORK, SHIFT 1ST & 2ND                   | 49. KEY, FORWARD SYN CLUTCH             |
| 17. SHAFT, FORWARD SHIFT                    | 50. GEAR, 4TH SPEED                     |
| 18. RING, "O" SHIFT SHAFT SEAL              | 51. SHAFT, MAIN                         |
| 19. RETAINER, SHIFT SHAFT SEAL              | 52. GEAR, SPEEDO DRIVE                  |
| 20. SPRING, DETENT                          | 53. CLIP, SPEEDO DRIVE GEAR             |
| 21. RING, "E"                               | 54. GEAR, 2ND SPEED                     |
| 22. CAM, DETENT                             | 55. SYNCHRONIZER ASM, TRANS 1ST & 2ND   |
| 23. LEVER, CONTROL SHIFT 3RD & 4TH          | 56. RING, SYN CLUTCH GEAR SNAP          |
| 24. WASHER, LK                              | 57. GEAR, 1ST SPEED                     |
| 25. BOLT                                    | 58. RING, MAIN SHAFT BEARING OUTER SNAP |
| 26. WASHER, FLAT                            | 59. BEARING, CLUTCH GEAR                |
| 27. NUT                                     | 60. GASKET, EXTENSION                   |
| 28. LEVER, CONTROL SHIFT 1ST & 2ND          | 61. WASHER, LK                          |
| 29. COVER, TRANS                            | 62. SCREW                               |
| 30. LEVER, REVERSE SHIFT                    | 63. VENTILATOR, EXTENSION               |
| 31. SHAFT, REVERSE SHIFT                    | 64. EXTENSION, TRANS                    |
| 32. SPRING, REVERSE SHIFT SHAFT DETENT BALL | 65. BUSHING, TRANS EXTENSION            |
| 33. BALL, STEEL                             | 66. SEAL, EXTENSION OIL                 |

Fig. 2Ra--89mm Identification

12. Remove countershaft gear from bottom of case. Refer to Fig. 5R.
13. Remove the reverse idler gear shaft from transmission case.  
To remove the shaft, use a  $3/8"$  x  $3-1/2"$  bolt with a free spinning nut and a  $7/16"$  deep socket  $3/8$  inch drive. Place the bolt and socket in the case with the socket against the shaft and the head of the bolt against the case. Holding the head of the bolt, turn nut against the socket pushing shaft through its bore. Remove gear from shaft and remove shaft with woodruff key from transmission case. Refer to Fig. 6R.
14. Remove reverse gear shift lever shaft from case by pushing shaft inward and remove it from the case. Remove "O" ring and retainer from case bore.

15. Remove backup light switch from case.

### DISASSEMBLY OF MAINSHAFT

Refer to Fig. 7R for locations of various gears, synchronizer sleeves and clutches before disassembling mainshaft.

1. Remove snap ring that retains 3rd and O/D synchronizer clutch gear and sleeve assembly. Then slide 3rd and O/D synchronizer assembly off end of mainshaft. Refer to Fig. 8R.
2. Slide O/D gear and stop ring off mainshaft. Mark and separate synchronizer parts for cleaning and inspection.
3. Using long nose pliers, spread snap ring that retains mainshaft ball bearing in extension housing, then pull

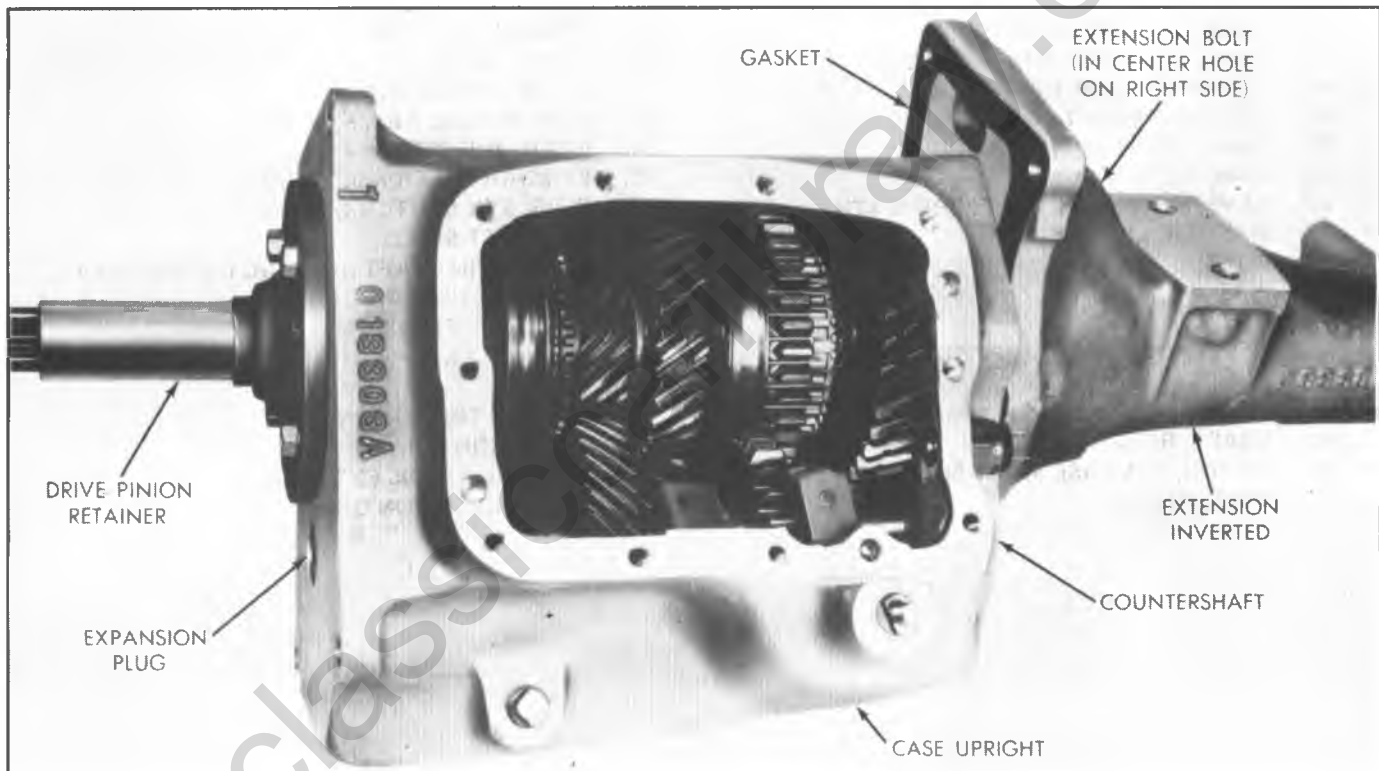

Fig. 3R--Rotating Extension Housing

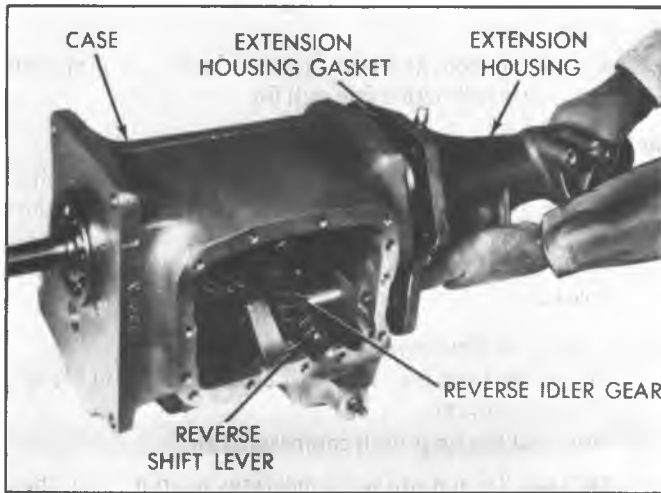

Fig. 4R--Remove or Install Extension Housing and Mainshaft Assembly

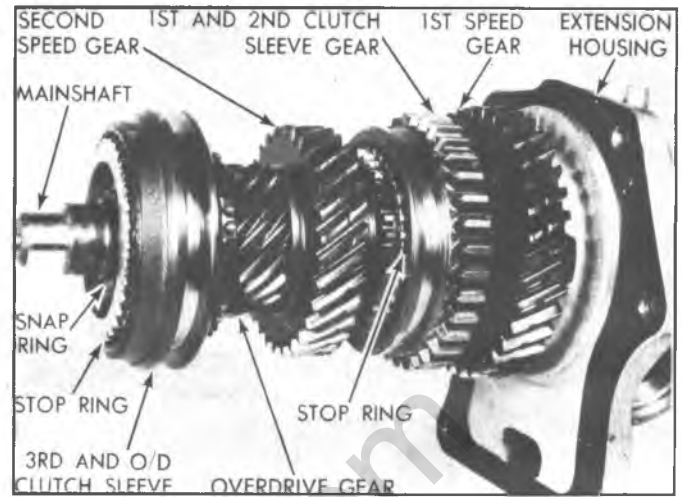

Fig. 7R--Mainshaft Gear Identification

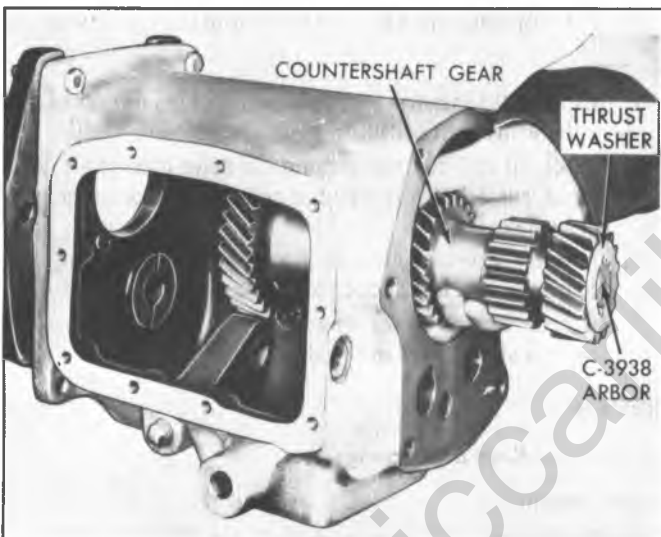

Fig. 5R--Remove or Install Countershaft Gear and Arbor Assembly

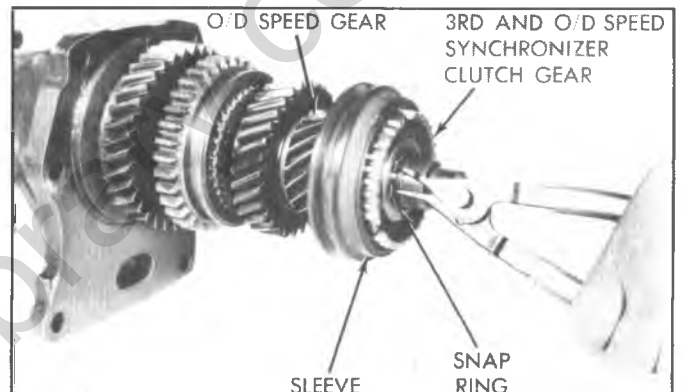

Fig. 8R--Disassembling Mainshaft

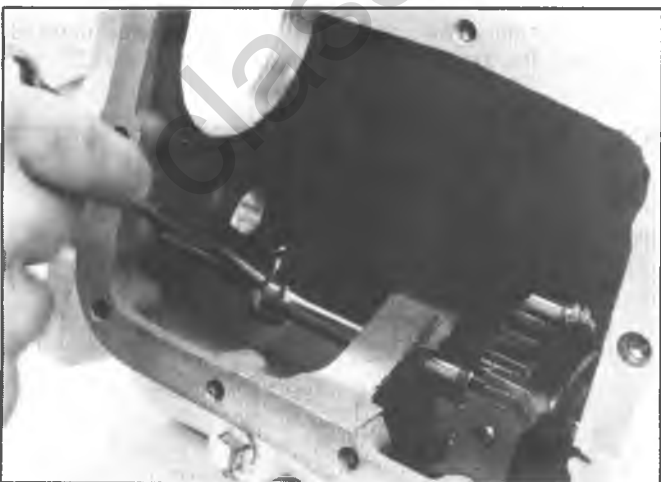

Fig. 6R--Reverse Idler Shaft Removal  
mainshaft assembly out of the extension housing. Refer to Fig. 9R.



Fig. 9R--Remove or Install Mainshaft Bearing Snap Ring

4. Remove speedometer drive gear from mainshaft.
5. Remove snap ring that retains mainshaft bearing on the shaft. Refer to Fig. 10R. Remove bearing from mainshaft by inserting steel plate on the front side of 1st gear, then press mainshaft through bearing. (Be careful not to damage gear teeth).
6. Remove bearing, bearing retainer ring, 1st gear, and 1st speed stop ring from the shaft.

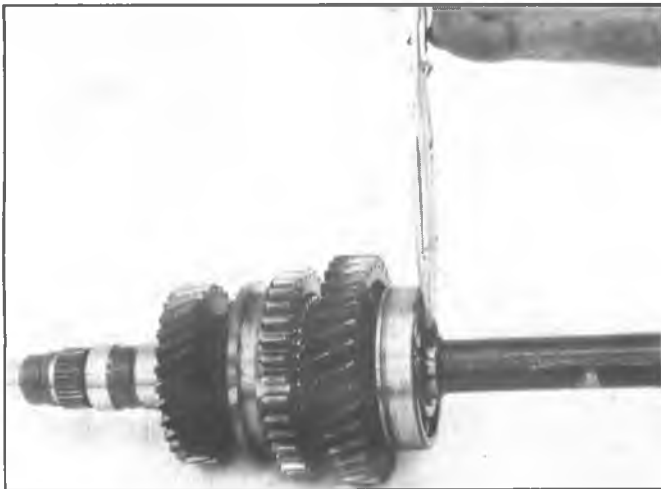

Fig. 10R--Removing/Installing Mainshaft Bearing Snap Ring

7. Remove snap ring that retains 1st and 2nd clutch gear and sleeve assembly. Then slide 1st and 2nd clutch gear and sleeve assembly from the mainshaft. Remove 2nd gear. Before cleaning, mark all parts for reassembly. Refer to Fig. 11R.
8. Inspect mainshaft gear bearing surfaces for signs of wear, scoring, or any condition that would not allow shaft to be used.
9. Remove tool J-29793 from the countershaft gear, 76 needle type bearings, thrust washers, and spacers.
10. Remove outer snap ring on the drive gear. Using an arbor press, remove bearing from drive gear, if bearing is to be replaced.
11. Remove inner snap ring and 16 bearing rollers from cavity of drive gear.

## CLEANING AND INSPECTION

### Transmission Case

1. Wash the transmission thoroughly inside and outside using a suitable solvent, then inspect the case for

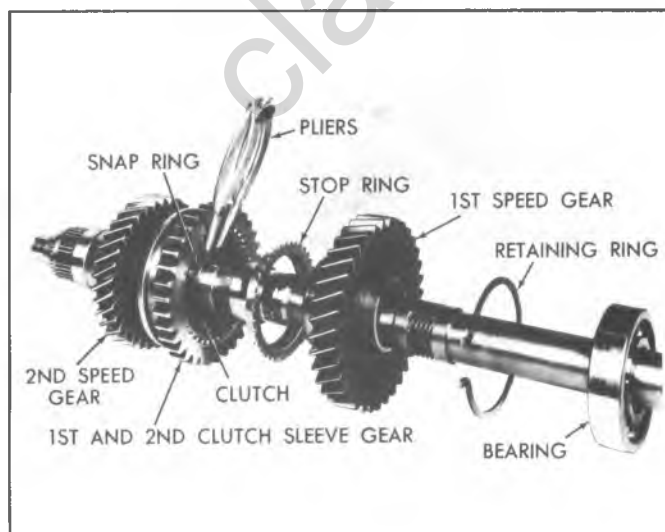

Fig. 11R--Remove or Install Clutch Gear Snap Ring

cracks. The magnetic disc is glued in place, wipe with a clean cloth.

2. Check the front and rear faces for burrs and if present, dress them off with a fine mill file.

### Roller Bearings and Spacers

1. All main drive gear and countergear bearing rollers should be inspected closely and replaced if they show wear. Inspect countershaft and reverse idler shaft at the same time, replace if necessary. Replace all worn spacers.

### Front and Rear Bearings

1. Wash the front and rear ball bearings thoroughly in a cleaning solvent.
2. Blow out bearings with compressed air.

**NOTICE:** Do not allow the bearings to spin. Turn them slowly by hand. Spinning bearings may damage the race and balls.

3. Lubricate bearings with a light engine oil and check them for roughness by slowly turning the race by hand.

### Gears

1. Inspect all gears for excessive wear, chips or cracks and replace any that are worn or damaged.
2. Check oil seal contact area on the drive gear shaft, if its pitted, rusted or scratched, a new gear is recommended for best seal life.
3. Inspect interlock levers for cracks at detent and clearance notches at each end of levers.
4. Inspect shift forks for wear on pads and shafts. Inspect the fork shaft bores in the shift lever for galling.

## REPAIRS

### Synchronizer Keys and Springs

#### Replacement

The synchronizer hubs and sliding sleeves are a selected assembly and should be kept together as originally assembled, but the keys and springs may be replaced if worn or broken.

1. If relation of hub and sleeve are not already marked, mark for assembly purposes. Refer to Fig. 12R and 13R.

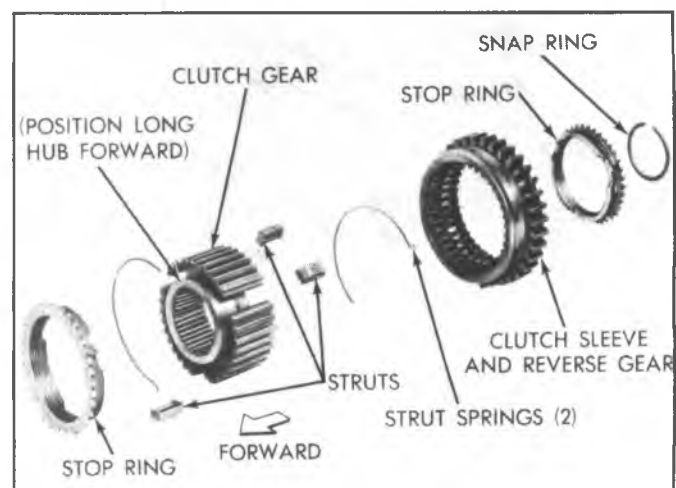

Fig. 12R--1st-2nd Synchronizer-Disassembled

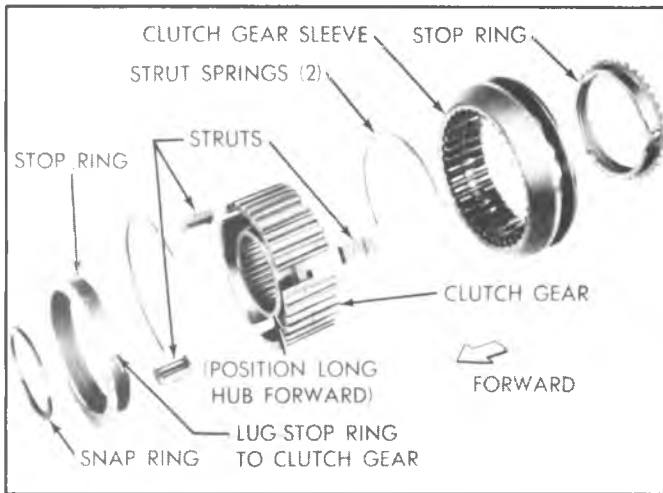

Fig. 13R--3rd-O/D Synchronizer-Disassembled

2. Push the hub from the sliding sleeve, the keys will fall free and the spring may be easily removed.
3. Place the keys in position and while holding them in place, slide the sleeve onto the hub, aligning the marks made before disassembly.
4. Place the two springs in position (one on each side of hub), so all three keys are engaged by both springs.

**Extension Oil Seal and/or Bushing**

**Replacement**

1. Pry oil seal out of extension housing, using a screwdriver or small chisel.
2. Drive the brushing out of housing, using tool J-8092 with J-21424-9.
3. Slide a new brushing on tool J-23596 and drive brushing into place. Refer to Fig. 14R.
4. Position a new seal in opening of extension housing and drive it into the housing with tool J-21426. Refer to Fig. 15R.

**Drive Gear Bearing Retainer Oil**

**Seal Replacement**

1. Pry out old seal.



Fig. 14R--Installing Rear Extension Bushing



Fig. 15R--Installing Rear Extension Seal

2. Using a new seal, install new seal into retainer using Tool J-23096 until it bottoms in bore. Refer to Fig. 16R.  
Lubricate I.D. of seal with transmission lubricant.

**Transmission Side Cover (Fig. 17R)**

The following three steps need only be done if oil leakage is visible around gearshift lever shifts, or the interlock levers are cracked.

1. Remove nuts that attach shift operating levers to the shafts. Disengage levers from flats on shafts and remove.  
Make sure shafts are free of burrs before removal, otherwise the bores may be scored resulting in leakage after reassembly.
2. Pull gearshift lever shafts out of cover.
3. Remove "O" ring retainers and "O" rings from housing.
4. Remove "E" ring from interlock lever pivot pin and remove interlock levers and spring from cover.
5. To assemble side cover, install interlock levers on pivot pin and fasten with "E" ring. Use pliers to install spring on interlock lever hangers.



Fig. 16R--Installing Drive Gear Bearing Retainer Seal

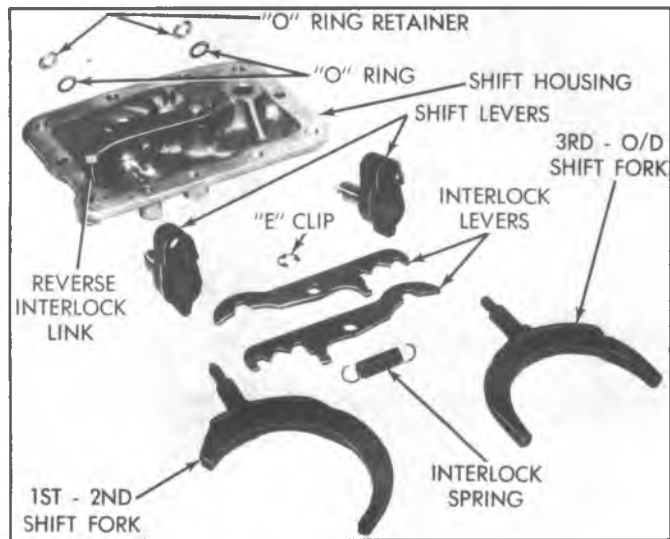

Fig. 17R--Side Cover Exploded View

6. Grease housing bores and push each shaft into its proper bore followed by greased "O" ring and retainer.
7. Install operating levers and tighten retaining nuts to 18 ft. lbs. (24 N·m). Be sure 3rd-O/D operating levers point downward.

### ASSEMBLY OF COUNTERGEAR

1. Coat inside bore of countergear at each end with a thin film of grease and install spacer with Tool J-29793 into gear. Center spacer and arbor.
2. Install 19 roller bearings, followed by a spacer ring and 19 more bearings and a spacer ring into each end of gear.
3. If countershaft thrust washers are worn or scored, install new thrust washers. Coat washers with grease and install one at the front of the countergear on the arbor with the tang side facing the case bore. Install the other washer after the countergear assembly is positioned in the bottom of the case.

### Assembly of Drive Gear

1. Press drive gear bearing on drive gear seating bearing fully against shoulder on gear. Be sure outer snap ring groove is toward the front. Refer to Fig. 18R.

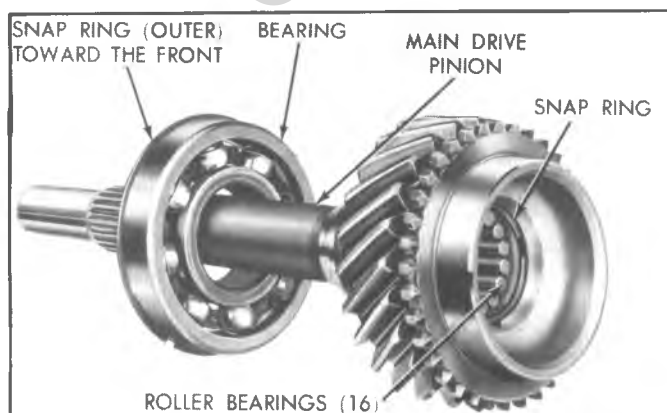

Fig. 18R--Drive Pinion and Bearing Assembly

2. Install a new snap ring on shaft to retain bearing. Be sure snap ring is seated. This snap ring is a select fit for minimum end play.
3. Place drive gear in a vise (with soft jaws), then install 16 bearing rollers in cavity of shaft. Coat bearing rollers with grease, then install bearing retaining snap ring in its groove.

### ASSEMBLY OF MAINSHAFT

1. Slide second gear over mainshaft (synchronizer cone toward rear) and down against shoulder on shaft. Refer to Fig. 11R.
2. Slide 1st-2nd synchronizer assembly (including stop ring with lugs indexed in hub slots) over mainshaft, down against 2nd gear cone and secure with a new snap ring. Slide next stop ring over shaft and index lugs into clutch hub slots. Refer to Fig. 11R.
3. Slide first gear (synchronizer cone toward clutch sleeve gear just installed) over mainshaft into position against clutch sleeve gear.
4. Install mainshaft bearing retainer ring, followed by mainshaft rear bearing. Using an arbor and a suitable tool, drive or press bearing down into position. Install a new snap ring on shaft to secure bearing. Refer to Fig. 10R. This snap ring is a select fit for minimum end play.
5. Install partially assembled mainshaft into extension housing far enough to engage bearing retaining ring in slot in extension housing. Expand snap ring with pliers so that mainshaft ball bearing can move in and bottom against its thrust shoulder in extension housing. Release ring and seat it all around its groove in extension housing. Refer to Fig. 9R.
6. Slide overdrive gear over mainshaft (with synchronizer cone toward front) followed by O/D gear stop ring.
7. Install 3rd-O/D synchronizer clutch gear assembly on mainshaft (shift fork slot toward rear) against O/D gear. Be sure to index rear stop ring with clutch gear struts. Install retaining snap ring. Refer to Fig. 8R.
8. Using grease, position front stop ring over clutch gear, again indexing ring lugs with struts.

### ASSEMBLY OF TRANSMISSION

1. Place the transmission case on its side with the shift cover opening toward the assembler.
2. Install countergear assembly into the case aligning the tangs on the front washer with the slots in the case. Next install the rear washer aligning the tangs with the slot at the rear of the case and then let the countergear rest in the bottom of the case. (Be sure thrust washers stay in position). Refer to Fig. 5R.
3. Coat a new extension gasket with grease, then place it in position on the extension.
4. Insert mainshaft assembly into the case tilting it as required to clear the countershaft gear.
5. Rotate the extension housing to expose the rear of the countershaft bore. Install one bolt to hold the extension in inverted position and prevent it from moving rearward. Refer to Fig. 3R.



6. Install drive gear assembly through the front of the case and position it in the front bore. Install outer snap ring in bearing groove. Tap lightly into place using a soft faced hammer. If everything is in proper position, the outer snap ring will bottom onto the case face without excessive effort. If not, check to see if a strut, roller bearing, or a stop ring is out of position.
7. Raise the countergear assembly into position with the teeth meshed with the drive gear. Make sure thrust washer remain in position on ends of the arbor and tangs are aligned with slots in case.
8. Start the countershaft into the rear bore of the case and push forward until the shaft is approximately half way through the gear. Install woodruff key and push the shaft forward until end is flush with case. Remove arbor Tool J-29793.
9. Install reverse shift lever in case bore followed by greased "O" ring and retainer.
10. Remove extension housing bolt and rotate extension to provide clearance for installation of the reverse idler gear in end of case.
11. Push the shaft in far enough to position reverse idler gear on protruding end of shaft with fork slot toward rear. At the same time, engage slot with reverse shift fork.
12. Install woodruff key shaft and drive shaft in flush with end of case.
13. Align extension housing to case and install bolts. Tighten housing bolts to 50 ft. lbs. (68 N·m).
14. Install drive gear bearing retainer and gasket. Coat threads with sealing compound, then install bolts and tighten to 30 ft. lbs. (41 N·m).
15. Install new expansion plug coated with sealing compound in countershaft bore at front of case.
16. Position both synchronizer sleeves in neutral. Place the 1-2 shift fork into the groove of the 1-2 synchronizer sleeve. Slide reverse idler gear to neutral.
17. Rotate each shift lever to neutral position (straight up) and install 3rd/overdrive shift fork into its bore and under both interlock levers.
18. Position side cover gasket on case using grease to retain it. Install reverse detent ball followed by the spring into its bore in the case.



Fig. 19R--Side Cover Bolt Identification

19. Lower the side cover onto the case guiding the 3rd/overdrive shift fork into its synchronizer groove, then lead the shaft of the 1-2 shift fork into its bore in the side cover. Hold the reverse interlock link against the 1-2 shift lever to provide clearance as the side cover is lowered into position.  
To finish the installation of the side cover, use a screwdriver and raise the interlock lever against its spring tension to allow the 1-2 shift fork to slip under the levers. Be sure the reverse detent spring is positioned in the cover bore.
20. Eight of the side cover bolts are shoulder bolts with one having a longer shoulder which acts as a dowel to accurately locate the side cover. The remaining two bolts are standard bolts. Install cover bolts finger tight and shift through all gears to insure proper operation. Refer to Fig. 19R for location of cover bolts.
21. Tighten side cover bolts evenly to 15 ft. lbs. (20 N·m).
22. Install reverse shift lever, retaining nut and tighten to 18 ft. lbs. (24 N·m).
23. Shift the transmission into each gear to insure correct shift travel and smooth operation.  
The reverse shift lever and 1-2 shift lever have cam surfaces which mate in reverse position to lock the 1-2 lever, fork and synchronizer in neutral position. Slight motion of the 1-2 shift lever toward low gear is normal during shifting into reverse gear.
24. Install backup light switch and tighten to 15 ft. lbs. (20 N·m).

# 4-SPEED 117MM TRANSMISSION

## INDEX

Disassembly of Transmission .....	7B-35	Drive Gear Bearing Retainer Oil Seal.....	7B-39
Subassembly Operations .....	7B-35	Mainshaft.....	7B-40
Transmission Cover .....	7B-35	Disassembly.....	7B-40
Disassembly .....	7B-35	Inspection .....	7B-40
Assembly .....	7B-35	Assembly .....	7B-41
Drive Gear .....	7B-38	Countershaft.....	7B-42
Disassembly .....	7B-38	Disassembly.....	7B-42
Inspection .....	7B-38	Assembly .....	7B-42
Assembly .....	7B-39	Assembly of Transmission.....	7B-42

## DISASSEMBLY OF TRANSMISSION

### Refer to Figures 7B-1L and 7B-2L

1. Mount transmission in suitable holding fixture and remove cap screws attaching transmission cover assembly to transmission case. If required, insert two 5/16 x 18 screws in cover flange threaded holes and turn evenly to raise cover dowel pins from case.

Move reverse shifter fork so that reverse idler gear is partially engaged before attempting to remove cover. Forks must be positioned so rear edge of the slot in the reverse fork is in line with the front edge of the slot in the forward forks as viewed through tower opening.

2. Place transmission in two gears at once to lock gears. Remove the universal joint flange nut, universal joint front flange and brake drum assembly.

On models equipped with 4-wheel drive transfer case, use Tool J-23070 to remove mainshaft rear lock nut (Fig. 7B-26L).

3. Remove parking brake and brake flange plate assembly on models equipped with propeller shaft parking brake. Refer to Section 5, Truck Service Manual.

4. Remove rear bearing retainer and gasket.

5. Slide speedometer drive gear off mainshaft.

6. Remove drive gear bearing retainers and gasket.

7. Remove countergear front bearing cap and gasket.

8. Pry countergear front bearing out by inserting a two-pronged puller J-28509 through the cast slots in case.

9. Remove countergear rear bearing retaining rings (snap ring) from shaft and bearing. Using Tool J-22832 and J-8433-1 remove countergear rear bearings (Fig. 7B-3L). This will allow countergear assembly to rest on bottom of case.

Make sure Tool J-22832 engages full circumference of groove in bearing to prevent tool damage.

10. Remove drive gear bearing outer race to case retaining ring.

11. Remove drive gear and bearing by tapping gently on bottom side of drive gear shaft and prying directly opposite against the case and bearing snap ring groove at the same time. Remove 4th gear synchronizer ring.

Index cut out section of drive gear in down position with countergear to obtain clearance for removing clutch gear.

12. Remove rear mainshaft bearing retainer ring (snap ring) and using Tool J-22832 and J-8433-1, remove bearing from case (Fig. 7B-4L). Slide 1st speed gear thrust washer off mainshaft.

13. Raise rear of mainshaft assembly and push rearward in case bore, then swing front end up and lift from case. Remove synchronizer cone from shaft.

14. Slide reverse idler gear rearward and move countergear rearward until front end is free of case, then lift to remove from case.

15. To remove reverse idler gear, drive reverse idler gear shaft out of case from front to rear using a drive. Remove reverse idler gear from case.

## SUBASSEMBLY OPERATIONS

### TRANSMISSION COVER

#### Disassembly (Fig. 7B-5L)

1. Using a small punch drive out pins retaining 1st-2nd and 3rd-4th shifter forks to shifter shafts and also drive out expansion plugs.

The pin retaining the third and fourth shifter fork to the shaft must be removed, and the shifter fork removed from the cover before the reverse shifter head pin can be removed.

2. With shifter shafts in neutral position, drive shafts out of cover and shifter forks.

**NOTICE:** Exercise care so shaft detent balls, springs and innerlock pin located in the cover are not lost as the shifter shafts are removed.

3. Drive out pin holding reverse shifter head and drive out the shaft.

**NOTICE:** Exercise care during shaft removal since detent balls are under spring tension in the rear rail boss holes.

#### Assembly (Fig. 7B-6L)

1. In reassembling the transmission cover care must be used in installing the shifter shafts. They should be installed in the order shown in Fig. 7B-7L, namely, reverse, 3rd-4th, and 1st-2nd. Fig. 7B-6L illustrates the difference in the shafts.

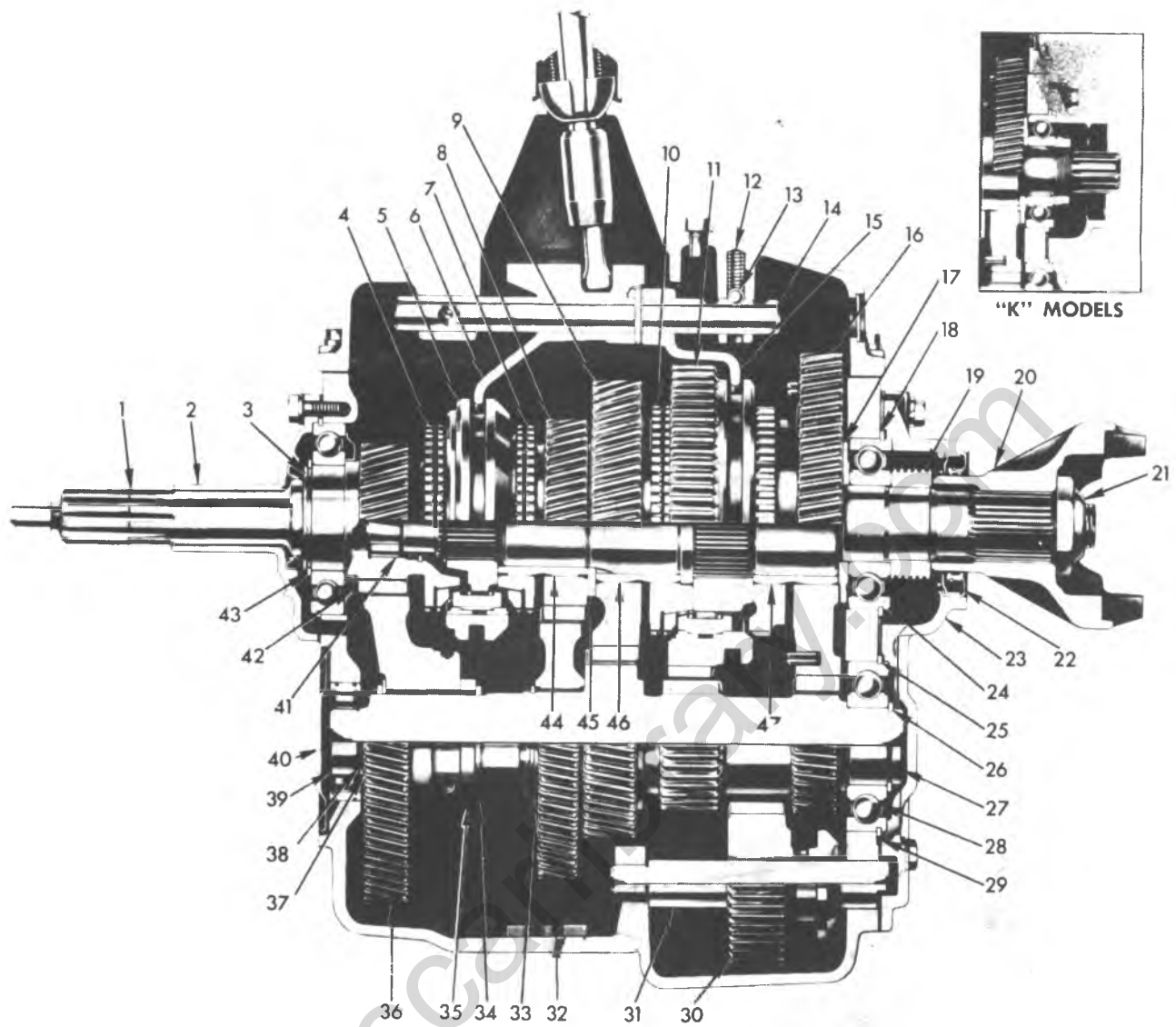

- |  |                                    |                               |                                |
|--|------------------------------------|-------------------------------|--------------------------------|
| 1. Main Drive Gear                     | 11. Reverse Driven Gear            | 24. Mainshaft Rear Bearing    | 37. Thrust Washer              |
| 2. Drive Gear Bearing Retainer         | 12. Poppet Spring                  | 25. Rear Bearing Snap Ring    | 38. Snap Ring                  |
| 3. Snap Ring-Outer                     | 13. Poppet Ball                    | 26. Snap Ring                 | 39. Front Countershaft Bearing |
| 4. 3rd and 4th Synchronizer Ring       | 14. Shift Rail                     | 27. Countershaft              | 40. Countergear Front Cover    |
| 5. 3rd and 4th Synchronizer Collar     | 15. 1st and 2nd Shift Fork         | 28. Countershaft Rear Bearing | 41. Pilot Bearing Rollers      |
| 6. 3rd and 4th Shift Fork              | 16. 1st Speed Gear                 | 29. Bearing Snap Ring         | 42. Clutch Gear Oil Slinger    |
| 7. 3rd and 4th Speed Synchronizer Ring | 17. Thrust Washer                  | 30. Reverse Idler Gear        | 43. Snap Ring                  |
| 8. 3rd Speed Gear                      | 18. Bearing Snap Ring              | 31. Reverse Idler Shaft       | 44. 3rd Speed Gear Bushing     |
| 9. 2nd Speed Gear                      | 19. Speedometer Drive Gear         | 32. Case Magnet               | 45. Thrust Washer              |
| 10. 1st and 2nd Synchronizer Assembly  | 20. Output Yoke                    | 33. Snap Ring                 | 46. 2nd Speed Gear Bushing     |
|  | 21. Flange Nut                     | 34. Snap Ring                 | 47. 1st Speed Gear Bushing     |
|  | 22. Rear Bearing Retainer Oil Seal | 35. Spacer                    |                                |
|  | 23. Rear Bearing Retainer          | 36. Countergear               |                                |

Fig. 7B-1L-4-Speed 117mm Transmission Assembly--Cross Section

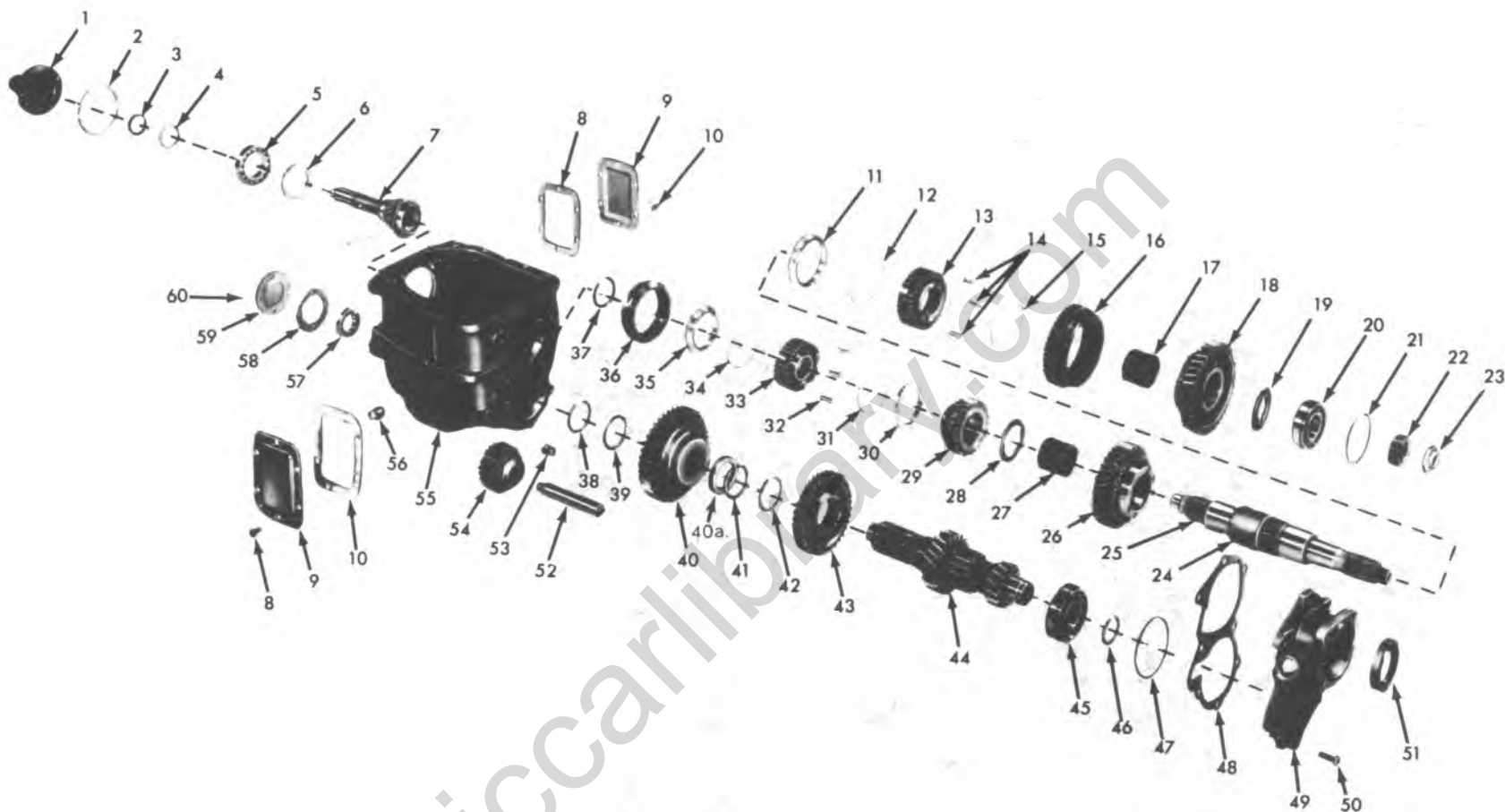

Fig. 7B-2L-4-Speed 117mm Transmission Exploded View

- |                                  |                                    |                                       |                              |                               |
|----------------------------------|------------------------------------|---------------------------------------|------------------------------|-------------------------------|
| 1. Drive Gear Bearing Retainer   | 13. 1st-2nd Speed Synchronizer Hub | 26. 2nd Speed Gear                    | 37. Snap Ring                | 48. Rear Retainer Gasket      |
| 2. Retainer Gasket               | 14. Synchronizer Keys              | 27. 3rd Gear Bushing                  | 38. Snap Ring                | 49. Rear Retainer             |
| 3. Lip Seal                      | 15. Synchronizer Spring            | 28. Thrust Washer                     | 39. Thrust Washer            | 50. Retainer Bolts            |
| 4. Snap Ring                     | 16. Reverse Driven Gear            | 29. 3rd Speed Gear                    | 40. Clutch Countergear       | 51. Retainer Lip Seal         |
| 5. Drive Gear Bearing            | 17. 1st Gear Bushing               | 30. 3rd Speed Blocker Ring            | 40a. Spacer                  | 52. Reverse Idler Shaft       |
| 6. Oil Slinger                   | 18. 1st Gear                       | 31. Synchronizer Spring Ring          | 41. Snap Ring                | 53. Drain Plug                |
| 7. Drive Gear and Pilot Bearings | 19. Thrust Washer                  | 32. Synchronizer Keys                 | 42. Snap Ring                | 54. Reverse Idler Gear Case   |
| 8. Power Take-Off Cover Gasket   | 20. Rear Main Bearing              | 33. 3rd-4th Synchronizer Hub          | 43. 3rd Speed Countergear    | 55. Fill Plug                 |
| 9. Power Take-Off Cover          | 21. Bearing Snap Ring              | 34. Synchronizer Spring               | 44. Countergear Shaft        | 57. Countergear Front Bearing |
| 10. Retaining Screws             | 22. Speedometer Gear               | 35. 3rd-4th Speed Blocker Ring        | 45. Countergear Rear Bearing | 58. Gasket                    |
| 11. 1st-2nd Speed Blocker Ring   | 23. Rear Mainshaft Lock Nut        | 36. 3rd-4th Speed Synchronizer Sleeve | 46. Snap Ring                | 59. Front Cover               |
| 12. Synchronizer Spring          | 24. 2nd Speed Bushing (On Shaft)   |                                       | 47. Bearing Outer Snap Ring  | 60. Cover Screws              |

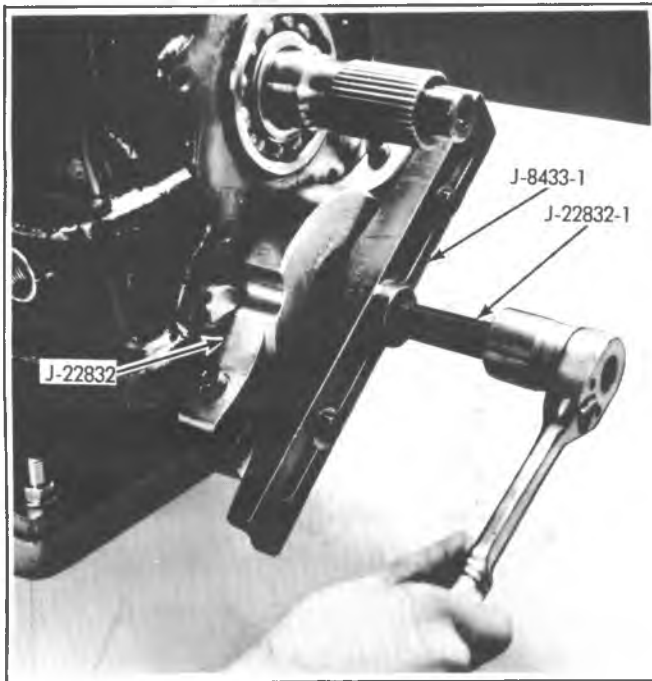

Fig. 7B-3L--Removing Countergear Rear Bearing

2. Place fork detent ball springs and balls in position in holes in cover.

3. Start shifter shafts into cover; depress detent balls with small punch and push shafts on over balls. (See Fig. 7B-7L). Hold reverse fork in position and push shaft through yoke. Install split pin in fork and shaft; then, push fork in neutral position.

4. Hold 3rd and 4th fork in position and push shaft through yoke, but not through front support bore.

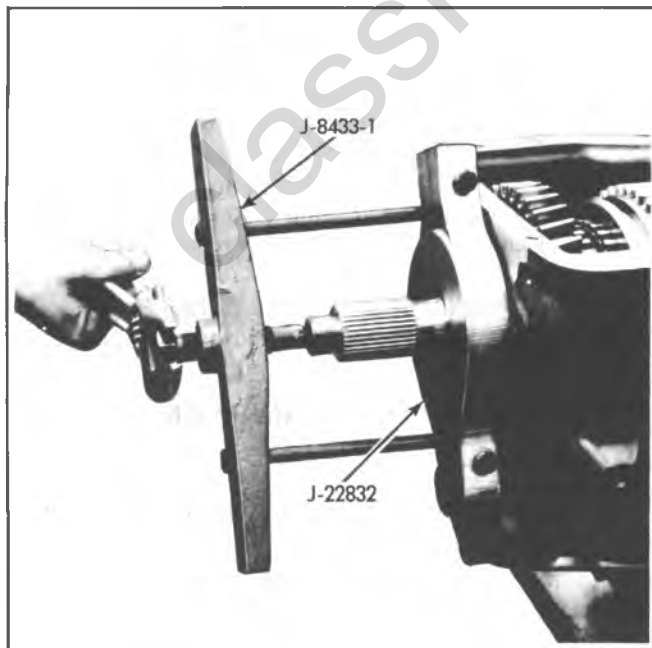

Fig. 7B-4L--Removing Mainshaft Rear Bearing

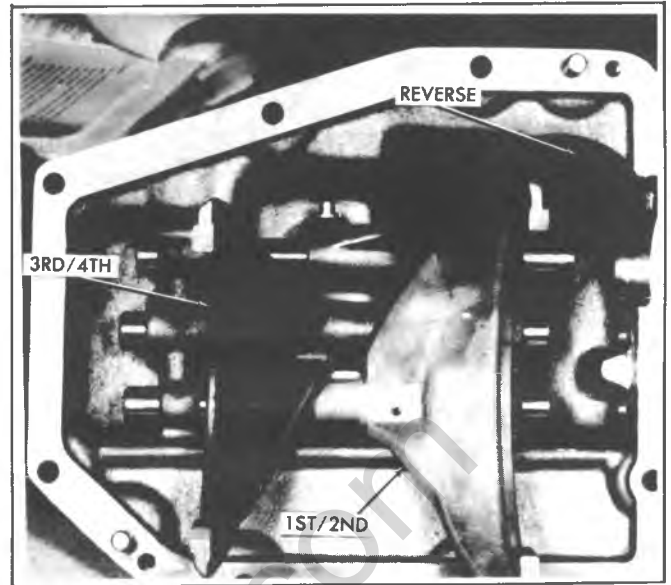

Fig. 7B-5L--Cover Assembly

5. Place two (2) interlock balls in cross-bore in front support boss between reverse and 3rd and 4th shifter shaft. Install the interlock pin in the 3rd and 4th shifter shaft hole. Apply grease to hold in place. Push 3rd and 4th shaft through fork and cover bore, keeping both balls and pin in position between shafts until retaining holes line up in fork and shaft. Install retaining pin and move to neutral position.

6. Place two (2) interlock balls between the 1st and 2nd shifter shaft and 3rd and 4th shifter shaft in the cross-bore of the front support boss. Hold 1st and 2nd fork in position and push shaft through cover bore in fork until retainer hole and fork line up with hole in shaft. Install retainer pin and move to neutral position.

7. Install new shifter shaft hole expansion plugs and expand in place.

### DRIVE GEAR (FIG. 7B-8L)

#### Disassembly

1. Remove mainshaft pilot bearing rollers (17) from drive gear if not already removed, and remove roller retainer. Do not remove snap ring on inside of drive gear.

2. Remove snap ring securing bearing on stem of drive gear.

3. To remove bearing, position Tool J-22872 to the bearing (Fig. 7B-9L) and using an arbor press and Tool J-0358 press gear and shaft out of bearing (Fig. 7B-10L).

#### Inspection

1. Wash all parts in clearing solvent.
2. Inspect roller bearings for pits or galling.
3. Inspect bearing diameter in shaft recess for galling.
4. Inspect gear teeth for excessive wear.
5. Inspect clutch shaft pilot for excessive wear.
6. Re-oil bearing, then rotate drive gear bearing slowly by hand and check for roughness.

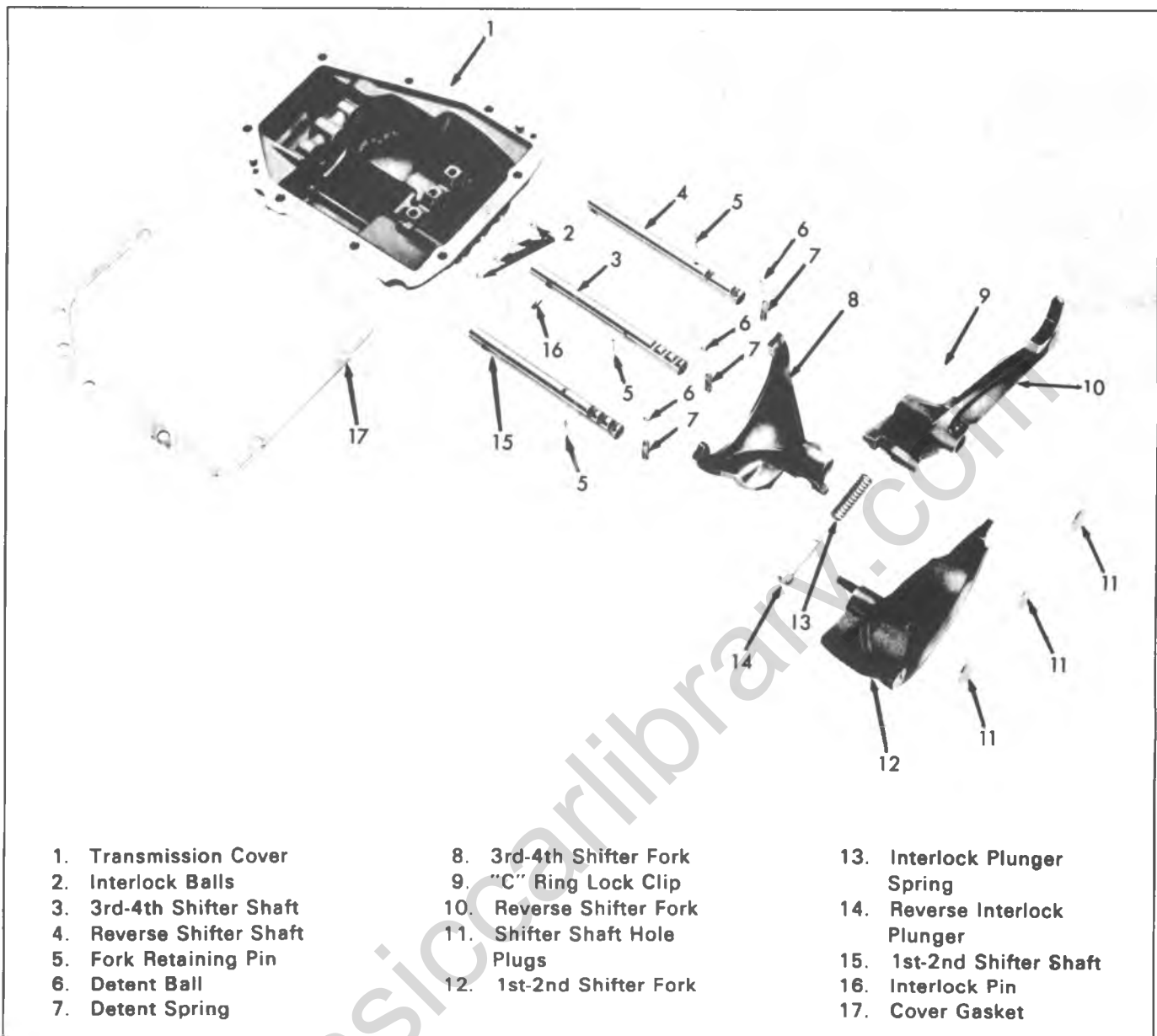

Fig. 7B-6L—Cover Assembly Exploded View

## Assembly

1. Press bearing and new oil slinger onto drive gear shaft using Tool J-22872 (Fig. 7B-11L). Slinger should be located flush with bearing shoulder on drive gear. See Figure 7B-8L for direction of slinger installation.

**NOTICE:** Exercise care to prevent distortion of the oil slinger.

2. Install snap ring to secure bearing on drive gear shaft.

3. Install bearing retainer ring in groove on O.D. of bearing. The bearing must turn freely, after it is installed on the shaft.

4. Install snap ring on I.D. of mainshaft pilot bearing bore in clutch gear (if previously removed).

5. Apply a small amount of grease to bearing surface in shaft recess, install transmission mainshaft pilot roller bearings (17) and install roller bearing retainer (Fig. 7B-12L).

This roller bearing retainer holds bearing in position and in final transmission assembly is pushed forward into recess by mainshaft pilot.

## DRIVE GEAR BEARING RETAINER OIL SEAL

### Replacement

1. Remove retainer and oil seal assembly and gasket.

2. Pry oil seal out of retainer.

3. Install new seal on Tool J-22833 with lip of seal toward flange of tool.

4. Support front surface of retainer in press, start seal and tool in retainer bore and drive seal into retainer until flange of tool bottoms on retainer (Fig. 7B-13L).

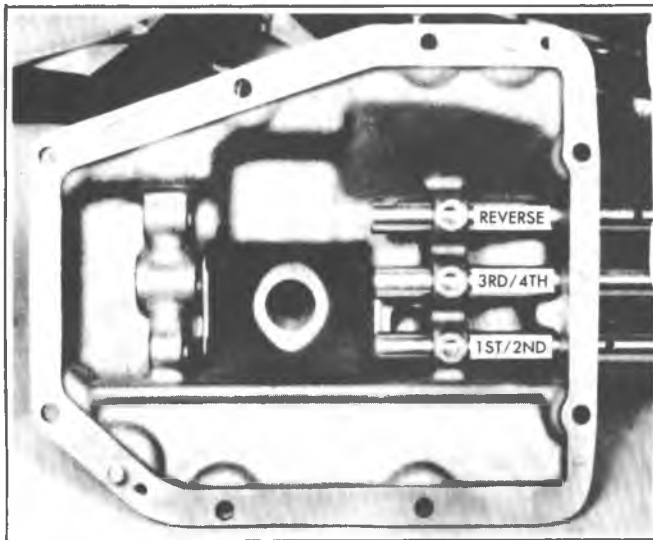

Fig. 7B-7L-Shifter Shaft Installation

5. Install new gasket on retainer and install retainer on transmission case (when assembling transmission).

**MAINSHAFT ASSEMBLY**

**Disassembly (Fig. 7B-14L)**

1. Remove first speed gear and thrust washer.
2. Remove snap ring in front of 3rd-4th synchronizer assembly.
3. Remove reverse driven gear.
4. Press behind second speed gear to remove 3rd-4th synchronizer assembly, 3rd speed gear and 2nd speed gear along with 3rd speed gear bushing and thrust washer (Fig. 7B-15L).
5. Remove 2nd speed synchronizer ring.
6. Supporting 2nd speed synchronizer hub at front face, press mainshaft through removing 1st speed gear bushing

and 2nd speed synchronizer hub.

7. Split 2nd speed gear bushing with chisel and remove bushing from shaft. Exercise care not to damage mainshaft.

**Inspection**

1. Wash all parts in cleaning solvent.
2. Inspect mainshaft for scoring or excessive wear at thrust surfaces or splines.
3. Inspect clutch hub and clutch sleeve for excessive wear and make sure sleeve slides freely on clutch hub. Also check fit of clutch hub on mainshaft splines.  
Third and fourth speed clutch sleeve should slide freely on third and fourth speed clutch hub but clutch hub should be snug fit on shaft splines.
4. Inspect 3rd speed gear thrust surfaces for excessive scoring and inspect third speed gear mainshaft bushing for excessive wear. Third speed gear must be a running fit on mainshaft bushing and mainshaft bushing should be press fit on shaft.
5. Check second speed thrust washer for excessive scoring.
6. Inspect 2nd speed gear for excessive wear at thrust surface. Check synchronizer springs for looseness or breakage.
7. Inspect second gear synchronizing ring for excessive wear.
8. Inspect bronze synchronizer cone on 2nd speed gear for excessive wear or damage. Also inspect clutch gear synchronizer cone and third speed gear synchronizer cone for excessive wear or damage.

First and reverse sliding gear must be sliding fit on synchronizer hub and must not have excessive radial or circumferential play. If sliding gear is not free on hub, inspect for burrs which may have rolled up on front end of half-tooth internal splines and remove by honing as necessary.

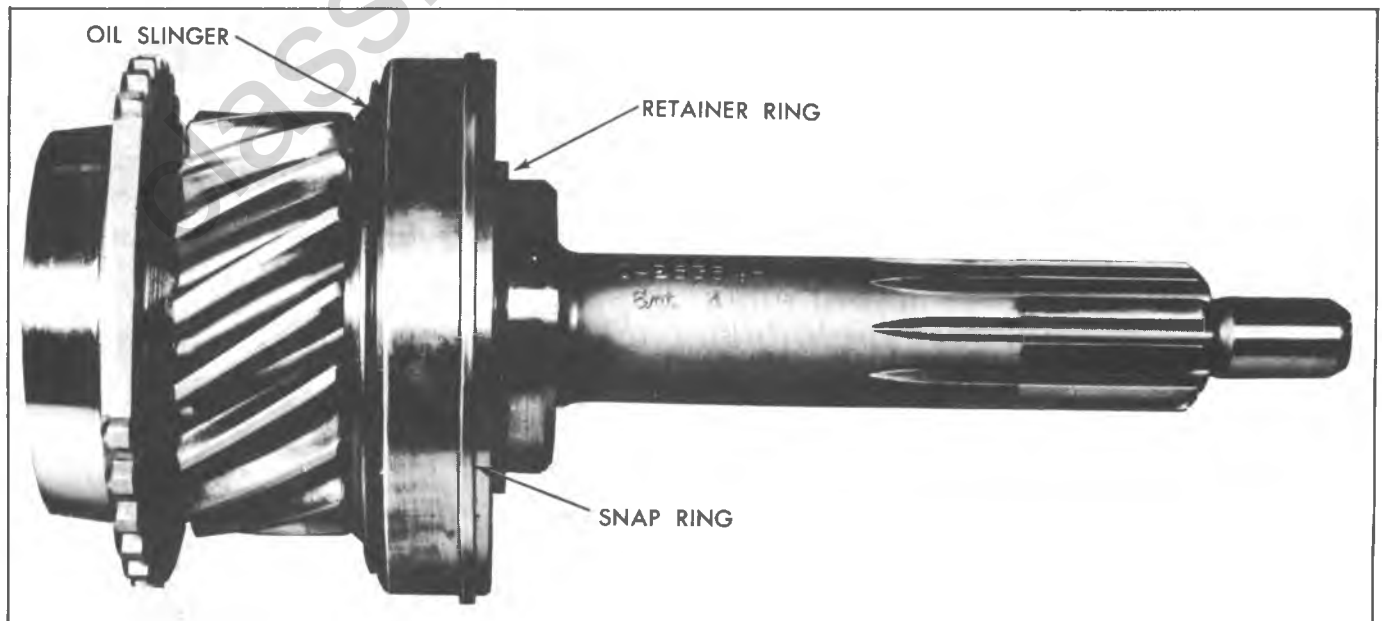

Fig. 7B-8L-Drive Gear Assembly

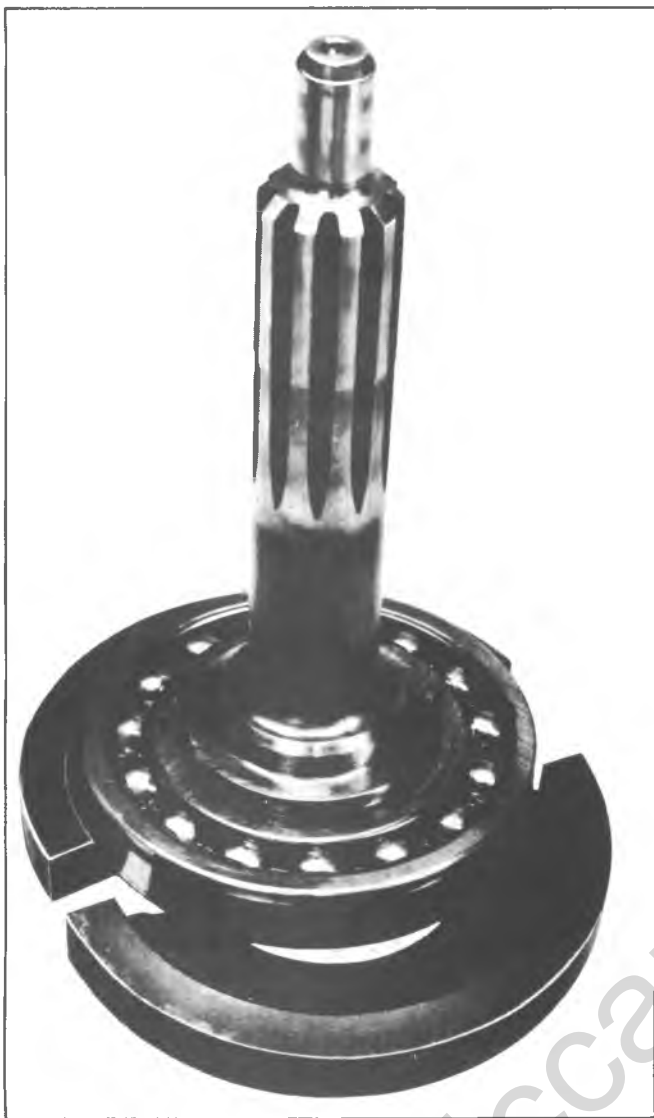

Fig. 7B-9L—Positioning Tool J-22872 to Drive Gear

9. Inspect all gear teeth for excessive wear.

### Assembly

1. Using Tool J-22873 press 2nd speed bushing onto mainshaft until it bottoms against shoulder (Fig. 7B-16L).

Lubricate bushing with E.P. oil before pressing.

**NOTICE:** 1st, 2nd and 3rd speed gear bushings are sintered iron, exercise care when installing, or damage may occur.

2. Press 1st and 2nd speed synchronizer hub onto mainshaft until it bottoms against shoulder with annulus toward rear of shaft.

3. Install 1st and 2nd synchronizer keys and springs (if previously removed).

4. Using Tool J-22873 press 1st speed gear bushing onto mainshaft until it bottoms against hub (Fig. 7B-17L). Lubricate all bushings with E.P. oil before installation of gears.

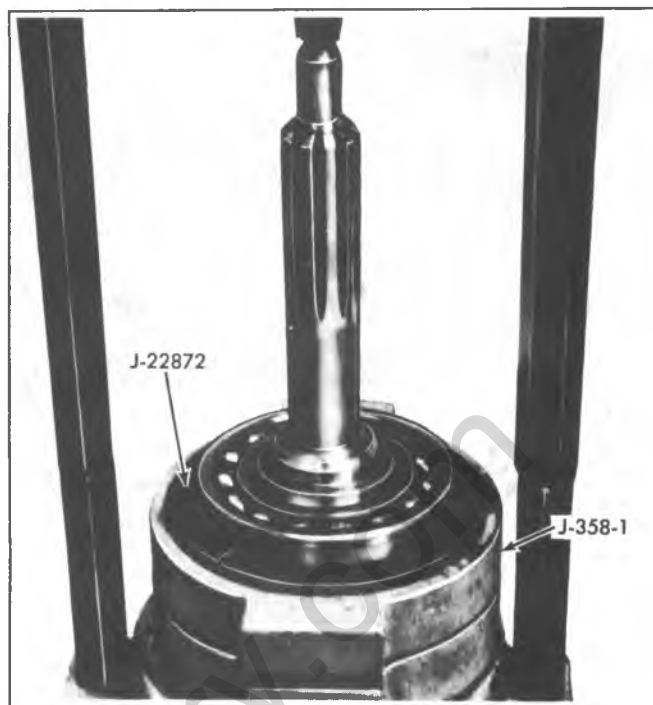

Fig. 7B-10L—Removing Drive Gear Bearing

5. Install synchronizer blocker ring and 2nd speed gear onto mainshaft and against synchronizer hub. Index synchronizer key slots with keys in synchronizer hub.

6. Install 3rd speed gear thrust washer onto mainshaft with tang on thrust washer in slot on shaft and against 2nd speed gear bushing. Then press 3rd speed gear bushing onto mainshaft using Tool J-22875 until it bottoms against thrust washer (Fig. 7B-18L).

7. Install 3rd speed gear synchronizer blocker ring and 3rd speed gear onto mainshaft, against 3rd speed gear thrust washer.

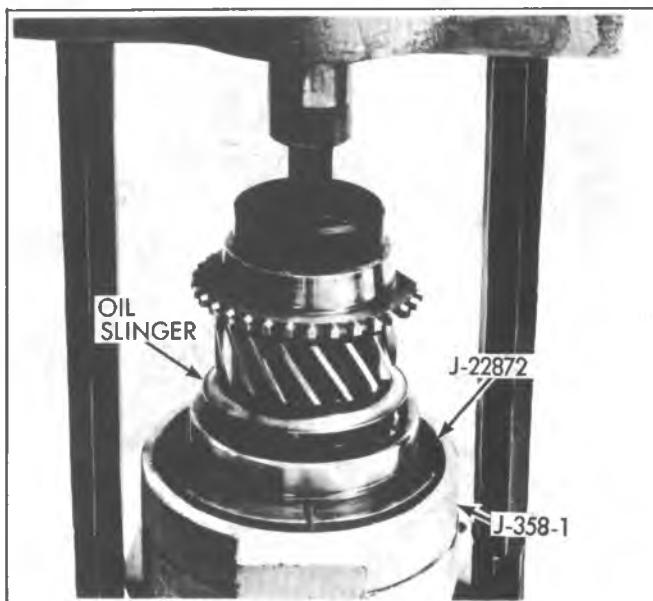

Fig. 7B-11L—Replacing Drive Gear Bearing



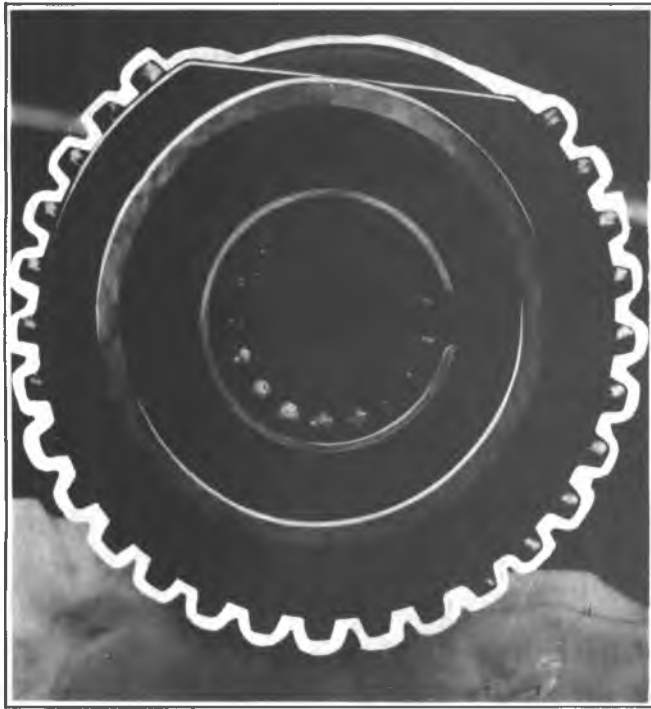

Fig. 7B-12L—Pilot Roller Bearing Installed

8. Index synchronizer ring key slots with synchronizer assembly keys and press 3rd and 4th synchronizer assembly onto mainshaft using Tool J-22875 and against 3rd speed gear bushing thrust face toward 3rd speed gear (Fig. 7B-19L). Retain synchronizer assembly with snap ring.

9. Install reverse driven gear with fork groove toward rear.

10. Install 1st speed gear onto mainshaft and against 1st and 2nd synchronizer hub. Install 1st speed gear thrust washer.



Fig. 7B-13L—Installing Bearing Retainer Oil Seal

## COUNTERSHAFT ASSEMBLY

### Disassembly

1. Remove front countergear retaining ring and thrust washer. Discard snap ring.

2. Install Tool J-22832 or suitable press plates on countershaft, open side to spacer, (Fig. 7B-20L); support assembly in an arbor press and press countershaft out of clutch countergear assembly. Countergear is a slip fit and pressing may not be required.

3. Remove clutch countergear rear retaining ring.

4. Remove 3rd speed countergear retaining ring.

5. Position assembly on an arbor press and press shaft from 3rd speed countergear.

### Assembly

1. Position 3rd speed countergear and shaft in arbor press and press the gear onto the shaft. Install gear with the machined surface to mate with the snap ring, toward the front (rear side of the gear is undercut). The 3rd speed gear must be installed with a load of 1500 lb. If the gear requires less than 1500 lb., another gear must be selected for installation. The press fit is required for proper operation.

2. Install new 3rd speed countergear retaining ring using snap ring pliers.

3. Install new clutch countergear rear retaining ring using Tool J-22830, J-22873 and snap ring pliers as follows:

Install Tool J-22830 on end of shaft and position snap ring on Tool (Fig. 7B-21L). Using Tool J-22873, push down on snap ring until it engages groove on shaft. Using snap ring pliers, carefully expand ring until it just slides onto splines, then push ring down shaft until it engages groove on shaft.

**NOTICE:** Do not over stress snap ring or damage may occur.

4. Position clutch countergear and spacer on shaft and press countergear onto shaft against snap ring using Tool J-22873, (Fig. 7B-22L). Countergear is a slip fit and pressing may not be required.

5. Install clutch countergear thrust washer and front retaining ring using Tool J-22830 and J-22873 (Fig. 7B-21L).

**NOTICE:** Do not over stress snap ring, or damage may occur. Ring should be tight in groove without side play.

### ASSEMBLY OF TRANSMISSION

1. Lower the countergear into the case until it rests on bottoms of case.

2. Place reverse idler gear in transmission case with gear teeth toward the front. Install idler gear shaft from rear to front, being careful to have slot in end of shaft in facing down. Shaft slot face must be at least flush with case.

3. Install mainshaft assembly into case with rear of shaft protruding out rear bearing hole in case. Position Tool J-22874 in clutch gear case opening and engaging front mainshaft (Fig. 7B-23L). Rotate case onto front end.

Install 1st speed gear thrust washer on shaft, if not previously installed.

4. Install snap ring on bearing O.D. and position rear mainshaft bearing on shaft. Using Tool J-22874-1 drive bearing onto shaft and into case (Fig. 7B-23L). Rotate case

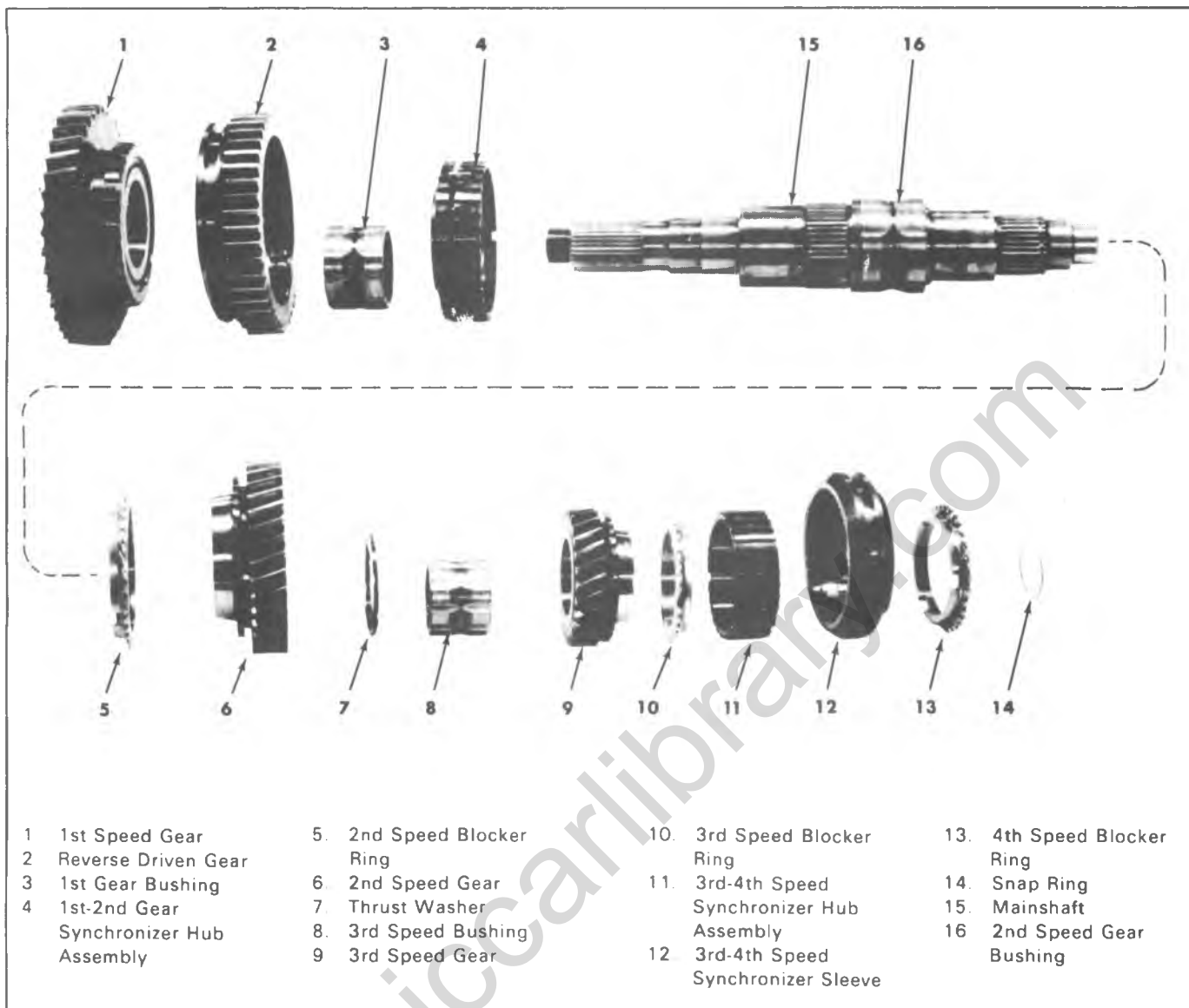

Fig. 7B-14L—Mainshaft Assembly Exploded View

and remove Tool J-22874-5.

5. Install synchronizer cone on pilot end of mainshaft and slide rearward to clutch hub. Make sure three cut out sections of 4th speed synchronizer cone align with three clutch keys in clutch assembly.

6. Install snap ring on drive gear bearing O.D. Index cut out portion of drive gear teeth to obtain clearance over countershaft drive gear teeth, and install clutch gear assembly onto case. Raise mainshaft to get clutch gear started and tap bearing outer race with plastic tip hammer.

7. Install drive gear bearing retainer using a new gasket. Install bolts and tighten to 15-18 ft. lbs.

8. Install appropriate tool in countergear front bearing opening in case to support countergear and rotate case onto front end. (Fig. 7B-24L).

9. Install snap ring on countergear rear bearing O.D. position, bearing on countergear and using Tool J-22874-1, drive bearing into place (Fig. 7B-25L). Rotate case, install snap ring on countershaft at rear bearing and then remove Tool J-22874-1.

10. Tap countergear front bearing assembly into case.

11. Install countergear front bearing cap and new gasket. Torque screws to 20-30 in. lbs.

12. Slide speedometer drive gear over mainshaft to bearing.

13. Install rear bearing retainer with new gasket. Be sure snap ring ends are in lube slot and cut out in bearing retainer. Install bolts and tighten to 15-18 ft. lbs. Install brake backing plate assembly on models equipped with propeller shaft brake.

On models equipped with 4-wheel drive, install rear lock nut and washer using Tool J-23070 (Fig. 7B-26L). Torque lock nut to 120 ft. lbs. and bend washer tangs to fit slots in nut.

14. Install parking brake drum and/or universal joint flange. Apply light coat of oil to seal surface.

15. Lock transmission in two gears at once. Install universal joint flange locknut and tighten to 90-120 ft. lbs.

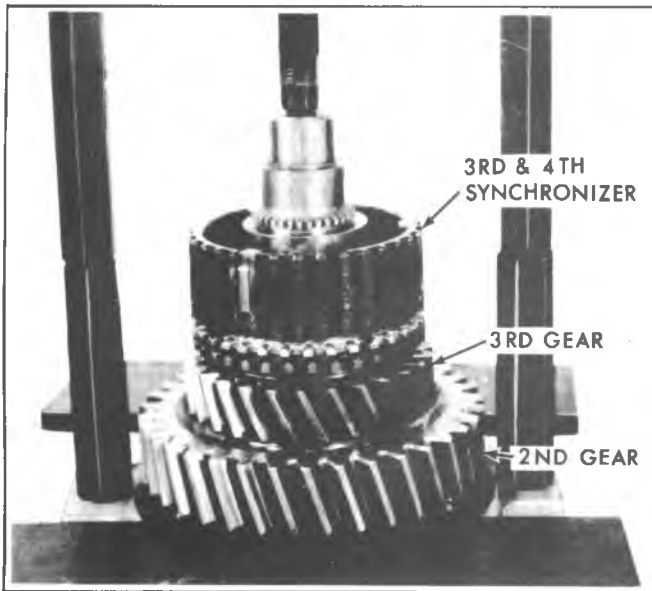

Fig. 7B-15L-Disassembly of Mainshaft

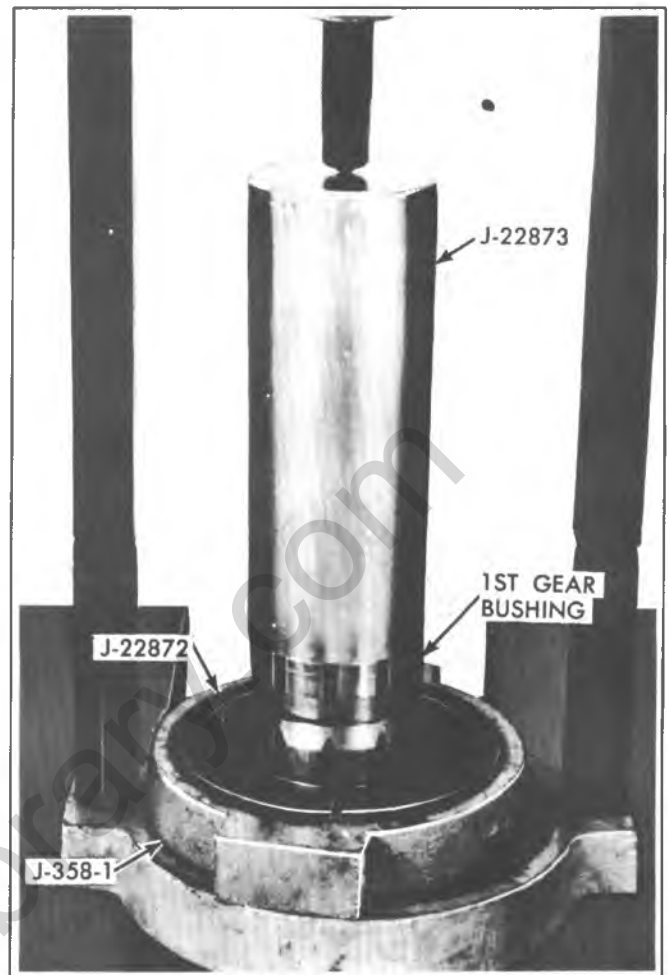

Fig. 7B-17L-Installing 3rd Speed Gear Bushing

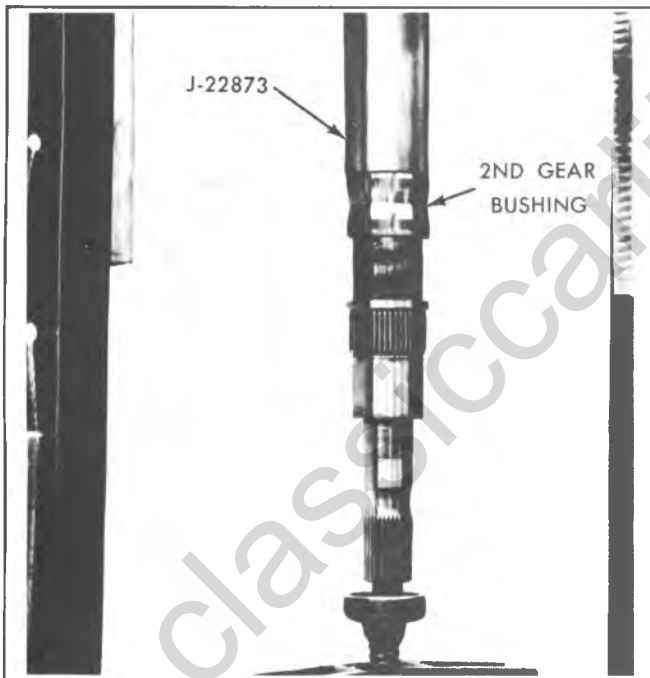

Fig. 7B-16L-Installing 2nd Speed Gear Bushing

16. Move all transmission gears to neutral except the reverse idler gear which should be engaged approximately  $\frac{3}{8}$  of an inch (leading edge of reverse idler gear teeth lines up with the front edge of the 1st speed gear). Install cover assembly with new gasket to transmission case. Shifting forks must slide into their proper positions on clutch sleeves and reverse idler gear. Forks must be positioned as in removal.

17. Install cover attaching bolts and torque to 20-25 ft. lbs.

b 18. Using Tool J-8109, replace gearshift lever and check operation of transmission.

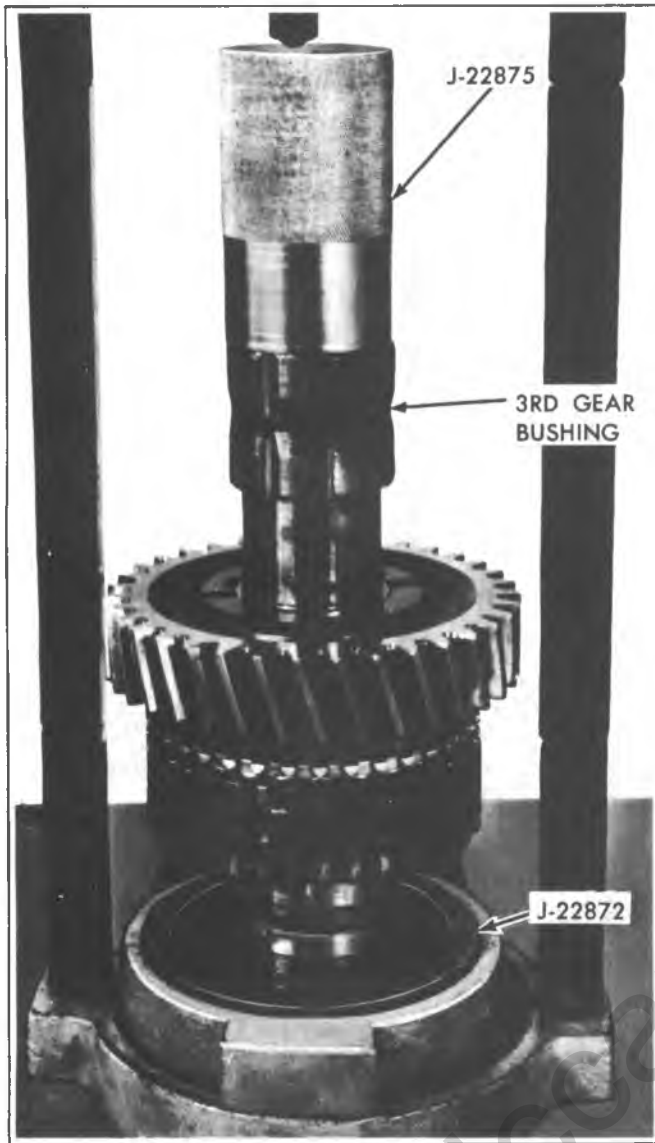

Fig. 7B-18L—Installing 3rd Speed Gear Bushing

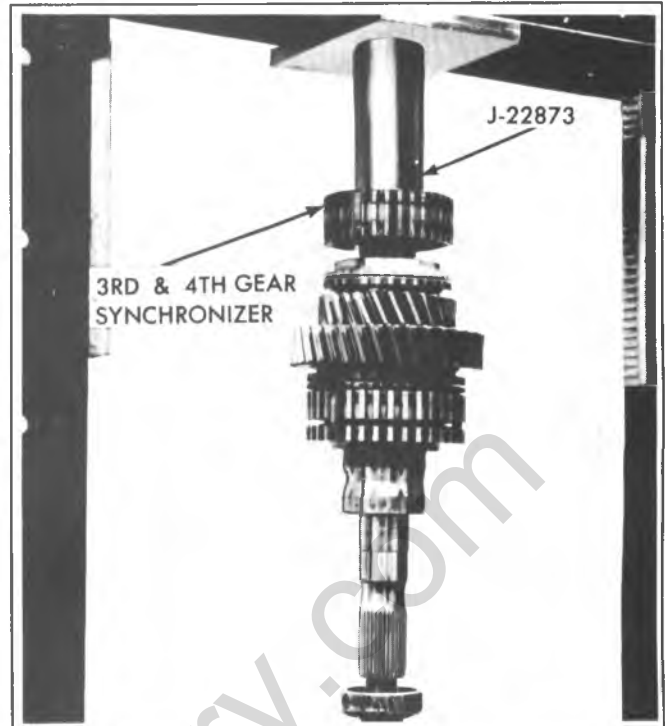

Fig. 7B-19L—Installing 3rd and 4th Gear Synchronizer

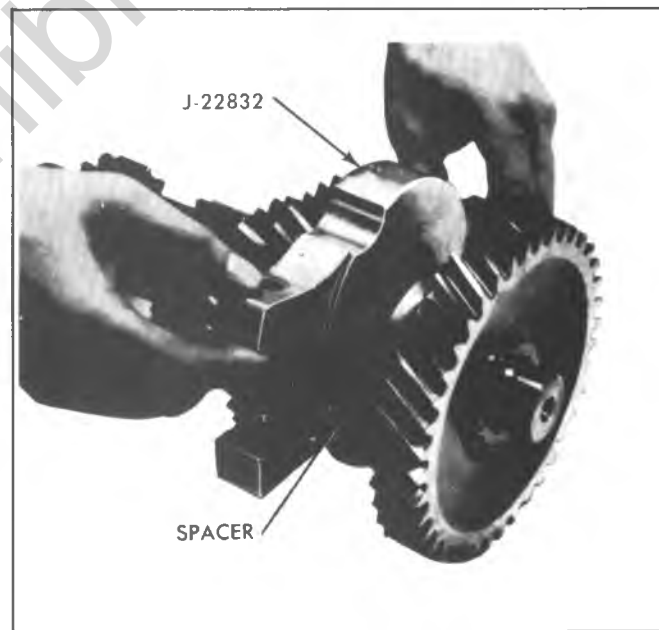

Fig. 7B-20L—Positioning Tool J-22832 on Countershaft

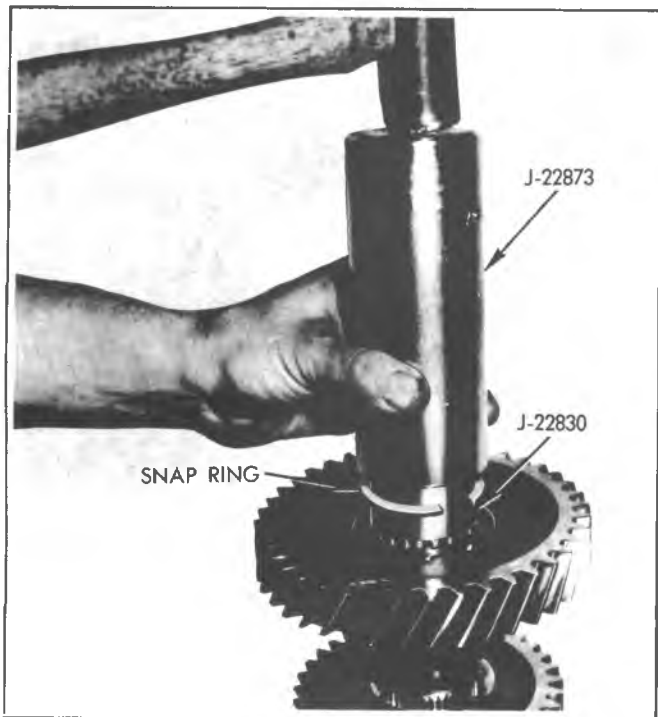

Fig. 7B-21L--Installing Counter Gear Snap Ring

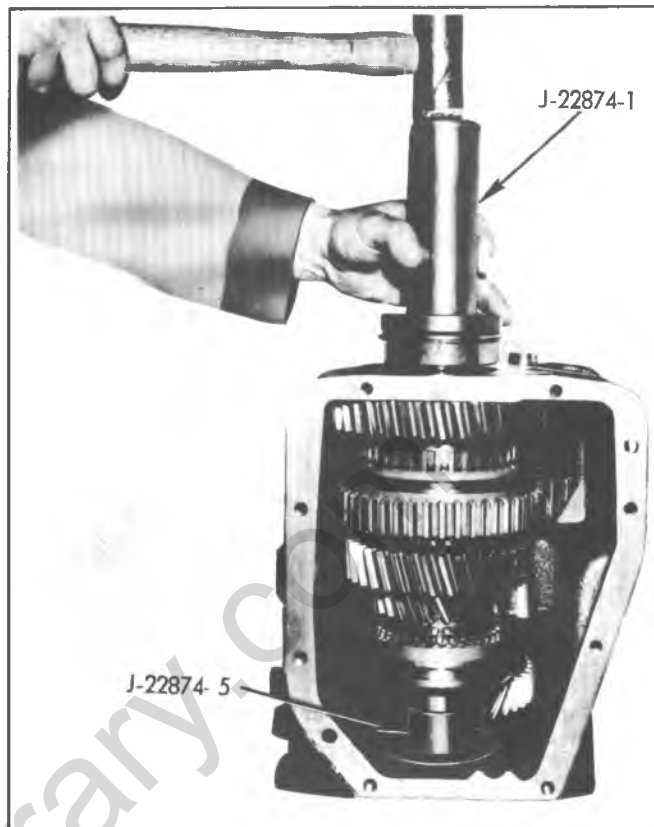

Fig. 7B-23L--Installing Mainshaft Rear Bearing

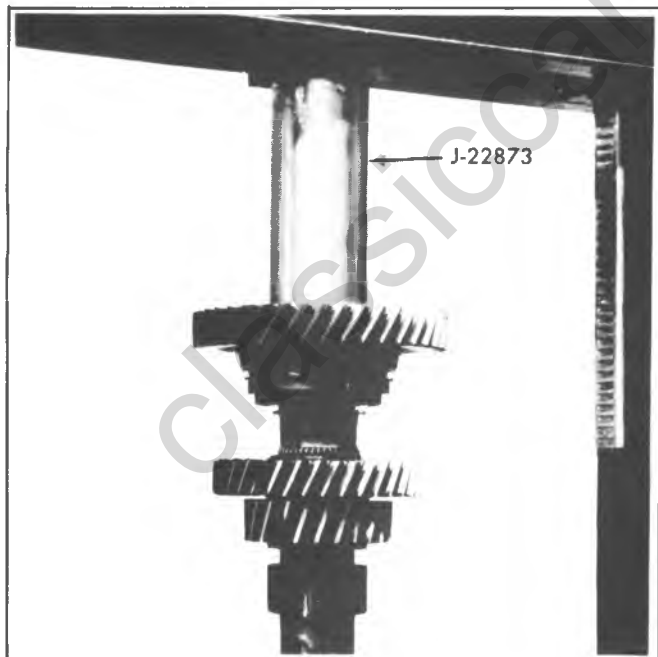

Fig. 7B-22L--Installing Clutch Countergear

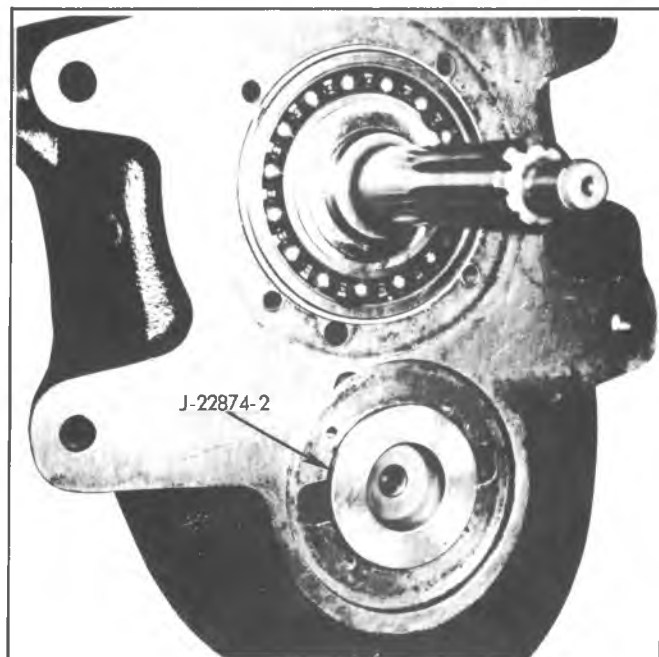

Fig. 7B-24L--Countergear Front Support Tool



Fig. 7B-25L—Installing Countergear Rear Bearing

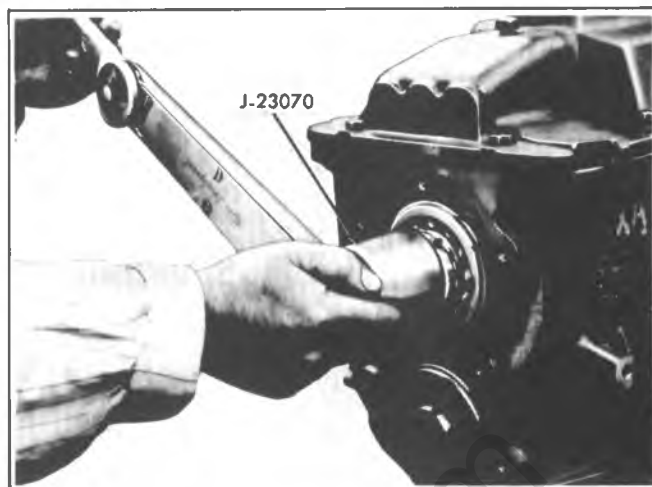

Fig. 7B-26L—Installing Mainshaft Rear Bearing Lock Nut (4-Wheel Drive only)

classiccarlibrary.com



## SPECIAL TOOLS



- |     |           |  |     |           |  |
|-----|-----------|--|-----|-----------|--|
| 1.  | J-21424-9 | REAR BUSHING REMOVER WITH HANDLE J-8092              | 7.  | J-1453-01 | SPEEDOMETER DRIVE GEAR PRESS PLATES AND PRESS PLATE HOLDER J-358-1 |
| 2.  | J-8059    | RETAINER SNAP RING PLIERS                            | 8.  | J-2228    | REAR BEARING PRESS PLATES  |
| 3a. | J-22246   |  | 9.  | J-933     | MAIN DRIVE GEAR WRENCH   |
| 3b. | J-22379   | COUNTER GEAR LOADING TOOLS                           | 10. | J-1126    | TRANSMISSION GUIDE PINS  |
| 3c. | J-29793   |  | 11. | J-5590    | CLUTCH GEAR BEARING INSTALLER                                      |
| 4.  | J-5778    | EXTENSION BUSHING REMOVER AND INSTALLER              | 12. | J-9772    | CLUTCH GEAR BEARING INSTALLER                                      |
| 5.  | J-5154    | EXTENSION SEAL INSTALLER                             | 13. | J-23096   | CLUTCH GEAR RETAINER SEAL INSTALLER                                |
| 6.  | J-5814-01 | SPEEDOMETER DRIVE GEAR REMOVER AND ADAPTER J-5814-15 | 14. | J-21426   | REAR EXTENSION SEAL INSTALLER                                      |
|     |           |  | 15. | J-5752    | TRANSMISSION HOLDING FIXTURE                                       |
|     |           |  | 16. | J-23596   | REAR EXTENSION BUSHING INSTALLER                                   |

Manual Transmission Special Tools (Except 4-Speed, 117mm)



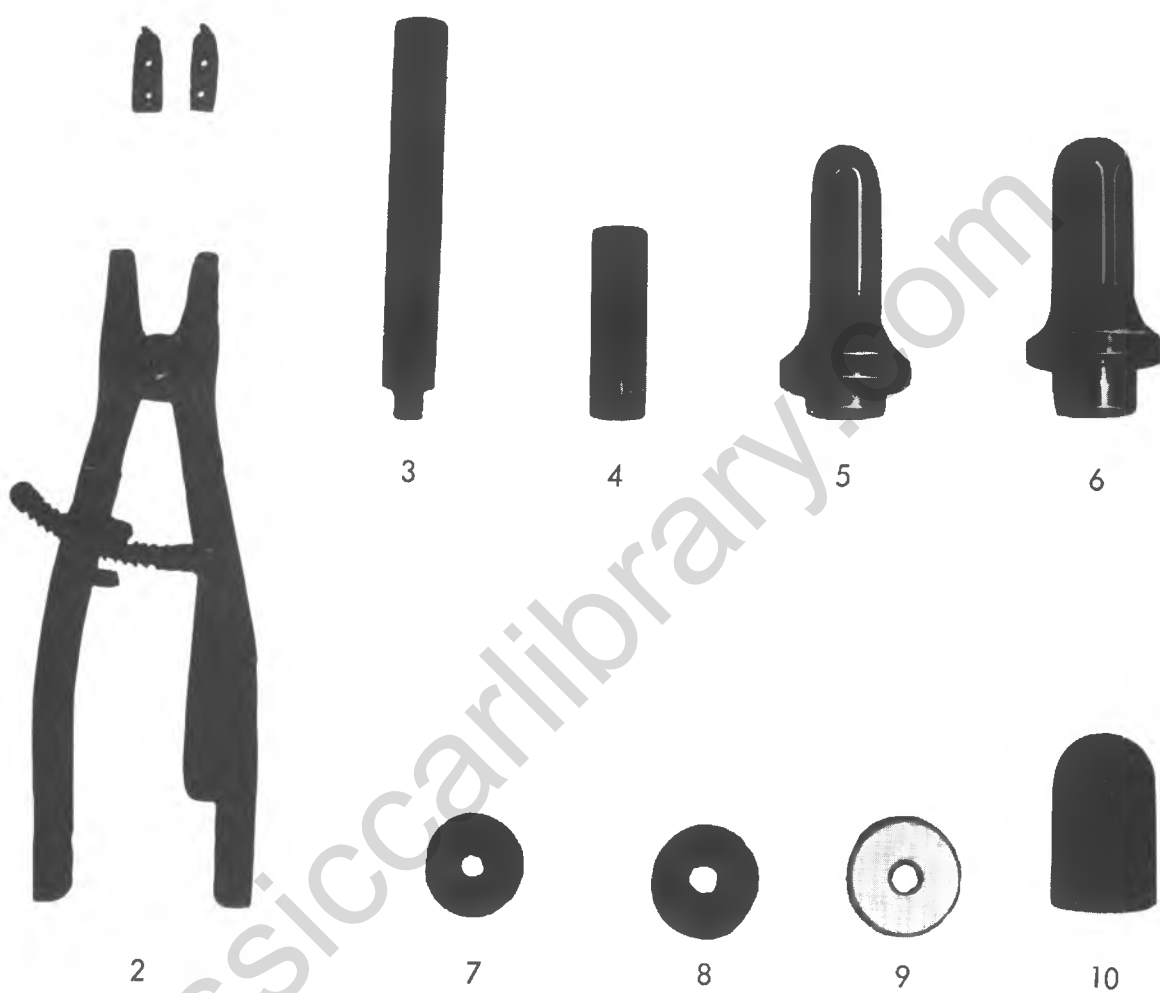

- 1. J-23432 1 Snap Ring Picks.
- 2. J-23432 Snap Ring Pliers.
- 3. J-8092 Handle.
- 4. J-23429 Intermediate Shaft Remover and Installer.
- 5. J-22836 Front Output Shaft Bearing Retainer Seal Installer.
- 6. J-21359 Rear Output Shaft Bearing Retainer Seal Installer.
- 7. J-23431 Rear Output Shaft Housing Bearing Remover and Installer.
- 8. J-7137 Adapter Seal Installer.
- 9. J-9276 2 Intermediate Gear Bearing Cup Installer.
- 10. J-22875 Rear Output Shaft Rear Bearing Installer.

4-Speed, 117mm, Transmission Special Tools

classicalibrary.com

## SECTION 7C

# CLUTCHES

### CONTENTS

Single Plate Diaphragm Spring Clutch.....	7C-1
Single Plate Coil Spring Clutch .....	7C-3
Special Tools .....	7C-7

## SINGLE PLATE DIAPHRAGM CLUTCH

### INDEX

Disassembly .....	7C-2
Inspection .....	7C-2
Assembly .....	7C-2
Pilot Bearing Replacement .....	7C-2

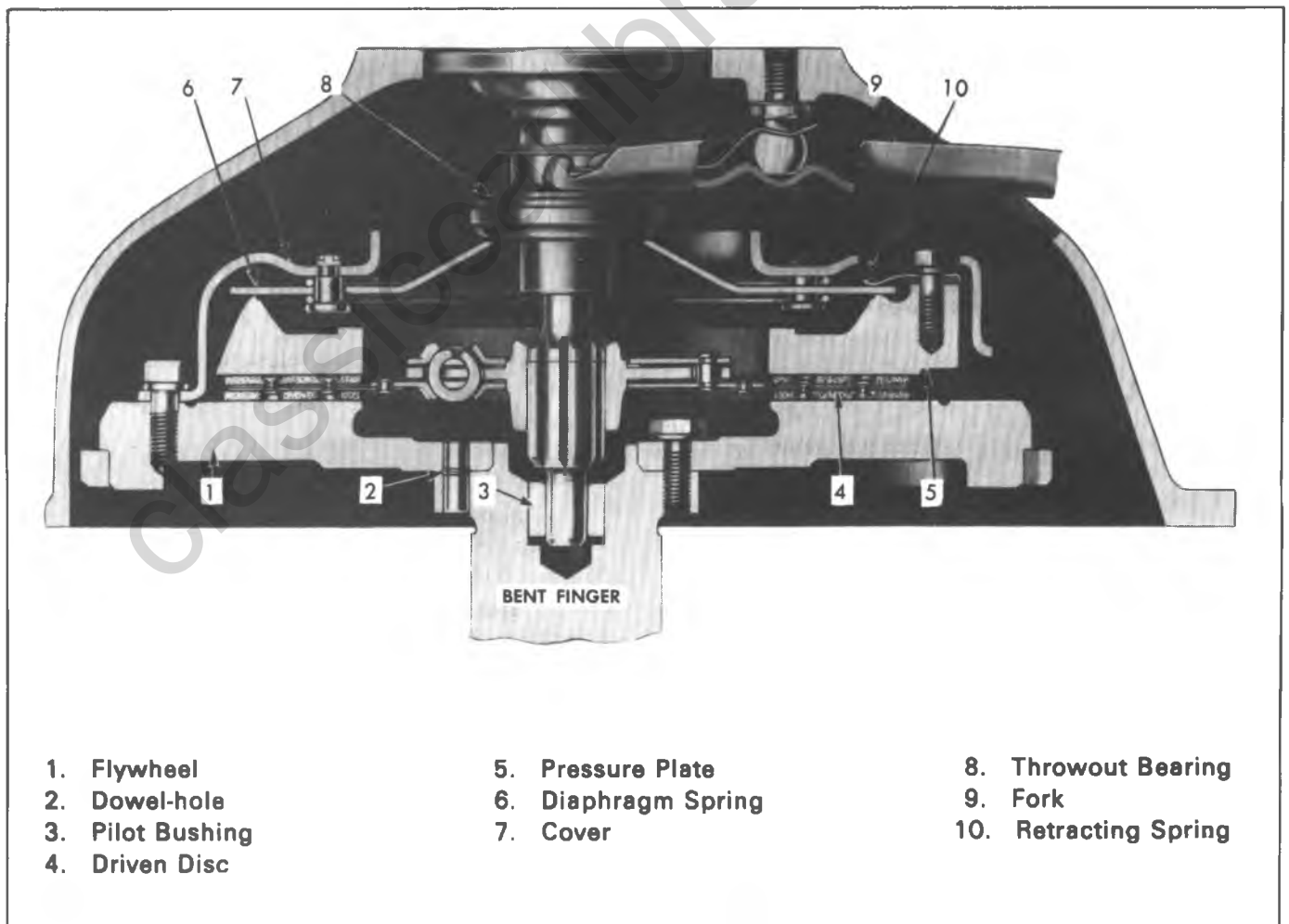

Fig. 7C-1A—Bent Finger Clutch Cross-Section (Typical)

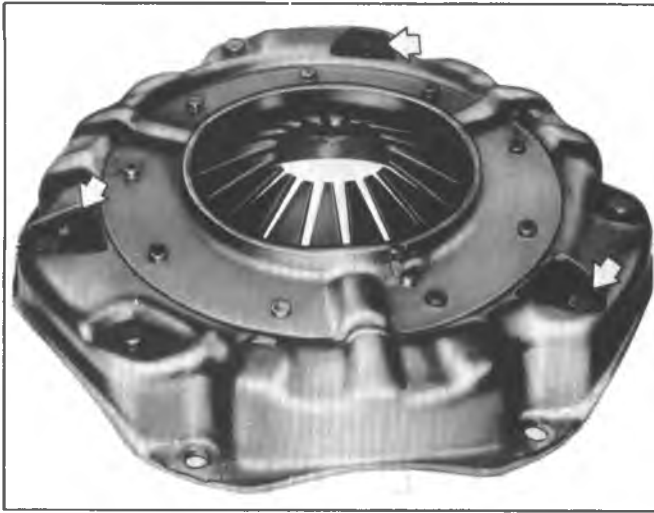

Fig. 7C-2A—Retracting Spring Location (Typical)

### DISASSEMBLY (FIG. 7C-2A)

**NOTICE:** When disassembling, mark edge of pressure plate and cover. These marks must be aligned in assembly to maintain balance.

1. Remove three drive-strap to pressure plate bolts and retracting springs and remove pressure plate from clutch cover.

2. The clutch diaphragm spring and two pivot rings are riveted to the clutch cover. Spring, rings and cover should be inspected for excessive wear or damage and if there is a defect, it is necessary to replace the complete cover assembly.

### INSPECTION

1. Check drive straps for looseness at the clutch cover and evidence of looseness at pressure plate bolt holes.

2. Wash all parts, except driven disk and throwout bearing, in cleaning solvent.

**NOTICE:** The throwout bearing is permanently packed with lubricant and should not be soaked in cleaning solvent as this will dissolve the lubricant.

3. Inspect pressure plate and flywheel for scores on the contact surfaces. Use a straight-edge and check for flatness of contact surfaces.

4. Check throwout bearing for roughness and free fit on the sleeve of the transmission clutch gear bearing retainer. Replace retainer if rough.

5. Inspect clutch disc for worn, loose or oil soaked facings, broken springs, loose rivets, etc. Replace if necessary.

### PILOT BEARING REPLACEMENT

The clutch pilot bearing is an oil impregnated type bearing pressed into the crankshaft. This bearing requires attention when the clutch is removed from the vehicle, at which time it should be cleaned and inspected for excessive wear or damage and should be replaced if necessary.

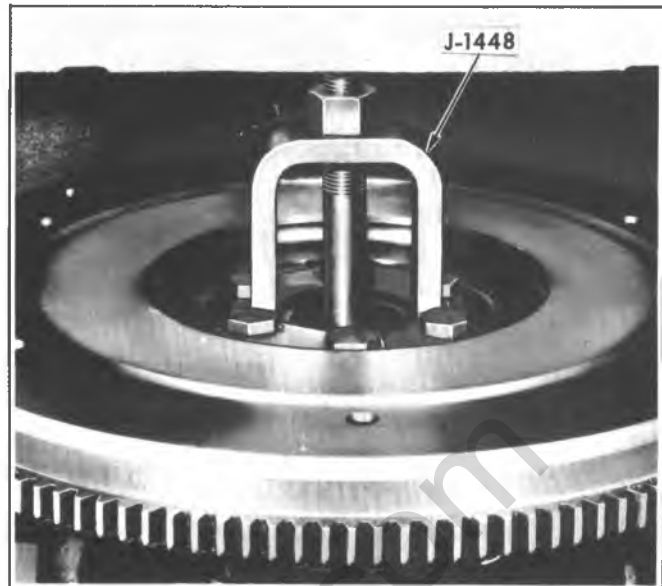

Fig. 7C-3A—Clutch Pilot Bearing Removal (Typical)

6. Examine splines in hub and make sure they slide freely on splines of transmission clutch shaft. If splines are worn, the clutch disc or clutch gear should be replaced as necessary.

7. Inspect clutch fork ball socket and fingers for wear and ball retaining spring for damage. Spring should hold fork tightly to ball stud.

**NOTICE:** Ball spring on fork may be bent in toward fork if necessary.

8. Inspect ball stud for wear. Replace if scored.

9. Check run out of transmission pilot hole in clutch housing by removing a flywheel bolt and installing a dial indicator. The run out should be within .000-.015".

10. Lubricate ball stud before reassembly.

11. Lubricate bearing I.D. and groove before reassembly.

### ASSEMBLY

1. Install the pressure plate in the cover assembly, lining up the punch marks on the edge of the pressure plate with the punch marks on the edge of the cover.

2. Install pressure plate retracting springs and drivestrap to pressure plate bolts and lock washers and tighten to 11 ft. lbs. torque. The clutch is now ready to be installed.

To remove, install Tool J-1448 and remove bearing from crankshaft, as shown in (Fig. 7C-3A). In replacing this bearing, use Tool J-1522. Place bearing on pilot of tool with radius in bore of bearing next to shoulder on tool and drive into crankshaft. Lubricate with several drops of machine oil.

# SINGLE PLATE COIL SPRING CLUTCH

## INDEX

Disassembly .....	7C-3
Inspection .....	7C-3
Assembly .....	7C-3
Adjusting Levers .....	7C-4

### DISASSEMBLY

1. Place the cover assembly on the bed of an arbor or drill press with a block under the pressure plate so arranged that the cover is left free to move down.

2. Place a block or bar across the top of the cover with the spindle. Hold compressed while the adjusting nuts are removed as shown in Fig. 7C-2E. , Then slowly release pressure to prevent springs flying out.

3. Lift off cover and all parts will be available for inspection. Note carefully the location of all parts including

arrangement of springs. See Fig. 7C-3E.

4. To remove levers grasp lever and eyebolt between thumb and fingers as shown in Figure 7C-4E, so that inner end of lever and upper end of eyebolt are close together, keeping eyebolt pin seated in its socket in lever.

5. Lift strut over ridge on end of lever, as in Fig. 7C-5E.

6. Lift lever and eyebolt off pressure plate.

**NOTICE:** It is important to replace all parts which show wear.

### INSPECTION

In addition to applicable items listed under Diaphragm Clutch Inspection, check the following items.

1. Check driving lugs for wear.
2. Check clutch cover for distortion or cracks.
3. Check release levers for wear or cracks.

### ASSEMBLY

1. Lay the pressure plate on the block in the press and coat the lugs with a thin film of approved lubricant such as lubriplate. See Fig. 7C-6E.

2. Assemble lever, eyebolt and pin, holding eyebolt and lever as close together as possible and with the other hand grasp strut as shown in Fig. 7C-7E.

3. Insert strut in the slots in the pressure plate lug, drop slightly and tilt the lower edge until it touches vertical milled surface of lug.

4. Insert lower end of eyebolt in hole in pressure plate. The short end of the lever will then be under the hook of the pressure plate and near the strut, as in Fig. 7C-5E.

5. Slide the strut upward in the slots of the lug, lifting it over the ridge on the short end of the lever and drop it

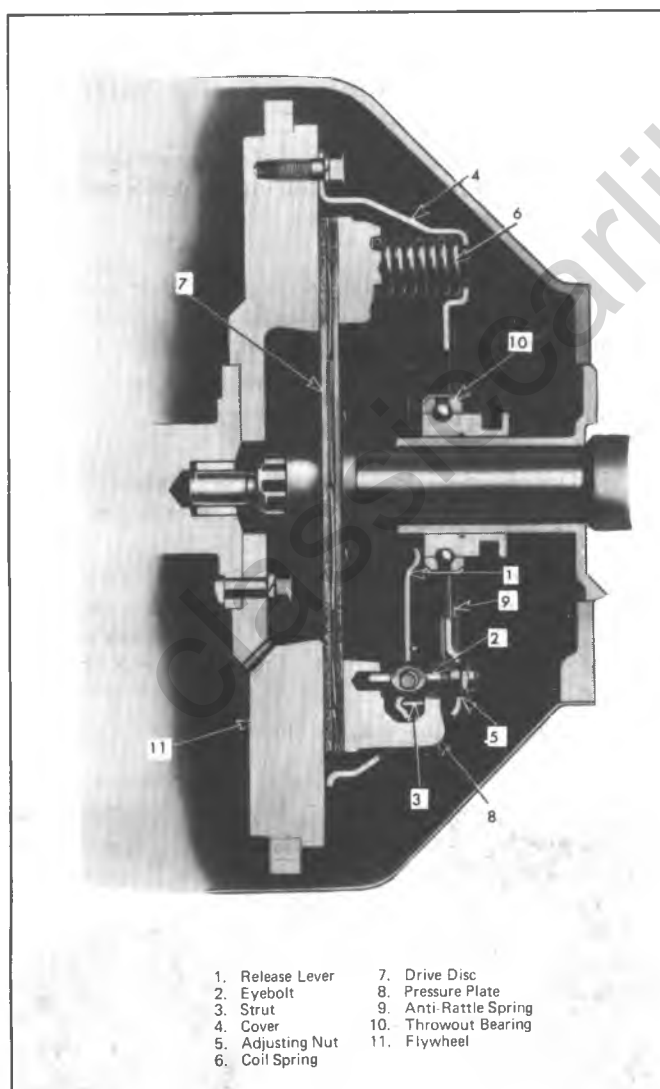

Fig. 7C-1E—Coil Spring Clutch Cross-Section (Single Plate)



Fig. 7C-2E—Compressing Clutch

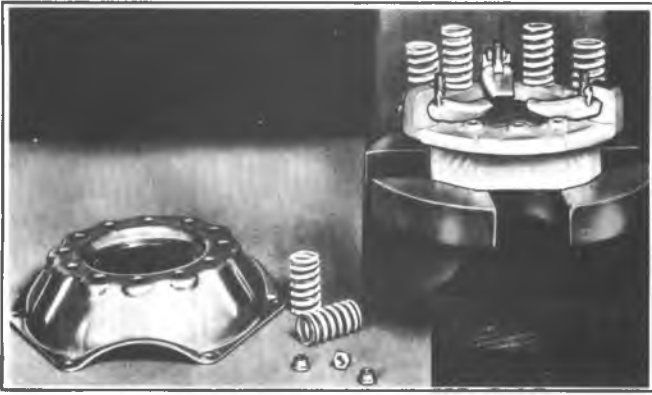

Fig. 7C-3E--Disassembly of Clutch

into the groove in the lever, as shown in Fig. 7C-4E.

6. Assemble the pressure springs, on the small bosses of the pressure plate in accordance with Fig. 7C-8E in order to retain original balance.

**NOTICE:** If there are spaces for more springs than specified for the particular assembly, or if two different colors of springs are used, Fig. 7C-8E shows the proper sequence. It is very important that each group be arranged in like sequence.

7. Assemble anti-rattle springs in cover. See Fig. 7C-9E. The spring to the left is in operating position.

8. Lower the cover on top of the assembled parts, as in Fig. 7C-10E. Be sure that the anti-rattle springs are in correct position and also that the punch marks made before dismantling are matched to insure retaining the original balance.

9. Place a bar across the cover and slowly compress, guiding the holes in the cover over the pressure plate lugs and all springs into their spring seats in the cover.

10. Assemble adjusting nuts on the eyebolts and screw them down until their tops are flush with the tops of the eyebolts. Slowly release pressure of spindle and remove cover assembly from press.

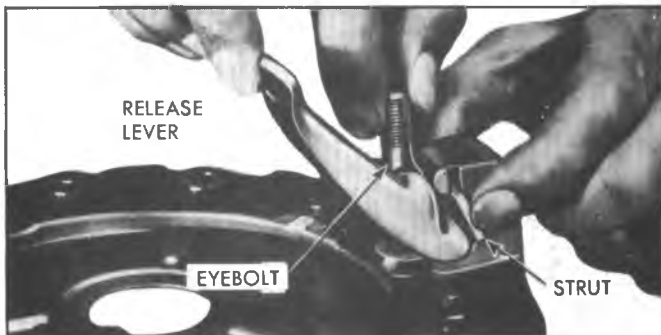

Fig. 7C-4E--Grasping Lever and Strut

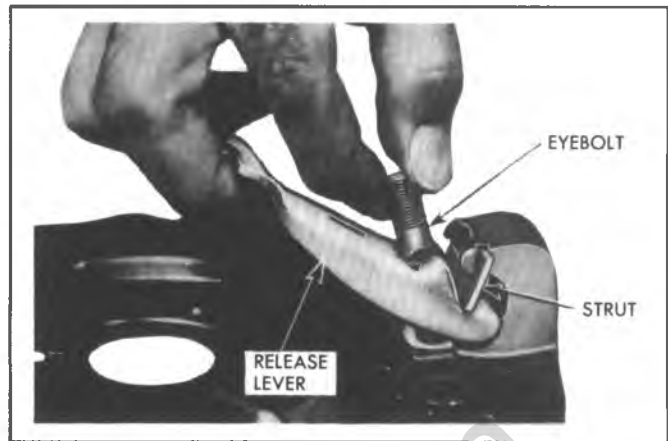

Fig. 7C-5E--Removing or Installing Lever

### ADJUSTING LEVERS

While no wear adjustment is needed because of the coil spring design, it is imperative that the clutch release levers are each set to exactly the same height at the time of rebuild to insure uniform clutch application. To obtain exactly the same adjustment at each release lever, use gauge plate J-1048 and release lever height gauge J-6456 as follows:

1. Place gauge plate J-1048 on the flywheel in position normally occupied by driven plate. See Fig. 7C-11E.

**NOTICE:** It is recommended that a spare flywheel be obtained so that this operation may be performed at the bench.

2. Bolt cover on flywheel with gauge plate center.

**NOTICE:** On assemblies with three levers, the three flat machined lands of the gauge plate must be located directly under the levers.

3. Depress each lever several times with a hammer handle to settle all parts into working position, as shown in Fig. 7C-12E.

4. Position height gauge J-6456-01 on the hub of the gauge plate and the bearing surface of one lever. Refer to Fig. 7C-13E. Turn adjusting nut until lever is flush with the 12" step of J-6456-01. Adjust remaining levers in same manner.

5. Stake adjusting nut, as shown in Fig. 7C-14E, to eyebolt with a dull punch to lock adjustment.



Fig. 7C-6E--Greasing Lug

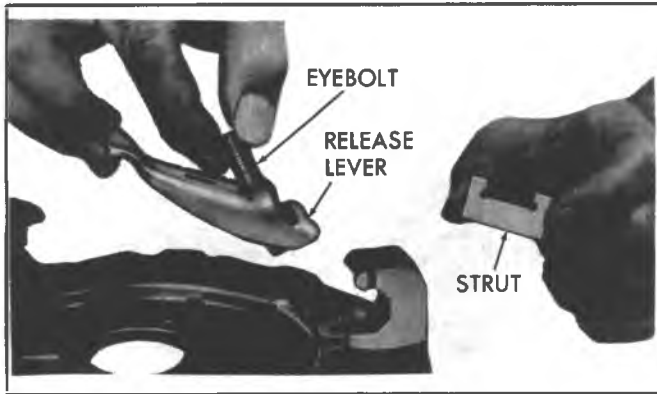

Fig. 7C-7E-Installing Lever

6. Loosen the cover to flywheel bolts a turn or two at a time and in rotation until spring pressure is relieved to allow clutch and gauge plate to be removed.

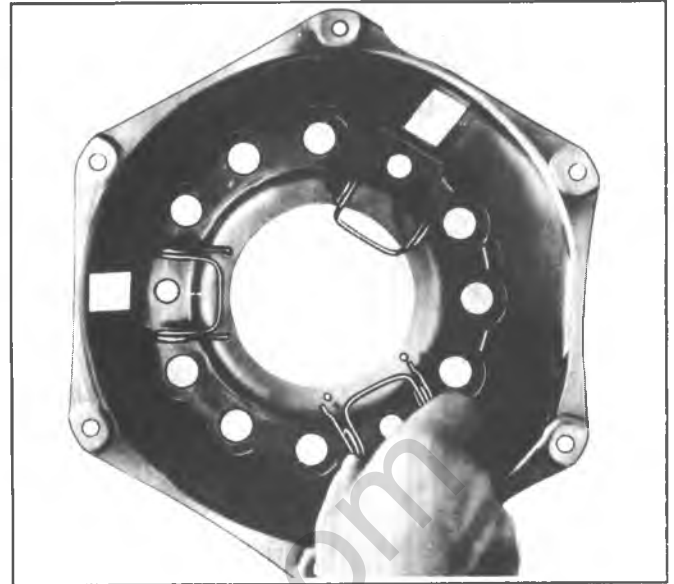

Fig. 7C-9E-Installing Anti-Rattle Spring

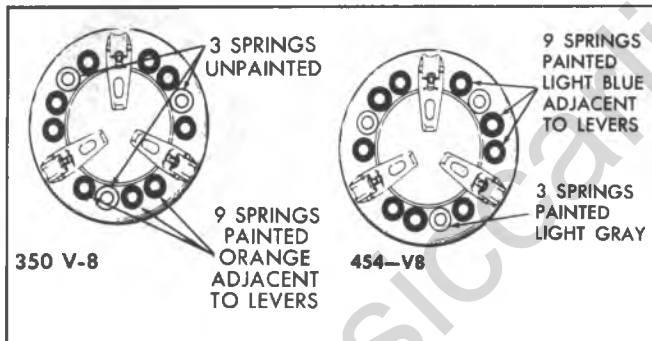

Fig. 7C-8E-Spring Arrangement Diagram



Fig. 7C-10E-Assembling Cover and Pressure Plate



Fig. 7C-11E-Gauge Plate Position

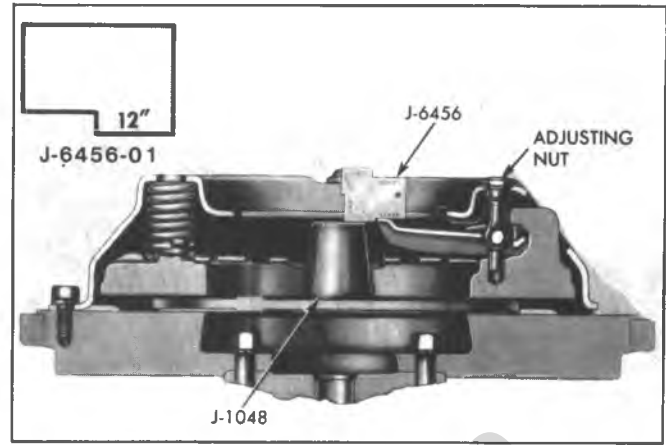

Fig. 7C-13E-Coil Spring Clutch Adjustment



Fig. 7C-12E-Depressing Lever



Fig. 7C-14E-Staking Nut

classiccarlibrary.com



## SPECIAL TOOLS

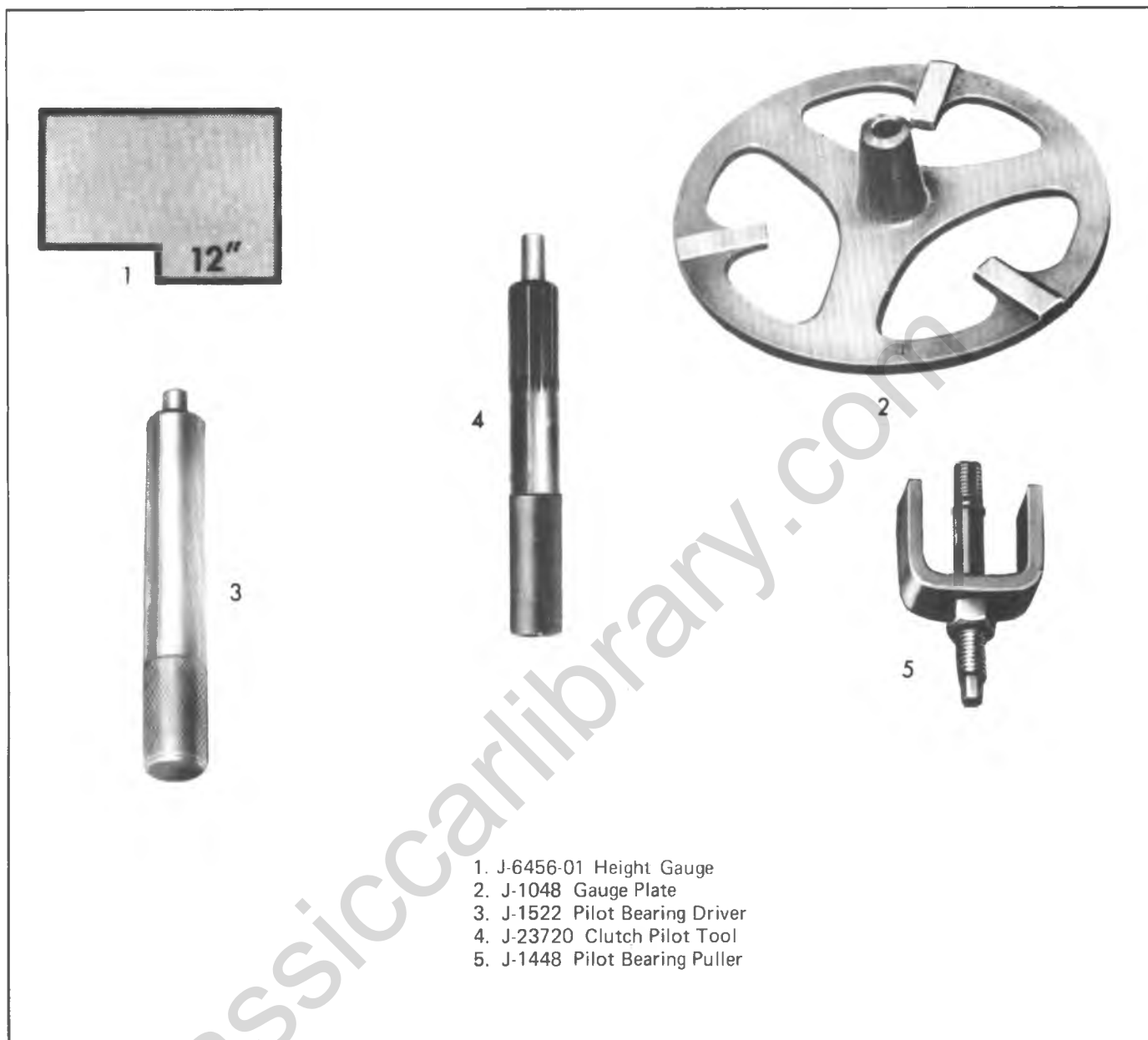

Fig. 7C-1ST-Clutch Special Tools

classiccarylbrary.com

## SECTION 7E

# TRANSFER CASE

## CONTENTS

Model 208 Transfer Case (10 and 20 Series) .....	7E-1
Model 205 Transfer Case (30 Series).....	7E-12
Specifications .....	7E-20
Special Tools.....	7E-21

### MODEL 208 TRANSFER CASE

### CONTENTS

Disassembly .....	7E-3
Cleaning and Inspection.....	7E-4
Subassembly Overhaul .....	7E-5
Reassembly and Installation .....	7E-9

classiccarlibrary.com

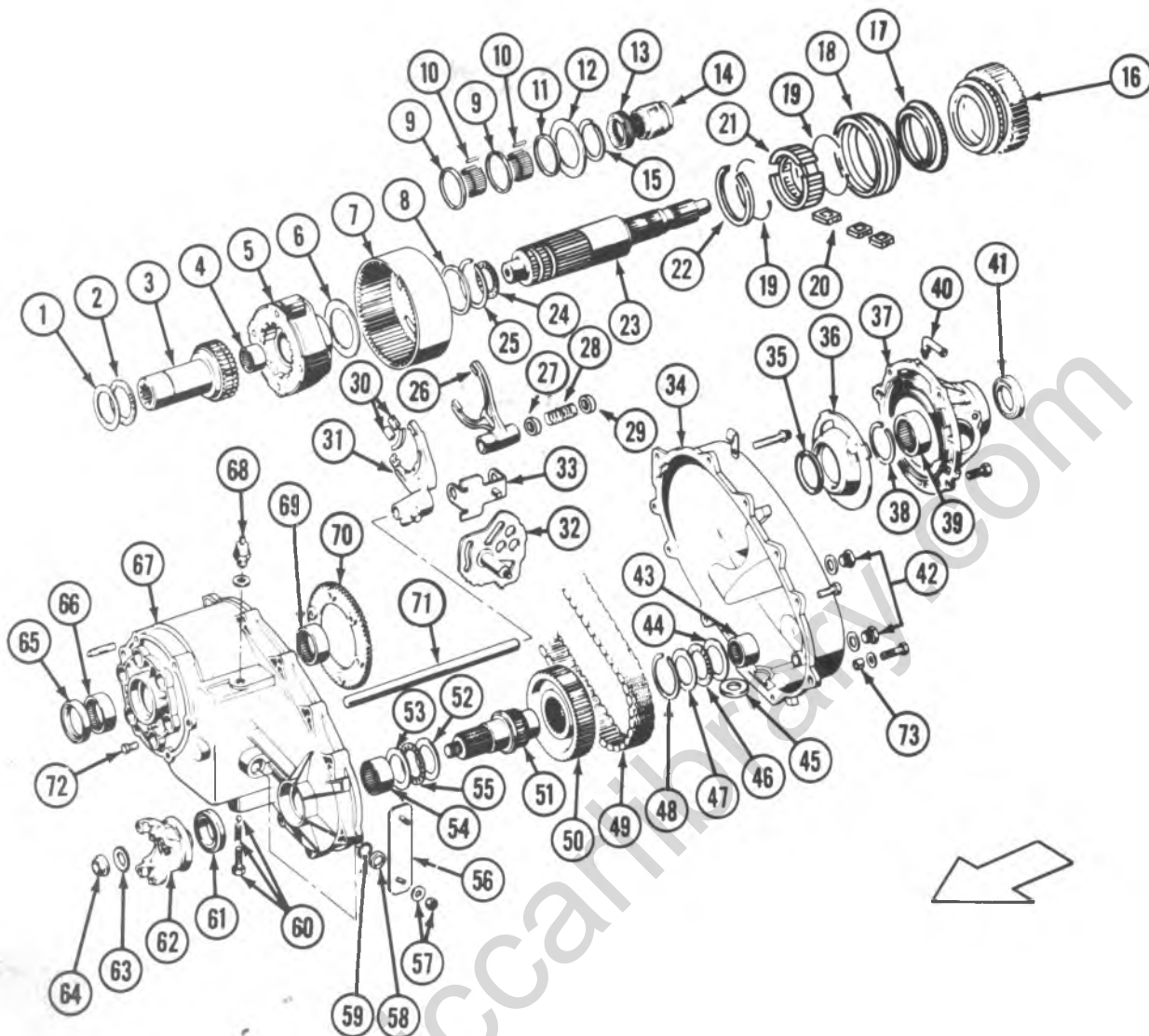

- |                                     |                                    |                                |
|-------------------------------------|------------------------------------|--------------------------------|
| 1. INPUT GEAR THRUST WASHER         | 33. MODE FORK BRACKET              | 57. WASHER AND LOCKNUT         |
| 2. INPUT GEAR THRUST BEARING        | 34. REAR CASE                      | 58. RANGE SECTOR SHAFT SEAL    |
| 3. INPUT GEAR                       | 35. SEAL                           | RETAINER                       |
| 4. MAINSHAFT PILOT BEARING          | 36. PUMP HOUSING                   | 59. RANGE SECTOR SHAFT SEAL    |
| 5. PLANETARY ASSEMBLY               | 37. REAR RETAINER                  | RETAINER                       |
| 6. PLANETARY THRUST WASHER          | 38. BEARING SNAP RING              | 60. DETENT BALL, SPRING AND    |
| 7. ANNULUS GEAR                     | 39. REAR OUTPUT BEARING            | RETAINER BOLT                  |
| 8. ANNULUS GEAR THRUST WASHER       | 40. VENT TUBE                      | 61. FRONT SEAL                 |
| 9. NEEDLE BEARING SPACERS           | 41. REAR SEAL                      | 62. FRONT YOKE                 |
| 10. MAINSHAFT NEEDLE BEARINGS (120) | 42. DRAIN AND FILL PLUGS           | 63. YOKE SEAL WASHER           |
| 11. NEEDLE BEARING SPACER           | 43. FRONT OUTPUT SHAFT REAR        | 64. YOKE NUT                   |
| 12. SPACER WASHER                   | BEARING                            | 65. INPUT GEAR OIL SEAL        |
| 13. OIL PUMP GEAR                   | 44. FRONT OUTPUT SHAFT REAR THRUST | 66. INPUT GEAR FRONT BEARING   |
| 14. SPEEDOMETER GEAR                | BEARING RACE (THICK)               | 67. FRONT CASE                 |
| 15. DRIVE SPROCKET SNAP RING        | 45. CASE MAGNET                    | 68. LOCK MODE INDICATOR SWITCH |
| 16. DRIVE SPROCKET                  | 46. FRONT OUTPUT SHAFT REAR THRUST | AND WASHER                     |
| 17. BLOCKER RING                    | BEARING                            | 69. INPUT GEAR REAR BEARING    |
| 18. SYNCHRONIZER SLEEVE             | 47. FRONT OUTPUT SHAFT REAR THRUST | 70. LOCKPLATE                  |
| 19. SYNCHRONIZER SPRING             | BEARING RACE (THIN)                | 71. SHIFTER FORK SHAFT         |
| 20. SYNCHRONIZER KEY                | 48. DRIVEN SPROCKET RETAINING RING | 72. LOCKPLATE BOLTS            |
| 21. SYNCHRONIZER HUB                | 49. DRIVE CHAIN                    | 73. CASE ALIGNMENT DOWELS      |
| 22. SYNCHRONIZER HUB SNAP RING      | 50. DRIVEN SPROCKET                |                                |
| 23. MAINSHAFT                       | 51. FRONT OUTPUT SHAFT             |                                |
| 24. MAINSHAFT THRUST BEARING        | 52. FRONT OUTPUT SHAFT FRONT       |                                |
| 25. INTERNAL GEAR SNAP RING         | THRUST BEARING RACE (THIN)         |                                |
| 26. MODE FORK                       | 53. FRONT OUTPUT SHAFT FRONT       |                                |
| 27. BUSHING, SHIFT ROD              | THRUST BEARING RACE (THICK)        |                                |
| 28. SPRING                          | 54. FRONT OUTPUT SHAFT FRONT       |                                |
| 29. SPRING RETAINER                 | BEARING                            |                                |
| 30. RANGE FORK PADS                 | 55. FRONT OUTPUT SHAFT FRONT       |                                |
| 31. RANGE FORK                      | THRUST BEARING                     |                                |
| 32. RANGE SECTOR                    | 56. OPERATING LEVER                |                                |

Fig. 7E-1-208 Transfer Case (Exploded View)

**TRANSFER CASE DISASSEMBLY**

1. Remove fill and drain plugs (Fig. 7E-1).
2. Remove front yoke. Discard yoke seal washer and yoke nut.
3. Turn transfer case on end and position front case on wood blocks. Cut "V" notches in wood blocks to clear mounting studs in front case if necessary.
4. Remove lock mode indicator switch and washer (Fig. 7E-1).
5. Remove detent bolt, spring and ball (Fig. 7E-2).
6. Remove rear retainer attaching bolts and remove retainer and pump housing as assembly (Fig. 7E-3). Tap retainer from case using plastic mallet only. DO NOT pry.
7. Remove pump housing from retainer and remove pump seal from housing (Fig. 7E-3). Discard seal.
8. Remove speedometer drive gear from mainshaft.
9. Remove oil pump from mainshaft. Note the position of pump for assembly reference. Side facing case interior has recess in it (Fig. 7E-4).
10. Remove bolts attaching rear case to front case and remove rear case. To remove the rear case, insert screwdrivers into the slots cast in the case ends and gently pry upward. DO NOT attempt to wedge the case halves apart at any point on the mating surfaces.
11. Remove bushing, retainer and spring from shift rod.
12. Remove front output shaft rear thrust bearing assembly (Fig. 7E-5). Note position of bearing and races for assembly reference.
13. Remove driven sprocket retaining snap ring (Fig. 7E-6).
14. Remove drive sprocket retaining snap ring and remove spacer washer (Fig. 7E-7).
15. Remove drive and driven sprockets and drive chain as assembly (Fig. 7E-8). Lift evenly on both sprockets to remove assembly. Mainshaft roller bearings may drop out of driven sprocket.
16. Remove front output shaft and front thrust bearing assembly (Fig. 7E-9).
17. Remove synchronizer blocker ring (Fig. 7E-10).
18. Remove synchronizer, mode fork bushing, mode fork and bracket as assembly (Fig. 7E-11). The synchronizer keys may fall free from the hub.
19. Remove shift rail.
20. Remove mainshaft with synchronizer hub and snap ring attached (Fig. 7E-12).
21. Remove annulus gear snap ring and thrust washer.
22. Remove annulus gear and range fork as assembly. Turn fork counterclockwise to disengage fork lug from range sector and lift assembly out of case (Fig. 7E-13).
23. Remove planetary thrust washer and remove planetary assembly (Fig. 7E-14).
24. Remove mainshaft thrust bearing from input gear (Fig. 7E-15) and remove input gear. Lift gear straight up and out of case.
25. Remove input gear thrust bearing and race (Fig. 7E-16). NOTE the position of bearing and race for assembly reference.
26. Remove range sector operating lever attaching nut and washer. Remove lever and remove sector shaft seal and seal retainer (Fig. 7E-1).
27. Remove range sector.
28. Inspect lock plate (Fig. 7E-16). If lock plate is loose or is worn, broken or cracked, remove lock plate. Refer to replacement procedure in Subassembly Overhaul section.
29. Remove output shaft seals from front and rear case seal bores.

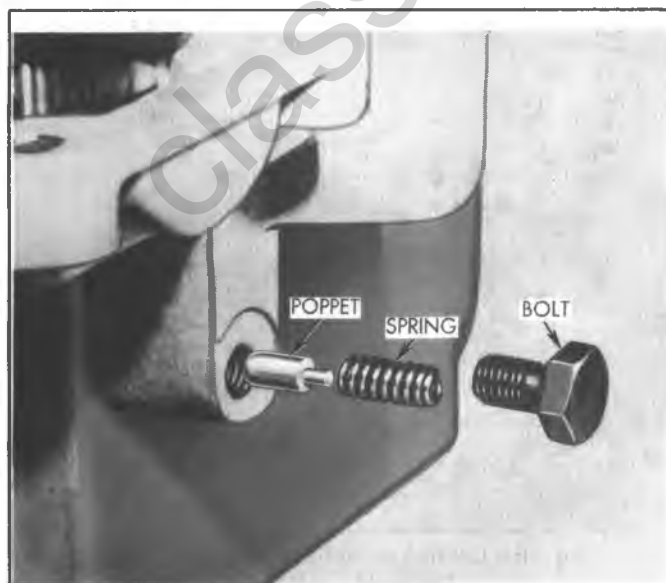

Fig. 7E-2-Poppet, Spring and Bolt Removal/  
Installation

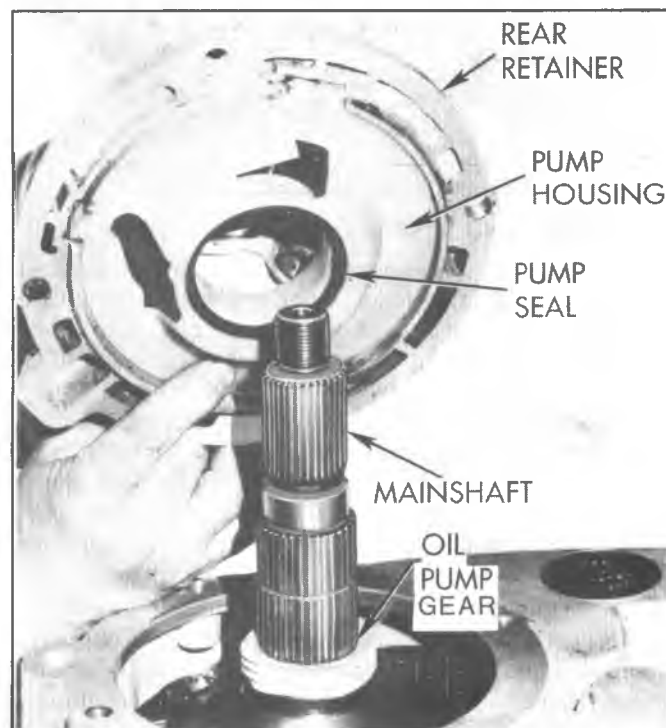

Fig. 7E-3-Rear Retainer Removal & Installation



Fig. 7E-4-Oil Pump Removal&amp;Installation

### CLEANING AND INSPECTION

Wash all parts thoroughly in clean solvent. Be sure all old lubricant, metallic particles, dirt, or foreign material are removed from the surfaces of every part. Apply compressed air to each oil feed port and channel in each case half to remove any obstructions or cleaning solvent residue.

Inspect all gear teeth for signs of excessive wear or damage and check all gear splines for burrs, nicks, wear or damage. Remove minor nicks or scratches on oil stone. Replace any part exhibiting excessive wear or damage.

Inspect all snap rings and thrust washers for evidence of excessive wear, distortion or damage. Replace any of these parts if they exhibit these conditions.

Inspect the two case halves for cracks, porosity, damaged mating surfaces, stripped bolt threads, or distortion. Replace any part that exhibits these conditions. Inspect the low range lock plate in the front case. If the lock plate teeth or the plate hub is cracked, broken, chipped, or



Fig. 7E-5-Front Output Shaft Rear Thrust Bearing Assembly

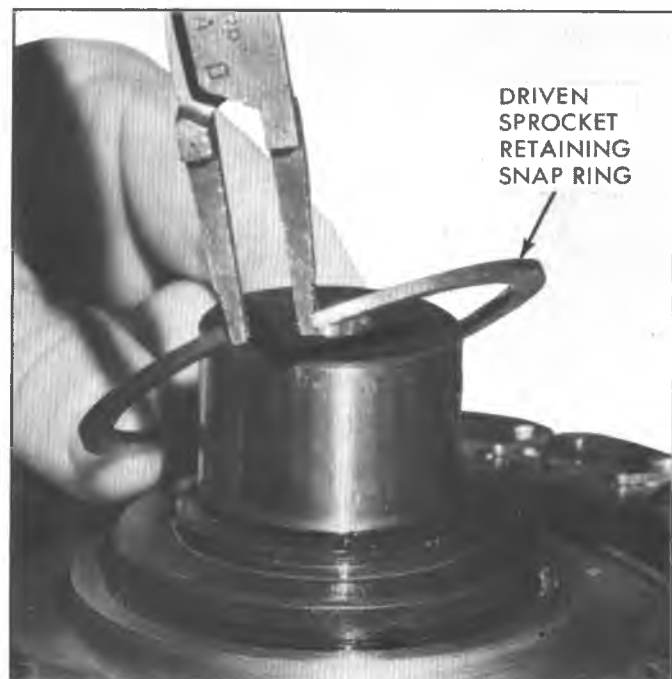

Fig. 7E-6-Driven Sprocket Retaining Snap Ring Removal&amp;Installation



Fig. 7E-7-Drive Sprocket Thrust Washer Removal&Installation

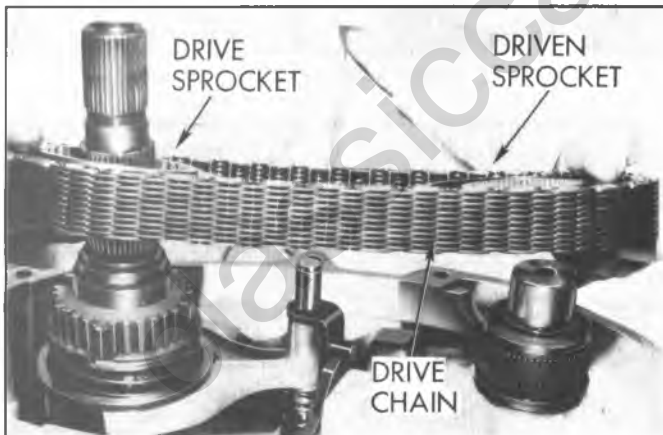

Fig. 7E-8-Sprocket and Chain Removal&Installation  
excessively worn, replace the lock plate and the lock plate attaching bolts. Refer to the Lock Plate Replacement procedure.

Inspect the condition of all needle, roller and thrust bearings in the front and rear case halves and the input gear. Also, check the condition of the bearing bores in both cases and in the input gear, rear output shaft, side gear, and rear retainer. Replace any part that exhibits signs of excessive wear or damage. If the case or input gear bearings require replacement, refer to Bearing Replacement.

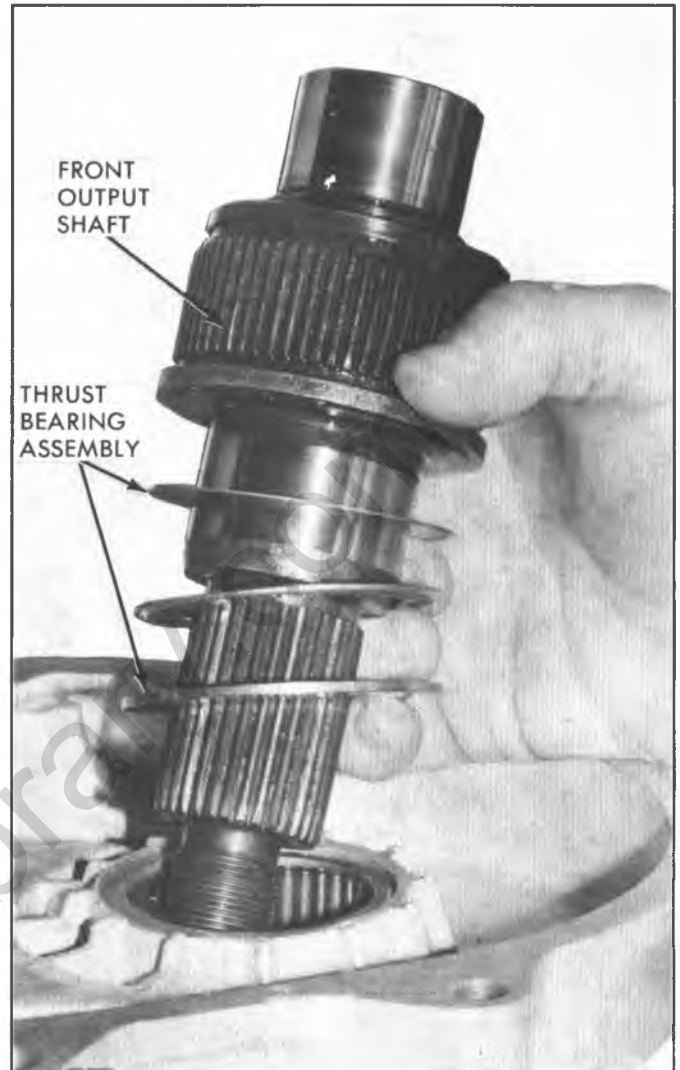

Fig. 7E-9-Front Output Shaft and Front Thrust Bearing Assembly Removal&Installation

## SUBASSEMBLY OVERHAUL

### Lock Plate Replacement

1. Remove and discard lock plate attaching bolts.
2. Remove lock plate from case.
3. Coat case and lock plate surfaces around bolt holes with Loctite 515 sealant, or equivalent.
4. Position new lock plate in case and align bolt holes in lock plate and case.
5. Coat new lock plate attaching bolts with Loctite 271 sealant, or equivalent.
6. Install and tighten lock plate attaching bolts to 30 ft.lb. (41N·m).

### Bearing and Bushing Replacement

All of the bearings used in the transfer case must be correctly positioned to avoid covering the bearing oil feed holes. After replacing any bearings check the bearing position to be sure the feed hole is not obstructed or blocked by a bearing.



Fig. 7E-10-Synchronizer Blocker Ring Removal & Installation

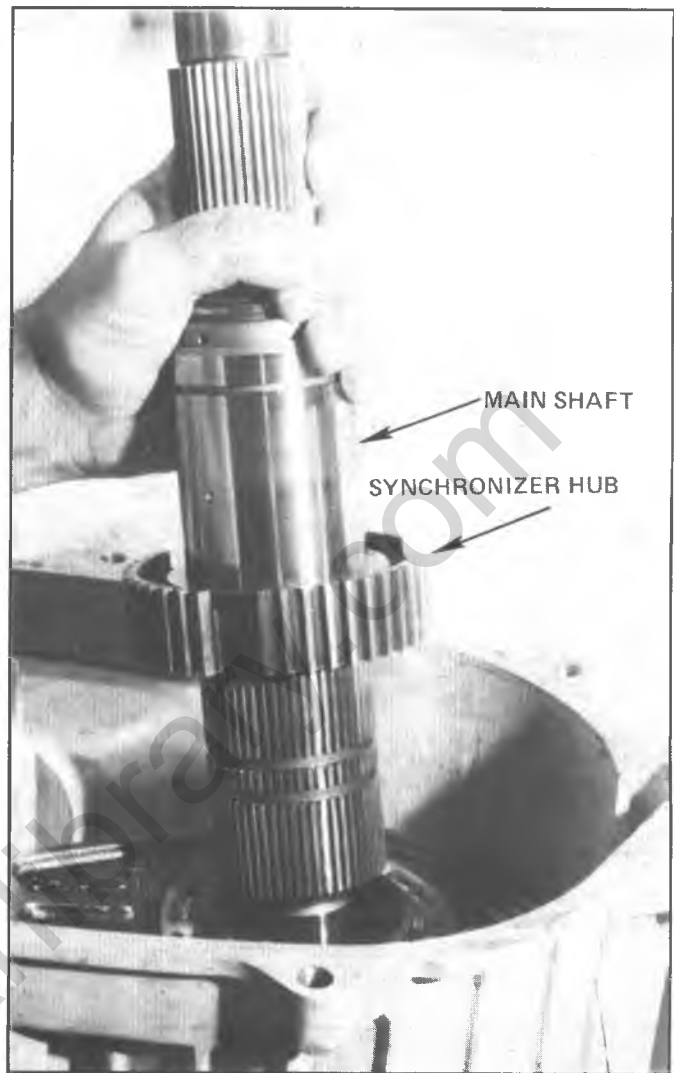

Fig. 7E-12-Mainshaft Removal&Installation

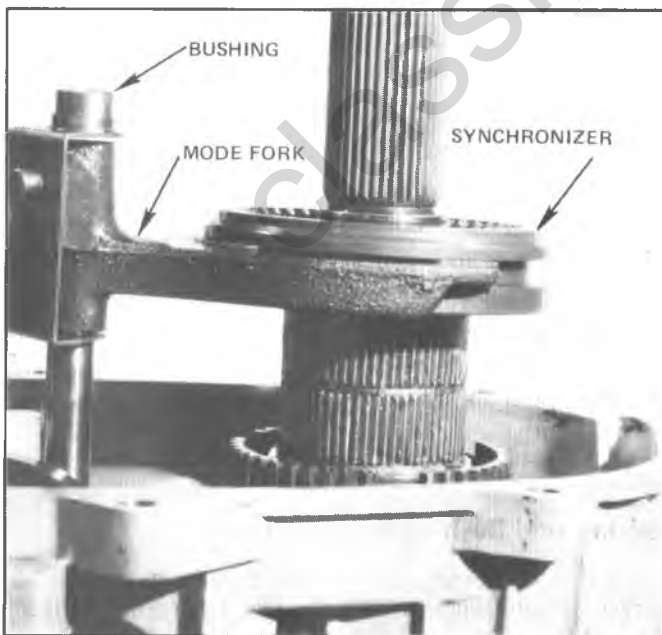

Fig. 7E-11-Synchronizer, Mode Fork Bushing, Mode Fork and Bracket

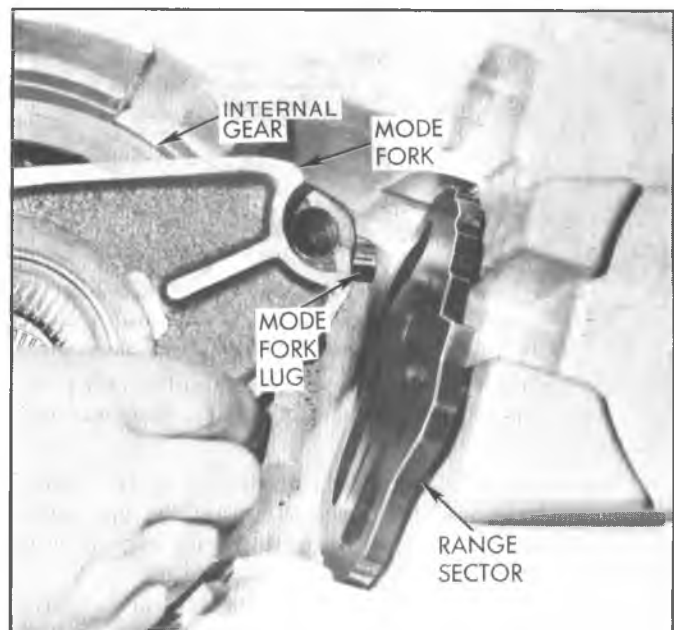

Fig. 7E-13-Annulus Gear and Mode Fork Removal&Installation





Fig. 7E-14-Planetary Thrust Washer and Planetary Assembly

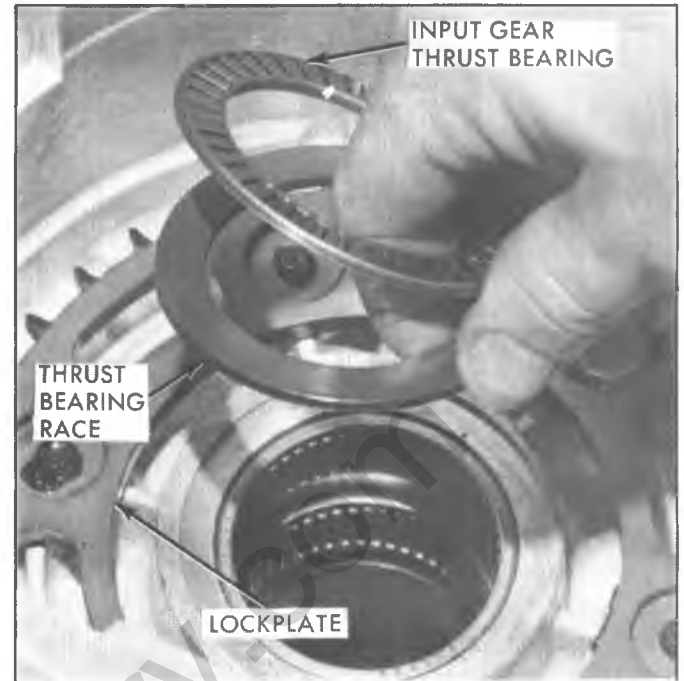

Fig. 7E-16-Input Gear Thrust Bearing and Race Removal&Installation



Fig. 7E-15-Mainshaft Thrust Bearing and Input Gear

#### Rear Output Bearing and Rear Seal Replacement

1. Drive bearing out of retainer using mallet or brass drift.
2. Remove rear seal using screwdriver or brass drift.
3. Install new bearing using Tool J-7818 (Fig. 7E-17). Be sure shielded side of bearing faces interior of case.
4. Install bearing retaining snap ring.
5. Install new rear seal using Tool J-29162 (Fig. 7E-18).

#### Front Output Shaft /Front Bearing Replacement

1. Remove bearing using Tools J-8092 and J-29168 (Fig. 7E-19).
2. Install new bearing using Tools J-8092 and J-29167 (Fig. 7E-20).
3. Remove installer tools and check bearing position to be sure oil feed hole is not covered.

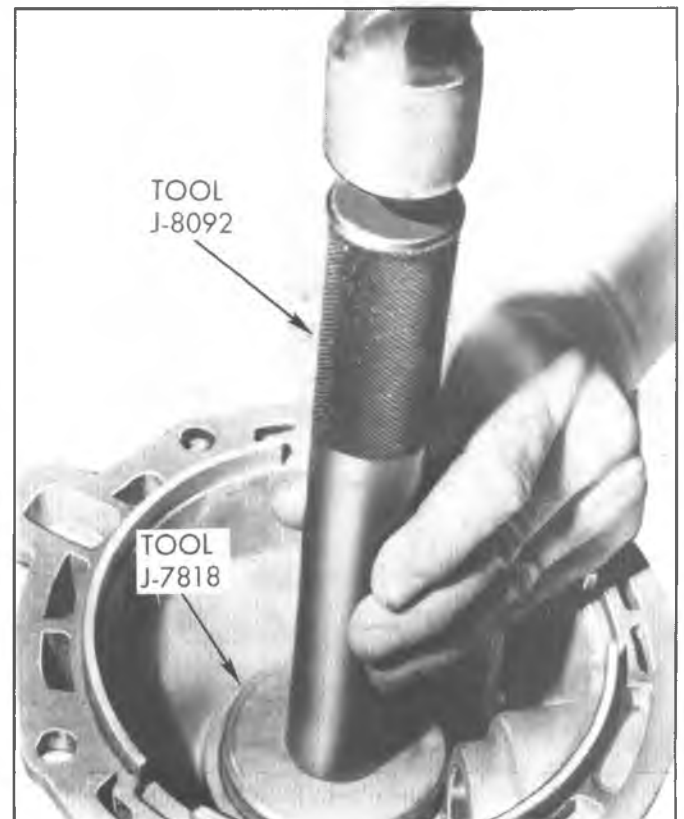

Fig. 7E-17-Rear Output Bearing Installation

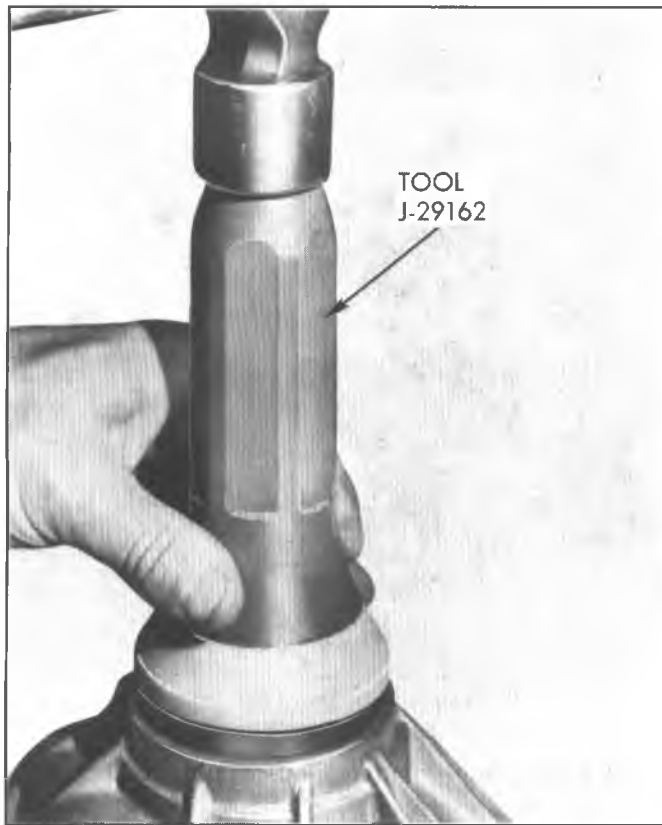

Fig. 7E-18-Rear Seal Installation

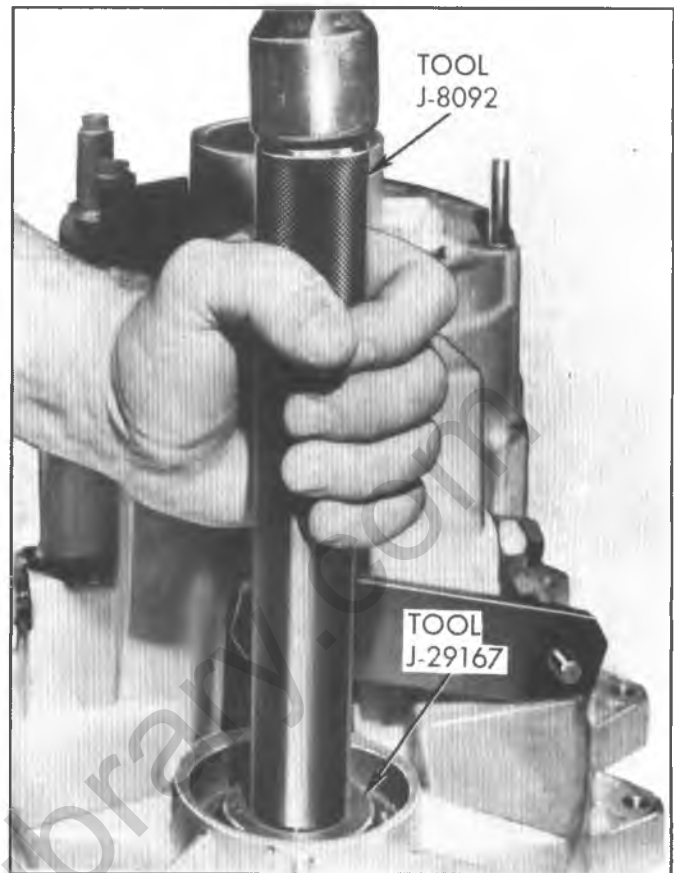

Fig. 7E-20-Front Output Shaft Front Bearing Installation

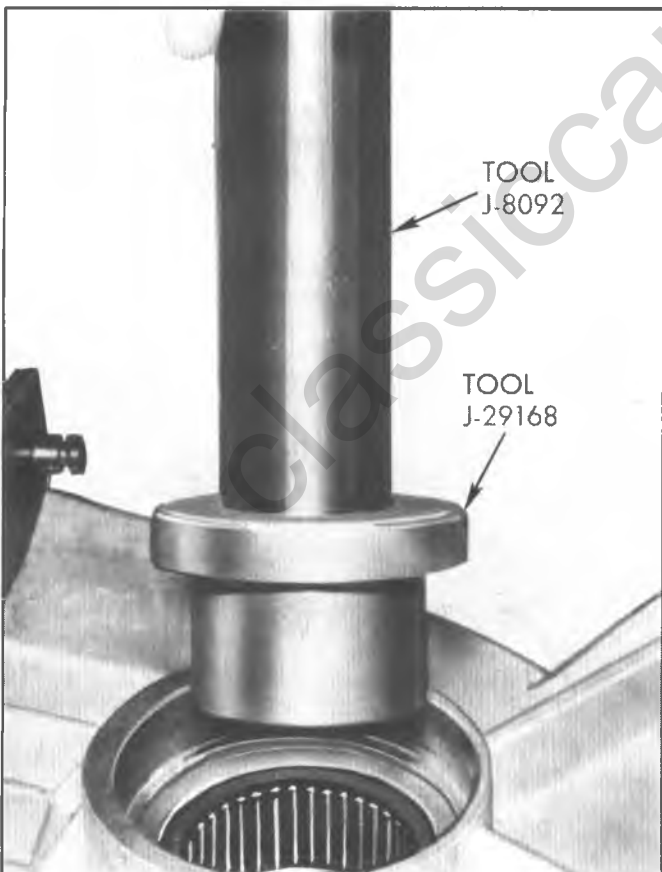

Fig. 7E-19-Front Output Shaft Front Bearing Removal

#### Front Output Shaft Rear Bearing Replacement

1. Remove bearing using Remover J-26941 and Slide Hammer J-2619-01 (Fig. 7E-21).
2. Install new bearing using Driver Handle J-8092 and Installer J-29163 (Fig. 7E-22).
3. Remove installer tools and check bearing position to be sure oil feed hole is not covered. Also, be sure bearing is seated flush with edge of case bore to allow room for thrust bearing assembly.

#### Input Gear Front/Rear Bearing Replacement

1. Remove both bearings simultaneously using Driver Handle J-8092 and Remover J-29170 (Fig. 7E-23).
2. Install new bearings one at a time. Install rear bearing first; then install front bearing. Use Driver Handle J-8092 and Installer J-29169 (Fig. 7E-24).
3. Remove installer tools and check bearing position to be sure oil feed holes are not covered. Also, be sure bearings are flush with case bore surfaces.

#### Mainshaft Pilot Bearing Replacement

1. If bearing cannot be removed by hand, remove it using Slide Hammer J-2619-01 and Remover J-29369-1 or similar internal type blind hole bearing puller (Fig. 7E-25).
2. If necessary, install new bearing using Driver Handle J-8092 and Installer J-29174 (Fig. 7E-26).
3. If bearing was seated using installer tools, check bearing position to be sure oil feed hole is not covered.

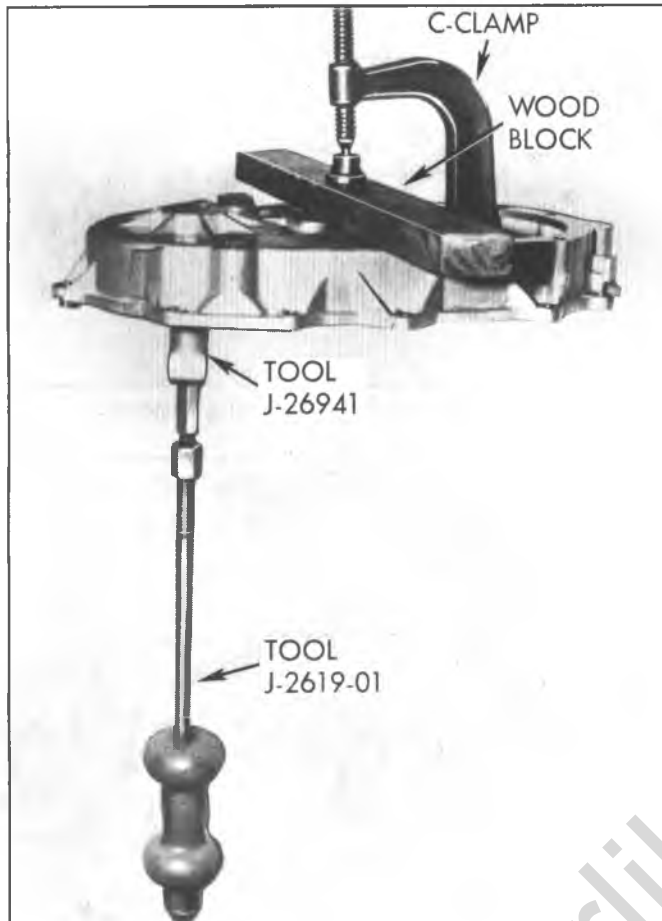

7E-21-Front Output Shaft Rear Bearing Removal

Also, be sure bearing is seated flush with edge of oil hole.

### REASSEMBLY AND INSTALLATION

During assembly, lubricate components with Dexron<sup>®</sup> II or petroleum jelly.

1. Install input gear race and thrust bearing in front case (Fig. 7E-16).
2. Install input gear.
3. Install mainshaft thrust bearing in input gear (Fig. 7E-27).
4. Install range sector shaft seal and seal retainer (Fig. 7E-1).
5. Install range sector.
6. Install operating lever on range sector shaft. Install shaft washer and tighten locknut to 18 ft. lb. (24 N·m).
7. Install planetary assembly over input gear (Fig. 7E-27). Be sure planetary is fully seated and meshed with gear.
8. Install planetary thrust washer on planetary hub (Fig. 7E-14).
9. Install inserts in range fork, if removed.
10. Engage range fork in annulus gear and install annulus gear over planetary assembly (Fig. 7E-28). Be sure that the range fork lug is fully inserted in range sector slot (Fig. 7E-13).
11. Install annulus gear snap ring.
12. Align shaft bores in case and range fork, and install shift rail (Fig. 7E-28).
13. Install mainshaft (Fig. 7E-12). Be sure mainshaft thrust bearing is properly seated in input gear before installing mainshaft.
14. Position synchronizer keys and install synchronizer and mode fork as assembly.
15. Install synchronizer blocker ring.
16. Coat mainshaft with liberal amount of petroleum jelly and position bearing retainer. Install two rows of 60 needle bearings on mainshaft separated by bearing retainer. Total of 120 bearings are used.
17. Install front output shaft front thrust bearing assembly in front case (Fig. 7E-9). Correct installation sequence is thick race-thrust bearing-thin race.
18. Install front output shaft.
19. Install sprockets and drive chain as assembly. Position sprockets in chain, align sprockets with shafts and install assembly (Fig. 7E-8). Be sure the drive sprocket is installed with the tooth side of the sprocket facing the case interior.
20. Install spacer on drive sprocket (Fig. 7E-7) and install sprocket retaining snap ring.
21. Install driven sprocket snap ring (Fig. 7E-6).

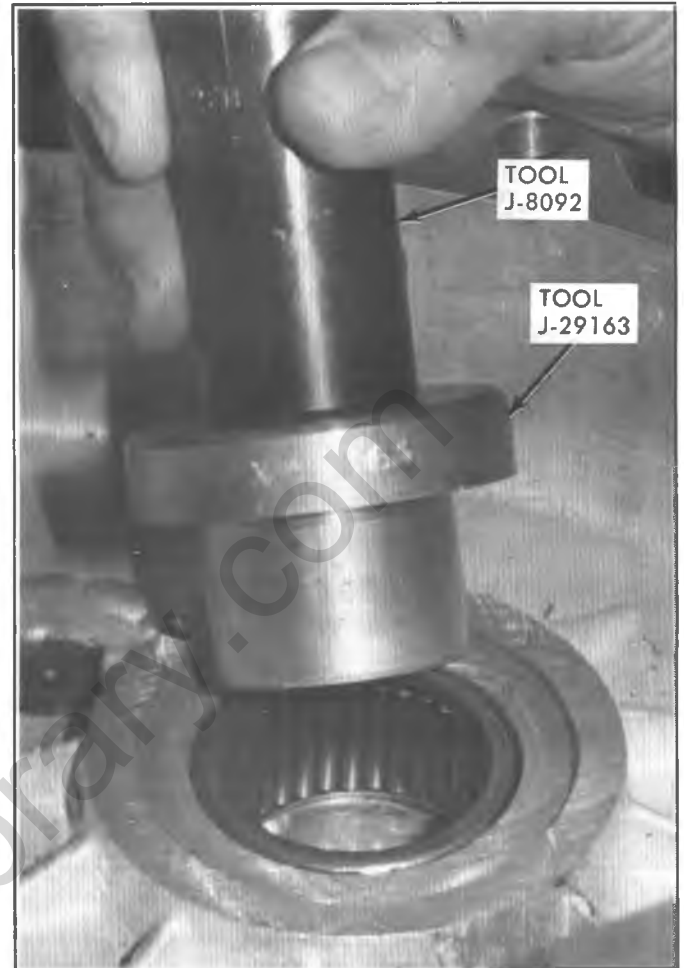

Fig. 7E-22-Front Output Shaft Rear Bearing Installation

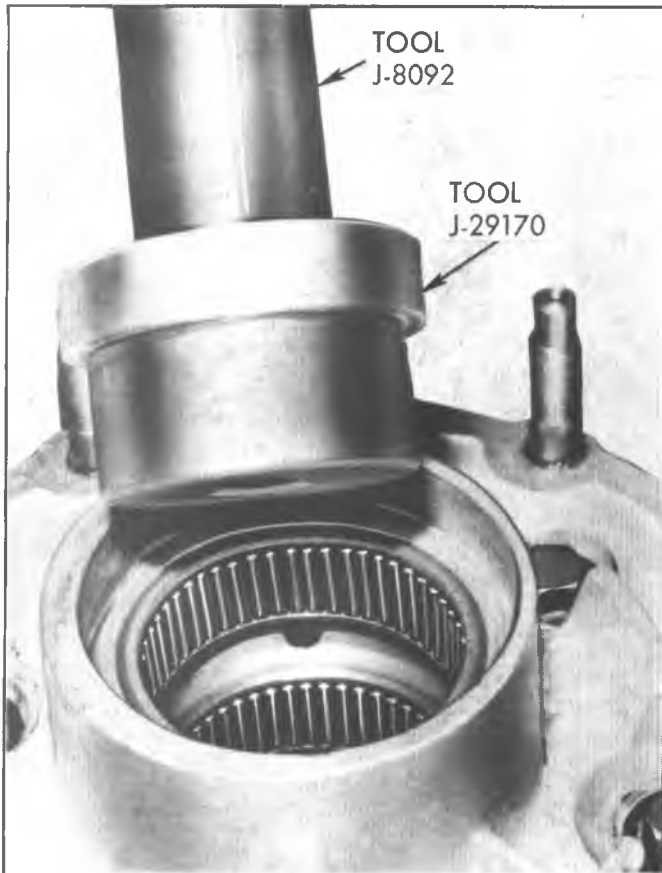

Fig. 7E-23-Input Gear Bearing Removal

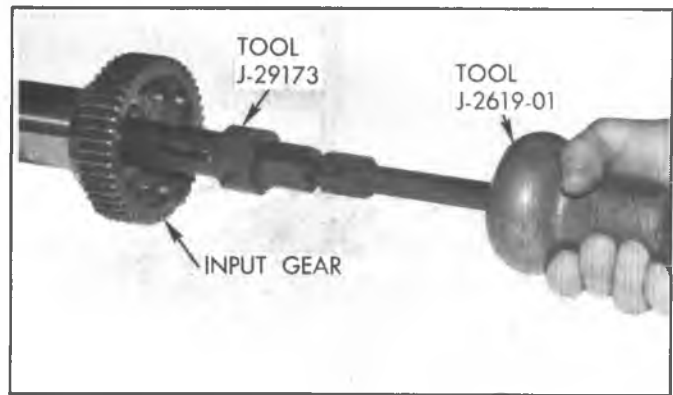

Fig. 7E-25 Mainshaft Pilot Bearing Removal

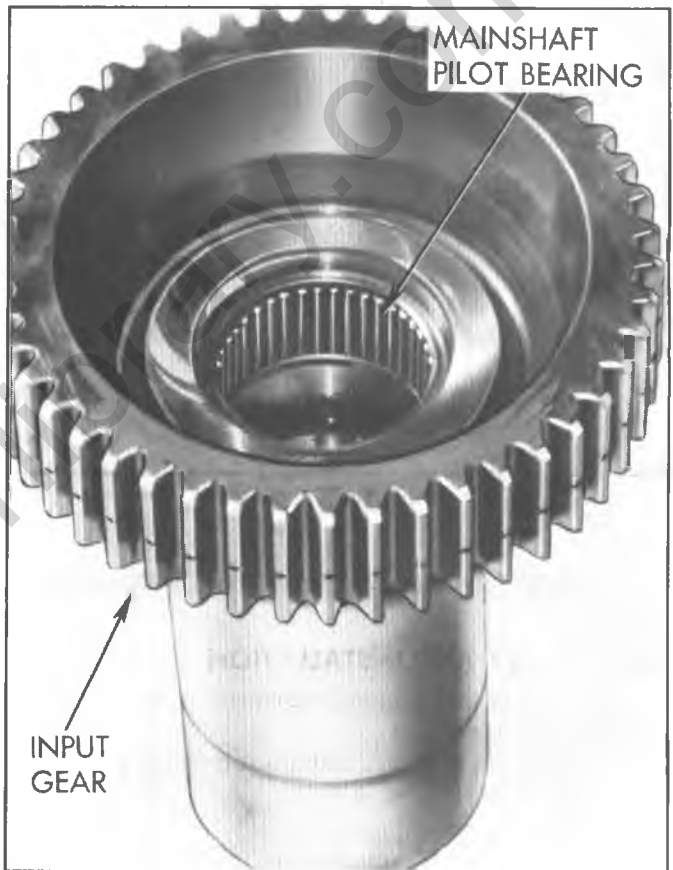

Fig. 7E-26 Mainshaft Pilot Bearing Installation

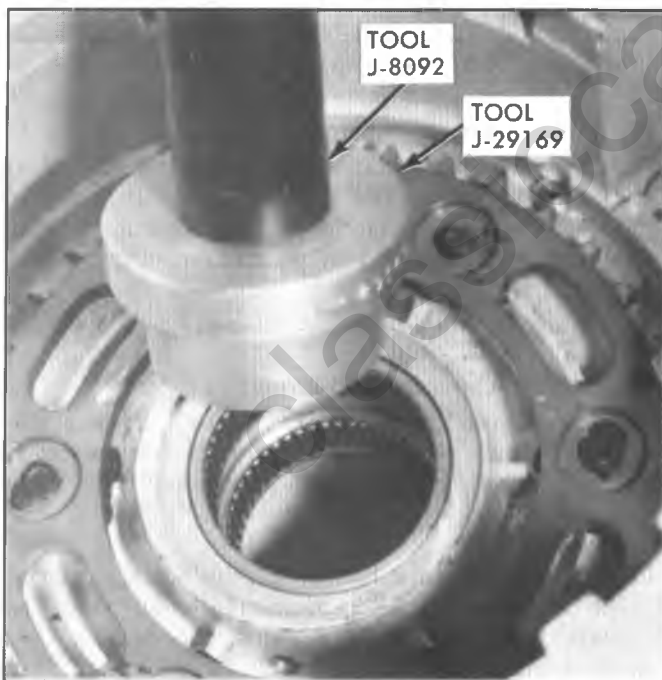

Fig. 7E-24-Input Gear Bearing Installation

22. Install front output shaft rear thrust bearing assembly on front output shaft (Fig. 7E-5). Correct installation sequence is thin race-thrust bearing- thick race.
23. Install oil pump gear on mainshaft. Be sure recessed side of pump faces downward toward case interior.
24. Install speedometer drive gear on mainshaft.

25. Install magnet in front case, if removed.
26. Install bushing, spring and retainer on shift rail.
27. Apply Loctite 515 sealant, or equivalent, to mating surface of front case and install rear case on front case. Be sure front output shaft rear thrust bearing assembly is seated in the rear case.
28. Align case bolt holes and alignment dowels and install bolts. Tighten bolts alternately and evenly to 23 ft.lb. (31 N·m). Be sure to install flat washers on the two bolts installed at the opposite ends of the case.
29. Install seal in pump housing. Apply petroleum jelly to pump housing tabs and install housing in rear retainer.
30. Apply Loctite 515 sealant, or equivalent, to mating surface of rear retainer.

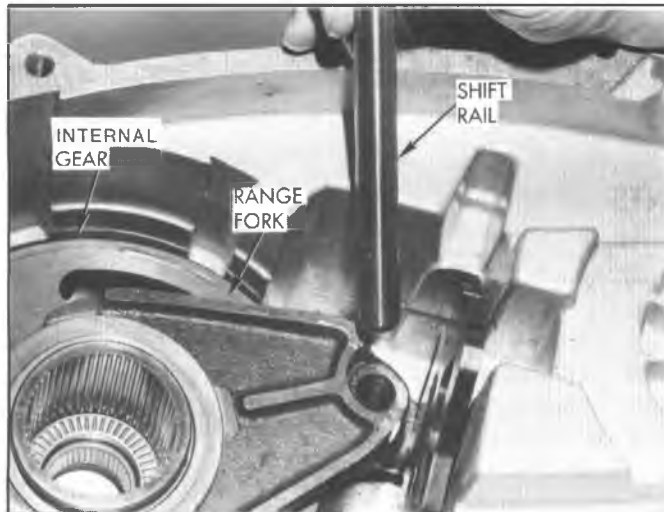

Fig. 7E-28-Annulus Gear and Shift Rail Installation

31. Align rear retainer and case index marks and install retainer. Install and tighten retainer bolts to 23 ft.lb. (31 N·m).
32. Install oil seal in rear retainer bore. Coat seal lip with petroleum jelly before installation.
33. Install washer and indicator switch. Tighten switch to 18 ft.lb. (24 N·m).
34. Apply small quantity of Loctite 515 sealant, or equivalent, to detent retainer bolt and install detent ball, spring and bolt (Fig. 7E-2). Tighten bolt to 23 ft.lb. (31 N·m).

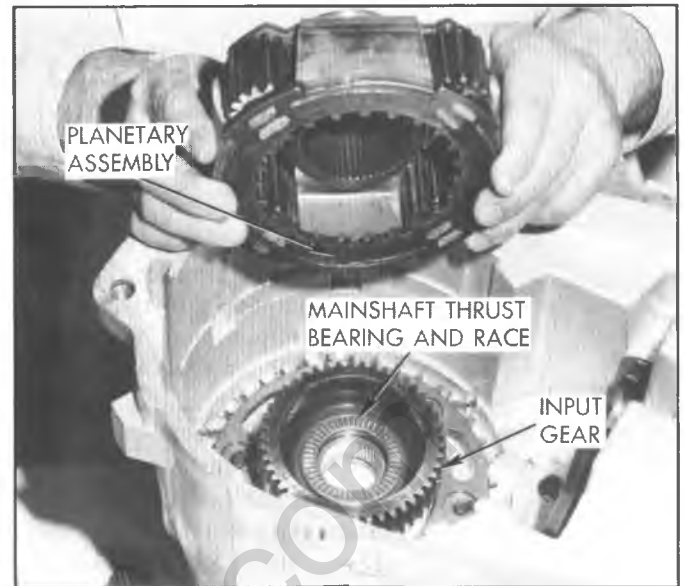

Fig. 7E-27-Input Gear, Mainshaft Thrust Bearing and Planetary Installation

35. Install drain plug and gasket. Tighten plug to 18 ft.lb. (24 N·m).
36. Install oil seal in front case output shaft bore.
37. Install front yoke.
38. Install yoke seal washer and yoke nut. Tighten nuts to 120 ft.lb. (163 N·m).
39. Pour 6 pints (3 liters) of Dexron<sup>®</sup> II into transfer case through fill plug hole and install and tighten fill plug to 18 ft.lb. (24 N·m).

classiccarr.com

# MODEL 205 TRANSFER CASE

## CONTENTS

Disassembly of Transfer Case.....	7E-12
Rear Output Shaft Assembly.....	7E-12
Front Output Shaft Assembly.....	7E-12
Shift Rail and Fork Assemblies.....	7E-13
Idler Gear.....	7E-13
Cleaning and Inspection.....	7E-13
Assembly of Transfer Case.....	7E-13
Idler Gear.....	7E-13
Shift Rail and Fork Assemblies.....	7E-15
Front Output Shaft Assembly.....	7E-15
Rear Output Shaft Assembly.....	7E-17

### DISASSEMBLY OF TRANSFER CASE (FIG. 7E-4R)

#### Rear Output Shaft and Yoke Assembly (Fig. 7E-1R)

1. Loosen rear output shaft yoke nut.
2. Remove rear output shaft housing bolts and remove housing and retainer assembly from case.

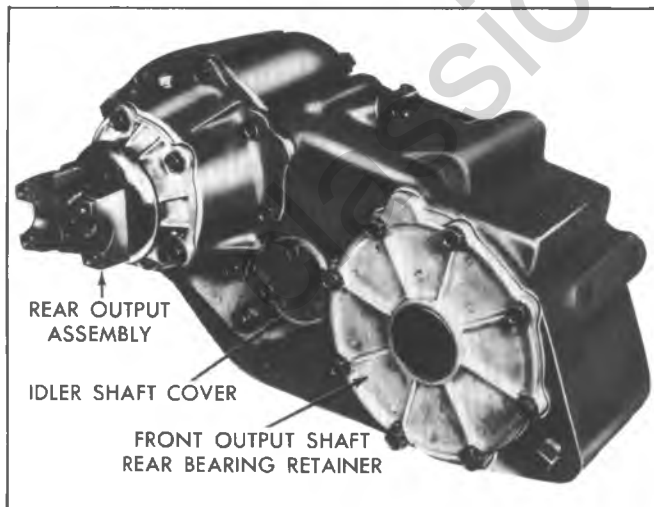

Fig. 7E-1R--Rear View of Transfer Case

3. Remove retaining nut and yoke from shaft, then remove shaft assembly from housing.

4. Remove snap ring using Tool J-23432 and discard.

5. Remove thrust washer and washer pin.

6. Remove tanged bronze washer. Remove gear needle bearings (32 per row), spacer and second row of needle bearings.

7. Remove tanged bronze thrust washer from shaft.

8. Remove pilot rollers (15), retainer ring and washer.

9. Remove oil seal retainer, ball bearing, speedometer gear and spacer. Discard all gaskets. Press out bearing as required.

10. Remove oil seal from the retainer.

#### Front Output Shaft Assembly (Fig. 7E-2R)

1. Remove lock nut, washer and yoke.

2. Remove front bearing retainer attaching bolts and retainer.

3. Remove front output shaft rear bearing retainer attaching bolts.

4. Tap on output shaft with a soft hammer (Fig. 7E-3R) and remove shaft, gear assembly, and rear bearing retainer from case.

Remove the sliding clutch from output high gear, washer, and bearing which will have remained in the case.

5. Using large snap ring picks, such as J-23432-1, remove the gear retaining ring from the shaft (Fig. 7E-5R) and discard.

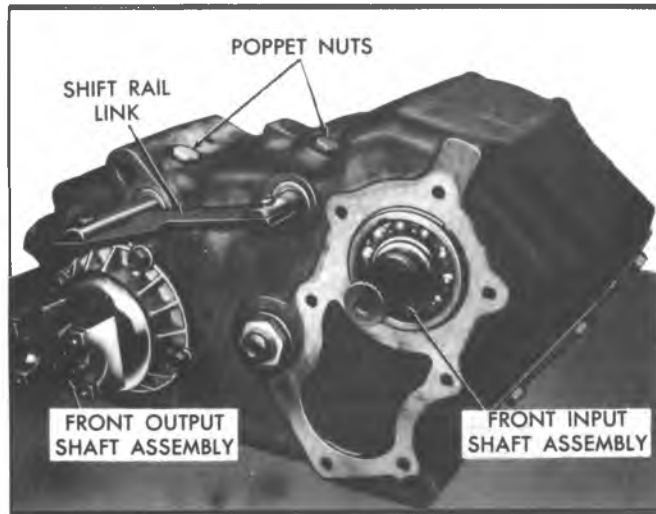

Fig. 7E-2R--Front View of Transfer Case

6. Remove thrust washer and pin from shaft.
7. Remove gear, needle bearings (32 per row) and spacer.
8. If necessary to replace front output shaft rear bearing, support cover and press bearing from cover. Position new bearing to outside face of cover and using a piece of pipe or wood to cover outside diameter of bearing, press bearing into cover until flush with opening.

#### Shift Rail and Fork Assemblies

1. Remove the two poppet nuts on top of case, two poppet springs, and using a magnet, remove the poppet balls.
2. Drive cup plugs into case using a 1/4 inch punch.
3. Position both shift rails in neutral and using a long, narrow punch, drive shift fork pins through shift rails into the case (Fig. 7E-6R).
4. Remove clevis pins and shift rail link.
5. Remove shift rails (Fig. 7E-7R), upper (range) rail first, then lower (4-wheel) rail.

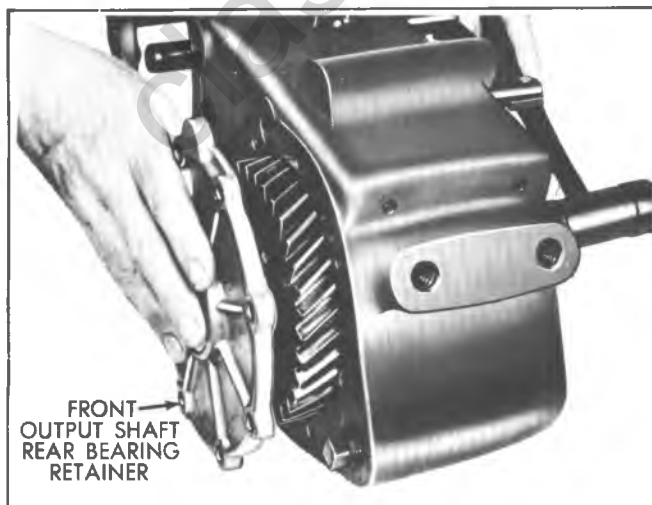

Fig. 7E-3R--Removing Front Output Shaft Rear Bearing Retainer

6. Remove shift forks and sliding clutch from case.
7. Remove the front output high gear, washer, and bearing from the case. Remove the shift rail cup plugs and pins from the case.

8. Remove snap ring in front of bearing. Using a soft hammer, tap shaft out rear of case. Tap bearing out front of case.

9. Tip case on P.T.O. and remove two interlock pins from inside of case.

#### Idler Gear

1. Remove idler gear shaft nut.
2. Remove idler shaft rear cover.
3. Remove idler gear shaft using a soft hammer and tool J-23429 (Fig. 7E-8R).
4. Roll idler gear to front output shaft hole and remove from case.
5. Remove bearing cups (2) as required from idler gear.

#### CLEANING AND INSPECTION

**Bearings** --Place all bearings and rollers in cleaning solution and allow to remain long enough to loosen all accumulated lubricant. Bearings should be sloshed up and down and turned slowly below surface of solution to remove as much lubricant as possible. Remove bearings and blow out with compressed air, being careful to direct air across bearing so that bearings do not spin.

**Shafts and Gears** --Clean all shafts in cleaning solution to remove all accumulations. Dry with compressed air.

**Case, Cover and Bearing Cups** --Transfer case, cover, and bearing cups must be thoroughly cleaned in solution to remove all accumulation of lubricant and dirt. Remove all trace of gaskets from surface where used.

**Inspection** --Carefully inspect all bearings and rollers for evidence of chipping, cracks, or worn spots that would render bearing unfit for further service. Bearings are non-adjustable and if worn or damaged, must be replaced with new parts.

Inspect shaft splines and gears. If any indication of failure, such as chipped teeth or excessive wear, is indicated, those parts should be replaced with new parts.

#### ASSEMBLY OF TRANSFER CASE (FIG. 7E-9R)

##### Idler Gear

1. Press the two bearing cups in the idler gear (if previously removed) using Tool J-9276-2 and Handle J-8092 (Fig. 7E-10R).

2. Assemble the two bearing cones, spacer, shims and idler gear on dummy shaft J-23429 with bore up. Check end play (Fig. 7E-11R). Limits are .001 to .002 inch.

3. Install idler gear assembly with dummy shaft into case through front output bore, large end first (Fig. 7E-12R).

4. Install idler shaft from large bore side and drive through using a soft hammer (Fig. 7E-13R).

5. Install washer and new locknut. Check for end play and free rotation. Torque nut to 150 ft. lbs.

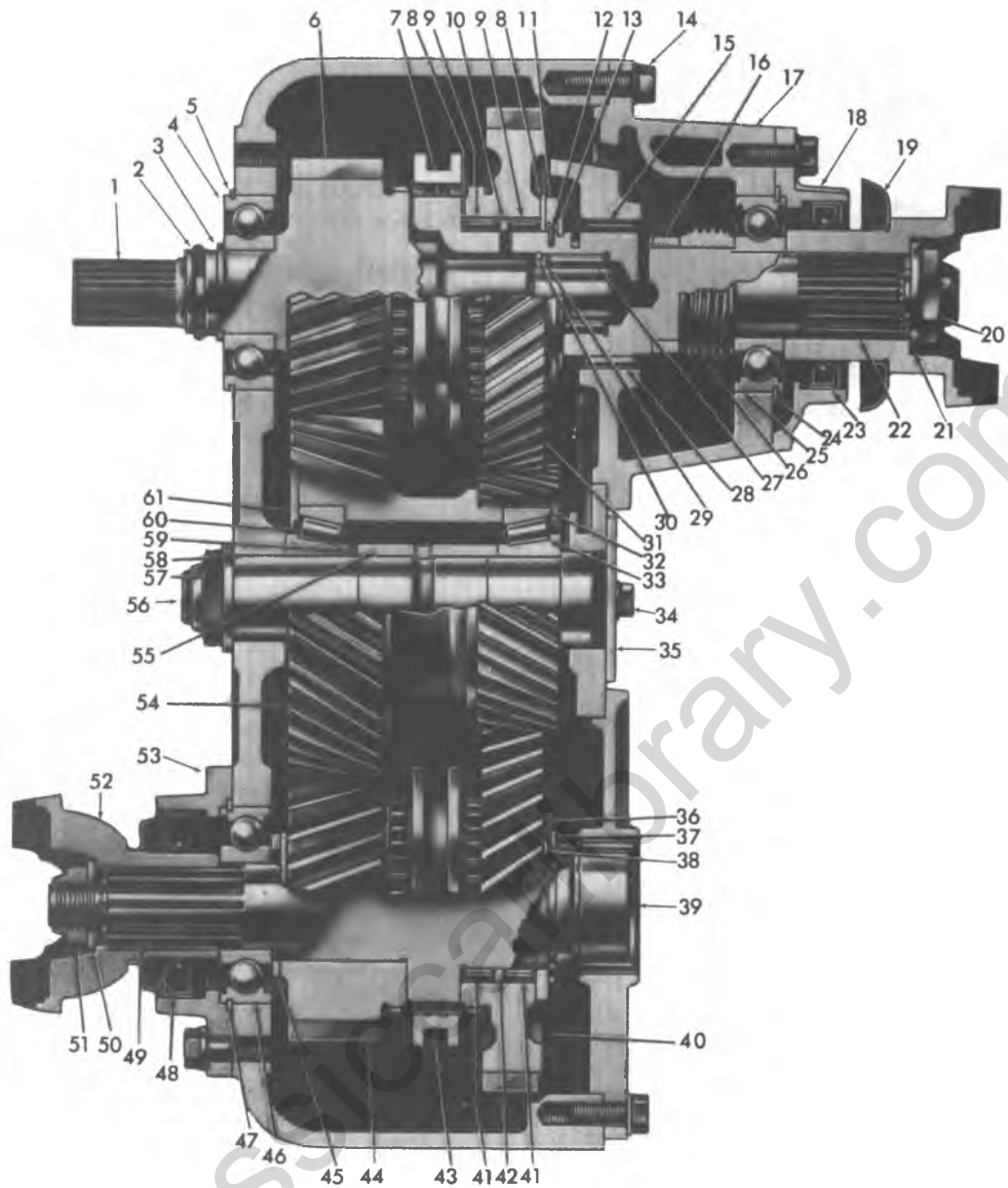

- |                                |                                     |  |                         |
|--------------------------------|-------------------------------------|--|-------------------------|
| 1. Input Shaft                 | 18. Rear Bearing Retainer           | 32. Idler Gear Shaft Bearing Cup                 | 43. Sliding Clutch      |
| 2. "O" Ring                    | 19. Rear Yoke Assembly              | 33. Idler Shaft Bearing Cone                     | 44. Front Wheel Hi-Gear |
| 3. Snap Ring                   | 20. Locknut                         | 34. Idler Shaft Cover Bolts and Lockwasher       | 45. Spacer              |
| 4. Bearing                     | 21. Washer                          | 35. Idler Shaft Gear Cover and Gasket            | 46. Bearing             |
| 5. Snap Ring                   | 22. Rear Output Shaft               | 36. Thrust Washer                                | 47. Snap Ring           |
| 6. Input Shaft Gear            | 23. Bearing Retainer Seal           | 37. Snap Ring                                    | 48. Seal                |
| 7. Sliding Clutch              | 24. Snap Ring                       | 38. Thrust Washer Pin                            | 49. Front Output Shaft  |
| 8. Tanged Bronze Thrust Washer | 25. Bearing                         | 39. Rear Bearing Retainer and Output Shaft Cover | 50. Washer              |
| 9. Roller Bearings             | 26. Speedometer Gear                | 40. Front Wheel Drive Low Gear                   | 51. Locknut             |
| 10. Spacer                     | 27. Pilot Bearings                  | 41. Roller Bearings                              | 52. Output Yoke         |
| 11. Thrust Washer              | 28. Rear Output Shaft Front Bearing | 42. Spacer                                       | 53. Bearing Retainer    |
| 12. Thrust Washer Pin          | 29. Washer                          |  | 54. Idler Gear          |
| 13. Snap Ring                  | 30. Bearing Retainer                |  | 55. Idler Gear Spacer   |
| 14. Bolt and Lockwasher        | 31. Rear Wheel Drive Low Gear       |  | 56. Idler Shaft         |
| 15. Needle Bearings            |                                     |  | 57. Locknut             |
| 16. Spacer                     |                                     |  | 58. Washer              |
| 17. Rear Output Shaft Housing  |                                     |  | 59. Bearing Cone        |
|                                |                                     |  | 60. Bearing Cup         |

Fig. 7E-4R--Model 205 Transfer Case Cross Section



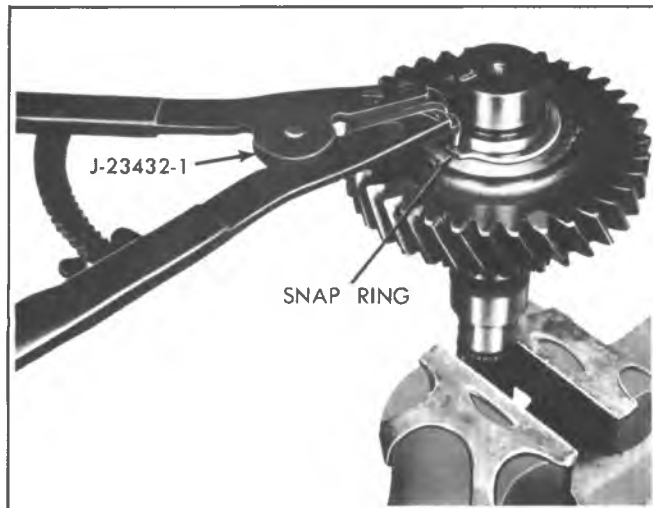

Fig. 7E-5R--Removing Gear Retaining Ring

6. Install idler shaft cover and gasket. Torque bolts to 20 ft. lbs. Flat on cover must be located adjacent to front output shaft rear cover (Fig. 7E-14R).

### Shift Rail and Fork Assemblies

1. Press the two rail seals into the case. Seals should be installed with metal lip outward.

2. Install interlock pins through large bore or P.T.O. opening.

3. Start front output drive shift rail into case from back, slotted end first, with poppet notches up.

4. Install shift fork (long end inward) into rail, push rail through to neutral position.

5. Install input shaft bearing and shaft into case.

6. Start range rail into case from front, with poppet notches up.

7. Install sliding clutch onto fork, place over input shaft in case. Position to receive range rail and push rail through to neutral position.

8. Install new lock pins through holes at top of case and drive them into the forks (Fig. 7E-15R). Tip case on P.T.O. opening when installing range rail lock pin.



Fig. 7E-6R--Removing Shift Fork Pins

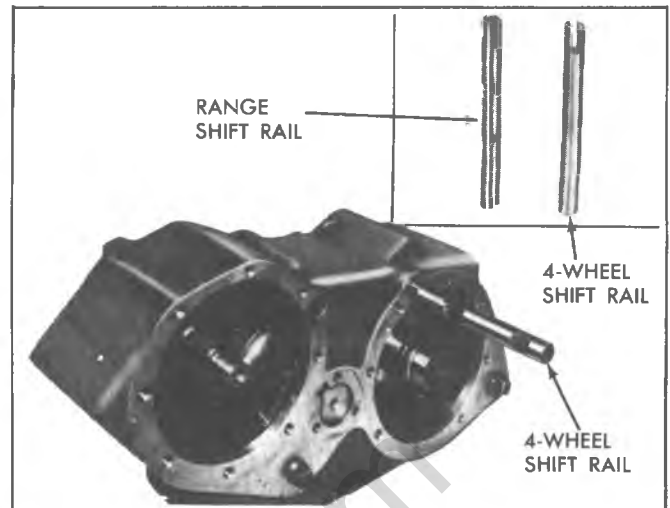

Fig. 7E-7R--Shift Rail Removal

### Front Output Shaft and Gear Assembly

1. Install two rows of needle bearings (32 each) separated by a spacer in the front low output gear and retain with a sufficient amount of grease.

2. Place front output shaft in soft jawed vise, spline end down. Install front low gear over shaft with clutch gear facing down and install thrust washer pin, thrust washer and new snap ring using Tool J-23432. Position the snap ring so that the opening is opposite the pin.

3. Position front wheel hi-gear and washer in case. Install sliding clutch in the shift fork, then put fork and rail in the front wheel drive (4-Hi) position with the clutch teeth in mesh with the teeth of the front wheel hi-gear.

4. Line up washer, high gear, and sliding clutch with bearing bore. Insert front output shaft and low gear assembly through the high gear assembly.

5. Install new seal in bearing retainer using Tool J-22836 (Fig. 7E-16R) and install the front output bearing and retainer in the case.

6. Clean and grease rollers in front output rear bearing retainer. Install onto case using one gasket. Dip bolts into



Fig. 7E-8R--Removing Idler Gear Shaft

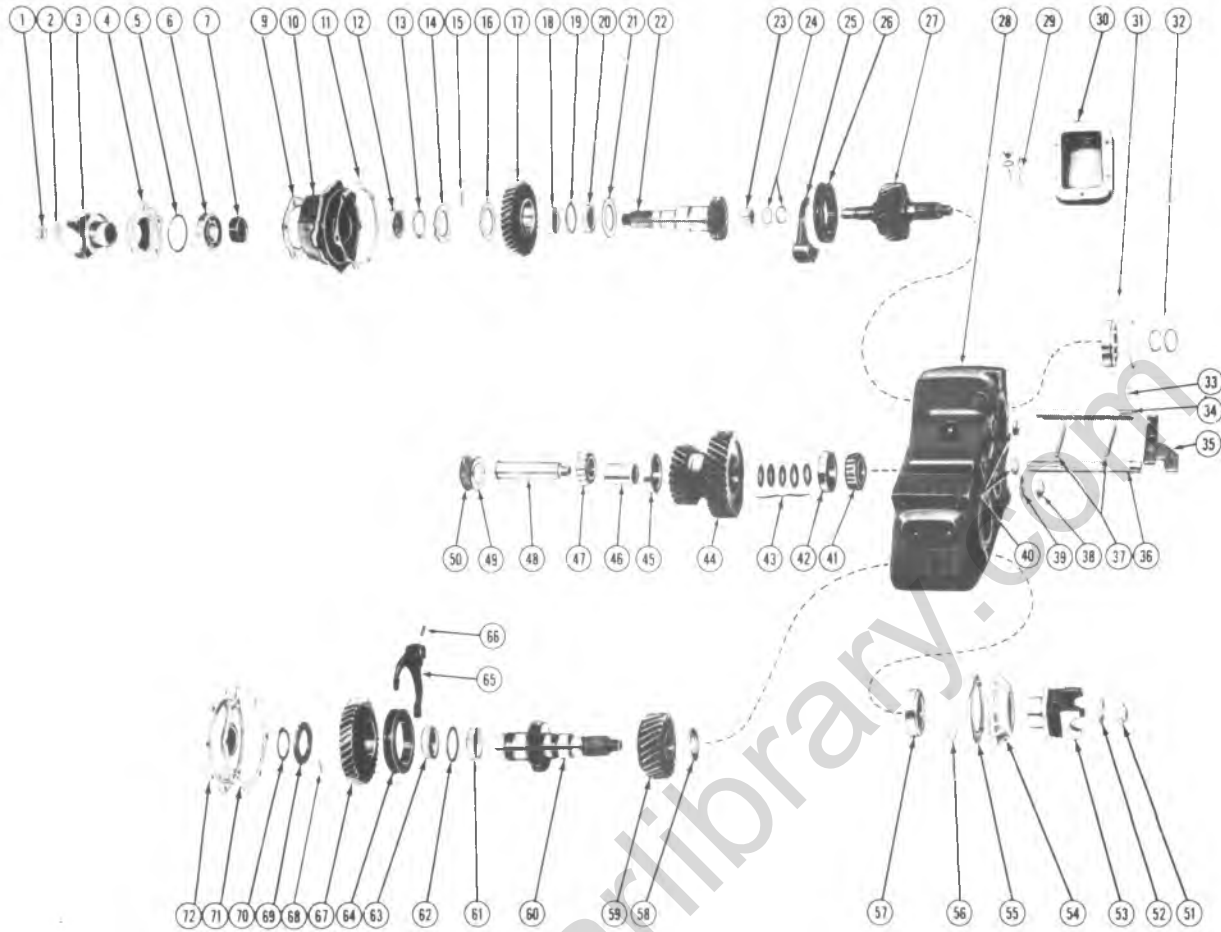

- |                                       |                                       |                                |
|---------------------------------------|---------------------------------------|--------------------------------|
| 1. Rear Output Shaft Locknut          | 26. Sliding Clutch                    | 49. Cover Gasket               |
| 2. Washer                             | 27. Input Shaft                       | 50. Rear Cover                 |
| 3. Yoke                               | 28. Transfer Case                     | 51. Front Output Shaft Locknut |
| 4. Bearing Retainer and Seal Assembly | 29. Poppet Plug, Spring and Ball      | 52. Washer                     |
| 5. Snap Ring                          | 30. P.T.O. Gasket and Cover           | 53. Yoke                       |
| 6. Bearing                            | 31. Input Shaft Bearing and Snap Ring | 54. Bearing Retainer and Seat  |
| 7. Speedometer Gear                   | 32. Snap Ring and Rubber "O" Ring     | 55. Gasket                     |
| 9. Gasket                             | 33. Shift Link Clevis Pin             | 56. Snap Ring                  |
| 10. Housing                           | 34. Range Shift Rail                  | 57. Front Bearing              |
| 11. Gasket                            | 35. Shift Rail Connector Link         | 58. Thrust Washer              |
| 12. Bearing                           | 36. Front Wheel Drive Shift Rail      | 59. Front Wheel High Gear      |
| 13. Snap Ring                         | 37. Interlock Pins                    | 60. Front Output Shaft         |
| 14. Thrust Washer                     | 38. Rear Idler Lock Nut               | 61. Needle Bearings            |
| 15. Thrust Washer Lock Pin            | 39. Washer                            | 62. Spacer                     |
| 16. Thrust Washer (Tanged)            | 40. Shift Rail Seals                  | 63. Needle Bearing             |
| 17. Low Speed Gear                    | 41. Idler Shaft Bearing               | 64. Sliding Clutch Gear        |
| 18. Needle Bearings                   | 42. Bearing Cup                       | 65. Shift Fork                 |
| 19. Spacer                            | 43. Shims                             | 66. Roll Pin                   |
| 20. Needle Bearings                   | 44. Idler Gear                        | 67. Front Output Low Gear      |
| 21. Tanged Washer                     | 45. Bearing Cup                       | 68. Thrust Washer Lock Pin     |
| 22. Rear Output Shaft                 | 46. Spacer                            | 69. Thrust Washer              |
| 23. Needle Bearings                   | 47. Idler Shaft Bearing               | 70. Snap Ring                  |
| 24. Washer and Retainer               | 48. Idler Shaft                       | 71. Rear Cover Gasket          |
| 25. Shift Fork                        |                                       | 72. Rear Cover and Bearing     |

Fig. 7E-9R--New Process Model 205 Transfer Case Exploded View

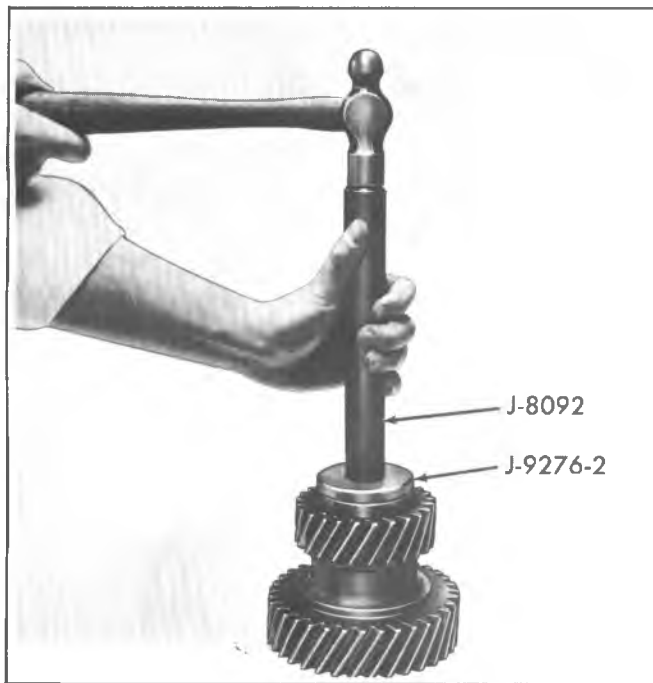

Fig. 7E-10R—Installing New Bearing Cups

sealant. Install bolts and torque to 30 ft. lbs.

7. Install front output yoke, washer and lock nut. Torque nut to 150 ft. lbs.

### Rear Output Shaft Assembly

1. Install two rows of needle bearings (32 each) separated by a spacer into the output low gear. Use sufficient grease to retain needles.

2. Install thrust washer onto rear output shaft, tang down in clutch gear groove. Install output low gear onto shaft with clutch teeth facing down.

3. Install thrust washer over gear with tab pointing up and away from gear. Install washer pin and also large thrust washer over shaft and pin. Rotate washer until tab fits into

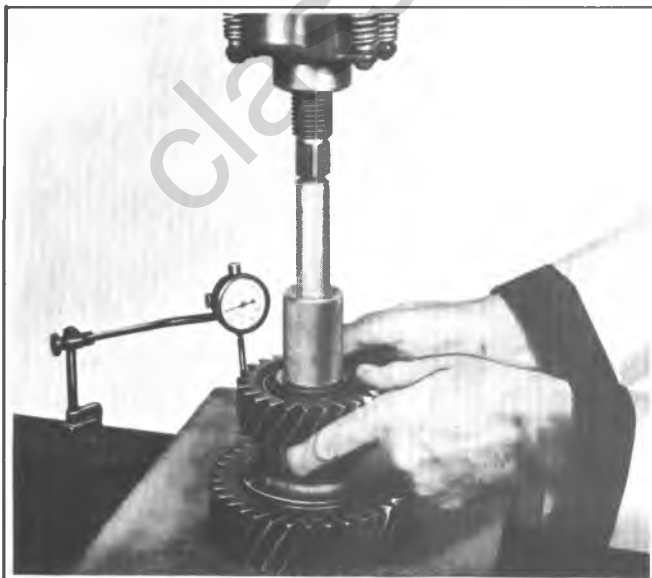

Fig. 7E-11R—Checking Idler Gear End Play

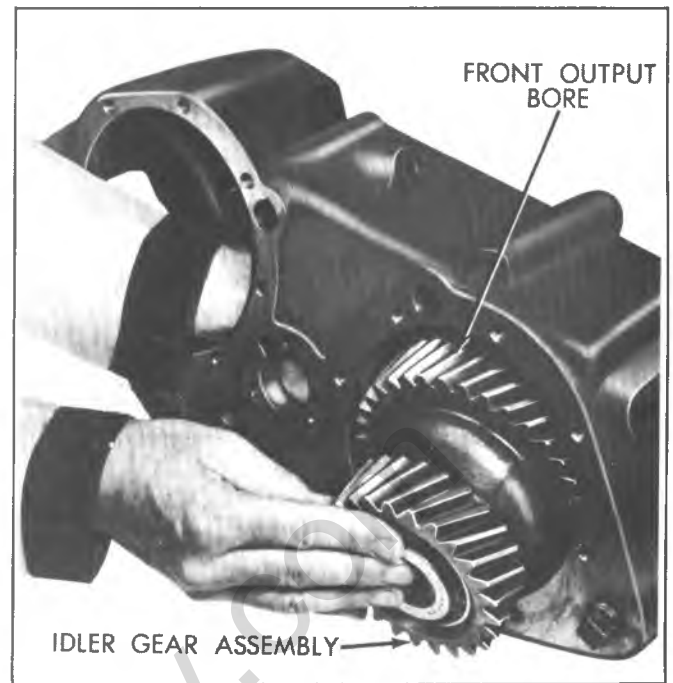

Fig. 7E-12R—Installing Idler Gear

slot approximately 90 degrees away from pin. Finally, install snap ring using Tool J-23423 and J-23423-1 and check end play which should be within .002-.027 inch.

4. Grease pilot bore or rear output shaft and install needle bearings (15). Install thrust washer and new snap ring in bore.

5. Clean, grease, and install new bearing in retainer housing using Tool J-23431 (Fig. 7E-17R).

6. Install housing onto output shaft assembly, install spacer and speedometer gear, then install bearing (Fig. 7E-18R).

7. Install rear bearing retainer seal using Tool J-21359 or J-22834-2 (Fig. 7E-19R).

8. Install bearing retainer assembly onto housing with one or two gaskets, depending on clearance. Torque bolts to 30 ft. lbs.



Fig. 7E-13R—Installing Idler Shaft

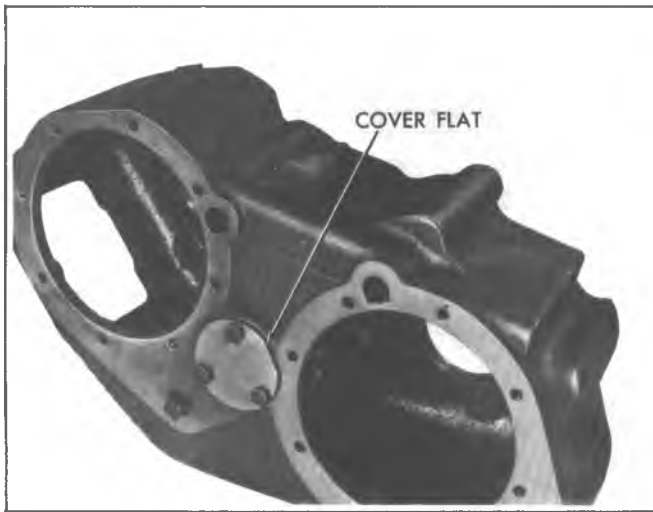

Fig. 7E-14R—Installing Idler Shaft Rear Cover

9. Install yoke, washer, and lock nut output shaft.
10. Position range rail in 'high' and install output shaft and retainer assembly on transfer case. Torque housing bolts to 30 ft. lbs.

**Miscellaneous**

1. Install P.T.O. cover and gasket. Torque bolts to 15 ft. lbs.
2. Install and seal cup plugs at rail pin holes, if not previously done.
3. Install drain and filler plugs and torque to 30 ft. lbs.
4. Install shift rail cross link, clevis pins and lock pins.

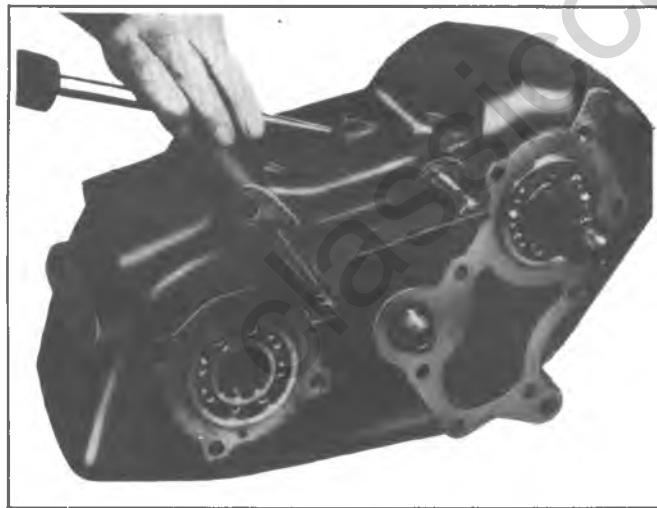

Fig. 7E-15R—Installing Shift Rail Lock Pins

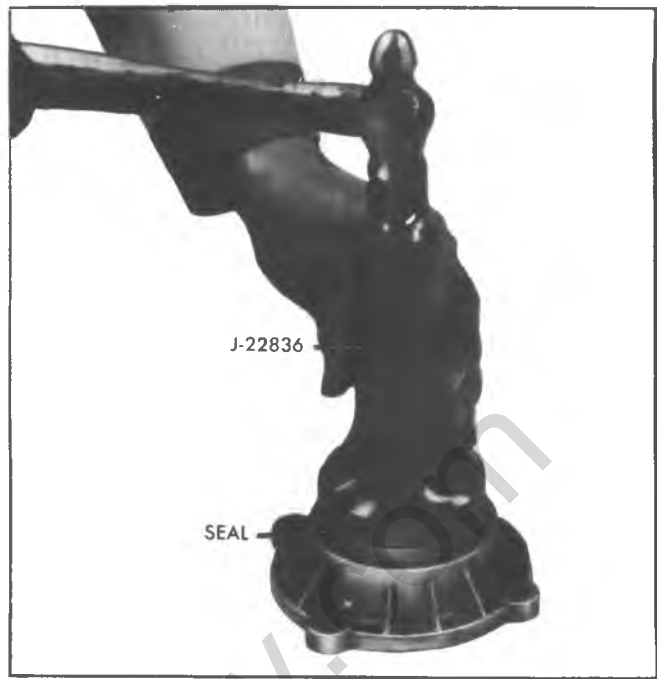

Fig. 7E-16R—Installing Front Output Bearing Retainer Seal

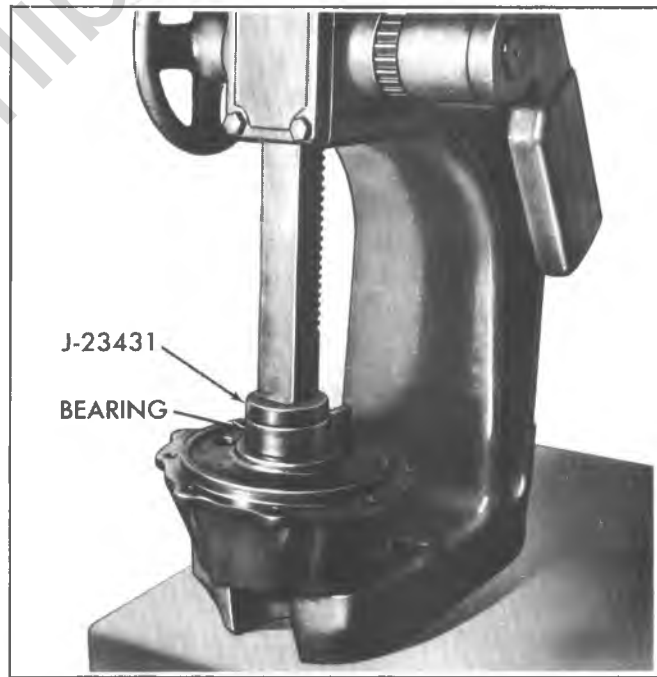

Fig. 7E-17R—Installing Rear Output Shaft Housing Bearing

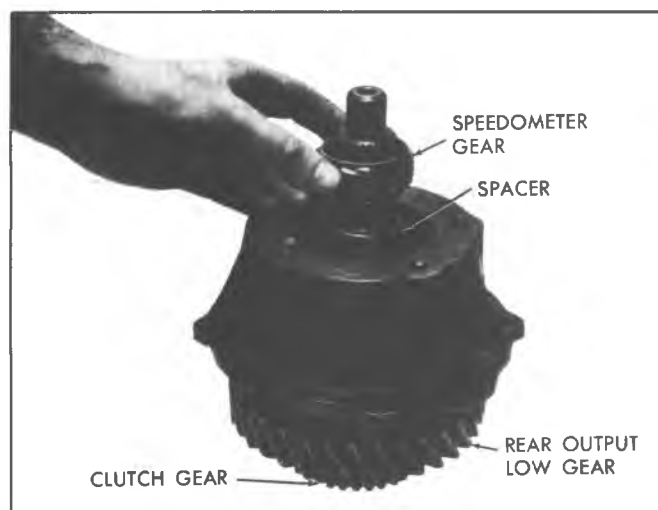

Fig. 7E-18R—Installing Rear Output Shaft Spacer and Speedometer Gear

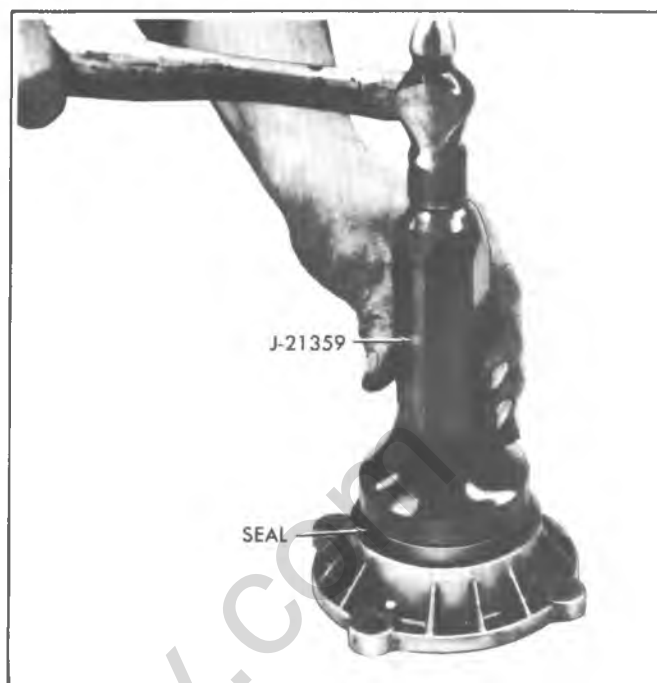

Fig. 7E-19R—Installing Rear Bearing Retainer Seal

classiccarlibrary.com

## SPECIFICATIONS

	N·m MODEL 205	N·m MODEL 208
NUT, SHIFT LEVER-TO-SHIFTER ASSEMBLY	—	19-27
NUT, KNOB ASSEMBLY-TO-SHIFT LEVER	26-40	26-40
BOLT, SHIFTER ASSEMBLY-TO-TRANSFER CASE	120-150	120-140
NUT, SHIFT ARMS-TO-CASE	14-20	14-20
SCREW, SHIFT LEVER BOOT RETAINER	2.2-3.2	2.2-3.2
BOLT, DETENT RETAINER	—	27-34
SWITCH, INDICATOR	—	122-176
BOLT, ADAPTER-TO-TRANSMISSION	26-40	26-40
BOLT, ADAPTER-TO-TRANSFER CASE	26-40	26-40
FILLER PLUG	40-48	40-54
BOLTS P.T.O. COVER	20-24	—
NUT, SKID PLATE-TO-CROSSMEMBER	55-70	55-70
BOLT, SUPPORT STRUT ROD		
— TRANSMISSION END	40-54	40-54
— TRANSFER CASE END	150-200	150-200

MODEL NO.	205 (PART TIME)	208 (PART TIME)
<b>AVAILABILITY</b>	ALL K30 SERIES	ALL K10-20 SERIES
<b>RATIOS: HI RANGE LO RANGE</b>	1.00 TO 1 1.96 TO 1	2.61 TO 1
<b>LEVER POSITIONS</b>	4-LO (ALL WHEEL UNDERDRIVE) N (NEUTRAL) 2-HI (REAR WHEEL DRIVE) 4-HI (ALL WHEEL DIRECT DRIVE)	4-LO (ALL WHEEL UNDERDRIVE) N (NEUTRAL) 2-HI (REAR WHEEL DRIVE) 4-HI (ALL WHEEL DIRECT DRIVE)
<b>LEVER LOCATION</b>	REAR OF TRANS. SHIFT LEVER	REAR OF TRANS. SHIFT LEVER
<b>POWER TAKE-OFF DATA: OPENING AND LOCATION</b>	SAE 6-BOLT; LEFT SIDE	
<b>LUBRICANTS: OIL CAPACITY</b>	5.2 PINTS*	8 PINTS*
<b>TYPE, GRADE</b>	SEE OWNER'S MANUAL	SEE OWNER'S MANUAL

\*TO BE FILLED WITHIN ONE INCH OF FILL PLUG.

## SPECIAL TOOLS

TRANSFER CASE 7E-21



1. J-29162 – Rear Retainer Oil Seal Installer
2. J-29170 – Input Gear Bearing Remover
3. J-29163 – Ft. Output Shaft Rear Bearing Installer
4. J-29169 – Input Gear Bearing Installer
5. J-29168 – Ft. Output Shaft Ft. Bearing Remover
6. J-29174 – Mainshaft Bearing Installer
7. J-29167 – Ft. Output Shaft Ft. Bearing Installer

Fig. 7E-1ST--Model 208 Transfer Case Special Tools

## SPECIAL TOOLS



1. J-22836 – Front Output Shaft Bearing Retainer Seal Installer
2. J-22388 – Rear Output Shaft Seal Installer
3. J-21359 – Input gear Bearing Retainer Seal Installer
4. J-24745 – Cluster Gear Loading Tool
5. J-8614-1 – Companion Flange Remover

Fig. 7E-2ST-Model 205 (Part Time) Transfer Case Special Tools



## SECTION 10

# METRIC & FASTENER INFORMATION

### USE OF METRIC AND CUSTOMARY NUTS, BOLTS AND SCREWS

Some of the 1980 model cars present special service requirements to the technician due to the use of both metric and customary (inch) type nuts, bolts and screws on the same car. Many are metric and some are very close in dimension to customary nuts, bolts and screws in the inch system. Mismatched or incorrect nuts, bolts and screws can result in damage, malfunction or possible personal injury. Nuts, bolts and screws removed from the car should be saved for re-use whenever possible. If they are not re-usable, care should be taken to select a replacement that matches the original.

General Motors Engineering Standards have adopted a portion of the standard metric fastener sizes defined by SI (Système International). This was done to reduce the number of sizes used and yet retain the best strength characteristics in each thread size. For example, the customary 1/4-20 and 1/4-28 screws are replaced by the metric M6.3 x 1 screw which has nearly the same diameter and 25.4 threads per inch. The thread pitch is in between the customary coarse and fine thread pitches.

Metric and customary thread notation differ slightly. The difference is illustrated below.

#### CUSTOMARY

1/4

Thread Major  
Diameter  
in Inches

20

Number of  
Threads  
per Inch

#### METRIC

M6.3

Thread Major  
Diameter  
in Millimeters

1

Distance  
Between Threads  
in Millimeters

Care should be taken when servicing the car to guard against cross threading or improper retention due to interchanged metric and inch nuts and bolts.

When obtaining metric or customary nuts, bolts, and screws locally for servicing the car, care must be exercised in selecting parts that are equivalent to the original parts in dimensions, strength, and pitch of threads.

# REUSE OF PREVAILING TORQUE NUT(S) AND BOLT(S)

PREVAILING TORQUE NUTS ARE THOSE NUTS WHICH INCORPORATE A SYSTEM TO DEVELOP AN INTERFERENCE BETWEEN NUT AND BOLT THREADS INTERFERENCE IS MOST COMMONLY ACHIEVED BY DISTORTING TOP OF ALL-METAL NUT, BUT ALSO MAY BE ACHIEVED BY DISTORTING AT MIDDLE OF HEX FLAT, BY NYLON PATCH ON THREADS, BY NYLON WASHER INSERT AT TOP OF NUT AND BY NYLON INSERT THROUGH NUT.

PREVAILING TORQUE BOLTS ARE THOSE BOLTS WHICH INCORPORATE A SYSTEM TO DEVELOP AN INTERFERENCE BETWEEN BOLT AND NUT OR TAPPED HOLE THREADS. INTERFERENCE IS ACHIEVED BY DISTORTING SOME OF THE THREADS (SEVERAL METHODS EXIST), BY APPLYING A NYLON PATCH OR STRIP OR BY ADHESIVE COATING ON THREADS.

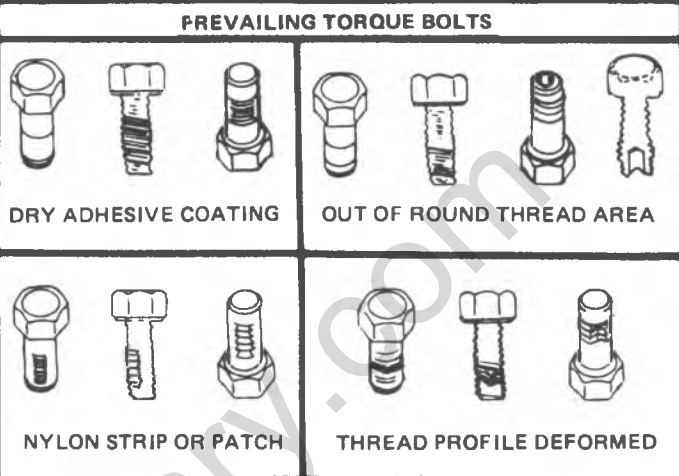
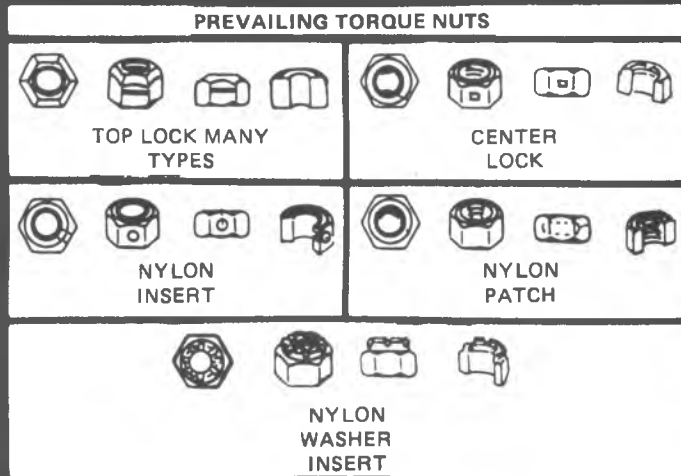

**RECOMMENDATIONS FOR REUSE**

- A. CLEAN, UNRUSTED PREVAILING TORQUE BOLTS AND NUTS MAY BE REUSED AS FOLLOWS:
1. CLEAN DIRT AND OTHER FOREIGN MATERIAL OFF NUT AND BOLT.
  2. INSPECT BOLT AND NUT TO ASSURE THERE ARE NO CRACKS, ELONGATION OR OTHER SIGNS OF ABUSE OR OVERTIGHTENING. LIGHTLY LUBRICATE THREADS. (IF ANY DOUBT, REPLACE WITH NEW PREVAILING TORQUE FASTENER OF EQUAL OR GREATER STRENGTH.)
  3. ASSEMBLE PARTS AND START BOLT OR NUT.
  4. OBSERVE THAT BEFORE FASTENER SEATS, IT DEVELOPS PREVAILING TORQUE PER CHART BELOW. (IF ANY DOUBT, INSTALL NEW PREVAILING TORQUE FASTENER OF EQUAL OR GREATER STRENGTH).
  5. TIGHTEN TO TORQUE SPECIFIED IN SERVICE MANUAL.
- B. BOLTS AND NUTS WHICH ARE RUSTY OR DAMAGED SHOULD BE REPLACED WITH NEW PARTS OF EQUAL OR GREATER STRENGTH.

		METRIC SIZES							
		6 & 6.3	8	10	12	14	16	20	
NUTS AND ALL METAL BOLTS	N·m	0.4	0.8	1.4	2.2	3.0	4.2	7.0	
	In. Lbs.	4.0	7.0	12	18	25	35	57	
ADHESIVE OR NYLON COATED BOLTS	N·m	0.4	0.6	1.2	1.6	2.4	3.4	5.6	
	In. Lbs.	4.0	5.0	10	14	20	28	46	
		INCH SIZES							
		.250	.312	.375	.437	.500	.562	.625	.750
NUTS AND ALL METAL BOLTS	N·m	0.4	0.6	1.4	1.8	2.4	3.2	4.2	6.2
	In. Lbs.	4.0	5.0	12	15	20	27	35	51
ADHESIVE OR NYLON COATED BOLTS	N·m	0.4	0.6	1.0	1.4	1.8	2.6	3.4	5.2
	In. Lbs.	4.0	5.0	9.0	12	15	22	28	43

METRIC BOLT AND NUT IDENTIFICATION

Common metric fastener strength property classes are 9.8 and 10.9 with the class identification embossed on the head of each bolt. Customary (inch) strength classes range from grade 2 to 8 with line identification embossed on each bolt head. Markings correspond to two lines less than the actual grade (i.e. grade 7 bolt will exhibit 5 embossed lines on the bolt head). Some metric nuts will be marked with single digit strength identification numbers on the nut face. The following figure illustrates the different strength markings.

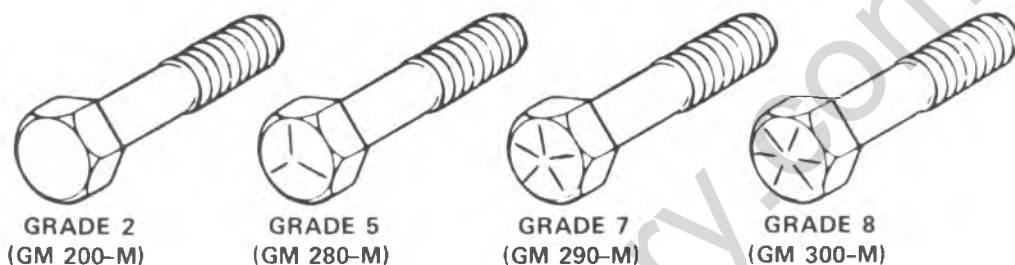

Customary (inch) bolts - Identification marks correspond to bolt strength - Increasing numbers represent increasing strength.



Metric Bolts - Identification class numbers correspond to bolt strength - Increasing numbers represent increasing strength.

MANUFACTURERS IDENTIFICATION



NUT STRENGTH IDENTIFICATION



POSIDRIV SCREW HEAD



IDENTIFICATION MARKS (4)

SI METRIC-CUSTOMARY CONVERSION TABLE

Multiply	by	to get equivalent number of:	Multiply	by	to get equivalent number of:
<b>LENGTH</b>					
Inch	25.4	millimeters (mm)	Foot/sec <sup>2</sup>	0.304 8	meter/sec <sup>2</sup> (m/s <sup>2</sup> )
Foot	0.304 8	meters (m)	Inch/sec <sup>2</sup>	0.025 4	meter/sec <sup>2</sup>
Yard	0.914 4	meters	<b>TORQUE</b>		
Mile	1.609	kilometers (km)	Pound-inch	0.112 98	newton-meters (N·m)
<b>AREA</b>					
Inch <sup>2</sup>	645.2	millimeters <sup>2</sup> (mm <sup>2</sup> )	Pound-foot	1.355 8	newton-meters
Foot <sup>2</sup>	6.45	centimeters <sup>2</sup> (cm <sup>2</sup> )	<b>POWER</b>		
Yard <sup>2</sup>	0.092 9	meters <sup>2</sup> (m <sup>2</sup> )	Horsepower	0.746	kilowatts (kW)
<b>VOLUME</b>					
Inch <sup>3</sup>	16 387.	mm <sup>3</sup>	<b>PRESSURE OR STRESS</b>		
Quart	16.387	cm <sup>3</sup>	Inches of mercury	3.377	kilopascals (kPa)
Gallon	0.016 4	liters (l)	Pounds/sq. in.	6.895	kilopascals
Yard <sup>3</sup>	0.946 4	liters	<b>ENERGY OR WORK</b>		
<b>MASS</b>					
Pound	3.785 4	liters	BTU	1 055.	joules (J)
Ton	0.764 6	meters <sup>3</sup> (m <sup>3</sup> )	Foot-pound	1.355 8	joules
Ton			Kilowatt-hour	3 600 000	joules (J = one W's)
<b>FORCE</b>					
Kilogram	0.453 6	kilograms (kg)	<b>LIGHT</b>		
Ounce	907.18	kilograms (kg)	Foot candle	10.764	lumens/meter <sup>2</sup> (lm/m <sup>2</sup> )
Pound	0.907	tonne (t)	<b>FUEL PERFORMANCE</b>		
<b>TEMPERATURE</b>					
Degree Fahrenheit	(°F-32) ÷ 1.8	degree Celsius (C)	Miles/gal	0.425 1	kilometers/liter (km/l)
<b>VELOCITY</b>					
			Miles/hour	1.609 3	kilometers/hr. (km/h)

## DECIMAL AND METRIC EQUIVALENTS

Fractions	Decimal In.	Metric MM.	Fractions	Decimal In.	Metric MM.
1/64	.015625	.39688	33/64	.515625	13.09687
1/32	.03125	.79375	17/32	.53125	13.49375
3/64	.046875	1.19062	35/64	.546875	13.89062
1/16	.0625	1.58750	9/16	.5625	14.28750
5/64	.078125	1.98437	37/64	.578125	14.68437
3/32	.09375	2.38125	19/32	.59375	15.08125
7/64	.109375	2.77812	39/64	.609375	15.47812
1/8	.125	3.1750	5/8	.625	15.87500
9/64	.140625	3.57187	41/64	.640625	16.27187
5/32	.15625	3.96875	21/32	.65625	16.66875
11/64	.171875	4.36562	43/64	.671875	17.06562
3/16	.1875	4.76250	11/16	.6875	17.46250
13/64	.203125	5.15937	45/64	.703125	17.85937
7/32	.21875	5.55625	23/32	.71875	18.25625
15/64	.234375	5.95312	47/64	.734375	18.65312
1/4	.250	6.35000	3/4	.750	19.05000
17/64	.265625	6.74687	49/64	.765625	19.44687
9/32	.28125	7.14375	25/32	.78125	19.84375
19/64	.296875	7.54062	51/64	.796875	20.24062
5/16	.3125	7.93750	13/16	.8125	20.63750
21/64	.328125	8.33437	53/64	.828125	21.03437
11/32	.34375	8.73125	27/32	.84375	21.43125
23/64	.359375	9.12812	55/64	.859375	21.82812
3/8	.375	9.52500	7/8	.875	22.22500
25/64	.390625	9.92187	57/64	.890625	22.62187
13/32	.40625	10.31875	29/32	.90625	23.01875
27/64	.421875	10.71562	59/64	.921875	23.41562
7/16	.4375	11.11250	15/16	.9375	23.81250
29/64	.453125	11.50937	61/64	.953125	24.20937
15/32	.46875	11.90625	31/32	.96875	24.60625
31/64	.484375	12.30312	63/64	.984375	25.00312
1/2	.500	12.70000	1	1.00	25.40000

classiccarylbrary.com

classiccarylbrary.com

classicalibrary.com



classiccarylbrary.com

classiccarlibrary.com

CUT ON DOTTED LINE

POSTAGE  
WILL BE PAID  
BY  
ADDRESSEE



NO  
POSTAGE STAMP  
NECESSARY  
IF MAILED IN THE  
UNITED STATES

**BUSINESS REPLY MAIL**

FIRST CLASS PERMIT NO. 302 WARREN, MICHIGAN



CHEVROLET MOTOR DIVISION  
GENERAL MOTORS CORPORATION  
30007 VAN DYKE AVE.  
WARREN, MICHIGAN 48090

CUT ON DOTTED LINE

POSTAGE  
WILL BE PAID  
BY  
ADDRESSEE

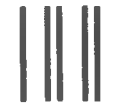

NO  
POSTAGE STAMP  
NECESSARY  
IF MAILED IN THE  
UNITED STATES

**BUSINESS REPLY MAIL**

FIRST CLASS PERMIT NO. 302 WARREN, MICHIGAN



CHEVROLET MOTOR DIVISION  
GENERAL MOTORS CORPORATION  
30007 VAN DYKE AVE.  
WARREN, MICHIGAN 48090

### To Our Service Manual Users:

Chevrolet has tried to make your service manual as accurate and as useful as possible. We'll try to make future manuals even better. Perhaps you will help.

This pre-addressed and prepaid form is provided in the hope that you will let us know of any errors or omissions you find in this manual.

We would also welcome your suggestions for improving or extending our service manual coverage.

Thank you for your help.

### CHEVROLET MOTOR DIVISION

Name \_\_\_\_\_ Position \_\_\_\_\_  
Street \_\_\_\_\_ State \_\_\_\_\_ Zip \_\_\_\_\_  
City \_\_\_\_\_  
Manual Year and Title \_\_\_\_\_  
Manual No. \_\_\_\_\_ Section \_\_\_\_\_ Page \_\_\_\_\_  
Comments: (Do not use for Shop Manual orders) \_\_\_\_\_  
\_\_\_\_\_  
\_\_\_\_\_  
\_\_\_\_\_  
\_\_\_\_\_  
\_\_\_\_\_  
\_\_\_\_\_  
\_\_\_\_\_  
\_\_\_\_\_

### NOTICE

These reply cards should not be used for ordering Service Manuals. If you wish to purchase a service manual, follow these instructions:

### OWNERS

An order form with which you may purchase service manuals and other service literature has been provided at the rear of your Owner's Manual.

For information on all available Chevrolet Service Manuals, please write to the following address:

Helm, Inc.  
P.O. Box 07130  
Detroit, Michigan 48203

### CHEVROLET DEALERS

When ordering Service Manuals for your dealership, please use Form No. GSD-338.

Name \_\_\_\_\_ Position \_\_\_\_\_  
Street \_\_\_\_\_ State \_\_\_\_\_ Zip \_\_\_\_\_  
City \_\_\_\_\_  
Manual Year and Title \_\_\_\_\_  
Manual No. \_\_\_\_\_ Section \_\_\_\_\_ Page \_\_\_\_\_  
Comments: (Do not use for Shop Manual orders) \_\_\_\_\_  
\_\_\_\_\_  
\_\_\_\_\_  
\_\_\_\_\_  
\_\_\_\_\_  
\_\_\_\_\_  
\_\_\_\_\_  
\_\_\_\_\_  
\_\_\_\_\_

classiccarylbrary.com

