

Classiccarlibrary.com

1987

LIGHT DUTY TRUCK SERVICE MANUAL

R-V, P-TRUCK AND G-VAN MODELS

The Table of Contents on this page indicates the sections covered in this manual. At the beginning of each individual section is a Table of Contents which gives the page number on which each major subject begins.

When reference is made in this manual to a brand name, number, or specific tool, an equivalent product may be used in place of the recommended item.

All information, illustrations, and specifications contained in this Manual are based on the latest product information available at the time of publication approval. The right is reserved to make changes at any time without notice.

SEC	NAME
0	GENERAL INFORMATION 0A General Information 0B Maintenance and Lubrication
1	HEATING AND AIR CONDITIONING 1A Heating 1B Air Conditioning
2	FRAME AND CAB 2A Frame and Bumpers 2B Sheet Metal
3	STEERING, SUSPENSION, WHEELS AND TIRES 3A Front End Alignment 3B1 Steering Linkage 3B2 Manual Steering 3B3 Power Steering 3B4 Steering Column 3C Front Suspension and Axle 3D Rear Suspension 3E Wheels and Tires
4	PROPELLER SHAFT AND AXLES 4A Propeller Shaft 4B Rear Axle 4C Front Driving Axle
5	BRAKES
6	ENGINE 6A Engine 6A3 4.3 Liter V6 6A4 Small Block 6A5 7.4 Liter V8 6A6 6.2 Liter Diesel 6A7 4.8 Liter L6 6B1 Engine Cooling 6B2 Radiator 6C Fuel System 6C1 Carburetors 6C2 Diesel Fuel Injection 6D Engine Electrical 6E Drivability And Emissions 6E8 Drivability And Emissions - Carburetor 6E9 Drivability And Emissions - Diesel 6F Exhaust 6H Vacuum Pump
7	TRANSMISSION AND CLUTCH 7A Automatic Transmission 7B Manual Transmission 7C Clutch 7D1 205 Transfer Case 7D2 208 Transfer Case
8	ELECTRICAL 8A Cab Electrical 8B Chassis Electrical 8C Instrument Panel
9	ACCESSORIES
10	BODY 10A1 Doors 10A2 Seats 10A3 Glass 10A4 Interior Trim 10A5 Endgate
	INDEX

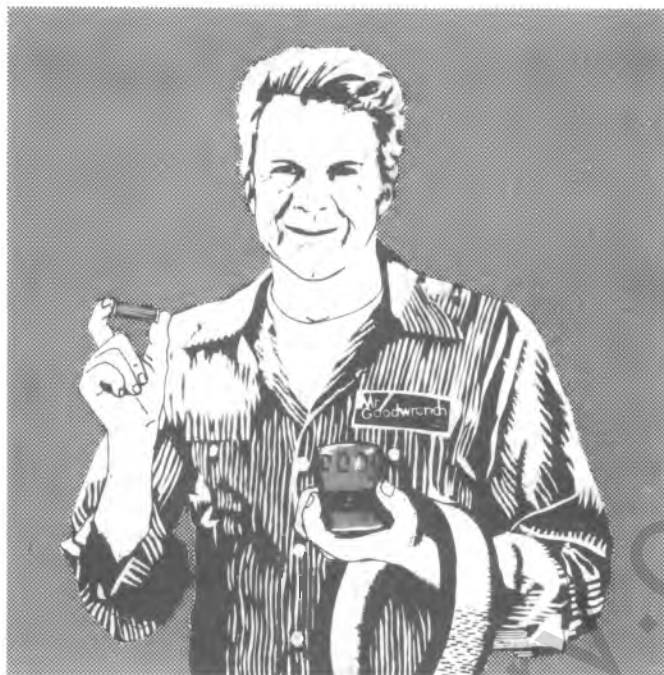

He knows
quality parts
make a difference
even on
simple jobs.

Mr. Goodwrench wants you to have the right parts for your truck—whether you see him for service or whether you do the work yourself.

That's why Mr. Goodwrench wants to have a good stock of genuine GM Parts available. Everything from exclusive GM Goodwrench replacement engines and transmissions to GM Goodwrench Motor Oil that meets or exceeds all specifications for General Motors cars or light trucks. And Mr. Goodwrench has a complete line of GM chemicals for fine care of your GM vehicle. Plus accessories to add convenience— or just a little extra style.

So keep that great GM feeling with genuine GM parts at participating independent Mr. Goodwrench dealers selling Chevrolets, Pontiacs, Oldsmobiles, Buicks, Cadillacs, GMC and Chevy Trucks.



Mr. Goodwrench

B-05884

FOREWORD

This service manual contains diagnosis, "On-Vehicle" maintenance, and light repair for Light Duty Truck Models ("R-V, P-Truck, and G-Van"). Fuel and emissions related components for throttle body injection vehicles are covered in a separate manual. Procedures involving disassembly and assembly of major components for these vehicles are published in a separate "Truck Unit Repair Manual." Wiring diagrams for these models are also published in a separate "Truck Wiring Diagram" booklet.

This manual should be kept in a handy place for ready reference. If properly used, it will meet the needs of technicians and vehicle owners.

R.P.O.-LL4="J" Eng. HDD DIESEL

CAUTION:

These vehicles contain some parts dimensioned in the metric system as well as in the customary system. Some fasteners are metric and are very close in dimension to familiar customary fasteners in the inch system. It is important to note that, during any vehicle maintenance procedures, replacement fasteners must have the same measurements and strength as those removed, whether metric or customary. (Numbers on the heads of metric bolts and on surfaces of metric nuts indicate their strength. Customary bolts use radial lines for this purpose, while most customary nuts do not have strength markings.) Mismatched or incorrect fasteners can result in vehicle damage or malfunction, or possibly personal injury. Therefore, fasteners removed from the vehicle should be saved for re-use in the same location whenever possible. Where the fasteners are not satisfactory for re-use, care should be taken to select a replacement that matches the original. For information and assistance, see your authorized dealer.

CHEVROLET MOTOR DIVISION
General Motors Corporation
Detroit, Michigan

CAUTION

To reduce the chance of personal injury and/or property damage, the following instructions must be carefully observed.

Proper service and repair are important to the safety of the service technician and the safe, reliable operation of all motor vehicles. If part replacement is necessary, the part must be replaced with one of the same part number or with an equivalent part. Do not use a replacement part of lesser quality.

The service procedures recommended and described in this service manual are effective methods of performing service and repair. Some of these procedures require the use of tools specially designed for the purpose.

Accordingly, anyone who intends to use a replacement part, service procedure or tool, which is not recommended by the vehicle manufacturer, must first determine that neither his safety nor the safe operation of the vehicle will be jeopardized by the replacement part, service procedure or tool selected.

It is important to note that this manual contains various Cautions and Notices that must be carefully observed in order to reduce the risk of personal injury during service or repair, or the possibility that improper service or repair may damage the vehicle or render it unsafe. It is also important to understand that these 'Cautions' and 'Notices' are not exhaustive, because it is impossible to warn of all the possible hazardous consequences that might result from failure to follow these instructions.

SECTION 0

GENERAL INFORMATION

CONTENTS

<u>SUBJECT</u>	<u>PAGE</u>
General Information	0A- 1
Maintenance and Lubrication	0B- 1

SECTION 0A

GENERAL INFORMATION

CONTENTS

<u>SUBJECT</u>	<u>PAGE</u>
Service Parts Identification Label	0A- 1
Vehicle Identification Plate	0A- 1
Certification Label	0A- 2
Model Reference	0A- 2
Engine identification Number	0A- 2
Vehicle Lifting Procedures	0A- 3
Emergency Starting Due to a Discharged Battery	0A- 8
Graphic Symbols	0A- 8
Metric Fasteners	0A-10
Fastener Strength Identification	0A-10
Prevailing Torque Fasteners	0A-11
Six Lobed Socket Head Fasteners	0A-12
RPO Listing (Regular Production Option)	0A-15

SERVICE PARTS IDENTIFICATION LABEL

The Truck Service Parts Identification Label is provided on all models (figure 1). It is located on the inside of the glove box door (or on an inner body panel for Forward Control models). The Label lists the VIN (Vehicle Identification Number), wheelbase, paint information and all Production options or Special Equipment on the vehicle when it was shipped from the factory. ALWAYS REFER TO THIS INFORMATION WHEN ORDERING PARTS.

VEHICLE IDENTIFICATION NUMBER

The VIN is the legal identifier of the vehicle. On all models except Forward Control, it is located on a plate which is attached to the left top of the instrument panel and can be seen through the windshield from the outside of the vehicle (figure 2). On Forward Control models, the plate is on the dash and toe panel. To find out the

Printed in U.S.A.	15516776		
SERVICE PARTS IDENTIFICATION			
V.I.N. _____	W/BASE _____		
NOTE: THE OPTIONAL EQUIPMENT LISTED BELOW HAS BEEN INSTALLED ON THIS VEHICLE FOR PROPER IDENTIFICATION OF REPLACEMENT PARTS. BE SURE TO SPECIFY THE APPLICABLE OPTION NUMBERS.			
OPTION NO.	DESCRIPTION	OPTION NO.	DESCRIPTION
NOTE: THIS INFORMATION IS SUPPLIED AS AN AID IN IDENTIFYING PARTS FOR SERVICE. SERVICE PARTS REQUIREMENTS FOR THIS VEHICLE MAY VARY FROM THOSE LISTED. BEFORE ORDERING ANY OF THE ABOVE PARTS, ALWAYS HAVE YOUR GENERAL MOTORS TRUCK DEALER CHECK THIS VEHICLE'S BROADCAST SUPPLEMENT FOR POSSIBLE PART CHANGES.			
IMPORTANT: RETAIN THIS PLATE AS A PERMANENT RECORD			
B-05559			

Figure 1—Service Parts Identification Label

manufacturer, model and chassis type, engine type, GVW range, model year, plant code, and sequential number, refer to figure 3.

0A-2 GENERAL INFORMATION

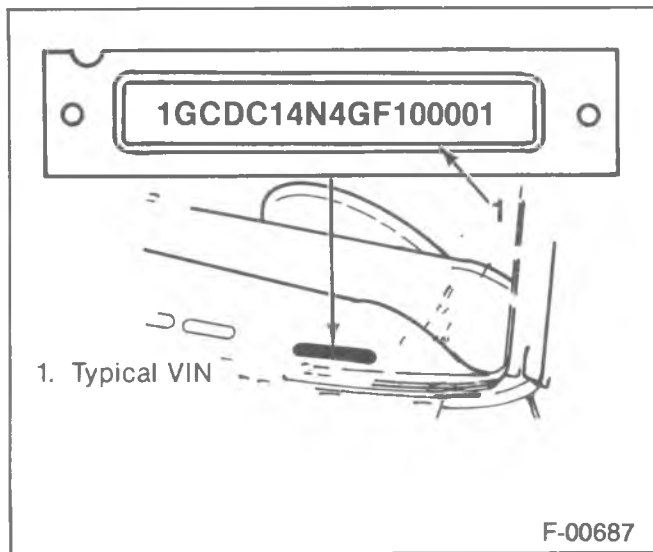

Figure 2—VIN Location

GVWR. Also, the front and rear gross axle weights must not exceed the front and rear GAWRs.

The Payload Rating shown on the label is the maximum allowable cargo load (including the weight of the driver and all occupants) that the vehicle can carry based on all factory installed equipment on the vehicle. The Payload Rating is reduced if any accessories or other equipment is added to the vehicle after final date of manufacture. The weight of these items should be determined and deducted from the Payload Rating.

The vehicle may also have a GCWR (Gross Combination Weight Rating). The GCW (Gross Combination Weight) is the total weight of the loaded tow vehicle (including passengers) and a loaded trailer.

The tires on the vehicle must be the proper size and properly inflated for the load which you are carrying. The vehicle Certification Label shows the originally equipped tire size and recommended inflation pressures. For more information on tires, refer to WHEELS AND TIRES (Sec.3E).

CERTIFICATION LABEL

The Certification Label shows the GVWR, and the front and rear GAWRs, and the Payload Rating for your vehicle (figure 4).

Gross Vehicle Weight (GVW) is the weight of the originally equipped vehicle and all items added to it after it has left the factory. This would include bodies, winches, booms, etc.; the driver and all occupants; and the load the vehicle is carrying. The GVW must not exceed the

MODEL REFERENCE

Refer to figures 5 and 6 to determine the vehicle model. For R/V models, a "R" is a two-wheel drive vehicle and a "V" is a four-wheel drive vehicle.

ENGINE IDENTIFICATION NUMBER

Refer to figure 7 to determine the location of the engine I.D. number.

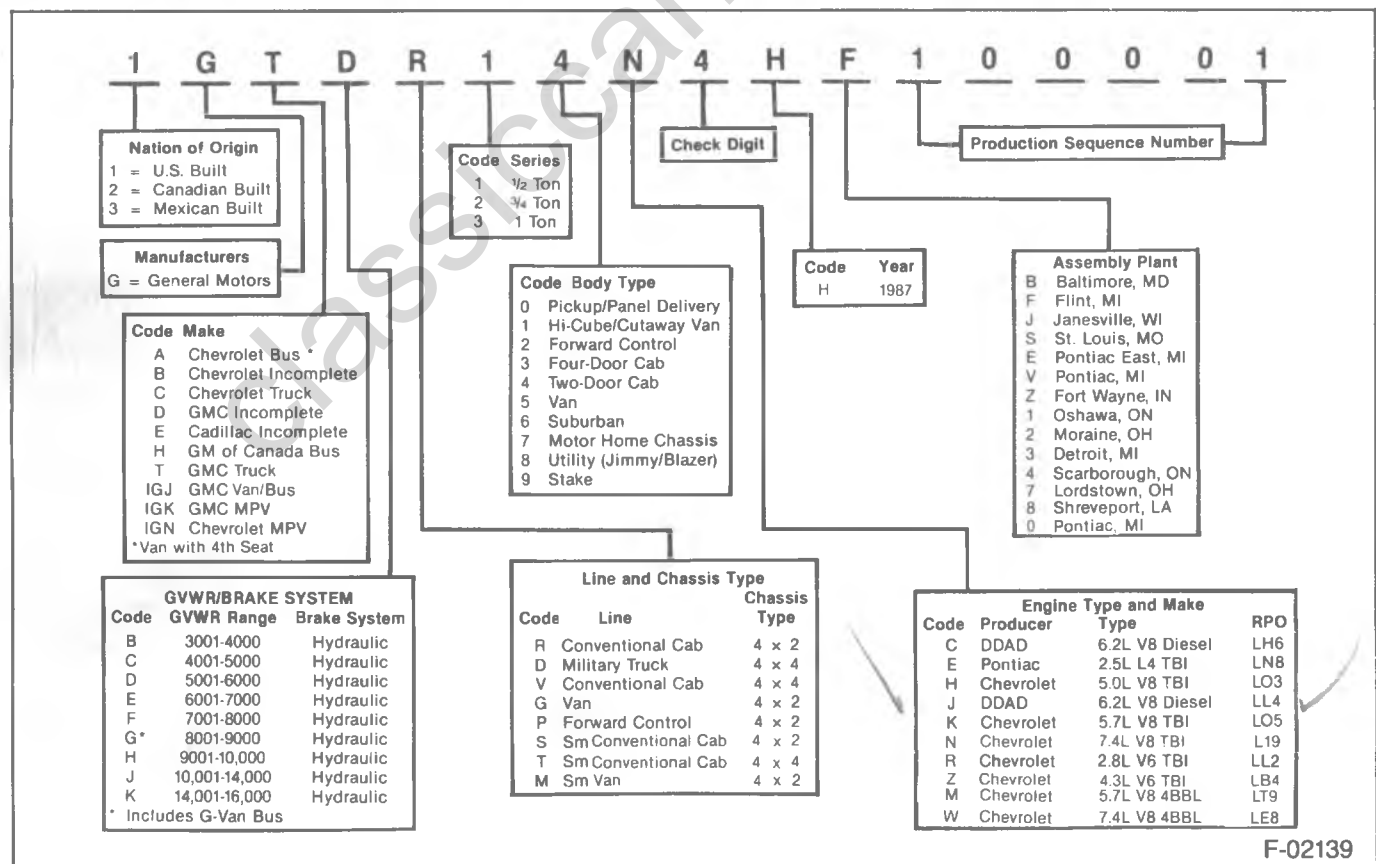

Figure 3—Vehicle Identification Number (VIN)

F-02139

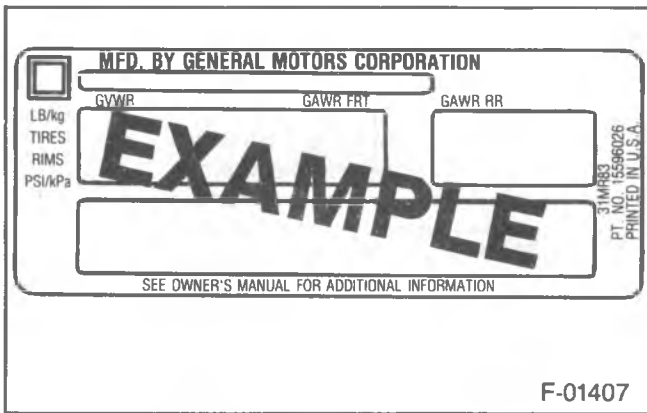

Figure 4—Certification Label

VEHICLE LIFTING PROCEDURES

For lifting a vehicle, various lift points are recommended. Refer to figures 8, 9, 10, and 11.

When lifting the R vehicle with a hoist, the rear hoist pads should be positioned under the rear spring front hangers.

When lifting the V vehicle with a hoist, the front hoist pads should be positioned under the frame, at the front body mount. The rear hoist pads should be positioned under the rear spring front hangers.

When lifting the front of the V vehicle with a floor jack, position the jack pad at the center of the axle, not under the front differential.

When lifting the P vehicle with a hoist, the rear hoist pads should be positioned under the frame and inboard of the rear spring front hangers.

When lifting the G vehicle with a hoist, the rear hoist pads should be positioned under the rear spring forward hangers.

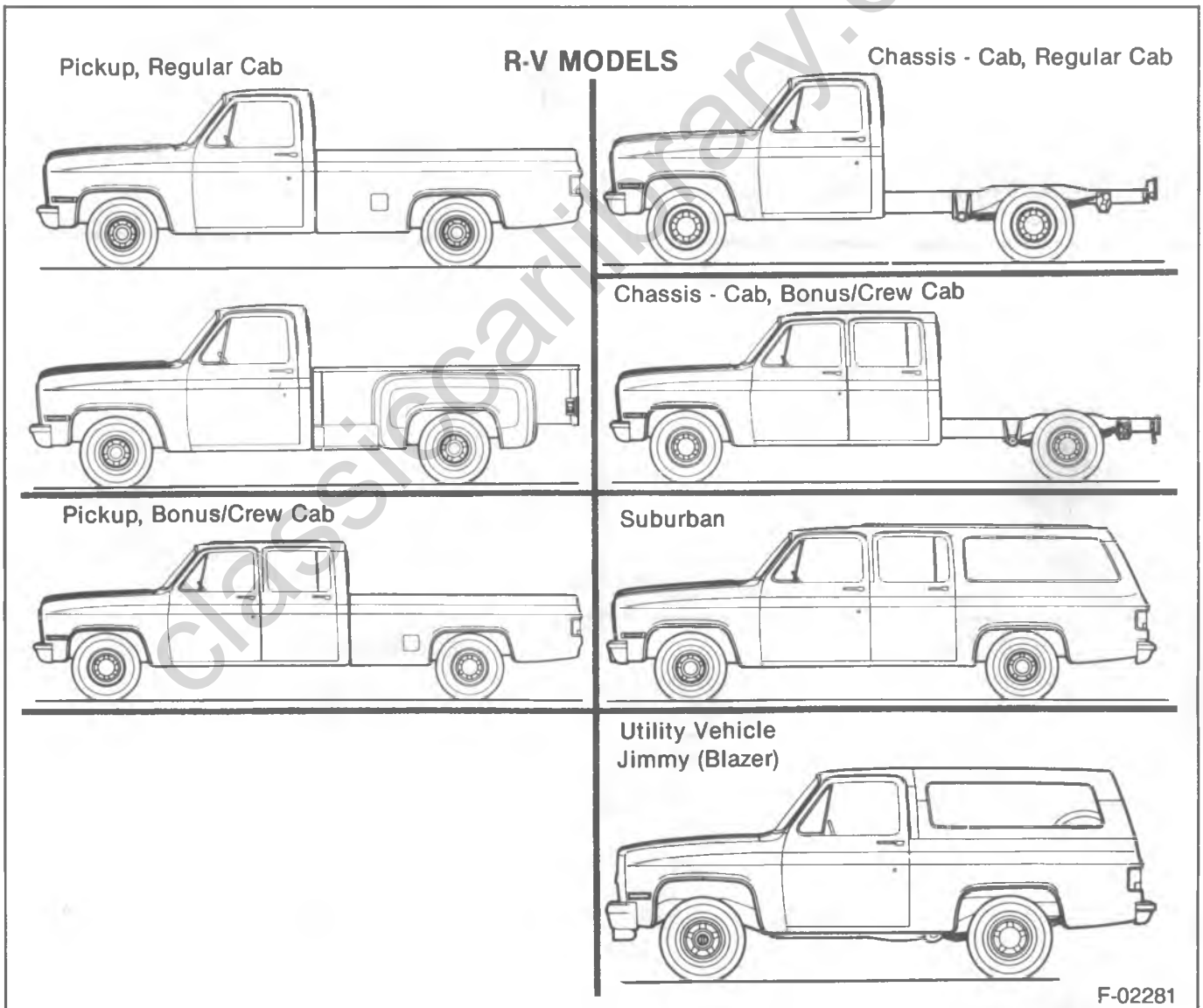

Figure 5—RV Models

F-02281

0A-4 GENERAL INFORMATION

G VAN MODELS

RALLY (SPORTVAN)

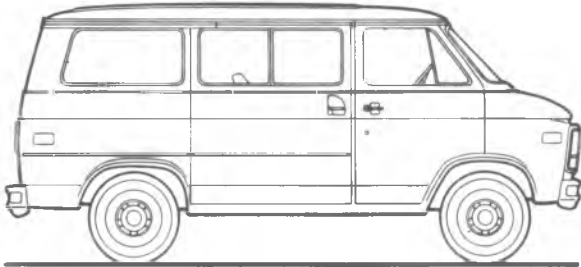

VANDURA (CHEVY VAN)

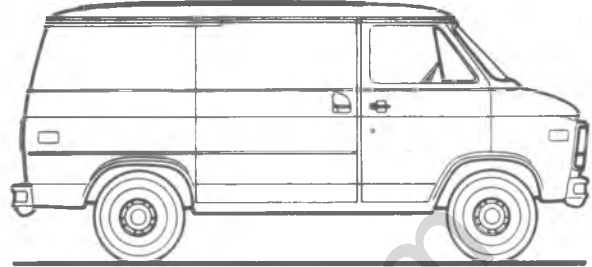

CUTAWAY VAN

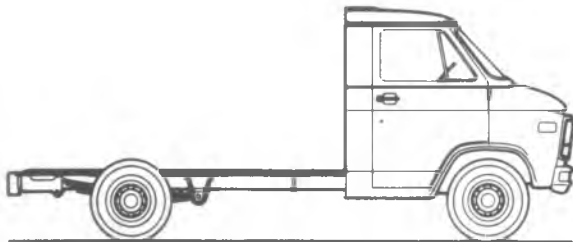

MAGNAVAN (HI-CUBE VAN)

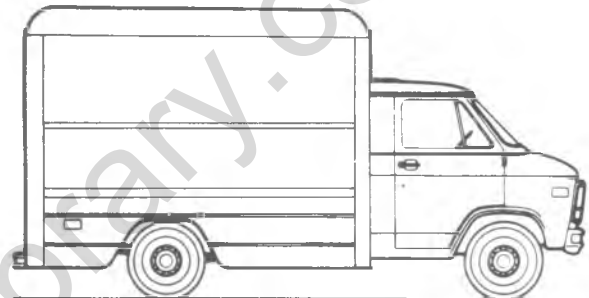

P MODELS

VALUE VAN (STEP VAN)
(ALUMINUM)

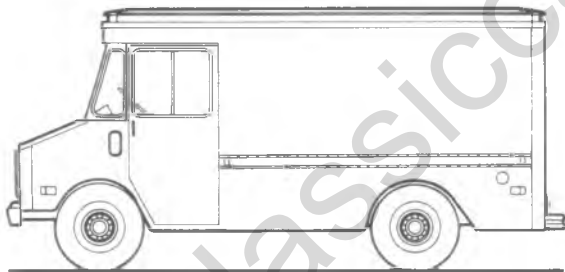

MOTOR HOME CHASSIS

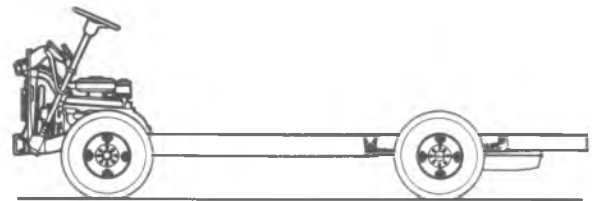

VALUE VAN (STEP VAN)
(STEEL)

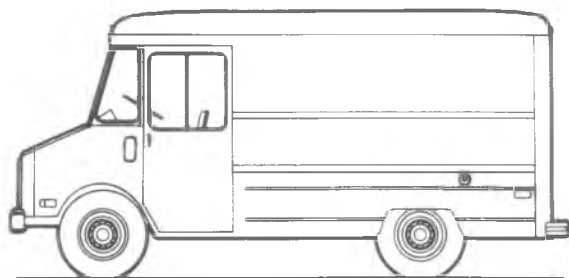

FORWARD CONTROL CHASSIS

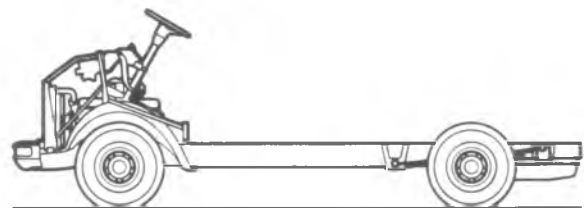

B-09178

Figure 6—G Van and P Models

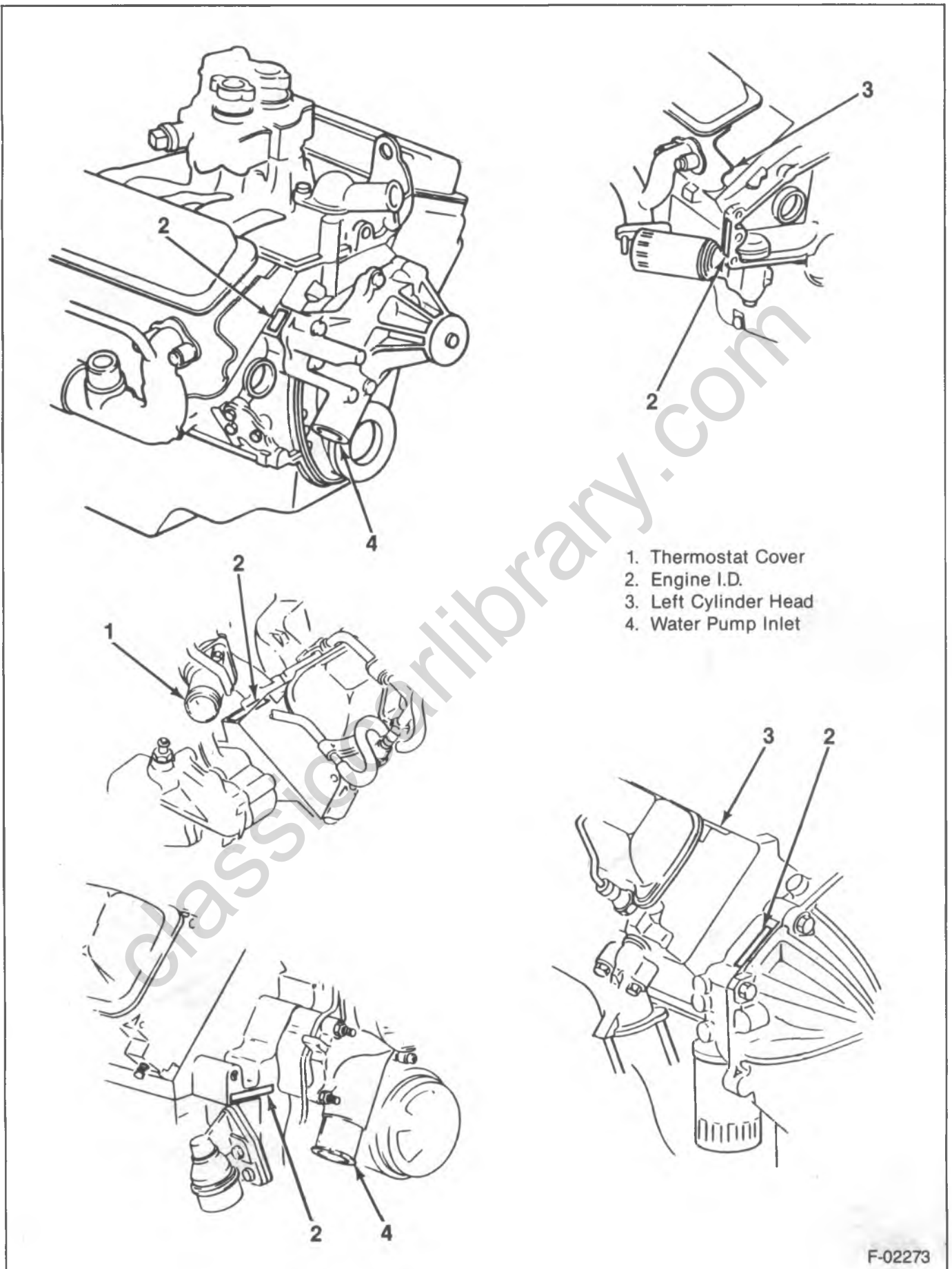

Figure 7—Engine I.D. Number Location

0A-6 GENERAL INFORMATION

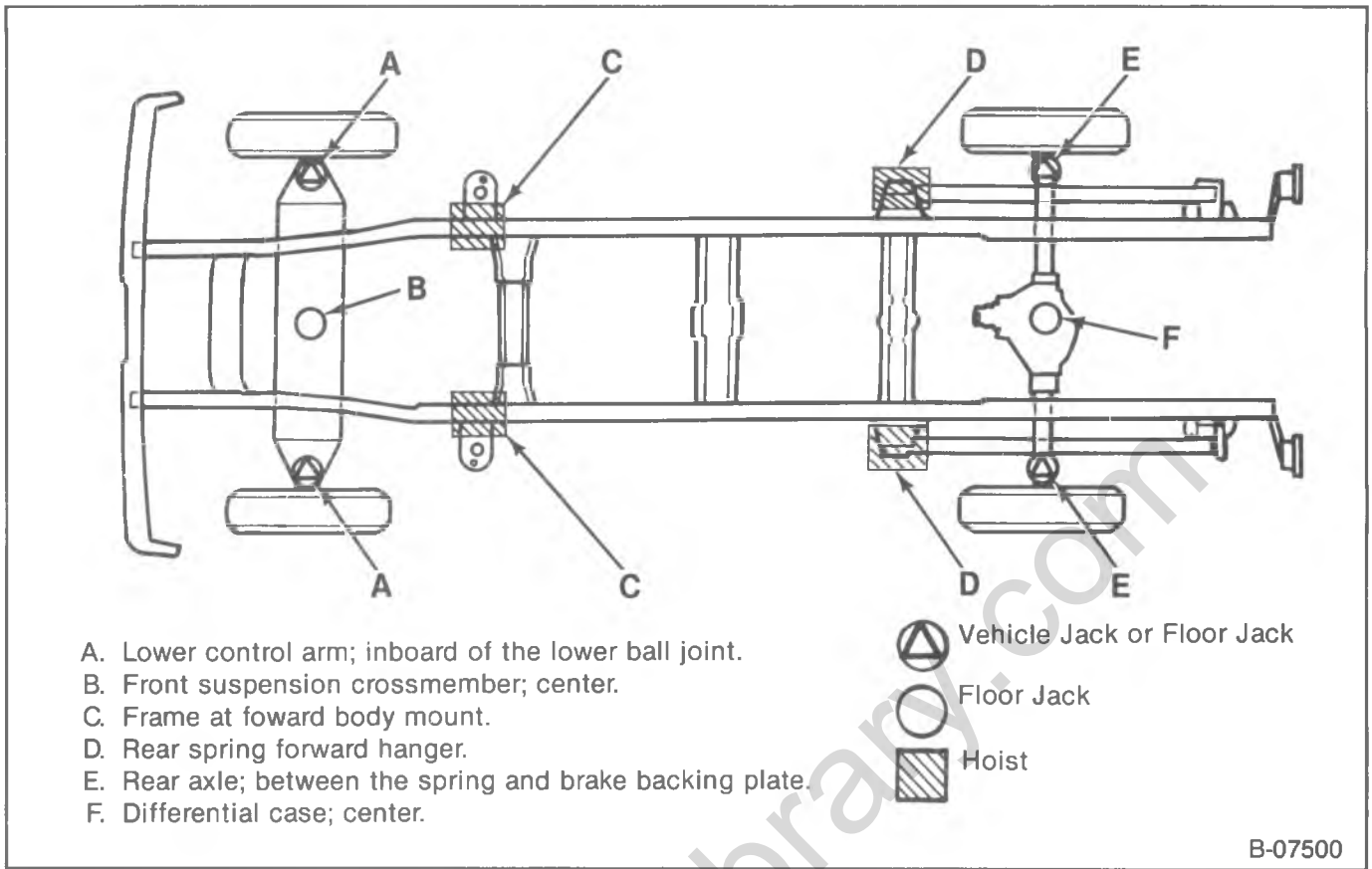

Figure 8—Chassis Lift Points — R Model

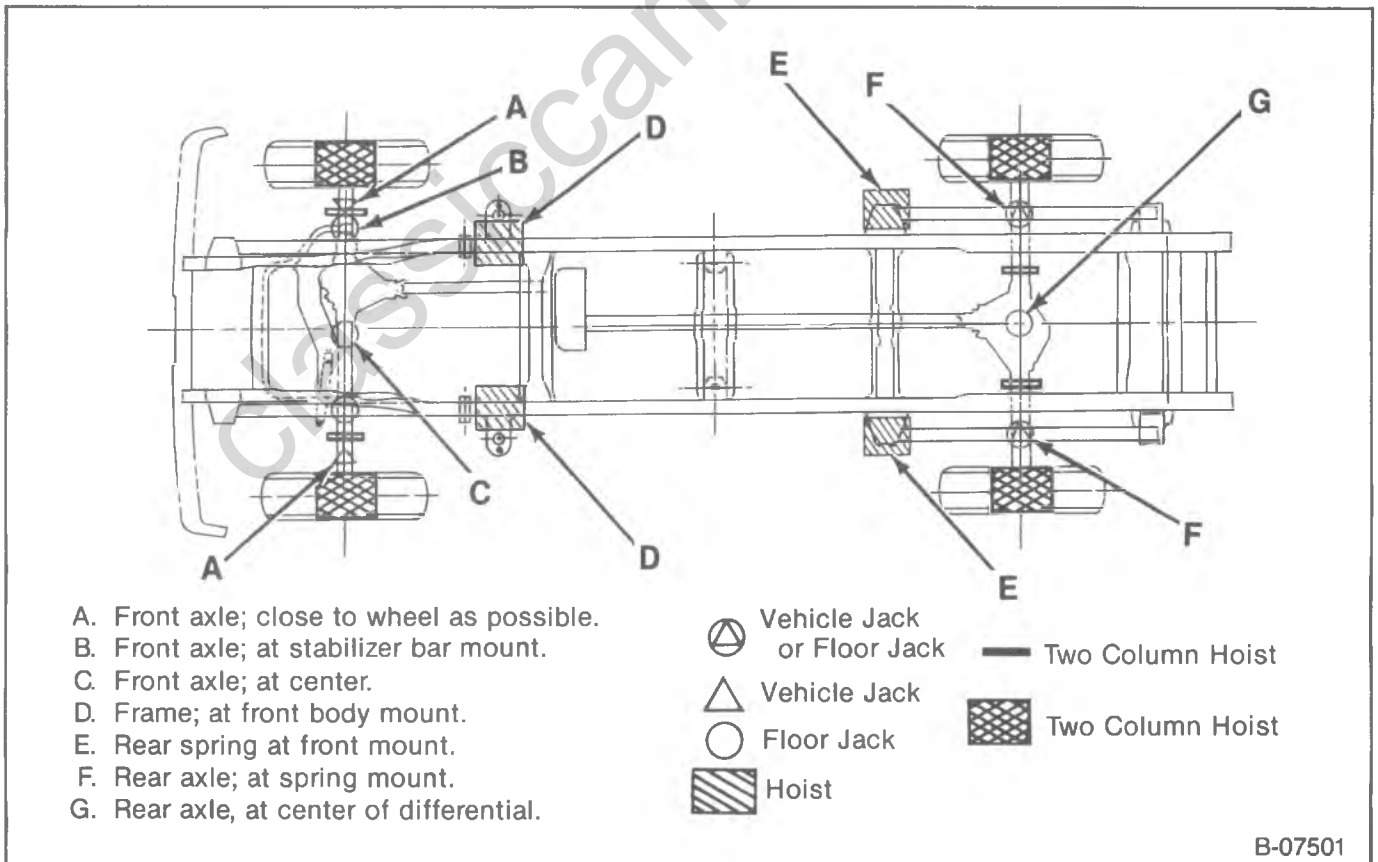

Figure 9—Chassis Lift Points — V Model

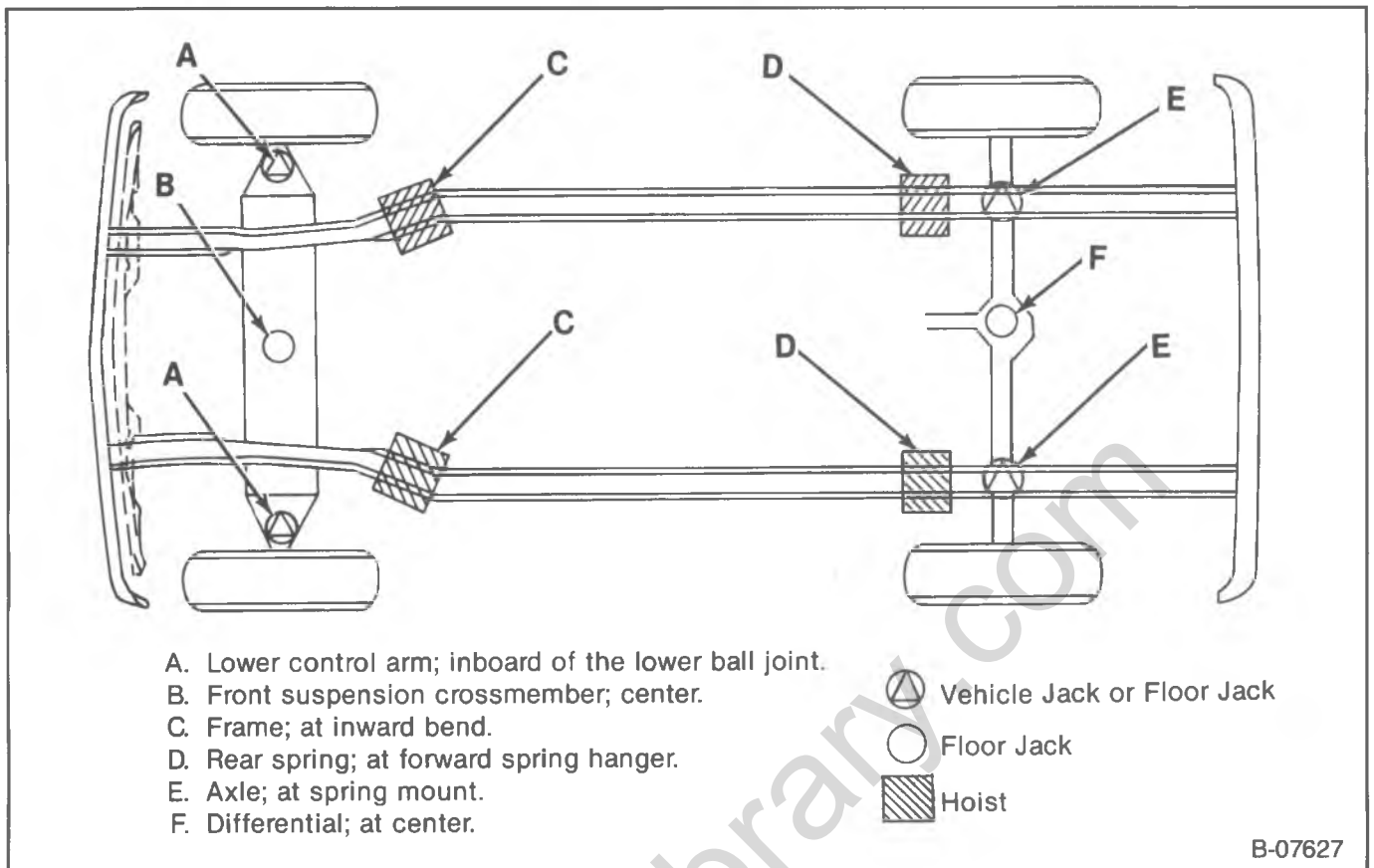

Figure 10—Chassis Lift Points — G Model

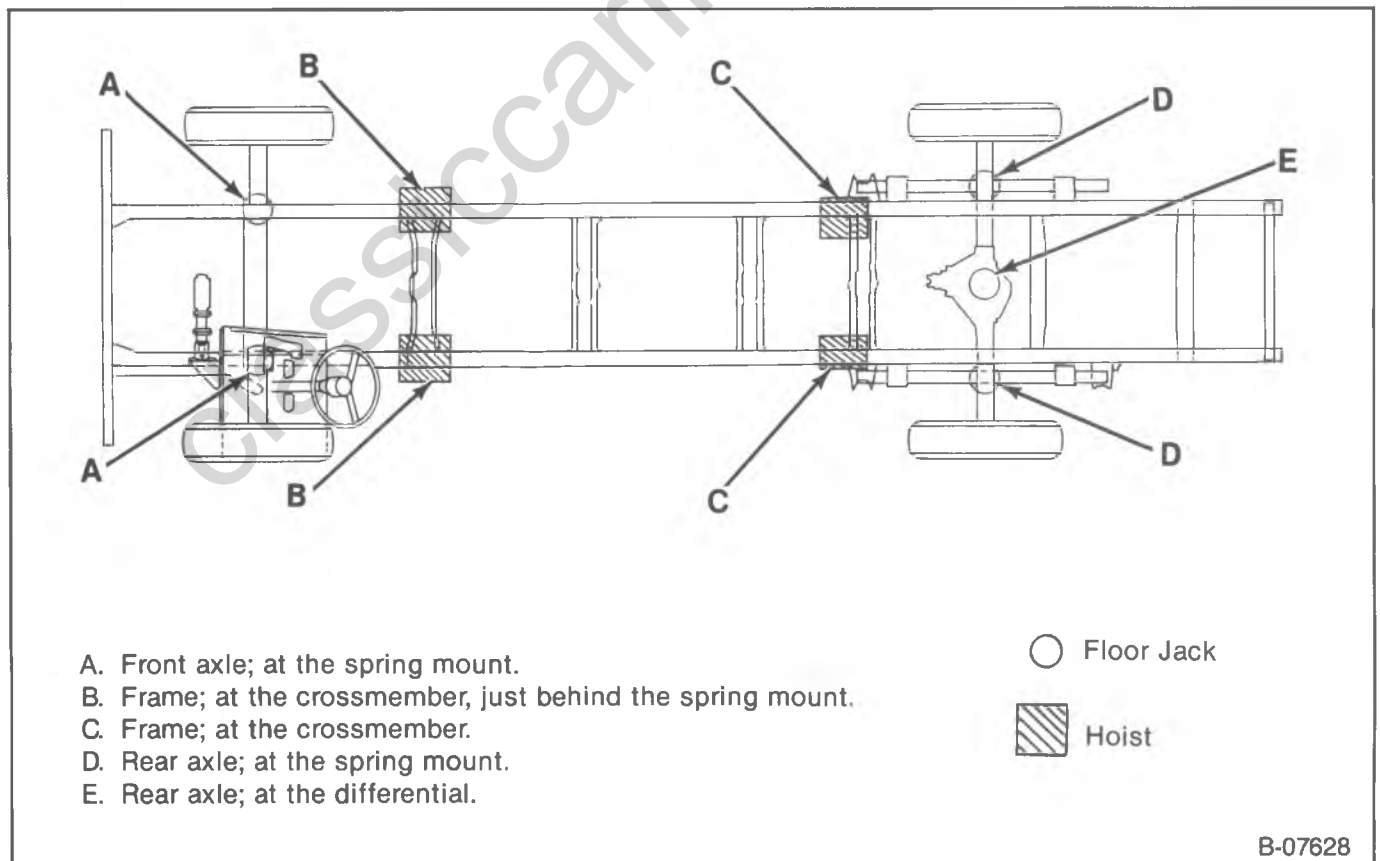

Figure 11—Chassis Lift Points — P Model

0A-8 GENERAL INFORMATION

Any time a vehicle is lifted with a vehicle jack or a floor jack, the wheels at the opposite end of the lifted end should be chocked. Also, jack stands should be used to provide support. When supporting the vehicle with jack stands, the jack stands should be placed under the frame, the front suspension crossmember or the axle.

When removing major components of the vehicle while the vehicle is on a hoist, the vehicle frame should be chained to the hoist pads in order to prevent tip-off.

NOTICE: When jacking or lifting a vehicle, be certain that the lift pads do not contact the catalytic converter, brake lines, brake cables, or fuel lines. Such contact may result in damage or unsatisfactory vehicle performance.

EMERGENCY STARTING YOUR VEHICLE DUE TO A DISCHARGED BATTERY

If your vehicle will not start due to a discharged battery, it can often be started by using energy from another battery - a procedure called "jump starting."

Should your vehicle have an optional diesel engine with two batteries:

- P models and G Van models — use only the battery on the driver's side when jump starting.
- R/V models — use only the battery on the passenger's side when jump starting.

These battery locations are closer to the starter, thus reducing electrical resistance. Ignore the second battery.

NOTICE: Do not push or tow this vehicle to start it. Under some conditions this may damage the catalytic converter or other parts of the vehicle. Also, since this vehicle has a 12 volt battery, be sure the vehicle or equipment used to jump start your engine is also 12 volt. Use of any other type system may damage the vehicle's electrical components.

At low temperatures, it may not be possible to start your diesel engine from a single battery in another vehicle. However, you can use your vehicle to jump start another vehicle.

JUMP STARTING INSTRUCTIONS

CAUTION: Batteries produce explosive gases, contain corrosive acid, and supply levels of electrical current high enough to cause burns. Therefore, to reduce the risk of personal injury when working near a battery:

- Always shield your eyes and avoid leaning over the battery whenever possible.
- Do not expose the battery to open flames or sparks.
- Be sure any batteries that have filler caps are properly filled with fluid.
- Do not allow battery acid to contact eyes of skin. Flush any contacted area with water immediately and thoroughly, and get medical help.
- Follow each step in the jump starting instructions.

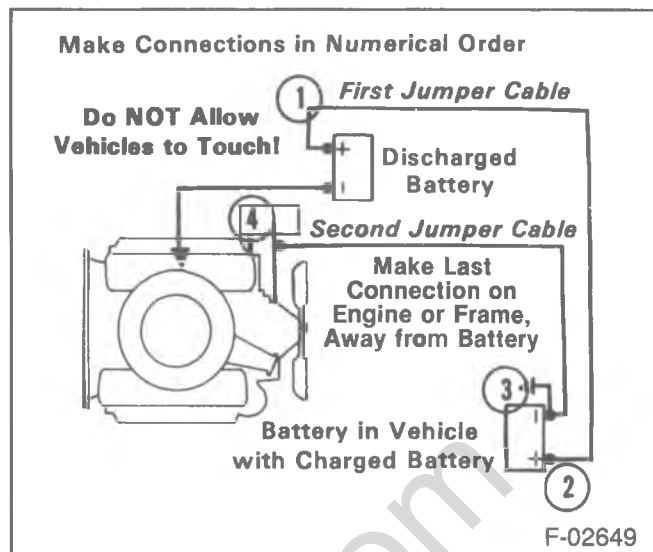

Figure 12—Jump Starting Connections

1. Position the vehicle with the good (charged) battery so that the booster (jumper) cables will reach, but never let the vehicles touch. Also, be sure booster cables do not have loose or missing insulation.
2. In both vehicles:
 - Turn off the ignition and all lights and accessories except the hazard flasher or any lights needed for the work area.
 - Apply the parking brake firmly, and shift the automatic transmission to Park (or manual transmission to Neutral).
3. Making sure the cable clamps do not touch any other metal parts, clamp one end of the first booster cable to the positive (+) terminal on one battery, and the other end to the positive terminal on the other battery (figure 12). Never connect (+) to (-).
4. Clamp one end of the second cable to the negative (-) terminal of the good (charged) battery and make the final connection to a heavy metal bracket (such as the mounting bracket for the generator or air conditioner compressor if so equipped) on the engine about 450 millimeters (18 inches) from the discharged battery. Make sure the cables are not on or near pulleys, fans, or other parts that will move when the engine is started.
5. Start the engine of the vehicle with the good (charged) battery and run the engine at a moderate speed for several minutes. Then, start the engine of the vehicle that has the discharged battery.
6. Remove the booster cables by reversing the above installation sequence exactly. While removing each clamp, take care it does not touch any other metal while the other end remains attached.

GRAPHIC SYMBOLS

Graphic symbols are used on some controls and displays on the vehicle (figure 13). Many of these symbols are used internationally.







































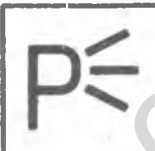

 BRAKE	 POWER TRAIN OIL TEMPERATURE	 WINDSHIELD WASHER	 WINDSHIELD WIPER & WASHER	 VENTILATING FAN	 WINDSHIELD DEFROSTER	 FUSE
 ENGINE COOLANT LEVEL	 ENGINE STOP	 REAR WINDOW DEFOGGER	 FASTEN SEAT BELTS	 FUEL	 ENGINE OIL PRESSURE	 REAR WINDOW WIPER & WASHER
 FILTER WATER SEPARATOR	 IDENTIFICATION LAMPS	 LIGHTS OR HIGH BEAM	 TURN SIGNALS	 HAZARD WARNING FLASHER	 WINDSHIELD WIPER	 CLEARANCE LAMPS
 ILLUMINATION CONTROL	 FOG LAMP	 SPEAKER	 BRAKE	 CAUSTIC BATTERY ACID COULD CAUSE BURNS	 AVOID SPARKS OR FLAMES	 PROTECT EYES BY SHIELDING
 HORN	 CAUTION POSSIBLE INJURY	 LIGHTER	 DOOR LOCK/UNLOCK	 RADIO SELECTOR	 RADIO VOLUME	 SPARK OR FLAME COULD EXPLODE BATTERY
 PARKING LIGHTS	 CHOKE	 HEATER	 ENGINE COOLANT TEMPERATURE	 BATTERY CHARGING SYSTEM	 SEATBACK WINGS IN/OUT	 HEADLIGHT LOWER BEAM
 POWER WINDOW	 ENGINE OIL TEMPERATURE	 kPa MANIFOLD VACUUM	 TRANSMISSION OIL TEMPERATURE	 HOOD RELEASE	 MAIN SWITCH LIGHT	

Figure 13—Graphic Symbols

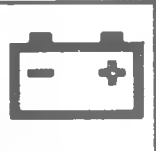
METRIC FASTENERS

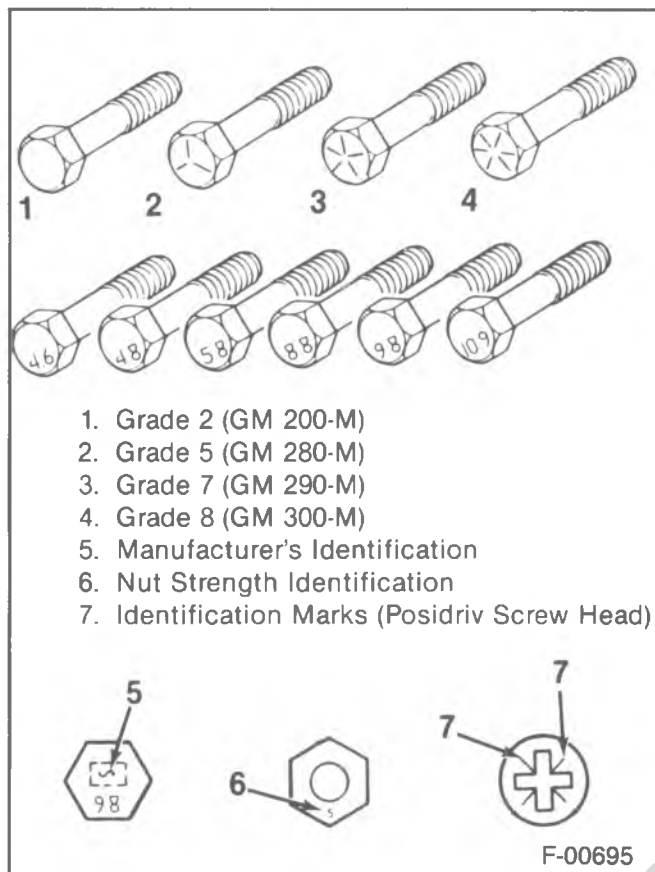

Figure 14—Bolt and Nut Identification

Models are primarily dimensioned in the metric system. Many fasteners are metric and are very close in dimension to well-known customary fasteners in the inch system. It is most important that replacement fasteners be of the correct nominal diameter, thread pitch and strength.

Original equipment metric fasteners (except "beauty" bolts, such as exposed bumper bolts, and cross recess head screws) are identified by a number marking indicating the strength of the material in the fastener as outlined later. Metric cross recess screws are identified by a Posidriv or Type 1A shown in figure 14. Either a Phillips head or Type 1A cross recess screwdriver can be used in Posidriv recess screw heads, but Type 1A cross recess screwdrivers will perform better.

NOTICE: Most metric fasteners have a blue color coating. However, this should not be used as positive identification as some fasteners are not color coated.

General Motors Engineering Standards, along with other North American Industries, have adopted a portion of the standard metric fastener sizes defined by ISO (International Standards Organization). This was done to reduce the number of fastener sizes used and yet retain the best strength qualities in each thread size. For example, the customary 1/4-20 and 1/4-28 screws are replaced by

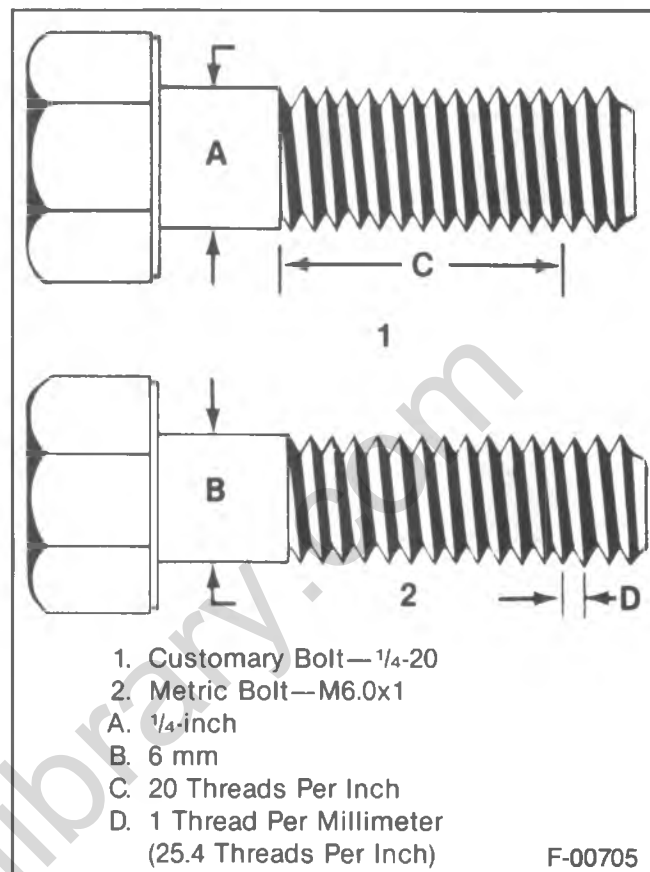

Figure 15—Thread Notation

the metric M6.0X1 screw which has nearly the same diameter and has 25.4 threads per inch. The thread pitch is in between the customary coarse and fine thread pitches.

Metric and customary thread notation differ slightly. The difference is shown in figure 15.

FASTENER STRENGTH IDENTIFICATION

Most commonly used metric fastener strength property classes are 9.8 and 10.9 with the class identification embossed on the head of each bolt. Customary (inch) strength classes range from grade 2 to 8 with radial line identification embossed on each bolt head. Markings correspond to two lines less than the actual grade (i.e. grade 7 bolt will exhibit 5 embossed radial lines on the bolt head). Some metric nuts will be marked with single digit strength identification numbers on the nut face. Figure 14 shows the different strength markings.

When replacing metric fasteners, be careful to use bolts and nuts of the same strength or greater than the original fasteners (the same number marking or higher). It is likewise important to select replacement fasteners of the correct size. Correct replacement bolts metric fasteners available in the aftermarket parts channels were designed to metric standards of countries other than the United States, and may be of a lower strength, may not have the numbered head marking system. and may be of a

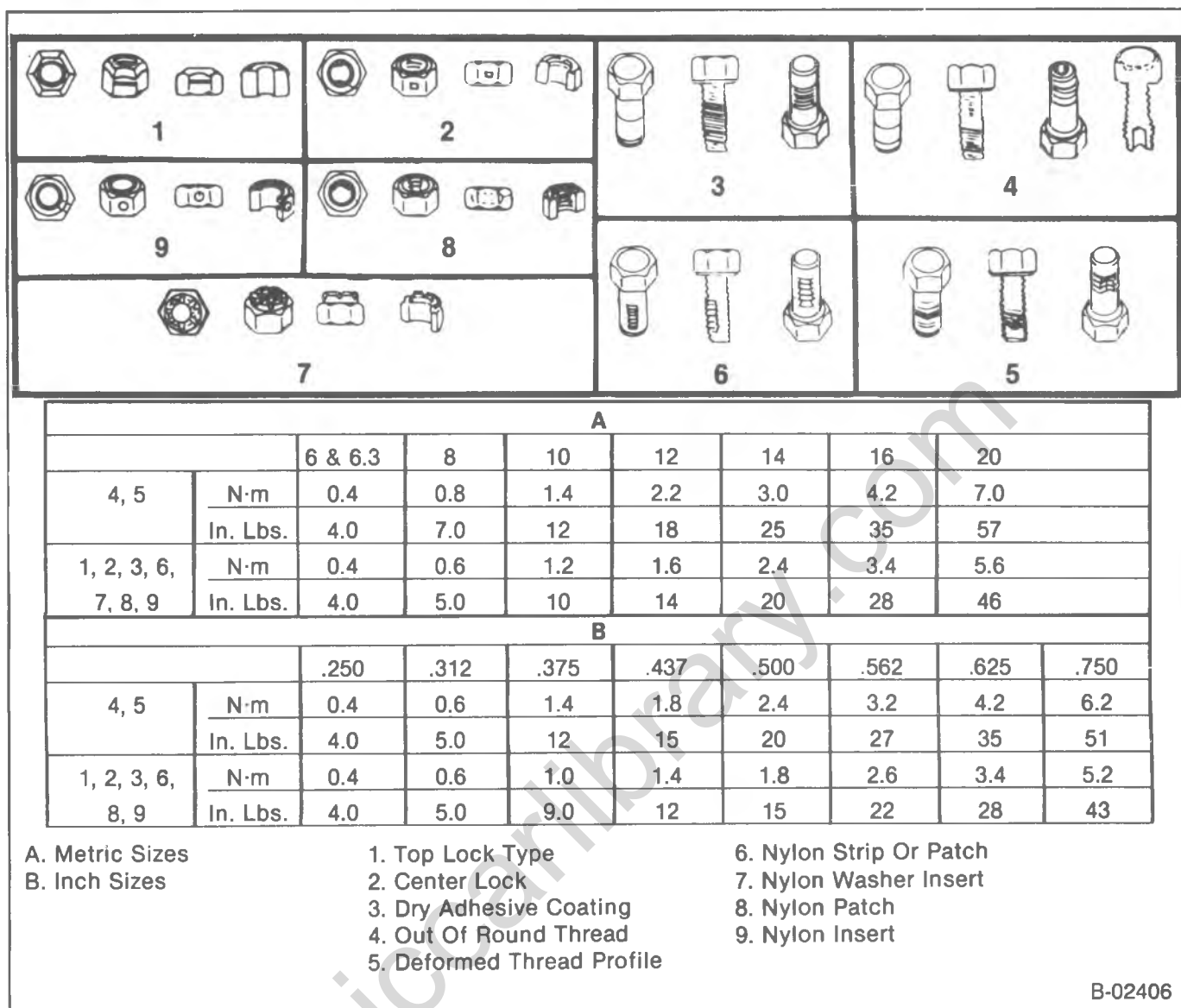

Figure 16—Torque Nuts and Bolts Chart

different thread pitch. The metric fasteners used on GM products are designed to new, international standards that may not yet be manufactured by some non-domestic bolt and nut suppliers. In general, except for special applications, the common sizes and pitches are:

M6.0 x 1 M 10 x 1.5
M 8 x 1.25 M 12 x 1.75

PREVAILING TORQUE FASTENERS

A prevailing torque nut is designed to develop an interference between the nut and bolt threads. This is most often accomplished by distortion of the top of an all-metal nut by using a nylon patch on the threads in the middle of the hex flat. A nylon insert may also be used as a method of interference between nut and bolt threads (figure 16).

A prevailing torque bolt is designed to develop an interference between bolt and nut threads, or the threads of a tapped hole. This is accomplished by distorting some of the threads or by using a nylon patch or adhesive (figure 12).

RECOMMENDATIONS FOR REUSE:

1. Clean, unrudded prevailing torque nuts and bolts may be reused as follows:
 - a. Clean dirt and other foreign material off the nut or bolt.
 - b. Inspect the nut or bolt to insure there are no cracks, elongation, or other signs of abuse or overtightening. (If there is any doubt, replace with a new prevailing torque fastener or equal or greater strength).
 - c. Assemble the parts and hand start the nut or bolt.
 - d. Observe that, before fastener seats, it develops torque per the chart in figure 10 (if there is any doubt, replace with a new prevailing torque fastener of equal or greater strength).
 - e. Tighten the fastener to the torque specified in the appropriate section of this manual.
2. Bolts and nuts which are rusty or damaged should be replaced with new parts or equal or greater strength.

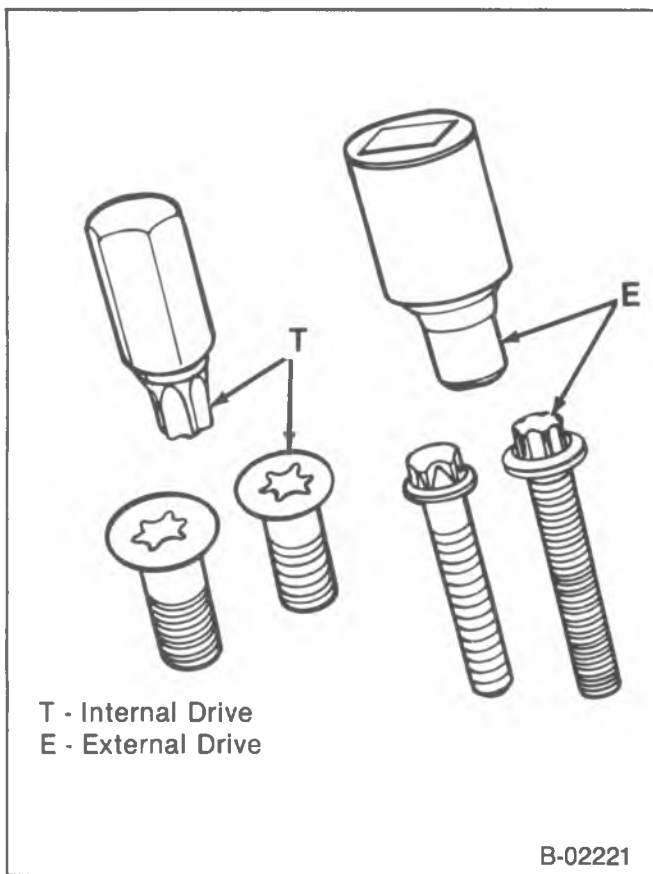

Figure 17—Six Lobed Socket Head Fasteners

SIX LOBED SOCKET HEAD FASTENERS

Six lobed socket head fasteners are used in some applications on vehicles covered in this manual (figure 17). The door striker bolt is of this design.

Tools designed for these fasteners are available commercially. However, in some cases, if the correct tool is not available, a hex socket head wrench may be used.

CONVERSION TABLE

Multiply	by	to get equivalent number of:	Multiply	by	to get equivalent number of:
LENGTH			ACCELERATION		
Inch	25.4	millimeters (mm)	Foot/sec ²	0.304 8	meter/sec ² (m/s ²)
Foot	0.304 8	meters (m)	Inch/sec ²	0.025 4	meter/sec ²
Yard	0.914 4	meters	TORQUE		
Mile	1.609	kilometers (km)	Pound-inch	0.112 98	newton-meters (N·m)
AREA			Pound-foot	1.355 8	newton-meters
Inch ²	645.2	millimeters ² (mm ²)	POWER		
	6.45	centimeters ² (cm ²)	Horsepower	0.746	kilowatts (kW)
Foot ²	0.092 9	meters ² (m ²)	PRESSURE OR STRESS		
Yard ²	0.836 1	meters ²	Inches of water	0.249 1	kilopascals (kPa)
VOLUME			Pounds/sq. in.	6 895	kilopascals
Inch ³	16.387	mm ³	ENERGY OR WORK		
	16.387	cm ³	BTU	1 055	joules (J)
	0.016 4	liters (l)	Foot-pound	1.355 8	joules
Quart	0.946 4	liters	Kilowatt-hour	3 600 000	joules (J \$ one W)
Gallon	3.785 4	liters		or 3.6 x 10 ⁶	
Yard ³	0.764 6	meters ³ (m ³)	LIGHT		
MASS			Foot candle	1.076 4	lumens/meter ² (lm/m ²)
Pound	0.453 6	kilograms (kg)	FUEL PERFORMANCE		
Ton	907.18	kilograms (kg)	Miles/gal	0.425 1	kilometers/liter (km/l)
Ton	0.907	tonne (t)	Gal/mile	2.352 7	liter/kilometer (l/km)
FORCE			VELOCITY		
Kilogram	9.807	newtons (N)	Miles/hour	1.609 3	kilometers/hr. (km/h)
Ounce	0.278 0	newtons			
Pound	4.448	newtons			
TEMPERATURE					
Degree Fahrenheit	(°F-32) ÷ 1.8	degree Celsius (C)			

Figure 18—Conversion Table

B-05497

DECIMAL AND METRIC EQUIVALENTS

Fractions	Decimal In.	Metric mm	Fractions	Decimal In.	Metric mm
1/64	0.015625	0.39688	33/64	0.515625	13.09687
1/32	0.03125	0.79375	17/32	0.53125	13.49375
3/64	0.046875	1.19062	35/64	0.546875	13.89062
1/16	0.0625	1.58750	9/16	0.5625	14.28750
5/64	0.078125	1.98437	37/64	0.578125	14.68437
3/32	0.09375	2.38125	19/32	0.59375	15.08125
7/64	0.109375	2.77812	39/64	0.609375	15.47812
1/8	0.125	3.1750	5/8	0.625	15.87500
9/64	0.140625	3.57187	41/64	0.640625	16.27187
5/32	0.15625	3.96875	21/32	0.65625	16.66875
11/64	0.171875	4.36562	43/64	0.671875	17.06562
3/16	0.1875	4.76250	11/16	0.6875	17.46250
13/64	0.203125	5.15937	45/64	0.703125	17.85937
7/32	0.21875	5.55625	23/32	0.71875	18.25625
15/64	0.234375	5.95312	47/64	0.734375	18.65312
1/4	0.250	6.3500	3/4	0.750	19.05000
17/64	0.265625	6.74687	49/64	0.765625	19.44687
9/32	0.28125	7.14375	25/32	0.78125	19.84375
19/64	0.296875	7.54062	51/64	0.796875	20.24062
5/16	0.3125	7.93750	13/16	0.8125	20.63750
21/64	0.328125	8.33437	53/64	0.828125	21.03437
11/32	0.34375	8.73125	27/32	0.84375	21.43125
23/64	0.359375	9.12812	55/64	0.859375	21.82812
3/8	0.375	9.52500	7/8	0.875	22.22500
25/64	0.390625	9.92187	57/64	0.890625	22.62187
13/32	0.40625	10.31875	29/32	0.90625	23.01875
27/64	0.421875	10.71562	59/64	0.921875	23.41562
7/16	0.4375	11.11250	15/16	0.9375	23.81250
29/64	0.453125	11.50937	61/64	0.953125	24.20937
15/32	0.46875	11.90625	31/32	0.96875	24.60625
31/64	0.484375	12.30312	63/64	0.984375	25.00312
1/2	0.500	12.7000	1	1.00	25.40000

Figure 19—Decimal and Metric Equivalents

RPO LISTING (REGULAR PRODUCTION OPTION)

The RPO list contains RPOs used on R-V Models, G Vans, and Forward Control Chassis Models. Refer to the Service Parts Identification Label for a list of the RPOs used on each specific vehicle.

- AA3 Windows - Deep Tint, Side Windows Only
- AC2 Window - Sliding, Right Front Door
- AD5 Window - Right Rear, Side, Sliding
- AD8 Door Check
- AE7 Seat - Front, Split
- AJ1 Window - Deep Tint, Except Windshield and Doors
- AM7 Seat - Right Rear Folding
- AP7 Partition - Sliding Plywood
- AQ3 Seat - Rear Center
- AQ4 Seat - Rear
- AS3 Seat - Right Rear, Suburban
- AT5 Seat - Center Folding, Suburban
- AU2 Lock - Cargo Door
- AU3 Power Lock - Side Door
- AU6 Power Lock - Tailgate Remote Control
- AV5 Seat - High Back, Bucket
- AW4 Door - Sliding Side Extension
- AX5 Partition - Expanded Metal, Left Side
- AX7 Partition - Expanded Metal w/Center Sliding Door
- AX9 Latch - Rear Cargo Door
- A01 Window - Tinted, All Shaded Windshield
- A02 Windshield - Tinted, Shaded Upper
- A07 Window - Body
- A08 Window - Body, Right Side
- A12 Window - Stationary, Back Door
- A13 Window - Stationary, Side Rear Door
- A17 Window - Left Side Swing-Out
- A18 Window - Rear Door, Swing-Out
- A19 Glass - Side Rear Door, Swing-Out
- A20 Window RR Quarter Vent, Swing Out
- A28 Window - Right Rear, Full Width, Sliding
- A31 Window - Side, Power
- A33 Window - Tailgate, Power
- A50 Seat - Front Bucket
- A51 Seat - Front Bucket
- A52 Seat - Front Bench
- A57 Seat - Auxillary, One Passenger, Folding
- A82 Head Restraints
- A95 Seat - Front Bucket, High Back, Reclining
- BA8 Compartment - Front Seat Storage
- BB5 Ornamentation
- BF3 Floor Covering - Step Well Mat
- BG9 Floor Covering, Rubber
- BW2 Ornamentation - Deluxe Body Side Molding
- B3D School Bus Equipment
- B3J Diesel Equipment
- B30 Floor Carpet
- B32 Floor Mats - Front
- B33 Floor Mats - Rear
- B84 Extra Molding - Body Side
- B85 Extra Molding - Belt Reveal
- B93 Extra Molding - Door Edge Guard
- B96 Extra Molding - Wheel Opening
- CD4 Wiper System - Pulse
- C36 Heater - Auxillary
- C42 Heater - Deluxe Outside Air
- C49 Defogger - Rear Window, Electric
- C55 Vent - Roof
- C60 Air Conditioning - Front Manual Controls
- C69 Air Conditioner - Roof Mounted
- C91 Lamp - Interior Courtesy
- C95 Lamp - Interior Courtesy, Dual Reading
- DF1 Mirror - Camper Type, Painted
- DF2 Mirror - Camper Type, SST
- DG5 Mirror - West Coast Type
- D20 Sunshade - Windshield, Passenger Side
- D34 Mirror - Visor Vanity
- D44 Mirror - Outside, Painted
- D45 Mirror - Outside, SST
- D46 Mirror - West Coast Type with Clearance Lights
- D49 Mirror - Chrome
- D73 Pickup Box Hand Rail
- D92 Stripe - Lower Decor
- E24 Door - Cargo Side, Hinged
- E31 Body - Steel, 10 ft.
- E34 Body - Steel, 10 ft. Standard Width
- E36 Body - Aluminum, 10 ft.
- E38 Body - Steel, 12 ft. x 8 ft.
- E39 Body - Aluminum, 12 ft. x 8 ft.
- E46 Door - 66 in., Overhead Sliding w/Window
- E53 Door - 87 in., Wrap-Around
- E55 End Gate, Suburban
- E62 Pickup Box - Stepside (Fenderside)
- E63 Pickup Box - Fleetside (Wideside)
- E76 Door - 60 in., Rear
- E79 Door - 74 in., Rear, Strap Hinges
- E94 Rally (Beauville) Equipment
- F42 Suspension - Front Heavy Duty
- F51 Shock Absorbers - Front and Rear, Heavy Duty
- F58 Stabilizer Shaft - Front, Heavy Duty
- F59 Stabilizer Shaft - Front
- F60 Spring - Front, Heavy Duty
- G50 Spring - Rear, Heavy Duty
- G51 Spring - Rear, Special Heavy
- G52 Spring - Rear 15000 lbs.
- G60 Spring - Rear Auxiliary
- G80 Axle - Rear, Limited Slip
- KC4 Engine Oil Cooler System
- KL7 Gas Conversion - LP
- K05 Engine Block Heater
- K09 Generator - 120 Amp
- K22 Generator - 94 Amp
- K34 Cruise Control
- K46 Air Cleaner - Heavy Duty, Pre-Cleaner
- K60 Generator - 100 Amp
- K68 Generator - 105 Amp
- K81 Generator - 66 Amp
- K99 Generator - 85 Amp
- LB4 Engine - 4.3L V6 TBI
- LH6 Engine - 6.2L V8, Diesel
- LL4 Engine - 6.2L V8, Heavy Duty Diesel
- L03 Engine - 5.0L V8 TBI
- L05 Engine - 5.7L V8 TBI
- L19 Engine - 7.4L V8 TBI

0A-16 GENERAL INFORMATION

- LT9 Engine - 5.7L V8 4BBL. Heavy Duty
- MD8 Transmission - Auto. 4 Speed, THM700 R4
- MY6 Transmission - Manual 4-Speed w/Overdrive
- M20 Transmission - Manual 4 Speed, 6.55 1st.
- M40 Transmission - Auto, 3 Speed, Torque Conv. Var. 1
- M62 Transmission - Manual 3 Speed, 2.85 Ratio
- M64 Transmission - Manual 3 Speed, 3.50 Ratio
- NA1 Emission System - Light Duty
- NA4 Emission System - Heavy Duty
- NA5 Emission System - Federal Requirements
- NA6 Emission System - High Altitude Requirements
- NB2 Emission System - California Requirements
- NE2 Fuel Tank - 40 gal.
- NK7 Fuel Tank - 31 gal.
- NL2 Fuel Tank - Auxiliary
- NL7 Fuel Tank - 33 gal.
- NM5 Emission System - Canadian Requirement
- NM8 Emission System - Leaded Fuel
- NY1 Fuel Tank Shield
- N05 Fuel Filler Cap Lock
- N31 Steering Wheel - Custom
- N33 Steering Column - Tilt
- N40 Steering - Non-Variable
- N41 Steering - Power
- N51 Steering - Manual
- N67 Wheel - Rally Type
- N90 Wheel - Aluminum Cast
- PA1 Wheel - Trim Discs, Var. 5
- PA6 Wheel - Styled, Painted
- PF2 Wheel - 15 x 7 Aluminum
- P01 Wheel - Trim Discs, Var. 1
- P10 Carrier - Spare Tire
- P11 Carrier - Spare Tire, Glide Out
- P13 Carrier - Spare Tire, Side-Mounted
- P14 Carrier - Inside Mounted Spare Tire, Left Side
- P15 Carrier - Inside Mounted Spare Tire, Right Side
- P17 Cover - Spare Wheel/Tire
- QE6 Wheel - 16.5 x 6
- R05 Wheel Conversion - Dual Rear
- TP2 Battery - Auxiliary Camper
- TR9 Lamp Group
- TT4 Headlamps - Halogen, Pencil Beam
- TT5 Headlamps - Halogen
- TVR Lamp - Rear Dome and Reading
- T63 Headlamps - Warning System
- T84 Headlamps - Right Rule
- T85 Headlamps - Left Rule
- UA1 Battery - High Capacity
- UB4 Lamps - Rear Side Marker
- UD4 Alarm - Vehicle Speed
- UF2 Lamp - Cargo
- UJ1 Indicator System, Brake Warning
- UM6 Radio - AM/FM Stereo, Seek/Scan, Cassette, Clock
- UN3 Radio - AM/FM Stereo, Cassette
- UY1 Wiring Harness - Camper
- UY7 Wiring Harness - Truck Trailer, Heavy Duty
- U01 Lamp - Roof Marker
- U18 Speedometer - Kilometer
- U35 Electric Clock
- U37 Cigarette Lighter
- U58 Radio - AM/FM Stereo
- U63 Radio - AM
- U66 Speaker System - Dual Front, Dual Rear
- U69 Radio - AM/FM
- U76 Antenna - Windshield
- U89 Wiring Harness - Trailer
- VE5 Bumper - Front and Rear Impact Strip
- VF1 Bumper - Rear Chrome
- VG3 Front Bumper Impact Strip
- VG5 Rear Bumper Impact Strip
- VR2 Trailer Hitch
- VR4 Trailer Hitch - Weight Distributing
- V01 Radiator - Heavy Duty
- V02 Radiator - Heavy Duty w/Trans. Oil Cooler
- V05 Radiator - Heavy Duty
- V22 Radiator Grille - Chrome
- V31 Bumper Guards - Front, Chrome
- V35 Bumper, Rear w/Recessed Lighting
- V37 Bumper - Front and Rear Chrome
- V42 Bumper - Rear Step, Chrome
- V43 Bumper - Rear Step, Painted
- V46 Bumper - Front, Chrome
- V76 Front Hook Towing Device
- X6W Hub - Manual Locking
- X6Z Hub - Automatic Locking
- YE9 Equipment Package, Level 3
- YG1 Molding, Body Side and Wheel Opening
- YJ6 Decor Package - Econo
- ZM2 Trim Package, Bonaventure
- ZW9 Base Body or Chassis
- ZY1 Color Combination - Solid
- ZY2 Color Combination - Two Tone
- ZY4 Color Combination - Deluxe Two Tone
- Z53 Gage Package - Voltmeter, Oil Press. and Temp.
- Z62 Equipment Package - Level 1
- Z72 Trailering Package - L.D. Ball-Type Hitch
- Z73 Trim - Special Interior
- Z75 Shock Absorbers - Four Front
- Z76 Special Chassis - Camper Package
- Z80 Trim - Special Exterior
- Z81 Camper - Special
- Z82 Trailer Hitch - Special Reese Type
- 12A Stripe Accent - White
- 12K Color Combination - White (Auxiliary Top)
- 12L Secondary Color - White
- 12U Primary Color - White
- 15A Stripe Accent - Grey
- 18C Trim Combination - Charcoal, Stnd. Cloth
- 18D Trim Combination - Charcoal, Velour Cloth
- 18I Interior Trim - Charcoal
- 18V Trim Combination - Charcoal, Vinyl Striped
- 18W Trim Combination - Charcoal, Dual Grain Vinyl
- 19A Stripe Accent - Black and Grey Two Tone
- 19I Interior Trim - Black
- 19K Color Combination - Black (Auxiliary Top)
- 19L Secondary Color - Black
- 19U Primary Color - Black
- 19W Trim Combination - Black, Dual Grain Vinyl
- 21L Secondary Color - Lt. Blue Metallic
- 21U Primary Color - Lt. Blue Metallic
- 23D Trim Combination - Blue, Velour Cloth
- 23G Trim Combination - Blue Cloth
- 23I Interior Trim - Blue Vinyl
- 23V Trim Combination - Blue Vinyl, Striped
- 23W Trim Combination - Blue Dual Grain Vinyl
- 28A Stripe Accent - Dk Blue and Lt Blue
- 28L Secondary Color - Dk. Blue Metallic
- 28U Primary Color - Dk. Blue Metallic

- 29A Stripe Accent - Dk. and Lt. Blue
29K Color Combination - Dk. Blue (Auxiliary Top)
29L Secondary Color - Dk. Blue
29U Primary Color - Dk. Blue
55L Second Color - Russet Metallic
55U Primary Color - Russet Metallic
61K Color Combination - Tan (Auxiliary Top)
61L Secondary Color - Tan
61U Primary Color - Tan
62C Trim Combination - Lt. Saddle, Stnd. Cloth
62D Trim Combination - Lt. Saddle, Velour Cloth
62G Trim Combination - Saddle Cloth
62I Interior Trim - Lt. Saddle
62V Trim Combination - Lt. Saddle Vinyl, Striped
62W Trim Combination - Lt. Saddle, Dual Grain Vinyl
66K Color Combination - Dk. Brown
66L Secondary Color - Dk. Brown Metallic
66U Primary Color - Dk. Brown Metallic
67L Secondary Color - Lt. Saddle Metallic
67U Primary Color - Lt. Saddle Metallic
72A Stripe Accent - Bright Red
72L Secondary Color - Bright Red
72U Primary Color - Bright Red
76C Trim Combination - Bronze, Stnd. Cloth
76D Trim Combination - Bronze, Velour Cloth
76G Trim Combination - Dk. Claret and Gold, Garnet Red
76I Interior Trim - Bronze
76V Trim Combination - Bronze, Striped Vinyl
76W Trim Combination - Bronze, Dual Grain Vinyl
77C Trim Combination - Dk. Maple, Stnd. Cloth
77D Trim Combination - Dk. Maple, Velour Cloth
77G Trim Combination - Dk. Maple Cloth
77I Interior Trim - Dk. Maple
77V Trim Combination - Dk. Maple, Striped Vinyl
77W Trim Combination - Dk. Maple, Dual Grain Vinyl
78U Primary Color - Med. Rosewood Metallic
82D Trim Combination - Med. Dk. Grey Velour Cloth
82G Trim Combination - Med. Dk. Grey Cloth
82I Interior Trim - Med. Dk. Grey
82W Trim Combination - Dk. Grey, Dual Grain Vinyl
90K Color Combination - Med. Grey (Auxiliary Top)
90L Secondary Color - Grey Metallic
90U Primary Color - Grey Metallic
93U Primary Color - Lt. Driftwood Pearl mist
9V8 Color Combination - Cardinal Red

classiccarylbrary.com

SECTION 0B

MAINTENANCE AND LUBRICATION

CONTENTS

SUBJECT	PAGE
Capacities0B-1
Lubrication0B-6
Maintenance Schedule0B-7

CAPACITIES

Figures 2 through 6 show the approximate capacities of the differential gear, the transmission, the cooling system, the crankcase, the fuel tank, the front axle and the transfer case. Engine code letters are used in the charts. Refer to figure 1 for an explanation of the code.

VIN Engine Code	ENGINE DESCRIPTION			Produced In
	Liter Displacement	Type	Fuel System	
Z	4.3	V6	TBI	USA
H	5.0	V8	TBI	USA, Can.
K	5.7	V8	TBI	USA, Can.
M	5.7	V8	4 BBL	USA, Can.
N	7.4	V8	TBI	USA
W	7.4	V8	4 BBL	USA
T	4.8	L6	1 BBL	Mexico
C	6.2	V8	F.I. @	USA
J	6.2	V8	F.I. @	USA

Figure 1—1987 Engine Code Identification

Items	Metric Measure	U.S. Measure
Differential		
8½" Ring Gear	2.0 L	4.2 pts.
9½" Ring Gear	3.1 L	6.5 pts.
10½" Ring Gear (Chev.)	3.1 L	6½ pts.
9¾" Ring Gear (Dana)	2.8 L	6.0 pts.
12 Ring Gear (Rockwell)	5.9 L	12.5 pts.
Transmission		
Automatic		
400 — Pan Removal	4.0 L	9.0 pts.
Overhaul	10.0 L	22.0 pts.
700-R4 — Pan Removal	4.7 L	10.0 pts.
Overhaul	10.9 L	23.0 pts.
Manual		
4 Speed 117 mm	4.0 L	4.2 qts.
4 Speed 89 mm	4.0 L	4.2 qts.
3 Speed 76 mm	1.5 L	1.6 qts.

Figure 2—Approximate Capacities—All Models

CAPACITIES

Items	Metric Measure	U.S. Measure
Cooling System (Approx.)▲ Code: H, K, M Without A/C With A/C Code: N Without A/C With A/C Diesel Engines Code: C, J With or Without A/C	16.5 Liters 17 Liters 22 Liters 23 Liters 23 Liters	17.5 Quarts 18 Quarts 23 Quarts 24.5 Quarts 25 Quarts
Crankcase• Gasoline Engines Code: H, K and M Without Filter With Filter Code: N Without Filter With Filter Diesel Engines† Code: C, J With Filter	3.8 Liters 4.8 Liters 4.8 Liters 5.7 Liters 6.5 Liters	4 Quarts 5 Quarts 5 Quarts 6 Quarts 7 Quarts
Fuel Tank (Approx.) Standard, All — Gas — Diesel NK7 Option, All — Gas — Diesel NE2 Option, Suburban Only — Gas — Diesel	95 Liters 102 Liters 117 Liters 121 Liters 151 Liters 155 Liters	25 Gallons 27 Gallons 31 Gallons 32 Gallons 40 Gallons 41 Gallons
Front Axle V15/10-V25/20 V35/30	1.9 Liters 2.8 Liters	2 Quarts 3 Quarts
Transfer Case V15/10-V25/20 V35/30	4.9 Liters 2.4 Liters	5.2 Quarts 2.5 Quarts

• After refill, fluid level must be checked as outlined under "Service and Maintenance," in Section 5 of this manual.

† Oil filter should be changed at EVERY oil change.

▲ Equipped with Auxiliary Heater add 2.68L/2.84 Qts.

Figure 3—Approximate Capacities—Blazer/Jimmy, Suburban

CAPACITIES

Items	Metric Measure	U.S. Measure
Cooling System (approx.)		
4.8L (L6) Engine Code T P30042 Models With or Without A/C	13.1 Liters	13.8 Quarts
5.7L (V8) Engine Code M, K P30042 Models With or Without A/C	14.6 Liters	15.5 Quarts
7.4 L (V8) Engine Code W P30032 Models Without A/C	21.2 Liters	22.5 Quarts
6.2L (V8) Diesel Engine Code J P30042 Models With or Without A/C	23.5 Liters	25 Quarts
P30032 Models Without A/C	23.4 Liters	24.7 Quarts
Crankcase (approx.)*		
Engine Code: M, K Without Filter	3.8 Liters	4 Quarts
With Filter	4.8 Liters	5 Quarts
Engine Code: T Without Filter	4.8 Liters	5 Quarts
With Filter	5.7 Liters	6 Quarts
Engine Code: W Without Filter	5.7 Liters	6 Quarts
With Filter	6.5 Liters	7 Quarts
Engine Code: J† With Filter	6.5 Liters	7 Quarts
Fuel Tank Data		
P25-35	151 Liters	40 Gallons
P30042 School Bus	151 Liters	40 Gallons
P30032 Motor Home•	151 Liters	40 Gallons

* After refill, fluid level should be checked as outlined under "Service and Maintenance," in Section 5 of the Owner's Manual.

† Oil Filter should be changed at EVERY oil change.

• Optional 60 gallon fuel tank available.

Figure 4—Approximate Capacities—Forward Control

CAPACITIES

Items	Metric Measure	U.S. Measure
Cooling System (Approx.) Code: Z - V6 With or Without A/C	10.3 Liters	10.9 Quarts
Code: H, K—V-8 Without A/C	16.5 Liters	17.5 Quarts
With A/C	17 Liters	18 Quarts
Code: N—V-8 Without A/C	22 Liters	23 Quarts
With A/C	23 Liters	24.5 Quarts
Diesel Engines Code: C, J With or Without A/C	23 Liters	25 Quarts
Crankcase▲ Gasoline Engines Code: H, K, Z Without Filter	3.8 Liters	4 Quarts
With Filter	4.8 Liters	5 Quarts
Code: T Without Filter	4.8 Liters	5 Quarts
With Filter	5.7 Liters	6 Quarts
Code: N Without Filter	4.8 Liters	5 Quarts
With Filter	5.7 Liters	6 Quarts
Diesel Engines† Code: C, J	6.5 Liters	7 Quarts
Fuel Tank (Approx.) Long Bed " " " " " " Single Tank, Gas	76 Liters	20 Gallons
@ *Dual Tanks, Gas	61 Liters	16 Gallons
Single Tank, Diesel	76 Liters	20 Gallons
*Dual Tanks, Diesel	76 Liters	20 Gallons
Front Axle V15/10-V25/20	1.9 Liters	2 Quarts
V35/30	2.8 Liters	3 Quarts
Transfer Case V15/10-V25/20	4.9 Liters	5.2 Quarts
V-35/30	2.4 Liters	2.5 Quarts

▲After refill, fluid level must be checked as outlined under "Service and Maintenance," in Section 5 of the Owner's Manual.

† Oil filter should be changed at EVERY oil change.

* Listed quantity is for each tank.

@Above 8600 GVWR — Both tanks 76 liters, 20 gallons.

Figure 5—Approximate Capacities—Pickup Models

CAPACITIES

Item	Metric Measure	US Measure
Cooling System (Approx.)▲ 4.3 L (Z) V8's Except Diesel	10.5 L	11 Qts.
Without A/C	16 L	17 Qts.
With A/C	16 L	17 Qts.
6.2 L (C) Diesel	23 L	24 Qts.
6.2 L (J) Diesel	24.2 L	25.5 Qts.
Crankcase (Approx.)* All engines except diesel		
Without Filter	3.8 L	4 Qts.
With Filter	4.8 L	5 Qts.
Diesel Engines — With Filter	6.5 L	7 Qts.
Fuel Tank (Approx.) Gasoline and Diesel Engines		
Standard	83 L	22 Gal.
Optional	125 L	33 Gal.

* After refill, fluid level should be checked as outlined under "Service and Maintenance" Section 5 of the Owner's Manual.

▲ If equipped with Auxiliary Heater add 2.68L/2.84 Qts.

† Oil Filter should be changed at EVERY oil change.

Figure 6—Approximate Capacities-G Van

0B-6 MAINTENANCE AND LUBRICATION

LUBRICATION

Figures 7, 8 and 9 show chassis lubrication points for the R, V, G and P chassis.

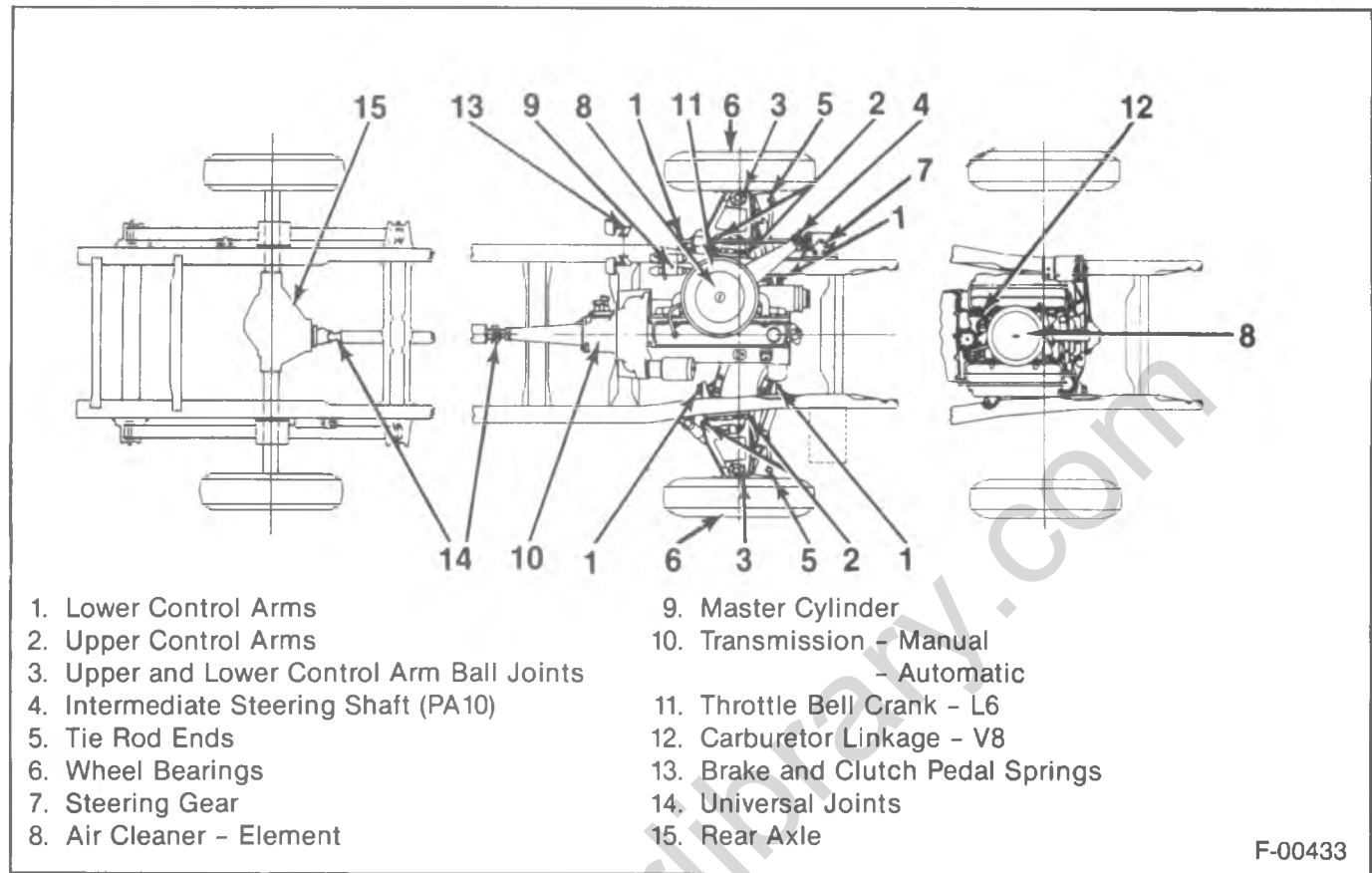

Figure 7—Lubrication Points For The Conventional And Forward Control Models

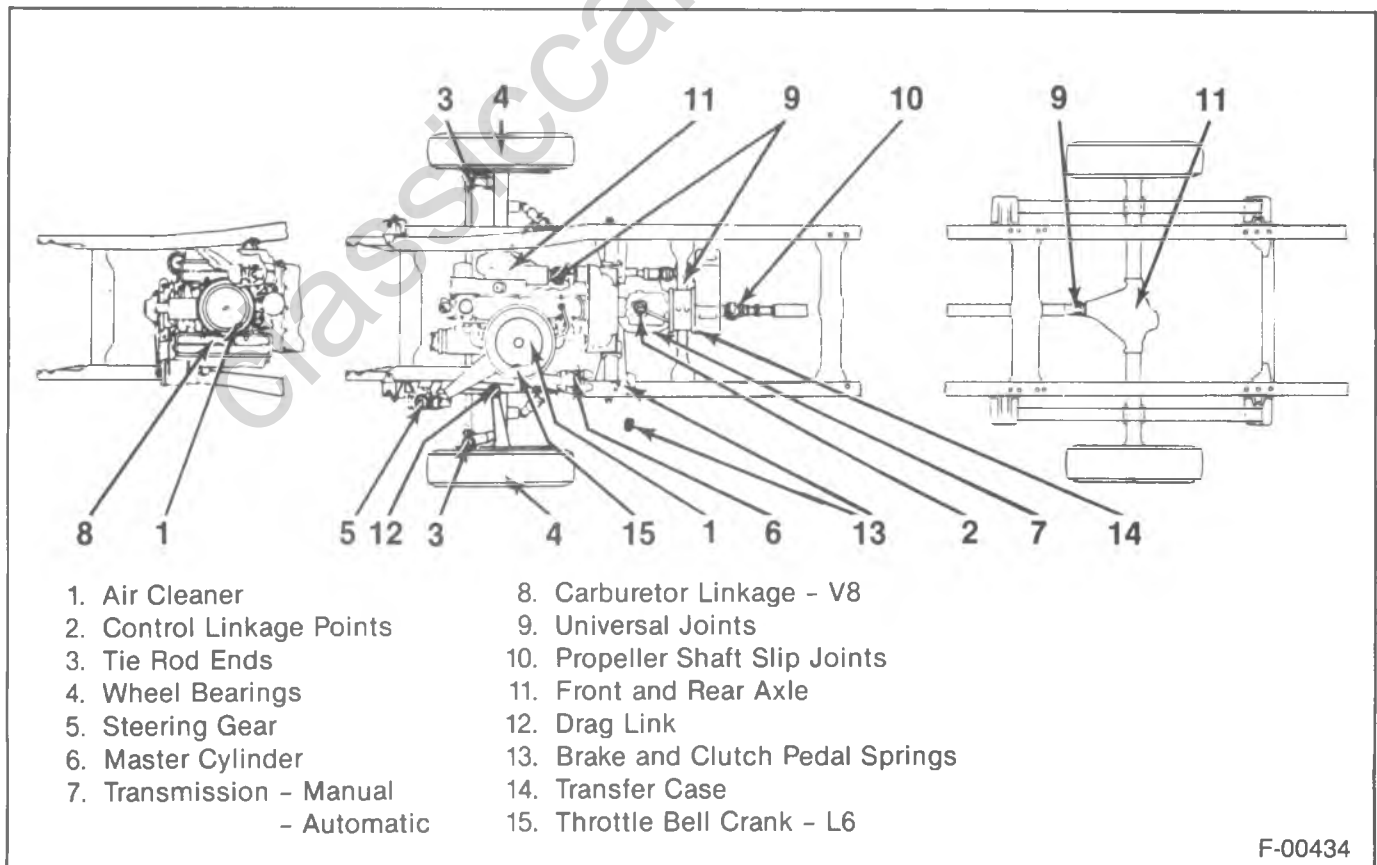

Figure 8—Lubrication Points For The RV Four Wheel Drive Models

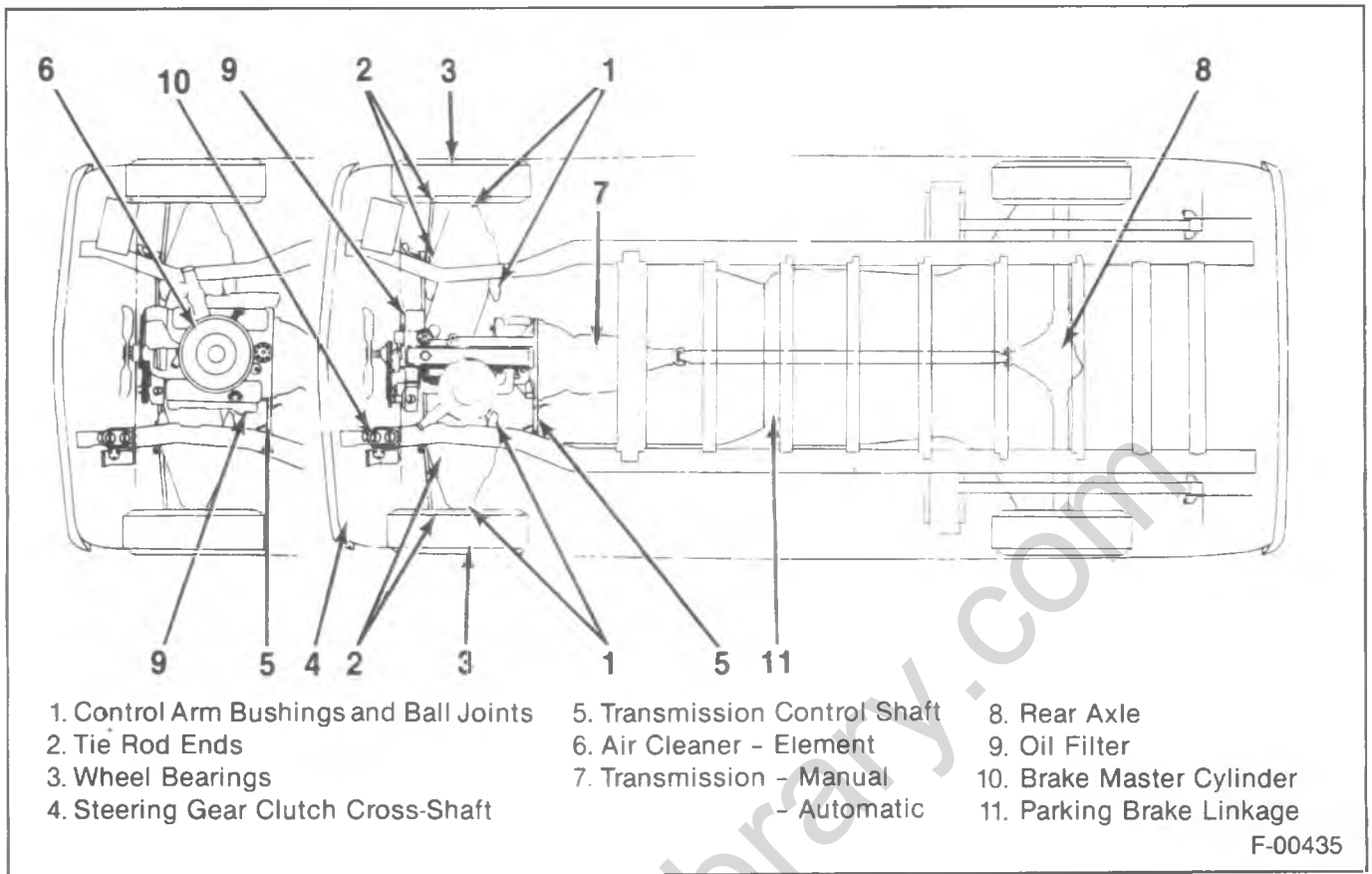

Figure 9—Lubrication Points For The G Van

The information shown on pages 0B-8 through 0B-25 is the same as shown in the 1987 Light Duty Maintenance Schedule and Log.

1987 GENERAL MOTORS LIGHT DUTY TRUCK MAINTENANCE SCHEDULES

This booklet covers the maintenance required for your General Motors vehicle. It is essential that your vehicle receive this maintenance to retain the safety, dependability, and emission control performance originally built into your vehicle.

Maintenance service should be done by your General Motors truck dealer or any other qualified automotive service or repair establishment which is able to provide such services and which can be relied upon to use proper parts and practices.

In addition to the in-shop type services shown in Sections A and B, this booklet also includes owner inspections and services in Section C which you or a qualified technician should perform periodically.

Always keep this booklet in your vehicle, and leave it with the vehicle when sold. The maintenance record, plus maintenance receipts, may be needed for warranty repairs. It is suggested that receipts be kept with this booklet.

SELECTING YOUR VEHICLE'S MAINTENANCE

DETERMINING VEHICLE EMISSIONS CLASSIFICATION

To determine the emissions classification for your vehicle, refer to the "Engine Emission Classification by VIN Code" chart. This chart classifies your engine as a Light Duty Emissions Engine or Heavy Duty Emissions Engine using the engine code identifier of the Vehicle Identification Number (VIN).

The VIN is located on the plate on the top left corner of the instrument panel. (It is also on the Certification Label and the Service Parts Identification Label.) The Engine Code is the eighth character in this number. Locate your vehicle's Engine Code on the following Engine Emission Classification Chart to determine your vehicle's emissions class.

ENGINE EMISSION CLASSIFICATION BY VIN CODE

Engine Description		VIN Code	
Engine Displ./Type	RPO	Light Duty Emissions	Heavy Duty Emissions
2.5L L4/TBI	LN8	E	
2.8L V6/TBI	LL2	R	
4.3L V6/TBI	LB4	Z	
4.8L L6/Carbureted	L25		T
5.0L V8/TBI	LO3	H	
5.7L V8/TBI	LO5	K	
5.7L V8/Carbureted	LT9		M
6.2L V8/Diesel	LL4		J
6.2L V8/Diesel	LH6	C	
7.4L V8/TBI	L19	N	
7.4L V8/Carbureted	LE8		W

NOTE: TBI is a throttle body injection system.

SELECTING THE PROPER MAINTENANCE CHART

Select the proper maintenance from pages 6 through 13 depending on your vehicle's engine (gas or diesel) and engine emissions classification.

SELECTING THE PROPER MAINTENANCE SCHEDULE

Select and follow either Maintenance Schedule 1 or Maintenance Schedule 2 based on how you use your vehicle.

MAINTENANCE SCHEDULE 1

Follow Maintenance Schedule 1 denoted by a white circle (○) if you mainly operate your vehicle under one or more of the following conditions:

- When most trips are less than 4 miles (6 kilometers).
- When most trips are less than 10 miles (16 kilometers) and outside temperatures remain below freezing.
- Towing a trailer.
- Operating in dusty areas.
- Idling and/or low-speed operation in stop-and-go traffic.

NOTE: Schedule 1 should also be followed if the vehicle is used for delivery service, police, taxi, or other commercial applications.

MAINTENANCE SCHEDULE 2

Follow Maintenance Schedule 2 denoted by a black circle (●) only if none of the driving conditions specified in Maintenance Schedule 1 apply.

SECTION A—SCHEDULED MAINTENANCE SERVICES FOR YOUR 1987 VEHICLE

The services shown in this schedule up to 60,000 miles (100 000 km) are to be performed after 60,000 miles (100 000 km) at the same intervals.						
Item No.	Service	Miles (000)	3	6	9	12
		Kilometers (000)	5	10	15	20
1	Engine Oil Change *		○	●	○	○●
	Oil Filter Change *		○	●	○	○
2A	Chassis Lubrication		○	●	○	○●
2B	Clutch Fork Ball Stud					
3	Engine Idle Speed Adjustment * - At First 6 Months or,					○
4	Cooling System Service *- Every 24 Months or					
5	Air Cleaner, A.I.R. and PCV Filter Replacement ▲*					
6	Front Wheel Bearing Repack					○
7	Transmission Service - Refer to Section B for Service Intervals					
8A	PCV System Inspection *					○●
9	Fuel Filter Replacement *					○
10	Carburetor Choke and Hoses Inspection *					○●
11	Vacuum Advance System Inspection *					○●
12	Spark Plugs *					○● ¹
13	Spark Plug Wire Inspection *					○●
14	EGR System Inspection *					○● ²
16	Engine Timing Check * ▲					○●

FOOTNOTES:

- * An Emission Control Service
- ▲ Also a Noise Emission Control Service
- Applicable only to vehicles sold in the United States
- † To determine the emissions classification of your engine refer to page 4.
- 1. For vehicles using leaded fuel.
- 2. For vehicles using unleaded fuel.

WITH HEAVY DUTY EMISSIONS - GASOLINE ENGINES †

○ Maintenance Schedule 1 - Refer to Page 9															
● Maintenance Schedule 2 - Refer to Page 9															
15	18	21	24	27	30	33	36	39	42	45	48	51	54	57	60
25	30	35	40	45	50	55	60	65	70	75	80	85	90	95	100
○	○●	○	○●	○	○●	○	○●	○	○●	○	○●	○	○●	○	○●
○	○●	○	○	○	○●	○	○	○	○●	○	○	○	○●	○	○
○	○●	○	○●	○	○●	○	○●	○	○●	○	○●	○	○●	○	○●
					○●										○●
				○●			○				○●				○
			○●								○●				
			○●				○				○●				○
															○●
				○●			○				○●				○
															○●
			○● ¹		○● ²		○● ¹				○● ¹				○● ^{1,2}
															○●
			○● ¹								○● ¹				○● ²
			○●								○●				

The maintenance services contained in Maintenance Schedule 1 and 2 are based on the assumption that your vehicle will be used as designed:

- To carry passengers and cargo within the limits shown on the tire placard located on the edge of the driver's door.
- On reasonable road surfaces within legal driving limits.
- With the proper fuels specified for your vehicle.

SECTION A—SCHEDULED MAINTENANCE SERVICES FOR YOUR 1987 VEHICLE WITH HEAVY DUTY EMISSIONS - GASOLINE ENGINES † (Continued)

Item No. Service		The services shown in this schedule up to 60,000 miles (100 000 km) are to be performed after 60,000 miles (100 000 km) at the same intervals.				○ Maintenance Schedule 1 - Refer to Page 9 ● Maintenance Schedule 2 - Refer to Page 9																
		Miles (000)	3	6	9	12	15	18	21	24	27	30	33	36	39	42	45	48	51	54	57	60
		Kilometers (000)	5	10	15	20	25	30	35	40	45	50	55	60	65	70	75	80	85	90	95	100
17	Fuel Tank, Cap and Lines Inspection *								○									○				○●
18	Early Fuel Evaporation System Inspection *					○			○●					○				○●				○
19	Thermostatically Controlled Air Cleaner Inspection * ▲								○●									○●				
20	Engine Accessory Drive Belts Inspection *					○●			○●				○●					○●				○●
21	Evaporative Control System Inspection *								○									○				○●
22	Shields and Underhood Insulation Inspection ▲■					○●			○●				○●					○●				○●
23	Air Intake System Inspection ▲■								○●									○●				
24	Thermostatically Controlled Engine Cooling Fan Check ▲■ - Every 12 Months or					○●			○●				○●					○●				○●
25	Manifold Heat Valve Check ▲ *					○			○●				○					○●				○
26	Idle Speed Control Device * - Every 12 Months or					○			○●				○					○●				○
27	Throttle Return Control Check * - Every 12 Months or					○			○●				○					○●				○
28	Engine Idle Mixture Adjustment (4.8 L only) *																					○●
29	Governor Check ▲■ - Every 48 Months or																	○●				
31	Tire Rotation - Refer to Section B for Service Intervals																					

FOOTNOTES:

- * An Emission Control Service
- ▲ Also a Noise Emission Control Service
- Applicable only to vehicles sold in the United States
- † To determine the emissions classification of your engine refer to page 4.
- 1. For vehicles using leaded fuel.
- 2. For vehicles using unleaded fuel.

The maintenance services contained in Maintenance Schedule 1 and 2 are based on the assumption that your vehicle will be used as designed:

- To carry passengers and cargo within the limits shown on the tire placard located on the edge of the driver's door.
- On reasonable road surfaces within legal driving limits.
- With the proper fuels specified for your vehicle.

SECTION A—SCHEDULED MAINTENANCE SERVICES FOR YOUR

1987 VEHICLE WITH A 6.2 L DIESEL ENGINE †

The services shown in this schedule up to 60,000 miles (100 000 km) are to be performed after 60,000 miles (100 000 km) at the same intervals.

Item No.	Service	Miles (000)						
		2.5	5	7.5	10	12.5	15	
		Kilometers (000)						
		4	8	12	16	20	24	
1	Engine Oil Change *	○	○●	○	○●	○	○●	
	Oil Filter Change *	○	○●	○	○●	○	○●	
2A	Chassis Lubrication	○	○●	○	○●	○	○●	
2B	Clutch Fork Ball Stud							
3	Engine Idle Speed Adjustment *		○● ¹					
4	Cooling System Service * — Every 24 Months or							
5	Air Cleaner Element Replacement* ²							
6	Front Wheel Bearing Repack						○	
7	Transmission Service - Refer to Section B for Service Intervals							
8B	CDRV System Inspection *							
20	Drive Belts Inspection							
22	Shields and Underhood Insulation Inspection ■▲				○●			
23	Air Intake System Inspection ■▲				○●			
24	Thermostatically Controlled Engine Cooling Fan Check ■▲ —Every 12 Months or				○●			
30	Exhaust Pressure Regulator Valve Inspection *							
31	Tire Rotation - REfer to Section B for Service Intervals							

○ Maintenance Schedule 1 - Refer to Page 9		● Maintenance Schedule 2 - Refer to Page 9															
17.5	20	22.3	25	27.5	30	32.5	35	37.5	40	42.5	45	47.5	50	52.5	55	57.5	60
28	32	36	40	44	48	52	56	60	64	68	72	76	80	84	88	92	96
○	○●	○	○●	○	○●	○	○●	○	○●	○	○●	○	○●	○	○●	○	○●
○	○●	○	○●	○	○●	○	○●	○	○●	○	○●	○	○●	○	○●	○	○●
○	○●	○	○●	○	○●	○	○●	○	○●	○	○●	○	○●	○	○●	○	○●
					○●												○●
					○● ¹												○●
					○●												○●
					○● ¹												○●
					○●						○						○●
																	○●
																	○●
																	○●
																	○●
																	○●
																	○●
																	○●

FOOTNOTES:

- In California, these are the minimum Emission Control Maintenance Services an owner must perform according to the California Air Resources Board. General Motors, however, urges that all Emission Control Maintenance Services shown be performed. To maintain your other new vehicle warranties, all services shown in this booklet should be performed.
 - For vehicles with engine VIN Code J (RPO LL4), replace element every 15,000 miles (24 000 km).
 - * An Emission Control Service
 - Applicable only to trucks sold in the United States.
 - ▲ Also, a Noise Control Service (applicable to vehicles with engine VIN Code J (RPO LL4).
- † This maintenance schedule applies to all diesel emission classifications.

NOTE: Refer to Section 0 of your owner's manual for VIN code identification information.

The maintenance services contained in Maintenance Schedule 1 and 2 are based on the assumption that your vehicle will be used as designed:

- To carry passengers and cargo within the limits shown on the tire placard located on the edge of the driver's door.
- With No. 1, blend or No. 2 grade diesel fuel.
- On reasonable road surfaces within legal driving limits.

SECTION A—SCHEDULED MAINTENANCE SERVICES FOR YOUR

Item No.	Service	The services shown in this schedule up to 60,000 miles (100 000 km) are to be performed after 60,000 miles (100 000 km) at the same intervals.					
		Miles (000)	3	6	7.5	9	12
		Kilometers (000)	5	10	12.5	15	20
1	Engine Oil Change *		<input type="checkbox"/>	<input type="checkbox"/>	<input checked="" type="checkbox"/>	<input type="checkbox"/>	<input type="checkbox"/>
	Oil Filter Change *		<input type="checkbox"/>	<input type="checkbox"/>	<input checked="" type="checkbox"/>	<input type="checkbox"/>	<input type="checkbox"/>
2A	Chassis Lubrication		<input type="checkbox"/>	<input type="checkbox"/>	<input checked="" type="checkbox"/>	<input type="checkbox"/>	<input type="checkbox"/>
2B	Clutch Fork Ball Stud						
4	Cooling System Service * — Every 24 Months or						
5	Air Cleaner Element *						
6	Front Wheel Bearing Repack						
7	Transmission Service - Refer to Section B for Service Interval						
8A	PCV System Inspection *						
9	Fuel Filter Replacement *						
12	Spark Plugs *						
13	Spark Plug Wire Inspection *						
15	Electronic Vacuum Regulator Valve (EVRV) Inspection *						
16	Engine Timing Check *						
17	Fuel Tank, Cap and Lines Inspection *						
20	Engine Accessory Drive Belts Inspection *						
31	Tire Rotation		<input type="checkbox"/>	<input checked="" type="checkbox"/>	<input type="checkbox"/>	<input type="checkbox"/>	<input type="checkbox"/>

1987 VEHICLE WITH LIGHT DUTY EMISSIONS - GASOLINE ENGINES †

○ Maintenance Schedule 1 - Refer to Page 9		● Maintenance Schedule 2 - Refer to Page 9																	
15	18	21	22.5	24	27	30	33	36	37.5	39	42	45	48	51	52.5	54	57	60	
25	30	35	37.5	40	45	50	55	60	62.5	65	70	75	80	85	87.5	90	95	100	
<input checked="" type="checkbox"/>	<input type="checkbox"/>	<input type="checkbox"/>	<input checked="" type="checkbox"/>	<input type="checkbox"/>	<input type="checkbox"/>	<input checked="" type="checkbox"/>	<input type="checkbox"/>	<input type="checkbox"/>	<input checked="" type="checkbox"/>	<input type="checkbox"/>	<input type="checkbox"/>	<input checked="" type="checkbox"/>	<input type="checkbox"/>	<input type="checkbox"/>	<input checked="" type="checkbox"/>	<input type="checkbox"/>	<input type="checkbox"/>	<input checked="" type="checkbox"/>	
<input type="checkbox"/>	<input type="checkbox"/>	<input type="checkbox"/>	<input checked="" type="checkbox"/>	<input type="checkbox"/>	<input type="checkbox"/>	<input type="checkbox"/>	<input type="checkbox"/>	<input type="checkbox"/>	<input checked="" type="checkbox"/>	<input type="checkbox"/>	<input type="checkbox"/>	<input type="checkbox"/>	<input type="checkbox"/>	<input type="checkbox"/>	<input checked="" type="checkbox"/>	<input type="checkbox"/>	<input type="checkbox"/>	<input type="checkbox"/>	
<input checked="" type="checkbox"/>	<input type="checkbox"/>	<input type="checkbox"/>	<input checked="" type="checkbox"/>	<input type="checkbox"/>	<input type="checkbox"/>	<input checked="" type="checkbox"/>	<input type="checkbox"/>	<input type="checkbox"/>	<input checked="" type="checkbox"/>	<input type="checkbox"/>	<input type="checkbox"/>	<input checked="" type="checkbox"/>	<input type="checkbox"/>	<input type="checkbox"/>	<input checked="" type="checkbox"/>	<input type="checkbox"/>	<input type="checkbox"/>	<input checked="" type="checkbox"/>	
						<input type="checkbox"/>	<input checked="" type="checkbox"/>											<input type="checkbox"/>	<input checked="" type="checkbox"/>
						<input type="checkbox"/>	<input checked="" type="checkbox"/>											<input type="checkbox"/>	<input checked="" type="checkbox"/>
							<input type="checkbox"/>											<input type="checkbox"/>	<input checked="" type="checkbox"/>
							<input type="checkbox"/>											<input type="checkbox"/>	<input checked="" type="checkbox"/>
																		<input type="checkbox"/>	<input checked="" type="checkbox"/>
																		<input type="checkbox"/>	<input checked="" type="checkbox"/>
																		<input type="checkbox"/>	<input checked="" type="checkbox"/>
																		<input type="checkbox"/>	<input checked="" type="checkbox"/>
																		<input type="checkbox"/>	<input checked="" type="checkbox"/>
																		<input type="checkbox"/>	<input checked="" type="checkbox"/>
																		<input type="checkbox"/>	<input checked="" type="checkbox"/>
																		<input type="checkbox"/>	<input checked="" type="checkbox"/>
																		<input type="checkbox"/>	<input checked="" type="checkbox"/>
																		<input type="checkbox"/>	<input checked="" type="checkbox"/>
																		<input type="checkbox"/>	<input checked="" type="checkbox"/>
																		<input type="checkbox"/>	<input checked="" type="checkbox"/>
																		<input type="checkbox"/>	<input checked="" type="checkbox"/>
																		<input type="checkbox"/>	<input checked="" type="checkbox"/>
																		<input type="checkbox"/>	<input checked="" type="checkbox"/>
																		<input type="checkbox"/>	<input checked="" type="checkbox"/>
																		<input type="checkbox"/>	<input checked="" type="checkbox"/>
																		<input type="checkbox"/>	<input checked="" type="checkbox"/>
																		<input type="checkbox"/>	<input checked="" type="checkbox"/>
																		<input type="checkbox"/>	<input checked="" type="checkbox"/>
																		<input type="checkbox"/>	<input checked="" type="checkbox"/>

FOOTNOTES:

1. In California, these are the minimum Emission Control Maintenance Services an owner must perform according to the California Air Resources Board. General Motors, however, urges that all Emission Control Maintenance Services shown be performed. To maintain your other new vehicle warranties, all services shown in this booklet should be performed.

* An Emission Control Service

† To determine the emissions classification of your engine refer to page 4.

The maintenance services contained in Maintenance Schedule 1 and 2 are based on the assumption that your vehicle will be used as designed:

- To carry passengers and cargo within the limits shown on the tire placard located on the edge of the driver's door.
- On reasonable road surfaces within legal driving limits.
- With unleaded fuel.

SECTION B — EXPLANATION OF SCHEDULED MAINTENANCE SERVICES

The services listed in the preceding Maintenance Schedules are further explained below. After services are completed, fill in the Maintenance Record at the end of this booklet. When the following maintenance services are performed, make sure all parts are replaced and all necessary repairs are done before operating your vehicle. Be sure to use the proper fluids and lubricants as shown in Section E.

Item No.

1. **ENGINE OIL AND OIL FILTER CHANGE *** — ALWAYS USE SF/CC or SF/CD QUALITY, ENERGY CONSERVING OILS OF THE PROPER VISCOSITY. Also always change oil and filter as soon as possible after driving in a dust storm. Refer to Section 5 of your Owner's Manual for further details.
- 2A. **CHASSIS LUBRICATION** — Lubricate the front suspension (except when equipped with "maintenance-free" ball joint), steering linkage, transmission, clutch, and transfer case shift linkage, parking brake cable guides, propshaft, universal joints, brake pedal springs, and clutch pedal springs. On vehicles without hydraulic clutches lubricate clutch cross shaft every 30,000 miles (50 000 km).
- 2B. **CLUTCH FORK BALL STUD** — Refer to the Service Parts Identification Label located on the inside of the glove box. Match the three digit/RPO code to the appropriate RPO code below. Follow the maintenance as detailed for your particular vehicle.

RPO codes: MC0, MG5, M20, MY6, M62, M64 — Lubricate the clutch fork ball stud through the fitting on the clutch housing found on some models. Lubricate this ball stud "sparingly," as too much lubrication may cause problems with the clutch assembly.
3. **ENGINE IDLE SPEED ADJUSTMENT (CARBURETED ENGINES ONLY) *** — Adjust to the specifications shown on the underhood label. You must use calibrated test equipment. Check that idle stop solenoid or dashpot work properly (if so equipped).
4. **COOLING SYSTEM SERVICE *** — Drain, flush and refill system with new coolant. Refer to Section 5 of your Owner's Manual for further details.
5. **AIR CLEANER ELEMENT REPLACEMENT, A.I.R. AND PCV FILTER REPLACEMENT (SOME MODELS) *** — Replace at specified intervals. Replace more often under dusty conditions. Ask your dealer for the proper replacement intervals for your driving conditions.
6. **FRONT WHEEL BEARING REPACK** — Clean and repack the front wheel bearings at each brake relining, or at the specified interval, whichever comes first.

* An Emission Control Service

7. TRANSMISSION SERVICE

Automatic Transmission — Change the transmission fluid and filter every 15,000 miles (25 000 km) for vehicles under 8600 GVWR or every 12,000 miles (20 000 km) for vehicles over 8600 GVWR if the vehicle is mainly driven under one or more of these conditions:

- In heavy city traffic where the outside temperature regularly reaches 90°F (32°C) or higher.
- In hilly or mountainous terrain.
- Frequent trailer pulling.
- Uses such as taxi, police, delivery or other commercial service.

If the vehicle is not used mainly under any of these conditions, change the fluid and filter every 30,000 miles (50 000 km) for vehicles under 8600 GVWR or every 24,000 miles (40 000 km) for vehicles over 8600 GVWR. Refer to Section 5 of your Owner's Manual for further details.

Manual Transmission — Refer to the Service Parts Identification Label located on the inside of the glove box. Match the three digit/RPO code to the appropriate RPO code below. Follow the maintenance schedule recommended for your particular transmission.

RPO Code:

M73 (4-Speed)

— Change transmission fluid at 7,500 miles (12 500 km), then every 30,000 miles (50 000 km).

RPO Codes:

M62 and M64 (3-Speed)

M20, MCO, MC9, and MF2 (4-Speed)

MY6 (4-Speed Overdrive)

ML2, ML3, MH3 (5-Speed)

MG5 (5-Speed Overdrive)

— Transmission fluid does not require periodic changing.

- 8A. **PCV SYSTEM INSPECTION *** — Check that PCV (Positive Crankcase Ventilation) system works properly. Replace the valve and any worn, plugged or collapsed hoses as necessary.
- 8B. **CDRV System Inspection *** — Check the Crankcase Depression Regulator Valve System for any worn, plugged or collapsed hoses. Have the system checked as described in the Service Manual.
9. **FUEL FILTER REPLACEMENT *** — Replace the fuel filter at the specified interval or sooner if clogged.
10. **CARBURETOR CHOKE AND HOSES INSPECTION *** — Verify that choke and vacuum break work properly and within specifications. Correct any binding caused by damage or gum on the choke shaft. Inspect hoses for proper hookup, cracks, chafing, or decay. Correct as necessary.

* An Emission Control Service

OB-16 MAINTENANCE AND LUBRICATION

11. **VACUUM ADVANCE SYSTEM INSPECTION *** — Check that the system works properly. Check hoses for proper hookup, cracks, chafing or decay. Replace parts as needed.
12. **SPARK PLUGS *** — Replace spark plugs with the type listed in Section 6 of your Owner's Manual.
13. **SPARK PLUG WIRE INSPECTION *** — Clean wires and inspect for burns, cracks or other damage. Check the wire boot fit at the distributor and at the spark plugs. Replace wires as needed.
14. **EGR SYSTEM INSPECTION *** — Conduct EGR SYSTEM CHECK as referenced in the Maintenance and Lubrication Section of the Service Manual.
15. **ELECTRONIC VACUUM REGULATOR VALVE (EVRV) INSPECTION *** — Inspect filter for excessive contamination or plugging. If required, clean element with a solution of biodegradable soap and water, let dry and reinstall element.
16. **ENGINE TIMING CHECK AND DISTRIBUTOR CHECK (SOME MODELS)*** — Adjust timing to underhood label specifications. Inspect the inside and outside of the distributor cap and rotor for cracks, carbon tracking and corrosion. Clean or replace as needed.
17. **FUEL TANK, CAP AND LINES INSPECTION *** — Inspect the fuel tank, cap and lines for damage or leaks. Remove fuel cap, inspect gasket for an even filler neck imprint, and any damage. Replace parts as needed.
18. **EARLY FUEL EVAPORATION (EFE) SYSTEM INSPECTION *** — Check that valve works properly; correct any binding. Check that thermal vacuum switch works properly. Check hoses for cracks, chafing, or decay. Replace parts as needed.
19. **THERMOSTATICALLY CONTROLLED AIR CLEANER INSPECTION * ▲** — (If so equipped.) Inspect all hoses and ducts for proper hookup. Make sure valve works properly.
20. **ENGINE ACCESSORY DRIVE BELTS INSPECTION *** — Inspect belts. Look for cracks, fraying, wear, and proper tension. Adjust or replace as needed.
21. **EVAPORATIVE CONTROL SYSTEM (ECS) INSPECTION *** — Check all fuel and vapor lines and hoses for proper hookup, routing, and condition. Check that bowl vent and purge valves work properly, if equipped. Remove canister, and check for cracks or damage. Replace as needed.
22. **SHIELDS AND UNDERHOOD INSULATION INSPECTION ▲ ■** — Inspect shields and underhood insulation for damage or looseness. Adjust or replace as required.

* An Emission Control Service

▲ Also a Noise Emission Control Service

■ Applicable only to vehicles sold in the United States

23. **AIR INTAKE SYSTEM INSPECTION ▲■** — Check the air intake system installation to see that gaskets are seated properly and all hose connections, fasteners, and other components are tight. Also check to be sure that the air cleaner housing is properly seated, that the cover fits tightly, and the wingnut(s) is tight. Tighten connections and fasteners or replace damaged parts as required.
24. **THERMOSTATICALLY CONTROLLED ENGINE COOLING FAN INSPECTION ▲■** — (If so equipped.) With the engine off and below normal operating temperature, check to see that the fan can be rotated by hand on fluid coupling or viscous drives. Replace as necessary.
25. **MANIFOLD HEAT VALVE CHECK▲■** — Some engines are equipped with a manifold heat valve which should be inspected and repaired as necessary to insure free operation.
26. **IDLE SPEED CONTROL DEVICE *** — Check that parts work properly. Replace them as needed.
27. **THROTTLE RETURN CONTROL (TRC) SYSTEM INSPECTION *** — Inspect hoses for proper connections, cracking, abrasion, or deterioration and replace as necessary. Check for proper operation of system. Check for shorted or broken wires and ensure electrical connectors are fully engaged at distributor, speed switch and vacuum solenoid.
28. **ENGINE IDLE MIXTURE ADJUSTMENT (4.8 L ONLY) *** — At designated intervals or in case of a major carburetor overhaul, or when poor idle quality exists, adjust mixture by a mechanical method (lean drop), following the specifications shown on the label under the hood.
29. **GOVERNOR CHECK ▲■** — (If so equipped). Check the engine no-load governed speed and reset to specifications as required.
30. **EXHAUST PRESSURE REGULATOR VALVE INSPECTION *** — Check that valve works properly. Correct any binding. Inspect hoses for cracks, chafing or decay. Replace parts as needed.
31. **TIRE ROTATION AND WHEEL INSPECTION** — Rotate your tires at the specified maintenance service interval as follows:
 Schedule 1 (○) — Every 6,000 miles (10 000 km).
 Schedule 2 (●) — Every 7,500 miles (12 500 km).
 Inspect tires and wheels for abnormal wear or damage. Refer to Section 5, "Tires" in your Owner's Manual for further information. For dual wheels, whenever the vehicle, wheels, or fasteners are new, have the wheel fastener torque set at the first 100,1,000, and 6,000 miles (160, 1 600, and 10 000 km).

* An Emission Control Service

▲Also a Noise Emission Control Service

■ Applicable only to vehicles sold in the United States

SECTION C — OWNER INSPECTIONS AND SERVICES

Listed below are inspections and services which should be made by either you or a qualified technician at the intervals shown to help ensure proper safety, emission performance and dependability of your vehicle. Take any problems promptly to your dealer or another qualified technician for service advice. Whenever repairs are necessary, have them completed at once. For your safety and that of others, any safety-related parts that could have been damaged in an accident should be inspected, and all needed repairs should be done before operating your vehicle. Be sure to use the proper fluids and lubricants as shown in Section E.

WHILE OPERATING YOUR VEHICLE

Automatic transmission shift indicator operation — Make sure the indicator points to the gear chosen.

Horn operation — Blow the horn occasionally to make sure it works. Check all button locations.

Brake system operation — Be alert to abnormal sounds, increased brake pedal travel or repeated pulling to one side when braking. Also, if a brake warning light goes on, something may be wrong with part of the brake system.

Exhaust system — Be alert to any changes in the sound of the system or any smell of fumes. These are signs the system may be leaking or overheating. Have it inspected and repaired at once. Also, refer to Section 2 “Engine Exhaust Gas Caution (Carbon Monoxide),” and Section 5 “Catalytic Converter” in your Owner’s Manual.

Tire and wheel — Be alert to a vibration of the steering wheel or seat at normal highway speeds. This may mean a wheel balance is needed. Also, a pull right or left on a straight, level road may show the need for a tire pressure adjustment or wheel alignment.

Steering system operation — Be alert to changes in steering action. An inspection is needed when the steering wheel is harder to turn or has too much free play or if abnormal sounds are noted when turning or parking.

Headlight aim — Take note of the light pattern occasionally. If beam aim doesn’t look right, headlights should be adjusted.

AT EACH FUEL FILL

Engine oil level check † — Check engine oil level and add if necessary. Refer to Section 5 of your Owner’s Manual for further details.

† A large loss in these systems may indicate a problem. Have them inspected and repaired at once.

Engine coolant level and condition † — Check engine coolant level in coolant reservoir tank and add if necessary. Replace if dirty or rusty. Refer to Section 5 of your Owner's Manual for further details.

Windshield washer fluid level check — Check washer fluid level in container and add if necessary.

Hood latch operation — When opening hood, note the operation of secondary latch. It should keep hood from opening all the way when primary latch is released. Make sure that hood closes firmly.

AT LEAST MONTHLY

Tire pressure check and wheel inspection — Keep pressures as shown on Tire Placard on the driver's door (including spare). Pressure should be checked when tires are cold. Inspect tires and wheels for abnormal wear or damage. Refer to Section 5, "Tires" in your Owner's Manual for further information.

Light operation check — Check operation of license plate light, side marker light, headlights including high beams, parking lights, taillights, brake lights, turn signals, backup lights, instrument panel illumination and hazard warning flashers.

Fluid leak check — After the vehicle has been parked for a while, inspect the surface beneath the vehicle for water, oil, fuel or other fluids. Water dripping from the air conditioning system after use is normal. If you notice fuel leaks or fumes, the cause should be found and corrected at once.

AT LEAST TWICE A YEAR (FOR EXAMPLE, EVERY SPRING AND FALL)

Power steering pump level check † — Check power steering pump fluid in accordance with the instructions in Section 5 of your Owner's Manual and add fluid if necessary.

Brake master cylinder reservoir fluid level check † — Check fluid level in accordance with the instructions in Section 5 of your Owner's Manual, and add fluid if necessary. A low fluid level can indicate that worn disc brake pads may need to be serviced.

Clutch pedal free travel (except hydraulic clutch) — Check the clutch pedal free travel. The free travel should be about one inch. Adjust linkage whenever there is little or no free travel.

Key lock cylinder — Lubricate key lock cylinders. Lock deicers which contain alcohol may wash away lubricants. It is recommended that you lubricate the lock cylinder after you have used a deicer of this type. Refer to Section E in this booklet for the proper lubricants.

† A large loss in these systems may indicate a problem. Have them inspected and repaired at once.

Weatherstrip lubrication — Clean surface and then apply a thin film of silicone grease with a clean cloth.

EACH TIME OIL IS CHANGED

Automatic or manual transmission fluid level check † — Check transmission fluid level and add as required. Refer to Section 5 of your Owner's Manual for further details.

Steering and suspension † — Inspect front and rear suspension and steering system for damaged, loose or missing parts, signs of wear or lack of lubrication. Inspect power steering lines and hoses for proper hookup, binding, leaks, cracks, chafing, etc. (On vehicles equipped with manual steering gear, check for seal leakage.) Inspect final drive axle output shaft seals for leaking.

Brake systems inspection — For convenience the following should be done when wheels are removed for rotation: Inspect lines and hoses for proper hookup, binding, leaks, cracks, chafing, etc. Inspect disc brake pads for wear and rotors for surface condition. Also inspect drum brake linings for wear and cracks. Inspect other brake parts, including drums, wheel cylinders, parking brake, etc. at the same time. Check parking brake adjustment. **Inspect brakes more often if driving habits or conditions result in frequent braking.**

Exhaust system inspection * — Inspect complete system including catalytic converter. Inspect body near the exhaust system. Look for broken, damaged, missing or out-of-position parts, as well as, open seams, holes, loose connections or other conditions which could cause a heat buildup in the floor pan or could let exhaust fumes seep into the passenger compartments.

Throttle linkage inspection — Inspect for interference, binding, damaged or missing parts. Replace parts as needed.

Engine drive belts inspection — Inspect all belts for cracks, fraying, wear and proper tension. Adjust or replace as needed.

Axle rear/front, transfer case (four-wheel drive) — Refer to Section 0 in your Owner's Manual to determine the GVWR for your vehicle. Check fluid level and add if needed.

- **Locking differential - under 8600-lbs. GVWR** — Drain fluid at first oil change and refill. Check fluid level and add as needed at subsequent oil changes. In dusty areas, or trailer towing applications drain fluid at every oil change and refill. †
- **Locking differential - over 8600-lbs. GVWR** — Drain fluid at first oil change and refill. Change fluid at every other oil change and check and add fluid at subsequent oil changes. In dusty areas, or trailer towing applications, drain fluid at every oil change and refill as specified. †

† A large loss in these systems may indicate a problem. Have them inspected and repaired at once.

* An Emission Control Service

- **Standard differential - under 8600-lbs. GVWR** — Check fluid level and add as needed at every oil change. In dusty areas, or trailer towing applications, drain fluid every oil change and refill. †
- **Standard differential - over 8600-lbs. GVWR** — Drain fluid every fourth oil change and refill. Check fluid level and add as needed at every oil change. In dusty areas, or trailer towing applications, drain fluid at every oil change and refill. †
- **Transfer case (four-wheel drive)** — Every 12 months or at oil change intervals, check front axle and transfer case and add lubricant when necessary. Lubricate propeller shaft slip joint, constant velocity universal joint and steering linkage. Oil the control lever pivot point and all exposed control linkage. Check vent hose at transfer case for kinks and proper installation. More frequent lubrication may be required on heavy-duty off-road use. †

AT LEAST ONCE A YEAR

Starter safety switch operation —

CAUTION: Before performing the following safety switch check, be sure to have enough room around the vehicle. Then, firmly apply both the parking brake (see your Owner's Manual for procedure) and the regular brakes. Do not use the accelerator pedal. If the engine starts, be ready to turn off the ignition promptly. Take these precautions because the vehicle could move without warning and possibly cause personal injury or property damage.

- On automatic transmission vehicles, try to start the engine in each gear. The starter should crank only in "Park" or "Neutral."
- On manual transmission vehicles place the shift lever in "Neutral," push the clutch halfway and try to start. The starter should crank only when the clutch is fully depressed.

Steering column lock operation — While parked, try to turn key to "Lock" position in each gear range. The key should turn to "Lock" only when gear is in "Park" on automatic or "Reverse" on manual transmission. On vehicles with a key release lever, try to turn the key to "Lock" without depressing the lever. The key should turn to "Lock" only with the key lever depressed. On all vehicles, the key should come out only in "Lock."

† A large loss in these systems may indicate a problem. Have them inspected and repaired at once.

Parking brake and transmission "Park" mechanism operation—

CAUTION: Before checking the holding ability of the parking brake and automatic transmission "Park" mechanism, park on a fairly steep hill with enough room for movement in the downhill direction; to reduce the risk of personal injury or property damage, be prepared to apply the regular brakes promptly if the vehicle begins to move.

- To check the parking brake with the engine running and transmission shift lever in "Neutral," slowly remove foot pressure from the regular brake pedal until the vehicle is held by only the parking brake.
- To check the automatic transmission "Park" mechanism holding ability, release all brakes after shifting the transmission to "Park."

Lap and shoulder belts condition and operation — Inspect belt system, including: webbing, buckles, latch plates, retractors, guide loops and anchors. Have any defects repaired immediately.

Movable head restraint operation — On vehicles with movable head restraints, make sure restraints stay in the desired position. Refer to Section 1 in your Owner's Manual for adjustment instructions in your Owner's Manual.

Seatback latch and recliner operation on vehicles equipped with recliner seat — Be sure seatbacks latch on those vehicles with folding seats using mechanical latches. Make sure the recliner is holding by pushing and pulling on the top of the seatback while it is reclined. Refer to Section 1 of your Owner's Manual for seat operating information.

Spare tire and jack storage — Be alert to rattles in the rear of the vehicle. Make sure the spare tire, all jacking equipment, and any covers or doors are securely stowed at all times. Oil the jack ratchet or screw mechanism after each use.

Underbody flushing — At least every spring, flush the underbody with plain water to remove any corrosive materials used for ice and snow removal, and dust control. Take care to thoroughly clean any areas where mud and other debris can collect. Sediment packed in closed areas of the vehicle should be loosened before being flushed.

Engine cooling system service * † — Inspect coolant and freeze protection. If dirty or rusty, drain, flush and refill with new coolant. Keep coolant at the proper mixture as specified in Section 5 of your Owner's Manual. This provides proper freeze protection, corrosion inhibitor level and engine operating temperature. Inspect hoses and replace if cracked, swollen or deteriorated. Tighten hose clamps. Clean outside of radiator and air conditioning condenser. Wash radiator filler cap and neck. To help ensure proper opera-

* An Emission Control Service

† A large loss in these systems may indicate a problem. Have them inspected and repaired at once.

tion, a pressure test of both the cooling system and cap is also recommended. See maintenance schedule charts in Section A for the recommended coolant change interval.

Body Lubrication Service — Lubricate all body door hinges including the tailgate (if equipped) also lubricate the body hood, fuel door and rear compartment hinges and latches including interior glove box and console doors, and any folding seat hardware.

classiccarylbrary.com

SECTION E — RECOMMENDED FLUIDS & LUBRICANTS

NOTE: Fluids and lubricants identified below by name, part number or specification may be obtained from your GM Truck Dealer.

USAGE	FLUID/LUBRICANT
Engine Oil	GM Goodwrench Motor Oil or equivalent for API Service SF/CC or SF/CD of the recommended viscosity
Engine Coolant	Mixture of water and a good quality ethylene glycol base antifreeze conforming to GM-1825-M GM Part No. 1052753
Brake and Hydraulic Clutch Systems	Delco Supreme 11 fluid GM Part No. 1052535 or DOT-3
Parking Brake Cables	Chassis grease meeting requirements of GM-6031-M GM Part No. 1052497
Power Steering System	GM Power Steering Fluid GM Part No. 1050017 or equivalent
Manual Steering Gear	GM Lubricant Part No. 1052182 or equivalent
Automatic Transmission	DEXRON [®] II Automatic Transmission Fluid GM Part No. 1051855
Manual Transmission:	
3-Speed (RPO M62 and M64)	SAE-80W GL-5 or SAE-80W-90 GL5 gear lubricant GM Part No. 1052271 (use SAE-80W GL-5 in Canada)
4-Speed (RPO MC9, MF2, and M73)	Dexron [®] II Automatic Transmission Fluid GM Part No. 1051855
4-Speed (RPO M20)	SAE-80W GL-5 or SAE-80W-90 GL5 gear lubricant GM part No. 1052271 (use SAE-80W GL-5 in Canada)
4-Speed Overdrive (RPO MY6)	Dexron [®] II Automatic Transmission Fluid GM Part No. 1051855
4-Speed Without Creeper Gear (RPO MC0)	Manual Transmission Fluid GM Part No. 1052931.
5-Speed (RPO ML2, ML3 and MH3)	Dexron [®] II Automatic Transmission Fluid GM Part No. 1051855
5-Speed (RPO MG5)	Manual Transmission Fluid GM Part No. 1052931
Differential:	
Standard - Front and Rear Axle	SAE-80W-90 GL-5 gear lubricant GM Part No. 1052271 (use SAE-80W GL-5 in Canada).
Locking	SAE-80W-90 gear lubricant GM Part No. 1052271 (use SAE-80W GL-5 in Canada)

**RECOMMENDED FLUIDS & LUBRICANTS
(Cont'd.)**

Transfer Case	Dexron [®] II Automatic Transmission Fluid GM Part No. 1051855
Manual Transmission Shift Linkage, Column Shift, Propeller Shaft Slip Joint	Chassis grease meeting requirements of GM-6031-M GM Part No. 1052497
Clutch Linkage (Manual Transmission without hydraulic clutches only) a. Pivot points b. Pushrod to clutch fork joint, and shaft pressure fitting	a. Engine oil b. Chassis grease meeting requirements of GM-6031-M GM No. 1051344
Hood Latch Assembly a. Pivots and spring anchor b. Release pawl	a. Engine oil or GM Part No. 1050109 b. Chassis Grease meeting requirements of GM-6031-M GM Part No. 1052497
Front Wheel Bearings	GM Lubricant Part No. 1051344
Constant Velocity Universal Joint	GM Lubricant Part No. 1052497.
Automatic Transmission Shift Linkage, Floor Shift Linkage, Hood and Door Hinges, Body Door Hinge Pins, Tailgate Hinge and Linkage, Folding Seat, Fuel Door Hinge	Engine oil
Key Lock Cylinders	Light oil (10W-30) or Dri-Slide lubricant GM Part No. 1052948, or general-purpose silicone lubricant, GM Part No. 1052276.
Chassis Lubrication	Chassis grease meeting requirements of GM-6031M, GM Part No. 1052497.
Windshield Washer Solvent	GM Optikleen washer solvent GM Part No. 1051515 or equivalent.
Weatherstrip	Silicone grease GM Part No. 1052863 or equivalent.

NOTE: Silicone lubricants should not be used on lock cylinders with plastic caps.

classiccarlibrary.com

SECTION 1

HEATING AND AIR CONDITIONING

CONTENTS

<u>SUBJECT</u>	<u>PAGE</u>
Heating	1A-1
Air Conditioning	1B-1

SECTION 1A

HEATING

CONTENTS

<u>SUBJECT</u>	<u>PAGE</u>
R/V And G Series Heaters — Description	1A- 2
Blower And Air Inlet Assembly	1A- 2
Heater Distributor Assembly	1A- 2
Functional Test	1A- 2
Insufficient Heat Diagnosis	1A- 5
Heater Circuit Diagnosis	1A- 8
Diagnosis of the Heater System	1A- 9
R/V Series Heater — On-Vehicle Service	1A-10
Blower Motor Replacement	1A-10
Heater Hose Routing	1A-10
Heater Distributor Case and Core Replacement	1A-10
Control Assembly Replacement	1A-11
Control Cable Replacement	1A-12
Cable Adjustment	1A-14
Blower Switch Replacement	1A-14
Resistor Replacement	1A-14
Vent Replacement	1A-14
R/V Series Auxilliary Heater	1A-15
Description	1A-15
Diagnosis	1A-17
On-Vehicle Service	1A-17
Blower Motor Replacement	1A-17
Heater Core Replacement	1A-17
Resistor Replacement	1A-17
Auxilliary Blower Switch Replacement	1A-17
Coolant-Control Valve Replacement	1A-17
G Series Heater — On-Vehicle Service	1A-18
Blower Motor Replacement	1A-18
Heater Hose Routing	1A-18
Heater Distributor Case and Core Replacement	1A-19
Distributor And Defroster Duct Replacement	1A-21
Control Assembly and/or Blower Switch Replacement	1A-22
Control Cable Replacement	1A-22
Cable Adjustment	1A-22
Resistor Replacement	1A-22
Vent Replacement	1A-22
G Series Auxilliary Heater	1A-23
Description	1A-23
Diagnosis	1A-25
On-Vehicle Service	1A-25
Blower Motor Replacement	1A-25
Heater Core Replacement	1A-26
Coolant-Control Valve Replacement	1A-26
Resistor Replacement	1A-26
Specifications	1A-26

R/V AND G SERIES HEATERS-DESCRIPTION

Heating components are attached to the right side of the cowl. The blower and air inlet assembly and water hoses are located on the forward side of the cowl panel while the heater core and distributor duct are on the passenger side.

The heater system is an air-mix type system in which outside air is heated and then mixed in varying amounts with cooler outside air to attain the desired air temperature. The system consists of (1) a blower and air inlet assembly, (2) a heater distributor assembly and (3) a heater control assembly.

BLOWER AND AIR INLET ASSEMBLY

The blower and air inlet assembly draws outside air through the outside air inlet grille located forward of the windshield reveal molding and channels the air into the heater distributor assembly. The operation of the blower motor is controlled by the fan switch on the heater control. The motor is connected in series with the fan switch and the blower resistor assembly.

HEATER DISTRIBUTOR ASSEMBLY

The heater distributor assembly houses the heater core and the doors necessary to control mixing and channeling of the air. Since the unit has no water valve, water circulation keeps the core hot at all times. That portion of the air passing through the core receives maximum heat from the core. Air entering the distributor assembly is channeled as follows:

Air entering the distributor can be directed out the purge door opening on the right end of the distributor assembly by the temperature door. If the temperature door is closed, air is directed through and/or around the heater core by the temperature door. Air is then directed into the passenger compartment through the heater (floor) outlets and/or the defroster (dash) outlets by the defroster door. The temperature of the outlet air is dependent on the ratio of heated to unheated air (controlled by the temperature door).

FUNCTIONAL TEST

Perform this test as one operation:

1. For R/V Series, refer to figure 1.
2. For G Series, refer to figure 2.

FUNCTIONAL TEST—R-V SERIES

Perform this test as one operation by one inspector in one station roll-off test.

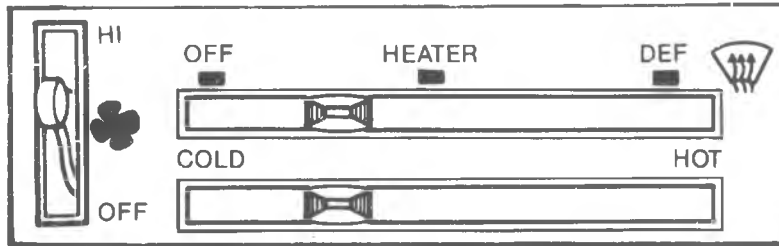

STEP	CONTROL SETTINGS			SYSTEM RESPONSE			
	MODE LEVER	TEMPERATURE LEVER	FAN SWITCH	BLOWER SPEED	HEATER OUTLET	DEFROSTER OUTLETS	SEE REMARKS
1	OFF	COLD	OFF	OFF	NO AIR FLOW	NO AIR FLOW	
2	OFF	COLD	OFF TO HI	OFF TO HI	NO AIR FLOW	NO AIR FLOW	A
3	HEAT	HOT	HI	HIGH	AIR FLOW	MIN AIR FLOW	B, C
4	DEFROST	HOT	HI	HIGH	MIN AIR FLOW	AIR FLOW	B

REMARKS:

- A. A change in blower speed must occur from Low, Medium to High.
- B. Detent engagement must be felt in each mode.
- C. Check the temperature lever for effort and travel (Cold to Hot).

F-02037

Figure 1—Functional Test-R/V Trucks

1A-4 HEATING

Heater Functional Test—G Series

Perform this test as one operation by one inspector in one station—off roll test.

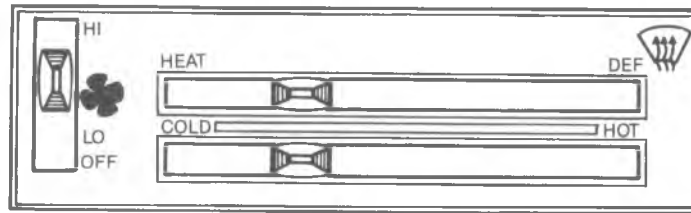

STEP	CONTROL SETTINGS		
	MODE CONTROL	TEMPERATURE CONTROL	FAN SWITCH
1	HTR	COLD (BLUE)	OFF
2	HTR	COLD	OFF TO HI
3	HTR	HOT (RED)	HI
4	DEFROST	HOT	HI

SYSTEM RESPONSE			
BLOWER SPEED	HEATER OUTLET	DEFROSTER OUTLETS	SEE REMARKS
OFF	NO AIR FLOW	NO AIR FLOW	
OFF TO HI	AIR FLOW	MIN AIR FLOW	A
HI	AIR FLOW	MIN AIR FLOW	B, C
HI	MIN AIR FLOW	AIR FLOW	B

REMARKS:

- A. A noticeable blower speed must occur from low, medium to high.
- B. The engagement detent must be felt in each mode.
- C. Check the temperature lever for effort and full travel (cold to hot).

Hot Air Check

With the mode lever in defrost , the temperature lever in hot, the fan switch in HI, the temperature from the defroster outlet should be above the temperature outside the vehicle.

F-02134

Figure 2—Functional Test—G Vans

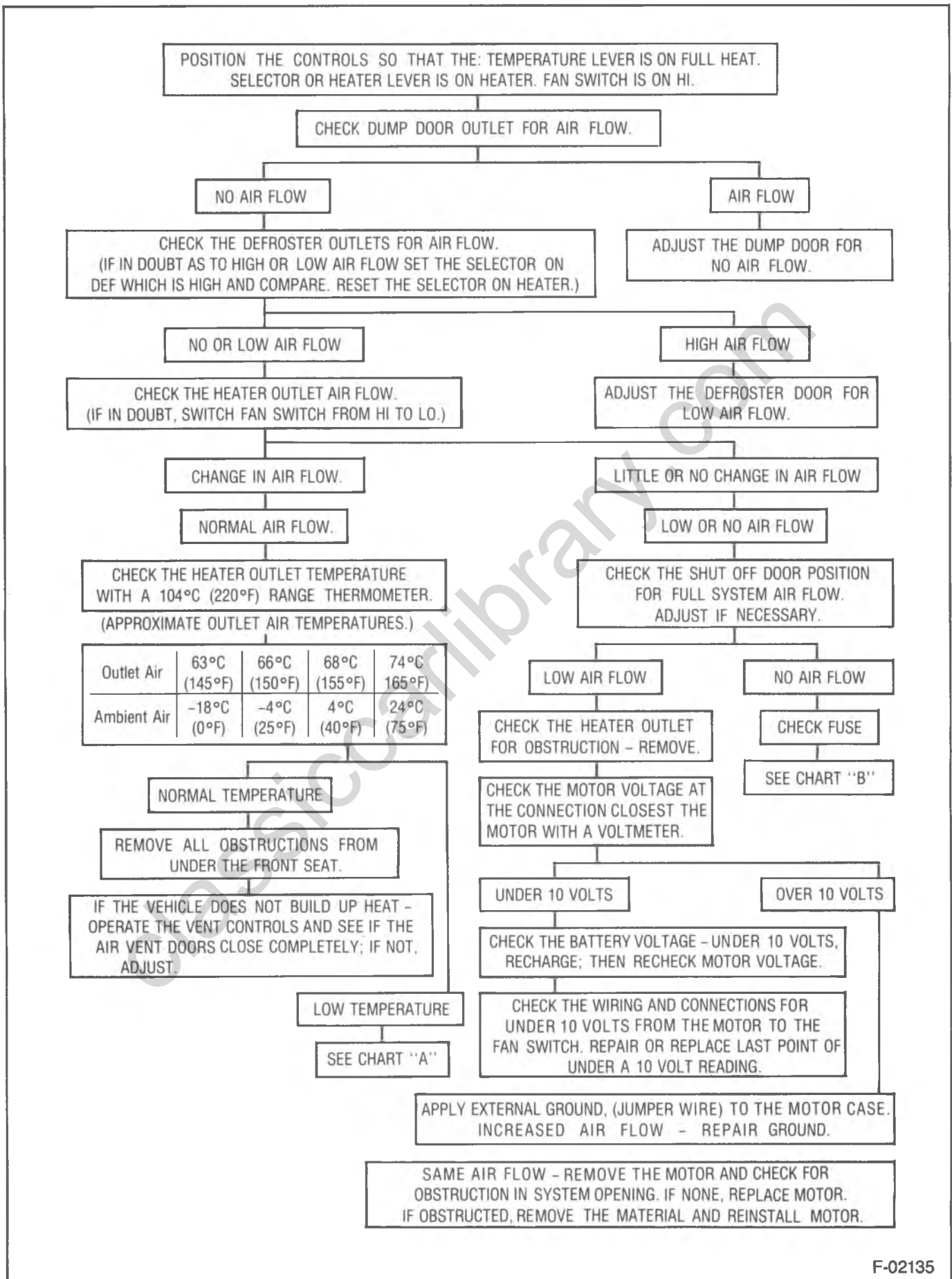
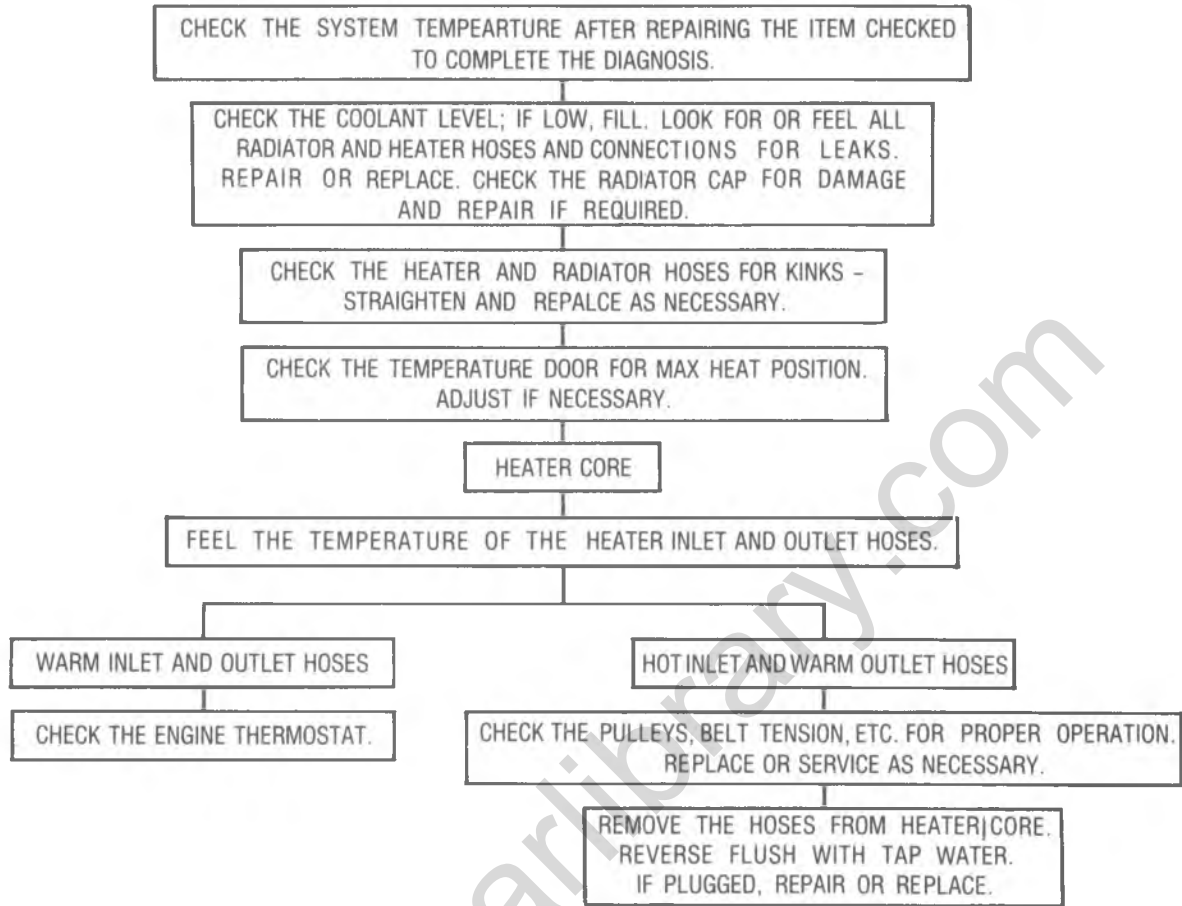

Figure 3—Insufficient Heat Diagnosis

CHART A



F-02136

Figure 4—Insufficient Heat Diagnosis

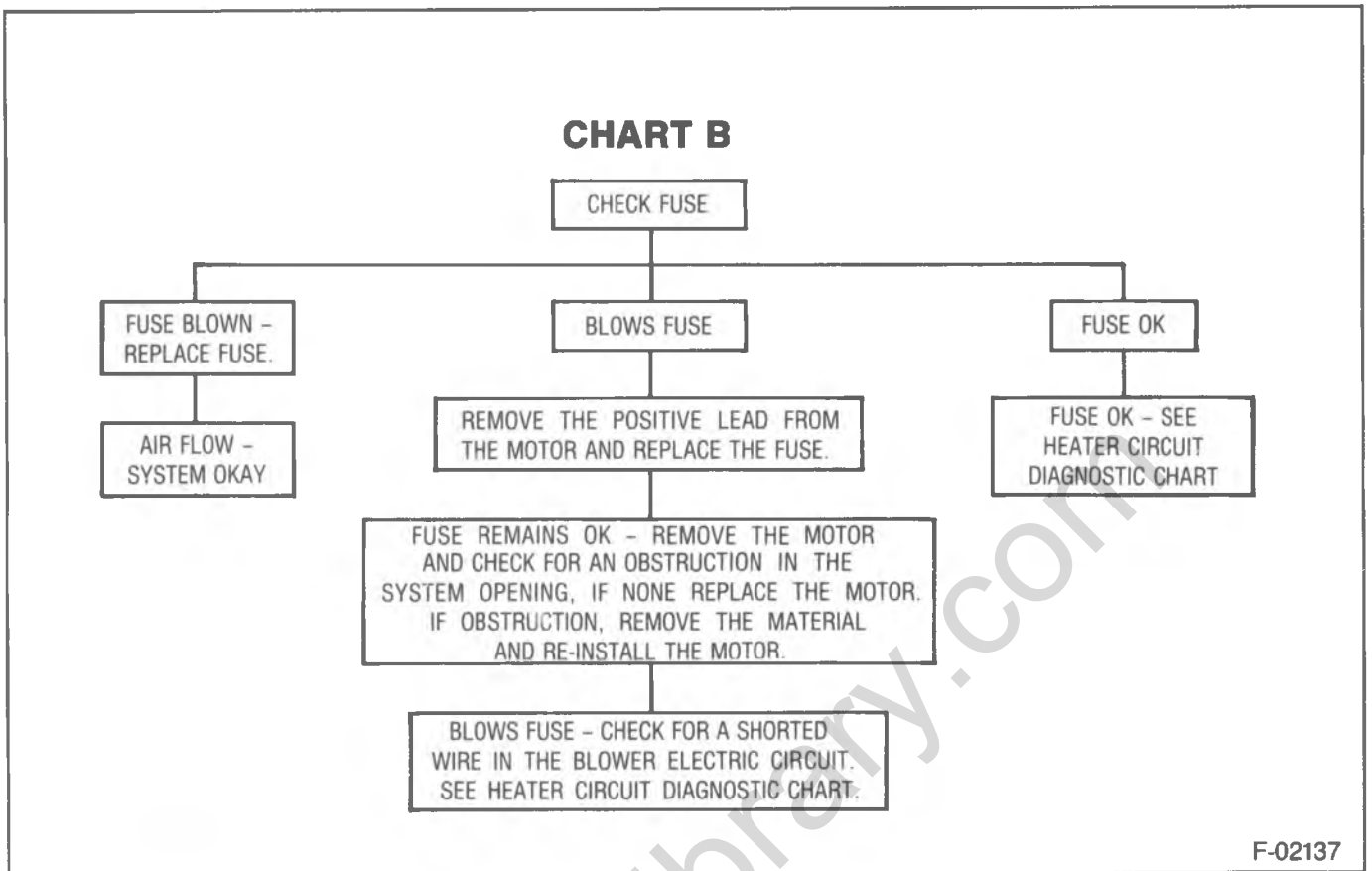

Figure 5—Insufficient Heat Diagnosis

HEATER CIRCUIT DIAGNOSIS

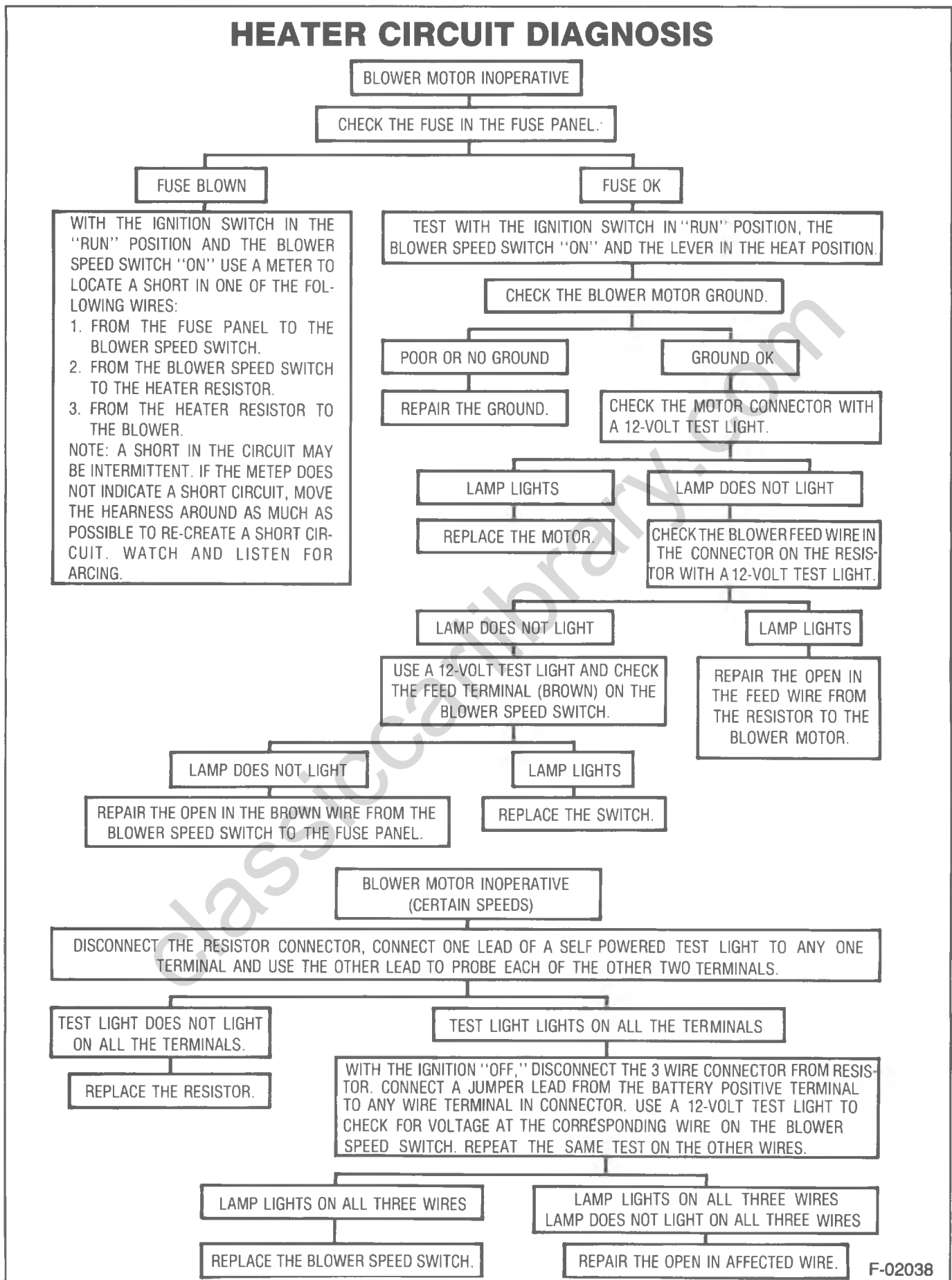

Figure 6—Heater Circuit Diagnosis

DIAGNOSIS OF THE HEATER SYSTEM

PROBLEM	POSSIBLE CAUSE	CORRECTION
Temperature Of Heater Air At The Outlets Is Too Low To Heat Up Passenger Compartment	Refer to "Insufficient Heat Diagnosis."	Refer to "Insufficient Heat Diagnosis."
Temperature Of Heater Air At The Outlets Is Adequate But The Vehicle Will Not Build Up Sufficient Heat	<ol style="list-style-type: none"> 1. Floor side kick pad ventilators partially open. 2. Leaking grommets in dash. 3. Leaking welded seams along the rocker panel and windshield. 4. Leaks through the access holes and screw holes. 5. Leaking rubber molding around the door and windows. 6. Leaks between the sealing edge of blower and the air inlet assembly and cowl, and between the sealing edge of the heater distributor assembly and cowl. 	<ol style="list-style-type: none"> 1. Check and adjust. 2. Reseal or replace. 3. Clean and rewash. 4. Reseal or replace. 5. Reseal or replace. 6. Reseal or replace.
Inadequate Defrosting Action	<ol style="list-style-type: none"> 1. Check that the DEFROST lever completely opens the defroster door in the DEF position. 2. Insure that the temperature and air doors open fully. 3. Look for obstructions in the defroster ducts. 4. Check for air leak in the ducting between the defroster outlet on heater assembly and the defroster duct under the instrument panel. 5. Check the position of the bottom of the nozzle to the heater locating tab. 6. Check the position of the defroster nozzle openings relative to instrument panel openings. Mounting tabs provide positive position if properly installed. 	<ol style="list-style-type: none"> 1. Adjust if necessary. 2. Adjust. 3. Remove any obstructions. 4. Seal area as necessary. 5. Adjust. 6. Adjust the defroster nozzle openings.
Inadequate Circulation Of Heated Air Through The Vehicle	<ol style="list-style-type: none"> 1. Check the heater outlet for correct installation. 2. Inspect the floor carpet to insure that the carpet lies flat under the front seat and does not obstruct air flow. Also inspect around the outlet ducts to insure that the carpet is well fastened to floor to prevent cupping of the air flow. 	<ol style="list-style-type: none"> 1. Remove and install. 2. Correct as necessary.
Erratic Heater Operation	<ol style="list-style-type: none"> 1. Check the coolant level. 2. Check for kinked heater hoses. 3. Check the operation of all bowden cables and doors. 4. Sediment in the heater lines and radiator causing the engine thermostat to stick open. 5. Partially plugged heater core. 	<ol style="list-style-type: none"> 1. Fill to the proper level. 2. Relieve kinks or replace hoses. 3. Adjust as necessary. 4. Flush the system and clean or replace thermostat as necessary. 5. Backflush core as necessary.

DIAGNOSIS OF THE HEATER SYSTEM (CONT.)

PROBLEM	POSSIBLE CAUSE	CORRECTION
Hard Operating Or Broken Controls	<ol style="list-style-type: none"> 1. Check for loose cable tab screws or mis-adjusted cables. 2. Check for sticking heater system door(s). 	<ol style="list-style-type: none"> 1. Correct as required. 2. Lubricate as required using a silicone spray.

R/V SERIES HEATER—ON-VEHICLE SERVICE

BLOWER MOTOR REPLACEMENT

↔ Remove or Disconnect (Figures 7 and 8)

1. Battery ground cable.
2. Blower motor wiring harness (3) (figure 7).
3. Motor (13) and fan (15) assembly (figure 8).
 - Five mounting screws.
 - Gently pry on the blower flange if the sealer acts like an adhesive.
4. Shaft nut (16).
5. Fan (15) from the motor (13).

↔ Install or Connect (Figures 7 and 8)

1. Fan (15) from the motor (13).
 - Locate the open end of the wheel away from the blower motor.
2. Shaft nut (16).
3. Motor (13) and fan (15) assembly to the case (14).
 - New bead of sealer to the mounting flange.
 - Five mounting screws.
4. Blower motor wiring harness.
5. Battery ground wire.
6. Test the motor (13).

HEATER HOSES ROUTING

Heater hoses are routed from the thermostat housing or inlet manifold and water pump (radiator on some automatic transmission vehicles) to the core inlet and outlet pipes. Hoses are attached at each end with screw-type clamps. (Refer to figures 9, 10 and 11).

REPLACEMENT

When replacing heater hoses, maintain a 13 mm (1/2-inch) minimum clearance between the hose clip and the upper control arm, a 38 mm (1 1/2-inch) minimum clearance between the hoses and the propshaft, and a 32 mm (1 1/4-inch) minimum clearance between the auxiliary heater core lines and the exhaust pipe.

The heater core can be damaged near the tube attachment seams if force is applied on them. If the heater hoses do not come off, cut the hoses forward of the core tubes. Cut the hose on core tubes to remove.

! Important

- Draw hoses tight to prevent sagging or rubbing against other components. Route hoses through all clamps as installed originally.

HEATER DISTRIBUTOR CASE AND CORE REPLACEMENT

↔ Remove or Disconnect (Figures 8 through 14)

1. Battery ground cable.
2. Heater hoses (40 and 41) at the core tubes (20) (figures 8, 9, 10 and 11).
 - Drain the engine coolant into a clean pan.
 - Plug the core tubes to prevent spillage.
3. Screws (31) and nuts (24) from the studs (6) that project into the engine compartment (figures 8 and 12).
4. Instrument panel compartment.
5. Defroster (51) and temperature cables (52) (figure 13).
6. Floor outlet (37).
7. Screw (12) that holds the defroster duct to the heater distributor (figure 14).
8. Heater distributor from the dash panel.
 - Pull the assembly rearward to reach the wiring harness.
9. Wiring harness.
10. Heater case (24).
11. Core retaining clamps (18 and 19).
12. Core (20).

↔ Install or Connect (Figures 8 through 14)

1. Core (20) to the case (24).
2. Core retaining clamps (18 and 19).
3. Heater case (24) to the vehicle.
4. Screws (31) and nuts to the studs (6).
5. Wiring harness.
6. Floor outlet (37).
7. Defroster (51) and temperature cables (52).
8. Instrument panel compartment.
9. Heater hoses (40 and 41) to the core tubes (20).
10. Battery ground cable.
11. Coolant to the radiator.

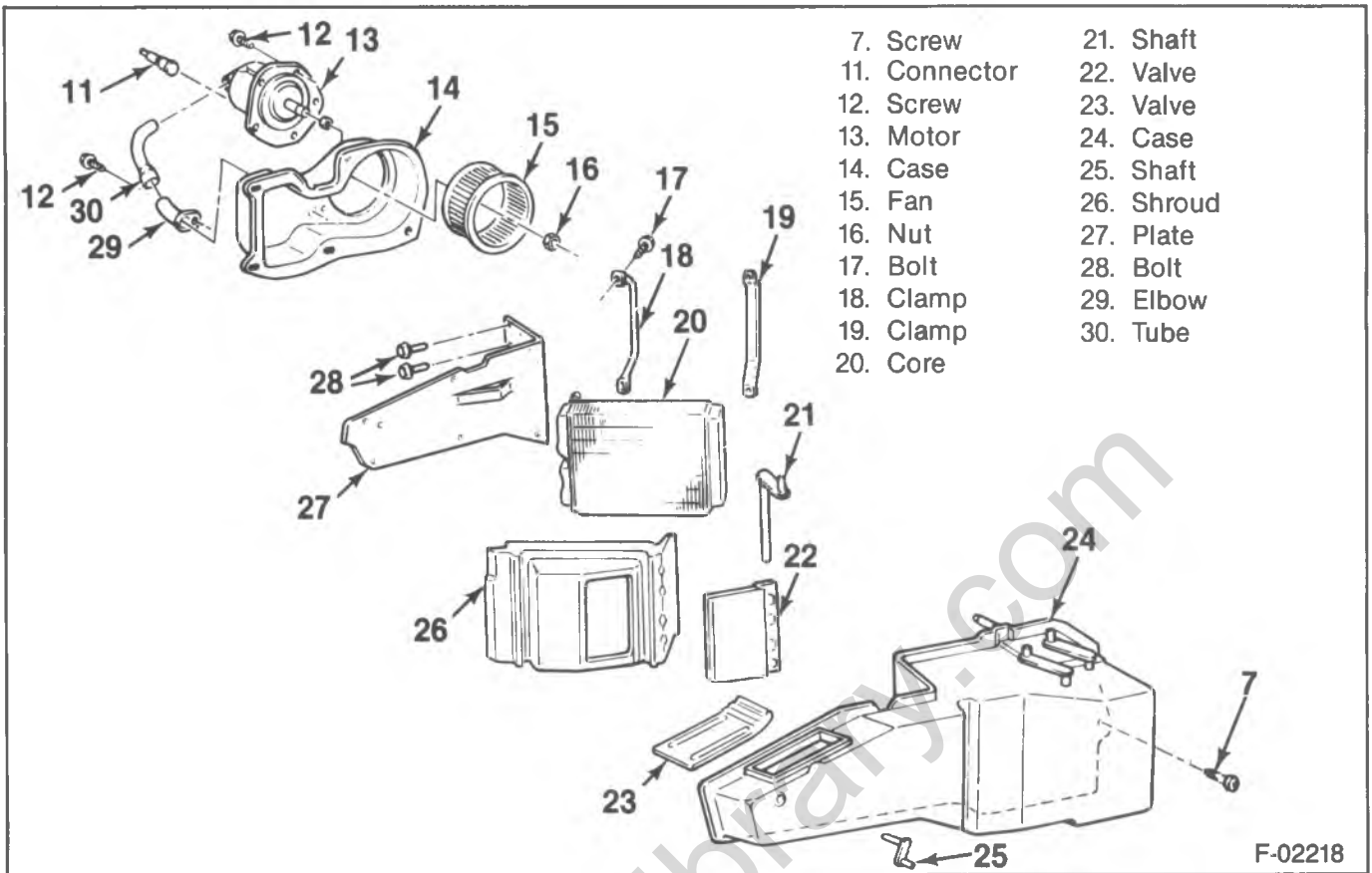

Figure 8—Blower Motor Assembly—Component View—R/V

CONTROL ASSEMBLY REPLACEMENT

←→ Remove or Disconnect (Figure 13)

1. Battery ground cable.
2. Instrument panel bezel.
3. Defroster (51) and temperature cables (52).
4. Blower switch wiring harness.
5. Assembly through the opening above the control.

→← Install or Connect (Figures 13)

- If a new unit is being installed, transfer the blower switch to the new unit.

1. Assembly through the opening above the control.
2. Blower switch wiring harness.
3. Defroster (51) and temperature cables (52).
4. Instrument panel bezel.
5. Battery ground cable.

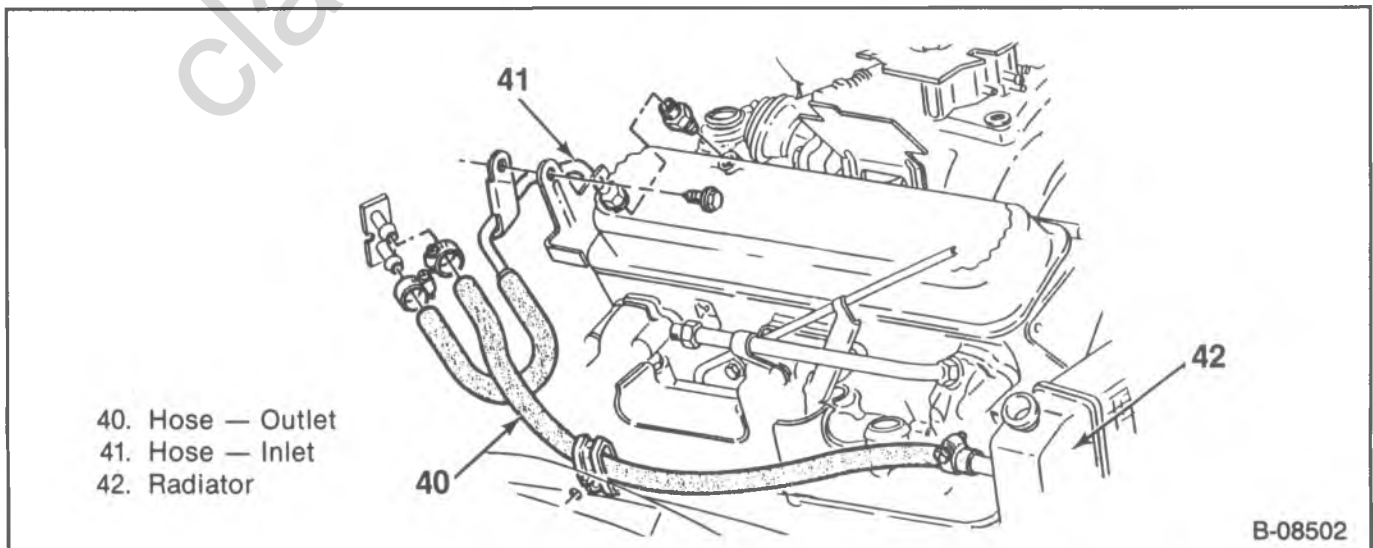

Figure 9—Heater Hose Routing—4.3L, 5.0L and 5.7L Engines

1A-12 HEATING

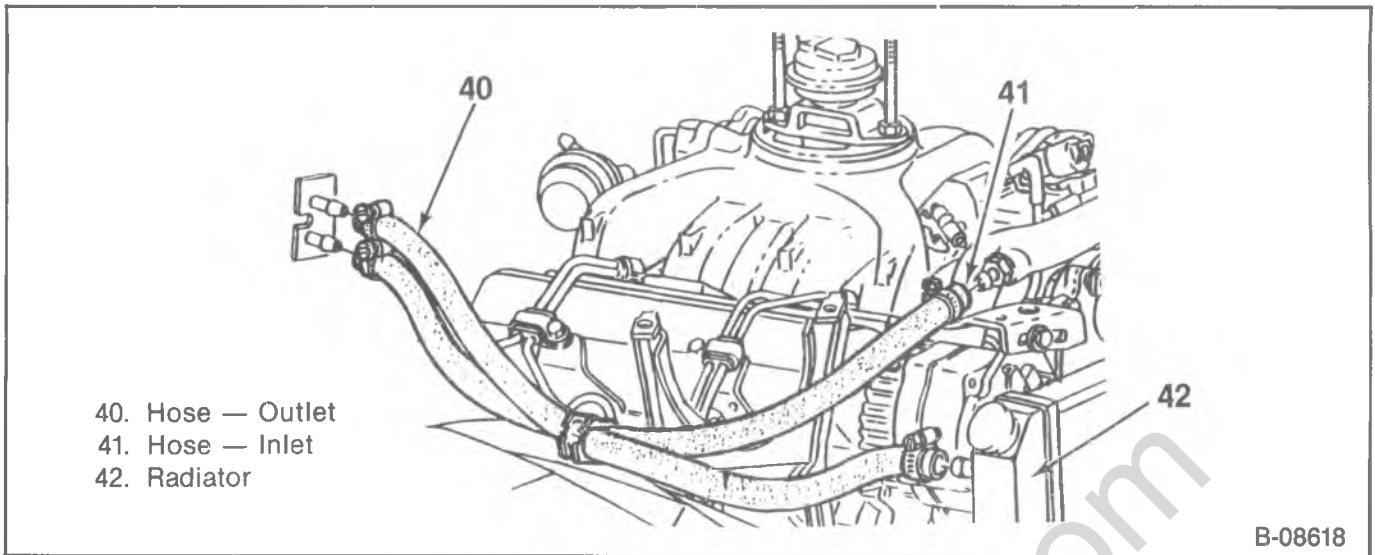

Figure 10—Heater Hose Routing—6.2L Engine

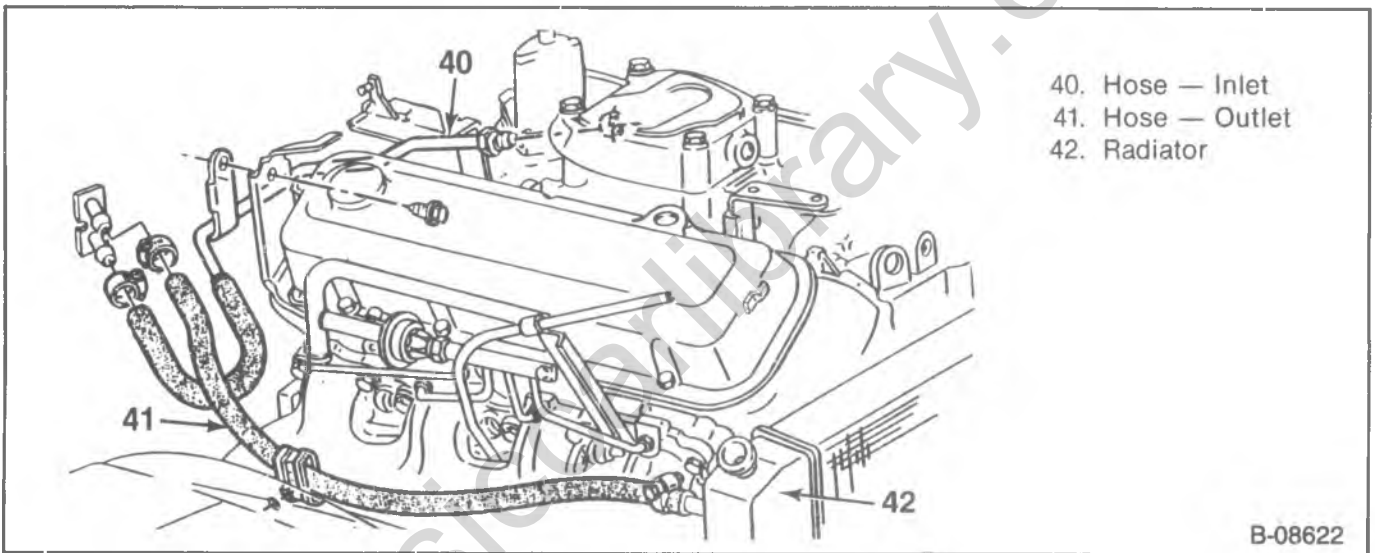

Figure 11—Heater Hose Routing—7.4L Engine

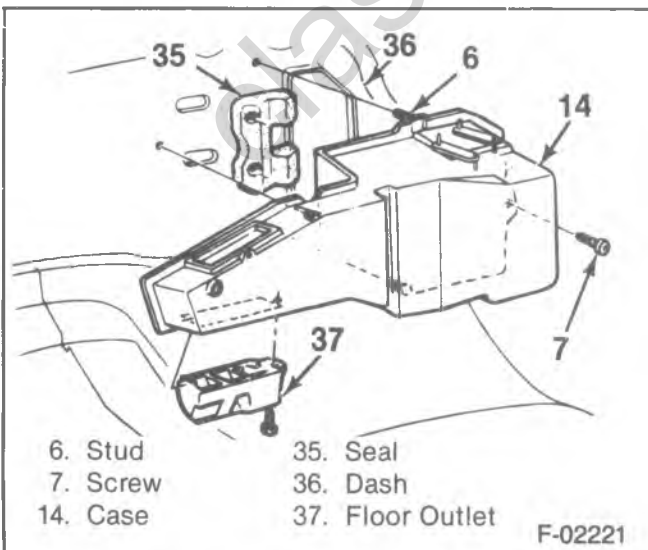

Figure 12—Heater Distributor Assembly

CONTROL CABLE REPLACEMENT

↔ Remove or Disconnect (Figure 13)

1. Battery ground cable.
2. Instrument panel bezel.
3. Control assembly from the instrument panel.
4. Cable retainers (53) and tab attaching screws (54).
 - Pull the control out from the instrument panel for access.
5. Instrument panel compartment.
6. Cable retainers (53) and tab attaching screws (54) at the heater case.
7. Cable from the retaining clip (58).
8. Cable (50 or 51).

↔ Install or Connect (Figures 13)

1. Cable (51 or 52).

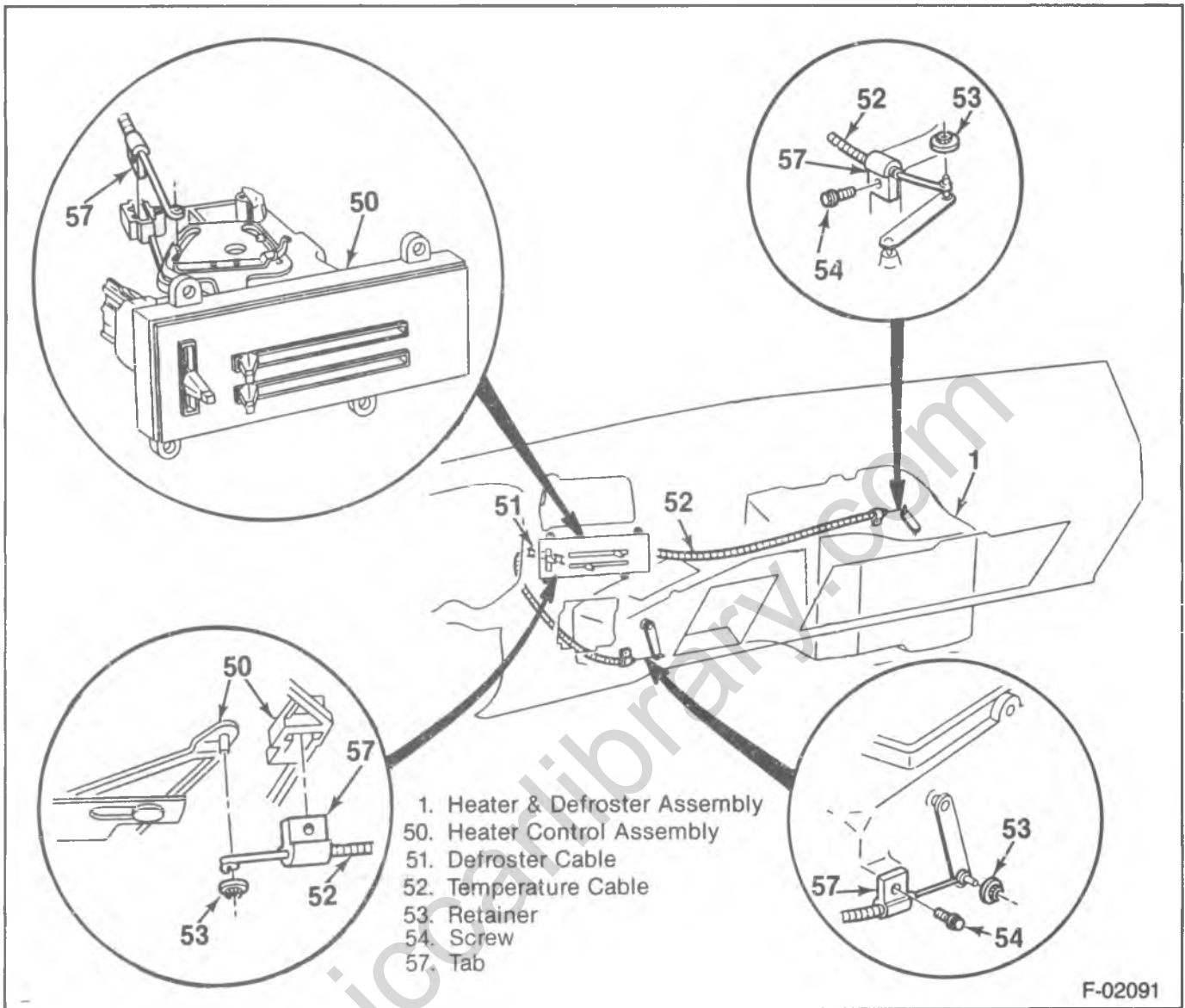

Figure 13—Control Assembly and Cables

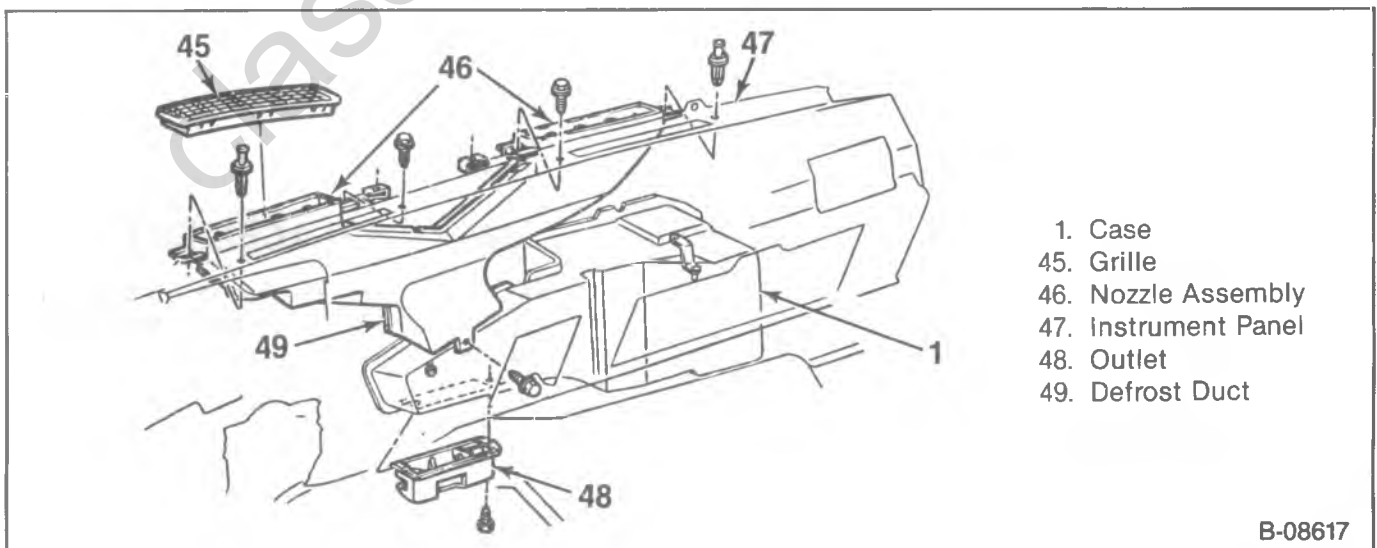
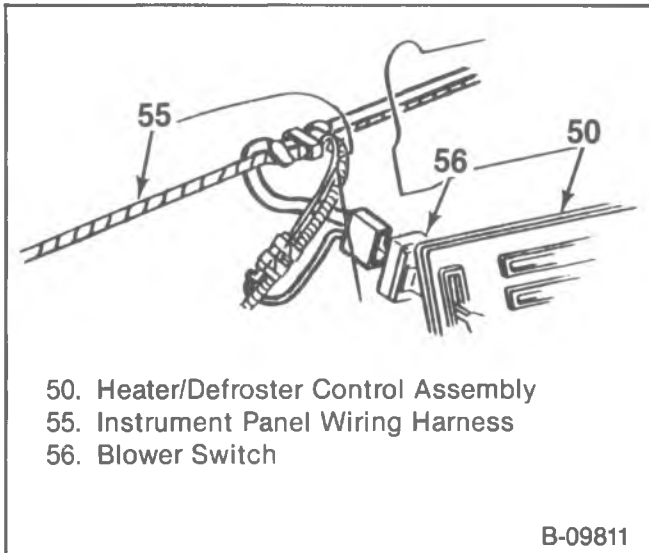

Figure 14—Floor and Defroster Vents

1A-14 HEATING



50. Heater/Defroster Control Assembly
55. Instrument Panel Wiring Harness
56. Blower Switch

B-09811

Figure 15—Blower Switch



Important

- Do not kink the cable. Route the cable as removed. Check the adjustment.
2. Cable to the retaining clip (58) at the heater case (24).
 3. Cable retainers (53) and the tab screws at the heater case.
 4. Instrument panel compartment.
 5. Cable (51 or 52) to the control assembly (50).
 6. Cable retainers (53) and tab screws (54).
 7. Control assembly (50) to the instrument panel.
 8. Instrument panel bezel.

CABLE ADJUSTMENT



Remove or Disconnect (Figure 13)

1. Instrument panel compartment.
2. Retainer (53).
3. Screw (54) from cable tab (57).
4. Cable (51 or 52) from the heater case (24).



Adjust

- Hold the cable with a pair of pliers and rotate the mounting tab (57) to lengthen or shorten the cable.

NOTICE: Do not pinch the cable.



Install or Connect (Figure 13)

1. Cable (51 or 52) to the heater case (24).
2. Tab (57) to the clip (58).
3. Screw (54).
4. Instrument panel compartment.

BLOWER SWITCH REPLACEMENT



Remove or Disconnect (Figure 15)

1. Battery ground cable.
2. Instrument panel bezel.
3. Control assembly (50) mounting screws.

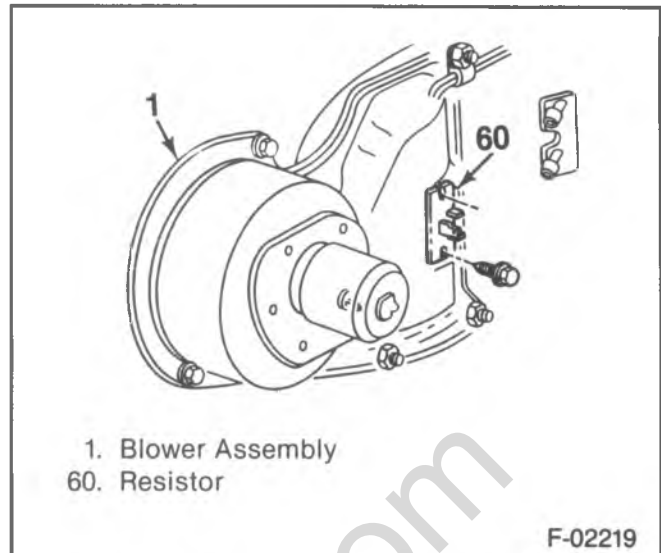

1. Blower Assembly
60. Resistor

F-02219

Figure 16—Blower Motor Resistor

4. Control assembly (50) (figure 15).
 - Pull the control out from the instrument panel.
5. Blower switch wiring harness.
6. Switch (56).



Install or Connect (Figure 15)

1. Switch (56) to the control assembly (50).
2. Wiring harness to the blower switch (56).
3. Control assembly (50) to the instrument panel.
4. Instrument panel bezel.
5. Battery ground cable.

RESISTOR REPLACEMENT



Remove or Disconnect (Figures 7 and 16)

1. Battery ground cable.
2. Connector (4) (figure 16).
3. Screws.
4. Resistor (60).



Install or Connect

1. Resistor (60).
2. Screws.
3. Connector (4).
4. Battery ground cable.

VENT REPLACEMENT

Right and left vents are installed in the kick panels under the instrument panel. Replace the vents by removing the attaching screws (figure 17).

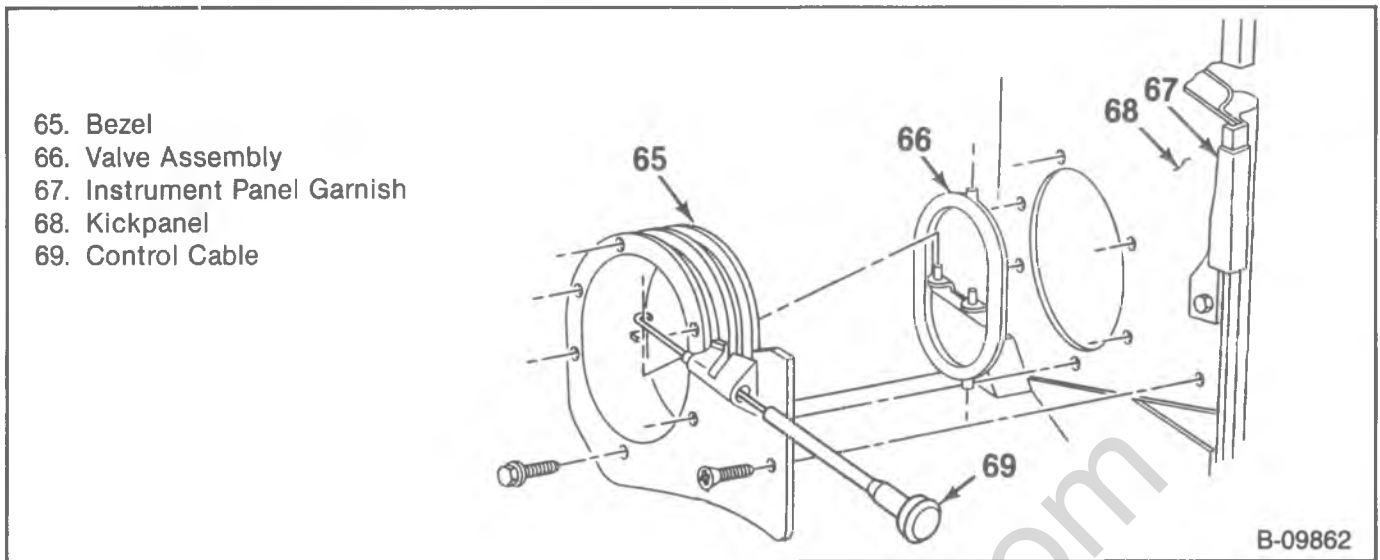

Figure 17—Vent Assembly

R/V SERIES AUXILIARY HEATER DESCRIPTION

An auxiliary heater provides additional heating capacity for the rear of the Suburban model.

This unit operates independently of the standard heater, and is regulated through its own controls at the instrument panel.

This system consists of a separate core and fan unit mounted in the rear of the vehicle.

Heater hoses extend from the unit to the front of the vehicle where they are connected to the standard heater hoses with "tees." An "on-off" vacuum operated valve is installed in the heater core inlet line in the engine compartment. This valve cuts off coolant flow to the auxiliary core during warm weather and eliminates radiant heat (figure 18).

Two control methods are used:

COOLANT-CONTROL VALVE

When heat is desired, and the blower switch is any position except off, a vacuum operated valve controlled by the switch, opens the coolant line to permit hot coolant circulation through the heater core. In the OFF position the valve is closed to prevent unwanted heat.

BLOWER SWITCH

The three-speed blower switch is located in the instrument panel to the right of the steering column.

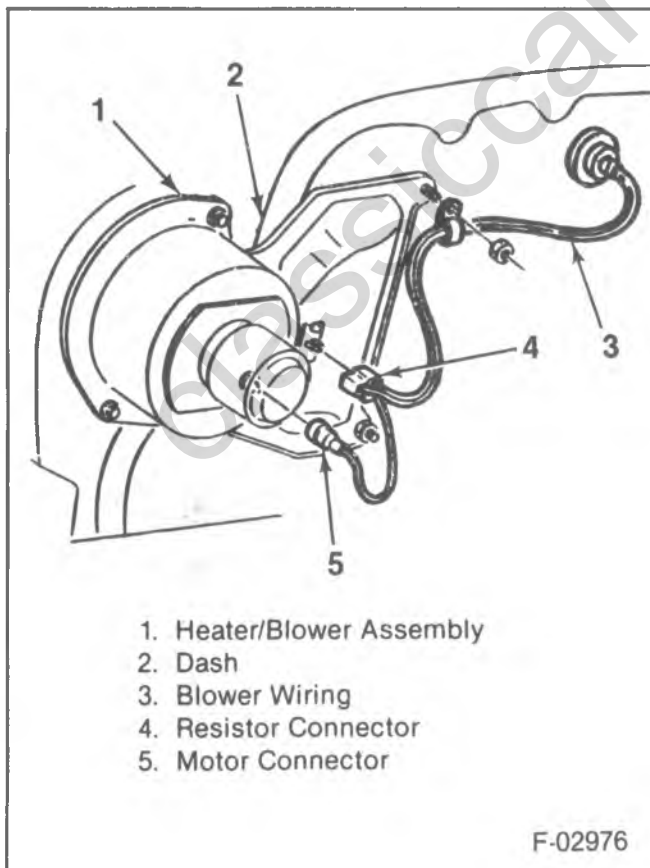
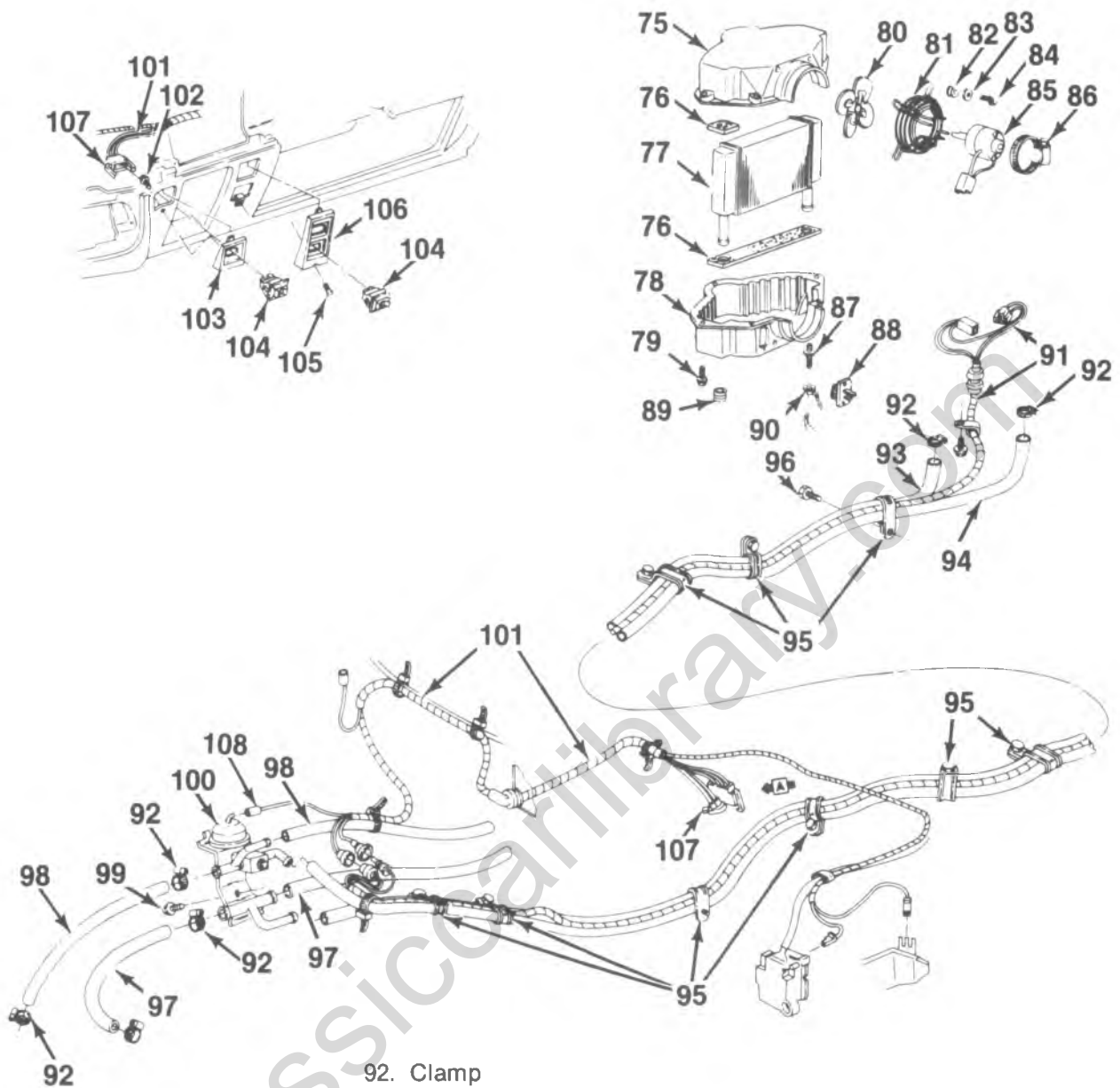

Figure 7—Blower Motor Assembly Wiring R/V

1A-16 HEATING



- | | |
|----------------|--|
| 75. Upper Case | 92. Clamp |
| 76. Seal | 93. Auxiliary Heater Inlet Rear Hose |
| 77. Core | 94. Auxiliary Heater Outlet Rear |
| 78. Lower Case | 95. Clip |
| 79. Screw | 96. Screw |
| 80. Fan | 97. Water Heater Outlet Hose |
| 81. Support | 98. Water Heater Inlet Hose |
| 82. Grommet | 99. Screw |
| 83. Washer | 100. Valve |
| 84. Screw | 101. Harness |
| 85. Motor | 102. Screw |
| 86. Clamp | 103. Auxiliary Heater Switch (Single Function) Bezel |
| 87. Stud | 104. Auxiliary Heater Control Switch |
| 88. Resistor | 105. Screw |
| 89. Seal | 106. Auxiliary Heater/Rear Air Conditioning Control Switch (Dual Function) |
| 90. Nut | 107. Connector |
| 91. Harness | 108. Vacuum Line |

F-02222

Figure 18—Auxiliary Heater—Suburban

DIAGNOSIS

To diagnose the heater system, refer to "Insufficient Heat Diagnosis," "Heater Circuit Diagnosis," and "Diagnosis of the Heater System."

ON-VEHICLE SERVICE

BLOWER MOTOR REPLACEMENT

↔ Remove or Disconnect (Figure 18)

1. Battery ground cable.
2. Blower motor wiring harness (91).
3. Clamp (86).
4. Screws (84) and washer (83).
5. Motor (85).

↔ Install or Connect (Figure 18)

1. Motor (85).
2. Screws (84) and washers (83).
3. Clamp (86).
4. Blower motor wiring harness (91).
5. Battery ground cable.

HEATER CORE REPLACEMENT

↔ Remove or Disconnect (Figure 18)

1. Battery ground cable.
2. Coolant from the radiator.
3. Hoses (93 and 94) from the core (77).
4. Wiring harness (91).
5. Clamp (86).
6. Motor (85), support (81) and fan (80) as an assembly.
7. Upper case (75).
8. Seal (76).
9. Core (77).

↔ Install or Connect (Figures 18)

1. Core (77) to lower case (78).
2. Seal (76).
3. Upper case (75).
4. Motor (85), support (81) and fan (80).
5. Clamp (86).
6. Wiring harness (91).
7. Hoses (93 and 94) to the core (77).
8. Coolant to the radiator.
9. Battery ground cable.

RESISTOR REPLACEMENT

↔ Remove or Disconnect (Figure 18)

1. Battery ground cable.
2. Wiring harness (101).
3. Screws.
4. Resistor (88).

↔ Install or Connect (Figure 18)

1. Resistor (88).
2. Screws.
3. Wiring harness (101).
4. Battery ground cable.

AUXILIARY BLOWER SWITCH REPLACEMENT

↔ Remove or Disconnect (Figure 18)

1. Battery ground cable.
2. Wiring harness (107) at the switch (104).
3. Screws (102).
4. Bezel (103).
5. Switch (104).

↔ Install or Connect (Figure 18)

1. Switch (104) to the bezel (103).
2. Bezel (103) to the instrument panel.
3. Screw (102).
4. Wiring harness (107) to the switch (104).
5. Battery ground cable.

COOLANT-CONTROL VALVE REPLACEMENT

The coolant-control valve is mounted to the right front fender. To diagnose the vacuum system, refer to AIR CONDITIONING (SEC. 1B).

↔ Remove or Disconnect (Figure 18)

1. Coolant from the radiator.
2. Clamps (92).
3. Hoses (93, 94, 97 and 98) from the valve.
4. Vacuum hose (108).
5. Valve (100).

↔ Install or Connect (Figure 18)

1. Valve (100).
2. Vacuum hose (108).
3. Hoses (93, 94, 97 and 98).
4. Clamps (92).
5. Coolant to the radiator.
6. Leak test.

G SERIES HEATER—ON-VEHICLE SERVICE

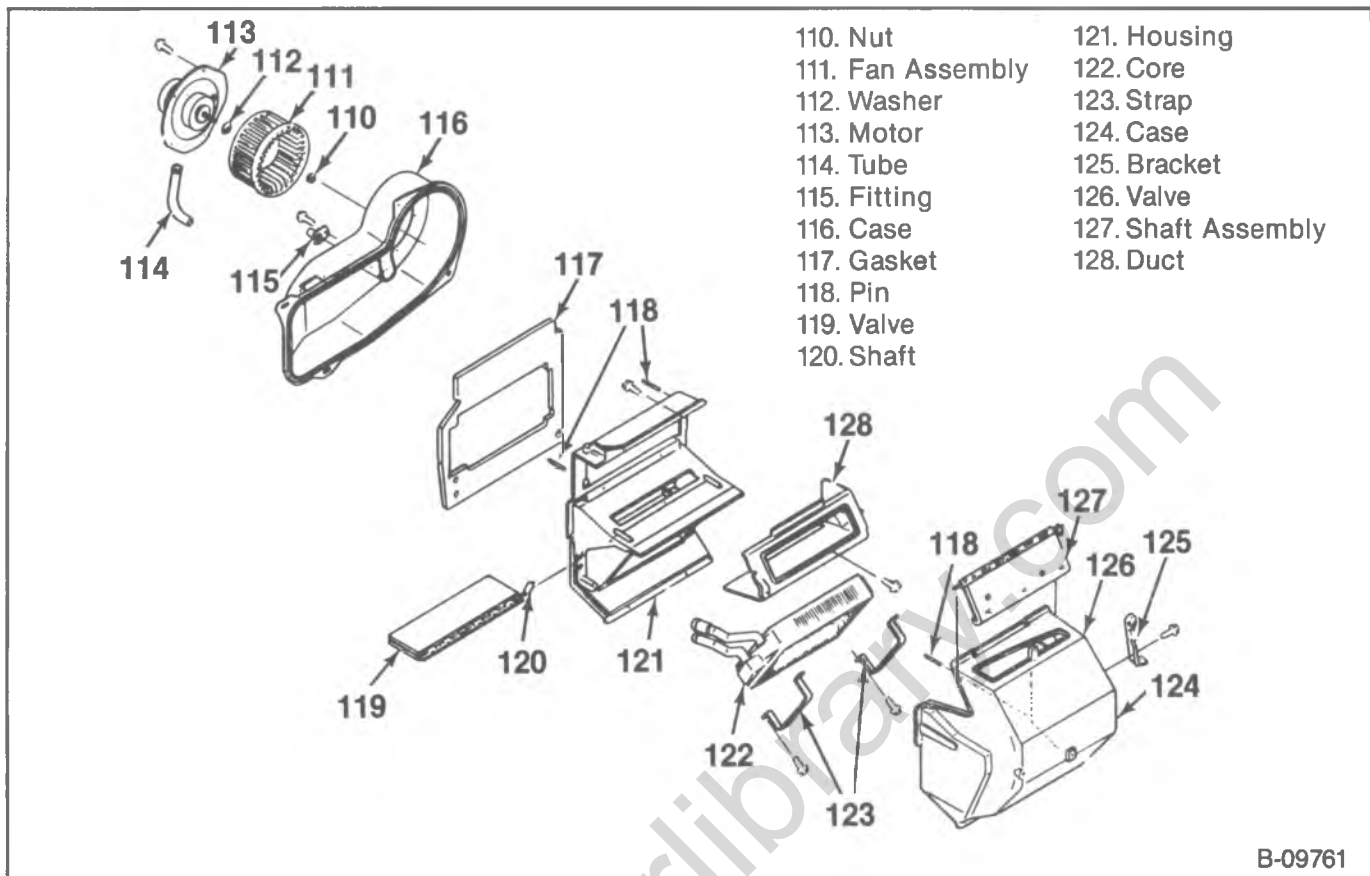

Figure 19—Blower Motor Assembly Component View

BLOWER MOTOR REPLACEMENT

↔ Remove or Disconnect (Figure 19)

1. Battery ground cable.
2. Coolant overflow hose from the recovery bottle.
3. Fasteners.
4. Bottle from the vehicle.
5. Blower motor and wiring harness.
6. Motor (113) and fan (111) assembly (figure 19).
 - Five mounting screws.
 - Gently pry on the blower flange if the sealer acts like an adhesive.
7. Nut (110).
8. Fan (111) from the motor (113).

→ Install or Connect (Figure 19)

1. Fan (111) to the motor (113).
 - Locate the open end of the wheel away from the blower motor.
2. Nut (110).
3. Motor (113) and fan (111) assembly.
 - Bead of sealer to the mounting flange.
4. Blower motor wiring harness.
5. Coolant bottle to the vehicle.
6. Fasteners.
7. Coolant hose.
8. Battery ground cable.
9. Test the motor.

HEATER HOSE ROUTING

Heater hoses are routed from the thermostat housing or inlet manifold and water pump (radiator on some automatic transmission vehicles) to the core inlet and outlet pipes. Hoses are attached at each end with screw-type clamps. (Refer to figures 20, 21 and 22).

REPLACEMENT

When replacing heater hoses, maintain a 13 mm (1/2-inch) minimum clearance between the hose clip and the upper control arm, a 38 mm (1 1/2-inch) minimum clearance between the hoses and the propshaft, and a 32 mm (1 1/4-inch) minimum clearance between the auxiliary heater core lines and the exhaust pipe.

The heater core can be damaged near the tube attachment seams if force is applied on them. If the heater hoses do not come off, cut the hoses forward of the core tubes. Cut the hose on the core tubes to remove.

! Important

- Draw hoses tight to prevent sagging or rubbing against other components. Route hoses through all clamps as installed originally.

B-09761

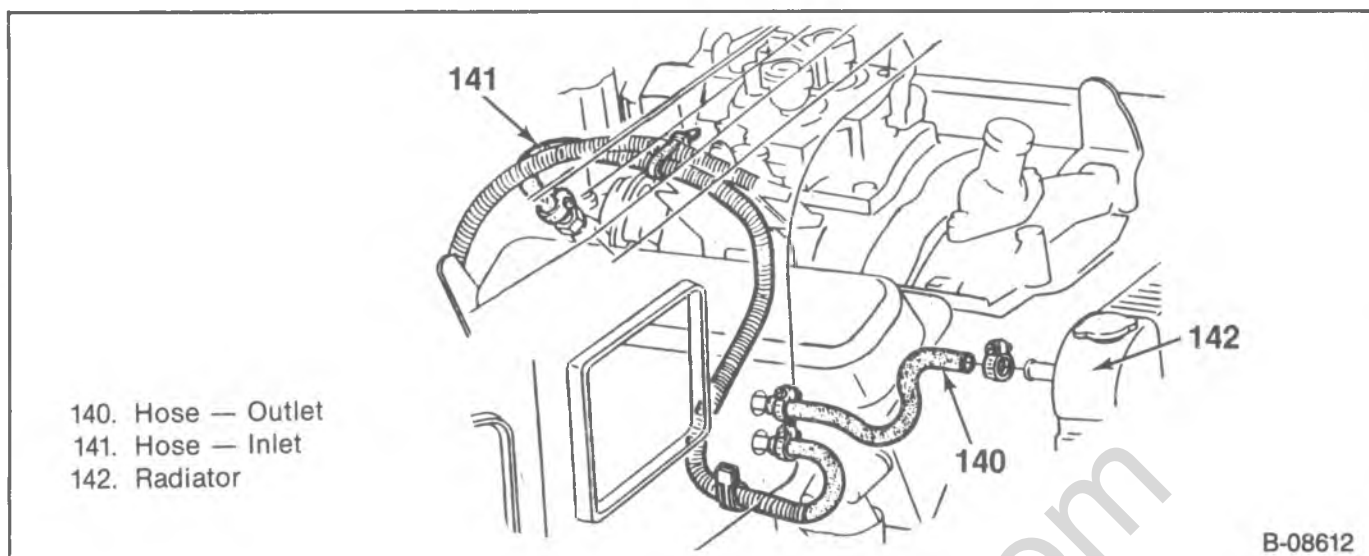

Figure 20—Heater Hose Routing—4.3L, 5.0L and 7.4L Engines

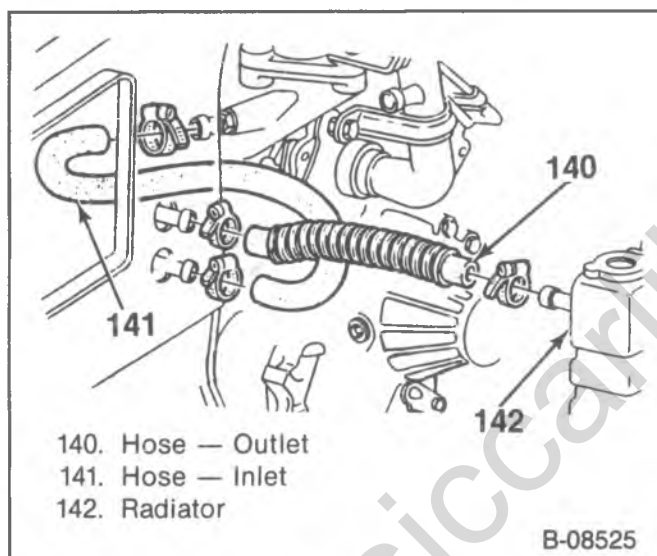

Figure 21—Heater Hose Routing—6.2L Engine

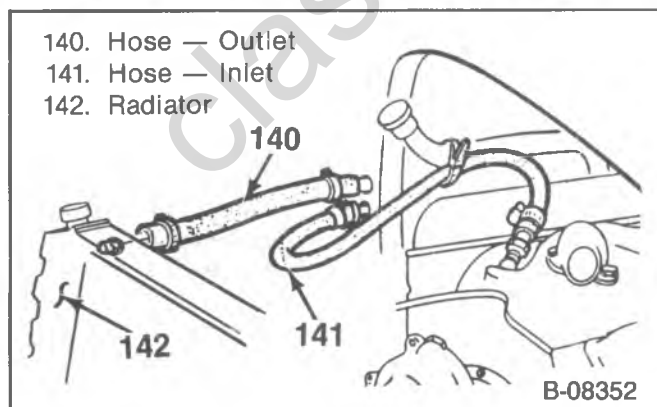
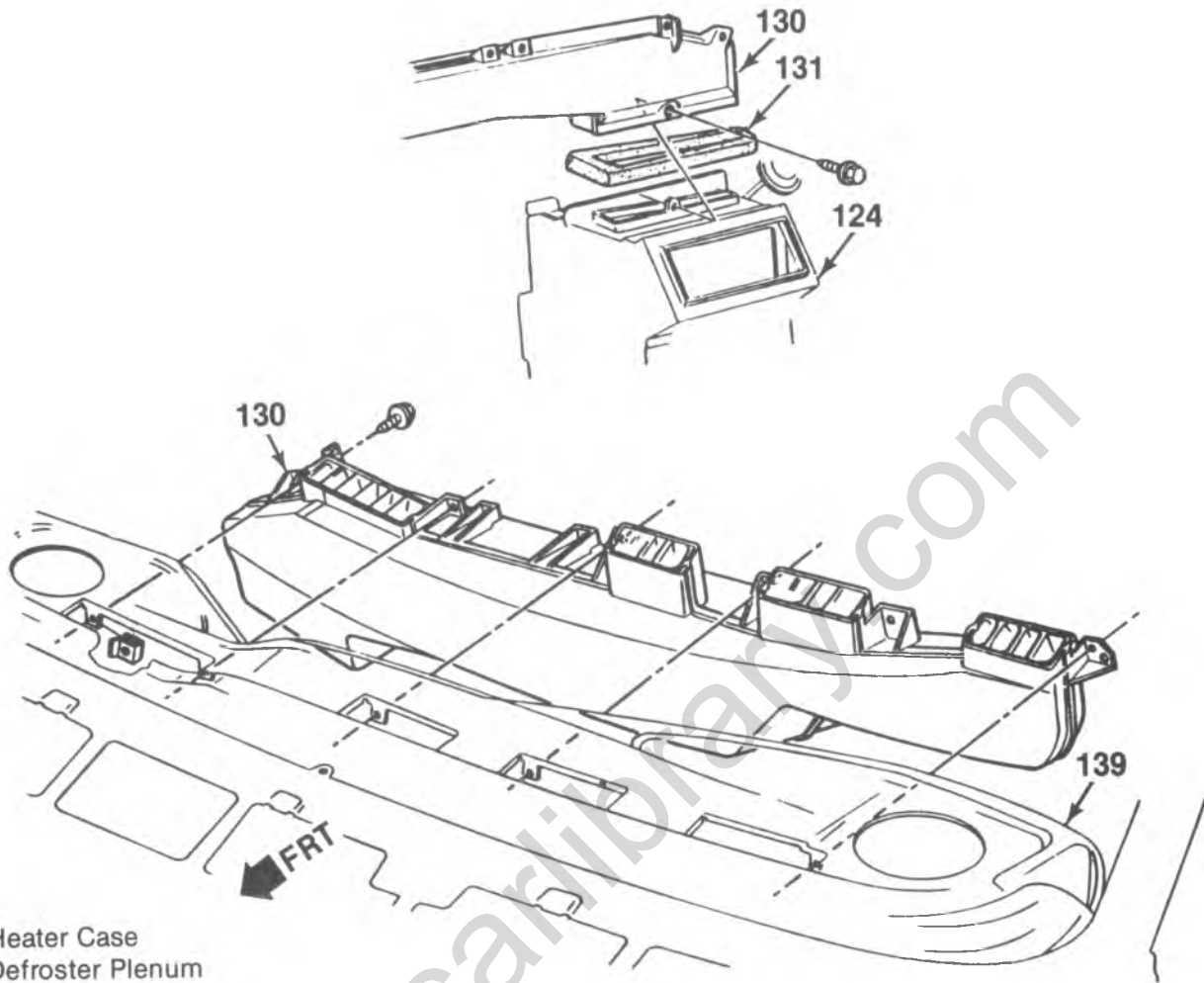

Figure 22—Heater Hose Routing—7.4L Engine

HEATER DISTRIBUTOR CASE AND CORE REPLACEMENT

↔ Remove or Disconnect (Figures 19 through 24)

1. Battery ground cable.
2. Coolant recovery tank.
3. Heater core hoses (140 and 141) (figures 20, 21 and 22).
 - Place a clean pan under the vehicle to catch any coolant spillage.
 - Plug the hoses.
 - Allow coolant in the core to drain into the pan.
4. Heater distributor duct (134) (figure 23).
 - Remove the screws that hold the distributor duct to the distributor case and the distributor duct to the engine cover.
5. Engine housing cover.
 - Refer to INTERIOR TRIM (SEC. 10A4).
 - Remove the screws at the windshield, all lower screws and the right instrument panel support bracket at the door pillar and the engine housing.
6. Instrument panel.
7. Lower the steering column.
 - Refer to STEERING COLUMN (SEC. 3B4).
 - Raise and support the right side of the instrument panel.
8. Defroster duct (130) to distributor case (124) attaching screws.
9. Distributor to heater case (2) screws.
10. Temperature door cable (145) (figure 24).
 - Fold the cable back for access.
11. Heater case (124) and core (122).
 - Three nuts at the engine compartment side of the distributor case and one screw on the passenger side.
 - Tilt the case assembly rearward at the top while lifting up until the core tubes clear the dash openings.
12. Core retaining straps (123).
13. Core (122).



- 124. Heater Case
- 130. Defroster Plenum
- 131. Seal
- 133. Left-hand Outlet Assembly
- 134. Duct Assembly
- 135. Right-hand Outlet Assembly
- 136. Engine Cover Assembly
- 137. Engine Cover Insulator
- 138. Defroster Plenum Outlet
- 139. Upper Instrument Panel

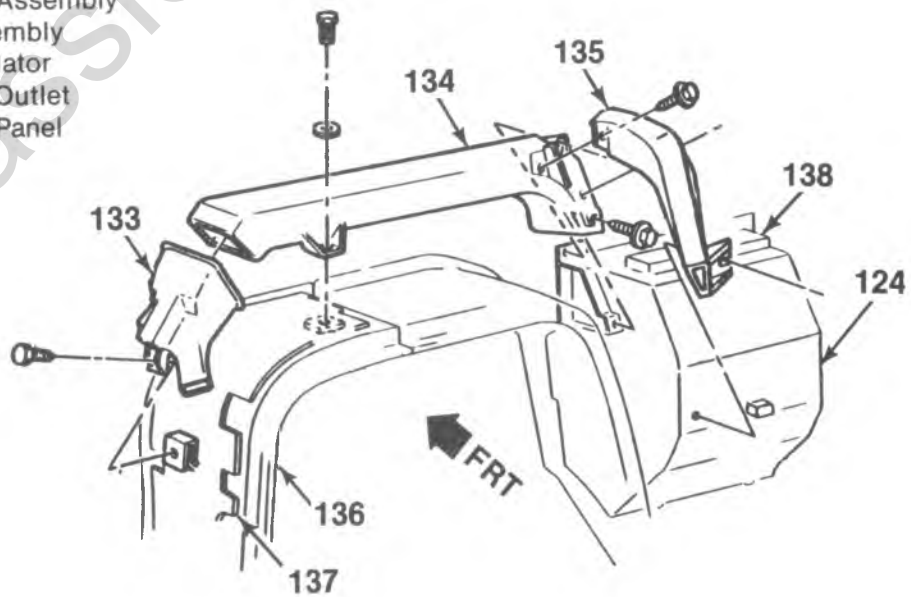

F-00659

Figure 23—Distributor Ducts

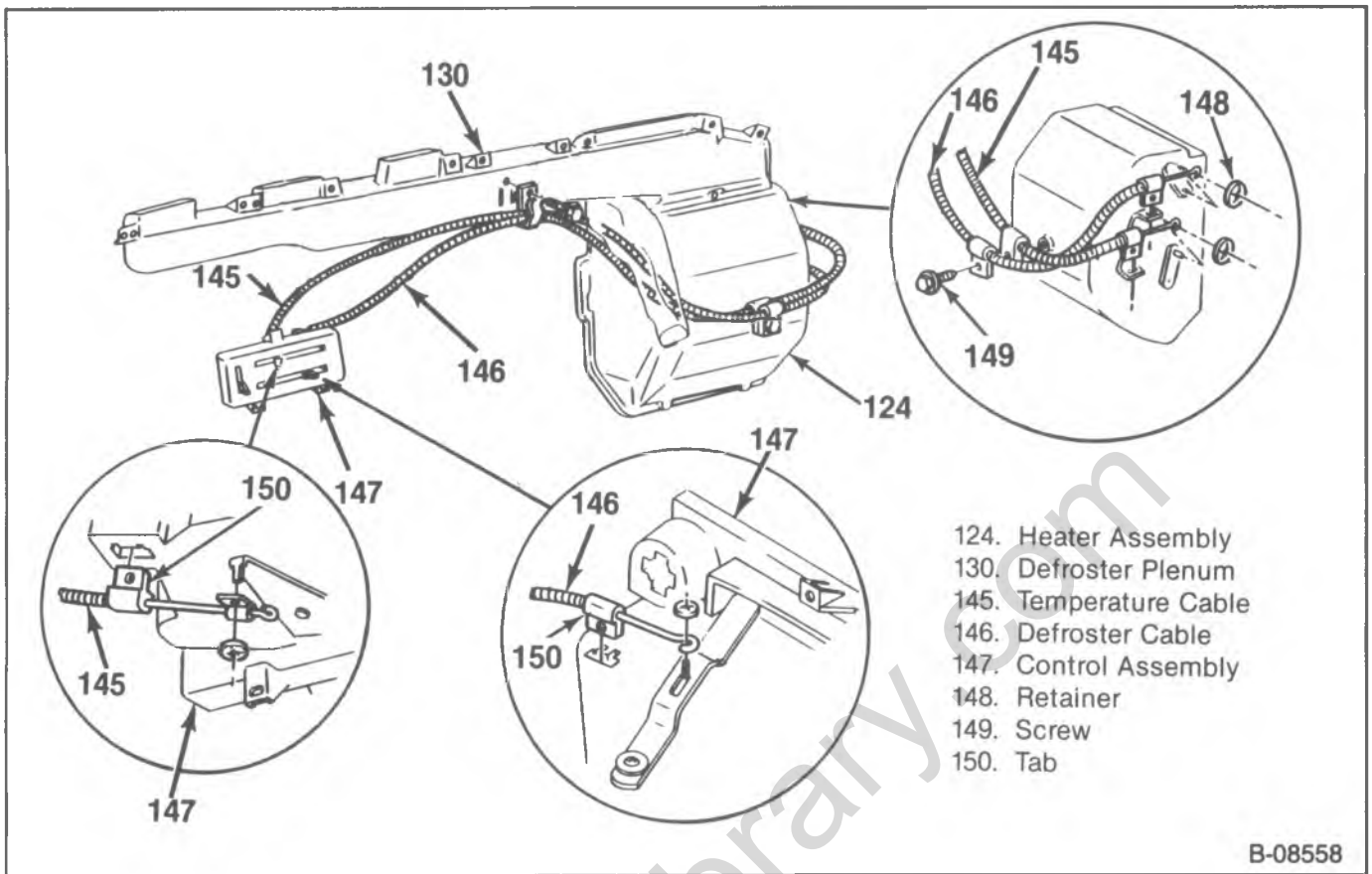

Figure 24—Control Assembly and Cables

Install or Connect (Figures 19 through 24)

1. Core (122) to the heater case (124).
 - Apply a bead of sealer between the core and the case.
2. Core retaining straps (123).
3. Heater case (124) to the vehicle.
 - Apply a bead of sealer between the heater case and the opening in the vehicle.
 - Tilt the case until the core tubes clear the cowl opening.
4. Temperature cable (145) to the heater case (124).
5. Distributor duct (134) to the heater case (124).
6. Defroster duct (130) to the heater case (124).
7. Instrument panel.
8. Steering column.
 - Refer to STEERING COLUMN (SEC. 3B4).
9. Engine housing cover.
 - Refer to INTERIOR TRIM (SEC. 10A4).
10. Heater core hoses (100 and 141).
11. Coolant recover tank.
12. Coolant to the radiator.
13. Leak test.

DISTRIBUTOR AND DEFROSTER DUCT REPLACEMENT

Remove or Disconnect (Figure 23)

1. Battery ground cable.
2. Raise the instrument panel at the right side.
3. Engine cover.
 - Refer to INTERIOR TRIM (SEC. 10A4).
 - Unsnap the engine cover front latches and remove the two cover-to-floor pan screws.
4. Distributor duct (134) from the heater case (124).
 - Pull the center distributor duct to the right.
5. Defroster duct (130).
 - Screws that hold the defroster duct to the instrument panel.

Install or Connect (Figure 23)

1. Defroster duct (130).
2. Distributor duct (134) to the heater case (124).
3. Engine cover.
 - Refer to INTERIOR TRIM (SEC. 10A4).
4. Instrument panel.
5. Battery ground cable.

CONTROL ASSEMBLY AND/OR BLOWER SWITCH REPLACEMENT

↔ Remove or Disconnect (Figures 15 and 24)

1. Battery ground cable.
2. Instrument panel bezel.
3. Control assembly (147) from the instrument panel.
 - Pull the control assembly out to reach the defroster (145) and temperature cables (146).
4. Defroster (145) and temperature cables (146).
5. Wiring harness to the blower switch and the illumination bulb.
6. Control assembly (147) from the vehicle.
7. Blower switch (56).

↔ Install or Connect (Figures 15 and 24)

1. Blower switch (56) to the control assembly (147).
2. Wiring harness to the blower switch (56) and the illumination bulb.
3. Defroster (145) and temperature (146) cables.
4. Control assembly (147) to the instrument panel.
5. Instrument panel bezel.
6. Battery ground cable.

CONTROL CABLE REPLACEMENT

↔ Remove or Disconnect (Figures 15 and 24)

1. Battery ground cable.
2. Instrument panel bezel.
 - For additional room, place the transmission shift lever in "low."
3. Control assembly (147) from the instrument panel.
4. Cable retainers (148) and tab screws (149).
 - Raise or lower the control assembly as necessary.
5. Cable (145 or 146) from the control assembly (147).
6. Instrument panel compartment.
7. Cable retainer (148) and tab screws at the heater case.

↔ Install or Connect (Figures 15 and 24)

1. Cable (145 or 146) to the heater assembly (124).
 - Retaining clip (150) and screw (149).
 - Retainers (148).
2. Instrument panel compartment.
3. Cable (145 or 146) to the control assembly (147).
 - Retaining clip (150) and screw (149).
 - Retainer (148).
4. Control assembly (147) to the instrument panel.
5. Instrument panel bezel.
6. Battery ground cable.

CABLE ADJUSTMENT

🔑 Adjust (Figure 24)

1. Attach the inner cable and sheath to the instrument panel control.
2. Move the temperature cable (145) to cold.
3. Attach the loop on the inner cable to the temperature door (145 on the heater case (124).

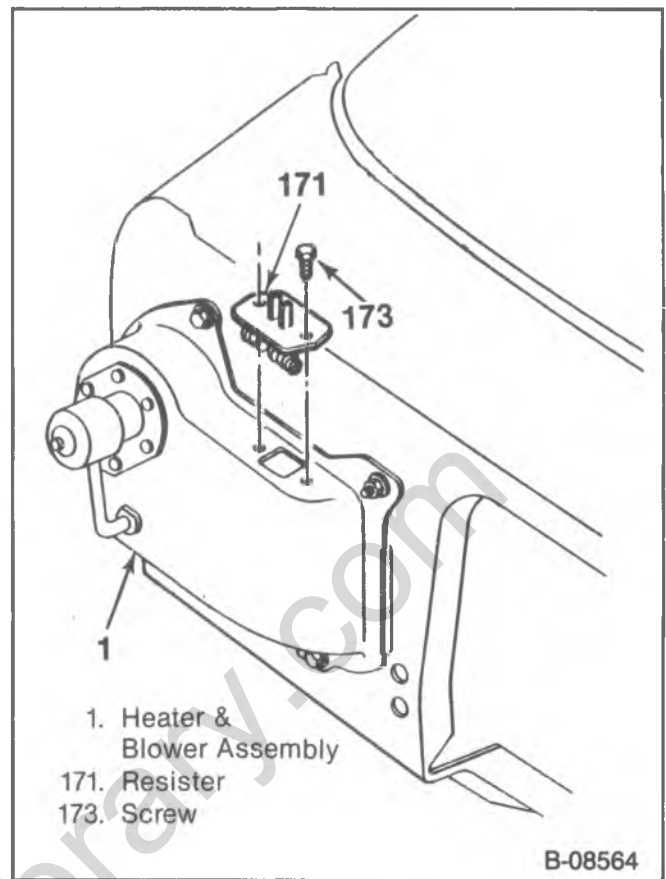

Figure 25—Resistor Replacement

4. Attach the cable sheath to the heater case (124).
5. Move the temperature lever to full heat. This will require force to slide the inner cable clip to its proper position.

RESISTOR REPLACEMENT

↔ Remove or Disconnect (Figure 25)

1. Battery ground cable.
2. Wiring harness from the resistor (171) (figure 25).
3. Screws (173).
4. Resistor (171).

↔ Install or Connect (Figure 25)

1. Resistor (171).
2. Screws (173).
3. Wiring harness to the resistor (171).
4. Battery ground cable.

VENT REPLACEMENT

↔ Remove or Disconnect (Figure 26)

1. Screws (204).
2. Valve assembly (202).

↔ Install or Connect (Figure 26)

1. Valve assembly (202).
2. Screws (204).

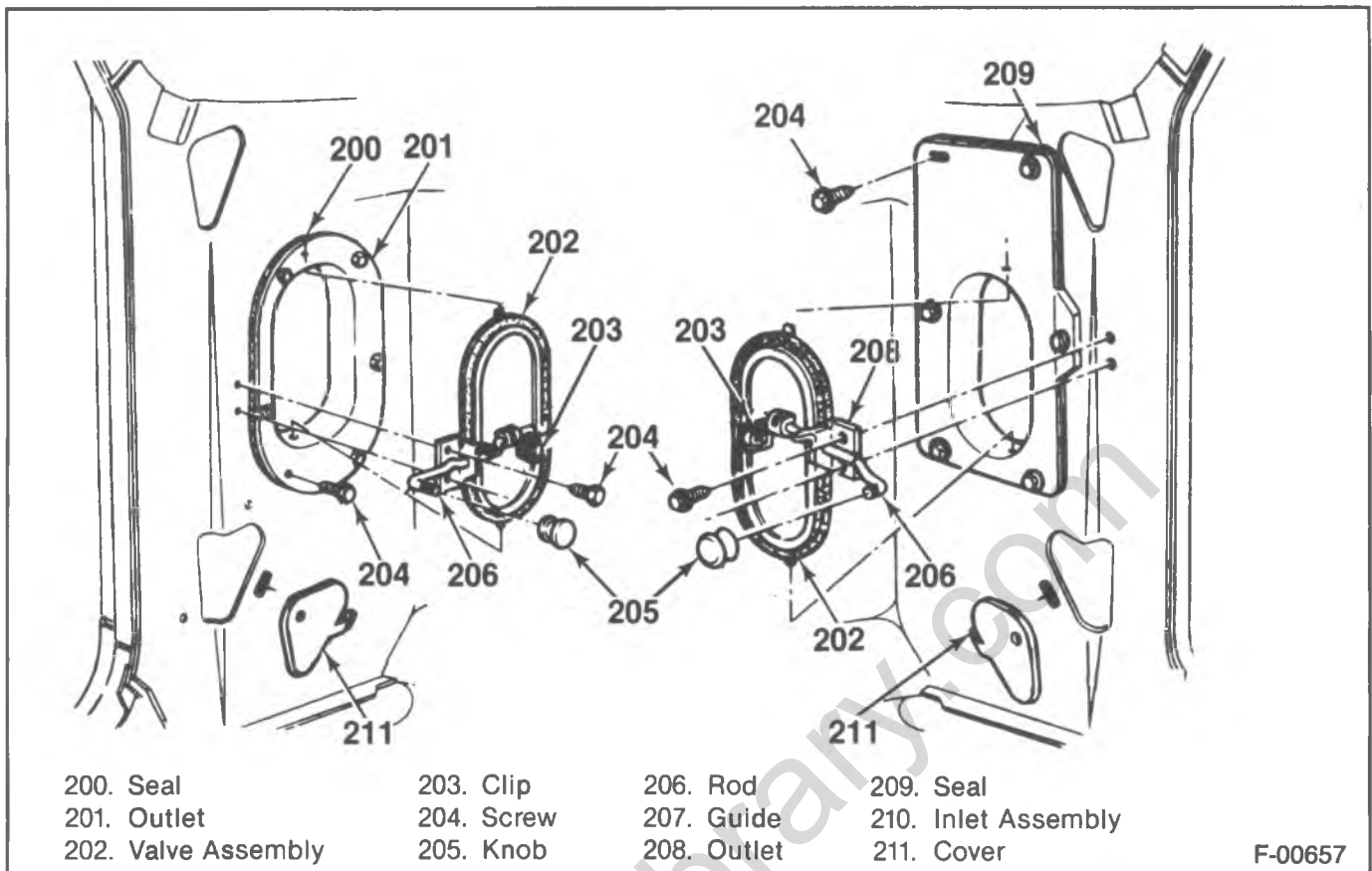

Figure 26—Vent Replacement

G SERIES AUXILIARY HEATER

DESCRIPTION

An auxiliary heater provides additional heating for the rear area of the vehicle.

It operates independently of the standard heater, and is regulated through its own control at the instrument panel.

This system consists of a separate core fan vent (figures 27 and 28).

Heater hoses extend from the unit to the front of the vehicle where they are connected to the standard heater hoses with "tees."

There are two control methods:

COOLANT-CONTROL VALVE

An "on-off" vacuum-operated, coolant-control valve installed in the heater core inlet in the engine compartment controls coolant flow to the auxiliary heater and eliminates radiant heat during warm weather. To diagnose the vacuum system refer to AIR CONDITIONING (SEC. 1B).

BLOWER SWITCH

For heating, the blower switch is placed in any position except off. The switch opens the coolant-control valve which permits hot coolant to enter the heater core. In the OFF position, the valve is closed to prevent unwanted heat during warm weather.

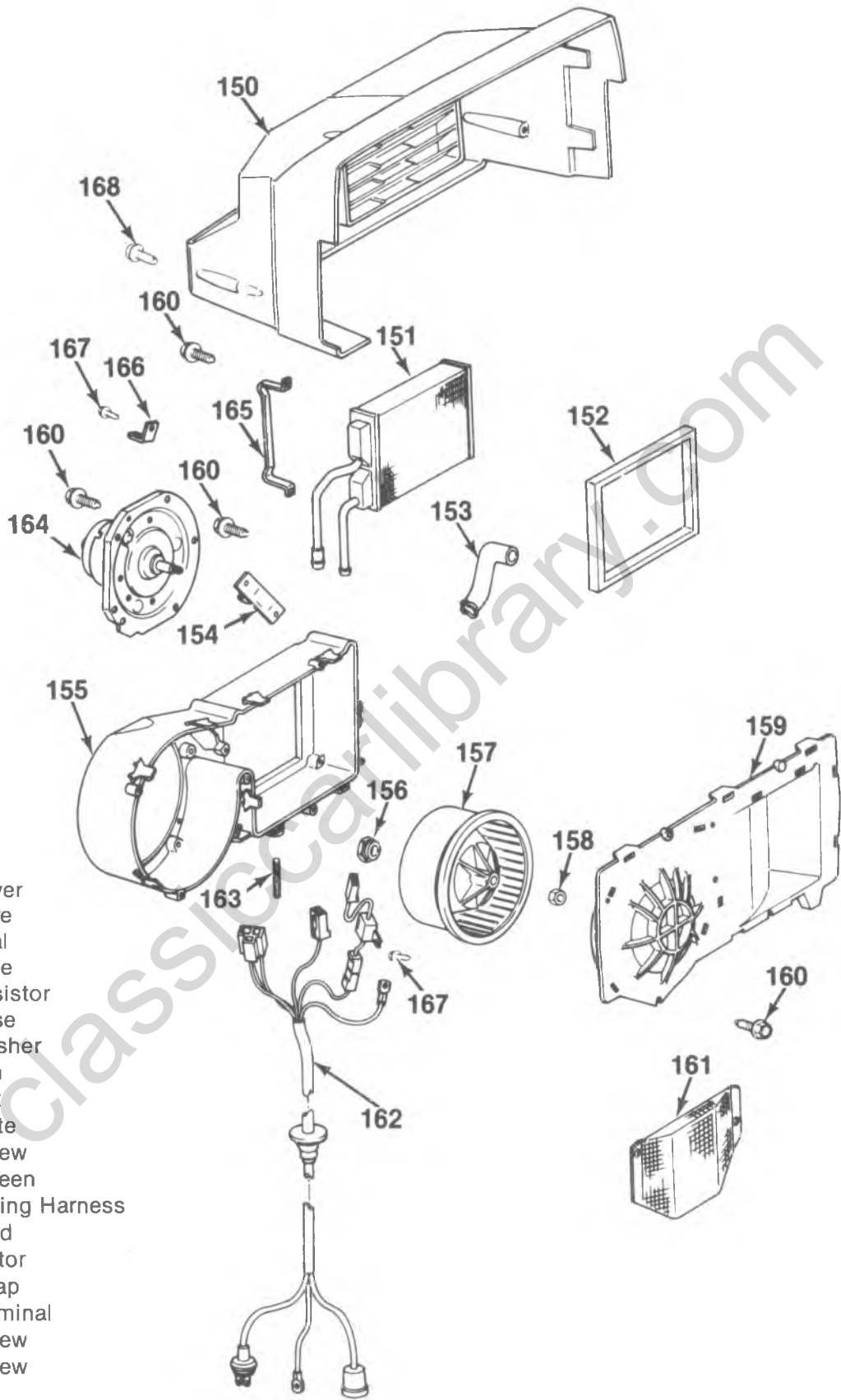

- 150. Cover
- 151. Core
- 152. Seal
- 153. Tube
- 154. Resistor
- 155. Case
- 156. Washer
- 157. Fan
- 158. Nut
- 159. Plate
- 160. Screw
- 161. Screen
- 162. Wiring Harness
- 163. Stud
- 164. Motor
- 165. Strap
- 166. Terminal
- 167. Screw
- 168. Screw

Figure 27—Auxillary Heater Component View

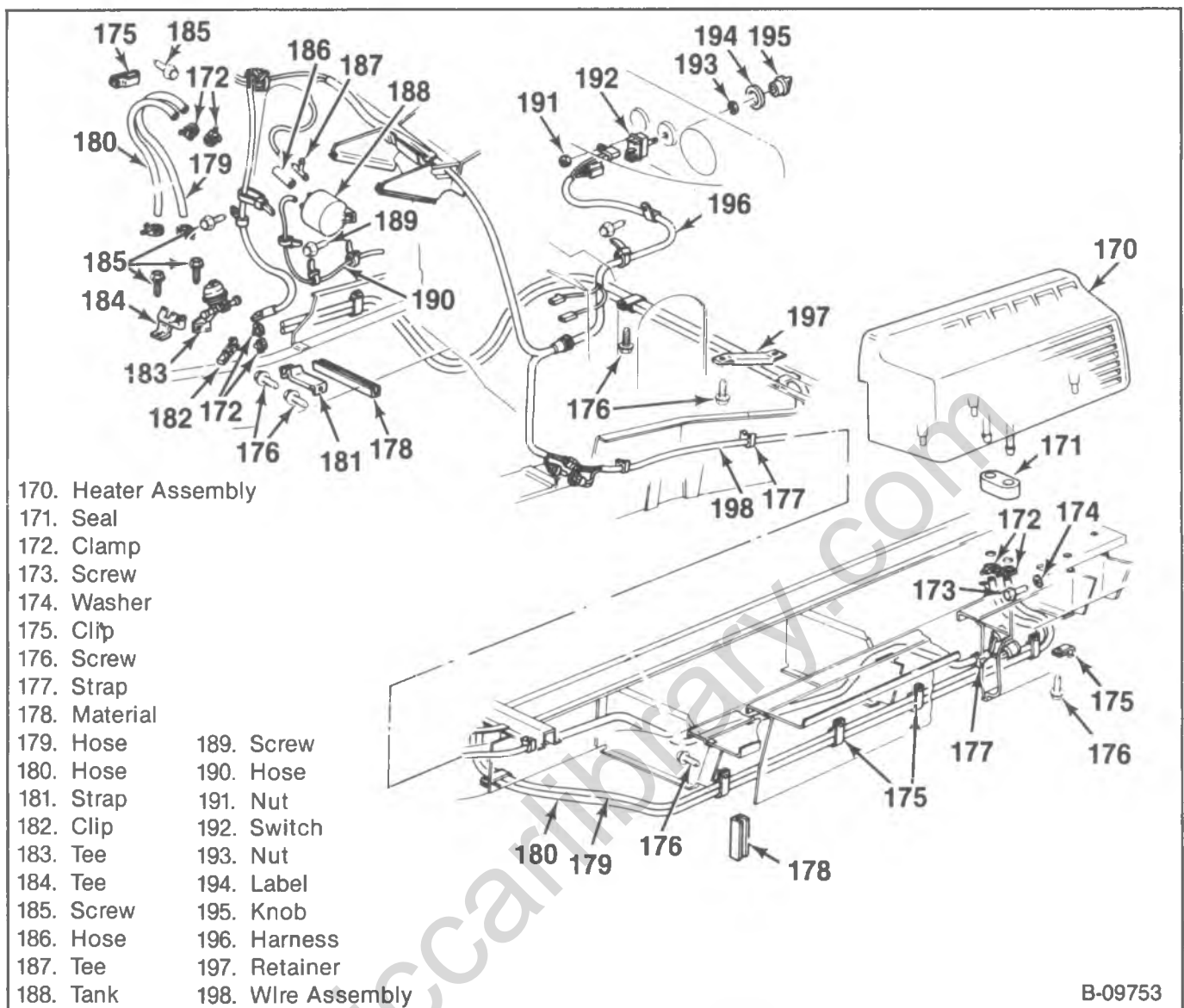

Figure 28—Auxiliary Heater Plumbing Component View

DIAGNOSIS

To diagnose the auxiliary heater, refer to "Insufficient Heat Diagnosis," "Heater Circuit Diagnosis" and "Diagnosis of the Heater System."

ON-VEHICLE SERVICE

BLOWER MOTOR REPLACEMENT

←→ Remove or Disconnect (Figure 27)

1. Battery ground cable.
2. Screws (168).
3. Cover (150).
4. Wiring harness to the motor (162).
5. Screws (160).
6. Motor (164) and fan (157) assembly.
7. Nut (158) from the motor (164).
8. Fan (157) from the motor (164).
9. Motor (164).

→← Install or Connect (Figure 28)

1. Fan (157) to the motor (164).
2. Nut (158) to the motor (164) shaft.
3. Motor (164), fan (157) and nut (158) to the case (155).
 - Apply a bead of sealer to the motor (164) flange.
4. Screws (160).
5. Wiring harness (162) to the motor (168).
6. Cover (150).
7. Screws (168).
8. Battery ground cable.

HEATER CORE REPLACEMENT

↔ Remove or Disconnect (Figures 27 and 28)

1. Coolant from the radiator.
2. Battery ground cable.
3. Clamps (172) from the coolant hoses (179 and 180).
4. Coolant hoses (179 and 180) from the core (151).
5. Studs (163) from the case (155).
6. Screws (168).
7. Cover (150).
8. Wiring harness (162) from the motor (164) and the resistor (154).
9. Case (155) and plate (159) from the vehicle.
10. Screws (160).
11. Plate (159) from the case (155).
12. Seal (152).
13. Core (151).

↔ Install or Connect (Figures 27 and 28)

1. Core (151) to the case (155).
2. Seal (152) to the case (155).
3. Plate (159) to the case (155).
4. Screws (160).
5. Case (155) and plate (159) to the vehicle.
6. Wiring harness (162) to the motor (164) and the resistor (154).
7. Cover (150).
8. Screws (168).
9. Coolant hoses (179 and 180) to the case (155).
10. Clamps (172) to the coolant hoses (179 and 180).
11. Studs (163) to the case (155).
12. Battery ground cable.
13. Coolant to the radiator.
14. Leak test.

COOLANT CONTROL VALVE REPLACEMENT

The coolant-control valve is attached to the right side of the cowl in the engine compartment.

↔ Remove or Disconnect (Figure 28)

1. Coolant from the radiator.
2. Coolant hoses.
3. Vacuum line.
4. Screws.
5. Valve (183).

↔ Install or Connect (Figure 28)

1. Valve (183).
2. Screws.
3. Vacuum line.
4. Coolant hoses.
5. Coolant to the radiator.

RESISTOR REPLACEMENT

↔ Remove or Disconnect (Figure 28)

1. Battery ground cable.
2. Screws (168).
3. Cover (150).
4. Wiring harness (162) to the resistor (154).
5. Resistor (154).

↔ Install or Connect (Figure 28)

1. Resistor (154).
2. Wiring harness (169) to the resistor (154).
3. Cover (155).
4. Screws (168).
5. Battery ground cable.

SPECIFICATIONS

		HEATER		
		Volts	Amps. (Cold)	RPM (Cold)
Blower Motor				
R/V Series	13.5	6.25 Max.	2550 Min. 2950 Max.
G Series	13.5	7.1 Max.	2850 Min. 3250 Max.
Fuses				
R/V Series20 Amp.
G Series20 Amp.

AUXILIARY HEATER

	Volts	Amps. (Cold)	RPM (Cold)
Blower Motor	13.5	9.6 Max.	2700 Min.

SECTION 1B

AIR CONDITIONING

CONTENTS

<u>SUBJECT</u>	<u>PAGE</u>
Description	1B- 3
CCOT A/C System	1B- 3
Rear Interior Roof Mounted Systems (Suburban & G Series)	1B- 3
System Components	1B- 4
Periodic Maintenance and Servicing	1B- 4
System Operation — RV & G	1B- 4
Functional Test — R/V & G	1B- 4
Refrigerant-12 Operating Characteristics	1B- 9
System Components and Temperature and Pressure Relationships	1B- 9
Refrigerant and Oil Capacity	1B- 9
Handling Refrigerant-12	1B- 9
Handling Refrigerant Lines and Fittings	1B- 9
Maintaining Chemical Stability	1B- 9
Refrigerant System Diagnosis	1B-11
Insufficient Cooling “Quick-Check” Procedure	1B-11
System Performance Test	1B-11
Testing the Refrigerant System	1B-11
Leak Testing the Refrigerant System	1B-13
Pressure Sensing Switch	1B-13
Electrical/Vacuum Trouble Diagnosis	1B-18
Operational Test	1B-18
Vacuum System Diagnosis	1B-23
R/V and G Series	1B-23
Evacuating and Charging Procedures	1B-23
Evacuation and Charging Procedures	1B-23
Discharging, Evacuating, Adding Oil, Charging Procedures	1B-23
Discharging the System	1B-24
Refrigerant Oil Distribution	1B-24
Evacuating and Charging	1B-25
Gage Calibration	1B-26
Vacuum System Check	1B-26
Charging Station Method	1B-26
Disposable Can or Multi-Can Method	1B-26
Refrigerant Drum Method	1B-26
Charging the System	1B-26
Accumulator Assembly	1B-27
Specific Component Diagnosis	1B-27
Compressor	1B-27
Condenser	1B-27
Expansion Valve	1B-27
Evaporator	1B-27
Refrigerant Line Restrictions	1B-28
Refrigerant-11 Flushing Procedure	1B-28
On-Vehicle Service	1B-29
Compressor Replacement (R/V)	1B-29
Compressor Replacement (G)	1B-30

CONTENTS (CONTINUED)

SUBJECT	PAGE
A/C System—R/V Series	1B-34
Condenser Replacement	1B-34
Accumulator Replacement	1B-35
Blower Assembly Replacement	1B-35
Evaporator Core Replacement	1B-36
Orifice (Expansion Tube) Replacement	1B-36
Selector Duct and Heater Core Replacement	1B-36
Actuator-Plenum Side Vent Replacement	1B-37
Plenum Valve Replacement	1B-37
Control Assembly Replacement	1B-39
Temperature Door Cable Adjustment	1B-40
Blower Switch Replacement	1B-40
Vacuum Tank Replacement	1B-41
Blower Motor Resistor Replacement	1B-41
Blower Motor Relay Replacement	1B-41
Fuse Replacement	1B-43
Vacuum Line Replacement — Engine Compartment	1B-43
Vacuum Line Replacement — Dash	1B-43
Refrigerant-12 Hose Routing	1B-43
Rear Interior Roof Mounted System—Suburban	1B-46
Rear Duct Replacement	1B-46
Blower Motor Resistor Replacement	1B-46
Blower Motor Assembly Replacement	1B-49
Expansion Valve Replacement	1B-49
Evaporator Core Replacement	1B-49
Blower Motor Switch Replacement	1B-50
Fuse Replacement	1B-50
A/C System—G Series	1B-50
Condenser Replacement	1B-50
Accumulator Replacement	1B-50
Heater Core Replacement	1B-51
Orifice (Expansion Tube) Replacement	1B-53
Blower Motor Insulation (w/Diesel) Replacement	1B-53
Evaporator Core (w/Diesel) Replacement	1B-53
Evaporator Core Replacement	1B-53
Blower Motor Replacement	1B-54
Control Assembly Replacement	1B-55
Temperature Door Cable Adjustment	1B-55
Blower Switch Replacement	1B-57
Resistor Replacement	1B-57
Blower Motor Relay Replacement	1B-57
A/C Ductwork Replacement	1B-57
Defroster Duct Replacement	1B-57
Temperature Door Cable Replacement	1B-57
Vacuum Tank Replacement	1B-57
Vacuum Lines-Engine Compartment	1B-57
Refrigerant-12 Hose Routing	1B-58
Rear Interior Roof Mounted Systems—G Series	1B-63
A/C System—P Series	1B-65
Specifications	1B-66
Special Tools	1B-68

DESCRIPTION

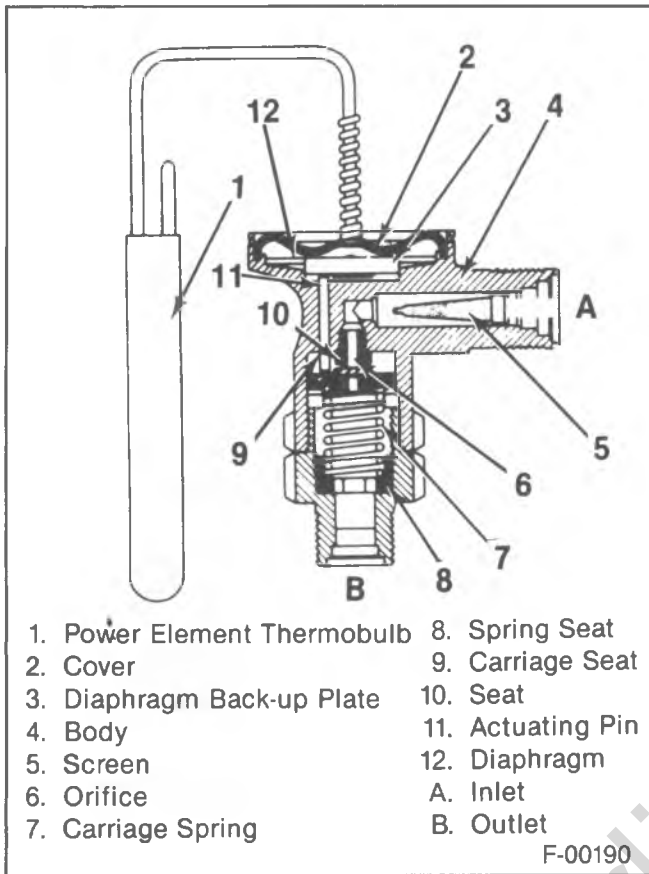

Figure 1—Thermostatic Expansion Valve

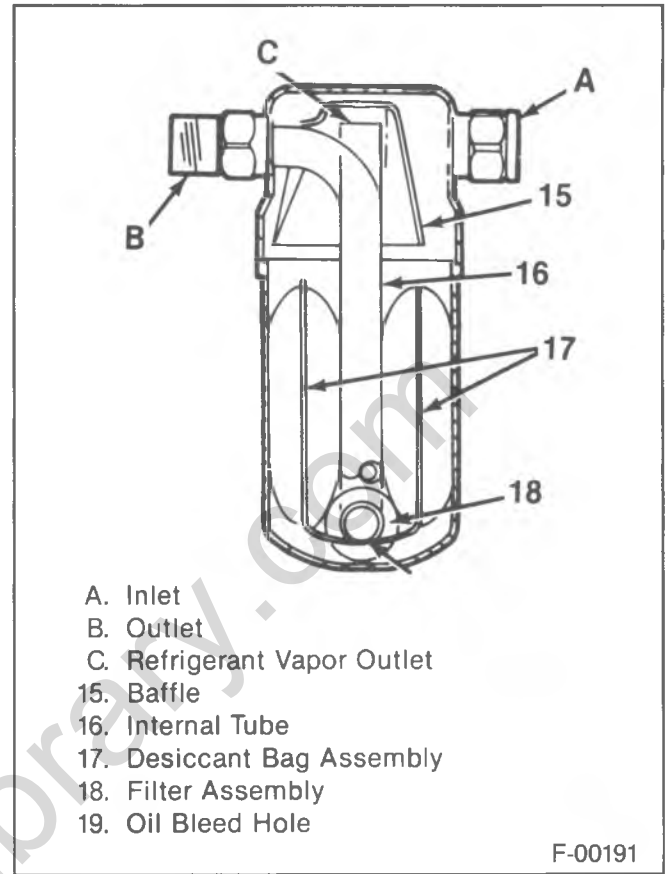

Figure 2—Accumulator R/V & G Series

CCOT A/C SYSTEM

The CCOT (Cycling Clutch Orifice Tube) A/C system performs heating and cooling. Air enters the vehicle and passes through the cooling unit (evaporator) and through (or around) the heating unit. The system is called a "reheat" system. The evaporator cools the air passing through the core when the air conditioning system is in the cooling mode.

On R/V and G series, a pressure sensing switch, located near the top of the accumulator, controls compressor operation. The switch responds to pressure changes to turn the compressor ON or OFF.

System operation:

Outside air or recirculated air enters the system and is forced through the system by the blower. As the air passes through the evaporator core, it receives maximum cooling if the air conditioning controls are positioned for cooling.

From the evaporator, the air enters the heater and air conditioner selector duct assembly where, by means of diverter doors, it passes through or bypasses the heater core in proportions necessary to provide the desired outlet temperature. The air enters the vehicle through either the floor distributor duct or the dash outlets.

During cooling, the air is cooled by the evaporator to below comfort level then warmed by the heater to the desired temperature. During "heating only" the evaporator does not operate, and ambient air is warmed to the desired level in the same manner.

REAR INTERIOR ROOF MOUNTED SYSTEMS (SUBURBAN & G SERIES)

These systems operate with the front system - they do not operate independently. However, control of the rear

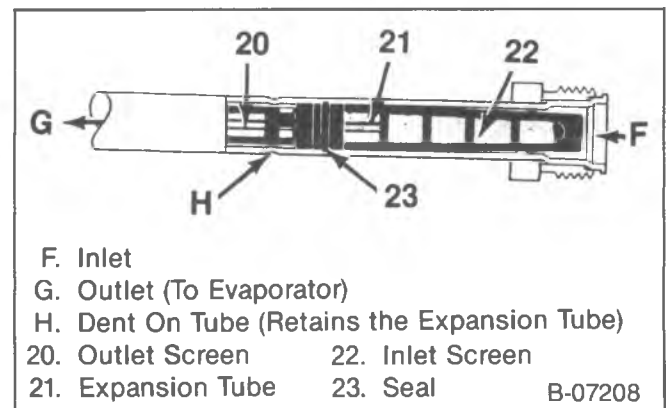

Figure 3—Orifice (Expansion Tube)

1B-4 AIR CONDITIONING

blower motor speed is possible when the front system is OFF. Rear air circulation without the refrigerant function is possible by operating the rear blower control switch.

These self-contained units operate on inside (recirculated) air. Air enters the unit and passes through the evaporator core into the passenger compartment through the air distributor duct. The front system controls the rear system. A three-speed blower switch controls the rear interior roof mounted system.

SYSTEM COMPONENTS

THERMOSTATIC EXPANSION VALVE

Suburban and G rear interior roof mounted and motor home chassis systems use a thermostatic expansion valve (figure 1).

The valve consists of the power element, body, actuating pins, seat and orifice. At the high pressure liquid inlet, a fine mesh screen prevents dirt, filings or other foreign matter from entering the valve orifice.

When the valve is connected in the system, high pressure liquid refrigerant enters the valve through the screen from the receiver-dehydrator or condenser and passes on to the seat and orifice where it changes into a low pressure liquid.

The low pressure liquid leaves the valve and flows into the evaporator core where it absorbs heat from the evaporator core and changes to a low pressure vapor and leaves the evaporator core. The power element bulb is clamped to the low pressure vapor line just beyond the outlet of the evaporator.

ACCUMULATOR R/V & G SERIES

The accumulator is located at the evaporator outlet. It separates liquid retained from vapor, retains the liquid and releases the vapor to the compressor (figure 2).

Flow from the accumulator to the compressor consists of vapor, entrained liquid and liquid flow through the oil bleed hole.

A bag of desiccant (dehydrating agent), located in the accumulator, collects moisture.

There is no sight glass in the accumulator with the CCOT system.

ORIFICE (EXPANSION TUBE) R/V & G SERIES

Pressure differences and sub-cooling determines expansion tube flow. The orifice is located in the evaporator inlet line (figure 3).

CYCLING PRESSURE SWITCH

This switch controls evaporator temperature. It cycles the compressor clutch off when the evaporator temperature gets too low. It cycles the compressor back on after evaporator temperature has increased (figure 4).

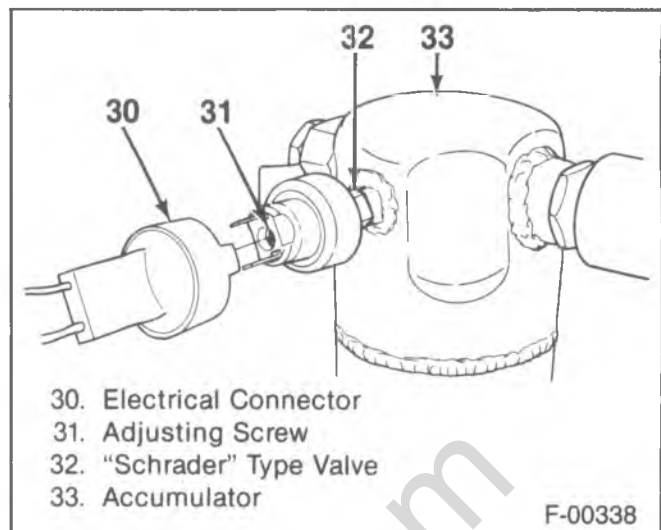

Figure 4—Pressure Cycling Switch

The cycling pressure switch provides inherent compressor protection so a separate low pressure switch is not necessary. The switch also acts as an ambient switch since at ambient freezing temperatures it will not allow the compressor to engage. Adjusting the set screw one-half turn left or right will rise or lower the settings 20.7 kPa (3 psi).

Cycling Pressure Switch Setting (Accumulator Readings)

Compressor Cut Out Pressure

Range71-81 kPa (21-24 psi)

Compressor Cut In Pressure

Range145.2-165.4 kPa (43-49 psi)

PERIODIC MAINTENANCE AND SERVICING

Inspect the system once a year, preferably in the spring before warm weather.

Check refrigerant lines for leaks.

Check refrigerant charge; evaluate and recharge as necessary.

SYSTEM OPERATION — RV & G

For information on selector switch, select valve and fan switch operating characteristic, refer to figures 5 and 6.

FUNCTIONAL TEST—RV & G

To check the operation of the control assembly, perform these tests as one complete operation, refer to figures 7 and 8.

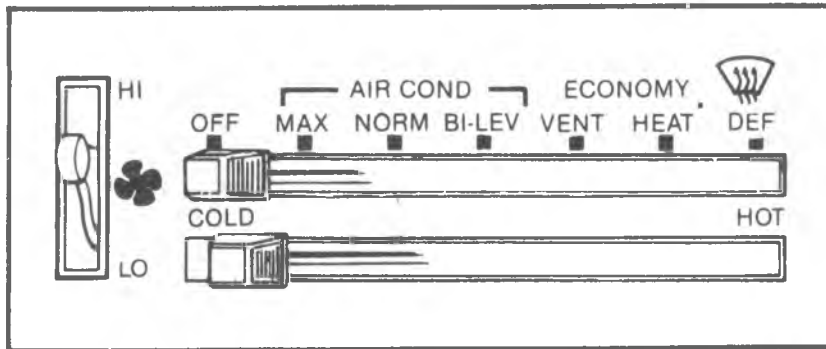

SELECTOR SWITCH OPERATING CHART

CONNECTION	TERMINAL NUMBER	OFF	MAX A/C	NORM A/C	BI-LEV A/C	VENT	HEATER	DEFROST
FAN SWITCH	2	NONE	3, 5	3, 5	3, 5	5	5	3, 5
COMPRESSOR	3	NONE	2, 5	2, 5	2, 5	NONE	NONE	2, 5
NOT USED	4	NOT USED						
BATTERY +	5	NONE	2, 3	2, 3	2, 3	2	2	2, 3

SELECT VALUE OPERATING CHART

CONNECTION	PORT	OFF	MAX A/C	NORM A/C	BI-LEV A/C	VENT	HEATER	DEFROST
INPUT	1	3	2, 4	2	NONE	2	3	3, 5
A/C MODE	2	VENT	1, 4	1	VENT	1	VENT	VENT
HTR MODE	3	1	VENT	VENT	VENT	VENT	1	1, 5
OUTSIDE AIR/ RECIRCULATION	4	VENT	1, 2	VENT	VENT	VENT	VENT	VENT
DEFROST	5	VENT	VENT	VENT	VENT	VENT	VENT	VENT
NOT USED	6	SEALED IN THE CONNECTOR						

BLOWER SWITCH

TERMINAL	POSITIONS			
	LO	MEDIUM 1	MEDIUM 2	HI
BATTERY +	NONE	MEDIUM 1	MEDIUM 2	HI
HI	NONE	NONE	NONE	BATTERY +
MEDIUM 1	NONE	BATTERY +	NONE	NONE
MEDIUM 2	NONE	NONE	BATTERY +	NONE

B-08404

Figure 5—System Operation — R/V

1B-6 AIR CONDITIONING

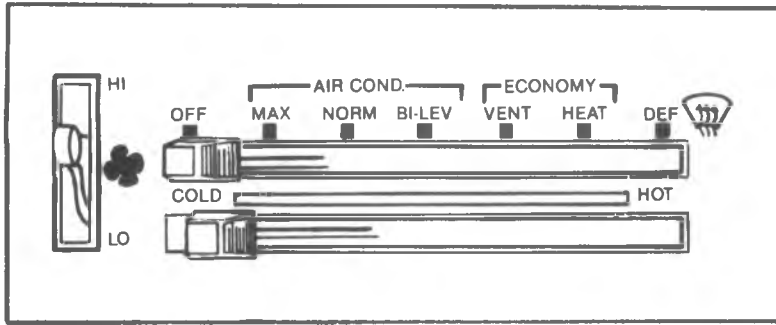

SELECTOR SWITCH OPERATING CHART

CONNECTION	TERMINAL NUMBER	OFF	MAX A/C	NORM A/C	BI-LEV A/C	VENT	HEATER	DEFROST
FAN SWITCH	2	NONE	3, 5	3, 5	3, 5	5	5	3, 5
COMPRESSOR	3	NONE	2, 5	2, 5	2, 5	NONE	NONE	2, 5
NOT USED	4	NOT USED						
BATTERY +	5	NONE	2, 3	2, 3	2, 3	2	2	2, 3

SELECT VALUE OPERATING CHART

CONNECTION	PORT	OFF	MAX A/C	NORM A/C	BI-LEV A/C	VENT	HEATER	DEFROST
	1	NOT USED — SEALED IN THE CONNECTOR						
OUTSIDE AIR/ RECIRCULATION	2	VENT	VACUUM	VENT	VENT	VENT	VENT	VENT
HEAT - DEF	3	VACUUM	VACUUM	VACUUM	VACUUM	VACUUM	VACUUM	VENT
INPUT	4	VACUUM	VACUUM	VACUUM	VACUUM	VACUUM	VACUUM	VACUUM
A/C MODE	5	VENT	VACUUM	VACUUM	VENT	VACUUM	VENT	VENT
	6	NOT USED — SEALED IN THE CONNECTOR						
	7	NOT USED — SEALED IN THE CONNECTOR						
	8	NOT USED — SEALED IN THE CONNECTOR						
BI-LEVEL	9	VENT	VACUUM	VACUUM	VACUUM	VACUUM	VENT	VENT

BLOWER SWITCH

TERMINAL	POSITIONS			
	LO	MEDIUM 1	MEDIUM 2	HI
BATTERY +	NONE	MEDIUM 1	MEDIUM 2	HI
HI	NONE	NONE	NONE	BATTERY +
MEDIUM 1	NONE	BATTERY +	OPTIONAL	NONE
MEDIUM 2	NONE	NONE	BATTERY +	OPTIONAL

B-08715

Figure 6—System Operation — G

R/V Functional Test — Air Conditioning

Perform this test as one operation by one inspector in one station—off roll test.

STEP	CONTROL SETTINGS			SYSTEM RESPONSE				
	MODE CONTROL	TEMPERATURE CONTROL	FAN SWITCH	BLOWER SPEED	HEATER OUTLETS	A/C OUTLETS	DEFROSTER OUTLETS	SEE REMARKS
1	OFF	COLD	OFF	OFF	NO AIR FLOW	NO AIR FLOW	NO AIR FLOW	
2	MAX	COLD	LO	LOW	NO AIR FLOW	AIR FLOW	NO AIR FLOW	A
3	MAX	COLD	LO TO HI	LOW TO HI	NO AIR FLOW	AIR FLOW	NO AIR FLOW	B
4	NORM	COLD	LO TO HI	LO TO HI	NO AIR FLOW	AIR FLOW	NO AIR FLOW	B
5	BI-LEV	COLD	HI	HI	AIR FLOW	AIR FLOW	MIN AIR FLOW	A
6	VENT	COLD	HI	HI	NO AIR FLOW	AIR FLOW	NO AIR FLOW	A
7	HTR	HOT	HI	HI	AIR FLOW	NO AIR FLOW	MIN AIR FLOW	A, D
8		HOT	HI	HI	MIN AIR FLOW	NO AIR FLOW	AIR FLOW	A

REMARKS

- A. Detent engagement must be felt in each mode.
- B. Blower speed increase must occur from low, medium 1, medium 2, and high.
- C. Listen for the reduction of air noise due to recirculation door closing.
- D. Check temperature lever for effort.

NOTE Check outlets for:

- 1. Barrel rotation.
- 2. Vane operation.
- 3. Barrel and vanes must hold position in high blower.

Cold/Hot Air Check

- 1. With the mode lever in maximum, the temperature lever in cold, the blower switch in high, the temperature from the center outlet should drop 20° from the temperature outside the vehicle (in room temperature or warmer conditions).
- 2. With the mode lever in (defrost), the temperature lever in hot, the blower switch in high, the temperature from the defrost outlet should be above the temperature outside the vehicle.

B-08705

Figure 7—Functional Test — R/V

1B-8 AIR CONDITIONING

G Functional Test — Air Conditioning

Perform this test as one operation by one inspector in one station—off roll test.

STEP	CONTROL SETTINGS			SYSTEM RESPONSE				SEE REMARKS
	MODE CONTROL	TEMPERATURE CONTROL	FAN SWITCH	BLOWER SPEED	HEATER OUTLETS	A/C OUTLETS	DEFROSTER OUTLETS	
1	OFF	COLD	OFF	OFF	NO AIR FLOW	NO AIR FLOW	NO AIR FLOW	
2	MAX	COLD	LO	LOW	NO AIR FLOW	AIR FLOW	NO AIR FLOW	A
3	MAX	COLD	LO TO HI	LOW TO HI	NO AIR FLOW	AIR FLOW	NO AIR FLOW	B
4	NORM	COLD	HI	HI	NO AIR FLOW	AIR FLOW	NO AIR FLOW	A, C
5	BI-LEV	COLD	HI	HI	AIR FLOW	AIR FLOW	NO AIR FLOW	A
6	VENT	COLD	HI	HI	NO AIR FLOW	AIR FLOW	NO AIR FLOW	A
7	HTR	HOT	HI	HI	AIR FLOW	NO AIR FLOW	MIN AIR FLOW	A, D
8		HOT	HI	HI	MIN AIR FLOW	NO AIR FLOW	AIR FLOW	A

REMARKS

- A. Detent engagement must be felt in each mode.
- B. Blower speed increase must occur from low, medium 1, medium 2, and high.
- C. Listen for the reduction of air noise due to recirculation door closing.
- D. Check temperature lever for effort.

NOTE Check outlets for:

1. Barrel rotation.
2. Vane operation.
3. Barrel and vanes must hold position in high blower.

Cold/Hot Air Check

1. With the mode lever in maximum, the temperature lever in cold, the blower switch in high, the temperature from the center outlet should drop 20° from the temperature outside the vehicle (in room temperature or warmer conditions).
2. With the mode lever in (defrost), the temperature lever in hot, the fan switch in high, the temperature from the defrost outlet should be above the temperature outside the vehicle.

B-08719

Figure 8—Functional Test — G

REFRIGERANT-12 OPERATING CHARACTERISTICS

SYSTEM COMPONENTS, TEMPERATURE AND PRESSURE RELATIONSHIPS

To review system components and Refrigerant-12 flow, refer to figure 9.

To find the pressure and temperature relationship between Refrigerant-12 and atmospheric pressure, refer to figure 10.

REFRIGERANT AND OIL CAPACITY

The refrigerant system requires refrigerant and oil in quantities listed:

1. Refrigerant-12 —

	C60 System
R/V Models	1.588 Kg (3 lbs. 8 ozs.)
G Models	1.588 Kg (3 lbs. 8 ozs.)
	Rear Interior System
R/V Models	2.381 Kg (5 lbs. 4 ozs.)
G Models	2.041 Kg (4 lbs. 8 ozs.)

2. 525 Viscosity Oil — 0.284 Kg (10 oz.).

HANDLING REFRIGERANT-12

Air conditioning systems contain Refrigerant-12, a chemical which requires special handling to avoid personal injury.

Always wear goggles and wrap a clean cloth around fittings, valves and connections when opening the system. Work in a ventilated area and do not weld or steam clean near air conditioning lines or components.

Refrigerant-12 drums are shipped with a metal screw cap that protects the valve and safety plug from damage. Replace the cap after each use.

Do not carry a container of Refrigerant-12 in the passenger compartment of a vehicle. Never subject any container to high temperatures. Do not breathe the smoke or fumes produced by burning Refrigerant-12.

If Refrigerant-12 touches exposed flesh do the following:

- Treat the area as if it were frost bitten or frozen.
- Call a doctor or eye specialist and obtain treatment.
- **DO NOT RUB THE EYE.** Splash the area with cold water to raise temperature above the freezing point.
- Use an antiseptic oil to provide a protective film over the eyeball to reduce the possibility of infection.

HANDLING OF REFRIGERANT LINES AND FITTINGS

Tighten tubing connections to the specified torque (figure 11). Insufficient or excessive torque causes loose joints or deformed joint parts. Either condition can cause refrigerant leakage.

- All metal tubing lines should be free of dents or kinks to prevent loss of system capacity due to a line restriction.

- Never bend a flexible hose line to a radius of less than 4 times the diameter of the hose.
- Never place a flexible hose line closer than 65 mm (2½-inch) to the exhaust manifold.
- Inspect flexible hose lines regularly for leaks or brittleness and replace if necessary.
- When disconnecting any fitting in the refrigeration system discharge the system. However proceed with caution. Open slowly. Keep face and hands away to prevent injury if there is liquid Refrigerant-12 in the line. Allow any pressure to bleed off as described under "Discharging, Evacuating, Adding Oil And Charging And Discharging The System."
- Cap or tape any line open to atmosphere to prevent dirt and moisture from entering the system.
- Use proper wrenches when making connections on seal (o-ring) fittings. Use two wrenches to prevent distorting the lines or components.
- When connecting the flexible hose connections, hold the swaged fitting, the flare nut and the coupling at the same time using three different wrenches to prevent turning the fitting and damaging the ground seat.
- Use seals (o-rings) in good condition. A burr or piece of dirt may cause a leak.
- Replace the seal when a connection has been broken. When replacing the seal first dip it in clean 525 viscosity refrigeration oil.
- When making steel to aluminum connections, use the torque for aluminum tubing. (Refer to figure 11).

MAINTAINING CHEMICAL STABILITY

The efficient operation of the air conditioning refrigeration system is dependent upon the chemical stability of Refrigerant-12.

Foreign matter can change the stability of Refrigerant-12, cause corrosion and wear. Do the following:

1. Before disconnecting a refrigerant connection, remove dirt or oil at and near the connection. Cap or plug both sides of the connection.
2. Keep tools clean and dry.
3. When adding 525 viscosity refrigerant oil (refer to ADDING OIL in the Discharging, Evacuating, Adding Oil and Charging Procedures for CCOT A/C systems), the transfer device and container should be clean and dry.
4. Have everything ready before opening a line. Do not leave the A/C system open longer than necessary.
5. After opening, evacuate before recharging with Refrigerant-12 according to the "Discharging, Evacuating, Adding Oil, Charging And Discharging The System."
6. Service parts are dehydrated and seated before shipping. Open just before making connections. Keep at room temperature before uncapping (this prevents moisture from entering the system). If the connections are not made, reseal the parts.

1B-10 AIR CONDITIONING

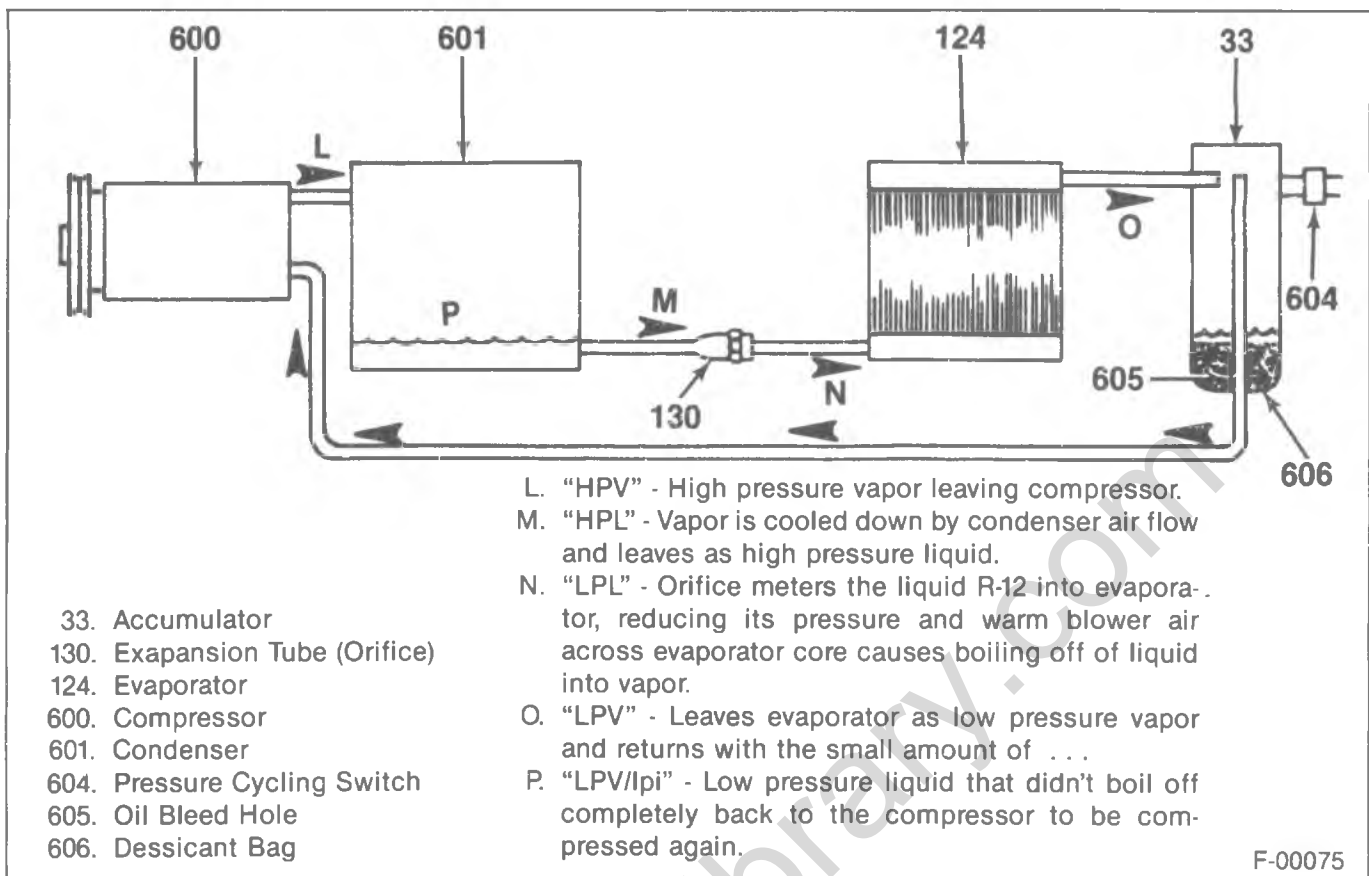

Figure 9—System Components

REFRIGERANT - 12 PRESSURE - TEMPERATURE RELATIONSHIP		°C	°F	kPa	PSIG	°C	°F	kPa	PSIG
		-29.8	21.7	0	Atmospheric	12.7	55	358.5	52.0
					Pressure	15.5	60	397.8	57.7
						18.3	65	439.2	63.7
The table below indicates the pressure of Refrigerant - 12 at various temperatures. For instance, a drum of Refrigerant at a temperature of 26.6°C (80°F) will have a pressure of 579.9 kPa (84.1 psi). If it is heated to 51.6°C (125°F), the pressure will increase to 1 154.9 kPa (167.5 psi). It also can be used conversely to determine the temperature at which Refrigerant - 12 boils under various pressures. For example, at a pressure of 207.5 kPa (30.1 psi), Refrigerant - 12 boils at 0°C (32°F).		-28.8	-20	16.5	2.4	21.1	70	482.7	70.1
		-23.3	-10	31.0	4.5	23.8	75	530.2	76.9
		-20.5	-5	46.9	6.8	26.6	80	579.9	84.1
		-17.7	0	63.4	9.2	29.4	85	632.3	91.7
		-15.0	5	81.4	11.8	32.2	90	686.7	99.6
		-12.2	10	101.4	14.7	35.0	95	745.3	108.1
		- 9.4	15	117.7	17.2	37.7	100	806.0	116.9
		- 6.6	20	145.5	21.1	40.5	105	870.2	126.2
		- 3.8	25	169.6	24.6	43.3	110	937.7	136.0
		- 1.1	30	196.5	28.5	46.1	115	1010.1	146.5
		0	32	207.5	30.1	48.8	120	1083.2	157.1
		1.6	35	224.8	32.6	51.6	125	1154.9	167.5
		4.4	40	255.1	37.0	54.4	130	1234.2	179.0
		7.2	45	287.5	41.7	60.0	140	1410.0	204.5
		10.0	50	322.0	46.7				

F-00177

Figure 10—Pressure Temperature Relationship of Refrigerant-12

Metal Tube Outside Diameter	Thread and Fitting Size	Steel Tubing Torque		Aluminum or Copper Tubing Torque		Nominal Torque Wrench Span
		N·m	LB. FT.	N·m	LB. FT.	
1/4	7/16	14-20	10-15	7-8	5-7	5/8
3/8	5/8	41-48	30-36	15-18	11-13	3/4
1/2	3/4	41-48	30-36	20-27	15-20	7/8
5/8	7/8	41-48	30-36	28-37	21-22	1 1/16
3/4	1 1/16	41-48	30-36	36-45	28-33	1 1/4

F-00161

Figure 11—Pipe and Hose Connections Torque

REFRIGERANT SYSTEM DIAGNOSIS

NOTICE: When performing air conditioning diagnosis on vehicles equipped with a catalytic converter, warm the engine to a normal operating temperature before attempting to idle the engine for periods greater than five minutes.

INSUFFICIENT COOLING “QUICK-CHECK” PROCEDURE

Use the following “Hand-Feel” procedure if the system has the proper charge of Refrigerant-12 (providing ambient temperature is above 21 °C (70 °F)).

1. Engine must be warm and at normal idle speed.
2. Hood and body doors open.
3. Selector (mode) lever set at NORM.
4. Temperature lever at COLD.
5. Blower on HI.
6. “Hand-Feel” the temperature of the evaporator inlet pipe after the orifice and accumulator with the compressor engaged.

— BOTH THE SAME TEMPERATURE AND SOME DEGREE COOLER THAN AMBIENT — Proper condition: check for other problems (refer to A/C System Diagnostic Procedure).

— INLET PIPE COOLER THAN ACCUMULATOR SURFACE indicates a low refrigerant charge.

- Add amounts 0.113 kg (4 oz.) of refrigerant UNTIL BOTH feel the same temperature. Allow stabilization time between additions.
- Then add 0.397 kg (.88 lbs.) one can additional refrigerant. The 0.397 kg/14 oz. disposable can of Refrigerant-12 is the equivalent to .88 lbs.).

SYSTEM PERFORMANCE TEST

Tool Required:

J-21213-A Four Jack-Dual Range Temperature Tester

1. Open doors or windows.
2. Position the right lever in the “NORM” mode.
3. Place the left lever in the cold (blue) position.
4. Place the blower switch at “HI.”
5. Install J-21213-A at the instrument panel right outlet.
6. Start the engine and run at 2000 rpm.
7. After one minute, the minimum drop in temperature from the center outlet should be:

Condenser Inlet Temperature	21°C (70°F)	26°C (80°F)	32-43°C (90-110°F)
Instrument Panel Right Outlet Temperature (Minimum Drop)	-7°C (20°F)	-4°C (25°F)	-1°C (30°F°)

TESTING THE REFRIGERANT SYSTEM

If a malfunction is suspected due to abnormal system pressures, check the following:

1. Outer radiator and condenser cores for plugging. Check between the condenser and radiator.
2. Restrictions or kinks in evaporator core or condenser core, hoses, tubes, etc.
3. Refrigerant leaks.
4. Air ducts for leaks or restrictions. Air restriction may indicate a plugged (or partially plugged) evaporator core.
5. Compressor clutch slippage.
6. Improper drive belt tension.

1B-12 AIR CONDITIONING

INSUFFICIENT COOLING — A/C SYSTEMS WITH CYCLING CLUTCH — EXPANSION TUBE (PRESSURE SENSING)

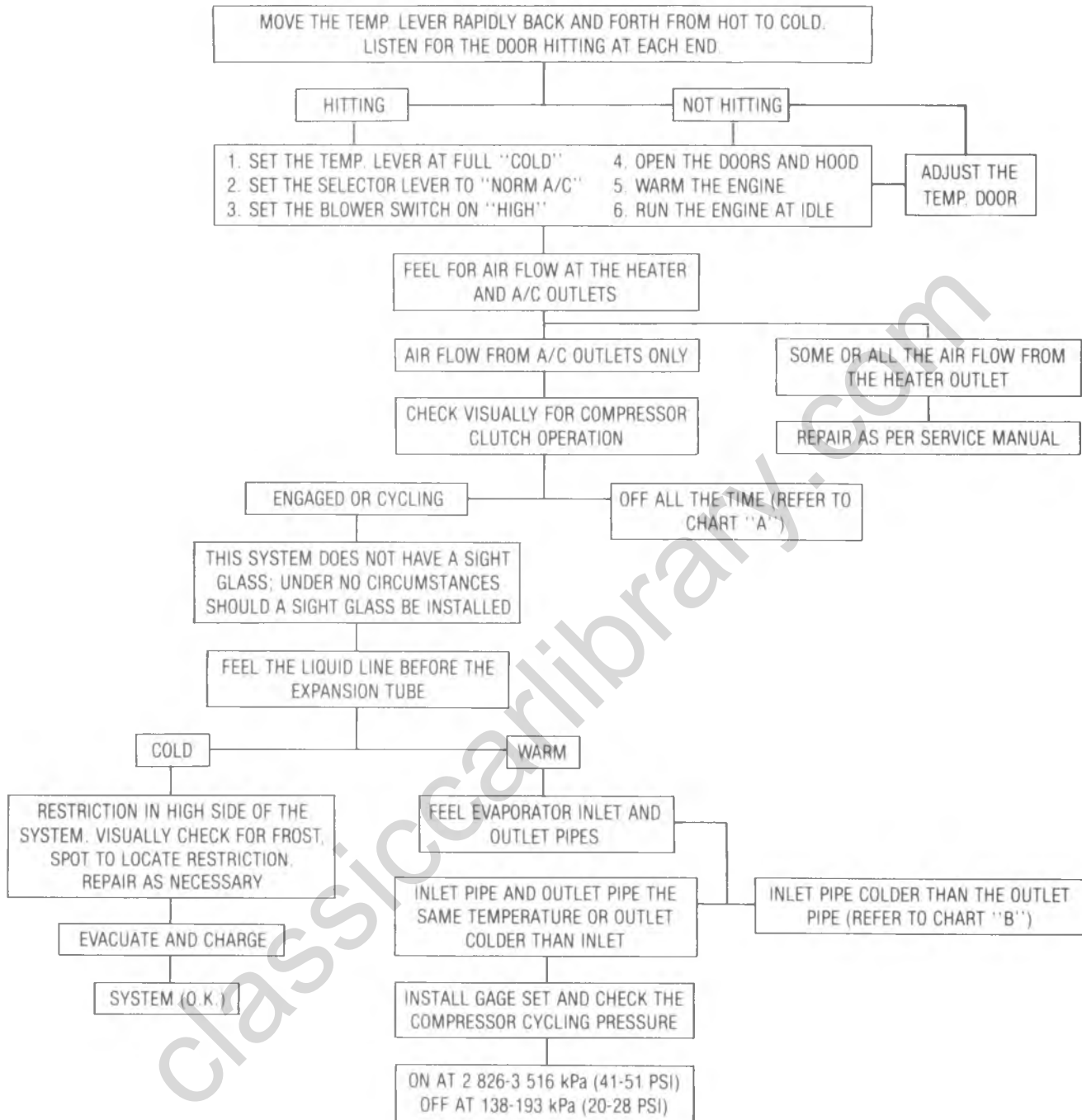

CONTINUED ON FOLLOWING PAGE

Figure 12—Insufficient Cooling Diagnosis

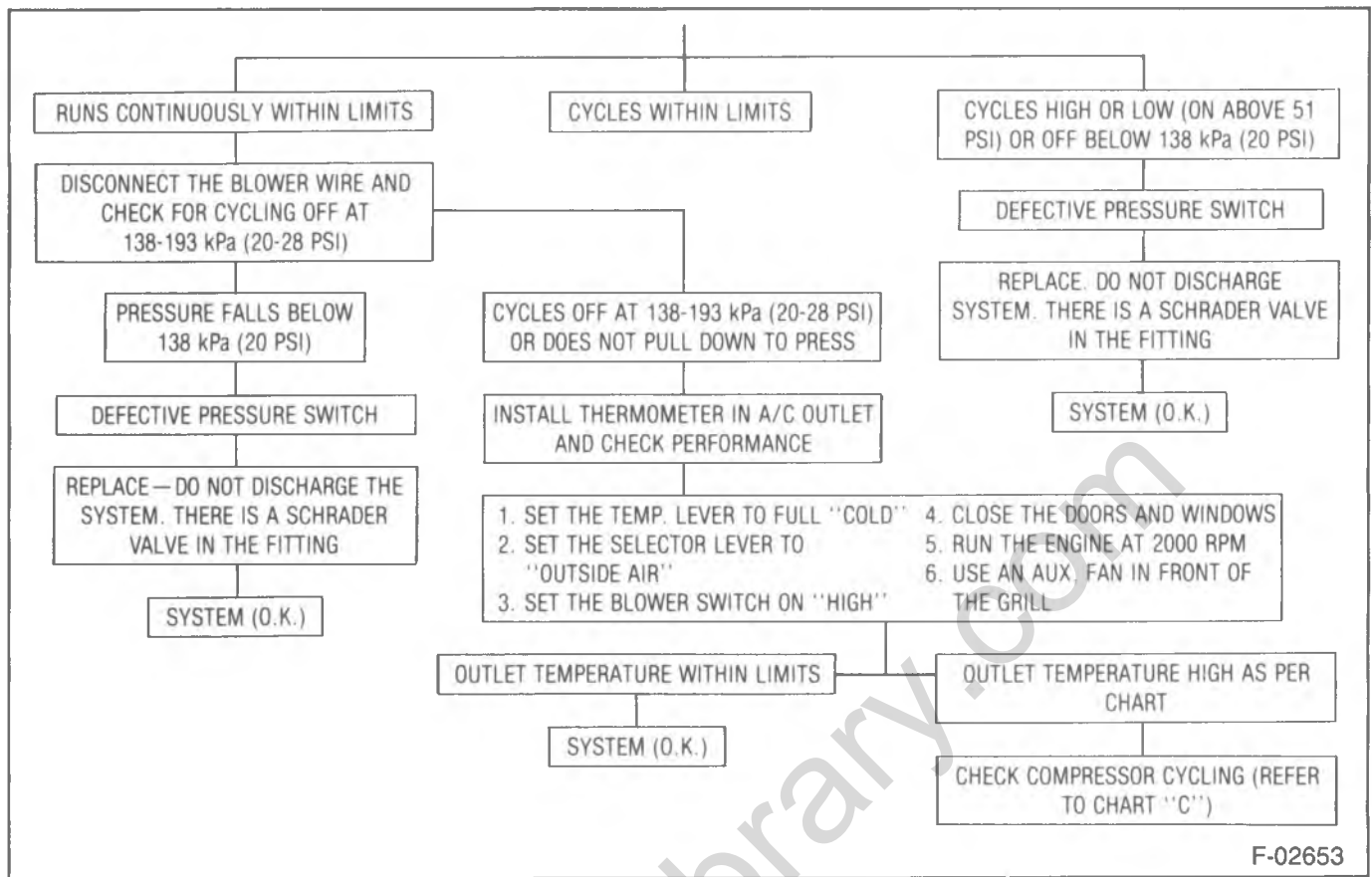

F-02653

Figure 12—Insufficient Cooling Diagnosis (Cont.)

- 7. Plugged accumulator, orifice (expansion tube) or plugged suction inlet screen (A6 compressor).
- 8. Moisture in the refrigerant system.

A green LED battery life monitor glows to indicate sufficient operating voltage when the unit is on. Field service is possible with replacement tips, filters and a sensing element which can be cleaned with common solvent.

LEAK TESTING THE REFRIGERANT SYSTEM

J-29547—AUTOBALANCE REFRIGERANT LEAK DETECTOR

Electronic circuitry detects refrigerant or halogen gas leaks as small as 1/2 oz. per year. J-29547 features a slide-type on-off switch that also resets the unit in contaminated areas.

Audible and visual leak detection is provided by a change in signal tone and flashing LED built into the 45.7 cm (18-inch) flexible probe. A 102 cm (40-inch) coiled extension permits detection in hard to reach places.

PRESSURE SENSING SWITCH

A pressure sensing switch located near the top of the accumulator, cycles the compressor clutch on R/V and G series systems. The switch also shuts off the compressor clutch when there is a low refrigerant charge.

The A/C system does not have to be discharged to replace the switch. The pressure switch fitting is equipped with a schrader-type valve.

When replacing the switch, use a new oiled seal (o-ring), and torque to 10 N·m (90 in. lbs.).

Refer to the following trouble shooting charts:

- 1. Insufficient Cooling Diagnosis (figures 12, 13, 14, and 15).
- 2. Compressor Diagnosis (figure 16).

1B-14 AIR CONDITIONING

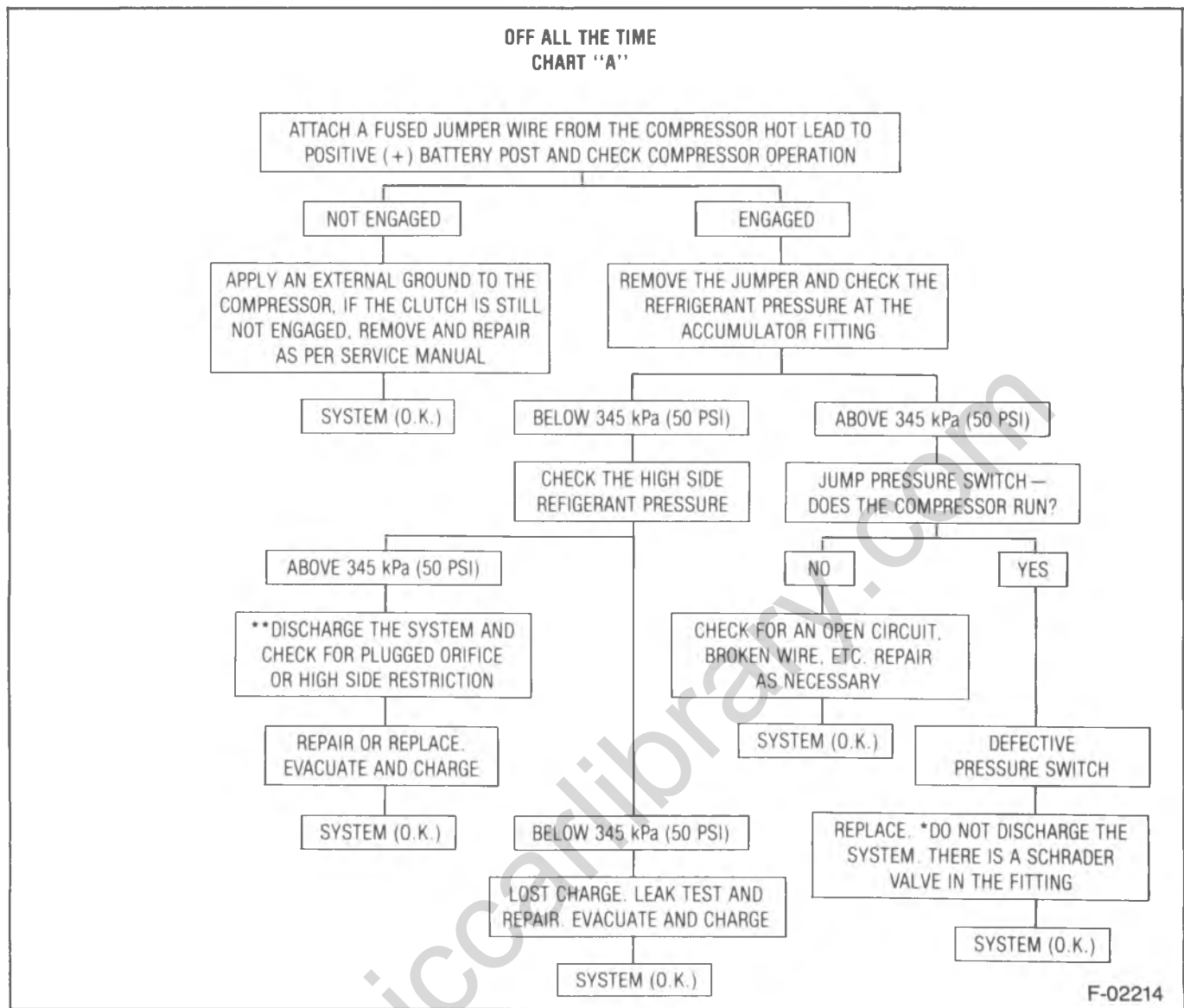
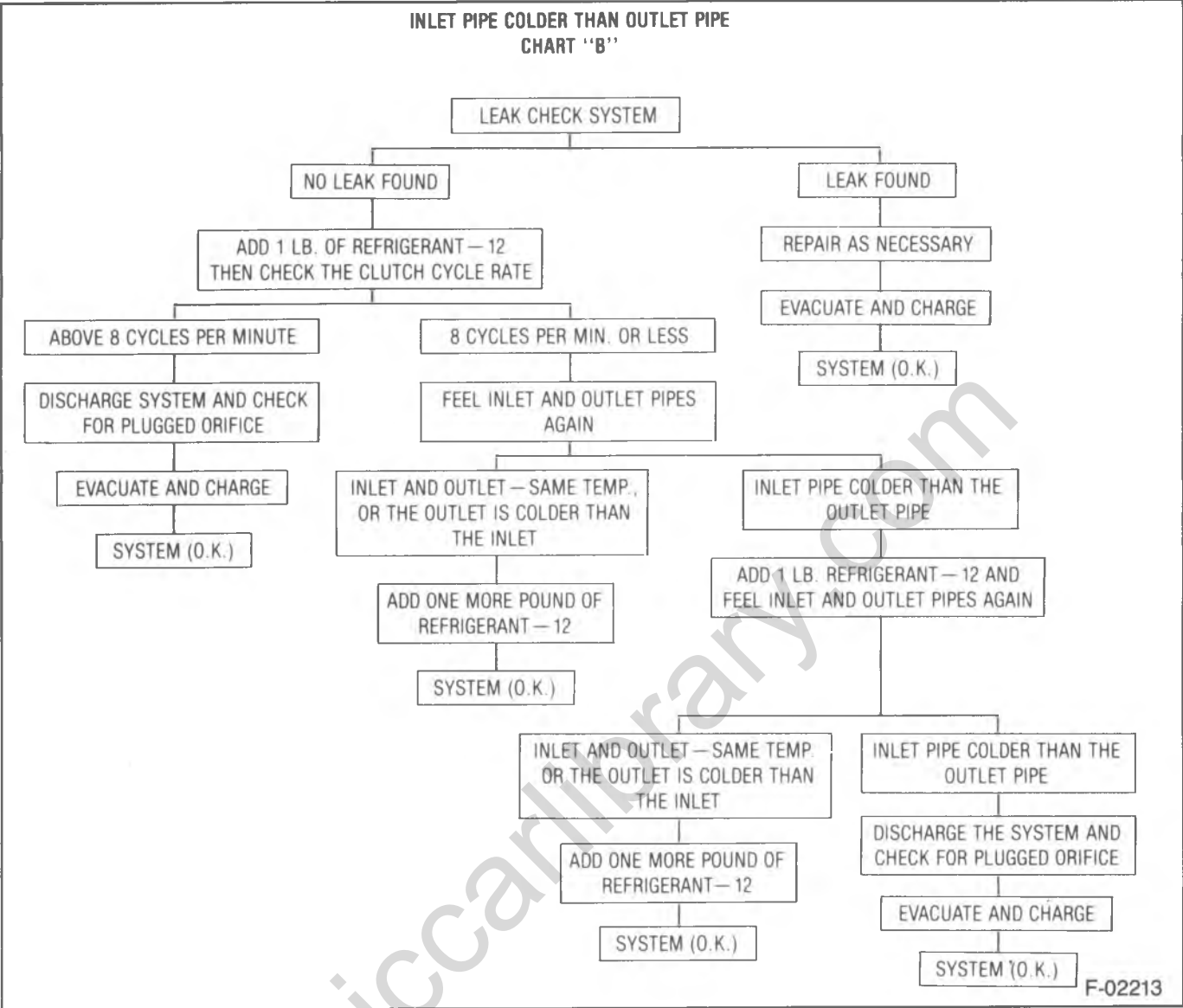

Figure 13—Insufficient Cooling Diagnosis — Chart A



F-02213

Figure 14—Insufficient Cooling Diagnosis — Chart B

1B-16 AIR CONDITIONING

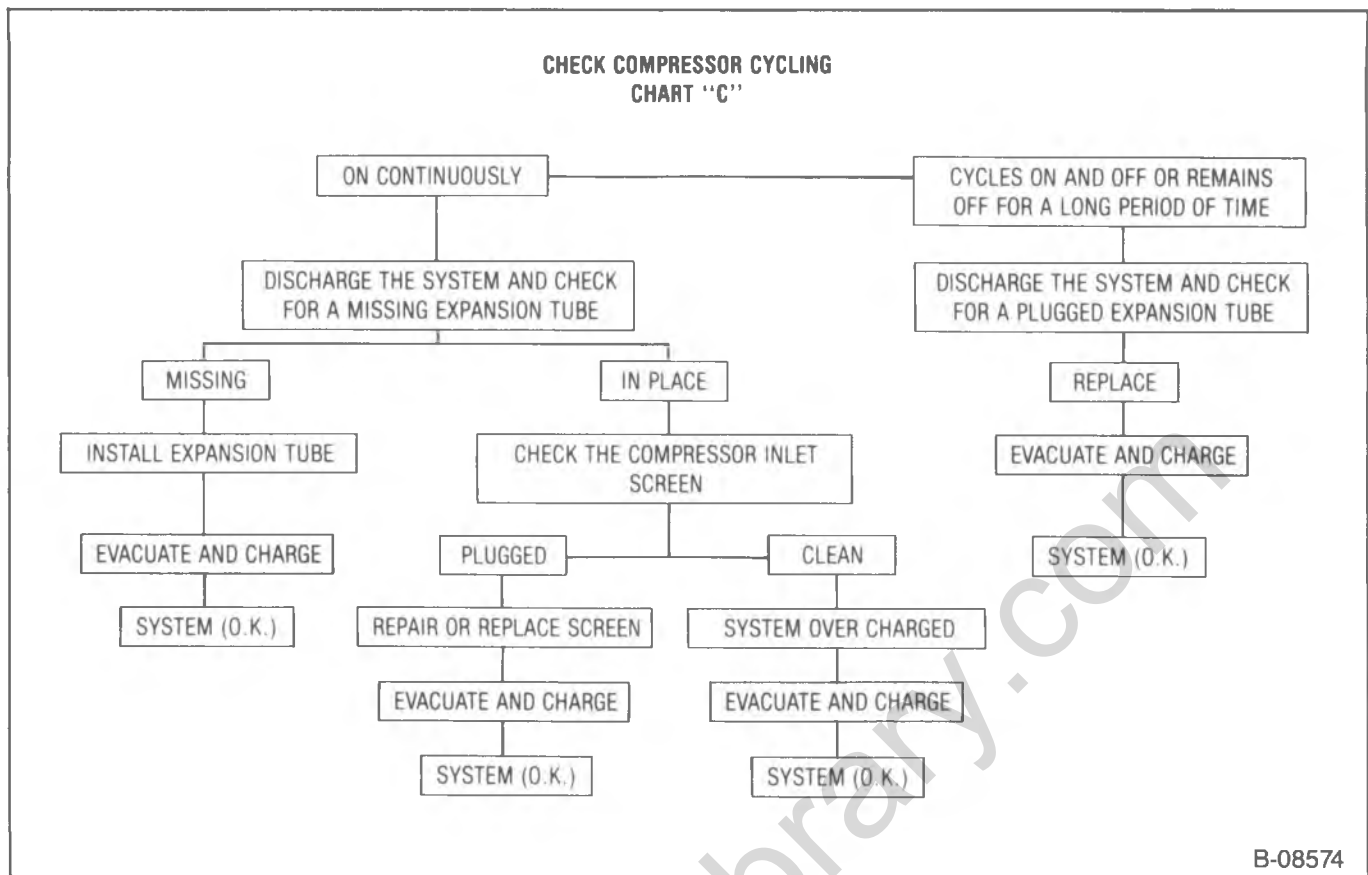

Figure 15—Insufficient Cooling Diagnosis — Chart C

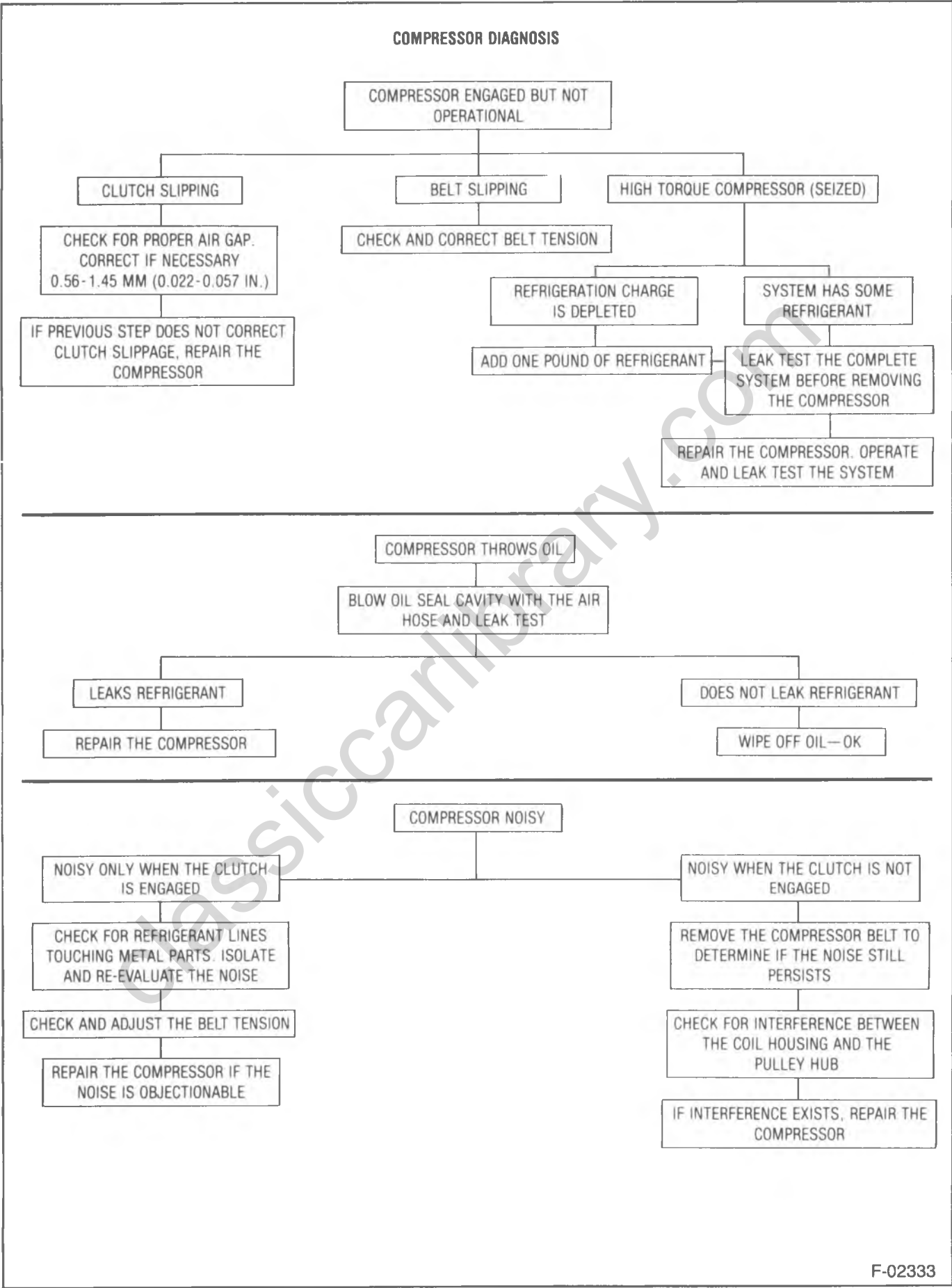

Figure 16—Compressor Diagnosis

ELECTRICAL/VACUUM TROUBLE DIAGNOSIS

When diagnosing problems in the electrical and vacuum systems, refer to "System Operation" and "Functional Test." For electrical wiring and vacuum diagrams, refer to figures 17, 18, 19, and 20.

Ports on rotary vacuum valves are illustrated to provide simplicity in following vacuum schematic lines but are numbered in consecutive order on the actual valve.

OPERATIONAL TEST

To determine if the electrical, vacuum and refrigeration systems are operating efficiently, do the following:

1. Operate the blower at four speeds and check the compressor clutch engagement. This indicates that the electrical circuits are working.
2. Check the hand felt temperature of the evaporator inlet pipe and accumulator surface. The same temperature indicates a properly charged system.
3. Operate the A/C control selector (mode) lever to distribute air from the outlets. This will check the vacuum and diaphragm function.

classiccarlibrary.com

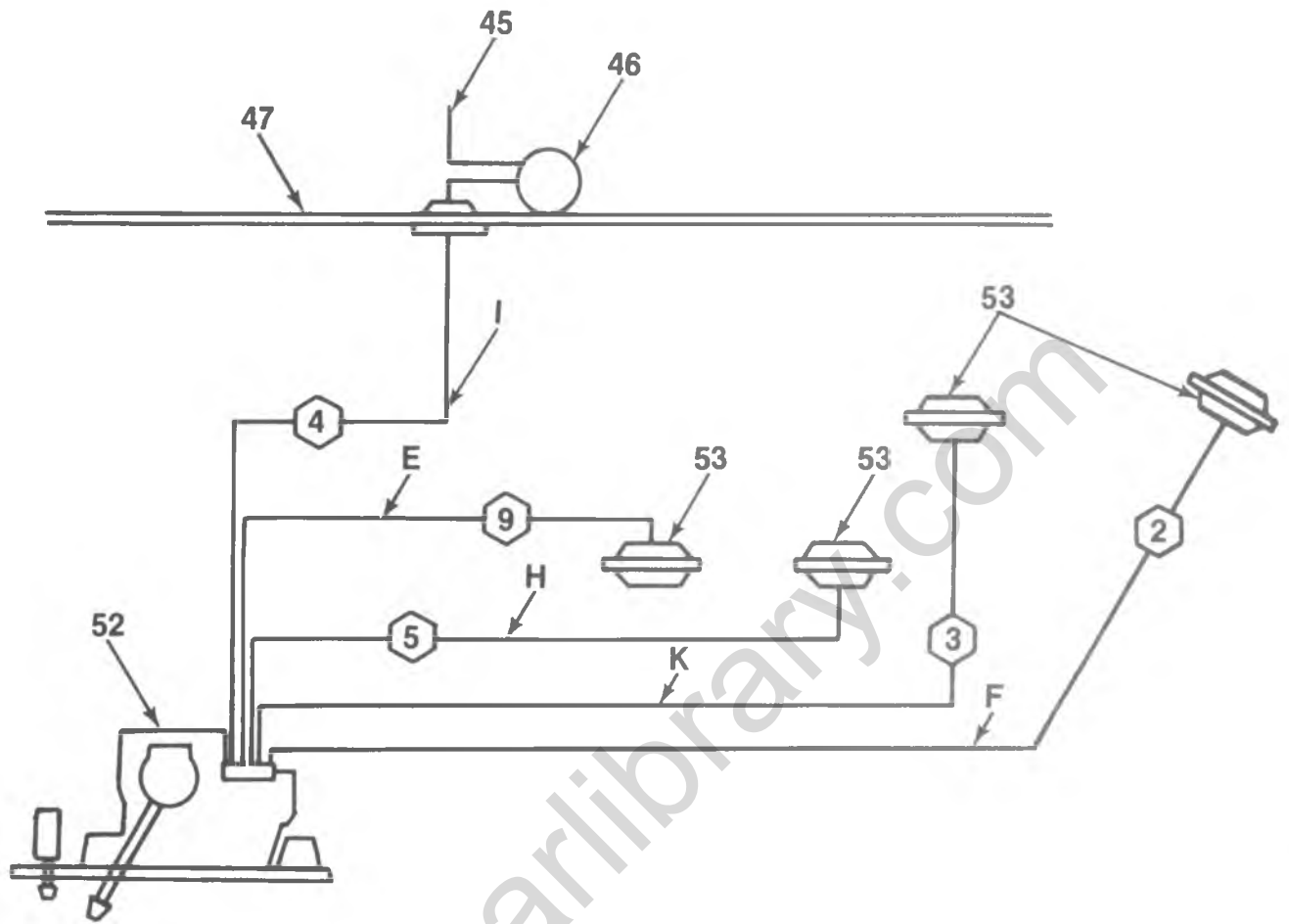

Connection	Port No.	Select Lever Valve Operation Chart						
		Off	Max A/C	Norm A/C	Bi-Level	Vent	Heat	Defrost
Source	4	Vacuum	Vacuum	Vacuum	Vacuum	Vacuum	Vacuum	Vacuum
Bi Level	9	Vent	Vacuum	Vacuum	Vacuum	Vacuum	Vacuum	Vent
Heat/Defrost	3	Vacuum	Vacuum	Vacuum	Vacuum	Vacuum	Vacuum	Vent
OSA/REC	2	Vent	Vacuum	Vent	Vent	Vent	Vent	Vent
AC Mode	5	Vent	Vacuum	Vacuum	Vent	Vent	Vent	Vent

Ports 1,6,7 & 8 Not Used (Sealed On Vacuum Hose Assembly)

- 45. Vacuum Source - Engine
- 46. Vacuum Tank - Gas
- 47. Cowl
- 52. Control
- 53. Actuator

- I. Vacuum Line - Tan (Source)
- E. Vacuum Line - Gray (Bi Level)
- H. Vacuum Line - Dark Blue (A/C)
- K. Vacuum Line - Red (Heat/Defrost)
- F. Vacuum Line - Orange (Recirculate)

B-06944

Figure 17—G Vacuum Schematic

ELECTRICAL SYSTEM DIAGNOSTIC CHART

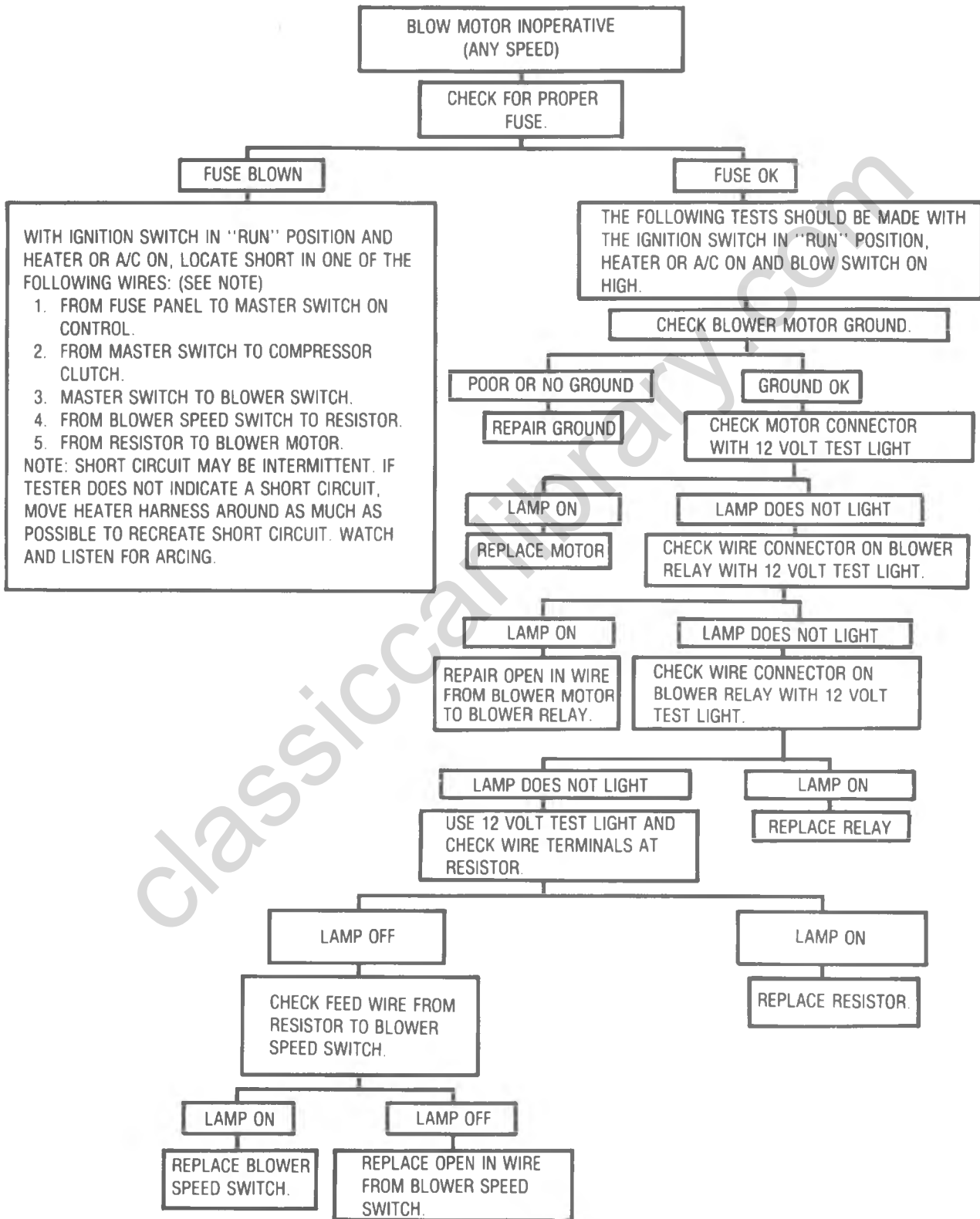

F-00167

Figure 18—Electrical System Diagnostic Chart

ELECTRICAL SYSTEM DIAGNOSTIC CHART (CONTINUED)

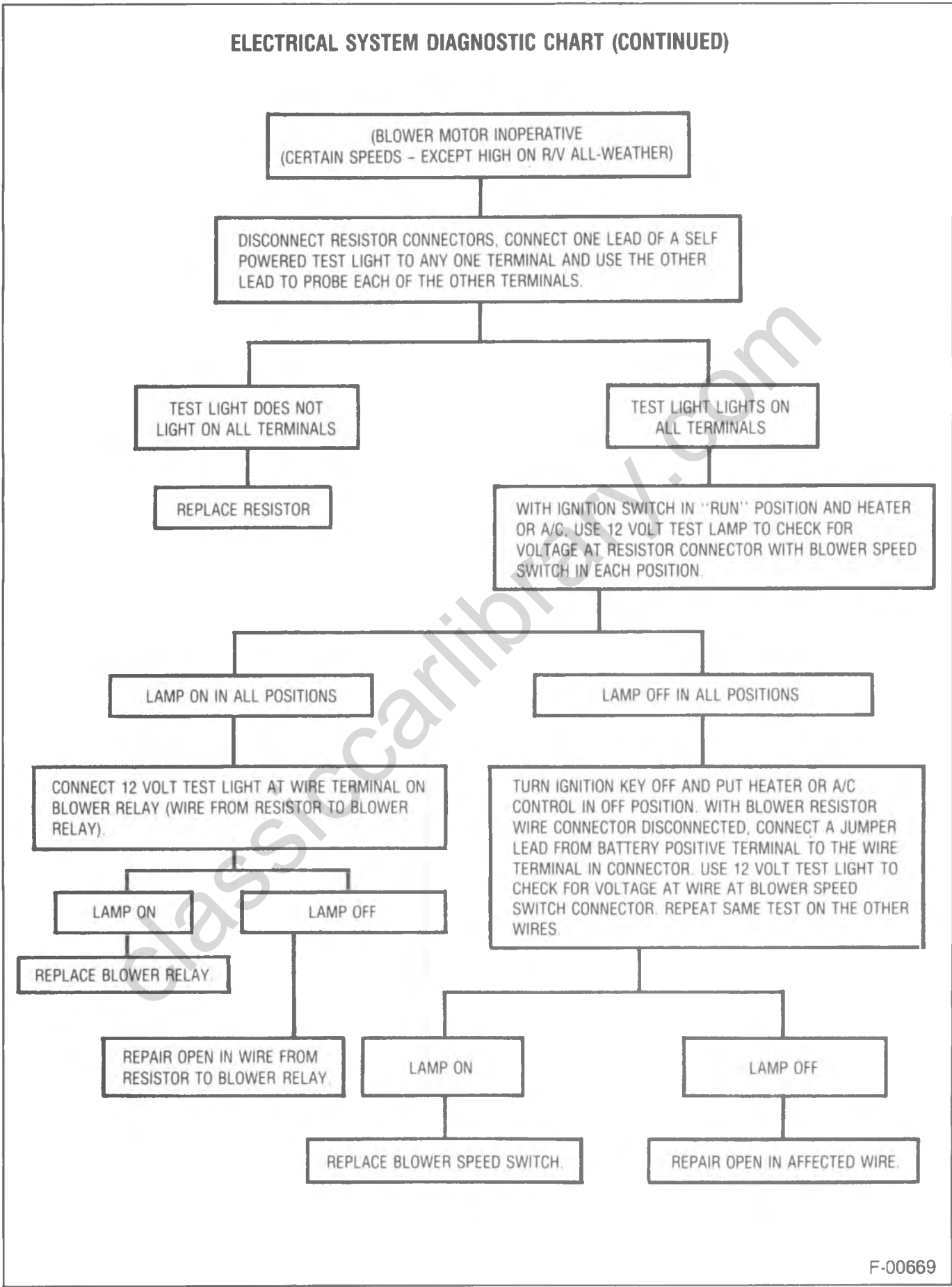

F-00669

Figure 19—Electrical System Diagnostic Chart

1B-22 AIR CONDITIONING

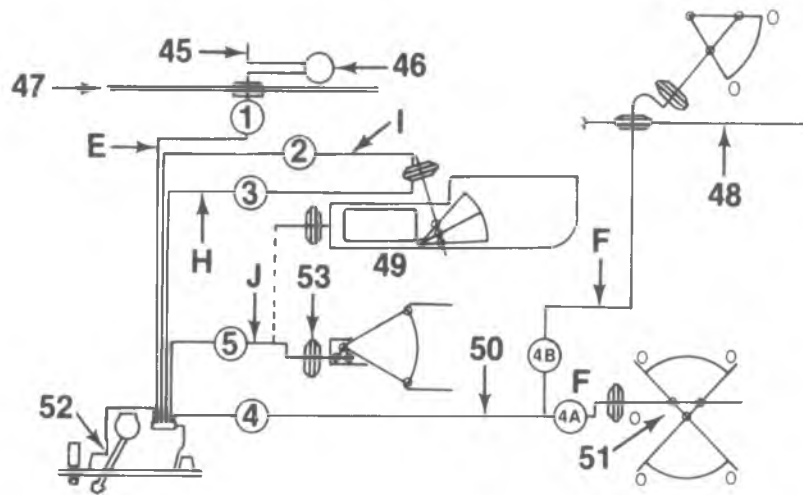

Connection	Port No.	Select Lever Valve Operation Chart						
		Off	Max A/C	Norm A/C	Bi-Level	Vent	Heat	Defrost
Source	1	←————— Vac —————→						
A/C Mode	2	Vent	Vacuum	←————— Vent —————→				
Heater/Mode	3	Vent	Optional	Optional	Vent	Optional	Vent	Vacuum
OSA/REC	4	Vacuum	Vent	Vent	Vent	Vent	Vacuum	Vacuum
Defroster	5	Vent	Vacuum	Vacuum	Vent	Vacuum	Vent	Vent
Ports 6,7,8 and 9 not used (sealed on vacuum hose assembly)								

- 45. Vacuum Source - Engine
- 46. Vacuum Tank (Gas)
- 47. Cowl
- 48. Plenum Valve

- 49. Mode Door
- 50. Defroster Door
- 51. Recirculator Door
- 53. Actuator

- E. Vacuum Line - Gary (Source)
- F. Vacuum Line - Orange (Defroster)
- H. Vacuum Line - Dark Blue (Heat)
- I. Vacuum Line - Tan (A/C)
- J. Vacuum Line - Black (Defroster)

F-00182

Figure 20—R/V Vacuum Schematic

VACUUM SYSTEM DIAGNOSIS

R/V AND G SERIES

Start the engine and allow it to idle. Move the selector lever to each position and refer to the vacuum diagrams and operational charts for airflow, air door functioning and vacuum circuits. If air flow is not out of the proper outlet at each selector lever position do the following:



Inspect

1. The hose connections at the vacuum actuators, control head valve and vacuum tank.
2. The vacuum source circuit:
 - Install a vacuum tee and gage (with restrictor) at the vacuum tank outlet. Idle the engine and read the vacuum (a normal vacuum is equivalent to manifold vacuum) at all selector lever positions.
 - Vacuum less than normal at all positions. Remove the tee and connect the vacuum gage line to the tank - read the vacuum. If still low, then the problem lies in the feed circuit, the feed circuit to the tank or in the tank itself. If vacuum is now normal, then the problem lies downstream.
 - Vacuum less than normal at some positions. If vacuum was low at one or several of the selector lever positions, a leak is indicated in these circuits.

- Vacuum normal at all positions. If vacuum was normal and even at all positions, then the malfunction may be caused by improperly connected or plugged lines or a malfunctioning vacuum valve or valves.
- 3. Specific vacuum circuit check:
 - Place the selector lever in the malfunctioning position and check for vacuum at the pertinent vacuum actuators.
 - If vacuum exists at the actuator but the door does not move, then the actuator is defective or the door is jammed.
 - If low or no vacuum exists at the actuator determine whether the cause is the vacuum harness or the vacuum valve.
 - Check the vacuum harness first.
- 4. Vacuum harness circuit check:
 - Disconnect the vacuum harness at the control head.
 - The black line should show engine vacuum; if not, trace back through connector to vacuum tank.
 - To check any individual circuit, place the selector lever at the involved circuit position and check for vacuum presence.

EVACUATING AND CHARGING PROCEDURES

EVACUATION AND CHARGING PROCEDURES

Before opening any refrigerant hose or component, read the information furnished in:

- Refrigerant-12 Operating Characteristics.
- Discharging, Evacuating, Adding Oil and Charging.

Remove sealing caps from subassemblies before making connections for final assembly. Use a small amount of clean 525 viscosity refrigerant oil on all tube and hose joints.

Use new seal (o-ring) dipped in the clean 525 viscosity refrigerant oil when assembling joints. The oil will aid in assembly and help provide a leak-proof joint.

When tightening joints, use a second wrench to hold the stationary part of the connection.

Tighten all tubing connections (figure 11). Insufficient or excessive torque can cause loose joints or deformed joint parts. Either condition can cause leakage.

DISCHARGING, EVACUATING ADDING OIL AND CHARGING PROCEDURES

Discharge, evacuate and charge using J-23500-01 air conditioning service Charging Station or the J-5725-04 Manifold Gage Set, and 0.397 kg. (14 oz.) disposable cans of Refrigerant-12 (figures 21 and 22).

Use gage adapters to connect the charging lines from the charging station or manifold and gage set to system service fittings. A straight gage Adapter J-5420 and a 90° angle gage Adapter J-9459 is available.

Wear goggles and wrap a clean cloth around fittings and connections.

- Discharge the system before removing and replacing refrigeration lines or components.
- Use the service valve and pressure gage sets during evacuation and charging procedures.
- Do not charge while the compressor system is hot.
- Always discharge the system at the low side service fitting and perform the evacuation and charging procedure through the low side service fitting.
- Do not connect the high pressure line or any line to the high side service fitting during discharging and charging procedures.

CAUTION: Never remove a gage line from its adapter when the line is connected to the A/C system. Always remove the line adapter from the service fitting to disconnect a line. Do not remove charging hose at gage set while attached to service low side fitting. This will discharge the system due to the depressed schrader valve in service low side fitting and may cause personal injury due to escaping Refrigerant-12.

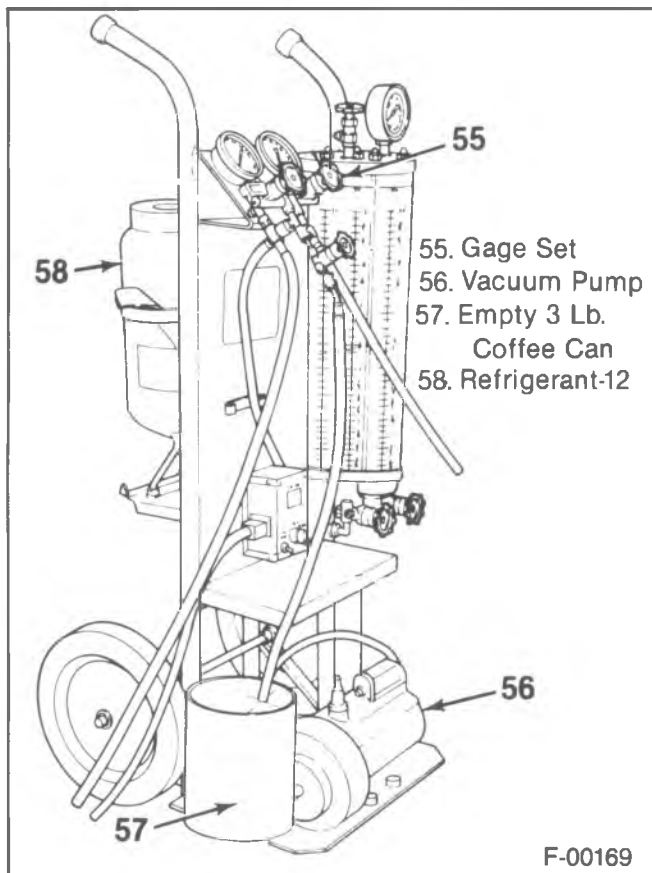

Figure 21—J-23500-01 Charging Station

DISCHARGING THE SYSTEM

Before replacing any component, discharge the system.

1. Discharge at the low side service fitting.
2. With the ignition turned OFF, remove the protective cap from LOW SIDE service fitting and connect Charging Station J-23500-01 Gage Set. (Refer to figure 21).
 - a. If charging station J-23500-01 is not being used, discharge the system by slowly connecting a gage hose to the low side service fitting on the accumulator and discharge into a bottle (figure 23).
 - b. As the hose is SLOWLY tightened down onto the schrader valve, Refrigerant-12 will discharge from the system into the container. If no discharge occurs, check for missing or defective schrader depressor in the hose fitting.
3. With the low side of the system discharged, check the high side system fitting (on the liquid line or muffler) for remaining pressure.
4. If pressure is found, attempt to discharge the high side using the same procedure as used for the low side. (This condition indicates a restriction on the high side. Diagnose and correct before evacuating and charging).
5. After discharging, (no vapor escaping with the hose fully-tightened down), measure and record the amount. If 0.0014 kg. (.05 ounce) or more, add this amount of new 525 viscosity refrigerant oil plus any

quantity in removed parts before evacuation and charging with Refrigerant-12 (refer to CCOT Refrigerant Oil Distribution for the quantity of oil normally retained in removed parts).

6. If adding oil is necessary, remove the suction hose at the accumulator outlet pipe connection and pour the correct quantity of refrigerant oil into the hose or pipe and then reconnect the hose or pipe. (Refer to step number 4 and Refrigerant Oil Distribution for specific quantity instructions).

REFRIGERANT OIL DISTRIBUTION

- A-6 COMPRESSOR—0.284 kg. (10 ounces) of 525 viscosity refrigerant oil.
- R-4 COMPRESSOR 0.170 kg. (6 ounces). Add new oil during the following component replacement and conditions:
 1. With no excessive oil leakage, add;
 - Compressor - Remove, drain oil, measure replace the same amount of new oil plus 0.0284 kg. (1 ounce).
 - Evaporator - Add 0.085 kg. (3 ounces).
 - Condenser - Add 0.0284 kg. (1 ounce).
 - Accumulator - R-4 Compressor - Remove drain oil, measure, replace the same amount of new oil plus 0.057 kg. (2 ounces) to compensate for that retained by the original accumulator dessicant.
 - DA-6 Compressor - Remove, drain oil, measure, replace same amount of new oil plus 0.085 kg. (3 ounces) to compensate for that retained by the original accumulator dessicant. If no oil can be drained from old accumulator, add 0.057 kg. (2 ounces) new oil to the new accumulator.
 2. With signs of excessive oil leakage;
 - A-6 COMPRESSOR**
Remove Compressor and Accumulator. Drain measure and record total oil from both components. Use new oil.
 - If less than 0.170 kg. (6 ounces), add 180 ml (6 ounces) of new oil to system.
 - If more than 0.170 kg. (6 ounces), add the same amount of new oil as drained.
 - If a new accumulator is installed to A-6 system, add 0.057 kg. (2 ounces) additional oil to compensate for that held/absorbed by the original accumulator dessicant.
 - DA-6 COMPRESSOR**
Remove the accumulator. Drain, measure and record quantity of oil in accumulator. It is not necessary to remove and drain the DA-6 compressor because the compressor only retains a minimum quantity of oil, it doesn't have an oil sump area.
 - If less than 0.085 kg. (3 ounces) add 0.085 kg. (3 ounces) of new oil to the system.
 - If more than 0.085 kg. (3 ounces) add the same amount of new oil as drained.

F-00169

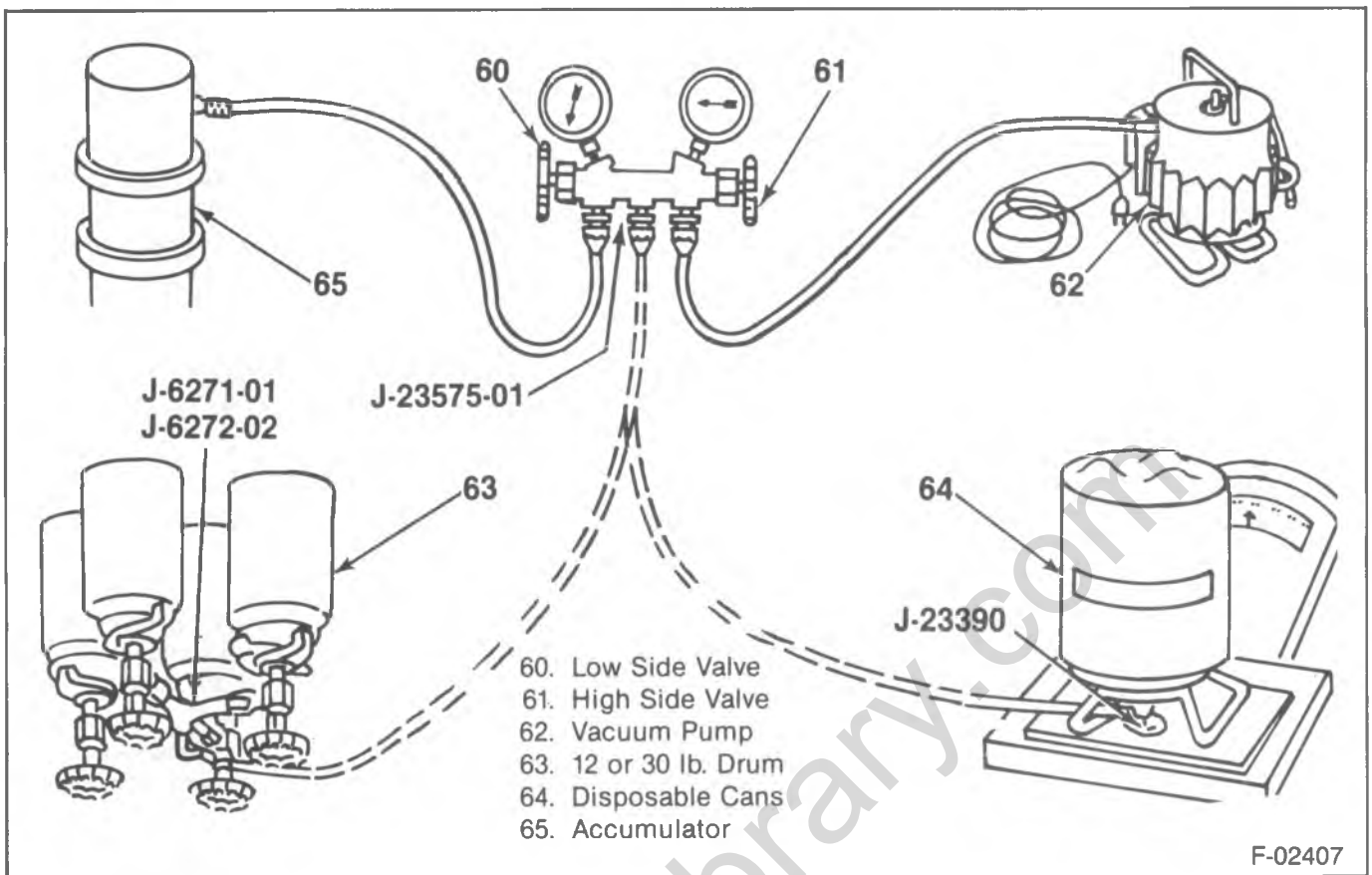

F-02407

Figure 22—Charging the System with a Disposable Can or Drum

- If a new accumulator is installed add 0.085 kg. (3 ounces) additional oil to compensate for that absorbed by the original accumulator dessicant.

R-4 COMPRESSOR

Remove the accumulator. Drain, measure and record quantity of oil in accumulator. It is not necessary to remove and drain the R-4 compressor because the compressor only retains a mininum quantity of oil.

- If less than 0.085 kg. (3 ounces), add 0.085 kg. (3 ounces) of new oil to system.
- If more than 0.085 kg. (3 ounces), add the same amount of new oil as drained.
- If a new accumulator is installed to system, add 0.057 (2 ounces) additional oil to compensate for that retained by the original accumulator dessicant.

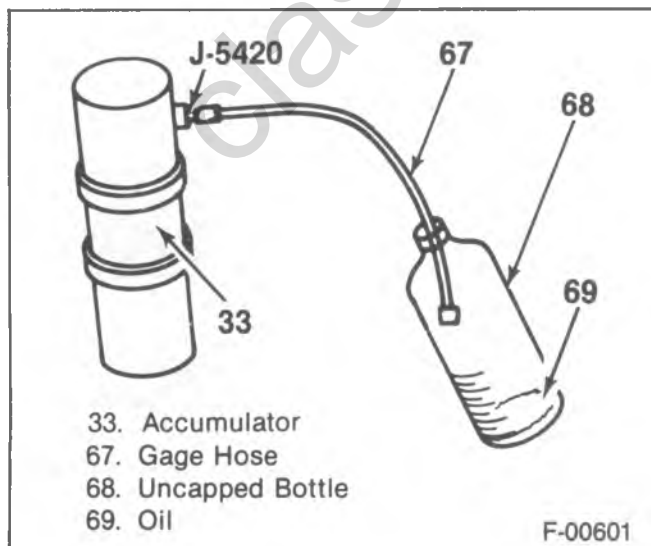

F-00601

Figure 23—Discharging without Charging Station J-23500-01

EVACUATING AND CHARGING

Before charging, evacuate the system if Refrigerant-12 is lost or if the system has been opened.

Evacuation and charging is a combined procedure. Purge all gage lines with Refrigerant-12 before charging.

There are three standard Refrigerant-12 evacuate and charge procedures:

- J-23500-01 Charging Station Method
- Disposable Can Method
- Drum Method

NOTICE: Do not use alcohol to remove moisture from the system. Alcohol can damage components.

GAGE CALIBRATION

Before evacuation, check the low pressure gage for proper calibration and vacuum system for proper operation. With the gage disconnected from the refrigeration system, be sure that the pointer indicates to the center of "0." Tap the gage to be sure the pointer is not sticking. If necessary, calibrate as follows:

- Remove the cover from the gage.
- Holding the gage pointer adjusting screw with one hand, carefully force the pointer in the proper direction to position the pointer at the "0" position. Tap the gage to be sure the pointer is not sticking. Replace the gage cover.

VACUUM SYSTEM CHECK

Before connecting the vacuum pump to the A/C system run the pump connected to the low pressure gage to determine the vacuum pump capability. If the vacuum system is unable to reach 711.2 - 736.6 mm (28 to 29 inches) or more vacuum check for leaks. If no leaks are found check the vacuum pump.

CHARGING STATION METHOD

Follow the J-23500-01 Charging Station instructions. Use with the following exceptions:

1. Do not connect the high pressure line to the air conditioning system.
2. Keep the high pressure valve on the charging station closed.
3. Perform the evacuate and charge procedure through the accumulator low side pressure service fitting.
4. Following these procedures will prevent high side pressure from damaging the charging station if an error is made during the sequence.

DISPOSABLE CAN OR MULTI-CAN METHOD

Tools Required:

J-6271-01 Single Can Refrigerant Dispensing Valve
J-6272-02 Four Can Refrigerant Dispensing Valve

1. Use tool J-6271-01 for single can or multi-can dispensing unit.
2. Use tool J-6272-02 multi-can open valve. When using disposable cans, close the tapping valve and then attach the can(s) following the instructions included with the tapping valve or tapping manifold adapter.

REFRIGERANT DRUM METHOD

Tool required:

J-23390 Refrigerant Dispensing Valve

1. Use tool J-23390 for a 5.443 kg (12 lb.) can. A 13.608 kg (30 lb.) can has a built in opener-valve. Place the drum on a scale and note weight before charging. During charging, watch the scale to determine the amount used.

! Important

- Close the outlet valve on the opener (clockwise) before installing the opener to the R-12 container.
- To evacuate the A/C system install Manifold Gage Set and Vacuum Pump.
 - SLOWLY open high and low side gage valves and begin vacuum pump operation. Pump the system until the low side gage reaches 459 - 475 mm (28 to 29 inches of mercury [vacuum]) or more.

The evacuation procedure will specify 459 - 475 mm (28 to 29 inches) of mercury at sea level. For each 304.8 mm (1,000 ft.) above sea level, lower the specification by one inch of vacuum. At 1524 mm (5,000) feet elevation only 376.9 mm (23 to 24 inches) of vacuum is required.

If the prescribed mercury (vacuum) cannot be reached, close the vacuum control valve, shut off the pump and look for a leak at the connections or the pump.

2. When the gage reaches the prescribed vacuum, the system is evacuated. Close the high side gage set valve and turn OFF the vacuum pump.
3. Watch the low side gage to be sure vacuum holds for five minutes. If the vacuum holds, disconnect the vacuum hose at the gage set and then proceed to charging.
4. If the vacuum does not hold for five minutes, charge the system with 0.227 kg. (8 ounces) Refrigerant-12 and leak check. Discharge the system again and repair any leaks. Repeat the evacuation procedure.

CHARGING THE SYSTEM

1. Start the engine, run with the choke open and the fast idle speed reduced to normal idle, set the A/C control lever on OFF.
2. With the drum or 0.397 kg (14 ounces) can(s) inverted, open source valve(s) and allow 0.454 Kg (one (1) pound) or more 0.397 kg (14 ounces) can of liquid Refrigerant-12 to enter the system through low side service fitting on accumulator.
3. When one 0.454 Kg (1 pound) or one 0.397 kg (14 ounces) can of liquid Refrigerant-12 enters the system, engage the compressor by setting the A/C control lever to NORM and blower speed on HI to draw in the remainder of the charge.

To speed up the operation, use a fan to pass air over the condenser. If the condenser temperature remains below the charging cylinder temperature, Refrigerant-12 will enter the system faster.

4. Shut off the source valve and run the engine for 30 seconds to clear lines and gages.
5. With the engine running, remove the charging low side hose adapter from the accumulator service fitting. Unscrew rapidly to prevent Refrigerant-12 from escaping.

CAUTION: Never remove a gage line from its adapter when the line is connected to the A/C system. Always remove the line adapter from the service fitting to disconnect a line. Do NOT remove the charging hose at the gage set while it is attached to the accumulator. This will discharge the system because of the depressed schrader valve in service low side fitting. Also, the escaping Refrigerant-12 may cause personal injury.

6. Replace the protective cap on the accumulator fitting.
7. Turn the engine off.
8. Leak the check system with a J-6084 Leak Detector.
9. Start the engine.
10. With the system charged and leak-checked, operate the system and test for pressures as outlined under Relative Humidity, Temperature and Pressure Relationship of Refrigerant-12 (figure 10).

ACCUMULATOR ASSEMBLY

The accumulator assembly has a service replacement which includes two seals (o-rings for the inlet and outlet connections). The desiccant is NOT serviced separately - it is part of the sealed accumulator assembly. Refer to CCOT Refrigerant Oil and Distribution for presence of refrigerant oil and service conditions when removing the accumulator from the vehicle to measure the oil.

Replace the accumulator assembly when:

1. A physical perforation produces a leak.
2. The (orifice) screen experiences continued or repeated plugging.
3. An evaporator fails because of inside-out internal corrosion.

DO NOT REPLACE the accumulator assembly where:

1. A dent is found in the outer shell of the accumulator.
2. A vehicle is involved in a collision and there is no perforation to the accumulator. Cap or place a plastic bag around an open refrigerant line.

SPECIFIC COMPONENT DIAGNOSIS

COMPRESSOR

Compressor defects can appear as noise, seizures, leakage or low discharge pressures.

NOTICE: Resonant compressor noises are normal; however, irregular noise or rattles may indicate broken parts or wear. To check seizure, de-energize the magnetic clutch and rotate the drive plate. If rotation is impossible the compressor is seized.

To check for a leak, refer to "Leak Testing The Refrigerant System." A faulty internal seal, a restriction or an insufficient refrigerant charge can cause a low discharge pressure. Check before servicing.

CONDENSER

A condenser may leak or be restricted. A restriction will cause excessive compressor discharge pressure. If a partial restriction is present, ice or frost will form after the restriction as the refrigerant expands after passing through the restriction.

Air flow restrictions through the condenser or radiator can cause high discharge pressures. During normal condenser operation, the outlet pipe will be cooler than the inlet pipe.

EXPANSION VALVE

There are five expansion valve malfunctions: valve stuck open, valve stuck closed, broken power element, a restricted screen or an improperly located or installed power element bulb. To correct the first three conditions, replace the valve; to correct the last two, replace the valve inlet screen and properly install a power element bulb.

Operating the system will indicate valve trouble.

1. Valve stuck open.
 - Noisy compressor.
 - No cooling - freeze up.
2. Valve stuck closed, broken power element or plugged screen.
 - Very low suction pressure.
 - No cooling.
3. Poorly located power element bulb.
 - Normal pressure.
 - Poor cooling.

DIAGNOSIS FOR MALFUNCTIONING VALVE

Use the following procedure to determine a malfunctioning valve.

1. Operate the system at normal idle. If the valve is malfunctioning, the low pressure readings (evaporator pressure) will be above specifications (figure 10).
2. The loss of system performance is not as evident when the compressor head pressure is below 1379 kPa (200 psi). Increase the system head pressure by partially blocking the condenser. Disconnect the blower lead wire and operate the system to determine if the evaporator pressure can be obtained.

EVAPORATOR

An inadequate supply of cool air can cause the evaporator to malfunction. Check for a plugged core, a cracked case or a leaking seal.

REFRIGERANT LINE RESTRICTIONS

There are three refrigerant line restrictions:

1. Suction Line - A restriction will cause low suction pressure at the compressor, low discharge pressure and little or no cooling.
2. Discharge Line - A restriction will cause the pressure relief valve to open.
3. Liquid Line - A restriction will be caused by low discharge and suction pressure, and insufficient cooling.

REFRIGERANT-11 FLUSHING PROCEDURE

Tool Required:

J-33883 Air Conditioning Flushing Kit

Flush the system when:

1. A compressor has failed resulting in debris in the air conditioning system refrigerant components or oil.
2. Inspection of the orifice tube shows the inlet screen to be 25% or more coated with debris.
3. Refrigerant oil is overcharged or contaminated.

Follow the kit's instructions and flush each component separately allowing the Refrigerant-11 to soak in each component for five minutes.

Flushing the system requires approximately 6.804 kg (15 lbs.) of R-11 and 1.814 (4 lbs.) of R-12 and up to 0.312 kg (11 oz.) of 525 viscosity refrigerant oil. The actual quantities of R-11, R-12 and oil depends on the system, the number of components flushed and the amount of debris in each component.

Remove Refrigerant-11 by purging each components with Refrigerant-12 followed by a system evacuation.

Refer to "On-Vehicle Service" for removal procedures for the system's components. Cap or plug all open connections when removing the components.

↔ Remove or Disconnect (Figure 24)

1. Battery ground cable.
2. Refrigerant from the system.
3. Compressor.
4. Accumulator.
5. Orifice tube.
6. Evaporator.

🔍 Inspect

- Each component for wear or damage. Replace if necessary.

🧼 Clean

- Flush each component with J-38833. Follow the directions included with the kit.

↔ Install or Connect (Figure 24)

1. Evaporator.
2. Orifice tube.
3. Accumulator.
4. Compressor.
5. Refrigerant-12 to the system.
 - Evacuate, charge and test the system.

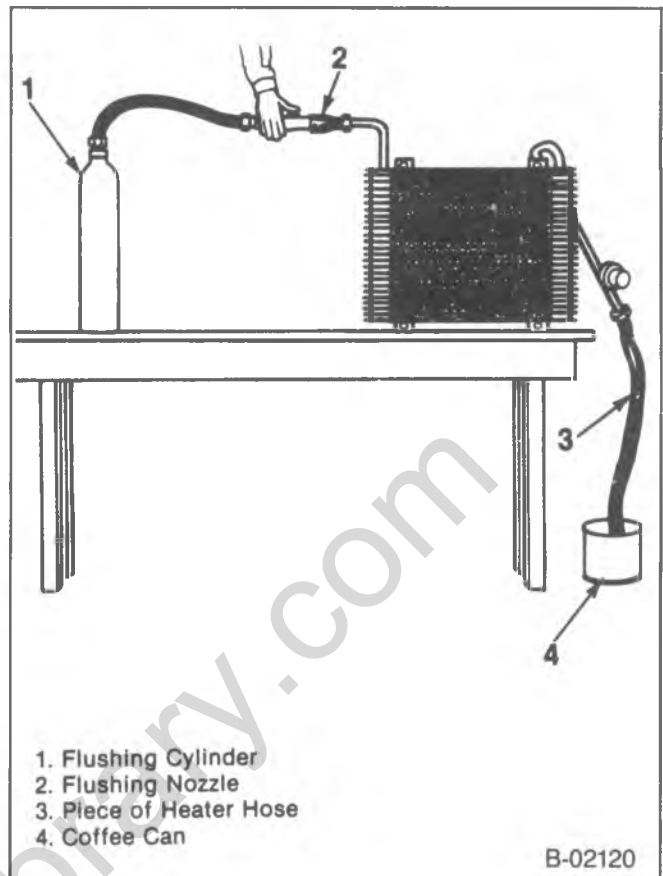

Figure 24—Flushing a Component with J-33883

- Refer to "Specifications" for Refrigerant-12 and 525 viscosity refrigerant oil.

ON VEHICLE SERVICE

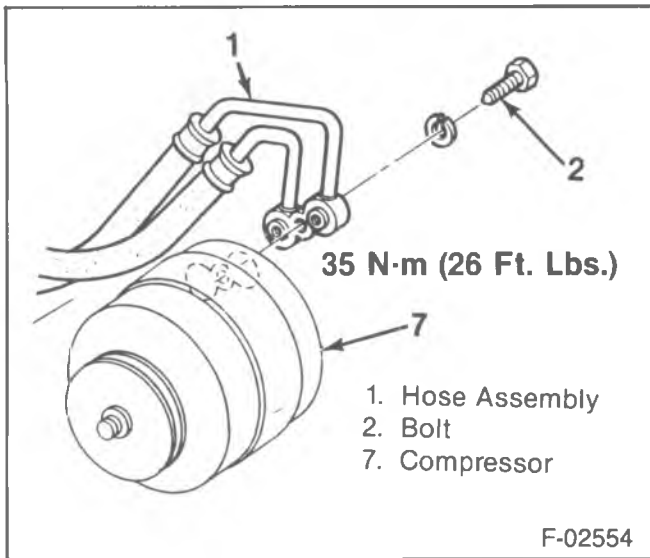

Figure 25—Hose Plate and Bolt Removal — Typical

COMPRESSOR REPLACEMENT (R/V)

↔ Remove or Disconnect (Figures 25, 26, 27 and 28)

1. Battery negative cable.
2. Refrigerant from the system.

3. Connector attaching bolt.
4. Connector.
 - Cap or plug open connections.
5. Electrical lead to the clutch actuating coil.
6. Bolt.
 - Loosen the bracket and pivot bolts.
7. Compressor.
 - Drain and measure the oil.
 - Check for contamination.

↔ Install or Connect (Figures 25, 26, 27 and 28)

1. Oil to the compressor.

! Important

- Replace with fresh oil. If the system was serviced, install a full, fresh charge of refrigeration oil.
2. Compressor.
 - Position to the mounting bracket.
 3. Nuts, bolts and spring washer.
 4. Connector assembly to the rear of the compressor.

! Important

- Use new seals (o-rings) coated with clean refrigeration oil.
5. Electrical lead to the coil.
 6. Compressor belt.
 7. Battery negative cable.

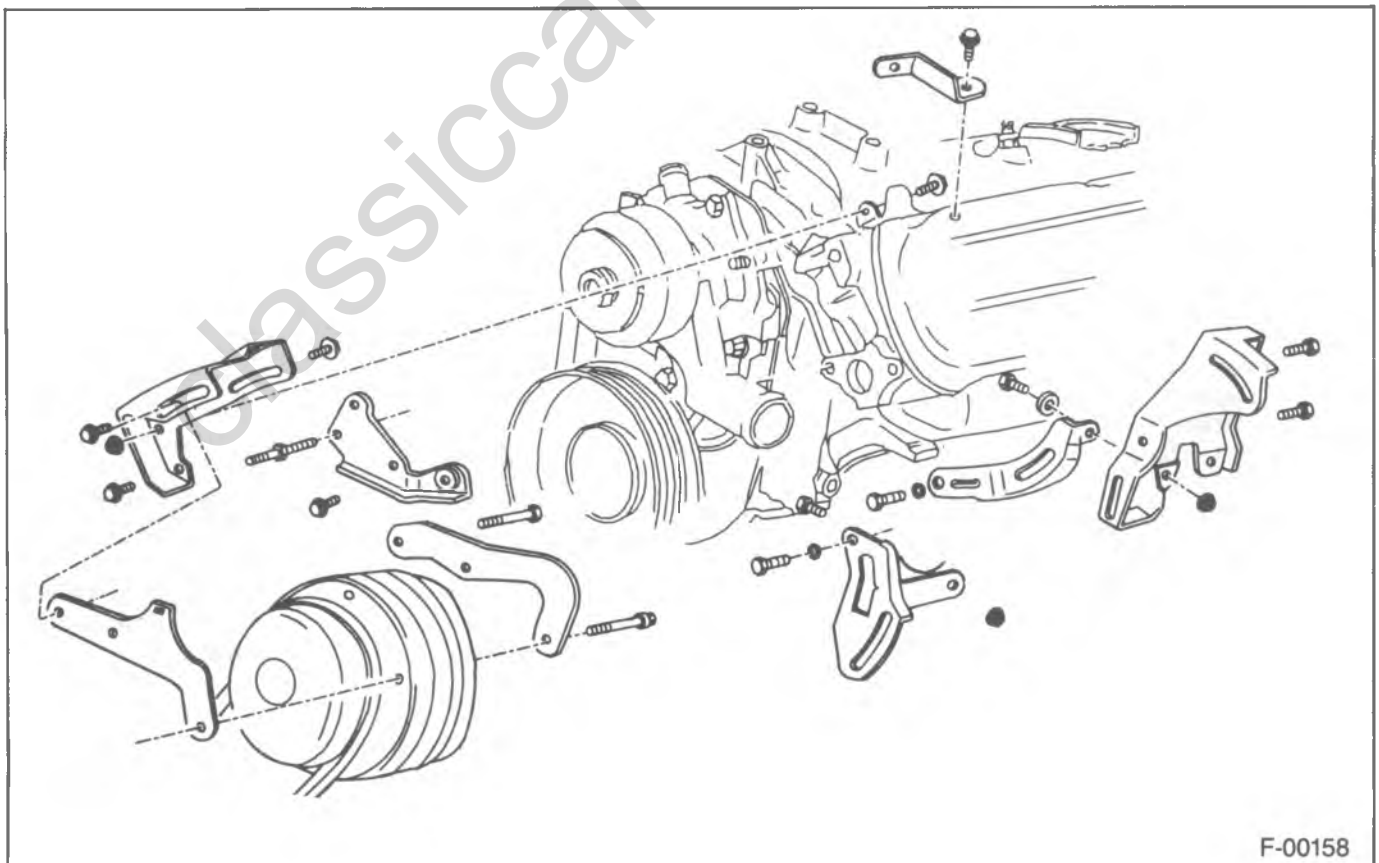
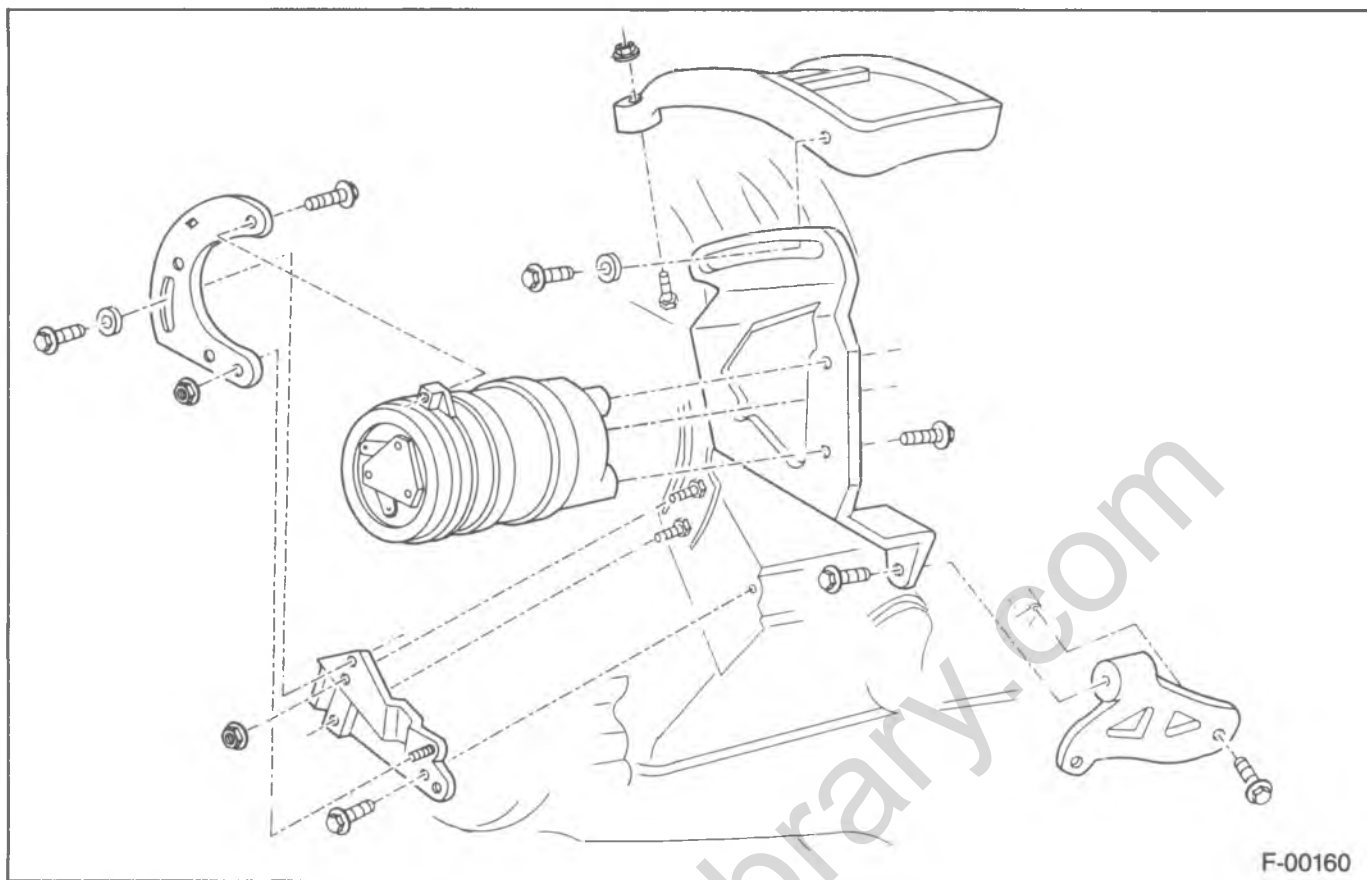

Figure 26—R/V Compressor Installation — 4.3L, 5.0L, 5.7L Engines



F-00160

Figure 27—R/V Compressor Installation — 6.2L Engine

 **Adjust**

- Belt. Refer to ENGINE COOLING (SEC. 6B1).
- 8. Evacuate, charge and check the system.

COMPRESSOR REPLACEMENT (G)

 **Remove or Disconnect (Figures 29, 30 and 31)**

1. Battery ground cable.
2. Compressor clutch connector.
3. Refrigerant from the system.
4. Belt.
 - Loosen the three bolts that hold the idler pulley to the air conditioning support bracket. Refer to ENGINE COOLING (SEC. 6B1).
 - Back off the idler pulley adjustment screw.
5. Engine cover.
6. Air cleaner.
7. Fitting and muffler assembly.
 - Cap or plug all open connections.
8. Compressor bracket.
9. Engine oil tube support bracket bolt and nut.
10. Clutch ground lead.
11. Compressor.

 **Important**

- Drain and measure the oil. Check for contamination.

 **Install or Connect (Figures 29, 30, and 31)**

1. Oil to the compressor.

 **Important**

- Replace with fresh oil. If the system was serviced, install a full, fresh charge of refrigeration oil.
2. Compressor.
 - Position to the mounting bracket.
 3. Nuts, bolts and spring washer.
 4. Connector assembly to the rear of the compressor.

 **Important**

- Use new seals (o-rings) coated with clean refrigerant oil.
5. Electrical lead to the coil.
 6. Compressor belt.

 **Adjust**

- Tighten the idler pulley adjustment screw. Measure the belt tension with J-23600-B. Refer to ENGINE COOLING (SEC. 6B1).
- Tighten the three bolts that hold the idler pulley bracket to the air conditioning compressor support bracket.

 **Tighten**

- Bolts to 33 N·m (24 ft. lbs.).
 - Recheck the belt tension with J-23600-B. Refer to ENGINE COOLING (SEC. 6B1).
7. Battery ground cable.
 8. Refrigerant to the system.
 - Evacuate, charge and leak test.

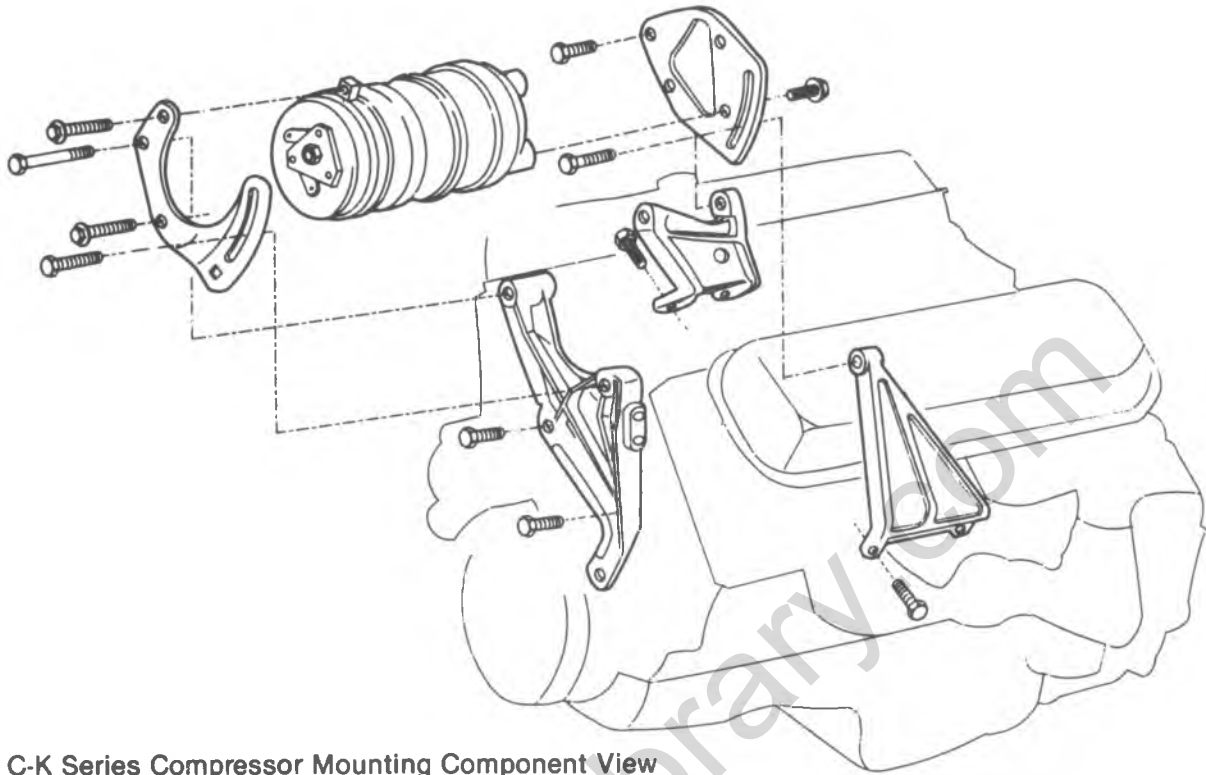

C-K Series Compressor Mounting Component View
V8 (7.4 Liter) Gas Engine - Federal Emissions

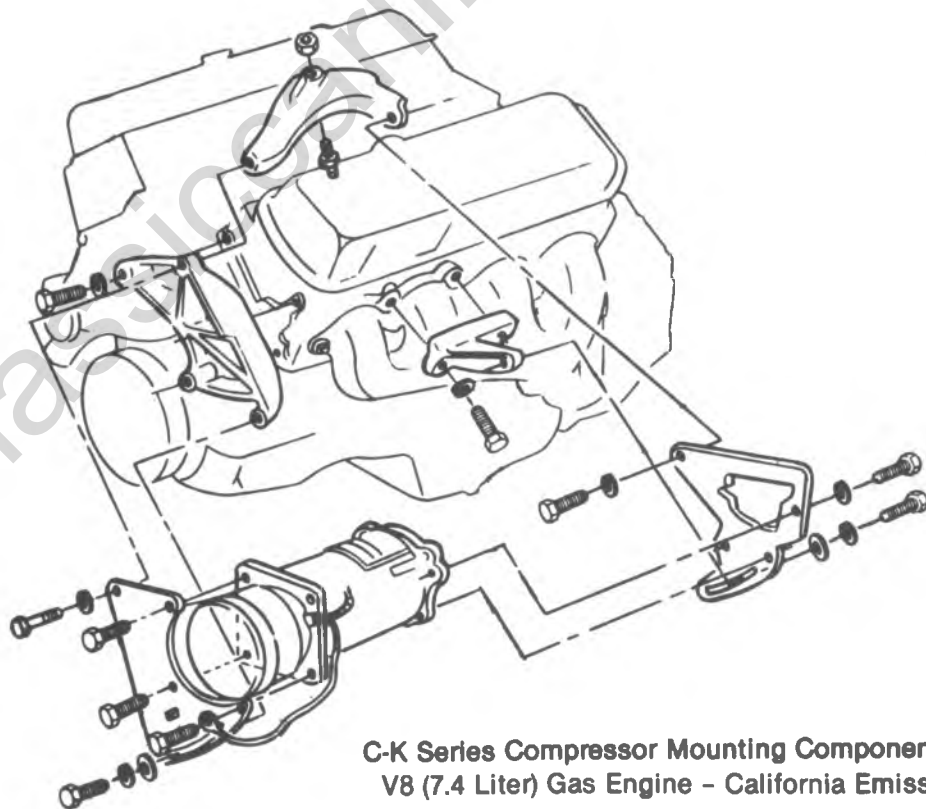

C-K Series Compressor Mounting Component View
V8 (7.4 Liter) Gas Engine - California Emissions

F-00159

Figure 28—R/V Compressor Installation — 7.4L Engine

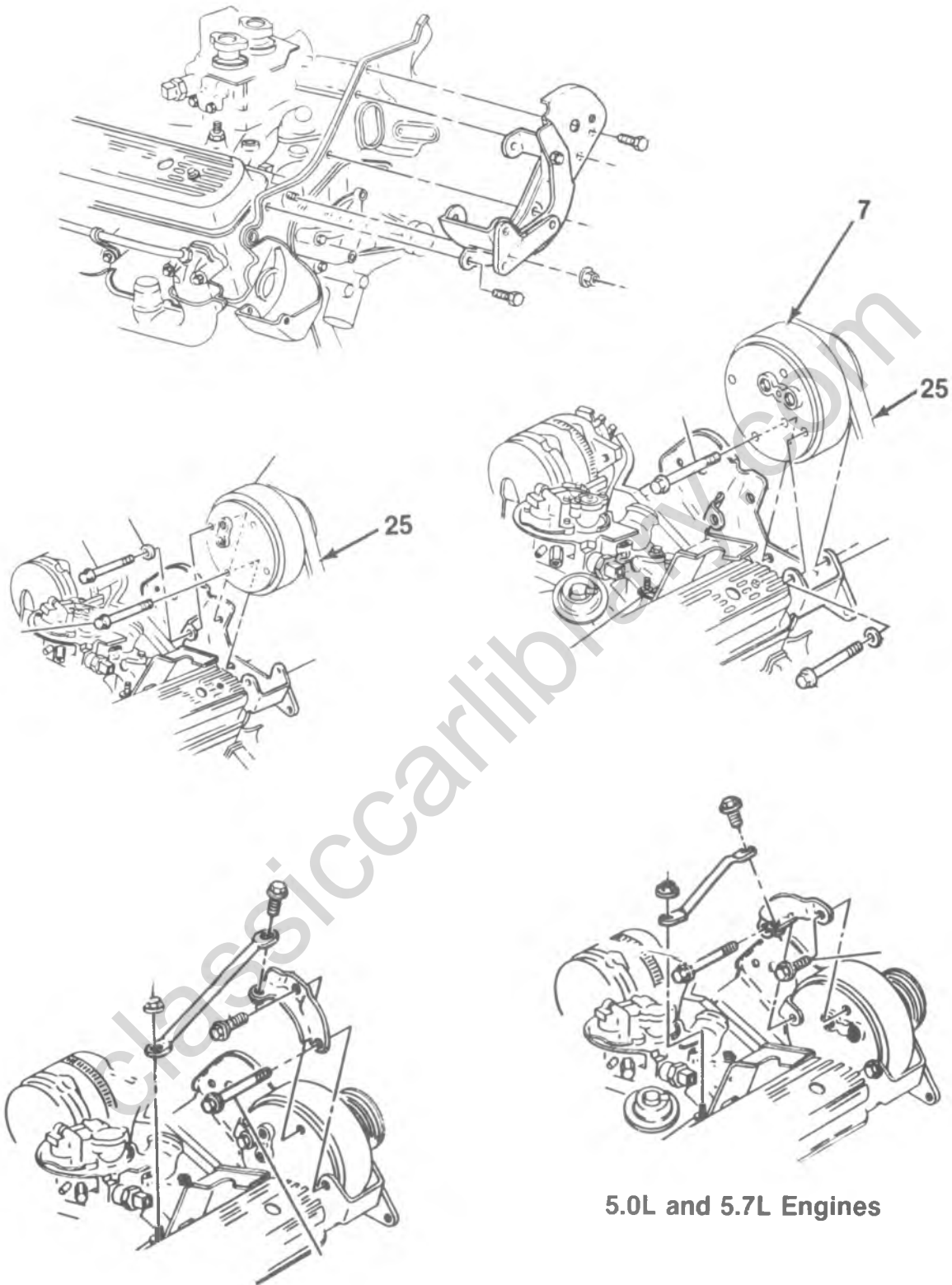

4.3L Engine

5.0L and 5.7L Engines

7. Compressor
25. Belt

Figure 29—G-Compressor Installation — 4.3L, 5.0L and 5.7L Engines (Serpentine Drive)

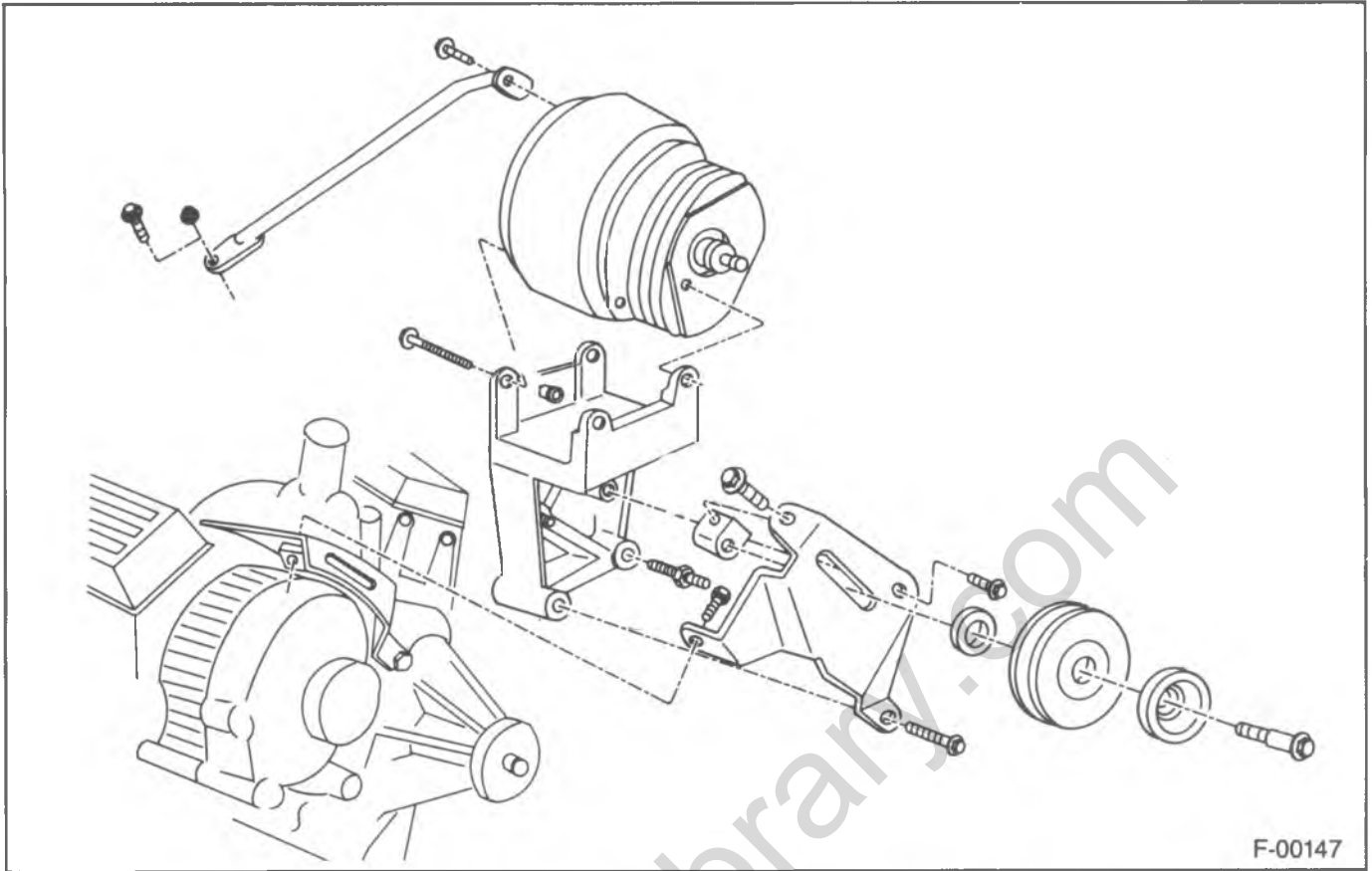

Figure 30—G-Compressor Installation — 5.7L Engine Carbureted

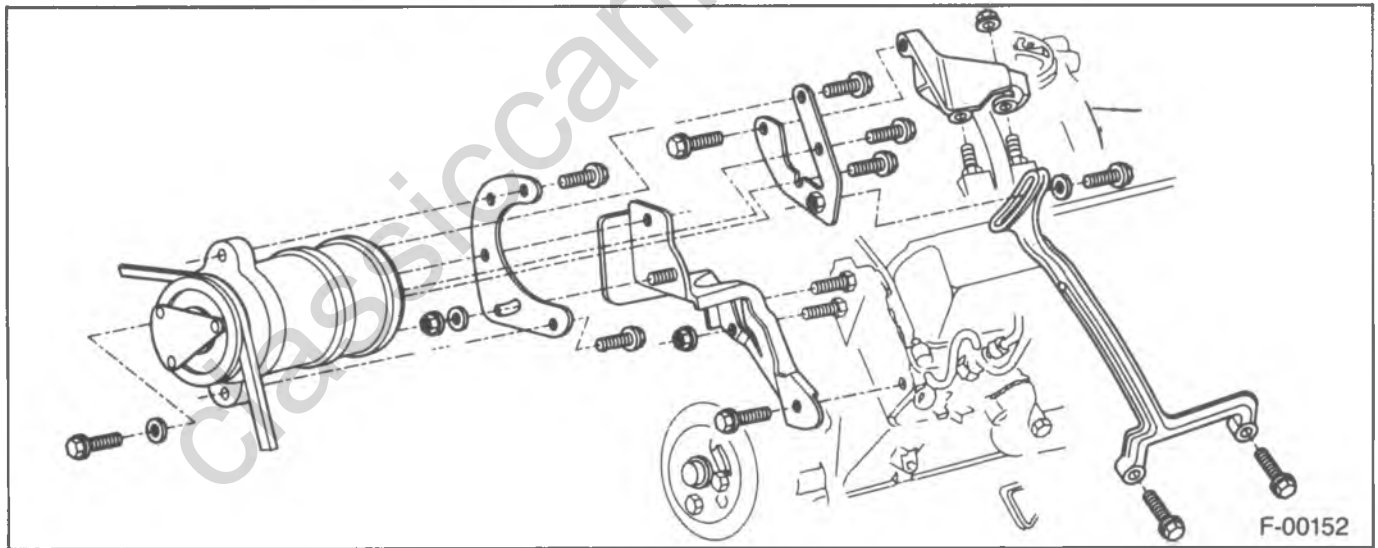
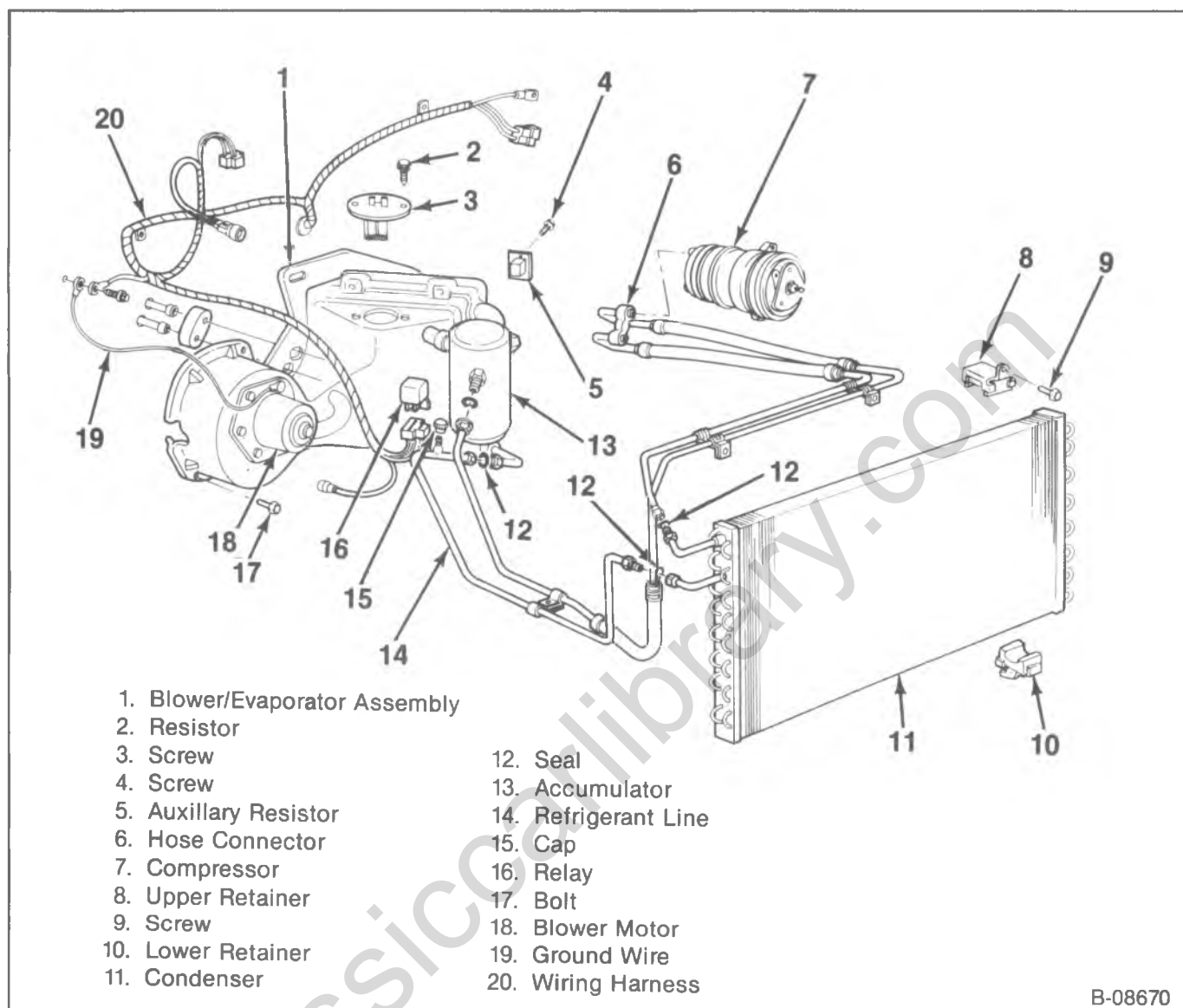

Figure 31—G-Compressor Installation — 6.2L Engine

A/C SYSTEM—R/V SERIES



B-08670

Figure 32—Air Conditioning System Component View — R/V

CONDENSER REPLACEMENT

↔ Remove or Disconnect (Figures 32 and 33)

1. Battery ground cable.
2. Refrigerant from the system.
3. Grille assembly.
4. Radiator grille center support.
5. Left grille support to upper fender support (2) screws.
6. Condenser inlet and outlet lines, and the outlet tube at the right end of the condenser (figure 32).

! Important

- Cap or plug all open connections.
7. Condenser to radiator support screws (figure 33).
 8. Bend the left grille support outboard to gain clearance for condenser removal.

9. Condenser assembly by pulling it forward and then lowering it from the vehicle.

↔ Install or Connect (Figures 32 and 33)

1. New condenser.

! Important

- Add 30 ml (1 ounce) of clean refrigeration oil to a new condenser.
2. Left grille support.
 3. Radiator support screws.
 4. Condenser inlet and outlet lines.

! Important

- Use new seals (o-rings) coated with clear refrigeration when connecting refrigerant lines.
5. Left grille support to the upper fender support screws.

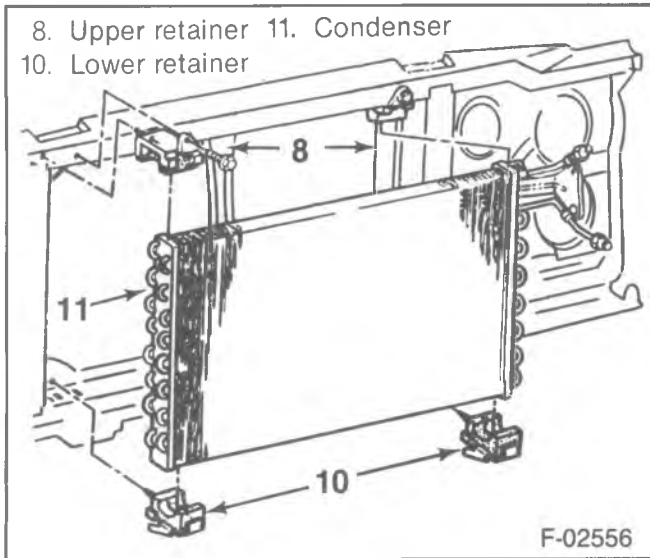

Figure 33—Condenser Replacement

- 8. Upper retainer
- 11. Condenser
- 10. Lower retainer

- 6. Radiator center support.
- 7. Grille assembly.
- 8. Battery ground cable.

ACCUMULATOR REPLACEMENT

↔ Remove or Disconnect (Figures 32 and 34)

1. Battery ground cable.
2. Compressor clutch connector.
3. Refrigerant from the system.

4. Inlet and outlet lines (97).

! Important

- Cap or plug open connections.

5. Bracket screws.
6. Accumulator (13) (figure 34).

! Important

- Drain excess refrigerant oil into a clean container. Measure and add new oil.

↔ Install or Connect (Figures 32 and 34)

1. New accumulator.

! Important

- Add 0.028 kg. (one ounce) of clean refrigerant oil. PLUS an amount equal to that drained.

2. Bracket screws.
3. Inlet and outlet lines.
4. Compressor clutch connector.
5. Battery ground cable.
6. Evacuate, charge and check the system.

BLOWER ASSEMBLY REPLACEMENT

↔ Remove or Disconnect (Figures 32, 34 and 35)

1. Battery ground cable.
2. Insulator - Diesel Engine (figure 35).
3. Blower motor lead and ground wires (134).

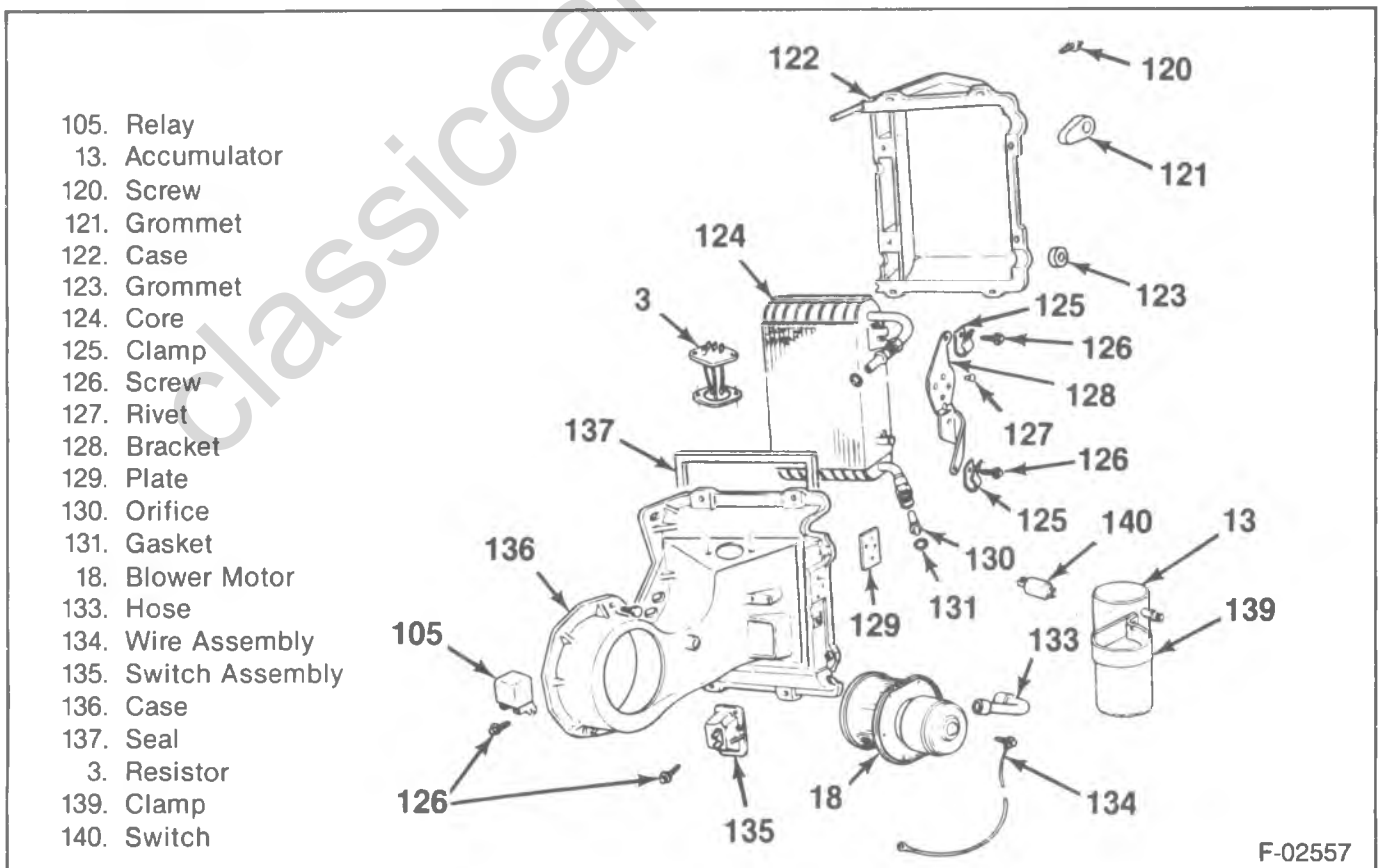

- 105. Relay
- 13. Accumulator
- 120. Screw
- 121. Grommet
- 122. Case
- 123. Grommet
- 124. Core
- 125. Clamp
- 126. Screw
- 127. Rivet
- 128. Bracket
- 129. Plate
- 130. Orifice
- 131. Gasket
- 18. Blower Motor
- 133. Hose
- 134. Wire Assembly
- 135. Switch Assembly
- 136. Case
- 137. Seal
- 3. Resistor
- 139. Clamp
- 140. Switch

Figure 34—Evaporator and Blower Assembly

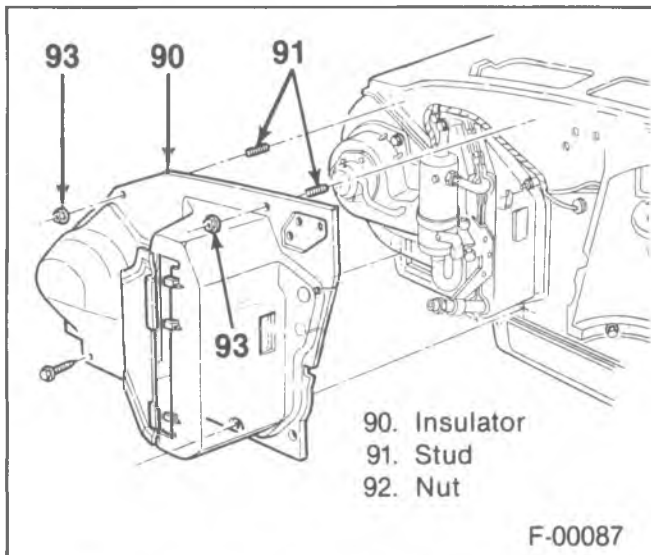

Figure 35—Dash Panel Insulator Removal

4. Blower motor cooling tube.
5. Blower assembly.
 - Case attaching screws.
 - Carefully pry the blower flange away from the case if the sealer acts as an adhesive.
6. Blower wheel from motor shaft.
 - Remove shaft nut.

→→ Install or Connect (Figures 32, 34 and 35)

1. Blower wheel to the motor shaft.
2. Blower assembly.
 - Use a new bead of sealer on the flange.
3. Blower assembly.
4. Blower motor cooling tube.
5. Blower motor lead and ground wires.
6. Battery ground cable.

EVAPORATOR CORE REPLACEMENT

→→ Remove or Disconnect (Figures 32 and 34)

1. Battery ground cable.
2. Discharge the system.
3. Nuts from the selector duct studs projecting through the dash panel.
4. Evaporator case cover (122).
5. Inlet and outlet lines.
 - Cap or inlet open connections.
6. Expansion tube. Refer to "Orifice (Expansion Tube) Replacement."
7. Evaporator core assembly.

→→ Install or Connect (Figures 32 and 34)

1. New core.
 - Add 90 ml (3 ounces) of clean refrigeration oil.
2. Expansion tube.
3. Inlet and outlet lines.
 - Use new seals (o-rings) coated with clean refrigeration oil.
4. Bead of sealer to cover.
 - Remove old sealer before applying new bead of sealer.

5. Evaporator case cover.
6. Nuts to the studs that project into the dash panel.
7. Battery ground cable.
8. Evacuate, charge and check the system.

ORIFICE (EXPANSION TUBE) REPLACEMENT

The expansion tube is located in the evaporator core inlet line.

→→ Remove or Disconnect (Figure 32)

1. Discharge the system.
2. Condenser to the evaporator line at the evaporator inlet (figure 35.)
 - Cap or plug the open line.
3. Expansion tube from the evaporator core inlet line.
 - Use needle-nose pliers to remove the core.
4. Expansion tube seal (o-ring) from the core inlet line.

→→ Install or Connect (Figures 4 and 35)

1. Expansion tube seal (o-ring) to the core inlet line.
 - Use new seal (o-ring) coated with clean refrigeration oil.
 - Insert the short screen and end of the orifice into the evaporator inlet line.
2. Expansion tube to the evaporator core inlet line.
3. Condenser to the evaporator line at the evaporator inlet.
4. Evacuate, charge and check the system.

SELECTOR DUCT AND HEATER CORE REPLACEMENT

→→ Remove or Disconnect (Figures 36 and 37)

1. Battery ground cable.
2. Drain the radiator.
3. Heater hoses from the core tubes (148) (figure 36).
 - Plug the core tubes to prevent spillage.
4. Instrument panel compartment and door.
5. Center duct to the selector duct (200) (figure 37).
6. Center lower and center upper ducts.
7. Temperature door cable.
8. Nuts from the three selector duct studs that project into the dash panel.
9. Selector duct to dash panel screw (inside the vehicle).
10. Selector duct assembly.
 - Pull rearward until the core tubes clear the dash panel.
 - Lower the selector assembly to reach the vacuum and electrical harness.
11. Vacuum and electrical harness.
12. Selector duct assembly.
13. Core mounting strap screws.
14. Core.

→→ Install or Connect (Figures 36 and 37)

1. Core.
2. Core mounting strap screws.
3. Selector duct assembly.
4. Vacuum and electrical harnesses.

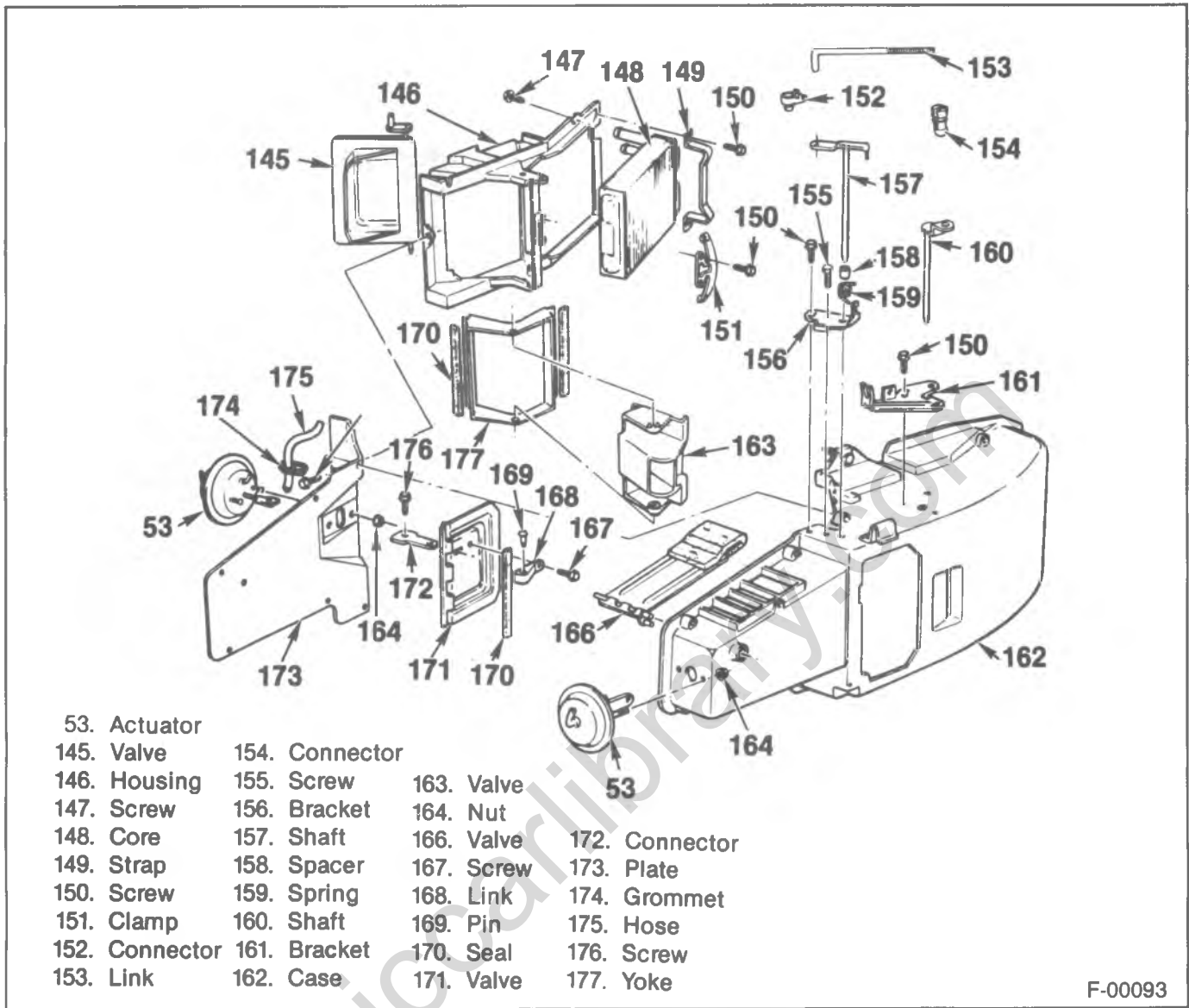

F-00093

Figure 36—Air Conditioning and Heater Component View

- 5. Selector duct assembly.
- 6. Temperature door cable.
- 7. Center lower and center upper ducts.
- 8. Center duct to selector duct.
- 9. Instrument panel bar and door.
- 10. Heater hoses.
- 11. Coolant to the radiator.
- 12. Battery ground cable.

Adjust

Temperature door cable. Refer to "Temperature Door Cable Adjustment."

ACTUATOR-PLENUM SIDE VENT REPLACEMENT

↔ Remove or Disconnect (Figure 38)

- 1. Vacuum hose at the actuator.
- 2. Valve return spring at the actuator end (216) (figure 38).
- 3. Actuator bracket mounting screws.

- 4. Cam to actuator arm screw (213).
- 5. Actuator and bracket from the cam.
- 6. Actuator to bracket nuts.
- 7. Actuator from the bracket (53).

↔ Install or Connect (Figure 38)

- 1. Actuator to the bracket (53).
- 2. Bracket nuts.
- 3. Actuator and bracket to the cam (211).
- 4. Cam to the actuator arm screw.
- 5. Actuator bracket mounting screws.
- 6. Valve return spring at the actuator end (216).
- 7. Vacuum hose to the actuator.

PLENUM VALVE REPLACEMENT

↔ Remove or Disconnect (Figure 39)

- 1. Raise the hood.
- 2. Cowl plastic grille.
- 3. Three cowl to valve assembly screws (226) (figure 39).

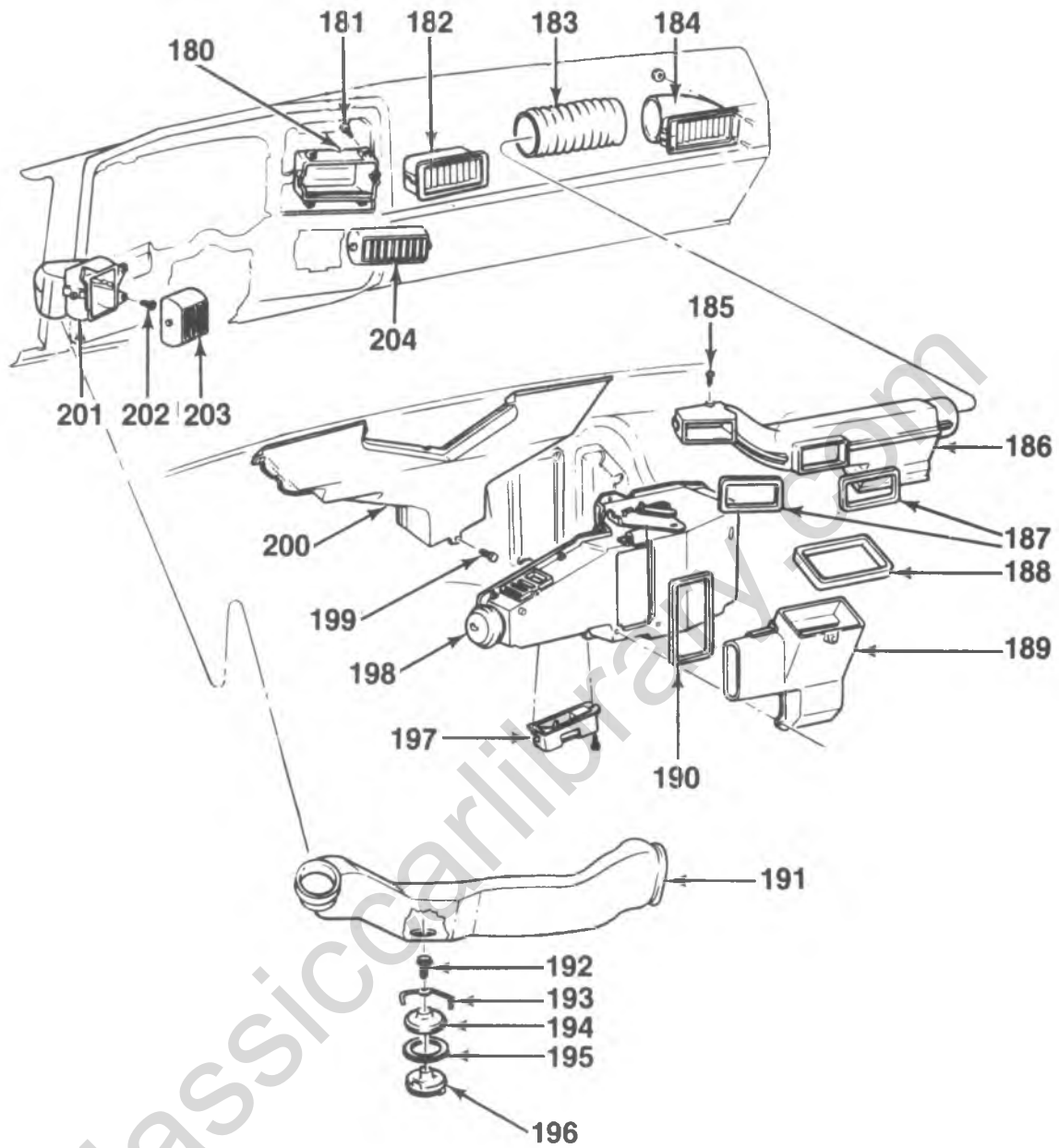

- | | |
|--------------------|--------------------------------|
| 180. Adapter | 193. Retainer |
| 181. Screw | 194. Adapter |
| 182. Adapter | 195. Felt |
| 183. Hose | 196. Deflector |
| 184. Duct Assembly | 197. Outlet |
| 185. Screw | 198. Air Conditioning Assembly |
| 186. Duct Assembly | 199. Bolt |
| 187. Seal | 200. Outlet Assembly |
| 188. Seal | 201. Outlet Assembly |
| 189. Duct Assembly | 202. Screw |
| 190. Gasket | 203. Deflector |
| 191. Duct Assembly | 204. Deflector |
| 192. Screw | |

Figure 37—Duct Assembly Component View

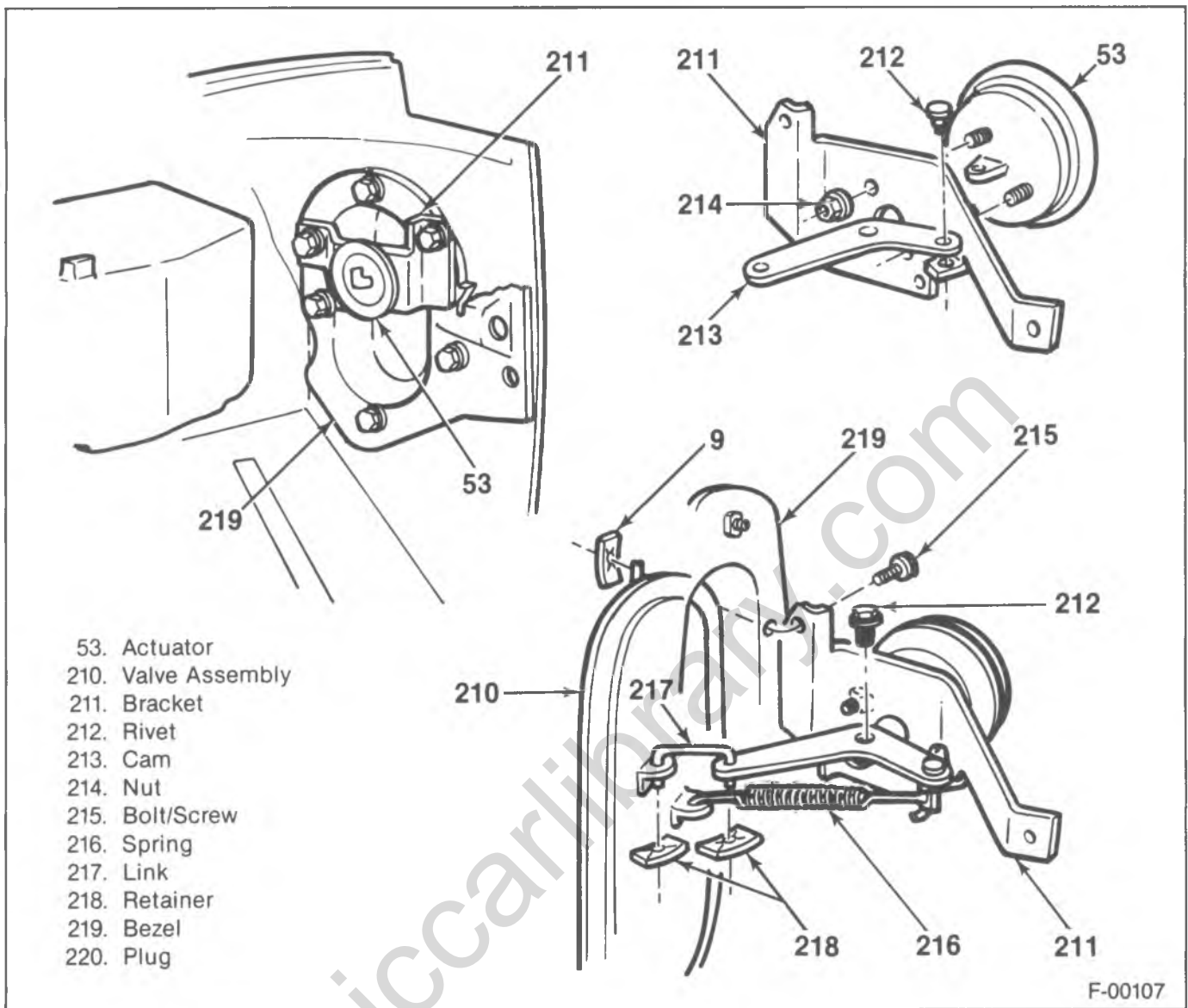

Figure 38—Actuator-Plenum Side Vent

- Valve assembly from the vehicle.
- 4. Actuator arm pushnut.
- 5. Actuator to valve nuts.
 - Separate the valve and actuator.

Install or Connect (Figure 39)

1. Actuator to valve nuts.
2. Actuator arm push nut (53).
3. Valve assembly to the vehicle.
4. Cowl plastic grille.
5. Close the hood.

CONTROL ASSEMBLY REPLACEMENT

Remove or Disconnect (Figure 40)

1. Battery ground cable.
2. Radio. Refer to RADIO (SEC. 9A).
3. Instrument panel bezel.
4. Control from the dash.

- Lower the control to gain access to the control assembly.

Important

- Do not kink the cable.

5. Cable (236) (figure 40).
6. Vacuum harness.
7. Electrical harness.
8. Control.

Install or Connect (Figure 40)

1. Blower switch to the new control.
2. Electrical harness.
3. Vacuum harness.
4. Cable (236).
5. Control to the dash.
6. Instrument panel bezel.
7. Radio. Refer to RADIO (SEC. 9A).
8. Battery ground cable.

F-00107

1B-40 AIR CONDITIONING

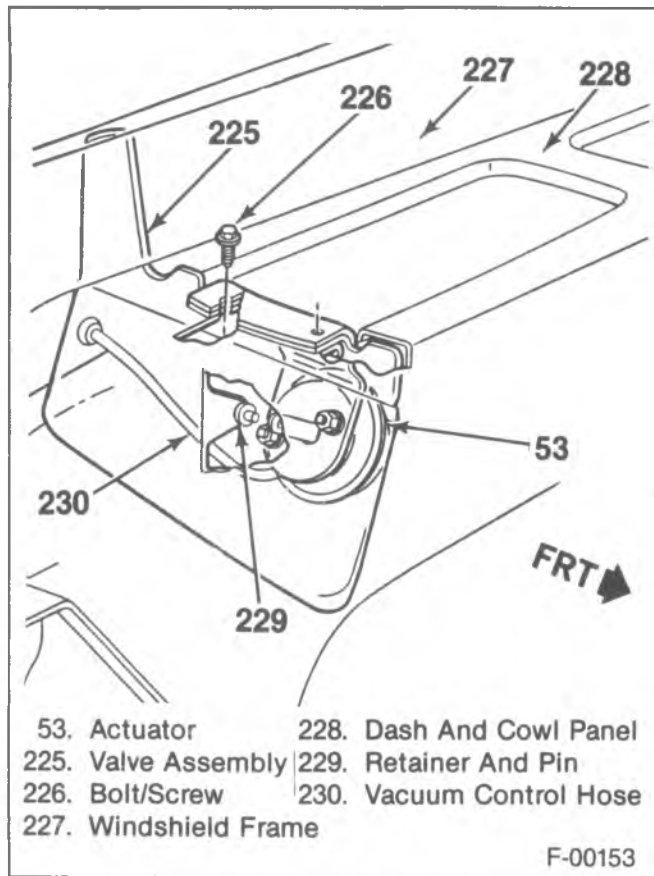

Figure 39—Plenum Air Inlet Door

TEMPERATURE DOOR CABLE ADJUSTMENT

Adjust (Figure 41)

1. Remove instrument panel compartment and door.
2. Loosen the cable attaching screw at the selector duct assembly.
 - Make sure the cable is installed in the bracket on the selector duct assembly.

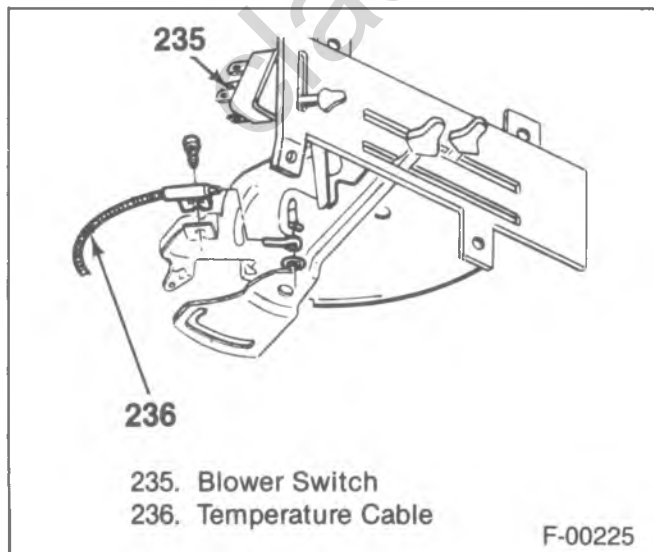

Figure 40—Control Assembly Replacement

3. Place the temperature lever in full COLD position and hold while tightening the cable attaching screw.
4. Install instrument panel compartment and door.

BLOWER SWITCH REPLACEMENT

The blower switch is located on the rear of the control assembly.

Remove or Disconnect (Figure 40)

1. Battery ground cable.
2. Instrument panel bezel.
3. Control to instrument panel screws.
 - Set the control on top of the radio.
4. Switch to control screws.
5. Electrical harness.
6. Vacuum harness at the master switch.
7. Switch (235).

Install or Connect (Figure 40)

1. Switch (235).
2. Vacuum harness.
3. Electrical harness.
4. Switch to control screws.
5. Control to the instrument panel.
6. Instrument panel bezel.
7. Battery ground cable.

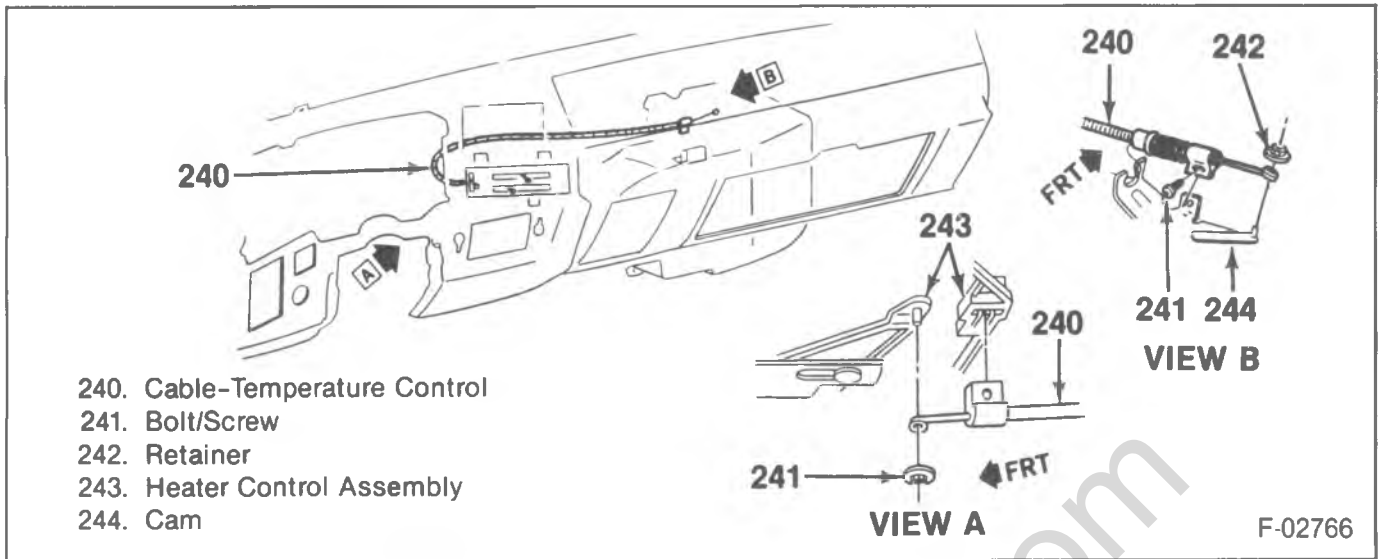

Figure 41—Temperature Door Cable Adjustment

VACUUM TANK REPLACEMENT

The vacuum tank is mounted to the cowl behind the left front fender.

↔ Remove or Disconnect (Figures 42, 43 and 44)

1. Vacuum lines at the tank.
2. Tank to dash panel screws.
3. Tank (251).

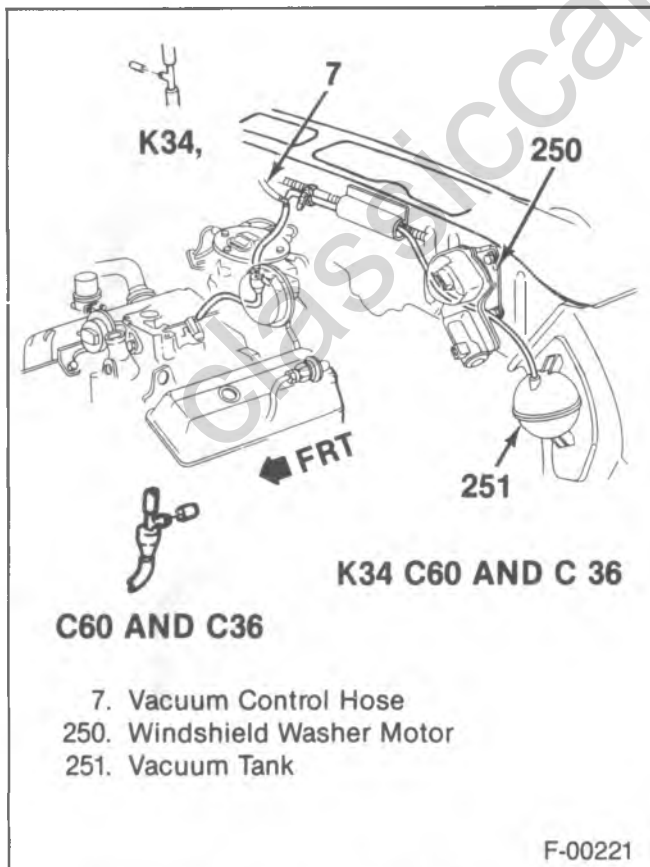

Figure 42—Vacuum Hose — 4.3L Engine

→ Install or Connect (Figures 42, 43 and 44)

1. Tank (251).
2. Vacuum hoses.

BLOWER MOTOR RESISTOR REPLACEMENT

The blower motor resistor is located in the blower side of the blower-evaporator case.

↔ Remove or Disconnect (Figure 32)

1. Wiring harness at the resistor.
2. Resistor to case attaching screws.
3. Resistor (81).

→ Install or Connect (Figure 32)

1. Resistor (81).
2. Screws.
3. Wiring harness.

BLOWER MOTOR RELAY REPLACEMENT

The blower motor relay is located on the blower side of the blower-evaporator case.

↔ Remove or Disconnect (Figure 32)

1. Wiring harness at the relay.
2. Attaching screws.
3. Relay (105).

→ Install or Connect (Figure 32)

1. Relay (105).
2. Mounting screws.
3. Wiring harness.

1B-42 AIR CONDITIONING

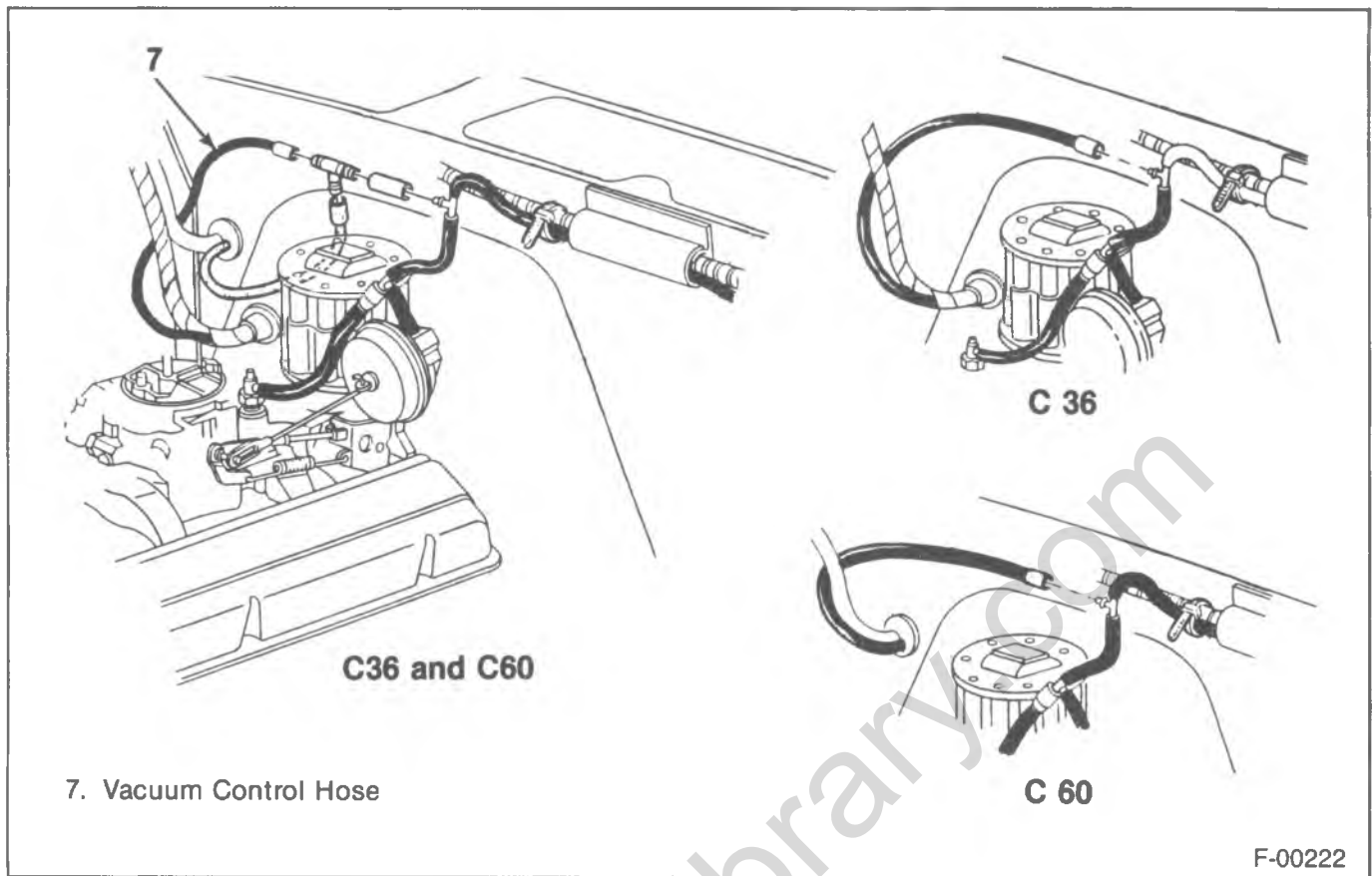

Figure 43—Vacuum Hose — 5.0, 5.7 and 7.4L Engine

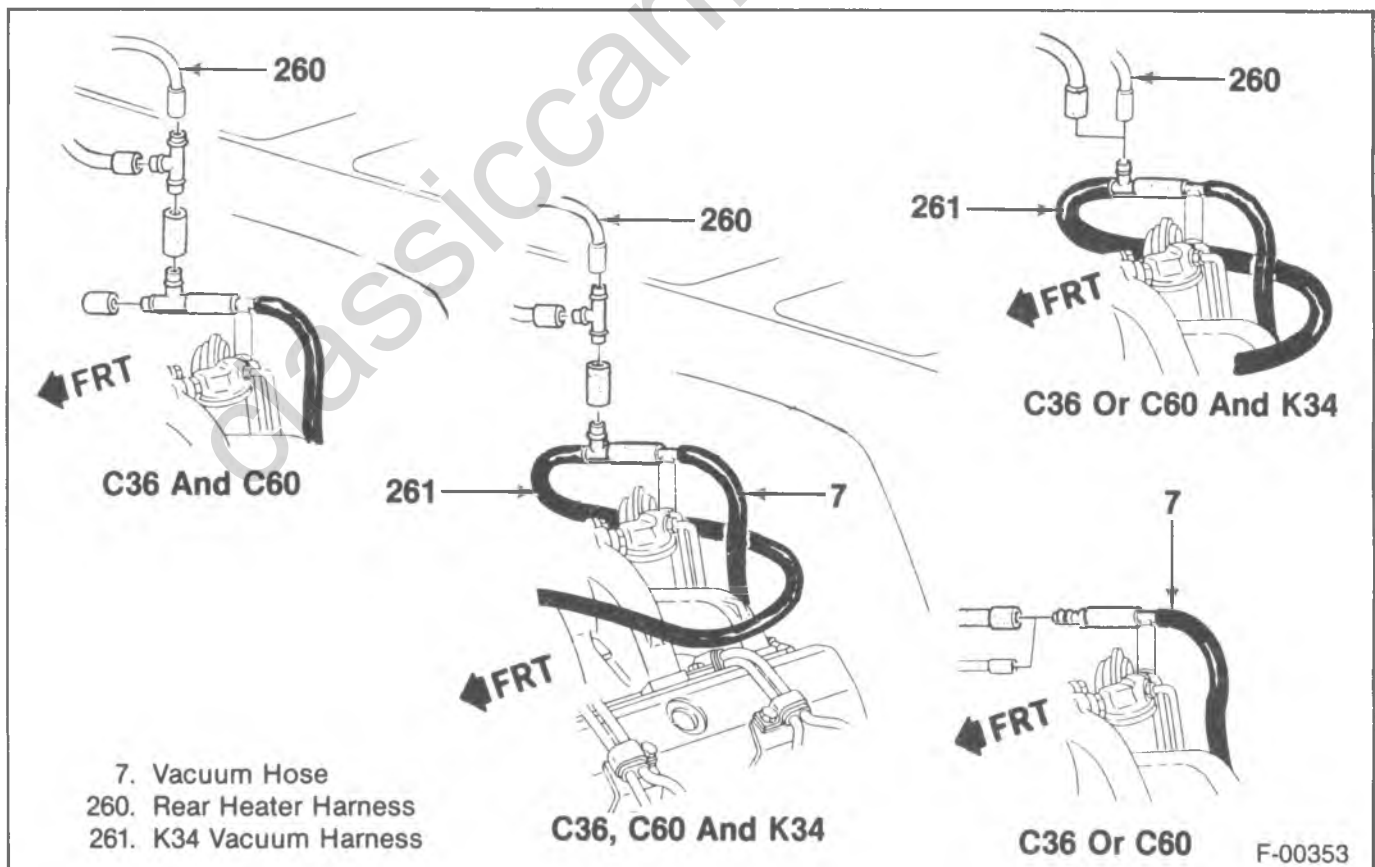

Figure 44—Vacuum Hose — 6.2L Engine

FUSE REPLACEMENT

A 25-amp fuse, located in the junction block, protects the system except for the blower circuit. The fuse for the blower circuit is located in the electrical wiring between the junction block and the blower relay.

VACUUM LINE REPLACEMENT— ENGINE COMPARTMENT

Rubber vacuum hoses can be repaired by cutting the hose at a leak, inserting a connector and pushing the hoses onto the connector.

If the entire hose needs replacing, pull the hose from each connector and thread a new hose into place. Follow the routing of the original hose.

For vacuum line routing, refer to figures 42, 43 and 44.

1. 4.3L engine (figure 42).
2. 5.0L, 5.7L and 7.4L engines (figure 43).
3. 6.2L engine (figure 44).

VACUUM LINE REPLACEMENT — DASH

These lines are molded to a connector which is attached to a vacuum control switch on the control assembly.

Repair a leaking vacuum hose by cutting the hose at the leak, inserting a connector and pushing the hoses onto the connector.

If an entire hose needs replacing, cut the hose off at the connector and attach the hose to the control assembly vacuum switch.

To find the dash vacuum harness and actuator installation, refer to figure 45.

REFRIGERANT-12 HOSE REPLACEMENT

Refrigerant hoses are replaced as a unit. The hose assembly must be removed from the compressor and the condenser.

The hose assembly has “captured” seals (o-rings) which are not replaced. New seals are installed on the new hose assembly. For installation, refer to figures 46, 47 and 48.

Remove or Disconnect (Figures 46, 47 and 48)

1. Refrigerant from the system.
2. Hose plate and bolt from the rear of the compressor (275).
3. Hose connections (97) at the condenser (70) and the accumulator (107).
 - Cap or plug all open connections.

Install or Connect (Figures 46, 47 and 48)

1. Hose connections (97) at the condenser (70).

Tighten

- Fittings to 24 N·m (18 ft. lbs.).
2. Hose connection (97) at the accumulator (107).

Tighten

- Fittings to 41 N·m (30 ft. lbs.).
3. Hose plate and bolt to the rear of the compressor (275).

Tighten

- Bolt to 34 N·m (25 ft. lbs.).
4. Refrigerant to the system.
 - Leak test.

1B-44 AIR CONDITIONING

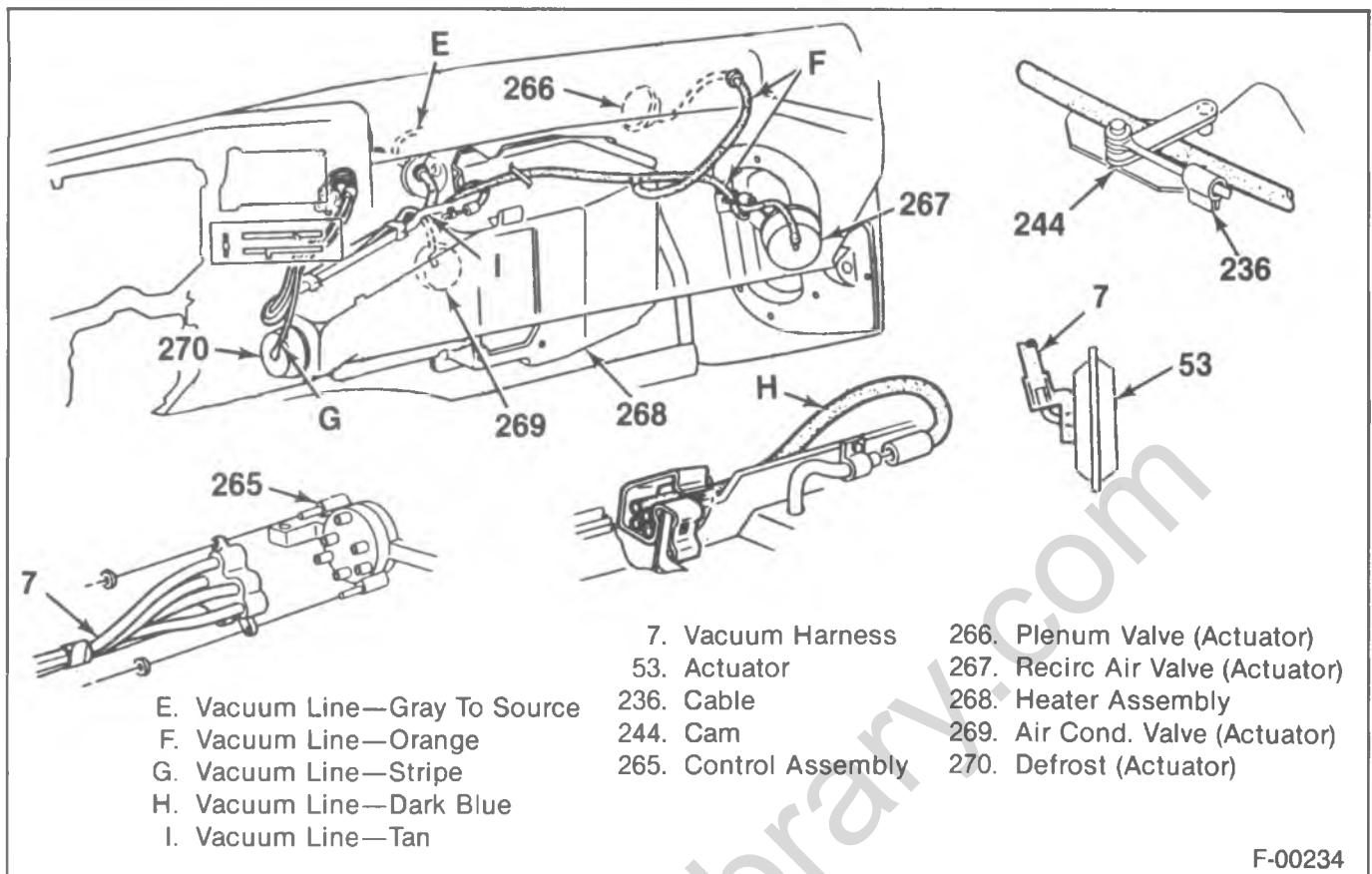

Figure 45—Vacuum Control Hose — Dash

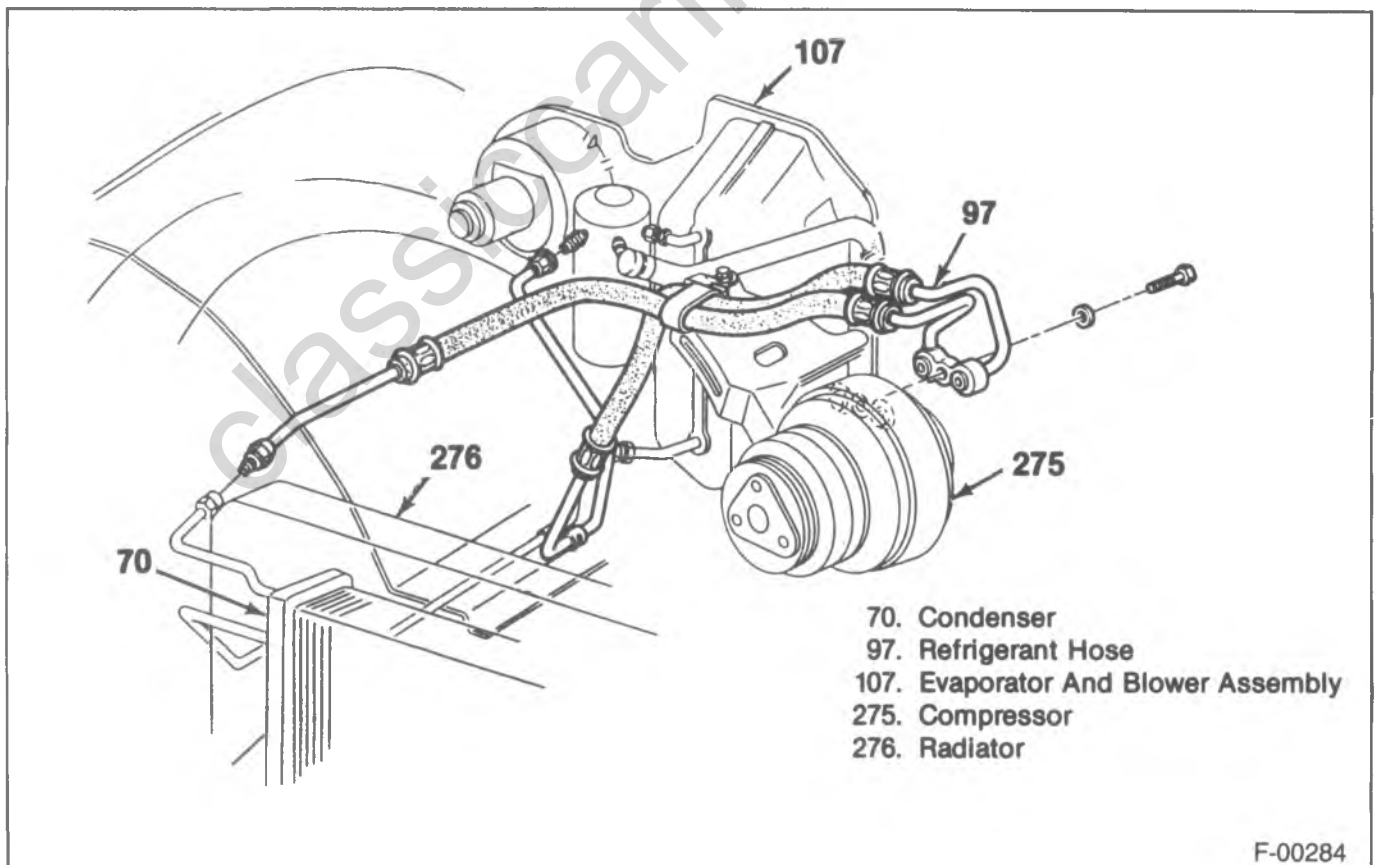

Figure 46—R/V — 4.3L Engine Refrigerant Hose Assembly

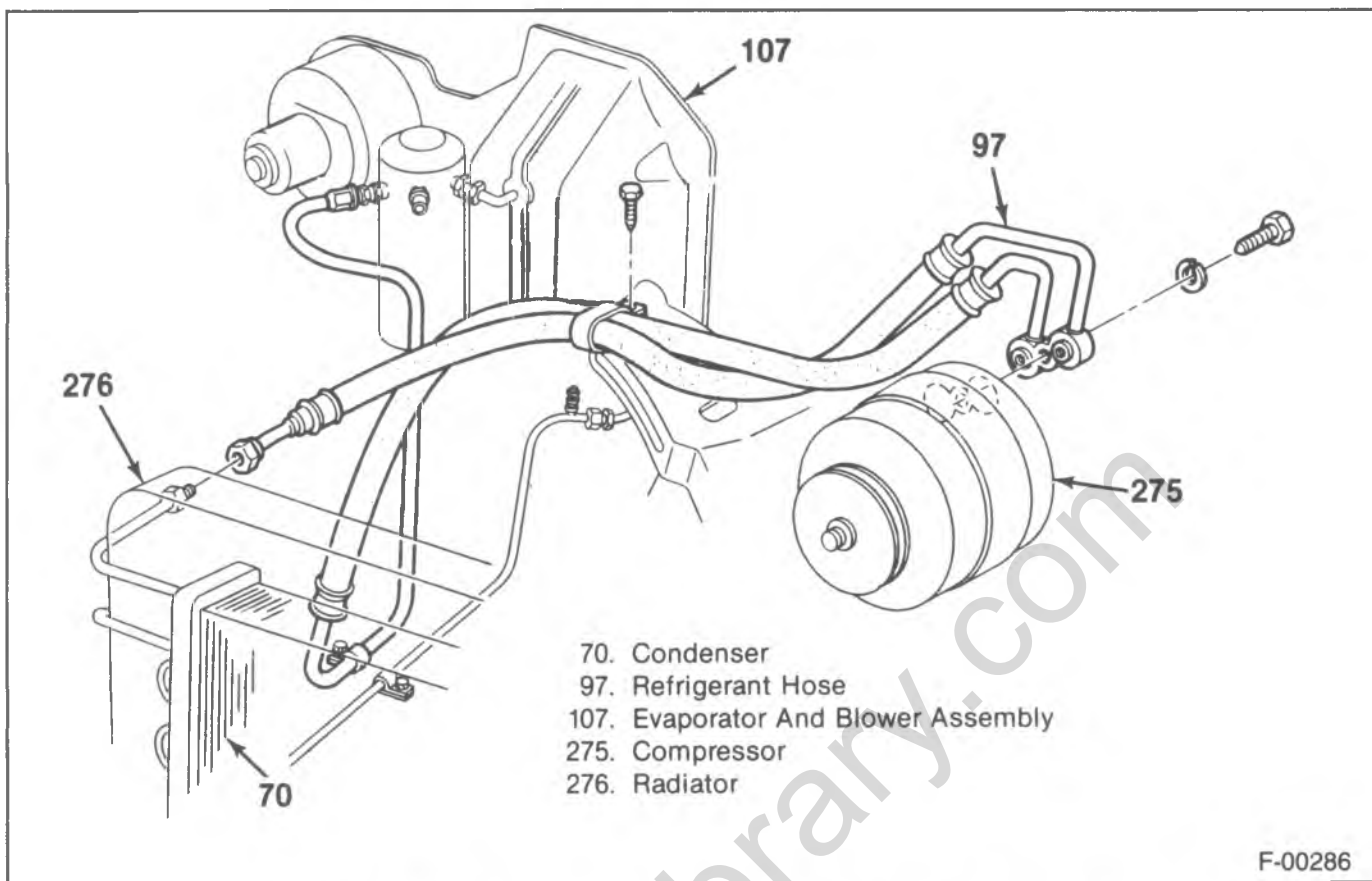

Figure 47—R/V — 5.0L, 5.7L and 7.4L Refrigerant Hose Assembly

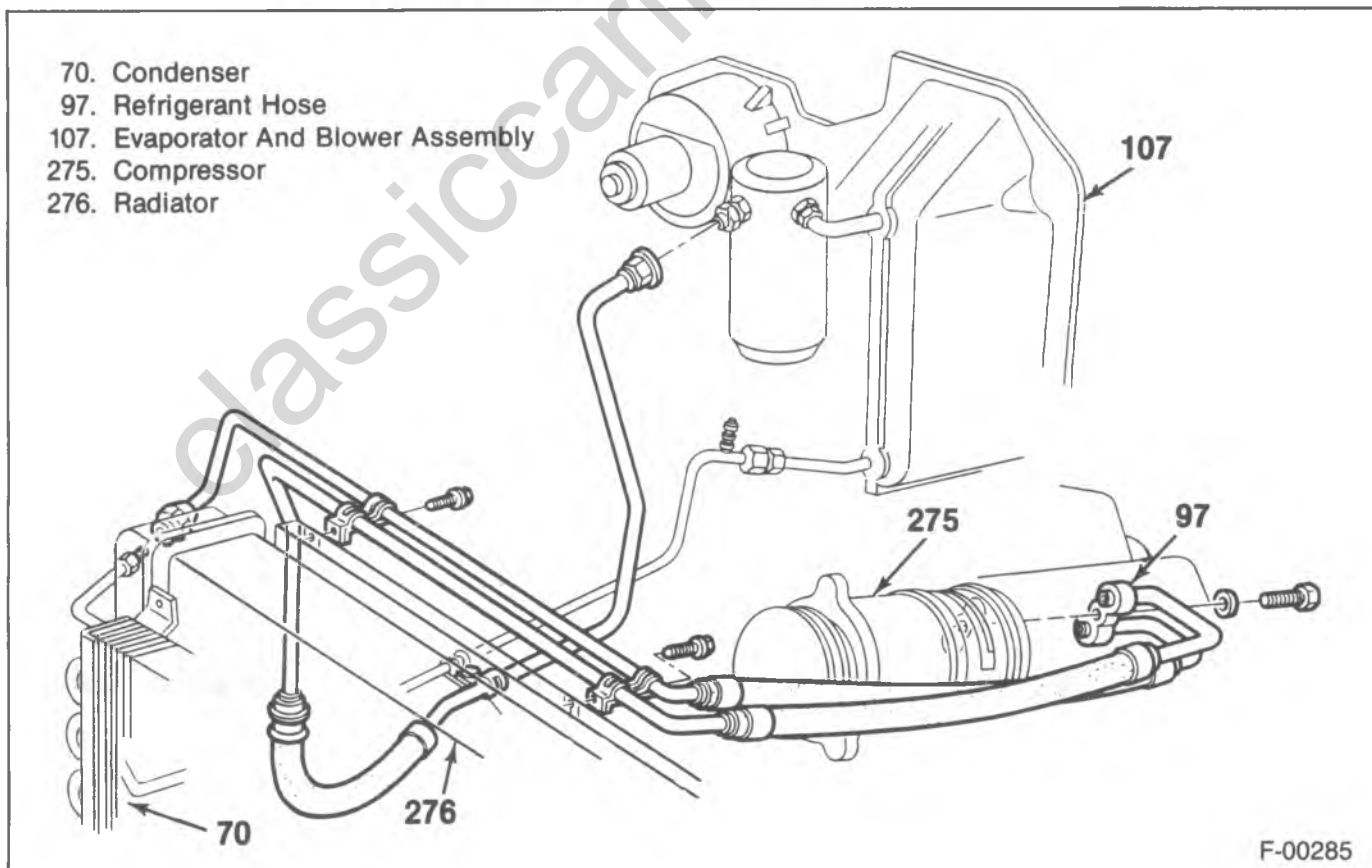

Figure 48—R/V — 6.2L Engine Refrigerant Hose Assembly

REAR INTERIOR ROOF MOUNTED SYSTEM—SUBURBAN

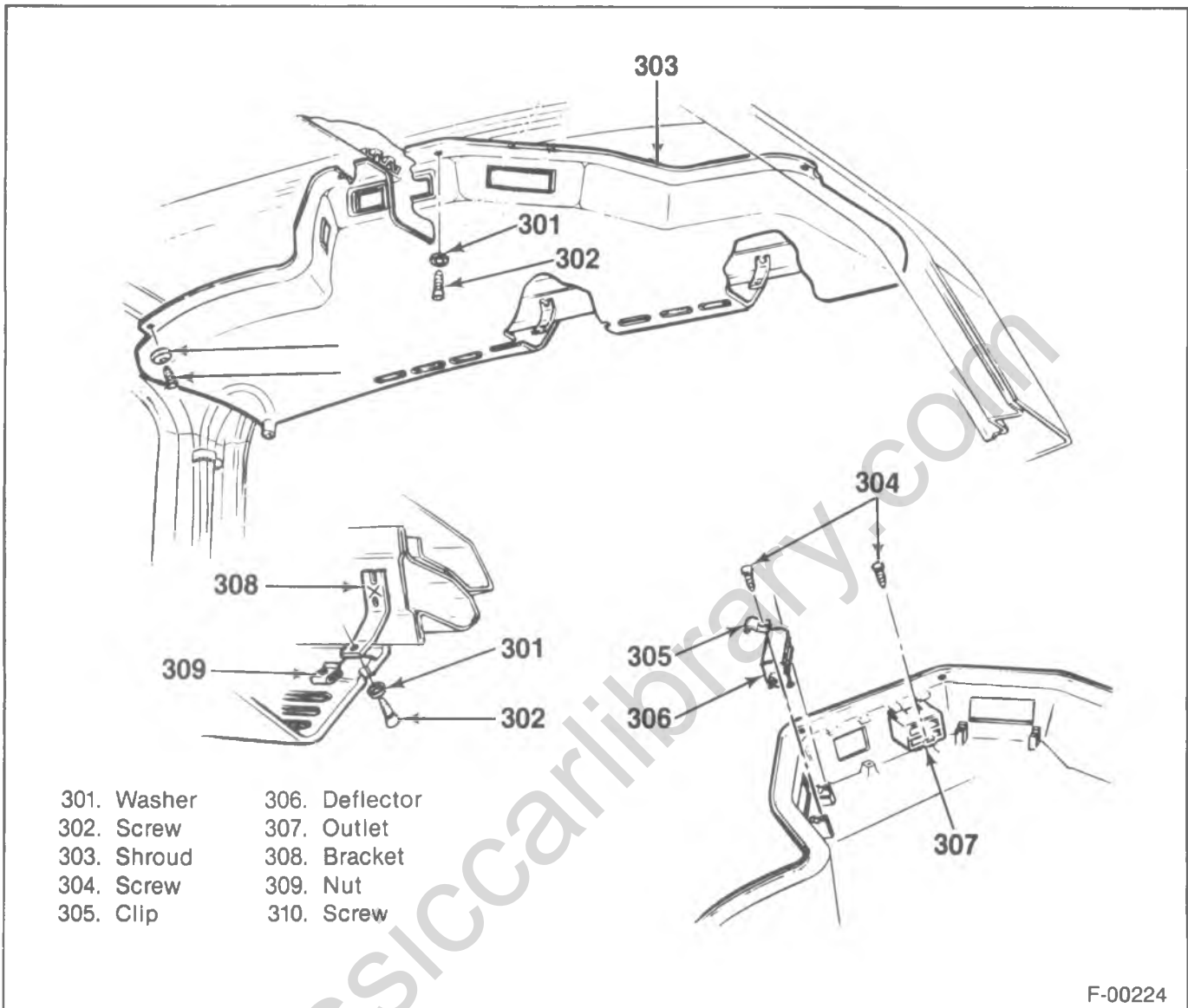

Figure 49—Rear Interior Roof Mounted System — Shroud

The rear interior roof mounted system is used with the front air conditioning system. Refer to figures 49, 50 and 51.

REAR DUCT REPLACEMENT

This duct covers the blower-evaporator assembly located at the rear of the vehicle. It has four adjustable air outlets (figure 49).

Remove or Disconnect (Figure 49)

1. Drain tube from the rear duct.
2. Screws securing the duct to the roof panel and rear header brackets.
3. Duct (303).

Install or Connect (Figure 49)

1. Duct (303).
2. Screws and brackets.
3. Drain tube.

BLOWER MOTOR RESISTOR REPLACEMENT

The blower motor resistor is located on the cover side of the blower-evaporator. To remove, refer to "Blower Motor Resistor, A/C System R/V Series."

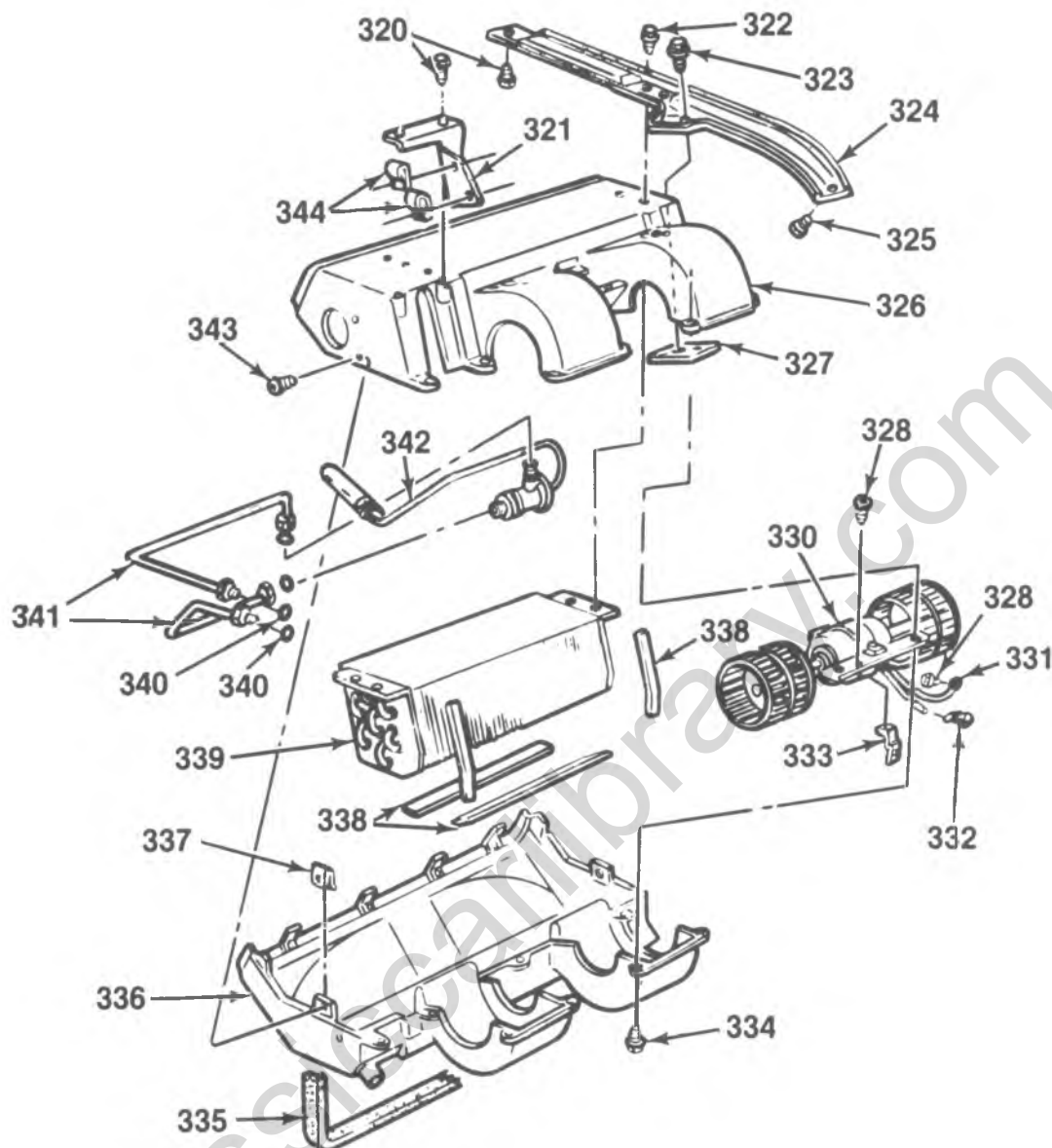

- | | |
|-----------------|------------------------|
| 320. Screw | 333. Bracket |
| 321. Bracket | 334. Screw |
| 322. Screw | 335. Seal |
| 323. Screw | 336. Case |
| 324. Support | 337. Clip |
| 325. Screw | 338. Seal |
| 326. Case | 339. Core Asm. |
| 327. Plate | 340. Seal (O-ring) |
| 328. Screw | 341. Refrigerant Lines |
| 329. Seal | 342. Valve Asm. |
| 330. Motor Asm. | 343. Screw |
| 331. Eyelet | 344. Clamps |
| 332. Terminal | |

Figure 50—Rear Interior Roof Mounted Evaporator and Blower Component View

1B-48 AIR CONDITIONING

- | | | |
|---------------|--------------------|------------------------------------|
| 2. Screw | 26. Lower Retainer | 45. Evaporator and Blower Assembly |
| 3. Bracket | 27. Upper Retainer | 46. Deflector |
| 4. Seal | 29. Tube | 47. Outlet |
| 5. Seal | 34. Connector | 48. Clamp |
| 6. Clip | 35. Retainer | 49. Tube |
| 7. Bolt | 36. Seal | 303. Shroud |
| 8. Clip | 37. Plate | 324. Support |
| 9. Wire | 38. Clip | |
| 10. Bracket | 41. Screw | |
| 11. Cover | 42. Bracket | |
| 12. Bracket | 44. Seal | |
| 13. Screw | | |
| 14. Bracket | | |
| 15. Hose | | |
| 16. Hose | | |
| 17. Clip | | |
| 18. Clip | | |
| 19. Bolt | | |
| 20. Washer | | |
| 21. Fitting | | |
| 25. Condenser | | |

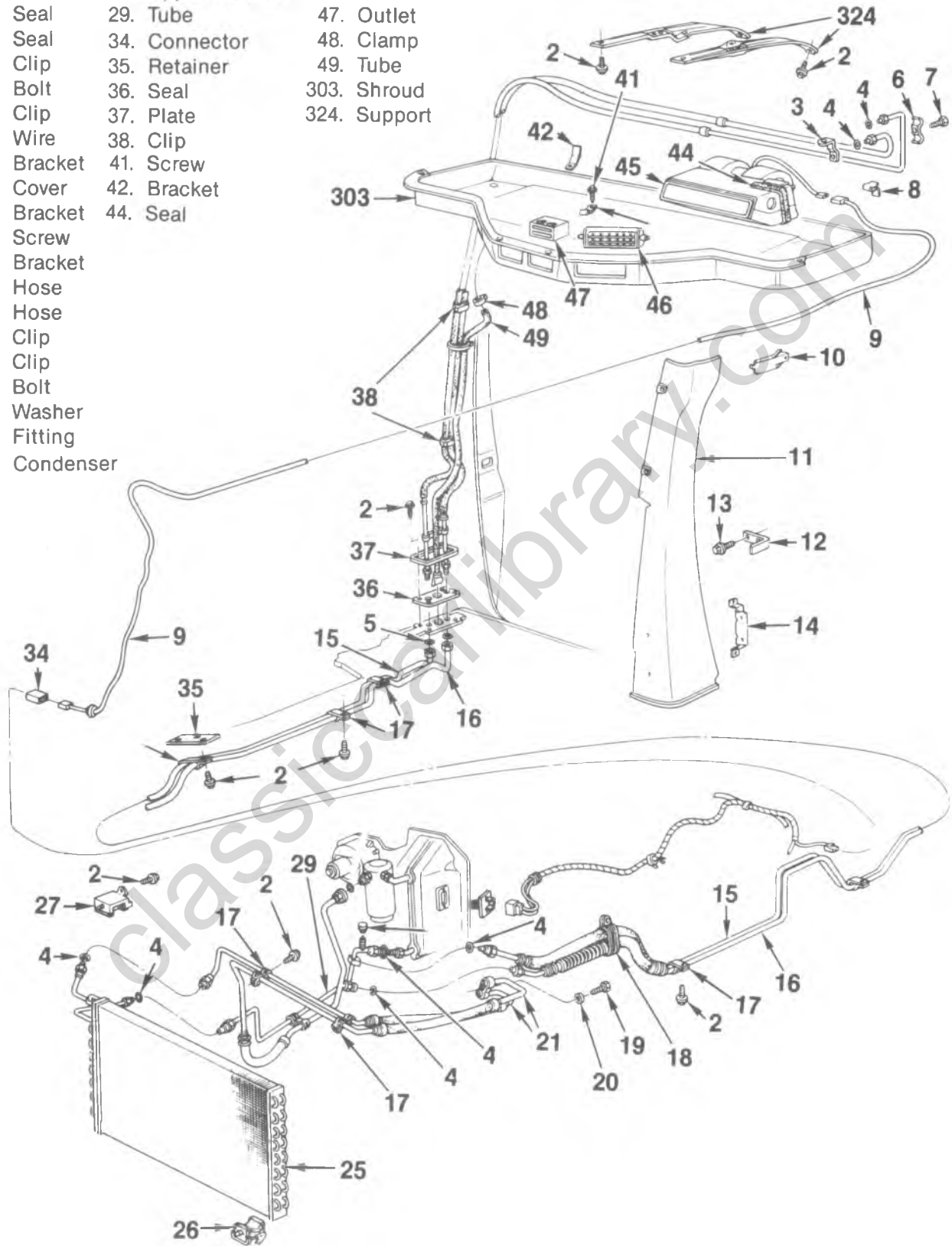

F-00667

Figure 51—Rear Interior Roof Mounted Evaporator Hoses Component View

BLOWER MOTOR ASSEMBLY REPLACEMENT

↔ Remove or Disconnect (Figure 50)

1. Battery ground cable.
2. Rear duct (303).
3. Blower motor ground strap.
4. Blower motor lead wire.
5. Lower to upper blower-evaporator case screws.
6. Case and motor assembly (326) (336).

! Important

- Before removing the case screws, support the lower case to prevent damage to the case or motor assembly.
7. Motor retaining strap.
 8. Motor and wheels (330).
 9. Wheels from the motor shaft.

↔ Install or Connect (Figure 50)

1. Wheels to the motor shaft (330).
 - Place the tension springs on the wheel hubs.
2. Motor and wheels to the case.
 - Align the wheels to prevent contact with the case.
3. Motor retaining strap and foam.
4. Lower case and blower motor assembly in the vehicle (336).
5. Lower to upper case screws.
 - Turn the blower wheels to prevent rubbing against the case.
6. Center ground strap.
7. Blower lead wire.
8. Rear duct.
9. Battery ground cable.

EXPANSION VALVE REPLACEMENT

This system incorporates an expansion valve which does not utilize an external equalizer line.

↔ Remove or Disconnect (Figures 50 and 51)

1. Battery ground cable.
2. Purge the system of refrigerant.
3. Rear duct.
4. Blower motor lead.
5. Ground wire.
6. Lower to upper blower-evaporator case screws.

! Important

- Before removing the case screws, support the lower case and motor assemblies to prevent damage to the case or motor assembly.
7. Lower case and motor assembly (336).
 8. Expansion valve sensing bulb clamps.
 9. Valve inlet and outlet lines.
 - Cap or plug open lines.
 10. Expansion valve assembly (342).

↔ Install or Connect (Figures 50 and 51).

1. New expansion valve assembly (342).
 - Remove caps or plug.
 - Use new seals (o-rings) coated with clean refrigeration oil.
2. Sensing bulb.
3. Lower case and blower motor assembly.
4. Blower motor lead.
5. Ground wires.
6. Rear duct.
7. Battery ground cable.
8. Evacuate, charge and check the system.

EVAPORATOR CORE REPLACEMENT

↔ Remove or Disconnect (Figures 50 and 51)

1. Battery ground cable.
2. Purge the system of refrigerant.
3. Rear duct.
4. Blower motor lead.
5. Ground wire.
6. Refrigerant lines at the rear of the blower-evaporator assembly (351).
 - Cap or plug the open connections.
7. Blower-evaporator support to roof rail screws.
8. Blower-evaporator (339).
 - Place the blower-evaporator upside down on a work bench.
9. Lower case assembly.
10. Upper case from the evaporator core.
11. Expansion valve inlet and outlet lines.
 - Cap or plug open connections.
12. Expansion valve capillary bulb from the evaporator outlet line.
13. Valve.
14. Plastic pins that hold the screen to the core.
15. Screen.

↔ Install or Connect (Figures 50 and 51)

1. Wire screen to the front of the core.
2. Plastic pins.
3. Expansion valve inlet and outlet lines (341).
 - Use new seals (o-rings) coated with clean refrigeration oil.
4. Sensing bulb to the evaporator outlet line (342).
 - Bulb must make good contact with the line.
 - Add 30 ml (3 ounces) of clean refrigeration oil to new core.
5. Upper case and supports to the core.
6. Lower core case and blower assembly.
7. Blower-evaporator assembly to the roof.
8. Support to roof rail screws.
9. Refrigerant lines to the blower-evaporator unit.
 - Use new seals (o-rings) with clean refrigeration oil.
10. Blower lead wire.
11. Ground wire.
12. Rear duct.
13. Battery ground cable.
14. Evacuate, charge and check the system.

BLOWER MOTOR SWITCH REPLACEMENT

The auxiliary heater and air conditioning blower switches are located to the right of the steering wheel.

↔ Remove or Disconnect (Figure 52)

1. Battery ground cable.
2. Switch retaining screws.
3. Wiring harness.
4. Switch.

→↔ Install or Connect (Figure 52)

1. Switch.
2. Wiring harness.
3. Switch retaining screws.
4. Battery ground cable.

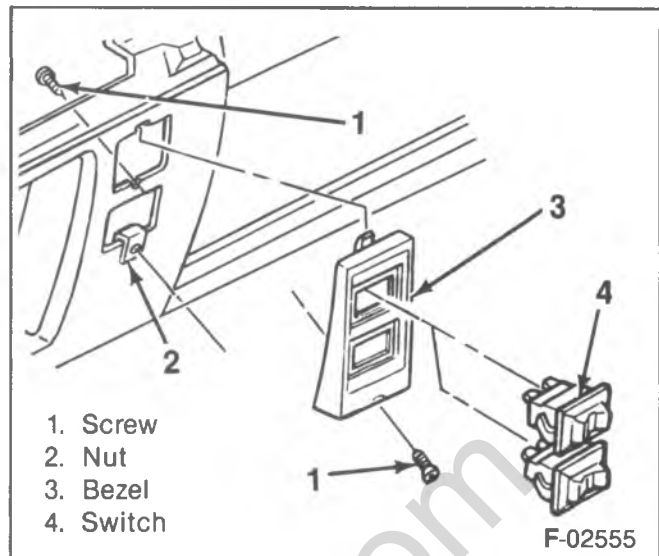

Figure 52—Blower Switch Replacement

FUSE REPLACEMENT

A-25 amp fuse at the junction box protects this system. A 20-amp fuse, located between the junction block and the rear blower motor switch, protects the rear blower high speed circuit.

A/C SYSTEM — G SERIES

CONDENSER REPLACEMENT

↔ Remove or Disconnect (Figure 53)

1. Battery ground cable.
2. Refrigerant from the system.
3. Grille, hood lock, and center hood lock support.
4. Condenser inlet and outlet lines at the condenser (70).
5. Screws attaching the left side condenser bracket to the radiator.
6. Screws attaching the right side condenser bracket to the condenser.
7. Condenser.
8. Left bracket from the condenser.

→↔ Install or Connect (Figure 53)

1. Left bracket to condenser.
2. Condenser (70).
 - Add 30 ml (1 ounce) of clean refrigeration oil to a new condenser.
3. Screws attaching the left side of the condenser bracket to the condenser.
4. Screws attaching the right side of the condenser bracket to the condenser.
5. Condenser inlet and outlet lines at the condenser (70).
6. Grille, hood lock and center hood lock support.
7. Refrigerant.
8. Battery ground cable.
9. Evacuate, charge and test the system.

ACCUMULATOR REPLACEMENT

↔ Remove or Disconnect (Figure 53 and 54)

1. Battery ground cable.
2. Compressor clutch cable.
3. Discharge the system.
4. Inlet and outlet lines.

! Important

- Cap or plug open connections.

5. Bracket screws.
6. Accumulator.

! Important

- Drain excess refrigerant oil into a clean container. Measure and record amount. Use fresh oil.

→↔ Install or Connect (Figure 53 and 54)

1. New accumulator.

! Important

- Add 30 ml (1 ounce) of clean refrigerant oil **PLUS** an amount equal to that drained.

2. Bracket screws.
3. Inlet and outlet lines.
4. Compressor clutch connector.
5. Battery ground cable.
6. Evacuate, charge and check the system.

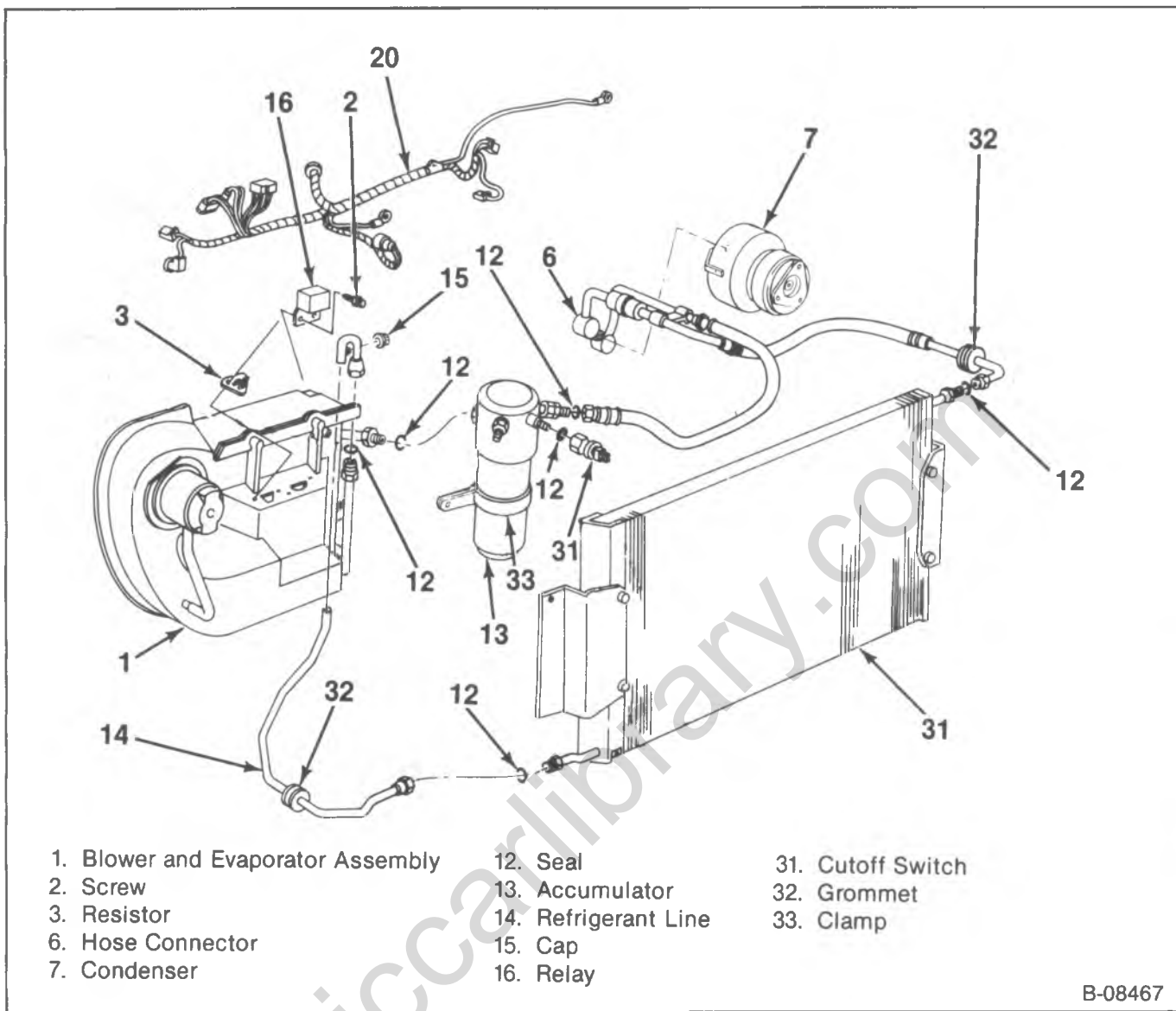

B-08467

Figure 53—Air Conditioning System Component View

HEATER CORE REPLACEMENT

↔ Remove or Disconnect (Figure 54)

1. Battery ground cable.
2. Engine cover.
3. Steering column to instrument panel.
 - Lower column.
4. Upper and lower instrument panel attaching screws and radio support bracket attaching screw.
5. Raise and support right side of the instrument panel.
6. Right lower instrument panel support bracket.
7. Recirculating air door vacuum actuator.
8. Temperature cable and vacuum hoses at the distributor case.
9. Heater distributor duct.
10. Defroster duct to dash panel attaching screws (below the windshield).
11. Heater hoses (457).

- Plug to prevent spillage.
12. Three nuts from the bolts that hold the heater core case to the dash panel and one screw at the lower right corner (inside).
 13. Distributor assembly from the vehicle.
 14. Gasket to expose the screws attaching the case sections together.
 15. Temperature cable support bracket.
 16. Case attaching screws and separate the case.
 17. Heater core (457).

↔ Install or Connect (Figure 54)

1. New heater core.
2. Screws and case.
3. Temperature cable support bracket.
4. Gasket.
5. Distributor assembly.
6. Heater core nuts to bolts.
7. Heater hoses.
8. Defroster duct to dash panel screws.
9. Heater distributor duct.

1B-52 AIR CONDITIONING

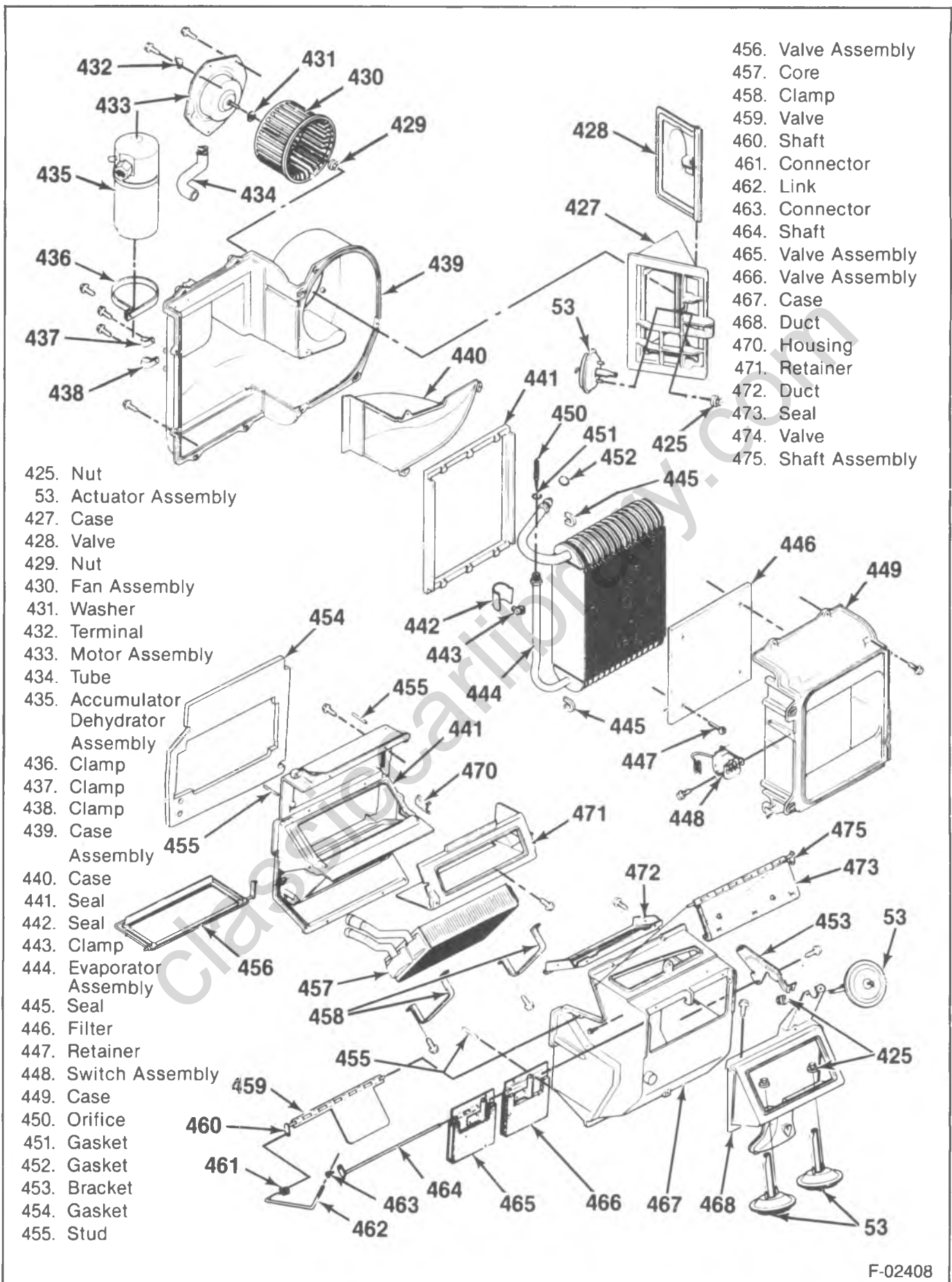

F-02408

Figure 54—Evaporator — Blower Component View

10. Temperature cable and vacuum hoses at the distributor.
11. Right lower instrument panel support bracket.
12. Right side of the instrument panel.
13. Upper and lower instrument panel screws.
14. Radio support bracket screw.
15. Steering column to instrument panel attaching bolts and raise the column.
16. Engine cover.
17. Battery ground cable.

ORIFICE (EXPANSION TUBE) REPLACEMENT

The orifice tube is located in the evaporator core inlet line.

Remove or Disconnect (Figure 53)

1. Discharge the system.
2. Condenser to the evaporator line at the evaporator inlet.
 - Cap or plug the open line.
3. Expansion tube from the evaporator core inlet line.
 - Use a needle nose pliers to remove the orifice from the tube.
4. Expansion tube seal (o-ring) from the core inlet line.

Install or Connect (Figure 53)

1. Expansion tube seal (o-ring) to the core inlet line.
 - Use a new seal (o-ring) coated with clean refrigeration oil.
 - Insert the short screen end of the orifice into the evaporator inlet line.
2. Expansion tube to the evaporator core inlet line.
3. Condenser to the evaporator line at the evaporator inlet.
4. Evacuate, charge and check the system.

BLOWER MOTOR INSULATION (W/DIESEL) REPLACEMENT

The 6.2 Liter Diesel Engine has extra insulation around the blower motor on vehicles without air conditioning and around the blower motor and evaporator core with air conditioning option (figure 55).

Remove or Disconnect (Figure 2 54 and 55)

1. Parking lamp assembly.
2. Radiator overflow tank.
3. Blower motor insulation (481).
 - Insulation through the hood opening.
4. Blower motor (482).

Install or Connect (Figures 54 and 55)

1. Blower motor (482).
2. Insulation (481).
3. Radiator overflow tank.
4. Parking lamp assembly.

EVAPORATOR CORE (W/DIESEL) REPLACEMENT

Remove or Disconnect (Figures 54 and 55)

1. Cold air intake.
2. Hood latch assembly and cable retainer and place it out of the way.
3. Windshield solvent tank.
4. Refrigerant from the system.

Important

- When removing A/C components, cap the lines and openings to prevent contamination.
5. Low pressure vapor line and move it out of the way.
 6. Accumulator.
 7. High pressure line inlet to the evaporator and the connecting bracket.
 8. Wiring harness going to the blower motor relay and resistor.
 9. Blower motor relay and resistor.
 10. Fan shroud upper half.
 11. Radiator.
 12. Heater valve assembly bracket and move it out of the way.
 13. Upper screws of the lower section.
 - Push it down and out of the way.
 14. Insulation mounting screws.
 15. Insulation through the hood opening.
 16. Proceed with the A/C evaporator procedure.

Install or Connect (Figures 54 and 55)

1. A/C evaporator core procedure.
2. Insulation (481).
3. Insulation mounting screws.
4. Lower section.
5. Heater valve assembly bracket.
6. Radiator.
7. Fan shroud upper half.
8. Blower motor relay and resistor.
9. Wiring harness.
10. High pressure line inlet and bracket.
11. Accumulator.
12. Low pressure vapor line.
13. Refrigerant to the system.
14. Windshield solvent tank.
15. Hood latch assembly and cable retainer.
16. Cold air intake.

EVAPORATOR CORE REPLACEMENT

Remove or Disconnect (Figure 54)

1. Battery ground cable.
2. Refrigerant from the system.
3. Coolant recovery tank and bracket.
4. Electrical connectors from the core case assembly.
5. Bracket at the evaporator case.
6. Right marker lamp for access.
7. Accumulator inlet and outlet lines, and the two brackets that attach the accumulator to the case.
8. Evaporator inlet line.

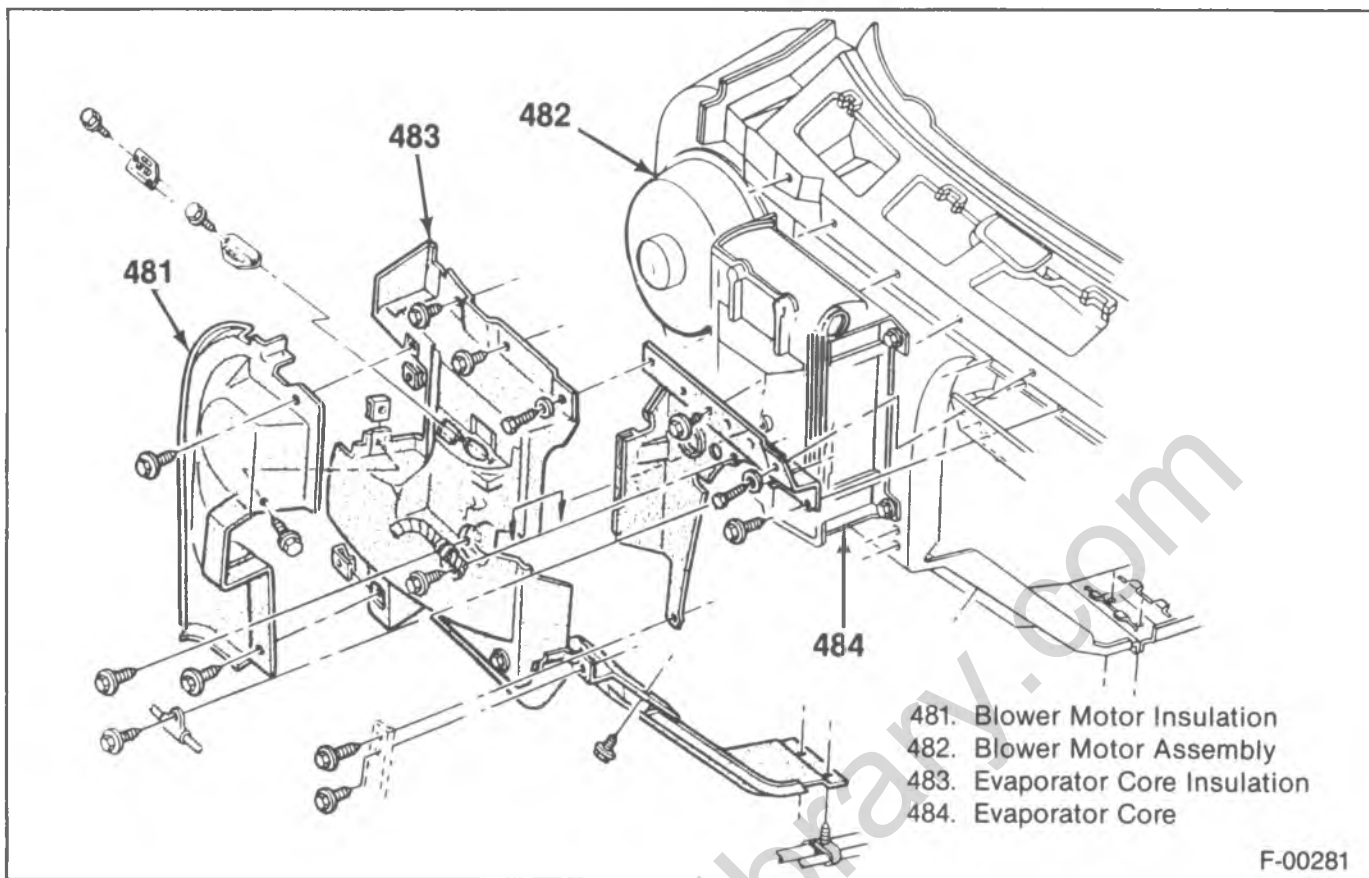

Figure 55—Blower Motor Insulation — 6.2L Engine

9. Three (3) nuts and one (1) screw attaching module to the dash panel.
10. Core case assembly from the vehicle.
11. Screws and separate the case sections.
12. Evaporator core.

↔ Install or Connect (Figure 54)

1. New core.
 - Add 90 ml (3 ounces) or 525 viscosity refrigeration oil to a new condenser.
2. Screws and the case sections.
3. Core case assembly to the vehicle.
4. Module to the dash panel.
5. Evaporator inlet line.
6. Accumulator inlet and outlet lines.
7. Two brackets that hold the accumulator to the case.
8. Right marker lamp.
9. Bracket to the evaporator case.
10. Electrical connectors.
11. Coolant recovery tank and bracket.
12. Evacuate, charge and check the system.
13. Battery ground cable.

BLOWER MOTOR REPLACEMENT

↔ Remove or Disconnect (Figure 54)

1. Battery ground cable.
2. Coolant recovery tank.
3. Power antenna.

4. Blower motor lead wire.
5. Motor and wheel assembly (433).
 - Five blower motor mounting screws.
 - Pry gently on the blower flange if the sealer acts as an adhesive.
6. Blower wheel to motor shaft nut.
7. Separate the wheel and motor assemblies.

↔ Install or Connect (Figure 54)

1. Wheel to the blower motor.
 - Assemble the blower wheel to the motor with the open end of the wheel away from the blower motor.
2. Blower wheel to the motor shaft nut.
3. Blower wheel and motor assembly to the vehicle.
 - If the motor mounting flange sealer has hardened or is not intact, remove the old sealer and apply a bead of sealer to the mounting flange.
 - Check blower operations: blower wheel should rotate with no interference.
4. Blower motor lead wire.
5. Coolant recovery tank and power antenna.
6. Battery ground cable.

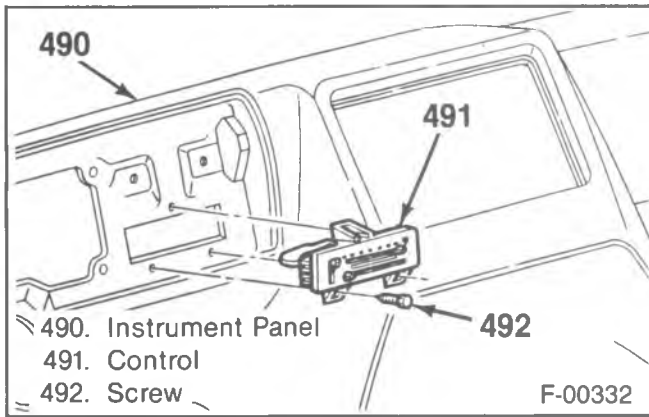

Figure 56—Control Assembly Removal

CONTROL ASSEMBLY REPLACEMENT

↔ Remove or Disconnect (Figures 56, 57, 58 and 59)

1. Battery ground cable.
2. Headlamp switch control knob.
3. Instrument panel bezel.
4. Control (491) (figure 56).
 - Screws.
 - Temperature cable eyelet clip and retainer (499) (figure 57).
 - Control lower right mounting tab through dash opening.
 - Upper tab.

- Lower right tab.
5. Electrical harness (502) (figure 58).
 6. Vacuum harness (506) (figure 59).
 7. Control assembly.

↔ Install or Connect (Figures 56, 57, 58 and 59)

1. Electrical and vacuum connection to the control.
2. Control into the opening in the dash panel.
3. Temperature cable.

🔑 Adjust

- Temperature door operation. Refer to "Temperature Door Cable Adjustment."
4. Instrument panel bezel.
 5. Headlamp switch control knob.
 6. Battery ground cable.

TEMPERATURE DOOR CABLE ADJUSTMENT

🔑 Adjust (Figure 56)

1. Remove instrument panel compartment and door.
2. Loosen the cable attaching screw at the selector duct assembly.
 - Make sure the cable is installed in the bracket on the selector duct assembly.
3. Place the temperature lever in full HOT position and hold while tightening the cable attaching screw.
4. Install instrument panel compartment and door.

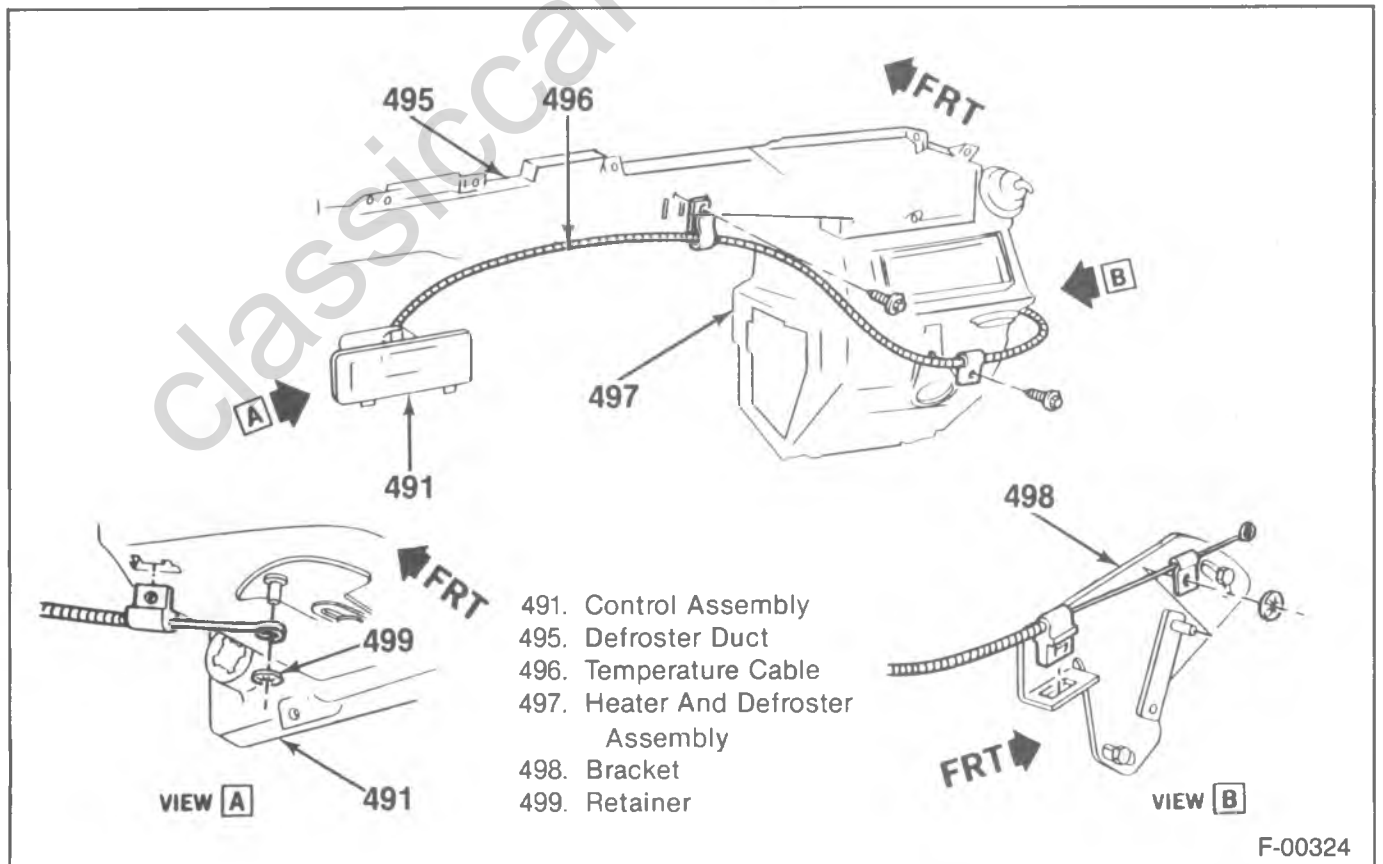

Figure 57—Temperature Control Cable

1B-56 AIR CONDITIONING

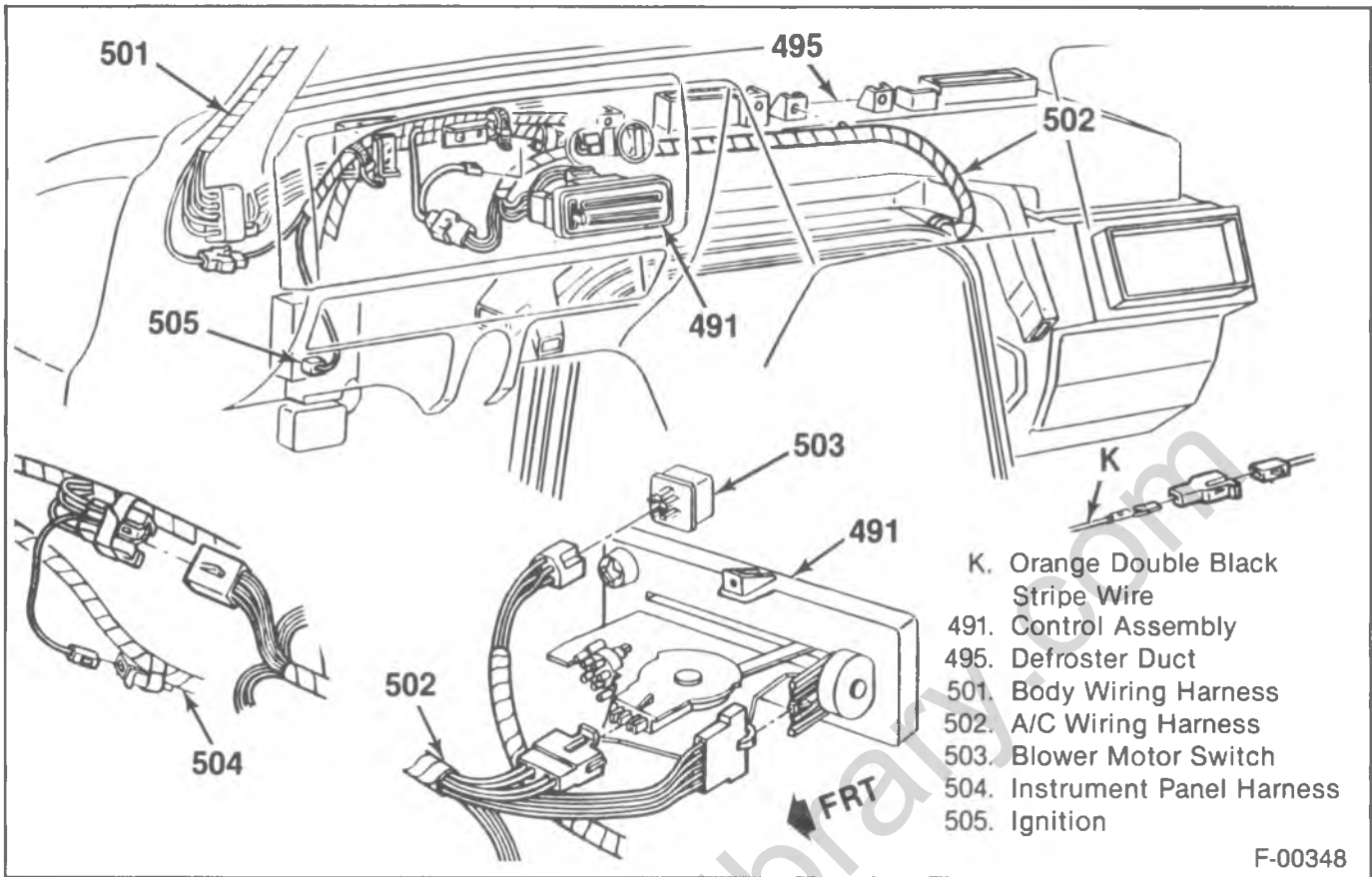

Figure 58—Instrument Panel Wiring Harness

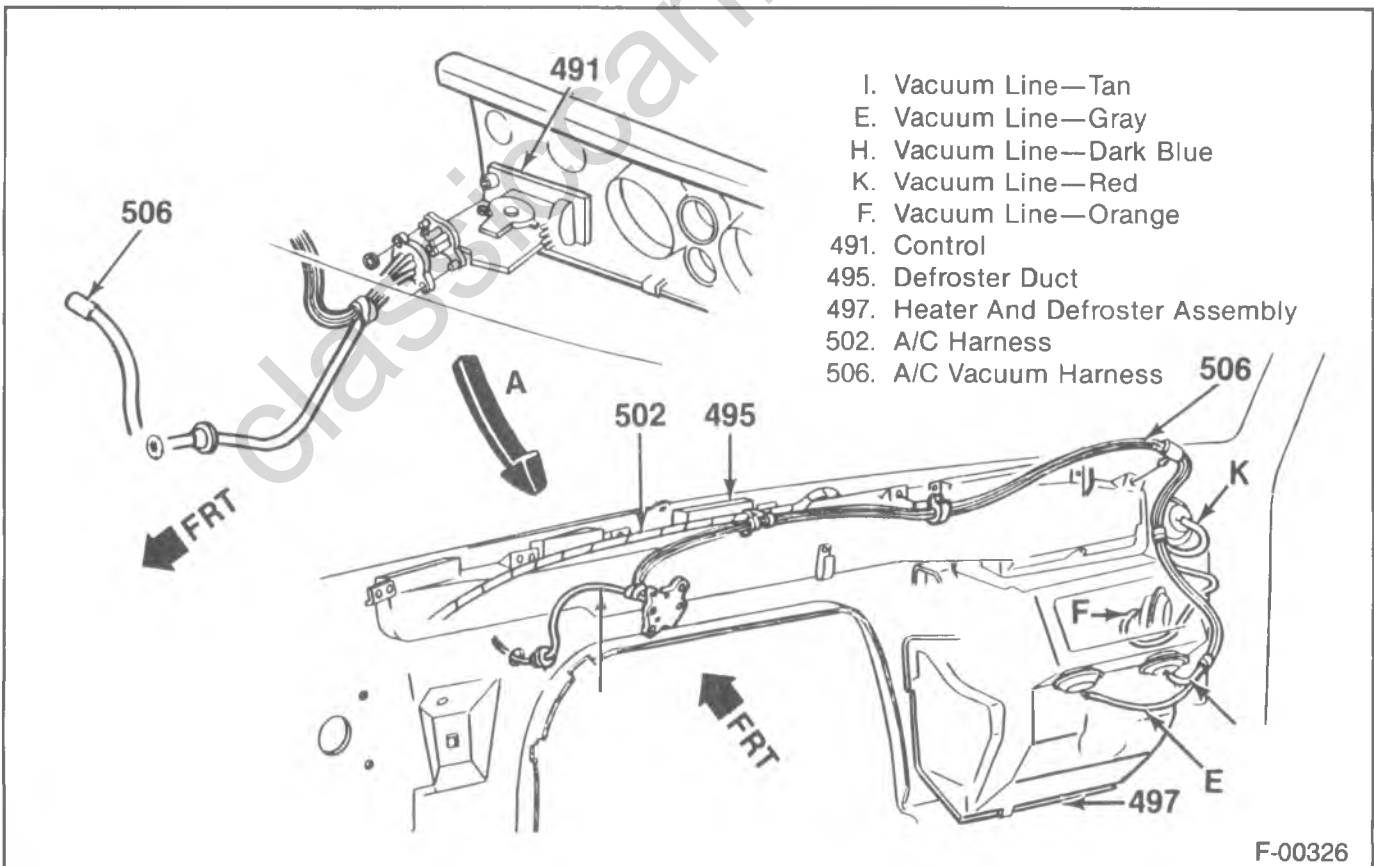

Figure 59—Vacuum Harness Assembly

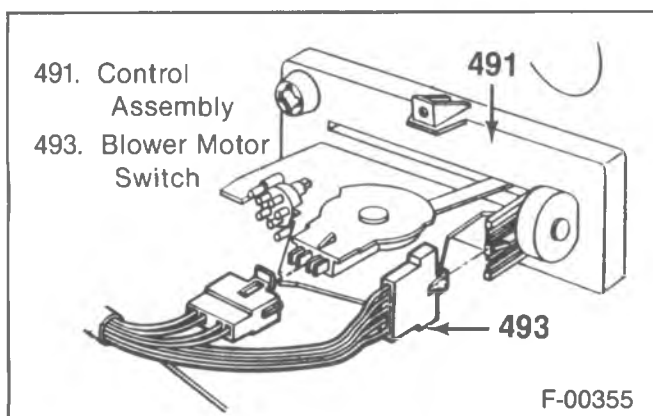

Figure 60—Blower Switch Wiring Harness

BLOWER SWITCH REPLACEMENT

↔ Remove or Disconnect (Figures 56, 57, 58 and 60)

1. Battery ground cable.
2. Left-foot cooler outlet assembly at the instrument panel attachment.
3. Electrical harness (figure 60).
4. Mounting screws.
5. Control assembly (491).
6. Switch (493).

↔ Install or Connect (Figures 56, 57, 58 and 59)

1. New switch.
 - Mounting screws.
2. Electrical harness.
3. Control assembly (491).
4. Left-foot cooler outlet assembly.
5. Battery ground cable.

RESISTOR REPLACEMENT

↔ Remove or Disconnect (Figure 61)

1. Electrical harness.
2. Resistor mounting screws.
3. Resistor (510) (figure 61).

↔ Install or Connect (Figure 61)

1. Resistor (510).
 - Screws.
2. Electrical harness.

BLOWER MOTOR RELAY REPLACEMENT

↔ Remove or Disconnect (Figure 61)

1. Electrical harness.
2. Relay mounting screw.
3. Relay (511).

↔ Install or Connect (Figure 61)

1. Relay (511).
 - Screws.
2. Electrical harness.

A/C DUCT WORK REPLACEMENT

↔ Remove or Disconnect (Figure 62)

1. Battery ground cable.
2. Engine cover.
3. Steering column to the instrument panel attaching screws.
4. Radio support bracket screw.
 - Pull the right side of the instrument panel rearward.
7. Duct (distributor) attaching screws.
8. Center deflector (527) (figure 62).

↔ Install or Connect (Figure 62)

1. Center deflector (527).
2. Instrument panel.
3. Radio support bracket.
4. Steering column.
5. Engine cover.
6. Battery ground cable.

DEFROSTER DUCT REPLACEMENT

To remove the defroster duct mounting, refer to figure 62.

TEMPERATURE DOOR CABLE REPLACEMENT

To remove the temperature door cable refer to "Control Assembly Replacement" and figure 57.

VACUUM TANK REPLACEMENT

↔ Remove or Disconnect (Figures 63, 64 and 65)

1. Raise the hood.
2. Vacuum harness at the tank (552).
3. Tank attaching screws.
4. Tank (551).

↔ Install or Connect (Figures 63, 64 and 65)

1. Tank (551).
2. Vacuum harness.
3. Lower the hood.

VACUUM LINES — ENGINE COMPARTMENT

For vacuum line assemblies, refer to figures:

1. 4.3L Engine (figure 63).
2. 5.0L and 5.7L Engine (figure 64).
3. 6.2L Engine (figure 65).

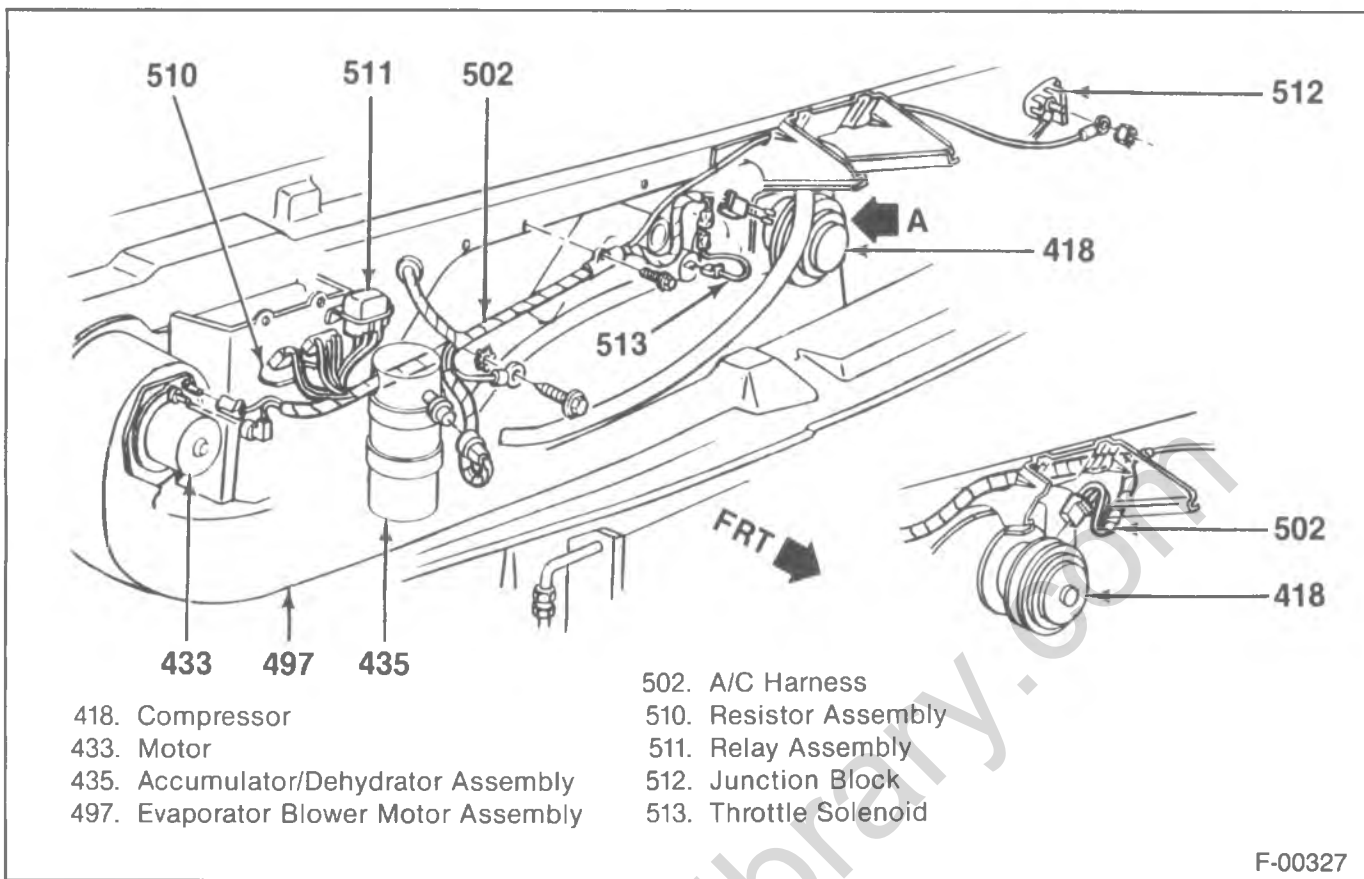
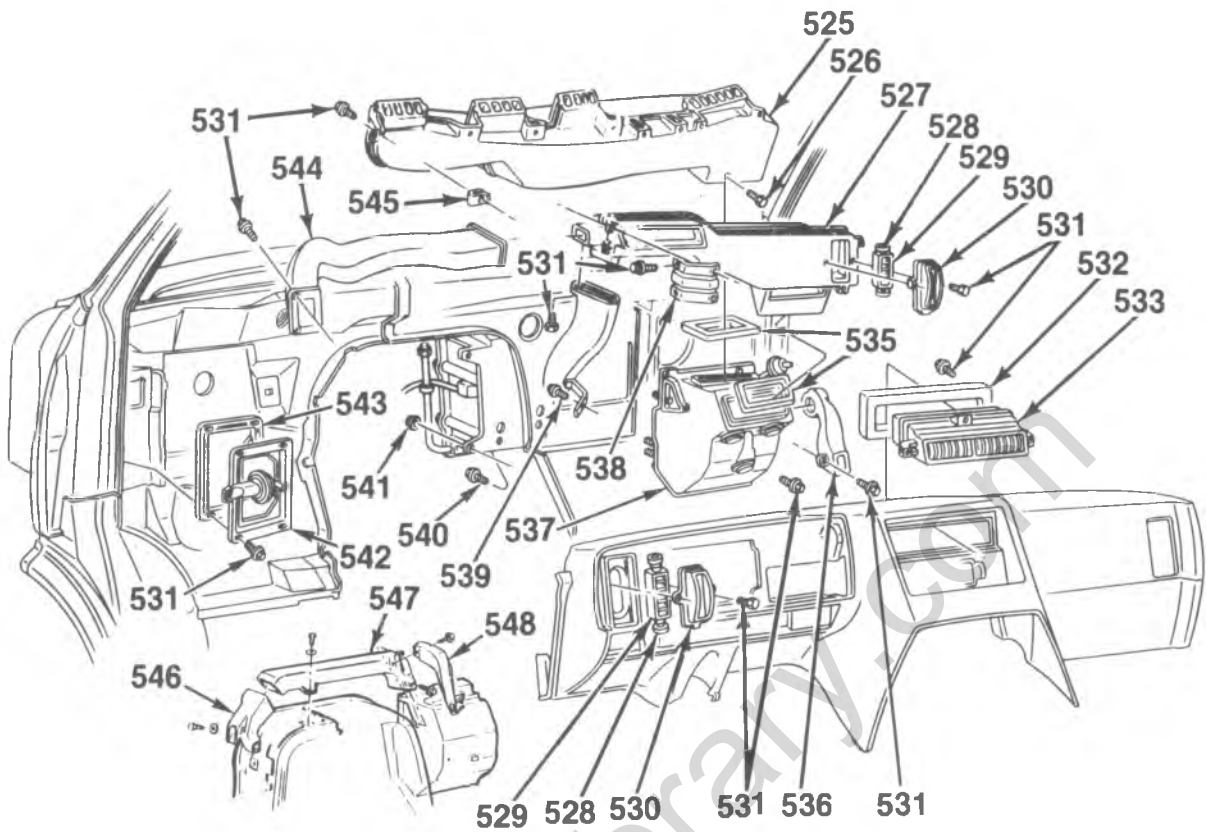

Figure 61—Wiring — Engine Compartment

**REFRIGERANT-12
 HOSE ROUTING**

For Refrigerant-12 hose assemblies refer to:

1. 4.3L Engine (figure 66).
2. 5.0L and 5.7L Engine (figure 67).
3. 6.2L Engine (figure 68).



- | | | | |
|-------------------------|----------------------|----------------------|-----------|
| 525. Duct Assembly | 531. Screw | 537. Heater Assembly | 543. Seal |
| 526. Screw | 532. Seal | 538. Support | 544. Duct |
| 527. Duct Assembly | 533. Outlet Assembly | 539. Outlet Assembly | 545. Nut |
| 528. Washer | 534. Gasket | 540. Screw | 546. Duct |
| 529. Deflector Assembly | 535. Gasket | 541. Nut | 547. Duct |
| 530. Bezel | 536. Duct | 542. Inlet Assembly | 548. Duct |

F-00279

Figure 62—Duct Component View

1B-60 AIR CONDITIONING

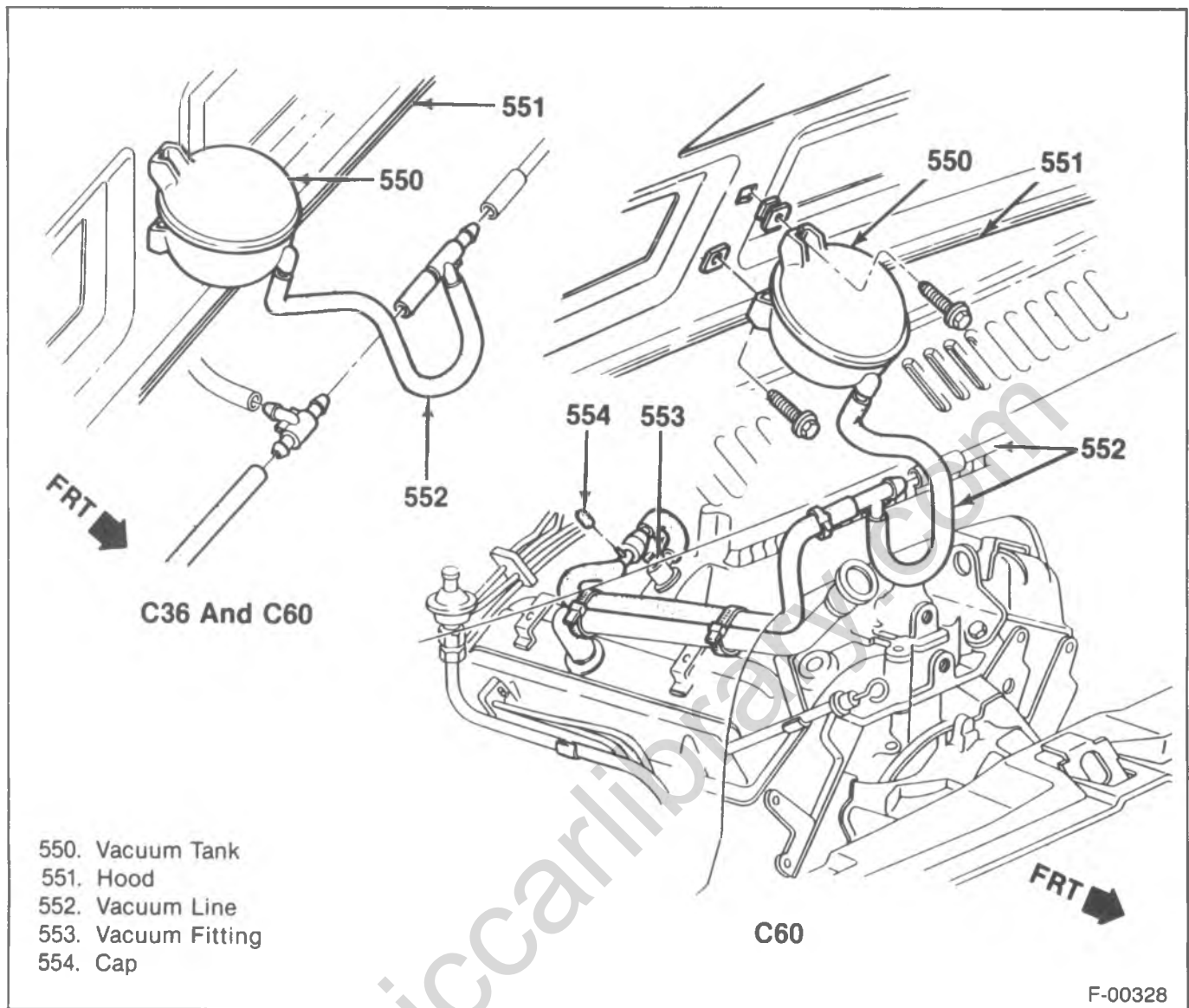

Figure 63—Vacuum Tank Assembly — 4.3L Engine

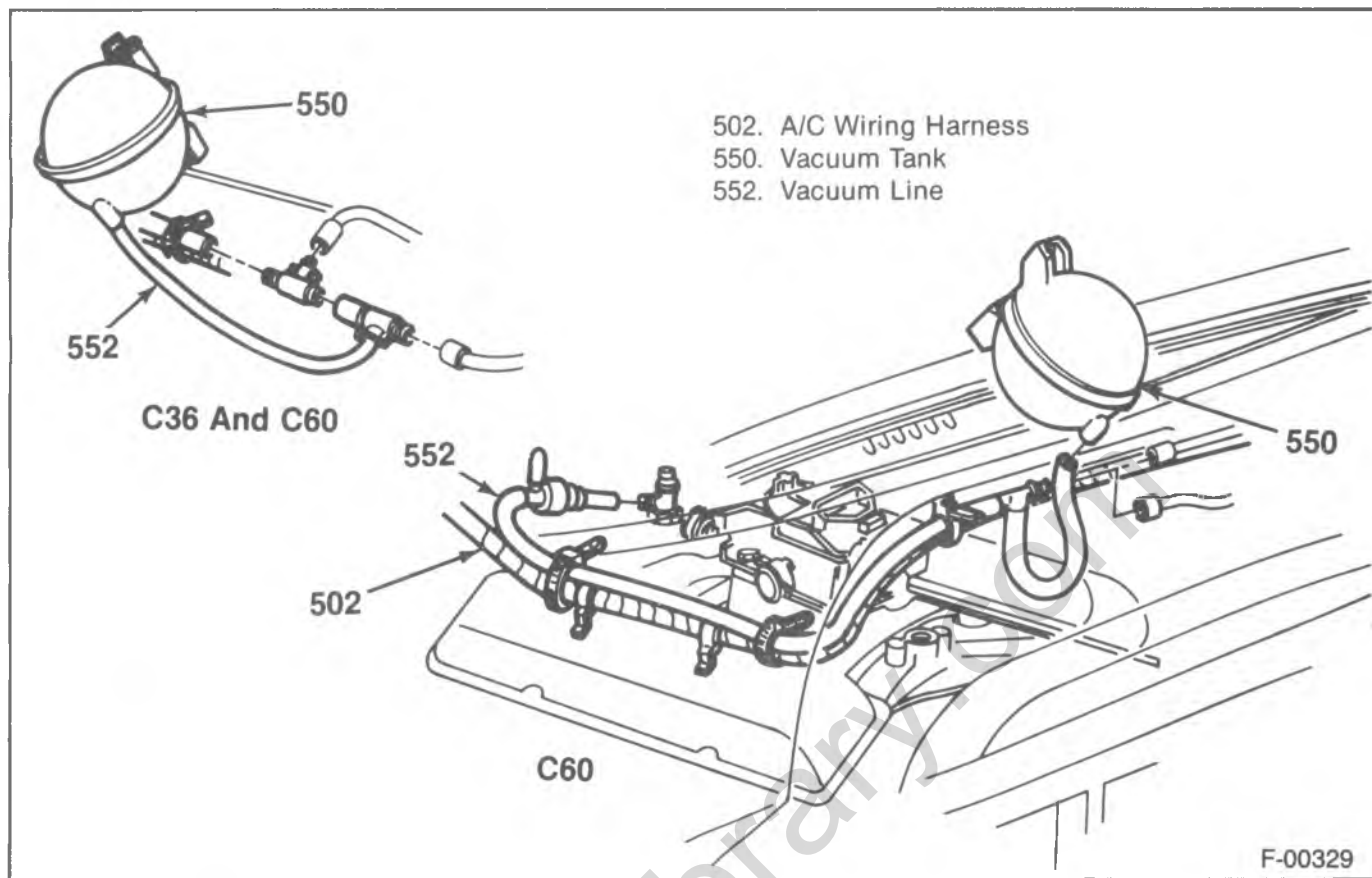

Figure 64—Vacuum Tank Assembly — 5.0 and 5.7L Engine

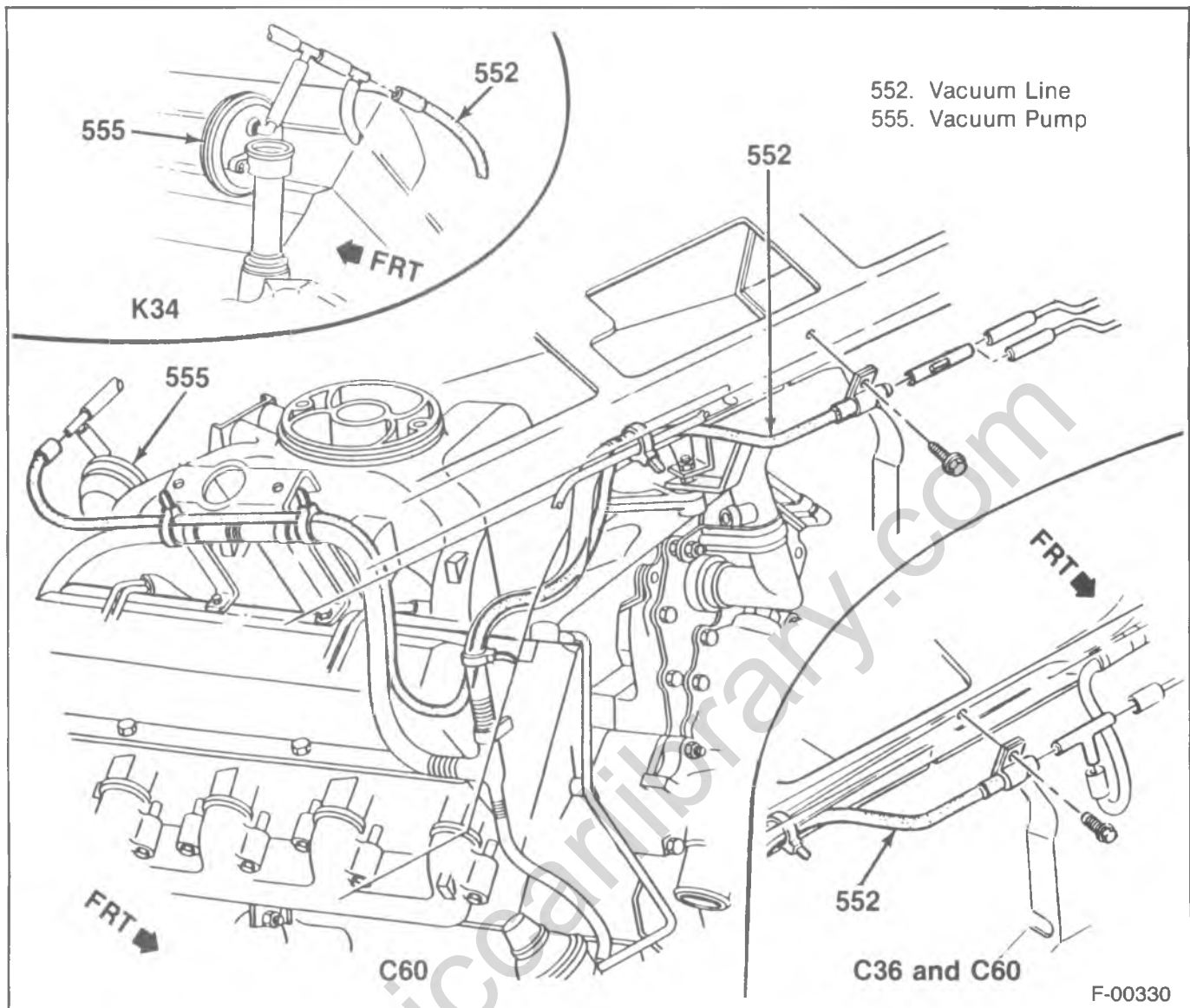

Figure 65—Vacuum Tank Assembly — 6.2L Engine

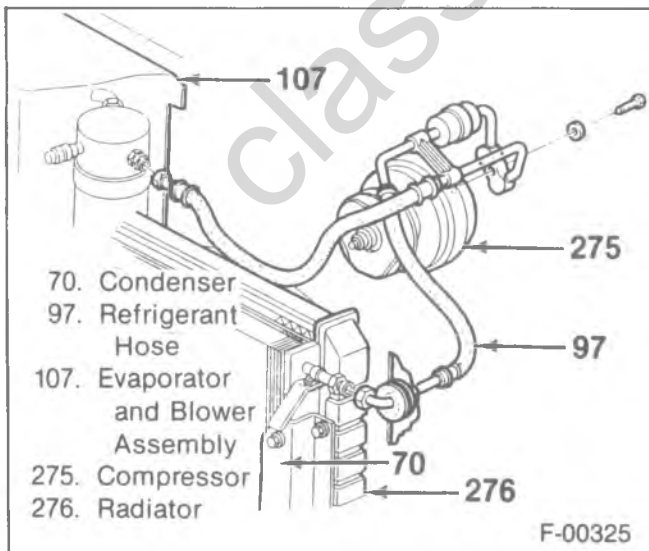

Figure 66—4.3L Engine Refrigerant Hose Assembly

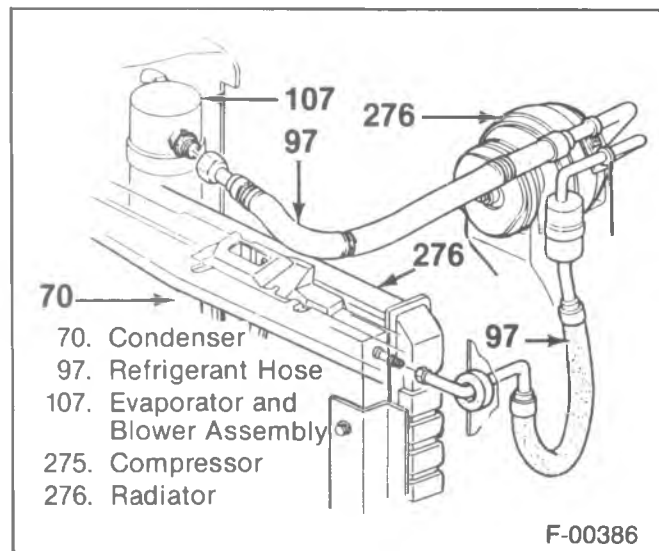

Figure 67—5.0L and 5.7L Engines Refrigerant Hose Assembly

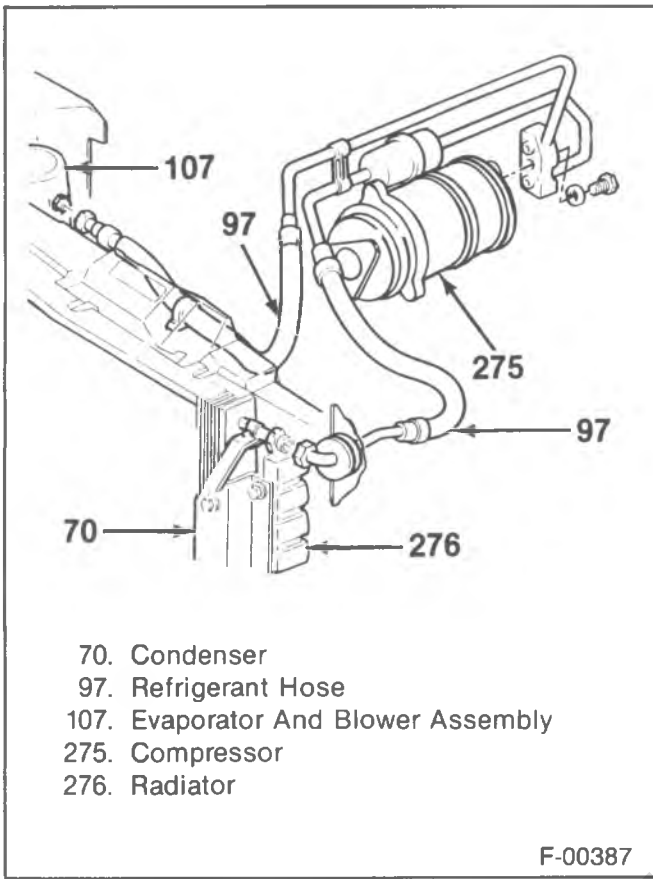
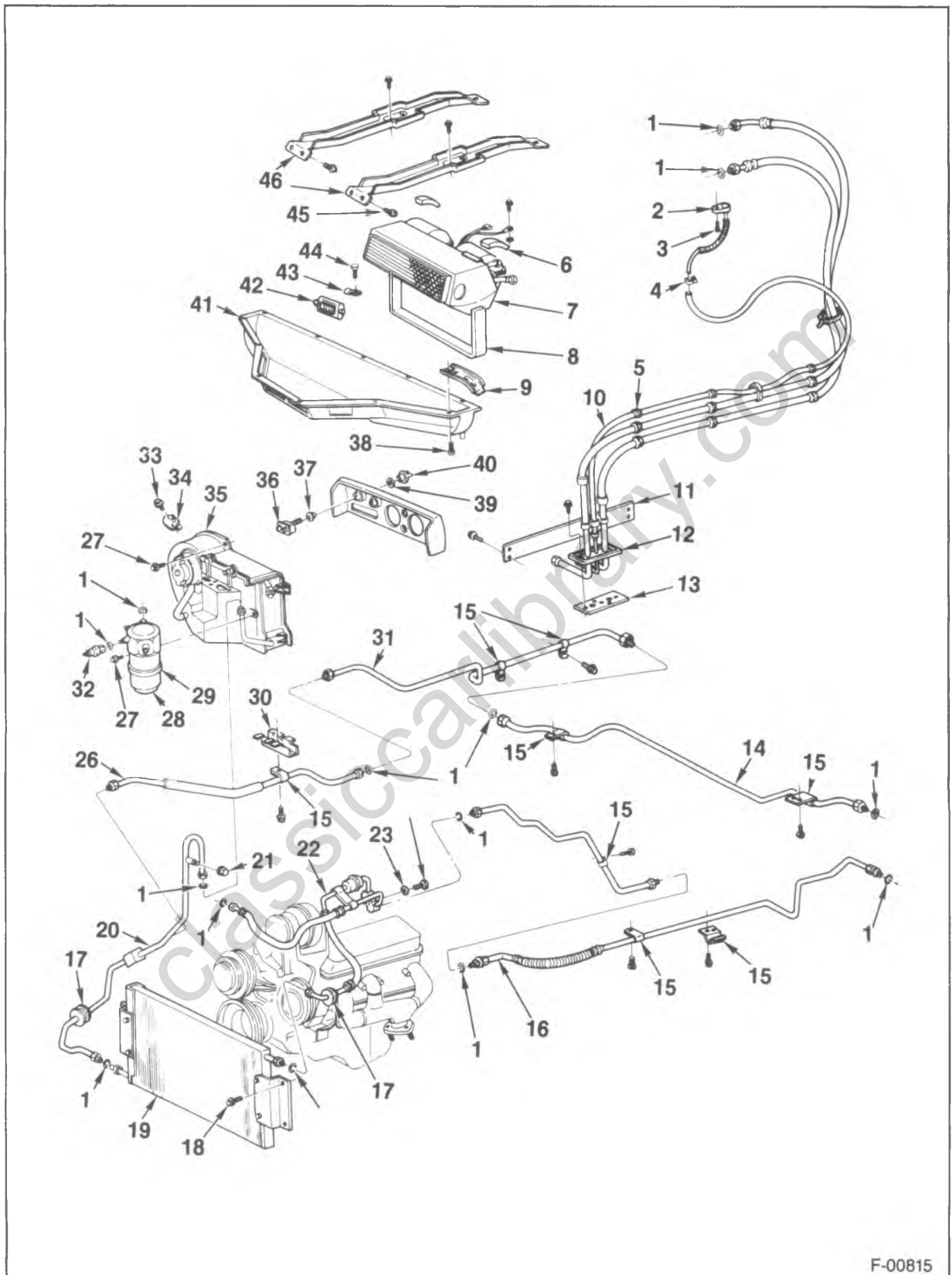

Figure 68—6.2L Engine Refrigerant Hose Assembly

REAR INTERIOR ROOF MOUNTED SYSTEM—G SERIES

This system is used in conjunction with the front mounted air conditioning system, and is almost identical to the R/V rear interior roof mounted system. For servicing, refer to figure 69.

1B-64 AIR CONDITIONING



F-00815

Figure 69—G-Rear Interior Roof Mounted System — Component View

- | | | | | |
|---------------|---------------|-----------------|--------------|---------------|
| 1. Seal | 11. Shield | 20. Tube | 31. Tube | 39. Washer |
| 2. Hose | 12. Plate | 21. Cap | 32. Switch | 40. Switch |
| 3. Screw | 13. Plate | 22. Fitting | 33. Screw | 41. Shroud |
| 4. Clamp | 14. Tube | 23. Washer | 34. Resistor | 42. Deflector |
| 5. Grommet | 15. Clip | 26. Tube | 35. Case | 43. Slip |
| 7. Evaporator | 16. Tube | 27. Screw | 36. Switch | 44. Screw |
| 8. Bracket | 17. Grommet | 28. Accumulator | 37. Nut | 45. Screw |
| 9. Bracket | 18. Screw | 29. Bracket | 38. Screw | 46. Support |
| 10. Hose | 19. Condenser | 30. Retainer | | |

F-03320

R-Rear Interior Roof Mounted System — Component View

A/C SYSTEM — P SERIES

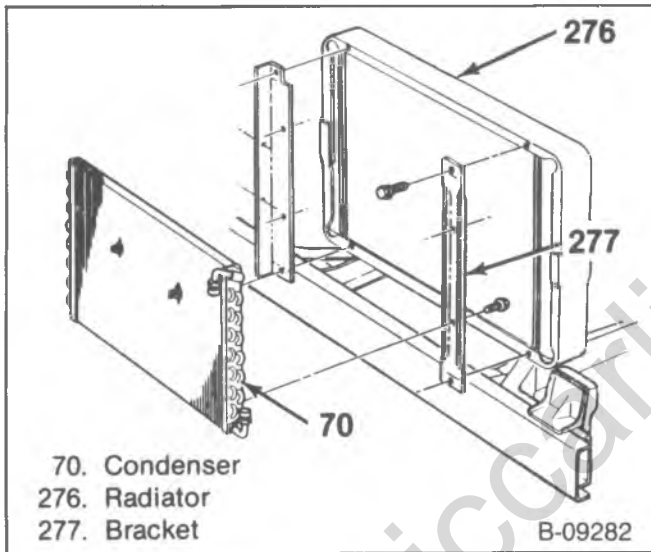

Figure 70—P-5.7L Engine Condenser Installation

The compressor and condenser are installed on the vehicle during assembly. They are removed and shipped separately.

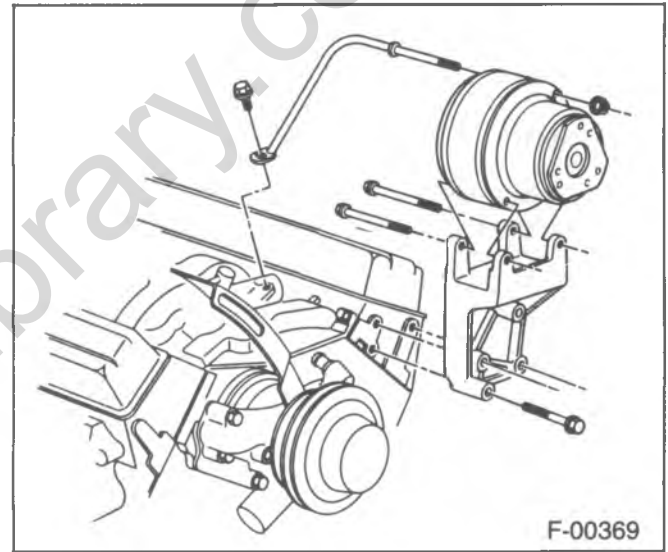

Figure 71—P-Compressor Installation

For reference refer to the following figures:
 1. Condenser Mounting - refer to figure 70.
 2. Compressor Installation - refer to figure 71.

SPECIFICATIONS**A-6 COMPRESSOR**

Type 6 Cylinder Axial
Displacement 12.6 Cu. In.
Rotation Clockwise

SYSTEM CAPACITIES

Refrigerant 1.587 6 kg (3 lbs. 8 ounces)
525 Viscosity Compressor Oil 0.284 Kg. (10 ounces)

TORQUE SPECIFICATIONS

Compressor Suction and Discharge Connector Bolt 24 N·m (18 ft. lb.s)
Oil Drain Screw 17 N·m (13 ft. lbs.)
Cycling Pressure Switch 10 N·m (7.5 ft. lbs.)
Engine Bracket Mounting Bolts 28 N·m (21 ft. lbs.)
Compressor Support Bracket Bolts 27 N·m (20 ft. lbs.)
All Other Mounting Bolts 43 N·m (32 ft. lbs.)

DA-6 COMPRESSOR

Type 6 Cylinder Axial
Displacement 10.0 Cu. In.
Rotation Clockwise

SYSTEM CAPACITIES

Refrigerant 1.587 kg (3 lbs. 8 ounces)
525 Viscosity Compressor Oil 0.227 Kg. (8 ounces)

TORQUE SPECIFICATIONS

Compressor Suction and Discharge Connector Bolt 24 N·m (18 ft. lbs.)
Shaft Nut 16 N·m (12 ft. lbs.)
Cycling Pressure Switch 10 N·m (7.5 ft. lbs.)
Front Mounting Bracket Bolts (R/V) 51 N·m (38 ft. lbs.)
Front Mount Bracket Nut (R/V) 24 N·m (18 ft. lbs.)
Rear Brace Bolts (R/V) 33 N·m (20 ft. lbs.)
Rear Compressor Support Bolt (R/V-6.2L Engine) 30 N·m (22 ft. lbs.)

R-4 COMPRESSOR

Type 4 Cylinder Radial
Displacement 10.0 Cu. In.
Rotation Clockwise

SYSTEM CAPACITIES

Refrigerant 1.587 6 kg (3 lbs. 8 ounces)
525 Viscosity Compressor Oil 0.312 Kg. (11 ounces)

TORQUE SPECIFICATIONS

Compressor Suction and Discharge Connector Bolt 24 N·m (18 ft. lbs.)
Oil Drain Screw 17 N·m (13 ft. lbs.)
Cycling Pressure Switch 10 N·m (7.5 ft. lbs.)
Front and Rear Compressor Support Belts 50 N·m (37 ft. lbs.)
Support Bracket Bolt 83 N·m (61 ft. lbs.)
Rear Support Brace Nut and Bolts 33 N·m (24 ft. lbs.)

SPECIFICATIONS (CONT.)

	Volts	Amps (Cold)	RPM (Cold)
Blower Motor			
R/V All Weather	12.0	12.8 Maximum	3400 Minimum
R/V-G Rear Interior Roof Mounted G Floor	12.0	13.7 Maximum	3400 Minimum
Compressor Clutch Coil			
Ohms (at 80° F)370
Amps (at 80° F)333 @ 12 Volts
Belt Tension			See Tune-Up Chart
Fuse Block			
R/V Series25 Amps
In Line			
R/V Series25 Amps
Circuit Breaker			
G Series45 Amps

classiccarylbrary.com

SPECIAL TOOLS

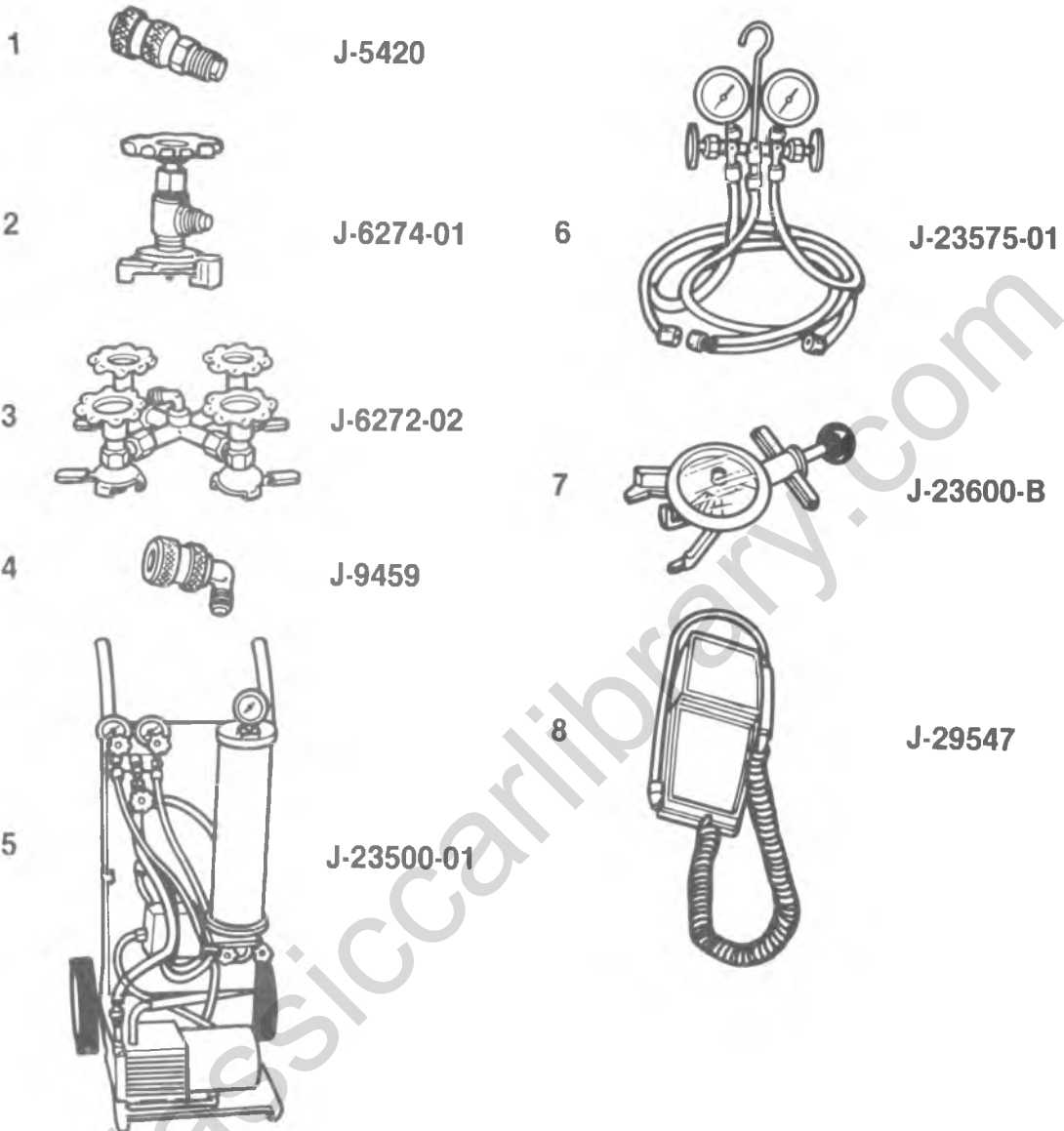

1. Straight Adapter
2. Refrigerant Can "Taps-All" Valve
3. Multi-Can Dispensing Valve
4. 90 Degree Adapter
5. Portable Charging Station
6. Complete Manifold Assembly
7. Belt Tension Gauge
8. Autobalance Refrigerant Leak Detector

SECTION 2

FRAME AND SHEET METAL

CONTENTS

<u>SUBJECT</u>	<u>PAGE</u>
Frame and Bumpers	2A-1
Sheet Metal	2B-1

SECTION 2A

FRAME AND BUMPERS

CONTENTS

<u>SUBJECT</u>	<u>PAGE</u>
R/V And P Model Frames	2A- 2
Description	2A- 2
Diagnosis Of The Frame	2A- 2
Minimizing Frame Service	2A- 4
Checking Frame Alignment	2A- 4
Straightening Frames	2A- 5
Repairing Cracks	2A- 5
Welding	2A- 6
G Model Underbody	2A- 6
Description	2A- 6
Underbody Alignment	2A- 6
R/V Model Bumpers	2A- 7
Front Bumper Replacement	2A- 7
Rear Bumper Replacement (Utility Vehicle and Suburban)	2A- 8
Rear Bumper Replacement (Regular Cab, Bonus Cab, and Crew Cab)	2A-11
Rear Step Bumper Replacement	2A-12
Rear Bumper License Plate Bracket Replacement	2A-13
Dead Weight Trailer Hitch Replacement (Utility Vehicle and Suburban)	2A-13
Weight Distribution Hitch Replacement (Suburban Only)	2A-14
Weight Distribution Hitch Replacement (Utility Vehicle Only)	2A-15
P Model Bumpers	2A-15
Front Bumper Replacement	2A-15
Front Bumper Replacement (With RPO FS3 Front Axle)	2A-16
G Model Bumpers	2A-18
Front Bumper Replacement	2A-18
Rear Bumper Replacement	2A-19
Rear License Plate Bracket Replacement	2A-19
Dead Weight Trailer Hitch Replacement	2A-20
Weight Distribution Hitch Replacement	2A-20
Specifications	2A-22

R/V AND P MODEL FRAMES

DESCRIPTION

The models covered under this part of the section include R/V, and P. The service information for the G model will be found in the underbody portion of this section.

Proper frame alignment is important to assure normal life and functioning of many other parts of the vehicle. If the vehicle has been involved in a fire, collision, or has been overloaded, there is cause to check the frame alignment. If, for any other reason, alignment is suspected it should be checked. A procedure for this is described later in this section under "Checking Frame Alignment."

It is possible that certain conditions make the frame appear to be out of alignment when, in fact, it is not. These conditions are also described under "Checking Frame Alignment."

Terms used later in this section are briefly defined below:

1. SECTION MODULUS—This is a measure of the strength of a frame, based on height, width, thickness and shape of the side rails. It does not account for the strength of the material used in the frame.
2. YIELD STRENGTH—This is a measure of the strength of the material from which the frame is made. It is the maximum load measured in kPa (psi) that can be placed on a material and still have it return to its original shape.
3. RESISTANCE TO BENDING MOMENT (RBM)—This is a single measure of frame strength that accounts for both the section modulus and the strength of the material used. It is the product of section modulus and yield strength.
4. SAG—This refers to a frame or side rail that is bent down from where it should be.
5. BUCKLE—This refers to a frame or side rail that is bent up from where it should be.
6. DIAMOND—This refers to the condition where one entire frame rail is moved forward from, or to the rear of, its correct alignment with the other rail.
7. TWIST—This refers to the condition where the entire frame has been twisted. One rail will basically slope up while the other rail will basically slope down.
8. SIDESWAY—This refers to a side rail that is bent to the side of where it should be.
9. TRACKING—This refers to the alignment of the vehicle axles with each other. A misaligned frame can cause improper tracking. If the vehicle is tracking correctly, all axles will be parallel to each other and perpendicular to the center line of frame.
10. WEB—The vertical part of a channel-type frame rail.

DIAGNOSIS OF THE FRAME

PROBLEM	POSSIBLE CAUSE	CORRECTION
Sag	<ol style="list-style-type: none"> 1. Loads greater than the frame is designed to carry. 2. Uneven load distribution. 3. Abrupt changes in section modulus. (For a brief definition of section modulus, see the "Description" at the beginning of this section. 4. Improper body, or accessory, mounting: <ul style="list-style-type: none"> — Holes drilled in the flange of the frame rail. — Too many holes in the web section of the rail. — Holes in the web section which are too close to each other. — Four or more holes in the same vertical line of the rail web. — Welds on the flange, particularly across the flange or along its edge. — Cutting holes in the rail with a torch. — Cutting notches anywhere on the rails. 5. A fire involving the vehicle. 6. A collision involving the vehicle. 7. The use of equipment for which the frame has not been designed or reinforced. 	<ol style="list-style-type: none"> 1-7. Straighten and reinforce the frame as described later in this section. See "Straightening Frames" and "Reinforcements."

DIAGNOSIS OF THE FRAME (CONT.)

PROBLEM	POSSIBLE CAUSE	CORRECTION
Buckle	<ol style="list-style-type: none"> 1. The use of equipment such as snow plows for which the frame was not designed. 2. A collision involving the vehicle. 3. A fire involving the vehicle. 4. In addition to these causes, refer to possible causes 3 and 4 under "Sag." These may contribute to "Buckle." 	<ol style="list-style-type: none"> 1-4. Straighten and reinforce the frame as described later in this section. See "Straightening Frames" and "Reinforcements."
Sidesway	<ol style="list-style-type: none"> 1. A collision involving the vehicle. 2. A fire involving the vehicle. 3. The use of equipment such as snow plows for which the frame was neither designed nor properly reinforced. 4. In addition to these causes, refer to possible causes 3 and 4 under "Sag." These may be contributing factors. 	<ol style="list-style-type: none"> 1-4. Straighten and reinforce the frame as described later in this section. Refer to "Straightening Frames" and "Reinforcements."
Diamond	<ol style="list-style-type: none"> 1. A collision involving the vehicle. 2. Towing another vehicle with a chain attached to one corner of the frame. 	<ol style="list-style-type: none"> 1-2. Straighten and reinforce the frame as described later in this section. Refer to "Straightening Frames" and "Reinforcements."
Twist	<ol style="list-style-type: none"> 1. An accident or collision involving the vehicle. 2. Operating the vehicle in very rough terrain. 	<ol style="list-style-type: none"> 1-2. Straighten and reinforce the frame as described later in this section. Refer to "Straightening Frames" and "Reinforcements."
Improper Tracking	<ol style="list-style-type: none"> 1. Frame is out of alignment. 2. Front or rear axle has shifted. 3. Incorrect wheel alignment may make the vehicle appear to be tracking incorrectly. 	<ol style="list-style-type: none"> 1. Straighten and reinforce the frame as described later in this section. 2. Realign and secure the axle. 3. Align the wheels. Refer to FRONT END ALIGNMENT (SEC. 3A) of this manual.
Cracks In The Web Of The Rails	<ol style="list-style-type: none"> 1. Loose crossmember attaching bolts. 2. Concentration of stress that may result from many different factors. Refer to "Sag" under "Diagnosis" previously described in this chart. Also refer to "Minimizing Frame Damage" and "Reinforcements" later in this section. 	<ol style="list-style-type: none"> 1. Replace, or weld and reinforce rail. Ream bolt holes and replace with larger bolts if necessary. Retighten bolts. 2. Replace, or weld and reinforce the rail. See the appropriate heading, later in this section.

2A-4 FRAME AND BUMPERS

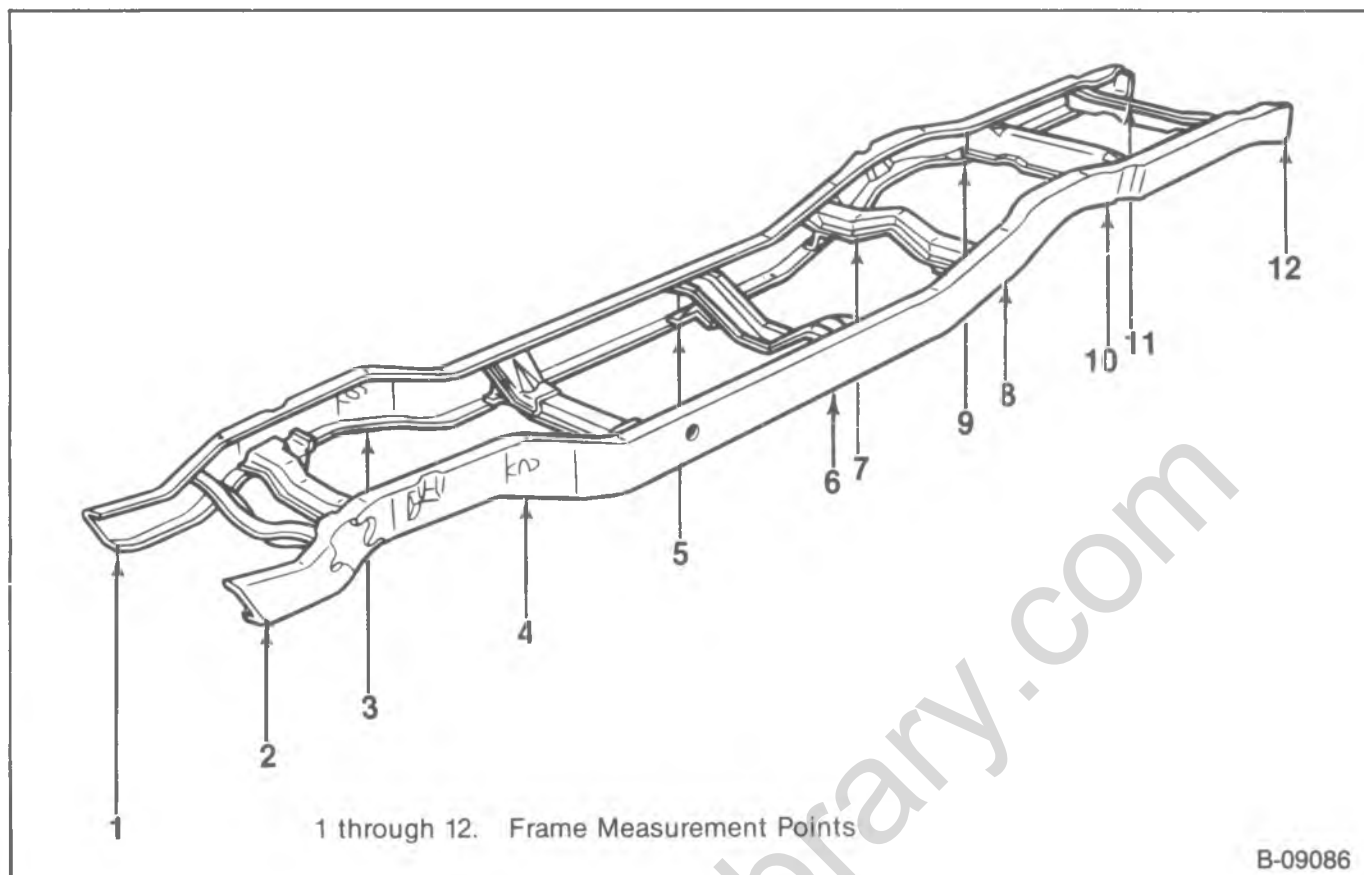

Figure 1—R/V and P Model Frames

MINIMIZING FRAME SERVICE

Generally, frame service can be minimized or eliminated by minimizing the concentration of stress in small areas of the frame.

1. Vehicles should be used only for those purposes for which they were designed.
 - They should not be overloaded.
 - They should be loaded evenly; localized loads should be avoided.
 - Do not operate the vehicle on extremely rough terrain.
 - Take into account the forces that will be placed on a frame from the operation of equipment such as snow plows when picking a frame for a new vehicle or reinforcing a frame.
2. Follow recommended practices when repairing a frame or when mounting a body or equipment on a frame.
 - Avoid sudden changes in the section modulus.
 - Do not drill holes in the frame rail flanges.
 - Space holes in the web section of a rail at least 13 mm (1/2-inch) from one another.
 - Use existing holes whenever possible.
 - Do not cut holes with a torch.
 - Do not overheat the frame rails.
 - Avoid welding on the flanges.
 - Do not allow four or more holes to exist on the same vertical line of the web.
 - Holes made in a reinforcement should be placed a distance of at least two times the material thickness from the edge of the reinforcement.

CHECKING FRAME ALIGNMENT

The main parts of a frame are the side rails and crossmembers. The rails carry the load and the crossmembers stabilize the rails.

Types of frame misalignment can be divided into five groups. The five groups are sag, buckle, diamond, sidesways, and twist. For a brief definition of these terms, refer to "Description" at the beginning of this section.

A misaligned frame rail may have moved forward from, up or down from, or to the side of where it should be. These possibilities must be checked.

The easiest way to check frame alignment is with gages made for this purpose. Detailed instructions are normally supplied with gages at the time of purchase. Therefore, instructions for gage use are not given in this manual.

It is possible to check certain portions of frame alignment without the proper gages. The procedure is described later in this section.

Whether alignment is checked with or without gages, the vehicle must be parked on a level section of floor.

Certain conditions call for preliminary checks before actually checking the frame. Suspension or axle problems may make it appear that the vehicle frame is out of alignment. If an axle has shifted, "Diamond" or "Sidesway" may appear to exist when, in fact, they do not. A weak spring may make the vehicle appear to have a twisted frame.

A visual inspection of the top and bottom flanges of each rail may reveal the specific area where sag or buckle exists. In the case of sag, wrinkles may appear on the top

of the upper flange; such wrinkles are definite evidence of sag. Wrinkles on the bottom of the lower flange are definite evidence of buckle.

DETERMINING THE FRAME CENTERLINE (Figure 1)

1. Move the vehicle to a level, well-lighted section of the floor.
2. Make a diagram of the frame on the floor beneath the vehicle as follows:
 - a. Using a plumb bob, transfer points 1, 2, 11, 12 from the inside of the web to the floor. Mark the points (figure 1).
 - b. Using a plumb bob, transfer the remaining points from the outside of the web to the floor. Mark the points. Be sure to use points from the same place on both the right and left frame rail.
3. Move the vehicle away from the points on the floor.
4. Measure the distance between points 1 and 2. This distance should be 704.85 mm (27.75-inch) for the standard front axle, and 847.25 mm (33.75-inch) if equipped with a 5000# I-Beam Front Axle.
5. Measure the distance between points 11 and 12. This distance should be 847.25 mm (33.75-inch). If both the measurements in steps 4 and 5 were correct, continue the procedure. If the measurements are not correct, refer to "Horizontal Check" step 2, and mark the centerline through the intersection of two sets of diagonals that have equal measurements.
6. Make a mark on the floor exactly halfway between points 1 and 2. Make a similar mark between points 11 and 12.
7. Use a chalk line to mark a line through the points. This is the centerline of the frame.

HORIZONTAL CHECK

1. Measure the distance between the frame rails, and the centerline at points 3-10. Each pair of corresponding points should be an equal distance from the centerline within 3 mm (1/8-inch). Example: Points 3 and 4 should measure equally from the centerline as should points 5 and 6, 7 and 8, and points 9 and 10.
2. Measure diagonally from point 1 to point 6, and from point 2 to point 5. Mark the floor where the diagonals pass the centerline. The diagonals should measure the same distance within 5 mm (3/16-inch), and should cross at the centerline. If the frame is within specifications, the frame within these points is properly aligned.
3. Repeat step 2 on other pairs of diagonals until the entire frame has been checked. Example: Point 3 to point 10 and point 4 to point 9 or point 5 to point 12 and point 6 to point 11, etc.
4. Refer to "Straightening Frames" to repair any damage that is found.

STRAIGHTENING FRAMES

Frame straightening can be complicated and usually requires special equipment. It should be attempted by competent personnel only.

A complete analysis of the condition of the frame should be made before any steps are taken to straighten it. Analyzing the cause of failure will help determine the correct sequence of steps in the repair. (Refer to

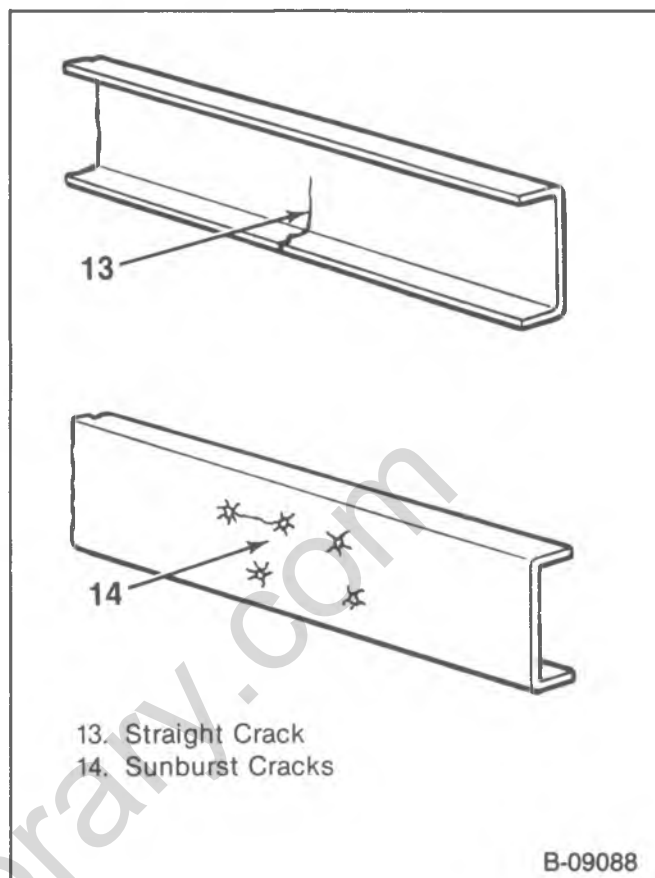

Figure 2—Types of Frame Cracks

"Possible Causes" under "Diagnosis" and "Minimizing Frame Service" previously outlined in this section.) Corrective procedures should be set up to reverse the flow of the damaging forces. In many instances, to reverse the flow of forces, pressure must be applied from different directions at the same time.

Careful use of controlled heat is important. Too much or too little heat, or the improper application of heat, is a major source of trouble. Frame heating should be done with a large sized tip (multi-hole heating tip) and a neutral flame should be used (oxygen adjust opened just enough to remove the feathers or stringers from the blue center at tip of torch). Heat the area that will be stretched as frame is straightened. Heat the area AFTER SUFFICIENT PRESSURE HAS BEEN EXERTED to cause a slight checking, or silvery cracks, to appear on the surface of the metal. Gradually increase the pressure while heating. Do not heat beyond 606°C (1200°F). A red glow indicates that the material is overheated. Overheating will cause distortion and stretching, as well as a change in the characteristics of the metal.

REPAIRING CRACKS

Two common types of cracks are shown in figure 2. The straight crack will normally start from the edge of a flange. It will go across the flange and through the web section of a rail. Finally, it will continue through the other flange. This type of crack may result from high concentrations of stress in small areas of the frame, excessive bending moment, and torsional loading. (Refer to "Minimizing Frame Service," previously outlined in this section).

2A-6 FRAME AND BUMPERS

Sunburst crack(s) will radiate out from a hole in the web section of a rail or crossmember. They are caused by high loads being applied at a mounting bracket or crossmember which is not securely or properly attached to the rail.

If cracks occur to both the rail and reinforcement at a particular area of the frame, they must be repaired separately. The flanges must react independently to prevent localized stress concentration. Use a copper spacer between the flanges of cracked base rail flanges and reinforcement flanges.

Crossmember mounting flange cracks may be repaired in the same manner as side rail cracks. However, weld bead should be built up to provide a good smooth radius. If a crossmember is greatly damaged replace it.

It may be necessary to align the frame and level the rails before repairing the frame.

1. Remove any equipment that will interfere with access to the crack.
2. Locate the extreme end of the crack and drill a 6 mm (0.25-inch) hole.
3. "V" grind the entire length of the crack from the starting point to the 6 mm (0.25-inch) hole at the extreme end.
4. Open up the bottom of the crack 2 mm ($\frac{1}{16}$ -inch) to allow good penetration of the weld. (A hack-saw blade may be used for this).
5. Weld with proper electrode and proper welding techniques. Refer to "Welding" outlined later in this section for tips on welding.
6. Grind the weld smooth on both the inside and the outside of the rail or crossmember. Be extremely careful to eliminate weld build-up or notches on the edge of the flange.

WELDING

Improper welding techniques are the cause of many weld and/or frame failures. The following information points out potential areas of difficulty and provides some general guidelines for successful frame welding.

Most weld failures occur at the end of the weld in areas of the frame that are under high stress. By eliminating the ends of a weld, failures can be reduced; this can be done by making a hole or slot in the part to be attached and then using a fillet weld around a slot or plug weld. Do not leave a notch at the end of a weld.

Over-welding can be harmful, especially if it is in an area of the frame that receives high concentrations of stress.

Small cracks in a crossmember may be welded. (Refer to "Repairing Cracks" previously outlined in this section).

When welding:

1. Do not use oxyacetylene welding equipment.
2. Whenever possible, use smaller diameter electrodes and make several passes; this is preferred to using a large diameter electrode and making fewer passes.
3. Do not use more heat than is necessary to give good penetration.
4. Do not run more passes than necessary.
5. Make sure the weld is free from craters and undercuts.
6. Make sure scale is removed from each successive pass.
7. If repairing a crack, grind the surface of the weld flush with the parent material.
8. When mounting accessories, do not weld across the flanges.
9. When mounting accessories, do not weld within 19 mm ($\frac{3}{4}$ -inch) of a flange.
10. Do not weld up to the edge of a part being welded to a frame. Leave 6 mm (0.25-inch) between the end of the weld and the edge of the part.
11. Do not weld cast brackets to the frame.
12. Do not weld the flanges of cracked reinforcements and base rails together.
13. Connect the welding machine ground cables as close to the working area as possible.
14. Avoid direct contact between the welding cables and any part of the vehicle.
15. Do not get the welding cables near the vehicle wiring.

G MODEL UNDERBODY

DESCRIPTION

The G Model incorporates a unitized body design comprised of side rails, cross sills, and outriggers which are all part of the welded underbody.

A misaligned underbody can affect the operation of many vehicle components. It is essential that underbody alignment be exact to within 1.6 mm ($\frac{1}{16}$ -inch).

UNDERBODY ALIGNMENT

To determine the alignment of the underbody it is necessary to use a good quality traming gage. This gage must be capable of measuring all points of the underbody up to three quarters of the body length.

Following the instructions given by the manufacturer of your gage, measure the horizontal and vertical points as shown in figure 3. Compare each measurement with the

specifications given in the figure to determine the damaged areas and the extend of the damage. When repairing the underbody it will be necessary to return the underbody to these original specifications within 1.6 mm ($\frac{1}{16}$ -inch).

Many different types and brands of unibody repair equipment are available; each system may be slightly different. A multiple pull system is most desirable in order to correct the damage in the same direction in which it was created. When making multiple pulls use the last in, first out procedure. This means that you correct the damage in the reverse sequence by which it was created. It is also important to correct the damage in the opposite direction in which the damage was created.

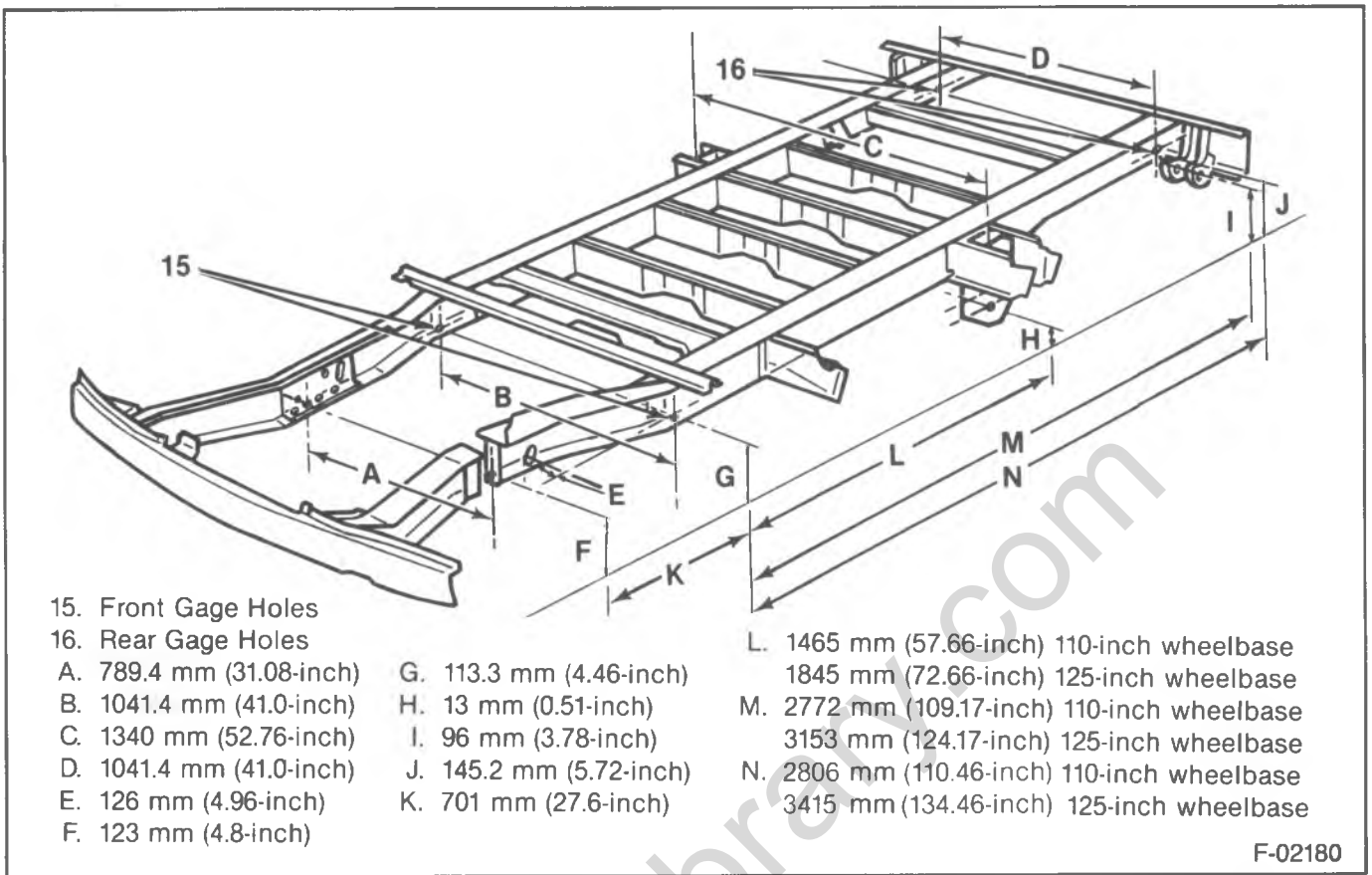

Figure 3—G Model Underbody

R/V MODEL BUMPERS

FRONT BUMPER REPLACEMENT

Remove or Disconnect

1. Brace to bumper nuts (52) (figure 1).
2. Bracket to bumper nuts (53).
3. Bumper from the vehicle.
4. Guard assemblies (where used) (figure 5).
5. Rub strips from the bumper and guards (where used) (figure 6).
 - From the rear of the bumper, press the tangs of the rub strip together, and push the strip from the bumper and/or guard.
6. Bumper bolts (56 and/or 58).
7. Brace bolts and washers (67 and 68) (figure 7) from the inside of the frame rail.
 - Braces (54).
8. Bracket bolts, washers, and nuts (66, 65 and 64) from the frame.
9. Tow hooks (70) (where used).
10. Brackets (55).

Install or Connect (Figures 4-8)

1. Brackets and tow hooks (where used) to the frame rails.
 - On vehicles without tow hooks, install the bolts and washers through the brackets and through the outside of the frame rail.
 - On vehicles with tow hooks, install the tow hook bolts and washers from inside the frame rail, then through the brackets and the tow hooks. Install the top bracket bolts and washers through the bracket, and into the top rail flange.
2. Washers and nuts to the bolts.

Tighten

- Nuts to 95 N·m (70 ft. lbs.).
3. Brace bolts and washers (67 and 68) through the frame rails and into the braces.

Tighten

- Bolts to 50 N·m (37 ft. lbs.).
4. Bumper bolts (56) onto the bumper.
 5. Rub strips to the bumper and guards (where used).
 - Place the tangs of the strips onto the slots in the bumper or guard. Using a rubber mallet, set the tangs in place starting at the center of the strip, and working toward each end.
 6. Guard assemblies (where used).
 7. Bumper to the vehicle.

2A-8 FRAME AND BUMPERS

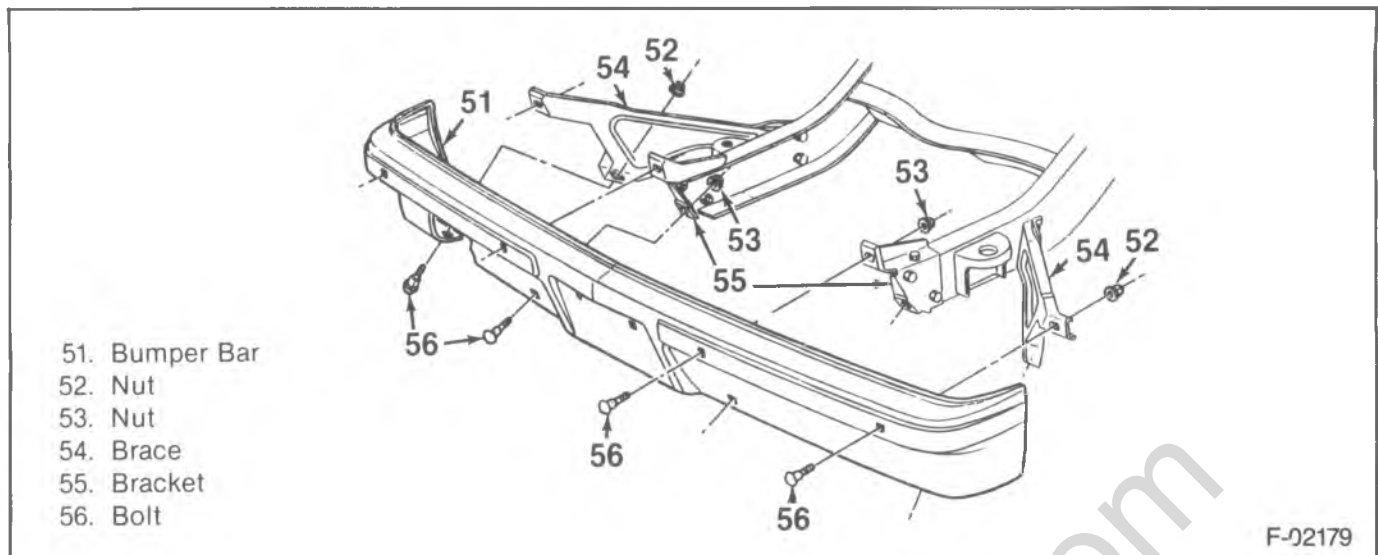

Figure 4—R/V Front Bumper Components

- Install the bumper with bolts through the right and left braces, and brackets.

8. Bracket to bumper nuts (53).



Tighten

- Nuts to 90 N·m (66 ft. lbs.).

9. Brace to bumper nuts (52).



Tighten

- Nuts to 90 N·m (66 ft. lbs.).

REAR BUMPER REPLACEMENT (UTILITY VEHICLE AND SUBURBAN)



Remove or Disconnect (Figure 8)

1. Brace to bumper nuts (71).
2. Bracket to bumper nuts (74).
3. Rear bumper.
4. Filler panel bolts (figures 9 and 10).
5. Filler panel.
6. Rub strips from the bumper (where used) (figure 24).
 - From the rear of the bumper, press the tangs of the bump strip together, and push the strip from the bumper.
7. Bumper bolts (82).
8. Brace nuts, washers, and bolts (76, 75 and 80).
 - Braces (72).
9. Bracket nuts, washers, and bolts (77, 78 and 79).
 - Brackets (72).

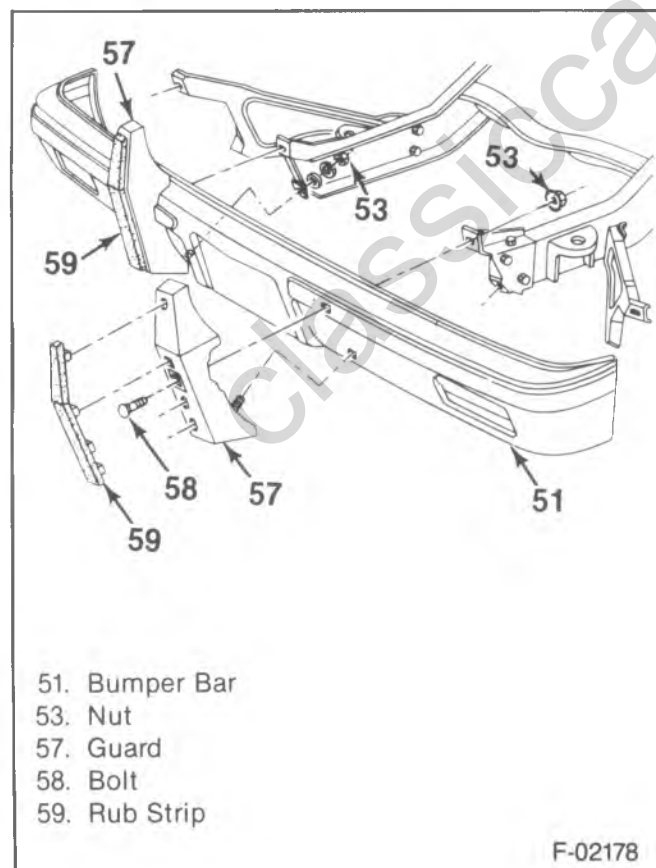

Figure 5—R/V Front Bumper Guards

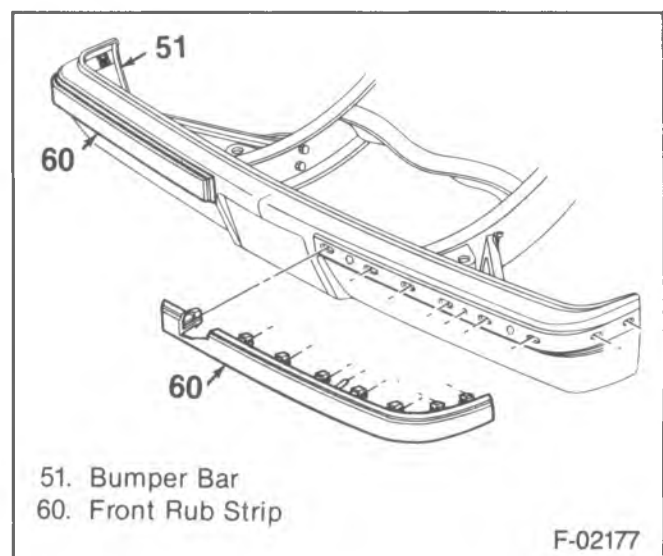

Figure 6—R/V Front Bumper Rub Strip

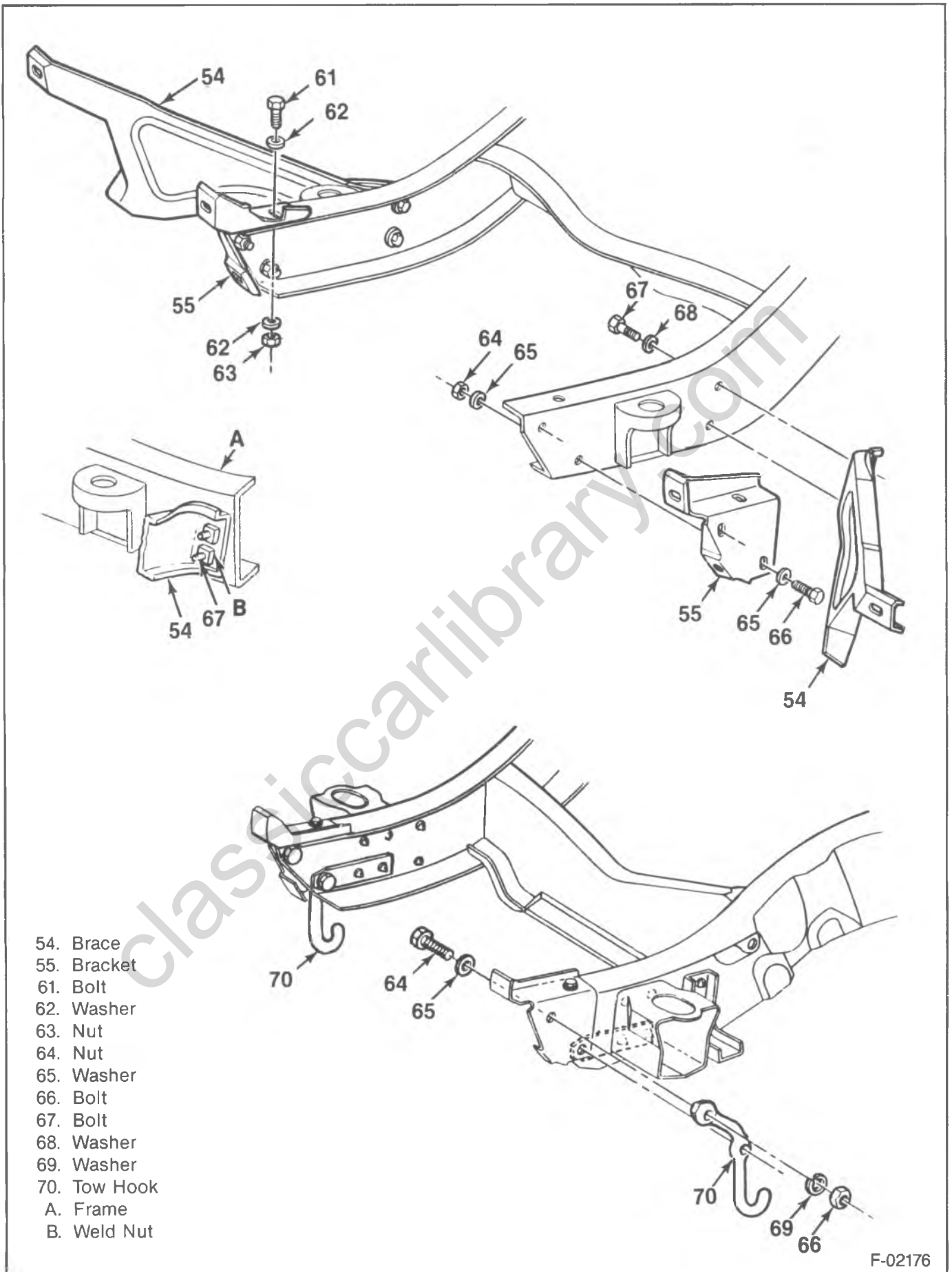

Figure 7—R/V Front Bumper Brackets, Braces, and Tow Hooks

2A-10 FRAME AND BUMPERS

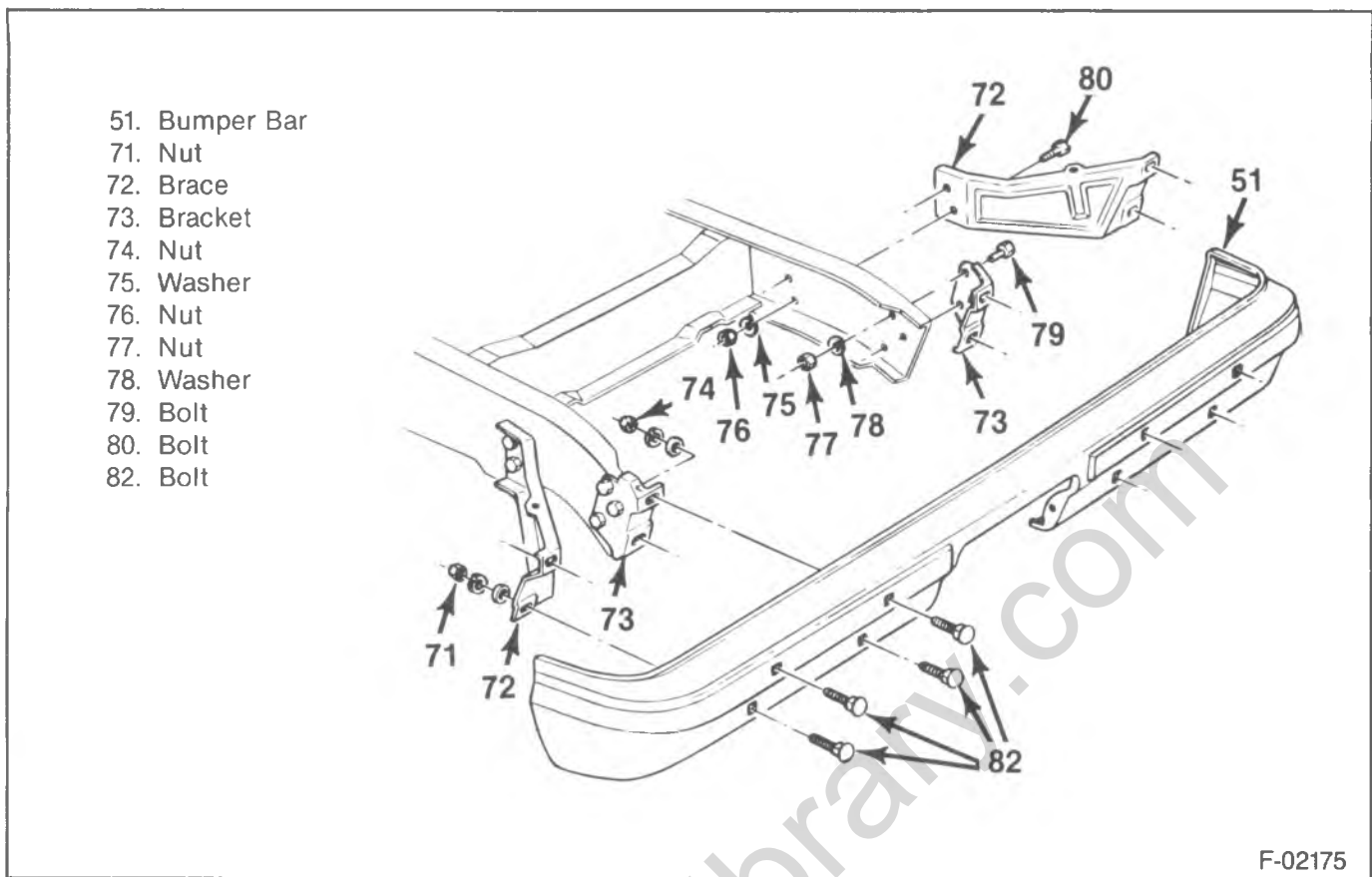

Figure 8—Utility Vehicle and Suburban Rear Bumper Components

Install or Connect (Figures 8-11)

1. Brackets to the frame rails (72).
 - Bracket bolts, washers, and nuts (79, 78 and 77).

Tighten

- Nuts to 95 N·m (70 ft. lbs.).
2. Braces to the frame rails (72).
 - Brace bolts, washers, and nuts (80, 75 and 76).

Tighten

- Nuts to 95 N·m (70 ft. lbs.).
3. Bumper bolts to the bumper (82).
 4. Rub strips to the bumper (where used).
 - Place the tangs of the strips onto the slots in the bumper guard. Using a rubber mallet, set the tangs in place starting at the center of the strip, working toward each end.
 5. Filler panel supports (Utility vehicle only) (figure 9).

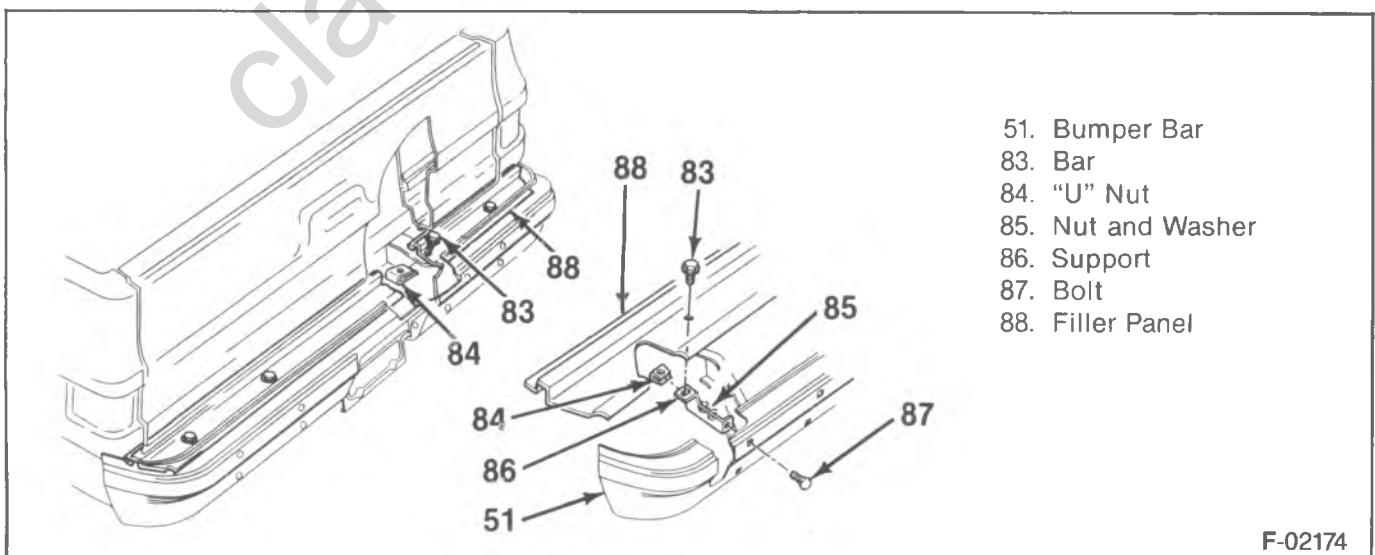

Figure 9—Rear Bumper Filler Strip

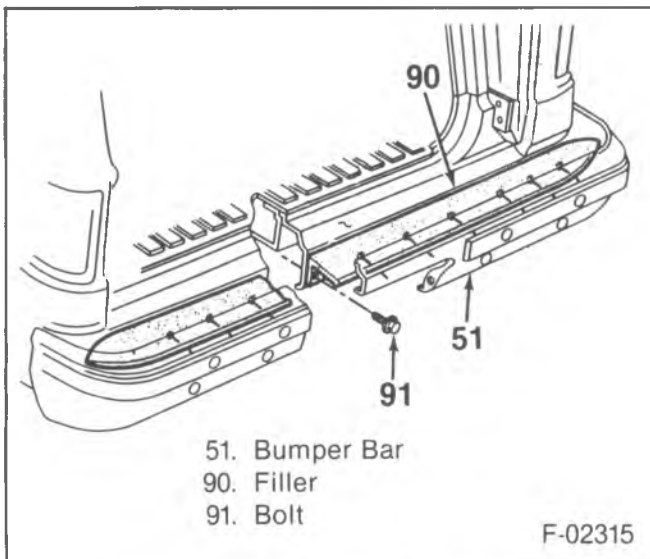

Figure 10—Rear Bumper Center Filler

- Place the filler panel bolts through the panel and into the support “U” nuts.

Tighten

- Bolts to 10 N·m (89 in. lbs.).

6. Filler panel (Suburban only) (figure 10).

- Bolts through the filler panel, and into the platform.

Tighten

- Bolts to 2.8 N·m (25 in. lbs.).

7. Bumper to the vehicle.

- Install the bumper bolts (82) into the braces, and brackets.

8. Filler panel (Utility vehicles only).

- Place the filler panel behind the bumper, and place the supports onto the bumper bolts behind the braces.

9. Filler panel bracket bolts (Utility vehicle only).

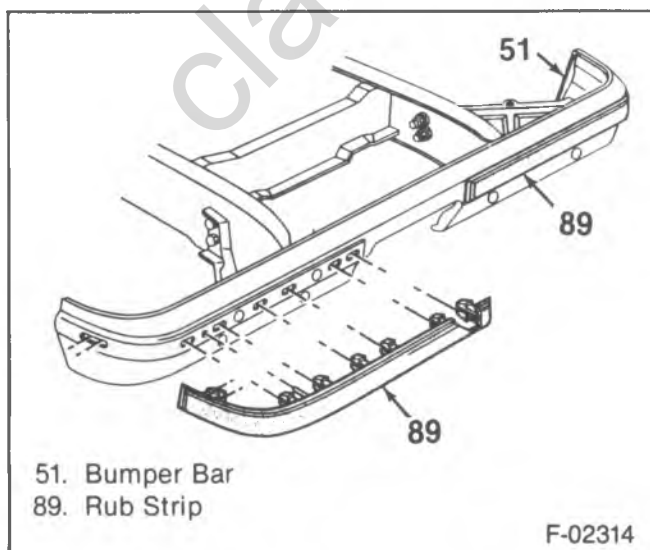

Figure 11—Rear Bumper Rub Strip

Tighten

- Bolts to 10 N·m (89 in. lbs.).

10. Bracket nuts (74).

Tighten

- Nuts to 41 N·m (30 ft. lbs.).

11. Brace nuts (71).

Tighten

- Nuts to 41 N·m (30 ft. lbs.).

**REAR BUMPER REPLACEMENT
(REGULAR CAB, BONUS CAB,
AND CREW CAB)**

Remove or Disconnect (Figure 12)

1. Brace nuts (93), spring washers (94), and washers (95) at the bumper.
2. Bracket nuts (99), spring washers (98), and washers at the bumper.
3. Rear bumper from the vehicle.
4. Bumper bolts (106).
5. Gravel deflector nuts (107) and bolts (81) (where used) (figure 13).
6. Gravel deflectors (105).
7. Brace to frame nuts (100), spring washers (102), and bolts (104).
8. Braces (92).
9. Bracket to frame rail nuts (101), spring washers (102) and bolts (103).
10. Brackets (96).

Install or Connect

1. Brackets to the frame rails.
2. Bolts (103), spring washers (102), and nuts (101).

Tighten

- Nuts to 95 N·m (70 ft. lbs.).

3. Braces to the frame rails.
4. Bolts (104), spring washers (102), and nuts (100).

Tighten

- Nuts to 95 N·m (70 ft. lbs.).

5. Gravel deflectors (where used).
6. Nuts (107) and bolts (81).

Tighten

- Nuts to 10 N·m (89 in. lbs.).

7. Bumper bolts (106) onto the bumper.

8. Rear bumper.

- Place the bumper bolts through the brackets and braces.

9. Bracket washers (97), spring washers (98), and nuts (99) to the bumper.

Tighten

- Nuts to 90 N·m (66 ft. lbs.).

10. Brace washers (95), spring washers (94), and nuts (93) to the bumper.

2A-12 FRAME AND BUMPERS

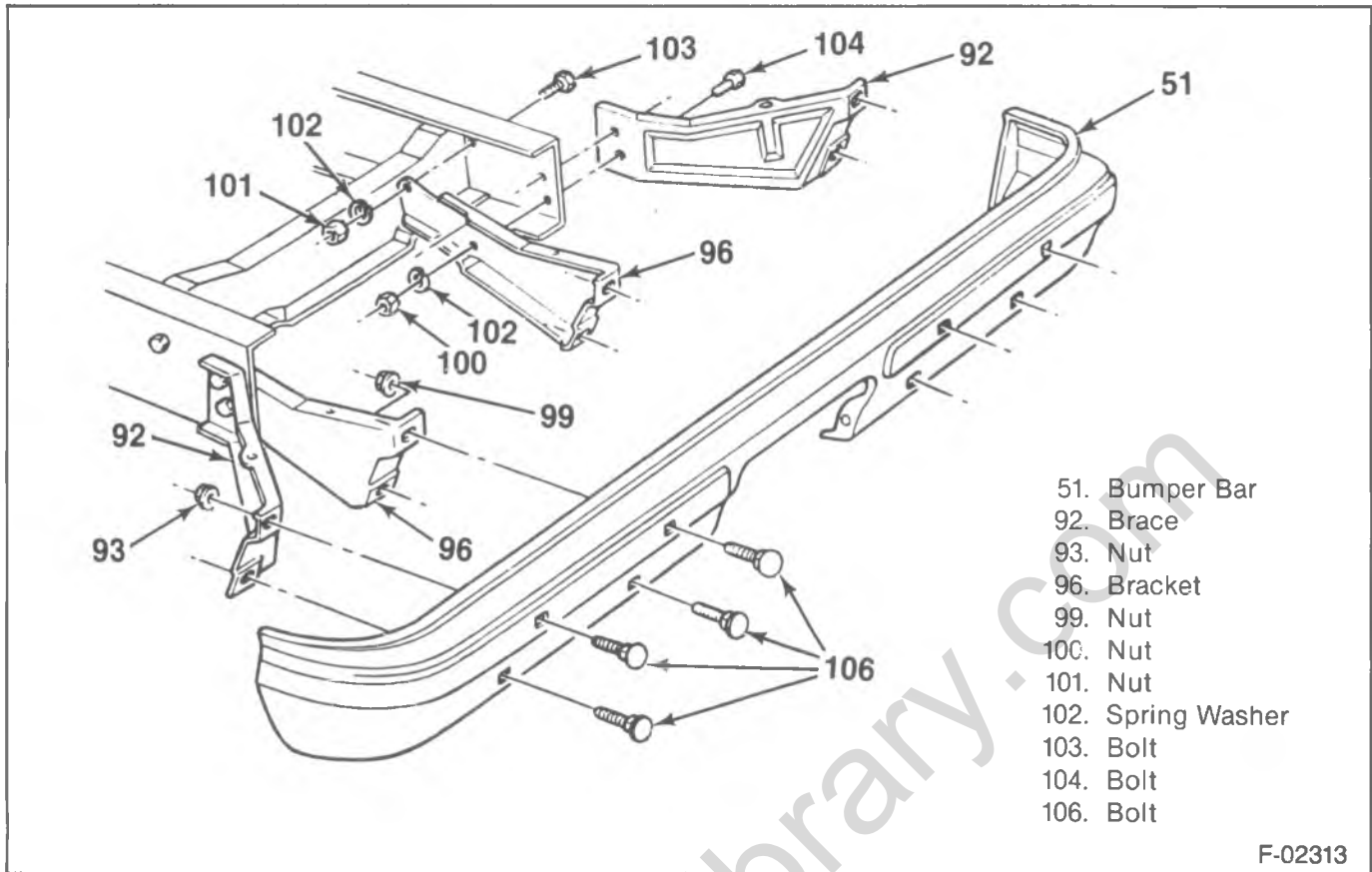

Figure 12—Regular Cab, Bonus Cab, and Crew Cab Rear Bumper Components



Tighten

- Nuts to 90 N·m (66 ft. lbs.).

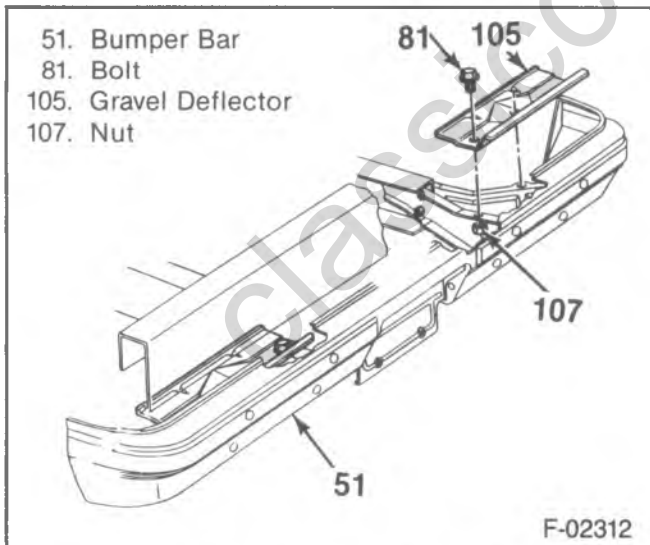

Figure 13—Rear Bumper Gravel Deflector

REAR STEP BUMPER REPLACEMENT



Remove or Disconnect (Figure 14)

1. Bracket to bumper nuts (111), and bolts (112).
2. Brace to bumper nuts (119), spring washers (118), washers (117), and bumper bolts.
3. Bumper from the vehicle.
4. Brace to frame nuts (108) and bolts (110).
5. Braces (54).
6. Bracket reinforcement nuts (115) and bolts (109) (and washers (114) where used).
7. Bracket reinforcements (113).
8. Bracket to frame nuts (108), and bolts (110).
9. Brackets (55).



Install or Connect (Figure 14)

1. Brackets (55) and braces (54) to the frame.
2. Bolts (110) and nuts (108) loosely.
3. Bracket reinforcements (113).
 - The reinforcements are marked as right or left on their inboard sides.
4. Bolts (109) and nuts (115), and washers (114) (where used).



Tighten

- Reinforcement nuts to 70 N·m (52 ft. lbs.).
 - Bracket and brace nuts to 70 N·m (52 ft. lbs.).
5. Bumper to the vehicle.

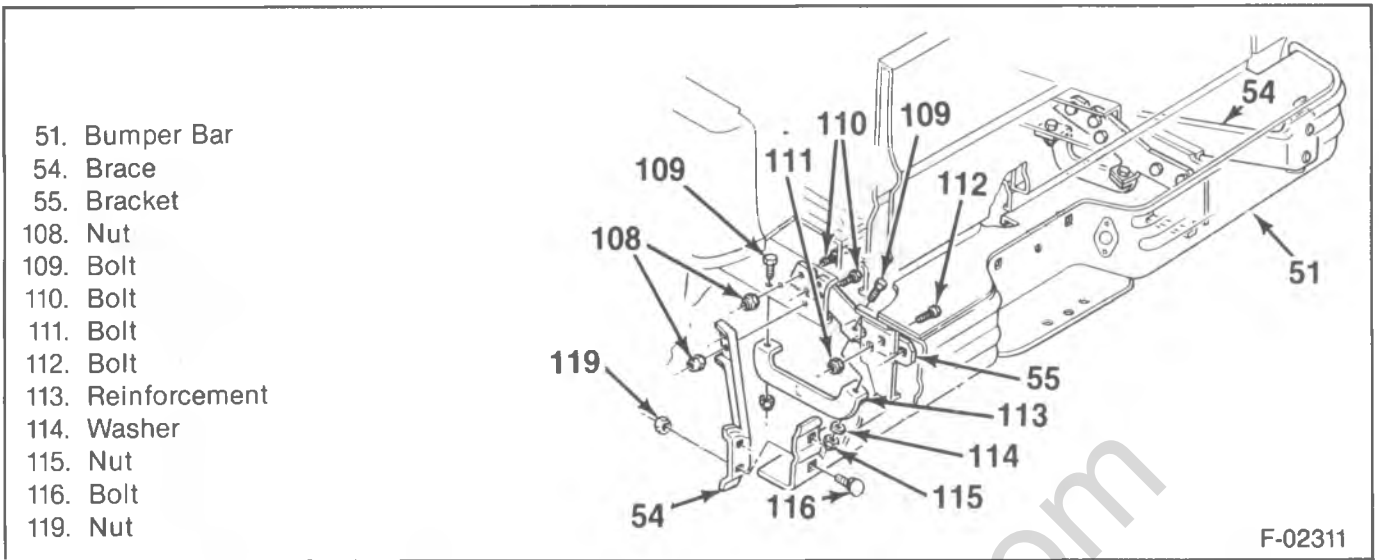

Figure 14—Rear Step Bumper Components

- Bumper to brace bolts (116), washers (117), spring washers (118), and nuts (119).

Tighten

- Nuts to 70 N·m (52 ft. lbs.).

- Bumper to bracket bolts (112) and nuts (111).

Tighten

- Nuts to 70 N·m (52 ft. lbs.).

REAR BUMPER LICENSE PLATE BRACKET REPLACEMENT

Remove or Disconnect (Figure 15)

- License plate bracket to bumper nuts (123), spring washers (122), washers (121), and bolts (124).
- License plate bracket (120).

Install or Connect (Figure 28)

- License plate bracket (120).
- License plate bracket to the bumper bolts (124), washers (121), spring washers (122), and nuts (123).

Tighten

- Nuts to 29 N·m (21 ft. lbs.).

DEAD WEIGHT TRAILER HITCH REPLACEMENT (UTILITY VEHICLE AND SUBURBAN)

Remove or Disconnect (Figures 16 and 17)

- Bracket assembly nuts, washers, and bolts from the frame.
- Support nuts, washers, and bolts from the bumper.
- Hitch assembly.
- Chain bracket nut, washer, and bolt.

- Chain bracket.
- Support.
- Bar assembly bolt and washer from the bracket.
- Bar assembly.

Install or Connect (Figures 16 and 17)

- Bracket assembly to the frame with bolts, washers, and nuts.

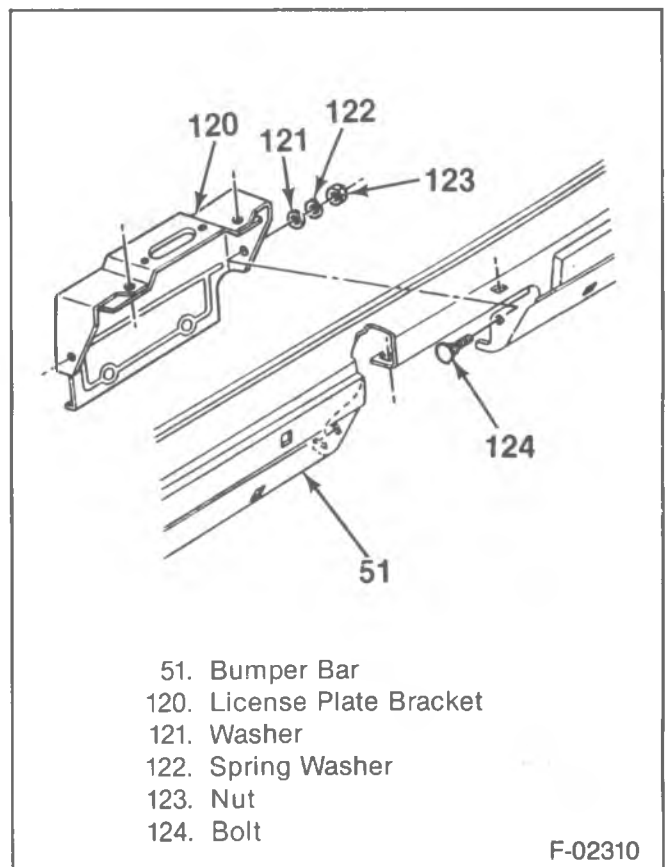

Figure 15—Rear License Plate Bracket

2A-14 FRAME AND BUMPERS

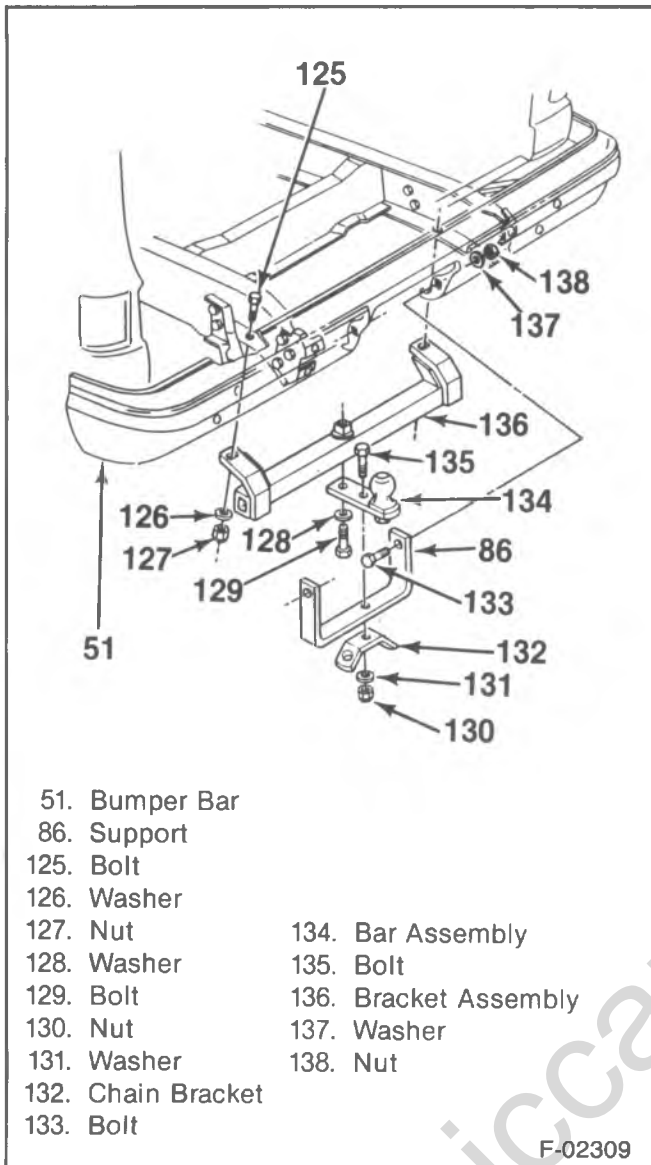

Figure 16—Suburban Dead Weight Trailer Hitch Components

Tighten

- Nuts to 70 N·m (52 ft. lbs.).
2. Bar assembly to the support.
 - Place the bolt through the bar assembly, support and the chain bracket. Install the washer and nut loosely.
 3. Support assembly bolts through the support and the bumper.
 4. Washers and nuts loosely.
 5. Bar assembly bolt with washer through the bar and into the bracket assembly.

Tighten

- Bar to bracket bolt to 95 N·m (70 ft. lbs.).
- Bar to support nut to 70 N·m (52 ft. lbs.).
- Support to bumper nuts to 33 N·m (24 ft. lbs.).

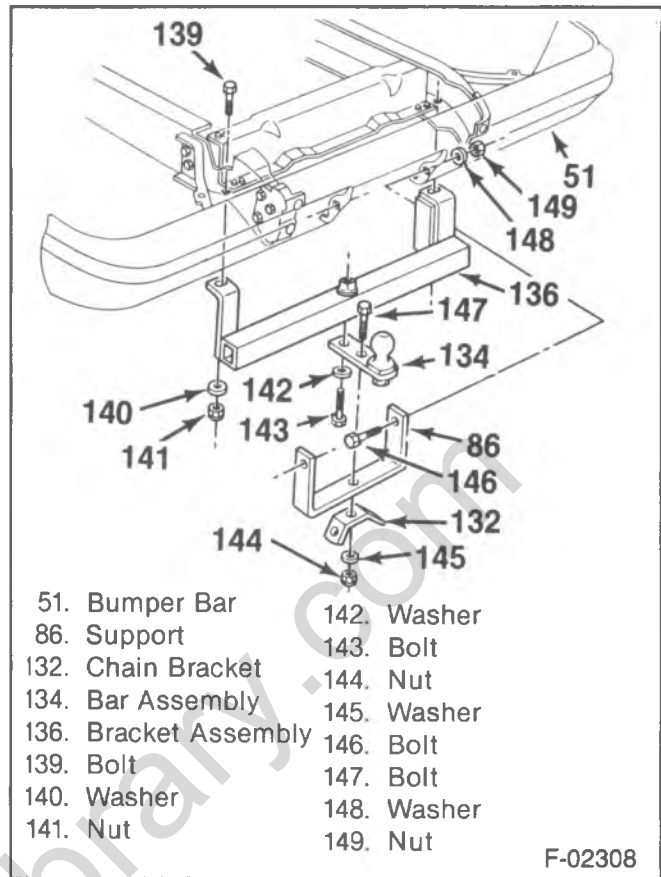

Figure 17—Utility Vehicle Dead Weight Trailer Hitch

WEIGHT DISTRIBUTION HITCH REPLACEMENT (SUBURBAN ONLY)

Remove or Disconnect (Figure 18)

1. Rear bolts, washers, and nuts from the hitch.
2. Front nuts, washers, and bolts from the hitch.
3. Hitch platform from the vehicle.

Install or Connect (Figure 18)

1. Hitch platform to the vehicle.
 - There must be no contact between the platform and the rear bumper.
2. Front bolts, washers, and nuts to the hitch.
 - Assemble loosely.
3. Rear nuts, washers, and bolts to the hitch.
 - Install the nuts with the cut-off side outboard.

Tighten

- Rear bolts to 95 N·m (70 ft. lbs.).
- Front nuts to 70 N·m (52 ft. lbs.).

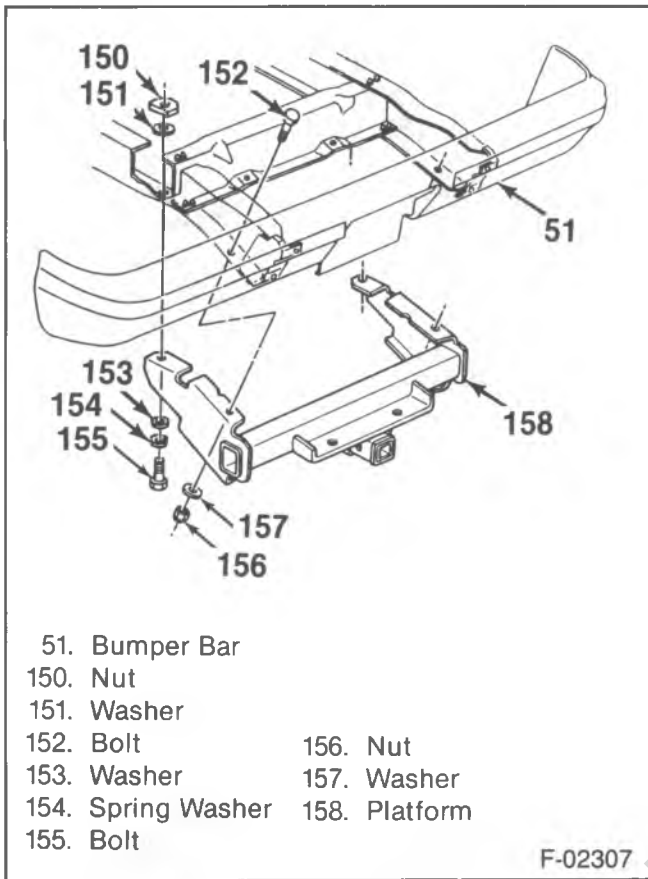

- 51. Bumper Bar
- 150. Nut
- 151. Washer
- 152. Bolt
- 153. Washer
- 154. Spring Washer
- 155. Bolt
- 156. Nut
- 157. Washer
- 158. Platform

F-02307

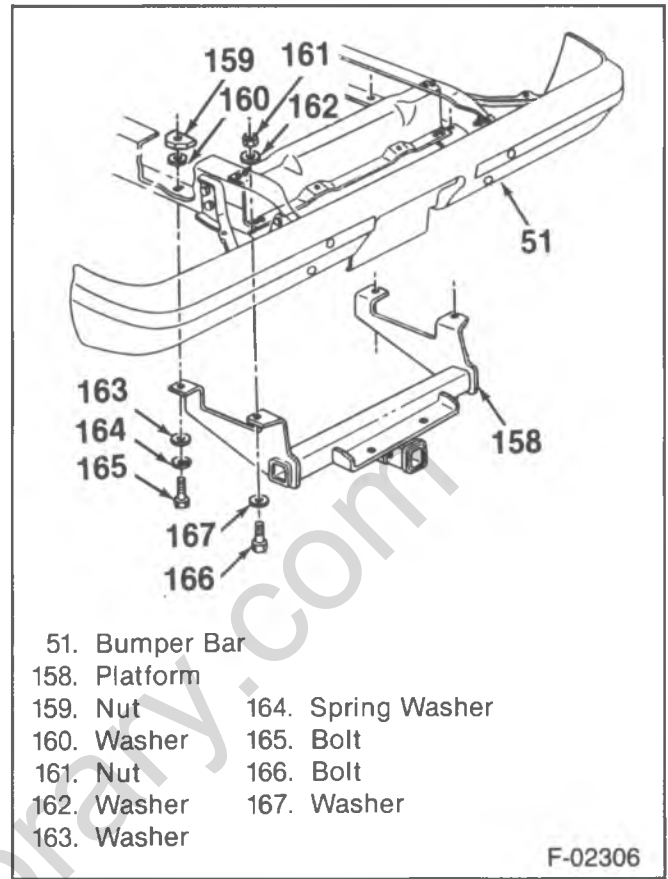

- 51. Bumper Bar
- 158. Platform
- 159. Nut
- 160. Washer
- 161. Nut
- 162. Washer
- 163. Washer
- 164. Spring Washer
- 165. Bolt
- 166. Bolt
- 167. Washer

F-02306

Figure 18—Suburban Weight Distribution Hitch Components

Figure 19—Utility Vehicle Weight Distribution Hitch Components

WEIGHT DISTRIBUTION HITCH REPLACEMENT (UTILITY VEHICLE ONLY)

↔ Remove or Disconnect (Figure 19)

1. Rear bolts, washers, and nuts from the hitch.
2. Front bolts, washers, and nuts from the hitch.
3. Hitch platform from the vehicle.

↔ Install or Connect (Figure 19)

1. Hitch platform to the vehicle.
2. Front bolts, washers, and nuts to the hitch.
 - Assemble loosely.
3. Rear bolts, washers, and nuts to the hitch.
 - Install nuts with the cut off side inboard.

⌚ Tighten

- Rear bolts to 73 N·m (54 ft. lbs.).
- Front bolts to 70 N·m (51 ft. lbs.).

P MODEL BUMPERS

FRONT BUMPER REPLACEMENT

↔ Remove or Disconnect (Figures 20 and 21)

1. Brace to frame nuts (203), spring washers (202), washers (201), and bolts (199).
2. Bracket to frame nuts (206), spring washers (205), washers (204), and bolts (195).
3. Bumper to frame nuts (187), spring washers (186), washers (185), spacers (198) (where used), and bolts (197).
4. Bumper from the vehicle.
5. Brace to bumper nuts (192), spring washers (193), washers (194), and bolts (197).

6. Braces (54).
7. Bracket to bumper nuts (191), spring washers (190), washers (189), and bolts (197).

↔ Install or Connect (Figures 20 and 21)

1. Braces to the bumper with bolts (197), washers (194), spring washers (193), and nuts (192).
 - Assemble loosely.
2. Bracket to the bumper with bolts (197), washers (194), spring washers (193), and nuts (191).
 - Assemble loosely.
3. Bumper to vehicle.
4. Bumper to frame spacers (198) (where used), spring washers (186), washers (185), bolts (197), and nuts (187).

2A-16 FRAME AND BUMPERS

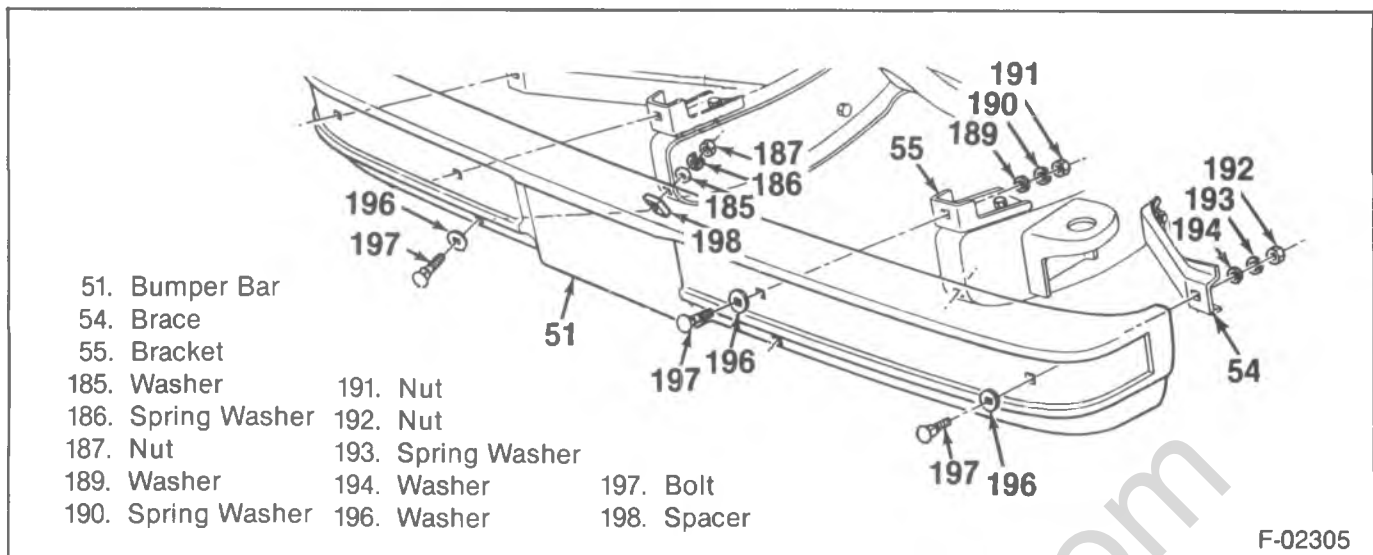

Figure 20—P-Front Bumper Components



Tighten

- Nuts to 47 N·m (35 ft. lbs.).

5. Brackets to the frame rails with bolts (195), washers (204), spring washers (205), and nuts (206).



Tighten

- Bracket to frame nuts to 95 N·m (70 ft. lbs.).
- Bracket to bumper nuts to 47 N·m (35 ft. lbs.).

6. Braces to the frame rails with bolts (199), washers (201), spring washers (202), and nuts (203).



Tighten

- Brace to frame nuts to 85 N·m (63 ft. lbs.).
- Brace to bumper nuts to 47 N·m (35 ft. lbs.).

FRONT BUMPER REPLACEMENT (WITH RPO FS3 FRONT AXLE)



Remove or Disconnect (Figures 22 and 23)

1. Bracket to frame nuts (207) and washers (208).
2. Brace to frame nuts (222), washers (221), and bolts (219).
3. Front bumper from the vehicle.
4. Bracket to bumper nuts (218 and 223), spring washers (217 and 224), washers (216 and 225), spacers (198), and bolts (215).
5. Brackets (55).
6. Brace to bumper nuts (209), spring washers (210), washers (211), and bolts (213).
7. Braces (54).



Install or Connect (Figures 22 and 23)

1. Braces to the bumper with bolts (215), washers (211), spring washers (210), and nuts (209).



Tighten

- Nuts to 47 N·m (35 ft. lbs.).

2. Brackets to the bumper with bolts (213), spacers (198), spring washers (217 and 224), washers (216 and 225), and nuts (218 and 223).



Tighten

- Nuts to 47 N·m (35 ft. lbs.).

3. Front bumper to the vehicle.
 - Place the bracket assembly studs into the frame crossmember.
4. Brace to frame bolts (219), washers (221), and nuts (222).

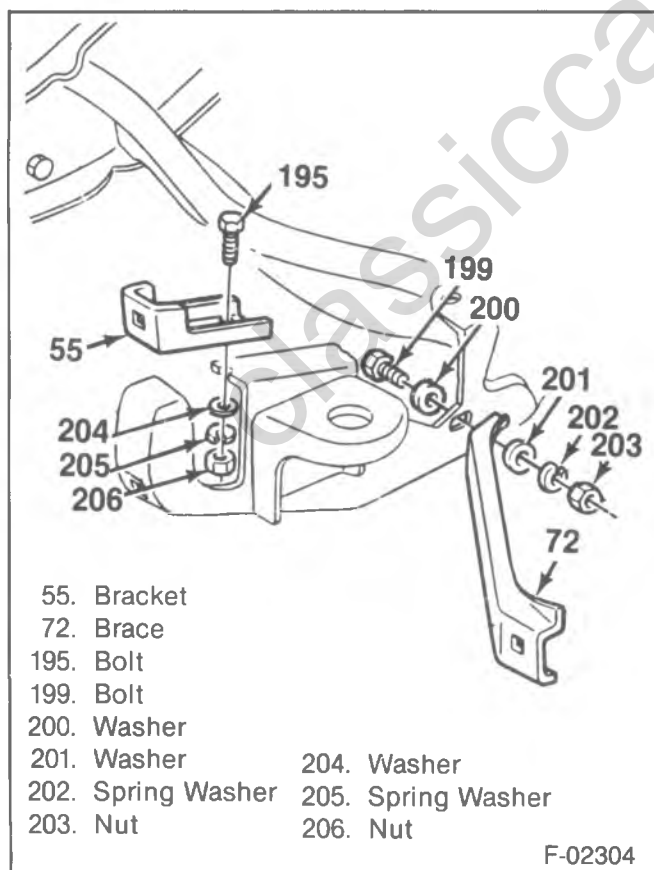

Figure 21—P-Front Bumper Braces and Brackets

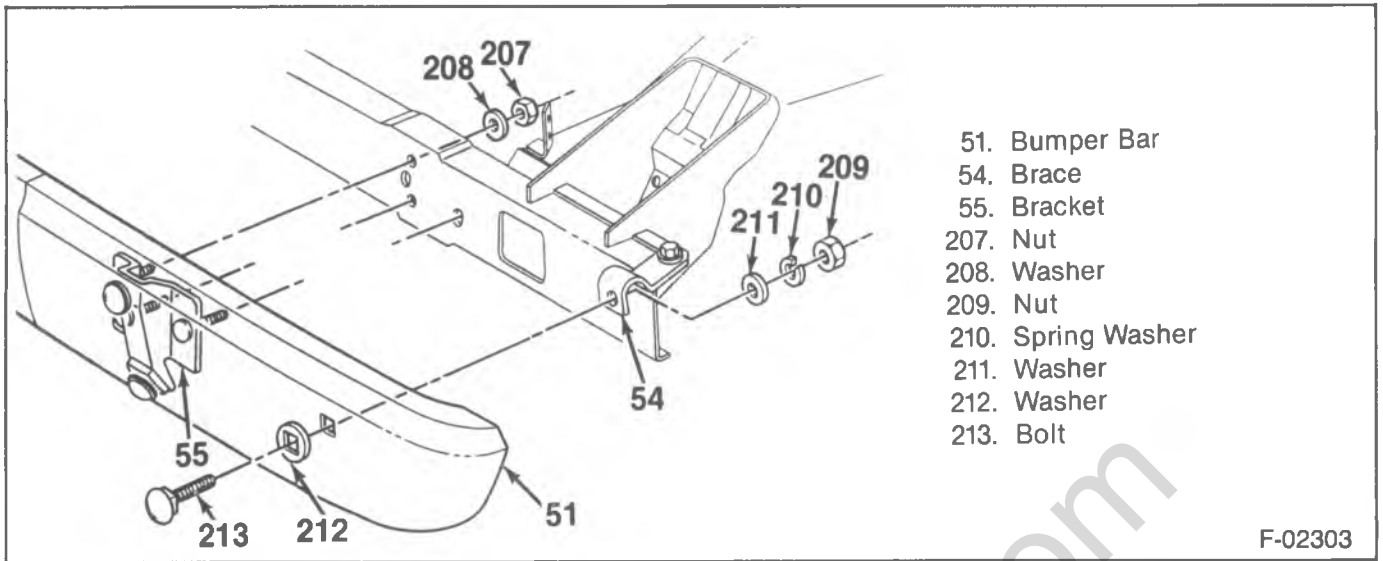

Figure 22—P-Front Bumper Components (RPO FS3 Front Axle)



Tighten

- Nuts to 40 N·m (30 ft. lbs.).
5. Bracket to frame washers (208) and nuts (207).



Tighten

- Nuts to 64 N·m (47 ft. lbs.).

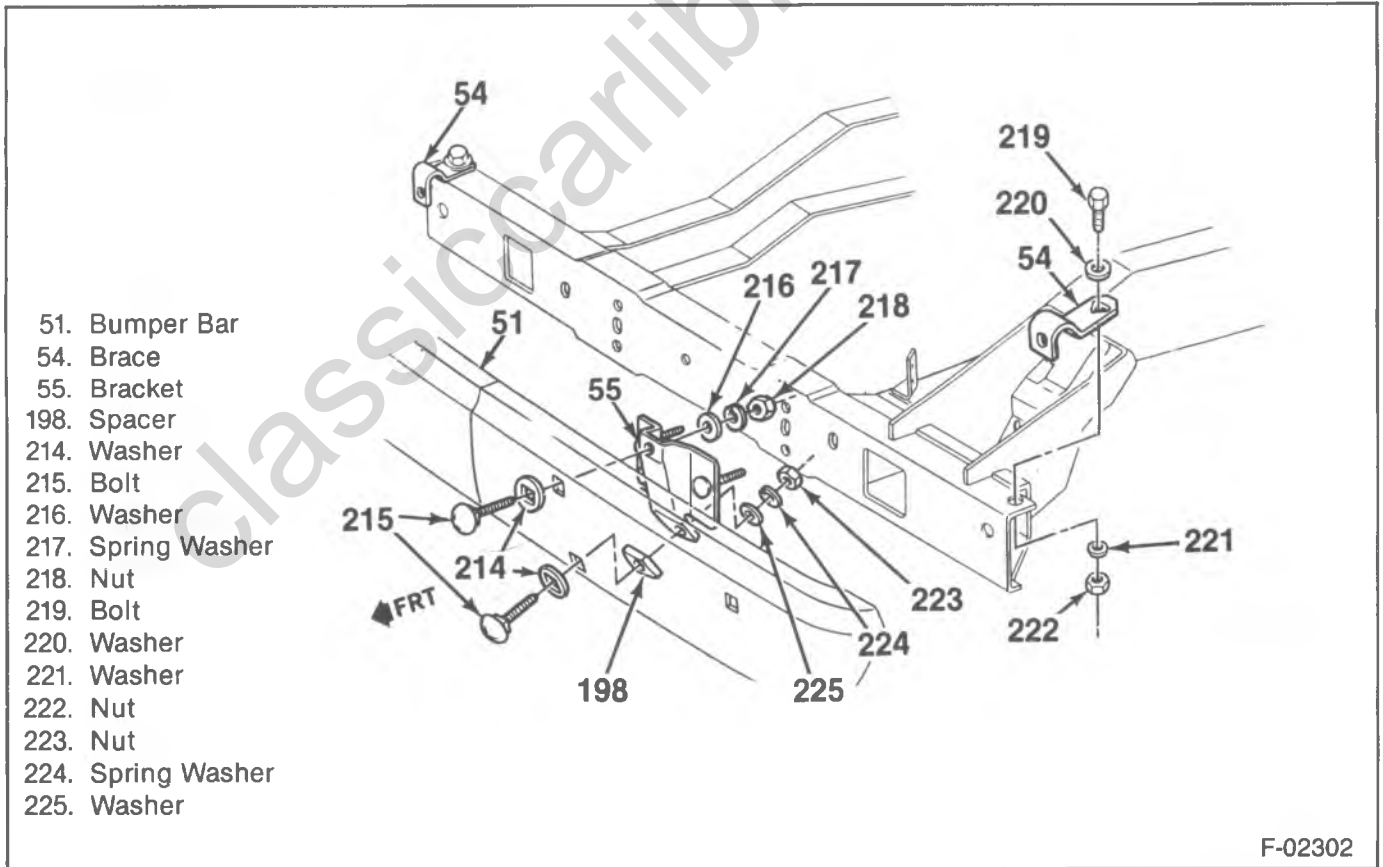

Figure 23—P-Front Bumper Braces and Brackets (RPO FS3 Front Axle)

G MODEL BUMPERS

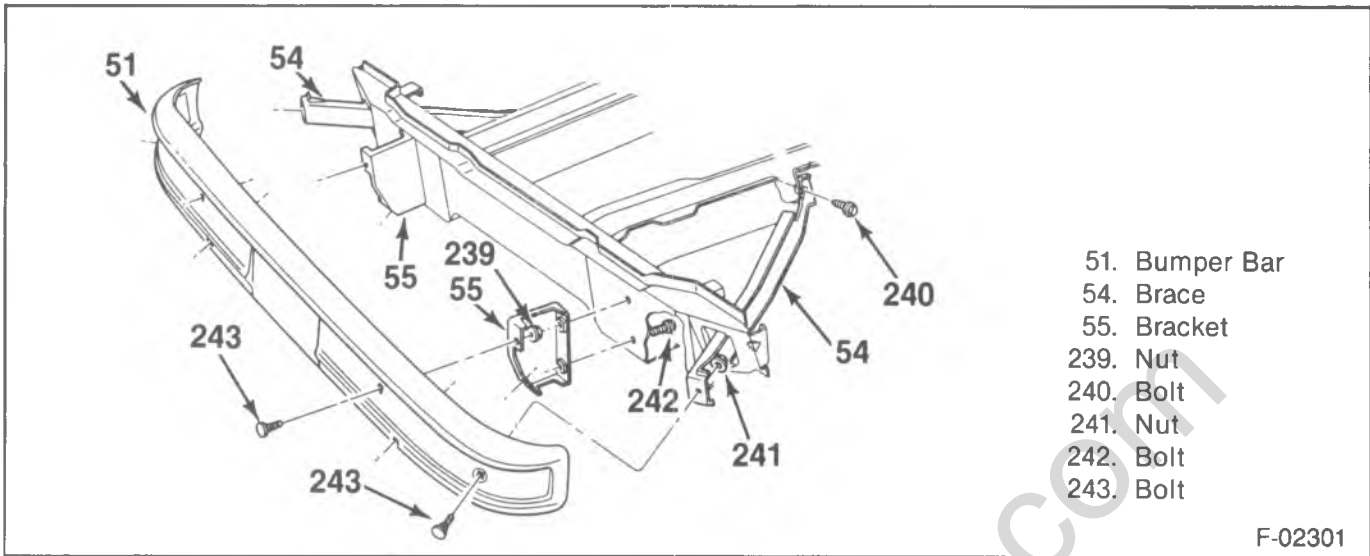

Figure 24—G-Front Bumper Components

FRONT BUMPER REPLACEMENT

↔ Remove or Disconnect (Figure 24)

1. Bracket to cross sill bolts (242).
2. Brace to bumper nuts (241) and bolts (243).
3. Bumper from the vehicle.
4. Bracket to bumper nuts (239), bolts (243), and guards (where used).
5. Brackets (55).
6. Rub strips from the guards (where used) (figure 38).
 - From the rear of the guard, press the tangs of the bump strip together, and push the strip from the guard.
7. Brace to frame bolts (240).
 - Braces (54).

↔ Install or Connect (Figures 24 and 25)

1. Braces to the frame.
 - Place braces through the holes in the cross sill, and install the bolts (240) loosely.
2. Bolts (245) into the guards (where used).
3. Rub strips to the guards (where used).
 - Place the tangs of the strips onto the slots in the guard. Using a rubber mallet, set the tangs in place starting at the center of the strip, and working toward each end.
4. Bracket to bumper bolts (243) or guards (where used), nuts (239), and guard lower bolts.

Tighten

- Nuts to 29 N·m (21 ft. lbs.).
- Guard lower bolts to 41 N·m (30 ft. lbs.).

5. Bumper to the vehicle.
6. Bracket to cross sill bolts (242).

Tighten

- Bolts to 41 N·m (30 ft. lbs.).

7. Brace to bumper bolts (243) and nuts (241).

Tighten

- Brace to bumper nuts to 29 N·m (21 ft. lbs.).
- Brace to frame bolts to 41 N·m (30 ft. lbs.).

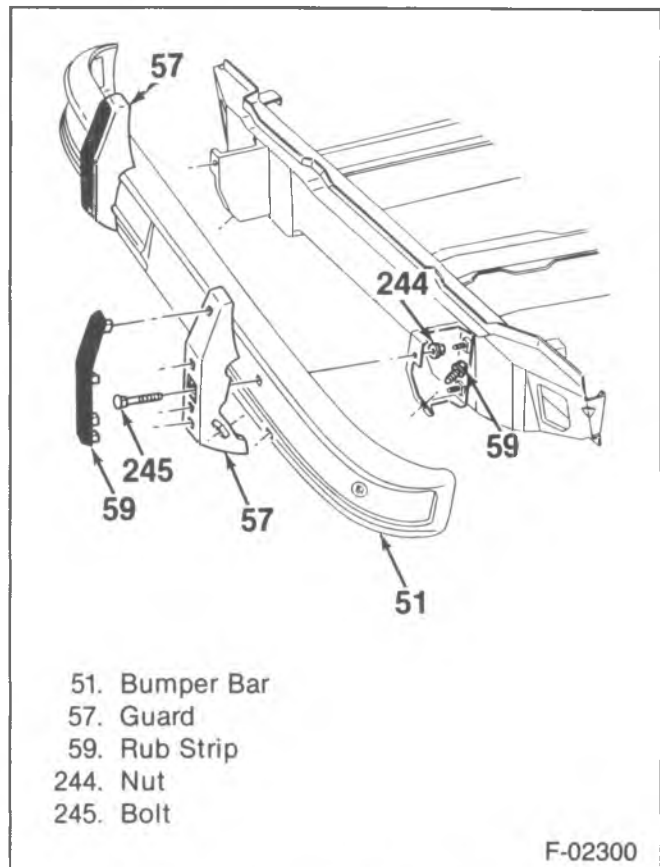

- 51. Bumper Bar
- 57. Guard
- 59. Rub Strip
- 244. Nut
- 245. Bolt

F-02300

Figure 25—G-Front Bumper Guards

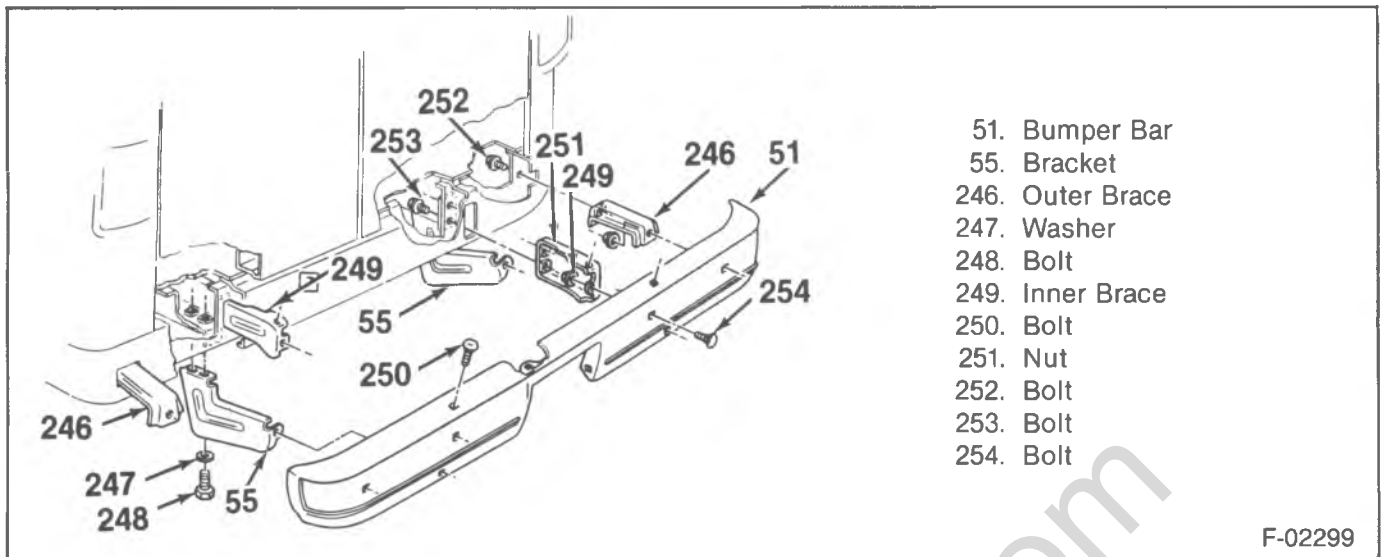

- 51. Bumper Bar
- 55. Bracket
- 246. Outer Brace
- 247. Washer
- 248. Bolt
- 249. Inner Brace
- 250. Bolt
- 251. Nut
- 252. Bolt
- 253. Bolt
- 254. Bolt

F-02299

Figure 26—G-Rear Bumper Components

REAR BUMPER REPLACEMENT

Remove or Disconnect (Figure 26)

1. Outer brace to bumper nuts (251) and bolts (254).
2. Inner brace to cross sill bolts (253).
3. Bracket to frame bolts (248) and washers (247).
4. Bumper from the vehicle.
5. Outer brace to cross sill bolts (252).
6. Outer braces (246).
7. Bracket to bumper nuts and bolts (254).
8. Brackets (55).
9. Inner brace to bumper nuts (251) and bolts (254).
10. Inner braces (249).

Install or Connect (Figure 26)

1. Inner braces (249) to the bumper.
 - Assemble the top bolts (250) and nuts (251).

Tighten

- Nut to 30 N·m (22 ft. lbs.)
- Assemble the lower bolts (254) and nuts (251).

Tighten

- Nut to 30 N·m (22 ft. lbs.).

2. Brackets to the frame with washers (247) and bolts (248).

- Assemble loosely.

3. Outer braces (246) to the cross sill with bolts (252).

Tighten

- Bolts to 41 N·m (30 ft. lbs.).

4. Bumper to the vehicle.

- Place the inner braces into the inner brace panel holes.

5. Inner braces to the cross sill with bolts (253).

Tighten

- Bolts to 41 N·m (30 ft. lbs.).

6. Bumper to bracket bolts (254) and nuts.

Tighten

- Nuts to 29 N·m (21 ft. lbs.).
 - Bracket to frame bolts to 68 N·m (50 ft. lbs.).
7. Outer bracket to bumper bolts (254) and nuts (251).

Tighten

- Nuts to 68 N·m (50 ft. lbs.).

REAR LICENSE PLATE BRACKET REPLACEMENT

Remove or Disconnect (Figure 27)

1. License plate bracket nuts and bolts.
2. License plate bracket.

Install or Connect (Figure 27)

1. License plate bracket.
2. License plate bracket nuts and bolts.

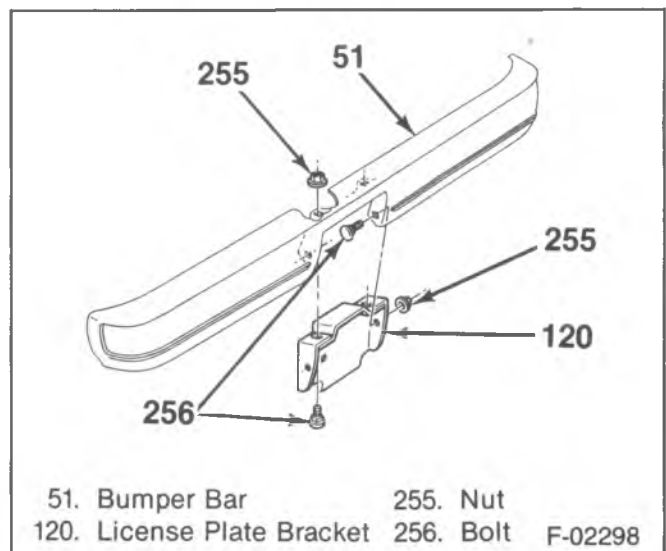

- 51. Bumper Bar
 - 120. License Plate Bracket
 - 255. Nut
 - 256. Bolt
- F-02298

Figure 27—Rear License Plate Bracket Components

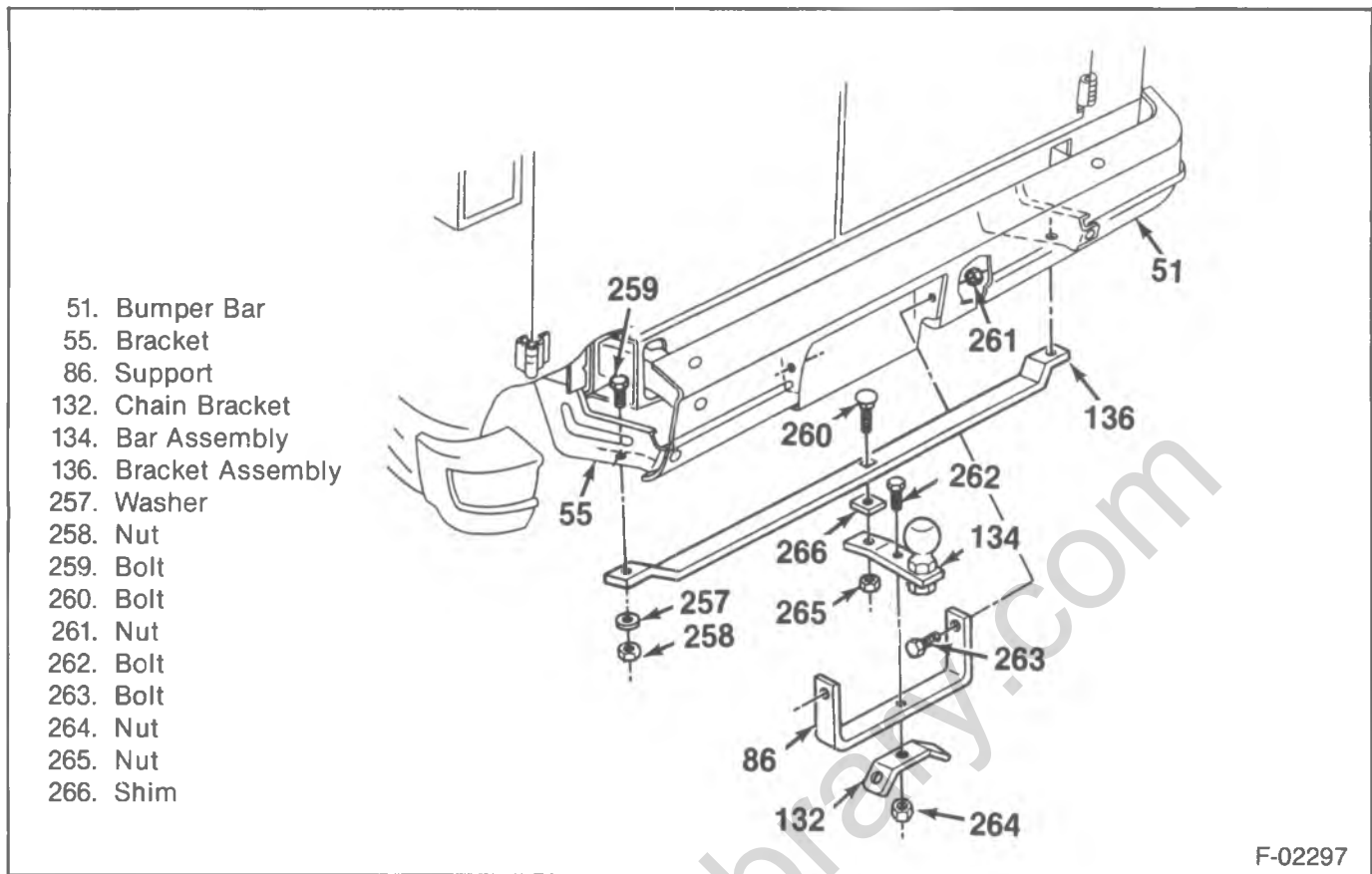

F-02297

Figure 28—Dead Weight Trailer Hitch



Tighten

- Nuts to 29 N·m (21 ft. lbs.).

DEAD WEIGHT TRAILER HITCH REPLACEMENT



Remove or Disconnect (Figure 28)

1. Hitch bracket to bumper bracket nuts, washers, and bolts.
2. Support to bumper nuts and bolts.
3. Hitch from the vehicle.
4. Chain bracket to bar assembly nut and bolt.
 - Chain bracket.
 - Support.
 - Bar assembly.
5. Bar assembly to hitch bracket nut and bolt.
 - Bar assembly.
 - Shim(s).
 - Hitch bracket.



Install or Connect (Figure 28)

1. Hitch bracket to the bumper brackets with bolts, washers, and nuts.



Tighten

1. Nuts to 24 N·m (18 ft. lbs.).
2. Bar assembly with shims (as required) to the hitch bracket with bolts and nuts.
 - Assemble loosely.

3. Support to the bumper with bolts and nuts.
 - Assemble loosely.

4. Bar assembly and chain bracket to the support with a bolt and nut.



Tighten

- Bar assembly to chain bracket nut to 68 N·m (50 ft. lbs.).
- Bar assembly to hitch bracket bolt to 68 N·m (50 ft. lbs.).
- Support to bumper nuts to 29 N·m (21 ft. lbs.).

WEIGHT DISTRIBUTION HITCH REPLACEMENT



Remove or Disconnect (Figure 29)

1. Bumper nuts and bolts.
2. Bumper.
3. Rear hitch nuts and washers.
4. Front bolts and washers.
5. Hitch from the vehicle.



Install or Connect (Figure 29)

1. Hitch to the vehicle.
2. Front bolts and washers.



Tighten

- Bolts to 70 N·m (52 ft. lbs.).
- 3. Rear washers and nuts.

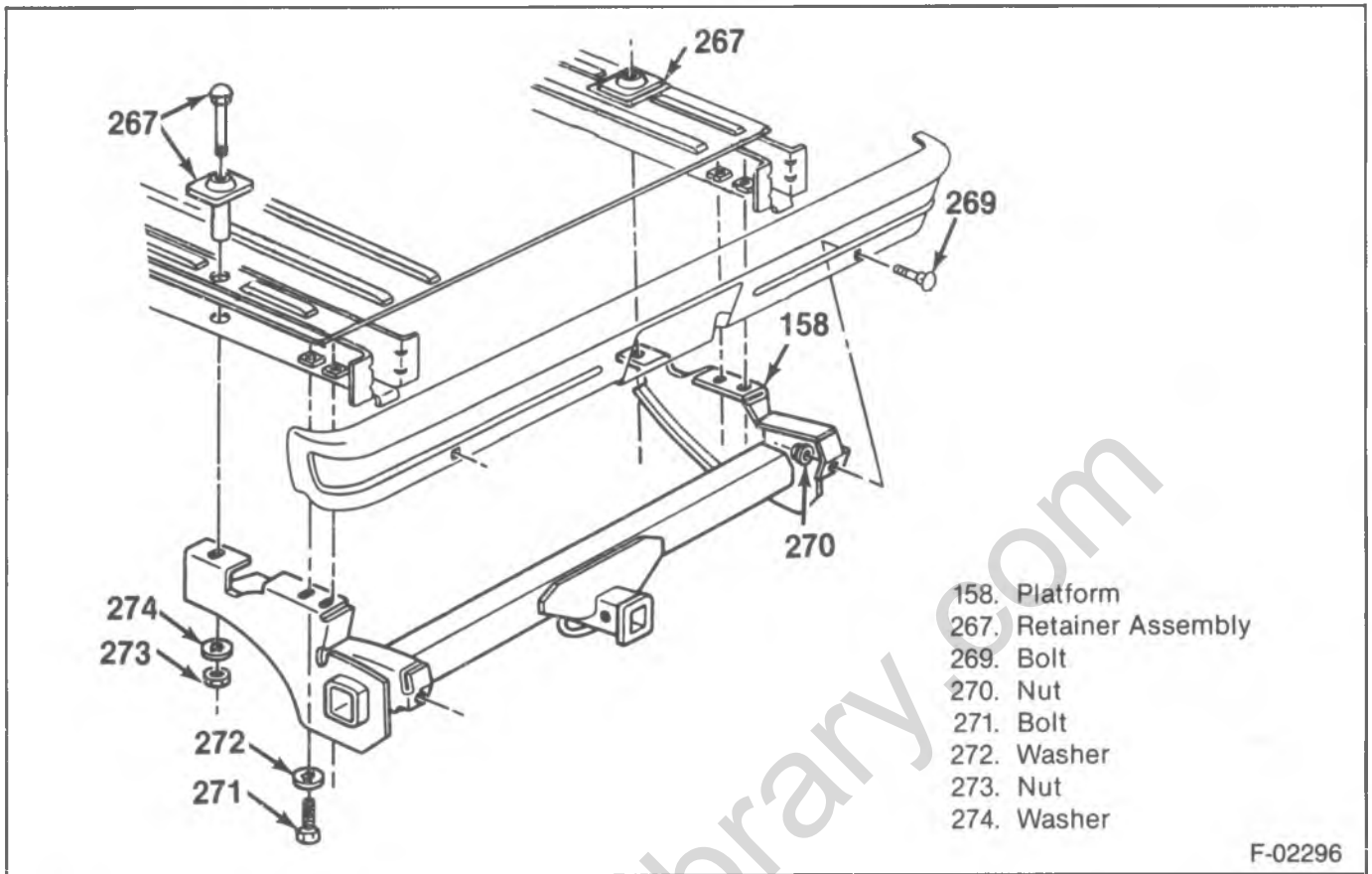

Figure 29—Weight Distribution Hitch



Tighten

- Nuts to 63 N·m (47 ft. lbs.).

4. Bumper to the vehicle with nuts and bolts.



Tighten

- Nuts to 29 N·m (21 ft. lbs.).

SPECIFICATIONS

BUMPER TORQUE SPECIFICATIONS

FASTENER	N-m	Ft. Lbs.	In. Lbs.
R/V Models			
Front Bumper			
Bracket to Frame Rail Nuts	95	70	
Brace to Frame Rail Bolts	50	37	
Bracket to Bumper Nuts	90	66	
Brace to Bumper Nuts	90	66	
Rear Bumper (Utility Vehicle and Suburban)			
Bracket to Frame Rail Nuts	95	70	
Brace to Frame Rail Nuts	95	70	
Filler Panel to Support Bolts (Utility Vehicle)	10		89
Filler Panel to Support Bolts (Suburban)	2.8		25
Filler Panel Bracket Nuts	41	30	
Brace to Bumper Nuts	41	30	
Rear Bumper (Regular Cab, Bonus Cab, Crew Cab)			
Bracket to Frame Rail Nuts	95	70	
Brace to Frame Rail Nuts	95	70	
Gravel Deflector Nuts	10		89
Bumper to Bracket Nuts	90	66	
Brace to Bumper Nuts	90	66	
Rear Step Bumper			
Bracket Reinforcement Nuts	70	52	
Bracket to Brace Nuts	70	52	
Bumper to Brace Nuts	70	52	
Bumper to Bracket Nuts	70	52	
License Plate Bracket to Bumper Nuts	29	21	
Trailer Hitch (Utility Vehicle and Suburban)			
Bracket to Frame Nuts	70	52	
Bar Assembly to Bracket Bolt	95	70	
Bar Assembly to Support Nut	70	52	
Support to Bumper Nuts	33	24	
Weight Distribution Hitch			
Suburban			
Hitch to Vehicle Rear Bolts	95	70	
Hitch to Vehicle Front Nuts	70	52	
Utility Vehicle			
Hitch to Vehicle Rear Bolts	73	54	
Hitch to Vehicle Front Bolts	70	51	
P Models			
Front Bumper			
Bumper to Frame Nuts	47	35	
Bracket to Frame Rail Nuts	95	70	
Bracket to Bumper Nuts	47	35	
Brace to Frame Nuts	85	63	
Brace to Bumper Nuts	47	35	
Front Bumper (FS3 Front Axle)			
Brace to Bumper Nuts	47	35	
Bracket to Bumper Nuts	47	35	
Brace to Frame Nuts	40	30	
Bracket to Frame Nuts	64	47	

SPECIFICATIONS (CONT.)

BUMPER TORQUE SPECIFICATIONS (CONT.)

FASTENER	N·m	Ft. Lbs.	In. Lbs.
G Models			
Front Bumper			
Bracket to Bumper Nuts.....	29	21	
Bracket to Guard Bolts.....	41	30	
Bracket to Cross Sill Bolts.....	41	30	
Brace to Bumper Nuts.....	29	21	
Brace to Frame Bolts.....	41	30	
Rear Bumper			
Brace to Bumper Top Nuts.....	30	22	
Brace to Bumper Lower Nuts.....	30	22	
Bracket to Frame Bolts.....	41	30	
Brace to Cross Sill Bolts.....	41	30	
Bumper to Bracket Nuts.....	29	21	
Bracket to Frame Bolts.....	68	50	
Bracket to Bumper Nuts.....	68	50	
License Plate Bracket Nuts.....	29	21	
Trailer Hitch			
Hitch Bracket to Bumper Bracket Nut.....	24	18	
Bar Assembly to Chain Bracket Nut.....	68	50	
Bar Assembly to Hitch Bracket Bolt.....	68	50	
Support to Bumper Nuts.....	29	21	
Weight Distribution Hitch			
Hitch to Vehicle Bolts.....	70	52	
Hitch to Vehicle Nuts.....	63	47	
Bumper to Vehicle Nuts.....	29	21	

Classiccarlibrary.com

classicalibrary.com

SECTION 2B

SHEET METAL

NOTICE: All hood latch fasteners are important attaching parts in that they could affect the performance of vital parts and systems, and/or could result in major repair expense. They must be replaced with one of the same part number or with an equivalent part if replacement becomes necessary. Do not use a replacement part of lesser quality or substitute design. Torque values must be used as specified during reassembly to assure proper retention of all parts.

CONTENTS

<u>SUBJECT</u>	<u>PAGE</u>
R/V Models2B- 2
Hood Replacement2B- 2
Spring Assembly Replacement2B- 2
Hood Hinge Replacement2B- 2
Primary Hood Latch Replacement2B- 2
Secondary Hood Latch And Spring Replacement2B- 3
Hood Release Cable Replacement2B- 3
Hood Ornament Replacement2B- 4
Cowl Vent Grille Replacement2B- 4
Grille And Molding Replacement2B- 5
Front Fender Replacement2B- 6
Wheelhouse Panel Replacement2B- 7
Rear Fender Replacement2B- 8
Radiator Support Replacement2B-10
Sheet Metal Unit Replacement2B-11
Sheet Metal Adjustments2B-11
G Models2B-13
Hood Replacement2B-13
Hood Hinge Replacement2B-13
Primary Hood Latch Replacement2B-13
Secondary Hood Latch And Spring Replacement2B-14
Hood Release Cable Replacement2B-15
Cowl Vent Grille Replacement2B-15
Grille Replacement2B-15
Front End Sheet Metal Cross Panel Replacement2B-17
Sheet Metal Vertical Support Replacement2B-17
Front End Panel Replacement2B-17
Cab Mounts2B-18
Cab Mount Replacement2B-18
Specifications2B-23
Special Tools2B-23

R/V MODELS

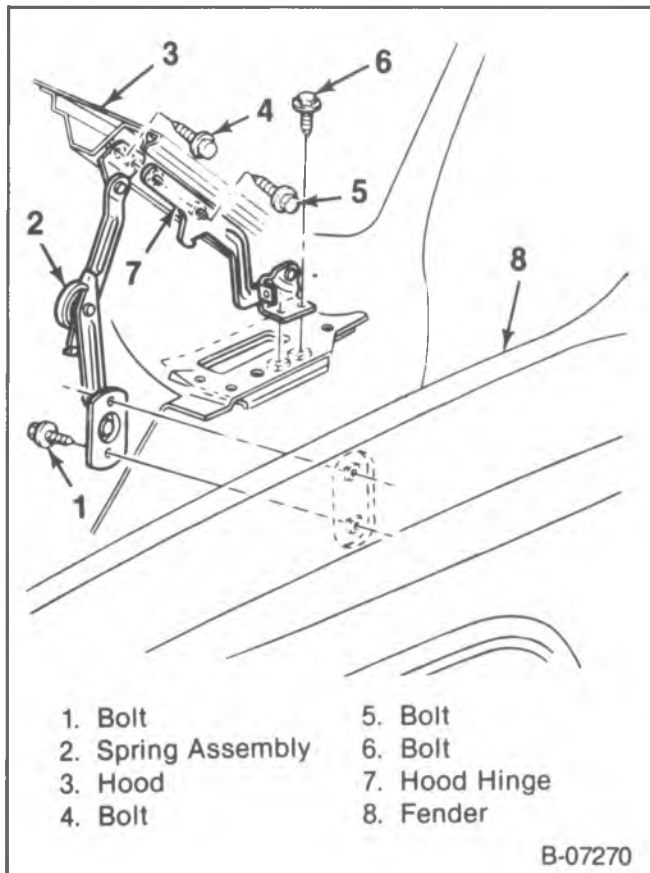

Figure 1—Hood Hinge Components

HOOD REPLACEMENT

↔ Remove or Disconnect (Figure 1)

- Raise and support the hood at front and rear.
 - Place protective coverings over the cowl and the fenders.
 - Mark the position of the hinge on the hood.
1. Spring assembly to hood bolts (4).
 2. Hood hinge to hood bolts (5).
 3. Hood from the vehicle.

↔ Install or Connect (Figure 1)

1. Hood to the vehicle.
 - Align the hood with the previously made marks.
2. Hood hinge to hood bolts (5).

Tighten

- Bolts to 25 N·m (18 ft. lbs.).

3. Spring assembly to hood bolts (4).

Tighten

- Bolts to 25 N·m (18 ft. lbs.).

SPRING ASSEMBLY REPLACEMENT

↔ Remove or Disconnect (Figure 1)

- Raise and support the front of the hood.
1. Spring assembly to hood bolts (4).
 2. Spring assembly to fender bolts (1).
 3. Spring assembly from the vehicle.

↔ Install or Connect (Figure 1)

1. Spring assembly to the vehicle.
2. Spring assembly to fender bolts (1).

Tighten

- Bolts to 25 N·m (18 ft. lbs.).
3. Spring assembly to hood bolts (4).

Tighten

- Bolts to 25 N·m (18 ft. lbs.).

HOOD HINGE REPLACEMENT

↔ Remove or Disconnect (Figure 1)

- Raise and support the hood at front and rear.
1. Cowl vent grille. Refer to "Cowl Vent Grille Replacement."
 2. Hinge to hood bolts (5).
 3. Hinge to cowl bolts (6).
 4. Hinge from the vehicle.

↔ Install or Connect (Figure 1)

1. Hinge to the vehicle.
2. Hinge to cowl bolts (6).

Tighten

- Bolts to 43 N·m (32 ft. lbs.).

3. Hinge to hood bolts (5).

Tighten

- Bolts to 25 N·m (18 ft. lbs.).

4. Cowl vent grille. Refer to "Cowl Vent Grille Replacement."

PRIMARY HOOD LATCH REPLACEMENT

↔ Remove or Disconnect (Figure 2)

- Raise the hood.
1. Hood latch release cable from the latch. Refer to "Hood Release Cable Replacement."
 2. Bracket to hood latch bolts (9).
 3. Hood latch from the vehicle.
 4. Bracket to radiator support bolts (10).
 5. Bracket from the vehicle.

Adjust

- Front hood bumpers, so that the top of the hood is flush with the fenders.

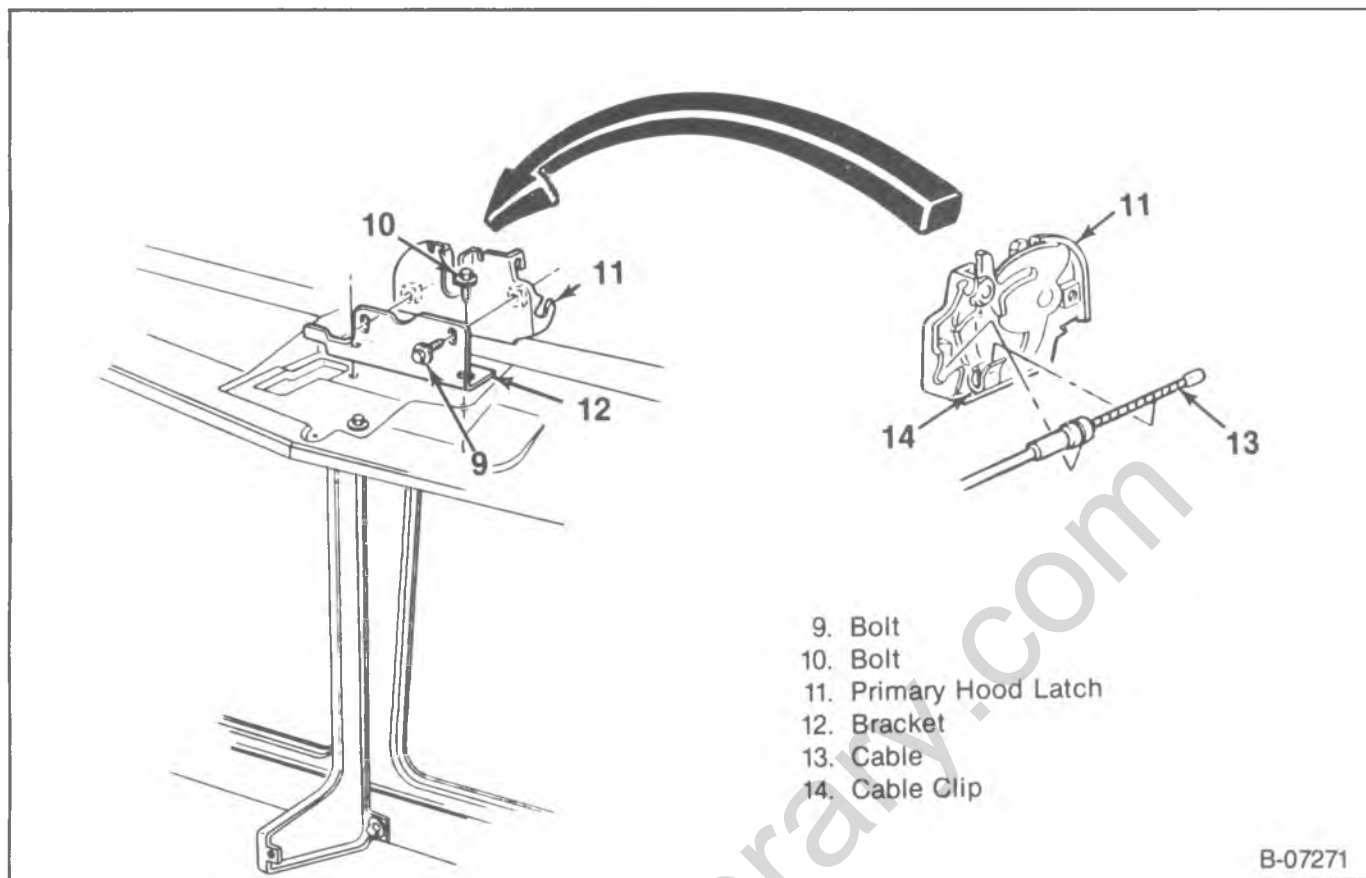

Figure 2—Hood Primary Latch Components

↔ Install or Connect (Figure 2)

1. Bracket to the radiator support.
2. Bracket to support bolts (10) loosely.
3. Primary hood latch to the bracket.
4. Latch to bracket bolts (9) loosely.
5. Hood latch release cable to the latch.

🔑 Adjust

NOTICE: For Steps 1 and 2 refer to "Notice" on page 2B-1.

1. Hood latch bracket left and right until the striker in the hood easily engages the primary latch.
- Raise the hood.

🔩 Tighten

- Bracket to radiator support bolts to 27 N·m (20 ft. lbs.).
2. Hood latch height so that when the hood is closed, the hood is held securely against the front hood bumpers. Mark this height.
 - Raise the hood.

NOTICE: Refer to "Notice" on page 2C-1 of this section.

🔩 Tighten

- Bracket to hood latch bolts to 27 N·m (20 ft. lbs.).

SECONDARY HOOD LATCH AND SPRING REPLACEMENT

↔ Remove or Disconnect (Figure 3)

- Mark the position of the secondary hood latch on the hood.
1. Secondary hood latch to hood bolts (18).
 2. Secondary hood latch from the vehicle.
 3. Spring from the hood.
 - Twist the spring from the reinforcement.

↔ Install or Connect (Figure 3)

1. Spring to the hood.
 - Twist the spring into the reinforcement.
2. Secondary hood latch to the vehicle.
3. Secondary hood latch to hood bolts (18).

🔩 Tighten

- Bolts to 27 N·m (20 ft. lbs.).

HOOD RELEASE CABLE REPLACEMENT

↔ Remove or Disconnect (Figure 4)

- If the cable is broken, release the hood by pressing the primary latch tab on the right side of the lock assembly. Use a rod to press the tab.
 - Raise the hood.
1. Cable from the primary latch.

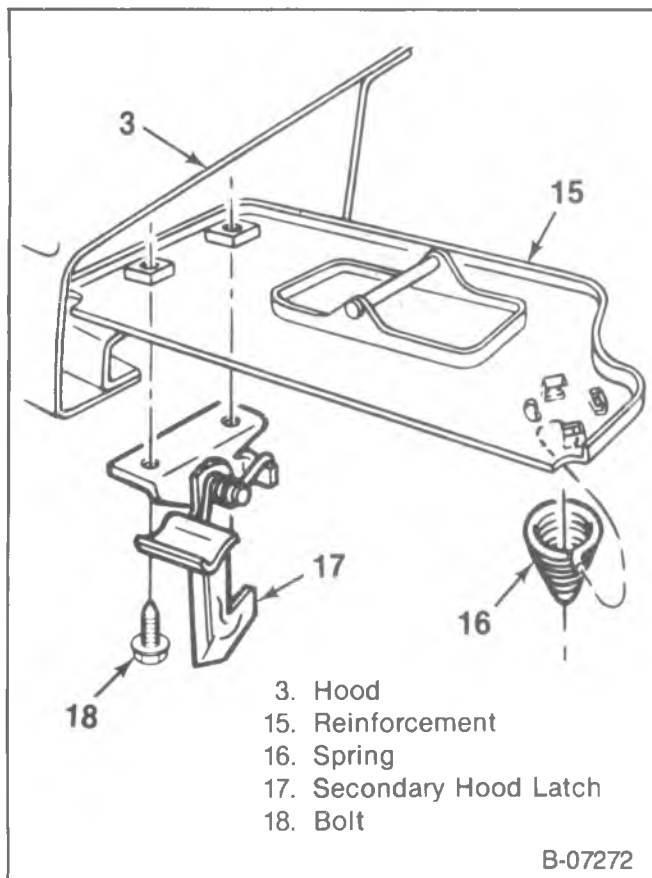

Figure 3—Hood Secondary Latch Components

- Insert a screwdriver into the clip, and lift the cable from the lock. Then, carefully pry the cable grommet from the lock flange.
- 2. Cable from the radiator support, and the wheelhouse retaining strap.
- 3. Grommet from the cowl.
 - Cut the grommet down to the cable casing on the engine side of the cowl.
 - Push the cable and grommet through the cowl.
- 4. Cable handle to air vent bezel bolts.
- 5. Cable from the vehicle.

↔ Install or Connect (Figure 4)

1. New cable to the vehicle.
2. Cable through the drivers side of the cowl.
 - Push the grommet into the drivers side of the cowl.
3. Cable bolts through the cable handle, and into the air vent bezel.
4. Cable through the wheelhouse retaining strap, and the radiator support.
5. Cable to the primary latch.

HOOD ORNAMENT REPLACEMENT

↔ Remove or Disconnect (Figure 5)

- Raise hood.
- 1. Hood ornament nuts (21).
- 2. Hood ornament from the hood.
- 3. Seal from the hood.

↔ Install or Connect (Figure 5)

1. Hood seal to the ornament.
2. Hood ornament to the hood.
3. Hood ornament nuts (21).

COWL VENT GRILLE REPLACEMENT

↔ Remove or Disconnect (Figure 6)

1. Wiper arms.
2. Cowl vent grille panel screws.
3. Cowl vent grille plastic fasteners from the windshield frame.
4. Cowl vent grille from the vehicle.

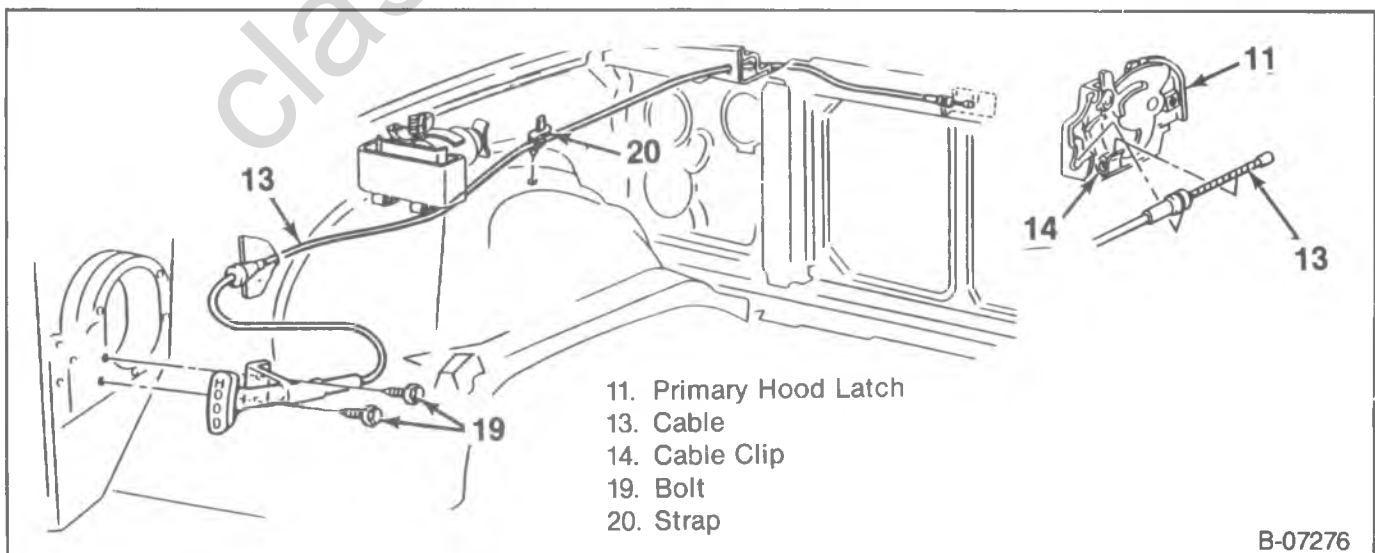

Figure 4—Hood Release Cable

B-07276

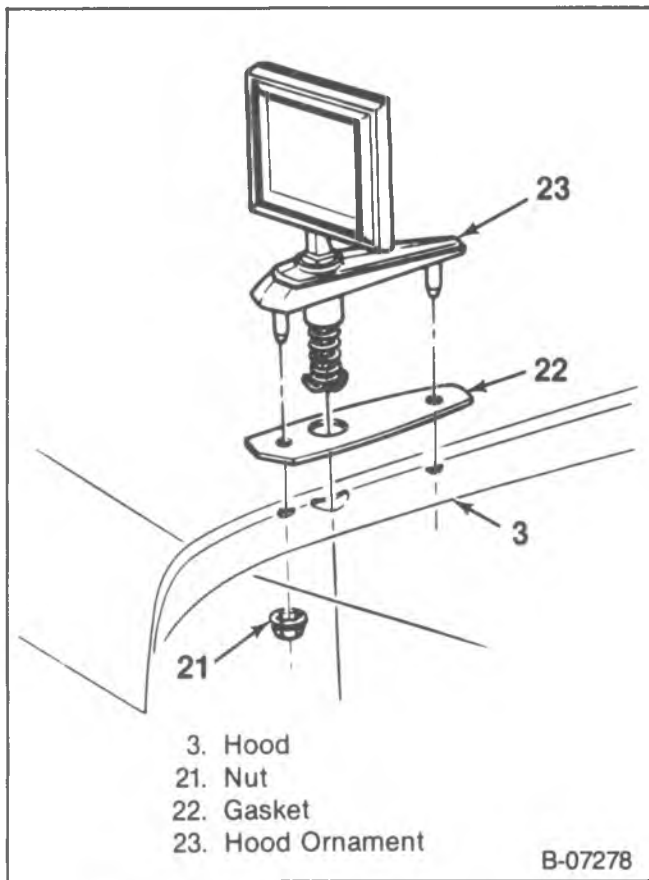

Figure 5—Hood Ornament Components

Install or Connect (Figure 6)

1. Cowl vent grille to the vehicle.
2. Cowl vent grille plastic fasteners to the windshield frame.
3. Cowl vent grille panel screws.
4. Wiper arms.

GRILLE AND MOLDING REPLACEMENT

Remove or Disconnect (Figure 7)

1. Lower radiator grille to grille bolt (39).
2. Radiator support to grille bolts (30).
3. Grille from the vehicle.
 - Slide the bottom of the grille from the vehicle, and then lower the grille from the vehicle.
4. Headlamp bezels.
5. Headlamp assemblies.
6. Molding assembly to fender, radiator support, and lower grille panel nuts (33, 34 and 37).
7. Molding assembly from the vehicle.
8. Right and left moldings from the upper and lower moldings.
9. Clips from the moldings.
10. Lower radiator grille to fender bolts (38).

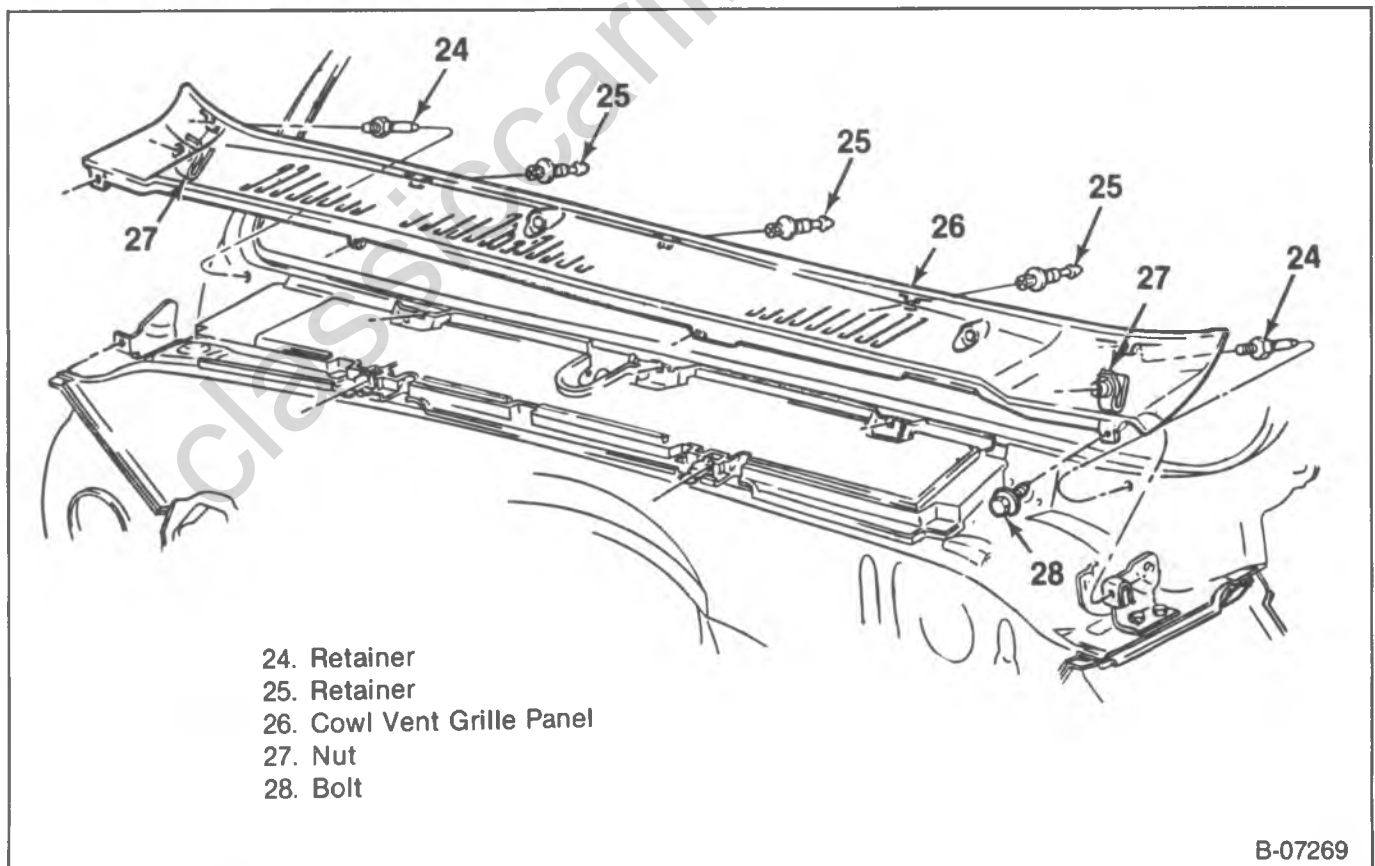

Figure 6—Cowl Vent Grille Components

2B-6 SHEET METAL

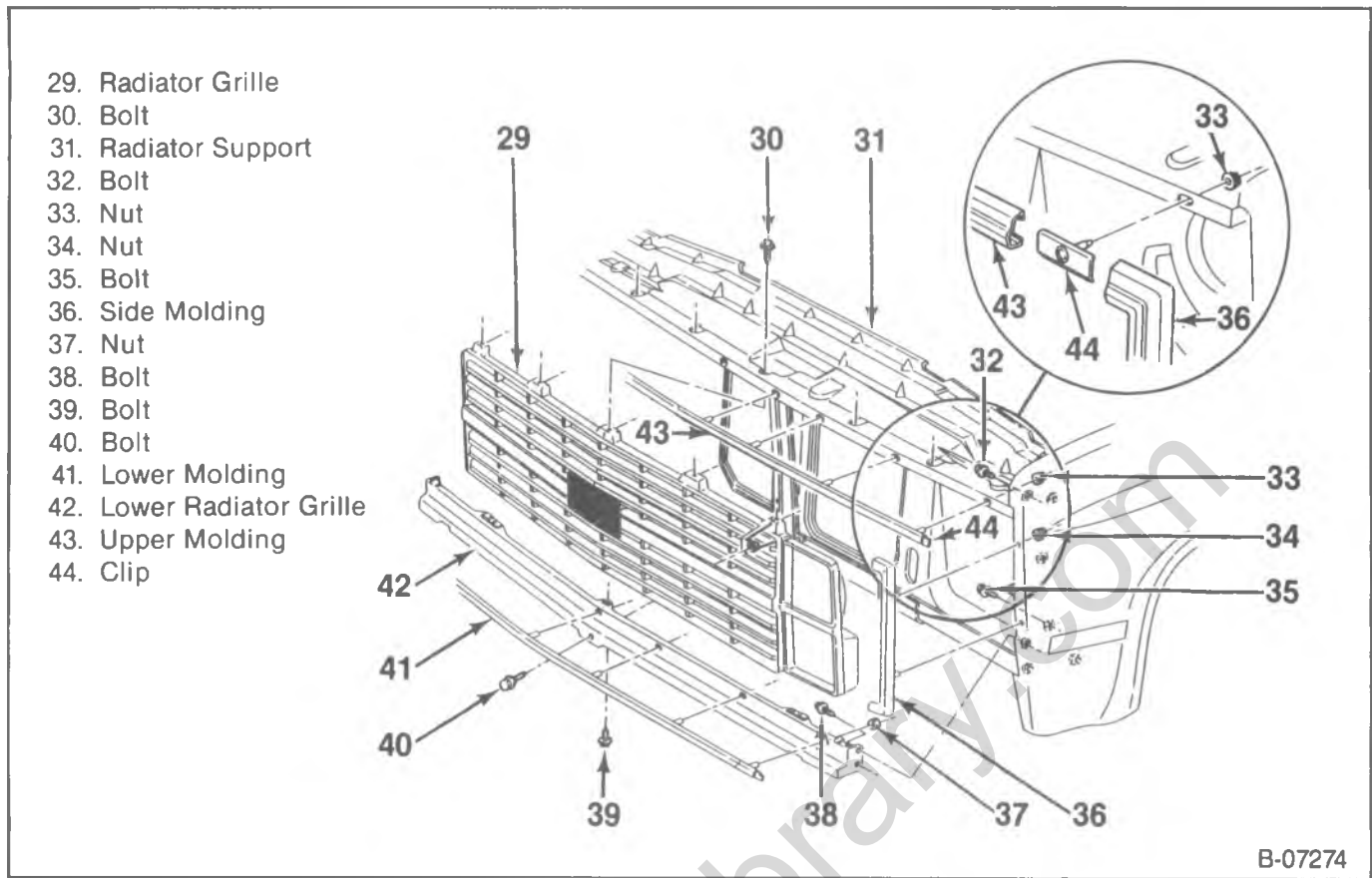

Figure 7—Grille Components

11. Lower radiator grille to the sheet metal support bolts (40).
12. Lower radiator grille from the vehicle.

→→ Install or Connect (Figure 7)

1. Lower radiator grille to the vehicle.
2. Lower radiator grille to the sheet metal support bolts (40).
3. Lower radiator grille to fender bolts (38).
4. Upper molding to the radiator support with clips (44), and nuts (33).
 - Assemble loosely.
5. Lower molding to the radiator support with clips (44), and nuts (37).
 - Assemble loosely.
6. Right and left moldings to the fenders.
 - The moldings must butt against the upper and lower moldings, and be joined to those moldings by the clips.
7. Right and left molding nuts (34).
 - Tighten upper and lower molding nuts (33 and 37).
8. Headlamp assemblies.
9. Headlamp bezels.
10. Grille to the vehicle.
 - Insert the top of the grille to the underside of the radiator support, and then slide the bottom of the grille into place.
11. Lower radiator grille to grille bolt (39).
12. Radiator support to grille bolts (30).

FRONT FENDER REPLACEMENT

↔ Remove or Disconnect (Figures 7, 8 and 9)

Tool Required:

J-24595-B Door Trim Pad Remover.

- Raise and support the hood.
1. Head lamp bezel.
 2. Head lamp.
 3. Right or left radiator grille molding nuts (34).
 4. Upper and lower molding clip nuts (33 and 37).
 5. Right or left radiator grille molding (36).
 6. Lower radiator grille to fender bolts (38).
 7. Cowl vent grille. Refer to "Cowl Vent Grille Replacement."
 8. Hood spring assembly. Refer to "Spring Assembly Replacement."
 9. Radiator support to fender bolts (119).
 10. Wheelhouse panel to shield bolts.
 11. Shield to underbody retainers using J-24595-B.
 12. Shield from the vehicle.
 13. Wheelhouse panel to fender bolts (50).
 14. Lower door pillar to fender bolt (45) and shim(s) (46).
 15. Fender to cowl bolt (47) and shim(s) (46).
 - Open the front door.
 16. Upper fender to door pillar bolt (48) and shim(s) (46).
 17. Fender from the vehicle.
 18. Insulator from the fender.

→→ Install or Connect (Figures 8 and 9)

1. Insulator to the fender.
2. Fender to the vehicle.

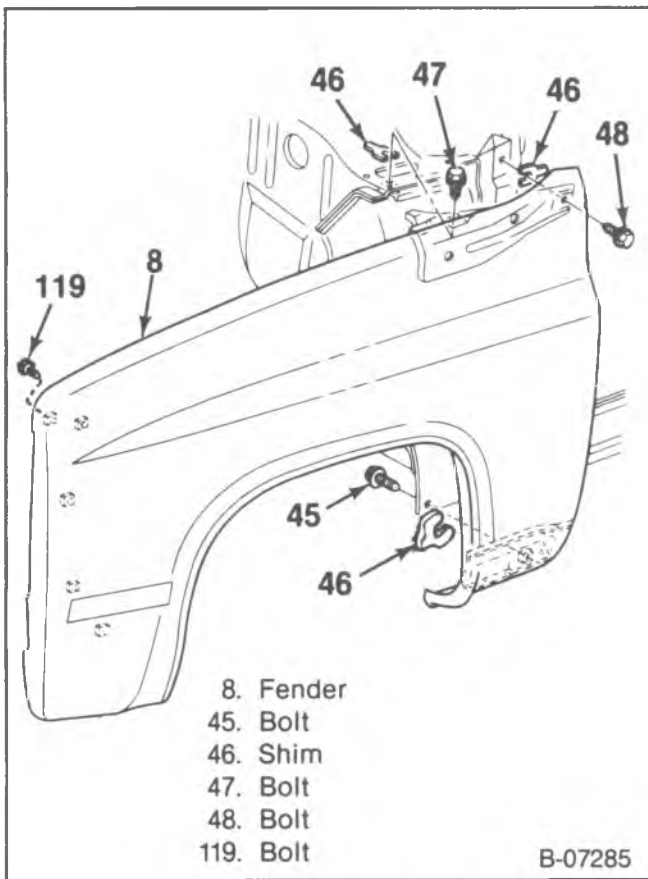

Figure 8—Front Fender Attachment

3. Upper fender to the door pillar bolt (48) and shim(s) (46) as required.
 - Assemble loosely.
4. Fender to cowl bolt (47) and shim(s) (46) as required.
 - Assemble loosely.
5. Lower door pillar to fender bolt (45) and shim(s) (46) as required.
 - Assemble loosely.
6. Radiator support to fender bolts (119).

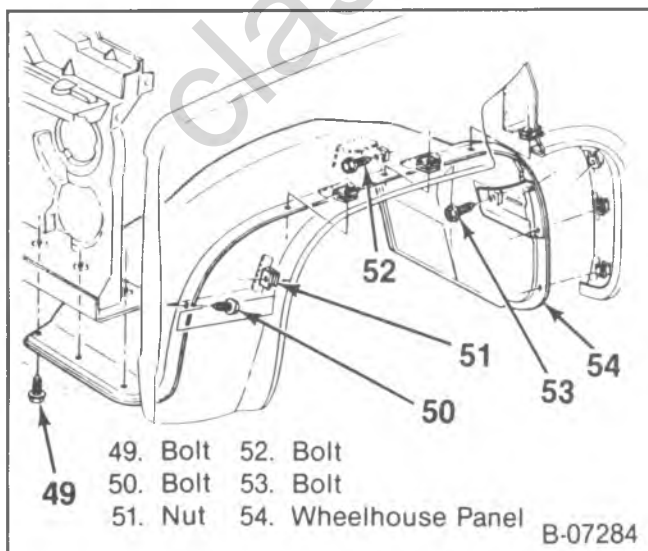

Figure 9—Wheelhouse Panel Attachment

Tighten

- Bolts to 17 N·m (13 ft. lbs.).
7. Wheelhouse to fender bolts (50).

Tighten

- Wheelhouse to fender bolts (50) to 17 N·m (13 ft. lbs.).
 - Lower door pillar to fender bolt to 43 N·m (31 ft. lbs.).
8. Shield to the vehicle.
 9. Shield to underbody retainers.
 10. Wheelhouse panel to shield bolts.

Tighten

- Fender to cowl bolt (47) to 43 N·m (31 ft. lbs.).
 - Upper fender to door pillar bolt to 43 N·m (31 ft. lbs.).
11. Hood spring assembly. Refer to "Spring Assembly Replacement."
 12. Cowl vent grille. Refer to "Cowl Vent Grille Replacement."
 13. Lower radiator grille to fender bolts (38).
 14. Right or left radiator grille molding (36).
 15. Upper and lower molding clip nuts (33 and 37).
 16. Right or left radiator grille molding nuts (34).
 17. Head lamp.
 18. Head lamp bezel.

WHEELHOUSE PANEL REPLACEMENT

RIGHT PANEL REPLACEMENT

Remove or Disconnect (Figure 9)

1. Jack handle.
2. Lug wrench.
3. Coolant recovery reservoir.
4. Air conditioning line retainers (if equipped).
 - Raise and support the vehicle.
5. Right front wheel.
6. Wheelhouse panel to radiator support bolts (49).
7. Wheelhouse panel to underbody shield bolts.
8. Wheelhouse panel reinforcement to underbody bolts (52) and (53).
9. Wheelhouse panel to fender bolts (50).
10. Wheelhouse panel from the vehicle.
 - Slide the panel forward to clear the lower back side of the fender well.
 - Tilt the wheelhouse panel out of the vehicle.

Install or Connect (Figure 9)

1. Wheelhouse panel to the vehicle.
 - Tilt the wheelhouse panel into the vehicle.
 - Slide the panel into position.
2. Wheelhouse panel to fender bolts (50).

Tighten

- Bolts to 17 N·m (13 ft. lbs.).
3. Wheelhouse panel reinforcement to underbody bolts (52) and (53).

Tighten

- Bolts (52) to 17 N·m (13 ft. lbs.).
 - Bolt (53) to 47 N·m (35 ft. lbs.).
4. Wheelhouse panel to underbody shield bolts.
 5. Wheelhouse panel to radiator support bolts (49).

Tighten

- Bolts to 17 N·m (13 ft. lbs.).
6. Right front wheel.
 - Lower the vehicle.
 7. Air conditioning line retainers (if equipped).
 8. Coolant recovery reservoir.
 9. Lug wrench.
 10. Jack handle.

LEFT PANEL REPLACEMENT

Remove or Disconnect (Figure 9)

1. Jack.
2. Windshield washer fluid reservoir.
3. Wiring harness.
4. Hood release cable.
5. Air conditioning hose bracket (if equipped).
 - Raise and support the vehicle.
6. Left front wheel.
7. Wheelhouse panel to radiator support bolts (49).
8. Wheelhouse panel to underbody shield bolts.
9. Wheelhouse panel reinforcement to underbody bolts (52) and (53).
10. Wheelhouse panel to fender bolts (50).
11. Wheelhouse panel from the vehicle.
 - Slide the panel forward to clear the lower back side of the fender well.
 - Tilt the wheelhouse panel out of the vehicle.

Install or Connect (Figure 9)

1. Wheelhouse panel to the vehicle.
 - Tilt the wheelhouse panel into the vehicle.
 - Slide the panel into position.
2. Wheelhouse panel to fender bolts (50).

Tighten

- Bolts to 17 N·m (13 ft. lbs.).
3. Wheelhouse panel reinforcement to underbody bolts (52) and (53).

Tighten

- Bolt (52) to 17 N·m (13 ft. lbs.).
 - Bolt (53) to 47 N·m (35 ft. lbs.).
4. Wheelhouse panel to underbody shield bolts.
 5. Wheelhouse panel to radiator support bolts (49).

Tighten

- Bolts to 17 N·m (13 ft. lbs.).
6. Left front wheel.
 - Lower the vehicle.
 7. Air conditioning hose bracket (if equipped).
 8. Hood release cable.
 9. Wiring harness.
 10. Windshield washer fluid reservoir.
 11. Jack.

REAR FENDER REPLACEMENT

STEPSIDE MODEL FENDER REPLACEMENT

Remove or Disconnect (Figure 10)

1. Parking lamp wiring from the fender.
2. Brace to fender bolts (59).
3. Side panel to fender bolts (56).
4. Fender from the vehicle.
5. Side panel to brace bolt (56).
6. Brace (58).
7. Cross sill to brace bolt (63).
8. Brace (62).
9. Sealer from the fender and the side panel.

Install or Connect (Figure 10)

1. A medium bodied sealer onto the fender to side panel flange.
2. Brace (62).
3. Cross sill to brace bolt (63).
 - Assemble loosely.
4. Brace (58) to the vehicle.
5. Side panel to brace bolt (56).
 - Assemble loosely.
6. Fender to the vehicle.
7. Side panel to fender bolts (56).
 - Assemble loosely.
8. Brace to fender bolts (59).

Tighten

- Brace to fender bolts to 17 N·m (13 ft. lbs.).
 - Side panel to fender bolts to 10 N·m (7 ft. lbs.).
 - Cross sill to brace bolt to 17 N·m (13 ft. lbs.).
9. Parking lamp wiring to the fender.
 - Clean excess sealant from the fender.

DUAL REAR WHEEL MODEL FENDER REPLACEMENT

Remove or Disconnect (Figure 11)

1. Parking lamp wiring from the fender.
2. Fender to brace bolts (71).
3. Fender to side panel bolts (72 and 69) and nuts (68).
4. Side panel to fender nuts (66).
5. Fender from the vehicle.
6. Sealer from the side panel and fender.

Install or Connect (Figure 11)

1. A medium bodied sealer onto the fender to side panel flange.
2. Fender to the vehicle.
3. Side panel to fender nuts (66).
 - Assemble loosely.
4. Fender to side panel bolts (72 and 69) and nuts (68).
 - Assemble loosely.
5. Fender to brace bolts (71).

Tighten

- All of the nuts and bolts to 17 N·m (13 ft. lbs.).
6. Parking lamp wiring to the fender.
 - Clean excess sealant from the fender.

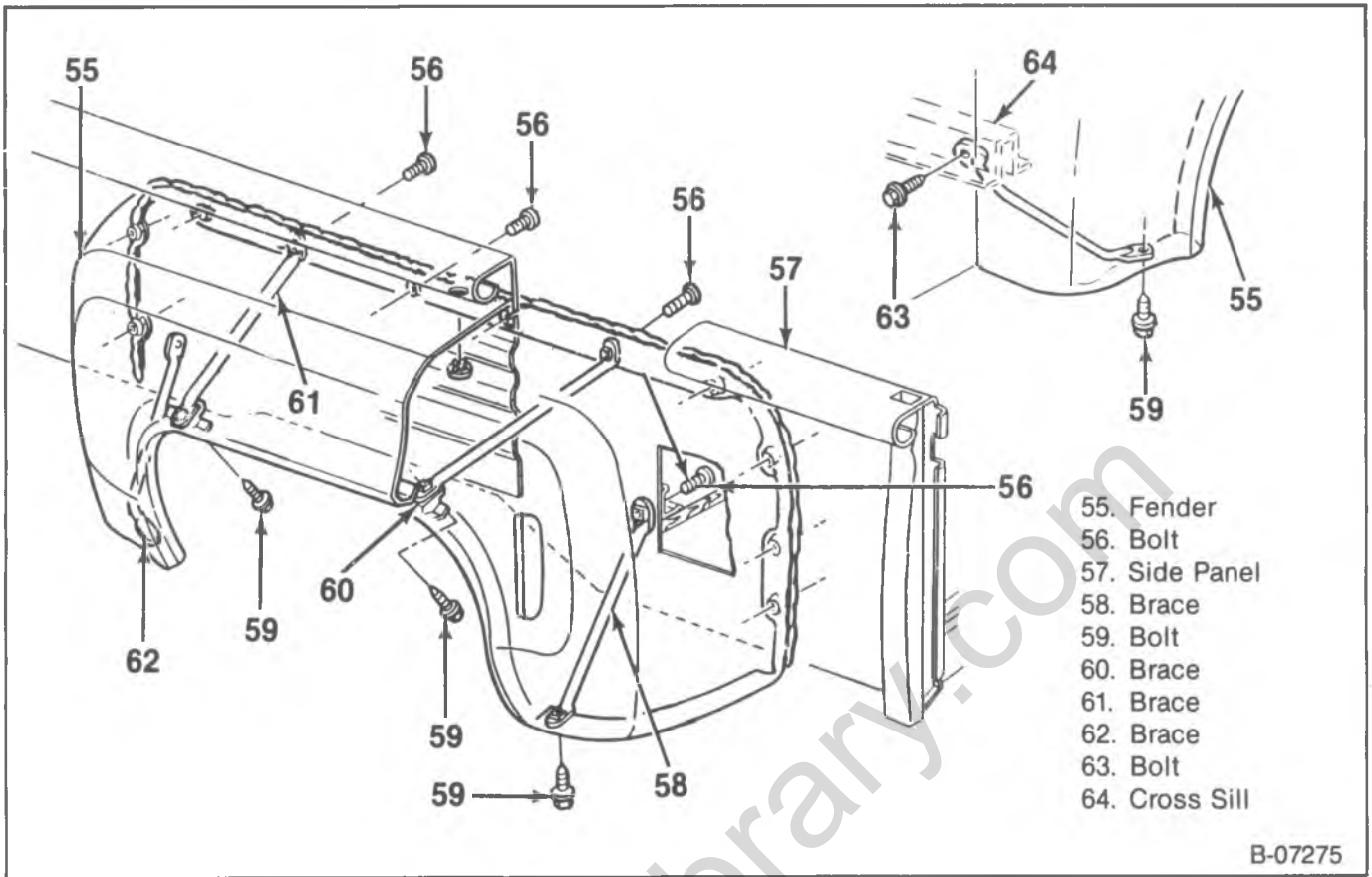

Figure 10—Stepside Rear Fender Attachment

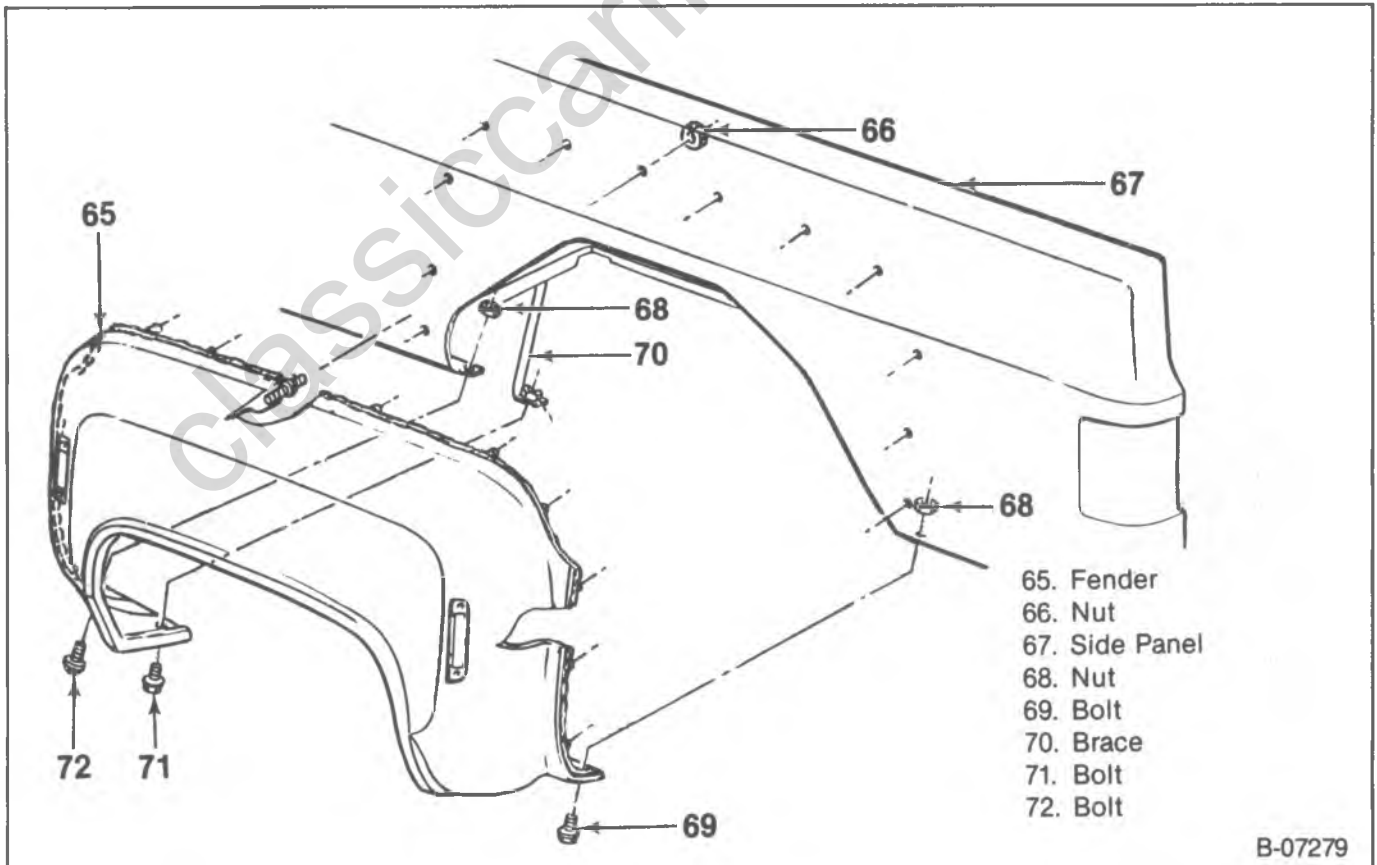

Figure 11—Dual Rear Fender Attachment

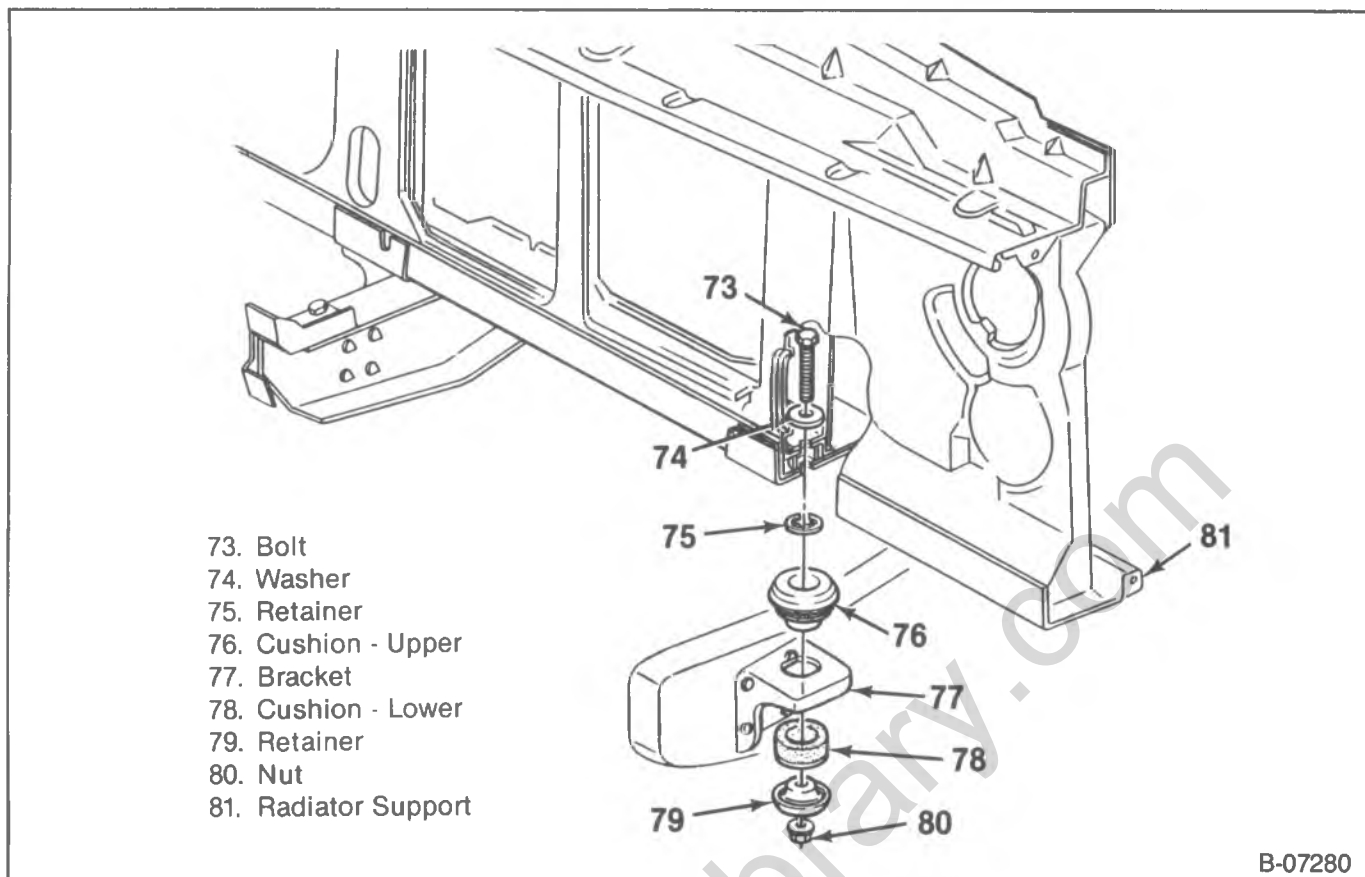

Figure 12—Radiator Support Mounting

RADIATOR SUPPORT REPLACEMENT

↔ Remove or Disconnect (Figure 12)

1. Radiator from the vehicle.
 - Refer to ENGINE COOLING (SEC. 6B).
2. Air conditioning condenser from the vehicle.
 - Refer to AIR CONDITIONING (SEC. 1B).
3. Battery.
 - Refer to ENGINE ELECTRICAL (SEC. 6D).
4. Headlamp and parking lamp wires from the lamps.
5. Headlamp and parking lamp wiring harness from the radiator support.
6. Headlamp bezels.
7. Headlamp assemblies.
8. Ground wires from the radiator support.
9. Fuel vapor canister from the radiator support.
10. Air cleaner inlet from the radiator support.
11. Primary hood latch bracket to the radiator support bolts.
12. Grille from the vehicle.
13. Lower radiator grille panel from the vehicle.
14. Sheet metal support to radiator support bolts.
15. Sheet metal support from the vehicle.
16. Radiator support to fender bolts (119) (figure 8).
17. Wheelhouse panel to radiator support bolts (49) (figure 9).
18. Radiator support to frame nuts (80), lower retainers (79), lower cushions (78), upper cushions (76), retainers (75), bolts (73), and washers (74).
19. Radiator support from the vehicle.

- Tilt the radiator support to the rear, and lift it up and out of the vehicle.

↔ Install or Connect (Figure 12)

1. Radiator support to the vehicle.
 - Lower the radiator support into the vehicle, and tilt it into position.
2. Radiator support to frame washers (74), bolts (73), retainers (75), upper cushions (76), lower cushions (78), lower retainers (79), and frame nuts (80).
 - Assemble loosely.
3. Wheelhouse panel to radiator support bolts (49) (figure 9).

Tighten

- Bolts to 17 N·m (13 ft. lbs.).
4. Radiator support to fender bolts (119) (figure 8).

Tighten

- Bolts to 17 N·m (13 ft. lbs.).
5. Sheet metal support to the vehicle.
 6. Sheet metal support to radiator support bolts.

Tighten

- Bolts to 17 N·m (13 ft. lbs.).
 - Radiator support to frame nuts (80) to 47 N·m (35 ft. lbs.).
7. Lower radiator grille panel to the vehicle.
 8. Grille to the vehicle.
 9. Primary hood latch bracket to the radiator support bolts.



Adjust

- Hood latch left or right so that the hood properly engages the hood latch.



Tighten

- Bracket to radiator support bolts to 27 N·m (20 ft. lbs.).

- Air cleaner inlet to the radiator support.
- Fuel vapor canister to the radiator support.
- Ground wires to the radiator support.
- Headlamp assemblies.
- Headlamp bezels.
- Headlamp and parking lamp wiring harness to the radiator support.
- Headlamp and parking lamp wires to the lamps.
- Battery.
 - Refer to ENGINE ELECTRICAL (SEC. 6D).
- Air conditioning condenser.
 - Refer to AIR CONDITIONING (SEC. 1B).
- Radiator.
 - Refer to ENGINE COOLING (SEC. 6B).

SHEET METAL UNIT REPLACEMENT

Tool Required:

J-24595-B Door Trim Pad Remover.



Remove or Disconnect

- Hood.
 - Refer to "Hood Replacement" earlier in this section.
- Battery.
 - Refer to ENGINE ELECTRICAL (SEC. 6D).
- Radiator.
 - Refer to ENGINE COOLING (SEC. 6B).
- Air conditioning condenser.
 - Refer to AIR CONDITIONING (SEC. 1B).
- Headlamp and parking lamp wires from the lamps.
- Headlamp and parking lamp wiring harness from the radiator support.
- Ground wires from the radiator support.
- Fuel vapor canister from the radiator support.
- Air cleaner inlet from the radiator support.
- Bumper from the vehicle.
 - Refer to FRAME AND BUMPERS (SEC. 2A).
- Wheelhouse panel to fender bolts (50) (figure 9).
- Fender to cowl bolts (47) (figure 8).
- Upper fender to door pillar bolt (48).
- Wheelhouse panel to shield bolts.
- Shield to underbody retainers using J-24595-B.
- Shield from the vehicle.
- Lower fender to door pillar bolt (45).
- Radiator support to frame nuts (80), lower retainers (79), lower cushions (78), upper cushions (76), retainers (75), bolts (73), and washers (74) (figure 12).
- Sheet metal assembly.
 - With the aid of a helper, lift the sheet metal from the chassis.



Install or Connect

- Sheet metal assembly.
 - With the aid of a helper, lift the sheet metal onto the chassis.
- Radiator support to frame washers (74), bolts (73), retainers (75), upper cushions (76), lower cushions (78), lower retainers (79), and nuts (80) (figure 12).
- Lower fender to door pillar bolts (45) (figure 8).



Tighten

- Bolt to 43 N·m (31 ft. lbs.).
- Shield to the vehicle.
 - Shield to underbody retainers.
 - Wheelhouse panel to shield bolts.
 - Upper fender to door pillar bolt (48) (figure 8).



Tighten

- Bolt to 43 N·m (31 ft. lbs.).
- Fender to cowl bolts (47).
 - Wheelhouse panel to fender bolts (50) (figure 9).



Tighten

- Wheelhouse panel to fender bolts to 17 N·m (13 ft. lbs.).
- Bumper.
 - Refer to FRAME AND BUMPERS (SEC. 2A).
 - Air cleaner inlet to the radiator support.
 - Fuel vapor canister to the radiator support.
 - Ground wires to the radiator support.
 - Headlamp and parking lamp wiring harness to the radiator support.
 - Head lamp and parking lamp wires to the lamps.
 - Air conditioning condenser.
 - Refer to AIR CONDITIONING (SEC. 1B).
 - Radiator to the vehicle. Refer to ENGINE COOLING (SEC. 6B).
 - Battery to the vehicle.
 - Hood to the vehicle.

SHEET METAL ADJUSTMENTS

In order to have the proper operation and appearance of sheet metal components, it is important that certain fits and gaps between components be maintained. The gaps given in this procedure are suggested as the best alignment for these components (figure 13).

In aligning sheet metal, it is best to start with the rearmost component, and work forward.

- Starting with the fenders, align the rear edge of each fender to the rocker panel, and the door. The gap between these components should be 5 mm \pm 2.3 mm (0.19-inch \pm 0.09-inch). This adjustment should be accomplished by moving the fender forward or rearward. The surface of the fender should be flush with the rocker panel and the door. Add or remove shims to perform this adjustment.
- Align the fender to the cowl vent grille to obtain a gap of 4.6 mm \pm 1 mm (0.18-inch \pm 0.03-inch). The surface of the cowl vent grille should be flush with the fender surface.

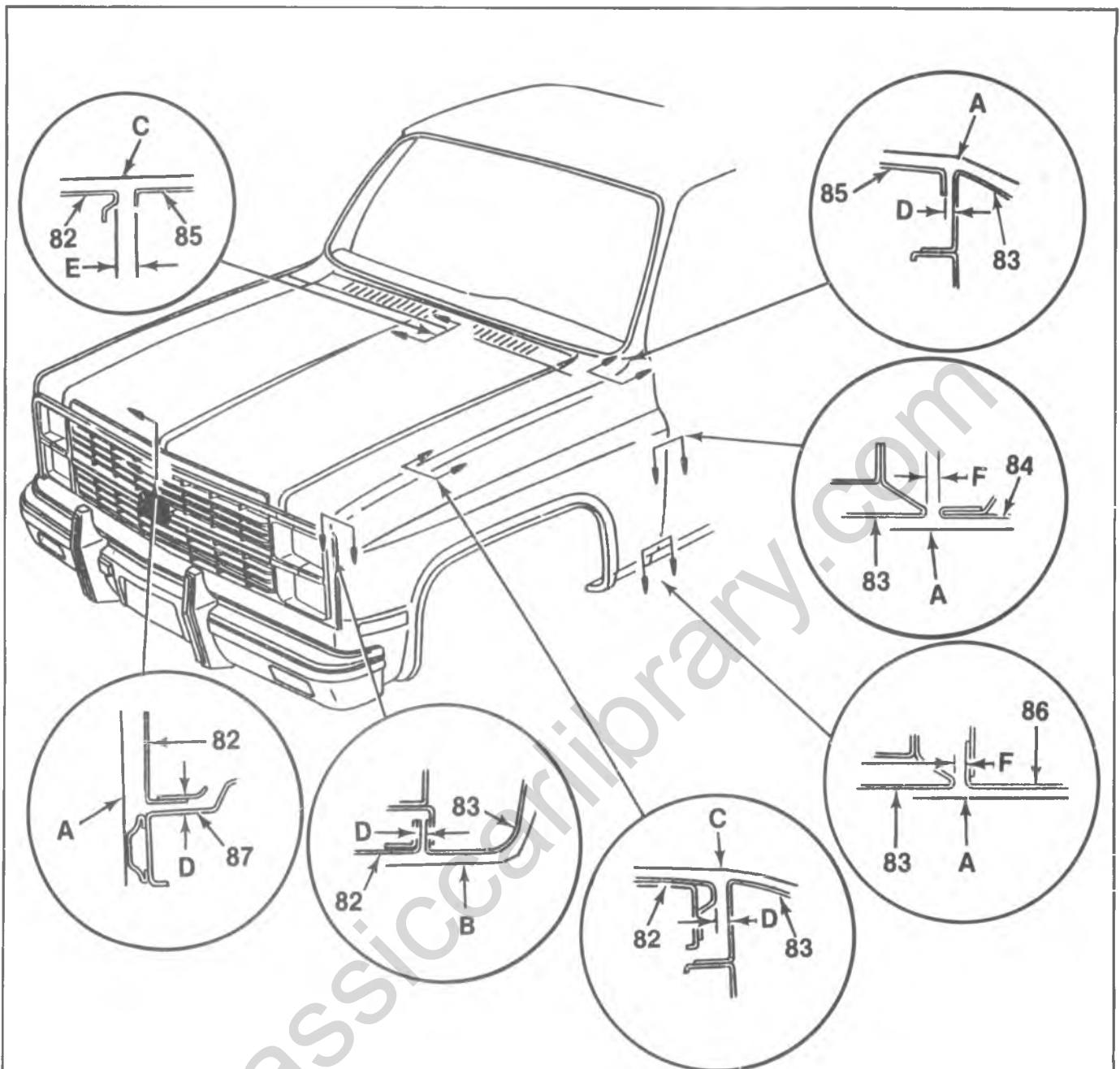

- 82. Hood
- 83. Fender
- 84. Door
- 85. Cowl Vent Grille
- 86. Rocker Panel
- 87. Radiator Support Upper Panel
- A. Flush Fit
- B. Flush ± 1 mm (0.03-inch)
- C. Flush $+0.00$ mm or -1.5 mm ($+0.00$ -inch or -0.06 -inch)
- D. 4.6 mm ± 1 mm (0.18 -inch ± 0.03 -inch)
- E. 8 mm ± 1 mm (0.31 -inch ± 0.03 -inch)
- F. 5 mm ± 2.3 mm (0.19 -inch ± 0.09 -inch)

Figure 13—Sheet Metal Gap Specifications

3. Align the hood with the cowl vent grille, so that there is a gap of $8 \text{ mm} \pm 1 \text{ mm}$ ($0.31\text{-inch} \pm 0.03\text{-inch}$) between the rear edge of the hood and the front edge of the cowl vent grille. The hood surface should be flush with the cowl vent grille surface within $+0.0\text{--}1.5 \text{ mm}$ ($+0.00\text{--}0.06\text{-inch}$).
4. Align the left and right edges of the hood so that a gap of $4.6 \text{ mm} \pm 1 \text{ mm}$ ($0.18\text{-inch} \pm 0.03\text{-inch}$) exists between the hood and the fenders. The hood surface should be flush with the fender surface within $+0.0\text{--}1.5 \text{ mm}$ ($+0.00\text{--}0.06\text{-inch}$). If this gap is difficult to obtain, and the hood appears to be cocked in between the fenders, the radiator support may need to be

shifted. By shifting the radiator support, the entire front end sheet metal can be aligned as a unit. Loosen the support to the frame bolts, and shift the radiator support to obtain the proper gaps. Then, while holding the support in position, retighten the radiator support to frame bolts.

5. Align the front face of the hood to obtain a gap of $4.6 \text{ mm} \pm 1 \text{ mm}$ ($0.18\text{-inch} \pm 0.03\text{-inch}$) between the hood and the radiator support upper panel. The hood bumpers on the top of the radiator support should be adjusted to give the proper support to hood gap. The surface of the hood should be flush with the radiator support upper panel (not the grille molding).

G MODELS

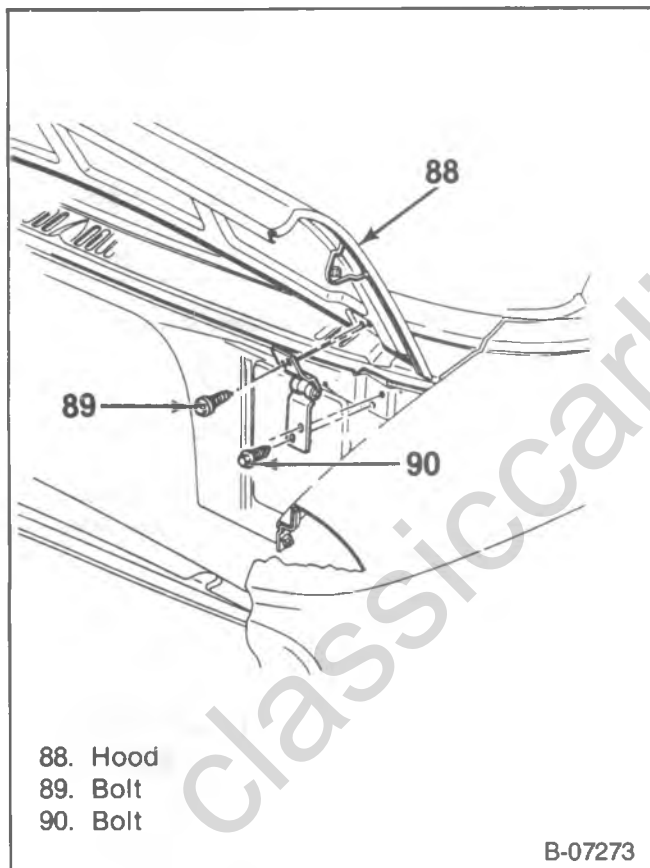

Figure 14—Hood Hinge Components

HOOD REPLACEMENT

↔ Remove or Disconnect (Figure 14)

- Raise and support the hood. Place a protective covering over the fenders, and the cowl vent grille.
 - Mark the position of the hinges on the hood.
1. Hood hinge to hood bolts (89).
 2. Hood from the vehicle.

↔ Install or Connect (Figure 14)

1. Hood to the vehicle.
2. Hood hinge to hood bolts (89).
 - Align the hood with the previously made marks.

⌚ Tighten

- Bolts to $17 \text{ N}\cdot\text{m}$ (13 ft. lbs.).
- Remove the protective coverings, and lower the hood.

HOOD HINGE REPLACEMENT

↔ Remove or Disconnect (Figure 14)

- Raise and support the hood. Also support the rear corner of the hood.
 - Mark the position of the hinge on the hood and the cowl.
1. Hood hinge to hood bolts (89).
 2. Hood hinge to cowl bolts (90).
 3. Hood hinge from the vehicle.

↔ Install or Connect (Figure 14)

1. Hood hinge to the vehicle.
2. Hood hinge to cowl bolts (90).
3. Hood hinge to hood bolts (89).
- Align the hinge with the previously made marks.

⌚ Tighten

- Bolts to $17 \text{ N}\cdot\text{m}$ (13 ft. lbs.).

PRIMARY HOOD LATCH REPLACEMENT

↔ Remove or Disconnect (Figure 15)

- Raise and support the hood.
1. Hood latch release cable from the latch.
 2. Bracket to hood latch bolts (94).
 3. Hood latch from the vehicle.
 4. Bracket to the sheet metal cross panel bolts (91).
 5. Bracket from the vehicle.

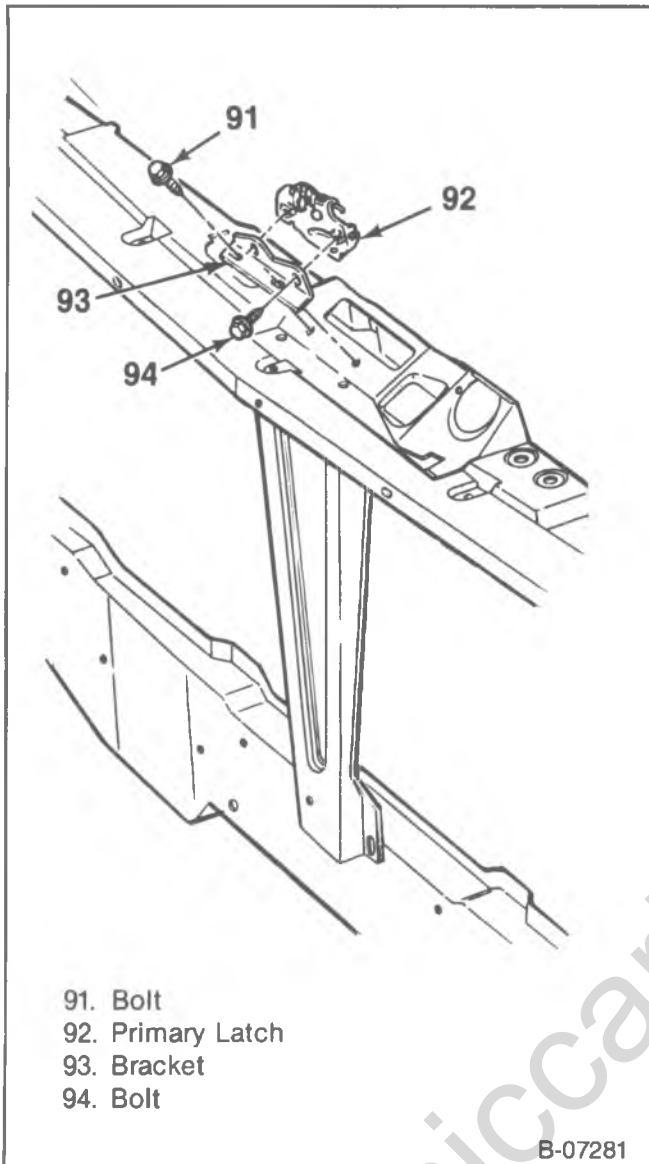

- 91. Bolt
- 92. Primary Latch
- 93. Bracket
- 94. Bolt

B-07281

Figure 15—Primary Hood Latch Attachment

Adjust

- Front hood bumpers, so that the top of the hood is flush with the fenders.

Install or Connect (Figure 15)

1. Bracket to the sheet metal cross panel.
2. Bracket to cross panel bolts (91) loosely.
3. Primary hood latch to the bracket.
4. Latch to bracket bolts (94) loosely.
5. Hood latch release cable to the latch.

NOTICE: For Steps 1 and 2 refer to “Notice” on page 2B-1.

Adjust

1. Hood latch bracket left and right until the striker in the hood easily engages the primary latch.
- Raise and support the hood.

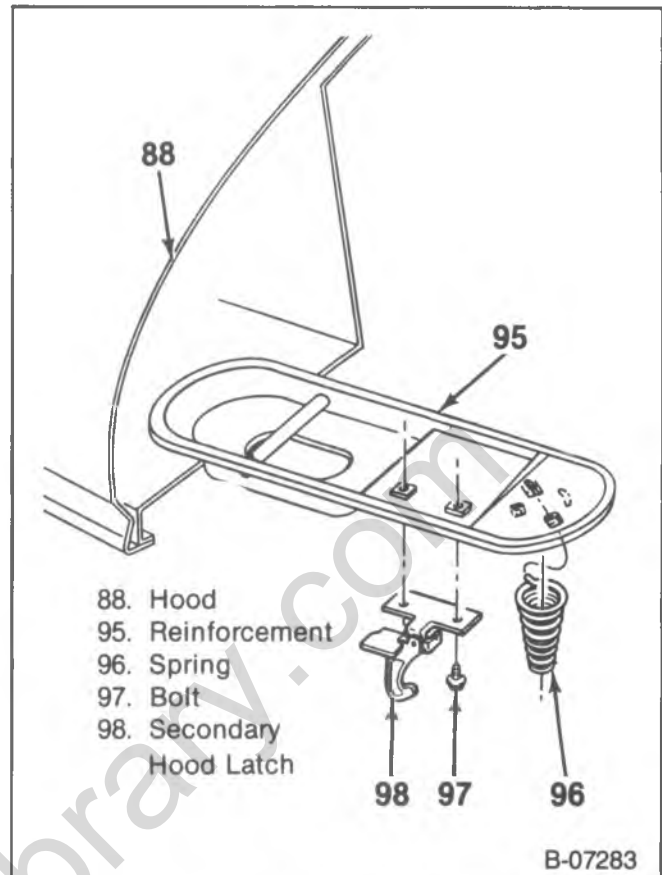

B-07283

Figure 16—Secondary Hood Latch Attachment

Tighten

- Bracket to radiator support bolts to 27 N·m (20 ft. lbs.)
2. Hood latch height so that when the hood is closed, the hood is held securely against the front hood bumpers.
 - Raise and support the hood.

Tighten

- Bracket to hood latch bolts to 27 N·m (20 ft. lbs.).

SECONDARY HOOD LATCH AND SPRING REPLACEMENT

Remove or Disconnect (Figure 16)

- Mark the position of the secondary hood latch on the hood.
1. Secondary hood latch to hood bolts (97).
 2. Secondary hood latch from the vehicle.
 3. Spring from the hood.
 - Twist the spring from the reinforcement.

Install or Connect (Figure 16)

1. Spring to the hood.
 - Twist the spring into the reinforcement.
2. Secondary hood latch to the vehicle.
3. Secondary hood latch to hood bolts (97).

Tighten

- Bolts to 27 N·m (20 ft. lbs.).

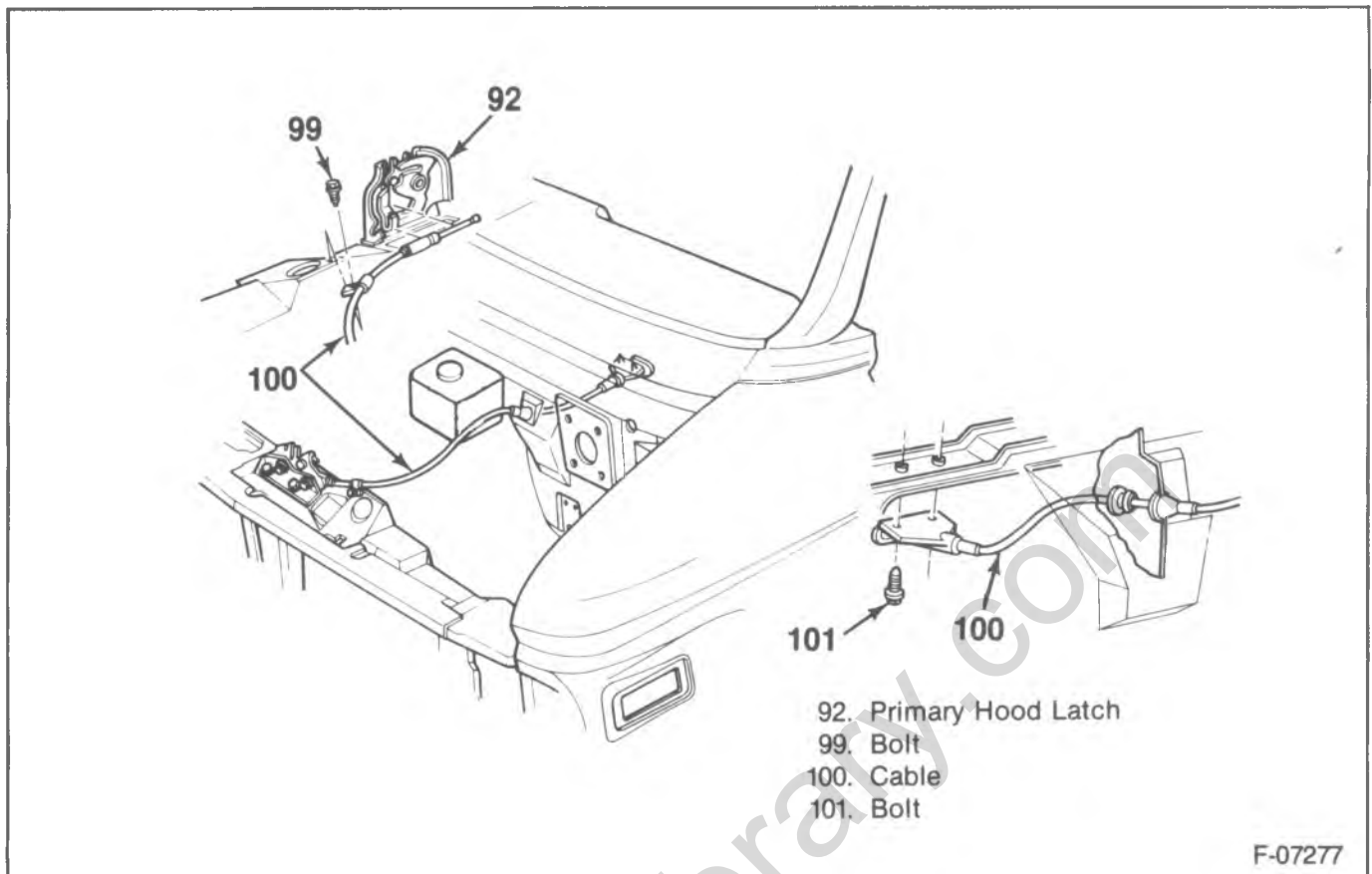

Figure 17—Hood Release Cable Attachment

HOOD RELEASE CABLE REPLACEMENT

↔ Remove or Disconnect (Figure 17)

- If the cable is broken, release the hood by pressing the primary latch tab on the right side of the lock assembly. Use a rod to press the tab.
 - Raise and support the hood.
1. Cable from the primary latch.
 - Insert a screwdriver into the clip, and lift the cable from the lock. Then, carefully pry the cable grommet from the lock flange.
 2. Cable from the sheet metal cross panel clip.
 3. Grommet from the cowl.
 - Cut the grommet down to the cable casing on the engine side of the cowl.
 - Push the cable and the grommet through the cowl.
 4. Cable handle to dash screws.
 5. Cable from the vehicle.

→← Install or Connect (Figure 17)

1. New cable to the vehicle.
2. Cable through the drivers side of the cowl.
 - Push the grommet into the drivers side of the cowl, and then push the insert into the grommet.
3. Cable handle to dash screws.
4. Cable into the sheet metal cross panel clip.
5. Cable to the primary latch.

COWL VENT GRILLE REPLACEMENT

↔ Remove or Disconnect (Figure 18)

- Raise and support the hood.
1. Windshield wiper arms.
 2. Cowl vent grille to cowl bolts (104) and screws (103).
 3. Cowl vent grille from the vehicle.
 4. Cowl seal from the vehicle.

→← Install or Connect (Figure 18)

1. Cowl seal to the vehicle.
2. Cowl vent grille to the vehicle.
3. Cowl vent grille to cowl bolts (104) and screws (103).
4. Windshield wiper arms.

GRILLE REPLACEMENT

↔ Remove or Disconnect (Figures 19 and 20)

- Raise and support the hood.
1. Headlamp bezels.
 2. Sheet metal cross panel to grille bolts.
 3. Grille to lower front end panel bolts.
 4. Grille from the vehicle.
 5. Sheet metal to upper and lower radiator grille molding nuts (110 and 112).
 6. Upper and lower radiator grille moldings from the vehicle.

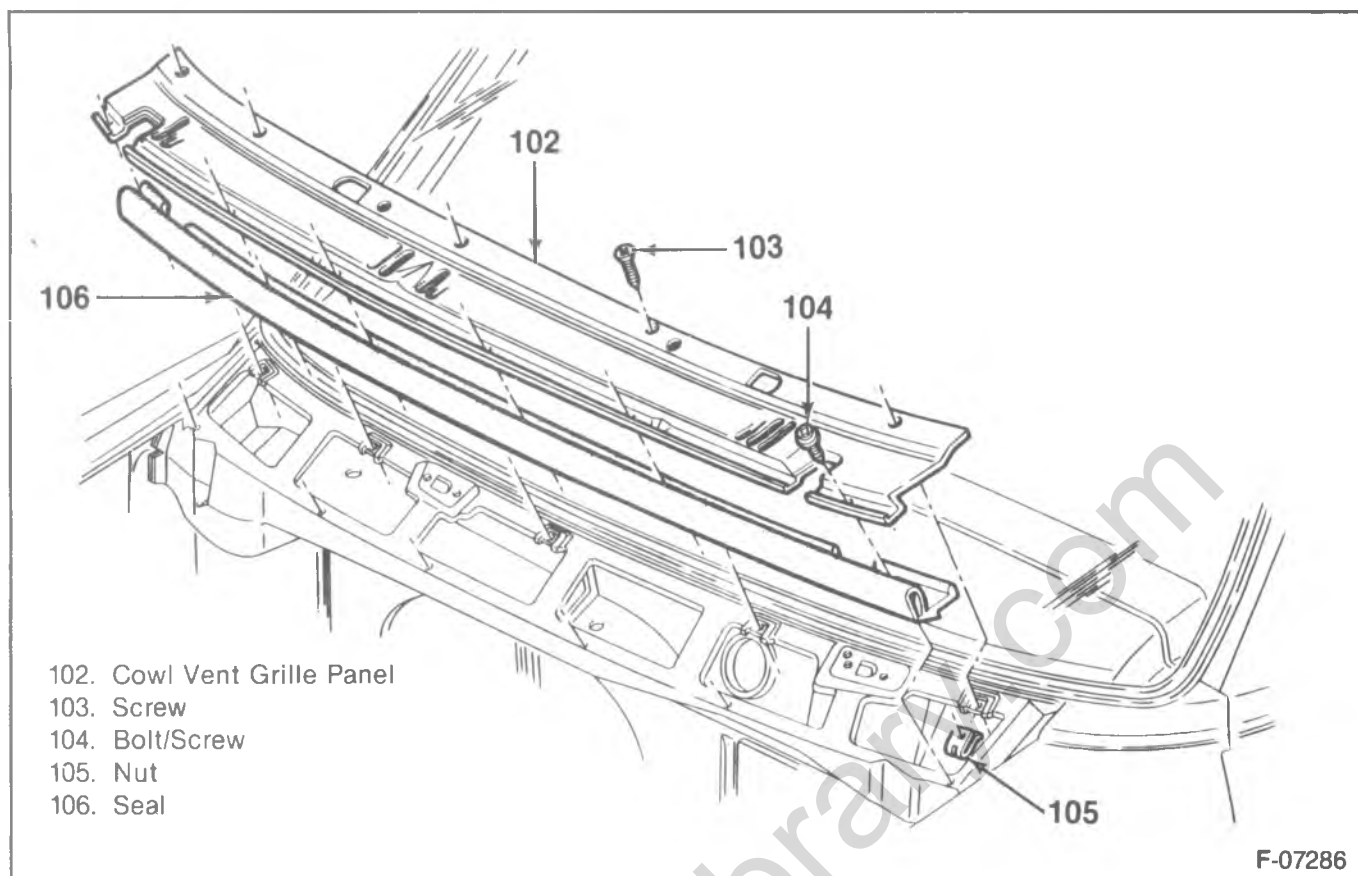

Figure 18—Cowl Vent Grille Components

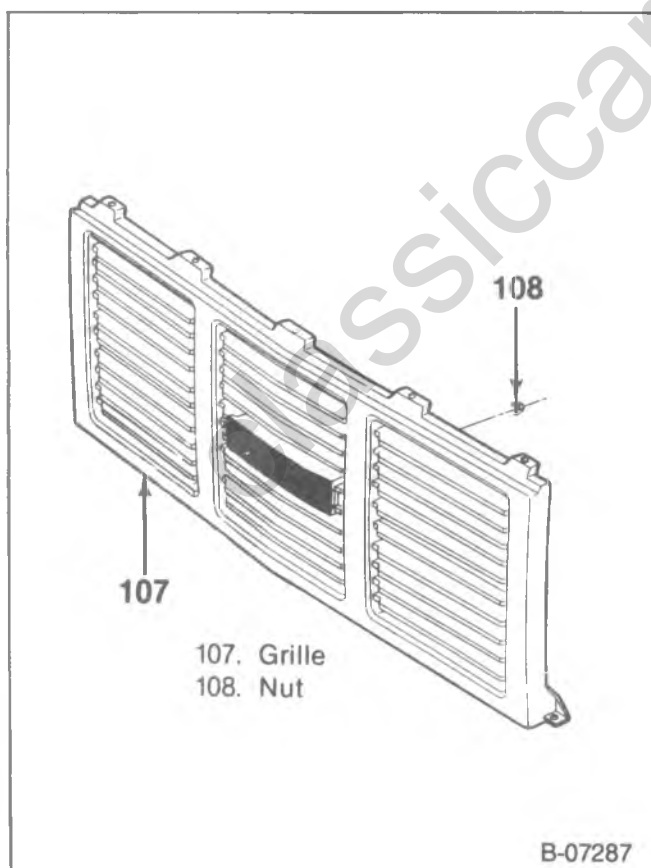

Figure 19—Radiator Grille

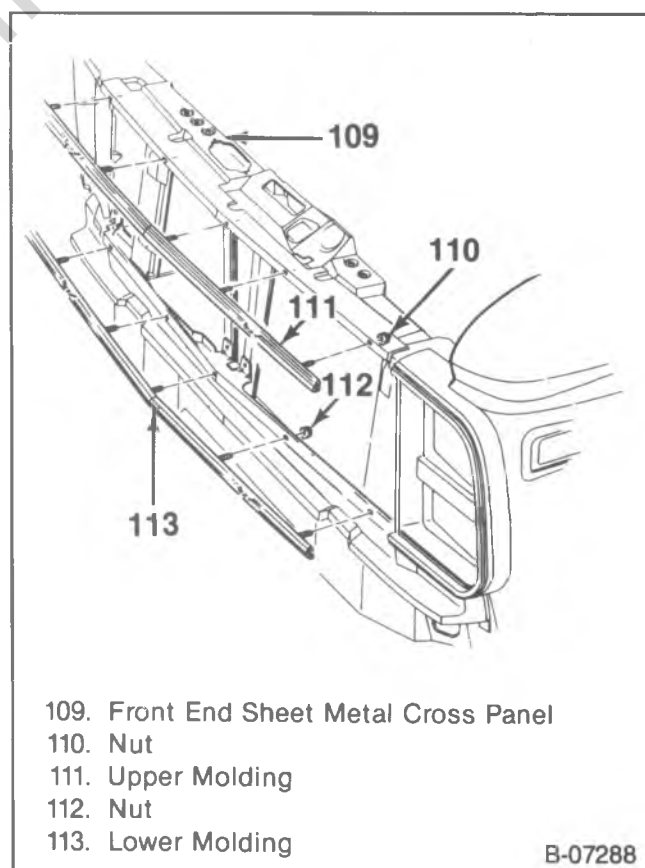
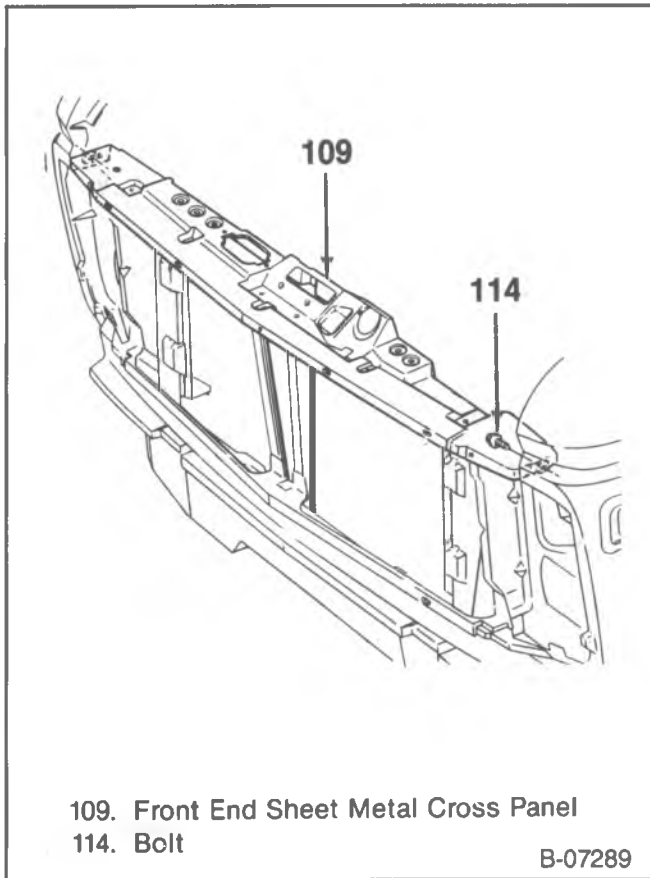

Figure 20—Radiator Grille Molding Attachment



109. Front End Sheet Metal Cross Panel
114. Bolt

B-07289

Figure 21—Front End Sheet Metal Cross Panel Attachment

Install or Connect (Figures 19 and 20)

1. Upper and lower radiator grille moldings to the vehicle.
2. Sheet metal to upper and lower radiator grille molding nuts (110 and 112).
3. Grille to the vehicle.
4. Grille to lower front end panel bolts.
5. Sheet metal cross panel to grille bolts.
6. Headlamp bezels.
 - Lower the hood.

FRONT END SHEET METAL CROSS PANEL REPLACEMENT

Remove or Disconnect (Figure 21)

- Raise and support the hood.
1. Headlamp bezels.
 2. Grille. Refer to "Grille Replacement."
 3. Primary hood latch. Refer to "Primary Hood Latch Replacement."
 4. Air intake snorkel.
 5. Upper radiator mount to sheet metal cross panel bolts.
 6. Upper radiator mounts.
 7. Sheet metal cross panel to fender bolts (114).
 8. Sheet metal cross panel to the hood latch bracket bolts (91).
 9. Sheet metal cross panel to radiator support baffle panel bolts.
 10. Sheet metal cross panel to the headlamp bezel support bolts.
 11. Sheet metal cross panel from the vehicle.

Install or Connect (Figure 21)

1. Sheet metal cross panel to the vehicle.
2. Sheet metal cross panel to the headlamp bezel support bolts.
 - Assemble loosely.
3. Sheet metal cross panel to the radiator support baffle panel bolts.
 - Assemble loosely.
4. Sheet metal cross panel to the hood latch bracket bolts (91).
 - Assemble loosely.
5. Sheet metal cross panel to the fender bolts (114).

Tighten

- Bolts in steps 2 through 5 to 27 N·m (20 ft. lbs.).
6. Upper radiator mounts.
 7. Upper radiator mount to sheet metal cross panel bolts.
 8. Air intake snorkel.
 9. Primary hood latch. Refer to "Primary Hood Latch Replacement."
 10. Grille. Refer to "Grille Replacement."
 11. Headlamp bezels.
 - Lower the hood.

SHEET METAL VERTICAL SUPPORT REPLACEMENT

Remove or Disconnect (Figure 22)

1. Grille. Refer to "Grille Replacement."
2. Vertical support to sill bolts (17).
3. Front end panel to vertical support bolts (120).
4. Sheet metal cross panel to vertical support bolts (115).
5. Vertical support from the vehicle.

Install or Connect (Figure 22)

1. Vertical support to the vehicle.
2. Sheet metal cross panel to vertical support bolts (115).

Tighten

- Bolts to 27 N·m (20 ft. lbs.).
3. Front end panel to vertical support bolts (120).

Tighten

- Bolts to 18 N·m (13 ft. lbs.).
4. Vertical support to sill bolts (117).

Tighten

- Bolt to 10 N·m (7 ft. lbs.).
5. Grille. Refer to "Grille Replacement."

FRONT END PANEL REPLACEMENT

Remove or Disconnect (Figure 23)

1. Headlamp bezels.
2. Grille. Refer to "Grille Replacement."
3. Front end panel to headlamp bezel support bolts (118).
4. Front end panel to sill bolts (121).
5. Front end panel to vertical support bolts (120).
6. Front end panel from the vehicle.

2B-18 SHEET METAL

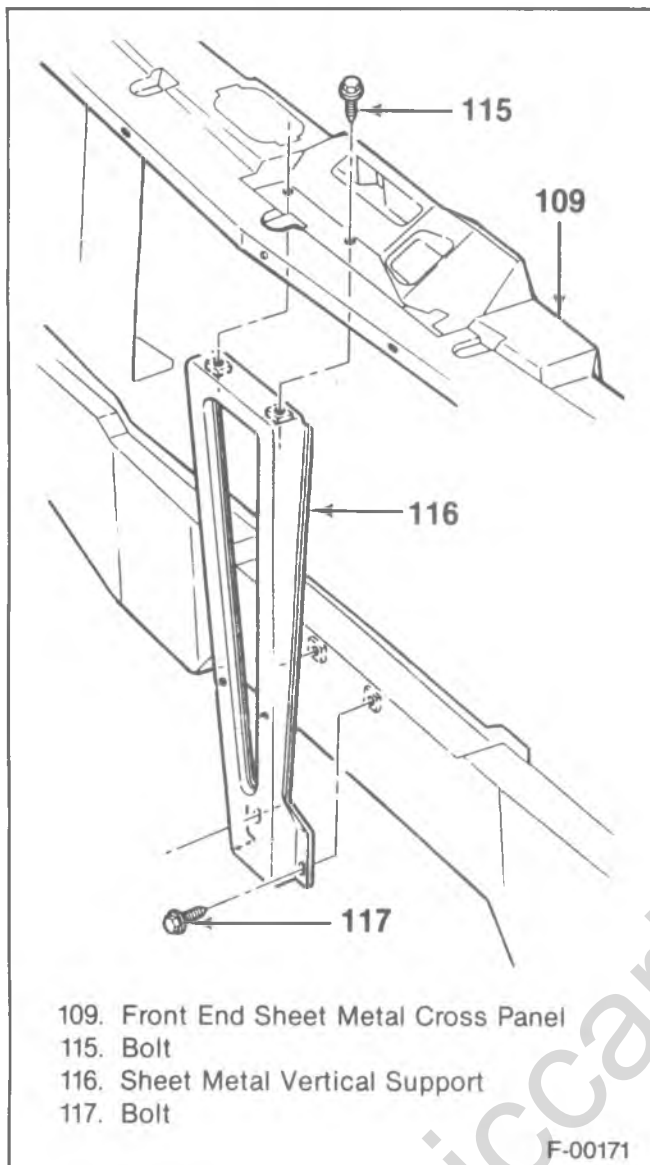

Figure 22—Front End Sheet Metal Vertical Support

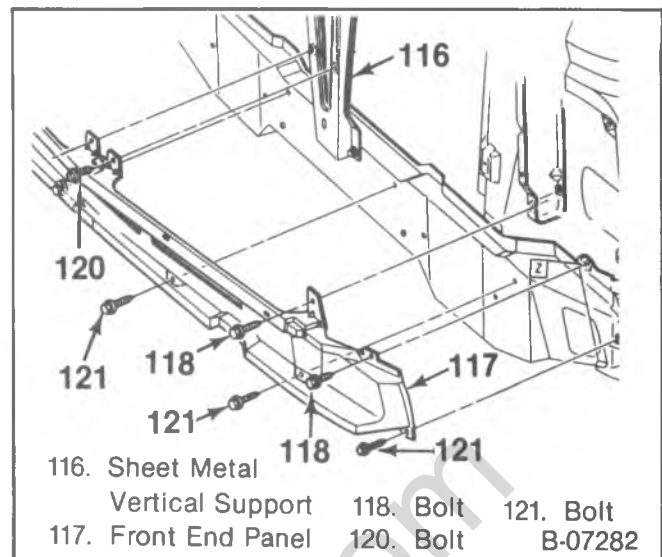

Figure 23—Front End Panel Attachment

Install or Connect (Figure 23)

1. Front end panel to the vehicle.
2. Front end panel to vertical support bolts (120).
 - Assemble loosely.
3. Front end panel to sill bolts (121).
4. Front end panel to headlamp bezel support bolts (118).
5. Grille. Refer to "Grille Replacement."
6. Headlamp bezels.

Tighten

- Bolts to 18 N·m (13 ft. lbs.).

CAB MOUNTS

CAB MOUNT REPLACEMENT

When changing cab mounts, it is important to properly support the frame while changing the mount. If only one mount is to be changed, the entire side on which the mount is placed must be lowered enough to provide clearance for the mount.

Remove or Disconnect (Figures 24 through 26)

- Raise the vehicle slightly on the hoist.
 - Place jack stands under the body on the side of the vehicle where the mounts will be replaced.
1. Bolt (279), retainer (278), and lower cushion (277) or nut (283), washer (277), cushion (277) and spacer (281).

- Lower the hoist enough to leave the body supported by the jacks.
2. Shim (275) and upper cushion (276).

Install or Connect (Figures 24 through 26)

1. Upper cushion (276) and shim (275).
 - Raise the frame on the hoist slightly.
2. Lower cushion (277), retainer (278) and bolt (279) or spacer (281), cushion (277), washer (277) and nut (283).
- Remove the jacks.

Tighten

- Bolts to 75 N·m (55 ft. lbs.).
- Nuts to 47 N·m (35 ft. lbs.).
- Lower the hoist.

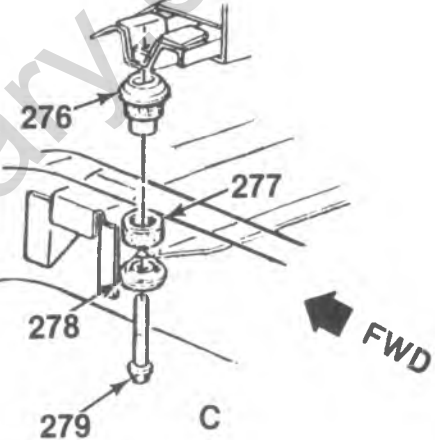
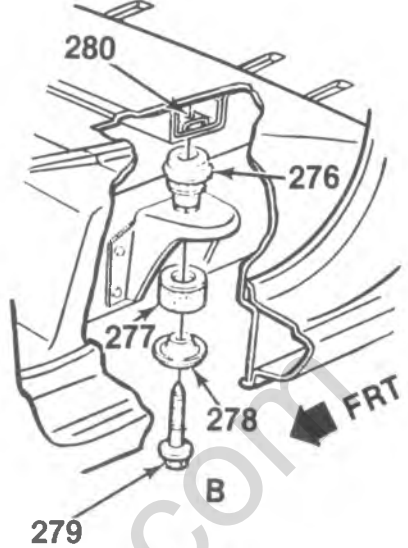
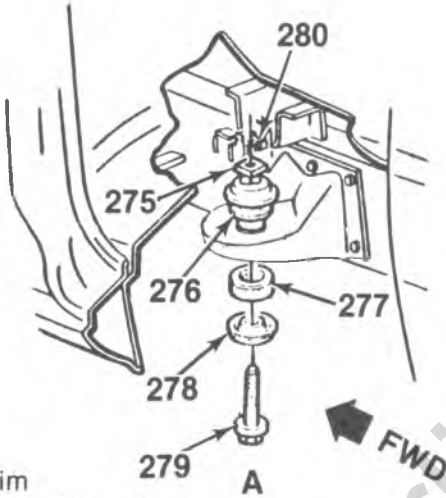
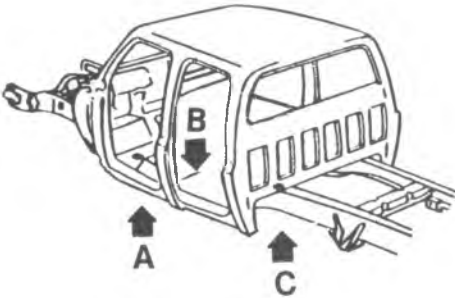

- 275. Shim
 - 276. Upper Cushion
 - 277. Lower Cushion
 - 278. Retainer
 - 279. Bolt
 - 280. Weld Nut
- A. Mount No. 1
 - B. Mount No. 2
 - C. Mount No. 3

F-02294

Figure 24—Cab Mounts for the R/V Chassis with a Bonus or Crew Cab

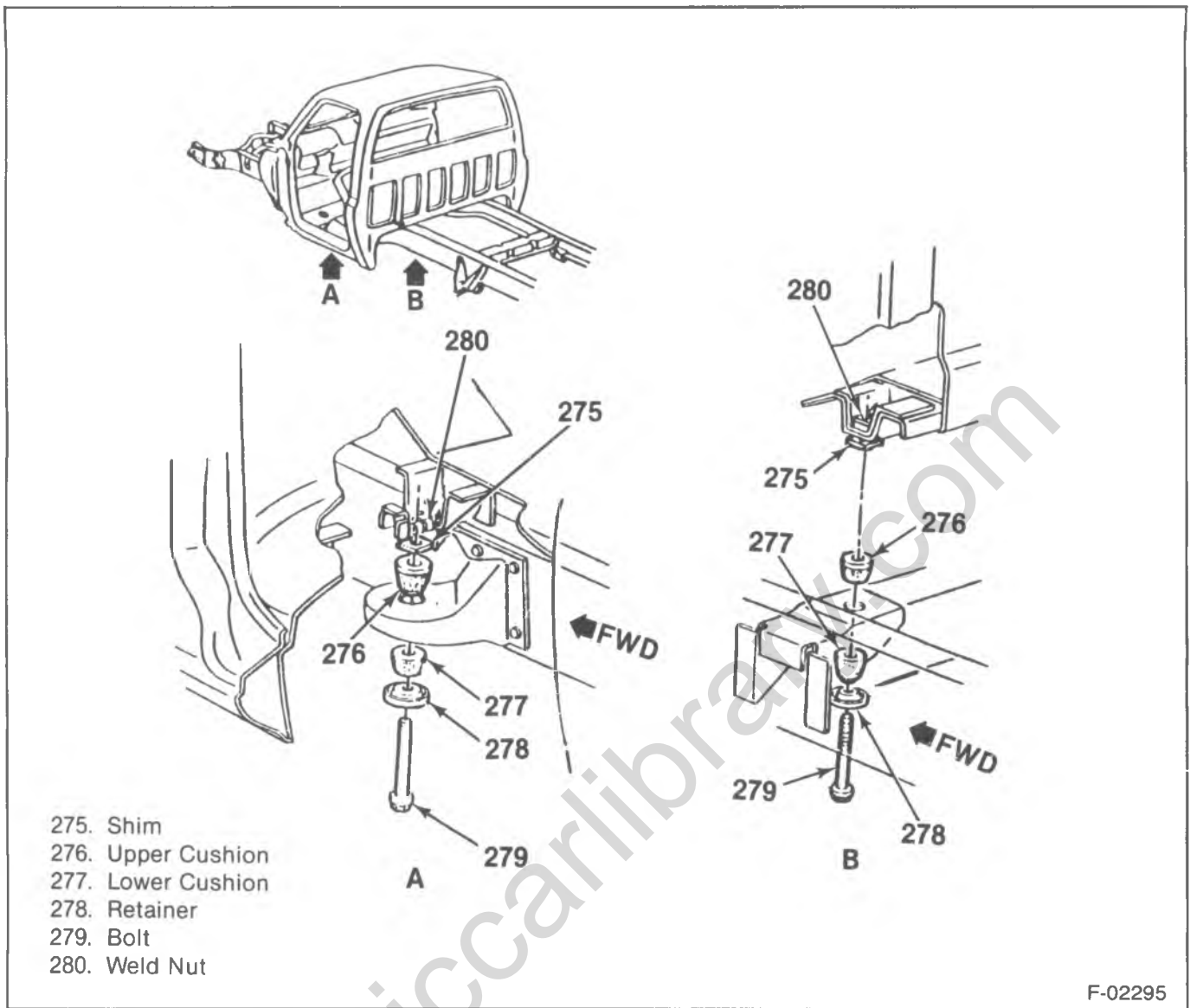
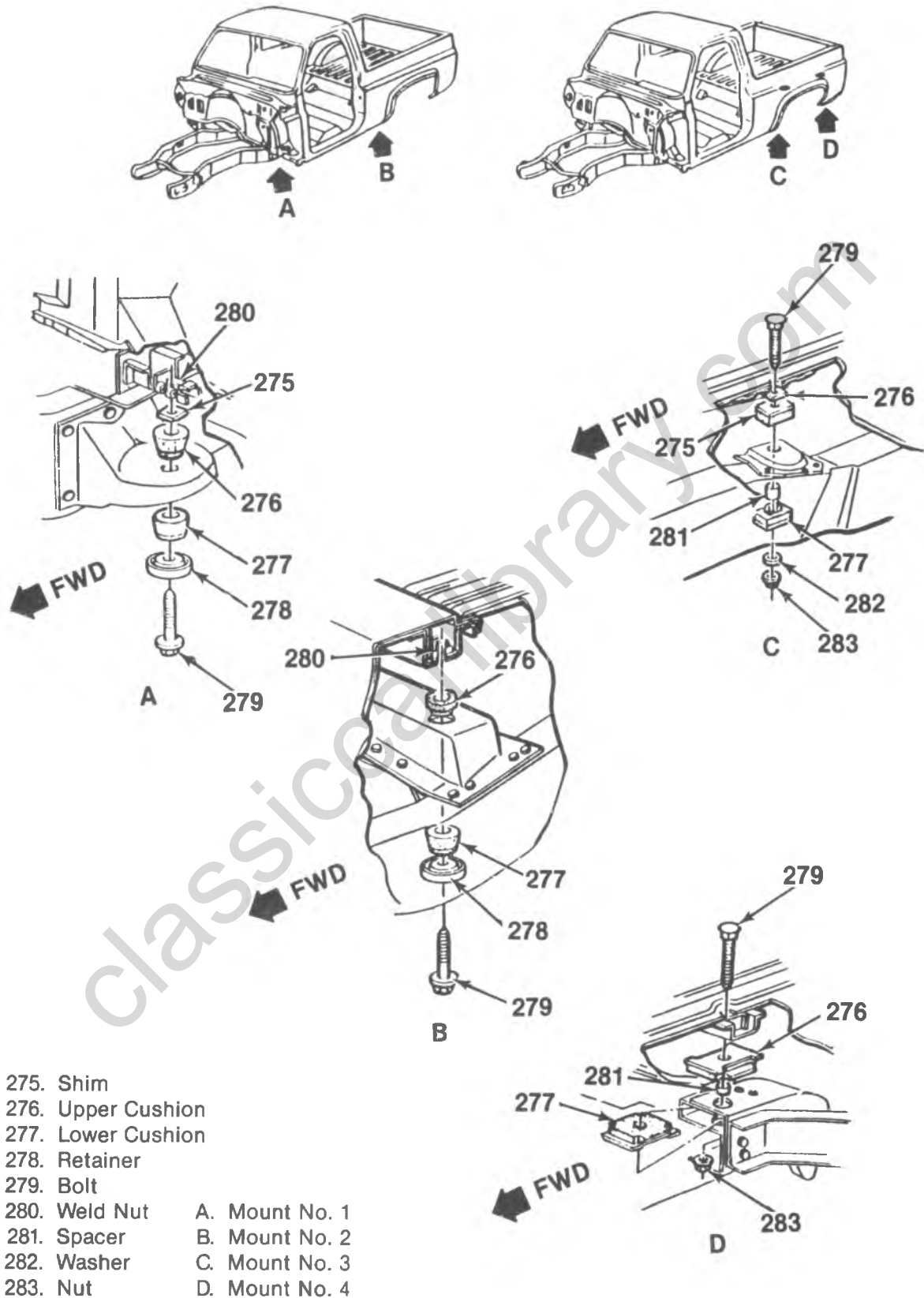

Figure 25—Cab Mounts for the R/V Chassis with a Regular Cab



F-02293

Figure 26—Cab Mounts for the R/V Pickup

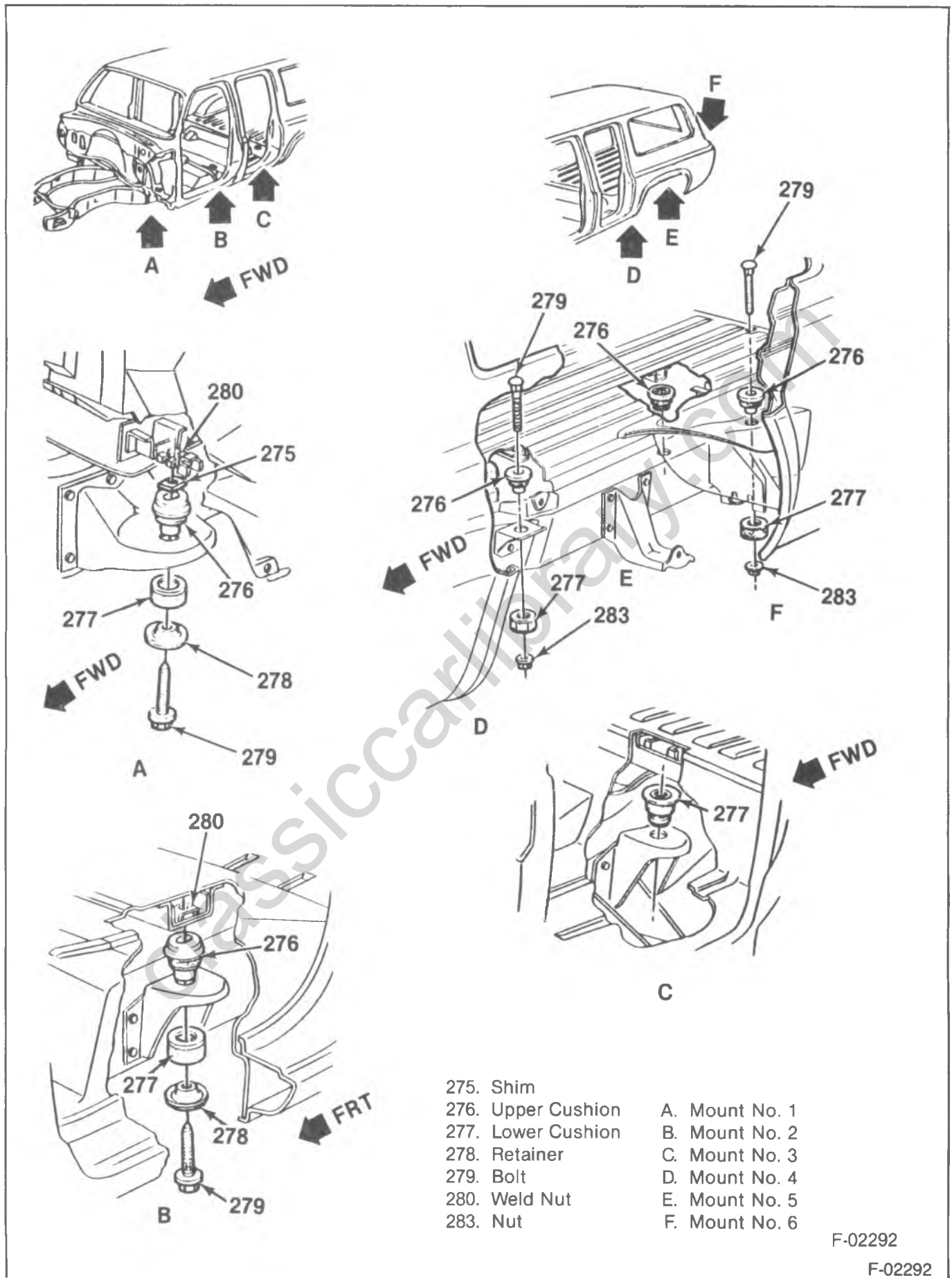



Figure 27—Cab Mounts for the Suburban

SPECIFICATIONS

	TORQUE	
	N·m	Ft. Lbs.
R/V Models		
Hood Hinge to Hood Bolts	25	18
Hood Hinge to Cowl Bolts	43	32
Spring Assembly to Hood Bolts	25	18
Spring Assembly to Fender Bolts	25	18
Primary Hood Latch Bracket to Radiator Support Bolts	27	20
Bracket to Primary Hood Latch Bolts	27	20
Secondary Hood Latch to Hood Bolts	27	20
Sheet Metal Support to Radiator Support Bolts	17	13
Radiator Support to Fender Bolts	17	13
Radiator Support to Frame Nuts	47	35
Wheelhouse to Fender Bolt	43	31
Fender to Cowl Bolt	43	31
Upper Fender to Door Pillar Bolt	43	31
Wheelhouse Panel Reinforcement to Underbody Bolts (52)	17	13
(53)	47	35
Wheelhouse to Radiator Support Bolts	17	13
Stepside Models		
Brace to Rear Fender Bolts	17	13
Side Panel to Rear Fender Bolts	10	7
Side Panel to Brace Bolts	10	7
Fleetside Models		
All Rear Fender to Side Panel Bolts, and Nuts	17	13
G Models		
Hood Hinge to Hood Bolts	17	13
Primary Hood Latch Bracket to Radiator Support Bolts	27	20
Bracket to Primary Hood Latch Bolts	27	20
Secondary Hood Latch to Hood Bolts	27	20
Sheet Metal Cross Panel to Headlamp Bezel Support Bolts	27	20
Sheet Metal Cross Panel to Radiator Support Baffle Panel Bolts	27	20
Sheet Metal Cross Panel to Hood Latch Bracket Bolts	27	20
Sheet Metal Cross Panel to Fender Bolts	28	20
Sheet Metal Cross Panel to Vertical Support Bolts	27	20
Front End Panel to Vertical Support Bolts	18	13
Vertical Support to Sill Bolts	10	7
Front End Panel to Vehicle Bolts	18	13
Cab Mounts		
Cab Mount Bolts	75	55
Cab Mount Nuts	47	35

SPECIAL TOOLS

1.



J-24595-B

1. Door Trim Pad Remover

F-02347

classiccarlibrary.com

SECTION 3

STEERING, SUSPENSION, WHEELS AND TIRES

CONTENTS

<u>SUBJECT</u>	<u>PAGE</u>
Front End Alignment3A-1
Steering Linkage3B1-1
Manual Steering3B2-1
Power Steering3B3-1
Steering Column3B4-1
Front Suspension And Axle3C-1
Rear Suspension3D-1
Wheels And Tires3E-1

SECTION 3A

FRONT END ALIGNMENT

The following "Notice" applies to one or more steps in the assembly procedure of components in this portion of the manual as indicated at appropriate locations by the terminology: "NOTICE": See 'Notice' on page 3A-1 on this section."

NOTICE: *Front end alignment fasteners are important attaching parts in that they could affect the performance of vital parts and systems, and/or could result in major repair expense. They must be replaced with one of the same part number or with an equivalent part if replacement becomes necessary. Do not use a replacement part of lesser quality or substitute design. Torque values must be used as specified during reassembly to assure proper retention of all parts.*

CONTENTS

<u>SUBJECT</u>	<u>PAGE</u>
Description3A-2
Definition of Terms3A-2
Diagnosis of Front End Alignment3A-3
On-Vehicle Service3A-3
Inspection3A-3
Front End Alignment Requirements3A-3
Alignment Adjustments3A-4
Specifications3A-6

DESCRIPTION

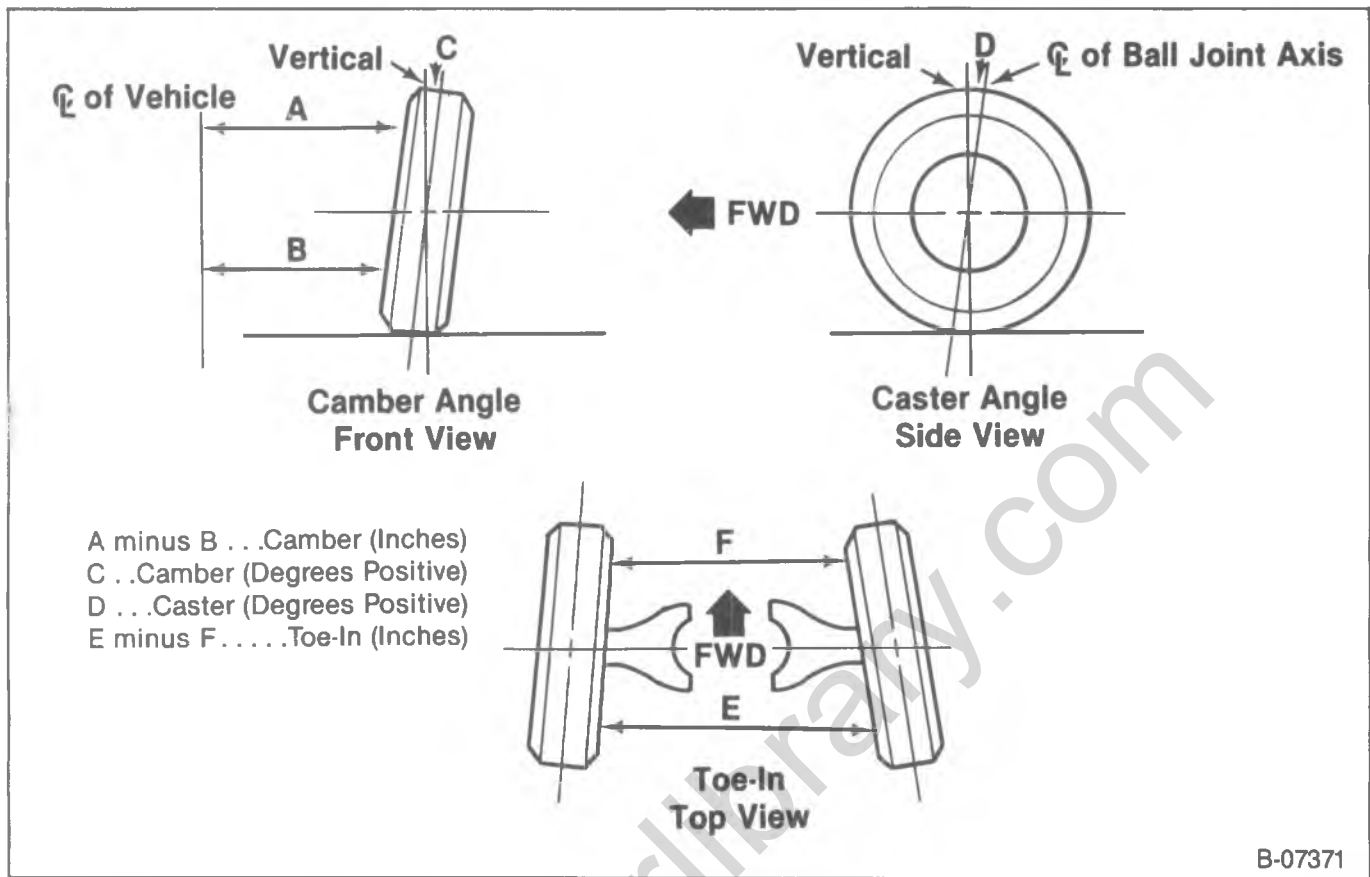

Figure 1—Caster-Camber-Toe-In

“Front End Alignment” refers to the angular relationship between the front wheels, the front suspension attaching parts and the ground.

Proper front end alignment must be maintained in order to insure efficient steering, good directional stability and to prevent abnormal tire wear.

The most important factors of front end alignment are wheel toe-in, wheel camber, and axle caster (Figure 1).

DEFINITION OF TERMS

CAMBER

Camber is the inward or outward tilting of the front wheels from the vertical. When the wheels tilt outward at the top, the camber is positive (+). When the wheels tilt inward at the top, the camber is negative (—). The amount of tilt measured in degrees from the vertical is called the camber angle. Camber is designed into the front axle assembly of all four-wheel drive vehicles and is non-adjustable.

If camber is extreme or unequal between the wheels, improper steering and excessive tire wear will result. Negative camber causes wear on the inside tire, while positive camber causes wear to the outside.

CASTER (Figure 1)

Caster is the tilting of the wheel axis either forward or backward from the vertical (when viewed from the side of the vehicle). A backward tilt is positive (+) and a forward tilt is negative (—).

On the short and long arm type suspension you cannot see a caster angle without a special instrument, but if you look straight down from the top of the upper control arm to the ground, the ball joints do not line up (fore and aft) when a caster angle other than 0 degree is present. With a positive angle, the lower ball joint would be slightly ahead (toward the front of the vehicle) of the upper ball joint center line. Caster is designed into the front axle assembly on all four-wheel drive vehicles, and is non-adjustable.

TOE-IN

Toe-in is the turning of the front wheels. The actual amount of toe-in is normally a fraction of a degree. Toe-in is measured from the center of the tire treads or from the inside of the tires. The purpose of toe-in is to insure parallel rolling of the front wheels and to offset any small deflections of the wheel support system which occurs when the vehicle is rolling forward. Incorrect toe-in results in excessive toe-in and unstable steering. Toe-in is the last alignment to be set in the front end alignment procedure.

DIAGNOSIS OF FRONT END ALIGNMENT

PROBLEM	POSSIBLE CAUSE	CORRECTION
Noisy Front End	<ol style="list-style-type: none"> 1. Worn tie rod ends. 2. Loose suspension bolts. 3. Lack of proper lubrication. 4. Loose shock absorbers or worn bushings. 5. Loose stabilizer bar. 	<ol style="list-style-type: none"> 1. Replace ends. 2. Refer to FRONT SUSPENSION (SEC. 3C). 3. Refer to MAINTENANCE AND LUBRICATION (SEC. 0B). 4. Tighten bolts and/or replace the bushings. 5. Tighten
Wheel Bounce	<ol style="list-style-type: none"> 1. Tire and wheel out of balance. 2. Blister or bump on the tire. 3. Improper shock absorber action. 4. Excessive wheel or tire run-out. 5. Tire "Lead." 	<ol style="list-style-type: none"> 1. Refer to WHEELS AND TIRES (SEC. 3E). 2. Replace the tire. 3. Replace the shock absorber. 4. Refer to WHEELS AND TIRES (SEC. 3E). 5. Refer to WHEELS AND TIRES (SEC. 3E).
Excessive Tire Wear	<ol style="list-style-type: none"> 1. Incorrect wheel alignment. 2. Failure to rotate tires. 3. Faulty shock absorbers. 4. Improper tire pressure. 5. Overloaded or improperly loaded vehicle. 6. Broken or sagging springs. 	<ol style="list-style-type: none"> 1. Align the wheels. 2. Refer to WHEELS AND TIRES (SEC. 3E). 3. Replace shock absorber. 4. Refer to WHEELS AND TIRES (SEC. 3E). 5. Avoid overloading vehicle. 6. Replace springs.

ON-VEHICLE SERVICE

INSPECTION

Before making any adjustments affecting caster, camber or toe-in, the following front end inspection should be made:



Inspect (Figure 2)

1. Tires for proper inflation pressure. Refer to WHEELS AND TIRES (SEC. 3E).
2. Front wheel bearing for proper adjustment. Refer to FRONT SUSPENSION (SEC. 3C).
3. Ball joints, tie rod ends, and relay rods. If excessive looseness is noted, correct before adjusting. Refer to STEERING LINKAGE (SEC. 3B1).
4. Wheels and tires for run-out. Refer to WHEELS AND TIRES (SEC. 3E).
5. Dimension "BC" in (figure 2). If not within specifications, the correction must be made before adjusting caster.
6. Steering gear for looseness at the frame.
7. Shock absorbers for leaks or any noticeable noise. Refer to FRONT SUSPENSION (SEC. 3C).
8. Control arms or stabilizer bar attachments for looseness. Refer to FRONT SUSPENSION (SEC. 3C).

9. Alignment equipment. Follow the manufacturer's instructions.

10. Level of the vehicle. The vehicle must be on a level surface fore and aft and transversely.

FRONT END ALIGNMENT REQUIREMENTS

Satisfactory vehicle operation may occur over a wide range of front end alignment settings. If the settings vary beyond certain tolerances, adjustments are advisable. The "Specifications" at the back of this section is a guideline for vehicle diagnosis or for repairs.

Set the front end alignment to specifications while the vehicle is in its **normally loaded** condition. Vehicles which are **consistently operated with heavy loads should have toe-in adjusted with the vehicle under heavy load**. This procedure should result in longer tire life.

3A-4 FRONT END ALIGNMENT

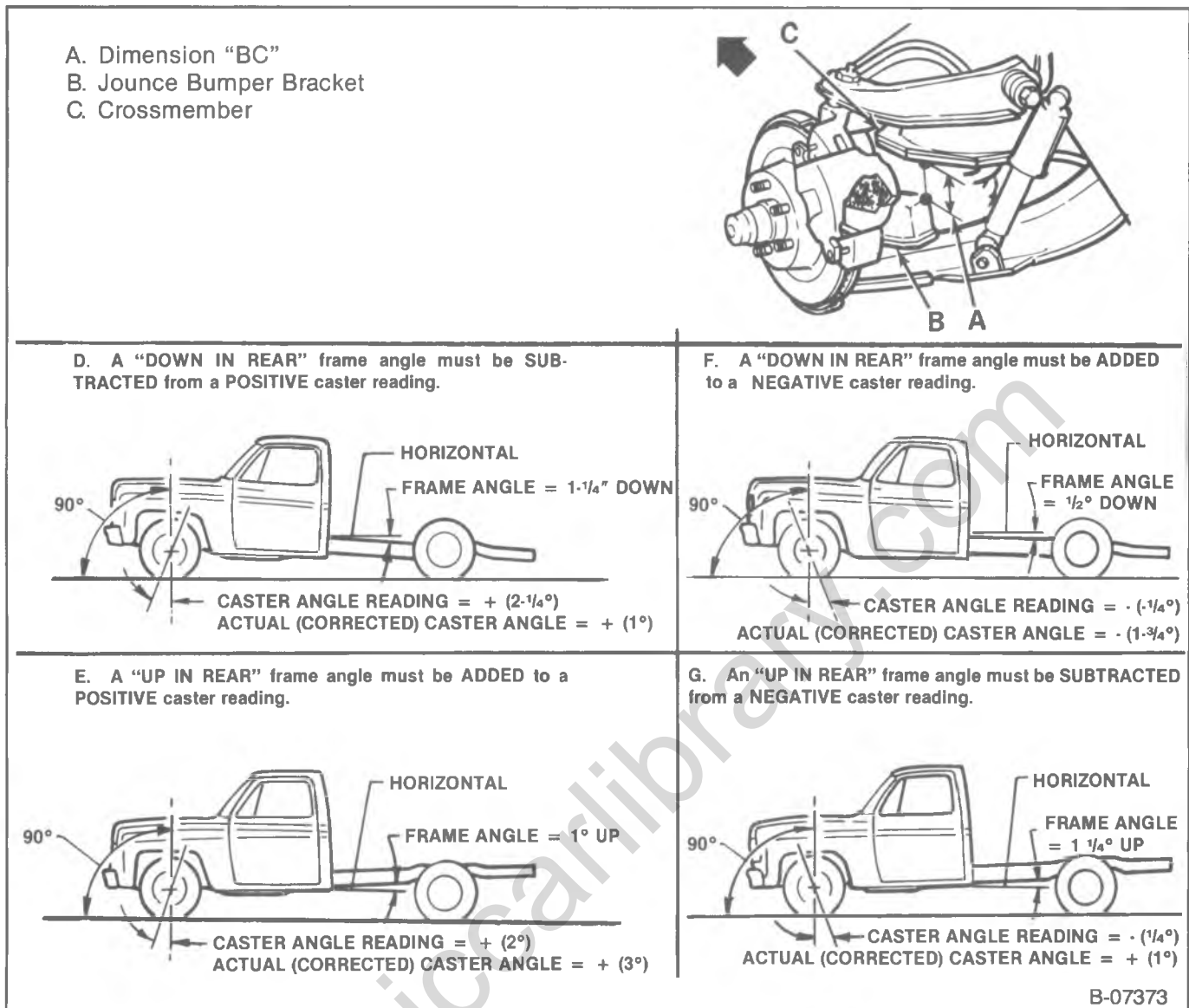

Figure 2—Determining Caster

ALIGNMENT ADJUSTMENTS

A normal shim pack will leave at least two threads of the bolt exposed beyond the nut. If two threads cannot be obtained, check for control arms and related parts. The difference between front and rear shim packs must not exceed 7.62 mm (0.03 inch). Front shim pack must be at least 2.54 mm (0.10 inch).

ACCESS TO SHIM PACKS

Models with $\frac{3}{4}$ -Inch Nut

Jack up the frame to raise the wheel off the ground. This will allow the proper upper control arm to drop down far enough to use a socket on the nuts and permit shim adjustment. Torque to specifications, refer to FRONT SUSPENSION AND AXLE (SEC. 3C).

Models with $\frac{7}{8}$ -Inch Nut

Remove the upper control arm bumper; then follow the same procedure as with $\frac{3}{4}$ -inch Nut. Torque to specifications. Reinstall the upper control arm bumper when alignment is completed. Refer to FRONT SUSPENSION AND AXLE (SEC. 3C).

CASTER

All caster specifications are given with a frame angle of zero. Therefore, it will be necessary to know the angle of the frame (whether "up" in rear or "down" in rear) before a corrected caster reading can be determined. Camber and toe-in can be read "as is" from the alignment equipment.

How To Determine Caster (Figure 2 and 3)

All caster specifications are given with vehicle frame angle of zero.

1. Position the vehicle on a smooth level surface.
2. Use a bubble protractor or inclinometer to measure the frame angle. Frame angle is the degree of tilt in the frame from the level position.
3. Determine whether the frame angle is "up in rear" or "down in rear."
4. Determine the caster angle reading from the alignment equipment.
5. Refer to figure 3. To determine an "actual (corrected) caster reading" with various frame angles and caster readings, one of the following rules apply:

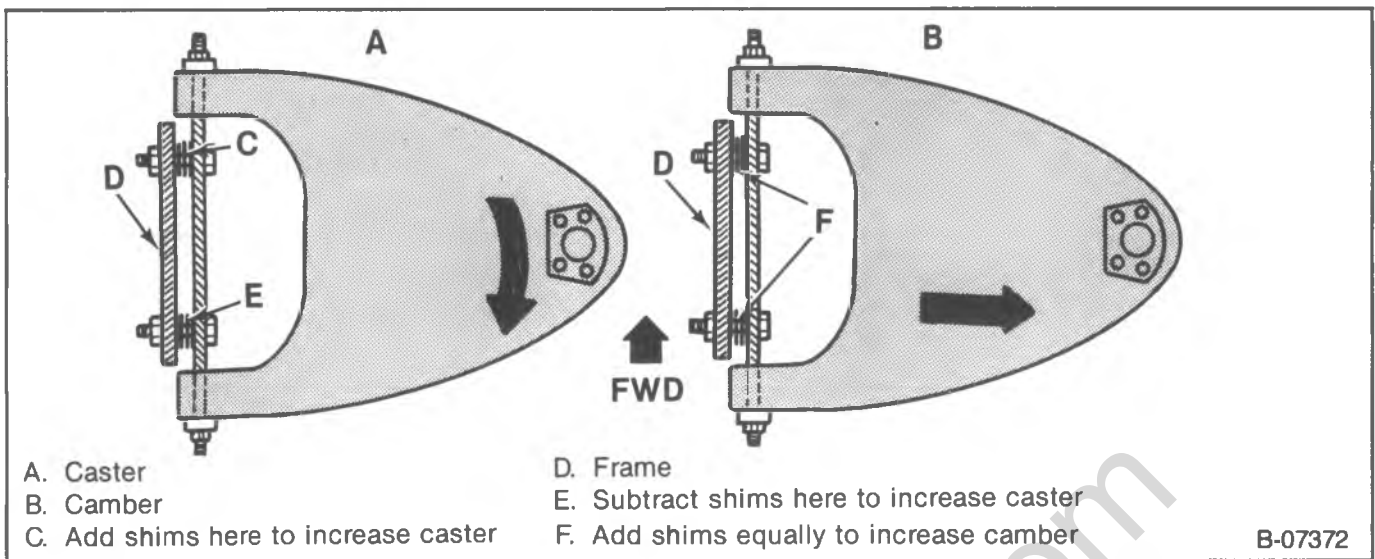

Figure 3—Caster-Camber Adjustment

- a. A "DOWN IN REAR" frame angle must be **SUBTRACTED** from a **POSITIVE** caster reading.
 - b. An "UP IN REAR" frame angle must be **ADDED** to a **POSITIVE** caster reading.
 - c. A "DOWN IN REAR" frame angle must be **ADDED** to a **NEGATIVE** caster reading.
 - d. An "UP IN REAR" frame angle must be **SUBTRACTED** from a **NEGATIVE** caster reading.
6. Dimension "BC" measured 90 degrees from the lower surface of the crossmember (C) and to the inboard rear corner of the jounce bumper bracket (B).
 7. Using dimension "BC" and the caster, camber, wheel toe-in chart sheet, find the recommended caster angle.
 8. If the actual (corrected) caster cycle (Step 5) is not within the recommended caster angle (Step 7) make the necessary shim changes.

CAMBER

1. Determine the camber angle from the alignment equipment.
2. Add or subtract shims from both the front and rear bolts to affect a change.

TOE-IN

1. Determine the toe-in from the alignment equipment.
2. Change the length of both tie rod sleeves to affect a toe change. Toe-in can be increased or decreased by changing the length of the tie rod ends. A threaded sleeve is provided for this purpose. When the tie rod ends are mounted ahead of the steering knuckle they must be decreased in length in order to increase toe-in. When the tie rod ends are mounted behind the steering knuckle they must be lengthened in order to increase toe-in. Refer to **STEERING LINKAGE (SEC. 3B1)** for clamping instructions.

SPECIFICATIONS (CONTINUED)

CAMBER AND TOE-IN CHART

Model	Camber	Toe Angle	Total Toe-In
R100 (00)	0.70°	0.36°	4.5 mm (0.18 inch)
R200 + 300 (00)	0.25°		
V100 + 200 + 300 (00)	+ 1.5° Nominal (Reference only no means of adjustment provided).	0°	0 mm (0 inch)
G100 + 200 (00)	0.50°	0.36°	4.5 mm (0.18 inch)
G300 (00)	0.25°		
P200 + 300 (32, 42) Except FS3	0.25°	0.36°	4.5 mm (0.18 inch)
P30/3500 (32,42) with FS3	+ 1.5° Nominal (Reference only no means of adjustment provided).	0.1°	3.0 mm (0.12 inch)

CASTER, CAMBER, WHEEL TOE-IN ALIGNMENT SETTING TOLERANCES

	Check	Re-Set
Caster	± 1.00°	± 0.50°
Camber	± 0.75°	± 0.50°
Total Toe-In	± 3.0 mm (0.12 inch) ± 0.232°	± 1.5 mm (0.06 inch) ± 0.116°

classiccarlibrary.com

SECTION 3B1

STEERING LINKAGE

The following "Notice" applies to one or more steps in the assembly procedure of components in this portion of the manual as indicated at appropriate locations by the terminology: "NOTICE: See 'Notice' on page 3B1-1 of this section."

NOTICE: All steering linkage fasteners are important attaching parts in that they could affect the performance of vital parts and systems, and/or could result in major repair expense. They must be replaced with one of the same part number or with an equivalent part if replacement becomes necessary. Do not use a replacement part of lesser quality or substitute design. Torque values must be used as specified during reassembly to assure proper retention of all parts.

CONTENTS

<u>SUBJECT</u>	<u>PAGE</u>
Description.....	3B1- 1
Diagnosis Of Steering Linkage.....	3B1- 2
On-Vehicle Service	3B1- 2
Idler Arm Inspection	3B1- 2
Idler Arm Adjustment (P30(32) Motorhome)	3B1- 2
Idler Arm Replacement	3B1- 3
Relay Rod Replacement	3B1- 4
Pitman Arm Replacement	3B1- 5
Steering Shock Absorber Inspection	3B1- 6
Steering Shock Absorber Replacement.....	3B1- 7
Tie Rod Replacement (R, G, P20 and 30(42) Models)	3B1- 7
Tie Rod Replacement (V and P30(00)FS3 Models).....	3B1- 8
Connecting Rod Replacement (V and P30(00)FS3 Models).....	3B1-10
Connecting Rod Replacement (P30(32) Motorhome)	3B1-11
Specifications	3B1-13
Special Tools	3B1-14

DESCRIPTION

The steering linkage for the R, G, and P20 + 30(42) model is composed of a pitman arm, idler arm, relay rod, two adjustable tie rods and a steering shock absorber (G-model). When the steering wheel is turned, the gear rotates the pitman arm which forces the relay rod to one side. The tie rods, which are connected to the relay rod by ball studs, transfers the steering force to the wheels. The tie rods are adjustable and are used for toe-in adjustments. The relay rod is supported by the pitman arm and idler arm. The idler arm pivots on a support attached to the frame rail. On the G-model the steering shock absorber is attached to a relay rod and a mounting bracket to steering gear.

The P30(32) Motorhome model steering linkage has a similar adjustable tie rod assembly as described above. When the steering wheel is turned, the gear rotates the pitman arm which forces the nonadjustable connecting rod and relay arm to move the relay rod to one side. The

relay arm and idler arm are attached to the frame by support assemblies. The support assemblies are adjustable for shaft end play. The steering shock absorber is attached to the frame and relay arm (figures 1 through 3).

The V model has a front driving axle assembly and the P30(00) with RPO-FS3 has an I-Beam axle assembly. The steering linkage consists of an adjustable connecting rod, steering shock absorber, pitman arm and a tie rod which connects the two steering knuckles together (figures 7 and 8).

The overall condition of the steering linkage affects steering performance. If parts are bent, damaged, worn or poorly lubricated, improper and possibly dangerous steering action will result.

Whenever any steering linkage components are repaired or replaced, check the steering geometry and front end alignment. Refer to FRONT END ALIGNMENT (SEC. 3A).

DIAGNOSIS OF STEERING LINKAGE

Refer to MANUAL STEERING (SEC. 3B2) or POWER STEERING (SEC. 3B3) in this manual, depending on vehicle equipment.

ON-VEHICLE SERVICE

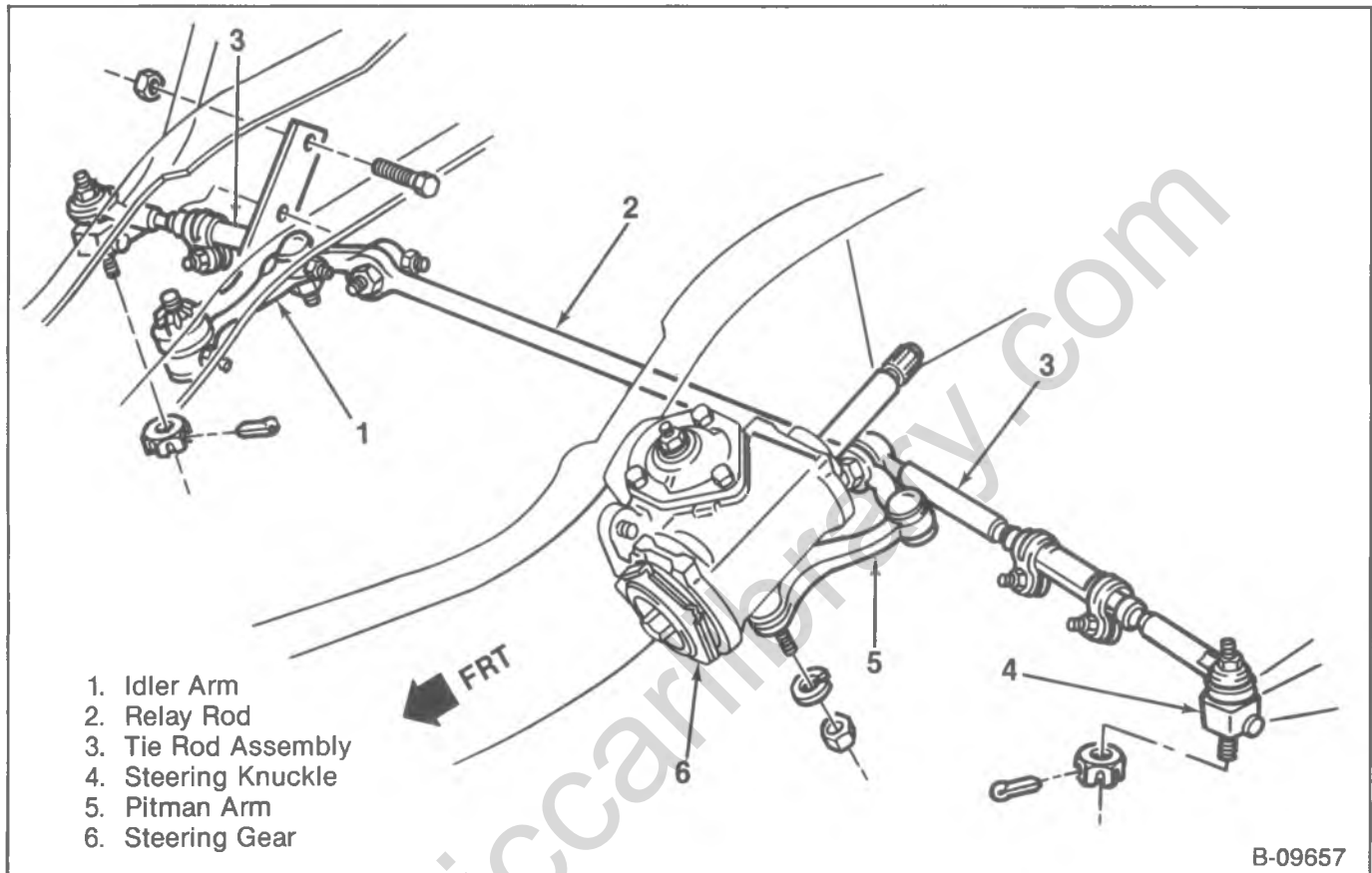

Figure 1—Steering Linkage — R, P20, and P30 (42) Models

IDLER ARM INSPECTION

Inspect (Figures 4 and 5)

1. Raise the vehicle. Allow the front wheels to rotate freely and the steering mechanism freedom to turn. Position the wheels in a straight ahead position.
2. Place a spring scale near the relay rod end of the idler arm. Exert a 110 N (25 lb.) force upward and then downward (G model the force is forward and rearward) while measuring the total distance the arm moves. The allowable deflection is $\pm 3.18\text{mm}$ ($1/8$ inch) for a total of 6.35mm ($1/4$ inch) (figures 4 and 5). Replace the idler arm if it fails this test with the exception of the P model motorhome. Refer to "Idler Arm Adjustment (P30(32) Motorhome)," in this section.

Important

- Jerking the right wheel and tire assembly back and forth, causing an up and down movement of the idler arm, is NOT an acceptable testing procedure. There is no control on the amount of force being applied to the idler arm.

- Care should be used whenever shimmy complaints are suspected of being caused by loose idler arms. Before suspecting suspension or steering components, technicians should consider areas such as dynamic imbalance, runout or force variation of wheel and tire assemblies and road surface irregularities. Refer to WHEELS AND TIRES (SEC. 3E).

IDLER ARM ADJUSTMENT (P30(32) MOTORHOME)

The frame mounted idler support assembly (10) is adjustable for support shaft end play. Check for idler arm movement as described in "Idler Arm Inspection." If the idler arm fails this test, adjust the support shaft end-play.

Adjust (Figure 3)

1. Loosen the support assembly jam nut.
2. Tighten the adjuster plug to metal-to-metal contact.
3. Back off the adjuster plug $1/8$ of a turn ($1/2$ of a flat on the square nut).

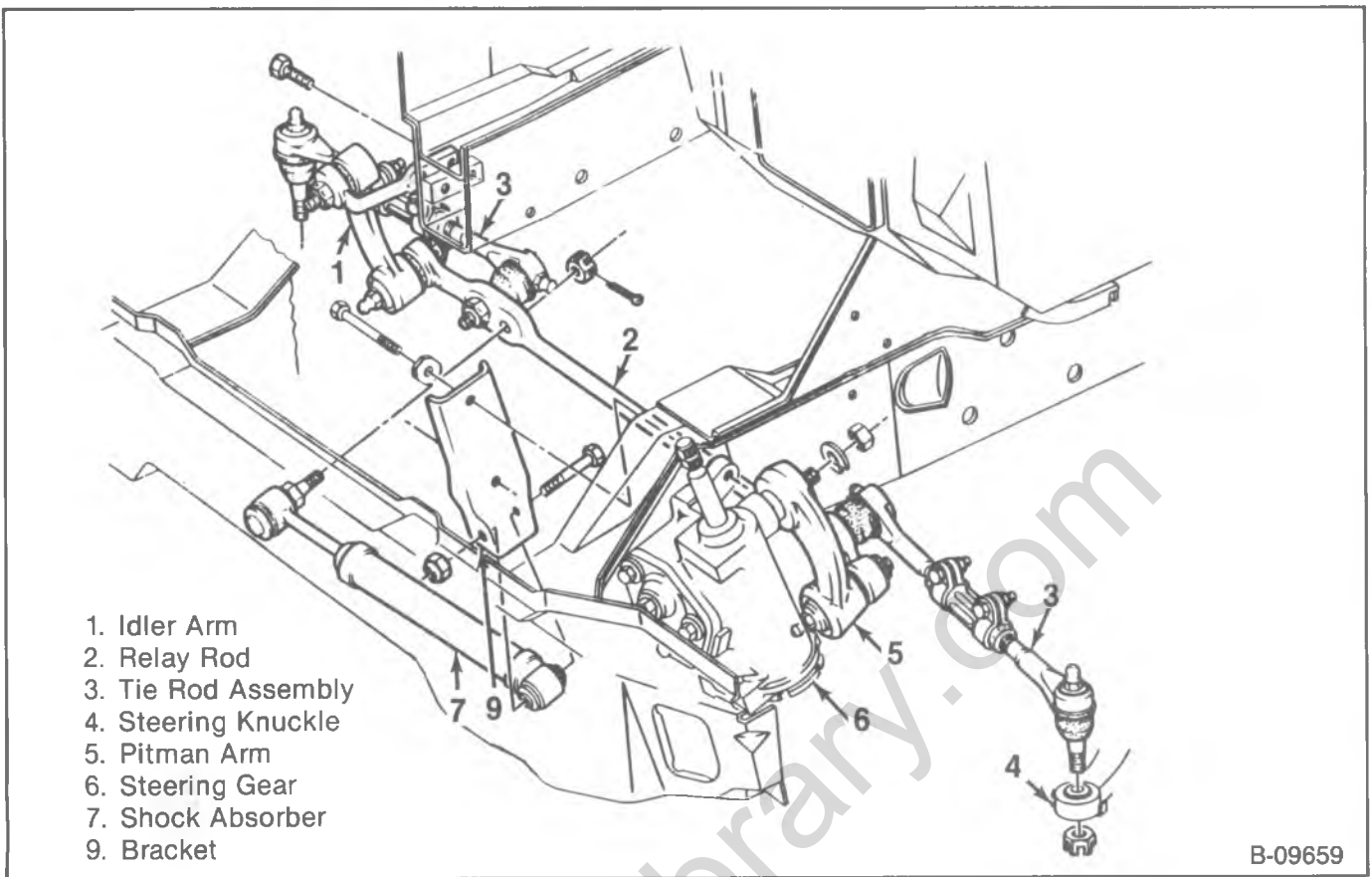

Figure 2—Steering Linkage — G Model



Tighten

- Jam nut to 40 N·m (30 ft. lbs.). The adjusting plug should not rotate.

IDLER ARM REPLACEMENT



Important

- Do not attempt to free the ball stud by using a pickle fork or wedge type tool, because seal or bushing damage could result (figure 6). Use the proper tool to separate all ball joints.



Remove or Disconnect (Figures 1 and 2)

Tool Required:

J-24319-01 Steering Linkage Puller.

- Raise the vehicle.
- 1. Idler arm frame bolts.
- 2. Nut from the idler arm ball stud.
- 3. Idler arm (1) from the relay rod (2). Use J-24319-01.



Inspect

- Ball stud threads for damage.
- Ball stud seal for cuts or other damage.



Clean

- Threads on the ball stud and in the ball stud nut.



Install or Connect (Figures 1 and 2)

Tools Required:

J-29193 Steering Linkage Installer (12mm).

J-29194 Steering Linkage Installer (14mm).

NOTICE: For steps 1 and 3 see "Notice" on page 3B1-1 of this section.

- Position the idler arm (1) on the frame.
- 1. Frame bolts to the idler arm.



Tighten

- Bolts to "Specifications" at the end of this section.
- 2. Relay rod (2) to the idler arm ball stud. Make certain the seal is on the stud. Tighten tool J-29193 or J-29194 to 54 N·m (40 ft. lbs.) to seat the tapers. Remove the tool.
- 3. Prevailing torque nut to the idler arm ball stud.



Tighten

- Nut to "Specifications" at the end of this section.
- Lower the vehicle.



Adjust

- Toe-in if necessary. Refer to FRONT END ALIGNMENT (SEC. 3A) in this manual.

3B1-4 STEERING LINKAGE

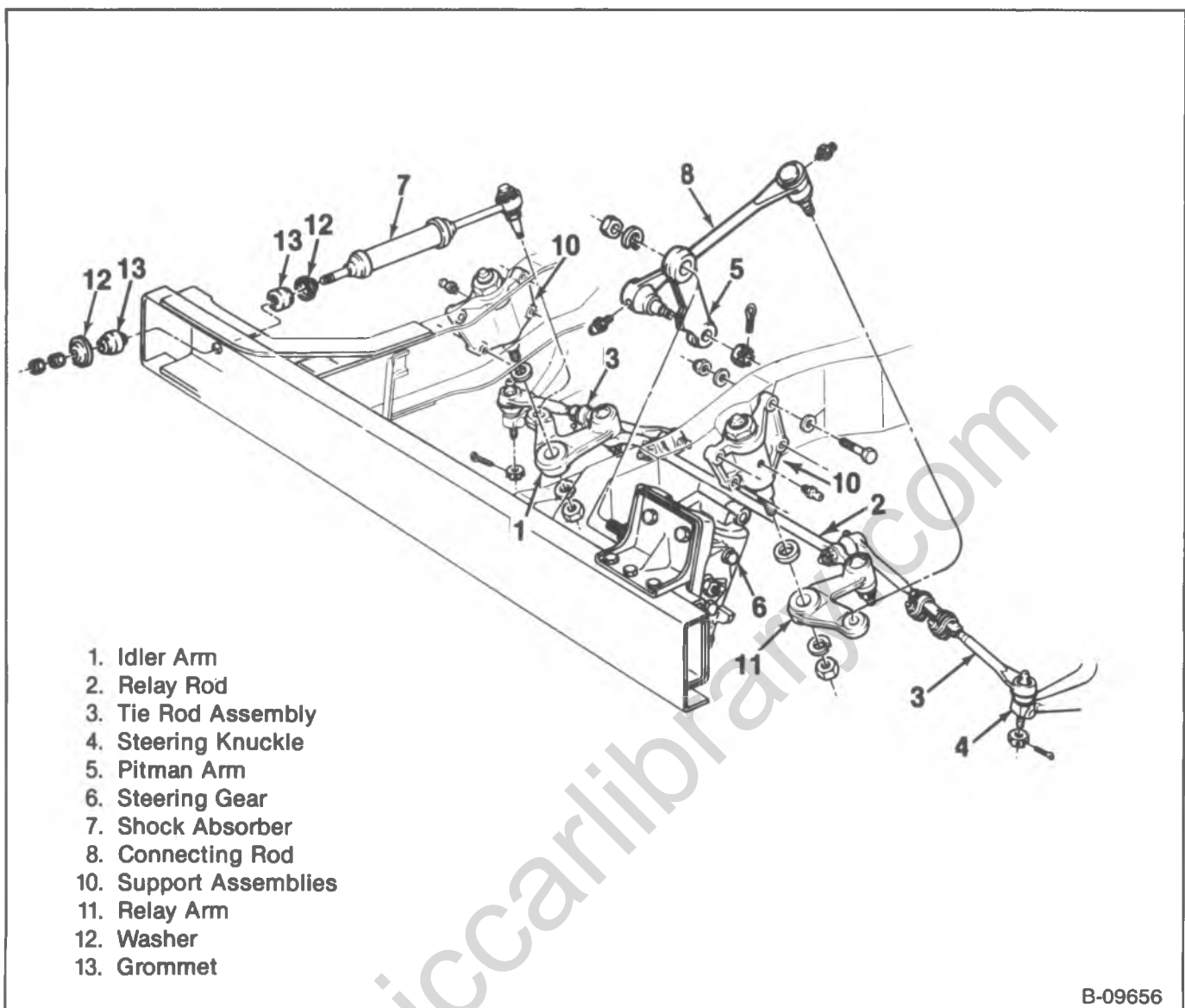

Figure 3—Steering Linkage — P30 (32) Motorhome

RELAY ROD REPLACEMENT

! Important

- Use the proper tool to separate all tie rod and ball joints.

↔ Remove or Disconnect (Figures 1 through 3)

Tool Required:

J-24319-01 Steering Linkage Puller.

- Raise the vehicle.
1. Inner tie rod (3) from the relay rod (2). Refer to "Tie Rod Replacement" in this section.
 2. Nuts from the idler arm (1) and pitman arm (5) or relay arm (11) ball studs at the relay rod (2).
 3. Relay rod (2) from the idler arm (1). Use J-24319-01.
 4. Relay rod (2) from the pitman arm (5) or relay arm (11). Use J-24319-01.

🔍 Inspect

- Threads on the tie rod and the tie rod end for damage.
- Ball stud threads for damage.
- Ball stud seals for excessive wear.

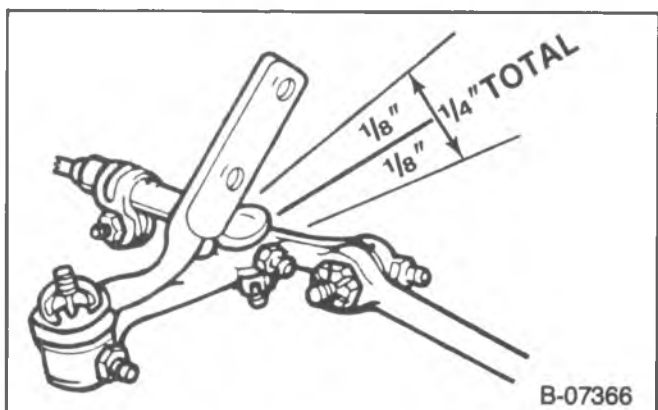
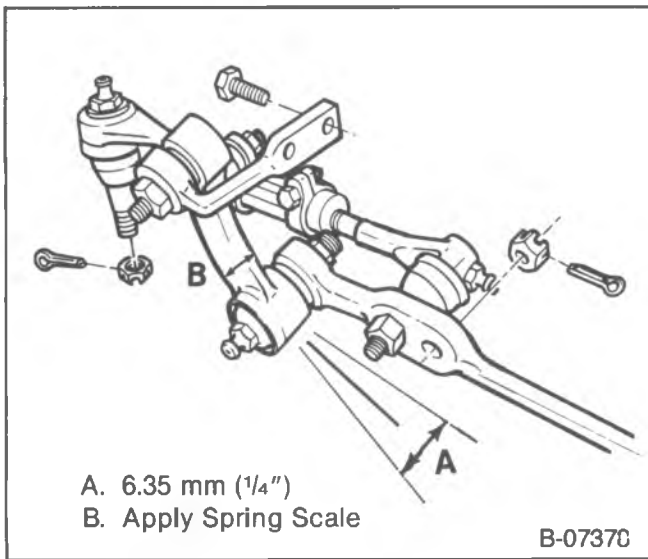

Figure 4—Checking Idler Arm Movement



- A. 6.35 mm (1/4")
- B. Apply Spring Scale

B-07370

Figure 5—Checking Idler Arm Movement—G Model



Clean

- Threads on the ball stud and the ball stud nut.



Install or Connect (Figures 1 through 3)

Tools Required:

J-29193 Steering Linkage Installer (12mm).

J-29194 Steering Linkage Installer (14mm).

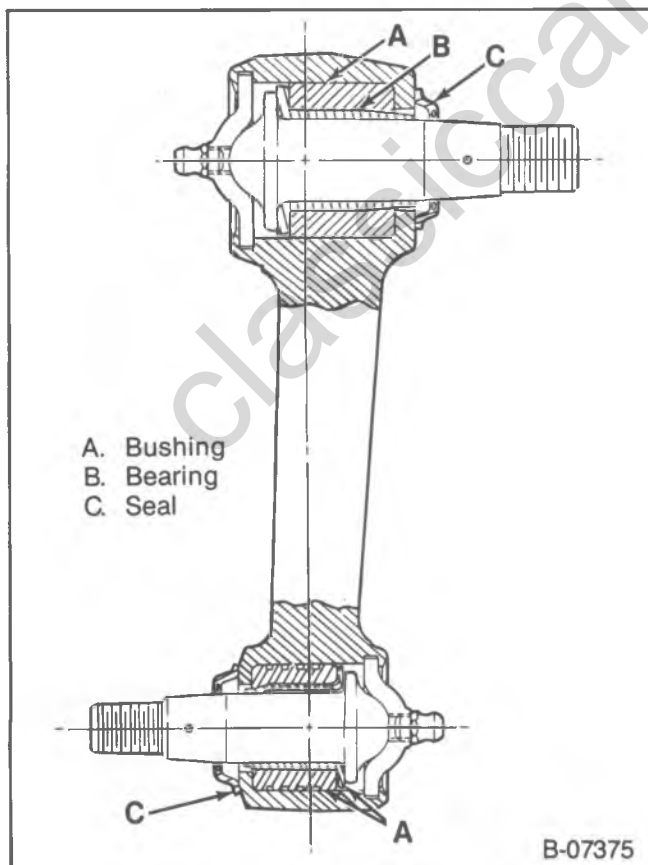

- A. Bushing
- B. Bearing
- C. Seal

B-07375

Figure 6—Idler Arm (Internal View)

1. Relay rod (2) to the idler arm (1) and the pitman arm (5) or relay arm (11) ball stud. Make certain the seal is on the stud. Tighten J-29193 or J-29194 to 54 N·m (40 ft. lbs.) to seat the tapers. Remove the tool.

NOTICE: See "Notice" on page 3B1-1 of this section.

2. Nuts to the idler arm and the pitman arm or relay arm ball stud.



Tighten

- Nuts to "Specifications" at the end of this section.
3. Inner tie rod (3) to the relay rod. Refer to "Tie Rod Replacement."
 - Lower the vehicle.

PITMAN ARM REPLACEMENT



Important

- Use the proper tool to separate all ball joints.



Remove or Disconnect (Figures 1, 2, 3, 7 and 8)

Tools Required:

J-24319-01 Steering Linkage Puller.

J-29107 Pitman Arm Puller.

J-6632-01 Pitman Arm Remover.

- Raise the vehicle.
1. Relay rod nut or connecting rod nut and cotter pin from the pitman arm ball stud.
 2. Relay rod (2) or connecting rod (8) from the pitman arm (5). Use J-24319-01.
 3. Pitman arm nut and washer.
 - Mark the pitman arm and the pitman shaft. This will permit proper alignment at assembly.

NOTICE: Do not hammer on pitman arm, pitman shaft, or puller. Damage to pitman arm or steering gear may result.

4. Pitman arm (5). Use J-6632-01 or J-29107.



Inspect

- Ball stud threads for damage.
- Ball stud seals for excessive wear.



Clean

- Threads on the ball stud and ball stud nut.



Install or Connect (Figures 1, 2, 3, 7 and 8)

Tools Required:

J-29193 Steering Linkage Installer (12mm).

J-29194 Steering Linkage Installer (14mm).

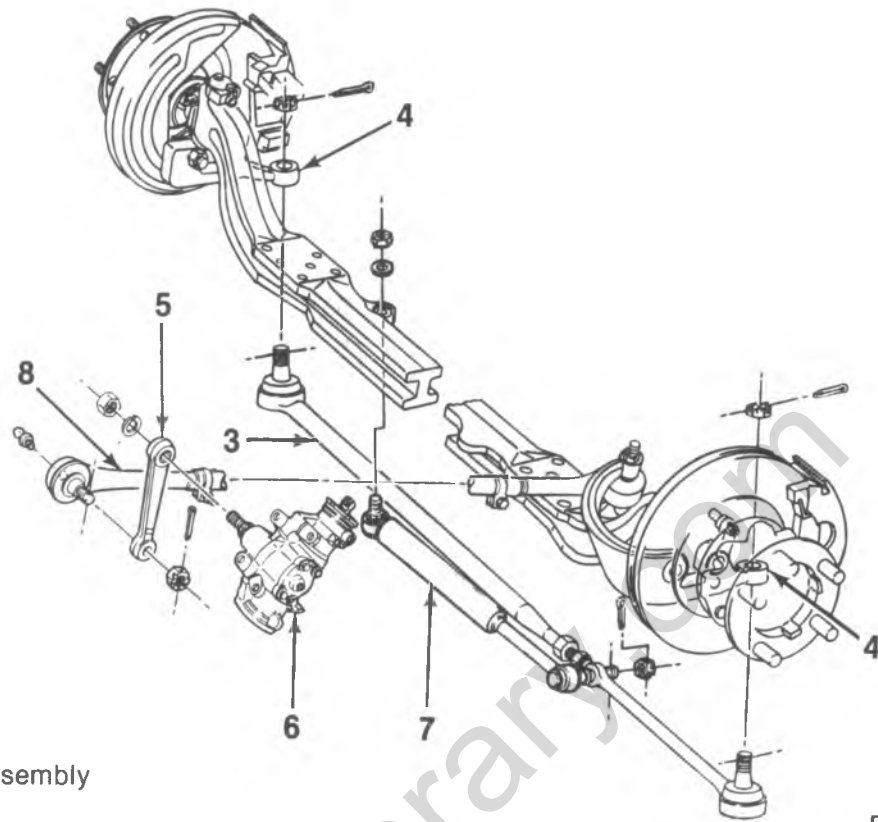

- 3. Tie Rod Assembly
- 4. Steering Knuckle
- 5. Pitman Arm
- 6. Steering Gear
- 7. Shock Absorber
- 8. Connecting Rod Assembly

B-07367

Figure 7—Steering Linkage—P30(00)FS3

NOTICE: For steps 2 and 4 see "Notice" on page 3B1-1 of this section.

NOTICE: If a clamp type pitman arm is used, spread the pitman arm just enough, with a wedge, to slip the arm onto the pitman shaft. Do not spread the pitman arm more than required to slip over the pitman shaft with hand pressure. Do not hammer, or damage to the steering gear may result.

1. Pitman arm (5) on the pitman shaft. Line up the marks made at removal.
2. Pitman arm washer and nut.

 **Tighten**

- Pitman arm nut to "Specifications" at the end of this section.

3. Relay rod (2) or connecting rod (8) to the pitman arm ball stud. Make certain the seal is on the stud. Tighten tool J-29193 or J-29194 to 54 N·m (40 ft. lbs.) to seat the tapers. Remove the tool.
4. Relay rod nut or the connecting rod castellated nut and cotter pin to the pitman arm ball stud.

 **Tighten**

- Castellated nut to "Specifications" as instructed at the end of this section.

- Lower the vehicle.

STEERING SHOCK ABSORBER INSPECTION

Steering shock absorbers are a sealed assembly and are nonrepairable. Replace the complete assembly if damaged.

 **Inspect (Figures 2, 3, 7 and 8)**

1. Shock absorber for fluid leakage. A slight film of fluid is allowable near the shaft seal. If there is excessive fluid leakage, be sure it's from the shock absorber and then replace the shock absorber.

2. Shock absorber bushing for excessive wear. Replace the shock absorber if necessary.

3. Test the shock absorber.

- Disconnect the shock absorber from the frame or axle end.

- Extend and compress the shock absorber using as much travel as possible. Resistance should be smooth and constant for each stroking rate. Replace the shock absorber if any binding or unusual noises are present.

- Install the end of the shock absorber. Torque to specifications.

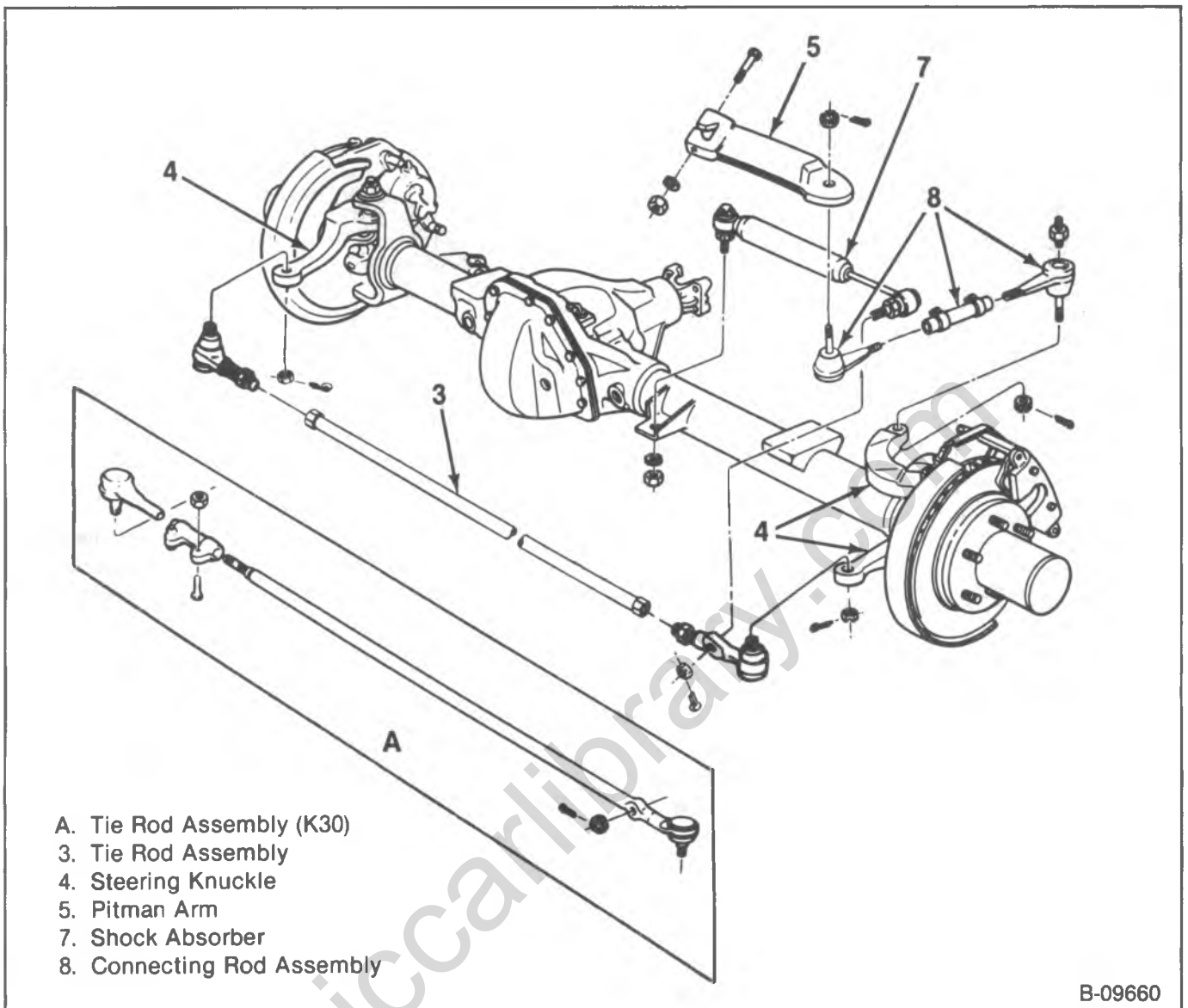

- A. Tie Rod Assembly (K30)
- 3. Tie Rod Assembly
- 4. Steering Knuckle
- 5. Pitman Arm
- 7. Shock Absorber
- 8. Connecting Rod Assembly

B-09660

Figure 8—Steering Linkage—V Models

STEERING SHOCK ABSORBER REPLACEMENT

↔ Remove or Disconnect

1. Shock absorber mounting nuts and washers.
 - Washer (12) and grommet (13) (P30(32) model).
2. Cotter pin and castellated nut.
3. Shock absorber (7).

👁 Inspect

- Shock absorber for leaks and damage.
- Shock absorber bushings for wear and damage.
- Grommet (13) for wear.

→ Install or Connect

NOTICE: For steps 2 and 3 see "Notice" on page 3B1-1 of this section.

1. Shock absorber with bushings to the axle bracket.

- Washer (12) and grommet (13) (P30(32) model).
2. Shock absorber mounting nuts and washers.

🔩 Tighten

- Shock absorber nuts to "Specifications" at the end of this section.
3. Castellated nut and cotter pin.

🔩 Tighten

- Castellated nut to "Specifications" as instructed at the end of this section.

TIE ROD REPLACEMENT (R, G, P20 AND 30(42) MODELS)

There are two tie rod assemblies. Each assembly is of a five piece construction, consisting of an adjuster tube, two clamps and two tie rod ends. The ends are threaded into the sleeve and secured with the clamps. Right and left hand threads are used for toe-in adjustments and steering gear centering. The tie rod ends should be replaced when

3B1-8 STEERING LINKAGE

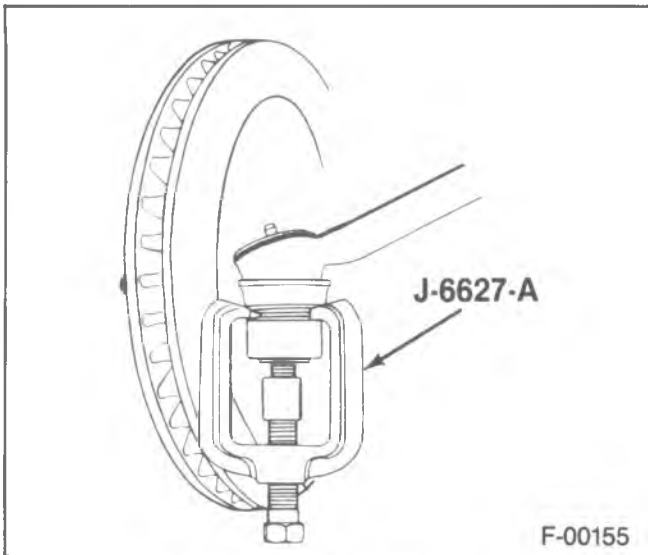

Figure 9—Ball Stud Removal

excessive up and down motion is present, or when excessive end play or loss of motion at the ball stud exists.

Before servicing, note the position of the tie rod adjuster tube and the direction the bolts are installed. The tie rod adjuster tube components may be rusted. If the torque required to remove the nut from bolt exceeds 9 N·m (7 ft. lbs.) discard the nuts and bolts. Apply penetrating oil between the clamp and tube and rotate the clamps until they move freely. Install all parts, with the correct part number, in the proper position.

! Important

- Use the proper tool to separate all tie rod and ball joints.

↔ Remove or Disconnect (Figures 1, 2, 3, and 9)

Tool Required:

J-6627-A Wheel Stud Remover and Tie Rod Remover.

- Raise the vehicle.
1. Cotter pins and castellated nuts from the outer tie rod ball stud.
 2. Outer tie rod ball studs from the steering knuckle (4). Use J-6627-A (figure 9).
 3. Inner tie rod ball stud from the relay rod (2). Use J-6627-A.
 4. Tie rod ends from the adjuster tube. Loosen the clamp bolts and unscrew the end assemblies.

🔍 Inspect

- Tie rod end for damage.
- Tie rod end seals for excessive wear.
- Threads on the tie rod and tie rod end for damage.
- Ball stud threads for damage.
- Adjuster tube for bending or damaged threads.

🧼 Clean

- The tapered surfaces.
- Threads on the ball stud and in the ball stud nut.

↔ Install or Connect (Figures 1 through 3)

Tools Required:

J-29193 Steering Linkage Installer (12mm).

J-29194 Steering Linkage Installer (14mm).

NOTICE: For steps 3 and 5 see "Notice" on page 3B1-1 of this section.

- If the rod ends were removed, lubricate the tie rod threads with chassis lubricant.
1. Tie rod ends to the adjuster tube. The number of threads on both the inner and outer rod ends must be equal within three threads.
 2. Inner tie rod ball studs to the relay rod (2). The seal must be on the stud. Tighten J-29193 or J-29194 to 54 N·m (40 ft. lbs.) to seat the tapers. Remove the tool.
 3. Prevailing torque nut to the inner tie rod ball stud.

🔩 Tighten

- Nut to "Specifications" at the end of this section.
4. Outer tie rod ball studs to the steering knuckle.
 5. Castellated nuts and cotter pins to the outer rod ball studs.

🔩 Tighten

- Castellated nuts to "Specifications" as instructed at the end of this section.

🔧 Adjust (Figures 10, 11, and 12)

- Toe-in. Refer to FRONT END ALIGNMENT (SEC. 3A) in this manual.
6. Adjuster tube clamp bolts (figures 10, 11 and 12). Before tightening the clamp bolts, be sure the following conditions have been met:
 - The clamp must be positioned between the locating dimples at either end of the adjuster tube.
 - The clamps must be positioned within the angular travel shown in figures 10, 11 or 12.
 - Both inner and outer tie rod ends must rotate for their full travel. The position of each tie rod end must be maintained as the clamps are tightened to ensure free movement of each joint.
 - The clamp ends may touch when nuts are torqued to specification, but the gap next to the adjuster tube must NOT be less than the minimum dimension shown in figures 10, 11 or 12.

🔩 Tighten

- Adjuster tube clamp bolts to "Specifications" at the end of this section.

TIE ROD REPLACEMENT (V AND P30(00)FS3 MODELS)

↔ Remove or Disconnect (Figures 7 and 8)

Tool Required:

J-6627-A Wheel Stud Remover and Tie Rod Remover.

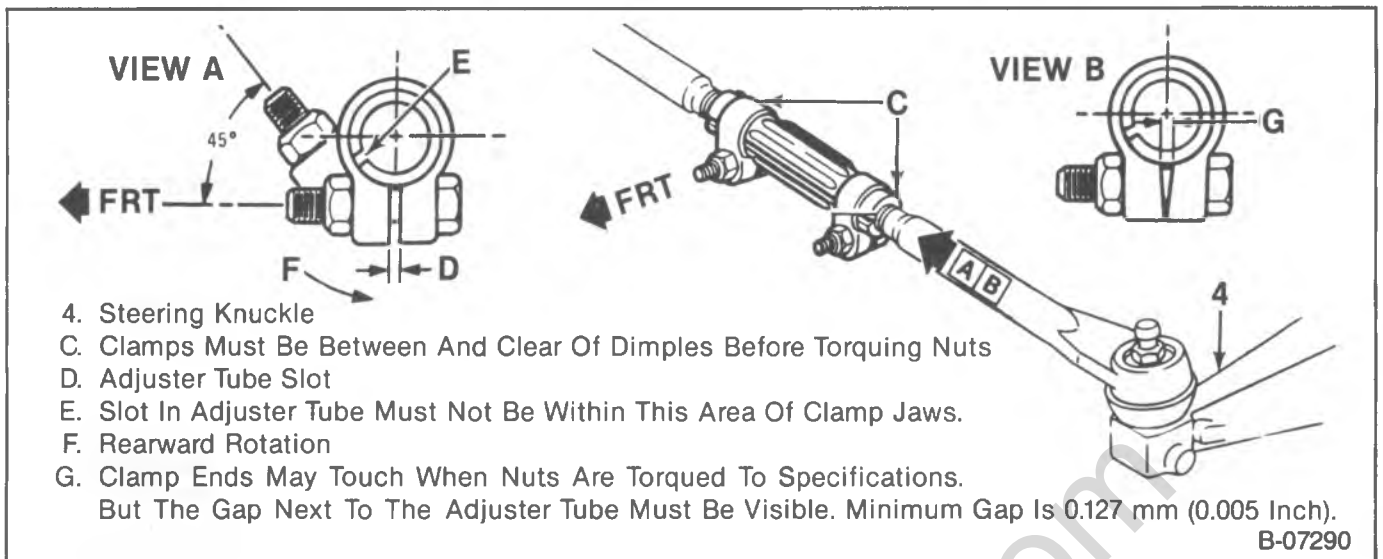

Figure 10—Tie Rod Clamp and Adjuster Tube Positioning — R Model

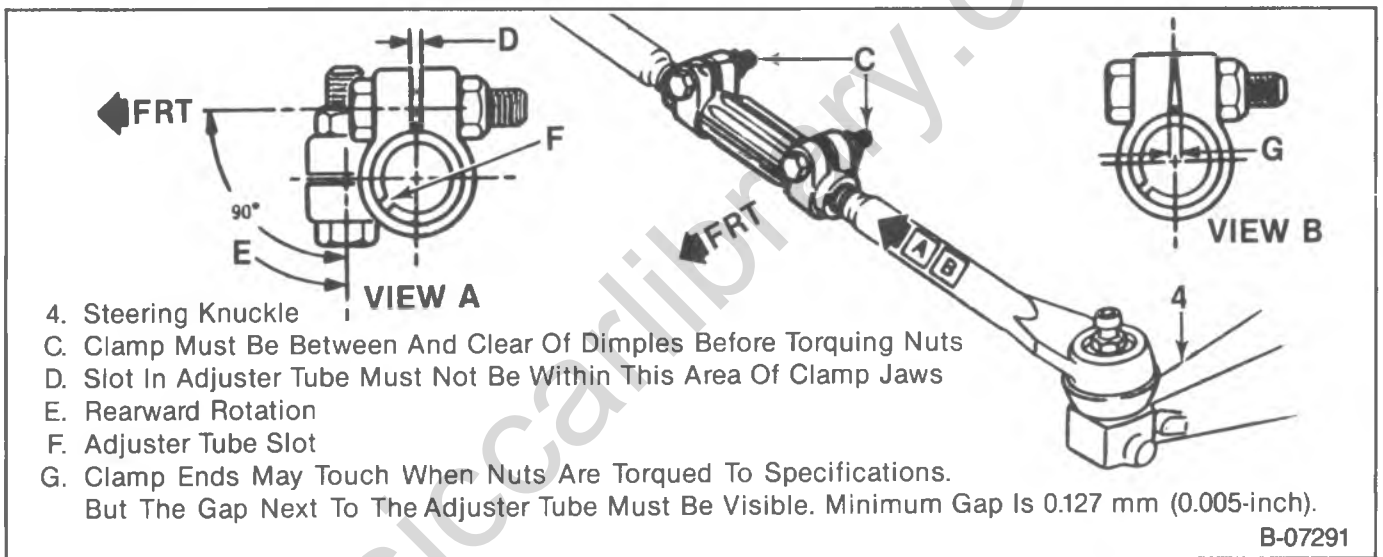

Figure 11—Tie Rod Clamp and Adjuster Tube Positioning — G Model

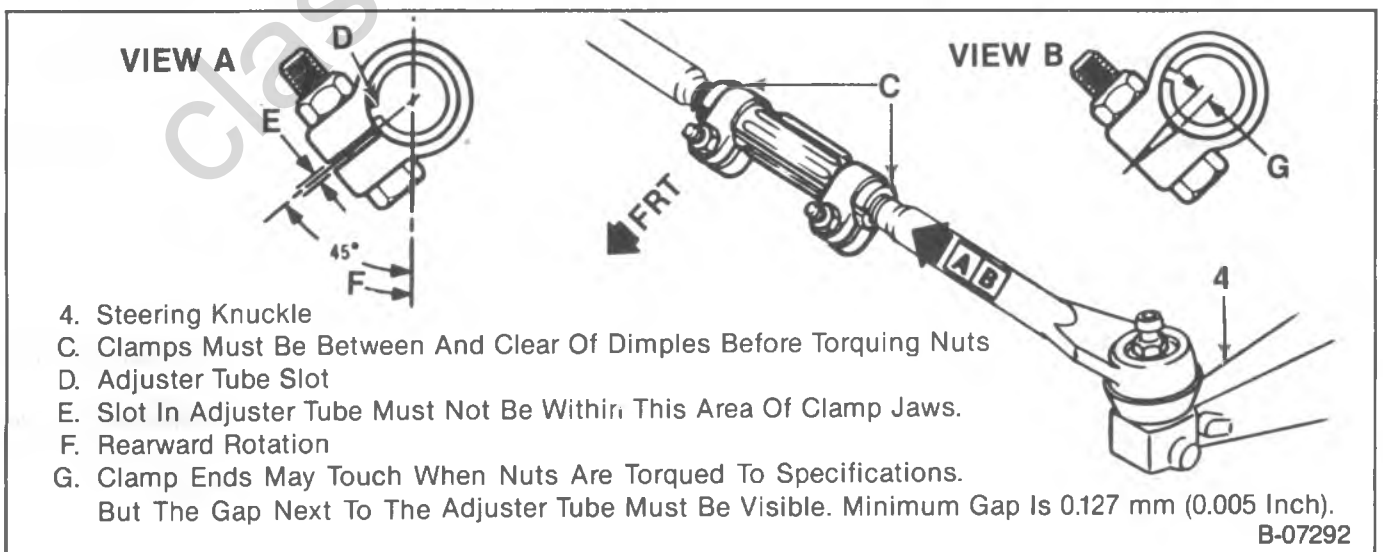

Figure 12—Tie Rod Clamp and Adjuster Tube Positioning — All Models, Excluding FS3

3B1-10 STEERING LINKAGE

1. Cotter pins and castellated nuts from the rod assembly (3).
2. Shock absorber (7) from the tie rod assembly (3).
3. The rod ball studs from the steering knuckle (4). Use J-6627-A.
4. Tie rod end bodies. Count the number of turns needed to remove the tie rod end bodies.
5. Tie rod ends from the adjuster tube. On V30 models, note the position of the adjuster tube, and the direction from which the bolts are installed.

Inspect

- Tie rod for bending or damaged threads.
- Tie rod end seals for wear.
- Ball stud threads for damage.
- Adjuster tube for bending or damaged threads (V30).

Clean

- The tapered surfaces.
- Threads on the ball stud and in the ball stud nut.

Install or Connect (Figures 7 and 8)

- If the tie rod ends were removed, lubricate the tie rod threads with chassis lubricant.
1. Tie rod end bodies to the tie rod (if removed). Screw the rod assembly on the same number of turns as when removed.
 - Tie rod ends to the adjuster tube (V30).
 2. Outer tie rod ball studs to the steering knuckle (4).
 3. Shock absorber (7) to the tie rod assembly.

NOTICE: See "Notice" on page 3B1-1 of this section.

4. Castellated nuts and cotter pins to the tie rod assembly.

Tighten

- Castellated nuts to "Specifications" as instructed at the end of this section.

Adjust

- Toe-in. Refer to FRONT END ALIGNMENT (SEC. 3A) in this manual.

Tighten

- Jam nut at the tie rod end bodies to "Specifications" at the end of this section.
- Adjuster tube clamp bolts to "Specifications" at the end of this section (V30).

CONNECTING ROD REPLACEMENT (V AND P30(00)FS3 MODEL)

The adjustable connecting rod is used for centering the steering gear with the front axle. Replace the connecting rod if the rod is bent or if the ball stud is loose.

Important

- Use the proper tool to separate all ball joints.

Remove or Disconnect (Figures 7 and 8)

Tool Required:

J-24319-01 Steering Linkage Puller.

- Raise the vehicle.
1. Castellated nuts and cotter pins from the connecting rod (8).
 2. Connecting rod (8) from the pitman arm (5). Use J-24319-01.
 3. Connecting rod (8) from the steering knuckle (4). Use J-24319-01.

Important

- Before removing the connecting rod adjuster tube, note the position of the tube and the direction from which the bolts are installed.
4. Connecting rod ends from the adjuster tube. Loosen the clamp bolts and unscrew the end assemblies.
 - The connecting rod adjuster tube components may be rusted. If the torque required to remove the nut from the bolt exceeds 9 N·m (7 ft. lbs.) discard the nuts and bolts.
 - Apply penetrating oil between the clamps and the tube. Rotate the clamps until they move freely.

Inspect

- Ball stud threads for damage.
- Ball stud seals for wear.
- Adjuster tube for bending or damaged threads.

Clean

- Threads on the ball stud and ball stud nut.

Install or Connect (Figures 7, 8, 13, and 14)

NOTICE: For steps 3 and 5 see "Notice" on page 3B1-1 of this section.

- If the connecting rod ends were removed, lubricate the connecting rod threads with chassis lubrication.
1. Connecting rod ends to the adjuster tube. The number of threads on both the inner and outer connecting rod ends must be equal within three threads.
 2. Inner connecting rod (8) ball stud to the pitman arm (5) (on V models install the short end). Make certain the seal is on the stud.
 3. Castellated nut and cotter pin to the inner connecting rod ball stud.

Tighten

- Castellated nut to "Specifications" as instructed at the end of this section.
4. Outer connecting rod ball stud to the steering knuckle (4).
 5. Castellated nut and cotter pin to the outer connecting rod ball stud.

Tighten

- Castellated nut to "Specifications" as instructed at the end of this section.

- The connecting rod ends to the pitman arm and steering knuckle must be in correct relationship to each other after adjustment within ± 2 degrees (V model).



Adjust

- Steering gear high point centering. Refer to POWER STEERING (SEC. 3B3) in this manual.
6. Adjuster tube clamp bolts (figures 13 and 14). Before tightening the clamp bolts, be sure the following conditions have been met.
- The clamps must be positioned between the locating dimples at either end of the adjuster tube.
 - The clamps must be positioned within the angular travel shown in figures 13 and 14.
 - The clamp ends may touch when nuts are torqued to specification, but the gap adjacent to adjuster tube must NOT be less than minimum dimension shown in figures 13 and 14.
 - Both inner and outer connecting rod ends must rotate for their full travel. The position of each connecting rod end must be maintained as the clamps are tightened to ensure free movement of each joint.



Tighten

- Adjuster tube bolts to "Specifications" at the end of this section.
- Lower the vehicle.

CONNECTING ROD REPLACEMENT (P30(32) MOTORHOME)

The non-adjustable connecting rod is used to connect the pitman arm to the relay arm. Replace the connecting rod if the rod is bent or the ball stud is loose.



Important

- Use the proper tool to separate the ball joints.



Remove or Disconnect (Figure 3)

Tool Required:

J-24319-01 Steering Linkage Puller.

- Raise the vehicle.
1. Castellated nuts and cotter pins from the connecting rod (8).
 2. Connecting rod (8) from the pitman arm (5). Use J-24319-01.
 3. Connecting rod (8) from the relay arm (11). Use J-24319-01.



Inspect

- Ball stud threads for damage.
- Ball stud seals for excessive wear.



Clean

- Threads on the ball stud and ball stud nut.

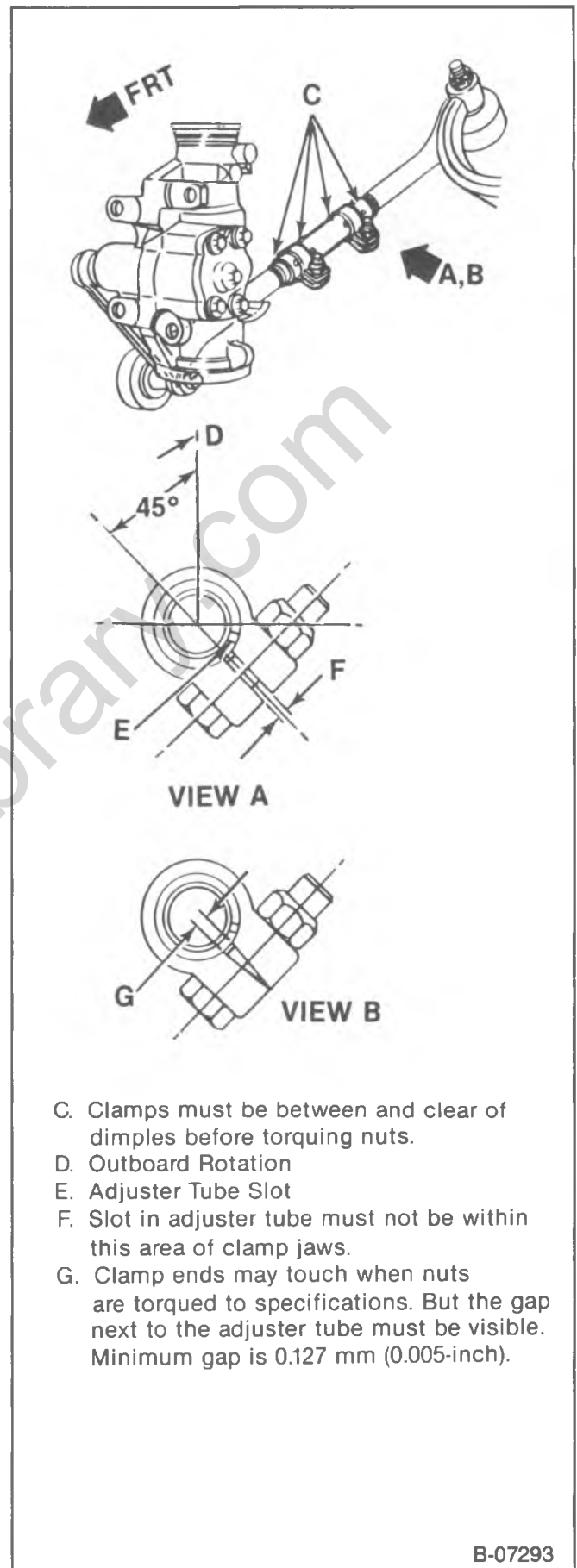

- C. Clamps must be between and clear of dimples before torquing nuts.
- D. Outboard Rotation
- E. Adjuster Tube Slot
- F. Slot in adjuster tube must not be within this area of clamp jaws.
- G. Clamp ends may touch when nuts are torqued to specifications. But the gap next to the adjuster tube must be visible. Minimum gap is 0.127 mm (0.005-inch).

B-07293

Figure 13—Connecting Rod Clamp and Adjuster Tube Positioning—P30(00)FS3

3B1-12 STEERING LINKAGE

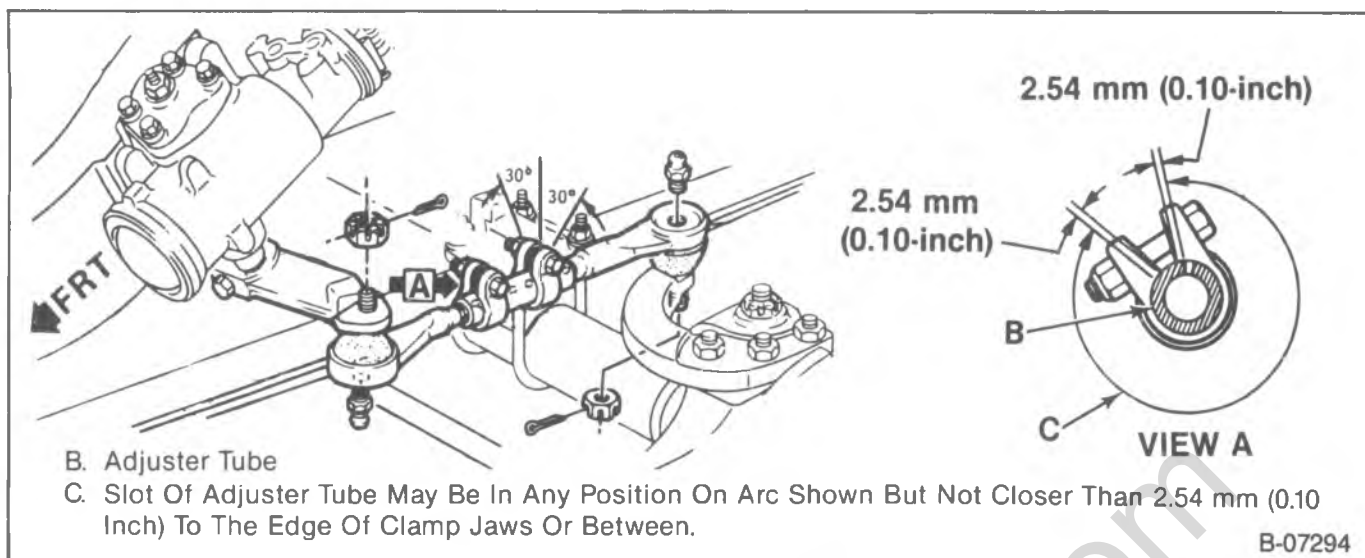

Figure 14—Connecting Rod Clamp and Adjuster Tube Positioning — V Model

Install or Connect (Figure 3)

1. Connecting rod (8) to the pitman arm (5) and relay arm (11).
2. Castellated nuts and cotter pins.

Tighten

- Castellated nuts to "Specifications" as instructed at the end of this section.
- Lower the vehicle.

SPECIFICATIONS

	R Model		G Model		P20 AND 30(42)		P30(32) Motorhome		P30(00)FS3		V Model	
	N-m	Ft. Lbs.	N-m	Ft. Lbs.	N-m	Ft. Lbs.	N-m	Ft. Lbs.	N-m	Ft. Lbs.	N-m	Ft. Lbs.
Tie Rod (3) End To Steering Knuckle (4)*	62	46	62	46	62	46	62	46	220	162	55	40
Tie Rod (3) Adjuster Tube Bolts	19	14	19	14	19	14	19	14	—	—	55	40
Tie Rod (3) To Relay Rod (2)	90	66	90	66	90	66	90	66	—	—	—	—
Idler Arm (1) To Relay Rod (2)	90	66	90	66	90	66	90	66	—	—	—	—
Idler Arm (1) To Frame	40	30	47	35	40	30	—	—	—	—	—	—
Pitman Arm (5) To Relay Rod (2)	90	66	90	66	90	66	—	—	—	—	—	—
Pitman Arm (5) To Steering Gear (6)	250	184	250	184	250	184	170	125	170	125	125	92
Bolt To Shock Absorber Bracket (9)	—	—	89	66	—	—	—	—	—	—	—	—
Shock Absorber (7) To Tie Rod (3)*	—	—	62	46	—	—	—	—	62	46	62	46
Shock Absorber (7) To Frame	—	—	62	46	—	—	11	8	47	35	110	81
Shock Asborber (7) To Idler Arm (1)*	—	—	—	—	—	—	62	46	—	—	—	—
Connecting Rod (8) To Adjuster Tube Bolts	—	—	—	—	—	—	—	—	68	50	54	40
Connecting Rod (8) To Pitman Arm (5)*	—	—	—	—	—	—	95	70	95	70	120	89
Connecting Rod (8) To Steering Knuckle (4)*	—	—	—	—	—	—	—	—	95	70	120	89
Connecting Rod (8) To Relay Arm (11)*	—	—	—	—	—	—	95	70	—	—	—	—
Support Assemblies (10) To Frame	—	—	—	—	—	—	65	48	—	—	—	—
Idler Arm (1) And Relay Arm (11) To Support Assemblies (10)	—	—	—	—	—	—	170	125	—	—	—	—
Relay Rod (2) To Relay Arm (11)	—	—	—	—	—	—	90	66	—	—	—	—
Tie Rod Jam Nut (V10, 20) & P30(00)FS3	—	—	—	—	—	—	—	—	375	277	125	92

* Tightening Procedure (Castellated Nuts)

1. Tighten to the specified torque.
2. Advance the nut to align the nut slot with the cotter pin hole. Never back the nut off to align the cotter pin hole.
3. Insert a new cotter pin of the correct size.

SPECIAL TOOLS

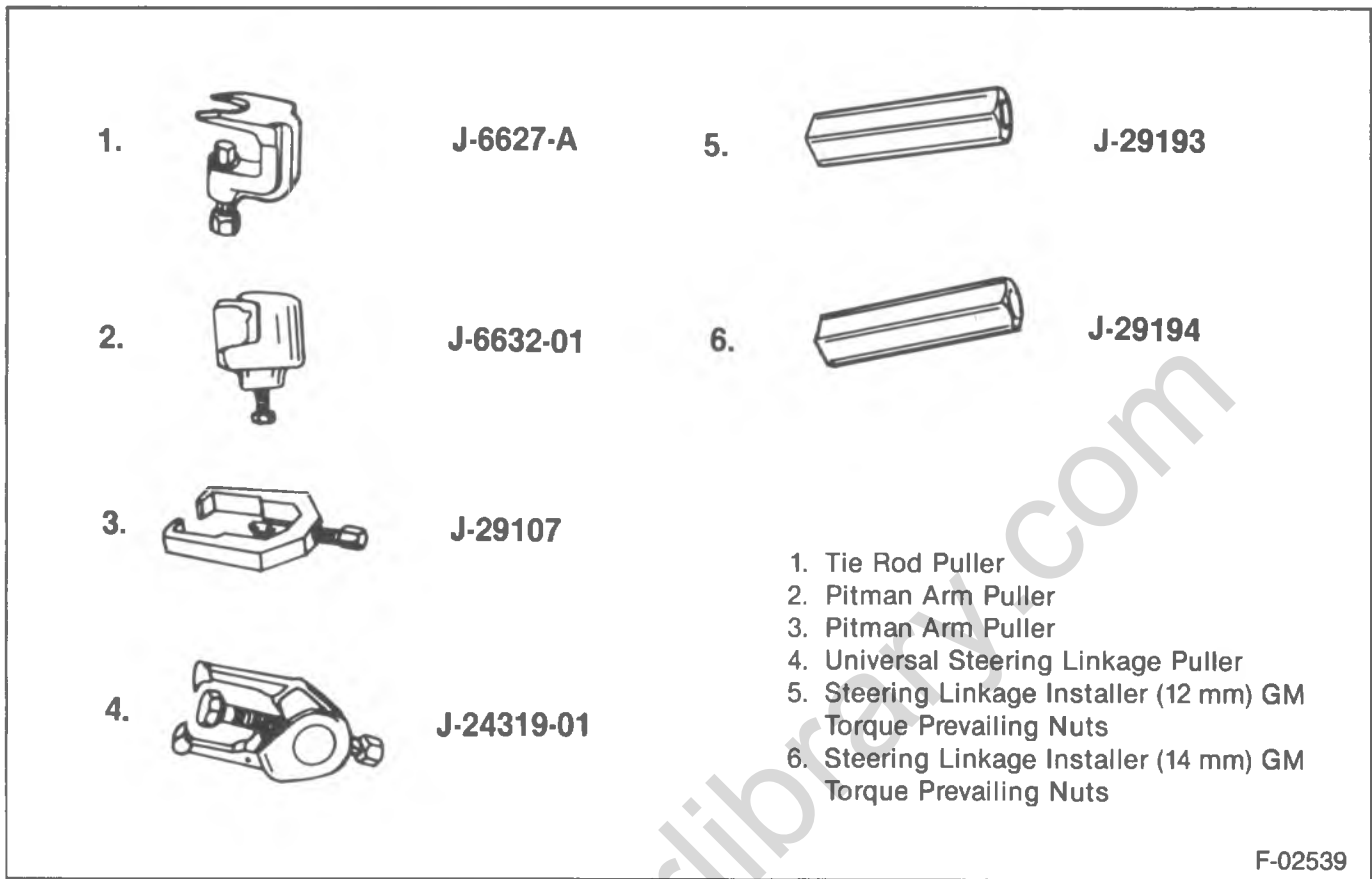

Figure 15—Special Tools

SECTION 3B2

MANUAL STEERING GEAR

The following notice applies to one or more steps in the assembly procedure of components in this portion of the manual as indicated at appropriate locations by the terminology "NOTICE: See 'Notice' on page 3B2-1 of this Section."

NOTICE: These fasteners are important attaching parts in that they could affect the performance of vital components and systems, and/or could result in major repair expense. They must be replaced with one of the same part number or with an equivalent part if replacement becomes necessary. Do not use a replacement part of lesser quality or substitute design. Torque values must be used as specified during reassembly to assure proper retention of these parts.

CONTENTS

<u>SUBJECT</u>	<u>PAGE</u>
Description	3B2- 1
Diagnosis Of Manual Steering System	3B2- 2
On-Vehicle Service	3B2- 3
Maintenance	3B2- 3
Steering Gear Replacement	3B2- 3
Pitman Shaft Seal Replacement	3B2- 5
Steering Gear Adjustments	3B2- 5
Steering Gear High Point Centering	3B2- 7
Specifications	3B2- 7
Special Tools	3B2- 8

DESCRIPTION

The steering gear is the recirculating ball nut and worm type. The worm is located on the lower end of the steering shaft. The ball nut is mounted on the worm and the steel balls act as a rolling thread between the worm and nut to provide a low friction drive between them.

Teeth on the ball nut engage teeth on the pitman shaft sector. The teeth on the ball nut are made so that a tighter fit exists between the ball nut and pitman shaft sector

teeth when the front wheels are in the straight ahead position. The sector teeth are slightly tapered so that a proper preload may be obtained by moving the pitman shaft endways by means of a preload adjuster screw which extends through the gear housing side cover. The head of the preload adjuster and a selectively fitted shim fit snugly into a T-slot in the end of the pitman shaft, so that the screw also controls the end play of the shaft (figure 1).

3B2-2 MANUAL STEERING GEAR

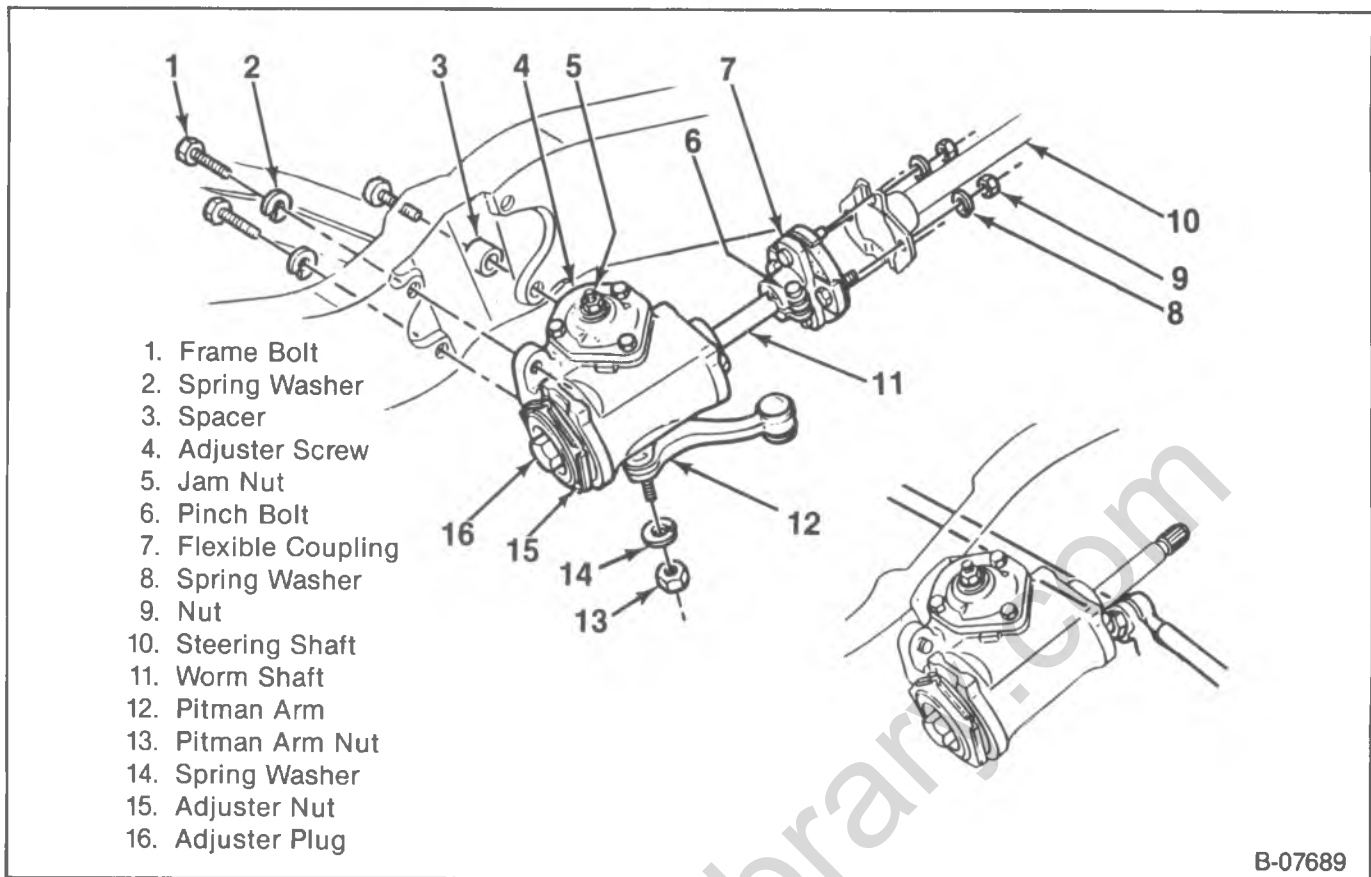

Figure 1—Steering Gear - R Models

DIAGNOSIS OF MANUAL STEERING SYSTEM

PROBLEM	POSSIBLE CAUSE	CORRECTION
Rattle Or Chuckle In The Steering Gear	<ol style="list-style-type: none"> 1. Insufficient or improper lubricant in the steering gear. 2. Pitman arm loose on the shaft or the steering gear mounting bolts loose. 3. Loose or worn steering shaft bearing. 4. Excessive over-center lash or worm thrust bearings adjusted too loose. On turns a slight rattle may occur, due to the increased lash between ball nut and pitman shaft as gear moves off the center of "high point" position. This is normal and lash must not be reduced to eliminate this slight rattle. 	<ol style="list-style-type: none"> 1. Add specified lube. 2. Tighten to specified torque. 3. Replace steering shaft bearing. 4. Adjust steering gear to specified preloads.
Poor Return Of The Steering Wheel	<ol style="list-style-type: none"> 1. Steering column misaligned. 2. Insufficient or improper lubricant in the steering gear or front suspension. 3. Steering gear adjusted too tight. 4. Front wheel alignment incorrect (Caster). 	<ol style="list-style-type: none"> 1. Align the column. 2. Lubricate as specified. 3. Adjust over-center and thrust bearing preload to specifications. 4. Adjust to specifications.
Excessive Play Or Looseness In The Steering System	<ol style="list-style-type: none"> 1. Front wheel bearings loosely adjusted. 2. Steering system out of alignment. 3. Worn upper ball joints. 	<ol style="list-style-type: none"> 1. Adjust bearings or replace with new parts as necessary. 2. Align caster, camber, and toe-in. 3. Check and replace ball joints if necessary.

DIAGNOSIS OF MANUAL STEERING SYSTEM (CONT.)

PROBLEM	POSSIBLE CAUSE	CORRECTION
Excessive Play Or Looseness In The Steering System (Cont.)	<ol style="list-style-type: none"> 4. Steering wheel loose on the shaft, loose pitman arm, tie rods, steering arms or steering linkage ball nuts. 5. Tires badly worn, edge of tires rounded off. 6. Excessive over-center lash. 7. Worm thrust bearings loosely adjusted. 	<ol style="list-style-type: none"> 4. Tighten to specification, replace if worn or damage. 5. Install new tires, and check alignment. 6. Adjust over-center preload to specifications. 7. Adjust the worm thrust bearing preload to specifications.
Hard Steering — Excessive Effort Required At The Steering Wheel	<ol style="list-style-type: none"> 1. Low or uneven tire pressure. 2. Insufficient or improper lubricant in the steering gear or front suspension. 3. Steering shaft flexible coupling misaligned. 4. Steering gear adjusted too tight. 5. Front wheel alignment incorrect. 	<ol style="list-style-type: none"> 1. Inflate to specified pressures. 2. Lubricate as specified. Relubricate at specified intervals. 3. Align the column and couplings. 4. Adjust over-center and thrust bearing preload to specifications. 5. Check the alignment and correct as necessary.

ON-VEHICLE SERVICE

MAINTENANCE

The steering gear is factory-filled with steering gear lubricant. Seasonal change of the lubricant should not be performed and the housing should not be drained. No additional lubrication is required for the life of the steering gear.

At intervals specified in MAINTENANCE AND LUBRICATION (SEC. 0B) of this manual, the gear should be inspected for seal leakage (actual solid grease — not just oily film). If a seal is replaced or the gear is overhauled, the gear housing should be refilled with Steering Gear Lubricant meeting GM specification 1051052 (or equivalent).

NOTICE: DO NOT USE EP Chassis Lube to lubricate the gear. DO NOT OVER-FILL the gear housing, or damage may occur.

STEERING GEAR REPLACEMENT

↔ Remove or Disconnect (Figure 1, 2 and 3)

Tools Required:

- J-6632-01 Pitman Arm Remover
- J-29107 Pitman Arm Puller

- Place the front wheels in a straight ahead position.
1. Flexible coupling to steering shaft nuts (9) (R-Models).

2. Lower universal joint pinch bolt (6) (G-Models). Mark the relationship of the clamp (20) to the wormshaft (11).
 - Mark the relationship of the pitman arm (12) to the pitman shaft (21).
3. Pitman shaft nut (13) and washer (14).
4. Pitman arm (12) from the pitman shaft (21). Use J-6632-01 or J-29107 (figure 3).
5. Frame bolts (1) and washers (2).
6. Pinch bolt (6) and coupling (7) from the wormshaft (11) (C-Models).
7. Gear assembly.

↔ Install or Connect (Figure 1 and 2)

NOTICE: See "Notice" on page 3B2-1 of this section for steps 3, 5 and 8.

C-Models

1. Flexible coupling (7) onto the steering gear wormshaft (11).
 - Align the flat in the coupling with the flat on the shaft.
 - Push the coupling onto the shaft until the wormshaft bottoms on the coupling reinforcement.
2. Pinch bolt (6) and torque to 41 N·m (30 ft. lbs.). The bolt must pass through the shaft undercut.
 - Place the steering gear in position, guiding the coupling bolt into the shaft flange.
3. Steering gear to frame bolts (1) and torque to 100 N·m (75 ft. lbs.).

3B2-4 MANUAL STEERING GEAR

- | | |
|-------------------|--------------------|
| 1. Frame Bolt | 13. Pitman Arm Nut |
| 2. Washer | 14. Spring Washer |
| 4. Adjuster Screw | 15. Adjuster Nut |
| 5. Jam Nut | 20. Lower Clamp |
| 6. Pinch Bolt | 21. Pitman Shaft |
| 11. Worm Shaft | |
| 12. Pitman Arm | |

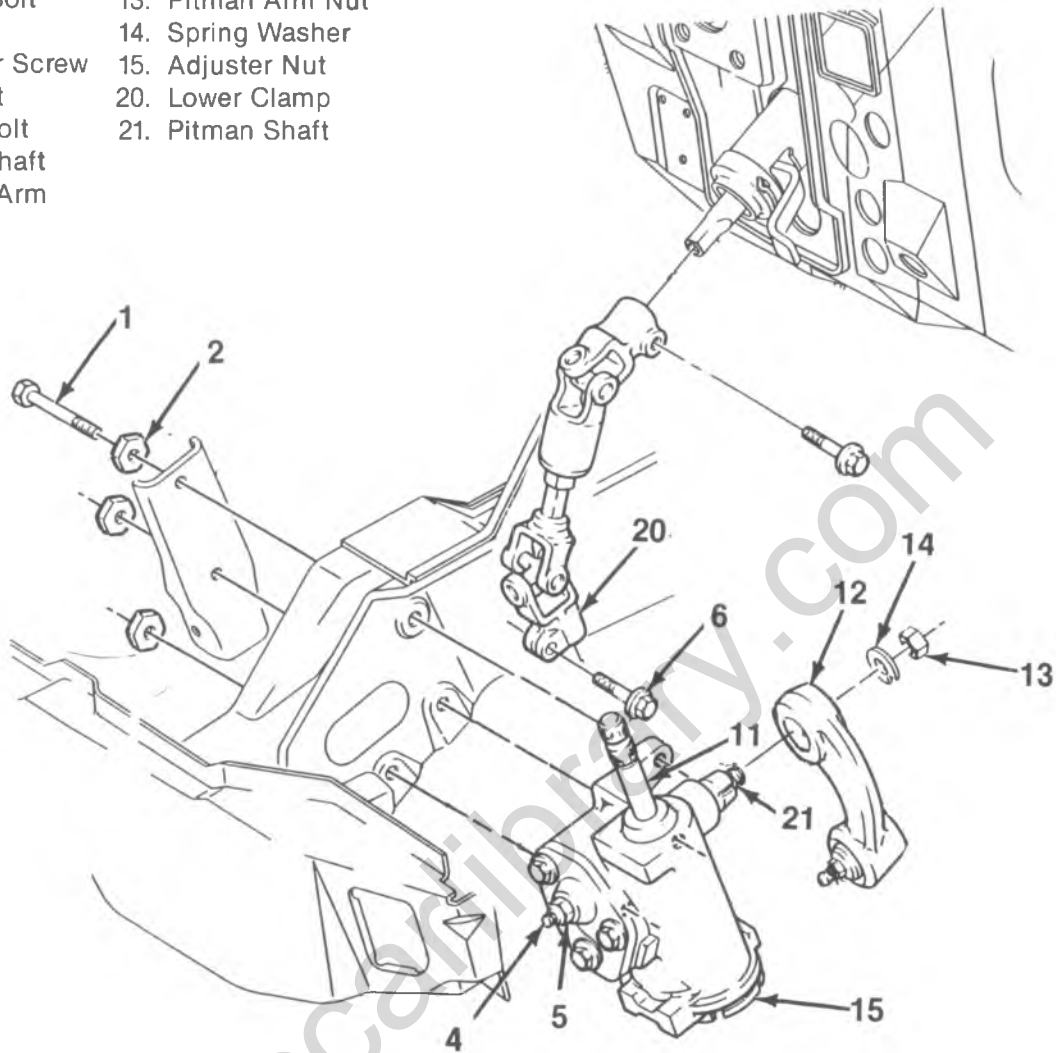

B-07688

Figure 2—Steering Gear - G Models

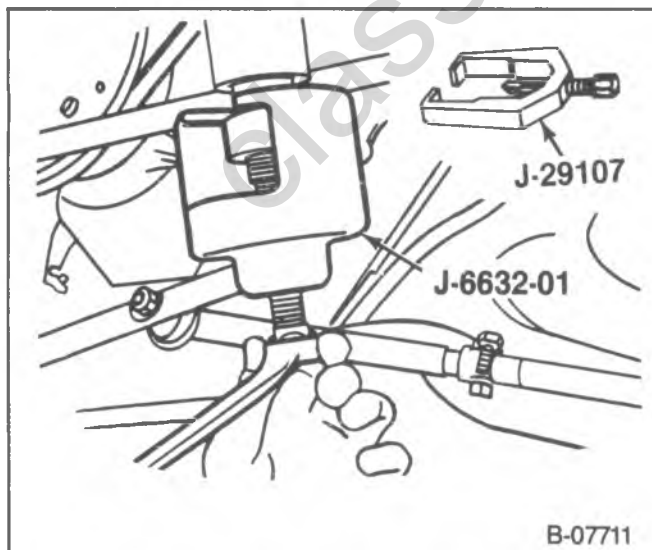

Figure 3—Removing the Pitman Arm

! Important

- If flexible coupling alignment pin plastic spacers were used, make sure they are bottomed on the pins.
- If flexible coupling alignment pin plastic spacers were not used, center the pins in the slots in the steering shaft flange.

4. Washer (8) and nut (9) onto the coupling bolts.

Tighten

- Nut to 24 N·m (18 ft. lbs.).

G-Models

- Place the steering gear in position, guiding the wormshaft into the universal joint assembly and lining up the marks made at removal. If a new gear was installed, line up the mark on the wormshaft with the slit in the universal joint yoke.

5. Steering gear to frame bolts (1).

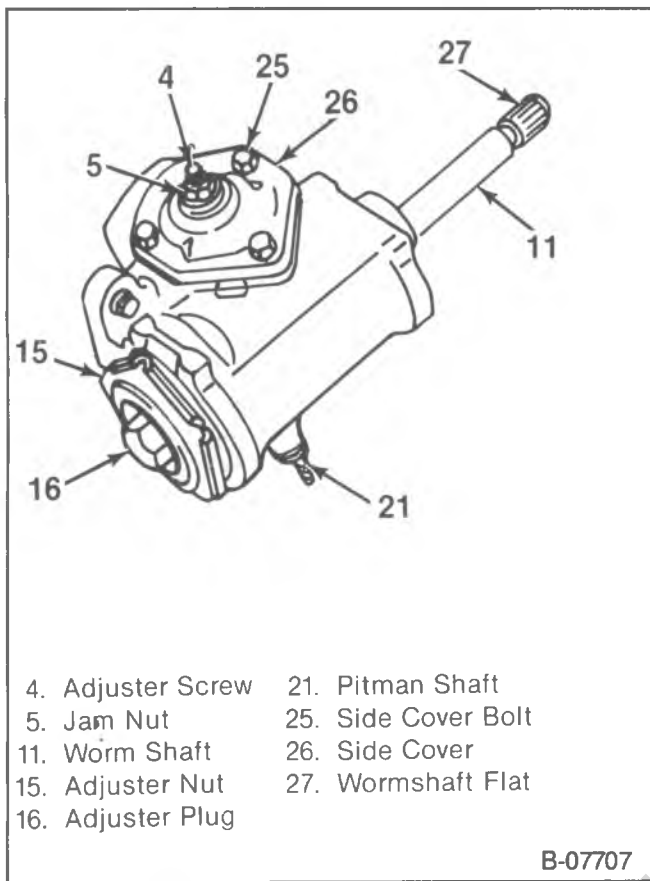

- | | |
|-------------------|---------------------|
| 4. Adjuster Screw | 21. Pitman Shaft |
| 5. Jam Nut | 25. Side Cover Bolt |
| 11. Worm Shaft | 26. Side Cover |
| 15. Adjuster Nut | 27. Wormshaft Flat |
| 16. Adjuster Plug | |

B-07707

Figure 4—Steering Gear Assembly

Tighten

- Bolts to 100 N·m (75 ft. lbs.).
6. Universal joint pinch bolt. The pinch bolt must pass through the shaft undercut. Torque to 60 N·m (44 ft. lbs.).

ALL MODELS

7. Pitman arm (12) onto the pitman shaft. Line up the marks made at removal.
8. Washer (14) and nut (13).

Tighten

- Nut to 250 N·m (185 ft. lbs.)

PITMAN SHAFT SEAL REPLACEMENT

The pitman shaft seal may be replaced without removing the steering gear. Remove the pitman arm as outlined under "Steering Gear Replacement" or refer to STEERING LINKAGE (SEC. 3B1).

Remove or Disconnect (Figure 4)

- Rotate the steering wheel from stop to stop, counting the total number of turns. Then turn back exactly halfway, placing the gear on center (the wormshaft flat (27) should be at the 12 o'clock position).
1. Side cover bolts (25).
 2. Pitman shaft (21) and side cover (26) assembly from the housing.

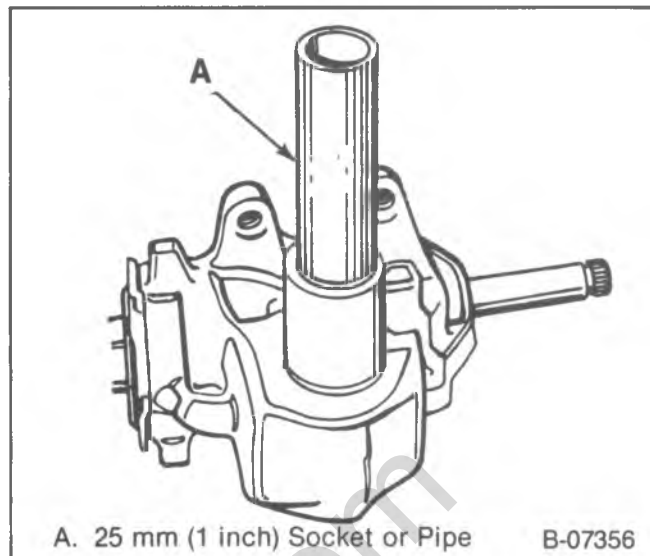

A. 25 mm (1 inch) Socket or Pipe B-07356

Figure 5—Pitman Shaft Seal Replacement

3. Pitman shaft seal from the gear housing using a screwdriver. Be careful not to damage the housing bore.
4. Jam nut (5).
5. Side cover (26) from the pitman shaft assembly. Turn the adjuster screw (4) clockwise.

Inspect

- Gear lubricant for contamination. If contaminated, the gear must be removed and overhauled.

Install or Connect (Figure 4 and 5)

- Lubricate the new pitman shaft seal with steering gear lubricant.
1. Pitman shaft seal. Position the seal in the pitman shaft bore and tap into position using a 25 mm (1 inch) pipe or socket (figure 5).
 - Place the pitman shaft (21) in the steering gear so that the center tooth of the pitman shaft sector enters the center tooth space of the ball nut.
 - Fill the steering gear housing with Steering Gear Lubricant meeting GM Specification 1051052 (or equivalent).
 2. New gasket onto the gear housing.
 3. Side cover (26) onto the adjuster screw (4). Reach through the threaded hole in the side cover with a small screwdriver and turn the adjuster screw counterclockwise until it bottoms and turns back in 1/4 turn.
 4. Side cover bolts (25) and torque to specifications.
 5. Jam nut (5).

Adjust

- Steering gear as outlined under "Steering Gear Adjustments."
6. Pitman arm.

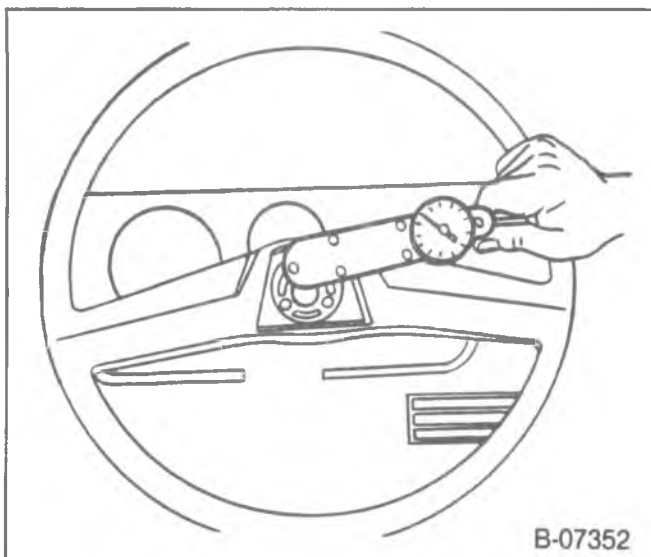

Figure 6—Steering Wheel Torque

STEERING GEAR ADJUSTMENTS

Before any adjustments are made to the steering gear, in an attempt to correct such conditions as shimmy, loose or hard steering etc., a careful inspection should be made of the front end alignment, shock absorbers, wheel balance and tire pressure for the possible steering system problem.

Correct adjustment of the steering gear is very important. Perform adjustments following the sequence listed below.

↔ Remove or Disconnect (Figures 1, 2, 3 and 4)

Tools Required:

J-6632-01 Pitman Arm Remover
J-29107 Pitman Arm Puller

1. Battery ground cable.
 - Raise the vehicle.
2. Pitman arm nut (13) and washer (14).
 - Mark the relationship of the pitman arm to the pitman shaft.
3. Pitman arm using J-6632-01 or J-5504-D (figure 2).
 - Loosen the adjuster nut (15) and then back the adjuster plug (16) off 1/4 turn.
4. Horn cap or cover.
 - Turn the steering wheel gently in one direction until stopped by the gear; then turn back one-half turn.

NOTICE: Do not turn the steering wheel hard against the stops when the steering linkage is disconnected from the gear as damage to the ball guides could result.

📏 Measure (Figure 6)

- “Bearing drag” by applying a torque wrench with the socket on the steering wheel nut and rotate through a 90 degree arc. Do not use a torque wrench having a maximum torque reading of more than 6 N·m (50 in. lbs.).

🔑 Adjust (Figure 4)

- Thrust bearing preload as follows:
 1. Tighten the adjuster plug (16) until the proper “loading preload” is 0.6-1 N·m (5-8 in. lbs.).

NOTICE: See “Notice” on page 3B2-1 of this section.

2. Tighten the adjuster nut (15) to 115 N·m (85 ft. lbs.).
 3. If the gear feels “lumpy” after adjustment, there is probably damage in the bearings due to severe impact or improper adjustment; the gear must be disassembled for replacement of damaged parts.
- Over-center preload as follows:
 1. Turn the steering wheel gently from one stop all the way to the other carefully counting the total number of turns. Turn the wheel back exactly half-way to the center position.
 2. Turn the over center adjuster screw (4) clockwise to take out all lash between the ball nut and pitman shaft sector teeth and then tighten the jam nut (5).

🔩 Tighten

- Jam nut (5) to 30 N·m (22 ft. lbs.).
3. Check the torque at the steering wheel, taking the highest reading as the wheel is turned through center position. Refer to “Specifications” for the proper over-center preload.
 4. If necessary, loosen jam nut (5) and adjust over center adjuster screw (4) to obtain proper torque. Tighten the jam nut (5) and recheck torque reading through center of travel.

! Important

- If maximum torque is exceeded, turn over center adjuster screw (4) counterclockwise, then come up on adjustment by turning the jam nut (5) in a clockwise motion.

↔ Remove or Disconnect (Figures 1 and 2)

1. Pitman arm (12) onto the pitman shaft (21). Line up the marks made during disassembly.

NOTICE: See “Notice” on page 3B2-1 of this section.

2. Washer (14) and nut (13).

🔩 Tighten

- Nut to 250 N·m (185 ft. lbs.).
3. Horn cap or cover.
 - Lower the vehicle to the floor.
 4. Battery ground cable.

STEERING GEAR HIGH POINT CENTERING

1. Set the front wheels in the straight ahead position. This can be checked by driving the vehicle a short distance on a **flat** surface.
2. With the front wheels set straight ahead, check the position of the mark on the wormshaft designating the steering gear high point. This mark should be at the top side of the shaft at 12 o'clock position and lined up with the mark in the coupling lower clamp.

3. If the gear has been moved off high point when setting wheel in straight ahead position, loosen adjusting sleeve clamp on both left and right hand tie rods. Then turn both sleeves an equal number of turns in the same direction to bring gear back on high point.

! Important

- Turning the sleeves an unequal number of turns or in different directions will disturb the toe-in setting of the wheels.
4. Adjust toe-in as outlined in FRONT END ALIGNMENT (SEC. 3A) (if necessary).
 5. Orient sleeves and clamps when fastening and torquing clamps to specifications. Refer to STEERING LINKAGE (SEC. 3B1).

SPECIFICATIONS

MANUAL STEERING GEAR

Manufacturer.....Saginaw Steering Gear
 Ratio......24 to 1
 Type.....Recirculating Ball

PRELOAD ADJUSTMENTS

	N·m	In. Lbs.
Worm Thrust Bearing Preload	0.6-1.0	5-8
Over Center Sector Preload	0.5-1.2*	4-10*
Total Steering Gear Preload	1.8 Max.	16 Max.

*In excess of worm bearing preload.

TORQUE SPECIFICATIONS

	N·m	Ft. Lbs.
Steering Gear to Frame Nuts	100	75
Pitman Shaft Nut	250	185
Side Cover Bolts	45	33
Adjuster Screw Jam Nut	30	22
Adjuster Plug Nut	115	85

SPECIAL TOOLS

1

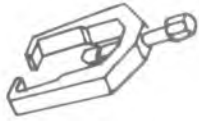

J-29107

2



J-6632-01

- 1. Pitman Arm Puller
- 2. Pitman Arm Puller

B-07710

classiccarylbrary.com

SECTION 3B3

POWER STEERING

The following "Notice" applies to one or more steps in the assembly procedure of components in this portion of the manual as indicated at appropriate locations by the terminology: "NOTICE: See 'Notice' on page 3B3-1 of the section."

NOTICE: All steering fasteners are important attaching parts in that they could affect the performance of vital parts and systems, and/or could result in major repair expense. They must be replaced with one of the same part number or with an equivalent part if replacement becomes necessary. Do not use a replacement part of lesser quality or substitute design. Torque values must be used as specific during reassembly to assure proper retention of all parts.

CONTENTS

<u>SUBJECT</u>	<u>PAGE</u>
Description3B3- 1
Integral Power Steering Gear3B3- 1
Hydraulic Pumps3B3- 1
Diagnosis Of Power Steering System3B3- 5
Oil Leak Check3B3- 8
Power Steering System Test3B3- 8
Power Steering System On-Vehicle Service3B3-11
Maintenance3B3-11
Pump Belt Tension Adjustment3B3-11
Fluid Level Adjustment3B3-12
Bleeding The Power Steering System3B3-12
Flushing The Power Steering System3B3-12
Steering Gear High Point Centering3B3-13
Power Steering Gear Replacement3B3-13
Pitman Shaft Seal Replacement3B3-14
Steering Gear Adjustments3B3-17
Power Steering Pump Replacement3B3-19
Power Steering Hoses3B3-19
Specifications3B3-34
Special Tools3B3-36

DESCRIPTION

The hydraulic power steering system consists of a pump, an oil reservoir, a steering gear, a pressure hose, and a return hose (figure 1).

INTEGRAL POWER STEERING GEAR

The power steering gear (figure 2) has a recirculating ball system which acts as a rolling thread between the worm shaft and the rack piston. The worm shaft is supported by a thrust bearing preload and two conical thrust races at the lower end, and a bearing assembly in the adjuster plug at the upper end. When the worm shaft is turned right, the rack piston moves up in gear. Turning the worm shaft left moves the rack piston down in gear. The rack piston teeth mesh with the sector, which is part of the pitman shaft. Turning the worm shaft turns the pitman shaft, which turns the wheels through the steering linkage.

The control valve in the steering gear directs the power steering fluid to either side of the rack piston. The rack piston converts the hydraulic pressure into a mechanical force. If the steering system becomes damaged and loses hydraulic pressure, the vehicle can be controlled manually.

HYDRAULIC PUMPS

The hydraulic pump is a vane-type design. There are two types, submerged and nonsubmerged. Submerged pump (P models) have a housing and internal parts that are inside the reservoir and operate submerged in oil. The nonsubmerged pump (TC models with or without reservoir) function the same as the submerged pump except that the reservoir is separate from the housing and internal parts (figure 3).

There are two bore openings at the rear of the pump housing. The larger opening contains the cam ring, pressure plate, thrust plate, rotor and vane assembly, and

3B3-2 POWER STEERING

1. Pitman Shaft
2. Housing Ball Plug
3. Adjuster Plug
4. Stub Shaft
5. Torsion Bar
6. Adjuster Plug Nut
7. Return Line
8. Stud Bolt O-ring Seals
9. Reservoir
10. Reservoir Cap
11. Reservoir O-ring Seal
12. Pump Shaft Seal
13. Pump Housing
14. Pressure Port Seat
15. Pressure Hose
16. Pressure And Return Port Seat
17. Adjusting Screw Jam Nut
18. End Cover O-ring Seal
19. Side Cover Seal
20. Gear Housing

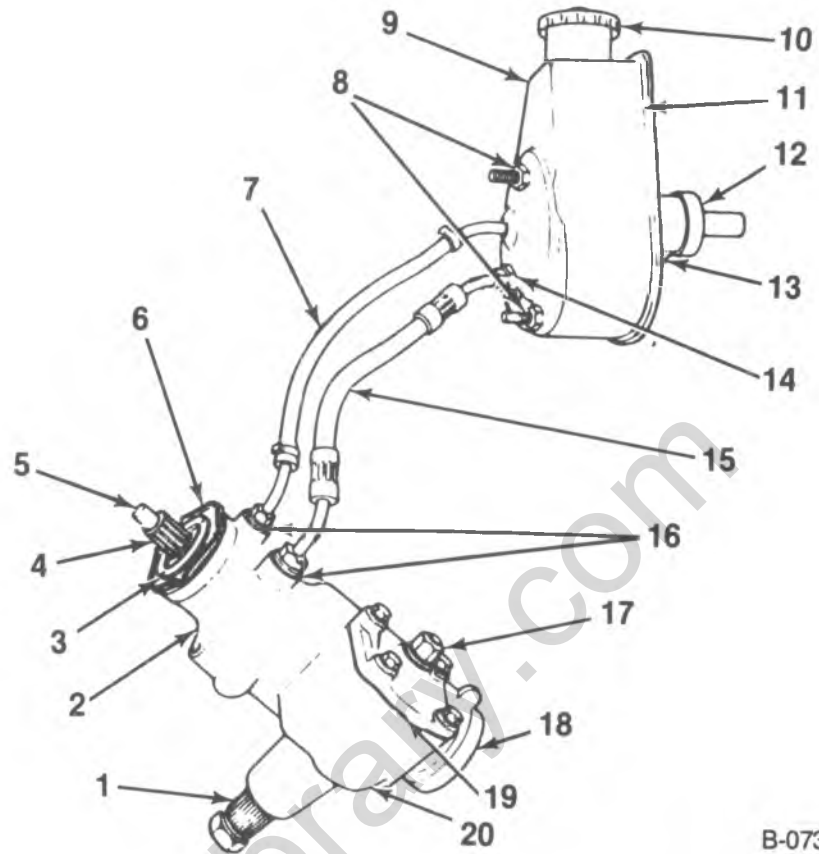

B-07320

Figure 1—Power Steering System — Typical

end plate. The smaller opening contains the pressure line union, flow control valve, and spring. The flow control orifice is part of the pressure line union. The pressure relief valve inside the flow control valve limits the pump pressure (figure 4).

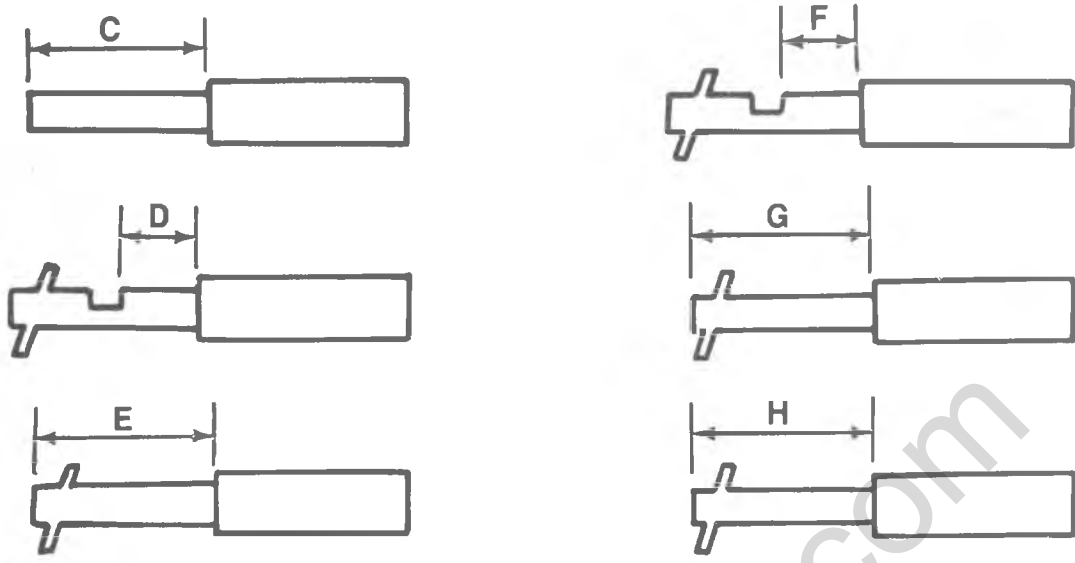

- C. 346.7 mm (13.64 inches) RV MODEL (Tilt Column)
- D. 72 mm (2.8 inches) RV MODEL (Standard Column-Column Shift)
- E. 353 mm (14 inches) RV MODEL (Standard Column-Floor Shift)
- F. 81.7 mm (3.21 inches) G MODEL (Tilt Column-Column Shift)
- G. 144.9 mm (5.70 inches) G MODEL (Tilt Column-4 Speed)
- H. 192 mm (7.5 inches) G MODEL (Standard Column-Column Shift)
- J. 80 mm (3.1 inches) G MODEL (Tilt Column-Floor Shift)

F-02585

Figure 2—Power Steering Gear

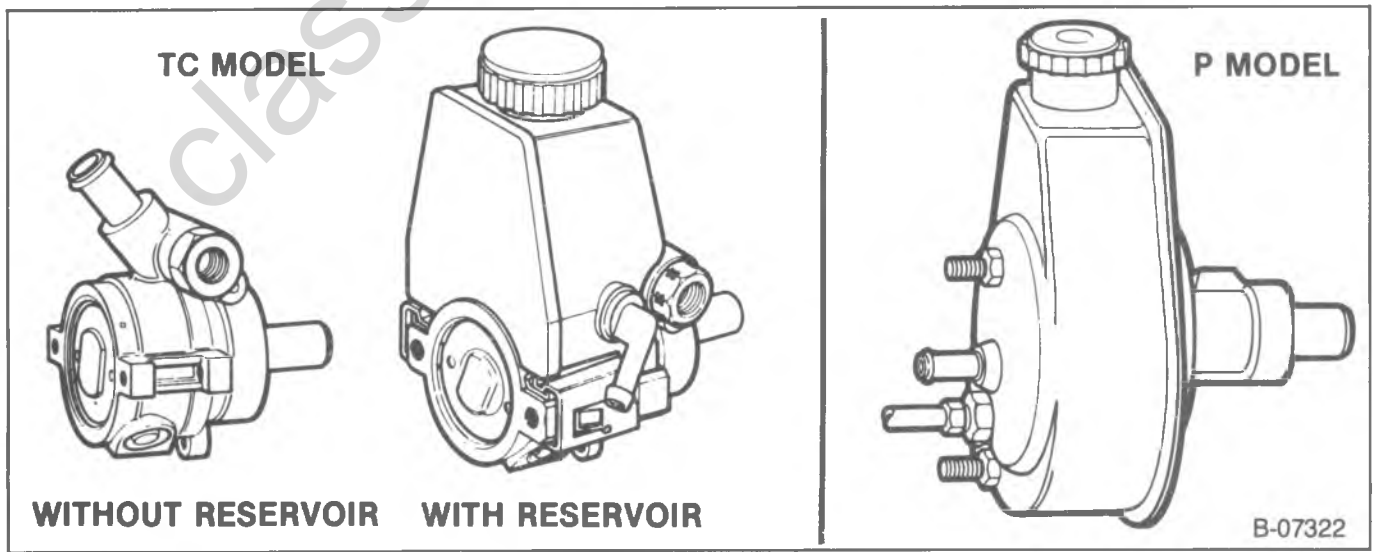

B-07322

Figure 3—TC and P Pump Models

3B3-4 POWER STEERING

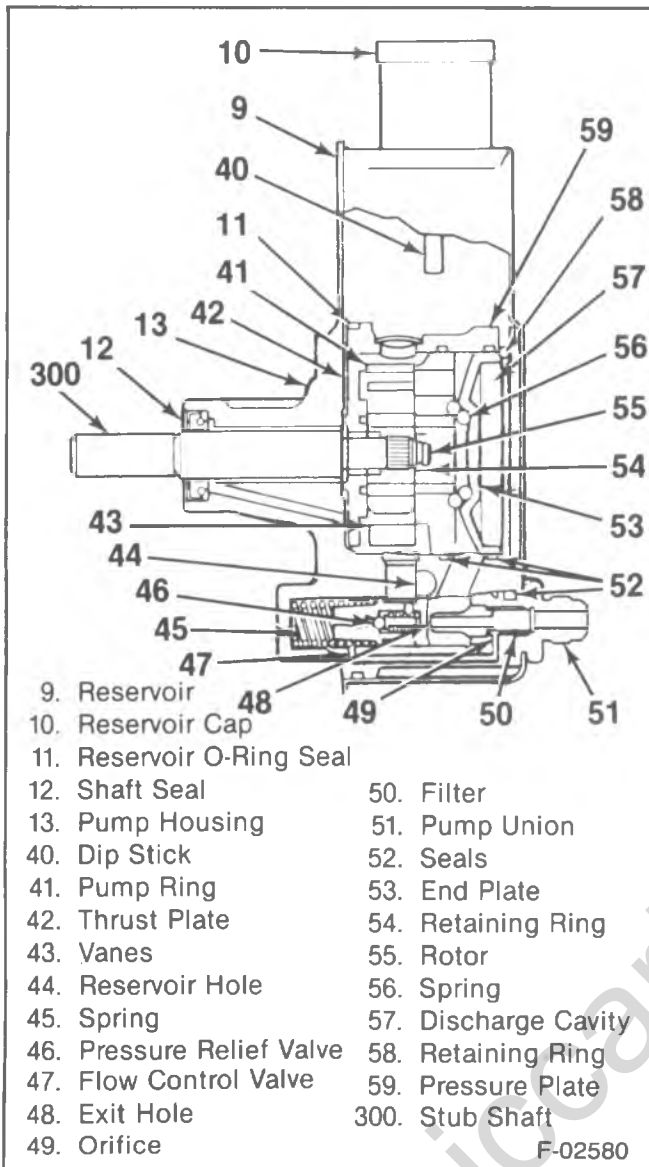

Figure 4—Power Steering Pump

DIAGNOSIS OF POWER STEERING SYSTEM

PROBLEM	POSSIBLE CAUSE	CORRECTION
Objectionable "Hiss"	<ol style="list-style-type: none"> 1. Noisy relief valve in the hydraulic pump. 2. Any metal-to-metal contacts through flexible coupling. 	<ol style="list-style-type: none"> 1. There is some noise in all power steering systems. One of the most common is a hissing sound most evident at standstill parking. Hiss is a high frequency noise. The noise is present in every valve and results from high velocity fluid passing valve orifice edges. There is no relationship between this noise and performance of the steering. "Hiss" may be expected when steering wheel is at end of travel or when slowly turning at standstill. Do not replace valve unless "hiss" is extremely objectionable. A replacement valve will also exhibit slight noise and is not always a cure for the objection. 2. Align the steering shaft and gear so the flexible coupling rotates in a flat plane and is not distorted as the shaft rotates.
Rattle Or Chuckle Noise In Steering Gear	<ol style="list-style-type: none"> 1. Gear loose on the frame. 2. Steering linkage looseness. 3. Pressure hose touching other parts of vehicle. 4. Loose pitman arm. 5. Improper over-center adjustment. A slight rattle may occur on turns because of increase clearance off the "high point." This is normal and clearance must not be reduced below specified limits to eliminate this slight rattle. 	<ol style="list-style-type: none"> 1. Check the gear mounting bolts. Torque the bolts to specifications. 2. Check linkage pivot points for wear. Replace if necessary. 3. Adjust the hose position. Do not bend tubing by hand. 4. Torque the pitman arm bolt. 5. Adjust to specifications.
Excessive Wheel Kick-Back Or Loose Steering	<ol style="list-style-type: none"> 1. Air in the system. 2. Steering gear mounting loose. 3. Steering linkage joints worn. 4. Front wheel bearings incorrectly adjusted or worn. 5. Steering gear improperly adjusted. 6. Worn or missing poppet valve (steering gear). 7. Steering gear flexible coupling too loose on the shaft or the rubber disc mounting screws loose. 8. Damaged or worn steering gear. 	<ol style="list-style-type: none"> 1. Add oil to the pump reservoir and bleed. Check hose connectors for proper torque. 2. Tighten attaching bolts to specified torque. 3. Replace loose parts. 4. Adjust the bearings or replace with new parts as necessary. 5. Adjust to specifications. 6. Replace the poppet valve. 7. Tighten to specifications. 8. Disassemble and repair the steering gear as outlined in the unit repair manual.

DIAGNOSIS OF POWER STEERING SYSTEM (CONT.)

PROBLEM	POSSIBLE CAUSE	CORRECTION
<p>Vehicle Leads To One Side Or The Other (Keep In Mind The Road And Wind Conditions). Test The Vehicle, Going In Both Directions, On A Flat Road.</p>	<ol style="list-style-type: none"> 1. Front end misaligned. 2. Unbalanced steering gear valve. If this is cause, steering effort will be very light in direction of lead and heavy in opposite direction. 3. Steering shaft rubbing the ID of the shaft tube. 4. Steering linkage not level. 	<ol style="list-style-type: none"> 1. Adjust to specifications. 2. Replace the gear valve. 3. Align the column. 4. Adjust as required.
<p>Momentary Increase In Effort When Turning The Wheel Quickly To The Right Or Left</p>	<ol style="list-style-type: none"> 1. Low oil level in the pump. 2. Pump belt slipping (if used). 3. High internal linkage (steering gear or pump). 	<ol style="list-style-type: none"> 1. Add power steering fluid as required. 2. Tighten or replace belt. 3. Refer to "Power Steering System Test" in this section.
<p>Poor Return Of Steering</p>	<ol style="list-style-type: none"> 1. Tires under-inflated. 2. Lower coupling flange rubbing against the steering gear adjuster plug. 3. Steering wheel rubbing against directional signal housing. 4. Tight or frozen steering shaft bearings. 5. Steering linkage or ball joints binding. 6. Steering gear to column misalignment. 7. Tie rod pivots not centralized. 8. Lack of lubricant in the suspension ball joints and the steering linkage. 9. Sticky or plugged valve spool. 10. Rubber spacer binding in the shift tube. 11. Improper front end alignment. 12. Tight steering shaft bearings. 13. Steering gear adjusted too tightly. 14. Kink in return hose. 	<ol style="list-style-type: none"> 1. Inflate to specified pressure. 2. Loosen the pinch bolt and assemble properly. 3. Adjust the steering jacket. 4. Replace the bearings. 5. Replace the affected parts. 6. Align the steering column. 7. Adjust tie rod ends as required to center pivots. 8. Lubricate. Refer to MAINTENANCE AND LUBRICATION (SEC. 0B). 9. Remove and clean or replace the valve. 10. Make certain the spacer is properly seated. Lubricate inside the diameter with silicone lubricant. 11. Check and adjust to specifications. 12. Replace the bearings. 13. Adjust over-center and thrust bearing preload to specifications. 14. Replace the hose.
<p>Steering Wheel Surges Or Jerks When Turning With Engine Running Especially During Parking</p>	<ol style="list-style-type: none"> 1. Low oil level in pump. 2. Loose pump belt. 3. Sticky flow control valve. 4. Insufficient pump pressure. 5. Faulty gear relief valve. 	<ol style="list-style-type: none"> 1. Add power steering fluid as required. 2. Adjust tension to specification. 3. Replace or clean the control valve. 4. Refer to "Power Steering System Test" in this section. 5. Replace the gear relief valve.
<p>Hard Steering Effort In Both Directions</p>	<ol style="list-style-type: none"> 1. Low tire pressure. 2. Lack of lubricant in suspension or ball joints. 3. Steering gear to column misalignment. 4. Loose pump belt. 	<ol style="list-style-type: none"> 1. Adjust the tire pressure. 2. Lubricate and relubricate at proper intervals. Refer to MAINTENANCE AND LUBRICATION (SEC. 0B). 3. Align the steering column. 4. Adjust belt tension to specifications.

DIAGNOSIS OF POWER STEERING SYSTEM (CONT.)

PROBLEM	POSSIBLE CAUSE	CORRECTION
Hard Steering Effort In Both Directions (Continued)	5. Low fluid level in reservoir. 6. High internal leakage (steering gear or pump). 7. Sticky flow control valve. 8. Lower coupling flange rubbing against steering gear adjuster plug. 9. Steering gear adjusted too tight. 10. Improper front end alignment.	5. Fill to proper level. Inspect lines and joints for external leakage. 6. Refer to "Power Steering System Test" in this section. 7. Replace or clean the valve. 8. Loosen the pinch bolt and assemble properly. 9. Adjust over-center and thrust bearing preload to specifications. 10. Check and adjust to specifications.
Foaming Milky Power Steering Fluid, Low Level And Possible Low Pressure	Air in the fluid, and loss of fluid due to internal pump leakage causing overflow.	Check for leak and correct. Bleed system. Extremely cold temperatures will cause system aeration should the oil level be low. If oil level is correct and pump still foams, remove pump from vehicle and separate reservoir from housing. Check welsh plug and housing for cracks. If plug is loose or housing is cracked, replace housing.
Low Oil Pressure Due To Restriction In The Hose	1. Check for kinks in the hose. 2. Foreign object stuck in the hose.	1. Remove the kinks or replace the hose. 2. Remove the foreign object or replace the hose.
Low Oil Pressure Due To Steering Gear. Refer To "Power Steering System Test" In This Section.	1. Pressure loss in cylinder due to worn piston ring or scored housing bore. 2. Leakage at the valve rings and valve body to the worm seal. 3. Leakage at the valve body or a loose fitting spool. 4. Damaged poppet valve.	1. Disassemble the steering gear as outlined in the unit repair manual. Inspect the ring and housing bore. Replace the affected parts. 2. Disassemble steering gear and replace seals. 3. Replace the valve. 4. Replace the poppet valve.
Low Oil Pressure Due To Steering Pump. Refer To "Power Steering System Test" In This Section.	1. Flow control valve stuck or inoperative. 2. Pressure plate not flat against the cam ring. 3. Extreme wear of cam ring. 4. Scored pressure plate, thrust plate or rotor. 5. Vanes sticking in rotor slots. 6. Vanes not installed properly. 7. Air in oil. 8. Low oil level. 9. Loose belt. 10. Damaged hoses or steering gear.	1. Replace or clean the valve. 2. Replace the pressure plate. 3. Replace and flush the system. 4. Replace parts. (If rotor, replace with rotating group), flush the system. 5. Free-up by removing burrs, varnish or dirt. 6. Install properly. Radius edge to the outside. 7. Locate source of leak and correct. Bleed the system. 8. Add power steering fluid as required. 9. Adjust tension to specifications. 10. Replace as necessary.

DIAGNOSIS OF POWER STEERING SYSTEM (CONT.)

PROBLEM	POSSIBLE CAUSE	CORRECTION
Chirp Noise In Steering Pump	1. Loose belt.	1. Adjust belt tension.
Belt Squeal (Particularly Noticeable At Full Wheel Travel And Standstill Parking)	1. Loose belt.	1. Adjust belt tension.
Growl Noise In Steering Pump	1. Excessive back pressure in hoses or steering gear caused by restriction.	1. Locate restriction and correct. Replace part if necessary.
Growl Noise In Steering Pump (Particularly Noticeable At Standstill Parking)	1. Scored pressure plates, thrust plate or rotor. 2. Extreme wear of cam ring.	1. Replace parts and flush system. 2. Replace parts.
Groan Noise In Steering Pump	1. Low oil level. 2. Air in the oil. Poor pressure hose connection.	1. Add power steering fluid as required. 2. Torque the connector. Bleed the system.
Rattle Or Knock Noise In Steering Pump	1. Loose pump pulley nut. 2. Pump vanes sticking in rotor slots. 3. Pressure hose touching other parts of vehicle.	1. Torque nut. 2. Free up by removing burrs, varnish or dirt. 3. Adjust hose position.
Swish Noise In Steering Pump	1. Faulty flow control valve.	1. Replace part.
Whine Noise In Steering Pump	1. Pump shaft bearing scored.	1. Replace the housing and shaft. Flush the system.

OIL LEAK CHECK

1. With the vehicle's engine off, wipe the complete power steering system dry (gear, pump, hoses, and connections).
2. Check the oil level in the pump's reservoir and adjust as directed. Refer to "Fluid Level Adjustment" in this section.
3. Start the engine and turn the steering wheel from stop to stop several times. Do not hold the wheel against the stops as this may damage the pump.
4. Find the exact areas of leakage and use the recommended method of repair as shown in figure 5.

POWER STEERING SYSTEM TEST

The power steering system may be tested using either J-5176-D, Power Steering Gage, or with J-25323, Power Steering Analyzer. J-25323 will measure the flow rate in addition to the pressure (figure 6).

The power steering system test is a method used to identify and isolate hydraulic circuit difficulties. Prior to performing this test the following inspection, and corrections if necessary, must be made.

Inspect

- Pump reservoir for proper fluid level.
- Pump belt for proper tension.
- Tires for correct air pressure.
- Power steering system, replacing parts as necessary.

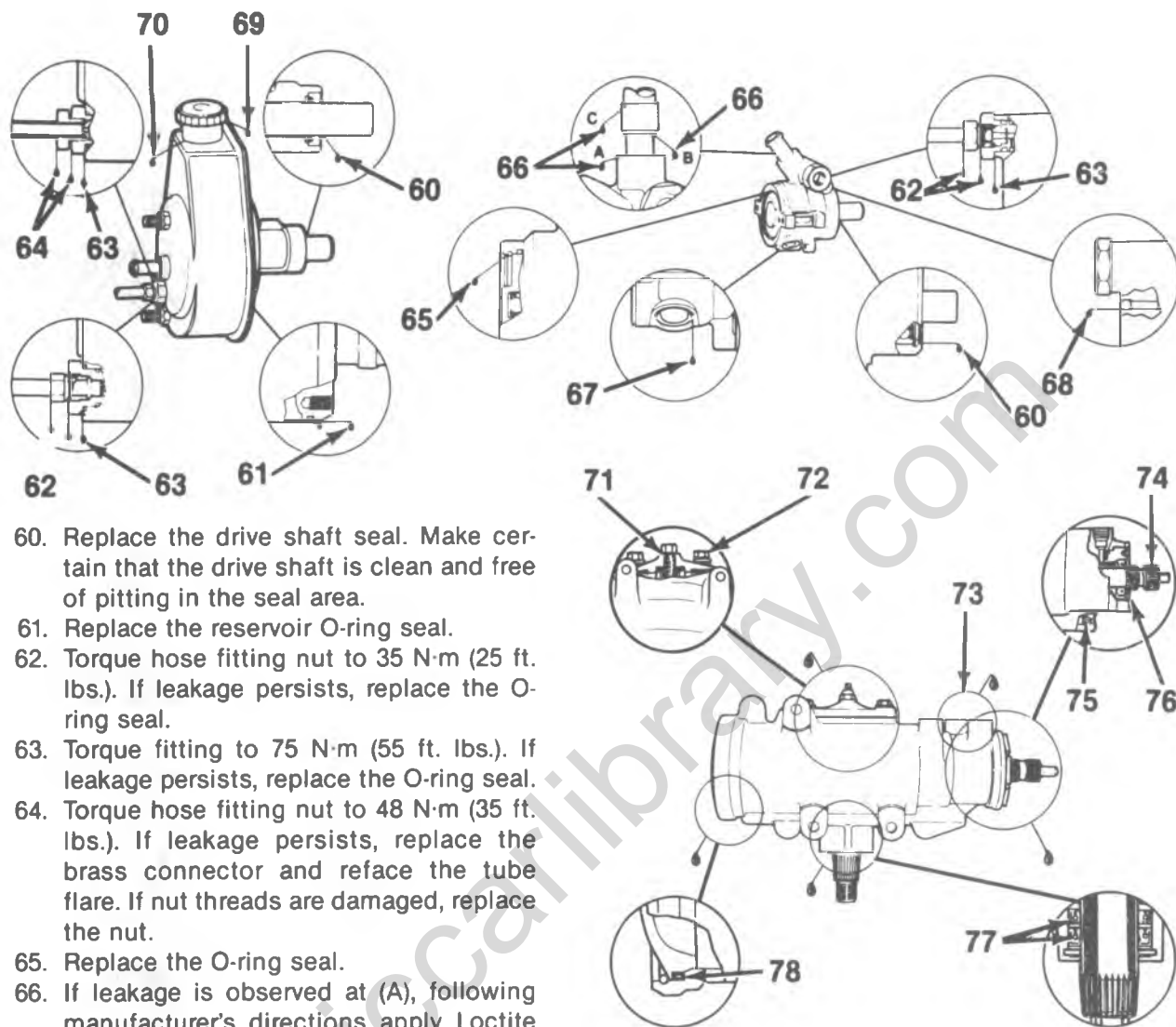

60. Replace the drive shaft seal. Make certain that the drive shaft is clean and free of pitting in the seal area.
61. Replace the reservoir O-ring seal.
62. Torque hose fitting nut to 35 N·m (25 ft. lbs.). If leakage persists, replace the O-ring seal.
63. Torque fitting to 75 N·m (55 ft. lbs.). If leakage persists, replace the O-ring seal.
64. Torque hose fitting nut to 48 N·m (35 ft. lbs.). If leakage persists, replace the brass connector and reface the tube flare. If nut threads are damaged, replace the nut.
65. Replace the O-ring seal.
66. If leakage is observed at (A), following manufacturer's directions apply Loctite 75559 solvent and Loctite 290 adhesive, or equivalent, to tube-housing connection. If leakage is coming from (B), replace the return tube. If coming from (C), replace the hose or clamp.
67. Seat the plug in the housing. Following manufacturer's directions apply Loctite 75559 solvent and Loctite 290 adhesive, or equivalent, to plug-housing area.
68. Seat the ball in the housing with a blunt punch. Following manufacturer's directions apply Loctite 75559 solvent and Loctite 290 adhesive, or equivalent, to area.
69. Check the oil level; if leakage persists with the level correct and cap tight, replace the cap.
70. If a cracked or bent reservoir is detected, replace the reservoir.

71. Torque jam nut to 48 N·m (35 ft. lbs.). Replace the nut if leakage persists.
72. Torque side cover bolts to 60 N·m (45 ft. lbs.). Replace the side cover seal if leakage persists.
73. Torque hose fitting nut to 27 N·m (20 ft. lbs.). If leakage persists, replace the O-ring seal.
74. Check for seepage between the torsion bar and stub shaft. Replace the rotary valve assembly.
75. Seat the ball in the housing with a blunt punch. Apply Loctite 75559 solvent and Loctite 290 adhesive, or equivalent, to the ball area.
76. Replace the adjuster plug seals.
77. Replace both pitman shaft seals.
78. Replace end plug O-ring seal.

B-07323

Figure 5—System Leak Diagnosis

3B3-10 POWER STEERING

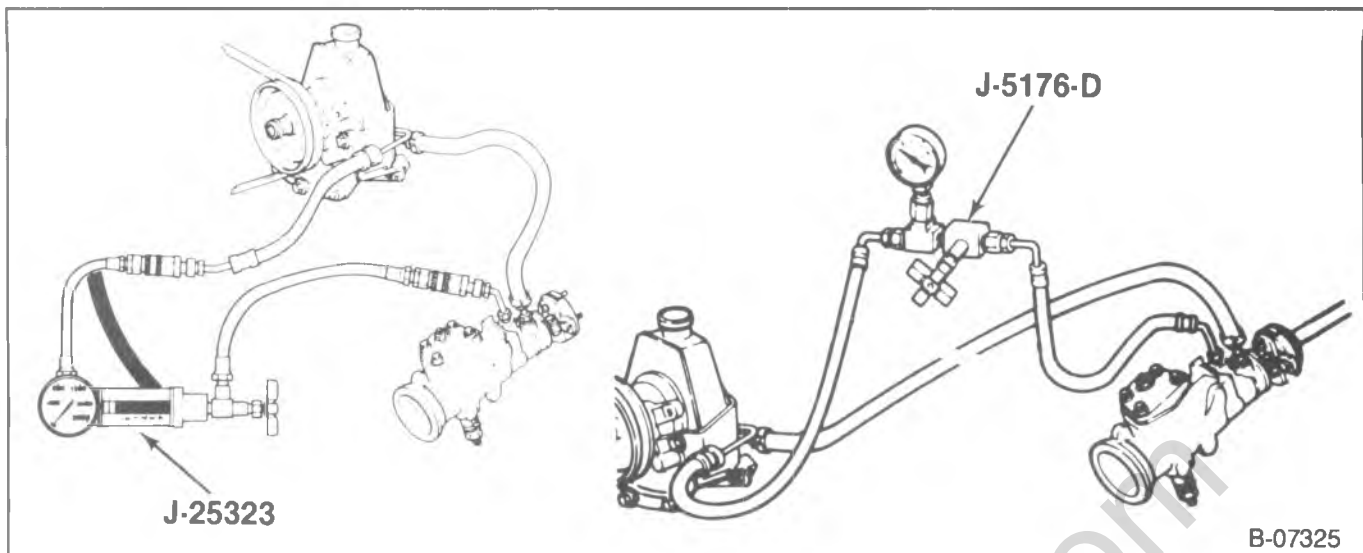

Figure 6—Tools for Power Steering System Test

! Important

- All tests are made with the engine idling at normal operating temperature. Check the idle adjustment and if necessary adjust the engine idle speed to the correct specification. Refer to FUEL SYSTEMS (SEC. 6C).

Test With J-5176-D

1. Place a container under the steering gear or pump to catch the fluid when disconnecting or connecting the hoses.
2. With the engine NOT running, disconnect the pressure hose at the steering gear or power steering pump and install J-5176-D to both hoses using adapter fitting J-5176-20. The gage must be between the shut-off valve and pump. Open the shut-off valve.
3. Remove the filler cap from the pump reservoir and check the fluid level. Fill the pump reservoir, with power steering fluid, to the full mark on the dipstick. Start the engine and, momentarily holding steering wheel against stop, check the connections at J-5176-D for leakage.
4. Bleed the system. Refer to "Bleeding the Power Steering System."
5. Insert thermometer J-5421-02 in the reservoir filler opening. Move the steering wheel from stop to stop several times until the thermometer indicates that the hydraulic fluid in the reservoir has reached a temperature of 65° to 77°C (150° to 170°F).

! Important

- To prevent scrubbing flat spots on the tires, do not turn the steering wheel more than five times without rolling the vehicle to change the tire-to-floor contact area.
6. Start the engine and check the pumps fluid level. Add power steering fluid if required. When the engine is at normal operating temperature, the initial pressure read on the gage (valve open) should be in the 550-860 kPa (80-125 psi) range. Should this

pressure be in excess of 1380 kPa (200 psi) — check the hoses for restrictions and the poppet valve for proper assembly.

NOTICE: Do not leave valve fully closed for more than 5 seconds as the pump could be damaged internally.

7. Close the gate valve fully 3 times. Record the highest pressures attained each time.
 - If the pressures recorded are within the specifications at the end of this section, and the range of readings is within 345 kPa (50 psi), the pump is functioning within its specifications.
 - If the pressures recorded are high, but do not repeat within 345 kPa (50 psi), the flow controlling valve is sticking. Remove the valve, clean it and remove any burrs using crocus cloth or fine hone. If the system contains some dirt, flush it. If it is exceptionally dirty, both the pump and gear must be completely disassembled, cleaned, flushed and reassembled before further usage.
 - If the pressures recorded are constant but more than 690 kPa (100 psi), below the minimum listed specification, replace the flow control valve and recheck. If the pressures are still low, replace the rotating group in the pump.
8. If the pump checks within specifications, leave the valve open and turn (or have turned) the steering wheel into both corners. Record the highest pressures and compare with the maximum pump pressure recorded. If this pressure cannot be built in either (or one) side of the gear, the gear is leaking internally and must be disassembled and repaired.
9. Shut the engine off, remove the testing gage, reconnect the pressure hose, check the fluid level and/or make the needed repairs.
10. If the problem still exists, the steering and front suspension must be thoroughly examined. Refer to "Diagnosis of Power Steering System."

Test With J-25323

1. Place a container under the steering gear or pump to catch the fluid when disconnecting or connecting the hoses.
2. With the engine NOT running, disconnect the pressure hose at the steering gear or power steering pump. Thread J-29525 female adapter into the pressure hose and the male adapter into the gear or pump. Connect J-25323 analyzer hoses to the adapters.
3. If the analyzer has never been used, it will be necessary to bleed the power steering system to remove all the air. Refer to "Bleeding the Power Steering System" in this section. The analyzer gate must be open during this procedure.
4. Add power steering fluid to the pump if required.
5. Run the engine at idle speed **with the gate valve open** and record flow (A) and pressure (B).
 - If the flow is below 7.4 L/min. (2 gpm), the pump appears to be in need of repair, but continue the test.
 - If the pressure is above 1035 kPa (150 psi), check the hoses for restriction and check the steering gear.
6. Partially close the gate valve to build 4278 kPa (620 psi). Record the flow (C).
 - If the flow (C) drops more than 3.7 L/min. (1 gpm) under flow (A), disassemble the pump and replace the ring, rotor, and vanes. If the pressure plates are worn or cracked, replace them. Replace all O-ring seals when reassembling the pump. Continue the test.
7. Completely close and partially open the gate valve three times (**do not allow the valve to remain closed for more than 5 seconds**). Record the "gate closed" pressure (D).
8. Check the pressure specifications, at the end of this section for the correct pump model, and if the pump pressure recorded is 690 kPa (100 psi) lower than the minimum specification listed, replace the flow control valve in the pump. If the pressure recorded is above the maximum specification listed, the flow control valve in the pump should be removed and cleaned or replaced. If the system is exceptionally dirty, both the steering gear and pump must be completely disassembled and cleaned before reassembly.
9. Increase the engine speed from idle to about 1500 rpm. Record the flow (E).
 - If flow (E) varies more than 1 gpm from flow (A), then the flow control valve should be removed and cleaned or replaced, the same as in step 8.
10. Have the steering wheel turned into the left and then right corner lightly against the wheel stops. Record the pressure and flow (F).
 - Pressures developed in both corners should be nearly the same as the maximum pump output (D). At the same time the flow should drop below 1.85 L/min. (0.5 gpm).
 - If the pressure does not reach maximum output or the flow does not drop below the specified value, excessive internal leakage is occurring. Remove and disassemble the steering gear and remove the control valve. Repair the steering gear as outlined in the Unit Repair Manual.
11. Have the steering wheel turned slightly in both directions and release quickly while watching the pressure gage. The needle should move from the normal back pressure reading and snap back as the wheel is released. If it comes back slowly, or sticks, the rotary valve in the steering gear is sticking. Remove, disassemble and clean the rotary valve. If the system contains a lot of dirt and foreign material, disassemble the pump the gear, clean and reassemble.
12. If the problem still exists, the steering and front suspension must be thoroughly examined. Refer to "Diagnosis of Power Steering System" in this section.

POWER STEERING SYSTEM ON-VEHICLE SERVICE

MAINTENANCE

The hydraulic system should be kept clean and at regular intervals the pump steering fluid level in the reservoir should be checked and fluid added when required. Refer to MAINTENANCE AND LUBRICATION (SEC. 0B) of this manual for type of fluid to be used and intervals for filling.

If the system contains some dirt, flush it as detailed later in this section. If it is exceptionally dirty, both the pump and the gear must be completely disassembled before further usage.

All tubes, hoses, and fittings should be inspected for leakage at regular intervals. Fittings must be tight. Make sure the clips, clamps and supporting tubes and hoses are in place and properly secured.

Inspect the hoses with the wheels in the straight-ahead position, then turn the wheels fully to the left and right, while observing the movement of the hoses. Correct any

hose contact with other parts of the vehicle that could cause chafing or wear.

Power steering hoses and lines must not be twisted, kinked or tightly bent. The hoses should have sufficient natural curvature in the routing to absorb movement and hose shortening during vehicle operation.

Air in the system will cause spongy action and noisy operation. When a hose is disconnected or when fluid is lost, for any reason, the system must be bled after refilling. Refer to "Bleeding the Power Steering System" in this section.

PUMP BELT TENSION ADJUSTMENT

When adjusting a power steering pump belt, never pry against the pump reservoir or pull against the filler neck. Two systems are used for belt adjustment. On some models, the pump is loosened from the bracket and

3B3-12 POWER STEERING

moved outward to increase the tension. On other models, a half-inch square drive hole is located in the bracket, and this hole is used to rotate the pump-and-bracket assembly outward to increase belt tension.



Adjust

Tool Required:

J-23600-B Belt Tension Gage.

1. Place belt tension gage, J-23600-B or equivalent, midway between the pulleys on drive belts being checked.
- Power steering pump driven by a single belt.
 - Loosen the pump attaching bolts and adjust the belt to correct tension by moving the pump outward, away from the engine.
 - Tighten finger tight all pump mounting bolts and remove the pry bar.
 - Tighten all pump mounting bolts. Refer to "Power Steering Pump Replacement" in this section.
 - Inspect belt tension and remove the belt tension gage.
2. Loosen the pivot bolt and pump brace adjusting nuts.

NOTICE: Do not move the pump by prying against the reservoir or by pulling on the filler neck, or damage may occur.

3. Move the pump, with the belt in place until the belt is tensioned to specifications. Refer to ENGINE COOLING (SEC. 6B1).
4. Tighten the pump bracket adjusting nut and the pivot bolt nut. Refer to "Power Steering Pump Replacement" in this section.
5. Inspect the belt tension and remove the belt tension gage.

FLUID LEVEL ADJUSTMENT

1. Run the engine until the power steering fluid reaches normal operating temperature, about 80°C (170°F), then shut the engine off.
2. Remove the reservoir cap and check the fluid level on the dipstick. On models equipped with a remote reservoir, the fluid level should be about 12.7 to 25.4 mm (1/2 to 1-inch) from the top when the wheels are in full left turn position.
3. If the fluid level is low, add power steering fluid (GM #1050017 or equivalent) to the proper level and install the reservoir cap.
4. When checking the fluid level after the steering system has been serviced, air must be bled from the system. Refer to "Bleeding the Power Steering System" in this section.

BLEEDING THE POWER STEERING SYSTEM

When a power steering pump or gear has been installed, or an oil line has been disconnected, the air that has entered the system must be bled out before the vehicle is operated. If air is allowed to remain in the power

steering fluid system, noisy and unsatisfactory operation of the system may result. Bleed air from the hydraulic system as follows:

- When bleeding the system, and any time fluid is added to the power steering system, be sure to use only power steering fluid as specified in MAINTENANCE AND LUBRICATION (SEC. 0B).
1. Fill the pump fluid reservoir to the proper level and let the fluid settle for at least two minutes.
 2. Start the engine and let it run for a few seconds. Then turn the engine off.
 3. Add fluid if necessary.
 4. Repeat the above procedure until the fluid level remains constant after running the engine.
 5. Raise the front end of the vehicle so that the wheels are off the ground.
 6. Start the engine. Slowly turn the steering wheel right and left, lightly contacting the wheel stops.
 7. Add power steering fluid if necessary.
 8. Lower the vehicle and turn the steering wheel slowly from lock to lock.
 9. Stop the engine. Check the fluid level and refill as required.
 10. If the fluid is extremely foamy, allow the vehicle to stand a few minutes and repeat the above procedure.



Inspect

- Belt for tightness.
- Pulley for looseness or damage. The pulley should not wobble with the engine running.
- Hoses so they are not touching any other parts of the vehicle.
- Fluid level and fill to the proper level.
- Fluid for air and if present attempt to bleed the system.

FLUSHING THE POWER STEERING SYSTEM

1. Raise the front end of the vehicle off the ground until the wheels are free to turn.
2. Remove the fluid return line at the pump inlet connector and plug the connector port on the pump. Position the line towards a large container to catch the draining fluid.
3. While an assistant is filling the reservoir with new power steering fluid, run the engine at idle. Turn the steering wheel from stop to stop. DO NOT contact wheel stops or hold the wheel in a corner or fluid will stop and the pump will be in pressure relief mode. A sudden overflow from the reservoir may develop if the wheel is held at a stop.
4. Install all the lines, hoses and components (if removed) on the vehicle. Fill the system with new power steering fluid and bleed the system as described in "Bleeding The Power Steering System." Operate the engine for about 15 minutes. Remove the pump return line at the pump inlet and plug the connection on the pump. While refilling the reservoir, check the draining fluid for contamination. If foreign material is still evident, replace all lines,

disassemble and clean or replace the power steering system components. Do not re-use any drained power steering fluid.

STEERING GEAR HIGH POINT CENTERING

1. Set the front wheels in the straight ahead position. This can be checked by driving the vehicle a short distance on a flat surface.
2. With the front wheels set straight ahead, check the position of the mark on the wormshaft designating steering gear high point. This mark should be at the top side of the shaft at the 12 o'clock position and lined up with the mark in the coupling lower clamp.
3. On R, G and P models except P30(00)FS3, if the steering gear has been moved off high point when setting the wheel in the straight ahead position, loosen the adjuster tube clamps on both the left and right hand tie rods. Then turn both adjuster tubes an equal number of turns in the same direction to bring the gear back on high point.

Important

- Turning the adjuster tubes an unequal number of turns or in different directions will disturb the toe-in setting of the wheels.
4. On V and P30(00)FS3 models, if the gear has been moved off high point when setting the wheels in the straight ahead position, loosen the adjuster tube clamps on the connecting rod. Then turn the adjuster tube to bring the gear back on high point.
 5. Adjust toe-in. Refer to FRONT END ALIGNMENT (SEC. 3A).
 6. Refer to STEERING LINKAGE (SEC. 3B1) for adjuster tube clamping instructions.

POWER STEERING GEAR REPLACEMENT

Remove or Disconnect (Figures 7, 8, 9, 10, 11, and 12)

- Place a drain pan below the steering gear.
1. Battery ground cable.
 2. Hoses from the steering gear. Raise the hose up to prevent oil drainage. Cap or tape the ends of the hose and gear fittings to prevent the entrance of dirt.
 - Remove the flexible coupling to steering shaft flange bolts (C, K and P300(32) models).
 - Remove the lower universal joint pinch bolt. Mark the relationship of the universal yoke to the stub shaft (G and P models).
 3. Pitman arm. Refer to STEERING LINKAGE (SEC. 3B1).
 4. Steering gear frame bolts and the steering gear.
 - Tap lightly, using a soft mallet, on the flexible coupling to remove the coupling from the steering gear stub shaft (R, V, and P300(32) models).

R, V And P300(32) Models

Install or Connect (Figures 7, 8, 10, 11, and 12)

NOTICE: For steps 2, 3 and 4 see "Notice" on page 3B3-1.

1. Flexible coupling onto the steering gear stub shaft.
 - Align the flat in the coupling with the flat on the shaft.
 - Push the coupling onto the stub shaft until the coupling reinforcement bottoms against the end of the shaft.
2. Pinch bolt into the split clamp. **The pinch bolt must pass through the shaft undercut.**

Tighten

- Pinch bolt to 42 N·m (31 ft. lbs.).
 - Place the steering gear into position, guiding the coupling bolts into the proper holes in the shaft flange.
3. Steering gear to frame bolts. Torque to "Specifications" at the end of this section.
 4. Coupling flange nuts and washers. The coupling alignment pins should be centered in the flange slots.

Tighten

- Coupling flange nuts to 27 N·m (20 ft. lbs.). Maintain a coupling to flange dimension of 6.4 to 9.5 mm (0.250 to 0.375-inch).
5. Pitman arm. Refer to STEERING LINKAGE (SEC. 3B1).
 - Remove the plugs and caps from the steering gear and hoses.
 6. Hoses to the steering gear. Torque hose fittings to "Specifications" at the end of this section.

G And P Models

Install or Connect (Figures 9, 10, 11, and 12)

- Place the steering gear in position. Guide the stub shaft into the universal joint assembly by lining up the marks made at removal.
1. Steering gear to the frame bolts. Torque to "Specifications" at the end of this section.
 2. Intermediate shaft pinch bolt. Torque to "Specifications" at the end of this section. **The pinch bolt must pass through the shaft undercut.**
 3. Pitman arm. Refer to STEERING LINKAGE (SEC. 3B1).
 - Remove the plugs and caps from the steering gear and hoses.
 4. Hoses to the steering gear. Torque hose fittings to "Specifications" at the end of this section.

3B3-14 POWER STEERING

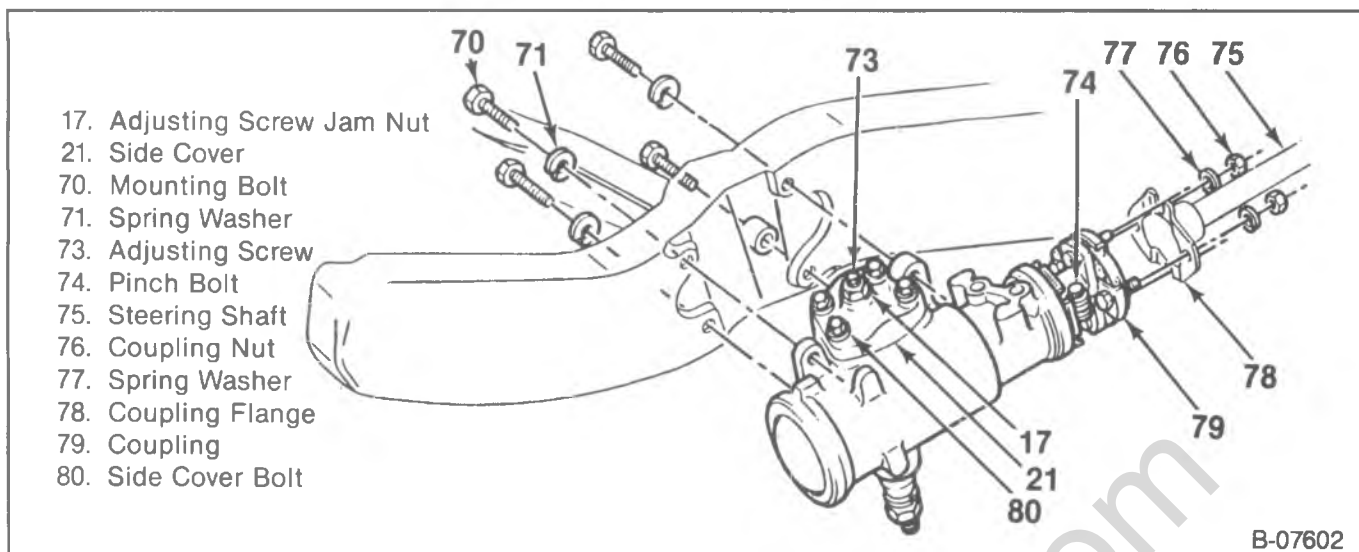

Figure 7—Steering Gear Installation—R Model

PITMAN SHAFT SEAL REPLACEMENT

Remove or Disconnect

Tools Required:

J-29107 Pitman Arm Puller.

J-4245 Internal Snap Ring Pliers.

- Mark the position of the pitman arm to the pitman shaft. Remove the pitman arm using J-29107. Refer to STEERING LINKAGE (SEC. 3B1).
 - Position a drain pan under the steering gear.
1. Retaining ring using J-4245.
 - Start the engine and full turn the steering wheel to the left-turn position for one or two seconds at a time. This will force the pitman shaft seals and washers out of the housing.
 - Stop the engine.
 2. Pitman shaft seals and washers from the pitman shaft.

Inspect

- Pitman shaft seal surfaces for roughness or pitting. If pitted, replace the shaft.
- Housing for burrs. Remove the burrs before installing the new seals.

Clean

- Pitman shaft and seal areas using a crocus cloth.

Install or Connect

Tools Required:

J-6219 Steering Gear Pitman Shaft Oil Seal Installer.

J-4245 Internal Snap Ring Pliers.

- Lubricate the new seals with power steering fluid.
- Apply a single layer of tape to the pitman arm shaft to avoid damaging the seals.

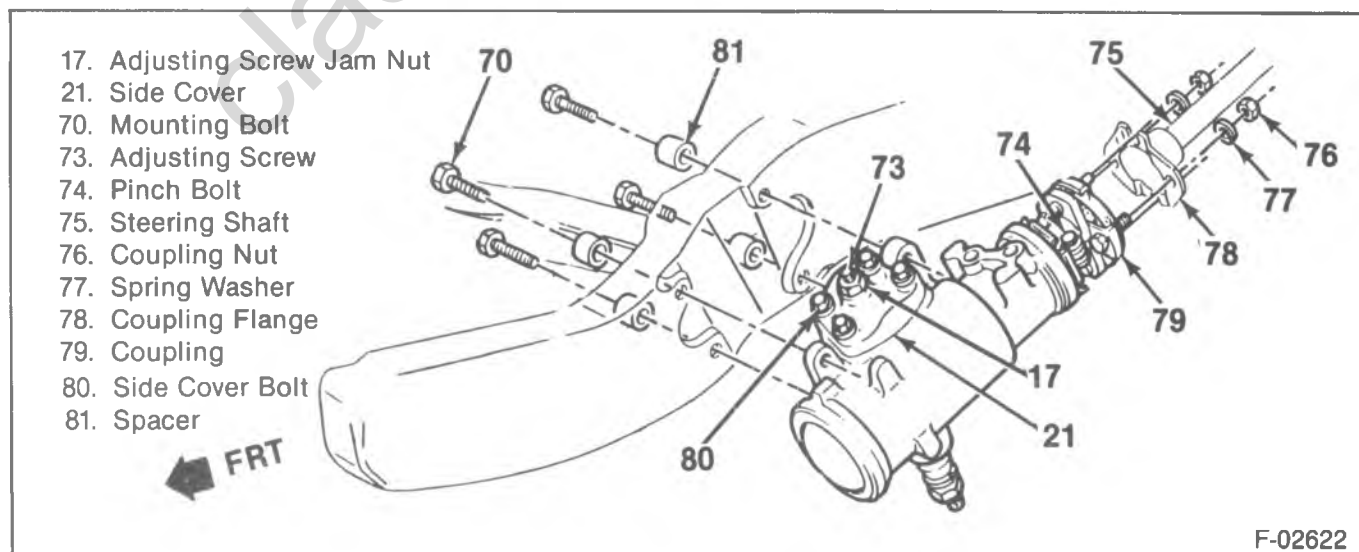

Figure 8—Steering Gear Installation—V Model

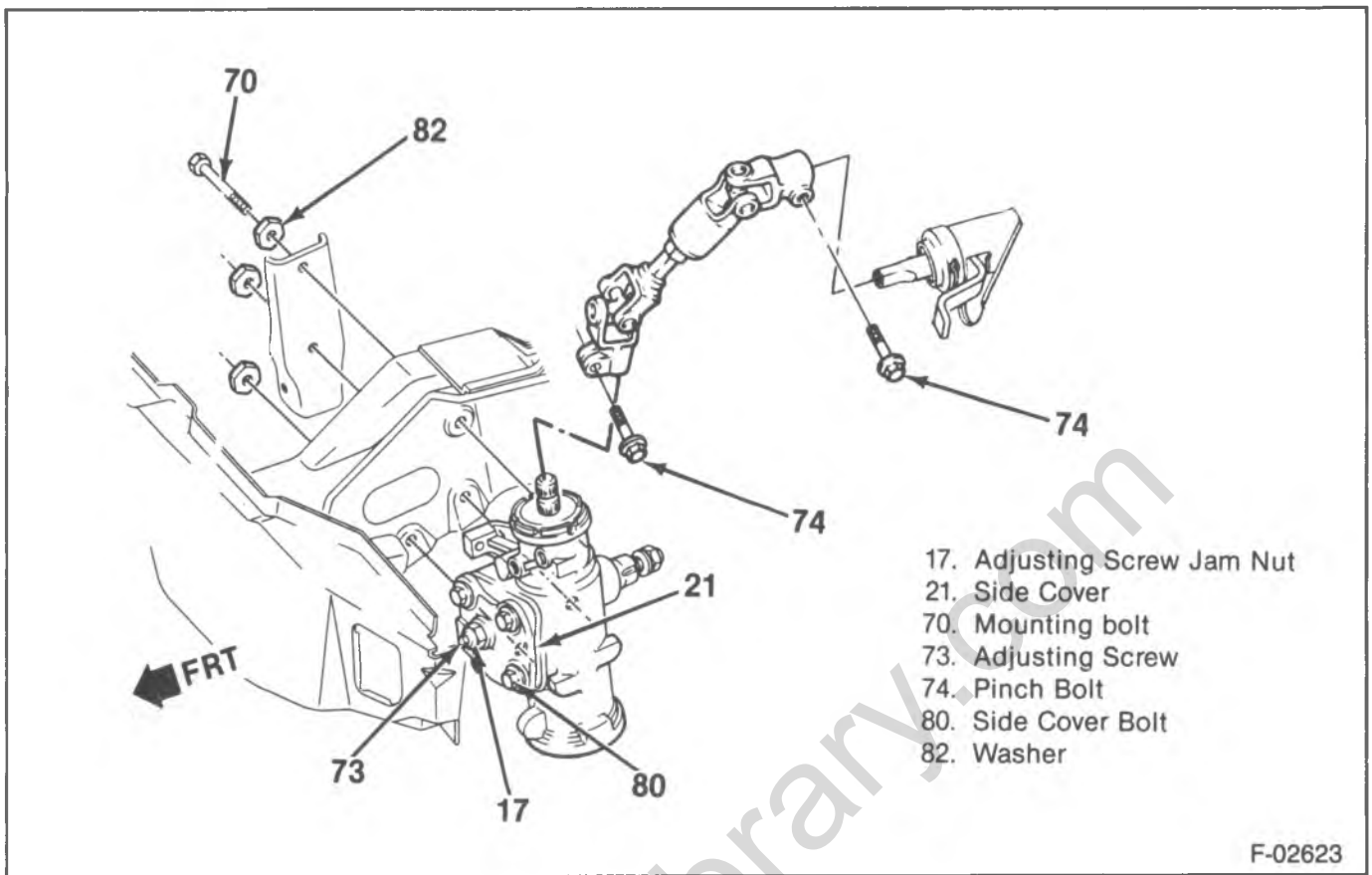

Figure 9—Steering Gear Installation—G Model

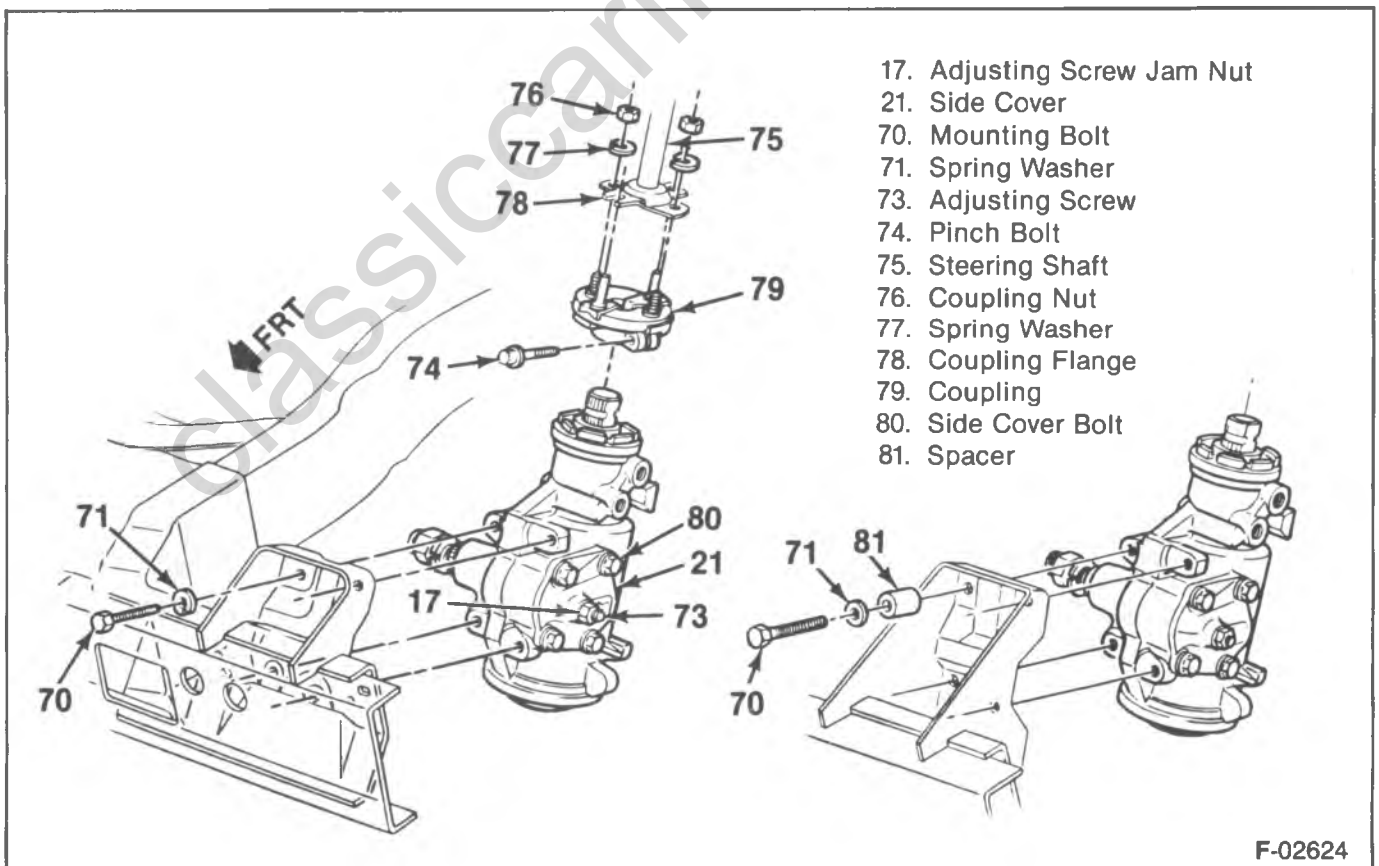
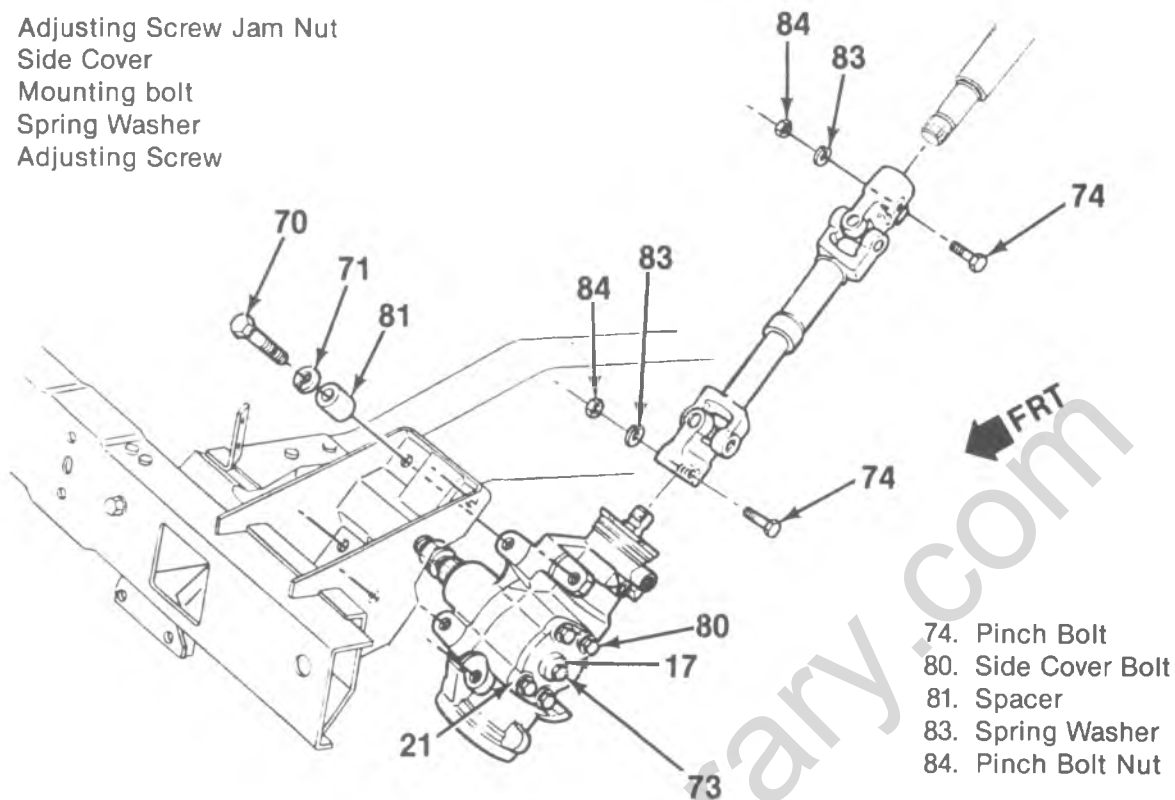

Figure 10—Steering Gear Installation—P Model, P300(32) and Solid Front Axle

3B3-16 POWER STEERING

- 17. Adjusting Screw Jam Nut
- 21. Side Cover
- 70. Mounting bolt
- 71. Spring Washer
- 73. Adjusting Screw



- 74. Pinch Bolt
- 80. Side Cover Bolt
- 81. Spacer
- 83. Spring Washer
- 84. Pinch Bolt Nut

F-02625

Figure 11—Steering Gear Installation—P Model, P300(42) + Solid Front Axle

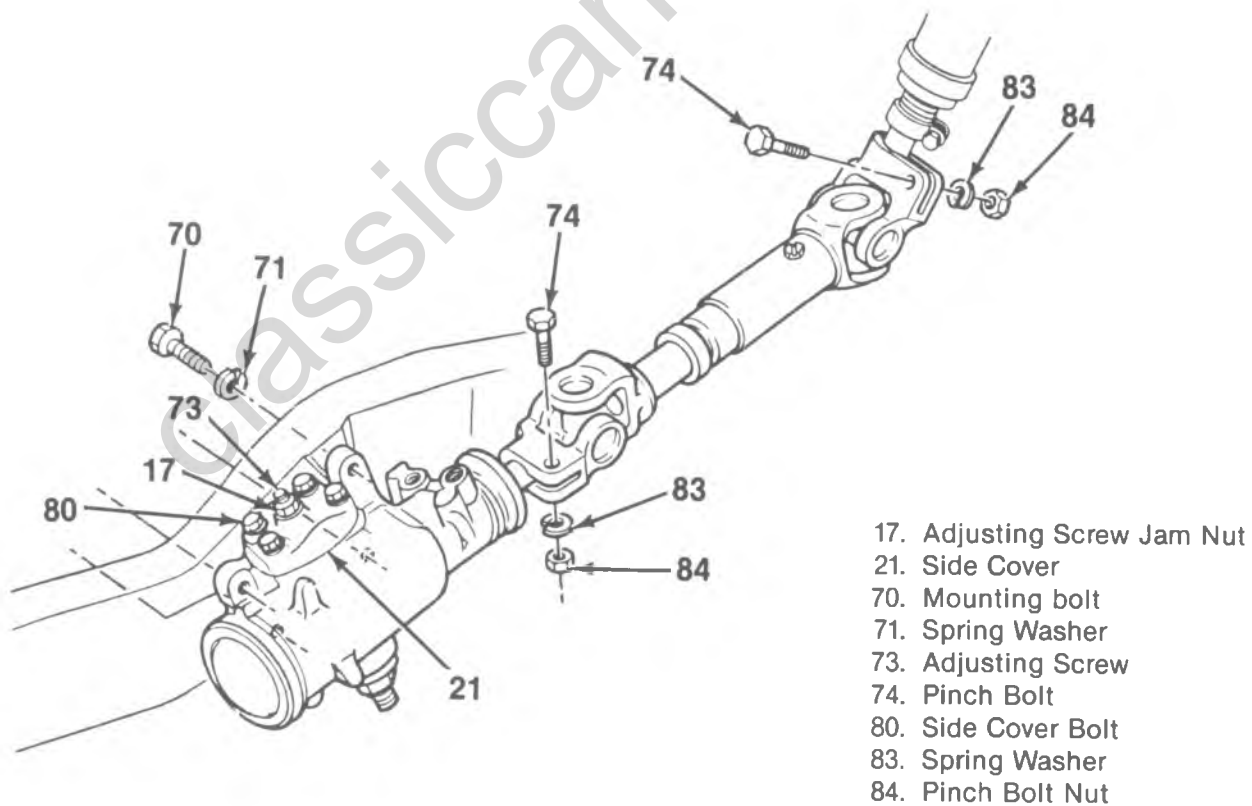

- 17. Adjusting Screw Jam Nut
- 21. Side Cover
- 70. Mounting bolt
- 71. Spring Washer
- 73. Adjusting Screw
- 74. Pinch Bolt
- 80. Side Cover Bolt
- 83. Spring Washer
- 84. Pinch Bolt Nut

F-02626

Figure 12—Steering Gear Installation—P Model, P200, P300(42) Except FS3

1. Single lip seal and washer use J-6219. Install far enough to provide clearance for the remaining seal, washer and retaining ring. DO NOT allow the seal to bottom on the end of the counter bore.
2. Double lip seal and washer use J-21553.
3. Retaining ring use J-4245.
4. Pitman arm. Refer to STEERING LINKAGE (SEC. 3B1).

STEERING GEAR ADJUSTMENTS

Important

- Before any adjustments are made to the steering gear, refer to "Diagnosis of Power Steering System" for reviewing the possible steering system problems.

The steering gear adjustment is made only as a correction and not as a periodic adjustment. Adjusting the steering gear in the vehicle is NOT recommended for two reasons:

1. The complexity involved in adjusting the worm thrust bearing preload.
2. The friction effect provided by the hydraulic fluid in the steering gear.

For proper adjustment, remove the steering gear from the vehicle. Drain the power steering fluid from the gear. Mount the gear in a vise and make the following adjustments.

The steering gear requires two adjustments which are: the worm thrust bearing preload and the pitman shaft over-center preload adjustment.

The worm thrust bearing preload is controlled by the amount of compression force exerted on the conical worm bearing thrust races by the adjuster plug.

The pitman shaft over-center preload is controlled by the pitman shaft adjuster screw which determines the clearance between the rack piston and the pitman shaft sector teeth.

Important

- Adjust the worm thrust bearing preload first, then adjust the pitman shaft over-center preload.

Worm Bearing Preload

Adjust (Figures 1, 2, 13, 14, 15, 16, and 17)

Tool Required:

J-7624 Adjustable Spanner Wrench.

1. Loosen and remove the adjuster plug nut (6) (figure 13).
2. Turn the adjuster plug (3) in (clockwise), using J-7624, until the plug and thrust bearing are firmly bottomed in the housing.

Tighten

- Adjuster plug to 27 N·m (20 ft. lbs.).
3. Place an index mark on the housing even with one of the holes in the adjuster plug (figure 14).
 4. Measure back (counterclockwise) 4.7-6.3 mm ($\frac{3}{16}$ - $\frac{1}{4}$ -inch) from the index mark and mark the housing (figure 15).

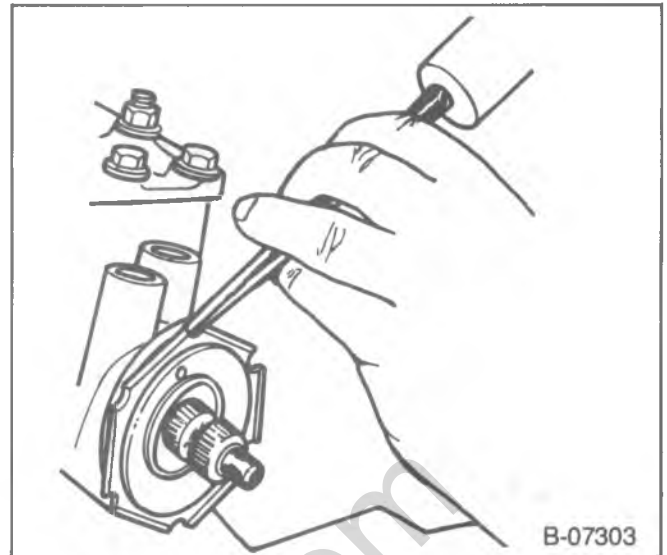

Figure 13—Loosening Adjuster Plug Nut

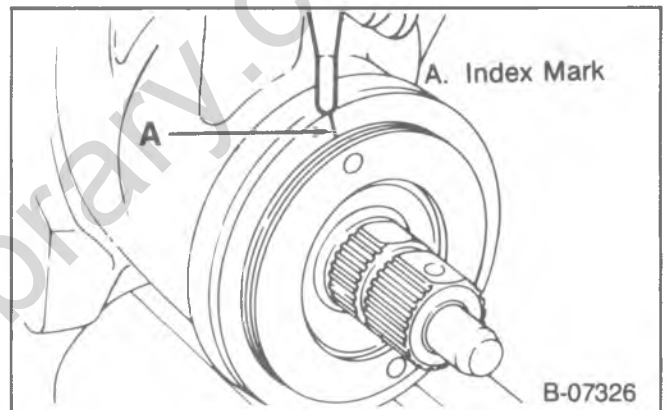

Figure 14—Marking Housing Even with Adjuster Plug

5. Rotate the adjuster plug back (counterclockwise) until the hole in the plug is aligned with the second mark on the housing (figure 16).

6. Install the adjuster plug nut (6).

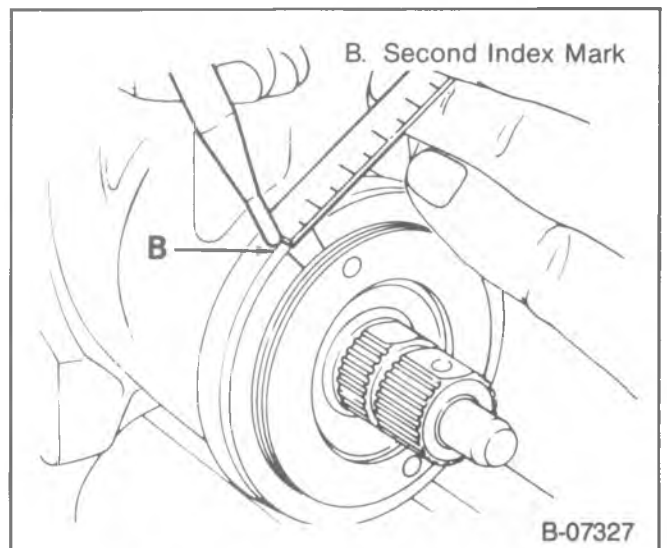

Figure 15—Remarking the Housing

3B3-18 POWER STEERING

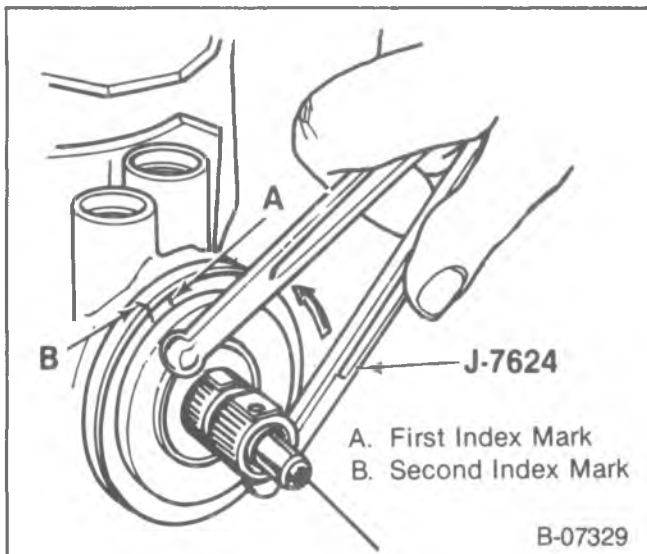

Figure 16—Aligning the Adjuster Plug to the Second Mark



Tighten

- Nut to 110 N·m (81 ft. lbs.). Be sure the adjuster plug does not turn when tightening the nut.
7. Use a inch-pound torque wrench and a 12-point deep socket to measure the required torque to turn the stub shaft (4). Take the reading with the handle of the torque wrench near the vertical position. Turn the stub shaft to the right stop and then back (counterclockwise) $\frac{1}{4}$ turn at an even rate (figure 17). Record the torque reading.
 8. The torque required to turn the stub shaft should be 0.45-1.13 N·m (4-10 in. lbs.). If the reading is above or below the specified torque; the adjuster plug may not be tightened properly or may have turned when the adjuster plug nut was tightened, or the thrust bearings and races (22) may be damaged.

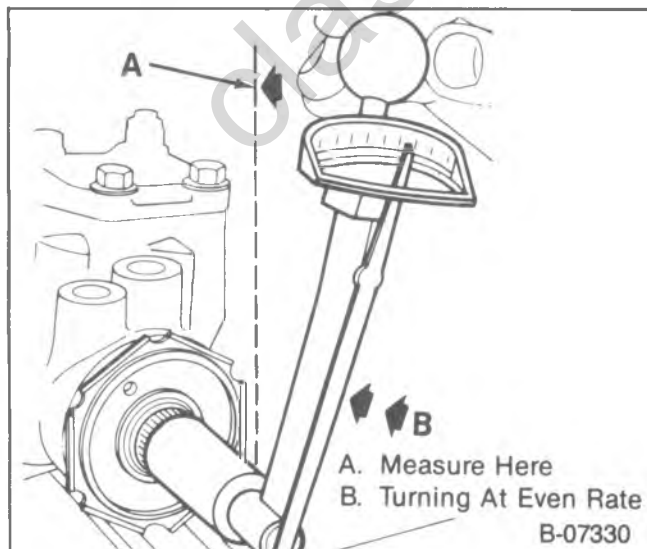

Figure 17—Checking Rotational Torque

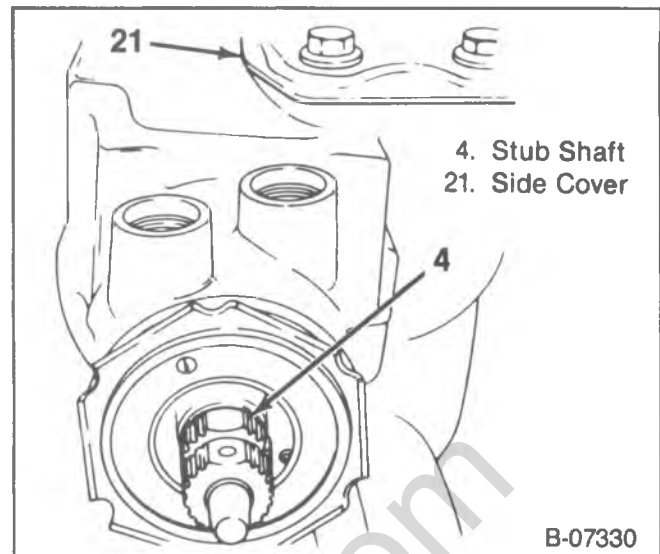

Figure 18—Aligning the Stub Shaft

Over Center Preload



Adjust (Figures 1, 2, 18, 19,, and 20)

1. Turn the pitman shaft adjuster screw (73) counterclockwise until fully extended, then turn back $\frac{1}{2}$ turn clockwise.
2. Rotate the stub shaft (4) from stop to stop and count the number of turns.
3. Starting at either stop, turn the stub shaft back $\frac{1}{2}$ the total number of turns. This is the "center" of the gear.
 - When the gear is centered, the flat on the stub shaft should face upward and be parallel with the side cover (21) (figure 14) and the master spline on the pitman shaft should be in line with the adjuster screw (73) (figure 19).
4. Place the torque wrench, in the vertical position, on the stub shaft. Rotate the torque wrench 45 degrees each side of the center and record the highest drag torque measured on or near center (figure 20).

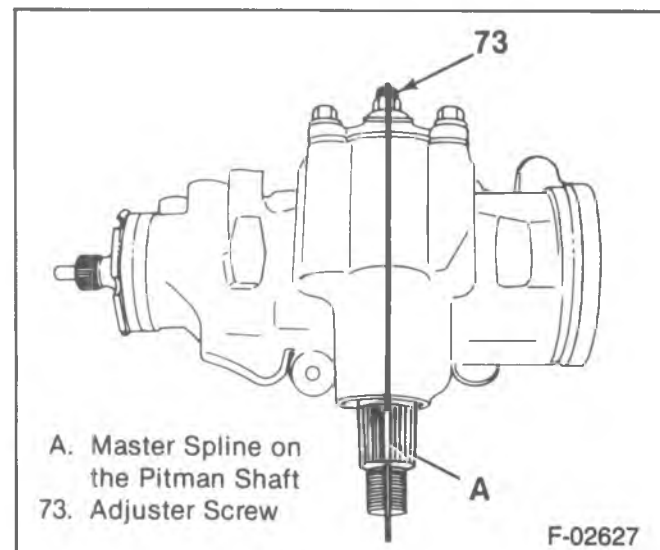

Figure 19—Aligning the Pitman Shaft Master Spline

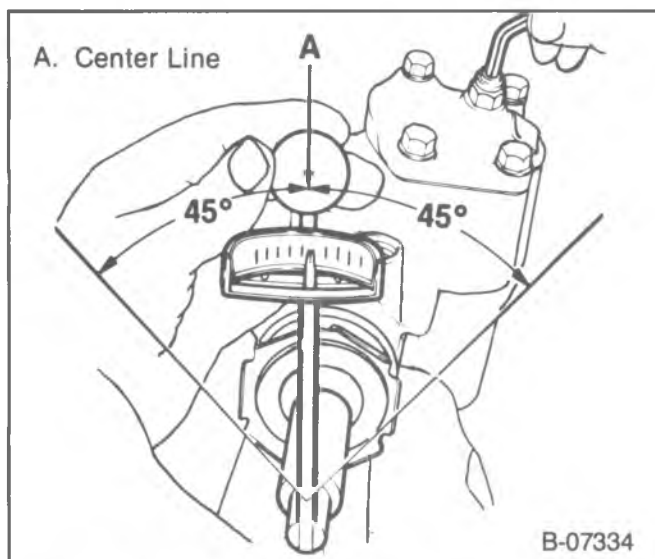

Figure 20—Checking Over-Center Rotational Torque

5. Adjust over-center drag torque by loosening the adjuster screw jam nut (17) and turning the pitman shaft adjuster screw (79) clockwise until the correct drag torque is obtained.
 - On new steering gears (under 400 miles), add 0.6-1.2 N·m (6-10 in. lbs.) torque to the previously measured worm bearing preload torque but do not exceed a total steering gear preload of 2 N·m (18 in. lbs.).
 - On used steering gears (400 miles or more) add 0.5-0.6 N·m (4-5 in. lbs.) torque to the previously measured worm bearing preload torque but do not exceed a total steering gear preload of 1.5 N·m (14 in. lbs.).

Tighten

- Adjuster screw jam nut (17) to 47 N·m (35 ft. lbs.).
6. Install the steering gear. Refer to "Steering Gear Installation" in this section.
 7. Fill the pump reservoir with power steering fluid and bleed the system. Refer to "Bleeding the Power Steering System" in this section.

POWER STEERING PUMP REPLACEMENT

↔ Remove or Disconnect (Figures 21, 22, 23, 24, 25, 26, 27, and 28)

Tool Required:

J-29785-A Water Pump and Power Steering Pulley Remover.

- Place a drain pan below the pump.
1. Battery ground cable.
 2. Hoses at the pump. Raise the hose up to prevent drainage of the oil. Cap or tape the ends of the hose and pump to prevent the entrance of dirt.
 - On models with remote reservoir, disconnect the reservoir hose at the pump. Cap the hose pump fittings.
 - Loosen the pump adjusting bolts and nuts.
 3. Pump belt.

4. Pump adjusting bolts, nuts and brackets.
5. Pump assembly.
6. Pulley from the pump.
 - Install J-29785-A. Be sure the pilot bolt bottoms in the pump shaft by turning the nut to the top of the pilot bolt.
 - Hold the pilot bolt and turn the nut counterclockwise (figure 28).

↔ Install or Connect (Figures 21, 22, 23, 24, 25, 26, 27, and 28)

Tool Required:

J-25033-B Power Steering Pump Pulley Installer.

1. Brackets to the pump.
2. Pulley to the pump.
 - Place pulley on the end of the pump shaft and install J-25033-B. Be sure the pilot bolt bottoms in the shaft by turning the nut to the top of the pilot bolt.
 - Hold the pilot bolt and turn the nut clockwise (figure 28).
- On models equipped with a remote power steering pump reservoir fill the pump housing with as much fluid as possible before mounting.
3. Pump assembly and attaching parts loosely to the engine.
4. Power steering hoses to the pump. Hoses installed out of position may be subjected to chafing or other abuses during sharp turns. Refer to "Power Steering Hoses" in this section.

! Important

- Do not start the engine with any power steering hose disconnected. After connecting the power steering hoses make sure there is clearance between the hoses and the drive belt, sheet metal or any other components where hose rub or interference could result.
- Fill the reservoir. Bleed the pump by turning the pulley backwards (counter-clockwise as viewed from the front) until the air bubbles cease to appear.
- 5. Pump belt over the pulley.

🔧 Adjust

- Belt tension. Refer to "Pump Belt Tension Adjustment" in this section.
- Fill and bleed the system. Refer to "Bleeding the Power Steering System" in this section.

POWER STEERING HOSES

When either a hose is reinstalled or replaced, the following points are essential:

- Route hoses in the same position they were in before removal (figures 29 through 36).
- Route hoses smoothly, avoid sharp bends and kinking.
- Tighten the pump end hose fitting, gear line fitting, and booster line fitting to specifications. Refer to "Specifications" at the end of this section.

3B3-20 POWER STEERING

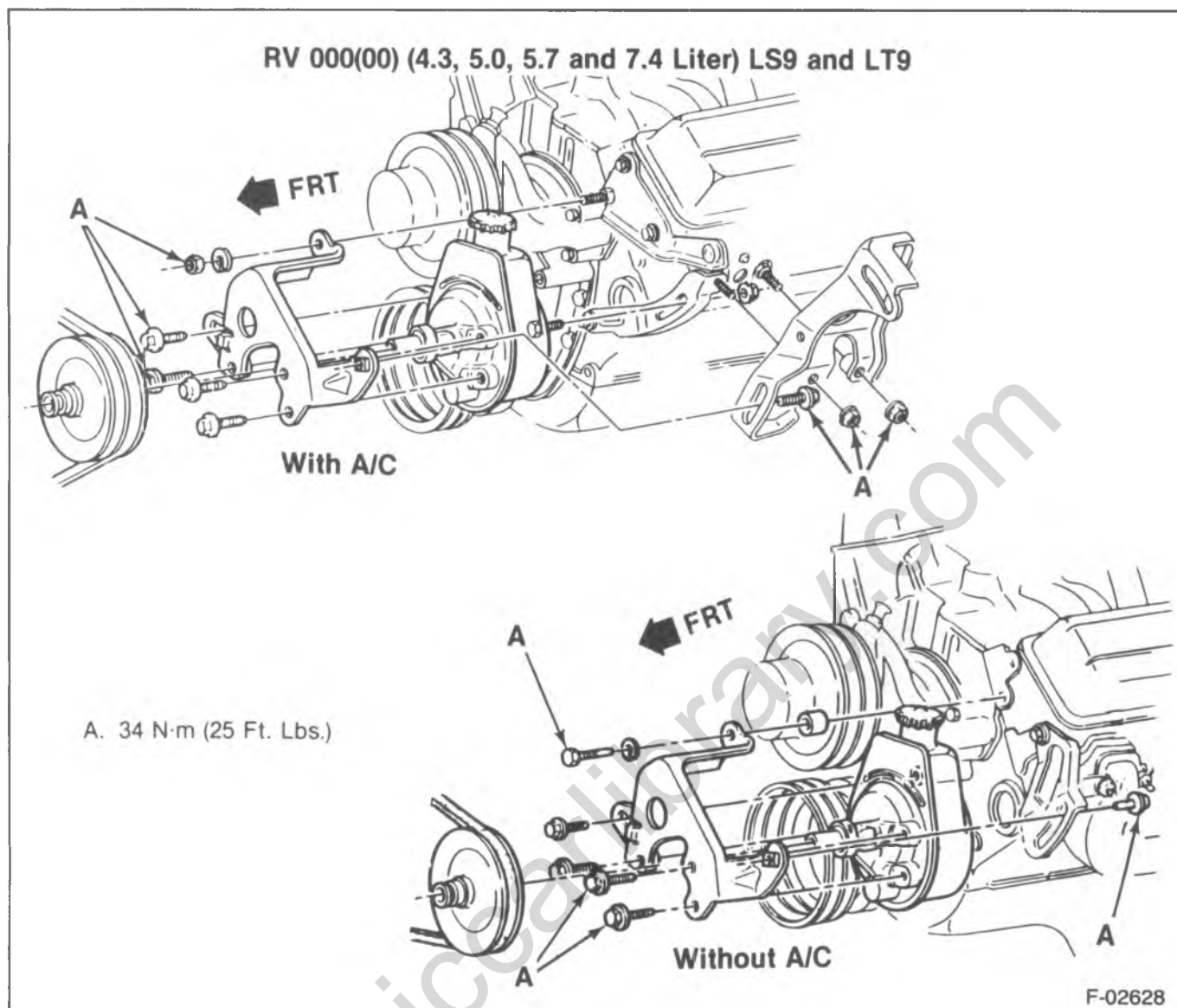

Figure 21—Power Steering Pump Mounting—RV (4.3, 5.0, and 5.7 Liter)

- After hoses are installed, check for leaks while the system is being bled. Refer to "Bleeding the Power Steering System" in this section.

NOTICE: Do not start the engine with any power steering hose disconnected, or damage to the components could occur.

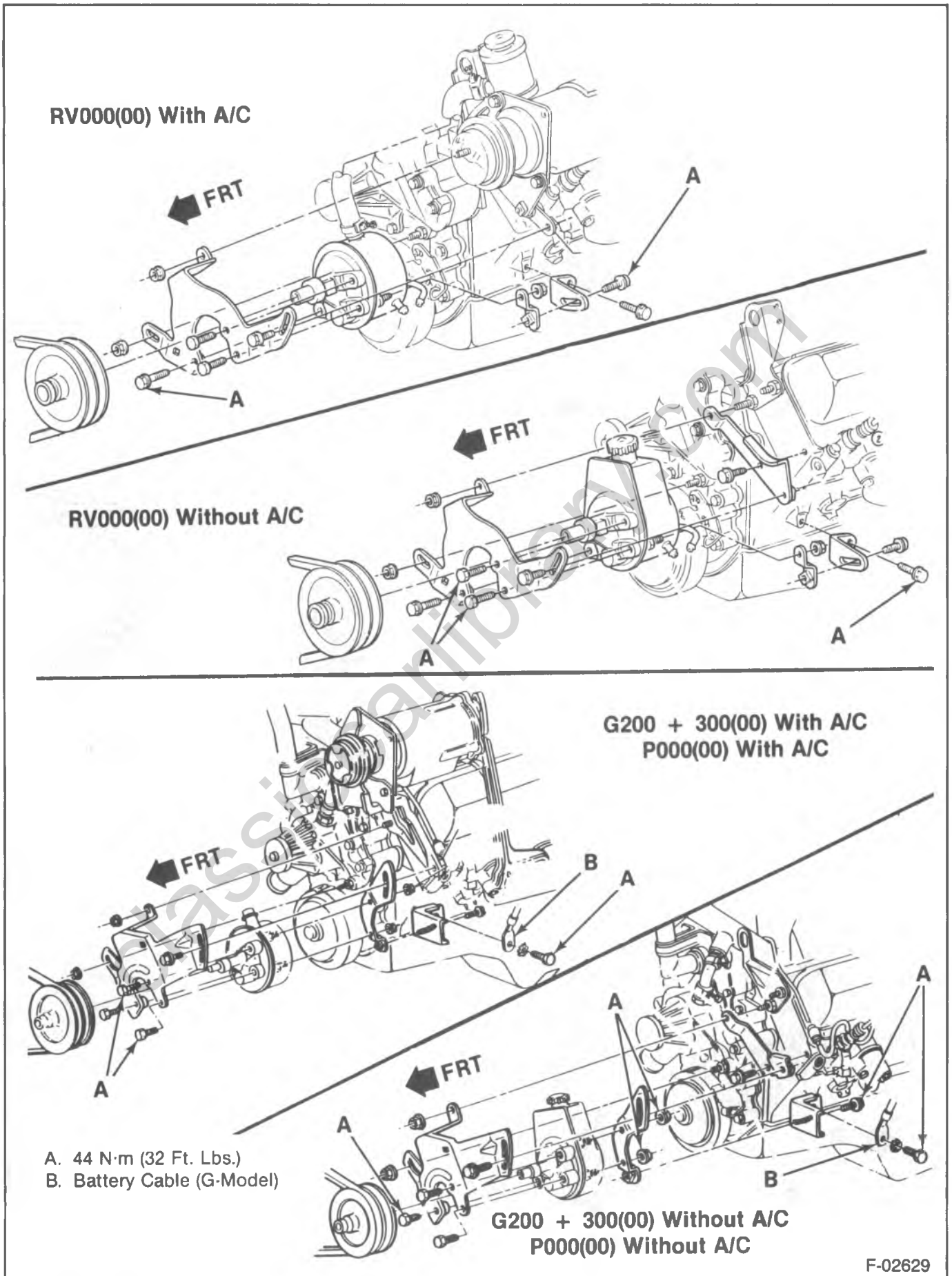
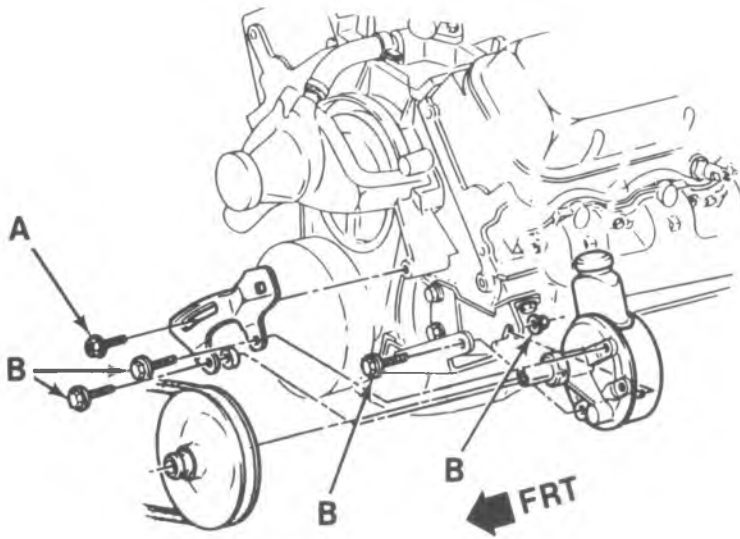
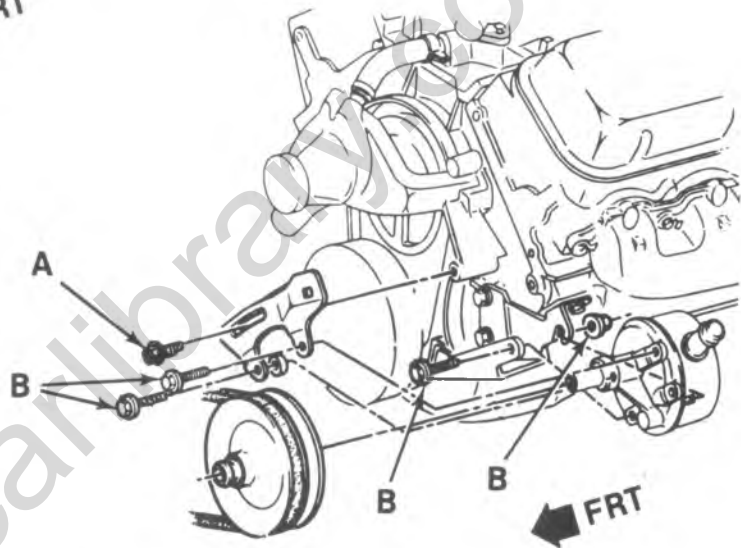

Figure 22—Power Steering Pump Mounting (6.2 Liter)

3B3-22 POWER STEERING



C200(00) (7.4 Liter)



P300(00) (7.4 Liter)

- A. 88 N·m (65 Ft. Lbs.)
- B. 50 N·m (37 Ft. Lbs.)
- C. 44 N·m (32 Ft. Lbs.)
- D. 24 N·m (18 Ft. Lbs.)

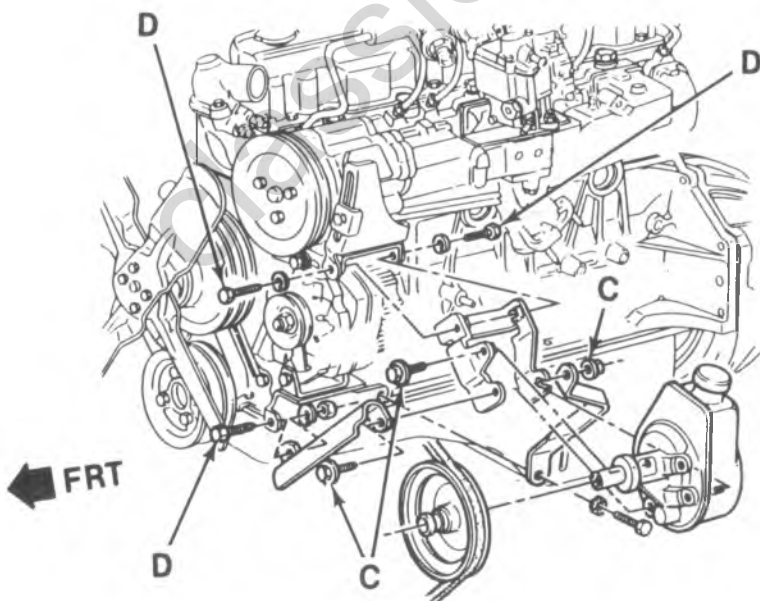

P000(42) (4.8 Liter)

F-02631

Figure 23—Power Steering Pump Mounting (4.8 and 7.4 Liter)

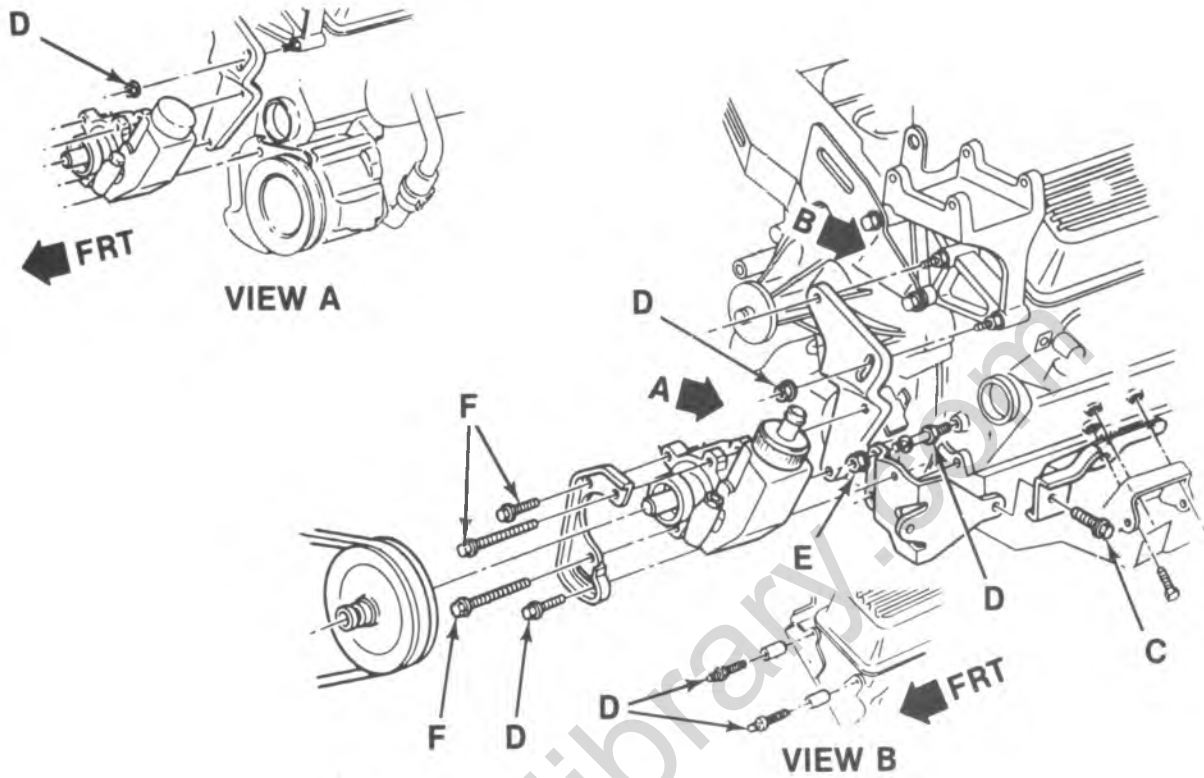

G000(00) (4.3,5.0 And 5.7 Liter)

- C. 84 N·m (62 Ft. Lbs.)
- D. 44 N·m (32 Ft. Lbs.)
- E. 34 N·m (25 Ft. Lbs.)
- F. 25 N·m (18 Ft. Lbs.)

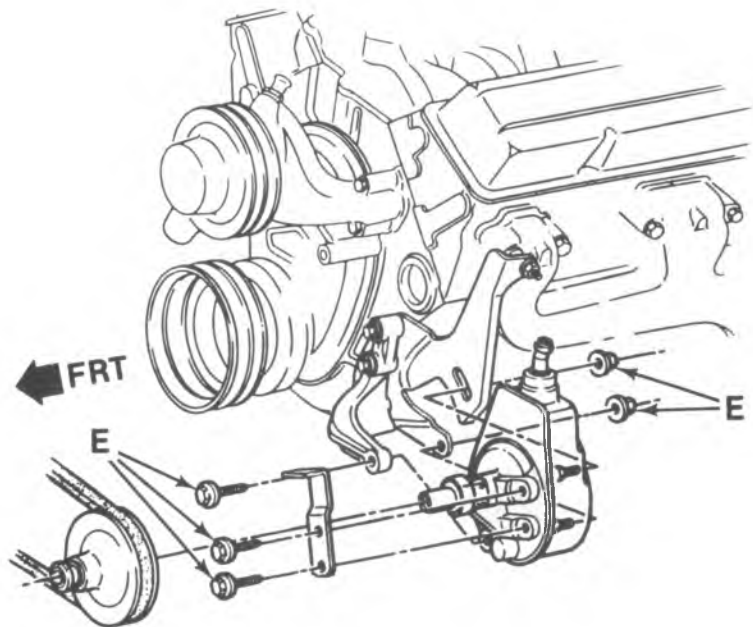

P000(42) (5.7 Liter)

Figure 24—Power Steering Pump Mounting (4.3, 5.0, and 5.7 Liter)

3B3-24 POWER STEERING

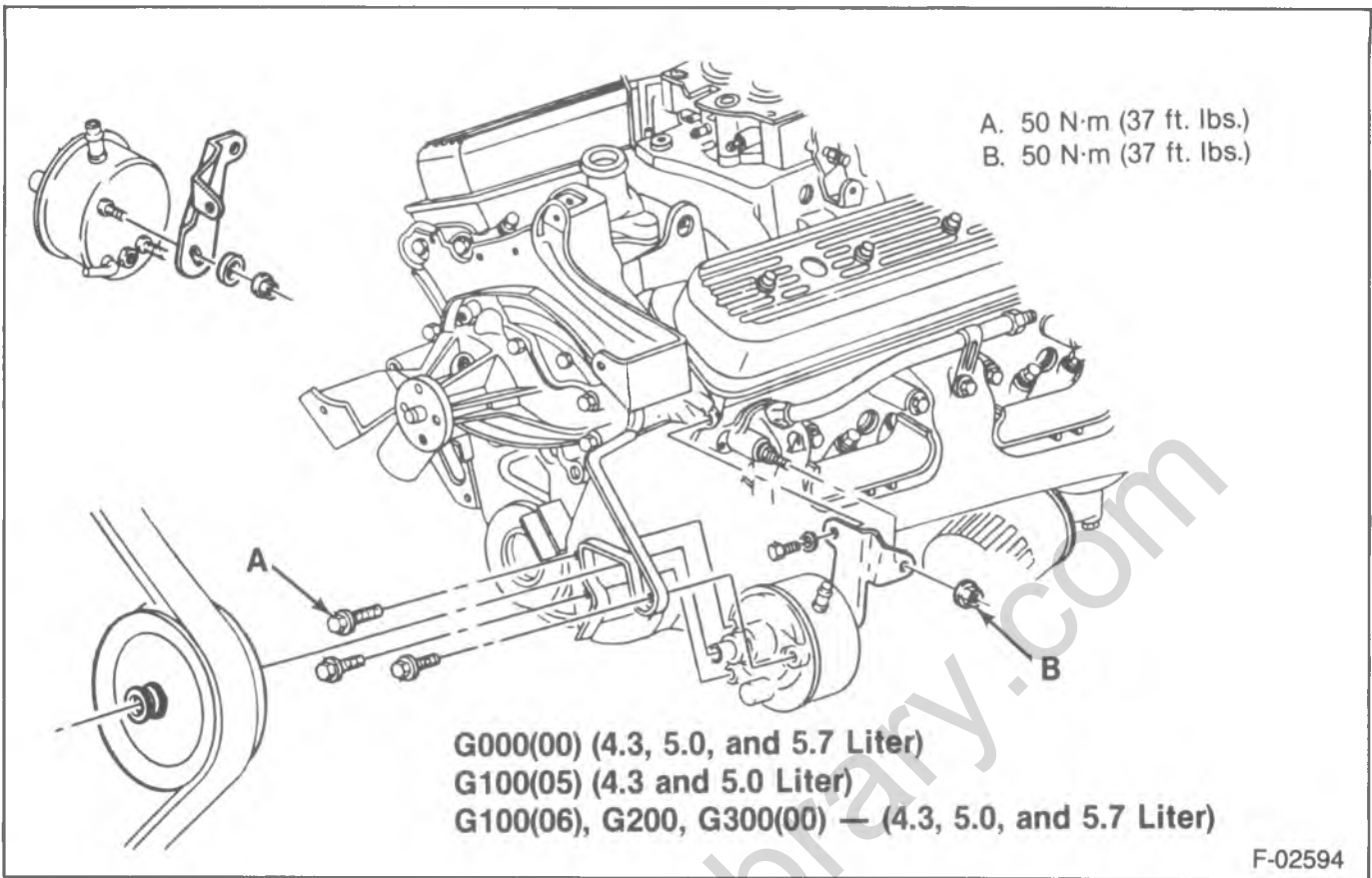

Figure 25—Power Steering Pump Mounting—G Model (4.3, 5.0, and 5.7 Liter)

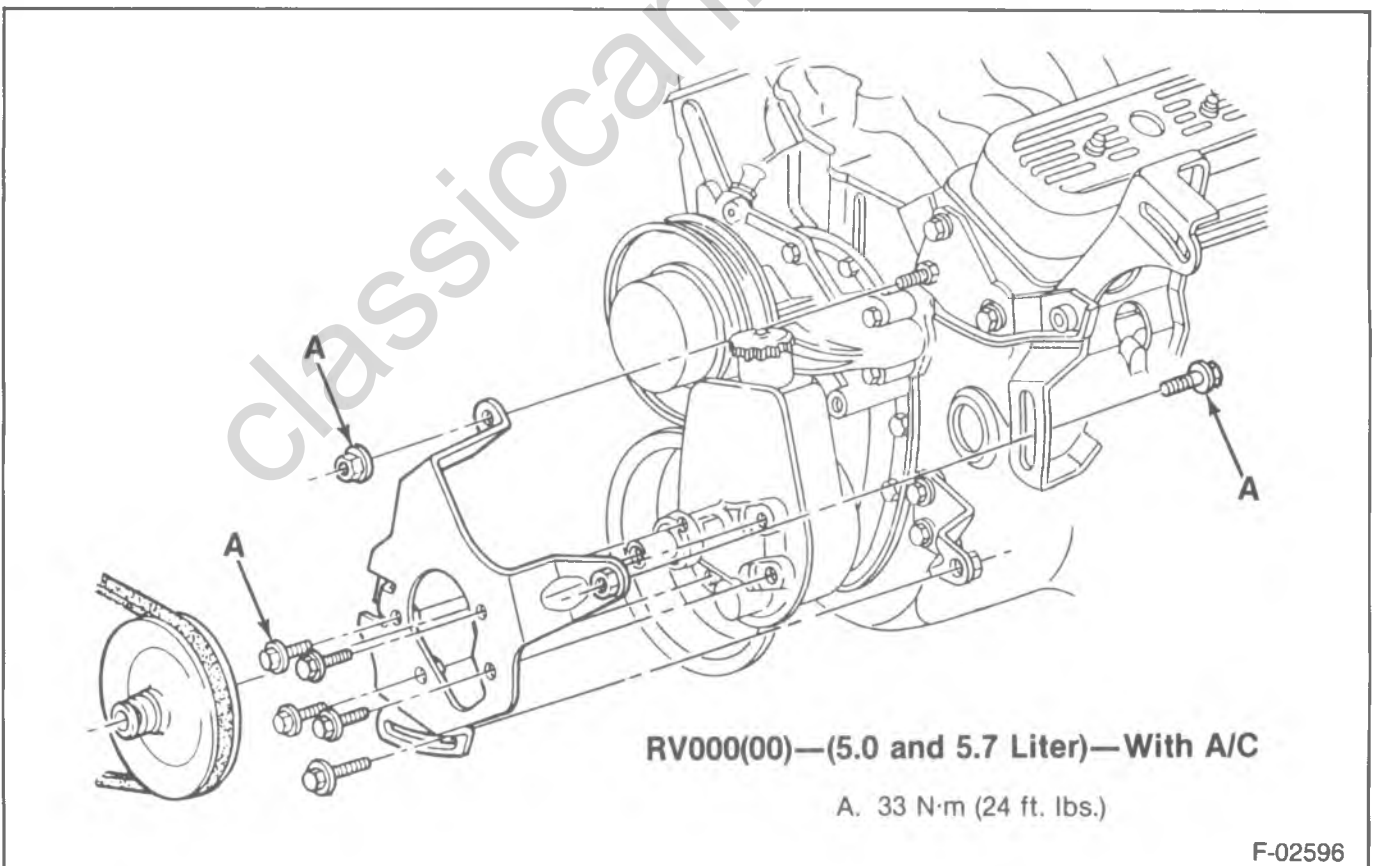

Figure 26—Power Steering Pump Mounting—RV 000(00)—(5.0 and 5.7 Liters) with A/C

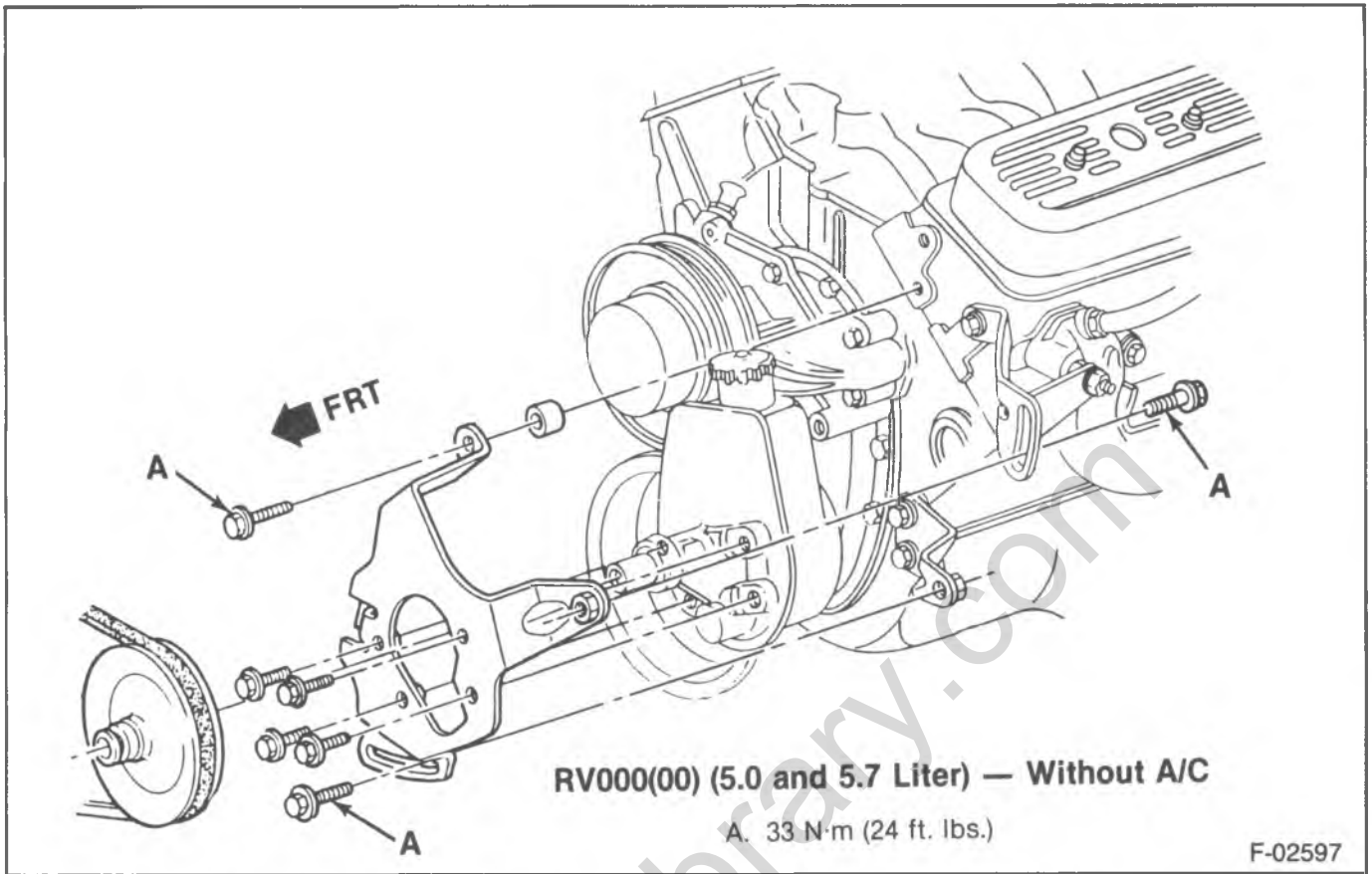

Figure 27—Power Steering Pump Mounting—RV 000(00) (5.0 and 5.7 Liters) without A/C

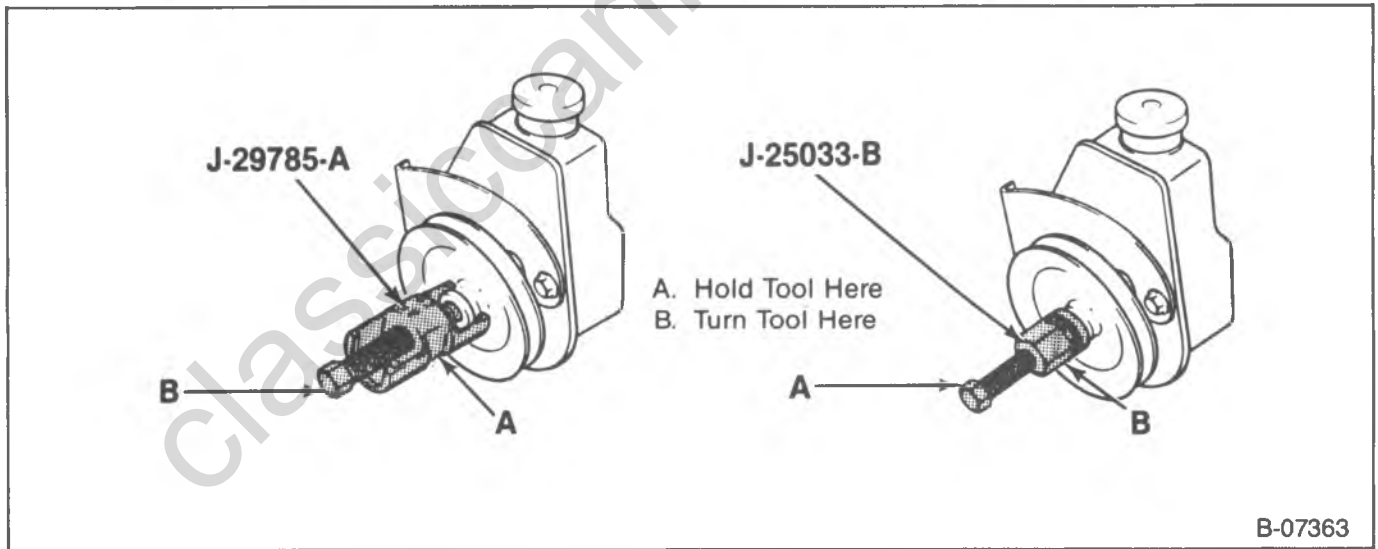

Figure 28—Installing and Removing Pulley

3B3-26 POWER STEERING

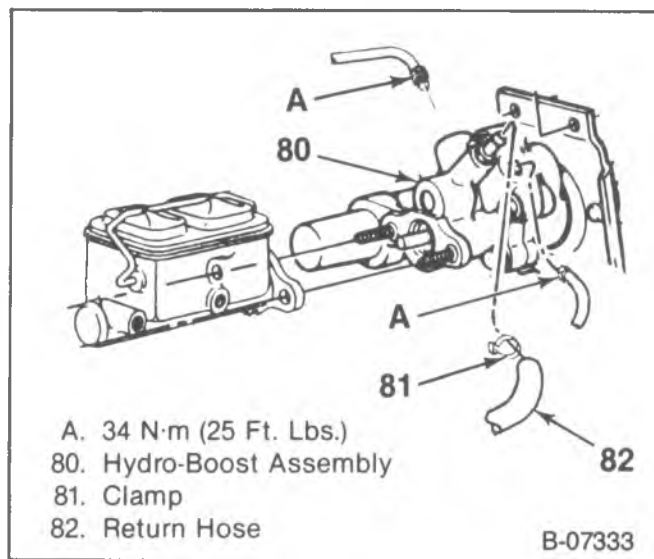
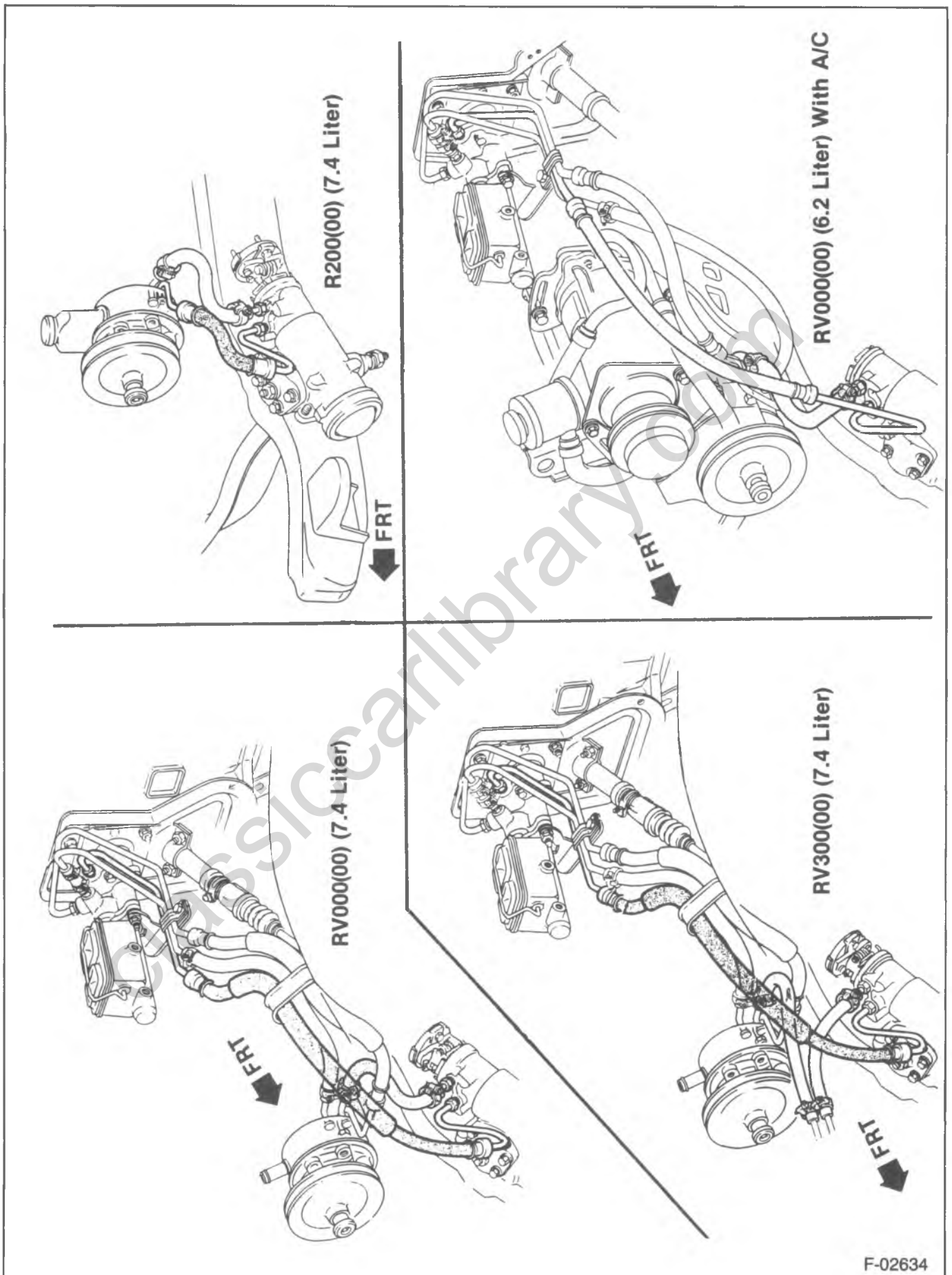

Figure 29—Hydro-Boost Lines

classiccarlibrary.com



F-02634

Figure 30—Power Steering Hoses

3B3-28 POWER STEERING

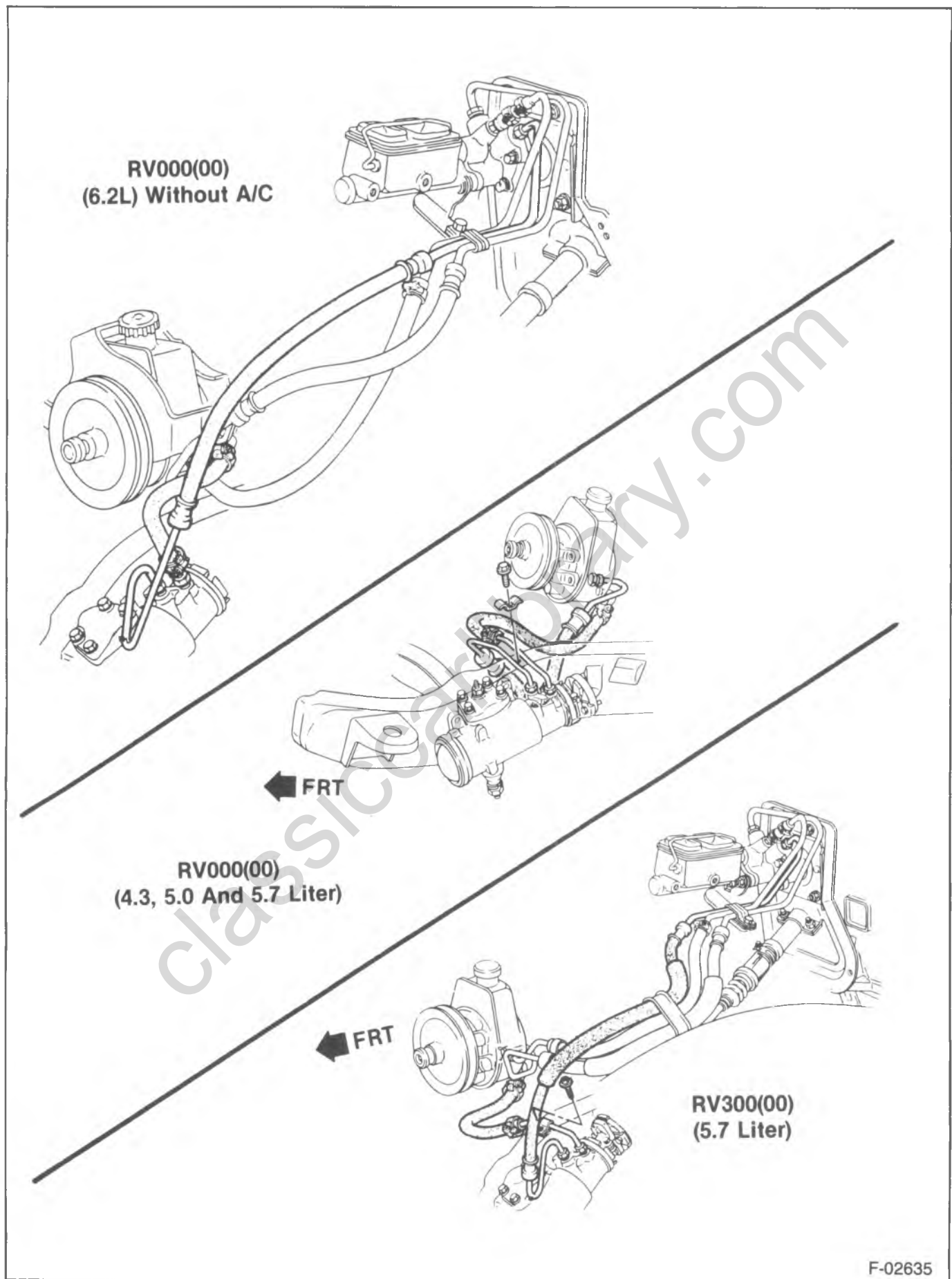
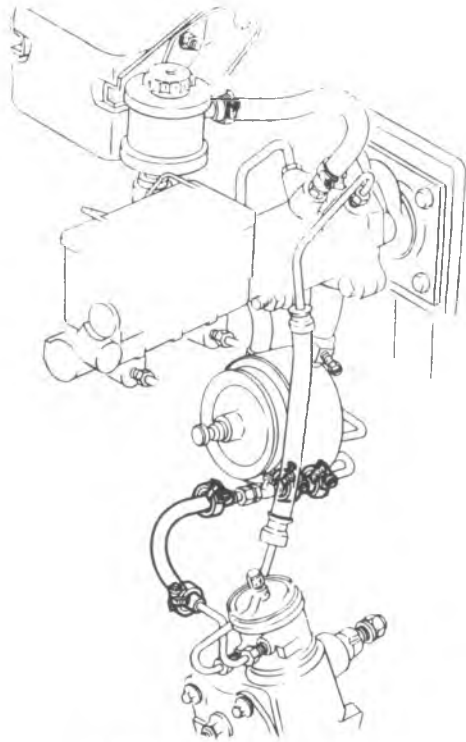
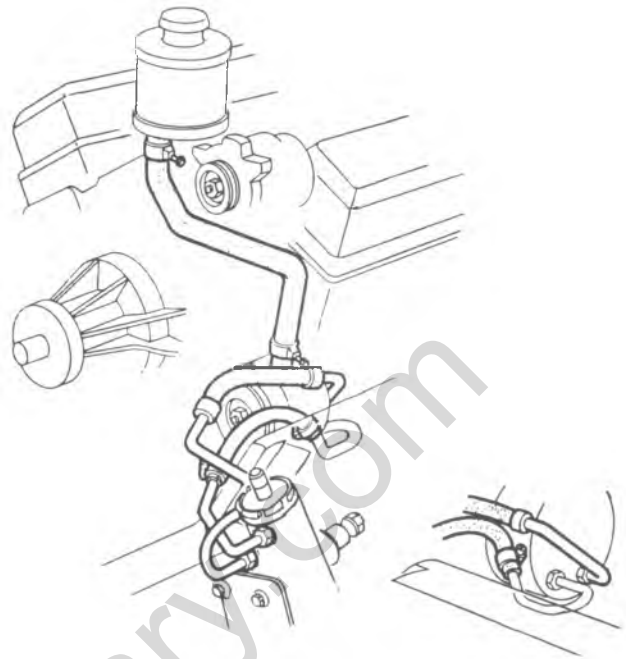

Figure 31—Power Steering Hoses—RV (4.3, 5.0, 5.7, and 6.2 Liter)



G000(00) (4.3 Liter)



G-000(00) (5.0 and 5.7 Liter)

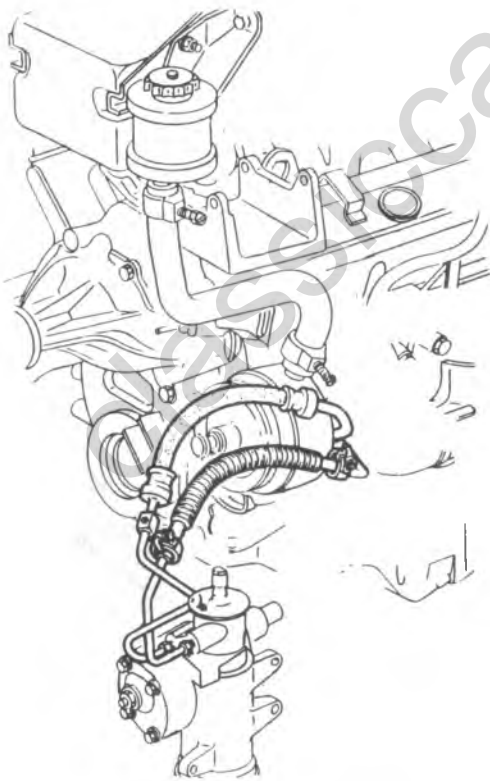

G300(00) (5.7 Liter)

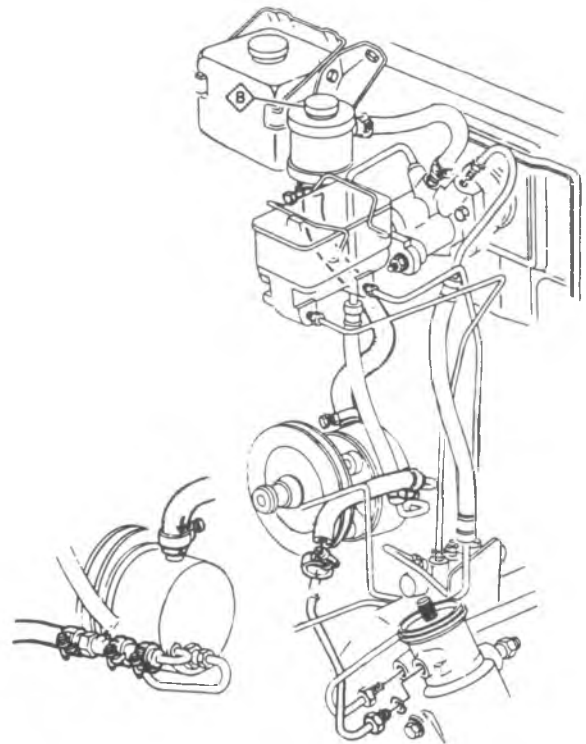

G000(00) (6.2 Liter)

Figure 32—Power Steering Hoses—G Model (4.3, 5.0, 5.7, and 6.2 Liter)

3B3-30 POWER STEERING

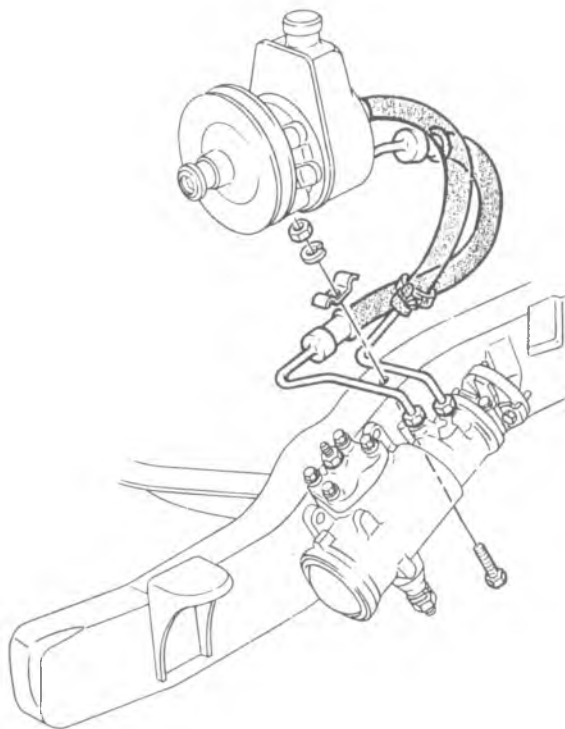

P000(42) (4.8 Liter)

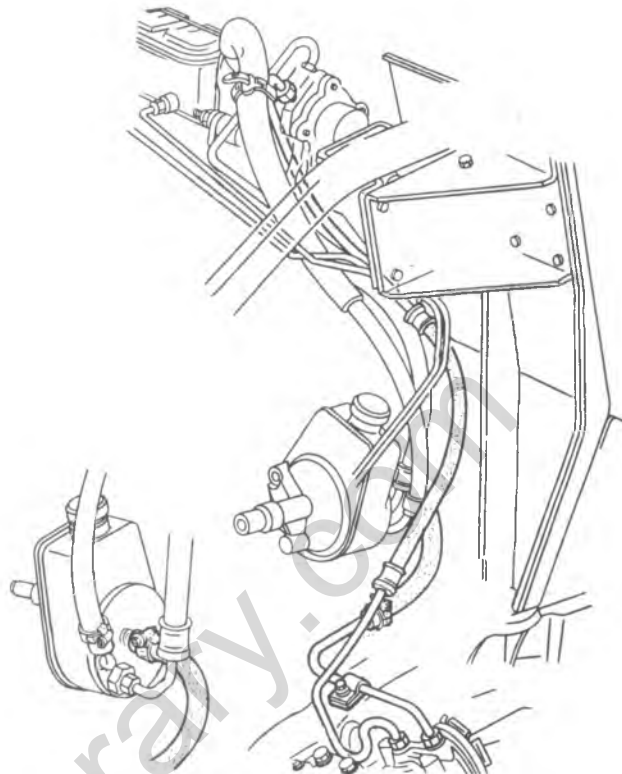

**P300(42) (4.8 Liter)
With Disc/Drum Brake
And 4 Wheel Disc Brake**

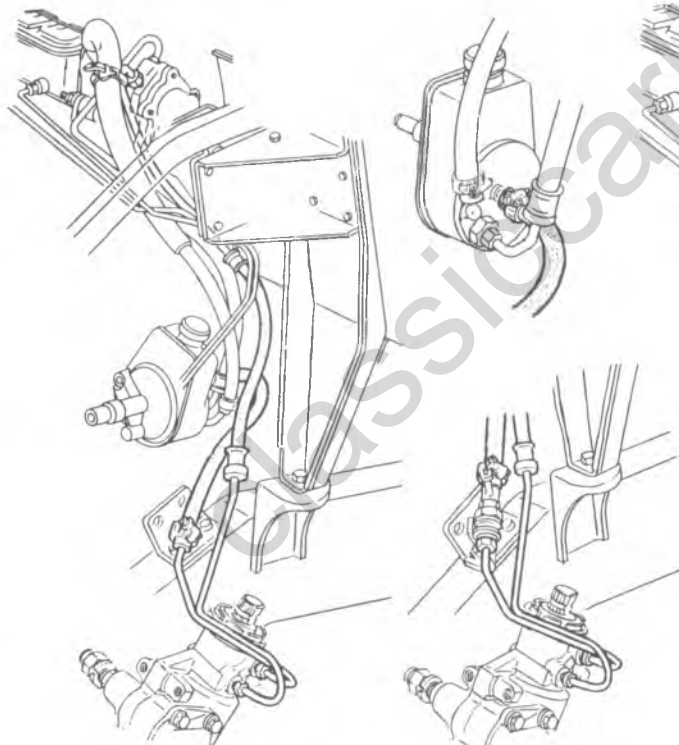

**P300(42) (4.8 Liter)
With Disc/Drum Brake
With 4 Wheel Disc Brake
With Front I Beam Axle
With Warning Switch**

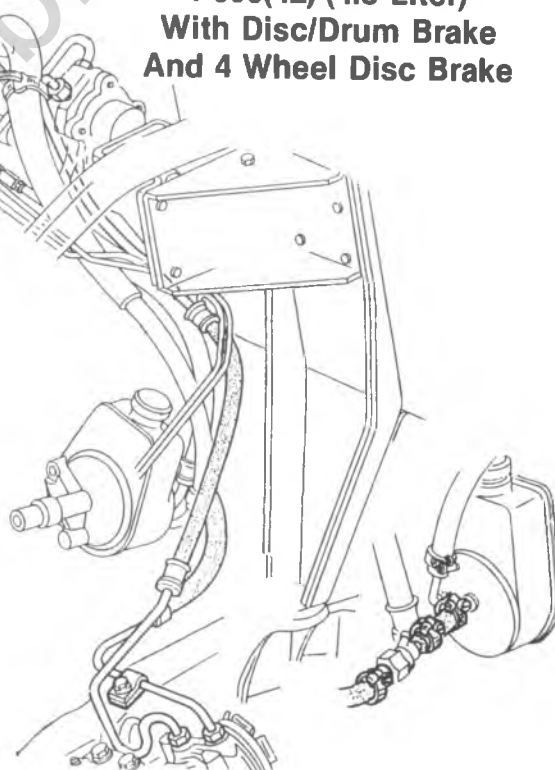

**P300(42) (4.8 Liter)
With Disc/Drum Brake
With 4 Wheel Disc Brake
With Warning Switch**

F-02643

Figure 33—Power Steering Hoses—P Model (4.8 Liter)

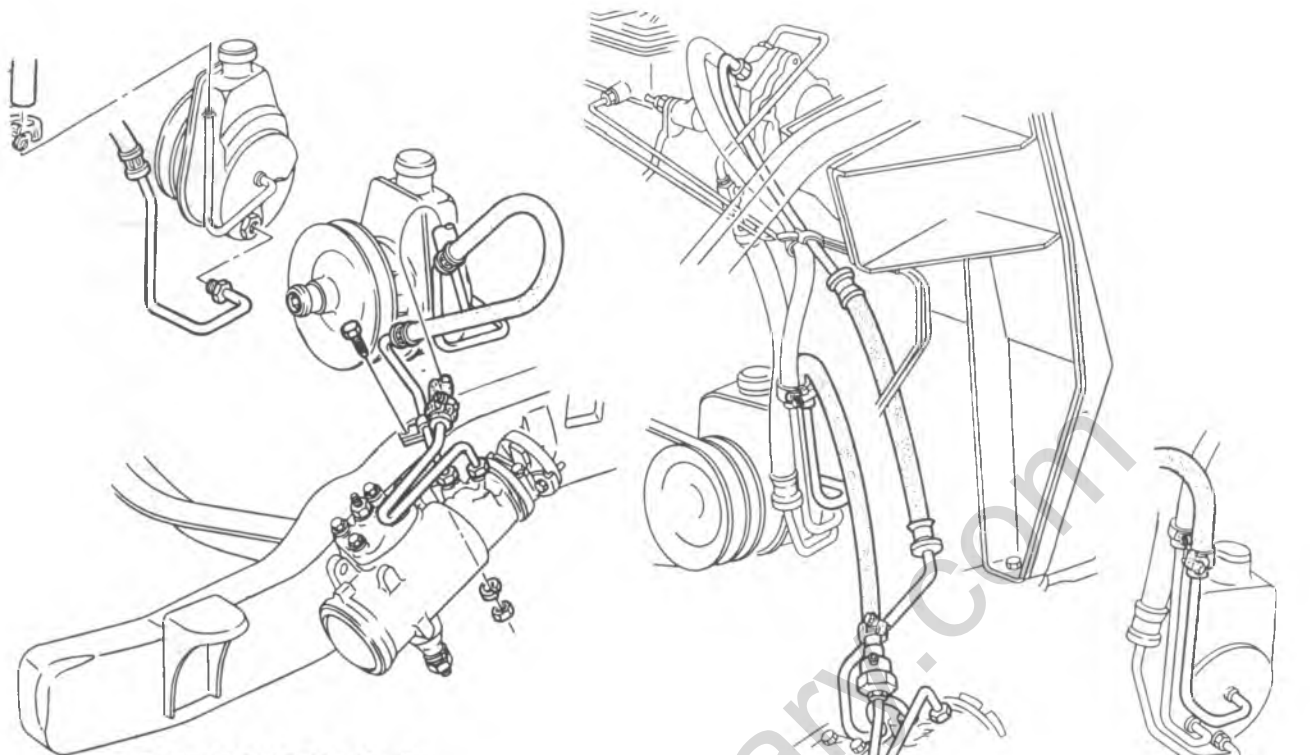

P300(42) (5.7 Liter)

**P300(42) (5.7 Liter)
With Disc/Drum Brakes
With 4 Wheel Disc Brakes
With Brake Warning Switch**

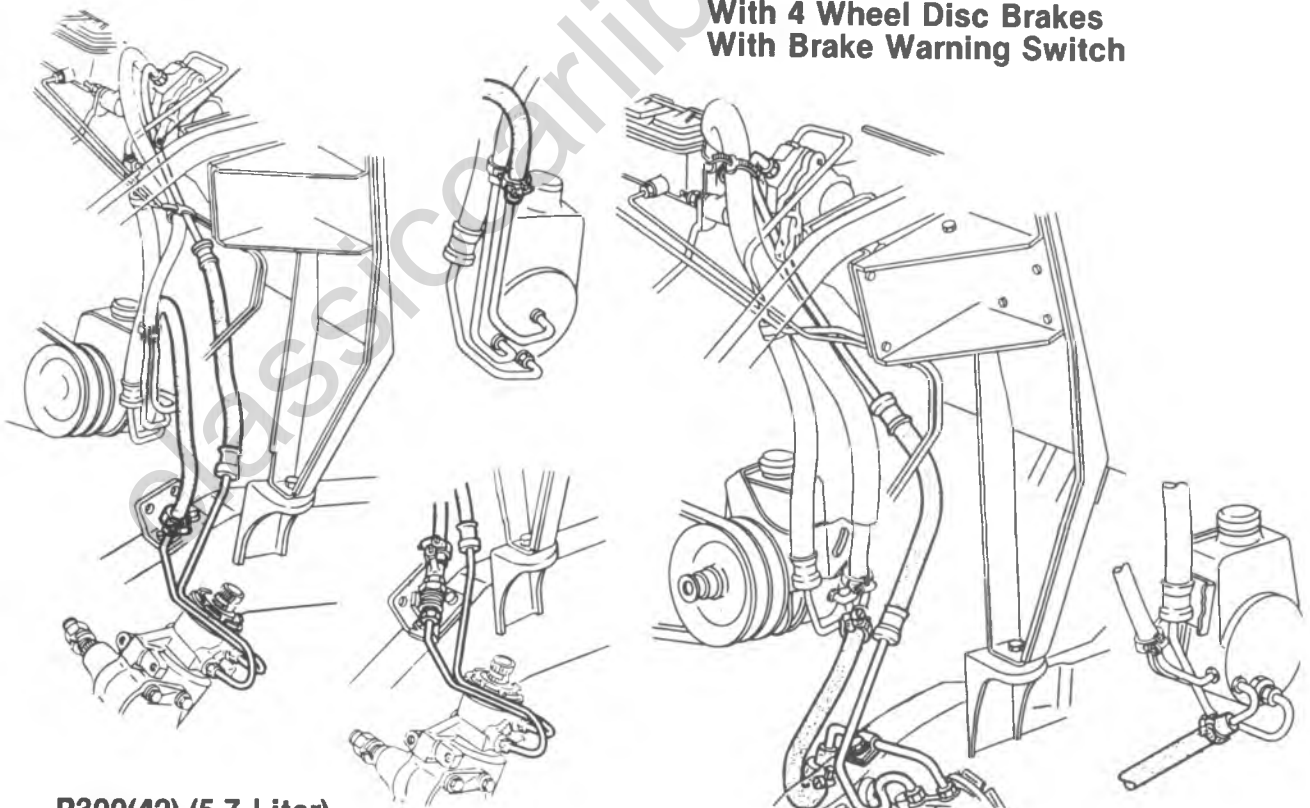

**P300(42) (5.7 Liter)
With Disc/Drum Brake
With 4 Wheel Disc Brake
With Front I-Beam Axle**

**P300(42) (5.7 Liter)
With Disc/Drum Brake
With 4 Wheel Disc Brake**

F-02644

Figure 34—Power Steering Hoses—P Model (5.7 Liter)

3B3-32 POWER STEERING

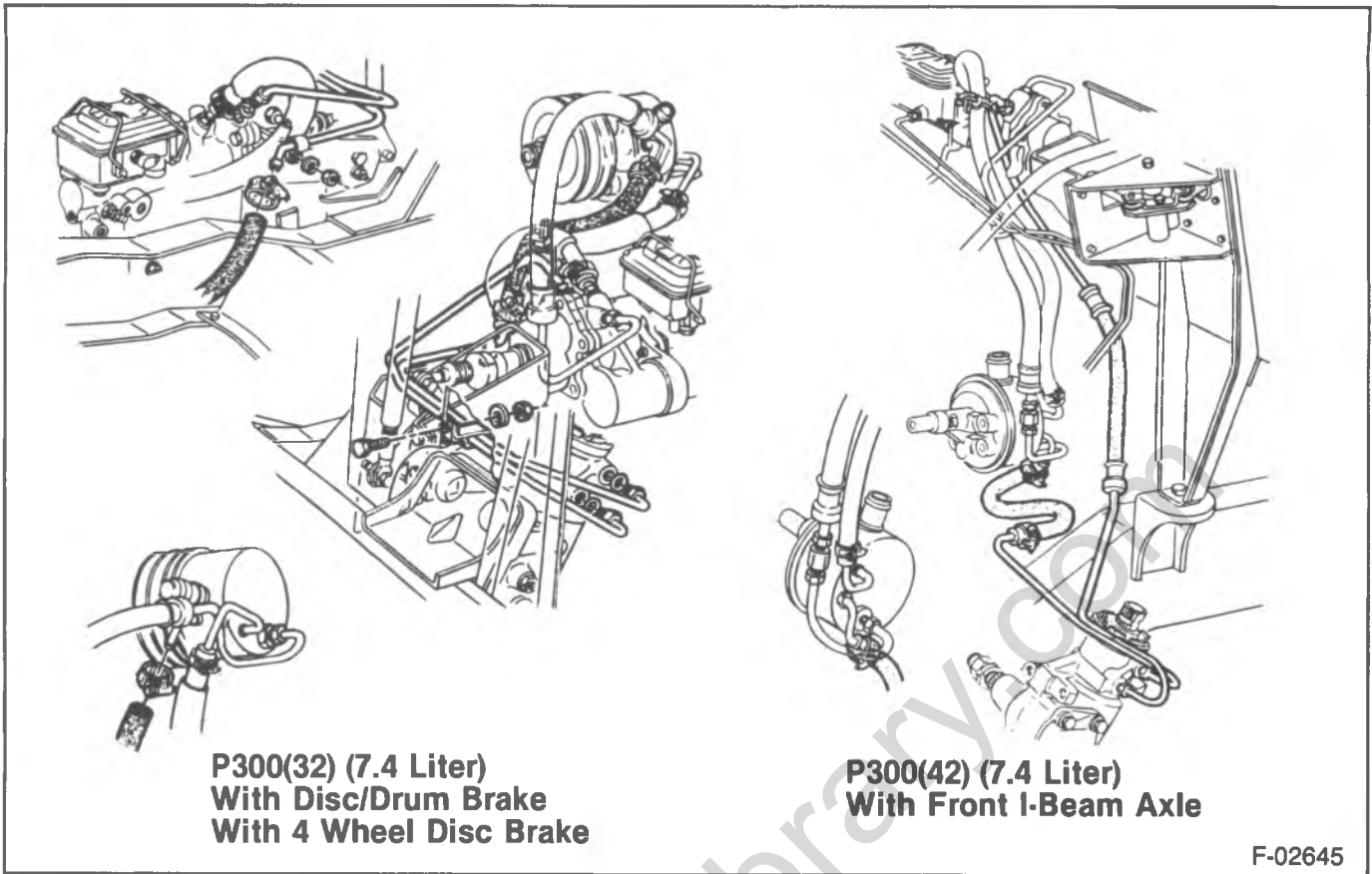
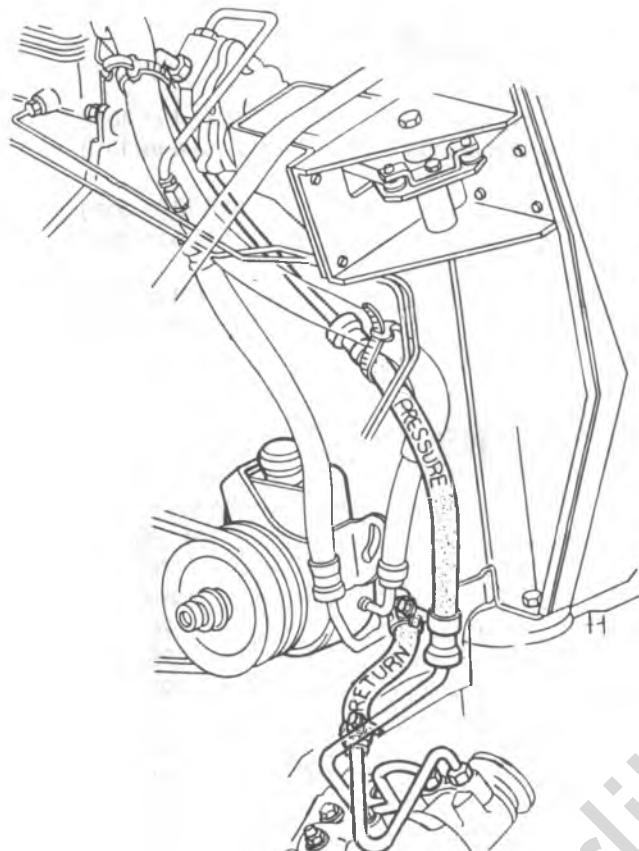
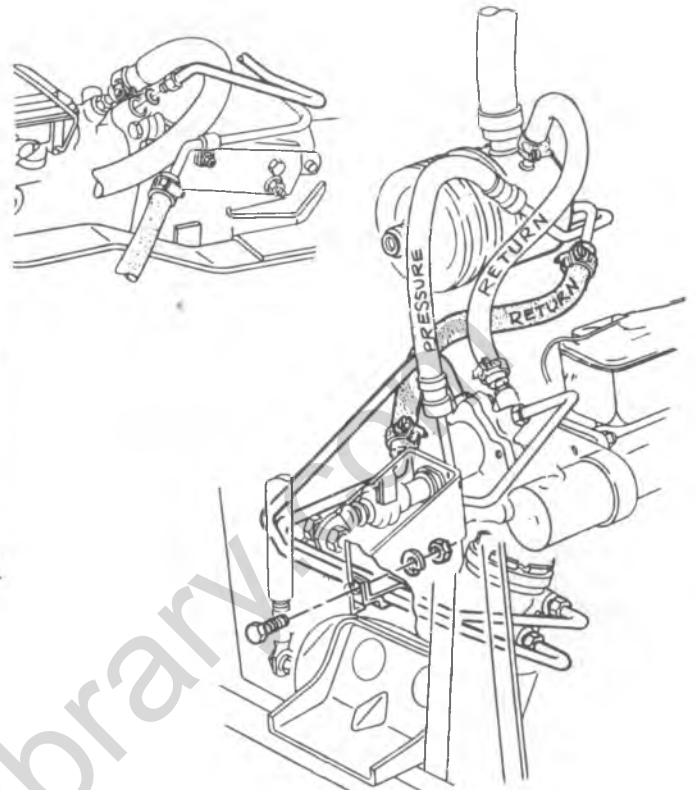

Figure 35—Power Steering Hoses—P Model (7.4 Liter)



**P300(42) (6.2 Liter)
With Disc/Drum Brake
With 4 Wheel Disc Brake**



**P300(32) (6.2 Liter)
With Disc/Drum Brake
With 4 Wheel Disc Brake**

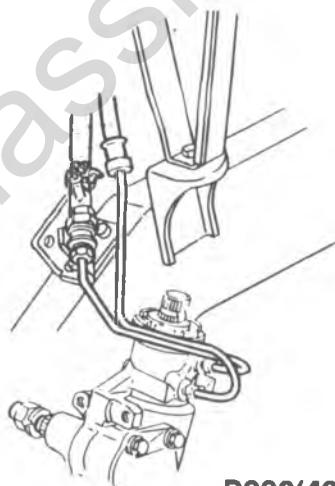

**P300(42) (6.2 Liter)
With Front I-Beam Axle
With Disc/Drum Brake
With 4 Wheel Disc Brake**

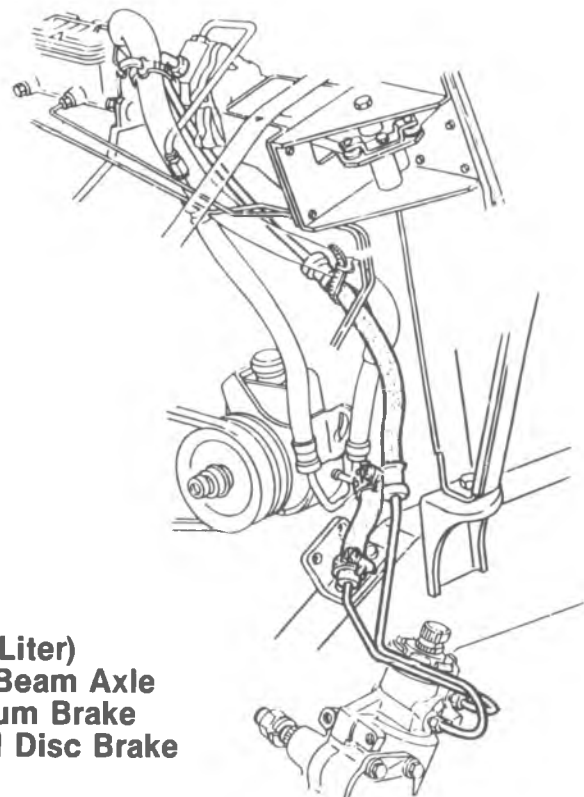

F-02646

Figure 36—Power Steering Hoses—P Model (6.2 Liter)

SPECIFICATIONS**STEERING GEAR ADJUSTMENTS**

Valve Assembly And Seal Drag01-0.4 N·m (1-4 in. lbs.)
Thrust Bearing Preload (In Excess Of Valve Assembly And Seal Drag)03-0.4 N·m (3-4 in. lbs.)
Pitman Shaft Over Center Preload	
New Gear06-1.2 N·m (6-10 in. lbs.)
Used Gear04-0.5 N·m (4-5 in. lbs.)
Final Over Center Reading (Total-Maximum)	
New Gear2 N·m (18 in. lbs.)
Used Gear	1.6 N·m (14 in. lbs.)

TORQUE SPECIFICATIONS

	TORQUE	
	N·m	Ft. Lbs.
Steering Gear To Frame Nuts (R, V, and G Models)	102	75
Steering Gear To Frame Nuts (P300(32) and P300(42)FS3)	108	80
Steering Gear To Frame Nuts (P200 + 300(42) Excluding FS3)	95	70
High Pressure Line Fitting (At Gear)	34	25
Oil Return Line Fitting (At Gear)	34	25
Pitman Shaft Adjuster Screw Jam Nut	47	35
Side Cover To Housing Bolt	60	45
Adjuster Plug Nut	110	81
Reservoir Bolt (At Pump)	48	35
Flow Control Fitting (At Pump)	48	35
Pressure Hose (At Pump)	27	20
Power Steering Pump To Booster Line	34	25
Booster To Gear Line	34	25
Return Line At Booster And Gear	34	25
Coupling Flange Nuts	27	20
Coupling Flange Pinch Bolt	42	31
Lower Intermediate Shaft Pinch Bolt (G Model)	62	46
Upper Intermediate Shaft Pinch Bolt (G Model)	47	35
Intermediate Shaft Pinch Bolts (P200 + 300(42) Excluding FS3)	102	75
Intermediate Shaft Pinch Bolts (P300(42)FS3)	108	80

SPECIFICATIONS (CONTINUED)

PUMP SPECIFICATIONS

Vehicle	Part Number	Model	Minimum Output (1)		Maximum Output (2)		Relief Valve Settings			
			GPM	L/Min.	GPM	L/Min.	Minimum		Maximum	
							PSI	kPa	PSI	kPa
R V Model	7838933	132-P-122	1.32	5.00	3.1-3.5	11.7-13.2	1200	8274	1300	8964
	7838934	132-P-123	1.32	5.00	3.1-3.5	11.7-13.2	1350	9308	1450	9998
	7838935	132-P-124	1.32	5.00	3.1-3.5	11.7-13.2	1200	8274	1300	8964
	7838936	132-P-125	1.32	5.00	3.1-3.5	11.7-13.2	1350	9308	1450	9998
	7839797	132-P-143	1.32	5.00	3.1-3.5	11.7-13.2	1350	9308	1450	9998
	7839798	132-P-144	1.32	5.00	3.1-3.5	11.7-13.2	1350	9308	1450	9998
	7839799	132-P-145	1.32	5.00	3.1-3.5	11.7-13.2	1350	9308	1450	9998
	7839800	132-P-146	1.32	5.00	3.1-3.5	11.7-13.2	1200	8274	1300	8964
	7839801	132-P-147	1.32	5.00	3.1-3.5	11.7-13.2	1200	8274	1300	8964
	7839802	132-P-148	1.32	5.00	3.1-3.5	11.7-13.2	1200	8274	1300	8964
	7839804	132-P-150	1.32	5.00	3.1-3.5	11.7-13.2	1200	8274	1300	8964
	7839813	132-P-159	1.32	5.00	3.1-3.5	11.7-13.2	1350	9308	1450	9998
	7839816	132-P-161	1.32	5.00	3.1-3.5	11.7-13.2	1350	9308	1450	9998
	7839818	132-P-163	1.32	5.00	3.1-3.5	11.7-13.2	1200	8274	1300	8964
	26000518	132-P-260	1.32	5.00	3.1-3.5	11.7-13.2	1200	8274	1300	8964
G Model	7841731	132-P-222	1.32	5.00	3.1-3.5	11.7-13.2	1350	9308	1450	9998
	7842049	132-P-228	1.32	5.00	3.1-3.5	11.7-13.2	1350	9308	1450	9998
	7847616	T115-PT-003	1.15	4.35	3.1-3.5	11.7-13.2	1350	9308	1450	9998
	7849229	132-P-253	1.32	5.00	3.1-3.5	11.7-13.2	1350	9308	1450	9998
P Model	7839808	132-P-154	1.32	5.00	2.4-2.8	9.1-10.6	1200	8274	1300	8964
	7839809	132-P-155	1.32	5.00	2.4-2.8	9.1-10.6	1200	8274	1300	8964
	7839812	132-P-158	1.32	5.00	2.4-2.8	9.1-10.6	1350	9308	1450	9998
	7839817	132-P-162	1.32	5.00	2.4-2.8	9.1-10.6	1200	8274	1300	8964
	7842032	132-P-226	1.32	5.00	3.1-3.5	11.7-13.2	1200	8274	1300	8964
	7842033	132-P-227	1.32	5.00	3.1-3.5	11.7-13.2	1200	8274	1300	8964
	7842489	132-P-230	1.32	5.00	3.1-3.5	11.7-13.2	1200	8274	1300	8964
	7842490	132-P-231	1.32	5.00	2.4-2.8	9.1-10.6	1350	9308	1450	9998
7842491	132-P-232	1.32	5.00	3.1-3.5	11.7-13.2	1200	8274	1300	8964	

1 — Output of Power Steering Fluid at 32°C (90°F) temperature when operating pump at 465 rpm against 4585-5068 kPa (665-735 psi) pressure.

2 — Output of Power Steering Fluid at 32°C (90°F) temperature when operating pump at 1500 rpm against 345 kPa (50 psi) pressure.

SPECIAL TOOLS

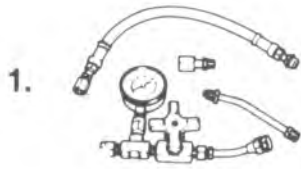

1. J-5176-D

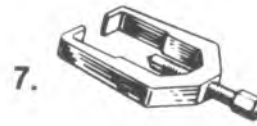

7. J-29107

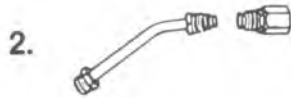

2. J-5176-20

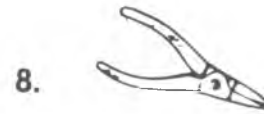

8. J-4245

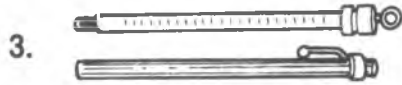

3. J-5421-02



9. J-6219

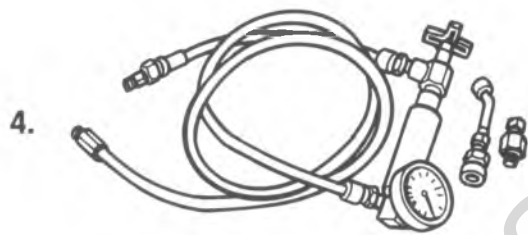

4. J-25323



10. J-7624



5. J-29525



11. J-29785-A



6. J-23600-B



12. J-25033-B

1. Power Steering Pressure Tester
2. Gauge Adapter 18mm Power Steering
3. Thermometer
4. Power Steering System Analyzer
5. Power Steering Analyzer 18mm Adapter
6. V-belt Universal Tension Gauge

7. Pitman Arm Puller
8. Snap Ring Pliers #23 Internal
9. Pitman Shaft Seal Installer
10. Bearing Preload Spanner Wrench
11. Water Pump Pulley Remover
12. Power Steering Pump Pulley Installer

SECTION 3B4

STEERING COLUMN

The following "Notice" applies to one or more steps in the assembly procedure of components in this portion of this manual as indicated at appropriate locations by the terminology "See NOTICE on page 3B4-1 of this section."

NOTICE: All steering column fasteners are important attaching parts in that they could affect the performance of vital components and systems, and/or could result in major repair expense. They must be replaced with one of the same part number or with an equivalent part if replacement becomes necessary. Torque values must be used as specified during reassembly to assure proper retention of all parts.

CONTENTS

<u>SUBJECT</u>	<u>PAGE</u>
Description	3B4- 2
Diagnosis Of The Steering Column	3B4- 2
Steering Column Electrical Component Analyzer	3B4-10
Steering Column On-Vehicle Service (All Models)	3B4-10
Inspection	3B4-10
Steering Wheel Replacement	3B4-12
Flexible Coupling Replacement	3B4-13
Intermediate Shaft Replacement	3B4-13
Steering Column On-Vehicle Service (R, V And G Models)	3B4-15
RV Model Steering Column Replacement	3B4-15
G Model Steering Column Replacement	3B4-16
Turn Signal Switch Replacement	3B4-16
Lock Cylinder Replacement	3B4-17
Tone Alarm Switch Replacement	3B4-18
Ignition Switch Replacement	3B4-18
Standard Steering Column Unit Repair (R, V And G Models)	3B4-19
Standard Steering Column Lower Bearing Adjustment	3B4-23
Tilt Steering Column Unit Repair (R, V And G Models)	3B4-26
Steering Column On-Vehicle Service P(32) Models	3B4-33
Turn Signal Switch Replacement	3B4-33
Tilt Steering Column Replacement	3B4-33
Tilt Steering Column Bearing Housing Replacement	3B4-35
Tilt Steering Column Unit Repair P(32) Models	3B4-38
Steering Column On-Vehicle Service P(42) Models	3B4-38
Standard Steering Column Replacement	3B4-38
Upper Bearing Replacement	3B4-39
Lower Bearing Replacement	3B4-41
Steering Column Lower Bearing Adjustment	3B4-41
Shift Tube Adjustment	3B4-41
Standard Steering Column Unit Repair P(42) Models	3B4-42
Intermediate Shaft Unit Repair P(42) Models	3B4-43
Specifications	3B4-44
Special Tools	3B4-45

DESCRIPTION

The locking energy absorbing steering column includes three important features in addition to the steering function:

1. The column is energy absorbing, designed to compress in a front-end collision to minimize the possibility of injury to the driver of the vehicle.
2. The ignition switch and lock are mounted on the column.
3. With the column mounted lock, the ignition, steering and gearshifting operation can be locked to inhibit theft of the vehicle.

The column may be disassembled and reassembled. To insure the energy absorbing action, it is important that the specified screws, bolts and nuts be used only as designated and that they are tightened to the specified torque.

When the column is removed from the vehicle, such actions as a sharp blow on the end of the steering shaft or shift lever, leaning on the column assembly, or dropping of the assembly could shear or loosen the plastic fasteners that maintain column rigidity.

DIAGNOSIS OF THE STEERING COLUMN

PROBLEM	POSSIBLE CAUSE	CORRECTION
Lock System Will Not Unlock	<ol style="list-style-type: none"> 1. Lock bolt damaged. 2. Faulty lock cylinder. 3. Damaged housing. 4. Damaged or collapsed sector. 5. Damaged rack. 	<ol style="list-style-type: none"> 1. Replace the lock bolt. 2. Replace or repair the lock cylinder. 3. Replace the housing. 4. Replace the sector. 5. Replace the rack.
Lock System Will Not Lock	<ol style="list-style-type: none"> 1. Lock bolt spring is broken. 2. Damaged sector tooth. 3. Faulty lock cylinder. 4. Damaged housing. 5. Damaged rack. 6. Interference between the bowl and coupling. 7. Ignition switch stuck. 8. Actuator rod restricted or bent. 9. Transmission linkage adjustment is incorrect. 	<ol style="list-style-type: none"> 1. Replace the spring. 2. Replace the sector tooth. 3. Replace the lock cylinder. 4. Replace the housing. 5. Replace the rack. 6. Adjust or replace. 7. Adjust or replace. 8. Adjust or replace. 9. Adjust.
Lock System—High Lock Effort	<ol style="list-style-type: none"> 1. Lock cylinder is faulty. 2. Ignition switch is faulty. 3. Rack preload spring is broken or weak. 4. Burrs on the sector, rack, housing, support, tang of the shift gate or actuator rod coupling. 5. Bent sector shaft. 6. Distorted rack. 7. Misalignment of the housing to the cover (tilt only). 8. Distorted coupling slot in the rack (tilt only). 9. Bent or restricted actuator rod. 10. Ignition switch mounting bracket is bent. 	<ol style="list-style-type: none"> 1. Replace the lock cylinder. 2. Replace the ignition switch. 3. Replace the spring. 4. Remove the burrs. 5. Replace the shaft. 6. Replace the rack. 7. Replace either or both. 8. Replace the rack. 9. Straighten or replace the rod. 10. Straighten or replace the bracket.

DIAGNOSIS OF THE STEERING COLUMN (CONT.)

PROBLEM	POSSIBLE CAUSE	CORRECTION
Lock Cylinder—High Effort Between The “Off” and “Off-Lock” Positions	<ol style="list-style-type: none"> 1. Burr on tang of shift gate. 2. Distorted rack. 	<ol style="list-style-type: none"> 1. Remove the burr. 2. Replace the rack.
Sticks In “Start” Position	<ol style="list-style-type: none"> 1. Actuator rod is deformed. 2. Any high effort condition. 	<ol style="list-style-type: none"> 1. Straighten or replace the rod. 2. See “correction” under the high effort diagnosis.
Key Cannot Be Removed In The “Off-Lock” Position	<ol style="list-style-type: none"> 1. Ignition switch is not set correctly. 2. Faulty lock cylinder. 	<ol style="list-style-type: none"> 1. Adjust ignition switch. 2. Replace the lock cylinder.
The Lock Cylinder Can Be Removed Without Depressing The Retainer	<ol style="list-style-type: none"> 1. Faulty retainer. 2. Burr over the retainer slot in the housing cover. 	<ol style="list-style-type: none"> 1. Replace the lock cylinder. 2. Remove the burr.
Lock Bolt Hits The Shaft Lock In The “Off” And “Park” Positions	Ignition switch is not set correctly.	Adjust the ignition switch.
Noise In The Column	<ol style="list-style-type: none"> 1. Flexible coupling pulled apart. 2. Column not correctly aligned. 3. One click in Off-Unlock position and when the steering wheel is moved. 4. Horn contact ring not lubricated. 5. Lack of grease on the bearings or bearing surface. 6. Lower shaft bearing is tight or frozen. 7. Upper shaft bearing is tight or frozen. 8. Lock plate retaining ring is not seated. 9. Steering shaft snap ring is not seated. 10. Shroud or housing is loose. 11. Sheared intermediate shaft plastic joint. 	<ol style="list-style-type: none"> 1. Align the column and replace the flexible coupling. 2. Align the column. 3. Normal seating of the lock bolt. 4. Lubricate. 5. Lubricate the bearings. 6. Replace the bearing. Inspect the shaft and replace if scored. 7. Replace the housing assembly. 8. Replace the retaining ring. Inspect for proper seating in the groove. 9. Replace the snap ring. Inspect for proper seating in the groove. 10. Tighten mounting screws. 11. Repair or replace the steering shaft. Align the column.
High Steering Shaft Effort	<ol style="list-style-type: none"> 1. Column assembly is misaligned in the vehicle. 2. Tight or frozen upper or lower bearings. 3. Binding intermediate shaft U-joints. 	<ol style="list-style-type: none"> 1. Align correctly. 2. Replace the bearings. 3. Repair or replace the intermediate shaft.

3B4-4 STEERING COLUMN

DIAGNOSIS OF THE STEERING COLUMN (CONT.)

PROBLEM	POSSIBLE CAUSE	CORRECTION
High Shift Effort	<ol style="list-style-type: none">1. Column assembly is misaligned in the vehicle.2. Lower bowl bearing is not aligned correctly.3. Lack of grease on the bearing or seal areas.4. Shift tube is bent or broken.	<ol style="list-style-type: none">1. Align correctly.2. Align correctly.3. Lubricate bearings and seals.4. Replace the shift tubes.
Improper Transmission Shifter	<ol style="list-style-type: none">1. Sheared shift tube joint.2. Improper transmission linkage adjustment.3. Loose lower shift lever.4. Sheared lower shift lever weld.	<ol style="list-style-type: none">1. Replace the shift tube assembly.2. Adjust the linkage.3. Replace the shift tube assembly.4. Replace the shift tube assembly.
Lash In Mounted Column Assembly	<ol style="list-style-type: none">1. Column mounting bracket bolts loose.2. Broken weld nuts on the jacket.3. Column bracket capsule sheared.4. Loose shoes in the housing (tilt only).5. Loose tilt head pivot pins (tilt only).	<ol style="list-style-type: none">1. Tighten to specifications.2. Replace the jacket assembly.3. Replace the bracket assembly.4. Replace the shoes.5. Replace the pivot pins.
Driver Can Lock Steering In The Second Gear (Manual Transmission Columns)	<ol style="list-style-type: none">1. Faulty upper shift lever.2. Faulty shift lever gate.3. Loose relay lever on the shift tube.	<ol style="list-style-type: none">1. Replace the shift lever.2. Replace the shift lever gate.3. Replace the shift tube assembly.
Excessive Play In The Mounted Steering Column Assembly (Tilt Column)	<ol style="list-style-type: none">1. Column mounting bracket bolts loose.2. Loose support screws.3. Loose tilt head pivot pins.4. Loose lock shoe pin in the support.	<ol style="list-style-type: none">1. Tighten to specifications.2. Tighten to specifications.3. Replace the pivot pins.4. Replace the pin.
Housing Loose (Tilt Column)	<ol style="list-style-type: none">1. Excessive clearance between the holes in the support or the housing and pivot pin diameter.2. Faulty anti-lash spring in the centering spheres.3. Upper bearing not seating in the bearing race.4. Upper bearing inner race seat missing.5. Bearing preload spring broken.6. Loose support screws.	<ol style="list-style-type: none">1. Replace either or both.2. Replace the spring.3. Replace both.4. Install the seat.5. Replace preload spring.6. Tighten to specifications.
Housing Scraping On The Bowl (Tilt Column)	Bowl bent or not concentric with the hub.	Replace the bowl.

DIAGNOSIS OF THE STEERING COLUMN (CONT.)

PROBLEM	POSSIBLE CAUSE	CORRECTION
Steering Wheel Loose Every Other Tilt Position (Tilt Column)	Loose fit between the lock shoe and pivot pin.	Replace both.
Steering Column Will Not Lock In Any Tilt Position (Tilt Column)	<ol style="list-style-type: none"> 1. Lock shoe grooves may have burrs or dirt. 2. Lock shoe spring is weak or broken. 3. Lock shoe seized on its pivot pin. 	<ol style="list-style-type: none"> 1. Replace lock shoes and clean the grooves. 2. Replace the spring. 3. Replace both lock shoes.
Noise When Tilting The Column (Tilt Column)	<ol style="list-style-type: none"> 1. Tilt spring rubbing in the housing. 2. Tilt bumpers are worn. 	<ol style="list-style-type: none"> 1. Lubricate. 2. Replace the tilt bumpers.
Steering Wheel Fails To Return To The Top Tilt Position (Tilt Column)	<ol style="list-style-type: none"> 1. Pivot pins are bound up. 2. Wheel tilt spring is faulty. 3. The turn signal switch wires are too tight. 	<ol style="list-style-type: none"> 1. Replace the pivot pins. 2. Replace the spring. 3. Reposition the wires.
Dimmer Switch Will Not Function	<ol style="list-style-type: none"> 1. Loose connector at the dimmer switch. 2. Improper adjustment. 3. Internally damaged or worn switch. 	<ol style="list-style-type: none"> 1. Tighten or replace. 2. Readjust. 3. Replace.
Turn Signal Will Not Cancel	<ol style="list-style-type: none"> 1. Loose switch mounting screws. 2. Switch or anchor bosses broken. 3. Broken, missing or out of position detent, return or cancelling spring. 4. Uneven or incorrect cancelling cam to cancelling spring interference. 	<ol style="list-style-type: none"> 1. Tighten screws to 2.8 N·m (25 in. lbs.). 2. Replace the switch. 3. Reposition or replace the springs as required. 4. Adjust the switch position. <ul style="list-style-type: none"> • If the interference is correct and switch will still not cancel, replace the switch. • If the interference cannot be corrected by the switch adjustment, replace the cancelling cam.
Turn Signal Difficult To Operate	<ol style="list-style-type: none"> 1. Actuator rod loose. 2. Yoke broken or distorted. 3. Loose or misplaced springs. 4. Foreign parts and/or materials. 5. Switch mounted loosely. 	<ol style="list-style-type: none"> 1. Tighten mounting screw to 1.4 N·m (12 in. lbs.). 2. Replace the switch. 3. Reposition or replace the springs. 4. Remove the foreign parts and/or material. 5. Tighten mounting screws to 2.8 (25 in. lbs.).
Turn Signal Will Not Indicate Lane Change	<ol style="list-style-type: none"> 1. Broken lane change pressure pad or spring hanger. 2. Broken, missing or misplaced lane change spring. 3. Jammed base or wires. 	<ol style="list-style-type: none"> 1. Replace the switch. 2. Replace or reposition as required. 3. Loosen mounting screws, reposition base or wires and tighten the screws to 2.8 N·m (25 in. lbs.).

DIAGNOSIS OF THE STEERING COLUMN (CONT.)

PROBLEM	POSSIBLE CAUSE	CORRECTION
Turn Signal Will Not Stay In Turn Position	<ol style="list-style-type: none"> 1. Foreign material or loose parts impeding movement of the yoke. 2. Broken or missing detent or cancelling springs. 3. None of the above. 	<ol style="list-style-type: none"> 1. Remove material and/or parts. 2. Replace the spring. 3. Replace the switch.
Hazard Switch Cannot Be Turned Off	Foreign material between hazard support cancelling leg and yoke.	Remove the foreign material. <ul style="list-style-type: none"> • No foreign material. Replace the turn signal switch.
Hazard Switch Will Not Stay On Or Difficult To Turn Off	<ol style="list-style-type: none"> 1. Loose switch, mounting screws. 2. Interference with other components. 3. Foreign material. 4. None of the above. 	<ol style="list-style-type: none"> 1. Tighten mounting screws to 2.8 N_m (25 in. lbs.). 2. Remove the interference. 3. Remove the foreign material. 4. Replace the switch.
No Turn Signal Lights	<ol style="list-style-type: none"> 1. Faulty or blown fuse. 2. Inoperative turn signal flasher. 3. Loose chassis to column connector. 4. Disconnect column to chassis connector. Connect new switch to chassis and operate switch by hand. If vehicle lights now operate normally, signal switch is inoperative. 5. If vehicle lights do not operate, check chassis wiring for opens, grounds, etc. 	<ol style="list-style-type: none"> 1. Replace fuse and check operation. 2. Replace the turn signal flasher. 3. Connect securely, check operation. 4. Replace the signal switch. 5. Repair the chassis wiring.
Turn Indicator Lights On, But Not Flashing	<ol style="list-style-type: none"> 1. Inoperative turn flasher. 2. Loose chassis to column connection. 3. Inoperative turn signal switch. 4. To determine if turn signal switch is faulty, substitute a new switch into the circuit and operate the switch by hand. If the vehicle's lights operate normally, the signal switch is inoperative. 5. If the vehicle's lights do not operate, check light sockets for high resistance connections, the chassis wiring for opens, grounds, etc. 	<ol style="list-style-type: none"> 1. Replace the turn flasher. 2. Connect securely and check operation. 3. Replace the turn signal switch. 4. Replace the signal switch. 5. Repair the chassis wiring.
Front Or Rear Turn Signal Lights Are Not Flashing	<ol style="list-style-type: none"> 1. Burned out fuse. 2. Burned out or damaged turn signal bulb. 3. High resistance connection to ground at the bulb socket. 4. Loose chassis to column connector. 	<ol style="list-style-type: none"> 1. Replace fuse and check operation. 2. Replace the bulb. 3. Remove or repair the faulty connection and check operation. 4. Connect securely and check operation.

DIAGNOSIS OF THE STEERING COLUMN (CONT.)

PROBLEM	POSSIBLE CAUSE	CORRECTION
Front Or Rear Turn Signal Lights Are Not Flashing (Cont.)	<ol style="list-style-type: none"> 5. Disconnect column to the chassis connector. Connect a new switch into the system and operate the switch by hand. If turn signal lights are now on and flash, the turn signal switch is inoperative. 6. If vehicle lights do not operate, check the chassis wiring harness to light sockets for opens, grounds, etc. 	<ol style="list-style-type: none"> 5. Replace the turn signal switch. 6. Repair the chassis wiring.
Stop Light Not On When Turn Indicated	<ol style="list-style-type: none"> 1. Burned out fuse. 2. Loose column to chassis connection. 3. Disconnect column to chassis connector. Connect new switch into system without removing old. Operate switch by hand. If brake lights work with switch in the turn position, signal switch is faulty. 4. If brake lights do not work, check connector to stop light, the sockets for grounds, opens, etc. 	<ol style="list-style-type: none"> 1. Replace fuse and check operation. 2. Connect securely and check operation. 3. Replace the signal switch. 4. Repair connector to stop lights circuits.
Turn Indicator Panel Lights Not Flashing	<ol style="list-style-type: none"> 1. Burned out bulbs. 2. High resistance to ground at the bulb socket. 3. Opens, grounds in wiring harness from the front turn signal bulb socket to the indicator lights. 	<ol style="list-style-type: none"> 1. Replace the bulbs. 2. Replace the socket. 3. Locate and repair as required.
Turn Signal Lights Flash Very Slowly	<ol style="list-style-type: none"> 1. Inoperative turn signal flasher. 2. System charging voltage low. 3. High resistance ground at light sockets. 4. Loose chassis to column connection. 5. Disconnect column to chassis connector. Connect new switch into system without removing old. Operate switch by hand. If flashing occurs at normal rate, the signal switch is faulty. 6. If the flashing rate is still extremely slow, check chassis wiring harness from the connector to the light sockets for high resistance. 	<ol style="list-style-type: none"> 1. Replace the turn signal flasher. 2. Increase voltage to specifications. Refer to (SEC. 6D ENGINE ELECTRICAL) in this manual. 3. Repair high resistance grounds at the light sockets. 4. Connect securely and check operation. 5. Replace signal switch. 6. Locate and repair as required. Refer to SEC. 8B (CHASSIS ELECTRICAL) in this manual.

DIAGNOSIS OF THE STEERING COLUMN (CONT.)

PROBLEM	POSSIBLE CAUSE	CORRECTION
<p>Hazard Signal Lights Will Not Flash—Turn Signal Functions Normally</p>	<ol style="list-style-type: none"> 1. Blown fuse. 2. Inoperative hazard warning flasher. 3. Loose chassis to column connection. 4. Disconnect column to chassis connector. Connect new switch into system without removing old. Depress the hazard warning button and observe the hazard warning lights. If they now work normally, the turn signal switch is faulty. 5. If the lights do not flash, check wiring harness "K" lead (brown) for open between hazard flasher and harmonica connector. If open, fuse block is faulty. 	<ol style="list-style-type: none"> 1. Replace fuse and check operation. 2. Replace the hazard warning flasher. 3. Connect securely and check operation. 4. Replace the turn signal switch. 5. Replace fuse block. Refer to SEC. 8B (CHASSIS ELECTRICAL) in this manual.
<p>Tone Alarm Does Not Sound With Key Fully Inserted In Lock Cylinder With Driver's Door Open</p>	<ol style="list-style-type: none"> 1. Loose connection at the tone alarm. 2. Voltage not available to the tone alarm. 3. Faulty tone alarm. 4. Door jamb switch on the driver's side is maladjusted or inoperative. 5. Short in the chassis wiring. 6. Short or fault in the signal switch wiring. 7. Chips, burrs, foreign material is preventing actuator tip function. NOTICE: Key must be removed or the cylinder in the "run" position before removing the lock cylinder. 8. Faulty lock cylinder. 9. Chips, foreign material affecting the tone alarm switch operation. 10. Damaged or broken tone alarm switch. 11. Inoperative tone alarm switch (switch appears good but will not make the tone alarm switch function check). 12. Tone alarm switch contact gap is too large. 	<ol style="list-style-type: none"> 1. Connect securely. 2. Check the continuity of the chassis wiring and repair as required. 3. Replace the tone alarm. 4. Adjust or replace as required. 5. Check by separating chassis to column connector. Connect E and F female contacts on the chassis side (bent paper clip will work). If tone alarm sounds, continue diagnosis. If not, locate and repair chassis wiring. 6. Connect male E and F contacts of connector with the jumper. Check buzzer switch pads with the ohmmeter. If contact is made, function is normal. If not, replace the signal switch. 7. Remove chips and burrs. Reassemble and check. 8. With the lock cylinder out (refer to "Notice" under step 7), fully insert and remove the key. The actuator should extend and retract smoothly. Total expansion of tip should be 1.25 mm (0.050 inch). If not, replace the lock cylinder. 9. Remove and clean as required—reassemble and check. 10. Replace the tone alarm switch. 11. Connect the ohmmeter leads to the tone alarm switch probes. Press on the actuator pad until the interior points contact. If contact is not made, replace the tone alarm switch. 12. Reset the contact gap.

DIAGNOSIS OF THE STEERING COLUMN (CONT.)

PROBLEM	POSSIBLE CAUSE	CORRECTION
Tone Alarm Does Not Sound With Key Fully Inserted In Lock Cylinder With Driver's Door Open (Cont.)	13. If the tone alarm fault has not yet been detected, connect a continuity meter (or light) to the male E and F connector contacts. Insert the key the full depth into the lock cylinder. If contact is made with the key in, and is not made with it out, the function is normal. Retrace the initial diagnostic steps. If contact is not established, the fault is in the column. 14. If the fault has not yet been isolated and repaired, connect ohmmeter to the tone alarm switch probes. Fully insert and remove the key from the lock cylinder. If contact is made with the key in, and is broken with it out, the function is normal. Retrace the diagnostic steps. If contact is not made, the fault is in the lock cylinder or tone alarm switch.	13. With the fault isolated in the column, disassemble the upper end of the column until the signal switch mounting screws have been removed. Lift the switch and check the probes of the tone alarm switch to ensure good contact with the pads in the signal switch. Bend the probes, if required, then reseat the signal switch and install the three screws. Check the function. 14. Setting the contact gap. Press a 0.75 mm (0.030 inch) wire type spark plug gap wire with flat piece of stock on the actuator pad. If contact is not made, adjust switch until positive contact is made (use ohmmeter). With positive contact at 0.75 mm (0.030 inch) use a 0.65 mm (0.025 inch) plug gap wire beneath the flat stock. No contact should occur. Adjust. When the switch will make contact with the 0.75 mm (0.030 inch) wire and not with the 0.65 mm (0.025 inch) wire, the tone alarm switch is set at the low limit.
Tone Alarm Continues To Operate With Key In The Lock Cylinder With The Driver's Door Either Opened Or Closed And Ceases When Key Is Removed	1. Door jamb switch on driver's side maladjusted or inoperative. 2. Wire from signal switch to door jamb switch shorted.	1. Adjust or replace as required. 2. If on signal switch side, replace signal switch. If on chassis side, find and repair. This condition indicates the lock cylinder or tone alarm switch is at fault. To verify, check for continuity at the E and F male connector contacts with the key removed from the cylinder. If continuity exists, the fault is in the column.
Tone Alarm Continues To Operate With Key Out, But Stops When Driver's Door Is Closed	1. Lock cylinder binding (turn lock toward start position. If tone alarm stops in the run position or when turned past run towards the start, the problem is a sticky lock cylinder actuator). 2. Chips, foreign material in lock cylinder bore. 3. Sticky lock cylinder actuator tip. 4. Damaged or broken tone alarm switch. 5. Tone alarm switch contact gap is too close.	1. Replace the lock cylinder. 2. Remove, assemble and recheck function. 3. Replace the lock cylinder. 4. Replace the tone alarm switch. 5. Adjust as specified.

STEERING COLUMN ON-VEHICLE SERVICE (ALL MODELS)

INSPECTION

SHIFTER SHAFT

Separation of the shifter shaft sections will be internal and cannot be visually identified. Hold lower end of the "shifter shaft" and move the "shift lever" on the column through its ranges and up and down. If there is little or no movement of the "shifter shaft," the plastic joints are sheared.

STEERING SHAFT

If the steering shaft plastic pins have been sheared, the shaft will rattle when struck lightly from the side and some lash may be felt when rotating the steering wheel while holding the rag joint. If the steering shaft pins are sheared due to minor collision without serious damage to other components, the vehicle can be safely steered; however, steering shaft replacement is recommended.

COLUMN JACKET

Inspect the jacket section of the column for looseness, and/or bends.

COLUMN SUPPORT BRACKET

Damage in this area will be indicated by separation of the mounting capsules from the bracket. The bracket will have moved forward toward the entire compartment and will usually result in collapsing of the jacket section of the steering column.

STEERING COLUMN FOR ACCIDENT DAMAGE

NOTICE: Vehicles involved in accidents resulting in frame damage, major body or sheet metal damage, or where the steering column has been impacted may also have a damaged or misaligned steering column.

Inspect (Figures 1 through 3)

1. Capsules on the steering column bracket assembly. The capsules must be within 1.59 (1/16 inch) from the bottom of the slots (figure 1). If not, the bracket should be replaced.

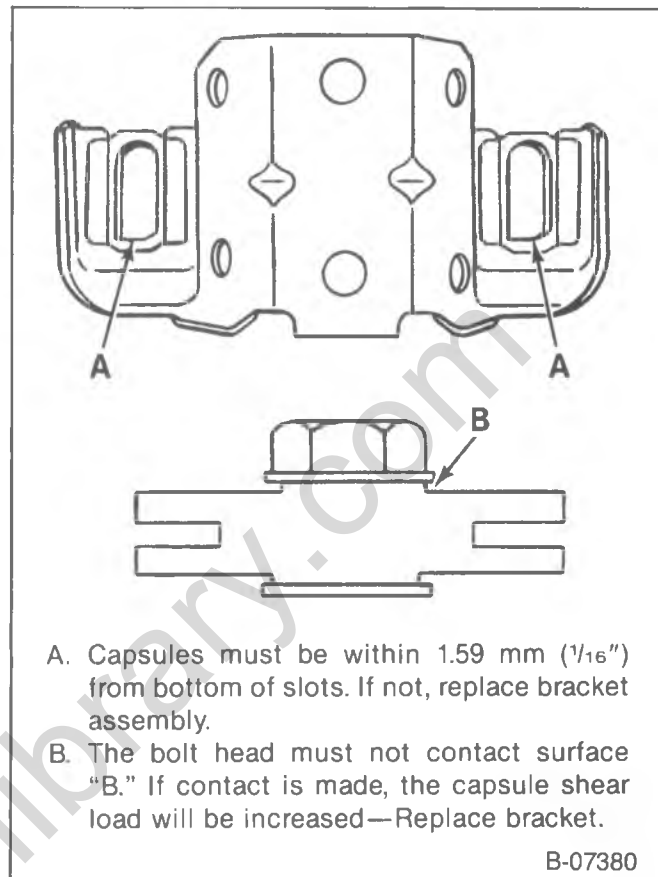
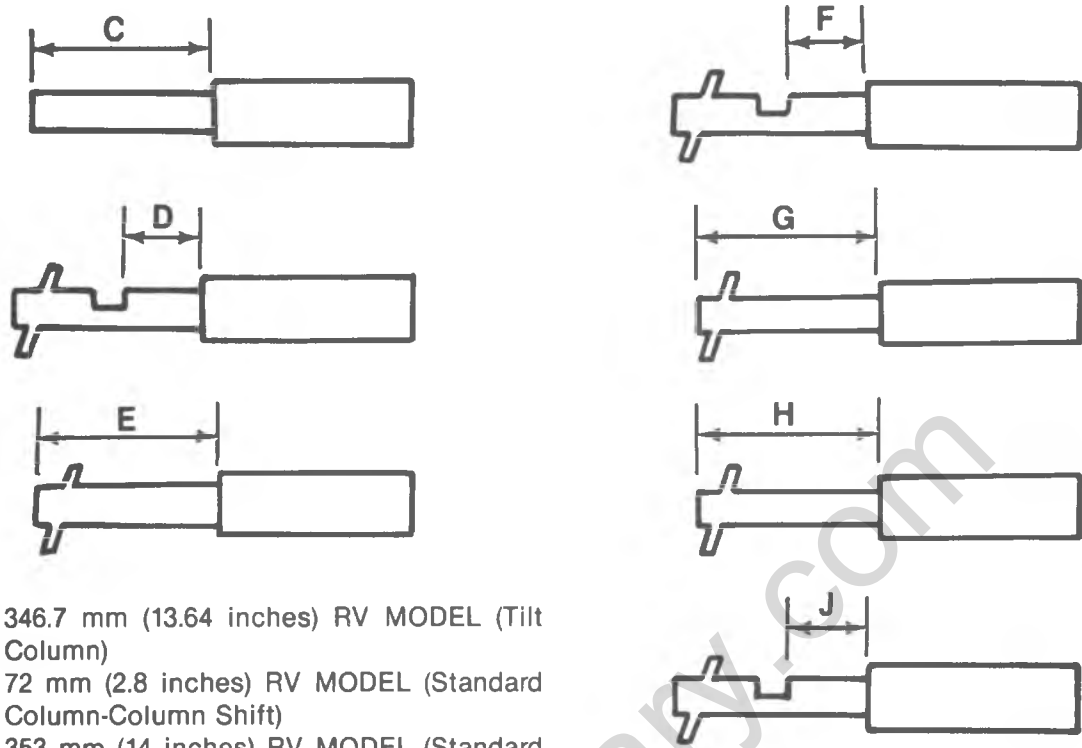

Figure 1—Steering Column Collapse Inspection

2. Contact surface (figure 1). The bolthead must not contact surface "B" or the shear load would be increased. If contact is made, replace the bracket.
3. Shift lever operation on vehicles with automatic transmission and column shift. If the shift lever is able to move to the "Park" position without raising the lever, the upper shift tube plastic bearing is broken.
4. Jacket collapse. Measure the jacket collapse dimensions, depending on the vehicle and steering column, in either of the following ways (figure 2):
 - Measure from the end of the bearing assembly to the lower edge of the upper jacket (C).



- C. 346.7 mm (13.64 inches) RV MODEL (Tilt Column)
- D. 72 mm (2.8 inches) RV MODEL (Standard Column-Column Shift)
- E. 353 mm (14 inches) RV MODEL (Standard Column-Floor Shift)
- F. 81.7 mm (3.21 inches) G MODEL (Tilt Column-Column Shift)
- G. 144.9 mm (5.70 inches) G MODEL (Tilt Column-4 Speed)
- H. 192 mm (7.5 inches) G MODEL (Standard Column-Column Shift)
- J. 80 mm (3.1 inches) G MODEL (Tilt Column-Floor Shift)

F-02585

Figure 2—Steering Column Collapse Inspection

ClassicCarLibrary.com

3B4-12 STEERING COLUMN

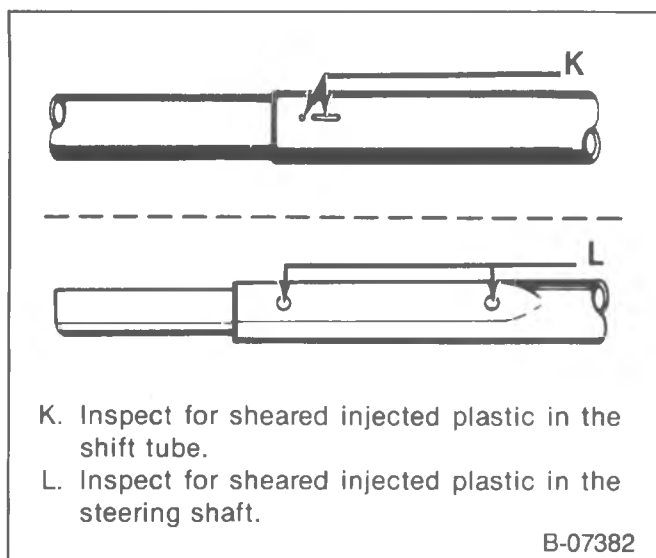

Figure 3—Steering Column Collapse Inspection

- Measure from the collar on the toe plate flange to the lower edge of the upper jacket (E, G and H).
- Measure from the edge of the back-up switch window to the lower edge of the upper jacket (D, F and J).

If the jacket dimensions are not within specifications, a new jacket must be installed.

- Visually inspect for sheared injected plastic in the shift tube, and the steering shaft (figure 3). If either one or both are sheared, replace with new parts.
5. Any frame damage that could cause a bent steering shaft must have the steering shaft runout checked in the following manner: Remove intermediate shaft. Hold a ruler against the lower end of steering shaft and have the steering wheel rotated. The runout must not exceed 1.59 mm ($1/16$ inch). A dial indicator may be used instead of a ruler.

STEERING WHEEL REPLACEMENT

↔ Remove or Disconnect (Figure 4)

Tools Required:

J-1859-03 Steering Wheel Puller

1. Battery ground cable.
2. Horn button cap.
3. Retainer and steering wheel nut.
4. Horn lead assembly (some models).
 - Mark the relationship of the steering wheel to the steering shaft.
5. Steering wheel. Use J-1859-03 (figure 4). Do not hammer on the puller, or damage could result to the steering column.

↔ Install or Connect (Figure 5)

NOTICE: For step 3 see "Notice" on page 3B4-1.

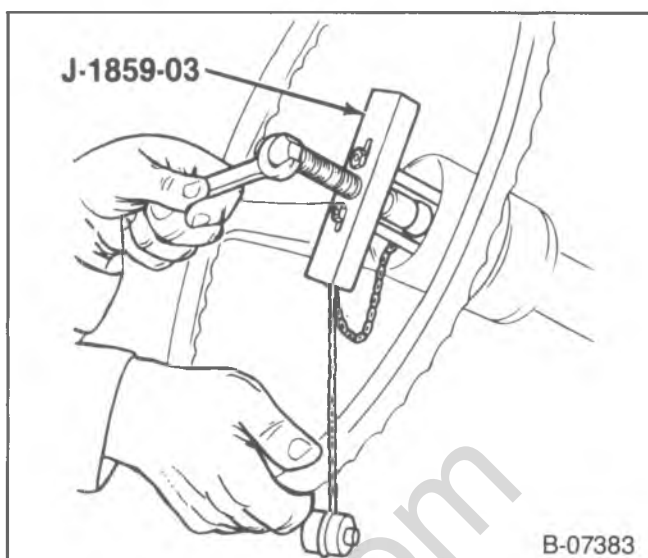

Figure 4—Steering Wheel Removal

- The turn signal control assembly must be in the neutral position when assembling the steering wheel.
1. Steering wheel onto the steering shaft. Align the marks made at removal.

! Important

- Do not misalign the steering wheel more than 25.4 mm (1 inch) from the horizontal centerline (figure 5).
2. Horn lead assembly (some models).
 3. Steering wheel nut.

⤵ Tighten

- Nut to 40 N·m (30 ft. lbs.).
4. Retainer.
 5. Horn button cap.
 6. Battery ground cable.

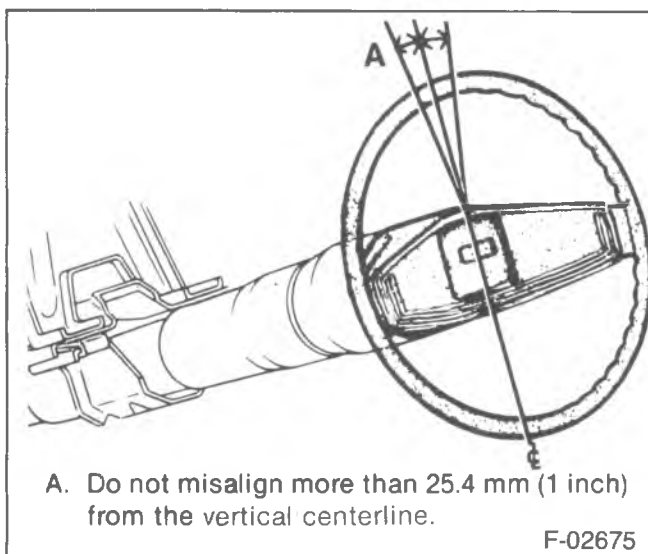

Figure 5—Steering Wheel Alignment

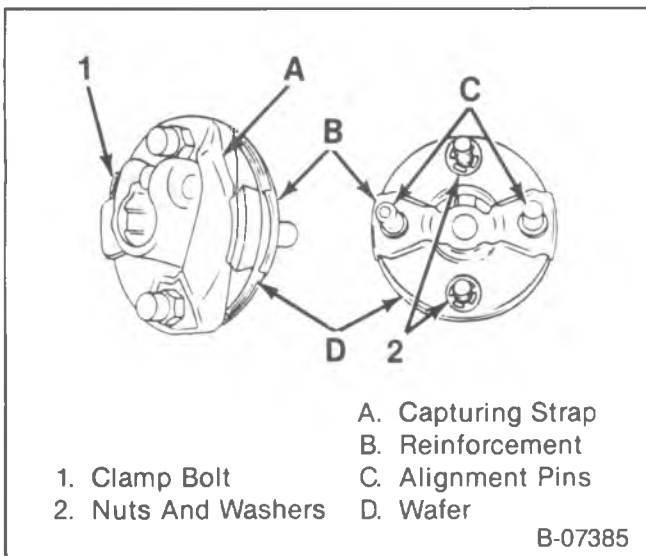

Figure 6—Flexible Type Steering Coupling

FLEXIBLE COUPLING REPLACEMENT

↔ Remove or Disconnect (Figure 6)

1. Coupling to flange bolt nuts and washers (2).
2. Clamp bolt (1).
3. Steering gear frame bolts. Lower the steering gear far enough to remove the flexible coupling.
4. Flexible coupling from the steering gear wormshaft. Tap lightly with a soft mallet.

→← Install or Connect (Figure 6)

NOTICE: For steps 2, 3 and 4 see "Notice" on page 3B4-1.

1. Flexible coupling onto the steering gear wormshaft. Align the flat on the shaft with the flat in the coupling.
 - Push the coupling onto the wormshaft until the coupling reinforcement bottoms against the end of the worm.
2. Clamp bolt (1) into the split clamp. The bolt must pass through the shaft undercut.

⌚ Tighten

- Bolt to 42 N·m (31 ft. lbs.).
- Place the steering gear into position, guiding the flexible coupling bolts into the proper holes in the steering shaft flange.

3. Steering gear and frame bolts.

⌚ Tighten

- Bolts to "Specifications" at the end of this section.

4. Coupling to flange bolt nuts and washers (2).

- The coupling alignment pins should be centered in the flange slots.

⌚ Tighten

- Nuts to 27 N·m (20 ft. lbs.).

⌚ Measure

- Coupling to flange dimension. Maintain a 6.4 to 9.5 mm (0.250 to 0.375 inch) dimension.

INTERMEDIATE SHAFT REPLACEMENT

↔ Remove or Disconnect (Figure 7)

- Set front wheels in the straight ahead position.
 - Mark the upper universal joint yoke to steering shaft and the lower yoke to steering gear wormshaft relationship.
1. Upper and lower universal yoke pinch bolt.
 2. Steering gear frame bolts. Lower the steering gear.
 - It is not necessary to disconnect the pitman arm from the steering gear pitman shaft.
 3. Intermediate steering shaft and universal joint assembly.

→← Install or Connect (Figure 7)

NOTICE: For steps 2, 3 and 4 see "Notice" on page 3B4-1.

1. Intermediate shaft lower yoke onto the steering gear wormshaft. Align the marks made at removal.
2. Pinch bolt. The pinch bolt must pass through the shaft undercut.

⌚ Tighten

- Pinch bolt to "Specifications" at the end of this section.
 - Raise the steering gear into position while guiding the upper yoke assembly onto the steering shaft. The marks on the coupling and steering shaft must align.
3. Steering gear and frame bolts.

⌚ Tighten

- Bolt to "Specifications" at the end of this section.
4. Pinch bolt to the upper yoke assembly. The pinch bolt must pass through the shaft undercut.

⌚ Tighten

- Pinch bolt to "Specifications" at the end of this section.

⌚ Measure (Figure 8)

- Carden joint operating angle (G-Model). The angle must not exceed 39 degrees maximum or 34 degrees minimum.

3B4-14 STEERING COLUMN

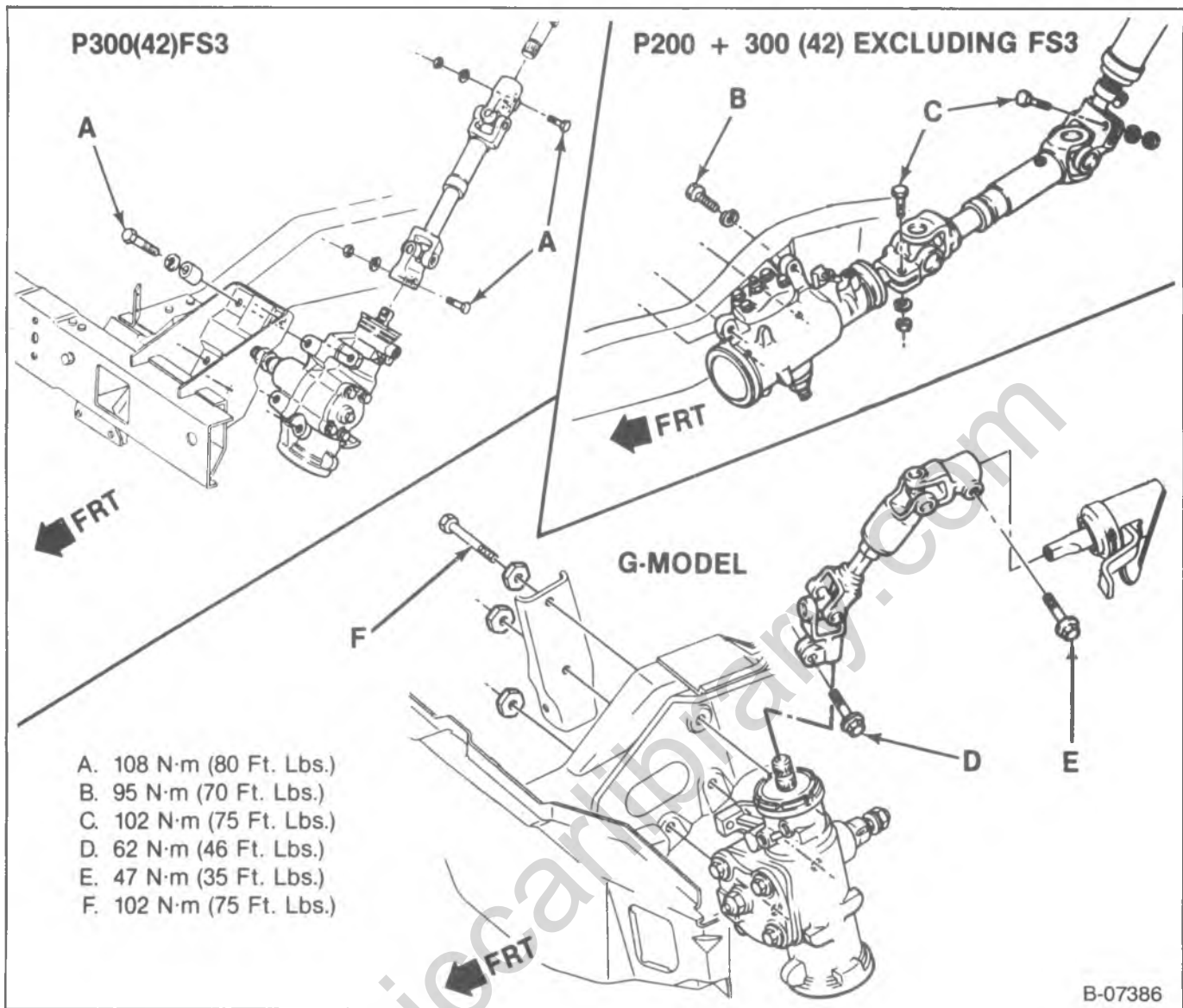

Figure 7—Intermediate Shaft Installation

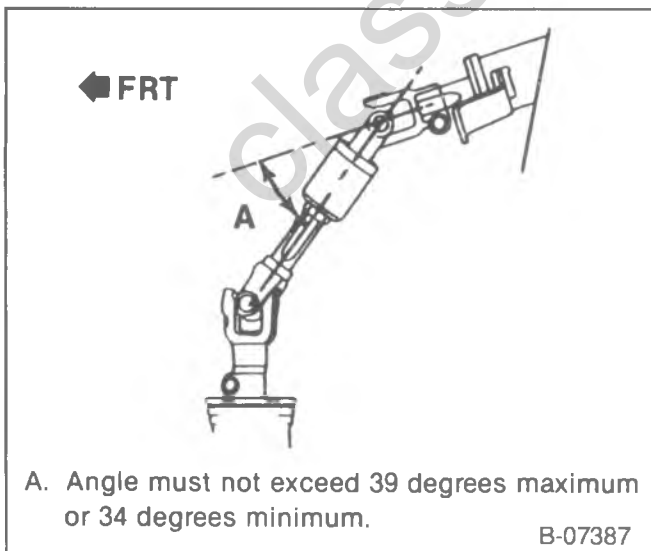
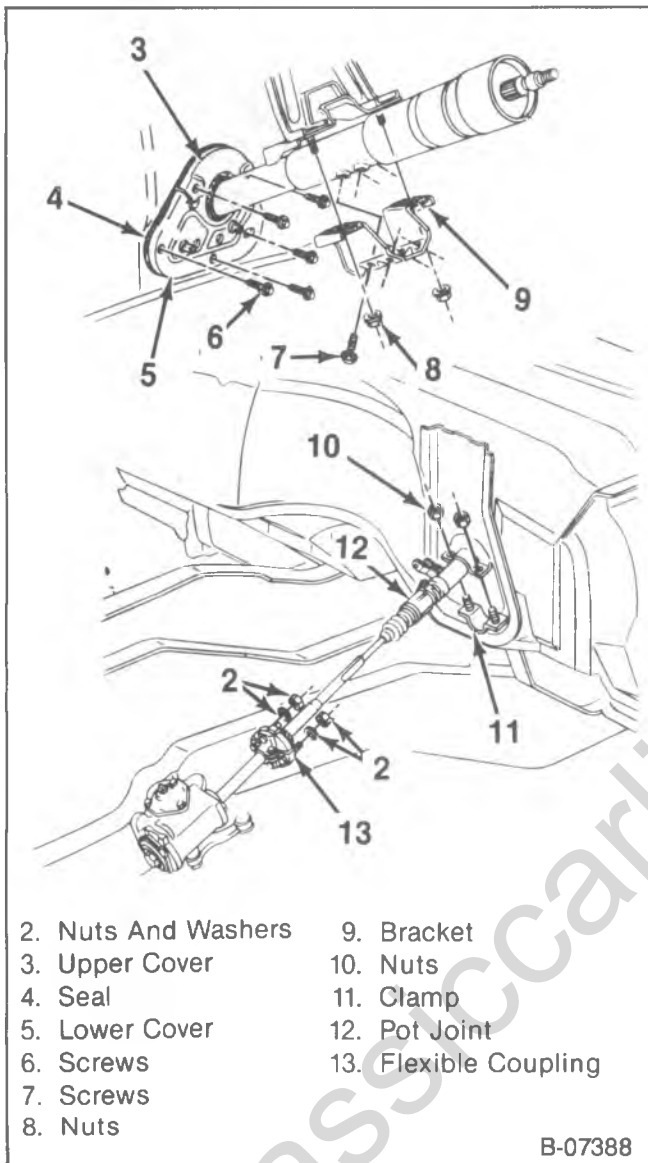

Figure 8—Carden Joint Angle (G-Model)

STEERING COLUMN ON-VEHICLE SERVICE (R, V AND G MODELS)



B-07388

Figure 9—Steering Column Installation (RV Model)

RV MODEL STEERING COLUMN REPLACEMENT

↔ Remove or Disconnect (Figure 9)

1. Battery ground cable.
2. Transmission control linkage from the column shift tube levers.
3. Nuts and washers (1) that secure the flanged end of the steering shaft to the flexible coupling.
4. Nuts (10) and clamp (11).
5. Steering wheel. Refer to "Steering Wheel Replacement" in this section.
6. Steering column harness at the connector.
 - Disconnect the neutral-start switch and back-up lamp switch connectors (some models). Refer to SEC. 8B (CHASSIS ELECTRICAL) in this manual.

7. Transmission indicator cable (some models).
8. Screws (6), upper cover (3), lower cover (5), and seal (4).
9. Screws (7), nuts (8) and bracket (9).
10. Steering column assembly. Rotate the column so the shift lever clears the dash opening.

↔ Install or Connect (Figure 9)

NOTICE: For steps 4 and 12 see "Notice" on page 3B4-1.

1. Plastic spacers onto the flexible coupling alignment pins.
2. Lower end of the steering column through the dash opening.
3. Lower steering shaft flange onto the flexible coupling (13).
4. Flange to coupling washers and nuts (1).

⌚ Tighten

- Nuts to 27 N·m (20 ft. lbs.).
 - The flexible coupling (13) on manual steering must be installed prior to column installation.
5. Screws (7) and (8) and bracket (9) loosely. Tighten screws and nuts finger tight.
 6. Clamp (11) and nuts (10).

⌚ Tighten

- Nuts (10) to 24 N·m (18 ft. lbs.).
 - Screws (7) and nuts (8) to 30 N·m (22 ft. lbs.).
7. Seal (4) and covers (3, 5) to the dash.
 8. Screws (6).

- Remove plastic spacers from the flexible coupling pins.

📏 Measure

- Pot joint (12) operating angle must not exceed 12 degrees.
 - Flexible coupling (13) must not be distorted greater than ± 1.5 mm (0.06 inch) due to pot joint bottoming, in either direction.
10. Transmission indicator cable (some models).
 11. Connectors to the steering column harness.
 - Connect the neutral-start switch and back-up lamp switch connectors (some models). Refer to SEC. 8B (CHASSIS ELECTRICAL) in this manual.
 12. Steering wheel. Refer to "Steering Wheel Replacement" in this section.
 13. Transmission control linkage.
 14. Battery ground cable.

3B4-16 STEERING COLUMN

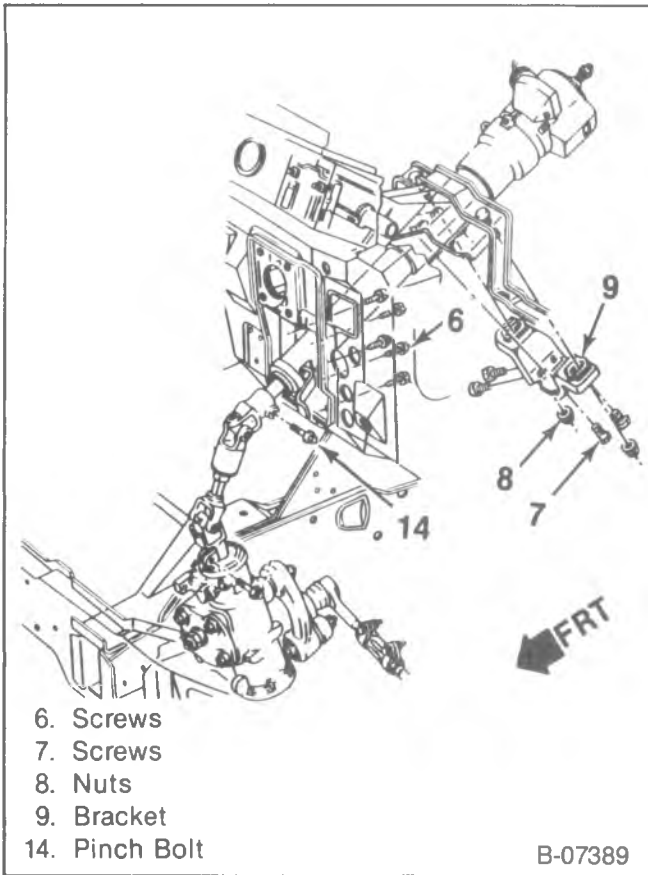

Figure 10—Steering Column Installation (G Model)

G MODEL STEERING COLUMN REPLACEMENT

↔ Remove or Disconnect (Figure 10)

1. Battery ground cable.
2. Transmission control linkage from the column shift tube levers.
3. Upper universal joint pinch bolt (14) from the intermediate shaft. Mark the relationship of the universal yoke to the steering shaft.
4. Screws (7), nuts (8) and bracket (9).
5. Screws (6) from the cover and seal.
6. Steering wheel. Refer to "Steering Wheel Replacement" in this section.
7. Steering column harness at the connectors.
 - Disconnect the neutral-start switch and back-up lamp switch connectors (some models). Refer to SEC. 8B (CHASSIS ELECTRICAL) in this manual.
8. Steering column assembly. Rotate the column so the shift lever clears the dash opening.

↔ Install or Connect (Figure 10)

NOTICE: For steps 3 and 5 see "Notice" on page 3B4-1.

1. Lower end of the steering column through the dash opening.
2. Bracket (9), screws (7) and nuts (8) loosely. Tighten screws and nuts finger tight.

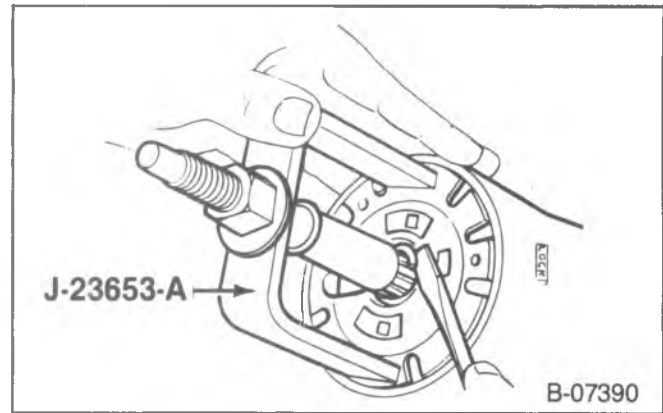

Figure 11—Retaining Ring Removal

- Guide the steering shaft into the universal yoke, lining up the marks made at removal.
3. Upper universal joint pinch bolt (14). The pinch bolt must pass through the shaft undercut.

⌚ Tighten

- Pinch bolt to 47 N·m (35 ft. lbs.).

📏 Measure

- Carden joint operating angle. The angle must not exceed 39 degrees maximum or 34 degrees minimum (figure 8).

⌚ Tighten

- Screws (7) and nuts (8) to 30 N·m (22 ft. lbs.).
3. Screws (6) through the cover and seal to the dash panel.
 4. Connectors to the steering column harness.
 - Connect the neutral-start switch and back-up lamp switch connectors (some models). Refer to SEC. 8B (CHASSIS ELECTRICAL) in this manual.
 4. Steering wheel. Refer to "Steering Wheel Replacement" in this section.
 6. Transmission control linkage.
 7. Battery ground cable.

TURN SIGNAL SWITCH REPLACEMENT

↔ Remove or Disconnect (Figures 11 through 13)

Tools Required:

J-23653-A Lock Plate Compressor

1. Steering wheel. Refer to "Steering Wheel Replacement" in this section.
2. Instrument panel trim cover.
 - Position a screwdriver blade into the steering shaft lock plate cover slot. Pry up and out to free the cover from the lock plate.
 - Screw the center post of J-23653-A onto the steering shaft as far as it will go. Compress the lock plate by turning the center post nut clockwise. Pry the retaining ring out of the shaft (figure 11). Remove J-23653-A.

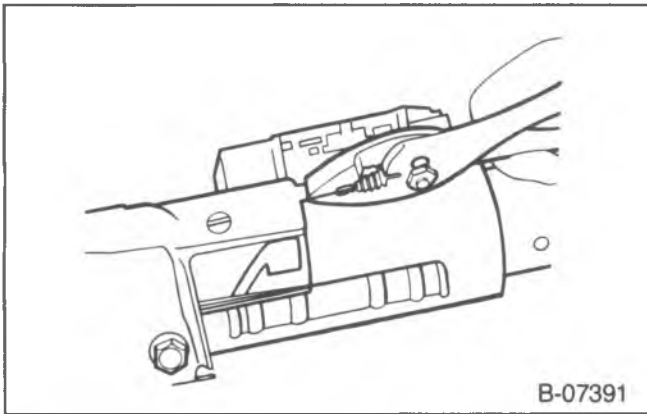

B-07391

Figure 12—Turn Signal Wire Protector Removal

! Important

- If the column is being disassembled on a bench, the shaft could slide out of the end of the mast jacket when the snap ring is removed.

3. Lock plate.
4. Turn signal lever screw and lever.
6. Hazard warning knob. Press the knob inward and then unscrew.
7. Turn signal mounting screws.
 - Pull the switch connector out of the bracket on the jacket and feed switch connector through column support bracket and pull switch straight up, guiding the wiring harness through the column housing and protector.
8. Wire protector. Pull downward out of the column with pliers using the tab provided (figure 12).
 - Position the turn signal and shifter housing in the "low" position. Remove the harness cover by pulling toward the lower end of the column, be careful not to damage the wires (tilt column).
9. Turn signal switch. Pull the switch straight up, guiding the wiring harness and cover through the column housing (figure 13).

↔ Install or Connect (Figure 14)

Tools Required:

J-23653-A Lock Plate Compressor

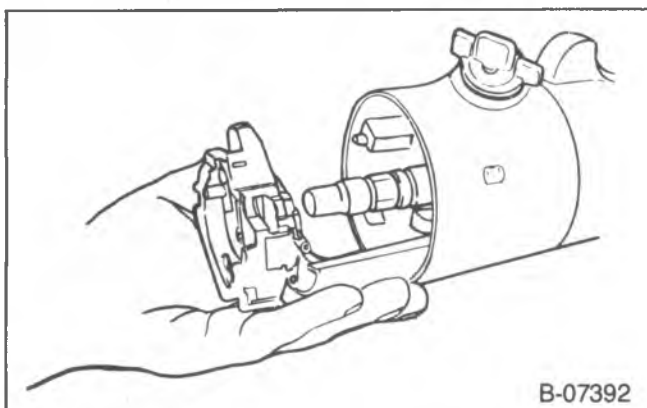

B-07392

Figure 13—Turn Signal Switch Assembly Removal

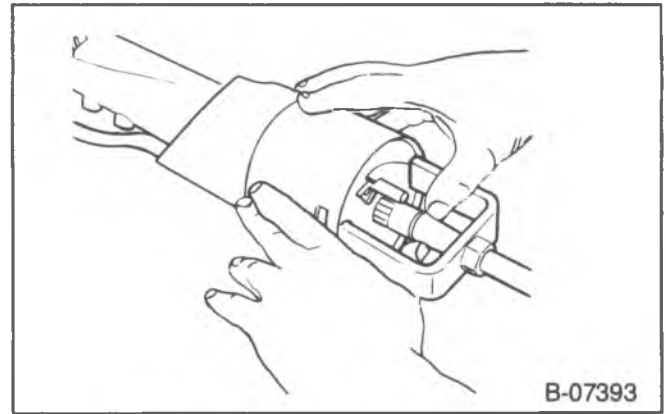

B-07393

Figure 14—Retaining Ring Installation

! Important

- Use only the specified screws, bolts and nuts at assembly. The use of overlength screws could prevent a portion of the assembly from compressing under impact.
 - On non-tilt columns, be sure the wiring harness is on the protector. Feed the connector and cover down through the housing and under the mounting bracket.
 - On tilt columns, feed the connector down through the housing and under the mounting bracket. Install the cover on the harness.
1. Turn signal mounting screws.
 - Clip the connector to the bracket on the jacket.
 2. Instrument panel trim plate.
 3. Hazard warning knob.
 4. Turn signal lever and screws.
 - Put the turn signal switch in the "Neutral" position. Pull "out" on the hazard warning knob.
 5. Washer, upper bearing preload spring and cancelling cam onto the upper end of the shaft.
 6. Lock plate onto the end of the shaft.
 - Screw the center post of J-23653-A onto the steering shaft as far as it will go. Place a NEW retaining ring over the center post. Place the "C" bar over the center post and then compress the lock plate by turning the nut clockwise. Slide the new retaining ring down the tapered center post and into the shaft groove (figure 14). Remove J-23653-A.
 7. Cover on the lock plate and snap into position.
 8. Steering wheel. Refer to "Steering Wheel Replacement" in this section.

LOCK CYLINDER REPLACEMENT

↔ Remove or Disconnect (Figure 15)

- Place the lock cylinder in the "Run" position.
1. Steering wheel. Refer to "Steering Wheel Replacement" in this section.
 2. Turn signal switch. Refer to "Turn Signal Switch Replacement" in this section.

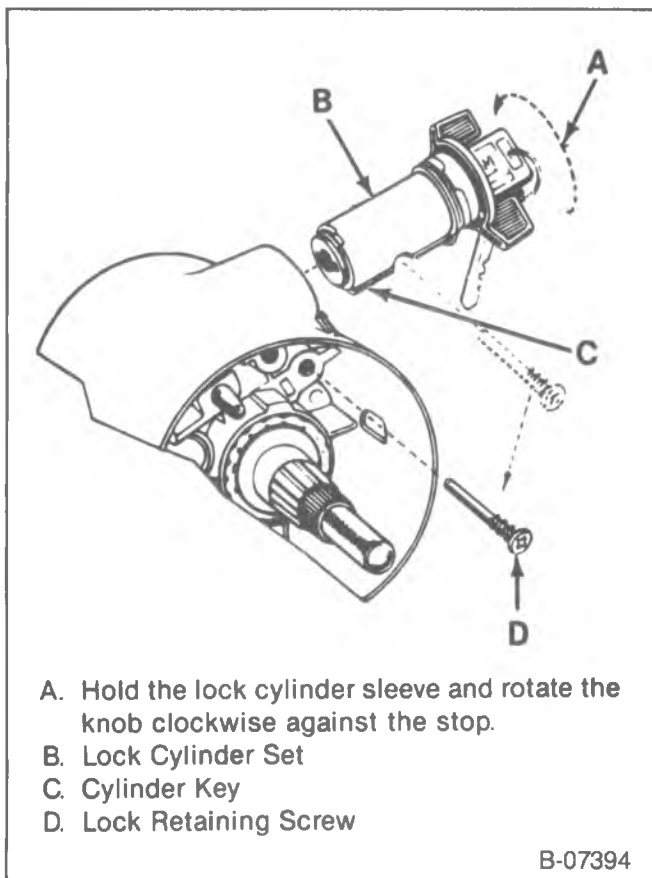

Figure 15—Lock Cylinder Installation

- It is not necessary to completely remove the turn signal switch from the column. Pull the switch rearward far enough to slip it over the end of the shift. Do not pull the harness out of the column.
3. Retaining screw and the lock cylinder set.

! Important

- If the retaining screw is dropped on removal, it could fall into the column, requiring a complete disassembly to retrieve the screw.

↔ Install or Connect (Figure 15)

1. Lock cylinder set.
 - Align the cylinder key with the keyway in the housing. Rotate as shown in figure 15.
 - Push the lock all the way in.
2. Retaining screw.

Tighten

- Screw to 4.5 N·m (40 in. lbs.) (Non-Tilt Columns).
 - Screw to 2.5 N·m (22 in. lbs.) (Tilt Columns).
3. Turn signal switch. Refer to "Turn Signal Switch Replacement" in this section.
 4. Steering wheel. Refer to "Steering Wheel Replacement" in this section.

tone alarm switch replacement

↔ Remove or Disconnect

1. Steering wheel. Refer to "Steering Wheel Replacement" in this section.
 - Pull the turn signal switch up far enough to allow access to the tone alarm switch. Refer to "Turn Signal Switch Replacement" in this section.
 - The tone alarm switch may be removed without removing the lock cylinder. The lock cylinder must be in the "Run" position.
2. Tone alarm switch assembly.
 - Pull the tone alarm switch straight out of the housing using a paper clip or similar tool. A flat spring wedges the switch toward the lock cylinder.

? Important

- Be careful not to let the flat spring fall down into the housing and do not pull on the switch contacts or plastic material of the switch when removing.

↔ Install or Connect

1. Tone alarm switch to the spring clip with the formed end of the clip around the lower end of the switch. The spring is bowed away from the switch.
 - Lay the spring on the switch opposite the contacts.
2. Tone alarm switch and spring into the hole with the contacts toward the lock cylinder bore.
3. Turn signal switch. Refer to "Turn Signal Switch Replacement" in this section.
4. Steering Wheel. Refer to "Steering Wheel Replacement" in this section.

IGNITION SWITCH REPLACEMENT

The ignition switch is mounted on top of the column jacket near the front of the dash. For anti-theft reasons, the switch is located inside the channel section of the brake pedal support.

The switch is actuated by a rod and rack assembly. A portion of the rack is toothed and engages a gear on the end of the lock cylinder. This enables the rod and rack to be moved axially (with respect to the column) to actuate the switch when the lock cylinder is rotated.

↔ Remove or Disconnect

- Lower the steering column. Refer to "CK Model or G Model Steering Column Replacement" in this section. It is not necessary to remove the steering wheel.

? Important

- Properly support the steering column if it is not removed from the vehicle.
- Put the ignition switch in the "Lock" position.

- If the lock cylinder was removed, the actuating rod to the switch should be pulled up until there is a definite stop, then moved down one detent, which is the "Lock" position.

1. Two ignition switch screws.
2. Ignition switch assembly.

↔ Install or Connect (Figure 16)

- Put the ignition switch in the "Lock" position (figure 16).
1. Activating rod into the ignition switch.
 2. Ignition switch and screws to the column.
 3. Steering column assembly. Refer to "Steering Column Replacement" in this section.

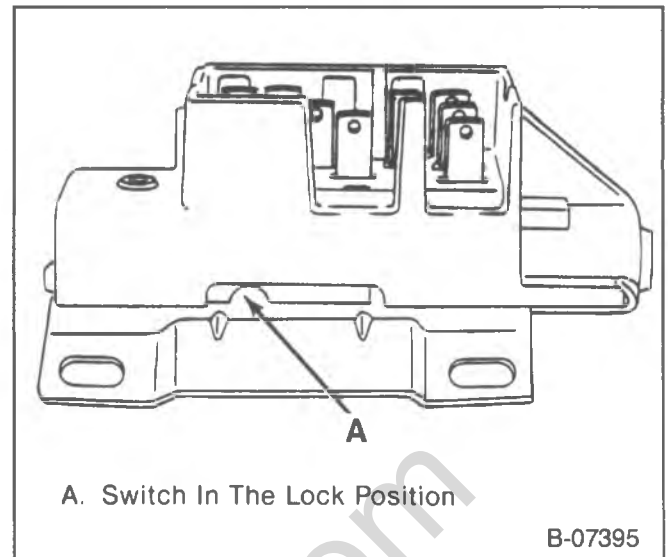

A. Switch In The Lock Position

B-07395

Figure 16—Ignition Switch Assembly

STANDARD STEERING COLUMN UNIT REPAIR (R, V AND G MODELS)

↔ Remove or Disconnect

- Steering column assembly. Refer to "RV or G Model Steering Column Replacement" in this section.

✦ Disassemble (Figures 17 through 25)

1. Dash panel bracket and screws from the column.
 2. Clamp the steering column in a vise.
 - Clamp at the lower end of the jacket.
 3. Steering wheel. Refer to "Steering Wheel Replacement" in this section.
 4. Turn signal switch. Refer to "Turn Signal Switch Replacement" in this section.
 5. Lock cylinder. Refer to "Lock Cylinder Replacement" in this section.
 6. Tone alarm switch, if it needs to be serviced. Refer to "Tone Alarm Switch Replacement" in this section.
- ! Important**
- The buzzer switch does not have to be removed to remove the upper bearing housing.
7. Ignition switch. Refer to "Ignition Switch Replacement" in this section.
 8. Shift lever pivot pin and lever. (Column Shift Models).
 9. Upper bearing washer.
 10. Screws attaching the turn signal and ignition lock housing.
 11. Housing assembly (figure 23).
 12. Bushing and retainer from the lower side of the housing.
 13. Ignition switch actuating rod, rack assembly, rack preload spring, shaft lock bolt and spring assembly from the housing.
 14. Shift lever detent plate.

15. Ignition switch actuator sector through the lock cylinder hole by pushing firmly on the block tooth of the sector with a blunt punch or screwdriver (figure 24).
16. Gear shift lever housing and shroud from the jacket assembly.
 - On floor shift models remove the transmission control lock tube housing and shroud.
17. Shift lever spring from the gear shift lever housing.
 - On floor shift models remove the lock tube spring.
18. Steering shaft from the lower end of the jacket assembly.
19. Back-up switch or neutral-safety switch. Refer to SEC. 8B (CHASSIS ELECTRICAL) in this manual.
20. Lower bearing retaining clip (figure 25).
 - On Automatic and Floorshift Columns.
 - Remove the lower bearing retainer, bearing adapter assembly, shift tube spring and washer. The lower bearing may be removed from the adapter by light pressure on the bearing outer race.
 - Slide out the shift tube assembly.
 - On Manual Transmission (Column Shift)
 - Remove the lower bearing adapter, bearing and the first reverse shift lever. The lower bearing may be removed from the adapter by light pressure on the bearing outer race.
 - Remove the three screws from the bearing at the lower and slide out the shift tube assembly.
 - Remove the gear shift housing lower bearing from the upper end of the mast jacket.

✦ Assemble (Figures 17 through 22, 26 and 27)

- Apply a thin coat of lithium grease to all friction surfaces.

3B4-20 STEERING COLUMN

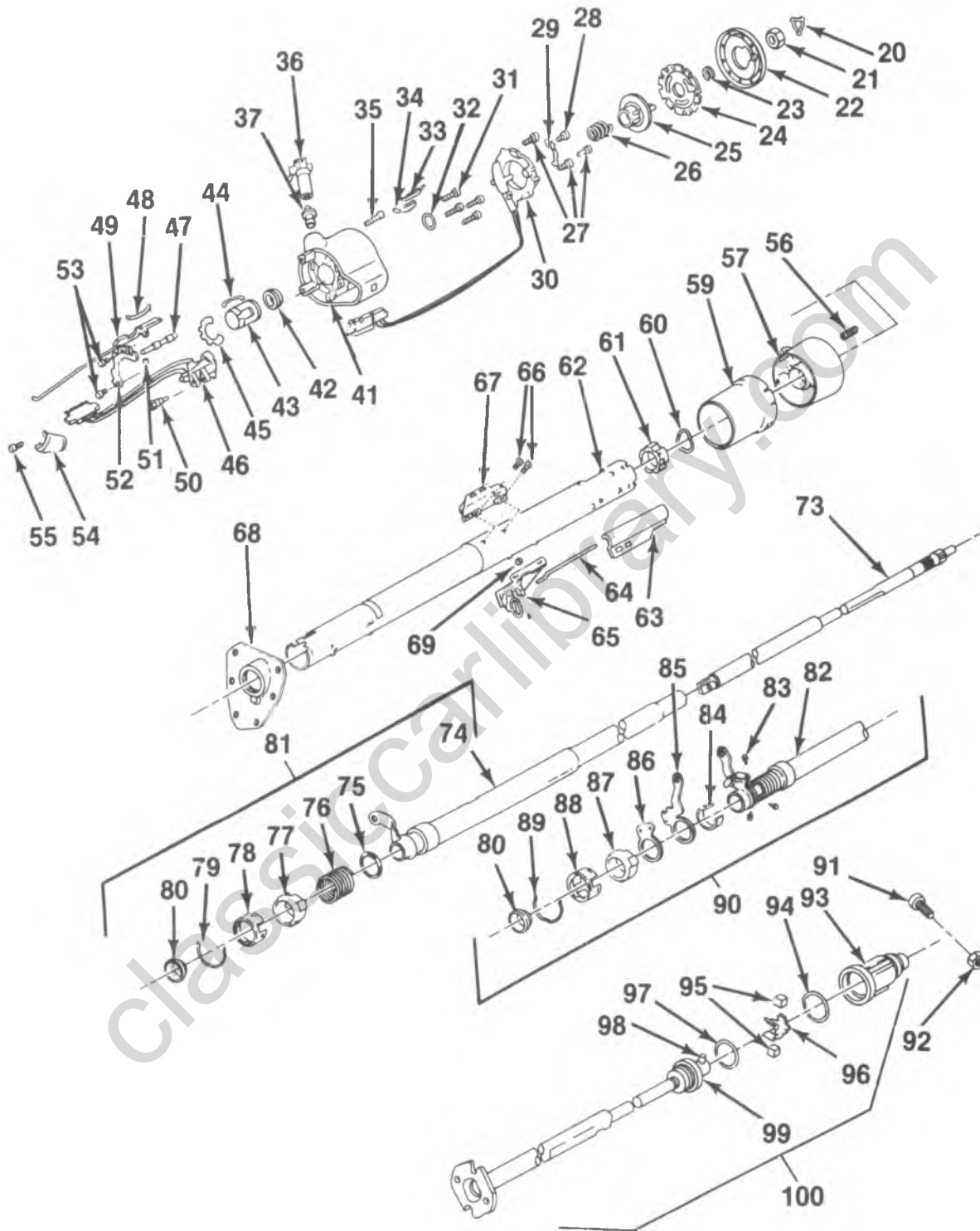

B-07396

Figure 17—Standard Steering Column—Column Shift (RV Model)

20. Retainer	47. Shaft Lock Bolt	77. Adapter
21. Nut	48. Switch Rack Preload Spring	78. Reinforcement
22. Lock Plate Cover	49. Actuator Rack	79. Adapter Clip
23. Retainer	50. Actuator Pivot Pin	80. Lower Bearing
24. Lock Plate	51. Washer	81. Automatic Transmission
25. Cancelling Cam	52. Shift Lever Gate	82. Shift Tube
26. Bearing Preload Spring	53. Shift Lever Screw	83. Bolt
27. Turn Signal Screws	54. Housing Cover	84. Spacer
28. Tap Screw	55. Cover Screw	85. Lower Shift Lever
29. Actuator Arm	56. Shift Lever Spring	86. Adapter Plate
30. Turn Signal Switch	57. Gear Shift Housing	87. Adapter
31. Turn Signal Housing Screws	59. Gear Shift Shroud	88. Retainer
32. Washer	60. Washer	89. Adapter Clip
33. Tone Alarm Switch	61. Gear Shift Housing Bearing	90. Manual Transmission
34. Retainer Clip	62. Jacket	91. Bolt
35. Retainer Screw	63. Wiring Protector	92. Nut
36. Ignition Lock	64. Actuator Rod	93. Coupling
37. Actuator Sector	65. Dimmer Switch	94. Retainer
41. Housing Assembly	66. Ignition Switch Screw	95. Bearing
42. Bearing	67. Ignition Switch	96. Spring
43. Bushing	68. Dash Seal	97. Washer
44. Horn Contact	73. Shaft	98. Pin
45. Upper Bearing Retainer	74. Shift Tube	99. Seal
46. Dimmer Pivot And Wiper Switch	75. Washer	100. Intermediate Shaft
	76. Spring	

B-07361

Figure 18—Standard Steering Column—Column Shift (RV Model)

1. Sector into the turn signal and lock cylinder housing.
 - Install the sector in the lock cylinder hole over the sector shaft with the tang end to the outside of the hole.
 - Press the sector over the shaft with a blunt tool.
2. Shift lever detent plate onto the housing.
3. Rack preload spring into the housing from the bottom side. The long section should be toward the handwheel and hook onto the edge of the housing (figure 26).
4. Locking bolt onto the crossover arm on the rack and insert the rack and lock bolt assembly into the housing from the bottom with the teeth up (toward handwheel) and toward the centerline of the column.
 - Align the first tooth on the sector with the first tooth on the rack; if aligned properly, the block teeth will line up when the rack assembly is pushed all the way in.
5. Retainer and bushing.
6. Gear shift housing lower bearing. Insert the bearing from the very end of the jacket.
 - Align the indentations in the bearing with the projections on the jacket (figure 27). If the bearing is not installed correctly, it will not rest on the stops provided.
7. Shift lever spring into the gear shift lever (or lock tube) housing.
8. Housing and shroud assemblies onto the upper end of the mast jacket.
 - Rotate the housing to be sure it is seated in the bearing.
9. Turn signal and lock cylinder housing onto the jacket.
 - The gear shift housing should be in the "Park" position and the rack pulled downward.
 - Seat the turn signal housing and install the four screws.
10. Lower bearing into the adapter assembly.
11. Shift tube assembly into the lower end of the jacket. Rotate until the upper shift tube key slides into the housing keyway.
 - On Automatic and Floor Shift Columns
 - Install the spring and lower bearing adapter assembly into the bottom of the jacket.
 - Hold the adapter in place and install the lower bearing reinforcement and retainer clip. The clip snaps into the jacket and reinforcement slots.
 - On Manual Transmission (Column Shift)
 - Loosely attach the three screws in the jacket and shift tube bearing.
 - Assemble the first reverse lever, lower bearing and adapter assembly into the bottom of the jacket.
 - Hold the adapter in place and install the bearing reinforcement and retaining clip. The clip snaps into the jacket and reinforcement slots.
 - Adjust the lower bearing. Refer to the "Manual Transmission (Column Shift) Lower Bearing Adjustment" in this section.

3B4-22 STEERING COLUMN

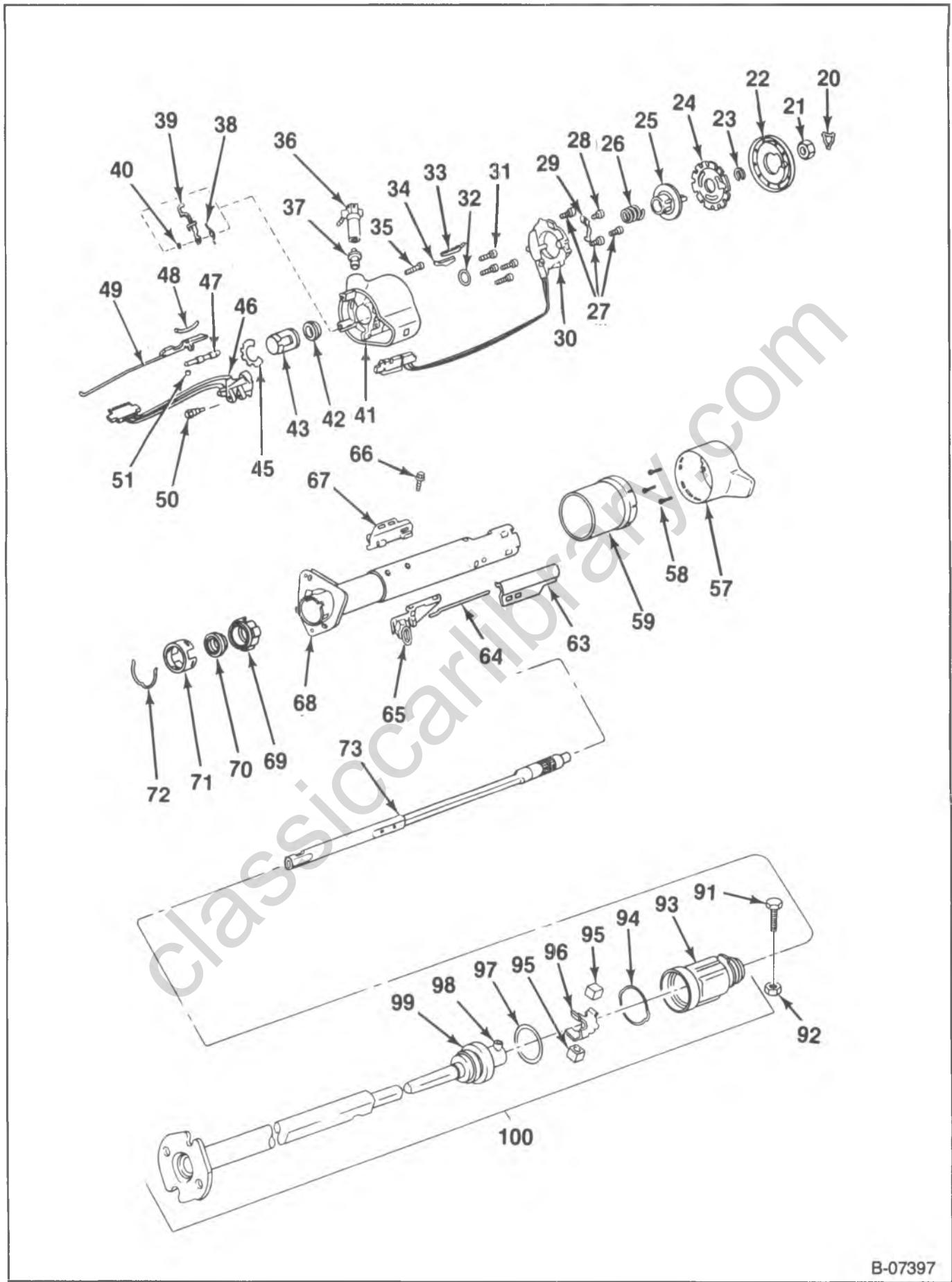

Figure 19—Standard Steering Column (RV Model)

- | | | |
|--------------------------------|-----------------------------------|---------------------------|
| 20. Retainer | 39. Key Release Lever | 65. Dimmer Switch |
| 21. Nut | 40. Key Release Washer | 66. Ignition Switch Screw |
| 22. Lock Plate Cover | 41. Housing Assembly | 67. Ignition Switch |
| 23. Retainer | 42. Bearing | 68. Dash Seal |
| 24. Lock Plate | 43. Bushing | 69. Adapter |
| 25. Cancelling Cam | 44. Horn Contact | 70. Bearing |
| 26. Bearing Preload Spring | 45. Upper Bearing Retainer | 71. Reinforcement |
| 27. Turn Signal Screws | 46. Dimmer Pivot And Wiper Switch | 72. Adapter Clip |
| 28. Tap Screw | 47. Shaft Lock Bolt | 73. Shaft |
| 29. Actuator Arm | 48. Switch Rack Preload Spring | 91. Bolt |
| 30. Turn Signal Switch | 49. Actuator Rack | 92. Nut |
| 31. Turn Signal Housing Screws | 50. Actuator Pivot Pin | 93. Coupling |
| 32. Washer | 51. Washer | 94. Retainer |
| 33. Tone Alarm Switch | 57. Gear Shift Housing | 95. Bearing |
| 34. Retainer Clip | 58. Signal Switch Mounting Screws | 96. Spring |
| 35. Retainer Screw | 59. Gear Shift Housing | 97. Washer |
| 36. Ignition Lock | 62. Jacket | 98. Pin |
| 37. Actuator Sector | 63. Wiring Protector | 99. Seal |
| 38. Key Release Spring | 64. Actuator Rod | 100. Intermediate Shaft |

B-07362

Figure 20—Standard Steering Column (RV Model)

12. Back-up switch or neutral-safety switch. Refer to SEC. 8B (CHASSIS ELECTRICAL) in this manual.
13. Steering shaft into the column.
14. Upper bearing washer.
15. Ignition switch. Refer to "Ignition Switch Replacement" in this section.
16. Tone alarm switch, if removed. Refer to "Tone Alarm Switch Replacement" in this section.
17. Lock cylinder. Refer to "Lock Cylinder Replacement" in this section.
18. Turn signal switch. Refer to "Turn Signal Switch Replacement" in this section.
19. Steering wheel. Refer to "Steering Wheel Replacement" in this section.
20. Shift lever and pivot pin.
 - Remove the column from the vise.
21. Dash panel bracket and screws to the column.



Install or Connect

- Steering column assembly. Refer to "RV or G Model Steering Column Replacement" in this section.

STANDARD STEERING COLUMN LOWER BEARING ADJUSTMENT

MANUAL TRANSMISSION (COLUMN SHIFT)



Adjust (Figure 28)

1. Put the transmission in neutral and disconnect the transmission rods.
2. Test for rotational drag by turning the shift lever through the 2-3 shift arc. The drag measured must not be more than 9N (2 lbs.).
3. Loosen the three clamping screws.
 - Increase clearance by sliding the clamping screws in the direction of arrow "B" until the first reverse lever is free of drag (figure 28).
 - Decrease clearance by sliding the clamping screws in the direction of arrow "A" until a slight drag is felt at the first reverse shift lever (figure 28).
4. Install a 0.13 mm (0.005 inch) thick shim between the space and either of the shift levers.
5. Slide the clamping screws in the direction of arrow "B" until the system is loose. Slide the screws in the opposite direction until a drag is felt at the first reverse shift lever.
6. Tighten the clamping screws.
7. Remove the shim.
8. Install the transmission rods.

3B4-24 STEERING COLUMN

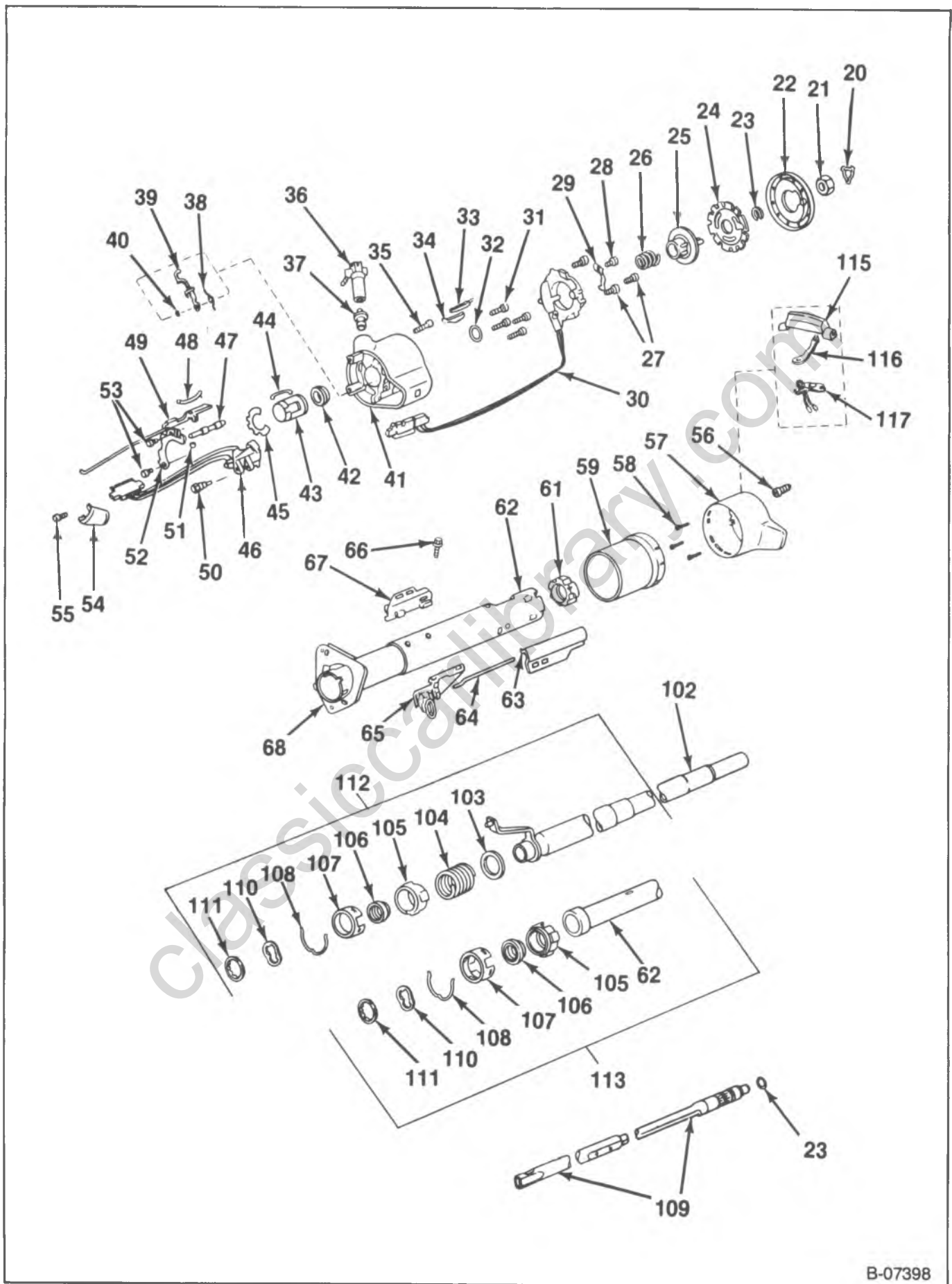

B-07398

Figure 21—Standard Steering Column (G Model)

- | | | |
|--------------------------------|-----------------------------------|--------------------------------|
| 20. Retainer | 41. Housing Assembly | 61. Gear Shift Housing Bearing |
| 21. Nut | 42. Bearing | 62. Jacket |
| 22. Lock Plate Cover | 43. Bushing | 63. Wiring Protector |
| 23. Retainer | 44. Horn Contact | 64. Actuator Rod |
| 24. Lock Plate | 45. Upper Bearing Retainer | 65. Dimmer Switch |
| 25. Cancelling Cam | 46. Dimmer Pivot And Wiper Switch | 66. Ignition Switch Screw |
| 26. Bearing Preload Spring | 47. Shaft Lock Bolt | 67. Ignition Switch |
| 27. Turn Signal Screws | 48. Switch Rack Preload Spring | 68. Dash Seal |
| 28. Tap Screw | 49. Actuator Rack | 102. Shift Tube |
| 29. Actuator Arm | 50. Actuator Pivot Pin | 103. Washer |
| 30. Turn Signal Switch | 51. Washer | 104. Spring |
| 31. Turn Signal Housing Screws | 52. Shift Lever Gate | 105. Adapter |
| 32. Washer | 53. Shift Lever Screw | 106. Bearing |
| 33. Tone Alarm Switch | 54. Housing Cover | 107. Reinforcement |
| 34. Retainer Clip | 55. Cover Screw | 108. Adapter Clip |
| 35. Retainer Screw | 56. Shift Lever Spring | 109. Shaft |
| 36. Ignition Lock | 57. Gear Shift Housing | 110. Bearing Washer |
| 37. Actuator Sector | 58. Signal Switch Mounting Screws | 111. Retainer |
| 38. Key Release Spring | 59. Gear Shift Shroud | 112. Automatic Transmission |
| 39. Key Release Lever | | 113. Manual Transmission |
| 40. Key Release Washer | | |

B-07364

Figure 22—Standard Steering Column (G Model)

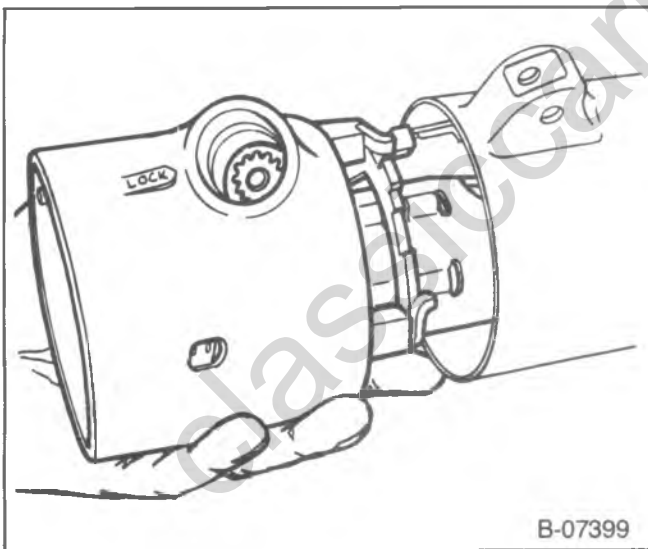

B-07399

Figure 23—Turn Signal Housing Removal

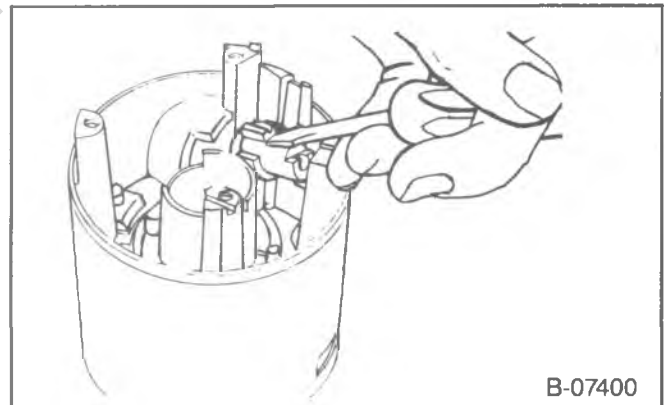

B-07400

Figure 24—Ignition Switch Actuator Sector Removal

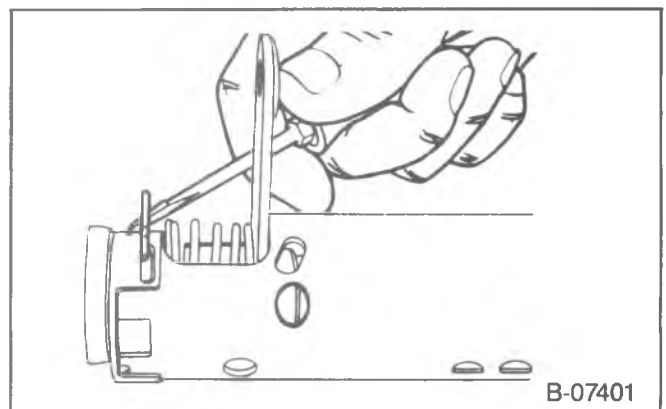

B-07401

Figure 25—Lower Bearing Retainer Removal

3B4-26 STEERING COLUMN

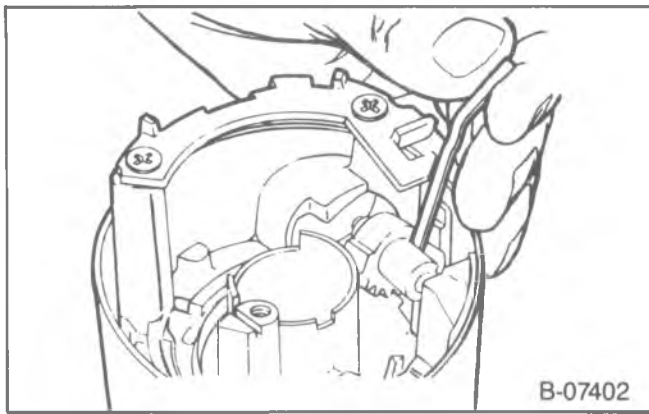

Figure 26—Rack Preload Spring Installation

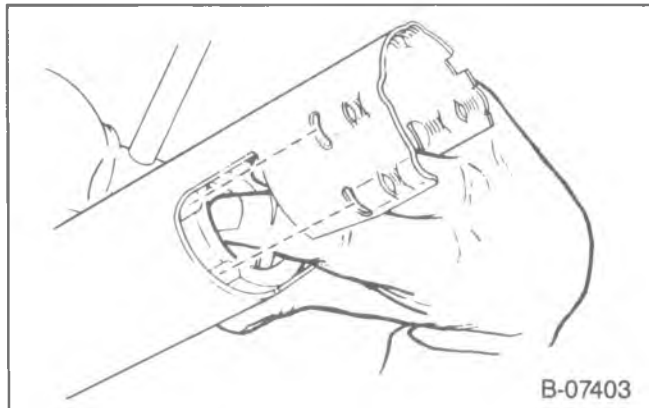

Figure 27—Gearshift Housing Lower Bearing Installation

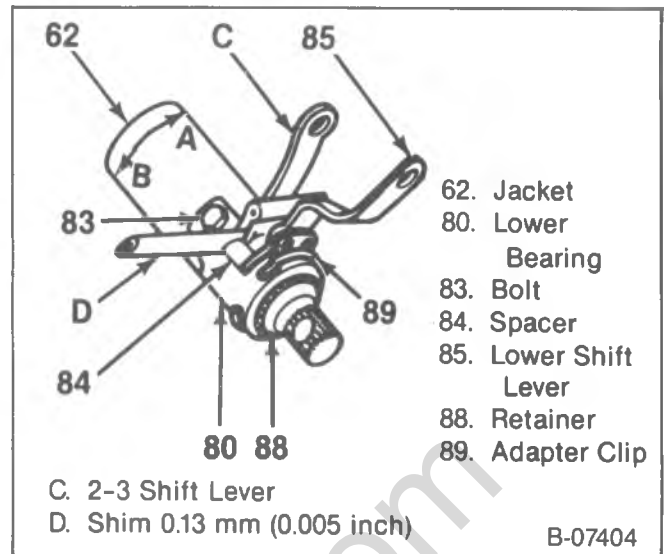

Figure 28—Lower Bearing Adjustment

TILT STEERING COLUMN UNIT REPAIR (R, V AND G MODELS)

↔ Remove or Disconnect

- Steering column assembly. Refer to "RV or G Model Steering Column Replacement" in this section.

✦ Disassemble (Figures 29 through 36)

Tools Required:

J-22635 Lock Shoe and Release Lever Pin Remover and Installer

J-21854-01 Pivot Pin Remover

J-23072 Shift Tube Remover

- Dash panel bracket and screws from the column.
- Clamp the steering column in a vise.
 - Clamp at the lower end of the jacket.
- Turn signal switch. Refer to "Turn Signal Switch Replacement" in this section.
- Lock cylinder. Refer to "Lock Cylinder Replacement" in this section.
- Tone alarm switch, if it needs to be serviced. Refer to "Tone Alarm Switch Replacement" in this section.

! Important

- The tone alarm switch does not have to be removed to remove the upper bearing housing.
- Ignition switch. Refer to "Ignition Switch Replacement" in this section.
 - Tilt release lever.
 - Shift lever pivot pin and lever.
 - Housing cover screws and housing cover.
 - Install the tilt release lever and place the column in the "up" position.
 - Tilt lever spring retainer, spring and guide. Use a screwdriver to turn the retainer until it aligns with the grooves in the housing then remove the retainer.
 - Pot joint to steering shaft clamp bolt and remove the intermediate shaft and pot joint assembly (RV Model).
 - Upper bearing inner race and seat. Push the upper steering shaft in enough to remove the race and seat.
 - Lower bearing retainer clip.
 - Bearing reinforcement, bearing and bearing adapter assembly from the lower end of the mast jacket.

15. Upper bearing housing pivot pins. Use J-21854-01 (figure 33).
 - Install the tilt release lever and disengage the lock shoes.
16. Bearing housing by pulling upward to extend the rack full down, and then moving the housing to the left to disengage the ignition switch rack from the actuator rod.
17. Steering shaft assembly from the upper end of the column.
18. Steering shaft by removing the centering spheres and the anti-lash spring.
19. Transmission indicator wire, if so equipped.
20. Bearing housing support to gearshift housing screws and remove the bearing housing support.
21. Ignition switch actuator rod.
22. Shift tube retaining ring and washer.

NOTICE: When removing the shift tube, be sure to guide the lower end through the slotted opening in the mast jacket. If the tube is allowed to interfere with the jacket in any way, damage to the tube and jacket could result.

- Install J-23072 into the lock plate, making sure that the tool screws have good thread engagement in the lock plate. Then, turning the center screw clockwise, force the shift tube from the housing (Figure 34). Remove the shift tube (transmission control lock tube on floor shift models) from the lower end of the mast jacket. Remove J-23072.
23. Lock plate and washer.
 - Slide the lock plate out of the jacket notches by tipping it down toward the housing hub and sliding it under the jacket opening.
 24. Shift lever housing from the mast jacket. (Transmission control lock tube housing on floor shift models).
 - Disassemble the bearing housing as follows:
 25. Tilt lever opening shield.
 26. Lock bolt spring. Remove the retaining screws and move the spring clockwise to remove it from the bolt (figure 35).
 27. Snap ring from the sector drive shaft.
 - With a small punch, lightly tap the drive shaft from the sector (figure 36).
 28. Drive shaft, sector and lock bolt.
 29. Rack and rack spring.
 30. Tilt release lever pin. Use J-22635.
 31. Release lever and spring.

Important

- To relieve the load on the release lever, hold the shoes inward and wedge a block between the top of the shoes (over slots) and bearing housing.
32. Lock shoe retaining pin. Use J-22635.
 33. Lock shoes and springs.
 34. Bearings from the bearing housing only if they are to be replaced.
 - Remove the separator and balls from the bearings.

- Place the housing on a work bench and with a pointed punch against the back surface of the race, carefully hammer the race out of the housing until a bearing puller can be used. Repeat for the other race.

Assemble (Figures 29 through 39)

Tools Required:

J-23073-01 Shift Tube Installer

J-22635 Lock Shoe and Release Lever Pin Remover and Installer

- If the bearing housing was disassembled, repeat steps 1–9.
 - Apply a thin coat of lithium grease to all friction surfaces.
1. Bearings into the bearing housing, if removed.
 2. Lock shoe springs, lock shoes and shoe pin in the bearing housing. Use J-22635 or a 4.5 mm (0.180 inch) diameter rod to line up the shoes for pin installation.
 3. Release lever, spring and pin.

Important

- To relieve the load on the release lever, hold the shoes inward and wedge a block between the top of the shoes (over slots) and bearing housing.
4. Sector drive shaft into the housing.
 - Lightly tap the sector onto the shaft far enough to install the snap ring.
 5. Snap ring.
 6. Lock bolt. Engage the bolt with the sector cam surface.
 7. Rack and spring. The block tooth on the rack should engage the block tooth on the sector (figure 37).
 8. Tilt release lever.
 9. Lock bolt spring and retaining screw.

Tighten

- Screw to 4 N·m (35 in. lbs.).
10. Shift lever spring into the housing. Wind the spring up with pliers and push it into the housing.
 - On floor shift models, install the plunger and slide the gearshift lever housing onto the mast jacket.
 11. Washer and lock plate. Slide the lock plate into the notches in the jacket.

NOTICE: Do not push or tap on the end of the shift tube. Be sure that the shift tube lever is aligned with the slotted opening at the lower end of the mast jacket or damage to the shift tube and mast jacket could result.

12. Shift tube into the lower end of the mast jacket.
 - Align the keyway in the tube with the key in the shift lever housing.
 - Install the wobble plate end of J-23073-01 into the upper end of the shift tube far enough to reach the enlarged portion of the tube.
 - Install the adapter over the end of the tool, seating it against the lock plate.

3B4-28 STEERING COLUMN

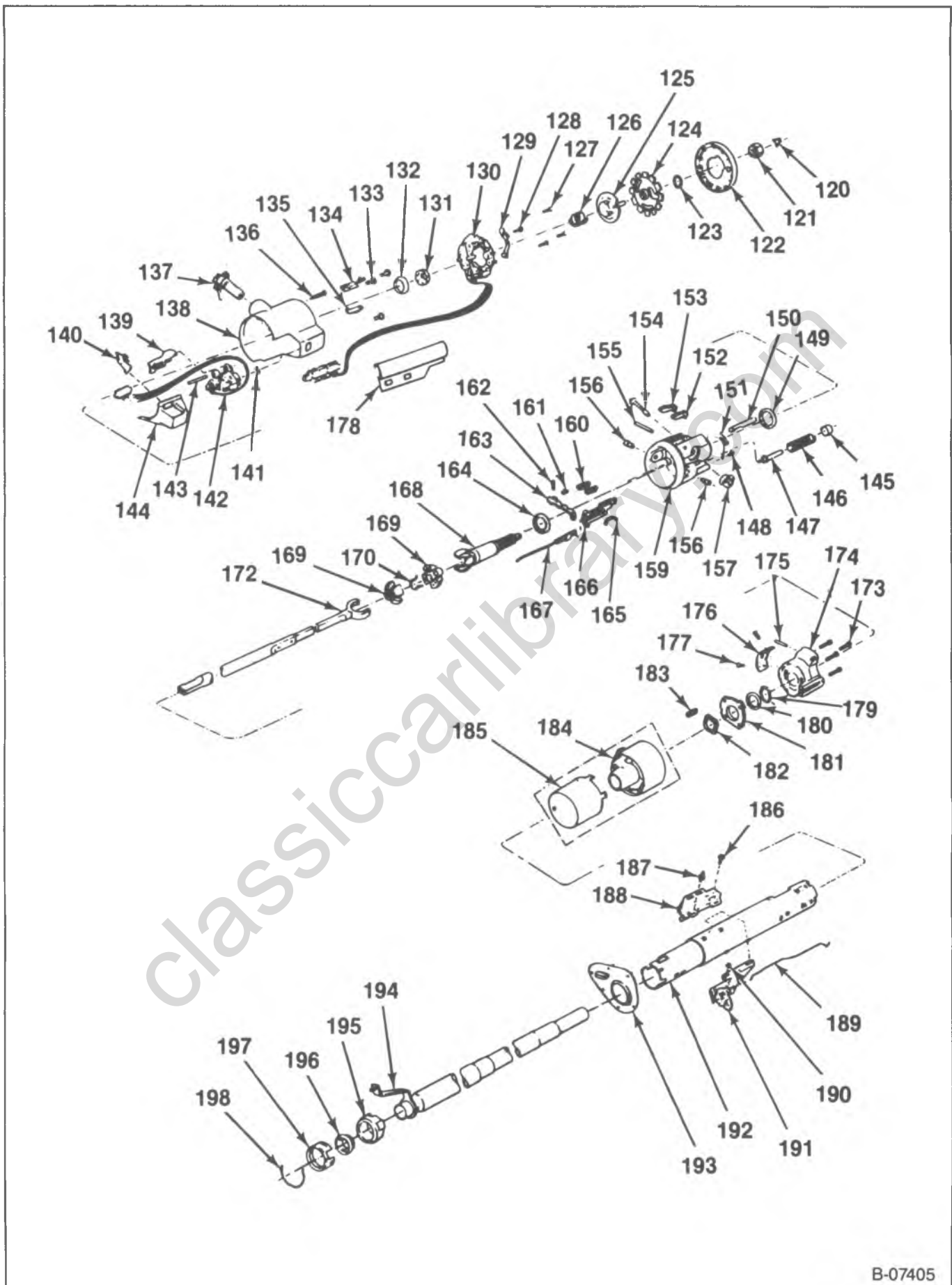

B-07405

Figure 29—Tilt Steering Column (RV and G Models)

120. Retainer	146. Tilt Spring	174. Housing Support
121. Nut	147. Spring Guide	175. Pin
122. Lock Plate Cover	148. Screw	176. Shift Lever Gate
123. Retainer	149. Bearing	177. Detent Plate Screw
124. Lock Plate	150. Lock Bolt	179. Retaining Ring
125. Cancelling Cam	151. Lock Bolt Spring	180. Washer
126. Bearing Preload Spring	152. Lock Shoe	181. Lock Plate
127. Turn Signal Screws	153. Lock Shoe	182. Wave Washer
128. Tap Screw	154. Sector Shaft	183. Gear Shift Lever Spring
129. Actuator Arm	155. Lock Shoe Pin	184. Gear Shift Lever Bowl
130. Turn Signal Switch	156. Pivot Pin	185. Shroud
131. Inner Race Seat	157. Actuator Sector	186. Screw
132. Bearing Race	159. Housing Assembly	187. Stud
133. Screw	160. Shoe Release Springs	188. Switch
134. Tone Alarm Switch	161. Spring	189. Dimmer Switch Rod
135. Retainer Clip	162. Shoe Release Lever Pin	190. Nut
136. Lock Retainer Screw	163. Shoe Release Lever	191. Dimmer Switch
137. Ignition Lock	164. Lower Bearing	192. Jacket
138. Housing Cover	165. Rack Preload Spring	193. Dash Seal
139. Dimmer Switch Actuator	166. Actuator Rack	194. Shift Tube
140. Shield	167. Ignition Switch Actuator	195. Adapter
141. Pin Preload Spring	168. Sphere Spring	196. Lower Bearing
142. Pivot Switch	169. Centering Spheres	197. Retainer
143. Actuator Pivot Pin	170. Spring	198. Adapter Clip
144. Cap	172. Lower Steering Shaft	
145. Retainer	173. Housing Support Screws	

B-07365

Figure 30—Tilt Steering Column—(TV and G Models)

- Place the nut on the threaded end of the tool and pull the shift tube into the housing (figure 38).
 - Remove J-23073-01.
13. Bearing support washer and retaining ring. Pull the shift lever housing up far enough to compress the lock plate washer.
 14. Bearing support. Align the "V" in the support with the "V" in the jacket.
 15. Screws through the support and into the lock plate.
 - Screws to 6.8 N·m (60 in. lbs.).
 - Align the lower bearing adapter with the notches in the jacket.
 16. Adapter into the lower end of the jacket.
 17. Lower bearing, bearing reinforcement and retaining clip.
 - Align the retaining clip with the slots in the reinforcement, jacket and adapter.
 18. Centering spheres and anti-lash spring in the upper shaft.
 19. Lower shaft from the same side of the spheres that the spring ends protrude.
 20. Steering shaft assembly into the shift tube from the upper end. Carefully guide the shaft through the shift tube and bearing.
 21. Ignition switch actuator rod through the shift lever housing and insert it in the slot in the bearing support.
 - Extend the rack downward from the bearing housing.
 22. Bearing housing over the steering shaft.
 - Engage the rack over the end of the actuator rod (figure 39).
 - With the release lever installed, hold the lock shoes in the disengaged positions.
23. Bearing housing over the steering shaft until the pivot pin holes line up.
 24. Pivot pins.
 - Place the bearing in the full "up" position.
 25. Tilt lever spring guide, spring and retainer.
 - With a suitable screwdriver, push the retainer in and turn clockwise to engage it in the housing.
 26. Tilt lever opening shield.
 - Remove the tilt release lever.
 27. Turn signal housing and retaining screws.
-  **Tighten**
- Screws to 5 N·m (45 in. lbs.).
28. Tilt release lever and shift lever.
 29. Ignition switch. Refer to "Ignition Switch Replacement" in this section.
 30. Tone alarm switch, if removed. Refer to "Tone Alarm Switch Replacement" in this section.
 31. Lock cylinder. Refer to "Lock Cylinder Replacement" in this section.
 32. Turn signal switch. Refer to "Turn Signal Switch Replacement" in this section.
 - Remove the column from the vise.
 - Align the groove across the upper end of the pot joint with the flat on the steering shaft. Install the pot joint and intermediate shaft assembly to the upper shaft (RV Model).

3B4-30 STEERING COLUMN

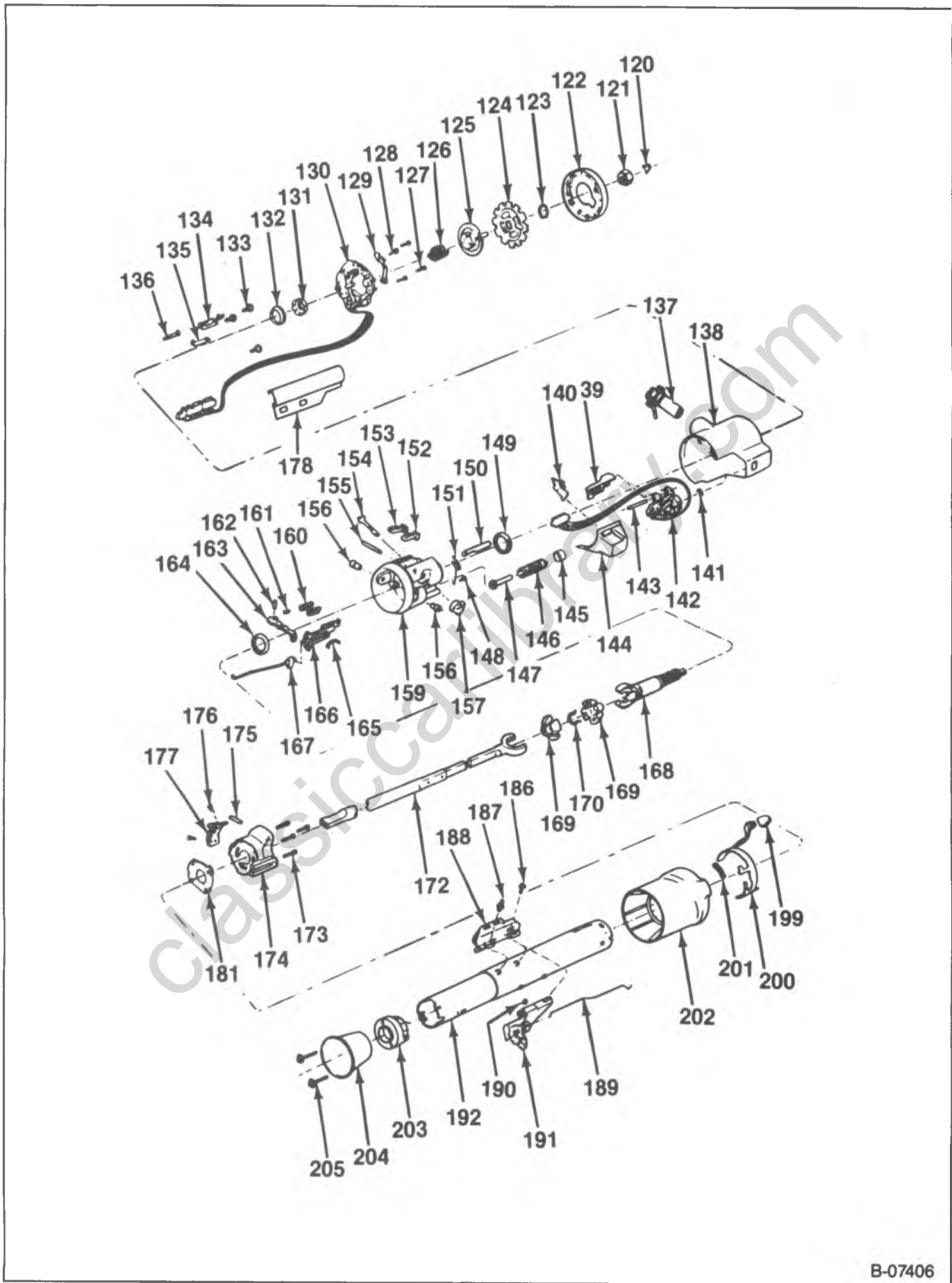

B-07406

Figure 31—Tilt Steering Column—Floor Shift (RV and G Models)

- | | | |
|-----------------------------|-----------------------------|-------------------------------|
| 120. Retainer | 143. Actuator Pivot Pin | 167. Ignition Switch Actuator |
| 121. Nut | 144. Cap | 168. Sphere Spring |
| 122. Lock Plate Cover | 145. Retainer | 169. Centering Spheres |
| 123. Retainer | 146. Tilt Spring | 170. Spring |
| 124. Lock Plate | 147. Spring Guide | 172. Lower Steering Shaft |
| 125. Cancelling Cam | 148. Screw | 173. Housing Support Screws |
| 126. Bearing Preload Spring | 149. Bearing | 174. Housing Support |
| 127. Turn Signal Screws | 150. Lock Bolt | 175. Pin |
| 128. Tap Screw | 151. Lock Bolt Spring | 176. Shift Lever Gate |
| 129. Actuator Arm | 152. Lock Shoe | 177. Detent Plate Screw |
| 130. Turn Signal Switch | 153. Lock Shoe | 181. Lock Plate |
| 131. Inner Race Seat | 154. Sector Shaft | 182. Screw |
| 132. Bearing Race | 155. Lock Shoe Pin | 187. Stud |
| 133. Screw | 156. Pivot Pin | 188. Switch |
| 134. Tone Alarm Switch | 157. Actuator Sector | 189. Dimmer Switch Rod |
| 135. Retainer Clip | 159. Housing Assembly | 190. Nut |
| 136. Lock Retainer Screw | 160. Shoe Release Springs | 191. Dimmer Switch |
| 137. Ignition Lock | 161. Spring | 199. Pad |
| 138. Housing Cover | 162. Shoe Release Lever Pin | 200. Key Release Lever |
| 139. Dimmer Switch Actuator | 163. Shoe Release Lever | 201. Key Release Spring |
| 140. Shield | 164. Lower Bearing | 202. Shroud |
| 141. Pin Preload Spring | 165. Rack Preload Spring | 203. Lower Bearing |
| 142. Pivot Switch | 166. Actuator Rack | 204. Retainer |
| | | 205. Screws |

B-07368

Figure 32—Tilt Steering Column—Floor Shift (RV and V Models)

- Install the clamp, bolt and nut. The clamp bolt must pass through the shaft undercut.



Tighten

- Nut to 60 N·m (44 ft. lbs.).

33. Dash panel bracket and screws to the column.



Install or Connect

- Steering column. Refer to "RV or G Model Steering Column Replacement" in this section.

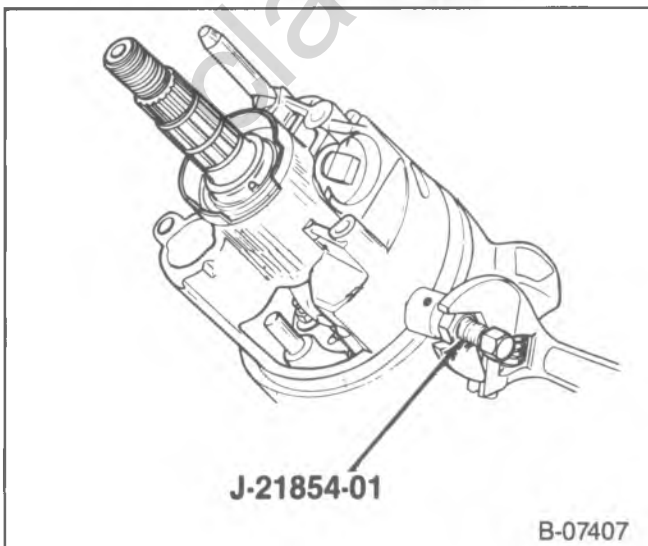

B-07407

Figure 33—Bearing Housing Pivot Pins Removal

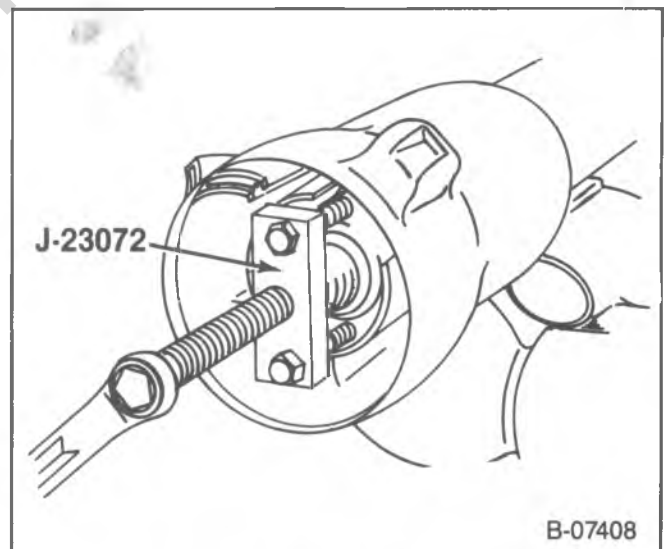

B-07408

Figure 34—Shift Tube Removal

3B4-32 STEERING COLUMN

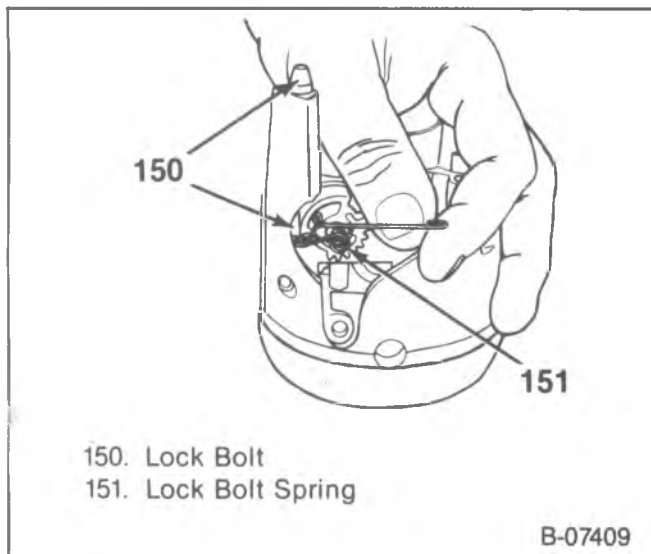

Figure 35—Lock Bolt Spring Replacement

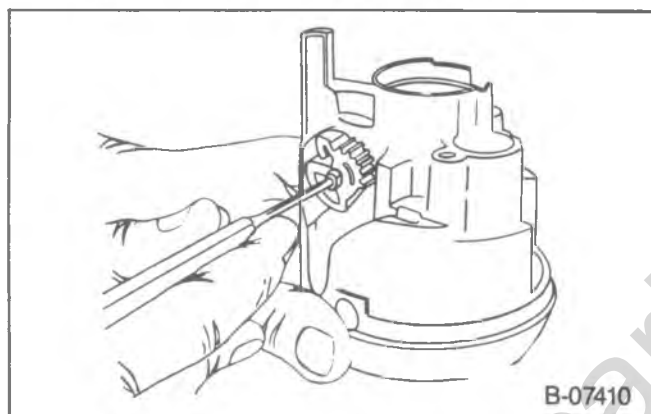

Figure 36—Sector Drive Shaft Removal

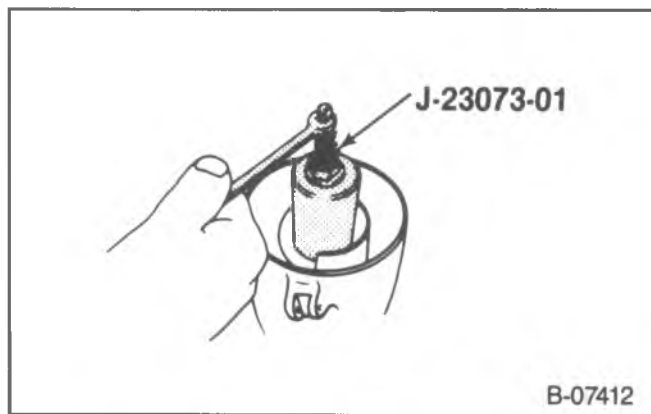

Figure 38—Shift Tube Assembly Installation

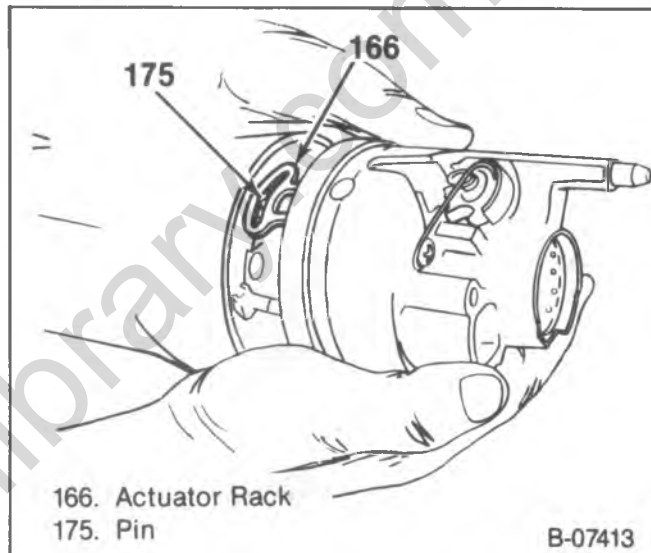

Figure 39—Bearing Housing Installation

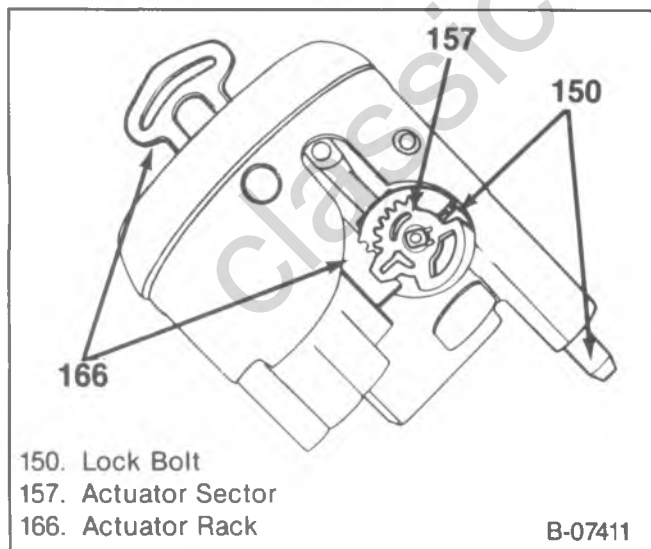

Figure 37—Lock Bolt and Rack Assemblies Installation

STEERING COLUMN ON-VEHICLE SERVICE P(32) MODELS

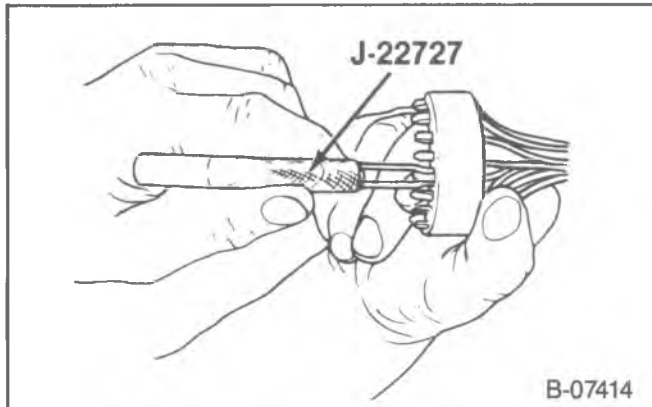

Figure 40—Connector Wire Removal

TURN SIGNAL SWITCH REPLACEMENT

↔ Remove or Disconnect (Figure 40)

Tools Required:

J-22727 Electrical Terminal Remover

1. Steering wheel. Refer to "Steering Wheel Replacement" in this section.
2. Cancelling cam and spring (standard columns).
3. Instrument panel trim plate (some models).
4. Turn signal switch wiring harness at the half-moon connector.
 - Pry the wiring harness protector out of the column retaining slots.
 - Mark the location of each wire in the half-moon connector and then remove each individual wire from the connector. Use J-22727 (figure 40). Insert the tool into the lower end of the connector and push in until the tool bottoms on the connector. Remove the tool and then pull the wire from the connector.
5. Turn signal lever screw and lever.
6. Hazard warning light knob. Press the knob inward and unscrew.
 - On tilt columns.
 - Remove the PRNDL dial screws, dial and indicator needle. Remove the cap and dial illumination bulb from the housing cover (Automatic Transmission Model).
 - Unscrew and remove the tilt release lever.
 - Remove the turn signal housing cover, using a pulley remover with reversed jaws.
7. Turn signal switch mounting screws.
8. Turn signal switch assembly from the column. Guide the wiring harness through the opening in the shift lever housing.

→← Install or Connect

- Wrap the ends of the turn signal switch wires with tape and then guide them through the opening at

the lower left hand side of the bearing housing (tilt columns) out the lower end of the shift lever housing and under the dash seal.

- Place the turn signal switch in position.
1. Turn signal switch mounting screws.

⌚ Tighten

- Screws to 2.8 N·m (25 in. lbs.).
 - On tilt columns.
 - Align the openings in the turn signal switch cover with the proper lever positions. Tap the cover into place using a plastic hammer.
 - Install the tilt release lever.
 - Install the PRNDL dial, pointer, dial illumination bulb and cap (Automatic Transmission Models).
2. Turn signal switch lever and screws.
 3. Hazard warning knob.
 - Bend the wire retaining tabs, on each wire in the wiring harness, enough to provide proper retention of the wire in the half-moon connector.
 4. Each wire in its marked location in the half-moon connector. Push in until the square part of the clip is flush with the bottom side of the connector.
 5. Turn signal switch wiring harness.
 6. Wiring harness protector into the column retaining slots.
 7. Cancelling cam and spring (non-tilt column).
- NOTICE: For step 8 see "Notice" on page 3B4-1.**
8. Steering wheel. Refer to "Steering Wheel Replacement" in this section.
 9. Instrument panel trim plate (some models).

TILT STEERING COLUMN REPLACEMENT

↔ Remove or Disconnect (Figure 41)

1. Battery ground cable.
2. Transmission control linkage from the column shift tube levers.
3. Nuts and washers that secure the flanged end of the steering shaft to the flexible coupling.
4. Steering wheel. Refer to "Steering Wheel Replacement" in this section.
5. Turn signal wiring harness.
 - On an automatic transmission, disconnect the single wire at the fuse block and unclip it from the parking brake bracket.
6. Screws from the cover of the dash and toe panel assembly.
7. Screws (211) and clamp (210) from the column support bracket.
8. Steering column assembly.

3B4-34 STEERING COLUMN

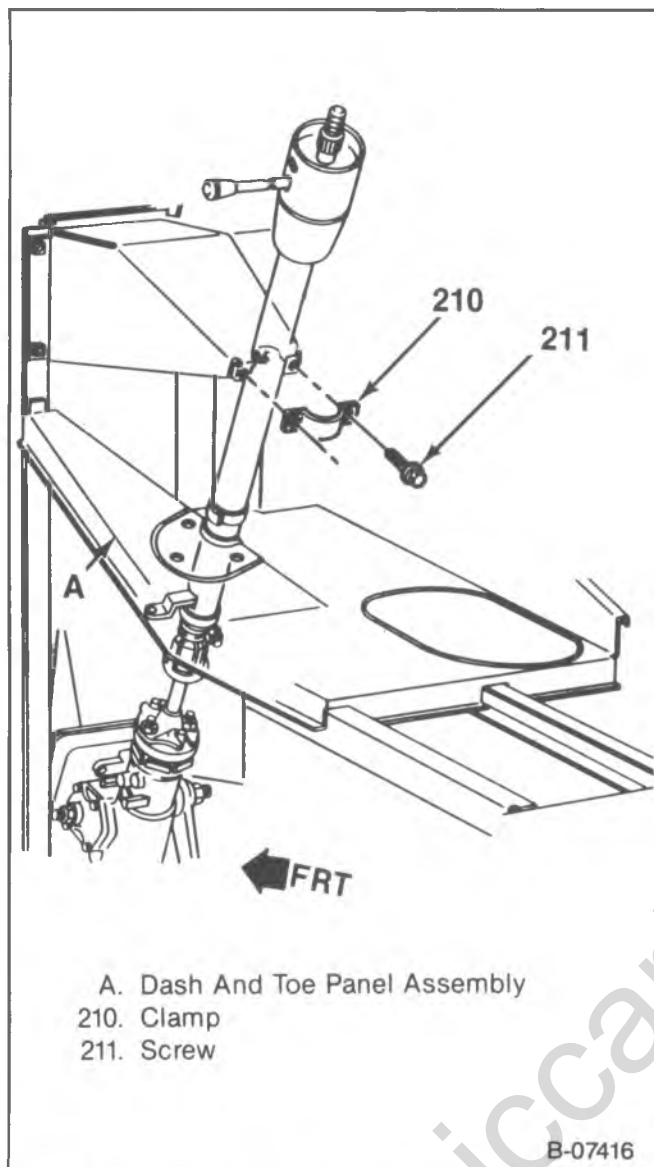

Figure 41—Steering Column Installation—P(32) Model

- Lower and then withdraw the column assembly. Rotate the column so the shift lever clears the dash and toe panel assembly.

Install or Connect (Figures 41 and 42)

NOTICE: For steps 4 and 8 see "Notice" on page 3B4-1.

- Adjust the lower bearing preload. Refer to "Steering Column Lower Bearing Adjustment" in this section.
1. Plastic spacers onto the flexible coupling alignment pins.
 2. Lower end of the steering column through the toe panel opening.
 3. Lower steering shaft flange onto the flexible coupling.
 4. Flange to coupling nuts.

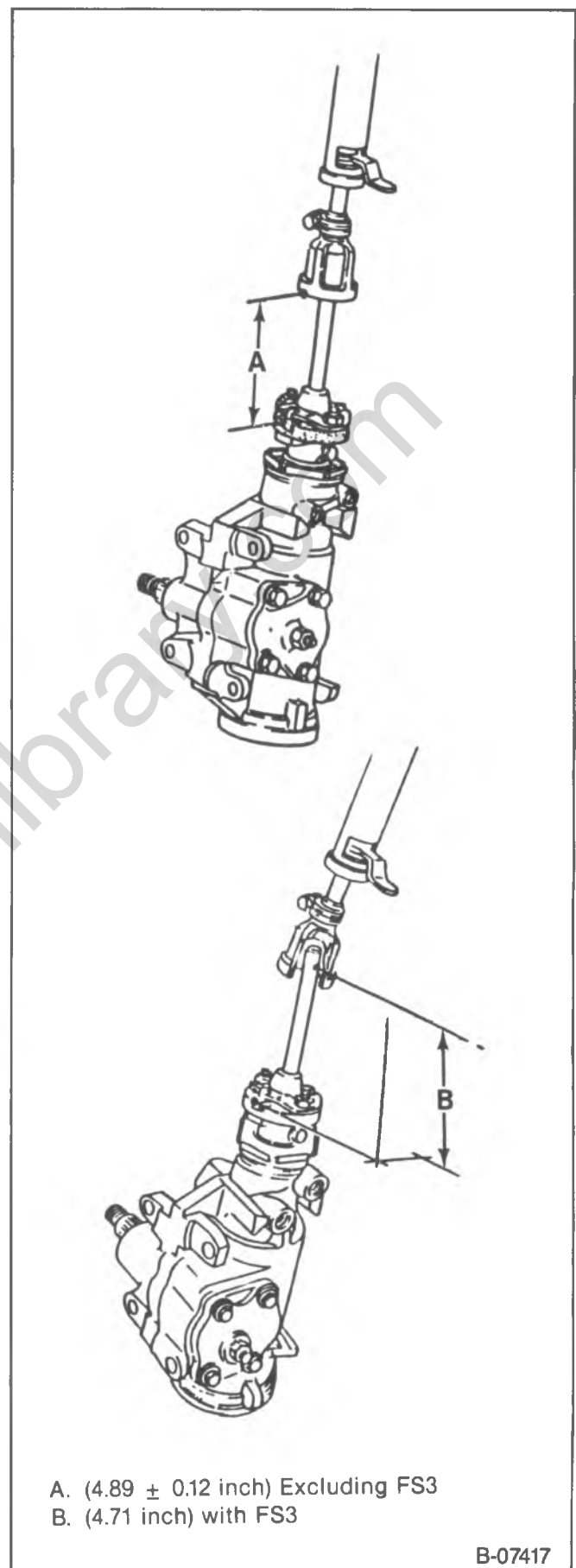

Figure 42—Coupling Assembly Measurement



Tighten

- Nuts to 27 N·m (20 ft. lbs.).
 - Align the index slot in the steering column jacket with the protrusion on the column support bracket.
5. Clamp (210) and screws (211) to the column support bracket. Tighten bolts finger tight.
 - Push the column down until the steering shaft flange bottoms on the plastic spacers on the flexible coupling.



Tighten

- Screws (211) to 25 N·m (18 ft. lbs.).
- Remove the plastic spacer from the alignment pins.



Measure

- Coupling assembly dimensions (figure 42). Raise or lower steering column if necessary.
6. Cover and mounting screws to the dash and toe panel assembly.
 7. Turn signal switch wiring harness.
 - On an automatic transmission, connect the single wire to the fuse block and clip it to the parking brack bracket.
 8. Steering wheel. Refer to "Steering Wheel Replacement" in this section.
 9. Transmission control linkage.
 10. Battery ground cable.

TILT STEERING COLUMN BEARING HOUSING REPLACEMENT



Remove or Disconnect (Figures 43 through 47)

Tools Required:

- J-22635 Lock Shoe and Release Lever Pin Remover and Installer
- J-21854-01 Pivot Pin Remover
- J-5822 Steering Gear Shaft Main Bearing Cup Remover
- J-2619-01 Slide Hammer

1. Battery ground cable.
2. Steering wheel. Refer to "Steering Wheel Replacement" in this section.
3. Turn signal switch. Refer to "Turn Signal Switch Replacement" in this section.
 - On column shift models, use a suitable size punch to drive out the shift lever pivot and remove the shift lever.
 - Install the tilt release lever and place the column in the "up" position.
4. Retainer (230) and spring (232). Use a screwdriver to turn the retainer until it aligns with the grooves in the housing, then remove the retainer and spring.
5. Upper bearing nut (253).
6. Seat (254) and race (255).
7. Housing pivot pins (221). Use J-21854-01 (figure 45).
8. Bearing housing (219). Pull up on the tilt release lever, this will disengage the shoes (224), and remove the housing.
9. Upper and lower bearings (218, 220).
 - Remove the bearing races using J-5822 and J-2619-01 (figure 46).
10. Tilt release lever.

11. Shoe release pivot pin (228). Use J-22635 or a suitable punch (figure 47).
12. Spring (227) and lever (229).
13. Shoe kit assembly (225).
 - If the upper steering shaft, lower steering shaft, or centering spheres are being removed, proceed as follows.
14. Steering shaft assembly through the upper end of the column. If it is necessary to disassemble the shaft, proceed as follows:
 - Disconnect the shaft at the pot joint coupling clamp and remove the lower steering shaft.
 - Turn the upper shaft 90 degrees to the lower shaft and slide the upper shaft and centering sphere from the lower shaft.
 - Rotate the centering spheres 90 degrees and remove the centering spheres and spring from the upper shaft.
 - If the bearing housing support is being replaced, proceed as follows:
15. Screws (231).
16. Support (233).



Install or Connect (Figures 43 and 44)

NOTICE: For steps 4 and 11 see "Notice" on page 3B4-1.

- Lubricate the ID of the bearing housing support and install the support and screws.
1. Steering shaft assembly.
 - Lubricate and assemble the centering spheres and spring.
 - Install the spheres into the upper (short) shaft and rotate 90 degrees.
 - Install the lower shaft 90 degrees to the upper shaft and over the centering spheres. Slowly straighten the shafts while compressing the spring.
 2. Steering shaft assembly into the housing from the upper end.
 3. Lower steering column shaft to the intermediate shaft (pot joint) assembly (269).
 4. Clamp (262) bolt (261) and nut (263). The bolt must pass through the shaft undercut.



Tighten

- Bolt to 60 N·m (44 ft. lbs.).
5. Bearing housing (219) assembly.
 - Press the new upper and lower bearing races into the bearing housing.
 - Lubricate and install the bearings into the bearing races.
 - Place the shoe springs in position in the housing. Install each shoe in place and compress the spring in position. Once the shoes are in place, drive in the shoe retaining pin (226).
 - Install the shoe release lever (229), spring (227) and pivot pin (228).
 - Install the tilt release lever.
 - Lubricate the shoes and release lever.
 6. Bearing housing assembly to the support (233).

3B4-36 STEERING COLUMN

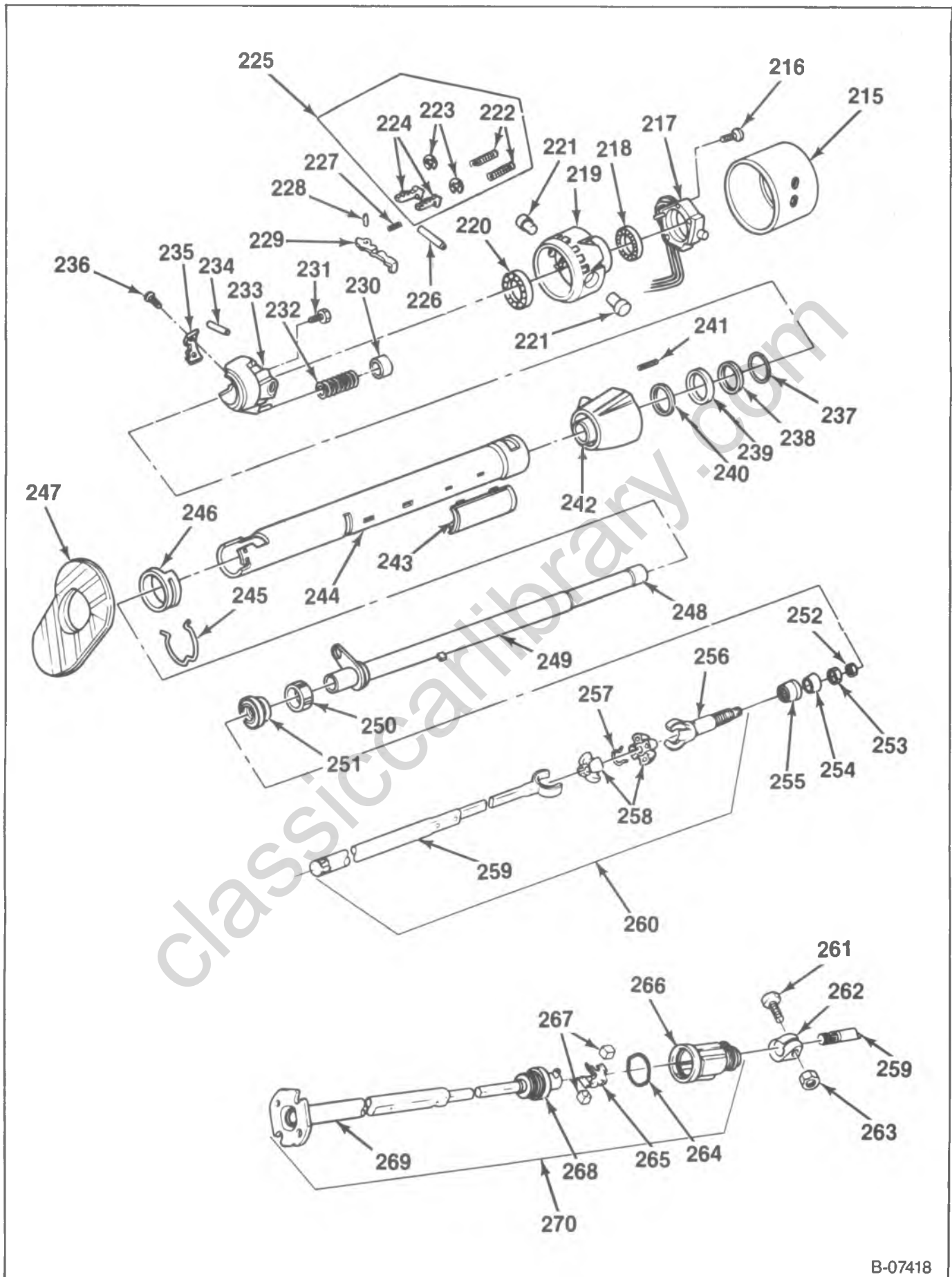

B-07418

Figure 43—Tilt Steering Column—P(32) Model

215. Housing Cover	229. Lever	243. Guide	257. Spring
216. Turn Signal Mounting Screw	230. Retainer	244. Jacket	258. Sphere Assembly
217. Turn Signal Switch	231. Screws	245. Bearing	259. Lower Shaft
218. Upper Bearing	232. Spring	Retainer Clip	260. Shaft Assembly
219. Bearing Housing	233. Support	246. Reinforcement	261. Bolt
220. Lower Bearing	234. Pin	247. Dash Seal	262. Clamp
221. Pivot Pins	235. Detent Plate	248. Seal	263. Nut
222. Shoe Spring	236. Screw	249. Shift Tube	264. Retainer
223. Spacer	237. Retaining Ring	250. Adapter	265. Spring
224. Shoes	238. Washer	251. Bearing	266. Coupling Assembly
225. Shoe Kit Assembly	239. Lock Plate	252. Nut	267. Bearings
226. Shoe Retaining Pin	240. Washer	253. Nut	268. Seal
227. Spring	241. Gear Shift Lever Spring	254. Seat	269. Intermediate Shaft Assembly
228. Pivot Pin	242. Gear Shift Housing	255. Race	
		256. Shaft	

B-07369

Figure 44—Tilt Steering Column—P(32) Model

- Hold the tilt release lever in the “up” position until the shoes have fully engaged the support.
 - Lubricate and install the bearing housing pivot pins (221). Press the pins in flush with the housing.
 - Place the housing in the “up” position.
7. Spring (232) and retainer (230). Push the retainer into the housing about 5 mm ($\frac{3}{16}$ inch) and rotate counterclockwise $\frac{1}{8}$ turn.
 - Lubricate the upper bearing race (255), seat (254) and nut (253).
 8. Race (255), seat (254) and nut (253).
 - Remove the tilt release lever.
 9. Turn signal switch. Refer to “Turn Signal Switch Replacement” in this section.
 10. Shift lever and pivot pin. (Column Shift Models).
 11. Steering Wheel. Refer to “Steering Wheel Replacement” in this section.
 12. Tilt release lever.

Inspect

- Electrical and mechanical functioning of the steering column.

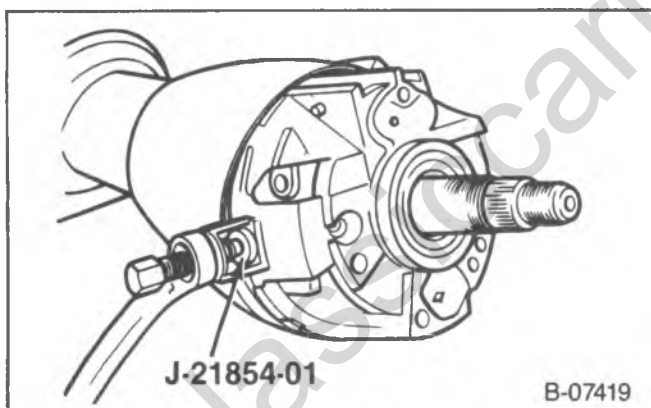

Figure 45—Bearing Housing Pivot Pin Removal

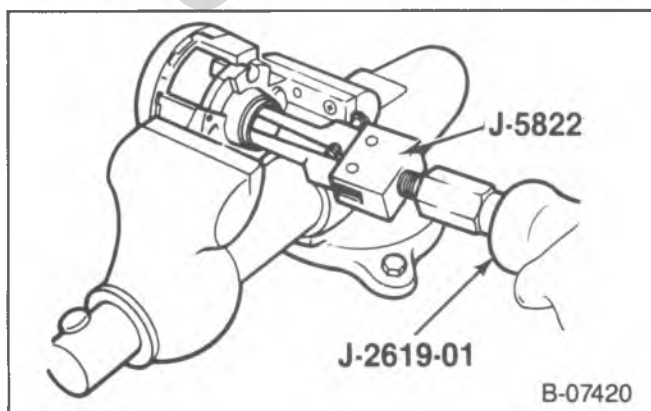

Figure 46—Bearing Race Removal

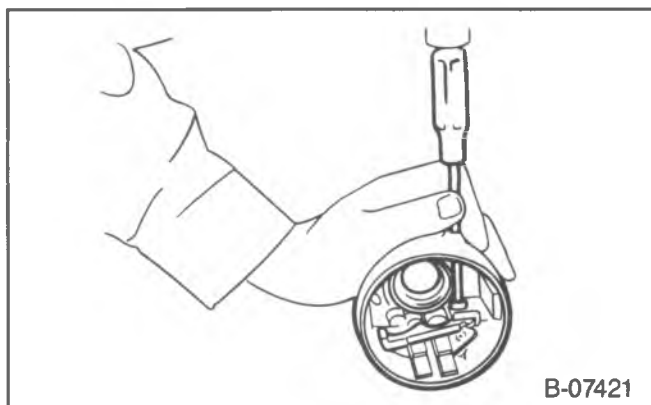

Figure 47—Release Lever Pivot Pin Removal

TILT STEERING COLUMN UNIT REPAIR P(32) MODELS

Remove or Disconnect

- Steering column assembly. Refer to "Tilt Steering Column Replacement" in this section.

Disassemble (Figures 43 and 44)

Tool Required:

J-23072 Shift Tube Remover

1. Clamp the steering column in a vise.
 - Clamp at the lower end of the jacket.
2. Intermediate shaft assembly (270), with the universal joint (pot joint), from the steering column shaft.
3. Bearing retainer clip (245) and reinforcement (246).
4. Bearing (251) and adapter (250).
5. Bearing housing assembly and steering shaft assembly. Refer to "Tilt Steering Column Bearing Housing Replacement" in this section.
 - If the shift tube index plate must be removed, remove the two retaining screws and plate. (Column Shift Models).
6. Shift tube retaining ring (237) and washer (238).
7. Neutral-safety or back-up lamp switch screws and switch. Refer to SEC. 8B (CHASSIS ELECTRICAL) in this manual.
8. Shift tube (249) assembly. Use J-23072. Do not hammer or pull on the shift tube during removal (figure 29).
 - Insert the hooked end of the tool into the notch in the shift tube just below the shift lever housing key. Pilot the sleeve over the threaded end of the tool and into the upper end of the shift tube. Force the shift tube out of the housing by turning the nut onto the tool. If the shift tube is not completely free when the nut is bottomed on the threads, complete the removal by hand.
 - On column shift models, guide the lower shift lever through the slotted opening in the column to prevent damage to the tube or column.
9. Lock plate (239) and washer (240). Tip the lock plate downward towards the housing, then remove.

10. Shift lever housing.
 - Remove the shift lever spring by winding the spring up with pliers (Column Shift Models).

11. Dash panel seal from the column jacket.

Assemble (Figures 43 and 44)

Tools Required:

J-23073-01 Shift Tube Installer

- Apply a thin coat of lithium grease to all friction surfaces.
1. Dash panel seal.
 - Press a new shift lever spring into the shift lever housing (Column Shift Models).
 2. Shift lever housing. Slide the housing over the upper end of the column.
 3. Washer (240) and lock plate (239).
 - Apply lithium grease to the lock plate and the upper end of the shift tube.
 4. Shift tube (249) and seal (248) into the lower end of the column. Do not hammer or force the shift tube.
 - Align the keyway in the shift tube with the key in the shift lever housing and install the shift tube using J-23073-01 (figure 38).
 - The shift lever housing key must bottom in the shift tube slot.
 5. Neutral-safety or back-up lamp switch and screws. Refer to SEC. 8B (CHASSIS ELECTRICAL) in this manual.
 6. Washer (238) and retaining ring (237). Pull up on the shift lever housing when installing the washer and retaining ring.
 - Seat the retaining ring in both slots in the shift tube.
 7. Steering shaft assembly and bearing housing assembly. Refer to "Tilt Steering Column Bearing Housing Replacement" in this section.

Install or Connect

- Steering column assembly. Refer to "Tilt Steering Column Replacement" in this section.

STEERING COLUMN ON-VEHICLE SERVICE P(42) MODELS

STANDARD STEERING COLUMN REPLACEMENT

Remove or Disconnect (Figure 48)

1. Battery ground cable.
2. Transmission control linkage from the column shift tube levers (Column Shift Models).
3. Upper universal joint pinch bolt from the intermediate shaft. Mark the relationship of the universal yoke to the steering shaft.
4. Nut (282), bolt (280) and clamp (281). Slide the clamp down the column.

5. Screws (277) from the cover (278) and seal (279). Slide the cover and seal up the column.
6. Steering wheel. Refer to "Steering Wheel Replacement" in this section.
7. Turn signal wiring harness.
 - On an automatic transmission, disconnect the conductor tube at the instrument panel.
8. Bolts (275) and clamp (276) from the column support bracket.
9. Bolt, nut and outer brace (283) from the column support bracket (P200 + 300 (42) models).
10. Steering column assembly.

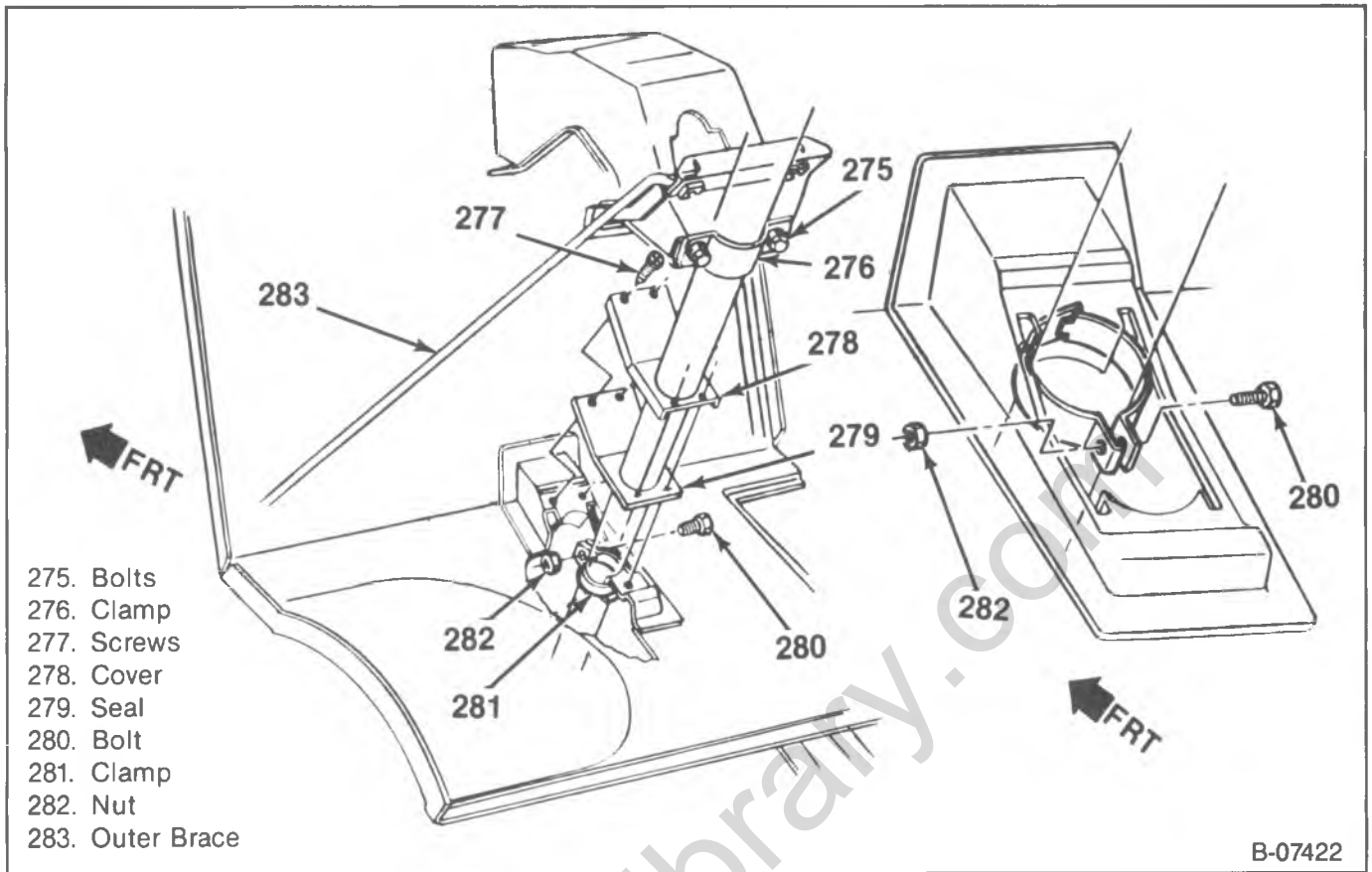

Figure 48—Steering Column Installation—P(42) Model

- Lower and then withdraw the column assembly. Rotate the column so the shift lever clears the dash and toe panel assembly.

↔ Install or Connect (Figure 48)

NOTICE: For steps 2, 3, 4 and 9 see "Notice" on page 3B4-1.

1. Adjust the lower bearing preload. Refer to "Steering Column Lower Bearing Adjustment" in this section.
2. Lower end of the steering column through the toe panel opening.
 - Guide the steering shaft into the universal yoke, lining up the marks made at removal.
 - Upper universal pinch bolt. The pinch bolt must pass through the shaft undercut.

⌚ Tighten

- Pinch bolt to "Specifications" at the end of this section.
 - Align the seal (279) and cover (278) with the floor and dash panel assembly.
 - Align the column support bracket protrusion with the index slot in the steering column.
3. Clamp (281), bolt (280) and nut (282). Position the clamp as shown in figure 48.

⌚ Tighten

- Nut to 15 N-m (11 ft. lbs.).
4. Clamp (276) and bolt (275).

⌚ Tighten

- Bolt to 25 N-m (18 ft. lbs.).

5. Seal (279), cover (278) and screws (277) to the dash panel assembly.
6. Outer brace (283), bolt and nut to the column support bracket (P200 + 300 (42) models).

⌚ Tighten

- Bolt to 25 N-m (18 ft. lbs.).

7. Transmission control linkage to the shift tube levers (Column Shift Models).
8. Turn signal wiring harness.
 - On a standard column with automatic transmission connect the conductor tube at the instrument panel.
9. Steering wheel. Refer to "Steering Wheel Replacement."
10. Battery ground cable.

UPPER BEARING REPLACEMENT

↔ Remove or Disconnect (Figure 49)

1. Steering wheel. Refer to "Steering Wheel Replacement" in this section.
2. Cancelling cam (286).
3. Upper bearing (289).

3B4-40 STEERING COLUMN

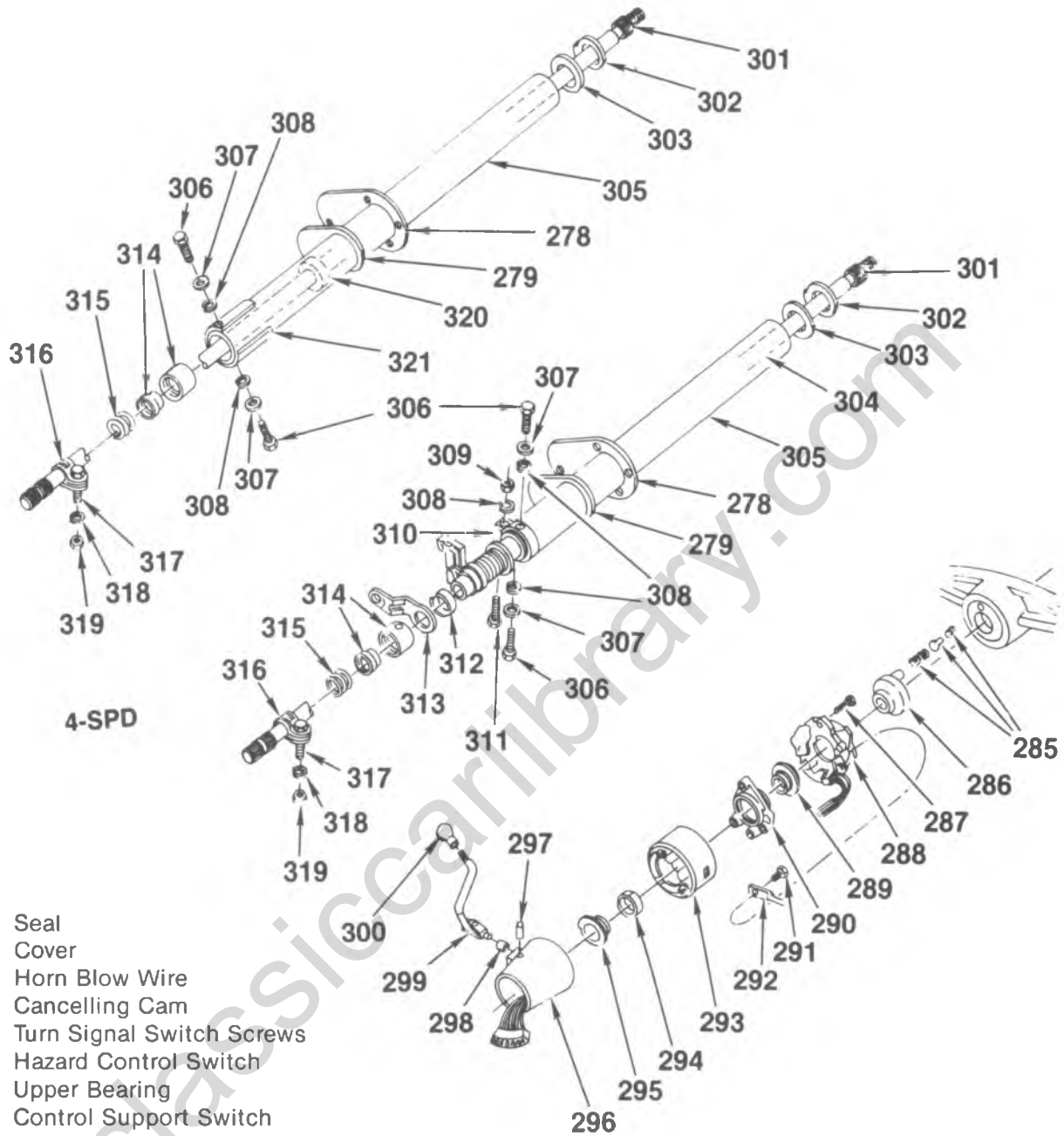

- | | | |
|--------------------------------|---|-------------|
| 278. Seal | 304. Shift Tube | 315. Spring |
| 279. Cover | 305. Jacket | 316. Clamp |
| 285. Horn Blow Wire | 306. Bolts | 317. Bolt |
| 286. Cancelling Cam | 307. Washer | 318. Washer |
| 287. Turn Signal Switch Screws | 308. Washer | 319. Nut |
| 288. Hazard Control Switch | 309. Nut | 320. Seal |
| 289. Upper Bearing | 310. Clamp | 321. Cover |
| 290. Control Support Switch | 311. Bolt | |
| 291. Screw | 312. Spacer | |
| 292. Control Lever | 313. Lever | |
| 293. Housing | 314. Adjusting Pin And Bearing Assembly | |
| 294. Washer | | |
| 295. Washer | | |
| 296. Shift Lever Housing | | |
| 297. Pivot Pin | | |
| 298. Sleeve | | |
| 299. Shift Lever | | |
| 300. Knob | | |
| 301. Shaft | | |
| 302. Bushing | | |
| 303. Seat | | |

B-07423

Figure 49—Standard Steering Column—P(42) Model

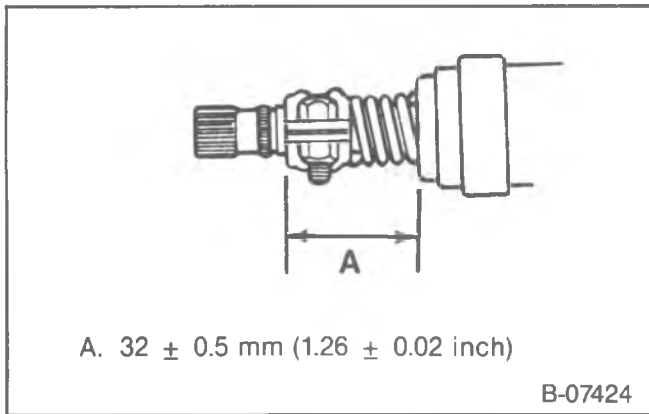

Figure 50—Lower Bearing Adjustment

Install or Connect (Figure 49).

NOTICE: For step 3 see "Notice" on page 3B4-1.

1. New upper bearing (289).
2. Cancelling cam (286).
3. Steering wheel. Refer to "Steering Wheel Replacement" in this section.

LOWER BEARING REPLACEMENT

Remove or Disconnect (Figure 49)

1. Intermediate steering shaft. Refer to "Intermediate Shaft Replacement" in this section.
2. Nut (319), washer (318), bolt (317) and clamp (316).
3. Bearing assembly (315, 314).

Install or Connect (Figures 49 and 50)

NOTICE: For steps 2 and 3 see "Notice" on page 3B4-1.

1. New adjusting ring and bearing assembly (314, 315).

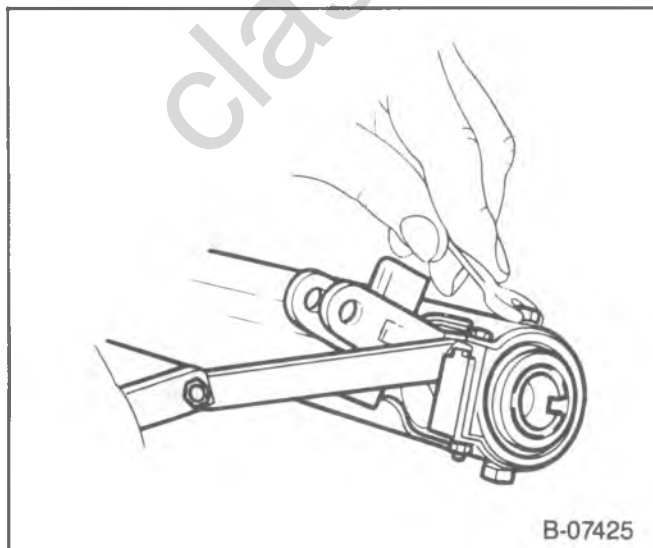

Figure 51—Shift Tube Adjustment—3 Speed Manual Transmission

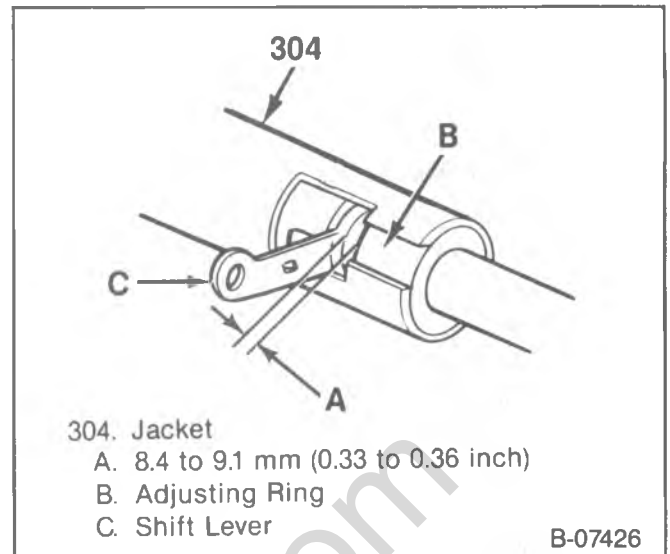

Figure 52—Shift Tube Adjustment—Automatic Transmission

2. Clamp (316), bolt (317), washer (318) and nut (319). Maintain the clearance dimension shown in figure 50.

Tighten

- Nut to 14 N·m (10 ft. lbs.).
3. Intermediate shaft. Refer to "Intermediate Shaft Replacement" in this section.

STEERING COLUMN LOWER BEARING ADJUSTMENT

1. Loosen clamp bolt (317).
2. Apply 222 N (50 lbs.) force to the steering wheel end of the steering shaft.
3. Adjust the clamp to obtain a clearance of 32 ± 0.5 mm (1.26 ± 0.02 inch) (figure 51).

SHIFT TUBE ADJUSTMENT

3-SPEED MANUAL TRANSMISSION

1. Loosen the adjusting ring bolts (306).
2. Loosen the clamp bolt (317).
3. Rotate the adjusting ring to give a 0.13 mm (0.005 inch) end play between the adjusting ring and first and reverse lever (figure 51).

Tighten

- Adjusting ring bolt (306) to 8 N·m (70 in. lbs.).
- Clamp bolt (317) to 14 N·m (10 ft. lbs.).

AUTOMATIC TRANSMISSION

1. Place the shift tube lever in "Neutral" or "Drive."
2. Loosen the adjusting ring bolt (306).
3. Rotate the shift tube adjusting ring to obtain a 8.4 to 9.1 mm (0.33 to 0.36 inch) clearance between the shift tube lever and adjusting ring (figure 52).

Tighten

- Adjusting ring bolt to 8 N·m (70 in. lbs.).

STANDARD STEERING COLUMN UNIT REPAIR P(42) MODELS

Remove or Disconnect

- Steering column assembly. Refer to "Standard Steering Column Replacement" (P42 Model) in this section.

Disassemble (Figure 49)

- Slide the steering shaft assembly from the lower end of the steering column.
1. Lower bearing bolt (317), washer (318), nut (319), clamp (316) and spring (315).
 2. Back-up lamp switch.
 3. Pivot pin (297) and shift lever (299).
 4. Cancelling cam (286).
 5. Control lever screw (291) and lever (292).
 6. Column wiring harness cover.
 7. Turn signal switch screws (287).
 8. Housing (293). Rotate the housing counterclockwise.
 - The housing and switch cannot be completely removed from the column until the shift lever housing is removed.
 9. Washer assembly (294, 295) and shift lever housing (296) (or extension housing) from the column.
 - Separate the turn signal switch, switch control support assembly, turn signal housing and shift lever housing (or housing extension) assemblies.
 10. Upper bearing (289). Press the bearing out of the switch contact support (290).
 11. Bushing (302) and seat (303).
 12. Bolts (306), washers (307, 308) and adjusting ring clamp (310).
 13. Adjusting ring and bearing (314) assembly.
 - Press the bearing out of the adjusting ring.
 14. First-reverse shift lever and spacer (3-Speed Column).
 15. Selector plate clamping screws (Automatic Columns).
 - Place the column upright on the floor, supporting it with two pieces of wood. Place a block of wood on the upper end of the shift tube. Press down on the shift lever with foot while tapping on the wood block to withdraw the tube from the column jacket.
- NOTICE:** In some tolerance stack-up cases it may be necessary to use a press. Be careful not to damage the tube or jacket.
16. Seal (320) and cover (321).
 17. Cover (279), seal (278) and clamp from steering column jacket (305).

Assemble (Figure 49)

- Apply a thin coat of lithium grease to all friction surfaces.
1. Clamp, seal (278) and cover (279) over the end of the jacket (305).
 - Apply lithium grease to all bearing surfaces on the shift tube.
 2. Seal (320) onto the shift tube and place the shift tube in the jacket.
 - Temporarily install the spacer, first-reverse shift lever and lower adjusting ring. Place a block of wood on top of the adjusting ring and tap until the shift tube bottoms. Remove the adjusting ring, shift lever and spacer (3-Speed Columns).
 - Align the three holes in the selector plate with the three holes in the jacket. Position the clamping ring and install the three screws. The shift tube spring retainer must bottom against the jacket stops (Automatic Columns).
 - Lubricate and install the spacer and first-reverse shift lever. The tang of the lever is toward the top of the column (3-Speed Column).
 3. Bearing in the adjusting ring (314).
 4. Adjusting ring and bearing (314) assembly, clamp (310), washers (308, 307) and bolts (306).
 5. Seat (303) and bushing (302) to the upper end of the housing.
 - Thread the turn signal switch wiring harness through the switch and lever (or extension) housing.
 - Lubricate the inner diameter of the shift housing.
 6. Shift lever (or extension) housing onto the upper end of the column.
 7. Washer assembly (295, 294).
 8. Upper bearing into the switch contact support.
 9. Turn signal switch housing (293), contact support, bearing, switch and switch screws. Tighten screws to 2.8 N·m (25 in. lbs.).
 10. Wiring harness cover and back-up lamp switch.
 11. Control lever (292) and the gear shift lever (299).

Adjust

- Shift tube. Refer to "Shift Tube Adjustment" in this section.
12. Spring (315), clamp (316), bolt (317), washer (318) and nut (319). Tighten the bolt finger tight.
 - Slide the steering shaft assembly up through the column assembly.

Install or Connect

- Steering column assembly. Refer to "Standard Steering Column Replacement" in this section.

INTERMEDIATE SHAFT UNIT REPAIR P(42) MODELS

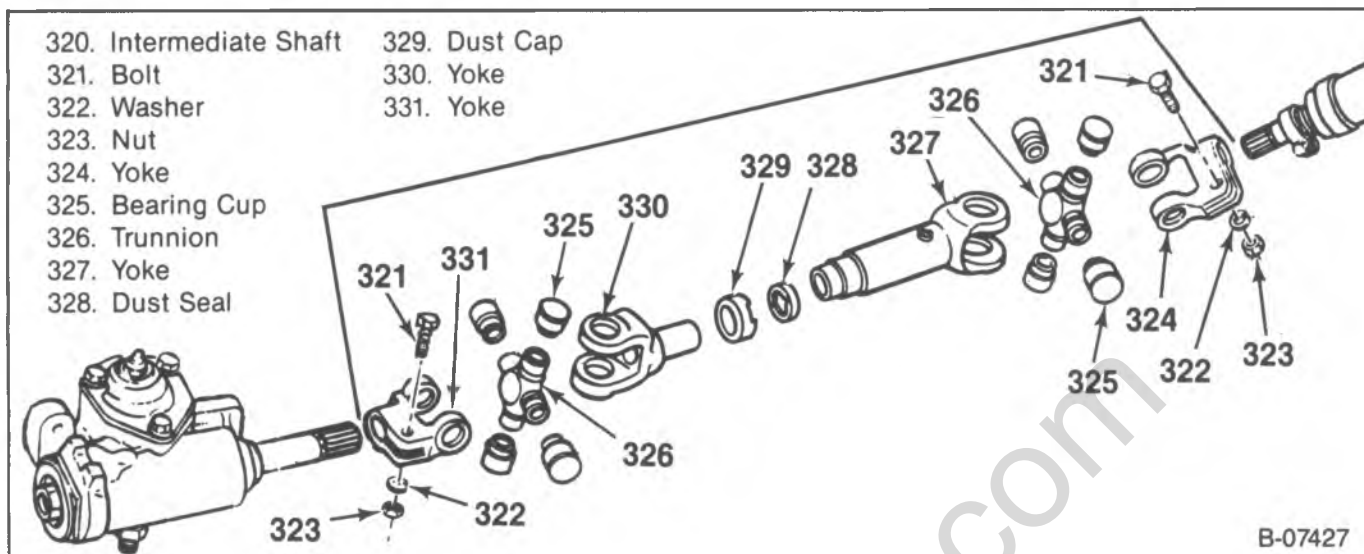

Figure 53—Intermediate Shaft—P(42) Model

↔ Remove or Disconnect

- Intermediate shaft. Refer to "Intermediate Shaft Replacement" in this section.

⊠ Disassemble (Figure 54)

- If the upper and lower half of the intermediate shaft is to be replaced, proceed as follows:
- Place the intermediate shaft (320) on a bench and straighten the tangs on the dust cap (329). Separate the upper and lower portions of the shaft assembly.
 1. Dust cap (329) and dust seal (328).
 - If the trunnion assemblies are to be replaced, proceed as follows:
 2. Bearing cups (325).
 - Support the yoke on a bench vise and drive out one bearing cup by tapping on the opposite bearing cup. Use a soft drift and hammer.
 - Support the other side of the yoke and drive out the remaining bearing cups, as described in the previous step.
 3. Trunnion (326) from the yokes (324, 327).
 4. Trunnion (326) from the yokes, (331, 330).

⊠ Assemble (Figure 53)

- If the yoke trunnions were removed, assemble as follows:
 1. Trunnion (326) into the yokes (331, 330).
 2. Trunnion (326) into the yokes (327, 321).
 3. Bearing cups (325) into the yokes.
 - Reassemble the intermediate shaft assembly as follows:
 4. Dust cap (329) and dust seal (328) over the shaft of the lower yoke (330) assembly.
 - Align the arrow on the lower yoke assembly shaft with the arrow on the upper yoke assembly tube and push the two assemblies together.
 - Push the dust seal (328) and dust cap (329) into position on the lower end of the upper yoke assembly and bend the tangs of the dust cap down against the yoke tube.

↔ Install or Connect

- Intermediate shaft. Refer to "Intermediate Shaft Replacement" in this section.

3B4-44 STEERING COLUMN

SPECIFICATIONS

	N·m	Ft. Lbs.	In. Lbs.
Turn Signal Switch Attaching Screws	4.0		35
Ignition Switch Attaching Screws	4.0		35
Dimmer Switch Attaching Screws	4.0		35
Steering Wheel Nut	40	30	
Flexible Coupling Clamp Bolt	42	31	
Flexible Coupling To Flange Bolt Nuts	27	20	
Steering Gear To Frame Bolts (C, K And G Models)	102	75	
Steering Gear To Frame Bolts P300 (32, 42) FS3	108	80	
Steering Gear To Frame Bolts P200 & 300(42) Excluding FS3	95	70	
Upper Intermediate Shaft Pinch Bolt (G Model)	47	35	
Lower Intermediate Shaft Pinch Bolt (G Model)	62	46	
Intermediate Shaft Pinch Bolt P300 (42) FS3	108	80	
Intermediate Shaft Pinch Bolt P200 & 300(42) Excluding FS3	102	75	
Steering Column Support Bracket Screws (C, K And G Models)	30	22	
Steering Column Support Bracket Clamp Nuts (P Models)	25	18	
Steering Column Shaft To Intermediate Shaft (Pot Joint) Assembly	60	44	

classiccarlibrary.com

SPECIAL TOOLS

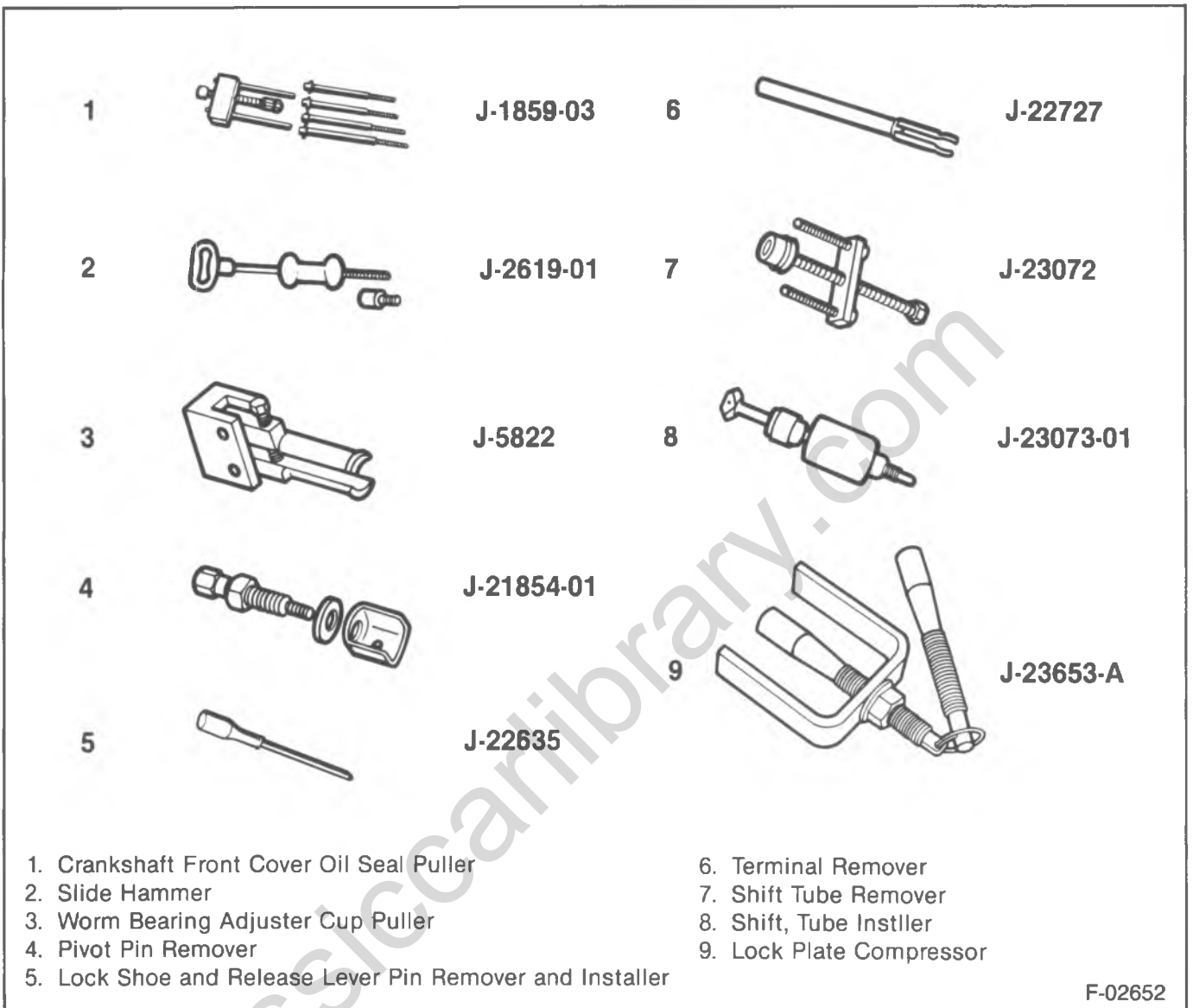

F-02652

Figure 54—Special Tools

classiccarlibrary.com

SECTION 3C

FRONT SUSPENSION

The following "Notice" applies to one or more steps in the assembly procedure of components in this portion of the manual as indicated at appropriate locations by the terminology "NOTICE: Refer to 'Notice' on page 3C-1 of this section."

NOTICE: All front suspension fasteners are important attaching parts in that they could affect the performance of vital parts and systems, and/or could result in major repair expense. They must be replaced with one of the same part number or with an equivalent part if replacement becomes necessary. Do not use a replacement part of lesser quality or substitute design. Torque values must be used as specified during reassembly to assure proper retention of these parts.

CONTENTS

<u>SUBJECT</u>	<u>PAGE</u>
General Description3C- 2
Diagnosis of Front Suspension3C- 2
Shock Absorber Bench Test3C- 3
Diagnosis of Wheel Bearings3C- 3
On-Vehicle Service: Independent Front Suspension3C- 8
Shock Absorber3C- 8
Stabilizer Bar3C- 8
Wheel Hub/Rotor Assembly3C- 8
Wheel Bearing Adjustment3C-13
Wheel Hub Bolt3C-15
Steering Knuckle3C-15
Coil Spring3C-17
Lower Ball Joint3C-17
Upper Ball Joint3C-19
Lower Control Arm Pivot Shaft and Bushings3C-20
Upper Control Arm Pivot Shaft and Bushings3C-23
Lower Control Arm3C-24
Upper Control Arm3C-25
Suspension Unit3C-26
On-Vehicle Service: I-Beam (RPO FS3) Front Suspension3C-28
Shock Absorber3C-28
Stabilizer Bar3C-30
Wheel Hub/Rotor Assembly3C-31
Wheel Bearing Adjustment3C-32
Wheel Hub Bolt3C-33
Steering Arm, Knuckle and Spindle3C-33
Front Axle3C-34
Leaf Springs3C-34
On-Vehicle Service: Four Wheel Drive Front Suspension3C-36
Shock Absorber3C-36
Stabilizer Bar3C-36
Wheel Hub/Rotor Assembly3C-36
Bearing Adjustment3C-37
Wheel Hub Bolt3C-41
Spindle3C-41
Steering Knuckle and Arm3C-45
Ball Joints (V10/1500 and 20/2500 Models Only)3C-48
Leaf Spring And Bushings3C-49
Specifications3C-51
End Play3C-51
Fastener Torque3C-51
Special Tools3C-53

GENERAL DESCRIPTION

An independent suspension is standard on the R-G-P model vehicles. This suspension features unequal length control arms (the lower control arm is the load carrying member), coil springs and shock absorbers to reduce vibration and shock load, plus a stabilizer bar to control sway or roll. Air cylinders inside coil springs are available to minimize "crash through" on large road bumps. A

special heavy duty front suspension is available on P model vehicles. This suspension (RPO FS3), centered around a solid I-beam axle, includes leaf springs, shock absorbers, and a stabilizer bar.

The V model (four wheel drive) suspension includes leaf springs, shock absorbers, and a stabilizer bar.

DIAGNOSIS OF FRONT SUSPENSION

PROBLEM	POSSIBLE CAUSE	CORRECTION
Hard Steering	<ol style="list-style-type: none"> 1. Ball joints and steering linkage need lubrication. 2. Low or uneven front tire pressure. 3. Incorrect front wheel alignment (manual steering). 	<ol style="list-style-type: none"> 1. Lubricate the ball joints and linkage. 2. Inflate tires to the recommended pressure. 3. Check and align the front suspension.
Poor Directional Stability	<ol style="list-style-type: none"> 1. Ball joints and steering linkage need lubrication. 2. Low or uneven front or rear tire pressure. 3. Loose wheel bearings. 4. Incorrect front wheel alignment (caster). 5. Broken springs. 6. Malfunctioning shock absorber. 7. Broken stabilizer bar or a missing link. 	<ol style="list-style-type: none"> 1. Lubricate the ball joints and linkage. 2. Inflate tires to the recommended pressure. 3. Adjust the wheel bearings. 4. Check and align the front suspension. 5. Replace the springs. 6. Check and replace the shock absorber. 7. Replace the stabilizer bar or link.
Front Wheel Shimmy (Smooth Road Shake)	<ol style="list-style-type: none"> 1. Tire and wheel are out of balance or out of round. 2. Worn or loose wheel bearings. 3. Worn ball joints. 4. Malfunctioning shock absorber. 	<ol style="list-style-type: none"> 1. Balance the tires, check run-out. 2. Adjust the wheel bearings. 3. Replace the ball joints. 4. Check and replace the shock absorber.
Vehicle Pulls To One Side (No Braking Action)	<ol style="list-style-type: none"> 1. Low or uneven tire pressure. 2. Front or rear brakes dragging. 3. Broken or sagging front spring. 4. Incorrect front wheel alignment (camber). 	<ol style="list-style-type: none"> 1. Inflate the tires to the recommended pressure. 2. Adjust the brakes. 3. Replace the spring. 4. Check and align the front suspension.
Noise In The Front End	<ol style="list-style-type: none"> 1. Ball joints and steering linkage need lubrication. 2. Loose shock absorber or worn bushings. 3. Worn control arm bushings. 4. Worn or loose wheel bearings. 5. Loose stabilizer bar. 6. Loose wheel nuts. 7. Spring is improperly positioned. 8. Loose suspension bolts. 	<ol style="list-style-type: none"> 1. Lubricate at the recommended intervals. 2. Tighten the bolts or replace the shock absorber. 3. Replace the bushings. 4. Adjust or replace the wheel bearings. 5. Tighten all the stabilizer bar attachments. 6. Tighten the wheel nuts. 7. Reposition the spring. 8. Tighten to specifications or replace.
Wheel Tramp	<ol style="list-style-type: none"> 1. Tire and the wheel are out of balance. 2. Tire and the wheel are out of round. 3. Blister or bump on the tire. 4. Improper shock absorber action. 	<ol style="list-style-type: none"> 1. Balance the wheels. 2. Replace the tire. 3. Replace the tire. 4. Replace the shock absorber.

DIAGNOSIS OF FRONT SUSPENSION (CONT.)

PROBLEM	POSSIBLE CAUSE	CORRECTION
Excessive or Uneven Tire Wear	<ol style="list-style-type: none"> 1. Underinflated or overinflated tires. 2. Improper toe-in. 3. Wheels are out of balance. 4. Hard driving. 5. Overloading the vehicle. 	<ol style="list-style-type: none"> 1. Inflate the tire to the recommended pressure. 2. Adjust toe-in setting. 3. Balance the wheels. 4. Follow proper driving techniques. 5. Do not exceed the maximum recommended payload rating.
Scuffed Tires	<ol style="list-style-type: none"> 1. Toe-in is incorrect. 2. Excessive speed on turns. 3. Tires are improperly inflated. 4. Suspension arm is bent or twisted. 	<ol style="list-style-type: none"> 1. Adjust toe-in setting. 2. Follow proper driving techniques. 3. Inflate the tires to the recommended pressure. 4. Replace the suspension arm.
Cupped Tires	<ol style="list-style-type: none"> 1. Front shock absorbers are defective. 2. Worn ball joints. 3. Wheel bearings are incorrectly adjusted or worn. 4. Wheel and tire is out of balance. 5. Excessive tire or wheel runout. 	<ol style="list-style-type: none"> 1. Replace the shock absorbers. 2. Replace the ball joints. 3. Adjust or replace the wheel bearings (also replace the races). 4. Balance the wheel and tire. 5. Check and compensate for runout.

SHOCK ABSORBER BENCH TEST

SPIRAL GROOVE SHOCK ABSORBERS

1. Purge the air from the pressure chamber.
 - Extend the shock vertically—top end up.
 - Turn the shock over and collapse it vertically—top end down.
 - Repeat the above step five times.
2. Place the shock absorber in a vise with the jaws clamped onto the shock's bottom mount.
 - Shock absorber should be positioned vertically in the vise—top end up.
 - Do not clamp the vise jaws on the shock's reservoir tube.
3. Pump the shock absorber at various rates of speed and observe the rebound force.
 - Rebound force is normally stronger than the compression force (approximately two to one).
 - Rebound force should be smooth and constant for each stroke rate.
4. Compare with a good shock absorber.
5. If one of the following are observed, replace the shock absorber.
 - A skip or lag at reversal near mid-stroke.
 - A seize (except at the extreme ends of travel).
 - A noise (grunt or squeal) after completing one full stroke in both directions.
 - A clicking noise at fast reversal.

NON-SPIRAL GROOVE SHOCK ABSORBERS

- Purging air from non-spiral groove shock absorbers is not necessary. The shock absorbers have a gas filled cell in their reservoirs (as opposed to the air filled cell in the spiral groove shock absorber reservoirs).
1. Place the shock absorber in a vise with the jaws clamped on the shock absorber's top mount.
 - Shock absorber should be held vertically in the vise with its bottom end up.
 - Do not clamp the vise jaws on the shock's reservoir tube.
 2. Pump the shock absorber at various rates of speed and observe the rebound force.
 - Rebound force is normally stronger than the compression force (approximately two to one).
 - Rebound force should be smooth and constant for each stroke rate.
 3. Compare with a good shock absorber.
 4. If one of the following are observed, replace the shock absorber.
 - A skip or lag at reversal near mid-stroke.
 - A seize (except at the extreme ends of travel).
 - A noise (grunt or squeal) after completing one full stroke in both directions.
 - A clicking noise at fast reversal.

DIAGNOSIS OF WHEEL BEARINGS

When diagnosing bearing condition, keep in mind the general condition of all parts during disassembly and

inspection. Use Figures 1, 2, 3 and 4 to classify the failure, and follow the recommended repair procedures.

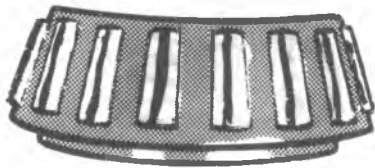

ABRASIVE ROLLER WEAR

Pattern on races and rollers caused by fine abrasives.

Clean all parts and housings, check seals and bearings and replace if leaking, rough or noisy.



ABRASIVE STEP WEAR

Pattern on roller ends caused by fine abrasives.

Clean all parts and housings, check seals and bearings and replace if leaking, rough or noisy.



GALLING

Metal smears on roller ends due to overheat, lubricant failure or overload.

Replace bearing, check seals and check for proper lubrication.



ETCHING

Bearing surfaces appear gray or grayish black in color with related etching away of material usually at roller spacing.

Replace bearings, check seals and check for proper lubrication.

Figure 1—Diagnosis of Front Wheel Bearings

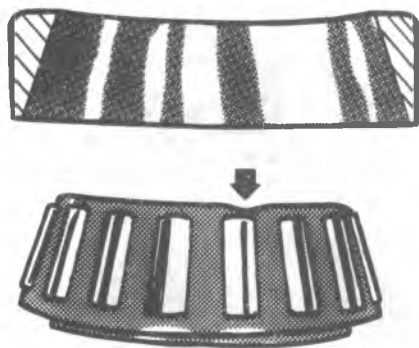

BENT CAGE

Cage damaged due to improper handling or tool usage.
Replace bearing.

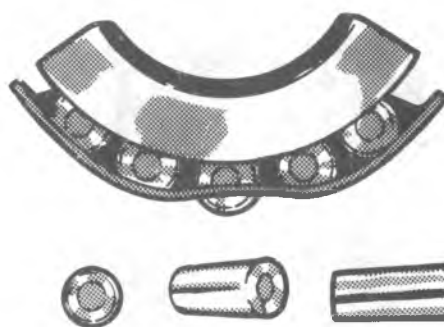

BENT CAGE

Cage damaged due to improper handling or tool usage.
Replace bearing.

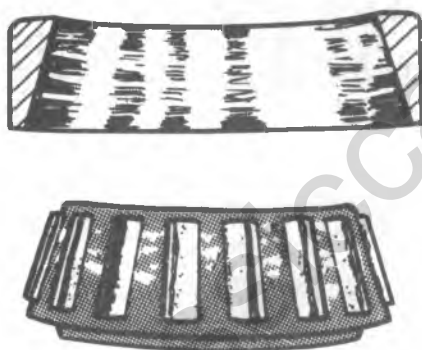

CAGE WEAR

Wear around outside diameter of cage and roller pockets caused by abrasive material and inefficient lubrication.
Clean related parts and housings.
Check seals and replace bearings.



INDENTATIONS

Surface depressions on race and rollers caused by hard particles of foreign material.
Clean all parts and housings. Check seals and replace bearings if rough or noisy.

Figure 2—Diagnosis of Front Wheel Bearings

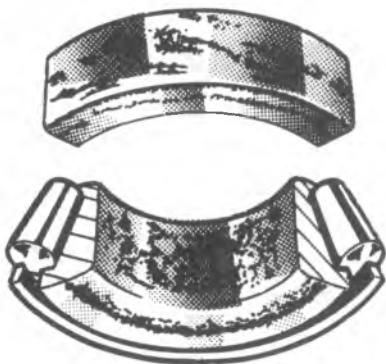

FRETTAGE

Corrosion set up by small relative movement of parts with no lubrication. Replace bearing. Clean related parts. Check seals and check for proper lubrication.



SMEARS

Smearing of metal due to slippage. Slippage can be caused by poor fits, lubrication, overheating, overloads or handling damage. Replace bearings, clean related parts and check for proper fit and lubrication.



STAIN DISCOLORATION

Discoloration can range from light brown to black caused by incorrect lubricant or moisture. Re-use bearings if stains can be removed by light polishing or if no evidence of overheating is observed. Check seals and related parts for damage.



HEAT DISCOLORATION

Heat discoloration can range from faint yellow to dark blue resulting from overload or incorrect lubricant. Excessive heat can cause softening of races or rollers. To check for loss of temper on races or rollers a simple file test may be made. A file drawn over a tempered part will grab and cut metal, whereas, a file drawn over a hard part will glide readily with no metal cutting. Replace bearings if over heating damage is indicated. Check seals and other parts.

B-00531

Figure 3—Diagnosis of Front Wheel Bearings

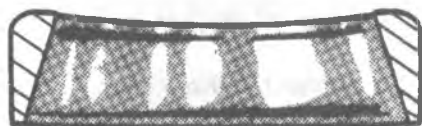

MISALIGNMENT

Outer race misalignment due to foreign object.
Clean related parts and replace bearing. Make sure races are properly seated.



CRACKED INNER RACE

Race cracked due to improper fit, cocking, or poor bearing seats.
Replace bearing and correct bearing seats.



FATIGUE SPALLING

Flaking of surface metal resulting from fatigue.
Replace bearing, clean all related parts.

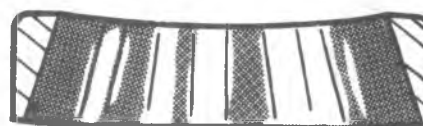

BRINELLING

Surface indentations in raceway caused by rollers either under impact loading or vibration while the bearing is not rotating.
Replace bearing if rough or noisy.

Figure 4—Diagnosis of Front Wheel Bearings

ON-VEHICLE SERVICE: INDEPENDENT FRONT SUSPENSION

SHOCK ABSORBER

 **Remove or Disconnect (Figures 5, 6, 7, 8, and 9)**

- Raise the vehicle on a hoist.
- 1. Shock absorber (20) from the lower control arm.
 - Nuts (23), washers (22) and bolts (21) (Figure 9).
- 2. Shock absorber (20) from the frame.
 - Nuts (16), washers (17), and bolts (21) (Figure 9).

 **Inspect**

- Shock absorbers for damage and leaking.
- Test the shock absorbers. Refer to "Shock Absorber Bench Test" in this section.

 **Install or Connect (Figures 5 through 9)**

NOTICE: Refer to "Notice" on page 3C-1 of this section.

1. Shock absorber (20) onto the vehicle.
 - Bolts (21), washers (17, 22), and nuts (16, 23) (figure 9).

 **Tighten**

- R models.
 - Nut (16) to 190 N·m (140 ft. lbs.).
 - Bolt (21) to 80 N·m (59 ft. lbs.).
 - G models.
 - Bolts (21) to 103 N·m (80 ft. lbs.).
 - P models.
 - Nut (16) to 190 N·m (140 ft. lbs.).
 - Nut (23) to 80 N·m (59 ft. lbs.).
2. Lower the vehicle.

STABILIZER BAR

 **Remove or Disconnect (Figures 5 through 8 and 10)**

- Raise the vehicle and support with suitable safety stands. Remove the wheel and tire assembly.
- 1. Stabilizer bar (59) from the frame.
 - Bolts (54), nuts (58), washers (55, 57) and clamps (52).
- 2. Stabilizer bar (59) from the lower control arm (36).
 - Bolts (43), nuts (38), washers (39, 41) and clamps (42).
 - Stabilizer bar (59) drops down—remove the bushings (40, 53).

 **Inspect**

- Rubber bushings (40, 53) for excessive wear, aging, or other damage. Replace as necessary.

 **Install or Connect (Figures 5 through 10)**

1. Bushings (40, 53) to the stabilizer bar (59).
 - Slit on the insulator faces forward.
 - Use rubber lubricant to ease the installation.

NOTICE: Refer to "Notice" on page 3C-1 of this section.

2. Stabilizer bar (59) to the vehicle.
 - Position the stabilizer bar and attach the clamps (52), bolts (54), washers (55, 57) and nuts (58).
 - Clamps (42), bolts (43), washers (39, 41) and nuts (38).

 **Tighten**

- R and P models.
 - Nuts (38, 58) to 33 N·m (24 ft. lbs.).
 - G models.
 - Nut (38) to 29 N·m (21 ft. lbs.).
 - Bolt (54) to 33 N·m (24 ft. lbs.).
3. Wheel and tire assembly. Lower the vehicle.

1. Bolt	36. Lower Control Arm
2. Washer	37. Lower Ball Joint
3. Nut	38. Nut
4. Bolt	39. Washer
5. Washer	40. Bushing
6. Bolt	41. Washer
7. Washer	42. Bracket
8. Reinforcement	43. Bolt
9. Bracket	44. U-Bolt
10. Nut	45. Rivet
11. Rivet	46. Bushing
12. Fitting	47. Bracket
13. Upper Ball Joint	48. Washer
14. Nut	49. Nut
15. Cotter Pin	50. Pivot Shaft
16. Nut	51. Rivet
17. Washer	52. Bracket
18. Shim Pack	53. Bushing
19. Spacer	54. Bolt
20. Shock Absorber	55. Washer
21. Bolt	56. Bracket
22. Washer	57. Washer
23. Nut	58. Nut
24. Nut	59. Stabilizer Bar
25. Retainer	60. Bolt
26. Bushing	61. Washer
27. Nut	62. Washer
28. Upper Control Arm	63. Nut
29. Pivot Shaft	64. Brace
30. Bumper	65. Bolt
31. Steering Knuckle	66. Washer
32. Coil Spring	67. Nut
33. Bumper	68. Seal
34. Cotter Pin	69. Air Cylinder
35. Nut	

B-07469

Figure 5—R-G-P Models Front Suspension

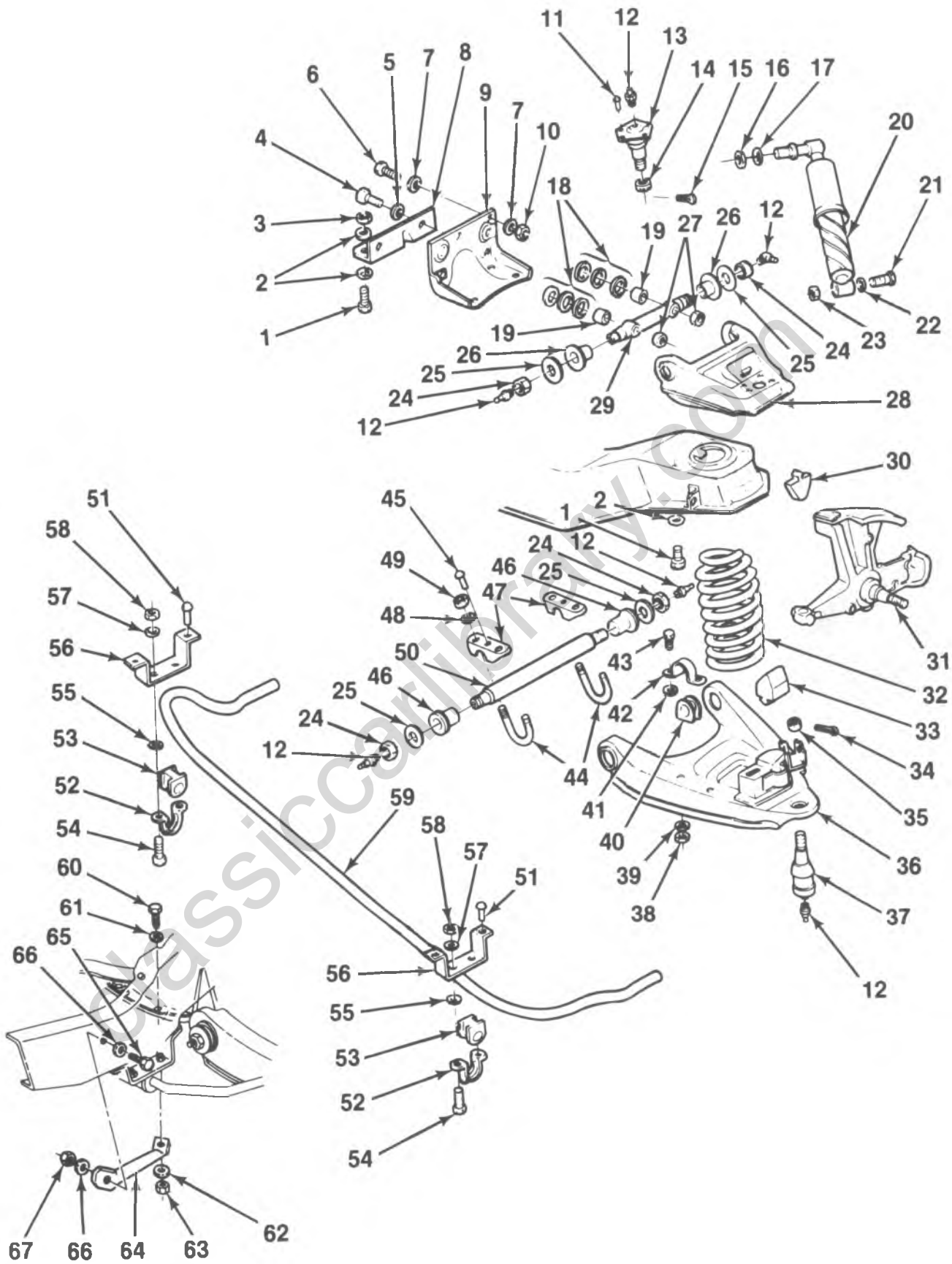

B-07466

Figure 6—R Model Front Suspension Components

3C-10 FRONT SUSPENSION

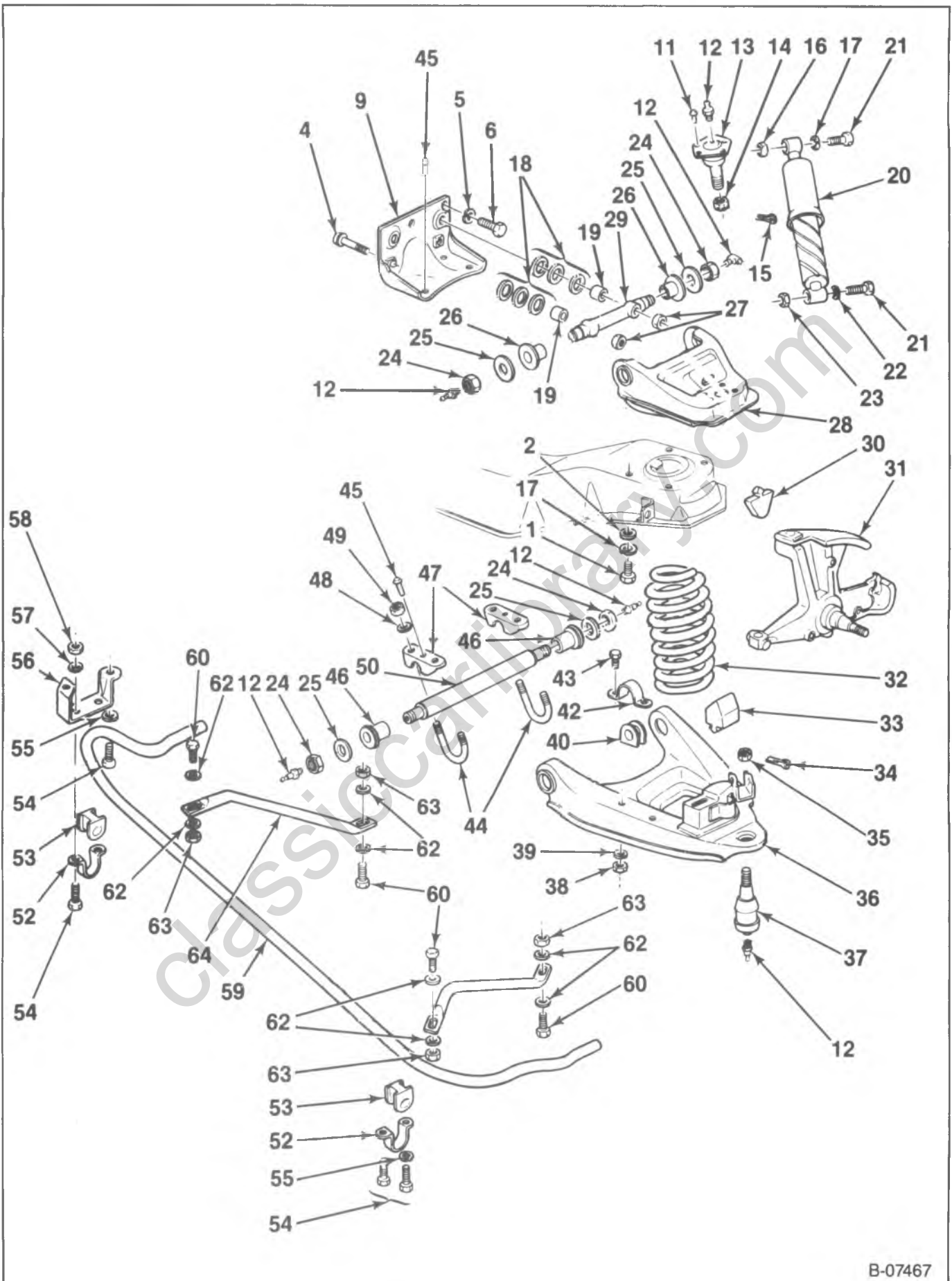

B-07467

Figure 7—G Model Front Suspension Components

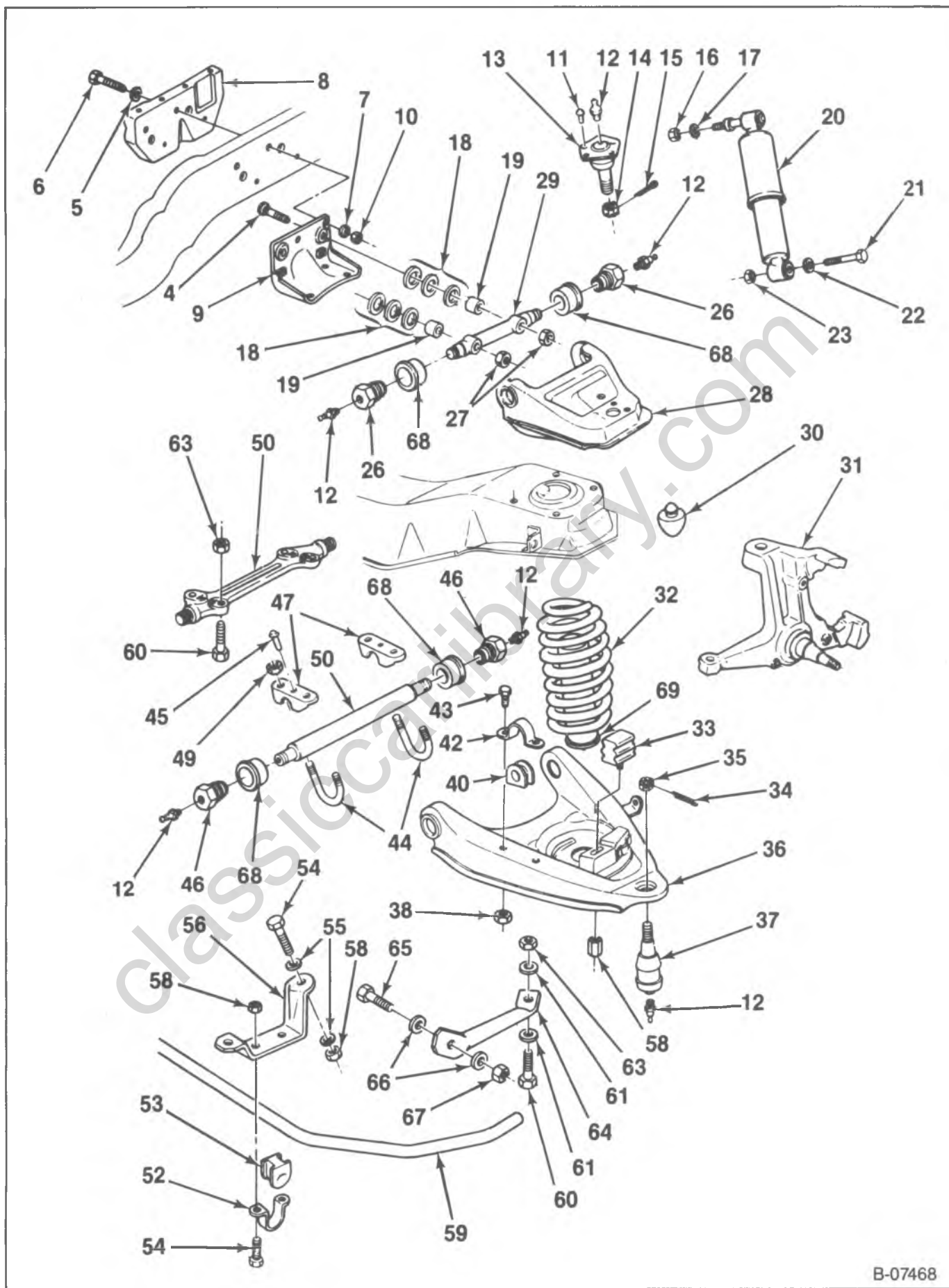

B-07468

Figure 8—P Model Front Suspension Components

3C-12 FRONT SUSPENSION

WHEEL HUB/ROTOR ASSEMBLY

Remove or Disconnect (Figures 5 through 8, and 11)

- Raise the vehicle and support it with suitable safety stands. Remove the wheel and tire assembly.
1. Caliper. Refer to BRAKES (SEC. 5).

NOTICE: Support the caliper with a piece of wire to prevent damage to the brake line.

2. Wheel Hub/Rotor (81)
 - Dust cap (79).
 - Cotter pin (80), nut (78), and washer (77).
 - Pull the hub/rotor free, making sure the outer wheel bearing (76) comes free of the hub/rotor.
 - Do not damage the steering knuckle (70) spindle threads.
3. Inner wheel bearing (73).
 - Pry out the seal (72).
4. Races (75, 82).
 - Drive out each race using a brass drift inserted behind the race in notches in the hub.

Clean

1. Grease from the hub/rotor (81) and steering knuckle spindle.
 - Remove grease from inside the hub.
2. Grease from the wheel bearings (73, 76) and races (72, 75).
 - Use clean solvent and a small brush (no loose bristles).
 - Do not spin the wheel bearings with compressed air to dry them—the wheel bearings may be damaged.

Inspect

1. Wheel bearings (73, 76) and their races (72, 75) for damage or wear.
 - Refer to "Diagnosis of Wheel Bearings," in this section.
 - If either a bearing or its race is damaged or worn, replace both.
2. Hub/rotor for damage.
 - Out-of-round or scored conditions.
 - Pitting or cracks.

Install or Connect (Figures 5 through 8, 11 and 12)

Tools Required:

- J-8092 Driver Handle
- J-8457 Wheel Bearing Race Installer
- J-8849 Wheel Bearing Race Installer
- J-9746-02 Hub/Rotor Support

NOTICE: Start the races squarely inside the hub/rotor to avoid distortion and possible cracking.

1. Races (72, 75) into the hub/rotor (81).
 - Place the hub/rotor on J-9746-02 and rest this assembly on press bars.

- Use J-8457 to drive the outer bearing outer race (75) into position (figure 12).
- Turn over the hub/rotor, remove J-9746-02, and drive in the inner bearing outer race (82) with J-8449.

Important

- Use an approved high-temperature front wheel bearing grease to lubricate the bearings. Refer to MAINTENANCE AND LUBRICATION (SEC. 0B).
 - Do not mix different greases as mixing may change the grease's properties resulting in poor performance.
2. Apply a thin film of grease to the steering knuckle spindle at the outer wheel bearing seat and at the inner wheel bearing seat, shoulder, and seal seat.
 3. Put a small quantity of grease inboard of each wheel bearing dust cap (79).

NOTICE: Failure to completely pack the wheel bearing (cones, rollers, and cage) with grease will result in premature wheel bearing damage and/or wear.

4. Fill each wheel bearing (cone and roller assembly) full of grease.
 - Use a cone-type grease machine that forces grease into the bearing.
 - If a cone-type grease machine is not available, pack the wheel bearing by hand.
 - When packing the wheel bearing by hand, work the grease into the bearings between the rollers, cones, and the cage.
5. Inner wheel bearing (73) into the hub/rotor (81).
 - Put an additional quantity of grease outboard of this bearing.
6. New seal (72).
 - Use a flat plate or block to install the seal to insure it is flush with the hub/rotor flange.
 - Lubricate the seal lip with a thin layer of grease.
7. Hub/rotor (81).
 - Do not damage the steering knuckle spindle threads.
8. Outer wheel bearing (76).
 - Slide it over the spindle until the wheel bearing (76) fully seats against the hub/rotor outer race (75).

NOTICE: Refer to "Notice" on page 3C-1 of this section.

9. Washer (77), nut (78), and cotter pin (80).
 - Do not place the cotter pin through the hole in the spindle until the wheel bearings are adjusted.

Tighten

- Nut (78) to 16 N·m (12 ft. lbs.) while turning the hub/rotor assembly in either direction.
10. Put an additional quantity of grease outboard of the wheel bearing (76).
 11. Adjust the wheel bearings.
 - Refer to "Wheel Bearing Adjustment," in this section.

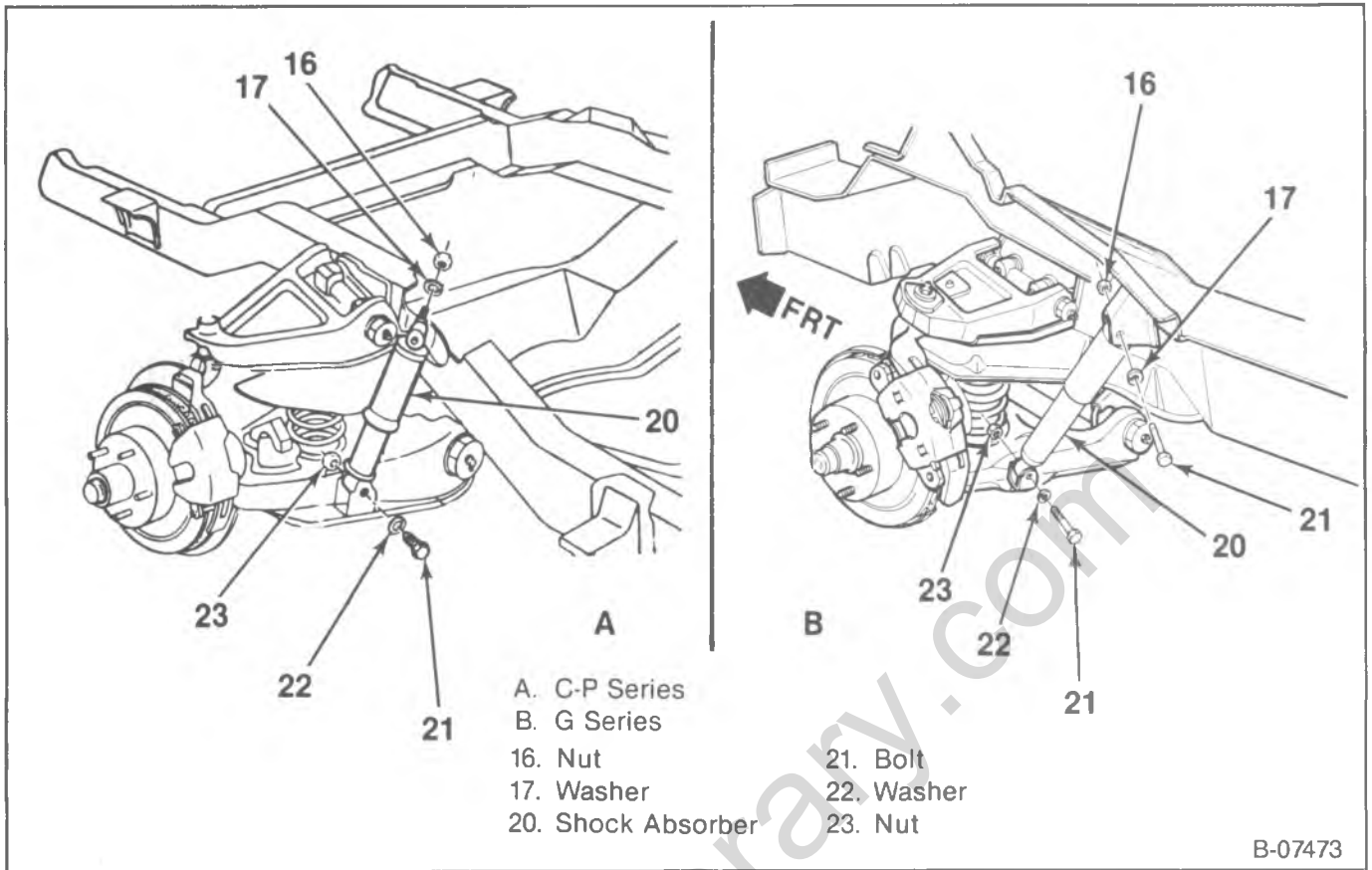

Figure 9—Shock Absorber Attachment Points

- 12. Dust cap (79) on the hub/rotor (81).
- 13. Caliper. Refer to BRAKES (SEC. 5).
- 14. Tire and wheel assembly and lower the vehicle.

be a slip fit on the spindle and the inside diameter of the wheel bearing must be lubricated to ensure the bearings will creep. The spindle nut (78) must have a free-running fit on the spindle threads.

WHEEL BEARING ADJUSTMENT

! Important

- The proper functioning of the front suspension cannot be maintained unless the front wheel bearings are correctly adjusted. The bearings must

NOTICE: Never preload the front wheel bearings. Damage can result by the steady thrust on the roller ends which comes from preloading.

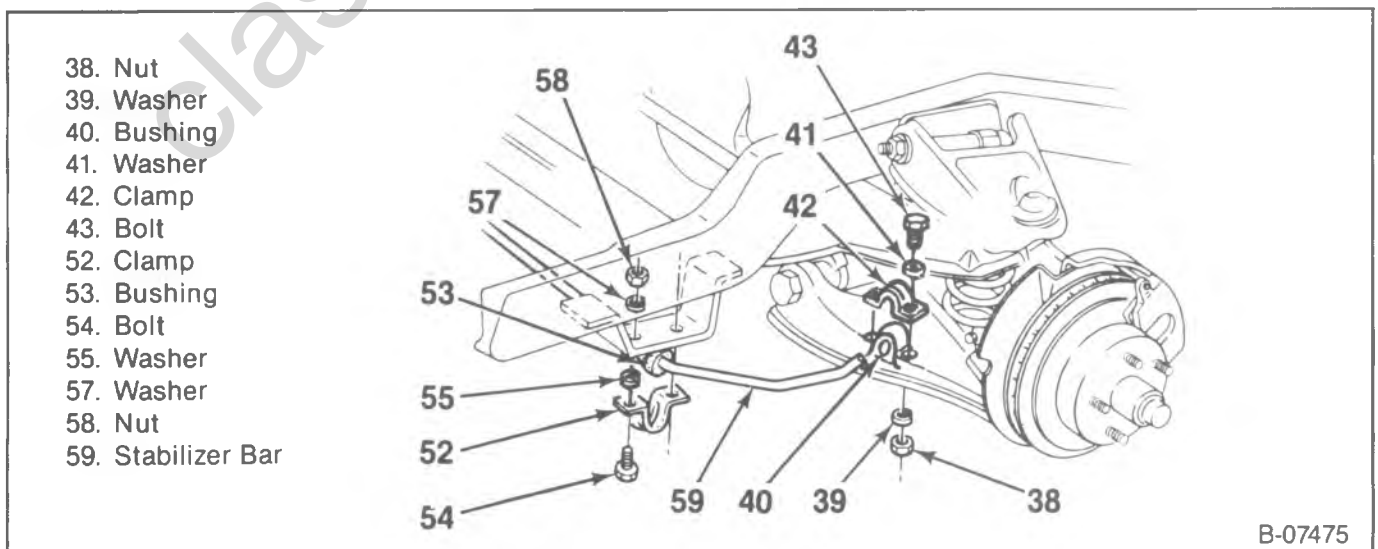

Figure 10—Stabilizer Bar Attachment Points

3C-14 FRONT SUSPENSION

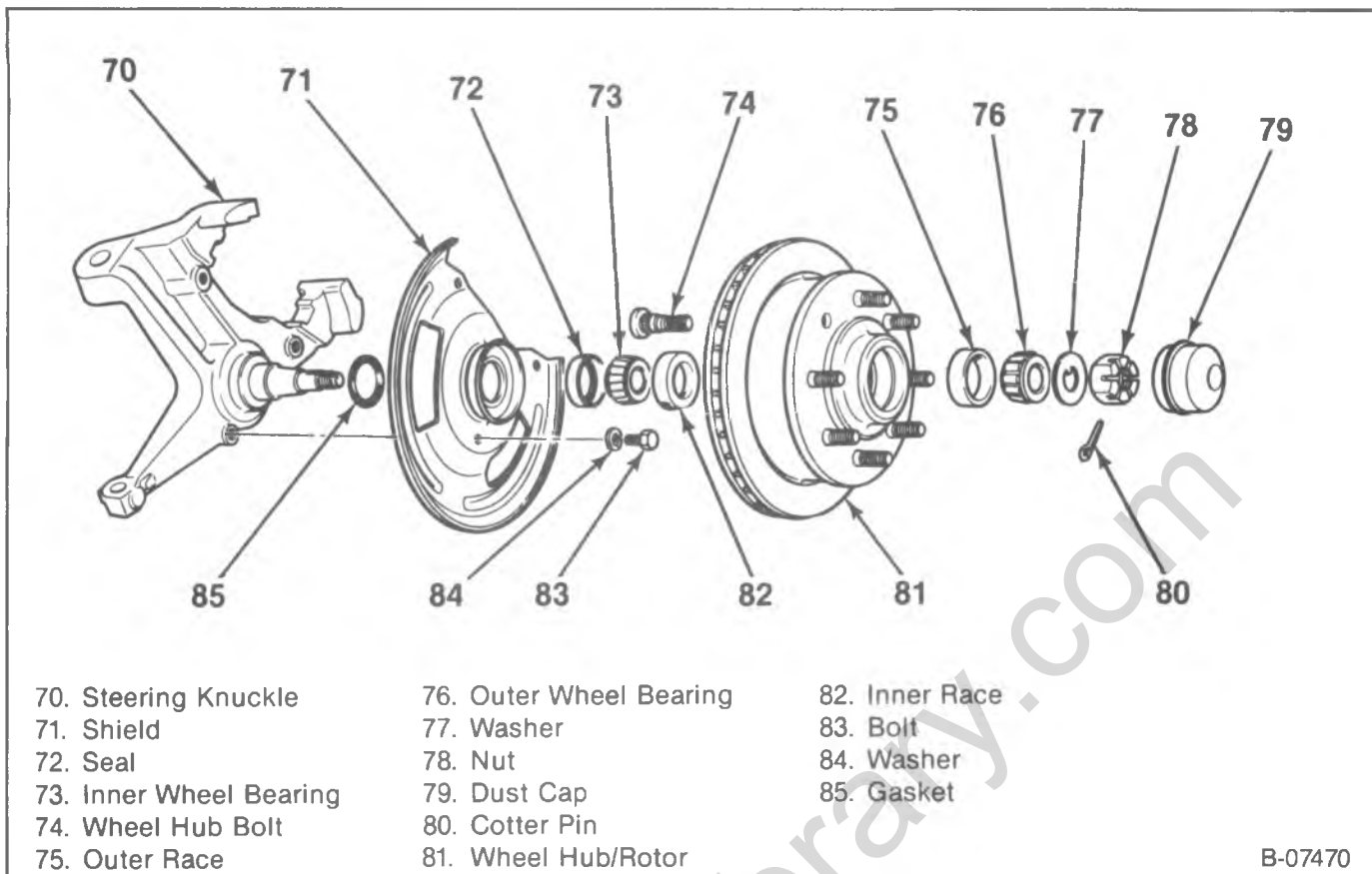

Figure 11—Steering Knuckle and Hub Components

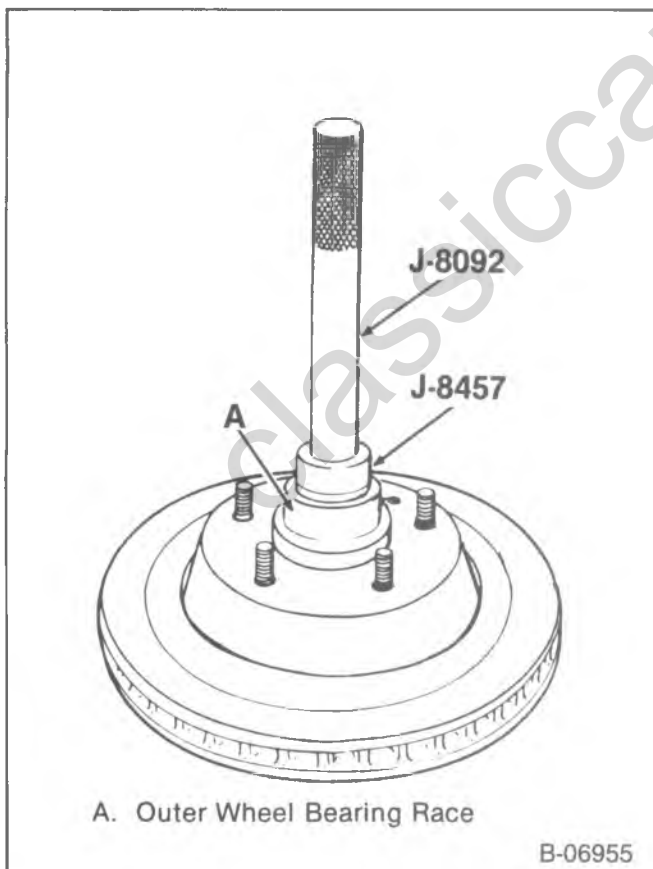

Figure 12—Installing the Outer Wheel Bearing Race

Adjust

- Raise the vehicle and support it with suitable safety stands under the lower control arms.

1. Remove the dust cap (79) from the hub/rotor (81).
2. Remove the cotter pin (80).

Tighten

- Nut (78) to 16 N·m (12 ft. lbs.) while rotating the wheel and tire assembly (this will seat the bearings).

3. Back off the nut (78) to the "just loose" position.
4. Hand tighten the nut (78).
5. Back off the nut (78) until the hole in the spindle lines up with a slot on the nut.

- Do not back off more than 1/2 of a flat.

6. New cotter pin (80).

- Make sure the bent ends do not interfere with the dust cap (79).

Measure

- Endplay in the hub/rotor assembly (81).
- It should measure between 0.03 mm (0.0012 inches) and 0.13 mm (0.005 inches) when properly adjusted.

7. Install the dust cap (79) on the hub/rotor (81).

8. Install the wheel and tire assembly if removed and lower the vehicle.

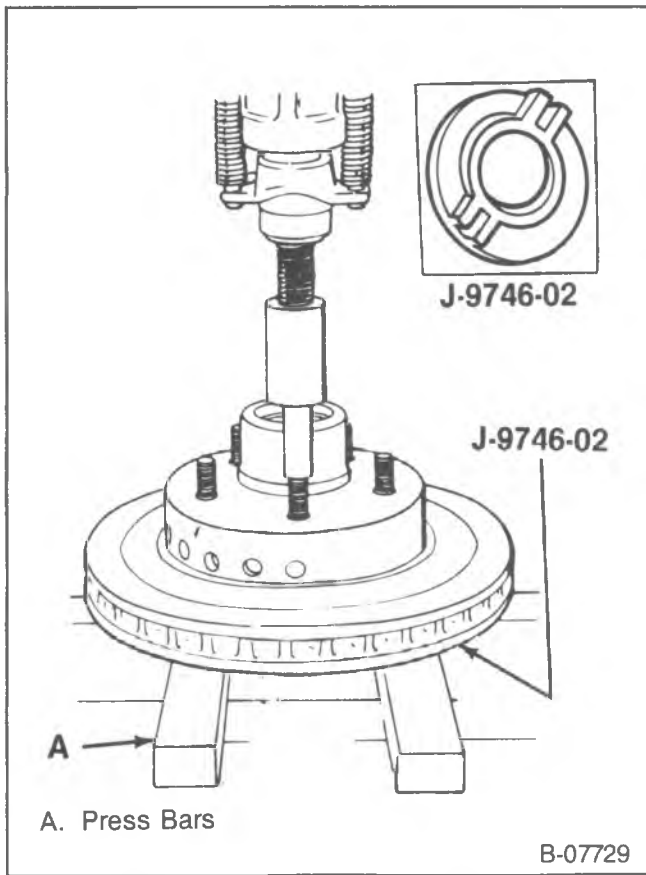

Figure 13—Removing the Hub Bolts

WHEEL HUB BOLT

↔ Remove or Disconnect (Figures 5 through 8, and 13)

Tools Required:

J-9746-02 Hub/Rotor Support

1. Hub/rotor from the vehicle.
 - Refer to "Wheel Hub, Bearing and Race" in this section.

NOTICE: Place J-9746-02 between the press bars and the hub/rotor to protect the rotor surfaces.

2. Wheel hub bolts (74) with a press.
 - Support the hub/rotor (81) using J-9746-02 and press bars (figure 13).
 - Do not damage the wheel mounting surface on the hub/rotor flange.

↔ Install or Connect (Figures 5 through 8, and 14)

NOTICE: Refer to the "Notice" on page 3C-1 of this section.

1. Wheel hub bolts (74) into the hub/rotor (81).
 - Place four washers onto the bolt, then fasten a nut onto the bolt until the nut bottoms on the washers (figure 14).
 - Tighten the nut until the bolt fully seats into the hub/rotor (81).

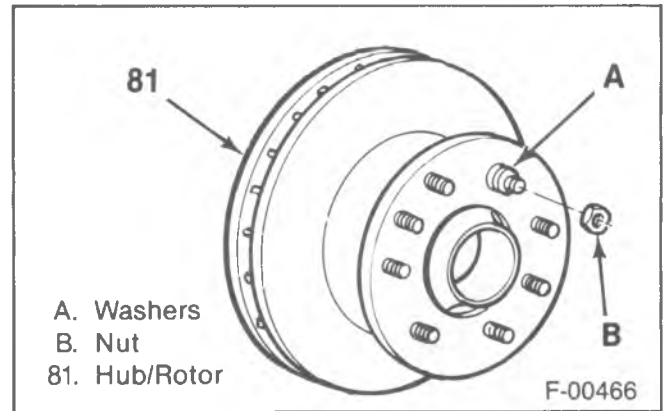

Figure 14—Installing the Hub Bolts

- Remove the nut and washers.
2. Hub/rotor to the vehicle.
 - Refer to "Wheel Hub, Bearing and Race," in this section.
 3. Wheel and tire assembly. Lower the vehicle.

STEERING KNUCKLE

↔ Remove or Disconnect (Figures 5 through 8, 15 and 16)

Tools Required:

J-23742 Ball Joint Separator

! Important

- It is recommended that the vehicle be raised and

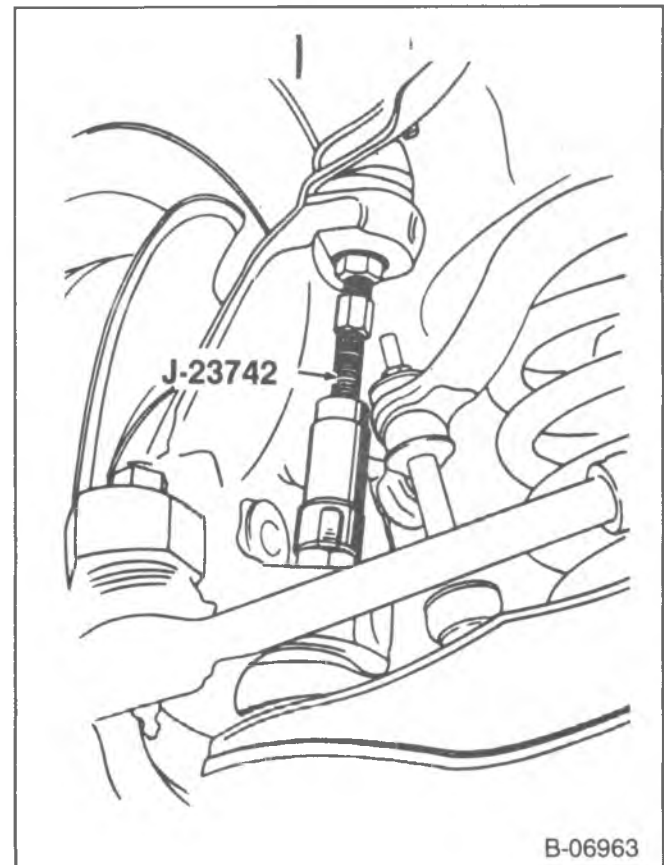

Figure 15—Disconnecting the Upper Ball Joint

3C-16 FRONT SUSPENSION

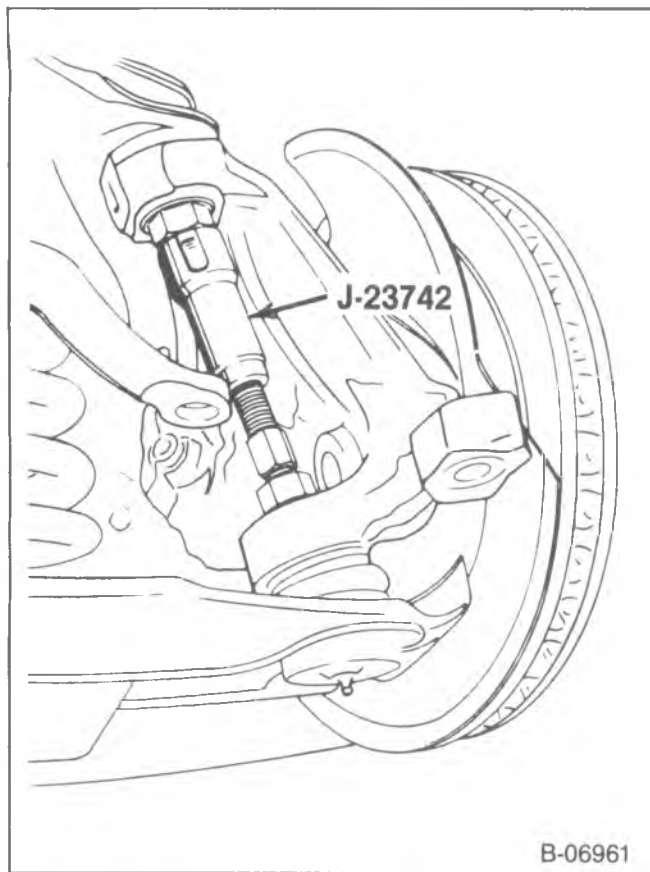

Figure 16—Disconnecting the Lower Ball Joint

supported as on a twin-post hoist so that the front coil spring remains compressed, yet the wheel and steering knuckle assembly remain accessible. If a frame hoist is used, support the lower control arm with an adjustable jackstand to safely retain the spring in its curb height position.

1. Wheel and tire assembly.
2. Caliper.
 - Refer to BRAKES (SEC. 5).
3. Hub/Rotor (81).
 - Refer to "Wheel Hub, Bearing and Race," in this section.
4. Splash shield (71).
 - Bolts (83) and washers (84).
 - Gaskets (85).
5. Steering knuckle from the tie rod end.
 - Refer to STEERING LINKAGE (SEC. 3B1).
6. Steering knuckle (70) from the upper ball joint (13).
 - Position a floor jack under the lower control arm (36) near the spring seat.
 - Raise the jack until it just supports the lower control arm.
 - Use J-23742 to break the upper ball joint free of the steering knuckle (figure 15).
 - Raise the upper control arm (28) to disengage the upper ball joint from the steering knuckle.

! Important

- Floor jack must remain under the lower control arm spring seat during removal and installation to retain the spring and the lower control arm in position.

7. Steering knuckle (70) from the lower ball joint (37).
 - Use J-23742 to break the lower ball joint free from the steering knuckle (figure 16).
 - Lift the steering knuckle off the lower ball joint.

🔍 Inspect

1. Tapered holes in the steering knuckle that attach to the ball joints and the tie rod end.
 - Remove any dirt.
 - If any tapered hole is out of round, deformed, or damaged in any way, replace the steering knuckle (70).
2. Spindle for wear or damage.
 - The steering knuckle (70) must be replaced if the spindle is damaged or worn.

NOTICE: For steps 3 and 8, refer to the "Notice" on page 3C-1 of this section.

➡ Install or Connect (Figures 5 through 8)

1. Steering knuckle (70) to the lower ball joint (37).
 - Press the steering knuckle onto the lower ball joint (37) until it is fully seated.
2. Steering knuckle (70) to the upper ball joint (13).
 - Lower the upper control arm (28) to seat the upper ball joint (13) into the steering knuckle.
3. Nuts (14, 35).

🔧 Tighten

- R10/1500, G10/1500 and G20/2500 models.
 - Nut (14) to 68 N·m (50 ft. lbs.).
 - Nut (35) to 122 N·m (90 ft. lbs.).
 - All other models.
 - Nuts (14, 35) to 122 N·m (90 ft. lbs.).
4. Cotter pins (15, 34).
 - Tighten the nuts (14, 35), if needed.

! Important

- R10/1500, G10/1500 and G20/2500 models.
 - Nut (14), maximum torque to align the cotter pin is 122 N·m (90 ft. lbs.).
 - Nut (35), maximum torque to align the cotter pin is 175 N·m (130 ft. lbs.).
 - All other models.
 - Nuts (14, 35), maximum torque to align the cotter pin is 175 N·m (130 ft. lbs.).
5. Remove the floor jack.
 6. Gasket.
 7. Tie rod end to the steering knuckle (70).
 - Refer to STEERING LINKAGE (SEC. 3B1).
 8. Splash shield (71).
 - Washers (84) and bolts (83) in position.

🔧 Tighten

- Bolts (83) to 13.5 N·m (120 in. lbs.).
4. Hub/rotor assembly.
 - Refer to "Wheel Hub, Bearing and Race" in this section.
 5. Caliper.
 - Refer to BRAKES (SEC. 5).
 6. Adjust the wheel bearings.
 - Refer to "Wheel Bearing Adjustment" in this section.

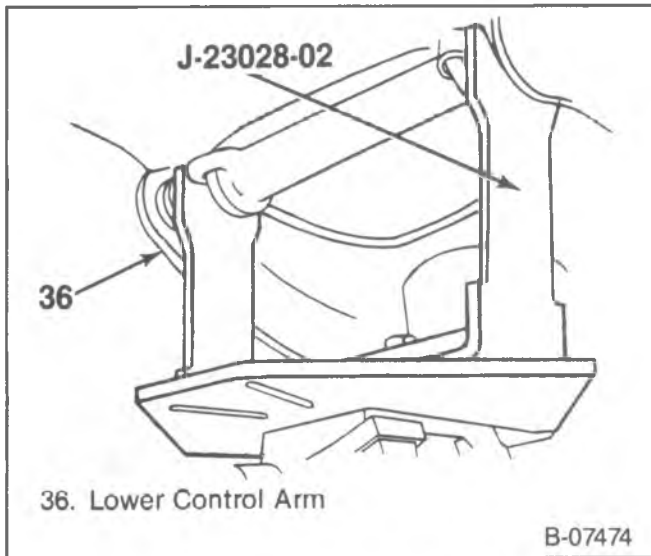

Figure 17—Removing the Coil Spring

7. Check the front alignment and reset as required.
 - Refer to FRONT END ALIGNMENT (SEC. 3A).
8. Wheel and tire assembly, and lower the vehicle to the ground.

COIL SPRING

↔ Remove or Disconnect (Figures 5 through 8, and 17)

Tools Required:

J-23028-02 Spring Remover

- Raise the vehicle and support it with suitable safety stands, allowing the control arms to hang free. Remove the wheel and tire assembly.
1. Shock absorber (20) at the lower end and move it aside.
 2. Stabilizer bar (59) from the lower control arm (36).
 - Nuts (38), bolts (43), washers (41) and clamp (42).

CAUTION: Failure to secure J-23028 to a suitable floor jack could result in personal injury.

3. J-23028-02 to a suitable jack.
4. Place J-23028-02 under the lower control arm shaft (50) as shown in figure 17.

! Important

- Install a chain around the coil spring (32) and through the lower control arm (36) as a safety precaution.
5. Raise the jack to remove the tension from the lower control arm shaft (50) and remove the "U" bolts.
 - Nuts (49) and washers (48).
 6. Lower the control arm by slowly releasing the jack until the spring can be removed.
 - Do not damage the ball joint (37) by applying too much force on it.
 7. Spring (32) and safety chain only after all compression is removed from the spring.
 - Proper maneuvering of the spring will allow for easy removal.

NOTICE: For steps 3, 5 and 6, refer to the "Notice" on page 3C-1 of this section.

↔ Install or Connect Connect (Figures 5 through 8 and 17)

Tools Required:

J-23028-02 Spring Remover

1. Coil spring (32) into position on the lower control arm (36).

! Important

- Install a chain around the coil spring and through the lower control arm as a safety precaution.

CAUTION: Failure to secure J-23028 to a suitable floor jack could result in personal injury.

2. Slowly lift the lower control arm into position.
 - Line up the front indexing hole in the shaft (50) with the crossmember attaching studs.
 - Do not damage the lower ball joint (37).
 - Use J-23028-02 bolted on a floor jack.
3. U-bolts (44), washers (48), and nuts (49).

⤵ Tighten

- G10/1500-20/2500 models to 88 N·m (65 ft. lbs.).
 - All other models to 115 N·m (85 ft. lbs.).
4. Lower the floor jack, and remove J-23028-02.
 5. Stabilizer bar (59) to the lower control arm (36).
 - Clamp (42), washers (41), bolts (43) and nuts (38).

⤵ Tighten

- Nuts (38) to 33 N·m (24 ft. lbs.).
6. Shock absorber (20) to the lower control arm (36).
 - Washer (22), bolt (21), and nut (23).

⤵ Tighten

- R models.
 - Bolt (21) to 80 N·m (59 ft. lbs.).
 - G models.
 - Bolt (21) to 103 N·m (80 ft. lbs.).
 - P models.
 - Nut (23) to 80 N·m (59 ft. lbs.).
7. Check the front end alignment.
 - Refer to FRONT END ALIGNMENT (SEC. 3A).
 8. Wheel and tire and lower the vehicle.

LOWER BALL JOINT

🔍 Inspect (Figures 5 through 8, and 18)

1. Raise the vehicle and remove the wheel and tire assembly. Support the weight of the control arms at the wheel hub and drum.
2. Measure the distance between the tip of the ball joint stud and the tip of the grease fitting below the ball joint (figure 18).
3. Move the support to underneath the control arm allowing the wheel hub and drum to hang free.
4. Measure the distance as in Step 2.

3C-18 FRONT SUSPENSION

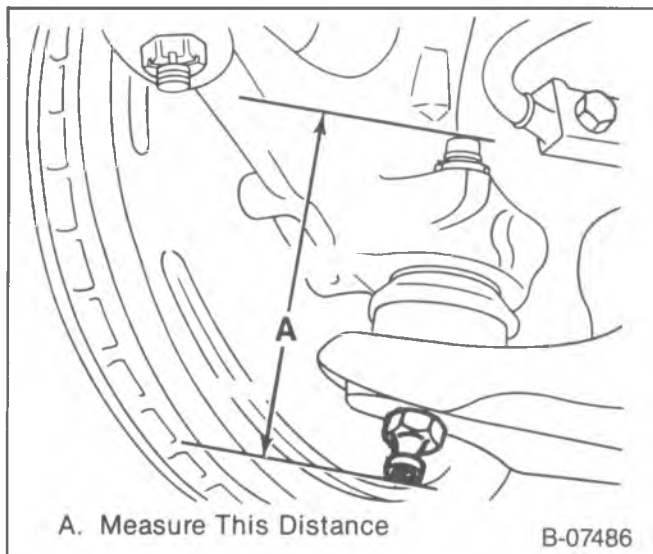

Figure 18—Inspecting the Lower Ball Joint

- If the difference in measurements exceeds 2.38 mm ($\frac{3}{32}$ inches), for all models, the ball joint is worn and must be replaced.
5. If the ball joint seals are cracked, cut, or torn, replace them.

↔ Remove or Disconnect (Figures 5 through 8, and 19)

Tools Required:

J-23742 Ball Joint Separator
 J-9519-7 Ball Joint Remover
 J-9519-28 Ball Joint Remover
 J-21474-30 Ball Joint Fixture

- Raise the vehicle on a hoist. If a frame hoist is used it will be necessary to support the lower control arm with a floor stand. Remove the tire and wheel assembly.
1. Cotter pin (34), nut (35), and lube fitting (12).
 - Loosen (two turns) but do not remove the nut (35).
 2. Loosen the ball joint in the steering knuckle (31).

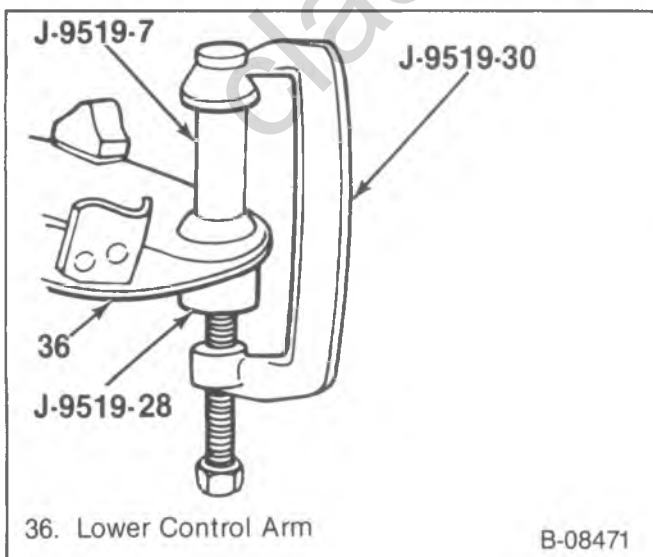

Figure 19—Removing the Lower Ball Joint

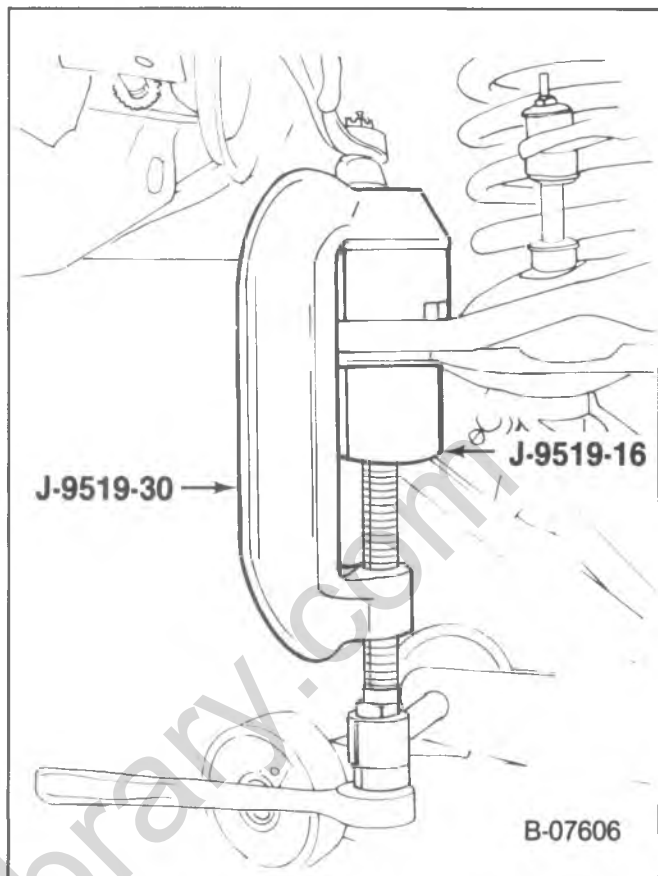

Figure 20—Installing the Lower Ball Joint

- Use J-23742 between the ball joint studs (figure 16).
 - It may be necessary to remove the caliper and wire it to the frame to gain clearance for J-23742. Refer to BRAKES (SEC. 5).
 - Extend J-23742 until the lower ball joint (37) breaks free from the steering knuckle (31).
 - Remove the nut (35) and J-23742.
3. Hub/rotor (70) and the knuckle assembly off the lower ball joint (37).
 - Install J-21474-13, J-9519-7, J-9519-28, and J-9519-30 (figure 19).
 4. Ball joint (37) from the lower control arm (36).
 - Install J-21474-13, J-9519-22, J-9519-16, and J-9519-10 (figure 19).
 - Turn the hex head screw until the ball joint is free of the lower control arm.
 - Remove the tools and the ball joint (37).

↔ Install or Connect (Figures 5 through 8, and 20)

Tools Required:

J-9519-16 Ball Joint Installer
 J-9519-30 Ball Joint Fixture

1. Ball joint (37) into the lower control arm (36).
 - Start the ball joint into the control arm and install J-9519-16 and J-9519-30 (figure 20).
 - Position the bleed vent in the rubber boot facing inward.
 - Turn the hex head screw until the ball joint is seated in the lower control arm.
2. Ball joint into the steering knuckle (31).

- Mate the steering knuckle (31) to the lower ball joint (37).
3. Caliper if it was removed.
 - Refer to BRAKES (SEC. 5).

NOTICE: Refer to "Notice" on page 3C-1 of this section.

4. Nut (35).

 **Tighten**

- Nut (35) to 122 N·m (90 ft. lbs.).

5. Cotter pin (34).

- Tighten the nut (35) if needed.

 **Important**

- Maximum torque to align the cotter pin is 175 N·m (130 ft. lbs.).

5. Fitting (12).

- Lubricate the ball joint (37) with recommended lubricant.

6. Tire and wheel assembly and lower the vehicle to the floor.

UPPER BALL JOINT

 **Inspect**

- The upper ball joint (13) is spring loaded in its socket. Replace the ball joint if there is any lateral shake or if it can be twisted in its socket with the fingers.
- The ball joint seals for cuts or tears. Replace the ball joint if any are found.

 **Remove or Disconnect (Figures 5 through 8, and 15)**

Tools Required:

J-23742 Ball Joint Separator

- Raise the vehicle on a hoist. If a frame hoist is used, support the lower control arm with a floor jack.
1. Cotter pin (15) from the upper ball joint (13).
 - Loosen the nut (14) two turns, but do not remove the nut.
 2. Caliper.
 - Refer to BRAKES (SEC. 5).
 3. Upper ball joint (13) from the steering knuckle (31).
 - Use J-23742 to separate the upper ball joint from the steering knuckle (figure 15).
 - Nut (14), and lift the upper control arm (28) free of the ball joint.
 4. Ball joint (13) from the upper control arm (28).
 - Drill 6.35 mm (1/4 inch) deep holes in the rivet heads using a 3.175 mm (1/8 inch) diameter drill bit.
 - Drill off the rivet heads using a 12.7 mm (1/2 inch) diameter drill bit.
 - Punch out the rivets and remove the upper ball joint from the upper control arm.

NOTICE: For steps 1 and 2 refer to the "Notice" on page 3C-1 of this section.

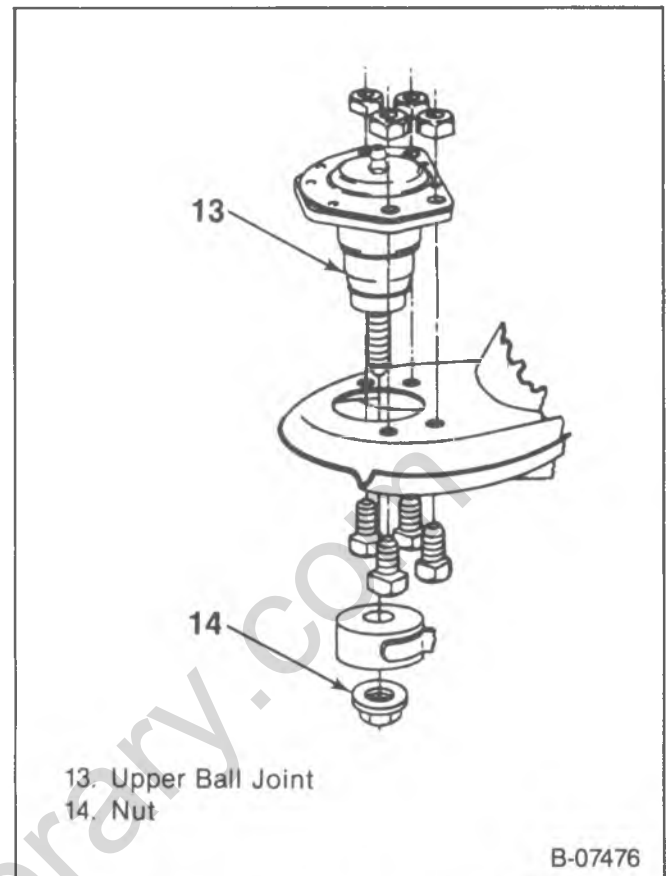

Figure 21—Installing the Upper Ball Joint

 **Install or Connect (Figures 5 through 8, and 21)**

1. Upper ball joint (13) into the upper control arm (28).
 - Position into the upper control arm and install four attaching bolts and nuts (A) (figure 21).

 **Tighten**

- Nuts (A) to 25 N·m (18 ft. lbs.).

2. Upper ball joint to the steering knuckle (31).

- The upper ball joint must be fully seated into the steering knuckle.
- Nut (14).

 **Tighten**

- R10/1500, G10/1500 and G20/2500 models.
 - Nut (14) to 68 N·m (50 ft. lbs.).
- All other models.
 - Nut (14) to 122 N·m (90 ft. lbs.).

3. Cotter pin (15).

- Tighten the nut (14) if needed.

 **Important**

- R10/1500, G10/1500 and G20/2500 models.
 - Maximum torque to align the cotter pin is 122 N·m (90 ft. lbs.).
- All other models.
 - Maximum torque to align the cotter pin is 175 N·m (130 ft. lbs.).

4. Upper ball joint grease fitting (12).

5. Grease the upper ball joint (13).

- Use a recommended lubricant.

3C-20 FRONT SUSPENSION

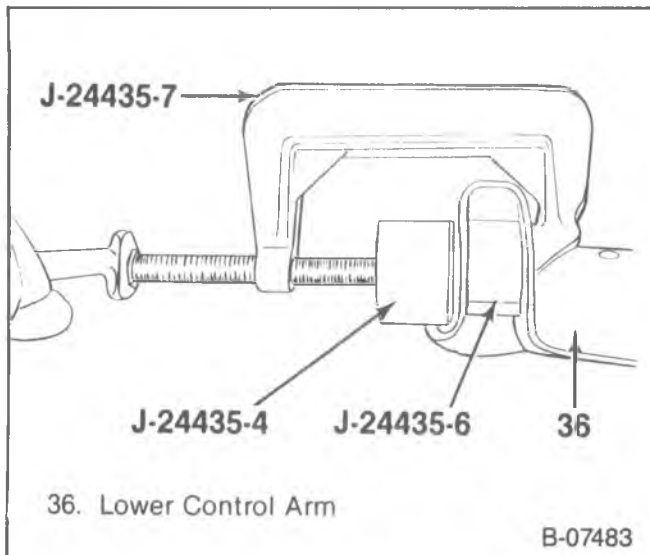

Figure 22—Removing the Lower Control Arm Bushings (R10/1500, G10/1500 and G20/2500 Models)

6. Caliper.
 - Refer to BRAKES (SEC. 5).
7. Tire and wheel assembly.
8. Check the front end alignment.
 - Refer to FRONT END ALIGNMENT (SEC. 3A).

LOWER CONTROL ARM PIVOT SHAFT AND BUSHINGS

R10/1500 SERIES MODELS

↔ Remove or Disconnect (Figures 5, 8, 17 and 22)

Tools Required:

- J-23028-02 Coil Spring Remover
- J-22717 Lower Control Arm Bushing Stake Remover
- J-24435-2 Lower Control Arm Bushing Spacer
- J-24435-3 Lower Control Arm Bushing Remover
- J-24435-6 Lower Control Arm Bushing Spacer
- J-24435-7 Lower Control Arm Bushing Fixture

If just the bushings (46) or the pivot shaft (50) need replacement, the lower control arm (36) does not have to be removed from the vehicle.

- Raise the vehicle on a hoist and support the frame so the lower control arms hang free.

CAUTION: Failure to install J-23028-02 to a suitable floor jack could result in personal injury.

1. J-23028-02 to a suitable floor jack and raise it into position [under the lower control arm (26)] inboard of the spring and into the depression of the lower control arm.

! Important

- Install a chain over the upper control arm (28) inboard of the stabilizer bar (59) and outboard of the shock absorber (20).
2. Shock absorber (20) from the lower control arm (28).

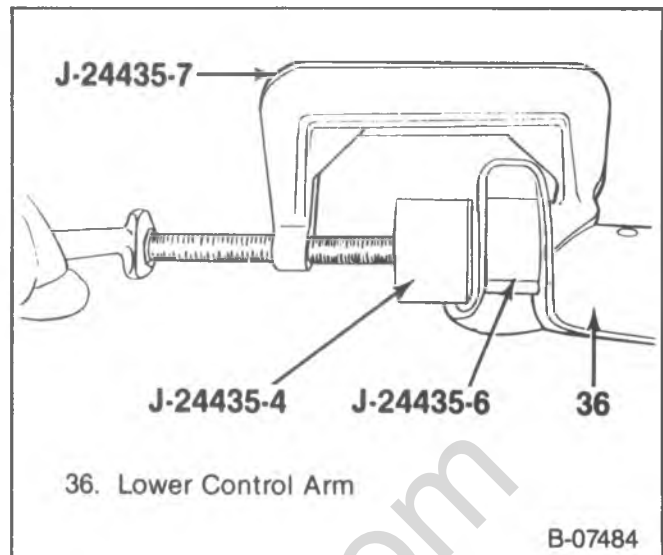

Figure 23—Installing the Lower Control Arm Bushings (R10/1500, G10/1500 and G20/2500 Models)

3. Stabilizer bar (59) from the lower control arm (28).
 - Nuts (38), washers (39, 41), clamp (42), and bolts (43).
4. Pivot shaft end nuts (24).
 - Loosen only, do not remove.
5. Lower control arm from the frame.
 - Nuts (49), washers (48), and U-bolts (44).
 - SLOWLY lower the floor jack until all compression is released from the spring (32).
6. Stakes on the front bushing.
 - Use J-22717 or an equivalent tool.
7. Bushings (46) and the pivot shaft (50) from the lower control arm (36).
 - Use J-24435-2, J-24435-3, J-24435-6, and J-24435-7 (figure 22).
 - Tighten the bolt on J-24435-7 to remove the bushing. Discard the old bushing.
 - The pivot shaft (50) will slide out of the lower control arm after one bushing is removed.
 - Leave the pivot shaft (50) inside the lower control arm (36) to remove the remaining bushing.

NOTICE: For steps 3, 4, 5 and 6, refer to the "Notice" on page 3C - 1 of this section.

↔ Install or Connect (Figure 5, 8 and 23)

Tools Required:

- J-23028-02 Coil Spring Compressor
- J-24435-4 Lower Control Arm Bushing Installer
- J-24435-6 Lower Control Arm Bushing Spacer
- J-24435-7 Lower Control Arm Bushing Fixture

1. Bushings (46) and the pivot shaft (50).
 - Use J-24435-4, J-24435-6, and J-24435-7 (figure 23).
 - Tighten the bolt on J-24435-7 to install the bushings.
 - Install one bushing, then insert the pivot shaft and install the remaining bushing.
 - Make sure J-24435-6 is in position to prevent collapsing the control arm.

2. Stake the front bushing in at least two places.

CAUTION: Failure to secure J-23028-02 to a suitable floor jack could result in personal injury.

3. Lower control arm (36) to the frame.
 - SLOWLY raise the floor jack until the front indexing hole in the pivot shaft (50) lines up with the crossmember attaching studs.
 - Do not damage the ball joint (37).
 - J-23028-02 is bolted to a suitable floor jack.
 - U-bolts (44), washers (48), and nuts (49).

Tighten

- U-bolt nuts (49) to 115 N·m (85 ft. lbs.).
4. Pivot shaft end nuts (24).

Tighten

- Nuts (24) to 95 N·m (70 ft. lbs.).
5. Stabilizer bar (59) to the lower control arm (28).
 - Washers (39, 41), clamp (42), bolts (43), and nuts (38).

Tighten

- Nuts (38) to 34 N·m (25 ft. lbs.).
6. Shock absorber (20) to the lower control arm (36).
 - Washers (22), bolt (21), and nut (23).

Tighten

- Nut (23) to 81 N·m (60 ft. lbs.).
7. Check the front end alignment.
 - Refer to FRONT END ALIGNMENT (SEC. 3A).
 8. Wheel and tire and lower the vehicle.

G10/1500-20/2500 MODELS (EXCEPT 20/2500 MODELS W/6.2L DIESEL)

Remove or Disconnect (Figures 6, 8, and 22)

Tools Required:

J-22717 Lower Control Arm Bushing Stake Remover
 J-24435-2 Lower Control Arm Bushing Spacer
 J-24435-3 Lower Control Arm Bushing Remover
 J-24435-6 Lower Control Arm Bushing Spacer
 J-24435-7 Lower Control Arm Bushing Fixture

1. Lower control arm.
 - Refer to "Lower Control Arm," in this section.
2. Pivot shaft nuts (24) and washers (25).
3. Rear bushing (46).
 - Place the lower control arm in an arbor press.
 - Press the front end of the pivot shaft (50) to remove the rear bushing. Discard the old bushing.
 - The pivot shaft can be removed at this time.
4. Front bushing (46).
 - Stakes from the front bushing using J-22717 or an equivalent tool.
 - Use J-24435-7, J-24435-3, J-24435-2, and J-24435-6.
 - Tighten J-24435-7 until the bushing comes free. Discard the old bushing (figure 22).

Install or Connect (Figures 6, 8, 23 and 24)

Tools Required:

J-24435-4 Lower Control Arm Bushing Installer
 J-24435-6 Lower Control Arm Bushing Spacer
 J-24435-7 Lower Control Arm Bushing Fixture

1. New bushing (46) using J-24435-6, J-24435-4, and J-24435-7 (figure 23).
 - Tighten J-24435-7 until the bushing fully seats.
 - The outer tube hole must be lined up so it faces to the front or forward to the staked bushing.
2. Stake the front bushing in at least two places.
3. Pivot shaft (50) into installed bushing.
4. Remaining bushing (46) into the lower control arm.

NOTICE: Refer to "Notice" on page 3C-1 of this section.

5. Pivot shaft washers (25) and nuts (24).

Tighten

- Nuts (24) to 156 N·m (115 ft. lbs.).
6. Lower control arm (76).
 - Refer to "Lower Control Arm," in this section.
 - This results with the vehicle being completely assembled and lowered to the ground.

G20/2500 MODELS WITH RPO LH6/LL4 (6.2L DIESEL ENGINE)

Remove or Disconnect (Figures 5 through 8, and 25)

Tools Required:

J-24435-1 Lower Control Arm Bushing Remover
 J-24435-3 Lower Control Arm Bushing Remover
 J-24435-7 Lower Control Arm Bushing Fixture

1. Lower control arm (36).
 - Refer to "Lower Control Arm," in this section.
2. Bushings (46) and the pivot shaft (50) from the lower control arm (36).
 - Use J-24435-1, J-24435-3, and J-24435-7 (figure 25).
 - Tighten the clamp (J-24435-7) to remove the bushing (46).
 - The pivot shaft can be slipped out at this time.
 - Repeat the procedure on the remaining bushing (46) to remove it from the lower control arm (36).

Install or Connect (Figures 5 through 8, and 26)

Tools Required:

J-24435-4 Lower Control Arm Bushing Installer
 J-24435-5 Lower Control Arm Bushing Installer
 J-24435-7 Lower Control Arm Bushing Fixture

1. Bushings (46) and the pivot shaft (50) into the lower control arm (36).
 - Use J-24435-4, J-24435-5, and J-24435-7 (figure 26).
 - Tighten the clamp (J-24435-7) to install the bushing (26).
 - Slide the pivot shaft (50) into the lower control arm (36), then install the other bushing (36).
2. Lower control arm (36).
 - Refer to "Lower Control Arm," in this section.

3C-22 FRONT SUSPENSION

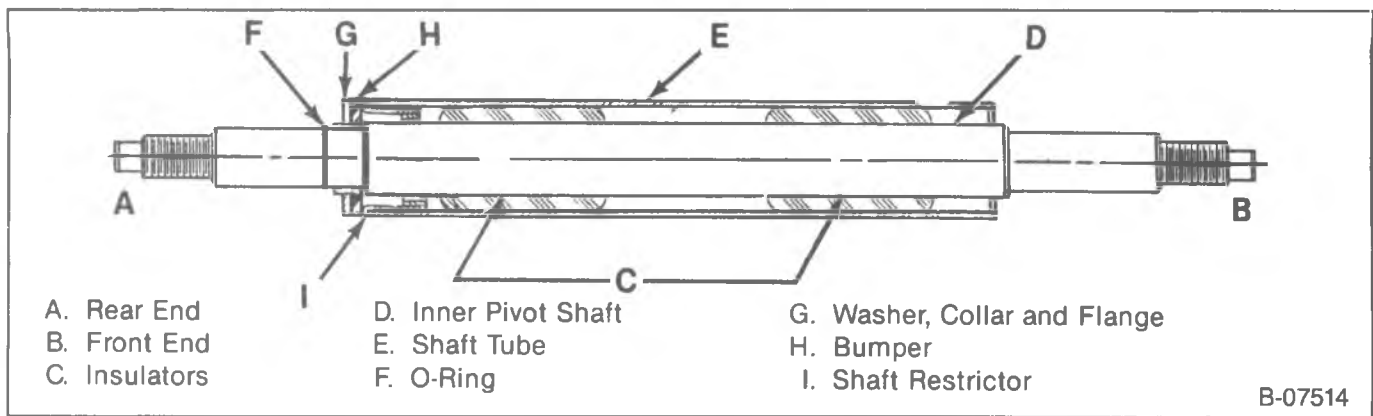

Figure 24—Lower Control Arm Pivot Shaft (G10/1500 and G20/2500 Models w/o 6.2L Diesel)

- This results with the vehicle being completely assembled and lowered to the ground.

R-P20/2500-30/3500, G30/3500 MODELS

↔ Remove or Disconnect (Figures 5 through 8)

- Raise the vehicle and support the frame so the control arms hang free. Remove the tire and wheel assembly.
1. Position an adjustable floor jack under the lower control arm (36) inboard of the spring and into the depression in the lower control arm.

! Important

- Install a chain over the upper control arm (28) inboard of the stabilizer bar (59) and outboard of the shock absorber (20).
2. Shock absorbers (20) from the lower control arm (36).
 - Nut (23), washer (22) and bolt (21).
 3. Stabilizer bar (59) from the lower control arm (36).
 - Nuts (38), washers (39, 41), bolts (43) and clamp (42).
 4. Lower control arm (36) from the frame crossmember.
 - Nuts (49), washer (48), and U-bolts (44).

- SLOWLY lower the floor jack to access the pivot shaft (50).
5. Grease fittings (12).
 6. Bushings (46) and bushing seals, and pivot shaft (50).
 - Unscrew the bushings.
 - Slide the pivot shaft out of the lower control arm.
 - Seals are mounted between the bushings and the pivot shaft. Discard the old seals.

NOTICE: For steps 1, 3, 4, and 5 refer to the "Notice" on page 3C-1 of this section.

↔ Install or Connect (Figures 5 through 8, and 27)

1. Pivot shaft (50), seals, and bushings (46), to the lower control arm (36).
 - New seals onto the pivot shaft.
 - Pivot shaft into the lower control arm. Attach the bushings. Center the shaft in the lower control arm (figure 27).

⊠ Tighten

- Bushings (46) to 379 N·m (280 ft. lbs.).

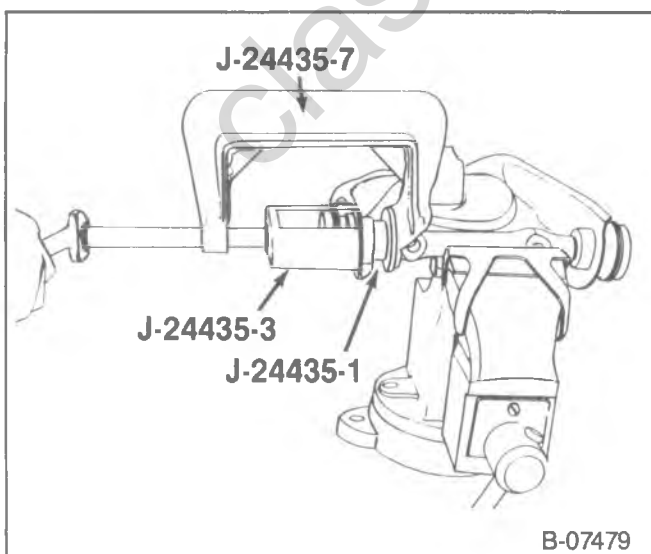

Figure 25—Removing the Lower Control Arm Bushing (G20/2500 w/6.2L Diesel)

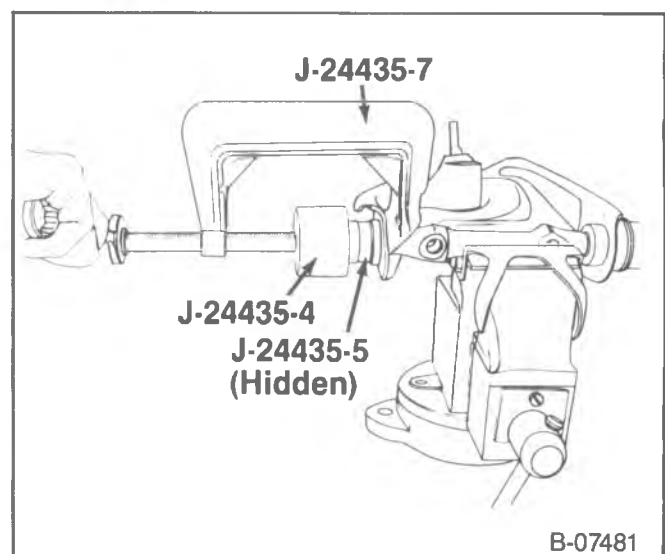

Figure 26—Installing the Lower Control Arm Bushing (G20/2500 w/6.2L Diesel)

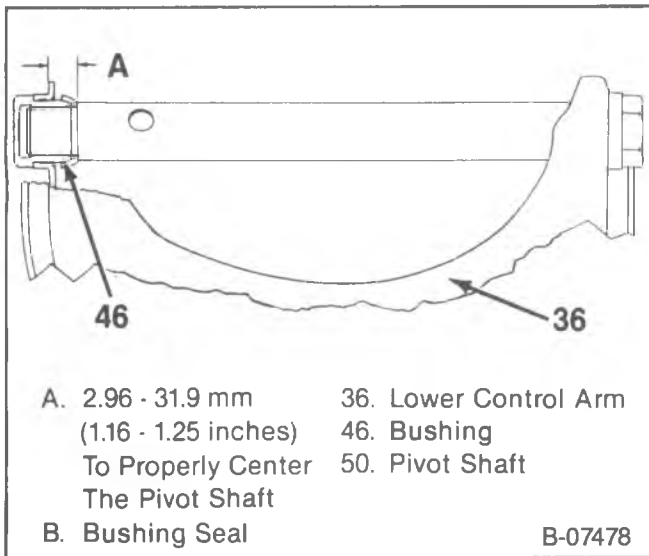

Figure 27—Centering the Lower Control Arm Shaft (R-P20/2500, 30/3500 and G30/3500 Models)

Inspect

- Pivot shaft (50) for free rotation.
- Grease fitting (12).
 - Lubricate the bushings with an approved grease.
 - Refer to MAINTENANCE AND LUBRICATION (SEC. 0B).
 - Lower control arm (36) to the frame crossmember.
 - SLOWLY raise the floor jack until the lower control arm (36) is in position.

Important

- Be sure the hole in the pivot shaft mates with the bolt head in the frame crossmember saddle.
- U-bolts (44), washers (48), and nuts (49).

Tighten

- Nuts (49) to 115 N·m (85 ft. lbs.).
- Stabilizer bar (59) to the lower control arm (36).
 - Nuts (38), washers (39, 41), bolts (43), and clamp (42).

Tighten

- Nuts (38) to 33 N·m (24 ft. lbs.).
- Shock absorbers (20) to the lower control arm (36).
 - Bolt (21), washer (22), and nut (23).

Tighten

- R models.
 - Bolt (21) to 80 N·m (59 ft. lbs.).
 - G models.
 - Bolt (21) to 103 N·m (80 ft. lbs.).
 - P models.
 - Nut (23) to 80 N·m (59 ft. lbs.).
- Remove the safety chain and the floor jack. Install the tire and wheel assembly and lower the vehicle to the ground.

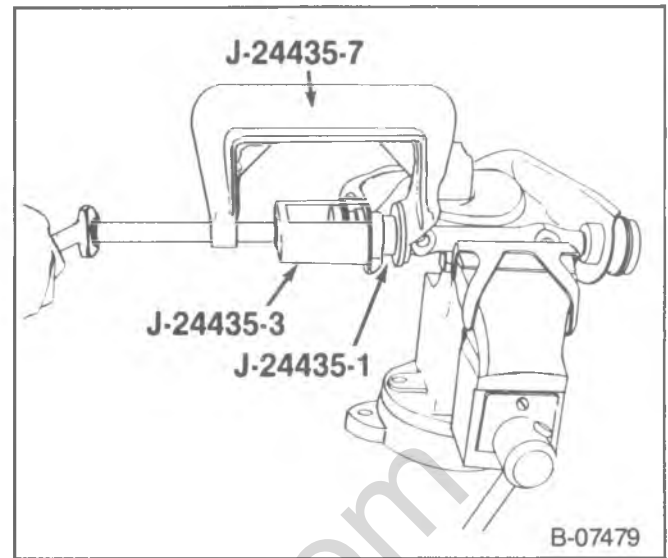

Figure 28—Removing the Upper Control Arm Bushings (R10/1500, G10/1500 and G20/2500 Models)

UPPER CONTROL ARM PIVOT SHAFT AND BUSHINGS

R10/1500, G10/1500-20/2500 MODELS

Remove or Disconnect (Figures 5 through 8, and 28)

Tools Required:

- J-24435-1 Lower Control Arm Bushing Remover
- J-24435-3 Lower Control Arm Bushing Remover
- J-24435-7 Lower Control Arm Bushing Fixture

- Upper control arm (28).
 - Refer to "Upper Control Arm," in this section.
- Nuts (24), bushings (26) and the pivot shaft (29) from the upper control arm (28).
 - Use J-24435-1, J-24435-3, and J-24435-7 (figure 28).
 - Tighten J-24435-7 to remove the bushing (26).
 - Pivot shaft (29) can be pulled free at this time.
 - Repeat this procedure on the remaining bushing (26). Discard the old bushings.

Install or Connect (Figures 5 through 8, and 29)

Tools Required:

- J-24435-4 Lower Control Arm Bushing Installer
- J-24435-5 Lower Control Arm Bushing Installer
- J-24435-7 Lower Control Arm Bushing Fixture

NOTICE: Refer to the "Notice" on page 3C-1 of this section.

- Bushings (26) and the pivot shaft (29) into the upper control arm (28).
 - Use J-24435-4, J-24435-5, and J-24435-7 (figure 29).
 - Tighten the clamp (J-24435-7) to install the bushing (26).
 - Slide the pivot shaft (29) into the upper control arm (28), then install the other bushing (26).

3C-24 FRONT SUSPENSION

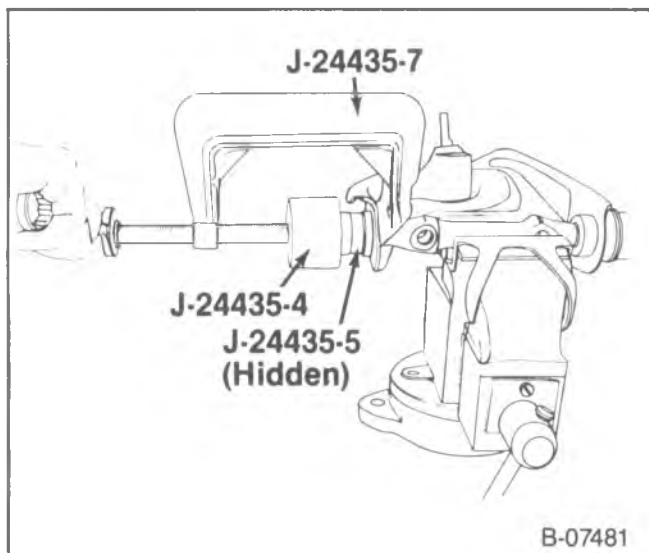

Figure 29—Installing the Upper Control Arm Bushings (R10/1500, G10/1500 and G20/2500 Models)

- Nuts (24) in place.



Tighten

- Nuts (24) to 156 N·m (115 ft. lbs.).
2. Upper control arm (28) to the crossmember.
 - Refer to "Upper Control Arm," in this section.
 3. Caliper if it was removed.
 - Refer to BRAKES (SEC. 5).
 4. Check the front end alignment.
 - Refer to FRONT END ALIGNMENT (SEC. 3A).
 5. Remove the supports and lower the vehicle to the ground.

R-P20/2500-30/3500, G30/3500 MODELS



Remove or Disconnect (Figures 5 through 8)

- Raise the vehicle and support the lower control arms with a floor jack positioned under or near the ball joint assembly. Remove the wheel and tire assembly.
1. Loosen, but do not remove the pivot shaft to frame nuts (27).
 2. Shim packs (18).
 - Tape each pack together and mark their position to assure exact replacement during installation.
 3. Pivot shaft to frame nuts (27), bolts (4), and spacers (19).
 - Do not allow the upper control arm (28) to swing too far from the frame crossmember.



Important

- Install a chain over the upper control arm (28) inboard of the stabilizer bar (59) and outboard of the shock absorber (20), to retain the upper control arm in a close relationship to the frame crossmember.
4. Pivot shaft (29) and bushings (26).
 - Grease fitting (12).
 - Unscrew the bushings (26).
 - Slide the pivot shaft out of the upper control arm. Remove and discard the inner seals (between the bushings and the pivot shaft).



Install or Connect (Figures 6 through 8, and 30)

1. Pivot shaft (29), seals, and bushings (26) onto the upper control arm (28).
 - New inner seals onto the pivot shaft.
 - Slide the pivot shaft into position inside the upper control arm. Screw on the new bushings. Do not tighten.



Important

- The pivot shaft (29) must be centered in the upper control arm (28) as shown in figure 30.



Tighten

- Bushings (26) to 257 N·m (190 ft. lbs.).



Inspect

- Pivot shaft for free rotation.
2. Grease fitting (12).
 - Grease the bushings (29). Refer to MAINTENANCE AND LUBRICATION (SEC. 0B).

NOTICE: Refer to the "Notice" on page 3C-1 of this section.

3. Pivot shaft (29) to the frame.
 - Bolts (4), shim packs (18), spacers (19), and nuts (27).
 - Shims are positioned into their original positions. Make sure the convex and concave sides of the shims are together.



Tighten

- Nuts (27) to 142 N·m (105 ft. lbs.).
4. Remove the safety chain and install the wheel and tire assembly.
 5. Check the front end alignment.
 - Refer to FRONT END ALIGNMENT (SEC. 3A).
 6. Lower the vehicle to the ground.

LOWER CONTROL ARM



Remove or Disconnect (Figures 5 through 8, and 16)

Tools Required:

J-23742 Ball Joint Separator

- Raise the vehicle and support it with suitable safety stands. Remove the wheel and tire assembly.
1. Caliper.
 - Refer to BRAKES (SEC. 5).
 2. Coil spring (32).
 - Refer to "Coil Spring," in this section.
 - The lower control arm is separated from the frame.
 3. Use a jack to support the inboard end of the lower control arm (36).
 4. Lower control arm (36) from the steering knuckle (31).
 - Cotter pin (34), then loosen the nut (35) one turn.
 - Install J-23742, with the large cup end over the upper ball joint nut (14). Extend threaded end until the ball joint stud loosens from the steering knuckle. Remove J-23742 and the nut (35).

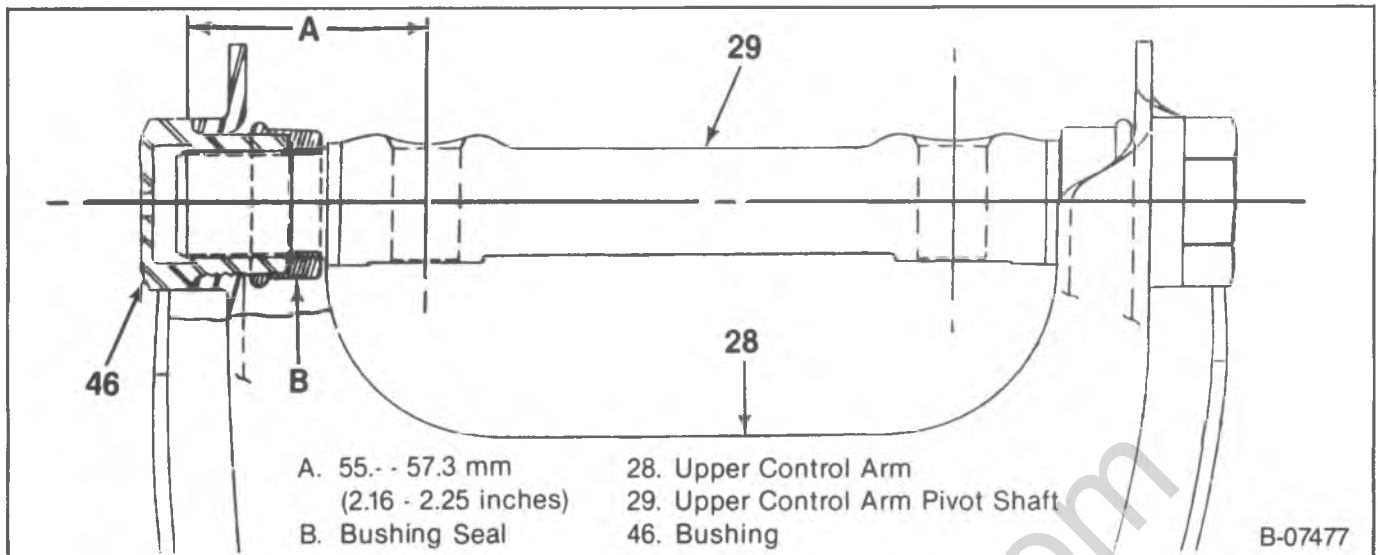

Figure 30—Centering the Upper Control Arm Shaft (R-P20/2500, 30/3500 and G30/3500 Models)

↔ Install or Connect (Figures 5 through 8)

1. Lower control arm (36) to the steering knuckle (31).
 - Position the lower control arm ball joint stud (37) into the steering knuckle (31).
 - Nut (35) onto the stud. Do not tighten.
2. Coil spring (32).
 - Refer to "Coil Spring," in this section.
 - This step results with the lower control arm being attached to the frame.

NOTICE: Refer to "Notice" on page 3C-1 of this section.

3. Nut (35) and cotter pin (34).

Tighten

- Nut (35) to 122 N·m (90 ft. lbs.).
- Tighten the nut if needed to install the cotter pin.

! Important

- Maximum torque to align the cotter pin is 175 N·m (130 ft. lbs.).

4. Caliper.
 - Refer to BRAKES (SEC. 5).
5. Check the front end alignment.
 - Refer to FRONT END ALIGNMENT (SEC. 3A).
6. Tire and wheel assembly and lower the vehicle.

UPPER CONTROL ARM

↔ Remove or Disconnect (Figures 5 through 8, and 15)

Tools Required:

J-23742 Ball Joint Separator

- Raise the vehicle and support it with suitable safety stands. Remove the wheel and tire assembly. Place an adjustable jackstand under the lower control arm for support.
1. Caliper.
 - Refer to BRAKES (SEC. 5).
 2. Upper control arm (28) from the steering knuckle (31).

- Cotter pin (15).
 - Loosen the nut (14). Do not remove it.
 - Install J-23742 with the large cupped end over the lower control arm ball joint stud nut (35). Expand J-23742 until the upper control arm separates.
 - Nut (14) from the upper ball joint stud and raise the upper control arm to clear the steering knuckle.
3. Upper control arm (28) from the frame bracket (9).
 - Nuts (27), spacers (19), shims (18), washers (5) and bolts (6).

! Important

- Tape the shims together in their original positions and tag for proper relocation.

↔ Install or Connect (Figures 5 through 8)

NOTICE: For steps 2 and 3, refer to "Notice" on page 3C-1 of this section.

1. Shims (18) into position on the upper control arm frame bracket (9).
 - Make sure the shims are positioned with concave and convex sides together.
2. Upper control arm (28) to the frame bracket (9).
 - Spacers (19) and nuts (27), washers (5), and bolts (6).

! Important

- A normal shim pack will leave at least two threads of the bolt (6) exposed beyond the nut.
- If two threads cannot be obtained; check for damaged control arm or related parts. The difference between the front and rear shim packs must not exceed 7.62 mm (0.30 inches). The front shim pack must be at least 6.09 mm (0.24 inches).
- Always tighten the thinner shim pack's nut (27) first for improved shaft to frame clamping force and torque retention.

3C-26 FRONT SUSPENSION



Tighten

- R10/1500, G10/1500 and G20/2500 models.
 - Nuts (27) to 95 N·m (70 ft. lbs.).
 - All other models.
 - Nuts (27) to 142 N·m (105 ft. lbs.).
- Upper control arm (28) to the steering knuckle (31).
 - Insert the upper control arm ball joint stud (13) into the steering knuckle (31).
 - Nut (14) and cotter pin (15).
 - Tighten the nut if needed to install the cotter pin.



Tighten

- R10/1500, G10/1500 and G20/2500 models.
 - Nut (14) to 68 N·m (50 ft. lbs.).
- All other models.
 - Nut (14) to 122 N·m (90 ft. lbs.).



Important

- R10/1500, G10/1500 and G20/2500 models.
 - Maximum torque to align the cotter pin is 122 N·m (90 ft. lbs.).
 - All other models.
 - Maximum torque to align the cotter pin is 175 N·m (130 ft. lbs.).
- Caliper.
 - Refer to BRAKES (SEC. 5).
 - Check the front end alignment.
 - Refer to FRONT END ALIGNMENT (SEC. 3A).
 - Wheel and tire assembly. Lower the vehicle to the ground.

SUSPENSION UNIT

The front suspension and frame crossmember can be removed or installed as a unit if extensive service is required.



Remove or Disconnect (Figure 5 through 8, and 31 through 33)

- Raise the hood and disconnect the battery negative cable.
 - Hoist the vehicle and support it with suitable safety stands placed at the frame side rails. Remove the tire and wheel assembly and then lower the hoist.
- Front brake hose clip from each upper control arm.
 - Brake hoses from the calipers.
 - Clean the area adjacent to the brake hose fittings.
 - Discard the special washers (2 on each hose) and cover the disconnected ends of each hose with suitable material.
 - Refer to BRAKES (SEC. 5).
 - Tie rod ends from the steering knuckle (31).
 - Refer to STEERING LINKAGE (SEC. 3B1).
 - Front stabilizer from the lower control arms (36).
 - Nuts (38), washers (39, 41), bolts (43), and clamps (42).
 - Shock absorbers (20) from the lower control arms (36).
 - Nut (23), washer (22), and bolt (21).
 - Brake line clip bolts from the front suspension crossmember.
 - On C series models the clip is located under the right side engine mount support bracket.

NOTICE: Failure to disconnect these clips from the suspension unit will result in severe damage to the brake line when the unit is lowered from the vehicle.

- Suspension crossmember from the engine mounts.
 - Refer to ENGINE (SEC. 6A).
- Suspension crossmember from the frame rail (figure 31).
- Raise the hoist to support the suspension crossmember.
- Support the engine.
 - Must be done before the suspension unit is lowered from the vehicle.
- Suspension unit and crossmember from the vehicle.
 - Upper control arm bracket to the frame side rail nuts (10), washer (7), and bolts (6).
 - Lower the suspension unit and the crossmember to bring the unit clear of the vehicle.

NOTICE: For steps 3, 7, and 8, refer to the "Notice" on page 3C-1 of this section.



Install or Connect (Figures 5 through 8 and 31 through 33)

- Position the new suspension unit and crossmember and raise it with the hoist to align the suspension crossmember and frame holes.
- Suspension crossmember to the frame rail bolts (figure 31).
- Upper control arm (28) and the frame bracket bolts (6).
 - Washers (7) and nuts (10). Do not tighten.



Tighten

- R models.
 - Bolts (6) to 87 N·m (64 ft. lbs.), except R30/3500 with F42.
 - Bolts (6) to 135 N·m (100 ft. lbs.), R30/3500 with F42.
- G models.
 - Bolts (4) to 125 N·m (92 ft. lbs.).
- P models.
 - Bolts (4, 6) to 87 N·m (64 ft. lbs.), except P30/3500 motor home.
 - Bolts (4, 6) to 135 N·m (100 ft. lbs.), P30/3500 motor home.



Important

- The upper control arm to frame bracket bolts must be tightened first.
 - The crossmember must be in contact with the frame side rails.
- Crossmember to frame bolts (1), through the reinforcement (8).
 - Washers (2) and nuts (3) as used.



Tighten

- R30/3500 models with F42.
 - Nut (3) to 180 N·m (133 ft. lbs.).
- P30/3500 motor home.
 - Bolt (1) to 290 N·m (214 ft. lbs.).

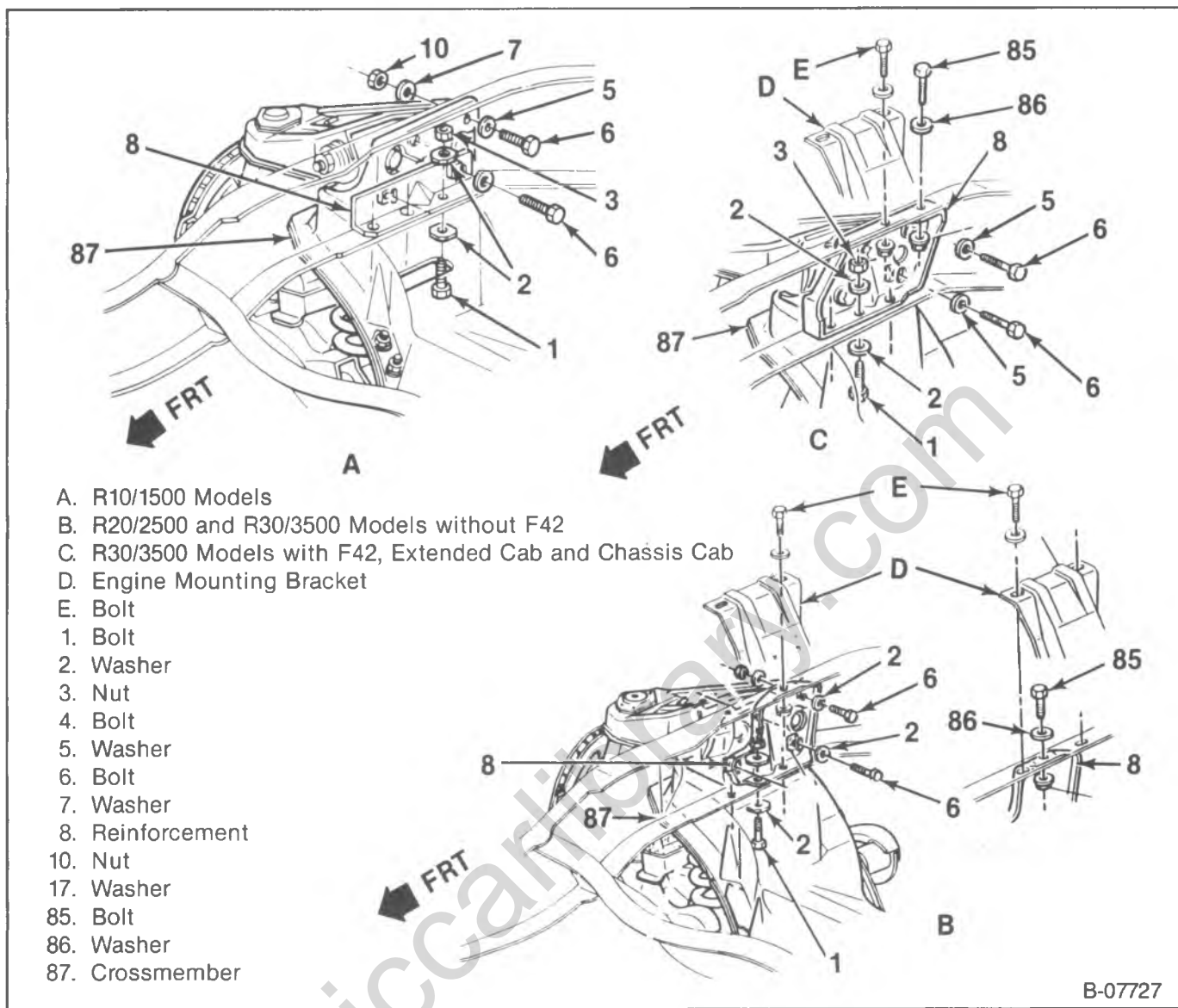

- A. R10/1500 Models
- B. R20/2500 and R30/3500 Models without F42
- C. R30/3500 Models with F42, Extended Cab and Chassis Cab
- D. Engine Mounting Bracket
- E. Bolt
- 1. Bolt
- 2. Washer
- 3. Nut
- 4. Bolt
- 5. Washer
- 6. Bolt
- 7. Washer
- 8. Reinforcement
- 10. Nut
- 17. Washer
- 85. Bolt
- 86. Washer
- 87. Crossmember

B-07727

Figure 31—R Model Suspension Unit Attachment

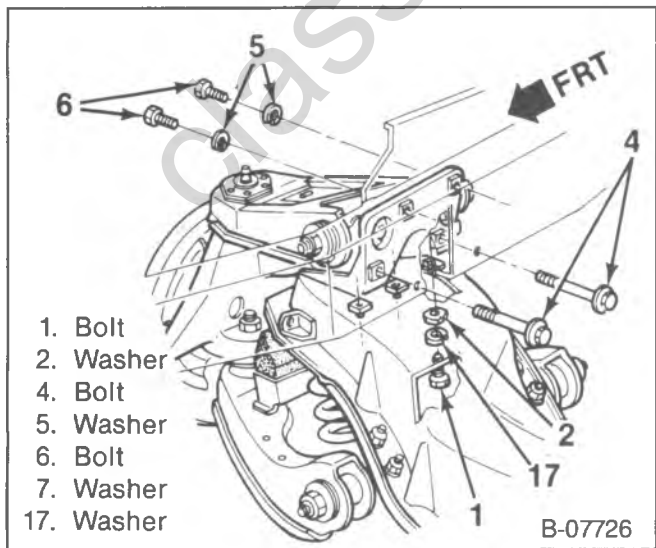

- 1. Bolt
- 2. Washer
- 4. Bolt
- 5. Washer
- 6. Bolt
- 7. Washer
- 17. Washer

B-07726

Figure 32—G Model Suspension Unit Attachment

- All other models.
 - Bolt (1) to 125 N·m (92 ft. lbs.).
- 5. Engine mount support bracket to the suspension crossmember bolts.
- 6. Remove the engine support and lower the hoist.
 - Refer to ENGINE (SEC. 6A).
- 7. Brake line clip to the crossmember.
 - Refer to BRAKES (SEC. 5).
- 8. Shock absorber to the lower control arm (28).
 - Washers (22), nuts (23), and bolts (21).

 **Tighten**

- R models.
 - Bolt (21) to 80 N·m (59 ft. lbs.).
- G models.
 - Bolt (21) to 103 N·m (80 ft. lbs.).
- P models.
 - Nut (23) to 80 N·m (59 ft. lbs.).
- 9. Stabilizer bar (59) to the lower control arm (28).
 - Clamps (42), bolts (43), washers (39) and nuts (38).

3C-28 FRONT SUSPENSION

- A. P20/2500 and 30/3500 Models
 B. P30/3500 Motorhome
 D. Engine Mounting Bracket
 E. Bolt

1. Bolt
 2. Washer
 5. Washer
 6. Bolt
 7. Washer

8. Reinforcement
 10. Nut
 85. Bolt
 86. Washer
 87. Crossmember

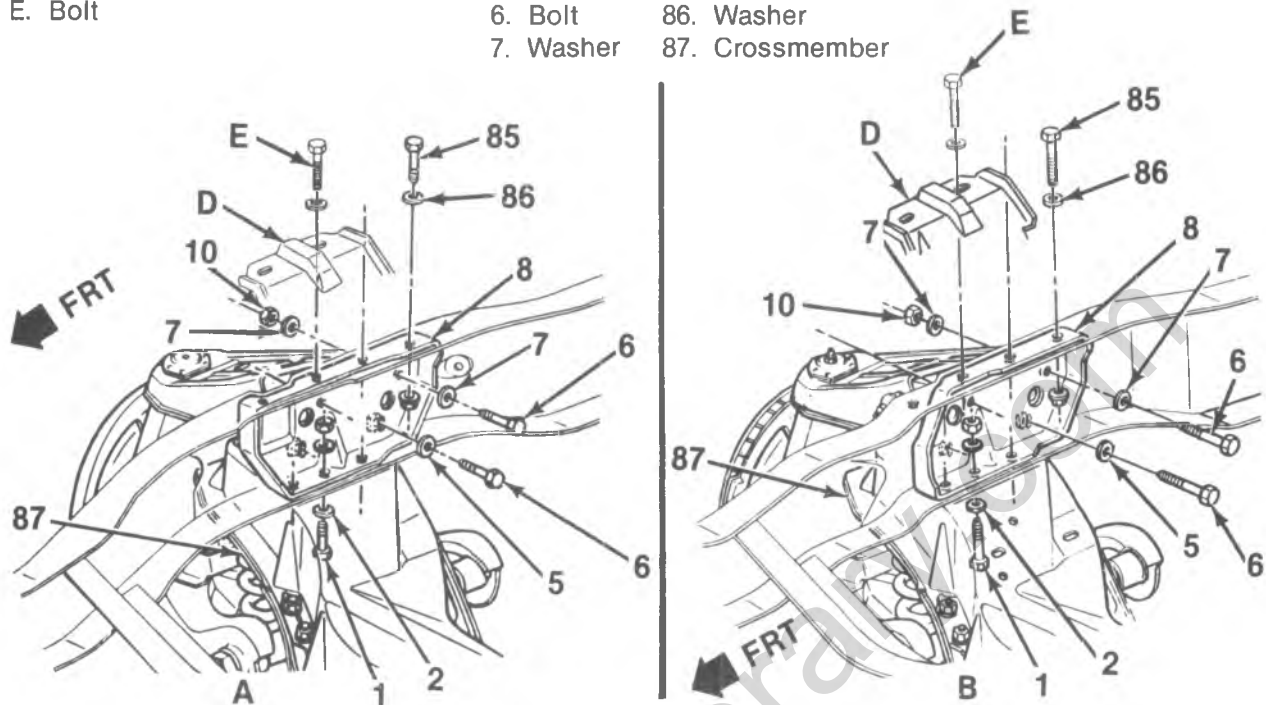

B-07724

Figure 33—P Model Suspension Unit Attachment



Tighten

- R and P models.
 - Nuts (38, 58) to 33 N·m (24 ft. lbs.).
 - G models.
 - Nut (38) to 29 N·m (21 ft. lbs.).
 - Bolt (54) to 33 N·m (24 ft. lbs.).
10. Tie rod ends to the steering knuckle (31).
 • Refer to STEERING LINKAGE (SEC. 3B1).
11. Brake hose to the caliper.
 • Refer to BRAKES (SEC. 5).
12. Brake hose clips to the upper control arms.
 • Refer to BRAKES (SEC. 5).
13. Bleed the brake system.
 • Refer to BRAKES (SEC. 5).
14. Tires and wheels and lower the vehicle.
15. Battery cable.

ON-VEHICLE SERVICE: I-BEAM (RPO FS3) FRONT SUSPENSION

SHOCK ABSORBER



Remove or Disconnect (Figures 34 through 36)

- Raise the vehicle and support it with suitable safety stands. Remove the wheel and tire assembly.
1. Shock absorber (113) from the leaf spring spacer (158).
 - Nut (109) and washer (111).
 2. Shock absorber (113) from the frame.
 - Nut (109) and washer (111).
 - Pull the shock free from the vehicle.



Inspect

- Shock absorbers for damage and leaking.
- Test the shock absorbers. Refer to "Shock Absorber Bench Test" in this section.



Install or Connect (Figures 34 through 36)

1. Shock absorber (113) to the frame (figure 36).
 - Insert the shock's upper stud into the hole in the frame.
 - Washer (111) and nut (109). Do not tighten.

NOTICE: Refer to the "Notice" on page 3C-1 of this section.

2. Shock absorber (113) to the leaf spring spacer (158) (figure 36).
 - Position the shock's lower mount onto the stud.
 - Washer (111) and nut (109).



Tighten

- Shock absorber upper nut to 185 N·m (136 ft. lbs.).

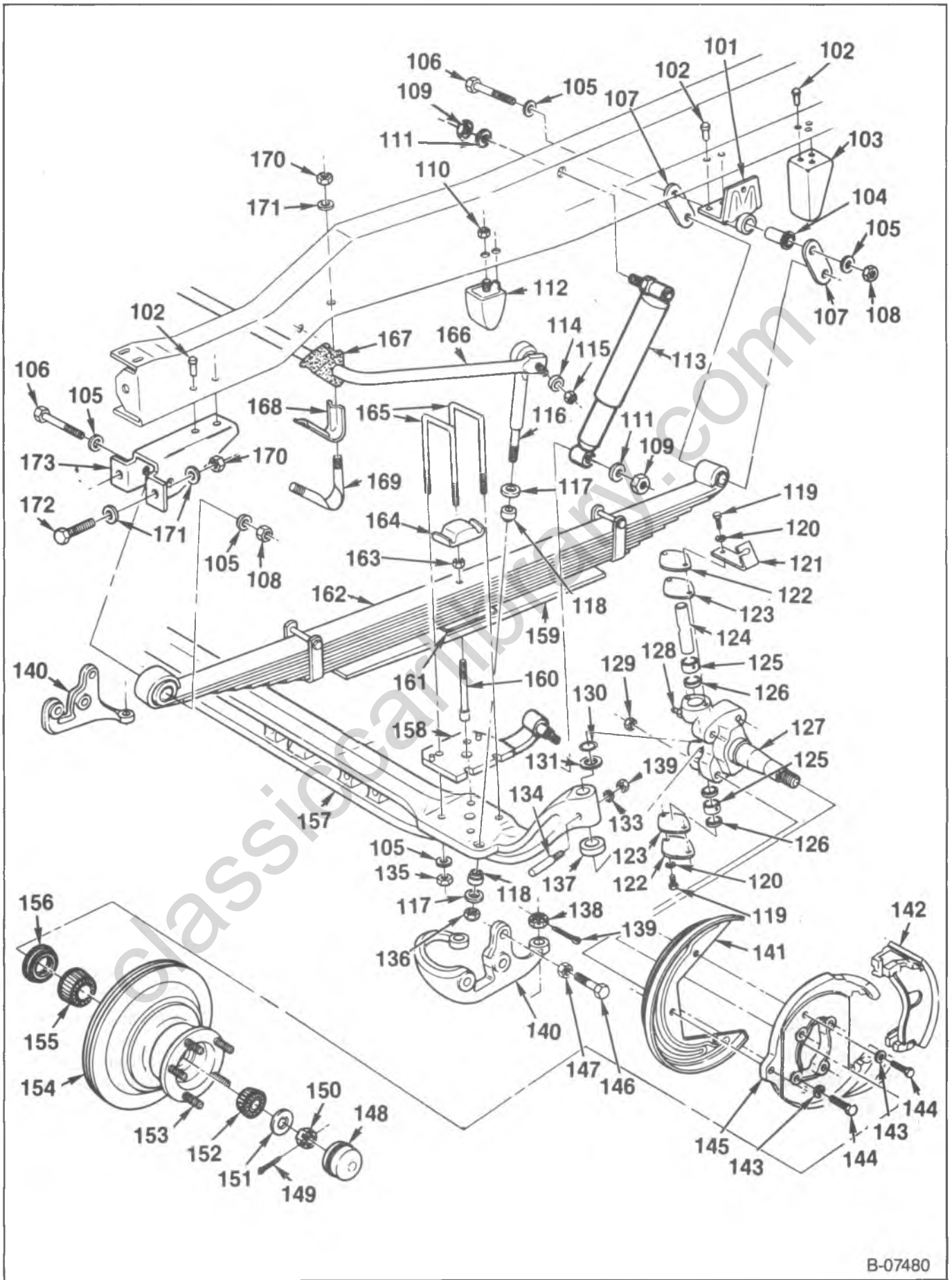

B-07480

Figure 34—P Model I-Beam Front Suspension Components

3C-30 FRONT SUSPENSION

101. Spring Hanger	126. Spacer	150. Nut
102. Rivet	127. Steering Knuckle	151. Washer
103. Spring Stop	128. Fitting	152. Outer Wheel Bearing And Race
104. Hanger Bushing	129. Nut	153. Wheel Hub Bolt
105. Washer	130. Dust Seal	154. Hub/Rotor
106. Bolt	131. Shim	155. Inner Wheel Bearing And Race
107. Shackle	132. Nut	156. Bearing Seal
108. Nut	133. Washer	157. Front Axle
109. Nut	134. Lock Pin	158. Spring Spacer
110. Nut	135. Nut	159. Spring Leaf
111. Washer	136. Nut	160. Bolt
112. Bumper	137. Thrust Bearing	161. Spacer
113. Shock Absorber	138. Nut	162. Front Spring
114. Spacer	139. Cotter Pin	163. Nut
115. Nut	140. Steering And Third Arm	164. Spacer
116. Stabilizer Link	141. Splash Shield	165. U-Bolt
117. Retainer	142. Brake Caliper	166. Stabilizer Bar
118. Insulator	143. Washer	167. Insulator
119. Bolt	144. Bolt	168. Clamp
120. Washer	145. Anchor Plate	169. Bolt
121. Brake Hose Bracket	146. Stop Bolt	170. Nut
122. Cap	147. Stop Nut	171. Washer
123. Gasket	148. Retainer/Cap	172. Bolt
124. King Pin	149. Cotter Pin	173. Spring Hanger
125. Bushing		

B-07485

Figure 35—P Model I-Beam Front Suspension Components

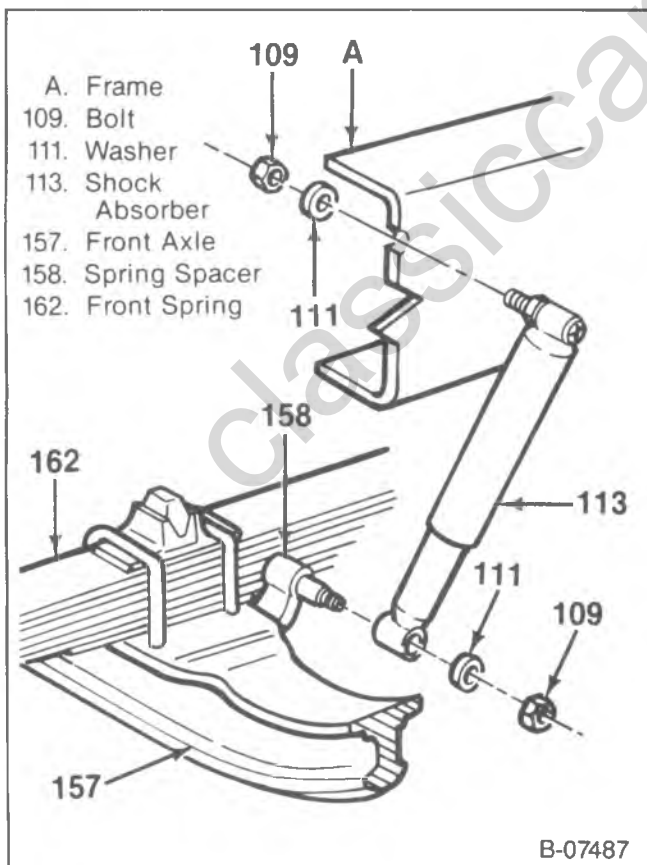

B-07487

Figure 36—Shock Absorber Attachment Points

- Shock absorber lower nut to 50 N·m (37 ft. lbs.).

3. Wheel and tire on the vehicle. Lower the vehicle to the ground.

STABILIZER BAR

- ↔ Remove or Disconnect (Figures 34, 35, and 37)

Tools Required:

J-6627-A Wheel Stud and Tie Rod Remover

- Raise the vehicle and support it with suitable safety stands. Remove the tire and wheel assembly.
1. Stabilizer bar (166) from the stabilizer link (116).
 - Nut (115) and washer (114).
 - Use J-6627-A to separate the stabilizer link from the stabilizer end.
 2. Stabilizer bar (166) from the frame (figure 37).
 - Nuts (170), washers (171), clamp bolts (169) and clamps (168).
 - Slide the insulator (167) from the stabilizer bar (166).
 3. Stabilizer link (116) from the front axle (157) (figure 37).
 - Nut (136), retainer (117), insulator (118).
 - Pull the link from the axle. Another insulator (118) and retainer (117) will come off the link.

NOTICE: For steps 1, 2, and 3, refer to the "Notice" on page 3C-1 of this section.

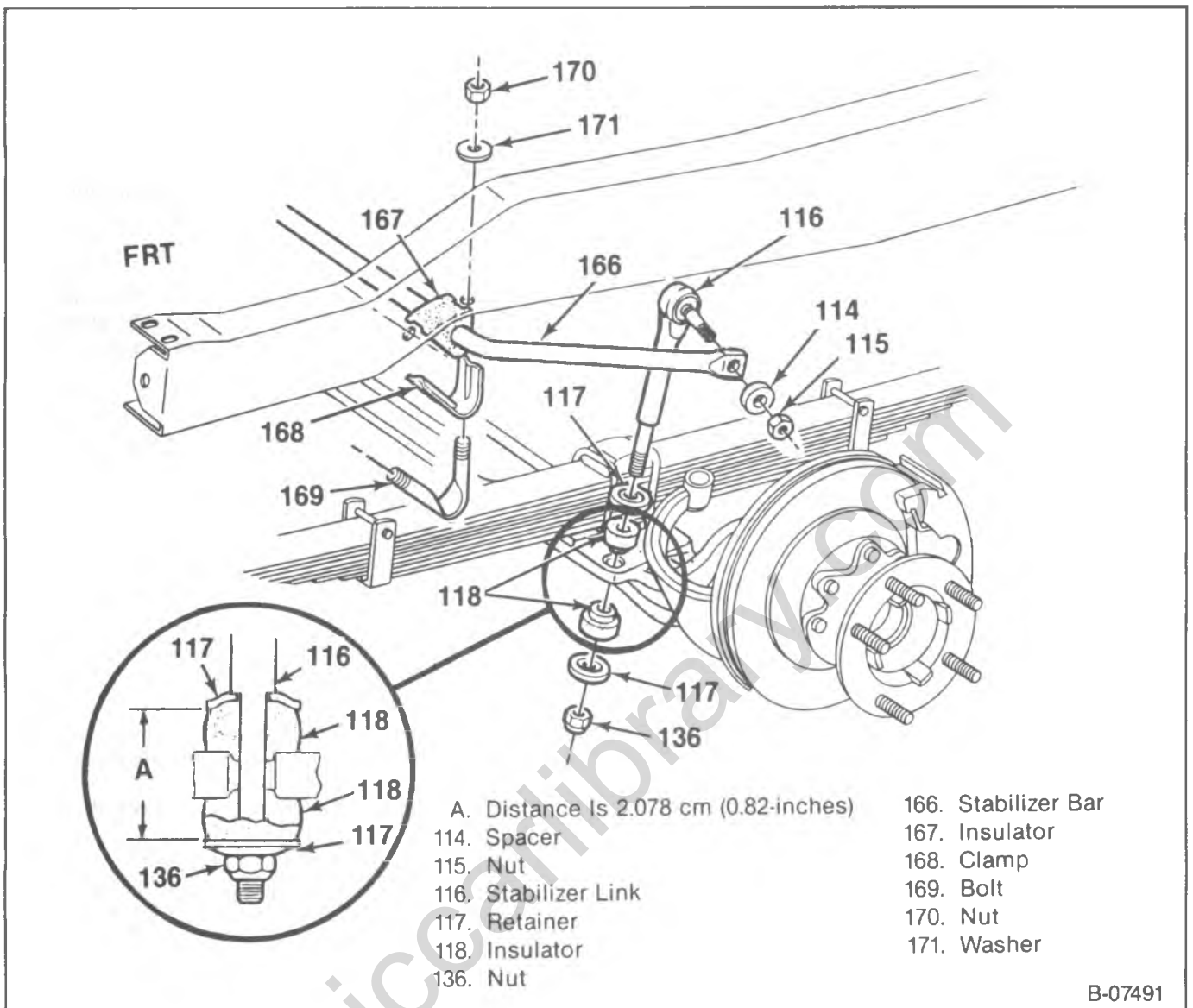

Figure 37—Stabilizer Bar Attachment Points

↔ Install or Connect (Figures 34, 35, and 37)

1. Stabilizer link (116) to the front axle (157) (figure 37).
 - Slide a retainer (117) and an insulator (118) on to the link and insert the link into the proper hole in the front axle.
 - Insulator (118), retainer (117) and nut (136).

⌚ Tighten

- Nut (136) until the distance between each retainer (117) is 2.08 cm (0.82 inches) (figure 37).
2. Stabilizer bar (166) to the frame (figure 37).
 - Insulators (167) onto the stabilizer bar (166).
 - Clamps (168), clamp bolts (169), washers (171), and nuts (170).

⌚ Tighten

- Nuts (170) to 28 N·m (21 ft. lbs.).
3. Stabilizer bar (166) to the stabilizer link (116).
 - Washer (114) and nut (115).

⌚ Tighten

- Nuts (115) to 68 N·m (50 ft. lbs.).
4. Wheel and tire assembly. Lower the vehicle to the ground.

WHEEL HUB/ROTOR ASSEMBLY

↔ Remove or Disconnect (Figures 34 and 35)

- Raise the vehicle and support it with suitable safety stands. Remove the tire and wheel assembly.
1. Caliper (142).
 - Refer to BRAKES (SEC. 5).

NOTICE: Support the caliper with a piece of wire to prevent damage to the brake line.

2. Wheel hub/rotor (154) (figures 34, 35).
 - Retainer/cap (148).
 - Cotter pin (149), nut (150) and washer (151).
 - Pull the hub/rotor free from the spindle, making sure the outer wheel bearing (152) comes free.

B-07491

3C-32 FRONT SUSPENSION

- Do not damage the steering knuckle spindle threads.
3. Inner wheel bearing (155).
 - Pry out the seal (156).
 4. Races.
 - Drive out each race using a brass drift.



Clean

1. Grease from the hub/rotor (154) and steering knuckle spindle.
 - Grease from inside the hub.
2. Grease from the wheel bearings (152, 155) and races.
 - Use clean solvent and a small brush (no loose bristles).
 - Do not spin the wheel bearings with compressed air to dry them—the wheel bearings may be damaged.



Inspect

1. Wheel bearings (152, 155) and their races for damage or wear.
 - Refer to "Diagnosis of Wheel Bearings," in this section.
 - If either a bearing or its race is damaged or worn, replace both.
2. Hub/rotor (154) for damage or wear.
 - Check for out-of-round or scored conditions.
 - Check for pitting or cracks.
 - Repair or replace as necessary.



Install or Connect (Figures 34 and 35)

Tools Required:

- J-8092 Driver Handle
- J-29040 Outer Bearing Race Installer
- J-9746-02 Hub/Rotor Support

NOTICE: Start the races squarely inside the hub/rotor (154) to avoid distortion and possible cracking.

1. Races into the hub/rotor (154).
 - Place the hub/rotor on J-9746-02 and rest this assembly on press bars.
 - Use J-29040 to drive the outer bearing race into position.
 - Remove J-9746-02 and use a 7.6 cm (3 inch) diameter bar, or equivalent tool to drive the inner bearing race into position. If the bar is larger than 7.6 cm (3 inches), it may damage the bearing seal seat.



Important

- Use an approved high temperature front wheel bearing grease to lubricate the bearings. Refer to MAINTENANCE AND LUBRICATION (SEC. 0B).
 - Do not mix different greases as mixing may change the grease's properties resulting in poor performance.
2. Apply a thin film of grease to the steering knuckle spindle at the outer wheel bearing seat and at the inner wheel bearing seat, shoulder, and seal seat.
 3. Put a small quantity of grease inboard of each wheel bearing retainer/cap (148).

4. Fill each wheel bearing (cone and roller assembly) full of grease.

- Use a cone-type grease machine that forces grease into the bearing.
- If a cone-type grease machine is not available, pack the wheel bearing by hand.
- When packing the wheel bearing by hand, work the grease into the bearings between the rollers, cones, and the cage.

NOTICE: Failure to completely pack the wheel bearing (cones, rollers, and cage) with grease will result in premature wheel bearing damage and/or wear.

5. Inner wheel bearing (155) into the hub/rotor (154).
 - Put an additional quantity of grease outboard of this bearing.
6. New seal (156).
 - Use a flat plate or block to install the seal to insure it is flush with the hub/rotor flange.
 - Lubricate the seal lip with a thin layer of grease.
7. Hub/rotor (154).
 - Do not damage the steering knuckle spindle threads.
8. Outer wheel bearing (152).
 - Slide it over the spindle until the wheel bearing (152) fully seats against the hub/rotor outer race.

NOTICE: Refer to the "Notice" on page 3C-1 of this section.

9. Washer (151), nut (150) and cotter pin (149).
 - Do not place the cotter pin through the hole in the spindle until the wheel bearings are adjusted.



Tighten

- Nut (150) to 16 N·m (12 ft. lbs.) while turning the hub/rotor assembly in either direction.
10. Put an additional amount of grease outboard of the wheel bearing (152).
 11. Adjust the wheel bearings.
 - Refer to "Wheel Bearing Adjustment," in this section.
 12. Retainer/cap (148) in place.
 13. Caliper (142).
 - Refer to BRAKES (SEC. 5).
 14. Tire and wheel assembly. Lower the vehicle to the ground.

WHEEL BEARING ADJUSTMENT



Important

- The proper functioning of the front suspension cannot be maintained unless the front wheel bearings are correctly adjusted. The bearings must be a slip fit on the spindle and the inside diameter of the wheel bearing must be lubricated to ensure the bearings will creep. The spindle nut (150) must have a free-running fit on the spindle threads.

NOTICE: Never preload the front wheel bearings. Damage can result by the steady thrust on the roller ends which comes from preloading.



Adjust

- Raise the vehicle and support it with suitable safety stands under the lower control arms.
- 1. Remove the retainer/cap (148).
- 2. Remove the cotter pin (149).



Tighten

- Nut (150) to 16 N·m (12 ft. lbs.) while rotating the wheel and tire assembly (or the hub/rotor). This will seat the bearings.
- 3. Back off the nut (150) one flat.
 - If the hole in the spindle lines up with the slot in the nut, insert the cotter pin (149).
 - If they do not line up, back off the nut until they do—not more than one additional flat.



Measure

- Endplay in the hub/rotor should measure between 0.013–0.20 mm (0.0005–0.008 inches) when properly adjusted.
- 4. Install the retainer/cap (148).
- 5. Lower the vehicle to the ground.

WHEEL HUB BOLT



Remove or Disconnect

Tools Required:

J-9746-02 Hub/Rotor Support

- 1. Hub/rotor assembly from the vehicle.
 - Refer to “Wheel Hub/Rotor Assembly,” in this section.

NOTICE: Place J-9746-02 between the press bars and the hub/rotor to protect the rotor surfaces.

- 2. Wheel hub bolts (153) with a press.
 - Support the hub/rotor (153) using J-9746-02 and the press bars.
 - Do not damage the wheel mounting surface on the hub/rotor flange.



Install or Connect

NOTICE: Refer to the “Notice” on page 3C – 1 of this section.

- 1. Wheel hub bolts (153) into the hub/rotor (154).
 - Place four washers onto the bolt, then fasten a nut onto the bolt until the nut bottoms on the washers.
 - Tighten the nut until the bolt fully seats into the hub/rotor (154).
 - Remove the nut and washers.
- 2. Hub/rotor to the vehicle.
 - Refer to “Wheel Hub/Rotor Assembly,” in this section.

- 3. Wheel and tire assembly. Lower the vehicle to the ground.

STEERING ARM, KNUCKLE AND SPINDLE



Remove or Disconnect (Figures 34 and 35)

- Raise the vehicle and support it with suitable safety stands. Remove the tire and wheel assembly.
- 1. Caliper (142).
 - Refer to BRAKES (SEC. 5).
- 2. Hub/rotor assembly (154).
 - Refer to “Wheel Hub/Rotor Assembly,” in this section.
- 3. Anchor plate (145), splash shield (141), and the steering arm (140).
 - Bolts (146), washers (147) and nuts (129), and pull the anchor plate and splash shield off the knuckle. Steering arm hangs by tie rods.
 - Bolts (144) and washers (143) to separate the anchor plate from the splash shield.
 - Refer to STEERING LINKAGE (SEC. 3B1) to separate the steering arm from the tie rod and pitman arm.
- 4. Caps (122) from the steering knuckle (127).
 - Bolts (119) and washers (120).
 - Brake hose bracket (121).
 - Gaskets (123) come off.
- 5. Lock pin (134).
 - Nut (132) and washer (133).
- 6. King pin (124) from the steering knuckle (127).
 - Drive it out using a drift.
 - Spacers (126) and bushings (125) will also come out.
- 7. Steering knuckle (127) from the axle (157).
 - Dust seal (130), shim (131), and thrust bearing (137) will come free.

NOTICE: For steps 3, 4, and 5 refer to the “Notice” on page 3C – 1 of this section.



Install or Connect (Figures 34 and 35)

- 1. Bushings (125).
 - Ream new bushings to 29.982-30.022mm (1.1804-1.1820 in.) after installing.
- 2. Steering knuckle (127).
 - Thrust bearing (137), shim and the dust seal.
 - Prelube the thrust bearing. Refer to MAINTENANCE AND LUBRICATION (SEC. 0B).
- 3. King pin (124) and the lock pin (134).
 - Insert the spacers in the proper order.
 - Prelube the king pin.
 - Washer (133) and the nut (132).



Tighten

- Nut (132) to 40 N·m (29 ft. lbs.).
- 4. Caps (122) to the steering knuckle (127).

3C-34 FRONT SUSPENSION

- Gaskets (123) in place.
- Brake hose bracket (121).
- Washers (120) and bolts (119).



Tighten

- Bolts (119) to 7 N·m (5 ft. lbs.).
5. Steering arm (140), splash shield (141), and the anchor plate (145).
 - Bolts (144) and washers (143) to attach the splash shield to the anchor plate.
 - Bolts (146), washers (147) and nuts (129) to attach the anchor plate and steering arm to the steering knuckle.



Tighten

- Bolts (144) to 16 N·m (12 ft. lbs.).
 - Nuts (129) to 312 N·m (230 ft. lbs.).
6. Steering arm (140) to the steering linkage.
 - Refer to STEERING LINKAGE (SEC. 3B1).
 7. Hub/Rotor assembly (154).
 - Refer to "Wheel Hub/Rotor Assembly," in this section.
 8. Adjust the wheel bearings.
 - Refer to "Wheel Bearing Adjustment," in this section.
 9. Caliper (142).
 - Refer to BRAKES (SEC. 5).
 10. Wheel and tire assembly. Lower the vehicle to the ground.
 11. Check the front end alignment.
 - Refer to FRONT END ALIGNMENT (SEC. 3A).

FRONT AXLE



Remove or Disconnect (Figures 34 through 38)

Tools Required:

J-6627-A Wheel Stud and Tie Rod Remover

- Raise the vehicle and support it with suitable safety stands on the frame. Remove the wheel and tire assembly. Support the axle with a floor jack to eliminate any load on the springs.
1. Steering arm, knuckle, and spindle.
 - Refer to "Steering Arm, Knuckle, and Spindle," in this section.
 2. Shock absorber (113) from the axle (157) (figure 36).
 - Nut (109) and washer (111).
 3. Stabilizer link (116) from the stabilizer bar (166) (figure 37).
 - Nut (115) and washer (114).
 - Use J-6627-A to separate the stabilizer bar from the stabilizer link.
 4. Stabilizer link (116) from the axle (157) (figure 37).
 - Nut (136), retainer (117) and insulator (118).
 - Pull the link free from the axle, making sure not to loose the other insulator (118) and retainer (117).
 5. Leaf spring (162) from the axle (157) (figure 38).
 - Nuts (135), washers (105) and U-bolts (165).
 - Spacer (164), and spring spacer (158).
 6. Steering damper from the axle.
 - Refer to STEERING LINKAGE (SEC. 3B1).
 7. Lower the floor jack and pull the axle clear of the vehicle.

NOTICE: For steps 4, 5, and 6, refer to the "Notice" on page 3C-1 of this section.



Install or Connect (Figures 34 through 38)

1. Line up the axle under the leaf springs.
 - Raise it into position using a floor jack.
2. Steering damper to the axle.
 - Refer to STEERING LINKAGE (SEC. 3B1).
3. Axle (157) to the leaf springs (162).
 - Refer to "Leaf Spring," in this section.
4. Stabilizer link (116) to the axle (157) (figure 37).
 - Link into the hole on the spring spacer (158) and axle.
 - Insulator (118), retainer (117), and nut (136).



Tighten

- Nut (136) until the distance between each retainer (117) is 2.08 cm (0.82 inches) (figure 37).
5. Stabilizer link to the stabilizer bar (166) (figure 37).
 - Washer (114) and nut (115).
 6. Shock absorber (113) to the axle (157) (figure 36).
 - Washer (111) and nut (109).



Tighten

- Nut (115) to 68 N·m (50 ft. lbs.).
6. Shock absorber (113) to the axle (157) (figure 36).
 - Washer (111) and nut (109).
 7. Steering arm, knuckle, and spindle.
 - Refer to "Steering Arm, Knuckle, and Spindle," in this section.



Tighten

- Nut (109) to 50 N·m (37 ft. lbs.).
7. Steering arm, knuckle, and spindle.
 - Refer to "Steering Arm, Knuckle, and Spindle," in this section.
 8. Adjust the wheel bearings.
 - Refer to "Wheel Bearing Adjustment" in this section.
 9. Wheel and tire assembly. Lower the vehicle to the ground.
 10. Check the front end alignment.
 - Refer to FRONT END ALIGNMENT (SEC. 3B1).

LEAF SPRINGS



Remove or Disconnect (Figures 34 through 38)

Tools Required:

J-6627-A Wheel Stud and Tie Rod Remover

- Raise the vehicle and support it with suitable safety stands. Support the axle separately to eliminate any load on the springs. Remove the tire and wheel assembly.
1. Shock absorber (113) from the axle (157) (figure 36).
 - Nut (109) and washer (111).
 2. Stabilizer link (116) from the stabilizer bar (166) (figure 37).
 - Nut (115) and washer (114).
 - Use J-6627-A to separate the stabilizer bar from the stabilizer link.
 3. Stabilizer link (116) from the axle (157) (figure 37).
 - Nut (136), retainer (117), insulator (118).
 - Pull the link free from the axle, making sure not to loose the other insulator (118) and retainer (117).
 4. Leaf spring (162) from the axle (157) (figure 38).

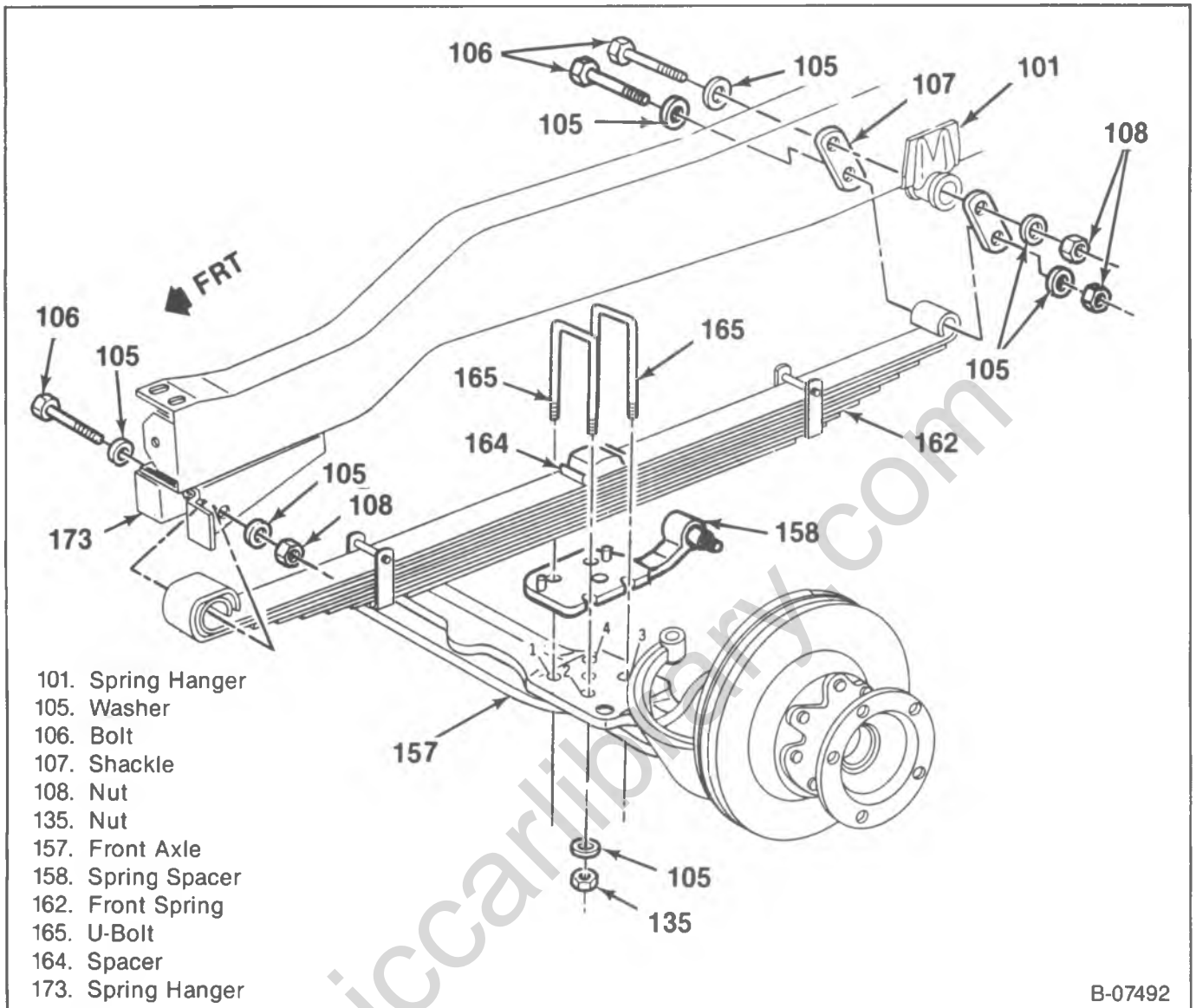

- 101. Spring Hanger
- 105. Washer
- 106. Bolt
- 107. Shackle
- 108. Nut
- 135. Nut
- 157. Front Axle
- 158. Spring Spacer
- 162. Front Spring
- 165. U-Bolt
- 164. Spacer
- 173. Spring Hanger

B-07492

Figure 38—Axle and Leaf Spring Attachment Points

- Nuts (135), washers (105) and U-bolts (165).
 - Spacer (164) and spring spacer (158).
5. Leaf spring (162) from the frame (figure 38).
 - Nut (108), washer (105), bolt (106) and washer (105) to separate the spring from the rear shackle (107).
 - Nut (108), washer (105), bolt (106), and washer (105) to separate the spring from the front hanger (173).
 - Pull the leaf spring backward and out.

NOTICE: For steps 1, 2, 3, 4 and 5, refer to the "Notice" on page 3C-1 of this section.

Install or Connect (Figures 34 through 38).

1. Leaf spring (162) to the frame (figure 38).
 - Line up the spring with the rear shackle (107) and the front hanger (173). Double wrap end is toward the front of the vehicle.

- Washer (105), bolt (106), washer (105) and nut (108) to attach the spring to the front hanger (173).
- Washer (105), bolt (106), washer (105) and nut (108) to attach the spring to the rear shackle (107).

Tighten

- Nut (108) to 125 N·m (92 ft. lbs.).
2. Leaf spring (162) to the axle (157) (figure 38).
 - Position the spring spacer (158) onto the axle. Either aligning pin can contact the edge of the leaf spring after the assembly is complete.
 - Spacer (164), U-bolts (165), washers (105) and nuts (135). Tighten nuts to 25 N·m (18 ft. lbs.) in a diagonal sequence (e.g., 1-3-4-2).

Tighten

- Nuts (135) in a diagonal sequence (e.g., 1-3-4-2) to 109 N·m (80 ft. lbs.).
3. Stabilizer link (116) to the axle (157) (figure 37).

3C-36 FRONT SUSPENSION

- Insert the link into the proper hole in the axle after the retainer (117) and insulator (118) are attached.
- Insulator (118), retainer (117), and nut (136).

Tighten

- Nut (136) until the distance between each retainer (117) is 2.08 cm (0.82 inches) (figure 37).
4. Stabilizer link (116) to the stabilizer bar (166) (figure 37).
 - Washer (114) and nut (115).

Tighten

- Nut (115) to 68 N·m (50 ft. lbs.).
5. Shock absorber (113) to the axle (157) (figure 34).
 - Washer (111) and nut (109).

Tighten

- Nut (109) to 50 N·m (37 ft. lbs.).
6. Wheel and tire assembly. Lower the vehicle to the ground.
 7. Check the front end alignment.
 - Refer to FRONT END ALIGNMENT (SEC. 3B1).

ON-VEHICLE SERVICE: FOUR WHEEL DRIVE FRONT SUSPENSION

SHOCK ABSORBER

Remove or Disconnect (Figures 39 through 41)

- Raise the vehicle on a hoist.
1. Shock absorber (220) from the frame.
 - Nut (212), washer (213) and bolt (219) (figure 38).
 2. Shock absorber (220) from the axle.
 - Nut (212), washer (213) and bolt (225).
 - Quad shocks (RPO Z75) have a spacer (246) between them (figure 41).

Inspect

- Shock absorbers for damage and leaking.
- Test the shock absorbers. Refer to "Shock Absorber Bench Test" in this section.

NOTICE: For steps 1 and 2, refer to the "Notice" on page 3C-1.

Install or Connect (Figures 39 and 40)

1. Shock absorber (220) to the axle.
 - Bolt (225), washer (213), and nut (212).
 - Spacer (246) must be positioned between the shock absorbers (220) on vehicles with quad shocks, RPO Z75 (figure 41).

Tighten

- Nut (212) to 88 N·m (65 ft. lbs.).
 - Nut (212) to 120 N·m (89 ft. lbs.) on quad shocks (RPO Z75).
2. Shock absorber (220) to the frame.
 - Bolt (219), washer (213) and nut (212).

Tighten

- Nut (212) to 88 N·m (65 ft. lbs.).
3. Lower the vehicle to the floor.

STABILIZER BAR

Remove or Disconnect (Figures 39, 40 and 42)

- Raise the vehicle on a hoist.
1. Stabilizer bar (230) from the frame brackets (237).
 - Nuts (231), washers (232), brackets (233), and bolts (238) (figure 39).
 2. Stabilizer bar (230) from the spring plate (224).
 - Bolts (229), and washers (228).
 - Stabilizer bar is free of the vehicle.
 - Bushings (234) can be removed from the stabilizer bar.

Install or Connect (Figures 39, 40 and 42)

1. Stabilizer bar (230) to the frame brackets (237).
 - Bushings (234) onto the stabilizer bar.
 - Use rubber lubricant when installing the bushings (slit faces forward) on the stabilizer bar.
 - Brackets (233), bolts (238), washers (232), and nuts (231) (figure 39). Do not tighten.

NOTICE: Refer to "Notice" on page 3C-1 of this section.

2. Stabilizer bar (230) to the spring plate (224).
 - Washers (228) and bolts (229) (figure 42).

Tighten

- Nuts (231) to 70 N·m (52 ft. lbs.).
 - Bolts (229) to 180 N·m (133 ft. lbs.).
3. Lower the vehicle to the ground.

WHEEL HUB/ROTOR ASSEMBLY

Remove or Disconnect (Figures 39, 40, and 43 through 45)

Tools Required:

- J-6893-D Wheel Bearing Nut Wrench (V10/1500-20/2500 Models)
- J-23446 Torque Wrench Adapter
- J-26878-A Wheel Bearing Nut Wrench (V30/3500 Models)

- Raise the vehicle and support it with suitable safety stands. Remove the tire and wheel assembly.
1. Caliper
 - Refer to BRAKES (SEC. 5).
 2. Locking hub (249).
 - Refer to FRONT AXLE (SEC. 4C).
 3. Locking nut (250), ring (251) and adjusting nut (252).
 - Use J-6893-D and J-23446 for V10/1500-20/2500 models.
 - Use J-26878-A for V30/3500 models.
 4. Hub/Rotor Assembly (257).
 - Outer wheel bearing (253) will slide off the spindle (265) ahead of the hub/rotor (257).
 - Use a brass drift and hammer for the seal (260) and races (254, 258).
 - The inner bearing (259), race (258) are behind the seal (260).



Inspect

1. Rotor braking surfaces for scoring, pitting, or cracks.
 - Repair or replace as necessary.
2. Wheel bearings (253, 259) and races (254, 258).
 - Refer to "Diagnosis of Wheel Bearings," in this section.
 - If either a bearing or its race is damaged or worn, replace both.



Install or Connect (Figures 39, 40, and 43 through 45)

Tools Required:

- J-8092 Driver Handle
- J-6368 Bearing Race Installer (Outer)
- J-23448 Bearing Race Installer (Inner)
- J-6893-D Wheel Bearing Nut Wrench (V10/1500-20/2500 models)
- J-26878-A Wheel Bearing Nut Wrench (V30/3500 models)
- J-23446 Torque Wrench Adapter

1. Races (254, 258) into the rotor/hub (257).
 - Use J-8092 and J-6368 for installation of the outer bearing outer race (254).
 - Use J-8092 and J-23448 for installation of the inner bearing outer race (258).
 - Do not damage the hub/rotor during the race installations.



Clean

- Grease from the rotor/hub (257) and spindle (265).
- Grease from the wheel bearings (253, 259).
- Use clean solvent and a small brush (no loose bristles).
- Do not spin the wheel bearings with compressed air to dry them—the wheel bearings may be damaged.



Important

- Use an approved high-temperature front wheel bearing grease. Refer to MAINTENANCE AND LUBRICATION (SEC. 0B).
 - Do not mix greases as mixing may change the grease's properties resulting in poor performance.
2. Apply a thin film of grease to the spindle at the outer wheel bearing seat and at the inner wheel bearing seat, shoulder, and seal seat.

3. Put a small quantity of grease inboard of each wheel bearing cup, inside the rotor/hub (257).
4. Fill the wheel bearing (cone and roller assemblies) full of grease.
 - Use a cone-type grease packer that forces grease into the bearing.
 - If a cone-type grease packer is not available, pack the wheel bearings by hand.
 - If packing the wheel bearings by hand, work the grease into the bearings between the rollers, cones, and the cage.

NOTICE: Failure to completely pack the wheel bearings (cones, rollers, and cage) with grease will result in premature wheel bearing damage and/or wear.

5. Inner wheel bearing (259) into the rotor/hub (257).
 - Put an additional quantity of grease outboard of this wheel bearing.
6. New seal (260).
 - Use a flat plate to install the seal so it is flush with the rotor/hub flange.
 - Lubricate the seal lip with a thin layer of grease.
7. Rotor/hub (257).
 - Do not damage the spindle threads.
8. Outer wheel bearing (253).
 - Press on the spindle until the wheel bearing fully seats against the rotor/hub outer race.
9. Adjusting nut (252).
10. Adjust the wheel bearing.
 - Refer to "Wheel Bearing Adjustment," in this section.

NOTICE: Refer to the "Notice" on page 3C-1 of this section.

11. Ring (251) and locking nut (250).
 - Tang on the inside diameter of the ring must pass onto the slot on the spindle (265).
 - The hole in the ring must align with the pin on the lock nut (250). Move the adjustment nut (252) to align the pin.
 - Use J-6893-D or J-26878-A and J-23446.



Tighten

- Lock nut (250) to 217 N·m (160 ft. lbs.) minimum.
12. Locking hub (249).
 - Refer to FRONT AXLE (SEC. 4C).
 13. Caliper.
 - Refer to BRAKES (SEC. 5).
 14. Wheel and tire. Lower the vehicle to the ground.

BEARING ADJUSTMENT



Important

- The proper functioning of the front suspension cannot be maintained unless the front wheel bearings are correctly adjusted. The cones must be a slip fit on the spindle and the inside diameter of the cones must be lubricated to insure the cones will creep. The adjusting nut must have a free-running fit on the spindle threads.

3C-38 FRONT SUSPENSION

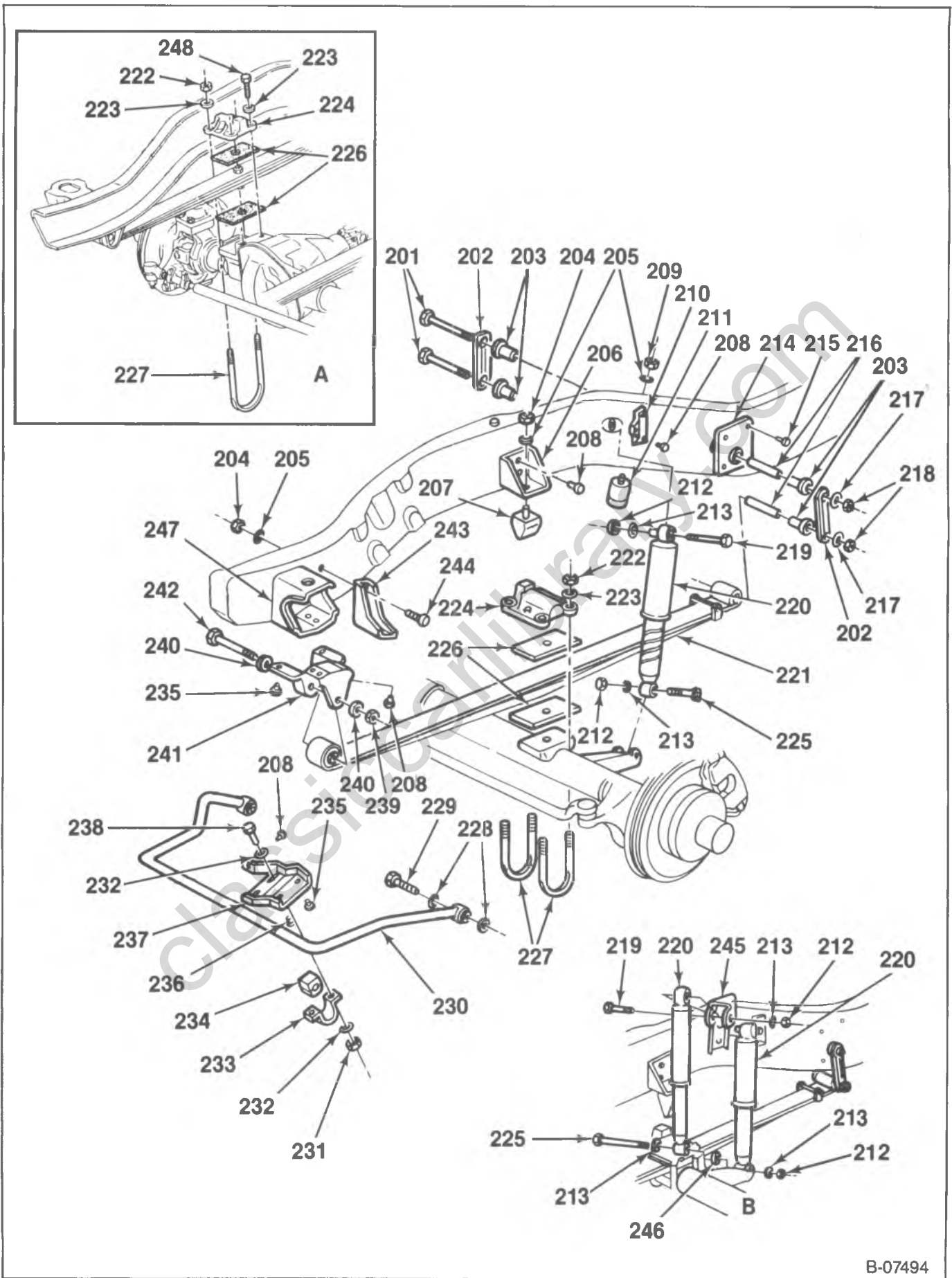

B-07494

Figure 39—V Model Front Suspension

- | | | | |
|--------------|-----------------------|--------------------|-----------------|
| 201. Bolt | 216. Spacer | 231. Nut | 247. Bracket |
| 202. Shackle | 217. Washer | 232. Washer | 248. Bolt |
| 203. Bushing | 218. Nut | 233. Bracket | A. K3500 Series |
| 204. Nut | 219. Bolt | 234. Bushing | Right Side |
| 205. Washer | 220. Shock Absorber | 235. Rivet | B. Quad Shock |
| 206. Bracket | 221. Leaf Spring | 236. Rivet | RPO Z75 |
| 207. Bumper | 222. Nut | 237. Bracket | |
| 208. Rivet | 223. Washer | 238. Bolt | |
| 209. Nut | 224. Plate | 239. Nut | |
| 210. Bracket | 225. Bolt | 240. Washer | |
| 211. Bumper | 226. Spacer | 241. Hanger | |
| 212. Nut | 227. Bolt | 242. Bolt | |
| 213. Washer | 228. Washer | 243. Reinforcement | |
| 214. Hanger | 229. Bolt | 245. Bracket | |
| 215. Rivet | 230. Stabilizer Shaft | 246. Spacer | |

B-07495

Figure 40—V Model Front Suspension

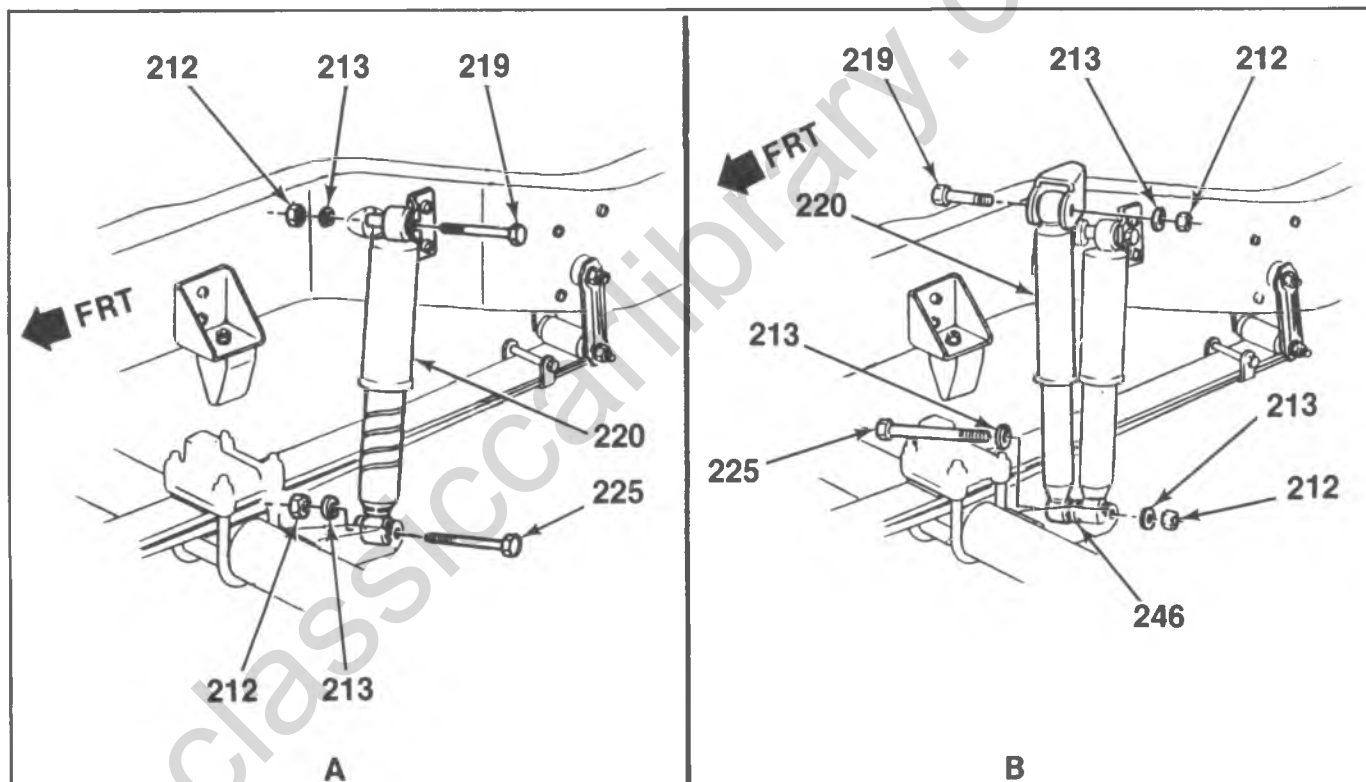

- A. K Series Standard Shock Absorber Mounting
 B. K Series RPO Z75 Quad Shock Absorber Mounting

212. Nut
 213. Washer
 219. Bolt
 220. Shock Absorber
 225. Bolt
 246. Spacer

B-07493

Figure 41—Shock Absorber Attachment Points

3C-40 FRONT SUSPENSION

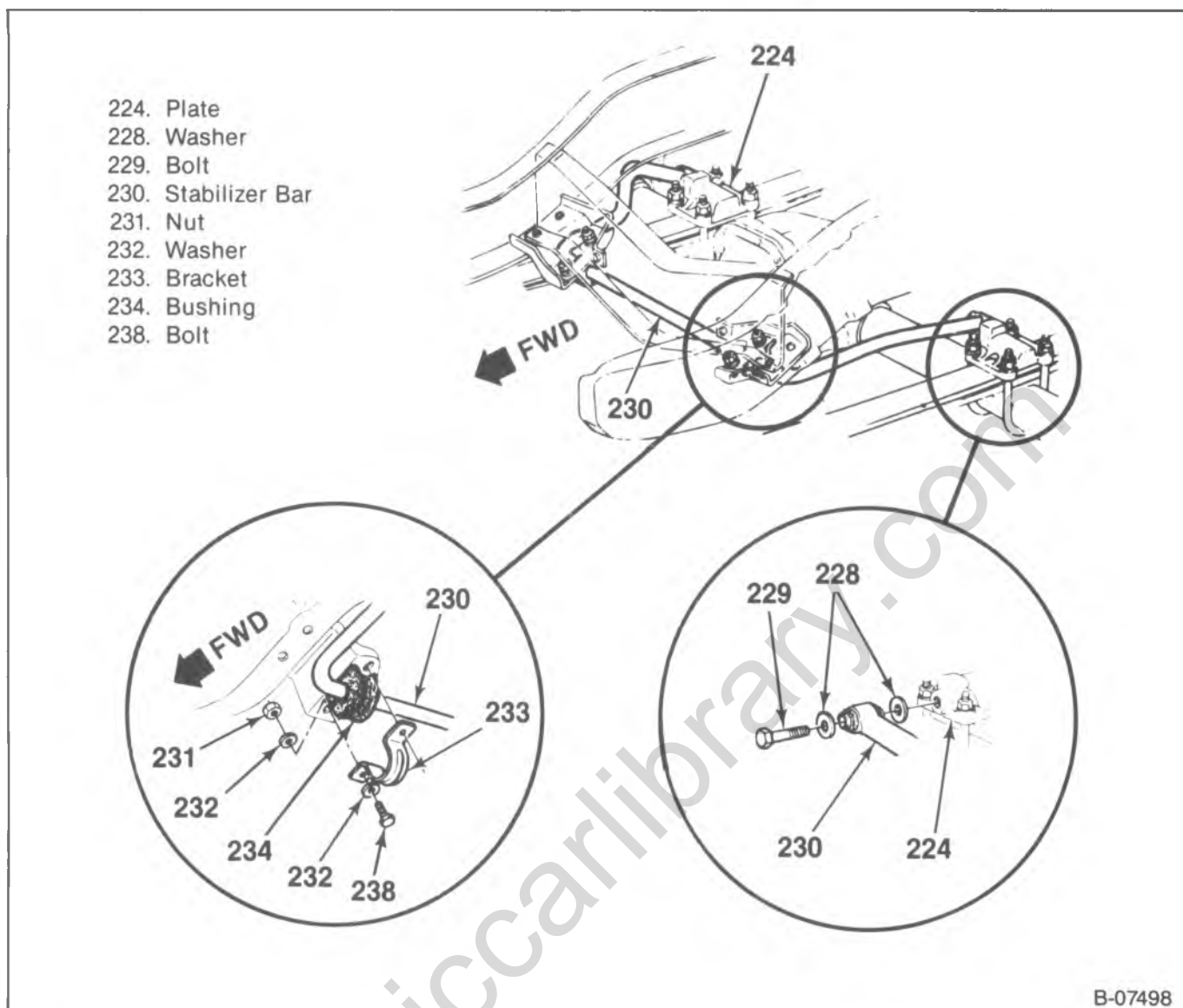

B-07498

Figure 42—Stabilizer Bar Attachment Points



Adjust

- Raise the vehicle and support it with safety stands.
1. Remove the locking hub assembly (249), lock nut (250), and the ring (251).



Tighten

- Adjusting nut (252) to 60 N·m (50 ft. lbs.) while rotating the hub/rotor in order to seat the bearings.
2. Back off the adjusting nut (252) and retighten.



Tighten

- For Automatic Hubs, torque the adjusting nut to 47 N·m (35 ft. lbs.) while rotating the wheel.
 - For Manual Hubs, torque the adjusting nut to 60 N·m (50 ft. lbs.) while rotating the wheel.
3. Back off the adjusting nut (252).
 - For Automatic hubs, back off $\frac{3}{8}$ of a turn maximum.
 - For Manual hubs, back off enough to free the bearing.

4. Ring (251) and lock nut (252).
 - Tang on the inside diameter of the ring must pass onto the slot on the spindle (265).
 - The hole in the ring must align with the pin on the lock nut (250). Move the adjustment nut (252) to align the pin.



Tighten

- Lock nut (250) to 217 N·m (160 ft. lbs.) minimum.



Measure

- Endplay in the hub/rotor assembly. It should be set between 0.025 to 0.254 mm (0.001 to 0.010-inch).
5. Locking hub assembly (249).
 - Refer to FRONT AXLE (SEC. 4C).
 6. Lower the vehicle to the ground.

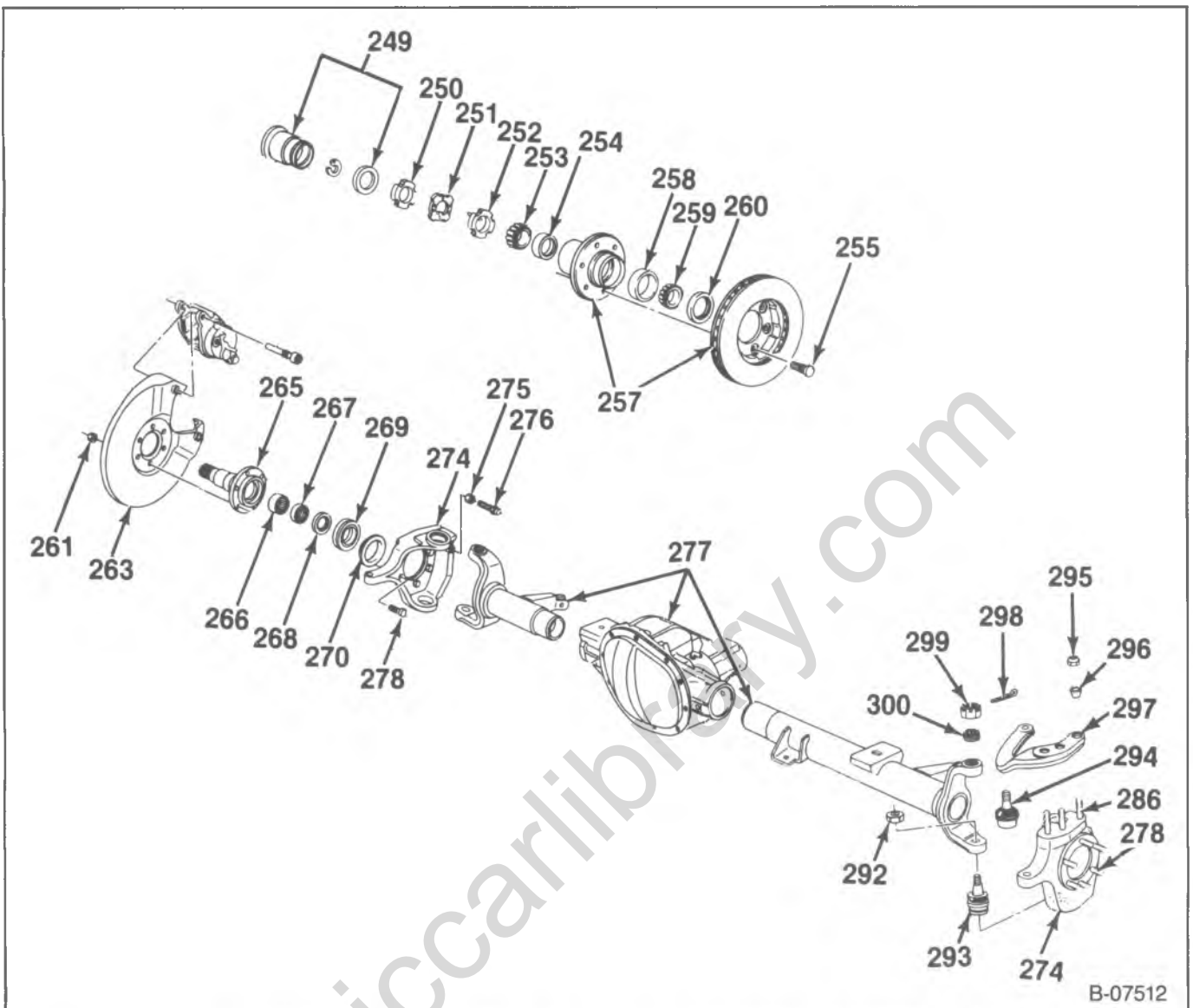

Figure 43—Knuckle and Hub/Rotor Components (V10/1500 and 20/2500 Models)

WHEEL HUB BOLT

↔ Remove or Disconnect (Figures 39, 40, and 46)

Tools Required:

J-9746-02 Hub/Rotor Support

1. Hub/rotor assembly from the vehicle.
 - Refer to "Wheel Hub/Rotor Assembly," in this section.
2. Wheel hub bolts (255) with a press.
 - Support the hub/rotor using J-9746-02 to prevent damage to the rotor face (figure 46).
 - Do not damage the wheel mounting surface on the hub/rotor flange.

↔ Install or Connect (Figures 39, 40, and 47)

Tools Required:

J-9746-02 Hub/Rotor Support

NOTICE: Refer to "Notice" on page 3C-1 of this section.

1. New, serrated bolt (255) into the hole in the hub/rotor.
 - Place four washers onto the bolt, then fasten a nut onto the bolt until the nut bottoms on the washers (figure 47).
 - Tighten the nut until the bolt fully seats into the hub/rotor.
 - Remove the nut and washers.
2. Hub/rotor to the vehicle.
 - Refer to "Wheel Hub/Rotor Assembly," in this section.
3. Wheel and tire assembly. Lower the vehicle.

SPINDLE

↔ Remove or Disconnect (Figures 39, 40, 48 and 49)

- Raise the vehicle and support it with suitable safety stands. Remove the tire and wheel assembly.

3C-42 FRONT SUSPENSION

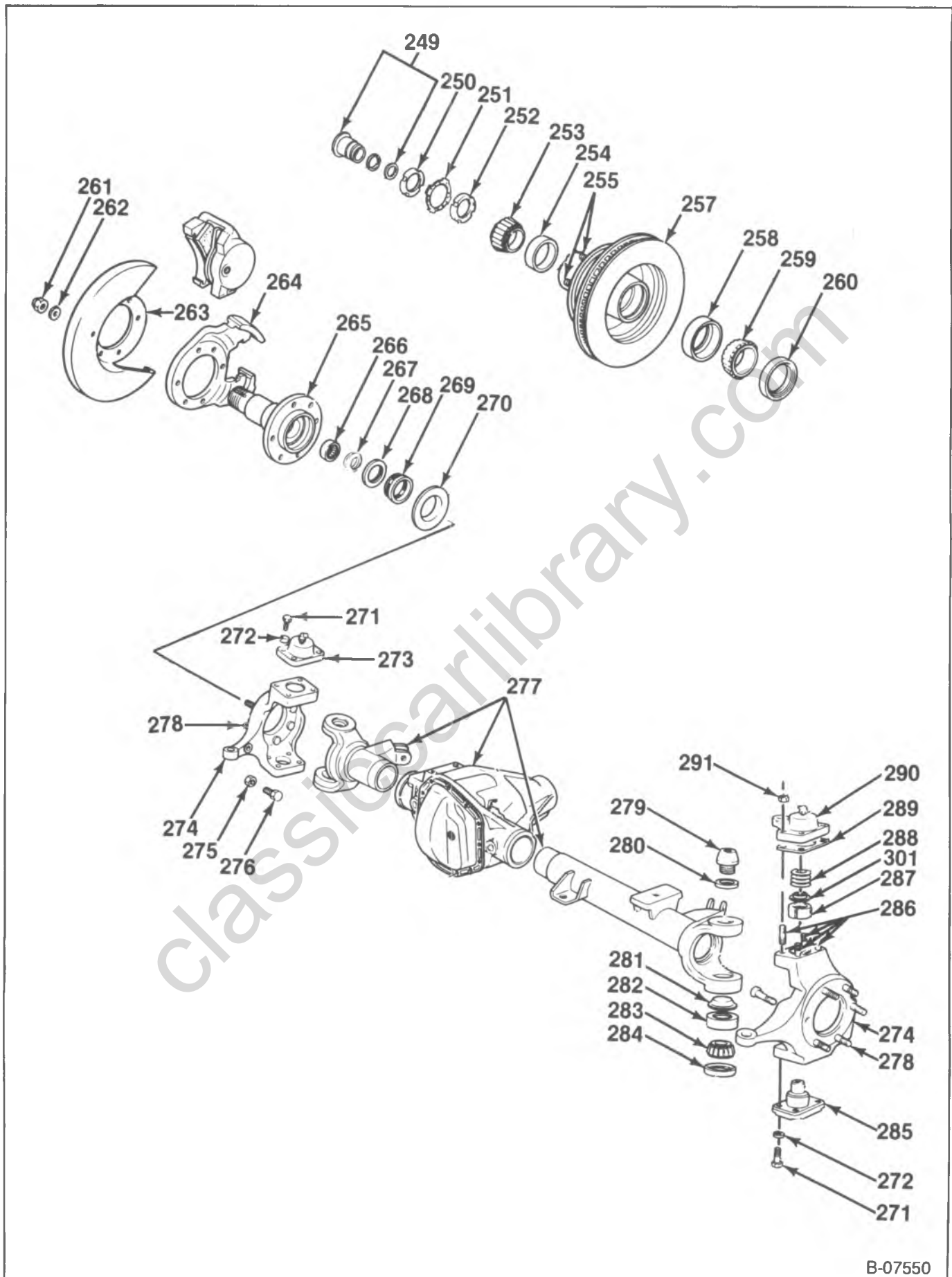

Figure 44—Knuckle and Hub/Rotor Components (V30/3500 Models)

B-07550

249. Locking Hub Assembly	263. Plate	276. Bolt	289. Gasket
250. Locking Nut	264. Bracket	278. Bolt	290. Steering Arm
251. Ring	265. Spindle	279. King Pin	291. Nut
252. Adjusting Nut	266. Shaft Bearing	280. Seal	292. Nut
253. Outer Wheel Bearing	267. Bearing Seal	281. Retainer	293. Lower Ball Joint
254. Outer Race	268. Spacer	282. Race	294. Upper Ball Joint
255. Wheel Hub Nut	269. Seal	283. Bearing	295. Nut
257. Rotor/Hub	270. Oil Deflector	284. Seal	296. Adapter
258. Inner Race	271. Bolt	285. Bearing Cap and King Pin	297. Steering Arm
259. Inner Wheel Bearing	272. Washer	286. Bolt	298. Cotter Pin
260. Seal	273. Cap	287. Bushing	299. Nut
261. Nut	274. Steering Knuckle	288. Spring	300. Adjusting Ring
262. Washer	275. Nut		301. Retainer

B-07464

Figure 45—Knuckle and Hub/Rotor Components (V30/3500)

1. Wheel hub/rotor assembly.
 - Refer to "Wheel Hub/Rotor Assembly," in this section.
2. Spindle (265) from the steering knuckle (274).
 - Nuts (261) and plate (263) for V10/1500-20/2500 models.
 - Nuts (261), washers (262), plate (263) and the bracket (264) for V30/3500 models.
 - Tap the end of the spindle with a plastic or rubber mallet to break it loose from the steering knuckle (274) (figure 48).

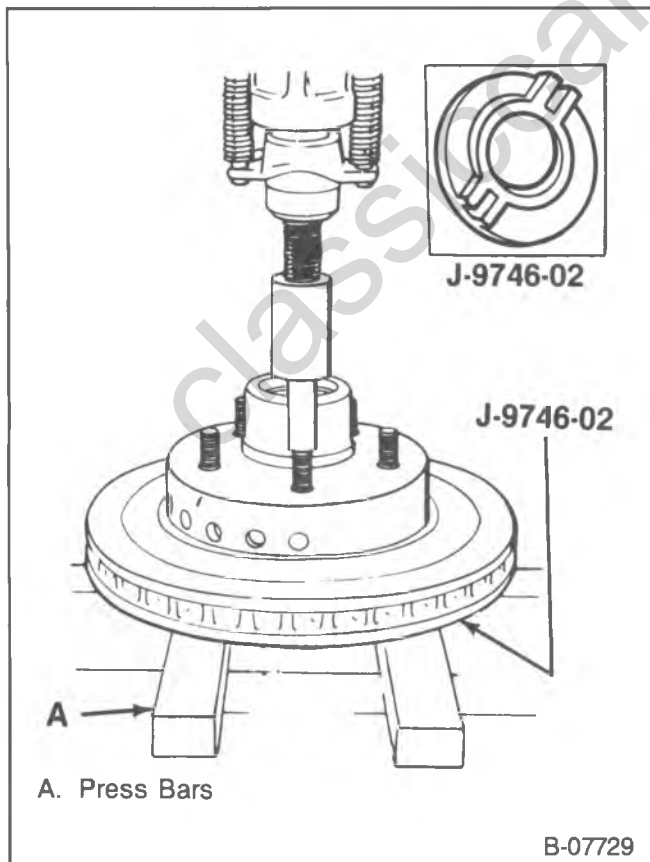

Figure 46—Removing the Hub Bolts

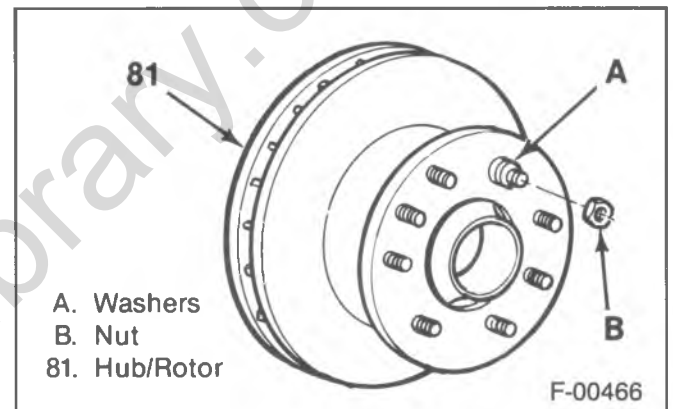

Figure 47—Installing the Hub Bolts

NOTICE: The machined surface of the spindle must not be damaged by vise jaws.

3. Spindle components.
 - Secure the spindle in a vise by locating on the high step diameter.

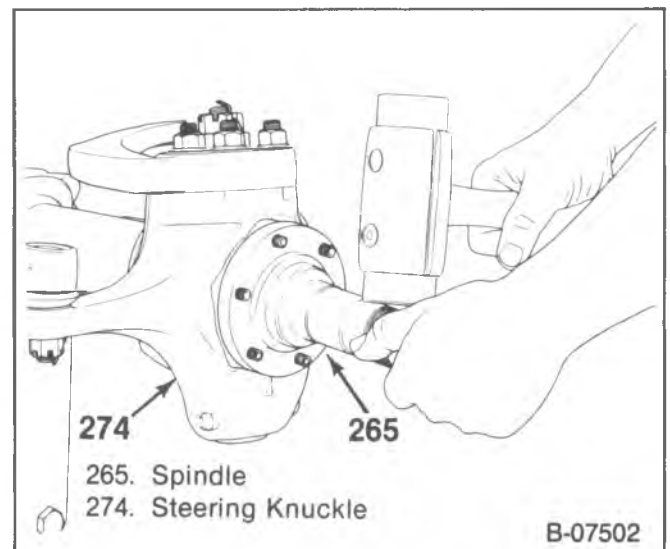

Figure 48—Removing the Spindle

3C-44 FRONT SUSPENSION

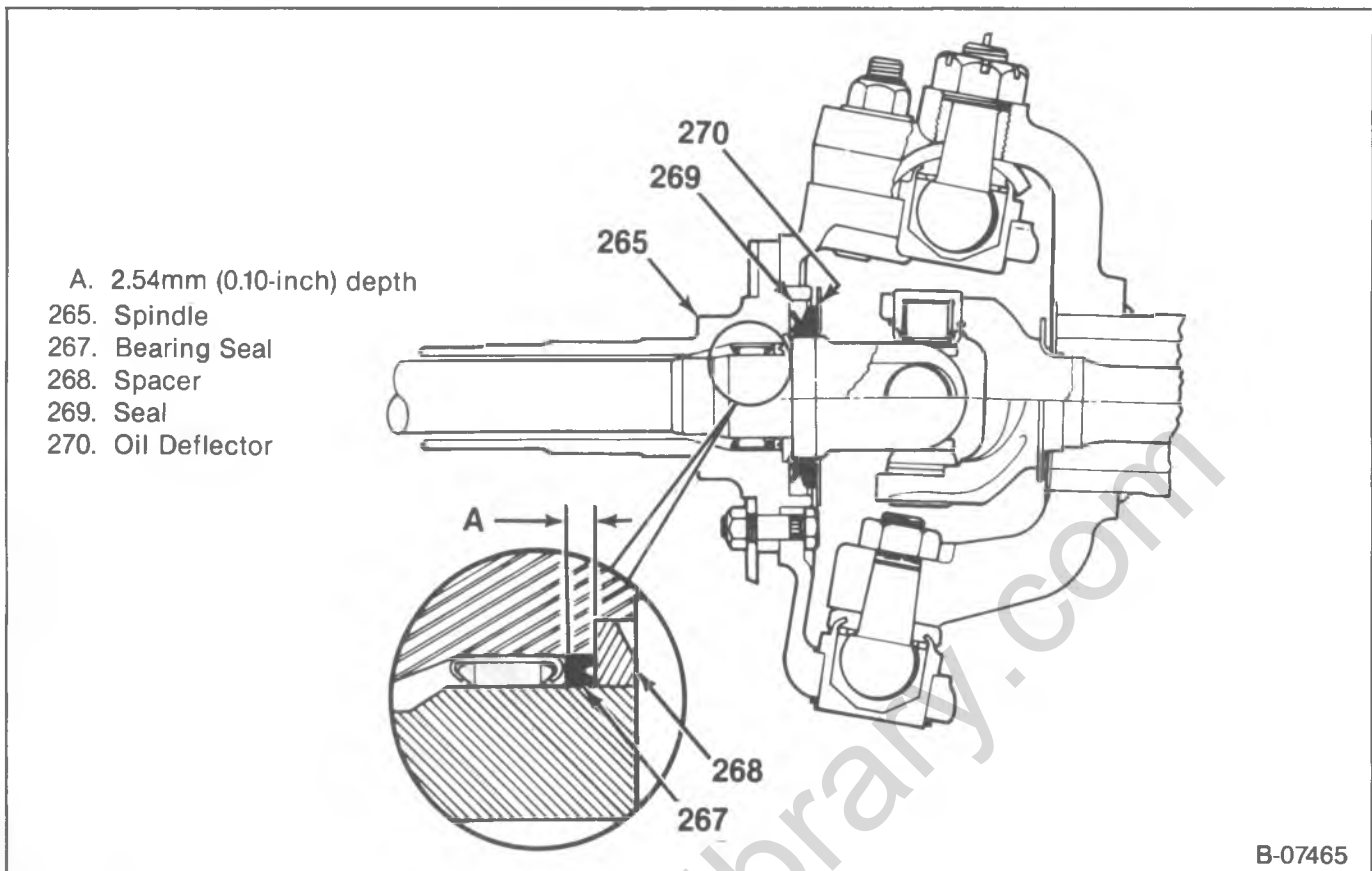

Figure 49—Spindle Components

- Bearing seal (267) and shaft bearing (266) (figure 49).
- Spacer (268), seal (269), and oil deflector (270) from the axle shaft (figure 49).

Inspect

- Spacer (268). Replace if it is worn.
- Spindle (265) for any heat burns, scoring, or wear. Replace if necessary.

Install or Connect (Figures 39, 40, 49 and 50)

Tools Required:

- J-23445-A Needle Bearing Installer (V10/1500-20/2500 models)
- J-8092 Driver Handle
- J-21465-17 Bearing Installer (V30/3500 models)

- Relubricate the shaft bearing (266) and the spindle (265) with a high melting point type wheel bearing grease. Refer to MAINTENANCE AND LUBRICATION (SEC. 0B).
1. Shaft bearing (266) and bearing seal (267) into the spindle (265) (figure 47).
 - For V10/1500-20/2500 models, use J-8092 and J-23445-A.
 - For V30/3500 models, use J-8092 and J-21465-17.
 2. Oil deflector (270) and seal (269) onto the axle shaft.
 - Seal (269) onto the oil deflector (270) with the deflector lip toward the spindle (265).
 3. Spacer (268) onto the axle shaft.
 - The chamfer points toward the oil deflector (270) (figure 50).

4. Spindle (265) onto the steering knuckle (274).
 - Slide the spindle over the axle shaft until it seats on the steering knuckle. The bolts (278) must protrude through the spindle.

NOTICE: Refer to "Notice" on page 3C-1 of this section.

5. Bracket (264) and plate (263).
 - Only the V30/3500 models use a bracket (264).

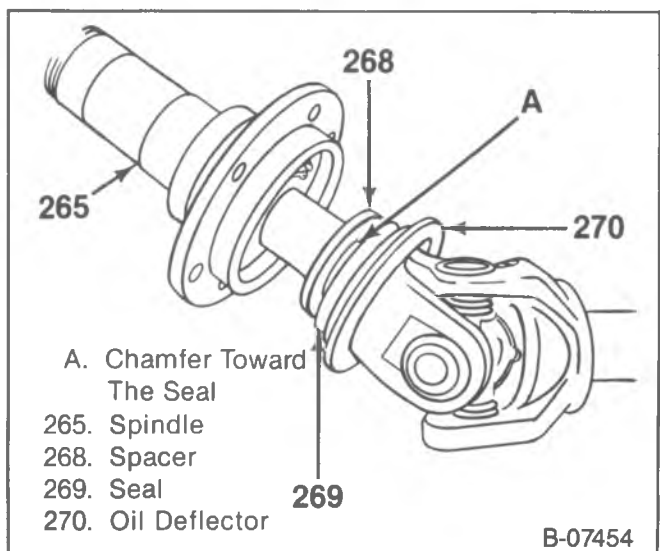

Figure 50—Installing the Spindle

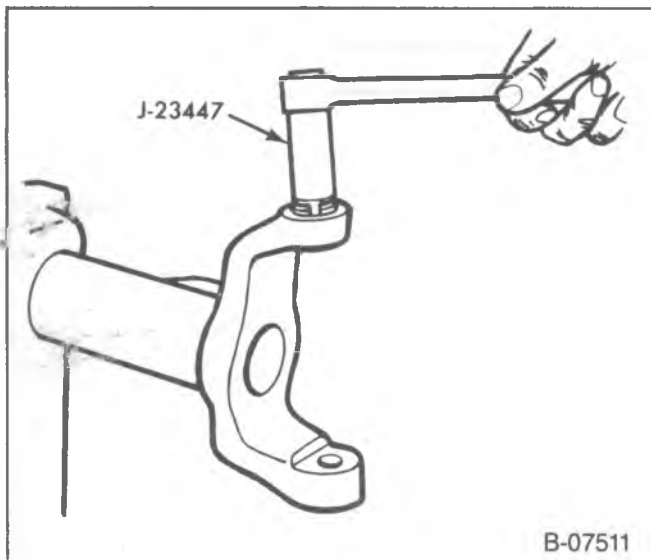

Figure 51—Tightening the Adjusting Ring

- Washers (262) (V30/3500 models only) and NEW nuts (261).

Tighten

- Nuts (261) to 88 N·m (65 ft. lbs.).
6. Wheel hub/rotor assembly.
 - Refer to "Wheel Hub/Rotor Assembly," in this section.
 7. Wheel and tire. Lower the vehicle to the ground.

STEERING KNUCKLE AND ARM

V10/1500-20/2500 MODELS (WITH BALL JOINTS)

Remove or Disconnect (Figures 39, 40, and 51)

- Raise the vehicle and support with suitable safety stands. Remove the tire and wheel assembly.
1. Locking hub assembly (249).
 - Refer to FRONT AXLE (SEC. 4C).
 2. Wheel hub/rotor assembly.
 - Refer to "Wheel Hub/Rotor Assembly," in this section.
 3. Spindle (265) from the steering knuckle (274).
 - Refer to "Spindle," in this section.
 4. Tie rod from the steering arm (297).
 - Refer to STEERING LINKAGE (SEC. 3B1).
 5. Steering arm (297) from the steering knuckle (274).
 - Nuts (295) and adapters (296).
 - Discard the nuts (295).

NOTICE: Do not remove the adjusting ring (300) unless new ball joints are being installed. If it is necessary to loosen the ring to remove the knuckle, do not loosen it more than two threads. Use J-23447 (figure 51). The nonhardened threads in the yoke can be easily damaged by the hardened threads in the adjusting ring if caution is not used during knuckle removal.

6. Steering knuckle (274) from the axle yoke.
 - Cotter pin (298), nuts (292, 299).

- Insert a wedge-shaped tool between the lower ball joint (293) and the yoke. Tap on the tool to release the knuckle assembly.
- Insert the wedge-shaped tool between the upper ball joint (294) and the yoke. Tap on the tool to release the knuckle assembly.

NOTICE: For steps 2, 3, 4, 6 and 7, refer to "Notice" on page 3C-1 of this section.

Install or Connect (Figure 39, 40 and 51)

Tools Required:

J-23447 Ball Stud Nut Wrench

1. Steering knuckle (274) to the axle yoke.
 - Ball joints (293, 294) into their respective sockets in the axle yoke.
 - Finger tighten the nuts (292, 299) onto the ball joints (293, 294). The nut with the cotter pin slot goes with the upper ball joint.
2. Push up on the steering knuckle [to keep the ball joint (293) from turning in the knuckle] and partially torque the lower ball joint nut (292).

Tighten

- Nut (292) to 40 N·m (30 ft. lbs.).
3. Torque the adjusting ring (300).
 - Use J-23447 (figure 48).

Tighten

- Adjusting ring (300) to 70 N·m (50 ft. lbs.).
4. Torque the upper ball joint nut (299).

Tighten

- Nut (299) to 135 N·m (100 ft. lbs.).
5. Cotter pin (298) into the nut (299).
 - Do not loosen the nut. Apply additional torque, if necessary, to line up the hole in the ball joint with the slot in the nut.
 6. Apply the final torque to the lower ball joint nut (292).

Tighten

- Nut (292) to 95 N·m (70 ft. lbs.).
7. Steering arm (297) to the steering knuckle (274).
 - Adapters (296) and NEW nuts (295).

Tighten

- Nuts (295) to 120 N·m (90 ft. lbs.).
8. Tie rod to the steering arm (297).
 - Refer to STEERING LINKAGE (SEC. 3B1).
 9. Spindle (265) to the steering knuckle (274).
 - Refer to "Spindle," in this section.
 10. Wheel hub/rotor assembly.
 - Refer to "Wheel Hub/Rotor Assembly," in this section.
 11. Adjust the wheel bearings.
 - Refer to "Wheel Bearing Adjustment," in this section.
 12. Locking hub assembly (249).
 - Refer to FRONT AXLE (SEC. 4C).
 13. Wheel and tire assembly.
 14. Check the front end alignment.
 - Refer to FRONT END ALIGNMENT (SEC. 3A).
 15. Lower the vehicle to the ground.

3C-46 FRONT SUSPENSION

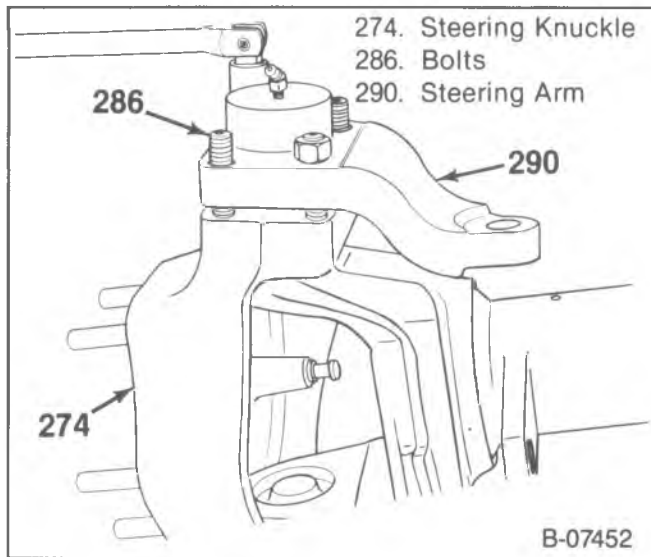

Figure 52—Removing the Cap and Steering Arm Fasteners

V30/3500 MODELS (WITH KING PINS)

↔ Remove or Disconnect (Figures 39, 40, and 52 through 55)

Tools Required:

J-26871 King Pin Socket

- Raise the vehicle and support with suitable safety stands. Remove the tire and wheel assembly.
1. Locking hub (249).
 - Refer to FRONT AXLE (SEC. 4C).
 2. Wheel hub/rotor assembly.
 - Refer to "Wheel Hub/Rotor Assembly," in this section.
 3. Spindle (265).
 - Refer to "Spindle," in this section.
 4. Upper cap (273) and/or steering arm (290).
 - For the cap, remove the bolts (271) and washers (272) alternately as the compression spring will force the cap up.

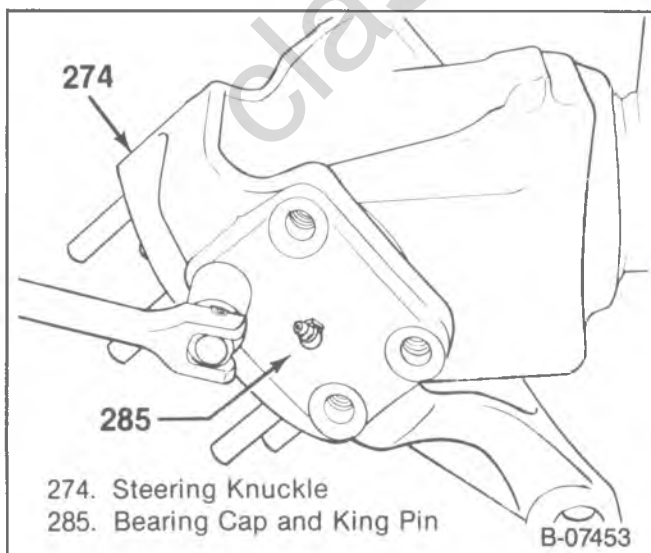

Figure 53—Removing the Lower Bearing Cap and King Pin

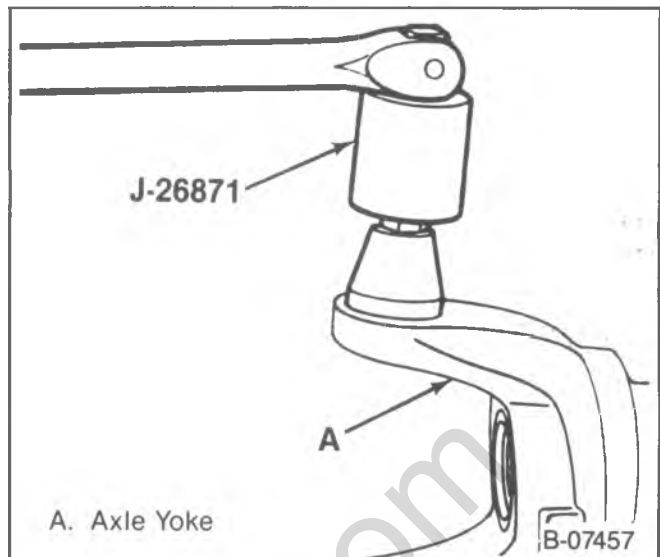

Figure 54—Removing the Upper King Pin

- For the steering arm, remove the nuts (291) alternately as the compression spring will force the steering arm up (figure 52).
5. Gasket (289), and compression spring (288).
 - Discard the old gasket (289).
 6. Lower bearing cap and king pin (285).
 - Bolts (271) and washers (272) (figure 53).
 7. Upper king pin bushing (287).
 - Pull it out through the steering knuckle (274).
 8. Steering knuckle (274) from the axle yoke.
 - Seal (301).
 9. Upper king pin (279) from the axle yoke.
 - Use a large breaker bar and J-26871 (figure 54).
 - Apply 677–813 N·m (500–600 ft. lbs.) of torque to break the king pin free.
 10. Retainer (281), race (282), bearing (283) and the seal (284) from the axle yoke.
 - Punch all the components out at once (figure 55).
 - Discard the old seal (284).
 - If the retainer (281) is damaged, discard it.

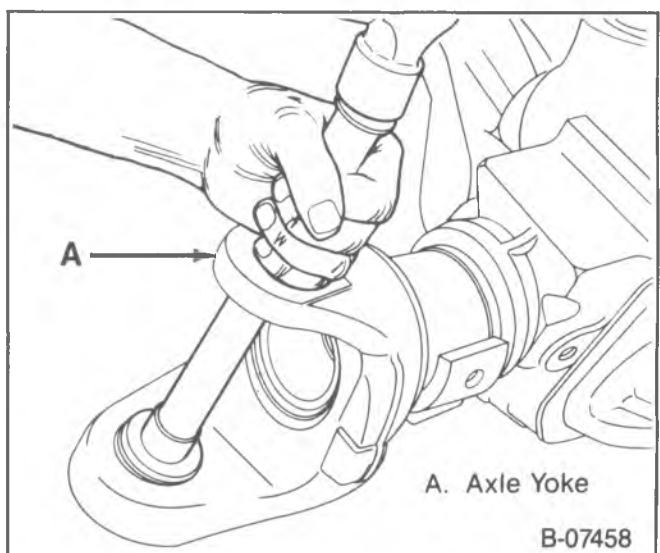

Figure 55—Removing the Retainer, Race, Bearing and the Seal

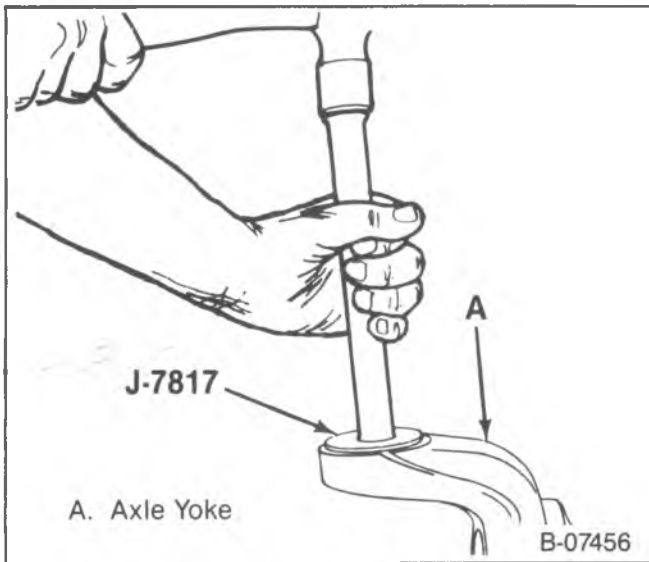

Figure 56—Installing the Retainer

NOTICE: For steps 4, 6, 7, refer to "Notice" on page 3C-1 of this section.

⇔ Install or Connect (Figures 40, 41 and 56 through 58)

Tools Required:

- J-7817 Front Pinion Bearing Installer
- J-22301 King Pin Bearing Seal Installer
- J-28871 King Pin Installer

1. Retainer (281) and the race (282).
 - Use a new retainer.
 - Use J-7817 (figure 56).
2. Fill the area in the retainer (281) and race with an approved high temperature bearing lubricant. Grease the bearing (282).
 - Use a cone-type grease packer that forces grease into the bearing.
 - If a cone-type grease packer is not available, pack the bearing by hand. Work the grease between the rollers, cones, and cage.

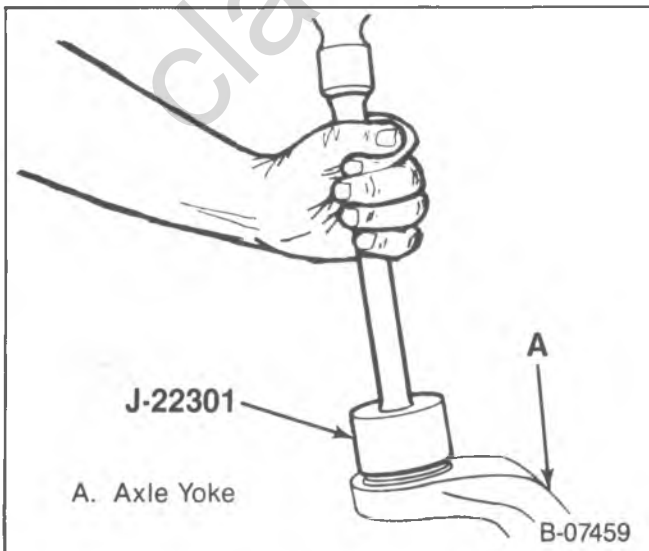

Figure 57—Installing the Seal

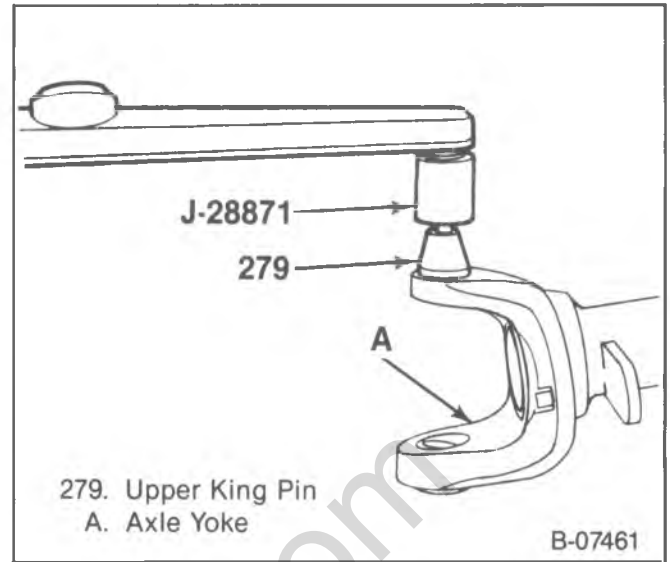

Figure 58—Installing the Upper King Pin

NOTICE: Failure to completely pack the bearing (cones, rollers, and cage) with grease will result in premature bearing damage and/or wear.

- Refer to MAINTENANCE AND LUBRICATION (SEC. 0B).
- 3. Bearing (283) and seal (284).
 - Use J-22301 to install the NEW seal (Figure 57).
 - Do not distort the seal. It will protrude slightly from the surface of the axle yoke flange when fully seated.
- 4. Upper king pin (279).
 - Use J-28871 (figure 58).

 Tighten

- King pin (279) to 745 N·m (550 ft. lbs.).
- 5. Steering knuckle (274) and bushing (287).
 - Felt seal (280) to the king pin (279) through the steering knuckle.
 - Knuckle onto the king pin (279).
 - Place the bushing (287) over the king pin (279).
- 6. Bearing cap and king pin (285) to the steering knuckle (278).
 - 4 bolts (271) and washers (272).

 Tighten

- Bolts (271) alternately and evenly to 108 N·m (80 ft. lbs.).
- 7. Steering arm (290) to the steering knuckle (274).
 - Compression ring (288), gasket (289), and steering arm (290).
 - Nuts (291).

 Tighten

- Nuts (291) alternately and evenly to 108 N·m (80 ft. lbs.).
- 8. Spindle (265).
 - Refer to "Spindle," in this section.
- 9. Wheel hub/rotor assembly.
 - Refer to "Wheel Hub/Rotor Assembly," in this section.
- 10. Adjust the wheel bearings.

3C-48 FRONT SUSPENSION

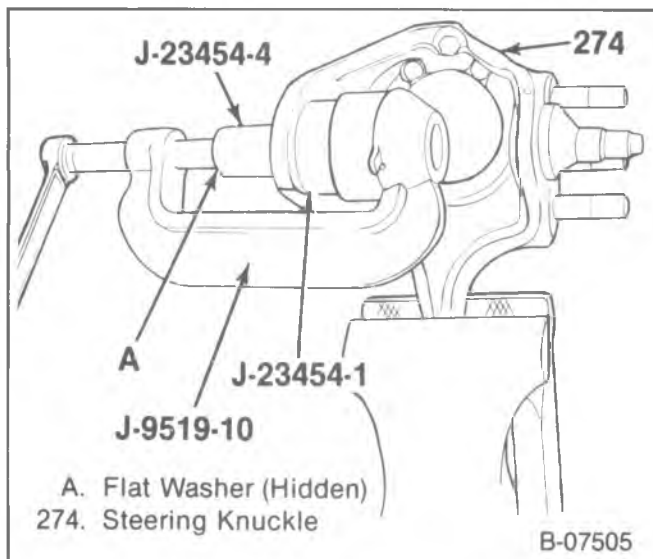

Figure 59—Removing the Lower Ball Joint

- Refer to "Wheel Bearing Adjustment" in this section.
- 11. Locking hub (249).
 - Refer to FRONT AXLE (SEC. 4C).
- 12. Wheel and tire assembly.
- 13. Check the front end alignment.
 - Refer to FRONT END ALIGNMENT (SEC. 3A).
- 14. Lower the vehicle to the ground.

BALL JOINTS (V10/1500-20/2500 MODELS ONLY)

↔ Remove or Disconnect (Figures 39, 40, 59 and 60)

Tools Required:

- J-9519-10 Ball Joint Fixture
- J-23454-1 Lower Ball Joint Spacer
- J-23454-3 or
- J-6382 Upper Ball Joint Spacer
- J-23454-4 Upper and Lower Ball Joint Sleeve

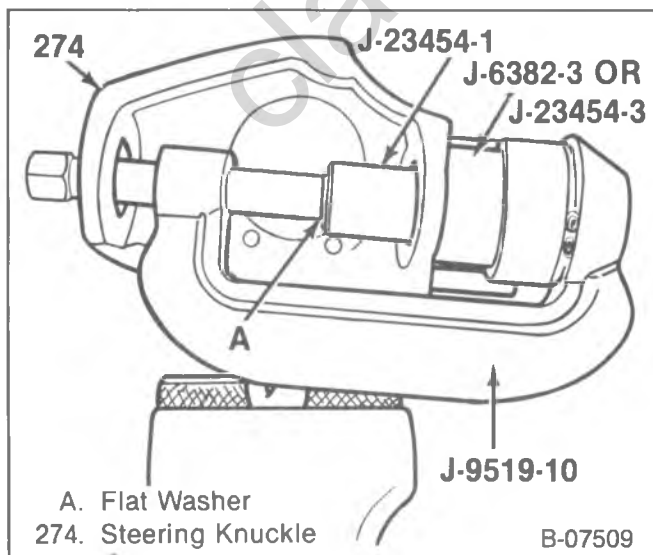

Figure 60—Removing the Upper Ball Joint

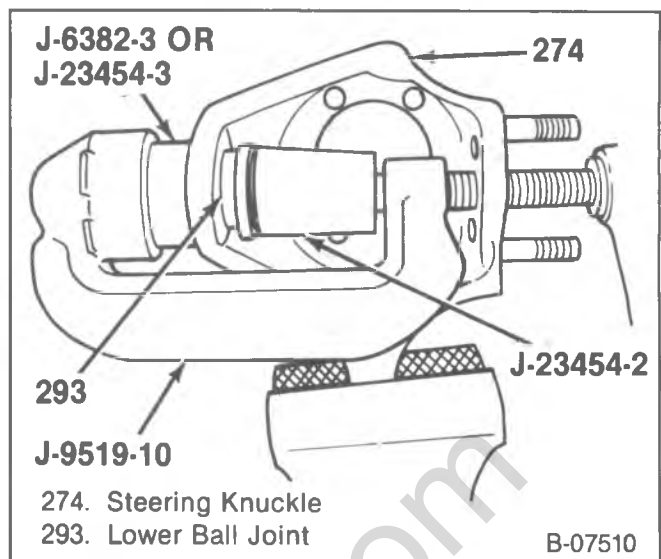

Figure 61—Installing the Lower Ball Joint

- Raise the vehicle and support with suitable safety stands. Remove the wheel and tire assembly.
- 1. Wheel hub/rotor assembly.
 - Refer to "Wheel Hub/Rotor Assembly," in this section.
- 2. Spindle.
 - Refer to "Spindle," in this section.
- 3. Steering knuckle (274) and steering arm (290).
 - Remove the steering arm (290) only if removing the left axle yoke ball joints.
 - Refer to "Steering Knuckle and Arm," in this section.
 - Place the steering knuckle in a vise (figure 59).
- 4. Lower ball joint (293).
 - Must be removed before any service can be done to the upper ball joint (294).
 - Snap ring from the lower ball joint (293).
 - Use J-9519-10, J-23454-1, J-23454-4 or equivalent (figure 59). Tighten until the ball joint breaks free of the steering knuckle.
- 5. Upper ball joint (294).
 - Use J-9519-10, J-23454-3 (or J-6382-3) and J-23454-4 (figure 60). Tighten until the ball joint breaks free of the steering knuckle.

↔ Install or Connect (Figures 39, 40, 61 and 62)

Tools Required:

- J-9519-10 Ball Joint Fixture
- J-23454-2 Upper and Lower Ball Joint Sleeve
- J-23454-3 or
- J-6382-3 Upper and Lower Ball Joint Spacer
- 1. Lower ball joint (293) into the steering knuckle (274).
 - The ball joint (no cotter pin hole in the threaded end) must be positioned straight.
 - Use J-9519-10, J-23454-2, and J-23454-3 or J-6382-3 (figure 61). Tighten until the ball joint fully seats.
 - Snap ring in position.
- 2. Upper ball joint (294) into the steering knuckle (274).
 - Use J-9519-10, J-23454-2, and J-23454-3 or J-6382-3 (figure 62). Tighten until the ball joint fully seats.
- 3. Steering arm (290) and steering knuckle (274).

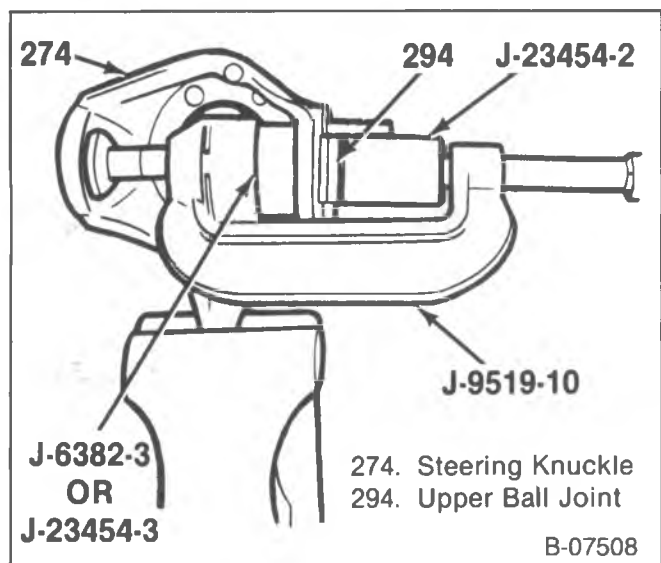

Figure 62—Installing the Upper Ball Joint

- Steering arm only if removed.
 - Refer to "Steering Knuckle and Arm," in this section.
4. Spindle (265).
 - Refer to "Spindle," in this section.
 5. Wheel hub/rotor assembly.
 - Refer to "Wheel Hub/Rotor Assembly," in this section.
 6. Adjust the wheel bearings.
 - Refer to "Wheel Bearing Adjustment," in this section.
 7. Wheel and tire assembly.
 8. Check the front end alignment.
 - Refer to FRONT END ALIGNMENT (SEC. 4C).
 9. Lower the vehicle to the ground.

LEAF SPRING AND BUSHINGS

↔ Remove or Disconnect (Figures 39, 40, and 63)

- Raise the vehicle on a hoist and support the front axle with a floor jack. Raise the floor jack until all tension is relieved from the springs.
1. Spring (221) from the frame.
 - Nut (218), washer (217), shackle (202), bolt (201), bushings (203) and spacer (216) (figure 61).
 2. Spring (221) from the hanger (241).
 - Nut (239), washers (240), and bolt (242) (figure 61).
 3. Spring (221) from the axle.
 - For V10/1500–20/2500 and the left side of V30/3500 models, remove nuts (222), washers (223), U-bolts (227), plate (224) and the spacers (226).
 - For the right side of V30/3500 models, remove the bolts (248), nuts (222), washers (223), U-bolt (227), plate (224) and the spacers (226) (figure 63).
 4. Shackle (202) from the spring (221).
 - Nut (218), washer (217), bolt (201), bushings (203) and spacer (216) (figure 63).
 5. Bushing from the spring eye.

- Place the spring in a press and press out the bushing using a suitable rod, pipe, or tool.

↔ Install or Connect (Figures 39, 40, 63 and 64)

1. Bushing into the spring eye.
 - Press in a new bushing, making sure the tool presses on the steel outer shell of the bushing.
 - Bushing must protrude an equal amount on either side of the spring eye when properly installed.
2. Shackle (202) into the spring (221).
 - Spacer (216), bushings (203), washers (217), bolt (201) and nut (218).
 - Do not tighten.
3. Upper spacer (226) onto the spring (221).
4. Spring into the hanger (241).
 - Bolt (242), washers (240) and nut (239).
 - Do not tighten.
5. Spring into the frame.
 - Bushings (203) and the spacer (216) into the frame.
 - Shackle (202) into position and attach bolt (201), washer (217) and nut (218).
 - Do not tighten.

NOTICE: Refer to the "Notice" on page 3C-1 of this section.

6. Spring to the axle.
 - For V10/1500–20/2500 models and the left side of V30/3500 models, attach the lower spacer (226), plate (224), U-bolts (227), washers (223) and nuts (222) (figure 63).
 - For the right side of V30/3500 models, attach the lower spacer (226), plate (224), U-bolt (227), washers (223), bolts (248) and nuts (222) (figure 63).

⊠ Tighten

- Nuts (222) and bolts (248) in sequence (2-4-1-3) to 203 N·m (150 ft. lbs.) (figure 64).
6. Torque the spring to frame and hanger fasteners.
 - Nuts (239) to 122 N·m (90 ft. lbs.).
 - Nuts (218) to 68 N·m (50 ft. lbs.).
 7. Lower the floor jack, and lower the vehicle to the ground.

3C-50 FRONT SUSPENSION

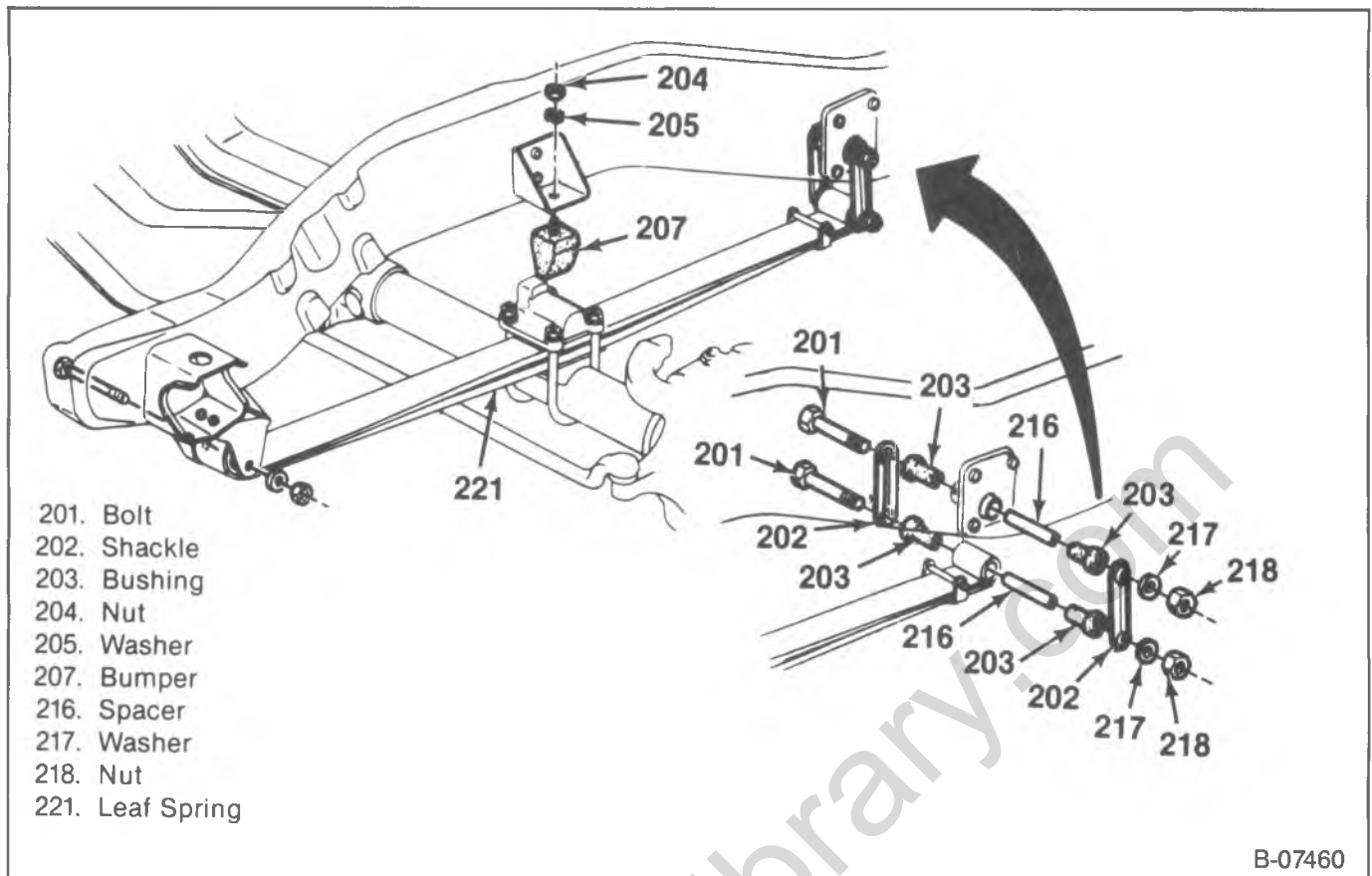

Figure 63—Leaf Spring Attaching Parts

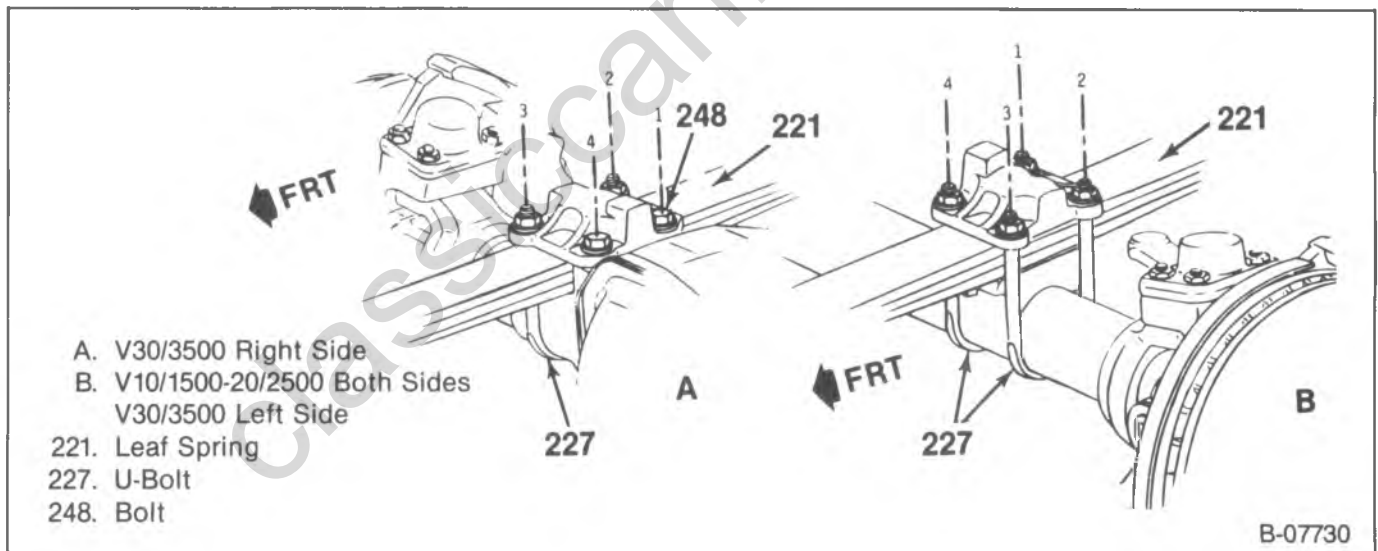

Figure 64—U-Bolt Tightening Order

SPECIFICATIONS

ENDPLAY

R-G-P Models	0.03-0.13 mm (0.0012-0.005 inches)
V Models	0.025-0.25 mm (0.001-0.010 inches)
P Motorhome w/FS3	0.013-0.20 mm (0.0005-0.008 inches)

FASTENER TORQUE

INDEPENDENT FRONT SUSPENSION

	N·m	Ft. Lbs.
R and P Models		
Shock Absorber to Frame	190	140
Shock Absorber to Lower Control Arm	80	59
Stabilizer to Frame	33	24
Stabilizer to Lower Control Arm	33	24
Steering Knuckle to Upper Ball Joint		
R10/1500	68	50
All Other Models	122	90
Steering Knuckle to Lower Ball Joint	122	90
Ball Joint Cotter Pin Alignment		
R10/1500 Upper Ball Joint — Maximum	122	90
All Other Ball Joints — Maximum	176	130
Splash Shield to Knuckle	13	10
Lower Control Arm Bushings (Exc. R10/1500)	379	280
Lower Pivot Shaft End Nuts (R10/1500 only)	95	70
Lower Pivot Shaft U-Bolt Nuts	115	85
Upper Control Arm Bushings (Exc. R10/1500)	257	190
Upper Pivot Shaft End Nuts (R10/1500 only)	156	115
Upper Pivot Shaft Thru-Bolt Nuts		
R10/1500	95	70
All Other Models	142	105
Upper Bolt Joint to Upper Control Arm	25	18
Crossmember to Bottom Frame Rail		
Motorhome	291	215
Van Models with JF9	176	130
All Other Models	122	90
Crossmember to Frame Side Rails		
P Models with JF9	135	100
All Other Models	88	65
Suspension Bumper		
R10/1500 Models	20	15
All Other Models	26	19
Crossmember to Support Struts	81	60
G Models		
Shock Absorber to Frame	103	80
Shock Absorber to Lower Control Arm	103	80
Stabilizer to Frame	29	21
Stabilizer to Lower Control Arm	33	24
Steering Knuckle to Upper Ball Joint		
G30/3500	122	90
All Other Models	68	50
Steering Knuckle to Lower Ball Joint	122	90
Ball Joint Cotter Pin Alignment		
G10/1500 and G20/2500 Models Upper Ball Joint — Maximum ..	122	90
All Other Ball Joints — Maximum	176	130

SPECIFICATIONS (CONT.)

G Models (Cont.)	N·m	Ft. Lbs.
Splash Shield to Knuckle.....	13	10
Lower Control Arm Bushings (G30/3500 only).....	379	280
Lower Pivot Shaft End Nuts (Exc. G30/3500).....	156	115
Lower Pivot Shaft U-Bolt Nuts		
G30/3500.....	115	85
All Other Models.....	88	65
Upper Control Arm Bushings (G30/3500 only).....	258	190
Upper Pivot Shaft End Nuts (Exc. G30/3500).....	156	115
Upper Pivot Shaft Thru-Bolt Nuts		
G30/3500 Models.....	142	105
All Other Models.....	95	70
Upper Bolt Joint to Upper Control Arm.....	25	18
Crossmember to Bottom Frame Rail.....	122	90
Crossmember to Side Frame Rail.....	88	65
Suspension Bumper.....	20	15
Crossmember to Support Struts.....	81	60

I-BEAM (RPO FS3) FRONT SUSPENSION

P30 Models

















Shock Absorber to Frame.....	185	136
Shock Absorber to Axle.....	50	37
Stabilizer to Frame.....	29	21
Stabilizer to Stabilizer Link.....	68	50
Splash Shield to Anchor Plate.....	16	12
Steering Arm to Knuckle.....	312	230
Caps to Steering Knuckle.....	7	5
Lock Pin to Steering Knuckle.....	40	29
Spring to Hanger Nuts.....	125	92
Spring to Shackle Nuts.....	125	92
Spring to Axle U-Bolt Nuts.....	109	80
Shackle to Frame Nuts.....	125	92
Suspension Bumper.....	34	25

FOUR WHEEL DRIVE FRONT SUSPENSION

V Models

Shock Absorber to Frame.....	88	65
Shock Absorber to Axle.....	88	65
Stabilizer to Frame		
V30/3500.....	70	52
All Other Models.....	95	70
Stabilizer to Spring Plate.....	180	133
Steering Knuckle to Upper Ball Joint (Exc. V30/3500).....	135	100
Steering Knuckle to Lower Ball Joint (Exc. V30/3500).....	40	30
Ball Joint Cotter Pint Alignment (Exc. V30/3500)		
Upper Ball Joint — Maximum.....	176	130
Adjusting Ring to Spindle (Exc. V30/3500).....	70	50
Caps to Steering Knuckle (V30/3500 only).....	108	80
King Pin to Knuckle (V30/3500 only).....	745	550
Anchor Plate to Knuckle.....	88	65
Steering Arm to Knuckle.....	120	90
Lock Pin to Steering Knuckle.....	217	160
Spring to Hanger Nuts.....	122	90
Spring to Shackle Nuts.....	68	50
Spring to Axle U-Bolt Nuts.....	203	150
Shackle to Frame Nuts.....	68	50
Suspension Bumper.....	20	15

SPECIAL TOOLS

- | | | | | | |
|----|---|-----------|-----|--|------------|
| 1. |  | J-24435-A | 9. |  | J-9519-D |
| 2. |  | J-23448 | 10. |  | J-23742 |
| 3. |  | J-23454-D | 11. |  | J-22301 |
| 4. |  | J-26878-A | 12. |  | J-21365-17 |
| 5. |  | J-6368 | 13. |  | J-8092 |
| 6. |  | J-7817 | 14. |  | J-23447 |
| 7. |  | J-6893-D | 15. |  | J-9746-02 |
| 8. |  | J-6627-A | 16. |  | J-23028-01 |

1. Needle Bearing Installer
2. Inner Bearing Race Installer
3. Ball Joint Remover and Installer
4. Wheel Bearing Nut Wrench
5. Outer Bearing Race Installer
6. Front Pinion Bearing Installer
7. Wheel Bearing Nut Wrench
8. Wheel Stud and Tie Rod Remover

9. Ball Joint Remover and Installer
10. Ball Joint Separator
11. King Pin Bearing Seal Installer
12. Bearing Installer
13. Driver Handle
14. Ball Stud Nut Wrench
15. Hub/Rotor Support
16. Spring Remover

Tools Not Shown

- | | | | |
|------------|------------------------------|------------|---|
| A. J-8457 | Wheel Bearing Race Installer | D. J-23446 | Torque Wrench Adapter |
| B. J-8849 | Wheel Bearing Race Installer | E. J-28871 | King Pin Installer |
| C. J-29040 | Outer Bearing Race Installer | F. J-22717 | Lower Control Arm Bushing Stake Remover |

classiccarylbrary.com

SECTION 3D

REAR SUSPENSION

The following "Notice" applies to one or more steps in the assembly procedure of components in this portion of the manual as indicated at appropriate locations by the terminology "Notice: Refer to the 'Notice' on page 3D-1 of this section.

NOTICE: *These rear suspension fasteners are important attaching parts in that they could affect the performance of vital parts and systems, and/or could result in major repair expense. They must be replaced with one of the same part number or with an equivalent part if replacement becomes necessary. Do not use a replacement part of lesser quality or substitute design. Torque values must be used as specified during reassembly to assure proper retention of these parts.*

CONTENTS

<u>SUBJECT</u>	<u>PAGE</u>
General Description	3D- 1
On Vehicle Service	3D- 8
Shock Absorber Replacement	3D- 8
Stabilizer Bar Replacement	3D- 8
Leaf Spring Assembly Replacement	3D- 9
Bushing Replacement	3D-10
Specifications	3D-12

GENERAL DESCRIPTION

All 10/1500 through 30/3500 series vehicles use a leaf spring and solid rear axle suspension system (figures 1 through 7).

The rear axle assembly is attached to multi-leaf springs by U-bolts. The front ends of the springs are attached to the frame at the front hangers, through rubber bushings.

The rear ends of the springs are attached to the frame by the use of shackles which allow the springs to "change their length" while the vehicle is in motion.

Ride control is provided by two identical direct double acting shock absorbers angle-mounted between the frame and brackets attached to the axle tubes.

3D-2 REAR SUSPENSION

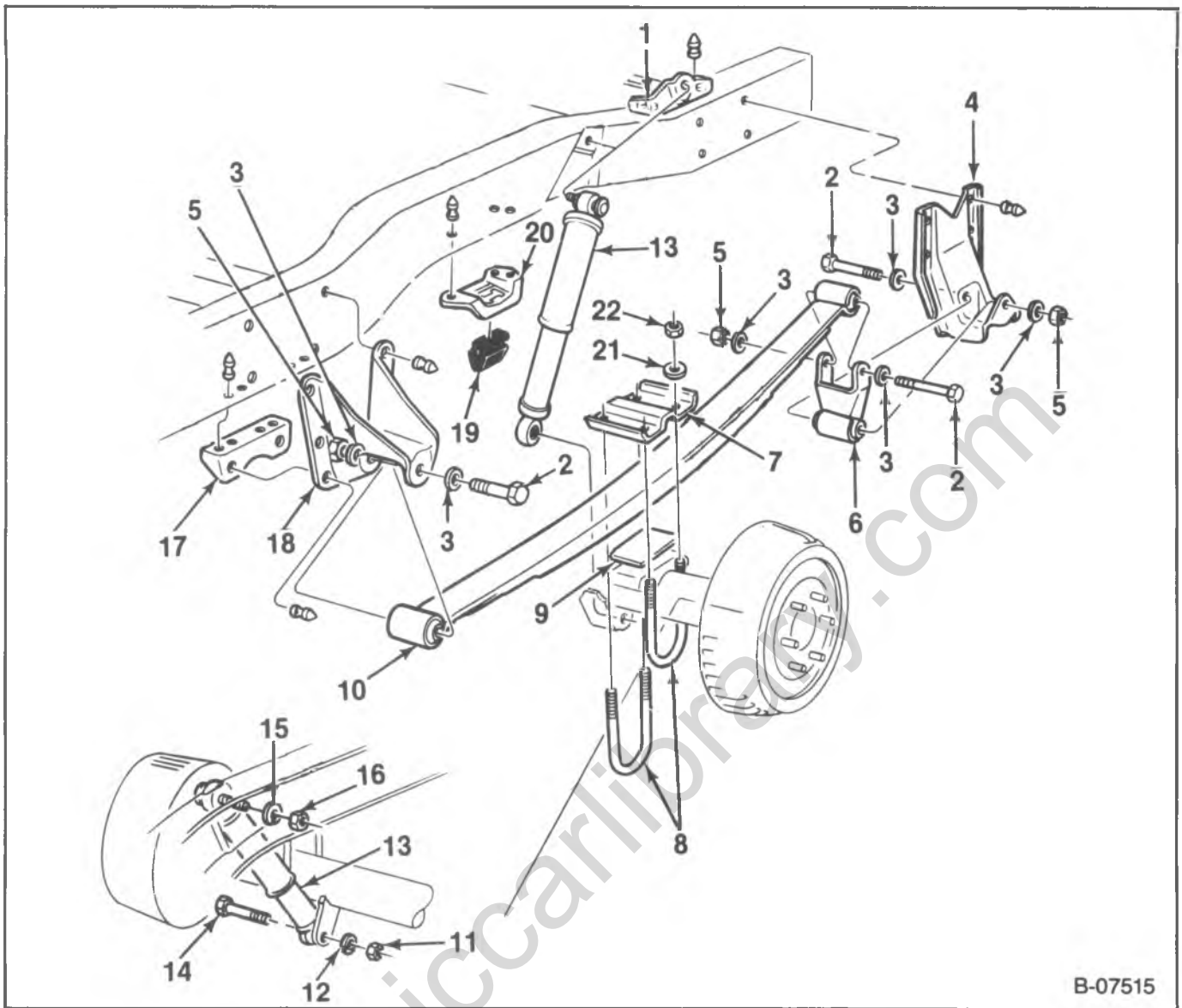

B-07515

Figure 1—Rear Suspension (R/V 10/1500, 20/2500 Pickup, Suburban, and Blazer/Jimmy)

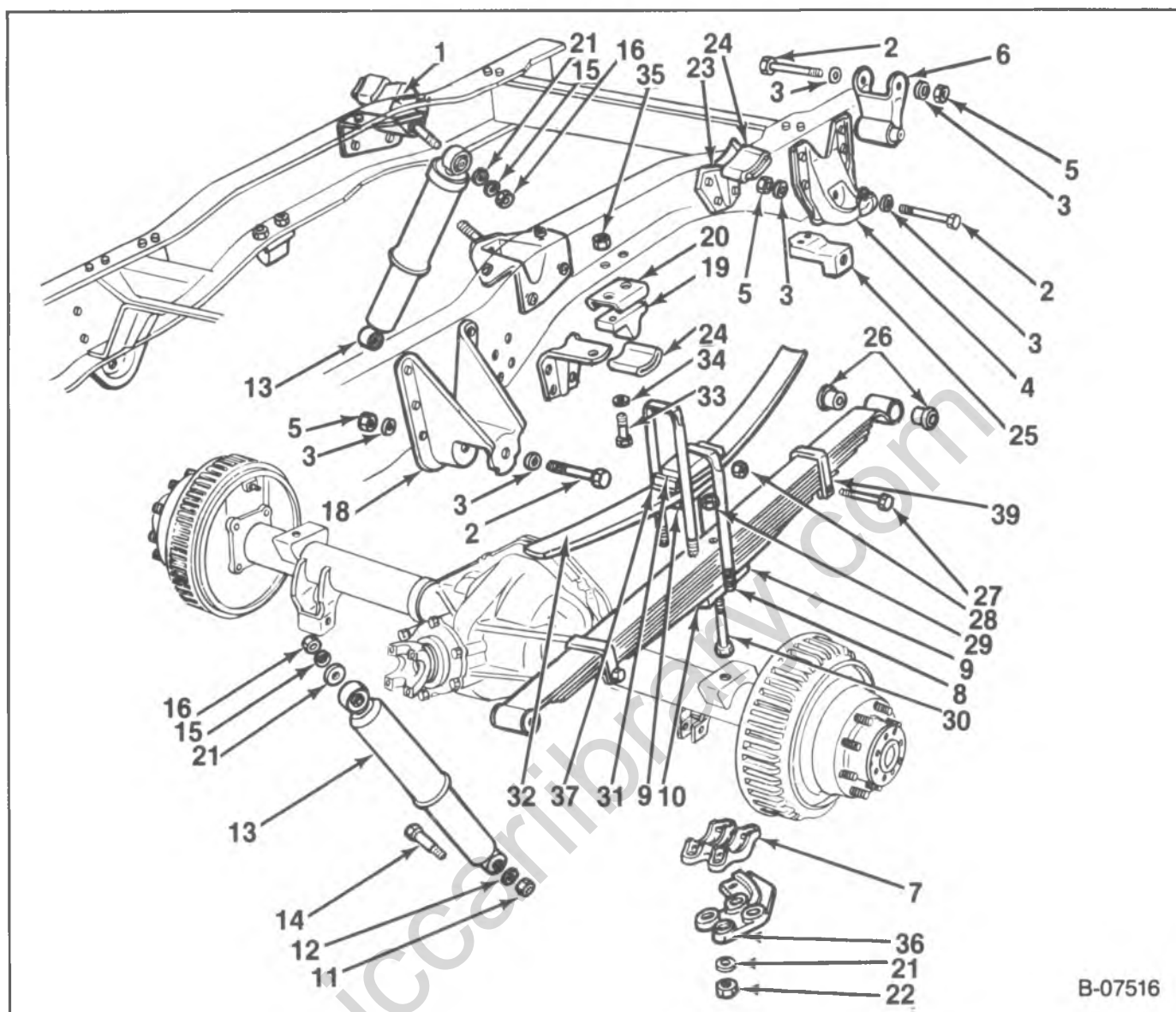

B-07516

Figure 2—Rear Suspension (R/V 30/3500 Series Vehicles)

3D-4 REAR SUSPENSION

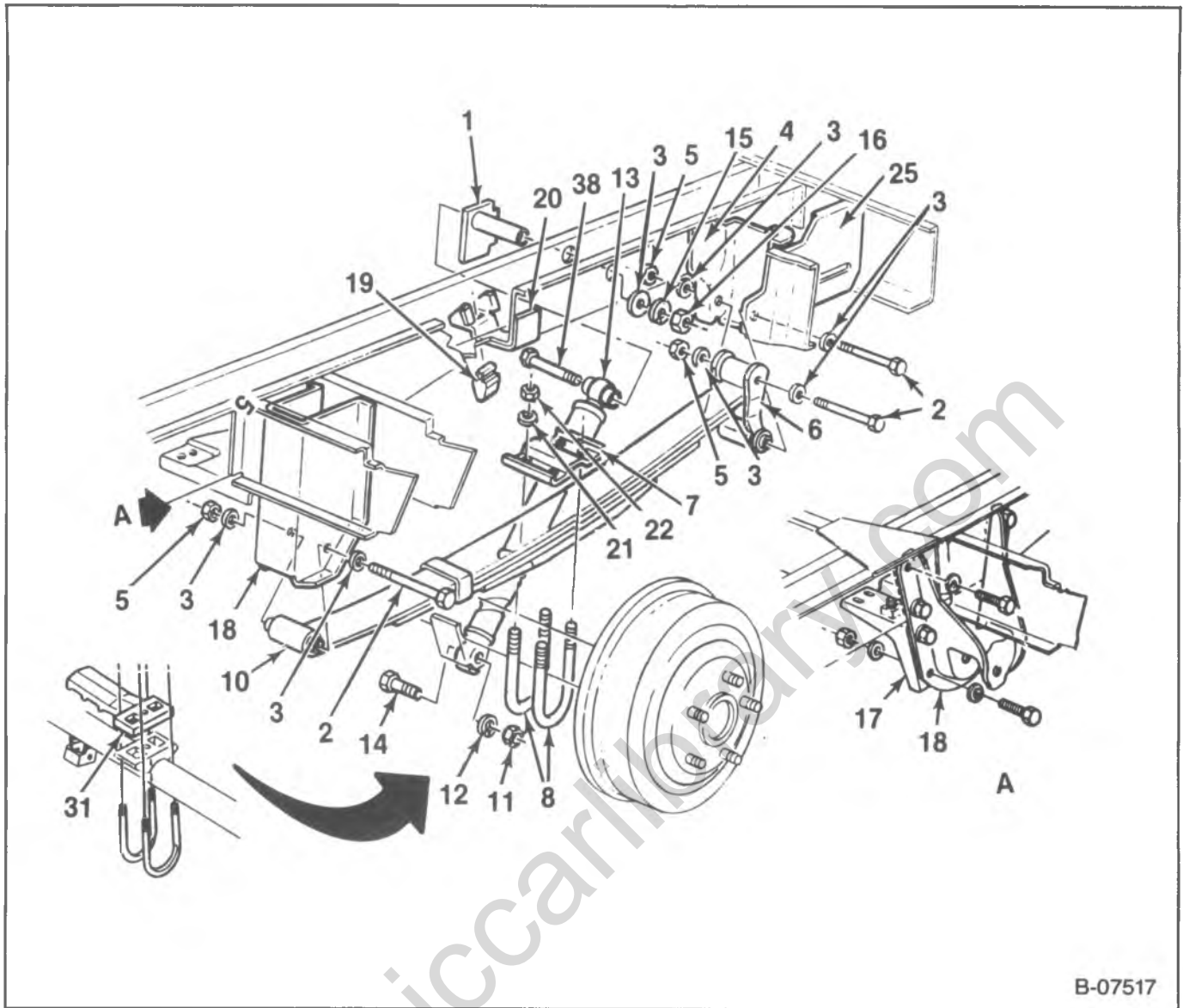
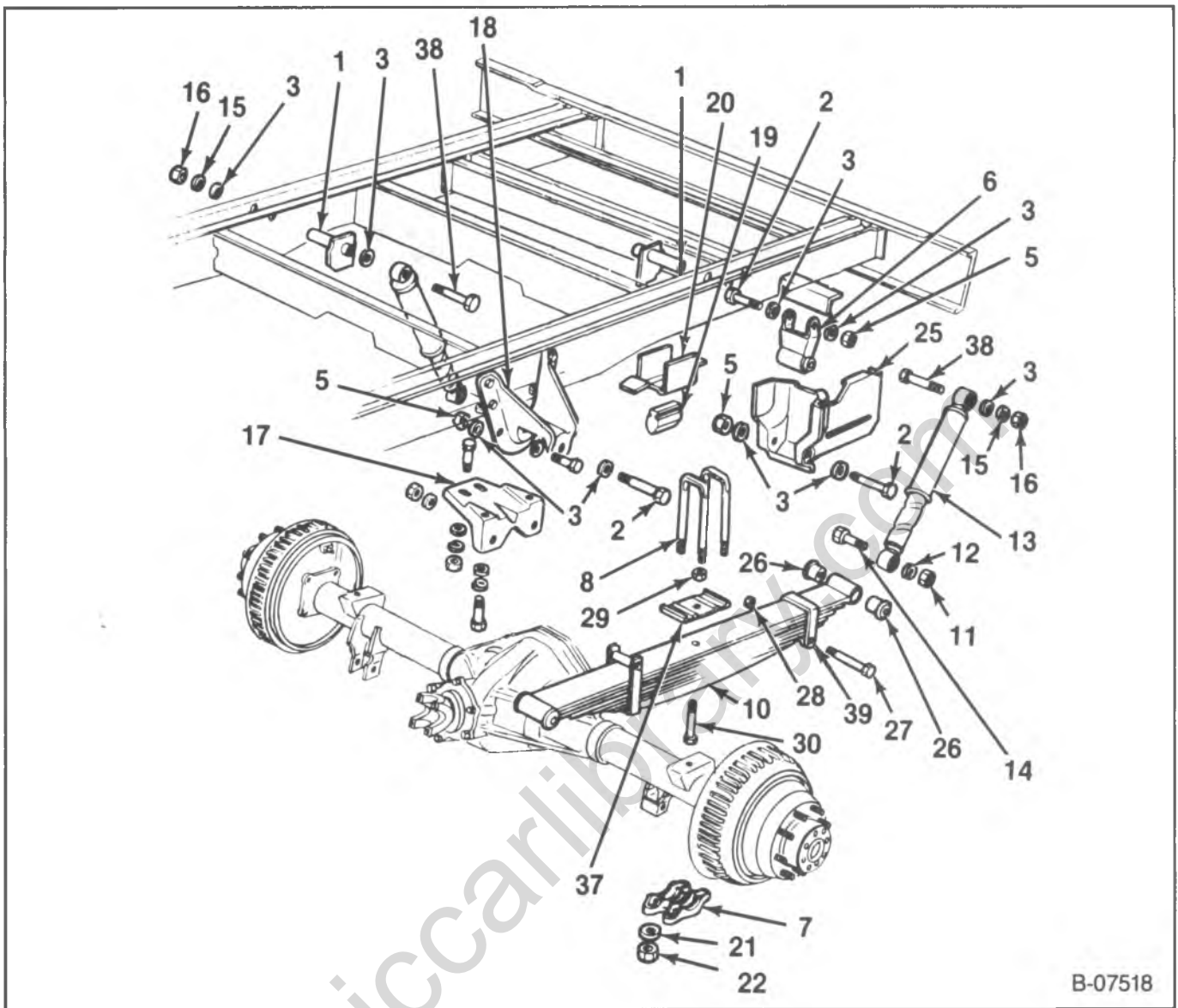

Figure 3—Rear Suspension (G 10/1500-30/3500 Series Vehicles)



B-07518

Figure 4—Rear Suspension (G30/3500 Series Cutaway Van with RPO M40)

3D-6 REAR SUSPENSION

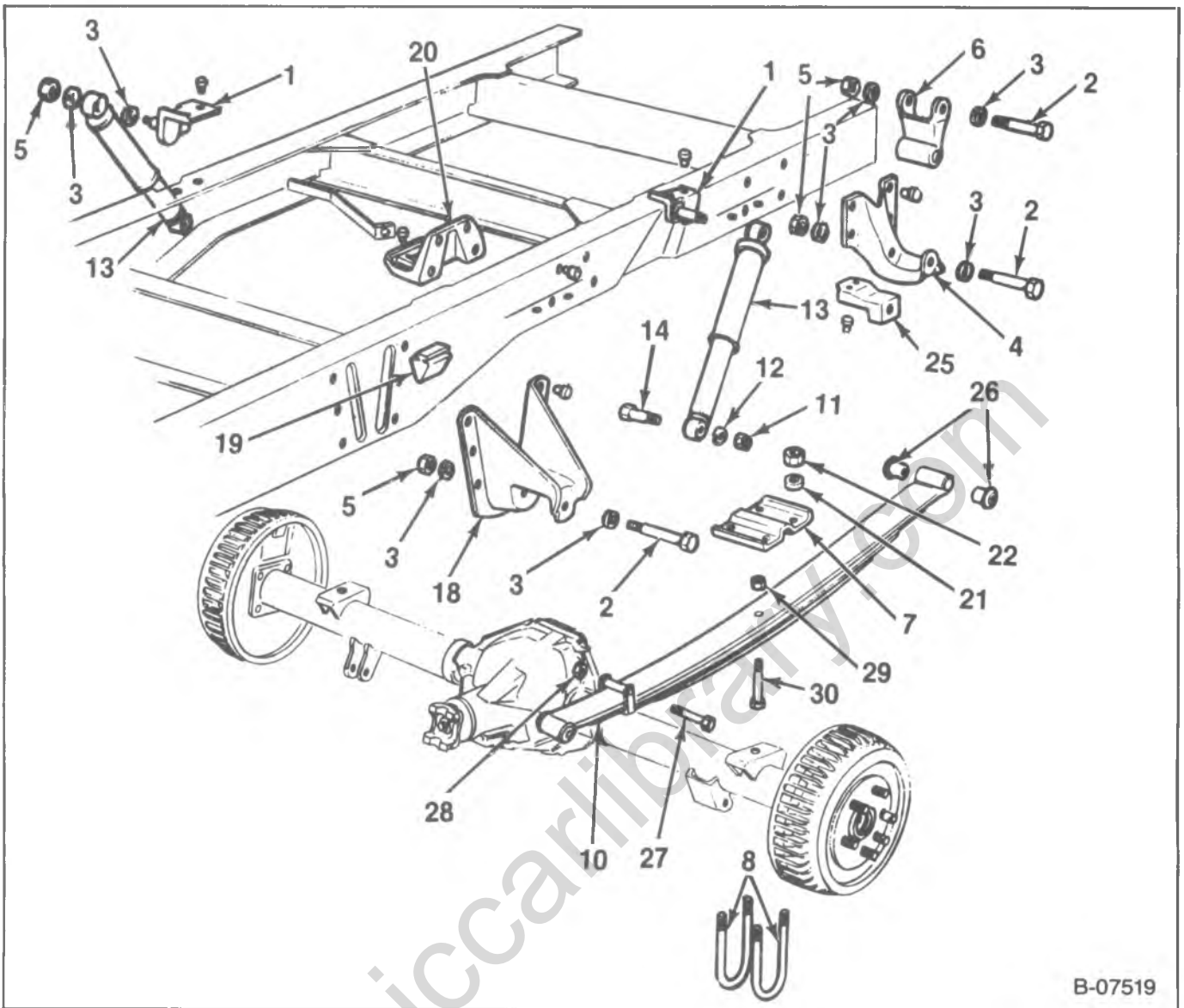

B-07519

Figure 5—Rear Suspension (P20/2500 Series Vehicles)

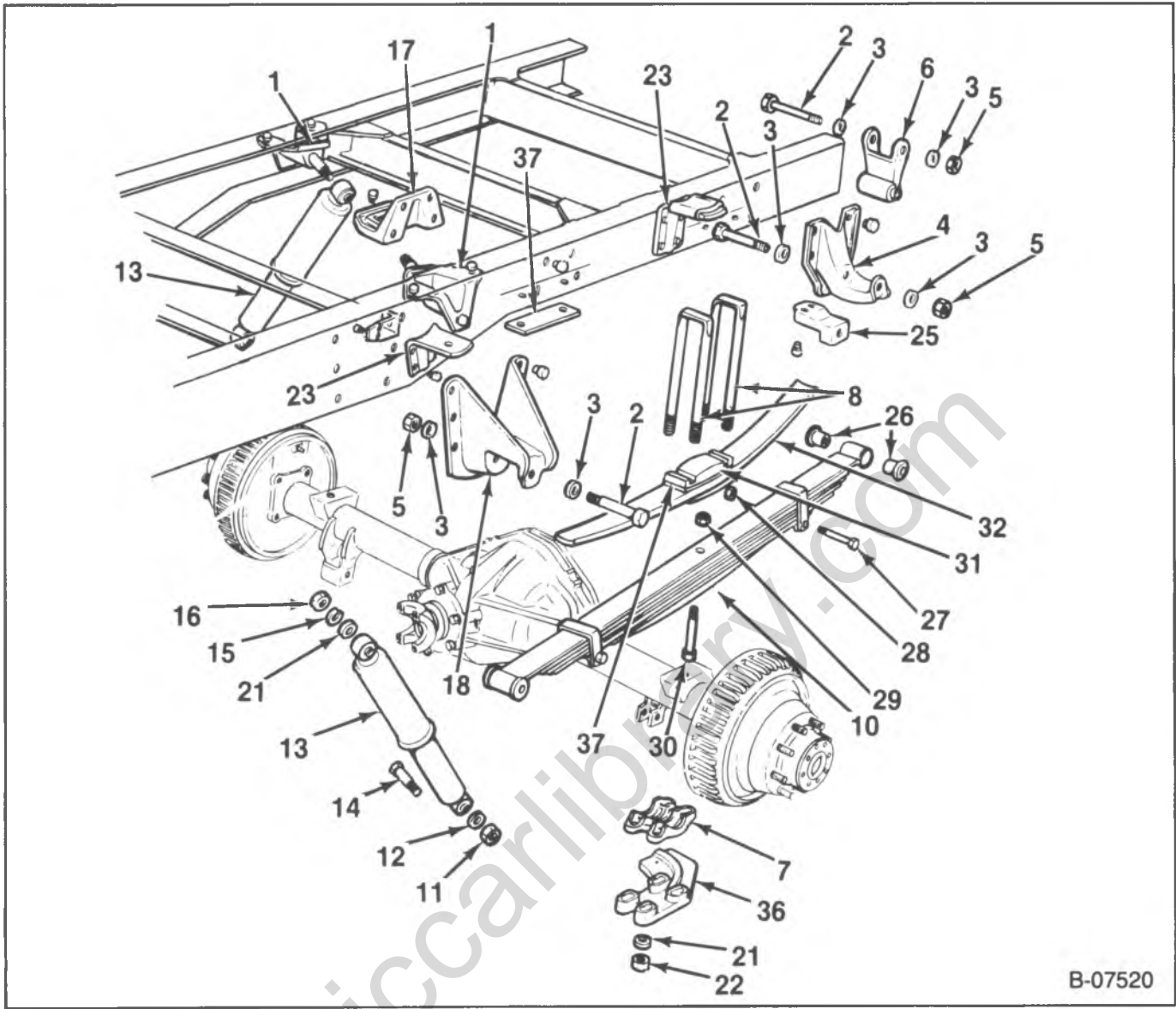

B-07520

Figure 6—Rear Suspension (P30/3500 Series Vehicles)

1. Bracket	12. Spring Lock Washer	23. Bracket	32. Optional Rear Auxiliary Spring
2. Bolt	13. Rear Shock Absorber	24. Cushion	33. Bolt
3. Washer	14. Bolt	25. Rear Hanger Reinforcement	34. Washer
4. Rear Hanger	15. Spring Lock Washer	26. Leaf Spring Eye Bushing	35. Nut
5. Nut	16. Nut	27. Bolt	36. Stabilizer Bar Anchor
6. Rear Shackle	17. Front Hanger Support	28. Nut	37. Spacer
7. Anchor Plate	18. Front Hanger	29. Nut	38. Bolt
8. U-bolt	19. Axle Bumper	30. Bolt	39. Spring Clip
9. Shim	20. Bumper Bracket	31. Spacer	
10. Leaf Spring	21. Washer		
11. Nut	22. Nut		

B-07521

Figure 7—Rear Suspension Legend

ON-VEHICLE SERVICE

SHOCK ABSORBER
REPLACEMENT

↔ Remove or Disconnect (Figures 1 through 7)

- Raise the vehicle on a hoist.
- Shock absorber (13) from the frame.
 - For R/V and P series vehicles; nut (16), spring-washer (15), and/or washer (21).
 - For G series vehicles; nut (16), spring washer (15), washer (3), and bolt (38).
 - Shock absorber (13) from the axle.
 - Nut (11), spring-washer (12), and bolt (14).
 - Pull the shock absorber free.

→ Install or Connect (Figures 1 through 7)

NOTICE: For steps 1 and 2, refer to the "Notice" on page 3D-1 of this section.

- Shock absorber (13) to the frame.
 - For R/V and P series vehicles; spring-washer (15) and/or washer (21), plus the nut (16).
 - For G series vehicles; bolt (38), washer (3), spring-washer (15), and nut (16).

⌚ Tighten

- Nuts (16) to "Specifications" at the end of this section.
- Shock absorber (13) to the axle.
 - Line shock absorber up with the axle bracket.
 - Bolt (14), spring-washer (12), and nut (11).

⌚ Tighten

- For all R/V and P series vehicles; nut (11) to 155 N·m (114 ft. lbs.).
 - For all G series vehicles; nut (11) to 102 N·m (75 ft. lbs.).
- Lower the vehicle to the ground.

STABILIZER BAR REPLACEMENT

↔ Remove or Disconnect (Figures 8, 9, and 10)

- Raise the vehicle on a hoist.
- Stabilizer bar (108) from the frame.
 - For R 30/3500 series vehicles; nut (120), and washer (116). Slide the link bolt (115) out along with the grommets (117), washers (116), and link (118).
 - For P 30/3500 series vehicles; nuts (105), washers (106), bolts (111), and the clamp (110).
 - Stabilizer bar (108) from the anchor plates (107).
 - Nuts (105), washers (106), bolts (111), and the clamps (110).
 - Insulators (109) from the stabilizer bar (108).

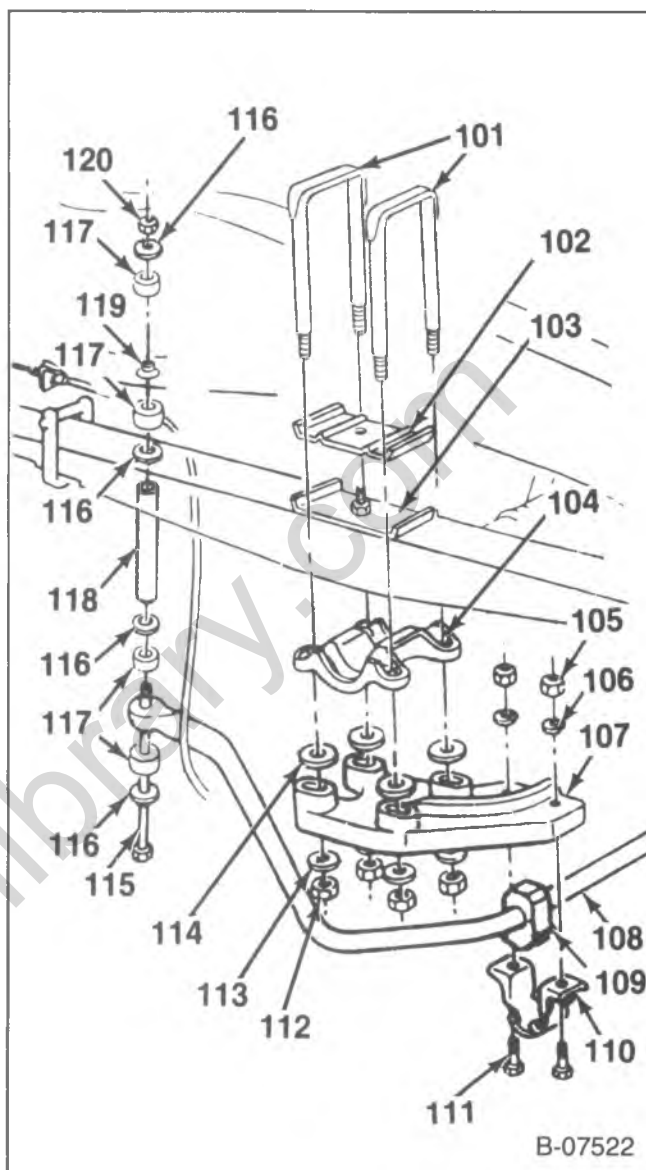

Figure 8—Rear Stabilizer Attachments
(R30/3500 Series Vehicles)

↔ Install or Connect (Figures 8, 9 and 10)

NOTICE: For steps 2 and 3, refer to the "Notice" on page 3D-1 of this section.

- Insulators (109) to the stabilizer bar (108).
- Stabilizer bar (108) to the anchor plates (107).
 - Clamps (110), bolts (111), washers (106), and nuts (105).

⌚ Tighten

- Refer to "Specifications" at the end of this section.

! Important

- Route the parking brake cable over the stabilizer bar.
- Stabilizer bar (108) to the frame.

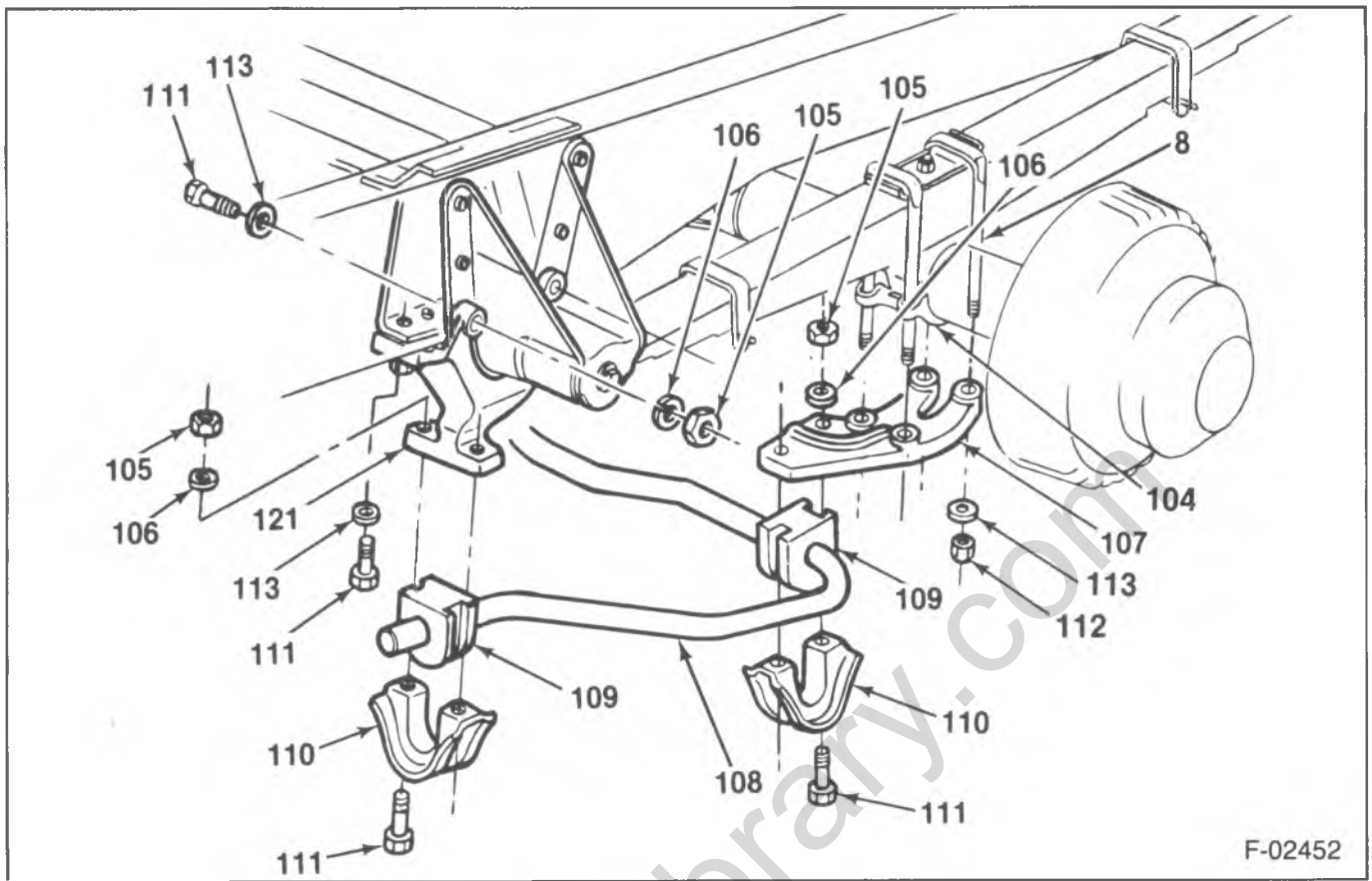

F-02452

Figure 9—Rear Stabilizer Attachments (P Series)

- For the R 30/3500 series vehicles; position the link bolt (115), washers (116), grommets (117), link (118), retainer (119) and nut (120).
- For the P 30/3500 series vehicles; attach the clamp (110), bolts (111), washers (106), and nuts (105) in position.

Tighten

- Nuts (120 and 105) to the "Specifications" at the end of this section.

4. Lower the vehicle to the ground.

101. U-bolt	112. Nut
102. Spacer	113. Washer
103. Spring Spacer	114. Spacer
104. Anchor Plate	115. Bolt
105. Nut	116. Washer
106. Spring Lock Washer	117. Grommet
107. Stabilizer Bar Anchor	118. Link
108. Stabilizer Bar	119. Retainer
109. Bushing	120. Nut
110. Bracket	121. Bracket
111. Bolt	

B-07524

Figure 10—Rear Stabilizer Attachments Legend

LEAF SPRING ASSEMBLY REPLACEMENT

↔ Remove or Disconnect (Figures 1 through 7)

- Raise the vehicle on a hoist and support the rear axle independently to relieve tension on the leaf springs.
1. Stabilizer bar from the vehicle if equipped.
 - Refer to "Stabilizer Bar Replacement," in this section.
 2. Leaf spring (10) from the rear hanger (25).
 - Loosen, but do not remove, the spring-to-shackle nut and bolt.
 - Nut and the bolt securing the shackle to the rear hanger (25).
 3. Leaf spring (10) from the front hanger (18).
 - Nut and the bolt securing the leaf spring (10) to the front hanger (18).
 4. Shackle (6) from the leaf spring (10).
 - Nut and bolt securing the shackle to the leaf spring.
 5. Leaf spring from the axle.
 - Nuts (22), and washers (21).
 - Rear stabilizer anchor (36) if equipped, the anchor plate, spacers, shims, and the auxiliary spring (32), if equipped.
 - U-bolts (8).
 - Leaf spring is free of the vehicle.

3D-10 REAR SUSPENSION

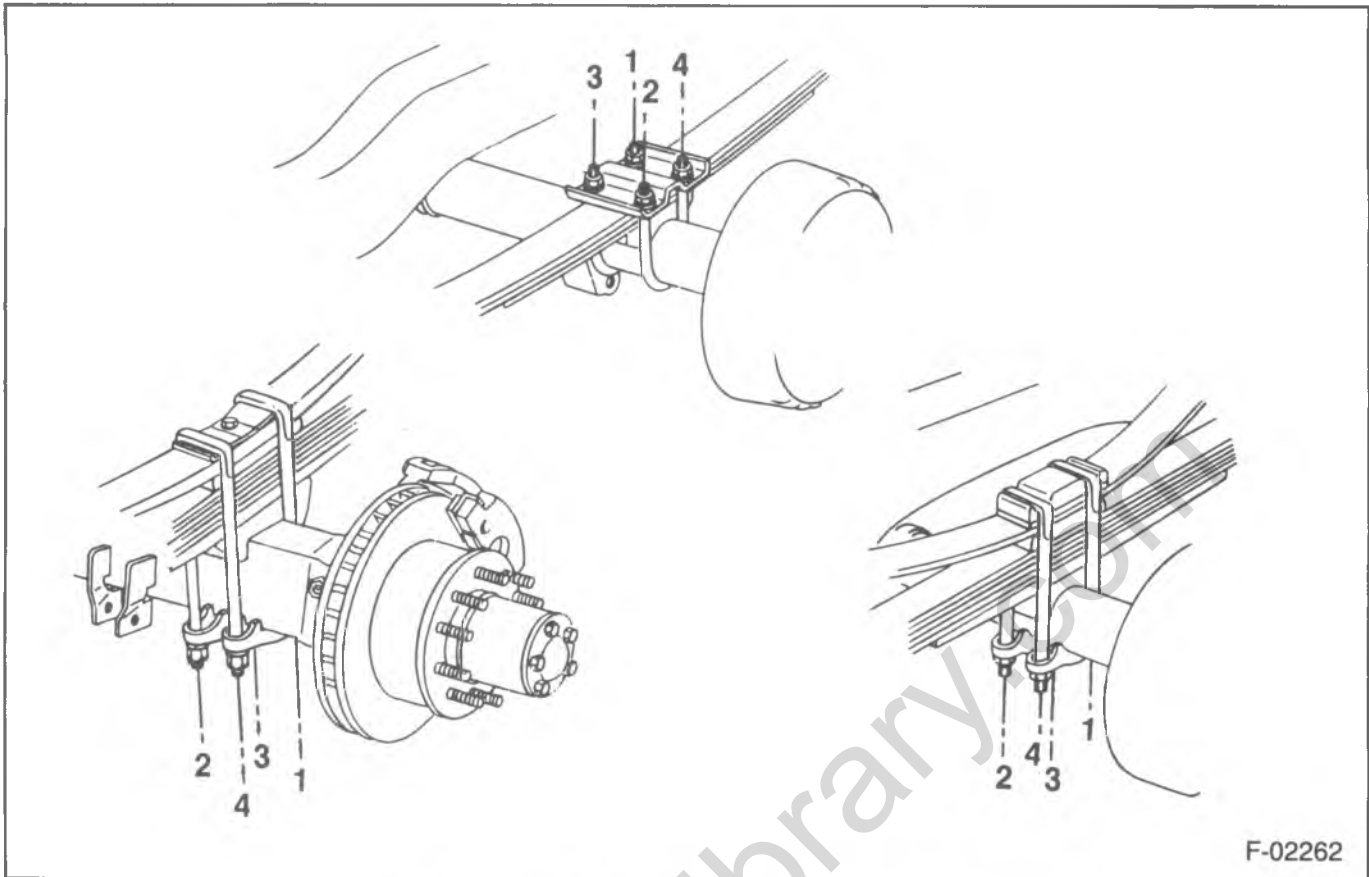

F-02262

Figure 11—Spring to Axle Tightening Sequence

↔ Install or Connect (Figures 1 through 7, and 11)

NOTICE: For steps 1 and 4, refer to the "Notice" on page 3D-1 of this section.

1. Leaf spring (10) to the rear axle.
 - Leaf spring into position.
 - Spacers, shims, the auxiliary spring (32) if equipped, and the anchor plate.
 - U-bolts (8), washers (21), and nuts (22).

⌚ Tighten

- Nuts (22), in a diagonal sequence as shown in figure 11, initially to 25 N·m (18 ft. lbs.). Then final torque in a diagonal sequence as shown in figure 11 to the "Specifications" at the end of this section.
2. Shackle (6) to the leaf spring (10).
 - Bolt (2), washers (3), and nuts (5), making sure the bolt is positioned correctly (figures 1 through 7).
 - Do not tighten.
 3. Leaf spring to the front hanger (18).
 - Bolt (2), washers (3), and nut (5).
 - Do not tighten.
 4. Leaf spring to the rear hanger (25).
 - Bolt (2), washers (3), and nut (5).

⌚ Tighten

- Nuts (5) and bolts (2), to the "Specifications" at the end of this section.
5. Stabilizer bar to the vehicle if equipped.
 - Refer to "Stabilizer Bar Replacement," in this section.
 6. Lower the support on the rear axle. Lower the vehicle to the ground.

BUSHING REPLACEMENT

PRESS OUT TYPE BUSHINGS

↔ Remove or Disconnect (Figures 1, 3, and 7)

1. Leaf spring (10) from the vehicle.
 - Refer to "Leaf Spring Assembly Replacement," in this section.
2. Bushing from the leaf spring (10).
 - Place the leaf spring in a press and press out the bushing.

↔ Install or Connect (Figures 1, 3 and 7)

1. Bushing into the leaf spring (10).
 - Use a press to properly position the bushings.
2. Leaf spring (10) to the vehicle.
 - Refer to "Leaf Spring Assembly Replacement," in this section.

PRY OUT TYPE BUSHINGS

↔ Remove or Disconnect (Figures 2 and 4 through 7)

1. Leaf spring (10) from the vehicle.
 - Refer to "Leaf Spring Assembly Replacement," in this section.
2. Bushings (26) from the leaf spring (10).
 - Pry the bushings out of each side of the spring eye.

→← Install or Connect (Figures 2 and 4 through 7)

1. Bushings (26) into the leaf spring (10).
 - Press each bushing (26) into its side of the spring eye.
2. Leaf spring (10) onto the vehicle.
 - Refer to "Leaf Spring Assembly Replacement," in this section.

classiccarylbrary.com

3D-12 REAR SUSPENSION

SPECIFICATIONS

FASTENER NAME	TORQUE N·m (FT. LBS.)										
	R10/15	R20/25	R30/35	V10/15	V20/25	V30/35	G10/15	G20/25	G30/35	P20/25	P30/35
Shock Absorber To Frame Nut	190 (140)	*190 (140)	70 (52)	190 (140)	190 (140)	70 (52)	102 (75)	102 (75)	102 (75)	33 (24)	70 (52)
Shock Absorber To Axle Nut	155 (114)	*155 (114)	155 (114)	155 (114)	155 (114)	155 (114)	102 (75)	102 (75)	102 (75)	155 (114)	155 (114)
Stabilizer Bar To Frame Nut	—	—	**	—	—	—	—	—	—	—	29 (21)
Stabilizer Bar To Anchor Nut	—	—	33 (24)	—	—	—	—	—	—	—	29 (21)
Stabilizer Bar Bracket To Hanger	—	—	—	—	—	—	—	—	—	—	33 (24)
Stabilizer Bar Bracket To Frame	—	—	—	—	—	—	—	—	—	—	33 (24)
Anchor Plate To U-bolt Nut (U-bolts Facing Up)	170 (125)	170 (125)	170 (125)	170 (125)	170 (125)	170 (125)	155 (114)	155 (114)	205 (151)	170 (125)	—
Anchor Plate to U-bolt Nut (U-bolts Facing Down)	200 (147)	200 (147)	200 (147)	200 (147)	200 (147)	200 (147)	—	—	205 (151)	—	***200 (147)
Spring To Hanger Nut	125 (92)	125 (92)	125 (92)	125 (92)	125 (92)	125 (92)	125 (92)	125 (92)	125 (92)	125 (92)	N/A
Spring To Hanger Bolt	150 (110)	150 (110)	150 (110)	150 (110)	150 (110)	150 (110)	185 (136)	185 (136)	185 (136)	150 (110)	•150 (110)
Spring To Shackle Nut	125 (92)	125 (92)	125 (92)	125 (92)	125 (92)	125 (92)	125 (92)	125 (92)	125 (92)	125 (92)	•125 (92)
Spring To Shackle Bolt	150 (110)	150 (110)	150 (110)	150 (110)	150 (110)	150 (110)	185 (136)	185 (136)	185 (136)	150 (110)	•150 (110)
Shackle To Hanger Nut	125 (92)	125 (92)	125 (92)	125 (92)	125 (92)	125 (92)	N/A	N/A	N/A	125 (92)	•125 (92)
Shackle To Hanger Bolt	150 (110)	150 (110)	150 (110)	150 (110)	150 (110)	150 (110)	185 (136)	185 (136)	185 (136)	150 (110)	•150 (110)

• For Models with RPO JF9 or P318(32) Torque Spring to Hanger Bolt to 200 N·m (147 ft. lbs.) and Tighten Shackle Fasteners to 135 N·m (99 ft. lbs.).

* Crew Cab Model Torque is 70 N·m (52 ft. lbs.) for Shock to Frame, and 155 N·m (114 ft. lbs.) for Shock to Axle.

** Tighten The Nut To The Unthreaded Portion Of The Link Bolt.

*** Torque Is 240 N·m (177 Ft. Lbs.) When Equipped With RPO JF9.

SECTION 3E

WHEELS AND TIRES

CONTENTS

<u>SUBJECT</u>	<u>PAGE</u>
General Description3E- 1
Certification Label3E- 1
Tire Load Limits And Inflation Pressure3E- 1
Diagnosis Of Wheels And Tires3E- 3
Checking Wheel And Tire Runout3E- 3
On-Vehicle Service3E- 4
Measuring Wheel And Tire Runout3E- 4
Excessively Tight Wheels3E- 5
Separating The Tire From The Wheel3E- 6
Mounting The Tire On The Wheel3E- 6
Installing The Wheel And Tire Assembly3E- 7
Aluminum Wheel Refinishing3E- 8
Wheel And Tire Balancing3E- 8
Optional Spare Tire Carriers3E- 8
Specifications3E-11
Wheel Runout3E-11
Wheel Stud Nut Torque (Single Front And Rear Wheels)3E-11
Wheel Stud Nut Torque (Single Front And Dual Rear Wheels)3E-11
Tire Load Limits And Inflation Pressure3E-12
Wheel Codes And Load Limits3E-12

GENERAL DESCRIPTION

This section details special service procedures that are not covered in the vehicle's Owner's Manual. For jacking instructions, basic tire changing and rotation instructions, and a detailed explanation of all other owner-oriented information, refer to the proper section in the vehicle's Owner's Manual.

Correct tire pressures and driving techniques influence tire life. Underinflated tires can cause handling problems, poor fuel economy, shortened tire life, and tire overloading. Heavy cornering, excessively rapid acceleration, and unnecessary braking also increase tire wear.

CERTIFICATION LABEL

The certification label contains information used to determine which tire size and type the vehicle uses. For further information, refer to GENERAL INFORMATION (SEC. 0A).

Important

- The use of wheels and/or tires with higher load capacity ratings than originally equipped on the vehicle will not increase the Gross Axle Weight Rating (GAWR) or Gross Vehicle Weight Rating (GVWR) of the vehicle.

TIRE LOAD LIMITS AND INFLATION PRESSURE

The factory installed wheels and tires are designed to handle loads up to and including their rated load capacity when inflated to the recommended inflation pressures. Refer to "Tire Load Limits And Inflation Pressure" at the end of this section.

3E-2 WHEELS AND TIRES

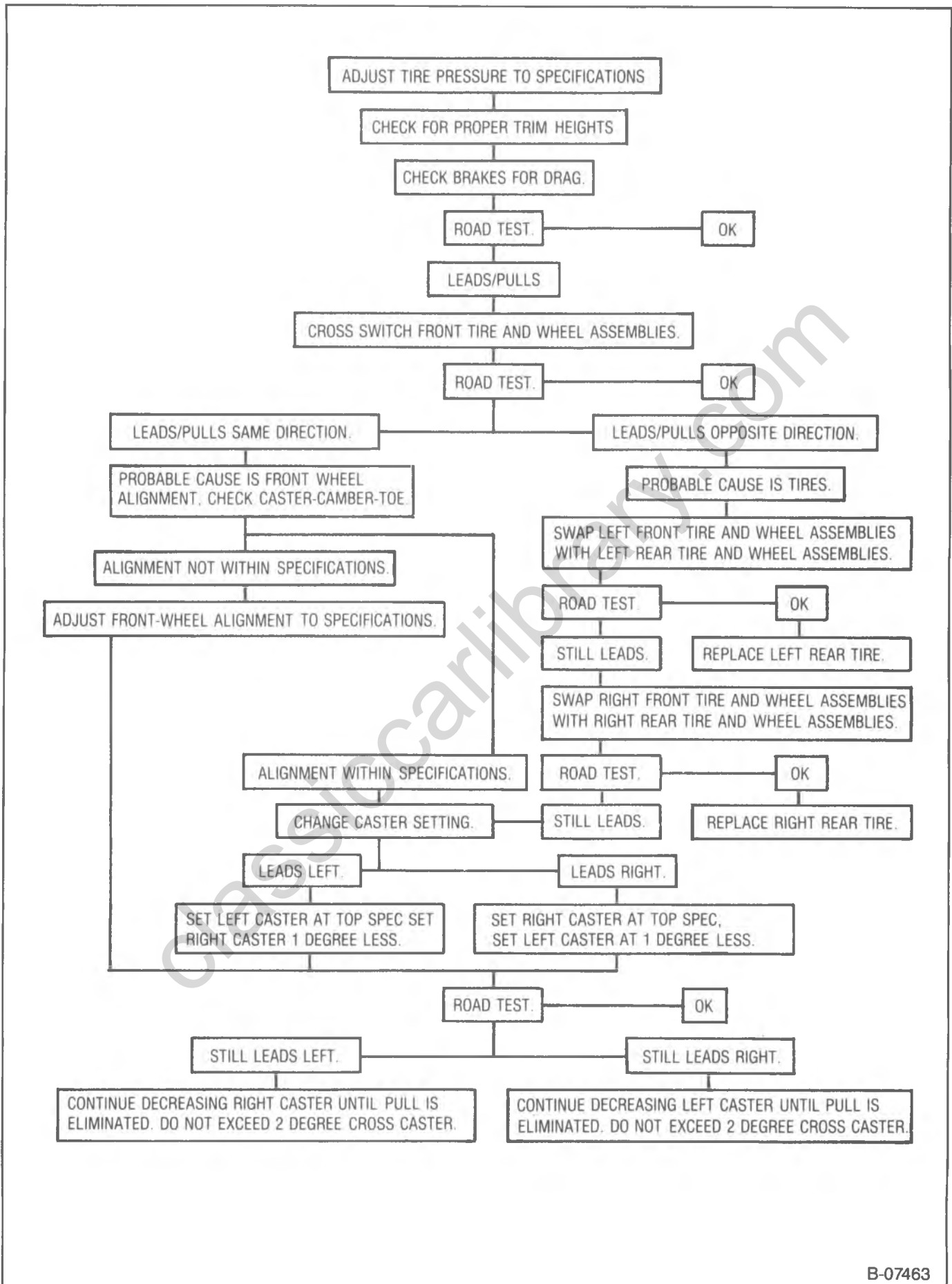

Figure 1—Radial Tire Lead/Pull Diagnosis Chart

DIAGNOSIS OF WHEELS AND TIRES

The following information (including figure 1) will help to identify certain tire-related durability and drivability problems.

PROBLEM	POSSIBLE CAUSE	CORRECTION
Excessive Heel And Toe Wear	High speed driving, excessive use of brakes.	Correct as required, rotate tires regularly.
Excessive Tire Edge(s) Wear	<ol style="list-style-type: none"> 1. Underinflated tires. 2. Vehicle overloaded. 3. High speed cornering. 4. Incorrect toe setting. 	<ol style="list-style-type: none"> 1. Inflate to recommended pressure. 2. Correct as required—refer to certification label. 3. Correct as required. 4. Set to correct specifications.
Excessive Tire Wear (Center Of Tread)	Overinflated tires.	Deflate to recommended pressure.
Uneven Tire Wear	<ol style="list-style-type: none"> 1. Improper tire pressure. 2. Incorrect tire and wheel usage. 3. Worn shock absorbers. 4. Front end out of alignment. 5. Loose, worn, or damaged steering linkage, joints, suspension components, bushings and/or ball joints. 6. Out of balance wheel/tire. 	<ol style="list-style-type: none"> 1. Inflate to recommended pressure. 2. Install correct tire-wheel combination. 3. Replace shock absorbers. 4. Align the front end. 5. Inspect, repair or replace as required. 6. Balance wheel/tire.
Radial Tire Waddle (Side To Side Movement At Speeds Between 5 and 15 MPH)	Worn tires.	Replace worn tires.
Vibration	<ol style="list-style-type: none"> 1. Out of balance wheel/tire. 2. Tire runout. 3. Wheel runout. 4. Worn tire. 	<ol style="list-style-type: none"> 1. Balance wheel/tire. 2. Replace tire. 3. Replace wheel. 4. Replace tire.

CHECKING WHEEL AND TIRE RUNOUT

Some vehicles are sensitive to tire and wheel assembly runout. Tires that are satisfactory on one vehicle might be unsatisfactory on another. When analyzing vibration problems, it is important to keep this in mind. In addition, different wheel positions on a vehicle may have different sensitivity levels. You should check for wheel runout or total wheel and tire runout in the following cases:

- If the tire and wheel vibration occurs below 40 miles per hour.
- If all wheels are balanced well within one ounce of static balance and five ounces of dynamic balance, and a vibration occurs.
- If there appears to be a bulge in a tire or an out-of-round condition as a tire rotates on a balancer.
- If any wheel damage is noticed.
- If there is a poor wheel fit on the hub and the vehicle exhibits vibration.

ON-VEHICLE SERVICE

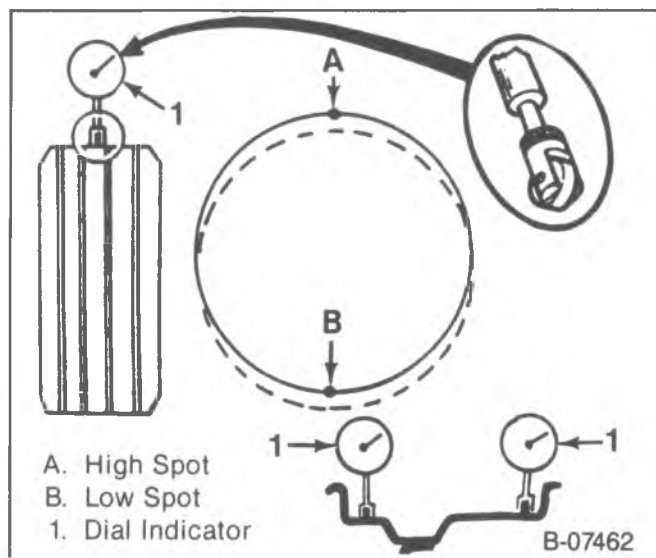

Figure 2—Measuring Radial Runout

MEASURING WHEEL AND TIRE RUNOUT

Runout measurements of the wheel and tire assembly can be taken both on and off the vehicle. These measurements can be taken radially and laterally. A dial indicator equipped with a roller contact point, mounted on a heavy, solid base is the measurement device.

RADIAL RUNOUT

Radial runout is the egg-shaped difference from a perfect circle. Measure tire radial runout from the center tire tread rib although other tread ribs can be measured as well. The total runout is the reading from the gage, and the high spot is the location of the maximum runout. On a rim, if either flange is beyond specifications, replace the rim (figure 2).

LATERAL RUNOUT

Lateral runout is a sideways variation causing a twist or wobble and is measured on a side surface. On the tire and wheel assembly, measure the sidewall of the tire as close to the trend shoulder design edge as possible. The total runout is the reading from the gage, and the high spot is the location of the maximum runout. On a rim, if either flange is beyond guidelines, replace the rim (figure 3).

MEASUREMENT PROCEDURES

1. Inflate the tires to specifications.
2. Warm up the tires prior to taking measurements to eliminate flat spotting.
 - Newly installed tires usually do not require warming up.
3. Raise the vehicle on a lift.
 - If measurements will be taken off the vehicle, mount each tire and wheel assembly on a dynamic balance machine.
4. Mark the tire and wheel assemblies for exact replacement.
 - Mark a wheel hub bolt and its exact position on the wheel.

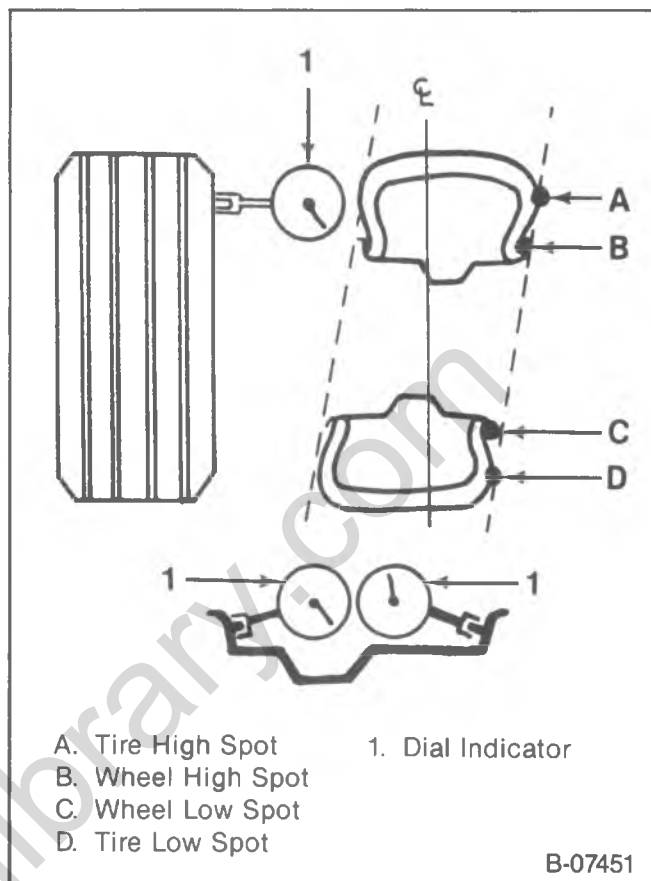

Figure 3—Measuring Lateral Runout

- Mark each tire and wheel assembly for replacement on the exact hub/rotor assembly.
5. Take either a radial or lateral runout measurement.
 - Place the dial indicator in position.
 - Rotate the tire and wheel assembly (or just the wheel) to find its low spot. Adjust the dial indicator to read zero.
 - Rotate again to verify the low spot location—the dial indicator must return to zero.
 - Disregard any instantaneous dial jumps due to welds, paint runs, scratches, etc. on the wheel.
 - Rotate the tire and wheel assembly (or just the wheel) and note the amount of variance (runout) from zero. Locate and mark the high spot.
6. If there is a large difference in runout measurements from ON vehicle to OFF vehicle, the runout problem is likely due to excessive runout of the bolt circle or hub.
7. If measured runouts are not within the guidelines (located in "Wheel Runout Specifications" at the end of this section), proceed to "Vectoring" to correct the problem.

VECTORING

Vectoring is a technique used to reduce radial or lateral runout—and even dynamic balance on tire and wheel assemblies. Vectoring can be accomplished by positioning of the tire on the wheel and positioning of the tire and wheel assembly on the hub/rotor.

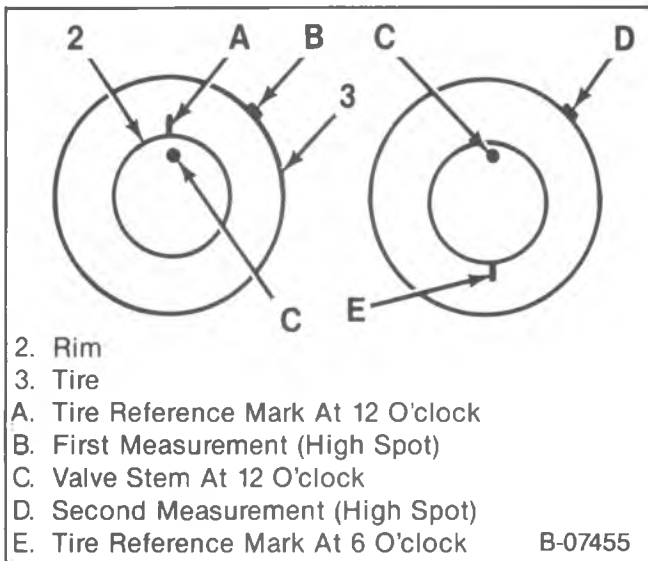

Figure 4—Checking Tire to Wheel Vectoring

! Important

- Always rebalance the tire and wheel assembly after vectoring.

Tire To Wheel Vectoring

- Determine which runout needs to be minimized.
 - Determine visually.
- If radial runout is the problem, take a measurement on the center tread rib.
 - If the trend is uneven, wrap tape tightly around the tire, record the runout magnitude, and mark the high spot location (figure 4).
- If lateral runout is the problem, take a measurement on the sidewall just below the edge of the tread shoulder.
 - Record the runout magnitude, and mark the high spot location.
- Mark the tire sidewall at the valve location.
 - This is the 12 o'clock position.
 - The location of the high spot is always with respect to the clock location on the wheel.
- Break the tire and wheel assembly down on a tire mounting machine and rotate the tire 6 hours (180°) on the rim (figure 4).
 - Reinflate the tire and measure the runout in question.
 - Record the magnitude and the location of the high spot. (Valve stem is 12 o'clock.)
- If the clock location of the high spot remained at or near the clock location of the original high spot, the rim is the major contributor to the runout problem.
 - Confirm by removing the tire from the wheel and check the wheel rim runout.
 - If the wheel rim runout exceeds guidelines, replace the wheel.
- If the clock position of the high spot is 6 hours from the original high spot, the tire is the major contributor to the runout problem (figure 5).
 - Replace the tire.
- After correcting the tire to the wheel vectoring, rebalance the wheel and tire assembly.

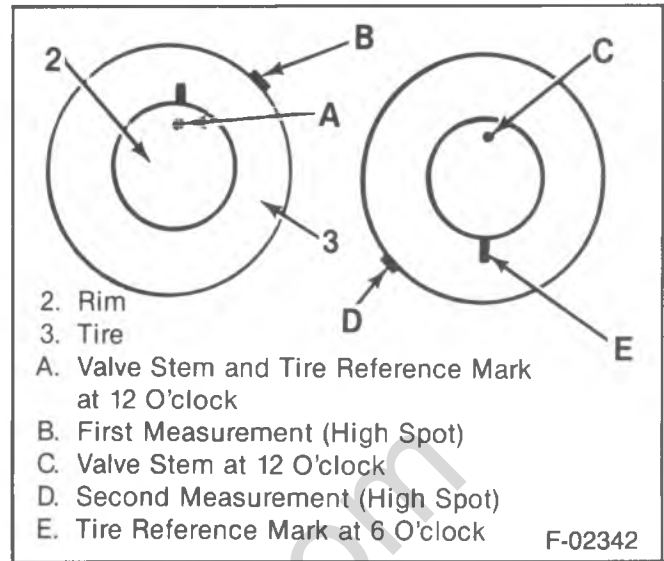

Figure 5—Tire to Wheel Vectoring—Excessive Runout

Tire And Wheel Assembly To Hub/Rotor Vectoring

- Mark the wheel hub bolt nearest the valve stem for reference (figure 6).
- Rotate the assembly two wheel hub bolts and recheck the runout (figure 6).
 - Several positions may have to be tried to locate the optimum location.
 - This can be effective for both radial and lateral runouts.
- If there is some looseness in the wheel hub bolt holes, radial runout can be reduced by loosening the hub bolt nuts slightly, moving the wheel position on the bolts and then retightening the nuts.
- Balance the tire and wheel to hub/rotor assembly.
 - Compensates for any imbalance in the brake rotor, drum, or wheel cover.

EXCESSIVELY TIGHT WHEELS

Use this procedure to remove the wheel and tire assembly if it does not break free of the hub using a standard removal procedure.

- Tighten all the lug nuts on the affected wheel.
 - Do not torque.
- Raise the vehicle.

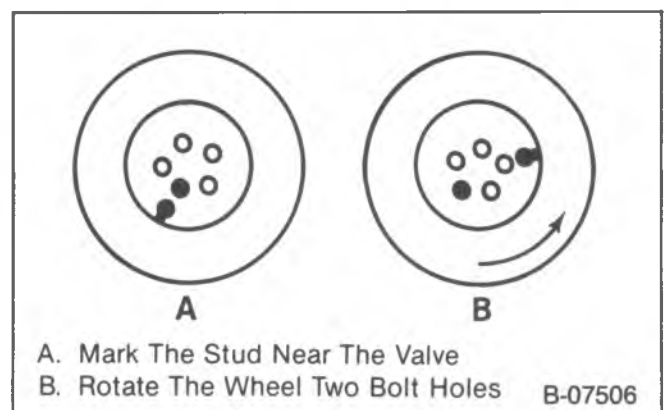

Figure 6—Tire and Wheel Assembly to Hub/Rotor Vectoring

3E-6 WHEELS AND TIRES

- Loosen each nut two turns.
- Lower the vehicle to the floor.
- Rock the vehicle from side to side to loosen the wheel. Or rock the vehicle from forward to reverse allowing the vehicle to move several feet in each direction. Apply quick, hard jabs on the brake pedal to loosen the wheel.
- Raise the vehicle and remove the lug nuts and the wheel.

SEPARATING THE TIRE FROM THE WHEEL

NOTICE: Use a tire changing machine to demount tires. Do not use hand tools or tire irons alone to remove the tire from the wheel. Damage to the tire beads or wheel rim could result.

- Follow the tire changing machine manufacturer's instructions to properly separate the tire from the wheel.

MOUNTING THE TIRE ON THE WHEEL

BIAS PLY TIRES

- Clean the tire bead area.
- Clean the rim bead seats with a wire brush or coarse steel wool to remove lubricants, old rubber, and light rust.
- Apply an approved tire lubricant to the tire bead area.
- Attach the tire to the wheel.
 - Use a tire changing machine. Follow the equipment manufacturer's instructions.

CAUTION: Do not stand over tire when inflating. The bead may break when it snaps over the safety hump, and cause serious personal injury. Do not exceed 275 kPa (40 psi) pressure when inflating. If 275 kPa (40 psi) pressure will not seat beads, deflate, re-lubricate and reinflate. Overinflation may cause the bead to break and result in personal injury.

- Install a valve core and inflate to the specified pressure (figure 2).
 - The locating rings on each side of the tire must show above the rim flanges, positioned in direct relation to the wheel (not eccentric as compared with the rim).
- Check the bead seating.
 - Tires must be mounted and inflated in accordance with the safety precautions included with the tire mounting equipment.

RADIAL PLY TIRES

NOTICE: Recommended vehicle tire mounting and inflation procedures are especially important with radial tires. Failure to follow these procedures can cause bead deformation in both tube type and tubeless tires due to incorrect bead seating. Bead deformation may lead to chafing, lower sidewall and bead area cracking, eccentric wear, ride vibration and nonretreadable castings.

Tube Type Tires

Important

- Only use rims approved for radial tire usage by the rim manufacturer.
- Clean the rim parts.
 - Remove all rust and other foreign material.
 - Make sure the rim parts match and are not sprung or broken.
 - Lubricate the tire beads, the portion of the tube between the beads, and the flaps with an approved rubber lubricant.
 - Radial tubes are identifiable by the letter "R" in the size designation. A red band in the valve stem and an "R" in the flap size designation also identify radial parts.

NOTICE: Do not use silicone base lubricants—this could cause the tire to slip on the wheel.

- Inflate to operating pressure, deflate completely, and reinflate to operating pressure.
 - Allows the tube, flap, and tire to fit together properly.
- Check the bead seating.
 - Visually check the slot and side ring gap (on two piece rims) to make sure the bead is seated.
- Check the spacing between the rim flange and one of the three lower sidewall rim line rings while the tire is laying flat to verify bead seating.
 - Measurements must be taken each 90 degrees around the circumference of the rim flange.
 - If the spacing is uneven around the bead from side to side, repeat steps 1 through 3, then recheck.

Installing Synthetic Tubes

NOTICE: When the tube and the flap are not properly lubricated, and mounted, they will stretch thin in the tire bead and rim region. This will cause premature wear.

- Clean the inside of the casing.
- Insert the tube in the tire and inflate until it is nearly rounded out.
- Inspect the rim for rust scale and bent flanges.
 - Clean rust scale and straighten the flanges where necessary.

4. Apply a solution of neutral vegetable oil soap to the inside and outside of the tire beads, and also the rim side of the tube.
 - Use a brush or a cloth swab.
 - Do not allow the soap solution to run down into the tire.
5. Follow the standard procedure when mounting the tube and tire on a drop center rim. Be sure the tire is centered on the rim so the beads are out of the rim well before inflating. Do not allow the tire to hang loosely on the wheel while inflating.
6. Center the valve and pull it firmly against the rim. Hold in this position and inflate until the tire beads are firmly seated on the rim against the flanges.
7. Remove the valve core to completely deflate the tire.
8. Reinflate the tire to the recommended pressure.
 - Refer to "Tire Load Limits And Inflation Pressure" at the end of this section.

Tubeless Tires

Important

- Only use rims approved for radial tire usage by the rim manufacturer.
1. Clean the rim.
 - Remove all rust and other foreign material.
 2. Lubricate tire beads and rim bead seats with an approved rubber lubricant.

NOTICE: Do not use silicone base lubricants—this could cause the tire to slip on the wheel.

3. Inflate the tire to operating pressure.
 - Due to the construction of radial truck tires, particularly in the lower sidewall and bead area, it may be difficult to get the tire to take air.
 - An inflation aid may be necessary to help seat the bead of tubeless radial tires. Two types of inflation aids are commercially available—metal rings which use compressed air to seat beads, and rubber rings which seal between the tire bead and rim bead seat allowing the bead to move out and seat. Lubrication is necessary with both aids.
4. Check the spacing between the rim flange and one of the three lower sidewall rim line rings while the tire is laying flat to verify bead seating.
 - Measurements must be taken each 90 degrees around the circumference of the rim flange.
 - If the spacing is uneven around the bead from side to side, repeat steps 1 through 3, then recheck.

Important

- This procedure must be followed to insure proper bead seating in order to prevent bead deformation.
- Radial tires, as well as bias tires, must be mounted and inflated in accordance with safety precautions noted in RMA Radial and Bias Truck Tire Service Manuals.

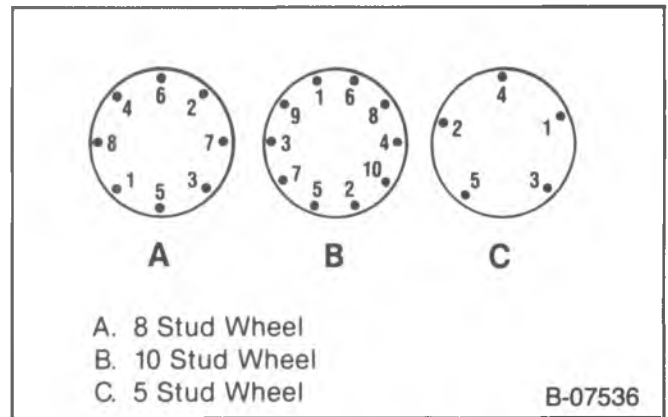

Figure 7—Wheel Tightening Sequence

INSTALLING THE TIRE AND WHEEL ASSEMBLY

CAUTION: Before re-installing the wheels, remove any build up of corrosion on the wheel mounting surface and brake drum or disc mounting surface by scraping and wire brushing. Installing wheels with good metal-to-metal contact at the mounting surfaces can cause wheel nuts to loosen. This can lead to a wheel coming off while the vehicle is moving, possibly causing loss of control.

SINGLE WHEELS

Install or Connect (Figure 7)

1. Wheel and tire assembly in position on the hub/rotor, and lug nuts installed loosely.
2. Turn the wheel until one nut is at the top of the bolt circle. Tighten the nut just snug.
3. Snug up the remaining nuts criss-cross to minimize runout.

Tighten

- Nuts to "Specifications" at the end of this section.
- Tighten evenly and alternately to avoid excessive runout (figure 7).

DUAL WHEELS

Install or Connect (Figure 7)

1. Inner and outer wheel and clamp ring on the rear wheel, or wheel and clamp ring on the front wheel.
 - Be sure the pins on the clamp ring face outward.
2. Lub nuts finger tight.

Tighten

- Nuts to "Specifications" at the end of this section.
- For P30 models, tighten to 210 N·m (155 ft. lbs.), then tighten again to 237 N·m (175 ft. lbs.).
- Tighten evenly and alternately to avoid excessive runout (figure 7).

3E-8 WHEELS AND TIRES

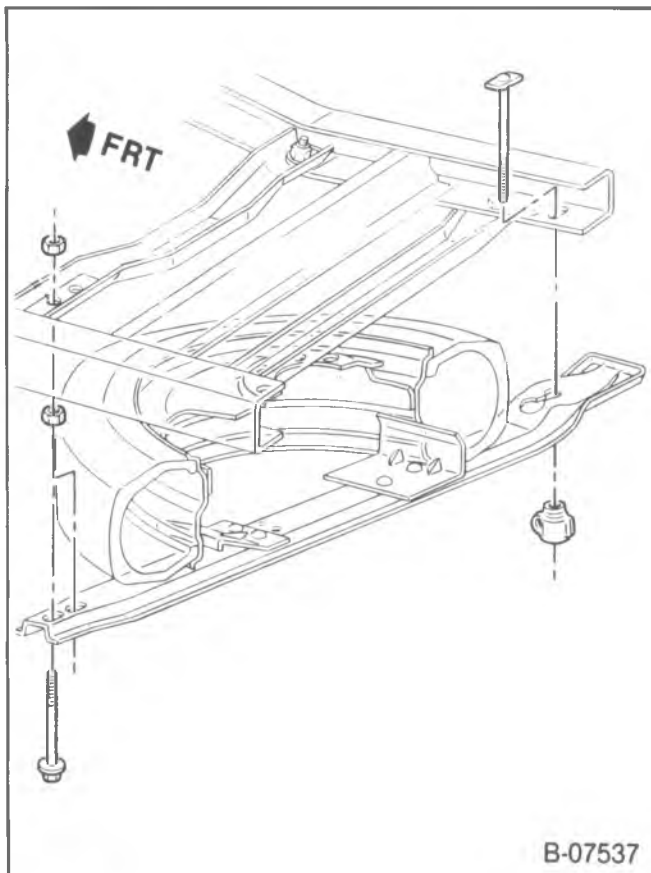

Figure 8—Underbody Swing Out Spare Tire Carrier (RPO P10)

Measure

- Lateral runout should not exceed 3.18 mm (0.125 inches) on the front wheel or 4.76 mm (0.187 inches) on the rear wheel.

ALUMINUM WHEEL REFINISHING

- Remove the tire and wheel assembly from the vehicle.
- Mark the position of the wheel weights on the tire for correct reinstallation after recoating the wheel. Remove the wheel weights and mask off the tire.

1. Remove the original clear coating.
 - Apply a chemical stripper such as 3M brand Troubleshooter to the wheel rim surface.
 - Wait 10 to 15 minutes, then wet scrub the surface using a 3M #98 Scotchbrite Cleaning Pad (3M part number 07445).
 - Rinse the surface thoroughly with clean water.

CAUTION: Use of eye goggles is necessary to prevent personal injury.

2. Remove surface oxidation.
 - Use 3M Superbuff Buffing Pad (3M part number 05701) and a medium type compound such as 3M part number 05955 or 05931.
 - Hose off the rim with water and scrub with a small brush to remove excess compound, then air blow dry.
3. Recoat the wheels.

- Clean the surface of any contaminants using Prekleno.
- Apply #801 Metal Conditioner, taking care to use rubber gloves and a clean cloth during the application. Keep the surface wet while applying.

Important

- Make sure #801 Metal Conditioner is reduced one part metal conditioner to three parts of water.
 - Wipe off #801 Metal Conditioner carefully while the surface is still wet. Use a clean, dry cloth.
4. Apply the clear coat.
 - Apply R & M's 893 2K Clear with 894 Urethane Catalyst Hardener. Refer to the label for specific directions.
 - Wear proper respiratory protection such as a 3M Paint Respirator (part number 06984) or Easi-Air Respirator (part number 06986) or equivalent.
 5. Allow the wheel to air dry overnight (minimum) before installing on the vehicle.
 6. Attach balance weights and install the wheel and tire assembly on the vehicle.
 - Mount the weights in the marked positions and remove the masking from the tire.

WHEEL AND TIRE BALANCING

To insure successful, accurate balancing, the following precautions must be observed:

- The wheel and tire must be clean and free of all foreign matter.
- The tire should be in good condition and properly mounted using the balance mark on the tire, if any, or lined up with the inflation valve.
- Bent wheels that have a runout over 1.6 mm ($\frac{1}{16}$ -inch) should be replaced.
- Inspect the wheel and tire assembly to determine if an out-of-round condition exists.

Important

- A severe out-of-round condition cannot be "balanced out." A wheel and tire assembly having an out-of-round condition exceeding 4.7 mm ($\frac{3}{16}$ -inch) is not suitable for the front of the vehicle. Its use on the rear of the vehicle must be governed by its general condition and whether the roundness problem seriously detracts from overall ride quality.
- Follow the wheel balancer machine instructions while performing the balancing operation.

OPTIONAL SPARE TIRE CARRIERS

UNDERBODY SWING OUT SPARE TIRE CARRIER (RPO P10)

The underbody swing out spare tire carrier is standard equipment on RV 10/1500 series pickups. It is available as an option (RPO P10) on RV 20/2500 and 30/3500 series pickups (figure 8).

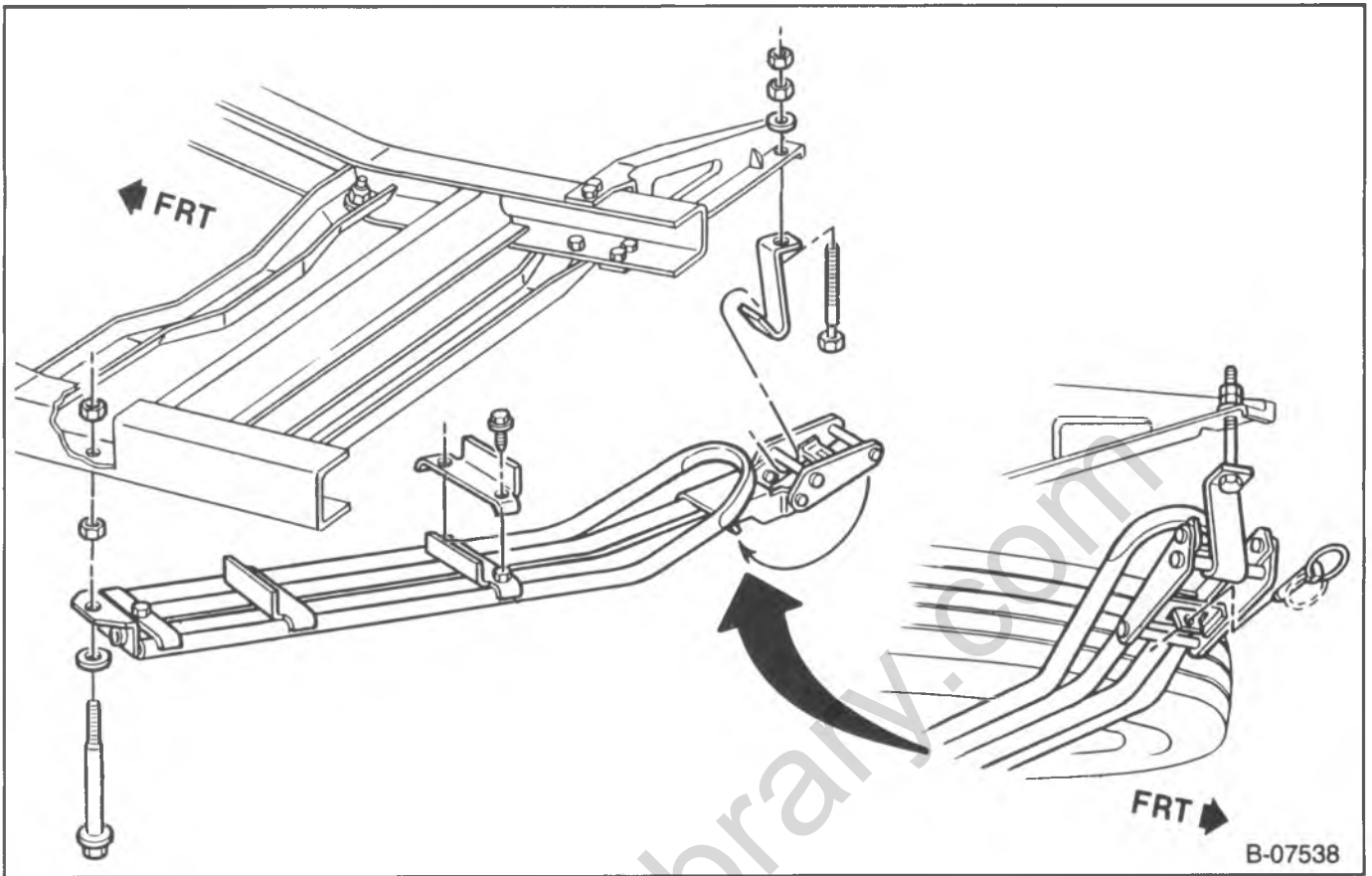

Figure 9—Underbody Glide Out Spare Tire Carrier (RPO P11)

UNDERBODY GLIDE OUT SPARE TIRE CARRIER (RPO P11)

The underbody glide out spare tire carrier is available as an option (RPO P11) on all RV series pickups (figure 9).

SIDE PANEL MOUNTED SPARE TIRE CARRIER (RPO P13)

The side panel mounted spare tire carrier is available as an option on all C-K series pickups (figure 10).

classiccarslibrary.com

3E-10 WHEELS AND TIRES

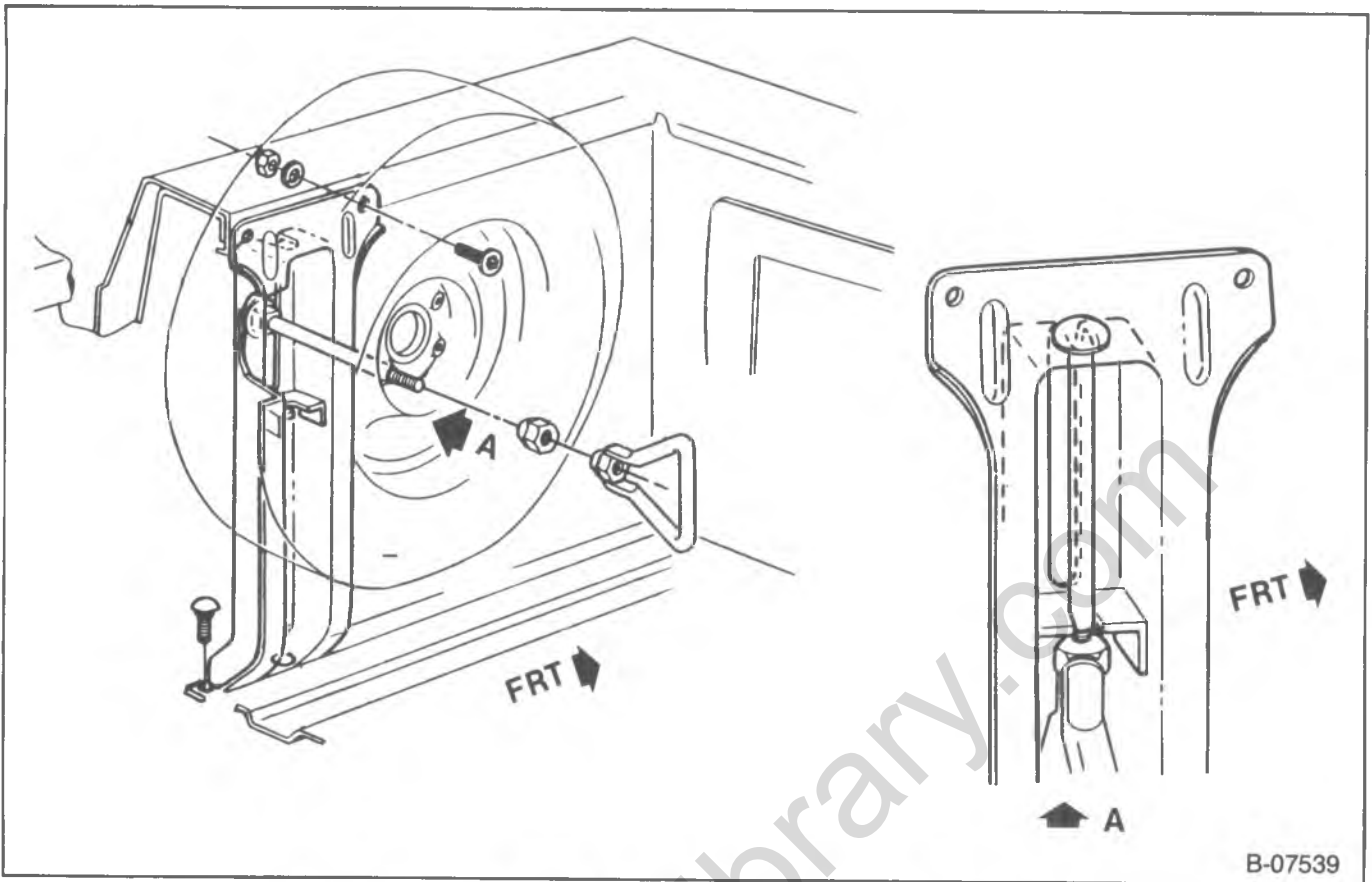

Figure 10—Side Panel Mounted Spare Tire Carrier (RPO P13)

SPECIFICATIONS

WHEEL RUNOUT

	Steel Wheels	Aluminum Wheels
Radial Runout	1.01 mm (0.04 inches)	0.76 mm (0.03 inches)
Lateral Runout	1.14 mm (0.045 inches)	0.76 mm (0.03 inches)

WHEEL STUD NUT TORQUE (SINGLE FRONT AND REAR WHEELS)

Series	Number Of Studs	Nut Torque
R10/1500	5 studs	140 N·m (100 ft. lbs.) (steel wheels)
V10/1500	6 studs	120 N·m (88 ft. lbs.) (steel wheels)
R10/1500	5 studs	140 N·m (100 ft. lbs.) (aluminum wheels)
V10/1500	6 studs	140 N·m (100 ft. lbs.) (aluminum wheels)
RV20/2500	8 studs	160 N·m (120 ft. lbs.) (all)
RV30/3500	8 studs	160 N·m (120 ft. lbs.) (all)
G10/1500-20/2500	5 studs	140 N·m (100 ft. lbs.) (steel wheels)
G10/1500-20/2500	5 studs	140 N·m (100 ft. lbs.) (aluminum wheels)
G30/3500	8 studs	160 N·m (120 ft. lbs.) (all)
P20/2500 & 30/3500	8 studs	160 N·m (120 ft. lbs.) (all)

WHEEL STUD NUT TORQUE (SINGLE FRONT AND DUAL REAR WHEELS)

Series	Number Of Studs	Nut Torque
RV30/3500	8 studs	190 N·m (140 ft. lbs.) (all)
G 30/3500	8 studs	190 N·m (140 ft. lbs.) (all)
P 30/3500	8 studs	190 N·m (140 ft. lbs.) (with RPO JB8)
P 30/3500	10 studs	210 N·m (155 ft. lbs.) (with RPO JF9)

3E-12 WHEELS AND TIRES

TIRE AND WHEEL LOAD LIMIT CHARTS
(TIRE & WHEEL LOAD LIMITS ARE SHOWN BELOW. VEHICLE LOADING MUST BE LIMITED SUCH THAT NEITHER THE WHEEL OR TIRE INFLATION PRESSURE OR LOAD LIMITS ARE EXCEEDED).

RADIAL TIRE SIZE AND LOAD LIMITS - kg (LBS)
Metric Radial Tires Used As Singles

Tire Size	Load Range	Inflation Pressure - kPa (PSI)		
		250 (36)	300 (44)	350 (51)
LT215/85R16	C	695 (1532)	790 (1742)	880 (1940)
LT215/85R16	D	695 (1532)	790 (1742)	880 (1940)
LT235/85R16	D	790 (1742)	900 (1984)	1000 (2205)
LT235/85R16	E	790 (1742)	900 (1984)	1000 (2205)

Metric Radial Tires Used As Duals

Tire Size	Load Range	Inflation Pressure - kPa (PSI)		
		250 (36)	300 (44)	350 (51)
LT215/85R16	C	630 (1389)	720 (1587)	800 (1764)
LT215/85R16	D	630 (1389)	720 (1587)	800 (1764)

BIAS TIRE SIZE AND LOAD LIMITS -- kg (LBS)
Bias Tires Used As Singles

Tire Size	Load Range	Inflation Pressure - kPa (PSI)			
		207 (30)	241 (35)	276 (40)	310 (45)
7 50 16	C	735 (1620)	803 (1770)	875 (1930)	934 (2060)
7 50-16	D	735 (1620)	803 (1770)	875 (1930)	934 (2060)
7 50-16	E	735 (1620)	803 (1770)	875 (1930)	934 (2060)

Bias Tires Used As Duals

Tire Size	Load Range	Inflation Pressure - kPa (PSI)			
		207 (30)	241 (35)	276 (40)	310 (45)
7 50-16	C	649 (1430)	710 (1565)	767 (1690)	823 (1815)
7 50-16	D	649 (1430)	710 (1565)	767 (1690)	823 (1815)

B-07548

Figure 11—Tire Load Limits and Inflation Pressure (RV)

TIRE LOAD LIMITS AND INFLATION PRESSURE

Refer to Figures 11, 12, 14, 15, 17, and 18 for tire load limits given an inflation pressure range.

Metric Radial Tires Used As Singles (Cont.)

Inflation Pressure - kPa (PSI)			
400 (58)	450 (65)	500 (73)	550 (80)
965 (2127)	1050 (2315)		
1100 (2425)	1190 (2623)		
1100 (2425)	1190 (2623)	1290 (2844)	1380 (3042)

Metric Radial Tires Used As Duals (Cont.)

Inflation Pressure - kPa (PSI)			
400 (58)	450 (65)	500 (73)	550 (80)
870 (1918)	955 (2105)		

Bias Tires Used As Singles (Cont.)

Inflation Pressure - kPa (PSI)					
345 (50)	379 (55)	414 (60)	448 (65)	483 (70)	517 (75)
993 (2190)	1048 (2310)	1107 (2440)			
993 (2190)	1048 (2310)	1107 (2440)	1161 (2560)	1211 (2670)	1261 (2780)

Bias Tires Used As Duals (Cont.)

Inflation Pressure - kPa (PSI)					
345 (50)	379 (55)	414 (60)	448 (65)	483 (70)	517 (75)
875 (1930)	925 (2040)	971 (2140)			

B-07549

Figure 12—Tire Load Limits and Inflation Pressure (RV)

WHEEL CODES AND LOAD LIMITS

Refer to Figures 13, 16, and 19 for wheel load limits for each wheel size (coded).

Code *	Wheel Size	Max. Load kg (lbs.)	Max. Pressure kPa (psi)
AA	16 x 6.5	1,381 (3 045)	621 (90)
AF	16 x 6	1,107 (2 440)	517 (75)
BF	16 x 16.5	1,261 (2 780)	586 (85)
BK	15 x 7	757 (1 670)	276 (40)
CF	15 x 7	757 (1 670)	276 (40)
CK	15 x 8	866 (1 910)	276 (40)
DAB	15 x 8	921 (2 030)	276 (40)
DAC	15 x 8	921 (2 030)	282 (41)
GBA	15 x 8	900 (1 984)	282 (41)
GBB	15 x 7	921 (2 030)	282 (41)
UA	15 x 7	921 (2 030)	282 (41)
XAH	15 x 6	900 (1 984)	438 (70)
XH	15 x 6	719 (1 585)	276 (40)
CC	15 x 6	757 (1 670)	379 (55)
XX	15 x 6	925 (2 040)	483 (70)

* Wheel code is located on the wheel just to the right of the valve stem hole.

B-08072

Tire Load Limits: Bias Tire Used As Singles — kg (lbs.) (Cont.)

Inflation Pressure — kPa (PSI)					
379 (55)	414 (60)	448 (65)	483 (70)	517 (75)	552 (80)
882 (1 945)	928 (2 045)				
1016 (2 240)	1066 (2 350)				
1016 (2 240)	1066 (2 350)	1120 (2 470)	1166 (2 570)	1216 (2 680)	

Tire Load Limits: Bias Tires Used As Duals — kg (lbs.) (Cont.)

Inflation Pressure — kPa (PSI)					
379 (55)	414 (60)	448 (65)	483 (70)	517 (75)	552 (80)
776 (1 710)	816 (1 800)				

Tire Load Limits: Radial Tires Used As Singles — kg (lbs.) (Cont.)

Inflation Pressure — kPa (PSI)					
379 (55)	414 (60)	448 (65)	483 (70)	517 (75)	552 (80)
957 (2 110)	1016 (2 240)	1066 (2 350)	1120 (2 470)	1166 (2 570)	1216 (2 680)

B-08075

Figure 13—Wheel Codes and Load Limits (RV)

Figure 15—Tire Load Limits and Inflation Pressure (G)

TIRE AND WHEEL LOAD LIMIT CHARTS

(Tire and wheel load limits are shown below. Vehicle loading must be limited so that neither the wheel or tire inflation pressure or load limits are exceeded)

Tire Load Limits: Bias Tires Used As Singles — kg (lbs)

Tire Size	Load Range	Inflation Pressure — kPa (PSI)				
		207 (30)	241 (35)	276 (40)	310 (45)	345 (50)
8.00-16.5	C	617 (1 360)	676 (1 490)	730 (1 610)	785 (1 730)	
8.00-16.5	D	617 (1 360)	676 (1 490)	730 (1 610)	785 (1 730)	835 (1 840)
8.75-16.5	D	712 (1 570)	780 (1 720)	839 (1 850)	903 (1 990)	957 (2 110)
8.75-16.5	E	712 (1 570)	780 (1 720)	839 (1 850)	903 (1 990)	957 (2 110)

Tire Load Limits: Bias Tires Used As Duals — kg (lbs)

Tire Size	Load Range	Inflation Pressure — kPa (PSI)				
		207 (30)	241 (35)	276 (40)	310 (45)	345 (50)
8.00-16.5	C	542 (1 195)	594 (1 310)	642 (1 415)	689 (1 520)	
8.00-16.5	D	542 (1 195)	594 (1 310)	642 (1 415)	689 (1 520)	735 (1 620)

Tire Load Limits: Radial Tires Used As Singles — kg (lbs)

Tire Size	Load Range	Inflation Pressure — kPa (PSI)				
		207 (30)	241 (35)	276 (40)	310 (45)	345 (50)
8.75 R16.5	E		712 (1 570)	780 (1 720)	839 (1 850)	903 (1 990)

B-08074

Wheel Code and Load Limits

Code *	Wheel Size	Max. Load — kg (lbs.)	Max. Pressure — kPa (PSI)
DAS	15 x 6.5	835 (1 843)	282 (41)
GBC	15 x 6.5	835 (1 843)	282 (41)
XH	15 x 6	719 (1 585)	276 (40)
XAH	15 x 6	900 (1 984)	483 (70)
YH	16.5 x 6	1216 (2 680)	586 (85)
XJ	16.5 x 6.75	1216 (2 680)	586 (85)

* Wheel code is located on the wheel just to the right of the valve stem hole.

B-08076

Figure 16—Wheel Codes and Load Limits (G)

Figure 14—Tire Load Limits and Inflation Pressure (G)

3E-14 WHEELS AND TIRES

TIRE LOAD LIMIT CHARTS

(Tire load limits at different inflation pressures are shown below. Vehicle loading must be limited such that neither the tire inflation pressures or load limits are exceeded)

METRIC RADIAL TIRES — kg (LBS.)

Tire Size	Load Range	Single Dual	Inflation Pressure - kPa (PSI)		
			250 (36)	300 (44)	350 (51)
LT215/85R16	C	S	695 (1532)	790 (1742)	880 (1940)
		D	630 (1389)	720 (1587)	800 (1764)
LT215/85R16	D	S	695 (1532)	790 (1742)	880 (1940)
		D	630 (1389)	720 (1587)	800 (1764)
LT235/85R16	D	S	790 (1742)	900 (1984)	1000 (2205)
		—			
LT235/85R16	E	S	790 (1742)	900 (1984)	1000 (2205)
		—			

STANDARD RADIAL TIRES — kg (LBS.)

Tire Size	Load Range	Single Dual	Inflation Pressure - kPa (PSI)		
			310 (45)	345 (50)	379 (55)
8R19.5	D	S			
		D			

BIAS TIRES — kg (LBS.)

Tire Size	Load Range	Single Dual	Inflation Pressure — kPa (PSI)			
			207 (30)	241 (35)	276 (40)	310 (45)
7.50-16	C	S	735 (1630)	803 (1770)	875 (1930)	934 (2060)
		D	649 (1430)	710 (1565)	767 (1690)	823 (1815)
7.50-16	D	S	735 (1620)	803 (1770)	875 (1930)	934 (2060)
		D	649 (1430)	710 (1565)	767 (1690)	823 (1815)
7.50-16	E	S	735 (1620)	803 (1770)	875 (1930)	934 (2060)
		—				
8-19.5	D	S				
		D			839 (1850)	903 (1990)
8-19.5	E	S				
		D			839 (1850)	903 (1990)

B-08077

Figure 17—Tire Load Limits and Inflation Pressure (P)

TIRE LOAD LIMIT CHARTS (CONT.)

METRIC RADIAL TIRES (CONT.) — kg (LBS.)

Inflation Pressure - kPa (PSI)			
400 (58)	450 (65)	500 (73)	550 (80)
965 (2127)	1050(2315)		
870 (1918)	955 (2105)		
1100 (2425)	1190 (2623)		
1100 (2425)	1190 (2623)	1290 (2844)	1380 (3042)

STANDARD RADIAL TIRES (CONT.) — kg (LBS.)

Inflation Pressure — kPa (PSI)				
414 (60)	448 (65)	483 (70)	517 (75)	552 (80)
1030 (2270)	1093 (2410)	1152 (2540)	1216 (2680)	1270 (2800)
1012 (2230)	1066 (2350)	1116 (2460)		

BIAS TIRES (CONT.) — kg (LBS.)

Inflation Pressure — kPa (PSI)					
345 (50)	379 (55)	414 (60)	448 (65)	483 (70)	517 (75)
993 (2190)	1048 (2310)	1107 (2440)			
875 (1930)	925 (2040)	971 (2140)			
993 (2190)	1048 (2310)	1107 (2440)	1161 (2560)	1211 (2670)	1261 (2780)
957 (2110)	1030 (2270)	1093 (2410)	1152 (2540)	1216 (2680)	1270 (2800)
957 (2110)	1012 (2230)	1066 (2350)	1116 (2460)		
957 (2110)	1030 (2270)	1093 (2410)	1152 (2540)	1216 (2680)	1270 (2800)
957 (2110)	1012 (2230)	1066 (2350)	1116 (2460)	1166 (2570)	1216 (2680)

B-08078

Figure 18—Tire Load Limits and Inflation Pressure (P)

WHEEL CODE AND LIMITS

Code*	Wheel Size	Max Load kg (Lbs.)	Max Pressure kPa (PSI)
AA	16 x 6.5 L	1381 (3045)	621 (90)
AF	16 x 6 K	1107 (2440)	517 (75)
BF	16 x 6.5 L	1261 (2780)	586 (85)
ZT	19.5 x 6	1261 (2780)	655 (95)
ZY	19.5 x 6	1152 (2540)	552 (80)

*Wheel code is located on the wheel just to the right of the valve stem hole.

B-08079

Figure 19—Wheel Codes and Load Limits (P)

SECTION 4A

PROPELLER SHAFT

The following "Notice" applies to one or more steps in the assembly procedure of components in this portion of this manual as indicated at appropriate locations by the terminology "Notice: See 'NOTICE' on page 4A-1 of this section".

NOTICE: All propeller shaft to pinion flange fasteners are important attaching parts in that they could affect the performance of vital parts and systems, and/or could result in major repair expense. They must be replaced with one of the same part number or with an equivalent part if replacement becomes necessary. Do not use a replacement part of lesser quality or substitute design. Torque values must be used as specified during reassembly to assure proper retention of all parts.

CONTENTS

SUBJECT	PAGE
Description	4A- 1
Propeller Shaft	4A- 1
Center Bearing	4A- 1
Universal Joint	4A- 1
Diagnosis Of Driveline Vibration (Road Test)	4A- 3
Diagnosis Of Propeller Shaft and Universal Joint	4A- 4
On-Vehicle Service	4A- 5
Propeller Shaft Balance Check	4A- 5
Propeller Shaft Runout Check	4A- 5
Propeller Shaft Replacement (Rear Drive)	4A- 6
Propeller Shaft Replacement (Front Drive)	4A- 7
Lubrication	4A- 9
Specifications	4A-10
Special Tools	4A-10

DESCRIPTION

PROPELLER SHAFT

Torque is transmitted from the transmission to the rear axle through one or more propeller shafts and universal joint assemblies. The number of propeller shafts and universal joint assemblies vary with the vehicle wheel base, and the combination of transmission, transfer case (front drive) and rear axle equipment.

All propeller shafts are the balanced tubular type (figure 1). A splined slip joint is provided in some drivelines and others use a companion flange at the transmission end of the driveline. If two or more propeller shafts are used on a vehicle the slip joint is usually at the forward end of the rear propeller shaft.

Phasing

The propeller shaft is designed and built with the yoke lugs (ears) in line with each other (figure 1). This design produces the smoothest running shaft possible, and is called phasing.

Vibration can be caused by an out of phase propeller shaft. The propeller shaft will absorb vibrations from speeding up and slowing down each time the universal joint goes around. This vibration would be the same as a person snapping a rope and watching the "wave" reaction flow to the end. A propeller shaft working in

phase would be similar to two persons snapping a rope at the same time, and watching the "waves" meet and cancel each other out. In comparison this would be the same as the universal joints on a propeller shaft. A total cancellation of vibration produces a smooth flow of power in the driveline. It is very important to reference mark the propeller shaft before removal, to assure phased installation alignment. Some propeller shafts have alignment marks or arrows stamped on the shaft at the time of production.

CENTER BEARING

Center bearings support the driveline when two or more propeller shafts are used. The center bearing is a ball type bearing mounted in a rubber cushion that is attached to a frame crossmember. The bearing is pre-lubricated and sealed by the manufacturer (figure 2).

UNIVERSAL JOINT

A universal joint is two Y-shaped yokes connected by a crossmember called a spider. The spider is shaped like a cross having arms of equal length called trunnions (figure 3).

4A-2 PROPELLER SHAFT

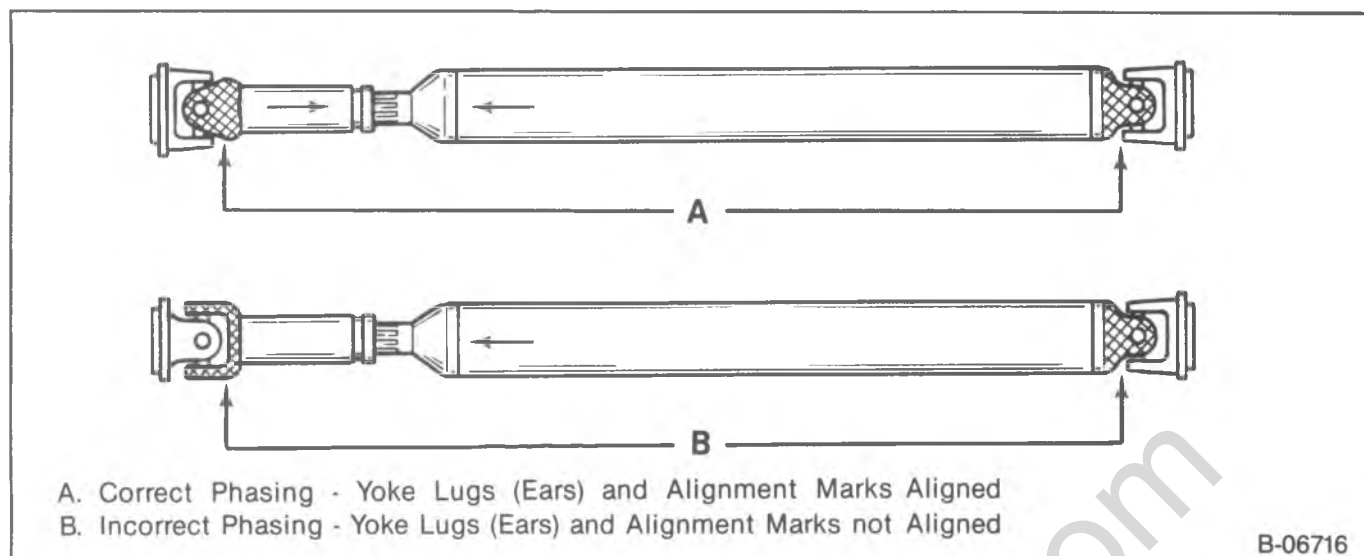

Figure 1—Propeller Shaft Assembly Phased

Universal joints are designed to handle the effects of various loadings and rear axle windup during acceleration. Within the designed angle variations the universal joint will operate efficiently and safely. When the design angle is changed or exceeded the operational life of the joint may decrease.

The trunnion bearings used in universal joints are the needle roller type. The needle rollers are held in place on the trunnions by round bearing cups. The bearing cups

are held in the yokes by either (depending on the manufacturer) snap rings or injected plastic.

When a driveline has a large or deep angle a constant velocity joint is used. Essentially, the constant velocity joint is made of two universal joints coupled by a yoke and phased for constant velocity. A centering ball socket between the joints keeps a relative position between the two joints. This centering device causes each of the two units to operate through one half of the complete angle between the propeller shaft and the differential carrier

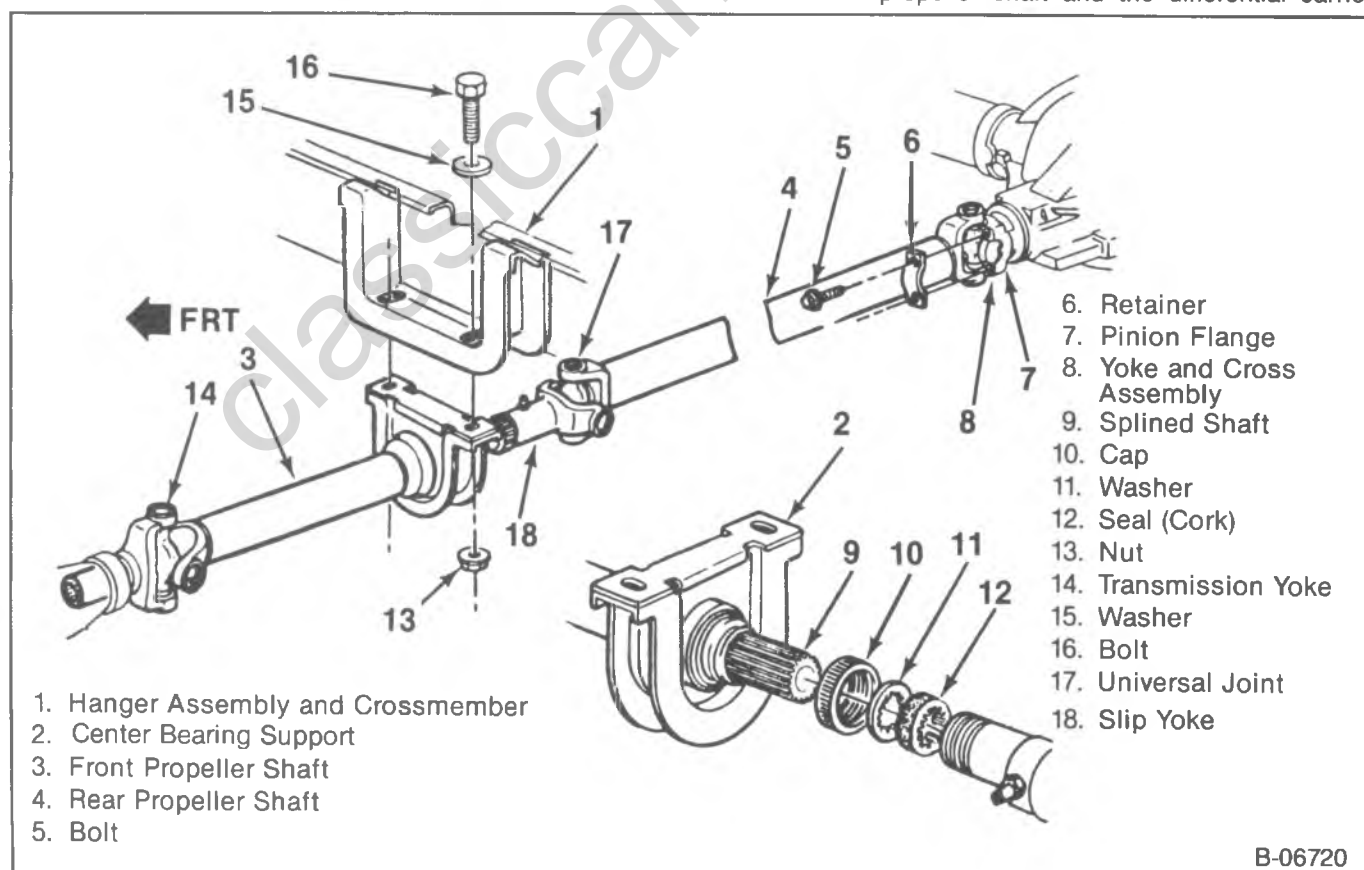

Figure 2—Center Bearing and Propeller Shaft Detail

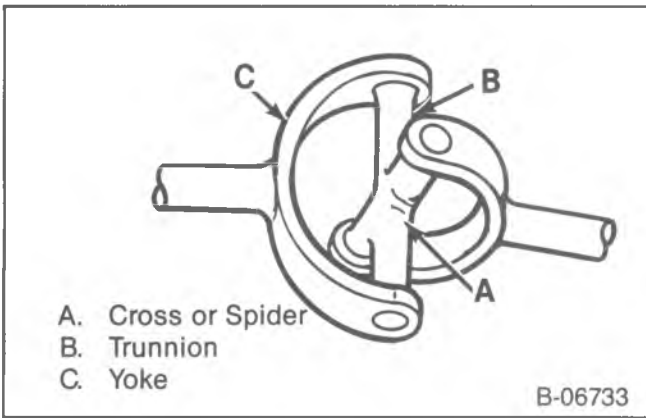

Figure 3—Simple Universal Joint

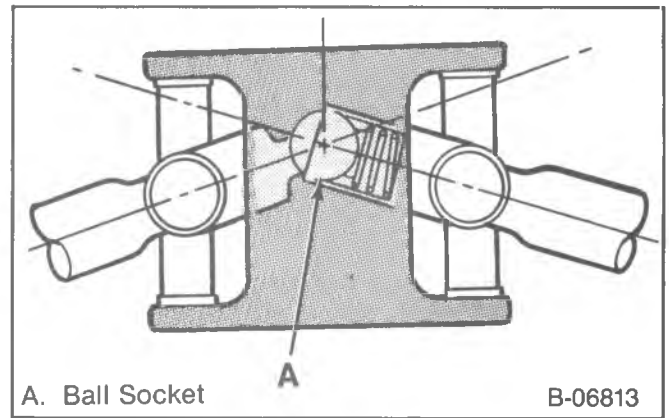

Figure 4—Constant Velocity Joint

(figure 4). The ball socket on a constant velocity universal joint requires periodic lubrication through the fitting provided.

DIAGNOSIS OF DRIVELINE VIBRATION (ROAD TEST)

Four major component groups are usually the cause of or are related to vibration. When a technician is road testing a vehicle for vibration he must remember the four major component groups:

1. Engine and mounts.
2. Clutch and transmission.
3. Tires, wheels and brake drums.
4. Propeller shaft and universal joints.

Before road testing a vehicle, check the following:

1. In or out of phase propeller shaft.
2. All fasteners for tightness at universal joints, wheel lugs and engine mounts.
3. Tire air pressure.
4. Load conditions.

ROAD TEST

A technician should road test the vehicle to diagnose exactly what the complaint is. Record the speed and rpm at which the greatest vibration occurs. The vibration is likely to be in two places, in the steering wheel or in the seat bottom. The road test can be helpful in locating the vibration source either forward or aft.

COAST TEST

Drive the vehicle past the vibration speed, shift into neutral and coast back through the vibration speed. In this test two kinds of vibration normally occur; a shaking or a buzzing. A shaking vibration is usually tires or a wheel and brake drum/disc assembly problem. A buzzing vibration is usually a driveline problem.

4A-4 PROPELLER SHAFT

DIAGNOSIS OF THE PROPELLER SHAFT AND UNIVERSAL JOINT

PROBLEM	POSSIBLE CAUSE	CORRECTION
Leak At The Front Slip Yoke (An Occasional Drop Of Lubricant Leaking From The Splined Yoke Is Normal And Requires No Attention)	<ol style="list-style-type: none"> 1. Rough surface on splined yoke; burred, nicked or worn. 2. Defective transmission rear oil seal. 	<ol style="list-style-type: none"> 1. Replace the seal. Minor burrs can be smoothed by careful use of crocus cloth or fine stone honing. Replace the yoke if badly burred. 2. Replace the transmission rear oil seal and replenish the transmission oil.
Universal Joint Noise	<ol style="list-style-type: none"> 1. Center bearing. 2. Worn universal joint bearings. 3. Improper lubrication. 4. Loose flange bolts. 	<ol style="list-style-type: none"> 1. Replace the center bearing. 2. Replace. 3. Lubricate as directed. 4. Tighten to "Specifications" later in this section.
Ping, Snap, Or Click In Drive Line (Usually Heard On Initial Load After The Transmission Is In Gear; Forward Or Reverse)	<ol style="list-style-type: none"> 1. Loose bushing bolts on the rear springs or upper and lower control arms. 2. Loose or out of phase companion flange. 	<ol style="list-style-type: none"> 1. Tighten the bolts to specified torque. 2. Remove companion flange, turn 180 degrees from its original position, lubricate the splines and install. Tighten the bolts and pinion nut to specified torque.
Knocking Or Clunking Noise In The Driveline When Operating The Vehicle In A Floating Condition In High Or Neutral Gear At 10 MPH (16 km/h)	<ol style="list-style-type: none"> 1. Worn or damaged universal joint. 2. Side gear hub counterbore in the differential is worn oversize. 	<ol style="list-style-type: none"> 1. Replace the worn or damaged universal joint. 2. Replace the differential case and/or the sidegears.
Roughness Or Vibration	<ol style="list-style-type: none"> 1. Bent or dented propeller shaft. 2. Undercoating on propeller shaft. 3. Tire unbalance, 30-80 mph (48-129 km/h). Not throttle conscious. 4. Tight universal joints. 5. Worn universal joints. 6. Burrs or gouges on companion flange. Check snap ring locating surfaces on flange yoke. 7. Propeller shaft, parking brake drum or companion flange is unbalanced. 8. Incorrect rear joint angle. The angle is usually too large when it is a factor. 9. Excessive looseness at the slip spline. 10. Distorted or damaged yokes or flanges. 11. Yokes out of phase. 12. Propeller shaft runout at 50 mph (80 km/h). Throttle conscious. 	<ol style="list-style-type: none"> 1. Replace propeller shaft. 2. Clean propeller shaft. 3. Balance or replace as required. 4. Impact yokes with a shaft hammer to free up. If unable to free up or if joint feels rough when rotated, replace. 5. Replace. 6. Rework or replace the companion flange. 7. Check for a missing balance weight on the propeller shaft. Rotate the companion flange 180 degrees. 8. Check and correct trim height at curb weight. Check and correct joint angle. 9. Replace necessary parts. 10. Install new yokes or flanges. 11. Remove companion flange, turn 180 degrees from the original position, lubricate the splines and install. Tighten bolts to specified torque. 12. Check propeller shaft runout at front and rear. Should be less than specified. If above, rotate propeller shaft 180 degrees and recheck. Replace the propeller shaft if runout is still over specification.

DIAGNOSIS OF THE PROPELLER SHAFT AND UNIVERSAL JOINT (CONTINUED)

PROBLEM	POSSIBLE CAUSE	CORRECTION
Scraping Noise	Slinger, companion flange, or end yoke rubbing on rear axle or center bearing.	Correct the interference.
Roughness Above 35 MPH (56 km/h) Felt And/Or Heard	Tires unbalanced or worn.	Balance or replace as required.
Squeak	1. Lack of lubricant. 2. Center bearing.	1. Lubricate joints and splines. Also check for worn or brinelled parts. 2. Replace or lubricate.
Whine Or Whistle	Center support bearing.	Place the vehicle on a hoist with rear wheels free to rotate and diagnose for source of noise, replace.
Shudder On Acceleration, (Low Speed)	1. Loose or missing bolts at the center bearing or flanges. 2. Incorrectly set front joint angle. 3. Worn universal joint.	1. Replace or tighten bolts to specified torque. 2. Shim under the transmission support mount to change the front joint angle. 3. Replace.

ON-VEHICLE SERVICE

PROPELLER SHAFT BALANCE CHECK

- Raise the vehicle on a twin post hoist so the wheels can spin.

Remove or Disconnect

1. Tire and wheel assemblies and the brake drums.
 - **DO NOT APPLY THE BRAKE WITH THE DRUMS REMOVED.**

Inspect

- Propeller shaft, universal joints and attachments for mud, undercoating or loose fasteners.

Clean

- Propeller shaft, universal joints and attachments.

Tighten

- Any loose attachments or fasteners.

Important

- Run the vehicle in gear at the speed where the disturbance peaks; observe the intensity of the disturbance.
 - Stop the engine.
2. Propeller shaft.

- Rotate the propeller shaft 180 degrees from the original position.

Install or Connect

1. Propeller shaft.
 - Determine the position which gives the best balance.
2. Rear drums, wheel and tire assemblies.
 - Determine the position which gives the best driveline response by road testing the vehicle for a final check of the propeller shaft balance.
 - Unacceptable balance, replace the propeller shaft.

PROPELLER SHAFT RUNOUT CHECK

Noise or vibration at high speed could be caused by a bent propeller shaft. The propeller shaft could have been damaged by rough handling or a collision. Check for propeller shaft straightness.

1. Raise the vehicle on a twin post hoist so the wheels can spin.
2. Attach a dial indicator having a magnetic base to a smooth place on the vehicle underbody.
3. Take dial indicator readings at the propeller shaft check points shown in figure 5. For runout specifications, refer to figure 6.

4A-6 PROPELLER SHAFT

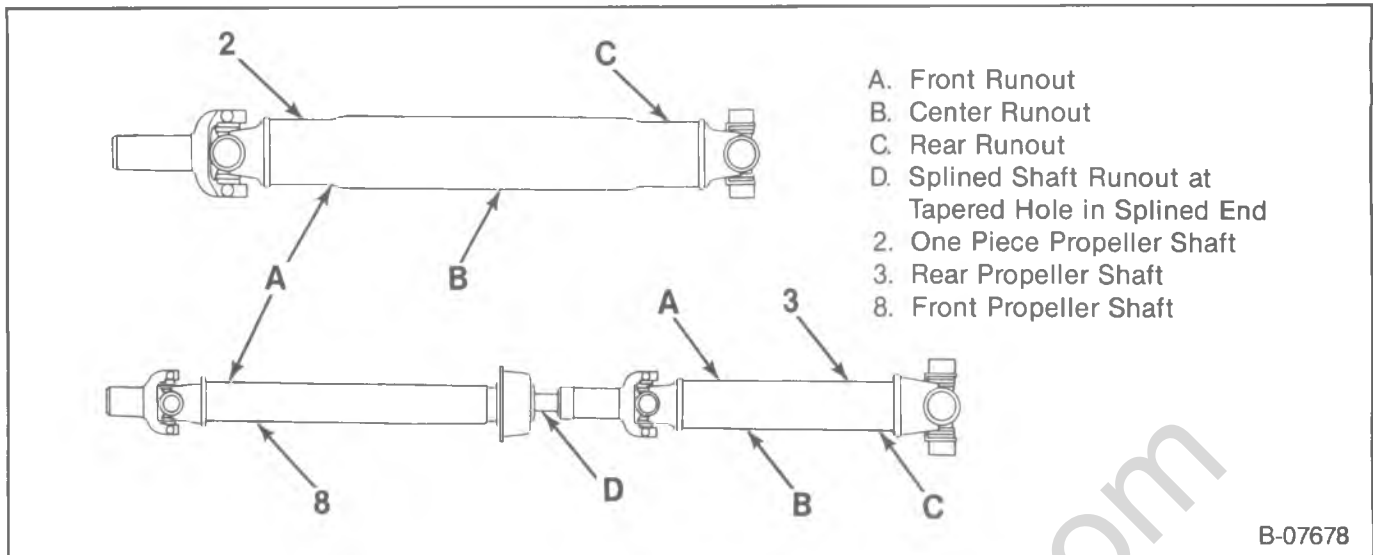

Figure 5—Checking Propeller Shaft Runout

! Important

- Do not attach the dial indicator base at a weld.
4. With the transmission in neutral, hand rotate the axle pinion flange or the transmission yoke and take the necessary dial indicator readings on the propeller shaft. Record the readings. Models having a two-piece driveline, measure the rear propeller shaft runout (figure 5). Reference mark the position of the rear propeller shaft yoke to the pinion flange, then remove the rear propeller shaft and measure the front propeller

shaft runout on the tube and at the tapered hole on the splined shaft end (figure 5). If the runout exceeds specification, rotate the propeller shaft 180 degrees at the companion flange and install. Check the runout.

5. If the runout is still over specification at one or more check points, replace the propeller shaft after checking for vibration or noise. Check the runout on the replacement propeller shaft.
6. If the new propeller shaft runout is over specification, check for a bent companion flange.

! Important

- The splined end of the front propeller shaft is critical to the smooth operation of a two-piece driveline. Be sure the dial indicator readings are accurate.

PROPELLER SHAFT REPLACEMENT (REAR DRIVE)

↔ Remove or Disconnect (Figure 2)

Tool Required:

J-33051, Driveshaft Wrench.

- Raise the vehicle on a hoist.
- Skid plate if used.
 - Reference mark the propeller shaft (4) to pinion flange (7) connection.
 - Bolts (5).
 - Retainers(6).

! Important

- Do not pound on the original propeller shaft yoke ears. The injection joints may fracture. Never pry or place any tool between a yoke and a universal joint.
- Yoke and cross assembly (8).
 - Tape bearing cups to prevent the loss of bearing rollers.
 - Propeller shaft (4).
 - Slide the propeller shaft (4) forward.

PROPELLER SHAFT	FRONT CHECK	CENTER CHECK	REAR CHECK
ONE PIECE	.040	.050	.055
TWO PIECE FRONT	.020		.008▲
TWO PIECE REAR	.030*	.030	.035

▲NOTE: This measurement must be taken at the tapered hole on the splined shaft after the rear propeller shaft is removed.

* NOTE: This measurement must be taken with the rear propeller shaft mounted on the front shaft which is within specifications.

B-07557

Figure 6—Propeller Shaft Runout Specifications

- Lower the propeller shaft (4) and withdraw under the rear axle.
- Do not allow the universal joint (17) to incline greatly; the joint may fracture.

Models with a two-piece propeller shaft

- Nut (13).
- Bolt (16) and washer (15).
- Center bearing support (2).
 - Support the propeller shaft (3).
- Cap (10).
- Washer (11).
- Seal (12).
- Front propeller shaft (3).
 - Always support the propeller shaft (3).
 - Do not allow the universal joint (14) to bend deeply as the universal joint could fracture.
 - Withdraw the propeller shaft (3) with a rearward movement.



Clean

- All parts.



Inspect

- Outer diameter of transmission yoke (14) for burrs. Any burring will damage the transmission seal.
- For proper installation and uniform seating of bearing cups.
- Slip yoke (18) splines for wear.
- For twisted slip yoke splines or possibly the wrong universal joint.



Install or Connect (Figures 2 and 7)

One-Piece Propeller Shaft

- Propeller shaft (4) into the transmission.
 - Lubricate slip joint.
- Yoke and cross assembly (8) onto the pinion flange (7).
 - Align the reference marks on the pinion flange (7) and the propeller shaft rear yoke (8). Seat the yoke properly.
- Retainer (6).

NOTICE: See "Notice" on page 4A-1 of this section.

- Bolt (5).



Tighten

- Bolt (5) to torque in "Specifications" at the end of this section.

Two-Piece Propeller Shaft

- Propeller shaft (3) into the transmission.
 - Be sure joint is lubricated.
 - Bottom the propeller shaft (3) yoke in the transmission.
- Center bearing support (2) onto hanger (1).
 - Align the center bearing support 90 degrees to the propeller shaft (3, 4) center lines. Refer to figure 7.
- Bolt (16).
- Washer (15).
- Nut (13).



Tighten

- Nut (13) to torque specification later in this section. Maintain alignment (figure 7).



Important

- Set the transmission yoke (14) ears in a vertical position for proper phasing (figure 7).
- Cap (10).
 - Washer (11).
 - Seal (12).
 - Locate the bridged tooth on the splined shaft (9).
 - Slip yoke (18) onto the splined shaft (9).
 - Mate the missing tooth in the yoke (18) with the bridged tooth on the splined shaft (9) figure 7. Support the propeller shaft (4).
 - Be sure the slip yoke (18) ears are horizontal, figure 7.
 - Propeller shaft (4).
 - Align reference marks.
 - Check bearings for proper fit.
 - Retainer (6).

NOTICE: See "Notice" on page 4A-1 of this section.

- Bolt (5).

- Check for proper joint fit.



Tighten

- Bolts (5) to specified torque. Refer to "Specifications" at the end of this section.
- Lubricate the slip yoke (18).

PROPELLER SHAFT REPLACEMENT (FRONT DRIVE)



Remove or Disconnect (Figure 8)

Tool Required:

J-22610, Keystone Clamp Pliers.

- Raise the vehicle on a hoist.
 - Remove skid plate if used.
 - Reference mark the relationship of the propeller shaft (14) to the front axle and the transfer case flange (17).
- Slip yoke (13) from the front axle yoke (12).
 - Nut (10), washer (11) and U-bolt (15).
 - Bolt (20) and retainer (22).



Important

- Do not pound on the joint to disconnect.
- Bolt (18) at the flange (17).
- Boot (21) if used.
 - Release boot retainers using J-22610.
 - Slide the propeller shaft (14) forward, enough to disengage, then withdraw the propeller shaft (14) rearward.
 - Avoid dropping cap assemblies from the yoke ends.



Clean

- All parts.

4A-8 PROPELLER SHAFT

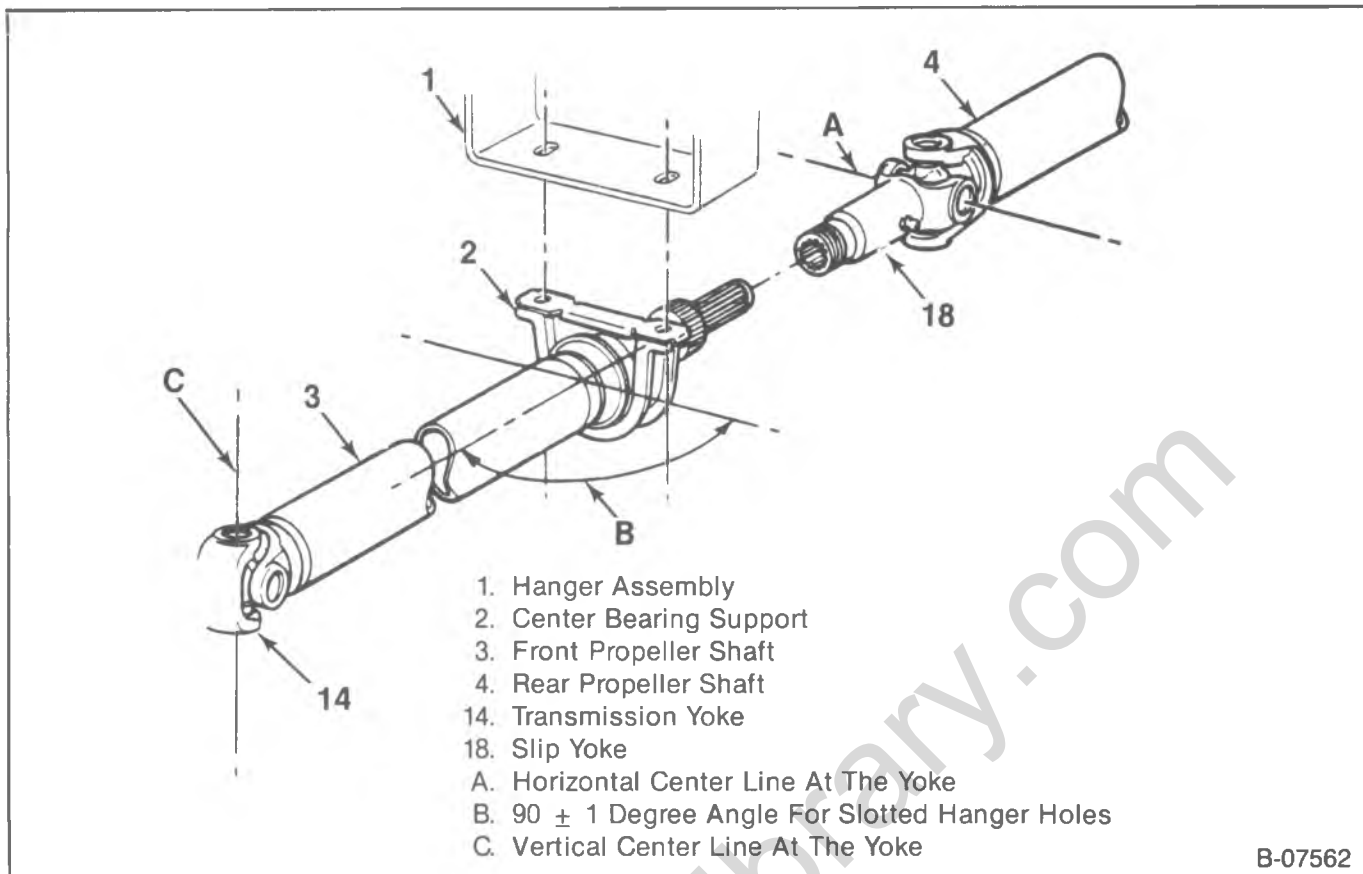

Figure 7—Alignment for Two-Piece Propeller Shaft In Phase, G and V Models

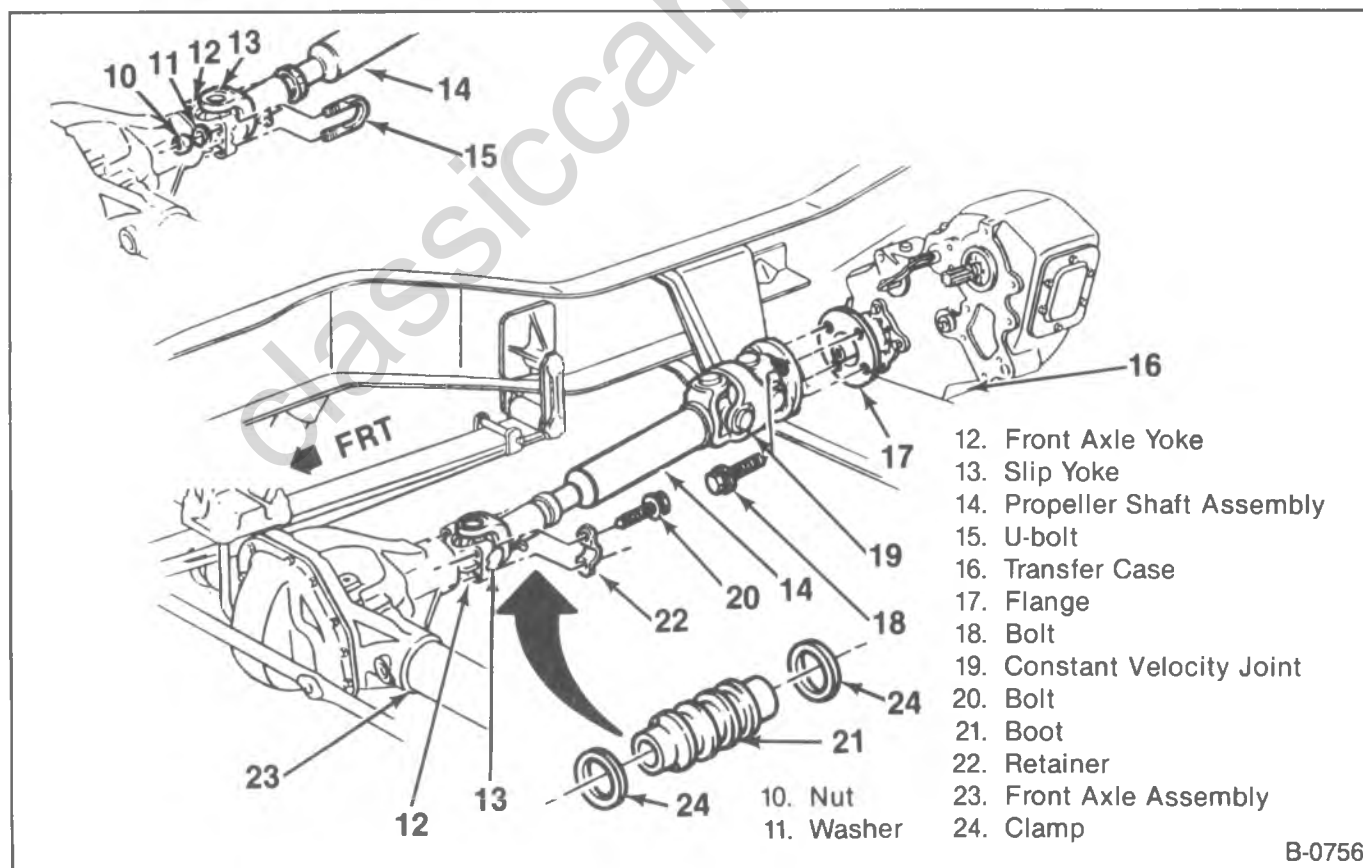

Figure 8—Front Propeller Shaft and Driveline Detail

Inspect

- Splines for damage, wear, burrs and twisting.
- Bearings for wear.
- Propeller shaft (14) for straightness.

Install or Connect (Figure 8)

Tools Required:

J-22610, Keystone Clamp Pliers.
 J-25512, CV Propshaft Lube Gun (1/8-inch pipe).
 J-25512-2, Needle point.

- Lubricate the slip yoke (13) before installing the boot (21). Refer to "Lubrication" later in this section.
1. Boot (21) if used.
 - Retainers (24) using J-22610.
 2. Slip yoke (13) to the axle yoke (12).
 - Adjust propeller shaft (14) length.

- Mate the joint using reference marks.
 - U-bolt, washer (11) and nut (10).
 - Retainer (22) and bolt (20).
- Support the propeller shaft (14).

NOTICE: See "Notice" on page 4A-1 of this section.

Tighten

- All fasteners to specified torque. Refer to "Specifications" at the end of this section.
3. Bolt (18) at the flange (17).
 - Mate the joint using reference marks.
 - Lubricate the Constant Velocity Joint (19). Refer to "Lubrication" later in this section.
 4. Skid plate, if used.

Tighten

- All fasteners to specified torque. Refer to "Specifications" later in this section.

LUBRICATION

The front axle propeller shaft found on four-wheel drive vehicles requires a special lubricant at two locations: the constant velocity joint, and the slip yoke.

Constant Velocity Joint (C/V Joint)

The constant velocity (C/V) joint, located at the transfer case end of the front propeller shaft, must be lubricated periodically with a special lubricant, 1050679 or equivalent. If the lubrication fitting cannot be seen from beneath the vehicle refer to figure 9 which shows how the C/V joint may be lubricated from above, with a special adapter J-25512-2 on the end of a flex hose (figure 9).

Slip Spline

Apply chassis lubricant at the slip spline grease fitting until the grease begins to leave through the vent hole.

If the slip spline is dry or corroded, it may be necessary to disconnect the propeller shaft from the vehicle, remove the slip yoke, and wire brush the affected area. Wipe clean before installation.

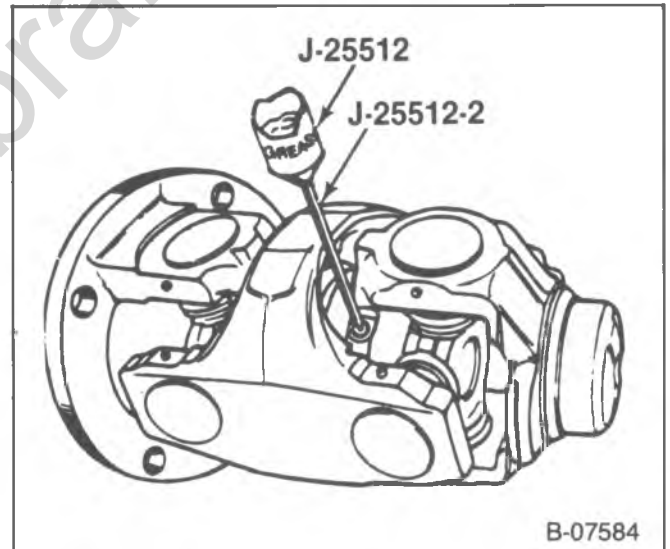

Figure 9—Lubricating the Constant Velocity Joint Fitting

B-07584

4A-10 PROPELLER SHAFT

SPECIFICATIONS

APPLICATION	MODEL	TORQUE	
		N·m	FT. LBS.
Propeller Shaft:			
To Rear Axle (Retainer or Strap)	R, G, P	20*	15*
To Rear Axle	R, V, G300, P	35	26
Two Piece Propeller Shaft—Front			
To Brake Hub Studs	P300	27	20
To Transmission Flange/Yoke	R, G, P	20	15
To Transfer Case Yoke (Nut)	V	27	20
Center Bearing Support:			
To Hanger (Nut)	P300	33	24
To Hanger	R	20	15
To Hanger (Nut)	P	35	26
To Hanger	V	27	20
To Hanger (Top of Crossmember)	R	33	24
To Hanger (Slotted Holes)	R, G	33	24
Two Piece Propeller Shaft—Rear:			
To Rear Axle (Nut)	P	27	20
To Rear Axle	R, G, P	20	15
To Rear Axle	R, V, G300, P300	33	24
Propeller Shaft:			
To Transfer Case (Front-Flange Bolt)	V	100	74
To Front Axle Assembly (Bolt)	V100, 200	20	15
To Front Axle Assembly (U-Bolt and Nut)	V300	20	15

*Torque Specification Is For Hex Head Bolt.

SPECIAL TOOLS

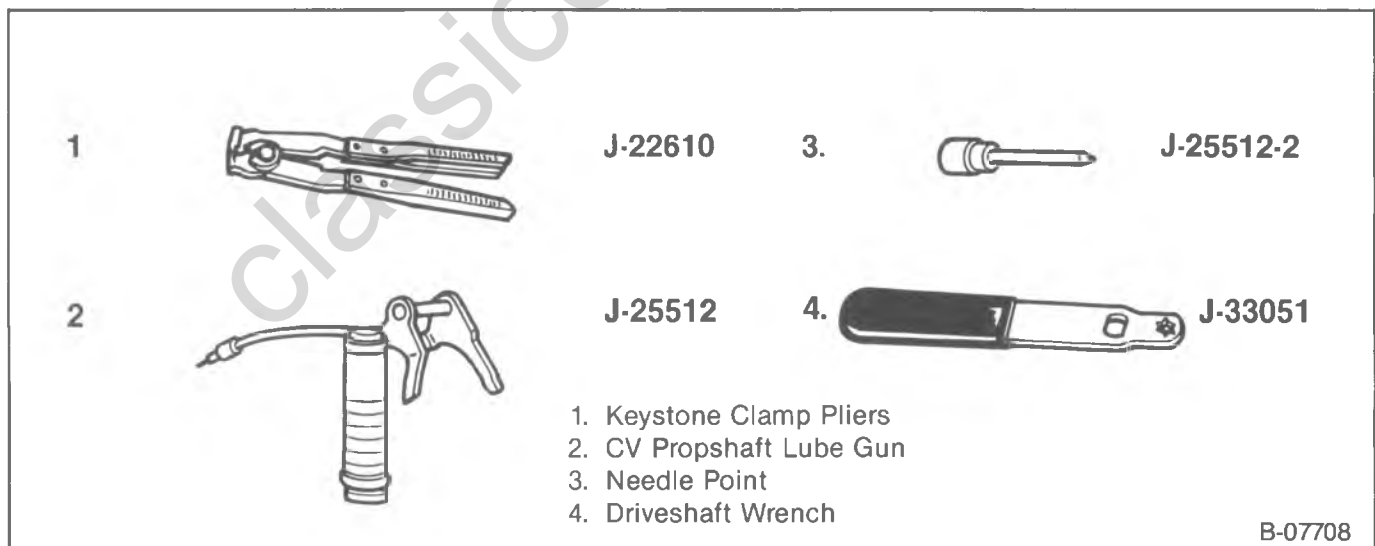

B-07708

Figure 10—Special Tools

SECTION 4B1

REAR AXLE

The following "Notice" applies to one or more steps in the assembly procedure of components in this portion of the manual as indicated at appropriate locations by the terminology: "NOTICE: See 'Notice' on page 4B-1 of this section."

NOTICE: All rear axle fasteners are important attaching parts in that they could affect the performance of vital parts and systems, and/or could result in major repair expense. They must be replaced with one of the same part number or with an equivalent part if replacement becomes necessary. Do not use a replacement part of lesser quality or substitute design. Torque values must be used as specified during reassembly to assure proper retention of all parts.

CONTENTS

SUBJECT	PAGE
Description	4B1- 1
Rear Axle Operation	4B1- 1
Diagnosis of the Rear Axle	4B1- 2
Determining the Type of Noise	4B1- 2
On-Vehicle Service	4B1- 8
Rear Axle Assembly Replacement (All Axles)	4B1- 8
Semi Floating Axle (8 ¹ / ₂ -9 ¹ / ₂ -Inch Ring Gear)	4B1- 9
Axle Shaft, Oil Seal and Bearing Replacement	4B1- 9
Brake Backing Plate Replacement	4B1-11
Wheel Stud Replacement	4B1-11
Pinion Flange, Dust Deflector/Oil Seal Replacement	4B1-12
Full Floating Axle (9 ³ / ₄ -10 ¹ / ₂ -Inch Ring Gear)	4B1-14
Axle Shaft Replacement	4B1-14
Hub And Drum Assembly Replacement	4B1-14
Wheel Bearing/Cup Replacement	4B1-15
Non-Demountable Type Drum Replacement	4B1-16
Wheel Bolt Replacement	4B1-16
Bearing Adjustment	4B1-16
Pinion Oil Seal/Companion Flange Replacement	4B1-17
Full Floating Axle (12-Inch Ring Gear)	4B1-18
Axle Vent Replacement	4B1-18
Axle Shaft Replacement	4B1-18
Bearing Adjustment	4B1-18
Drive Pinion Oil Seal Replacement	4B1-19
Specifications	4B1-20
Special Tools	4B1-21

DESCRIPTION

Light duty trucks use various rear axles. These axles can be identified by ring gear size in inches, by manufacturer (Corporate, Dana, or Rockwell) and by the type of axle shaft used (Semi-Floating or Full Floating). Corporate axles include the 8¹/₂, 9¹/₂ and 10¹/₂-inch ring gear axles. Dana also supplies a 10¹/₂-inch ring gear axle as well as a 9³/₄-inch ring gear axle. The 12-inch ring gear axle is supplied by Rockwell, and uses rear wheel disc brakes.

REAR AXLE OPERATION

A basic differential has a set of four gears. Two are called differential side gears and the other two are differential pinion gears. Some differentials have more than two pinions. Each side gear is splined to an axle

shaft, therefore each axle shaft must turn when its side gear rotates.

The differential pinion gears are mounted on a differential pinion shaft, and the gears are free to rotate on this shaft. The pinion shaft is fitted into a bore in the differential case and is at right angles to the axle shafts.

Power flow through the differential is as follows: the drive pinion rotates the ring gear. The ring gear, being bolted to the differential case, rotates the case. The differential pinion, as it rotates with the case, forces the pinion gears against the side gears. When both wheels have equal traction, the pinion gears do not rotate on the pinion shaft because the input force on the pinion gear is equally divided between the two side gears. Therefore, the pinion gears revolve with the pinion shaft, but do not

4B1-2 REAR AXLE

rotate around the shaft itself. The side gears, being splined to the axle shafts and in mesh with the pinion gears, rotate the axle shafts.

If a vehicle were always driven in a straight line, the ring and pinion gears would be sufficient. The axle shaft could then be solidly attached to the ring gear and both driving wheels would turn at equal speed.

However, if it became necessary to turn a corner, the tires would scuff and slide because the outside wheel would travel further than the inside wheel. To prevent tire scuffing and sliding, the differential becomes effective and allows the axle shafts to rotate at different speeds.

When the vehicle turns a corner, the outer rear wheel must turn faster than the inner wheel. The inner wheel turns slower than the outer wheel and slows its rear axle side gear (as the axle shaft is splined to the side gear) and the rear axle pinion gears will roll around the slowed rear axle side gear, driving the other rear axle side gear and wheel faster.

LOCKING REAR AXLE

Eaton Locking Differential

The locking rear differential allows for normal differential function as indicated in the standard rear axle description. Additionally, the locking rear differential uses multi-disc clutch packs and a speed sensitive engagement mechanism that locks both wheels together if one wheel should spin excessively during slow vehicle operation.

Under light loads, the clutch plates alone tend to lock axle shafts to the differential case, and therefore, each other. This is due primarily to the gear separating load developed on the right side clutch pack. This induced clutch torque capacity resists motion between the side gear and the rear axle differential case. The axle shaft torques developed when turning a corner will overcome this capacity and allow differentiation. Also, heavier throttle application will cause differential, but this starts the full-lock feature of the unit.

Full locking is accomplished through the use of a heavyweight governor mechanism, cam system, and multi-disc clutch packs. The flyweights on the governor mechanism move outward to engage a latching bracket whenever the wheel-to-wheel speed varies by approximately 100 rpm or more. This action retards a cam which, in turn, compresses the multi-disc clutch packs locking both side gears to the case. The 100 rpm wheel-to-wheel speed allows for cornering without differential lock-up.

At vehicle speeds above approximately 32.2 km/h (20 mph), the latching bracket overcomes a spring preload and swings away from the flyweights. At this vehicle speed or greater, the differential will not lock, as the added traction is generally not required.

All gear axle parts of vehicles equipped with the locking rear axle are interchangeable with those equipped with the conventional rear axle, except for the case assembly.

DIAGNOSIS OF THE REAR AXLE

The most essential part of rear axle service, as with any mechanical repair, is proper diagnosis of the problem, and, in axle work one of the most difficult areas to diagnose is noise. Locating a broken axle shaft, or broken differential gear, presents little or no problem, but, locating and isolating axle noise can be an entirely different matter.

Degree of Noise

Any gear driven unit, especially an automotive drive axle where engine torque multiplication occurs at a 90 degree turn in the drive line, produces a certain amount of noise. Therefore, an interpretation must be made for each vehicle to determine whether the noise is normal or if a problem actually exists. A normal amount of noise must be expected and cannot be eliminated by conventional repairs or adjustment.

Acceptable noise can be defined as a slight noise heard only at a certain speed or under unusual or remote conditions. For example, this noise tends to reach a "peak" at speeds from 40 to 60 miles per hour (60 to 100 km/h) depending on road and load conditions, or on gear ratio and tire size. This slight noise is in no way indicative of trouble in the axle assembly.

Drive line noises may baffle even the best diagnostician. Vehicle noises coming from tires, transmission, propeller shaft, universal joints, and front or rear wheel bearings, are often mistaken for axle noise. Such practices as: raising tire pressure to eliminate tire

noise (although this will not silence tread noise of mud and snow tires), listening for the noise at varying speeds and road surfaces, on drive, float, and coast conditions will aid in locating the source of alleged axle noises. Thus, every effort should be made to isolate the noise to a specific drive line component instead of making a random guess that could be a costly waste of time.

DETERMINING THE TYPE OF NOISE

External Noise

When a rear axle is suspected of being noisy, it is advisable to make a thorough test to determine whether the noise originates in the tires, road surface, front wheel bearings, engine, transmission, or rear axle assembly. Noise which originates in other places cannot be corrected by adjustment or replacement of parts in the rear axle assembly.

Road Noise—Some road surfaces, such as brick or rough-surfaced concrete, cause noise which may be mistaken for tire or rear axle noise. Driving on a different type of road, such as smooth asphalt or dirt, will quickly show whether the road surface is the cause of noise. Road noise usually is the same on drive or coast.

Tire Noise—Tire noise may easily be mistaken for rear axle noise, even though the noisy tires may be located on the front wheels. Tires worn unevenly, or having surfaces on non-skid divisions worn in saw-tooth fashion, are

usually noisy and may produce vibrations which seem to originate elsewhere in the vehicle. This is particularly true with low tire pressure.

Tire Noise Test—Tire noise changes with different road surfaces, but rear axle noise does not. Temporarily inflating all tires to 345 kilopascals (50 pounds per square inch) pressure, for test purposes only will materially alter noise caused by tires but will not affect noise caused by the rear axle. Rear axle noise usually stops when coasting at speeds under 30 miles per hour; however, tire noise continues but with lower tone as the vehicle speed is reduced. Rear axle noise usually changes when comparing “pull” and “coast” but tire noise remains about the same.

Engine and Transmission Noises—Sometimes a noise which seems to originate in the rear axle is actually caused by the engine or transmission. To determine which unit is actually causing the noise, observe approximate car speeds and conditions under which the noise is most pronounced; then stop the vehicle in a quiet place to avoid interfering noises. With the transmission in neutral, run the engine slowly up and down through the engine speeds corresponding to the vehicle speed at which the noise was most pronounced. If a similar noise is produced with the vehicle standing, it is caused by the engine or transmission and not the rear axle.

Front Wheel Bearing Noise—Loose or rough front wheel bearings will cause noise which may be confused with rear axle noise; however, front wheel bearing noise does not change when comparing “pull” and “coast.” Light application of the brake, while holding the vehicle speed steady, will often cause the wheel bearing noise to diminish, as this takes some weight off of the bearing. Front wheel bearings may be easily checked for noise by jacking up the wheels and spinning them, and also by shaking the wheels to determine if the bearings are excessively loose.

Body Boom Noise or Vibration—Objectional “body boom” noise or vibration at 55–65 mph (90–100 km/h) can be caused by an unbalanced propeller shaft. Excessive looseness at the spline can contribute to this unbalance.

Other items that may also contribute to the noise problem are as follows:

1. Undercoating or mud on the shaft, causing unbalance.
2. Shaft or companion flange balance weights missing.
3. Shaft damage, such as bending, dents, or nicks.
4. Tire-type roughness. Switch tires from a known good vehicle to determine a tire fault.

If, after making a comprehensive check of the vehicle, all indications point to the rear axle, further diagnostic steps are necessary to determine the axle components at fault. True rear axle noise generally falls into two categories: gear noise and bearing noise.

Rear Axle Noises

If a careful test of the vehicle shows that the noise is not caused by external items, it is then reasonable to assume that noise is caused by the rear axle assembly. Test the rear axle on a smooth level road to avoid road noise. It is not advisable to test the rear axle for noise by running with the rear wheels jacked up.

Noise in the rear axle assembly may be caused by a faulty propeller shaft, faulty rear wheel bearings, faulty differential or pinion shaft bearings, misalignment

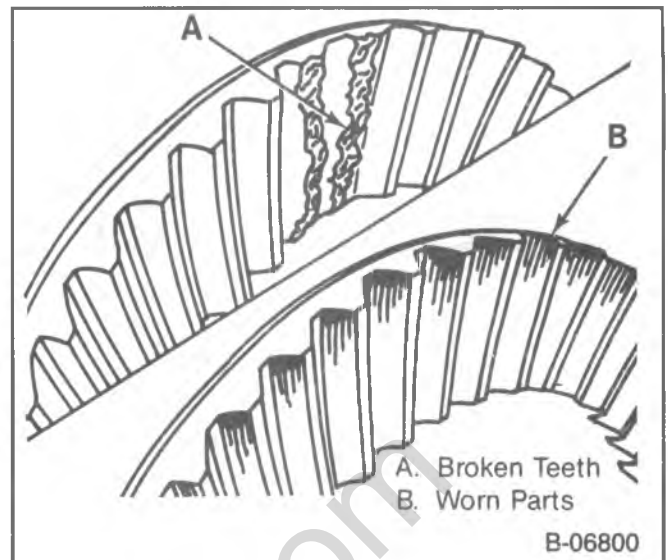

Figure 1—Causes of Gear Noise

between two U-joints, or worn differential side gears and pinions; noise may also be caused by a mismatched, improperly adjusted, or scored, ring and pinion gear set.

Rear Wheel Bearing Noise—A rough rear wheel bearing produces a vibration or growl which continues with the vehicle coasting and the transmission in neutral. A brinelled rear wheel bearing causes a knock or click approximately every two revolutions of the rear wheel, since the bearing rollers do not travel at the same speed as the rear axle and wheel. With the rear wheels jacked up, spin the rear wheels by hand while listening at the hubs for evidence of a rough or brinelled wheel bearing.

Differential Side Gear and Pinion Noise—Differential side gears and pinions seldom cause noise since their movement is relatively slight on straight ahead driving. Noise produced by these gears will be most pronounced on turns.

Pinion Bearing failures can be distinguished because they rotate at higher speeds than differential side bearings and axle shaft bearings. Rough or brinelled pinion bearings produce a continuous low pitched whirring or scraping noise starting at a low speed.

Side Bearings produce a constant rough noise pitched lower than pinion bearing noise. Side bearing noise may also fluctuate in the above rear wheel bearing test.

Gear Noise

There are two basic types of gear noise. The first type is produced by broken, bent, or forcibly damaged gear teeth and is usually quite audible over the entire speed range and presents no particular problem in diagnosis. For example, hypoid gear tooth scoring generally results from the following: insufficient lubricant, improper break-in, improper lubricant, insufficient gear backlash, improper ring and pinion gear alignment, or loss of drive pinion nut torque. The scoring will progressively lead to complete erosion of the gear tooth, or gear tooth pitting and then eventual fracture if the initial scoring condition is not corrected (figure 1). Another cause of hypoid tooth fracture is extended overloading of the gear set which will produce fatigue fracture, or shock loading which will result in sudden failure.

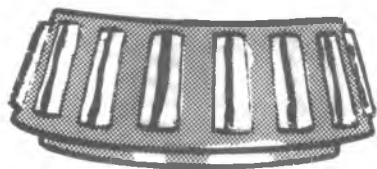

ABRASIVE ROLLER WEAR

Pattern on races and rollers caused by fine abrasives.

Clean all parts and housings, check seals and bearings and replace if leaking, rough or noisy.



ABRASIVE STEP WEAR

Pattern on roller ends caused by fine abrasives.

Clean all parts and housings, check seals and bearings and replace if leaking, rough or noisy.



GALLING

Metal smears on roller ends due to overheating, lubricant failure or overload.

Replace bearing, check seals and check for proper lubrication.



ETCHING

Bearing surfaces appear gray or grayish black in color with related etching away of material usually at roller spacing.

Replace bearings, check seals and check for proper lubrication.

Figure 2—Diagnosis of Tapered Roller Bearings

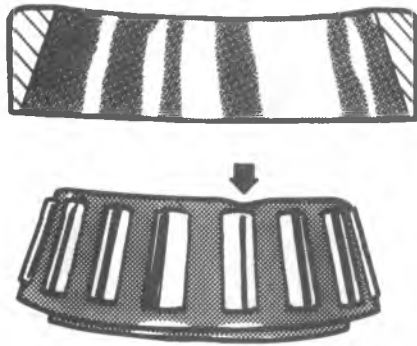

BENT CAGE

Cage damaged due to improper handling or tool usage.
Replace bearing.

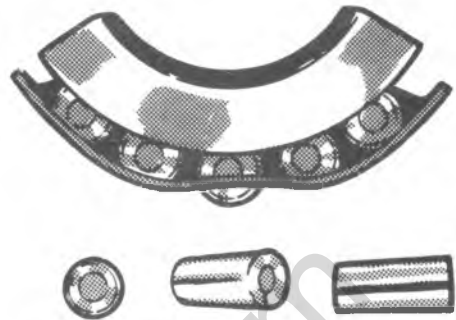

BENT CAGE

Cage damaged due to improper handling or tool usage.
Replace bearing.

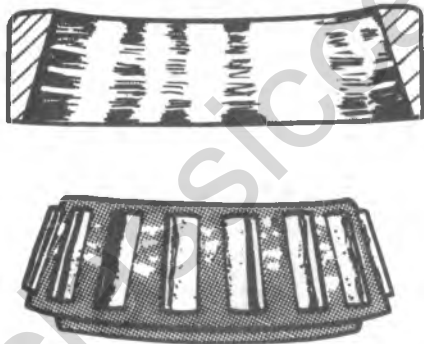

CAGE WEAR

Wear around outside diameter of cage and roller pockets caused by abrasive material and inefficient lubrication.
Clean related parts and housings.
Check seals and replace bearings.

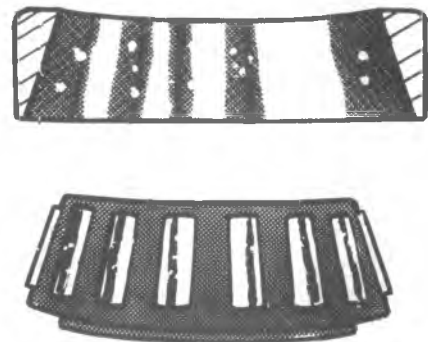

INDENTATIONS

Surface depressions on race and rollers caused by hard particles of foreign material.
Clean all parts and housings. Check seals and replace bearings if rough or noisy.

Figure 3—Diagnosis of Tapered Roller Bearings

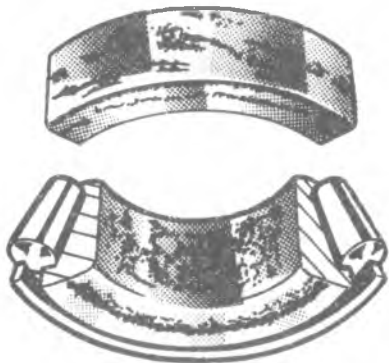

FRETTAGE

Corrosion set up by small relative movement of parts with no lubrication. Replace bearing. Clean related parts. Check seals and check for proper lubrication.



SMEARS

Smearing of metal due to slippage. Slippage can be caused by poor fits, lubrication, overheating, overloads or handling damage. Replace bearings, clean related parts and check for proper fit and lubrication.



STAIN DISCOLORATION

Discoloration can range from light brown to black caused by incorrect lubricant or moisture. Re-use bearings if stains can be removed by light polishing or if no evidence of overheating is observed. Check seals and related parts for damage.



HEAT DISCOLORATION

Heat discoloration can range from faint yellow to dark blue resulting from overload or incorrect lubricant. Excessive heat can cause softening of races or rollers. To check for loss of temper on races or rollers a simple file test may be made. A file drawn over a tempered part will grab and cut metal, whereas, a file drawn over a hard part will glide readily with no metal cutting. Replace bearings if over heating damage is indicated. Check seals and other parts.

Figure 4—Diagnosis of Tapered Roller Bearings

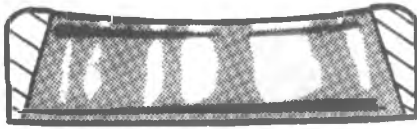

MISALIGNMENT

Outer race misalignment due to foreign object.
Clean related parts and replace bearing. Make sure races are properly seated.



CRACKED INNER RACE

Race cracked due to improper fit, cocking, or poor bearing seats.
Replace bearing and correct bearing seats.



FATIGUE SPALLING

Flaking of surface metal resulting from fatigue.
Replace bearing, clean all related parts.



BRINELLING

Surface indentations in raceway caused by rollers either under impact loading or vibration while the bearing is not rotating.
Replace bearing if rough or noisy.

Figure 5—Diagnosis of Tapered Roller Bearings

4B1-8 REAR AXLE

Differential pinion and side gears rarely give trouble. Common causes of differential failure are shock loading, extended overloading, and seizure of the differential pinions to the cross shaft resulting from excessive wheel spin and consequent lubrication breakdown. The second type of gear noise pertains to the mesh pattern of the gear teeth. This form of abnormal gear noise can be recognized because it produces a cycling pitch (whine) and will be very pronounced in the speed range at which

it occurs, appearing under either "drive," or "float" or "coast" conditions. "Drive" is acceleration or heavy pull. "Coast" is with a closed throttle and the vehicle in gear and "float" is using just enough throttle to keep the vehicle from driving the engine; the vehicle slows down gradually but the engine still pulls slightly. Gear noise tends to peak in a narrow speed range or ranges, and will tend to remain constant in pitch. Bearing noise will vary in pitch with vehicle speeds.

Refer to figures 2 through 5 for bearing diagnosis.

ON-VEHICLE SERVICE

REAR AXLE ASSEMBLY REPLACEMENT (ALL AXLES)

- Raise the vehicle on a hoist and support the axle assembly with a suitable lifting device.
- For 9 $\frac{3}{4}$ -inch ring gear and 10 $\frac{1}{2}$ -inch ring gear axles, raise the vehicle and place jack stands under the frame side rails for support.
- Drain the lubricant from the axle housing.

Remove or Disconnect

1. Propeller shaft. Refer to PROPELLER SHAFT (SEC. 4A).
 - Tie the propeller shaft to a side rail or crossmember.
 - Tape the bearing cups to prevent loss of the rollers.
2. Wheel and brake drum or hub and drum assembly.
3. Parking brake cable from the lever and at the brake flange plate.
4. Hydraulic brake lines from the connectors.
5. Shock absorbers from the axle brackets.
6. Vent hose from the axle vent fitting if used.
7. Height sensing and brake proportional valve linkage if used.
8. Stabilizer shaft if used.
- Support the assembly with a hydraulic floor jack.
9. Nuts and washers from the U-bolts.
10. U-bolts, spring plates and spacers from the axle assembly.
 - Lower the jack and the axle assembly.

Install or Connect

1. Axle assembly under the vehicle.
 - Align the axle assembly with the springs.
2. Spacers, spring plates and U-bolts to the axle assembly.
 - Raise the axle assembly.
3. Washers and nuts to the U-bolts.
 - Thread the nuts on firmly.
 - Adjust alignment of semi-float axles.
4. Stabilizer shaft if used.
5. Height sensing and brake proportional valve linkage if used.
6. Vent hose to the axle vent fitting if used.
7. Shock absorbers to the axle brackets.
8. Hydraulic brake lines to the connectors.
9. Parking brake cable to the lever and the flange plate.
10. Wheel and brake drum or hub and drum assembly.
11. Propeller shaft.

NOTICE: See "Notice" on page 4B1-1 of this section.

Tighten

- All fasteners to "Specifications" later in this section.

Important

- Check axle lubricant level at the filler plug hole. Lubricate as needed.
- Bleed the brake system, check operation and adjust if necessary. Refer to BRAKES (SEC. 5).
- Check axle and brake operation.
- Check for fluid leaks and road test the vehicle.

SEMI-FLOATING AXLE (8 1/2- AND 9 1/2-INCH RING GEAR)

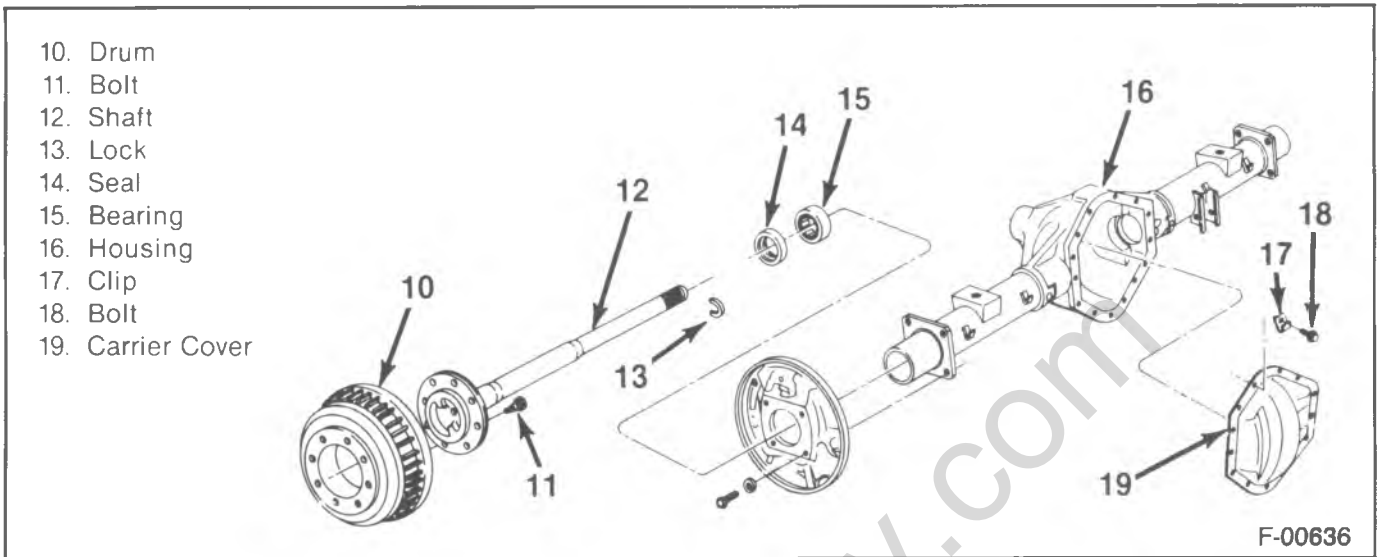

Figure 6—Axle Shaft and Housing Components

AXLE SHAFT, OIL SEAL AND BEARING REPLACEMENT

- Raise the vehicle on a hoist.
- Clean dirt from around the carrier cover.

↔ Remove or Disconnect (Figure 6)

Tools Required:

- J-2619-01 Slide Hammer with Adapter
- J-23689 Axle Shaft Bearing Remover (large shaft)
- J-29712 Axle Shaft Bearing Remover (9 1/2-inch ring gear)

1. Wheel and tire assembly.
2. Brake drum.
3. Carrier cover (19).
 - Catch the oil in a drain pan.
 - Remove gasket material if used.
4. Screw (A) (figures 7 and 8).
5. Pinion shaft (B).
 - Remove the shaft from the case on vehicles without a locking differential.
 - With a locking differential remove the shaft (B) part way and rotate the case until the pinion shaft touches the housing (figure 9).
 - Use a screwdriver or similar tool to enter the case and rotate the lock until it aligns with the thrust block (figure 10).
6. Lock (13) (figure 11).
 - Push the flange of the axle shaft towards the differential. Do not force or hammer the shaft to move the shaft.
 - Remove the lock from the button end of the axle shaft.
7. Axle shaft (12).
 - Slide the axle shaft out, being careful not to damage the seal.
8. Seal (14) using J-23689.

9. Bearing (15).

- Use J-23689 for 8 1/2-inch ring gear axle or J-29712 for 9 1/2-inch ring gear to pull the bearing from the axle.
- Insert the tool into the axle bore so that it grasps behind the bearing (15) (figure 12). Tighten the nut and washer against the face of the bearing (15).

🔍 Inspect

- All parts. Replace as necessary.

→↔ Install or Connect (Figures 6 and 10)

Tools Required:

- J-8092 Driver Handle
- J-21128 Axle Shaft and Pinion Oil Seal Installer
- J-23690 Axle Shaft Bearing Installer

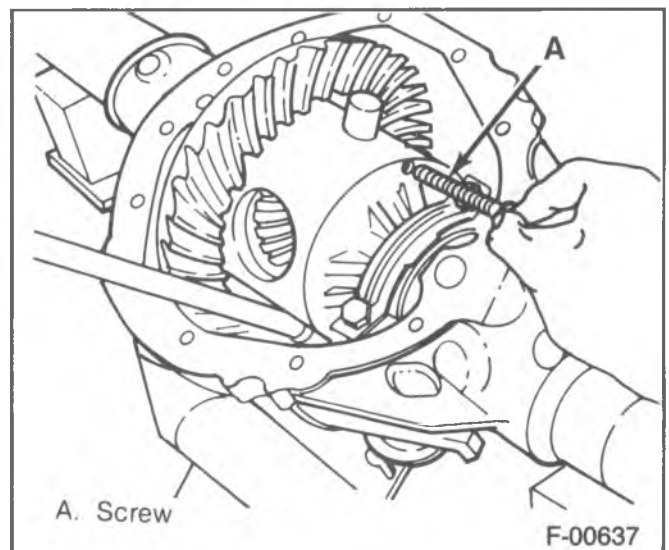

Figure 7—Removing the Lock Screw

4B1-10 REAR AXLE

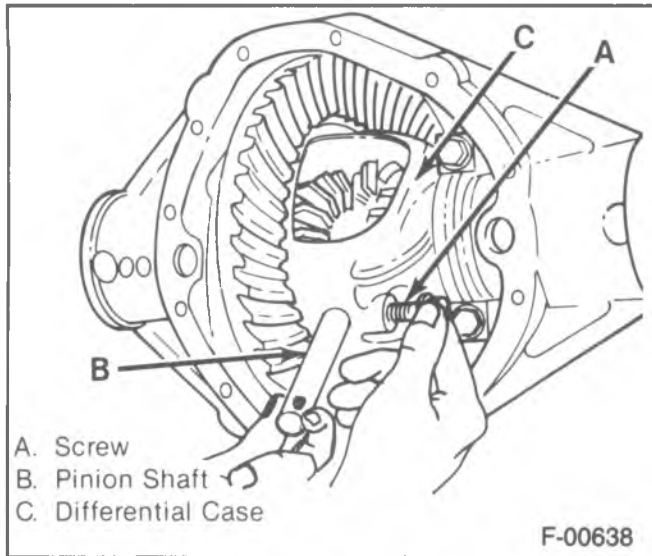

Figure 8—Removing/Installing the Differential Pinion

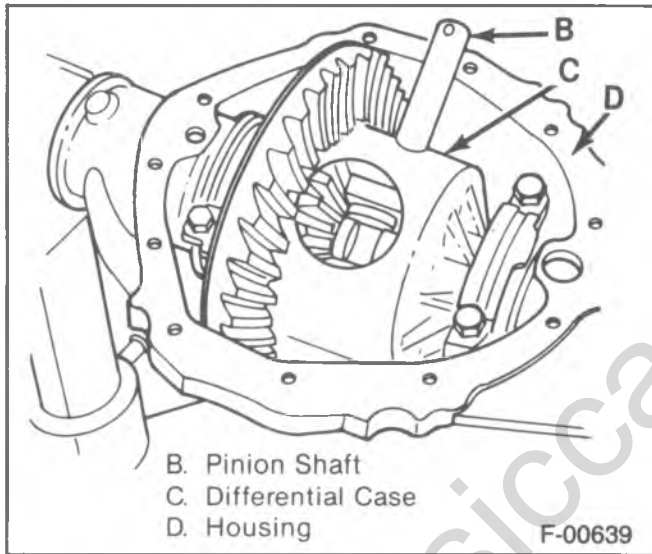

Figure 9—Positioning the Case for Best Clearance

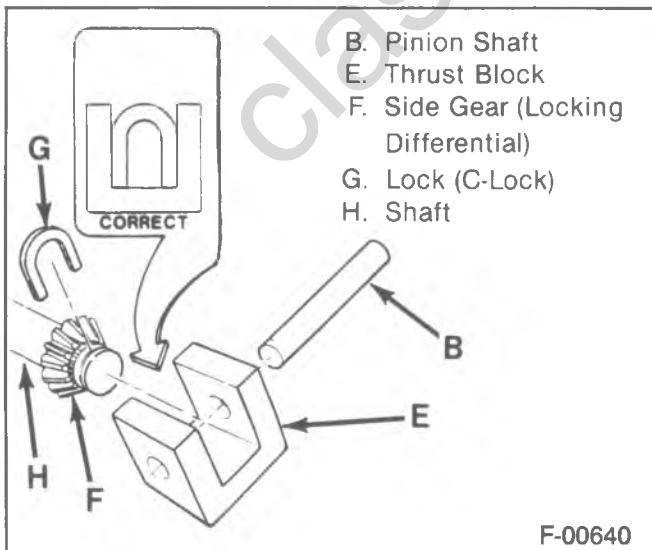

Figure 10—Aligning the Lock

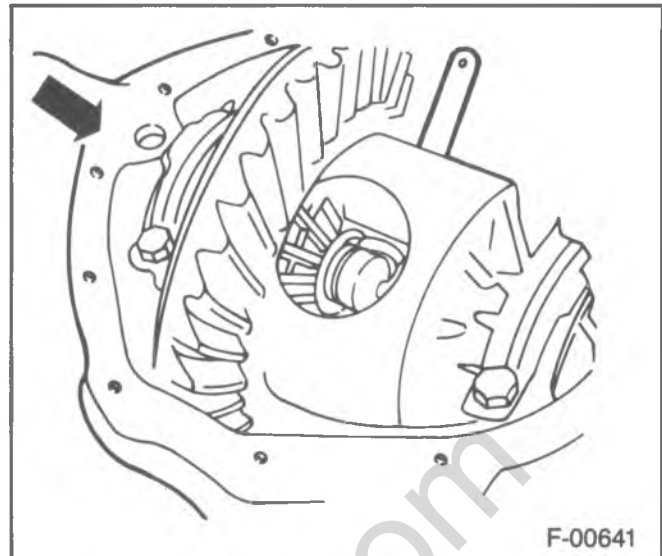

Figure 11—Pushing the Axle Shaft Inward

J-29709 Axle Shaft Bearing Installer (9 1/2-inch ring gear)

J-29713 Axle Shaft Seal Installer (9 1/2-inch ring gear)

- Lubricate the axle cavity between the seal (14) lips and the bearing (15) with wheel bearing lubricant. Refer to MAINTENANCE AND LUBRICATION (SEC. 0B).

1. Bearing (15).

- Use J-23690 for the 8 1/2-inch gear axle and J-29709 for the 9 1/2-inch ring gear axle.
- Bearing (15) into the axle (16) housing until the tool bottoms against the tube. Refer to figure 13.

2. Seal (14).

- Use J-21128 for 8 1/2-inch ring gear axle and J-29713 for the 9 1/2-inch ring gear axle.
- Drive the tool into the bore until the seal (14) bottoms flush with the end of the tube (figure 14).

3. Axle shaft (12).

- Be careful not to damage the seal (14) when inserting the axle shaft (12).

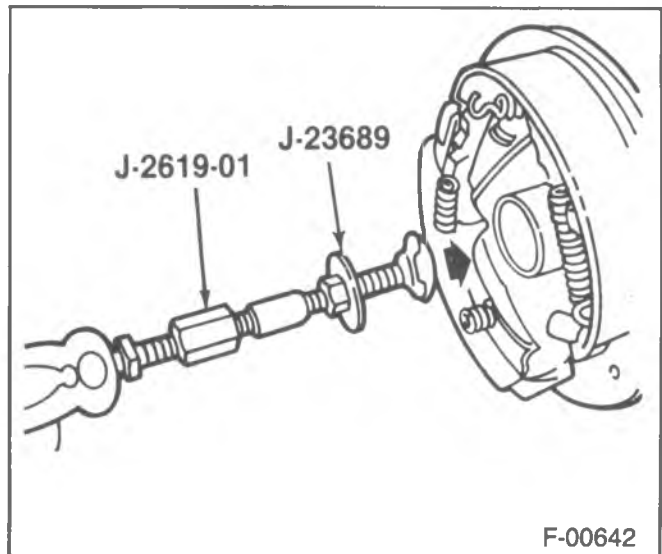

Figure 12—Removing the Bearing and Seal

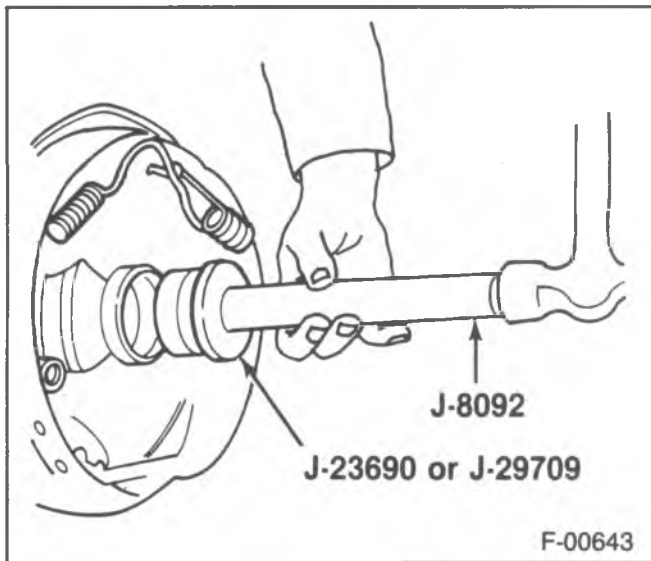

Figure 13—Installing the Wheel Bearing

- Slide the axle shaft (12) into place allowing the splines to engage the differential side gear (F) figure 10.
4. Lock (13).
 - Without locking differential:
 - Place the lock on the button end of the axle shaft (12), then pull the shaft flange outward to seat the lock in the differential side gear.
 - With locking differential.
 - Keep the pinion shaft partially withdrawn (figure 9).
 - Place the lock in the position shown in figure 10. Pull the shaft flange outward to seat the lock in the differential side gear.
 5. Pinion shaft (figure 8).
 - Align the hole in the pinion shaft with the screw hole in the differential case.
 6. Screw (A).
 - Tighten
 - Screw to 34 N·m (25 ft. lbs.).
 7. Carrier cover gasket or RTV (if used).

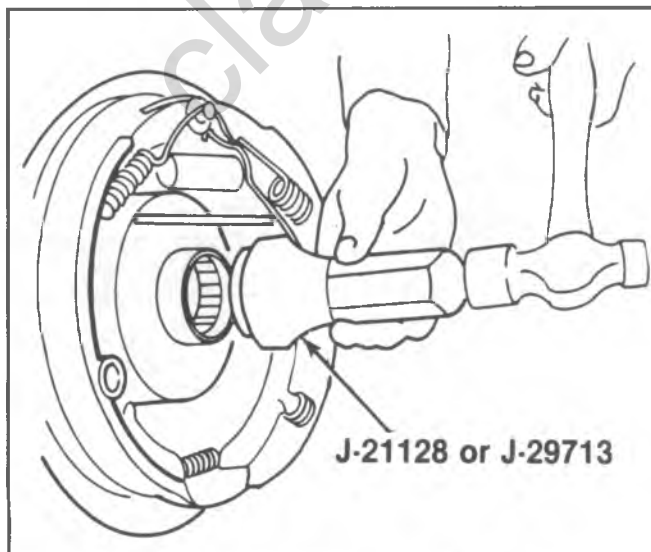

Figure 14—Installing the Seal

8. Carrier cover (19).
9. Bolts (18) and clip (17).
 - Tighten bolts (18) in a crosswise pattern.
10. Brake drum.
11. Wheel and tire assembly.
 - Lower the vehicle.
12. Axle lubricant. Fill to the filler plug hole level. Refer to MAINTENANCE AND LUBRICATION (SEC. 0B).

BRAKE BACKING PLATE REPLACEMENT

- Raise the vehicle on a hoist.

↔ Remove or Disconnect

1. Wheel, tire and brake drum.
2. Axle shaft. Refer to "Axle Shaft Replacement" earlier in this section.
3. Brake line from the cylinder inlet.
4. Brake components from the backing plate. Refer to BRAKES (SEC. 5).
5. Bolts and washers from the axle.
6. Backing plate.

↔ Install or Connect

1. Backing plate to the axle.
2. Bolts and washers to the plate.
3. Brake components to the backing plate. Refer to BRAKES (SEC. 5).
4. Brake line to the cylinder inlet.
 - Refer to BRAKES (SEC. 5) for bleeding and adjustment procedure.
5. Axle shaft. Refer to "Axle Shaft Replacement" earlier in this section.
6. Wheel, tire and brake drum.

WHEEL STUD REPLACEMENT

- Raise the vehicle on a hoist and allow the axle to hang free.

↔ Remove or Disconnect

Tool Required:

J-6627-A Wheel Stud Remover

1. Wheel, tire and brake drum.
2. Stud from the axle flange using J-6627-A (figure 15).

↔ Install or Connect

1. Stud in the axle flange hole. Refer to figure 15.
 - Start the new stud into the axle flange hole by pressing firmly with your hand.
 - Thread on a lug nut with the flat side to the vehicle.
 - Tighten the lug nut and draw the stud head into the rear of the flange.
 - Thread the lug nut off.
2. Wheel, tire and brake drum.
 - Lower the vehicle.

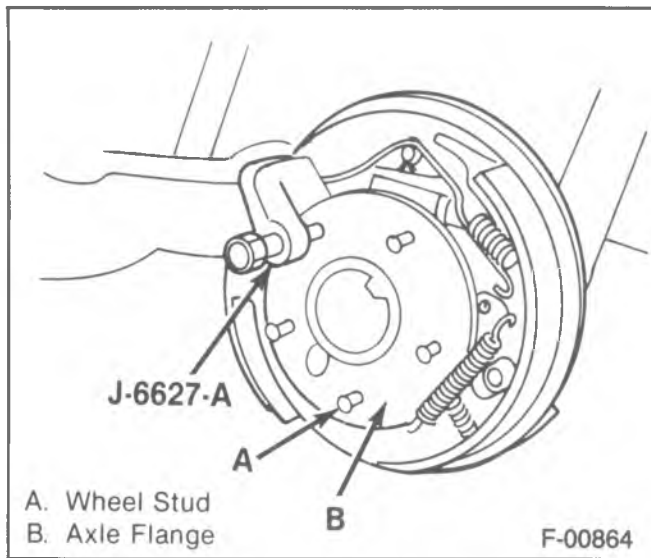

Figure 15—Pressing Out A Wheel Stud

PINION FLANGE, DUST DEFLECTOR/OIL SEAL REPLACEMENT

- Raise the vehicle on a hoist.

Remove or Disconnect

Tool Required:

J-8614-01 Companion Flange Holder and Remover

1. Propeller shaft from the axle.
 - Tie the propeller shaft to a frame rail or crossmember.

Measure

- The torque required to rotate the pinion (figure 16). Record the torque value for later reference.

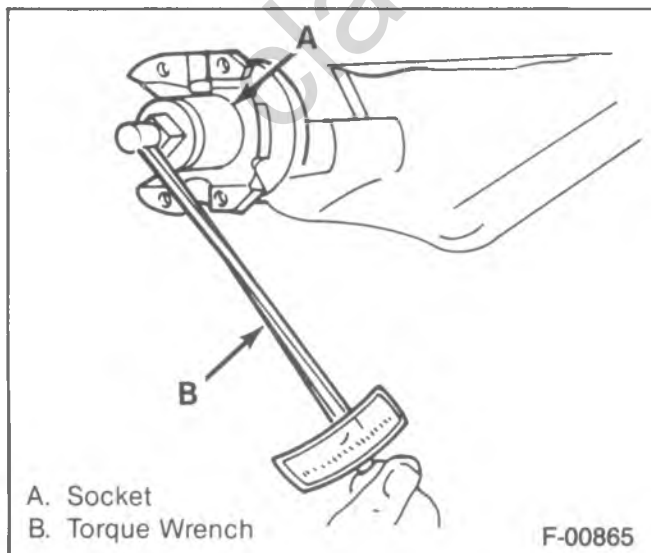

Figure 16—Measuring Pinion Rotating Torque

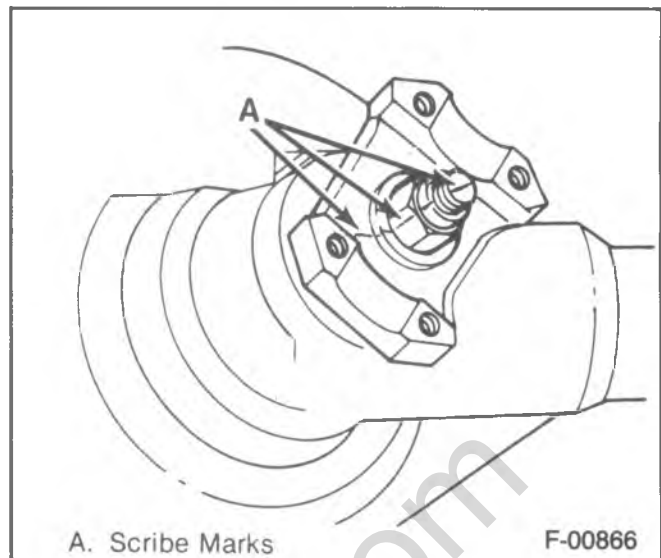

Figure 17—Scribed Marks

Important

- Scribe a line on the pinion stem, pinion nut and the companion flange and record the number of exposed threads on the pinion stem. Use the scribed reference and the exposed threads as a reinstallation guide (figure 17).
2. Nut using J-8614-01.
 3. Flange using J-8614-01
 - Use the special nut and forcing screw to remove the flange (figure 19).
 4. Oil seal. Use a screw driver to pry the seal out of the bore.

Inspect

- The pinion flange for a smooth oil seal surface, for worn drive splines, damaged ears and for smoothness of the bearing contact surface. Replace if necessary.
5. Dust deflector.

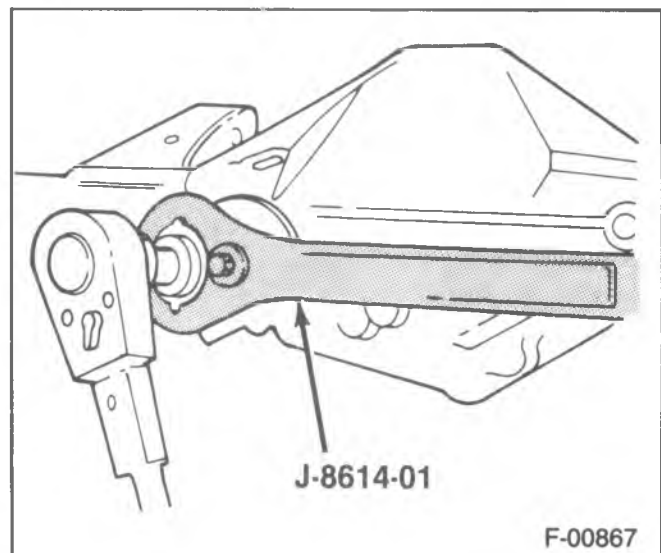

Figure 18—Removing the Drive Pinion Nut

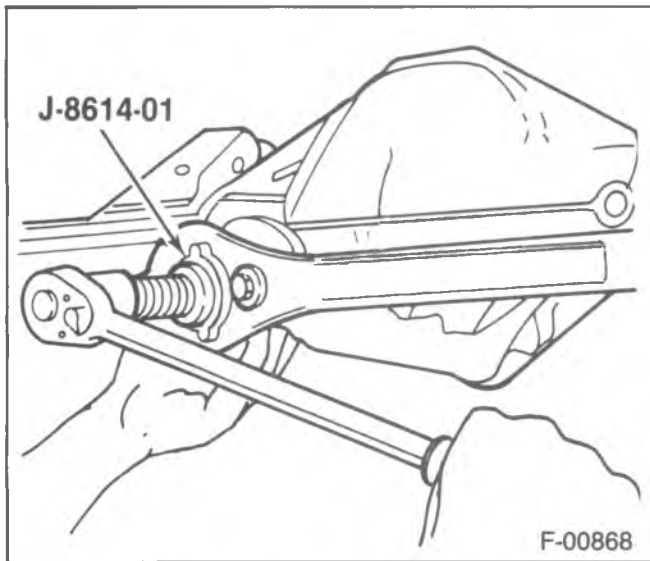

Figure 19—Removing the Drive Pinion Flange

- Tap the deflector from the flange if replacement is necessary.
- Clean up the stake points on the flange.
- Clean all foreign material from the contact area.

Install or Connect

Tools Required:

- J-8614-01 Companion Flange Holder and Remover
- J-22388 Pinion Oil Seal Installer (9½-inch ring gear)
- J-22804-1 Pinion Oil Seal Spacer
- J-22836 Pinion Seal Installer (8½-inch ring gear)

- Dust deflector on the flange.
 - Stake new deflector at three new equally spaced positions. Staking must be such that the seal operating surface is not damaged.
- Oil seal.
 - Pack the cavity between the lips of the oil seal with extreme pressure lithium-base lubricant.
 - Position the oil seal in the bore then place J-22804-1 over the oil seal and flat against the seal flange (figure 20).
 - Use J-22836 for the 8½-inch ring gear or J-22388 for the 9½-inch ring gear to press the oil seal into the bore (figure 20).
 - Turn J-22804-1 from installed position 180 degrees to assure proper installation against the pinion flange.
 - Pack the cavity between the end of the pinion splines and the pinion flange with a non-hardening sealer such as PERMATEX TYPE A or equivalent.
- Flange onto the pinion using J-8614-01.
 - Place washer and nut on the pinion threads and tighten the nut to the original scribed position using the scribe marks and exposed threads as a reference (figure 21). **DO NOT ATTEMPT TO HAMMER THE FLANGE ONTO THE PINION SHAFT.**

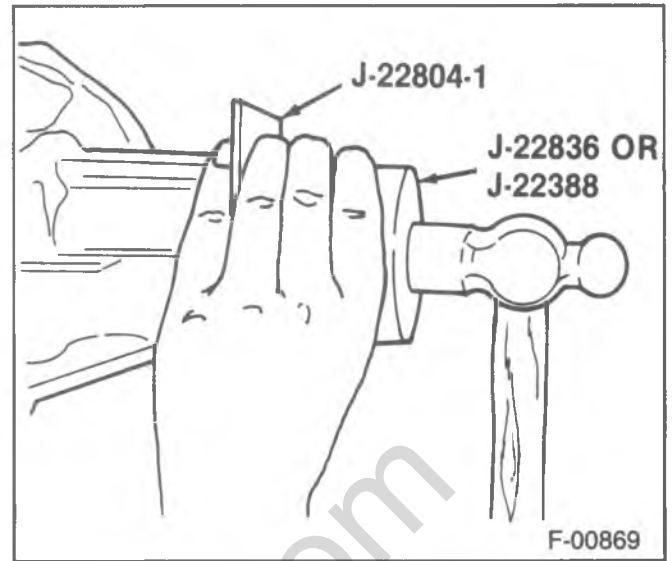

Figure 20—Installing the Pinion Seal



Measure

- The rotating torque of the pinion and compare with the torque recorded earlier (figure 16).



Tighten

- The pinion nut in additional small increments until the torque necessary to rotate the pinion exceeds the original recorded value by 0.35 N·m (3 in. lbs.).
- Propeller shaft.
 - Lower the vehicle and road test.

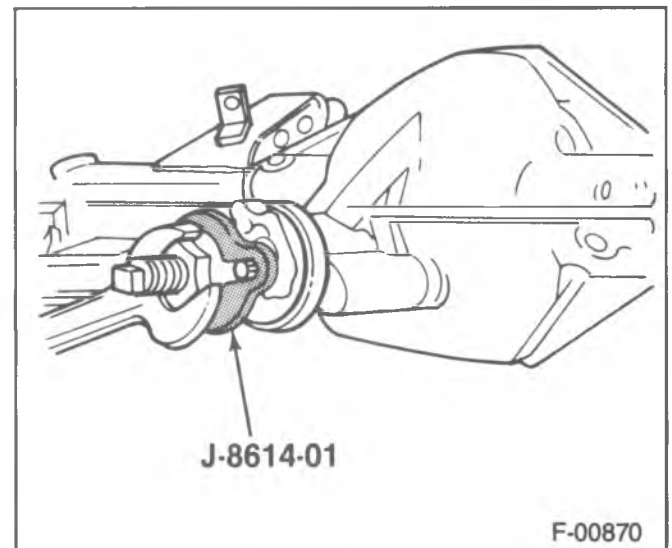

Figure 21—Installing the Pinion Flange

FULL FLOATING AXLE (9³/₄- AND 10¹/₂-INCH RING GEAR)

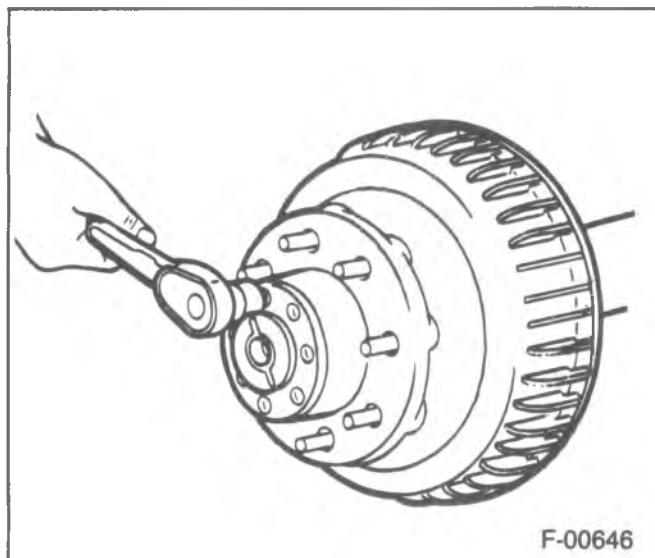

Figure 22—Removing or Installing Flange-to-Hub Bolts

AXLE SHAFT REPLACEMENT

↔ Remove or Disconnect (Figures 22 and 23)

1. Bolts (55).
 - Rap the axle shaft (53) flange lightly with a soft faced hammer to loosen the shaft.
 - Grip the rib on the axle shaft (53) flange with a locking plier and twist, to start shaft removal.
2. Axle shaft (53) from the tube.

🧼 Clean

- Axle shaft (53) flange. Remove old RTV or gasket (51).
- Outside face of the hub assembly.

🔍 Inspect

- All parts and replace as necessary.

↔ Install or Connect (Figure 23)

1. Axle shaft (53) with a gasket or RTV applied.
 - Be sure the shaft splines mesh into the differential side gear.
 - Align the axle shaft holes with the hub holes.
2. Bolts (55) figures 22 and 23.

🔩 Tighten

- Bolts (35) to specified torque later in this section.

HUB AND DRUM ASSEMBLY REPLACEMENT

↔ Remove or Disconnect (Figure 23)

- Raise the vehicle until the wheel is free to rotate.

Tool Required:

J-2222-C Wheel Bearing Nut Wrench

1. Wheel and tire.
2. Axle shaft (52) as outlined earlier in this section.
3. Nut (40) use J-2222-C or retaining ring (56). Refer to figure 24.
4. Lock (41) or key (57).
5. Adjusting nut (42, 58). Refer to figure 24.
6. Washer (43).
7. Hub and Drum (48, 49).

🔍 Inspect

- All parts and replace as necessary.

↔ Install or Connect (Figure 23)

NOTICE: For steps 3, 4 and 5 see "Notice" on page 4B-1 of this section.

Tool Required:

J-2222-C Wheel Bearing Nut Wrench

1. Hub and drum (48, 49) to the tube.
 - Be sure the bearings and the oil seal are positioned properly.
 - Apply a light coat of high melting point EP bearing lubricant to the contact surfaces and the outside of the axle tube.
2. Washer (43). Tang into key way.
3. Adjusting nut (42, 58). Refer to figure 24.

🔩 Tighten

- Adjusting nut (42, 58) to specified torque later in this section while turning the hub.
4. Lock (41) or key (57).
 - Bend the tang to the flat of the adjusting nut (42) or insert the key (57).
 5. Nut (40) or retaining ring (56). Refer to figure 24.

🔩 Tighten

- Nut (40) to specified torque later in this section.
6. Axle shaft (52) earlier in this section.
 7. Wheel and tire.
 - Lower the vehicle.

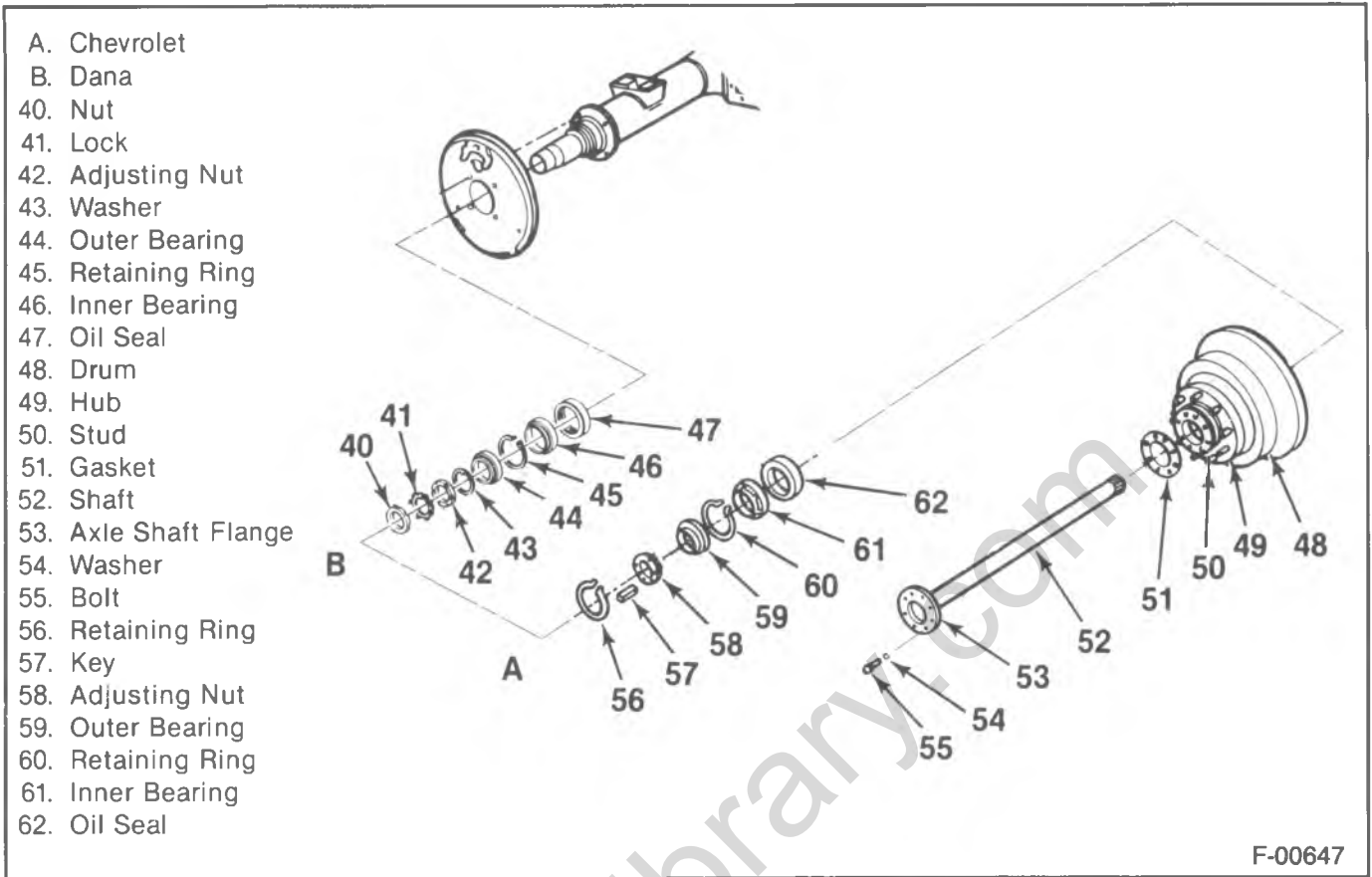

Figure 23—Full Floating Axle, Hub and Drum Assembly Components

WHEEL BEARING/CUP REPLACEMENT

Remove or Disconnect (Figure 23)

- Raise the vehicle till the wheels are free to rotate.
- Tools Required:
- J-8092 Driver Handle
 - J-24426 Outer Wheel Bearing Cup Installer
1. Axle shaft (52) as outlined earlier in this section.

2. Hub and drum (48, 49) as outlined earlier in this section.
3. Oil seal (47) or (62).
4. Inner bearing (46) or (61). Use a drift to remove the bearing and cup.
5. Retaining ring (45) or (60).
 - Use snap ring pliers to remove the ring.
6. Outer bearing (44) or (59) using J-8092 with J-24426 (figure 25).
 - Drive the bearing (44, 59) and cup from the hub (49).

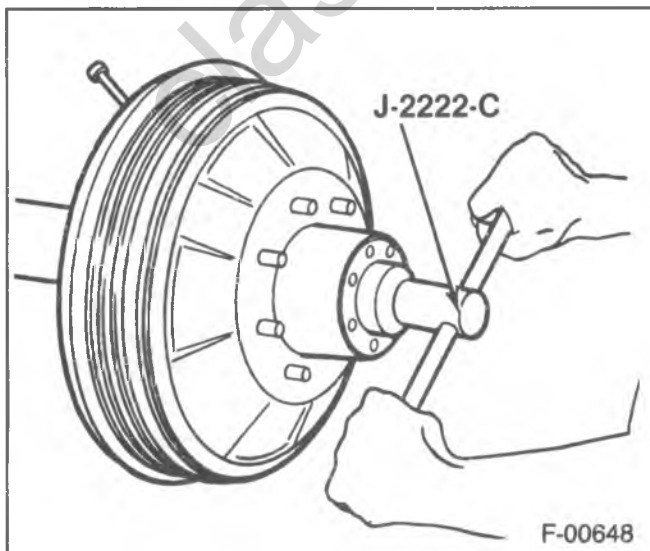

Figure 24—Removing or Installing Bearing Adjusting Nut

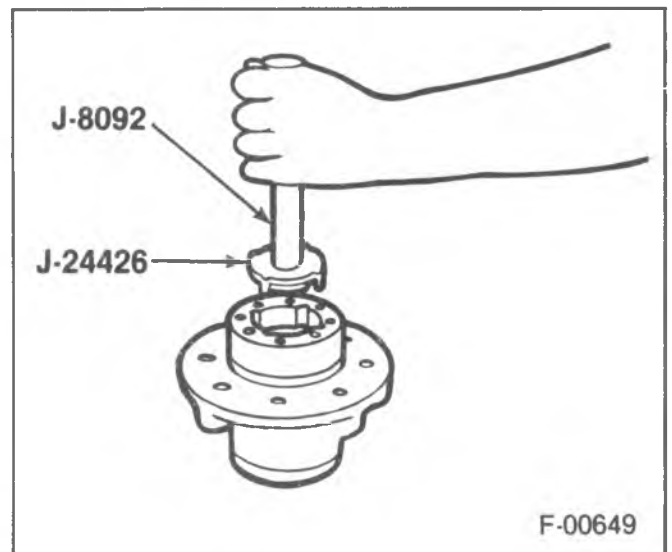

Figure 25—Removing the Outer Bearing and Cup

4B1-16 REAR AXLE



Clean

- Old sealing compound from the oil seal (47, 62) bore in the hub (49).
- Bearing assemblies in a solvent using a stiff brush to remove the old lubricant. Dry the bearings with compressed air. **Do not spin them.**
- Lubricant from the axle housing and inside the hub (49).
- Gasket material from the hub (49), axle shaft (52).



Inspect

- Bearings for wear, chipped edges or other damage. Check for flat or rough spots on the rollers.
- Cups for pits and cracks.
- Oil seal for wear or roughness. Replace parts as necessary.



Install or Connect (Figure 23)

Tools Required:

- J-8092 Driver Handle
- J-8608 Pinion Bearing Cup Installer
- J-24426 Outer Wheel Bearing Cup Installer
- J-24427 Inner Wheel Bearing Cup Installer
- J-24428 Axle Shaft Seal Installer

1. Outer bearing cup (44, 59) into the hub (49).
 - Drive the cup into the hub using J-8092 and J-8608. **Be sure J-8608 is installed upside down on J-8092 so that the chamfer does not contact the bearing cup.** Drive the cup beyond the retaining ring groove.
2. Retaining ring into the groove.
 - Drive the cup back onto the retaining ring using J-24426.
3. Inner bearing cup using J-8092 and J-24427.
 - Drive the cup into place until it is seated against the hub shoulder.
4. Inner bearing (46) or (61).
5. New oil seal using J-24428.
6. Hub and drum assembly.
7. Outer bearing (44) or (59).



Adjust

- Bearing preload. Refer to "Bearing Adjustment."
8. Axle shaft (52).

NON-DEMOUNTABLE TYPE DRUM REPLACEMENT

- Construction of the non-demountable type drum and hub assembly is such that replacement cannot be done with the hub assembly installed on the vehicle.



Remove or Disconnect

- Raise the vehicle.
1. Hub and drum assembly. Refer to "Hub and Drum Assembly Replacement" earlier in this section.
 2. Retaining bolts, stud nuts or wheel studs.
 - Separate the drum, hub and oil deflector.

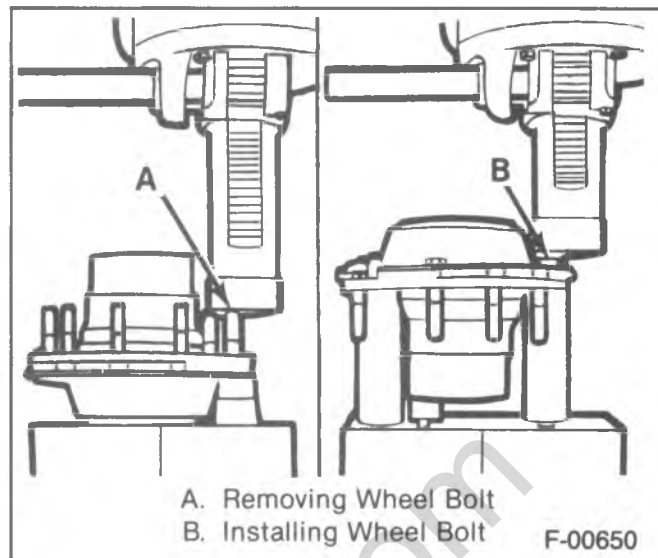

Figure 26—Wheel Bolt Replacement

- Press the wheel studs out of the drum. Replace parts as necessary.



Install or Connect

1. Drum to the hub.
 - Make certain drain holes are in alignment.
2. Oil deflector to the drum.
 - Apply a light coating of sealing compound to the oil deflector contact surface.
3. Retaining bolts, stud nuts or wheel studs.
 - Press the wheel studs into the drum.

WHEEL BOLT REPLACEMENT

- Wheel bolts are serrated and may also be swaged in place; however, replacement procedure remains the same for both types of installation. Press the wheel bolts out of the hub flange, then press new wheel bolts into place, making sure of a tight fit. When replacing all of the wheel bolts be sure that the hub oil deflector is in position under the wheel bolt heads. Refer to figure 26.

BEARING ADJUSTMENT

- Make sure the brakes are fully released and do not drag.
- Check the wheel bearing play by grasping the tire at the top and pulling and pushing back and forth, or by using a pry bar under the tire. If the wheel bearings are properly adjusted, movement of the brake drum in relation to the brake flange plate will be barely noticeable and the wheel will turn freely. If the movement is excessive, adjust the bearings.



Remove or Disconnect (Figure 23)

Tool Required:

- J-2222-C Wheel Bearing Nut Wrench
 - Raise the vehicle until the wheel is free to spin.
1. Axle shaft (52). Refer to "Axle Shaft Replacement" earlier in this section.

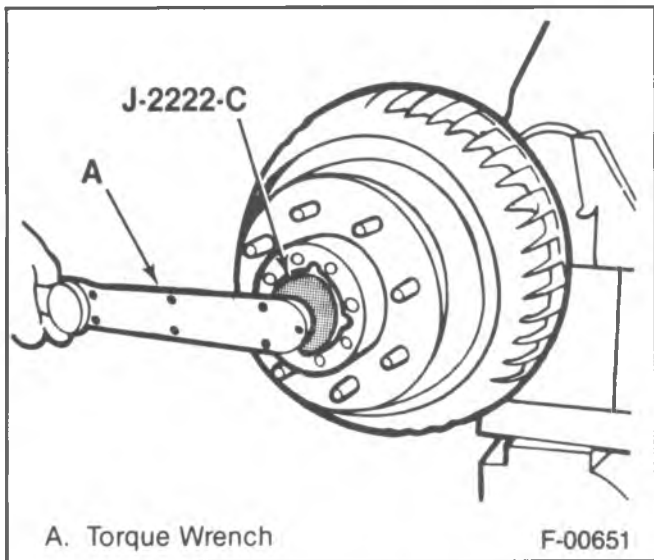

Figure 27—Tightening the Adjusting Nut

- Be sure the keyway, threads and adjusting nut (42, 58) are clean and free of chips, burrs and shavings.
2. Nut (40) or retaining ring (56).
 - Disengage the tang from the nut (40).
 3. Lock (41) or key (57).

Tighten

- Adjusting nut (42, 58) to 70 N·m (50 ft. lbs.) using J-2222-C (figures 27 and 28).
- Be sure the bearings are seated and in contact with the spindle shoulder.

Adjust

- Nut (42, 58). Back the nut (42, 58) off until just loose, but not more than one slot of the lock or the axle spindle using J-2222-C. Align the adjusting nut (58) slot with the keyway in the axle spindle.

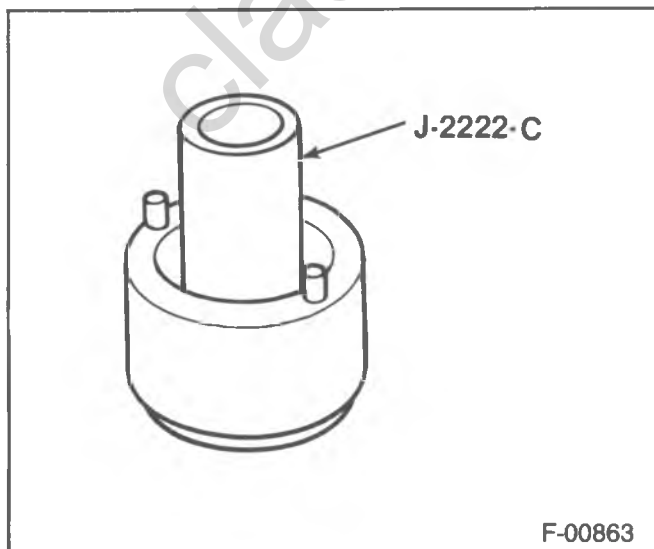

Figure 28—Wheel Bearing Nut Wrench

Install or Connect (Figure 23).

1. Key (57) if used or new lock (41).
 - Key (57) into the keyway and adjusting nut (58) slot.
 - Bend the lock (41) tang to the flat of the adjusting nut (42).
2. Retaining ring (56) or nut (40) if used.
 - Bend the lock (41) tang to the flat of the nut (40).
 - Be sure the retaining ring (56) is seated.
3. Axle shaft (52). Refer to "Axle Shaft Replacement" earlier in this section.

PINION OIL SEAL/COMPANION FLANGE REPLACEMENT

- The pinion oil seal and the companion flange may be replaced with the carrier assembly installed in the vehicle.

Remove or Disconnect

Tools Required:

- J-8614-01 Companion Flange Holder and Remover
 - Raise the vehicle.
1. Propeller shaft. Refer to PROPELLER SHAFT (SEC. 4A).
 - Tie the propeller shaft to a frame rail or crossmember.

Important

- Scribe a line on the pinion stem, pinion nut and companion flange to be used as a guide for reinstallation (figure 17).
2. Nut using J-8614-01 (figure 18).
 3. Flange using J-8614-01.
 - Use the special nut and forcing screw to remove the flange (figure 19).
 4. Oil seal.
 - Pry the oil seal from the bore. Do not damage the machined surfaces. Thoroughly clean foreign material from the contact area.
 - Replace parts as necessary.

Install or Connect

Tools Required:

- J-8614-01 Companion Flange Holder and Remover
 - J-24384 Pinion Oil Seal Installer (Dana 10½-inch ring gear axle).
 - J-24434 Pinion Oil Seal Installer (Chevrolet 10½-inch ring gear axle).
1. Oil seal into the bore using J-24384 or J-24434.
 - Lubricate the cavity between the new seal lips with a high melting point bearing lubricant.
 2. Flange using J-8614-01.
 - Use scribed marks for reinstallation.
 3. Nut, use J-8614-01 (figure 18).
 - Use scribe mark as an installation reference.
 4. Propeller shaft. Refer to PROPELLER SHAFT (SEC. 4A).

FULL FLOATING AXLE (12-INCH RING GEAR)

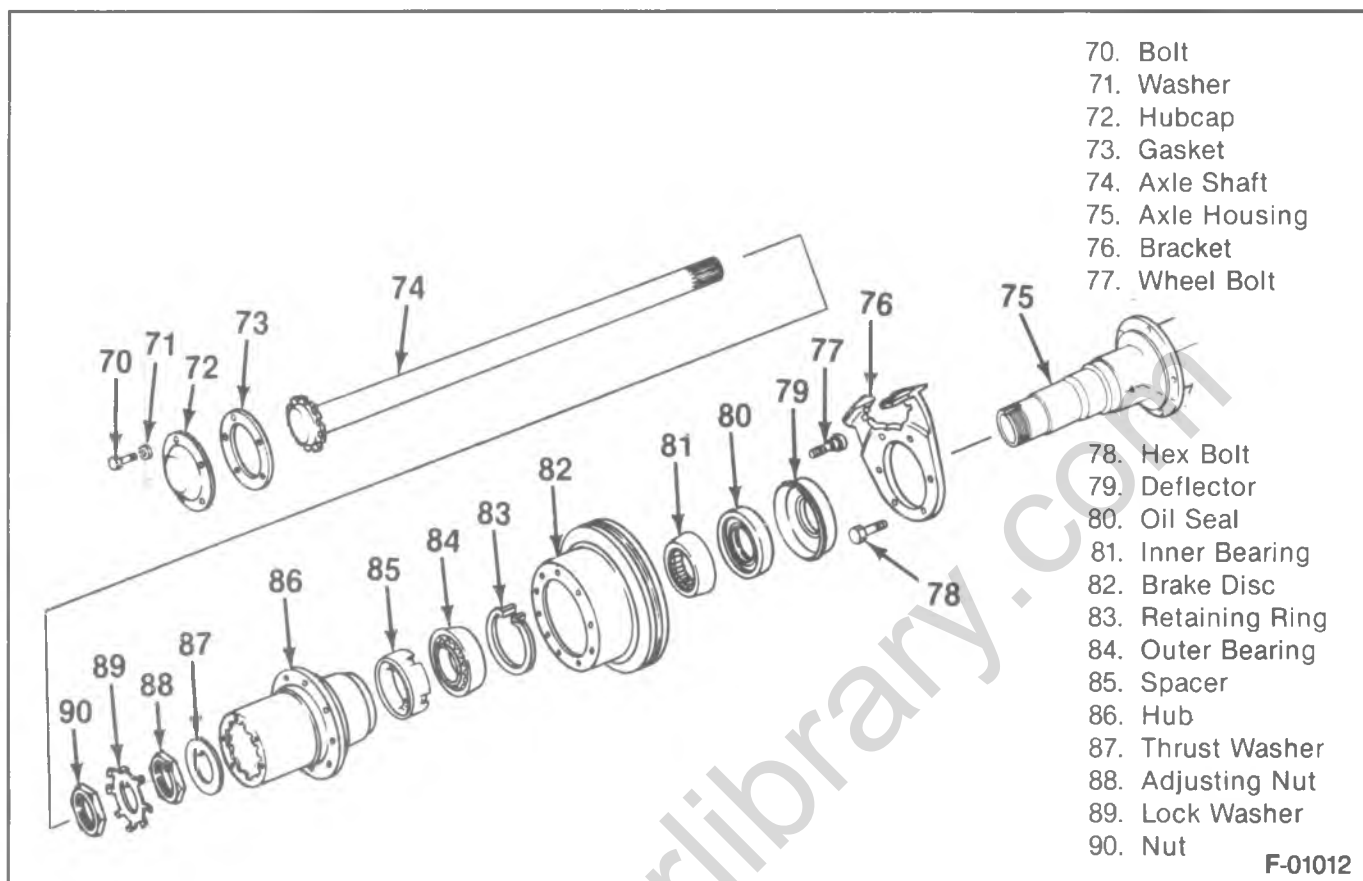

Figure 29—Rockwell 12-Inch Ring Gear Axle and Hub Components

AXLE VENT REPLACEMENT

- A threaded type axle vent is used on the Rockwell 12-inch ring gear axle and must be replaced if the vent cap is damaged or missing.

Clean

The area around the axle vent.

Remove or Disconnect

- Axle vent from the housing.

Install or Connect

- Axle vent to the housing.

AXLE SHAFT REPLACEMENT

- Raise the vehicle and place jack stands under the frame side rails.

Remove or Disconnect (Figure 29)

Tools Required:

J-2619-01 Slide Hammer

1. Bolts (70) and washers (71).
2. Hub cap (72).
 - Thread J-8117 into the tapped hole on the axle shaft (74) flange.
3. Axle shaft (74) using J-2619-01.

Clean

- Old gasket material from the hub (86) and hub cap (72) and the axle shaft (74) flange and mating surface in the hub (86).

Install or Connect (Figure 29)

Tools Required:

J-2619-01 Slide Hammer

1. Axle shaft (74).
 - Tap the axle shaft (74) into position using J-2619-01.
 - Index the axle shaft (74) splines into the hub (86) splines.
2. Gasket (73).
3. Hub cap (72).
4. Washers (71) and bolts (70).

BEARING ADJUSTMENT

- Make sure the brakes are fully released and do not drag.
- Check the wheel bearing play by grasping the tire at the top and pulling and pushing back and forth, or by using a pry bar under the tire. If the wheel bearings are properly adjusted, movement of the hub or disc will be barely noticeable. If the movement is excessive, adjust the bearings.

↔ Remove or Disconnect (Figure 29)

Tool Required:

- J-25510 Wheel Bearing Nut Wrench
- Raise the vehicle until the wheel is free to spin.

1. Axle shaft (74). Refer to "Axle Shaft Replacement."
2. Nut (90) using J-25510.
 - Release the tang.
3. Lock washer (89).

🔑 Adjust

- Nut (88) using J-25510. Tighten the nut (88) while the hub is rotating to 68 N·m (50 ft. lbs.). Make sure the bearing surfaces are in contact and then back the nut (88) off 1/8 turn.

↔ Install or Connect (Figure 29)

1. Lock washer (89).
 - Bend a tang over a flat of the adjusting nut (88).
2. Nut (90) using J-25510.
 - Tighten the nut (90) to 339 N·m (250 ft. lbs.).
 - Bend a long tang of the lock washer (89) over a flat of the nut (90).
3. Axle shaft (74). Refer to "Axle Shaft Replacement."
 - Lower the vehicle.

DRIVE PINION OIL SEAL REPLACEMENT

↔ Remove or Disconnect (Figure 30)

Tools Required:

- J-8614-01 Companion Flange Holder and Remover

- Raise the vehicle.
1. Propeller shaft. Refer to PROPELLER SHAFT (SEC. 4A).

! Important

- Scribe a reference line on the pinion stem, pinion nut and companion flange.
2. Cotter key (91) and nut (92) using J-8614-01.
 3. Companion flange (94).
 4. Bolts (97).
 5. Oil seal retainer (95).
 6. Oil seal (96).
 - Pry the oil seal (96) from the bore being careful not to damage the machined surfaces.

🧼 Clean

- The seal contact area.

↔ Install or Connect (Figure 30)

- Lubricate the cavity between the new seal (96) lips with a high melting point bearing lubricant. Refer to MAINTENANCE AND LUBRICATION (SEC. 0B).

1. Oil seal (96) into the bore using a suitable tool.
 - Be sure the seal (96) bottoms against the bore shoulder.
2. Oil seal retainer (95).
3. Bolts to the retainer (97).

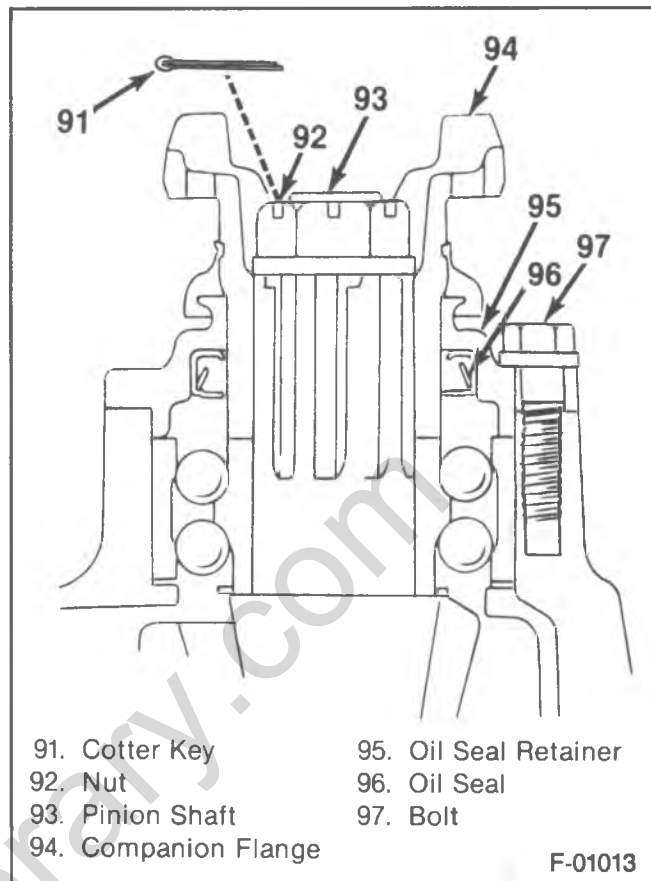

91. Cotter Key
 92. Nut
 93. Pinion Shaft
 94. Companion Flange
 95. Oil Seal Retainer
 96. Oil Seal
 97. Bolt

F-01013

Figure 30—Drive Pinion Oil Seal Components

4. Companion flange (94) use the scribed reference mark.
5. Nut (92) using J-8614-01.

🔩 Tighten

- Nut (92). Align the castellated nut with the hole in the pinion shaft (93) stem and the reference mark.
6. Cotter key (91).
 7. Propeller shaft. Refer to PROPELLER SHAFT (SEC. 4A).

SPECIFICATIONS

TORQUES

















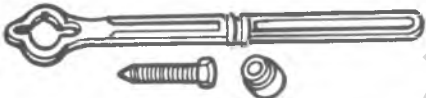

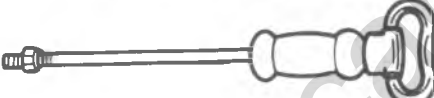
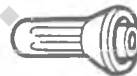

	8½" RING GEAR— SEMI FLOATING AXLE		9½" RING GEAR— SEMI FLOATING AXLE		DANA 9¾"–10½" RING GEAR AXLE—FULL FLOATING		CHEVROLET 10½" RING GEAR AXLE—FULL FLOATING		ROCKWELL 12" RING GEAR AXLE—FULL FLOATING	
	N·m	FT. LBS.	N·m	FT. LBS.	N·m	FT. LBS.	N·m	FT. LBS.	N·m	FT. LBS.
Filler Plug	34	25	24	18	14	10	24	18	47	35
Lock Screw	34	25	34	25	—	—	—	—	—	—
Brake Backing Plate	47	35	142	105	142	105	142	105	—	—
Axle Shaft to Hub Bolts	—	—	—	—	156	115	156	115	—	—
Carrier Cover	27	20	27	20	47	35	41	30	—	—
Axle Lubricant Capacity	Liters	Pints	Liters	Pints	Liters	Pints	Liters	Pints	Liters	Pints
	2.0	4.2	2.6	5.5	2.6	5.5	3.4	7.2	6.6	14.0

WHEEL BEARING ADJUSTMENT VALUES

RING GEAR SIZE	BEARING ADJUSTING NUT TORQUE*	ADJUSTING NUT BACK-OFF*	OUTER LOCKNUT TORQUE	RESULTING BEARING ADJUSTMENT	TYPE OF BEARING
9¾" Ring Gear	68.0 N·m 50 ft. lbs.	**	88.1 N·m 65 ft. lbs.	0.0254 to 0.254 mm .001 to .010 inch End Play	TAPERED ROLLER
10 ½" Ring Gear	68.0 N·m 50 ft. lbs.	—	—		
12" Ring Gear	68.0 N·m 50 ft. lbs.	⅛ Turn	339.0 N·m 250 ft. lbs.		

*With wheel rotating.

**Back-off the nut and retighten to 47 N·m (35 ft. lbs.). Then back the nut off ¼ turn.

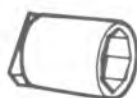
- | | | | | | |
|-----|---|-----------|-----|---|-----------|
| 1. |  | J-6627-A | 11. |  | J-24428 |
| 2. |  | J-8092 | 12. |  | J-24434 |
| 3. |  | J-5853-B | 13. |  | J-22349 |
| 4. |  | J-8614-01 | 14. |  | J-23689 |
| 5. |  | J-2919-01 | 15. |  | J-21128 |
| 6. |  | J-2222-C | 16. |  | J-23690 |
| 7. |  | J-24426 | 17. |  | J-29709 |
| 8. |  | J-24427 | 18. |  | J-29713 |
| 9. |  | J-8608 | 19. |  | J-22388 |
| 10. |  | J-24384 | 20. |  | J-22804-1 |
| | | | 21. |  | J-22836 |
| | | | 22. |  | J-25510 |

B-07587

Figure 31—Special Tools

4B1-22 REAR AXLE

- | | |
|--|--|
| 1. Wheel Stud Remover | 12. Pinion Oil Seal Installer |
| 2. Driver Handle | 13. Wheel Bearing Inner Cup Installer |
| 3. Inch/Pound-Torque Wrench | 14. Axle Shaft Bearing Remover |
| 4. Companion Flange Holder and Remover | 15. Axle Shaft and Pinion Oil Seal Installer |
| 5. Slide Hammer with Adapter | 16. Axle Shaft Bearing Installer |
| 6. Wheel Bearing Nut Wrench | 17. Axle Shaft Bearing Installer (9 $\frac{1}{2}$ -Inch Ring Gear) |
| 7. Outer Wheel Bearing Cup Installer | 18. Axle Shaft Seal Installer (9 $\frac{1}{2}$ -Inch Ring Gear) |
| 8. Inner Wheel Bearing Cup Installer | 19. Pinion Oil Seal Installer (9 $\frac{1}{2}$ -Inch Ring Gear) |
| 9. Outer Pinion Bearing Cup Installer | 20. Pinion Oil Seal Spacer |
| 10. Pinion Oil Seal Installer | 21. Pinion Seal Installer (8 $\frac{1}{2}$ -Inch Ring Gear) |
| 11. Axle Shaft Seal Installer | 22. Wheel Bearing Nut Wrench |

B-07586

Figure 32—Special Tools

classiccarylbrary.com

SECTION 4C

FRONT AXLE

The following "Notice" applies to one or more steps in the assembly procedure of components in this portion of the manual as indicated at appropriate locations by the terminology: "NOTICE: See 'Notice' on page 4C-1 of this section."

NOTICE: All front axle fasteners are important attaching parts in that they could affect the performance of vital parts and systems, and/or could result in major repair expense. They must be replaced with one of the same part number or with an equivalent part if replacement becomes necessary. Do not use a replacement part of lesser quality or substitute design. Torque values must be used as specified during reassembly to assure proper retention of all parts.

CONTENTS

<u>SUBJECT</u>	<u>PAGE</u>
Description	4C-1
Diagnosis Of The Front Axle	4C-2
Road Test	4C-2
Tire Noises	4C-2
Engine or Exhaust Noises	4C-2
Test For Wheel Bearing Noise	4C-2
Test For Differential Bearing Noise	4C-2
Test For Pinion Bearing Noise	4C-2
On-Vehicle Service	4C-2
Axle Shaft Replacement	4C-2
Front Axle Assembly Replacement	4C-3
Axle Joint Component Replacement	4C-4
Locking Hub Component Replacement	4C-4
Automatic Hub To The Wheel Adjustment	4C-7
Manual Locking Hub Replacement	4C-7
Manual Locking Hub Rebuild Procedure	4C-8
Specifications	4C-8
Special Tools	4C-8

DESCRIPTION

The front axle is a hypoid gear axle unit equipped with steering knuckles and an automatic or manual locking hub. The V-10/15 and 20/25 models use a Chevrolet front axle having an 8¹/₂-inch ring gear axle rated at 3600 pounds for the V-10/15 and 3800 pounds for the V-20/25. A Dana (60 Series) axle is used on the V-30/35 model and is

rated at 4500 pound capacity. The Dana axle has a 9³/₄-inch ring gear. Automatic hub locks are used on all models to engage the hub whenever four-wheel drive is selected. A manual locking hub is used on the V-30/35 model only and must be engaged manually whenever four-wheel drive is selected.

DIAGNOSIS OF THE FRONT AXLE

ROAD TEST

- Check tires for irregular wear.
- Check tire pressure.
- Check axle lubricant level.
- Drive to warm up the front axle.
- Test at various speeds in drive, float, coast and while cornering.
- Verify that the hubs are locked.

TIRE NOISES

- Change the tire pressure to minimize noises.
- Drive over different road surfaces.
- Smooth black-top minimizes tire noise.
- Cross switch the tires, if necessary.
- Snow tire treads and studs cause added noises.

ENGINE OR EXHAUST NOISES

- Drive slightly above the speed where the noise occurs, place transmission in neutral.
- Let the engine speed drop to idle.
- Stop the vehicle.
- Run the engine at various speeds.

TEST FOR WHEEL BEARING NOISE

- Drive the vehicle at low speed on a smooth road.
- Turn the vehicle to develop left and right motions, traffic permitting.

- Noise should change due to cornering loads.
- Jack-up wheels to verify roughness at the wheels.

*TEST FOR DIFFERENTIAL BEARING NOISE

- Drive the vehicle at low speed on a smooth road.
- Constant low pitch bearing noise may be heard.
- Noise should not change in reversing turns.
- The noise pattern should vary with the wheel speed.

*TEST FOR PINION BEARING NOISE

- Rough running or a whine noise should increase with speed.
- Noise pitch should be higher than differential noise.
- Perform the test on a smooth road to minimize tire noises.
- Perform test at various speeds in drive, float, and coast.
- Rear pinion bearing noise may be louder on acceleration.
- Front pinion bearing noise may be louder on deceleration.
- Gear noise tends to peak in a narrow speed range.

*Bearing tests should be done in 2H (after 4H selection to lock hubs). This removes the transfer case whine.

ON-VEHICLE SERVICE

AXLE SHAFT REPLACEMENT

Remove or Disconnect (Figure 1)

- Raise the vehicle.
- 1. Wheel and tire.
- 2. Brake caliper (40).

Important

- Support the brake caliper (40) so as not to stretch or damage the brake hose.
- 3. Hub lock mechanism (20).
- 4. Rotor and hub (28).
- 5. Inner bearing (31) and seal (32).
- 6. Splash shield (41), brake bracket (39) and spindle (38).
- 7. Axle shaft (46).

Clean

- Inner and outer wheel bearing (31, 26).
- Hub and disc (28), spindle (38).

Inspect

- All parts and replace as necessary.

Important

- Lube the spindle bearing (37) and spindle (38).
- Pack the inner and outer wheel bearing (31, 26).

NOTICE: For steps 3, 4 and 5, see "Notice" on page 4C - 1 of this section.

Install or Connect (Figure 1)

1. Seal (36) and spacer (35) to the axle shaft (46).
2. Axle shaft (46) into the housing (42).
3. Spindle (38) to the knuckle (44). Be sure the seal (34) and outer deflector (33) are in place.
4. Brake bracket (39).
5. Splash shield (41).
 - New washers (48) and nuts (49) to the studs. Torque the nuts (49) to 88 N·m (65 ft. lbs.).
6. Hub and disc (28).
 - Adjust the wheel bearings (26, 31). Refer to FRONT SUSPENSION (SEC. 3C).
7. Retainer (22) and ring (21).
8. Hub lock mechanism (20).

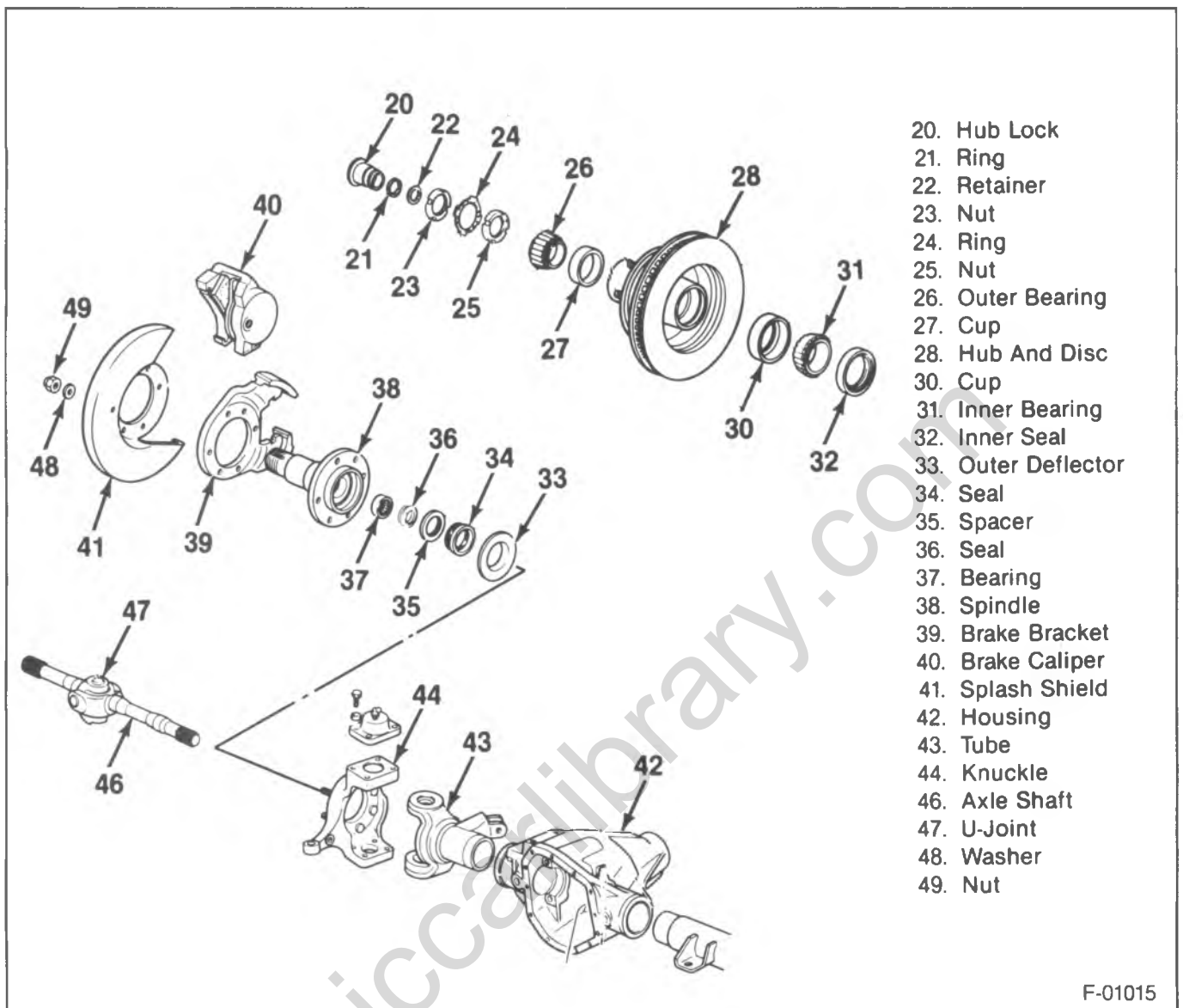

- 20. Hub Lock
- 21. Ring
- 22. Retainer
- 23. Nut
- 24. Ring
- 25. Nut
- 26. Outer Bearing
- 27. Cup
- 28. Hub And Disc
- 30. Cup
- 31. Inner Bearing
- 32. Inner Seal
- 33. Outer Deflector
- 34. Seal
- 35. Spacer
- 36. Seal
- 37. Bearing
- 38. Spindle
- 39. Brake Bracket
- 40. Brake Caliper
- 41. Splash Shield
- 42. Housing
- 43. Tube
- 44. Knuckle
- 46. Axle Shaft
- 47. U-Joint
- 48. Washer
- 49. Nut

F-01015

Figure 1—Front Axle Components

NOTICE: See "Notice" on page 4C-1 of this section.

- 9. Brake caliper (40).
 - Do not stretch or damage the brake hose.
- 10. Wheel and tire.
 - Lower the vehicle and test.

FRONT AXLE ASSEMBLY REPLACEMENT

↔ Remove or Disconnect (Figure 1)

- Raise the vehicle until the weight is removed from the front springs. Support the vehicle with jack stands placed behind the front springs.
- 1. Propeller shaft. Refer to "Propeller Shaft" (Sec. 4A).
- 2. Connecting rod from the steering arm. Refer to FRONT SUSPENSION (SEC. 3C).
- 3. Brake caliper (40).

- Support the brake caliper (40) so as not to stretch or damage the brake hose.

- 4. Shock absorbers from the axle brackets.
- 5. Front stabilizer bar.
- 6. Axle vent tube and clips (figure 2).
- 7. Nuts, washers, U-bolts, spacers and plates.
 - Support the axle with a jack.
- 8. Axle assembly out from under the vehicle.



Clean

- Axle assembly.



Inspect

- The assembly and repair or replace as necessary.

NOTICE: For steps 1, 5, 6 and 7, see "Notice" on page 4C-1 of this section.



Install or Connect (Figure 1)

- Axle assembly positioned under the vehicle.
- 1. Plates, spacers, U-bolts, washers and nuts.

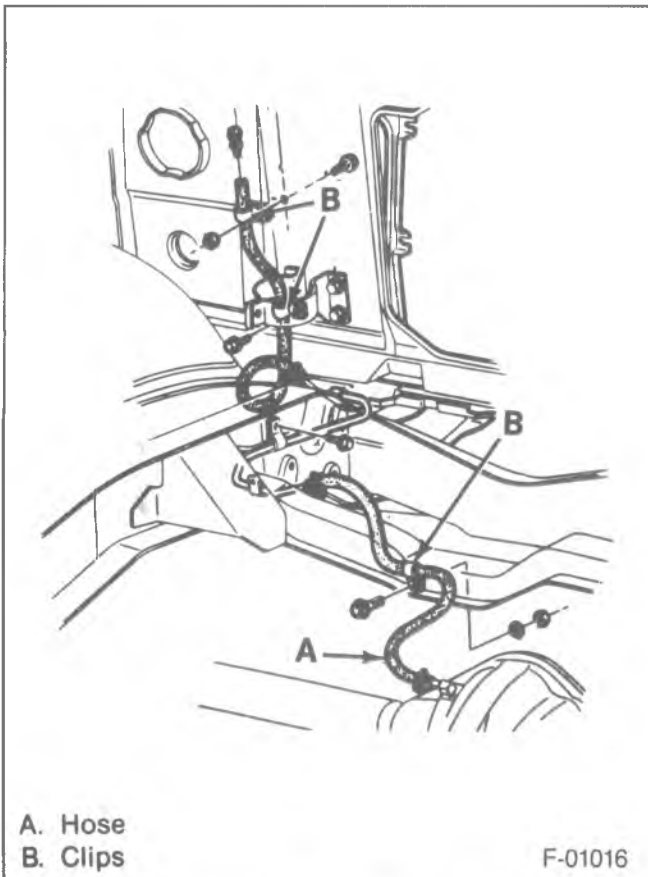

Figure 2—Axle Vent Hose Routing

2. Axle vent tube and clips. Refer to figure 2.
3. Front stabilizer bar.
4. Shock absorbers to the axle brackets.
5. Brake caliper (40).
6. Connecting rod to the steering arm.
7. Propeller shaft.
 - Lower the vehicle.

AXLE JOINT COMPONENT REPLACEMENT

↔ Remove or Disconnect

- Raise the vehicle.
1. Axle shaft. Refer to "Axle Shaft Replacement" earlier in this section.
 - Support the shaft yoke in a bench vise or on a short piece of pipe.
 2. Trunnion
 - Using a brass drift and soft hammer drive on the end of a trunnion bearing enough to drive the opposite bearing from the yoke.
 - Support the other yoke and drive the trunnion bearing out in the same manner.

🧼 Clean

- The bearings and yokes.

🔍 Inspect

- The bearings and yokes. Replace parts as necessary.

↔ Install or Connect

- Lubricate the new bearings with a high melting point type wheel bearing grease.
1. Bearing in a yoke ear.
 2. Trunnion in the bearing.
 3. Another bearing in the opposite yoke ear with the trunnion aligned.
 4. Bearing in each ear of the companion yoke.
 - Press the bearings in beyond the lock ring grooves.
 5. Lock ring at each bearing.
 - Tap the yoke lightly to seat the bearings against the lock rings.

LOCKING HUB COMPONENT REPLACEMENT

AUTOMATIC HUB COMPONENT REPLACEMENT

↔ Remove or Disconnect (Figure 3)

1. Screws (50) and O-ring seals (52).
2. Cover (52).
3. Seal (53).
4. Keeper (60).
5. Spring (54).
6. Inner race (55).
7. Bearing (56).
8. Retainer (58).
9. Ring (57) using needle nose plier.
 - Pull the remaining components from the wheel.
10. Retaining ring (77) from the sleeve (67) groove.
 - Rotate the drag sleeve (75) until it drops into engagement with the gear (59).
 - Lift and cock the drag sleeve (75) to unlock the tangs of the brake band (74) from the "window" of the inner cage (72), then move the drag sleeve (75) and brake assembly away.

! Important

- NEVER REMOVE THE BRAKE BAND (74) FROM THE DRAG SLEEVE (75). The spring tension of the brake band (74) can be changed if the coils are over expanded and the operation of the hub could be affected.
11. Ring (73) from the groove in the clutch gear (59).
 12. Inner cage (72).
 - While removing the inner cage (72) use a small screw driver to pry the plastic outer cage (71) away.
 13. Outer cage (71).
 - Pry the plastic outer cage (71) tabs free from the groove in the clutch gear (59) and move the outer cage (71) away.
 14. Sleeve (67) from the clutch gear (59).
 - Compress the return spring (64) and hold the assembly in a compressed condition by using the clamps shown in figure 4.
 - Position the assembly with the clamps in place in a vice and hold both ends of the sleeve (67).

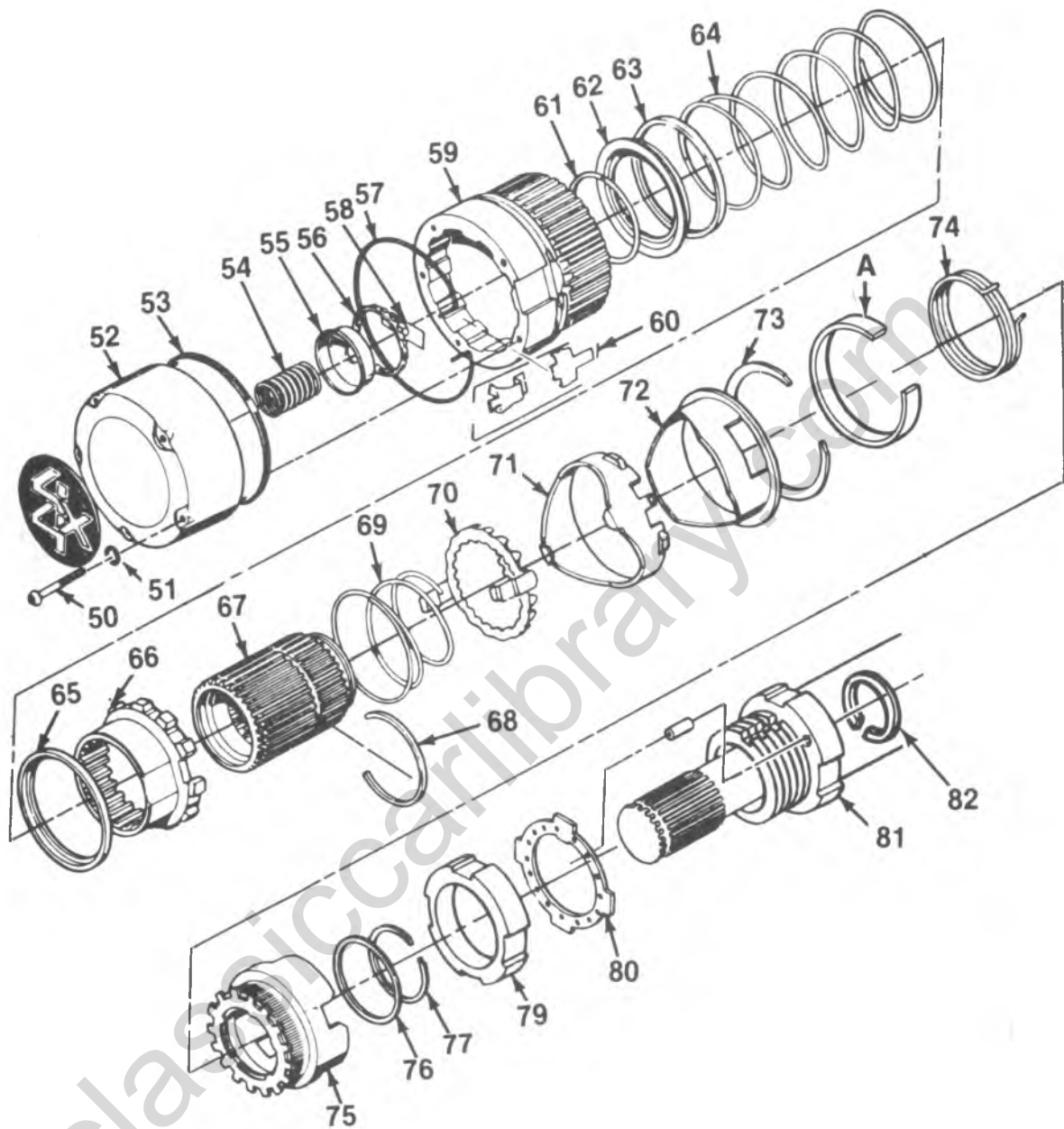

- | | | |
|-----------------|--------------------|--------------------|
| 50. Screw | 62. Retainer Plate | 74. Brake Band |
| 51. O-Ring Seal | 63. Retainer | 75. Drag Sleeve |
| 52. Cover | 64. Return Spring | 76. Spacer |
| 53. Seal | 65. Retainer | 77. Retaining Ring |
| 54. Spring | 66. Gear | 79. Adjusting Nut |
| 55. Inner Race | 67. Sleeve | 80. Lock Ring |
| 56. Bearing | 68. Stop Ring | 81. Nut With Pin |
| 57. Ring | 69. Spring | 82. Ring |
| 58. Retainer | 70. Cam | A. Shield |
| 59. Clutch Gear | 71. Outer Cage | |
| 60. Keeper | 72. Inner Cage | |
| 61. Ring | 73. Ring | |

F-03523

Figure 3—Automatic Hub Components, V10/15, V20/25 and V30/35

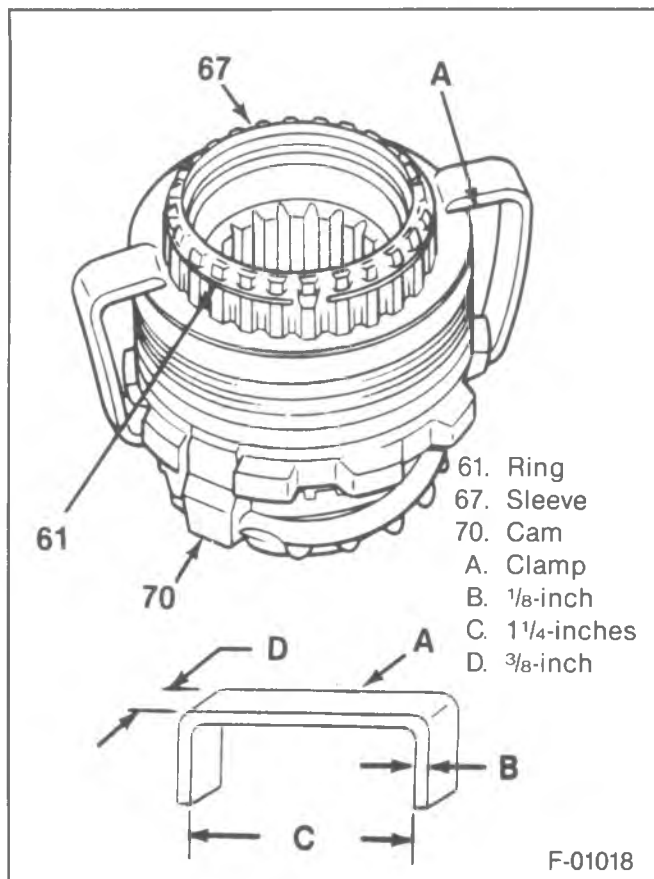

Figure 4—Compressing the Return Spring

15. Ring (61).
 - While holding the sleeve (67) in the vise, remove the clamps holding the return spring (64) and then open the vise and release the return spring (64).
16. Retainer plate (62).
17. Retainer (63).
18. Stop ring (68).
 - Align the ends of the stop ring (68) with the legs of the cam (70) to allow removal.
19. Spring (69).
20. Cam (70) from the gear (66).

Inspect

- All parts and replace as necessary.

Install or Connect (Figure 3)

1. Cam (70) over the flats of the gear (66).
2. Spring (69).
 - Compress the spring (69) and slide the large diameter end against the gear (66).
3. Gear (66) over the splines of the sleeve (67).
 - Cam (70) should locate at the end of the sleeve (67) having no splines.

Important

- The gear (66) and spring (69) should slide freely over the splines of the sleeve (67).
4. Stop ring (68) to the groove of the sleeve (67).
 5. Retainers (63 and 65) to each end of the spring (64).
 - Retainer (65) to the shoulder of the gear (66).
 6. Retainer plate (62) to the retainer (63).

- Compress the return spring (64) and hold the assembly together with clamps (figure 4).
7. Ring (61) in the groove of the sleeve (67).
 - Place the assembly (steps 1 through 7) into the clutch gear (59) and support the clutch gear (59) above a flat surface allowing the assembly to drop down so that the tangs of the brake band (74) may be assembled later.
 8. Outer cage (71) into the clutch gear (59).
 - The ramps of the outer cage (71) must face the cam (70).
 - Locate the outside tabs of the outer cage (71) into the wide grooves of the clutch gear (59).
 9. Inner cage (72) into the outer cage (71).
 - Align the tab of the outer cage (71) with the "window" of the inner cage (72).
 10. Ring (73).
 - Into the groove of the clutch gear (59) above the outer cage (71).

Important

- Service the brake band (74) and drag sleeve (75) as an assembly and be sure the original lubricant has not been removed or contaminated. Lubricant number 1052750 or its equivalent **must be used** in this assembly.
11. Brake band (74) tangs.
 - Place the tangs of the brake band (74) on each side of the lug of the outer cage (71) located in the "window" of the steel inner cage (72). Cock these parts to engage the tangs in this position.
 12. Spacer (76) and retaining ring (77).
 - To the sleeve (67) above the drag sleeve (75).
 13. Hub assembly to the vehicle.
 14. Ring (57) to the clutch gear (59) unsplined end.
 - Locate the tangs of the ring (57) pointing away from the vehicle.
 15. Keeper (60).
 - Hold the tangs of the ring (57) together and attach the keeper (60). For K10 and K20 assemble the O-ring seal (53) in the clutch gear (59) groove and over the keeper (60).
 16. Bearing (56) over the inner race (55).
 - Lubricate the bearing (56) with light wheel bearing grease.
 - Steel balls should be visible when bearing (56) is properly installed.
 17. Retainer (58) into the outer race (55) hole.
 - Bearing (56) inner race (55) and retainer (58) into the sleeve (67).
 18. Spring (54) into the cover (52) bore.
 - Align cover (52) screw holes with the screw thread holes in the clutch gear (59).
 19. O-ring seals (51) and screws (50) in the cover (52).
 - The hub sleeve (67) and attached parts should turn freely after assembly.

Tighten

- Screws (50) to 5.1 N·m (45 in. lbs.).

Important

- The five cover screws (50) must be loosened (three or four turns) and then pushed inward to

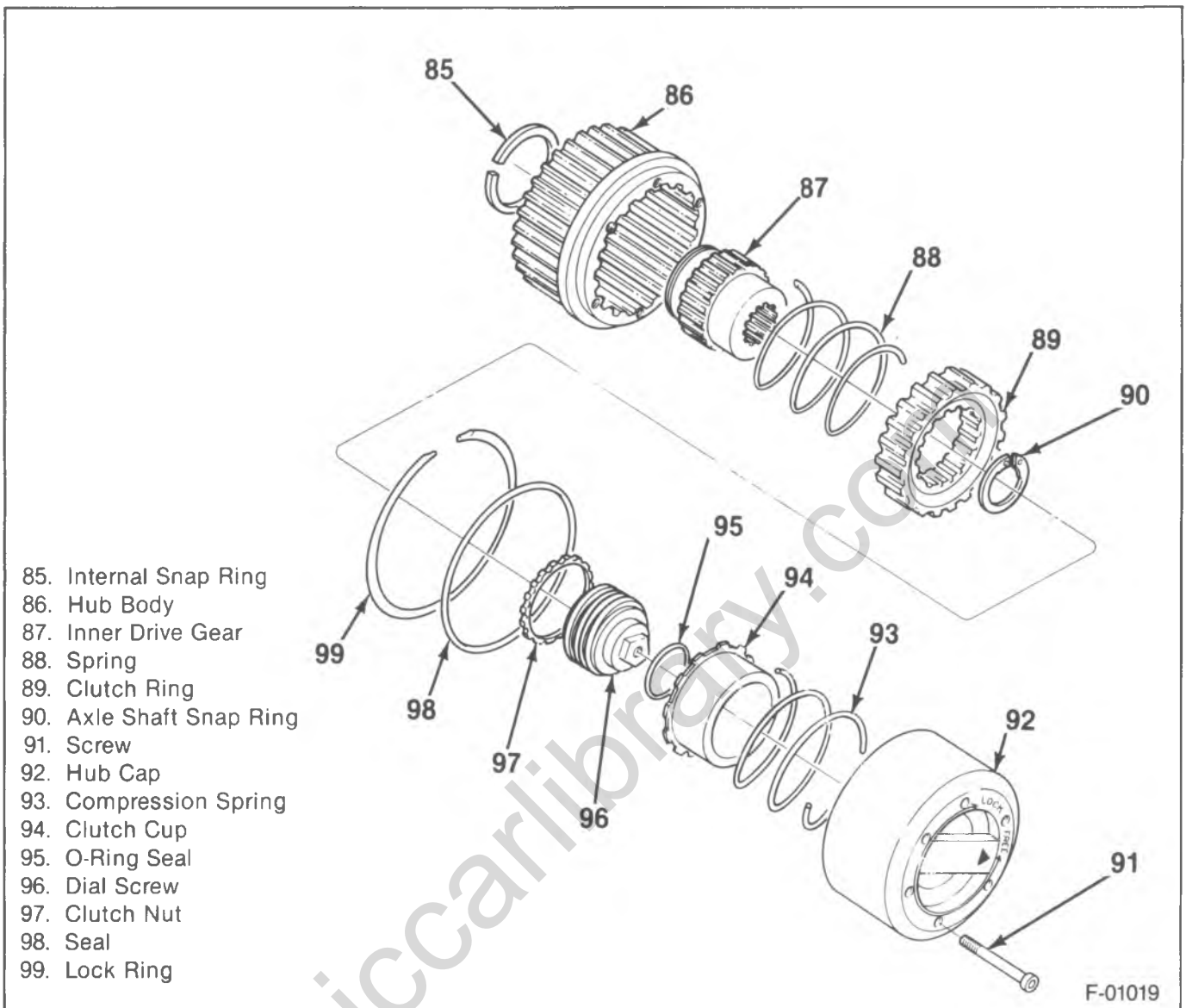

- 85. Internal Snap Ring
- 86. Hub Body
- 87. Inner Drive Gear
- 88. Spring
- 89. Clutch Ring
- 90. Axle Shaft Snap Ring
- 91. Screw
- 92. Hub Cap
- 93. Compression Spring
- 94. Clutch Cup
- 95. O-Ring Seal
- 96. Dial Screw
- 97. Clutch Nut
- 98. Seal
- 99. Lock Ring

F-01019

Figure 5—Manual Hub Components, V30/35

allow the retaining ring (57) to expand when assembling the automatic locking hub to the vehicle.

AUTOMATIC HUB TO THE WHEEL ADJUSTMENT

A lock ring (80) is supplied with each new automatic hub assembly. Assemble this lock ring (80) between the nut with pin (81) and the adjusting nut (79) as follows:

Use J-6893 to torque the nut with pin (81) to 68 N·m (50 ft. lbs.) to seat the wheel bearings; then back off the nut with pin (81) and torque to 47 N·m (35 ft. lbs.) while rotating the hub (figure 3).

Then back the nut with pin (81) off a maximum of 3/8 turn. Assemble the lock ring (80) over the axle shaft against the nut with pin (81) so that the inner tang enters the axle shaft keyway. One of the holes in the lock ring (80) must engage the pin on nut (81). Thread the adjusting nut (79) onto the axle shaft and tighten to 247 N·m (183 ft. lbs.).

Align the cut-outs on the drag sleeve (75) with the tabs on the lock ring (80) as the splines of the clutch gear (59) mesh with the splines of the wheel hub. Loosen the five cover screws (50) three or four turns and push in on the screws (50) to allow the ring (57) to expand into the groove in the wheel hub. Torque the screws (50) to 5.1 N·m (45 inch lbs.).

MANUAL LOCKING HUB REPLACEMENT

↔ Remove or Disconnect (Figure 5)

1. Screws (91).
2. Outer hub locking assembly (92, 93, 94, 95, 96, 97, 98, and 99).
3. Snap ring (90) from the axle shaft end.
4. Internal snap ring (85) from hub.
5. Body assembly (86, 87, 88 and 89).

👁 Inspect

- All parts and replace as necessary.

4C-8 FRONT AXLE

→→ Install or Connect (Figure 5)

1. Body assembly (86, 87, 88 and 89).
2. Internal snap ring (85) to the hub.
3. Snap ring (90) onto the axle shaft end.
4. Outer hub locking assembly (92, 93, 94, 95, 96, 97, 98 and 99).
5. Screws (91).

MANUAL LOCKING HUB REBUILD PROCEDURE

- Outer hublock knob assembly should be replaced only as a unit, because timing relationships are difficult to restore if disassembly occurs. The inner body may be disassembled for cleaning and component replacement.

←→ Remove or Disconnect (Figure 5)

1. Screws (91).
2. Hub body (86).

3. Spring (88).
4. Internal snap ring (85).
5. Inner drive gear (87) with thrust washers.
6. Plastic sleeve.

🔍 Inspect

- All parts and replace as necessary.

→→ Install or Connect (Figure 5)

- Lubricate inner body parts with ATF or a light coat of wheel bearing grease.
1. Plastic sleeve.
 2. Inner drive gear (87) with thrust washers.
 3. Internal snap ring (85).
 4. Spring (88).
 5. Hub body (86).
 6. Screws (91).

SPECIFICATIONS

	N·m	Ft. Lbs.
Nut-Splash Shield Retaining	88	65
Nut With Pin (Bearing Preload)	68	50
(Final Torque)	47	35
Cover Screw-Automatic Hub	5.1	45 (inch lbs.)
Adjusting Nut-Axle Shaft	247	183

SPECIAL TOOLS

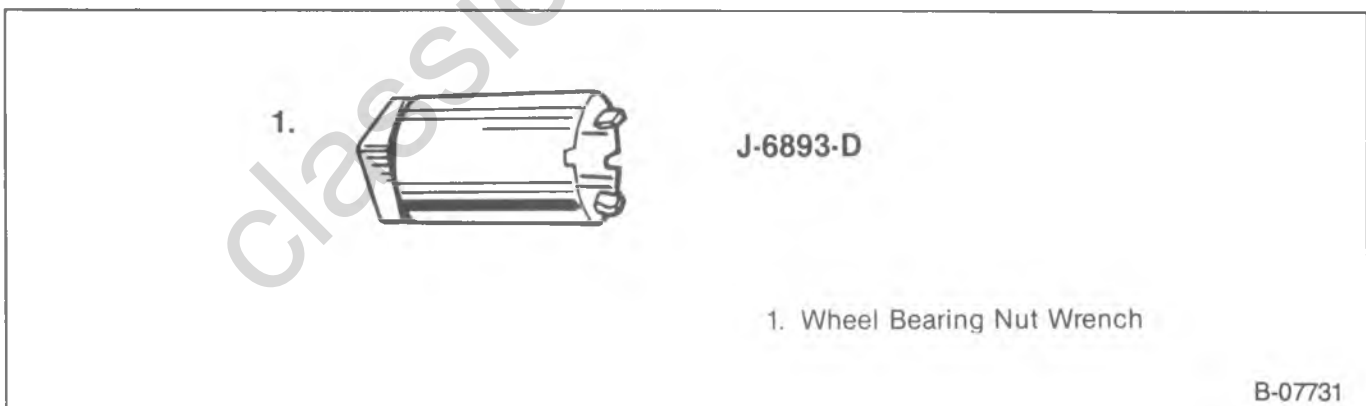

Figure 6—Special Tools

SECTION 5 BRAKES

CONTENTS

<u>SUBJECT</u>	<u>PAGE</u>
Hydraulic Brakes	5A-1
Hydraulic Brake Booster Systems	5A1-1
Hydraulic Foundation Brakes	5A2-1

SECTION 5A HYDRAULIC BRAKES

The following notice applies to one or more steps in the assembly procedure of components in this portion of the manual as indicated at appropriate locations by the terminology NOTICE: See 'Notice' on page 5A-1 of this section.

NOTICE: *This fastener is an important attaching part in that it could affect the performance of vital components and system, and/or could result in major repair expense. It must be replaced with one of the same part number or with an equivalent part if replacement becomes necessary. Do not use a replacement part of lesser quality or substitute design. Torque values must be used as specified during reassembly to assure proper retention of this part.*

CAUTION: When servicing wheel brake parts, do not create dust by grinding or sanding brake linings or by cleaning wheel brake parts with a dry brush or with compressed air. (A water dampened cloth should be used). Many wheel brake parts contain asbestos fibers which can become airborne if dust is created during servicing. Breathing dust containing asbestos fibers may cause serious bodily harm.

CONTENTS

<u>SUBJECT</u>	<u>PAGE</u>
Brake System Diagnosis	5A- 2
Road Testing the Brakes	5A- 2
Diagnosis of Brake System	5A- 2
On - Vehicle Service	5A- 5
Bleeding the Brake Hydraulic System	5A- 5
Flushing the Brake Hydraulic System	5A- 6
Brake Pipes and Hoses	5A- 6
Combination Valve	5A- 7
Height Sensing Brake Proportioning Valve	5A- 9
Brake Pedal Assembly	5A-13
Checking Pedal Travel	5A-13
Brake Pedal Replacement	5A-13
Brake Pedal Rod Replacement	5A-15
Stoplamp Switch	5A-16
Parking Brake System	5A-17
Parking Brake Pedal or Handle Replacement	5A-17
Cable Replacement	5A-18
Propeller Shaft Brake Replacement	5A-22
Parking Brake Adjustment	5A-22
Master Cylinders	5A-24
Description	5A-24
Master Cylinder Replacement	5A-24
Bench Bleeding	5A-26
Specifications	5A-26
Special Tools	5A-28

BRAKE SYSTEM DIAGNOSIS

ROAD TESTING THE BRAKES

BRAKE TEST

The brakes should be tested on a dry, clean, reasonably smooth and level roadway. A true test of brake performance cannot be made if the roadway is wet, greasy or covered with loose dirt so that all the tires do not grip the road equally. The testing will be adversely affected if the roadway is crowned so as to throw the weight of the vehicle toward the wheels on one side or if the roadway is so rough that the wheels tend to bounce.

Test the brakes at different vehicle speeds with both light and heavy pressure; however, avoid locking the wheels and sliding the tires on the roadway. Locked wheels and sliding tires do not indicate brake efficiency since heavily braked turning wheels will stop the vehicle in less distance than locked wheels. More tire-to-road friction is present with a heavily braked turning tire than with a sliding tire.

EXTERNAL CONDITIONS THAT AFFECT BRAKE PERFORMANCE

1. **Tires**—Tires having unequal contact and grip on the road will cause unequal braking. The tires must be equally inflated and the tread pattern of the right and left tires must be about equal.
2. **Vehicle Loading**—When the vehicle has unequal loading, the most heavily loaded wheels require more braking power than the others.
3. **Front Wheel Bearings**—Loose front wheel bearings permit the disc to tilt and have spotty contact with the linings causing erratic action.
4. **Front End Alignment**—Misalignment of the front end, particularly in regard to limits on camber and caster, will cause the brakes to pull to one side.

DIAGNOSIS OF BRAKE SYSTEM

PROBLEM	POSSIBLE CAUSE	CORRECTION
Uneven Brake Action (Brakes Pull)	<ol style="list-style-type: none"> 1. Incorrect tire pressure. 2. Front end out of alignment. 3. Loose suspension parts. 4. Worn out brake lining. 5. Incorrect lining material. 6. Malfunctioning caliper assembly. 7. Loose calipers. 8. Contaminated brake linings. 9. Malfunctioning rear brakes. 10. Leaking wheel or piston cylinder seal. 11. Restricted brake tubes or hoses. 12. Unmatched tires on the same axle. 	<ol style="list-style-type: none"> 1. Inflate evenly on both sides to specifications. 2. Check and align to specifications. 3. Check all suspension mountings. 4. Replace with lining of correct material. 5. Replace with linings of correct material. 6. Check for frozen or sluggish pistons and the lubrication of the retainer bolts. Caliper should slide. 7. Check and torque. 8. Repair as necessary. Replace linings in complete axle sets. 9. Check for inoperative self adjusters. Weak return springs. Leaking wheel cylinders. 10. Repair as necessary. 11. Check for collapsed rubber hoses or damaged lines. Repair as necessary. 12. Same style tires with about the same tread should be used on the same axle.

DIAGNOSIS OF BRAKE SYSTEM (CONT.)

PROBLEM	POSSIBLE CAUSE	CORRECTION
Brakes Squeak	<ol style="list-style-type: none"> 1. Worn out linings. 2. Glazed brake lining. 3. Heat spotted rotors or drums. 4. Weak or incorrect brake shoe retention springs. 5. Contaminated brake linings. 6. Incorrect lining material. 7. Brake assembly attachments missing or loose. 8. Excessive brake lining dust. 	<ol style="list-style-type: none"> 1. Replace linings. 2. Replace linings. 3. Check per instructions. If within specifications machine the rotor or drum. 4. Replace with new retention springs. 5. Repair as necessary. Replace linings in complete axle sets. 6. Replace with linings of correct material. 7. Repair as necessary. 8. Clean dust from brake assembly.
Brake Pedal Pulsates	<ol style="list-style-type: none"> 1. Excessive rotor lateral runout. 2. Rear drums out of round. 3. Heat spotted rotors or drums. 4. Incorrect wheel bearing adjustments. 5. Out of balance wheel assembly attachments missing or loose. 6. Brake assembly attachments missing or loose. 	<ol style="list-style-type: none"> 1. Check per instructions. If within specifications machine the rotor. 2. Check per instructions. If within specifications machine the drum. 3. Check per instructions. If within specifications machine the rotor or drum. 4. Repair as necessary. 5. Repair as necessary. 6. Repair as necessary.
Excessive Pedal Effort	<ol style="list-style-type: none"> 1. Leaking vacuum system. 2. Malfunctioning power brake unit. 3. Worn out linings. 4. Malfunctioning proportioning valve. 5. Incorrect lining material. 6. Incorrect wheel cylinder. 	<ol style="list-style-type: none"> 1. Repair as necessary. 2. Repair as necessary. 3. Replace linings. 4. Repair as necessary. 5. Replace with linings of correct materials. 6. Replace with correct size wheel cylinder.
Excessive Pedal Travel	<ol style="list-style-type: none"> 1. Insufficient fluid in master cylinder reservoir. 2. Air in brake system. 3. Malfunctioning self adjusters. 4. Master cylinder. 5. Incorrect wheel bearing adjustment. 6. Improperly adjusted master cylinder pushrod. 	<ol style="list-style-type: none"> 1. Fill reservoir with approved brake fluid. Check for leaks and air in the system. Check indicator light. 2. Check for leaks in lines, wheel cylinders, or master cylinder. Bleed the system. 3. Repair as necessary. 4. Replace or repair as necessary. 5. Repair as necessary. 6. Adjust master cylinder pushrod.

5-4 HYDRAULIC BRAKES

DIAGNOSIS OF BRAKE SYSTEM (CONT.)

PROBLEM	POSSIBLE CAUSE	CORRECTION
Brakes Drag	<ol style="list-style-type: none"> 1. Malfunctioning caliper assembly. 2. Contaminated or improper brake fluid. 3. Improperly adjusted parking brakes. 4. Restricted brake tube or hoses. 5. Malfunctioning proportioning valve. 6. Malfunctioning self adjusters. 7. Malfunctioning master cylinder. 8. Improperly adjusted master cylinder pushrod. 	<ol style="list-style-type: none"> 1. Check for frozen or sluggish pistons and the lubrication of the retainer bolts. Caliper should slide. 2. Repair as necessary. 3. Repair as necessary. 4. Check for collapsed rubber hoses or damaged lines. Repair as necessary. 5. Replace or repair as necessary. 6. Repair as necessary. 7. Repair as necessary. 8. Adjust pushrod length.
Brake Indicator Light Comes On	<ol style="list-style-type: none"> 1. Air in the brake system. 2. Malfunctioning master cylinder. 3. Contaminated or improper brake fluid. 4. Parking brake on or not fully released. 5. Worn out brake lining. 6. Incorrect wheel bearing adjustment. 7. Malfunctioning self adjusters. 8. Brake assembly attachments missing or loose. 9. Improperly adjusted master cylinder pushrod. 	<ol style="list-style-type: none"> 1. Check fluid level. Check for leaks in lines, wheel cylinders, or master cylinder. Bleed the system. 2. Check for faulty metering valve, or leaking. Repair as necessary. 3. Repair as necessary. 4. Check parking brake. Repair as necessary. 5. Replace linings. 6. Repair as necessary. 7. Repair as necessary. 8. Replace or repair as necessary. 9. Adjust pushrod length.
Excessive Brake Pedal Effort	<ol style="list-style-type: none"> 1. Loose or broken power steering pump belt. 2. No fluid in the power steering reservoir. 3. Leaks at Hydro-Boost tube fittings. 4. External leakage at the accumulator. 5. Faulty booster piston seal causing leakage at the booster flange vent. 6. Faulty booster input rod seal with leakage at the input rod end. 7. Faulty booster cover seal with leakage between the housing and cover. 8. Faulty booster spool plug seal. 	<ol style="list-style-type: none"> 1. Tighten or replace the belt. 2. Fill reservoir and check for external leaks. 3. Tighten fittings or replace tube seats, if faulty. 4. Replace seal and retainer. 5. Overhaul with new seal or input rod and piston assembly. 6. Overhaul with new seal kit. 7. Overhaul with new seal kit. 8. Overhaul with spool plug seal kit.

ON VEHICLE SERVICE

BLEEDING THE BRAKE HYDRAULIC SYSTEM

A bleeding operation is necessary if air has been introduced into the hydraulic brake system.

It may be necessary to bleed the system at all four wheels if air has been introduced by a low fluid level condition in the master cylinder or if the brake pipes have been disconnected at either the master cylinder or the combination valve. If a pipe is disconnected at one wheel, then only bleed that particular wheel.

The time required to bleed the hydraulic system when the master cylinder is removed can be reduced if the master cylinder is filled with fluid and as much air as possible is bled from the cylinder before installing it on the vehicle.

MANUAL BLEEDING

If the vehicle is equipped with power brakes, deplete the vacuum reserve by applying the brakes several times with the engine off.

Use extreme care to prevent brake fluid from contacting any painted surface.

1. Fill the master cylinder reservoirs with brake fluid specified in MAINTENANCE AND LUBRICATION (Sec. OB).
 - Maintain the fluid level in the reservoir during the bleeding operation.
2. If the master cylinder is suspected to have air in the bore, it must be bled before any wheel cylinder or caliper.
 - Remove the forward brake pipe connection at the master cylinder.
 - Allow brake fluid to flow from the connector port.
 - Connect the brake pipe but do not tighten.
3. Slowly depress the brake pedal allowing the air to bleed from the loose fitting.
 - Tighten the fitting before releasing the pedal.
 - Wait 15 seconds, and repeat this sequence, including the 15 second wait until all the air is purged from the bore.
4. After all the air has been removed from the forward connection disconnect the rear pipe.
 - Allow brake fluid to flow from the connector port.
 - Connect the brake pipe but do not tighten.
5. Slowly depress the brake pedal allowing the air to bleed from the loose fitting.
 - Tighten the fitting before releasing the pedal.
 - Wait 15 seconds, and repeat this sequence, including the 15 second wait until all the air is purged from the bore.
6. If it is known that the calipers and wheel cylinders do not contain any air, then it will not be necessary to continue. Otherwise bleed each wheel in the following sequence.
 - Right rear
 - Left rear
 - Right front

- Left front
7. Attach a hose to the wheel cylinder/caliper bleeder screw.
 - Immerse the opposite end of the hose into a container partially filled with clean brake fluid.
 8. Slowly depress the brake pedal one time and hold.
 - Loosen the bleeder screw to purge the air from the wheel cylinder/caliper.
 - Tighten the bleeder screw and slowly release the pedal.
 - Wait 15 seconds, then repeat this sequence, including the 15 second wait until all the air is purged from the wheel cylinder/caliper.
 9. Continue steps 7 and 8 at each wheel until the entire brake system has been bled.
 10. Check the brake pedal for "sponginess" and the brake warning lamp for an indication of an unbalanced pressure. Repeat the entire bleeding procedure to correct either of these two conditions.

PRESSURE BLEEDING

The pressure bleeding equipment must be of the diaphragm type. It must have a rubber diaphragm between the air supply and the brake fluid to prevent air, moisture, oil, and other contaminants from entering the hydraulic system. Also adapters are needed, depending on the type of master cylinder used.

Tools Required:

- J-29567 Brake Bleeder Adapter (Plastic Reservoir)
- J-23518-01 Brake Bleeder Adapter (Cast Iron Reservoir)
- J-23709 Combination Valve Depressor

NOTICE: It is very important that the correct master cylinder bleeder adapter be used to avoid possible damage to the master cylinder reservoir.

1. Fill the pressure tank at least $\frac{1}{3}$ full of brake fluid. The bleeder must be re-bled each time fluid is added.
 - Charge the bleeder to 140 - 170 kPa (20 to 25 psi).
2. Use J-23709 to depress and hold the valve stem on the combination valve during the bleeding operation (figure 1).
 - Install the correct bleeder adapter (figures 2 and 3).
3. Bleed each wheel in the following sequence.
 - Right rear
 - Left rear
 - Right front
 - Left front
4. Connect the hose from the bleeder to the adapter at the master cylinder.
 - Open the tank valve.
5. Attach a hose to a brake bleeder screw.
 - Immerse the opposite end of the hose into a container partially filled with clean brake fluid.

5A-6 HYDRAULIC BRAKES

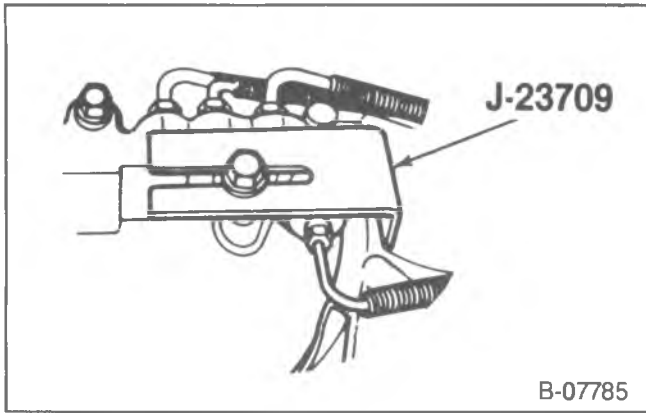

Figure 1—Installing Combination Valve Depresser

6. Open the bleeder screw at least $\frac{3}{4}$ of a turn and allow the fluid to flow until no air is seen in the fluid.
 - Close the bleeder screw.
7. Repeat step six at all the wheels.
8. Check the brake pedal for “sponginess”, repeat the entire bleeding procedure if this condition is found.
9. Remove J-23709.
 - Disconnect the line from the bleeder adapter.
 - Remove bleeder adapter.
10. Fill the master cylinder to the proper level with brake fluid.

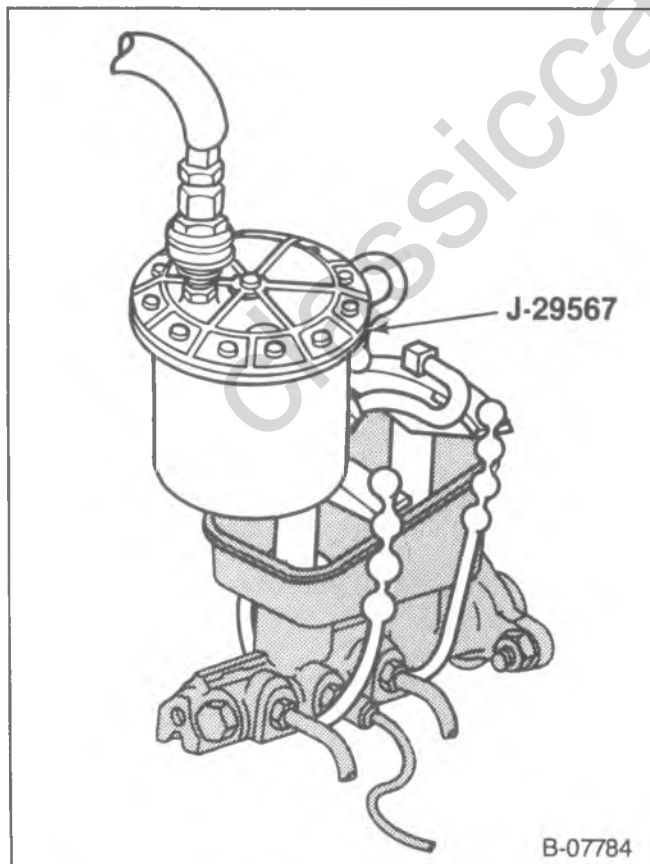

Figure 2—Plastic Reservoir Bleeder Adapter

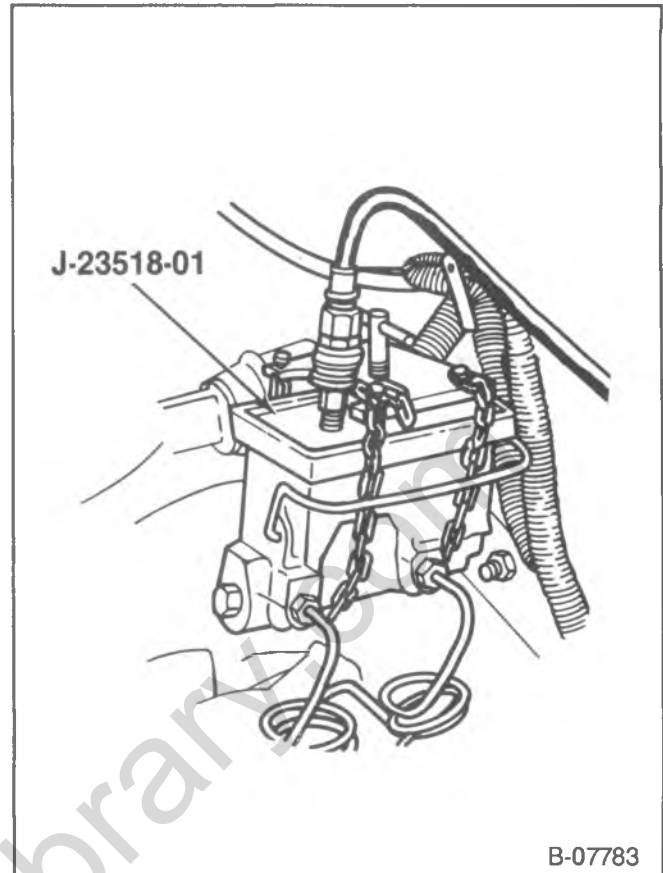

Figure 3—Cast Iron Reservoir Bleeder Adapter

FLUSHING THE BRAKE HYDRAULIC SYSTEM

It is recommended that the entire hydraulic system be thoroughly flushed with clean brake fluid whenever new parts are installed in the hydraulic system.

Flushing is also recommended if there is any doubt as to the grade of fluid in the system or if fluid has been used which contains the slightest trace of mineral oil. Flush the system whenever there is any question of contamination.

Flushing is performed at each bleeder valve in the same manner as the bleeding operation, except that the bleeder valve is opened $1\frac{1}{2}$ turns and the fluid is forced through the lines and bleeder valves until it emerges clear in color. Refer to “Bleeding the Brake Hydraulic System”, in this section.

Check master cylinder fluid level after flushing at each valve and replenish if required. When flushing is completed at all bleeder valves, make certain the master cylinder reservoir is filled to proper level.

BRAKE PIPES AND HOSES

The hydraulic brake system components are interconnected by special steel piping and flexible hoses. Flexible hoses are used between the frame and the front calipers, and the frame and rear differential. When the hydraulic pipes have been disconnected for any reason, the brake system must be bled after reconnecting the pipe, refer to “Bleeding the Brake Hydraulic System” in this section.

FLEXIBLE HOSE

On the front brakes the hose is connected to the caliper with a bolt and copper washers. The fitting at the other end of the hose is secured at the frame with either a nut or a clip.

At the rear differential one end of the hose is connected to the differential with a bolt. The other end is secured at the frame with either a nut or a clip.

Flexible Hose Inspection

The flexible hoses should be inspected for any signs of road damage which will cause cracks and chafing of the other cover. If any of these conditions are visible, replace the hose.

Hose Replacement

↔ Remove or Disconnect (Figure 4)

- Clean dirt, grease, and other foreign material off the hose fittings at both ends.

 1. Steel pipe.
 2. Clip or nut (31).
 3. Bolt (34).
 4. Washers (33).
 5. Hose (32).

↔ Install or Connect (Figure 4)

- Use new copper washers when installing the hose.

 1. Hose (32).
 - The hose must not be twisted.



Important

- The hose installation must not contact any suspension components.

 2. Washers (33).
 3. Bolt (34).
 4. Clip or nut (31).
 5. Steel pipe.

 - Bleed the brakes, refer to "Bleeding the Brake Hydraulic System" in this section.

BRAKE PIPES

When replacing a steel brake pipe, always use steel piping which is designed to withstand high pressure and resist corrosion. The same size pipe must be used as the one removed.

NOTICE: Never use copper tubing for hydraulic brake lines because copper is subject to fatigue cracking, and corrosion which could result in brake failure.

Brake pipes that run parallel to each other must maintain a 6 mm (1/4-inch) clearance.

Pipe Flaring (Figure 5)

Tools Required:

J-23530 Flaring Tool.

J-23533-B Tube Cutter.

In order to ensure a proper flare, a special flaring tool must be used. When using the tool, instruction furnished by the tool manufacturer should be followed. Always inspect newly formed flares for cracks or malformations which might cause leaks. After flaring, blow out the brake pipe with compressed air before installing on the vehicle.

NOTICE: Double lap flaring tool must be used, as single flaring tools cannot produce a flare strong enough to hold the necessary pressure.

1. Use steel pipe and fittings of the correct size. The outside diameter of the pipe is used to specify the size.
2. Cut the pipe to length. Add 3 mm (1/8-inch) to the length for each flare.
3. Flare the pipe ends by following the instructions with the tool.
4. Bend the pipe to match the old pipe by using a pipe bender.

COMBINATION VALVE

The combination valve is comprised of three sections, each serving a different function (figure 6).

The metering or hold off section of the valve limits the pressure to the front disc brakes until a predetermined front input pressure is reached, enough to overcome the rear shoe retractor springs. There is no restriction to the inlet pressures below 20 kPa (3 psi) to allow for pressure equalization during the no apply periods.

The proportioning section of the combination valve proportions outlet pressure to the rear brakes after a predetermined rear input pressure has been reached. This is done to prevent rear wheel lock-up on the vehicles with light rear wheel loads.

The valve is designed to have a By-Pass feature which assures full system pressure to the rear brakes in the event of a front brake system malfunction, also full front pressure is retained in the event of rear malfunction.

The pressure differential warning switch is designed to constantly compare front and rear brake pressure from the master cylinder and energize the warning lamp on the dash in the event of a front or rear system malfunction. The valve and switch are so designed that the switch will latch in the "warning" position once a malfunction has occurred. The only way the lamp can be turned off is to repair the malfunction and apply a pedal force required to develop about 3102 kPa (450 psi) line pressure.

ELECTRICAL CIRCUIT TEST

1. Disconnect the wire from the switch on the valve.
 - Connect a jumper wire from the switch wire to ground.
2. Turn the ignition key to "ON".
 - The warning lamp should light.
 - If the lamp will not light check the bulb. If the bulb is good, refer to Chassis Electrical (Sec. 8B) for further diagnosis.
3. Turn the ignition off.
 - Disconnect jumper wire and connect the wire to the switch terminal.

Valve Warning Switch Test

1. Raise the vehicle.
 - Support with suitable safety stands.
2. Attach a hose to a rear brake bleeder screw.
 - Immerse the opposite end of the hose into a container partially filled with clean brake fluid.
 - Make sure the master cylinder reservoir is full.

5A-8 HYDRAULIC BRAKES

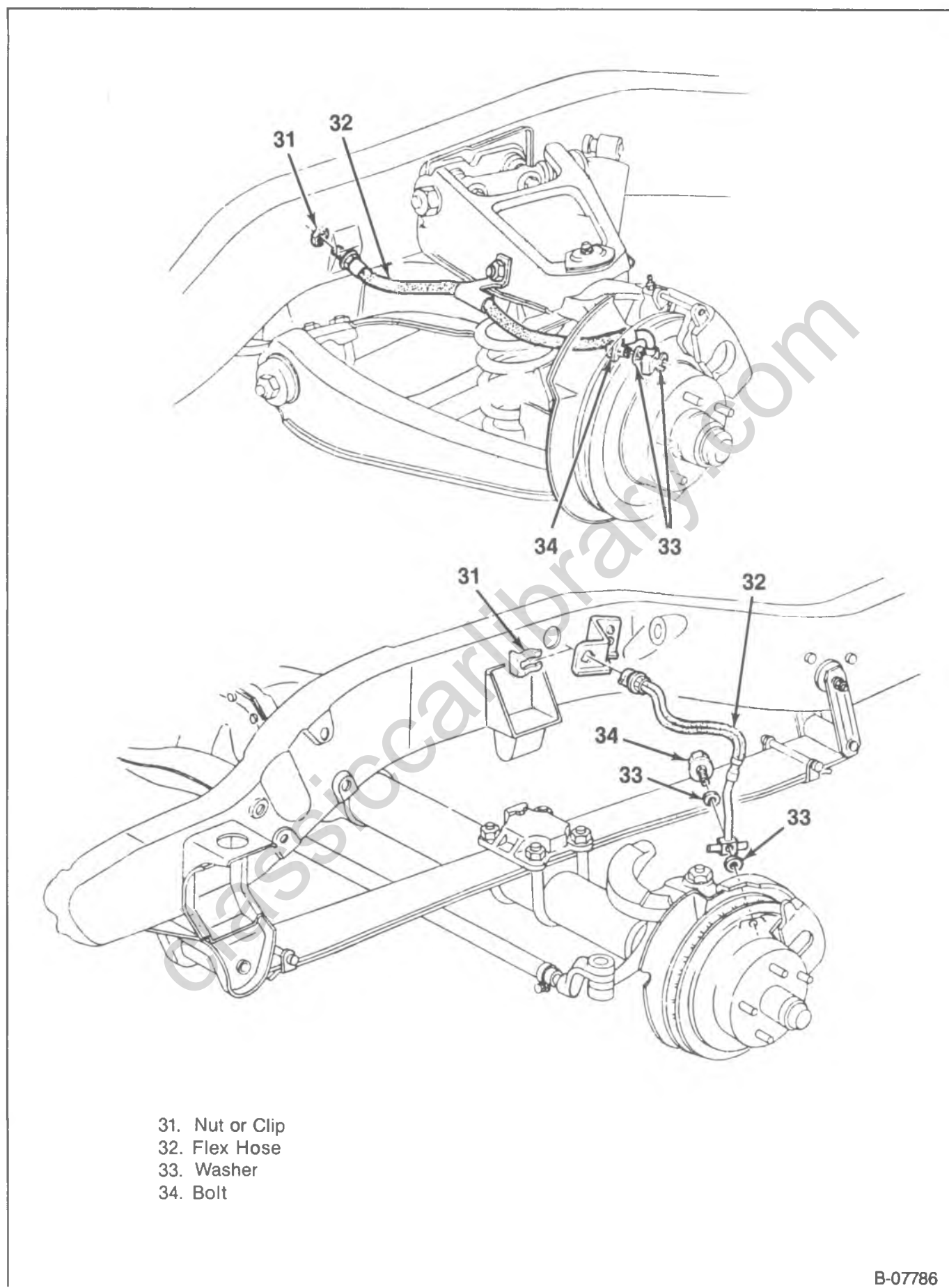

Figure 4—Flexible Hoses

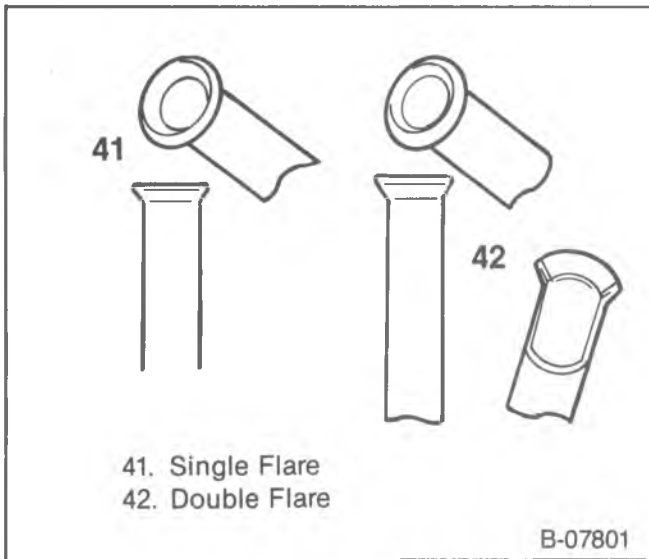

Figure 5—Double Flare

3. Turn the ignition key to "ON".
 - Open the bleeder screw while a helper applies moderate pressure to the brake pedal.
 - The warning lamp should light.
 - Close the bleeder screw before the helper releases the brake pedal.
4. Reapply the brake pedal with moderate to heavy pressure.
 - The lamp should go out.
5. Attach a hose to a front brake bleeder screw.
 - Immerse the opposite end of the hose into a container partially filled with clean brake fluid.
 - Make sure the master cylinder reservoir is full.
6. Open the bleeder screw while a helper applies moderate pressure to the brake pedal.
 - The warning lamp should light.
 - Close the bleeder screw before the helper releases the brake pedal.
7. Reapply the brake pedal with moderate to heavy pressure.
 - The lamp should go out.

8. Turn the ignition key off.
 - If the warning lamp does not light during steps 3 and 6 but does light when a jumper is connected to ground, the warning switch portion of the valve is faulty. Do not disassemble any portion of the valve. It must be replaced.
9. Remove the safety stands.
 - Lower the vehicle.
 - Check and fill the master cylinder to the proper level.

VALVE REPLACEMENT

↔ Remove or Disconnect (Figure 7)

- The combination valve is not repairable and must be replaced as a complete assembly.
 - Care must be taken to prevent brake fluid from contacting any painted surface.
1. Hydraulic pipes.
 - Plug the pipes to prevent the loss of fluid or the entrance of dirt.
 2. Warning switch harness.
 3. Bolts.
 4. Combination valve.

↔ Install or Connect (Figure 7)

1. Position valve on the bracket.
2. Bolts.
3. Warning switch harness.
4. Hydraulic pipes.
 - Bleed the brake system. Refer to "Bleeding Brake System" in this section.

HEIGHT SENSING BRAKE PROPORTIONING VALVE

The height sensing brake proportioning valve is used on series 30 models (figure 8). This will provide optimum brake balance and efficiency. The vehicle braking force is distributed to the front and rear wheels as determined by either a light or heavy payload condition.

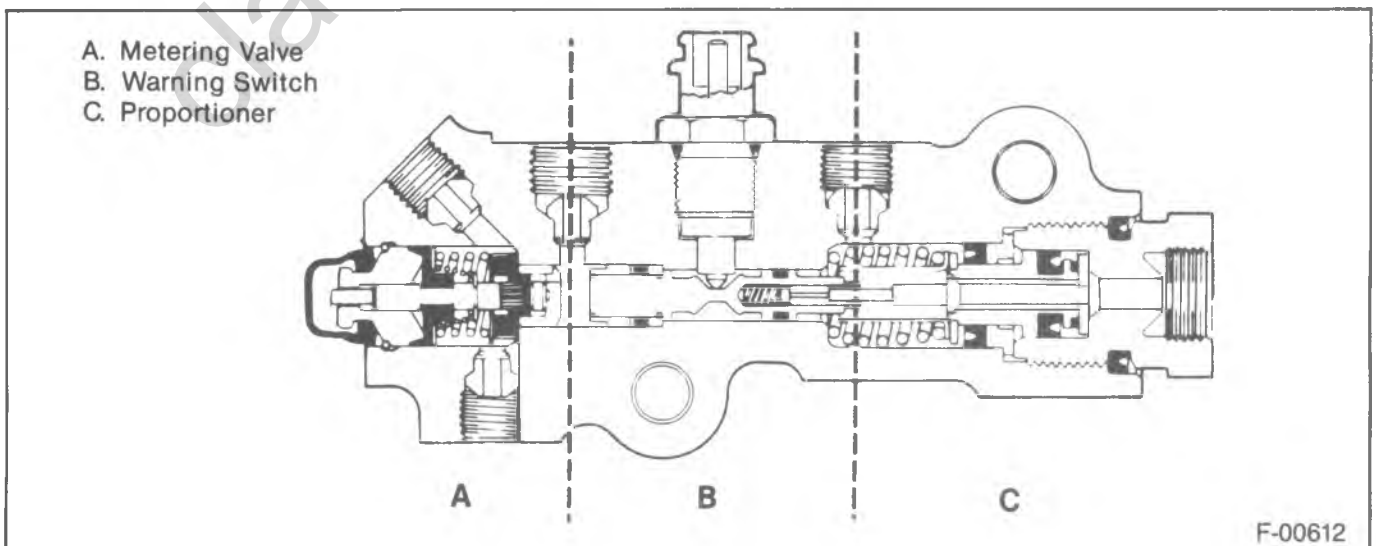
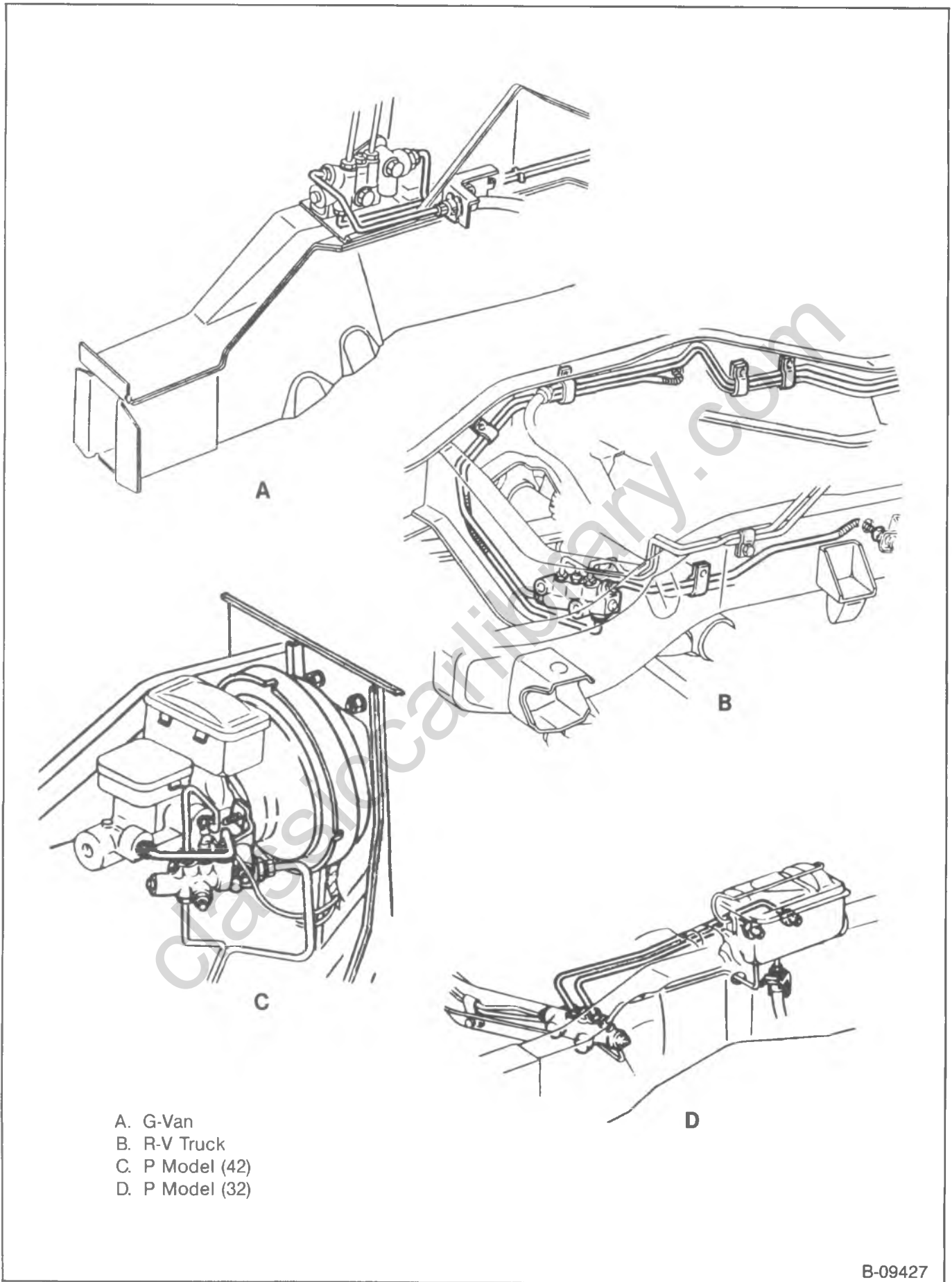

Figure 6—Combination Valve

5A-10 HYDRAULIC BRAKES



B-09427

Figure 7—Combination Valves

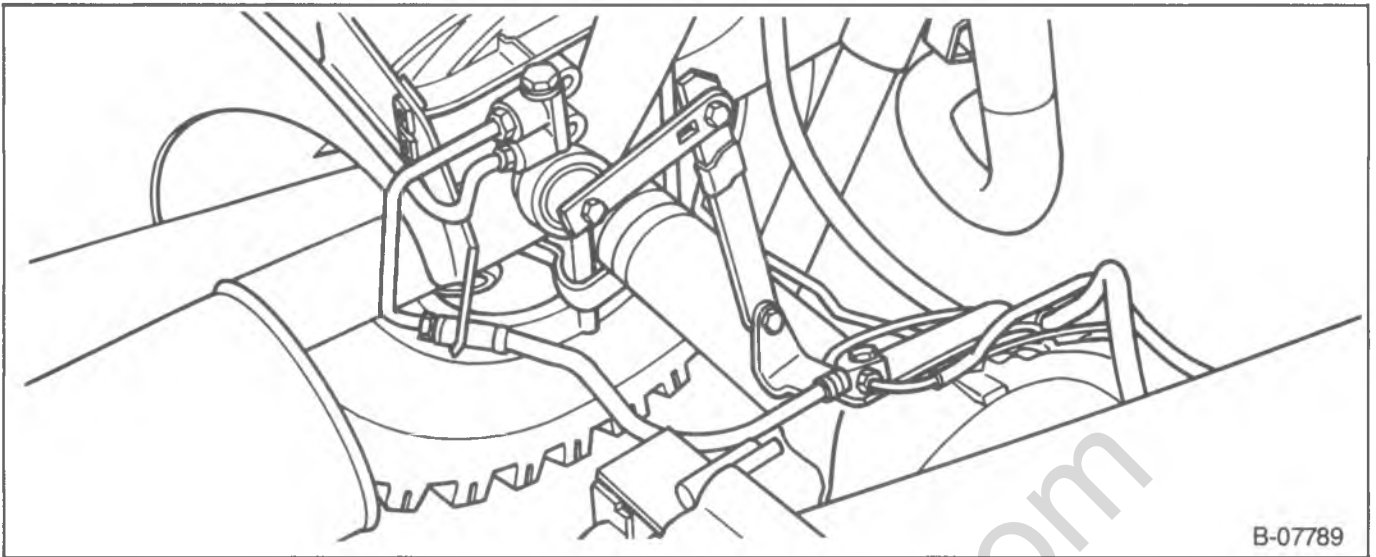

Figure 8—Height Sensing Proportioning Valve

The valve is mounted on the frame, and a linkage connects the valve to a bracket that is mounted on the axle.

CAUTION: Adding any suspension accessories or other equipment (such as load leveling kits, air shocks, suspension lift kits, additional spring leaves, etc.), or making modification that will change the distance between the axle and the frame without changing the load, will provide a false reading to the brake proportioning valve. This could result in unsatisfactory brake performance which in turn could result in an accident and possibly personal injury.

VALVE REPLACEMENT

↔ Remove or Disconnect (Figure 9)

- Raise the vehicle.
- Support the frame with suitable safety stands. The axle must be allowed to hang free.

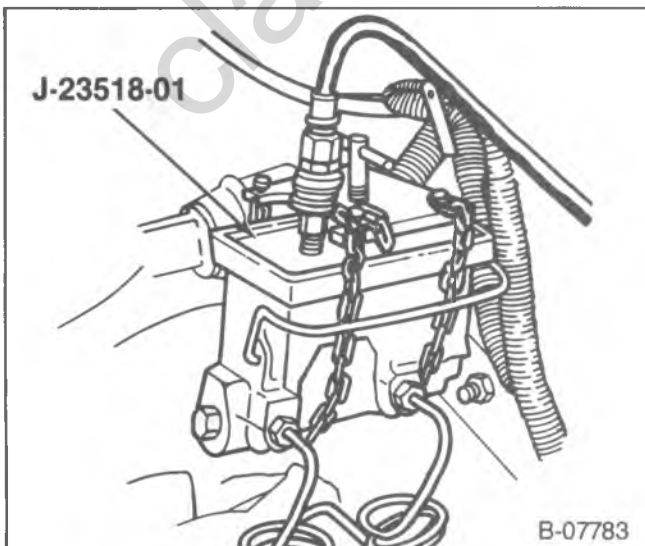

Figure 9—Removing Proportioning Valve

- Clean the exterior of the valve to prevent dirt from contaminating the hydraulic system.

1. Brake pipes (51).
2. Nut from the shaft (48).
3. Lever (49).
4. Bolts (46) and washers (47).
5. Valve (50).

↔ Install or Connect (Figure 9).

1. Position the valve on the mounting bracket.
2. Washer (47) and bolts (46).
3. Lever (49).
 - Refer to “Proportioning Valve Adjustment” in this section.
4. Nut (48). Torque to 10 N·m (89 in. lbs.).
5. Brake pipes (51).
 - Bleed brakes. Refer to “Bleeding the Brake Hydraulic System”, in this section.
 - Remove the safety stands.
 - Lower the vehicle.
 - Test the brakes.

PROPORTIONING VALVE ADJUSTMENT

If a front wheel lockup is experienced when the vehicle is being operated near the maximum GVWR with a lower than desired brake application, the valve adjustment should be checked. Use the following procedure to check the adjustment.

1. Raise the vehicle.
 - Support the frame with suitable safety stands. The axle must be allowed to hang free.
2. Remove the nut from the valve shaft.
 - Remove the lever.
3. Select the appropriate adjustment gage from the chart.

5A-12 HYDRAULIC BRAKES

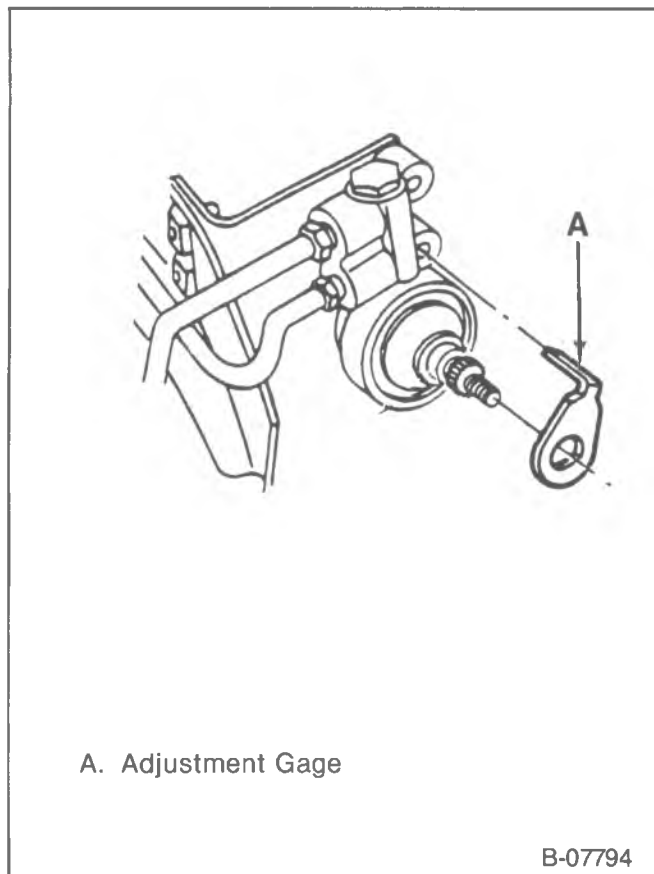

Figure 10—Installing Adjustment Gage

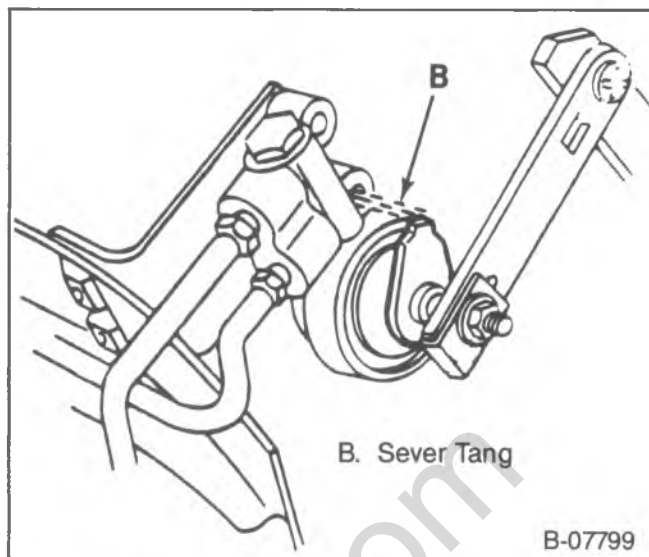

Figure 11—Severing the Adjustment Tang

5. Install the nut on the shaft. Torque to 10 N·m (89 in. lbs.)
6. Sever the tang on the adjustment gage (figure 11).
7. Remove the safety stands.
 - Lower the vehicle.
 - Test the brakes.

ADJUSTMENT GAGE CHART

Part Number	Code	Color	Vehicle Combination
14061394	A	Green	R/V 3500 with G52 R20903
14061395	B	Black	R3500 Less G52 R/V20903
14061396	C	Blue	G30005/06 with LB4/L05 V3500 Less G52 G31305/06 with LL4/LT9
15592484	D	Red	R/V20903 with VD1 V20906 with VD1
15548904	E	Yellow	V20906

RPO G52: Extra Capacity Rear Spring

RPO LB4: 4.3 Liter

RPO L05: 5.7 Liter

RPO LL4: 6.2 Liter

RPO LT9: 5.7 Liter H.D.

4. Rotate the valve shaft to permit the installation of the adjustment gage (figure 10).
 - The center hole of the adjustment gage must seat on the "D" shape of the valve shaft.
 - The gage tang must seat in the valve mounting hole.

NOTICE: Do not drive the lever assembly onto the valve shaft by using nut or proper valve setting may be disturbed.

BRAKE PEDAL ASSEMBLY

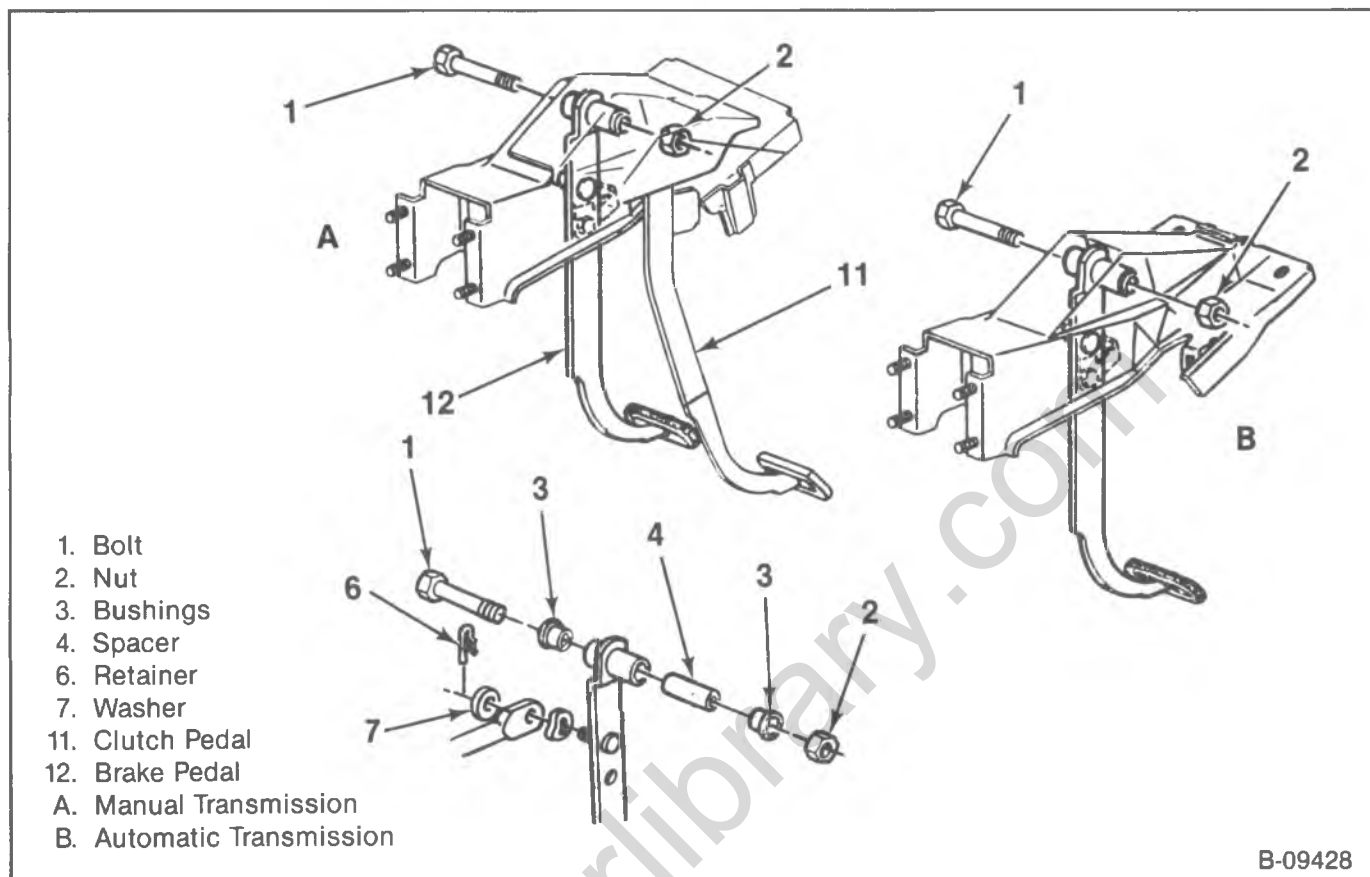

Figure 12—R-V Brake Pedal Components

CHECKING PEDAL TRAVEL

At frequent intervals the brake pedal should be checked for travel. Travel is the distance the pedal moves toward the floor from a full released position. This check should be made with the brakes cold and about 122 N (90 lbs.) of force on the pedal. On vehicles with power brakes the pedal must be pumped at least three times with the engine off before making the check. Follow the specifications below for the correct travel.

R-V-G Manual115 mm (4.5-inches)
R-V-G Power90 mm (3.5-inches)
P (Except JF9)90 mm (3.5-inches)
P (JF9)150 mm (6.0-inches)

BRAKE PEDAL REPLACEMENT

R-V AND P-30 (32) MODELS

↔ Remove or Disconnect (Figures 12 and 13)

1. Retainer (6).
2. Washer (7).
3. Pin (10) and washer (9).
4. Pushrod (8).
5. Return spring (5).
6. Nut (2) and bolt (1).
7. Brake pedal (12).

8. Clutch Pedal (11) (if equipped).
9. Bushings (3).
10. Spacer (4).

↔ Install or Connect (Figures 12 and 13)

1. Spacer (4).
2. Bushings (3).
3. Brake pedal (12).
4. Clutch pedal (11) (if equipped).

NOTICE: See "Notice" on page 5A-1 of this section.

5. Bolt (1) and nut (2).

⊠ Tighten

- Nut to 63 N·m (46 ft. lbs.) for P30 (32) Models.
 - Nut to 34 N·m (25 ft. lbs.) for R-V Models.
6. Return spring (5).
 7. Washer (9) and pin (10).
 8. Pushrod (8).
 9. Washer (7) and retainer (6).
 - Check the stoplamp switch adjustment. Refer to "Stoplamp Switch."

B-09428

5A-14 HYDRAULIC BRAKES

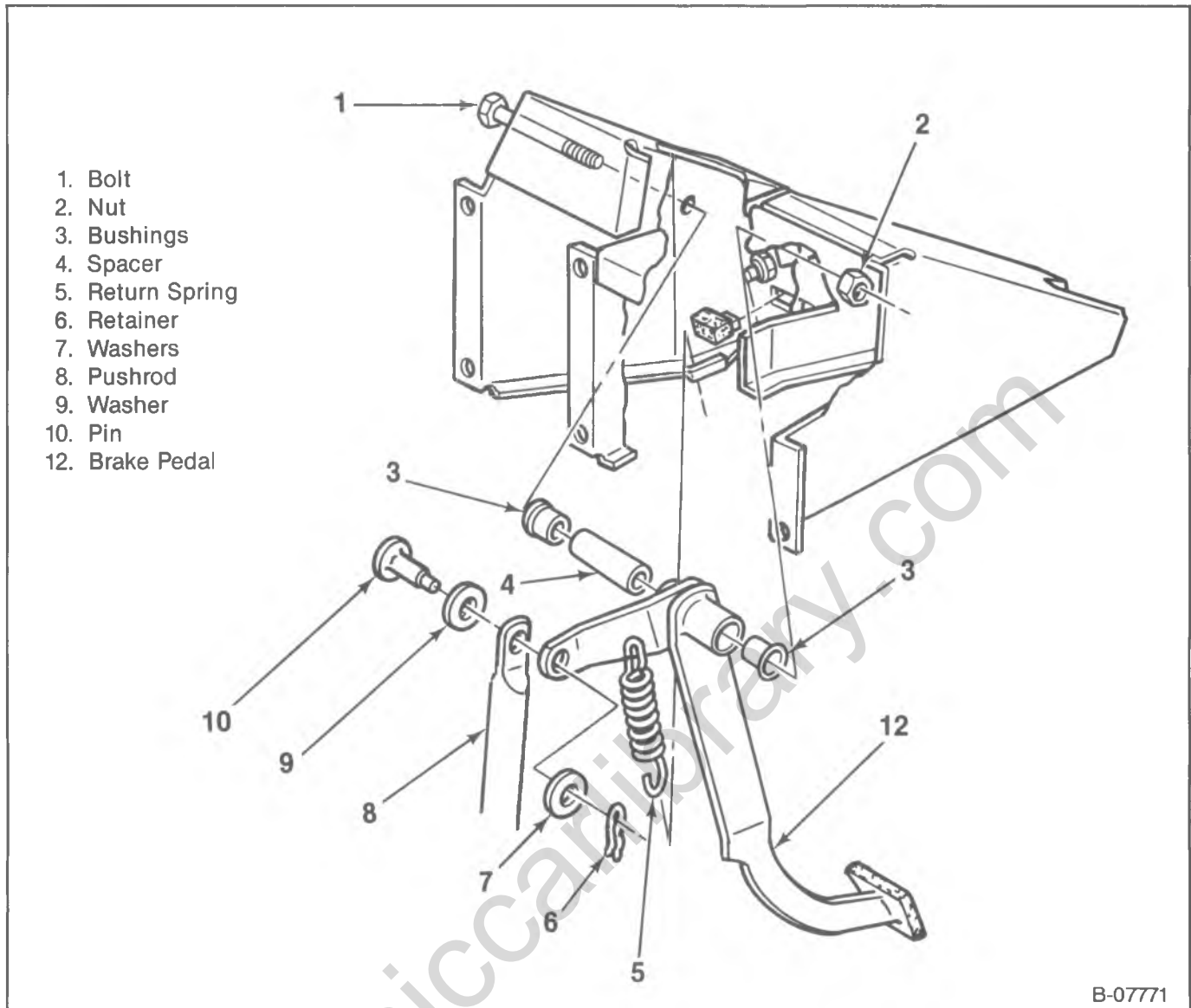

B-07771

Figure 13—P30(32) Brake Pedal Components

G-Model

↔ Remove or Disconnect (Figure 14)

1. Retainer (6).
2. Washer (9).
3. Pushrod (8).
4. Washer (7).
5. Return spring (5).
6. Retainer (14) or clutch attaching components (15) (if equipped).
7. Pin (13) or clutch pedal (11) (if equipped).
8. Brake pedal (12).
9. Bushings (3).

↔ Install or Connect (Figure 14)

1. Bushings (3).
2. Brake pedal (12).
3. Pin (13) or clutch pedal (11) (if equipped).
4. Retainer (14) or clutch attaching components (15) (if equipped).
5. Return spring (5).
6. Washer (7).

7. Pushrod (8).

8. Washer (9).

9. Retainer (6).

- Check the stoplamp switch adjustment. Refer to "Stoplamp Switch."

P 30 (42) MODEL

↔ Remove or Disconnect (Figure 15)

1. Retainer and washer.
2. Pushrod and washer.
3. Clutch attaching components (15) (if equipped).
4. Clutch pedal (11) (if equipped).
5. Return spring (5) (if equipped).
6. Nut (16) and bolt (18).
7. Shaft (17).
8. Brake pedal (12).
9. Bushings (3).

↔ Install or Connect (Figure 15)

- Lubricate the pivot points with Delco Brake Lube or equivalent.

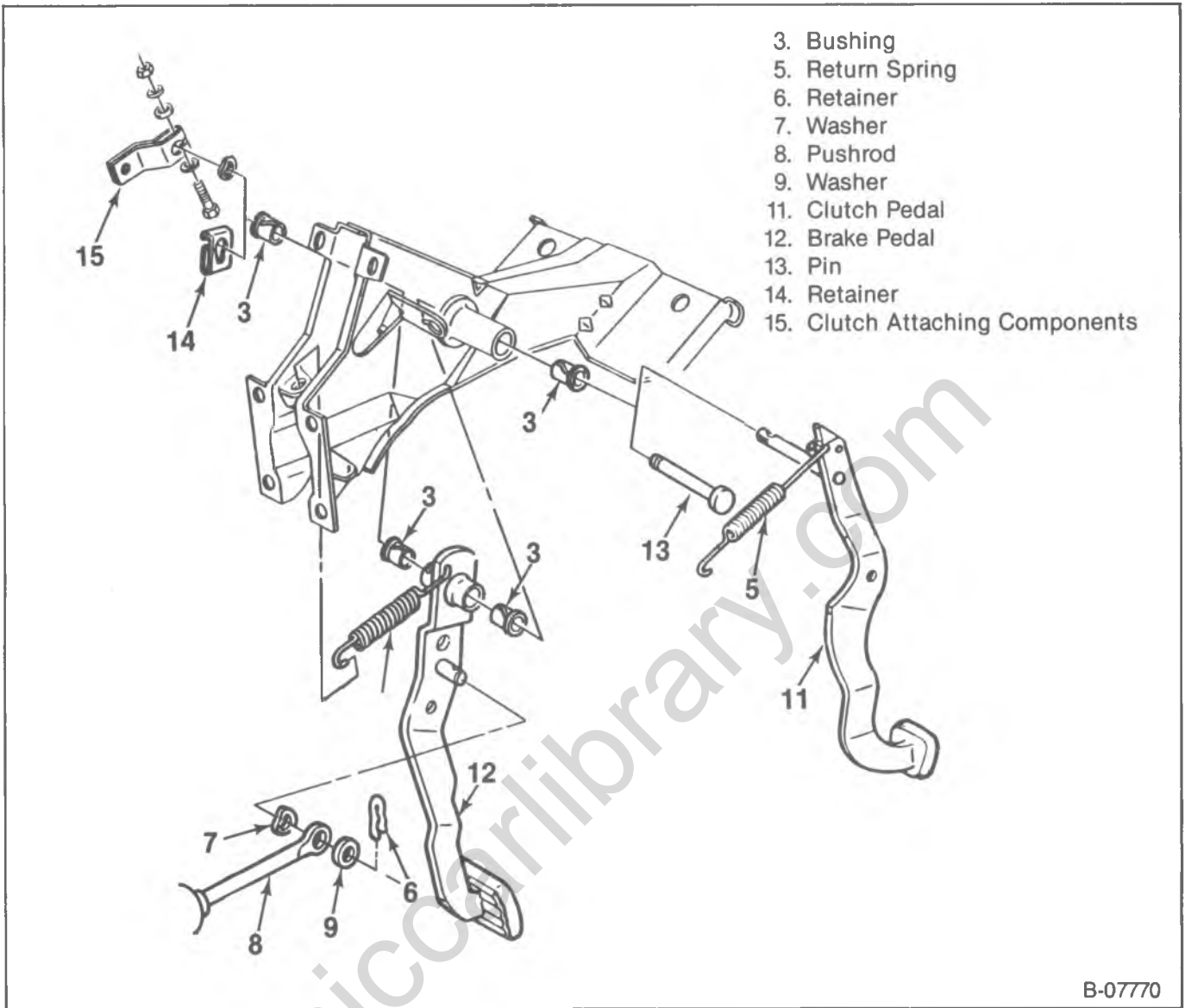

- 3. Bushing
- 5. Return Spring
- 6. Retainer
- 7. Washer
- 8. Pushrod
- 9. Washer
- 11. Clutch Pedal
- 12. Brake Pedal
- 13. Pin
- 14. Retainer
- 15. Clutch Attaching Components

B-07770

Figure 14—G-Van Brake Pedal Components

- 1. Bushings (3).
- 2. Brake pedal (12).
- 3. Shaft (17).
- 4. Bolt (18) and nut (16).
- 5. Clutch pedal (11) (if equipped).
- 6. Return spring (5) (if equipped).
- 7. Clutch attaching components (15).
- 8. Washer and pushrod.
- 9. Washer and retainer.
- Check the stoplamp switch adjustment, refer to "Stoplamp Switch."
- 4. Screws (18).
- 5. Raise the vehicle and support it with suitable safety stands.
- 6. Retainer (23).
- 7. Nut (22).
- 8. Bolt (19) and washers (20 and 21).
- 9. Brake rod (8).
- 10. Boot (24).

→← Install or Connect (Figure 16)

NOTICE: For steps 4 and 7 see "Notice" on page 5A-1 of this section.

- 1. Boot (24).

🔑 Adjust

- Brake rod to 790 mm (31.00-inches) from the centers of the bolt holes.

- 2. Brake rod (8).
- 3. Bolt (19) and washers (20 and 21).
- 4. Nut (22) and retainer (23).

**BRAKE PEDAL
ROD REPLACEMENT**

P 30 (32) MODEL

↔ Remove or Disconnect (Figure 16)

- 1. Retainer (6).
- 2. Nut (16).
- 3. Bolt (17) and washers (7 and 9).

5A-16 HYDRAULIC BRAKES

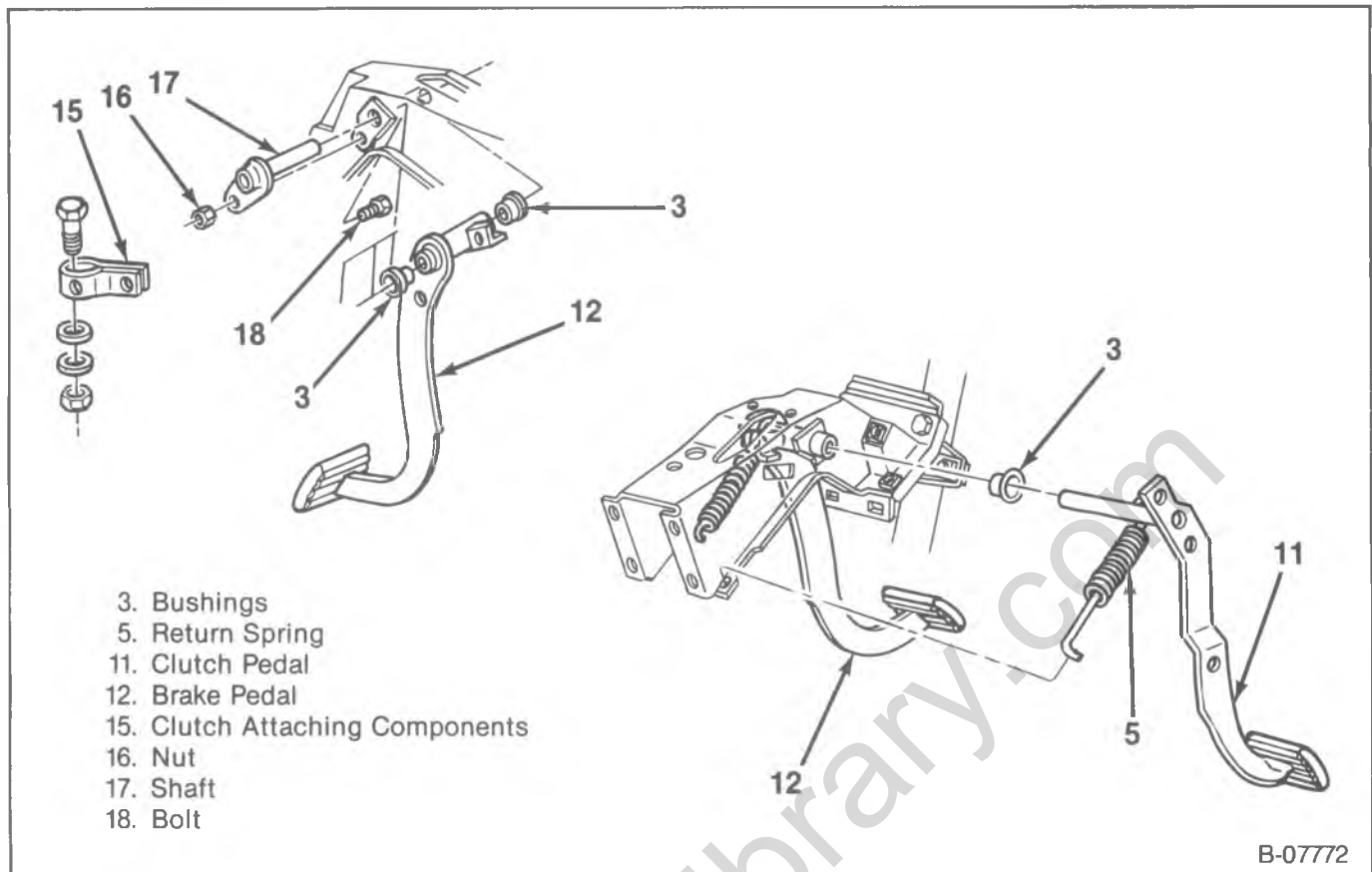

Figure 15—P30(42) Brake Pedal Components



Tighten

- Nut to 35 N·m (26 ft. lbs.).
- Lower the vehicle.
- 5. Screws (18).
- 6. Bolt (17) and washers (9 and 17).
- 7. Nut (16) and retainer (6).



Tighten

- Nut to 35 N·m (26 ft. lbs.).

STOPLAMP SWITCH

The design of the switch mounting provides for an automatic adjustment when the brake pedal is returned to its stop. There are two styles of switches, the determining factor is if the vehicle is equipped with cruise control. For electrical diagnosis of the stoplamp switch refer to CHASSIS ELECTRICAL (SEC. 8B).

SWITCH REPLACEMENT



Remove or Disconnect

1. Remove the negative battery cable.
2. Electrical connectors.
3. Switch.



Install or Connect

1. Switch.



Adjust

- Refer to "Switch Adjustment."
- 2. Electrical connectors.
- 3. Negative battery cable.

SWITCH ADJUSTMENT

1. Depress the brake pedal and press the switch in until it is firmly seated in the clip.
 - Audible "clicks" can be heard as the threaded portion of the switch is pushed through the clip.
2. Pull the brake pedal against the pedal stop until the audible "click" can no longer be heard.
3. Electrical contact should be made when the brake pedal is depressed the specified distance.
 - R-V models 25-31 mm (1.0-1.24 inches).
 - G-P models 11-24 mm (0.45-0.95 inches).

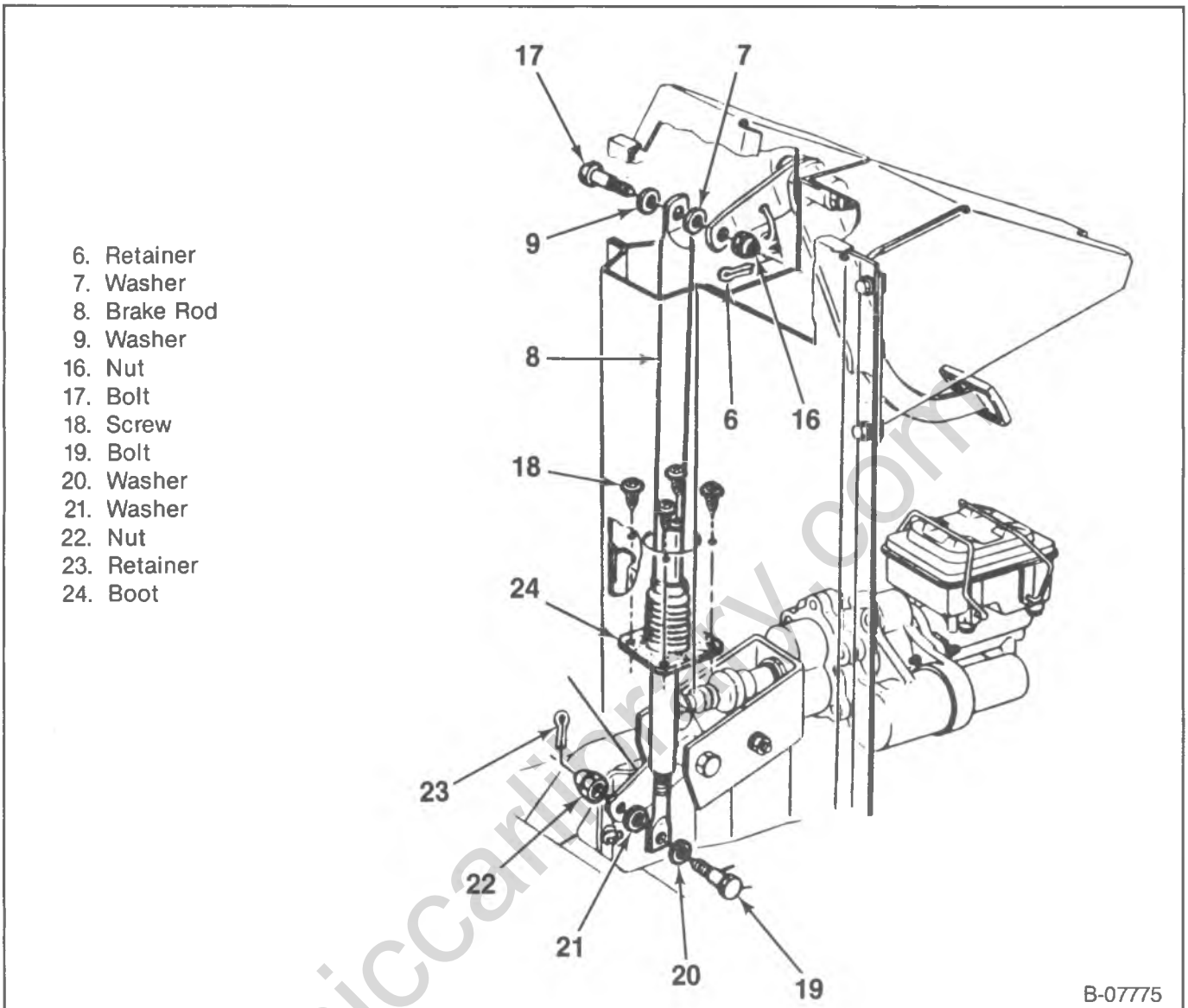

Figure 16—P30(32) Brake Pedal Rod Components

B-07775

PARKING BRAKE SYSTEM

PARKING BRAKE PEDAL OR HANDLE REPLACEMENT

R-V-G MODELS

←→ Remove or Disconnect (Figure 17)

- The parking brake must be in the released position.

1. Nuts (1).
2. Release rod (3).
3. Bolt (2).
4. Brake assembly.
5. Parking brake cable.

→← Install or Connect (Figure 17)

NOTICE: See "Notice" on page 5A-1 of this section for steps 2 and 4.

1. Parking brake cable.
2. Bolt.

Tighten

- Refer to "Torque Specifications" in this section.
3. Release rod (3).
 4. Nuts (1).

Tighten

- Refer to "Torque Specifications" in this section.
5. Check the parking brake adjustment, refer to "Parking Brake Adjustment" in this section.

5A-18 HYDRAULIC BRAKES

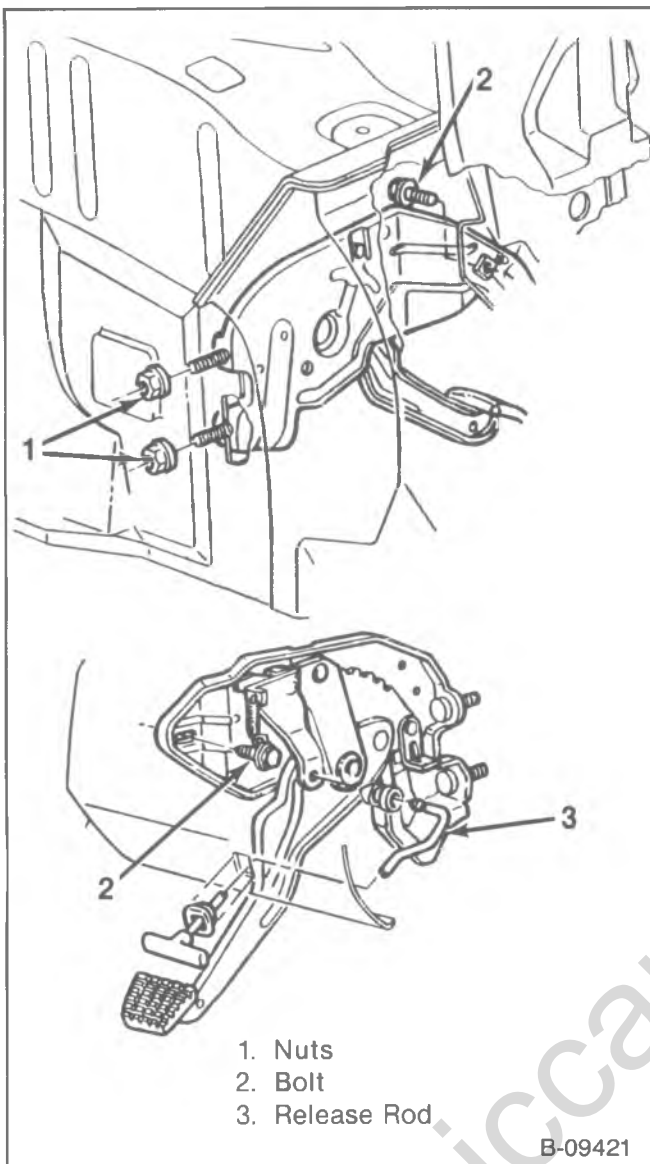

Figure 17—Removing Parking Brake Pedal on R-V and G Models

P MODELS

↔ Remove or Disconnect (Figure 18)

- The parking brake must be in the released position.
- 1. Nuts (10) and washers (11).
- 2. Bolts (12) and washers (13).
- 3. Spacers (14).
- 4. Cotter pin (15) and washer (16).
- 5. Clevis pin (17).
- 6. Nut (18) and washer (19).
- 7. Bolt (20).
- 8. Spacer (21).
- 9. Cable (22).
- 10. Handle assembly.

↔ Install or Connect (Figure 18)

1. Cable (22).
2. Clevis pin (17).
3. Washer (16) and cotter pin (15).
4. Spacer (21).
5. Bolt (20).

6. Washer (19) and nut (18).
7. Spacer (14).

NOTICE: See "Notice" on page 5A-1 of this section.

8. Washer (13) and bolts (12).
9. Washers (11) and nuts (10).

⚙ Tighten

- Nuts to 24 N·m (18 ft. lbs.)
- Check the parking brake adjustment, refer to "Parking Brake Adjustment" in this section.

CABLE REPLACEMENT

FRONT CABLE REPLACEMENT (R-V MODELS)

↔ Remove or Disconnect (Figures 19 and 20)

- Raise the vehicle and support with suitable safety stands.
- 1. Nut (31) from the equalizer (32).
- 2. Connector (33) from the front cable.
- 3. Bend retaining fingers (34) and (35).
- 4. Cable from the brake pedal assembly.
- 5. Cable assembly (36).
- Attach a piece of wire to the cable to help in installation.

↔ Install or Connect (Figures 19 and 20)

1. Cable assembly (36).
 - Make sure all the retaining fingers are completely through the holes.
2. Cable to the pedal assembly.
3. Connector (33).
4. Nut (31) onto the equalizer (32).

⚙ Adjust

- Refer to "Parking Brake Adjustment" in this section.
- Lower the vehicle.

FRONT CABLE REPLACEMENT (G AND P MODELS)

↔ Remove or Disconnect (Figures 19, 21 and 22)

- Raise the vehicle and support with suitable safety stands.
- 1. Nut (31) from the equalizer (32).
- 2. Connector (33) from the front cable.
- 3. Bolts (37) and clips (38).
- 4. Cable from the pedal/handle assembly.
 - Bend the retaining fingers (34).
- 5. Cable assembly (36).
 - Attach a piece of wire to the cable to help in installation.

↔ Install or Connect (Figures 19, 21 and 22)

1. Cable assembly (36).
 - Make sure all the retaining fingers are completely through the holes.
2. Cable to the pedal/handle assembly.

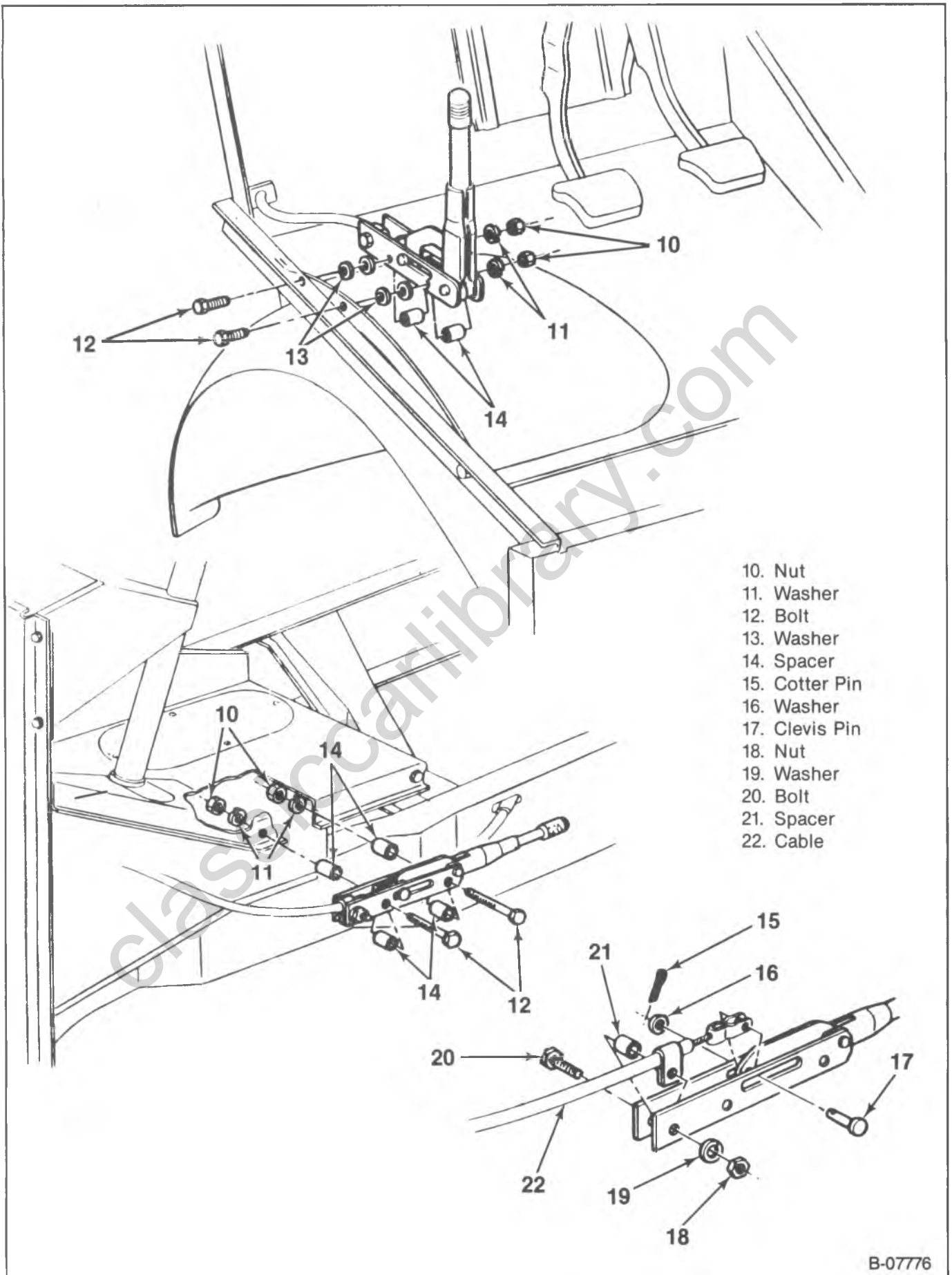

Figure 18—Removing Parking Brake Lever on P Models

5A-20 HYDRAULIC BRAKES

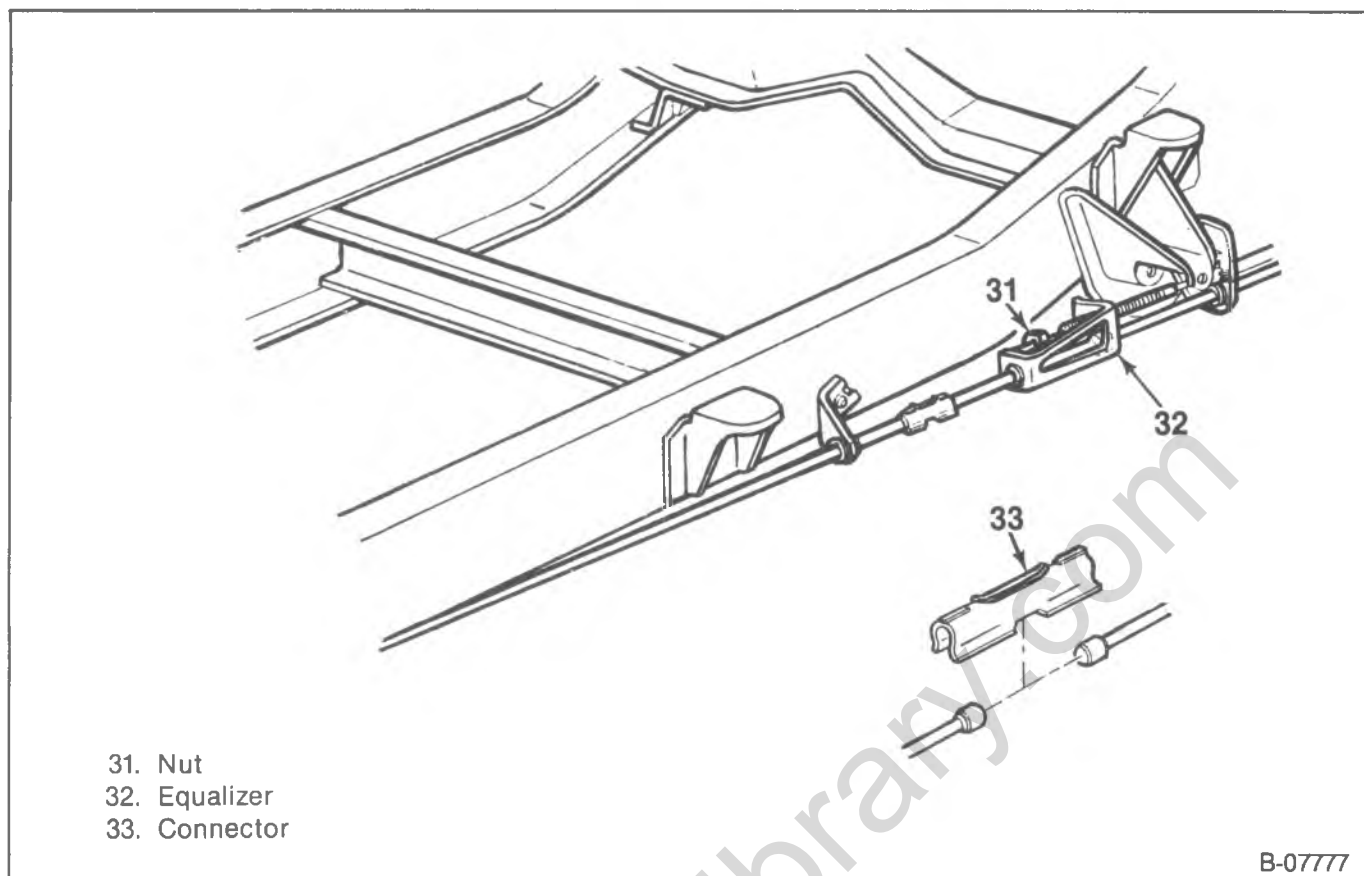

Figure 19—Equalizer Components

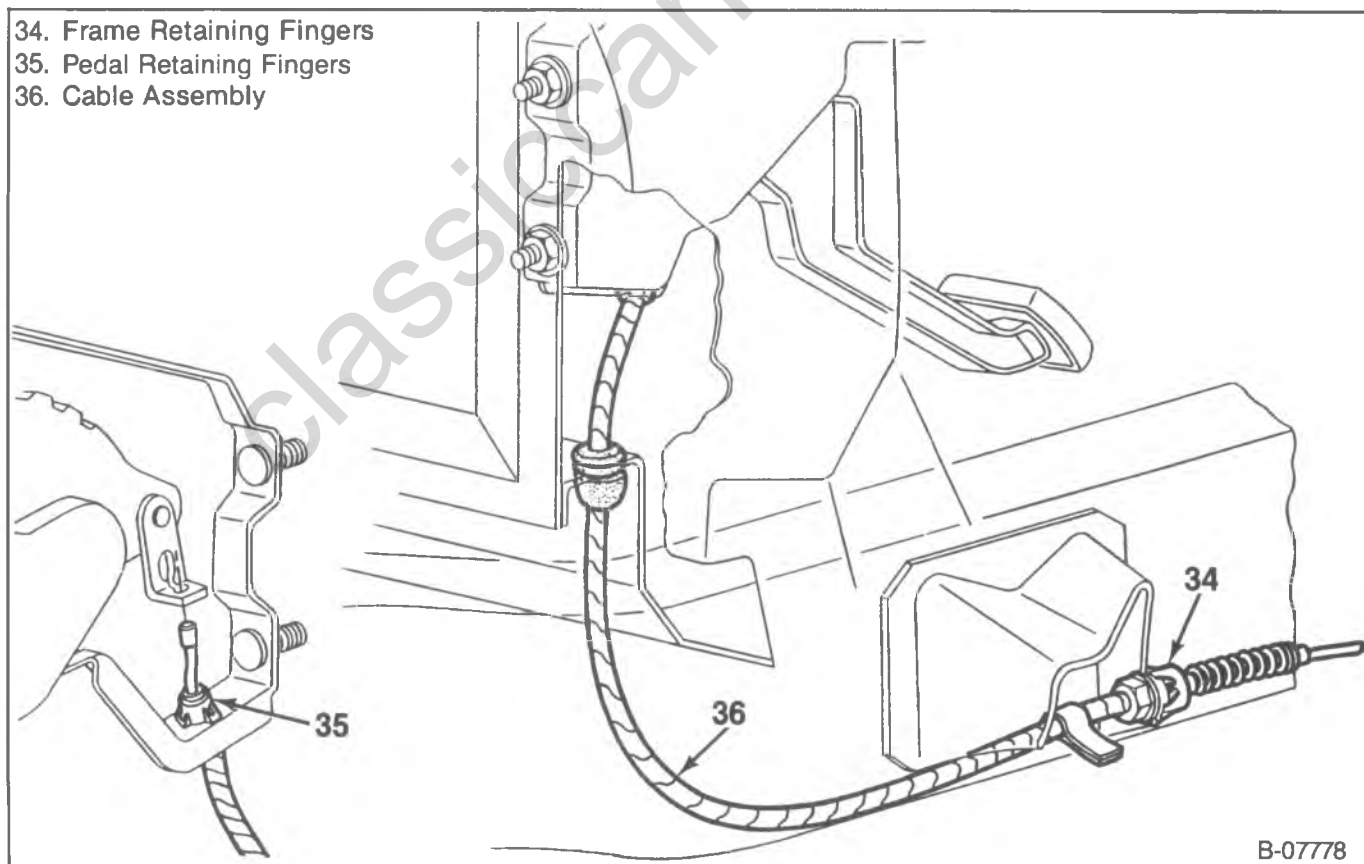

Figure 20—R-V Front Cable Components

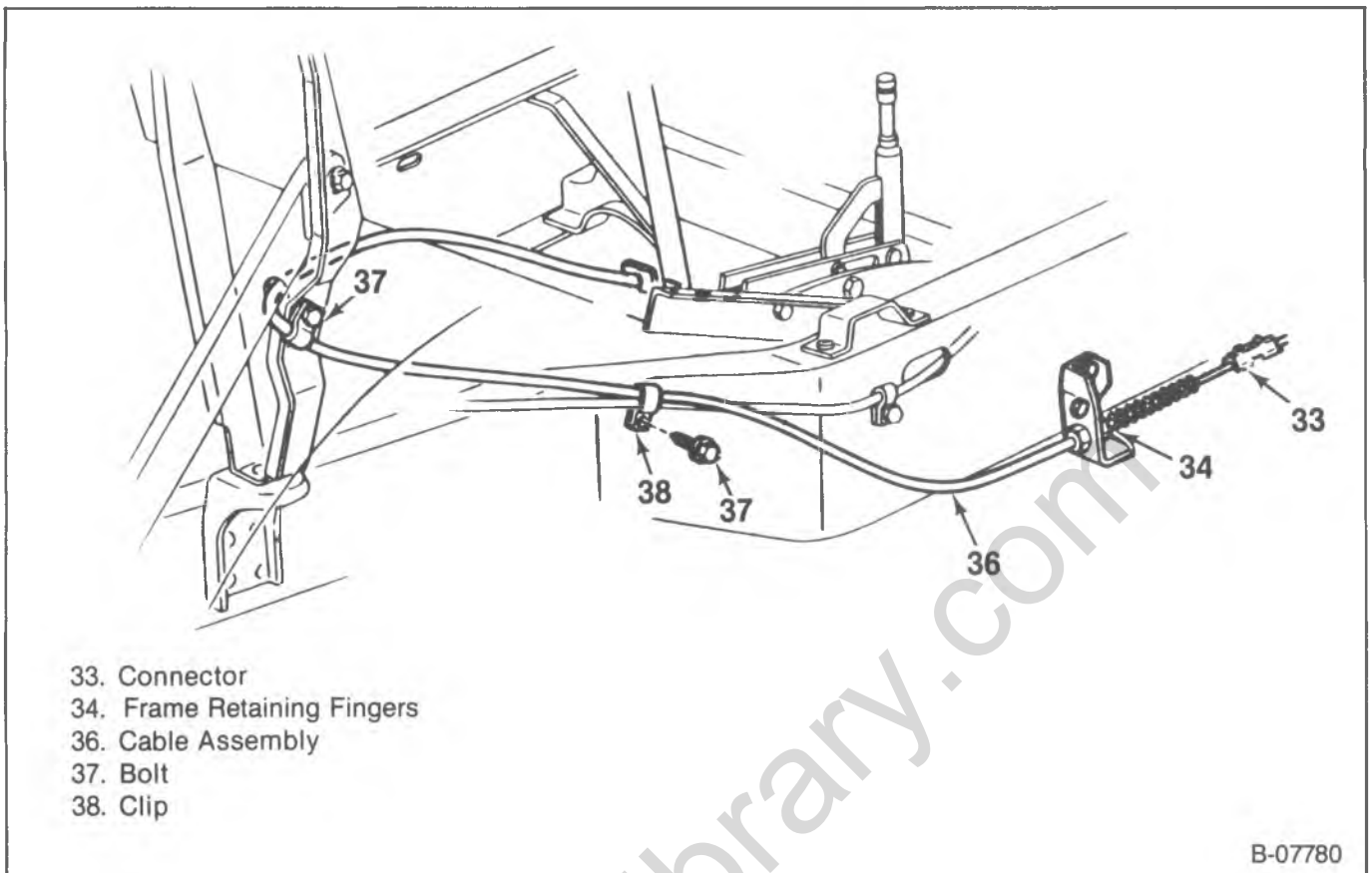

Figure 21—P Model Front Cable Components

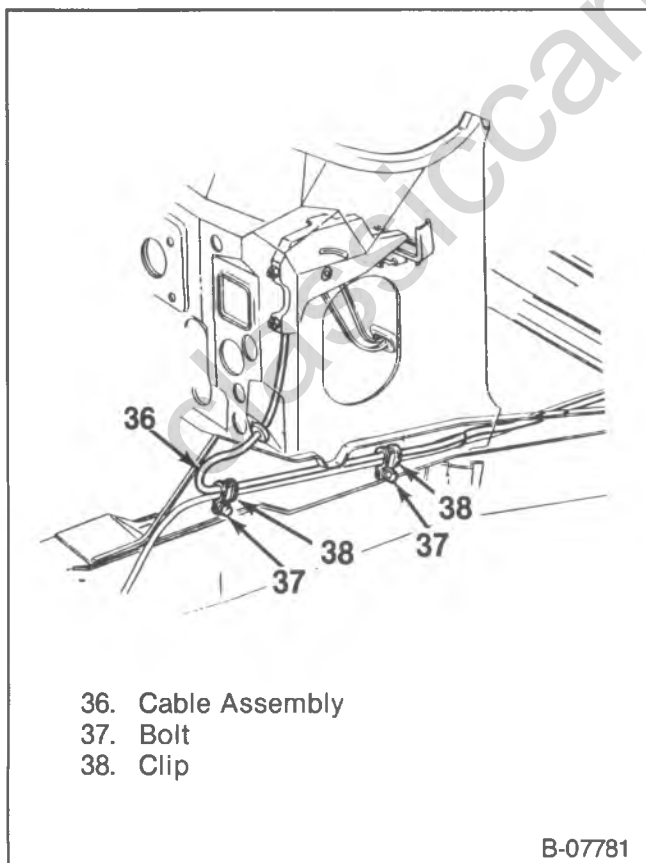

Figure 22—G Model Front Cable Components

3. Clips (38) and bolts (37).
4. Connector (33).
5. Nut (31) onto the equalizer (32).

 **Adjust**

- Parking brake. Refer to "Parking Brake Adjustment", in this section.
- Lower the vehicle.

CENTER CABLE REPLACEMENT

 **Remove or Disconnect (Figure 19)**

- Raise the vehicle and support with suitable safety stands.
1. Nut (31) from the equalizer (32).
 2. Both front and rear connectors (33).
 3. Cable.

 **Install or Connect (Figure 19)**

1. Cable.
2. Connector (33).
3. Nut (31) onto the equalizer (32).

 **Adjust**

- Parking brake. Refer to "Parking Brake Adjustment" in this section.
- Lower the vehicle.

5A-22 HYDRAULIC BRAKES

REAR CABLE REPLACEMENT

Remove or Disconnect (Figure 19)

- Raise the vehicle and support it with suitable safety stands.
1. Nut (31) from the equalizer (32).
 2. Connector (33).
 3. Brake drum and shoe assembly. Refer to HYDRAULIC FOUNDATION BRAKES (SEC. 5A2).
 - Bend in retaining fingers at the backing plate.
 4. Retaining clip at the frame support.
 5. Cable assembly.

Install or Connect (Figure 19)

1. Cable assembly.
 - Make sure all the retaining fingers are completely through the backing plate.
2. Retaining clip at the frame support.
3. Brake shoes and drum assembly. Refer to HYDRAULIC FOUNDATION BRAKES (SEC. 5A2).
4. Connector (33).
5. Nut (31) onto the equalizer (32).

Adjust

- Parking brake. Refer to "Parking Brake Adjustment" in this section.
- Lower the vehicle.

PROPELLER SHAFT BRAKE REPLACEMENT

Remove or Disconnect (Figure 23)

- Raise the vehicle and support with suitable safety stands.
1. Propeller shaft, refer to Propeller Shaft (Sec. 4A).

CAUTION: See "Caution" on page 5A-1 of this section.

2. Drum (66).
 - It may be necessary to back off the adjusting screw.
3. Return springs (56 and 71).
4. Return spring guide (72).
5. Hold down clips (65).
6. Hold down springs (64).
7. Washers (63).
8. Lever strut (55).
9. Strut spring (57).
10. Lever retaining ring (67).
11. Shoes (68).
12. Adjusting screw (60).
13. Adjusting screw spring (58).

Inspect

- All parts for discoloration due to heat, or stress. Replace if necessary.
- Brake drum for scoring and heat spots. Machine drum if needed.

Install or Connect (Figure 23)

- Lubricate the shoe pads and adjusting screw threads with a thin coat of white lithium grease.
1. Adjusting screw (60) and adjusting screw spring (58) to both shoes (68).
 2. Shoe assembly (68).
 3. Lever retaining ring (67).
 4. Lever strut (55) and strut spring (57).
 5. Washers (63).
 6. Hold down springs (64).
 7. Hold down clips (65).
 8. Return spring guide (72).
 9. Return springs (56 and 57)
 10. Drum (66).
 11. Propeller shaft, refer to PROPELLER SHAFT (Sec. 4A) in this manual.

Adjust

- Parking brake. Refer to "Parking Brake Adjustment" in this section.
- Lower the vehicle.

PARKING BRAKE ADJUSTMENT

The parking brakes must be adjusted whenever the parking brake cables have been replaced or disconnected. Also if the brake holding ability is not adequate. Before adjusting the parking brakes check the condition of the service brakes. The service brakes must be adjusted properly before proceeding with the parking brake adjustment.

CABLE INSPECTION

Check the parking brake system for free operation. The brake lever must return to the released position without sticking or binding. If a problem is present check the cable routings for kinks or binding. Clean and lubricate the parking brake assembly and cables with Delco brake lube or equivalent.

FOOT PEDAL TYPE

1. Block the front wheels.
 - Raise and support the rear axle with suitable safety stands.
2. Loosen the equalizer nut.
3. Set the parking brake pedal to four clicks.

Adjust

- Equalizer nut until the wheels rotate forward with a moderate drag.
4. Release the parking brake and rotate the rear wheels. There should be no brake drag.
 5. Remove the safety stands and lower the vehicle.
 6. Unblock the front wheels.

LEVER TYPE

1. Block the front wheels.
 - Raise and support the rear axle with suitable safety stands.
2. Turn the adjusting knob on the parking brake lever counterclockwise until it stops.
 - Apply parking brake.
3. Loosen the equalizer nut.

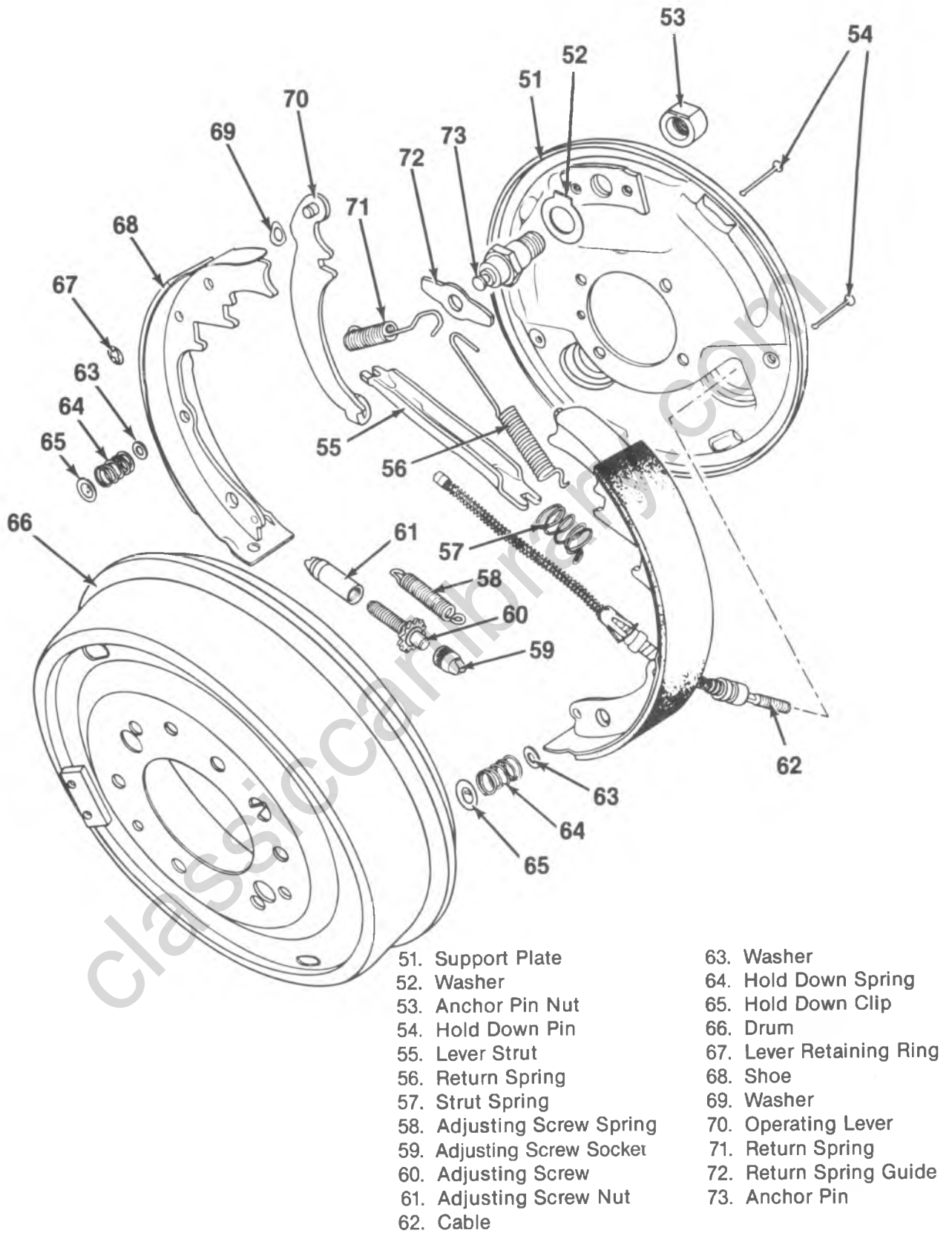

B-07779

Figure 23—Propeller Shaft Brake Components

5A-24 HYDRAULIC BRAKES



Adjust

- Equalizer nut until a light drag is felt while rotating the wheels forward.
 - Knob on the parking brake lever until a definite snap over center is felt.
4. Release the parking brake and rotate the rear wheels. There should be no brake drag.
 5. Remove the safety stands and lower the vehicle.
 6. Unblock the front wheels.

INTERNAL EXPANDING (PROPELLER SHAFT)

CAUTION: See "Caution" on page 5A-1 of this section.

1. Block the front wheels.
 - Raise and support the rear axle with suitable safety stands.
2. Remove the clevis pin connecting the pull rod and relay lever.
3. Rotate the brake drum to align the access hole with the adjusting screw.
 - **Manual transmissions** - the adjusting screw is located at the bottom of the shoe.
 - **Automatic transmission** - the adjusting screw is located at the top of the shoe.

- When adjusting the parking brake for the first time, it will be necessary to remove the lanced area from the drum. The drum must be removed to clean out all the metal shavings. Refer to PROPELLER SHAFTS (Sec. 4A).



Adjust

- Adjusting screw until the drum cannot be rotated by hand.
 - Back off the adjusting screw ten notches. The drum should rotate freely.
4. Place parking brake lever in the full release position.
 5. Take up the slack in the cable to overcome the spring tension.



Adjust

- The clevis of the pull rod to align with the hole in the relay lever.
6. Install the clevis pin.
 7. Install new cover in the drum access hold.
 8. Remove the safety stands and lower the vehicle.
 9. Unblock the front wheels.

MASTER CYLINDERS

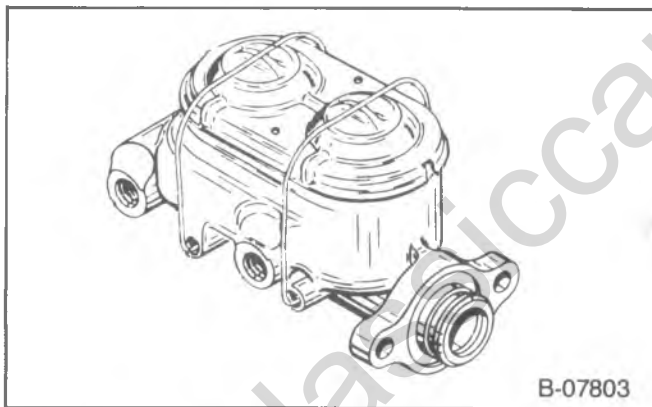

Figure 24—Cast Iron Master Cylinder

DESCRIPTION

There are two designs of master cylinders available depending on the brake option.

One is a full cast iron design incorporating a conventional front to rear brake split (figure 24). The primary piston provides the fluid pressure to the front brakes, while the secondary piston provides the fluid pressure to the rear brakes. If the pressure is lost from either system, the remaining system will function to stop the vehicle.

The second style master cylinder is designed for use with a system using the low drag calipers (figure 25). In addition to the standard master cylinder functions, a quick take-up feature is included. This provides a large volume of fluid to the wheels at low pressure with the initial brake

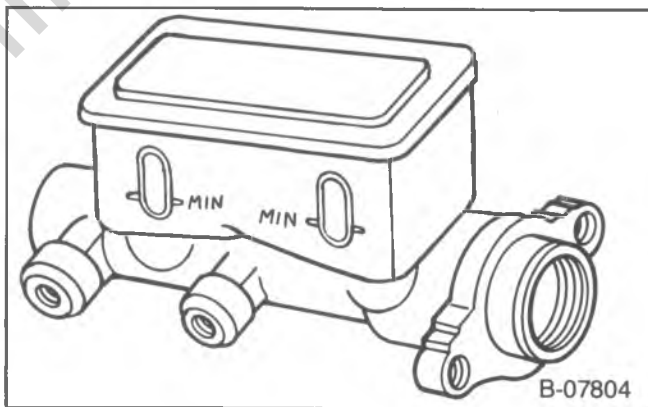

Figure 25—Composite Master Cylinder

application. This large volume of fluid is needed to overcome the clearance created by the seal retracting the pistons into the front calipers and the spring retraction of the rear drum brake shoes.

MASTER CYLINDER REPLACEMENT



Remove or Disconnect (Figure 26)

- Apply the vehicles parking brakes.
1. Brake pipes.
 - Cover the ends of the pipes to prevent dirt from entering the system.
 2. Mounting nuts.
 3. Master cylinder.

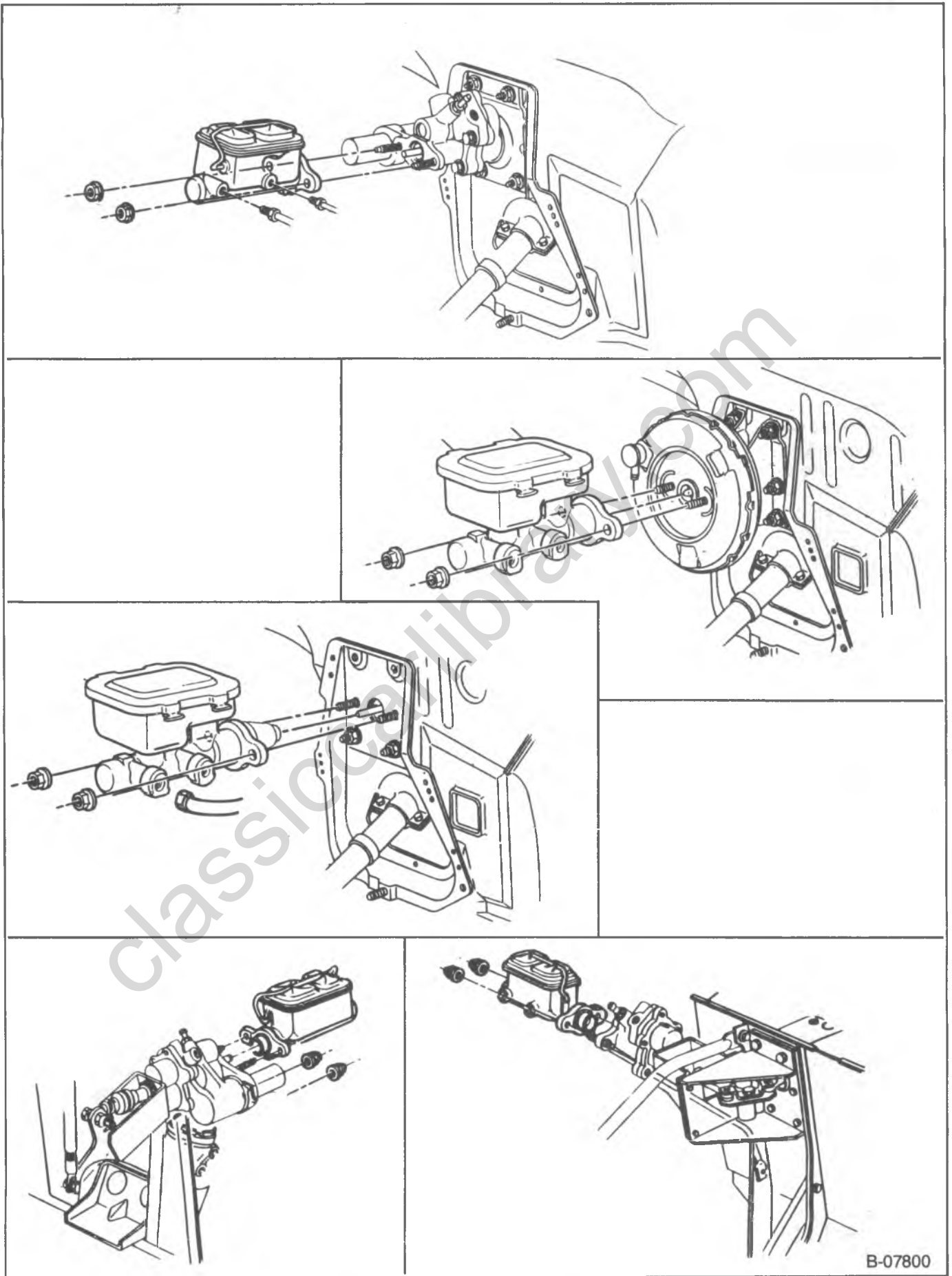

B-07800

Figure 26—Master Cylinder Installations

5A-26 HYDRAULIC BRAKES

- If the vehicle is equipped with manual brakes, refer to "Brake Pedal Replacement" for the removal of the pushrod from the pedal.

Install or Connect (Figure 26)

- Prior to installation, refer to "Bench Bleeding" in this section.
1. Master cylinder.
 - If the vehicle is equipped with manual brakes, refer to "Brake Pedal Replacement" for the installation of the pushrod to the pedal.

NOTICE: See "Notice" on page 5A-1 of this section.

2. Mounting nuts.

Tighten

- Nuts to 27 N·m (20 ft. lbs.), G and P models.
3. Brake pipes.
 4. Bleed the brakes, refer to "Bleeding the Brake Hydraulic System" in this section.
 - Release the parking brakes.

BENCH BLEEDING

The purpose of bench bleeding is to remove the air from the master cylinder so when it is installed on the vehicle, the brake system bleeding will be reduced.

1. Plug the outlet ports and mount the master cylinder in a vise with the front end tilted slightly down.
2. Fill the reservoir with clean brake fluid.

Using a tool with a smooth rounded end tool, stroke the primary piston about 25 mm (1-inch) several times.

As air is bled from the master cylinder, with the outlets plugged, the resistance to the primary piston travel will not allow the full 25 mm (1-inch) stroke.

3. Reposition the master cylinder in the vise with the front end of the master cylinder tilted slightly up. Again stroke the primary piston about 25 mm (1-inch) several times.
4. Reposition the master cylinder in the vise to the level position. Loosen the plugs one at a time and push the piston into the bore to force the air from the cylinder. To prevent air from being sucked back into the cylinder, tighten the plug(s) before allowing the piston to return to its original position.
5. Fill the reservoir.

Normal bleeding procedures should be followed after the master cylinder is installed.

SPECIFICATIONS

BRAKE SYSTEMS

SYSTEM	FRONT BRAKES	REAR BRAKES	BRAKE ASSIST
GASOLINE ENGINE VEHICLES			
R-MODELS			
JB1 Low Drag	Disc 11.86 x 1.04	Drum 11.0 x 2.00	None (Manual Brakes)
JB3 Low Drag	Disc 11.86 x 1.04	Drum 11.0 x 2.00	Vacuum—Single Diaphragm
G-MODELS			
JB1 Low Drag	Disc 11.86 x 1.29	Drum 11.00 x 2.00	None (Manual Brakes)
JB3 Low Drag	Disc 11.86 x 1.29	Drum 11.00 x 2.00	Vacuum—Single Diaphragm
ALL MODELS			
JB5 Low Drag	Disc 11.86 x 1.29	Drum 11.15 x 2.75	Vacuum—Dual Diaphragm
JB6 Low Drag	Disc 12.50 x 1.28	Drum 11.15 x 2.75	Vacuum—Dual Diaphragm
JB7 Conventional	Disc 12.50 x 1.28	Drum 13.00 x 2.50	Vacuum—Dual Diaphragm
JB8 Conventional	Disc 12.50 x 1.54	Drum 13.00 x 3.50	Hydraulic—Hydro-Boost
JF9 Conventional	Disc 14.25 x 1.54	Disc 13.75 x 1.54	Hydraulic—Hydro-Boost
DIESEL ENGINE VEHICLES			
JD3 Low Drag	Disc 11.86 x 1.29	Drum 11.00 x 2.00	Hydraulic—Hydro-Boost
JD5 Low Drag	Disc 11.86 x 1.29	Drum 11.15 x 2.75	Hydraulic—Hydro-Boost
JD6 Conventional	Disc 12.50 x 1.28	Drum 11.15 x 2.75	Hydraulic—Hydro-Boost
JD7 Conventional	Disc 12.50 x 1.28	Drum 13.00 x 2.50	Hydraulic—Hydro-Boost

SPECIFICATIONS (CONT.)

TORQUE SPECIFICATIONS

	R	V	G	P
Master Cylinder—to Dash or Booster	27 N·m (20 ft. lbs.)	27 N·m (20 ft. lbs.)	27 N·m (20 ft. lbs.)	27 N·m (20 ft. lbs.)
Combination Valve —Mounting Bolts	17 N·m (150 in. lbs.)	17 N·m (150 in. lbs.)	23 N·m (17 ft. lbs.)	23 N·m (17 ft. lbs.)
—Bracket	—	—	34 N·m (25 ft. lbs.)	34 N·m (25 ft. lbs.)
Brake Pedal —Bracket to Dash	34 N·m (25 ft. lbs.)	34 N·m (25 ft. lbs.)	17 N·m (150 in. lbs.)	34 N·m (25 ft. lbs.)
—Bracket to I.P.	34 N·m (25 ft. lbs.)	34 N·m (25 ft. lbs.)	—	—
—Pivot Bolt Nut	34 N·m (25 ft. lbs.)	34 N·m (25 ft. lbs.)	—	63 N·m (46 ft. lbs.)
—Sleeve to Bracket	—	—	—	9.5 N·m (85 in. lbs.)
—Stoplamp Switch Bracket	34 N·m (25 ft. lbs.)	34 N·m (25 ft. lbs.)	34 N·m (25 ft. lbs.)	—
—Push Rod to Pedal	—	—	—	34 N·m (25 ft. lbs.)
—Push Rod Adjusting Nut	—	—	—	30 N·m (22 ft. lbs.)
Parking Brake —to Dash	12 N·m (100 in. lbs.)	12 N·m (100 in. lbs.)	12 N·m (100 in. lbs.)	—
—to I.P. Kick Panel or Floorpan	17 N·m (100 in. lbs.)	17 N·m (100 in. lbs.)	12 N·m (100 in. lbs.)	24 N·m (18 ft. lbs.)
—Cable Clips—Screws	17 N·m (150 in. lbs.)	—	12 N·m (100 in. lbs.)	17 N·m (150 in. lbs.)
—Bolts	17 N·m (150 in. lbs.)	—	24 N·m (18 ft. lbs.)	6 N·m (55 in. lbs.)
Propshaft Parking Brake —Adjusting Nut	—	—	—	40 N·m (30 ft. lbs.)
—Bracket to Trans.	—	—	—	27 N·m (20 ft. lbs.)
—Cable Clip to Frame	—	—	—	17 N·m (150 in. lbs.)
—Cable Clip to Dash	—	—	—	6 N·m (55 in. lbs.)
—Cable Clip to Trans. Brkt.	—	—	—	27 N·m (20 ft. lbs.)
—Flange Plate	—	—	—	40 N·m (30 ft. lbs.)
—Drum	—	—	—	110 N·m (80 ft. lbs.)
Front Brake Hose —to Caliper	44 N·m (32 ft. lbs.)			
—to Frame Nut	7 N·m (58 in. lbs.)			
—Bracket Bolt	17 N·m (150 in. lbs.)	—	17 N·m (150 in. lbs.)	17 N·m (150 in. lbs.)
Rear Brake Hose—to Axle Bracket	27 N·m (20 ft. lbs.)	27 N·m (20 ft. lbs.)	10 N·m (90 in. lbs.)	17 N·m (150 in. lbs.)
—Bracket to Axle	17 N·m (150 in. lbs.)	17 N·m (150 in. lbs.)	—	17 N·m (150 in. lbs.)
Brake Line —Attaching Nuts	17 N·m (150 in. lbs.)			
—Retaining Clips—Screws	17 N·m (150 in. lbs.)	17 N·m (150 in. lbs.)	12 N·m (100 in. lbs.)	17 N·m (150 in. lbs.)
—Bolts	—	—	17 N·m (150 in. lbs.)	24 N·m (18 ft. lbs.)

SPECIAL TOOLS

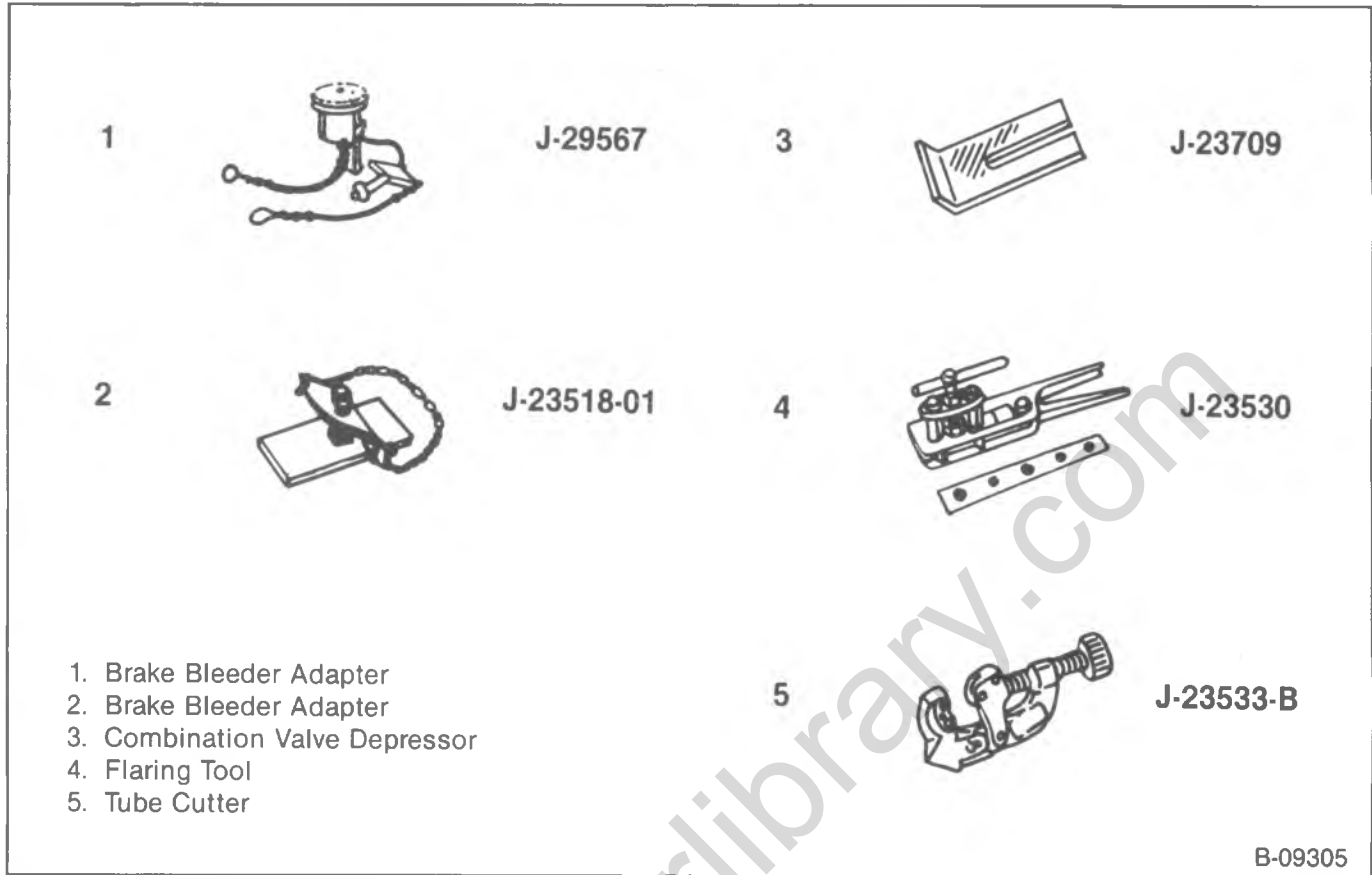

Figure 27—Special Tool Chart

SECTION 5A1

HYDRAULIC BRAKE BOOSTER SYSTEMS

The following notice applies to one or more steps in the assembly procedure of components in this portion of the manual as indicated at appropriate locations by the terminology NOTICE: See 'Notice' on page 5A1-1 of this section.

NOTICE: This fastener is an important attaching part in that it could affect the performance of vital components and system, and/or could result in major repair expense. It must be replaced with one of the same part number or with an equivalent part if replacement becomes necessary. Do not use a replacement part of lesser quality or substitute design. Torque values must be used as specified during reassembly to assure proper retention of this part.

CONTENTS

<u>SUBJECT</u>	<u>PAGE</u>
Diagnosis of Hydro-Boost System5A1-1
Hydro-Boost System Tests5A1-2
Vacuum Boosters5A1-3
Description5A1-3
Vacuum Booster Replacement5A1-3
Hydraulic Brake Booster (Hydro-Boost)5A1-4
Description5A1-4
Hydro-Boost Replacement5A1-4
Bleeding the Hydro-Boost System5A1-7
Specifications5A1-8

DIAGNOSIS OF HYDRO-BOOST SYSTEM

PROBLEM	POSSIBLE CAUSE	CORRECTION
Slow Brake Pedal Return	<ol style="list-style-type: none"> Excessive seal friction in booster. Faulty spool action. Restriction in return line from booster to pump reservoir. Damaged input rod end. 	<ol style="list-style-type: none"> Overhaul with new seal kit. Flush steering system while pumping brake pedal. Replace line. Replace input rod and piston assembly.
Grabby Brakes Booster Chatters - Pedal Vibrates	<ol style="list-style-type: none"> Faulty spool action caused by contamination in system. Power steering pump belt slips. Low fluid level in power steering pump. Faulty spool operation caused by contamination in system. 	<ol style="list-style-type: none"> Flush steering system while pumping brake pedal. Tighten belt. Fill reservoir and check for external leaks. Flush steering system while pumping brake pedal.
Accumulator Leak-Down System Does Not Hold Charge	<ol style="list-style-type: none"> Contamination in steering hydro-boost system. Internal leakage in accumulator system. 	<ol style="list-style-type: none"> Flush steering system while pumping brake pedal. Overhaul unit using accumulator rebuild kit and seal kit.

5A1-2 HYDRAULIC BRAKE BOOSTER SYSTEMS

HYDRO-BOOST SYSTEM TESTS

The Hydro-Boost system receives its source of power from the power steering system. Therefore a malfunctioning power steering system may affect the operation of the booster, just as a problem in the booster may affect the steering system. Prior to performing any tests, the following checks must be made.

1. Check all the power steering and brake pipe connections for leaks or restriction.

NOTICE: Power steering fluid and brake fluid cannot be mixed. If brake seals contact steering fluid or steering seals contact brake fluid, seal damage will result.

2. Check and fill the brake master cylinder with brake fluid.
3. Check and fill the power steering reservoir with power steering fluid. If fluid contains air refer to POWER STEERING (Sec. 3B3) for further diagnosis.
4. Check power steering pump belt for wear and tension. Adjust if needed, refer to POWER STEERING (Sec. 3B3).
5. Check engine idle speed, refer to the vehicles Emission Control Information label for idle specifications.
6. Check steering pump pressure. Refer to POWER STEERING (Sec. 3B3).

NOISE DIAGNOSIS

The following noises are associated with the Hydro-Boost and may or may not be cause for customer complaint. Some noises are normal and for the most part temporary in nature. Other noises may be a sign of excessive wear or the presence of air in either the booster or the steering system.

1. A moan or low frequency hum usually accompanied by a vibration in the pedal or steering column may be observed during parking maneuvers or other low speed maneuvers. This may be caused by a low fluid level in the power steering pump or by air in the fluid. Holding the pump at relief pressure (steering wheel held all the way in one direction) for more than five seconds will cause air to enter the system. Check the fluid level and fill if needed. The system must then sit for one hour to remove the air. If the condition persists, refer to POWER STEERING (Sec. 3B3).
2. A high speed fluid noise may be heard when the brake pedal is fully depressed, this condition is normal.
3. Whenever the accumulator pressure is used, a slight hiss may be noticed. It is the sound of the hydraulic fluid escaping through the accumulator valve, and is completely normal.
4. After the accumulator has been emptied, and the engine is started again, another hissing sound may be heard during the first brake application or the first steering maneuver. This is caused by the fluid rushing through the accumulator charging orifice. It is normal and will only be heard once after the accumulator is emptied. However, if this sound

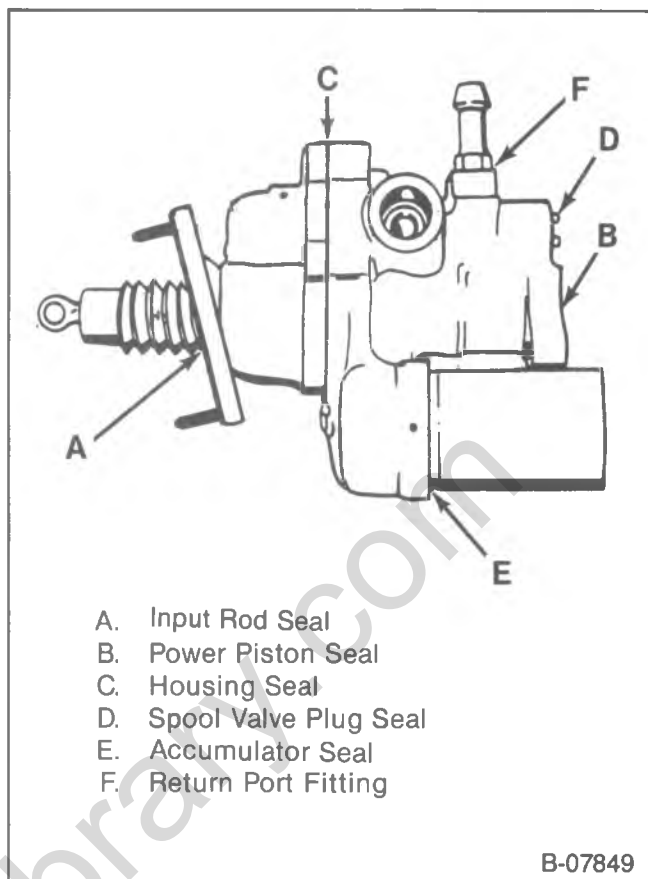

Figure 1—Hydro-Boost Seal Leak Diagnosis

continues, even though no apparent accumulator pressure assist was made, it could be an indication that the accumulator is not holding pressure and should be checked using the procedure for the "Accumulator Leakdown Test" in this section.

BOOSTER FUNCTIONAL TEST

With the engine off, apply the brake pedal several times until the accumulator is completely depleted. Depress the brake pedal using 180 N (40 lbs.) of force and start the engine. The pedal will fall and then push back against your foot.

ACCUMULATOR LEAKDOWN TEST

1. Start the engine and charge the accumulator by applying the brake pedal or by turning the steering wheel from stop to stop. Turn off the engine and let the vehicle sit for one hour. After one hour there should be at least two power assisted applications with the engine off.
2. If the reserve system will not retain a charge for one hour, but functions normally immediately following charging, the accumulator valves are at fault and the booster must be disassembled and the accumulator valves replaced.
3. If the accumulator can be heard charging and discharging, but it does not hold a charge, disassemble the booster and replace the accumulator valves.

4. Deplete the accumulator by pressing the brake pedal several times. If the accumulator can has lost its gas charge, it is possible to rotate or wobble the accumulator can with respect to the housing. Replace the accumulator assembly.

SEAL LEAK DIAGNOSIS (FIGURE 1)

- A. **INPUT ROD SEAL.** A damaged seal will show up as a fluid leak from the mounting bracket vent hole. The booster must be removed from the vehicle and disassembled. The input rod bore should be checked for any scratches that may cause the leak. If scratches are present, the housing cover must be replaced. If no excessive scratches are present, then the booster seal kit can be used to replace the appropriate seals.
- B. **POWER PISTON SEAL.** Power piston seal damage will be noticed by fluid leaking out at the common master cylinder brake booster vent and possible reduction in power assist. The booster must be

removed from the vehicle and disassembled. The piston should be checked for any scratches that may be the cause of the leak. If scratches are present, then the booster seal kit can be used to replace the appropriate seals.

- C. **HOUSING SEAL.** If the housing seal is damaged, fluid will leak out from between the two housings. The booster must be removed from the vehicle and disassembled. The booster seal kit should be used to replace the housing and input rod and power piston seals.
- D. **SPOOL VALVE PLUG SEAL.** Damage to this seal will be noticed by fluid leaking out past the plug. The booster need not be removed from the vehicle.
- E. **ACCUMULATOR SEAL.** Damage to this seal will result in fluid leakage past the accumulator cap. The seal can be replaced while the booster is installed on the vehicle.
- F. **RETURN PORT FITTING.** Tighten the fitting to 10 N·m (7 ft. lbs.). If the leak continues, replace the seal ring under the fitting.

VACUUM BOOSTERS

DESCRIPTION

SINGLE DIAPHRAGM MODEL

This booster is a single diaphragm vacuum suspended unit. It may have a single function vacuum switch to activate the brake warning light in case of low booster vacuum or vacuum pump malfunction. In a normal operating mode, with the service brakes in the released position, a vacuum suspended booster operates with vacuum on both sides of its diaphragm. When the brakes are applied, air at atmospheric pressure is admitted to one side of the diaphragm to provide the power assist.

TANDEM DIAPHRAGM MODEL

This booster is a tandem vacuum suspended unit. It may have a single dual function vacuum switch to activate the brake warning light in case of low booster vacuum or vacuum pump malfunction. In a normal operating mode, with the service brakes in the released position, a tandem vacuum suspended booster operates with vacuum on both sides of its diaphragms. When the brakes are applied, air at atmospheric pressure is admitted to one side of each diaphragm to provide the power assist.

VACUUM BOOSTER REPLACEMENT

↔ Remove or Disconnect (Figure 2)

- Apply the vehicles parking brakes.

 1. Mounting nuts.
 2. Master cylinder.
 - Support the master cylinder.
 3. Vacuum hose from the check valve.
 4. Booster pushrod, refer to "Brake Pedal Replacement" in HYDRAULIC BRAKES (SEC. 5A).

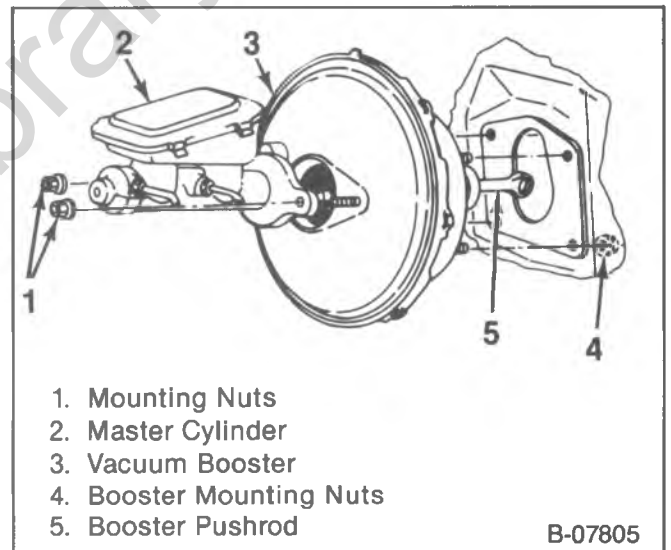

Figure 2—Removing Vacuum Boosters

5. Booster mounting nuts.
 - The mounting nuts must be removed from inside the vehicle.
6. Vacuum booster.

↔ Install or Connect (Figure 2)

NOTICE: For steps 2 and 6 see "Notice" on page 5A1-1 of this section.

1. Vacuum booster.
2. Booster mounting nuts.

⌚ Tighten

- Nuts to 29 N·m (21 ft. lbs.) for R-V-G Models.
- Nuts to 24 N·m (18 ft. lbs.) for P Models.

5A1-4 HYDRAULIC BRAKE BOOSTER SYSTEMS

3. Booster pushrod, refer to HYDRAULIC BRAKES (SEC. 5A).
4. Vacuum hose.
5. Master cylinder.
6. Mounting nuts.



Tighten

- Mounting nuts to 27 N·m (20 ft. lbs.)
7. Release the parking brakes.

HYDRAULIC BRAKE BOOSTER (HYDRO-BOOST)

DESCRIPTION

This system uses a hydraulic pump to power the system and a pneumatic accumulator as a reserve system.

In this system, no special fluids are used, however, care must be taken to use the correct fluids. The master cylinder and brake system operate on standard hydraulic brake fluid, while the hydraulic pump operates on power steering fluid. For diagnosis of the Hydro-Boost System, refer to "Hydro-Boost Systems Tests" and "Diagnosis of Hydro-Boost System" in this section.

HYDRO-BOOST REPLACEMENT

R-V AND G MODELS



Remove or Disconnect (Figure 3)

- Apply the vehicles parking brakes.
1. Hydraulic lines from the booster.
 2. Nuts (1).
 3. Master cylinder (2).
 - Support the master cylinder.
 4. Booster pushrod. Refer to HYDRAULIC BRAKES (SEC. 5A).
 5. Nuts (4) and (6).
 6. Hydro-Boost unit (3).
 7. Gasket (5).



Install or Connect (Figure 3)

NOTICE: For steps 3 and 6 see "Notice" on page 5A1-1 of this section.

1. Gasket (5).
2. Hydro-Boost unit (3).
3. Nuts (4) and (6).



Tighten

- Nuts to 24 N·m (18 ft. lbs.) for R-V Models.
 - Nuts to 29 N·m (21 ft. lbs.) for G Models.
4. Booster pushrod. Refer to HYDRAULIC BRAKES (SEC. 5A).
 5. Master cylinder. (2).
 6. Nuts (1).



Tighten

- Nuts to 27 N·m (20 ft. lbs.)
7. Hydraulic lines.
 - Bleed the booster, refer to "Bleeding the Hydro-Boost System" in this section.
 - Release the parking brakes.

P 30 (42) MODEL



Remove or Disconnect (Figures 4 and 5)

- Apply the vehicles parking brakes.
1. Hydraulic lines from the booster.
 2. Nuts (1) and washers (7).
 3. Master cylinder (2).
 - Support the master cylinder.
 4. Pushrod retainer (10).
 5. Retaining clip and washer.
 6. Booster pushrod (9).
 7. Nuts (4) and washers (8).
 8. Hydro-Boost unit (3).



Install or Connect (Figures 4 and 5)

NOTICE: For steps 2 and 7 see "Notice" on page 5A1-1 of this section.

1. Hydro-Boost unit (3).
2. Washers (8) and nuts (4).



Tighten

- Nuts to 29 N·m (21 ft. lbs.)
3. Booster pushrod (9).
 4. Washer and retaining clip.
 5. Pushrod retainer (10).
 6. Master cylinder (2).
 7. Washers (7) and nuts (1).



Tighten

- Nuts to 27 N·m (20 ft. lbs.)
8. Hydraulic lines.
 - Bleed the booster, refer to "Bleeding the Hydro-Boost System" in this section.
 9. Release the parking brakes.

P 30 (32) MODEL



Remove or Disconnect (Figure 6)

- Apply the vehicles parking brakes.
1. Hydraulic lines from the booster.
 2. Nuts (12) and washers (13).
 3. Master cylinder (2).
 - Support the master cylinder.
 4. Brake pedal rod. Refer to HYDRAULIC BRAKES (SEC. 5A).
 5. Nut (10) and washer (11).
 6. Bolt (16).
 7. Nut (14) and washers (15).
 8. Bolt (18).
 9. Nuts (12) and washer (13).
 10. Bolts (17).
 11. Hydro-Boost unit (3).

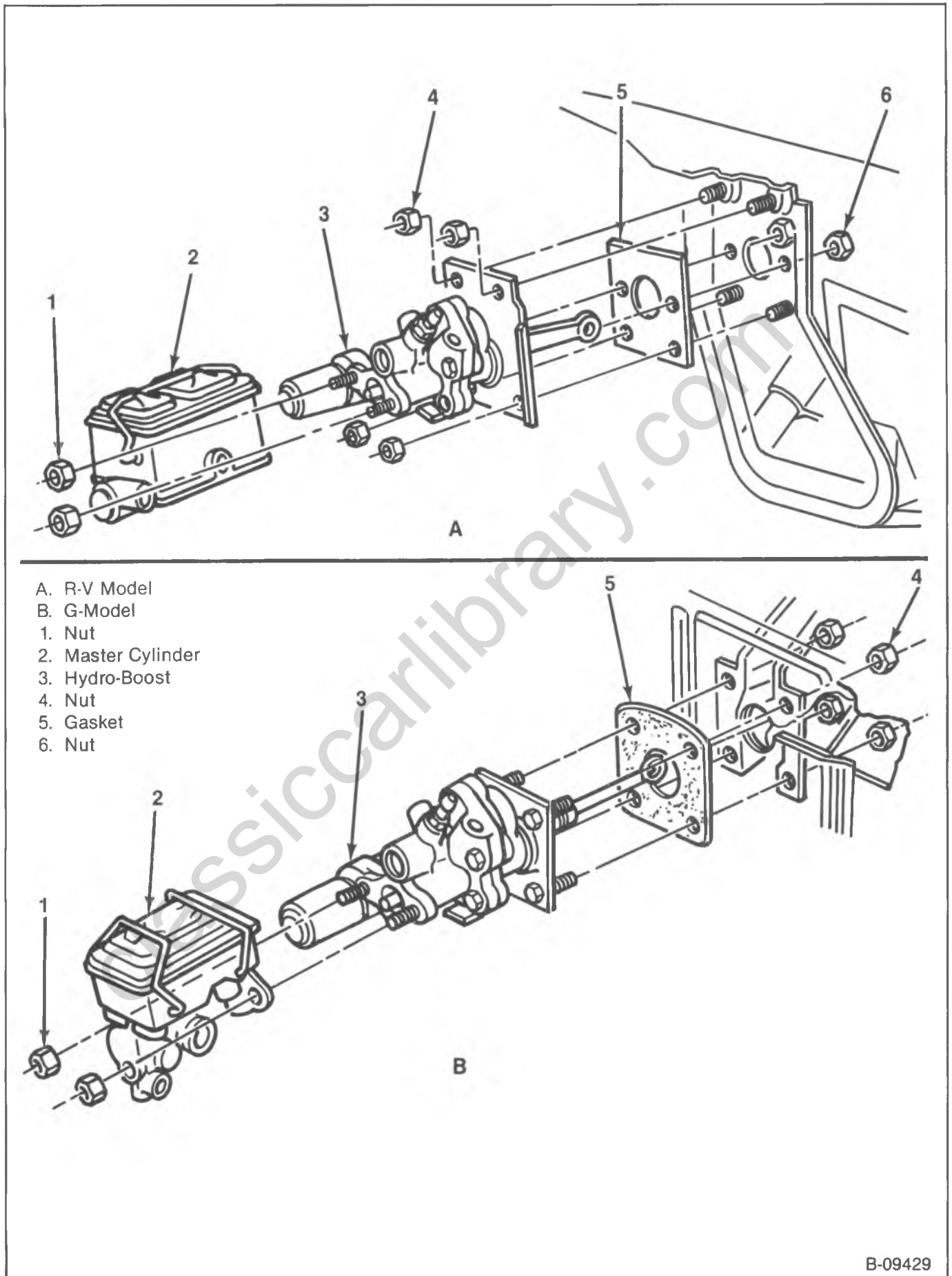
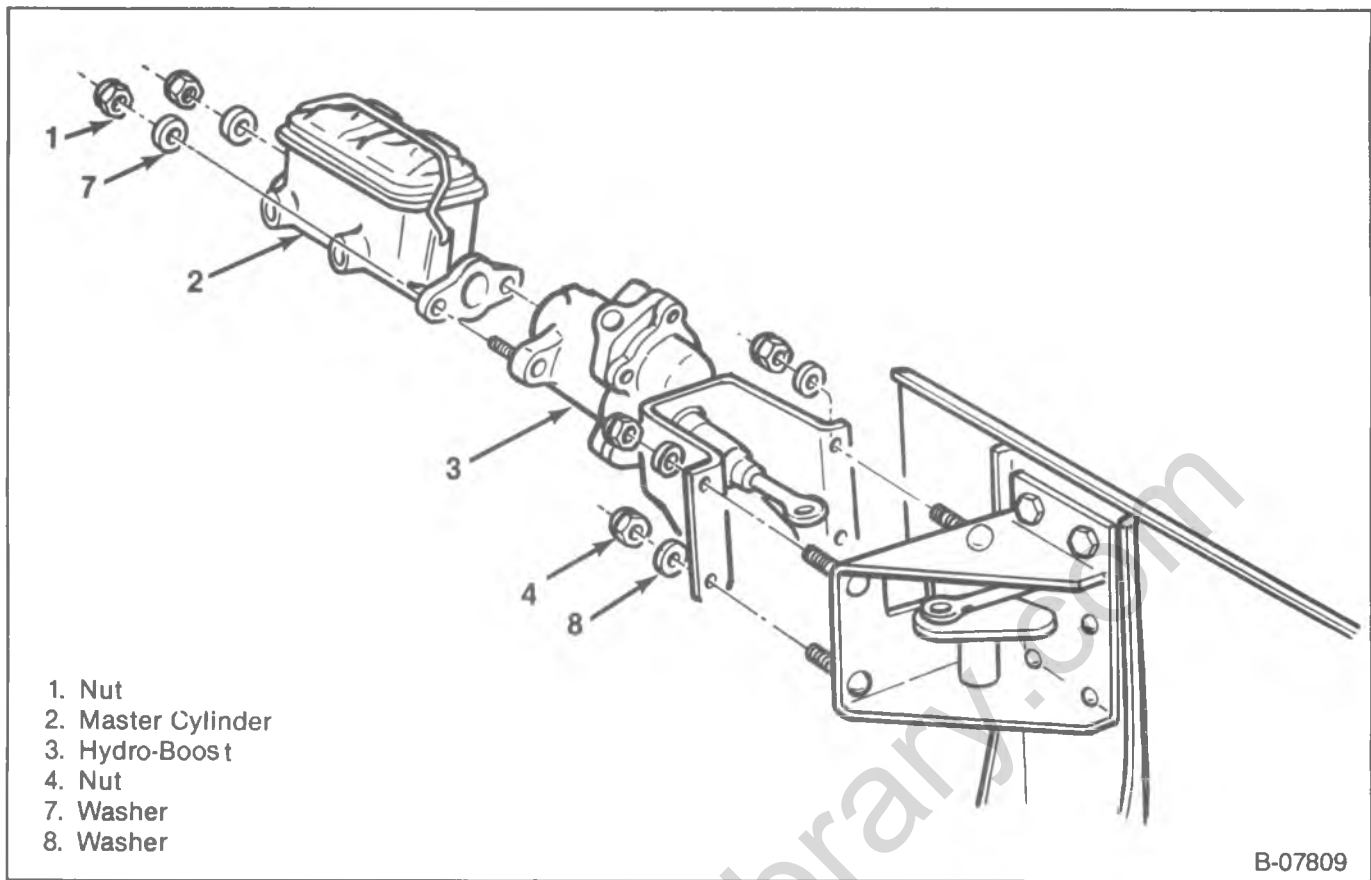

Figure 3—R-V and G Model Hydro-Boost Replacement

5A1-6 HYDRAULIC BRAKE BOOSTER SYSTEMS



1. Nut
2. Master Cylinder
3. Hydro-Boost
4. Nut
7. Washer
8. Washer

B-07809

Figure 4—P30(42) Hydro-Boost Replacement

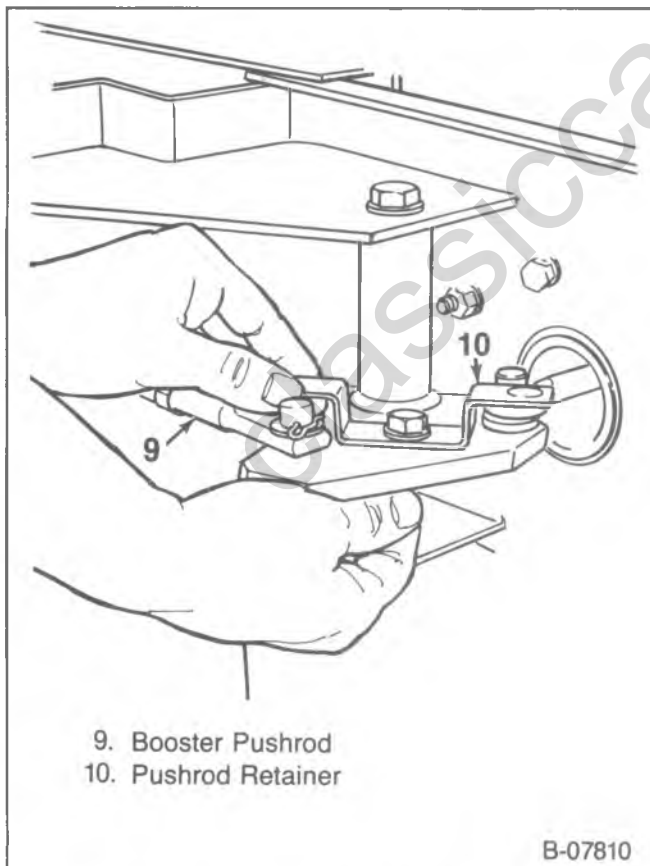

9. Booster Pushrod
10. Pushrod Retainer

B-07810

Figure 5—Removing Pushrod Retainer

Install or Connect (Figure 6)

NOTICE: For steps 2, 4, 6, and 9 see "Notice" on page 5A1-1 of this section.

1. Hydro-Boost unit (3).
2. Bolts (17).
3. Washers (13) and nuts (12). Leave finger tight.
4. Bolt (18).
5. Washer (15) and nut (14). Leave finger tight.
6. Bolt (16).
7. Washer (11) and nut (10). Leave finger tight.

Tighten

- Nuts (10, 14 and 12) to 34 N·m (25 ft. lbs.).
8. Brake pedal rod. Refer to HYDRAULIC BRAKES (SEC. 5A).
 9. Master cylinder (2).
 10. Washers (13) and nuts (12).

Tighten

- Nuts to 34 N·m (25 ft. lbs.)
11. Hydraulic lines.
 - Bleed the booster, refer to "Bleeding the Hydro-Boost System" in this section.
 - Release the parking brakes.

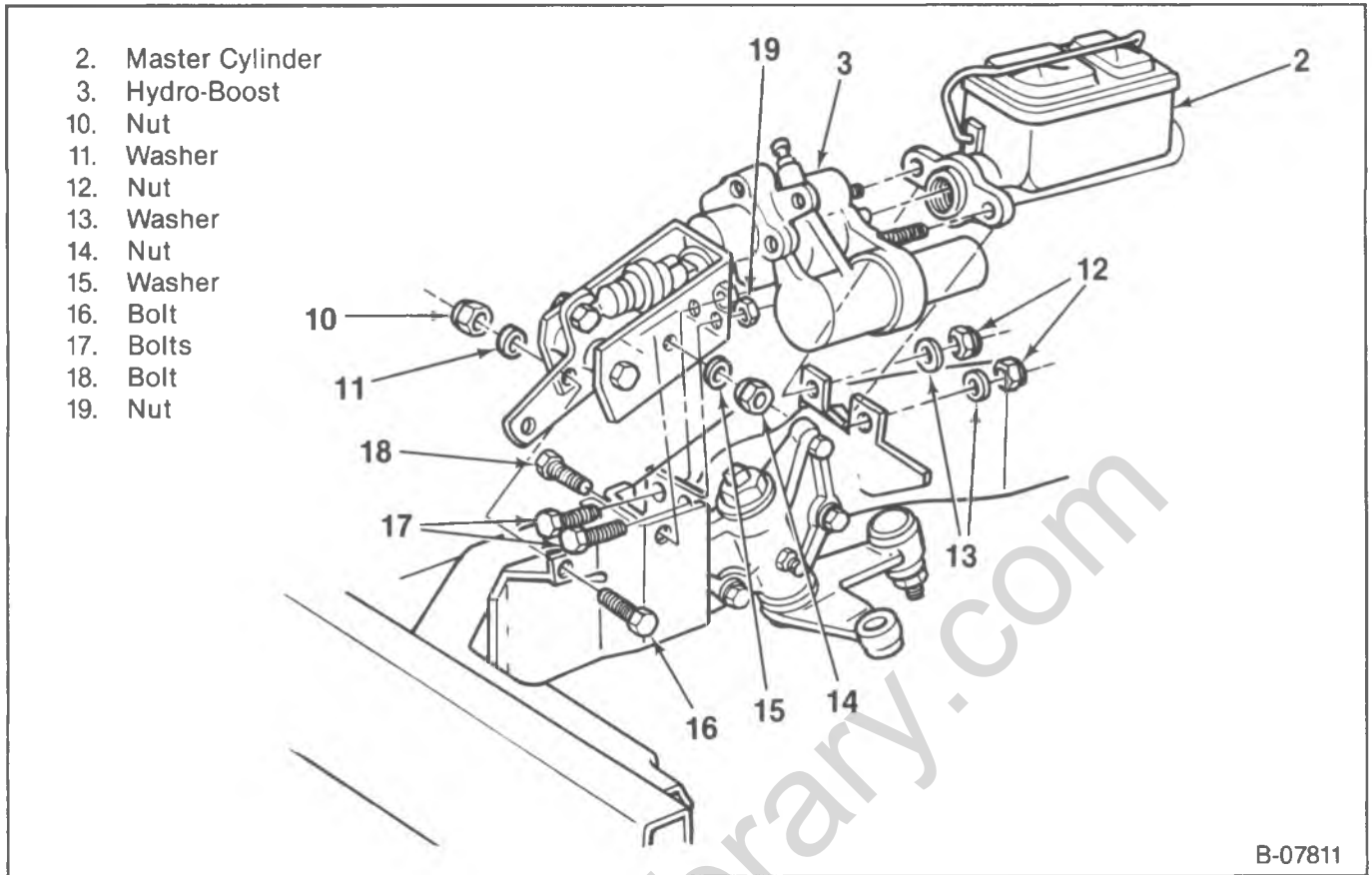

- 2. Master Cylinder
- 3. Hydro-Boost
- 10. Nut
- 11. Washer
- 12. Nut
- 13. Washer
- 14. Nut
- 15. Washer
- 16. Bolt
- 17. Bolts
- 18. Bolt
- 19. Nut

B-07811

Figure 6—P30(32) Hydro-Boost Replacement

BLEEDING THE HYDRO-BOOST SYSTEM

Whenever the booster is removed and reinstalled, the steering system should be bled.

NOTICE: The power steering fluid and brake fluid cannot be mixed. If the brake seals contact steering fluid or the steering seals contact brake fluid, seal damage will result.

1. Fill the power steering pump reservoir to the proper level and let the fluid remain undisturbed for at least two minutes.
2. Start the engine and run momentarily.
 - Add fluid, if necessary.
3. Repeat steps 1 and 2 until the fluid level remains constant after running the engine.
4. Raise the front of the vehicle so the wheels are off the ground.
 - Support the vehicle with suitable safety stands.
5. Turn the wheels from stop to stop, lightly contacting the stops.
 - Add fluid, if necessary.
6. Lower the vehicle.
7. Start the engine and depress the brake pedal several times while rotating the steering wheel from stop to stop.
8. Turn the engine off and then pump the brake pedal 4-5 times.
9. Check fluid level, add fluid if necessary.
10. If the fluid is extremely foamy, allow the vehicle to stand a few minutes with the engine off. Then repeat steps 7, 8 and 9.
11. Check for the presence of air in the oil. Air in the oil will have a milky appearance. Air in the system will also cause the fluid level in the pump to rise when the engine is turned off. If it becomes obvious that the pump will not bleed the air after a few attempts, refer to POWER STEERING (Sec. 3B3) for further diagnosis.

SPECIFICATIONS

BRAKE SYSTEMS

SYSTEM	FRONT BRAKES	REAR BRAKES	BRAKE ASSIST
GASOLINE ENGINE VEHICLES			
R-MODELS			
JB1 Low Drag	Disc 11.86 x 1.04	Drum 11.0 x 2.00	None (Manual Brakes)
JB3 Low Drag	Disc 11.86 x 1.04	Drum 11.0 x 2.00	Vacuum—Single Diaphragm
G-MODELS			
JB1 Low Drag	Disc 11.86 x 1.29	Drum 11.00 x 2.00	None (Manual Brakes)
JB3 Low Drag	Disc 11.86 x 1.29	Drum 11.00 x 2.00	Vacuum—Single Diaphragm
ALL MODELS			
JB5 Low Drag	Disc 11.86 x 1.29	Drum 11.15 x 2.75	Vacuum—Dual Diaphragm
JB6 Low Drag	Disc 12.50 x 1.28	Drum 11.15 x 2.75	Vacuum—Dual Diaphragm
JB7 Conventional	Disc 12.50 x 1.28	Drum 13.00 x 2.50	Vacuum—Dual Diaphragm
JB8 Conventional	Disc 12.50 x 1.54	Drum 13.00 x 3.50	Hydraulic—Hydro-Boost
JF9 Conventional	Disc 14.25 x 1.54	Disc 13.75 x 1.54	Hydraulic—Hydro-Boost
DIESEL ENGINE VEHICLES			
JD3 Low Drag	Disc 11.86 x 1.29	Drum 11.00 x 2.00	Hydraulic—Hydro-Boost
JD5 Low Drag	Disc 11.86 x 1.29	Drum 11.15 x 2.75	Hydraulic—Hydro-Boost
JD6 Conventional	Disc 12.50 x 1.28	Drum 11.15 x 2.75	Hydraulic—Hydro-Boost
JD7 Conventional	Disc 12.50 x 1.28	Drum 13.00 x 2.50	Hydraulic—Hydro-Boost

TORQUE SPECIFICATIONS

	R	V	G	P
Master Cylinder to Booster	27 N·m (20 ft. lbs.)	27 N·m (20 ft. lbs.)	27 N·m (20 ft. lbs.)	27 N·m (20 ft. lbs.)
Booster to Dash or Frame	29 N·m (21 ft. lbs.)	29 N·m (21 ft. lbs.)	29 N·m (21 ft. lbs.)	24 N·m (18 ft. lbs.)
Hydro—Boost				
—Pedal Rod — P30 (32) Models	—	—	—	34 N·m (25 ft. lbs.)
—Pedal Rod Boot — P 30 (32) Models	—	—	—	20 N·m (15 ft. lbs.)
—Pivot Lever Rod Retainer	—	—	—	34 N·m (25 ft. lbs.)
—Pivot Lever Bolt	—	—	—	60 N·m (45 ft. lbs.)
—Booster Brackets	—	—	—	34 N·m (25 ft. lbs.)
—Booster Brace at Dash or Rad. Supt.	—	—	—	17 N·m (150 in. lbs.)
—Power Steering Pump to Booster Line		34 N·m (25 ft. lbs.)		
—Booster to Gear Line		34 N·m (25 ft. lbs.)		
—Return Line at Booster and Gear		34 N·m (25 ft. lbs.)		
—Return Line Clamp Screw		1.6 N·m (15 in. lbs.)		
—Line Clamp to Bracket Screw		17 N·m (150 in. lbs.)		
—Hose Clamp to Skirt Screw	4.5 N·m (40 in. lbs.)	—	—	—
—Line Clamp to Frame Bolt	17 N·m (150 in. lbs.)	—	—	17 N·m (150 in. lbs.)
—Booster to Dash or Frame	24 N·m (18 ft. lbs.)	24 N·m (18 ft. lbs.)	29 N·m (21 ft. lbs.)	29 N·m (21 ft. lbs.)

SECTION 5A2

HYDRAULIC FOUNDATION BRAKES

The following notice applies to one or more steps in the assembly procedure of components in this portion of the manual as indicated at appropriate locations by the terminology NOTICE: See 'Notice' on page 5A2-1 of this section.

NOTICE: *This fastener is an important attaching part in that it could affect the performance of vital components and system, and/or could result in major repair expense. It must be replaced with one of the same part number or with an equivalent part if replacement becomes necessary. Do not use a replacement part of lesser quality or substitute design. Torque values must be used as specified during reassembly to assure proper retention of this part.*

CAUTION: When servicing wheel brake parts, do not create dust by grinding or sanding brake linings or by cleaning wheel brake parts with a dry brush or with compressed air. (A water dampened cloth should be used). Many wheel brake parts contain asbestos fibers which can become airborne if dust is created during servicing. Breathing dust containing asbestos fibers may cause serious bodily harm.

CONTENTS

<u>SUBJECT</u>	<u>PAGE</u>
Disc Brakes5A2- 1
Description5A2- 1
Brake Lining Inspection5A2- 1
Brake Lining Replacement5A2- 2
Servicing the Rotor5A2- 6
Rebuilding the Caliper5A2- 6
Drum Brakes5A2- 9
Description5A2- 9
Brake Lining Replacement5A2- 9
Servicing the Brake Drum5A2-10
Brake Adjustment5A2-10
Wheel Cylinder Replacement5A2-11
Rebuilding the Wheel Cylinder5A2-11
Specifications5A2-12
Special Tools5A2-13

DISC BRAKES

DESCRIPTION

The disc brake assembly consists of a caliper and piston assembly, rotor, linings, and an anchor plate. The caliper is mounted to the anchor plate, which allows the caliper to move laterally against the rotor. The caliper is a one-piece casting with the inboard side containing the piston bore. A square cut rubber seal is located in a groove in the piston bore which provides the hydraulic seal between the piston and the cylinder wall.

OPERATION

As the brake pedal is depressed, hydraulic pressure is applied against the piston. This pressure pushes the inboard brake lining against the inboard braking surface of the rotor. As the force increases against the rotor, the caliper assembly moves inboard thus providing a clamping action on the rotor.

When the brake pressure is released, the piston seal returns to its normal position, pulling the piston back into the caliper bore. This will create a running clearance between the inner brake lining and the rotor.

BRAKE LINING INSPECTION

Check the outer pad by looking at each end of the caliper (figure 1). Check the lining thickness on the inner pad by looking down through the inspection hole in the top of the caliper housing. Whenever the lining is worn to about the thickness of the pad, the lining should be removed for further measurements. The pad should be replaced anytime the lining is worn to within 0.80 mm ($\frac{1}{32}$ -inch) of a rivet head or the pad itself.

5A2-2 HYDRAULIC FOUNDATION BRAKES

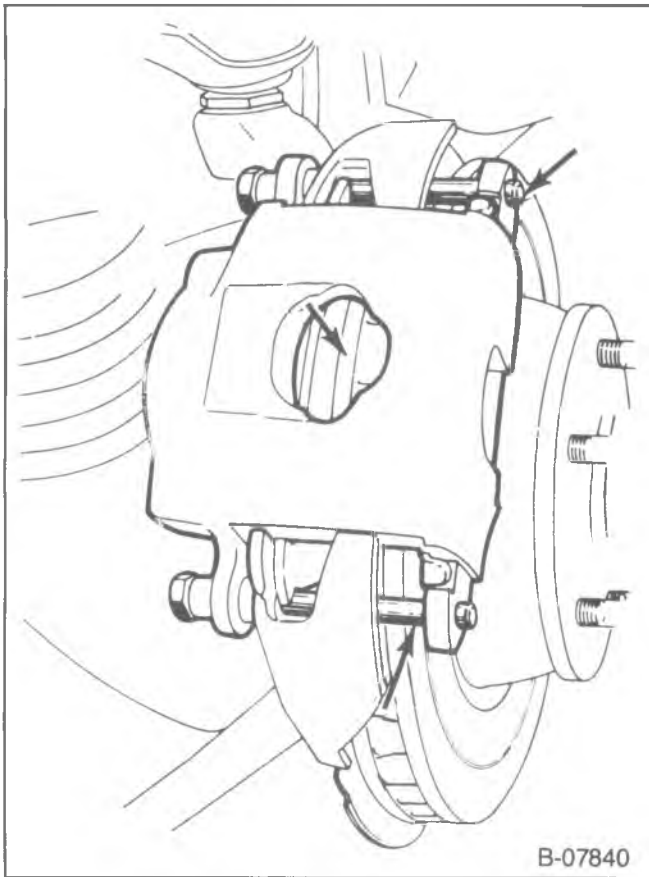

Figure 1—Lining Inspection Points

The disc brake pads have a wear indicator that makes a noise when the linings wear to a degree where replacement is required (figure 2).

Also check the flatness of the brake pads. Place the inboard and outboard lining surfaces together and check for a gap between the lining surfaces. This gap should not exceed 0.13 mm (.005-inch) at the middle of the lining surfaces. This applies to new or used brake pads.

BRAKE LINING REPLACEMENT

3000/3100 MODELS

Remove or Disconnect (Figure 3)

- Two-thirds of the brake fluid from the master cylinder.
 - Raise the vehicle and support it with suitable safety stands.
 - Mark the relationship of the wheel to the hub.
1. Wheel and tire assembly, refer to WHEELS AND TIRES (Sec. 3E).

CAUTION: See "Caution" on page 5A2-1 of this section.

- Position a C-clamp around the outer pad and caliper and tighten until the piston bottoms in its bore (figure 4).
2. C - clamp
 3. Mounting bolts (figure 5).
 4. Caliper assembly.

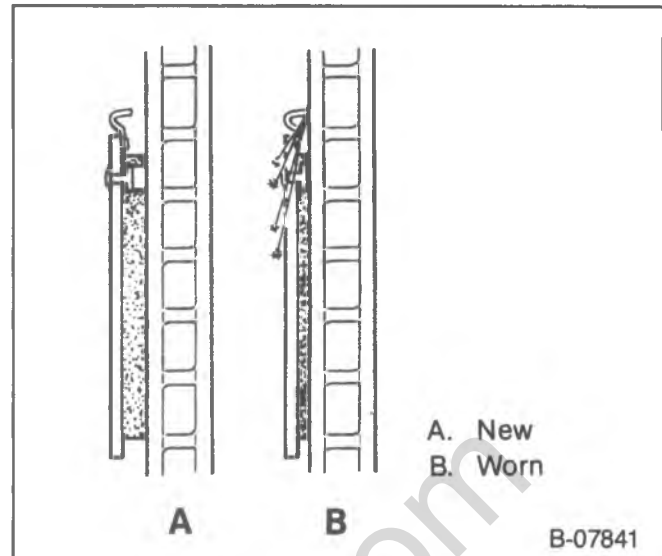

Figure 2—Warning Sensor

- Suspend the caliper from the suspension (figure 6).

Important

- Do not allow the brake components to hang from the flexible hoses as damage to the hoses may occur.

5. Inboard pad (6).
6. Retainer spring (5).
7. Outboard pad (7).

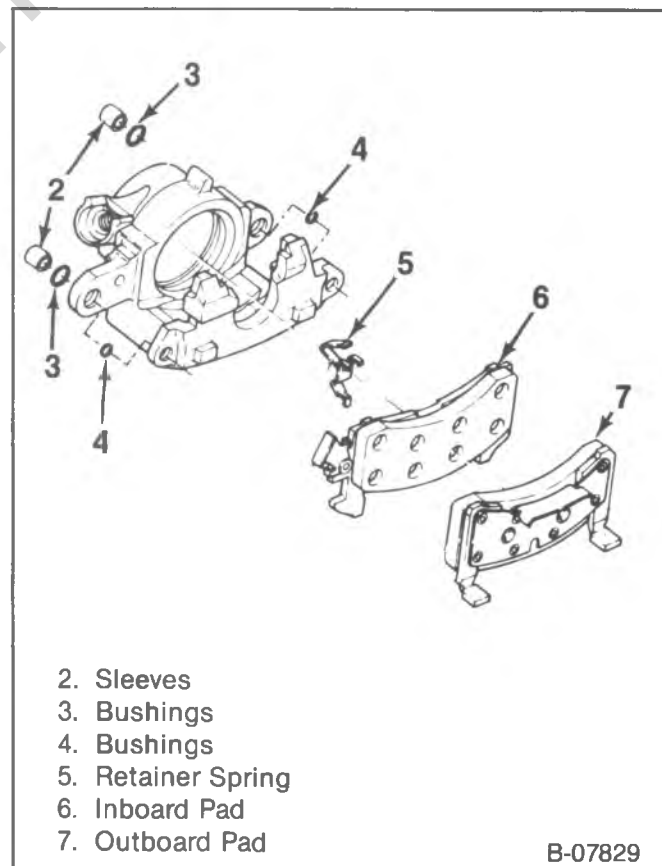

2. Sleeves
3. Bushings
4. Bushings
5. Retainer Spring
6. Inboard Pad
7. Outboard Pad

B-07829

Figure 3—Replacing Disc Brake Linings (3000/3100 Models)

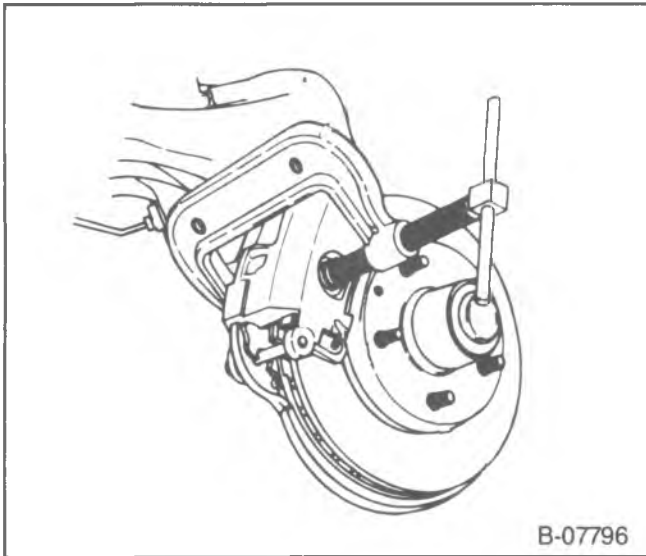

Figure 4—Compressing the Caliper Piston

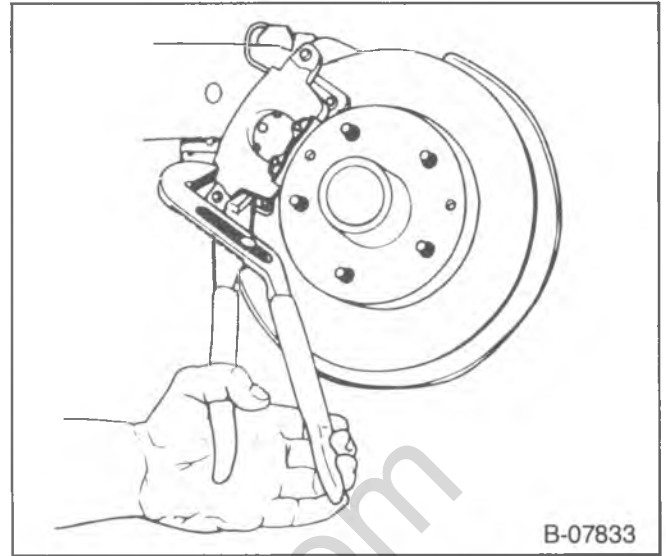

Figure 7—Compressing the Ear Pads

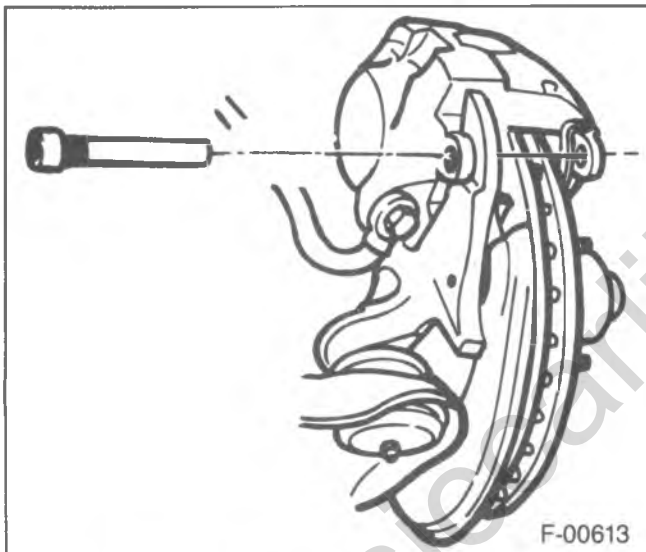

Figure 5—Removing the Mounting Bolts

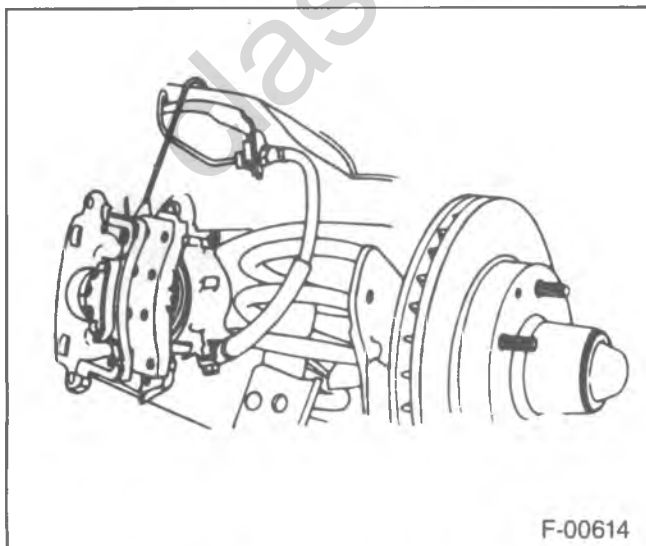

Figure 6—Suspending the Caliper

- 8. Sleeves (2).
- 9. Bushings (3 and 4).

 **Inspect**

- The inside of the caliper assembly for signs of fluid leakage, if found, refer to "Rebuilding the Caliper" in this section.
- Mounting bolts and sleeves for corrosion. Do not attempt to polish away corrosion, replace the bolts.

 **Install or Connect (Figure 3)**

- Lubricate the sleeves and bushings with Delco Silicone Lube or equivalent.
1. Bushings (3 and 4).
 2. Sleeves (2).
 3. Retainer spring (5) onto the inboard pad (6).
 4. Inboard pad (6).
 5. Outboard pad (7).
 6. Caliper assembly.

 **Important**

- Make sure that the brake hose is not twisted or kinked since damage to the hose could result.

NOTICE: See "Notice" on page 5A2-1 of this section.

7. Mounting bolts (Figure 5).

 **Tighten**

- Bolts to 48 N·m (35 ft. lbs.)
- Compress the pad ears to the caliper (figure 7).

 **Measure (Figure 8)**

- The clearance between the caliper and the steering knuckle. The clearance at each end of the caliper should be measured individually and added together, this total should be between 0.26 - 0.60 mm (0.010 - 0.024-inches).
8. Wheel and tire assembly, refer to WHEELS AND TIRES (Sec. 3E).
 - Lower the vehicle.

5A2-4 HYDRAULIC FOUNDATION BRAKES

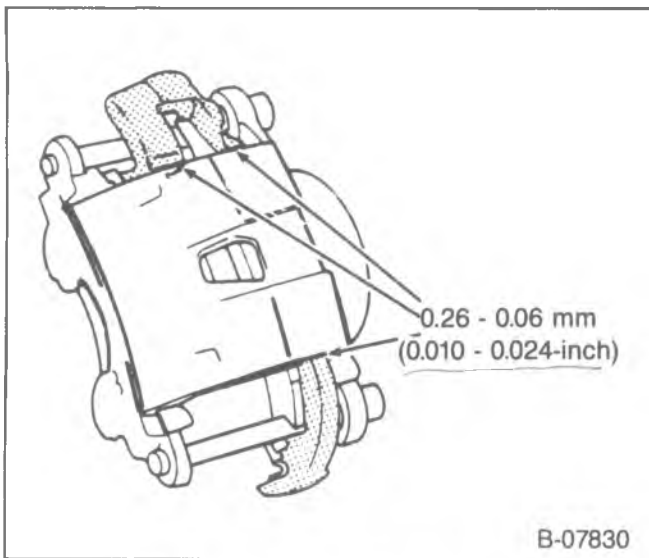

Figure 8—Caliper Clearances



Important

- Before moving the vehicle, pump the brake pedal several times to make sure that the pedal is firm. Do not move the vehicle until a firm pedal is obtained. Check the brake fluid level in the master cylinder after pumping the brakes.

BENDIX MODEL

↔ Remove or Disconnect (Figures 9 and 10)

- Two-thirds of the brake fluid from the master cylinder.
 - Raise the vehicle and support it with suitable safety stands.
 - Mark the relationship of the wheel to the hub.
1. Wheel and tire assembly, refer to WHEELS AND TIRES (Sec. 3E).

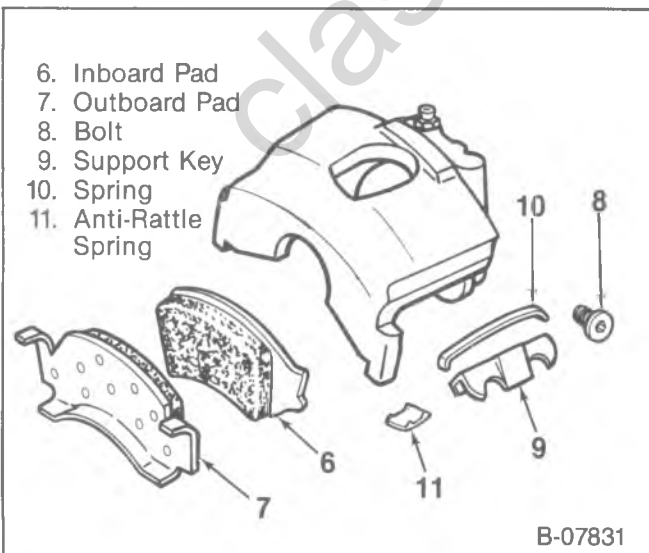

Figure 9—Replacing Disc Brake Linings (Bendix Models)

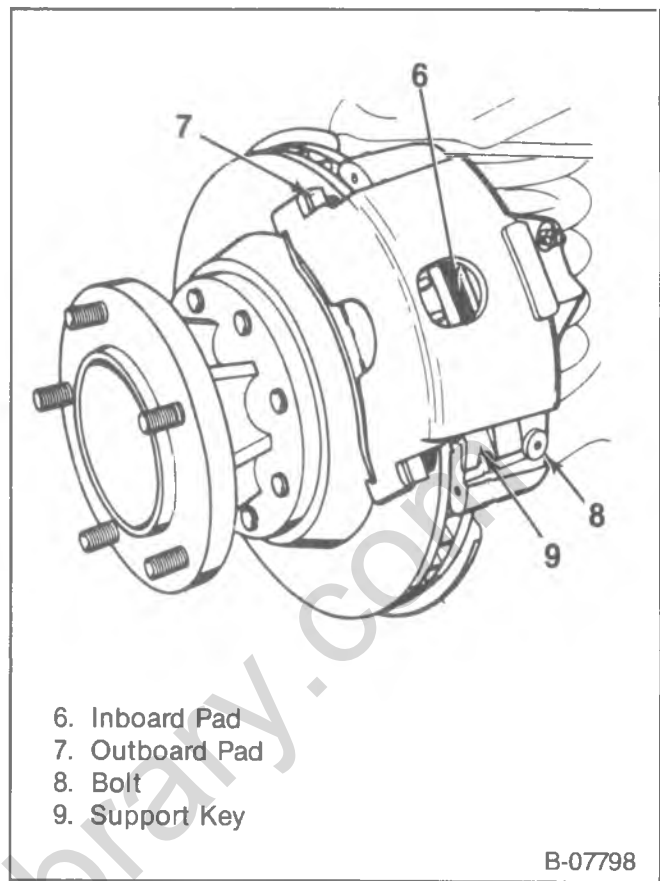

Figure 10—Bendix Disc Brake Assembly

CAUTION: See "Caution" on page 5A2-1 of this section.

- Position C - clamp and tighten until the piston bottoms in its bore (figure 11).
2. C - clamp.
 3. Bolt (8).
 4. Support key (9) and spring (10).
 - Use a brass punch and a hammer to drive the support key out (figure 12).
 5. Caliper assembly.

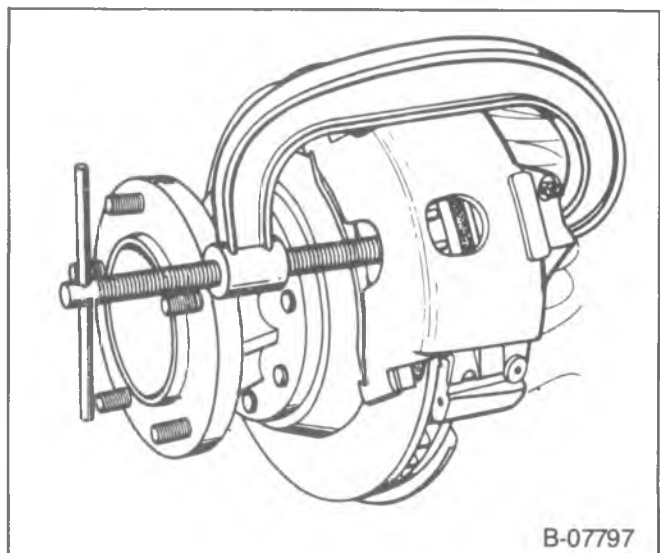

Figure 11—Compressing the Caliper Piston

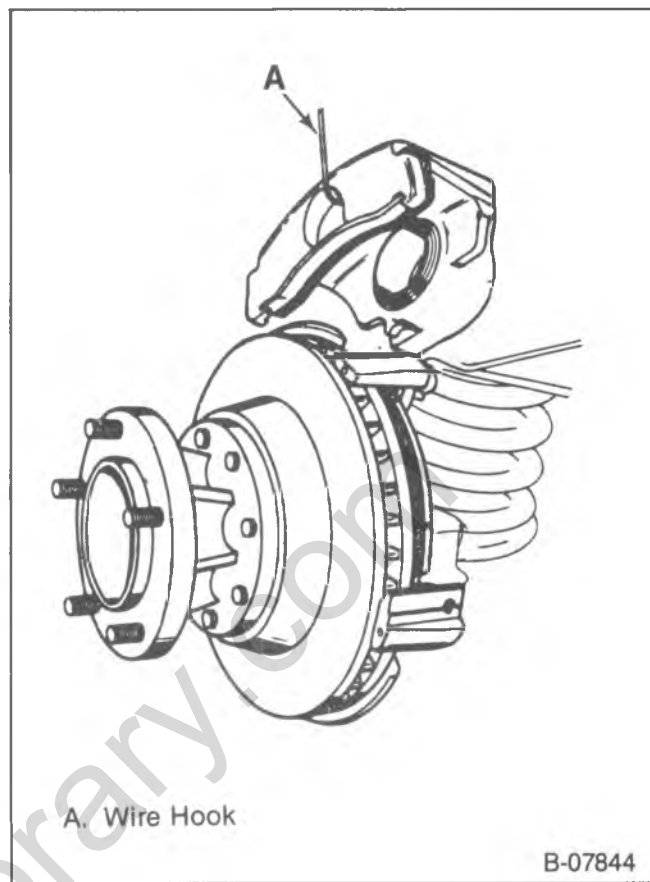
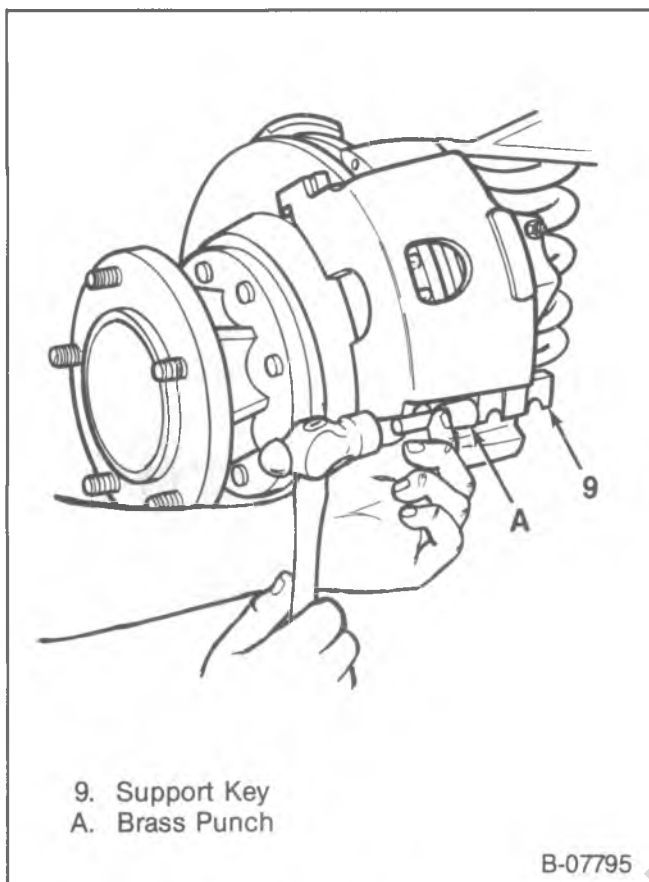

Figure 12—Removing the Support Key

- Suspend the caliper from the suspension (figure 13).

! Important

- Do not allow the brake components to hang from the flexible hoses as damage to the hoses may occur.

6. Inboard pad (6) from the steering knuckle or rear caliper support.
7. Anti-rattle spring (11).
8. Outboard pad (7).

🔍 Inspect

- The inside of the caliper assembly for signs of fluid leakage, if found, refer to "Rebuilding the Caliper" in this section.

🧼 Clean

- Use a wire brush to remove any corrosion from the machined surfaces of the steering knuckle and caliper.

↔ Install or Connect (Figures 9 and 10)

- Lubricate the caliper and steering knuckle (or support) sliding surfaces and spring with Delco Silicone Lube or equivalent.

1. Inboard pad (6) and anti-rattle spring (11).
2. Outboard pad (7) into the caliper assembly.
3. Caliper assembly.

! Important

- Make sure that the brake hose is not twisted or kinked since damage to the hose could result.

Figure 13—Suspending the Caliper

4. Spring (10) and support key (9).
 - Use a brass punch and a hammer to drive the support key in (figure 14).

NOTICE: See "Notice" on page 5A2-1 of this section.

5. Bolt (8).
 - The boss on the bolt must fully fit into the circular cutout in the key.

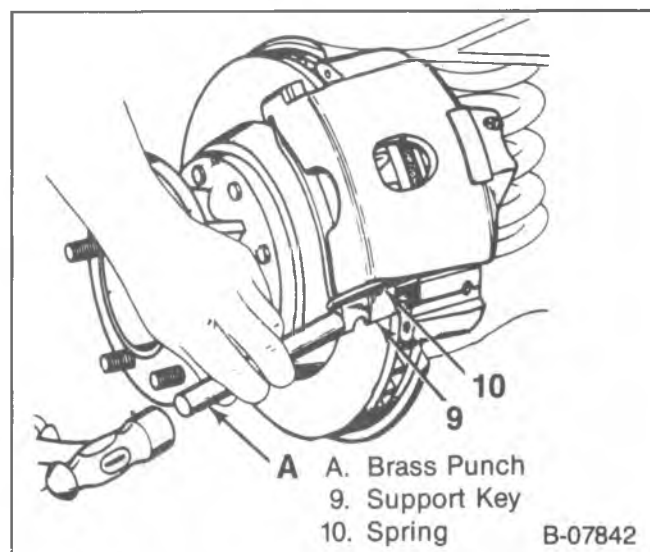

Figure 14—Installing the Support Key

5A2-6 HYDRAULIC FOUNDATION BRAKES



Tighten

- Bolt to 20 N·m (15 ft. lbs.).
6. Wheel and tire assembly, refer to WHEELS AND TIRES (Sec. 3E).
- Lower the vehicle.



Important

- Before moving the vehicle, pump the brake pedal several times to make sure that the pedal is firm. Do not move the vehicle until a firm pedal is obtained. Check the brake fluid level in the master cylinder after pumping the brakes.

SERVICING THE ROTOR

In the manufacturing of the brake rotor all the tolerances regarding surface finish, parallelism, and lateral runout are held very closely. The maintenance of these tolerances provide the surface necessary to prevent brake roughness.

Light scoring of the rotor surface not in excess of 0.38 mm (0.15-inch) in depth is normal. This condition does not affect the brake operation.

LATERAL RUNOUT

Lateral runout is the movement of the rotor from side to side as it rotates on the spindle. This could also be referred to as "rotor wobble".

This movement causes the brake pad and piston to be knocked back into it's bore. This results in additional pedal travel and a vibration during braking.

Checking Lateral Runout (Figure 15)

1. Tighten the wheel bearings to eliminate all freeplay.
2. Attach a dial indicator to some portion of the suspension.
 - The point of the styles must contact the rotor face about 25 mm (1-inch) from the rotor edge.
3. Move the rotor one complete rotation.
 - The lateral runout should not exceed 0.10 mm (0.004-inch).
4. Adjust the wheel bearings, refer to FRONT SUSPENSION (Sec. 3C).

PARALLELISM

Parallelism is the measurement of the thickness of the rotor at four or more points around the circumference of the rotor. All measurements must be made at the same distance in from the edge of the rotor. The rotor thickness must not vary more than 0.013 mm (0.0005-inch) from point to point.

MACHINING

Since accurate control of the rotor tolerances is necessary for proper performance of the disc brakes, machining of the rotor should be done only with precision equipment.

All brake rotors have a minimum thickness dimension cast into them. This dimension is the minimum wear dimension and not a refinish dimension. Do not use a brake rotor that will not meet the specifications, after refinishing. Replace with a new brake rotor. Refer to "Specifications" in this section for final machining tolerances.

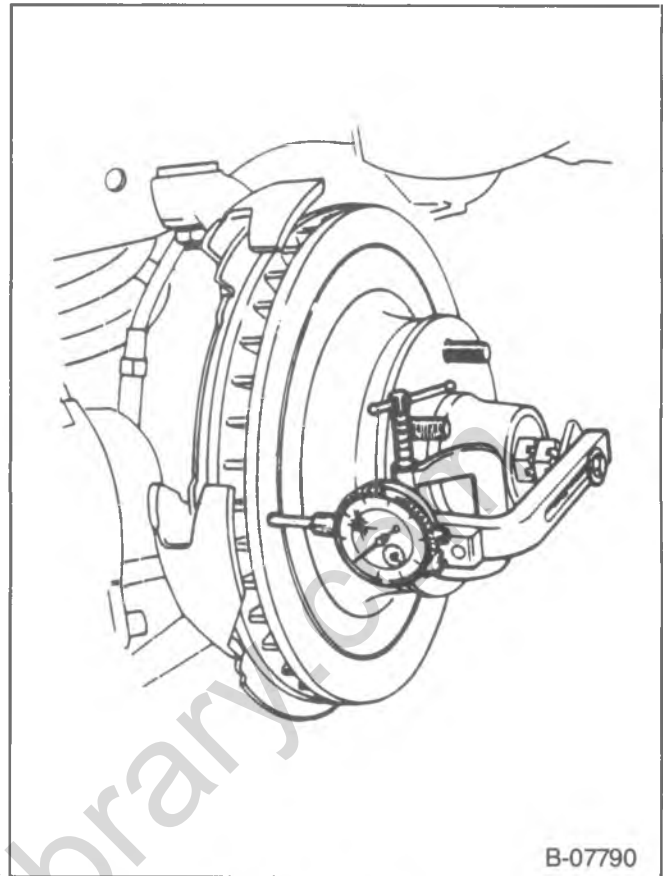

Figure 15—Checking for Lateral Runout

REBUILDING THE CALIPER

3000/3100 MODELS



Remove or Disconnect (Figure 16)

- Drain all the fluid from the caliper.
- Pad the interior of the caliper with clean shop towels.

CAUTION: Do not place your fingers in front of the piston in an attempt to catch or protect it when applying compressed air. This could result in serious injury.

NOTICE: Use just enough air to ease the piston out of the bore. If the piston is blown out—even with padding provided, it may be damaged.

1. Piston (22) by directing compressed air into the caliper fluid inlet (figure 17)
 - Use just enough air pressure to ease the piston out of the bore.
2. Boot (23) (figure 18).
 - Use care not to scratch the housing bore.
3. Piston seal (21).
 - Do not use any type of metal tool.
4. Bleeder valve (20).



Clean

- Bleeder valve, caliper bore, caliper passages, and piston with denatured alcohol. Use dry, filtered compressed air to dry parts and blow out passages.

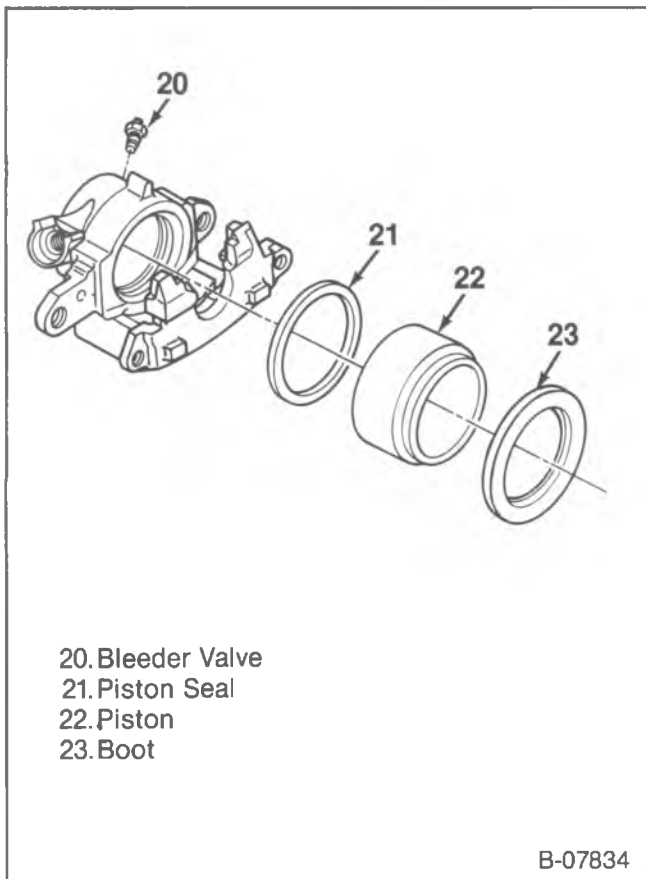

- 20. Bleeder Valve
- 21. Piston Seal
- 22. Piston
- 23. Boot

B-07834

Figure 16—Models 3000/3100 Caliper Components

Inspect

- Piston for scoring, corrosion and any damage to the chrome plating, replace if found.
- Caliper bore for scoring, pitting, or corrosion. Use crocus cloth to polish out any light corrosion. Replace caliper if corrosion cannot be removed.

Install or Connect (Figure 16)

Tool required:
J-26267 Piston Seal Installer

- Lubricate the new piston seal, caliper bore, and piston with clean brake fluid.
1. Piston seal (21).
 - Make sure the seal is not twisted in the caliper bore groove.

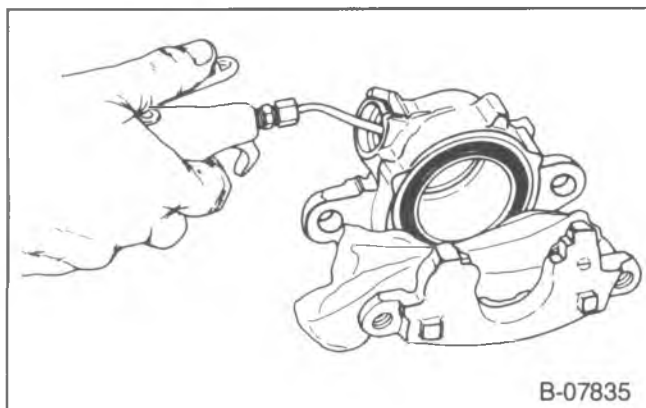

B-07835

Figure 17—Removing the Piston

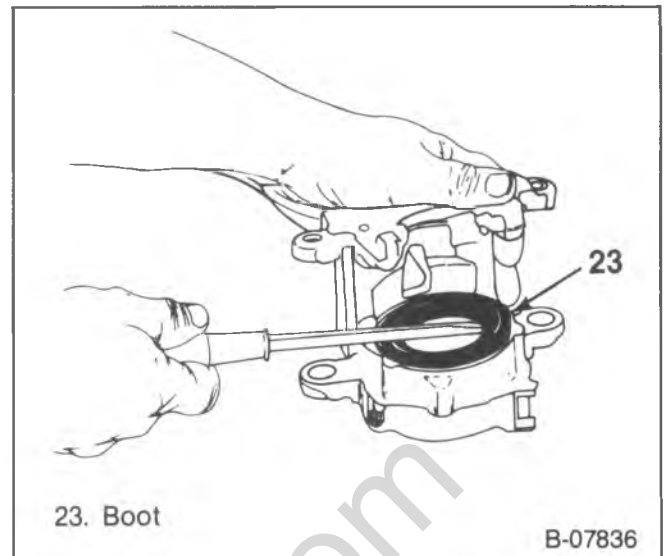

23. Boot

B-07836

Figure 18—Removing the Boot

2. Boot (23) onto the piston (22).
3. Piston (22).
4. Boot (23) into the caliper housing counterbore using J-26267 (figure 19).
5. Bleeder valve (20).

BENDIX MODEL

Remove or Disconnect (Figure 20)

- Drain all the fluid from the caliper.
- Pad the interior of the caliper with clean shop towels.

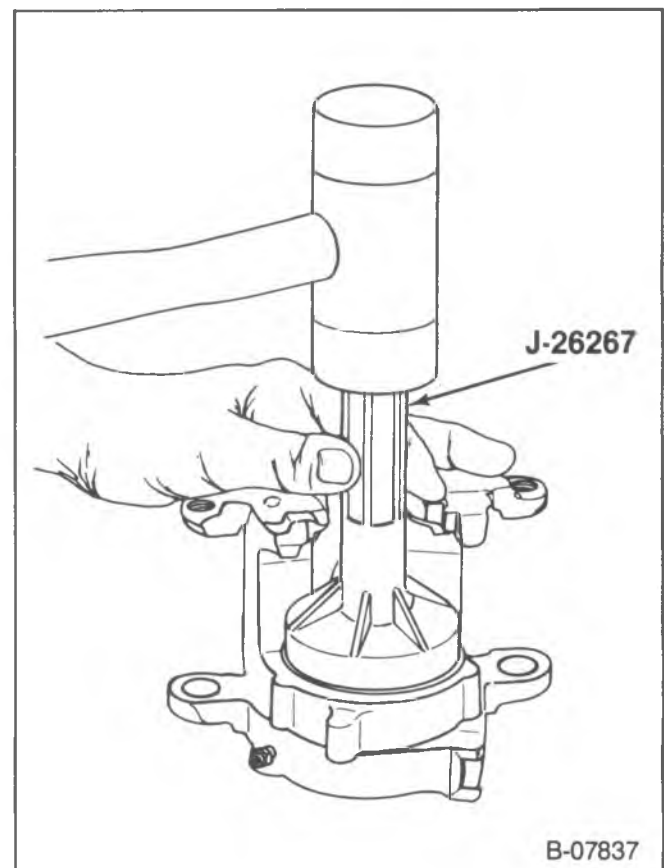

B-07837

Figure 19—Installing the Caliper Boot

5A2-8 HYDRAULIC FOUNDATION BRAKES

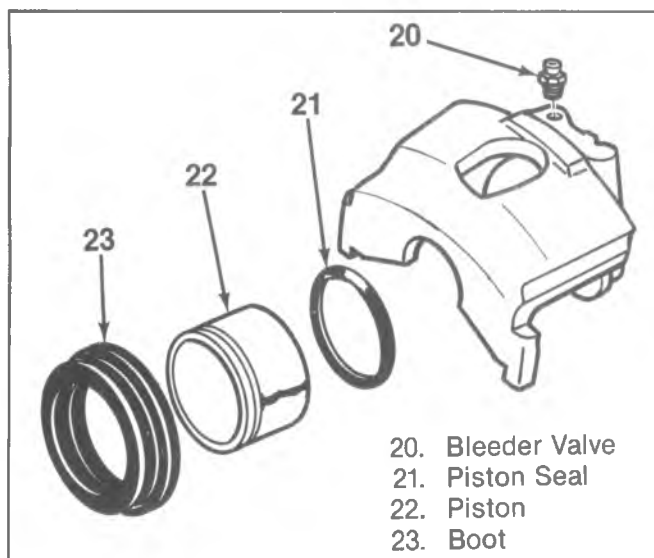

Figure 20—Bendix Model Caliper Components

CAUTION: Do not place your fingers in front of the piston in an attempt to catch or protect it when applying compressed air. This could result in serious injury.

NOTICE: Use just enough air to ease the piston out of the bore. If piston is blown out—even with padding provided, it may be damaged.

1. Piston (22) by directing compressed air into the caliper fluid inlet (figure 17).
 - Use just enough air pressure to ease the piston out of the bore.
2. Boot (23).
3. Piston seal (21).
 - Do not use any type of metal tool.
4. Bleeder valve (20).



Clean

- Bleeder valve, caliper bore, caliper passages, and piston with denatured alcohol. Use dry, filtered compressed air to dry parts and blow out passages.



Inspect

- Piston for scoring, corrosion and any damage to the chrome plating, replace if found.
- Caliper bore for scoring, pitting, or corrosion. Use corcus cloth to polish out any light corrosion. Replace caliper if corrosion cannot be removed.



Install or Connect (Figure 20)

Tool required:

J-24548 Piston Seal Installer

- Lubricate the new piston seal, caliper bore, piston, and seal lips on boot with clean brake fluid.
1. Piston seal (21).
 - Make sure the seal is not twisted in the caliper bore groove.
 2. Boot (23) on tool J-24548.
 - Place the large diameter of the boot over the tool first and ride the smaller diameter onto the tool.
 - The large diameter must then slide off the tool.

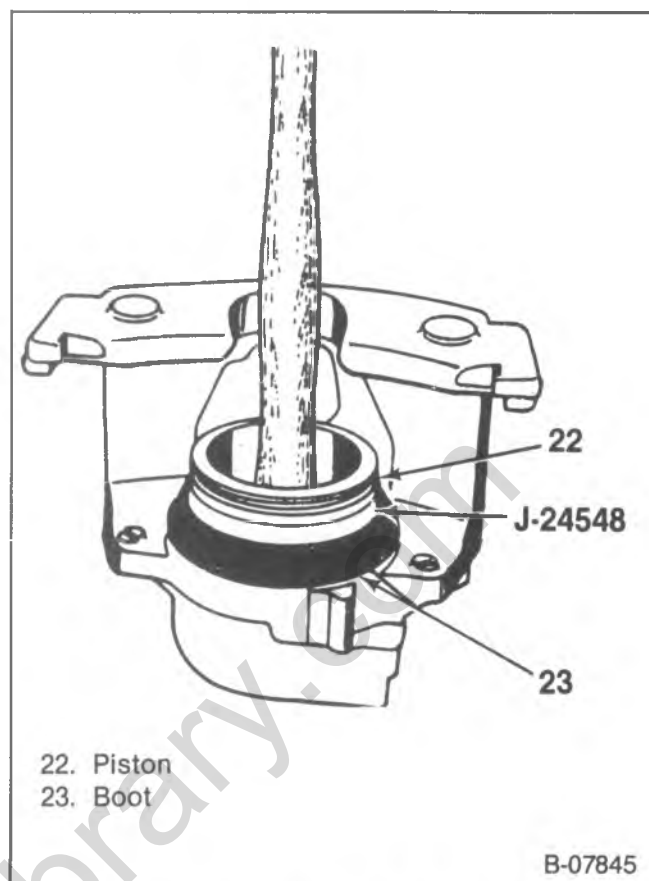

Figure 21—Installing the Piston

3. The large lip of the boot into the groove in the caliper bore.
 - The lip of the boot must be firmly seated in the groove.
4. Piston (22) inside J-24548 (figure 21).
5. Piston half way into its bore.
 - Remove J-24548.
 - Make sure the boot is firmly seated.
6. Bleeder valve (20).

DRUM BRAKES

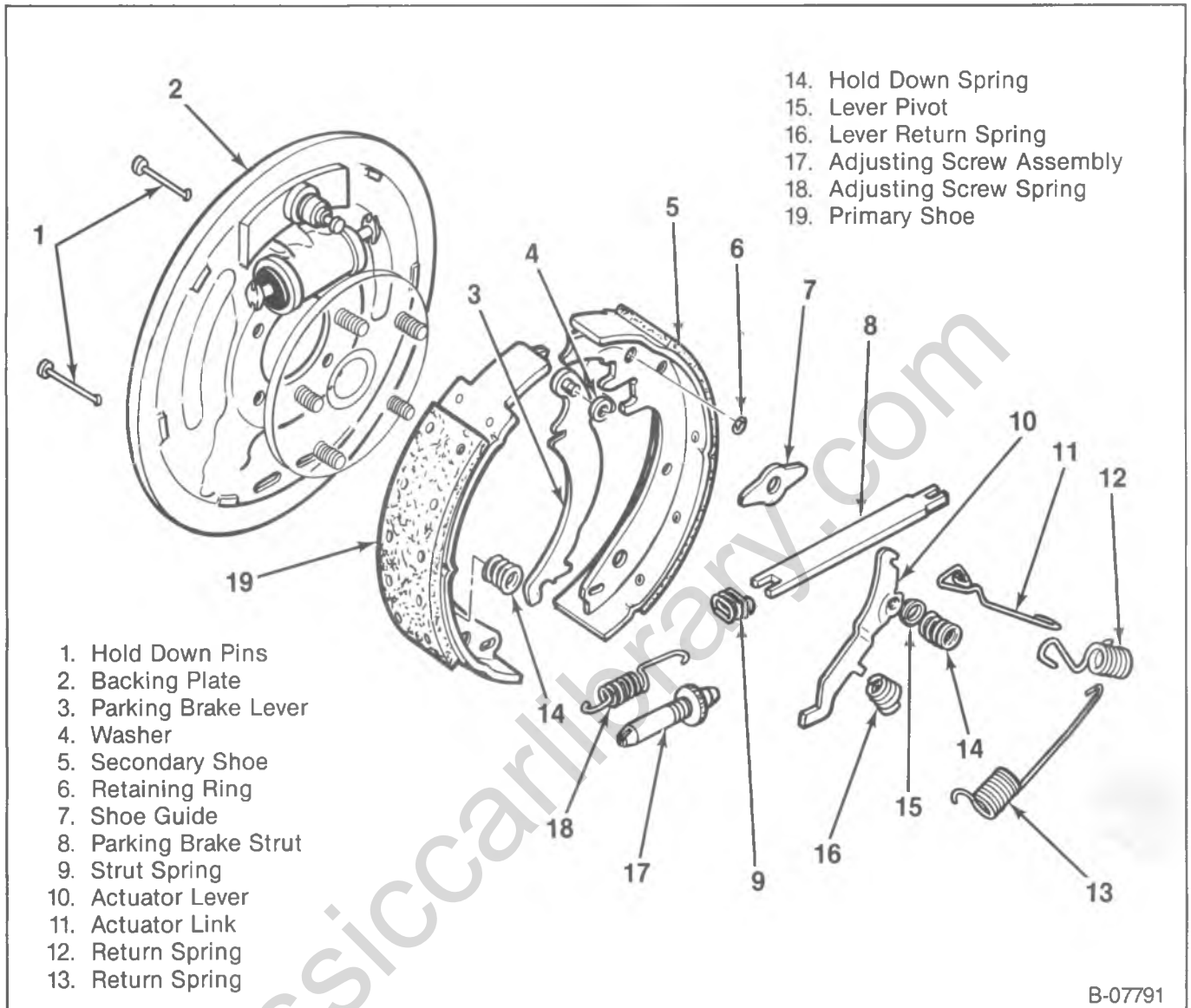

Figure 22—Drum Brake Components

DESCRIPTION

The drum brake assembly is a duo - servo design. With this particular design, the force which is applied by the wheel cylinder to the primary shoe is multiplied by the primary lining friction to provide a large applied force to the secondary shoe. The torque from the brake shoes is transferred to the anchor pin and through the backing plate, to the axle flange. Brake adjustments are automatic and are made during reverse brake applications.

BRAKE LINING REPLACEMENT

↔ Remove or Disconnect (Figure 22)

- Raise the vehicle and support with suitable safety stands.
- Mark the relationship of the wheel to the hub.

1. Wheel and tire assembly, refer to WHEELS AND TIRES (Sec. 3E).

CAUTION: See "Caution" on page 5A2-1 of this section.

2. Drum
 - Mark the relationship of the drum to the axle.
3. Return springs (12 and 13).
4. Shoe guide (7).
5. Hold down springs (14).
6. Hold down pins (1).
7. Actuator lever (10) and lever pivot (15).
8. Lever return spring (16).
9. Activator link (11).
10. Parking brake strut (8).
11. Strut spring (9).
12. Retaining ring (6).
13. Parking brake lever (4) and washer (4).

5A2-10 HYDRAULIC FOUNDATION BRAKES

14. Shoes (5 and 19).
15. Adjusting screw assembly (17).
16. Adjusting screw spring (18).



Important

- Do not interchange right and left adjusting screws.



Inspect

- All parts for discoloration due to heat, or stress. Replace if necessary.
- All parts for signs of wear. Replace if necessary.
- Wheel cylinder for signs of leakage, refer to "Rebuilding The Wheel Cylinder."
- Brake drum for scoring, and machining tolerance, refer to "Servicing The Brake Drum."



Install or Connect (Figure 22)

- Lubricate the shoe pads and adjusting screw threads with a thin coat of white lithium grease.
1. Adjusting screw (17) and adjusting screw spring (18) to both shoes (19 and 5).
 - The coils of the spring must not touch the adjusting screw.
 2. Shoe assembly.
 3. Parking brake lever (3) and washer (4) into the shoe.
 4. Retaining ring (6).
 5. Strut spring (9) onto the parking brake strut (8).
 6. Parking brake strut (8).
 7. Actuator lever (10) and lever pivot (15).
 8. Actuator link (11).
 9. Lever return spring (16).
 10. Hold down pins (1).
 11. Hold down springs (14).
 12. Return springs (12 and 13).
 13. Drum.
 - Align the marks made during disassembly.
 14. Wheel and tire assembly, refer to WHEELS AND TIRES (Sec. 3E).
 - Align the marks made during disassembly.
- Adjust the brakes, refer to "Brake Adjustment" in this section.

SERVICING THE BRAKE DRUM

Whenever the brake drums are removed, they should be thoroughly cleaned and inspected for cracks, scores, deep grooves and out-of-round.

CRACKED, SCORED, OR GROOVED DRUM

A cracked drum is unsafe for further service and must be replaced. Do not attempt to weld a cracked drum.

Smooth up any slight scores. Heavy or extensive scoring will cause excessive brake lining wear, and it will probably be necessary to machine the drum braking surface.

If the brake linings are slightly worn and the drum is grooved, the drum should be polished with fine emery cloth but should not be machined. At this stage, eliminating all the grooves in the drum and smoothing the

ridges on the lining would require the removal of too much metal and lining, while if left alone, the grooves and ridges match and satisfactory service can be obtained.

If brake linings are to be replaced, a grooved drum should be machined. A grooved drum, if used with a new lining, will not only wear the lining, but will make it difficult, if not impossible to obtain efficient brake performance.

OUT-OF-ROUND OR TAPERED DRUM

An out-of-round drum makes accurate brake shoe adjustment impossible and is likely to cause excessive wear of other parts of the brake mechanism due to its eccentric action. An out-of-round drum can also cause severe and irregular tire tread wear as well as a pulsing brake pedal. When the braking surface of a brake drum exceeds the specification limits in taper and/or out-of-round, the drum should be machined to true up the braking surface. Out-of-round as well as taper and wear can be accurately measured with an inside micrometer fitted with proper extension rods.

When measuring a drum for out-of-round, taper and wear, take measurements at the open and closed edges of machined surface and at right angles to each other.

MACHINING THE DRUM

If a drum is to be machined, only enough metal should be removed to obtain a true, smooth braking surface. If a drum does not clean-up when machined to a maximum diameter, it must be replaced. Refer to "Specifications" in this section. Removal of more metal will affect dissipation of heat and may cause distortion of the drum.

All brake drums have a maximum diameter cast into them. This diameter is the maximum wear diameter. Do not machine a brake drum that will not meet the specification. Refer to "Specifications" in this section.

BRAKE ADJUSTMENT

A manual adjustment of the rear brakes is required after the rear linings have been replaced. The front disc brakes require no adjustment.

CAUTION: Refer to "Caution" on page 5A2-1 of this section.

1. Remove the lanced area in the brake backing plate.
 - The metal lanced area must be removed from the brake assembly.



Adjust

- Brake adjusting screw until the wheel can just be turned by hand.
- The brake drag should be equal at both wheels.
- Back off the adjusting screw 33 notches.



Important

- Brakes should have no drag after the screw has been backed off about 15 notches. If a heavy drag is present refer to "Parking Brake Adjustment" in HYDRAULIC BRAKES (SEC. 5A).

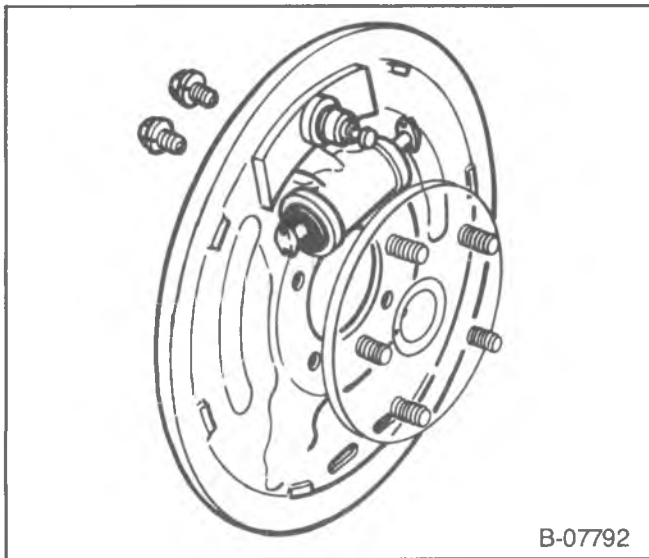

Figure 23—Removing the Wheel Cylinder

2. Install an adjusting hole cover in the brake backing plate.
3. Check parking brake adjustment.

WHEEL CYLINDER REPLACEMENT

↔ Remove or Disconnect (Figure 23)

CAUTION: See "Caution" on page 5A2-1 in this section.

1. Brake linings, refer to "Brake Lining Replacement."
2. Brake pipe.
3. Bolts.
4. Wheel cylinder.

↔ Install or Connect (Figure 23)

1. Wheel cylinder.
2. Bolts.

Tighten

- Bolts to specification.
3. Brake pipe.
 4. Brake linings, refer to "Brake Lining Replacement."
 5. Bleed brake system. Refer to HYDRAULIC BRAKES (SEC. 5A)."

REBUILDING THE WHEEL CYLINDER

↔ Remove or Disconnect (Figure 24)

1. Boots (54).
2. Pistons (53).
3. Seals (52).
4. Spring assembly (55).

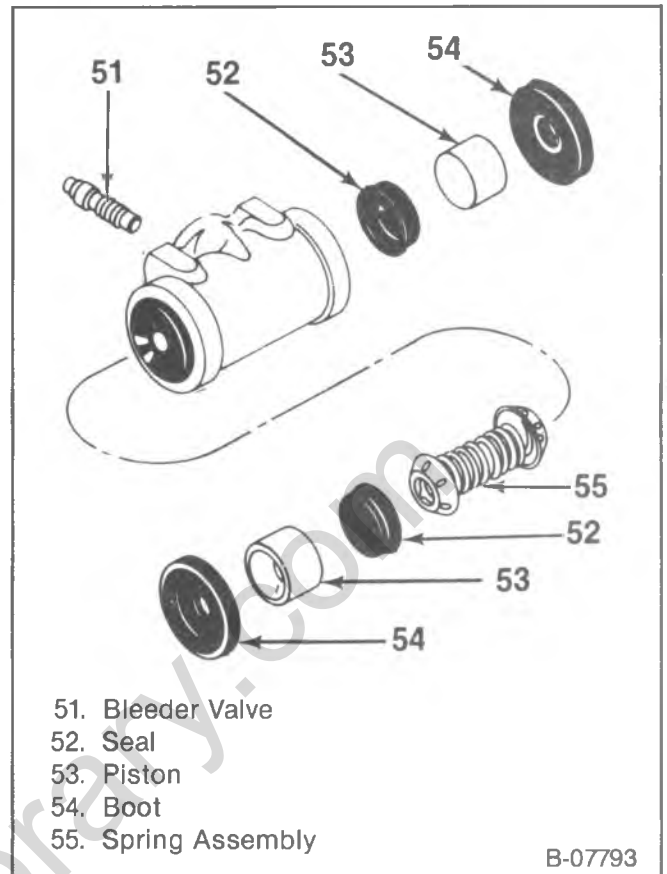

Figure 24—Wheel Cylinder Components

Inspect

- Cylinder bore for scoring and corrosion.
- Spring assembly for signs of discoloration due to heat. Replace if necessary.

Clean

- Inside the cylinder bore with crocus cloth. If the bore is still scored replace cylinder.
- Cylinder with clean brake fluid.

↔ Install or Connect (Figure 24)

- Lubricate seals and cylinder bore with clean brake fluid.
1. Spring assembly (55).
 2. Seals (52).
 3. Pistons (53).
 4. Boots (54).

SPECIFICATIONS

BRAKE SYSTEMS

SYSTEM	FRONT BRAKES	REAR BRAKES	BRAKE ASSIST
GASOLINE ENGINE VEHICLES			
C-MODELS			
JB1 Low Drag	Disc 11.86 x 1.04	Drum 11.0 x 2.00	None (Manual Brakes)
JB3 Low Drag	Disc 11.86 x 1.04	Drum 11.0 x 2.00	Vacuum—Single Diaphragm
G-MODELS			
JB1 Low Drag	Disc 11.86 x 1.29	Drum 11.00 x 2.00	None (Manual Brakes)
JB3 Low Drag	Disc 11.86 x 1.29	Drum 11.00 x 2.00	Vacuum—Single Diaphragm
ALL MODELS			
JB5 Low Drag	Disc 11.86 x 1.29	Drum 11.15 x 2.75	Vacuum—Dual Diaphragm
JB6 Low Drag	Disc 12.50 x 1.28	Drum 11.15 x 2.75	Vacuum—Dual Diaphragm
JB7 Conventional	Disc 12.50 x 1.28	Drum 13.00 x 2.50	Vacuum—Dual Diaphragm
JB8 Conventional	Disc 12.50 x 1.54	Drum 13.00 x 3.50	Hydraulic—Hydro-Boost
JF9 Conventional	Disc 14.25 x 1.54	Disc 13.75 x 1.54	Hydraulic—Hydro-Boost
DIESEL ENGINE VEHICLES			
JD3 Low Drag	Disc 11.86 x 1.29	Drum 11.00 x 2.00	Hydraulic—Hydro-Boost
JD5 Low Drag	Disc 11.86 x 1.29	Drum 11.15 x 2.75	Hydraulic—Hydro-Boost
JD6 Conventional	Disc 12.50 x 1.28	Drum 11.15 x 2.75	Hydraulic—Hydro-Boost
JD7 Conventional	Disc 12.50 x 1.28	Drum 13.00 x 2.50	Hydraulic—Hydro-Boost

DRUM DIAMETERS

ORIGINAL	MAXIMUM REFINISH	REPLACEMENT (DISCARD)
11.000	11.060	11.090
11.150	11.210	11.240
12.000	12.060	12.090
13.000	13.060	13.090

ROTOR THICKNESS

MINIMUM AFTER REFINISHING	REPLACEMENT (DISCARD)
1.480	1.465
1.230	1.215
0.980	0.965

SPECIFICATIONS (CONT.)

TORQUE SPECIFICATIONS

	N·m	Ft. Lbs.
Caliper Mounting Bolt	48	35
Support Plate to Knuckle	16	10
Wheel Cylinder to Flange Plate Bolt (All Except JB5, JB6, JB76, and JB8)	5.5	4
Wheel Cylinder to Flange Plate Bolt (JB5, JB6, JB7 and JB8)	20	15
Rear Brake Anchor Pin (All Except JB7 and JB8)	190	140
Rear Brake Anchor Pin (JB7 and JB8)	312	230
Brake Bleeder Valves	7	5

SPECIAL TOOLS

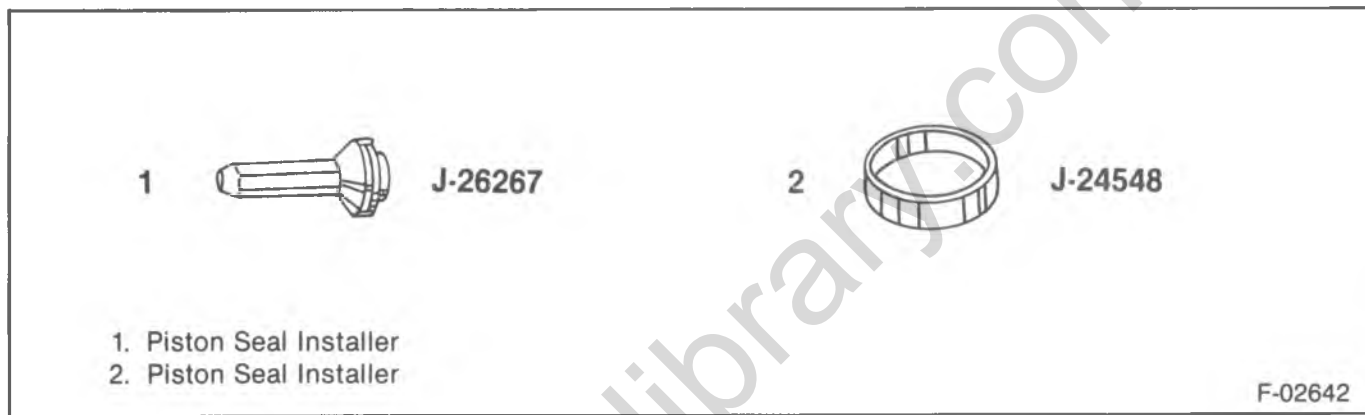

Figure 25—Special Tool Chart

classiccarlibrary.com

SECTION 6

ENGINE

CONTENTS

<u>SUBJECT</u>	<u>PAGE</u>
Engine.....	.6A-1
4.3 Liter V6.....	.6A3-1
Small Block.....	.6A4-1
7.4 Liter V8.....	.6A5-1
6.2 Liter Diesel.....	.6A6-1
4.8 Liter Diesel.....	.6A7-1
Engine Cooling.....	.6B1-1
Radiator.....	.6B2-1
Fuel System.....	.6C-1
Carburetors.....	.6C1-1
Diesel Fuel Injection.....	.6C2-1
Engine Electrical.....	.6D-1
Drivability And Emissions.....	.6E-1
Drivability And Emissions — Carburetor.....	.6E8-1
Drivability And Emissions — Diesel.....	.6E9-1
Exhaust.....	.6F-1
Vacuum Pump.....	.6H-1

GENERAL INFORMATION

Following are brief outlines of the information contained in Section 6. Use them as a guide to help locate information more quickly.

SECTION 6A ENGINE

This section contains information common to all engines, including:

- Use of gasket sealers.
- Diagnosis (for engine mechanical).
- Compression check procedure.

SECTIONS 6A3 THROUGH 6A7 4.3L V6, SMALL BLOCK, 7.4L V8, 6.2L DIESEL, 4.8L L6

These sections contain information for “on-vehicle” servicing of the basic engine, such as manifold, cylinder head, camshaft, and piston replacement.

Detailed repair information on components such as oil pump, cylinder head, etc. is not included. Refer to the “Light Duty Truck Unit Repair Manual” for this information.

SECTION 6B1 ENGINE COOLING

This section has information on cooling system components, including:

- Diagnosis
- Water Pump
- Fan and Fan Clutch
- Auxiliary Fan
- Belts
- Thermostat.

SECTION 6B2 RADIATORS

This section contains information on radiators and shrouds, including aluminum radiator repair procedures.

SECTION 6C FUEL SYSTEM

This section contains information on fuel system components, including:

- Accelerator controls
- Fuel tanks
- Air cleaners
- Fuel filters (carbureted vehicles)
- Fuel pump (carbureted vehicles)
- Fuel tank sending unit (carbureted vehicles)

6-2 ENGINE

- For fuel filter, pump, and sending unit information on TBI equipped vehicles, refer to the "Fuel and Emissions Service Manual."

SECTION 6C1 CARBURETORS

This section contains information for carburetor "on-vehicle" service and adjustments. For overhaul information, refer to the "Light Duty Truck Unit Repair Manual."

SECTION 6C2 DIESEL FUEL INJECTION

This section contains information on the fuel injection system used on 6.2L diesel engines, including:

- Timing adjustment and other adjustment procedures.
- Injection nozzle replacement and testing.
- Injection pump replacement and repairs.

SECTION 6D ENGINE ELECTRICAL

This section contains information on electrical components associated with engine operation, including:

- Spark plug wires
- Block heaters
- Battery
- Glow plug system
- Starters
- Generators
- Distributors.

"On-vehicle" service procedures are given. For overhaul information, refer to the "Light Duty Truck Unit Repair Manual."

SECTIONS 6E AND 6E8 EMISSIONS AND DRIVEABILITY AND EMISSIONS (CARBURETED)

This section contains information on the emissions systems on carbureted engines, including diagnosis and component replacement. For information on TBI emissions systems, refer to the "Fuel and Emissions Service Manual."

SECTION 6E9 DRIVEABILITY AND EMISSIONS (DIESEL)

This section contains information on the emissions systems of 6.2L diesel engines, including component repair. Driveability diagnosis can be found in ENGINE (SEC. 6A).

SECTION 6F EXHAUST

This section contains information on the exhaust system, including component replacement.

SECTION 6H VACUUM PUMPS

This section contains information on vacuum pumps, including replacement procedures and diagnosis.

SECTION 6A

ENGINE

CONTENTS

<u>SUBJECT</u>	<u>PAGE</u>
General Information6A- 1
Statement on Cleanliness and Care6A- 1
Tune-Up Information6A- 2
Use of RTV Sealer and Anaerobic Gasket Eliminator6A- 2
Replacing Engine Gaskets6A- 2
Gasoline Engine Mechanical Diagnosis6A- 2
Gasoline Engine Compression Check6A- 5
Diagnosis of Hydraulic Lifters6A- 6
Diagnosis of Diesel Engine6A- 8
Compression Check (6.2L Diesel Engine)6A-10
Cranking Speed Check (6.2L Diesel Engine)6A-10
Special Tools6A-11

All new General Motors vehicles are certified by the United States Environmental Protection Agency as conforming to the requirements of the regulations for the control of air pollution from new motor vehicles. This certification is contingent on certain adjustments being set to factory standards. In most cases, these adjustment points either have been permanently sealed and/or made inaccessible to prevent indiscriminate or routine adjustment in the field. For this reason, the factory procedure for temporarily removing plugs, caps, etc., for purposes of servicing the product must be strictly followed and, wherever practicable, returned to the original intent of the design. For vehicles sold in Canada and equipped with non-closed loop engines, also refer to the appropriate Canadian service manual supplement.

GENERAL INFORMATION

STATEMENT ON
CLEANLINESS AND CARE

- An engine is a combination of many machined, honed, polished and lapped surfaces with very fine tolerances.
- Whenever valve train components, cylinder head, cylinder, crankshaft, or connecting rod components are removed for service, they should be retained in order. At the time of installation, they should be installed in the same locations and with the same mating surfaces as when removed.
- Any time air cleaner, carburetor, or TBI unit is removed, the intake opening must be covered. If a diesel engine is being serviced, the recommended cover (J-29664-2 or J-26996-1) should be used. This will protect against the entrance of foreign material which could follow the intake passage into the cylinder and cause extensive damage when the engine is started.
- When any internal engine parts are serviced, care and cleanliness are important. A liberal coating of engine oil should be applied to friction areas during assembly to protect and lubricate the surfaces on initial operation. Throughout this section, it should be understood that proper cleaning and protection of machined surfaces and friction areas is part of the repair procedure. This is considered standard shop practice even if not specifically stated.
- On diesel engines, whenever the fuel injection pump or lines are removed or disconnected, care must be taken to prevent the entry of dirt into the pump, lines, and injectors. The entry of even small amount of dirt or other foreign material into the fuel injection system may cause serious damage.
- It should be kept in mind, while working on the engine, that the 12-volt electrical system is capable of violent and damaging short circuits. When performing any work where electrical terminals could possibly be grounded, the ground cable of the battery should be disconnected at the battery.
- Battery cables should be disconnected before any major work is performed on the engine. Failure to disconnect cables may result in damage to wire harness or other electrical parts.
- Cover or otherwise protect exposed electrical connections to prevent damage from oil and fuel.
- When raising or supporting the engine for any reason, do not use a jack under the oil pan. Due to the small clearance between the oil pan and the oil pump screen, jacking against the oil pan may cause it to be bent against the pump screen resulting in a damaged oil pickup unit.

TUNE-UP INFORMATION

All information required to tune up the vehicle's engine is given in the Engine Emission Control Label. This label is located in the engine compartment.

Information that can be found on the label includes:

- Spark plug type and gap.
- Ignition timing.
- Valve lash (if applicable).
- Idle, fast idle, and solenoid screw speeds, as applicable.
- The proper sequence for making the adjustments.
- Emission hose routing diagram (sometimes on a separate label).

USE OF RTV SEALER AND ANAEROBIC GASKET ELIMINATOR

Two types of sealer are commonly used in engines covered by this manual. These are RTV sealer and anaerobic "gasket eliminator" sealer.

It is important that these sealers be applied properly and in the proper place to prevent oil leaks. **THE TWO TYPES OF SEALER ARE NOT INTERCHANGEABLE.** Use the sealer recommended in the procedure.

- RTV (room temperature vulcanizing) sealer is used where a non-rigid part is assembled to a rigid part. Common examples are oil pans and rocker arm covers.
- Anaerobic gasket eliminator hardens in the absence of air. This sealer is used where two rigid parts (such as castings) are assembled together. When two rigid parts are disassembled and no sealer or gasket is readily noticeable, the parts were probably assembled using gasket eliminator.

USING RTV SEALER

1. Don't use RTV when extreme temperatures are expected, such as exhaust manifold, head gasket or where gasket eliminator is specified.

GASOLINE ENGINE MECHANICAL DIAGNOSIS

The following information pertains to the basic assembly only. For more diagnosis information, refer to the following:

- Overheating or other cooling system problems: Refer to COOLING (SEC. 6B).

2. When separating components sealed with RTV, use a rubber mallet and "bump" the part sideways to shear the RTV sealer. "Bumping" should be done at bends or reinforced areas to prevent distortion of parts. RTV is weaker in shear (lateral) strength than in tensile (vertical) strength.

Attempting to pry or pull components apart may result in damage to the part.

3. Surfaces to be resealed must be clean and dry. Remove all traces of oil and RTV. Clean with a chlorinated solvent such as carburetor spray cleaner. Don't use petroleum cleaners such as mineral spirits; they leave a film onto which RTV won't stick.
4. Apply RTV to one of the clean surfaces. Use a bead size as specified in the procedure. Run the bead to the inside of any bolt holes. Do not allow the sealer in any blind threaded holes, as it may prevent the bolt from seating properly or cause damage when the bolt is tightened.
5. Assemble while RTV is still wet (within 3 minutes). Don't wait for RTV to skin over.
6. Torque bolts to specifications. Don't over-torque.

USING ANAEROBIC GASKET ELIMINATOR

1. Clean surfaces to be resealed with a chlorinated solvent to remove all oil, grease and old material.
2. Apply a continuous bead of gasket eliminator to one flange.
3. Spread bead evenly with your finger to get a uniform coating on the complete flange.
4. Assemble parts in the normal manner and torque to specifications.

REPLACING ENGINE GASKETS

CAUTION: Composite type gaskets are used in some areas of the engine assembly. These gaskets have a thin metal core. Use caution when removing or handling composite gaskets to help avoid personal injury.

- Cranking and ignition system problems: Refer to ENGINE ELECTRICAL (SEC. 6D).
- Starting, driveability, fuel economy, etc. problems: Refer to DRIVEABILITY AND EMISSIONS (SEC. 6E) for carbureted engines, or to the "Fuel and Emissions Service Manual" for TBI engines.

GASOLINE ENGINE MECHANICAL DIAGNOSIS (CONT.)

PROBLEM	POSSIBLE CAUSE	CORRECTION
Engine Will Not Turn Over	<ol style="list-style-type: none"> 1. Battery, cranking system or other electrical problem. 2. Liquid in combustion chamber. 3. Seized engine. 	<ol style="list-style-type: none"> 1. Refer to ENGINE ELECTRICAL (SEC. 6D). 2. Remove with suction gun. 3. Repair.
Engine Cranks Normally But Does Not Start	<ol style="list-style-type: none"> 1. Fuel or ignition system problem. 2. Restricted exhaust system. 3. Low compression due to stuck or burned valves, stuck rings, blown head gasket, etc. 	<ol style="list-style-type: none"> 1. Refer to DRIVEABILITY AND EMISSIONS (SEC. 6E) (carbureted engines) or "Fuel and Emissions Service Manual" (TBI engines) and ENGINE ELECTRICAL (SEC. 6D). 2. Repair. 3. Perform a compression test, as outlined in this section. Repair engine as necessary.
Rough Idle	<ol style="list-style-type: none"> 1. Fuel, ignition system or emissions system problem. 2. Uneven cylinder compression. 3. Bent pushrod or broken valve spring. 4. Faulty engine mount. 	<ol style="list-style-type: none"> 1. Refer to DRIVEABILITY AND EMISSIONS (SEC. 6E) (carbureted engines) or "Fuel and Emissions Service Manual" (TBI engines) and ENGINE ELECTRICAL (SEC. 6D). 2. Perform a compression test, as outlined in this section. Repair engine as necessary. 3. Repair. 4. Repair or replace.
White Smoke	Usually caused by water vapor, which is a normal byproduct of combustion. Usually seen on cold days.	None required.
Black Smoke	Usually caused by rich fuel mixture.	Refer to FUEL SYSTEM (SEC. 6C) and/or DRIVEABILITY AND EMISSIONS (SEC. 6E) (carbureted engines) or "Fuel and Emissions Service Manual" (TBI engines).
Blue Smoke	Usually caused by oil burning in the combustion chambers.	Refer to Excessive Oil Loss diagnosis.
Excessive Oil Loss	<ol style="list-style-type: none"> 1. External oil leaks. 2. Improper reading of dipstick. 3. Improper oil viscosity. 4. Continuous high speed driving and/or severe usage. 5. Crankcase ventilation or PCV system malfunctioning. 6. Valve guides and/or valve stem seals worn, or seals missing. 7. Piston rings not seated. 8. Broken or worn piston rings. 9. Piston improperly installed. 	<ol style="list-style-type: none"> 1. Tighten bolts and/or replace gaskets and seals as necessary. 2. Check oil with vehicle on a level surface and allow adequate drain down time. 3. Use recommended viscosity for prevailing temperatures. 4. Continuous high speed operation and/or severe usage will normally cause decreased oil mileage. 5. Service as necessary. 6. Ream guides and install oversize service valves and/or new valve stem seals. 7. Allow adequate time for rings to seat. 8. Replace broken or worn rings as necessary. 9. Replace piston or repair as necessary.

GASOLINE ENGINE MECHANICAL DIAGNOSIS (CONT.)

PROBLEM	POSSIBLE CAUSE	CORRECTION
Low Oil Pressure	<ol style="list-style-type: none"> 1. Slow idle speed. 2. Incorrect or faulty oil pressure switch or sensor. 3. Incorrect or faulty oil pressure gage. 4. Improper oil viscosity. 5. Diluted engine oil 6. Oil pump worn or dirty. 7. Plugged oil filter 8. Oil pickup screen loose or plugged. 9. Hole in oil pickup tube. 10. Excessive bearing clearance. 11. Cracked, porous or plugged oil galleys. 12. Galley plugs missing or mis-installed. 	<ol style="list-style-type: none"> 1. Set idle speed to specifications. 2. Replace with proper switch or sensor. 3. Replace with proper gage. 4. Replace with proper oil. 5. Change engine oil and filter. Repair cause of dilution (rich mixture, etc.) 6. Clean pump and replace worn parts as necessary. 7. Replace filter and oil. 8. Clean or replace screen as necessary. 9. Replace tube. 10. Replace as necessary. 11. Repair or replace block. 12. Install plugs or repair as necessary.
Valve Train Noise	<ol style="list-style-type: none"> 1. Low oil pressure. 2. Loose rocker arm attachments. 3. Worn rocker arm and/or pushrod. 4. Broken valve spring. 5. Sticking valves. 6. Lifters worn, dirty or faulty. 7. Camshaft worn or faulty. 8. Worn valve guides. 	<ol style="list-style-type: none"> 1. Repair as necessary. (See diagnosis for low oil pressure). 2. Inspect and repair as necessary. 3. Replace as necessary. 4. Replace spring. 5. Free valves. 6. Refer to "Diagnosis of Hydraulic Lifters." 7. Replace camshaft. 8. Repair as necessary.
Engine Knocks Cold And Continues For Two To Three Minutes. Knock Increases With Torque.	<ol style="list-style-type: none"> 1. EFE equipped engines may have valve knock. 2. Flywheel contacting splash shield. 3. Loose or broken torsional damper or drive pulleys. 4. Excessive piston to bore clearance. 5. Bent connecting rod. 	<ol style="list-style-type: none"> 1. Replace EFE valve. 2. Reposition splash shield. 3. Tighten or replace as necessary. 4. Replace piston. 5. Replace connecting rod.
Engine Has Heavy Knock Hot With Torque Applied.	<ol style="list-style-type: none"> 1. Broken balancer or pulley hub. 2. Loose torque converter bolts. 3. Accessory belts too tight or nicked. 4. Exhaust system grounded. 5. Flywheel cracked or loose rivets on flywheel. 6. Excessive main bearing clearance. 7. Excessive rod bearing clearance. 	<ol style="list-style-type: none"> 1. Replace parts as necessary. 2. Tighten bolts. 3. Replace and/or tension to specs as necessary. 4. Reposition as necessary. 5. Replace flywheel. 6. Repair as necessary. 7. Repair as necessary.
Engine Has Light Knock Hot In Light Load Conditions.	<ol style="list-style-type: none"> 1. Faulty EST or ESC system. 2. Improper timing. 3. Poor quality fuel. 4. Loose torque converter bolts. 5. Exhaust leak at manifold. 6. Excessive rod bearing clearance. 	<ol style="list-style-type: none"> 1. Refer to DRIVEABILITY AND EMISSIONS (SEC. 6E) (carbureted engines) or "Fuel and Emissions Service Manual" (TBI engines). 2. Adjust to specifications. 3. Use fuel of recommended grade. 4. Tighten bolts. 5. Tighten bolts and/or replace gaskets. 6. Replace bearings as necessary.

GASOLINE ENGINE MECHANICAL DIAGNOSIS (CONT.)

PROBLEM	POSSIBLE CAUSE	CORRECTION
Engine Knocks On Initial Start Up But Only Lasts A Few Seconds.	<ol style="list-style-type: none"> 1. Fuel pump. 2. Improper oil viscosity. 3. Hydraulic lifter bleed down. 	<ol style="list-style-type: none"> 1. Replace pump. 2. Install proper oil viscosity for expected temperatures. 3. Refer to "Diagnosis of Hydraulic Lifters."
Engine Knocks At Idle Hot	<ol style="list-style-type: none"> 1. Loose or worn drive belts. 2. Compressor generator bearing. 3. Fuel pump. 4. Valve train. 5. Improper oil viscosity. 6. Excessive piston pin clearance. 7. Connecting rod alignment. 8. Insufficient piston to bore clearance. (Cold engine piston knock usually disappears when the cylinder's spark plug is grounded out. Cold engine piston knock which disappears in 1.5 minutes should be considered acceptable.) 9. Loose torsional damper. 	<ol style="list-style-type: none"> 1. Tension and/or replace as necessary. 2. Replace as necessary. 3. Replace pump. 4. Refer to "Valve Train Noise." 5. Install proper viscosity oil for expected temperature. 6. Install new piston, pin and/or connecting rod as needed. 7. Check and replace rods as necessary. 8. Hone and fit new piston, if required. 9. Torque any or replace worn parts.

GASOLINE ENGINE COMPRESSION CHECK

GASOLINE ENGINE COMPRESSION CHECK

1. Disconnect the primary lead from the distributor or ignition coil. Refer to ENGINE ELECTRICAL (SEC. 6D).
2. Remove all spark plugs.
3. Block the throttle plate and choke plate (if used) wide open.
4. Make sure the battery is fully charged.
5. Starting with the compression gage at zero, crank the engine through four compression strokes (four "puffs").
6. Make the compression check at each cylinder and record each reading.
7. If some cylinders have low compression, inject about 15 ml. (one tablespoon or about 3 squirts from a pump type oil can) of engine oil into the combustion chamber through the spark plug hole.
8. Minimum compression recorded in any one cylinder should not be less than 70 per cent of highest cylinder, and no cylinder should read less than 690 kPa (100 psi). For example, if the highest pressure in any one cylinder is 1035 kPa (150 psi), the lowest allowable pressure for any other cylinder would be 725 kPa (105 psi). ($1035 \times 70\% = 725$) ($150 \times 70\% = 105$).
 - Normal — Compression builds up quickly and evenly to specified compression on each cylinder.
 - Piston Rings Leaking — compression low on first stroke tends to build up on following strokes but does not reach normal. Improves considerably with addition of oil.
 - Valves Leaking — Low on first stroke. Does not tend to build up on following strokes. Does not improve much with addition of oil.
 - If two adjacent cylinders have lower than normal compression, and injecting oil into cylinders does not increase the compression, the cause may be a head gasket leak between the cylinders.

DIAGNOSIS OF HYDRAULIC LIFTERS

PROBLEM	POSSIBLE CAUSE	CORRECTION
Momentarily Noisy When Engine Is Started	This condition is normal. Oil drains from the lifters which are holding the valves open when the engine is not running. It will take a few seconds for the lifter to fill after the engine is started.	None needed.
Intermittently Noisy On Idle Only, Disappearing When Engine Speed Is Increased	<ol style="list-style-type: none"> 1. Dirt in hydraulic lifter. 2. Pitted or damaged check ball. 	<ol style="list-style-type: none"> 1. Disassemble and clean. 2. Replace the hydraulic lifter.
Noisy At Slow Idle Or With Hot Oil; Quiet At Higher Engine Speeds Or With Cold Oil	High leak down rate.	Replace the hydraulic lifter.
Noisy At High Vehicle Speeds, Quiet At Low Speeds	<ol style="list-style-type: none"> 1. High oil level — Oil level above the "Full" mark allows crankshaft counterweights to churn the oil into foam. When foam is pumped into the lifters, they will become noisy since a solid column of oil is required for proper operation. 2. Low oil level — Oil level below the "Add" mark allows the oil pump to pump air at high speeds which results in noisy lifters. 3. Oil pan bent against oil pump pickup screen. 4. Oil pump screen bent or loose. 	<ol style="list-style-type: none"> 1. Drain oil to proper level. 2. Add oil as needed. 3. Repair. 4. Repair.
Noisy At Idle, Becoming Louder As Engine Speed Is Increased To 1500 RPM	<ol style="list-style-type: none"> 1. This noise is not connected with lifter malfunction. It becomes most noticeable in the vehicle at 10 to 15 mph "L" (Low) range, or 30 to 35 mph "D" (Drive) range and is best described as a "hashy" sound. At slow idle, it may be entirely gone or appear as a light ticking noise in one or more valves. It is caused by one or more of the following: <ul style="list-style-type: none"> • Badly worn or scuffed valve tip and rocker arm pad. • Excessive valve stem to guide clearance. • Excessive valve seat runout. • Off square valve spring. • Excessive valve face runout. • Valve spring damper clicking on rotator. 	<ol style="list-style-type: none"> 1. Repair as necessary.

DIAGNOSIS OF HYDRAULIC LIFTERS (CONT.)

PROBLEM	POSSIBLE CAUSE	CORRECTION
Noisy At Idle, Becoming Louder As Engine Speed Is Increased To 1500 RPM (Continued)	2. Off square valve spring. Occasionally this noise can be eliminated by rotating the valve spring and valve. Crank engine until noisy valve is off its seat. Rotate spring. This will also rotate valve. Repeat until valve becomes quiet. If correction is obtained, check for an off square valve spring.	2. If the valve spring is more than 1.6mm (1/16-inch) off square, it should be replaced.
Noisy Regardless Of Engine Speed	1. Incorrect valve adjustment (excessive lash) (engines with adjustable valve lash). 2. Excessive valve lash. Check for valve lash by turning the engine so the piston in that cylinder is on TDC of the firing stroke. If valve lash is present, the pushrod can be freely moved up and down a certain amount with rocker arm held against valve. Excessive lash can be caused by: a. Worn pushrod upper end ball. b. Bent pushrod. c. Improper lubrication of the pushrod. d. Loose or damaged rocker arm. e. If pushrod and rocker arm are OK, trouble in the hydraulic lifter is indicated.	1. Adjust as specified. 2. Repair engine as needed. a. Replace pushrod and rocker arm. b. Replace pushrod. c. Replace pushrod and rocker arm. Check lubrication system feed to the pushrod. d. Replace rocker arm. e. Replace hydraulic lifter.

DIAGNOSIS OF DIESEL ENGINE

MOST LIKELY/POSSIBLE CAUSES

X = LIKELIEST CAUSES
• = POSSIBLE CAUSES

- SYMPTOMS**
- LOW/LOSS OF POWER
 - HARD TO START
 - WILL NOT START
 - WILL NOT START-HOT
 - ENGINE STARTS, THEN STALLS
 - ENGINE MISFIRE OR BACKFIRES
 - ROUGH/ERRATIC IDLE
 - ENGINE WON'T SHUT-OFF
 - ENGINE ACCELERATION
 - ENGINE SPEED FLUCTUATES
 - EXCESSIVE WHITE SMOKE
 - BLACK SMOKE AT LOAD (HOT)
 - EXCESSIVE ACCELERATION SMOKE
 - GREY SMOKE
 - BLUE SMOKE
 - EXCESSIVE LUBE OIL CONSUMPTION
 - EXCESSIVE FUEL CONSUMPTION
 - FUEL OR LUBE OIL LEAKS
 - LUBE OIL CONTAMINATED
 - COOLANT CONTAMINATED
 - HIGH COOLANT TEMPERATURE
 - NO HEAT FROM HEATER
 - CRANKCASE TEMPERATURE
 - LOW OIL SLUDGE
 - HIGH OIL PRESSURE
 - HIGH INLET RESTRICTION
 - MECHANICAL KNOCKS
 - FUEL INJECTION PRESSURE
 - EXCESSIVE ENGINE VIBRATION
 - SETTLE ENGINE COMPONENT
 - LOW CYLINDER COMPRESSION
 - ALL (1) OR MORE PLUGS FAILED
 - RELAY WILL NOT CYCLE-GLOW PLUGS D.K.
 - GLOW PLUG SYSTEM AND LIGHT INOP
 - WATER IN FUEL LIGHT DOWNLINKS

MECHANICAL/MAINTENANCE	1	2	3	4	5	6	7	8	9	10	11	12	13	14	15	16	17	18	19	20	21	22	23	24	25	26	27	28	29	30	31	32	33	34	35	36	37	38	39	40	
GASKET BLOW-BY OR SEAL LEAKAGE		•									•					•	•	•				X	•		X				•												
FAULTY DAMPER/FLYWHEEL BALANCE																																									
VALVE LEAKAGE		•	•	•	•		•				•		•		•		•	•											•												
BROKEN, SCORED OR WORN PISTONS/RINGS		•	•	•			•				•		•		•		•	•											•												
INCORRECT MAIN OR ROD BEARING CLEARANCE																													•												
DAMAGED CRANKSHAFT OR MAIN/ROD BEARINGS							•																																		
DAMAGED/WORN CAMSHAFT LOBES		•	•										•																												
FAULTY LIFTER OR GUIDE PLATE		•					•						•																												
FAULTY PUSHROD OR ROCKER ARM		•					•						•																												
WORN/MISALIGNED TIMING GEARS, CHAIN OR KEY(S)							•						•																												
LOW CYLINDER COMPRESSION (380 PSI MIN.)		•	•	X	•		•						•																												
OIL CHANGE INTERVAL																		•																							
EXTERNAL INJECTION PUMP THROTTLE LINKAGE									•																																
TIMING RETARDED		•	•				•					X																													
TIMING ADVANCED		•					•						X	•																			X								
STARTER CRANKING SPEED/BATTERIES (180 RPM MIN.)				•	X	•																																			
ENGINE MOUNTS/BOLTS OR FUEL LINE/OIL FILL TUBE CLAMPS																																									
LONG IDLE PERIODS											•		•																												
CRACKED CYLINDER HEAD OR WALL																																									
MISSING PRECHAMBER(S)		•					•																																		
ENGINE OVERLOADED/EXCESSIVE SPEED		•															X	X																							
IMPROPER STARTING PROCEDURES			•																																						
DEBRIS/FLUID IN CYLINDER(S)																																									
ELECTRICAL/EMISSIONS																																									
INOPERATIVE GLOW PLUGS			•		X			•																																	
FAULTY GLOW PLUG CONTROLLER/IP WIRE GROUNDS																																							X		
FAULTY ALTERNATOR DIODE/STARTER MOTOR WIRE CONNECTIONS																																								•	
INOPERATIVE GLOW PLUG CONTROLLER/RELAY			•																																					•	
SHORTED OR OPEN GLOW PLUG INHIBITOR SWITCH																																								•	
NO VOLTAGE TO CONTROLLER (KEY ON)																																								•	
EGR VALVE STUCK OPEN			•										•																												•
EPR VALVE STUCK CLOSED			•										•																												•
FAULTY EGR/EPR SOLENOIDS, ECM, OR MAP SENSOR			•										•																												•
MISADJUSTED OR FAULTY THROTTLE POSITION SWITCH													•																												•
HOUSING PRESSURE COLD ADVANCE SOLENOID OR SWITCH													•																												•
FAULTY CRANKCASE DEPRESSION REGULATOR (CDRI) VALVE					•	•							X																											•	
CRANKCASE DEPRESSION SYSTEM HOSE CONNECTIONS																																									•
MISADJUSTED OR FAULTY VACUUM REGULATOR VALVE																																									•
TRANSMISSION CONVERTER DOES NOT APPLY																																									•
FAULTY VACUUM PUMP (21" HG MIN.)																																								•	
FAULTY ENGINE SPEED SENSOR																																								•	
AIR SYSTEM																																									
RESTRICTED AIR INTAKE DUCTING OR MANIFOLD		X	•																																						•
HIGH EXHAUST BACK PRESSURE		•																																							•
THIN AIR IN HOT WEATHER OR HIGH ALTITUDE		•																																							•
PLUGGED AIR FILTER		X	•											X																											•
LOW AMBIENT TEMPERATURE						•																																			•
HIGH AMBIENT TEMPERATURE		•																																							•

B-07943

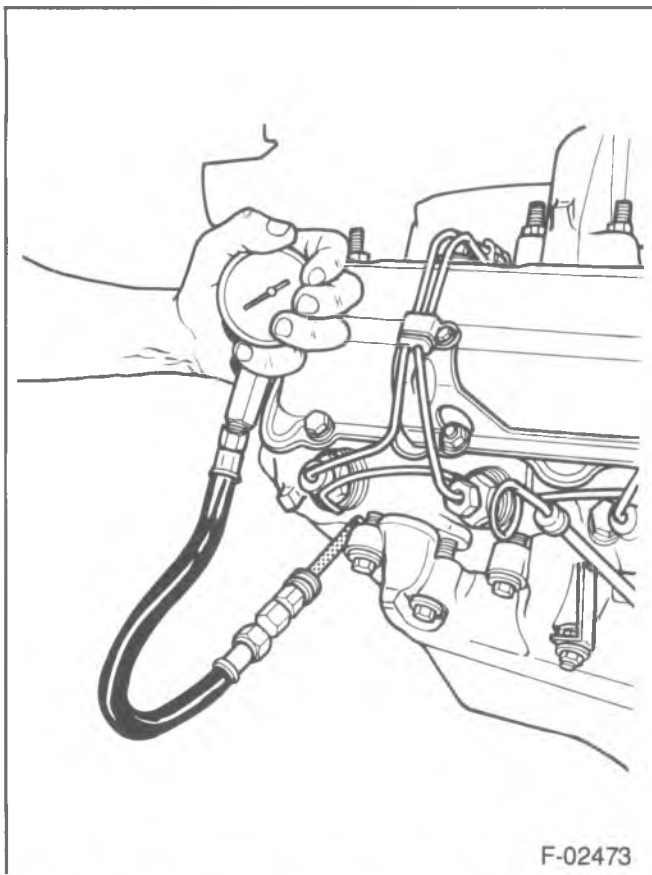

Figure 1—Checking Diesel Engine Compression

COMPRESSION CHECK (6.2L DIESEL ENGINE)

Tools Required:

J-29664-2 or J-26996-1 Intake Manifold Cover
J-26999-10 Compression Gage Adapter

1. Remove the air cleaner. Install J-29664-2 or J-26996-1 over the mouth of the intake manifold.
2. Disconnect the wire from the fuel solenoid terminal of the injection pump.
3. Disconnect wires from glow plugs then remove all glow plugs.
4. Screw J-26999-10 into the glow plug hole of the cylinder that is being checked. Connect to a suitable compression gage (figure 1).
5. Make sure the batteries are fully charged, and the engine is fully warmed up (engine oil hot).

6. Crank the engine. Allow six "puffs" per cylinder.
7. Make the compression check at each cylinder and record the readings.

NOTICE: Do not add oil to any cylinder during a compression test as extensive engine damage can result.

8. The lowest reading cylinder should not be less than 80 percent of the highest reading cylinder. No cylinder should read less than 2625 kPa (380 psi).
 - Normal: Compression builds up quickly and evenly to specified compression on each cylinder. Reading should be in the 2625-2760 kPa (380-400 psi) range.
 - Leaking: Compression low on first stroke tends to build up on following strokes but does not reach normal.

CRANKING SPEED CHECK (6.2L DIESEL ENGINE)

Tool Required:

J-26999-10 Compression Gage

Cranking speed is critical for a diesel to start, either hot or cold. Some tachometers are not accurate at cranking speed. An alternate method of checking cranking speed or determining the accuracy of a tachometer follows:

1. Connect J-26999-10 to any cylinder.
2. Disconnect the injection pump fuel solenoid lead on the top of the injection pump.
3. Install the digital tachometer to be checked (if desired).
4. Depress the pressure release valve on the compression gage.
5. With the aid of an assistant, crank the engine for 2 or 3 seconds to allow the starter to reach full speed, then without stopping, count the number of "puffs" at the compression gage that occur in the next 10 seconds. Multiply the number of "puffs" in the 10 second period by 12 and the resulting number will be the cranking speed in revolutions per minute (RPM).

Example:

10 seconds = 1/6 of a minute
1 puff = 2 RPM
RPM = No. of puffs x 2 x 6 or
RPM = No. of puffs x 12

Minimum cranking speed on the 6.2L diesel engine is 100 RPM cold and 180 RPM hot. The actual cranking speed needed will vary depending on the condition of the engine (compression) and nozzles.

SPECIAL TOOLS

1.



J-26999-10

2.



J-29664

1. Compression Gauge Adapter (6.2L Engines)
2. Manifold Cover Set (6.2L Engines)

B-07603

classiccarylbrary.com

classiccarlibrary.com

SECTION 6A3

4.3 LITER V6

The following "Notice" applies to one or more steps in the assembly procedure of components in this portion of the manual as indicated at appropriate locations by the terminology "NOTICE: See 'Notice' on page 6A3-1 of this section."

NOTICE: All engine fasteners are important attaching parts in that they could affect the performance of vital components and systems, and/or could result in major repair expense. They must be replaced with one of the same part number or with an equivalent part if replacement becomes necessary. Do not use a replacement part of lesser quality or substitute design. Torque values must be used as specified during reassembly to assure proper retention of this part.

CONTENTS

SUBJECT	PAGE
Description6A3- 2
Engine Lubrication6A3- 2
On-Vehicle Service6A3- 5
Rocker Arm Cover Replacement6A3- 5
Rocker Arm and Pushrod Replacement6A3- 5
Valve Adjustment6A3- 6
Valve Stem Seal and Valve Spring Replacement6A3- 6
Intake Manifold Replacement6A3- 7
Hydraulic Lifter Replacement6A3- 9
Rocker Arm Stud Replacement6A3-10
Exhaust Manifold Replacement6A3-11
Cylinder Head Replacement6A3-12
Torsional Damper And Front Crankshaft Seal Replacement6A3-13
Front Cover Replacement6A3-14
Oil Pan Replacement6A3-15
Oil Pump Replacement6A3-15
Rear Crankshaft Oil Seal Replacement6A3-16
Rear Crankshaft Oil Seal Retainer Replacement6A3-16
Measuring Camshaft Lobe Lift6A3-17
Camshaft Replacement6A3-17
Connecting Rod And Piston Replacement6A3-20
Main Bearing Replacement6A3-22
Oil Filter Adapter And Oil Filter Bypass Valve Replacement (Models With Engine Oil Cooler)6A3-23
Crankshaft Replacement6A3-23
Flywheel Replacement6A3-23
Engine Mountings6A3-23
Engine Replacement6A3-24
Specifications6A3-28
Special Tools6A3-31

DESCRIPTION

4.3L engines are 90-degree V6 type, overhead valve, water cooled, with cast iron block and heads.

The crankshaft is supported by four precision insert main bearings, with crankshaft thrust taken at the number four (rear) bearing.

The camshaft is supported by four plain type bearings and is chain driven. Motion from the camshaft is transmitted to the valves by hydraulic lifters, pushrods, and ball type rocker arms. The valve guides are integral in the cylinder head.

The connecting rods are forged steel, with precision insert type crankpin bearings. The piston pins are a press fit in the connecting rods.

The pistons are cast aluminum alloy. The piston pins are a floating fit in the piston.

ENGINE LUBRICATION

Lubrication schematics are shown in figures 1 and 2. The gear type oil pump is driven from the distributor shaft, which is gear driven from the camshaft. Oil is drawn into the oil pump through a pickup screen and pipe.

Pressurized oil is routed to the oil filter. In case of excessive oil pressure, a bypass valve is provided. Filtered oil flows into the main gallery and then to the camshaft and crankshaft bearings. The valve lifter oil gallery supplies oil to the valve lifters. Oil flows from the hydraulic lifters through the hollow pushrods to the rocker arms. Oil from the overhead drains back to the crankcase through oil drain holes.

The timing chain is drip fed from the front camshaft bearing. The pistons and piston pins are lubricated by oil splash.

classiccarslibrary.com

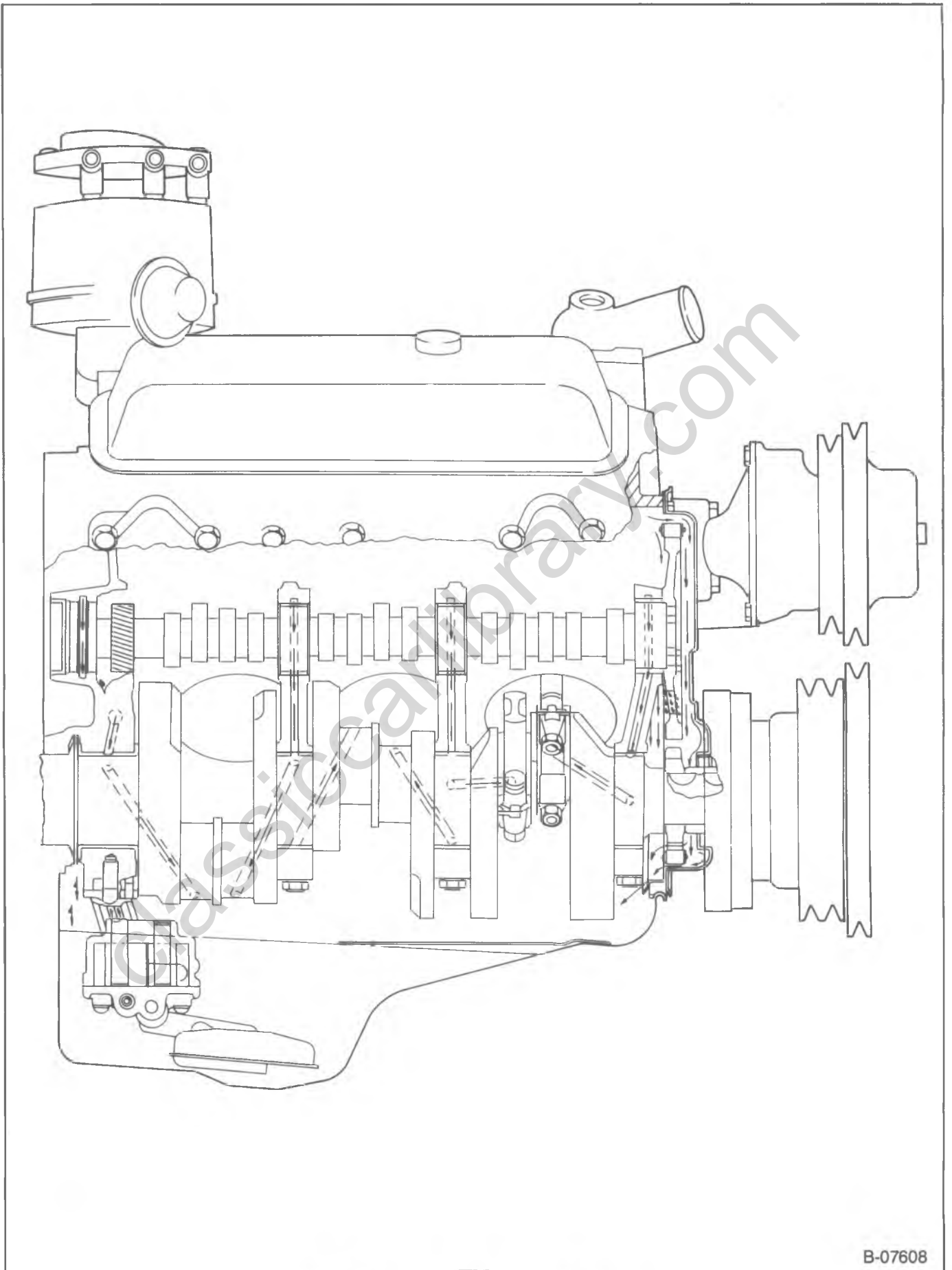

B-07608

Figure 1—Engine Lubrication Diagram

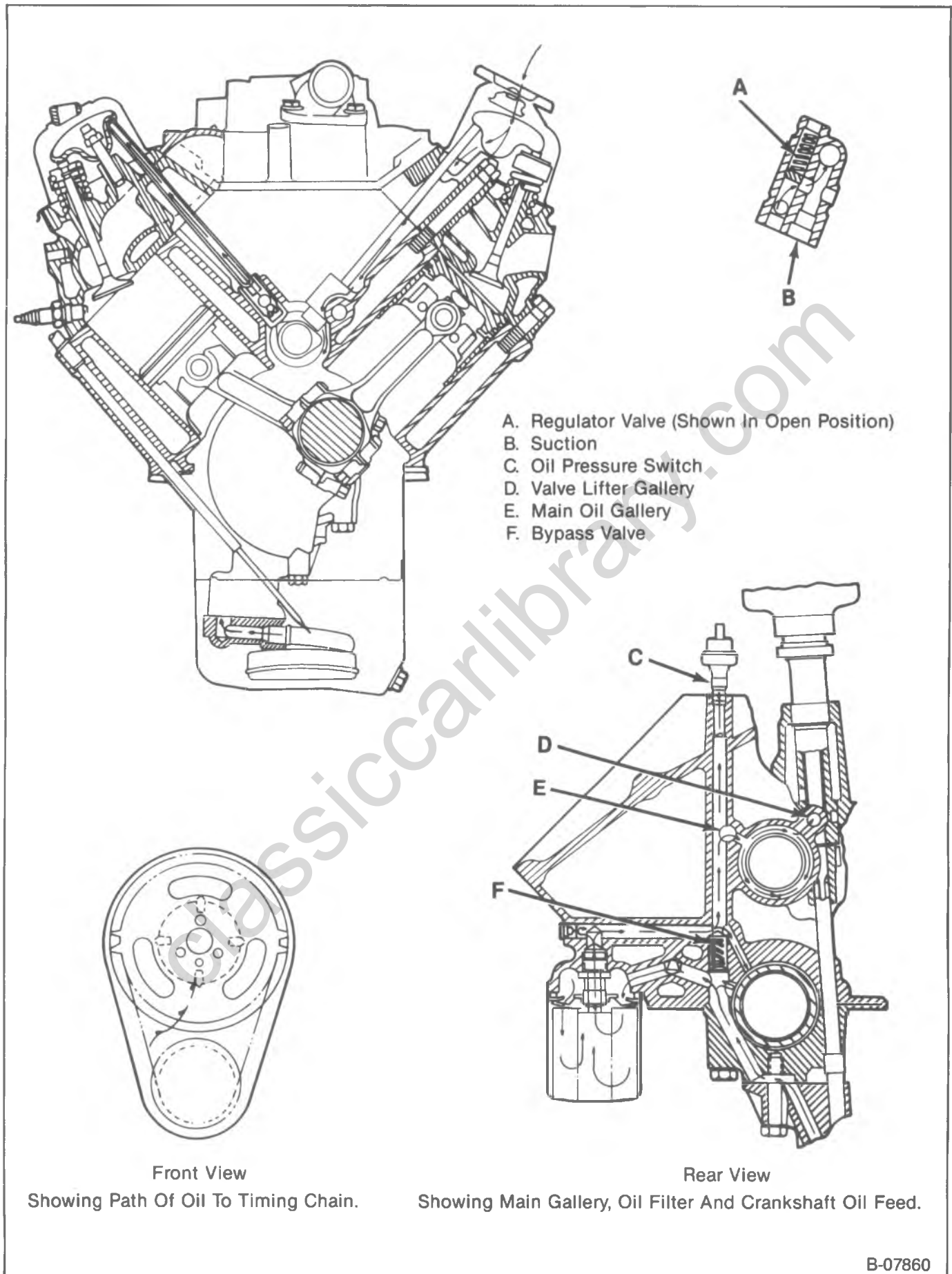

B-07860

Figure 2—Engine Lubrication Diagram

DESCRIPTION

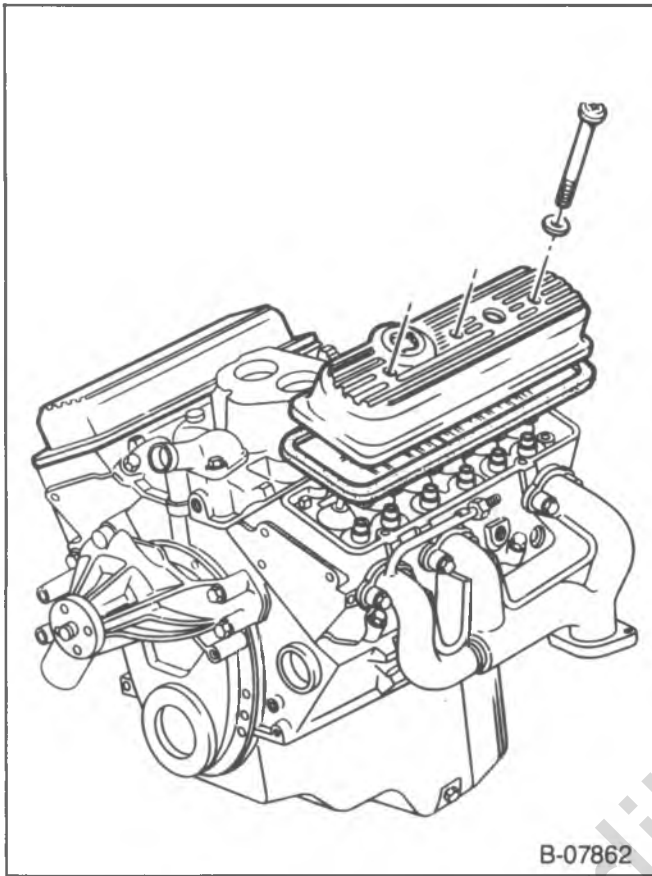

Figure 3—Rocker Arm Cover

ROCKER ARM COVER REPLACEMENT

REMOVAL — RIGHT SIDE

↔ Remove or Disconnect (Figure 3)

1. Battery negative cable.
2. Engine cover (G models).
3. Air cleaner and heat stove tube.
4. Diverter valve, bracket and hoses (G models).
5. Spark plug wire bracket at the side of the cylinder head (G models).
6. Spark plug wires and clip at the rear of the cylinder head (G models).
7. Wiring harnesses at the rocker arm cover. Move out of the way.
8. Rocker arm cover bolts.
9. Rocker arm cover and gasket.

REMOVAL — LEFT SIDE

↔ Remove or Disconnect (Figure 3)

1. Battery negative cable.
2. Engine cover (G models).
3. Oil fill tube (G models).
4. AIR pipe and check valve (G models).
5. Generator rear bracket (G models).
6. Air conditioning compressor, and lay aside (R and V models).

7. Power brake vacuum pipe, and move out of the way (R and V models).
8. Crankcase ventilation pipe at the rocker arm cover.
9. Rocker arm cover bolts.
10. Rocker arm cover and gasket.

CLEANING AND INSPECTION



Clean

- All traces of old gasket from the rocker arm cover and cylinder head.



Inspect

- Rocker arm cover sealing surface for distortion and damage. Replace if necessary.

INSTALLATION — RIGHT SIDE



Install or Connect (Figure 3)

1. Rocker arm cover and gasket.
2. Rocker arm cover bolts and washers.



Tighten

- Rocker arm cover bolts to 11.3 N·m (100 in. lbs.).
3. Wiring harness to the rocker cover.
 4. Spark plug wires, clips, and brackets (G models).
 5. Diverter valve, hoses, and bracket (G models).
 6. Air cleaner and heat stove tube.
 7. Engine cover (G models).
 8. Battery negative cable.

INSTALLATION — LEFT SIDE



Install or Connect (Figure 3)

1. Rocker arm cover and gasket.
2. Rocker arm cover bolts and washers.



Tighten

- Rocker arm cover bolts to 11.3 N·m (100 in. lbs.).
3. Crankcase ventilation pipe.
 4. Power brake vacuum pipe (R and V models).
 5. Air conditioning compressor (R and V models).
 6. Generator rear bracket (G models).
 7. AIR pipe and check valve (G models).
 8. Oil fill tube (G models).
 9. Engine cover (G models).
 10. Battery negative cable.

ROCKER ARM AND PUSHROD REPLACEMENT



Remove or Disconnect

1. Rocker arm cover, as outlined previously.
2. Rocker arm nut.
 - If only the pushrod is to be replaced, back the rocker arm nut off until the rocker arm can be swung away from the pushrod. Then pull the pushrod out.
3. Rocker arm with ball.
4. Pushrod.

! Important

- Store used components in order so they can be reassembled in the same location.

🔍 Inspect

- Rocker arms and balls at their mating surfaces. These surfaces should be smooth and free from scoring or other damage.
- Rocker arm areas which contact the valve stems and the sockets which contact the pushrods. These areas should be smooth and free of damage and wear.
- Pushrods for bending. Roll the pushrod on a flat surface to determine if it is bent. Replace if necessary.
- Ends of the pushrods for scoring or roughness.

↔ Install or Connect

1. Pushrod. Make sure the pushrod seats properly in the hydraulic lifter.
2. Rocker arm with ball.

! Important

- When new rocker arms and/or balls are installed, coat their bearing surfaces with "Molykote" or equivalent.
3. Rocker arm nuts.

🔑 Adjust

- Valves as outlined later.
4. Rocker arm cover, as outlined previously.

VALVE ADJUSTMENT

1. Remove the rocker arm cover as outlined previously.
2. Crank the engine until the mark on the torsional damper lines up with the "O" mark on the timing tab and the engine in the number one firing position. This may be determined by placing fingers on the number one valve as the mark on the damper comes near the "O" mark on the timing tab. If the rocker arms are not moving, the engine is in the number one firing position. If the rocker arms move as the mark comes up to the timing tab, the engine is in the number four firing position and should be turned over one more time to reach the number one position.
3. With the engine in the number one firing position as determined above, the following valves may be adjusted:
 - Exhaust: 1, 5, 6.
 - Intake: 1, 2, 3.

(Even numbered cylinders are in the right bank; odd numbered cylinders are in the left bank, when viewed from the rear of the engine).

4. Back out the adjusting nut until lash is felt at the pushrod then turn in the adjusting nut until all lash is removed. This can be determined by rotating the pushrod while turning the adjusting nut (figure 4). When the play has been removed, turn the adjusting nut in one full additional turn (to center the lifter plunger).
5. Crank the engine one revolution until the timing tab "O" mark and vibration damper mark are again in alignment. This is the number four firing position. The following valves may be adjusted:

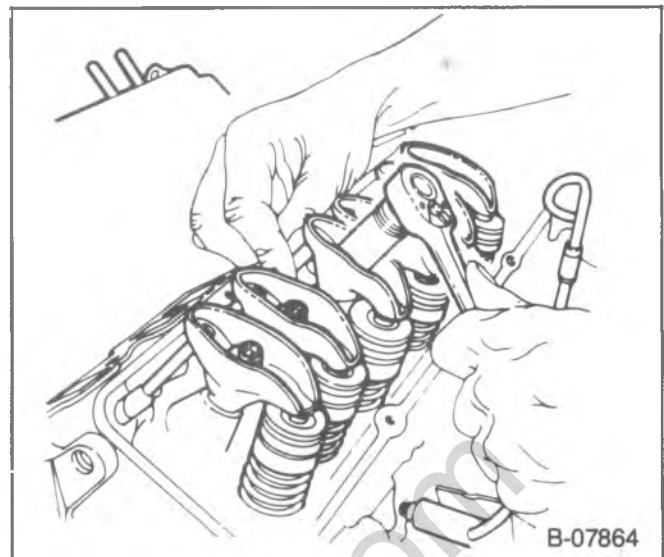

Figure 4—Adjusting the Valves

- Exhaust: 2, 3, 4.
 - Intake: 4, 5, 6.
6. Install the rocker arm cover as outlined previously.

VALVE STEM SEAL AND VALVE SPRING REPLACEMENT

↔ Remove or Disconnect (Figures 5 and 6)

Tools Required:

J-23590 Air Adapter.

J-5892-B Spring Compressor.

1. Rocker arm cover, as outlined previously.
2. Rocker arms, as outlined previously.
3. Spark plugs.
4. Valve keepers (20).
 - Install J-23590 into the spark plug hole.
 - Apply compressed air to hold the valves in place.
 - Install a rocker arm nut (figure 6).

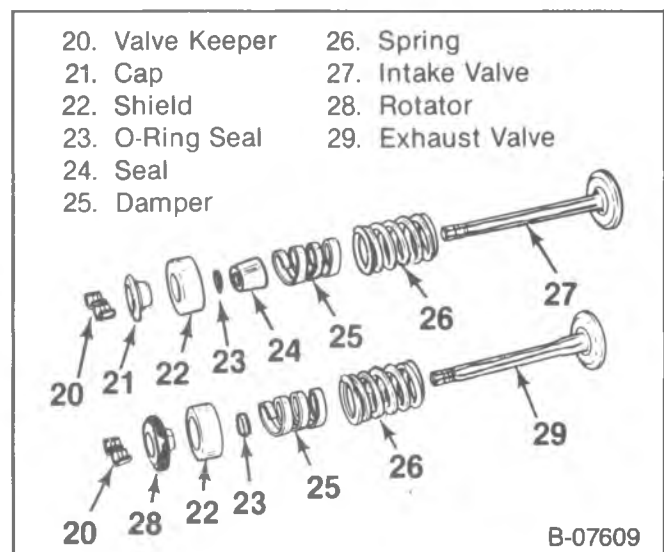

Figure 5—Valves and Components

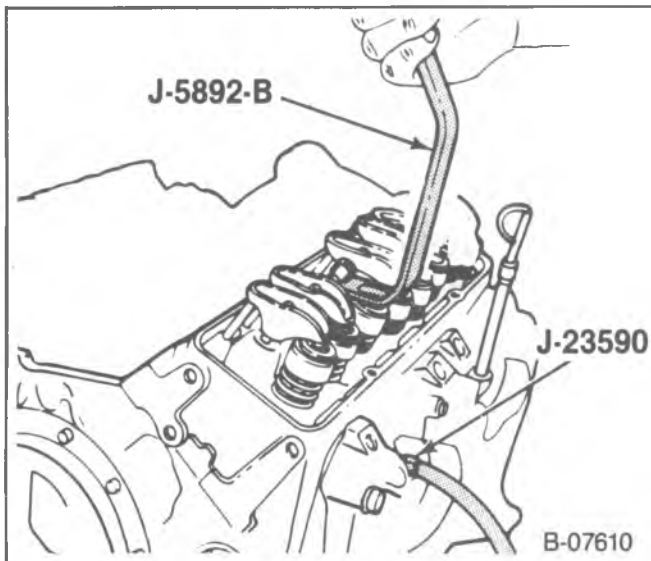

Figure 6—Compressing the Valve Springs

- Use J-5892-B to compress the valve spring (figure 6).
 - Remove the valve keepers.
 - Carefully release the spring tension. Remove J-5892-B.
5. Cap (21) and/or rotor (28), shield (22) and spring (26) with damper (25).
 6. O-ring seal (23), and seal (24) (intake valve only).

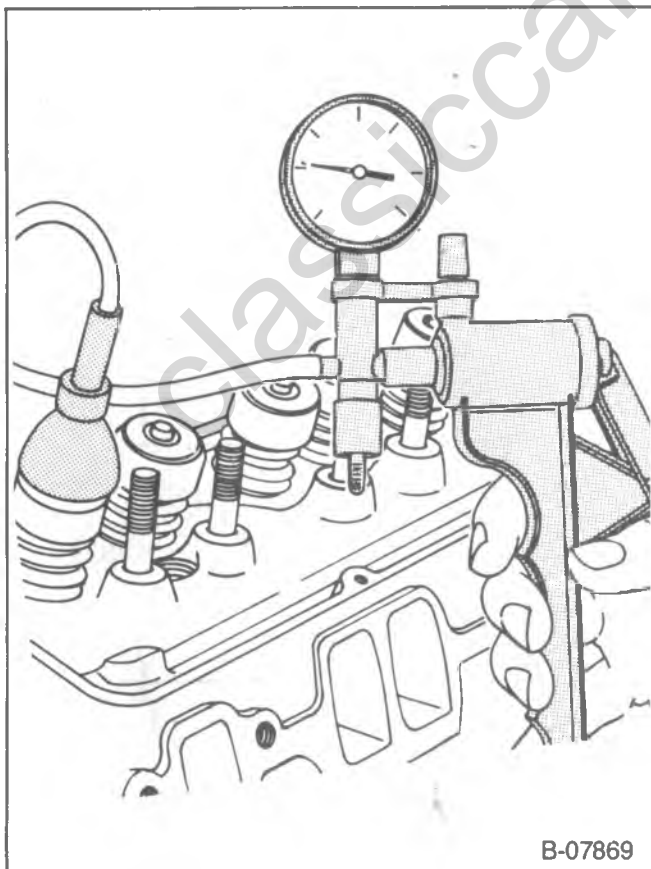

Figure 7—Testing the Valve Seals

↔ Install or Connect (Figures 5, 6, and 7)

Tools Required:

- J-23590 Air Adapter.
- J-5892-B Spring Compressor.
- J-23994-01 Adapter Cup.
- J-23738-A Vacuum Pump.

1. New seal (24) (intake valve only). Install the seal over the intake valve stem and seat it against the head.
2. Spring (26) with damper (25), shield (22) and cap (21) and/or rotor (28).
3. New O-ring seal (23) and valve keepers (20).
 - With air pressure applied to the cylinder with J-23590, compress the spring with J-5892-B (figure 6).
 - Lubricate the O-ring seal with engine oil. Install the seal on the valve stem. Make sure the seal is not twisted.
 - Install the valve keepers. Use grease to hold them in place.
 - Carefully release spring pressure. Make sure the valve keepers stay in place.
 - Remove J-5892-B and J-23590.
 - Check each O-ring seal for leakage (figure 7).
 - Place the suction cup furnished with J-23738-A over the shield.
 - Connect J-23738-A to the suction cup and apply a vacuum. Watch the vacuum pump gage. No air should be able to leak past the seal. If the seal will not hold a vacuum, it may have been damaged or improperly installed.
4. Spark plugs.
5. Rocker arms, as outlined previously.

🔧 Adjust

- Valves, as outlined previously.
6. Rocker arm cover, as outlined previously.

INTAKE MANIFOLD REPLACEMENT

↔ Remove or Disconnect

1. Battery negative cable.
2. Engine cover (G models).
3. Air cleaner and heat stove tube.
 - Drain the cooling system.
4. Distributor. Refer to ENGINE ELECTRICAL (SEC. 6D).
5. Accelerator, cruise control, and TVS cables and bracket.
6. Cruise control transducer, if equipped.
7. Air conditioning compressor, and lay aside (G models).
8. Air conditioning compressor rear brackets at the manifold (R and V models).
9. Generator bracket at the manifold.
10. Idler pulley bracket at the manifold (G models).
11. Fuel and vacuum lines and electrical connections at the TBI unit and manifold.
12. Heater pipe.
13. Upper radiator hose.
14. Power brake vacuum pipe.
15. Coil wires.
16. EGR vacuum line.

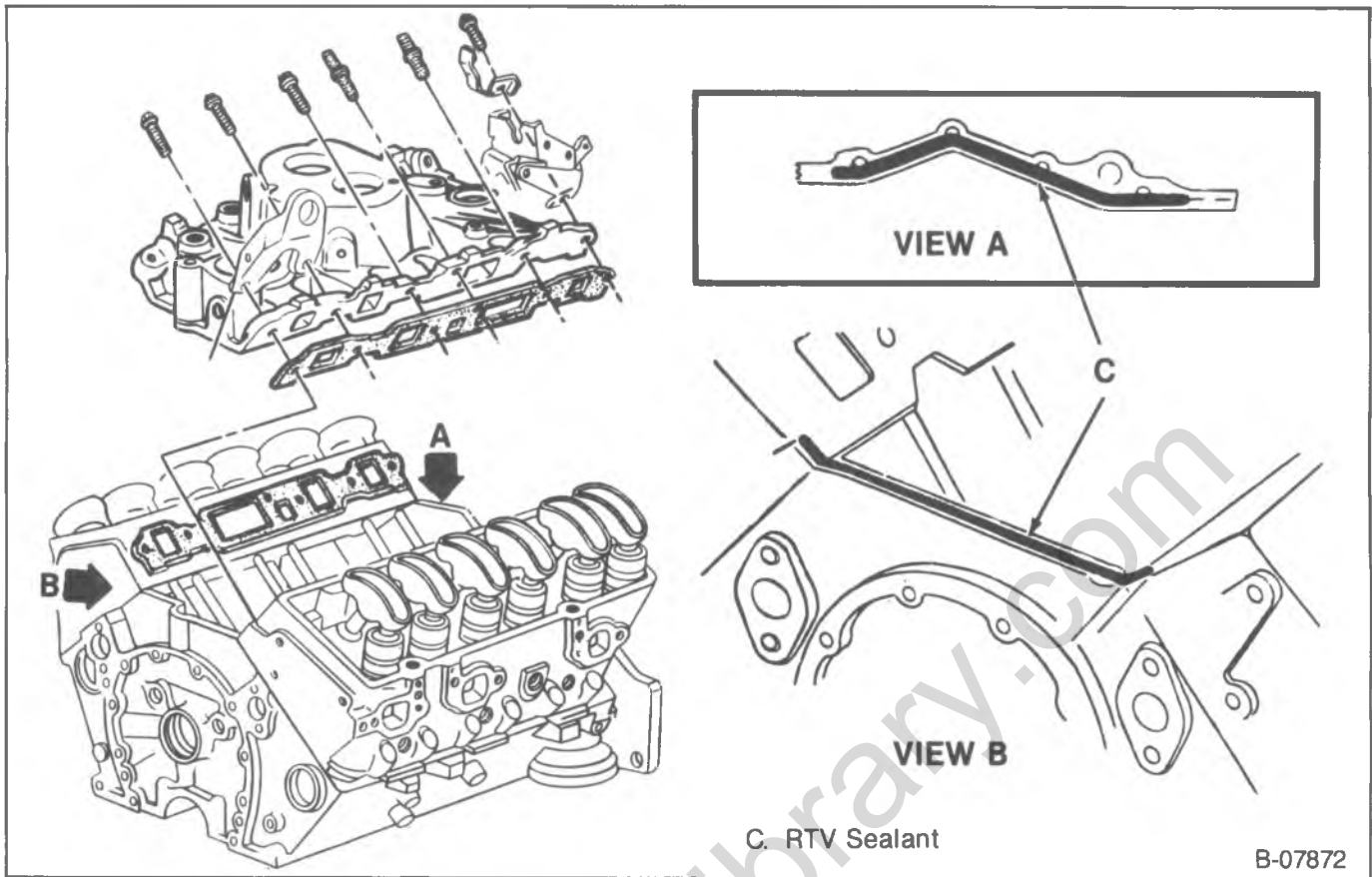

Figure 8—Intake Manifold

17. Sensors with bracket on right side.
18. Wiring harness on right side. Move out of the way.
19. Transmission dipstick tube (if equipped) (G models).
20. Intake manifold bolts.
21. Intake manifold and gaskets.

5. Transmission dipstick tube (if equipped) (G models).
6. Wiring harness.
7. Sensors with bracket.
8. EGR vacuum line.
9. Coil wires.
10. Power brake vacuum pump.
11. Upper radiator hose.
12. Heater pipe.
13. Fuel and vacuum lines and electrical connections at the TBI and manifold.
14. Idler pulley bracket (G models).

Clean

- Old gasket and RTV from the block, heads, and intake manifold. Remove all RTV that is loose or will cause interference at assembly.
- Excessive carbon deposits from the exhaust and EGR passages.
- Excessive scale and deposits from the coolant passages.

Inspect

- Manifold for cracks and gasket surface damage.

Install or Connect (Figures 8 and 9)

1. Gaskets to the cylinder head.
2. RTV to the front and rear sealing surfaces on the block (figure 8). Apply a 5 mm (3/16-inch) bead of RTV (part number 1052366 or equivalent) to the front and rear of the block as shown. Extend the bead 13 mm (1/2-inch) up each cylinder head to seal and retain the gaskets.
3. Intake manifold to the engine.
4. Intake manifold bolts.

Tighten

- Intake manifold bolts to 48 N·m (35 ft. lbs.). Use the tightening sequence shown in figure 9.

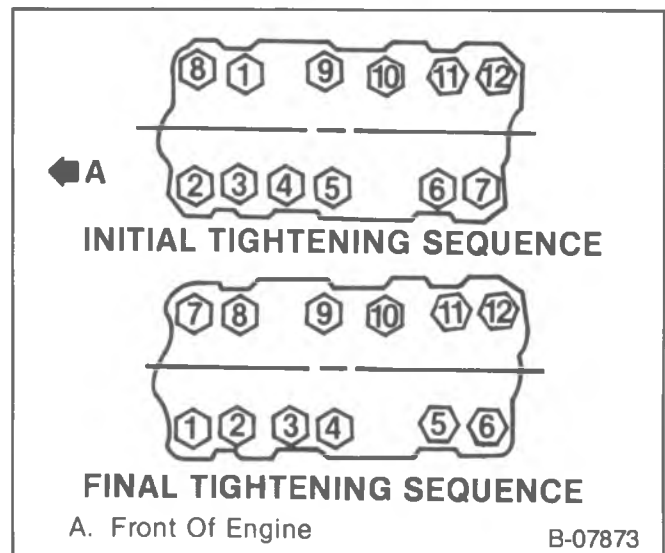
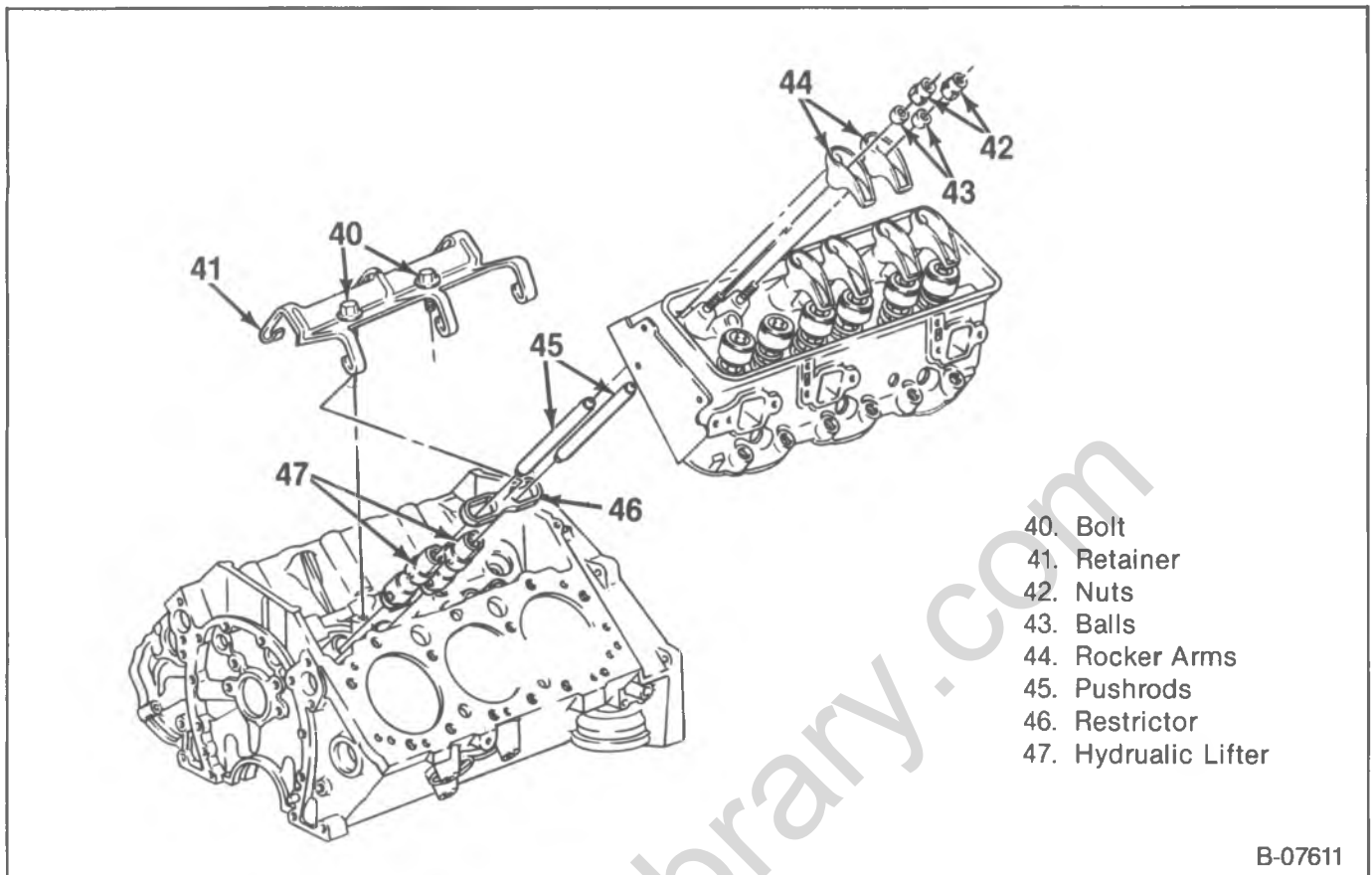

Figure 9—Intake Manifold Bolt Tightening Sequence



B-07611

Figure 10—Hydraulic Lifters and Components

15. Generator bracket.
16. Air conditioning compressor rear brackets (R and V models).
17. Air conditioning compressor (G models).
18. Cruise control transducer, if equipped.
19. Accelerator, cruise control, and TVS cables and bracket.
20. Distributor. Refer to ENGINE ELECTRICAL (SEC. 6D).
21. Air cleaner and heat stove tube.
22. Engine cover (G models).
23. Battery negative cable.
 - Fill the cooling system with the proper coolant.

HYDRAULIC LIFTER REPLACEMENT

↔ Remove or Disconnect (Figures 10)

1. Rocker arm cover, intake manifold, and pushrods, as outlined previously.
2. Bolts (40).
3. Retainer (41) with restrictors (46).
4. Hydraulic lifters.
 - Remove the hydraulic lifters one at a time and place them in an organizer rack. The lifters must be installed in the same bore from which they were removed.

🔍 Inspect

- Hydraulic lifter body for scuffing or scoring. If the lifter body wall is worn or damaged, the mating bore in the block should also be checked.

- Check the fit of each hydraulic lifter in its mating bore in the block. If the clearance is excessive, try a new lifter.
- Roller for freedom of movement.
- Roller for flat spots, pits and missing or broken needle bearings. If worn, pitted, or damaged, the mating camshaft lobe should also be checked.

Hydraulic Lifter Repair

- Refer to the proper unit repair manual.

↔ Install or Connect (Figure 10)

1. Hydraulic lifters to the block. Lubricate the lifter roller and body with Engine Oil Supplement or equivalent.

⚠ Important

- When any new hydraulic lifters or a new camshaft is installed, change the engine oil and filter. Engine Oil Supplement (or equivalent) should be added to the engine oil.
 - Replace all hydraulic lifters when a new camshaft is installed.
2. Retainer (41) with restrictors (46).
 3. Bolts (40).

🔧 Tighten

- Bolts (40) to 16.4 N·m (145 in. lbs.).
4. Intake manifold, as outlined previously.
 5. Pushrod, as outlined previously.

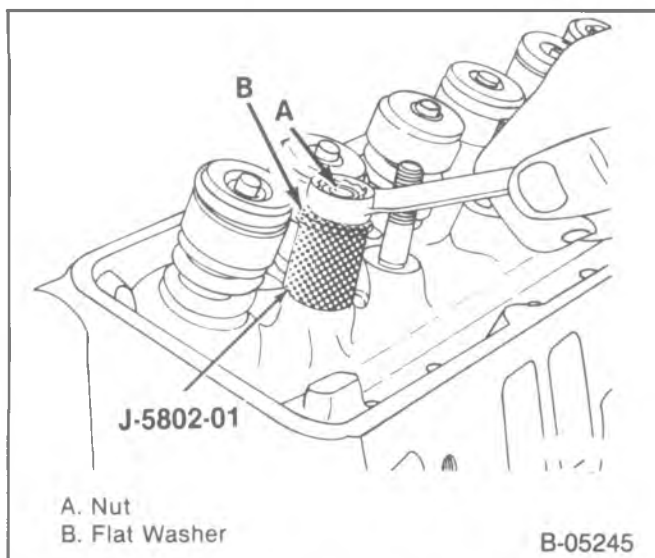

Figure 11—Removing the Rocker Arm Stud

 **Adjust**

- Valves, as outlined previously.
- 6. Rocker arm cover, as outlined previously.

ROCKER ARM STUD REPLACEMENT

 **Remove or Disconnect (Figure 11)**

Tool Required:

J-5802-01 Rocker Arm Stud Remover.

1. Rocker arm cover and rocker arm, as outlined previously.
2. Rocker arm stud.
 - Place J-5802-01 over the rocker arm stud.
 - Install a nut and flat washer.
 - Turn the nut to remove the stud (figure 11).



Figure 12—Reaming the Rocker Arm Stud Bore (Typical)

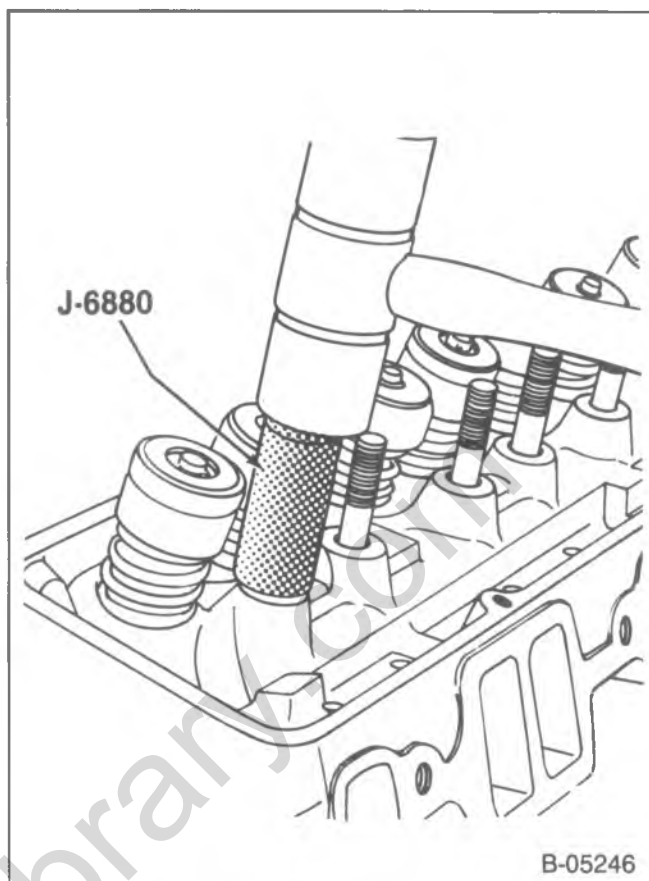

Figure 13—Installing the Rocker Arm Stud

 **Install or Connect (Figures 12 and 13)**

Tools Required:

J-5715 Reamer (0.003-inch oversize) or

J-6036 Reamer (0.013-inch oversize).

J-6880 Rocker Arm Stud Installer.

NOTICE: Do not attempt to install an oversize rocker arm stud without reaming the stud hole as this could damage the cylinder head.

- Ream the hole to the proper size for the replacement oversize rocker arm stud. Use J-5715 for 0.003-inch oversize studs; J-6036 for 0.013-inch oversize stud (figure 12).
 - Coat the lower end (press-fit area) of the rocker arm stud with hypoid axle lubricant.
1. Rocker arm stud. Use J-6880 (figure 13). Stud is installed to proper depth when the tool bottoms on the cylinder head.

2. Rocker arm, as outlined previously.

 **Adjust**

- Valves, as outlined previously.
3. Rocker arm cover, as outlined previously.

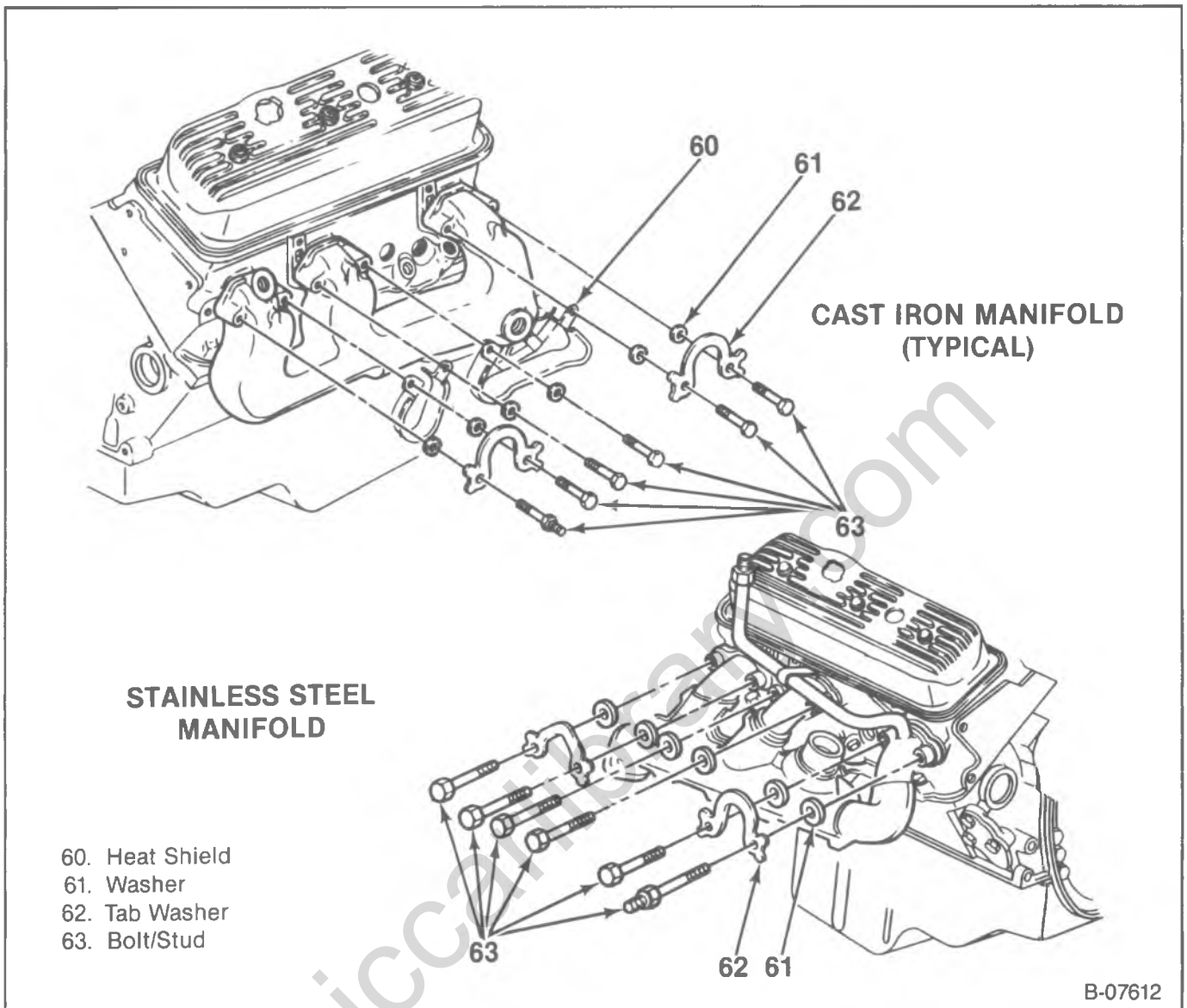

Figure 14—Exhaust Manifold

EXHAUST MANIFOLD REPLACEMENT

↔ Remove or Disconnect (Figure 14)

1. Battery negative cable.
2. Engine cover (G models).
 - Raise the vehicle. Support with suitable safety stands.
3. Exhaust pipe at the manifold.
 - Lower the vehicle.
4. Oxygen sensor wire (left side manifold). Do not remove the oxygen sensor from the manifold unless it is to be replaced.
5. Air conditioning compressor rear bracket at the manifold, if equipped (R and V models – left side manifold).
6. Power steering pump bracket at the manifold (G models – left side manifold).
7. Heat stove pipe (right side manifold).
8. AIR pipe at the diverter valve (R and V models – right side manifold).

9. Diverter valve bracket (R and V models – right side manifold).
10. Dipstick tube bracket at the manifold (G models – right side manifold).
11. AIR hose at the check valve.
12. Exhaust manifold bolts, washers, heat shield (left side manifold), and tab washers.
13. Exhaust manifold.



Clean

- Mating surfaces on the manifold and head.
- Threads on the exhaust manifold bolts.



Install or Connect (Figure 14)

1. Exhaust manifold, bolts, washers, heat shield (left side manifold), and tab washers.



Tighten

- Bolts on center exhaust tube to 36 N·m (26 ft. lbs.).
- Bolts on front and rear exhaust tubes to 28 N·m (20 ft. lbs.).

B-07612

- Bend the tab washers over the heads of all bolts.
- 2. AIR hose at the check valve.
- 3. Dipstick tube bracket at the manifold (G models – right side manifold).
- 4. Diverter valve bracket (R and V models – right side manifold).
- 5. AIR pipe at the diverter valve (R and V models – right side manifold).
- 6. Heat stove tube (right side manifold).
- 7. Power steering pump bracket at the manifold (G models – left side manifold).
- 8. Air conditioning compressor rear bracket, if equipped (R and V models – left side manifold).
- 9. Oxygen sensor wire (left side manifold).
 - Raise the vehicle. Support with suitable safety stands.
- 10. Exhaust pipe to the manifold.
 - Lower the vehicle.
- 11. Engine cover (G models).
- 12. Battery negative cable.

CYLINDER HEAD REPLACEMENT

REMOVAL — R AND V MODELS

Remove or Disconnect

1. Battery negative cable.
2. Intake manifold, as outlined previously.
3. Exhaust manifold, as described previously.
4. AIR pipe at the rear of the head.
5. Generator mounting bolt at the cylinder head (right cylinder head).
6. Power steering pump and brackets from the cylinder head, and lay aside (left cylinder head).
7. Air conditioning compressor and brackets, and lay aside (left cylinder head).
8. Rocker arm cover, as outlined previously.
9. Spark plug wires from the brackets.
10. Coolant sensor wire (left cylinder head).
11. Cruise control transducer bracket (left cylinder head).
12. Dipstick tube at the cylinder head, and move aside (right cylinder head).
13. Spark plugs.
14. Pushrods, as outlined previously.
15. Cylinder head bolts.
16. Cylinder head.
17. Gasket.

REMOVAL — G MODELS

Remove or Disconnect

1. Battery negative cable.
2. Engine cover.
3. Intake manifold, as outlined previously.
4. Exhaust manifold, as described previously.
5. AIR pipe at the rear of the head.
6. AIR pump mounting bolt and spacer at the cylinder head (right cylinder head).
7. Engine accessory bracket bolts and studs at the cylinder head. For left cylinder head removal, it may be necessary to loosen the remaining bracket bolts to provide clearance for head removal.
8. Spark plug wires at the brackets.

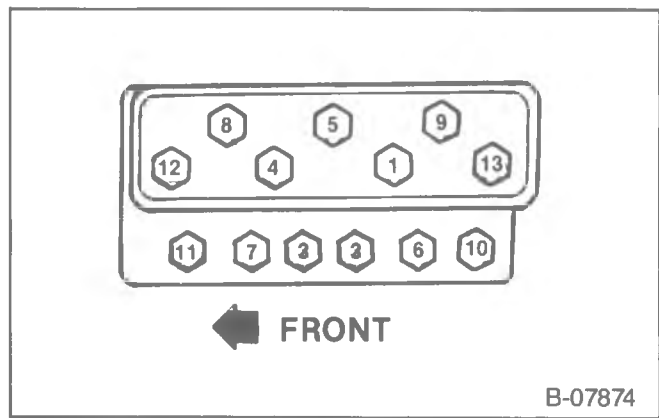

Figure 15—Cylinder Head Bolt Tightening Sequence

9. Wiring harness, clip and ground strap at the rear of the head (right cylinder head).
10. Fuel pipes and bracket at the rear of the cylinder head (left cylinder head).
11. Coolant sensor wire (left cylinder head).
12. Cruise control transducer bracket (left cylinder head).
13. Rocker arm cover, as outlined previously.
14. Spark plugs.
15. Pushrods, as outlined previously.
16. Cylinder head bolts.
17. Cylinder head.
18. Gasket.

CLEANING, INSPECTION, AND REPAIR

Clean

- Carbon deposits from combustion chambers.
- All traces of old head gasket from cylinder head and block.
- Cylinder head bolt threads and threads in the block.

Inspect

- Sealing surfaces of the block and cylinder head for nicks, heavy scratches, or other damage.

Cylinder Head Repair

- Refer to the proper Unit Repair Manual.

INSTALLATION — R AND V MODELS

Install or Connect (Figure 15)

1. Head gasket.
 - If a steel gasket is used, coat both sides of the gasket with sealer. Spread the sealer thin and even.
 - Do not use sealer on composition steel-asbestos gaskets.
 - Place the gasket over the block dowel pins with the bead up.
2. Cylinder head. Carefully guide the cylinder head into place over the dowel pins and gasket.
3. Cylinder head bolts. Coat threads of the cylinder head bolts with sealing compound (GM part number 1052080 or equivalent) and install finger-tight.

Tighten

- Cylinder head bolts, a little at a time, using the sequence shown in figure 15. Proper torque is 90 N·m (65 ft. lbs.).
4. Pushrods, as outlined previously.

Adjust

- Valves, as outlined previously.
5. Rocker arm cover, as outlined previously.
 6. Spark plugs.
 7. Dipstick tube (right cylinder head).
 8. Cruise control transducer bracket (left cylinder head).
 9. Coolant sensor wire (left cylinder head).
 10. Spark plug wires.
 11. Air conditioning compressor and brackets (left cylinder head).
 12. Power steering pump and brackets (left cylinder head).
 13. Generator mounting bolt (right cylinder head).
 14. AIR pipe.
 15. Exhaust manifold, as outlined previously.
 16. Intake manifold, as outlined previously.
 17. Battery negative cable.

INSTALLATION — G MODELS

Install or Connect (Figure 15)

1. Head gasket.
 - If a steel gasket is used, coat both sides of the gasket with sealer. Spread the sealer thin and even.
 - Do not use sealer on composition steel-asbestos gaskets.
 - Place the gasket over the block dowel pins with the bead up.
2. Cylinder head. Carefully guide the cylinder head into place over the dowel pins and gasket.
3. Cylinder head bolts. Coat threads of the cylinder head bolts with sealing compound (GM part number 1052080 or equivalent) and install finger-tight.

Tighten

- Cylinder head bolts, a little at a time, using the sequence shown in figure 15. Proper torque is 90 N·m (65 ft. lbs.).
4. Pushrods, as outlined previously.

Adjust

- Valves, as outlined previously.
5. Rocker arm cover, as outlined previously.
 6. Spark plugs.
 7. Cruise control transducer bracket (left cylinder head).
 8. Coolant sensor wire (left cylinder head).
 9. Fuel pipes and bracket (left cylinder head).
 10. Wiring harness, clip, and ground strap (right cylinder head).
 11. Spark plug wires.
 12. Engine accessory bracket bolts and studs.
 13. AIR pump mounting bolt and spacer (right cylinder head).
 14. AIR pipe.
 15. Exhaust manifold, as outlined previously.
 16. Intake manifold, as outlined previously.
 17. Engine cover.

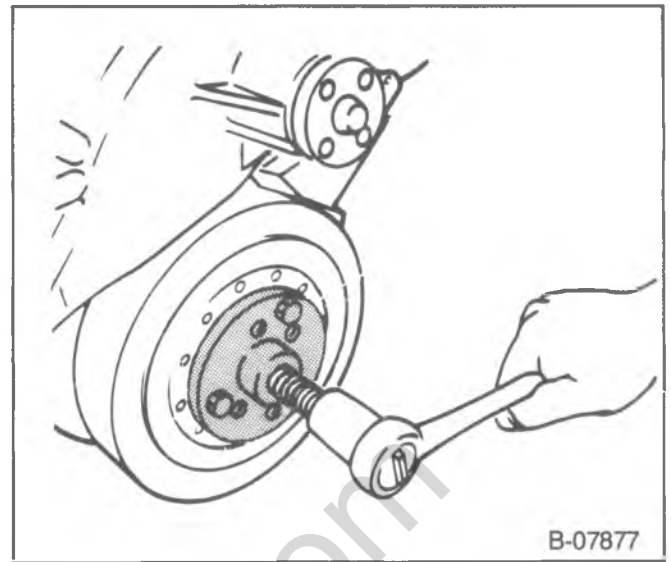

Figure 16—Removing the Torsional Damper

18. Battery negative cable.

TORSIONAL DAMPER AND FRONT CRANKSHAFT SEAL REPLACEMENT

Remove or Disconnect (Figure 16)

Tool Required:

J-23523-E Torsional Damper Puller and Installer.

1. Fan belts, fan, and pulley.
2. Fan shroud assembly.
3. Accessory drive pulley.
4. Torsional damper bolt.
5. Torsional damper. Use J-23523-E (figure 16).
6. Front crankshaft seal. Pry out with a large screwdriver. Take care not to distort the timing cover.
7. Crankshaft key, if necessary.

Inspect

- Oil seal contact area on the torsional damper shaft for grooving and roughness. Replace if necessary.

Install or Connect (Figures 17 and 18)

Tools Required:

J-35468 Seal Installer.

J-23523-E Torsional Damper Puller and Installer.

1. Crankshaft key, if removed.
2. Front crankshaft seal. Use J-35468 (figure 17). The open end of the seal faces inside the engine. Coat the seal lips with engine oil.

NOTICE: The inertia weight section of the torsional damper is assembled to the hub with a rubber type material. The correct installation procedures (with the proper tool) must be followed or movement of the inertia weight section of the hub will destroy the tuning of the torsional damper.

3. Stud (item A, figure 18) to the crankshaft. Thread the stud fully into the tapped hole in the crankshaft.

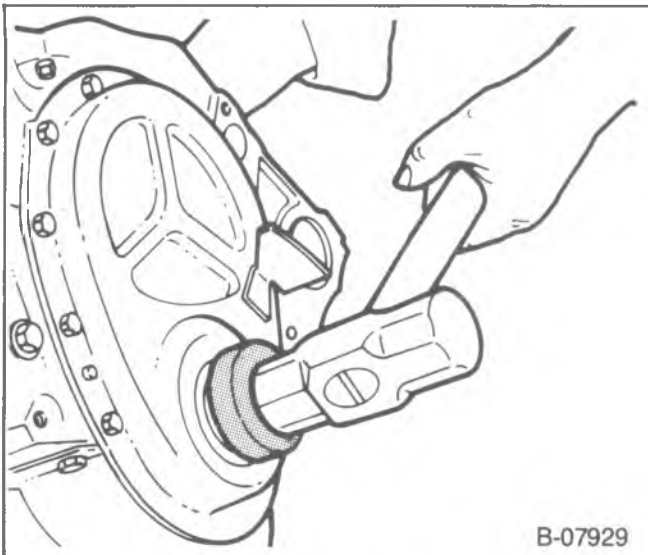

Figure 17—Installing the Front Crankshaft Oil Seal

4. Torsional damper over the end of the stud. Align the keyway in the torsional damper shaft with the crankshaft key.
5. Bearing, washer and nut (figure 18).
 - Turn the nut to pull the vibration damper into place.
 - Remove the tool.
 - Use a small amount of RTV sealant to seal the torsional damper key to crankshaft joint.
6. Torsional damper bolt and washer.

 **Tighten**

- Bolt to 95 N·m (70 ft. lbs.).
7. Accessory drive pulley.
 8. Fan shroud assembly.
 9. Fan pulley, fan, and fan belts.

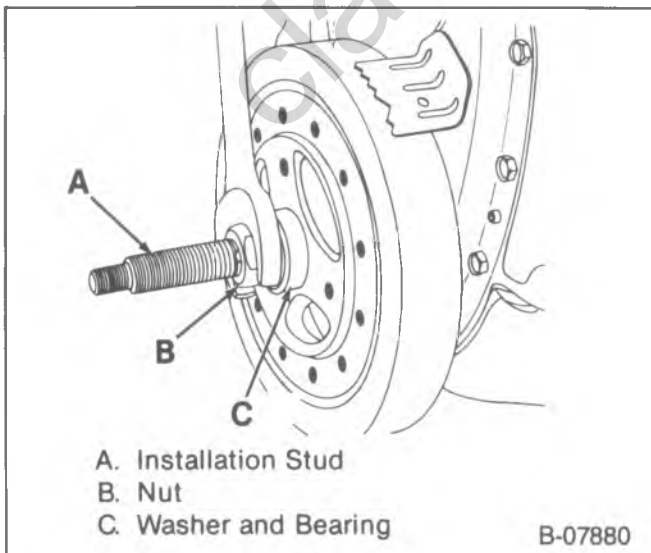

Figure 18—Installing the Torsional Damper

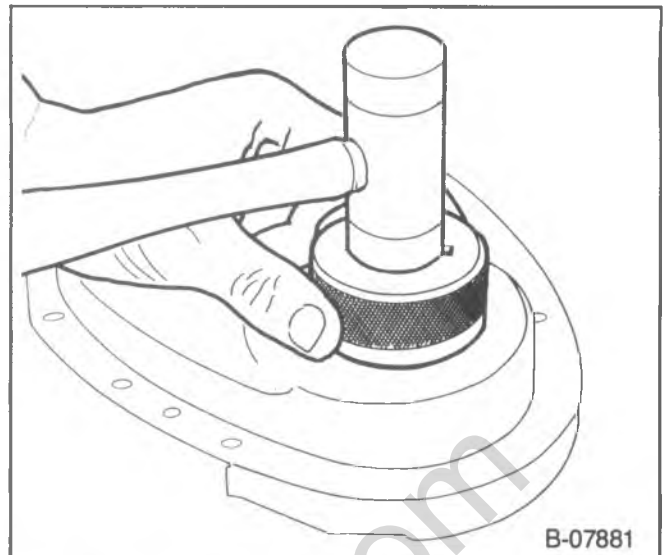

Figure 19—Installing the Front Crankshaft Oil Seal

FRONT COVER REPLACEMENT

 **Remove or Disconnect**

1. Torsional damper, as outlined previously.
2. Water pump. Refer to ENGINE COOLING (SEC. 6B1).
3. Oil pan, as outlined later.
4. Front cover bolts.
5. Front cover.
6. Front cover to block gasket.
7. Front crankshaft oil seal from the front cover. Pry out with a screwdriver. Take care not to distort the front cover.

 **Clean**

- Old gasket from the front cover, and block.

 **Inspect**

- Front cover for distortion and damage. Replace if necessary.

 **Install or Connect (Figure 19)**

Tool Required:

J-35468 Seal Installer.

1. Front crankshaft oil seal. Use J-35468 (figure 19). The open end of the seal faces inside the engine. Coat the seal lips with engine oil.
2. Front cover gasket to the front cover. Use gasket cement to hold them in place.
3. Front cover and bolts.

 **Tighten**

- Front cover bolts to 11.3 N·m (100 in. lbs.).
4. Oil pan, as outlined later.
 5. Water pump.
 6. Torsional damper, as outlined previously.

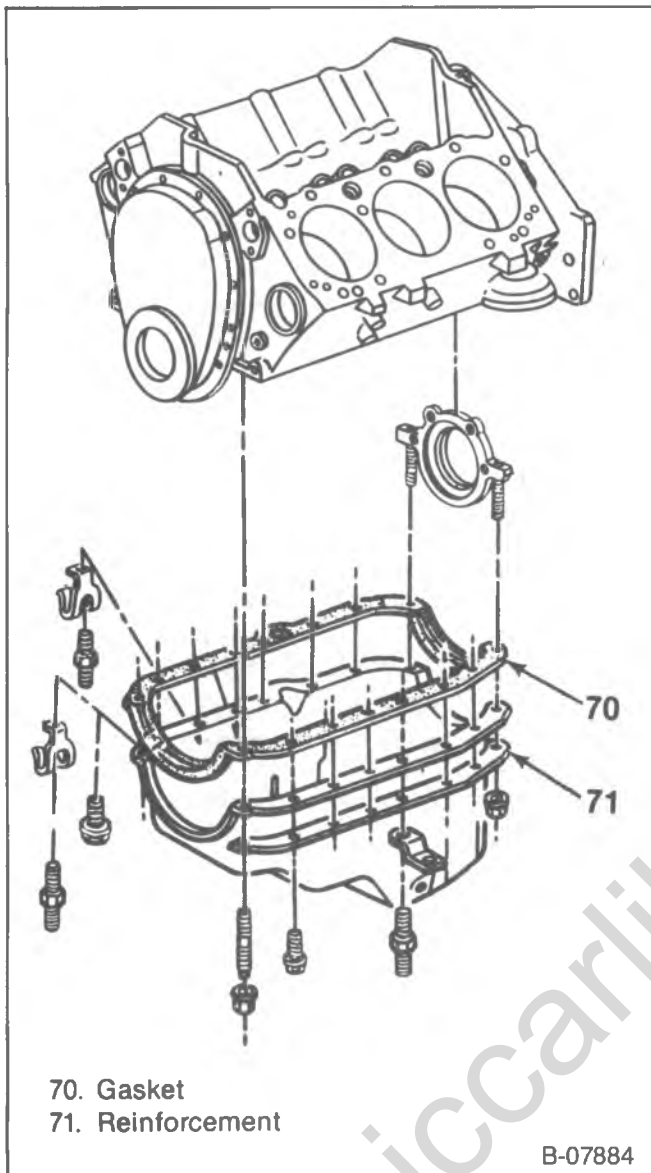

Figure 20—Oil Pan

OIL PAN REPLACEMENT

A one piece type oil pan gasket is used.

Remove or Disconnect (Figure 20)

1. Battery negative cable.
 - Raise the vehicle. Support with suitable safety stands.
 - Drain the engine oil.
2. Exhaust crossover pipe.
3. Torque converter cover (models with automatic transmission).
4. Strut rods at flywheel cover.
5. Strut rod brackets at the front engine mountings.
6. Starter.
7. Strut rods at engine mounts (V models with automatic transmission).
8. Oil pan bolts, nuts, and reinforcements.
9. Oil pan and gasket.

Clean

- Gasket surfaces on the engine and oil pan.

Inspect

- Oil pan gasket for damage. Replace if necessary.

Install or Connect (Figure 20)

- Apply sealant (GM part number 1052080 or equivalent) to the front cover to block joint and to the rear crankshaft seal to block joint. Apply the sealant for about 25 mm (1-inch) in both directions from each of the four corners.

1. Oil pan gasket to the oil pan.
2. Oil pan to the engine.
3. Oil pan bolts, nuts, and reinforcements.

Tighten

- Oil pan bolts to 11.3 N·m (100 in. lbs.).
 - Oil pan nuts at corners to 22.6 N·m (200 in. lbs.).
4. Strut rods at the engine mounts (V models with automatic transmission).
 5. Starter.
 6. Strut rod brackets at the front engine mountings.
 7. Strut rods at the flywheel cover.
 8. Converter housing under pan (models with automatic transmission).
 9. Exhaust crossover pipe.
 - Lower the vehicle.
 10. Proper quantity and grade of engine oil.
 11. Battery negative cable.

OIL PUMP REPLACEMENT

Remove or Disconnect

1. Oil pan, as outlined previously.
2. Oil pump to main bearing cap bolt.
3. Oil pump.

Inspect

- Oil pump pickup tube for looseness. If the tube is loose in the oil pump body, replace it, as outlined in the proper unit repair manual. A loose pickup tube can result in an air leak and loss of oil pressure.

Oil Pump Repair

- Refer to the proper unit repair manual.

Install or Connect

1. Oil pump to the engine. Align the slot in the oil pump shaft with the tang on the distributor shaft. The oil pump should slide easily into place. No gasket is used.
2. Oil pump to main bearing cap bolt.

Tighten

- Oil pump to main bearing cap bolt to 90 N·m (65 ft. lbs.).
3. Oil pan, as outlined previously.

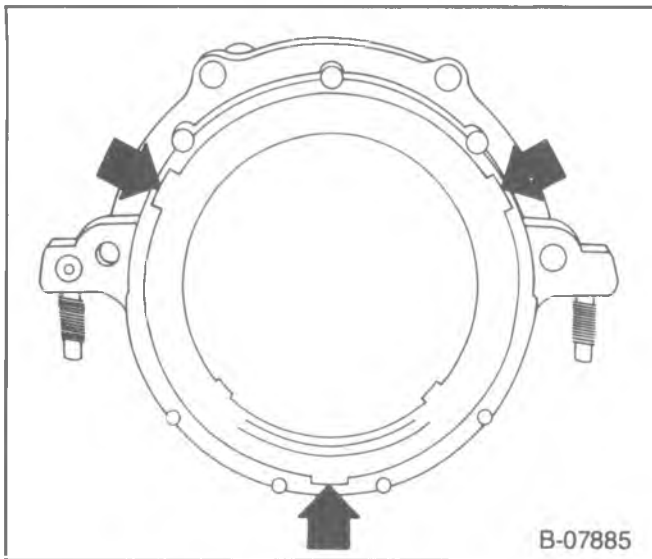

Figure 21—Seal Removal Notches

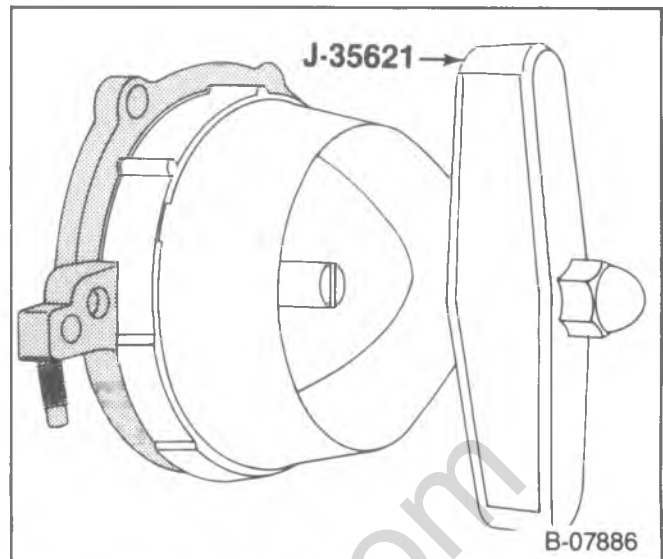

Figure 22—Installing the Rear Crankshaft Oil Seal

REAR CRANKSHAFT OIL SEAL REPLACEMENT

↔ Remove or Disconnect (Figure 21)

1. Transmission.
2. Clutch and flywheel or flexplate, as equipped.

NOTICE: Care should be taken when removing the rear crankshaft oil seal so as not to nick the crankshaft sealing surface.

3. Rear crankshaft oil seal. Insert a screwdriver into the notches provided in the seal retainer and pry the seal out (figure 21). Take care not to damage the crankshaft sealing surface.

👁 Inspect

- Chamfer on crankshaft for grit, loose rust, and burrs. Correct as necessary.

🧼 Clean

- Seal running surface on the crankshaft with a non-abrasive cleaner.

→→ Install or Connect (Figure 22)

Tool Required:

J-35621 Seal Installer.

1. Rear crankshaft oil seal (figure 22).
 - Lubricate the inner and outer diameter of the seal with engine oil.
 - Install the seal on J-35621.
 - Position J-35621 against the crankshaft. Thread the attaching screws into the tapped holes in the crankshaft.
 - Tighten the screws securely with a screwdriver. This will ensure that the seal is installed squarely over the crankshaft.
 - Turn the handle until it bottoms.
 - Remove J-35621.
2. Clutch and flywheel or flexplate, as equipped.
3. Transmission.

REAR CRANKSHAFT OIL SEAL RETAINER REPLACEMENT

↔ Remove or Disconnect (Figures 21 and 23)

1. Transmission.
2. Clutch and flywheel or flexplate, as equipped.
3. Oil pan, as outlined previously.
4. Screws (80) and nuts (81).
5. Seal retainer (82).
6. Gasket (84).
7. Rear crankshaft oil seal. Insert a screwdriver into the notches provided in the seal retainer and pry the seal out (figure 21).

🧼 Clean

- Gasket surfaces on block and seal retainer.

→→ Install or Connect (Figures 21 and 23)

- Whenever the seal retainer is removed, a new retainer gasket and rear crankshaft oil seal must be installed.

1. Gasket (84) to the block. It is not necessary to use sealant to hold the gasket in place.
2. Seal retainer (82).
3. Screws (80) and nuts (81).

🔩 Tighten

- Screws (80) and nuts (81) to 15.3 N·m (135 in. lbs.).
4. Oil pan, as outlined previously.
 5. Rear crankshaft oil seal as outlined previously.
 6. Clutch and flywheel or flexplate, as equipped.
 7. Transmission.

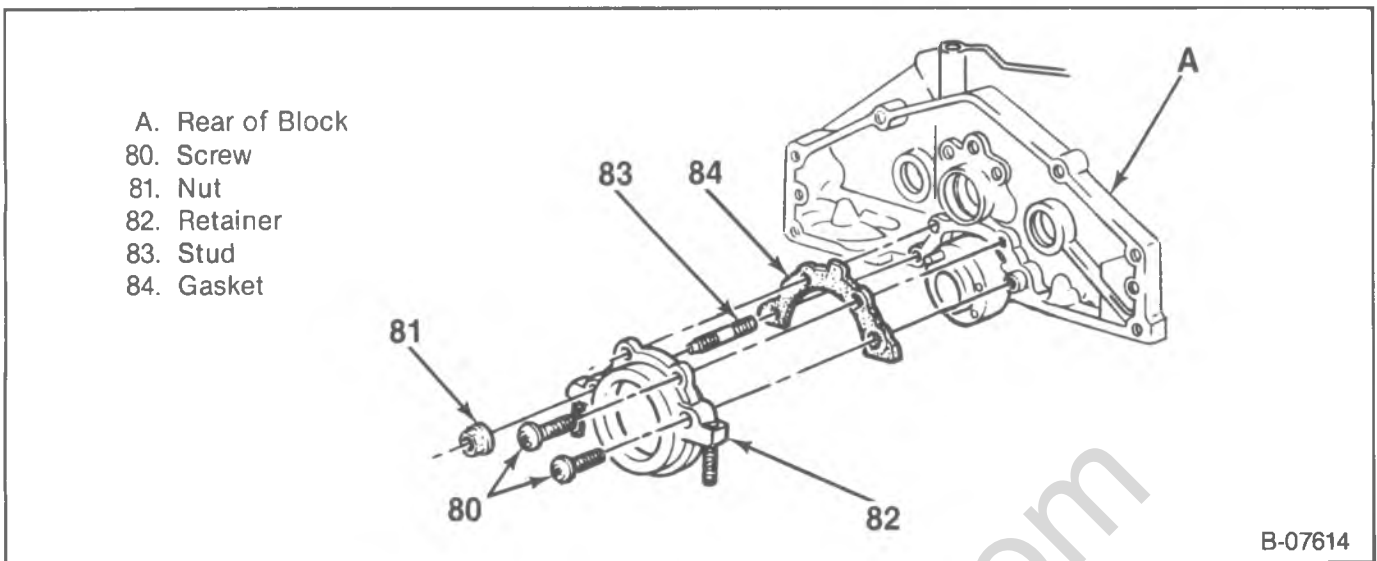

Figure 23—Rear Crankshaft Oil Seal Retainer

MEASURING CAMSHAFT LOBE LIFT

Tool Required:

J-8520 Camshaft Lobe Lift Indicator.

1. Remove the rocker arm as outlined previously.
2. Refer to figure 24. Position the dial indicator (part of J-8520) so the plunger rests on the pushrod end, as shown. Make sure the pushrod is in the lifter socket.
3. Rotate the crankshaft slowly in the direction of rotation until the lifter is on the heel of the cam lobe. At this point, the pushrod will be in its lowest position.
4. Set dial indicator on zero, then rotate the crankshaft slowly, or attach an auxiliary starter switch and "bump" the engine over, until the pushrod is in fully raised position.



Figure 24—Measuring Camshaft Lobe Lift

! Important

- Whenever the engine is cranked remotely at the starter, with a special jumper cable or other means, the distributor primary lead should be disconnected from the ignition coil.
5. Compare the total lift recorded from the dial indicator with specifications.
 6. If camshaft readings for all lobes are within specifications, remove dial indicator assembly.
 7. Install the rocker arm and adjust the valves as previously outlined.

CAMSHAFT REPLACEMENT

R AND V MODELS

↔ Remove or Disconnect (Figures 25 through 28)

Tool Required:

J-5825-A Crankshaft Sprocket Puller.

1. Battery negative cable.
2. Air cleaner.
3. Fan, shroud, and radiator. Refer to ENGINE COOLING (SEC. 6B1) and RADIATOR (SEC. 6B2).
4. Generator.
5. Rocker arm covers, as outlined previously.
6. Water pump. Refer to ENGINE COOLING (SEC. 6B1).
7. Torsional damper, as outlined previously.
8. Front cover, as outlined previously.
9. Distributor. Refer to ENGINE ELECTRICAL (SEC. 6D).
10. Intake manifold, as outlined previously.
11. Pushrods and hydraulic lifters, as outlined previously.
 - Align the timing marks (figure 26).
12. Camshaft sprocket bolts.
13. Camshaft sprocket and timing chain. The sprocket is a light interference fit on the camshaft. Tap the sprocket on its lower edge to loosen it.
14. Screws (88) and thrust plate (87).
15. Crankshaft sprocket (if required). Use J-5825-A (figure 27).
16. Engine mount through-bolts.
 - Raise the engine.
17. Camshaft.

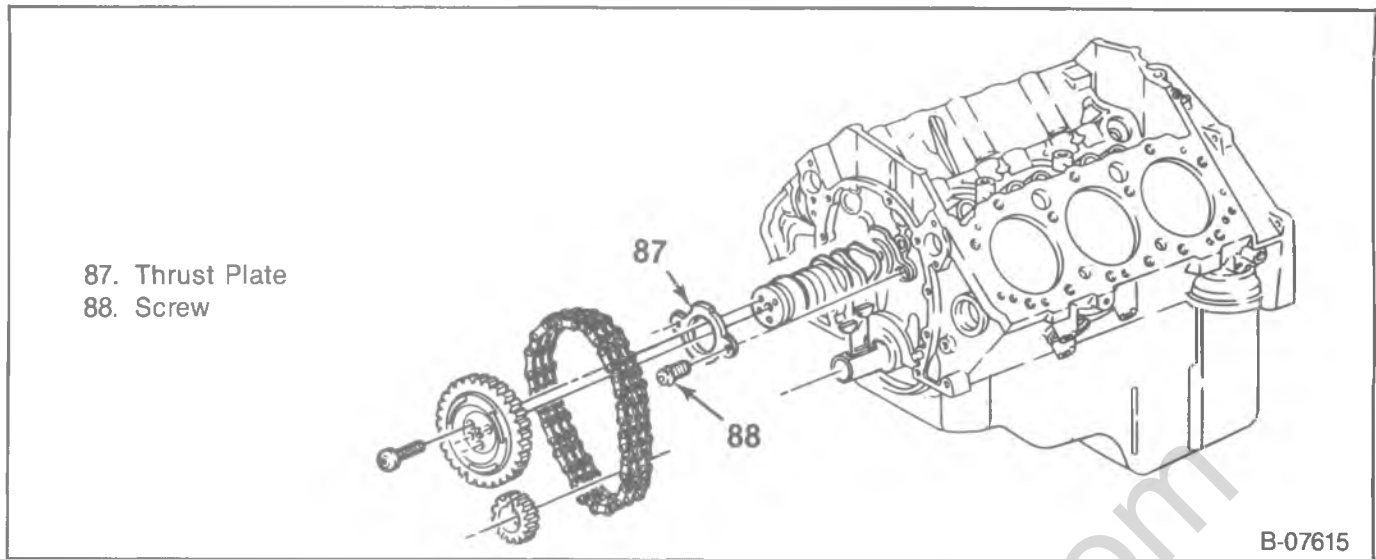

Figure 25—Camshaft and Components

- Install two or three $\frac{5}{16}$ -18 bolts 100-125 mm (4-5 inches) long into the camshaft threaded holes. Use these bolts to handle the camshaft (figure 28).
- Pull the camshaft from the block. Use care to prevent damage to the camshaft bearings.

Cleaning, Inspection And Repair

Clean, inspect and repair or replace the camshaft and related components, as outlined in the proper unit repair manual.

The unit repair manual also describes camshaft bearing replacement.

Install or Connect (Figures 25 through 28, 36, and 37)

Tool Required:

J-5590 Crankshaft Sprocket Installer.

- Coat the camshaft lobes and journals with a high quality engine oil supplement (GM Engine Oil Supplement or equivalent).

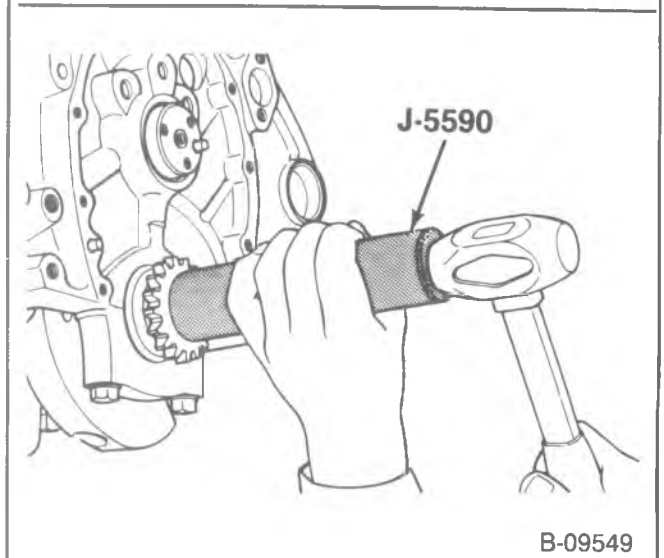
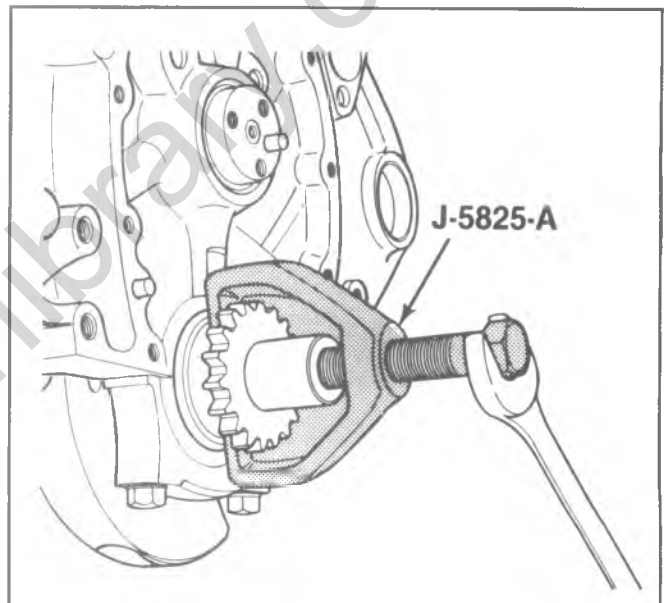

Figure 27—Replacing the Crankshaft Sprocket

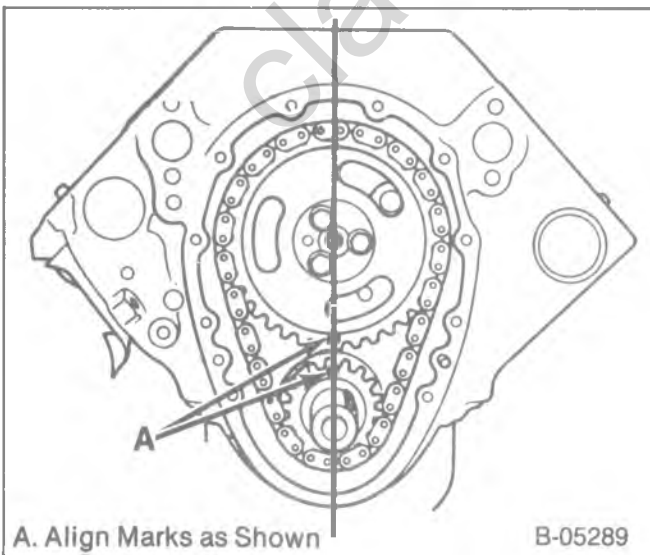
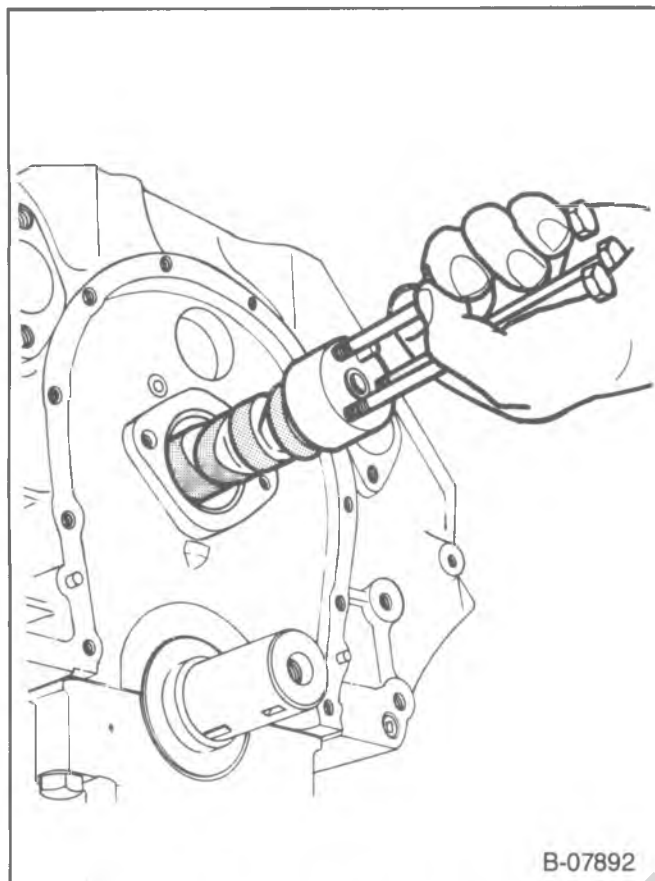

Figure 26—Timing Marks



B-07892

Figure 28—Replacing the Camshaft

- Two or three $\frac{5}{16}$ -18 bolts 100-125 mm (4-5 inches) long into the camshaft threaded holes. Use these bolts to handle the camshaft.
- Camshaft to the engine (figure 28). Handle the camshaft carefully to prevent damage to the camshaft bearings.
 - Lower the engine.
- Engine mount through-bolts.

 **Tighten**

- Through-bolts or nuts to specifications. Refer to figures 36 and 37.
- Crankshaft sprocket (if removed). Use J-5590 (figure 27). Make sure the timing mark faces outside.
 - Thrust plate (87) and screws (88).

 **Tighten**

- Screws (88) to 11.9 N·m (105 in. lbs.).
- Camshaft sprocket and timing chain.

 **Important**

- Line up the timing marks on the camshaft sprocket and crankshaft sprocket (figure 26).
- Camshaft sprocket bolts.

 **Tighten**

- Bolts to 23 N·m (17 ft. lbs.).
- Hydraulic lifters and pushrods, as outlined previously.

 **Important**

- Replace all hydraulic lifters, change the engine oil and filter, and add GM Engine Oil Supplement (or equivalent) to the engine oil whenever a new camshaft is installed.

 **Adjust**

- Valves, as outlined previously.
- Intake manifold, as outlined previously.
 - Distributor. Refer to ENGINE ELECTRICAL (SEC. 6D).
 - Front cover, as outlined previously.
 - Torsional damper, as outlined previously.
 - Water pump.
 - Rocker arm covers, as outlined previously.
 - Generator.
 - Fan, shroud, and radiator. Refer to ENGINE COOLING (SEC. 6B1) and RADIATOR (SEC. 6B2).
 - Air cleaner.
 - Battery negative cable.

G MODELS

 **Remove or Disconnect (Figures 25 through 28)**

Tool Required:

- J-5825-A Crankshaft Sprocket Puller.
- Battery negative cable.
 - Intake manifold, as outlined previously.
 - Rocker arm covers, as outlined previously.
 - Hydraulic lifters and pushrods, as outlined previously.
 - Outside air duct.
 - Power steering reservoir.
 - Upper fan shroud bolts.
 - Radiator. Refer to RADIATOR (SEC. 6B2).
 - Hood release cable at the latch.
 - Upper fan shroud.
 - Water pump.
 - Torsional damper, as outlined previously.
 - Front cover, as outlined previously.
 - Align the timing marks (figure 26).
 - Camshaft sprocket and timing chain. The sprocket is a light interference fit on the camshaft. Tap the sprocket on its lower edge to loosen it.
 - Screws (88) and thrust plate (87).
 - Crankshaft sprocket (if necessary). Use J-5825-A (figure 27).
 - Camshaft.

- Install two or three $\frac{5}{16}$ -18 bolts 100-125 mm (4-5 inches) long into the camshaft tapped holes. Use these bolts to handle the camshaft (figure 28).
- Pull the camshaft from the block. Use care to prevent damage to the camshaft bearings.

Cleaning, Inspection and Repair

Clean, inspect and repair or replace the camshaft and related components, as outlined in the proper unit repair manual.

The unit repair manual also describes camshaft bearing replacement.

 **Install or Connect (Figures 25 through 28)**

Tool Required:

- J-5590 Crankshaft Sprocket Installer.

- Coat the camshaft lobes and journals with a high quality engine oil supplement (GM Engine Oil Supplement or equivalent).
- 1. Two or three $\frac{5}{16}$ -18 bolts 100-125 mm (4-5 inches) long into the camshaft threaded holes. Use these bolts to handle the camshaft.
- 2. Camshaft to the engine (figure 28). Handle the camshaft carefully to prevent damage to the camshaft bearings.
- 3. Crankshaft sprocket. Use J-5590 (figure 27). Make sure the timing mark faces outside.
- 4. Thrust plate (87) and screws (88).

Tighten

- Screws (88) to 11.9 N·m (105 in. lbs.).
- 5. Camshaft sprocket and timing chain.

Important

- Line up the timing marks on the camshaft sprocket and crankshaft sprocket (figure 26).

6. Camshaft sprocket bolts.

Tighten

- Bolts to 23 N·m (17 ft. lbs.).

7. Front cover, as outlined previously.
8. Water pump.
9. Torsional damper, as outlined previously.
10. Front cover, as outlined previously.
11. Upper fan shroud.
12. Hood release cable.
13. Radiator. Refer to RADIATOR (SEC. 6B2).
14. Upper fan shroud bolts.
15. Outside air ducts.
16. Hydraulic lifters and pushrods, as outlined previously.

Adjust

- Valves, as outlined previously.

17. Rocker arm covers, as outlined previously.
18. Intake manifold, as outlined previously.
19. Battery negative cable.

CONNECTING ROD AND PISTON REPLACEMENT

Remove or Disconnect (Figure 29)

Tool Required:
J-5239 Guide Set.

1. Cylinder head, as outlined previously.
2. Oil pan, as outlined previously.
3. Oil pump, as outlined previously (if necessary).
4. Ridge or deposits from the upper end of the cylinder bores.
 - Turn the crankshaft until the piston is at BDC.
 - Place a cloth on top of the piston.
 - Perform the cutting operation with a ridge reamer.
 - Turn the crankshaft until the piston is at TDC.
 - Remove the cloth and cuttings.
5. Connecting rod cap. Check the connecting rod and cap for identification marks. Mark the parts if required. The connecting rod and cap must be kept together as mating parts.

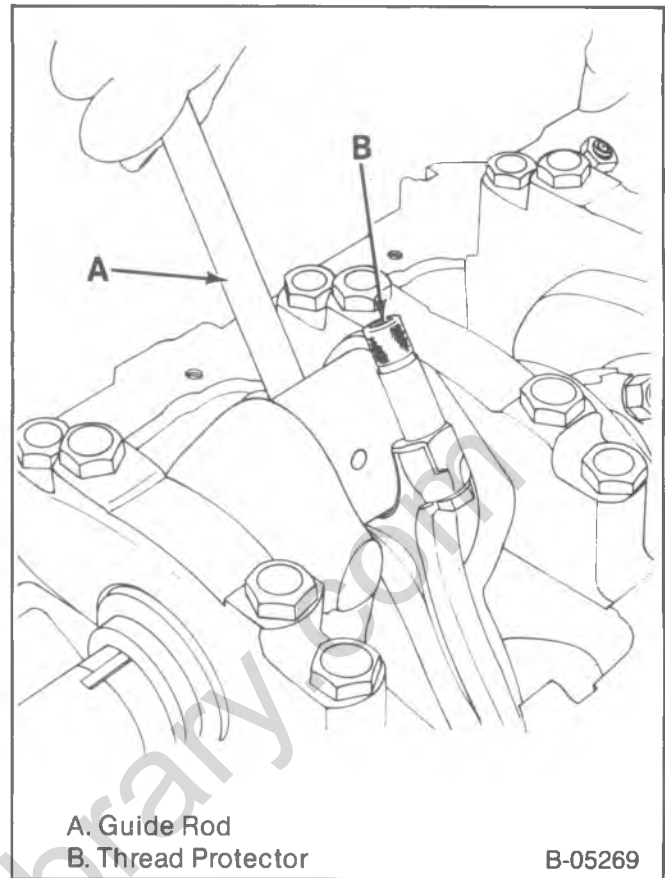

Figure 29—Replacing the Connecting Rod and Piston (Typical)

6. Connecting rod and piston.
 - Attach J-5239 to the connecting rod bolts (figure 29).
 - Use the long guide rod of J-5239 to push the connecting rod and piston out of the bore.
7. Connecting rod bearing.

Cleaning, Inspection, And Repair

Clean, inspect and repair or replace the components as necessary. Measure connecting rod bearing clearance, piston clearance, ring clearances, etc. Refer to the proper unit repair manual.

The unit repair manual contains information on:

- Connecting rod and piston.
- Piston rings.
- Connecting rod and crankpin.
- Cylinder bores.

Install or Connect (Figures 29 through 32)

Tools Required:
J-5239 Connecting Rod Guide Set.
J-8037 Ring Compressor.

- Make sure the cylinder walls are clean. Lubricate the cylinder wall lightly with engine oil.
 - Make sure the piston is installed in the matching cylinder.
1. Connecting rod bearings.
 - Be certain that the bearing inserts are of the proper size.
 - Install the bearing inserts in the connecting rod and connecting rod cap.

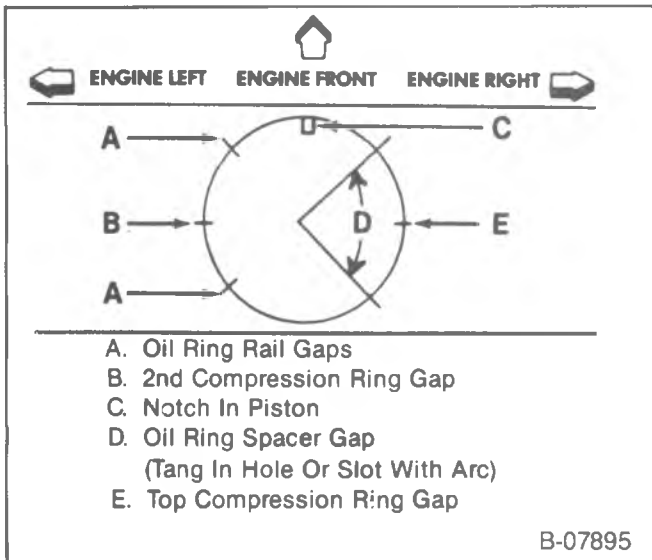

Figure 30—Piston Ring End Gap Locations

- Lubricate the bearings with engine oil.
- 2. Piston and connecting rod to the proper bore.
 - With the connecting rod cap removed, install J-5239 onto the connecting rod studs.
 - Locate the piston ring end gaps as shown in figure 30. Lubricate the piston and rings with engine oil.
 - Without disturbing the ring end gap location, install J-8037 over the piston (figure 31).

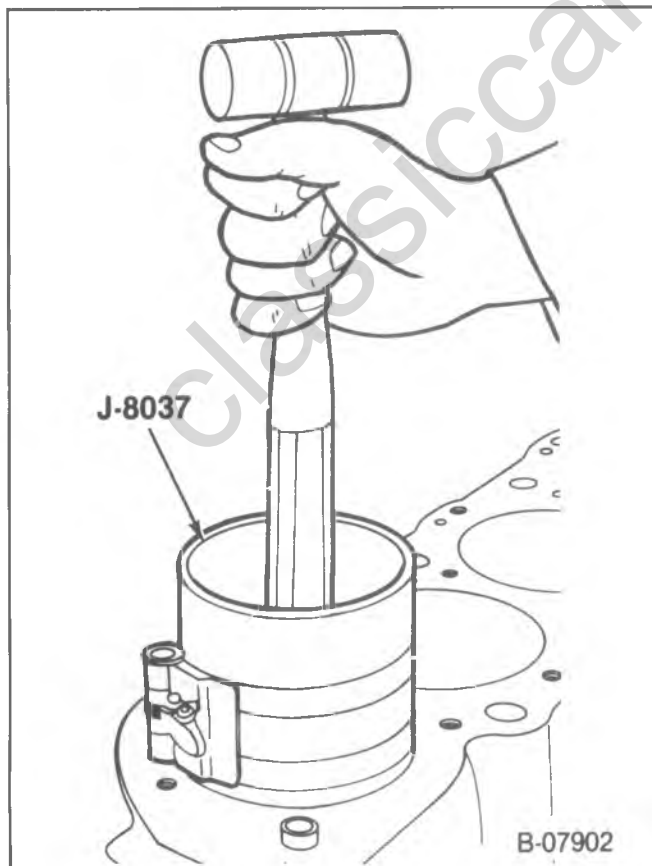

Figure 31—Installing the Piston



Figure 32—Measuring Connecting Rod Side Clearance

- The piston must be installed so that the notch in the piston faces the front of the engine (figure 30).
- Place the piston in its matching bore. The connecting rod bearing tang slots must be on the side opposite the camshaft. Using light blows with a hammer handle, tap the piston down into its bore (figure 31). At the same time, from beneath the vehicle guide the connecting rod to the crankpin with J-5239 (figure 29). Hold the ring compressor against the block until all rings have entered the cylinder bore.
- Remove J-5239 from the connecting rod bolts.

Important

- Each connecting rod and bearing cap should be marked, beginning at the front of the engine. Cylinders 1, 3 and 5 are at the left bank and, 2, 4 and 6 are the right bank. The numbers on the connecting rod and bearing cap must be on the same side when installed in the cylinder bore. If a connecting rod is ever transposed from block or cylinder to another, new connecting rod bearings should be fitted and the connecting rod should be numbered to correspond with the new cylinder number.

Measure

- Connecting rod bearing clearance. Refer to the proper unit repair manual.
3. Connecting rod cap and bearing.
 4. Connecting rod cap nuts.

Tighten

- Connecting rod cap nuts to 60 N·m (45 ft. lbs.).

Measure

- Connecting rod side clearance. Use a feeler gage between the connecting rod and crankshaft (figure 32). The correct clearance is 0.006-0.014-inch.
5. Oil pump (if removed), as outlined previously.

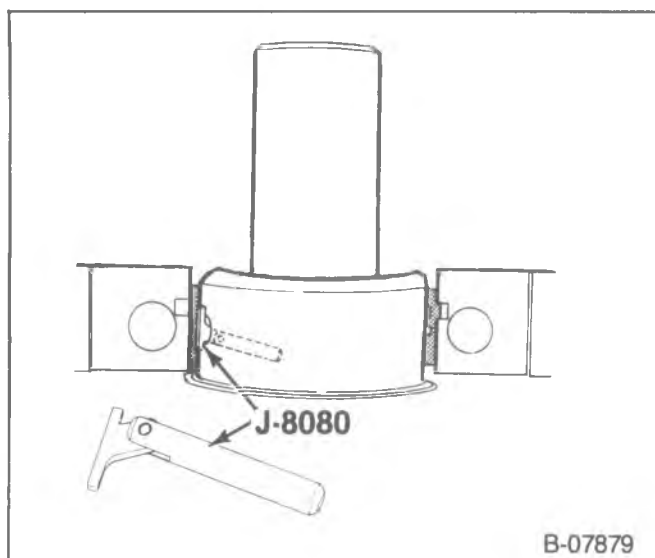

Figure 33—Removing the Main Bearing Insert

- Oil pan and cylinder head, as outlined previously.

MAIN BEARING REPLACEMENT

↔ Remove or Disconnect (Figure 33)

Tool Required:

J-8080 Main Bearing Remover/Installer.

- Spark plugs.
- Oil pan, as outlined previously.
- Oil pump, as outlined previously.
- Main bearing caps.
 - Check the main bearing caps for location markings. Mark the caps if necessary. The caps must be returned to their original locations during assembly.
- Lower main bearing inserts from the main bearing caps.
- Upper main bearing inserts.
 - Insert J-8080 into the crankshaft oil hole (figure 33).
 - Rotate the crankshaft to “turn” the bearing insert out of the block.

Cleaning, Inspection, And Repair

Clean, inspect, and repair or replace the components as required. Refer to the proper unit repair manual. The unit repair manual contains information on:

- Crankshaft.
- Main and connecting rod bearings.

↔ Install or Connect (Figures 33 and 34)

Tool Required:

J-8080 Main Bearing Remover/Installer.

- Upper main bearing inserts.
 - Insert J-8080 into a crankshaft main bearing oil hole (figure 33).
 - Apply engine oil to inserts of the proper size.
 - Insert the plain end (without the bearing tang) of the insert between the crankshaft and the notched side of the block.
 - Rotate the crankshaft to “roll” the insert into the block.

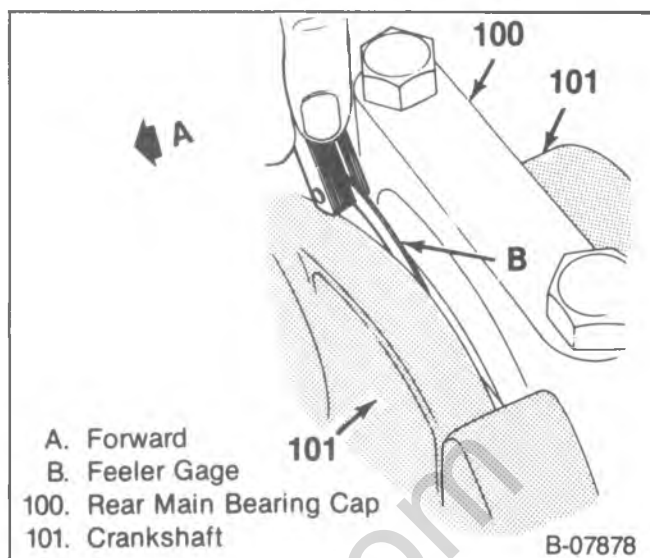

Figure 34—Measuring Crankshaft End Play

- Remove the tool.
- Lower main bearing inserts to the main bearing caps.
 - Make sure the inserts are of the proper size.
 - Apply engine oil to the inserts.

📏 Measure

- Main bearing clearance. Refer to the proper unit repair manual. If the engine is in the vehicle, the crankshaft must be supported upward to remove any clearance from the upper bearing. The total clearance can then be measured between the lower bearing and journal.
- Main bearing caps (except rear cap) and bolts to the block.

🔧 Tighten

- Main bearing cap bolts to 100 N·m (75 ft. lbs.).
- Rear main bearing cap.
 - Apply engine oil to the bearing insert.
 - Install the rear main bearing cap and bolts. Tighten the bolts temporarily to 14 N·m (10 ft. lbs.).

📏 Measure

- Crankshaft end play, as follows:
 - Tap the end of the crankshaft first rearward then forward with a lead hammer. This will line up the rear main bearing and crankshaft thrust surfaces.
 - Tighten the rear main bearing cap bolts to 100 N·m (75 ft. lbs.).
 - With the crankshaft forced forward, measure at the front end of the rear main bearing with a feeler gage (figure 34). The proper clearance is 0.002-0.006-inch.
 - If correct end play cannot be obtained, be certain that the correct size rear main bearing has been installed. Production engines may have rear main bearings that are 0.008-inch wider across the thrust faces than standard. Refer to the proper unit repair manual for more information.

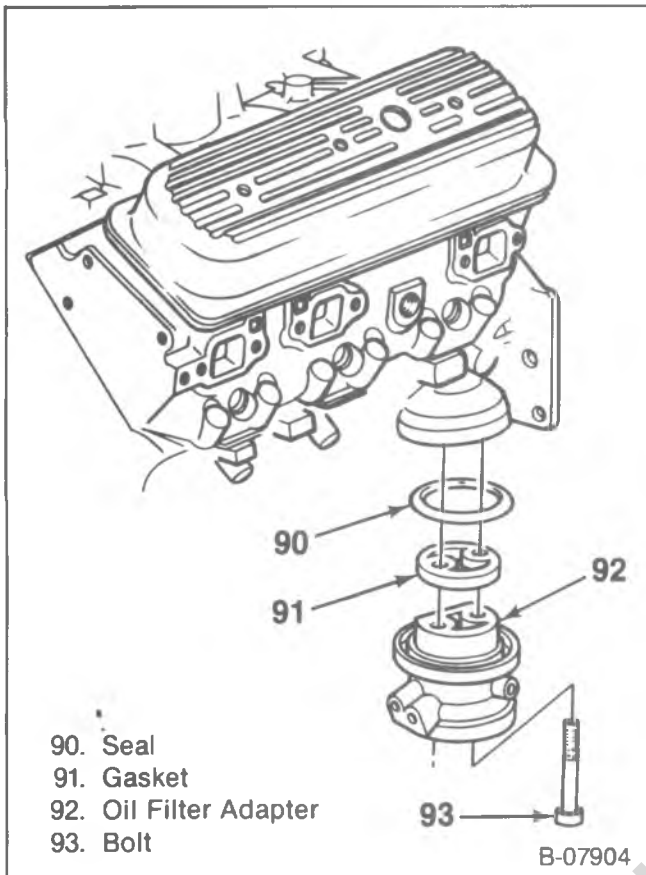

Figure 35—Oil Filter Adapter

8. Oil pump, as outlined previously.
9. Oil pan, as outlined previously.
10. Spark plugs.

OIL FILTER ADAPTER AND OIL FILTER BYPASS VALVE REPLACEMENT (MODELS WITH ENGINE OIL COOLER)

Remove or Disconnect (Figure 35)

1. Oil filter.

Inspect

- Bypass valve spring and fiber valve for proper operation, cracks, or other damage. If replacement is required, the bypass valve and oil filter adapter must be replaced as an assembly, as outlined following.

2. Oil cooler lines.
3. Bolts (93).
4. Oil filter adapter (92).
5. Gasket (91) and seal (90).

Install or Connect (Figure 33)

1. New gasket (91), new seal (90) and oil filter adapter (92) to the block.
2. Bolts (93).

Tighten

- Bolts (93) to 20 N·m (15 ft. lbs.).
3. Oil cooler lines.
 4. Oil filter.
 - Add engine oil as needed.

CRANKSHAFT REPLACEMENT

1. Remove the engine, as outlined later.
2. Refer to the proper unit repair manual for crankshaft replacement procedures.

FLYWHEEL REPLACEMENT

Remove or Disconnect

1. Transmission, flywheel housing, and clutch.
2. Flywheel bolts.
3. Flywheel.

Clean

- Mating surfaces of crankshaft and flywheel. Remove any burrs.

Inspect

- Flywheel for burning, scoring, warping, and wear. Replace the flywheel if necessary. Do not machine the flywheel.
- Flywheel ring gear for worn or broken teeth.

Flywheel Ring Gear Replacement

1. Use a torch to heat the gear around the entire circumference, then drive the gear off the flywheel, using care not to damage the flywheel.

NOTICE: Never heat starter gear to red heat as this will change metal structure.

2. Uniformly heat the flywheel gear to temperature which will expand the gear to permit installation. Temperature must not exceed 204°C (400°F).
3. As soon as the gear has been heated, install on the flywheel.

Install or Connect

1. Flywheel.
2. Flywheel bolts.

Tighten

- Flywheel bolts to 100 N·m (75 ft. lbs.).
3. Clutch, flywheel housing, and transmission.

ENGINE MOUNTINGS

NOTICE: Broken or deteriorated mountings can cause misaligned and eventual destruction of certain drive train components. When a single mounting breakage occurs, the remaining mountings are subjected to abnormally high stresses.

INSPECTING ENGINE MOUNTINGS

Front Engine Mountings

NOTICE: When raising or supporting the engine for any reason, do not use a jack under the oil pan, any sheet metal or crankshaft pulley. Due to the small clearance between the oil pan and the oil pump screen, jacking against the oil pan may cause it to be bent against the pump screen, resulting in a damaged oil pickup unit.

1. Raise the engine to remove weight from the mountings and to place a slight tension on the rubber cushion. Observe both mountings while raising the engine.
2. Replace the mounting if the following conditions exist:
 - Hard rubber surface covered with heat check cracks.
 - Rubber cushion separated from the metal palte of the mounting.
 - Rubber cushion split through the center.
3. If there is movement between a metal plate of the mounting and its attaching points, lower the engine and tighten the bolts or nuts attaching the mounting to the engine, frame, or bracket.

Rear Mountings

1. Push up and pull down on the transmission tailshaft. Observe the transmission mounting.
2. Replace the mounting if the following conditions exist:
 - Rubber cushion separated from the metal plate of the mounting.
 - Mounting bottomed out (tailshaft can be moved up but not down).
3. If there is relative movement between a metal plate of the mounting and its attaching point, tighten the bolts or nuts attaching the mounting to the transmission or crossmember.

FRONT MOUNTING REPLACEMENT

➔➔ Remove or Disconnect (Figures 36 and 37)

NOTICE: When raising or supporting the engine for any reason, do not use a jack under the oil pan, any sheet metal or crankshaft pulley. Due to the small clearance between the oil pan and the oil pump screen, jacking against the oil pan may cause it to be bent against the pump screen, resulting in a damaged oil pickup unit.

- Support the engine with a suitable jack. Do not load the engine mounting.
1. Engine mounting through-bolt and nut.

NOTICE: Raise the engine only enough for sufficient clearance. Check for interference between the rear of the engine and the dash panel which could cause distributor damage.

- Raise the engine only enough to permit removal of the engine mounting.
2. Mounting assembly bolts, nuts, and washers.
 3. Mounting assembly.

➔➔ Install or Connect (Figures 36 and 37)

1. Mounting assembly.

NOTICE: See "Notice" on page 6A3-1 of this section.

2. Mounting assembly bolts, nuts, and washers.

⌚ Tighten

- Fasteners to specifications. Refer to figures 36 and 37.
3. Engine mount through-bolt and nut. Lower the engine until the bolt can be inserted. Install the nut.

⌚ Tighten

- Through-bolt or nut to specifications. Refer to figures 36 and 37.

REAR MOUNTING RELACEMENT

➔➔ Remove or Disconnect (Figures 38 and 39)

NOTICE: When raising or supporting the engine for any reason, do not use a jack under the oil pan, any sheet metal or crankshaft pulley. Due to the small clearance between the oil pan and the oil pump screen, jacking against the oil pan may cause it to be bent against the pump screen, resulting in a damaged oil pickup unit.

- Support the rear of the engine to relieve the weight on the rear mountings.
1. Mounting to crossmember nut(s) and washer(s).
 2. Mounting to transmission bolts and washers.
 - Raise the rear of the engine only enough to permit removal of the mounting.
 3. Mounting.

➔➔ Install or Connect (Figures 38 and 39)

1. Mounting.
 - Lower the rear of the engine.
2. Mounting to transmission bolts and washers.

NOTICE: See "Notice" on page 6A3-1 of this section.

3. Mounting to crossmember nut(s) and washer(s).

⌚ Tighten

- Fasteners to specifications. Refer to figures 38 and 39.

ENGINE REPLACEMENT

"R" AND "V" MODELS

➔➔ Remove or Disconnect

1. Battery negative cable.
2. Hood.
 - Drain the cooling system.
3. Air cleaner.
4. All accessory drive belts.
5. Fan and water pump pulley.
6. Radiator and shroud. Refer to RADIATOR (SEC. 6B2).

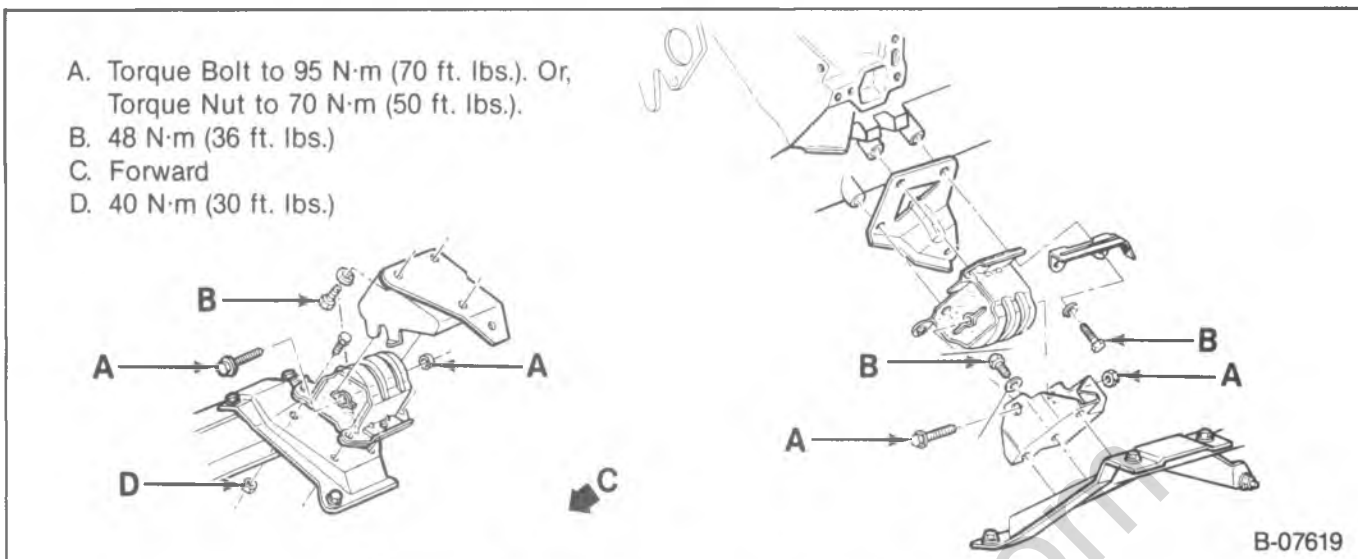

Figure 36—Front Engine Mounting (R and V Models)

- | | |
|--|---|
| <ul style="list-style-type: none"> 7. Heater hoses at the engine. 8. Accelerator cruise control, and detent linkage (if used) from the carburetor. 9. Air conditioning compressor (if used) and lay aside. 10. Power steering pump (if used) and lay aside. 11. Engine wiring harness from the engine. 12. Fuel line. 13. Vacuum lines from the intake manifold. <ul style="list-style-type: none"> • Raise the vehicle. Support with suitable safety stands. • Drain the crankcase oil. | <ul style="list-style-type: none"> 14. Exhaust pipes from the manifolds. 15. Strut rods at the engine mountings ("V" models with automatic transmission). 16. Flywheel or torque converter cover. 17. Wiring along oil pan rail. 18. Starter. 19. Wiring for fuel gage. 20. Converter to flex plate bolts (automatic transmission). <ul style="list-style-type: none"> • Lower the vehicle. • Support the transmission. |
|--|---|

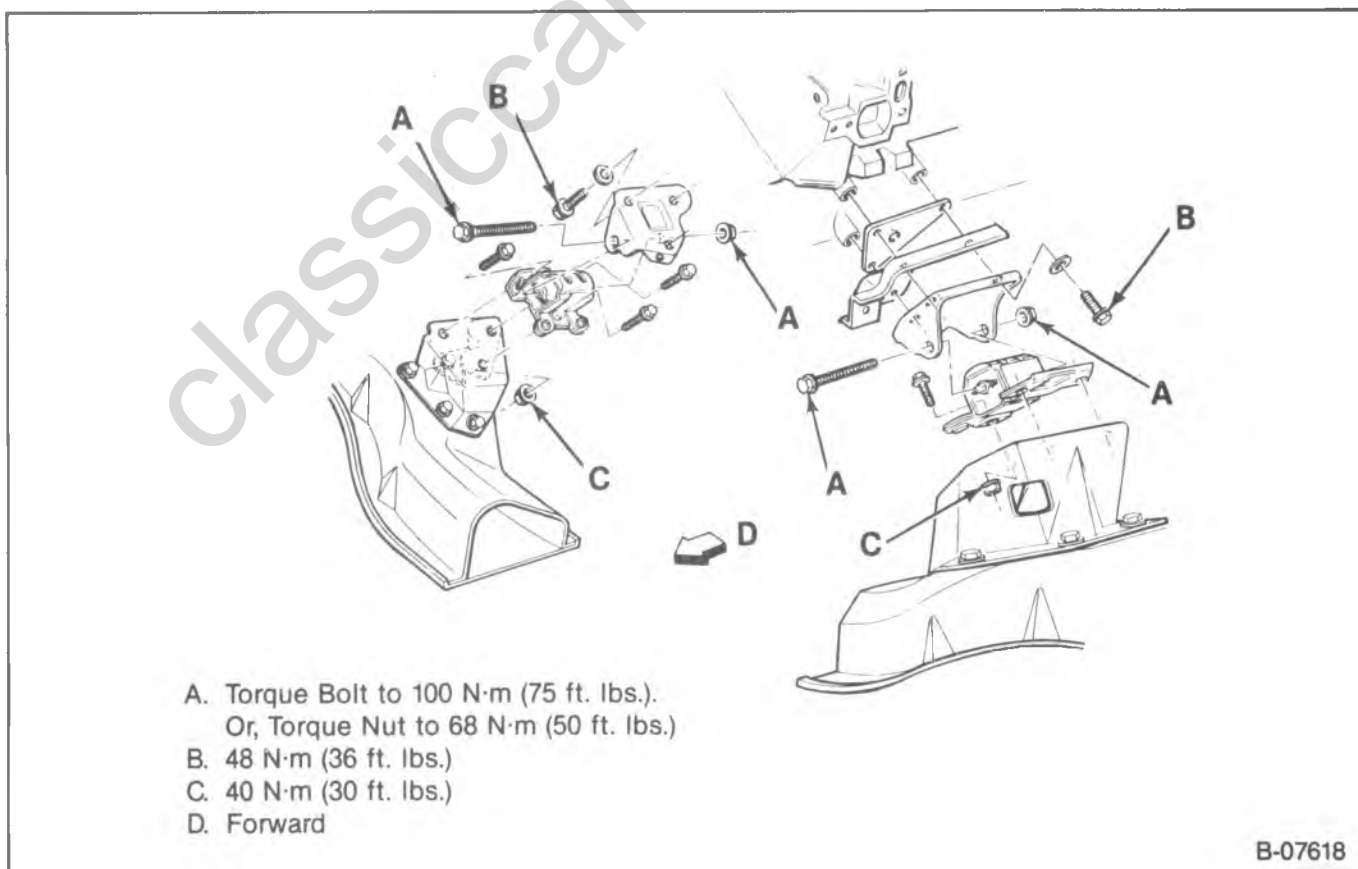

Figure 37—Front Engine Mounting (G Models)

- A. Torque Bolt to 100 N·m (75 ft. lbs.).
Or, Torque Nut to 68 N·m (50 ft. lbs.)
- B. 48 N·m (36 ft. lbs.)
- C. 40 N·m (30 ft. lbs.)
- D. Forward

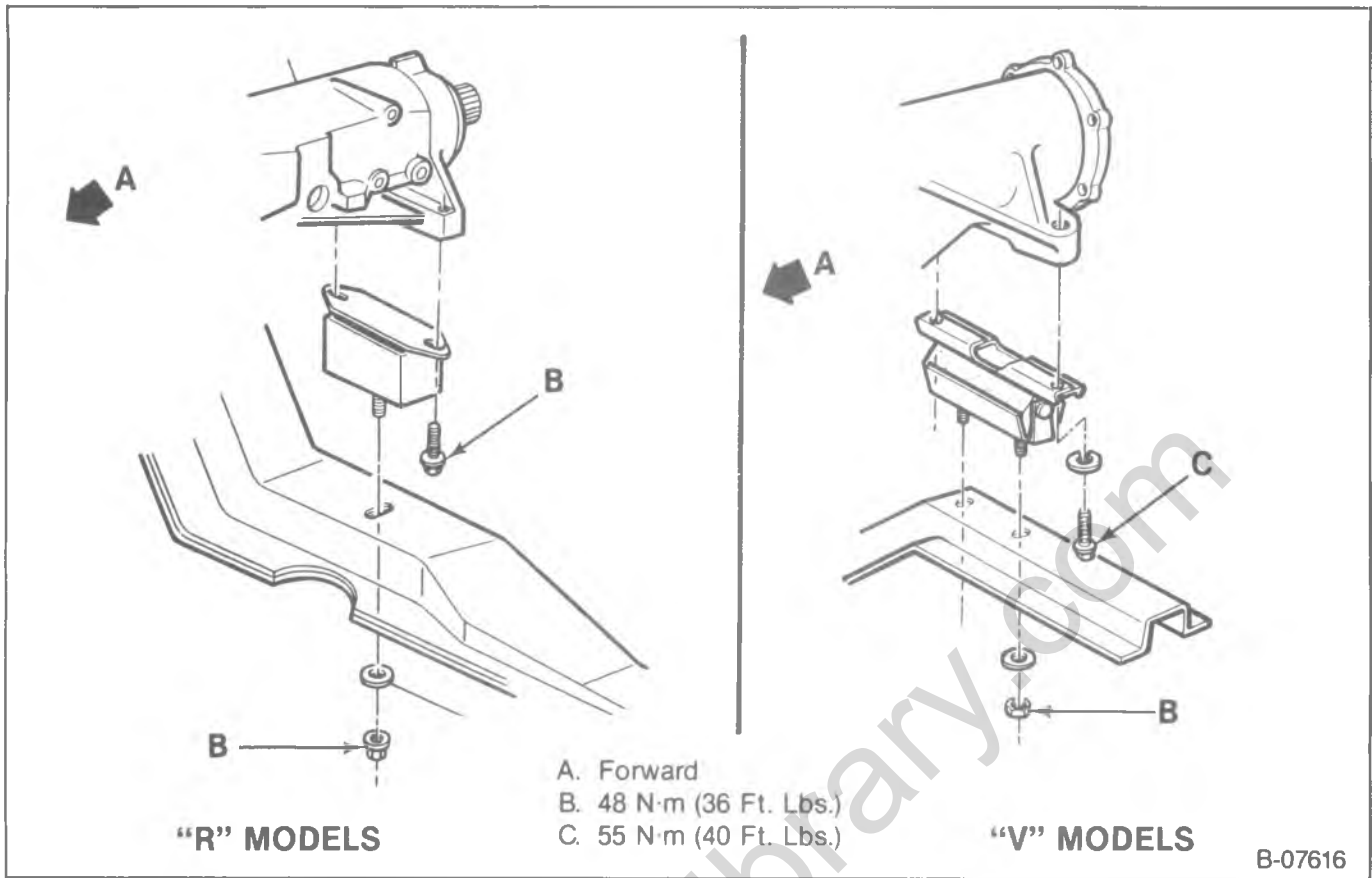

Figure 38—Rear Engine Mounting (R and V Models)

- Attach a suitable lifting fixture to the engine.
21. Bell housing to engine bolts.
 22. Engine mounting to frame bolts.
 23. Hood.
 24. Engine.

Install or Connect (Figure 36)

1. Engine to the vehicle.
 - Raise the vehicle. Support with suitable safety stands.

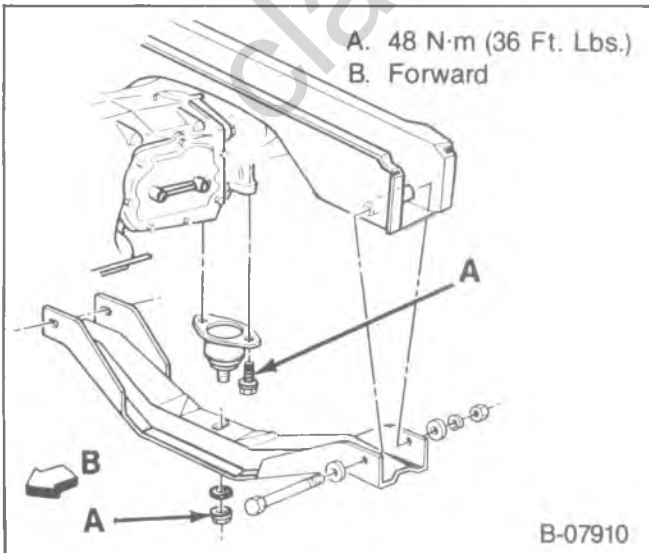

Figure 39—Rear Engine Mounting (G Models)

NOTICE: See "Notice" on page 6A3-1 of this section.

2. Engine mounting to frame bolts.

Tighten

- Fasteners to specifications. Refer to figure 36.
3. Bell housing to engine bolts. Remove the transmission support.
 4. Converter to flex plate bolts.
 5. Fuel gage wiring.
 6. Starter.
 7. Wiring along oil pan rail.
 8. Flywheel or torque converter cover.
 9. Strut rods at the engine mountings (V models with automatic transmission).
 10. Exhaust pipes to the manifolds.
 - Lower the vehicle.
 11. Vacuum lines to the intake manifold.
 12. Fuel line.
 13. Engine wiring harness.
 14. Power steering pump (if used).
 15. Air conditioning compressor (if used).
 16. Accelerator, cruise control, and detent linkages.
 17. Heater hoses.
 18. Radiator and shroud. Refer to RADIATOR (SEC. 6B2).
 19. Accessory drive belts.
 20. Air cleaner.
 21. Hood.
 22. Proper quantity and grade of coolant and crankcase oil.
 23. Battery negative cable.

“G” MODELS**Remove or Disconnect**

1. Battery negative cable.
2. Glove box.
3. Engine cover.
 - Drain the coolant.
4. Outside air duct.
5. Power steering fluid reservoir.
6. Hood release cable.
7. Upper fan shroud bolts.
8. Radiator. Refer to RADIATOR (SEC. 6B2).
9. Upper fan shroud.
10. Fan and pulley.
11. Air cleaner.
12. Cruise control transducer.
13. Vacuum hoses at the intake manifold.
14. Accelerator, cruise control, and TVS cables (if used).
15. TBI unit.
16. Distributor cap.
17. Diverter valve.
18. Coolant hose at the intake manifold.
19. PCV valve.
20. Other necessary vacuum hoses and wires.
21. Air conditioning compressor and brace. Refer to AIR CONDITIONING (SEC. 1B).
22. Upper half of engine dipstick tube.
23. Oil filler tube.
24. Transmission dipstick tube.
25. Accelerator cable at the dipstick tube.
26. Fuel hoses at the fuel pump.
27. Power steering pump.
28. Headlamp bezels and grille.
29. Upper radiator support.
30. Lower fan shroud and filler panel.
31. Hood latch support.
32. Condenser.
 - Raise the vehicle. Support with suitable safety stands.
 - Drain the crankcase.
33. Exhaust pipes at the manifolds.
34. Strut rods at the torque converter or flywheel underpan.
35. Torque converter or flywheel cover.
36. Starter.
37. Flexplate to torque converter bolts (automatic transmissions).
38. Bell housing to engine bolts.
39. Engine mounting through bolts.
 - Lower the vehicle and support the transmission.
40. Engine.

**Install or Connect (Figure 37)**

1. Engine to the vehicle.
 - Raise the vehicle. Support with suitable safety stands.

NOTICE: See “Notice” on page 6A3-1 of this section.

2. Engine mounting through-bolts.

**Tighten**

- Through-bolts or nuts to specifications. Refer to figure 37.
3. Bell housing to engine bolts.

4. Flex plate to torque converter bolts (automatic transmissions).
5. Starter.
6. Torque converter or flywheel cover.
7. Strut rods.
8. Exhaust pipes.
 - Lower the vehicle.
9. Condenser.
10. Hood latch support.
11. Lower fan shroud and filler panel.
12. Upper radiator support.
13. Headlamp bezels and grille.
14. Pump.
15. Fuel hoses.
16. Accelerator cable at the dipstick tube.
17. Transmission dipstick tube.
18. Oil filler tube.
19. Upper half of engine dipstick tube.
20. Air conditioning compressor and brace. Refer to AIR CONDITIONING (SEC. 1B).
21. Vacuum hoses and wires.
22. PCV valve.
23. Coolant hose at the intake manifold.
24. Diverter valve.
25. Distributor cap.
26. TBI unit.
27. Accelerator, cruise control, and detent cables.
28. Vacuum hoses at the intake manifold.
29. Cruise control servo.
30. Air cleaner.
31. Fan and pulley.
32. Upper fan shroud.
33. Radiator. Refer to RADIATOR (SEC. 6B2).
34. Upper fan shroud bolts.
35. Hood release cable.
36. Power steering fluid reservoir.
37. Outside air duct.
38. Glove box.
39. Proper quantity and grade of coolant and crankcase oil.
40. Engine cover.
41. Battery negative cable.
 - Evacuate and charge the air conditioning system. Refer to AIR CONDITIONING (SEC. 1B).

SPECIFICATIONS

ENGINE SPECIFICATIONS

All Specifications are in INCHES unless otherwise noted.

GENERAL DATA:				
Type	V6			
Displacement	4.3L (262 Cu. In.)			
RPO	LB4			
Bore	4.00			
Stroke	3.48			
Compression Ratio	9.3:1			
Firing Order	1 - 6 - 5 - 4 - 3 - 2			
Oil Pressure	10 psi @ 500 RPM; 30-35 psi @ 2000 RPM			
CYLINDER BORE:				
Diameter	3.9995-4.0025			
Out Of Round	Production	0.001 (Maximum)		
	Service	0.002 (Maximum)		
Taper	Production	Thrust Side	0.0005 (Maximum)	
		Relief Side	0.001 (Maximum)	
	Service	0.001 (Maximum)		
PISTON:				
Clearance	Production	0.0007-0.0017		
	Service Limit	0.0027 (Maximum)		
PISTON RING:				
C O M P R E S S I O N	Groove Clearance	Production	Top	0.0012-0.0032
			2nd	
	Service Limit		Hi Limit Production + 0.001	
	Gap	Production	Top	0.010-0.020
			2nd	0.010-0.025
		Service Limit		Hi Limit Production + 0.010
O I L	Groove Clearance	Production	0.002-0.007	
		Service Limit	Hi Limit Production + 0.001	
	Gap	Production	0.015-0.055	
		Service Limit	Hi Production + 0.010	
PISTON PIN:				
Diameter	0.9270-0.09273			
Clearance In Piston	Production	0.0002-0.0007		
	Service Limit	0.001 (Maximum)		
Fit In Rod	0.0008-0.0016 Interference			

SPECIFICATIONS (CONT.)

ENGINE SPECIFICATIONS (CONT.)

All specifications are in INCHES unless otherwise noted.

DISPLACEMENT:		4.3L		
CRANKSHAFT:				
Main Journal	Diameter	#1	2.4484-2.4493	
		#2, #3	2.4481-2.4490	
		#4	2.4479-2.4488	
	Taper	Production	0.0002 (Maximum)	
		Service Limit	0.001 (Maximum)	
	Out Of Round	Production	0.0002 (Maximum)	
Service Limit		0.001 (Maximum)		
Main Bearing Clearance	Production	#1	0.0008-0.0020	
		#2, #3	0.0011-0.0023	
		#4	0.0017-0.0032	
	Service Limit	#1	0.0010-0.0015	
		#2, #3	0.0010-0.0025	
		#4	0.0025-0.0035	
Crankshaft End Play		0.002-0.006		
Crankpin	Diameter	2.2487-2.2497		
		Taper	Production	0.0005
			Service Limit	0.001 (Maximum)
	Out Round	Production	0.0005	
		Service Limit	0.001 (Maximum)	
	Rod Bearing Clearance	Production	0.0013-0.0035	
Service Limit		0.0030		
Rod Side Clearance		0.006-0.014		
CAMSHAFT:				
Lobe Lift \pm 0.002	Intake		0.357	
	Exhaust		0.390	
Journal Diameter		1.8682-1.8692		
Camshaft End Play		0.004-0.012		
VALVE SYSTEM:				
Lifter		Hydraulic		
Rocker Arm Ratio		1.50:1		
Valve Lash	Intake	One Turn Down From Zero Lash		
	Exhaust			
Face Angle (Intake & Exhaust)		45°		
Seat Angle (Intake & Exhaust)		46°		
Seat Runout (Intake & Exhaust)		0.002 (Maximum)		
Seat Width	Intake		$1/32$ - $1/16$	
	Exhaust		$1/16$ - $3/32$	
Stem Clearance	Production	Intake	0.0010-0.0027	
		Exhaust	0.0010-0.0027	
	Service	Intake	High Limit Production + 0.001	
		Exhaust	High Limit Production + 0.002	
Valve Spring (Outer)	Free Length		2.03	
	Pressure lbs. @ in.	Closed	76-84 lbs. @ 1.70-in.	
		Open	194-206 lbs. @ 1.25-in.	
Installed Height \pm $1/32$ "		$1^{23/32}$		
Valve Spring Damper	Free Length		1.86	
	Approx. # of Coils		4	

SPECIFICATIONS (CONTINUED)

TORQUE SPECIFICATIONS

ITEM	N·m	FT. LBS.	IN. LBS.
Rocker Arm Cover Bolts	11.3	—	100
Intake Manifold Bolts	48	35	—
Exhaust Manifold Bolts			
Center Two Bolts	36	26	—
All Others	28	20	—
Cylinder Head Bolts	90	65	—
Torsional Damper Bolt	95	70	—
Front Cover Bolts	11.3	—	100
Oil Pan Nuts	22.6	—	200
Oil Pan Bolts	11.3	—	100
Oil Pump Bolt	90	65	—
Rear Crankshaft Oil Seal Retainer Screws and Nuts	15.3	—	135
Camshaft Sprocket Bolts	23	17	—
Connecting Rod Cap Nuts	60	45	—
Oil Filter Adapter Bolts	20	15	—
Main Bearing Cap Bolts	100	75	—
Oil Pump Cover Bolts	9.0	—	80
Flywheel Bolts	100	75	—
Spark Plugs	30	22	—
Water Outlet Bolts	28	21	—
Water Pump Bolts	40	30	—
Flywheel Housing Bolts	44	32	—
Camshaft Thrust Plate Screws	11.9	—	105
Hydraulic Lifter Restrictor Retainer Bolts	16.4	—	145
Oil Pan Studs to Oil Seal Retainer or Crankcase	1.7	—	15

SPECIAL TOOLS



J-23523-E



J-5892-B



J-23590



J-35468



J-8080



J-8037



J-5239



J-23738-A



J-5802-01



J-5715



J-6036



J-6880



J-5825-A



J-5590



J-8520



J-35621

1. Torsional Damper Remover and Installer
2. Valve Spring Compressor
3. Air Adapter
4. Crankshaft Seal Installer and Centering Tool
5. Main Bearing Replacer
6. Piston Ring Compressor
7. Guide Set
8. Vacuum Pump

9. Stud Remover
10. Reamer (0.003-inch oversize)
11. Reamer (0.013-inch oversize)
12. Stud Installer
13. Crankshaft Gear Puller
14. Crankshaft Gear Installer
15. Dial Indicator Adapter
16. Rear Crankshaft Seal Installer

classiccarslibrary.com

SECTION 6A4

SMALL BLOCK

The following "Notice" applies to one or more steps in the assembly procedure of components in this portion of the manual as indicated at appropriate locations by the terminology "NOTICE: See 'Notice' on page 6A4-1 of this section."

NOTICE: All engine fasteners are important attaching parts in that they could affect the performance of vital components and systems, and/or could result in major repair expense. They must be replaced with one of the same part number or with an equivalent part if replacement becomes necessary. Do not use a replacement part of lesser quality or substitute design. Torque values must be used as specified during reassembly to assure proper retention of this part.

CONTENTS

<u>SUBJECT</u>	<u>PAGE</u>
Description6A4- 2
Engine Lubrication6A4- 2
On-Vehicle Service6A4- 5
Rocker Arm Cover Replacement6A4- 5
Rocker Arm and Pushrod Replacement6A4- 6
Valve Adjustment6A4- 6
Valve Stem Seal and Valve Spring Replacement6A4- 7
Intake Manifold Replacement6A4- 8
Hydraulic Lifter Replacement6A4- 9
Rocker Arm Stud Replacement6A4-10
Exhaust Manifold Replacement6A4-11
Cylinder Head Replacement6A4-12
Torsional Damper and Front Crankshaft Seal Replacement6A4-13
Front Cover Replacement6A4-14
Oil Pan Replacement6A4-14
Oil Pump Replacement6A4-15
Rear Crankshaft Oil Seal Replacement6A4-15
Rear Crankshaft Oil Seal Retainer Replacement6A4-16
Measuring Camshaft Lobe Lift6A4-17
Camshaft Replacement6A4-17
Connecting Rod and Piston Replacement6A4-19
Oil Filter Bypass Valve6A4-20
Main Bearing Replacement6A4-21
Crankshaft Replacement6A4-22
Flywheel Replacement6A4-22
Engine Mountings6A4-22
Engine Replacement6A4-23
Specifications6A4-32
Special Tools6A4-35

DESCRIPTION

Small block engines covered by this manual are available in two displacements; 5.0L (305 cu. in.) and 5.7L (350 cu. in.).

Small block engines are 90-degree V8 type, overhead valve, water cooled, with cast iron block and heads.

The crankshaft is supported by five precision insert main bearings, with crankshaft thrust taken at the number five (rear) bearing.

The camshaft is supported by five plain type bearings and is chain driven. Motion from the camshaft is transmitted to the valves by hydraulic lifters, pushrods, and ball type rocker arms. The valve guides are integral in the cylinder head.

The connecting rods are forged steel, with precision insert type crankpin bearings. The piston pins are a press fit in the connecting rods.

The pistons are cast aluminum alloy. The piston pins are a floating fit in the piston.

ENGINE LUBRICATION

Lubrication schematics are shown in figures 1 and 2. The gear type oil pump is driven from the distributor shaft, which is gear driven from the camshaft. Oil is drawn into the oil pump through a pickup screen and pipe.

Pressurized oil is routed to the oil filter. In case of excessive oil pressure, a bypass valve is provided. Filtered oil flows into the main gallery and then to the camshaft and crankshaft bearings. The valve lifter oil gallery supplies oil to the valve lifters. Oil flows from the hydraulic lifters through the hollow pushrods to the rocker arms. Oil from the overhead drains back to the crankcase through oil drain holes.

The timing chain is drip fed from the front camshaft bearing. The pistons and piston pins are lubricated by oil splash.

classiccarslibrary.com

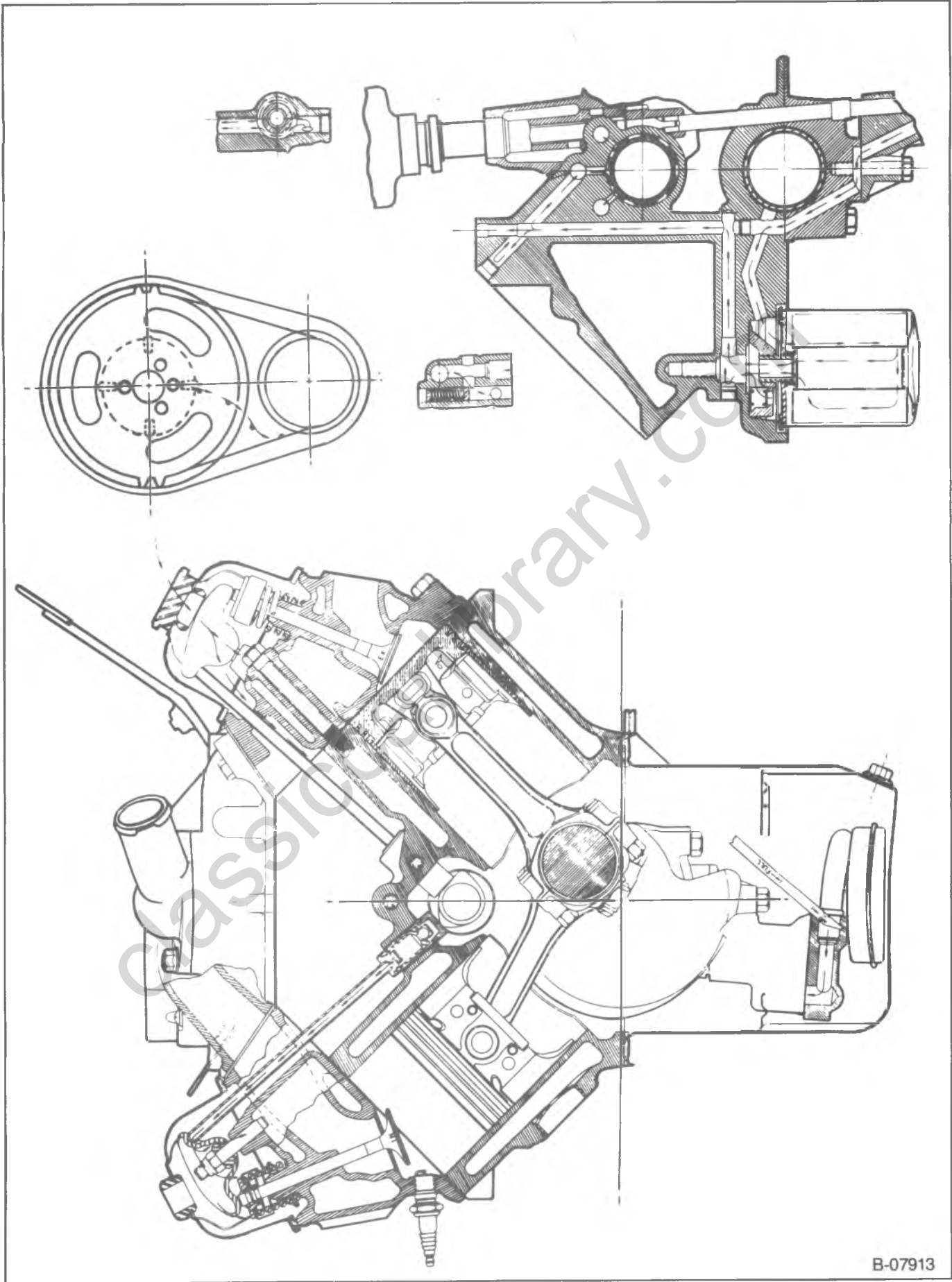
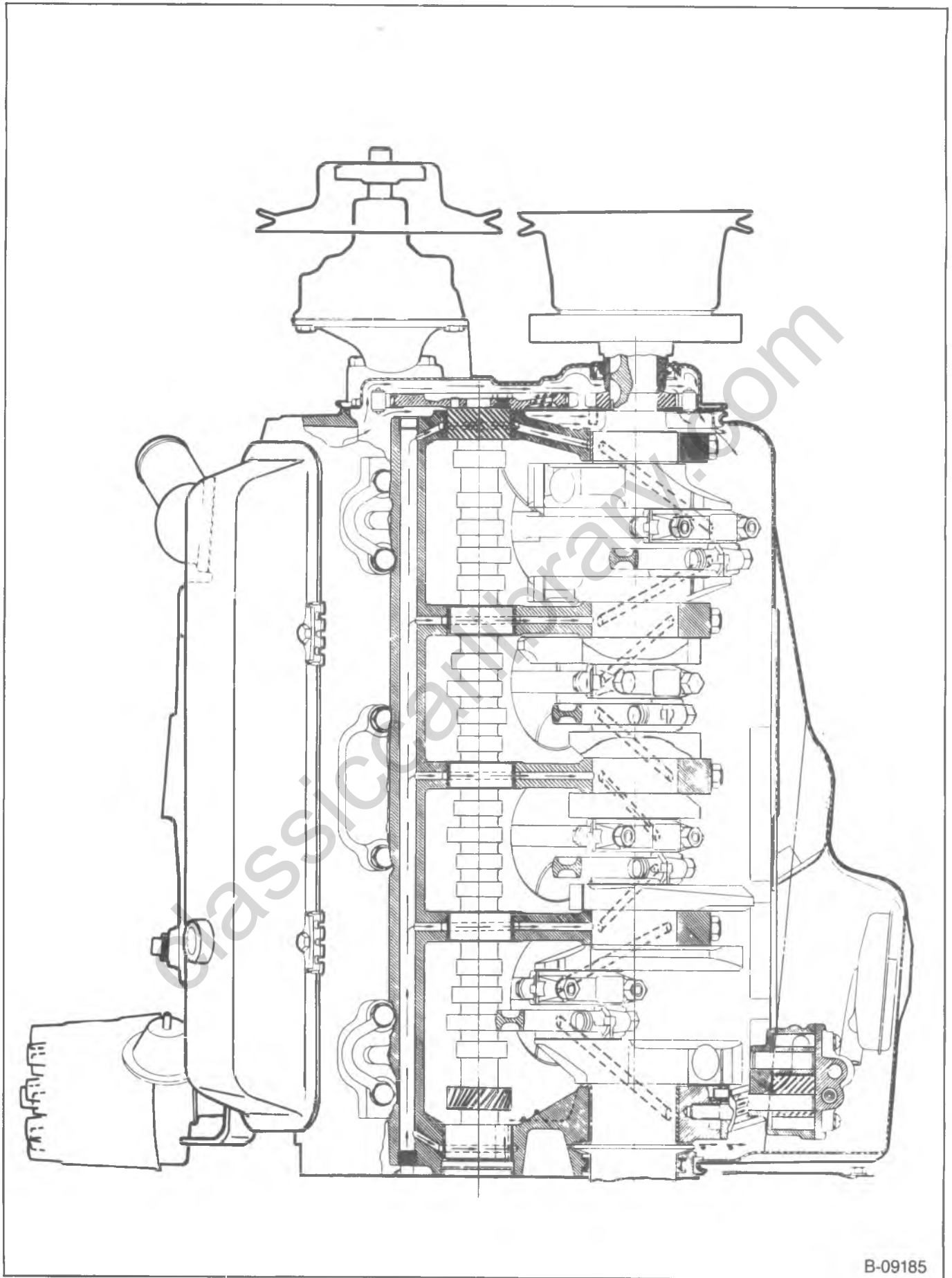

Figure 1—Engine Lubrication Diagram

B-07913



B-09185

Figure 2—Engine Lubrication Diagram

ON-VEHICLE SERVICE

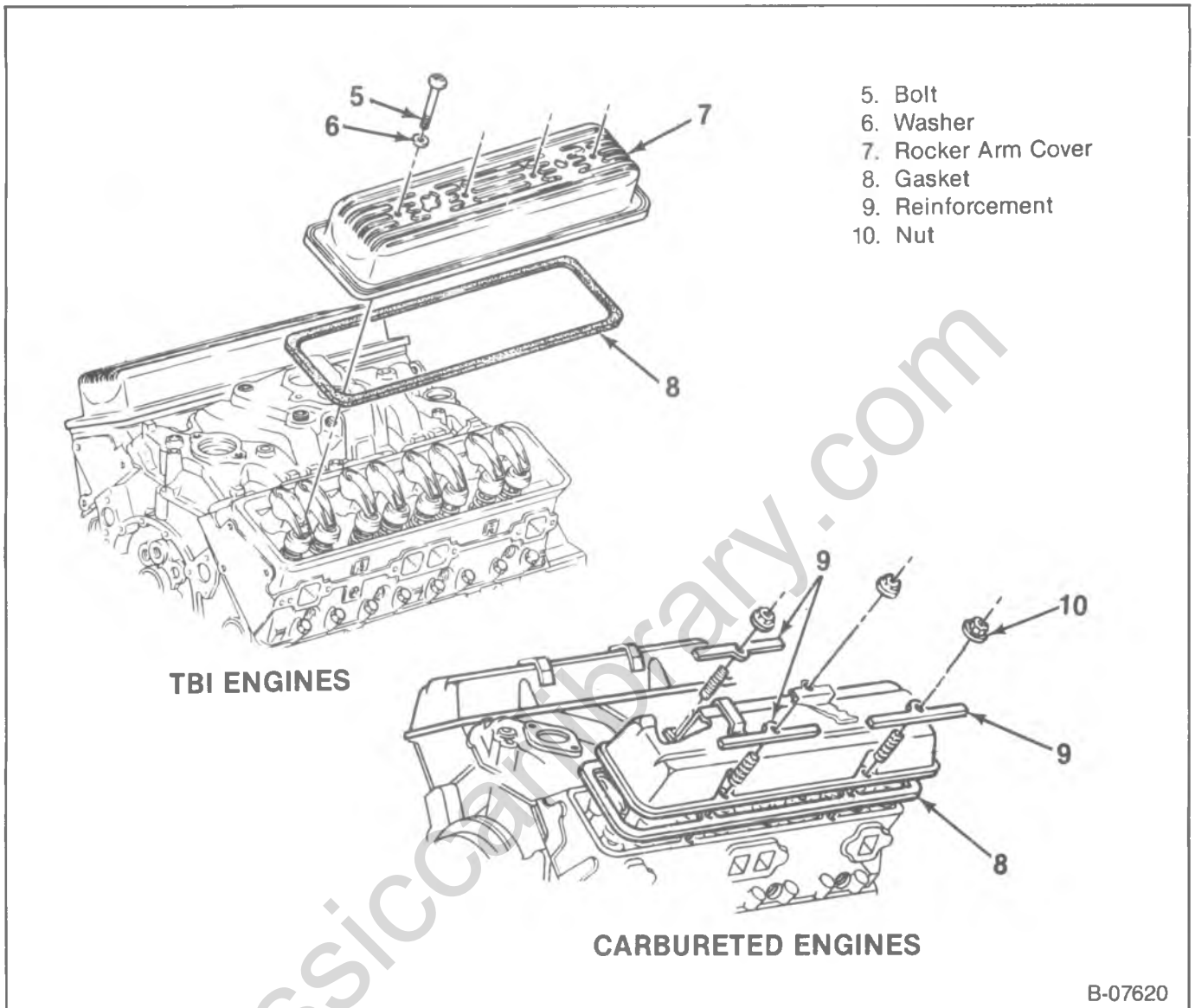

Figure 3—Rocker Arm Cover

ROCKER ARM COVER REPLACEMENT

REMOVAL — TBI ENGINES

↔ Remove or Disconnect (Figure 3)

1. Battery negative cable.
2. Engine cover (G models).
3. Air cleaner.
4. Crankcase ventilation hoses at the rocker arm covers.
5. Wiring harnesses from the clips, and move aside.
6. Components as follows for right rocker arm cover:
 - AIR hose from check valve (G models).
 - Diverter valve and hoses from bracket (G models).
 - PCV valve.
 - Upper dipstick bracket (G models).
 - Heat stove pipe.

7. Components as follows for left rocker arm cover:

- Generator rear brace (G models).
 - Oil fill tube (G models).
 - Power brake vacuum pipe and move aside (R and V models).
 - Air conditioning compressor, and lay aside (R and V models).
8. AIR pipe at manifold (G models).
 9. Rocker arm cover bolts and washers.
 10. Rocker arm cover and gasket.

REMOVAL — CARBURETED ENGINES

↔ Remove or Disconnect (Figure 3)

1. Battery negative cable.
2. Engine cover (G models).
3. Air cleaner.
4. Crankcase ventilation hoses at the rocker arm covers.
5. Wiring harnesses from the clips, and move aside.

B-07620

6A4-6 SMALL BLOCK

6. Diverter valve with bracket and hoses.
7. AIR check valve.
8. Oil fill tube (right side cover).
9. Heat stove pipe (right side cover).
10. Components as follows for left rocker arm cover:
 - Decel valve and bracket (G models).
 - Vacuum pipe from EFE valve.
 - Power brake vacuum pipe, and move aside.
 - Air conditioning compressor rear brace (if equipped).
11. Rocker arm cover nuts, reinforcements, and wire clips.
12. Rocker arm cover and gasket.

CLEANING AND INSPECTION



Clean

- All traces of old gasket from the rocker arm cover and cylinder head.



Inspect

- Rocker arm cover sealing surface for distortion. Replace if necessary.

INSTALLATION — TBI ENGINES



Install or Connect (Figure 3)

1. Rocker arm cover and new gasket.
2. Rocker arm cover bolts and washers.



Tighten

- Bolts to 11.3 N·m (100 in. lbs.).
3. AIR pipe at manifold (G models).
 4. Components as follows for left rocker arm cover:
 - Air conditioning compressor (R and V models).
 - Power brake vacuum pipe (R and V models).
 - Oil fill tube (G models).
 - Generator rear brace (G models).
 5. Components as follows for right rocker arm cover:
 - Heat stove pipe.
 - Upper dipstick bracket (G models).
 - PCV valve.
 - Diverter valve and hoses (G models).
 - AIR hose to check valve (G models).
 6. Wiring harnesses to the rocker arm clips.
 7. Crankcase ventilation hoses.
 8. Air cleaner.
 9. Engine cover (G models).
 10. Battery negative cable.

INSTALLATION — CARBURETED ENGINES



Install or Connect (Figure 3)

1. Rocker arm cover and new gasket.
2. Reinforcements, wire clips, nuts, and stud (if used).



Tighten

- Nuts to 7.3 N·m (65 in. lbs.).
3. Components as follows for left rocker arm cover:
 - Air conditioning compressor rear brace (if equipped).
 - Power brake vacuum pipe.
 - Vacuum pipe to EFE valve.
 - Decel valve and bracket.
 4. Heat stove pipe (right side cover).

5. Oil fill tube (right side cover).
6. AIR check valve.
7. Diverter valve, bracket, and hoses.
8. Wiring harnesses to the rocker arm clips.
9. Crankcase ventilation hoses.
10. Air cleaner.
11. Engine cover (G models).
12. Battery negative cable.

ROCKER ARM AND PUSHROD REPLACEMENT



Remove or Disconnect

1. Rocker arm cover, as outlined previously.
2. Rocker arm nut.
 - If only the pushrod is to be replaced, back the rocker arm nut off until the rocker arm can be swung away from the pushrod. Then pull the pushrod out.
3. Rocker arm with ball.
4. Pushrod.



Important

- Store used components in order so they can be reassembled in the same location.



Inspect

- Rocker arms and balls at their mating surfaces. These surfaces should be smooth and free from scoring or other damage.
- Rocker arm areas which contact the valve stems and the sockets which contact the pushrods. These areas should be smooth and free of damage and wear.
- Pushrods for bending. Roll the pushrod on a flat surface to determine if it is bent. Replace if necessary.
- Ends of the pushrods for scoring or roughness.



Install or Connect

1. Pushrod. Make sure the pushrod seats properly in the hydraulic lifter.
2. Rocker arm with ball.



Important

- When new rocker arms and/or balls are installed, coat their bearing surfaces with "Molykote" or equivalent.
3. Rocker arm nut.



Adjust

- Valves as outlined later.
4. Rocker arm cover, as outlined previously.

VALVE ADJUSTMENT

1. Remove the rocker arm cover as outlined previously.
2. Crank the engine until the mark on the vibration damper lines up with the "O" mark on the timing tab and the engine in the number one firing position. This may be determined by placing fingers on the number

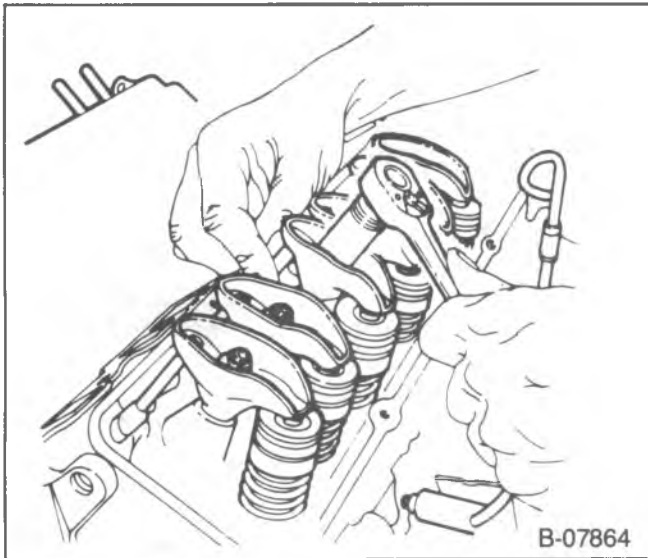

Figure 4—Adjusting the Valves

one valve as the mark on the damper comes near the "O" mark on the timing tab. If the rocker arms are not moving, the engine is in the number one firing position. If the rocker arms move as the mark comes up to the timing tab, the engine is in the number six firing position and should be turned over one more time to reach the number one position.

3. With the engine in the number one firing position as determined above, the following valves may be adjusted:

- Exhaust: 1, 3, 4, 8
- Intake: 1, 2, 5, 7

(Even numbered cylinders are in the right bank; odd numbered cylinders are in the left bank, when viewed from the rear of the engine).

4. Back out the adjusting nut until lash is felt at the pushrod then turn in the adjusting nut until all lash is removed. This can be determined by rotating the pushrod while turning the adjusting nut (figure 4). When the play has been removed, turn the adjusting nut in one full additional turn (to center the lifter plunger).

5. Crank the engine one revolution until the timing tab "O" mark and vibration damper mark are again in alignment. This is the number six firing position the following valves may be adjusted:

- Exhaust: 2, 5, 6, 7
- Intake: 3, 4, 6, 8

6. Install the rocker arm cover as outlined previously.

VALVE STEM SEAL AND VALVE SPRING REPLACEMENT

Remove or Disconnect (Figures 5 and 6)

Tools Required:

- J-23590 Air Adapter
- J-5892-B Spring Compressor

1. Rocker arm cover, as outlined previously.
2. Rocker arms, as outlined previously.
3. Spark plugs.
4. Valve keepers (20).

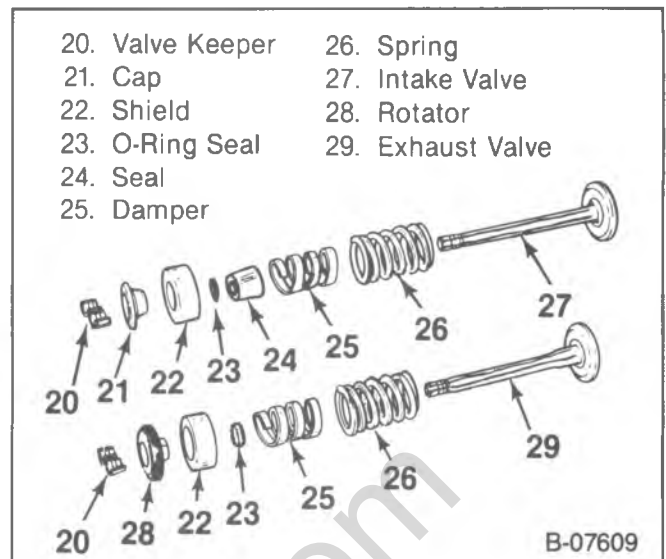

Figure 5—Valves and Components

- Install J-23590 into the spark plug hole.
 - Apply compressed air to hold the valves in place.
 - Install a rocker arm nut (figure 6).
 - Use J-5892-B to compress the valve spring (figure 6).
 - Remove the valve keepers.
 - Carefully release the spring tension. Remove J-5892-B.
5. Cap (21) and/or rotator (28), shield (22) and spring (26) with damper (25).
 6. O-ring seal (23).
 7. Seal (24) (intake valve only).

Install or Connect (Figures 5, 6, and 7)

Tools Required:

- J-23590 Air Adapter
- J-5892-B Spring Compressor
- J-23738-A Vacuum Pump

1. New seal (24) (intake valve only). Install the seal over the valve stem and seat it against the head.
2. Spring (26) with damper (25), shield (22) and cap (21) and/or rotator (28).

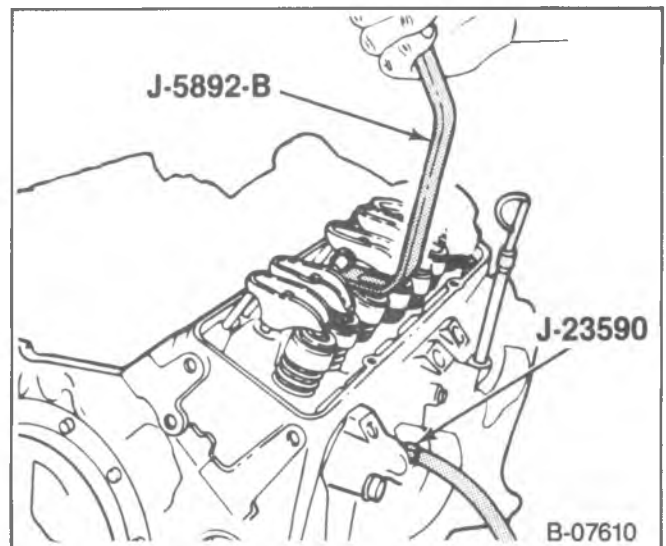

Figure 6—Compressing the Valve Springs

INTAKE MANIFOLD REPLACEMENT

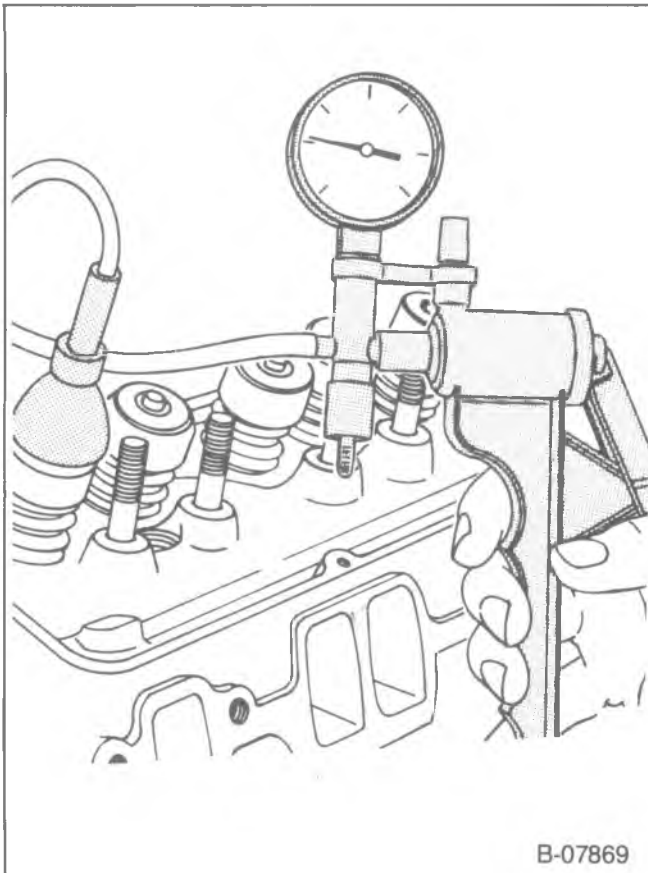

Figure 7—Testing the Valve Seals

3. New O-ring seal (23) and valve keepers (20).
 - With air pressure applied to the cylinder with J-23590, compress the spring with J-5892-B (figure 6).
 - Lubricate the O-ring seal with engine oil. Install the seal on the valve stem. Make sure the seal is not twisted.
 - Install the valve keepers. Use grease to hold them in place.
 - Carefully release spring pressure. Make sure the valve keepers stay in place.
 - Remove J-5892-B and J-23590.
 - Check each O-ring seal for leakage (figure 7).
 - Place the suction cup furnished with J-23738-A over the shield.
 - Connect J-23738-A to the suction cup and apply a vacuum. Watch the vacuum pump gage. No air should be able to leak past the seal. If the seal will not hold a vacuum, it may have been damaged or improperly installed.
4. Spark plugs.
5. Rocker arms, as outlined previously.

Adjust

- Valves, as outlined previously.
6. Rocker arm cover, as outlined previously.

Remove or Disconnect

1. Battery negative cable.
2. Engine cover (G models).
3. Air cleaner.
 - Drain the cooling system.
4. AIR crossover hose (G models with TBI engines).
5. Heater hose and upper radiator hose at the intake manifold.
6. Generator bracket at the manifold.
7. Vacuum hoses at the manifold, carburetor or TBI unit, and EGR valve.
8. Electrical connections at the manifold and carburetor or TBI unit.
9. Fuel line(s) at the carburetor or TBI unit.
10. Accelerator, cruise control, and TVS cables, as equipped.
11. Distributor. Refer to ENGINE ELECTRICAL (SEC. 6D).
12. Air conditioning compressor and bracket and lay aside (if equipped) (except G models with TBI engines).
13. Brake booster vacuum pipe.
14. Components as follows on TBI engines:
 - Coil wires.
 - Emission control sensors and bracket on right side.
 - Cruise control transducer and bracket.
 - Fuel line bracket at rear of manifold. Move the fuel lines aside.
 - Bracket at rear of belt idler (G models).
15. Carburetor or TBI unit (if necessary).
16. Intake manifold bolts.
17. Intake manifold.
18. Gaskets and clips (some TBI engines).

Clean

- Old gasket and RTV from the block, heads, and intake manifold. Remove all RTV that is loose or will cause interference at assembly.
- Excessive carbon deposits from the exhaust and EGR passages.
- Excessive scale and deposits from the coolant passages.

Inspect

- Manifold for cracks and gasket surface damage.

Install or Connect (Figures 8 and 9)

1. Gaskets to the cylinder head. On TBI engines so equipped, also install the clips over the gaskets to the rib between the intake ports. Then apply a dot of RTV to the upper side of the clip.
2. RTV to the front and rear sealing surfaces on the block (figure 8). Apply a 5 mm (³/₁₆-inch) bead of RTV (part number 1052366 or equivalent) to the front and rear of the block as shown. Extend the bead 13 mm (¹/₂-inch) up each cylinder head to seal and retain the gaskets.
3. Intake manifold to the engine.
4. Intake manifold bolts.

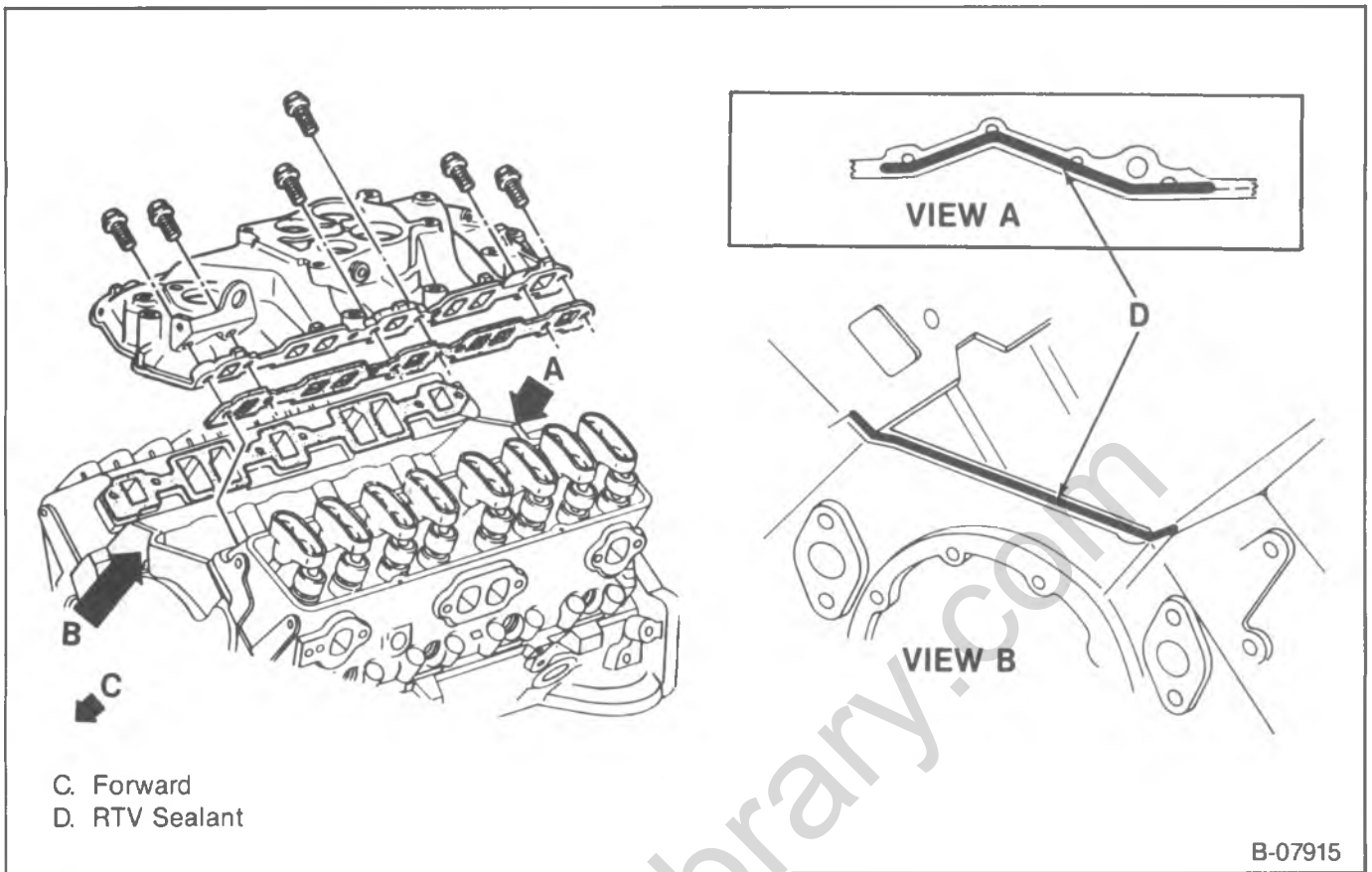

Figure 8—Intake Manifold

Tighten

- Intake manifold bolts to 48 N·m (35 ft. lbs.). Use the tightening sequence shown in figure 9.
- 5. Carburetor or TBI unit (if removed).
- 6. Components as follows on TBI engines:
 - Bracket at rear of belt idler (G models).
 - Fuel line bracket at rear of manifold.
 - Cruise control transducer and bracket.
 - Emission control sensors and brackets.
 - Coil wires.
- 7. Brake booster vacuum pipe.
- 8. Air conditioning compressor and bracket (if removed). Refer to AIR CONDITIONING (SEC. 1B).
- 9. Distributor. Refer to ENGINE ELECTRICAL (SEC. 6D).

- 10. Accelerator, cruise control, and TVS cables, as equipped.
- 11. Fuel line(s) at the TBI unit or carburetor.
- 12. Electrical connections.
- 13. Vacuum hoses.
- 14. Generator bracket.
- 15. Heater hose and upper radiator hose.
- 16. AIR crossover hose (G models with TBI engines).
- 17. Air cleaner.
- 18. Engine cover (G models).
- 19. Battery negative cable.
 - Fill the cooling system with the proper quantity and grade of coolant.

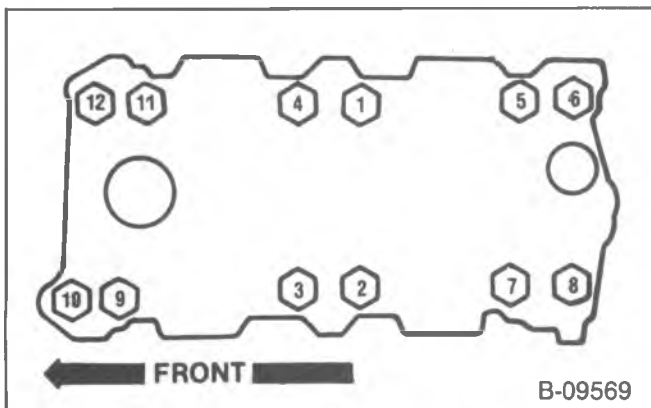

Figure 9—Intake Manifold Bolt Tightening Sequence

HYDRAULIC LIFTER REPLACEMENT

Remove or Disconnect (Figures 10 and 11)

Tools Required:

- J-3049 Hydraulic Lifter Remover (Plier Type) or
- J-9290-01 Hydraulic Lifter Remover (Slide Hammer Type)

1. Rocker arm cover, intake manifold, and pushrod, as outlined previously.
2. Hydraulic lifters.
 - Remove the hydraulic lifters one at a time and place them in an organizer rack. The lifters must be installed in the same bore from which they were removed.

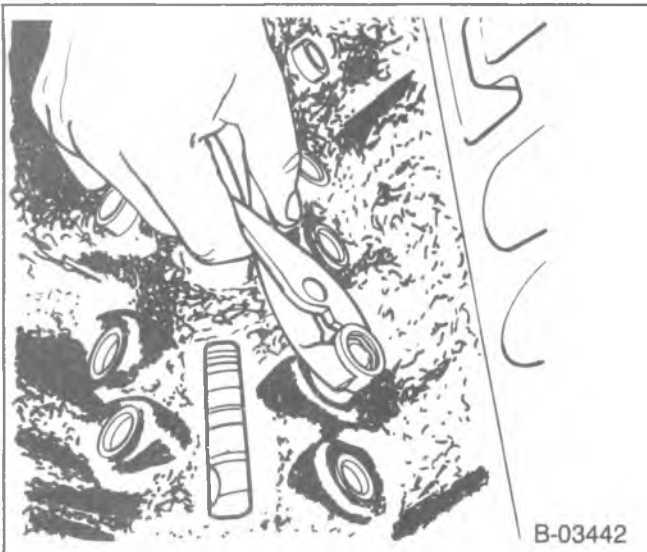

B-03442

Figure 10—Removing the Hydraulic Lifter

- A stuck hydraulic lifter can be removed using J-3049 (figure 10) or J-9290-01 (figure 11).

Inspect

- Hydraulic lifter body for scuffing and scoring. If the lifter body wall is worn or damaged, the mating bore in the block should also be checked.
- Check the fit of each hydraulic lifter in its mating bore in the block. If the clearance is excessive, try a new lifter.
- The hydraulic lifter foot must be smooth and slightly convex. If worn, pitted, or damaged, the mating camshaft lobe should also be checked.

Hydraulic Lifter Repair

- Refer to the proper unit repair manual.

Install or Connect

1. Hydraulic lifters to the block. Lubricate the lifter foot and body with Engine Oil Supplement or equivalent.

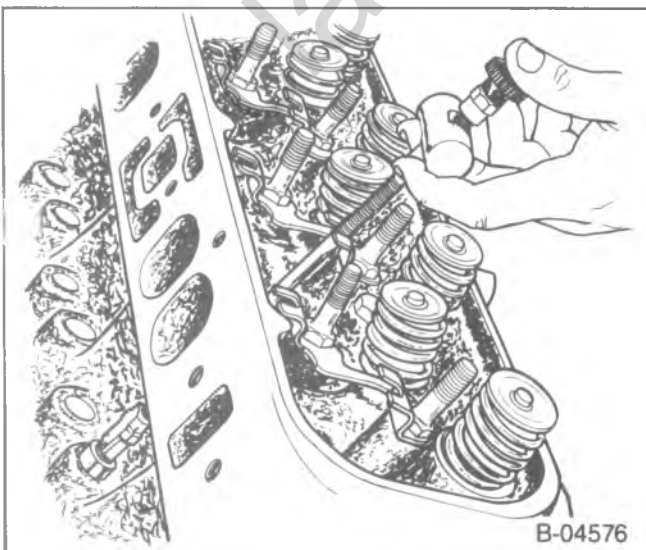

B-04576

Figure 11—Removing the Hydraulic Lifter (Typical)

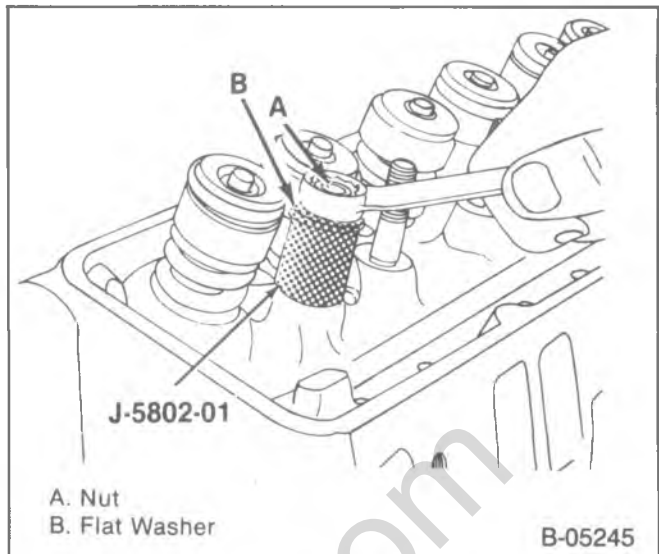

A. Nut
B. Flat Washer

B-05245

Figure 12—Removing the Rocker Arm Stud

Important

- When any new hydraulic lifters or a new camshaft is installed, change the engine oil and filter. Engine Oil Supplement (or equivalent) should be added to the crankcase oil.
- Replace all hydraulic lifters when a new camshaft is installed.

2. Intake Manifold, as outlined previously.
3. Pushrod, as outlined previously.

Adjust

- Valves, as outlined previously.
4. Rocker arm cover, as outlined previously.

ROCKER ARM STUD REPLACEMENT

Remove or Disconnect (Figure 12)

Tool Required:

J-5802-01 Rocker Arm Stud Remover

1. Rocker arm cover and rocker arm, as outlined previously.
2. Rocker arm stud.
 - Place J-5802-01 over the rocker arm stud.
 - Install a nut and flat washer.
 - Turn the nut to remove the stud (figure 12).

Install or Connect (Figures 13 and 14)

Tools Required:

J-5715 Reamer (0.003-inch oversize) or

J-6036 Reamer (0.013-inch oversize)

J-6880 Rocker Arm Stud Installer

NOTICE: Do not attempt to install an oversize rocker arm stud without reaming stud hole as this could damage the cylinder head.

- Ream the hole to the proper size for the replacement oversize rocker arm stud. Use J-5715 for 0.003-inch oversize studs; J-6036 for 0.013-inch oversize studs (figure 13).

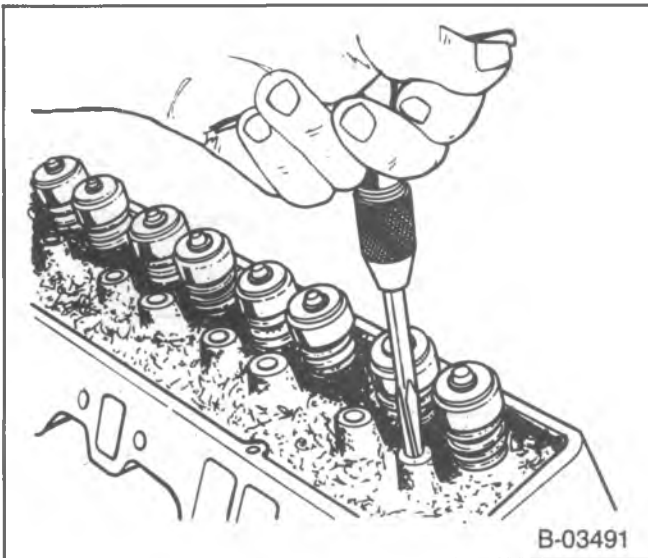

Figure 13—Reaming the Rocker Arm Stud Bore (Typical)

- Coat lower end (press-fit area) of rocker arm stud with hypoid axle lubricant.
1. Rocker arm stud. Use J-6880 (figure 14). Stud is installed to proper depth when the tool bottoms on the cylinder head.
 2. Rocker arm, as outlined previously.

 **Adjust**

- Valves, as outlined previously.
3. Rocker arm cover, as outlined previously.

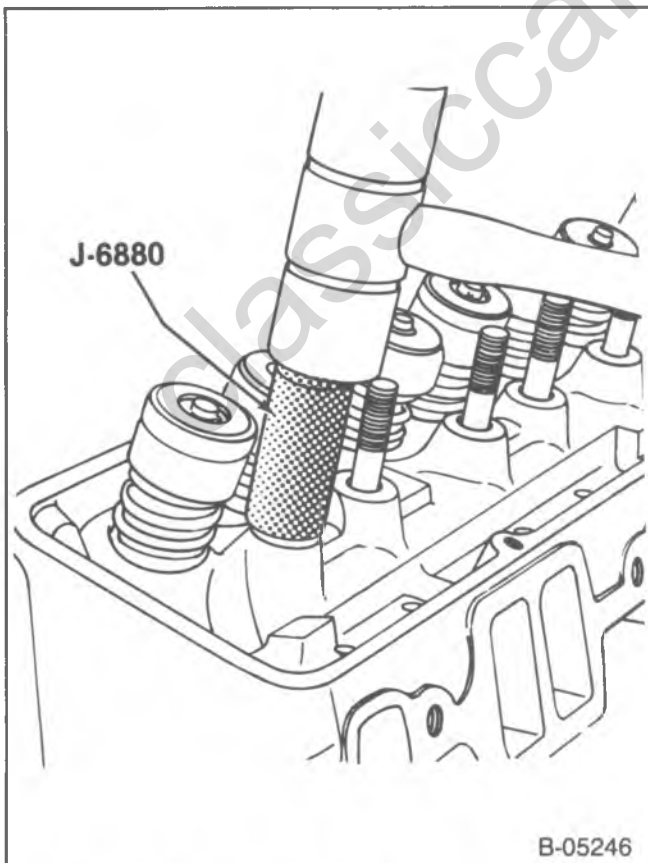

Figure 14—Installing the Rocker Arm Stud

EXHAUST MANIFOLD REPLACEMENT

 **Remove or Disconnect**

1. Battery negative cable.
2. Engine cover (G models).
 - Raise the vehicle. Support with suitable safety stands.
3. Exhaust pipe at the manifold.
 - Lower the vehicle.
4. Oxygen sensor wire (if used) (left side manifold). Do not remove the oxygen sensor unless replacement is required.
5. AIR hose at the check valve.
6. Heat stove pipe (right side manifold).
7. Components as follows on R and V models:
 - Air conditioning compressor rear bracket at the manifold (left side manifold).
 - Diverter valve and bracket (right side manifold).
8. Components as follows on G models with TBI engines:
 - Power steering pump rear bracket at the manifold (left side manifold).
 - Dipstick tube bracket (right side manifold).
9. AIR pipe bracket at the manifold stud (carbureted engines — left side manifold).
10. Exhaust manifold bolts, washers, tab washers and spark plug heat shields, as equipped.
 - Cast manifolds are retained by bolts, tab washers, and plain washers. Remove the outside bolts first, then the center bolts.
 - Tubular (stainless steel) manifolds are retained by bolts and plain washers.
11. Exhaust manifold.

 **Clean**

- Mating surfaces on the manifold and head.
- Threads on the exhaust manifold bolts.

 **Install or Connect**

1. Exhaust manifold to the cylinder head.
2. Exhaust manifold fasteners and spark plug heat shields (where used).
 - Cast manifolds: Install the flat washers against the manifold, then the tab washers and bolts.

 **Tighten**

- Two center bolts to 36 N·m (26 ft. lbs.).
- Outside bolts to 28 N·m (20 ft. lbs.).
- Bend the tab washers against the bolt heads.
- Tubular (stainless steel) manifolds: Install the bolts and flat washers.

 **Tighten**

- Bolts to 36 N·m (26 ft. lbs.).
3. Components as follows on G models with TBI engines:
 - Power steering pump rear bracket at the manifold (left side manifold).
 - Dipstick tube bracket (right side manifold).
 4. Components as follows on R and V models:
 - Air conditioning compressor rear bracket at the manifold (left side manifold).
 - Diverter valve and bracket (right side manifold).

5. AIR bracket at the manifold (carbureted engines — left side manifold).
6. Heat stove pipe (right side manifold).
7. AIR hose at the check valve.
8. Oxygen sensor wire (if used).
 - Raise the vehicle. Support with suitable safety stands.
9. Exhaust pipe.
 - Lower the vehicle.
10. Engine cover.
11. Battery negative cable.

CYLINDER HEAD REPLACEMENT

↔ Remove or Disconnect

1. Battery negative cable.
2. Engine cover (G models).
 - Drain the cooling system.
3. Intake manifold, as outlined previously.
4. Exhaust manifold, as outlined previously.
5. Ground strap at rear of cylinder head (right side cylinder head).
6. Components as follows for right side cylinder head on R and V models:
 - AIR pipe at the rear of the cylinder head.
 - Spark plug wires from the support brackets.
 - Generator, and lay aside.
7. Components as follows for left side cylinder head on R and V models:
 - Air conditioning compressor and front bracket (if equipped) and lay aside.
 - Power steering pump, and lay aside.
 - Coolant sensor wire.
 - Spark plug wires from the support brackets.
 - AIR pipe at the rear of the cylinder head.
8. Components as follows for right side cylinder head on G models with TBI engines:
 - AIR pump bolt and spacer at the cylinder head.
 - Nut and stud attaching air conditioning compressor to cylinder head.
 - Fuel pipe, plug wire and wiring harness brackets at the rear of the cylinder head.
9. Components as follows for left side cylinder head on G models with TBI engines:
 - Nut and stud attaching main accessory bracket to the cylinder head. It may be necessary to loosen the remaining bolts and studs and move the bracket forward slightly for clearance to remove the cylinder head.
 - Coolant sensor wire.
 - Cruise control transducer and spark plug wire brackets at the rear of the cylinder head.
10. Components as follows on carbureted engines:
 - Generator, and lay aside (right side cylinder head).
 - Air conditioning compressor and bracket, and lay aside (left side cylinder head).
11. Rocker arm cover, as outlined previously.
12. Spark plugs.
13. Pushrods, as outlined previously.
14. Cylinder head bolts.
15. Cylinder head.

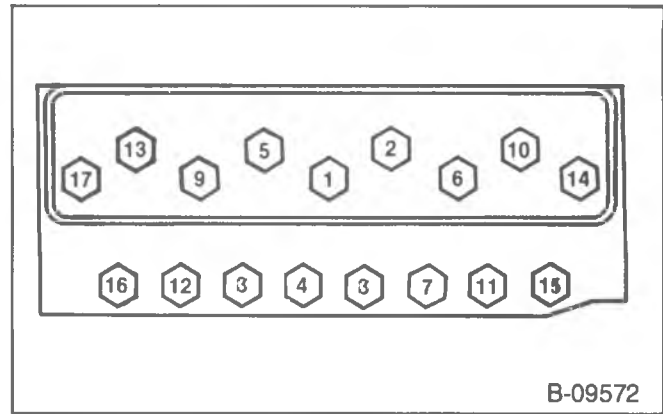

B-09572

Figure 15—Cylinder Head Bolt Tightening Sequence

16. Head gasket.

🧼 Clean

- Carbon deposits from combustion chambers.
- All traces of old head gasket from cylinder head and block.
- Cylinder head bolt threads and threads in the block.

🔍 Inspect

- Sealing surfaces of the block and cylinder head for nicks, heavy scratches, or other damage.

Cylinder Head Repair

- Refer to the proper Unit Repair Manual.

↔ Install or Connect (Figure 15)

1. Head gasket.
 - If a steel gasket is used, coat both sides of the gasket with sealer. Spread the sealer thin and even.
 - Do not use sealer on composition steel-asbestos gaskets.
 - Place the gasket over the block dowel pins with the bead up.
2. Cylinder head. Carefully guide the cylinder head into place over the dowel pins and gasket.

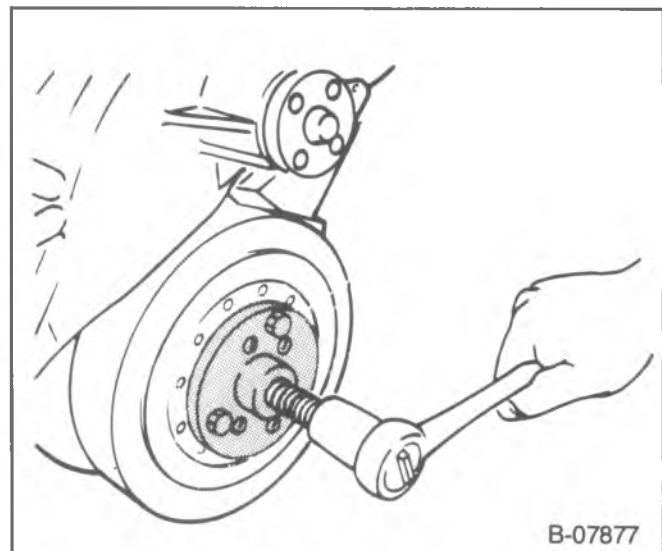

B-07877

Figure 16—Removing the Torsional Damper

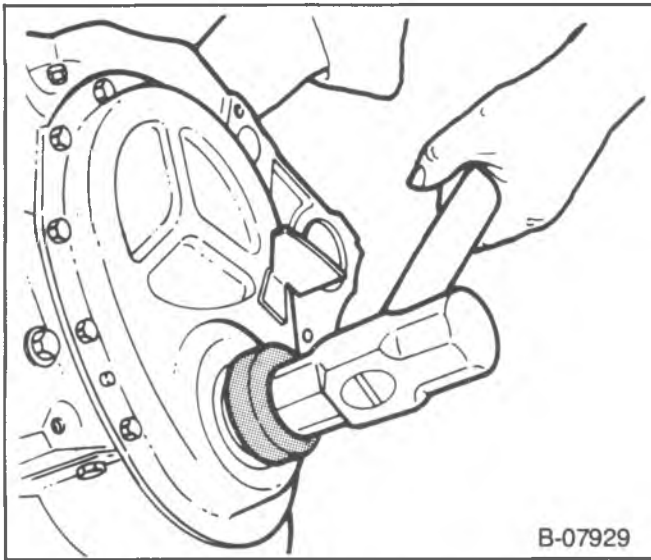

Figure 17—Installing the Front Crankshaft Oil Seal

3. Cylinder head bolts. Coat threads of the cylinder head bolts with sealing compound (GM part number 1052080 or equivalent) and install finger-tight.

 **Tighten**

- Cylinder head bolts, a little at a time, using the sequence shown in figure 15. Proper torque is 90 N·m (65 ft. lbs.).

4. Pushrods, as outlined previously.

 **Adjust**

- Valves, as outlined previously.

5. Rocker arm cover, as outlined previously.
6. Spark plugs.
7. Components as follows for right side cylinder head on R and V models:
 - AIR pipe at the rear of the cylinder head.
 - Spark plug wires to the support brackets.
 - Generator.
8. Components as follows for left side cylinder head on R and V models:

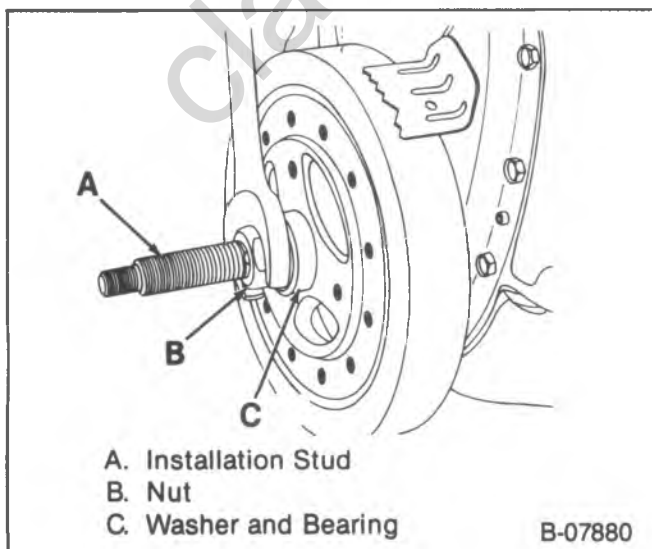

Figure 18—Installing the Torsional Damper

- Air conditioning compressor and front bracket (if equipped).
 - Power steering pump.
 - Coolant sensor wire.
 - Spark plug wires to the support brackets.
 - AIR pipe at the rear of the cylinder head.
9. Components as follows for right side cylinder head on G models with TBI engines:
 - AIR pump bolt and spacer at the cylinder head.
 - Nut and stud attaching the air conditioning compressor to the cylinder head.
 - Fuel pipe, plug wire and wiring harness brackets at the rear of the cylinder head.
 10. Components as follows for left side cylinder head on G models with TBI engines:
 - Nut and stud attaching main accessory bracket to the cylinder head.
 - Remaining main accessory bracket bolts and nuts, if necessary.
 - Coolant sensor wire.
 - Cruise control transducer and spark plug wire brackets at the rear of the cylinder head.
 11. Components as follows on carbureted engines:
 - Generator (right side cylinder head).
 - Air conditioning compressor and bracket (left side cylinder head).
 12. Ground strap at the rear of the cylinder head (right side cylinder head).
 13. Exhaust manifold, as outlined previously.
 14. Intake manifold, as outlined previously.
 15. Engine cover (G models).
 16. Battery negative cable.
 - Fill the cooling system with the proper quantity and grade of coolant.

TORSIONAL DAMPER AND FRONT CRANKSHAFT SEAL REPLACEMENT

 **Remove or Disconnect (Figure 16)**

Tool Required:

J-23523-E Torsional Damper Puller and Installer

1. Fan belts, fan, and pulley.
2. Fan shroud assembly.
3. Accessory drive pulley.
4. Torsional damper bolt.
5. Torsional damper. Use J-23523-E (figure 16).
6. Front crankshaft seal. Pry out with a large screwdriver. Take care not to distort the timing cover.
7. Crankshaft key, if necessary.

 **Inspect**

- Oil seal contact area on the torsional damper shaft for grooving and roughness. Replace if necessary.

 **Install or Connect (Figures 17 and 18)**

Tools Required:

J-35468 Seal Installer

J-23523-E Torsional Damper Puller and Installer

1. Crankshaft key, if removed.

6A4-14 SMALL BLOCK

2. Front crankshaft seal. Use J-35468 (figure 17). The open end of the seal faces inside the engine. Coat the seal lips with engine oil.

NOTICE: The inertia weight section of the torsional damper is assembled to the hub with a rubber type material. The correct installation procedures (with the proper tool) must be followed or movement of the inertia weight section of the hub will destroy the tuning of the torsional damper.

3. Stud (item A, figure 18) to the crankshaft. Thread the stud fully into the tapped hole in the crankshaft.
4. Torsional damper over the end of the stud. Align the keyway in the torsional damper shaft with the crankshaft key.
5. Bearing, washer and nut (figure 18).
 - Turn the nut to pull the vibration damper into place.
 - Remove the tool.
- Use a small amount of RTV sealant to seal the torsional damper key to crankshaft joint.
6. Torsional damper bolt and washer.

Tighten

- Bolt to 95 N·m (70 ft. lbs.).
7. Accessory drive pulley.
 8. Fan shroud assembly.
 9. Fan pulley, fan, and fan belts.

FRONT COVER REPLACEMENT

Remove or Disconnect

1. Torsional damper, as outlined previously.
2. Water pump.
3. Oil pan, as outlined later.
4. Front cover bolts.
5. Front cover.
6. Front cover to block gasket.
7. Front crankshaft seal from the front cover. Pry out with a screwdriver. Take care not to distort the front cover.

Clean

- Old gasket from the front cover and block.

Inspect

- Front cover for distortion and damage. Replace if necessary.

Install or Connect (Figure 19)

Tools Required:

J-35468 Seal Installer

1. Front crankshaft seal. Use J-35468 (figure 19). The open end of the seal faces inside the engine. Coat the seal lips with engine oil.
2. Front cover gasket to the front cover. Use gasket cement to hold it in place.
3. Front cover to the engine.

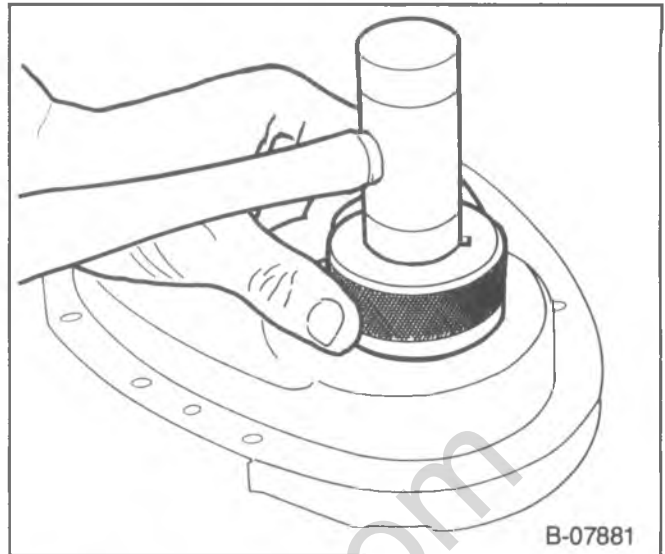

Figure 19—Installing the Front Crankshaft Oil Seal

Tighten

- Front cover to block bolts to 11.3 N·m (100 in. lbs.).
4. Oil pan, as outlined later.
 5. Water pump. Refer to ENGINE COOLING (SEC. 6B1).
 6. Torsional damper, as outlined previously.

OIL PAN REPLACEMENT

A one piece type oil pan gasket is used.

Remove or Disconnect (Figure 20)

1. Battery negative cable.
 - Raise the vehicle. Support with suitable safety stands.
 - Drain the engine oil.
2. Exhaust crossover pipe.
3. Flywheel/torque converter cover.
4. Strut rods at the engine mountings (V models with automatic transmissions).
5. Oil pan bolts, nuts, and reinforcements.
6. Oil pan and gasket.

Clean

- Gasket surfaces on the engine and oil pan.

Inspect

- Oil pan gasket for damage. Replace if necessary.

Install or Connect (Figure 20)

- Apply sealant (GM part number 1052080 or equivalent) to the front cover to block joint and to the rear crankshaft seal to block joint. Apply the sealant for about 25 mm (1 inch) in both directions from each of the four corners.

1. Oil pan gasket to the oil pan.
2. Oil pan to the engine.
3. Oil pan bolts, nuts, and reinforcements.

Tighten

- Oil pan bolts to 11.3 N·m (100 in. lbs.).
- Oil pan nuts to 22.6 N·m (200 in. lbs.).

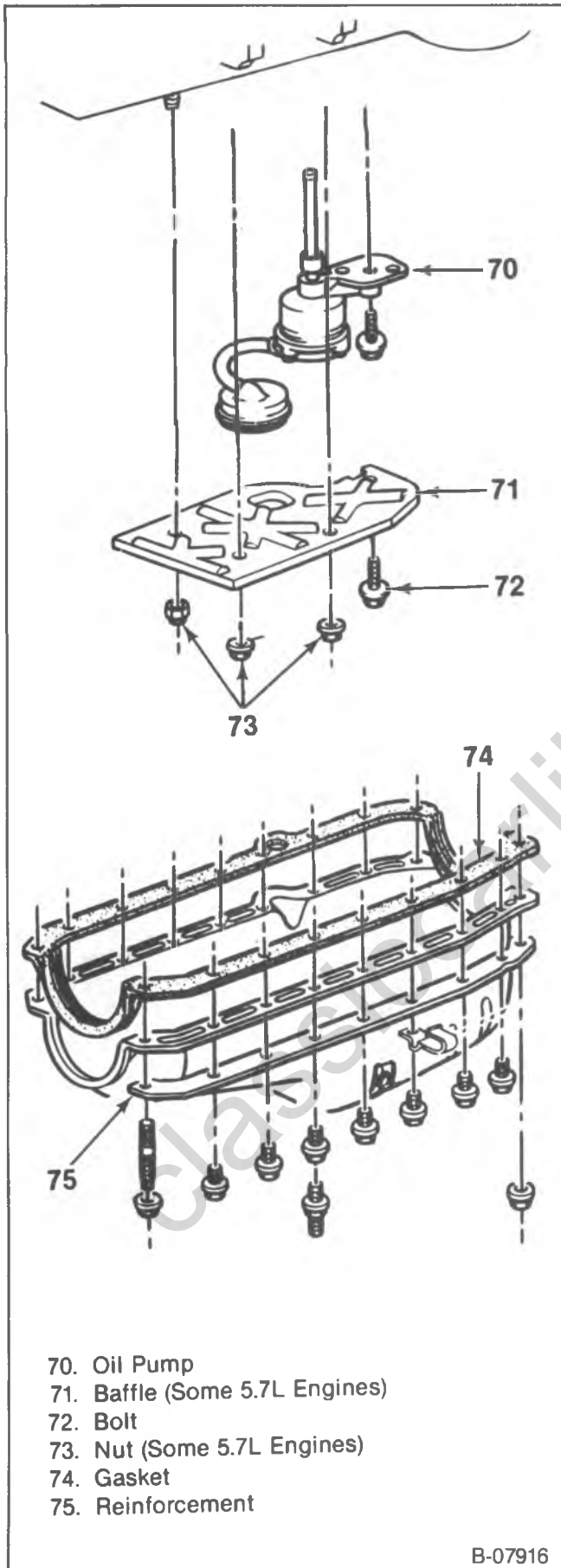

- 70. Oil Pump
- 71. Baffle (Some 5.7L Engines)
- 72. Bolt
- 73. Nut (Some 5.7L Engines)
- 74. Gasket
- 75. Reinforcement

B-07916

Figure 20—Oil Pan

4. Strut rods at the engine mount (V models with automatic transmissions).
5. Flywheel/torque converter cover.
6. Exhaust crossover pipe.
 - Lower the vehicle.
7. Proper quantity and grade of engine oil.
8. Battery negative cable.

OIL PUMP REPLACEMENT

↔ Remove or Disconnect (Figure 20)

1. Oil pan, as outlined previously.
2. Nuts (73) (if equipped).
3. Bolt (72).
4. Oil pump (70) and baffle (71) (if equipped).

👁 Inspect

- Oil pump pickup tube for looseness. If the tube is loose in the oil pump body, replace it, as outlined in the proper unit repair manual. A loose pickup tube can result in an air leak and loss of oil pressure.

Oil Pump Repair

- Refer to the proper unit repair manual.

↔ Install or Connect (Figure 20)

1. Oil pump to the engine. Align the slot in the oil pump shaft with the tang on the distributor shaft. The oil pump should slide easily into place. No gasket is used.
2. Baffle (71) (if equipped) and bolt (72).

🔧 Tighten

- Bolt (72) to 90 N·m (65 ft. lbs.).
3. Nuts (73) (if equipped).

🔧 Tighten

- Nuts (73) to 34 N·m (25 ft. lbs.).
4. Oil pan, as outlined previously.

REAR CRANKSHAFT OIL SEAL REPLACEMENT

↔ Remove or Disconnect (Figure 21)

1. Transmission.
2. Clutch and flywheel or flexplate, as equipped.

NOTICE: Care should be taken when removing the rear crankshaft oil seal so as not to nick the crankshaft sealing surface.

3. Rear crankshaft oil seal. Insert a screwdriver into the notches provided in the seal retainer and pry the seal out (figure 21). Take care not to damage the crankshaft seal surface.

👁 Inspect

- Chamfer on crankshaft for grit, loose rust, and burrs. Correct as necessary.

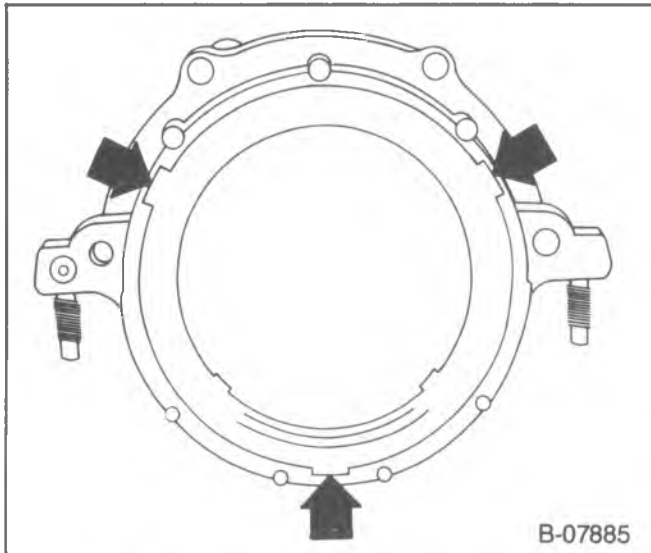

Figure 21—Seal Removal Notches



Clean

- Seal running surface on the crankshaft with a non-abrasive cleaner.



Install or Connect (Figure 22)

Tool Required:

J-35621 Seal Installer

1. Rear crankshaft oil seal (figure 22).
 - Lubricate the inner and outer diameter of the seal with engine oil.
 - Install the seal on J-35621.
 - Position J-35621 against the crankshaft. Thread the attaching screws into the tapped holes in the crankshaft.
 - Tighten the screws securely with a screwdriver. This will ensure that the seal is installed squarely over the crankshaft.
 - Turn the handle until it bottoms.
 - Remove J-35621.
2. Clutch and flywheel or flexplate, as equipped.
3. Transmission.

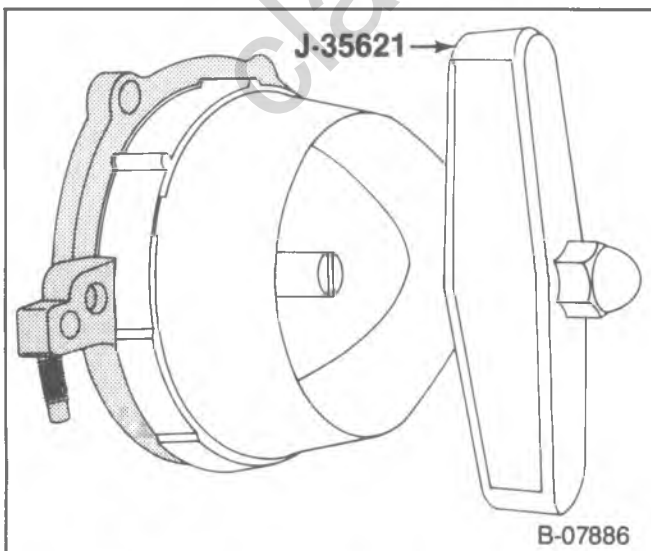

Figure 22—Installing the Rear Crankshaft Oil Seal

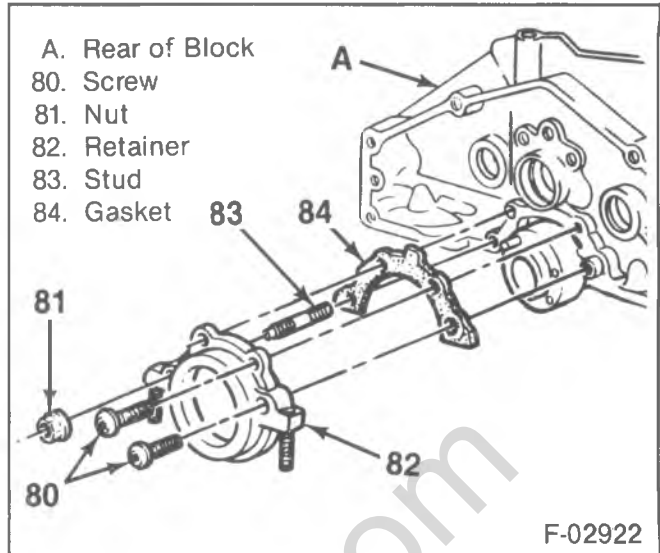

Figure 23—Rear Crankshaft Oil Seal Retainer

REAR CRANKSHAFT OIL SEAL RETAINER REPLACEMENT



Remove or Disconnect (Figures 21 and 23).

1. Transmission.
2. Clutch and flywheel or flexplate, as equipped.
3. Oil pan, as outlined previously.
4. Screws (80) and nuts (81).
5. Seal retainer (82).
6. Gasket (84).
7. Rear crankshaft oil seal. Insert a screwdriver into the notches provided in the seal retainer and pry the seal out (figure 21).



Clean

- Gasket surfaces on block and seal retainer.



Install or Connect (Figure 23)

- Whenever the seal retainer is removed, a new retainer gasket and rear crankshaft oil seal must be installed.
1. Gasket (84) to the block. It is not necessary to use sealant to hold the gasket in place.
 2. Seal retainer (82).
 3. Screws (80) and nuts (81).



Tighten

- Screws (80) and nuts (81) to 15.3 N·m (135 in. lbs.).
4. Oil pan, as outlined previously.
 5. Rear crankshaft oil seal as outlined previously.
 6. Clutch and flywheel or flexplate, as equipped.
 7. Transmission.

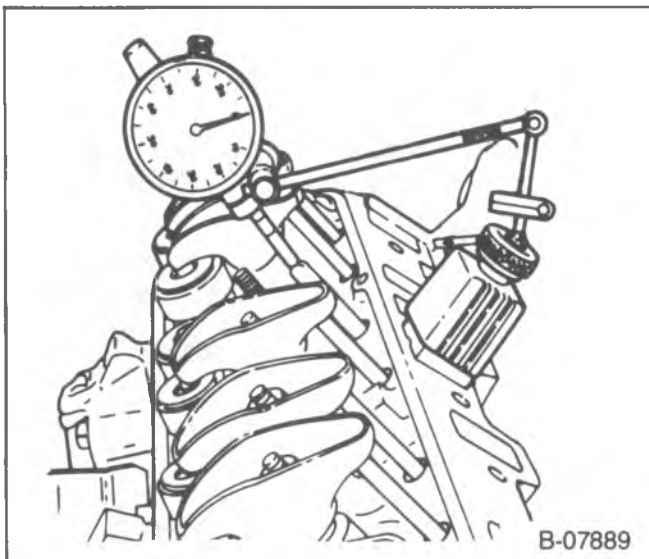

Figure 24—Measuring Camshaft Lobe Lift

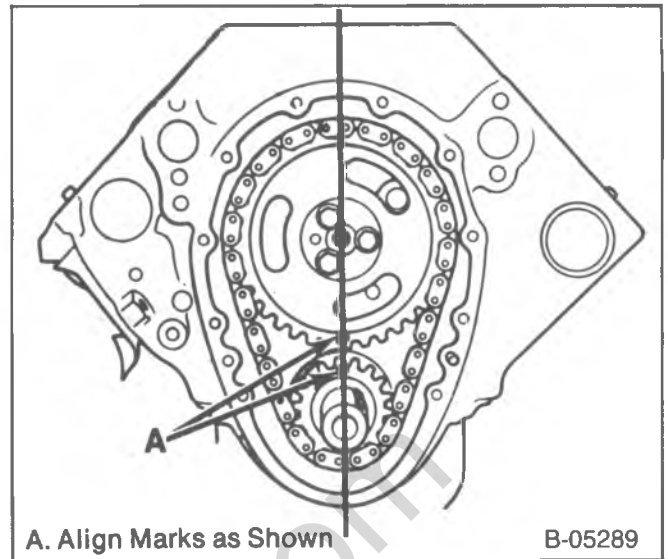

Figure 25—Timing Marks

MEASURING CHAMSHAFT LOBE LIFT

Tool Required:

J-8520 Camshaft Lobe Lift Indicator

1. Remove the rocker arm as outlined previously.
2. Refer to figure 24. Position the dial indicator (part of J-8520) so the plunger rests on the pushrod end, as shown. Make sure the pushrod is in the lifter socket.
3. Rotate the crankshaft slowly in the direction of normal rotation until the lifter is on the heel of the cam lobe. At this point, the pushrod will be in its lowest position.
4. Set dial indicator on zero, then rotate the crankshaft slowly, or attach an auxiliary starter switch and "bump" the engine over, until the pushrod is in fully raised position.

! Important

- Whenever the engine is cranked remotely at the starter, with a special jumper cable or other means, the distributor primary lead or coil primary leads should be disconnected.
5. Compare the total lift recorded from the dial indicator with specifications.
 6. If camshaft readings for all lobes are within specifications, remove dial indicator assembly.
 7. Install the rocker arm and adjust the valves as previously outlined.

CAMSHAFT REPLACEMENT

↔ Remove or Disconnect (Figures 25, 26, and 27)

Tool Required:

J-5825-A Crankshaft Sprocket Puller

1. Battery negative cable.
2. Engine cover (G models).
3. Air cleaner.
4. Grille (G models).
5. Air conditioning condensor from its mounting and swing it forward (G models).

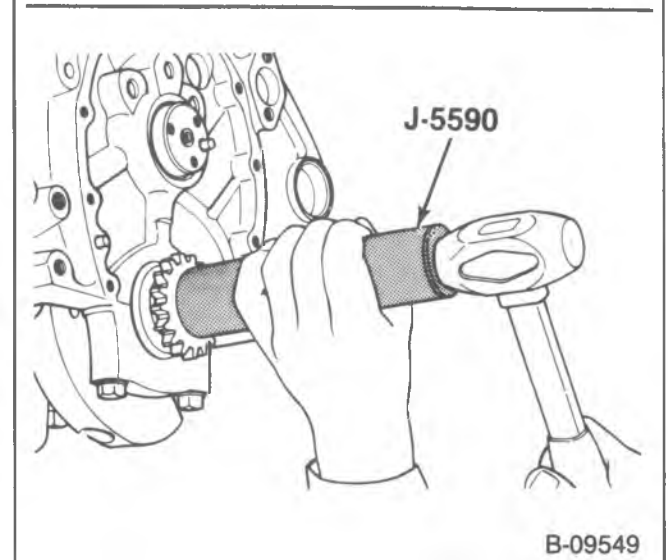
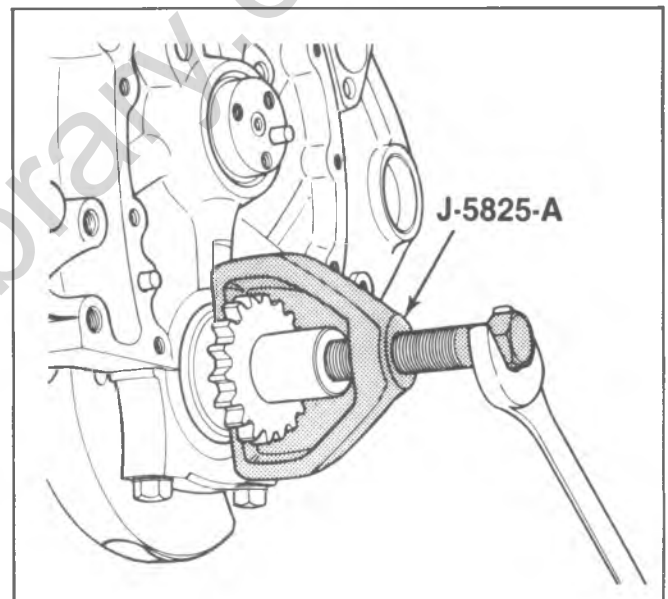
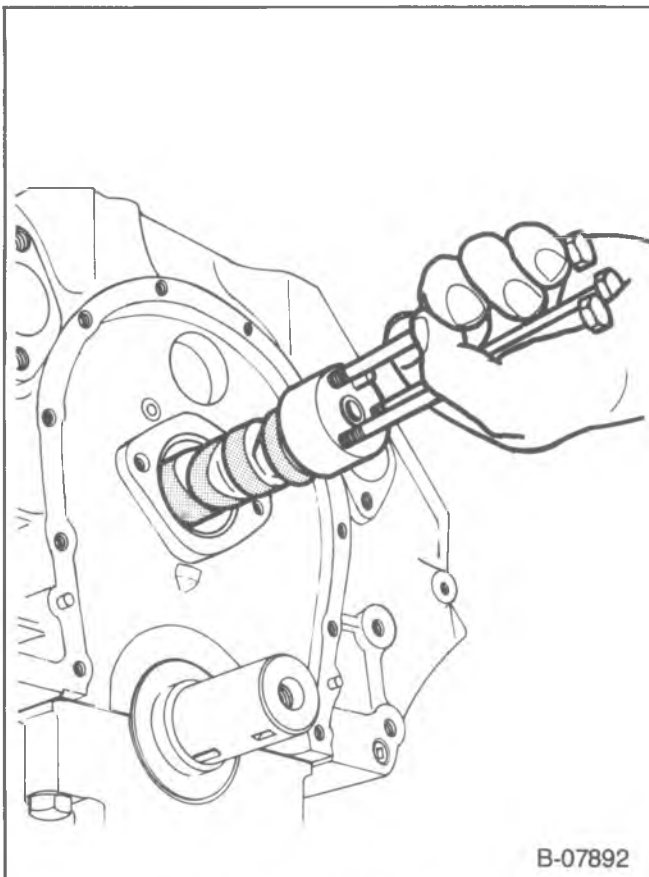

Figure 26—Replacing the Crankshaft Sprocket



B-07892

Figure 27—Replacing the Camshaft

6. Fan, shroud, and radiator. Refer to ENGINE COOLING (SEC. 6B).
7. Rocker arm covers, as outlined previously.
8. Water pump. Refer to ENGINE COOLING (SEC. 6B).
9. Torsional damper, as outlined previously.
10. Front cover, as outlined previously.
11. Distributor. Refer to ENGINE ELECTRICAL (SEC. 6D).
12. Intake manifold, as outlined previously.
13. Pushrods and hydraulic lifters, as outlined previously.
14. Fuel pump and pushrod (carbureted engines).
 - Align the timing marks (figure 25).
15. Camshaft sprocket bolts.
16. Camshaft sprocket and timing chain. The sprocket is a light interference fit on the camshaft. Tap the sprocket on its lower edge to loosen it.
17. Crankshaft sprocket (if required). Use J-5825 (figure 26).
18. Front engine mounting through bolts.

NOTICE: When raising or supporting the engine for any reason, do not use a jack under the oil pan, any sheet metal or crankshaft pulley. Due to the small clearance between the oil pan and the oil pump screen, jacking against the oil pany may cause it to be bent against the pump screen, resulting in a damaged oil pickup unit.

- Raise the engine.
19. Camshaft

- Install two or three $\frac{5}{16}$ -18 bolts 100-125 mm (4-5 inches) long into the camshaft threaded holes. Use these bolts to handle the camshaft (figure 27).
- Pull the camshaft from the block. Use care to prevent damage to the camshaft bearings.

Cleaning Inspection and Repair

Clean, inspect and repair or replace the camshaft and related components, as outlined in the proper unit repair manual.

The unit repair manual also describes camshaft bearing replacement.

Install or Connect (Figures 25 through 27 and 35 through 38)

Tool Required:

J-5590 Crankshaft Sprocket Installer

- Coat the camshaft lobes and journals with a high quality engine oil supplement (GM Engine Oil Supplement or equivalent).
1. Two or three $\frac{5}{16}$ -18 bolts 100-125 mm (4-5 inches) long into the camshaft threaded holes. Use these bolts to handle the camshaft.
 2. Camshaft to the engine (figure 27). Handle the camshaft carefully to prevent damage to the camshaft bearings.
 - Lower the engine.
 3. Engine mount through-bolts.

NOTICE: See "Notice" on page 6A4-1 of this section.

Tighten

- Through-bolts to specifications. Refer to figures 35 through 38.
4. Crankshaft sprocket (if removed). Use J-5590 (figure 26). Make sure the timing mark faces outside.
 5. Camshaft sprocket and timing chain.

Important

- Line up the timing marks on the camshaft sprocket and crankshaft sprocket (figure 25).
6. Camshaft sprocket bolts.

Tighten

- Bolts to 24 N·m (18 ft. lbs.).
7. Fuel pump and pushrod (carbureted engines).
 8. Hydraulic lifters and pushrods, as outlined previously.

Important

- Replace all hydraulic lifters, change the engine oil and filter, and add GM Engine Oil Supplement (or equivalent) to the engine oil whenever a new camshaft is installed.

Adjust

- Valves, as outlined previously.
9. Intake manifold, as outlined previously.
 10. Distributor. Refer to ENGINE ELECTRICAL (SEC. 6D).
 11. Front cover, as outlined previously.
 12. Torsional damper, as outlined previously.
 13. Water pump. Refer to ENGINE COOLING (SEC. 6B).

14. Rocker arm covers, as outlined previously.
15. Fan, shroud, and radiator. Refer to ENGINE COOLING (SEC. 6B).
16. Air conditioning condenser (G models).
17. Grille (G models).
18. Air cleaner.
19. Engine cover (G models).
20. Battery negative cable.
 - Fill the cooling system with the proper quantity and grade of coolant.

CONNECTING ROD AND PISTON REPLACEMENT

↔ Remove or Disconnect (Figure 28)

Tool Required:

J-5239 Guide Set

1. Cylinder head, as outlined previously.
2. Oil pan, as outlined previously.
3. Oil pump, as outlined previously (if necessary).
4. Ridge or deposits from the upper end of the cylinder bores.
 - Turn the crankshaft until the piston is at BDC.
 - Place a cloth on top of the piston.
 - Perform the cutting operation with a ridge reamer.
 - Turn the crankshaft until the piston is at TDC.
 - Remove the cloth and cuttings.
5. Connecting rod cap. Check the connecting rod and cap for identification marks. Mark the parts if required. The connecting rod and cap must be kept together as mating parts.
6. Connecting rod and piston.
 - Attach J-5239 to the connecting rod bolts (figure 28).
 - Use the long guide rod of J-5239 to push the connecting rod and piston out of the bore.
7. Connecting rod bearing.

Cleaning, Inspection, and Repair

Clean, inspect and repair or replace the components as necessary. Measure connecting rod bearing clearance, piston clearance, ring clearances, etc. Refer to the proper unit repair manual.

The unit repair manual contains information on:

- Connecting rod and piston.
- Piston rings.
- Connecting rod and crankpin.
- Cylinder bores.

↔ Install or Connect (Figures 28 through 31)

Tools Required:

J-5239 Connecting Rod Guide Set

J-8037 Ring Compressor

- Make sure the cylinder walls are clean. Lubricate the cylinder wall lightly with engine oil.
 - Make sure the piston is installed in the matching cylinder.
1. Connecting rod bearings.
 - Be certain that the bearings are of the proper size.

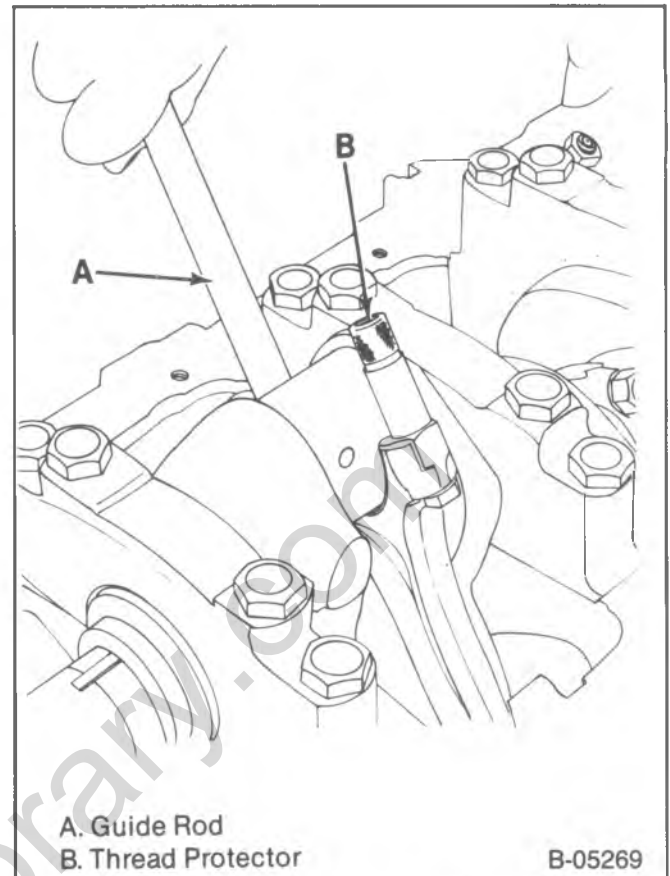

Figure 28—Replacing the Piston and Connecting Rod

- Install the bearings in the connecting rod and connecting rod cap.
 - Lubricate the bearings with engine oil.
2. Piston and connecting rod to the proper bore.
 - With the connecting rod cap removed, install J-5239 onto the connecting rod studs.
 - Locate the piston ring end gaps as shown in figure 29. Lubricate the piston and rings.
 - Without disturbing the ring end gap location, install J-8037 over the piston (figure 30).

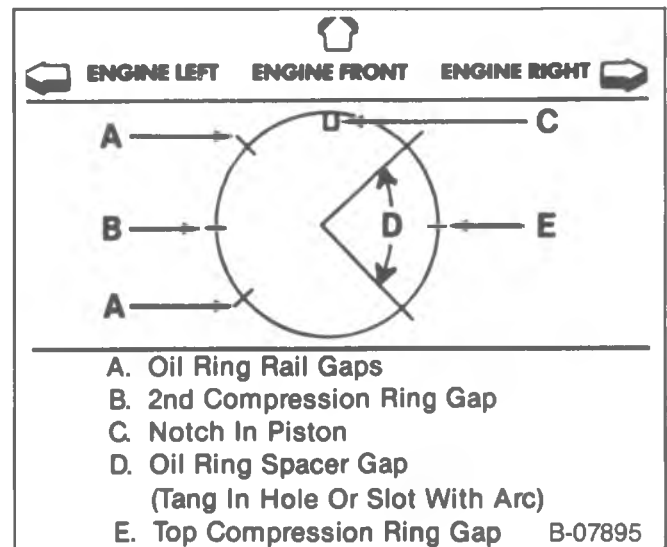

Figure 29—Piston Ring End Gap Locations

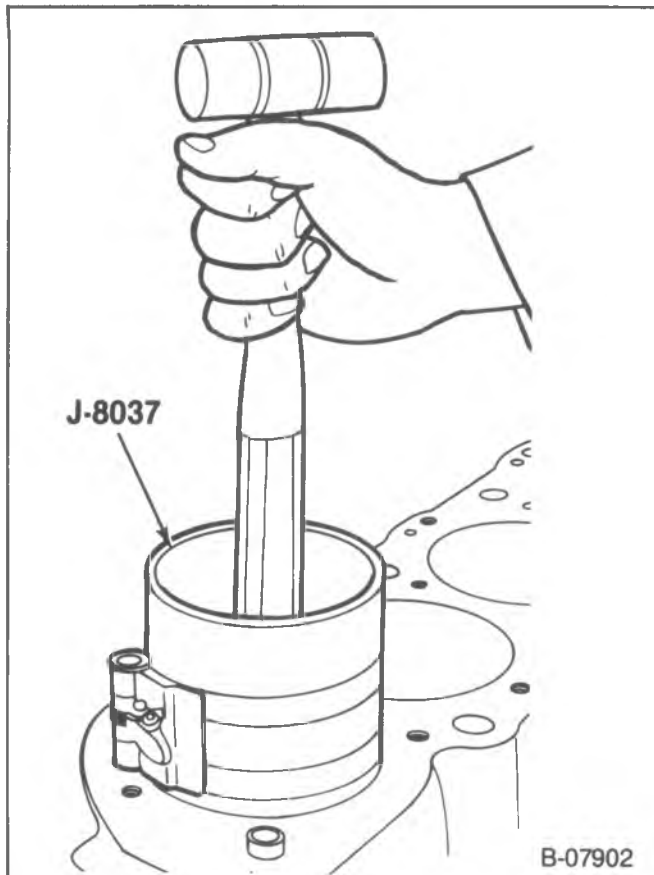

Figure 30—Installing the Piston

- The piston must be installed so that the notch in the piston faces the front of the engine (figure 29).
- Place the piston in its matching bore. The connecting rod bearing tang slots must be on the side opposite the camshaft. Using light blows with a hammer handle, tap the piston down into its bore (figure 30). At the same time, from beneath the vehicle guide the connecting rod to the crankpin with J-5239 (figure 28). Hold the ring compressor against the block until all rings have entered the cylinder bore.
- Remove J-5239 from the connecting rod bolts.

! Important

- Each connecting rod and bearing cap should be

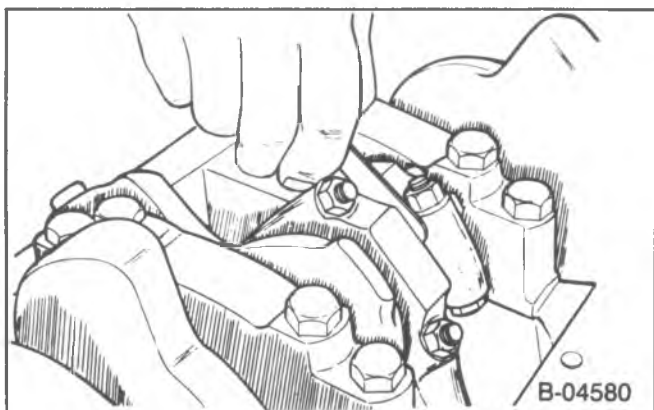

Figure 31—Measuring Connecting Rod Side Clearance

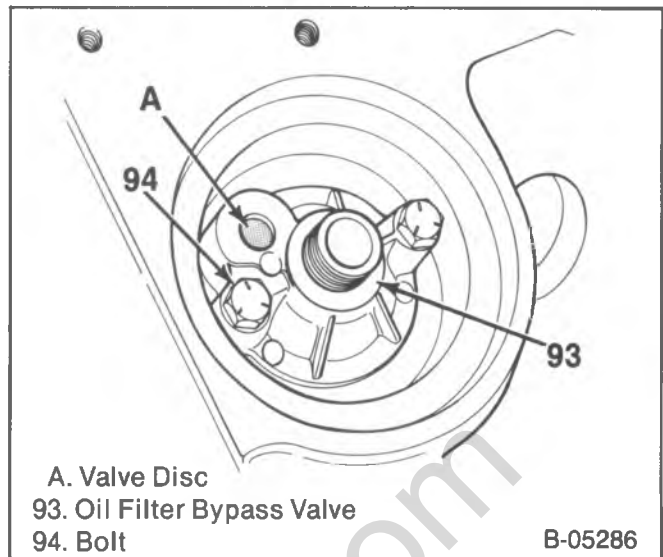

Figure 32—Oil Filter Bypass Valve

marked, beginning at the front of the engine. Cylinders 1, 3, 5 and 7 are the left bank and, 2, 4, 6, and 8 are the right bank. The numbers on the connecting rod and bearing cap must be on the same side when installed in the cylinder bore. If a connecting rod is ever transposed from one block or cylinder to another, new connecting rod bearings should be fitted and the connecting rod should be numbered to correspond with the new cylinder number.

📏 Measure

- Connecting rod bearing clearance. Refer to the proper unit repair manual.
3. Connecting rod cap and bearing.
 4. Connecting rod cap nuts.

🔧 Tighten

- Connecting rod cap nuts to 60 N·m (45 ft. lbs.).

📏 Measure

- Connecting rod side clearance. Use a feeler gage between the connecting rods (figure 31). The correct clearance is 0.006–0.014-inch.
5. Oil pump (if removed), as outlined previously.
 6. Oil pan and cylinder head, as outlined previously.

OIL FILTER BYPASS VALVE

↔ Remove or Disconnect (Figure 32)

1. Oil filter.

👁 Inspect

- Bypass valve spring and valve disc for proper operation, cracks, and damage. If replacement is needed, the oil filter bypass valve (93) must be replaced, as follows:

2. Bolts (94).
3. Oil filter bypass valve.

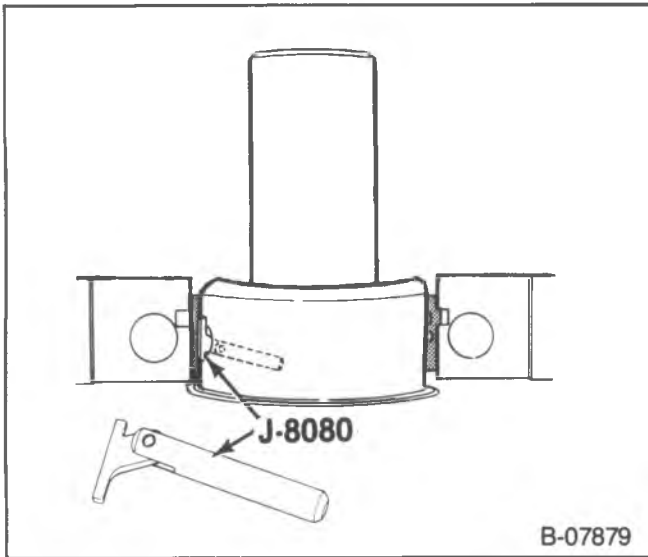

Figure 33—Removing the Main Bearing Insert



Clean

- Valve chamber in the block.



Install or Connect (Figure 32)

1. Oil filter bypass valve (93).
2. Bolts (94).



Tighten

- Bolts (94) to 26 N·m (20 ft. lbs.).
3. Oil filter.
 4. Engine oil, as needed.

MAIN BEARING REPLACEMENT



Remove or Disconnect (Figure 33)

Tool Required:

J-8080 Main Bearing Remover/Installer

1. Spark plugs.
2. Oil pan, as outlined previously.
3. Oil pump, as outlined previously.
4. Main bearing caps.
 - Check the main bearing caps for location markings. Mark the caps if necessary. The caps must be returned to their original locations during assembly.
5. Lower main bearing inserts from the main bearing caps.
6. Upper main bearing inserts.
 - Insert J-8080 into the crankshaft oil hole (figure 33).
 - Rotate the crankshaft to “turn” the bearing insert out of the block.

Cleaning, Inspection, and Repair

Clean, inspect, and repair or replace the components as required. Refer to the proper unit repair manual. The unit repair manual contains information on

- Crankshaft.
- Main and connecting rod bearings.

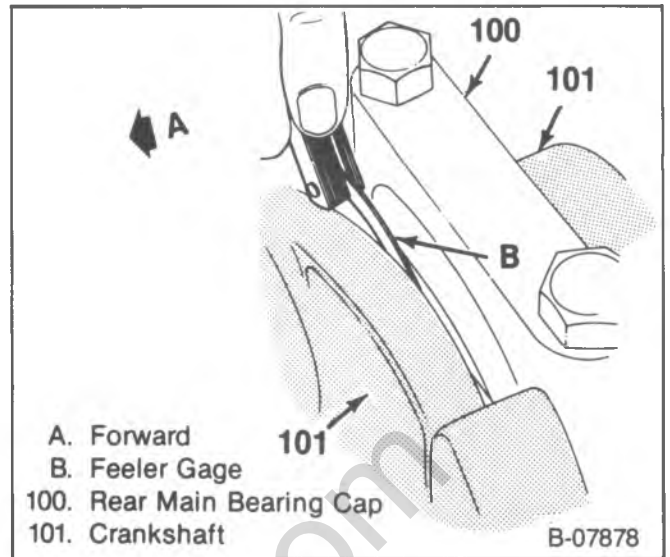

Figure 34—Measuring Crankshaft End Play

- Main bearing cap replacement (shimming procedure).



Install or Connect (Figures 33 and 34)

Tool Required:

J-8080 Main Bearing Remover/Installer

1. Upper main bearing inserts.
 - Insert tool J-8080 into a crankshaft main bearing oil hole (figure 33).
 - Apply engine oil to inserts of the proper size.
 - Insert the plain end (without the bearing tang) of the insert between the crankshaft and the notched side of the block.
 - Rotate the crankshaft to “roll” the insert into the block.
 - Remove the tool.
2. Lower main bearing inserts to the main bearing caps.
 - Make sure the inserts are of the proper size.
 - Apply engine oil to the inserts.



Measure

- Main bearing clearance. Refer to the proper unit repair manual. If the engine is in the vehicle, the crankshaft must be supported upward to remove any clearance from the upper bearing. The total clearance can then be measured between the lower bearing and journal.
3. Main bearing caps (except rear cap) and bolts to the block.



Tighten

- Main bearing cap bolts to specifications.
 - Outer bolts on #2, #3, and #4 main bearing caps: 95 N·m (70 ft. lbs.).
 - All others: 110 N·m (80 ft. lbs.).
4. Rear main bearing cap and bolts.



Tighten

- Rear main bearing cap bolts temporarily to 14 N·m (10 ft. lbs.).



Measure

- Crankshaft end play, as follows:
 - Tap the end of the crankshaft first rearward then forward with a lead hammer. This will line up the rear main bearing and crankshaft thrust surfaces.
 - Tighten the rear main bearing cap bolts to 110 N·m (80 ft. lbs.).
 - With the crankshaft forced forward, measure at the front end of the rear main bearing with a feeler gage (figure 34). The proper clearance is 0.002–0.006-inch.
 - If correct end play cannot be obtained, be certain that the correct size rear main bearing has been installed. Production engines may have rear main bearings that are 0.008-inch wider across the thrust faces than standard. Refer to the proper unit repair manual for more information.
- 8. Oil pump, as outlined previously.
- 9. Oil pan, as outlined previously.
- 10. Spark plugs.

CRANKSHAFT REPLACEMENT

1. Remove the engine, as outlined later.
2. Refer to the proper unit repair manual for crankshaft replacement procedures.

FLYWHEEL REPLACEMENT



Remove or Disconnect

1. Transmission, flywheel housing, and clutch.
2. Flywheel bolts.
3. Flywheel.



Clean

- Mating surfaces of crankshaft and flywheel. Remove any burrs.



Inspect

- Flywheel for burning, scoring, warping, and wear. Replace the flywheel if necessary. Do not machine the flywheel.
- Flywheel ring gear for worn or broken teeth.

Flywheel Ring Gear Replacement

1. Use a torch to heat the gear around the entire circumference, then drive the gear off the flywheel, using care not to damage the flywheel.

NOTICE: Never heat starter gear to red heat as this will change metal structure.

2. Uniformly heat the flywheel gear to temperature which will expand the gear to permit installation. Temperature must not exceed 204°C (400°F).
3. As soon as the gear has been heated, install on the flywheel.



Install or Connect

1. Flywheel.
2. Flywheel bolts.



Tighten

- Flywheel bolts to 100 N·m (75 ft. lbs.).
3. Clutch, flywheel housing, and transmission.

ENGINE MOUNTINGS

NOTICE: Broken or deteriorated mountings can cause misaligned and eventual destruction of certain drive train components. When a single mounting breakage occurs, the remaining mountings are subjected to abnormally high stresses.

INSPECTING ENGINE MOUNTINGS

Front Engine Mountings

NOTICE: When raising or supporting the engine for any reason, do not use a jack under the oil pan, any sheet metal or crankshaft pulley. Due to the small clearance between the oil pan and the oil pump screen, jacking against the oil pan may cause it to be bent against the pump screen, resulting in a damaged oil pickup unit.

1. Raise the engine to remove weight from the mountings and to place a slight tension on the rubber cushion. Observe both mountings while raising the engine.
2. Replace the mounting if the following conditions exist:
 - Hard rubber surface covered with heat check cracks.
 - Rubber cushion separated from the metal plate of the mounting.
 - Rubber cushion split through the center.
3. If there is movement between a metal plate of the mounting and its attaching points, lower the engine and tighten the bolts or nuts attaching the mounting to the engine, frame, or bracket.

Rear Mountings

1. Push up and pull down on the transmission tailshaft. Observe the transmission mounting.
2. Replace the mounting if the following conditions exist:
 - Rubber cushion separated from the metal plate of the mounting.
 - Mounting bottomed out (tailshaft can be moved up but not down).
3. If there is relative movement between a metal plate of the mounting and its attaching point, tighten the bolts or nuts attaching the mounting to the transmission or crossmember.

FRONT MOUNTING REPLACEMENT

↔ Remove or Disconnect (Figures 35 through 38)

NOTICE: When raising or supporting the engine for any reason, do not use a jack under the oil pan, any sheet metal or crankshaft pulley. Due to the small clearance between the oil pan and the oil pump screen, jacking against the oil pan may cause it to be bent against the pump screen, resulting in a damaged oil pickup unit.

- Support the engine with a suitable jack. Do not load the engine mounting.
- 1. Engine mounting through-bolt and nut.

NOTICE: Raise the engine only enough for sufficient clearance. Check for interference between the rear of the engine and the dash panel which could cause distributor housing damage.

- Raise the engine only enough to permit removal of the engine mounting.
- 2. Mounting assembly bolts, nuts, and washers.
- 3. Mounting assembly.

↔ Install or Connect (Figures 35 through 38)

- 1. Mounting assembly.

NOTICE: See "Notice" on page 6A4-1 of this section.

- 2. Mounting assembly bolts, nuts, and washers.

Tighten

- Fasteners to specifications. Refer to figures 35 through 38.

- 3. Engine mount through-bolt and nut lower the engine until the bolt can be inserted. Install the nut.

Tighten

- Through-bolt nut to specifications. Refer to figures 35 through 38.

REAR MOUNTING REPLACEMENT (EXCEPT P-MODELS WITH FLYWHEEL HOUSING MOUNTING)

↔ Remove or Disconnect (Figures 39 through 42)

NOTICE: When raising or supporting the engine for any reason, do not use a jack under the oil pan, any sheet metal or crankshaft pulley. Due to the small clearance between the oil pan and the oil pump screen, jacking against the oil pan may cause it to be bent against the pump screen, resulting in a damaged oil pickup unit.

- Support the rear of the engine to relieve the weight on the rear mountings.
- 1. Mounting to crossmember nut(s) and washer(s).
- 2. Mounting to transmission bolts and washers.
- Raise the rear of the engine only enough to permit removal of the mounting.
- 3. Mounting.

↔ Install or Connect (Figures 39 through 42)

- 1. Mounting.
 - Lower the rear of the engine.
- 2. Mounting to transmission bolts and washers.

NOTICE: See "Notice" on page 6A4-1 of this section.

- 3. Mounting to crossmember nut(s) and washer(s).

Tighten

- Fasteners to specifications. Refer to figures 39 through 42.

REAR MOUNTING REPLACEMENT (P MODELS WITH FLYWHEEL HOUSING MOUNTING)

↔ Remove or Disconnect (Figure 43)

- 1. Bolt, cushion, and spacer.

NOTICE: When raising or supporting the engine for any reason, do not use a jack under the oil pan, any sheet metal or crankshaft pulley. Due to the small clearance between the oil pan and the oil pump screen, jacking against the oil pan may cause it to be bent against the pump screen, resulting in a damaged oil pickup unit.

- Raise the rear of the engine only enough to permit removal of the mounting.
- 2. Engine mounting.

↔ Install or Connect (Figure 43)

- 1. Engine mounting. Align the hole in the mounting with the hole in the crossmember.
- Lower the engine.

NOTICE: See "Notice" on page 6A4-1 of this section.

- 2. Spacer, cushion, and bolt.

Tighten

- Bolt to 90 N·m (65 ft. lbs.).

ENGINE REPLACEMENT

R AND V MODELS

↔ Remove or Disconnect

- 1. Battery negative cable.
- 2. Hood.
 - Drain the cooling system.
- 3. Air cleaner.
- 4. All accessory drive belts.
- 5. Fan and water pump pulley.
- 6. Radiator and shroud. Refer to RADIATOR (SEC. 6B2).
- 7. Heater hoses at the engine.
- 8. Accelerator, cruise control, and detent linkage (if used) from carburetor.
- 9. Air conditioning compressor (if used) and lay aside.
- 10. Power steering pump (if used) and lay aside.
- 11. Engine wiring harness from the engine.

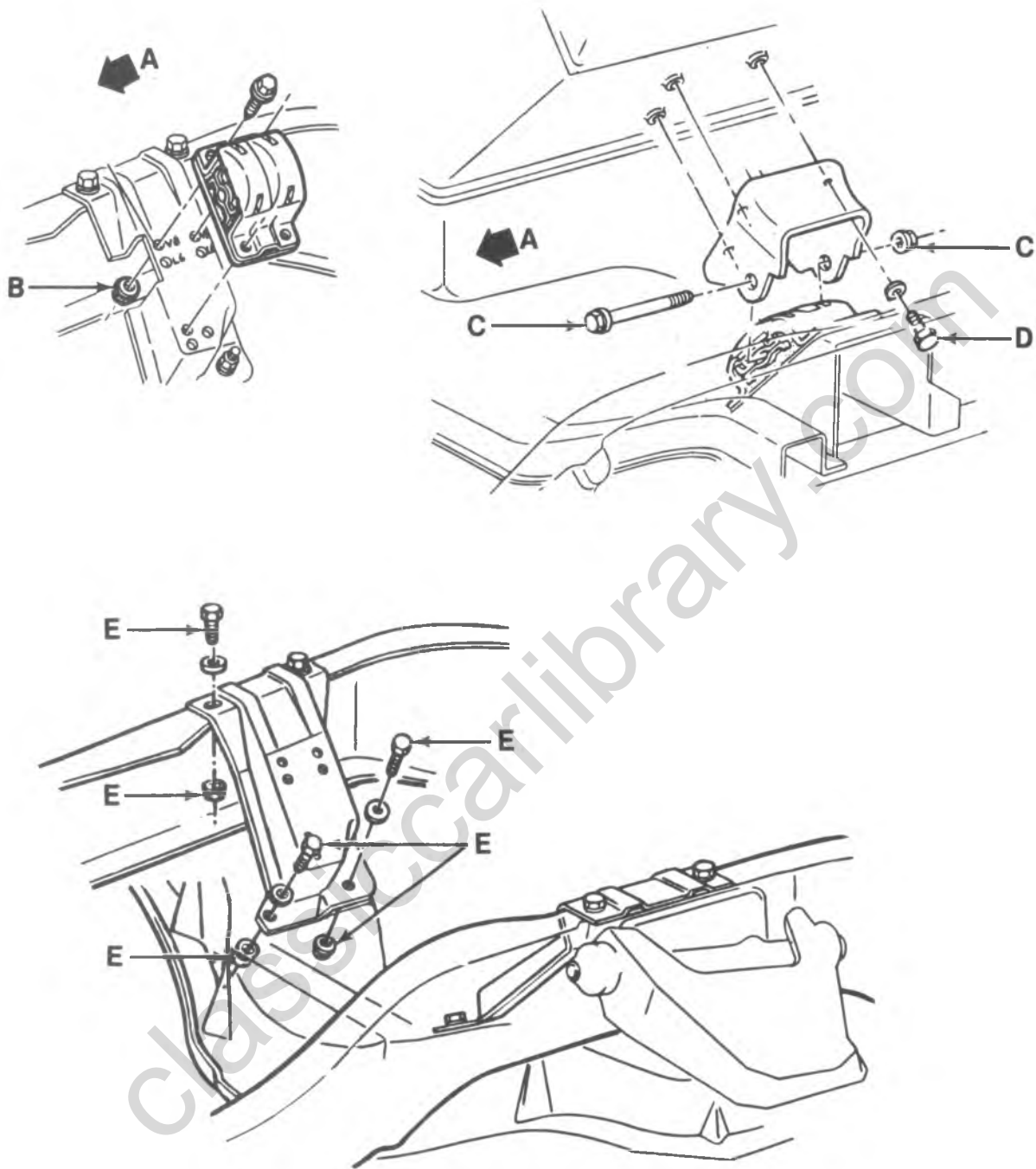

- A. Forward
- B. 40 N·m (30 Ft. Lbs.)
- C. Torque Bolt To 115 N·m (85 Ft. Lbs.) Or, Torque Nut To 75 N·m (55 Ft. Lbs.)
- D. 48 N·m (36 Ft. Lbs.)
- E. Torque Bolt To 48 N·m (36 Ft. Lbs.) Or, Torque Nut To 40 N·m (30 Ft. Lbs.)

B-07621

Figure 35—Front Engine Mounting (R Models)

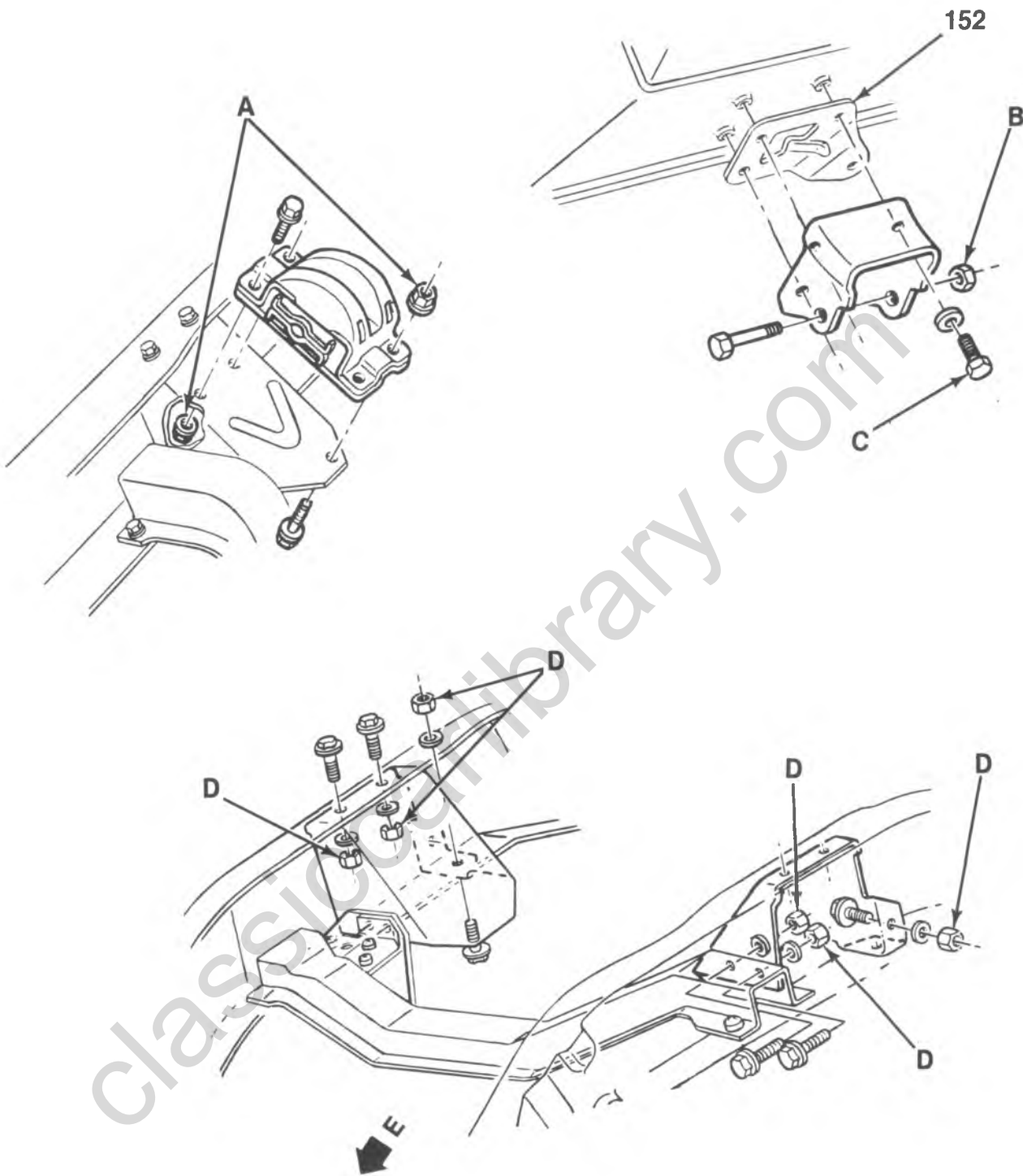

- A. 40 N·m (30 ft. lbs.)
- B. Torque bolt to 115 N·m (85 ft. lbs.) Or,
Torque nut to 75 N·m (55 ft. lbs.)
- C. 48 N·m (36 ft. lbs.)
- D. 65 N·m (48 ft. lbs.)
- E. Forward
- 152. Transmission Struck Bracket (Automatic Transmission)
Or Spacer (Manual Transmission)

B-07622

Figure 36—Front Engine Mounting (V Models)

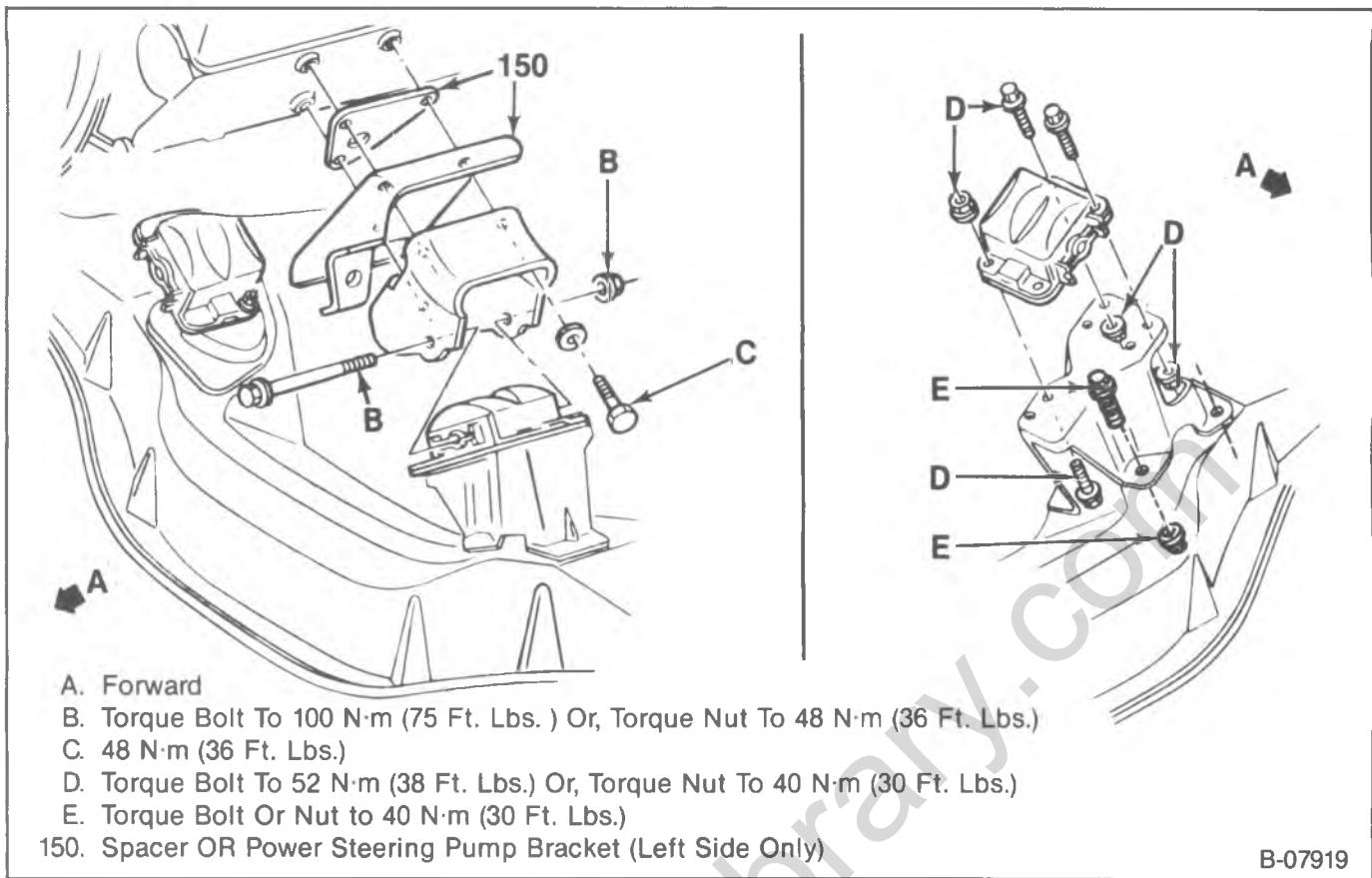

Figure 37—Front Engine Mounting (G Models)

12. Fuel lines.
13. Vacuum lines from the intake manifold.
 - Raise the vehicle. Support with suitable safety stands.
 - Drain the crankcase oil.
14. Exhaust pipes from the manifolds.
15. Strut rods at the engine mountings (V models with automatic transmission).
16. Flywheel or torque converter underpan.
17. Wiring along oil pan rail.
18. Starter.
19. Wiring for fuel gage.
20. Converter to flex plate bolts.
 - Lower the vehicle.
 - Support the transmission.
 - Attach a suitable lifting fixture.
21. Bell housing to engine bolts.
22. Front engine mounting to frame bolts.
23. Engine.

Install or Connect (Figures 35 and 36)

1. Engine to the vehicle.
 - Raise the vehicle. Support with suitable safety stands.

NOTICE: See "Notice" on page 6A4-1 of this section.

2. Front engine mounting to frame bolts.

Tighten

- Fasteners to specifications. Refer to figures 35 and 36.
3. Bell housing to engine bolts. Remove the transmission support.
 4. Converter to flex plate bolts.
 5. Fuel gage wiring.
 6. Starter.
 7. Wiring along oil pan rail.
 8. Flywheel or torque converter underpan.
 9. Strut rods at the engine mountings (V models with automatic transmission).
 10. Exhaust pipes to the manifolds.
 - Lower the vehicle.
 11. Vacuum lines to the intake manifold.
 12. Fuel line.
 13. Engine wiring harness.
 14. Power steering pump (if used).
 15. Air conditioning compressor (if used).
 16. Accelerator, cruise control, and detent linkages.
 17. Heater hoses.
 18. Radiator and shroud. Refer to RADIATOR (SEC. 6B2).
 19. Accessory drive belts.
 20. Air cleaner.
 21. Hood.
 22. Proper quantity and grade of coolant and crankcase oil.
 23. Battery negative cable.

- A. Front
- B. 100 N·m (75 Ft. Lbs.)
- C. 48 N·m (36 Ft. Lbs.)
- D. 40 N·m (30 Ft. Lbs.)

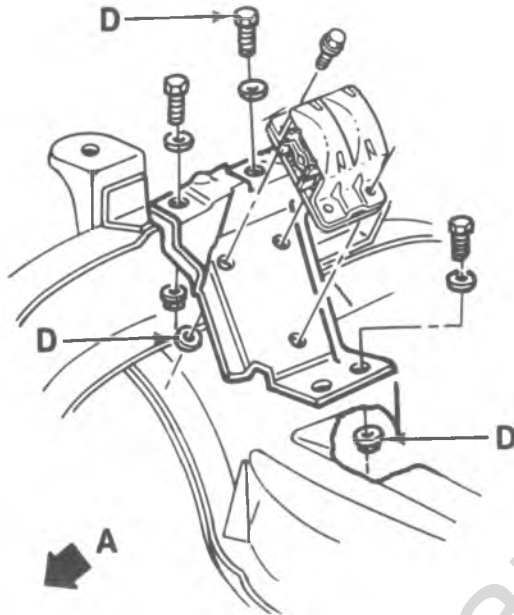
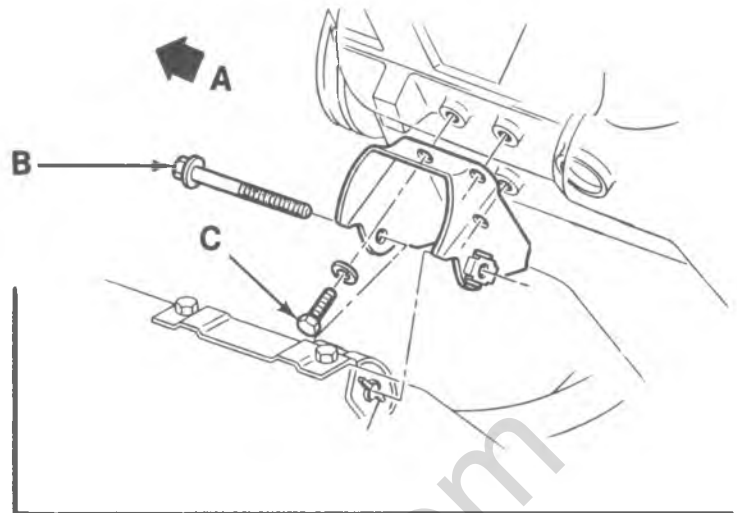

MODELS WITHOUT I-BEAM AXLE

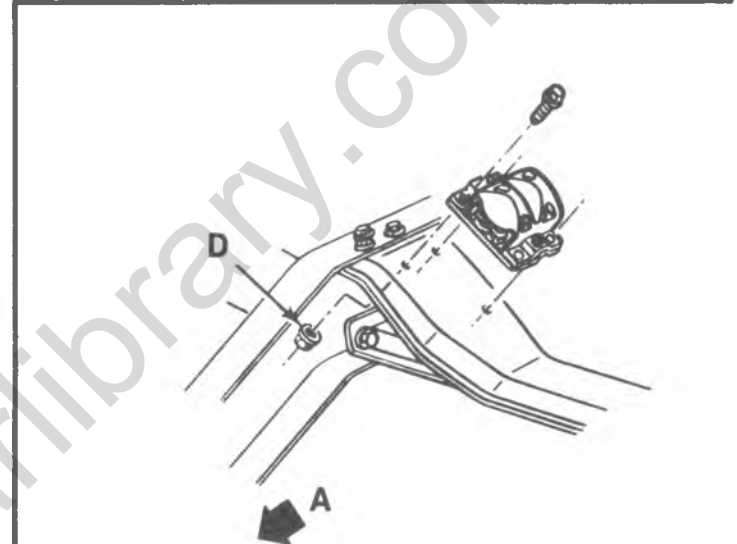

MODELS WITH I-BEAM AXLE (RPO-FS3)

B-07920

Figure 38—Front Engine Mounting (P Models)

G MODELS

↔ Remove or Disconnect

1. Battery negative cable.
 - Drain the cooling system.
2. Coolant reservoir bottle.
3. Grille and lower grille valance.
4. Upper radiator support.
5. Air conditioning condenser. Refer to AIR CONDITIONING (SEC. 1B).
6. Radiator. Refer to RADIATOR (6B2).
7. Power steering pump, and lay aside.
8. Engine cover.
9. Air cleaner.
10. Carburetor or TBI unit.
11. Engine wiring harness from the conductor on the dash panel.
12. Vacuum hoses and electrical wiring, as required.
13. Heater hoses at the engine.
14. Thermostat housing.
15. Oil filler tube.

16. Cruise control servo, bracket, and transducer (if equipped).
 - Raise the vehicle. Support with suitable safety stands.
17. Exhaust pipes at the exhaust manifolds.
18. Propeller shaft at the transmission. Plug the transmission end.
19. Transmission shift linkage and speedometer cable.
20. Fuel and vapor return hoses at the engine.
 - Drain the engine oil.
21. Rear engine mounting bolts.

NOTICE: When raising or supporting the engine for any reason, do not use a jack under the oil pan, any sheet metal or crankshaft pulley. Due to the small clearance between the oil pan and the oil pump screen, jacking against the oil pan may cause it to be bent against the pump screen, resulting in a damaged oil pickup unit.

- Support the engine with a suitable jack.
22. Front engine mounting bracket to frame bolts and nuts.

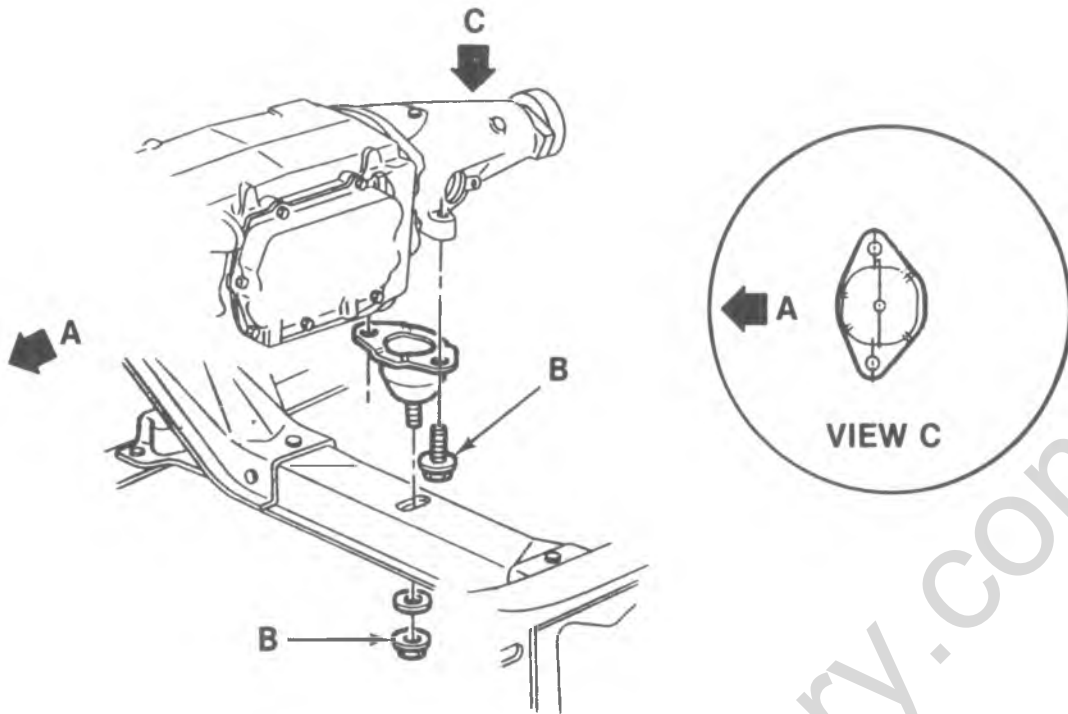

ALL MODELS EXCEPT WITH THM 400 TRANSMISSION (RPO-M40)

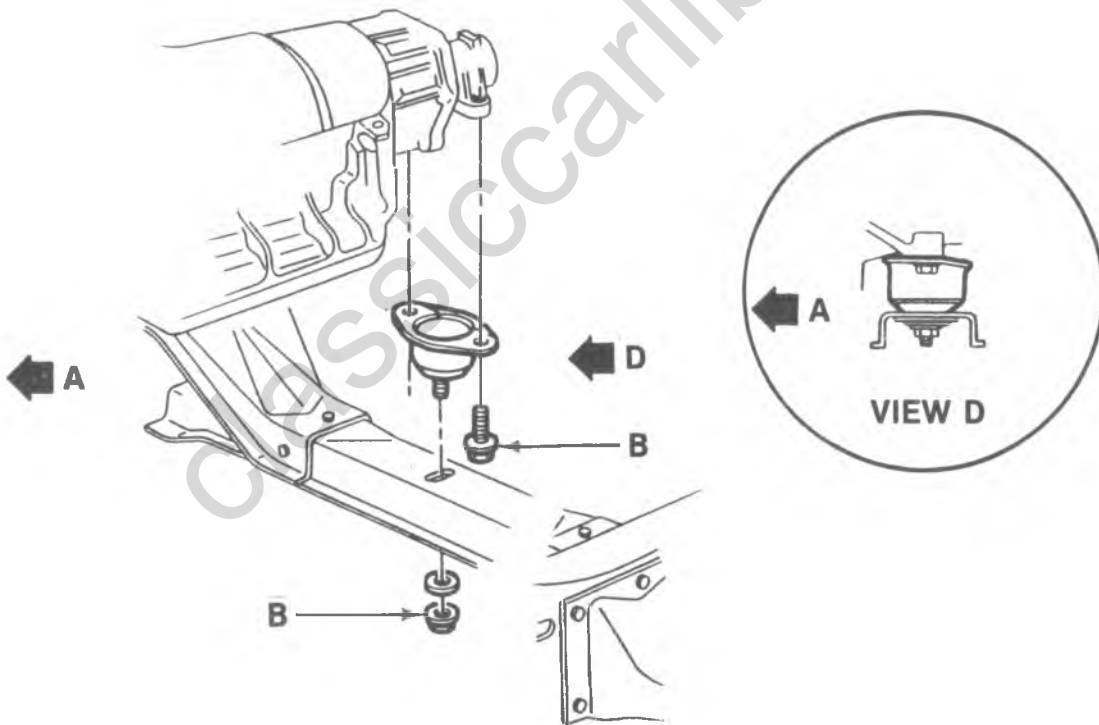

MODELS WITH THM 400 TRANSMISSION (RPO-M40)

- A. Forward
- B. 48 N·m (36 Ft. Lbs.)

Figure 39—Rear Engine Mounting (R Models)

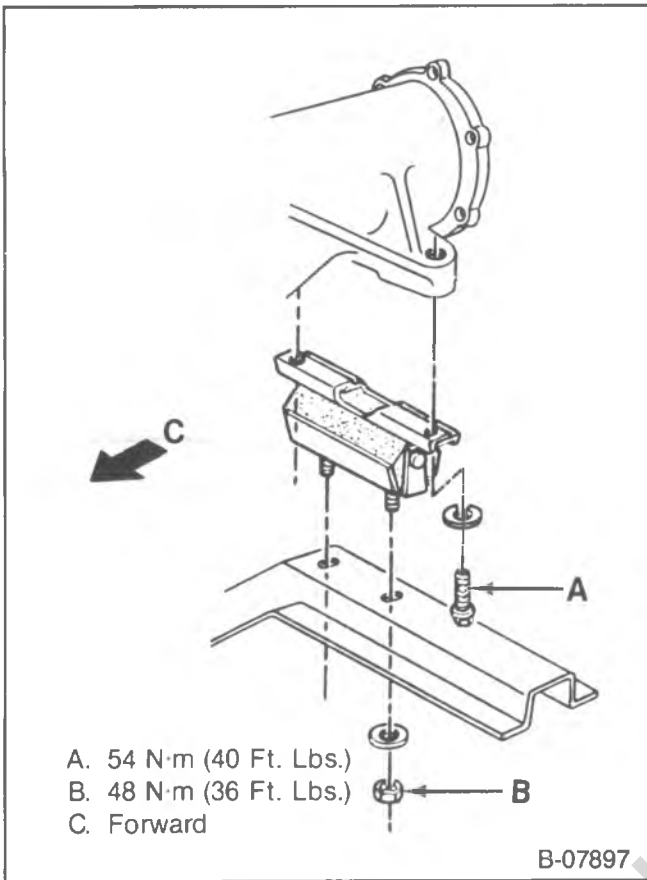

Figure 40—Rear Engine Mounting (V Models)

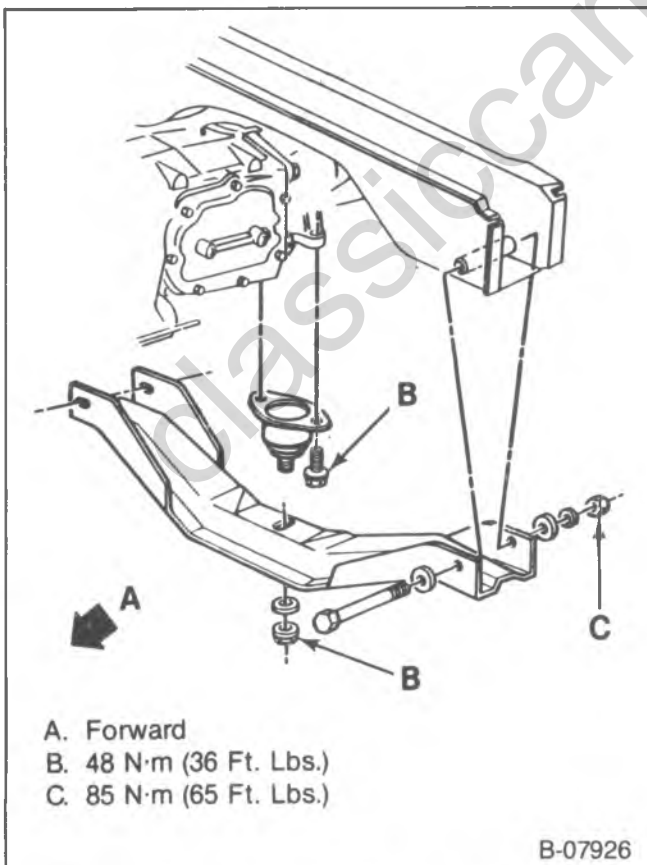

Figure 41—Rear Engine Mounting (G Models)

23. Front engine mounting through bolts.
24. Front engine mounting frame brackets. Raise the engine slightly to allow removal of the mounting bracket. Block the engine in place with wood blocks.
 - Lower the vehicle.
 - Install a suitable lifting fixture.
25. Engine and transmission from the vehicle.

↔ Install or Connect (Figure 37)

NOTICE: When raising or supporting the engine for any reason, do not use a jack under the oil pan, any sheet metal or crankshaft pulley. Due to the small clearance between the oil pan and the oil pump screen, jacking against the oil pan may cause it to be bent against the pump screen, resulting in a damaged oil pickup unit.

- Support the engine with a suitable jack.

NOTICE: See "Notice" on page 6A4-1 of this section.

2. Engine mounting frame brackets.
 - Raise the engine slightly and position the brackets against the engine mountings.
 - Install the through-bolts finger tight.
 - Lower the engine.
 - Install the mounting bracket to frame bolts and nuts.

⌚ Tighten

- Engine mounting fasteners to specifications. Refer to figure 37.

- Remove the jack.

3. Rear engine mounting bolts.

⌚ Tighten

- Engine mounting to transmission bolts to 48 N·m (36 ft. lbs.).

4. Fuel and vapor return lines.
5. Transmission shift linkage and speedometer cable.
6. Propeller shaft.
7. Exhaust pipes.
 - Lower the vehicle.
8. Cruise control servo, bracket, and transducer (if equipped).
9. Oil filler tube.
10. Thermostat housing.
11. Heater hoses.
12. Vacuum hoses and electrical wiring.
13. Engine wiring harness connector.
14. Carburetor or TBI unit.
15. Air cleaner.
16. Power steering pump.
17. Radiator. Refer to RADIATOR (SEC. 6B2).
18. Air conditioning condenser (if equipped). Refer to AIR CONDITIONING (SEC. 1B).
19. Upper radiator support.
20. Grille and lower grille valance.
21. Coolant reservoir bottle.
22. Battery negative cable.

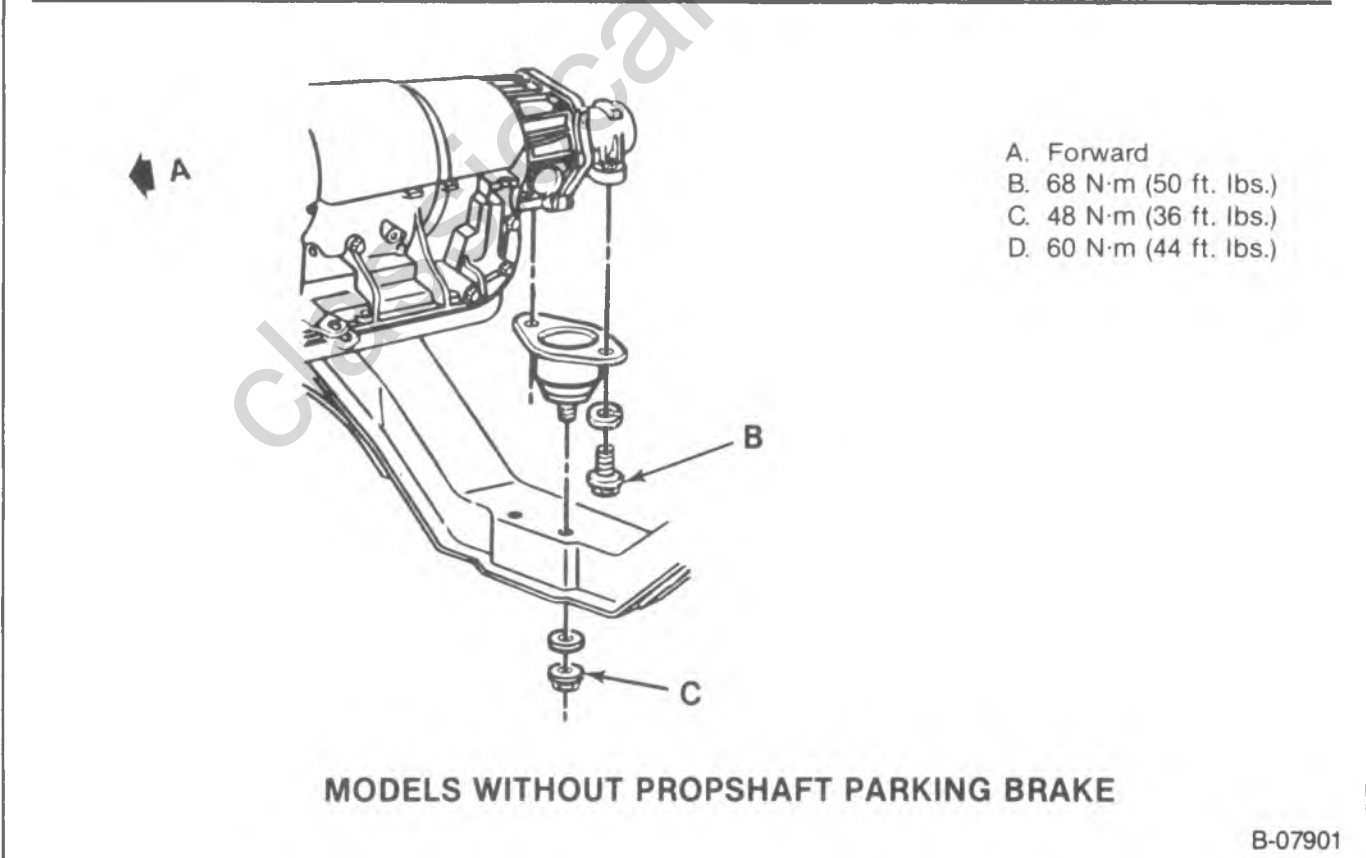
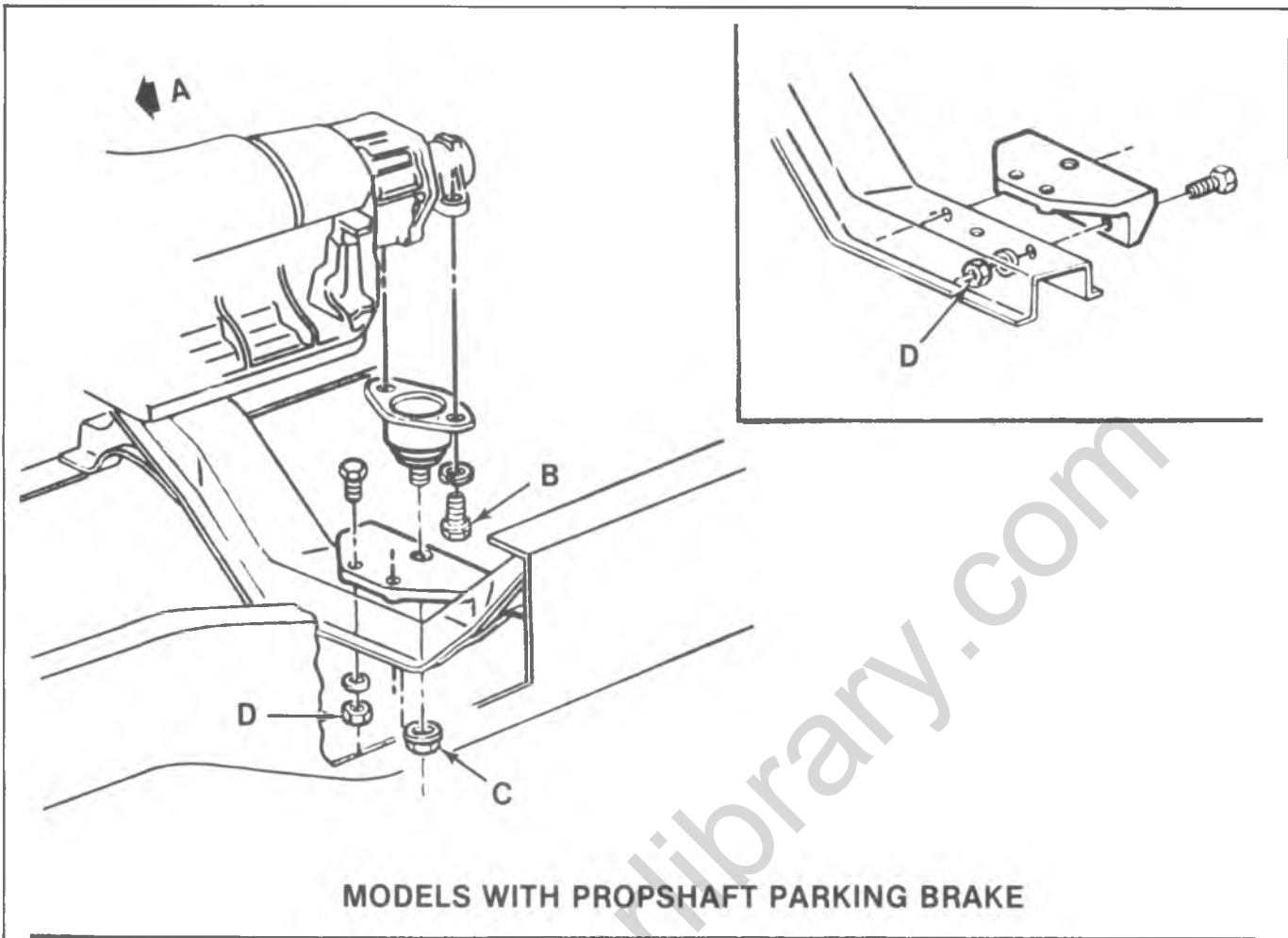

Figure 42—Rear Engine Mounting (P Models with Transmission Tail Type Mounting)

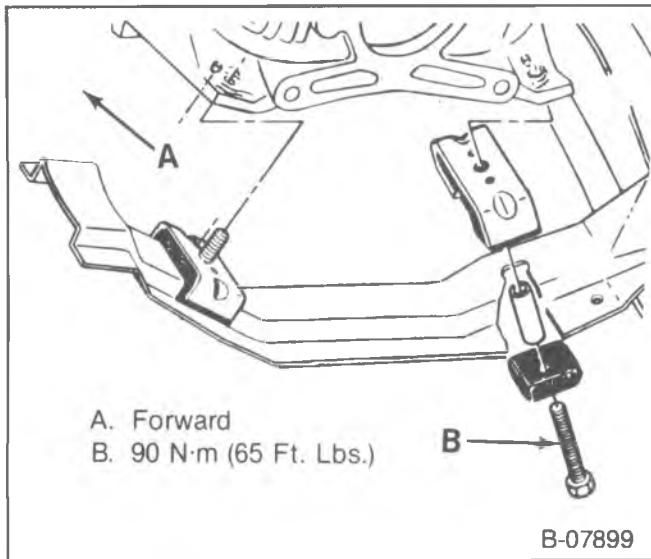

Figure 43—Rear Engine Mounting (P Models with Flywheel Housing Type Mounting)

23. Proper quantities and grades of coolant and engine oil.
- Evacuate and charge the air conditioning system. Refer to AIR CONDITIONING (SEC. 1B).

SPECIFICATIONS

ENGINE SPECIFICATIONS

All Specifications are in INCHES unless otherwise noted.

GENERAL DATA:					
Type	V8				
Displacement	5.0L (305 Cu. In.)		5.7L (350 Cu. In.)		
RPO (VIN Code)	L03 (H)	L05 (K)	LS9 (L)	LT9 (M)	
Bore	3.736		4.00		
Stroke	3.480				
Compression Ratio	9.3		*	8.3:1	
Firing Order	1 - 8 - 4 - 3 - 6 - 5 - 7 - 2				
Oil Pressure	10 psi @ 500 RPM; 30-55 psi @ 2000 RPM				
CYLINDER BORE:					
Diameter	3.7350-3.7385		♦ 3.9995-4.0025		
Out Of Round	Production	0.001 (Maximum)			
	Service	0.002 (Maximum)			
Taper	Production	Thrust Side	0.0005 (Maximum)		
		Relief Side	0.001 (Maximum)		
	Service	0.001 (Maximum)			
PISTON:					
Clearance	Production	0.0007-0.0017			
	Service Limit	0.0027 (Maximum)			
PISTON RING:					
C O M P R E S S I O N	Groove Clearance	Production	Top	0.0012-0.0032	
			2nd		
	Service Limit		Hi Limit Production + 0.001		
	Gap	Production	Top	0.010-0.020	
			2nd	0.010-0.025	
		Service Limit		Hi Limit Production + 0.010	
O I L	Groove Clearance	Production	0.002-0.007		
		Service Limit	Hi Limit Production + 0.001		
	Gap	Production	0.015-0.055		
		Service Limit	Hi Production + 0.010		
PISTON PIN:					
Diameter	0.9269-0.9271				
Clearance In Piston	Production	0.0002-0.0007			
	Service Limit	0.001 (Maximum)			
Fit In Rod	0.0008-0.0016 Interference				

*8.6:1 with RPO-NA4

9.3:1 with RPO-NA1

SPECIFICATIONS ENGINE SPECIFICATIONS (CONT.)

All specifications are in INCHES unless otherwise noted.

DISPLACEMENT			5.0L (305 Cu. In.)	5.7L (350 Cu. In.)	
CRANKSHAFT:					
Main Journal	Diameter	#1	2.4484-2.4493		
		#2, #3, #4	2.4481-2.4490		
		#5	2.4479-2.4488		
	Taper	Production	0.0002 (Maximum)		
		Service Limit	0.001 (Maximum)		
	Out Of Round	Production	0.0002 (Maximum)		
Service Limit		0.001 (Maximum)			
Main Bearing Clearance	Production	#1	0.0008-0.0020		
		#2, #3, #4	0.0011-0.0023		
		#5	0.0017-0.0032		
	Service Limit	#1	0.0010-0.0015		
		#2, #3, #4	0.0010-0.0025		
		#5	0.0025-0.0035		
Crankshaft End Play			0.002-0.006		
Crankpin	Diameter		2.0988-2.0998		
		Taper	Production	0.0005 (Maximum)	
			Service Limit	0.001 (Maximum)	
	Out Round	Production	0.0005 (Maximum)		
		Service Limit	0.001 (Maximum)		
	Rod Bearing Clearance	Production		0.0013-0.0035	
Service Limit		0.003 (Maximum)			
Rod Side Clearance			0.006-0.014		
CAMSHAFT:					
Lobe Lift \pm 0.002	Intake		0.2336	0.2565	
	Exhaust		0.2565	0.2690	
Journal Diameter			1.8682-1.8692		
Camshaft End Play			0.004-0.012		
VALVE SYSTEM:					
Lifter			Hydraulic		
Rocker Arm Ratio			1.50:1		
Valve Lash	Intake		One Turn Down From Zero Lash		
	Exhaust				
Face Angle (Intake & Exhaust)			45°		
Seat Angle (Intake & Exhaust)			46°		
Seat Runout (Intake & Exhaust)			0.002 (Maximum)		
Seat Width	Intake		$\frac{1}{32}$ - $\frac{1}{16}$		
	Exhaust		$\frac{1}{16}$ - $\frac{3}{32}$		
Stem Clearance	Production	Intake	0.0010-0.0027		
		Exhaust	0.0010-0.0027		
	Service	Intake	High Limit Production + 0.001		
		Exhaust	High Limit Production + 0.002		
Valve Spring (Outer)	Free Length		2.03		
	Pressure lbs. @ in.	Closed	76-84 lbs. @ 1.70"		
		Open	194-206 lbs. @ 1.25"		
	Installed Height \pm $\frac{1}{32}$ "		$1\frac{23}{32}$		
Valve Spring Damper	Free Length		1.86		
	Approx. # of Coils		4		



SPECIFICATIONS (CONT.)

TORQUE SPECIFICATIONS

Item	N·m	Ft. Lbs.	In. Lbs.
Rocker Arm Cover Nuts (Carbureted Engines).....	7.3	—	65
Rocker Arm Cover Bolts (TBI Engines).....	11.3	—	100
Intake Manifold Bolts.....	48	35	—
Exhaust Manifold Bolts.....			
Cast Manifolds:			
Two Center Bolts:.....	36	26	—
All Others:.....	28	20	—
Tubular (Stainless Steel) Manifolds (All Bolts).....	36	26	—
Cylinder Head Bolts.....	90	65	—
Torsional Damper Bolt.....	95	70	—
Front Cover Bolts.....	11.3	—	100
Oil Pan Nuts at Corners.....	22.6	—	200
Oil Pan Bolts.....	11.3	—	100
Oil Pump Bolt.....	90	65	—
Oil Pan Baffle Nuts (Some 5.7L Engines).....	34	25	—
Rear Crankshaft Oil Seal Retainer Screws and Nuts.....	15.3	—	135
Camshaft Sprocket Bolts.....	24	18	—
Connecting Rod Cap Nuts.....	60	45	—
Oil Filter Bypass Valve Bolts.....	26	20	—
Main Bearing Cap Bolts			
Outer Bolts on #2, #3, and #4 Caps.....	95	70	—
All Others.....	110	80	—
Oil Pump Cover Bolts.....	9.0	—	80
Flywheel Bolts.....	100	75	—
Spark Plugs.....	30	22	—
Water Outlet Bolts.....	28	21	—
Water Pump Bolts.....	40	30	—
Flywheel Housing Bolts.....	44	32	—
Rocker Arm Cover Studs to Head (Carbureted Engines).....	1.7	—	15
Oil Pan Studs to Back or Rear Oil Seal Retainer.....	1.7	—	15

classiccarlibrary.com

SPECIAL TOOLS

- | | | | | | |
|----|---|-----------|-----|---|-----------|
| 1. |  | J-23523-E | 10. |  | J-3049 |
| 2. |  | J-5892-B | 11. |  | J-5802-01 |
| 3. |  | J-23590 | 12. |  | J-5715 |
| 4. |  | J-35468 | 13. |  | J-6036 |
| 5. |  | J-8080 | 14. |  | J-6880 |
| 6. |  | J-8037 | 15. |  | J-5825-A |
| 7. |  | J-5239 | 16. |  | J-5590 |
| 8. |  | J-23738-A | 17. |  | J-8520 |
| 9. |  | J-9290-01 | 18. |  | J-35621 |

- | | |
|---|---|
| 1. Torsional Damper Remover and Installer | 10. Hydraulic Lifter Remover (Plier Type) |
| 2. Valve Spring Compressor | 11. Stud Remover |
| 3. Air Adapter | 12. Reamer (0.003-inch oversize) |
| 4. Crankshaft Seal Installer and Centering Tool | 13. Reamer (0.013-inch oversize) |
| 5. Main Bearing Replacer | 14. Stud Installer |
| 6. Piston Ring Compressor | 15. Crankshaft Gear Puller |
| 7. Guide Set | 16. Crankshaft Gear Installer |
| 8. Vacuum Pump | 17. Dial Indicator Adapter |
| 9. Hydraulic Lifter Remover (Slide Hammer Type) | 18. Rear Crankshaft Seal Installer |

classiccarylbrary.com

SECTION 6A5

7.4 LITER V8

The following "Notice" applies to one or more steps in the assembly procedure of components in this portion of the manual as indicated at appropriate locations by the terminology "NOTICE: See 'Notice' on page 6A5-1 of this section."

NOTICE: All engine fasteners are important attaching parts in that they could affect the performance of vital components and systems, and/or could result in major repair expense. They must be replaced with one of the same part number or with an equivalent part if replacement becomes necessary. Do not use a replacement part of lesser quality or substitute design. Torque values must be used as specified during reassembly to assure proper retention of this part.

CONTENTS

<u>SUBJECT</u>	<u>PAGE</u>
Description	6A5- 1
Engine Lubrication	6A5- 1
On-Vehicle Service	6A5- 3
Rocker Arm Cover Replacement	6A5- 3
Rocker Arm and Pushrod Replacement	6A5- 3
Valve Adjustment	6A5- 4
Valve Stem Seal and Valve Spring Replacement	6A5- 4
Intake Manifold Replacement	6A5- 5
Hydraulic Lifter Replacement	6A5- 6
Rocker Arm Stud Replacement	6A5- 7
Exhaust Manifold Replacement	6A5- 7
Cylinder Head Replacement	6A5- 7
Torsional Damper and Front Crankshaft Seal Replacement	6A5- 8
Front Cover Replacement	6A5- 9
Oil Pan Replacement	6A5-10
Oil Pump Replacement	6A5-11
Rear Crankshaft Oil Seal Replacement	6A5-11
Measuring Camshaft Lobe Lift	6A5-13
Camshaft Replacement	6A5-13
Connecting Rod and Piston Replacement	6A5-15
Oil Filter Bypass Valve	6A5-17
Main Bearing Replacement	6A5-17
Crankshaft Replacement	6A5-18
Flywheel Replacement	6A5-18
Engine Mountings	6A5-19
Engine Replacement	6A5-22
Specifications	6A5-27
Special Tools	6A5-30

DESCRIPTION

7.4L engines are 90-degree V8 type, overhead valve, water cooled, with cast iron block and heads.

The crankshaft is supported by five precision insert main bearings, with crankshaft thrust taken at the number five (rear) bearing.

The camshaft is supported by five plain type bearings and is chain driven. Motion from the camshaft is transmitted to the valves by hydraulic lifters, pushrods, and ball type rocker arms. The valve guides are integral in the cylinder head.

The connecting rods are forged steel, with precision insert type crankpin bearings. The piston pins are a press fit in the connecting rods.

The pistons are cast aluminum alloy. The piston pins are a floating fit in the piston.

ENGINE LUBRICATION

Lubrication schematics are shown in Figure 1. The gear type oil pump is driven from the distributor shaft, which is gear driven from the camshaft. Oil is drawn into the oil pump through a pickup screen and pipe.

Pressurized oil is routed to the oil filter. In case of excessive oil pressure, a bypass valve is provided. Filtered oil flows into the main gallery and then to the camshaft and crankshaft bearings. The valve lifter oil gallery supplies oil to the valve lifters. Oil flows from the hydraulic lifters through the hollow pushrods to the rocker arms. Oil from the overhead drains back to the crankcase through oil drain holes.

The timing chain is drip fed from the front camshaft bearing. The pistons and piston pins are lubricated by oil splash.

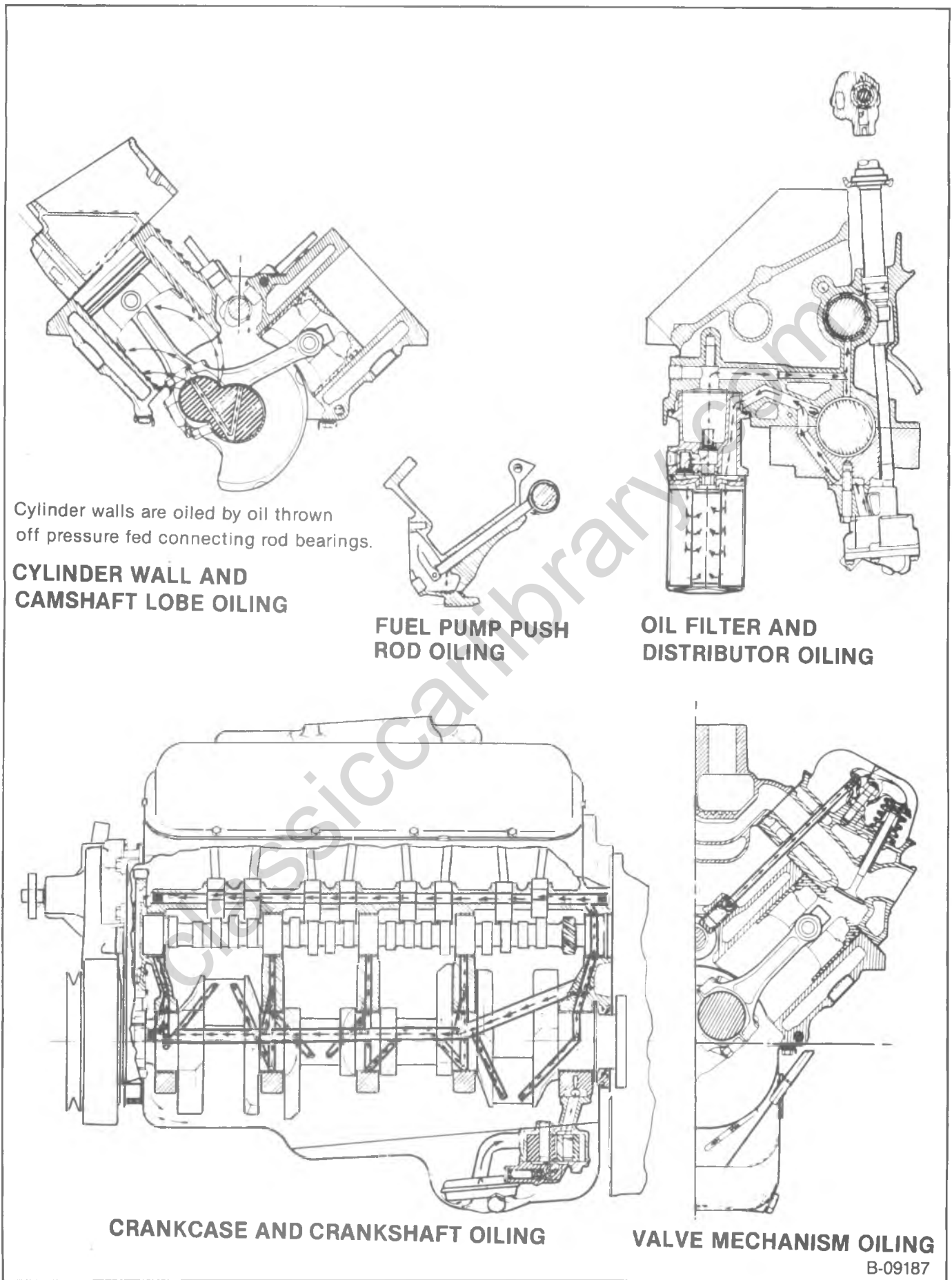

Figure 1—Engine Lubrication Diagram

ON-VEHICLE SERVICE

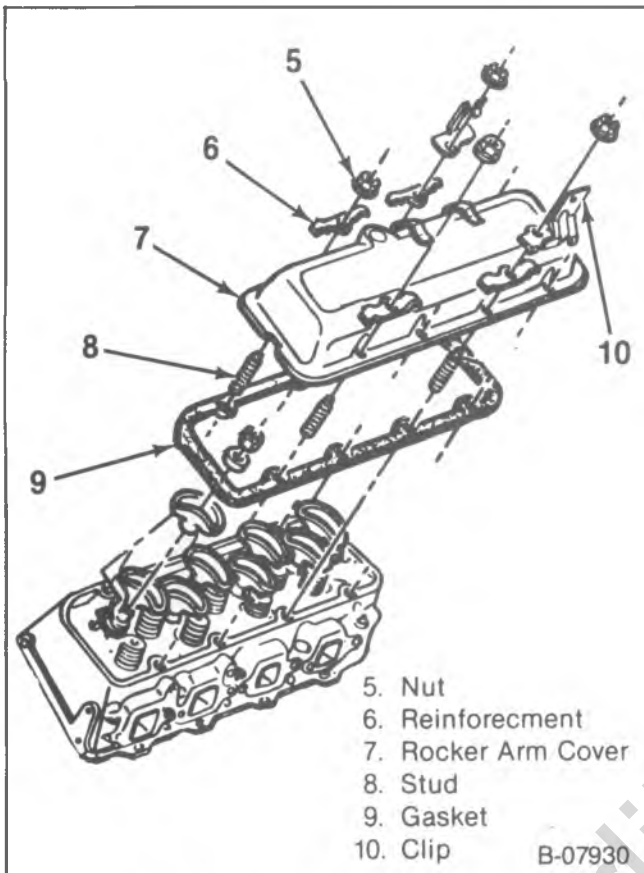

Figure 2—Rocker Arm Cover Installation

ROCKER ARM COVER REPLACEMENT

↔ Remove or Disconnect (Figure 2)

1. Battery negative cable.
2. Air cleaner.
3. Crankcase ventilation hoses at the rocker arm cover.
4. Wiring harnesses from the clips at the rocker arm cover.
5. Spark plug wire clip from the bracket. Move the spark plug wire loom out of the way (TBI engines).
6. Heat stove pipe (right side rocker arm cover).
7. Air conditioning compressor rear brace (if equipped) (left side rocker arm cover).
8. Rocker arm cover nuts, reinforcements, and clips.
9. Rocker arm cover and gasket.

🧼 Clean

- All traces of old gasket from the rocker arm cover and cylinder head.

🔍 Inspect

- Rocker arm cover sealing surface for distortion. Replace if necessary.

➡ Install or Connect (Figure 2)

1. Rocker arm cover and new gasket.
2. Reinforcements, clips, and nuts.

🔩 Tighten

- Nuts to 13.0 N·m (115 in. lbs.).
3. Air conditioning compressor rear brace (if removed).
 4. Heat stove pipe (if removed).
 5. Wiring harnesses and spark plug wire loom (TBI engines).
 6. Crankcase ventilation hoses.
 7. Air cleaner.
 8. Battery negative cable.

ROCKER ARM AND PUSHROD REPLACEMENT

↔ Remove or Disconnect

1. Rocker arm cover, as outlined previously.
2. Rocker arm nut.
 - If only the pushrod is to be replaced, back the rocker arm nut off until the rocker arm can be swung away from the pushrod. Then pull the pushrod out.
3. Rocker arm with ball.
4. Pushrod.

⚠ Important

- Store used components in order so they can be reassembled in the same location.

🔍 Inspect

- Rocker arms and balls at their mating surfaces. These surfaces should be smooth and free from scoring or other damage.
- Rocker arm areas which contact the valve stems and the sockets which contact the pushrods. These areas should be smooth and free of damage and wear.
- Pushrods for bending. Roll the pushrod on a flat surface to determine if it is bent. Replace if necessary.
- Ends of the pushrods for scoring or roughness.

➡ Install or Connect

1. Pushrod. Make sure the pushrod seats properly in the hydraulic lifter.
2. Rocker arm with ball.

⚠ Important

- When new rocker arms and/or balls are installed, coat their bearing surfaces with "Molykote" or equivalent.

3. Rocker arm nut.

🔧 Adjust

- Valves as outlined later.
4. Rocker arm cover, as outlined previously.

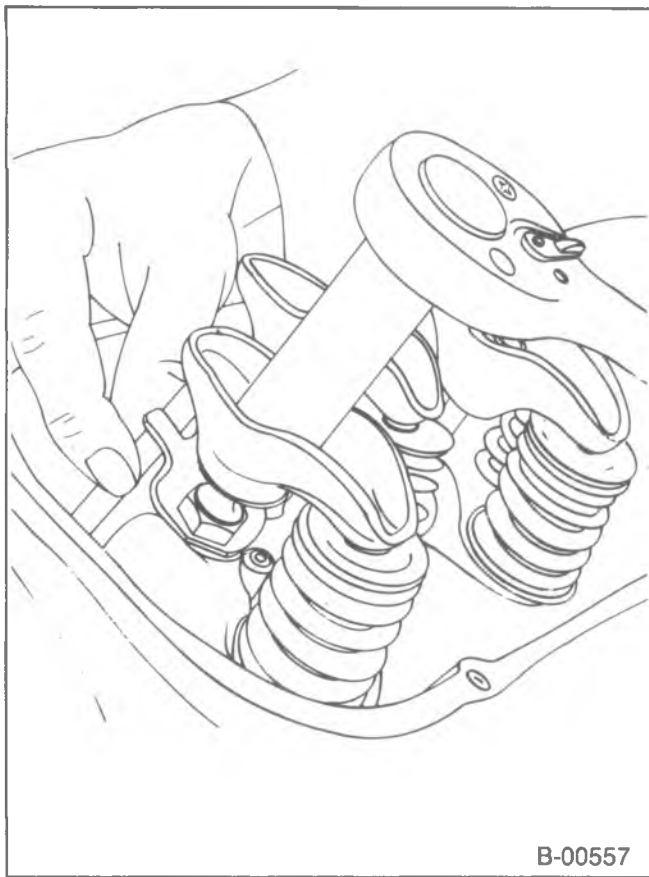

Figure 3—Adjusting the Valves

VALVE ADJUSTMENT

1. Remove the rocker arm cover as outlined previously.
2. Crank the engine until the mark on the vibration damper lines up with the "O" mark on the timing tab and the engine in the number one firing position. This may be determined by placing fingers on the number one valve as the mark on the damper comes near the "O" mark on the timing tab. If the rocker arms are not moving, the engine is in the number one firing position. If the rocker arms move as the mark comes up to the timing tab, the engine is in the number six firing position and should be turned over one more time to reach the number one position.
3. With the engine in the number one firing position as determined above, the following valves may be adjusted:
 - Exhaust: 1, 3, 4, 8
 - Intake: 1, 2, 5, 7

(Even numbered cylinders are in the right bank; odd numbered cylinders are in the left bank, when viewed from the rear of the engine).
4. Back out the adjusting nut until lash is felt at the pushrod then turn in the adjusting nut until all lash is removed. This can be determined by rotating the pushrod while turning the adjusting nut (figure 3). When the play has been removed, turn the adjusting nut in three quarters ($\frac{3}{4}$) additional turn (to center the lifter plunger).

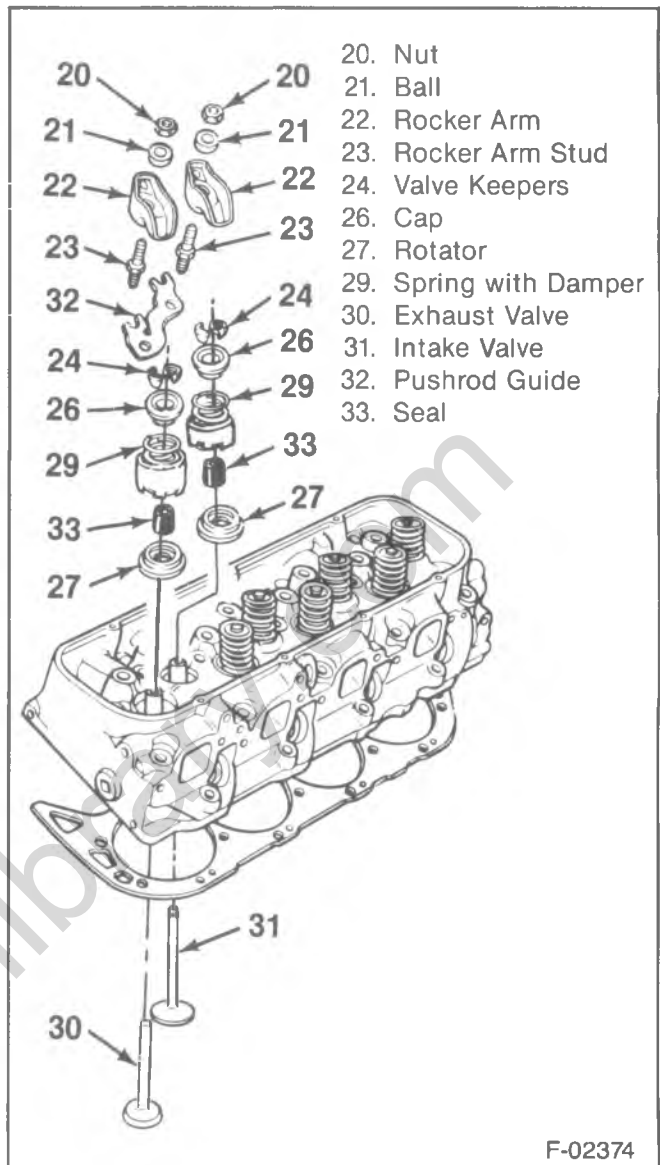

Figure 4—Cylinder Head and Components

5. Crank the engine one revolution until the timing tab "O" mark and vibration damper mark are again in alignment. This is the number six firing position the following valves may be adjusted:
 - Exhaust: 2, 5, 6, 7
 - Intake: 3, 4, 6, 8
6. Install the rocker arm cover as outlined previously.

VALVE STEM SEAL AND VALVE SPRING REPLACEMENT

↔ Remove or Disconnect (Figures 4 and 5)

Tools Required:

- J-23590 Air Adapter
- J-5892-B Spring Compressor

1. Rocker arm cover, as outlined previously.
2. Rocker arms, as outlined previously.
3. Spark plugs.
4. Valve keepers.
 - Install J-23590 into the spark plug hole.

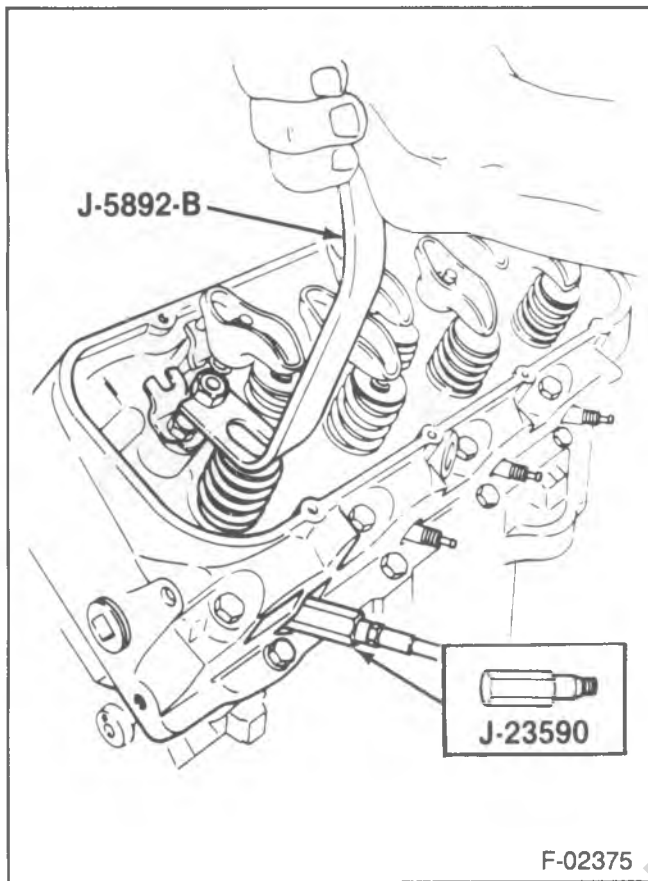

Figure 5—Compressing the Valve Spring

- Apply compressed air to hold the valves in place.
 - Install a rocker arm nut (figure 5).
 - Use J-5892-B to compress the valve spring (figure 5).
 - Remove the valve keepers.
 - Carefully release the spring tension. Remove J-5892-B.
5. Cap (25) and spring with damper (23).
 6. Seal (24).

↔ Install or Connect (Figures 4 and 5)

Tools Required:

J-23590 Air Adapter
J-5892-B Spring Compressor

1. New seal. Install the seal over the valve stem and seat it against the head.
2. Spring with damper, and cap.
3. Valve keepers.
 - With air pressure applied to the cylinder with J-23590, compress the spring with J-5892-B (figure 5).
 - Install the valve keepers. Use grease to hold them in place.
 - Carefully release spring pressure. Make sure the valve keepers stay in place.
 - Remove J-5892-B and J-23590.
4. Spark plugs.
5. Rocker arms, as outlined previously.

🔧 Adjust

- Valves, as outlined previously.
6. Rocker arm covers, as outlined previously.

INTAKE MANIFOLD REPLACEMENT

↔ Remove or Disconnect

1. Battery negative cable.
2. Air cleaner.
 - Drain the cooling system.
3. Upper radiator hose, and water pump bypass hose.
4. Heater hose and pipe (TBI engines) or heater hose (carbureted engines).
5. Wire at sensor at front of intake manifold (TBI engines).
6. Accelerator, cruise control, and TVS cables, as equipped.
7. Wiring harness from clips.
8. Cruise control transducer (if equipped).
9. Fuel line at carburetor or fuel lines at TBI unit.
10. Crankcase ventilation hoses.
11. Vacuum hoses, as necessary.
12. Distributor. Refer to ENGINE ELECTRICAL (SEC. 6D).
13. Wires at ignition coil (TBI engines).
14. EGR solenoid with bracket (TBI engines).
15. MAP sensor with bracket (TBI engines).
16. Air conditioning compressor rear bracket (if equipped).
17. Front generator/AIR pump bracket (TBI engines) or upper generator bracket (carbureted engines).
18. Intake manifold bolts.
19. Intake manifold.
20. Gaskets and seals.

🧼 Clean

- Old gaskets from the block, heads, and intake manifold.
- Excessive carbon deposits from the exhaust and EGR passages.
- Excessive scale and deposits from the coolant passages.

🔍 Inspect

- Manifold for cracks and gasket surface damage.

↔ Install or Connect (Figure 6)

1. Front and rear intake manifold seals to the block.
2. Side gaskets to the cylinder heads.
3. Intake manifold and bolts.

🔩 Tighten

- Bolts to 40 N·m (30 ft. lbs.). Use the tightening sequence shown in figure 6.
4. Front generator/AIR pump bracket (TBI engines) or upper generator bracket (carbureted engines).
 5. Air conditioning compressor rear bracket (if equipped).
 6. MAP sensor with bracket (TBI engines).
 7. EGR solenoid with bracket (TBI engines).

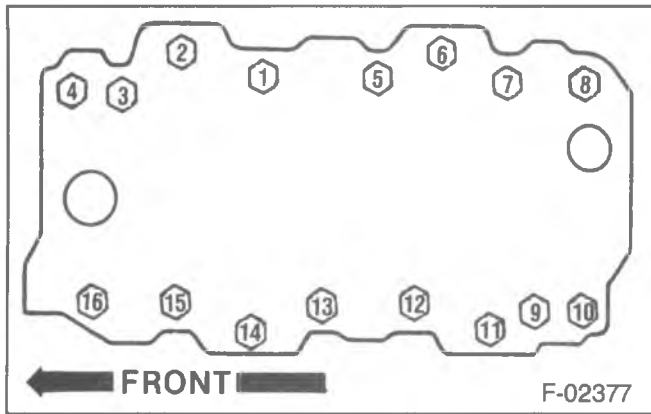

Figure 6—Intake Manifold Tightening Sequence

8. Wires at ignition coil (TBI engines).
9. Distributor. Refer to ENGINE ELECTRICAL (SEC. 6D).
10. Vacuum hoses.
11. Crankcase ventilation hoses.
12. Fuel line or lines.
13. Cruise control transducer (if equipped).
14. Wiring harnesses to the clips.
15. Accelerator, cruise control, and TV cables.
16. Sensor wire at front of manifold (TBI engines).
17. Heater hose and pipe (TBI engines) or heater hose (carbureted engines).
18. Water pump bypass hose, heater hose, and upper radiator hose.
19. Air cleaner.
20. Battery negative cable.
 - Fill the cooling system with the proper quantity and grade of coolant.

HYDRAULIC LIFTER REPLACEMENT

↔ Remove or Disconnect (Figures 7 and 8)

Tools Required:
J-3049 Lifter Remover (Plier Type) or



Figure 7—Removing the Valve Lifter

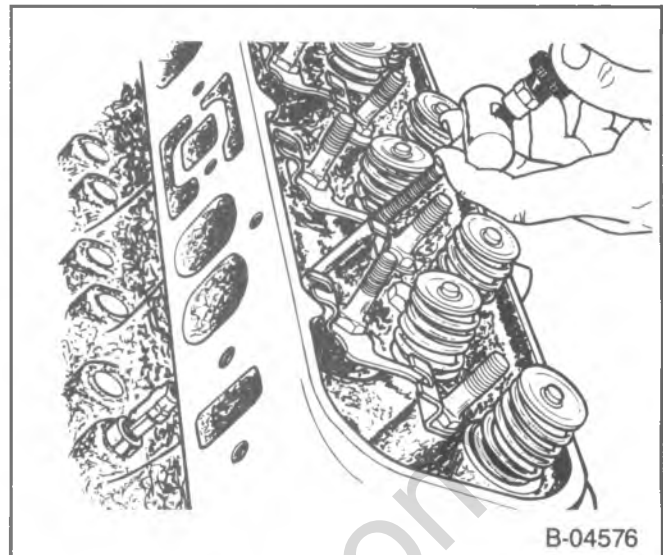

Figure 8—Removing the Valve Lifter

J-9290-01 Lifter Remover (Slide Hammer Type)

1. Rocker arm cover, intake manifold, and pushrod, as outlined previously.
2. Hydraulic lifters.
 - Remove the hydraulic lifters one at a time and place them in an organizer rack. The lifters must be installed in the same bore from which they were removed.
 - A stuck hydraulic lifter can be removed using J-3049 (figure 7) or J-9290-01 (figure 8).

🔍 Inspect

- Hydraulic lifter body for scuffing and scoring. If the lifter body wall is worn or damaged, the mating bore in the block should also be checked.
- Check the fit of each hydraulic lifter in its mating bore in the block. If the clearance is excessive, try a new lifter.
- The hydraulic lifter foot must be smooth and slightly convex. If worn, pitted, or damaged, the mating camshaft lobe should also be checked.

Hydraulic Lifter Repair

- Refer to the proper unit repair manual.

↔ Install or Connect

1. Hydraulic lifters to the block. Lubricate the lifter foot and body with Engine Oil Supplement or equivalent.

❗ Important

- When any new hydraulic lifters or a new camshaft is installed, replace the engine oil and filter. Engine Oil Supplement (or equivalent) should be added to the crankcase oil.
 - Replace all hydraulic lifters when a new camshaft is installed.
2. Intake Manifold, as outlined previously.
 3. Pushrod, as outlined previously.

🔧 Adjust

- Valves, as outlined previously.
4. Rocker arm cover, as outlined previously.

ROCKER ARM STUD REPLACEMENT

↔ Remove or Disconnect

1. Rocker arm cover and rocker arm, as outlined previously.
2. Rocker arm stud. Use a deep socket.

→ Install or Connect

1. Rocker arm stud.

⌚ Tighten

- Rocker arm stud to 68 N·m (50 ft. lbs.).
2. Rocker arm, as outlined previously.

🔑 Adjust

- Valves, as outlined previously.
3. Rocker arm cover, as outlined previously.

EXHAUST MANIFOLD REPLACEMENT

↔ Remove or Disconnect

1. Battery negative cable.
2. Heat stove pipe (right side manifold).
3. Dipstick tube (right side manifold).
4. Oxygen sensor wire (left side manifold) (TBI engines). Do not remove the sensor unless it is to be replaced.
5. AIR hose at the check valve.
6. Spark plugs.
7. Exhaust pipe at the manifold.
8. Exhaust manifold bolts and spark plug heat shields.
9. Exhaust manifold.

🧼 Clean

- Mating surface on the manifold and head.
- Threads on the exhaust manifold bolts.

→ Install or Connect

1. Exhaust manifold.
2. Exhaust manifold bolts and spark plug shields.

⌚ Tighten

- Exhaust manifold bolts to 54 N·m (40 ft. lbs.).
— Tighten the center bolts first, then continue outward each way.
3. Exhaust pipe.
 4. Spark plugs.
 5. AIR hose.
 6. Oxygen sensor wire (TBI engines) (left side manifold).
 7. Dipstick tube (right side manifold).
 8. Heat stove pipe (right side manifold).
 9. Battery negative cable.

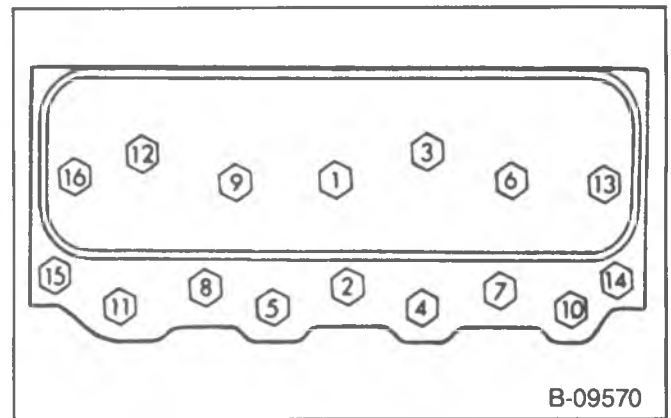

Figure 9—Cylinder Head Bolt Tightening Sequence

CYLINDER HEAD REPLACEMENT

↔ Remove or Disconnect

1. Intake manifold, as outlined previously.
2. Generator, and lay aside (right cylinder head).
3. AIR pump and generator/AIR pump brackets (right cylinder head on TBI engines).
4. Exhaust manifold, as outlined previously.
5. Air conditioning compressor and front bracket (if equipped). Lay the compressor aside.
6. Rocker arm cover, as outlined previously.
7. Spark plugs.
8. AIR pipe bolts at rear of cylinder head (TBI engines). Push the pipe out of the way.
9. Ground strap at the rear of the cylinder head.
10. Sensor wire at the cylinder head.
11. Pushrods, as outlined previously.
12. Cylinder head bolts.
13. Cylinder head.
14. Head gasket.

🧼 Clean

- Carbon deposits from combustion chambers.
- All traces of old head gasket from cylinder head and block.
- Cylinder head bolt threads and threads in the block.

🔍 Inspect

- Sealing surfaces of the block and cylinder head for nicks, heavy scratches, or other damage.

Cylinder Head Repair

- Refer to the proper Unit Repair Manual.

→ Install or Connect (Figure 9)

1. Head gasket.
 - If a steel gasket is used, coat both sides of the gasket with sealer. Spread the sealer thin and even.
 - Do not use sealer on composition steel-asbestos gaskets.
 - Place the gasket over the block dowel pins with the bead up.
2. Cylinder head. Carefully guide the cylinder head into place over the dowel pins and gasket.

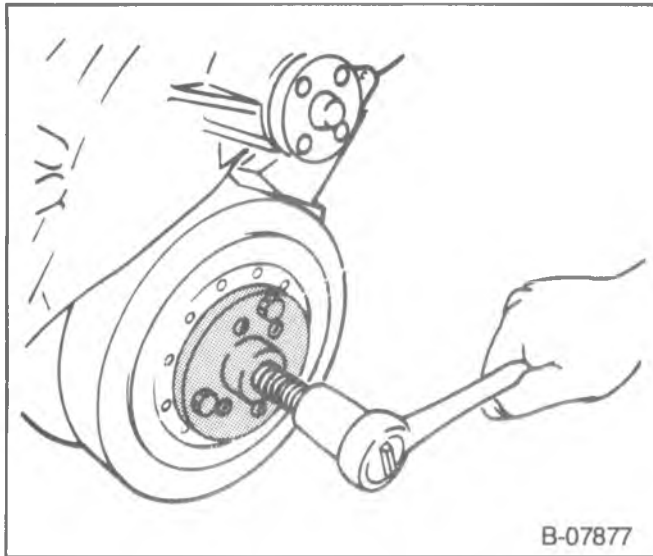

B-07877

Figure 10—Removing the Torsional Damper

3. Cylinder head bolts. Coat threads of the cylinder head bolts with sealing compound (GM part number 1052080 or equivalent) and install finger-tight.

Tighten

- Cylinder head bolts, a little at a time, using the sequence shown in figure 9. Proper torque is 110 N·m (80 ft. lbs.).

4. Pushrods, as outlined previously.

Adjust

- Valves, as outlined previously.

5. Sensor wire.
6. Ground strap at the rear of the cylinder head.
7. AIR pipe to the rear of the cylinder head (TBI engines).
8. Rocker arm cover, as outlined previously.
9. Spark plugs.
10. Air conditioning compressor and front bracket (if equipped).
11. Exhaust manifold, as outlined previously.
12. AIR pump and generator/AIR pump brackets (right cylinder head on TBI engines).
13. Generator (right cylinder head).
14. Intake manifold, as outlined previously.

TORSIONAL DAMPER AND FRONT CRANKSHAFT SEAL REPLACEMENT

Remove or Disconnect (Figure 10)

Tool Required:

J-23523-E Torsional Damper Puller and Installer

1. Battery negative cable.
2. Fan belts, fan, and pulley.
3. Fan shroud assembly.
4. Accessory drive pulley.
5. Torsional damper bolt.
6. Torsional damper. Use J-23523-E (figure 10).

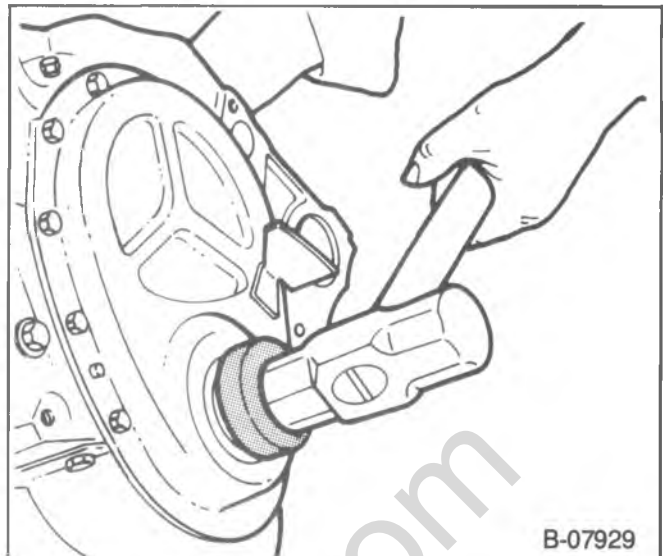

B-07929

Figure 11—Installing the Front Crankshaft Seal

7. Front crankshaft seal. Pry out with a large screwdriver. Take care not to distort the front cover.
8. Crankshaft key, if necessary.

Inspect

- Oil seal contact area on the torsional damper shaft for grooving and roughness. Replace if necessary.

Install or Connect (Figures 11 and 12)

Tools Required:

J-22102 Seal Installer

J-23523-E Torsional Damper Puller and Installer

1. Crankshaft key, if removed.
2. Front crankshaft seal. Use J-22102 (figure 11). The open end of the seal faces inside the engine. Coat the seal lips with engine oil.

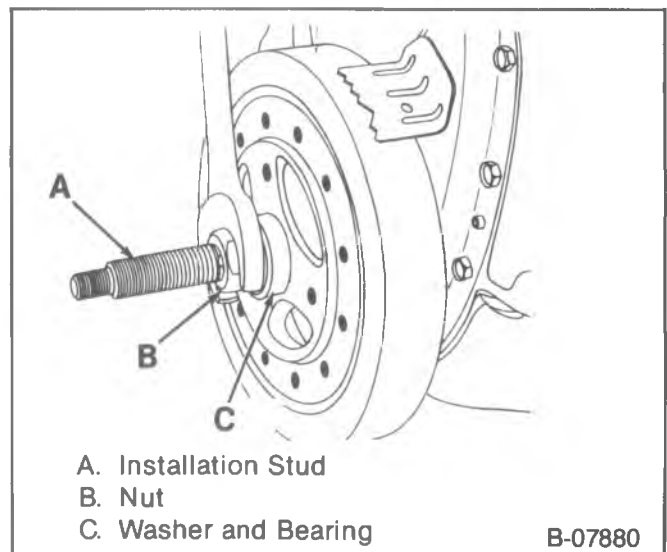

- A. Installation Stud
- B. Nut
- C. Washer and Bearing

B-07880

Figure 12—Installing the Torsional Damper

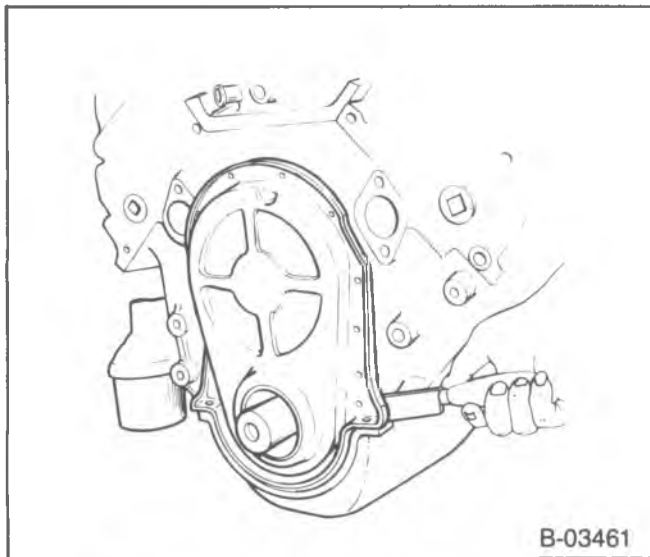

Figure 13—Cutting the Front Oil Pan Seal

NOTICE: The inertia weight section of the torsional damper is assembled to the hub with a rubber type material. The correct installation procedures (with the proper tool) must be followed or movement of the inertia weight section of the hub will destroy the tuning of the torsional damper.

3. Stud (item A, figure 12) to the crankshaft. Thread the stud fully into the tapped hole in the crankshaft.
4. Torsional damper over the end of the stud. Align the keyway in the torsional damper shaft with the crankshaft key.
 - Use a small amount of RTV sealer to seal the crankshaft key to crankshaft joint.
5. Bearing, washer and nut (figure 12).
 - Turn the nut to pull the vibration damper into place.
 - Remove the tool.
6. Torsional damper bolt and washer.
 - Bolt to 115 N m (85 ft. lbs.).
7. Accessory drive pulley.
8. Fan shroud assembly.
9. Fan pulley, fan, and fan belts.
10. Battery negative cable.



Tighten

- Bolt to 115 N m (85 ft. lbs.).
7. Accessory drive pulley.
 8. Fan shroud assembly.
 9. Fan pulley, fan, and fan belts.
 10. Battery negative cable.

FRONT COVER REPLACEMENT



Remove or Disconnect (Figure 13)

1. Battery negative cable.
2. Water pump. Refer to ENGINE COOLING (SEC. 6B).
3. Torsional damper, as outlined previously.
4. Oil pan to front cover bolts.
5. Front cover to block bolts.
6. Front cover.
 - Pull the cover forward enough to permit cutting of the front oil pan seal (figure 13).

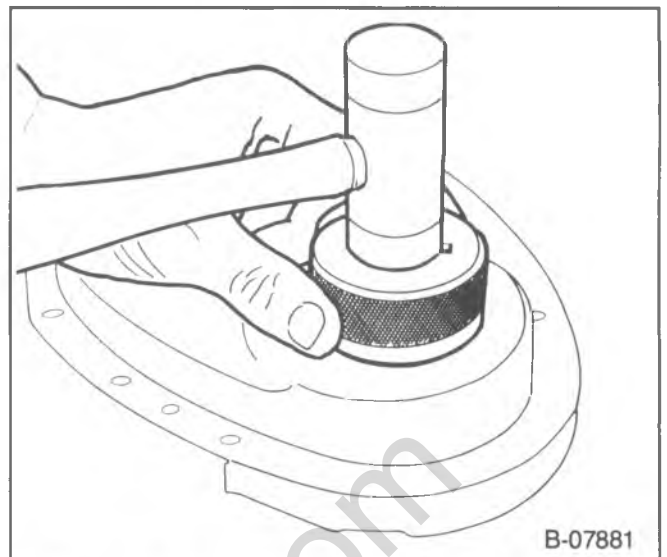
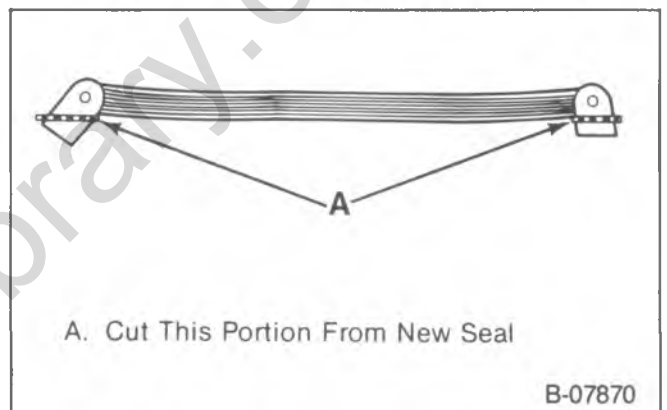

Figure 14—Installing the Front Crankshaft Seal



A. Cut This Portion From New Seal

Figure 15—Front Oil Pan Seal Modification

- Cut the front oil pan seal flush with the block on both sides (figure 13). Use a sharp cutting tool to ensure a clean cut.
 - Pull off the front cover.
7. Gasket and front oil pan seal.

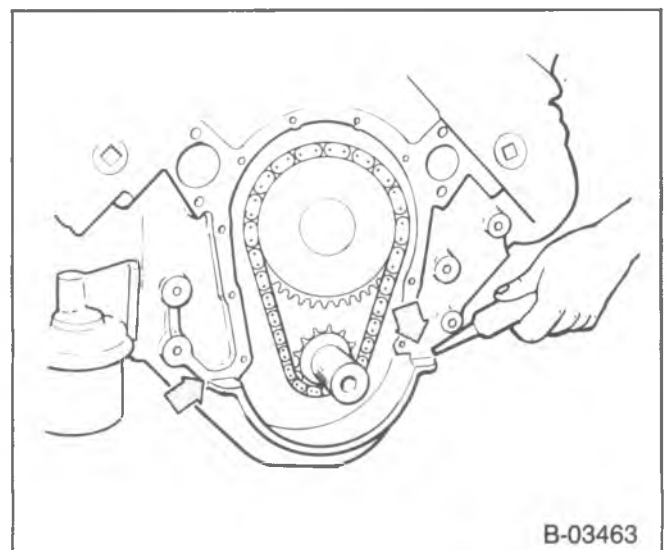

Figure 16—Applying Sealer

8. Front crankshaft oil seal from the front cover. Pry out with a screwdriver. Take care not to distort the front cover.



Clean

- Old gasket from the front cover, block, and oil pan.



Inspect

- Front cover for distortion and damage. Replace if necessary.



Install or Connect (Figures 14, 15, and 16)

Tool Required:

J-22102 Seal Installer

1. Front crankshaft seal. Use J-22102 (figure 14). The open end of the seal faces inside the engine. Coat the seal lips with engine oil.
2. Front oil pan seal.
 - Cut the tabs from a new seal (figure 15). Use a sharp cutting tool to ensure a clean cut.
 - Position the seal on the front cover. Push the seal locating tips into the holes in the front cover.
3. Front cover to block gasket to the front cover. Use gasket sealer to hold it in position.
 - Apply a 3 mm (1/8-inch) bead of RTV sealant (GM part number 1052366 or equivalent) to the front oil pan to block joint (figure 16).
4. Front cover to the engine. Press the cover down against the oil pan until the block dowel pins align with the holes in the cover. Position the cover against the block so that the dowels enter the cover holes without binding. Do not force the cover over the holes. Do not distort the cover flange or dowel pin holes. Hold the front cover in this position. Install and partially tighten the oil pan to front cover bolts.
5. Front cover to block bolts.



Tighten

- Front cover to block bolts to 10.8 N·m (96 in. lbs.).
 - Oil pan to front cover bolts to 7.9 N·m (70 in. lbs.).
6. Torsional damper, as outlined previously.
 7. Water pump. Refer to ENGINE COOLING (SEC. 6B).
 8. Battery negative cable.

OIL PAN REPLACEMENT



Remove or Disconnect (Figure 17)

1. Battery negative cable.
2. Fan shroud from the radiator and push rearward.
3. Air cleaner.
4. Distributor cap.
 - Raise the vehicle. Support with suitable safety stands.
 - Drain the engine oil.
5. Starter (vehicles with manual transmission).
6. Torque converter or clutch cover.
7. Oil filter.

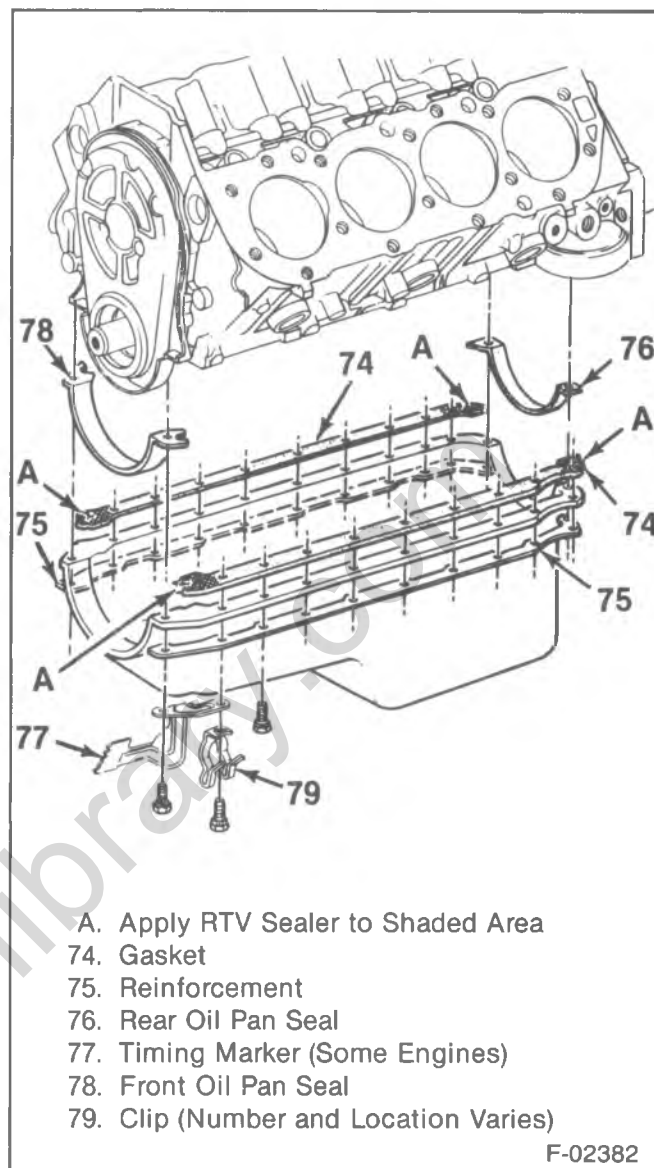

- A. Apply RTV Sealer to Shaded Area
- 74. Gasket
- 75. Reinforcement
- 76. Rear Oil Pan Seal
- 77. Timing Marker (Some Engines)
- 78. Front Oil Pan Seal
- 79. Clip (Number and Location Varies)

F-02382

Figure 17—Oil Pan

NOTICE: Oil pressure line must be removed from the side of the block to prevent crushing of the line when the engine is raised.

8. Oil pressure line from the side of the block.

NOTICE: When raising or supporting the engine for any reason, do not use a jack under the oil pan, any sheet metal or crankshaft pulley. Due to the small clearance between the oil pan and the oil pump screen, jacking against the oil pan may cause it to be bent against the pump screen, resulting in a damaged oil pickup unit.

- Support the engine with a suitable lifting fixture.
9. Engine mounting through-bolts.
 - Raise the engine only enough to permit oil pan removal.
 10. Oil pan bolts, timing marker (if used), clips, and reinforcements.
 11. Oil pan.
 12. Gaskets and seals.

**Clean**

- Gasket surfaces on the engine and oil pan.

**Install or Connect (Figure 17)**

- Apply RTV sealer to the front and rear corners of the gaskets (74).
1. Gaskets (74) to the block. Use gasket sealer to hold them in place.
 2. Rear oil pan seal (76) to the groove in the rear main bearing cap, with the ends mating against the gaskets (74).
 3. Front oil pan seal (78). Press the locating tips into the holes in the front cover. The ends should mate against the gaskets (74).
 4. Oil pan.
 5. Oil pan bolts, timing marker (if used), clips, and reinforcements.

**Tighten**

- Oil pan to front cover bolts to 7.9 N·m (70 in. lbs.).
 - Oil pan to block bolts to 18.1 N·m (160 in. lbs.).
- Lower the engine.

NOTICE: See "Notice" on page 6A5-1 of this section.

6. Engine mounting through bolts.
7. Oil pressure line.
8. Oil filter.
9. Torque converter or clutch cover.
10. Starter (if removed).
 - Lower the vehicle.
11. Distributor cap.
12. Air cleaner.
13. Fan shroud.
14. Proper quantity and grade of engine oil.
15. Battery negative cable.

OIL PUMP REPLACEMENT**Remove or Disconnect**

1. Oil pan, as outlined previously.
2. Oil pump to main bearing cup bolt.
3. Oil pump.

**Inspect**

- Oil pump pickup tube for damage and looseness. If the tube is loose or damaged, replace it as outlined in the proper unit repair manual.

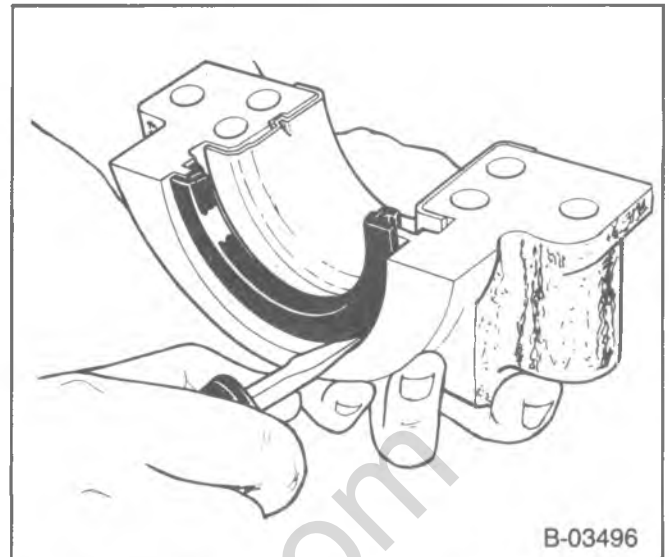

Figure 18—Removing the Lower Oil Seal Half

Oil Pump Repair

- Refer to the proper unit repair manual.

**Install or Connect**

1. Oil pump to the engine. Align the slot in the oil pump shaft with the tang on the distributor shaft. The oil pump should slide easily into place. No gasket is used.
2. Oil pump to main bearing cap bolt.

**Tighten**

- Oil pump bolt to 90 N·m (65 ft. lbs.).
3. Oil pan, as outlined previously.

REAR CRANKSHAFT OIL SEAL REPLACEMENT

The rear main bearing oil seal can be replaced (both halves) without removal of the crankshaft. Always replace the upper and lower seal as a unit. Install the seal with the lip facing the front of the engine. Extreme care should be exercised when installing this seal to protect the sealing bead located in the channel on the outside diameter of the seal. An installation tool should be used to protect the seal bead when positioning the seal. (Some seal kits include the tool as part of the service kit).

**Remove or Disconnect (Figures 18 and 19)**

1. Oil pan and oil pump, as outlined previously.
2. Rear main bearing cap.
3. Lower seal half (figure 18).
4. Upper seal half (figure 19).
 - Tap on the upper seal half, using a small drift and hammer.
 - Remove the upper seal half, using pliers.

**Clean**

- Sealing surfaces of the main bearing cap and block.

**Inspect**

- Crankshaft, seal channel, and sealing surfaces for nicks, scratches, etc.

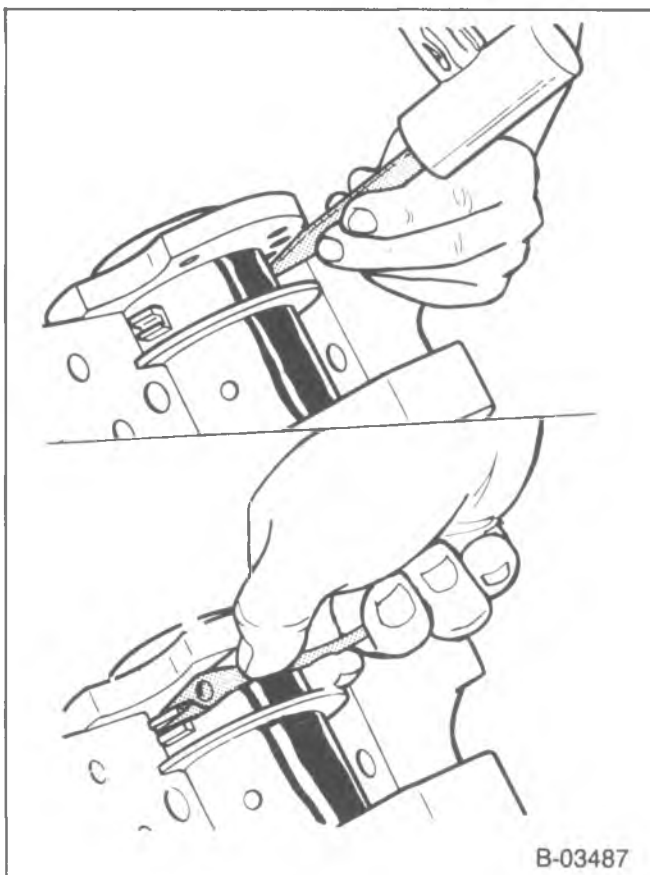

B-03487

Figure 19—Removing the Upper Oil Seal Half

Install or Connect (Figures 20, 21, and 22)

1. Upper seal half.

Important

- An oil seal installation tool (figure 20) should be fabricated (if not provided in the seal kit) to prevent seal damage during installation. Extreme care should be taken when installing this seal to protect the sealing bead located in the channel on the outside diameter of the seal.
- Coat the seal lips lightly with engine oil. Keep the oil off of the seal mating ends.
- Position the tip of the tool between the crankshaft and the seal seat in the block (figure 21).

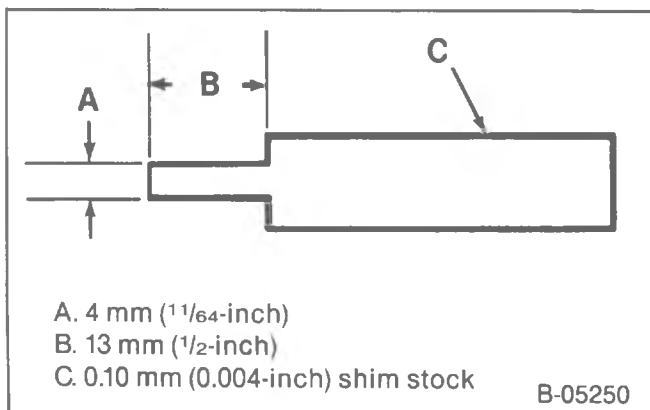

B-05250

Figure 20—Oil Seal Installation Tool

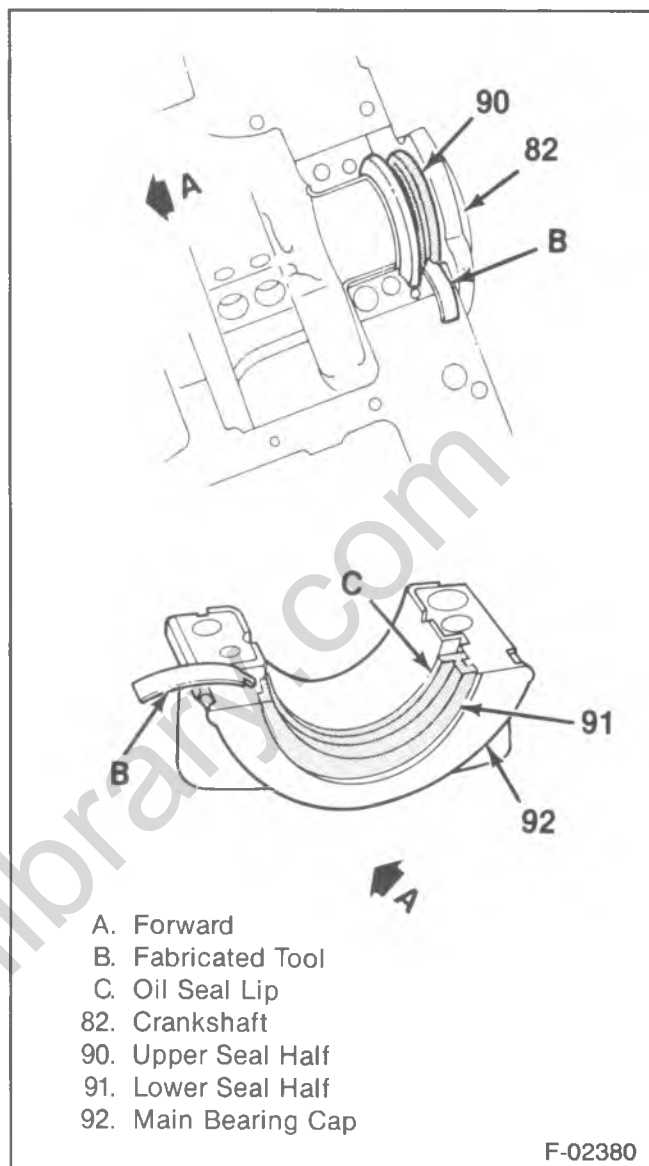

F-02380

Figure 21—Installing the Rear Crankshaft Oil Seal

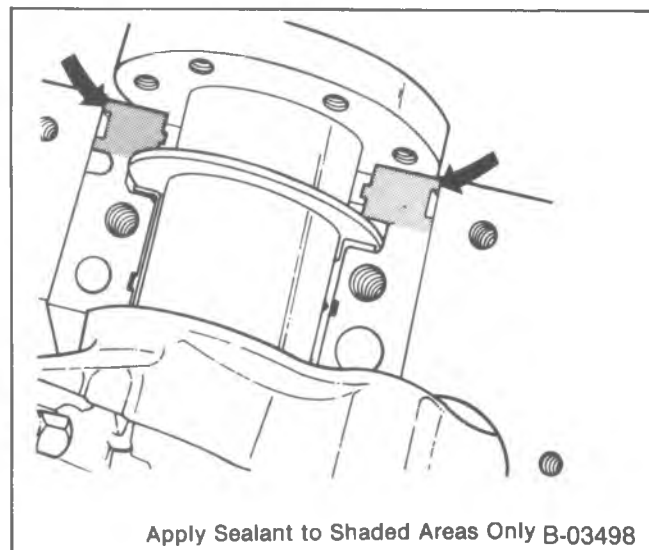



Figure 22—Applying Sealer to the Block

- Position the seal half between the crankshaft and the tip of the tool. Make sure that the oil seal lip is positioned toward the front of the engine.
 - Roll the seal around the crankshaft using the tool as a "shoe-horn" to protect the seal bead from the sharp corner of the seal seat surface in the block. The installation tool must remain in position until the seal half is properly positioned with both ends flush with the block.
 - Remove the tool, being careful not to withdraw the seal half.
2. Lower seal half.
- Coat the seal lips lightly with engine oil. Keep the oil off of the seal mating ends.
 - Insert the seal half into the rear main bearing cap. Use the tool to protect the seal half from the sharp edge of the seal seat. Feed the seal half into the rear main bearing cap, using light finger pressure. Make sure the oil seal lip faces the front of the engine (figure 21).
3. Rear main bearing cap with the lower main bearing.
- Apply a brush-on type oil sealing compound to the mating surface of the block and cap (figure 22). Do not allow any sealant on either crankshaft or rear oil seal.
 - Apply engine oil to the lower main bearing.
 - Position the cap to the block. Install the cap bolts.
-  **Tighten**
- Rear main bearing cap bolts temporarily to 14 N·m (10 ft. lbs.).
 - Tap the end of the crankshaft first rearward then forward with a lead hammer. This will line up the rear main bearing and crankshaft thrust surfaces.
-  **Tighten**
- Rear main bearing cap bolts to 150 N·m (110 ft. lbs.).
4. Oil pan and oil pump, as outlined previously.
5. The proper quantity and grade of engine oil.

MEASURING CAMSHAFT LOBE LIFT

Tools Required:

J-8520 Camshaft Lobe Lift Indicator

1. Remove the rocker arm as outlined previously.
2. Refer to figure 23. Position the dial indicator (part of J-8520) so the plunger rests on the pushrod end, as shown. Make sure the pushrod is in the lifter socket.
3. Rotate the crankshaft slowly in the direction of rotation until the lifter is on the heel of the cam lobe. At this point, the pushrod will be in its lowest position.
4. Set dial indicator on zero, then rotate the crankshaft slowly, or attach an auxiliary starter switch and "bump" the engine over, until the pushrod is in fully raised position.

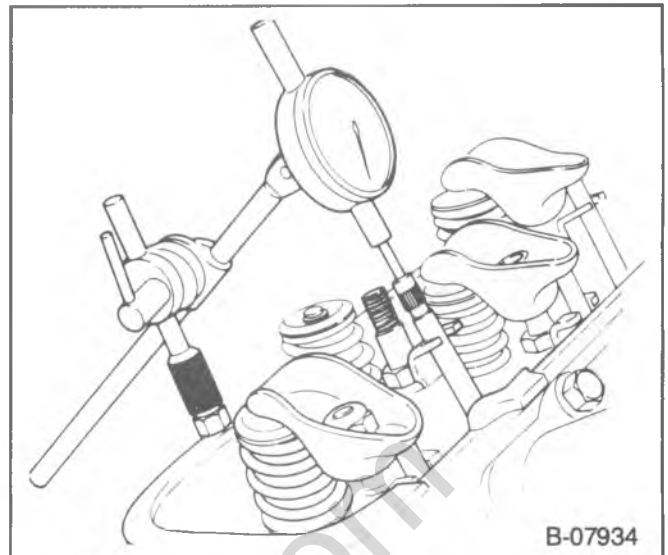

Figure 23—Measuring Camshaft Lobe Lift

Important

- Whenever the engine is cranked remotely at the starter, with a special jumper cable or other means, the primary leads should be disconnected from the distributor or ignition coil.
5. Compare the total lift recorded from the dial indicator with specifications.
 6. If camshaft readings for all lobes are within specifications, remove dial indicator assembly.
 7. Install the rocker arm and adjust the valves as previously outlined.

CAMSHAFT REPLACEMENT

Remove or Disconnect (Figures 24, 25, and 26)

Tool Required:

J-1619 Crankshaft Sprocket Puller

1. Battery negative cable.

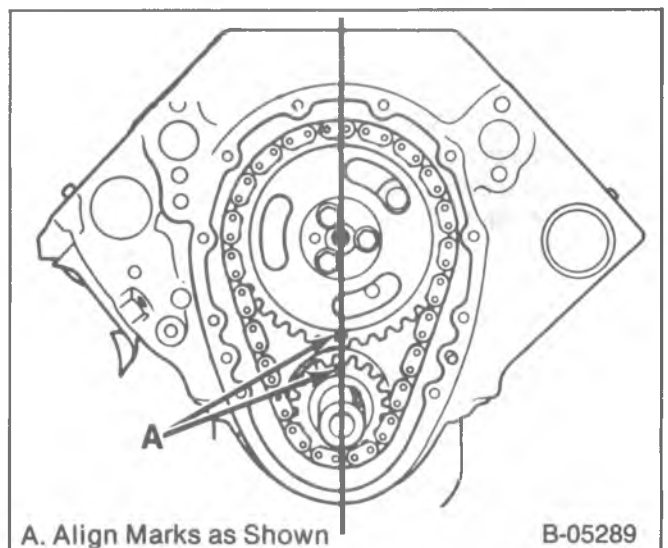

A. Align Marks as Shown

B-05289

Figure 24—Timing Marks

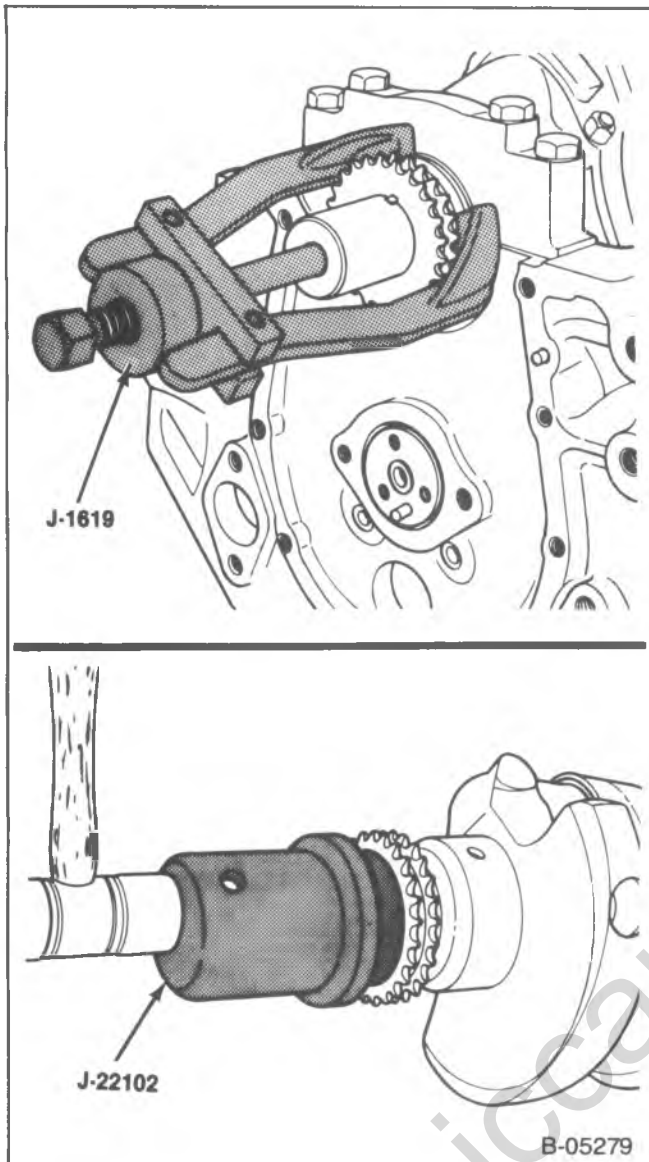

Figure 25—Replacing the Crankshaft Sprocket

2. Air cleaner.
3. Grille.
4. Air conditioning condenser from its mounting and swing it forward.
5. Fan, shroud, and radiator. Refer to ENGINE COOLING (SEC. 6B1) and RADIATOR (SEC. 6B2).
6. Generator and bracket.
7. Rocker arm covers, as outlined previously.
8. Fuel line (carbureted engines).
9. Water pump. Refer to ENGINE COOLING (SEC. 6B1).
10. Torsional damper, as outlined previously.
11. Front cover, as outlined previously.
12. Distributor. Refer to ENGINE ELECTRICAL (SEC. 6D).
13. Intake manifold, as outlined previously.
14. Pushrods and hydraulic lifters, as outlined previously.
15. Fuel pump and pushrod (carbureted engines).
 - Align the timing marks (figure 24).
16. Camshaft sprocket bolts.

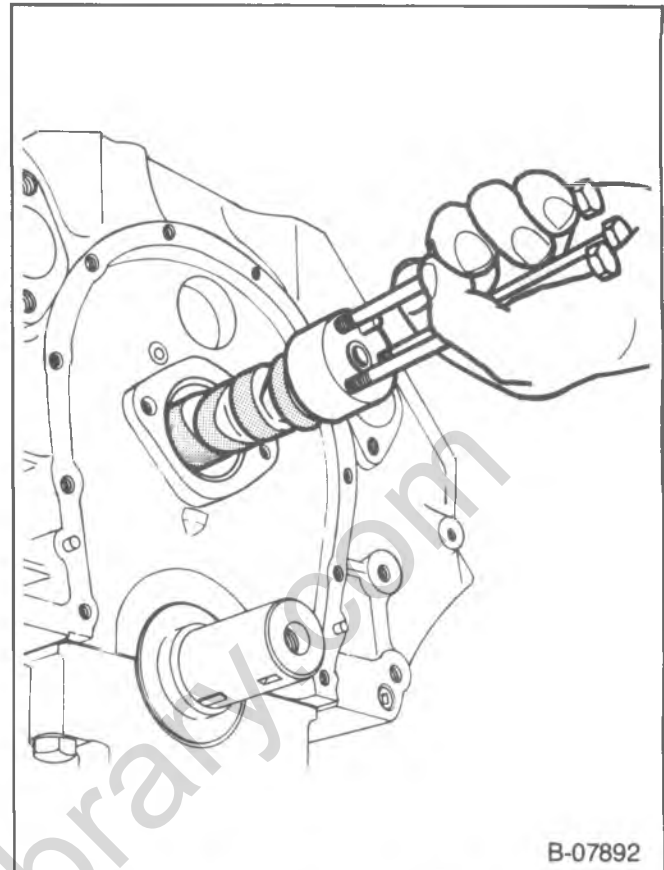

Figure 26—Replacing the Camshaft

17. Camshaft sprocket and timing chain. The sprocket is a light interference fit on the camshaft. Tap the sprocket on its lower edge to loosen it.
18. Crankshaft sprocket (if required). Use J-1619 (figure 25).
19. Camshaft.
 - Install two or three $\frac{5}{16}$ -18 bolts 100–125 mm (4–5 inches) long into the camshaft threaded holes. Use these bolts to handle the camshaft (figure 26).
 - Pull the camshaft from the block. Use care to prevent damage to the camshaft bearings.

Cleaning Inspection and Repair

Clean, inspect and repair or replace the camshaft and related components, as outlined in the proper unit repair manual.

The unit repair manual also describes camshaft bearing replacement.

Install or Connect (Figures 24, 25, and 26)

Tool Required:

J-22102 Crankshaft Sprocket Installer

- Coat the camshaft lobes and journals with a high quality engine oil supplement (GM Engine Oil Supplement or equivalent).
1. Two or three $\frac{5}{16}$ -18 bolts 100–125 mm (4–5 inches) long into the camshaft threaded holes. Use these bolts to handle the camshaft.
 2. Camshaft to the engine (figure 26). Handle the camshaft carefully to prevent damage to the camshaft bearings.

3. Crankshaft sprocket (if removed). Use J-22102 (figure 25). Make sure the timing mark faces outside.
4. Camshaft sprocket and timing chain.

! Important

- Line up the timing marks on the camshaft sprocket and crankshaft sprocket (figure 24).

5. Camshaft sprocket bolts.

Tighten

- Bolts to 27 N·m (20 ft. lbs.).

6. Fuel pump and pushrod (carbureted engines).
7. Hydraulic lifters and pushrods, as outlined previously.

! Important

- Replace all hydraulic lifters, crankcase oil and filter, and add GM Engine Oil Supplement (or equivalent) to the engine oil whenever a new camshaft is installed.

Adjust

- Valves, as outlined previously.

8. Intake manifold, as outlined previously.
9. Distributor. Refer to ENGINE ELECTRICAL (SEC. 6D).
10. Front cover, as outlined previously.
11. Torsional damper, as outlined previously.
12. Water pump. Refer to ENGINE COOLING (SEC. 6B1).
13. Fuel line (carbureted engines).
14. Rocker arm covers, as outlined previously.
15. Generator and bracket.
16. Fan, shroud, and radiator. Refer to ENGINE COOLING (SEC. 6B1) and RADIATOR (SEC. 6B2).
17. Air conditioning condenser.
18. Grille.
19. Air cleaner.
20. Battery negative cable.
 - Fill the cooling system with the proper quantity and grade of coolant.

CONNECTING ROD AND PISTON REPLACEMENT

↔ Remove or Disconnect (Figure 27)

Tool Required:

J-5239 Guide Set

1. Cylinder head, as outlined previously.
2. Oil pan, as outlined previously.
3. Oil pump, as outlined previously (if necessary).
4. Ridge or deposits from the upper end of the cylinder bores.
 - Turn the crankshaft until the piston is at BDC.
 - Place a cloth on top of the piston.
 - Perform the cutting operation with a ridge reamer.
 - Turn the crankshaft until the piston is at TDC.
 - Remove the cloth and cuttings.

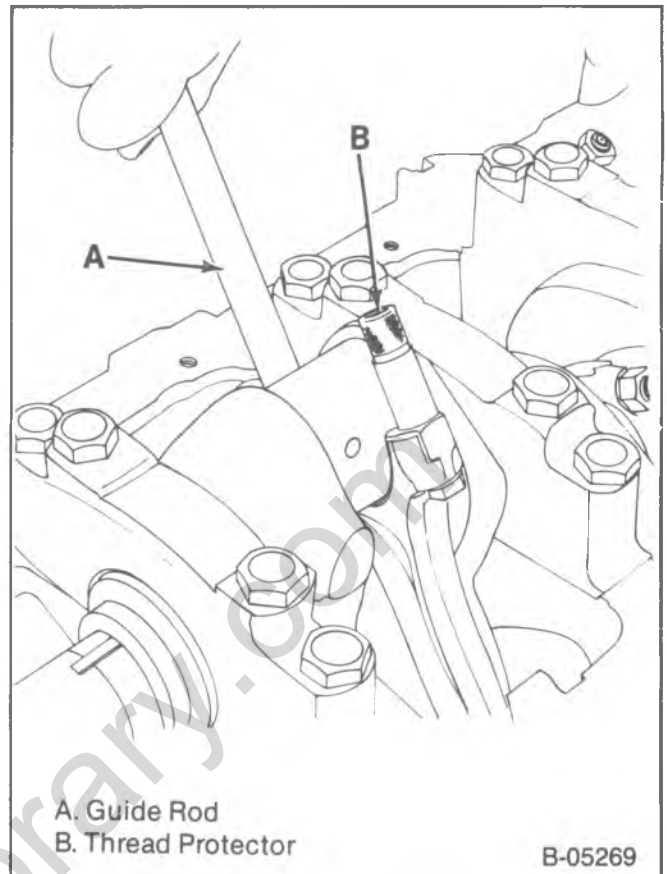

Figure 27—Replacing the Connecting Rod and Piston

5. Connecting rod cap. Check the connecting rod and cap for identification marks. Mark the parts if required. The connecting rod and cap must be kept together as mating parts.
6. Connecting rod and piston.
 - Attach J-5239 to the connecting rod bolts (figure 27).
 - Use the long guide rod of J-5239 to push the connecting rod and piston out of the bore.
7. Connecting rod bearing.

Cleaning, Inspection, and Repair

Clean, inspect and repair or replace the components as necessary. Measure connecting rod bearing clearance, piston clearance, ring clearances, etc. Refer to the proper unit repair manual.

The unit repair manual contains information on:

- Connecting rod and piston.
- Piston rings.
- Connecting rod and crankpin.
- Cylinder bores.

↔ Install or Connect (Figures 27 through 31)

Tools Required:

J-5239 Connecting Rod Guide Set

J-8037 Ring Compressor

- Make sure the cylinder walls are clean. Lubricate the cylinder wall lightly with engine oil.
 - Make sure the piston is installed in the matching cylinder for which it was fitted. Used pistons must be installed in the cylinder they were removed from.
1. Connecting rod bearings.

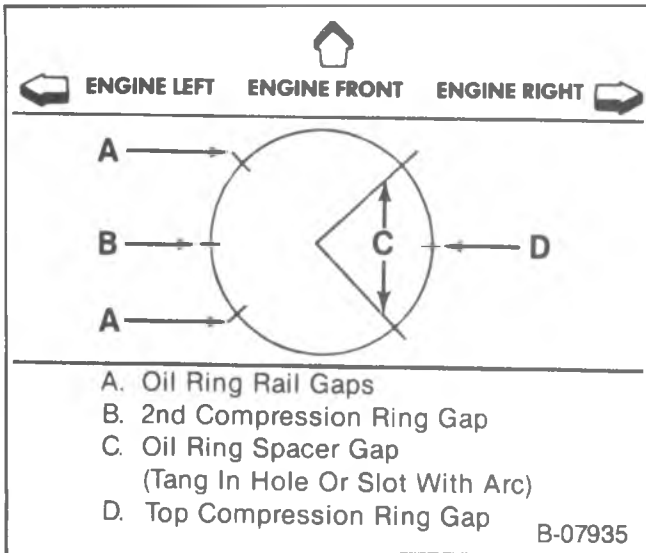

Figure 28—Ring End Gap Location

- Be certain that the bearings are of the proper size.
 - Install the bearings in the connecting rod and connecting rod cap.
 - Lubricate the bearings with engine oil.
2. Piston and connecting rod to the proper bore.
- With the connecting rod cap removed, install J-5239 onto the connecting rod studs.
 - Locate the piston ring end gaps as shown in figure 28. Lubricate the piston and rings with engine oil.
 - Without disturbing the ring end gap location, install J-8037 over the piston (figure 29).
 - The piston must be installed so that the valve clearance notches are towards the center of the engine (figure 30).
 - Place the piston in its matching bore. Using light blows with a hammer handle, tap the piston down into its bore (figure 29). At the same time, from beneath the vehicle guide the connecting rod to the crankpin with J-5239 (figure 27). Hold the ring compressor against the block until all rings have entered the cylinder bore.
 - Remove J-5239 from the connecting rod bolts.

Important

- Each connecting rod and bearing cap should be marked, beginning at the front of the engine. Cylinders 1, 3, 5 and 7 are the left bank and 2, 4, 6 and 8 are the right bank. The numbers on the connecting rod and bearing cap must be on the same side when installed in the cylinder bore. If a connecting rod is ever transposed from one block or cylinder to another, new connecting rod and bearings should be fitted and the connecting rod should be numbered to correspond with the new cylinder number.

Measure

- Connecting rod bearing clearance. Refer to the proper unit repair manual.

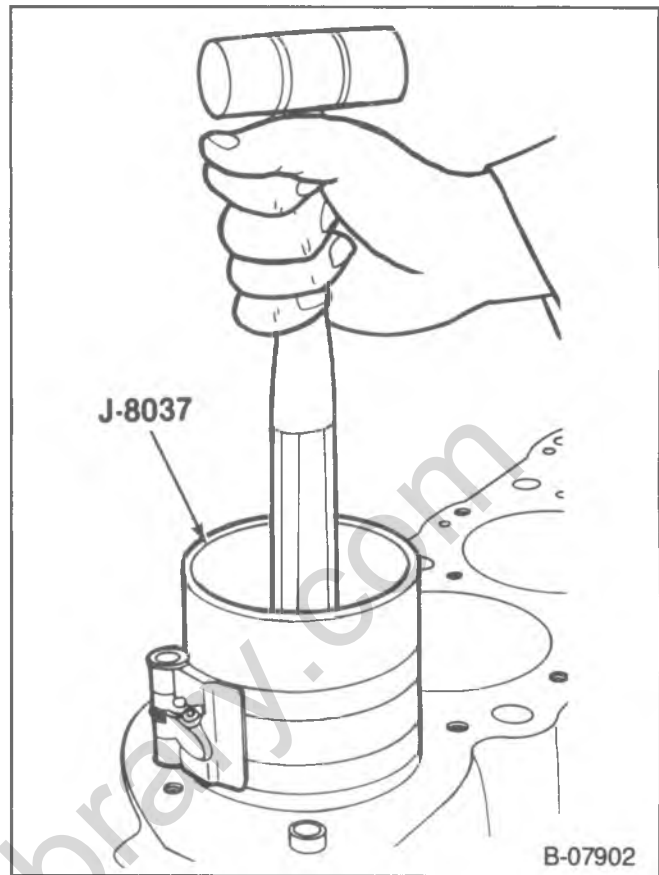

Figure 29—Installing the Piston

3. Connecting rod cap and bearing.
4. Connecting rod cap nuts.

Tighten

- Connecting rod cap nuts to 66 N·m (48 ft. lbs.).

Measure

- Connecting rod side clearance. Use a feeler gage between the connecting rod and crankshaft (figure 31). The correct clearance is 0.013–0.023–inch.

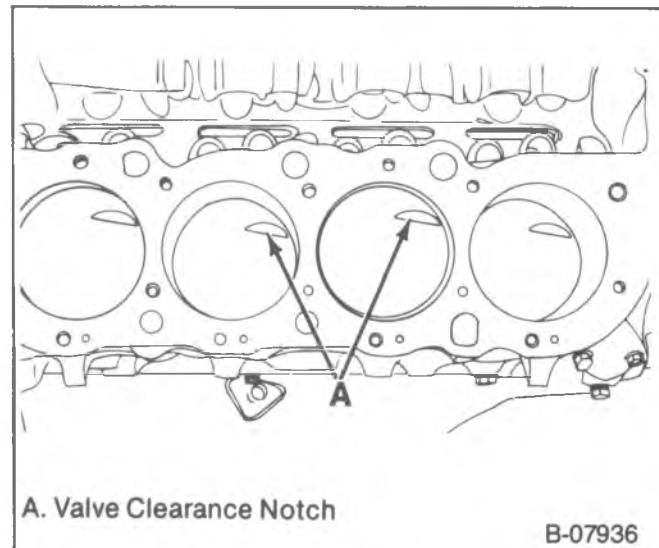

Figure 30—Pistons Installed

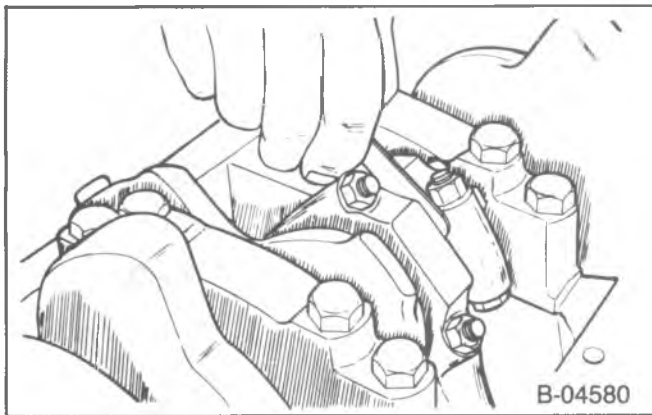

Figure 31—Measuring Connecting Rod Side Clearance

5. Oil pump (if removed), as outlined previously.
6. Oil pan and cylinder head, as outlined previously.

OIL FILTER BYPASS VALVE

↔ Remove or Disconnect (Figure 32)

1. Oil filter.

🔍 Inspect

- Bypass valve spring and valve disc for proper operation, cracks, and damage. If replacement is needed, the oil filter bypass valve (93) must be replaced, as follows:

2. Bolts (94).
3. Oil filter bypass valve.

🧼 Clean

- Valve chamber in the block.

↔ Install or Connect (Figure 32)

1. Oil filter bypass valve (93).
2. Bolts (94).

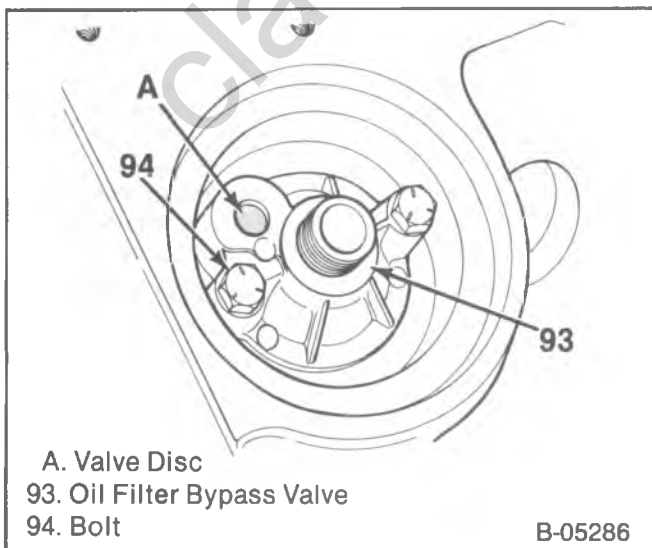

Figure 32—Oil Filter Bypass Valve

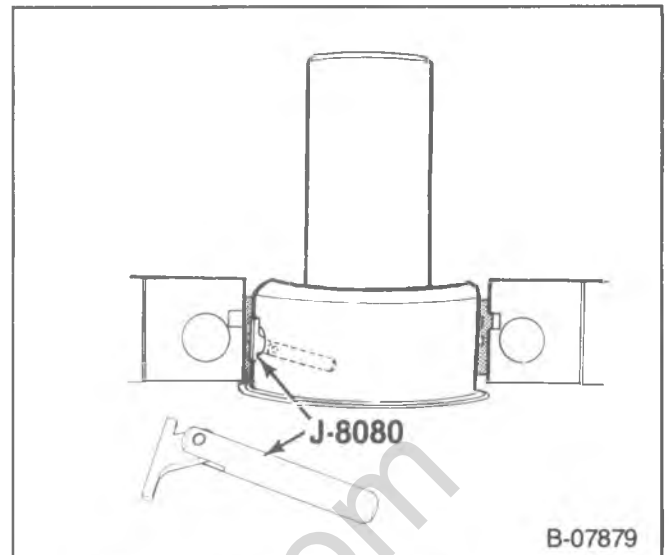

Figure 33—Removing the Main Bearing

🔧 Tighten

- Bolts (94) to 26 N·m (20 ft. lbs.).
3. Oil filter.
 4. Engine oil, as needed.

MAIN BEARING REPLACEMENT

↔ Remove or Disconnect (Figure 33)

Tool Required:

J-8080 Main Bearing Remover/Installer

1. Spark plugs.
2. Oil pan, as outlined previously.
3. Oil pump, as outlined previously.
4. Main bearing caps.
 - Check the main bearing caps for location markings. Mark the caps if necessary. The caps must be returned to their original locations during assembly.
5. Lower main bearing inserts from the main bearing caps.
6. Rear crankshaft oil seal, if necessary, as outlined previously.
8. Upper main bearing inserts.
 - Insert J-8080 into the crankshaft oil hole (figure 33).
 - Rotate the crankshaft to “turn” the bearing insert out of the block.

Cleaning, Inspection, and Repair

Clean, inspect, and repair or replace the components as required. Refer to the proper unit repair manual. The unit repair manual contains information on:

- Crankshaft.
- Main and connecting rod bearings.
- Main bearing cap replacement (shimming procedure).

↔ Install or Connect (Figures 22, 33, and 34)

Tool Required:

J-8080 Main Bearing Remover/Installer

1. Upper main bearing inserts.

- Insert tool J-8080 into a crankshaft main bearing oil hole (figure 33).
 - Apply engine oil to inserts of the proper size.
 - Insert the plain end (without the bearing tang) of the insert between the crankshaft and the notched side of the block.
 - Rotate the crankshaft to “roll” the insert into the block.
 - Remove the tool.
- Lower main bearing inserts to the main bearing caps.
 - Make sure the inserts are of the proper size.
 - Apply engine oil to the inserts.



Measure

- Main bearing clearance. Refer to the proper unit repair manual. If the engine is in the vehicle, the crankshaft must be supported upward to remove any clearance from the upper bearing. The total clearance can then be measured between the lower bearing and journal.
- Main bearing caps (except rear cap) and bolts to the block.



Tighten

- Main bearing cap bolts to 150 N·m (110 ft. lbs.).
- Rear crankshaft oil seal to the block and main bearing cap, as outlined previously.
 - Rear main bearing cap.
 - Apply a brush-on type oil sealing compound to the mating surface of the block and cap (figure 22). Do not allow any sealant on either crankshaft or rear oil seal.
 - Apply engine oil to the bearing insert.
 - Install the rear main bearing cap and bolts. Tighten the bolts temporarily to 14 N·m (10 ft. lbs.).



Measure

- Crankshaft end play, as follows:
 - Tap the end of the crankshaft first rearward then forward with a lead hammer. This will line up the rear main bearing and crankshaft thrust surfaces.
 - Tighten the rear main bearing cap bolts to 150 N·m (110 ft. lbs.).
 - With the crankshaft forced forward, measure at the front end of the rear main bearing with a feeler gage (figure 34). The proper clearance is 0.006–0.010–inch.
- Oil pump, as outlined previously.
 - Oil pan, as outlined previously.
 - Spark plugs.

CRANKSHAFT REPLACEMENT

- Remove the engine, as outlined later.
- Refer to the proper unit repair manual for crankshaft replacement procedures.

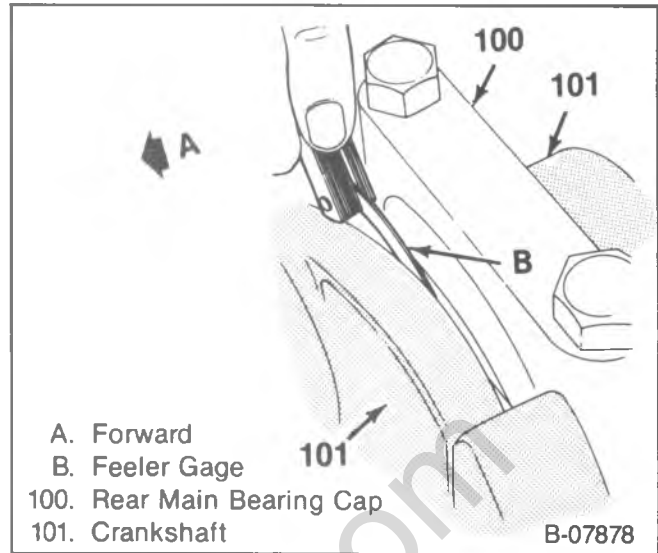

Figure 34—Measuring Crankshaft End Play

FLYWHEEL REPLACEMENT



Remove or Disconnect

- Transmission, flywheel housing, and clutch.
- Flywheel bolts.
- Flywheel.



Clean

- Mating surfaces of crankshaft and flywheel. Remove any burrs.



Inspect

- Flywheel for burning, scoring, warping, and wear. Replace the flywheel if necessary. Do not machine the flywheel.
- Flywheel ring gear for worn or broken teeth.

Flywheel Ring Gear Replacement

- Use a torch to heat the gear around the entire circumference, then drive the gear off the flywheel, using care not to damage the flywheel.

NOTICE: Never heat starter gear to red heat as this will change metal structure.

- Uniformly heat the flywheel gear to temperature which will expand the gear to permit installation. Temperature must not exceed 200°C (400°F).
- As soon as the gear has been heated, install on the flywheel.



Install or Connect

- Flywheel.
- Flywheel bolts.



Tighten

- Flywheel bolts to 90 N·m (65 ft. lbs.).
- Clutch, flywheel housing, and transmission.

ENGINE MOUNTINGS

NOTICE: Broken or deteriorated mountings can cause misaligned and eventual destruction of certain drive train components. When a single mounting breakage occurs, the remaining mountings are subjected to abnormally high stresses.

INSPECTING ENGINE MOUNTINGS

Front Engine Mountings

NOTICE: When raising or supporting the engine for any reason, do not use a jack under the oil pan, any sheet metal or crankshaft pulley. Due to the small clearance between the oil pan and the oil pump screen, jacking against the oil pan may cause it to be bent against the pump screen, resulting in a damaged oil pickup unit.

1. Raise the engine to remove weight from the mountings and to place a slight tension on the rubber cushion. Observe both mountings while raising the engine.
2. Replace the mounting if the following conditions exist:
 - Hard rubber surface covered with heat check cracks.
 - Rubber cushion separated from the metal plate of the mounting.
 - Rubber cushion split through the center.
3. If there is movement between a metal plate of the mounting and its attaching points, lower the engine and tighten the bolts or nuts attaching the mounting to the engine, frame, or bracket.

Rear Mountings

1. Push up and pull down on the transmission tailshaft. Observe the transmission mounting.
2. Replace the mounting if the following conditions exist:
 - Mounting bottomed out (tailshaft can be moved up but not down).
3. If there is relative movement between a metal plate of the mounting and its attaching point, tighten the bolts or nuts attaching the mounting to the transmission or crossmember.

FRONT MOUNTING REPLACEMENT

 **Remove or Disconnect (Figures 35, 36, and 37)**

1. Battery negative cable.

NOTICE: When raising or supporting the engine for any reason, do not use a jack under the oil pan, any sheet metal or crankshaft pulley. Due to the small clearance between the oil pan and the oil pump screen, jacking against the oil pan may cause it to be bent against the pump screen, resulting in a damaged oil pickup unit.

- Support the engine with a suitable jack. Do not load the engine mounting.

2. Engine mounting through-bolt and nut.

NOTICE: Raise the engine only enough for sufficient clearance. Check for interference between the rear of the engine and the dash panel which could cause distributor damage.

- Raise the engine only enough to permit removal of the engine mounting.
3. Mounting assembly bolts, nuts, and washers.
 4. Mounting assembly.

 **Install or Connect (Figures 35, 36, and 37)**

1. Mounting assembly.

NOTICE: See "Notice" on page 6A5-1 of this section.

2. Mounting assembly bolts, nuts, and washers.

 **Tighten**

- Fasteners to specifications. Refer to figures 35, 36, and 37.
3. Engine mount through-bolt and nut. Lower the engine until the bolt can be inserted. Install the nut.

 **Tighten**

- Through-bolt nut to specifications. Refer to figures 35, 36, and 37.
4. Battery negative cable.

REAR MOUNTING REPLACEMENT (EXCEPT P-MODELS WITH FLYWHEEL HOUSING MOUNTING)

 **Remove or Disconnect (Figures 38, 39, and 40)**

1. Battery negative cable.

NOTICE: When raising or supporting the engine for any reason, do not use a jack under the oil pan, any sheet metal or crankshaft pulley. Due to the small clearance between the oil pan and the oil pump screen, jacking against the oil pan may cause it to be bent against the pump screen, resulting in a damaged oil pickup unit.

- Support the rear of the engine to relieve the weight on the rear mountings.
2. Mounting to crossmember nut(s) and washer(s).
 3. Mounting to transmission bolts and washers.
 - Raise the rear of the engine only enough to permit removal of the mounting.
 4. Mounting.

 **Install or Connect (Figures 38, 39, and 40)**

1. Mounting.
 - Lower the rear of the engine.
2. Mounting to transmission bolts and washers.

NOTICE: See "Notice" on page 6A5-1 of this section.

3. Mounting to crossmember nut(s) and washer(s).

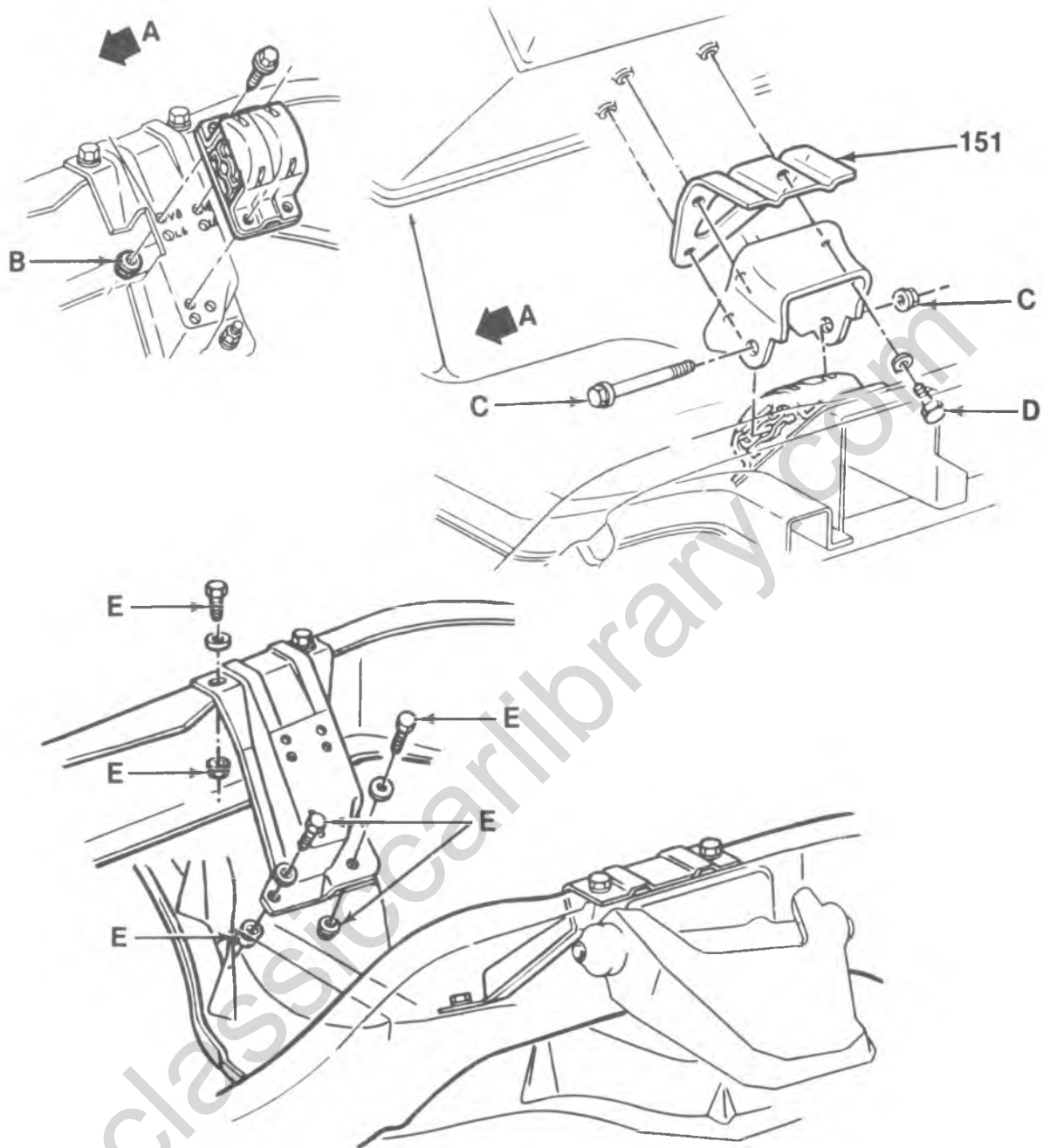

- A. Forward
- B. 40 N·m (30 Ft. Lbs.)
- C. Torque Bolt To 115 N·m (85 Ft. Lbs.) Or, Torque Nut To 75 N·m (55 Ft. Lbs.)
- D. 48 N·m (36 Ft. Lbs.)
- E. Torque Bolt To 48 N·m (36 Ft. Lbs.) Or, Torque Nut To 40 N·m (30 Ft. Lbs.)
- 151. Heat Shield (Engines With Federal Emissions — Left Side Only)

Figure 35—Front Engine Mounting (R Models)

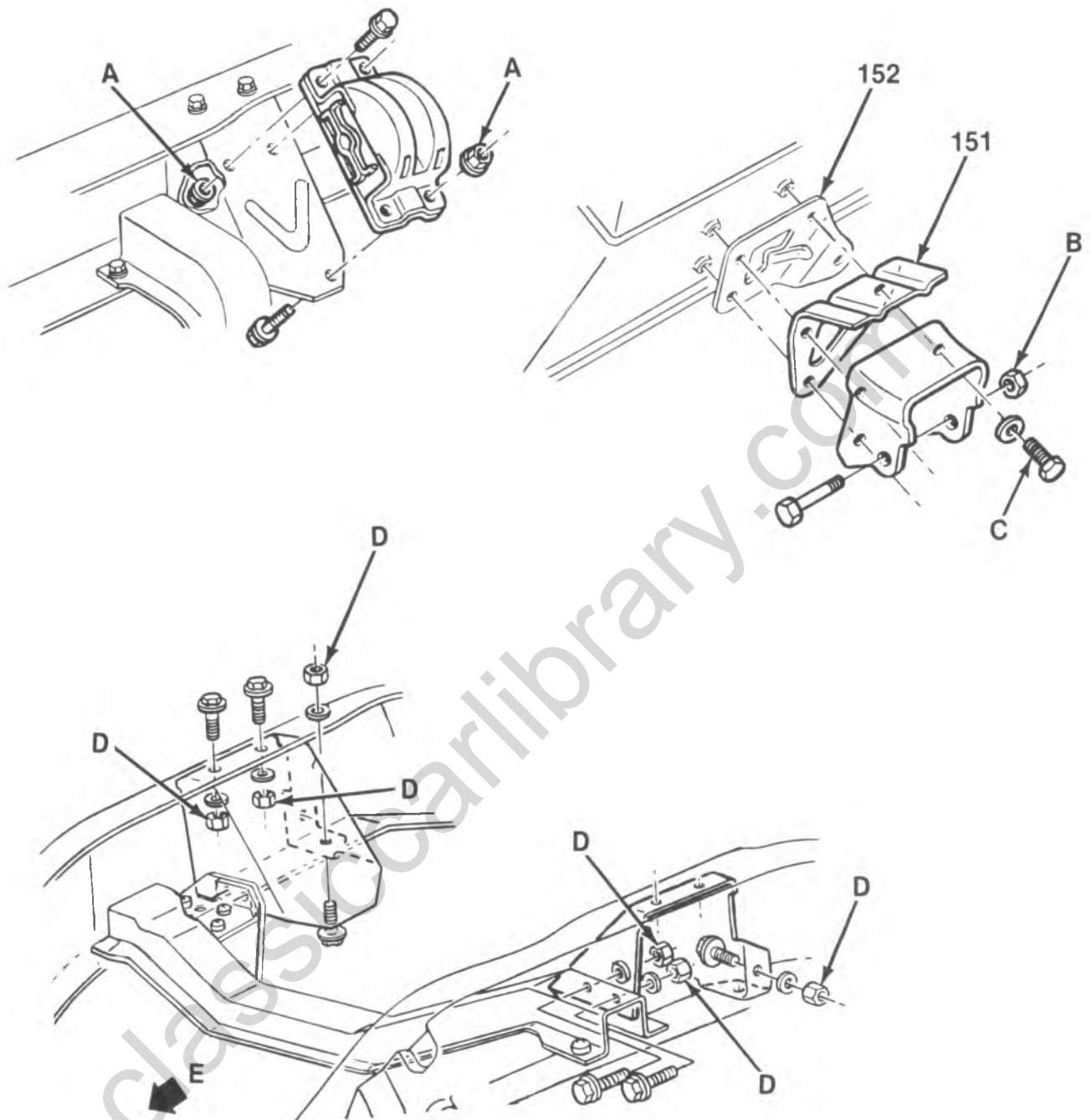

A. 40 N·m (30 Ft. Lbs.)

B. Torque Bolt to 115 N·m (85 Ft. Lbs.) Or, Torque Nut to 75 N·m (55 Ft. Lbs.)

C. 48 N·m (36 Ft. Lbs.)

D. 65 N·m (48 Ft. Lbs.)

E. Forward

151. Heat Shield (Engines with Federal Emissions-Left Side Only)

152. Transmission Strut Bracket (Automatic Transmission) or Spacer (Manual Transmissions).

B-07715

Figure 36—Front Engine Mounting (V Models)

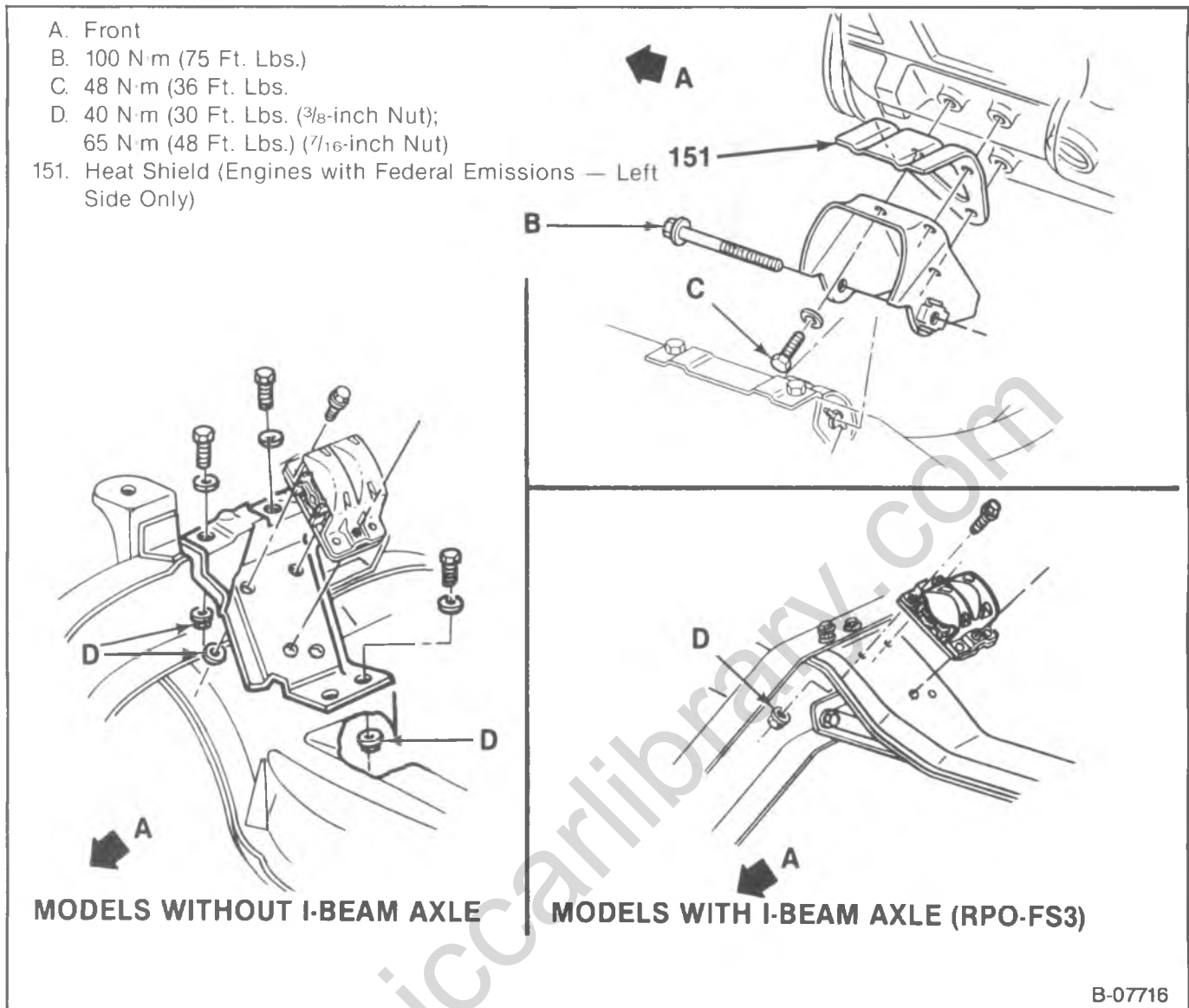

Figure 37—Front Engine Mounting (P Models)



Tighten

- Fasteners to specifications. Refer to figures 38, 39, and 40).

4. Battery negative cable.

REAR MOUNTING REPLACEMENT (P-MODELS WITH FLYWHEEL HOUSING MOUNTING)



Remove or Disconnect (Figure 41)

1. Battery negative cable.
2. Bolt, cushion, and spacer.

NOTICE: When raising or supporting the engine for any reason, do not use a jack under the oil pan, any sheet metal or crankshaft pulley. Due to the small clearance between the oil pan and the oil pump screen, jacking against the oil pan may cause it to be bent against the pump screen, resulting in a damaged oil pickup unit.

- Raise the rear of the engine only enough to permit removal of the mounting.

3. Engine mounting.



Install or Connect (Figure 41)

1. Engine mounting. Align the hole in the mounting with the hole in the crossmember.
 - Lower the engine.

NOTICE: See "Notice" on page 6A5-1 of this section.

2. Spacer, cushion, and bolt.



Tighten

- Bolt to 90 N·m (65 ft. lbs.).
3. Battery negative cable.

ENGINE REPLACEMENT



Remove or Disconnect

1. Hood.
2. Battery negative cable.
3. Air cleaner.

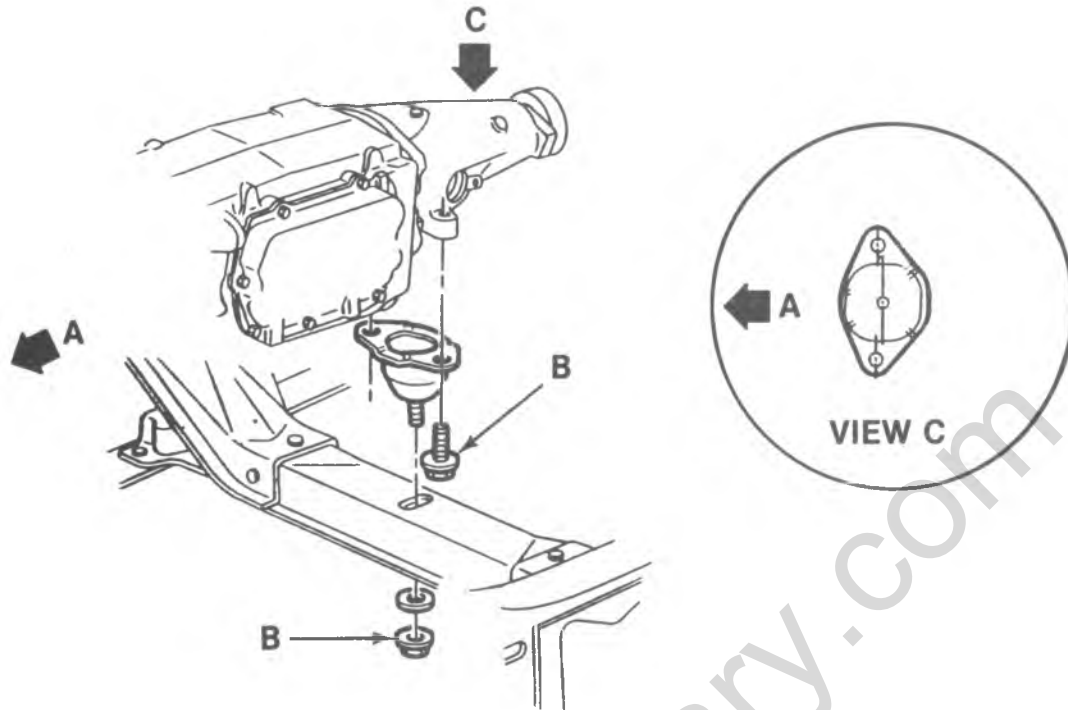

ALL MODELS EXCEPT WITH THM 400 TRANSMISSION (RPO-M40)

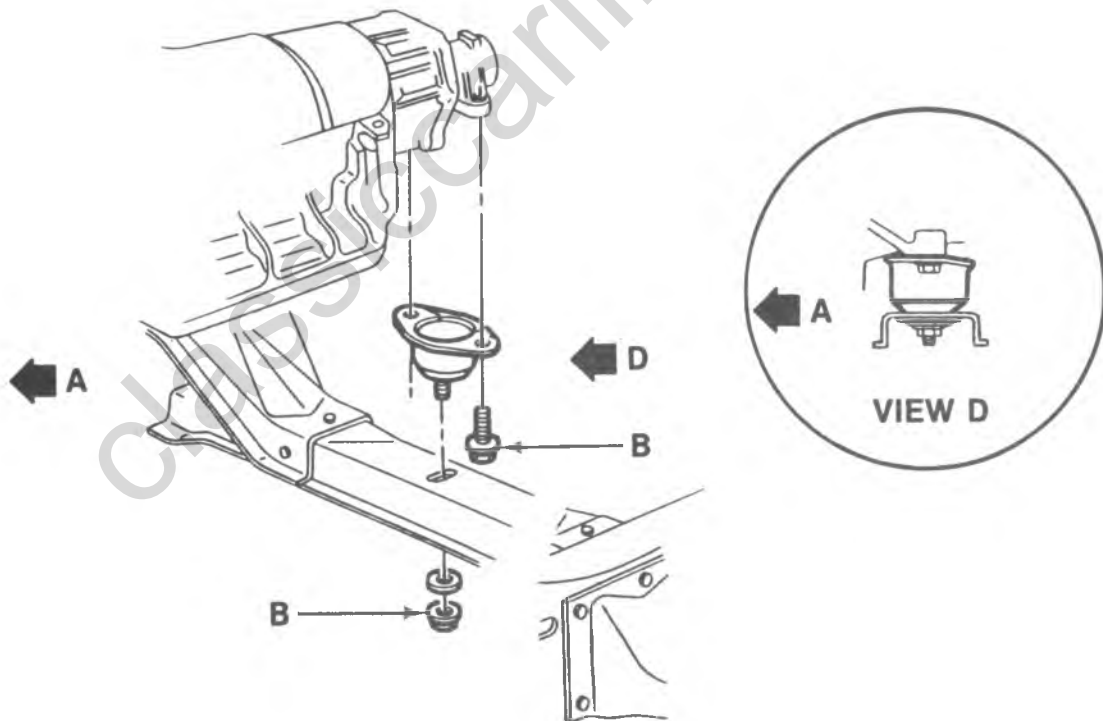

MODELS WITH THM 400 TRANSMISSION (RPO-M40)

- A. Forward
- B. 48 N·m (36 Ft. Lbs.)

B-07921

Figure 38—Rear Engine Mounting (R Models)

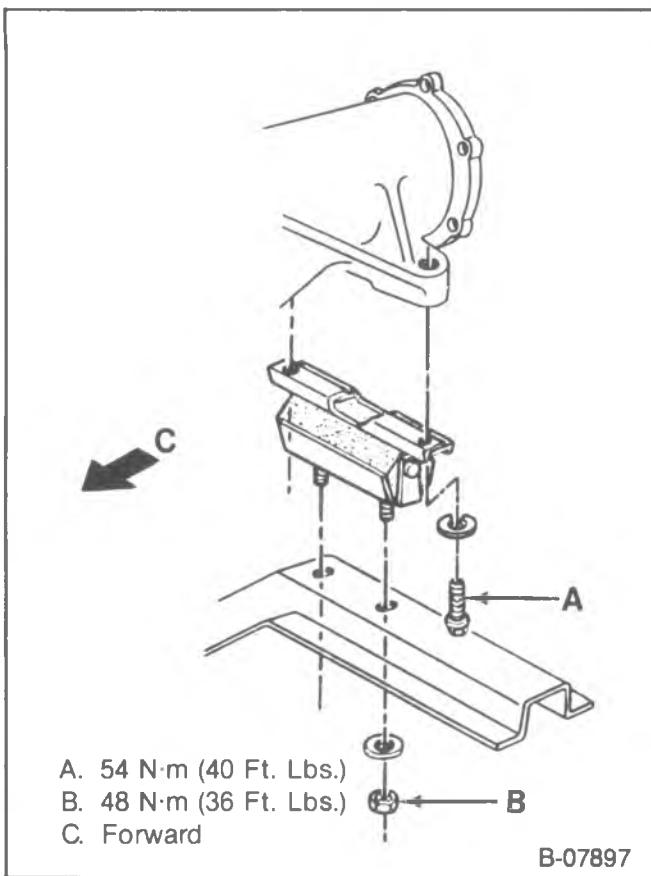

Figure 39—Rear Engine Mounting (V Models)

Install or Connect (Figures 36, 37, and 38)

1. Engine in the vehicle.

NOTICE: See "Notice" on page 6A5-1 of this section.

2. Engine mounting through bolts and nuts.

Tighten

- Fasteners to specifications. Refer to figures 36, 37, and 38.

3. Bell housing bolts.
 - Remove the lifting fixture and transmission jack.
 - Raise the vehicle. Support with suitable safety stands.
4. Flex plate to torque converter bolts (automatic transmission).
5. Flywheel or torque converter cover.
6. Starter.
7. Exhaust pipes at the manifolds.
8. Air conditioning compressor.
9. Power steering pump.
10. Vacuum hoses.
11. Fuel supply line.
12. Accelerator, cruise control, and TVS linkages, as equipped.
13. Engine wiring.
14. Radiator and fan shroud: Refer to ENGINE COOLING (SEC. 6B).
15. Air cleaner.
16. Hood.
17. Battery negative cable.
18. Proper quantity and grade of coolant.

4. Radiator and fan shroud. Refer to ENGINE COOLING (SEC. 6B).
5. Necessary engine wiring:
 - Starter and solenoid wires.
 - Generator wires.
 - Temperature sensor wire.
 - Oil pressure sender wire.
 - Distributor or coil wires.
 - Any other necessary wiring.
6. Accelerator, cruise control and TVS linkages, as equipped.
7. Fuel supply line.
8. Necessary vacuum hoses:
 - Evaporative emission hoses.
 - Vacuum booster hose (if used).
 - Cruise control hose (if used).
 - Any other necessary vacuum hoses.
9. Power steering pump, and lay aside.
10. Air conditioning compressor, and lay aside.
 - Raise the vehicle. Support with suitable safety stands.
11. Exhaust pipes at the manifolds.
12. Starter.
13. Flywheel or torque converter cover.
14. Flex plate to torque converter bolts (automatic transmission).
 - Lower the vehicle.
 - Support the transmission.
 - Attach a suitable lifting fixture.
15. Bell housing to engine bolts.
16. Front engine mounting through bolts.
17. Engine.

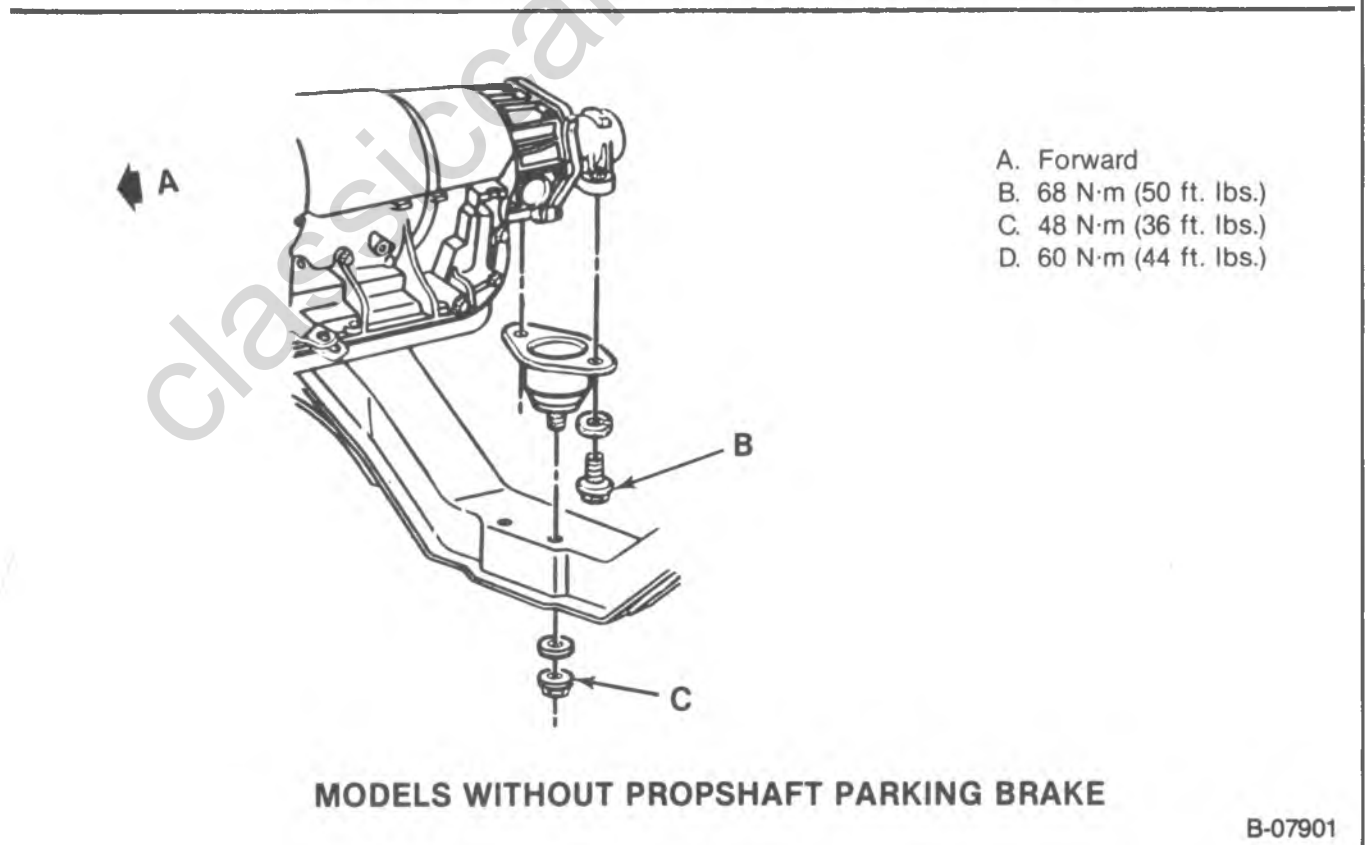
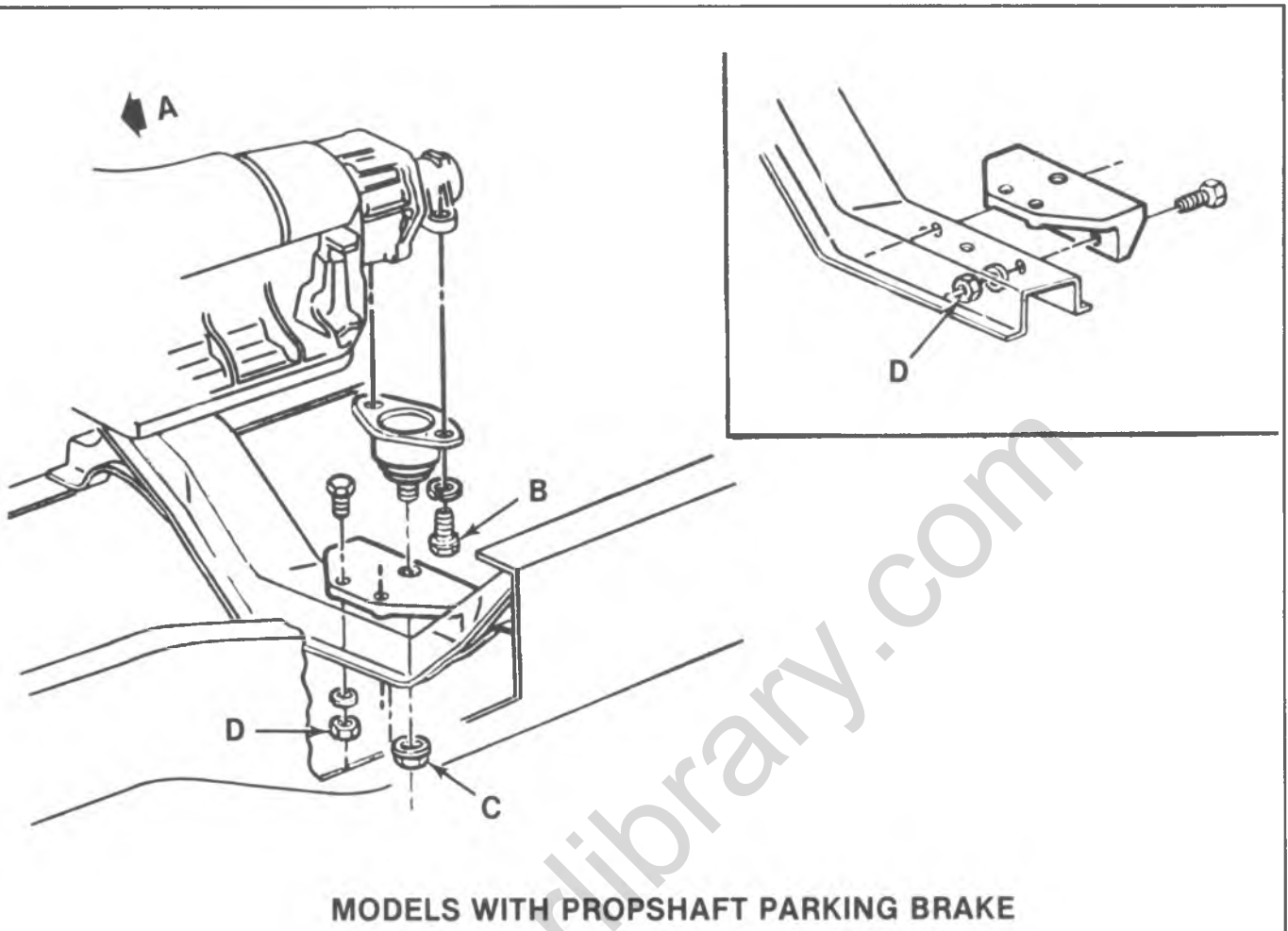

Figure 40—Rear Engine Mounting (P Models with Transmission Tail Type Mounting)

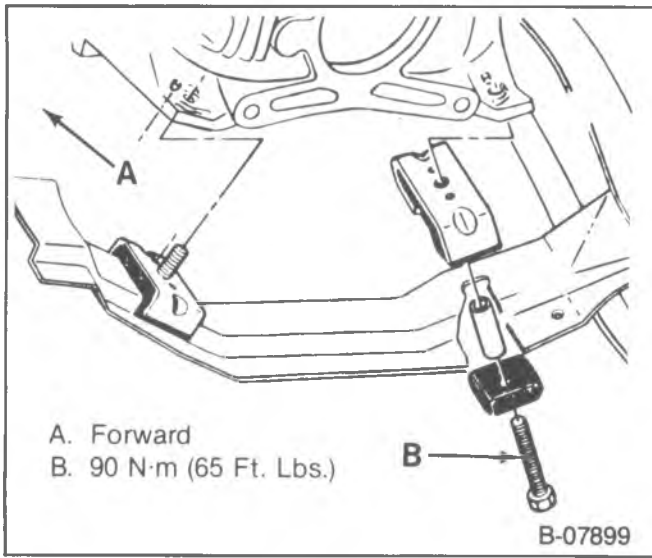

Figure 41—Rear Engine Mounting (P Models with Flywheel Housing Type Mounting)

classiccarlibrary.com

SPECIFICATIONS

ENGINE SPECIFICATIONS

All Specifications are in INCHES unless otherwise noted.

GENERAL DATA:				
Type	V8			
Displacement	7.4L (454 Cu. In.)			
RPO	L19, LE8			
Bore	4.25			
Stroke	4.00			
Compression Ratio	7.9:1			
Firing Order	1 - 8 - 4 - 3 - 6 - 5 - 7 - 2			
Oil Pressure	10 psi @ 500 RPM Minimum; 40-60 psi @ 2000 RPM			
CYLINDER BORE:				
Diameter	4.2495-4.2525			
Out Of Round	Production	0.001 (Maximum)		
	Service	0.002 (Maximum)		
Taper	Production	Thrust Side	0.0005 (Maximum)	
		Relief Side	0.001 (Maximum)	
	Service	0.001 (Maximum)		
PISTON:				
Clearance	Production	0.003-0.004		
	Service Limit	0.005 (Maximum)		
PISTON RING:				
C O M P R E S S I O N	Groove Clearance	Production	Top	0.0017-0.0032
			2nd	0.0017-0.0032
		Service Limit	Hi Limit Production + 0.001	
	Gap	Production	Top	0.010-0.020
			2nd	0.010-0.020
		Service Limit	Hi Limit Production + 0.010	
O I L	Groove Clearance	Production	0.0050-0.0065	
		Service Limit	Hi Limit Production + 0.001	
	Gap	Production	0.015-0.055	
		Service Limit	Hi Production + 0.010	
PISTON PIN:				
Diameter	0.9895-0.9898			
Clearance In Piston	Production	0.00025-0.00035		
	Service Limit	0.001 (Maximum)		
Fit In Rod	0.0013-0.0021 Interference			

SPECIFICATIONS

ENGINE SPECIFICATIONS (CONT.)

All specifications are in INCHES unless otherwise noted.









DISPLACEMENT		7.4L	
CRANKSHAFT:			
Main Journal	Diameter	#1, #2, #3, #4	2.7481-2.7490
		#5	2.7476-2.7486
	Taper	Production	0.0002 (Maximum)
		Service Limit	0.001 (Maximum)
	Out Of Round	Production	0.0002 (Maximum)
		Service Limit	0.001 (Maximum)
Main Bearing Clearance	Production	#1,#2, #3, #4	0.0013-0.0025
		#5	0.0024-0.0040
	Service Limit	#1, #2, #3, #4	0.0010-0.0025
		#5	0.0025-0.0035
Crankshaft End Play			0.006-0.010
Crankpin	Diameter	2.1990-2.200	
		Taper	Production
	Service Limit		0.001
	Out Round	Production	0.0005
		Service Limit	0.001
	Rod Bearing Clearance	Production	0.0009-0.0025
Service Limit		0.003 (Maximum)	
Rod Side Clearance			0.0013-0.023
CAMSHAFT:			
Lobe Lift \pm 0.002	Intake		0.2343
	Exhaust		0.2530
Journal Diameter			1.9482-1.9492
VALVE SYSTEM:			
Lifter			Hydraulic
Rocker Arm Ratio			1.70:1
Valve Lash	Intake	$\frac{3}{4}$ Turn Down From Zero Lash	
	Exhaust		
Face Angle (Intake & Exhaust)			45°
Seat Angle (Intake & Exhaust)			46°
Seat Runout (Intake & Exhaust)			0.002 (Maximum)
Seat Width	Intake		$\frac{1}{32}$ - $\frac{1}{16}$
	Exhaust		$\frac{1}{16}$ - $\frac{3}{32}$
Stem Clearance	Production	Intake	0.0010-0.0027
		Exhaust	0.0012-0.0029
	Service	Intake	High Limit Production + 0.001
		Exhaust	High Limit Production + 0.002
Valve Spring	Free Length		2.12
	Pressure lbs. @ in.	Closed	74-86 lbs. @ 1.80 in.
		Open	195-215 lbs. @ 1.40 in.
	Installed Height \pm $\frac{1}{32}$ "		$1\frac{5}{64}$
	Valve Spring Fit In Damper		

SPECIFICATIONS (CONT.)

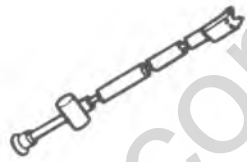
TORQUE SPECIFICATIONS

Item	N·m	Ft. Lbs.	In. Lbs.
Rocker Arm Cover Nuts	13.0	—	115
Intake Manifold Bolts	40	30	—
Rocker Arm Studs	54	40	—
Exhaust Manifold Bolts			
Cylinder Head Bolts	110	80	—
Torsional Damper Bolts	115	85	—
Front Cover to Block Bolts	10.8	—	96
Oil Pan to Front Cover Bolts	7.9	—	70
Oil Pan to Block Bolts	18.1	—	160
Oil Pump Bolt	90	65	—
Main Bearing Caps	150	110	—
Camshaft Sprocket Bolts	26	20	—
Connecting Rod Cap Nuts	66	48	—
Oil Filter Bypass Valve Bolts	26	20	—
Flywheel Bolts	90	65	—
Oil Pump Cover Bolts	9.0	—	80
Flywheel Housing Bolts	40	30	—
Water Pump Bolts	40	30	—
Water Outlet Bolts	40	30	—
Spark Plugs	30	22	—

SPECIAL TOOLS

- | | | | | | |
|----|---|-----------|-----|--|-----------|
| 1. |  | J-23523-E | 7. |  | J-5239 |
| 2. |  | J-5892-B | 8. |  | J-9290-01 |
| 3. |  | J-23590 | 9. |  | J-3049 |
| 4. |  | J-22102 | 10. |  | J-1619 |
| 5. |  | J-8080 | 11. |  | J-8520 |
| 6. |  | J-8037 | | | |

- | | |
|---|---|
| 1. Torsional Damper Remover and Installer | 7. Guide Set |
| 2. Valve Spring Compressor | 8. Hydraulic Lifter Remover (Slide Hammer Type) |
| 3. Air Adapter | 9. Hydraulic Lifter Remover (Plier Type) |
| 4. Crankshaft Seal Installer and Centering Tool | 10. Crankshaft Sprocket Puller |
| 5. Main Bearing Replacer | 11. Dial Indicator Adapter |
| 6. Piston Ring Compressor | |

SECTION 6A6

6.2L DIESEL

The following "Notice" applies to one or more steps in the assembly procedure of components in this portion of the manual as indicated at appropriate locations by the terminology "NOTICE: See 'Notice' on page 6A6-1 of this section."

NOTICE: All engine fasteners are important attaching parts in that they could affect the performance of vital components and systems, and/or could result in major repair expense. They must be replaced with one of the same part number or with an equivalent part if replacement becomes necessary. Do not use a replacement part of lesser quality or substitute design. Torque values must be used as specified during reassembly to assure proper retention of this part.

CONTENTS

<u>SUBJECT</u>	<u>PAGE</u>
Description6A6- 2
Engine Lubrication6A6- 2
On-Vehicle Service6A6- 3
Intake Manifold Replacement6A6- 3
Exhaust Manifold Replacement6A6- 3
Rocker Arm Cover Replacement6A6- 4
Rocker Arm, Shaft, and Pushrod Replacement6A6- 5
Hydraulic Lifter Replacement6A6- 6
Valve Stem Seal and Valve Spring Replacement6A6- 8
Cylinder Head Replacement6A6- 9
Oil Pump Drive Replacement6A6-12
Torsional Damper and Front Crankshaft Seal Replacement6A6-12
Front Cover Replacement6A6-13
Timing Chain and Sprocket Replacement6A6-14
Camshaft Replacement6A6-14
Dipstick Tube Replacement6A6-16
Oil Pan Replacement (R and V Models)6A6-17
Oil Pump Replacement (R and V Models)6A6-18
Oil Pan and Oil Pump Replacement (G Models)6A6-18
Rear Crankshaft Oil Seal Replacement6A6-18
Connecting Rod and Piston Replacement6A6-21
Main Bearing Replacement6A6-22
Crankshaft Replacement6A6-24
Oil Filter Bypass Valve Replacement6A6-24
Engine Mountings6A6-25
Engine Replacement6A6-28
Specifications6A6-33
Special Tools6A6-36

DESCRIPTION

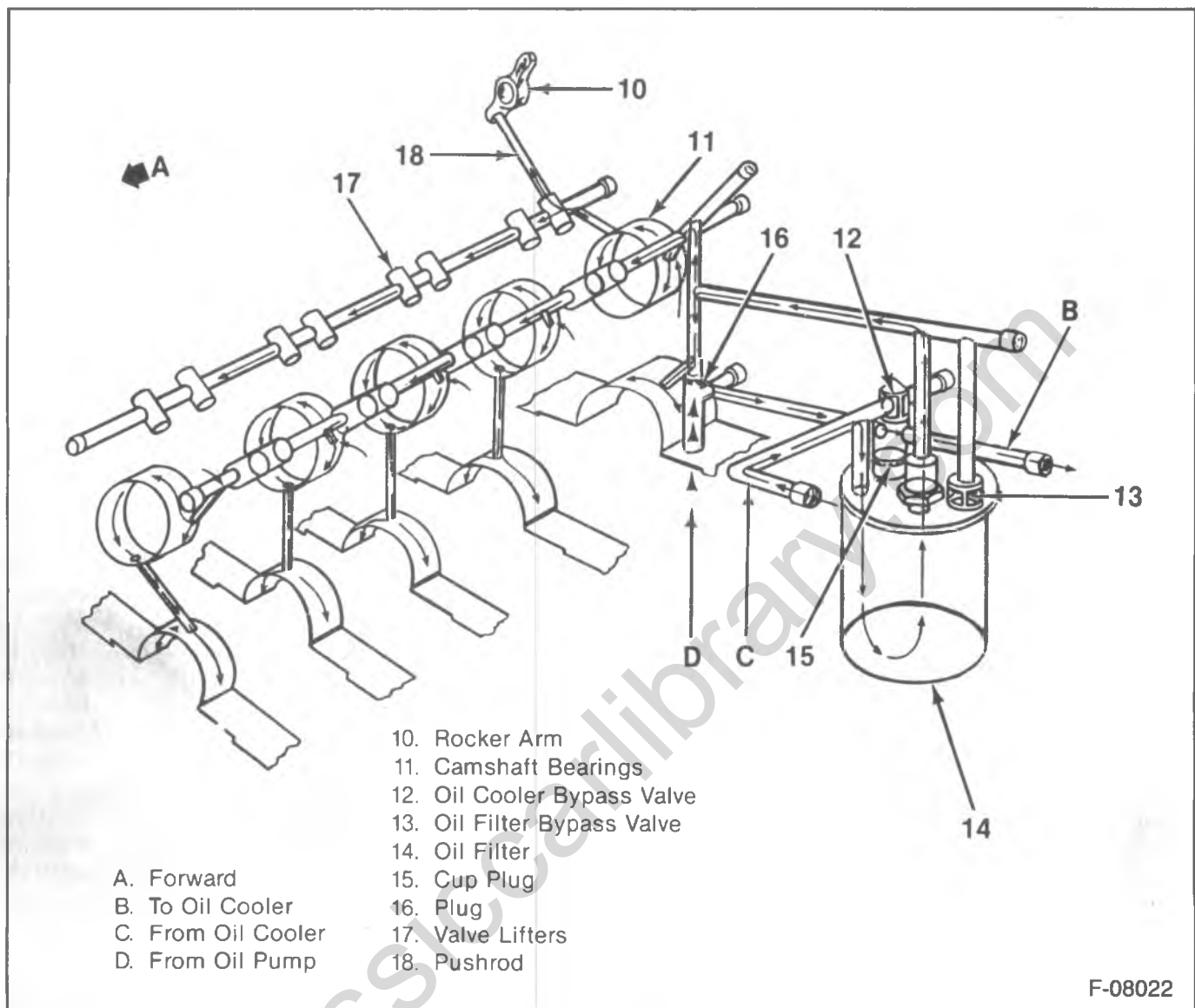

Figure 1—Lubrication Diagram

6.2 L diesel engines are 90 degree V8 type, naturally aspirated, with indirect type combustion chambers.

The crankshaft is supported by five precision insert main bearings, with crankshaft thrust taken at the number three (center) main bearing.

The camshaft is supported by five plain type bearings and is chain driven. Motion from the camshaft is transmitted to the overhead valves by roller type hydraulic lifters, pushrods, and spindle mounted rocker arms. The valve guides are integral in the cylinder head.

The connecting rods are forged steel, with precision insert type crankpin bearings. The piston pins are retained by snap rings.

ENGINE LUBRICATION

A lubrication schematic is shown in figure 1.

The gear type oil pump is driven from either the vacuum pump shaft or from a drive gear, depending on engine application. The vacuum pump or drive gear is

driven by the camshaft. Oil is drawn into the pump through a pickup screen and pipe.

Pressurized oil is routed to the oil cooler, located in the radiator. A bypass valve is provided should the oil cooler become restricted. Oil flows from the cooler to a full flow oil filter. An oil filter bypass valve is provided should the oil filter become restricted.

Oil flows from the oil filter to the oil galleries, providing pressurized lubrication to various components.

The hydraulic valve lifters receive oil from the oil galleries. Oil flows from the hydraulic lifters through hollow pushrods to the rocker arms. Oil from the overhead drains back to the crankcase through oil drain holes.

The pistons, piston rings, cylinder walls, and connecting rod small end bearing are lubricated by oil splash.

ON-VEHICLE SERVICE

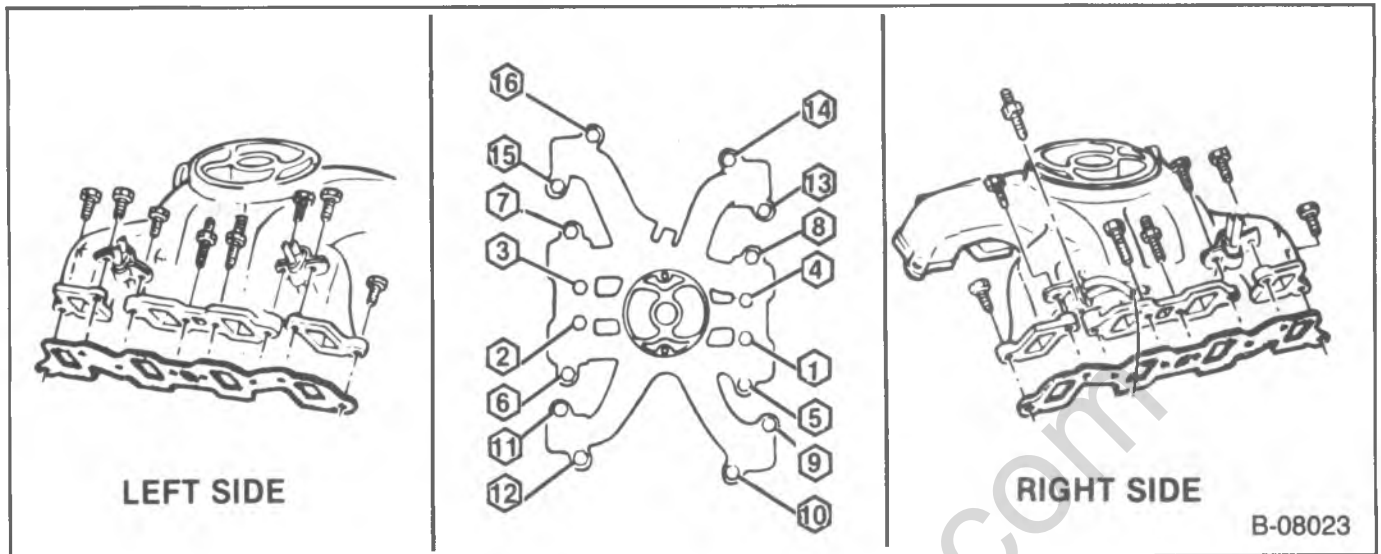

Figure 2—Intake Manifold

INTAKE MANIFOLD REPLACEMENT

↔ Remove or Disconnect

Tool Required:

J-29664 Manifold Cover Set

1. Battery cables.
2. Engine cover (G models).
3. Air cleaner.
4. EGR/EPR solenoids with bracket from the intake manifold studs.
5. CDR valve (G models).
6. EGR and crankcase ventilation hoses.
7. Rear air conditioning compressor bracket (if equipped).
8. Fuel line bracket and ground strap.
9. Fuel filter bracket at the intake manifold (G models).
10. Intake manifold bolts and fuel line clips. On models with gear driven vacuum pumps, it may be necessary to loosen the vacuum pump clamp bolt and turn the pump to provide access to an intake manifold bolt.
11. Intake manifold and gasket.

! Important

- If any further service work is to be done, cover the intake ports with J-29664-1.

☞ Clean

- Gasket surfaces on intake manifold and cylinder heads.

↔ Install or Connect (Figure 2)

1. New gaskets. Be sure to use the correct gasket. The gaskets for light duty emissions models have openings for the EGR ports, the gaskets for heavy duty emissions models do not.
2. Intake manifold.

3. Intake manifold bolts and fuel line clips.

☞ Tighten

- Intake manifold bolts to 42 N·m (32 ft. lbs.). Use the tightening sequence shown in figure 2.
 - Rotate the vacuum pump to the proper position and tighten the clamp bolt (gear driven vacuum pumps).
4. Fuel filter bracket (G models).
 5. Fuel line bracket and ground strap.
 6. Rear air conditioning compressor bracket (if equipped).
 7. EGR and crankcase ventilation hoses.
 8. CDR valve (G models).
 9. EGR/EPR solenoids with bracket.
 10. Air cleaner.
 11. Engine cover (G models).
 12. Battery cables.

EXHAUST MANIFOLD REPLACEMENT

R AND V MODELS (RIGHT SIDE)

↔ Remove or Disconnect

1. Battery cables.
 - Raise the vehicle. Support with suitable safety stands.
2. Exhaust pipe from the manifold.
 - Lower the vehicle.
3. Glow plug wires.
4. Air cleaner duct bracket.
5. Glow plugs.
6. Exhaust manifold bolts and exhaust manifold.

☞ Clean

- Sealing surfaces on exhaust manifold and cylinder head.

- Threads on manifold bolts.

Install or Connect

1. Exhaust manifold and bolts.

Tighten

- Bolts to 35 N·m (26 ft. lbs.).
2. Glow plugs.
 3. Air cleaner duct bracket.
 4. Glow plug wires.
 - Raise the vehicle. Support with suitable safety stands.
 5. Exhaust pipe to the manifold.
 - Lower the vehicle.
 6. Battery cables.

R AND V MODELS (LEFT SIDE)

Remove or Disconnect

1. Battery cables.
2. Dipstick tube.
3. Glow plugs.
4. Air conditioning compressor rear bracket (if equipped).
5. Exhaust manifold bolts.
 - Raise the vehicle. Support with suitable safety stands.
6. Exhaust pipe at the manifold.
7. Exhaust manifold, from below the vehicle.

Clean

- Sealing surfaces on the exhaust manifold and cylinder head.
- Threads on the exhaust manifold bolts.

Install or Connect

1. Exhaust manifold, from below the vehicle. Loosely install two or three bolts to hold the manifold in place.
2. Exhaust pipe to the manifold.
 - Lower the vehicle.
3. Remaining exhaust manifold bolts and air conditioning compressor rear bracket (if used).

Tighten

- Bolts to 35 N·m (26 ft. lbs.).
4. Glow plugs.
 5. Dipstick tube.
 6. Battery cables.

G MODELS (BOTH SIDES)

Remove or Disconnect

1. Battery cables.
 - Raise the vehicle. Support with suitable safety stands.
2. Exhaust pipe at the manifold.
 - Lower the vehicle.
3. Engine cover.
4. Glow plug wires.
5. Air conditioning compressor rear bracket (if equipped) (left side exhaust manifold).
6. Exhaust manifold bolts and exhaust manifold.

Clean

- Sealing surfaces on the exhaust manifold and cylinder head.
- Threads on the manifold bolts.

Install or Connect

1. Exhaust manifold.
2. Exhaust manifold bolts and air conditioning compressor rear bracket (if equipped) (left side exhaust manifold).

Tighten

- Bolts to 35 N·m (26 ft. lbs.).
3. Glow plug wires.
 4. Engine cover.
 - Raise the vehicle. Support with suitable safety stands.
 5. Exhaust pipe to the manifold.
 6. Lower the vehicle.
 7. Battery cables.

ROCKER ARM COVER REPLACEMENT

R AND V MODELS (BOTH SIDES) G MODELS (RIGHT SIDE)

Remove or Disconnect

1. Intake manifold, as outlined previously.
2. Fuel injection lines. Refer to DIESEL FUEL INJECTION (SEC. 6C2). (Injection lines for #5 and #7 cylinders do not have to be removed for right side rocker arm cover replacement).
3. Glow plug wires (G models).
4. Wiring harness from wiring harness clip.
5. Wiring harness bracket (left rocker arm cover).
6. Rocker arm cover bolts.

NOTICE: Do not pry on the rocker arm cover. Damage to sealing surfaces may result.

7. Rocker arm cover.

Clean

1. RTV from the rocker arm cover and cylinder head. All loose RTV, or pieces that will cause installation interference, must be removed.
2. Oil and grease from the sealing surfaces on the rocker arm cover and cylinder head. Use a suitable solvent.

Inspect

- Rocker arm cover sealing flanges for distortion. Replace as necessary.

Install or Connect (Figure 3)

NOTICE: Do not allow RTV sealant into the rocker arm cover bolt holes. This may cause a "hydraulic lock" condition when the bolts are tightened, damaging the cylinder head casting.

- Apply a 5 mm (3/16-inch) bead of RTV sealant (GM

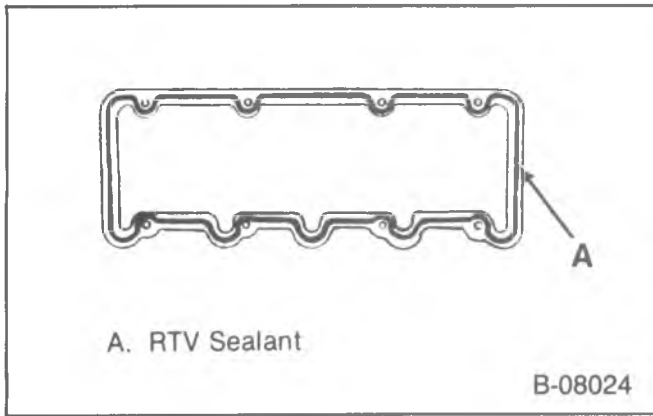

Figure 3—Applying Sealant to the Rocker Arm Cover

part number 1052915 or equivalent) to the cylinder head, inboard of the bolt holes. Refer to figure 3. The sealer must be wet to the touch when the bolts are torqued.

1. Rocker arm cover.
2. Rocker arm cover bolts.

Tighten

- Bolts to 22 N·m (16 ft. lbs.).
3. Wiring harness bracket.
 4. Wiring harness to the wiring harness clip.
 5. Glow plug wires (G models).
 6. Fuel injection lines. Refer to DIESEL FUEL INJECTION (SEC. 6C2).
 7. Intake manifold, as outlined previously.

G MODELS (LEFT SIDE)

Remove or Disconnect

1. Intake manifold, as outlined previously.
2. Fuel injection lines. Refer to DIESEL FUEL INJECTION (SEC. 6C2).
3. Upper fan shroud (vehicles with air conditioning).
4. Air conditioning compressor belt (if equipped).
5. Left exhaust manifold, as outlined previously (vehicles with air conditioning).
6. Air conditioning compressor (if equipped). Refer to AIR CONDITIONING (SEC. 1B).
7. Dipstick tube front bracket from stud.
8. Wiring harness brackets.
9. Rocker arm cover bolts and fuel return bracket.

NOTICE: Do not pry on the rocker arm cover. Damage to the sealing surfaces may result.

10. Rocker arm cover.

Clean

1. RTV from the rocker arm cover and cylinder head. All loose RTV, or pieces that will cause installation interference, must be removed.
2. Oil and grease from the sealing surfaces on the rocker arm cover and cylinder head. Use a suitable solvent.

Inspect

- Rocker arm cover sealing flanges for distortion. Replace as necessary.

Install or Connect (Figure 3)

NOTICE: Do not allow RTV sealant into the rocker arm cover bolt holes. This may cause a "hydraulic lock" condition when the bolts are tightened, damaging the cylinder head casting.

1. Rocker arm cover.
2. Rocker arm cover bolts and fuel return bracket.

Tighten

- Bolts to 22 N·m (16 ft. lbs.).
3. Wiring harness brackets.
 4. Dipstick tube front bracket.
 5. Air conditioning compressor (if equipped). Refer to AIR CONDITIONING (SEC. 1B).
 6. Left exhaust manifold, as outlined previously (if removed).
 7. Air conditioning compressor belt (if equipped).
 8. Upper fan shroud (if removed).
 9. Fuel injection lines. Refer to DIESEL FUEL INJECTION (SEC. 6C2).
 10. Intake manifold, as outlined previously.

ROCKER ARM, SHAFT, AND PUSHROD REPLACEMENT

Remove or Disconnect (Figures 4 and 5)

1. Rocker arm cover, as outlined previously.
2. Rocker arm shaft nuts.
3. Rocker arm shaft with rocker arms. Mark the assemblies so they can be returned to the original location at assembly.
4. Pushrods.

Important

- The pushrods must be installed in the original direction at assembly. This is because the pushrods have a different degree of hardness at each end. A paint stripe identifies the upper end of the pushrod. If the paint stripe is not visible, mark the pushrods on the upper end as they are removed.
 - The pushrods should be installed in the same location at assembly.
5. Rocker arms, if required.
 - Insert a screwdriver into the rocker arm shaft bore, and break off the end of the nylon rocker arm retainers.
 - Remove the rocker arm retainers with pliers (figure 5).
 - Slide the rocker arms from the shaft.

Install or Connect (Figures 4 and 6)

1. Rocker arms to the rocker arm shaft. One type of rocker arm is used at all locations.

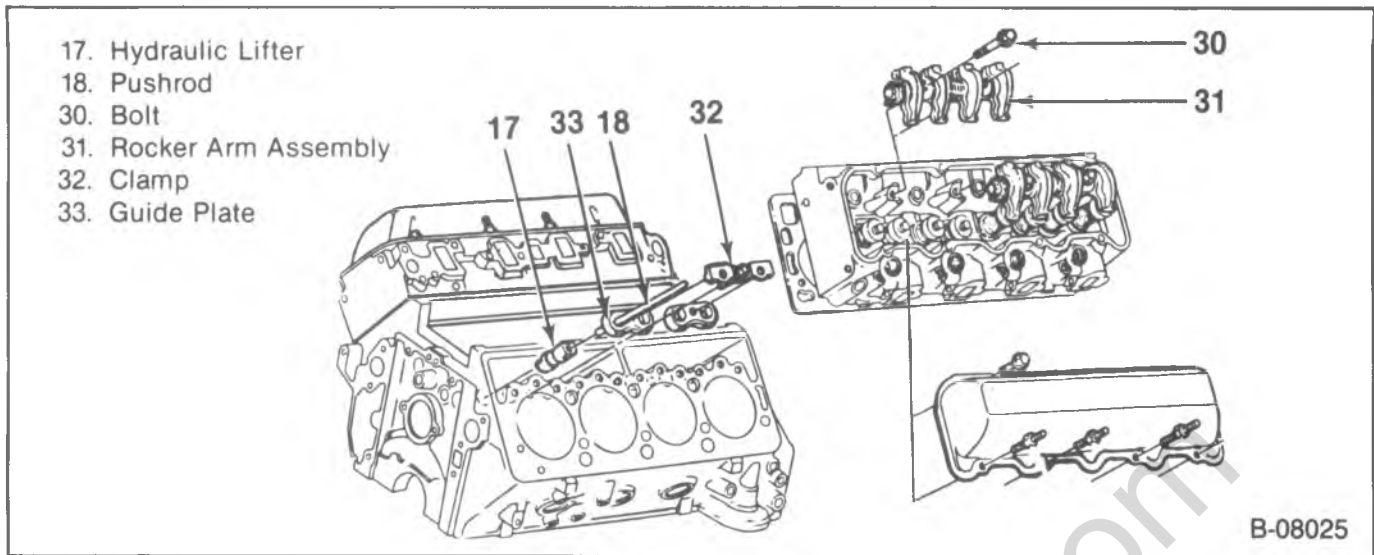

Figure 4—Valve Train Components

! Important

- Lubricate the rocker arms with engine oil before installing.
2. Rocker arm retainers.
 - Center the rocker arms on the corresponding holes in the rocker arm shaft.
 - Install new retainers. Use a drift of at least 13 mm (1/2-inch) diameter.

NOTICE: The pushrods must be installed with the marked or painted end up. Failure to do so may result in damage or premature wear.

3. Pushrods, with the painted or marked end up.
4. Rocker arm shaft assembly. Make sure the ball ends of the pushrods seat in the rocker arms.

NOTICE: Improper installation of the rocker arm shaft bolts may cause rocker arm shaft breakage and/or piston to valve contact.

5. Rocker arm shaft bolts.
 - Rotate the engine until the mark on the torsional damper aligns with the "0" mark on the timing tab.

- Rotate the engine counterclockwise 88 mm (3 1/2-inches), measured at the torsional damper. This measurement can be estimated by aligning the torsional damper mark with the first lower water pump bolt (figure 6). This procedure will position the engine so no valves are close to a piston crown.
- Install both bolts snug on the shaft.

⌚ Tighten

- Bolts alternately to 55 N·m (40 ft. lbs.).
6. Rocker arm cover, as outlined previously.

HYDRAULIC LIFTER REPLACEMENT

↔ Remove or Disconnect (Figures 4 and 7)

Tool Required:

J-29834 Hydraulic Lifter Remover (R and V Models)

1. Rocker arm covers, as outlined previously.
2. Rocker arm shaft with rocker arms and pushrods, as outlined previously.

! Important

- Rocker arm assemblies and pushrods must be marked for proper assembly, as outlined previously.
3. Cylinder head, as outlined later (G models).
 4. Clamps (32).
 5. Guide plates (33). Use mechanical fingers, if necessary.
 6. Hydraulic lifters, through the access hole in the cylinder head. On R and V Models, use J-29834 (figure 7) and a magnet. Place the lifters in an organizer rack. The lifters must be installed in the same bore from which they were removed.

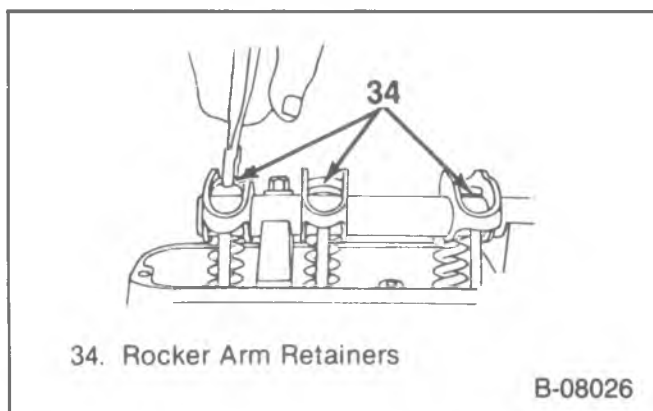

34. Rocker Arm Retainers

B-08026

Figure 5—Removing the Rocker Arm Retainers

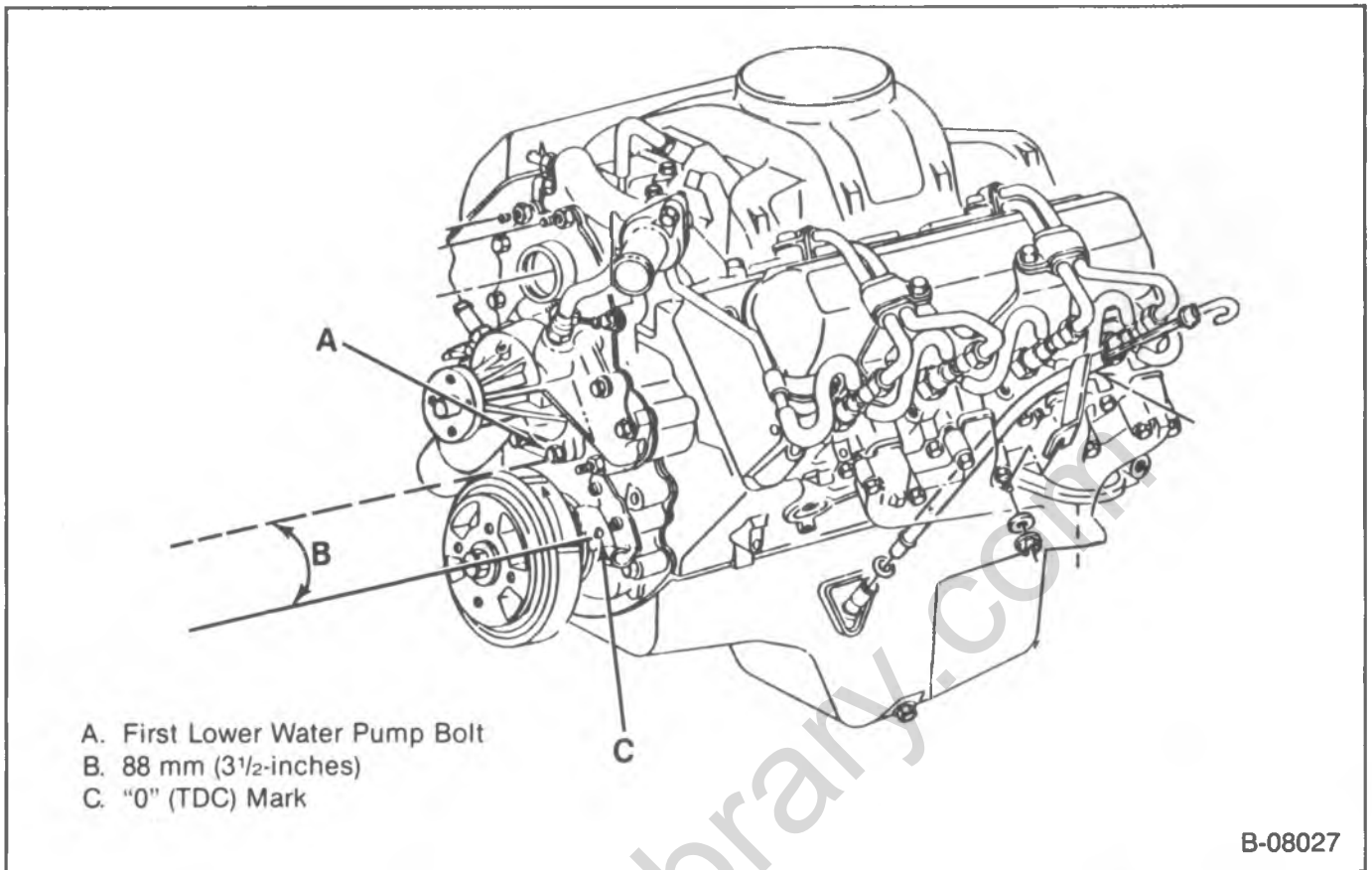

Figure 6—Aligning the Timing Mark

Inspect

- Hydraulic lifter body for scuffing and scoring. Replace the lifter if present.
- Roller for looseness and excessive play. Check for missing or broken needle bearings. Replace if necessary.
- Roller surface for pits and roughness. If present, the mating camshaft lobe should also be checked. If the lobe is pitted or rough, replace both camshaft and lifter.

Hydraulic Lifter Repair

- Refer to the proper unit repair manual.

Important

- Some engines will have both standard and 0.010-inch oversize hydraulic lifters. The oversize lifter will have a "10" etched on the side. The block will be stamped "O.S." on the cast pad adjacent to the lifter bore and on the top rail of the cylinder case above the lifter bore.

Install or Connect (Figure 4)

NOTICE: New hydraulic lifters must be primed before installation. Damage to the lifters may result if dry when the engine is started.

1. Hydraulic lifters to the engine. On R and V models, fabricate an installation tool from mechanic's wire.

Important

- Prime new hydraulic lifters before installation by working the lifter plunger while submerged in clean kerosene or diesel fuel.
- Coat the lifter roller and bearings with lubricant (GM part number 1052365 or equivalent).
- Lifters **MUST** be installed in their original locations.

2. Guide plates (33).

3. Clamps (32).

Tighten

- Clamp bolt to 26 N·m (18 ft. lbs.).

Important

- After all clamps are installed, turn the crankshaft by hand 720 degrees (two full turns), to insure free movement of the lifters in the guide plates. If the engine will not turn over by hand, one or more of the lifters may be binding in the guide plate.

4. Cylinder head, as outlined later (G models).

5. Rocker arm shaft with rocker arms and pushrods, in their original locations, as outlined previously. Hardened ends of the pushrods must face up.

6. Rocker arm covers, as outlined previously.

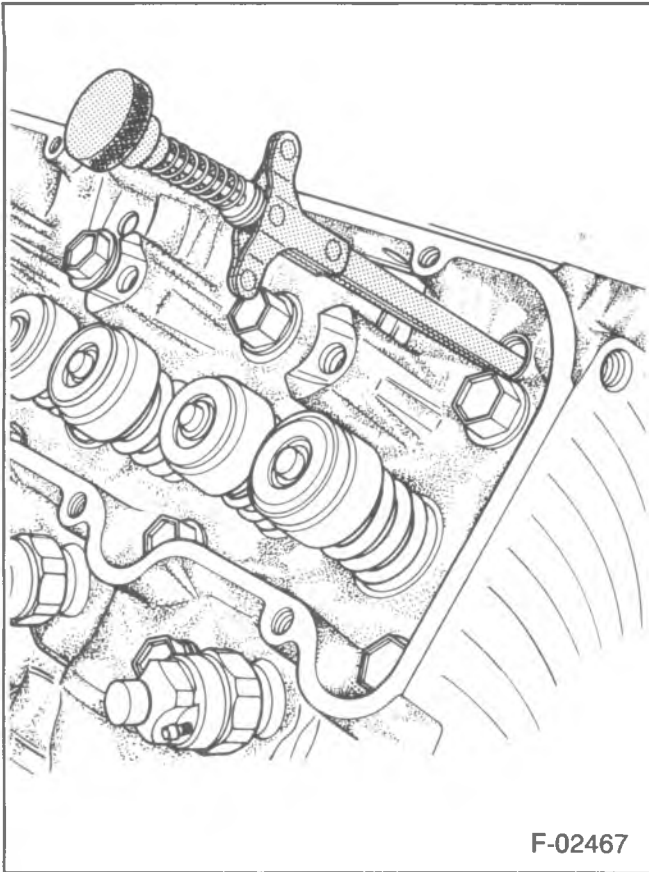

Figure 7—Removing the Hydraulic Lifter (R and V Models)

VALVE STEM SEAL AND VALVE SPRING REPLACEMENT

↔ Remove or Disconnect (Figures 8 and 9)

Tools Required:

J-29666 Air Line Adapter

J-26513-A Valve Spring Compressor

1. Rocker arm covers, as outlined previously.

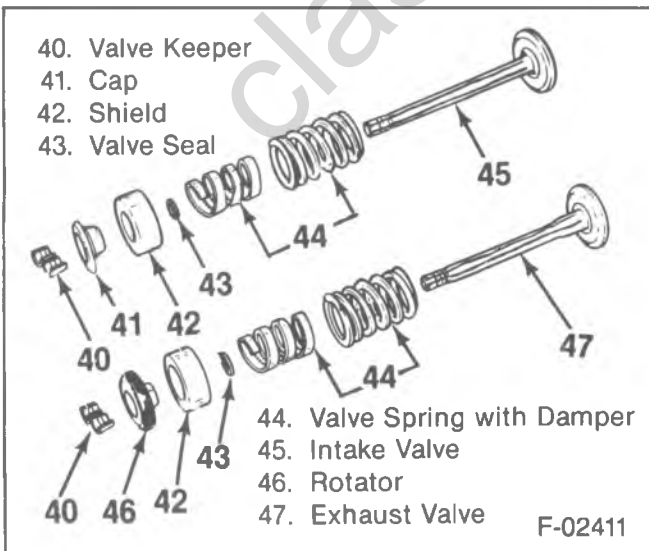

Figure 8—Valves and Components

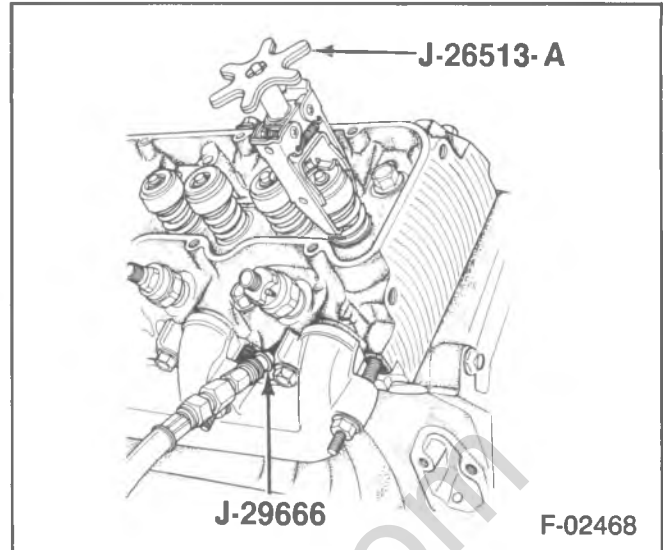

Figure 9—Compressing the Valve Spring

2. Rocker arm shaft with rocker arms, as outlined previously. Mark the assemblies so they can be returned to their original locations.
3. Glow plugs.
4. Valve keepers.
 - Rotate the engine until the piston for the cylinder being serviced is at TDC.
 - Install J-29666 into the glow plug hole.
 - Apply compressed air to hold the valves in place.
 - Use J-26513-A to compress the valve spring (figure 9). If the spring will not compress, tap on the tool lightly with a mallet to break the cap or rotator loose from the valve keepers.
 - Remove the valve keepers.
 - Carefully release spring tension. Remove J-26513-A.
5. Cap or rotator, shield, and valve spring with damper.
6. Valve seal.

↔ Install or Connect (Figures 8 and 9)

Tools Required:

J-29666 Air Line Adapter

J-26513-A Valve Spring Compressor

1. New valve seal.
2. Valve spring with damper, shield and cap or rotator.
3. Valve keepers.
 - With air pressure applied to the cylinder with J-29666, compress the valve spring with J-26513-A (figure 9).
 - Install the valve keepers. Use grease to hold them in place.
 - Carefully release spring pressure. Make sure the valve keepers stay in place.
 - Remove J-26513-A and J-29666.
5. Glow plugs.
6. Rocker arm shaft with rocker arms, as outlined previously.
7. Rocker arm covers, as outlined previously.

CYLINDER HEAD REPLACEMENT

REMOVAL (R AND V MODELS) (BOTH SIDES)

Remove or Disconnect

1. Intake manifold, as outlined previously.
2. Injection lines. Refer to DIESEL FUEL INJECTION (SEC. 6C2).
3. Rocker arm covers, as outlined previously.
 - Drain the cooling system.
4. Dipstick tube (left cylinder head).
5. Ground wire at the cowl (right cylinder head).
6. Glow plug relay (left cylinder head).
 - Raise the vehicle. Support with suitable safety stands.
7. Exhaust pipe from the manifold.
 - Lower the vehicle.
8. Air conditioning compressor (if equipped) and lay aside (left cylinder head).
9. Generator, and lay aside (right cylinder head).
10. Glow plug wires.
11. Glow plug temperature inhibit switch wire (right cylinder head).
12. Rocker arm assemblies and pushrods, as outlined previously.

Important

- Rocker arm assemblies and pushrods must be marked for proper assembly, as outlined previously.
13. Radiator, bypass and heater hoses.
 14. Ground strap.
 15. Water crossover pipe/thermostat housing assembly.
 16. Cylinder head bolts. Rear bolt in left cylinder head may have to remain in the head during removal.
 17. Cylinder head.

REMOVAL (G MODELS) (RIGHT SIDE)

Remove or Disconnect

1. Intake manifold, as outlined previously.
2. Injection lines. Refer to DIESEL FUEL INJECTION (SEC. 6C2).
3. Transducer (cruise control equipped vehicles).
4. Upper fan shroud and air conditioning compressor belt (vehicles with air conditioning).
 - Raise the vehicle. Support with suitable safety stands.
5. Exhaust pipe at the manifold.
6. Rear air conditioning compressor bracket at the exhaust manifold (if equipped).
7. Glow plug wires.
 - Lower the vehicle.
8. Air conditioning compressor (if equipped). Refer to AIR CONDITIONING (SEC. 1B).
9. Dipstick tube front bracket from the stud.
10. Oil fill tube upper bracket.
11. Rocker arm cover, as outlined previously.
12. Rocker arm assemblies and pushrods, as outlined previously.

Important

- Rocker arm assemblies must be marked for proper assembly, as outlined previously.
 - Drain the cooling system.
13. Air cleaner resonator and bracket.
 14. Transmission dipstick tube.
 15. Heater, radiator and bypass hoses at the engine.
 16. Generator upper bracket.
 17. Water crossover pipe/thermostat assembly.
 18. Cylinder head bolts.
 19. Cylinder head.

REMOVAL (G MODELS) (LEFT SIDE)

Remove or Disconnect

1. Intake manifold, as outlined previously.
2. Injection lines at the injection pump. Refer to DIESEL FUEL INJECTION (SEC. 6C2).
3. Transducer (cruise control equipped vehicles).
4. Upper fan shroud and air conditioning compressor belt (vehicles with air conditioning).
 - Raise the vehicle. Support with suitable safety stands.
5. Left exhaust manifold, as outlined previously.
6. Power steering pump lower adjusting bolts.
7. Glow plug wires.
8. Glow plug temperature inhibit switch.
9. Injection lines. Refer to DIESEL FUEL INJECTION (SEC. 6C2).
 - Lower the vehicle.
10. Air conditioning compressor (if equipped). Refer to AIR CONDITIONING (SEC. 1B).
11. Upper power steering pump brackets. Lay the pump aside.
12. Dipstick tube front bracket from the stud.
13. Transmission detent cable.
14. Glow plug controller, bracket, and relay.
15. Wiring harness bracket.
16. Vacuum line clip, at the cylinder head.
17. Fuel return line bracket.
18. Rocker arm cover, as outlined previously.
19. Rocker arm assemblies and pushrods, as outlined previously.

Important

- Rocker arm assemblies must be marked for proper assembly, as outlined previously.
 - Drain the cooling system.
20. Air cleaner resonator and bracket.
 21. Transmission dipstick tube at the front attaching stud and lay aside.
 22. Generator upper bracket.
 23. Water crossover pipe/thermostat assembly.
 24. Cylinder head bolts.
 25. Cylinder head.

CLEANING AND INSPECTION

Clean

- Carbon deposits from combustion chambers.
- All traces of old head gasket from cylinder head and block. Use of a motorized wire brush is not recommended.

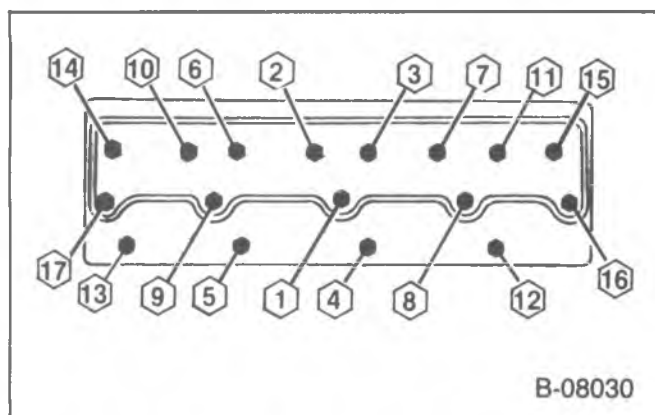

Figure 10—Head Bolt Tightening Sequence

- Cylinder head bolt threads using a wire brush.
- Metal chips and dirt from the threads in the block.

Inspect

- Cylinder head for cracks between the intake and exhaust ports. Use the magnaflux or dye method if available.
- Sealing surfaces of the block and cylinder head for nicks, heavy scratches, or other damage.
- Block for missing or damaged dowel pins, or dowel pins in the wrong location.

Measure

- Cylinder head warpage. If warped more than 0.15 mm (0.006-inch) longitudinally or 0.08 mm (0.003-inch) transversely, replace the cylinder head. Resurfacing is not recommended.
- Pre-chamber installed depth. The pre-chamber should be flush to a maximum of 0.05 mm (0.002-inch) protrusion.
 - Make the measurement at two or more points on the pre-chamber where the prechamber seats on the head gasket shield and sealing ring.
 - Measure the difference between the flat of the pre-chamber and the flat surface of the cylinder head.
 - The pre-chamber must not protrude out of the cylinder head more than 0.05 mm (0.002-inch).
 - The pre-chamber must not be recessed into the cylinder head.

CYLINDER HEAD REPAIR

- Refer to the proper unit repair manual.

INSTALLATION (R AND V MODELS) (BOTH SIDES)

Install or Connect (Figure 10)

1. Head gasket to the block, over the dowel pins.

Important

- The block gasket surfaces must be clean.
- DO NOT use a sealer on the head gasket. The head gasket is manufactured with the proper amount of sealant "printed" on its surface.

Additional sealer may cause leakage or malfunction. In addition, some sealers may attack the sealant already on the head gasket.

2. Rear cylinder head bolt to the cylinder head (left cylinder head). Apply sealant to the bolt as described in step 4. Due to clearances, the bolt must be installed at this time.
3. Cylinder head. Make sure the gasket surfaces are clean. Guide the head carefully into place over the dowel pins.
4. Cylinder head bolts.
 - Make sure the bolt threads are clean.
 - Apply sealant (GM part number 1052080 or equivalent) to the bolt threads and under the bolt heads.

Tighten

- Cylinder head bolts, as follows:
 - Using the sequence shown in figure 10, tighten all bolts to 25 N·m (20 ft. lbs.).
 - In sequence, tighten all bolts to 65 N·m (50 ft. lbs.).
 - In sequence, tighten all bolts an additional 90 degrees (1/4 turn).

5. Water crossover pipe/thermostat assembly. Use new gaskets.

Tighten

- Bolts to 42 N·m (31 ft. lbs.).

6. Ground strap.
7. Radiator, bypass, and heater hoses.
8. Pushrods and rocker arm assemblies, in their original locations, as described previously. Hardened ends of the pushrods must face up.
9. Glow plug temperature inhibit switch wire (right cylinder head).
10. Glow plug wires.
11. Generator (right cylinder head).
12. Air conditioning compressor (left side cylinder head).
 - Raise the vehicle. Support with suitable safety stands.
13. Exhaust pipe to the manifold.
 - Lower the vehicle.
14. Glow plug relay (left cylinder head).
15. Ground wire at the cowl (right cylinder head).
16. Dipstick tube (left cylinder head).
17. Rocker arm covers, as outlined previously.
18. Injection lines. Refer to DIESEL FUEL INJECTION (SEC. 6C2).
19. Intake manifold, as outlined previously.
 - Fill the cooling system with the proper quantity and grade of coolant.

INSTALLATION (G MODELS) (RIGHT SIDE)

Install or Connect (Figure 10)

1. Head gasket to the block, over the dowel pins.

Important

- The block gasket surfaces must be clean.
- DO NOT use a sealer on the head gasket. The head gasket is manufactured with the proper amount of sealant "printed" on its surface.

Additional sealer may cause leakage or malfunction. In addition, some sealers may attack the sealant already on the head gasket.

2. Cylinder head. Make sure the gasket surfaces are clean. Guide the head carefully into place over the dowel pins.
3. Cylinder head bolts.
 - Make sure the bolt threads are clean.
 - Apply sealant (GM part number 1052080 or equivalent) to the bolt threads and under the bolt heads.

Tighten

- Cylinder head bolts, as follows:
 - Using the sequence shown in figure 10, tighten all bolts to 25 N·m (20 ft. lbs.).
 - In sequence, tighten all bolts to 65 N·m (50 ft. lbs.).
 - In sequence, tighten all bolts an additional 90 degrees (1/4 turn).
- 4. Water crossover pipe/thermostat assembly. Use new gaskets.

Tighten

- Bolts to 42 N·m (31 ft. lbs.).
5. Generator upper bracket.
 6. Heater, radiator, and bypass hoses.
 7. Transmission dipstick tube.
 8. Air cleaner resonator and bracket.
 9. Pushrods and rocker arm assemblies, in their original locations, as described previously. Hardened ends of the pushrods must face up.
 10. Rocker arm cover, as outlined previously.
 11. Oil fill tube upper bracket.
 12. Dipstick tube front bracket.
 13. Air conditioning compressor (if equipped). Refer to AIR CONDITIONING (SEC. 1B).
 - Raise the vehicle. Support with suitable safety stands.
 14. Glow plug wires.
 15. Rear air conditioning compressor bracket (if equipped).
 16. Exhaust pipe.
 - Lower the vehicle.
 17. Upper fan shroud and air conditioning compressor belt (vehicles with air conditioning).
 18. Transducer (if equipped).
 19. Injection lines. Refer to DIESEL FUEL INJECTION (SEC. 6C2).
 20. Intake manifold, as outlined previously.
 - Fill the cooling system with the proper quantity and grade of coolant.

INSTALLATION (G MODELS) (LEFT SIDE)

Install or Connect (Figure 10)

1. Head gasket to the block, over the dowel pins.

Important

- The block gasket surfaces must be clean.
- DO NOT use a sealer on the head gasket. The head gasket is manufactured with the proper amount of sealant "printed" on its surface.

Additional sealer may cause leakage or malfunction. In addition, some sealers may attack the sealant already on the head gasket.

2. Cylinder head. Make sure the gasket surfaces are clean. Guide the head carefully into place over the dowel pins.
3. Cylinder head bolts.
 - Make sure the bolt threads are clean.
 - Apply sealant (GM part number 1052080 or equivalent) to the bolt threads and under the bolt heads.

Tighten

- Cylinder head bolts, as follows:
 - Using the sequence shown in figure 10, tighten all bolts to 25 N·m (20 ft. lbs.).
 - In sequence, tighten all bolts to 65 N·m (50 ft. lbs.).
 - In sequence, tighten all bolts an additional 90 degrees (1/4 turn).
- 4. Water crossover pipe/thermostat assembly. Use new gaskets.

Tighten

- Bolts to 42 N·m (31 ft. lbs.).
5. Generator upper bracket.
 6. Transmission dipstick tube.
 7. Air cleaner resonator and bracket.
 8. Pushrods and rocker arm assemblies, in their original locations; as described previously. Hardened ends of the pushrods must face up.
 9. Rocker arm cover, as outlined previously.
 10. Fuel return line bracket.
 11. Vacuum line clip.
 12. Wiring harness bracket.
 13. Glow plug controller, bracket, and relay.
 14. Transmission detent cable.
 15. Dipstick tube front bracket.
 16. Power steering pump and brackets.
 17. Air conditioning compressor (if equipped). Refer to AIR CONDITIONING (SEC. 1B).
 - Raise the vehicle. Support with suitable safety stands.
 18. Injection lines. Refer to DIESEL FUEL INJECTION (SEC. 6C2).
 19. Glow plug temperature inhibit switch.
 20. Glow plug wires.
 21. Power steering pump lower adjusting bolts.
 22. Left exhaust manifold, as outlined previously.
 - Lower the vehicle.
 23. Upper fan shroud and air conditioning compressor belt (vehicles with air conditioning).
 24. Transducer (if equipped).
 25. Intake manifold, as outlined previously.
 - Fill the cooling system with the proper quantity and grade of coolant.
 - Evacuate and charge the air conditioning system. Refer to AIR CONDITIONING (SEC. 1B).

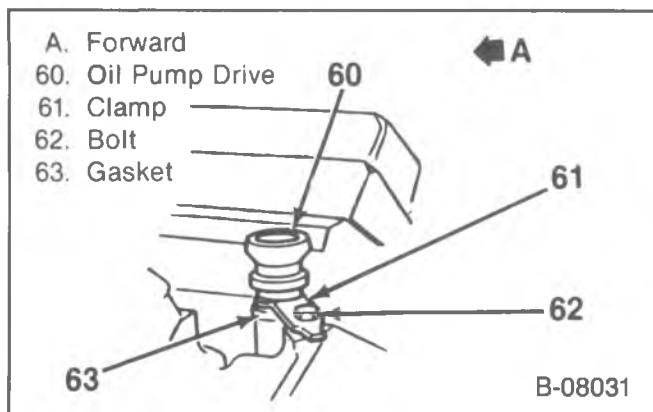

Figure 11—Oil Pump Drive

OIL PUMP DRIVE REPLACEMENT

For gear driven vacuum pump replacement, refer to VACUUM PUMP (SEC. 6H).

NOTICE: Do not run the engine without the gear driven vacuum pump or oil pump drive in place. This will cause extensive engine damage.

Remove or Disconnect (Figure 11)

1. Bolt and clamp.
2. Oil pump drive.
3. Gasket.

Install or Connect (Figure 11)

1. New gasket to the oil pump drive.
2. Oil pump drive to the engine. Index the drive with the camshaft gear and oil pump drive shaft. Make sure the drive seats fully.
3. Clamp and bolt.

Tighten

- Bolt to 42 N·m (31 ft. lbs.).

TORSIONAL DAMPER AND FRONT CRANKSHAFT SEAL REPLACEMENT

Remove or Disconnect (Figure 12)

Tools Required:

J-23523-E Torsional Damper Puller

1. Battery cables.
2. Upper fan shroud (G models).
3. Accessory drive belts.
 - Raise the vehicle (G models). Support with suitable safety stands.
4. Bolts and crankshaft pulley.
5. Torsional damper bolt and washer.
6. Torsional damper. Use J-23523 (figure 12).
7. Front crankshaft seal. Pry out with a screwdriver.

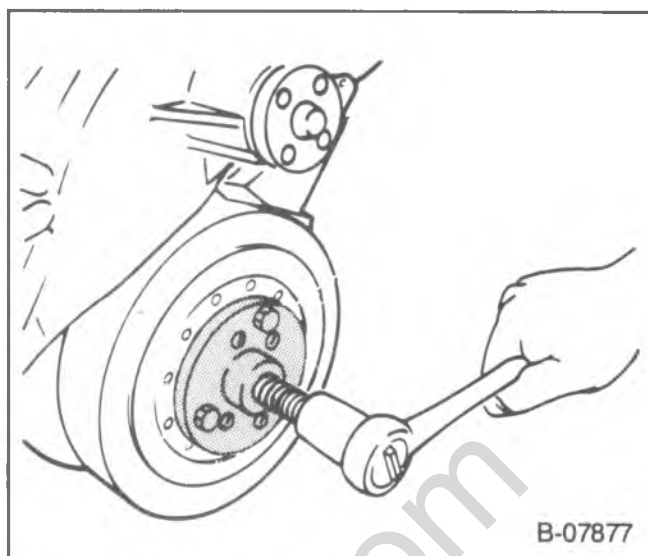

Figure 12—Removing the Torsional Damper

Install or Connect (Figure 13)

Tool Required:

J-22102 Seal Installer

1. New front crankshaft seal. Use J-22102 (figure 13). Lubricate the seal lips with engine oil.
 - Apply engine oil to the crankshaft stub.
2. Torsional damper. Tap into place with a mallet. Make sure the key is in place. Make sure the damper is all the way on the crankshaft.
3. Torsional damper bolt and washer.

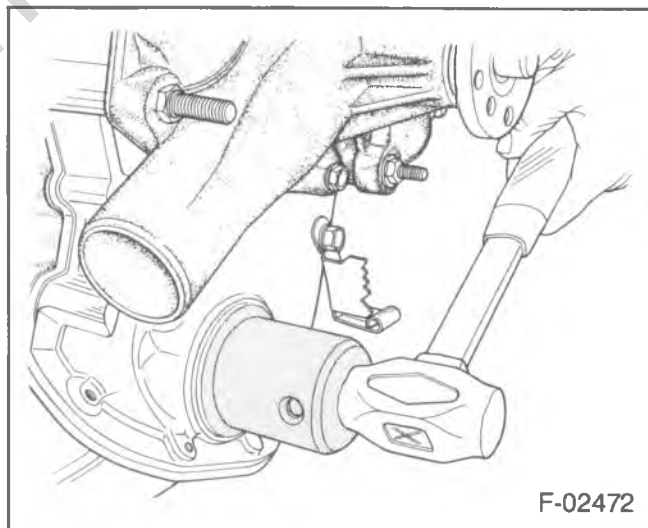

Figure 13—Installing the Front Crankshaft Seal

Tighten

- Bolt to 270 N·m (200 ft. lbs.).

4. Crankshaft pulley and bolts.

Tighten

- Bolts to 40 N·m (30 ft. lbs.).

- Lower the vehicle, if necessary.
5. Accessory drive belts. Tension as outlined in ENGINE COOLING (SEC. 6B).
6. Upper fan shroud (G models).
7. Battery cables.

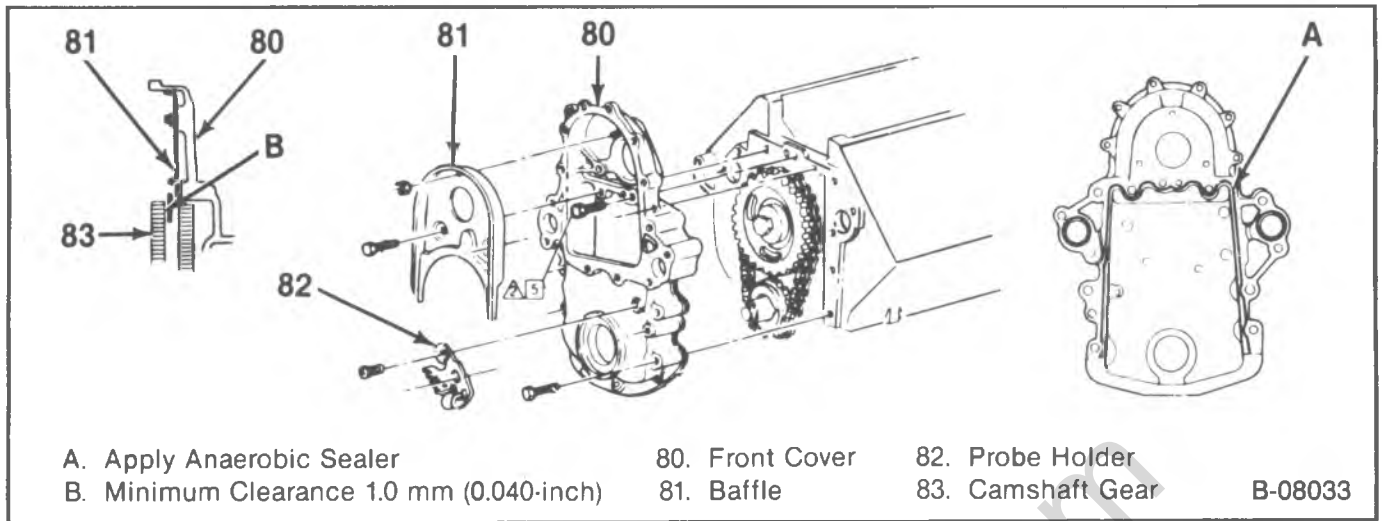

Figure 14—Front Cover and Components

FRONT COVER REPLACEMENT

↔ Remove or Disconnect (Figures 14 and 15)

- Drain the cooling system.
- 1. Water pump. Refer to ENGINE COOLING (SEC. 6B).
- Rotate the engine until the timing marks on the pump gear and camshaft gear are aligned (figure 15).
- Scribe a mark aligning the injection pump flange and front cover.
- 2. Torsional damper, as outlined previously.
- 3. Four front cover to oil pan bolts.
- 4. Two fuel return line clips.
- 5. Injection pump gear.
- 6. Injection pump retaining nuts at the front cover.
- 7. Baffle.
- 8. Front cover bolts.
- 9. Front cover.
- 10. Front crankshaft seal. Pry out with a screwdriver.

🧼 Clean

- RTV from oil pan sealing surface.
- Sealing surfaces on front cover.

👁 Inspect

- Front cover for cracks or damage to sealing surfaces.

↔ Install or Connect (Figures 14 and 15)

Tool Required:

J-22102 Seal Installer

1. New front crankshaft seal to the front cover. Use J-22102.
- Apply a 2 mm ($\frac{3}{32}$ -inch) bead of anaerobic sealant (GM part number 1052357 or equivalent) to the front cover sealing area shown in Figure 14.

Apply a 5 mm ($\frac{3}{16}$ -inch) bead of RTV sealant to the front cover sealing surface that mates against the oil pan.

2. Front cover to the engine. Install the attaching bolts.

🔩 Tighten

- Front cover to block bolts to 45 N·m (33 ft. lbs.).
- Oil pan to front cover bolts to 10.0 N·m (84 in. lbs.).

3. Baffle.

🔩 Tighten

- Baffle bolts and nut to 45 N·m (33 ft. lbs.).
 - Align the scribe marks on the front cover and injection pump. If a new front cover was installed, refer to "Marking TDC on the Front Housing" in DIESEL FUEL INJECTION (SEC. 6C2).
4. Injection pump nuts.

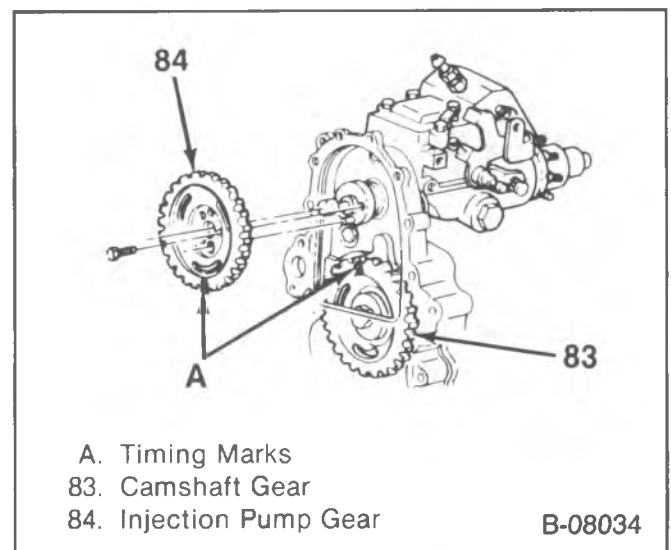
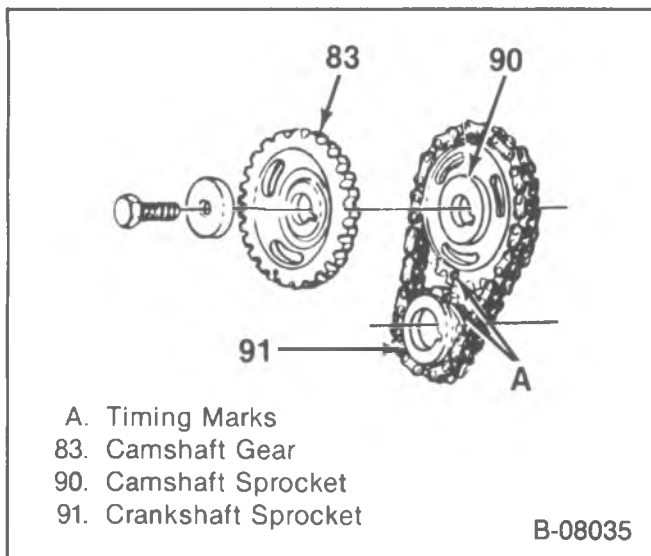

Figure 15—Injection Pump Gear and Timing Marks



- A. Timing Marks
- 83. Camshaft Gear
- 90. Camshaft Sprocket
- 91. Crankshaft Sprocket

B-08035

Figure 16—Timing Chain and Sprockets

 **Tighten**

- Nuts to 42 N·m (31 ft. lbs.).
5. Injection pump gear and bolts. Align the timing marks (figure 15).

 **Tighten**

- Injection pump gear bolts to 23 N·m (17 ft. lbs.).

 **Measure**

- Clearance between injection pump gear and baffle (figure 14). It is necessary to maintain a minimum of 1.0 mm (0.040-inch) between the gear and baffle, or noise may result.

6. Fuel return line bolts.
7. Torsional damper, as outlined previously.
8. Water pump. Refer to ENGINE COOLING (SEC. 6B).
- Fill the cooling system with the proper quantity and grade of coolant.

TIMING CHAIN AND SPROCKET REPLACEMENT

 **Remove or Disconnect (Figure 16)**

1. Front cover, as outlined previously.

 **Measure**

- Timing chain free play as follows:
 - Mount a dial indicator to the front of the block.
 - Position the dial indicator so that the plunger contacts the timing chain between the two gears.
 - Pull the chain outward (parallel to the front face of the block) the maximum amount with finger pressure on the inside of the chain.
 - Set the dial indicator to zero.

- Move the chain inward (parallel to the front face of the block) the maximum amount with finger pressure on the outside of the chain.
- The total indicator travel can be noted. With used parts, the deflection must not exceed 20.3 mm (0.800 inch). If the deflection exceeds this limit, the sprockets and timing chain must be inspected for wear and replaced as necessary. With new parts the maximum deflection must not exceed 12.7 mm (0.500 inch).

2. Injection pump gear.
3. Camshaft gear.
 - Align the timing marks (figure 16).
4. Camshaft sprocket with timing chain.
5. Crankshaft sprocket.

 **Install or Connect (Figures 14 and 16)**

1. Crankshaft sprocket.
2. Camshaft sprocket with timing chain.

 **Important**

- Align the timing marks (figure 16).
3. Camshaft gear, bolt, and washer.

 **Tighten**

- Bolt to 100 N·m (75 ft. lbs.).
4. Injection pump gear and bolts.

 **Important**

- Align the timing marks (figure 15).

 **Tighten**

- Bolts to 23 N·m (17 ft. lbs.).

5. Front cover, as outlined previously.

 **Adjust**

- Injection pump timing, if new gears, sprockets, or timing chain were installed. Refer to DIESEL FUEL INJECTION (SEC. 6C2).

CAMSHAFT REPLACEMENT

R AND V MODELS

 **Remove or Disconnect (Figure 17)**

1. Battery cables.
 - Drain the cooling system.
2. Radiator, shrouds, and fan. Refer to ENGINE COOLING (SEC. 6B).
3. Vacuum pump. Refer to VACUUM PUMP (SEC. 6H).
4. Power steering pump, generator, and air conditioning compressor and position aside.
5. Rocker arm covers, as outlined previously.
6. Rocker arm assemblies and pushrods, as outlined previously.

 **Important**

- Rocker arm assemblies and pushrods must be marked for proper assembly, as outlined previously.

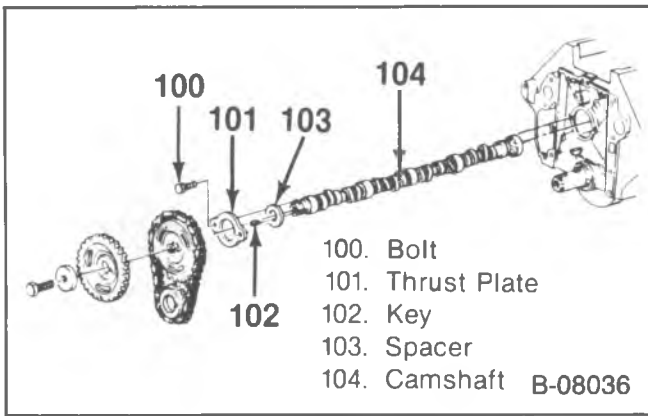

Figure 17—Camshaft and Components

7. Hydraulic lifters, as outlined previously. Place the lifters in an organizer rack. The lifters must be installed in the same bore from which they were removed.
8. Front cover, as outlined previously.
9. Timing chain and camshaft sprocket, as outlined previously.
10. Fuel pump (lift pump).
11. Front engine mounting through bolts.

NOTICE: When raising or supporting the engine for any reason, do not use a jack under the oil pan, any sheet metal or crankshaft pulley. Due to the small clearance between the oil pan and the oil pump screen, jacking against the oil pan may cause it to be bent against the pump screen, resulting in a damaged oil pickup unit.

- Raise the engine and block in position.
12. Air conditioning condenser mounting bolts (if equipped). Lift the condenser with the aid of an assistant.
 13. Bolts and thrust plate.
 14. Camshaft. Pull the camshaft from the block carefully to avoid damage to the camshaft bearings.
 15. Spacer (if necessary).

Cleaning, Inspection and Repair

Clean, inspect and repair or replace the camshaft and related components, as outlined in the proper unit repair manual.

The unit repair manual also describes camshaft bearing replacement.

Install or Connect (Figures 16, 17, 34 and 35).

- When a new camshaft is installed, replacement of all hydraulic lifters, engine oil, and oil filter is recommended.
1. Spacer, with the ID chamfer towards the camshaft.
 2. Camshaft.
 - Coat the camshaft lobes with "Molykote" or equivalent.
 - Lubricate the camshaft bearing journals with engine oil.
 - Insert the camshaft carefully into the block to avoid damage to the camshaft bearings.
 3. Thrust plate and bolts.

Tighten

- Bolts to 23 N·m (17 ft. lbs.).
- Lower the engine.

NOTICE: See "Notice" on page 6A6-1 of this section.

4. Engine mounting through bolts and nuts.

Tighten

- Fasteners to specifications. Refer to figures 34 and 35.
5. Timing chain and sprockets, as outlined previously.

Important

- Align the timing marks (figure 16).
6. Air conditioning condenser (if equipped).
 7. Fuel pump (lift pump).
 8. Front cover, as outlined previously.
 9. Hydraulic lifters, as outlined previously. Used lifters must be installed in the same bore from which they were removed.
 10. Rocker arm assemblies and pushrods, in their original locations, as outlined previously. Hardened ends of the pushrods must face up.
 11. Rocker arm covers, as outlined previously.
 12. Power steering pump, generator, and air conditioning compressor, as equipped.
 13. Vacuum pump. Refer to VACUUM PUMP (SEC. 6H).
 14. Fan, radiator, and radiator shrouds. Refer to ENGINE COOLING (SEC. 6B).
 15. Battery cables.
 - Fill the cooling system with the proper quantity and grade of coolant.

G MODELS

Remove or Disconnect (Figure 17)

1. Battery cables.
2. Headlight bezels.
3. Grille, bumper, and lower valence panel.
4. Hood latch.
5. Coolant recovery bottle.
6. Upper tie bar.
7. Air conditioning compressor. Refer to AIR CONDITIONING (SEC. 1B).
 - Drain the cooling system.
8. Radiator and fan. Refer to ENGINE COOLING (SEC. 6B).
9. Oil pump drive, as outlined previously.
10. Cylinder heads, as outlined previously.
11. Generator lower bracket.
12. Water pump. Refer to ENGINE COOLING (SEC. 6B).
13. Torsional damper, as outlined previously.
14. Front cover, as outlined previously.
15. Fuel pump (lift pump).
16. Rocker arm covers, as outlined previously.
17. Rocker arm assemblies and pushrods, as outlined previously.

Important

- Rocker arm assemblies and pushrods must be marked for proper assembly, as outlined previously.
18. Hydraulic lifters, as outlined previously. Place the lifters in an organizer rack. The lifters must be installed in the same bore from which they were removed.
 19. Timing chain and camshaft sprocket, as outlined previously.
 20. Bolts and thrust plate.
 21. Camshaft. Pull the camshaft from the block carefully to avoid damage to the camshaft bearings.
 22. Spacer, if necessary.

Cleaning, Inspection and Repair

Clean, inspect and repair or replace the camshaft and related components, as outlined in the proper unit repair manual.

The unit repair manual also describes camshaft bearing replacement.

Install or Connect (Figures 16 and 17).

- When a new camshaft is installed, replacement of all hydraulic lifters, engine oil, and oil filter is recommended.
1. Spacer, with the ID chamfer towards the camshaft.
 2. Camshaft.
 - Coat the camshaft lobes with "Molykote" or equivalent.
 - Lubricate the camshaft bearing journals with engine oil.
 - Insert the camshaft carefully into the block to avoid damage to the camshaft bearings.
 3. Thrust plate and bolts.

Tighten

- Bolts to 23 N·m (17 ft. lbs.).
4. Timing chain and camshaft sprocket, as outlined previously.
 - Align the timing marks (figure 16).
 5. Hydraulic lifters, as outlined previously. Used lifters must be installed in the same bore from which they were removed.
 6. Rocker arm assemblies and pushrods, in their original locations, as outlined previously. Hardened ends of the pushrods must face up.
 7. Rocker arm covers, as outlined previously.
 8. Fuel pump (lift pump).
 9. Front cover, as outlined previously.
 10. Torsional damper, as outlined previously.
 11. Water pump. Refer to ENGINE COOLING (SEC. 6B).
 12. Generator lower bracket.
 13. Cylinder heads, as outlined previously.
 14. Oil pump drive, as outlined previously.
 15. Radiator and fan. Refer to ENGINE COOLING (SEC. 6B).
 16. Air conditioning compressor. Refer to AIR CONDITIONING (SEC. 1B).
 17. Upper tie bar.
 18. Coolant recovery bottle.
 19. Hood latch.

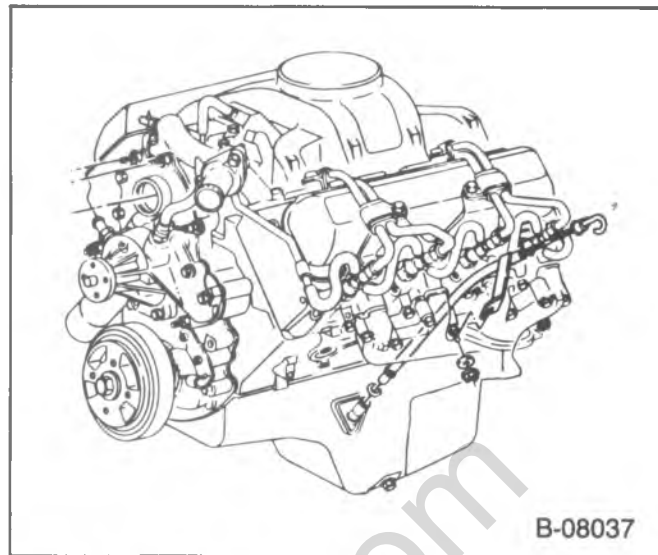

Figure 18—Oil Dipstick Tube (R and V Models)

20. Grille, bumper, and lower valence panel.
21. Headlight bezels.
22. Battery cables.
 - Fill the cooling system with the proper quantity and grade of coolant.
 - Evacuate and charge the air conditioning system (if equipped). Refer to AIR CONDITIONING (SEC. 1B).

DIPSTICK TUBE REPLACEMENT

R AND V MODELS

Remove or Disconnect (Figure 18)

1. Battery cables.
2. Dipstick tube bracket, nut and washer, at the exhaust manifold.
3. Dipstick tube.
4. O-ring from the dipstick tube.

Install or Connect (Figure 18)

1. New o-ring to the dipstick tube.
2. Dipstick tube to the engine.
3. Dipstick tube bracket nut and washer.
4. Battery cables.

G MODELS

Remove or Disconnect (Figure 19)

1. Battery cables.
2. Engine cover.
3. Air cleaner.
4. Dipstick tube bracket, at the thermostat housing.
5. Dipstick tube bracket, at the rocker arm cover bracket.
 - Raise the vehicle. Support with suitable safety stands.
6. Left exhaust manifold, as outlined previously.
7. Dipstick tube from the oil pan.
 - Lower the vehicle.
8. Dipstick tube from the vehicle.
9. O-ring.

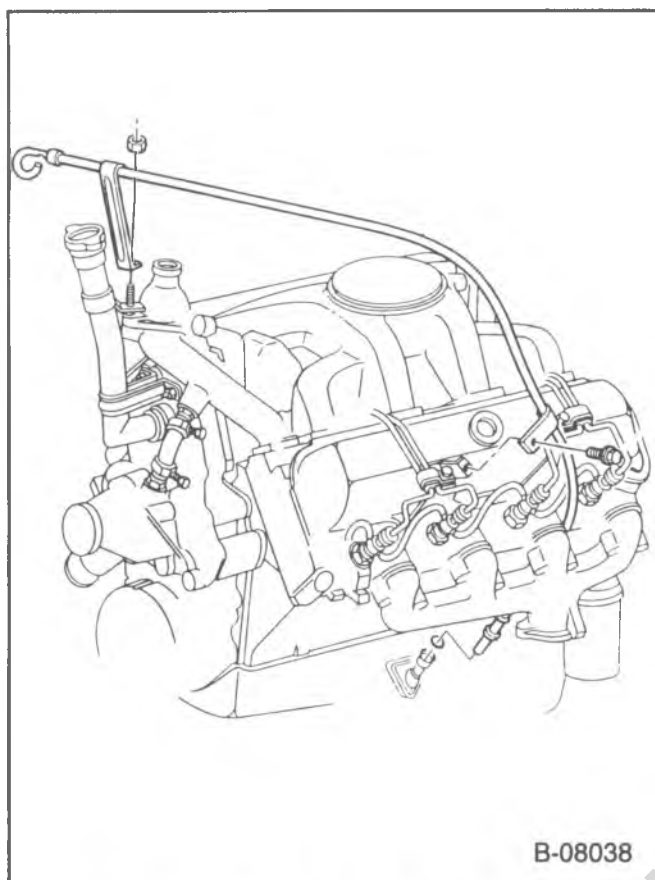

B-08038

Figure 19—Oil Dipstick (G Models)

Install or Connect (Figure 19)

1. New O-ring to the dipstick tube.
2. Dipstick tube to the vehicle.
 - Raise the vehicle. Support with suitable stands.
3. Dipstick tube to the oil pan.
4. Left exhaust manifold, as outlined previously.
 - Lower the vehicle.
5. Dipstick tube bracket at the rocker arm cover.
6. Dipstick tube bracket at the thermostat housing.
7. Air cleaner.
8. Engine cover.
9. Battery cables.

OIL PAN REPLACEMENT (R AND V MODELS)

Remove or Disconnect

1. Battery cables.
 - Raise the vehicle. Support with suitable safety stands.
 - Drain the engine oil.
2. Flywheel cover.
3. Left front engine mounting through-bolt.

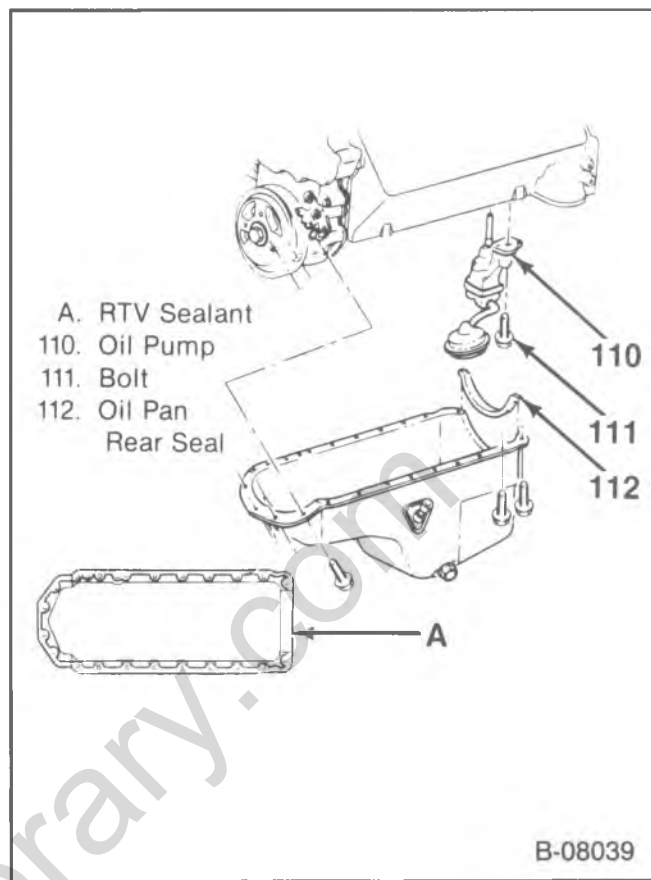

B-08039

Figure 20—Oil Pan and Oil Pump

NOTICE: When raising or supporting the engine for any reason, do not use a jack under the oil pan, any sheet metal or crankshaft pulley. Due to the small clearance between the oil pan and the oil pump screen, jacking against the oil pan may cause it to be bent against the pump screen, resulting in a damaged oil pickup unit.

- Raise the engine.
- 4. Oil pan bolts.
- 5. Oil pan.
- 6. Oil pan rear seal.



Clean

1. Old RTV from the oil pan and block.
2. All oil and grease from the gasket surfaces.



Install or Connect (Figures 20, 34, and 35)

- Apply a 5 mm (³/₁₆-inch) bead of RTV sealant (GM part number 1052915 or equivalent) to the oil pan sealing surface, inboard of the bolt holes (figure 20). The sealer must be wet to the touch when the oil pan is installed.
- 1. Oil pan rear seal.
- 2. Oil pan to the engine. Be sure to connect the oil dipstick.
- 3. Oil pan bolts.



Tighten

- All except rear two bolts to 10.0 N·m (84 in. lbs.).
- Rear two bolts to 23 N·m (17 ft. lbs.).

- Lower the engine.

NOTICE: See "Notice" on page 6A6-1 of this section.

4. Engine mounting through-bolt and nut.

Tighten

- Fasteners to specifications. Refer to figures 34 and 35.
5. Flywheel cover.
 - Lower the vehicle.
 6. Proper quantity and grade of engine oil.
 7. Battery cables.

OIL PUMP REPLACEMENT (R AND V MODELS)

Remove or Disconnect (Figure 20)

1. Oil pan, as outlined previously.
2. Oil pump to main bearing cap bolt.
3. Oil pump and extension shaft.

Inspect

- Oil pump pick up tube and screen for damage.
- Oil pump extension shaft bushing for cracks.

Oil Pump Repair

- Refer to the proper unit repair manual.

Install or Connect (Figure 20)

1. Oil pump and extension shaft to the engine. Align the extension shaft hex with the drive hex on the oil pump drive or vacuum pump. The oil pump should push easily into place.
2. Oil pump bolt.

Tighten

- Oil pump bolt to 90 N·m (65 ft. lbs.).
3. Oil pan, as outlined previously.

OIL PAN AND OIL PUMP REPLACEMENT (G MODELS)

Remove or Disconnect

1. Battery cables.
2. Engine cover.
3. Engine oil dipstick.
4. Engine oil dipstick tube at the rocker arm cover.
 - Raise the vehicle. Support with suitable safety stands.
5. Transmission. Refer to TRANSMISSION (SEC. 7).
 - Drain the engine oil.
6. Engine oil cooler lines at the block.
7. Starter.
8. Oil pan bolts.
9. Oil pan and oil pump.

- Lower the oil pan from the engine.
- Rotate the crankshaft so that the forward crankshaft throw and numbers 1 and 2 connecting rod journals are up.
- Oil pump to main bearing cap bolt.

- Let the oil pump and extension shaft fall into the oil pan.
- Remove the oil pan and oil pan rear seal.

Clean

1. Old RTV from the oil pan and block.
2. All oil and grease from the gasket surfaces.

Inspect

- Oil pump pick up tube and screen for damage.
- Oil pump extension shaft bushing for cracks.

Oil Pump Repair

- Refer to the proper unit repair manual.

Install or Connect (Figure 20)

- Apply a 5 mm ($\frac{3}{16}$ -inch) bead of RTV sealant (GM part number 1052915 or equivalent) to the oil pan sealing surface, inboard of the bolt holes (figure 18). The sealer must be wet to the touch when the oil pan is installed.

1. Oil pan rear seal to the oil pan.
2. Oil pan and oil pump to the engine.
 - Lay the oil pump and extension shaft in the oil pan.
 - Hold the oil pan and position the oil pump to the main bearing cap.
 - Align the extension shaft hex with the drive hex on the oil pump drive or vacuum pump. The oil pump should push easily into place. Install the oil pump bolt and tighten.
 - Position the oil pan against the engine. Be sure to connect the dipstick tube.

3. Oil pan bolts.

Tighten

- All except rear two oil pan bolts to 10.0 N·m (84 in. lbs.).
- Rear two oil pan bolts to 23 N·m (17 ft. lbs.).

4. Starter.
5. Engine oil cooler lines.
6. Transmission. Refer to TRANSMISSION (SEC. 7).
 - Lower the vehicle.
7. Engine oil dipstick tube at the rocker arm cover.
8. Engine oil dipstick.
9. Engine cover.
10. Proper quantity and grade of engine oil.
11. Battery cables.

REAR CRANKSHAFT OIL SEAL REPLACEMENT

The production rear crankshaft oil seal is a "rope" type seal. The rope seal can be replaced with a two piece type seal, if desired. Repair procedures for both types of seal follow.

The CDR and crankcase ventilation system should be thoroughly inspected and crankcase pressure should be checked before a new seal is installed. Refer to DRIVEABILITY AND EMISSIONS—DIESEL (SEC. 6E9).

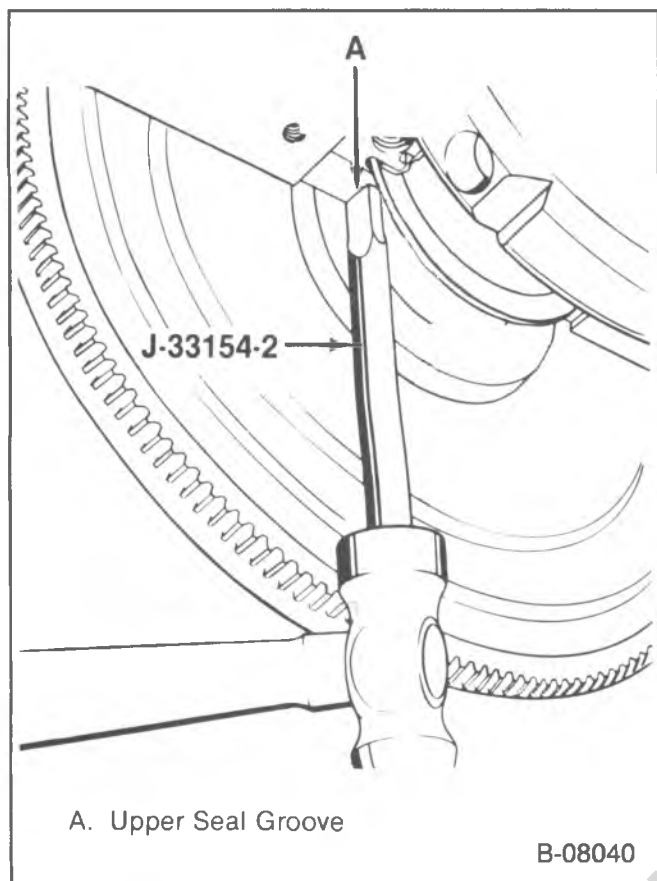

Figure 21—Packing the Upper Rear Crankshaft Rope Seal

ROPE TYPE SEAL

↔ Remove or Disconnect

1. Oil pan and oil pump, as outlined previously.
2. Rear main bearing cap.
3. Old rope seal from the main bearing cap. Do not discard.

🧼 Clean

- Main bearing cap and block mating surfaces.
- Rope seal groove in the main bearing cap.

→ Install or Connect (Figures 21 through 24)

Tools Required:

- J-33154 Rear Oil Seal Packer
- J-33153 Rear Oil Seal Installer

1. Rope seal pieces to the upper seal groove.
 - Use J-33154-2 and gently drive the upper seal into the groove about 6 mm (1/4-inch). Do this on both sides. Refer to figure 21.
 - Measure the amount the seal was driven up on one side. Add 1.5 mm (1/16-inch). Cut this length from the old seal removed from the main bearing cap. Use the main bearing cap as a holding fixture when cutting the seal (figure 22). Use a sharp tool. Repeat this procedure for the other side.
 - Install J-33154-1 onto the cylinder block (figure 23).

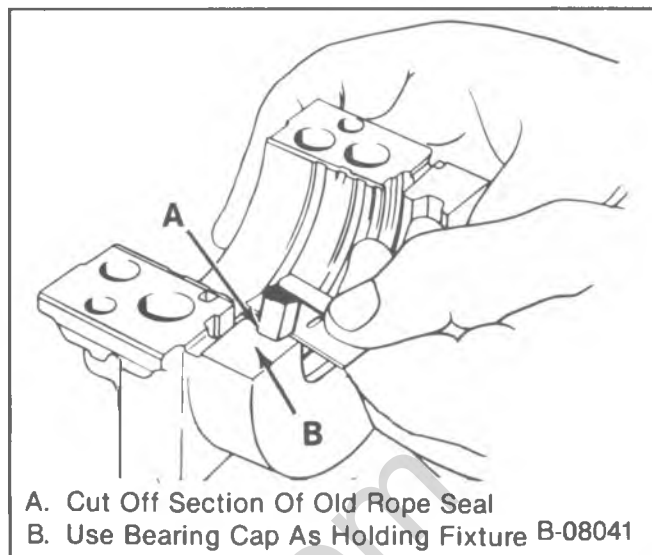

Figure 22—Cutting the Rope Seal

- Use J-33154-2 to work the short pieces of seal cut previously onto the guide tool and into the seal groove in the block (figure 23). It may help to use engine oil on the seal pieces. The tools have been machined to provide a built-in stop. Use this procedure for both sides.
- 2. New rope seal to the main bearing cap.
 - Apply adhesive (GM part number 1052621 [Loctite 414] or equivalent) to the seal groove.
 - Position the rope seal on the bearing cap.
 - Use J-33153 to install the seal (figure 24).
 - After correctly positioning the seal, rotate J-33153 slightly and cut the seal ends flush with the bearing cap surface. Use a sharp tool (figure 24).

📏 Measure

- Rear main bearing clearance, using plastic gaging material. Refer to the proper unit repair manual. If the clearance is out of specification,

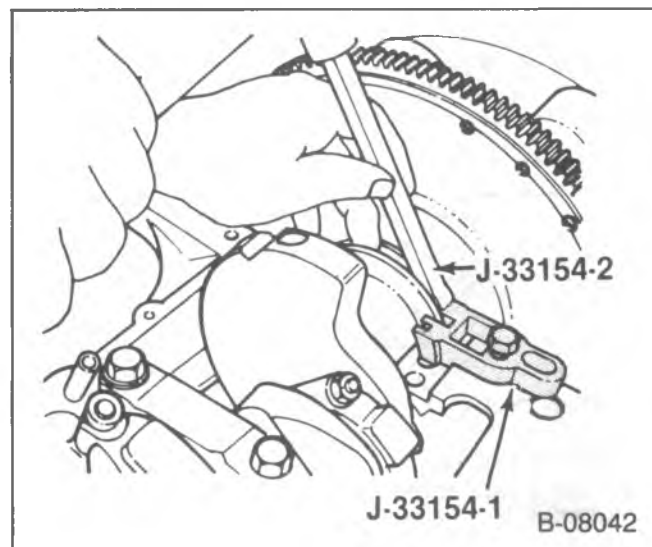

Figure 23—Installing the Rope Seal Pieces Rear Main Bearing Cap

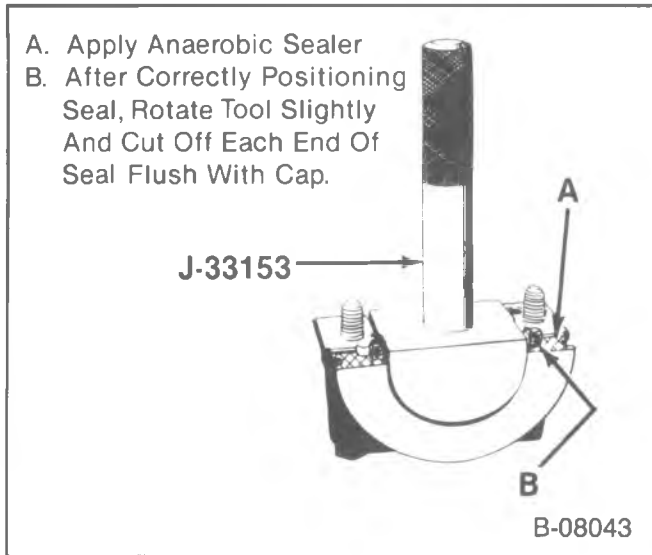

Figure 24—Installing the Lower Rope Seal Piece

check the ends of the seal for fraying that may prevent the main bearing cap from seating. Correct as necessary. Remove the gaging material from the bearing and journal.

NOTICE: The main bearing caps are to be tapped into place with a brass or leather mallet before the attaching bolts are installed. Do not use the attaching bolts to pull the main bearing caps into their seats, as this may damage the bearing cap and/or block.

3. Main bearing cap to the block.
 - Apply a thin film of anaerobic sealant (GM part number 1052756 or equivalent) to the bearing cap as shown in figure 25. Keep the sealant off the seal and bearing. Do not put sealant in the bearing cap oil relief slot.
 - Apply a light coat of engine oil to the crankshaft surface that will contact the seal.
 - Apply engine oil to the main bearing cap bolt threads.
 - Tap the main bearing cap into place with a brass or leather mallet. Then install the bolts.

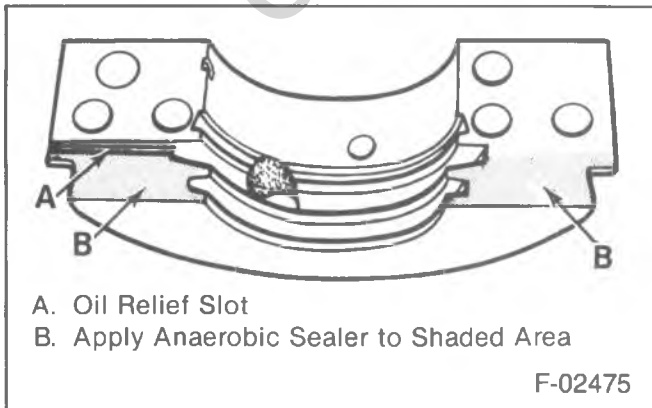

Figure 25—Applying Sealer to the Rear Main Bearing Cap

 **Tighten**

Bolts to specifications, in the following sequence:

- Inner bolts: 150 N·m (110 ft. lbs.).
- Outer bolts: 135 N·m (100 ft. lbs.).
- Re-tighten all bolts in the same sequence.

4. Oil pump and oil pan, as outlined previously.

TWO PIECE TYPE SEAL

 **Remove or Disconnect**

1. Oil pan and oil pump, as outlined previously.
2. Rear main bearing cap.
3. Upper and lower rope seal.

 **Clean**

- Upper and lower seal grooves and bearing cap slot with a chlorinated solvent, such as carburetor spray cleaner.
- Main bearing cap and block mating surfaces.

 **Measure**

- Rear main bearing clearance, using plastic gage material. Refer to the proper unit repair manual. If the clearance is outside specifications, correct as necessary.

 **Install or Connect (Figures 25 and 26)**

1. Seal halves to the block (figure 26).
 - Apply a light coat of engine oil to the seal lips where they contact the crankshaft.
 - “Roll” one seal half into the block seal groove until 13 mm (1/2-inch) of the seal’s one end is extending out of the block.
 - Insert the other seal half into the opposite side of the seal groove in the block.

 **Important**

- The contact ends of the seal halves should now be at the four and ten o'clock positions, or at the eight and two o'clock positions. This is necessary to align the rear main bearing cap and seal lips.

NOTICE: To prevent damage to the main bearing caps, the caps are to be tapped into the block using a brass or leather hammer. The new seal is used as a guide. The cap must NOT be pulled into the block with the bolts.

2. Main bearing cap to the block.
 - Lightly coat the seal groove in the main bearing cap with adhesive (GM part number 1052621 [Loctite 414] or equivalent).
 - Apply a thin film of anaerobic sealant (GM part number 1052756 or equivalent) to the main bearing cap as shown in figure 25. Do not put sealant in the oil relief slot.
 - Apply engine oil to the main bearing cap bolt threads.
 - Tap the main bearing cap into place with a brass or leather mallet. Then install the bolts.

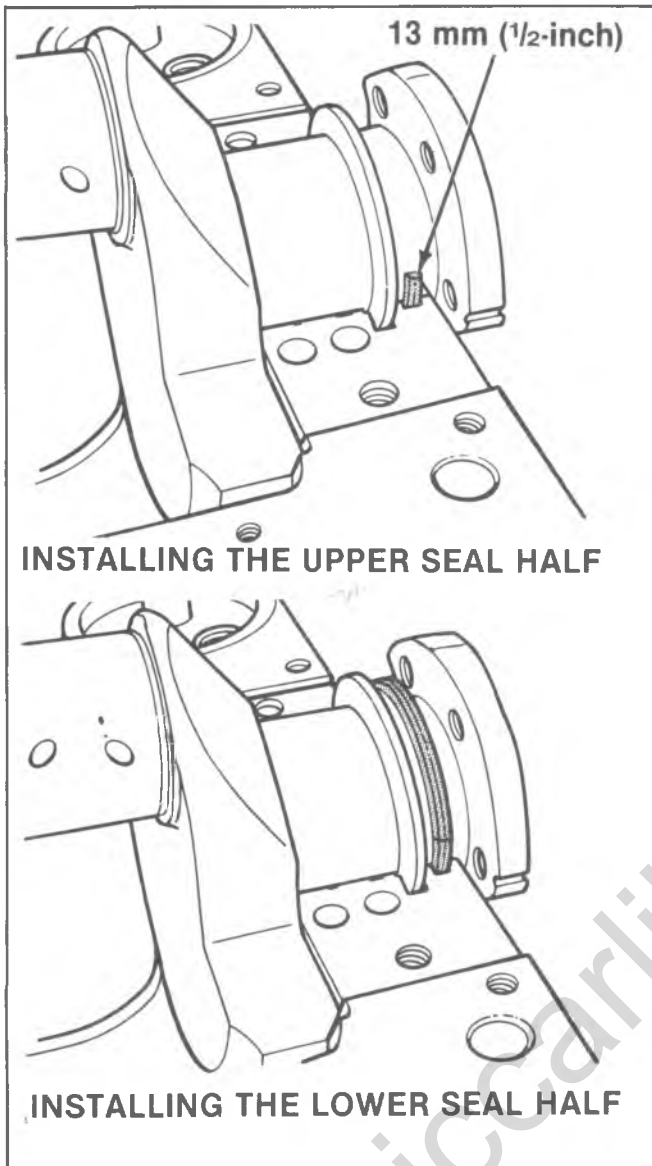

Figure 26—Installing the Two Piece Rear Crankshaft Seal



Tighten

- Main bearing cap bolts to specifications, in the following sequence:
 - Inner bolts: 150 N·m (110 ft. lbs.).
 - Outer bolts: 135 N·m (100 ft. lbs.).
 - Re-tighten all bolts using the same sequence.

3. Oil pump and oil pan, as outlined previously.

CONNECTING ROD AND PISTON REPLACEMENT



Remove or Disconnect (Figure 27)

1. Cylinder head, as outlined previously.
2. Oil pan, as outlined previously.
3. Oil pump, as outlined previously.
4. Ridge or deposits from the upper end of the cylinder bores.
 - Turn the crankshaft until the piston is at BDC.

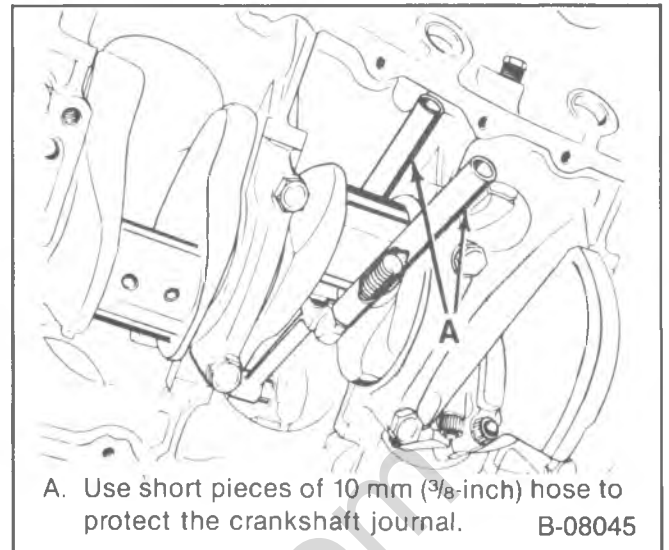

A. Use short pieces of 10 mm (3/8-inch) hose to protect the crankshaft journal. B-08045

Figure 27—Replacing the Connecting Rod and Piston

- Place a cloth on top of the piston.
 - Perform the cutting operation with a ridge reamer.
 - Turn the crankshaft until the piston is at TDC.
 - Remove the cloth and cuttings.
5. Connecting rod cap. Check the connecting rod and cap for identification marks. Mark the parts if required. The connecting rod and cap must be kept together as mating parts.
 6. Connecting rod and piston.
 - Attach two short pieces of 10 mm (3/8-inch) hose to the connecting rod bolts (figure 27). This will protect the crankshaft journal during removal.
 - Push the connecting rod and piston out of the bore.
 7. Connecting rod bearings. Place the bearings in a rack if they are to be reused, so they can be returned to their original locations.

Cleaning, Inspection and Repair

Clean, inspect and repair or replace the components as necessary. Measure connecting rod bearing clearance, piston clearance, ring clearances, etc. Refer to the proper unit repair manual.

The unit repair manual contains information on:

- Connecting rod and piston.
- Piston rings.
- Connecting rod and crankpin.
- Cylinder bores.



Install or Connect (Figures 27 through 30)

Tool Required:

J-8037 Ring Compressor

- Make sure the cylinder walls are clean. Lubricate the cylinder wall lightly with engine oil.
 - Make sure the piston is installed in the matching cylinder. Install new pistons in the cylinders for which they were fitted. Install used pistons in the cylinder from which they were removed.
1. Connecting rod bearings.

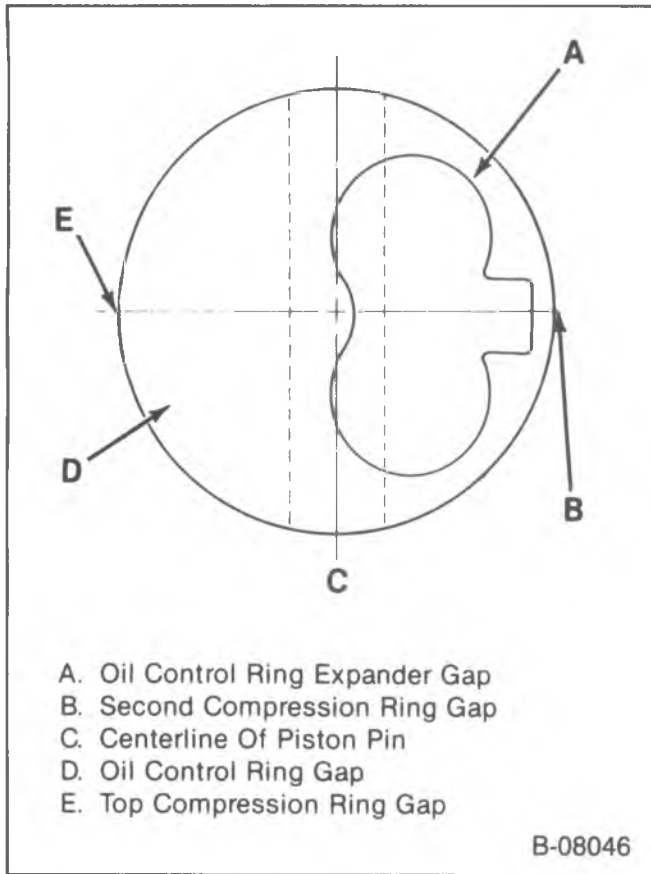

Figure 28—Ring Gap Location

- Be certain that the bearings are the proper size.
 - Install the bearings in the connecting rod and connecting rod cap.
 - Lubricate the bearings with engine oil.
2. Piston and connecting rod to the proper bore.
- With the connecting rod cap removed, install two short pieces of 10 mm (3/8-inch) hose onto the connecting rod studs.
 - Locate the piston ring end gaps as shown in figure 28. Lubricate the piston and rings with engine oil.
 - Without disturbing the ring end gap location, install J-8037 over the piston (figure 29).
 - The piston must be installed so that the depression in the piston crown is towards the outside of the engine. The connecting rod bearing tang slots must be opposite the camshaft.
 - Place the piston in its matching bore. Using light blows with a hammer handle, tap the piston down into its bore (figure 29). At the same time, from beneath the vehicle guide the connecting rod to the crankpin with the pieces of hose (figure 27). Hold the ring compressor against the block until all rings have entered the cylinder bore.
 - Remove the hoses from the connecting rod bolts.

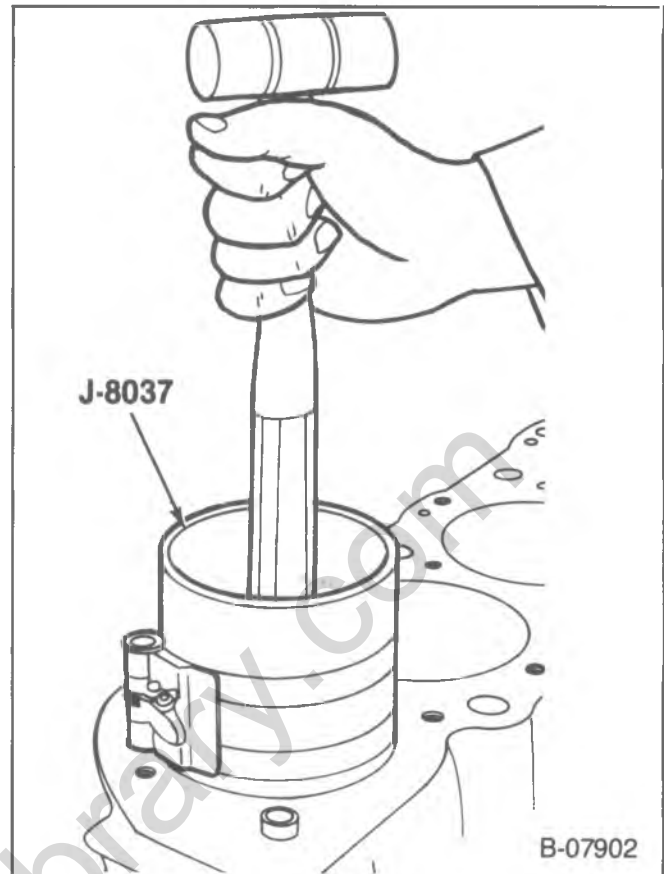

Figure 29—Installing the Piston and Connecting Rod



Measure

- Connecting rod bearing clearance. Refer to the proper unit repair manual.
3. Connecting rod cap and bearing.
 4. Connecting rod cap nuts.



Tighten

- Connecting rod cap nuts to 65 N·m (48 ft. lbs.).



Measure

- Connecting rod side clearance. Use a feeler gage between the connecting rod and crankshaft (figure 30). The correct clearance is 0.17–0.63 mm.
5. Oil pump (if removed), as outlined previously.
 6. Oil pan and cylinder head, as outlined previously.

MAIN BEARING REPLACEMENT



Remove or Disconnect (Figure 31)

Tool Required:

J-8080 Main Bearing Remover/Installer

1. Glow plugs.
2. Oil pan, as outlined previously.
3. Oil pump, as outlined previously.
4. Main bearing caps.

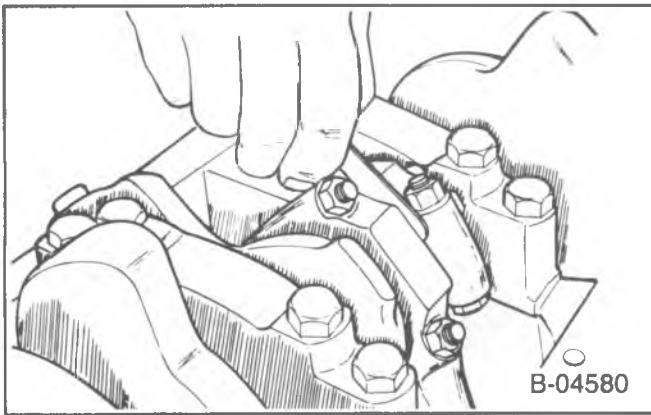

Figure 30—Checking Connecting Rod Side Clearance

- Check the main bearing caps for location markings. Mark the caps if necessary. The caps must be returned to their original locations during assembly.
5. Lower main bearing inserts from the main bearing caps.
 6. Rear crankshaft oil seal, if necessary, as outlined previously.
 7. Upper main bearing inserts.
 - Insert J-8080 into the crankshaft oil hole (figure 31).
 - Rotate the crankshaft to “turn” the bearing insert out of the block.

Cleaning, Inspection and Repair

Clean, inspect and repair or replace the components as required. Refer to the proper unit repair manual. The unit repair manual contains information on

- Crankshaft.
- Main and connecting rod bearings.

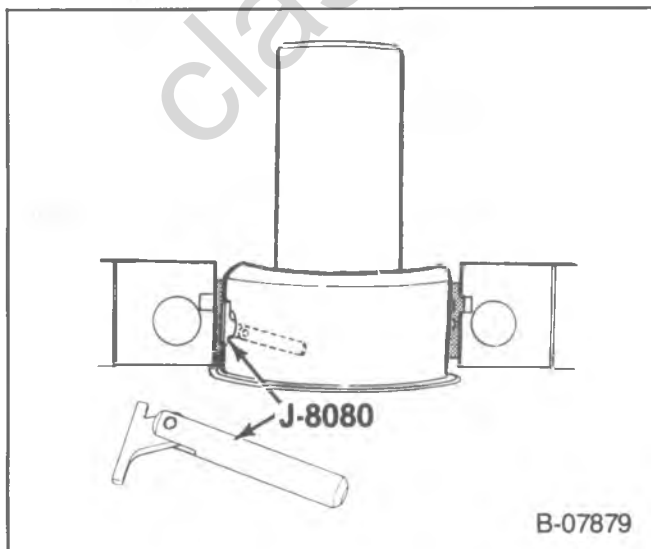

Figure 31—Removing the Main Bearings

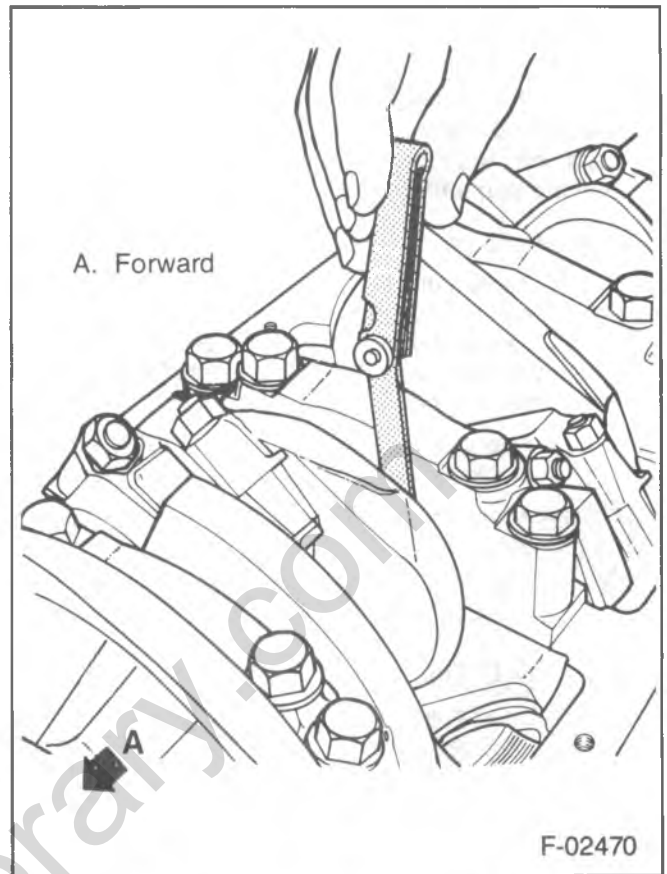

Figure 32—Measuring Crankshaft End Play

Install or Connect (Figures 26, 31 and 32)

Tool Required:

J-8080 Main Bearing Remover/Installer

1. Upper main bearing inserts.
 - Insert tool J-8080 into a crankshaft main bearing oil hole (figure 31).
 - Apply engine oil to inserts of the proper size.
 - Insert the plain end (without the bearing tang) of the insert between the crankshaft and the notched side of the block.
 - Rotate the crankshaft to “roll” the insert into the block.
 - Remove the tool.
 2. Lower main bearing inserts to the main bearing caps.
 - Make sure the inserts are of the proper size.
 - Apply engine oil to the inserts.
- Measure**
- Main bearing clearance. Refer to the proper unit repair manual. If the engine is in the vehicle, the crankshaft must be supported upward to remove any clearance from the upper bearing. The total clearance can then be measured between the lower bearing and journal.
3. Rear crankshaft oil seal (if necessary) as outlined previously.

NOTICE: The main bearing caps are to be tapped into place with a brass or leather mallet before the attaching bolts are installed. Do not use the attaching bolts to pull the main bearing caps into their seats, as this may damage the bearing cap and/or block.

4. Number 5 (rear) main bearing cap.

- Apply a thin film of anaerobic sealant (GM part number 1052756 or equivalent) to the bearing cap as shown in figure 25. Keep the sealant off the seal and bearing. Do not put sealant in the bearing cap oil relief slot.
- Apply a light coat of engine oil to the crankshaft surface that will contact the seal.
- Apply engine oil to the main bearing cap bolt threads.
- Tap the main bearing cap into place with a brass or leather mallet. Then install the bolts.

 **Tighten**

- Bolts to specifications, in the following sequence:
 - Inner bolts: 150 N·m (110 ft. lbs.).
 - Outer bolts: 135 N·m (100 ft. lbs.).
 - Re-tighten all bolts in the same sequence.

5. Numbers 1, 2, and 4 main bearing caps and bolts.

 **Tighten**

- Bolts to specifications. Refer to step 4.

6. Number 3 (center) main bearing cap and bolts. Tighten the bolts temporarily to 14 N·m (10 ft. lbs.).

 **Measure**

- Crankshaft end play, as follows:
 - Tap the end of the crankshaft first rearward then forward with a lead hammer. This will line up the rear main bearing and crankshaft thrust surfaces.
 - Tighten the rear main bearing cap bolts to specifications. Refer to step 4.
 - With the crankshaft forced forward, measure at the front end of the number 3 main bearing with a feeler gage (figure 32). The proper clearance is 0.10–0.25 mm.

7. Oil pump, as outlined previously.

8. Oil pan, as outlined previously.

9. Glow plugs.

CRANKSHAFT REPLACEMENT

1. Remove the engine, as outlined later.
2. Refer to the proper unit repair manual for crankshaft replacement procedures.

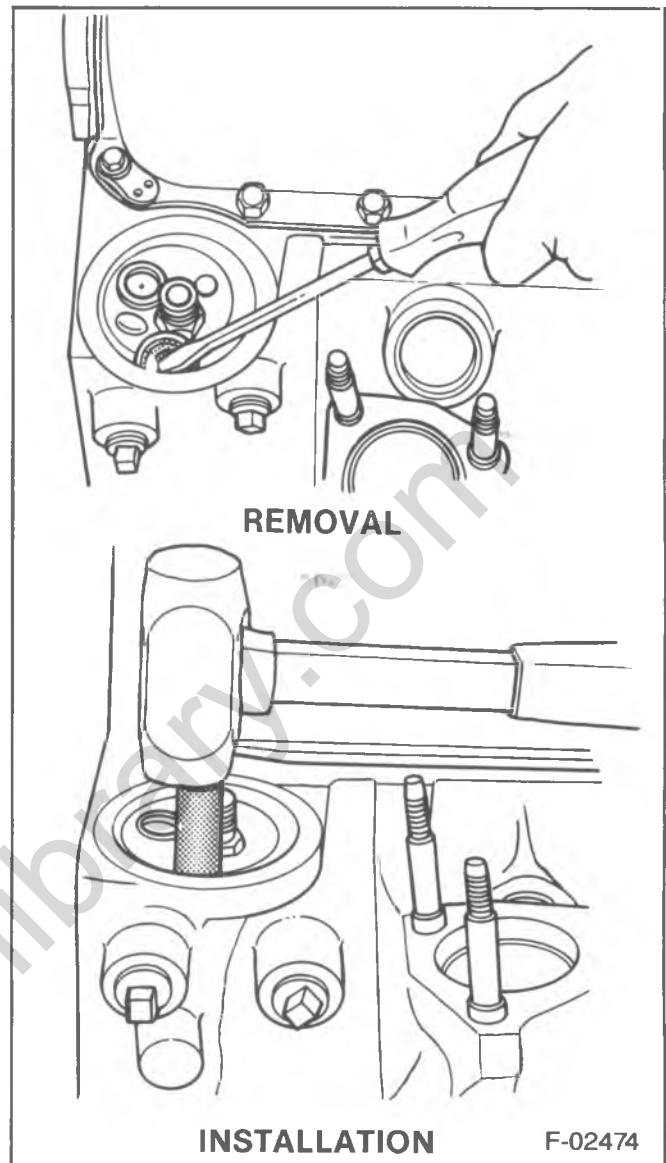

Figure 33—Replacing the Oil Filter Bypass Valve

OIL FILTER BYPASS VALVE REPLACEMENT

 **Remove or Disconnect (Figure 33)**

1. Oil filter.
2. Oil filter bypass valve. Pry out with a screwdriver.

 **Clean**

- Recess in the block.

 **Install or Connect (Figure 33)**

1. Oil filter bypass valve. Tap into place, using a 16 mm socket.
2. Oil filter.
3. Engine oil, as required.

ENGINE MOUNTINGS

NOTICE: Broken or deteriorated mountings can cause misaligned and eventual destruction of certain drive train components. When a single mounting breakage occurs, the remaining mountings are subjected to abnormally high stresses.

INSPECTING ENGINE MOUNTINGS

Front Engine Mountings

NOTICE: When raising or supporting the engine for any reason, do not use a jack under the oil pan, any sheet metal or crankshaft pulley. Due to the small clearance between the oil pan and the oil pump screen, jacking against the oil pan may cause it to be bent against the pump screen, resulting in a damaged oil pickup unit.

1. Raise the engine to remove weight from the mountings and to place a slight tension on the rubber cushion. Observe both mountings while raising the engine.
2. Replace the mounting if the following conditions exist:
 - Hard rubber surface covered with heat check cracks.
 - Rubber cushion separated from the metal plate of the mounting.
 - Rubber cushion split through the center.
3. If there is movement between a metal plate of the mounting and its attaching points, lower the engine and tighten the bolts or nuts attaching the mounting to the engine, frame, or bracket.

Rear Mountings

1. Push up and pull down on the transmission tailshaft. Observe the transmission mounting.
2. Replace the mounting if the following conditions exist:
 - Rubber cushion separated from the metal plate of the mounting.
 - Mounting bottomed out (tailshaft can be moved up but not down).
3. If there is relative movement between a metal plate of the mounting and its attaching point, tighten the bolts or nuts attaching the mounting to the transmission or crossmember.

FRONT MOUNTING REPLACEMENT

↔ Remove or Disconnect (Figures 34 through 37)

NOTICE: When raising or supporting the engine for any reason, do not use a jack under the oil pan, any sheet metal or crankshaft pulley. Due to the small clearance between the oil pan and the oil pump screen, jacking against the oil pan may cause it to be bent against the pump screen, resulting in a damaged oil pickup unit.

- Support the engine with a suitable jack. Do not load the engine mounting.
1. Engine mounting through-bolt and nut.

- Raise the engine only enough to permit removal of the engine mounting.
2. Mounting assembly bolts, nuts, and washers.
 3. Mounting assembly.

↔ Install or Connect (Figures 34 through 37)

1. Engine mounting assembly to the vehicle.
 - On V, G, and P models, the through-bolt must be inserted from the rear of the right side mounting before the mounting is installed in the vehicle.

NOTICE: See "Notice" on page 6A6-1 of this section.

2. Mounting assembly bolts, nuts, and washers.

⌚ Tighten

- Fasteners to specifications. Refer to figures 34 through 37.
- On V, G, and P models (right side), make sure there is 25 mm (1 inch) clearance between the through bolt head and mounting assembly.
- Lower the engine until the through bolts can be inserted.

NOTICE: See "Notice" on page 6A6-1 of this section.

3. Through bolts and nuts.

⌚ Tighten

- Fasteners to specifications. Refer to figures 34 through 37.

REAR MOUNTING REPLACEMENT (EXCEPT P MODEL FLYWHEEL HOUSING MOUNTING)

↔ Remove or Disconnect (Figures 38 through 41)

NOTICE: When raising or supporting the engine for any reason, do not use a jack under the oil pan, any sheet metal or crankshaft pulley. Due to the small clearance between the oil pan and the oil pump screen, resulting in a damaged oil pickup unit.

- Support the rear of the engine to relieve the weight on the rear mountings.
1. Mounting to crossmember nut(s) and washer(s).
 2. Mounting to transmission bolts and washers.
 - Raise the rear of the engine only enough to permit removal of the mounting.
 3. Mounting.

↔ Install or Connect (Figures 38 through 41)

1. Mounting.
 - Lower the rear of the engine.
2. Mounting to transmission bolts and washers.

NOTICE: See "Notice" on page 6A6-1 of this section.

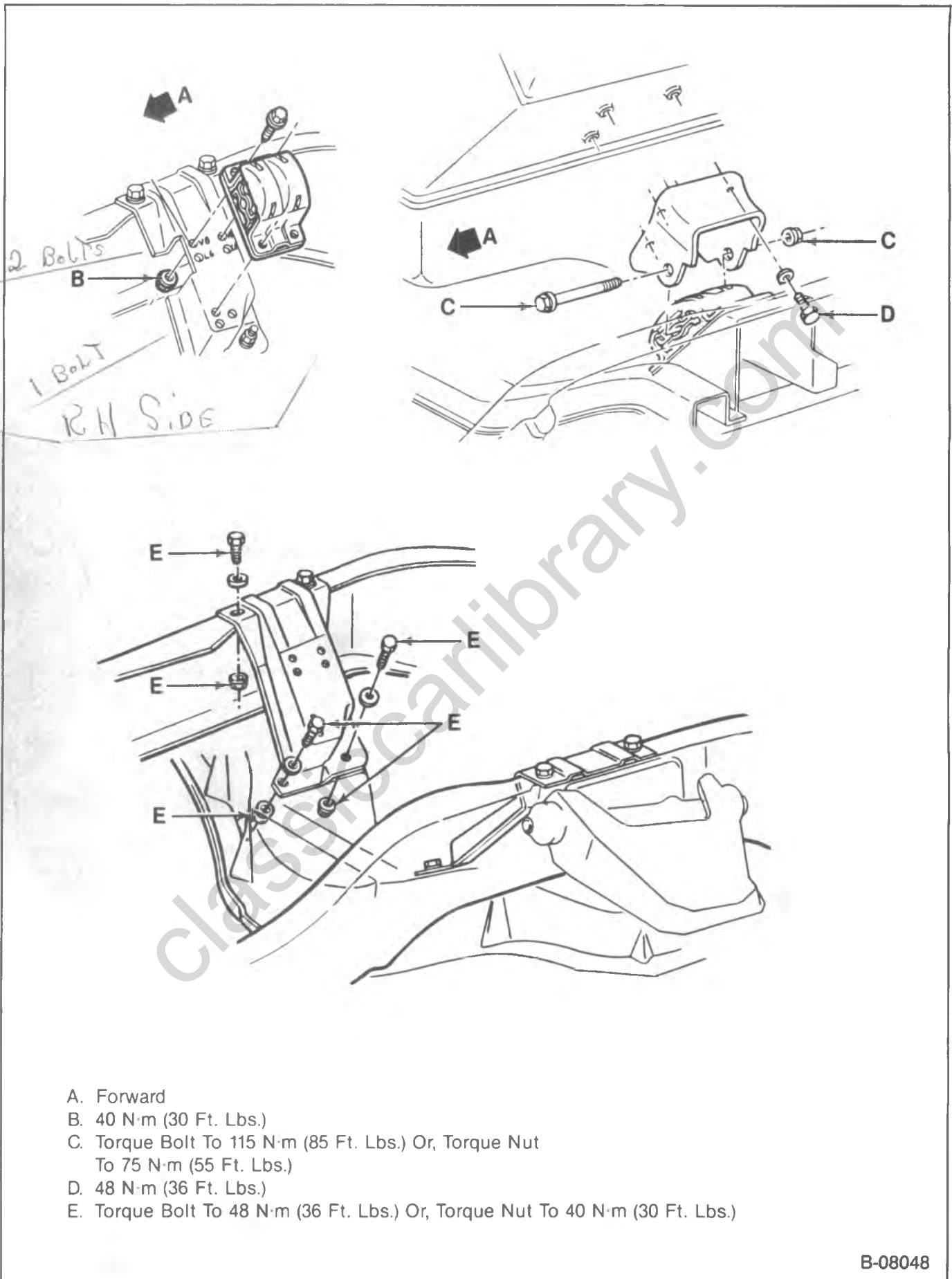

- A. Forward
- B. 40 N·m (30 Ft. Lbs.)
- C. Torque Bolt To 115 N·m (85 Ft. Lbs.) Or, Torque Nut To 75 N·m (55 Ft. Lbs.)
- D. 48 N·m (36 Ft. Lbs.)
- E. Torque Bolt To 48 N·m (36 Ft. Lbs.) Or, Torque Nut To 40 N·m (30 Ft. Lbs.)

B-08048

Figure 34—Front Engine Mountings (R Models)

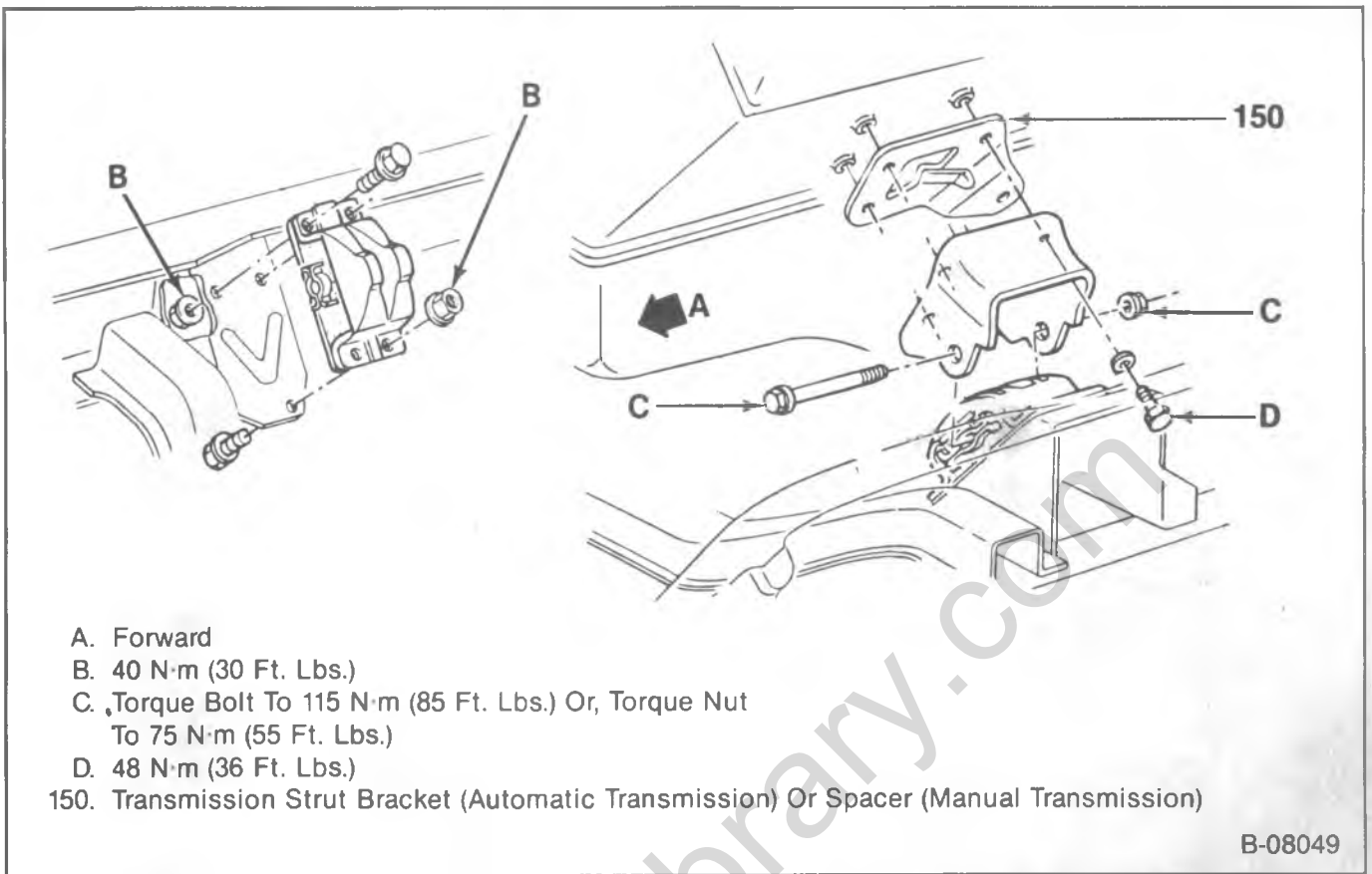

Figure 35—Front Engine Mountings (V Models)

FWO?

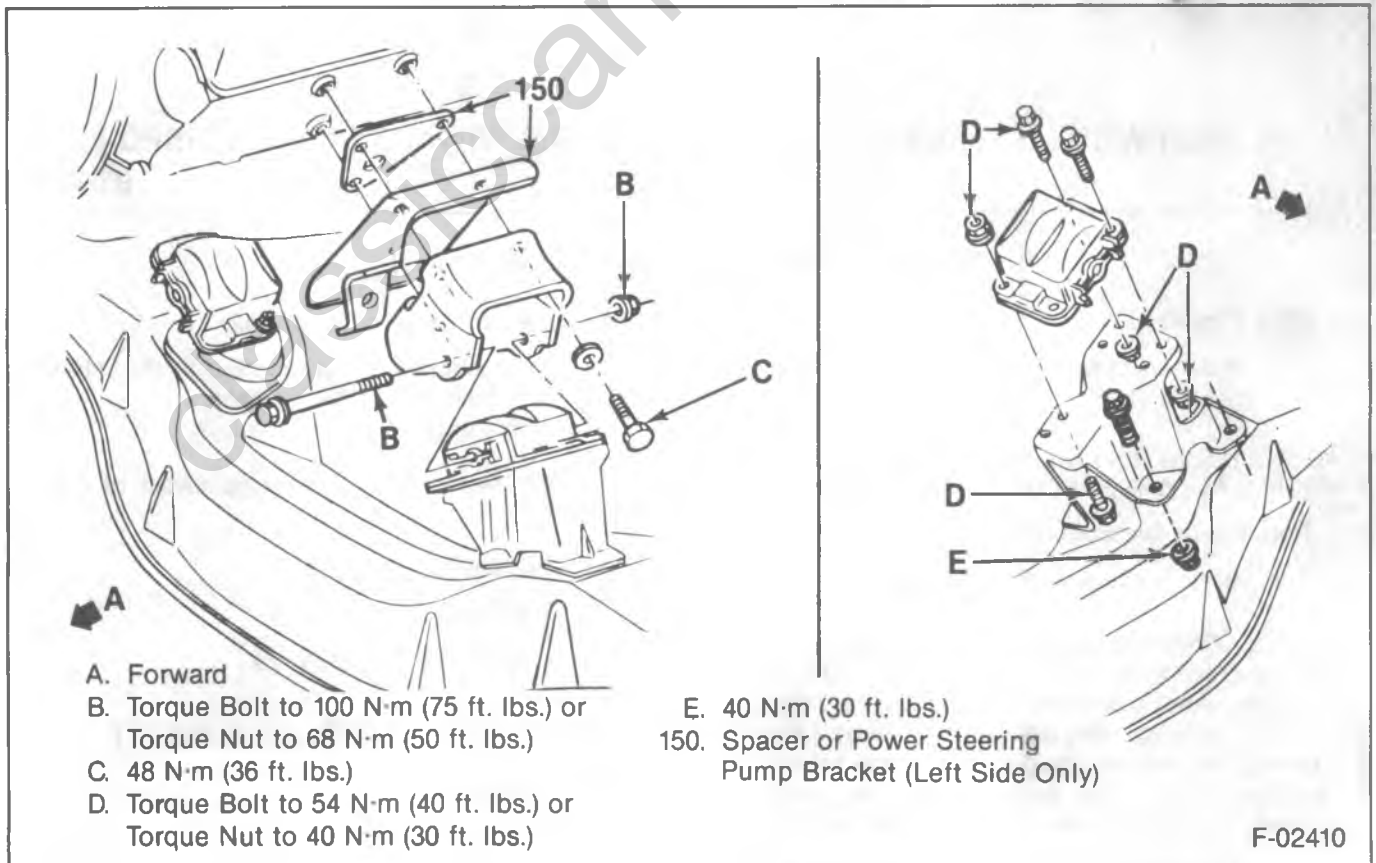
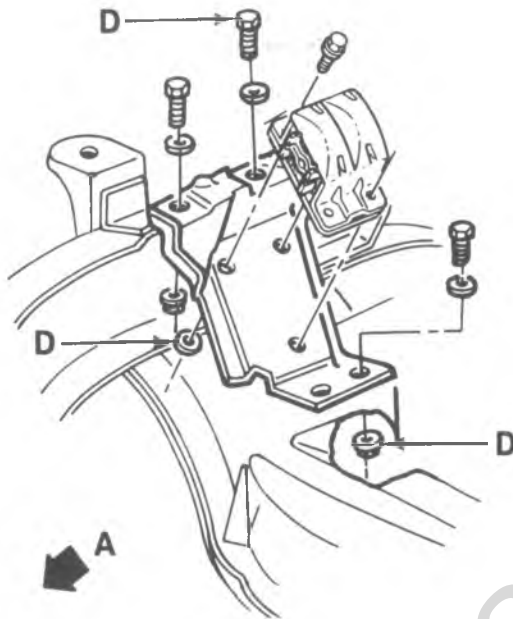
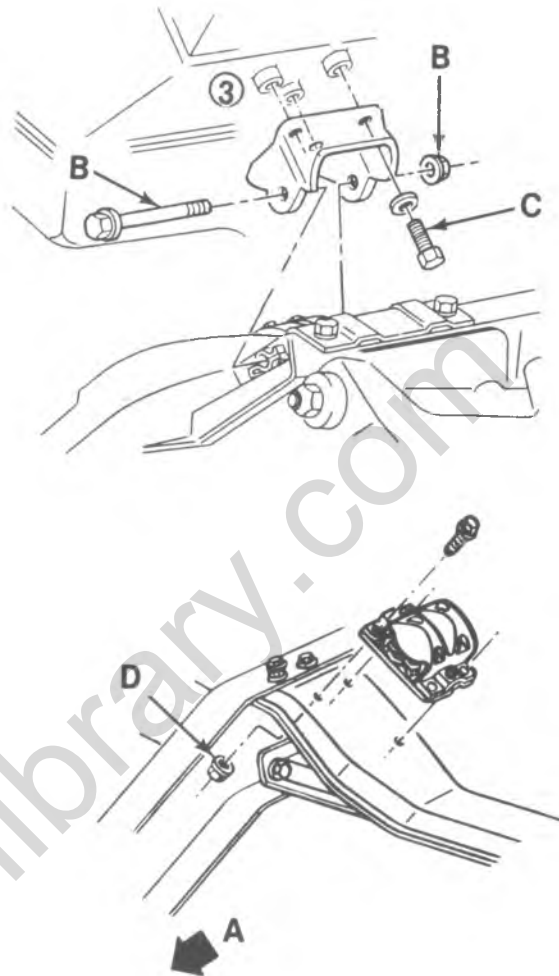

Figure 36—Front Engine Mountings (G Models)

- A. Front
- B. Tighten Bolt to 115 N·m (85 Ft. Lbs.) or, Tighten Nut to 75 N·m (55 Ft. Lbs.).
- C. 48 N·m (36 Ft. Lbs.).
- D. 40 N·m (30 Ft. Lbs.).



MODELS WITHOUT I-BEAM AXLE



MODELS WITH I-BEAM AXLE (RPO-FS3)

B-08050

Figure 37—Front Engine Mountings (P Models)



Tighten

- Fasteners to specifications. Refer to figures 38 through 41.

REAR MOUNTING REPLACEMENT (P MODELS FLYWHEEL HOUSING MOUNTING)



Remove or Disconnect (Figure 42)

1. Bolt, cushion, and spacer.

NOTICE: When raising or supporting the engine for any reason, do not use a jack under the oil pan, any sheet metal or crankshaft pulley. Due to the small clearance between the oil pan and the oil pump screen, jacking against the oil pan may cause it to be bent against the pump screen, resulting in a damaged oil pickup unit.

- Raise the rear of the engine only enough to permit removal of the mounting.
2. Engine mounting.



Install or Connect (Figure 42)

1. Engine mounting. Align the hole in the mounting with the hole in the crossmember.
 - Lower the engine.

NOTICE: See "Notice" on page 6A6-1 of this section.

2. Spacer, cushion, and bolt.



Tighten

- Bolt to 90 N·m (65 ft. lbs.).

ENGINE REPLACEMENT

R AND V MODELS



Remove or Disconnect

1. Battery cables.
 - Raise the vehicle. Support with suitable safety stands.

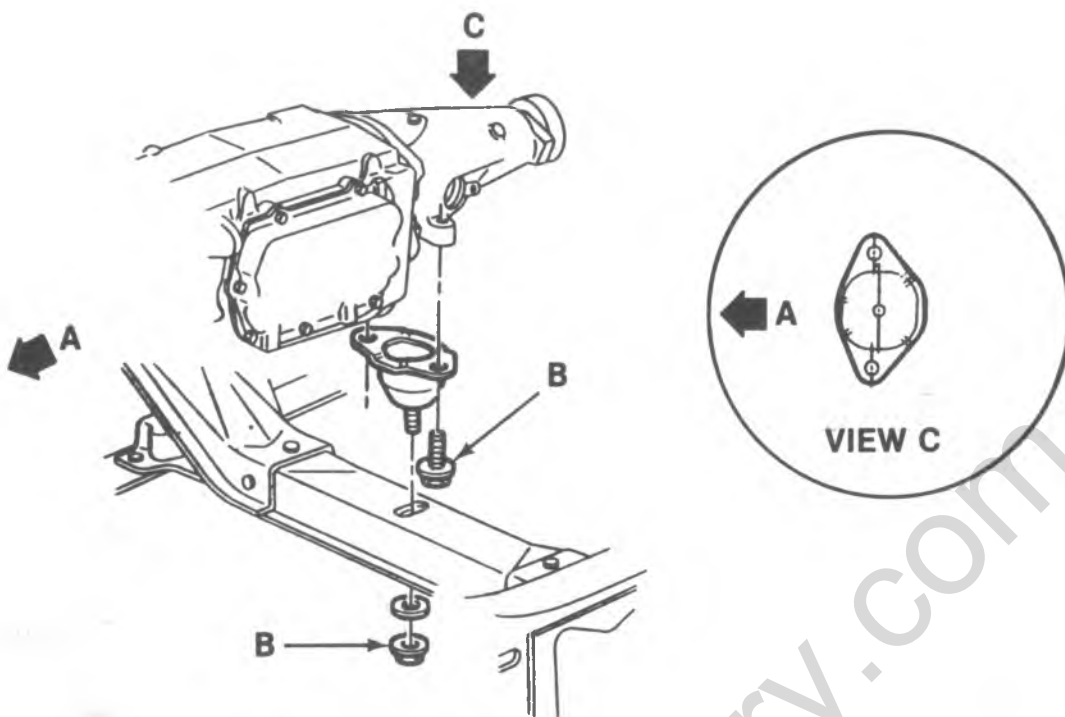

ALL MODELS EXCEPT WITH THM 400 TRANSMISSION (RPO-M40)

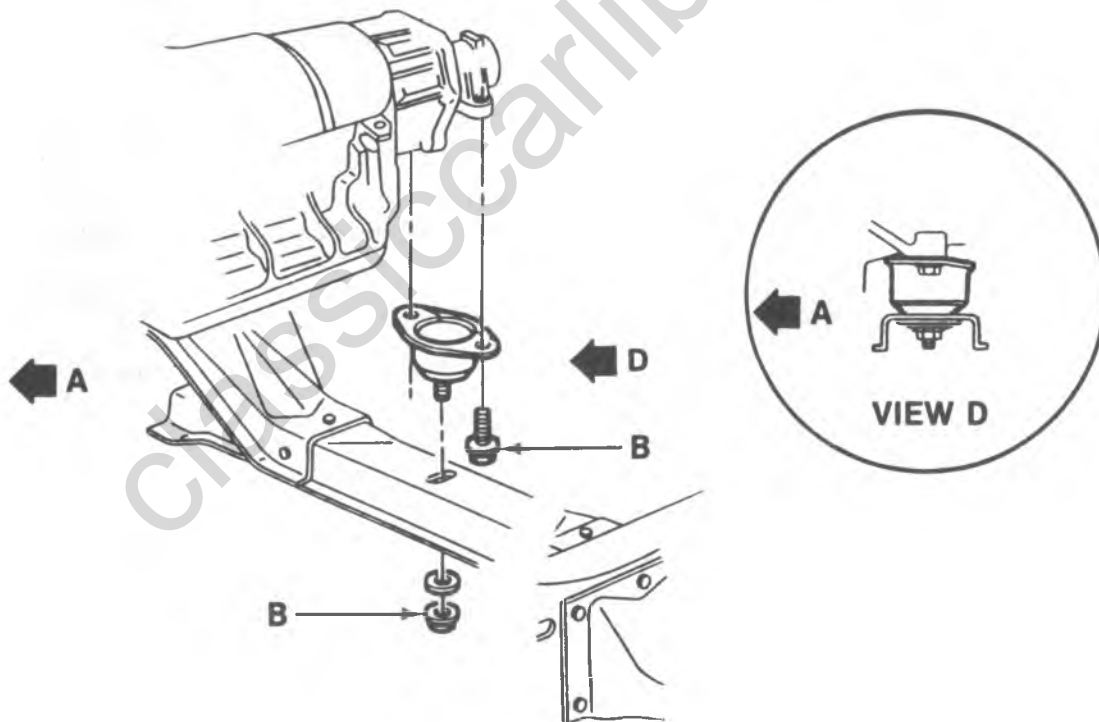

MODELS WITH THM 400 TRANSMISSION (RPO-M40)

- A. Forward
- B. 48 N·m (36 Ft. Lbs.)

B-07921

Figure 38—Rear Engine Mountings (R Models)

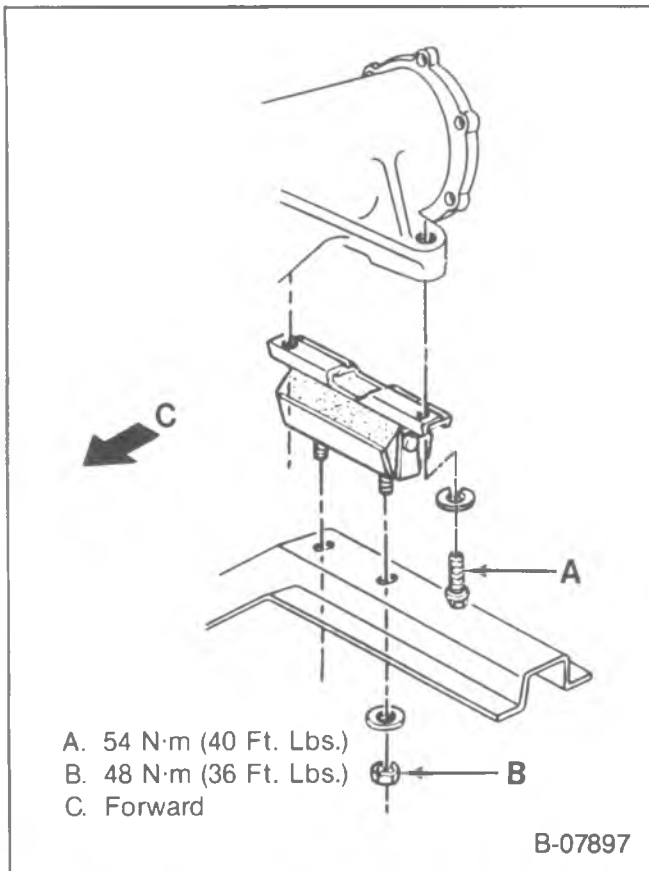

Figure 39—Rear Engine Mountings (V Models)

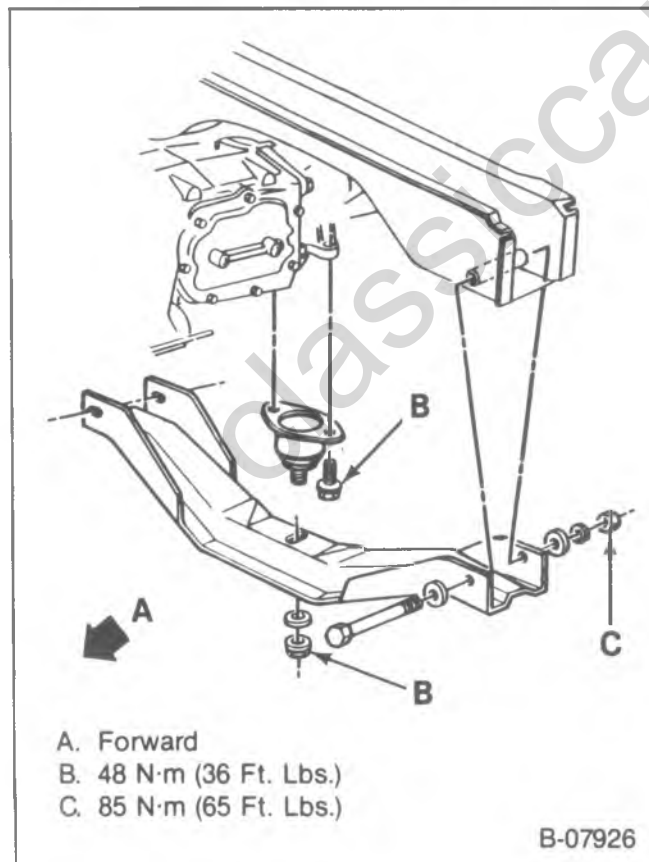

Figure 40—Rear Engine Mountings (G Models)

2. Flywheel cover.
3. Flywheel to torque converter bolts (automatic transmission).
4. Exhaust pipes at the manifolds.
5. Starter.
6. Bell housing bolts.
7. Front engine mounting through-bolts.
8. Block heater.
9. Wiring harness, transmission cooler lines, and front battery cable clamp at the oil pan.
10. Fuel return lines at the engine.
11. Oil cooler lines at the engine.
12. Lower fan shroud bolts.
 - Lower the vehicle.
13. Hood.
 - Drain the cooling system.
14. Air cleaner with resonator.
15. Fuel filter.
16. Ground cable at the generator bracket.
17. Generator wires and clips.
18. Wiring at the injection pump.
19. Wiring from rocker arm clips, including glow plug wires.
20. EGR-EPR solenoids, glow plug controller and temperature sensor. Move the harness aside.
21. Left side ground strap.
22. Fan.
23. Fan shroud.
24. Power steering pump and reservoir and lay aside.
25. Vacuum hose at the cruise control transducer (if equipped).
26. Accelerator, detent, and cruise control cables at the injection pump.
27. Heater hose at the engine.
28. Radiator. Refer to ENGINE COOLING (SEC. 6B).
 - Support the transmission with a suitable jack.
29. Engine.

Install or Connect (Figures 34 and 35)

1. Engine to the vehicle.
2. Radiator. Refer to ENGINE COOLING (SEC. 6B).
3. Heater hose.
4. Accelerator, detent, and cruise control cables.
5. Vacuum hose at the transducer.
6. Power steering pump and reservoir.
7. Fan shroud.
8. Fan.
9. Left side ground strap.
10. EGR-EPR, glow plug controller, and temperature sensor.
11. Wiring at the rocker arm clips, including glow plug wires.
12. Injection pump wiring.
13. Generator wires and clips.
14. Ground cable at the generator bracket.
15. Fuel filter.
16. Air cleaner and resonator.
17. Hood.
 - Raise the vehicle. Support with suitable safety stands.
18. Lower fan shroud bolts.
19. Oil cooler and fuel return lines.
20. Wiring harness, transmission cooler lines, and front battery cable clamp at the oil pan.

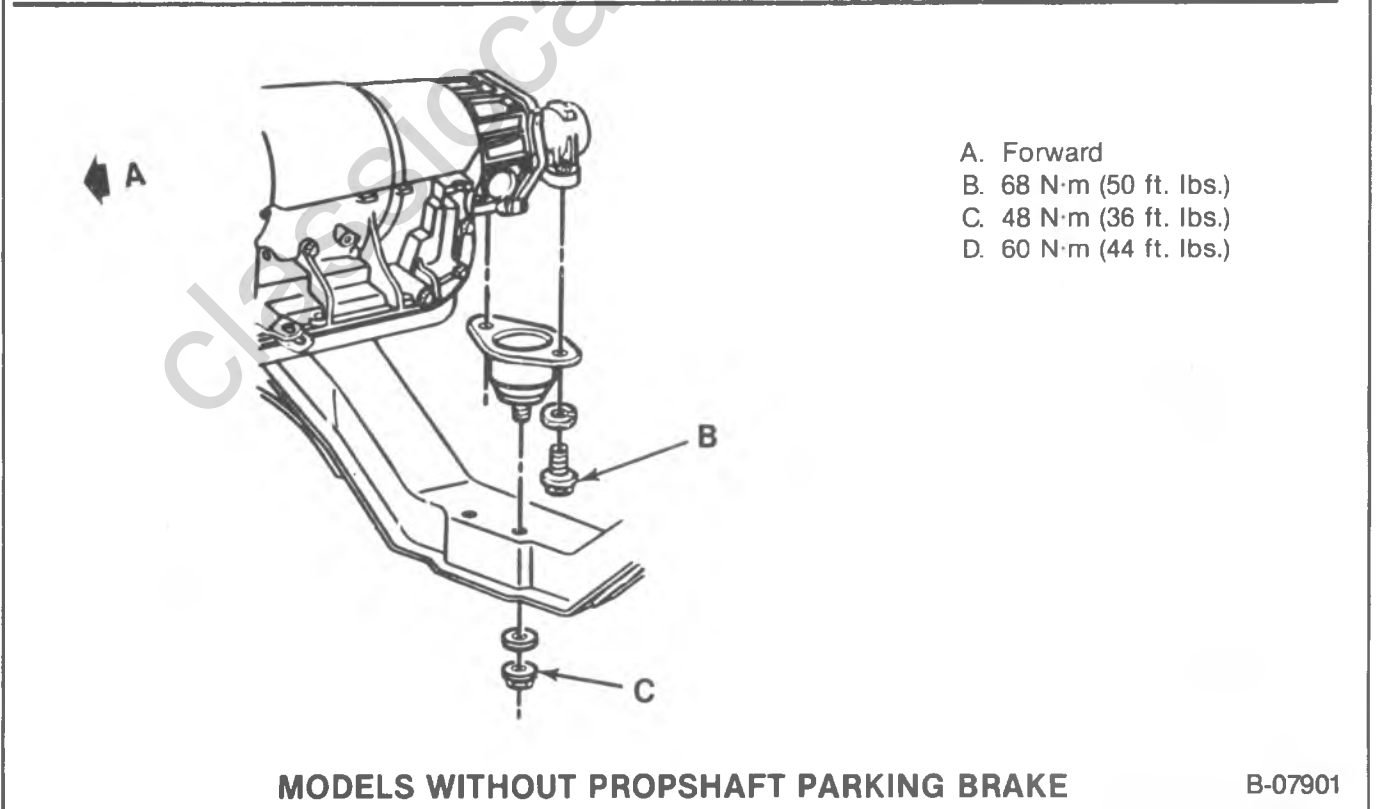
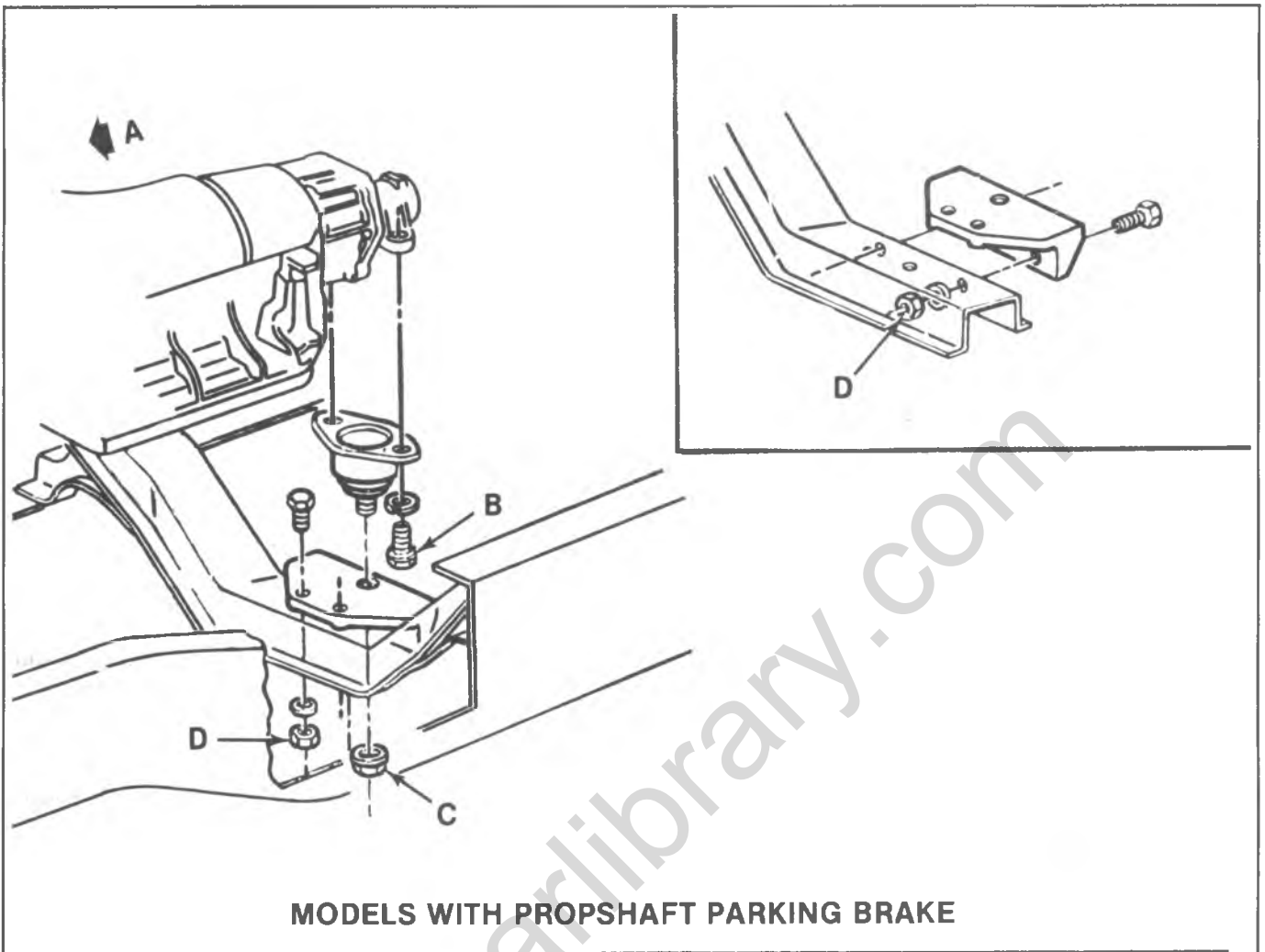

Figure 41—Rear Engine Mountings (P Models—Transmission Tail Type Mountings)

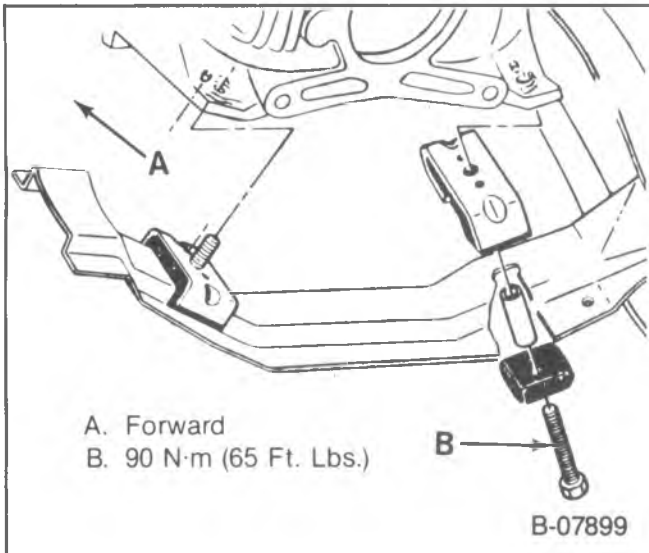

Figure 42—Rear Enging Mountings (P Models—Flywheel Housing Type Mounting)

21. Block heater.

NOTICE: See "Notice" on page 6A6-1 of this section.

22. Engine mounting through bolts.

Tighten

- Fasteners to specifications. Refer to figures 34 and 35.

23. Bell housing bolts.

24. Starter.

25. Exhaust pipes.

26. Flywheel to torque converter bolts (automatic transmission).

27. Flywheel cover.

- Lower the vehicle.

28. Battery cables.

- Fill the cooling system with the proper quantity and grade of coolant.

G MODELS

Remove or Disconnect

Tool Required:
J-33888 Lifting Fixture

- Battery cables.
- Headlight bezels, grille, bumper, and lower valence panel.
- Hood latch.
- Coolant recovery bottle.
- Upper fan shroud.
- Upper tie bar.
- Engine cover.
- Condenser (vehicles with air conditioning). Refer to AIR CONDITIONING (SEC. 1B).
- Radiator and fan. Refer to ENGINE COOLING (SEC. 6B).
- Injection pump. Refer to DIESEL FUEL INJECTION (SEC. 6C2).
 - Raise the vehicle. Support with suitable safety stands.

- Exhaust pipes at the manifolds.
- Flywheel cover.
- Flywheel to torque converter bolts (automatic transmission).
- Engine mounting through bolts.
- Block heater wires.
- Bellhousing bolts.
- Starter.
 - Lower the vehicle.
- Cruise control transducer (if equipped).
- Air conditioning compressor (if equipped). Refer to AIR CONDITIONING (SEC. 1B).
- Power steering pump, and lay aside.
- Oil fill tube upper bracket.
- Glow plug relay.
- Oil pressure sender harness.
- Air cleaner resonator and bracket.
- Transmission dipstick tube and move aside.
- Heater hoses at the engine.
- Generator upper bracket.
- Water crossover/thermostat assembly.
- Fuel lines at the fuel pump (lift pump).
- Engine
 - Attach J-33888 to the center intake manifold bolt holes. The two pieces of the tool should extend down into the "valley" between the cylinders.
 - Support the transmission.
 - Use a suitable lifting device to remove the engines.

Install or Connect (Figure 36)

1. Engine to the vehicle.

Remove or Disconnect

- J-33888, and lifting device.
 - Transmission support.
- Fuel lines to the fuel pump (lift pump).
 - Water crossover/thermostat assembly. Use new gaskets.

Tighten

- Bolts to 42 N·m (31 ft. lbs.).

- Generator upper bracket.
- Heater hoses.
- Transmission dipstick tube.
- Oil pressure sender harness.
- Glow plug relay.
- Oil fill tube upper bracket.
- Power steering pump.
- Air conditioning compressor (if equipped). Refer to AIR CONDITIONING (SEC. 1B).
- Cruise control transducer (if equipped).
 - Raise the vehicle. Support with suitable safety stands.
- Starter.
- Bellhousing bolts.
- Block heater wires.

NOTICE: See "Notice" on page 6A6-1 of this section.

17. Engine mounting through bolts.

**Tighten**

- Fasteners to specifications. (Refer to figure 36).
- 18. Flywheel to torque converter bolts (automatic transmission).
- 19. Flywheel cover.
- 20. Exhaust pipes.
 - Lower the vehicle.
- 21. Injection pump. Refer to DIESEL FUEL INJECTION (SEC. 6C2).
- 22. Radiator and fan. Refer to ENGINE COOLING (SEC. 6B).
- 23. Condenser (if equipped). Refer to AIR CONDITIONING (SEC. 1B).
- 26. Engine cover.
- 27. Upper tie bar.
- 28. Upper fan shroud.
- 29. Coolant recovery bottle.
- 30. Hood latch.
- 31. Lower valence panel, bumper, grille, and headlight bezels.
- 32. Battery cables.
 - Fill the cooling system with the proper quantity and grade of coolant.
 - Evacuate and charge the air conditioning system. Refer to AIR CONDITIONING (SEC. 1B).

SPECIFICATIONS**TORQUE SPECIFICATIONS**

Item	N·m	Ft. Lbs.	In. Lbs.
Intake Manifold Bolts	42	31	—
Exhaust Manifold Bolts	35	26	—
Rocker Arm Cover Bolts	22	16	—
Rocker Arm Shaft Bolts	55	40	—
Hydraulic Lifter Guide Plate Clamp Bolts	26	18	—
Cylinder Head Bolts—Refer to Procedure	—	—	—
Oil Pump Drive Clamp Bolt	42	31	—
Torsional Damper Bolt	270	200	—
Crankshaft Pulley Bolts	40	30	—
Front Cover to Block Bolts	45	33	—
Oil Pan Bolts (all except rear two bolts)	10.0	—	84
(rear two bolts)	23	17	—
Front Cover Baffle Bolts and Nut	45	33	—
Injection Pump Nuts	42	31	—
Injection Pump Gear Bolts	23	17	—
Camshaft Gear Bolt	100	75	—
Camshaft Thrust Plate	23	17	—
Oil Pump Bolt	90	65	—
Main Bearing Cap Bolts—Inner	150	110	—
Outer	135	100	—
Connecting Rod Cap Nuts	65	48	—
Glow Plugs	14	10	—
Water Crossover/Thermostat Housing Bolts	42	31	—
Fuel Pump to Block	34	25	—
Flywheel Bolts	90	65	—
Bell Housing Bolts	40	30	—

SPECIFICATIONS (CONT.)

ENGINE SPECIFICATIONS

All Specifications are in millimeters (mm) unless otherwise noted.

GENERAL DATA:			
Type	90-degree V8 Diesel		
Displacement	6.2L		
RPO	LH6 LL4		
Bore	101		
Stroke	97		
Compression Ratio	21.3:1		
Firing Order	1-8-7-2-6-5-4-3		
Oil Pressure	10 psi at idle (hot); 40-45 psi at 2000 RPM		
CYLINDER BORE:			
Diameter	100.987-101.065		
Diameter	0.02 (Maximum)		
Taper (Thrust Side)	0.02 (Maximum)		
PISTON:			
Clearance	Bohn Pistons	Bores 1 through 6	0.089-0.115
		Bores 7 and 8	0.102-0.128
	Zollner Pistons*	Bores 1 through 6	0.112-0.138
		Bores 7 and 8	0.125-0.151
PISTON RING:			
Compression	Groove Clearance	Top	0.076-0.178
		2nd	0.75-1.00
	Gap	Top	0.30-0.55
		2nd	0.75-1.00
Oil	Groove Clearance	0.040-0.096	
	Gap	0.25-0.51	
PISTON PIN:			
Diameter	30.9961-31.0039		
Clearance	0.0081-0.0309		
Fit in Rod	0.0081-0.0309		
CRANKSHAFT			
Main Journal	Diameter	#1, 2, 3, 4	74.917-74.941
		#5	74.912-74.936
	Taper		0.005 (Maximum)
	Out of Round		0.005 (Maximum)
Main Bearing Clearance	#1, 2, 3, 4		0.045-0.083
	#5		0.055-0.093
Crankshaft End Play			0.10-0.25
Crankpin	Diameter		60.913-60.939
	Taper		0.005 (Maximum)
	Out-of-Round		0.005 (Maximum)
Rod Bearing Clearance			0.045-0.100
Rod Side Clearance			0.17-0.63

*Not used in production — reference for service stock pistons only.









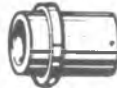

SPECIFICATIONS (CONT.)

ENGINE SPECIFICATIONS (CONT.)

All Specifications are in millimeters (mm) unless otherwise noted.

DISPLACEMENT		6.2 L	
CAMSHAFT:			
Lobe Lift ± 0.05	Intake	7.133	
	Exhaust	7.133	
Journal Diameter	#1, 2, 3, 4	54.975-55.025	
	#5	50.975-51.025	
Journal Clearance		0.026-0.101	
Camshaft End Play		0.051-0.305	
VALVE SYSTEM:			
Lifter		Hydraulic Roller	
Rocker Arm Ratio		1.5 : 1	
Valve Lash	Intake	Not Adjustable	
	Exhaust		
Face Angle (Intake & Exhaust)		45°	
Seat Angle (Intake & Exhaust)		46°	
Seat Runout (Intake & Exhaust)		0.05	
Seat Width	Intake	0.89-1.53	
	Exhaust	1.57-2.36	
Stem Clearance	Intake	0.026-0.069	
	Exhaust	0.026-0.069	
Valve Spring	Pressure Newtons @ mm	Closed	356 N @ 46.0 mm
		Open	1025 N @ 35.3 mm
	Installed Height	46	
Timing Chain Free Play	New Chain	12.7 mm (0.500-inch)	
	Used Chain	20.3 mm (0.800-inch)	

SPECIAL TOOLS

1.		J-8037	7.		J-22102
2.		J-33154	8.		J-23523-E
3.		J-33153	9.		J-29664
4.		J-26513-A	10.		J-8080
5.		J-29666	11.		J-33888
6.		J-29834			

- 1. Ring Compressor
- 2. Rear Oil Seal Packer
- 3. Rear Oil Seal Installer
- 4. Valve Spring Compressor
- 5. Air Line Adapter
- 6. Hydraulic Lifter Remover

- 7. Seal Installer
- 8. Torsional Damper Remover
- 9. Manifold Cover Set
- 10. Main Bearing Replacer
- 11. Engine Lifting Fixture (G Models)

F-02409

classiccarslibrary.com

SECTION 6A7

4.8 LITER L6

The following "Notice" applies to one or more steps in the assembly procedure of components in this portion of this manual as indicated at appropriate locations by the terminology "See NOTICE on page 6A7-1 of this section."

NOTICE: All engine fasteners are important attaching parts in that they could affect the performance of vital components and systems, and/or could result in major repair expense. They must be replaced with one of the same part number or with an equivalent part if replacement becomes necessary. Torque values must be used as specified during reassembly to assure proper retention of all parts.

CONTENTS

SUBJECT	PAGE
Description	6A7- 2
Engine Lubrication	6A7- 2
On-Vehicle Service	6A7- 4
Rocker Arm Cover Replacement	6A7- 4
Rocker Arm and Pushrod Replacement	6A7- 4
Valve Adjustment	6A7- 5
Valve Stem Seal And Valve Spring Replacement	6A7- 5
Pushrod Cover Replacement	6A7- 6
Hydraulic Lifter Replacement	6A7- 6
Intake And Exhaust Manifold Replacement	6A7- 7
Rocker Arm Stud Replacement	6A7- 8
Cylinder Head Replacement	6A7- 9
Torsional Damper And Front Crankshaft Seal Replacement	6A7-10
Timing Gear Cover Replacement	6A7-11
Oil Pan Replacement	6A7-12
Oil Pump Replacement	6A7-12
Rear Crankshaft Oil Seal Replacement	6A7-13
Checking Valve Timing	6A7-14
Measuring Camshaft Lobe Lift	6A7-14
Camshaft Replacement	6A7-15
Connecting Rod And Piston Replacement	6A7-16
Main Bearing Replacement	6A7-18
Crankshaft Gear Replacement	6A7-19
Oil Filter Bypass Valve Replacement	6A7-20
Crankshaft Replacement	6A7-20
Flywheel Replacement	6A7-20
Engine Mountings	6A7-21
Engine Replacement	6A7-24
Specifications	6A7-25
Special Tools	6A7-28

DESCRIPTION

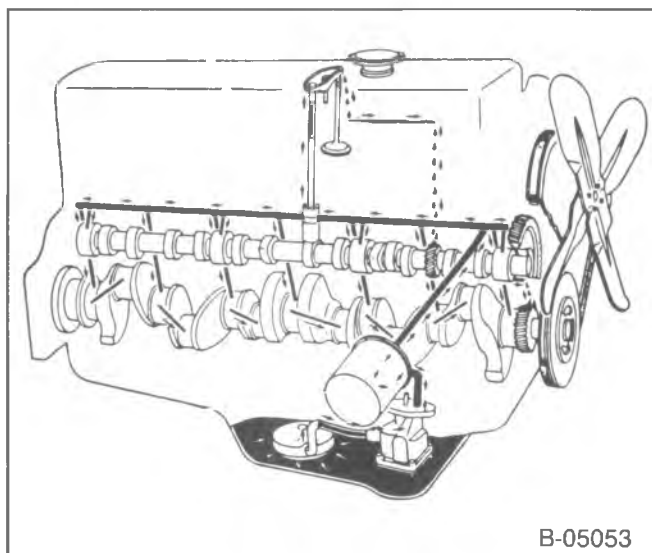

Figure 1—Lubrication Diagram (Side View)

4.8L engines are inline six cylinder type, overhead valve, water cooled, with cast iron block and head.

The crankshaft is supported by seven precision insert main bearings, with crankshaft thrust taken at the number seven (rear) bearing.

The camshaft is supported by four plain type bearings and is gear driven. Motion from the camshaft is transmitted to the valves by hydraulic lifters, pushrods, and ball-type rocker arms. The valve guides are integral in the cylinder head.

The connecting rods are forged steel, with precision insert type crankpin bearings. The piston pins are a press fit in the connecting rods.

The pistons are cast aluminum alloy. The piston pins are a floating fit in the pistons.

ENGINE LUBRICATION

Lubrication schematics are shown in figures 1 and 2. The gear type oil pump is driven through an extension shaft from the distributor drive shaft, which is gear driven from the camshaft. Oil is drawn into the oil pump through a pickup screen and pipe.

Pressurized oil is routed to the oil filter. In case of excessive backpressure at the oil filter, a bypass valve is provided. This valve will allow oil flow to the main oil gallery at the right side of the block. This gallery supplies oil to the camshaft bearings, hydraulic lifters, and main bearings. The connecting rods are supplied oil from the main bearings by means of drilled passages in the crankshaft. The valve train is supplied with oil by the hydraulic lifters. Oil is pumped from the lifters through the hollow pushrods to the rocker arms. Oil drains back to the crankcase through oil drain holes and the pushrod holes. The piston, piston pin, and timing gears are lubricated by oil splash.

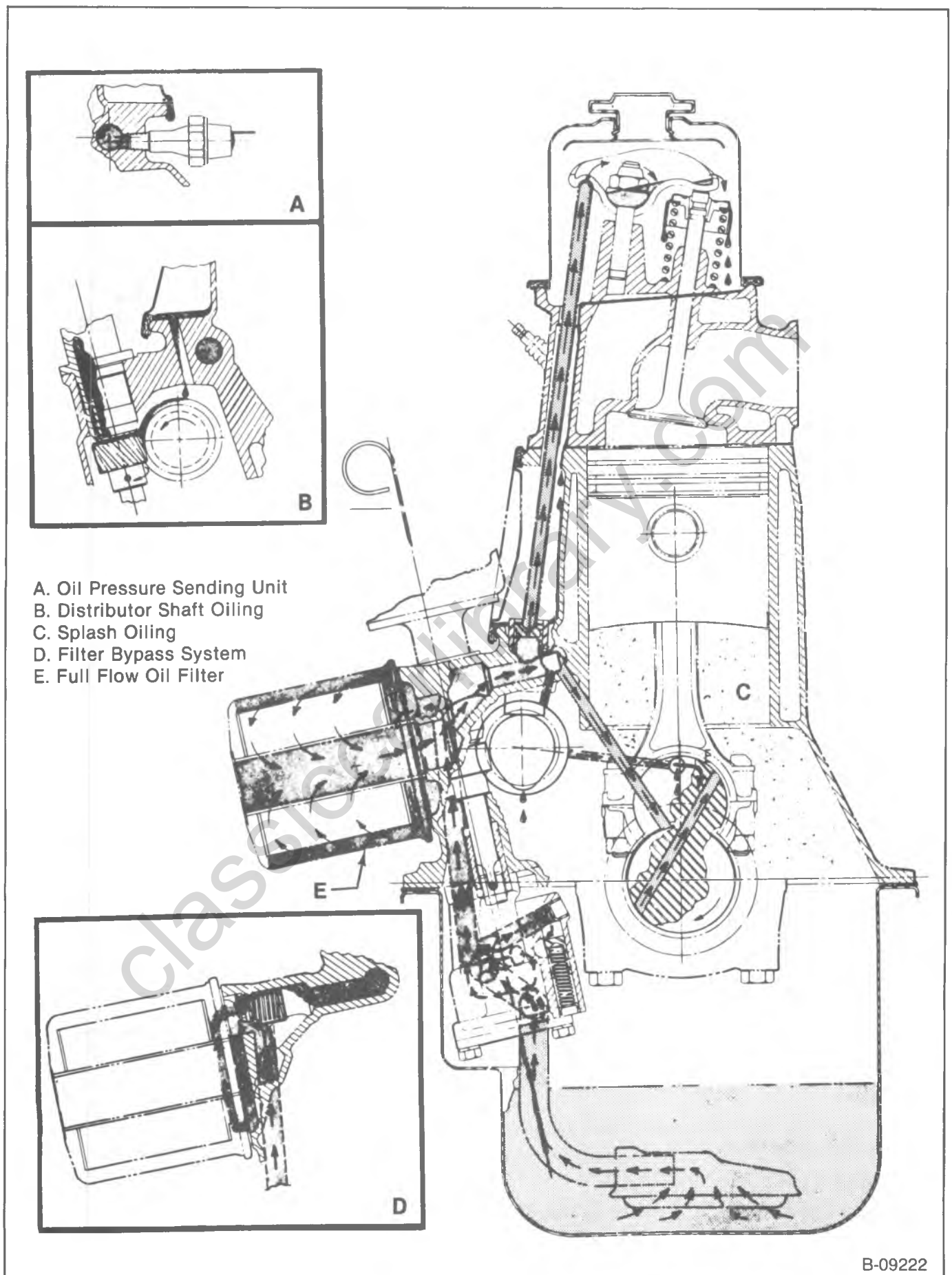

Figure 2—Lubrication Diagram (Front View)

ON-VEHICLE SERVICE:

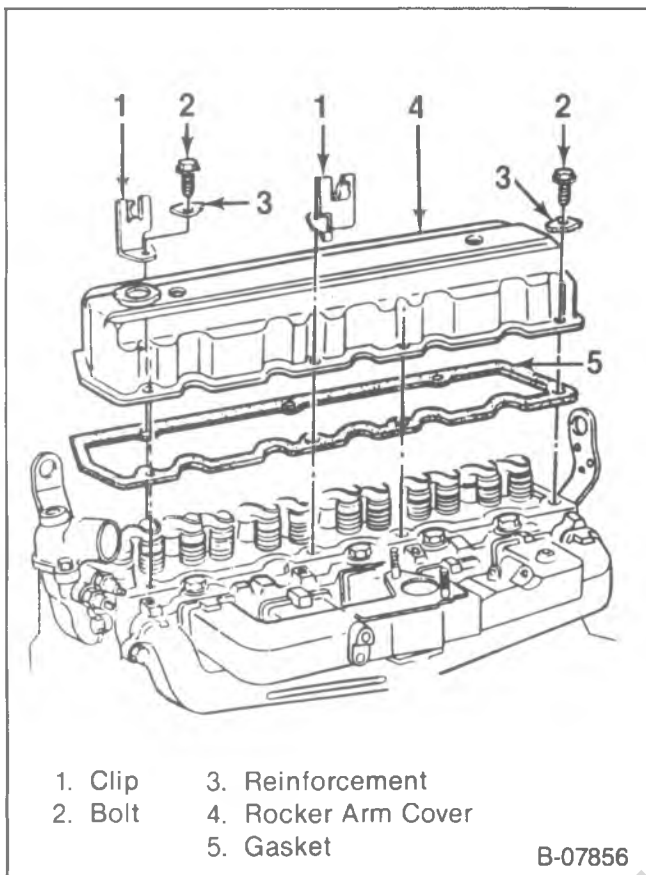

Figure 3—Rocker Arm Cover Installation

ROCKER ARM COVER REPLACEMENT

↔ Remove or Disconnect (Figure 3)

1. Crankcase ventilation hoses at the rocker arm cover.
2. Air cleaner.
3. Wiring, fuel and vacuum lines from the clips.
4. Bolts, reinforcements, and clips.
5. Rocker arm cover.

- If the rocker arm cover adheres to the cylinder head, try to shear the gasket by bumping the end of the cover with a rubber mallet. **DO NOT DISTORT THE SEALING FLANGE.**

6. Gasket.

🧼 Clean

- All traces of old gasket from the rocker arm cover and cylinder head.

🔍 Inspect

- Rocker arm cover sealing surfaces for distortion. Straighten or replace as needed.

→← Install or Connect (Figure 3)

1. New gasket.
2. Rocker arm cover.

3. Bolts, clips, and reinforcements.

🔧 Tighten

- Bolts to 4.3 N·m (38 in. lbs.).

4. Wiring, fuel and vacuum lines to the clips.
5. Air cleaner.
6. Crankcase ventilation hoses to the rocker arm cover.

ROCKER ARM AND PUSHROD REPLACEMENT

↔ Remove or Disconnect

1. Rocker arm cover, as outlined previously.
2. Rocker arm nut.
 - If only the pushrod is to be replaced, back the rocker arm nut off until the rocker arm can be swung away from the pushrod. Then pull the pushrod out.
3. Rocker arm with ball.
4. Pushrod.

! Important

- Store used components in order so they can be reassembled in the same location.

👁 Inspect

- Rocker arms and balls at their mating surfaces. These surfaces should be smooth and free from scoring or other damage.
- Rocker arm areas which contact the valve stems and the sockets which contact the pushrods. These areas should be smooth and free of damage and wear.
- Pushrods for bending. Roll the pushrod on a flat surface to determine if it is bent. Replace if necessary.
- Ends of the pushrods for scoring or roughness.

→← Install or Connect

1. Pushrod. Make sure the pushrod seats properly in the hydraulic lifter.
2. Rocker arm with ball.

! Important

- When new rocker arms and/or balls are installed, coat their bearing surfaces with "Molykote" or equivalent.

3. Rocker arm nut.

🔧 Adjust

- Valves as outlined later.

4. Rocker arm cover, as outlined previously.

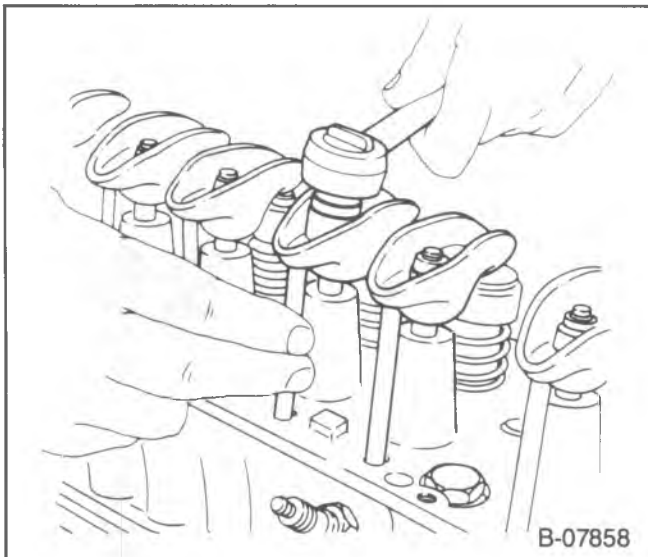

Figure 4—Adjusting The Valves

VALVE ADJUSTMENT

1. Remove the rocker arm cover as outlined previously.
2. Adjust the valves when the lifter is on the base circle of the camshaft lobe as follows:
 - a. Mark the distributor housing with chalk, at #1 and #6 plug wire positions. Remove the distributor cap and lay aside.
 - b. Crank the engine until the distributor rotor points to #1 cylinder position. The following valves can be adjusted with the engine in the #1 firing position:
 - #1 cylinder—Exhaust and Intake
 - #2 cylinder—Intake
 - #3 cylinder—Exhaust
 - #4 cylinder—Intake
 - #5 cylinder—Exhaust
 - c. Back out the adjusting nut until lash is felt at the pushrod, then turn in the adjusting nut until all lash is removed. This can be determined by rotating the pushrod while turning the adjusting nut (figure 4). When play has been removed, turn the adjusting nut in one full additional turn (to center the lifter plunger).
 - d. Crank the engine until the distributor rotor points to #6 position. The following valves can be adjusted with the engine in #6 firing position:
 - #2 cylinder—Exhaust
 - #3 cylinder—Intake
 - #4 cylinder—Exhaust
 - #5 cylinder—Intake
 - #6 cylinder—Intake and Exhaust
3. Install the distributor cap.
4. Install the rocker arm cover as outlined previously.

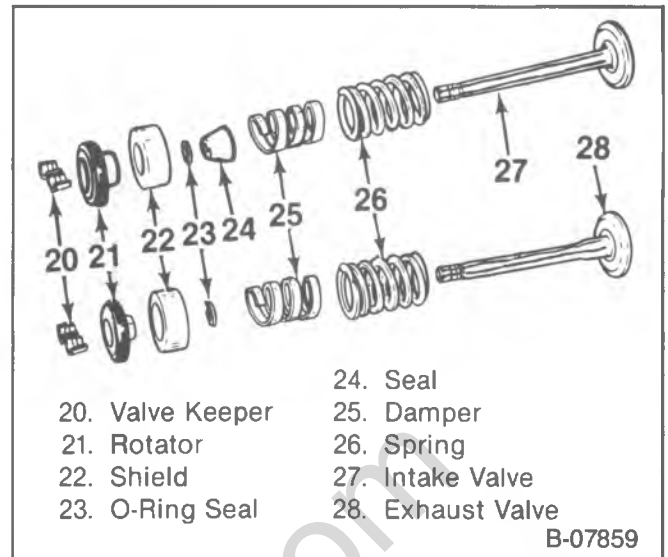

Figure 5—Valves And Components

VALVE STEM SEAL AND VALVE SPRING REPLACEMENT

➡ Remove or Disconnect (Figures 5 and 6)

Tools Required:

J-23590 Air Adapter.

J-5892-B Spring Compressor.

1. Rocker arm cover, as outlined previously.
2. Rocker arms, as outlined previously.
3. Spark plugs.
4. Valve keepers (20).
 - Install J-23590 into the spark plug hole.
 - Apply compressed air to hold the valves in place.
 - Install a rocker arm nut (figure 6).
 - Use J-5892-B to compress the valve spring (figure 6).
 - Remove the valve keepers.
 - Carefully release the spring tension. Remove J-5892-B.

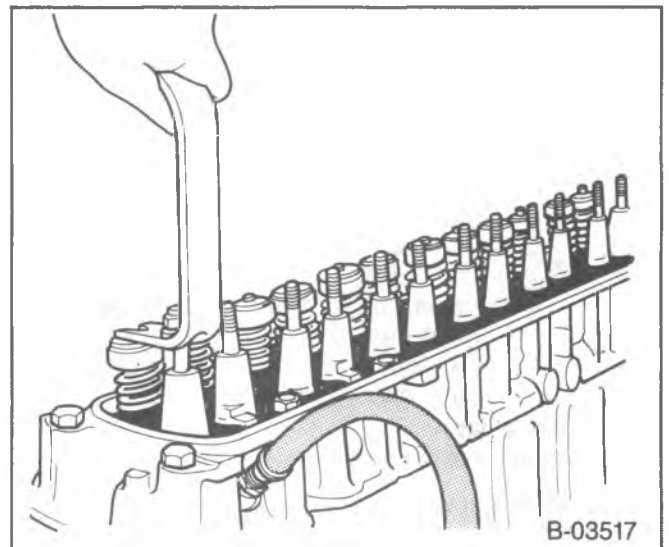

Figure 6—Compressing The Valve Springs

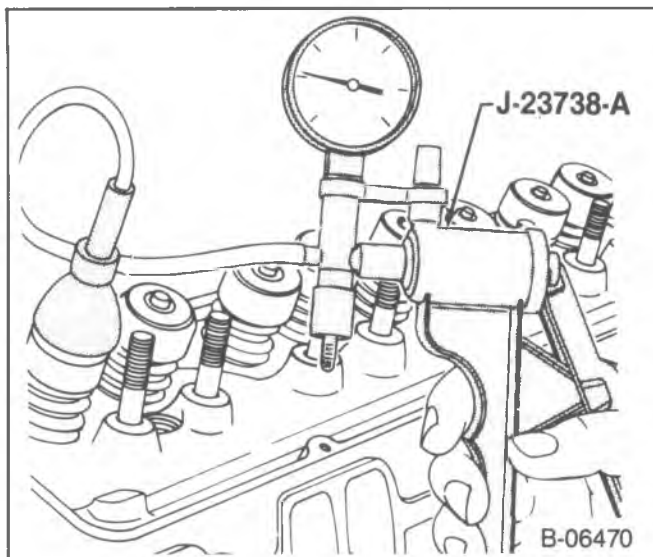

Figure 7—Testing The Valve Seals

5. Rotator (21), shield (22) and spring (26) with damper (25).
6. O-ring seal (23).
7. Seal (24) (intake valve only).

Install or Connect (Figures 5, 6, and 7)

Tools Required:

- J-23590 Air Adapter.
- J-5892-B Spring Compressor.
- J-23738-A Vacuum Pump.

1. New seal (24) (intake valve only). Install the seal over the valve stem and seat it against the head.
2. Spring (26) with the damper (25), shield (22) and rotator (21).
3. New O-ring seal (23) and valve keepers (20).
 - With air pressure applied to the cylinder with J-23590, compress the spring with J-5892-B (figure 6).
 - Lubricate the o-ring seal with engine oil. Install the seal on the valve stem. Make sure the seal is not twisted.
 - Install the valve keepers. Use grease to hold them in place.
 - Carefully release spring pressure. Make sure the valve keepers stay in place.
 - Remove J-5892-B and J-23590.
 - Check each o-ring seal for leakage (figure 7).
 - Place the suction cup furnished with J-23738-A over the shield.
 - Connect J-23738-A to the suction cup and apply a vacuum. Watch the vacuum pump gage. No air should be able to leak past the seal. If the seal will not hold a vacuum, it may have been damaged or improperly installed.
4. Spark plugs.
5. Rocker arms, as outlined previously.

Adjust

- Valves, as outlined previously.
6. Rocker arm cover, as outlined previously.

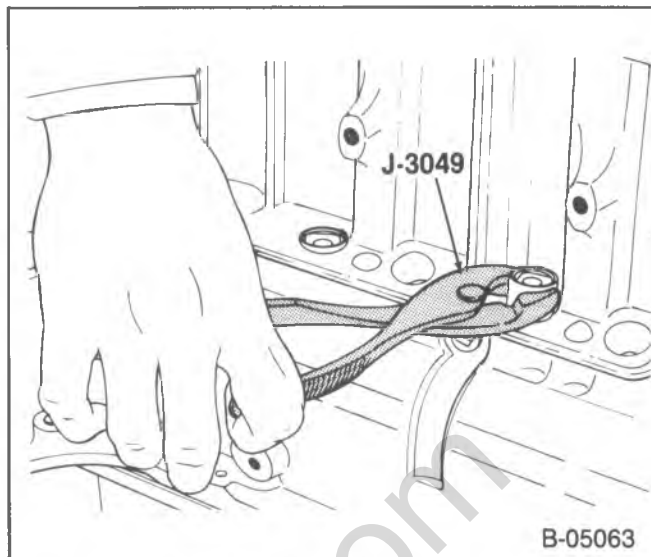

Figure 8—Removing The Hydraulic Lifter

PUSHROD COVER REPLACEMENT

Remove or Disconnect

1. Battery negative cable.
2. Dipstick tube.
3. Distributor. Refer to ENGINE ELECTRICAL (SEC. 6D).
4. Pushrod cover bolts.
5. Pushrod cover.
6. Gasket.

Clean

- Old gasket from pushrod cover and block.

Install or Connect

1. Pushrod cover and new gasket.
2. Pushrod cover bolts.

Tighten

- Pushrod cover bolts to 9.0 N·m (80 in. lbs.).
3. Distributor. Refer to ENGINE ELECTRICAL (SEC. 6D).
 4. Dipstick tube (if removed).
 5. Battery negative cable.

HYDRAULIC LIFTER REPLACEMENT

Remove or Disconnect (Figures 8 and 9)

Tools Required:

- J-3049 Hydraulic Lifter Remover (Plier Type) or J-9290-01 Hydraulic Lifter Remover (Slide Hammer Type)

1. Rocker arm cover, pushrod cover, and pushrod, as outlined previously.
2. Hydraulic lifters.

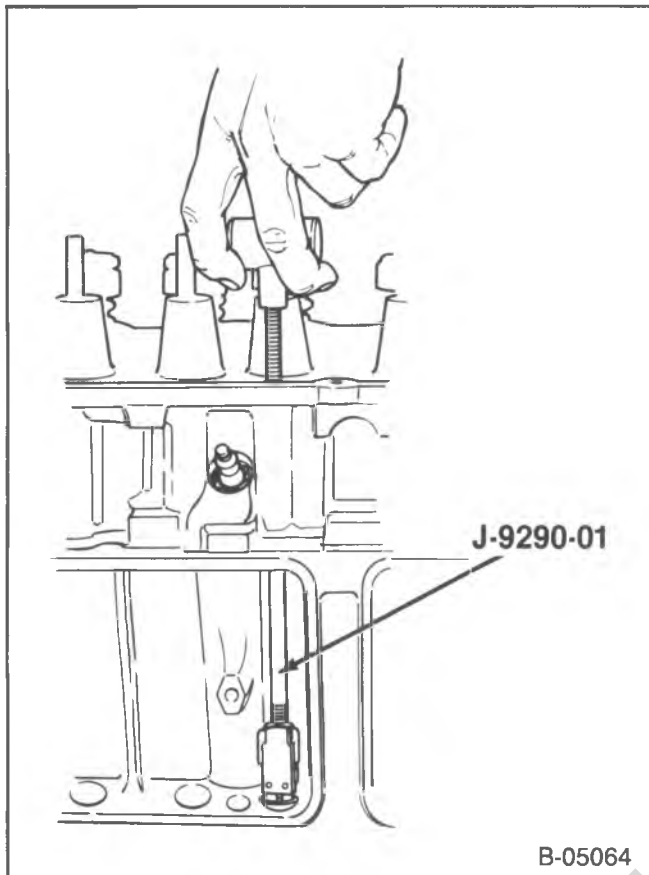

Figure 9—Removing The Hydraulic Lifter

- Remove the hydraulic lifters one at a time and place them in an organizer rack. The lifters must be installed in the same bore from which they were removed.
- A stuck hydraulic lifter can be removed using J-3049 (figure 8 or J-9290-01 (figure 9).

Inspect

- Hydraulic lifter body for scuffing and scoring. If the lifter body wall is worn or damaged, the mating bore in the block should also be checked.
- Check the fit of each hydraulic lifter in its mating bore in the block. If the clearance is excessive, try a new lifter.
- The hydraulic lifter foot must be smooth and slightly convex. If worn, pitted, or damaged, the mating camshaft lobe should also be checked.

Hydraulic Lifter Repair

- Refer to the proper unit repair manual.

Install or Connect

1. Hydraulic lifters to the block. Lubricate the lifter foot and body with Engine Oil Supplement or equivalent.
 - When any new hydraulic lifters or a new camshaft is installed, also replace the crankcase oil and filter. Engine Oil Supplement (or equivalent) should be added to the crankcase oil.
 - Replace all hydraulic lifters when a new camshaft is installed.

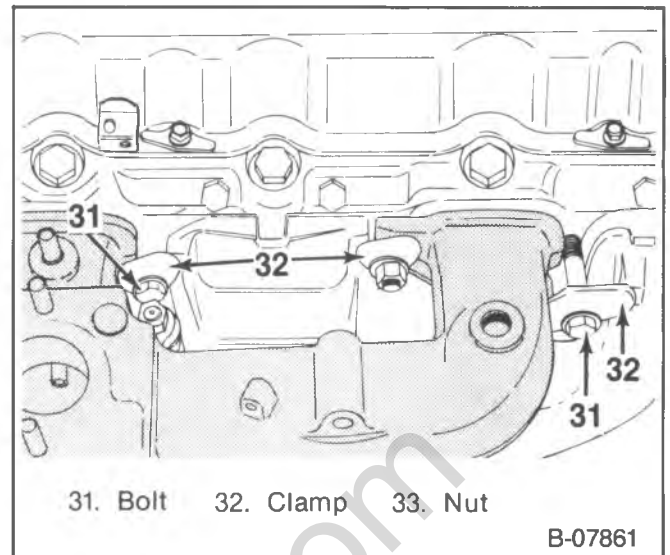

Figure 10—Manifold Installation

2. Pushrod cover, as outlined previously.
3. Pushrod, as outlined previously.

Adjust

- Valves, as outlined previously.
- 4. Rocker arm cover, as outlined previously.

INTAKE AND EXHAUST MANIFOLD REPLACEMENT

Remove or Disconnect (Figures 10 and 11)

1. Battery negative cable.
2. Air cleaner.
3. Throttle controls at the bell crank.
4. Carburetor (if necessary).
5. Fuel and vacuum lines from the manifold, EGR valve (if used) and EFE valve.
6. AIR pump and bracket.
7. PCV hose.
8. Exhaust pipe.
9. Manifold heat stove.
10. Clamps (32), bolts (31), nuts (33) and washers.
11. Manifold assembly and gasket.

Disassemble (Figure 11)

1. Bolt (35) and nuts (40).
2. Manifolds (34 and 39).
3. Gasket (38).

Clean

- All manifold bolts and studs. Then apply engine oil to the threads.
- All traces of old gaskets from the cylinder head and manifolds.

Inspect

- Manifolds for cracks or damage to gasket surfaces.
- Operation of EFE or manifold heat valve (if used).
- Gaskets, if necessary to diagnose a leakage problem.

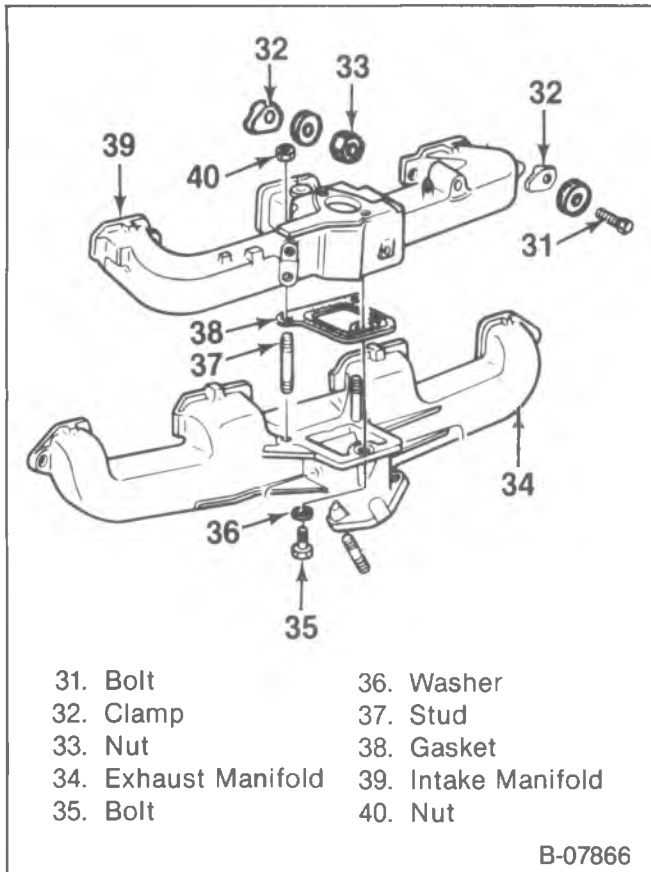

- | | |
|----------------------|---------------------|
| 31. Bolt | 36. Washer |
| 32. Clamp | 37. Stud |
| 33. Nut | 38. Gasket |
| 34. Exhaust Manifold | 39. Intake Manifold |
| 35. Bolt | 40. Nut |

B-07866

Figure 11—Manifolds And Components

Measure

- Manifold distortion. Lay a straight edge along the full length of the manifold exhaust port faces and measure any gaps between the straight edge and the port faces. If at any point a gap of 0.80 mm (0.030-inch) or more exists, it is likely that the manifold has distorted to a point where it will not seal properly. If a good exhaust seal is to be expected, the exhaust manifold must be replaced.

Assemble (Figure 11)

1. Gasket (38) to the exhaust manifold (34).
2. Intake manifold (39) to the exhaust manifold.
3. Both (35), washers (36) and nuts (40). LEAVE FINGER TIGHT.

Install or Connect (Figures 10 and 11)

1. New gasket, over the manifold studs on the cylinder head.
2. Manifold assembly.
3. Clamps (32).
4. Bolts (31), and nuts (33).

Important

- Always tighten the manifold to cylinder head bolts and nuts (31 and 33) BEFORE tightening the manifold center bolt and nuts (35 and 40).

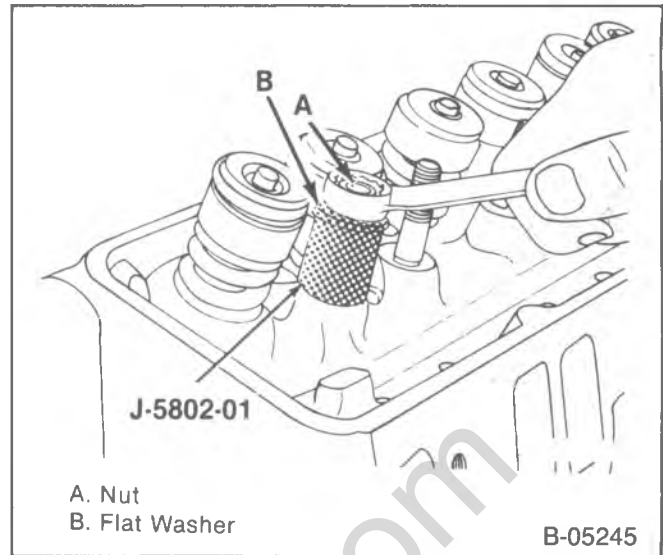

- A. Nut
B. Flat Washer

B-05245

Figure 12—Removing The Rocker Arm Stud

Tighten

- Bolts (31) and nuts (33) to 52 N·m (38 ft. lbs.).
 - Bolts (35) and nuts (40) to 60 N·m (44 ft. lbs.).
5. Manifold heat stove.
 6. Exhaust pipe.
 7. PCV hose.
 8. AIR pump and bracket.
 9. Fuel and vacuum lines from the manifold, EGR valve (if used) and EFE valve (if used).
 10. Carburetor (if removed).
 11. Throttle controls.
 12. Air cleaner.
 13. Battery negative cable.

Adjust

- Engine idle speed, if necessary.

ROCKER ARM STUD REPLACEMENT

Remove or Disconnect (Figure 12)

Tool Required:

J-5802-01 Rocker Arm Stud Remover

1. Rocker arm cover and rocker arm, as outlined previously.
2. Rocker arm stud.
 - Place J-5802-01 over the rocker arm stud.
 - Install a nut and flat washer.
 - Turn the nut to remove the stud (figure 12).

Install or Connect (Figures 13 and 14)

Tools Required:

- J-5715 Reamer (0.003-inch oversize) or
- J-6036 Reamer (0.013-inch oversize)
- J-6880 Rocker Arm Stud Installer

NOTICE: Do not attempt to install an oversize rocker arm stud without reaming stud hole as this could damage the cylinder head.

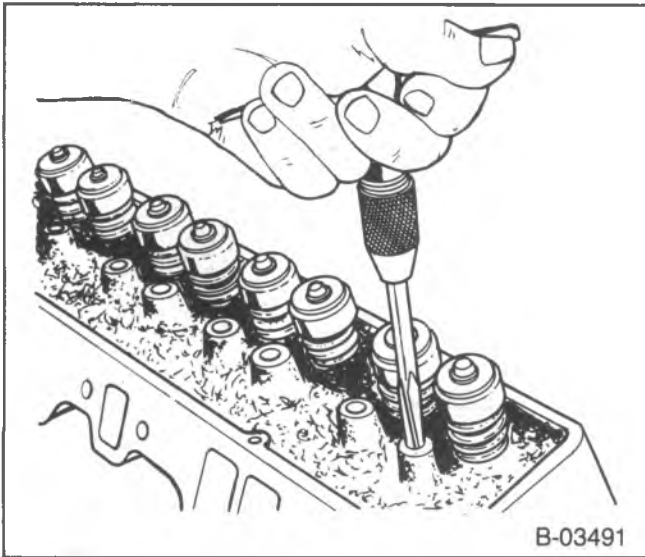

B-03491

Figure 13—Reaming The Rocker Arm Stud Bore

- Ream the hole to the proper size for the replacement oversize rocker arm stud. Use J-5715 for 0.003-inch oversize studs; J-6036 for 0.013-inch oversize stud (figure 13).
 - Coat lower end (press-fit area) of the rocker arm stud with hypoid axle lubricant.
1. Rocker arm stud. Use J-6880 (figure 14). Stud is installed to proper depth when the tool bottoms on the cylinder head.
 2. Rocker arm, as outlined previously.

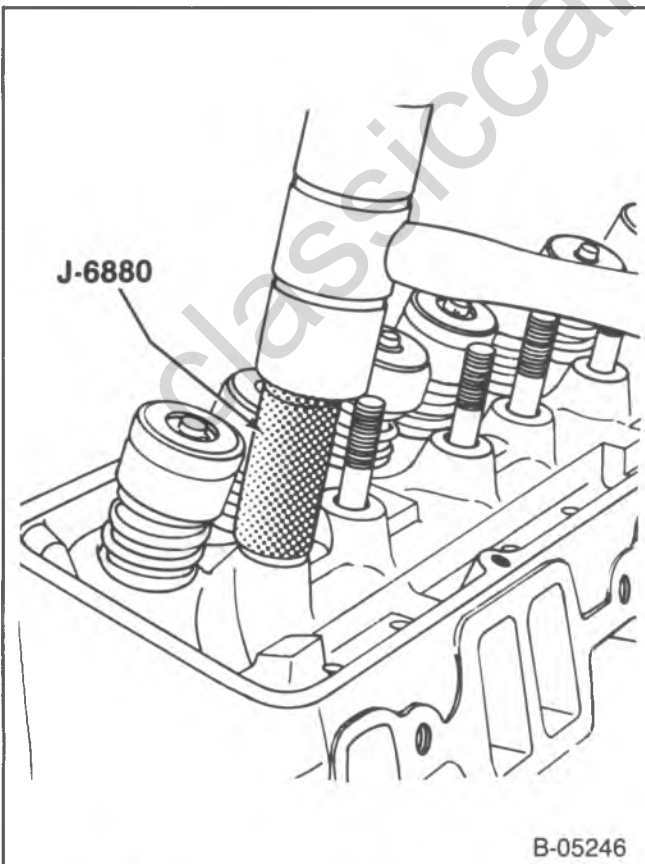

B-05246

Figure 14—Installing The Rocker Arm Stud

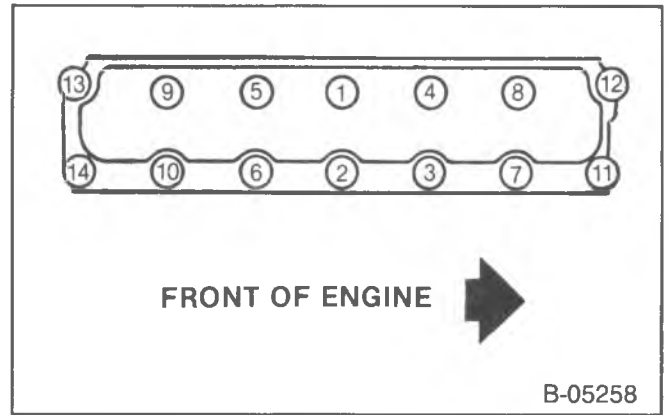

B-05258

Figure 15—Cylinder Head Bolt Tightening Sequence



Adjust

- Valves, as outlined previously.
3. Rocker arm cover, as outlined previously.

CYLINDER HEAD REPLACEMENT



Remove or Disconnect

1. Battery ground cable.
2. Manifold assembly, as outlined previously.
3. AIR check valve.
4. Rocker arm cover, as outlined previously.
5. Pushrods. Back off the rocker arm nuts. Turn the rocker arms aside, then remove the pushrods. Place the pushrods in a rack so they can be returned to their original locations at assembly.
6. Spark plug wires at the spark plugs.
7. Vacuum lines at the thermal vacuum switch on the water outlet.
 - Drain the radiator and block.
8. Upper radiator hose, heater hose, and water pump bypass hose.
9. Battery ground strap at the cylinder head.
10. Cylinder head bolts.
11. Cylinder head and gasket.



Clean

- Carbon deposits from combustion chambers.
- All traces of old head gasket from cylinder head and block.
- Cylinder head bolt threads and threads in the block.



Inspect

- Sealing surfaces of the block and cylinder head for nicks, heavy scratches, or other damage.

Cylinder Head Repair

- Refer to the proper Unit Repair Manual.



Install or Connect (Figure 15)

1. Head gasket.
 - If a steel gasket is used, coat both sides of the gasket with sealer. Spread the sealer thin and even.

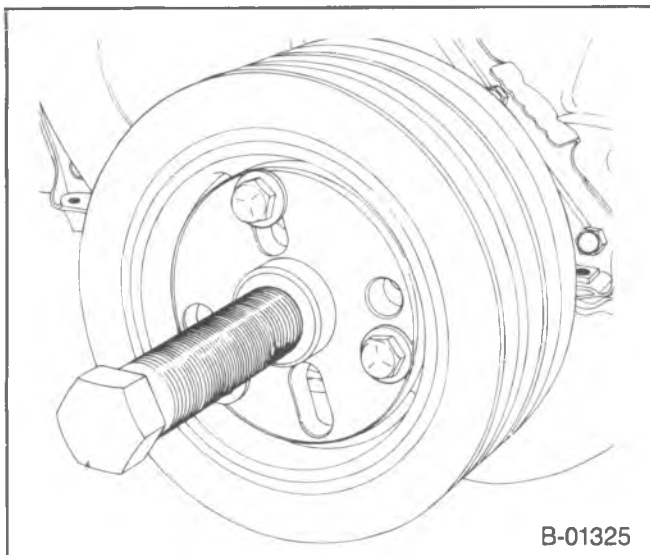

Figure 16—Removing The Torsional Damper

- Do not use sealer on composition steel-asbestos gaskets.
 - Place the gasket over the block dowel pins with the bead up.
2. Cylinder head. Carefully guide the cylinder head into place over the dowel pins and gasket.
 3. Cylinder head bolts. Coat threads of the cylinder head bolts with sealing compound and install finger tight.

 **Tighten**

- Cylinder head bolts, a little at a time, using the sequence shown in figure 15, until the specified torque is reached.
 - Left hand front bolt: 115 N·m (85 ft. lbs.).
 - All other bolts: 130 N·m (95 ft. lbs.).
- 4. Battery ground strap at the cylinder head.
- 5. Upper radiator hose, heater hose, and water pump bypass hose. Fill the cooling system with the proper coolant.
- 6. Vacuum lines at the thermal vacuum switch.
- 7. Spark plug wires.
- 8. Pushrods. Be sure to install them in their original locations.
- 9. Rocker arms to the pushrods.

 **Adjust**

- Valves, as outlined previously.
10. Rocker arm cover, as outlined previously.
 11. AIR check valve.
 12. Manifold assembly, as outlined previously.
 13. Battery ground cable.

TORSIONAL DAMPER AND FRONT CRANKSHAFT SEAL REPLACEMENT

 **Remove or Disconnect (Figure 16)**

Tool Required:
J-23523-E Torsional Damper Puller and Installer.

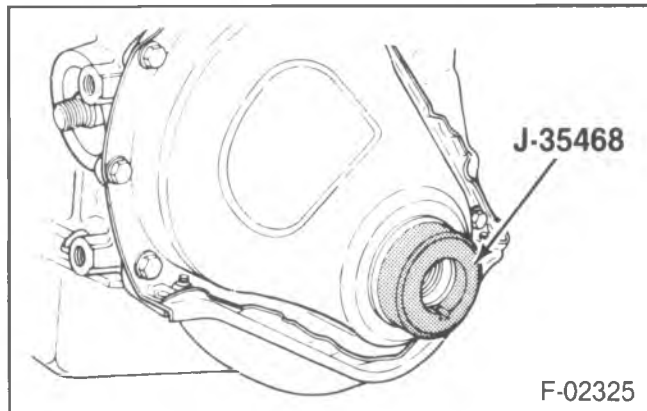

Figure 17—Installing The Timing Gear Cover And Seal

1. Battery negative cable.
2. Radiator. Refer to ENGINE COOLING (SEC. 6B).
3. Drive belts from the crankshaft pulley.
4. Torsional damper bolt and washer.
5. Torsional damper. Use J-23523-E (figure 16).
6. Front crankshaft seal. Pry out with a large screwdriver. Take care not to distort the timing gear cover.

 **Inspect**

- Oil seal contact area on the torsional damper for grooving and roughness. Replace if necessary.

 **Install or Connect (Figures 17 and 18)**

Tools Required:

- J-23523-E Torsional Damper Puller and Installer
- J-35468 Centering Tool and Seal Installer

1. Front crankshaft seal. Use J-35468 (figure 17). Coat the seal lips with engine oil. The open end of the seal faces inside the engine.

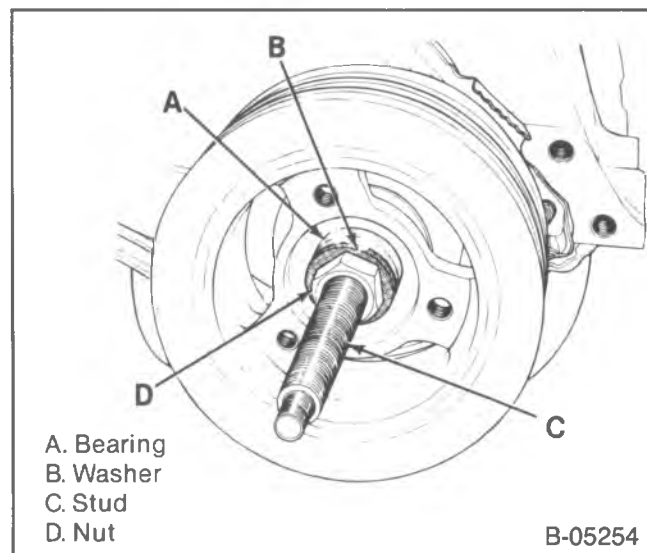

- A. Bearing
- B. Washer
- C. Stud
- D. Nut

Figure 18—Installing The Torsional Damper

NOTICE: The inertia weight section of the torsional damper is assembled to the hub with a rubber type material. The correct installation procedures (with the proper tool) must be followed or movement of the inertia weight section of the hub will destroy the turning of the torsional damper.

2. Crankshaft key (if removed).
 3. Stud (item C, figure 18) to the crankshaft. Thread the stud fully into the tapped end of the crankshaft.
 4. Torsional damper over the end of the stud. Align the keyway in the torsional damper shaft with the crankshaft key.
 5. Bearing, washer, and nut (figure 18).
 - Turn the nut to pull the torsional damper into place.
 - Remove the tool.
 6. Torsional damper bolt and washer.
-  **Tighten**
- Torsional damper bolt to 70 N·m (50 ft. lbs.).
7. Drive belts to the crankshaft pulley, and tension to specifications.
 8. Radiator. Refer to ENGINE COOLING (SEC. 6B).
 9. Battery negative cable.
 - Fill the cooling system with the proper coolant.

TIMING GEAR COVER REPLACEMENT

Remove or Disconnect

1. Battery negative cable.
2. Torsional damper, as described previously.
3. Oil pan to timing gear cover bolts.
4. Timing gear cover to block bolts.
5. Timing gear cover.
 - Pull the cover slightly forward only enough to permit cutting of the oil pan front seal.
 - Using a sharp knife or other suitable cutting tool, cut the oil pan front seal flush with the block at both sides of the oil pan.
 - Remove the cover and attached portion of the oil pan front seal.
6. Timing gear cover gasket.
7. Front crankshaft seal. Pry out with a screwdriver. Be careful not to distort the timing gear cover.

Clean

- Old gasket from the timing gear cover, block, and oil pan.

Install or Connect (Figures 17, 19, and 20)

Tool Required:

J-35468 Centering Tool and Seal Installer

1. Front crankshaft to the timing gear cover.
 - Lubricate the seal lips with engine oil.
 - Use J-35468 to press the seal into place (figure 19).
 - Leave the tool in position in the seal.
2. Timing gear cover to oil pan seal.

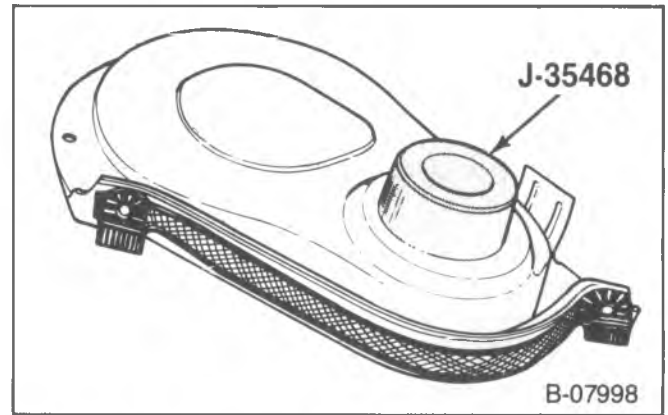

Figure 19—Installing The Front Crankshaft Seal

- Cut the tabs from a new seal as shown in figure 20. Use a sharp cutting tool to help make a clean, straight cut.
 - Position the seal against the cover. Press the retaining tips into the holes in the cover.
3. Timing gear cover to block gasket to the timing gear cover. Use gasket sealer to hold it in place.
 - Apply a 3 mm (1/8-inch) bead of RTV sealant to the joint formed at the oil pan and cylinder block.
 4. Timing gear cover, with J-35468 in place, to the block (figure 17).

Important

- The tool is used to align the timing gear cover so that the front crankshaft seal is properly centered around the crankshaft. The seal must be centered to prevent damage during hub installation.
5. Oil pan to timing gear cover bolts. Partially tighten the bolts.
 6. Timing gear cover to block bolts.

Tighten

- Timing gear cover to block bolts to 9.0 N·m (80 in. lbs.).
- Oil pan to timing gear cover bolts to 5.1 N·m (45 in. lbs.).

Remove or Disconnect

- J-35468 from the timing gear cover.
7. Torsional damper, as outlined previously.

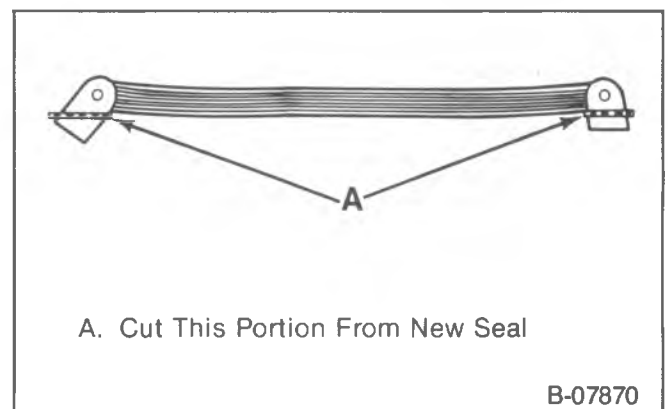

A. Cut This Portion From New Seal

Figure 20—Front Oil Pan Seal Modification

- Battery negative cable.

OIL PAN REPLACEMENT

↔ Remove or Disconnect

- Battery negative cable.
 - Drain the engine oil.
- Starter.
- Torque converter or flywheel cover.
- Front engine mount through-bolts.
 - Raise the engine and block in position.
- Oil pan bolts.
- Oil pan.
- Old gaskets and seals.

☑ Clean

- Old gasket and seals from the block and oil pan sealing surfaces.

→→ Install or Connect

- New rear oil pan seal to the rear main bearing cap.
- New front oil pan seal to the timing gear cover. Press the retaining tips into the holes in the cover.
- New oil pan to block gaskets to the block. Use gasket cement to hold them in place.
- Oil pan bolts.

⌚ Tighten

- 1/4-inch oil pan to block bolts to 9.0 N·m (80 in. lbs.).
 - 5/16-inch oil pan to block bolts to 18.6 N·m (165 in. lbs.).
 - Oil pan to timing gear cover to 5.1 N·m (45 in. lbs.).
- Lower the engine.
 - Front engine mount through-bolts.
 - Torque converter or flywheel cover.
 - Starter.
 - Proper quantity and grade of engine oil.
 - Battery negative cable.

OIL PUMP REPLACEMENT

↔ Remove or Disconnect

- Oil pan, as outlined previously.
- Oil pump pickup tube bracket to main bearing cap nut.
- Oil pump bolts.
- Oil pump.

🔍 Inspect

- Oil pump pickup tube for looseness. If the tube is loose in the oil pump body, replace it, as outlined in the proper unit repair manual. A loose pickup tube can result in an air leak and loss of oil pressure.

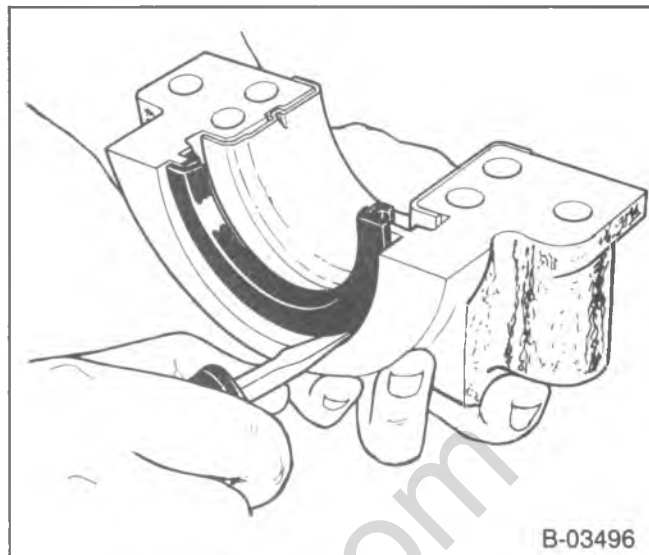

Figure 21—Removing The Lower Seal Half

Oil Pump Repair

- Refer to the proper unit repair manual.

↔ Install or Connect

- Oil pump to the engine. Align the slot in the oil pump shaft with the tang on the distributor shaft. The oil pump should slide easily into place. No gasket is used.
- Oil pump bolts.

⌚ Tighten

- Oil pump bolts to 13.0 N·m (115 in. lbs.).
- Oil pump pickup tube bracket to main bearing cap nut.

⌚ Tighten

- Nut to 34 N·m (25 ft. lbs.).
- Oil pan, as outlined previously.

REAR CRANKSHAFT OIL SEAL REPLACEMENT

The rear main bearing oil seal can be replaced (both halves) without removal of the crankshaft. Always replace the upper and lower seal as a unit. Install the seal with the lip facing the front of the engine. Extreme care should be exercised when installing this seal to protect the sealing bead located in the channel on the outside diameter of the seal. An installation tool (figure 23) should be used to protect the seal bead when positioning the seal. (Some seal kits include the tool as part of the service kit).

↔ Remove or Disconnect (Figures 21 and 22)

- Oil pan, as outlined previously.
- Rear main bearing cap.
- Lower seal half (figure 21).
- Upper seal half (figure 22).
 - Tap on the upper seal half, using a small drift and hammer.
 - Remove the upper seal half, using pliers.

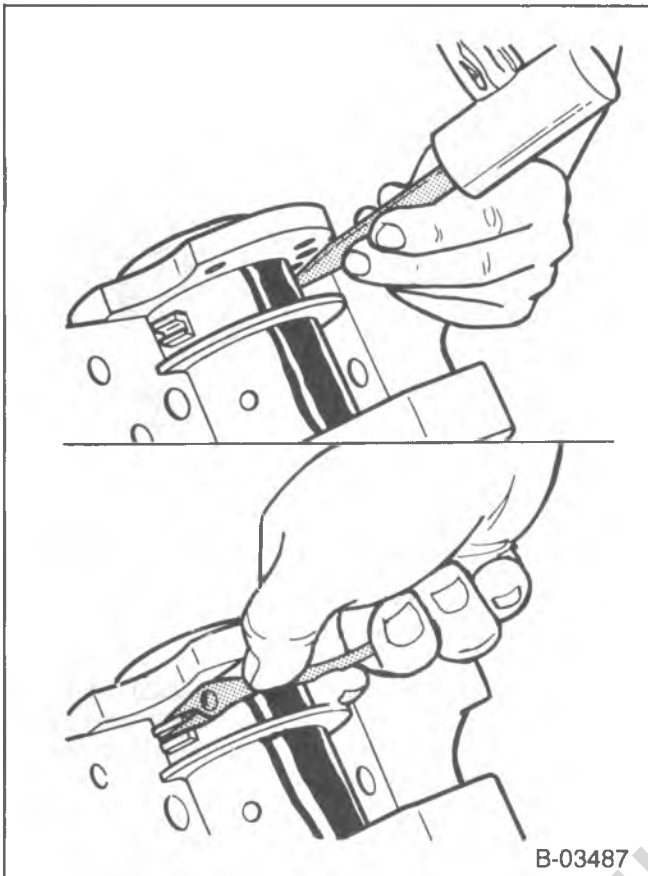

B-03487

Figure 22—Removing The Upper Seal Half



Clean

- Sealing surfaces of the main bearing cap and block.



Inspect

- Crankshaft, seal channel, and sealing surfaces for nicks, scratches, etc.



Install or Connect (Figures 23, 24, and 25)

1. Upper seal half.



Important

- An oil seal installation tool (figure 23) should be fabricated (if not provided in the seal kit) to prevent seal damage

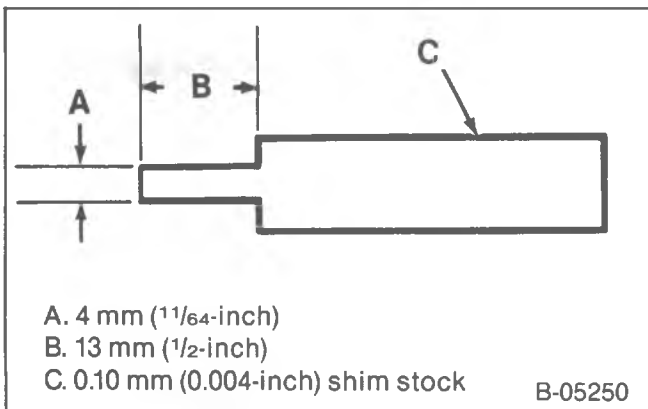

B-05250

Figure 23—Oil Seal Installation Tool

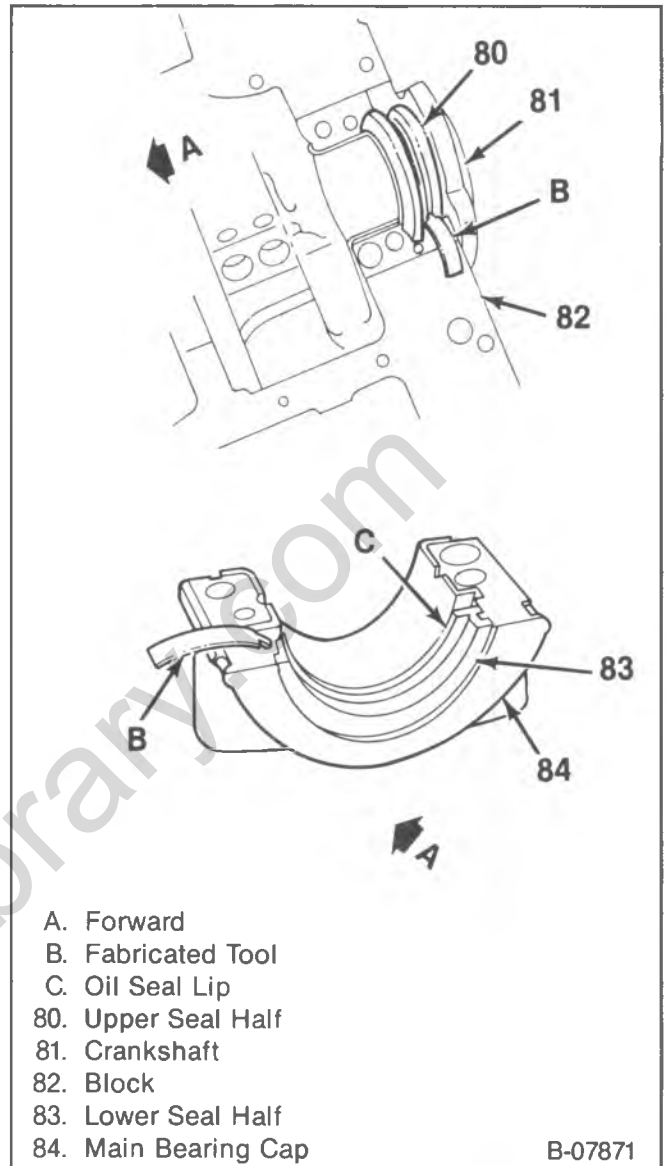

B-07871

Figure 24—Installing The Rear Crankshaft Oil Seal

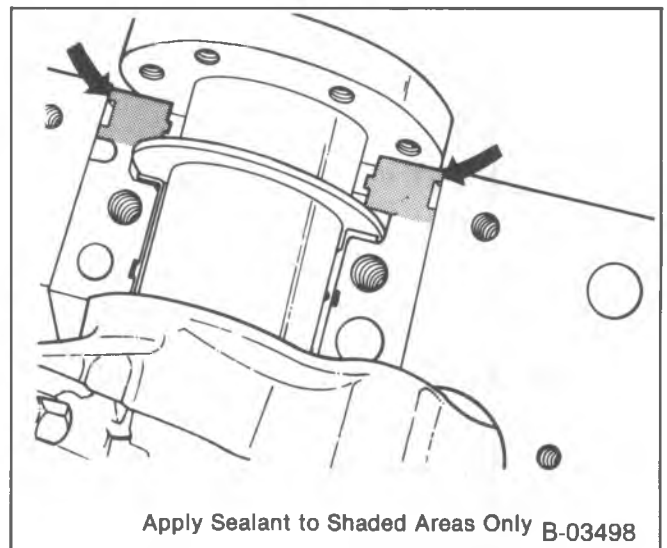

Figure 25—Applying Sealant To The Block

during installation. Extreme care should be taken when installing this seal to protect the sealing bead located in the channel on the outside diameter of the seal.

- Coat the seal lips lightly with engine oil. Keep the oil off of the seal mating ends.
- Position the tip of the tool between the crankshaft and the seal seat in the block (figure 24).
- Position the seal half between the crankshaft and the tip of the tool. Make sure that the oil seal lip is positioned toward the front of the engine.
- Roll the seal around the crankshaft using the tool as a "shoe-horn" to protect the seal bead from the sharp corner of the seal seat surface in the block. The installation tool must remain in position until the seal half is properly positioned with both ends flush with the block.
- Remove the tool, being careful not to withdraw the seal half.

2. Lower seal half.

- Coat the seal lips lightly with engine oil. Keep the oil off of the seal mating ends.
- Insert the seal half into the rear main bearing cap. Use the tool to protect the seal half from the sharp edge of the seal seal. Feed the seal half into the rear main bearing cap, using light finger pressure. Make sure the oil seal lip faces the front of the engine (figure 24).

3. Rear main bearing cap with the lower main bearing.

- Apply a brush-on type oil sealing compound to the mating surface of the block and cap (figure 25). Do not allow any sealant on either crankshaft or rear oil seal.
- Apply engine oil to the lower main bearing.
- Position the cap to the block. Install the cap bolts.

 **Tighten**

- Rear main bearing cap bolts temporarily to 14 N·m (10 ft. lbs.).
- Tap the end of the crankshaft first rearward then forward with a lead hammer. This will line up the rear main bearing and crankshaft thrust surfaces.

 **Tighten**

- Rear main bearing cap bolts to 90 N·m (65 ft. lbs.).

4. Oil pan, as outlined previously.

5. The proper quantity and grade of engine oil.

CHECKING VALVE TIMING

Tool Required:

J-8520-Dial Indicator Adaptor

When it becomes necessary to make a check of valve timing, the procedure following may be used:

1. Loosen the nut at the #1 intake valve rocker arm, swing the rocker arm away from the pushrod, then remove the pushrod.

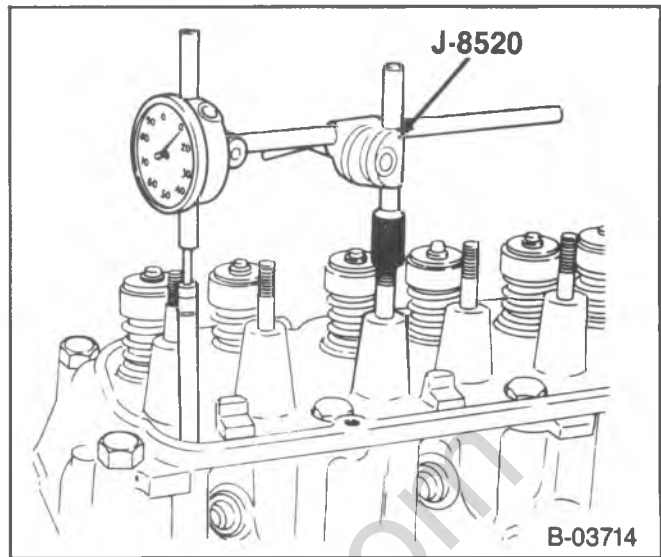

Figure 26—Checking Valve Timing Or Camshaft Lobe Lift

2. Install a dial indicator, along with J-8520 (figure 26). Turn the crankshaft until the #2 exhaust valve opens and the notch on the damper is aligned with the "0" mark on the timing tab.
3. Position the dial indicator to measure lifter movement and set indicator at zero. Turn the crankshaft 360 degrees and read the indicator. On correctly timed engines the indicator will read 0.012-0.020-inch.
4. If the reading is not as shown, reset the indicator at zero and turn the crankshaft 360 degrees, then read the indicator again. If reading is now within specifications, the engine is timed properly.
5. The chart following shows indicator readings with gears properly indexed for 4.8L engines and the indicator readings resulting from improperly indexed gears.

Engine		4.8L
Camshaft Part Number		3848000
Valve Lift		0.405"
Dial	Gears Properly Indexed	0.012-0.020"
Indicator	One Tooth Advanced	0.038"
Readings	One Tooth Retarded	0.007"

MEASURING CAMSHAFT LOBE LIFT

Tool Required:

J-8520 Dial Indicator Adaptor

To check for worn camshaft lobes, use the following procedure:

1. Remove the rocker arm as outlined previously.
2. Install a dial indicator (part of J-8520) (figure 26). Position the dial indicator so the plunger rests on the pushrod end, as shown, Make sure the pushrod is in the lifter socket.

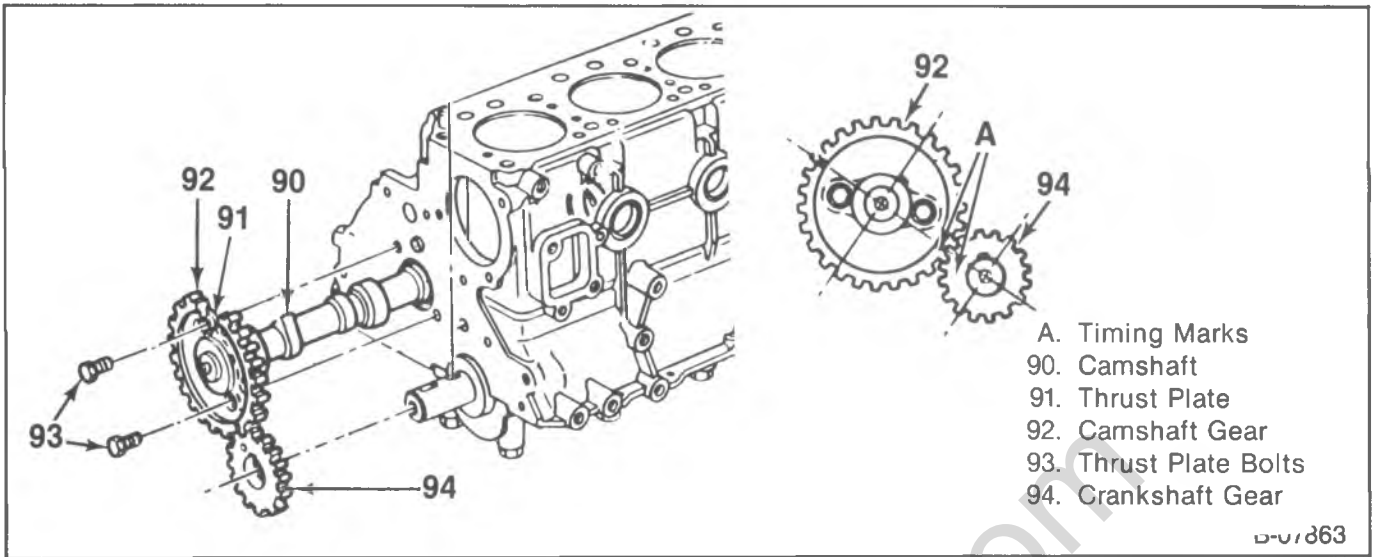

Figure 27—Camshaft And Components

3. Rotate the crankshaft slowly in the direction of rotation until the hydraulic lifter is on the heel of the cam lobe. At this point, the pushrod will be in its lowest position. Set dial indicator on zero, then rotate the crankshaft slowly until the pushrod is in the fully raised position.
4. Compare the total lift recorded from the dial indicator with specifications.
5. Continue to rotate the crankshaft until the indicator reads zero. This will be a check on the accuracy of the original indicator reading.
6. Remove the dial indicator and adaptor.
7. Install the rocker arm and adjust the valves as previously outlined.

CAMSHAFT REPLACEMENT

To check for worn camshaft lobes without disassembling the engine, refer to "Measuring Camshaft Lobe Lift" in this section.

Remove or Disconnect (Figures 27 and 28)

1. Front end sheet metal as required, depending on body builder design.
 - Drain the cooling system.
2. Radiator, fan shroud, fan, and pulley.
3. Air cleaner.
4. Fuel pump.
5. Rocker arm cover, as outlined previously.
6. Distributor. Refer to ENGINE ELECTRICAL (SEC. 6D).
7. Pushrod covers, as outlined previously.
8. Hydraulic lifters, as outlined previously.
9. Torsional damper, as outlined previously.
10. Timing gear cover, as outlined previously.
 - Align the timing marks (figure 27).
11. Thrust plate bolts (39) (figure 28).
12. Camshaft. Support the camshaft carefully to avoid damage to the camshaft bearings. On some vehicles, it may be necessary to disconnect the front engine mounting and raise the engine to provide clearance.

Inspect

- Camshaft lobes and journals for scratches, pitting, and wear.
- Timing gear for damaged teeth.

Measure (Figure 29)

- Thrust plate to camshaft clearance. Use a feeler gage (figure 29). The proper clearance is 0.003-0.008-inch. If the clearance is excessive, replace the thrust plate. If the clearance is insufficient, replace the spacer ring. Refer to the proper unit repair manual.

Camshaft Gear And Thrust Plate Replacement

- Refer to the proper unit repair manual.

Camshaft Bearing Replacement

- Refer to the proper unit repair manual.

Install or Connect (Figure 27)

- Coat the camshaft lobes and journals with a high quality engine oil supplement (GM Engine Oil Supplement or equivalent).

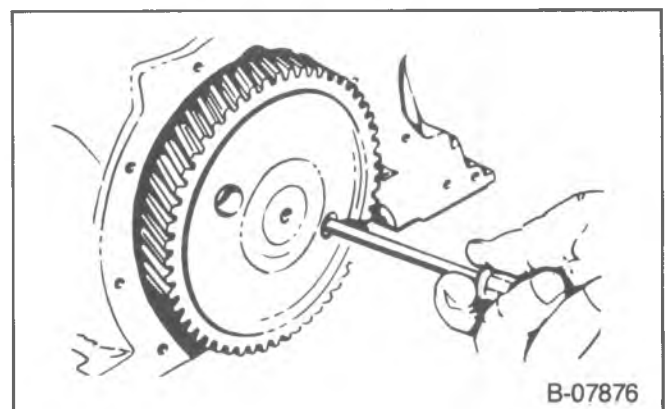

Figure 28—Removing The Camshaft Thrust Plate Bolts

B-07876

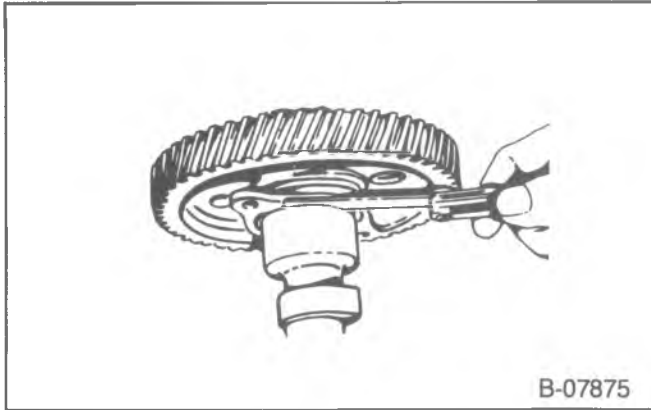

Figure 29—Measuring Camshaft To Thrust Plate Clearance

1. Camshaft (90) to the engine. Handle the camshaft carefully to prevent damage to the camshaft bearings.

! Important

- Line up the timing marks on the crankshaft gear and camshaft gear (figure 27).

2. Thrust plate bolts (94).

Tighten

- Thrust plate bolts to 9.0 N·m (80 in. lbs.).

Measure

- Camshaft and crankshaft gear run-out. Use a dial indicator. Camshaft gear run-out should not exceed 0.10 mm (0.004-inch), crankshaft gear run-out should not exceed 0.08 mm (0.003-inch). If gear run out is excessive, the gear will have to be removed and any burrs cleaned from the shaft or the gear will have to be replaced.
 - Timing gear backlash. Use a dial indicator. The correct backlash is 0.10-0.15 mm (0.004-0.006-inch) with new parts, 0.20 mm (0.008-inch) maximum with used parts.
4. Timing gear cover, as outlined previously.
 5. Torsional damper, as outlined previously.
 6. Hydraulic lifters, as outlined previously.

! Important

- Replace all hydraulic lifters, change the crankcase oil and filter, and add GM Engine Oil Supplement (or equivalent) to the engine oil if a new camshaft was installed.

7. Pushrod covers, as outlined previously.
8. Distributor. Refer to ENGINE ELECTRICAL (SEC. 6D).
9. Rocker arm cover, as outlined previously.
10. Fuel pump.
11. Air cleaner.
12. Radiator, fan, pulley, and shroud.
 - Fill the cooling system with the proper quantity and grade of coolant.
13. Front end sheet metal, as required.

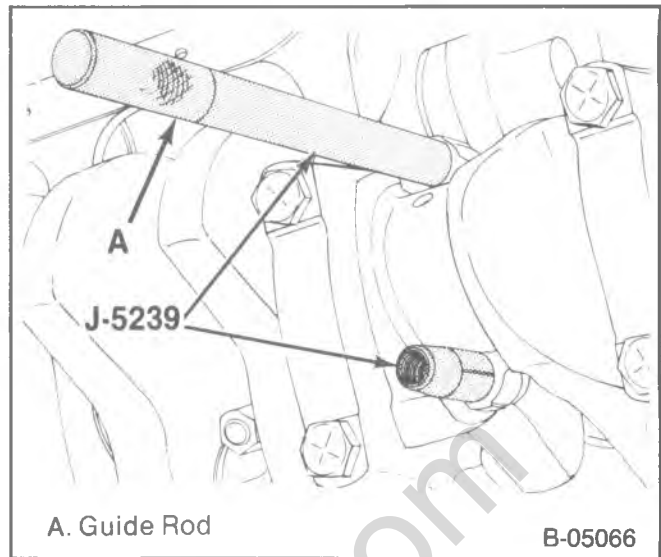

Figure 30—Replacing the Connecting Rod and Piston

CONNECTING ROD AND PISTON REPLACEMENT

↔ Remove or Disconnect (Figure 30)

Tool Required:

J-5239 Guide Set.

1. Cylinder head, as outlined previously.
2. Oil pan, as outlined previously.
3. Oil pump, as outlined previously (if necessary).
4. Ridge or deposits from the upper end of the cylinder bores.
 - Turn the crankshaft until the piston is at BDC.
 - Place a cloth on top of the piston.
 - Perform the cutting operation with a ridge reamer.
 - Turn the crankshaft until the piston is at TDC.
 - Remove the cloth and cuttings.
5. Connecting rod cap. Check the connecting rod and cap for identification marks. Mark the parts if required. The connecting rod and cap must be kept together as mating parts.
6. Connecting rod and piston.
 - Attach J-5239 to the connecting rod bolts (figure 30).
 - Use the long guide rod of J-5239 to push the connecting rod and piston out of the bore.
7. Connecting rod bearing.

Cleaning, Inspection, And Repair

Clean, inspect and repair or replace the components as necessary. Measure connecting rod bearing clearance, piston clearance, ring clearances, etc. Refer to the proper unit repair manual.

The unit repair manual contains information on:

- Connecting rod and piston.
- Piston rings.
- Connecting rod and crankpin.
- Cylinder bores.

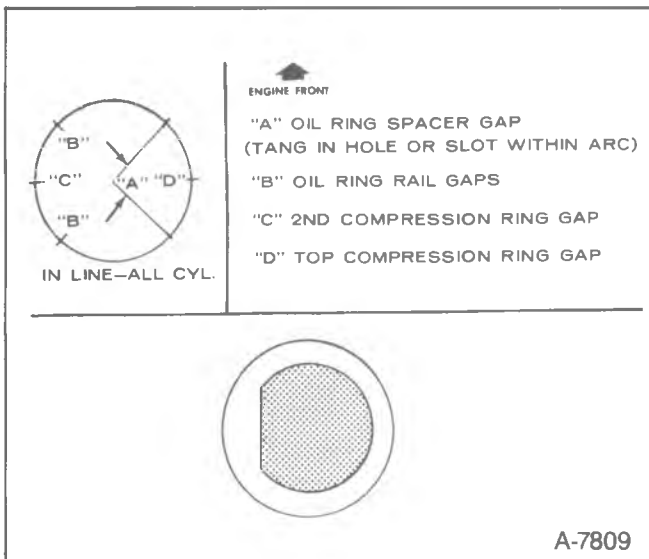

Figure 31—Piston Ring Gap Location

Install or Connect (Figures 30 through 34)

Tools Required:

- J-5239 Connecting Rod Guide Set
- J-8037 Ring Compressor

- Make sure the cylinder walls are clean. Lubricate the cylinder wall lightly with engine oil.
- Make sure the piston is installed in the matching cylinder.

1. Connecting rod bearings.
 - Be certain that the bearings are of the proper size.
 - Install the bearing inserts in the connecting rod and connecting rod cap.
 - Lubricate the bearings with engine oil.
2. Piston and connecting rod to the proper bore.
 - With the connecting rod cap removed, install J-5239 onto the connecting rod studs (figure 30).
 - Locate the piston ring end gaps as shown in figure 31. Lubricate the piston and rings with engine oil.
 - Without disturbing the ring end gap location, install J-8037 over the piston (figure 32).
 - The piston must be installed so that the piston crown depression's flat side faces to the engine's left side (figure 33).
 - Place the piston in its matching bore. Using light blows with a hammer handle, tap the piston down into its bore (figure 33). At the same time, from beneath the vehicle guide the connecting rod to the crankpin with J-5239 (figure 30). Hold the ring compressor against the block until all rings have entered the cylinder bore.
 - Remove J-5239 from the connecting rod bolts.

Measure

- Connecting rod bearing clearance. Refer to the proper unit repair manual.
3. Connecting rod cap and bearing.
 4. Connecting rod cap nuts.

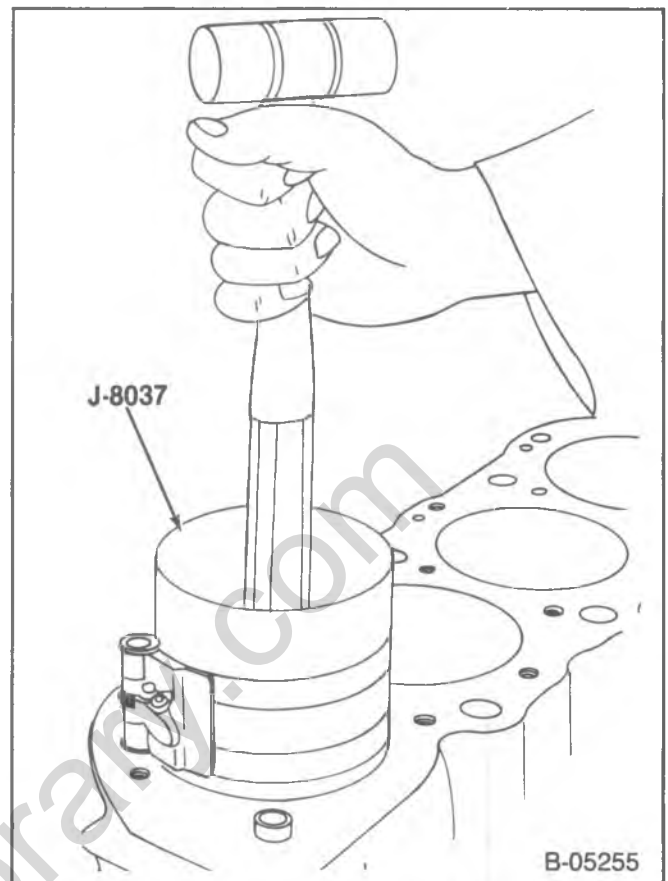

Figure 32—Installing The Piston

Tighten

- Connecting rod cap nuts to 60 N·m (44 ft. lbs.).

Measure

- Connecting rod side clearance. Use a feeler gage between the connecting rod and crankshaft (figure 34). The correct clearance is 0.006-0.017-inch.

5. Oil pump (if removed), as outlined previously.
6. Oil pan and cylinder head, as outlined previously.

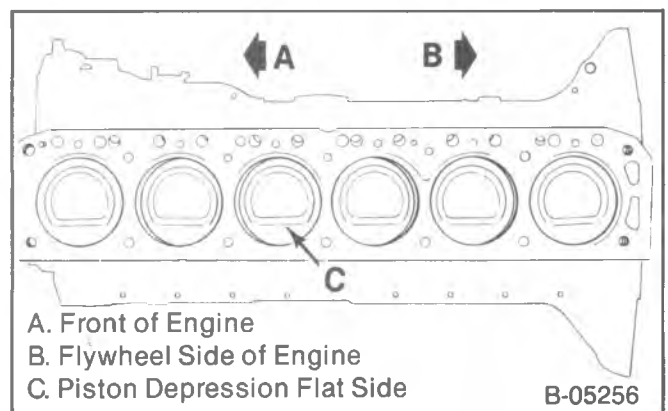

- A. Front of Engine
- B. Flywheel Side of Engine
- C. Piston Depression Flat Side

Figure 33—Pistons Installed

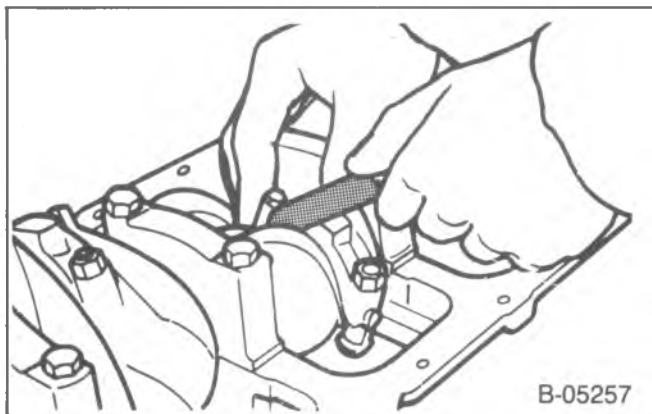

Figure 34—Measuring Connecting Rod Side Clearance

MAIN BEARING REPLACEMENT

↔ Remove or Disconnect (Figures 35 and 36)

Tool Required:

J-8080 Main Bearing Remover/Installer

1. Spark plugs.
2. Oil pan, as outlined previously.
3. Oil pump, as outlined previously.
4. Main bearing caps.
 - Check the main bearing caps for location markings. Mark the caps if necessary. The caps must be returned to their original locations during assembly.

5. Lower main bearing inserts from the main bearing caps.
6. Rear crankshaft oil seal, if necessary, as outlined previously.
7. Upper rear main bearing insert.
 - Use a small brass drift and hammer. Tap on the insert, on the side opposite the bearing tan, until the insert rotates out of position (figure 35).
 - Use a pair of pliers with the jaws taped to prevent damage to the crankshaft. Clamp the insert to the crankshaft flange (figure 35). Rotate the crankshaft to remove the bearing insert.
8. Upper main bearing inserts.
 - Insert J-8080 into the crankshaft oil hole (figure 36).
 - Rotate the crankshaft to "turn" the bearing insert out of the block.

Cleaning, Inspection, And Repair

Clean, inspect, and repair or replace the components as required. Refer to the proper unit repair manual. The unit repair manual contains information on:

- Crankshaft.
- Main and connecting rod bearings.
- Main bearing cap replacement (shimming procedure).

↔ Install or Connect (Figures 25, 35, 36, and 37)

Tool Required:

J-8080-Main Bearing Remover/Installer

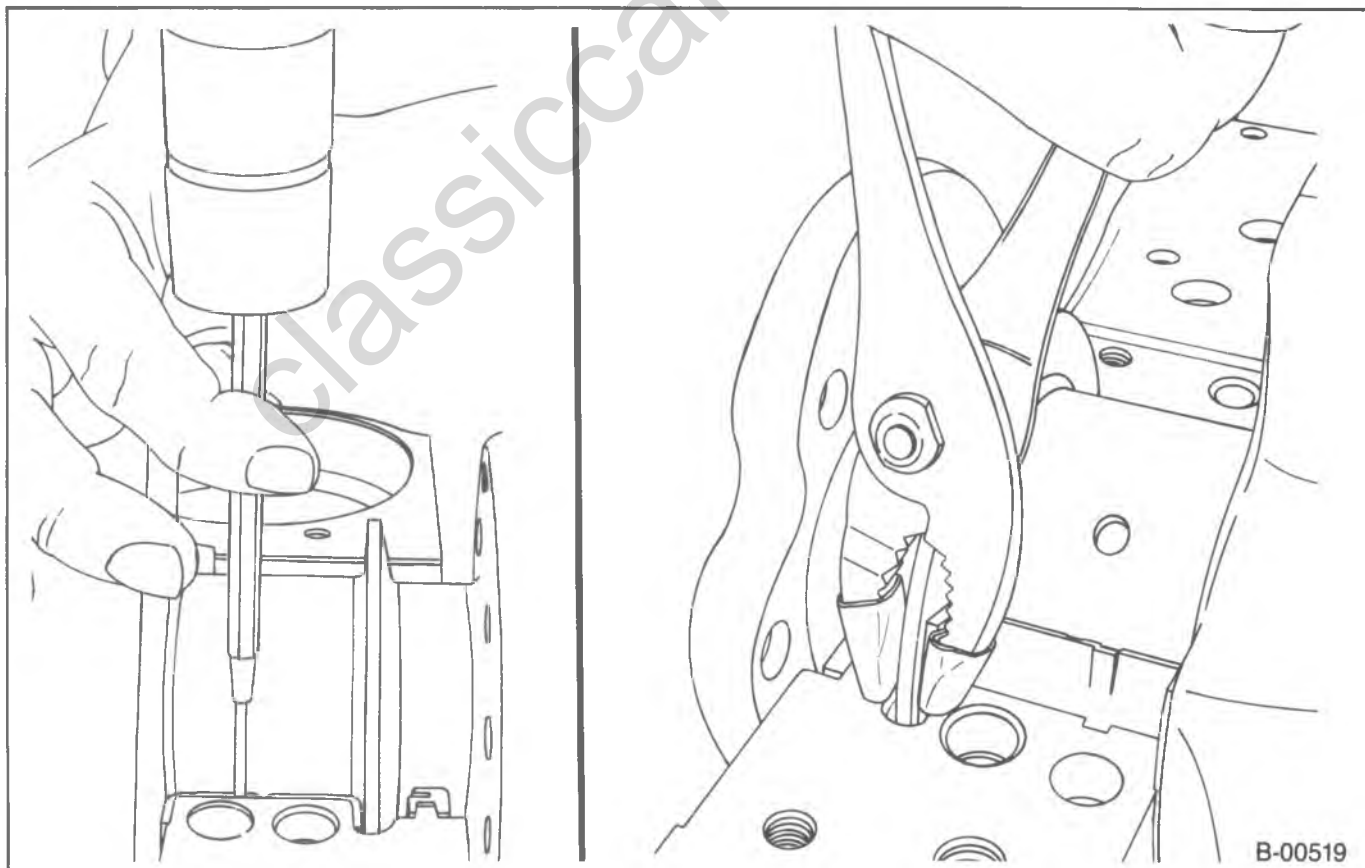

Figure 35—Removing The Upper Rear Main Bearing Insert

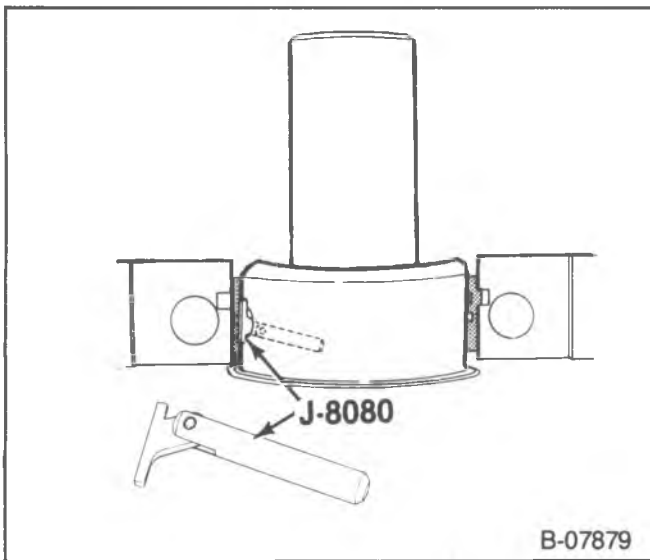
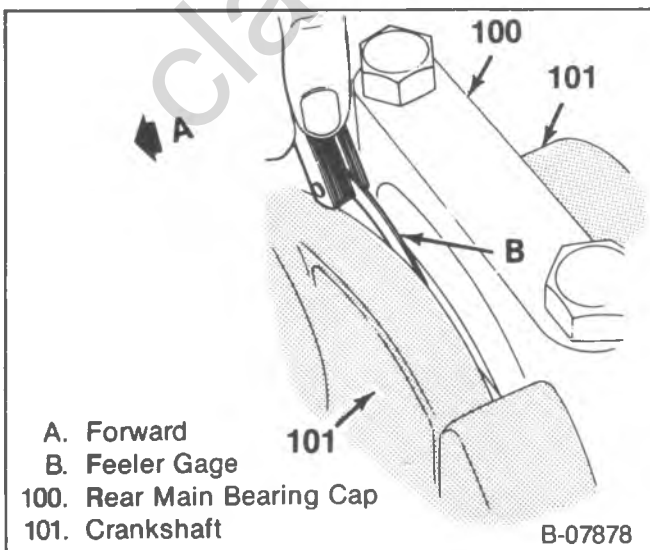

Figure 36—Removing The Upper Main Bearing Insert

1. Upper rear main bearing insert.
 - Apply engine oil to an insert of the proper size.
 - Insert the plain end (without the bearing tang) of the insert between the crankshaft journal and the notched side of the block.
 - Use pliers with taped jaws to clamp the bearing to the crankshaft as shown in figure 35. Rotate the crankshaft to “roll” the insert into the block. Then seat the insert using a small drift and hammer.
2. Lower rear main bearing insert.
 - Apply engine oil to an insert of the proper size.
 - Press the insert into the rear main bearing cap.
3. Upper main bearing inserts.
 - Insert tool J-8080 into a crankshaft main bearing oil hole (figure 36).
 - Apply engine oil to inserts of the proper size.
 - Insert the plain end (without the bearing tang) of the insert between the crankshaft and the notched side of the block.



- A. Forward
- B. Feeler Gage
- 100. Rear Main Bearing Cap
- 101. Crankshaft

Figure 37—Measuring Crankshaft End Play

- Rotate the crankshaft to “roll” the insert into the block.
 - Remove the tool.
4. Lower main bearing inserts to the main bearing caps.
 - Make sure the inserts are of the proper size.
 - Apply engine oil to the inserts.



Measure

- Main bearing clearance. Refer to the proper unit repair manual. If the engine is in the vehicle, the crankshaft must be supported upward to remove any clearance from the upper bearing. The total clearance can then be measured between the lower bearing and journal.
5. Main bearing caps (except rear cap) and bolts to the block. Make sure the special bolt which retains the oil pump screen bracket is installed in the proper position. (#5 main bearing cap, camshaft side hole.)



Tighten

- Main bearing cap bolts to 90 N·m (65 ft. lbs.).
6. Rear crankshaft oil seal to the block and main bearing cap, as outlined previously.
 7. Rear main bearing cap to the block.
 - Apply a brush-on type oil sealing compound to the mating surface of the block and cap (figure 25). Do not allow any sealant on either crankshaft or rear oil seal.
 - Apply engine oil to the bearing insert.
 - Install the rear main bearing cap and bolts. Tighten the bolts temporarily to 14 N·m (10 ft. lbs.).



Measure

- Crankshaft end play, as follows:
 - Tap the end of the crankshaft first rearward then forward with a lead hammer. This will line up the rear main bearing and crankshaft thrust surfaces.
 - Tighten the rear main bearing cap bolts to 90 N·m (65 ft. lbs.).
 - With the crankshaft forced forward, measure at the front end of the rear main bearing with a feeler gage (figure 37). The proper clearance is 0.05-0.15 mm (0.002-0.006-inch).
8. Oil pump, as outlined previously.
 9. Oil pan, as outlined previously.
 10. Spark plugs.

CRANKSHAFT GEAR REPLACEMENT



Remove or Disconnect (Figure 38)

Tool Required:

J-24420-A Puller.

1. Timing gear cover, as outlined previously.
2. Crankshaft gear. Use J-24220-A (figure 38).

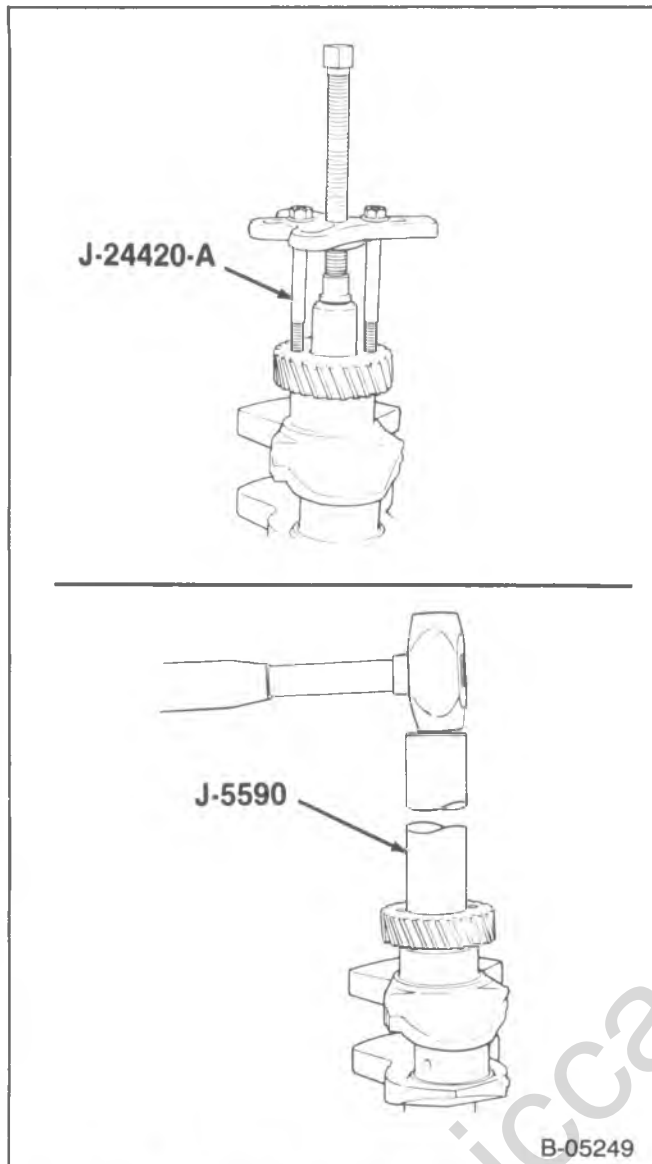

Figure 38—Replacing The Crankshaft Gear

Install or Connect (Figures 27 and 38)

Tool Required:

J-5590 Crankshaft Gear Installer.

1. Crankshaft gear. Use J-5590 (figure 38). Make sure the timing mark faces out.

Important

- Align the timing marks (figure 27).
2. Timing gear cover, as outlined previously.

OIL FILTER BYPASS VALVE REPLACEMENT

Remove or Disconnect (Figure 39)

1. Oil filter.
2. Oil filter relief valve. Pry it from the block with a screwdriver (figure 39).

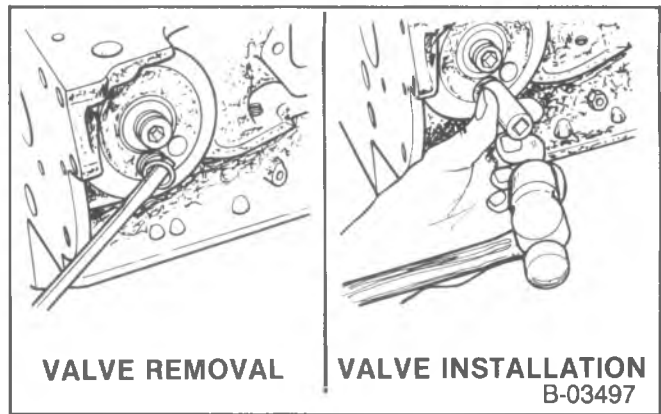

Figure 39—Replacing The Oil Filter Bypass Valve

Install or Connect (Figure 39)

1. Oil pressure relief valve. Tap into place. Use a 9/16-inch thin wall deep socket as a driver (figure 39).
2. Oil filter.
3. Engine oil, as necessary.

CRANKSHAFT REPLACEMENT

1. Remove the engine.
2. Refer to the proper unit repair manual for crankshaft replacement procedure.

FLYWHEEL REPLACEMENT

Remove or Disconnect (Figure 40)

1. Transmission, clutch housing, and clutch.
2. Rear main bearing cap. Refer to "Rear Crankshaft Oil Seal Replacement" in this section.
 - Mark the flywheel and crankshaft so the dowel pin holes can be aligned in their original positions at assembly (figure 40).
 - Loosen the flywheel bolts a few turns.
3. Flywheel dowel pins.
 - Turn the crankshaft so that a dowel pin is at the 6 o'clock position.
 - Drive the dowel pin out, using a hammer and drift.
 - Repeat the preceding steps to drive out the remaining dowel pins. The crankshaft must be turned each time so that the pin can be driven out without contacting the block.
4. Flywheel bolts.
5. Flywheel.

Clean

- Mating surfaces of crankshaft and flywheel. Remove any burrs.

Inspect

- Flywheel for burning, scoring, warping, and wear. Replace the flywheel if necessary. Do not machine the flywheel.
- Flywheel ring gear for worn or broken teeth.

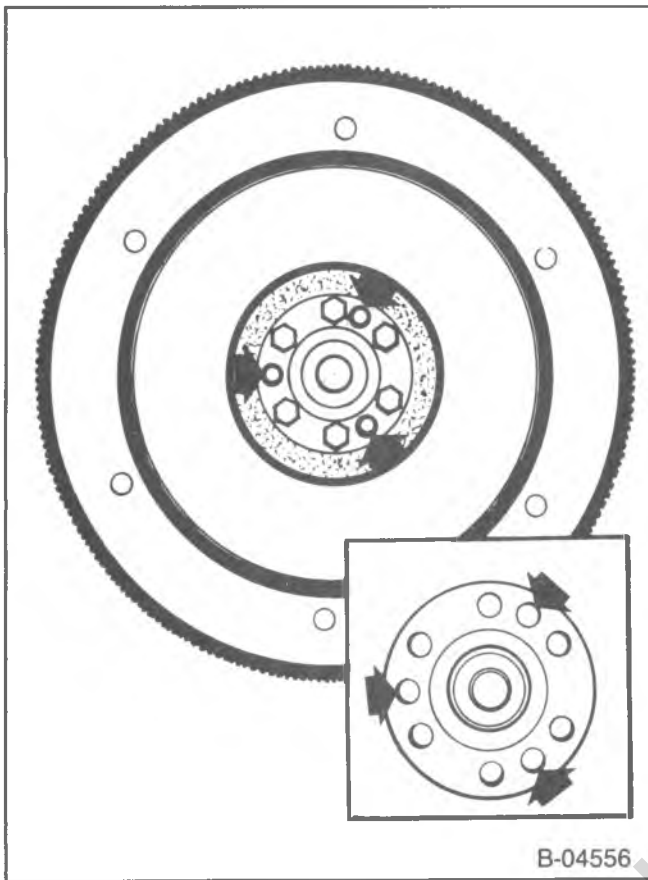

Figure 40—Flywheel Dowel Pin Hole Locations

Flywheel Ring Gear Replacement

1. Use a torch to heat the gear around the entire circumference, then drive the gear off the flywheel, using care not to damage the flywheel.

NOTICE: Never heat starter gear to red heat as this will change metal structure.

2. Uniformly heat the flywheel gear to temperature which will expand the gear to permit installation. Temperature must not exceed 204°C (400°F).
3. As soon as the gear has been heated, install on the flywheel.

↔ Install or Connect (Figure 40)

1. Flywheel to the crankshaft. Align the marks made at disassembly. Make sure the dowel holes in the crankshaft and flywheel are aligned.
2. Flywheel.

⌚ Tighten

- Bolts to 150 N·m (110 ft. lbs.).
3. Dowel pins.
 - The interference fit dowel pins must be replaced with an oversized dowel pin when installing the flywheel.
 - Ream the dowel pin holes to the proper size (0.4510-0.4517-inch).
 - Tap the dowel pins into place, flush with the flywheel retaining bolt surface.
 4. Rear main bearing cap. Refer to "Rear Crankshaft Oil Seal Replacement" in this section.

5. Transmission, clutch housing, and clutch.

ENGINE MOUNTINGS

NOTICE: Broken or deteriorated mountings can cause misaligned and eventual destruction of certain drive train components. When a single mounting breakage occurs, the remaining mountings are subjected to abnormally high stresses.

INSPECTING ENGINE MOUNTINGS

Front Engine Mountings

1. Raise the engine to remove weight from the mountings and to place a slight tension on the rubber cushion. Observe both mountings while raising the engine.
2. Replace the mounting if the following conditions exist:
 - Hard rubber surface covered with heat check cracks.
 - Rubber cushion separated from the metal plate of the mounting.
 - Rubber cushion split through the center.
3. If there is movement between a metal plate of the mounting and its attaching points, lower the engine and tighten the bolts or nuts attaching the mounting to the engine, frame, or bracket.

Rear Mountings

1. Push up and pull down on the transmission tailshaft. Observe the transmission mounting.
2. Replace the mounting if the following conditions exist:
 - Rubber cushion separated from the metal plate of the mounting.
 - Mounting bottomed out (tailshaft can be moved up but not down).
3. If there is relative movement between a metal plate of the mounting and its attaching point, tighten the bolts or nuts attaching the mounting to the transmission or crossmember.

FRONT MOUNTING REPLACEMENT

↔ Remove or Disconnect (Figures 41 and 42)

- Support the engine with a suitable lifting fixture. Do not load the engine mounting.
1. Engine mounting through-bolt and nut.
 - Raise the engine only enough to permit removal of the engine mounting.
 2. Mounting assembly bolts, nuts, and washers.
 3. Mounting assembly.

↔ Install or Connect (Figures 41 and 42)

NOTICE: See "Notice" on page 6A7-1 of this section for steps 2 and 3.

1. Mounting assembly.
2. Mounting assembly bolts, nuts, and washers.

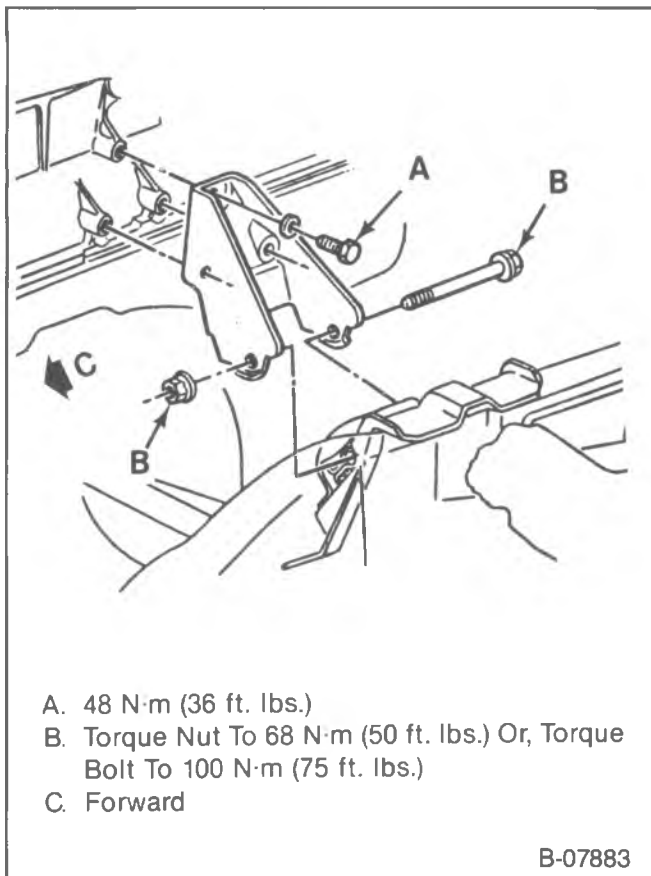

- A. 48 N·m (36 ft. lbs.)
- B. Torque Nut To 68 N·m (50 ft. lbs.) Or, Torque Bolt To 100 N·m (75 ft. lbs.)
- C. Forward

B-07883

Figure 41—Front Engine Mounting Brackets



Tighten

- Fasteners to specifications. Refer to figures 41 and 42.
3. Engine mount through-bolt and nut. Lower the engine until the bolt can be inserted. Install the nut.



Tighten

- Through-bolt or nut to specifications. Refer to figure 41.

REAR MOUNTING REPLACEMENT (P-MODELS WITH TRANSMISSION TAIL MOUNTING)



Remove or Disconnect (Figure 43)

- Support the rear of the engine to relieve the weight on the rear mountings.
1. Mounting to crossmember nut(s) and washer(s).
 2. Mounting to transmission bolts and washers.
 - Raise the rear of the engine only enough to permit removal of the mounting.
 3. Mounting.



Install or Connect (Figure 43)

1. Mounting.
- Lower the rear of the engine.
2. Mounting to transmission bolts and washers.

NOTICE: See "Notice" on page 6A7-1 of this section.

3. Mounting to crossmember nut and washer.

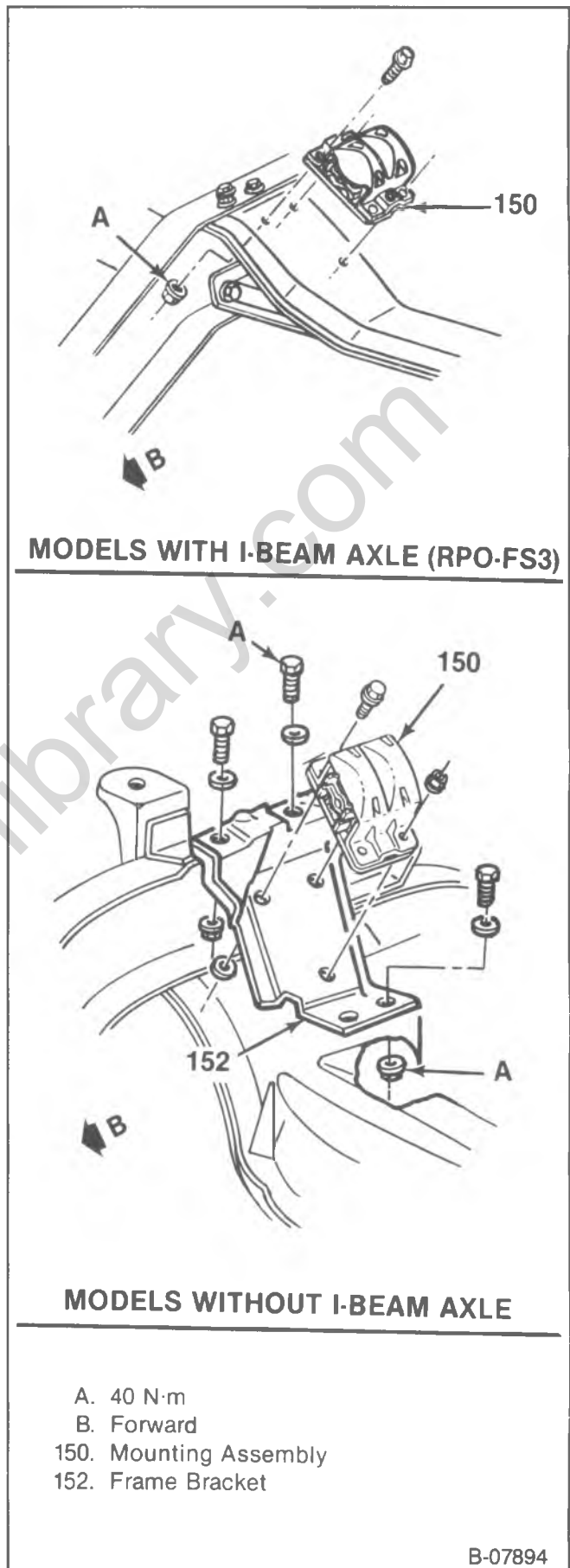

MODELS WITH I-BEAM AXLE (RPO-FS3)

MODELS WITHOUT I-BEAM AXLE

- A. 40 N·m
- B. Forward
- 150. Mounting Assembly
- 152. Frame Bracket

B-07894

Figure 42—Front Engine Mountings (P Models)

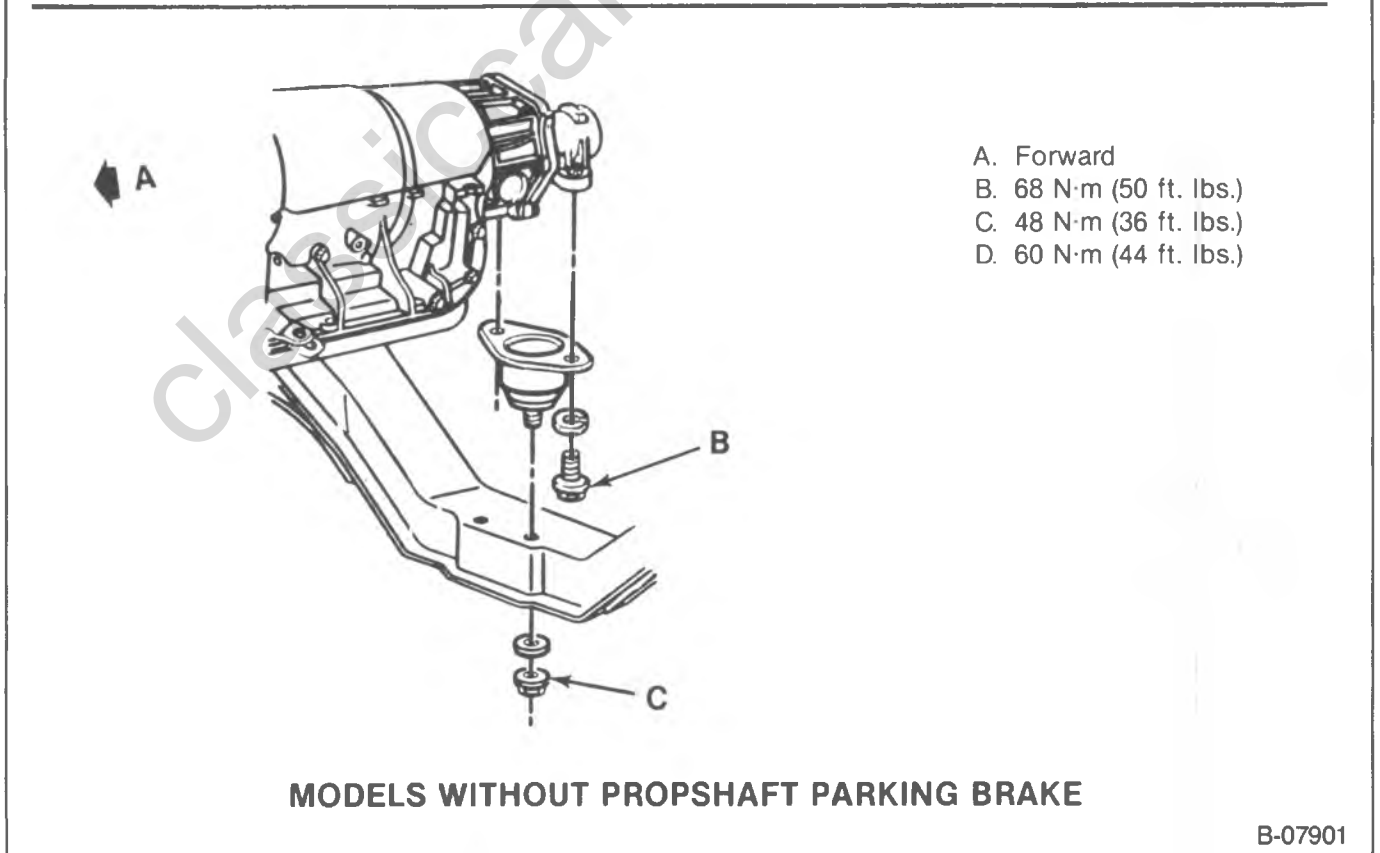
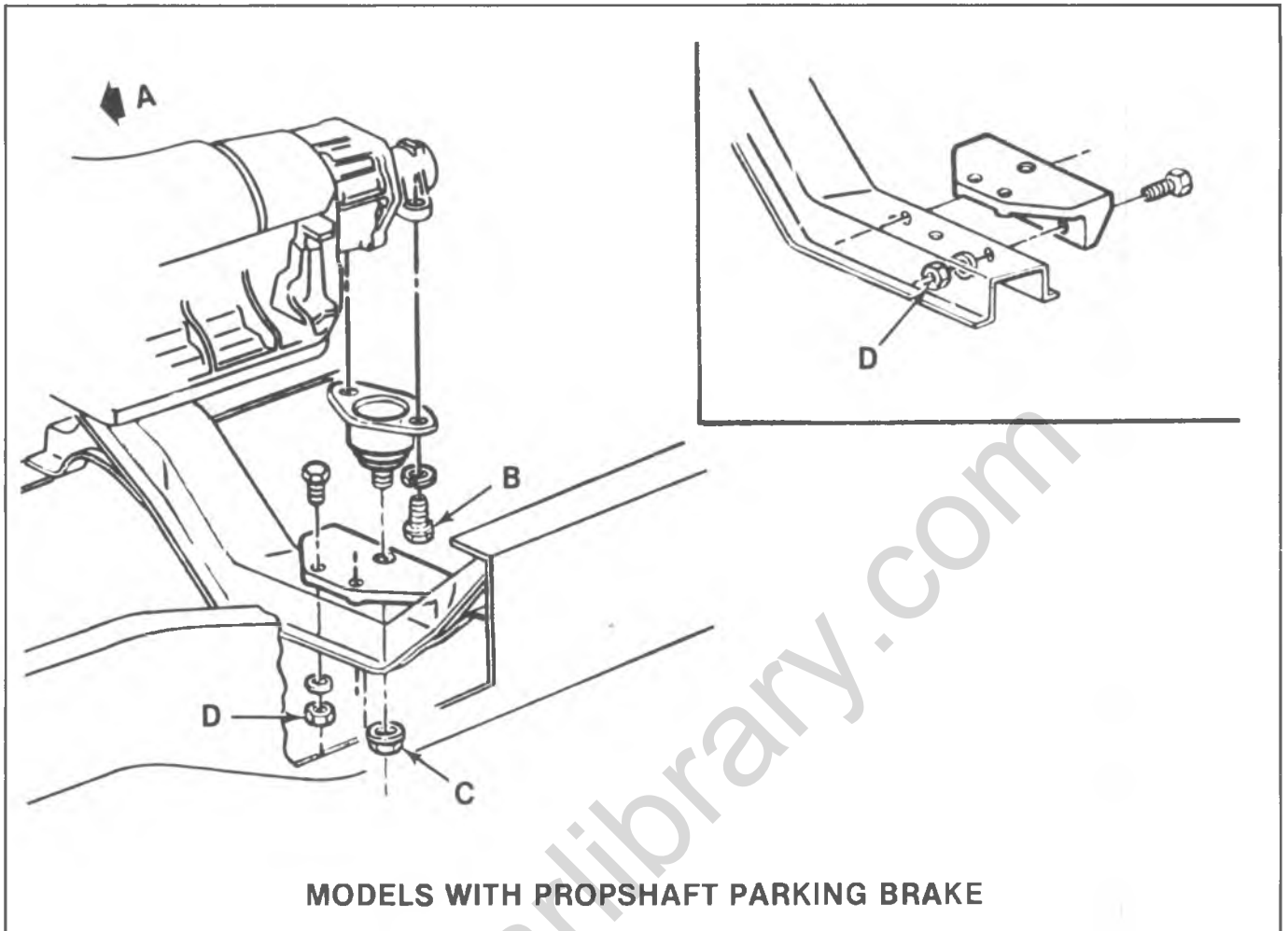

Figure 43—Rear Engine Mounting (P Models With Transmission Tail Type Mounting)

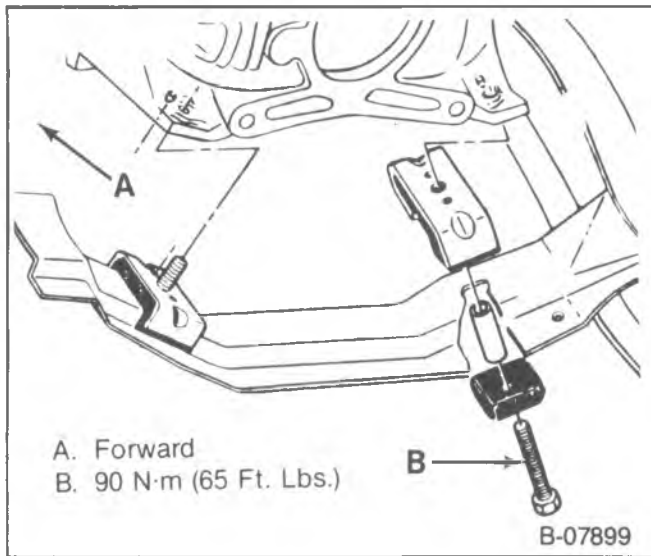

Figure 44—Rear Engine Mounting (P Models With Flywheel Housing Type Mounting)

 **Tighten**

- Fasteners to specifications. Refer to figure 43.

REAR MOUNTING REPLACEMENT (P-MODELS WITH FLYWHEEL HOUSING MOUNTING)

 **Remove or Disconnect (Figure 44)**

1. Bolt, cushion and spacer.
 - Raise the rear of the engine only enough to permit removal of the mounting.
2. Mounting.

 **Install or Connect (Figure 44)**

1. Mounting. Align the hole in the mounting with the hole in the crossmember.
 - Lower the rear of the engine.

NOTICE: See "Notice" on page 6A7-1 of this section.

2. Spacer, cushion and bolt.

 **Tighten**

- Bolt to 90 N·m (65 ft. lbs.).

ENGINE REPLACEMENT

Additional steps may be necessary on "P" models depending on body builder design.

 **Remove or Disconnect**

1. Battery negative cable.
2. Hood and sheet metal, as required.
3. Air cleaner.
4. Radiator.
5. Heater hoses from the engine.
6. Accelerator cable.
7. Transmission detent cable (if used).
8. Fan and water pump pulley.
9. Fuel lines from the fuel pump.

10. Evaporate emission and other vacuum hoses.
11. Engine wiring.
12. Starter.
13. Exhaust pipe at the exhaust manifold. Wire the pipe out of the way.
14. Flywheel cover.
15. Flywheel to torque converter bolts (automatic transmission).
 - Attach a suitable lifting device to the engine. Remove the weight from the engine mountings.
16. Front engine mounting through-bolts.
 - Support the transmission with a chain or transmission jack.
17. Bell housing to engine bolts.
18. Engine. Move the engine forward to disengage the transmission and remove.

 **Install or Connect (Figure 41)**

1. Engine. Move the engine rearward to engage the transmission.
2. Bell housing to engine bolts. Remove the transmission jack or support chain.
3. Front engine mounting through-bolts and nuts.

 **Tighten**

- Fasteners to specifications. Refer to figure 41.
 - Remove the lifting device.
4. Torque converter to flywheel bolts (automatic transmission).
 5. Flywheel cover.
 6. Exhaust pipe and new packing to the exhaust manifold.
 7. Starter.
 8. Engine wiring.
 9. Vacuum hoses.
 10. Fuel lines.
 11. Fan and water pump pulley.
 12. Transmission detent cable (if used).
 13. Accelerator cable.
 14. Heater hoses.
 15. Radiator.
 16. Air cleaner.
 17. Hood and sheet metal.
 18. Battery negative cable.
 19. Proper quantity and grade of coolant.

SPECIFICATIONS

ENGINE SPECIFICATIONS

All Specifications are in INCHES unless otherwise noted.

GENERAL DATA:				
Type	In Line			
Displacement	4.8L (292 Cu. In.)			
No. Of Cylinders	6			
Bore	3.876			
Stroke	4.12			
Compression Ratio	8.0:1			
Firing Order	1 - 5 - 3 - 6 - 2 - 4			
Oil Pressure	16 psi @ 700 RPM; 30-45 psi @ 1500 RPM			
CYLINDER BORE:				
Diameter	3.8750-3.8780			
Out Of Round	Production	0.0005 (Maximum)		
	Service	0.002 (Maximum)		
Taper	Production	Thrust Side	0.0005 (Maximum)	
		Relief Side	0.0005 (Maximum)	
	Service	0.001 (Maximum)		
PISTON:				
Clearance	Production	0.0026-0.0036		
	Service Limit	0.0045 (Maximum)		
PISTON RING:				
C O M P R E S S I O N	Groove Clearance	Production	Top	0.0020-0.0040
			2nd	
			Service Limit	Hi Limit Production \pm 0.001
	Gap	Production	Top	0.010-0.020
			2nd	0.010-0.020
				Service Limit
O I L	Groove Clearance	Production	0.005-0.0055	
		Service Limit	Hi Limit Production + 0.001	
	Gap	Production	0.015-0.055	
		Service Limit	Hi Production + 0.010	
PISTON PIN:				
Diameter	0.9270-0.09273			
Clearance In Piston	Production	0.00015-0.00025		
	Service Limit	0.001 (Maximum)		
Fit In Rod	0.0008-0.0016 Interference			

SPECIFICATIONS

ENGINE SPECIFICATIONS (CONT.)

All specifications are in INCHES unless otherwise noted.

CRANKSHAFT:			
Main Journal	Diameter		All 2.2979-2.2994
	Taper	Production	0.0002 (Maximum)
		Service Limit	0.001 (Maximum)
	Out of Round	Production	0.0002 (Maximum)
Service Limit		0.001 (Maximum)	
Main Bearing Clearance	Production		#1-#6: 0.0010-0.0024 #7: 0.0016-0.0035
	Service Limit		#1-#6: 0.0010-0.0025 #7: 0.0015-0.0035
Crankshaft End Play			0.002-0.006
Crankpin	Diameter		2.099-2.100
	Taper	Production	0.0005 (Maximum)
		Service Limit	0.001 (Maximum)
	Out Round	Production	0.0005 (Maximum)
Service Limit		0.001 (Maximum)	
Rod Bearing Clearance	Production		0.0010-0.0026
	Service Limit		0.0030 (Maximum)
Rod Side Clearance			0.006-0.017
CAMSHAFT:			
Lobe Lift \pm 0.002	Intake		0.2315
	Exhaust		0.2315
Journal Diameter			1.8677-1.8697
Camshaft Runout			0.020 (Maximum)
Camshaft End Play			0.003-0.008
VALVE SYSTEM:			
Lifter			Hydraulic
Rocker Arm Ratio			1.75:1
Valve Lash	Intake		One Turn Down From Zero Lash
	Exhaust		
Face Angle (Intake & Exhaust)			46°
Seat Angle (Intake & Exhaust)			46°
Seat Runout (Intake & Exhaust)			0.002 (Maximum)
Seat Width	Intake		0.035-0.060
	Exhaust		0.062-0.093
Stem Clearance	Production	Intake	0.0010-0.0027
		Exhaust	0.0015-0.0032
	Service	Intake	High Limit Production + 0.001
		Exhaust	High Limit Production + 0.002
Valve Spring (Outer)	Free Length		2.08
	Pressure lbs. @ in.	Closed	78-86 lbs. @ 1.66"
		Open	170-180 lbs. @ 1.26"
Installed Height \pm 1/32"			1 21/32
Valve Spring Damper	Free Length		1.94
	Approx. # of Coils		4

SPECIFICATIONS (CONT.)

TORQUE SPECIFICATIONS

Item	N·m	Ft. Lbs.	In. Lbs.
Flywheel Bolts	150	110	—
Flywheel Housing Bolts	40	30	—
Main Bearing Cap Bolts	90	65	—
Camshaft Thrust Plate Screws	9.0	—	80
Timing Gear Cover Bolts To Block	9.0	—	80
Torsional Damper Bolt	70	50	—
Connecting Rod Cap Nuts	60	44	—
Oil Pump Bolts	13.0	—	115
Oil Pump Pickup Tube Bracket Nut (To Main Bearing Cap Bolt)	34	25	—
Oil Pump Cover Bolts	7.9	—	70
Oil Pan Bolts (To Front Cover)	5.1	—	45
(To Block [1/4-20])	9.0	—	80
(To Block [5/16-18])	18.6	—	165
Cylinder Head Bolts (Left-Hand Front Bolt)	115	85	—
(All Others)	130	95	—
Rocker Arm Cover Bolts (Cork Gasket)	4.3	—	38
Pushrod Cover Bolts	9.0	—	80
Water Pump Bolts	20	15	—
Thermostat Housing To Block Bolts	38	28	—
Water Outlet to Thermostat Housing Bolts	28	20	—
Intake Manifold To Exhaust Manifold Bolts And Nuts	60	44	—
Manifold To Cylinder Head Bolts And Nuts	52	38	—
Spark Plug	20	15	—

SPECIAL TOOLS



1. J-23523-E



2. J-5892-B



3. J-23590



4. J-35468



5. J-8080



6. J-8037



7. J-5239



8. J-23738-A



9. J-9290-01



10. J-3049



11. J-5802-01



12. J-5715

13. J-6036



14. J-6880



15. J-24420-A



16. J-5590

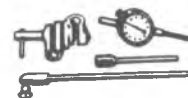

17. J-8520

1. Torsional Damper Remover and Installer
2. Valve Spring Compressor
3. Air Adapter
4. Crankshaft Seal Installer and Centering Tool
5. Main Bearing Replacer
6. Piston Ring Compressor
7. Guide Set
8. Vacuum Pump
9. Hydraulic Lifter Remover (Slide Hammer Type)

10. Hydraulic Lifter Remover (Plier Type)
11. Stud Remover
12. Reamer (0.003-inch oversize)
13. Reamer (0.013-inch oversize)
14. Stud Installer
15. Crankshaft Gear Puller
16. Crankshaft Gear Installer
17. Dial Indicator Adapter

SECTION 6B1

ENGINE COOLING

CONTENTS

<u>SUBJECT</u>	<u>PAGE</u>
Description6B1- 1
Diagnosis6B1- 2
System Checks6B1- 2
Fan Clutch Diagnosis6B1- 2
Thermostat Diagnosis6B1- 3
Coolant Level Indicator Diagnosis6B1- 3
Cooling System Diagnosis6B1- 5
Uncommon Cooling System Problems6B1- 5
On Vehicle Service6B1- 6
Flushing The Cooling System6B1- 6
Coolant Recovery Tank Replacement6B1- 6
Deaeration Tank Replacement6B1- 6
Thermostat Replacement6B1- 7
Thermostat Housing Crossover Removal6B1- 8
Drive Belt Replacement6B1-10
Fan And Fan Clutch Replacement6B1-13
Auxiliary Cooling Fan Replacement6B1-14
Water Pump Replacement6B1-15
Specifications6B1-30
Special Tools6B1-32

DESCRIPTION

All R/V, G, and P series vehicles have pressure type engine cooling systems with thermostatic control of the coolant circulation. The cooling system is sealed by a pressure type radiator cap that causes the system to operate at higher than atmospheric pressure. This higher pressure operation raises the boiling point of the coolant, thereby increasing the cooling efficiency of the radiator. The 105 kPa (15 psi) pressure cap raises the boiling point of the coolant to approximately 125°C (258°F) at seal level.

The pressure-vacuum valve radiator cap allows the coolant to expand through the pressure valve in the cen-

ter of the cap without building unnecessary pressure. This expanding coolant flows into the coolant reservoir. The vent valve closes due to expansion and coolant flow (the nominal 105 kPa (15 psi) pressure will not be reached until the system is working at maximum capacity). Any air or vapor in the cooling system will be forced into and out of the coolant reservoir through the vent tube at the top of the reservoir. As the system cools, the extra coolant in the reservoir will be drawn back to the radiator through the vent valve. In this manner, the radiator will keep itself full at all times.

DIAGNOSIS

SYSTEM CHECKS

EXHAUST LEAKS

To check for exhaust leaks into the cooling system, drain the system until the coolant level stands just above the top of the cylinder head(s), then disconnect the radiator upper hose and remove the thermostat and fan belt(s). Start the engine and accelerate several times. At the same time note any appreciable coolant rise or the appearance of bubbles which may indicate that exhaust gases are leaking into the cooling system.

NOTICE: A worn head gasket may allow exhaust gases to leak into the cooling system. This can damage the cooling system as the gases combine with the water to form acids which are harmful to the radiator and engine.

WATER PUMP

Check water pump operation by running the engine while squeezing the radiator upper hose. When the engine warms a pressure surge should be felt. Check for a plugged venthole in the pump.

RADIATOR

Test for restrictions in the radiator by warming the engine and then turning the engine off and feeling the radiator. The radiator should be hot along the left side and warm along the right side, with an even temperature rise from right to left. Cold spots in the radiator indicate clogged sections.

THERMOSTAT

Check the thermostat by hanging the thermostat on a hook in a 33% glycol solution, 25°C (4°F) above the temperature stamped on the thermostat valve. Submerge the valve and agitate the solution. The valve should open. Remove the thermostat and place it in a 33% glycol solution, -12°C (10°F) below the temperature indicated on the valve. With the valve submerged and coolant agitated, the valve should close.

OVERHEAT AND/OR NOISE

Restrictions in the cooling system can cause the engine to overheat and/or create cooling system noise.

Components prone to this condition are the cylinder head, water pump, block, thermostat housing and inlet manifold. Symptoms include:

- Engine may make snapping/cracking noises.
- Heater core may gurgle or surge.
- Radiator hoses may collapse and expand.
- Heater hoses may vibrate and thump.
- Overheat light may or may not come on.

Symptoms are the result of coolant boiling at some localized area and may be noticed after extending idling and/or while driving. Determine which side of the engine is involved and whether it is more at the front or rear of the engine.

Diagnosis/Inspection

1. Isolate the area by probing the engine with a sounding bar (large screwdriver).
2. With the radiator cap removed, observe the water being circulated in the radiator. Feel the front area of the radiator for cold spots which indicate blockage. Blocked radiators generally occur on units that have accrued miles and not on new vehicles.

CAUTION: The radiator cap should be removed from a cool engine only. If the radiator cap is removed from a hot cooling system, serious personal injury may result.

3. Inspect the thermostat to see if it opens.
4. Inspect the thermostat housing to make sure it is free of obstructions.
5. Remove the water pump from the vehicle and the back cover on the pump. Inspect internal passages using a flash light.
6. Inspect the cross over at the front of the inlet manifold. This entire passage can be seen with the thermostat removed.
7. Remove the heads, and check the block.
8. With the water pump and heads removed, inspect the coolant passages by using a pen light flash light. Replace the block if a restriction can be seen.
9. If none of the above inspections reveal the problem area, inspect the heads. Heads with blocked coolant passages generally have more than one area that is blocked. Inspect the heads for signs of overheat discoloration (a dark blue or black area). If none are found, look in the coolant passages for blockage and probe all accessible passages.

Use a substantial probe as a tag wire to go through or around a partially blocked area. If nothing is found by visual inspection and probing, inspect the passages for a rough, ragged appearance. The roughest internal passages are probably the ones that are blocked.

Replace a blocked or suspect head and inspect the replacement head before installation.

FAN CLUTCH DIAGNOSIS

NOISE

Fan noise is sometimes evident under the following normal conditions.

- When the clutch is engaged for maximum cooling.
- During the first few minutes after start-up until the clutch can re-distribute the silicone fluid back to its normal disengaged operating condition (after overnight settling).

Fan noise or an excessive roar will generally occur continuously under high engine speed conditions (2500 rpm and up) if the clutch assembly is locked up due to an internal failure. If the fan cannot be rotated by hand or there is a rough grating feel as the fan is turned, replace the clutch.

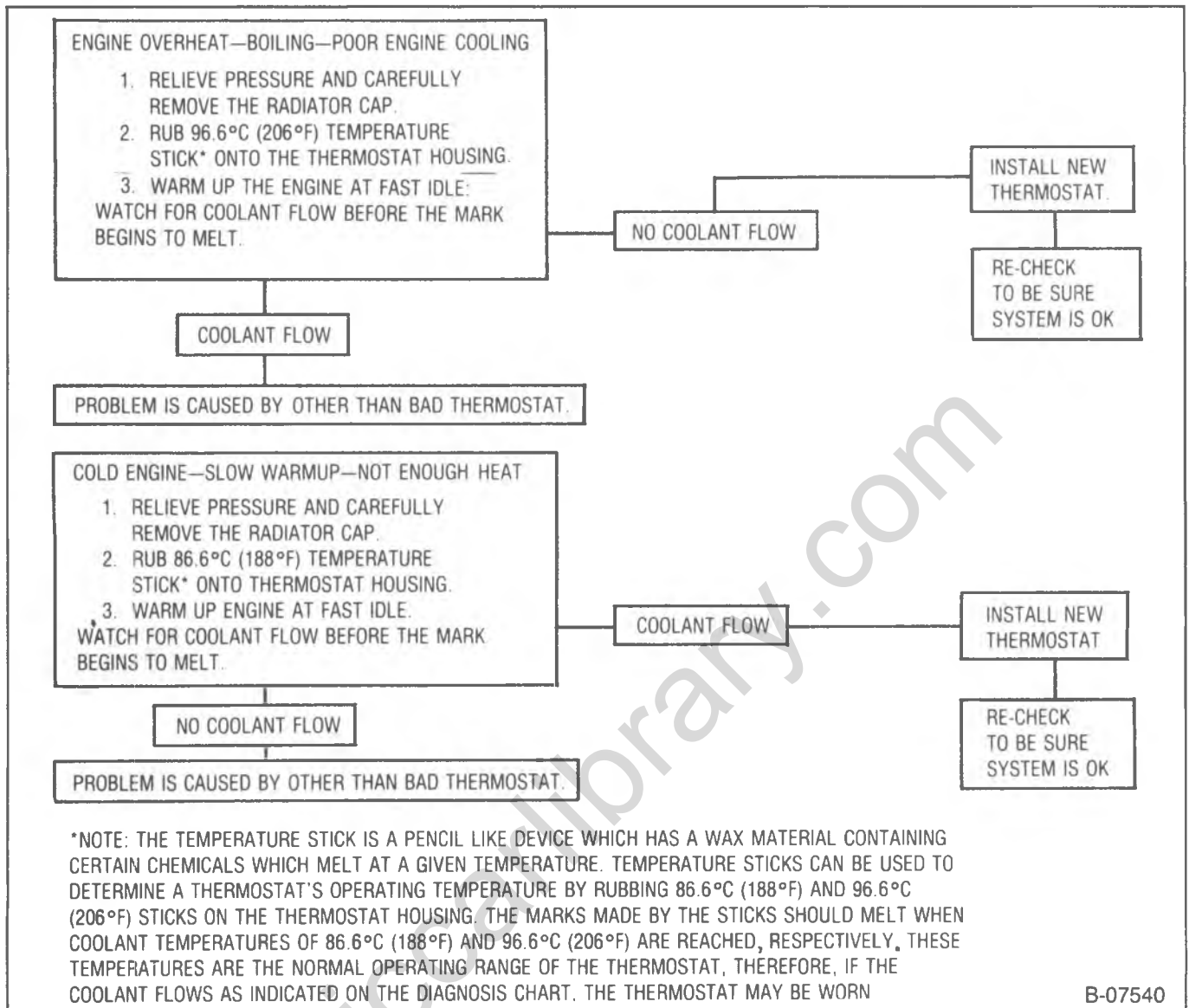

Figure 1—Thermostat Diagnosis Chart

LOOSENESS

Check a loose fan assembly for any wear and replace if necessary. Under various temperature conditions a visible lateral movement that can be observed at the tip of the fan blade. This is a normal condition due to the type of bearing used. Approximately 6.5 mm (1/4-inch) maximum lateral movement measured at the fan tip is allowable. This is not cause for replacement.

SILICONE FLUID LEAKS

The fan clutch operation is generally not affected by small fluid leaks which may occur in the area around the bearing assembly. If leakage appears excessive, replace the fan clutch (see below).

ENGINE OVERHEATING

If the fan and clutch assembly free-wheel with no drag (revolves more than five times when spun by hand), replace the clutch.

THERMOSTAT DIAGNOSIS

Refer to the thermostat diagnostic chart for thermostat diagnosis procedures (figure 1).

COOLANT LEVEL INDICATOR DIAGNOSIS**INDICATOR LAMP WILL NOT ILLUMINATE**

1. Turn the ignition switch to the CRANK position.
 - If the lamp illuminates, the lamp is OK and the connector is properly installed on the module. Go to Step 2.
 - If the lamp does not illuminate, check the bulb, socket and wiring between the socket and the module connector and the connector on the module. Replace or repair as required.
2. Turn the ignition switch to the ON position and disconnect the electrical lead at the coolant level sensor on the radiator.

COOLING SYSTEM DIAGNOSIS—CHART A

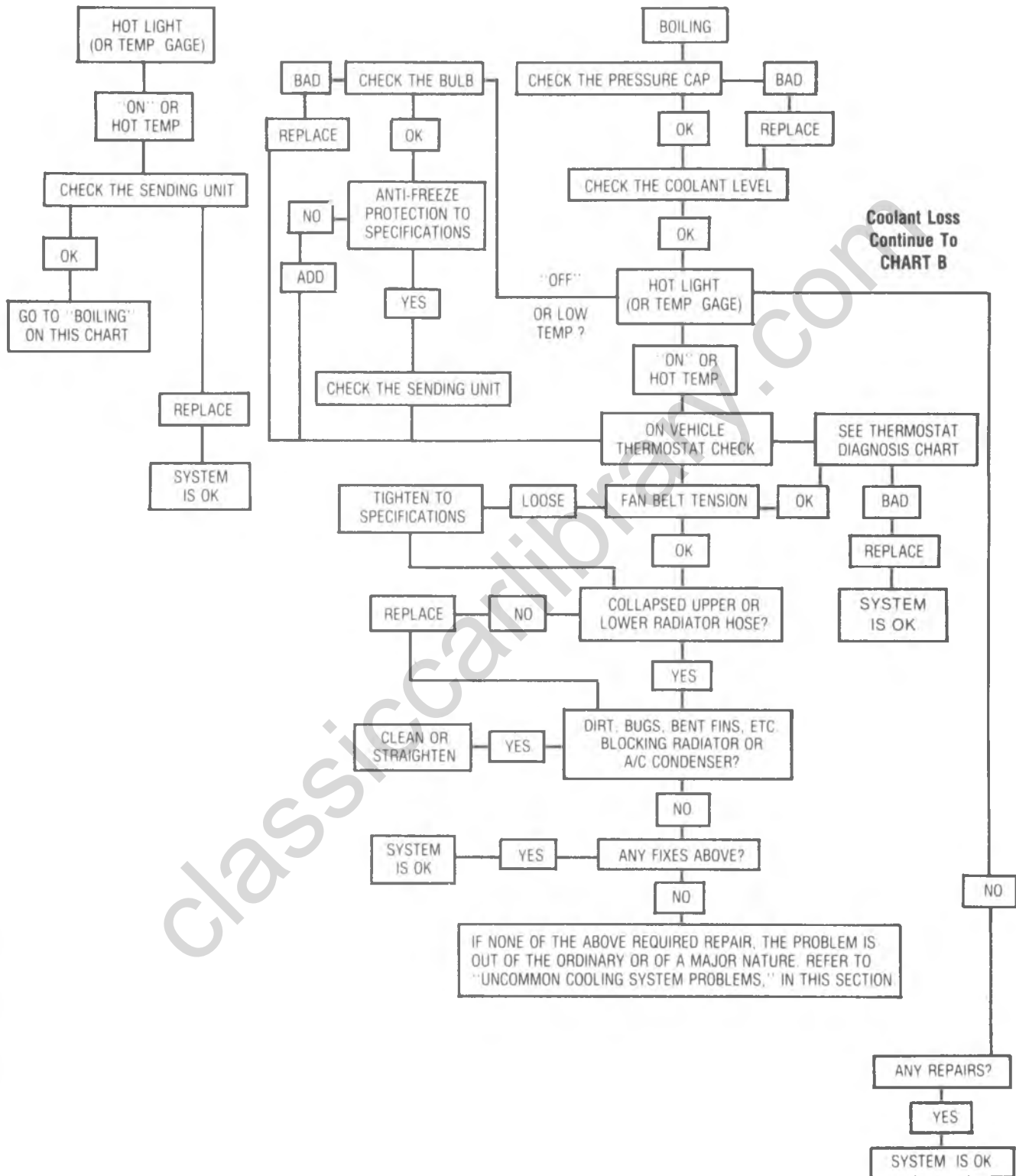
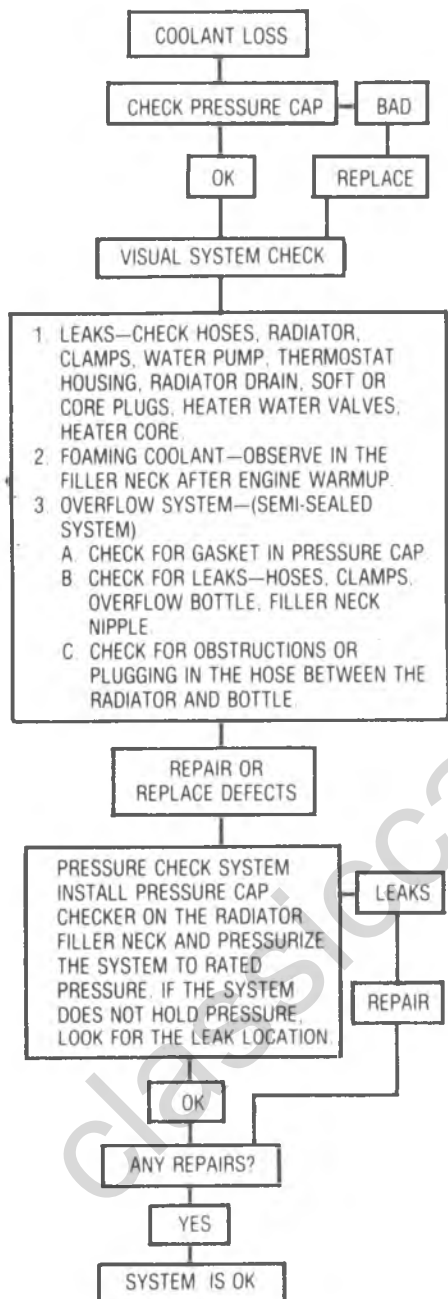

Figure 2—Cooling System Diagnosis Chart

COOLING SYSTEM DIAGNOSIS — CHART B



F-02620

Figure 3—Cooling System Diagnosis Chart

- If the lamp fails to illuminate, check the wiring between the coolant level sensor connector and the module for a short circuit to ground. If the circuit is OK, replace the module.

INDICATOR LAMP REMAINS ILLUMINATED

1. Turn the ignition switch to ON.
 - Check the coolant level. Add coolant if necessary.
 - If the lamp remains illuminated, go to Step 2.
2. Disconnect the electrical lead at the coolant level sensor on the radiator (use a jumper wire and "G" type electrical connector).
 - If the lamp does not illuminate, replace the sensor.
 - If the lamp remains illuminated, connect the electrical lead and go to Step 3.
3. Check for an open circuit between the sensor and the module.
 - If an open circuit is found, repair it.
 - If no open circuit is found, replace the module.

COOLING SYSTEM DIAGNOSIS

Refer to the cooling system diagnosis chart for detailed cooling system diagnostic procedures (figures 2 and 3).

UNCOMMON COOLING SYSTEM PROBLEMS

PROBLEMS NOT REQUIRING DISASSEMBLY OF THE COOLING SYSTEM

1. Locate and remove large obstructions blocking the radiator or the condenser.
 - Auxiliary oil cooler.
 - License plates.
 - Spare tires.
 - Ice, mud, or snow obstructing the grille.
2. Engine oil is overfilled.
3. Incorrect radiator for the application.
 - Check the part number.
4. Loose, damaged, or missing air seals.
5. Missing or damaged lower air baffle.
6. Incorrect ignition timing.

PROBLEMS REQUIRING DISASSEMBLY OF THE COOLING SYSTEM

1. Incorrect or damaged fan.
 - Could cause overheating at idle.
 - Damaged PCV valve, TVS or TCS.
3. Pressure check the cooling system with the pressure cap installed.
 - Shows if the pressure cap leaks because of radiator filler neck damage.
4. Worn or damaged water pump.
 - Impeller vanes eroded or broken.
 - Worn or damaged bearing and/or seal-check for shaft or bearing play.
5. Plugged radiator tubes.
 - Perform a flow check.
6. Internal system leaks.
 - Head gasket.

6B1-6 ENGINE COOLING

- Cracked block.
- Timing chain cover.
- Intake manifold gasket.

7. Plugged coolant passages in the cylinder heads.
 - Visual check.

ON VEHICLE SERVICE

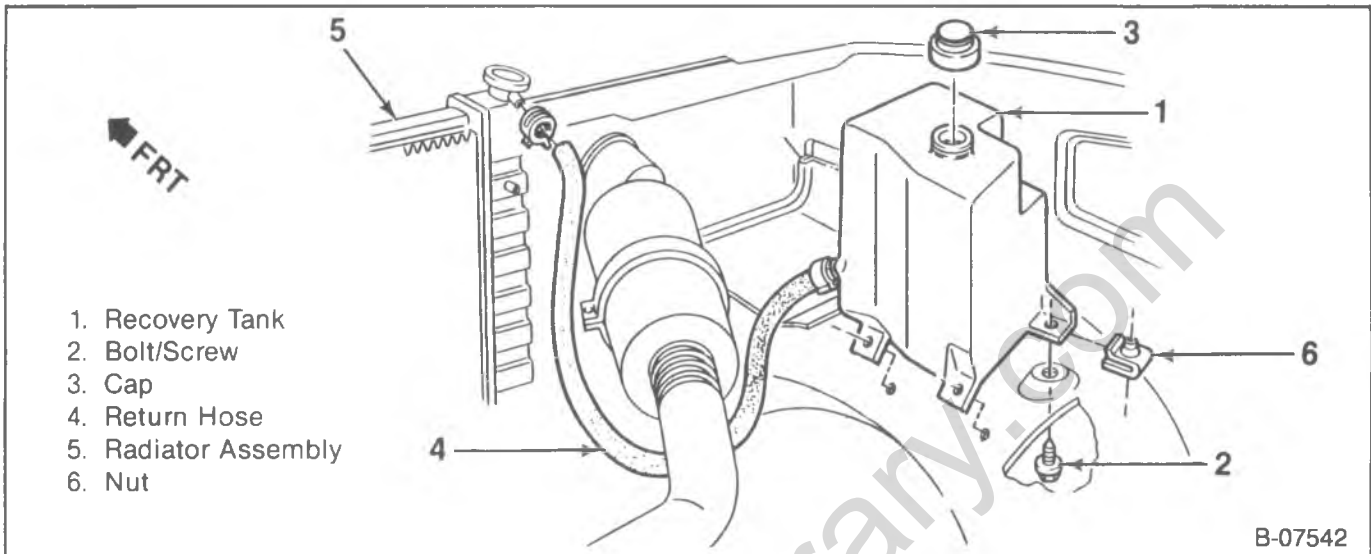

Figure 4—R/V - Coolant Recovery System

FLUSHING THE COOLING SYSTEM

Various methods and equipment can be used to flush the cooling system. If special equipment is used, follow the equipment manufacturer's instructions.

! Important

- Remove the thermostat before flushing the cooling system.

COOLANT RECOVERY TANK REPLACEMENT

↔ Remove or Disconnect (Figures 4, 5 and 6)

1. Coolant from the recovery tank (1).
2. Coolant overflow hose from the recovery tank (1).
3. Coolant recovery tank (1) from the vehicle.
 - Bolt/screw (2).

↔ Install or Connect (Figures 4, 5 and 6)

1. Coolant recovery tank (1), to the vehicle.
 - Bolt/screw (2).

Tighten

- Bolt/screw (2) to 2.0 N·m (1.5 ft. lbs.).
2. Coolant overflow hose to the recovery tank (1).
 3. Coolant to the recovery tank (1).

DEAERATION TANK REPLACEMENT

↔ Remove or Disconnect (Figures 7, 8 and 9)

1. Coolant from the deaeration tank (10).
2. Overflow hose from the filler neck.
3. Return hose (12) from the deaeration tank (10).
4. Deaeration tank (10) from the vehicle.
 - For R/V and P vehicles; bolts/screws (7), and the retaining straps (8) from the support brackets (9) (figures 6 and 8).
 - For the G series vehicle; bolts/screws (7) and nut (6) (figure 7).
 - The deaeration tank (10) is free of the vehicle.

↔ Install or Connect (Figures 7, 8 and 9)

1. Deaeration tank (10) to the vehicle.
 - For R/V and P vehicles; deaeration tank (10) onto the support brackets (9). Attach the retaining straps with bolts/screws around the tank and the lip on the support brackets (9).
 - For the G vehicle; deaeration tank (10) into position and attach with bolts/screws (7) and the nut (6).

Tighten

- Bolt/screws (7) and nut (6) to "Specifications."
2. Return hose (12) to the deaeration tank (10).
 3. Overflow hose to the filler neck.
 4. Coolant into the deaeration tank (10).

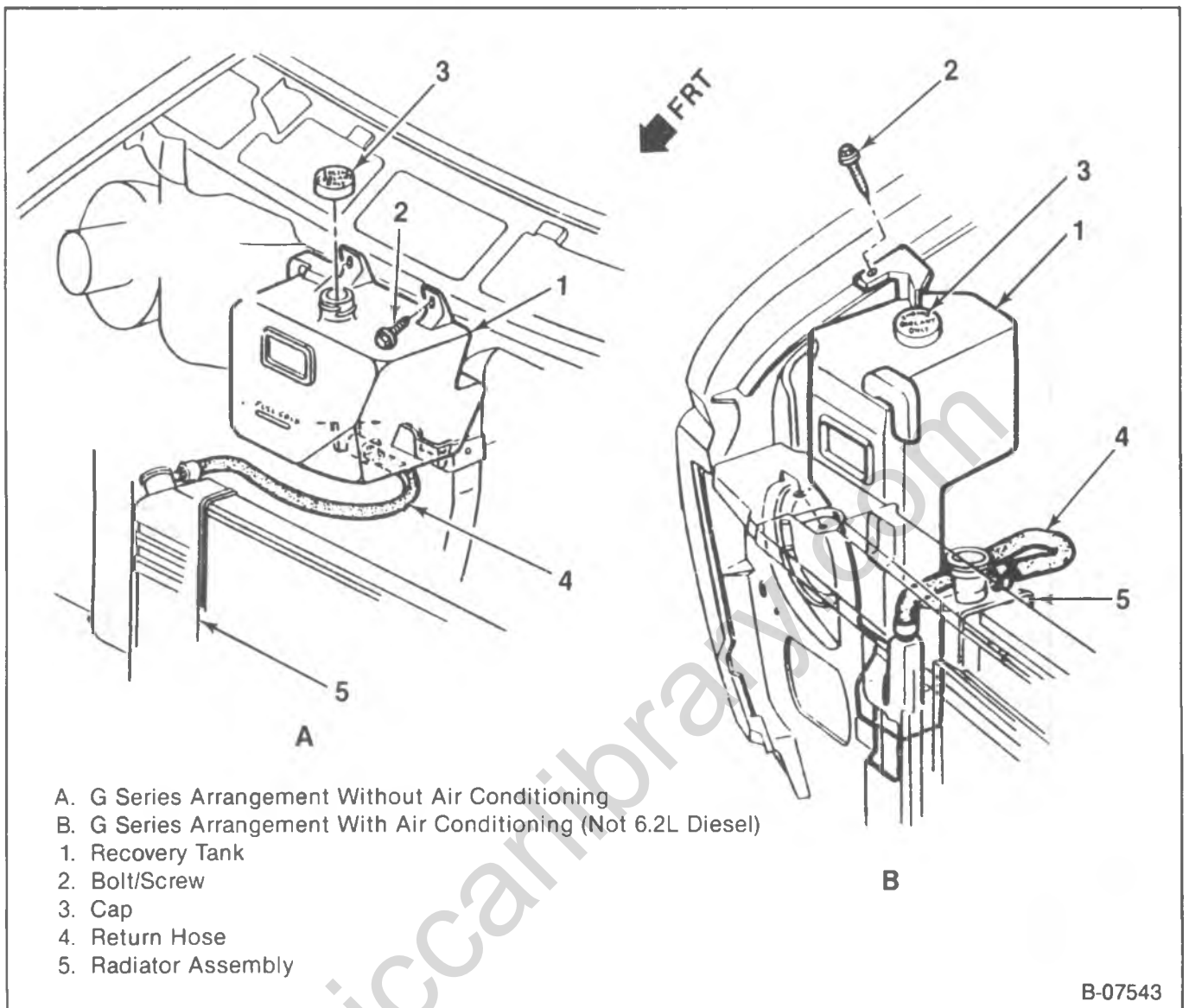

Figure 5—G - Coolant Recovery System

THERMOSTAT REPLACEMENT

VEHICLES EXCEPT THOSE WITH 6.2L ENGINE

↔ Remove or Disconnect (Figures 10 through 13)

1. Drain the cooling system until the radiator coolant level is below the thermostat.
2. Thermostat (23) from the vehicle.
 - Bolts (20) and the water outlet (21).
 - Thermostat from its housing.
 - Gasket.

↔ Install or Connect (Figures 10, 11 and 12)

- Make sure the thermostat housing and water outlet sealing surfaces are clean.
1. Thermostat (23) in its housing.
 2. New gasket (22) into position.
 3. Water outlet (21).
 - Bolts (20).

🔍 Tighten

- For bolts (20), refer to "Specifications."
4. Fill the cooling system.
 5. Start the engine and run with the radiator cap removed until the radiator upper hose becomes hot (thermostat is open).
 6. With the engine idling, add coolant to the radiator until the coolant level reaches the bottom of the filler neck.
 7. Radiator cap to the radiator, making sure the arrows line up with the overflow tube.

VEHICLES WITH THE 6.2L ENGINE

↔ Remove or Disconnect (Figures 14 and 15)

1. Upper fan shroud from the G vehicle.
 - Refer to RADIATOR (SEC. 6B2).
2. Drain the cooling system until the radiator coolant level is below the thermostat.
3. Engine oil dipstick tube brace and the oil fill brace on the G vehicle.

6B1-8 ENGINE COOLING

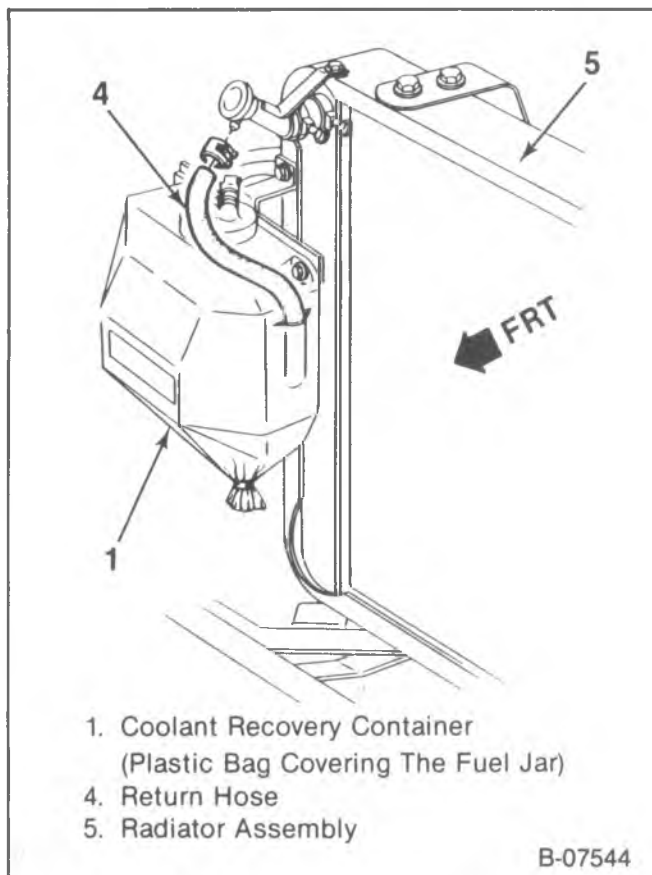

Figure 6—P - Coolant Recovery System

- Refer to 6.2L DIESEL (SEC. 6A6).
- 4. Thermostat (23) from the vehicle.
 - Studs (26) and the water outlet (21).
 - Upper radiator inlet hose.
 - Thermostat from its housing.
 - Gasket (22).

⇔ Install or Connect (Figures 15 and 16)

- Make sure the thermostat housing and water outlet sealing surfaces are clean.
- 1. Thermostat (23) into its housing.

2. Gasket (22) into position.
3. Water outlet (21).
 - Studs (26) and the upper radiator inlet hose.

🔧 Tighten

- Studs (26) to 47 N·m (35 ft. lbs.).
- 4. Engine oil dipstick tube brace and the oil fill brace on the G vehicle.
 - Refer to 6.2L DIESEL (SEC. 6A6).
- 5. Upper fan shroud on the G vehicle.
 - Refer to RADIATOR (SEC. 6B2).
- 6. Fill the cooling system.
- 7. Start the engine and run, with the radiator cap removed, until the radiator upper hose becomes hot (thermostat is open).
- 8. With the engine idling, add coolant to the radiator until the coolant level reaches the bottom of the filler neck.
- 9. Radiator cap to the radiator, making sure the arrows line up with the overflow tube.

THERMOSTAT HOUSING CROSSOVER REPLACEMENT

R/V VEHICLE WITH 6.2L ENGINE

⇔ Remove or Disconnect (Figure 16)

1. Coolant from the radiator.
2. Crankcase depression regulator valve.
3. Generator upper bracket.
4. By pass hose, upper radiator hose, and heater hose.
5. Crossover (32) from the vehicle.
 - Bolts (27) from the vehicle.
 - Thermostat (23) and water outlet (21) are attached to the crossover along with the thermal bypass nipple.

⇔ Install or Connect (Figure 15)

- Make sure the crossover sealing surfaces are clean.
- 1. New gasket (28) into position.
- 2. Crossover (32) to the vehicle.

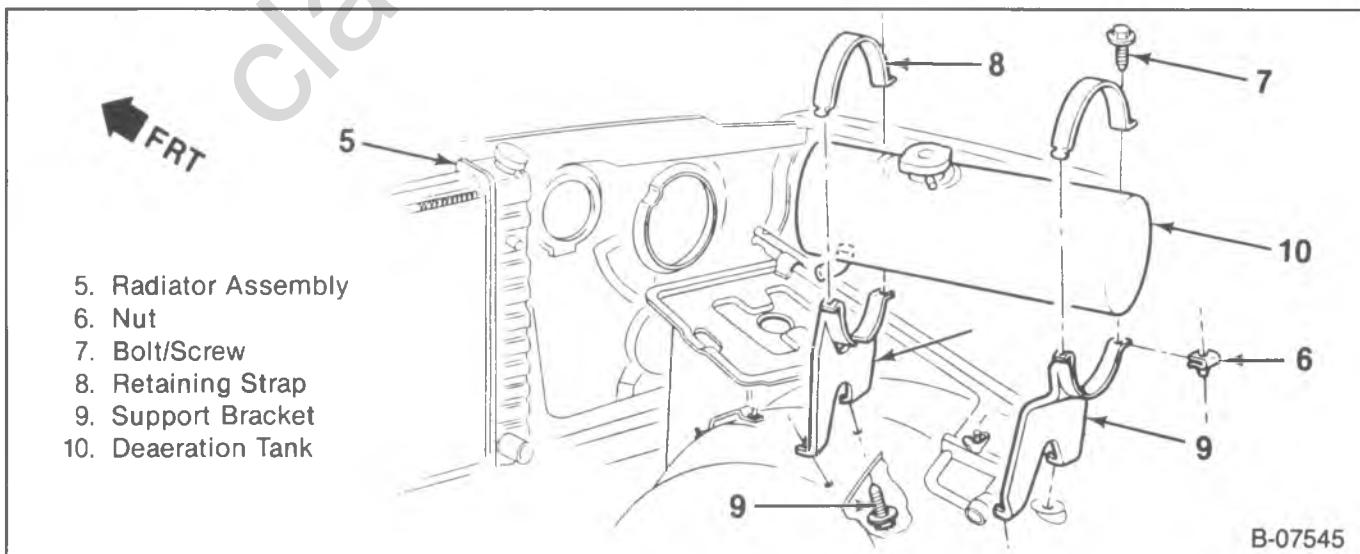

Figure 7—R/V - Deaeration Tank Installation

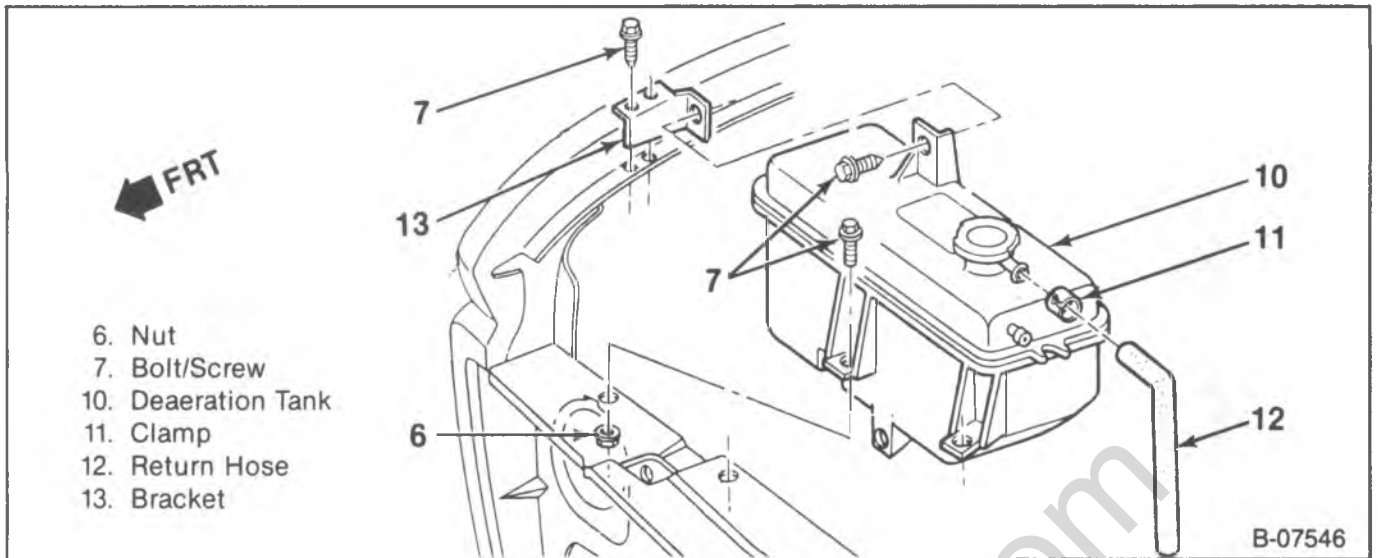

Figure 8—G - Deaeration Tank Installation

- 6. Nut
- 7. Bolt/Screw
- 10. Deaeration Tank
- 11. Clamp
- 12. Return Hose
- 13. Bracket



Tighten

- Bolts (27).
 - Bolts (27) to 47 N·m (35 ft. lbs.).
3. Heater hose, upper radiator hose, and bypass hose.
 4. Generator upper bracket.
 5. Crankcase depression regulator valve.
 6. Coolant to the radiator.
 7. Start the engine and run, with the radiator cap removed, until the radiator upper hose becomes hot (thermostat is open).

8. With the engine idling, add coolant to the radiator until the coolant level reaches the bottom of the filler neck.
9. Radiator cap to the radiator, making sure the arrows line up with the overflow tube.

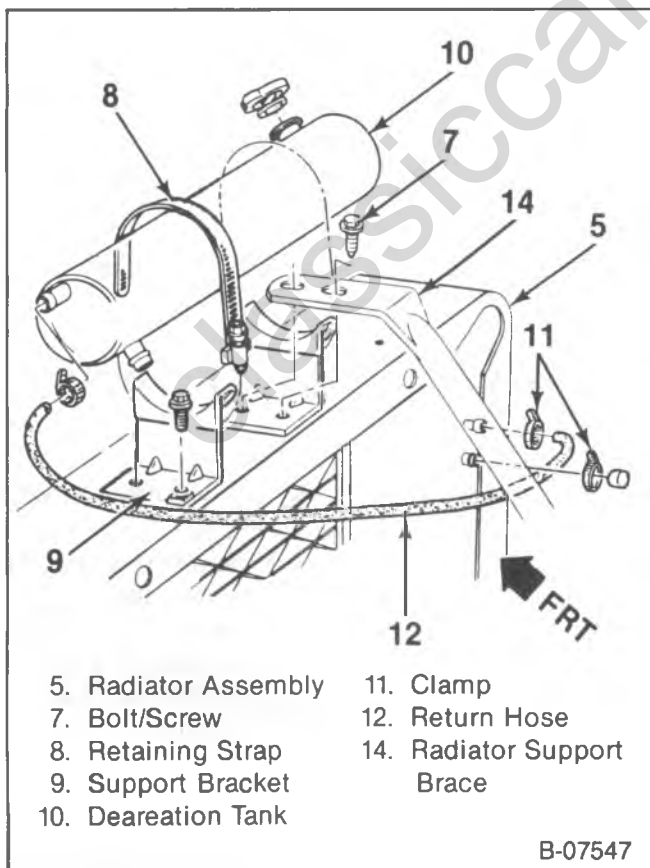

- 5. Radiator Assembly
- 7. Bolt/Screw
- 8. Retaining Strap
- 9. Support Bracket
- 10. Deaeration Tank
- 11. Clamp
- 12. Return Hose
- 14. Radiator Support Brace

B-07547

Figure 9—P - Deaeration Tank Installation

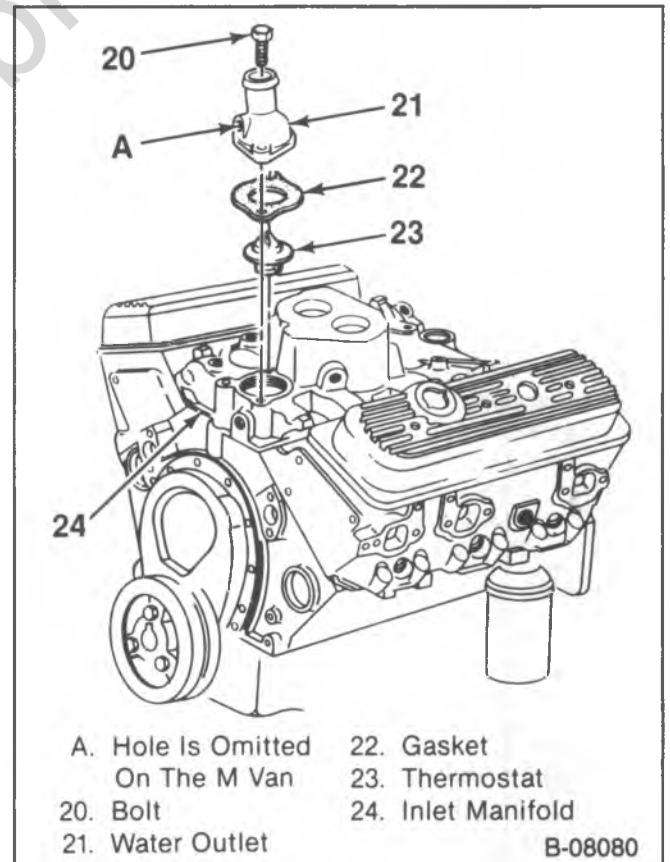

- A. Hole Is Omitted On The M Van
- 20. Bolt
- 21. Water Outlet
- 22. Gasket
- 23. Thermostat
- 24. Inlet Manifold

B-08080

Figure 10—4.3L Engine Thermostat Replacement (R/V and P)

6B1-10 ENGINE COOLING

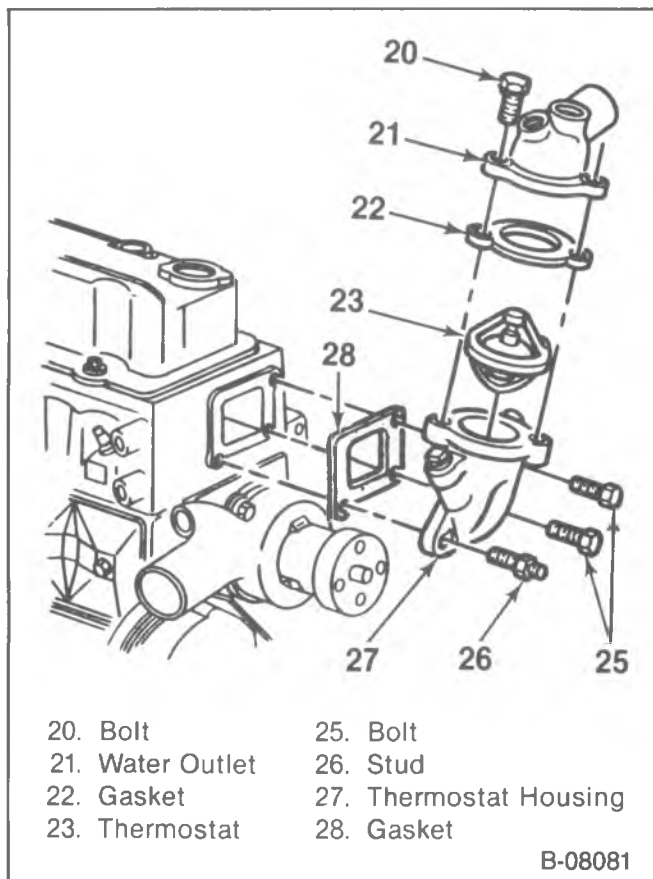

- | | |
|------------------|------------------------|
| 20. Bolt | 25. Bolt |
| 21. Water Outlet | 26. Stud |
| 22. Gasket | 27. Thermostat Housing |
| 23. Thermostat | 28. Gasket |

B-08081

Figure 11—4.8L Engine Thermostat Replacement (R/V and P)

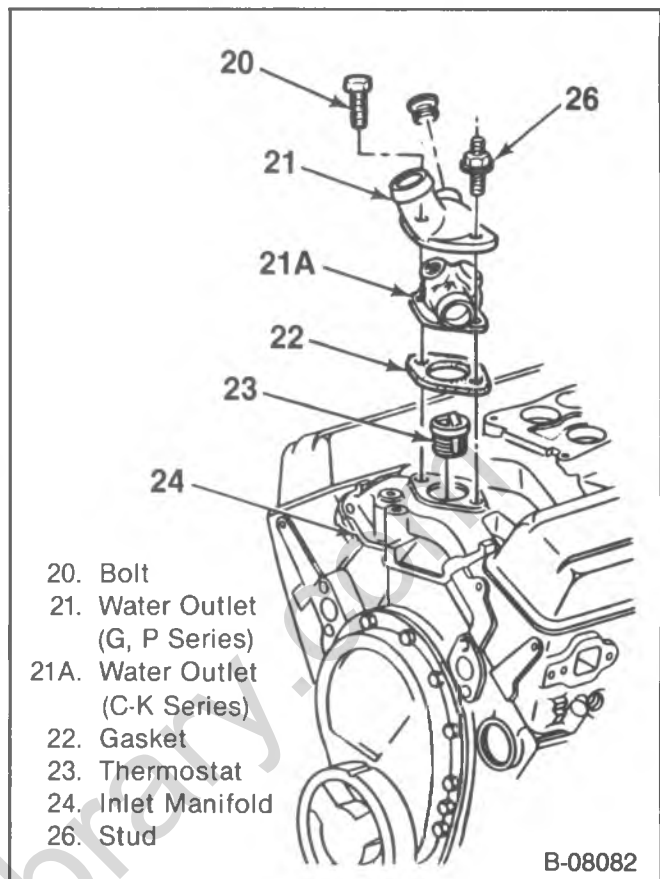

- | |
|--------------------------------|
| 20. Bolt |
| 21. Water Outlet (G, P Series) |
| 21A. Water Outlet (C-K Series) |
| 22. Gasket |
| 23. Thermostat |
| 24. Inlet Manifold |
| 26. Stud |

B-08082

Figure 12—5.0L and 5.7L Engine Thermostat Replacement (R/V, G and P)

G AND P VEHICLES WITH 6.2L ENGINES

↔ Remove or Disconnect (Figure 16)

1. Coolant from the radiator.
2. Engine cover from the G vehicle.
3. Air cleaner.
4. Air cleaner resonator and its bracket.
5. Upper fan shroud.
6. Generator upper bracket.
7. Bypass hose, upper radiator hose, and heater hose.
8. Crossover (32) from the vehicle.
 - Bolts (27), studs (26) and the gasket (28).
 - Thermostat (23) and the water outlet (21) are attached.

↔ Install or Connect (Figure 16)

- Make sure the crossover sealing surfaces are clean.
1. New gaskets (28) into position.
 2. Crossover (32) to the vehicle.
 - Bolts (27) and studs (26).



Tighten

- Bolts (27) to 47 N·m (35 ft. lbs.).
 - Studs (26) to 47 N·m (35 ft. lbs.).
3. Heater hose, upper radiator hose, and the bypass hose.
 4. Generator upper bracket.
 5. Upper fan shroud.
 6. Air cleaner resonator and its bracket.
 7. Air cleaner.
 8. Engine cover on the G vehicle.

9. Coolant to the radiator.
10. Start the engine and run, with the radiator cap removed, until the radiator upper hose becomes hot (thermostat is open).
11. With the engine idling, add coolant to the radiator until the coolant level reaches the bottom of the filler neck.
12. Radiator cap to the radiator, making sure the arrows line up with the overflow tube.

DRIVE BELT REPLACEMENT

PULLEY INSPECTION

Examine the pulleys for chips, nicks, tool marks, cracks, bent sidewalls, corrosion or other damage.

1. Place a straightedge or position a cord across the two pulleys so they touch at all points (figure 17).
2. Turn each pulley one half revolution and recheck with a straightedge or cord. Full contact at all points must be made. If contact is not made at all points, the pulley may be warped or its shaft could be bent. Replace any damaged parts.

DRIVE BELT INSPECTION

Replace frayed or cracked belts and tension to the proper specification. Do not use drive belt dressings to extend the belt life.

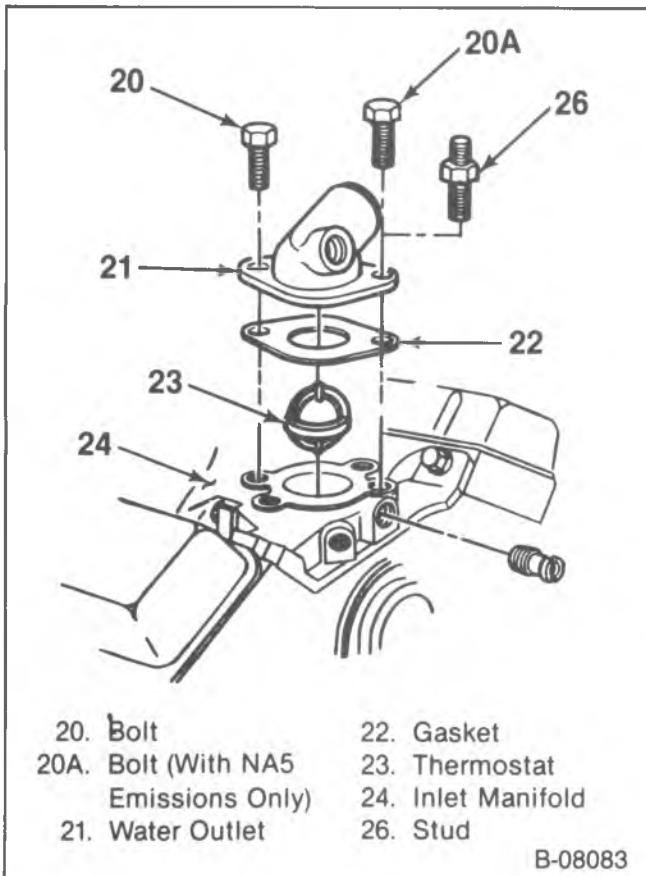

Figure 13—7.4L Engine Thermostat Replacement (R/V and P)

CAUTION: Avoid over or under-tightening drive belts. Loose belts result in slippage which can cause belt and pulley “glazing” and inefficient component operation. Once a belt has become “glazed,” replace the belt. Loose belts can also place high impact loads on driven component bearings due to the whipping action of a loose belt. Over tightening belts can lead to bearing damage and early belt failure.

DRIVE BELT REPLACEMENT - V-BELT

1. Remove the old belt.
 - Loosen the component driven by the belt (figures 18 through 22).

NOTICE: Place the belts into the pulley grooves by hand. Do not force a belt into a pulley groove by prying with a screwdriver, crowbar, or other wedge type tool. Prying a belt into position can damage both the belt and the belt drive components.

2. Install the new belt.
 - Tension the new belt to “Specifications”
 - Use J-23600-B to measure V-belt tension.
 - Place the gage at the center of the greatest span.

Tighten

- Component to mounting bracket fasteners to the “Specifications” at the end of this section.

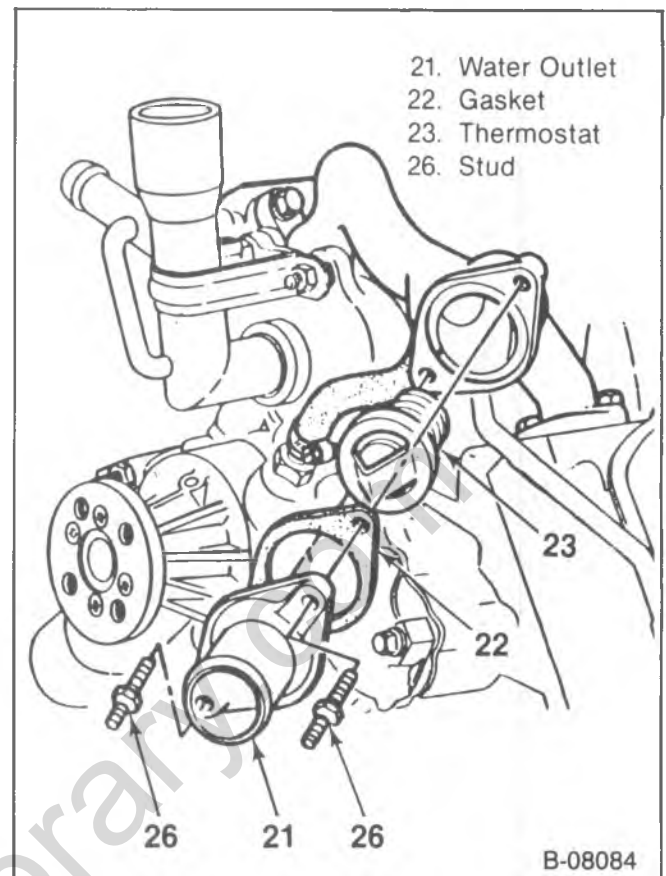

Figure 14—6.2L Engine Thermostat Replacement (R/V)

3. Run the engine at idle speed for a minimum of 15 minutes.
 - This allows the belt to seat itself in the pulleys, causing the belt fibers to relax, or stretch.
4. Allow the drive belt to cool until it is cool or at most, warm to the touch. Not hot.

NOTICE: A used belt is one that has been rotated at least one complete revolution on the engine pulleys. This begins the “seating” of the belt and it must never be tensioned to new belt specifications.

5. Check the belt tension.
 - Use J-23600-B to measure V-belt tension.
 - Place the gage at the center of the greatest span.
 - The belt tension should be at the maximum used belt specifications from the chart in “Specifications.”

DRIVE BELT ADJUSTMENT - V-BELT

Never tension a used belt to more than its specified tension limit.

1. Check the belt tension.
 - Belt should be cool or at least warm to the touch. Not hot.
 - Use J-23600-B to measure V-belt tension.
 - Place the gage at the center of the greatest span.
 - If the belt is below the minimum “used belt” tension specification, adjust the belt.

6B1-12 ENGINE COOLING

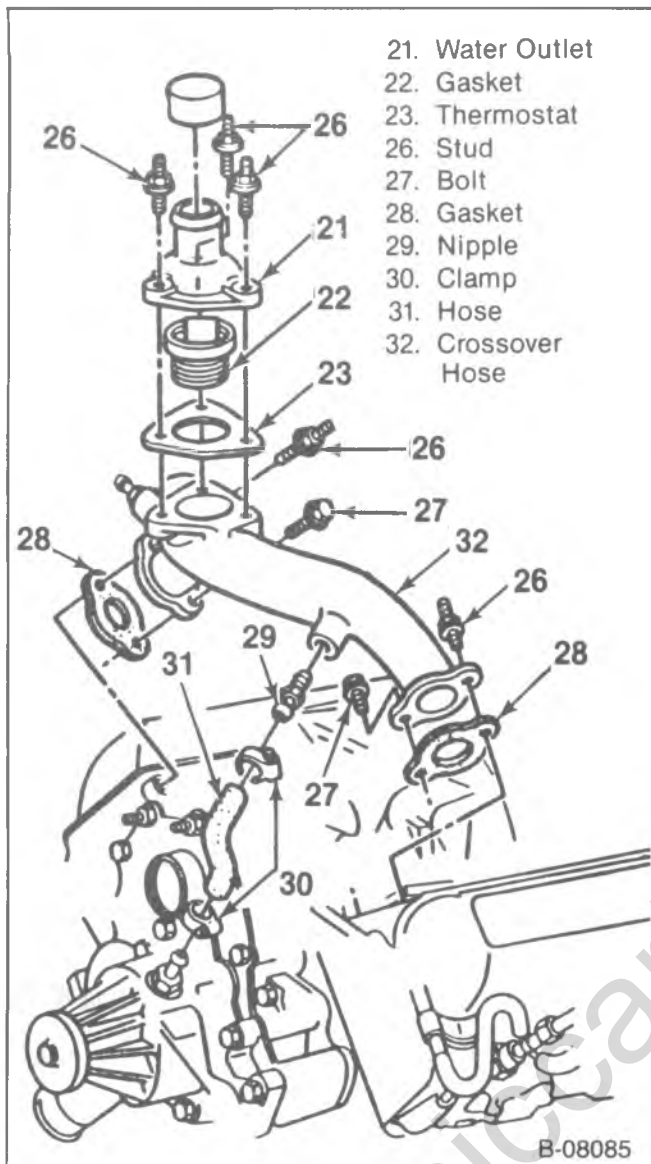

Figure 15—6.2L Engine Thermostat Replacement (G and P)

2. Loosen the component in its mounting bracket (figures 18 through 22).
3. Tension the belt to the maximum used belt specification from the chart in "Specifications."



Tighten

- Component to mounting bracket fasteners to the specifications at the end of this section.
4. Run the engine at idle for a minimum of 15 minutes.
 - This allows the belt to reseat itself in the pulleys.
 5. Allow the drive belt to cool.
 - Should be at most warm to the touch. Not hot.
 6. Check the belt tension.
 - Use J-23600-B to measure V-belt tension.
 - Place the gage at the center of the greatest span.
 - Re-adjust if not within the used belt specifications from the chart in "Specifications."

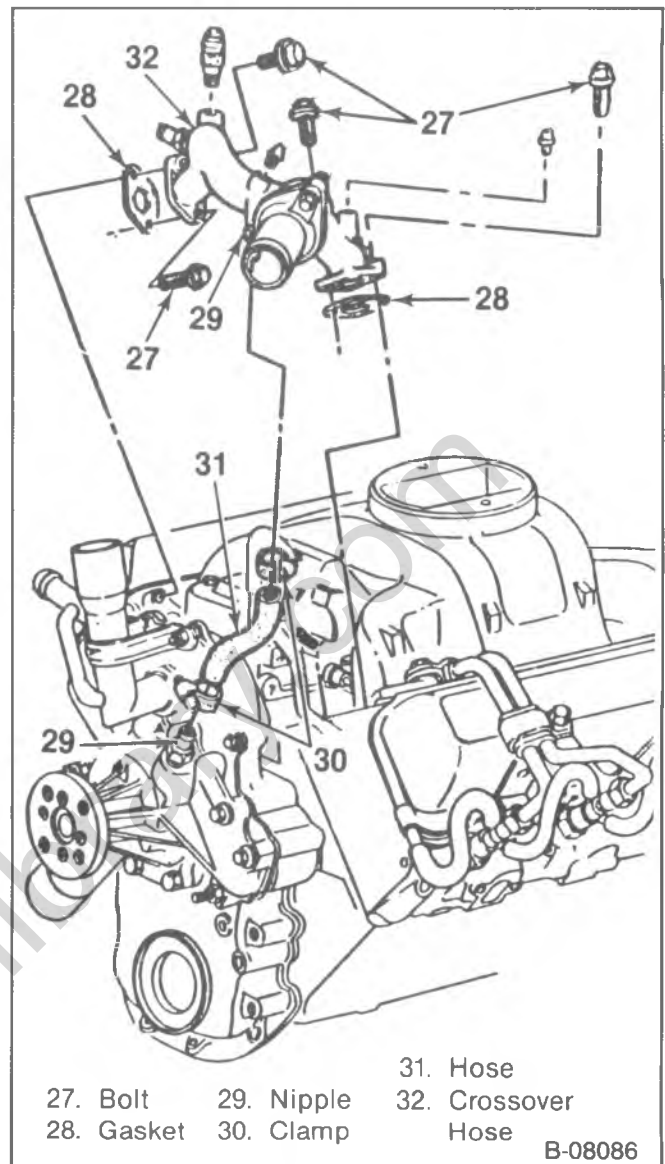

Figure 16—6.2L Engine - Crossover Replacement - (R/V)

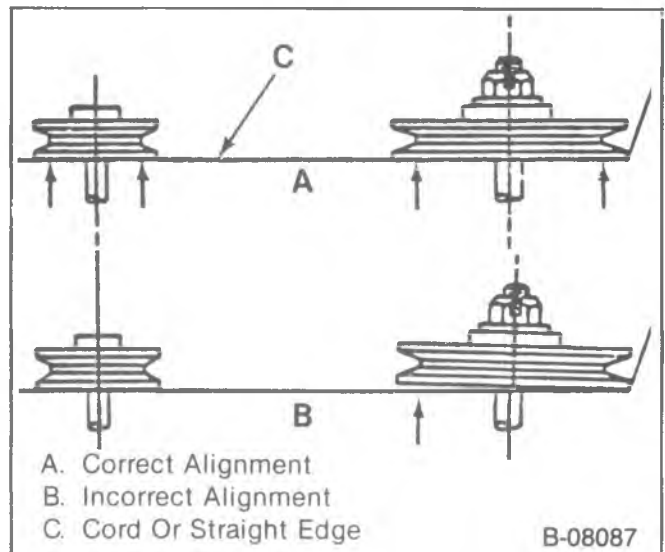

Figure 17—Checking the Pulley Alignment

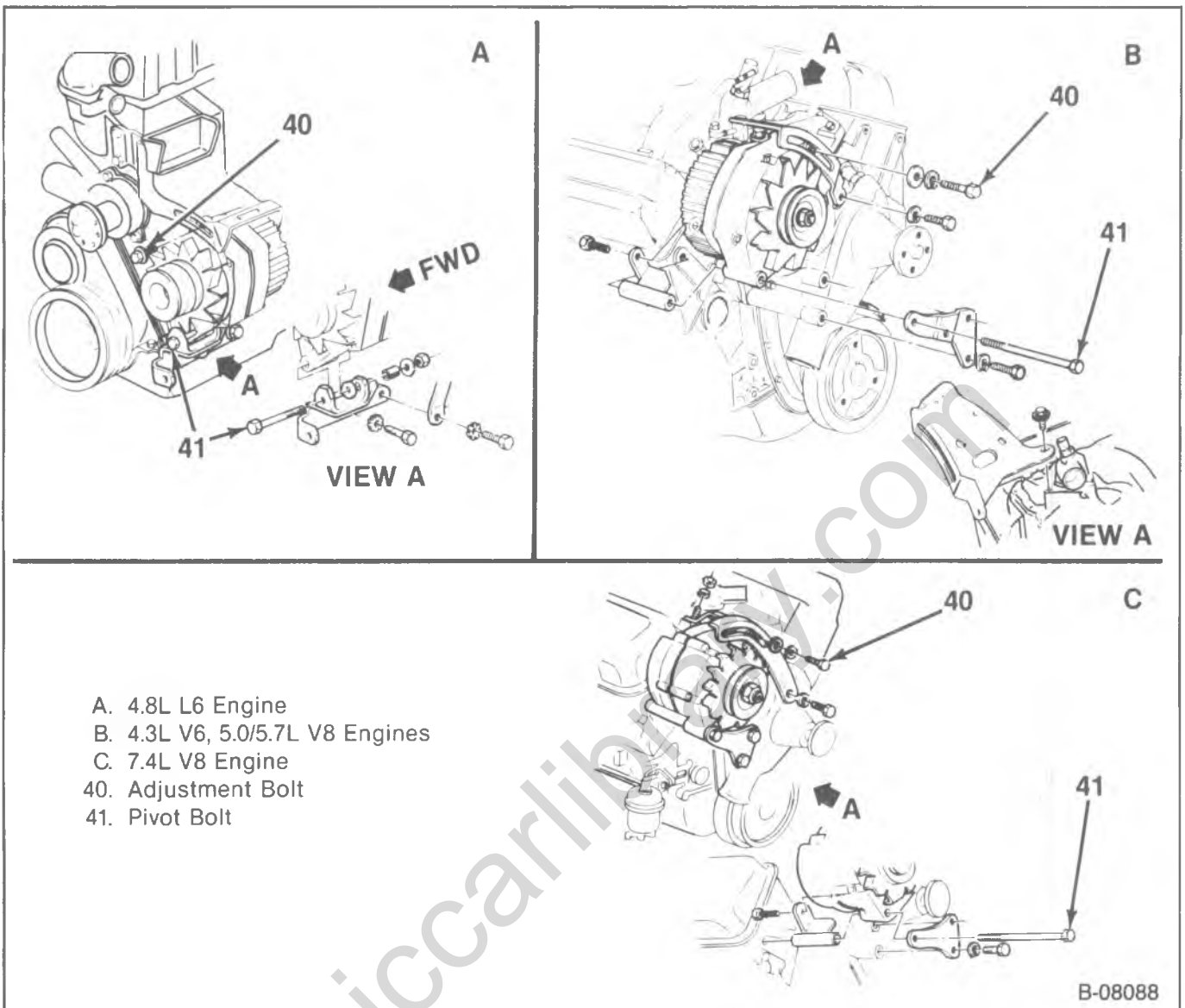

Figure 18—Generator Adjustment (R/V, G and P)

DRIVE BELT ROUTING

Refer to the drive belt routing diagrams if belt replacement becomes necessary. Refer to figures 23 to 32.

DRIVE BELT REPLACEMENT - SERPENTINE BELT

1. Remove the old belt (figure 33).
 - With a socket and breaker bar, release the tension by turning the tensioner pulley assembly. The tensioner pulley is sprung activated and it can be turned to the left or right to apply or release the pulley tension.
2. Install a new belt.
 - Thread the belt around the pulleys.
 - With a breaker bar apply the tension by turning the tensioner pulley assembly.

DRIVE BELT ROUTING - SERPENTINE BELT

Refer to drive belt routing diagrams if belt replacement becomes necessary (figure 33).

FAN AND FAN CLUTCH REPLACEMENT

↔ Remove or Disconnect (Figure 34)

1. Radiator fan shroud.
 - Refer to RADIATOR (SEC. 6B2).
2. Fan (73) and fan clutch (74) from the water pump pulley (70).
 - Nuts (75).
3. Fan (73) from the fan clutch (74).
 - Bolts (72).

↔ Install or Connect (Figure 34)

- Inspect the mating surfaces (the water pump hub and the fan clutch hub) for smoothness and rework as necessary to eliminate any burrs or other imperfections.

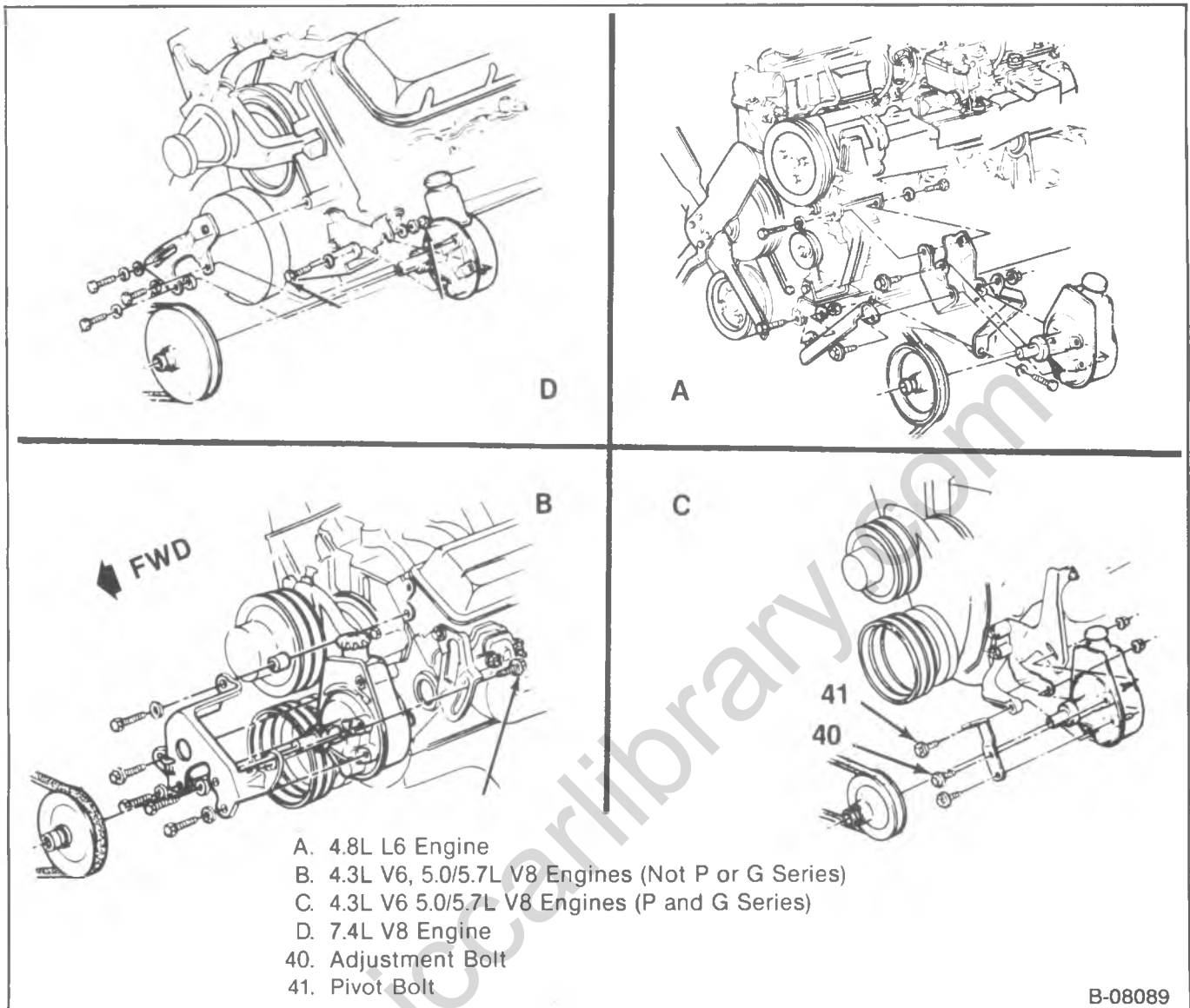

Figure 19—Power Steering Pump Adjustment (R/V, G and P)

B-08089

CAUTION: Do not repair and reuse a fan with a bent or damaged blade. Replace the fan as an assembly. A damaged blade can change the balance of a fan. A fan out of balance could fly apart during use and create a dangerous condition to the owner and vehicle.

1. Fan (73) to the fan clutch (74).



Tighten

- Bolts (72) to 25 N·m (18 ft. lbs.).

2. Fan and clutch assembly to the water pump pulley (70).

- Nuts (75). Align the yellow reference marks on the water pump hub and the fan clutch hub.



Tighten

- Nuts (75) to 25 N·m (18 ft. lbs.).

3. Fan shroud.

- Refer to RADIATOR (SEC. 6B2).

AUXILIARY COOLING FAN REPLACEMENT

The Auxiliary Cooling Fan is available when a 7.4L engine (RPO LE8) and Air Conditioning (C60, C69) are ordered. Its to provide additional cooling at low speed vehicle operations, extended idle, stop and go conditions, and when running the air conditioning system.



Remove or Disconnect (Figure 35)

1. Grille assembly.
 - Refer to SHEET METAL (SEC. 2B).
2. Fan harness connector (83).
3. Fan assembly (81) from the radiator support (80).
 - Bolts/screws (82).



Install or Connect (Figure 35)

1. Fan assembly (81) to the radiator support (80).
 - Bolts/screws (82).

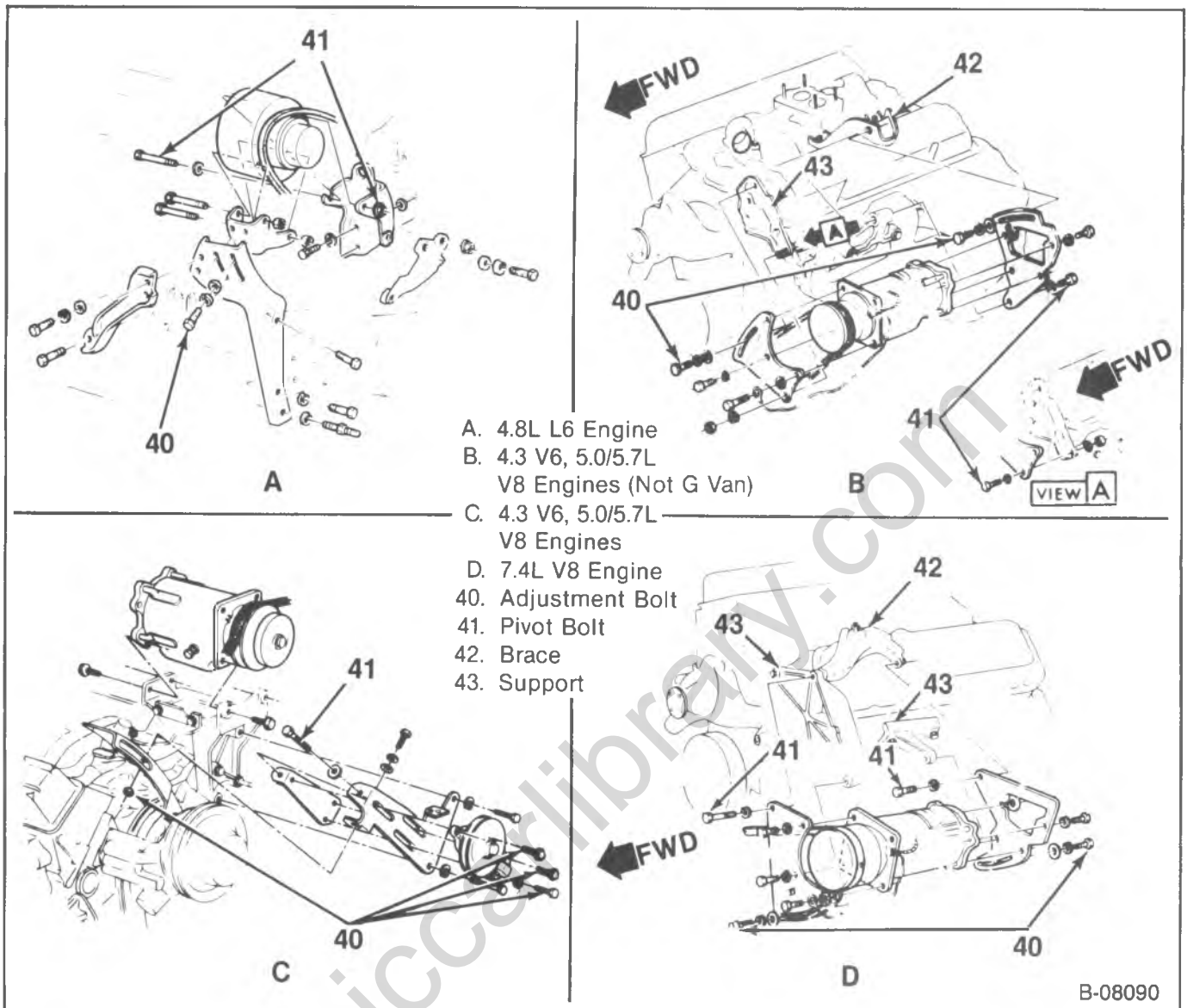

Figure 20—Air Conditioning Compressor Adjustment



Tighten

- Bolt/screw (82) to 6 N·m (53 ft. lbs.).
- 2. Fan harness connector (83).
- 3. Grille assembly.
 - Refer to SHEET METAL (SEC. 2B).

WATER PUMP REPLACEMENT

4.8L ENGINE



Remove or Disconnect (Figure 36)

- Coolant from the radiator.
- 1. Accessory drive belts.
 - Refer to "Drive Belt Replacement."
- 2. Fan (73) and fan clutch (74) (figure 36).
 - Nuts (75).
- 3. Water pump pulley (70).
 - Pulley off the water pump studs (71), but do not damage the threads.

- 4. Lower radiator hose and the heater hose from the water pump (91).
- 5. Water pump (91) from the engine block (figure 36).
 - Bolts (92, 93), and gasket (94).
 - Loosen the generator adjusting bolt to allow the brace to be moved away on vehicles where the brace will inhibit water pump removal.



Install or Connect (Figures 36)

- Clean the mating surfaces on the water pump and the engine block.
- 1. Water pump (91) to the engine block (figure 36).
 - New gasket (94) onto the water pump (91).
 - Place the generator adjusting brace back into position if moved.
 - Bolts (92 and 93).



Tighten

- Bolts (92 and 93) to the "Specifications" at the end of this section.
- 2. Lower radiator hose and the heater hose to the water pump (91).

6B1-16 ENGINE COOLING

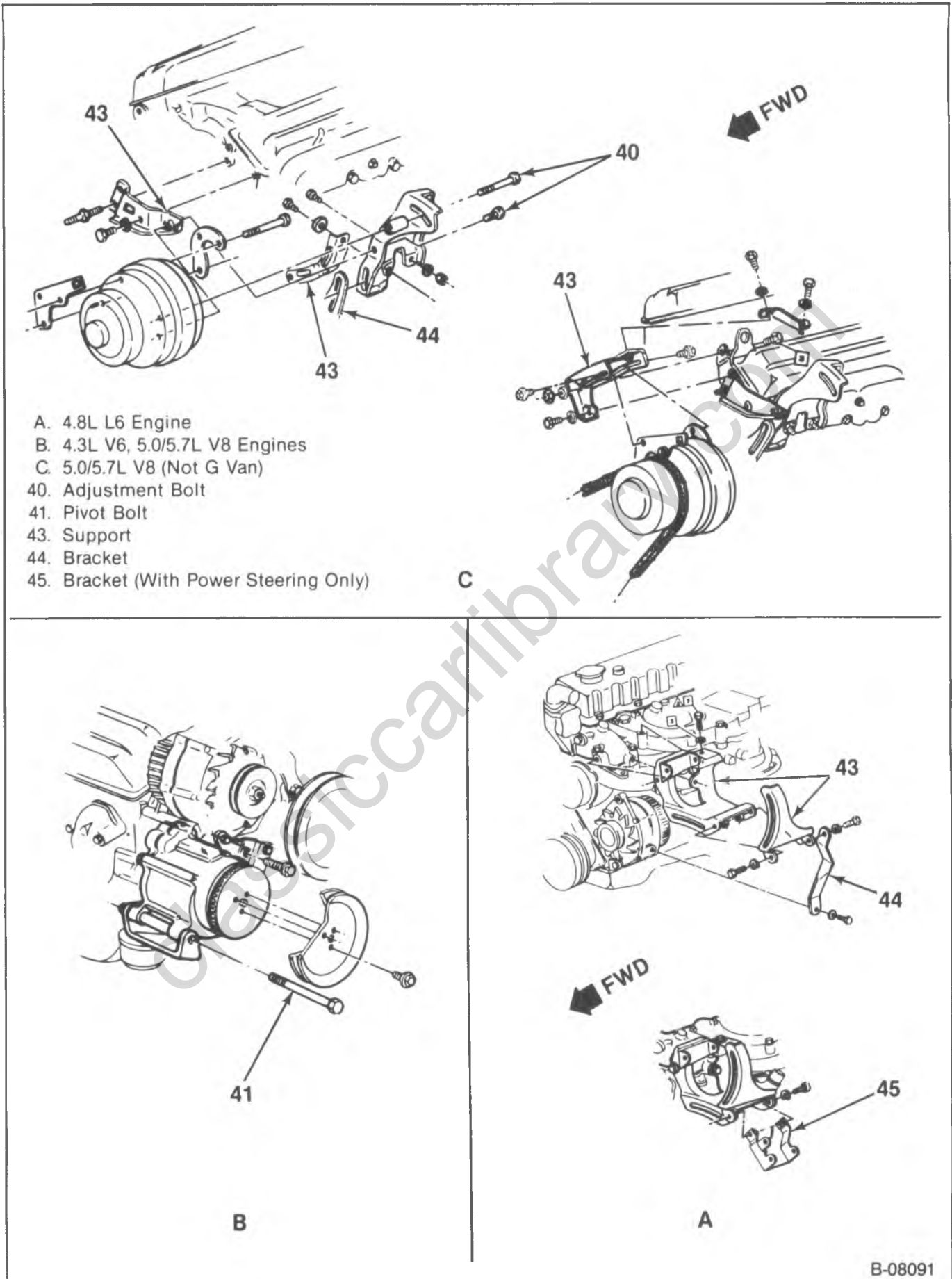

B-08091

Figure 21—Air Conditioning and A.I.R. Pump Adjustment (R/V, G and P)

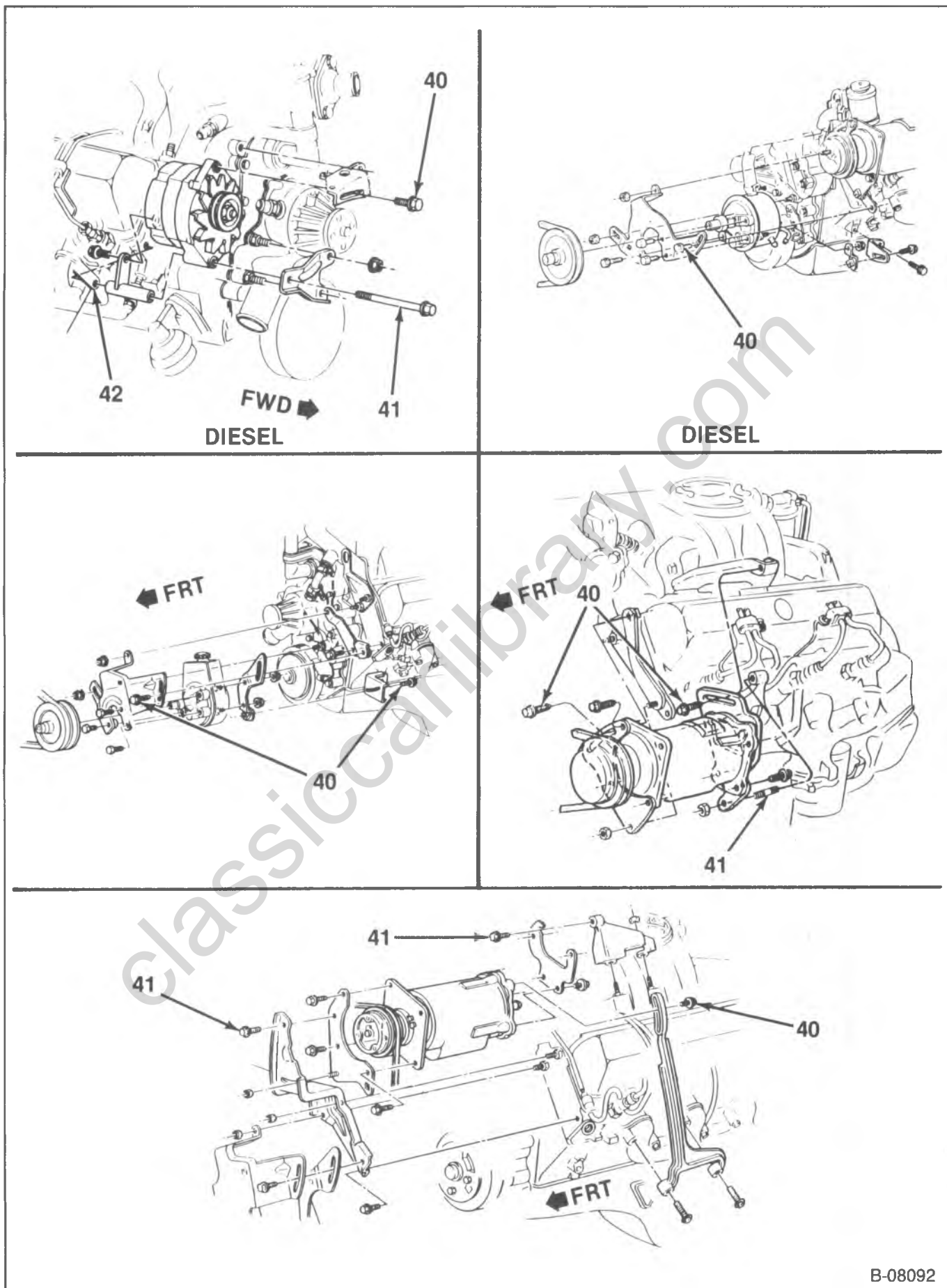

Figure 22—Drive Belt Adjustment - 6.2L Engine (R/V, G and P)

6B1-18 ENGINE COOLING

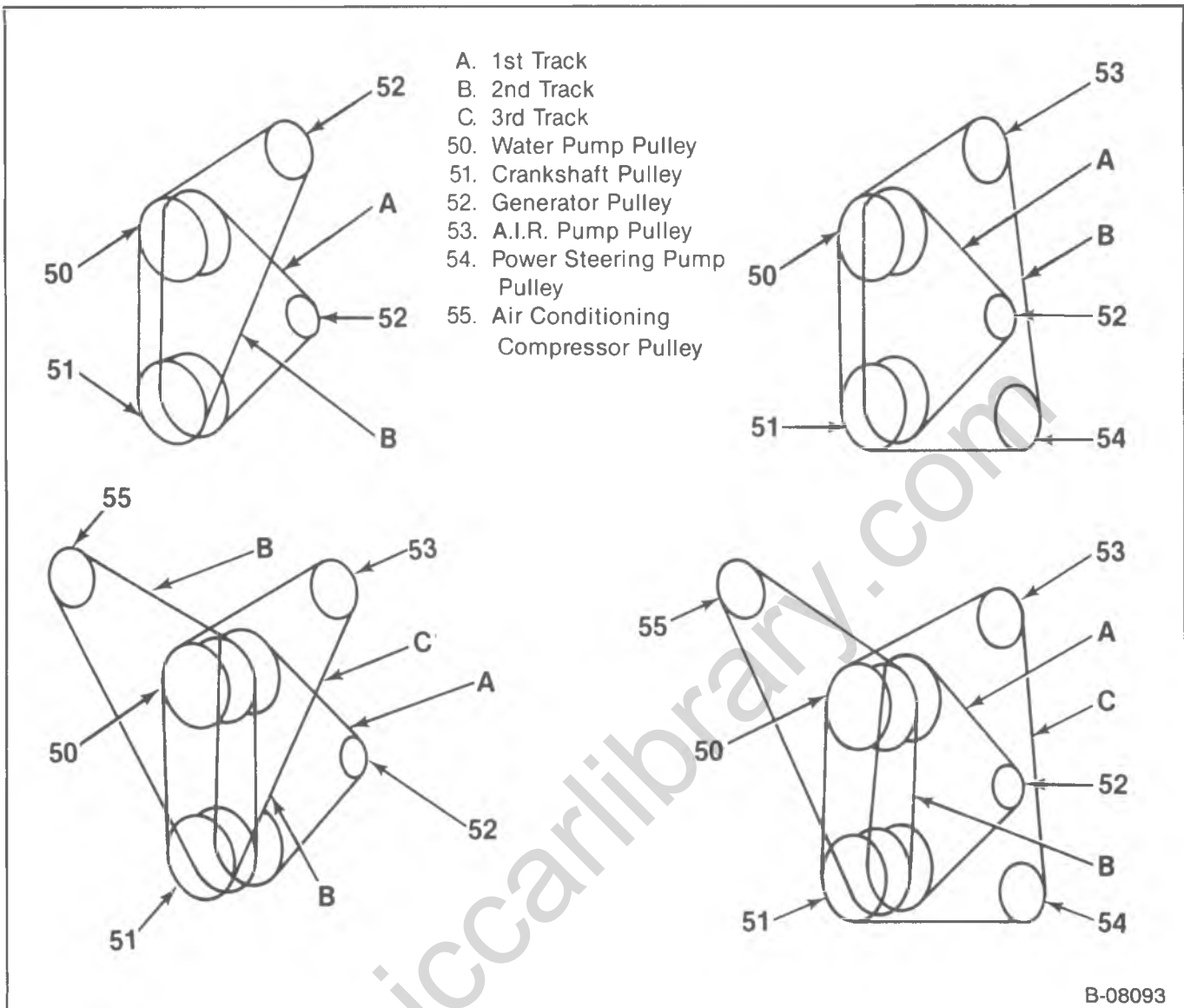

Figure 23—Engine Accessory Drive - R/V (4.8L Engine)

- Water pump pulley (70), fan (73), and fan clutch (74) on the water pump hub.



Tighten

- Nuts (75) to 25 N·m (18 ft. lbs.).
- Drive belts and adjust.
 - Refer to "Drive Belt Replacement."
 - Coolant to the radiator.
 - Start the engine and run, with the radiator cap removed, until the radiator upper hose (12) becomes hot (thermostat is open).
 - Add coolant to the radiator until the level reaches the bottom of the filler neck.
 - Engine must be running at idle speed.
 - Radiator cap, making sure the arrows line up with the overflow tube.

4.3L, 5.0L 5.7L AND 7.4L ENGINES



Remove or Disconnect (Figures 37, 38, and 39)

- Coolant from the radiator.
- Accessory drive belts.
 - Refer to "Drive Belt Replacement."
 - Fan (73), the fan clutch (74), and the pulley (70) from the water pump (91).
 - Nuts (75).
 - Generator lower brace attaching bolts and swing the brace down and out of the way.
 - Generator upper brace attaching bolts.
 - Lower radiator hose and heater hose from the water pump (91).
 - On the 7.4L engine, remove the bypass hose.
 - Water pump (91) from the engine block.
 - Bolts (92, 93) and studs (95).



Install or Connect (Figures 36, 37, 38 and 39)

- Clean the mating surfaces on the water pump and the engine block.

B-08093

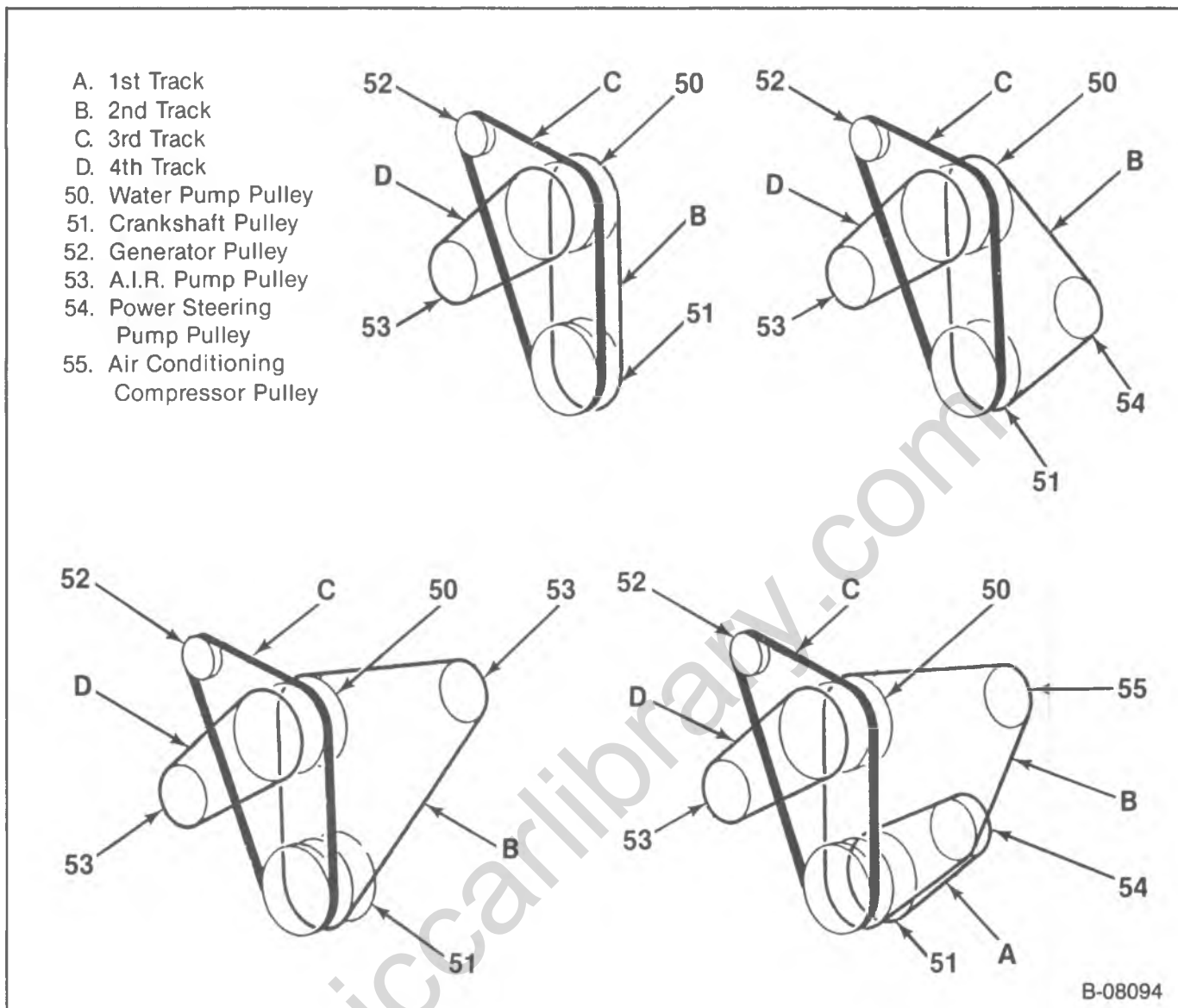

Figure 24—Engine Accessory Drive - 4.3L, 5.0L, 5.7L and 7.4L (R/V)

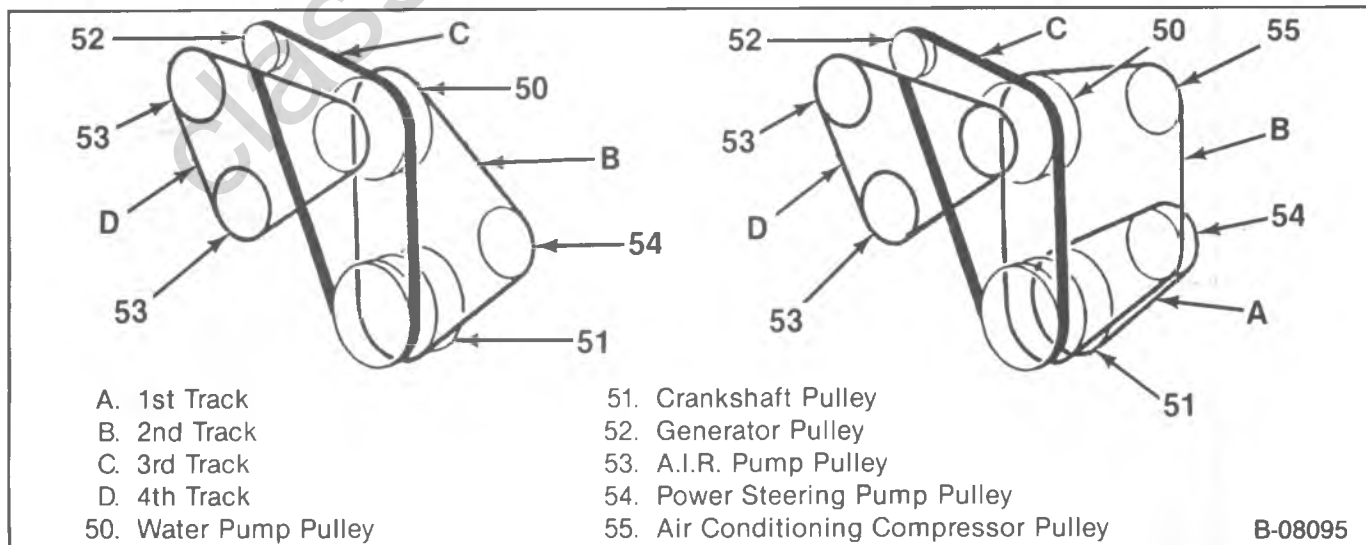

Figure 25—Engine Accessory Drive - Heavy Duty Emissions - 5.7L Engine (R/V)

6B1-20 ENGINE COOLING

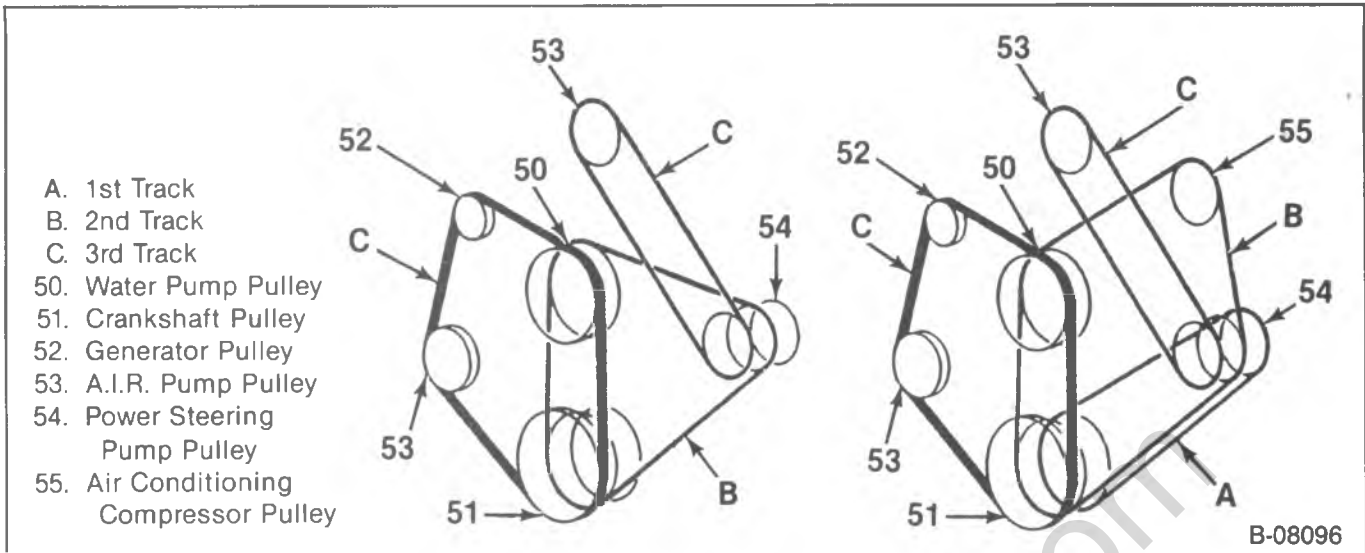

Figure 26—Engine Accessory Drive - Federal Emissions - 7.4L Engine (R/V)

1. Water pump (91) to the engine block.
 - New gaskets (94).
 - Place the pump against the block and retain it with bolts (92, 93 and 95).



Tighten

- Bolts (92 and 93) and studs (95) to the "Specifications."
2. Lower radiator hose and the heater hose to the water pump (91).
 - Bypass hose with 7.4L engine.
 3. Generator upper and lower braces to the water pump (91).
 4. Water pump pulley (70), fan (73) and fan clutch (74) to the water pump hub.
 - Nuts (75).



Tighten

- Nuts (75) to 25 N·m (18 ft. lbs.).
5. Accessory belt drive and adjust.
 - Refer to "Belt Drive Replacement."

6. Coolant to the radiator.
7. Start the engine and run, with the radiator cap removed, until the radiator upper hose (12) becomes hot (thermostat is open).
8. Add coolant to the radiator until the level reaches the bottom of the filler neck.
 - Engine must be running at idle speed.
9. Radiator cap, making sure the arrows line up with the overflow tube.

6.2L ENGINE



Remove or Disconnect (Figure 40)

- Coolant from the radiator.
1. Fan.
 - Refer to "Fan And Fan Clutch Replacement."
 2. Fan shroud.
 - Refer to RADIATOR (SEC. 6B2).
 3. Air conditioning hose bracket nuts.
 4. Oil fill tube.
 5. Generator drive belt.

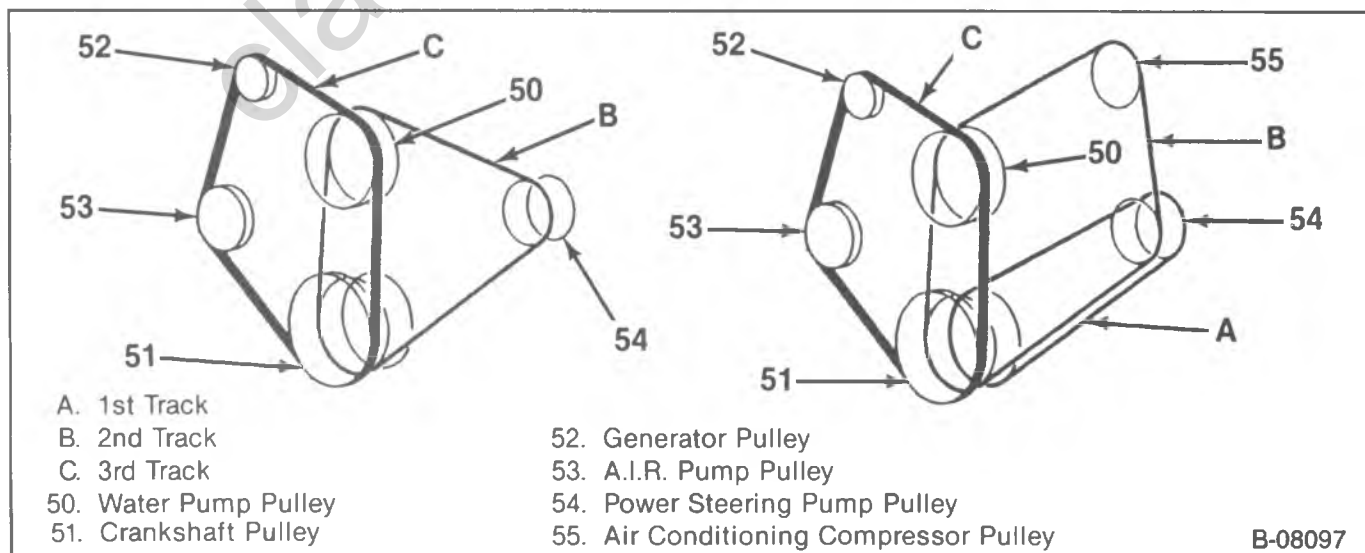

Figure 27—Engine Accessory Drive - California Emissions - 7.4L Engine (R/V)

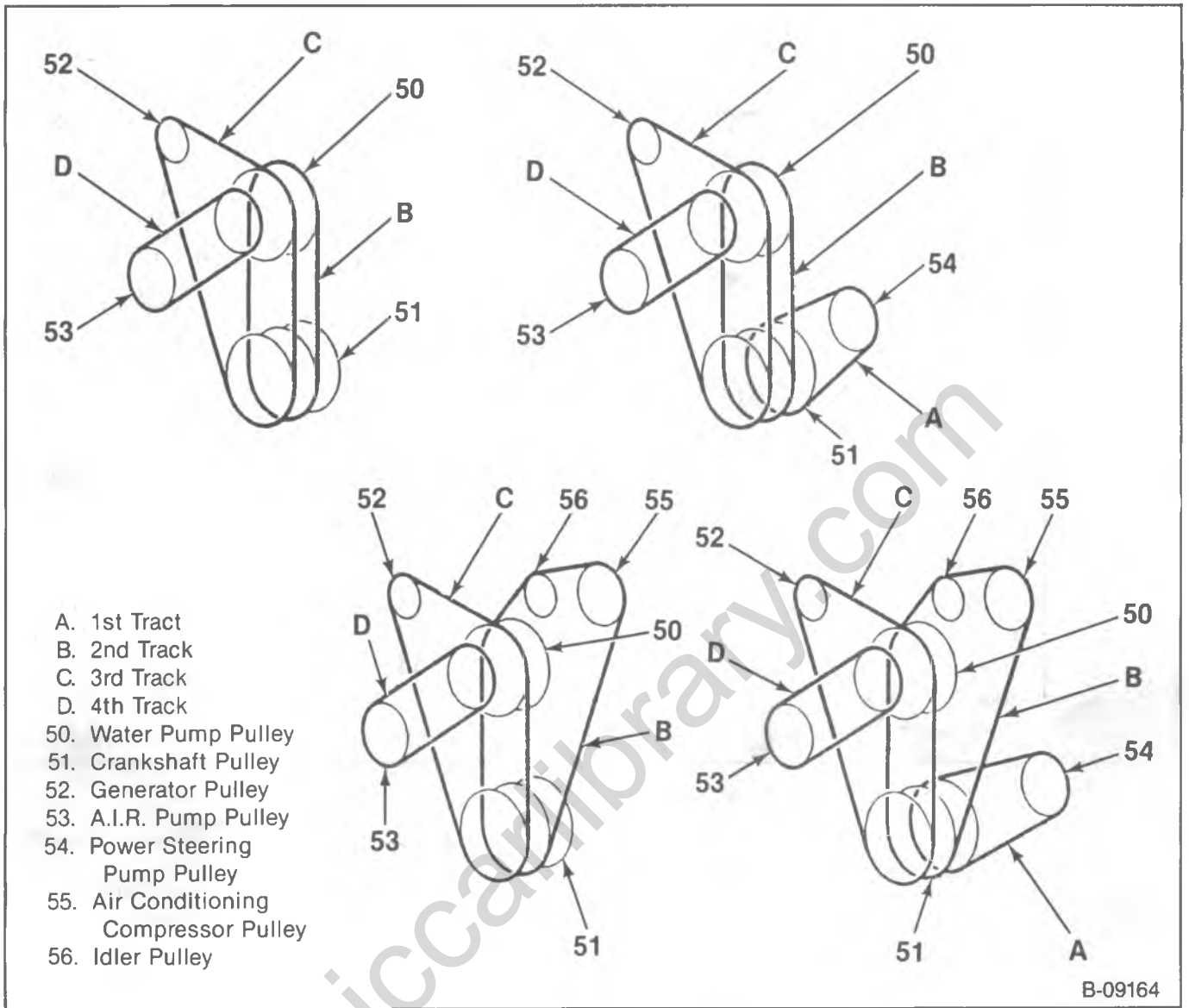

Figure 28—Engine Accessory Drive - 5.7L and 6.2L Engines - V-Belt (G)

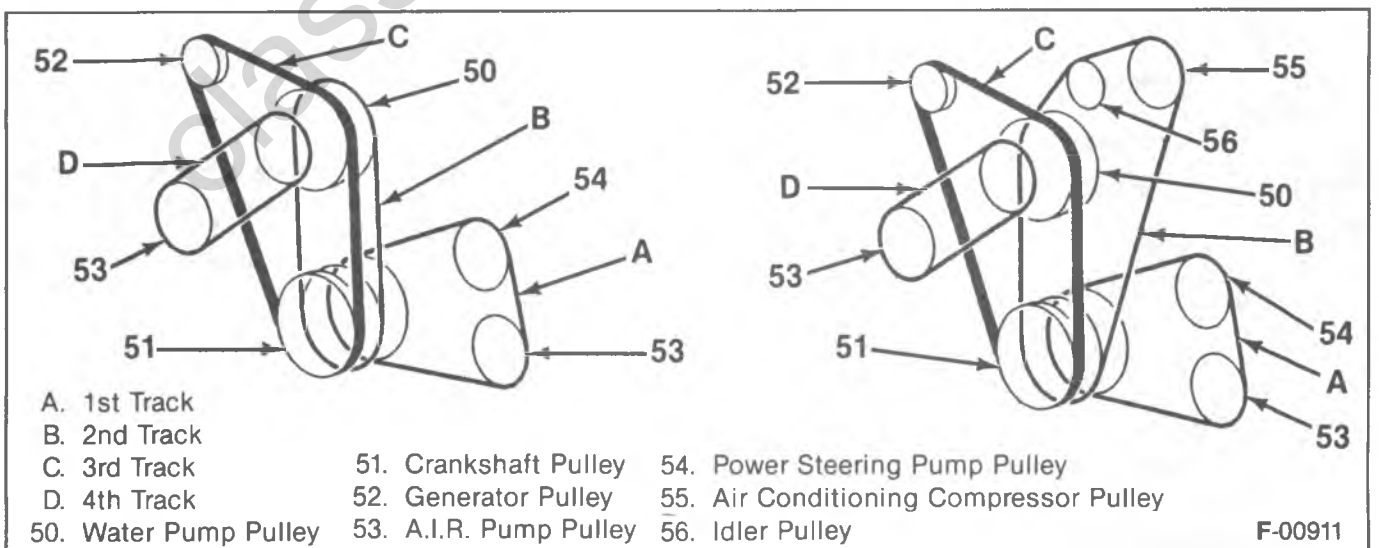

Figure 29—Engine Accessory Drive - Heavy Duty Emission - 5.7L Engine - V-Belt (G)

6B1-22 ENGINE COOLING

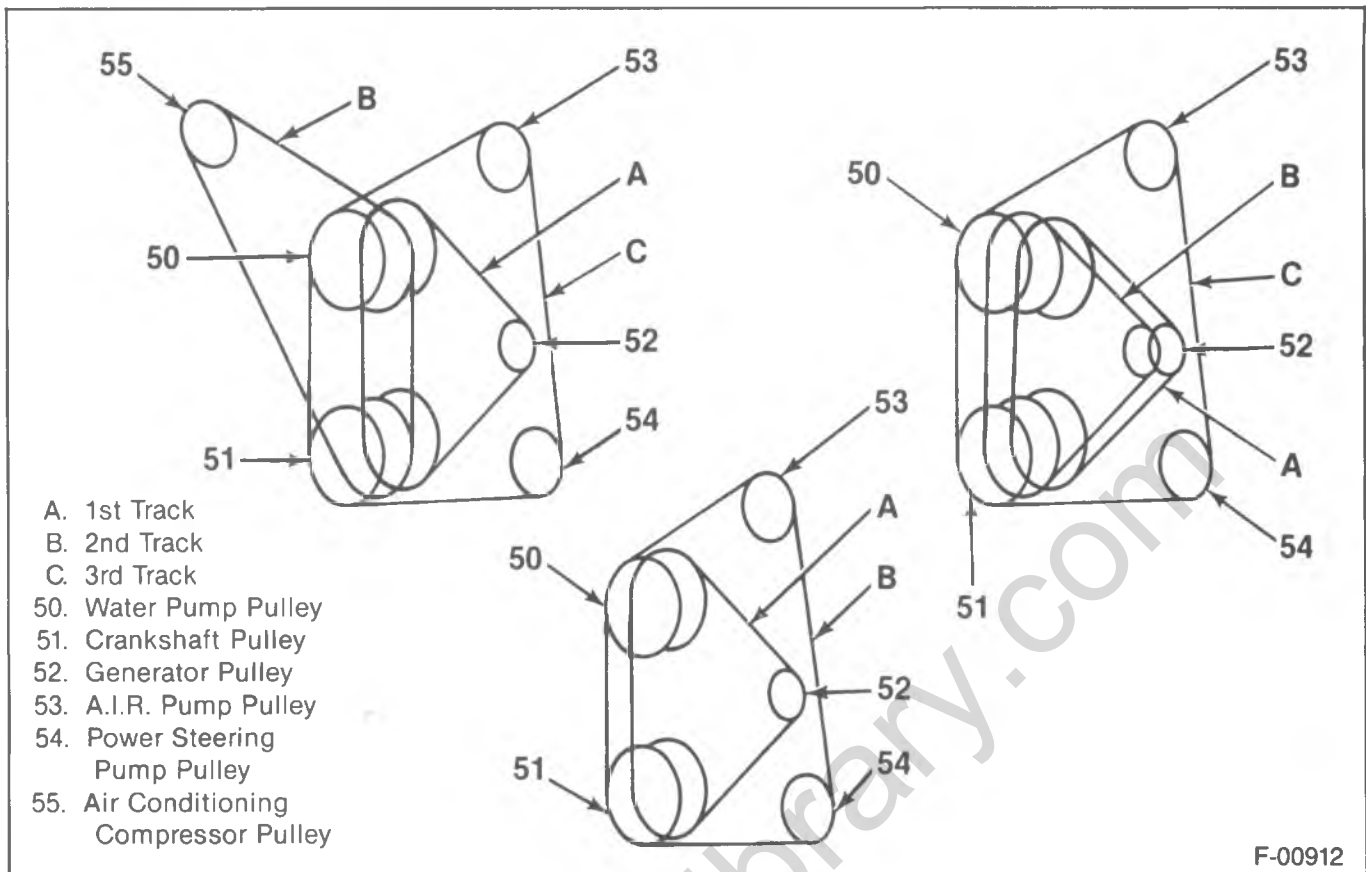

Figure 30—Engine Accessory Drive - (P) 4.8L Engine

- Generator pivot bolt.
 - Refer to "Drive Belt Replacement."
6. Generator lower bracket.
 7. Power steering belt.
 - Refer to "Drive Belts Replacement."
 8. Power steering pump.
 9. Air conditioning compressor belt, if equipped.
 - Refer to "Drive Belts Replacement."
 10. Bypass hose and the lower radiator hose.
 11. Water pump (91) (figure 44).
 - Bolts (96 and 97), water pump plate (99) and the water pump (91).
 12. Water pump plate (99) from the water pump (91).
 - Bolts (92 and 93) and the gasket (94).

⇔ Install or Connect (Figure 40)

! Important

- Flanges must be free of oil. Clean the mating surfaces on the water pump, both sides of the water pump plate, and the engine block.
1. Water pump (91) to the water pump plate (99).
 - Gasket (94) and bolts (92 and 93).

🔧 Tighten

2. Water pump (91) to the engine block.
 - Apply anaerobic sealer #1052357 or equivalent.
 - The sealer must be wet to the touch when the bolts are tightened.
 - Bolts (96 and 97).

🔧 Tighten

- Bolts (96 and 97) to "Specifications."
3. Bypass hose and lower radiator hose.
 4. Power steering pump.
 5. Generator in place.
 - Generator lower bracket.
 6. Drive belts and adjust.
 - Refer to "Drive Belts Replacement."
 7. Oil fill tube.
 8. Fan shroud.
 - Refer to RADIATOR (SEC. 6B2).
 9. Fan (73) assembly.
 - Refer to "Fan And Fan Clutch Replacement."
 10. Coolant to the radiator.
 11. Start the engine and operate with the radiator cap removed until the radiator upper hose (12) becomes hot (thermostat is open).
 12. Add coolant to the radiator until the level reaches the bottom of the filler neck.
 - Engine must be running at idle speed.
 13. Radiator cap, making sure the arrows line up with the overflow tube.

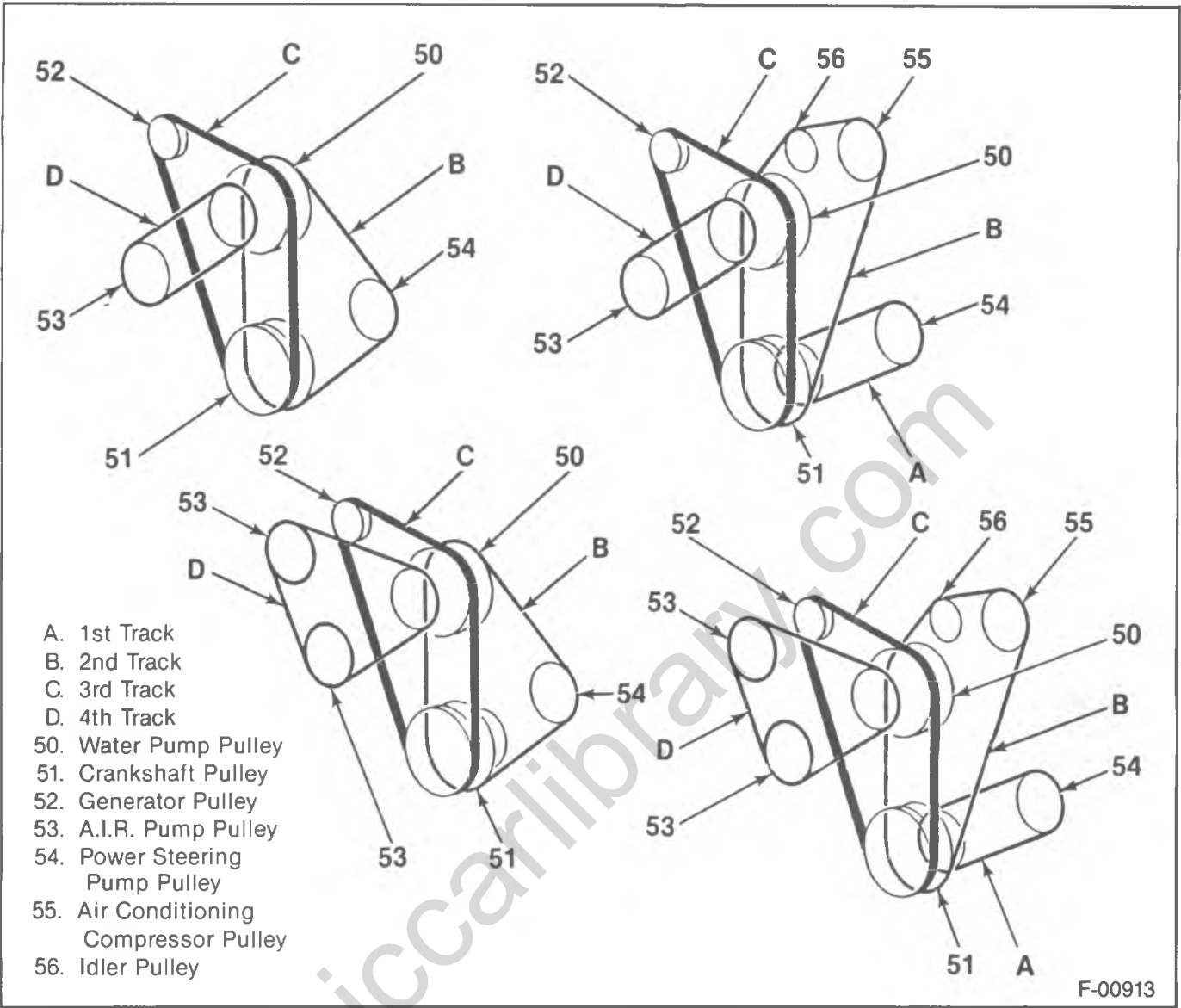

Figure 31—Engine Accessory Drive - Heavy Duty Emissions - 5.7L Engine (P)

6B1-24 ENGINE COOLING

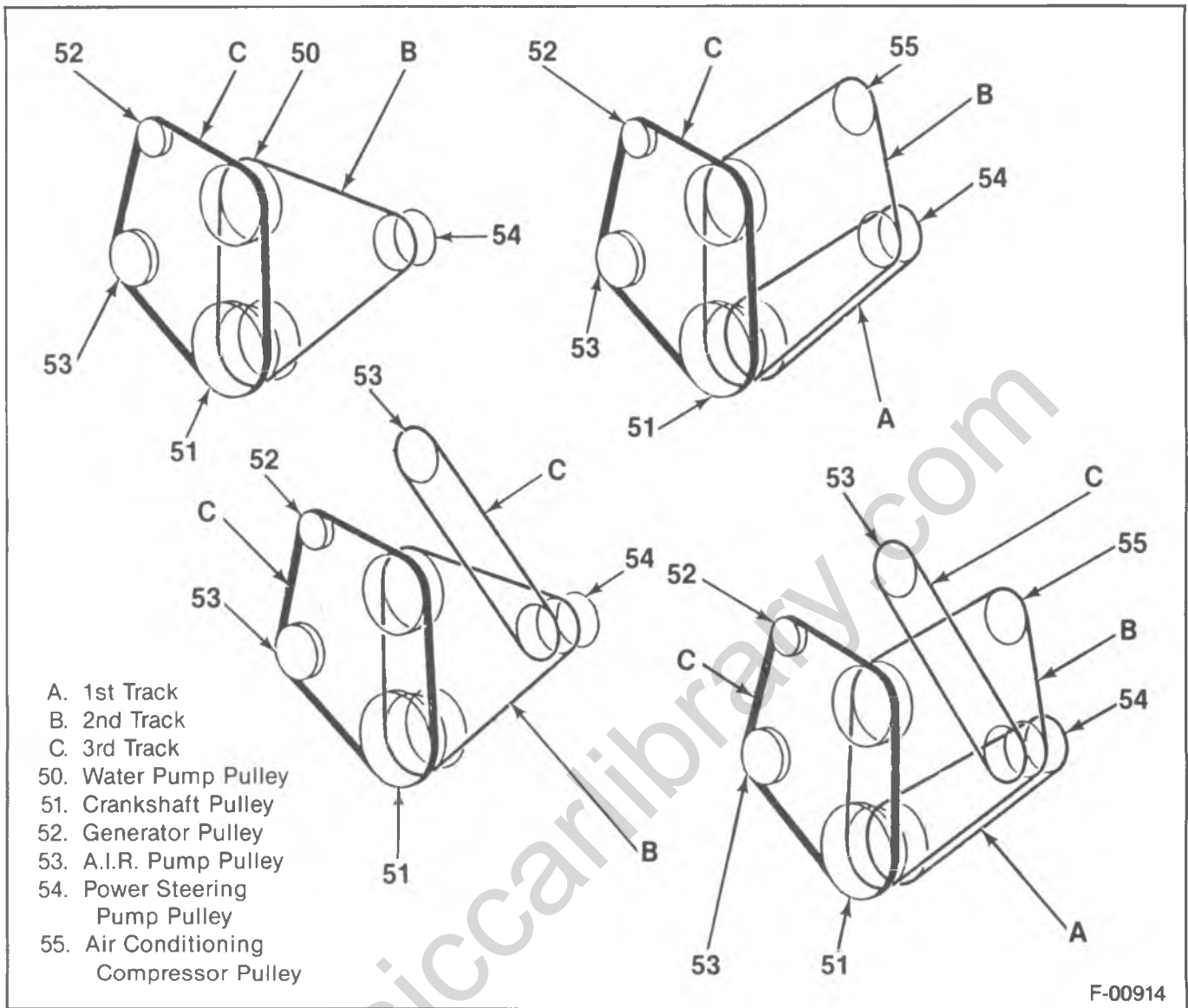
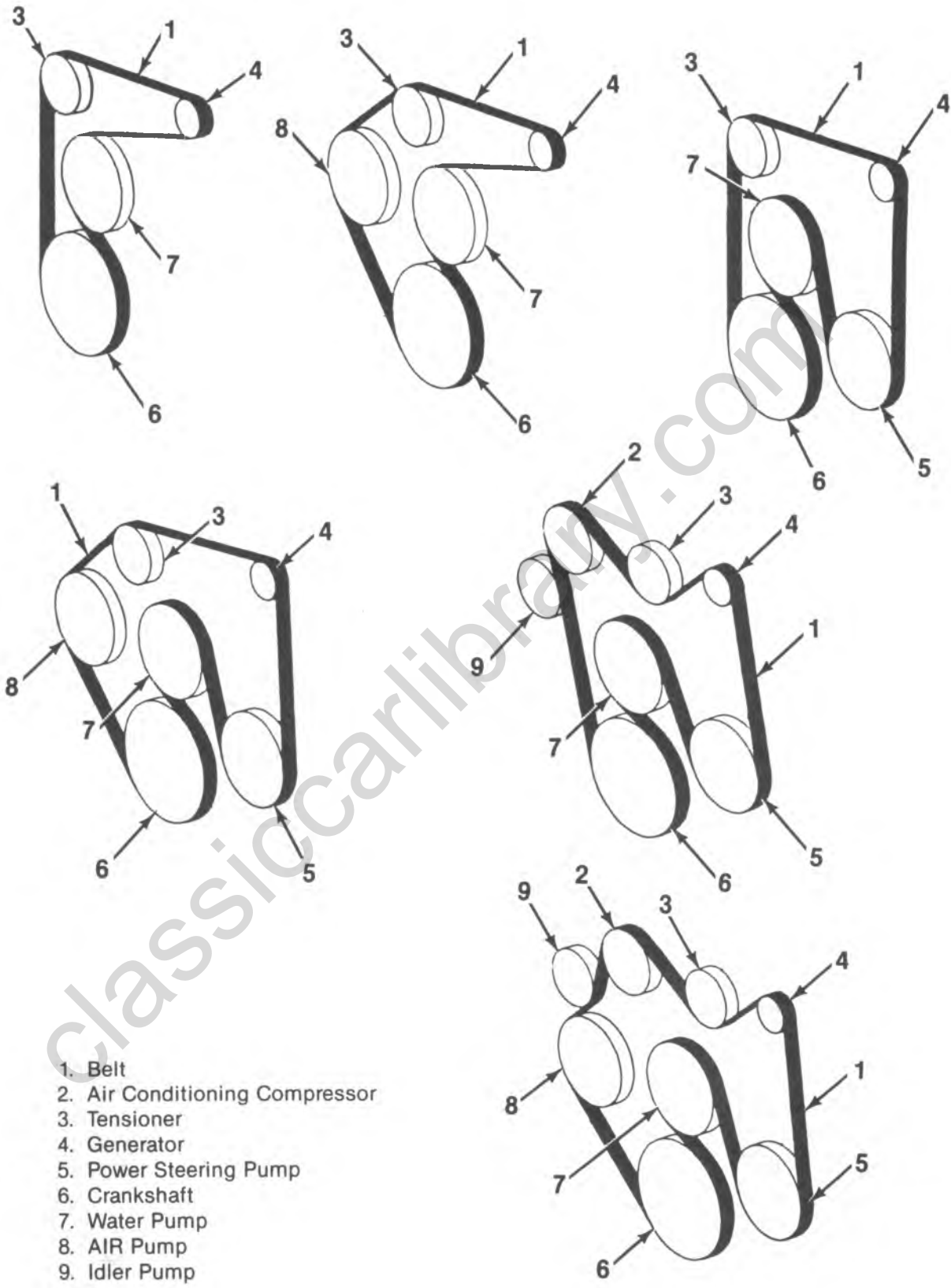

Figure 32—Engine Accessory Drive - 7.4L Engine (P)



G 4.3L, 5.0L and 5.7L Serpentine Accessory Drive

F-02581

Figure 33—Engine Accessory Drive - Serpentine Drive, 4.3L, 5.0L and 5.7L Engine (G)

6B1-26 ENGINE COOLING

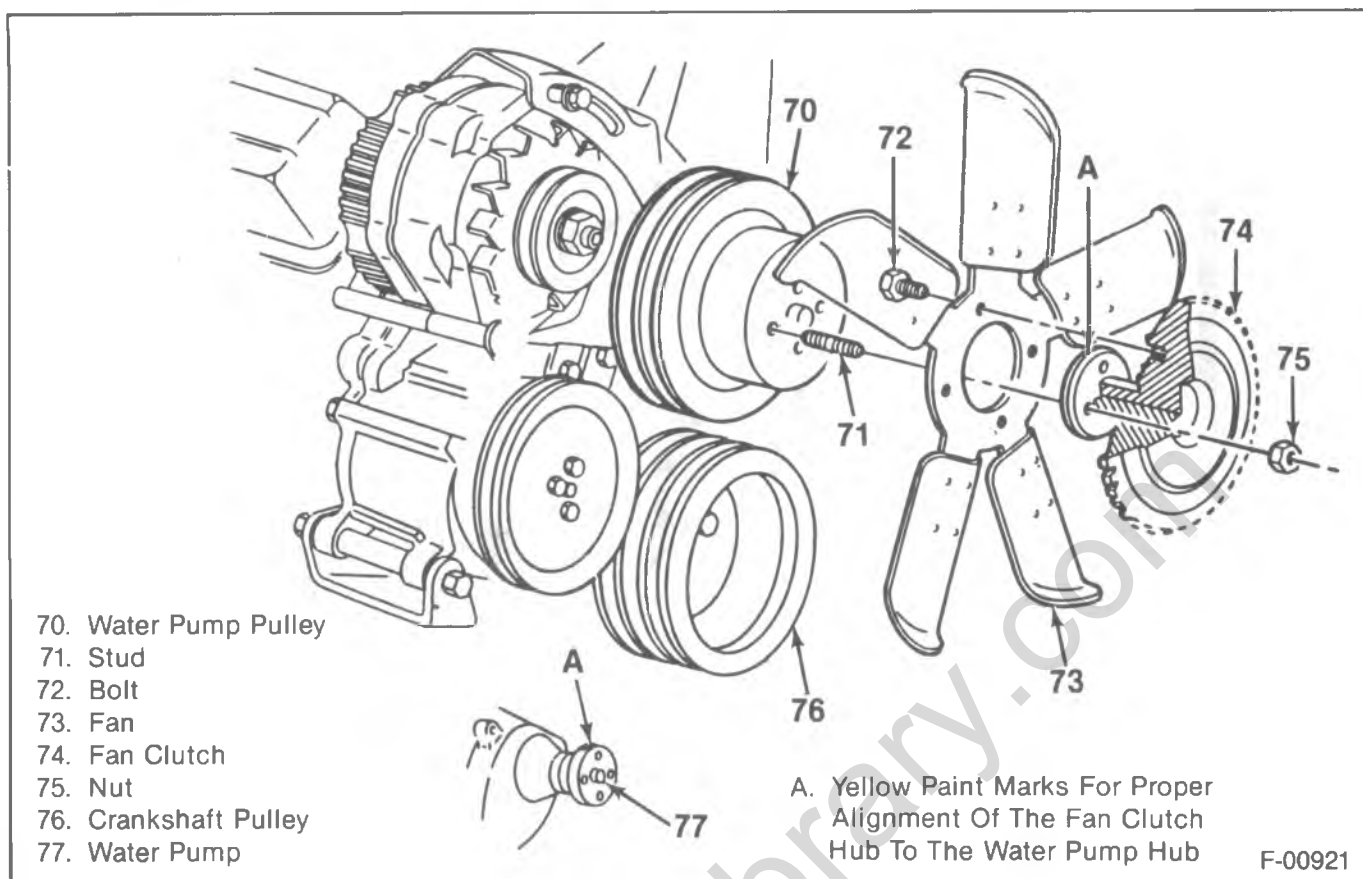

Figure 34—Fan and Fan Clutch Installation

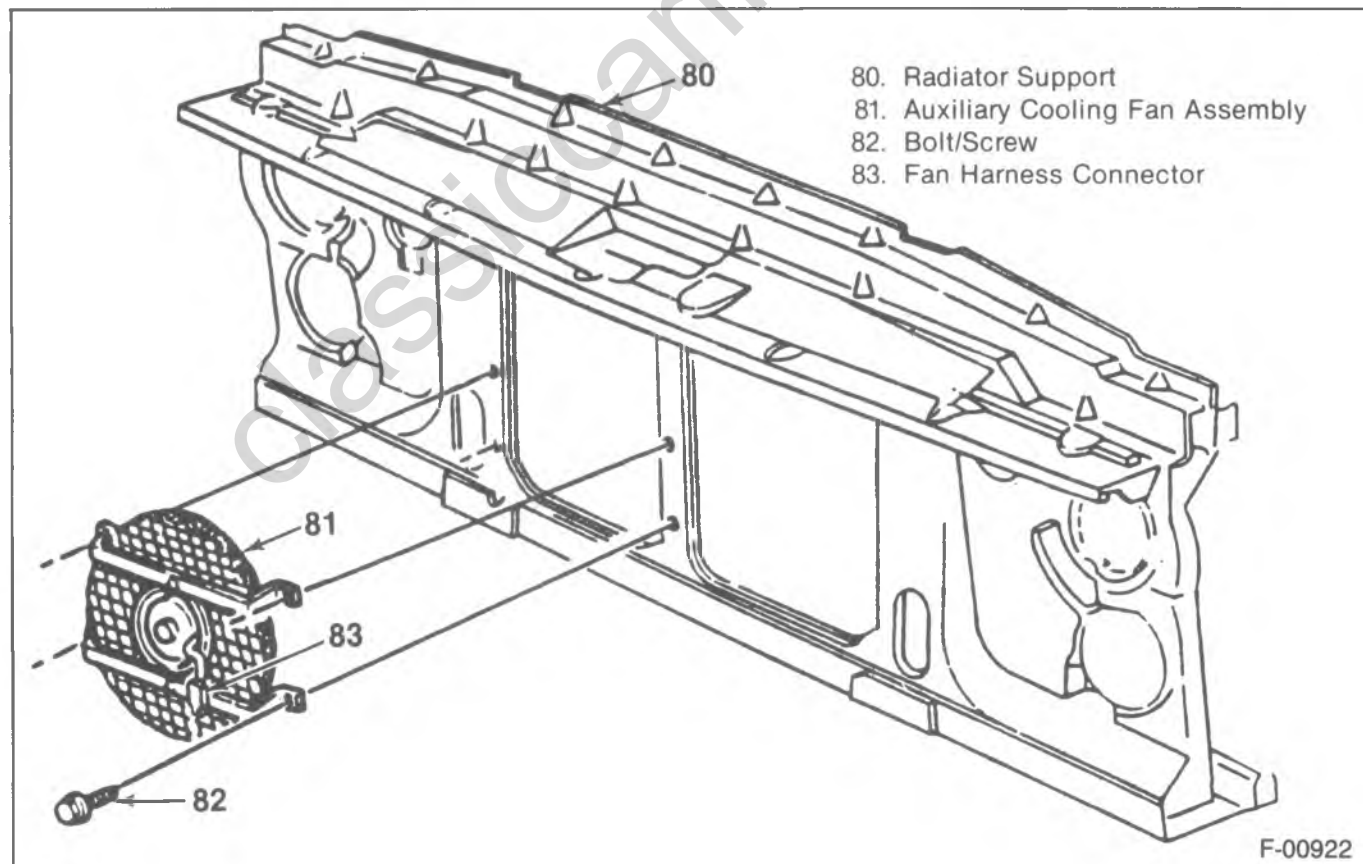

Figure 35—Auxiliary Cooling Fan Installation

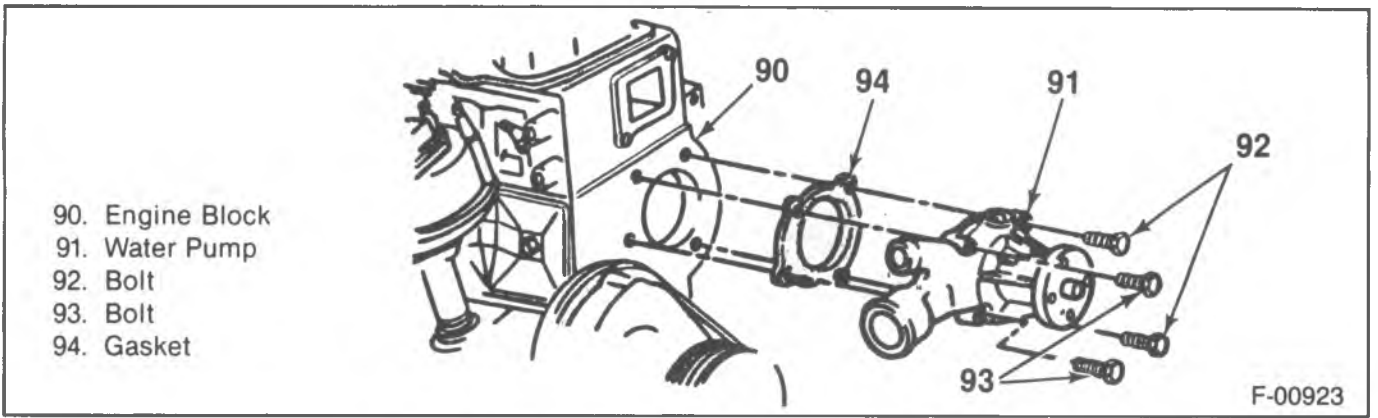

Figure 36—Water Pump Replacement - 4.8L Engine

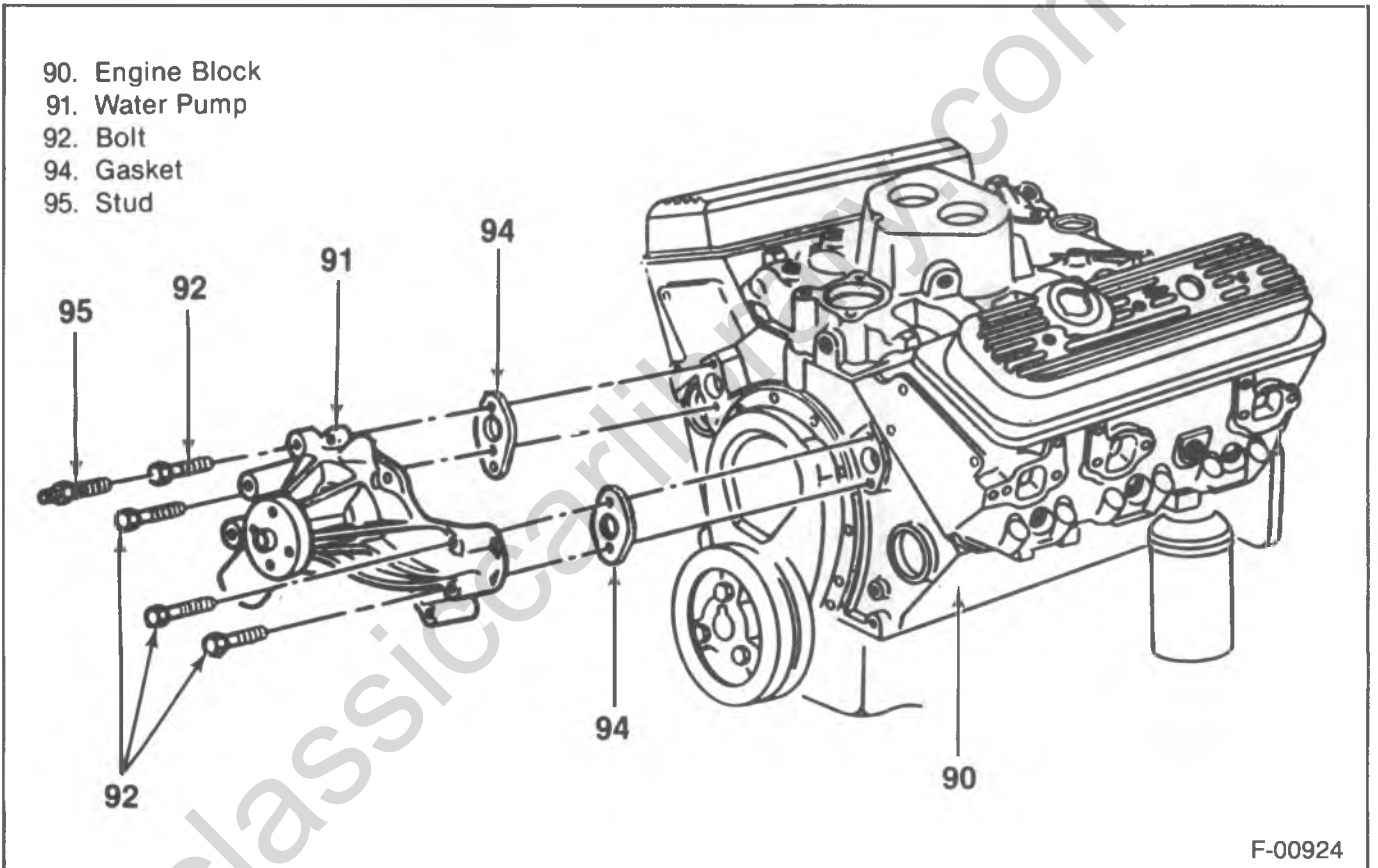

Figure 37—Water Pump Replacement - 4.3L Engine

6B1-28 ENGINE COOLING

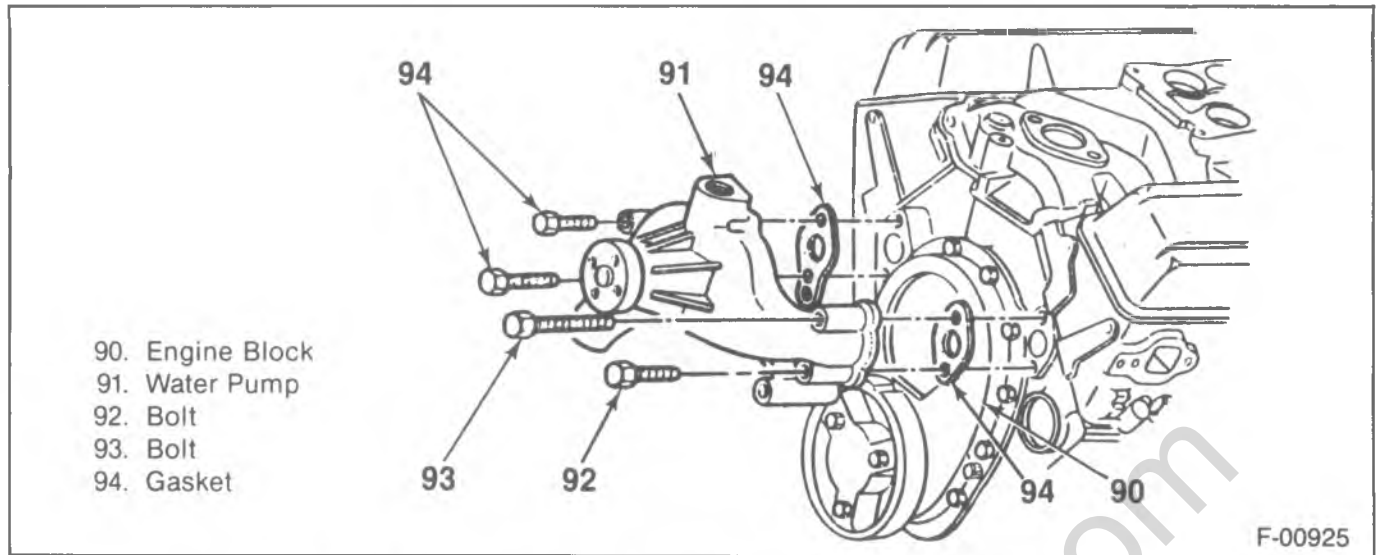

Figure 38—Water Pump Replacement - 5.0L and 5.7L Engines

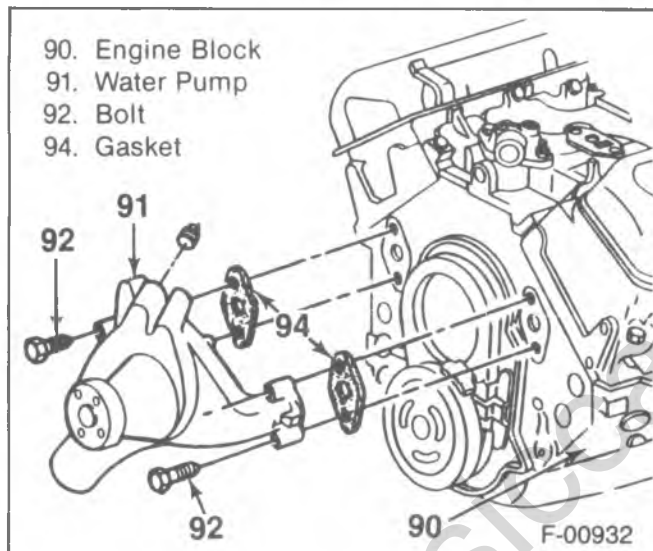

Figure 39—Water Pump Replacement - 7.4L Engine

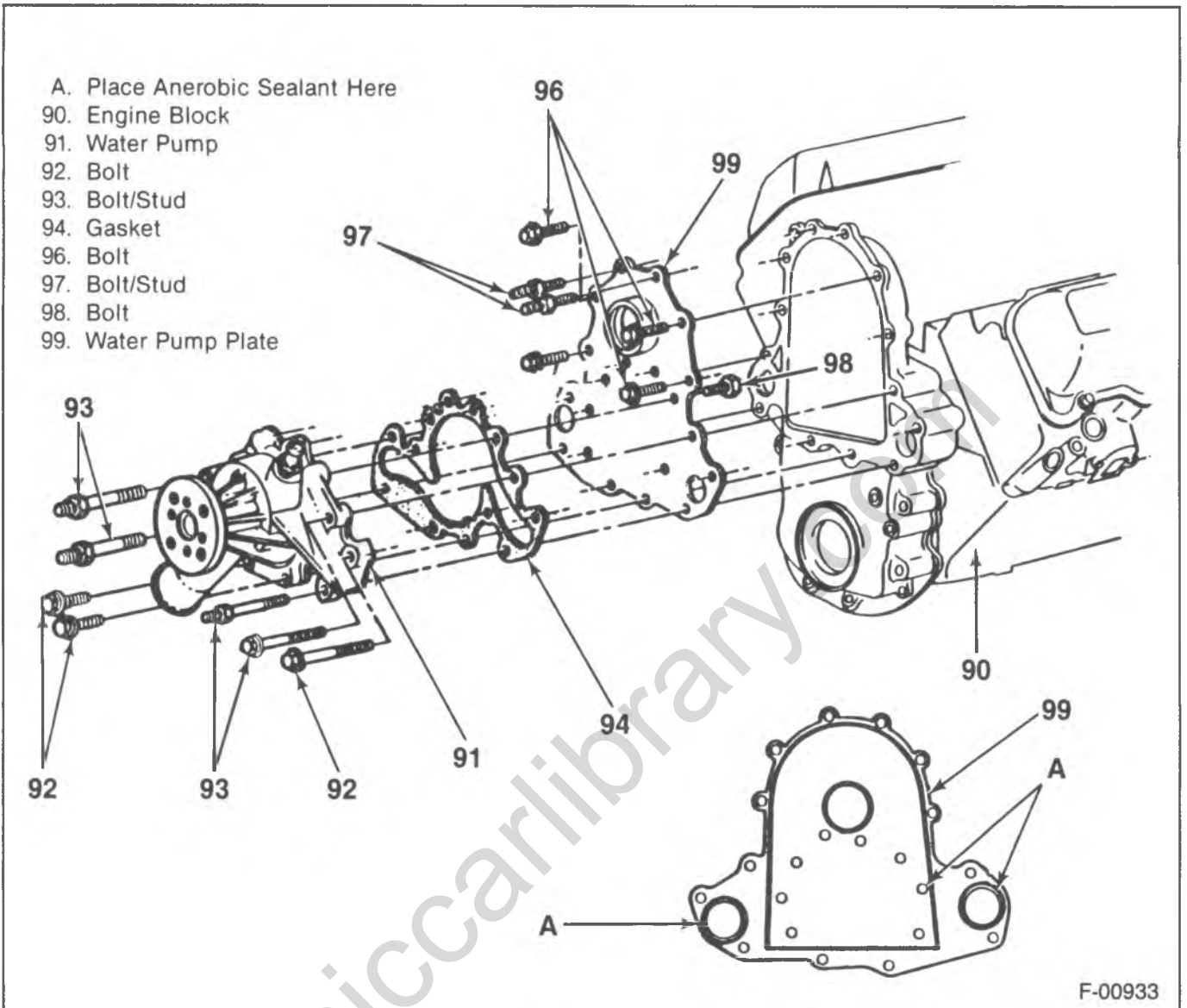

Figure 40—Water Pump Installation - 6.2L Engine

SPECIFICATIONS

DRIVE BELT TENSION SPECIFICATIONS

Engine	Tension Requirement	Generator	Power Steering Pump	Air Conditioning Compressor	A.I.R. Pump
4.8L L6	Before Operating The Engine (New Belt)	750 N (169 lb.)	750 N (169 lb.)	750 N (169 lb.)	750 N (169 lb.)
	After Operating The Engine (Old Belt)	400 N (90 lb.)	400 N (90 lb.)	400 N (90 lb.)	400 N (90 lb.)
4.3L V6	Before Operating The Engine (New Belt)	600 (135 lb.)	650 N (146 lb.)	750 N (169 lb.)	650 N (146 lb.)
	After Operating The Engine (Old Belt)	400 N (90 lb.)	300 N (67 lb.)	400 N (90 lb.)	300 N (67 lb.)
5.0L V8	Before Operating The Engine (New Belt)	600 N (135 lb.)	650N (146 lb.)	750 N (169 lb.)	650 N (146 lb.)
	After Operating The Engine (Old Belt)	400 N (90 lb.)	300 N (67 lb.)	400 N (90 lb.)	300 N (67 lb.)
5.7L V8	Before Operating The Engine (New Belt)	600 N (135 lb.)	650 N (146 lb.)	750 N (169 lb.)	650 N (146 lb.)
	After Operating The Engine (Old Belt)	400 N (90 lb.)	300 N (67 lb.)	400 N (90 lb.)	300 N (67 lb.)
7.4L V8	Before Operating The Engine (New Belt)	600 N (135 lb.)	650 N (146 lb.)	650 N (146 lb.)	*650 N (146 lb.)
	After Operating The Engine (Old Belt)	400 N (90 lb.)	400 N (90 lb.)	400 N (90 lb.)	*400 N (90 lb.)
6.2L V8 (Diesel)	Before Operating The Engine (New Belt)	650 N (146 lb.)	650 N (146 lb.)	750 N (169 lb.)	—
	After Operating The Engine (Old Belt)	300 N (67 lb.)	300 N (67 lb.)	400 N (90 lb.)	—

* When equipped with a right hand mounted pump and/or Federal Emissions (NAS) ONLY.

DO NOT exceed the "New Belt" tension specification when tensioning any belt, especially a used belt.

ACCESSORY DRIVE COMPONENT TORQUE SPECIFICATIONS

Fastener Name	4.8L L6	4.3L V6	5.0L V8	5.7L V8	6.2L V8	7.4L V8
Generator Adjustment Bolt	25 N·m (18 ft. lbs.)	25 N·m (18 ft. lbs.)	25 N·m (18 ft. lbs.)	25 N·m (18 ft. lbs.)	27 N·m (20 ft. lbs.)	*25 N·m (18 ft. lbs.)
Generator Pivot Bolt	23 N·m (17 ft. lbs.)	47 N·m (35 ft. lbs.)	47 N·m (35 ft. lbs.)	47 N·m (35 ft. lbs.)	43 N·m (32 ft. lbs.)	50 N·m (37 ft. lbs.)
Power Steering Pump Adjustment Bolt	43 N·m (32 ft. lbs.)	33 N·m (24 ft. lbs.)	33 N·m (24 ft. lbs.)	33 N·m (24 ft. lbs.)	43 N·m (32 ft. lbs.)	88 N·m (65 ft. lbs.)
Power Steering Pump Pivot Bolt	24 N·m (17 ft. lbs.)	33 N·m (24 ft. lbs.)	33 N·m (24 ft. lbs.)	33 N·m (24 ft. lbs.)	43 N·m (32 ft. lbs.)	50 N·m (37 ft. lbs.)
Air Conditioning Condenser Adjustment Bolt	34 N·m (25 ft. lbs.)	34 N·m (25 ft. lbs.)	34 N·m (25 ft. lbs.)	34 N·m (25 ft. lbs.)	34 N·m (25 ft. lbs.)	34 N·m (25 ft. lbs.)
Air Conditioning Condenser Pivot Bolt	34 N·m (25 ft. lbs.)	34 N·m (25 ft. lbs.)	34 N·m (25 ft. lbs.)	34 N·m (25 ft. lbs.)	34 N·m (25 ft. lbs.)	34 N·m (25 ft. lbs.)
Air Injection Reactor (A.I.R.) Pump Adjustment Bolt	25 N·m (18 ft. lbs.)	25 N·m (18 ft. lbs.)	25 N·m (18 ft. lbs.)	**25 N·m (18 ft. lbs.)	—	33 N·m (24 ft. lbs.)
Air Injection Reactor (A.I.R.) Pump Pivot Bolt	24 N·m (17 ft. lbs.)	24 N·m (17 ft. lbs.)	24 N·m (17 ft. lbs.)	**24 N·m (17 ft. lbs.)	—	33 N·m (24 ft. lbs.)

* For P series vehicles, torque is 64 N·m (47 ft. lbs.) with the K97 Generator.

** For the 5.7L V8 with Federal Emissions (RPO NA5), torque is 50 N·m (37 ft. lbs.)

SPECIFICATIONS (CONT.)

THERMOSTAT AND RESERVOIR RELATED TORQUE SPECIFICATIONS

Fastener Name	R/V	R/V	R/V	G	G	G	P	P
	10/1500	20/2500	30/3500	10/1500	20/2500	30/3500	20/2500	30/3500
Coolant Recovery Tank Bolt/Screw	2 N·m (18 in. lbs.)	2 N·m (18 in. lbs.)	2 N·m (18 in. lbs.)	2 N·m (18 in. lbs.)	2 N·m (18 in. lbs.)	2 N·m (18 in. lbs.)	— —	— —
Deaeration Tank Bolts/ Screws And Nuts	5 N·m (44 in. lbs.)	5 N·m (44 in. lbs.)	5 N·m (44 in. lbs.)	—	—	10 N·m (88 in. lbs.)	—	17 N·m (12 ft. lbs.)
Water Outlet To The Thermostat Housing Bolts	*•27 N·m (20 ft. lbs.)	*•27 N·m (20 ft. lbs.)	*•27 N·m (20 ft. lbs.)	*•27 N·m (20 ft. lbs.)	*•27 N·m (20 ft. lbs.)	*•27 N·m (20 ft. lbs.)	*•27 N·m (20 ft. lbs.)	*•27 N·m (20 ft. lbs.)
Thermostat Crossover To The Engine Bolts (6.2L Diesel ONLY)	47 N·m (35 ft. lbs.)	47 N·m (35 ft. lbs.)	47 N·m (35 ft. lbs.)	47 N·m (35 ft. lbs.)	47 N·m (35 ft. lbs.)	47 N·m (35 ft. lbs.)	47 N·m (35 ft. lbs.)	47 N·m (35 ft. lbs.)
Water Outlet To The Thermostat Housing Bolts (6.2L Diesel ONLY)	47 N·m (35 ft. lbs.)	47 N·m (35 ft. lbs.)	47 N·m (35 ft. lbs.)	47 N·m (35 ft. lbs.)	47 N·m (35 ft. lbs.)	47 N·m (35 ft. lbs.)	47 N·m (35 ft. lbs.)	47 N·m (35 ft. lbs.)

* On vehicles with a 6.2L Diesel, torque to 47 N·m (35 ft. lbs.)

• On vehicles with a 7.4L V8, torque to 41 N·m (30 ft. lbs.)

SPECIAL TOOLS

1.

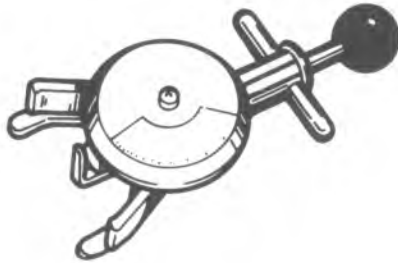

J-23600-B

1. Universal V-Belt Tension Gage

F-02615

classiccarlibrary.com

SECTION 6B2

RADIATOR

CONTENTS

<u>SUBJECT</u>	<u>PAGE</u>
Description	6B2- 1
Radiator Maintenance	6B2- 5
On-Vehicle Service	6B2- 6
Fan Shroud Replacement	6B2- 6
Radiator Replacement	6B2-10
Pressure Cap	6B2-13
Coolant Recovery System	6B2-14
Surge Tank	6B2-15
Aluminum Radiator Repair	6B2-15
Description	6B2-15
Diagnosis	6B2-15
Aluminum Radiator Service	6B2-17
Specifications	6B2-22
Special Tools	6B2-23

DESCRIPTION

The radiator in the R/V, G and P series vehicles is a crossflow tube and center type. Refer to figures 1 through 4.

All radiators are fitted with a shroud designed to assist the fan in directing air flow through the radiator core and to also serve as a fan guard. Provision for coolant expansion is achieved with a coolant recovery tank. This retards coolant overflow, and reduces frequent refills.

Pressure is maintained in the radiator and system by a pressure cap. The pressure cap has two valves; one relieves excessive pressure and the other compensates for coolant contraction when the engine is stopped. Radiator caps are provided in 105 kPa (15 psi) rating on all models.

6B2-2 RADIATOR

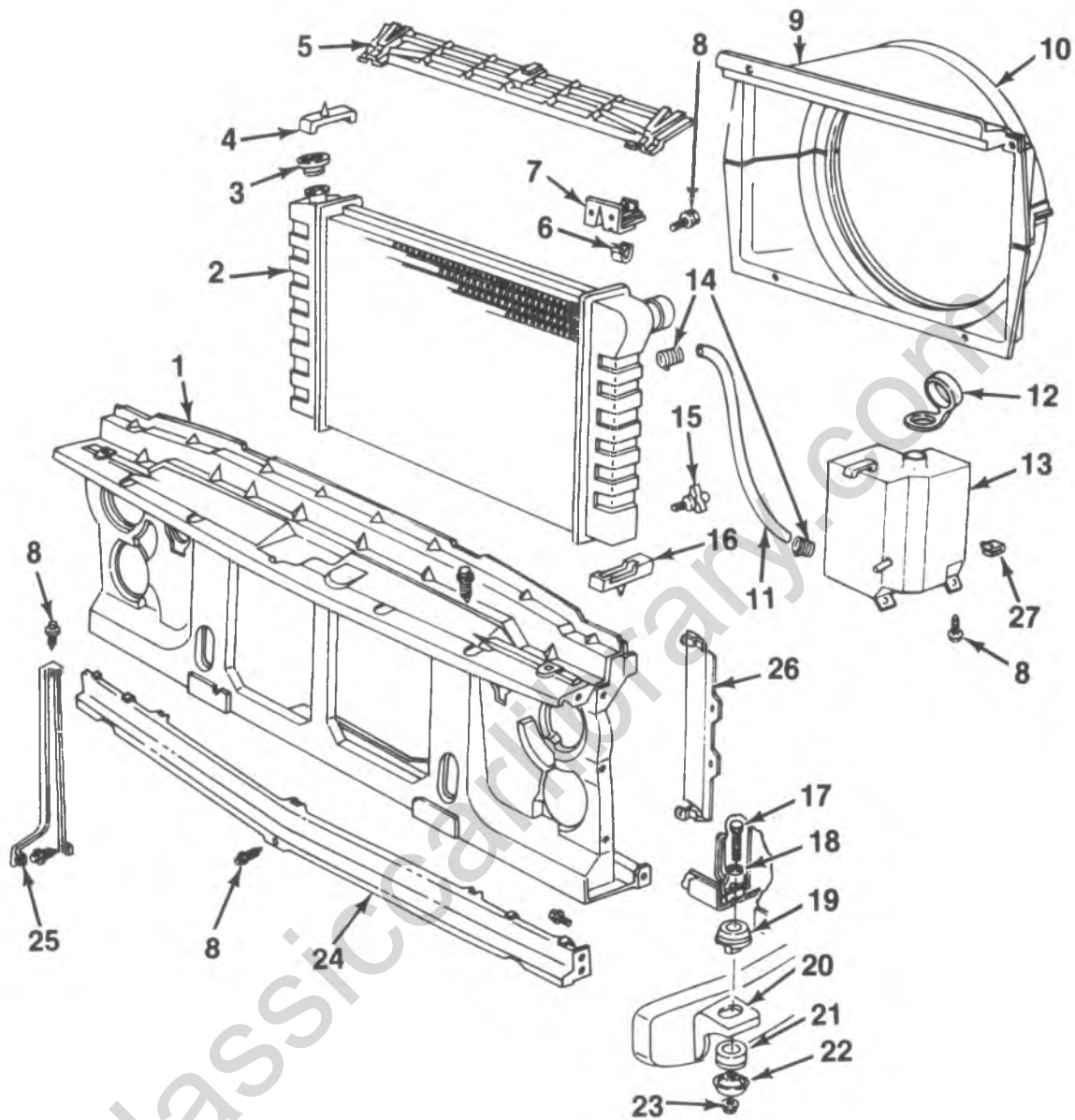

- | | | |
|--------------------|----------------------|------------------|
| 1. Support | 13. Reservoir | |
| 2. Radiator | 14. Worm Clamp | |
| 3. Filler Cap | 15. Drain Cock | |
| 4. Upper Insulator | 16. Lower Insulator | |
| 5. Upper Panel | 17. Bolt | |
| 6. U-Shaped Nut | 18. Washer | |
| 7. Shroud Bracket | 19. Upper Cushion | |
| 8. Screw | 20. Support Bracket | 24. End Panel |
| 9. Upper Shroud | 21. Lower Cushion | 25. Support |
| 10. Lower Shroud | 22. Cushion Retainer | 26. Right Baffle |
| 11. Hose | 23. Nut | 27. Nut |

B-07687

Figure 1—R/V — Radiator Mounting and Related Parts (Typical)

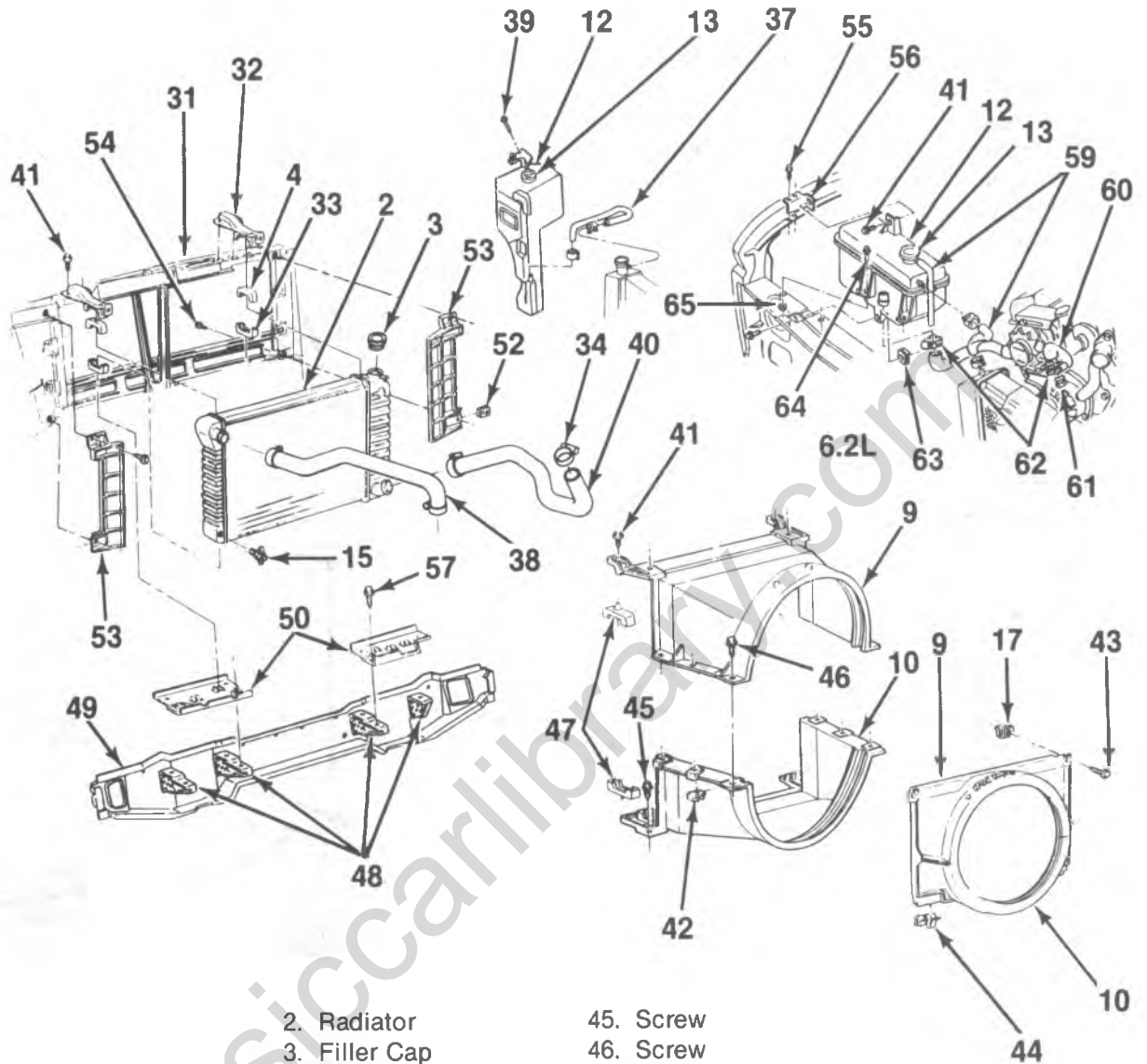

- | | |
|--------------------|----------------------|
| 2. Radiator | 45. Screw |
| 3. Filler Cap | 46. Screw |
| 4. Insulator | 47. Insulator |
| 9. Upper Shroud | 48. Mounting Bracket |
| 10. Lower Shroud | 49. Cross Sill |
| 12. Reservoir | 50. Right Panel |
| 13. Reservoir Cap | 51. Screw |
| 15. Drain Cock | 52. "U" Nut |
| 31. Panel | 53. Extension |
| 32. Upper Bracket | 54. Bolt |
| 33. Lower Pad | 55. Screw |
| 34. Screw | 56. Tank Bracket |
| 37. Reservoir Hose | 57. Surge Tank |
| 38. Inlet Hose | 59. Hose |
| 39. Clamp | 60. Inlet Hose |
| 40. Outlet Hose | 61. Hose Nipple |
| 41. Bolt | 62. Clamp |
| 42. "J" Nut | 64. Hex Bolt |
| 43. Screw | 65. Hex Nut |
| 44. Clip | |

Figure 2—G — Radiator Mounting and Related Parts (Typical)

6B2-4 RADIATOR

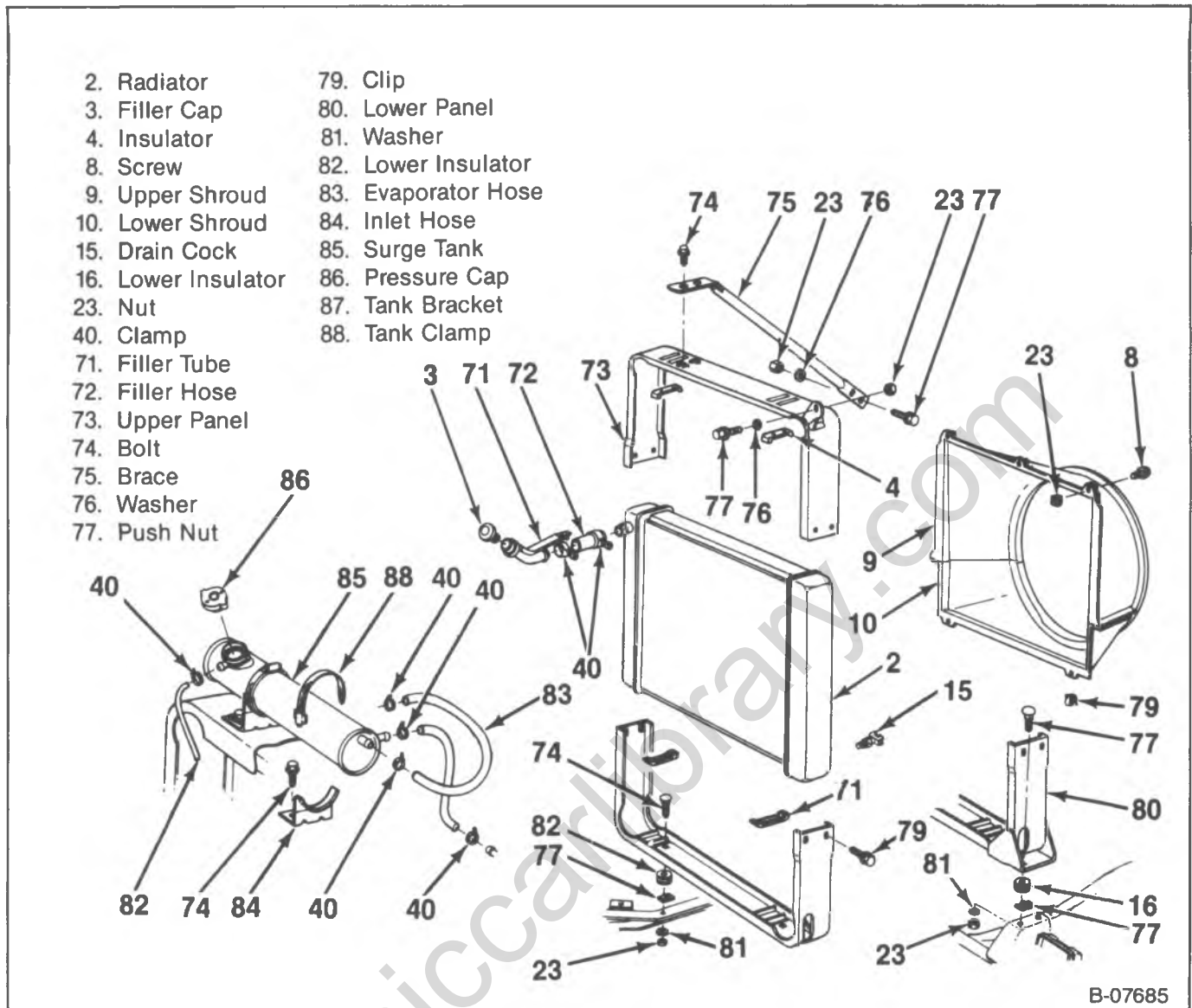

B-07685

Figure 3—P(32) — Radiator Mounting and Related Parts (Typical)

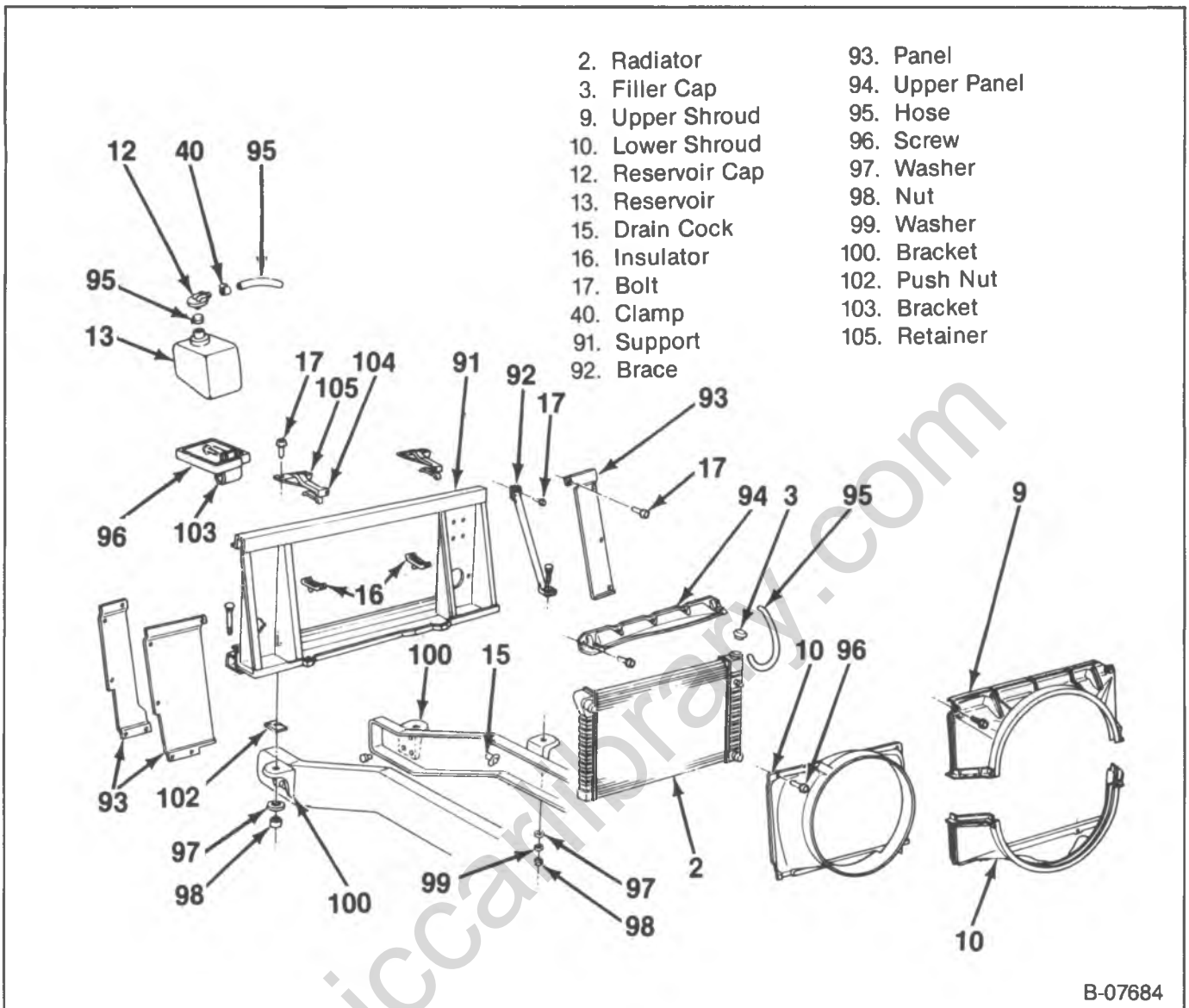

B-07684

Figure 4—P(42) — Radiator Mounting and Related Parts (Typical)

RADIATOR MAINTENANCE

Check the outside of the radiator for bent fins, or signs of leakage. Repair leaking radiator cores. Do not seal temporarily with a sealer type antifreeze or coolant additive. Remove any stones between the fins. Clean loose debris and road film from the radiator core with a quality grease solvent and compressed air. Direct the stream of solvent at the front of the core for more efficient cleaning.

To insure a thorough cleaning, remove the grille, fan guard, and fan shroud.

Remove the radiator cap and look for plugging and scale on the inside of the tank. Replace a badly plugged radiator. Test the radiator and system as described in ENGINE COOLING (SEC. 6B1).

1. Check the coolant level. If low, add recommended coolant as required.
2. Check the hose connections and tighten the clamps if leakage is evident. Replace cracked, stripped, or corroded clamps.

3. Check the coolant hoses for spongy or checked appearance. Replace deteriorated hoses or bursting could occur which would result in coolant loss and extensive engine damage due to overheating.
4. Check the radiator core for leaks and for accumulation of dirt which may obstruct the air passages and reduce heat transfer.
5. Check the surge tank or recovery tank for leaks. Plastic bottles may develop cracks for being damaged by flying objects. Check metal tanks at the weld seams.
6. Inspect the radiator rubber mountings and bumpers for deterioration and replace as necessary. Check the mounting bolts, supports, braces, tie rods, and stabilizer rods. Components should be securely fastened in place if mounting bolts are missing, loose, or stripped. Also check for damage to the core, side flanges, and supporting components.

6B2-6 RADIATOR

7. Check for clearance between the fan blades, core, and shroud. Check the fan attaching bolts for tightness and that none are missing. Replace the fan if any blade is bent. The distance between the blades and shroud should be equal around the perimeter of the shroud. Adjust as necessary after any adjustment has been made to the fan or the fan mounting bracket and hub.
8. Inspect the filler cap seal for evidence of cracking, separation, or deterioration. Replace as required.
9. To assist in maintaining efficient heat dissipation, an occasional external flushing with water will remove the majority of dirt accumulation and foreign matter from between core fins. Direct water under moderate pressure from behind the core to force debris out in the opposite direction of its entry. Direct the water stream in line with the fins to reduce the possibility of bending fins.

RADIATOR INTERNAL DEPOSITS

A radiator that has a dirty, obstructed core or is leaking will cause the engine to overheat. A scale deposit inside the radiator is a result of using hard, high mineral content water in the cooling system. The effect of heat on the minerals in the water causes the formation of scale, or hard coating, on metal surfaces within the radiator, thereby reducing the transfer of heat. Some hard water will produce a silt-like deposit which restricts the flow of water. This must be flushed out at least twice a year — more often if necessary.

SCALE REMOVAL

To remove the hardened scale, a direct chemical action is necessary. A flushing compound at the specified rate of 30 grams per liter (4 oz. per gallon) of radiator capacity, should be added to the coolant water in the form of a dissolved solution while the engine is running. Operate the engine for 15 minutes, then drain and flush the system with clean water.

There are various types of flushing compounds commercially available and should be obtained from a reliable source. Most compounds attack metals and should not remain in the engine for more than a few minutes. Use a neutralizer after a descaling solvent is used.

For extremely hard, stubborn coatings, such as lime scale, use a stronger solution. The corrosive action of a stronger solution will affect the thin metals of the radiator, thereby reducing its operating life. A complete flushing and rinsing is mandatory and must be accomplished skillfully.

After using the solvent and neutralizer and flushing the cooling system, drain the system and fill it with clean, soft water plus a rust inhibitor or high boiling point type antifreeze. After filling the cooling system, check for radiator, hose, and engine coolant leaks.

ON-VEHICLE SERVICE

FAN SHROUD REPLACEMENT

R/V VEHICLES

Remove or Disconnect (Figures 1, 5 and 6)

1. Fan shroud to radiator retainer attaching bolts (60).
2. Fan clutch to water pump hub attachments.
 - Refer to ENGINE COOLING (SEC. 6B1).
3. Fan shroud assembly (61 and 64).
 - Pull up and out of the lower retaining clips.
 - The fan shroud and fan clutch assembly must be removed together.

Install or Connect (Figures 5 and 6)

1. Lower fan shroud (64) and the fan clutch.
 - Position along the back of the radiator (63).
 - Make sure the lower edge fits into the lower retaining clips.
2. Fan clutch to water pump hub attachments.
 - Refer to ENGINE COOLING (SEC. 6B1).
3. Shroud (61) to the radiator retainer attaching bolts (60).

Tighten

- Bolts (60) to 6 N·m (53 in. lbs.)

G AND P VEHICLES

Remove or Disconnect (Figures 2, 3, 4, 7, 8, 9 and 10)

1. Vacuum reservoir, if equipped with air conditioning.
 - Refer to AIR CONDITIONING (SEC. 1B).
2. Windshield washer jar and its bracket.
3. Fan shroud retaining bolts (60).
4. Radiator support bracket (67).
5. Dipstick from the engine.
6. Dipstick from the automatic transmission, if equipped.
7. Radiator hose strap from the fan shroud (61).
8. Fan from the water pump.
 - Leave the pulley in place.
 - Refer to ENGINE COOLING (SEC. 6B1) in this section.
9. Fan and the fan shroud together.

Install or Connect (Figures 7 through 10)

1. Fan and the fan shroud together.
2. Fan to the water pump.
 - Refer to ENGINE COOLING (SEC. 6B1) in this section.
3. Radiator hose strap to the fan shroud.
4. Dipsticks into the engine, and transmission if applicable.
5. Radiator support brace (67).

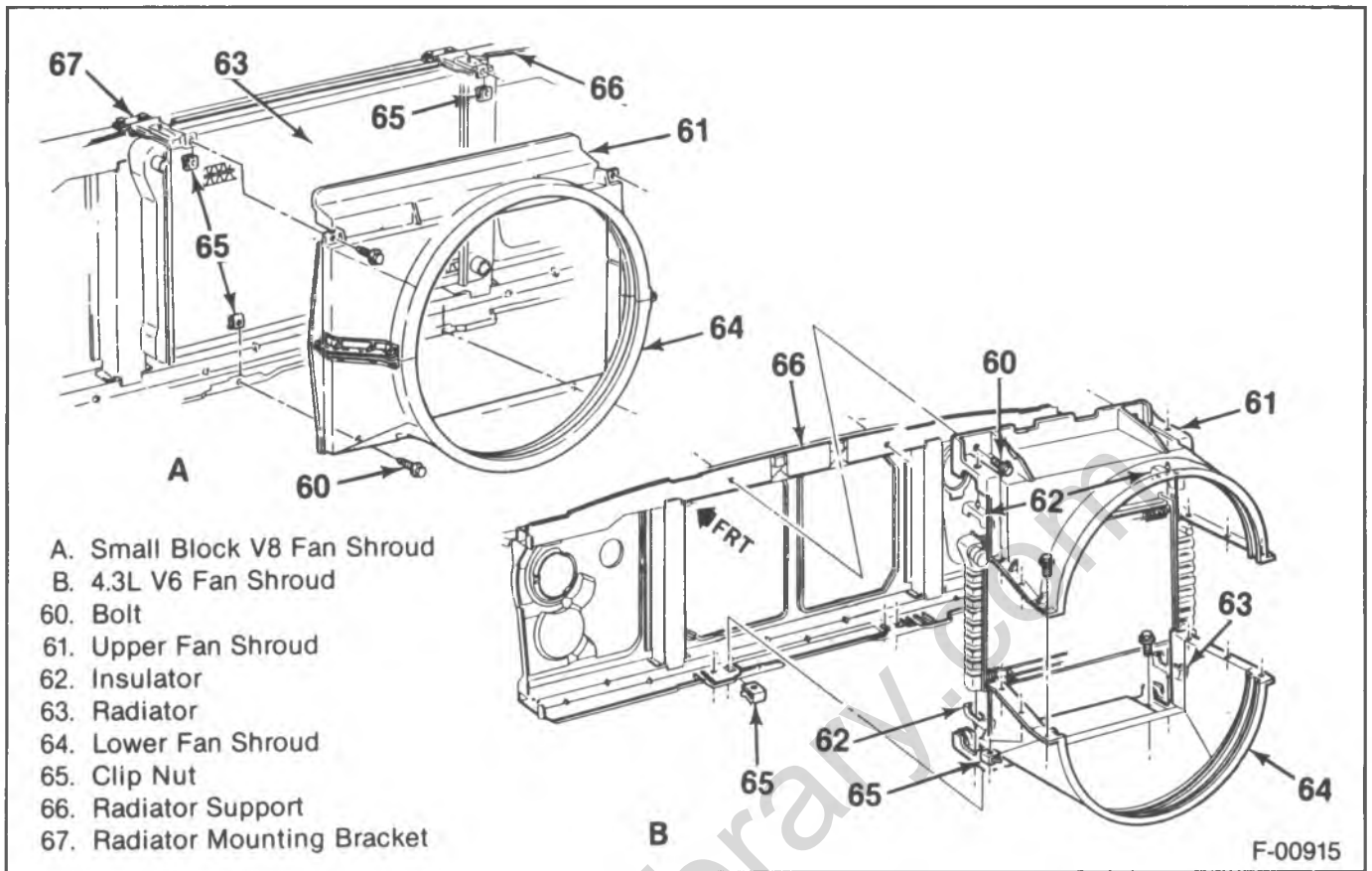

Figure 5—Fan Shroud — 4.3L, 5.0L and 5.7L Engines (R/V)

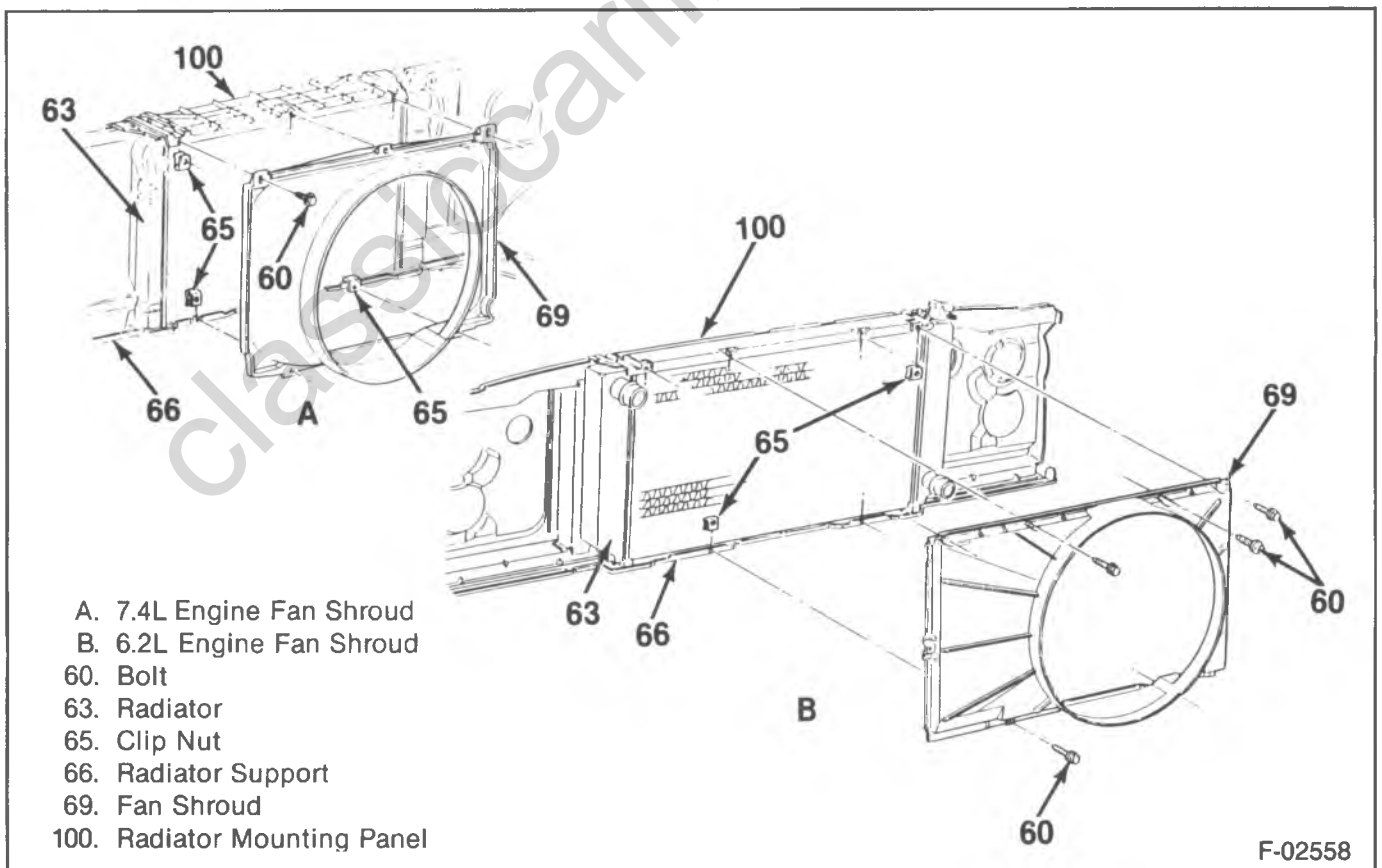

Figure 6—Fan Shroud — 6.2L and 7.4L Engines (R/V)

6B2-8 RADIATOR

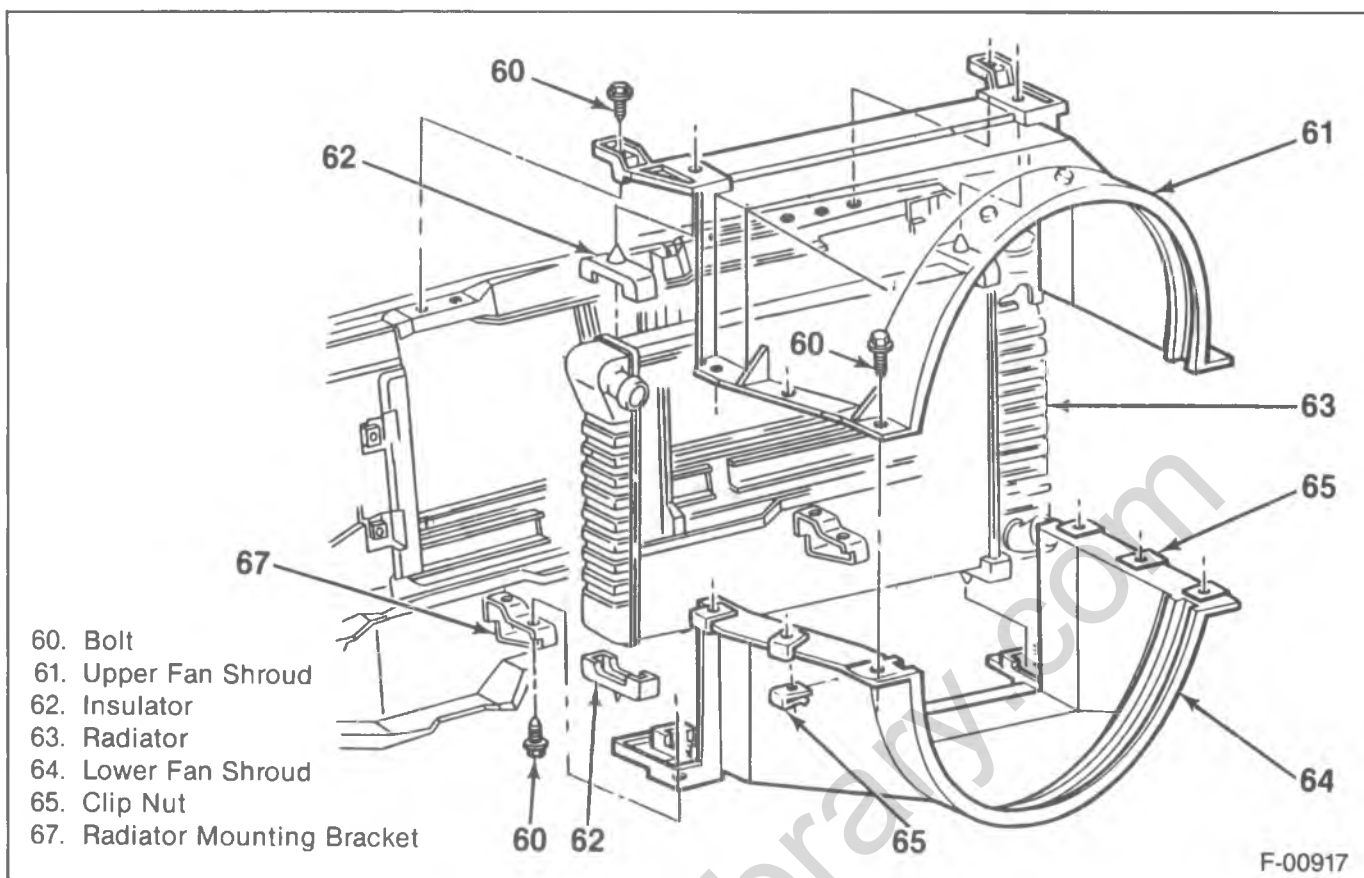

Figure 7—Fan Shroud — 4.3L Engine (G)

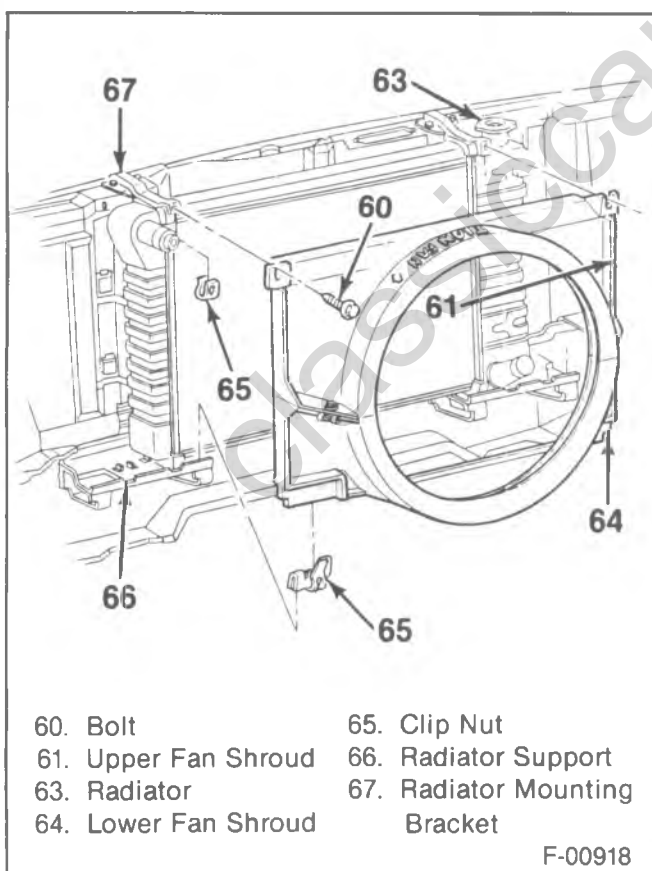

Figure 8—Fan Shroud — 5.0L, 5.7L and 6.2L Engines (G)

- Bolts (60).



Tighten

- Bolts (60) to 17 N·m (13 ft. lbs.).

6. Fan shroud retaining bolts (60).



Tighten

- Bolts (60) to 6 N·m (53 in. lbs.).
- Bolts (60) for 4.3L engine to 27 N·m (20 ft. lbs.).

7. Windshield washer jar and its bracket.
8. Vacuum reservoir, if equipped with air conditioning.
 - Refer to AIR CONDITIONING (SEC. 1B).

G AND P VEHICLES — 6.2L ENGINE



Remove or Disconnect (Figures 2, 3, 4, 8 and 10)

1. Air cleaner intake.
 - Rotate the snorkel up.
2. Fan shroud bolts (60).
3. Hood latch cable.
4. Windshield washer bottle.
5. Upper fan shroud (61).



Install or Connect (Figures 6 and 8)

1. Upper fan shroud (61).
 - Bolts (60).

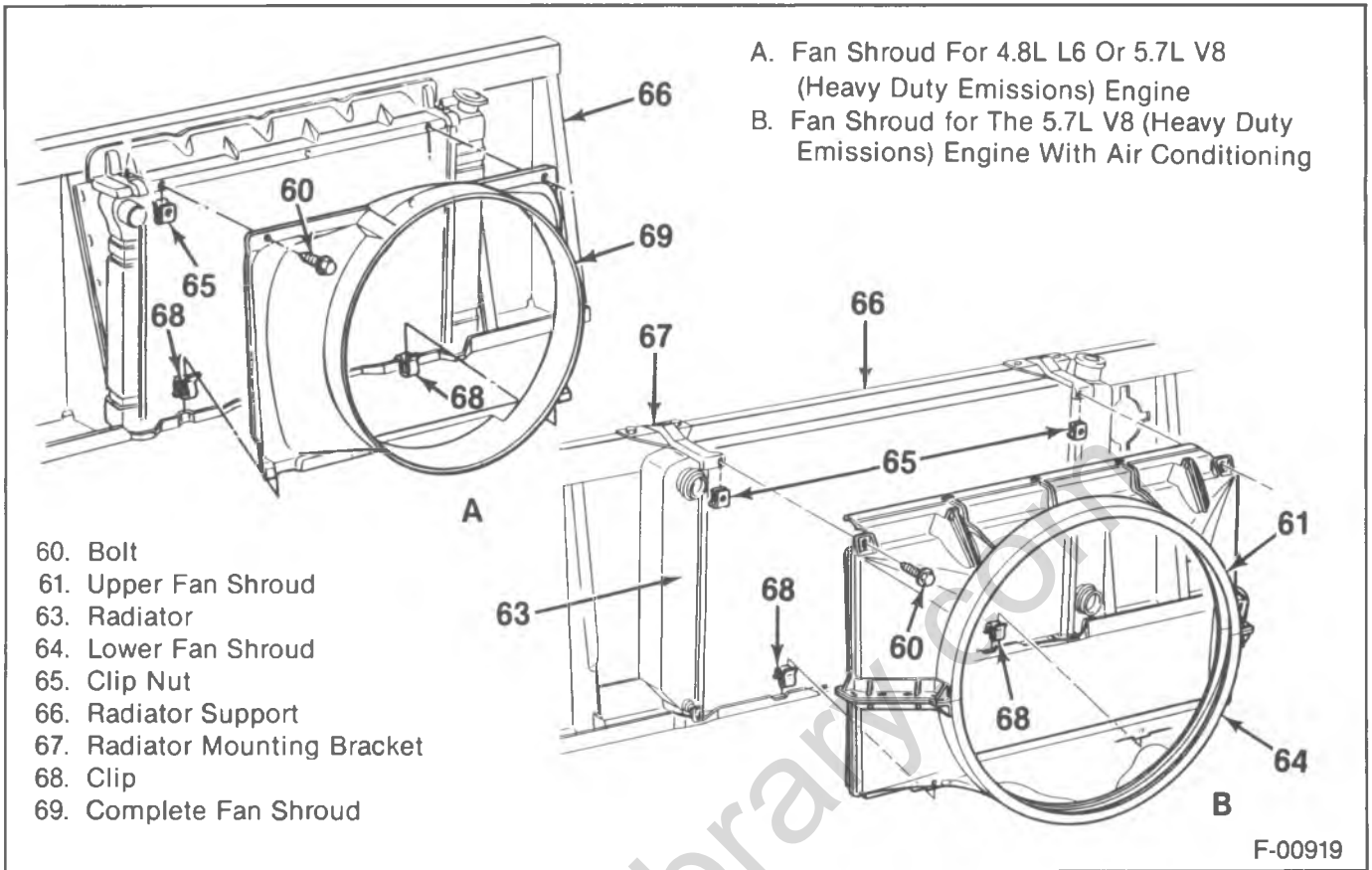

Figure 9—Fan Shroud — 4.8L and 5.7L Engines — P(42)

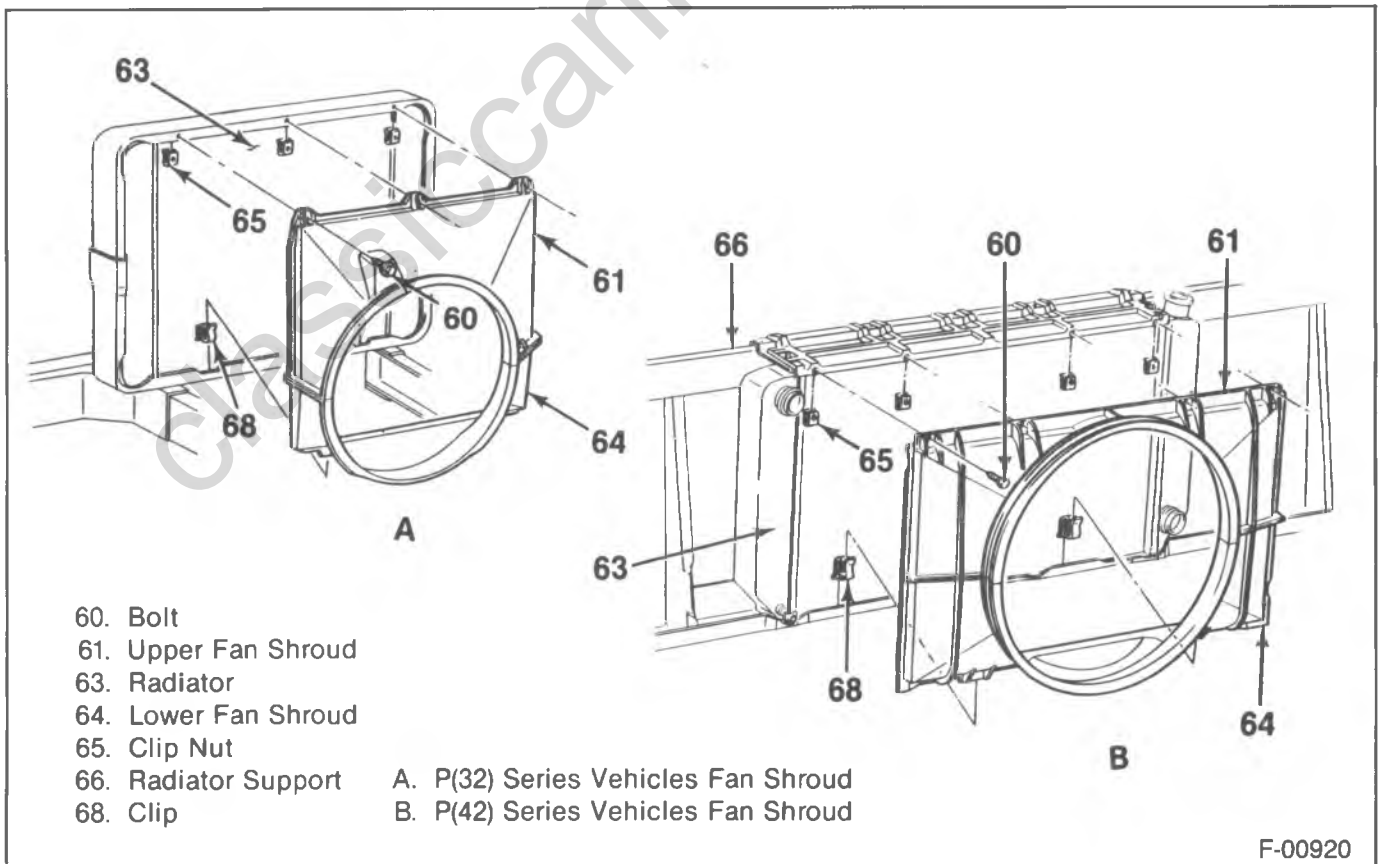

Figure 10—Fan Shroud — 6.2L and 7.4L Engines — (P-32 and 42)



Tighten

- Bolts (60) to 6 N·m (53 in. lbs.).
2. Windshield washer bottle.
 3. Hood latch cable.
 4. Fan shroud bolts (60).



Tighten

- Bolts (60) to 6 N·m (53 in. lbs.).
5. Air cleaner intake.

RADIATOR REPLACEMENT

The type of radiator core mounting varies according to model and engine type. Radiator assembly includes a shroud and may include an oil cooler in the core. Some models have a separate power steering oil cooler attached in front of the radiator core. On models so equipped it may be necessary to remove the oil cooler to facilitate removal of the radiator core. Refer to POWER STEERING (SEC. 3B3) in this manual for oil cooler removal and installation.

R/V, G, AND P VEHICLES (4.3L, 4.8L, 5.0L 5.7L AND 7.4L ENGINES)



Remove or Disconnect (Figures 11, 12 and 13)

- Coolant from the radiator.
1. Radiator hoses from the radiator.
 - Radiator inlet hose and radiator outlet hose.
 2. Overflow hose from the radiator.
 3. Fan shroud.
 - Refer to "Fan Shroud Replacement."
 4. Transmission cooler lines.
 5. Radiator from the vehicle.
 - Retainers from the radiator support.
 - Retainers from the upper mounting panel on R/V series vehicles.



Install or Connect (Figures 11, 12 and 13)

1. Radiator on the vehicle.
 - Radiator support on the upper mounting panel.



Tighten

- Fasteners to the "Specifications."
2. Transmission cooler lines.
 3. Fan shroud.
 - Refer to "Fan Shroud Replacement."
 4. Overflow hose to the radiator.
 5. Radiator hoses to the radiator.
 - Radiator inlet hose and radiator outlet hose.
 6. Coolant to the radiator.
 - Refer to the vehicle Owner's Manual.
 7. Remove the radiator pressure cap, start the engine, and let it run until the upper radiator hose becomes hot — thermostat is open.
 8. Add coolant, with the engine running at idle speed, until the coolant level reaches the bottom of the filler neck.
 9. Install the radiator pressure cap, making sure the arrows line up with the overflow tube.

R/V VEHICLES (6.2L ENGINE)



Remove or Disconnect (Figures 11, 12 and 13)

- Drain the cooling system.
1. Fan shroud.
 - Refer to "Fan Shroud Replacement."
 2. Engine and transmission oil cooler lines.
 3. Upper radiator hose and lower radiator hose from the radiator.
 4. Overflow hose from the radiator.
 5. Upper radiator supports.
 6. Radiator from the vehicle.



Install or Connect (Figures 11, 12 and 13)

1. Radiator to the vehicle.
2. Radiator supports and/or mounting panel.



Tighten

- Fasteners to the "Specifications."
3. Overflow hose to the radiator.
 4. Upper radiator hose and lower radiator hose to the radiator.
 5. Engine and transmission oil cooler lines.
 6. Fan shroud.
 7. Coolant to the radiator.
 8. Remove the radiator pressure cap, start the engine, and let it run until the upper radiator hose becomes hot — thermostat is open.
 9. Add coolant, with the engine running at idle speed, until the coolant level reaches the bottom of the filler neck.
 10. Install the radiator pressure cap, making sure the arrows line up with the overflow tube.

G AND P VEHICLES (6.2L ENGINE)



Remove or Disconnect (Figures 11, 12 and 13)

- Coolant from the radiator.
1. Air intake snorkel.
 2. Windshield washer bottle.
 3. Hood release cable.
 4. Upper fan shroud.
 - Refer to "Fan Shroud Replacement."
 5. Upper radiator hose from the radiator.
 6. Transmission cooler lines from the radiator.
 7. Low coolant sensor.
 8. Overflow hose from the radiator.
 9. Engine oil cooler lines from the radiator.
 10. Raise the vehicle.
 11. Lower radiator hose from the radiator.
 12. Lower the vehicle.
 13. Master cylinder from the booster.
 - Refer to BRAKES (SEC. 5A1).
 14. Radiator from the vehicle.



Install or Connect (Figures 11, 12, and 13)

1. Radiator into the vehicle.



Tighten

- Fasteners to the "Specifications."
2. Master cylinder to the booster.
 - Refer to BRAKES (SEC. 5A1).
 3. Raise the vehicle.

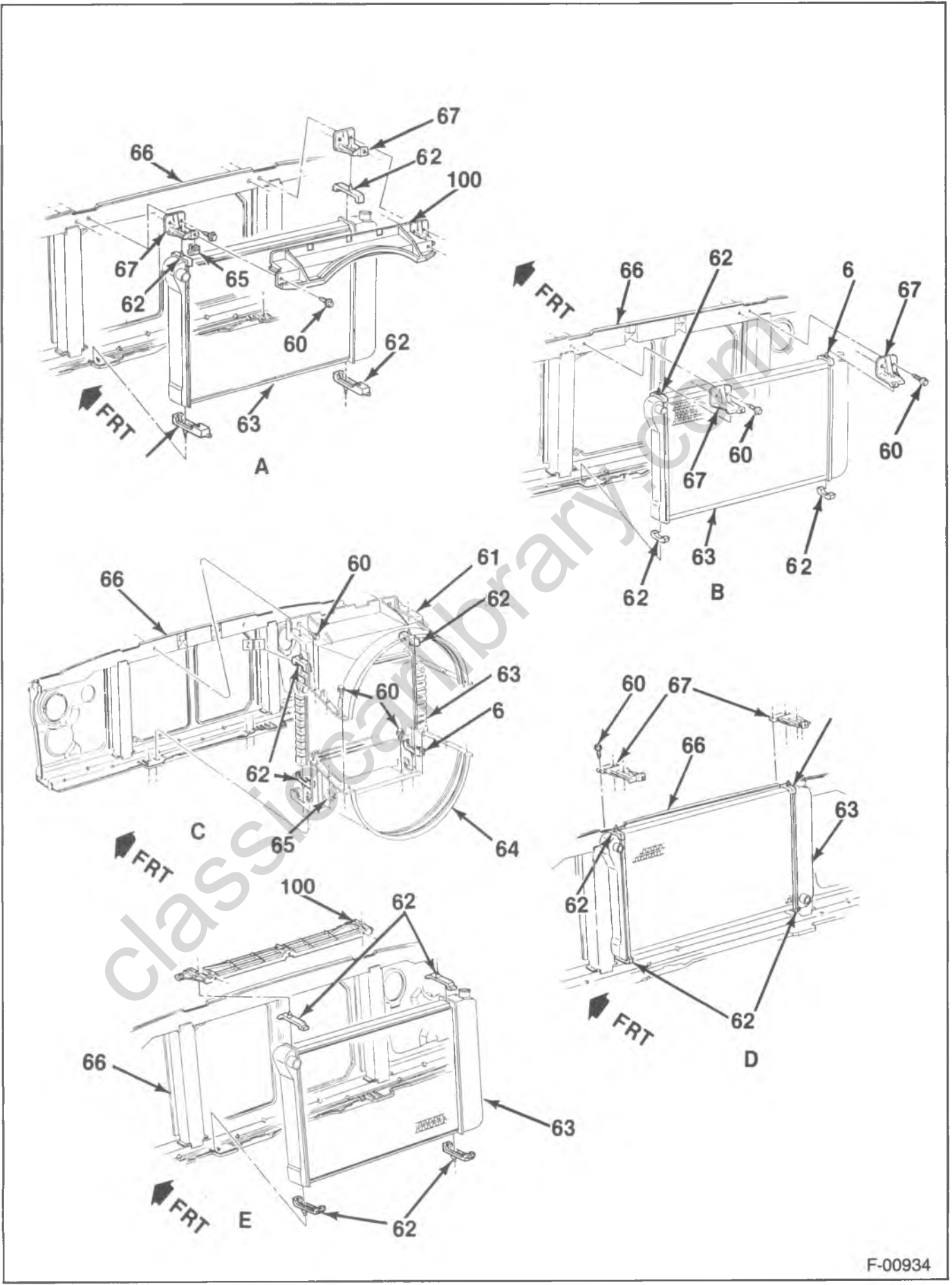

F-00934

Figure 11—Radiator Installation — R/V, G and P(42)

6B2-12 RADIATOR

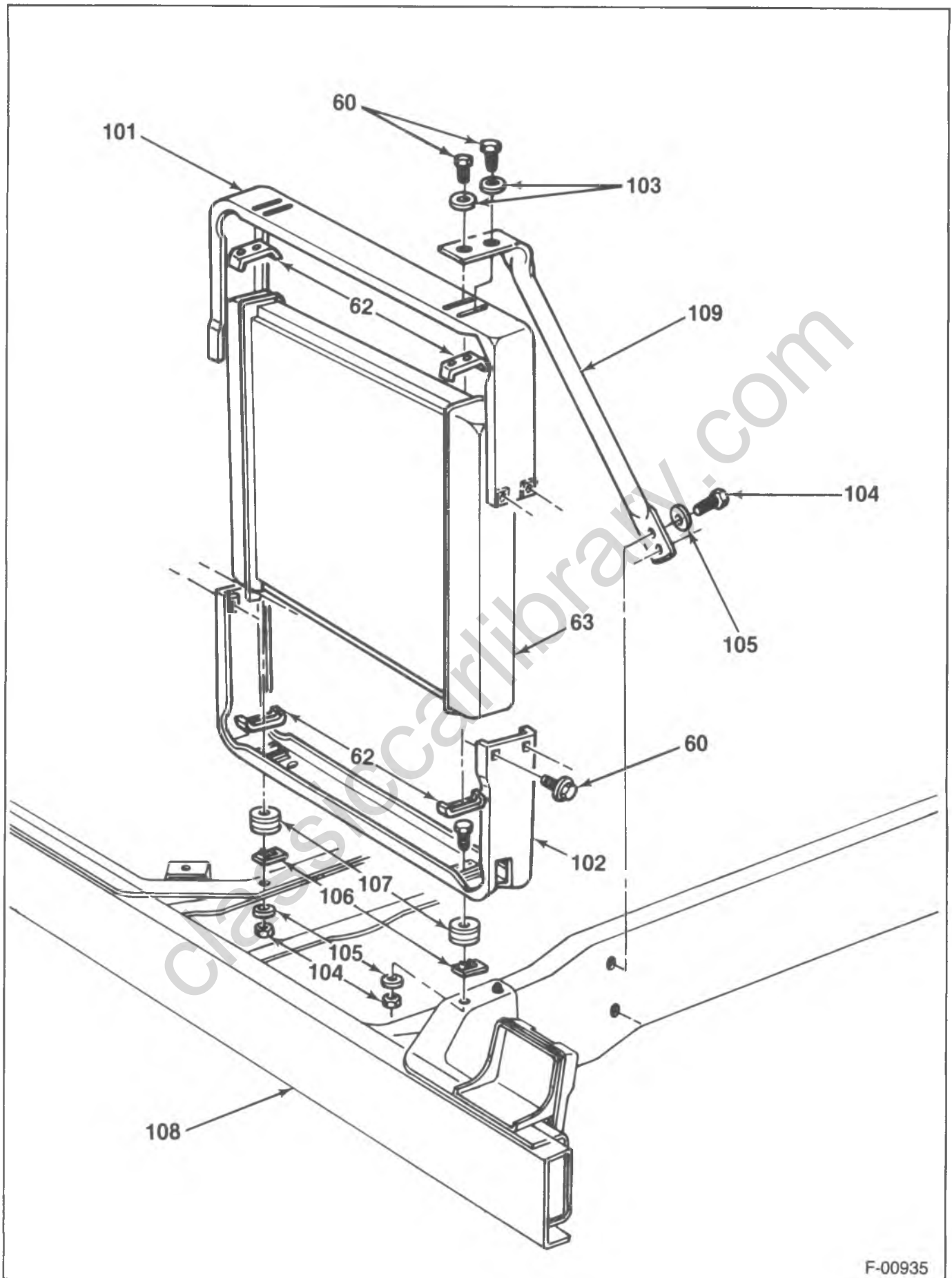

F-00935

Figure 12—Radiator Installation — P(32)

- A. Radiator Mounting For C-K Series With 4.8L L6 (Exc. C60), P(42) Series With 4.8L L6 And 5.7L V8
- B. Radiator Mounting For C-K Series With 4.8L L6 With C60
- C. Radiator Mounting For C-K And G Series With 4.3L V6
- D. Radiator Mounting For C-K Series With 5.0L, 5.7L; G Series (Exc. 4.3L V6); P(42) Series With 5.7L V8
- E. Radiator Mounting For C-K Series With 7.4L V8, 6.2L Diesel; P(42) Series With 7.4L V8, 6.2L Diesel
- 60. Bolt
- 61. Upper Fan Shroud
- 62. Insulator
- 63. Radiator
- 64. Lower Fan Shroud
- 65. Clip Nut
- 66. Radiator Support
- 67. Radiator Mounting Bracket
- 68. Clip
- 69. Complete Fan Shroud
- 100. Radiator Mounting Panel
- 101. Radiator Upper Mounting Panel
- 102. Radiator Lower Mounting Panel
- 103. Washer
- 104. Nut
- 105. Washer
- 106. Nut
- 107. Insulator
- 108. Extension Assembly
- 109. Radiator Support Brace

F-00936

Figure 13—Radiator Installation Legend

- 4. Lower radiator hose to the radiator.
- 5. Lower the vehicle.
- 6. Engine oil cooler lines to the radiator.
- 7. Overflow hose to the radiator.
- 8. Low coolant sensor.
- 9. Transmission oil cooler lines to the radiator.
- 10. Upper radiator hose to the radiator.
- 11. Upper fan shroud.
 - Refer to "Fan Shroud Replacement."
- 12. Hood release cable.
- 13. Windshield washer bottle.
- 14. Air intake snorkel.
- 15. Coolant to the radiator.
- 16. Remove the radiator pressure cap, start the engine and let it run until the upper radiator hose (12) becomes hot — thermostat is open.
- 17. Add coolant, with the engine running at idle speed, until the coolant level reaches the bottom of the filler neck.
- 18. Install the radiator pressure cap, making sure the arrows line up with the overflow tube.

PRESSURE CAP

The pressure relief valve assembly, integral with the filler cap, incorporates a pressure valve and a vacuum valve (figure 14). When pressure in the system reaches the valve setting, the pressure valve opens and vapor is allowed to escape.

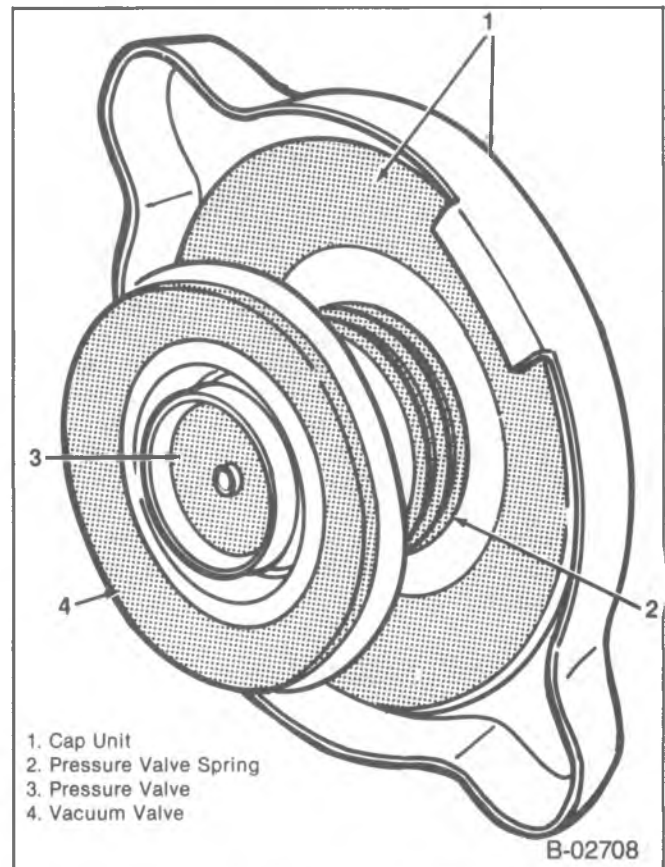

Figure 14—Pressure Cap

6B2-14 RADIATOR

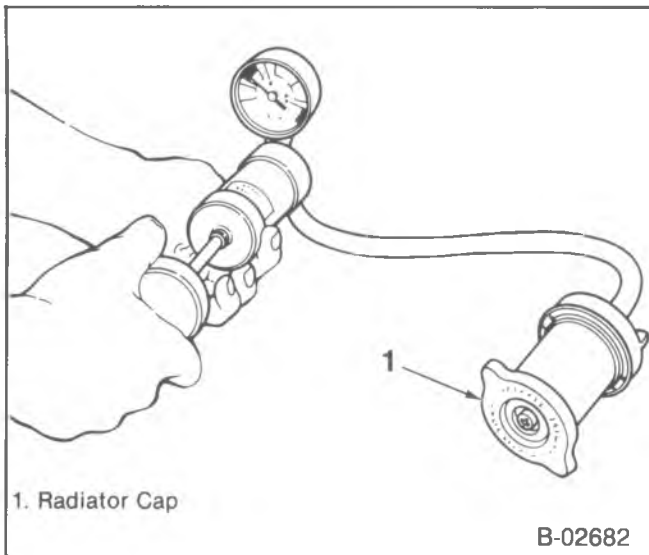

Figure 15—Testing The Radiator Cap

As liquid in the system cools it contracts; this allows the pressure valve to close and also creates a partial vacuum in the system. Atmospheric pressure acting through the overflow tube unseats the vacuum valve and allows air to enter the system. The overflow pipe connects to the valve outside the valve seal; thus no liquid or air can escape from the system when both valves are in the closed position.

The radiator filler cap is constructed with a spring-loaded rubber seal which is pressed firmly against the surface of the filler neck seat when the cap is installed. The rubber seal must be in good condition and the top of the radiator filler neck must be clean and smooth to form an airtight seal. The seal of the filler cap and the operation of the pressure relief valve can be checked using a conventional cooling system testing kit (figure 15).

When the engine is at normal operating temperature or above, the internal pressure buildup in the cooling system will blow out scalding fluid and vapors if the radiator cap is suddenly removed. To prevent loss of coolant and the danger of being burned check or add coolant when the engine is cool. If the cap must be removed when the engine is hot, place a cloth over the cap and rotate the cap slowly counterclockwise to first stop and allow pressure to escape. The cap and filler neck meet at right angles in a safety detent position. The cap locking tank is flat and the filler neck has a straight tab (figure 16). To turn the cap beyond this point and remove the cap, the cap must be pressed down to clear the safety detent and turned counterclockwise.

COOLANT RECOVERY SYSTEM

The coolant recovery system consists of a reservoir, pressure cap, and interconnecting hose.

Maintain the coolant level between the "HOT LEVEL" and "COLD LEVEL" markings on the tank. Refer to figures 1, 2, 3 and 4.

The pressure cap is similar to the radiator filler cap but has a gasket (figure 17). This gasket forms a seal at the radiator filler neck. A leak at this gasket will result in loss

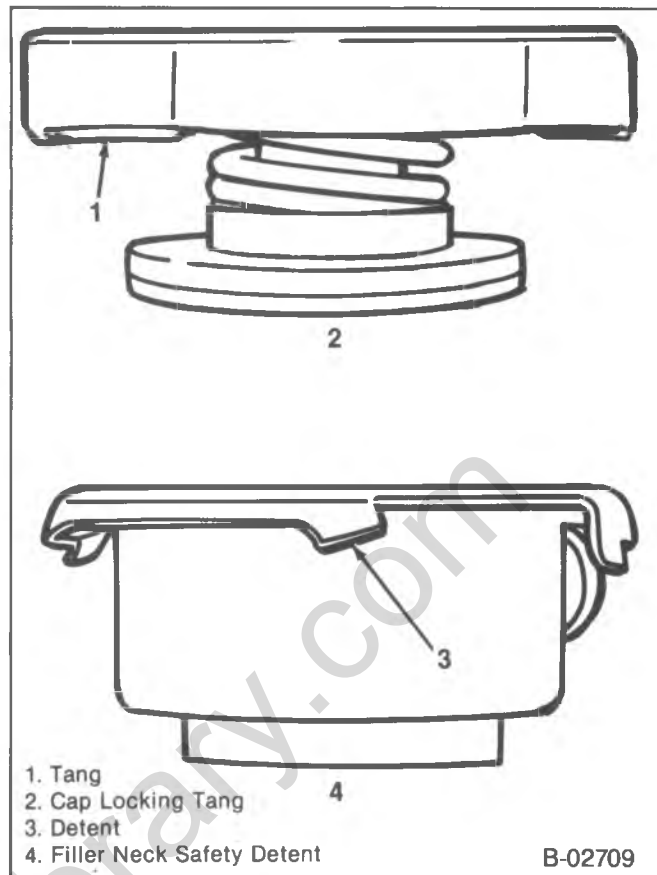

Figure 16—Radiator Cap and Filler Neck

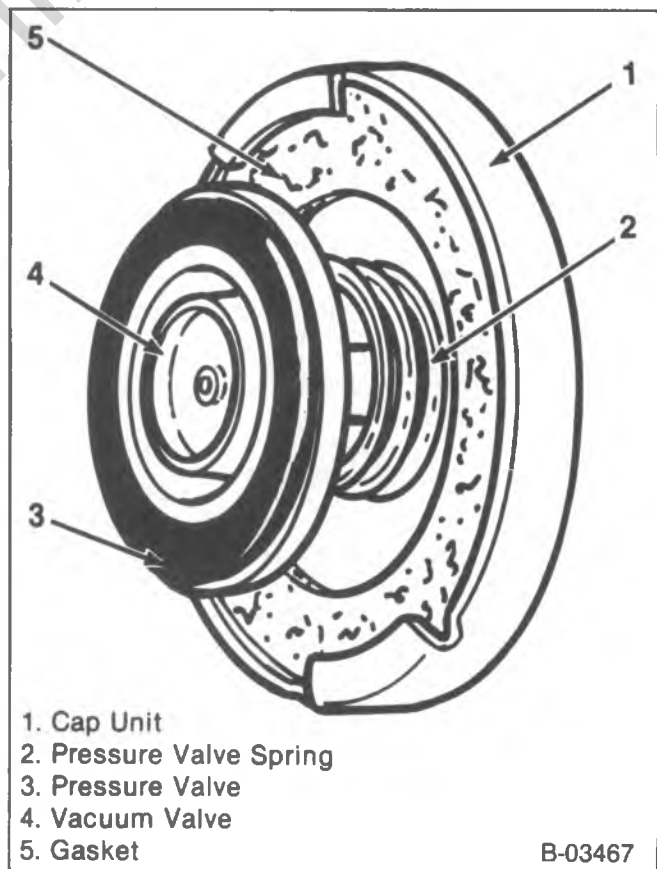

Figure 17—Coolant Recovery System Pressure Cap

of coolant during normal operation. Install the pressure cap so that the markings on top of the cap align with the overflow tube on the filler neck (figure 18).

SURGE TANK

The tank serves as a coolant reservoir for the radiator core. Hoses and pipes connect the tank to the radiator and water pump. The surge tank incorporates the cooling system filler cap.

At regular intervals check the tank and connecting hoses for leaks. Keep the hose clamps and mounting bolts tightened.

Check the mounting brackets and supports for cracks and broken attaching parts. Check insulators and straps; if deteriorated or loose from wear, replace.

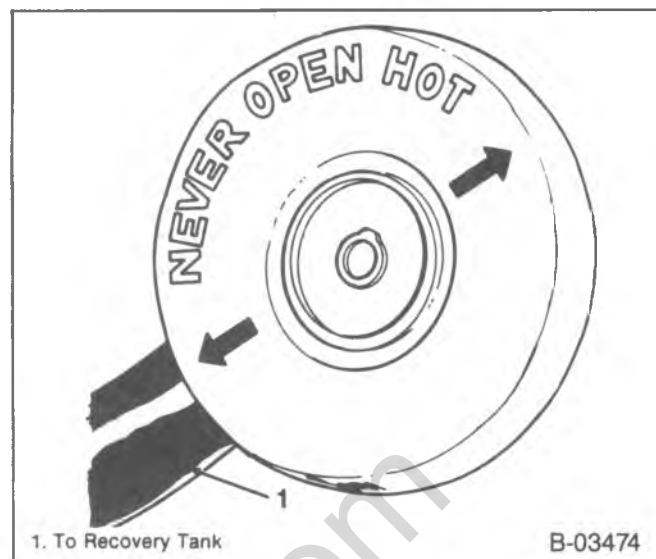

Figure 18—Pressure Cap Alignment Arrows

ALUMINUM RADIATOR REPAIR

DESCRIPTION

This radiator utilizes an aluminum core with plastic side tanks. The core and side tanks can be replaced separately and core repair is easily made with the hot melt adhesive method. A transmission oil cooler is located in one of the side tanks. The oil coolers can be replaced. The drain cock is located on the lower part of one of the tanks. The drain cock is also serviceable.

CORE

The core is made of aluminum and is of the crossflow design. It utilizes large tubes that resist plugging, and repairs to the tubes and core are easily made using the hot melt adhesive method.

The core is attached to the tanks by clinched tabs on the core that can be bent back if tank or core replacement is required.

If the damage to a tube is too severe, a tube can be blocked or plugged as explained in "Tube Blocking." No more than two tubes should ever be blocked on a core. Also replace the core if more than three tabs are broken on one side or if two adjacent tabs are broken.

TANKS

The tanks are attached to the core by clinched tabs attached to the sides of the core. The clinched tabs can be bent back if the tanks need to be removed from the core. Bend the tabs back only enough to remove the tank. Overbending will weaken the tabs.

A high temperature rubber gasket is used to seal the mating surface between the core and the tank (figure 19). The gasket must be replaced any time a tank is removed from the core.

TRANSMISSION OIL COOLER

Replace the oil cooler by removing the tank from the core.

A leaking oil cooler gasket can be replaced without removing the tank from the core.

DRAIN COCK

The aluminum/plastic radiator utilizes a two piece plastic drain cock and a rubber seal. The drain cock is serviceable (figure 20).

DIAGNOSIS

LEAK TESTING

Some core leaks can be detected by adding water to the radiator. Clean the core so that the damaged area can be found.

1. Remove dirt and insects from the fins with a common water hose without a nozzle. Excessive water pressure could damage the fins.
2. Scrub the core with a soft-bristle brush using clean, hot water or hot water with a mild detergent solution.

On-Vehicle Pressure Testing

You can pressure-test the aluminum-plastic radiator with J-24460-01 with J-23699 (figure 21). With the system at a cool temperature, remove the radiator cap, connect the gage, and apply normal system operating pressure. Do not exceed 138 kPa (20 psi). Watch the gage needle for an indication of a leak, and examine the radiator and other cooling system parts for escaping coolant.

Repair all hose and hose connections as required. Check the radiator cap to ensure that it will maintain the correct pressure.

If the radiator leaks during the pressure test, mark the leak area.

6B2-16 RADIATOR

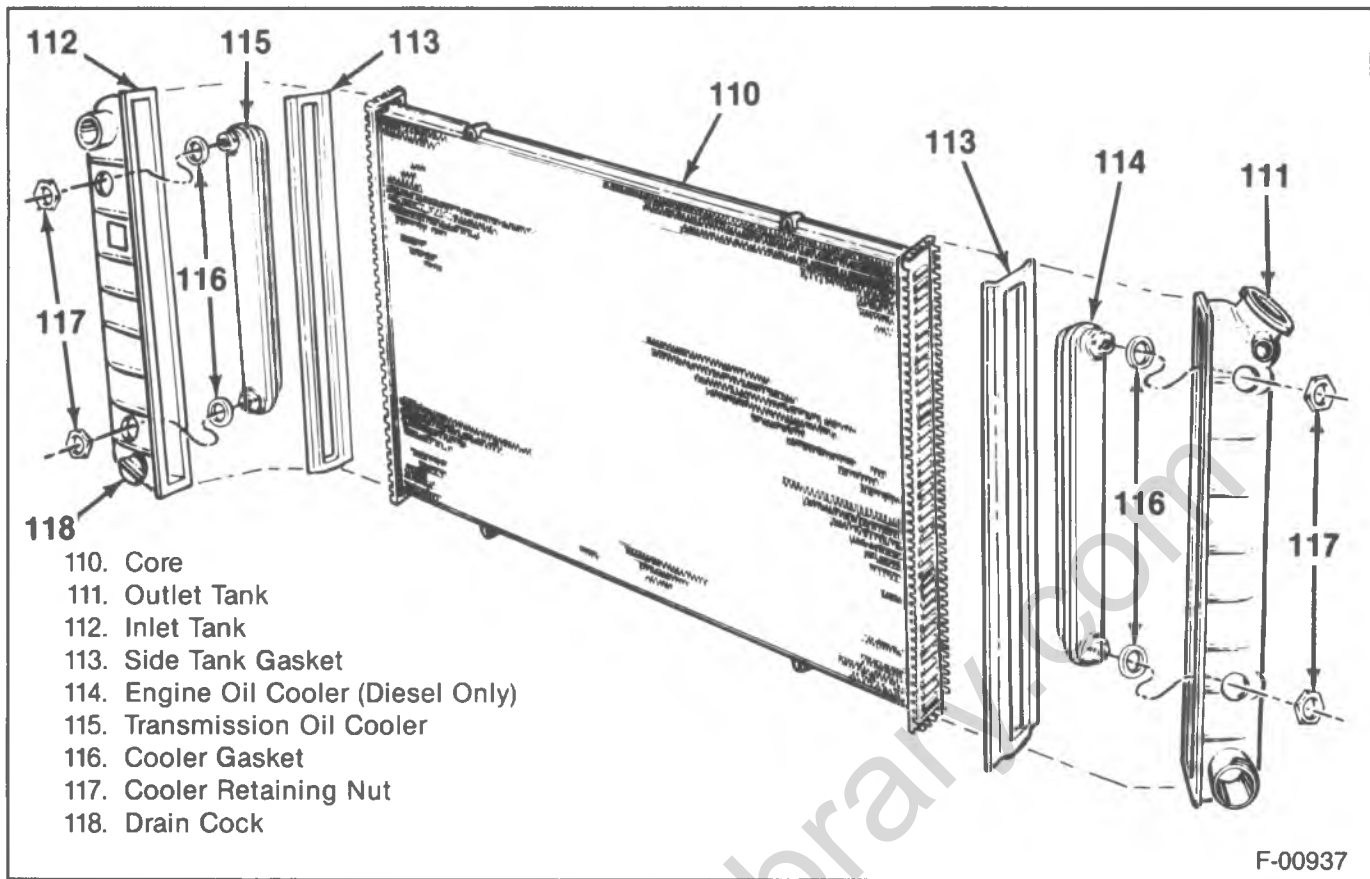

Figure 19—Aluminum Radiator Assembly

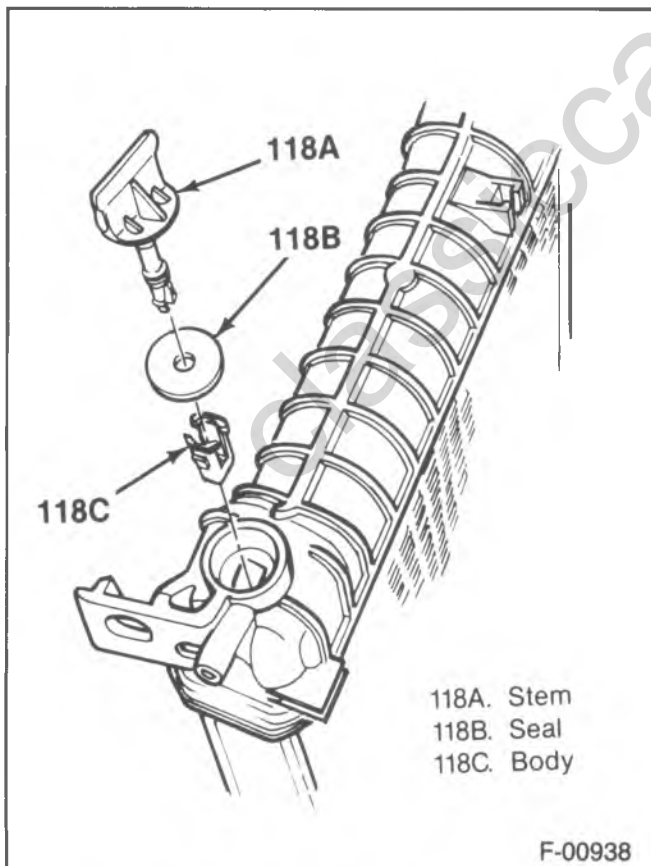

Figure 20—Aluminum Radiator Drain Cock

Off-Vehicle Leak Testing

NOTICE: Do not use boil-out tanks or vats or other tanks that have been used for copper and brass radiators. The flux, acid, and caustic cleaners remaining in these tanks will attack the aluminum and cause radiator failure. A separate test tank containing clean water is recommended for servicing aluminum/plastic radiators.

1. Install test fittings or rubber test caps in the inlet and outlet necks and seal the oil cooler fittings with metal plugs to protect the cooler and keep the fluid from running out (figure 22).

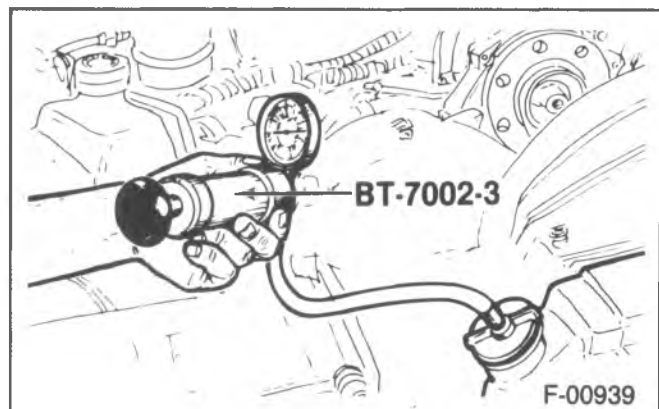

Figure 21—Pressure Testing the Radiator

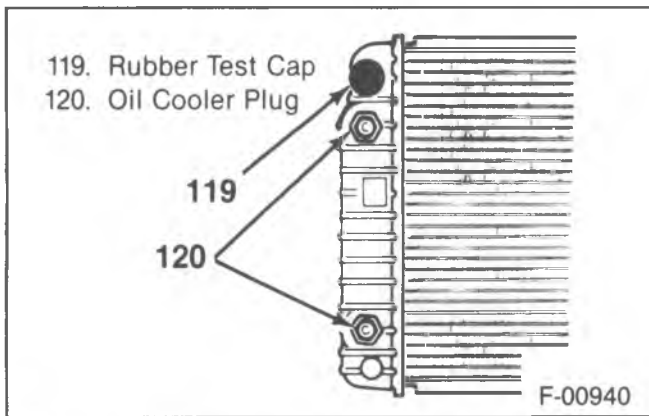

Figure 22—Aluminum Radiator and Oil Cooler Plugs

2. Attach the pressure tester and gradually apply air pressure until 138 kPa (20 psi) is attained. Do not exceed 138 kPa (20 psi). Check the pressure gage to see if there is a pressure loss. To ensure that there are no small leaks, run water over the repair area and look for bubbles. (A mild detergent is helpful).

If a large water tank is available, submerge the radiator and a check for air bubbles.

REPAIRABLE LEAKS

There are two types of leaks that can be repaired on the aluminum-plastic radiator: core leaks and gasket leaks. Leaks in the plastic tanks cannot be repaired (figure 23).

Core leaks can occur in a tube or in the joints between the tubes and headers. Gasket leaks can occur in the

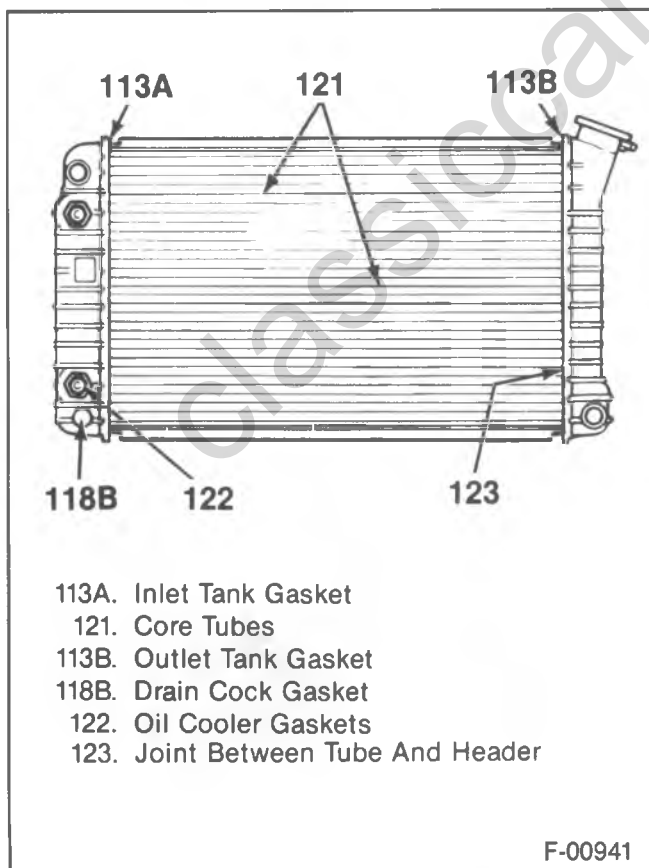

- 113A. Inlet Tank Gasket
- 121. Core Tubes
- 113B. Outlet Tank Gasket
- 118B. Drain Cock Gasket
- 122. Oil Cooler Gaskets
- 123. Joint Between Tube And Header

F-00941

Figure 23—Possible Leak Areas

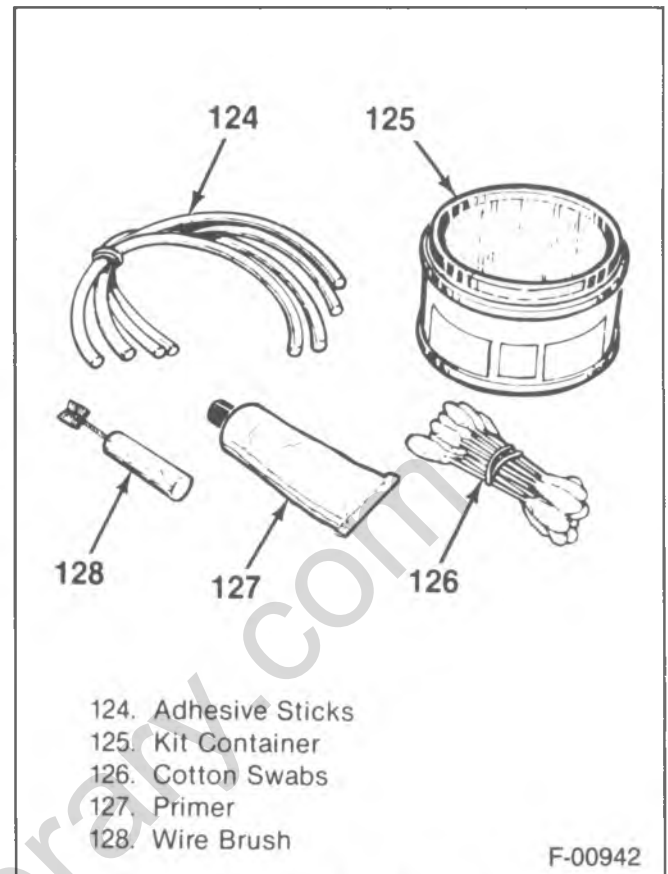

- 124. Adhesive Sticks
- 125. Kit Container
- 126. Cotton Swabs
- 127. Primer
- 128. Wire Brush

F-00942

Figure 24—Hot Melt Repair Kit

joints between the plastic tanks and the headers or in the joints between the oil cooler fittings and the tank. Some leaks can be repaired while the radiator is on the vehicle; however, it is usually best to remove the radiator.

Repair Methods

There are several methods that can be used to repair the radiator core, but the hot melt adhesive method is the most effective.

The kit contains adhesive sticks, cotton swabs, a wire brush and the primer. The adhesive stick is reusable, has an indefinite shelf life and is waste-free. Store the in a sealed container to keep them dry (figure 24).

ALUMINUM RADIATOR SERVICE

The aluminum-plastic radiator can be repaired at the dealership. The following components are easily replaced:

- Core
- Tanks and gaskets
- Oil coolers and gaskets
- Drain cock and gasket

The **tanks cannot be repaired** if broken or cracked. The radiator core can be replaced and the new core used with the original tanks and oil cooler.

6B2-18 RADIATOR

PRECAUTIONS

As with all cooling system service, take measures to prevent personal injury and damage to the system.

CAUTION: To help avoid the danger of being burned, do not remove the radiator cap while the engine and radiator are still hot. Scalding fluid and steam can be blown out under pressure if the cap is taken off too soon.

NOTICE: DO NOT USE "BOIL OUT" TANKS OR VATS. Common service methods may destroy an aluminum radiator. Do not use caustic or lye cleaning solutions for aluminum radiators. USE CLEAN WATER WHEN SERVICING ALUMINUM RADIATORS.

- Do not open the hood if you can see or hear steam or coolant escaping from the engine compartment.
- Do not remove the radiator cap if the radiator feels warm.
- Do not remove the radiator cap or coolant recovery tank cap if the coolant in the recovery tank looks like it is boiling.
- Wear eye protection.
- Wear gloves to protect your hands against excessive heat or the effects of chemicals on your skin.
- Prevent dirt and water from entering the transmission oil cooler.
- Do not use boil-out tanks or vats or other tanks that have been used for copper and brass radiators. The flux, acid, and caustic cleaners remaining in these tanks will attack the aluminum and cause radiator failure. A separate test tank containing clean water is recommended for servicing aluminum/plastic radiators.

NOTICE: Never use shop air to pressure test radiators that is not regulated at 138 kPa (20 psi). Pressures over 138 kPa (20 psi) will damage the radiator.

SPECIAL PREPARATION

For damaged areas that are between the cooling fins, it may be necessary to remove some of the fins. Do not remove more fins than necessary. Usually 6 mm (1/4-inch) beyond the leak or damage area is enough to make an effective repair (figure 25).

TUBE BLOCKING

If a tube is severely damaged, it can be blocked off (figure 26).

NOTICE: Do not block off more than two tubes in a radiator. Blocking off more than two tubes will reduce the cooling capability of the system.

Cut the tube off 6 mm (1/4-inch) from the header and pinch shut before it is cleaned and sealed. Refer to "General Core Sealing."

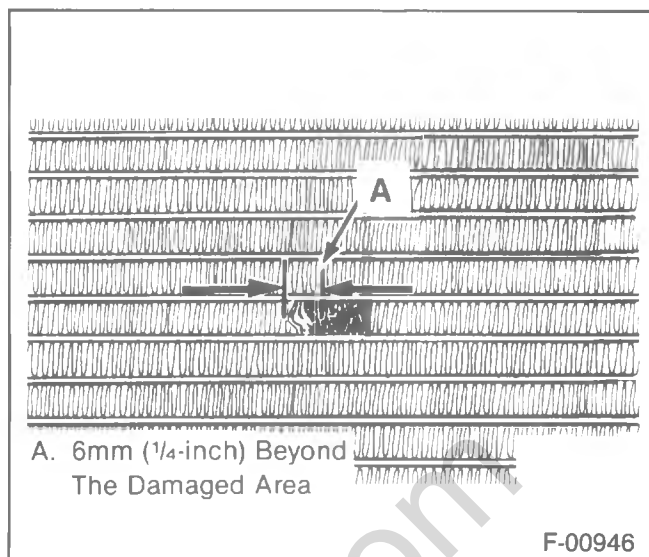

Figure 25—Removing the Fins from a Damage Area

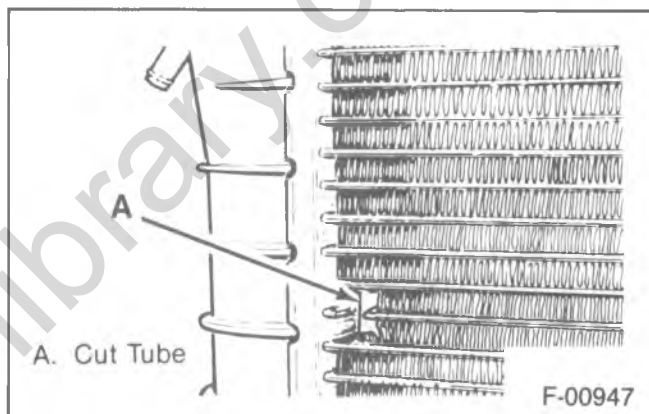

Figure 26—Tube Blocking

HEADER REPAIR

If the header or a tube near the header requires a repair, the side tank does not have to be removed. Place a damp cloth against the side tank where the repair has to be made (figure 27). The side tank can be submerged in a tank of water up to the header (figure 28).

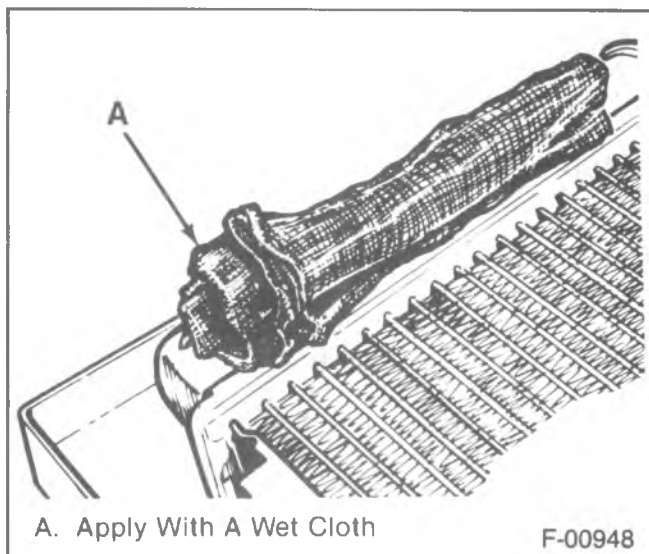

Figure 27—Using A Wet Cloth to Cool the Side Tank

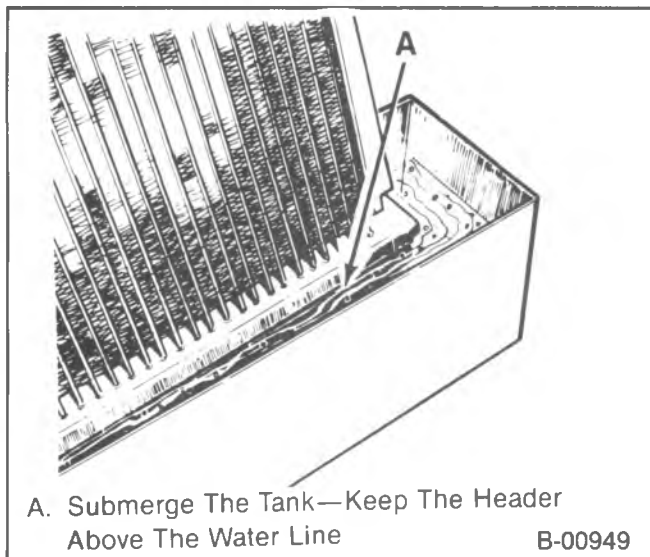

Figure 28—Submerging the Side Tank

NOTICE: One of these procedures have to be used when repairs are made on or near the header to prevent damage to the tank or gasket.

GENERAL CORE REPAIR

Preparation of the surface in the repair area cannot be overemphasized. If the leak area surface is not clean, none of the repair materials will stick to the surface.

1. Position the core so the repair area is accessible.
2. Apply a wet cloth if you are working near the plastic tanks or the joints between the core tubes and header (figure 27); or submerge the tank in water (figure 28).
3. Heat the repair area slightly with a small torch or heat gun to be sure it is dry. **Do not use a blow torch.**
4. Brush the area to be repaired with the small steel brush that is supplied in the kit and blow dust away from the repair area (figure 29).
5. Open the tube of primer, using the spurred cap or a pin, and apply primer to the repair area only. Use of the primer produces a stronger repair. **Do not heat the primer.**

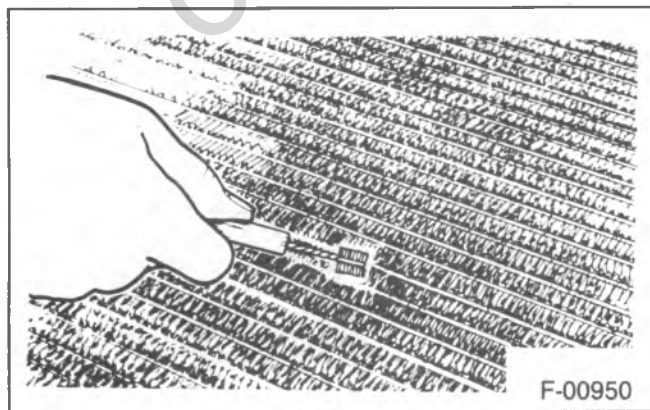

Figure 29—Cleaning the Repair Area with A Steel Brush

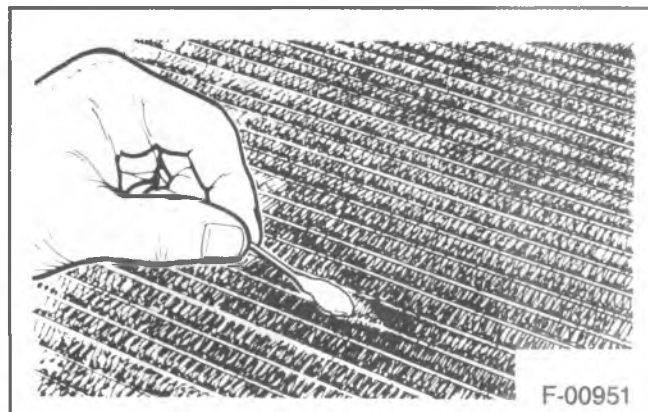

Figure 30—Scrubbing the Area with A Cotton Swab

CAUTION: The primer contains trichlorethane.

- It could be harmful or fatal if swallowed. If swallowed, get medical attention.
- Use with adequate ventilation.
- In case of eye contact, flush with water and get medical attention.
- In case of body contact, wash with soap and water.
- Do not mix the primer with water.

6. Scrub the repair area with a cotton swab until a fresh swab stays clean. The clear, yellow-brown coating does not have to be removed (figure 30).
7. Heat the repair area with a heat gun or by moving the torch in a circular pattern (figure 31). Use a soft, small blue flame (like a gas stove flame).
8. Withdraw the torch and rub the adhesive stick on the repair area (figure 32). The adhesive will flow at a temperature of approximately 260°C (500°F). If the stick doesn't start to melt, remove it and reapply the heat. **Do not heat the stick directly with a flame. High heat will burn and char the adhesive.**
9. Continue heating until the adhesive flows and wets the entire repair area and fills the joint. If a hole is in the center of a tube, heat the tube and let the hot surface melt and pull in the adhesive. The force of the flame or heat gun will also tend to guide the adhesive toward the hole. For leaks between a tube and header, flow the adhesive around the tube and header joint with the tank installed.

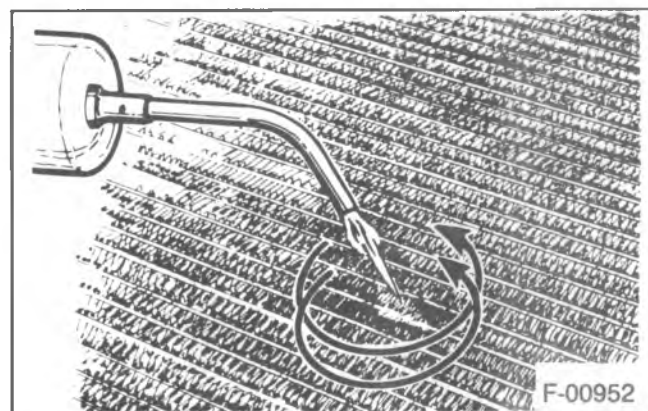

Figure 31—Heating the Repair Area



Figure 32—Apply Hot Melt Adhesive to the Repair Area

10. Heat the repair area until the adhesive is bubble-free and smooth, with a light yellow color. Curing is not required.
11. Test the radiator when cool. If the repair area still leaks, reheat it gently to dry it. Heat and reflow the adhesive or apply more as necessary to repair the leak.

TANK GASKET LEAK REPAIR

Tank gasket leaks can be mistaken for tank or header leaks. If a plastic tank leaks from the header joint gasket, tighten the clinch tabs with locking-type pliers (figure 33). If this method doesn't seal the leak, remove the tank for further inspection.

1. Pry open the clinch tabs, except those under the inlet, outlet, and filler necks, using J-33419-1 or a screwdriver (figure 34). Lift the tabs only enough to allow removal.

NOTICE: Do not overbend the tabs. Overbending could result in breakage. If there are more than 3 tabs broken on one side of the header, or more than 2 adjacent tabs together, replace the core.

2. Lift the tank and slide it out from under the remaining clinched tab. You may have to tap the tank with your hand to dislodge the gasket. Lift the remaining tab(s) with pliers.
3. Remove and discard the gasket.

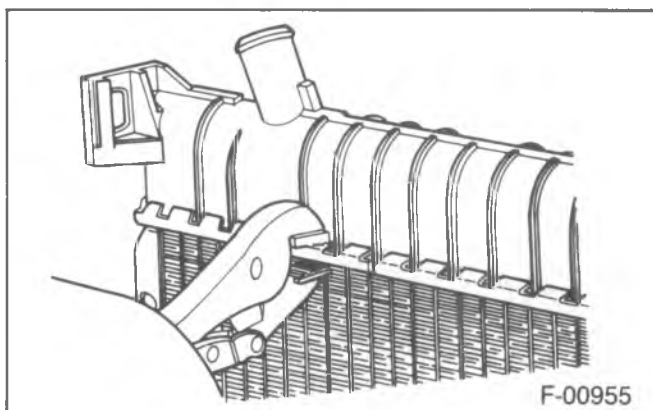

Figure 33—Tightening the Clinch Tabs

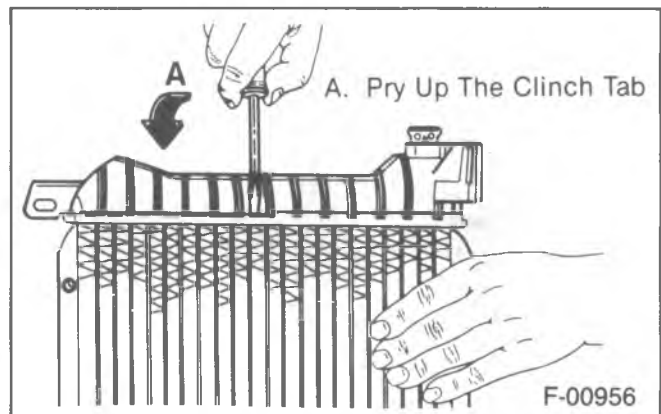

Figure 34—Opening the Clinch Tabs

4. Clean the header and gasket groove of all dirt and old rubber.
5. Clean the sealing edge of the plastic tank.
6. Examine the header gasket surface and tank flange for leakage, and clean or repair the surface to remove dirt, burrs, and bumps.
7. Remove the oil cooler, if equipped, and install it in the new tank, if used.
8. Dip or coat the new tank gasket in engine coolant and position it on the header surface. The coolant helps hold the gasket in place.
9. Position the tank and gasket to the header, clamp it in place and secure it by bending four clinch tabs as shown in figure 35.
10. Clamp remaining clinch tabs around the header using the clinching tool or pliers (figure 36).

NOTICE: Tighten the clinch tabs by starting at the center and working out to the ends.

11. Replace the core if there are more than three tabs broken on one side or two adjacent tabs broken.
12. Install the drain cock, if removed.
13. Test the radiator for leaks.

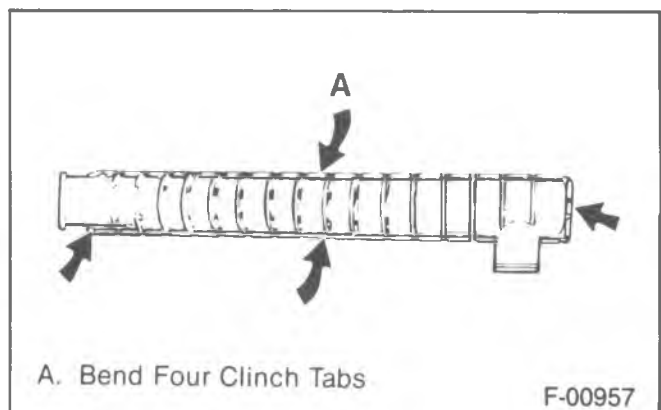

Figure 35—Sealing the Tank to the Radiator Core

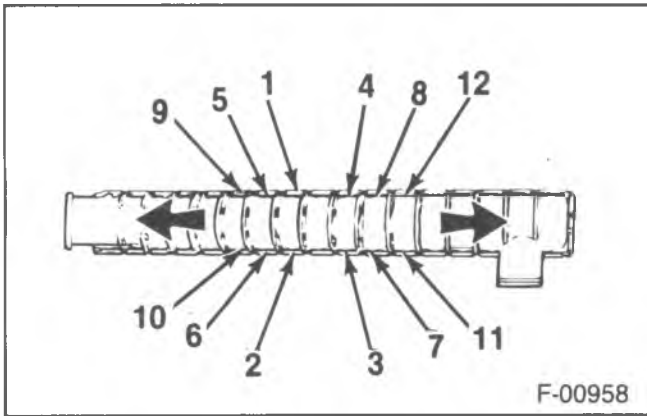

Figure 36—Clinching Sequence

OIL COOLER GASKET REPLACEMENT

Remove the outlet tank to replace the oil cooler. The oil cooler gaskets can be replaced without removing the tank.

Remove or Disconnect (Figure 37)

1. Radiator and lay it on a flat surface.
2. Bottom oil cooler nut and loosen the top nut.
3. Press the oil cooler into the hole and remove the gasket using a small hook (figure 37).
4. Flow-dry all surfaces on the tank and oil cooler.

Install or Connect (Figure 37)

1. Gasket **without lubrication**.
 - Be sure it is seated properly inside the tip of the fitting.
 - Reach into the oil cooler and push it into position against the tank.
2. Oil cooler nuts.

Tighten

- Nuts to 20 N·m (15 ft. lbs.).
 - Do not overtighten.
3. Leak test.
 4. Radiator to the vehicle.

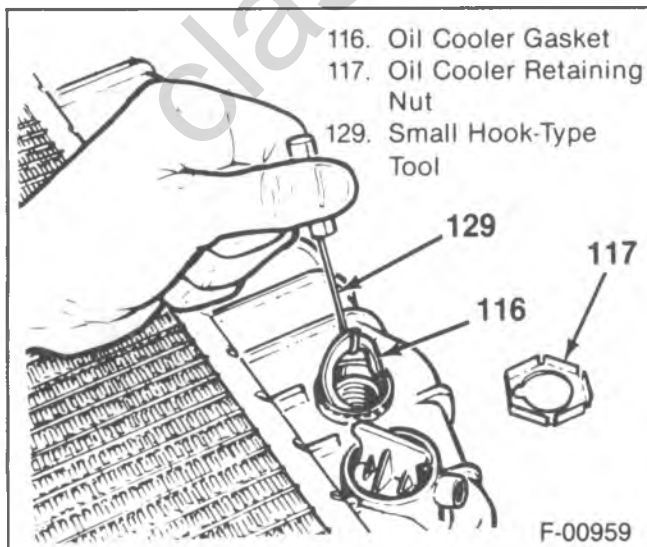

Figure 37—Removing the Oil Cooler Gasket

OIL COOLER REPLACEMENT

Remove or Disconnect

1. Outlet tank.
2. Nuts from the oil cooler fittings.
3. Oil cooler and gaskets from the tank.

Clean

- Clean and dry the gasket area.

Install or Connect

1. Gaskets to the oil cooler.
2. Oil cooler to the tank.
3. Nuts.

Tighten

- Nuts to 20 N·m (15 ft. lbs.).
4. Outlet tank.
 5. Test the radiator.

RECORE

If the radiator core is damaged beyond repair and the other parts are serviceable, install the original inlet and outlet tanks, oil cooler, radiator cap, and drain valve, along with the new core and new gaskets.

SPECIFICATIONS

R/V

	4.3L	5.0L	5.7L	6.2L	7.4L
Fan Shroud to the Radiator	6 N·m (53 in. lbs.)	6 N·m (53 in. lbs.)	6 N·m (53 in. lbs.)	6 N·m (53 in. lbs.)	6 N·m (53 in. lbs.)
Upper Fan Shroud to the Lower Fan Shroud				6 N·m (53 in. lbs.)	
Upper Mounting Panel					17 N·m (13 ft. lbs.)
Upper Mounting Brackets		17 N·m (13 ft. lbs.)	17 N·m (13 ft. lbs.)	17 N·m (13 ft. lbs.)	
Transmission Oil Cooler Lines				27 N·m (20 ft. lbs.)	
Engine Oil Cooler Lines	24 N·m (18 ft. lbs.)			24 N·m (18 ft. lbs.)	24 N·m (18 ft. lbs.)

G

	4.3L	5.0L	5.7L	6.2L	7.4L
Fan Shroud to the Radiator	27 N·m (20 ft. lbs.)	3 N·m (27 in. lbs.)	3 N·m (27 in. lbs.)	5 N·m (44 in. lbs.)	3 N·m (27 in. lbs.)
Upper Fan Shroud to the Lower Fan Shroud	6 N·m (53 in. lbs.)				
Transmission Oil Cooler Lines	30 N·m (22 ft. lbs.)	30 N·m (22 ft. lbs.)	30 N·m (22 ft. lbs.)	22 N·m (16 ft. lbs.)	30 N·m (22 ft. lbs.)
Engine Oil Cooler Lines	24 N·m (18 ft. lbs.)	24 N·m (18 ft. lbs.)	24 N·m (18 ft. lbs.)	24 N·m (18 ft. lbs.)	24 N·m (18 ft. lbs.)

P(32)

	6.2L	7.4L
Lower Mounting Panel	20 N·m (15 ft. lbs.)	20 N·m (15 ft. lbs.)
Lower Mounting Panel	17 N·m (13 ft. lbs.)	17 N·m (13 ft. lbs.)
Upper Mounting Brace	17 N·m (13 ft. lbs.)	17 N·m (13 ft. lbs.)
Fan Shroud to the Radiator	10 N·m (89 in. lbs.)	10 N·m (89 in. lbs.)
Fan Shroud to the Radiator (Heavy Duty Radiator)	17 N·m (13 ft. lbs.)	17 N·m (13 ft. lbs.)
Transmission Oil Cooler Lines	27 N·m (20 ft. lbs.)	27 N·m (20 ft. lbs.)

SPECIFICATIONS (CONT.)

P(42)

	4.8L	5.7L	6.2L	7.4L
Lower Mounting Panel	17 N·m (13 ft. lbs.)		17 N·m (13 ft. lbs.)	17 N·m (13 ft. lbs.)
Fan Shroud to the Radiator	6 N·m (53 in. lbs.)	6 N·m (53 in. lbs.)	6 N·m (53 in. lbs.)	6 N·m (53 in. lbs.)
Fan Shroud to the Radiator (Heavy Duty Radiator)		17 N·m (13 ft. lbs.)		17 N·m (13 ft. lbs.)
Transmission Oil Cooler Lines	27 N·m (20 ft. lbs.)	27 N·m (20 ft. lbs.)	27 N·m (20 ft. lbs.)	27 N·m (20 ft. lbs.)

SPECIAL TOOLS



1

J-23699



2

J-24460-01

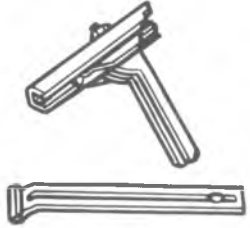

3

J-33419-A

1. Overflow Tube Pressure Adapter
 2. Quick Fill Adapter Cap
 3. Radiator Core Remover/Installer

F-02614

classiccarlibrary.com

SECTION 6C

FUEL SYSTEM

CONTENTS

<u>SUBJECT</u>	<u>PAGE</u>
Description6C- 1
Air Cleaner6C- 2
Air Filter Element Replacement6C- 2
Carbureted Engine Fuel Filters6C- 2
Fuel Filter Replacement6C- 2
Diagnosis Of "WATER IN FUEL" Light (Diesel Engine Only)6C- 3
Diesel Engine Fuel Filters6C- 3
Draining The Fuel Filter6C- 3
Diesel Fuel Filter Replacement6C- 4
Diesel Fuel Filter Assembly Component Replacement6C- 5
Fuel Pump6C- 5
Fuel Pump Tests (Carbureted Engine)6C- 5
Fuel Pump Tests (Diesel Engine)6C- 5
Fuel Pump Replacement6C- 6
Fuel Tank6C- 7
Draining The Fuel Tank6C- 7
Fuel System Cleaning (Carbureted Engine)6C- 8
Diesel Fuel System Contamination6C- 8
Fuel System Cleaning (Diesel Engine)6C- 9
Fuel Tank Purging6C- 9
Fuel Tank Leak Test6C-10
Fuel Tank Replacement6C-10
Fuel Tank Filler Neck6C-10
Fuel Lines6C-10
Fuel Gage Sending Unit6C-13
Fuel Gage Sending Unit Replacement6C-13
Fuel Tank Selector Valve6C-13
Diagnosis Of Selector Valve6C-13
Fuel Tank Selector Valve Replacement6C-13
Accelerator Controls6C-16
Accelerator Control Cable6C-16
Accelerator Pedal6C-16
Specifications6C-17
Special Tools6C-18

All new GM vehicles are certified by the United States Environmental Protection Agency as conforming to the requirements of the regulations for the control of air pollution from new motor vehicles. This certification is contingent on certain adjustments being set to factory standards. In most cases, these adjustment points either have been permanently sealed and/or made inaccessible to prevent indiscriminate or routine adjustment in the field. For this reason, the factory procedure for temporarily removing plugs, cap, etc., for purposes of servicing the product, must be strictly followed and, wherever practicable, returned to the original intent of the design. For vehicles sold in Canada and equipped with non-closed loop engines, also refer to the appropriate Canadian service manual supplement.

DESCRIPTION

This section covers information for carbureted and diesel engines only. For fuel system information on TBI equipped vehicles, refer to the "Fuel And Emissions Service Manual."

AIR CLEANER

CAUTION: The air cleaner also functions as a flame arrester in the event of engine backfire. The air cleaner should be installed at all times unless its removal is necessary for repair or maintenance. To help reduce the risk of personal injury and property damage, be sure that no one is near the engine compartment before starting the engine with the air cleaner removed. If engine backfire occurs with the air cleaner removed, there could be a burst of flame and possibly other fire in the engine compartment.

On vehicles with diesel engines, do not use starting fluids—immediate engine damage can result. Also take care not to let objects fall into the engine if the air cleaner is removed. If the engine is running, suction can pull loose objects into the engine. Objects pulled or dropped into the engine can cause costly engine damage.

When replacement of the air cleaner filter element is necessary, an AC air filter element is recommended.

Refer to "MAINTENANCE AND LUBRICATION" (SEC. 0B) for change intervals. Operation of the vehicle in dusty areas will necessitate more frequent replacement.

AIR FILTER ELEMENT REPLACEMENT

NOTICE: Extreme care should be taken when removing the filter element. Remove the filter element slowly to prevent dirt from falling into the engine.

Remove or Disconnect

1. Wing nut.
2. Air cleaner cover from the base.
3. Air filter element.
4. All accumulated dirt from the base.

Inspect

- Filter element for damage or excessive dirt accumulation. Replace as necessary.
- Seals or gaskets for damage.

Install or Connect

1. Air filter element.
2. Air cleaner cover.
3. Wing nut.

CARBURETED ENGINE FUEL FILTERS

The fuel filter element should be replaced at the intervals shown in MAINTENANCE AND LUBRICATION (SEC. 0B). Fuel filter elements are of the throw away type and should be replaced, not cleaned.

Internal fuel filters are located in the inlet fitting of the carburetor (Figure 1). The filter element (3) is placed in the inlet hole with the gasket (2) surface outward. A spring (4) pushes out against the element and compresses the gasket (2) against the fuel inlet nut (1). A check valve is also built into the filter element.

FUEL FILTER REPLACEMENT

Remove or Disconnect

1. Fuel line connection at the fuel inlet nut (1).
2. Fuel inlet nut (1).
3. Filter element (3), gasket (2), and spring (4).

Install or Connect (Figure 1)

1. Spring (4).
2. Filter element (3).
 - The inlet check valve must be installed in the filter element to meet Motor Vehicle Safety Standards (M.V.S.S.) for roll-over.
 - The new filter element must include the check valve.
 - The check valve end of the filter element must face toward the fuel line.
3. Fuel inlet nut (1).

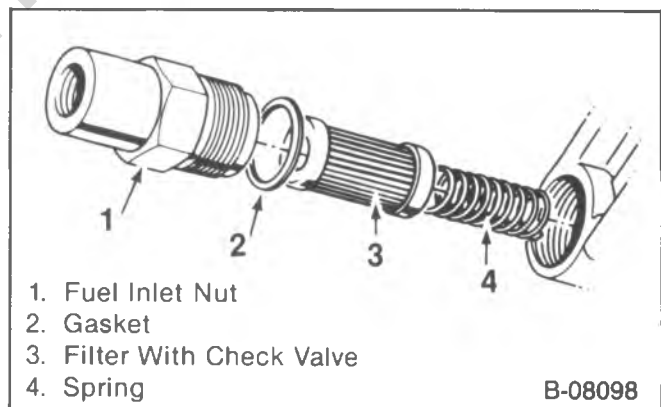

1. Fuel Inlet Nut
2. Gasket
3. Filter With Check Valve
4. Spring

B-08098

Figure 1—Carburetor Fuel Filter

Tighten

- Fuel inlet nut to "Specifications" at the end of this section.
4. Fuel line.
 - Start the engine and check for leaks.

DIAGNOSIS OF "WATER IN FUEL" LIGHT (DIESEL ENGINE ONLY)

PROBLEM	POSSIBLE CAUSE	CORRECTION
Intermittent Light	<ul style="list-style-type: none"> Water in fuel filter. 	<ul style="list-style-type: none"> Drain water from the fuel filter.
Light Stays On With Engine Running (Temperature Above Freezing)	<ul style="list-style-type: none"> Fuel filter is clogged or contains water. 	<ul style="list-style-type: none"> Drain the fuel filter. If no water is drained and the light stays on, replace the filter element.
Light Stays On With Engine Running (Temperature Below Freezing)	<ul style="list-style-type: none"> Fuel filter is clogged with ice. 	<ul style="list-style-type: none"> Drain the fuel filter. If no water is drained, open the air bleed and check for fuel pressure. Replace the filter element if there is no pressure.
Light Comes On At High Speed Or During Heavy Acceleration	<ul style="list-style-type: none"> Plugged fuel filter. 	<ul style="list-style-type: none"> Replace the filter element.
Light Stays On Continuously And Engine Stalls And Will Not Restart (After Initial Start-Up).	<ul style="list-style-type: none"> Fuel filter or lines plugged. 	<ul style="list-style-type: none"> Replace the filter element or check the lines.
Light Stays On Continuously And Engine Stalls And Will Not Restart (After Refueling).	<ul style="list-style-type: none"> Large amounts of water pumped into the tank. 	<ul style="list-style-type: none"> Purge the fuel tank.

DIESEL ENGINE FUEL FILTERS

The diesel engine fuel filter is an inline type filter which combines several different functions. It acts as a filter, water separator, water detector, water drain, and a fuel heater (Figure 2).

The first stage of the filter element is a water coalescer. The coalescer element combines small droplets of water into larger drops. The water collects in the bottom of the filter element for draining. The fuel then passes through the second stage of the filter element which is a paper filter.

The filter acts as a water detector by turning on the "WATER IN FUEL" light on the instrument panel. The probe of the water detector will touch water when 65 ml. (2.2 fluid ounces) of water has collected in the filter. This completes a circuit through the water to the cover assembly which turns on the "WATER IN FUEL" light.

NOTICE: If the "WATER IN FUEL" light comes on and the fuel system is not purged of water, fuel injection system damage may result.

When the light comes on, the filter should be drained as soon as practical, but within one to two hours of engine operation.

A water drain is located in the bottom of the fuel filter assembly. By opening the water drain valve, water that has collected in the bottom of the filter element can be drained.

A fuel heater is located in the fuel filter assembly to help prevent fuel waxing. The heater thermostat turns the heater on at about 0°C (32°F) and off at about 30°C (80°F). The heater uses 7 to 13 amps depending on fuel temperature.

DRAINING THE FUEL FILTER

1. Turn off the engine and apply the parking brake.
2. Remove the fuel filler cap to release any pressure or vacuum in the fuel tank.
3. Place a suitable container under the filter drain hose.

6C-4 FUEL SYSTEM

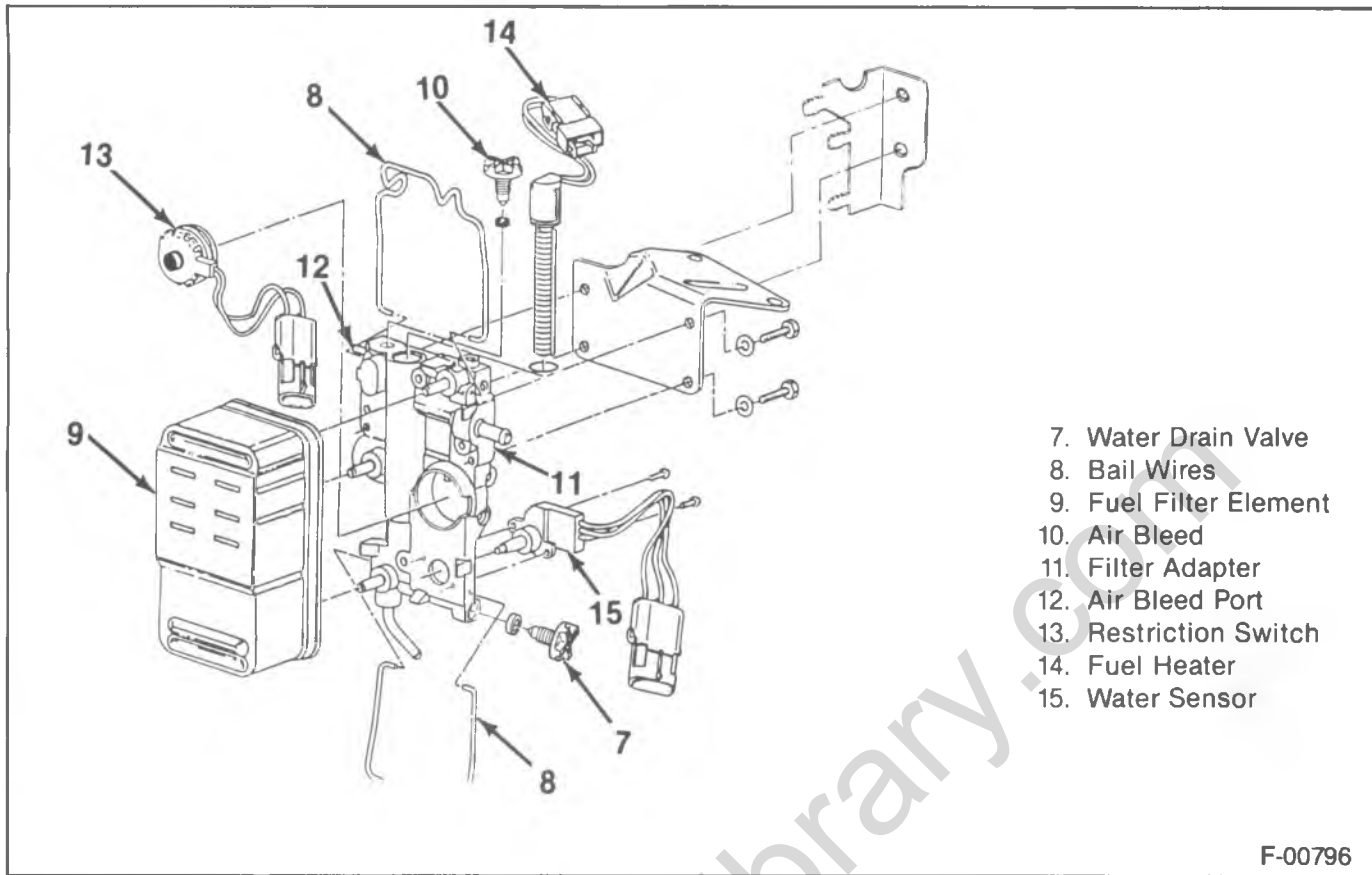

Figure 2—Diesel Fuel Filter

CAUTION: The water/diesel fuel mixture is flammable, and could be hot. To help avoid personal injury and/or property damage, do not touch the fuel coming from the drain hose, and do not expose the fuel to open flames or sparks.

Be sure you do not overfill the container. Heat (such as from the engine) can cause the fuel to expand. If the container is too full, fuel could be forced out of the container. This could lead to a fire and the risk of personal injury and/or vehicle damage.

4. Open the drain valve (7) two to three turns (figure 2).
5. Start the engine and allow it to idle for one to two minutes or until clear fuel is observed.
6. Stop the engine and close the drain valve (7).
7. Install the fuel filler cap.
8. Dispose of the drained mixture in a proper manner.

DIESEL FUEL FILTER REPLACEMENT

↔ Remove or Disconnect (Figure 2)

1. Fuel filler cap to release any pressure or vacuum in the fuel tank.
2. Both bail wires (8).
 - Drain fuel from the filter by opening the air bleed (10) and the water drain valve (7).
 - Allow the fuel to drain into a suitable container.

3. Fuel filter element (9).

☞ Clean

- Any dirt from the fuel sealing surfaces of the filter element and the filter adapter (11).

↔ Install or Connect (Figure 2)

1. New filter element.
2. Bail wires.
 - Close the drain valve (7).
3. A 3 mm (1/8-inch) inside diameter hose to the air bleed port (12).
 - The other end of the hose into a suitable container.
4. Disconnect the fuel injection pump shut-off solenoid wire.

NOTICE: If the engine is to be cranked or started with the air cleaner removed, take care not to let objects fall into the engine. If the engine is running, suction can pull loose objects into the engine. Objects pulled or dropped into the engine can cause costly engine damage.

- Crank the engine for 10 to 15 seconds and then wait one minute for the starter motor to cool. Repeat until clear fuel is observed coming from the air bleed.
- Close the air bleed.
- 5. Injection pump solenoid wire.
- 6. Fuel filler cap.
 - Start the engine and allow it to idle for five minutes.
 - Check the fuel filter for leaks.

DIESEL FUEL FILTER ASSEMBLY COMPONENT REPLACEMENT

All component parts of the fuel filter assembly are serviceable. These components include the filter adapter, restriction switch, fuel heater, and the water sensor (figure 2).

Always replace any damaged or worn O-rings, gaskets, or seals. After replacing components, bleed air from the filter to save cranking time. Start the engine and check for leaks after replacing components.

FUEL PUMP

All carbureted and diesel engines use a mechanical fuel pump located on the front right side of the engine. The pump is a diaphragm type pump and is actuated by a rocker arm through a link and pull rod.

Some engines have a special fuel pump that has a metering outlet for a vapor return system. Any vapor that forms is returned to the fuel tank along with hot fuel. This reduces the chance of vapor lock because cool fuel from the tank is always circulated through the fuel pump.

The fuel pump rocker arm is moved back and forth by a rod which rides on an eccentric on the engine camshaft. The rocker arm pulls down on the pump diaphragm against spring pressure. This causes a vacuum in the pump chamber which draws fuel from the tank through the inlet valve. The camshaft rotates and releases pressure on the rocker arm. This allows the spring to act on the diaphragm and force fuel out of the pump chamber through the outlet valve and into the fuel line to the carburetor or diesel fuel injection pump.

When the carburetor float rises and closes the needle valve, fuel cannot leave the pump chamber. The spring is held compressed by the fuel pressure in the pump chamber. The rocker arm idles on the cam eccentric and only moves enough to maintain pressure on the spring. A constant pressure is maintained on the fuel in the line to the carburetor. This pressure is proportional to the force of the spring.

When the immediate fuel needs of the diesel engine are satisfied, pressure builds in the fuel line and pump chamber. This pressure forces the diaphragm/piston to make shorter and shorter strokes, until more fuel is needed in the engine.

FUEL PUMP TESTS (CARBURETED ENGINE)

If the fuel system is suspected of not delivering enough fuel, it should be inspected as follows.



Inspect

- Make certain that there is fuel in the tank.
- For leaks at all fuel connections from the fuel tank to the carburetor.
 - The engine should be running.
 - Tighten any loose connections.
- All hoses for flattening or kinks that would restrict the flow of fuel.
- Air leaks or restrictions on the suction side of the fuel pump will seriously affect pump output.

FUEL PUMP FLOW TEST

1. Remove the fuel supply line from the carburetor or fuel injection pump and insert it into a suitable container.
2. Crank the engine.
3. The fuel pump should supply 237 ml (1/2-pint) or more in 15 seconds.
4. If the flow is insufficient, check for a restriction.
5. If there are no restrictions, check fuel pump vacuum and/or pressure.

FUEL PUMP PRESSURE TEST

1. Disconnect the fuel inlet line at the carburetor.
2. Install a low pressure gage to the line.
3. Start the engine.
4. Fuel pump pressure should be 27.5 to 44.8 kPa (4 to 6 1/2 psi).
5. If the pressure is low, check for restrictions in the fuel tank sender unit filter, lines, and hoses.

NOTICE: Hold the carburetor fuel inlet nut while tightening the fuel line fitting to prevent carburetor damage.

6. Connect the fuel inlet line to the carburetor.

FUEL PUMP VACUUM TEST

1. Disconnect the inlet hose at the fuel pump and connect a vacuum gage.
2. Crank or run the engine until the maximum vacuum is reached.
3. If the vacuum is less than 50.6 kPa (15-inches Hg), replace the fuel pump.
4. If the vacuum is 50.6 kPa (15-inches Hg), check the fuel lines and hoses for leaks, kinks, or splits by disconnecting each section of line and connecting a vacuum gage. Crank or run the engine until the maximum vacuum is reached. The vacuum should be at least 50.6 kPa (15-inches Hg).

FUEL PUMP TESTS (DIESEL ENGINE)

If the fuel system is suspected of not delivering enough fuel, it should be inspected as follows.



Inspect

- Make certain that there is fuel in the tank.
- For leaks at all fuel connections from the fuel tank to the injection pump.
 - The engine should be running.
 - Tighten any loose connections.

6C-6 FUEL SYSTEM

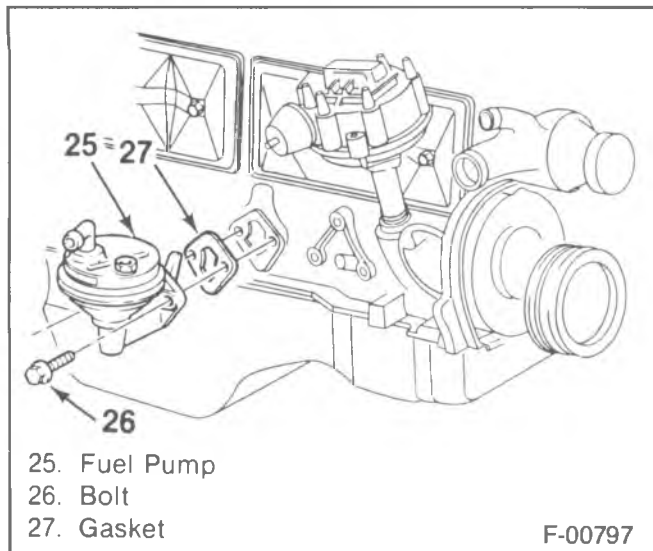

Figure 3—Fuel Pump—Carbureted 4.8L Engine

- All hoses for flattening or kinks that would restrict the flow of fuel.
- Air leaks or restrictions on the suction side of the fuel pump will seriously affect pump output.

FUEL PUMP FLOW TEST

↔ Remove or Disconnect

1. Fuel line at the fuel filter inlet.
2. Fuel injection pump electric shut-off solenoid wire (pink wire).
- Place a suitable container at the end of the fuel filter inlet line.
- Crank the engine for 15 seconds.
- The fuel pump should supply 237 ml (1/2-pint) or more in 15 seconds.

FUEL PUMP PRESSURE TEST

1. Disconnect the fuel line at the inlet to the fuel filter assembly.
2. Install a low pressure gage to the line.
3. Crank or run the engine for 10 to 15 seconds.
4. Fuel pressure should be 38 to 45 kPa (5.5 to 6.5 psi).

FUEL PUMP VACUUM TEST

1. Disconnect the inlet line at the fuel pump.
 - Plug the hose or position it so fuel does not leak.
2. Connect a vacuum gage to the fuel pump inlet.
3. Start the engine.
 - The engine will use fuel from the filter assembly.
4. Vacuum should be 41 kPa (12-inches Hg) or greater.
5. Replace the pump if vacuum is less than 41 kPa (12-inches Hg).

FUEL PUMP REPLACEMENT

ALL ENGINES EXCEPT 7.4L

↔ Remove or Disconnect (Figures 3 through 5)

1. Fuel pipes and hoses from the fuel pump (25).
2. Bolts (26).
3. Fuel pump (25).
4. Gasket (27).

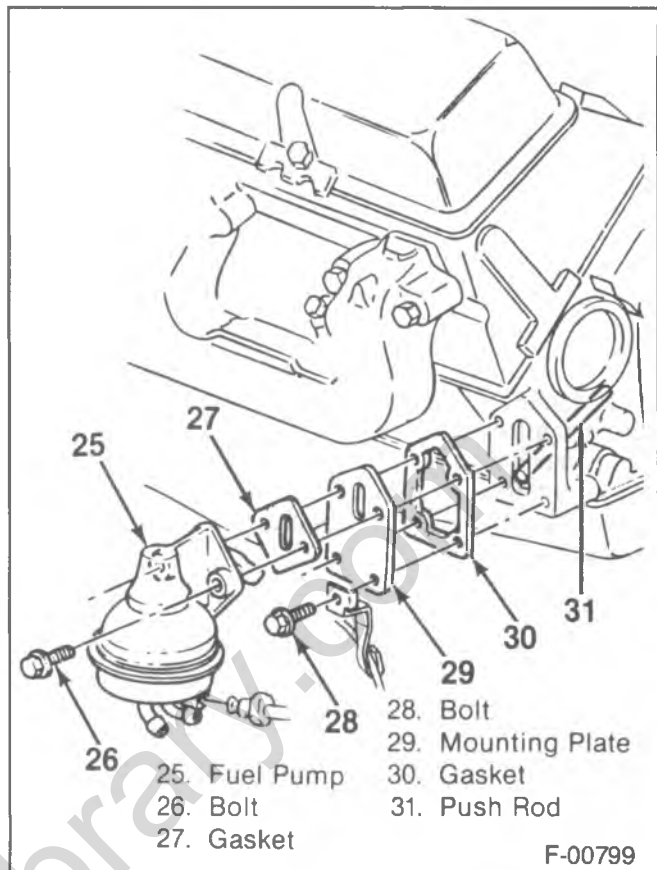

Figure 4—Fuel Pump—Carbureted 5.7L Engine

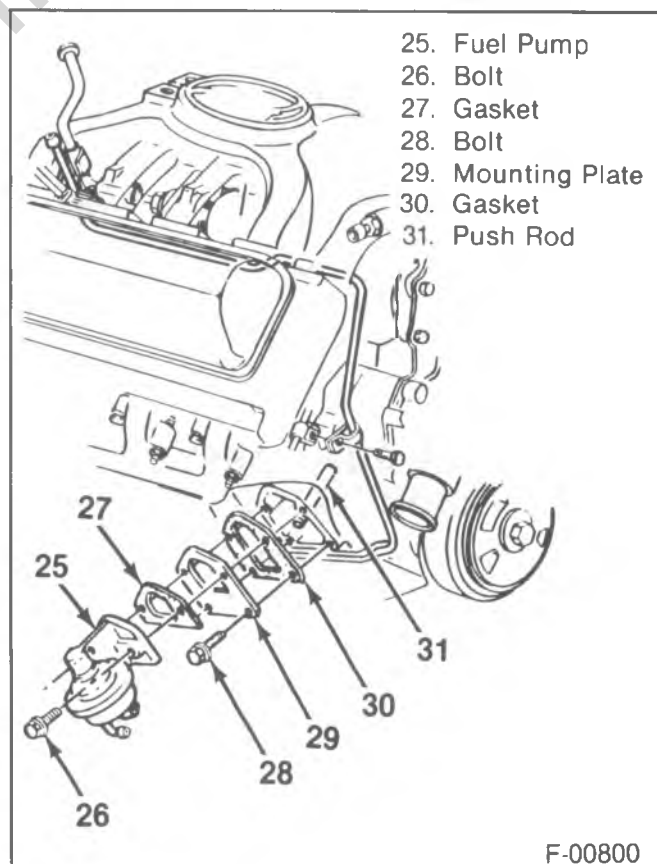

Figure 5—Fuel Pump—6.2L Engine

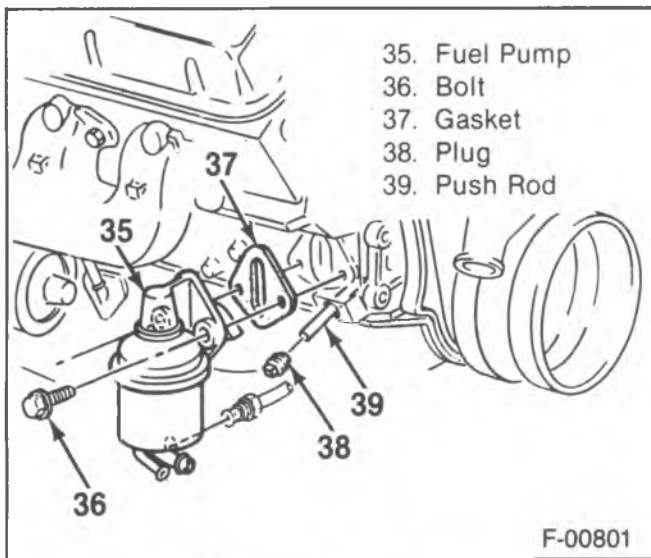

Figure 6—Fuel Pump—Carbureted 7.4L Engine

5. Bolts (28).
6. Mounting plate (29).
7. Gasket (30).
8. The push rod (31) (if necessary).

⇔ Install or Connect (Figures 3 through 5)

1. The push rod (if removed).
 - Apply some chassis grease to the rod to hold it up against the camshaft.
2. New gasket (30).
3. Mounting plate (29).
4. Bolts (28).

⌚ Tighten

- Bolts to specification.
5. New gasket (27).
 6. Fuel pump (25).
 7. Bolts (26).

⌚ Tighten

- Bolts to specification.
8. Fuel pipes and hoses to the fuel pump.
 - If it is difficult to start the outlet fitting, disconnect the line at the carburetor or the diesel fuel injection pump.
 - Start the engine and check for leaks.

7.4L ENGINE

⇔ Remove or Disconnect (Figure 6)

1. Fuel pipes and hoses from the fuel pump (35).
2. Bolts (36).
3. Fuel pump (35).
4. Gasket (37).
5. Plug (38).
6. The push rod (39).

⇔ Install or Connect (Figure 6)

1. The push rod (39).
 - Apply some chassis grease to the rod and hold it up against the camshaft.
2. Gasket sealer to the threads on the plug (38).
3. Plug (38).
4. Gasket (37).
5. Fuel pump (35).
6. Bolts (36).

⌚ Tighten

- Bolts alternately and evenly to 37 N·m (27 ft. lbs.).
7. Fuel pipes and hoses to the fuel pump.
 - If it is difficult to start the outlet fitting, disconnect the line at the carburetor.
 - Start the engine and check for leaks.

FUEL TANK

The fuel tank is located under the rear or the sides of the vehicle. The fuel tank is held in place by two metal straps that are attached to the underbody. Anti-squeak strips are used between the tank and the straps to reduce rattles and squeaks.

The fuel tank, filler cap, and fuel lines should be checked for damage which could cause leakage. Replace any damaged or worn parts.

Before servicing the fuel tank or lines:

- Disconnect the negative battery cable from the battery.
- Place "NO SMOKING" signs near work areas.
- Have a CO₂ fire extinguisher nearby.
- Wear safety glasses.
- Siphon or pump fuel into an explosion proof container.

DRAINING THE FUEL TANK

⇔ Remove or Disconnect

1. Negative battery cable.
 - There are two batteries in diesel engine vehicles.
 - Have a dry chemical (Class B) fire extinguisher in the work area.
2. Fuel filler cap.

CAUTION: Never drain or store gasoline or diesel fuel in an open container due to the possibility of fire or explosion.

3. Fuel through the filler tube using a hand operated pump.

6C-8 FUEL SYSTEM

- If a hand operated pump cannot be used to complete the draining, use a siphon at the main (not return) fuel pipe at the fuel pump or the fuel gage sending unit.

Install or Connect

1. Any lines or hoses.
2. Fuel filler cap.
3. Negative battery cable.

FUEL SYSTEM CLEANING (CARBURETED ENGINE)

CAUTION: This procedure will not remove all fuel vapor. Do not attempt any repair on the tank or filler neck where heat or flame is required, as an explosion resulting in personal injury could occur.

Contaminated fuel or other foreign material in the tank can usually be removed by cleaning; however, if the fuel tank is rusted internally, it should be replaced.

Remove or Disconnect

Tool Required:

J-24187 Fuel Gage Sending Unit Tool

1. Negative battery cable.
2. Engine harness connector at the distributor.
 - Have a dry chemical (Class B) fire extinguisher near the work area.
3. Fuel from the fuel tank.
 - Refer to "Draining the Fuel Tank."
4. Fuel tank.
 - Refer to "Fuel Tank Removal."
5. Fuel filter. Replace the filter if it is plugged.
6. Fuel gage sending unit using J-24187.
 - Locate the tank away from heat, flame, or other sources of ignition.
 - If the strainer is contaminated or clogged, a new strainer should be installed upon reassembly.
7. Remaining fuel from the tank by rocking the tank.
 - Flush the fuel tank with hot running water for at least five minutes.
8. Water from the fuel tank by rocking the tank.
 - Make sure that the water is completely removed.
9. Fuel feed pipe at the fuel pump.

Clean

- Fuel lines by applying air pressure in the opposite direction of fuel flow in the line.

Install or Connect

Tool Required:

J-24187 Fuel Gage Sending Unit Tool

1. Lines and pipes.

Tighten

- Fittings to 30 N·m (22 ft. lbs.).
2. New strainer on the fuel gage sending unit (if necessary).
 - Use low air pressure to clean the pipes of the fuel gage sending unit.

3. New fuel gage sending unit gasket.

NOTICE: Take care not to fold or twist the strainer when installing the sending unit as this will restrict fuel flow.

4. Fuel gage sending unit using J-24187.
5. Fuel tank.
6. Fuel gage wire harness to the body harness.
7. All fuel lines.
8. A hose to the carburetor inlet line.
 - Disconnect the inlet line from the carburetor.
9. The other end of the hose into a four liter (one gallon) fuel can.
10. Battery cable.
11. Six gallons of clean gasoline into the fuel tank.
 - Crank the engine until the fuel can is about one-half full. This will purge the fuel pump.
 - Do not overheat the starter.
12. Carburetor inlet line to the carburetor.
 - Check all connections for leaks and tighten all hose clamps.
13. Engine harness connector to the distributor.

DIESEL FUEL SYSTEM CONTAMINATION

Fungi and other micro-organisms can survive and multiply in diesel fuel if water is present. The fungi can be present in any part of the fuel handling system. These fungi grow into long strings and will form into large globules. The growths appear slimy and are usually black, green, or brown. The fungi may grow anywhere in the fuel but are most plentiful where diesel fuel and water meet. As the fuel is agitated (when service station tanks are being filled), fungi are distributed throughout the tank and may be pumped into a vehicle.

Fungi use the fuel as their main energy supply and need only trace amounts of water and minerals. As they grow and multiply, they change fuel into water, sludge, acids, and products of metabolism. The most common symptom is fuel filter plugging; however, various metal components (fuel tank, lines, and injection pump) can corrode.

CAUTION: To avoid personal injury, do not come into physical contact with biocides.

If fungi have caused fuel system problems, use a diesel fuel biocide to sterilize the fuel system. Do not exceed the dosage recommended on the label. Discontinue the use of a biocide when towing a trailer. It is permissible to have biocide in the fuel when starting to tow, but do not add any biocide while towing.

Steam cleaning may be necessary if most of the fungus growth cannot be removed with biocides.

FUEL SYSTEM CLEANING (DIESEL ENGINE)

CAUTION: Never drain or store diesel fuel in an open container due to the possibility of fire or explosion.

WATER IN THE FUEL SYSTEM

Remove or Disconnect

1. Battery cables.
2. Fuel from the tank.
 - Refer to "Draining the Fuel Tank."
3. Fuel tank.
4. Fuel gage sending unit.



Clean

- Fuel tank.
 - The tank should be replaced if it is rusted internally.
 - The pick-up filter or replace if necessary.
 - The check valve assembly.
5. Main fuel hose at the fuel pump.
 6. Fuel return line at the injection pump.
 - Use low air pressure to blow out the lines toward the rear of the vehicle.
 - Replace the pipes if they are rusted internally.
 7. Fuel injection pump shut-off solenoid wire.
 8. Fuel filter.

Install or Connect

1. Fuel gage sending unit.
2. Fuel tank.
3. Fuel lines to the tank.
4. Clean diesel fuel into the tank until it is 1/4 full.
5. Fuel tank cap.
6. Fuel hoses to the fuel pump.
7. Battery cables.
 - Crank the engine for 15 seconds with one minute cooling periods until clean fuel is pumped out.
 - Use a suitable container to catch the fuel.
8. New fuel filter. Refer to "Diesel Fuel Filter Replacement."
9. A hose from the return line at the fuel injection pump to a closed metal container with a capacity of at least 8L (2-gallons).
 - If the engine temperature is above 52°C (125°F), activate the HPCA (Housing Pressure Cold Advance) on the injection pump. This can be done by disconnecting the two lead connectors at the Engine Temperature Switch and bridging the connector with a jumper wire.
 - Crank the engine for 15 seconds with one minute cooling periods until clean fuel appears at the return line.
10. Two lead connectors to the Engine Temperature Switch.
 - Remove the jumper wire.
- Disconnect the lead to the HPCA solenoid (on the injection pump).
- Crack open each injection line at the nozzle. Use two wrenches to prevent nozzle damage.

- Crank the engine for 15 seconds with one minute cooling periods until clean fuel appears from each nozzle.

11. HPCA lead to the injection pump.



Tighten

- Injection line to nozzle fitting to 25 N·m (20 ft. lbs.).
 - Use two wrenches to prevent nozzle damage.
12. Fuel injection pump shut-off solenoid wire.
 - Start the engine and allow it to idle for 15 minutes.
 - Make sure the fuel return line is in the metal container and that the container does not overflow.
 - Remove the hose from the metal container.
 13. Fuel return line to the injection pump.
 - Check for leaks.

GASOLINE IN THE FUEL SYSTEM

Engine Will Run Or Start

1. Drain the fuel tank.
2. Fill the tank with diesel fuel.
3. Run the engine for 15 minutes.

Engine Will Not Run

1. Drain the fuel tank.
2. Fill the tank with diesel fuel.
3. Remove the fuel injection pump shut-off solenoid wire.
4. Remove the fuel line between the fuel filter and the injection pump.
5. Connect a hose to the fuel filter outlet and run it to a closed metal container.
6. Crank the engine for 15 seconds with one minute cooling periods to purge gasoline from the system.
7. Install the fuel line between the fuel filter and the injection pump.
8. If the engine temperature is above 52°C (125°F), activate the HPCA (Housing Pressure Cold Advance) on the injection pump. This can be done by disconnecting the two lead connectors at the Engine Temperature Switch and bridging the connector with a jumper wire.
9. Install the fuel injection pump shut-off solenoid wire.
10. Start the engine and remove the jumper wire.
11. Connect the two lead connector.
12. Run the engine for 15 minutes.

FUEL TANK PURGING

The fuel tank should be purged before being repaired.



Remove or Disconnect

1. Fuel tank from the vehicle.
2. Fuel gage sending unit.
3. All remaining fuel from the tank.



Inspect

- Fuel tank for any remaining fuel.

6C-10 FUEL SYSTEM

↔ Install or Connect

1. Tap water into the tank until it is full.
 - Move the tank to the flushing area (wash rack).
- Agitate the water vigorously and then drain it.
2. Gasoline emulsifying agent into the tank.
 - Use an available emulsifying agent such as Product-Sol No. 913 or equivalent.
3. Water to the fuel tank.
 - Refer to the emulsifying agent specifications for the mixture ratio.
- Agitate the mixture for ten minutes.
- Drain the tank completely.
- Fill the tank with water until it overflows.
- Completely flush out any remaining mixture.
- Drain the fuel tank.
- Use an explosion meter (if available) to check for a negative reading.
- Perform the required service work.

FUEL TANK LEAK TEST

If fuel is leaking from the tank, the tank should be replaced. Make sure that the fuel lines are not leaking onto the tank.

1. Remove the fuel tank.
2. Drain the tank.
3. Plug all of the outlets.
4. Apply 7 to 10 kPa (1 to 1½ psi) air pressure through the vent tube.
5. Test for leaks with a soap solution or by submersion.
6. Replace the tank if a leak is found.

FUEL TANK REPLACEMENT

CAUTION: To help avoid personal injury when a vehicle is on a hoist, provide additional support for the vehicle at the opposite end from which components are being removed. This will reduce the possibility of the vehicle falling off the hoist.

↔ Remove or Disconnect (Figures 7 through 9)

1. Fuel from the tank.
2. Fuel tank retaining straps.
 - Support the fuel tank.
3. Sending unit wire, hoses, and ground straps.
 - Lower the tank.
4. Fuel tank from the vehicle.

↔ Install or Connect (Figures 7 through 9)

1. Fuel tank into the vehicle.
 - Support the tank.
2. Sending unit wire, hoses, and ground straps.
3. Fuel tank retaining straps with the anti-squeak pieces.
 - Cement the anti-squeak material securely to the tank with 25 mm (1-inch) wide coverage for 10 cm (4-inches) on each end.

🔧 Tighten

- Retaining strap bolts or nuts to specifications.

FUEL TANK FILLER NECK

A restrictor and deflector is built into the fuel filler neck on gasoline engine vehicles to help prevent refueling with leaded gasoline. The opening in the restrictor will only admit the smaller unleaded gas nozzle spout. The nozzle must be fully inserted to bypass the deflector (figures 10 through 12).

FUEL FILLER CAP

The fuel tank filler neck is equipped with a screw type cap. The cap requires several turns counterclockwise to remove. The long threaded area allows fuel tank pressure to escape while the cap is being removed. A torque limiting device prevents overtightening. To install, turn the cap clockwise until a clicking noise is heard.

NOTICE: If a fuel filler cap requires replacement, use only a cap with the same features. Failure to use the correct cap can result in a serious malfunction of the system.

FUEL LINES

NOTICE: Fuel and vapor hoses and pipes are specially manufactured. It is important to use replacement hose or pipe meeting GM Specifications. Hoses and pipes not meeting GM Specification could cause early failure or failure to meet emission standards.

When replacing fuel feed and return pipes, always use welded steel tubing meeting GM Specification 124 M or its equivalent. The replacement pipe must have the same type fittings as the original pipes to ensure integrity of the connection.

- Never replace fuel pipe with copper or aluminum tubing.
- Check and replace any damaged O-rings or washers.
- Fuel pipes should be inspected occasionally for leaks, dents, or kinks.
- Follow the same routing as the original pipe.
- Pipes must be properly secured to the frame to prevent chafing. A minimum clearance of 6 mm (¼-inch) must be maintained to prevent contact and chafing.

FUEL AND VAPOR HOSES

NOTICE: Fuel and vapor hoses are specially manufactured. It is important to use replacement hoses that meet GM Specification 6163-M. These hoses are identified by the word "Fluoroelastomer" marked on them. Hoses not so marked could cause early failure or failure to meet emission standards.

Do not use rubber hose within 10 cm (4-inches) of any part of the exhaust system or within 25 cm (10-inches) of the catalytic converter.

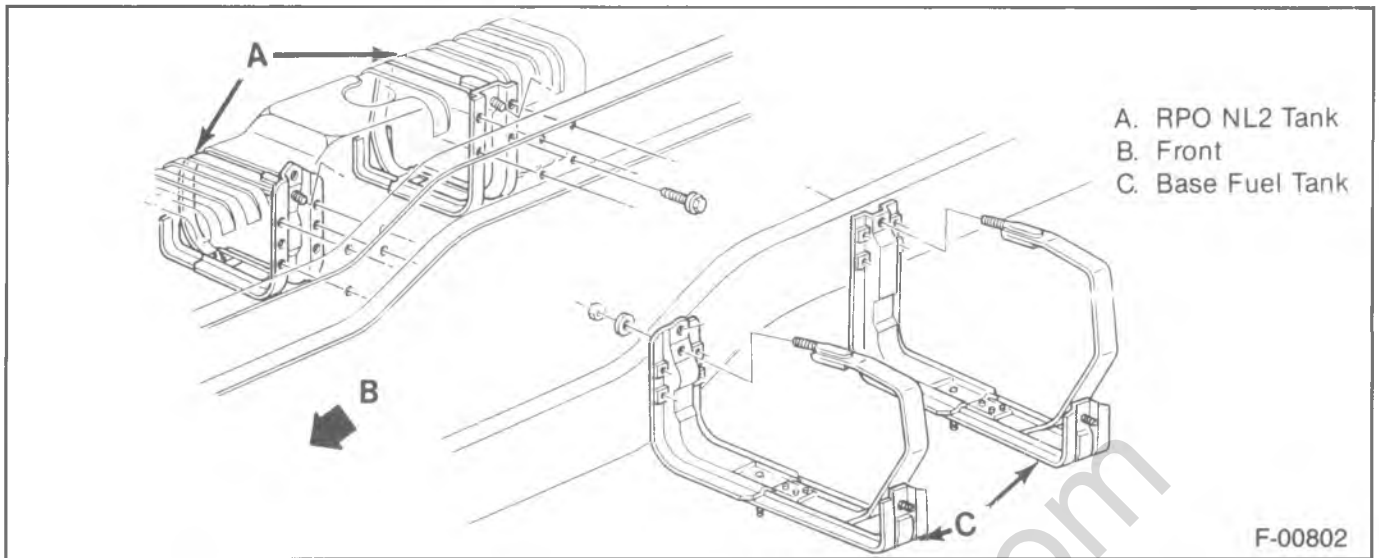

Figure 7—Fuel Tank Mounting—R/V Pickup

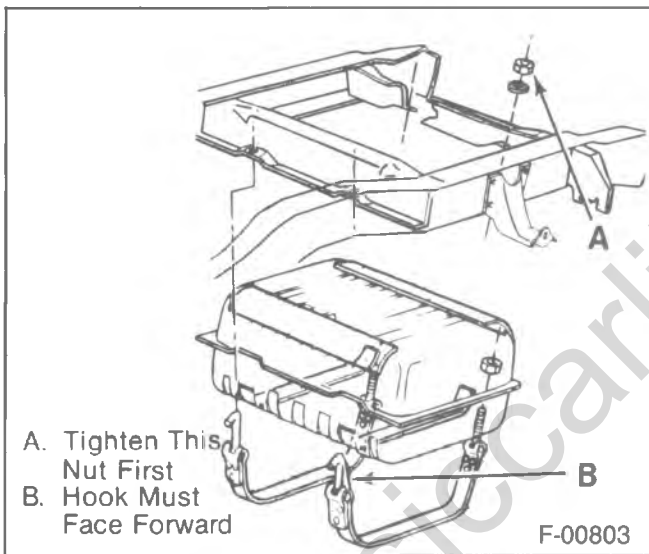

Figure 8—Fuel Tank Mounting — Utility Vehicle and Suburban

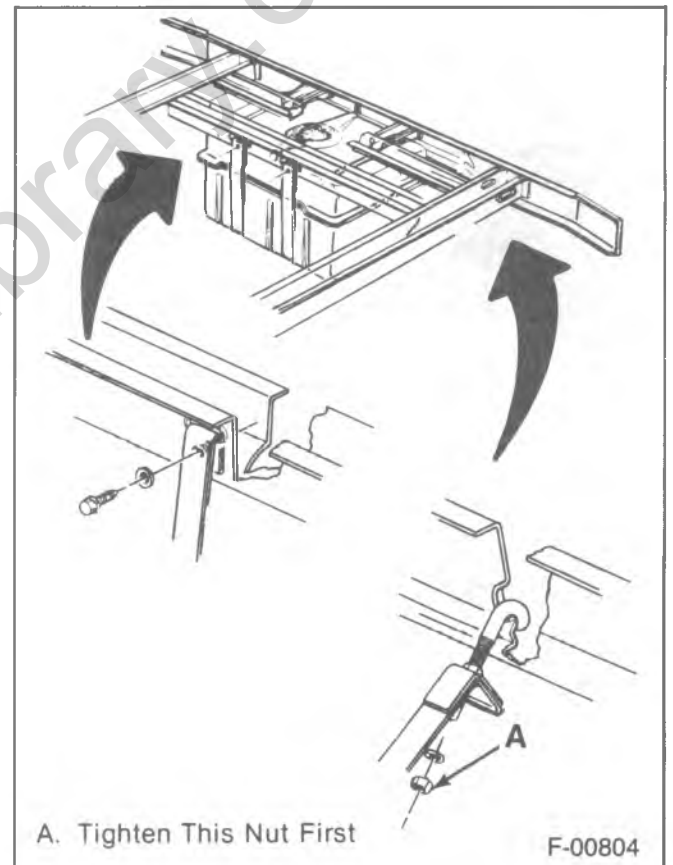

Figure 9—Fuel Tank Mounting — G Van

6C-12 FUEL SYSTEM

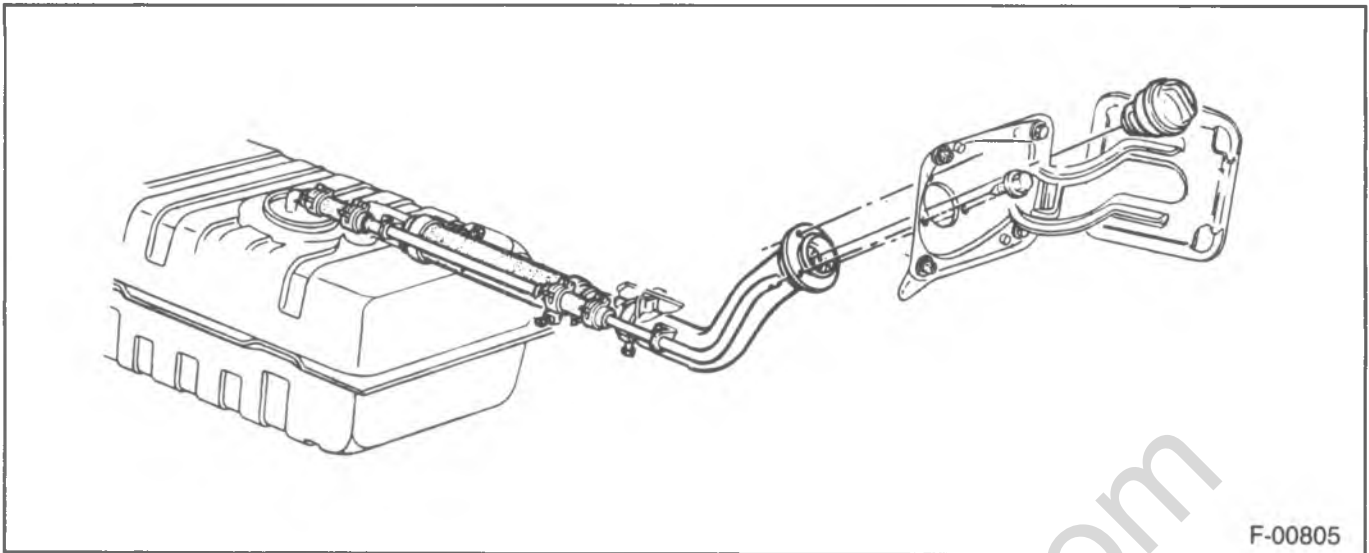

Figure 10—R/V Filler Neck

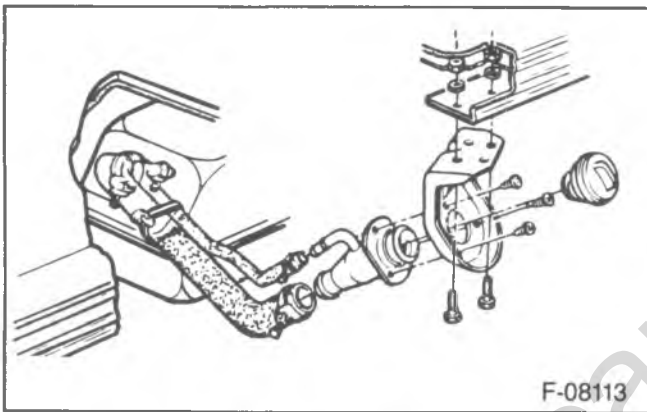

Figure 11—Chassis Cab Filler Neck

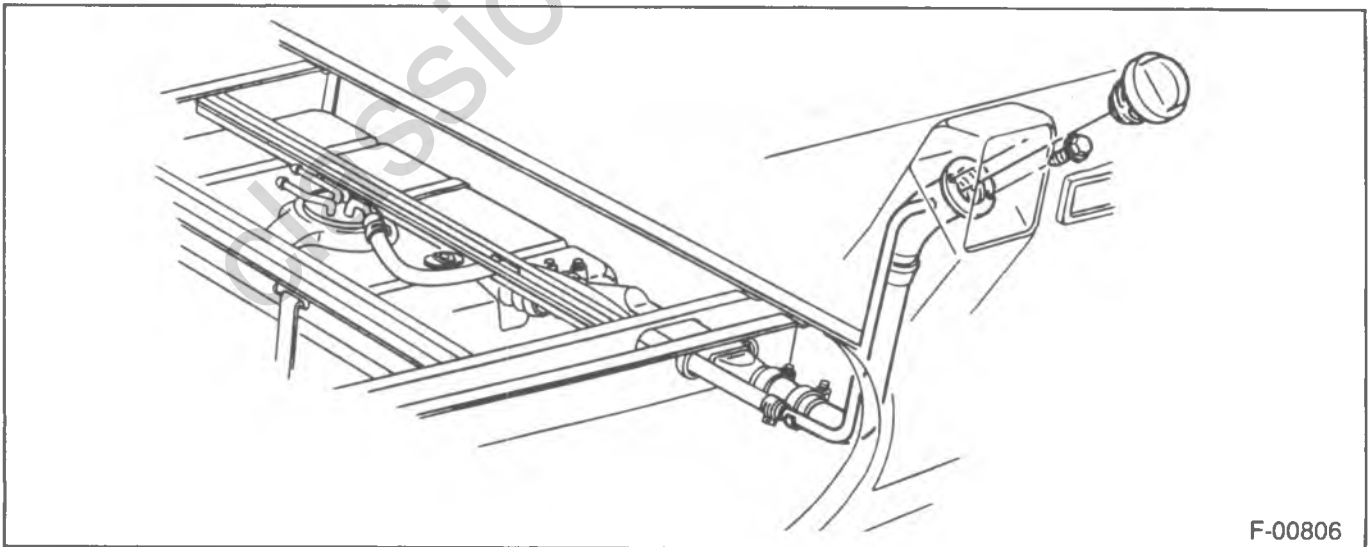

Figure 12—G-Van Filler Neck

FUEL GAGE SENDING UNIT

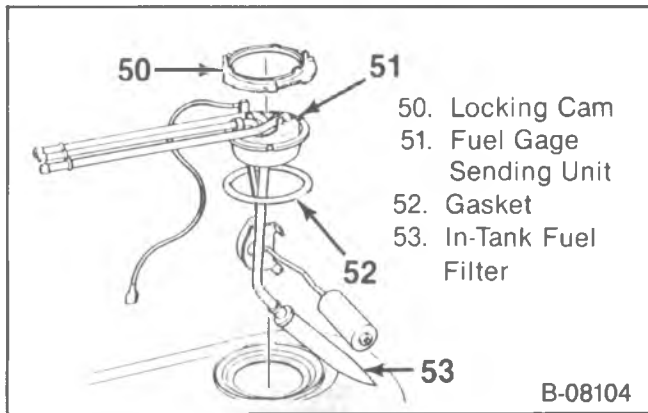

Figure 13—Fuel Gage Sending Unit

The fuel gage sending unit is mounted in the top of the fuel tank. It is held in place by a cam lock ring. A gasket is used between the tank and the sending unit.

Sending units have either two or three nipples to attach hoses. These hoses are the fuel feed, fuel return, and vapor hoses.

On some sending units a wire is attached to the unit; while on other sending units, connectors attach directly to the sender.

IN TANK FUEL FILTER

A woven plastic filter is located on the lower end of the fuel pickup tube in the fuel tank (figure 13). This filter prevents dirt and water from entering into the fuel line unless it becomes completely submerged in water. The filter is self cleaning and normally requires no maintenance. Fuel stoppage at this point indicates that the fuel tank contains an abnormal amount of sediment or water and should be thoroughly cleaned.

Diesel engine vehicles have a check valve that will permit fuel to pass if the tank filter becomes plugged with paraffin during cold weather operation.

When this plugging occurs, the last four gallons of fuel will not be used due to the location of the check valve. Therefore it is important to keep the fuel tank above the 1/4 mark at temperatures below -6°C (-20°F) when using number two diesel fuel.

FUEL GAGE SENDING UNIT REPLACEMENT

↔ Remove or Disconnect (Figure 13)

Tool Required:

J-24187 Fuel Gage Sending Unit Tool

1. Fuel from the tank.
2. Fuel tank from the vehicle.
3. Locking cam (50) using J-24187.
4. Fuel gage sending unit (51).
5. Gasket (52).

→ Install or Connect (Figure 13)

Tool Required:

J-24187 Fuel Gage Sending Unit Tool

1. New gasket.
2. Fuel gage sending unit.
 - Take care not to fold or twist the strainer or fuel flow will be restricted.
3. Locking cam using J-24187.
4. Fuel tank into the vehicle.

FUEL TANK SELECTOR VALVE

The fuel tank selector valve is operated by a switch on the instrument panel. The switch controls fuel tank switching and fuel gage indication in a single operation.

A simple check can be made to determine if the fuel tank selector valve is working by listening for selector valve motor operation when the switch is pressed.

DIAGNOSIS OF SELECTOR VALVE

CHECKING THE INSTRUMENT PANEL SIDE OF THE HARNESS

Refer to figures 14 through 16 to diagnose the instrument panel side of the selector valve harness.

CHECKING THE SELECTOR VALVE SIDE OF THE HARNESS

1. Make sure there is about 40 liters (10 gallons) of fuel in one tank and about 20 liters (5 gallons) in the other tank.
2. Remove the harness connector from the fuel tank selector valve.

3. Install a known good selector valve.
4. Activate the fuel tank selector switch and note the gage readings of the right and left tanks.
5. The system is operating properly if a change is indicated between the tanks. Therefore, the original selector valve was the problem.
6. If a change is not indicated, there is an open in the harness between the connector on the cowl and the selector valve.
7. Refer to INSTRUMENT PANEL (SEC. 8C) if the fuel gage does not register accurately.

FUEL TANK SELECTOR VALVE REPLACEMENT

↔ Remove or Disconnect (Figure 17)

1. Battery negative cable.
2. Hose shield (60) and brace (61).
3. Electrical connector from the selector valve (62).

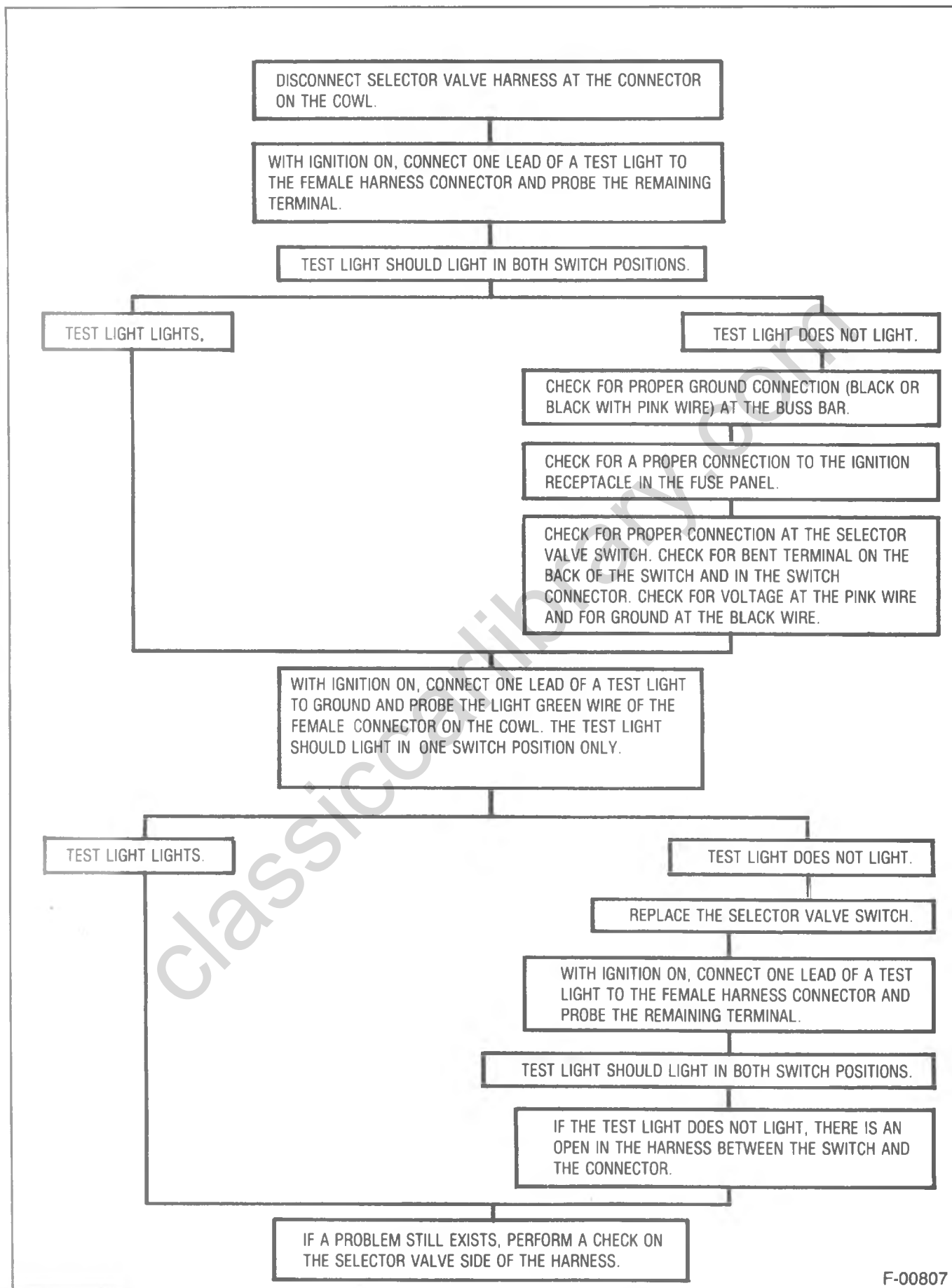

F-00807

Figure 14—Diagnosis of the Instrument Panel Side of the Selector Valve Harness

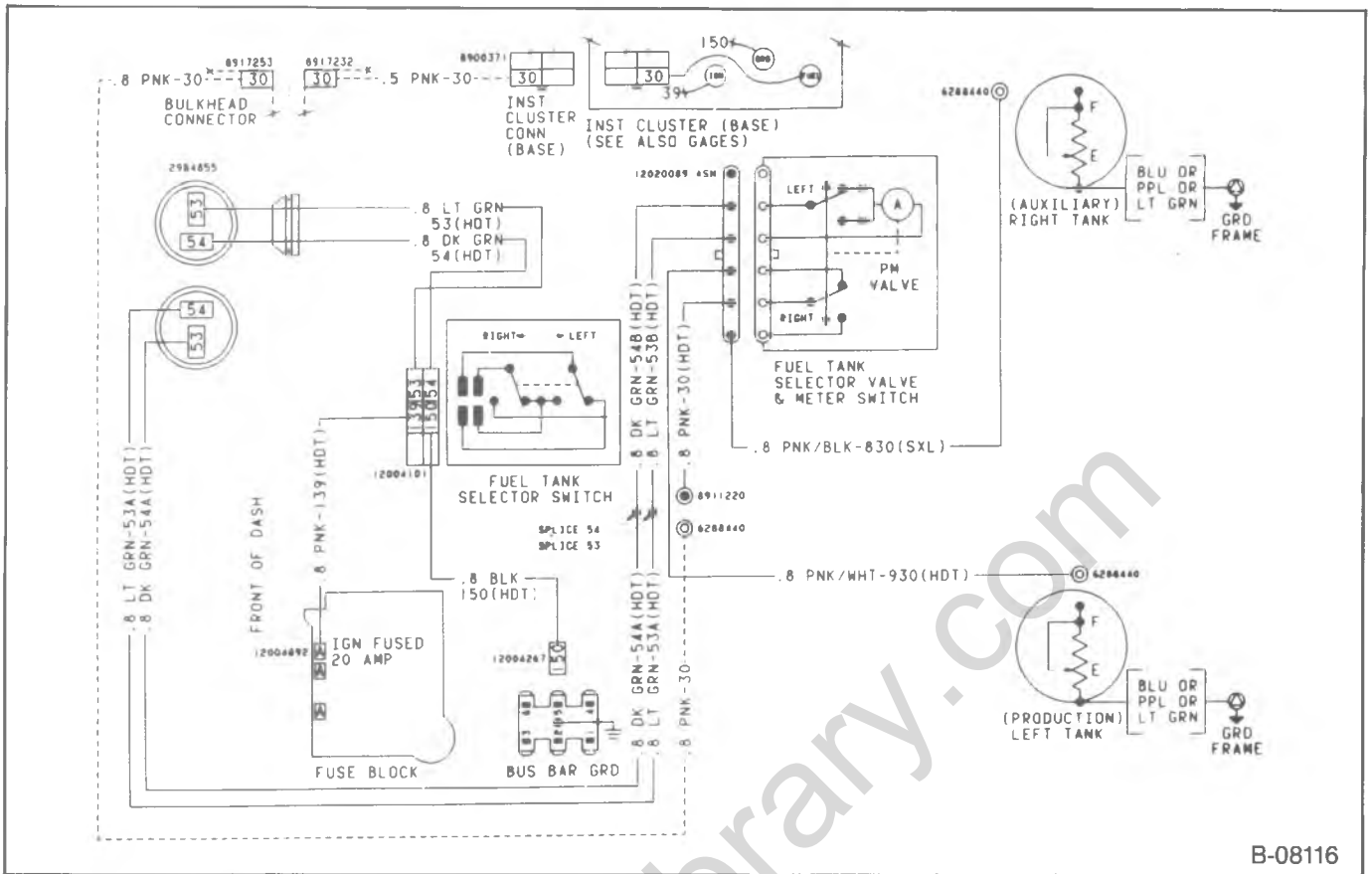

B-08116

Figure 15—Auxiliary Fuel Tank Wiring

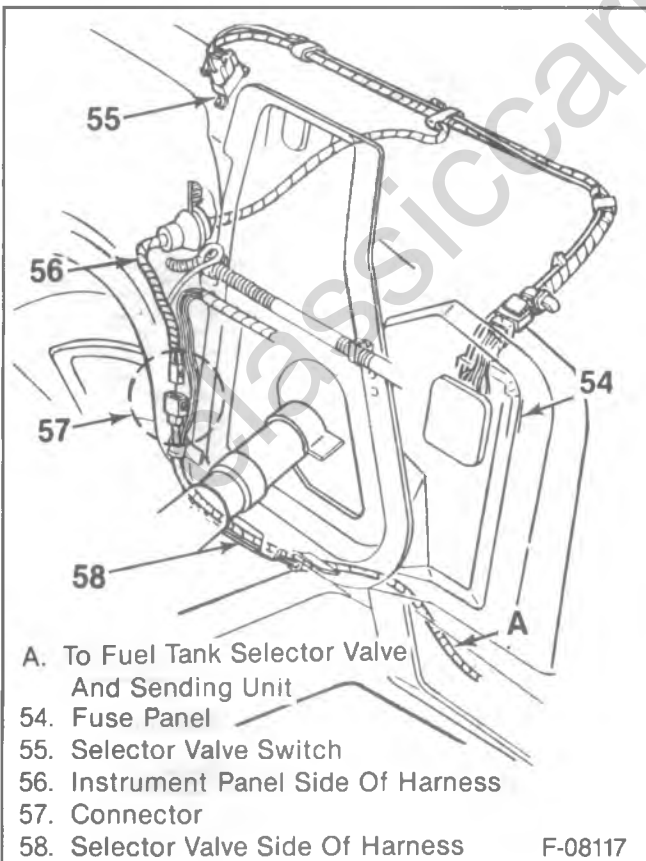

A. To Fuel Tank Selector Valve
And Sending Unit

- 54. Fuse Panel
- 55. Selector Valve Switch
- 56. Instrument Panel Side Of Harness
- 57. Connector
- 58. Selector Valve Side Of Harness

F-08117

Figure 16—Auxiliary Fuel Tank Instrument Panel Wiring

- 4. Fuel and vapor hoses.
 - Note the position of the hoses for installation.
- 5. Screws (63).
- 6. Valve (62).

Install or Connect (Figure 17)

- 1. Valve (62).
- 2. Screws (63).
- 3. Fuel and vapor hoses in the correct position.
- 4. Electrical connector.
- 5. Brace (61) and hose shield (60).
- 6. Battery negative cable.

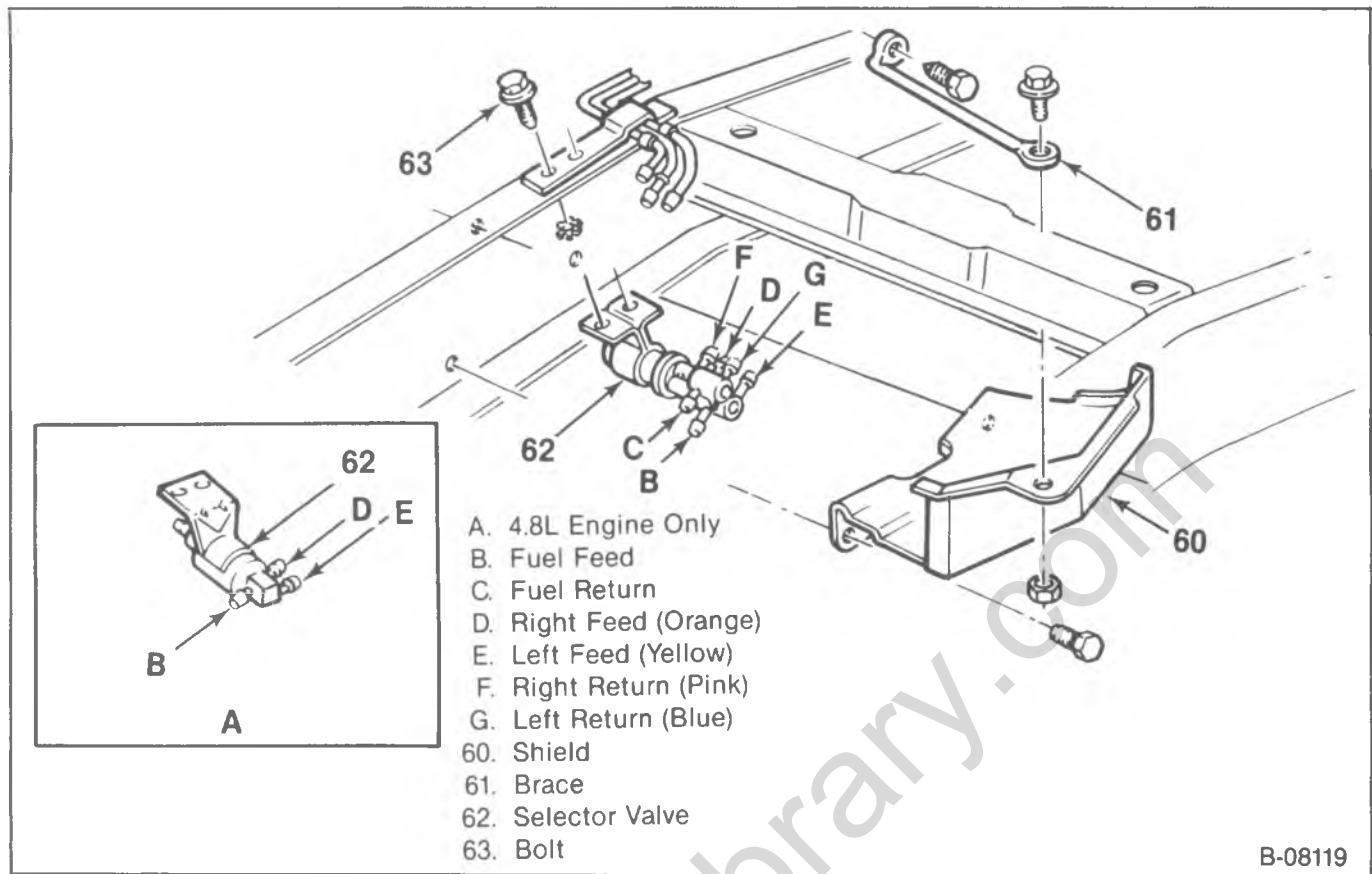

Figure 17—Selector Valve

ACCELERATOR CONTROLS

The accelerator pedal controls the throttle through a cable. There are no linkage adjustments. The throttle cable must be replaced with an identical replacement part.

All linkages and cables must be checked to assure free movement with no rubbing, chafing, or binding. The throttle must operate freely without binding between full closed and wide open throttle.

ACCELERATOR CONTROL CABLE

Observe the following when performing service on the accelerator control cable.

- The retainer must be installed with the tangs secured over the head of the stud (figure 18).
- The conduit fitting at both ends of the cable must have the locking tangs expanded and locked into the attaching holes.
- The braided portion of the cable must not come into contact with the front of dash sealer during replacement.
- Flexible components (hoses, wires, conduit, etc.) must not be routed within 50 mm (2-inches) of the moving parts of the accelerator linkage unless routing is positively controlled.
- Lube all pivot points with Accelerator Linkage Lubricant (1052541 or equivalent).

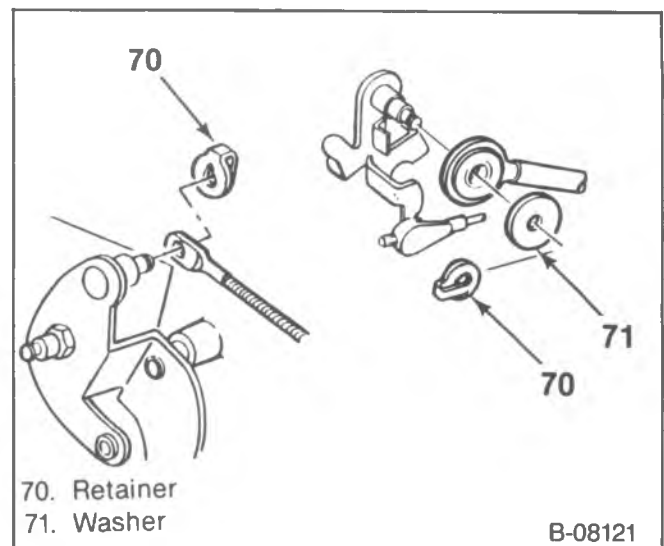

Figure 18—Control Cable Attachment

ACCELERATOR PEDAL

Observe the following when performing service on the accelerator pedal.

- The mounting surface between the support and the dash panel must be free of insulation. The carpet and padding in the pedal and tunnel area must be

positioned to lay flat and be free of wrinkles and bunches.

- Slip the accelerator control cable through the slot in the rod before installing the retainer in the rod. Make sure it is seated properly. Use care in pressing the retainer into the hole so the cable is not kinked or damaged (figure 19).
- The linkage must operate freely without binding between closed throttle and full throttle.
- Wire, hoses, cable, and other flexible components must not be placed within 13 mm (0.52-inch) of the cable or rod at any point in their travel.

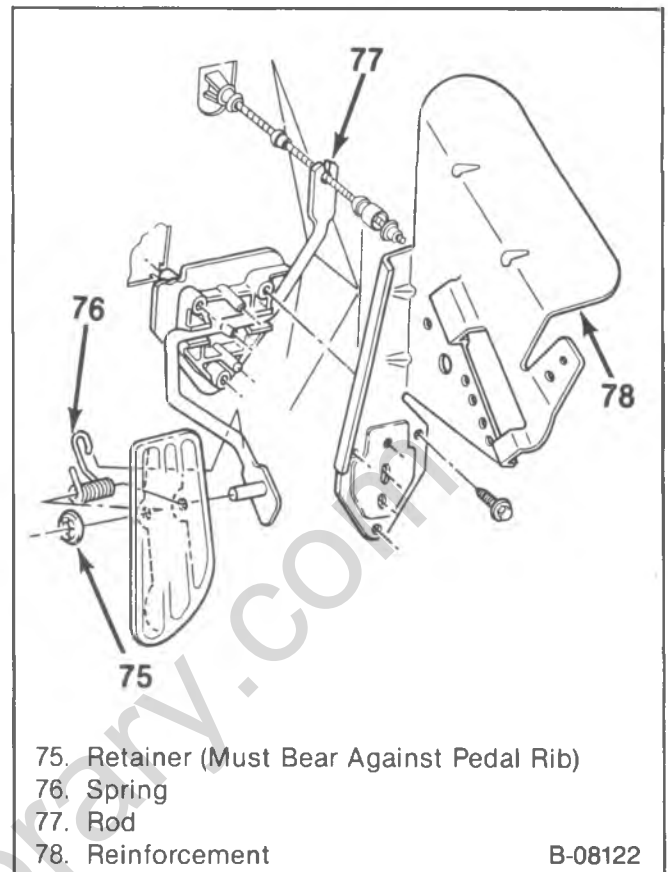

Figure 19—Accelerator Pedal Assembly

SPECIFICATIONS

FUEL PUMP BOLT TORQUE

4.8L Engine	.23 N·m (17 ft. lbs.)
5.7L Engines (Top Bolts)	.37 N·m (27 ft. lbs.)
5.7L Engines (Bottom Bolts)	.4 N·m (3 ft. lbs.)
6.2L Engine (Top Bolts)	.33 N·m (24 ft. lbs.)
6.2L Engine (Bottom Bolts)	.8 N·m (6 ft. lbs.)
7.4L Engine	.37 N·m (27 ft. lbs.)

FUEL TANK MOUNTING STRAP FASTENERS

R/V Model With Base Tank Nuts	.6 N·m (4 ft. lbs.)
R/V Model With RPO NL2 Bolts	.33 N·m (24 ft. lbs.)
Utility Vehicle And Suburban Nuts	.16 N·m (12 ft. lbs.)
G-Van With Base Tank Bolts	.5 N·m (45 in. lbs.)
G-Van With RPO NL7 Bolts	.11 N·m (95 in. lbs.)
G-Van Nuts	.13 N·m (10 ft. lbs.)

FUEL INLET NUT TORQUE

1-Barrel — 1 MEF	.45 N·m (33 Ft. Lbs.)
4-Barrel — M4ME	.62 N·m (46 Ft. Lbs.)

SPECIAL TOOLS

1.



J-24187

1. Fuel Gage Sending Unit Tool

F-02837

Figure 20—Special Tools

classiccarylbrary.com

SECTION 6C1

CARBURETORS

CONTENTS

<u>SUBJECT</u>	<u>PAGE</u>
Carburetor Model 1MEF	6C1- 2
Description	6C1- 2
Diagnosis of 1MEF Rochester Carburetor	6C1- 7
On-Vehicle Service (1MEF)	6C1-15
Electric Choke	6C1-15
Idle Solenoid	6C1-16
Carburetor Replacement	6C1-17
Carburetor Adjustments	6C1-17
Carburetor Models M4ME and M4MEF	6C1-21
Description	6C1-21
Carburetor Identification	6C1-21
Diagnosis of M4ME and M4MEF Rochester Carburetors	6C1-28
On-Vehicle Service (M4ME and M4MEF)	6C1-37
Float Level - External Check	6C1-37
Choke Checking Procedure	6C1-37
Checking idle Stop Solenoid (ISS)	6C1-37
Checking Throttle Kicker	6C1-38
Fuel Filter Replacement	6C1-38
Carburetor Mounting Torque	6C1-38
Carburetor Replacement	6C1-38
Idle Mixture Adjustment (Heavy-Duty Emission Vehicles Only)	6C1-39
Idle Speed Adjustment	6C1-40
Throttle Kicker Adjustment	6C1-40
Float Adjustment	6C1-40
Pump Adjustment	6C1-41
Air Valve Return Spring Adjustment	6C1-41
Choke Stat Lever Adjustment	6C1-42
Choke Link and Fast Idle Cam Adjustment	6C1-42
Primary Side Vacuum Break Adjustment	6C1-42
Secondary Side Vacuum Break Adjustment	6C1-44
Air Valve Link Adjustment	6C1-45
Unloader Adjustment	6C1-45
Secondary Throttle Lockout Adjustment	6C1-46
Specifications	6C1-47
Special Tools	6C1-48

All new GM vehicles are certified by the United States Environmental Protection Agency as conforming to the requirements of the regulations for the control of air pollution from new motor vehicles. This certification is contingent on certain adjustments being set to factory standards. In most cases, these adjustment points either have been permanently sealed and/or made inaccessible to prevent indiscriminate or routine adjustment in the field. For this reason the factory procedure for temporarily removing plugs, cap, etc., for purposes of servicing the product, must be strictly followed and, wherever practicable, returned to the original intent of the design. For vehicles sold in Canada and equipped with non-closed loop engines, also refer to the appropriate Canadian service manual supplement.

CARBURETOR MODEL 1MEF

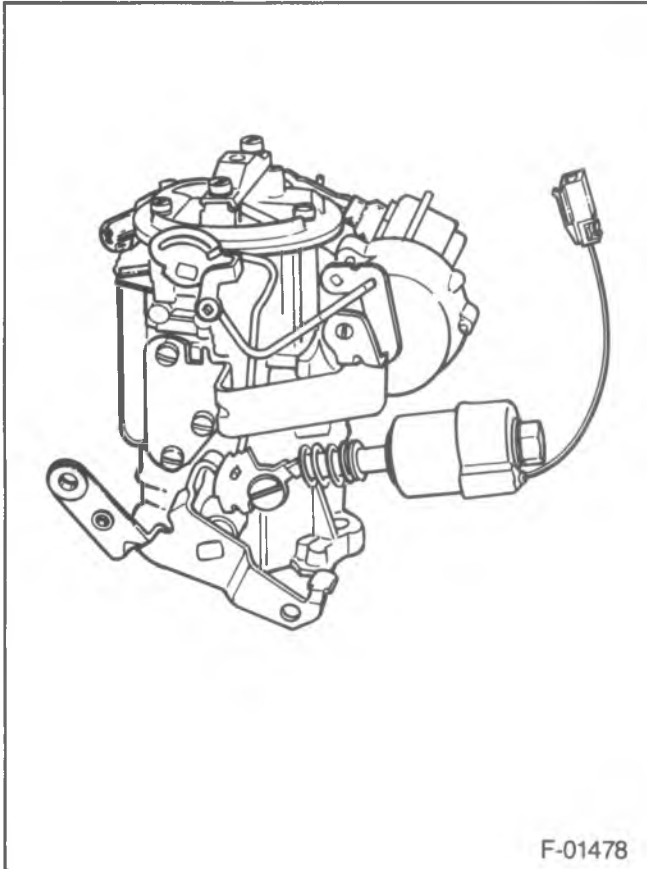

Figure 1—1 MEF Carburetor

DESCRIPTION

Model 1MEF carburetors are single bore downdraft carburetors using a triple venturi along with a discharge tube nozzle (figure 1).

A power valve piston assembly and metering rod control the fuel flow in the main metering and power systems of the carburetor. The tapered metering rod is

attached to the power piston and moves in a fixed metering jet to provide the fuel flow for varying engine demands. On 1MEF carburetors, a factory set metering rod adjusting screw controls the position of the metering rod in the jet. This screw is located in the air horn and should not be turned as this could result in engine damage or increased exhaust emissions.

Model 1MEF incorporates an integral automatic choke system which uses an electrically heated choke coil. The vacuum diaphragm unit is mounted externally on the air horn and connects to the thermostatic coil lever through a connecting link.

The electric choke coil is contained in a choke housing, which is mounted on a bracket attached to the float bowl. Special rivets are installed to retain the factory setting of the choke coil and provide a non-adjustable design.

An integral, pleated-paper fuel inlet filter is mounted in the fuel bowl behind the fuel inlet nut to give maximum filtration of incoming fuel. A check valve is used in the filter inlet to prevent fuel draining from the fuel system after rollover.

To improve hot engine starting and meet evaporative emission requirements, fuel vapors from the carburetor bowl are vented to a vapor canister on some models. A tube (location F) is added to the air horn to connect the air horn and canister.

Other features of the carburetors include an aluminum throttle body for decreased weight and improved heat distribution. A thick throttle body to bowl insulator gasket keeps excessive engine heat from the float bowl.

All 1MEF models have seals added in the float bowl to seal the power piston drive rod and the pump lever. This prevents fuel vapors from escaping to atmosphere. During unit repair, the seals and retainer, where used, must be removed prior to immersion of the float bowl in carburetor cleaner.

The carburetor model identification is stamped on a vertical portion of the float bowl, adjacent to the fuel inlet nut (figure 2).

If replacing the float bowl, follow the manufacturer's instructions contained in the service package so that the identification number can be transferred to the new float bowl.

An electrically operated idle stop solenoid and dual throttle return springs are used on all carburetors.

The throttle lever has a spun-in plastic bushing which is used as a bearing surface. The bushing will withstand normal cleaning time in an approved cold immersion type carburetor cleaner. The bushing is not serviced separately and should not be removed from the carburetor throttle lever.

Six basic systems of operation are used (figures 3 through 8).

- Float
- Idle
- Main Metering
- Power
- Pump
- Choke

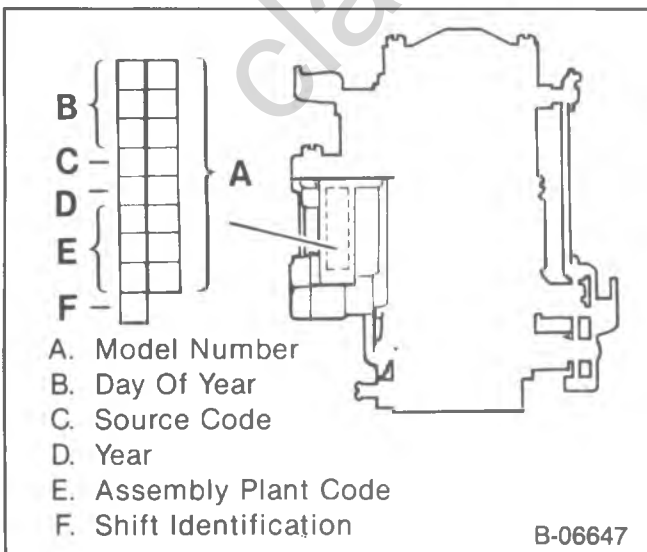
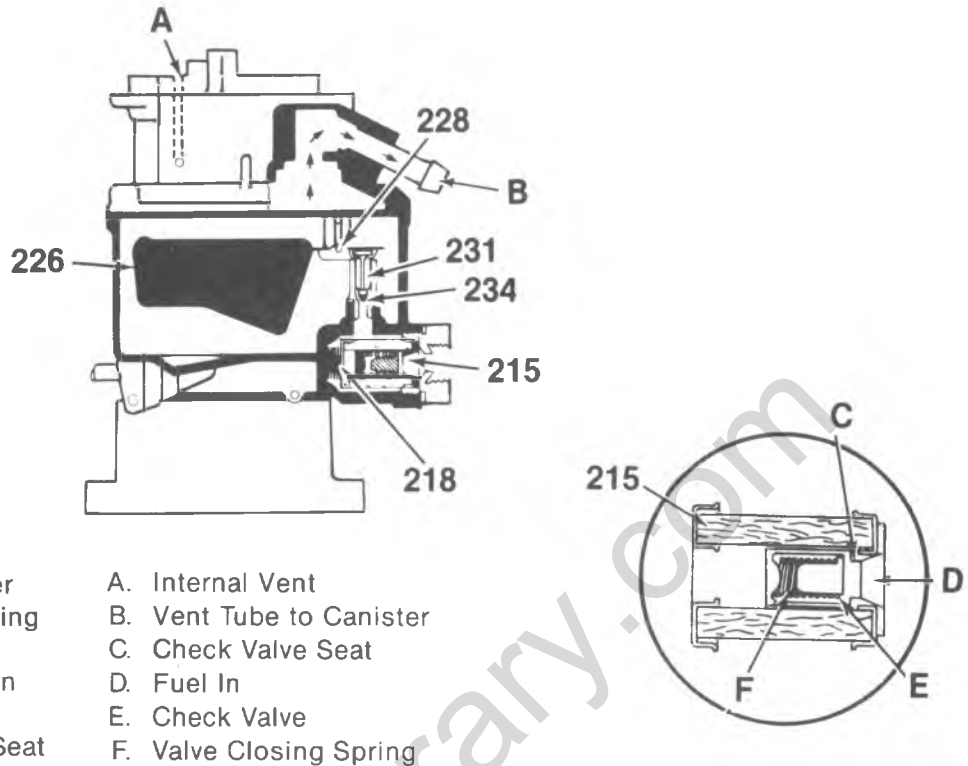

Figure 2—Carburetor Identification



F-01479

Figure 3—Float System

240. Rod - Pump
 247. Cup - Pump Plunger
 248. Spring - Pump Plunger
 252. Spring - Pump Return
 256. Guide - Pump Discharge Spring
 258. Spring - Pump Discharge Ball
 260. Ball - Pump Discharge
 310. Lever - Pump and Power Rod
 317. Link - Pump
 A. Pump Plunger Head
 B. Pump Duration Spring
 C. Pump Discharge Channel
 D. Pump Jet

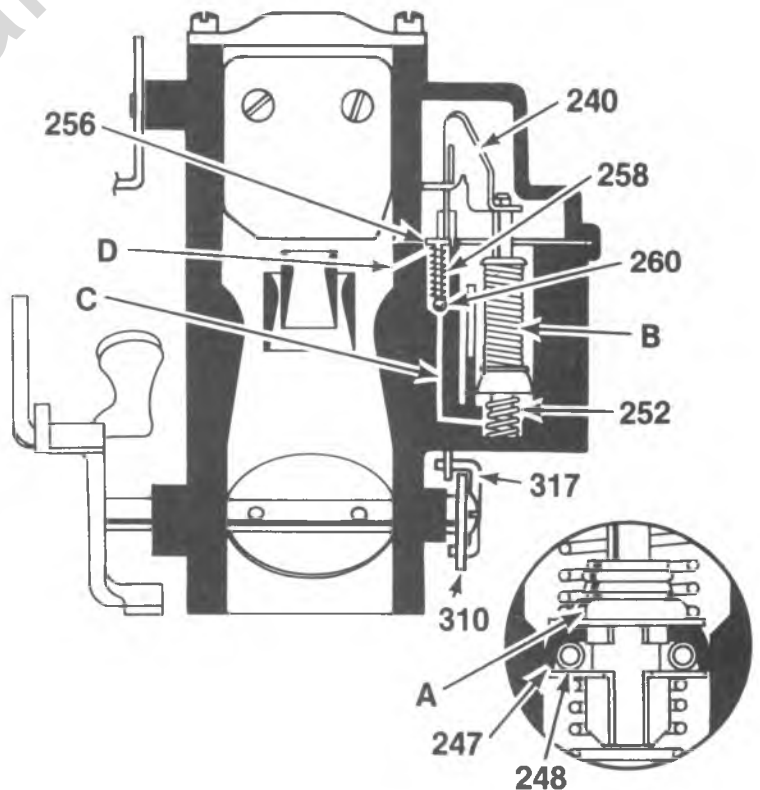

B-06645

Figure 4—Pump System

6C1-4 CARBURETORS

- 266. Rod - Power Piston
- 274. Power Valve Piston Assembly
- 276. Spring - Power Piston
- 279. Metering Rod and Spring Assembly
- 282. Jet - Main Metering
- A. Throttle Valve
- B. Vacuum Channel
- C. Main Venturi
- D. Boost Venturi
- E. Main Discharge Nozzle
- F. Lower Idle Air Bleed
- G. Main Well
- H. Fuel Feed Orifice
- I. Part Throttle Adjusting Screw
- J. Top Main Well Air Bleed
- K. Main Well to Aspirator Bleed

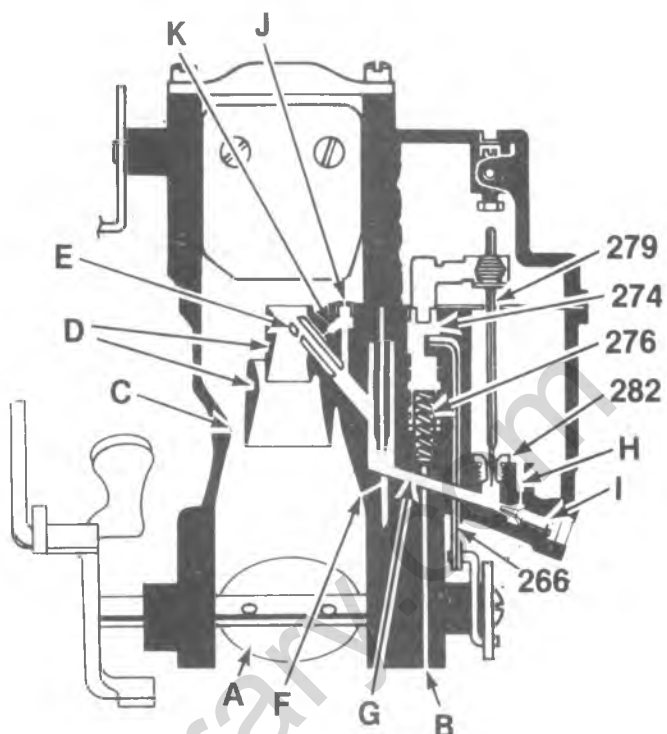

F-01481

Figure 5—Main Metering System - 1 MEF

- 266. Rod - Power Piston
- 274. Power Valve Piston Assembly
- 276. Spring - Power Piston
- 279. Metering Rod and Spring Assembly
- 282. Jet - Main Metering
- 310. Lever - Pump and Power Rod
- 314. Link - Power Rod
- A. Throttle Valve
- B. Vacuum Channel
- C. Main Discharge Nozzle
- D. Lower Idle Air Bleed
- E. Main Well
- F. Metering Rod Adjusting Screw
- G. Setscrew
- H. Metering Rod Adjusting Screw Plug
- I. Top Main Well Air Bleed
- J. Main Well to Aspirator Bleed

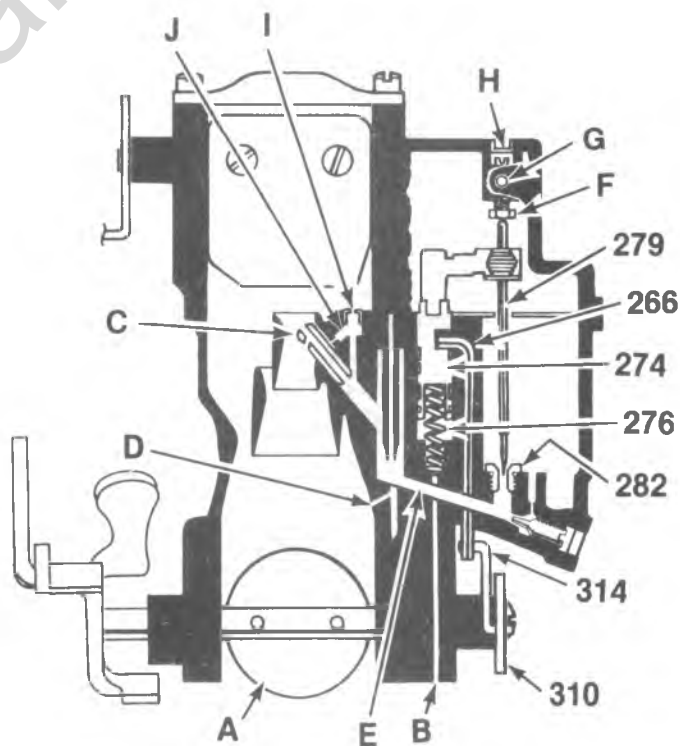

B-06644

Figure 6—Power System - 1 MEF

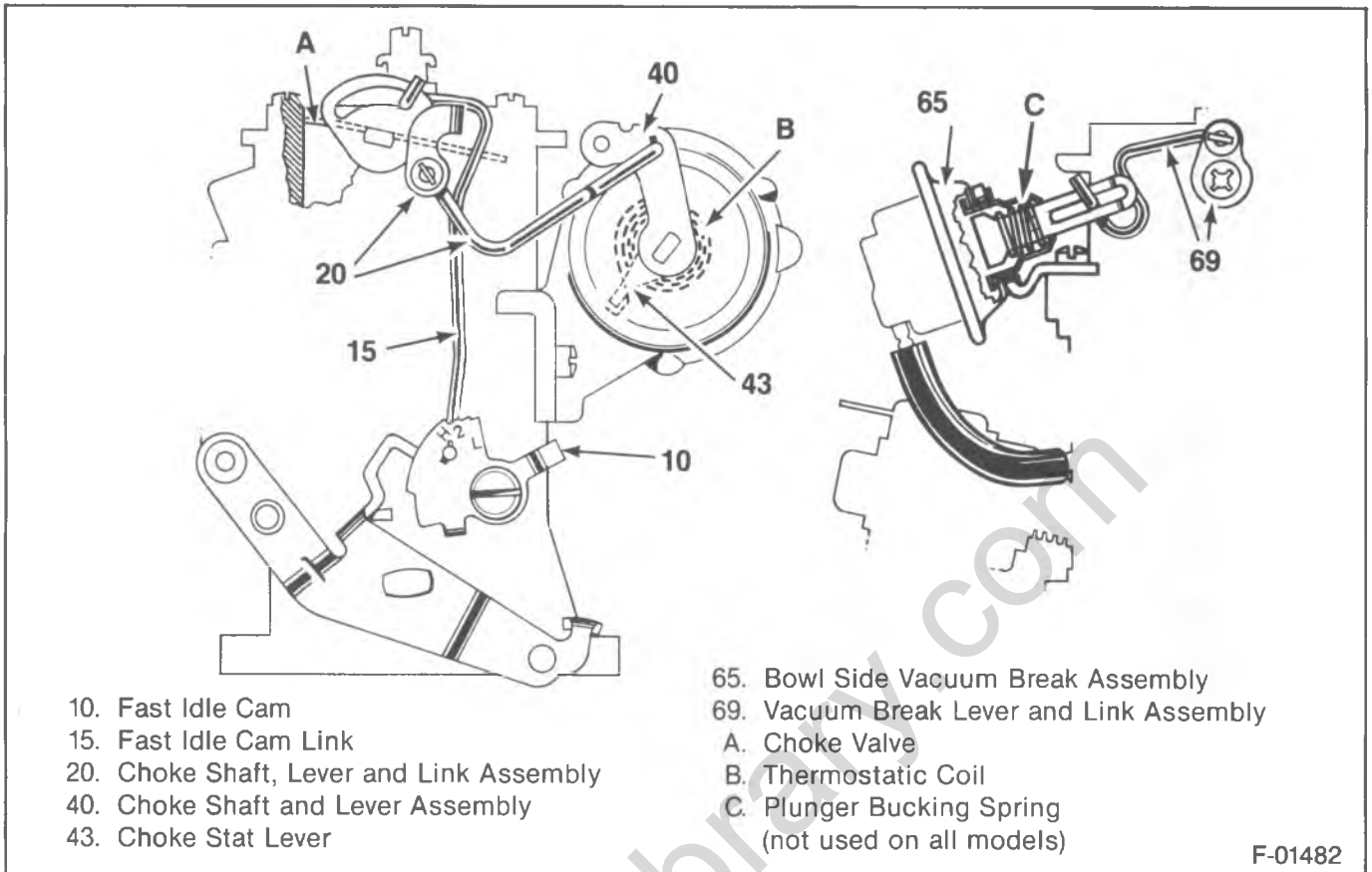

Figure 7—Choke System

6C1-6 CARBURETORS

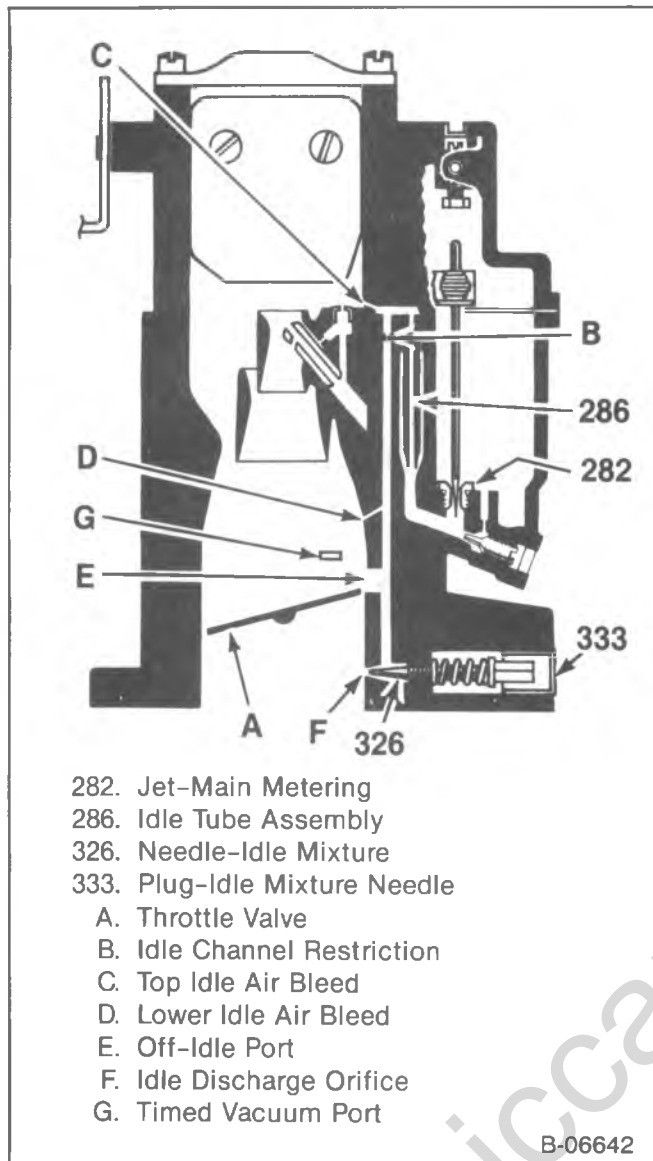

Figure 8—Idle System - 1 MEF

DIAGNOSIS OF 1MEF ROCHESTER CARBURETOR

The following diagnostic procedures are for carburetor related problems and their effects on vehicle performance. Other vehicle systems can also cause problems and should be checked when listed on the chart.

PROBLEM	POSSIBLE CAUSE	CORRECTION
<p>Engine Cranks Normally - Will Not Start or Starts Hard</p>	<ol style="list-style-type: none"> 1. Improper starting procedure used. 2. Ignition system malfunction. 3. Choke not operating properly. 4. Engine loaded with fuel. (Improper starting procedure used or choke unloader misadjusted.) 5. No fuel in carburetor. 6. Engine flooded. To check for flooding, remove the air cleaner and look into the carburetor venturi for fuel dripping from nozzle. 	<ol style="list-style-type: none"> 1. Check with the customer to determine if proper starting procedure, outlined in the "Owner's and Driver's Manual", is used. 2. Check ignition system. Refer to ENGINE ELECTRICAL (SEC. 6D). 3. Check for free movement, and complete opening and closing, of choke valve. See "Choke Checking Procedure" and "Checking Electric Choke" later in this section. 4. Check with the customer to determine if proper starting procedure, outlined in the "Owner's and Driver's Manual", is used. Adjust choke unloader. 5. Inspect fuel filter(s) for being plugged. Replace as necessary. Check fuel pump pressure and volume. Replace pump if necessary. Inspect fuel lines for leaks and restrictions. Check the float level, and adjust if necessary. 6. Remove the air horn. Check float for restricted movement or being loaded. Inspect float needle and seat for wear and dirt or chips. If foreign material is found in the carburetor, clean the fuel system and carburetor. Replace fuel filter(s) as necessary. Check float level, and adjust if necessary.
<p>Engine Starts - Will Not Keep Running</p>	<ol style="list-style-type: none"> 1. Improper starting procedure used. 2. Choke not operating properly. 3. Engine does not have correct fast idle speed when cold. 4. Vacuum break assembly malfunctioning or misadjusted. 	<ol style="list-style-type: none"> 1. Check with the customer to determine if proper starting procedure, outlined in the Owner's and Driver's Manual, is used. 2. Check for free movement and complete opening and closing of choke valve. See "Choke Checking Procedure" and "Checking Electric Choke" later in this section. 3. Check for free movement of fast idle cam and linkage. See "Choke Checking Procedure" later in this section. Adjust fast idle speed. See Emission Control Information Label. 4. See "Vacuum Break Checking Procedure" later in this section. Adjust vacuum break assembly to specification.

DIAGNOSIS OF 1MEF ROCHESTER CARBURETOR (CONT.)

PROBLEM	POSSIBLE CAUSE	CORRECTION
Engine Starts - Will Not Keep Running (Cont.)	5. Idle speed too low. 6. Air leaks at carburetor flange/insulator gasket(s), or at intake manifold gasket. Vacuum hoses disconnected or installed improperly. 7. Not enough fuel in carburetor. 8. Carburetor flooding.	5. Adjust idle speed. See Emission Control Information Label. 6. Use a pressure oil can to spray light oil or kerosene around carburetor throttle body (do not spray at throttle shaft ends), and manifold to head mounting surfaces. If engine RPM changes, torque carburetor to manifold bolts and/or intake manifold bolts to specification. If necessary, replace the carburetor flange/insulator gasket(s) and/or intake manifold gasket. Check condition and routing of vacuum hoses. Correct or replace as necessary. 7. Inspect fuel filter(s) for being partially plugged. Replace as necessary. Check fuel pump pressure and volume. Replace pump if necessary. Inspect fuel lines for leaks and restrictions. Check the float level, and adjust if necessary. 8. Remove the air horn. Check float for restricted movement or being loaded. Inspect float needle and seat for wear and dirt or chips. If foreign material is found in the carburetor, clean the fuel system and carburetor. Replace fuel filter(s) as necessary. Check float level, and adjust if necessary.
Engine Idles Abnormally (Too Fast or Too Slow)	1. Idle speed misadjusted. 2. Idle stop solenoid malfunctioning. Faulty solenoid circuit wiring. 3. Choke not operating properly or fast idle cam sticking or binding. 4. Throttle linkage or throttle shaft sticking or binding.	1. Adjust idle speeds. See Emission Control Information Label. 2. See "Idle Stop Solenoid Checking Procedure" later in this section. 3., Check choke valve and fast idle cam for free movement. Check for complete opening and closing of choke valve. See "Choke Checking Procedure" and "Checking Electric Choke" later in this section. 4. Check throttle linkage and throttle shaft for smooth and free operation. Clean with suitable solvent. Replace throttle body if necessary.

DIAGNOSIS OF 1MEF ROCHESTER CARBURETOR (CONT.)

PROBLEM	POSSIBLE CAUSE	CORRECTION
<p>Engine Idles Abnormally (Too Fast Or Too Slow) (Cont.)</p>	<p>5. Air leaks at carburetor flange/insulator gasket(s), or at intake manifold gasket. Vacuum hoses disconnected or installed improperly.</p> <p>6. PCV system malfunctioning.</p> <p>7. Ignition timing misadjusted.</p> <p>8. Distributor vacuum or mechanical advance malfunctioning.</p> <p>9. Idle system restricted or incorrect idle mixture adjustment.</p> <p>10. Restricted air cleaner element.</p> <p>11. Carburetor flooding.</p>	<p>5. Use a pressure oil can to spray light oil or kerosene around carburetor throttle body (do not spray at throttle shaft ends), and manifold to head mounting surfaces.</p> <p>If engine RPM changes, torque carburetor to manifold bolts and/or intake manifold bolts to specification. If necessary, replace the carburetor flange/insulator gasket(s) and/or intake manifold gasket. Check condition and routing of vacuum hoses. Correct or replace as necessary.</p> <p>6. Check PCV system. Clean or replace PCV valve and hoses as necessary.</p> <p>7. Adjust timing. See Emission Control Information Label.</p> <p>8. Check operation. Refer to the "Fuel and Emissions Service Manual."</p> <p>9. Clean carburetor if necessary. Adjust idle mixture per specified procedure.</p> <p>10. Replace if necessary.</p> <p>11. Remove the air horn.</p> <p>Check float for restricted movement or being loaded.</p> <p>Inspect float needle and seat for wear, and for dirt or chips.</p> <p>If foreign material is found in the carburetor, clean the fuel system and carburetor. Replace fuel filter(s) as necessary.</p> <p>Check float level, and adjust if necessary.</p>
<p>Engine Diesels (After Run) Upon Shut Off</p>	<p>1. Minimum idle speed misadjusted.</p> <p>2. Idle stop solenoid malfunctioning. Faulty solenoid circuit wiring.</p> <p>3. Choke not operating properly or fast idle cam sticking or binding.</p> <p>4. Throttle linkage or throttle shaft sticking or binding.</p> <p>5. Air leaks at carburetor flange/insulator gasket(s), or at intake manifold gasket. Vacuum hoses disconnected or installed improperly.</p>	<p>1. Adjust minimum idle speed. See Emission Control Information Label.</p> <p>2. See "Idle Stop Solenoid Checking Procedure" later in this section.</p> <p>3. Check choke valve and fast idle cam for free movement. Check for complete opening and closing of check valve. See "Choke Checking Procedure" and "Checking Electric Choke" later in this section.</p> <p>4. Check throttle linkage and throttle shaft for smooth and free operation. Clean with suitable solvent. Replace throttle body if necessary.</p> <p>5. Use a pressure oil can to spray light oil or kerosene around carburetor throttle body (do not spray at throttle shaft ends), and manifold to head mounting surfaces.</p> <p>If engine RPM changes, torque carburetor to manifold bolts and/or intake manifold bolts to specification. If necessary, replace the carburetor flange/insulator gasket(s) and/or intake manifold gasket. Check condition and routing of vacuum hoses. Correct or replace as necessary.</p>

DIAGNOSIS OF 1MEF ROCHESTER CARBURETOR (CONT.)

PROBLEM	POSSIBLE CAUSE	CORRECTION
<p>Engine diesels (After Run) Upon Shut Off (Cont.)</p>	<p>6. PCV system malfunctioning.</p> <p>7. Ignition timing retarded (causes throttle valve to be opened farther than normal to obtain correct idle speed).</p> <p>8. Lean idle mixture (causes throttle valve to be opened farther than normal to obtain correct idle speed).</p>	<p>6. Check PCV system. Clean or replace PCV valve and hoses as necessary.</p> <p>7. Adjust timing. See Emission Control Information Label.</p> <p>8. Clean carburetor if necessary. Adjust idle mixture per specified procedure.</p>
<p>Engine Hesitates On Acceleration * Hesitates During Cold Engine Operation.</p>	<p>1. Malfunctioning pump system. Make a quick check of the pump system: With the engine off, look into the carburetor bore and observe pump discharge jet; actuate throttle lever. A full stream of fuel should emit from the jet.</p> <p>2. * Choke not operating properly.</p> <p>3. * Vacuum break assembly malfunctioning or misadjusted.</p> <p>4. * Thermac system malfunctioning.</p> <p>5. * Early Fuel Evaporation (EFE) system malfunction.</p> <p>6. Ignition timing misadjusted.</p> <p>7. Distributor vacuum or mechanical advance malfunctioning.</p> <p>8. Float level too low.</p> <p>9. Power piston sticking. Missing or damaged power piston spring, power piston rod, power rod link, or pump and power rod lever.</p> <p>10. Metering rod hanger bent or metering rod misadjusted.</p>	<p>1. Remove air horn and check pump cup. If cracked or hardened, replace the pump plunger cup and spring. Inspect pump well for scoring. Replace float bowl if necessary. Check for restricted pump passages. Clean and blow out passages with compressed air. Check the pump discharge ball for proper seating.</p> <p>2. Check for complete opening and closing of choke valve. See "Choke Checking Procedure" and "Checking Electric Choke" later in this section.</p> <p>3. See "Vacuum Break Checking Procedure" later in this section. Adjust vacuum break to specification.</p> <p>4. Check operation. Refer to the "Fuel and Emissions Service Manual."</p> <p>5. Check operation. Refer to the "Fuel and Emissions Service Manual."</p> <p>6. Adjust timing. See Emission Control Information Label.</p> <p>7. Check operation. Refer to ENGINE ELECTRICAL (SEC. 6D).</p> <p>8. Check float level, and adjust if necessary.</p> <p>9. Check power piston operation: push piston down against piston rod and release; it should move freely in bore and return to its up position. Rotate throttle to wide open; piston should move upward in bore. If piston does not move freely, clean power piston and bore. If piston does not return when depressed, or does not move upward when throttle is opened, check for missing or damaged parts. Replace as necessary.</p> <p>10. Inspect metering rod hanger for damage. Replace power piston assembly if necessary. Adjust metering rod to specification.</p>

DIAGNOSIS OF 1MEF ROCHESTER CARBURETOR (CONT.)

PROBLEM	POSSIBLE CAUSE	CORRECTION
Engine Hesitates On Acceleration (Cont.)	11. Restricted main metering jet or adjustable part throttle fuel feed orifice.	11. If foreign material is found in the carburetor, clean the fuel system and carburetor. Replace fuel filter(s) as necessary.
Engine Has Less Than Normal Power At Normal Acceleration	1. Ignition system malfunction. 2. Ignition timing misadjusted. 3. Distributor vacuum or mechanical advance malfunctioning. 4. Plugged air cleaner element. 5. Exhaust system restricted. 6. Thermac system malfunction. 7. Early Fuel Evaporation (EFE) system malfunction. 8. Transmission malfunction. 9. Choke not operating properly. 10. Fuel filter(s) partially plugged. 11. Faulty fuel pump, or leaking or restricted fuel lines. 12. Float level too low. 13. Power piston sticking. Missing or damaged power piston spring, power piston rod, power rod link, or pump and power rod lever. 14. Metering rod hanger bent or metering rod misadjusted. 15. Restricted main metering jet or adjustable part throttle fuel feed orifice. Loose main metering jet.	1. Check ignition system. Refer to ENGINE ELECTRICAL (SEC. 6D). 2. Adjust timing. See Emission Control Information Label. 3. Check operation. Refer to ENGINE ELECTRICAL (SEC. 6D). 4. Replace element. 5. Check for restrictions. Correct as necessary. 6. Check operation. Refer to the "Fuel and Emissions Service Manual." 7. Check operation. Refer to the "Fuel and Emissions Service Manual." 8. Refer to transmission diagnosis. 9. Check for complete opening and closing of choke valve. "See Choke Checking Procedure" and "Checking Electric Choke" later in this section. 10. Inspect fuel filter(s). Replace as necessary. 11. Check fuel pump pressure and volume. Replace pump if necessary. Inspect fuel lines for leaks and restrictions. 12. Check the float level, and adjust if necessary. 13. Check power piston operation: push piston down against piston rod and release; it should move freely in bore and return to its up position. Rotate throttle to wide open; piston should move upward in bore. If piston does not move freely, clean power piston and bore. If piston does not return when depressed, or does not move upward when throttle is opened, check for missing or damaged parts. Replace as necessary. 14. Inspect metering rod hanger for damage. Replace power piston assembly if necessary. Adjust metering rod. 15. If foreign material is found in the carburetor, clean the fuel system and carburetor. Replace fuel filter(s) as necessary. If metering jet is loose, tighten.

DIAGNOSIS OF 1MEF ROCHESTER CARBURETOR (CONT.)

PROBLEM	POSSIBLE CAUSE	CORRECTION
Less Than Normal Power On Heavy Acceleration Or At High Speed	<ol style="list-style-type: none"> 1. Carburetor throttle valve not going wide open. 2. Ignition system malfunction. 3. Ignition timing misadjusted. 4. Distributor mechanical advance malfunctioning. 5. Plugged air cleaner element. 6. Exhaust system restricted. 7. Thermac system malfunction. 8. Early fuel Evaporation (EFE) system malfunction. 9. Transmission malfunction. 10. Choke not operating properly. 11. Fuel filter(s) partially plugged. 12. Faulty fuel pump or leaking or restricted fuel lines. 13. Float level too low. 14. Power piston sticking. Missing or damaged power piston spring, power piston rod, power rod link, or pump and power rod lever. 15. Metering rod hanger bent or metering rod misadjusted. 16. Restricted main metering jet or adjustable part throttle fuel feed orifice. Loose main metering jet. 	<ol style="list-style-type: none"> 1. Correct throttle linkage to obtain wide open throttle in carburetor. 2. Check ignition system. Refer to ENGINE ELECTRICAL (SEC. 6D). 3. Adjust timing. See Emission Control Information Label. 4. Check operation. Refer to ENGINE ELECTRICAL (SEC. 6D). 5. Replace element. 6. Check for restrictions. Correct as necessary. 7. Check operation. Refer to the "Fuel and Emissions Service Manual." 8. Check operation. Refer to the "Fuel and Emissions Service Manual." 9. Refer to transmission diagnosis. 10. Check for complete opening and closing of choke valve. See "Choke Checking Procedure" and "Checking Electric Choke" later in this section. 11. Inspect fuel filter(s). Replace as necessary. 12. Check fuel pump pressure and volume. Replace pump if necessary. Inspect fuel lines for leaks and restrictions. 13. Check the float level, and adjust if necessary. 14. Check power piston operation: push piston down against piston rod and release; it should move freely in bore and return to its up position. Rotate throttle to wide open; piston should move upward in bore. If piston does not move freely, clean power piston and bore. If piston does not return when depressed or does not move upward when throttle is opened, check for missing or damaged parts. Replace as necessary. 15. Inspect metering rod hanger for damage. Replace power piston assembly if necessary. Adjust metering rod. 16. If foreign material is found in the carburetor, clean the fuel system and carburetor. Replace fuel filter(s) as necessary. If metering jet is loose, tighten.
Engine Surges	<ol style="list-style-type: none"> 1. Ignition system malfunction. 2. Distributor mechanical advance malfunctioning. 3. Air leaks at carburetor flange/insulator gasket(s), or at intake manifold gasket. Vacuum hoses disconnected or installed improperly. 	<ol style="list-style-type: none"> 1. Check ignition system. Refer to ENGINE ELECTRICAL (SEC. 6D). 2. Check operation. Refer to ENGINE ELECTRICAL (SEC. 6D). 3. Use a pressure oil can to spray light oil or kerosene around carburetor throttle body (do not spray at throttle shaft ends), and manifold to head mounting surfaces.

DIAGNOSIS OF 1MEF ROCHESTER CARBURETOR (CONT.)

PROBLEM	POSSIBLE CAUSE	CORRECTION
<p>Engine Surges (Cont.)</p>	<p>4. PCV system malfunctioning.</p> <p>5. Exhaust system restricted.</p> <p>6. Thermax system malfunction.</p> <p>7. Early Fuel Evaporation (EFE) system malfunction.</p> <p>8. Contaminated fuel.</p> <p>9. Fuel filter(s) partially plugged.</p> <p>10. Faulty fuel pump or leaking or restricted fuel lines.</p> <p>11. Float level too low.</p> <p>12. Float needle sticking in seat.</p> <p>13. Power piston sticking. Missing or damaged power piston spring, power piston rod, power rod link, or pump and power rod lever.</p> <p>14. Metering rod hanger bent or metering rod misadjusted.</p> <p>15. Restricted main metering jet or adjustable part throttle fuel feed orifice.</p>	<p>3. Continued If engine RPM changes, torque carburetor to manifold bolts and/or intake manifold bolts to specification. If necessary, replace the carburetor flange/insulator gasket(s) and/or intake manifold gasket. Check condition and routing of vacuum hoses. Correct or replace as necessary.</p> <p>4. Check PCV system. Clean or replace PCV valve and hoses as necessary.</p> <p>5. Check for restrictions. Correct as necessary.</p> <p>6. Check operation. Refer to the "Fuel and Emissions Service Manual."</p> <p>7. Check operation. Refer to the "Fuel and Emissions Service Manual."</p> <p>8. Check for water or excessive alcohol in fuel.</p> <p>9. Inspect fuel filter(s). Replace as necessary.</p> <p>10. Check fuel pump pressure and volume. Replace pump if necessary. Inspect fuel lines for leaks and restrictions.</p> <p>11. Check the float level, and adjust if necessary.</p> <p>12. Replace float needle and seat.</p> <p>13. Check power piston operation: push piston down against piston rod and release; it should move freely in bore and return to its up position. Rotate throttle to wide open; piston should move upward in bore. If piston does not move freely, clean power piston and bore. If piston does not return when depressed or does not move upward when throttle is opened, check for missing or damaged parts. Replace as necessary.</p> <p>14. Inspect metering rod hanger for damage. Replace power piston assembly if necessary. Adjust metering rod.</p> <p>15. If foreign material is found in the carburetor, clean the fuel system and carburetor. Replace fuel filter(s) as necessary.</p>

DIAGNOSIS OF 1MEF ROCHESTER CARBURETOR (Cont.)

PROBLEM	POSSIBLE CAUSE	CORRECTION
Poor Gas Mileage * Black Smoke From Tail Pipe	<ol style="list-style-type: none"> 1. Customer driving habits. 2. Wrong speedometer gear. 3. Low tire pressure or incorrect tire size. 4. Transmission malfunction or in wrong gear. 5. Fuel leaks. 6. * Plugged air cleaner element. 7. * Choke not operating properly. 8. * Vacuum break assembly malfunctioning or misadjusted. 9. Ignition system malfunction. 10. Ignition timing misadjusted. 11. Distributor vacuum or mechanical advance malfunctioning. 12. Air leaks at carburetor flange/insulator gasket(s), or at intake manifold gasket. Vacuum hoses disconnected or installed improperly. 13. Engine in need of service. 14. Restricted exhaust system. 15. * High fuel level in carburetor or flooding. 16. Power piston sticking. Missing or damaged power piston spring, power piston rod, power rod link, or pump and power rod lever. 	<ol style="list-style-type: none"> 1. Run mileage test, with customer driving if possible. make sure vehicle has 2000-3000 miles (3 200-4 800 km) for the "break-in" period. 2. Check odometer against measured mile. Replace speedometer gear if necessary. 3. Inflate tires to specifications and use correct tire sizes. 4. Refer to transmission diagnosis. 5. Inspect fuel tank, fuel lines and fuel pump for any fuel leakage. 6. Replace element. 7. Check for complete opening and closing of choke valve. See "Choke Checking Procedure" and "Checking Electric Choke" later in this section. 8. See "Vacuum Break Checking Procedure" later in this section. Adjust vacuum break assembly to specification. 9. Check ignition system. Refer to ENGINE ELECTRICAL (SEC. 6D). 10. Adjust timing. See Emission Control Information Label. 11. Check operation. Refer to ENGINE ELECTRICAL (SEC. 6D). 12. Use a pressure oil can to spray light oil or kerosene around carburetor throttle body (do not spray at throttle shaft ends), and manifold to head mounting surfaces. If engine RPM changes, torque carburetor manifold bolts and/or intake manifold bolts to specification. If necessary, replace the carburetor flange/insulator gasket(s) and/or intake manifold gasket. Check condition and routing of vacuum hoses. Correct or replace as necessary. 13. Check engine compression. 14. Check for restrictions. Correct as necessary. 15. Inspect float for restricted movement or being loaded. Check float needle and seat for wear and dirt or chips. If foreign material is found in carburetor, clean fuel system and carburetor. Replace fuel filter(s) as necessary. Check float level; and adjust if necessary. 16. Check power piston operation: push piston down against piston rod and release; it should move freely in bore and return to its up position. Rotate throttle to wide open; piston should move upward in bore.

DIAGNOSIS OF 1MEF ROCHESTER CARBURETOR (Cont.)

PROBLEM	POSSIBLE CAUSE	CORRECTION
Poor Gas Mileage (Cont.)	17. Metering rod hanger bent or metering rod misadjusted. 18. * Metering rod worn or damaged. 19. * Main metering jet worn or loose.	16. Continued If piston does not move freely, clean power piston and bore. If piston does not return when depressed, or does not move upward when throttle is opened, check for missing or damaged parts. Replace as necessary. 17. Inspect metering rod hanger for damage. Replace power piston assembly if necessary. Adjust metering rod. 18. Inspect metering rod. Replace if necessary. 19. Inspect metering jet. Replace if necessary. If loose, tighten.
Gasoline Odor	1. Fuel feed or vapor return line leaking. 2. Leak in fuel tank. 3. Disconnected or leaking fuel tank vent lines or hoses to canister(s). 4. Purge lines not connected, improperly routed, plugged or pinched. 5. Carbon canister(s) loaded. 6. Faulty fill cap.	1. Repair/replace as required. 2. Purge tank and repair or replace tank as required. 3. Connect, repair/replace lines as required. 4. Connect, clean, or reroute lines as required. 5. Compare weight of canister with a new one. Replace if necessary. 6. Install new cap.
Fuel Starvation	1. Fuel filter(s) plugged. 2. Fuel lines leaking, restricted, or mis-routed. 3. Faulty fuel pump.	1. Inspect fuel filter(s). Replace as necessary. 2. Repair/replace, clean, or reroute as required. 3. Check fuel pump pressure and volume. Replace pump if necessary.

ON-VEHICLE SERVICE (1MEF)

ELECTRIC CHOKE



Inspect

- Remove the air cleaner. With the engine off, hold the throttle half open. Open and close the choke several times. Watch linkage to be certain all links are connected and there are no signs of damage.
- If the choke or linkage binds, sticks, or works sluggishly, clean it with Choke Cleaner X-20-A or equivalent. Use cleaner as directed on the can. Refer to the disassembly instructions for additional direction if cleaning does not correct the problem. Do not lubricate the linkage.
- Visually inspect the carburetor to be certain all vacuum hoses are connected. Inspect hoses for cracks, abrasions, hardness or other signs of deterioration. Replace or correct as necessary.
- The vacuum break diaphragm shaft should be fully extended when the engine is off. If the shaft is not fully extended, replace the vacuum break assembly. Start engine — the vacuum break diaphragm shaft should fully retract within 10 seconds. If the unit fails to retract, replace the vacuum break assembly.
- Allow the choke to cool so that when the throttle is opened slightly, the choke blade fully closes. This check must be performed at an ambient temperature of about 21°C (70°F).
- Start the engine and determine the time required for the choke blade to reach its' full open position. (Start timing when the engine starts.) If the choke plate fails to open fully within five minutes, proceed with the remaining steps.
- Check voltage at the choke heater connection with the engine running. If the voltage is approximately 12-15 volts, replace the electric choke unit. If the voltage is low or zero, check all wires and

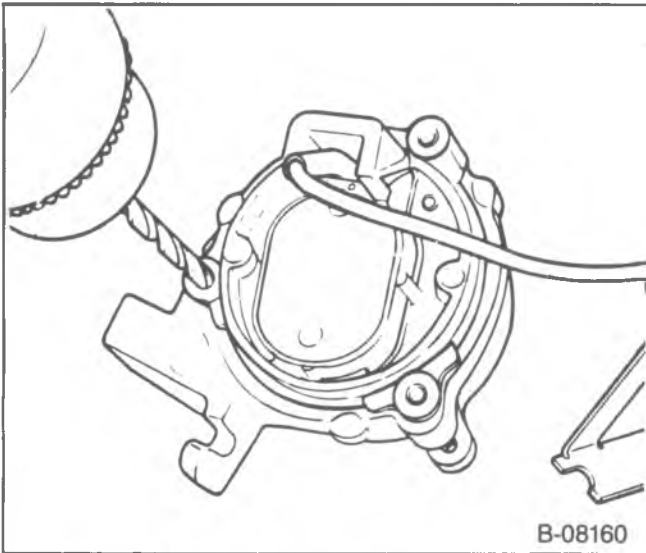

Figure 9—Drilling the Choke Coil Rivets

connections. If the connections at the oil pressure switch are dirty or corroded, the oil warning lamp will be off with the ignition switch "On" and the engine off. If the fuse is blown, the radio or turn signal indicator will be inoperative. Repair wires or replace fuses as necessary.

- If all wiring and fuses are good, replace the oil pressure switch.

↔ Remove or Disconnect

1. Air cleaner.
2. The choke electrical connector.
3. Rivet heads and retainers.
 - Align a #21 drill (0.156-inch) on the rivet head and drill only enough to remove the rivet head (figure 9).
 - Use a drift and a small hammer to drive the remainder of the rivets from the choke housing.
 - Use care in drilling to prevent damage to the choke cover or housing.
4. The choke cover assembly from the housing.
5. The choke coil from the housing.

→← Install or Connect

1. The choke cover and coil assembly in the choke housing.
 - Align the notch in the cover with the raised casting projection on the housing cover flange.
 - Make sure the coil pick-up tang engages the inside choke coil lever.
2. Retainers and rivets using a suitable blind rivet installing tool (figure 10).
3. Electrical connector.
 - Start the engine and check the operation of the choke.
4. Air cleaner.

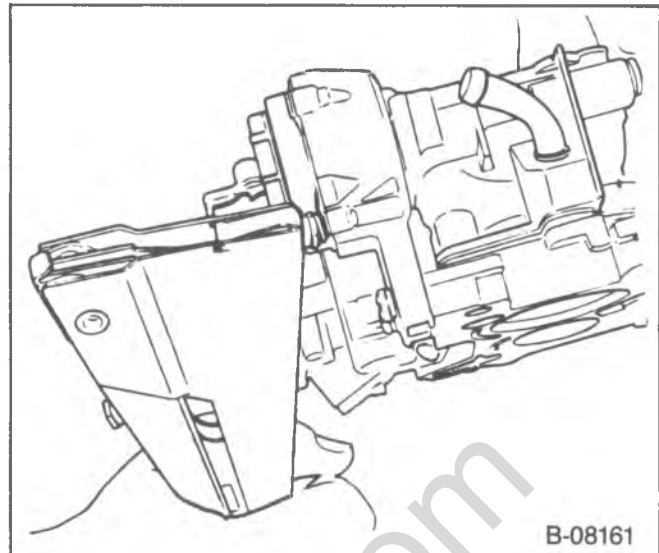

Figure 10—Installing the Choke Coil Rivets

IDLE SOLENOID

🔍 Inspect

1. Turn on the engine control switch, but do not start the engine.
2. Open the throttle to allow the solenoid plunger to extend.
3. Hold the throttle lever wide open, feel the end of the plunger and disconnect the wire at the solenoid.
4. Plunger should move. Some spring tension should be felt.
5. If the plunger did not move, back out 1/8 hex screw (counter clockwise) one full turn and repeat step 3 and 4.
6. If the plunger moves in step 5, connect the wire to the solenoid and adjust the idle speed.
7. If the plunger did not move in step 5, insert test light (1893 bulb or smaller) between the solenoid feed wire and ground.
8. If the light lights, replace the solenoid.
9. If the light does not light, locate the cause of the open circuit in the solenoid feed wire.

↔ Remove or Disconnect

1. Air cleaner.
2. Electrical connector from the solenoid.
3. Solenoid from the float bowl assembly.

→← Install or Connect

1. Solenoid.
 - Hold the choke valve wide open so the fast idle cam follower clears the fast idle cam.
 - Turn the solenoid until it contacts the lever tang.
2. Electrical connector.
3. Air cleaner.
 - Check and adjust the idle speed.

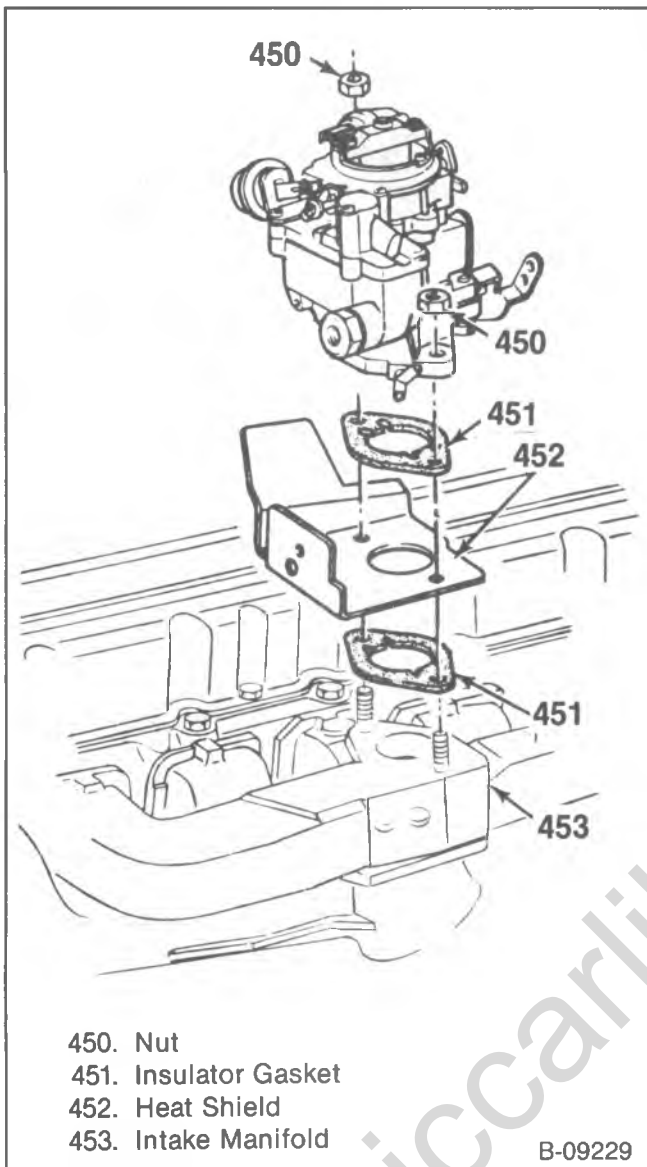

Figure 11—Carburetor installation

CARBURETOR REPLACEMENT

Flooding, stumble on acceleration and other performance complaints are, in many instances, caused by the presence of dirt, water or other foreign matter in the carburetor. To aid in diagnosing the cause, the carburetor should be removed carefully from the engine without draining fuel from the bowl. Contents of the fuel bowl may then be examined for foreign materials as the carburetor is disassembled.

Remove or Disconnect (Figure 11)

1. Air cleaner assembly.
2. Fuel and vacuum lines from the carburetor.
 - Make note of the vacuum hose routing.
3. Electrical connectors for the choke and idle solenoid.
4. Accelerator linkage.
5. Carburetor attaching nuts.
6. Carburetor.
7. Insulator gaskets and heat shield.

Clean

- All traces of the old gasket from the carburetor flange and intake manifold.

Install or Connect (Figure 11)

1. Heat shield and insulator gaskets to the intake manifold.

CAUTION: Extinguish all open flames while filling and testing carburetor with gasoline to avoid personal injury.

2. Carburetor.

- It is good shop practice to fill the carburetor float bowl before installing the carburetor. This reduces the strain on the starting motor and battery and reduces the possibility of backfiring while attempting to start the engine. Operate the throttle several times and check the discharge from pump jets before installing the carburetor.

3. Carburetor attaching nuts.

Tighten

- Both nuts to 4.1 N·m (36 in. lbs.) and then both nuts to 22 N·m (16 ft. lbs.).
4. Accelerator linkage.
 5. Electrical connectors for the choke and idle solenoid.
 6. Fuel and vacuum lines. Refer to the Emission Control Label, if necessary, for vacuum line routing information.
 7. Air cleaner.

Adjust

- Idle speed, as outlined later.

CARBURETOR ADJUSTMENTS

A carburetor is designed to meet the particular requirements of the engine, transmission and vehicle and although they may look alike, they are not usually interchangeable. Refer to carburetor part number and/or specifications when making adjustments.

Before suspecting the carburetor as the cause of poor engine performance or rough idle; check the ignition system including distributor, timing, spark plugs and wires. Check the air cleaner, evaporative emission system, EFE System, PCV system, EGR valve and engine compression. Also inspect intake manifold, vacuum hoses and connections for leaks and check torques of carburetor mounting bolts/nuts.

Make all adjustments with the engine at normal operating temperature, choke full open, and the air cleaner installed. Except as noted, air conditioning should be "off" and all vacuum lines and all electrical leads connected. Refer to "Specifications" at the end of this section for carburetor adjustment specifications. Gages and tools for making adjustments are included in the Universal Gage J-9789D.

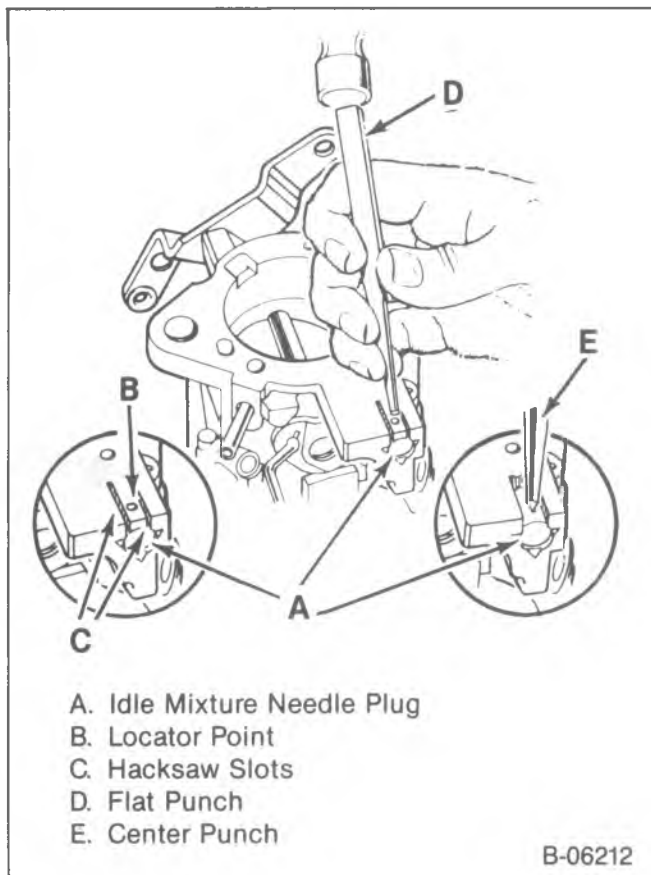

Figure 12—Removing the idle Mixture Needle Plug

IDLE MIXTURE ADJUSTMENT

In the case of a major carburetor overhaul, throttle body replacement, or high idle CO as indicated by an emissions inspection, the idle mixture may be adjusted. Adjusting the mixture by other than the following method may violate Federal and/or state laws.

Tool Required:

J-29030-B Idle Mixture Needle Socket

1. Set parking brake and block drive wheels.
2. Remove the carburetor from the engine.
3. Drain the fuel from the carburetor into a container.
4. Remove the idle mixture needle plug (figure 12).
 - Invert carburetor, and support it to avoid damaging external components.
 - Make two parallel hacksaw cuts in the throttle body, between the locator points near the idle mixture needle plug. The distance between the cuts depends on the size of the punch to be used.
 - Cut down to the plug, but not more than 1/8-inch beyond the locator point.
 - Place a flat punch at a point near the ends of the saw marks. Hold the punch at a 45° angle, and drive it into the throttle body to break the casting away, to expose the plug.
 - Use a center punch to break the plug apart, to uncover idle mixture needle.
 - Remove all loose pieces of plug.
5. Reinstall the carburetor on the engine.
6. Place the transmission in PARK (automatic transmission) or NEUTRAL (manual transmission).

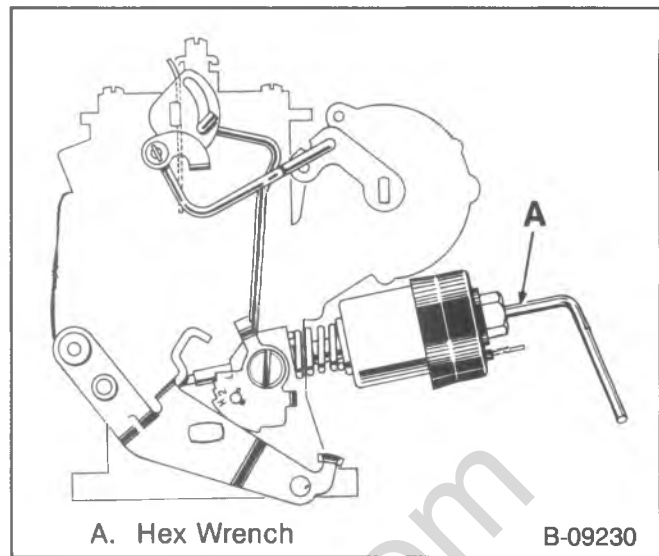

Figure 13—Base Idle Adjustment

7. Start the engine and bring it to a normal operating temperature, choke valve open, and the air conditioning off.
8. Connect an ACCURATE tachometer to the engine.
9. Check the ignition timing, and adjust if necessary, by following the procedure described on the Vehicle Emission Control Information label.
10. Use J-29030-B to turn the mixture needle (1/8 turn at time), in or out, to obtain the highest RPM (Best Idle).
11. Adjust the idle speed solenoid to obtain the curb idle speed on the Emission Control Information label.
12. Again try to readjust the mixture needle to obtain the highest idle RPM. The adjustment is correct when the highest RPM (Best Idle) is reached with the minimum number of mixture needle turns from the seated position.
13. If necessary, readjust the idle speed solenoid to obtain the specified curb idle speed.
14. Check and if necessary, adjust the base idle speed solenoid (solenoid deactivated) and the fast idle speed to the specification shown on the Emission Control Information label.
15. Turn off the engine, and remove the block from the drive wheels.

IDLE SPEED ADJUSTMENT (Figure 13)

1. Engine must be warm with the choke wide open.
2. The fast idle cam follower must be off the steps of the cam.
 - See the Emission Control Information label.
3. Set the curb idle to specification. Turn the solenoid in or out to adjust RPM.
 - The solenoid should be energized.
4. Turn a 1/8" Hex screw to adjust the low idle speed to 450 RPM.
 - The solenoid should not be energized.

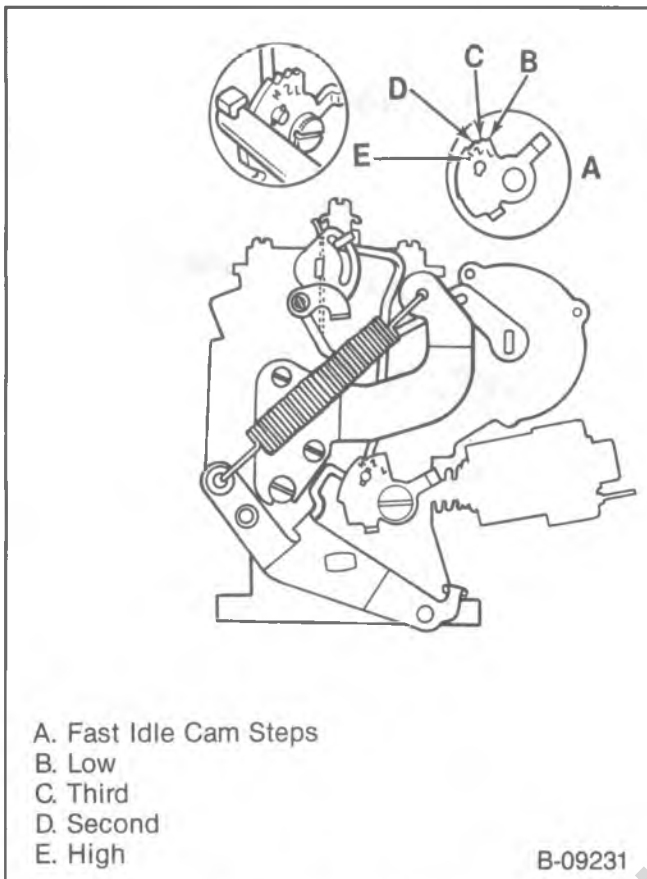

Figure 14—Fast Idle Adjustment

FAST IDLE ADJUSTMENT (Figure 14)

1. Prepare the vehicle for adjustments according to the Emission Control Information label.
 - Ignition timing must be set per label.
2. Adjust the curb idle speed with the idle stop solenoid.
3. Place the cam follower tang on the high step of the cam.
4. Support the lever with pliers and bend the tang in or out to obtain the specified fast idle RPM.

CHOKE COIL LEVER ADJUSTMENT (Figure 15)

1. Place the fast idle cam follower on the highest step of the fast idle cam.
2. Hold the choke valve completely closed.
3. Bend the link to adjust.
 - A 3 mm (0.120-inch) plug gage must pass through the hole in the lever and enter the hole in the casting.

CHOKE ROD (FAST IDLE CAM) ADJUSTMENT (Figure 16)

1. With the fast idle adjustment made, the fast idle cam follower must be held firmly on the second step of the fast idle cam and against the highest step.
2. Hold down on the choke valve so the rod is in the end of the slot.
3. Gage between the lower edge of the choke valve (at the center) and the inside air horn wall.
 - Refer to "Specifications."
4. Bend the rod at point A to adjust.

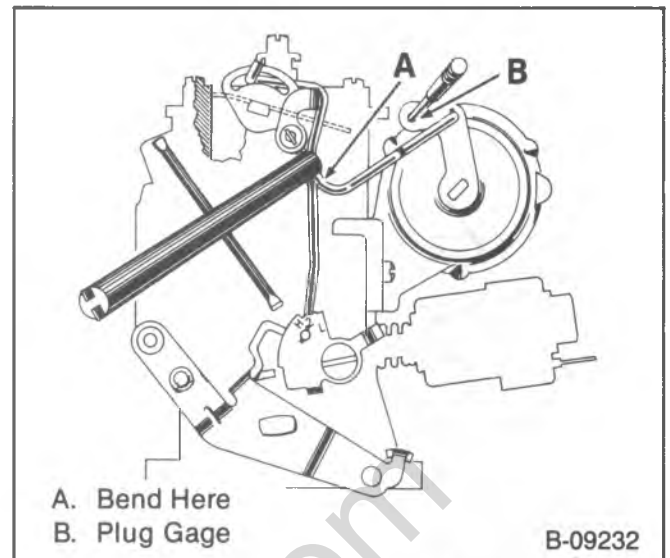
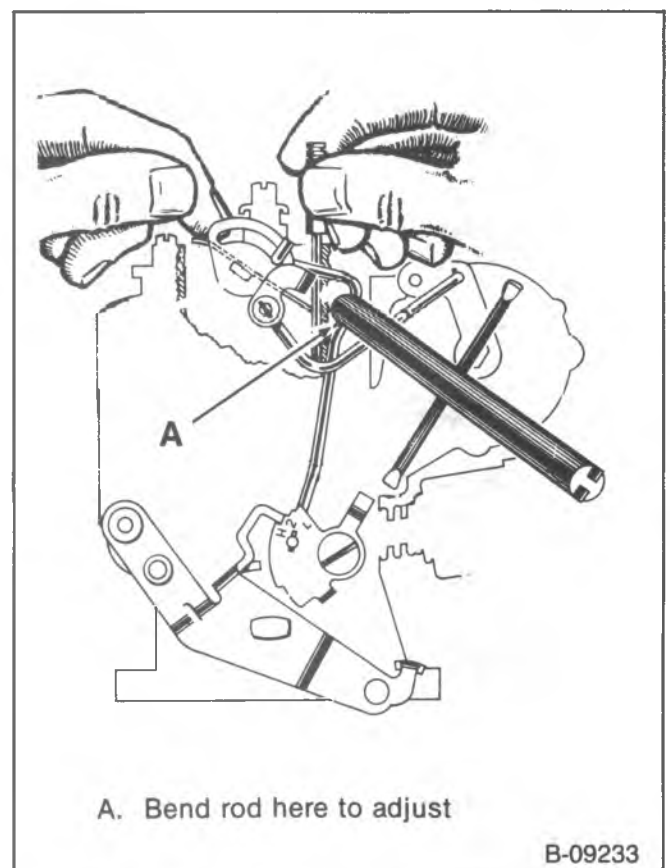

Figure 15—Choke Coil Lever Adjustment

CHOKE UNLOADER ADJUSTMENT (Figure 17)

1. If the choke coil is warm, cool it down to the point where the choke valve will close fully.
2. Hold the throttle valve wide open.
3. Gage between the lower edge of the choke valve and the inside of the air horn.
4. Bend the tang to adjust.



A. Bend rod here to adjust

B-09233

Figure 16—Choke Rod (Fast Idle Cam) Adjustment

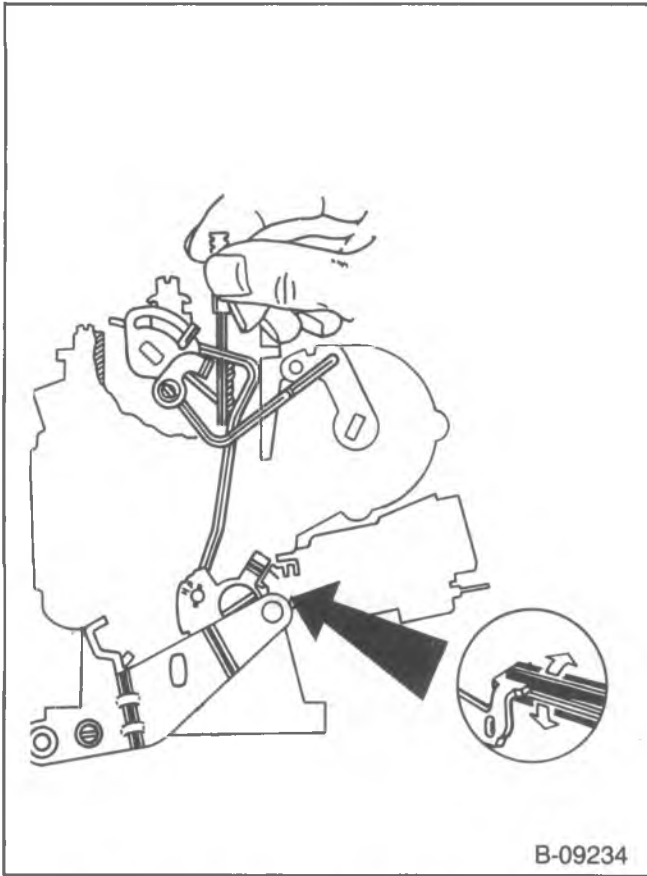

B-09234

Figure 17—Choke Unloader Adjustment

VACUUM BREAK ADJUSTMENT (Figure 18)

1. Place the fast idle cam follower on the highest step of the cam.
2. Use an outside vacuum source to seat the vacuum break diaphragm.
 - On delay feature models, cover the plug and the purge bleed hole with a 1 inch square of masking tape. Remove the tape after adjustment.

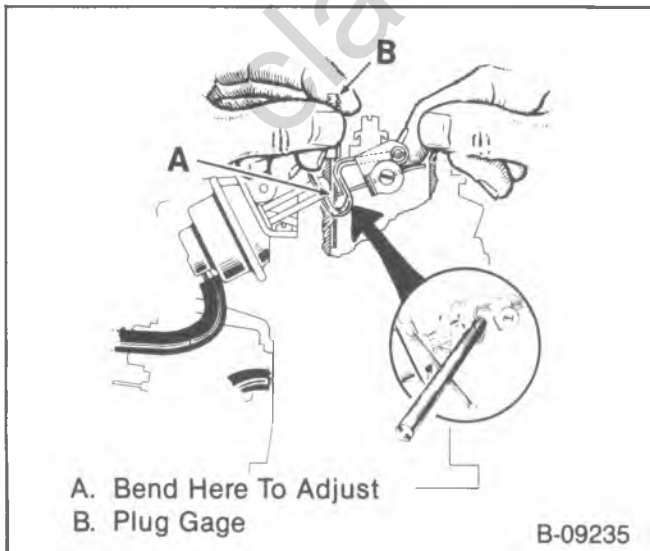

A. Bend Here To Adjust
B. Plug Gage

B-09235

Figure 18—Vacuum Break Adjustment

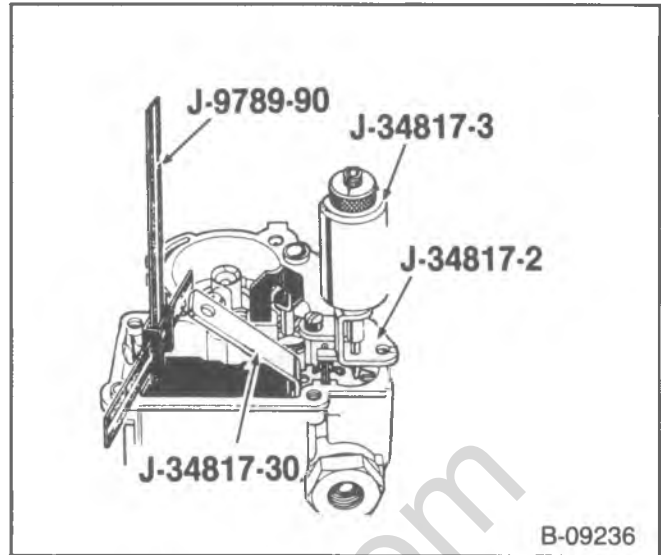

B-09236

Figure 19—Float Adjustment

3. Push down on the choke valve (compress the plunger bucking spring and seat the plunger stem on models so equipped).
4. Gage between the lower edge of the choke valve and the inside of the air horn wall.
 - Hold the gage vertical.
5. Bend the link at point "A" to adjust.

FLOAT ADJUSTMENT (Figure 19)

Tool Required:

J-34817 Float Positioning Tool Kit

1. Remove the air horn and gasket.
2. Attach J-34817-2 to the float bowl using an air horn attaching screw.
3. Place J-34817-3 in the base with the contact pin resting on the edge of the float lever.
4. Measure the distance from the top of the casting to the top of the index at the toe of the float.
 - Use J-9789-90.

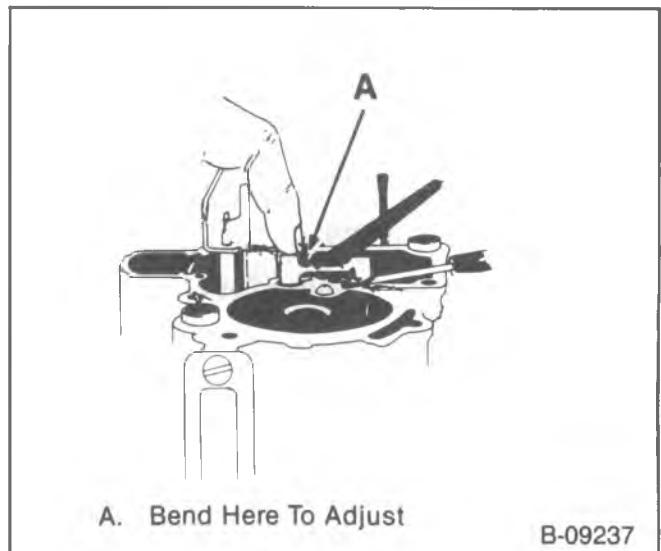

A. Bend Here To Adjust

B-09237

Figure 20—Metering Rod Adjustment

5. If more than $\pm 2/32$ " from specification, use J-34817-30 to bend the lever up or down. Remove J-34817-30 and measure, repeating until within specification.
6. Check float alignment.
7. Install the air horn and gasket.

METERING ROD ADJUSTMENT (Figure 20)

1. Remove the metering rod.
 - Hold the throttle valve wide open.
 - Push down on the metering rod against spring tension.
 - Slide the metering rod out of the slot in the holder.

2. Back out the idle stop solenoid.
 - Hold the throttle valve completely closed.
3. Hold the power piston down and swing the metering rod holder over the flat surface of the bowl casting next to the carburetor bore.
 - The gasket must be removed.
4. Gage between the end of the metering rod holder and the top of the casting.
 - Use the specified plug gage.
 - Gage should have a slide fit.
5. Bend at point "A" to adjust.

CARBURETOR MODELS M4ME AND M4MEF

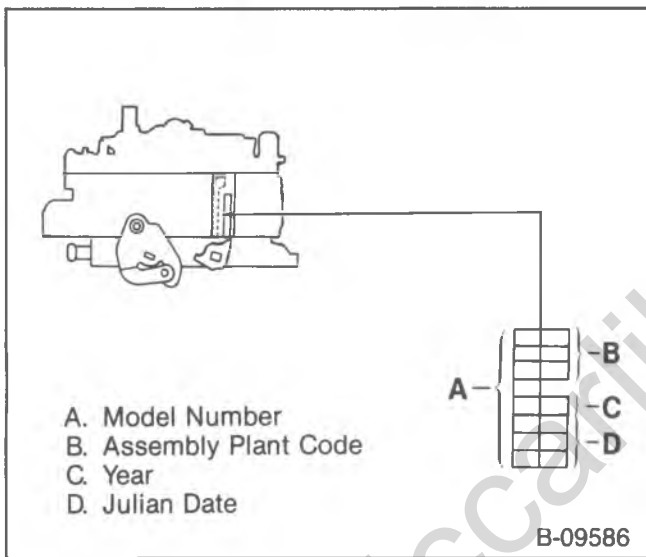

Figure 21—Carburetor Identification

DESCRIPTION

Models M4ME and M4MEF are four barrel, two stage carburetors with three major assemblies: the air horn, float bowl, and throttle body. They have six basic operating systems (figures 21 through 31).

- Float
- Idle
- Main Metering
- Power
- Pump
- Choke

The first "M" indicates this carburetor is of a Modified primary metering "open loop" design.

The "4M" is the model designation, indicating it is a four barrel carburetor. The remaining letters designate specific features.

E — Has an electric choke.

F — has an adjustable wide open throttle mixture control.

CARBURETOR IDENTIFICATION (Figure 21)

The carburetor identification number is stamped vertically on the float bowl near the secondary throttle lever. Refer to this number before servicing the carburetor. If replacing the float bowl assembly, follow instructions in

the service package, and stamp or engrave the number on the new float bowl.

METERING SYSTEMS

A single float chamber supplies fuel to all carburetor bores. A float, float needle with pull clip, and a float needle seat, are used to control the level of fuel in the float chamber. A vacuum-operated power piston and metering rods control the air/fuel metering in the primary bores of the carburetor. Tapered metering rods are attached to the power valve piston assembly, and move in fixed metering jets, to provide the fuel flow for varying engine demands. A factory-set adjustable part throttle screw, used on all models, precisely positions the tapered portion of the metering rods in the jets. (On M4MEF models, the factory-set rich stop adjusting bushing precisely positions the enrichment portion of the metering rods in the jets.)

Air valves and tapered metering rods control the air/fuel mixture in the secondary bores during increased engine air flow at wide open throttle. On M4MEF models, the factory-set secondary well air bleed adjusting screw provides additional control of the air/fuel mixture during wide open throttle.

PUMP SYSTEMS

The pump system on all models uses a throttle actuated pump plunger, operating in the pump well. The pump provides extra fuel during quick throttle openings.

CHOKE SYSTEMS

A electrically heated choke coil provides the choke valve closing force for cold startup and for correct opening timing during warmup. A vacuum break assembly(s) controls initial choke valve opening at startup to provide sufficient air flow to the engine. An unloader tang on the throttle lever forces the choke valve open to purge a flooded engine when the accelerator is pressed to the floor. The fast idle cam, following choke valve movement, acts as a graduated throttle stop to provide increased idle speed during warmup.

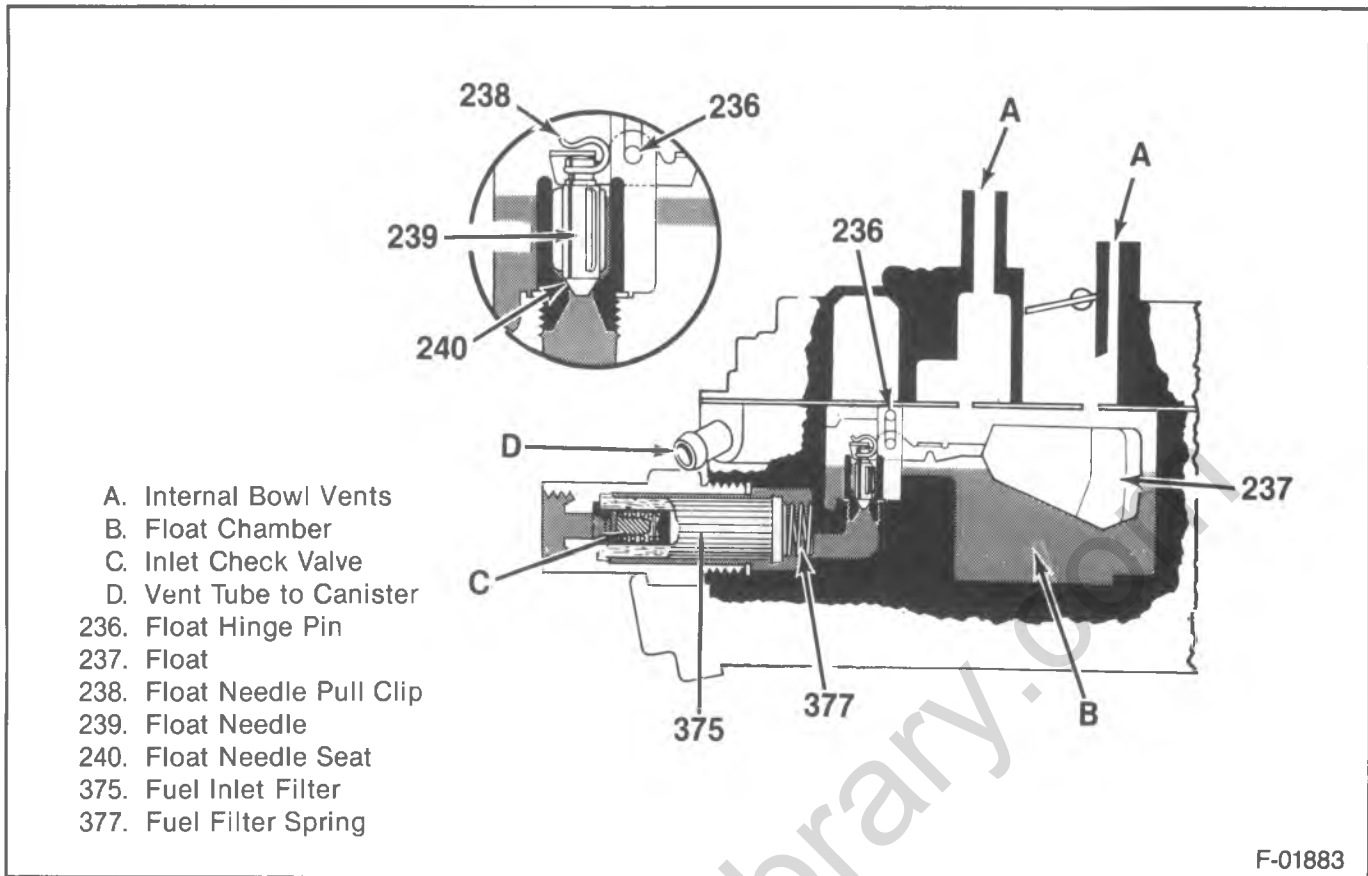

Figure 22—Float System

IDLE STOP SOLENOID (ISS)

Federal (Non-California) V8 Engines With Manual Transmission.

The electric Idle Stop Solenoid (ISS), on these applications, provides the desired engine idle speed, and prevents "dieseling" when the ignition is switched off.

THROTTLE KICKER ASSEMBLY

California V8 Engines

A vacuum operated Throttle Kicker assembly, found on these applications, retards throttle closing during deceleration, to improve emission control. Vacuum to the kicker is controller by the Throttle Return Control system, which is further described in DRIVEABILITY AND EMISSIONS - CARBURETED (SEC. 6E8).

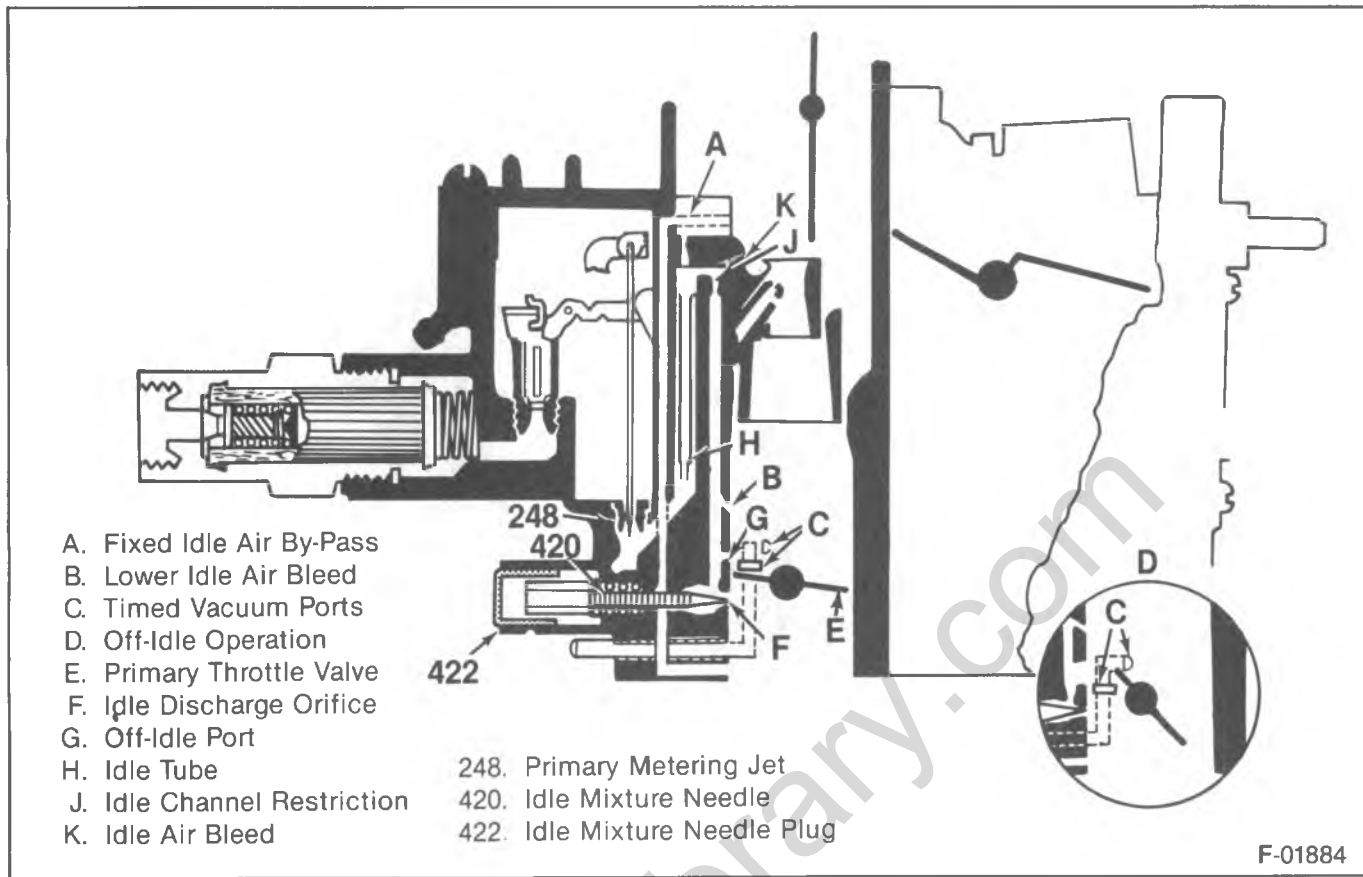

Figure 23—Idle System - M4ME

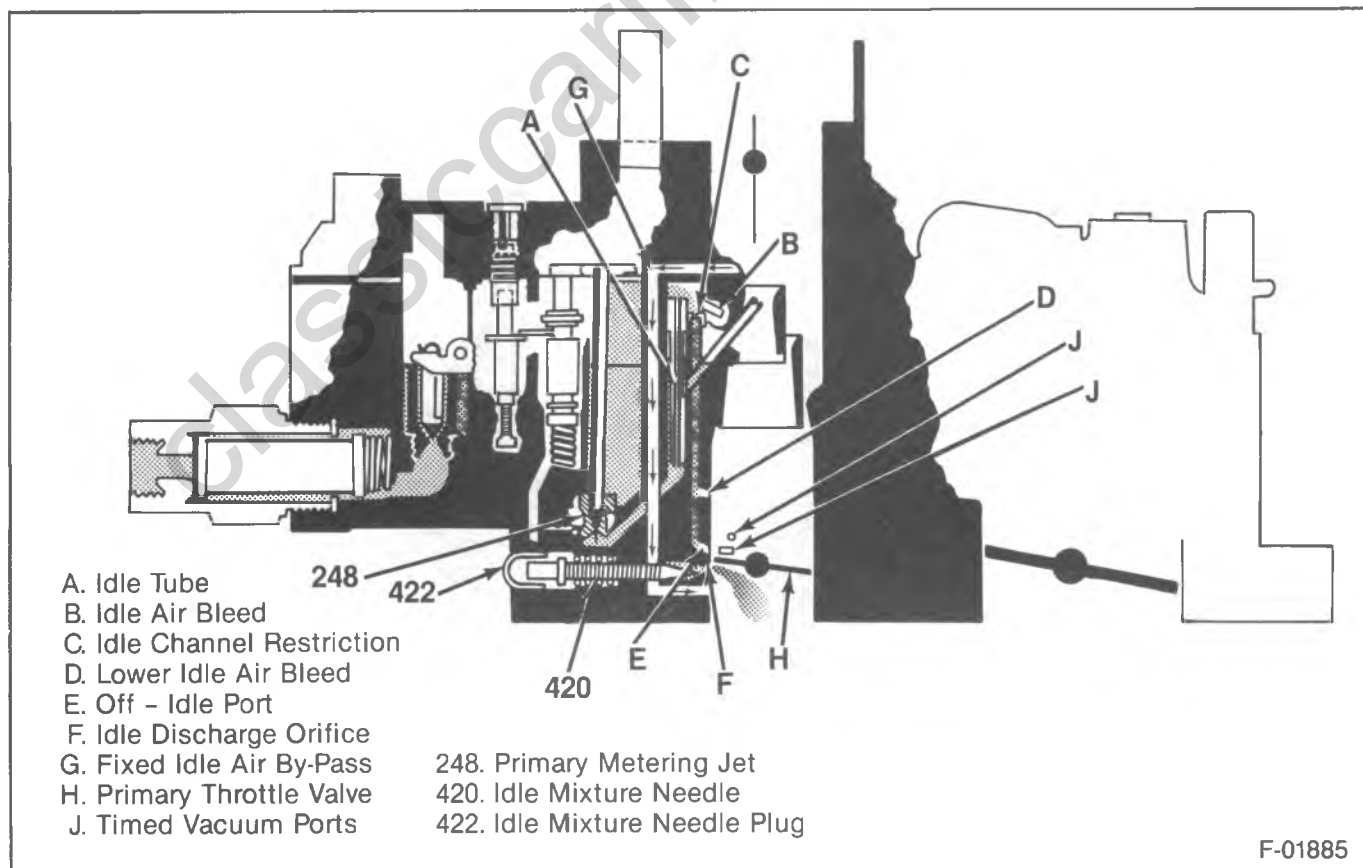
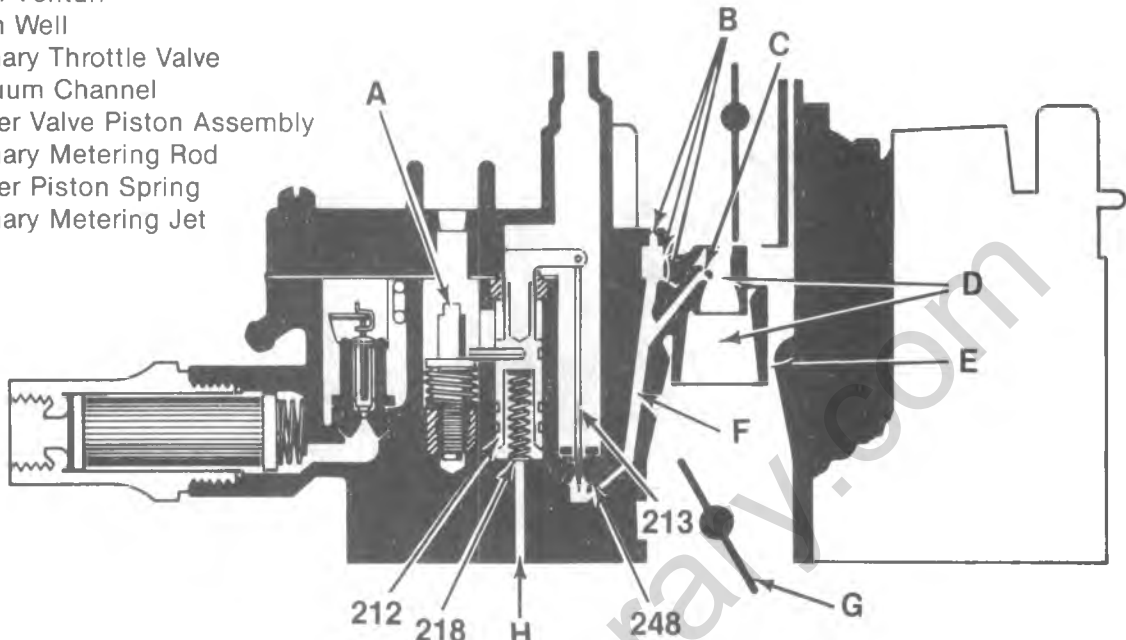

Figure 24—Idle System - M4MEF

6C1-24 CARBURETORS

- A. Part Throttle Adjusting Screw (Do Not Turn or Remove)
- B. Main Well Air Bleeds
- C. Main Discharge Nozzle
- D. Boost Venturi
- E. Main Venturi
- F. Main Well
- G. Primary Throttle Valve
- H. Vacuum Channel
- 212. Power Valve Piston Assembly
- 213. Primary Metering Rod
- 218. Power Piston Spring
- 248. Primary Metering Jet



F-01886

Figure 25—Main Metering System - M4ME

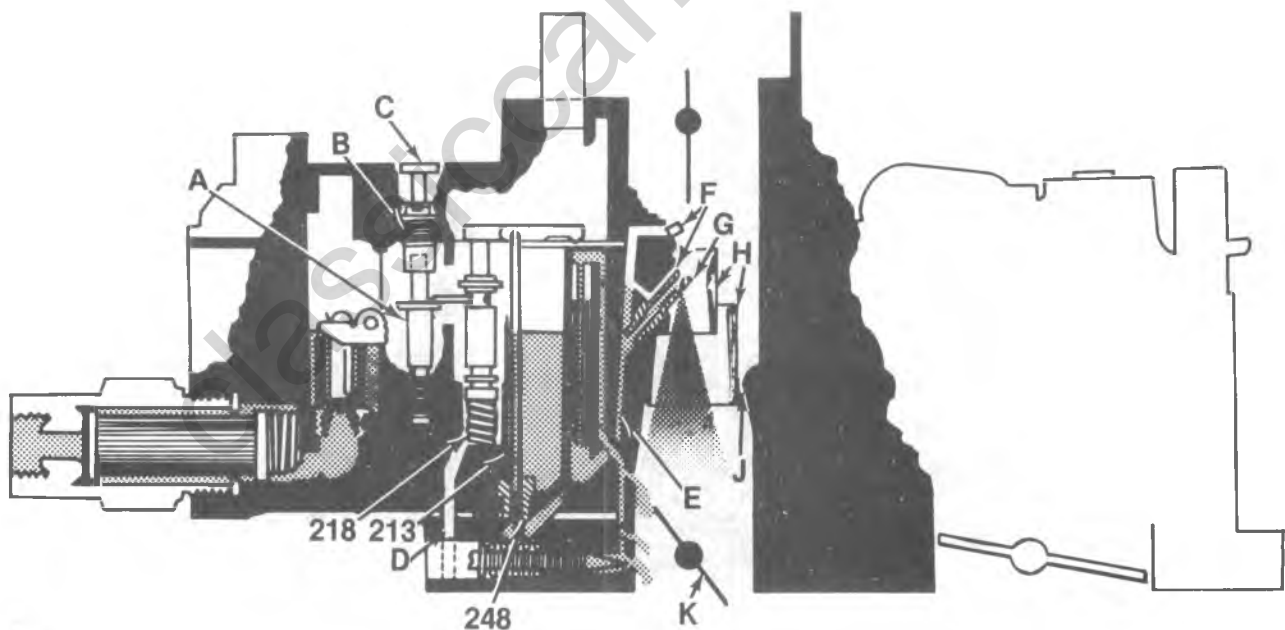

- | | | |
|---|---|--|
| <ul style="list-style-type: none"> A. Part Throttle Adjusting Screw (Do Not Turn or Remove) B. Rich Stop Adjusting Bushing (Do Not Turn or Remove) C. Rich Stop Adjust Plug D. Vacuum Channel | <ul style="list-style-type: none"> E. Main Well F. Main Well Air Bleeds G. Main Discharge Nozzle H. Boost Venturi J. Main Venturi K. Primary Throttle Valve | <ul style="list-style-type: none"> 213. Primary Metering Rod 218. Power Piston Spring 248. Primary Metering Jet |
|---|---|--|

F-02719

Figure 26—Main Metering System - M4MEF

- A. Air Valve
- B. Eccentric Cam
- C. Baffle
- D. Secondary Throttle Valve
- E. Secondary Discharge Nozzle
- F. Metering Disc
- G. Secondary Fuel Well
- H. Primary Throttle Valve
- 31. Secondary Metering Rod Holder
- 32. Secondary Metering Rod
- 50. Air Horn Baffle
- 212. Power Valve Piston Assembly
- 213. Primary Metering Rod
- 218. Power Piston Spring
- 248. Primary Metering Jet

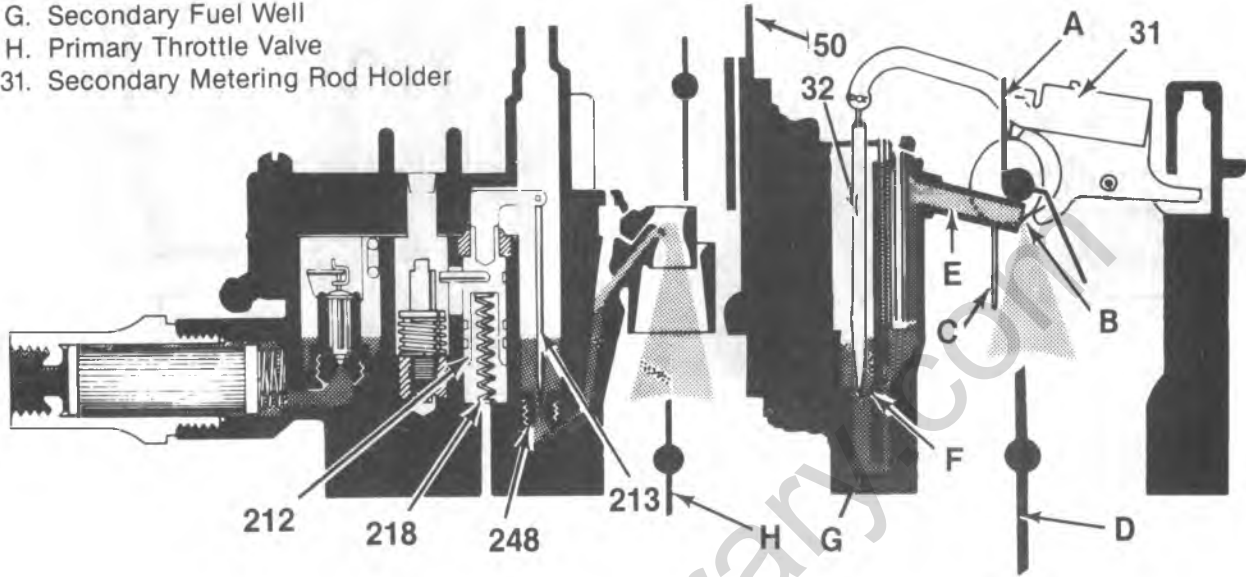

F-01888

Figure 27—Power System - M4ME

- A. Pump Suction Breaker
- B. Pump Jet
- C. Discharge Passage
- D. Pump Plunger Head
- E. Pump Duration Spring
- 41. Pump Lever
- 67. Pump Stem Seal Retainer
- 68. Pump Stem Seal
- 203. Pump Plunger Spring
- 204. Pump Plunger Cup
- 206. Pump Return Spring
- 250. Pump Discharge Plug (Retainer)
- 251. Pump Discharge Ball

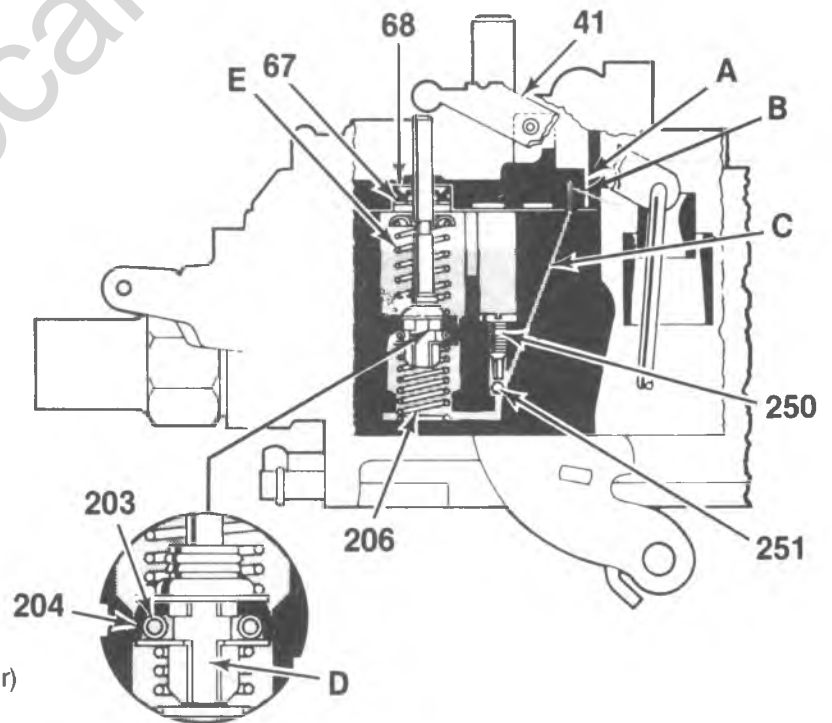

F-02717

Figure 28—Pump System

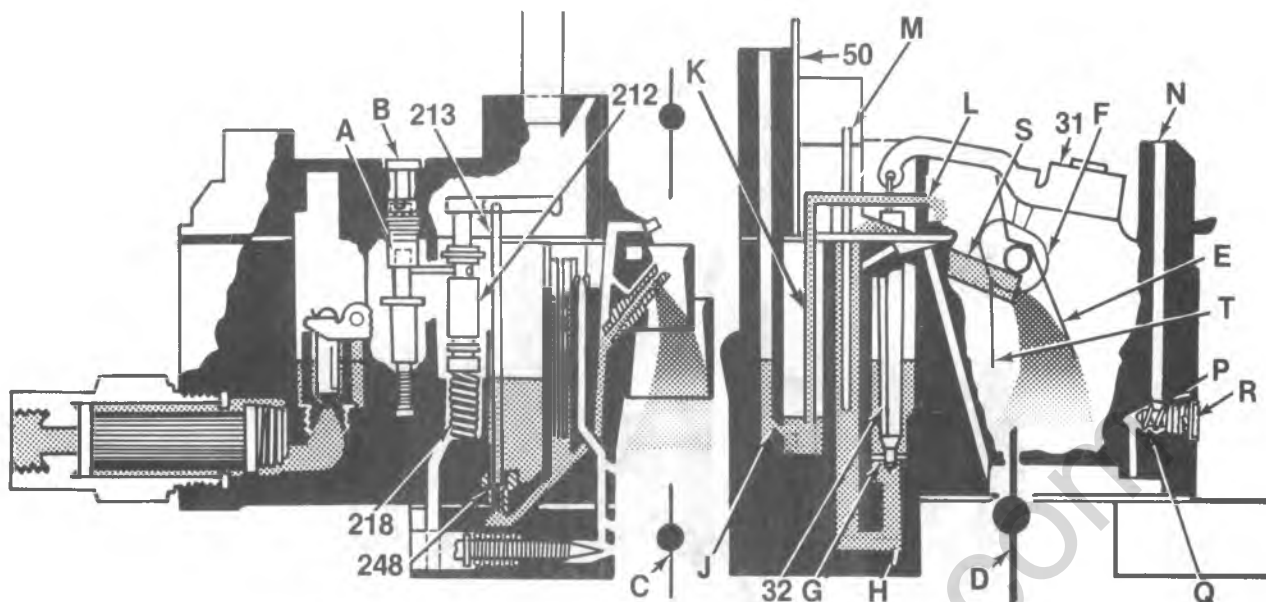

- | | |
|---|---|
| A. Rich Stop Adjusting Bushing
(Do not turn or remove) | N. Clean Air Inlet |
| B. Rich Stop Adjusting Plug | P. Secondary Well Bleed Adjust Screw
(Do not turn or remove) |
| C. Primary Throttle Valve | Q. Secondary Well Bleed Adjust Spring |
| D. Secondary Throttle Valve | R. Secondary Well Bleed Adjust Plug |
| E. Air Valve | S. Secondary Discharge Nozzle |
| F. Eccentric Cam | T. Baffle |
| G. Metering Disc | 31. Secondary Metering Rod Holder |
| H. Secondary Fuel Well | 32. Secondary Metering Rod |
| J. Accelerator Well Inlet Orifice | 50. Air Horn Baffle |
| K. Accelerator Well and Tube | 212. Power Valve Piston Assembly |
| L. Accelerator Well Discharge
Orifice | 213. Primary Metering Rod |
| M. Secondary Well Bleed Tube | 218. Power Piston Spring |
| | 248. Primary Metering Jet |

F-02718

Figure 29—Power System - M4MEF

- A. Choke Valve
- B. Vacuum Break Adjusting Screw
- C. Leaf-Type Bucking Spring
- D. Unloader Tang
- E. Fast Idle Cam Follower
- F. Thermostatic Coil
- G. Air Valve
- 55. Primary Side Vacuum Break Assembly
- 58. Primary Side Vacuum Break—
Air Valve Lever Link
- 356. Choke Link
- 360. Secondary Throttle Lockout Lever
- 425. Fast Idle Adjusting Screw

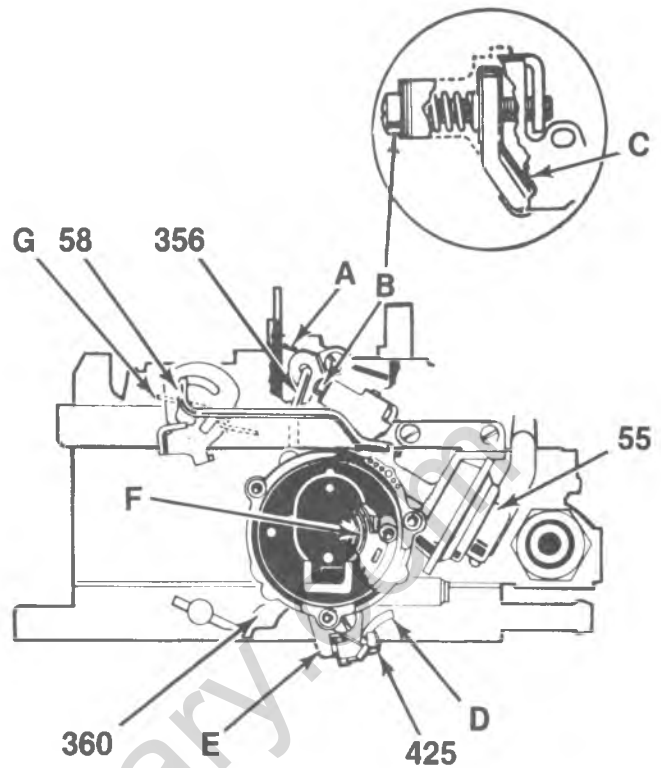

F-02716

Figure 30—Choke System - Electric - M4MEF (With Primary Side Vacuum Break Only)

- A. Choke Valve
- B. Thermostatic Coil
- C. Unloader Tang
- D. Fast Idle Cam Follower
- E. Plunger Bucking Spring
(Not Used On All Models)
- F. Air Valve
- 55. Primary Side Vacuum Break Assembly
- 58. Primary Side Vacuum Break to Air Valve Lever Link
- 320. Secondary Side Vacuum Break Assembly
- 322. Secondary Side Vacuum Break To Choke Link
- 356. Choke Link
- 360. Secondary Throttle Lockout Lever
- 425. Fast Idle Adjusting Screw

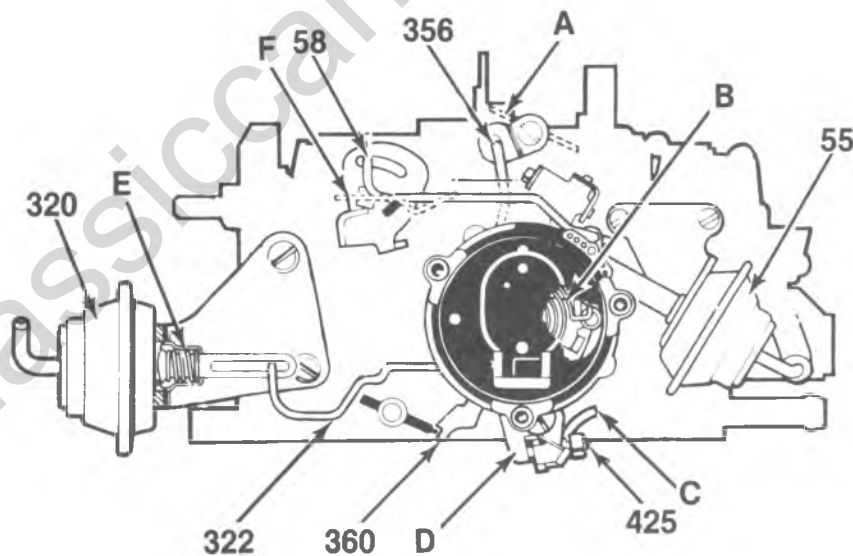

F-01894

Figure 31—Choke System - Electric - M4ME (With Primary Side and Secondary Side Vacuum Break)

DIAGNOSIS OF M4ME AND M4MEF ROCHESTER CARBURETOR

The following diagnostic procedures are for carburetor related problems and their effects on vehicle performance. Other vehicle systems can also cause problems and should be checked when listed on the chart.

PROBLEM	POSSIBLE CAUSE	CORRECTION
Engine Cranks Normally - Will Not Start or Starts Hard	<ol style="list-style-type: none"> 1. Improper starting procedure used. 2. Ignition system malfunction. 3. Choke not operating properly. 4. Engine loaded with fuel. (Improper starting procedure used or choke unloader misadjusted.) 5. No fuel in carburetor. 6. Engine flooded. To check for flooding, remove the air cleaner and look into the carburetor venturi for fuel dripping from nozzles. 	<ol style="list-style-type: none"> 1. Check with the customer to determine if proper starting procedure, outlined in the "Owner's and Driver's Manual", is used. 2. Check ignition system. Refer to ENGINE ELECTRICAL (SEC. 6D). 3. Check for free movement, and complete opening and closing, of choke valve. See "Choke Checking Procedure" and "Checking Electric Choke" later in this section. 4. Check with the customer to determine if proper starting procedure, outlined in the "Owner's and Driver's Manual", is used. Adjust choke unloader. 5. Inspect fuel filter(s) for being plugged. Replace as necessary. Check fuel pump pressure and volume. Replace pump if necessary. Inspect fuel lines for leaks and restrictions. Check the float level, and adjust if necessary. 6. Remove the air horn. Check float for restricted movement or being loaded. Check float needle pull clip location. Open end of clip should be installed over float lever cross bar, facing away from pontoon. Inspect float needle and seat for wear and for dirt or chips. If foreign material is found in the carburetor, clean the fuel system and carburetor. Replace fuel filter(s) as necessary. Check float level, and adjust if necessary.
Engine Starts - Will Not Keep Running	<ol style="list-style-type: none"> 1. Improper starting procedure used. 2. Choke not operating properly. 3. Engine does not have correct fast idle speed when cold. 	<ol style="list-style-type: none"> 1. Check with the customer to determine if proper starting procedure, outlined in the Owner's and Driver's Manual, is used. 2. Check for free movement and complete opening and closing of choke valve. See "Choke Checking Procedure" and "Checking Electric Choke" later in this section. 3. Check for free movement of fast idle cam and linkage. See "Choke Checking Procedure" later in this section. Adjust fast idle speed. See Emission Control Information Label.

DIAGNOSIS OF M4ME AND M4MEF ROCHESTER CARBURETOR (CONT.)

PROBLEM	POSSIBLE CAUSE	CORRECTION
<p>Engine Starts - Will Not Keep Running (Cont.)</p>	<p>4. Vacuum break assembly(s) malfunctioning or misadjusted.</p> <p>5. Idle speed too low.</p> <p>6. Air leaks at carburetor flange gasket, or at intake manifold gaskets. Vacuum hoses disconnected or installed improperly.</p> <p>7. Not enough fuel in carburetor.</p> <p>8. Carburetor flooding.</p>	<p>4. See "Vacuum Break Checking Procedure" later in this section. Adjust vacuum break assembly to specification.</p> <p>5. Adjust idle speed. See Emission Control Information Label.</p> <p>6. Use a pressure oil can to spray light oil or kerosene around carburetor throttle body (do not spray at throttle shaft ends), and manifold to head mounting surfaces. If engine RPM changes, torque carburetor to manifold bolts and/or intake manifold bolts to specification. If necessary, replace the carburetor flange gasket and/or intake manifold gaskets. Check condition and routing of vacuum hoses. Correct or replace as necessary.</p> <p>7. Inspect fuel filter(s) for being partially plugged. Replace as necessary. Check fuel pump pressure and volume. Replace pump if necessary. Inspect fuel lines for leaks and restrictions. Check the float level, and adjust if necessary.</p> <p>8. Remove the air horn. Check float for restricted movement or being loaded. Check float needle pull clip location. Open end of clip should be installed over float lever cross bar, facing away from pontoon. Inspect float needle and seat for wear and for dirt or chips. If foreign material is found in the carburetor, clean the fuel system and carburetor. Replace fuel filter(s) as necessary. Check float level, and adjust if necessary.</p>
<p>Engine Idles Abnormally (Too Fast or Too Slow)</p>	<p>1. Idle speed misadjusted.</p> <p>2. Idle stop solenoid or throttle kicker malfunctioning. Faulty solenoid circuit wiring.</p> <p>3. Choke not operating properly or fast idle cam sticking or binding.</p> <p>4. Throttle linkage or throttle shaft(s) sticking or binding.</p>	<p>1. Adjust idle speeds. See Emission Control Information Label.</p> <p>2. See "Idle Stop Solenoid Checking Procedure" and "Throttle Kicker Checking Procedure" later in this section. Refer to the "Fuel and Emissions Service Manual."</p> <p>3., Check choke valve and fast idle cam for free movement. Check for complete opening and closing of choke valve. See "Choke Checking Procedure" and "Checking Electric Choke" later in this section.</p> <p>4. Check throttle linkage and throttle shaft(s) for smooth and free operation. Clean with suitable solvent. Replace throttle body if necessary.</p>

DIAGNOSIS OF M4ME AND M4MEF ROCHESTER CARBURETOR (CONT.)

PROBLEM	POSSIBLE CAUSE	CORRECTION
Engine Idles Abnormally (Too Fast Or Too Slow) (Cont.)	<ol style="list-style-type: none"> 5. Air leaks at carburetor flange gasket, or at intake manifold gaskets. Vacuum hoses disconnected or installed improperly. 6. PCV system malfunctioning. 7. Ignition timing misadjusted. 8. Distributor vacuum or mechanical advance malfunctioning. 9. Idle system restricted or incorrect idle mixture adjustment. 10. Restricted air cleaner element. 11. Carburetor flooding. 	<ol style="list-style-type: none"> 5. Use a pressure oil can to spray light oil or kerosene around carburetor throttle body (do not spray at throttle shaft ends), and manifold to head mounting surfaces. If engine RPM changes, torque carburetor to manifold bolts and/or intake manifold bolts to specification. If necessary, replace the carburetor flange gasket and/or intake manifold gasket. Check condition and routing of vacuum hoses. Correct or replace as necessary. 6. Check PCV system. Clean or replace PCV valve and hoses as necessary. 7. Adjust timing. See Emission Control Information Label. 8. Check operation. Refer to ENGINE ELECTRICAL (SEC. 6D). 9. Clean carburetor if necessary. Adjust idle mixture per specified procedure. 10. Replace if necessary. 11. Remove the air horn. Check float for restricted movement or being loaded. Check float needle pull clip location. Open end of clip should be installed over float lever cross bar, facing away from pontoon. Inspect float needle and seat for wear, and for dirt or chips. If foreign material is found in the carburetor, clean the fuel system and carburetor. Replace fuel filter(s) as necessary. Check float level, and adjust if necessary.
Engine Diesels (After Run) Upon Shut Off	<ol style="list-style-type: none"> 1. Base idle speed misadjusted. 2. Idle stop solenoid or throttle kicker malfunctioning. Faulty solenoid circuit wiring. 3. Choke not operating properly or fast idle cam sticking or binding. 4. Throttle linkage or throttle shaft sticking or binding. 5. Air leaks at carburetor flange/insulator gasket(s), or at intake manifold gasket. Vacuum hoses disconnected or installed improperly. 	<ol style="list-style-type: none"> 1. Adjust base idle speed. See Emission Control Information Label. 2. See "Idle Stop Solenoid Checking Procedure" and "Throttle Kicker Checking Procedure" later in this section. Refer to the "Fuel and Emissions Service Manual." 3. Check choke valve and fast idle cam for free movement. Check for complete opening and closing of choke valve. See "Choke Checking Procedure" and "Checking Electric Choke" later in this section. 4. Check throttle linkage and throttle shaft for smooth and free operation. Clean with suitable solvent. Replace throttle body if necessary. 5. Use a pressure oil can to spray light oil or kerosene around carburetor throttle body (do not spray at throttle shaft ends), and manifold to head mounting surfaces.

DIAGNOSIS OF M4ME AND M4MEF ROCHESTER CARBURETOR (CONT.)

PROBLEM	POSSIBLE CAUSE	CORRECTION
<p>Engine Idles Abnormally (Too Fast Or Too Slow) (Cont.)</p>	<p>6. PCV system malfunctioning.</p> <p>7. Ignition timing retarded (causes throttle valve to be opened farther than normal to obtain correct idle speed).</p> <p>8. Lean idle mixture (causes throttle valve to be opened farther than normal to obtain correct idle speed).</p>	<p>5. Continued If engine RPM changes, torque carburetor to manifold bolts and/or intake manifold bolts to specification. If necessary, replace the carburetor flange/insulator gasket(s) and/or intake manifold gasket. Check condition and routing of vacuum hoses. correct or replace as necessary.</p> <p>6. Check PCV system. Clean replace PCV valve and hoses as necessary.</p> <p>7. Adjust timing. See Emission Control Information Label.</p> <p>8. Clean carburetor if necessary. Adjust idle mixture per specified procedure.</p>
<p>Engine Hesitates During Normal Acceleration * Hesitates During Cold Engine Operation.</p>	<p>1. Malfunctioning pump system or misadjusted pump. Make a quick check of the pump system: With the engine off, look into the carburetor bore and observe pump discharge jets; actuate throttle lever. A full stream of fuel should emit from the jets.</p> <p>2. * Choke not operating properly.</p> <p>3. * Vacuum break assembly(s) malfunctioning or misadjusted.</p> <p>4. * Thermac system malfunctioning.</p> <p>5. * Early Fuel Evaporation (EFE) system malfunction.</p> <p>6. Ignition timing misadjusted.</p> <p>7. Distributor vacuum or mechanical advance malfunctioning.</p> <p>8. Float level too low.</p> <p>9. Power piston sticking. Missing or damaged power piston spring.</p> <p>10. Primary metering rod hanger bent.</p>	<p>1. Remove air horn and check pump cup. If cracked or hardened, replace the pump plunger cup and spring. Check for restricted pump passages. Clean and blow out passages with compressed air. Check the pump discharge ball for proper seating. Adjust pump to specification.</p> <p>2. Check for complete opening and closing of choke valve. See "Choke Checking Procedure" and "Checking Electric Choke" later in this section.</p> <p>3. See "Vacuum Break Checking Procedure" later in this section. Adjust vacuum break(s) to specification.</p> <p>4. Check operation. Refer to the "Fuel and Emissions Service Manual."</p> <p>5. Check operation. Refer to the "Fuel and Emissions Service Manual."</p> <p>6. Adjust timing. See Emission Control Information Label.</p> <p>7. Check operation. Refer to ENGINE ELECTRICAL (SEC. 6D).</p> <p>8. Check float level, and adjust if necessary.</p> <p>9. Check power piston operation: push piston down and release; it should move freely in bore and return to its up position. If piston does not move freely, clean power piston and bore. If piston does not return when released, check for missing or damaged power piston spring. Replace if necessary.</p> <p>10. Inspect metering rod hanger for damage. Replace power piston assembly if necessary.</p>

**DIAGNOSIS OF M4ME AND M4MEF ROCHESTER
CARBURETOR (CONT.)**

PROBLEM	POSSIBLE CAUSE	CORRECTION
Engine Hesitates On Acceleration (Cont.)	11. Restricted primary metering jets.	11. If foreign material is found in the carburetor, clean the fuel system and carburetor. Replace fuel filter(s) as necessary.
Engine Has Less Than Normal Power At Normal Acceleration	1. Ignition system malfunction. 2. Ignition timing misadjusted. 3. Distributor vacuum or mechanical advance malfunctioning. 4. Plugged air cleaner element. 5. Exhaust system restricted. 6. Thermac system malfunction. 7. Early Fuel Evaporation (EFE) system malfunction. 8. Transmission malfunction. 9. Choke not operating properly. 10. Fuel filter(s) partially plugged. 11. Faulty fuel pump, or leaking or restricted fuel lines. 12. Float level too low. 13. Power piston sticking. Missing or damaged power piston spring. 14. Primary metering rod hanger bent. 15. Primary metering jets restricted or loose.	1. Check ignition system. Refer to ENGINE ELECTRICAL (SEC. 6D). 2. Adjust timing. See Emission Control Information Label. 3. Check operation. Refer to ENGINE ELECTRICAL (SEC. 6D). 4. Replace element. 5. Check restrictions. Correct as necessary. 6. Check operation. Refer to the "Fuel and Emissions Service Manual." 7. Check operation. Refer to the "Fuel and Emissions Service Manual." 8. Refer to transmission diagnosis. 9. Check for complete opening and closing of choke valve. "See Choke Checking Procedure" and "Checking Electric Choke" later in this section. 10. Inspect fuel filter(s). Replace as necessary. 11. Check fuel pump pressure and volume. Replace pump if necessary. Inspect fuel lines for leaks and restrictions. 12. Check the float level, and adjust if necessary. 13. Check power piston operation: push piston down and release; it should move freely in bore and return to its up position. If piston does not move freely, clean power piston and bore. If piston does not return when released, check for missing or damaged power piston spring. Replace if necessary. 14. Inspect metering rod hanger for damage. Replace power piston assembly if necessary. 15. If foreign material is found in the carburetor, clean the fuel system and carburetor. Replace fuel filter(s) as necessary. If metering jets are loose, tighten.

DIAGNOSIS OF M4ME AND M4MEF ROCHESTER CARBURETOR (CONT.)

PROBLEM	POSSIBLE CAUSE	CORRECTION
<p>Less Than Normal Power On Heavy Acceleration Or At High Speed</p>	<ol style="list-style-type: none"> 1. Throttle valves not opening completely, or secondary throttle valves not opening. 2. Ignition system malfunction. 3. Ignition timing misadjusted. 4. Distributor mechanical advance malfunctioning. 5. Plugged air cleaner element. 6. Exhaust system restricted. 7. Thermac system malfunction. 8. Early fuel Evaporation (EFE) system malfunction. 9. Transmission malfunction. 10. Choke not operating properly. 11. Secondary air valve shaft, valves, or air valve link sticking or binding. 12. Air valve link misadjusted. (May cause hesitation when secondary throttle valves are opened.) 13. Vacuum break assembly malfunctioning. (May cause hesitation when secondary throttle valves are opened.) 14. Air valve return spring broken or misadjusted. 15. Secondary metering rod holder bent. 16. Fuel filter(s) partially plugged. 17. Faulty fuel pump or leaking or restricted fuel lines. 18. Float level too low. Float needle pull clip missing or installed incorrectly. 19. Power piston sticking. Missing or damaged power piston spring. 20. Primary metering rod hanger bent. 	<ol style="list-style-type: none"> 1. Correct throttle linkage to obtain wide open throttle. Check secondary throttle lockout lever for sticking or incorrect adjustment. Clean or repair as necessary. Adjust lockout lever to specification. 2. Check ignition system. Refer to ENGINE ELECTRICAL (SEC. 6D). 3. Adjust timing. See Emission Control Information Label. 4. Check operation. Refer to ENGINE ELECTRICAL (SEC. 6D). 5. Replace element. 6. Check for restrictions. Correct as necessary. 7. Check operation. Refer to the "Fuel and Emissions Service Manual." 8. Check operation. Refer to the "Fuel and Emissions Service Manual." 9. Refer to transmission diagnosis. 10. Check for complete opening and closing of choke valve. See "Choke Checking Procedure" and "Checking Electric Choke" later in this section. 11. Check air valves for smooth operation. Clean, repair, or replace air horn and air valve link as necessary. 12. Adjust air valve link to specification. 13. See "Vacuum Break Checking Procedure" later in this section. 14. Replace air valve return spring if necessary. Adjust spring to specification. 15. Check holder for damage. Replace if necessary. 16. Inspect fuel filter(s). Replace as necessary. 17. Check fuel pump pressure and volume. Replace pump if necessary. Inspect fuel lines for leaks and restrictions. 18. Check the float level, and adjust if necessary. Check for presence of float needle pull clip. Replace if necessary. Open end of clip should be installed over float lever cross bar, facing away from pontoon. 19. Check power piston operation: push piston down and release; it should move freely in bore and return to its up position. If piston does not move freely, clean power piston and bore. If piston does not return when released, check for missing or damaged power piston spring. Replace if necessary. 20. Inspect metering rod hanger for damage. Replace power piston assembly if necessary.

DIAGNOSIS OF M4ME AND M4MEF ROCHESTER CARBURETOR (CONT.)

PROBLEM	POSSIBLE CAUSE	CORRECTION
Less Than Normal Power On Heavy Acceleration Or At High Speed (Cont.)	21. Primary metering jets restricted or loose. Secondary metering discs restricted or missing. Secondary accelerator well tubes restricted. (Will cause hesitation when secondary throttle valves are opened.)	21. If foreign material is found in the carburetor, clean the fuel system and carburetor. Replace fuel filter(s) as necessary. If the primary metering jets are loose, tighten. If secondary metering discs are missing, replace float bowl.
Engine Surges	1. Ignition system malfunction. 2. Distributor mechanical advance malfunctioning. 3. Air leaks at carburetor flange gasket, or at intake manifold gaskets. Vacuum hoses disconnected or installed improperly. 4. PCV system malfunctioning. 5. Exhaust system restricted. 6. Thermac system malfunction. 7. Early Fuel Evaporation (EFE) system malfunction. 8. Contaminated fuel. 9. Fuel filter(s) partially plugged. 10. Faulty fuel pump or leaking or restricted fuel lines. 11. Float level too low. 12. Float needle sticking in seat. 13. Power piston sticking. Missing or damaged power piston spring. 14. Primary metering rod hanger bent. 15. Restricted primary metering jets.	1. Check ignition system. Refer to ENGINE ELECTRICAL (SEC. 6D). 2. Check operation. Refer to ENGINE ELECTRICAL (SEC. 6D). 3. Use a pressure oil can to spray light oil or kerosene around carburetor throttle body (do not spray at throttle shaft ends), and manifold to head mounting surfaces. If engine RPM changes, torque carburetor to manifold bolts and/or intake manifold bolts to specification. If necessary, replace the carburetor flange gasket and/or intake manifold gaskets. Check condition and routing of vacuum hoses. Correct or replace as necessary. 4. Check PCV system. Clean or replace PCV valve and hoses as necessary. 5. Check for restrictions. Correct as necessary. 6. Check operation. Refer to the "Fuel and Emissions Service Manual." 7. Check operation. Refer to the "Fuel and Emissions Service Manual." 8. Check for water or excessive alcohol in fuel. 9. Inspect fuel filter(s). Replace as necessary. 10. Check fuel pump pressure and volume. Replace pump if necessary. Inspect fuel lines for leaks and restrictions. 11. Check the float level, and adjust if necessary. 12. Replace float needle and seat. 13. Check power piston operation: push piston down and release; it should move freely in bore and return to its up position. If piston does not move freely, clean power piston and bore. If piston does not return when released, check for missing or damaged power piston spring. Replace if necessary. 14. Inspect metering rod hanger for damage. Replace power piston assembly if necessary. 15. If foreign material is found in the carburetor, clean the fuel system and carburetor. Replace fuel filter(s) as necessary.

DIAGNOSIS OF M4ME AND M4MEF ROCHESTER CARBURETOR (Cont.)

PROBLEM	POSSIBLE CAUSE	CORRECTION
<p>Poor Gas Mileage * Black Smoke From Tail Pipe</p>	<ol style="list-style-type: none"> 1. Customer driving habits. 2. Wrong speedometer gear. 3. Low tire pressure or incorrect tire size. 4. Transmission malfunction or in wrong gear. 5. Fuel leaks. 6. * Plugged air cleaner element. 7. * Choke not operating properly. 8. * Vacuum break assembly malfunctioning or misadjusted. 9. Ignition system malfunction. 10. Ignition timing misadjusted. 11. Distributor vacuum or mechanical advance malfunctioning. 12. Air leaks at carburetor flange gasket, or at intake manifold gaskets. Vacuum hoses disconnected or installed improperly. 13. Engine in need of service. 14. Restricted exhaust system. 15. * High fuel level in carburetor or flooding. 	<ol style="list-style-type: none"> 1. Run mileage test, with customer driving if possible. make sure vehicle has 2000-3000 miles (3 200-4 800 km) for the "break-in" period. 2. Check odometer against measured mile. Replace speedometer gear if necessary. 3. Inflate tires to specifications and use correct tire sizes. 4. Refer to transmission diagnosis. 5. Inspect fuel tank, fuel lines and fuel pump for any fuel leakage. 6. Replace element. 7. Check for complete opening and closing of choke valve. See "Choke Checking Procedure" and "Checking Electric Choke" later in this section. 8. See "Vacuum Break Checking Procedure" later in this section. Adjust vacuum break assembly to specification. 9. Check ignition system. Refer to ENGINE ELECTRICAL (SEC. 6D). 10. Adjust timing. See Emission Control Information Label. 11. Check operation. Refer to ENGINE ELECTRICAL (SEC. 6D). 12. Use a pressure oil can to spray light oil or kerosene around carburetor throttle body (do not spray at throttle shaft ends), and manifold to head mounting surfaces. If engine RPM changes, torque carburetor manifold bolts and/or intake manifold bolts to specification. If necessary, replace the carburetor flange gasket and/or intake manifold gaskets. Check condition and routing of vacuum hoses. Correct or replace as necessary. 13. Check engine compression. 14. Check for restrictions. Correct as necessary. 15. Check float for restricted movement or being loaded. Check float needle pull clip location. Open end of clip should be installed over float lever cross bar, facing away from pontoon. Check float needle and seat for wear and dirt or chips. If foreign material is found in carburetor, clean fuel system and carburetor. Replace fuel filter(s) as necessary. Check float level, and adjust if necessary.

DIAGNOSIS OF M4ME AND M4MEF ROCHESTER CARBURETOR (Cont.)

PROBLEM	POSSIBLE CAUSE	CORRECTION
Poor Gas Mileage (Cont.)	16. Power piston sticking. Power piston spring stretched. 17. Primary metering rod hanger bent. 18. * Worn or damaged primary metering rods. Worn or damaged secondary metering rods (black smoke when secondary throttle valves are opened). 19. * Primary metering jets worn or loose. Secondary metering discs worn or missing (black smoke when secondary throttle valves are opened).	16. Check power piston operation: push piston down and release; it should move freely in bore and return to its up position. If piston does not move freely, clean power piston and bore. Check power piston spring for damage. Replace if necessary. 17. Inspect metering rod hanger for damage. Replace power piston assembly if necessary. 18. Inspect primary and secondary metering rods. Replace as necessary. 19. Inspect metering jets. Replace if necessary. If loose, tighten. If loose, tighten. Inspect secondary metering discs. If worn or missing, replace float bowl.
Gasoline Odor	1. Fuel feed or vapor return line leaking. 2. Leak in fuel tank. 3. Disconnected or leaking fuel tank vent lines or hoses to canister(s). 4. Purge lines not connected, improperly routed, plugged or pinched. 5. Carbon canister(s) loaded. 6. Faulty fill cap.	1. Repair/replace as required. 2. Purge tank and repair or replace tank as required. 3. Connect, repair/replace lines as required. 4. Connect, clean, or reroute lines as required. 5. Compare weight of canister with a new one. Replace if necessary. 6. Install new cap.
Fuel Starvation	1. Fuel filter(s) plugged. 2. Fuel lines leaking, restricted, or misrouted. 3. Faulty fuel pump.	1. Inspect fuel filter(s). Replace as necessary. 2. Repair/replace, clean, or reroute as required. 3. Check fuel pump pressure and volume. Replace pump if necessary.

ON-VEHICLE SERVICE (MODELS M4ME AND M4MEF)

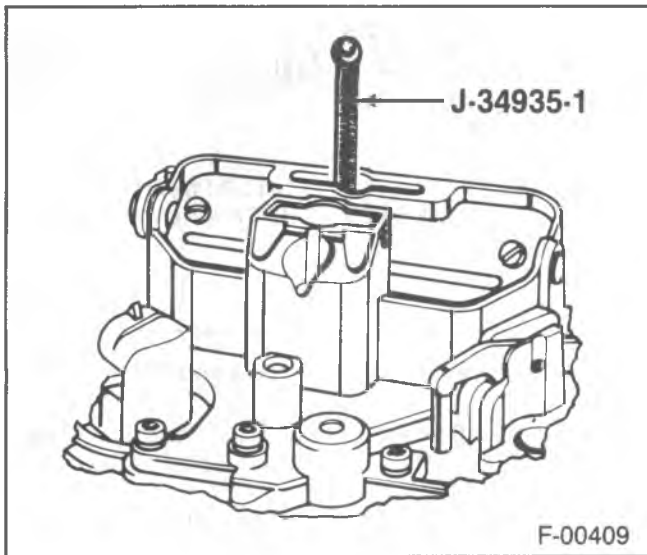

Figure 32—Float Level - External Check

FLOAT LEVEL - EXTERNAL CHECK

Tool Required:

J-34935-1 External float Level Gage

- With the engine idling and the choke valve wide open, insert J-34935-1 in the vent slot or vent hole (figure 32).
 - Allow the gage to float freely.

NOTICE: Do not press down on the gage. Flooding or float damage could result.

- Observe the mark on the gage that lines up with the top of the casting. The setting should be within 1.588mm (2/32-inch) of the specified float level setting.
 - Incorrect fuel pressure will adversely affect the fuel level.
- If not within specification, remove the air horn and adjust the float.

CHOKE CHECKING PROCEDURE - (ENGINE OFF)

- Remove the air cleaner assembly.
- Hold the throttle half way down.
- Open and close the choke several times. Be sure all links are connected, and are not damaged. Choke valve, linkage, and fast idle cam must operate freely.
 - If the choke valve, linkage, or fast idle cam is sticking due to varnish, clean with choke cleaner X-20-A or equivalent.
 - Do not lubricate linkage, as lubricant will collect dust and cause sticking.

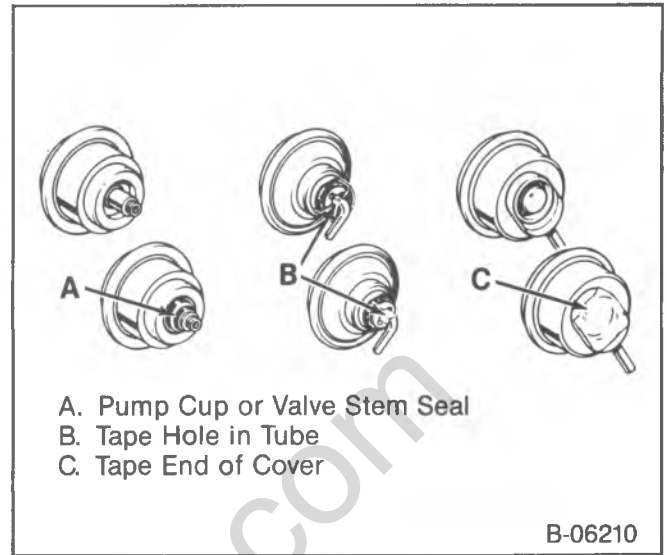

Figure 33—Plugging Vacuum Break Bleed Holes

CHECKING ELECTRIC CHOKE - ON VEHICLE

- Allow the choke stat to stabilize at about 21°C (70°F).
- Open the throttle, to allow the choke valve to close.
- Start the engine, determine the length of time for the choke valve to reach full open position:
 - If longer than five minutes, check the voltage at the choke stat connector, with the engine running:
 - If voltage is between 12 and 15 volts: Check for proper ground between choke cover and choke housing. If correct, replace choke cover assembly.
 - If the voltage is low or zero: Check all wires and connections. Refer to ENGINE ELECTRICAL (SEC. 6D).

VACUUM BREAK CHECKING PROCEDURE

Tool Required:

J-23738-A, Hand Operated Vacuum Pump

- If the vacuum break has an air bleed hole, plug it during this checking procedure (figure 33).
- Apply -51 kPa (15 in. Hg.) vacuum to the vacuum break.
 - Apply finger pressure to see if the plunger has moved through full travel. If not, replace the vacuum break.
 - Observe the vacuum gage. Vacuum should hold vacuum for at least twenty seconds. If not, replace the vacuum break.
- Replace vacuum break hoses that are cracked, cut or hardened.

CHECKING IDLE STOP SOLENOID (ISS)

A non-functioning idle stop solenoid (ISS) (if equipped) could cause stalling or rough idle.

- Turn the ignition on but do not start the engine.
- Open the throttle momentarily to allow the solenoid plunger to extend.

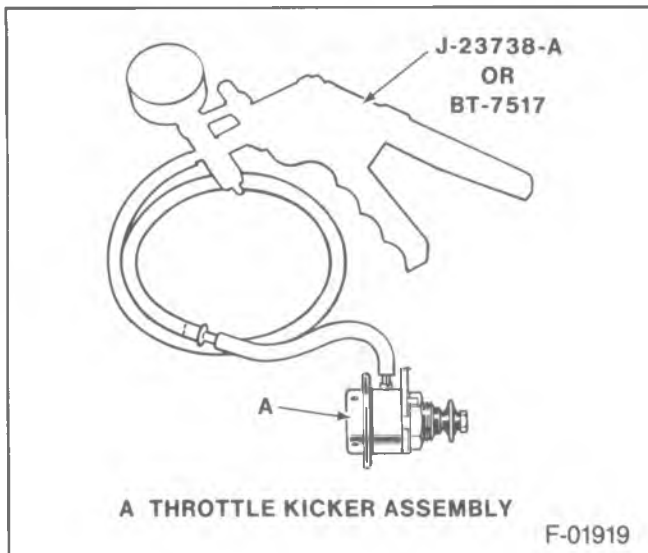

Figure 34—Checking Throttle Kicker

3. Disconnect the wire at the solenoid. The plunger should drop back from the throttle lever.
4. Connect the solenoid wire. The plunger should move out and contact the throttle lever.
5. If the plunger does not move in and out as the wire is disconnected and connected, check voltage across the feed wire.
 - If the voltage is 12 to 15 volts, replace the solenoid.
 - If the voltage is low, locate the cause of the open circuit in the solenoid feed wire; repair as necessary.

CHECKING THROTTLE KICKER

Tool Required:

J-23738-A, Hand Held Vacuum Pump

1. Hold the throttle half way open to allow the plunger to extend fully.
2. Apply -68 (20" Hg) vacuum to the throttle kicker (figure 34).
 - Apply finger pressure to the plunger to see if it has extended fully. If not, replace the throttle kicker.
 - Observe the vacuum gage. Vacuum should hold for at least twenty seconds. If not, replace the throttle kicker.
3. Release the vacuum to the throttle kicker.
 - If the plunger does not retract to its starting position, replace kicker.

FUEL FILTER REPLACEMENT

↔ Remove or Disconnect (Figure 35)

1. Fuel line connection at the fuel inlet nut.
2. Fuel inlet nut.
3. Fuel inlet filter, gasket, and spring.

↔ Install or Connect (Figure 35)

1. Fuel filter spring in float bowl.
2. New gasket on inlet nut.
3. Fuel inlet filter in inlet nut.

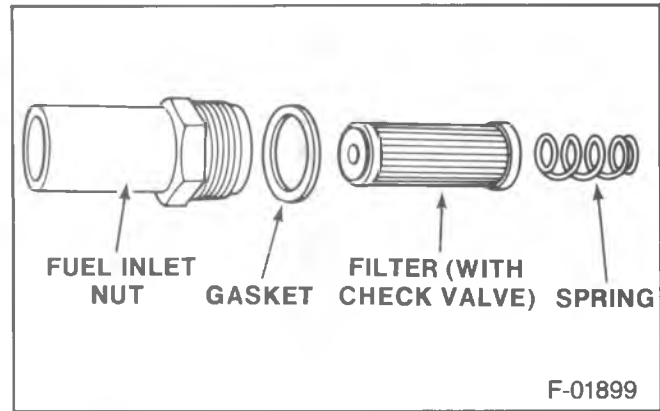

Figure 35—Fuel Inlet Nut and Filter

- The filter must include an inlet check valve to meet Motor Vehicle Safety Standards (M.V.S.S.) for roll-over.
 - The check valve end of the filter must face the fuel line.
4. Fuel inlet nut.
 - Inlet nut to 62 N·m (46 ft. lbs.).
 5. Fuel line to inlet nut.
 - Start engine and check for leaks.

CARBURETOR MOUNTING TORQUE

After servicing, tighten mounting bolts, in a clockwise direction, to 16 N·m (144 in. lbs.). When retightening carburetor at recommended maintenance intervals, check in clockwise direction. If less than 7 N·m (60 in. lbs.), retighten to 11 N·m (96 in. lbs.); but if greater than 7 N·m (60 in. lbs.), do not retighten.

CARBURETOR REPLACEMENT

Flooding, stumble on acceleration and other performance complaints are, in many instances, caused by the presence of dirt, water or other foreign matter in carburetor. To aid in diagnosing the cause, the carburetor should be removed carefully from the engine without draining fuel from the bowl. Contents of the fuel bowl then may be examined for foreign materials as the carburetor is disassembled.

↔ Remove or Disconnect

1. Negative battery terminal.
2. Air cleaner assembly and gasket.
3. Electrical connectors from the choke and idle stop solenoid.
4. Vacuum hoses.
 - Make note of the vacuum hose routing.
5. Accelerator linkage.
6. Downshift cable (automatic transmission only).
7. Cruise control linkage (if equipped).
8. Fuel line connection at the fuel inlet nut.
9. Carburetor attaching bolts.
10. Carburetor and flange insulator.



Clean

- Sealing surfaces on the intake manifold and carburetor.

CAUTION: Extinguish all open flames while filling and testing carburetor with gasoline to avoid personal injury.



Install or Connect

1. Carburetor with new flange gasket.
 - It is good shop practice to fill the carburetor float bowl before installing the carburetor. This reduces the strain on starting motor and battery and reduces the possibility of backfiring while attempting to start the engine. Operate the throttle several times and check the discharge from pump jets before installing the carburetor.
2. Carburetor attaching bolts.



Tighten

- Bolts to 16 N·m (144 in. lbs.)
 - Tighten in a criss-cross pattern.
3. Fuel line to the fuel inlet nut.
 4. Cruise control cable (if equipped).
 5. Downshift cable (automatic transmission only).
 6. Accelerator linkage.
 7. Vacuum hoses.
 - Refer to the Emission Control Information Label for vacuum hose routing information.
 8. Electrical connectors to the choke and idle stop solenoid.
 9. Air cleaner assembly with gasket.
 10. Negative battery terminal.



Adjust

- Idle mixture and idle speeds.

**IDLE MIXTURE ADJUSTMENT
(HEAVY DUTY EMISSION
VEHICLES ONLY)**

In case of a major carburetor overhaul, throttle body replacement, or high idle CO (when indicated by an emissions inspection), the idle mixture may be adjusted. Adjusting the mixture by other than the following method may violate Federal and/or state laws (figures 36 through 38).

Tool Required:

J-29030-B Idle Mixture Needle Socket.

1. Set parking brake and block drive wheels.
2. Remove the carburetor from the engine.
3. Drain fuel from the carburetor into a container. Dispose of the fuel in an approved container.
4. Remove idle mixture needle plugs (figure 36):
 - Invert the carburetor and support it to avoid damaging external components.

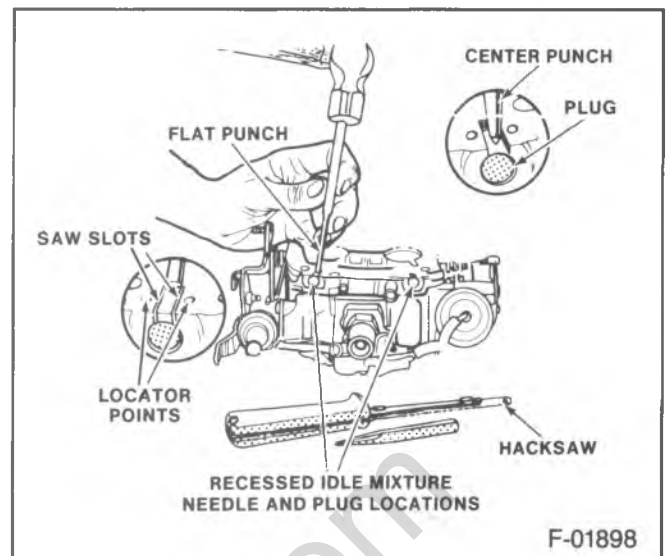

Figure 36—Removing idle Mixture Needle Plugs

- Make two parallel hacksaw cuts in the throttle body, between the locator points near one idle mixture needle plug. The distance between the cuts depends on the size of the punch to be used.
 - Cut down to the plug, but not more than 1/8-inch beyond the locator point.
 - Place a flat punch at a point near the ends of the saw marks. Hold the punch at a 45 degree angle and drive it into the throttle body until the casting breaks away, exposing the steel plug.
 - Use a center punch to break the plug apart, uncover idle mixture needle.
 - Remove all loose pieces of plug.
 - Repeat the previous steps for the other needle plug.
5. Use J-29030-B to lightly seat the idle mixture needles, then back out three turns.
 6. Reinstall carburetor on the engine.
 7. Place transmission in "P" (PARK) (automatic transmission) or "N" (NEUTRAL) (manual transmission).
 8. Start the engine and bring it to a normal operating temperature, choke valve open, and air conditioning off.
 9. Connect a known accurate tachometer to the engine.
 10. Check ignition timing, and adjust if necessary, by following the procedure described on the Emission Control Information Label.
 11. Use J-29030-B to turn the mixture needles equally (1/8 turn at a time), in or out, to obtain the highest RPM (best idle).
 12. Adjust the idle speed screw (throttle stop) to obtain the base idle speed specified on the Emission Control Information label.
 13. Again try to readjust mixture needles to obtain the highest idle RPM.

The adjustment is correct when the highest RPM (best idle) is reached with the minimum number of mixture needle turns from the seated position.

6C1-40 CARBURETORS

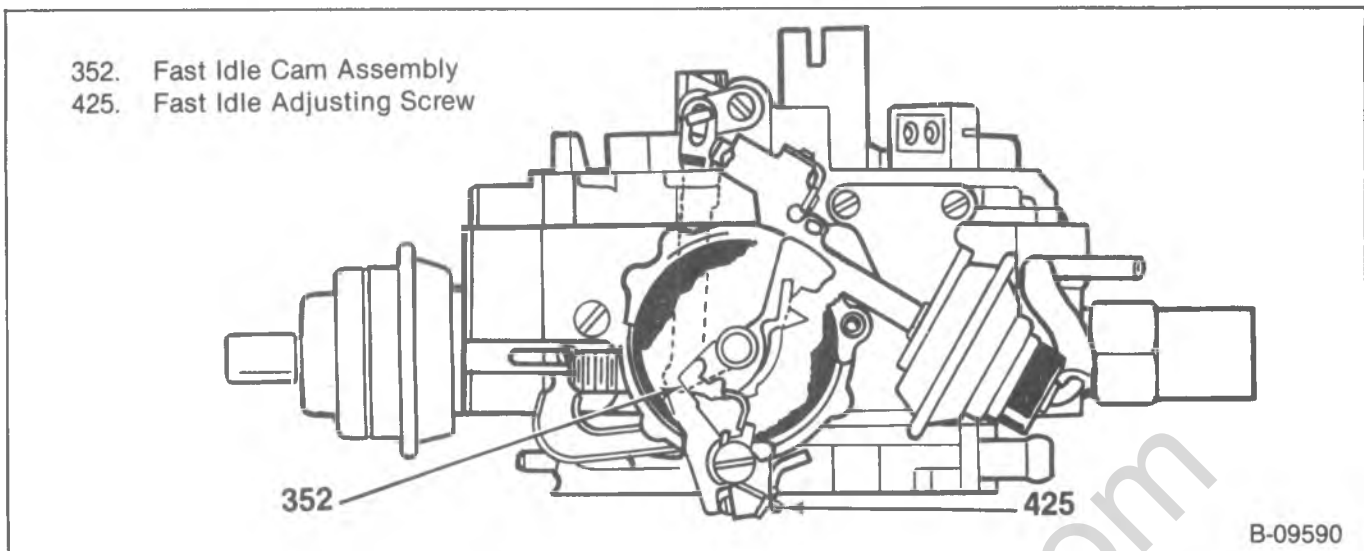

Figure 37—Fast Idle Adjustment

14. If necessary, readjust the idle speed screw (throttle stop) to obtain the specified base idle speed.
15. Check, (and if necessary, adjust), idle speed solenoid activated speed, and fast idle speed. Refer to figures 38 and 39 and the Emission Control Emission Information label.
16. Check the throttle kicker (TRC RPM), and adjust if necessary. Refer to the "Fuel and Emissions Service Manual" and to the Emission Control Information label.
17. Turn off the engine, and remove the block from the drive wheels.

IDLE SPEED ADJUSTMENT

Refer to figures 37 through 39 and the Emission Control Information label to adjust idle speed, idle speed solenoid activated speed, and fast idle speed.

THROTTLE KICKER ADJUSTMENT

Refer to the "Fuel and Emissions Service Manual" to adjust the throttle kicker.

FLOAT ADJUSTMENT

Tools Required:

J-9789-90, Float Level "T" Scale

J-34817, Float Positioning Tool Kit

1. Remove the air horn, gasket, power piston and metering rod assembly, and the float bowl insert (figure 40).
2. Attach J-34817-1 to the float bowl.
3. Place J-34817-3 in J-34817-1 with the contact pin resting on the outer edge of the float lever.
4. Measure the distance from the top of the casting to the top of the float at a point 3/16-inch from the large end of the float.
 - Use J-9789-90.

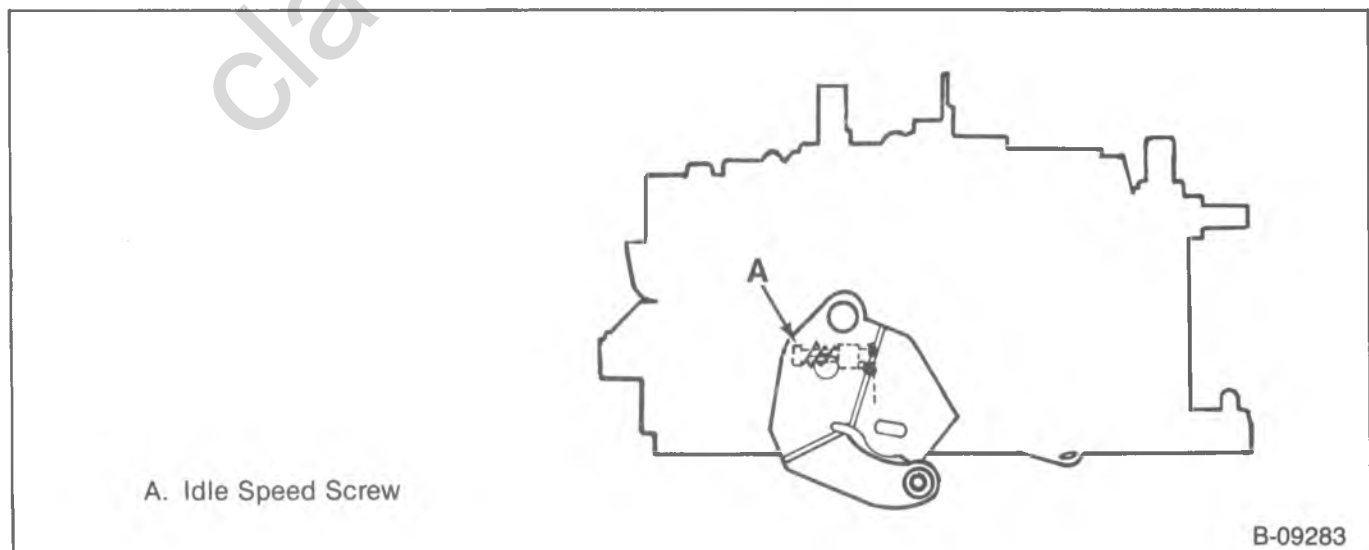

Figure 38—Idle Speed Adjustment - Without Idle Speed Solenoid

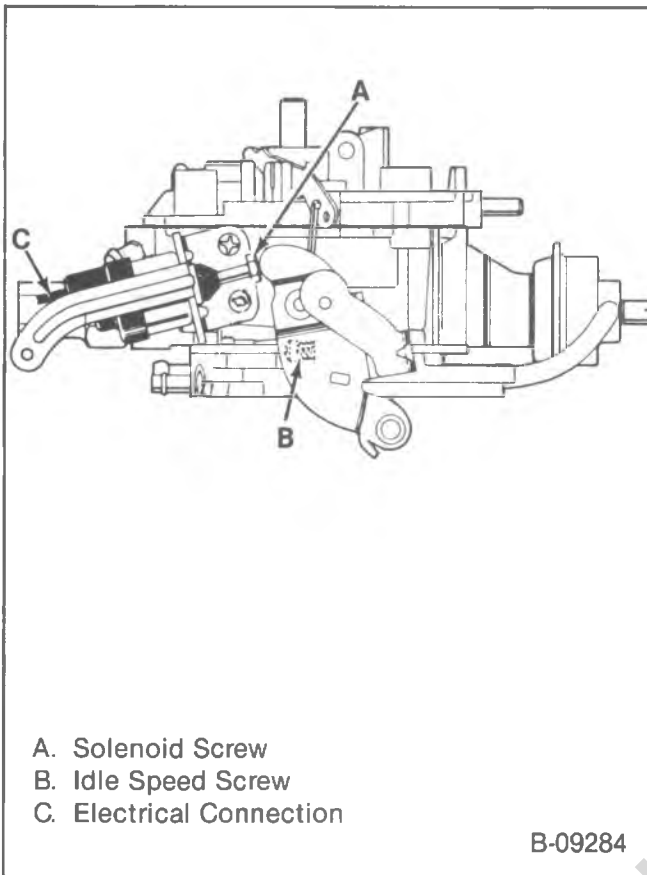

Figure 39—Fast Idle Adjustment

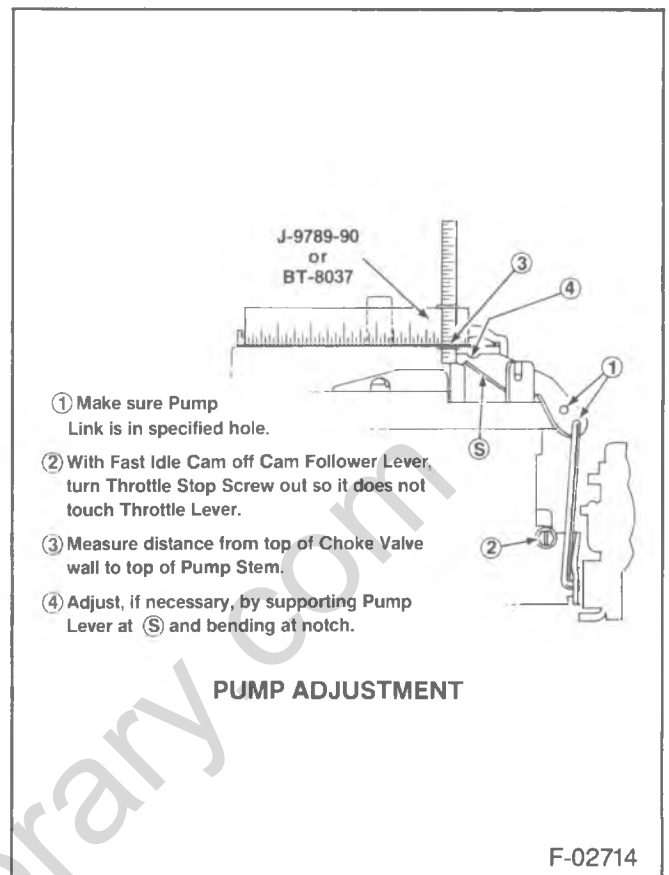

Figure 41—Pump Adjustment

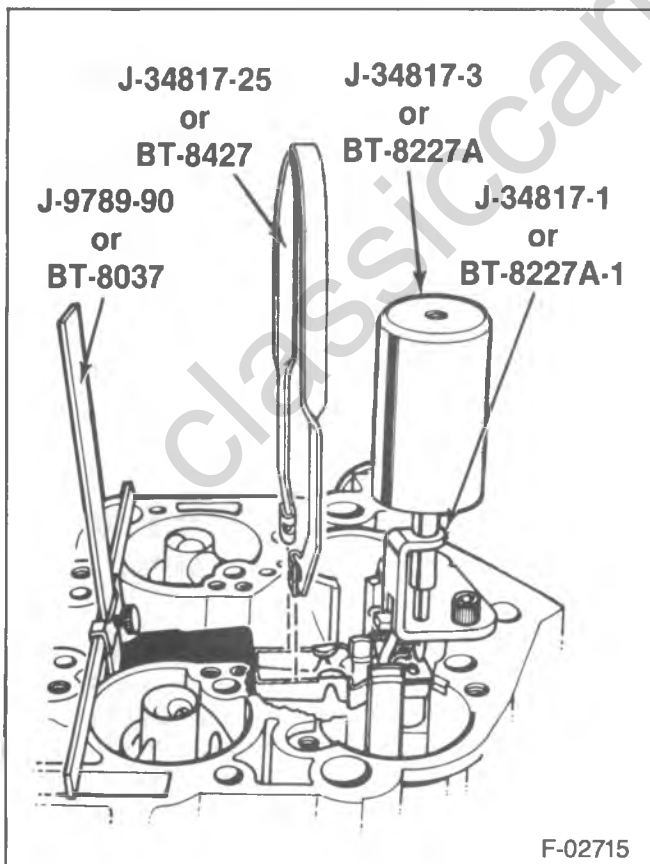

Figure 40—Float Adjustment

5. If more than $\pm 2/32$ -inch from specification, use J-34817-25 to bend the lever up or down.
 - Remove J-34817-25 and measure, repeating until within specification.
6. Check the float alignment.
7. Reassemble the carburetor.

PUMP ADJUSTMENT



Tool Required:

J-9789-90, Float Level "T" Scale

1. The pump link (410) must be in the specified hole (figure 41).
2. With the fast idle cam off the cam follower lever, turn the throttle stop screw (380) out so it does not touch the throttle lever.
3. Measure the distance from the top of the choke valve wall to the top of the pump stem.
4. Adjust, if necessary, by supporting the pump lever (41) with a screwdriver and bending it at the notch.

AIR VALVE RETURN SPRING ADJUSTMENT

1. Loosen the setscrew (figure 42).
2. a. Turn spring flucrum pin counterclockwise until the air valves open.
b. Turn the pin clockwise until the air valves close, then the additional turns specified.
3. Tighten the setscrew.
4. Apply lithium grease to the spring contact area.

- ① Loosen set screw .
- ②a Turn Spring Fulcrum Pin  until Air Valves  open.
- ②b Turn pin  until Air Valves close, then additional turns specified.
- ③ Tighten set screw.
- ④ Apply Lithium grease to spring contact area.

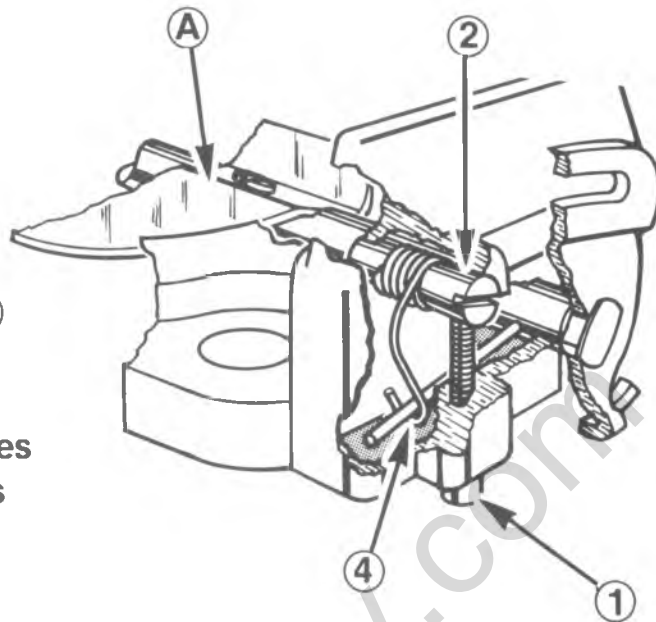

F-01927

Figure 42—Air Valve Return Spring Adjustment

CHOKE STAT LEVER ADJUSTMENT

Tool Required:

J-9789-111, Linkage Bending Tool

1. Drill out and remove the choke cover attaching rivets. Remove choke cover and stat assembly (figure 43).
2. Place fast idle cam on high step against the cam follower lever.
3. Push up on the choke stat lever to close the choke valve.
4. Check the stat lever for correct orientation by inserting a 0.120-inch plug gage hole in the choke housing.
 - The gage should fit in the hole and touch the edge of the lever.
5. Adjust, if necessary, by bending the choke link with J-9789-111.

CHOKE LINK AND FAST IDLE CAM ADJUSTMENT

Tool Required:

J-26701-A, Choke Valve Angle Gage

1. Attach a rubber band to the vacuum break lever of the intermediate choke shaft (figure 44 and 45).
2. Open the throttle to allow the choke valve to close.
3. Set up J-26701-A and set the angle to specification.
 - Rotate the degree scale until zero is opposite the pointer.

- Center the leveling bubble.
- Rotate the scale to the specified angle. — Refer to "Specifications."

4. Place the fast idle cam on the second step against the cam follower lever, with the lever contacting the rise of the high step. If the lever does not contact the cam, turn the fast idle adjusting screw in additional turn(s).

Important

- Final Fast Idle Speed Adjustment must be performed according to the Emission Control Information label.
5. Adjust, if bubble is not recentered, by bending the fast idle cam kick lever with pliers.

PRIMARY SIDE VACUUM BREAK ADJUSTMENT

Tools Required:

J-26701-A, Choke Valve Angle Gage

J-23738-A, Hand Operated Vacuum Pump

1. Attach rubber band to the vacuum break lever of the intermediate choke shaft (figures 44, 46 47).
2. Open the throttle to allow the choke valve to close.
3. Set up J-26701 and set angle to specifications.
 - Rotate the degree scale until zero is opposite the pointer.
 - Center the leveling bubble.
 - Rotate the scale to the specified angle. — Refer to "Specifications."

- ① If riveted, drill out and remove rivets. Remove Choke Cover and Stat Assembly.
 - ② Place Fast Idle Cam on high step against Cam Follower Lever.
 - ③ Push up on Choke Stat Lever to close Choke Valve.
 - ④ Check Stat Lever for correct orientation by inserting .120" plug gage in hole.
- Gage should fit in hole and touch edge of lever.
- ⑤ Adjust, if necessary, by bending Choke Link.

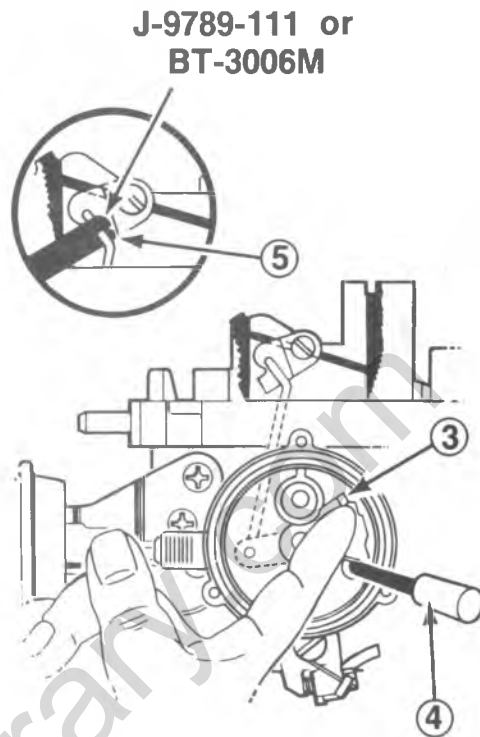

F-01928

Figure 43—Choke Stat Lever Adjustment

- ① Attach Angle Gage Magnet to closed Choke Valve.
- ② Rotate degree scale until zero is opposite pointer.
- ③ Center the leveling bubble.
- ④ Rotate scale to specified angle.
- ⑤ Open Choke Valve as described.
- ⑥ Adjust linkage if bubble is not recentered.

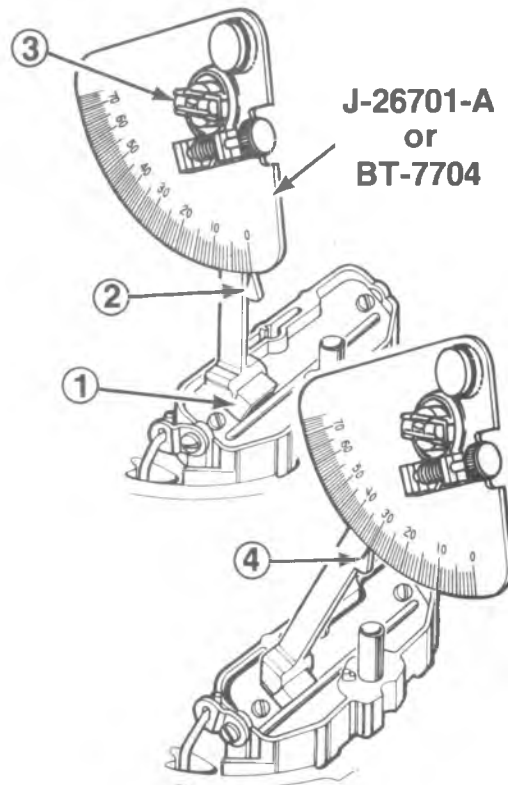

F-01929

Figure 44—Choke Valve Angle Gage

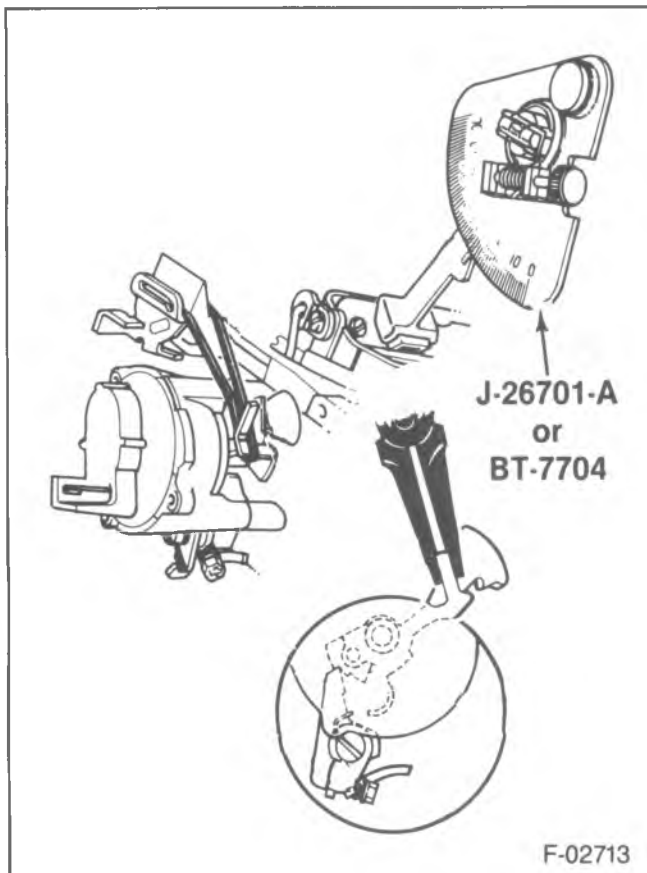

Figure 45—Choke Link - Fast Idle Cam Adjustment

4.
 - Plug vacuum break bleed holes, if applicable.
 - Apply -51 kPa (15-inches Hg) vacuum to seat the vacuum break plunger.
 - Seat bucking spring, if applicable.
 - If necessary, bend the air valve link to permit full plunger travel, then reapply vacuum to fully retract plunger.
5. Adjust, if bubble is not recentered, by turning the vacuum break adjusting screw.

SECONDARY SIDE VACUUM BREAK ADJUSTMENT

Tools Required:

- J-26701-A, Choke Valve Angle Gage
- J-23738-A, Hand Operated Vacuum Pump
- J-9789-111, Linkage Bending Tool

1. Attach a rubber band to the vacuum break lever of the intermediate choke shaft.
2. Open the throttle to allow the choke valve to close.
3. Set up J-26701 and set angle to specification (figure 44).
 - Rotate the degree scale until zero is opposite the pointer.
 - Center the leveling bubble.
 - Rotate the scale to the specified angle.
 - Refer to "Specifications."

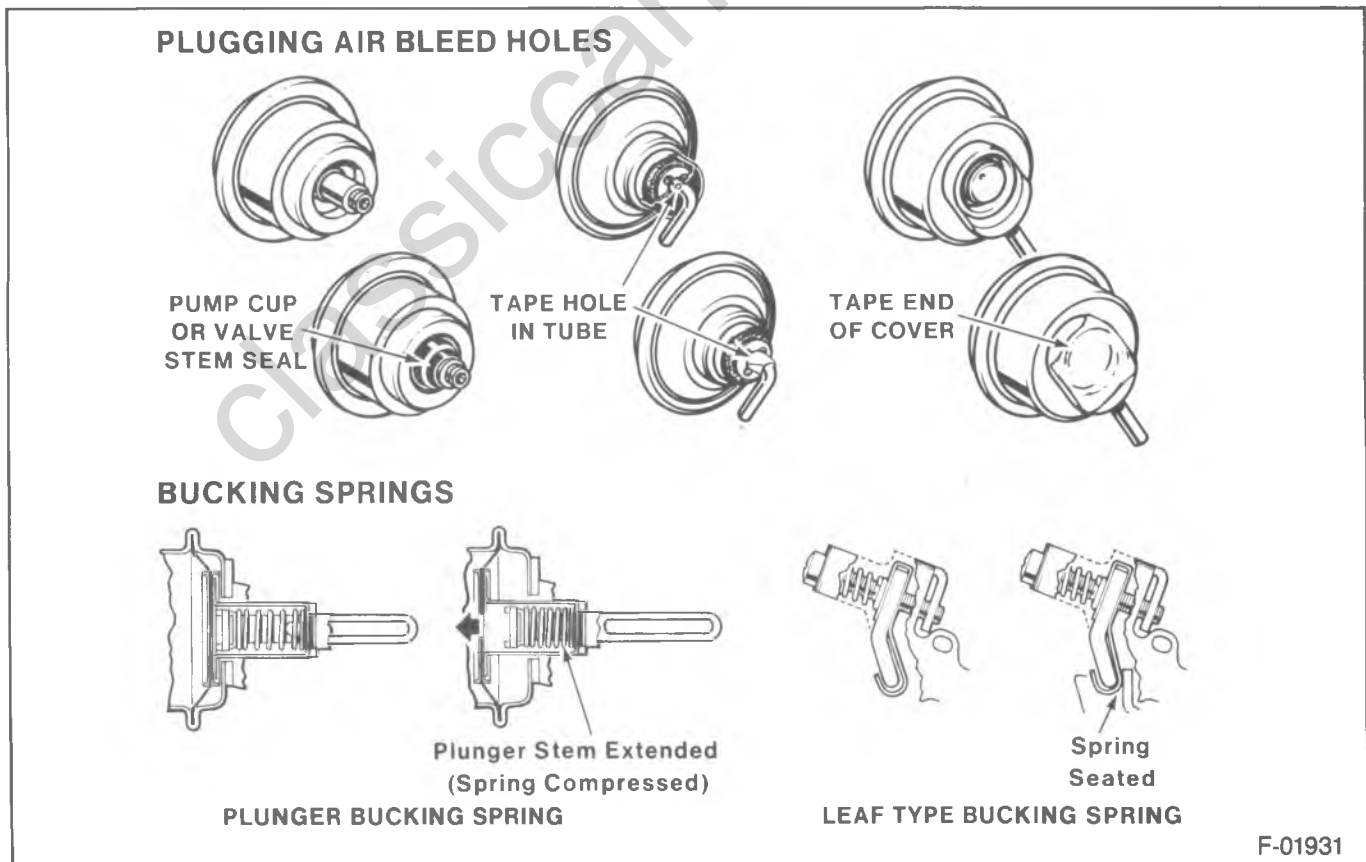

Figure 46—Vacuum Break Adjustment Information

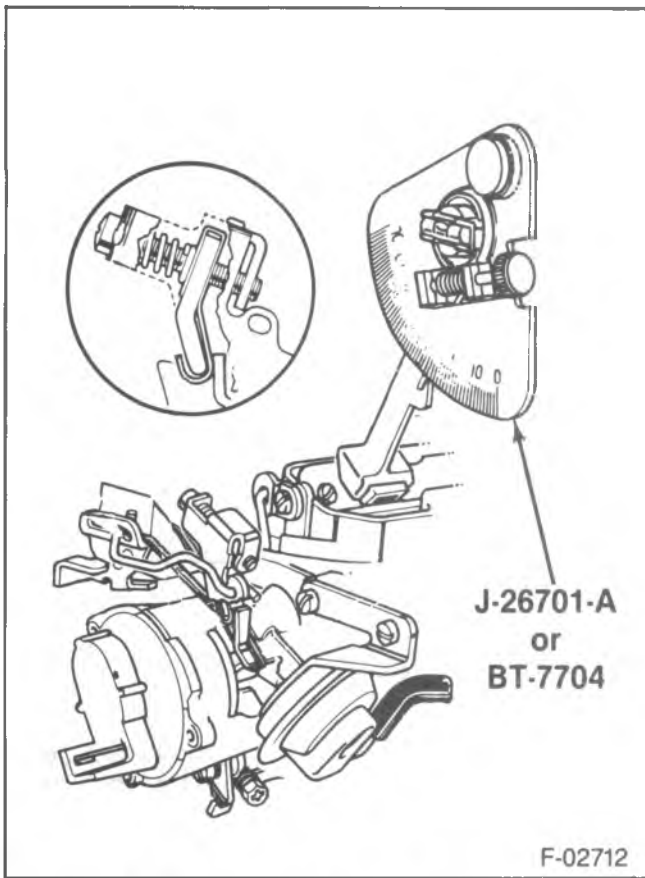

Figure 47—Primary Side Vacuum Break Adjustment

4.
 - Plug vacuum break bleed holes, if applicable.
 - Apply -51 kPa (15-inches Hg) vacuum to seat the vacuum break plunger.
 - Compress the plunger bucking spring, if applicable.
 - If necessary, bend the air valve link to permit full plunger travel, then reapply vacuum to fully retract the plunger (figures 46 and 47).
5. Adjust, if bubble is not recentered, by either:
 - Supporting the link where shown, and bending it with J-9789-111. Or
 - turning screw with a 1/8-inch hex wrench.

AIR VALVE LINK ADJUSTMENT

Tools Required:

J-23738-A, Hand Operated Vacuum Pump
 J-9789-111, Linkage Bending Tool

1. Plug vacuum break bleed holes, if applicable. With the air valves closed, apply -51 kPa (15-inches Hg) vacuum to seat the vacuum break plunger (figure 46 and 49).
2. Gage the clearance between the air valve link and the end of the slot in the air valve lever. Clearance should be 0.025-inch.
3. Adjust, if necessary, by bending link with J-9789-111.

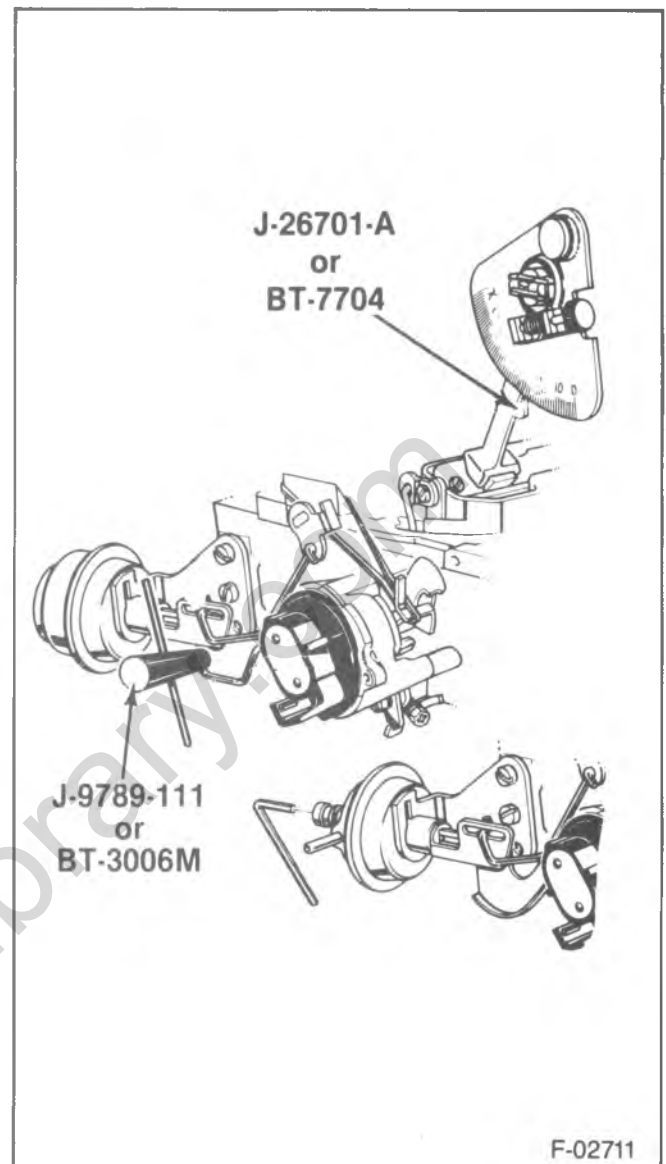

Figure 48—Secondary Side Vacuum Break Adjustment

UNLOADER ADJUSTMENT

Tools Required:

J-26701-A, Choke Valve Angle Gage
 J-9789-111, Linkage Bending Tool

1. Attach a rubber band to the vacuum break lever of the intermediate choke shaft (figures 44 and 50).
2. Open the throttle to allow the choke valve to close.
3. Set up J-26701-A and set angle to specifications.
 - Rotate the degree scale until zero is opposite the pointer.
 - Center the leveling bubble.
 - Rotate the scale to the specified angle.
 - Refer to "Specifications."
4. Hold the secondary lockout lever away from the pin.
5. Hold the throttle lever in wide open position.
6. Adjust, if bubble is not recentered, by bending fast idle lever with J-9789-111.

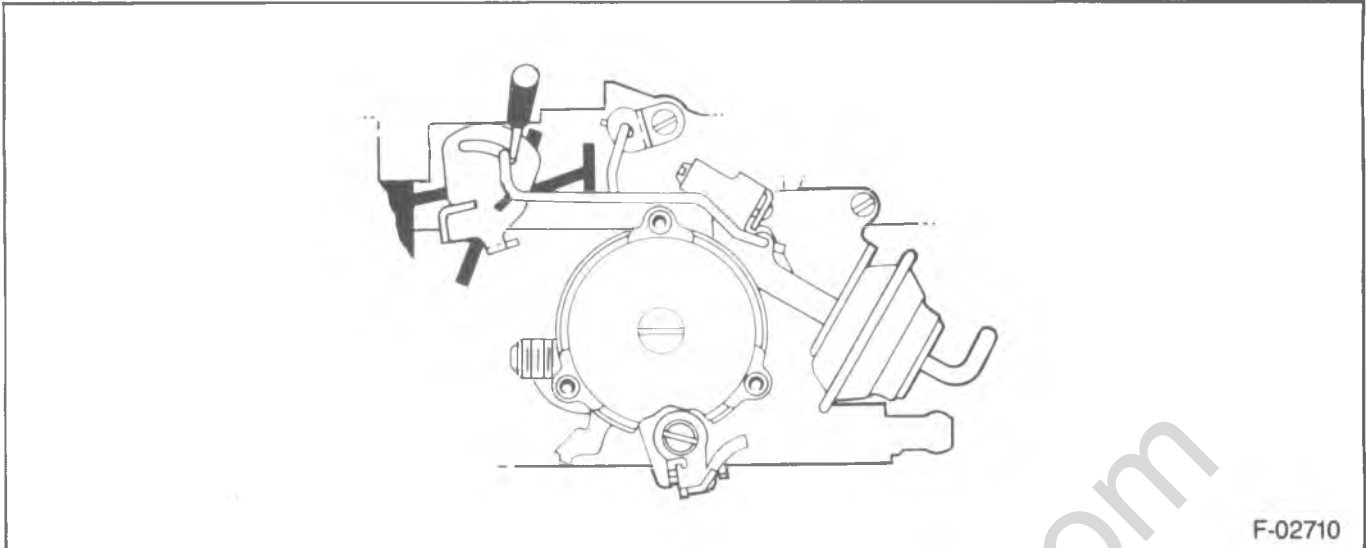

F-02710

Figure 49—Air Valve Link Adjustment

SECONDARY THROTTLE LOCKOUT ADJUSTMENT

1. Place the fast idle cam on the high step against the cam follower lever (figure 51).
2. Hold the throttle lever closed.
3. Gage the clearance between the lockout lever and pin. It must be 0.015-inch \pm 0.005-inch.
4. Adjust, if necessary, by bending pin.
5. Push down on tail of fast idle cam to move lockout lever away from pin.
6. Rotate the throttle lever to bring the lockout pin to the position of minimum clearance with the lockout lever.
7. Gage the clearance between the lockout lever and pin. The minimum must be 0.015-inch.
8. Adjust, if necessary, by filing the end of the pin.

- ① Attach rubber band to Vacuum Break Lever of Intermediate Choke Shaft.
- ② Open Throttle to allow Choke Valve to close.
- ③ Set up Angle Gage and set to specification.
- ④ On Quadrajets, hold Secondary Throttle Lockout Lever (A) away from pin (B).
- ⑤ Hold Throttle Lever in wide open position.
- ⑥ Adjust, if bubble is not recentered, by bending Fast Idle Lever.

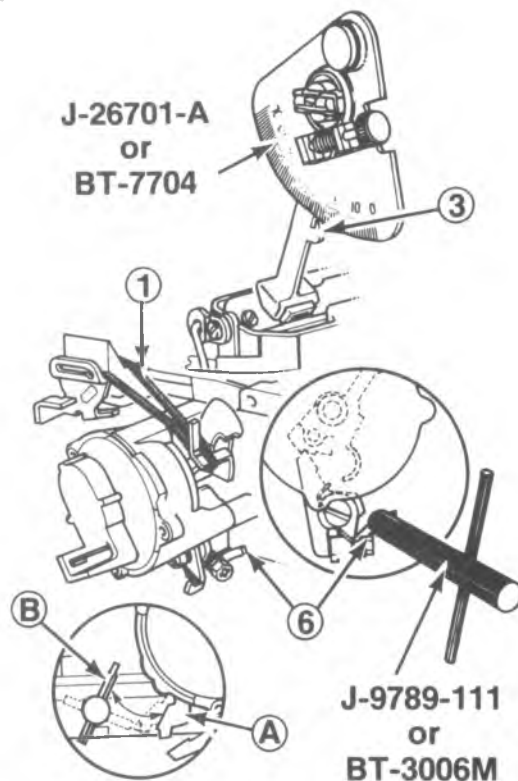

F-01936

Figure 50—Unloader Adjustment

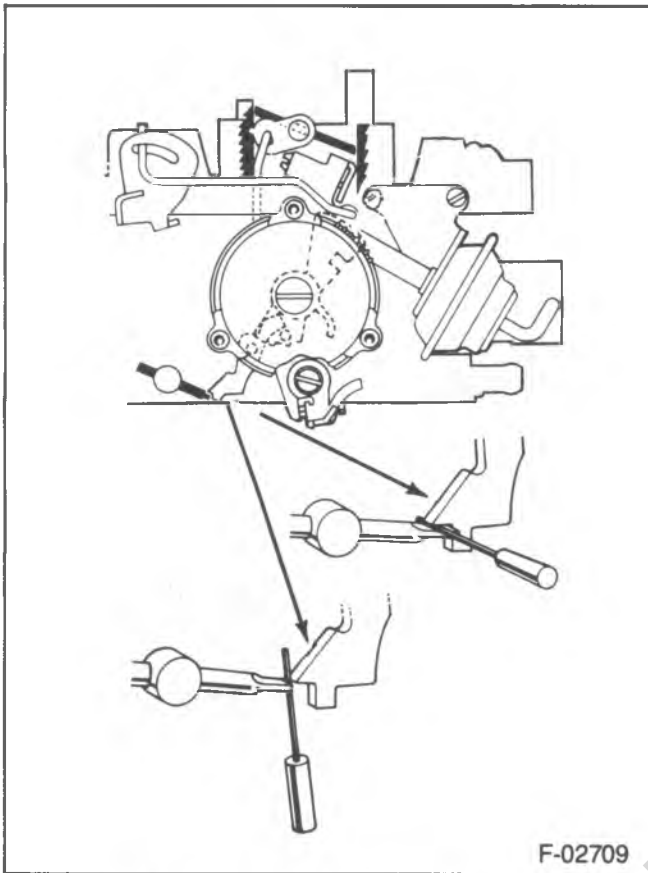

Figure 51—Secondary Lockout Adjustment

SPECIFICATIONS

MODEL 1ME AND 1MEF CARBURETORS

Carburetor Part No.	Float Level mm (Inches)	Metering Rod mm (Inches)	Choke Coil Lever mm (Inches)	Choke Rod Cam Adj mm (Inches)	Vacuum Break mm (Inches)	Unloader mm (Inches)
17086101	8.7 (11/32)	2.3 (0.090)	.120	7.0 (0.275)	5.0 (0.200)	13.2 (0.520)
17086102	8.7 (11/32)	2.3 (0.090)	.120	7.0 (0.275)	5.0 (0.200)	13.2 (0.520)

MODEL M4MC/M4ME CARBURETORS

Carburetor Part No.	Float Level mm (Inches) ± 2/32"	Pump Rod Setting mm (Inches)	Pump Rod Location	Air Valve Spring (Turns)	Choke Coll Lever	Fast Idle Cam Choke Rod ± 2.5°	Vacuum Break Front ± 2.5°	Vacuum Break Rear ± 3.5°	Air Valve Rod mm (Inches)	Unloader ± 4°	Propane Enrichment Speed
17085000	9.5 (12/32)	7.0 (9/32)	Inner	7/8	.120	46°	24°	30°	0.6 (0.025)	40°	—
17085001	9.5 (12/32)	7.0 (9/32)	Inner	1	.120	46°	23°	30°	0.6 (0.025)	40°	—
17085003	10.0 (13/32)	7.0 (9/32)	Inner	7/8	.120	46°	27°	—	0.6 (0.025)	35°	—
17085004	10.0 (13/32)	7.0 (9/32)	Inner	7/8	.120	46°	23°	—	0.6 (0.025)	35°	—
17085212	10.0 (13/32)	7.0 (9/32)	Inner	7/8	.120	46°	23°	—	0.6 (0.025)	35°	—
17085213	10.0 (13/32)	7.0 (9/32)	Inner	7/8	.120	46°	27°	—	0.6 (0.025)	35°	—

SPECIAL TOOLS

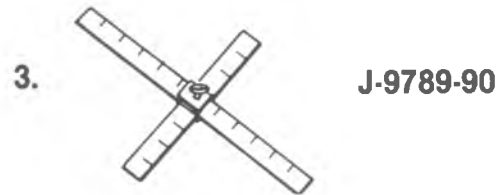

- 1. Idle Mixture Needle Socket
- 2. Float Positioning Tool Kit
- 3. Float Level "T" Scale
- 4. External Float Level Gage
- 5. Hand Operated Vacuum Pump
- 6. Linkage Bending Tool
- 7. Choke Valve Angle Gage

classiccarrlib.com

SECTION 6C2

DIESEL FUEL INJECTION

CONTENTS

<u>SUBJECT</u>	<u>PAGE</u>
Description	6C2- 1
On-Vehicle Service	6C2- 2
Fuel Filter Replacement	6C2- 2
Idle Speed Adjustment	6C2- 3
Throttle Position Switch Adjustment (LH6 Engine With 700 R4 Transmission)	6C2- 3
Vacuum Regulator Valve Adjustment (LL4 Engine With Automatic Transmission)	6C2- 4
Housing Pressure Cold Advance	6C2- 4
Injection Line Replacement	6C2- 4
Injection Pump Replacement	6C2- 5
Injection Timing Adjustment	6C2- 8
Marking TDC On The Front Housing	6C2- 8
Injection Nozzles	6C2-10
Injection Nozzle Replacement	6C2-10
Injection Nozzle Tests	6C2-10
Injection Pump On-Vehicle Service	6C2-12
Pump Cover Seal and/or Guide Stud Seal Replacement	6C2-12
Minimum-Maximum Governor Replacement	6C2-13
Throttle Shaft Seal Replacement	6C2-14
Shutdown And/Or Cold Advance Solenoid Replacement	6C2-16
Side Cover Gasket Replacement	6C2-17
Injection Pump Off-Vehicle Service	6C2-17
Advance Pin Hole Plug Seal Replacement	6C2-17
Advance Piston Seals Replacement	6C2-17
Advance Piston Replacement	6C2-18
Hydraulic Head Seal Replacement	6C2-18
Drive Shaft Seal Replacement	6C2-19
Pressure Testing The Injection Pump	6C2-19
Specifications	6C2-20
Special Tools	6C2-21

DESCRIPTION

The 6.2 L diesel engine fuel system is composed of:

- Fuel tank
- Mechanical fuel pump
- Fuel filter with water sensor and heater
- Fuel filter restriction switch
- Injection distributor pump
- High pressure lines
- Fuel injection nozzles

Fuel is drawn from the fuel tank by the mechanical pump which is located on the right side of the engine. The pump is driven by an eccentric lobe on the camshaft through a push rod. Fuel is then pumped through the filter / water separator. The filter / water separator is located on the engine side of the cowl (R-V models) or under the rear of the air cleaner (G-P models). The fuel is then transferred to the injection pump.

The injection pump is mounted on top of the engine under the intake manifold. The pump is driven by the camshaft through two gears, one attached to the front of the camshaft and the other attached to the end of the injection pump shaft. These gears are the same size and have the same number of teeth; therefore, the injection pump shaft turns at the same speed as the camshaft. The pump turns in the opposite direction of the camshaft and crankshaft.

The injection pump is a high pressure rotary type pump that meters, pressurizes, and distributes fuel to the eight injector nozzles. The eight high pressure lines are all the same length although their shape may be different. This prevents timing differences between cylinders. Injection lines should not be bent to ease removal.

ON-VEHICLE SERVICE

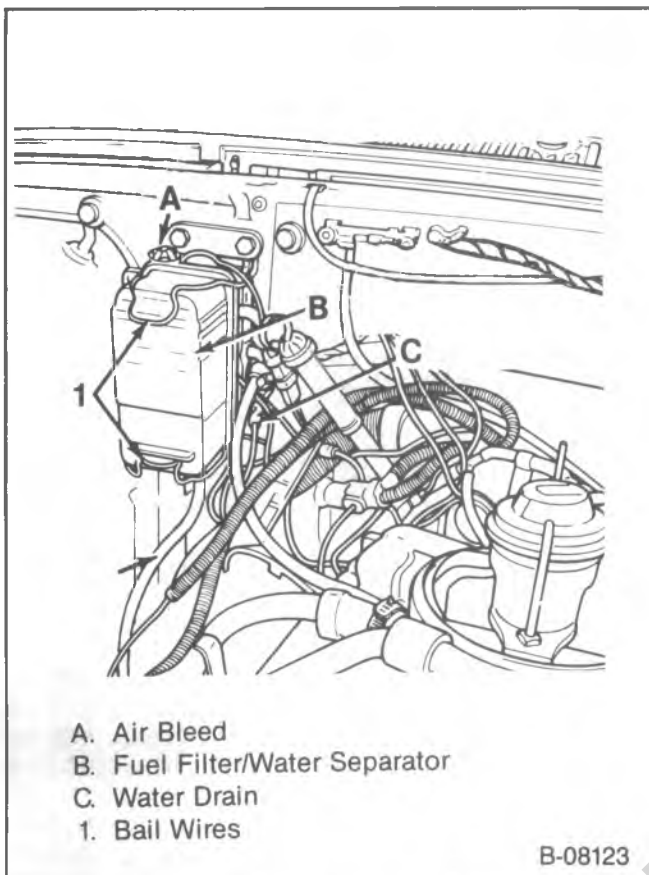

Figure 1—Fuel Filter on R-V Truck

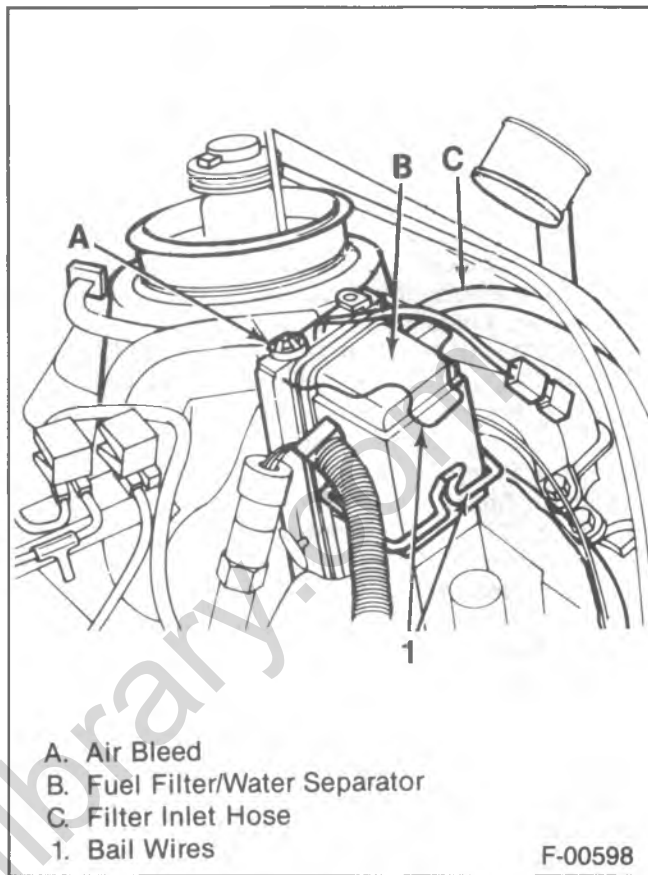

Figure 2—Fuel Filter on G Van

FUEL FILTER REPLACEMENT

The fuel filter on R-V models is located on the engine side of the cowl.

The fuel filter on G-P models is mounted on the rear of the inlet manifold under the air cleaner. It is accessible by removing the engine cover.

↔ Remove or Disconnect (Figures 1 and 2)

1. The fuel tank cap to release pressure or vacuum in the tank.
2. The bail wires (1) using a screwdriver.
 - Drain fuel from the filter by opening both the air bleed and water drain valves and allowing fuel to drain into an appropriate container.
3. Filter.

 Clean

- Any dirt from the fuel port sealing surface of the filter adapter and the new filter.

↔ Install or Connect (Figures 1 and 2)

1. New filter.
2. The bail wires.
 - Close the water drain valve and open the air bleed.
3. A 3.18 mm (1/8 inch) inside diameter hose to the air bleed port and the other end into a suitable container.
 - Disconnect the fuel injection pump shut off solenoid wire.

NOTICE: If the engine is to be cranked, or starting attempted with the air cleaner removed, care must be taken to prevent material from being pulled into the air inlet manifold which could result in engine damage.

- Crank the engine for 10-15 seconds and then wait one minute for the starter motor to cool. Repeat until clear fuel is observed coming from the air bleed.

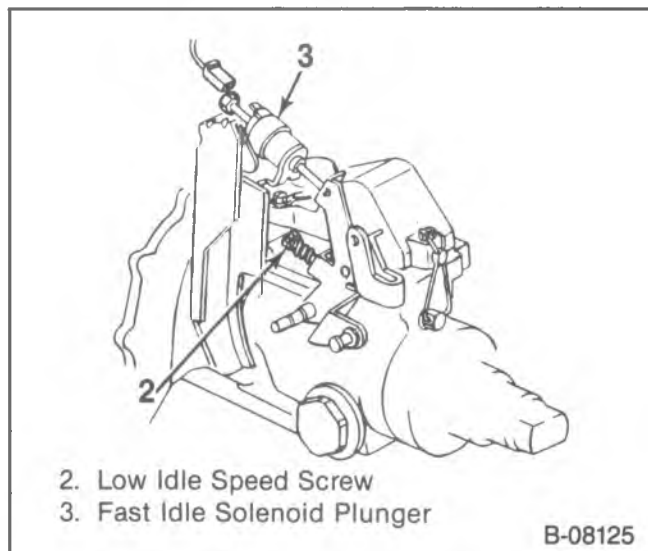

Figure 3—Idle Speed Adjustment Location

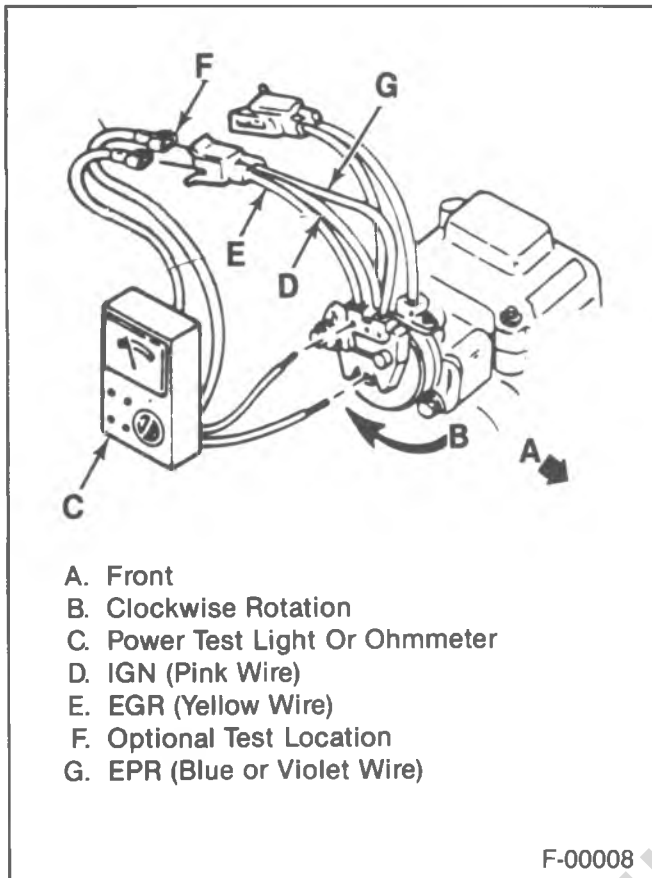

Figure 4—Testing the TPS for Continuity

- Close the air bleed.
- 4. Injection pump solenoid wire.
- 5. Fuel tank cap.
- Start the engine and allow it to idle for five minutes.



Inspect

- Fuel filter for leaks.

IDLE SPEED ADJUSTMENT

CURB IDLE SPEED (Figure 3)

Tool Required: J-26925, Tachometer

1. Set the parking brake and block the drive wheels.
2. Engine must be at normal operating temperature with the air cleaner on and all accessories turned off.
3. Install J-26925 or equivalent per manufacturers instructions.
4. Adjust the low idle speed screw (2) on the fuel injection pump to obtain the curb idle speed shown on the Emission Control Information label.

FAST IDLE SPEED (Figure 3)

Tool Required: J-26925, Tachometer

1. Set the parking brake and block the drive wheels.
2. Engine must be at normal operating temperature with the air cleaner on and all accessories turned off.
3. Install J-26925 or equivalent per manufacturers instructions.
4. Remove the connector from the fast idle solenoid.
5. Connect an insulated jumper wire from the positive battery terminal to the solenoid terminal. This will energize the solenoid.

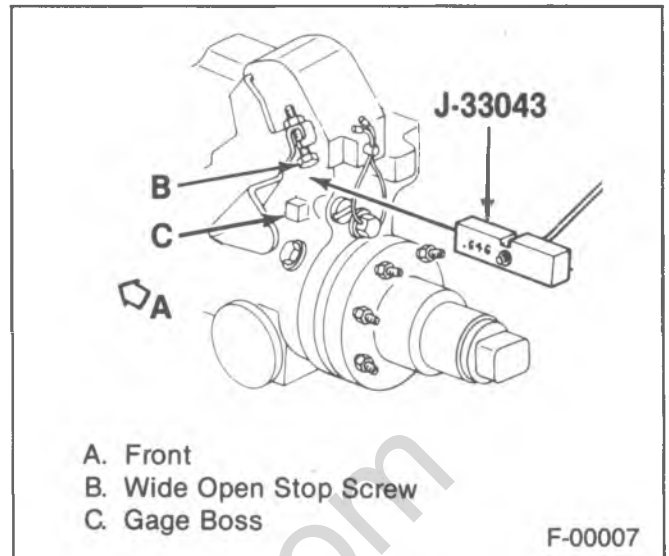

Figure 5—TPS Adjustment Block

6. Open the throttle momentarily to energize and fully extend the fast idle solenoid plunger.
7. Adjust the extended plunger (3) by turning the hex head to obtain the fast idle speed shown on the Emission Control Information label.
8. Remove the jumper wire and install the connector to the fast idle solenoid.

THROTTLE POSITION SWITCH ADJUSTMENT (LH6 ENGINE WITH 700 R4 TRANSMISSION)

Tool Required: J-33043-A, Gage Block

1. Disconnect the throttle position switch (TPS) connector.
2. Loosen the mounting screws that hold the TPS.
3. Connect an ohmmeter or test light to the IGN (pink) and EGR (yellow) terminals of the TPS (figure 4).
4. Insert the proper "switch closed" gage block between the gage boss on the injection pump and the wide open stop screw on the throttle shaft (figure 5).
 - Refer to the Emission Control Information label for correct gage block.
5. Rotate the throttle lever and hold the wide open stop screw against the gage block.
6. Rotate the TPS until there is continuity between the terminals.
7. Hold the TPS and tighten the mounting screws to 6 N·m (53 in. lbs.).
8. Return the throttle lever to the idle position and remove the gage block.
9. Insert the proper "switch open" gage block and rotate the throttle lever against the block. There should be no continuity. If there is continuity, repeat steps 1 through 9.
 - Refer to the Emission Control Information label for correct gage block size.
10. Remove the gage block and ohmmeter.
11. Connect the TPS connector.

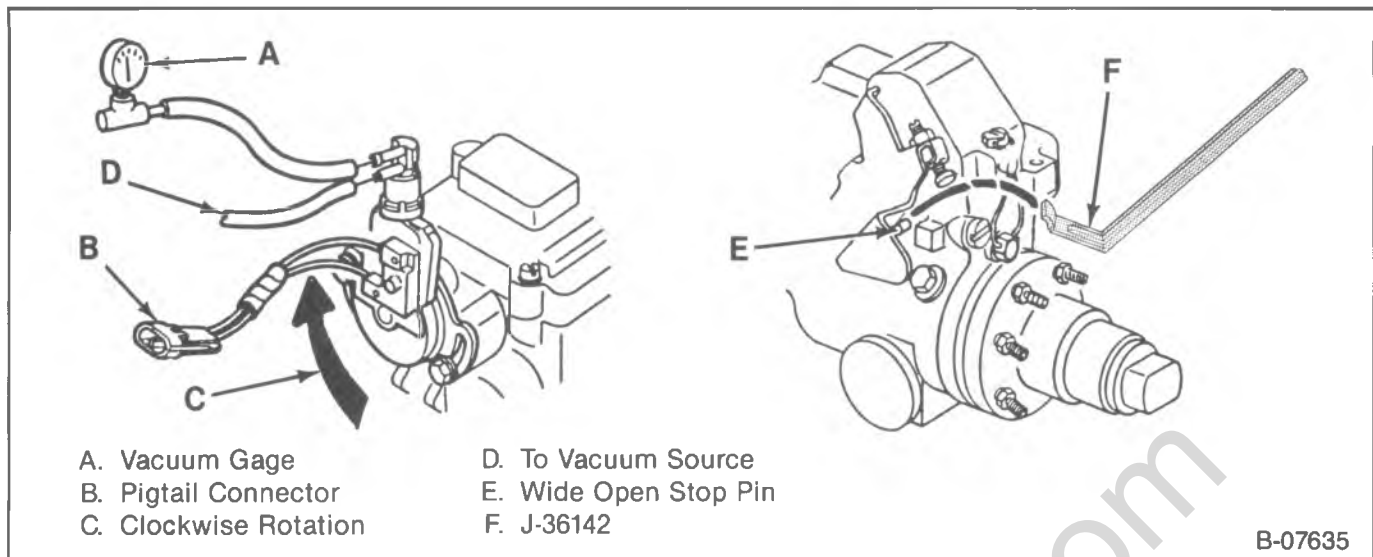

Figure 6—VRV/Detent Switch Adjustment

VACUUM REGULATOR VALVE ADJUSTMENT (LL4 ENGINE WITH AUTOMATIC TRANSMISSION)

Tool Required:

J-33043-A, Gage Block

J-36142, Switch Gage Tool

1. Loosen the vacuum regulator valve (VRV) so it is free to rotate on the pump.
 2. Attach a vacuum source of 67 ± 5 kPa (20 inches Hg ± 1.5 inch Hg) to the bottom vacuum port of the VRV.
 3. Attach a vacuum gage to the top vacuum port (figure 6).
 4. Insert the proper gage block between the gage boss on the injection pump and the wide open stop screw on the throttle lever (switch on position) (figure 5).
 - Refer to the Emission Control Information label for correct gage block size.
 5. Rotate the throttle shaft and hold it against the gage block.
- NOTICE: Valve must be set while rotating the valve body clockwise only.**
6. Slowly rotate the vacuum regulator valve body clockwise (facing the valve) until the vacuum gage reads 38.8 ± 2 kPa (11.5 ± 0.6 inches Hg). Hold the valve body at this position and tighten the mounting screws to 6 N·m (54 in. lbs.).
 7. Check by allowing the throttle shaft to return to the idle stop position. Then rotate the throttle shaft back against the gage block and read the vacuum gage. The gage should read 38.8 ± 2 kPa (11.5 ± 0.6 inches Hg). If vacuum is outside of limits, reset the valve.
 8. With the valve vacuum set, confirm the detent switch point by reading the resistance between the ignition terminal (pink with black stripe) and the detent terminal (orange).
 9. Insert J-36142 between the wide open stop pin and the wide open stop screw on the throttle lever.
 10. Rotate the throttle lever against the tool. There should be no continuity (infinite resistance).

11. Release the throttle lever and remove the switch gage tool.
12. Rotate the throttle lever to wide open throttle (the lever stop screw touching the pump stop pin).
13. Check the switch for continuity. The switch must have continuity (1 to 0 ohms) before the throttle reaches the wide open throttle position. If the switch does not meet these specifications, reset the assembly by returning to step 1 and repeating the entire procedure.

HOUSING PRESSURE COLD ADVANCE

The Housing Pressure Cold Advance feature advances the injection timing about four degrees during cold operation. This provides better cold starts, improved cold idle, and emission control.

The circuit is actuated by a coolant temperature switch on the rear of the right cylinder head. The switch is calibrated to open the circuit at 35°C (95°F). Below the switching point, timing is advanced by decreasing housing pressure from 68.95 kPa (10 psi) to zero. Above the switching point, the housing pressure is returned to 68.95 kPa (10 psi). The fast idle solenoid is energized by the same switch.

INJECTION LINE REPLACEMENT



Clean

- All line fittings that will be loosened or removed.



Remove or Disconnect (Figures 7 and 8)

Tool Required: J-29664-1, Protective Covers

1. Battery negative cables.
2. Engine cover (G-Van only).
3. Air cleaner at the valve cover.
4. Crankcase ventilator bracket.
5. Intake manifold bolts.

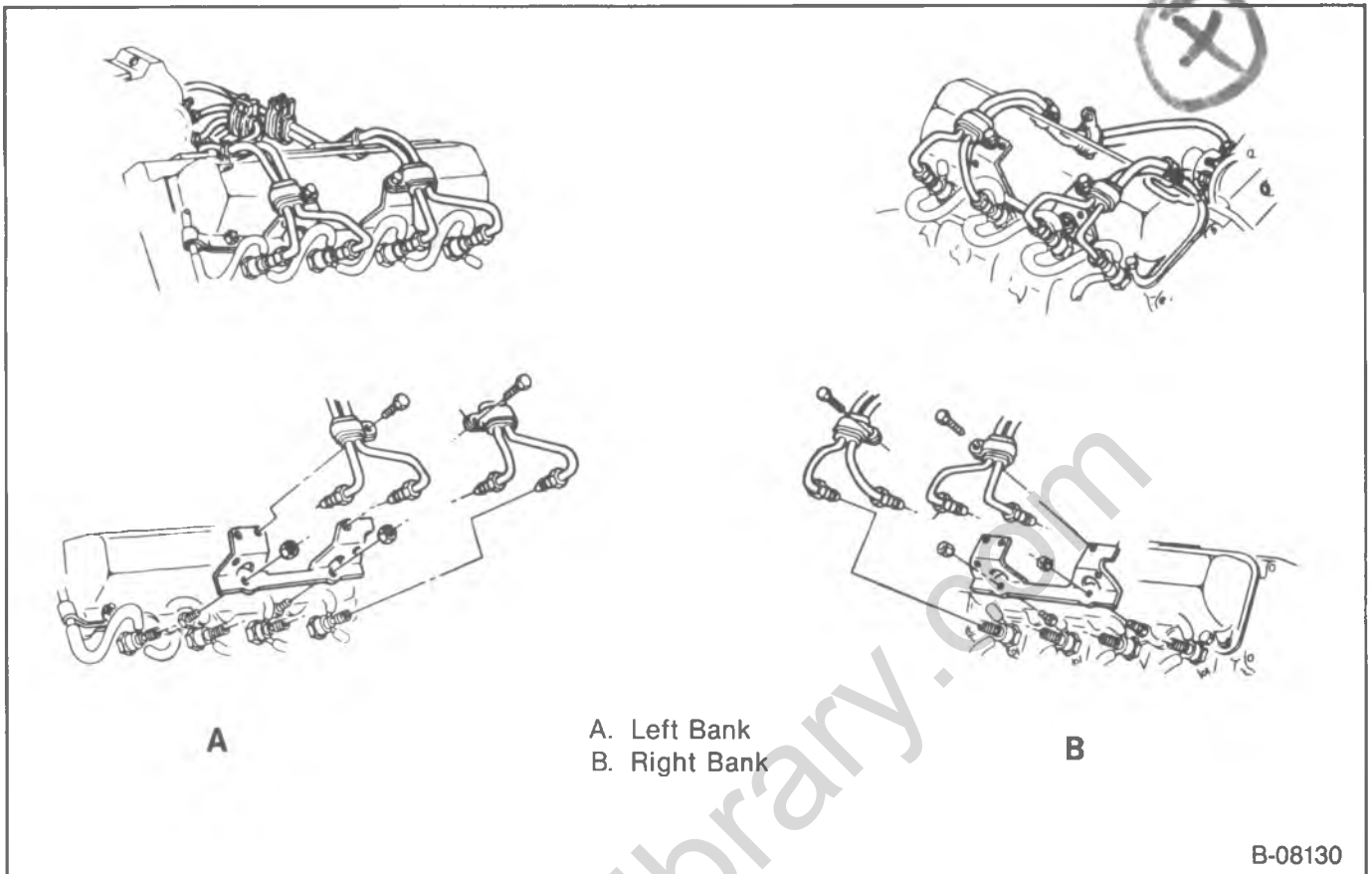

Figure 7—Fuel Injection Lines

- It may be necessary to loosen the vacuum pump hold down clamp and rotate the pump to gain access to all intake manifold bolts.
6. Injection line clips.
 7. Intake manifold.
 - Install J-29644-1 to the intake ports.
 8. Injection line clips at the loom brackets.
 - Raise the vehicle (left bank of G-Van only).
 9. Injection lines at the nozzles.
 - Cap the lines and nozzles immediately.
 - Do not bend injection lines.
 10. Injection lines at the pump.
 - Cap the lines and the pump fittings immediately.
 - Tag the lines for installation.

⇄ Install or Connect (Figures 7 and 8)

1. Injection lines at the pump.
 - Uncap the lines and pump fittings.
 - Refer to the tags for correct installation.
- Raise the vehicle (left bank of G-Van only).
2. Injection lines at the nozzles.
 - Uncap the lines and nozzles.

⌚ Tighten

- Fittings to 25 N·m (20 ft. lbs.).
3. Injection line clips at the loom brackets.
 4. Intake manifold.
 - Remove J-29664-1.
 5. Injection line clips.
 6. Intake manifold bolts.

⌚ Tighten

- Bolts to 40 N·m (30 ft. lbs.).
7. Crankcase ventilator bracket.
 8. Air cleaner.
 9. Engine cover (G-Van only).
 10. Battery negative cables.

INJECTION PUMP REPLACEMENT

R-V TRUCK

⇄ Remove or Disconnect

Tool Required: J29664-1, Protective Covers

1. Battery negative cable.
2. Intake manifold.
 - Refer to 6.2 LITER DIESEL (SEC. 6A6).
3. Injection lines.
4. Accelerator cable at the injection pump (figure 9).
5. Detent cable (if equipped).
6. Fuel return line at the top of the injection pump.
7. Fuel inlet line from the injection pump.
8. All necessary wires and hoses from the injection pump.
9. Air conditioning hose retainer bracket (if equipped).
10. Oil fill tube (includes CDR valve vent hose).
11. Grommet.
 - Scribe or paint a mark on the front cover and the injection pump flange.
 - Rotate the engine to gain access to the bolts that hold the driven gear to the injection pump.

B-08130

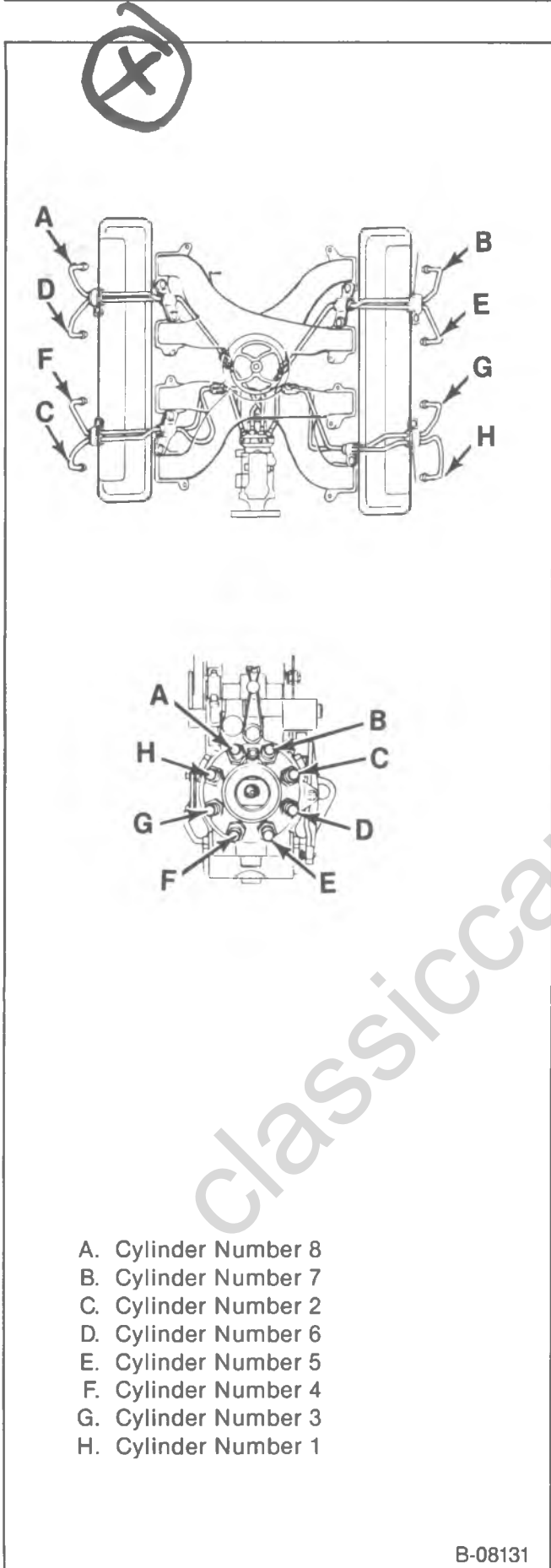

Figure 8—Injection Line Routing

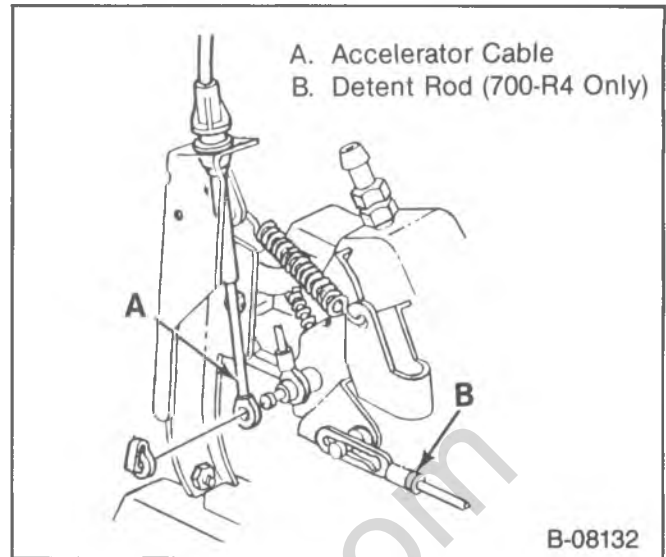

Figure 9—Accelerator Linkage

— Access is gained through the oil filler neck hole (figure 10).

12. Bolts (10).
13. Nuts (11) (figure 11).
14. Pump.
 - Cap all open lines and nozzles.
15. Gasket (12).

Install or Connect

1. New gasket (12).
2. Injection pump to the front cover.
 - Align the locating pin on the pump hub (14) with the slot in the injection pump driven gear (13) (figure 12).
 - Align the timing marks (figure 13).
3. Nuts (11) (figure 11).

Tighten

- Nuts to 40 N·m (30 ft. lbs.).
 - Check the timing mark alignment before fully torquing the nuts.
- 4. Drive gear to injection pump bolts (10) (figure 11).

Tighten

- Bolts to 25 N·m (20 ft. lbs.).
- 5. Grommet.

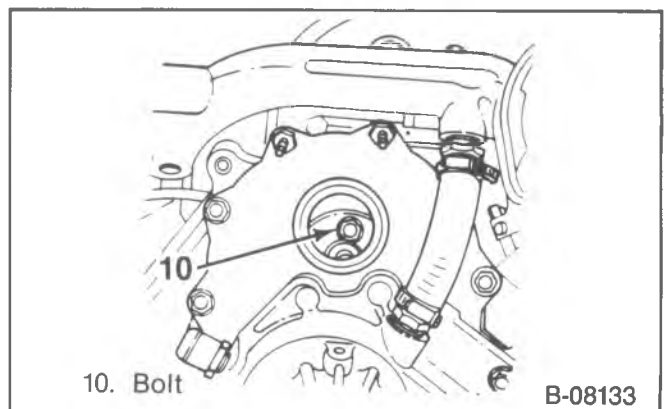

Figure 10—Pump Drive Gear Bolts

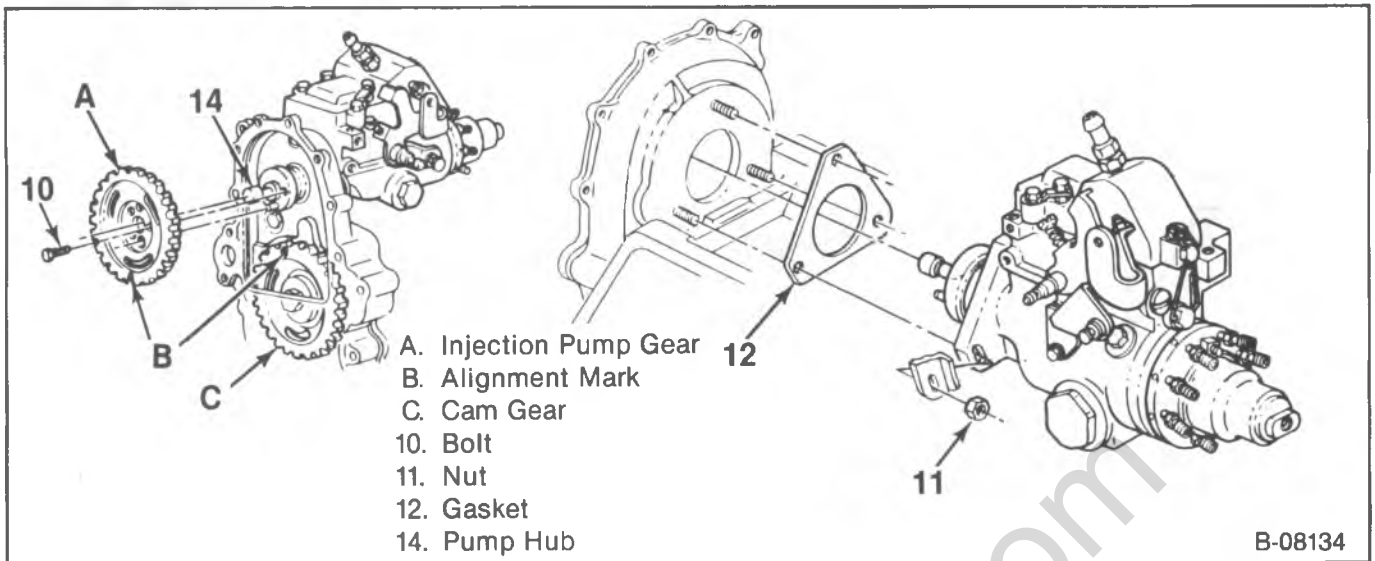

Figure 11—Injection Pump Installation

6. Oil fill tube including the CDR valve vent hose.
7. Air conditioning hose retainer bracket (if equipped).
8. Fuel feed line at the injection pump.



Tighten

- Fitting to 25 N·m (20 ft. lbs.).
9. Fuel return line to the top of the injection pump.
 10. Detent cable (if equipped).
 11. All necessary wires and hoses.
 12. Accelerator cable.
 13. Injection lines.
 14. Intake manifold.
 - Refer to 6.2 LITER DIESEL (SEC. 6A6).
 15. Battery negative cable.

G-VAN



Remove or Disconnect

Tool Required: J-29664-1, Protective Covers

1. Battery negative cable.
2. Engine cover.

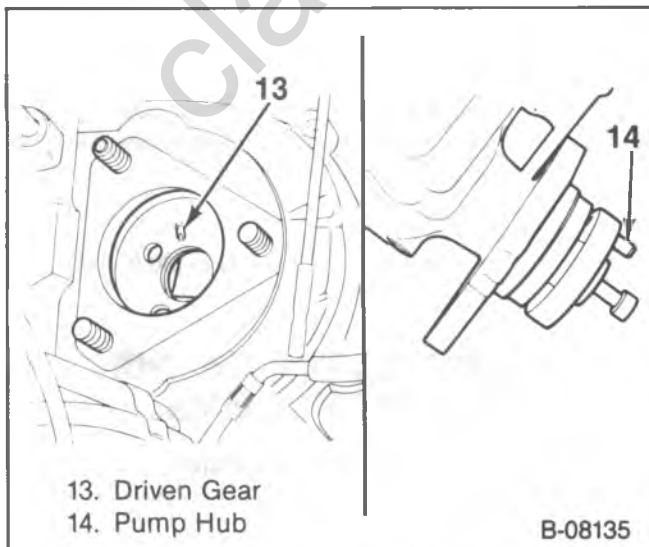

13. Driven Gear
14. Pump Hub

B-08135

Figure 12—Injection Pump Locating Pin

3. Intake manifold.
 - Refer to 6.2 LITER DIESEL (SEC. 6A6).
4. Air cleaner inlet hose.
 - Rotate the snorkel up.
5. Hood latch.
6. Hood latch cable and move it aside.
7. Windshield washer bottle.
8. Fan shroud bolts.
9. Upper fan shroud.
10. Rubber hose from the oil fill tube.
11. The oil fill tube nuts.
12. The oil fill tube.
13. The oil fill tube grommet.
14. The drive gear to injection pump bolts (10) (figure 10).
 - Rotate the engine as necessary.
15. Fuel filter and bracket including the line to the injection pump.
16. Wire looms from the injection lines.
17. Injection lines from the brackets.
18. The oil pan dipstick tube at the left cylinder head.
19. Electrical connections at the injection pump.
20. Detent cable (if equipped).
21. Accelerator cable.
22. Injection lines.
23. Fuel return line.
 - Scribe or paint a mark on the front cover and the injection pump flange.
24. Pump to front cover attaching nuts (11) (figure 11).
25. Injection pump.
 - Cap all open discharge fittings.
26. Gasket (12).



Install or Connect

1. New gasket.
2. Injection pump to the front cover.
 - Align the locating pin on the pump hub with the slot in the injection pump driven gear (figure 12).
 - Align the timing marks (figure 13).
3. Nuts (11).

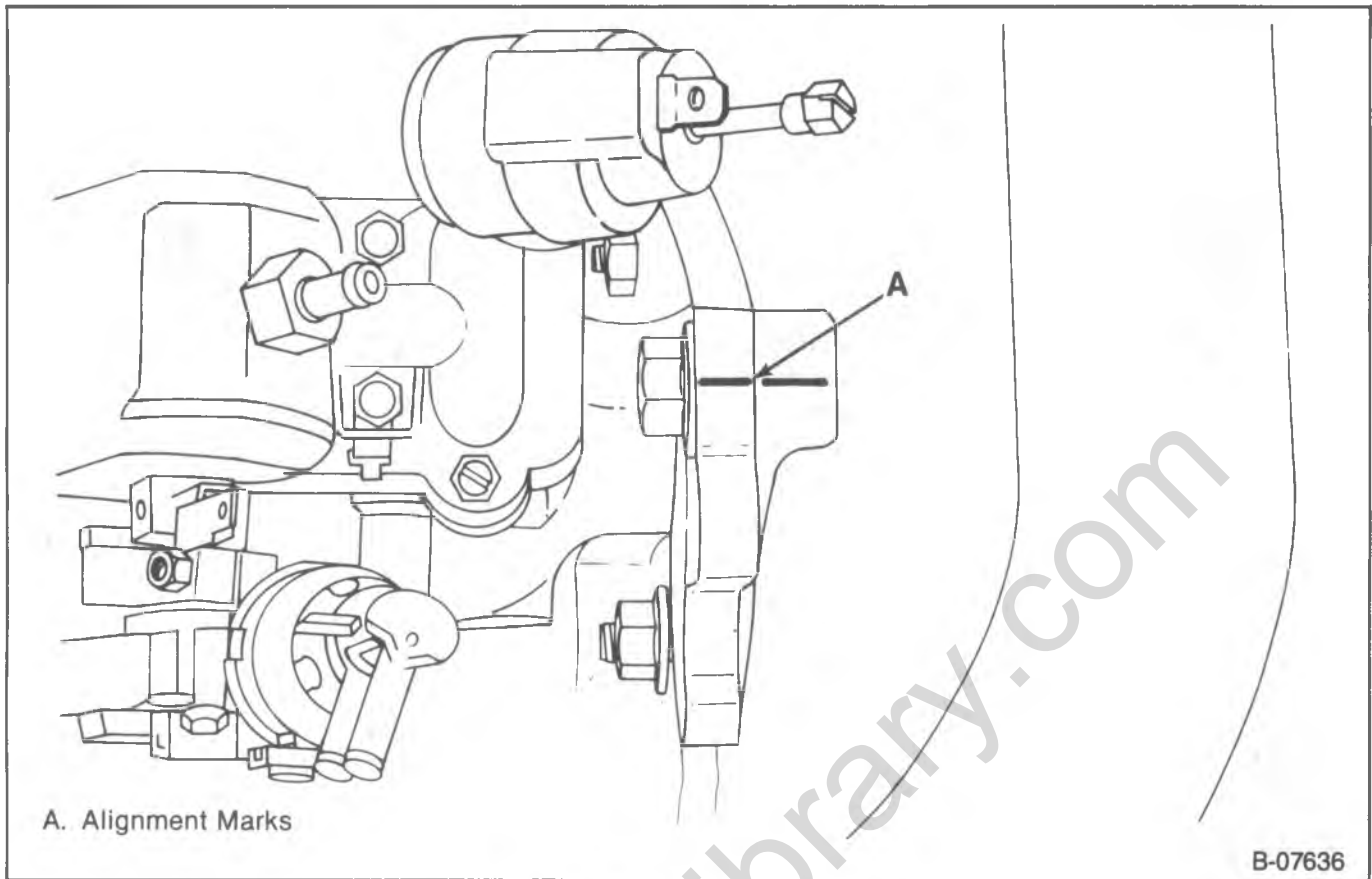

Figure 13—Timing Alignment Marks



Tighten

- Nuts to 40 N·m (30 ft. lbs.).
 - Check the timing mark alignment before fully torquing the nuts.

4. Drive gear to injection pump bolts (10).



Tighten

- Bolts to 25 N·m (20 ft. lbs.).
5. Fuel return line.
 6. Injection lines.
 7. Accelerator cable.
 8. Detent cable (if equipped).
 9. Electrical connections at the injection pump.
 10. The oil pan dipstick tube at the left cylinder head.
 11. Injection lines to the brackets.
 12. Wire looms to the injection lines.
 13. Fuel filter and bracket including the line to the injection pump.
 14. The oil fill tube grommet.
 15. The oil fill tube.
 16. The oil fill tube nuts.
 17. Rubber hose to the oil fill tube.
 18. Upper fan shroud.
 19. Fan shroud bolts.
 20. Windshield washer bottle.
 21. Hood latch cable.
 22. Hood latch.
 23. Air cleaner inlet hose.
 - Refer to 6.2 LITER DIESEL (SEC. 6A6).
 25. Engine cover.

26. Battery negative cable.

INJECTION TIMING ADJUSTMENT

For the engine to be properly timed, the marks on the top of the engine front cover must be aligned with the marks on the injection pump flange (figure 13). The engine must be off when the timing is reset. On Federal models, align the scribe marks. On California models, align the half circles.



Adjust

1. Injection timing.
 - Loosen the three pump retaining nuts.
 - Align the mark on the injection pump with the mark on the front cover.



Tighten

- Pump retaining nuts to 40 N·m (30 ft. lbs.).
2. Throttle rod.

MARKING TDC ON THE FRONT HOUSING

Tool Required: J-33042, Timing Fixture

1. Set the engine so that number 1 cylinder is at TDC (firing).
2. Install J-33042 in the injection pump location.
 - Do not use the gasket.

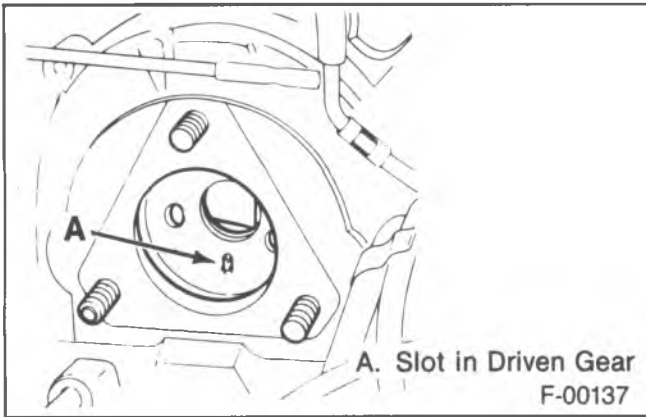

Figure 14—Slot In Injector Pump

3. The slot in the injection pump gear should be in the vertical 6 o'clock position (figure 14). If not, remove J-33042 and rotate the engine crankshaft 360 degrees. The timing marks on the gears will be aligned.
4. Fasten J-33042 to the gear and tighten (figure 15).
5. Install one 10 mm nut to the upper housing stud to hold the tool flange.
 - The nut should be finger tight.
6. Tighten the large bolt (18 mm head) clockwise (looking at the front of the engine) to 48 N·m (35 ft. lbs.).
7. Tighten the 10 mm nut.
8. Check that the crankshaft has not rotated and that the tools did not bind.
9. Strike the scribe with a mallet to mark TDC on the front housing.
10. Remove J-33042.

↔ Install or Connect

1. Gasket.
2. Injection pump.
3. Nuts (finger tight).
4. One 8 mm bolt to attach the gear to the pump hub.

⌚ Tighten

- Bolt to 25 N·m (20 ft. lbs.).
- Injection pump nuts to 40 N·m (30 ft. lbs.).

— Align the timing mark on the injection pump flange with the mark on the front cover.

5. Remaining pump gear attaching bolts.

- Rotate the engine to gain access to the bolts.

⌚ Tighten

- Bolts to 25 N·m (20 ft. lbs.).

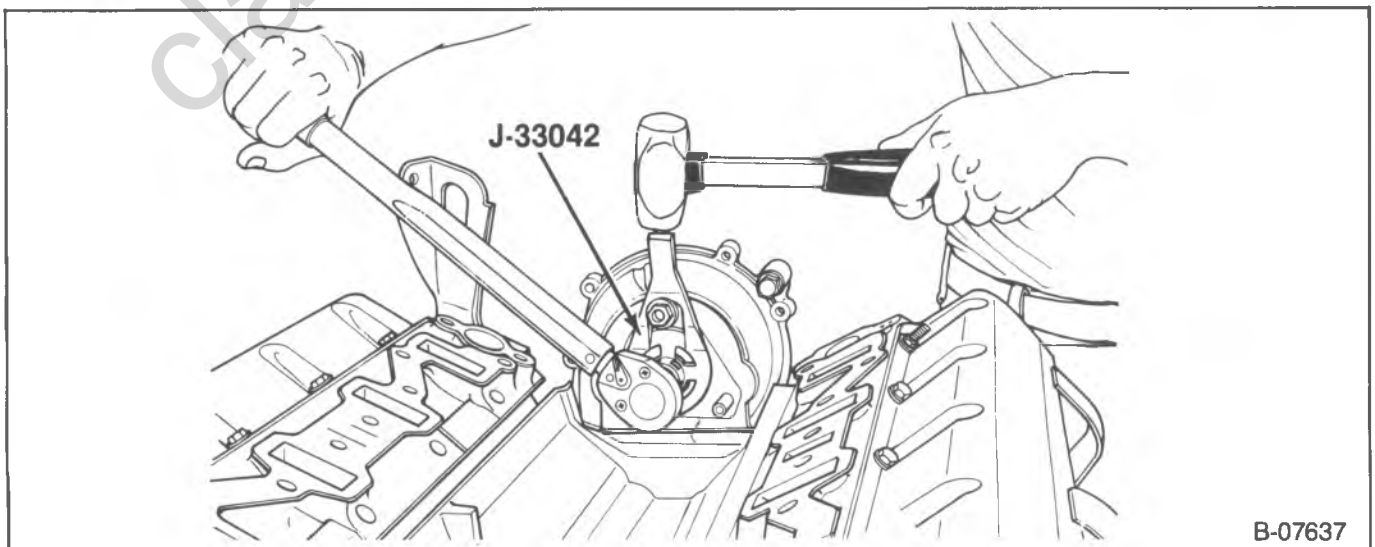

Figure 15—Marking TDC on the Front Housing

INJECTION NOZZLES

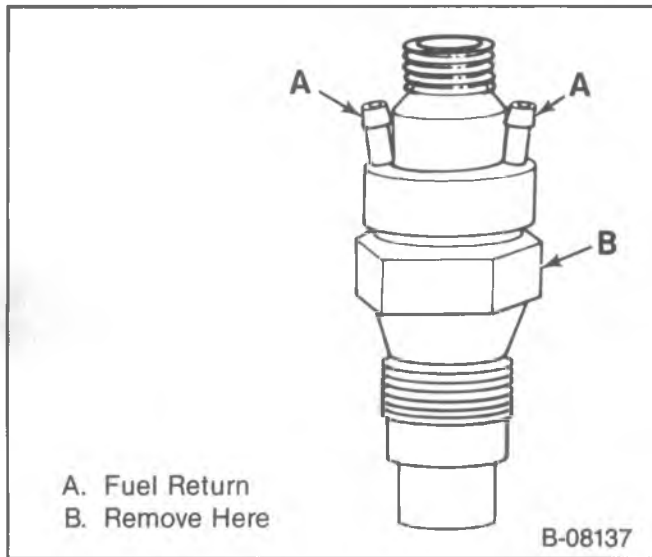

Figure 16—Injection Nozzle

Nozzles used in G models are shorter than nozzles used on R-V and P models. Attempts to use the incorrect nozzle will damage the cylinder heads. When replacing nozzles, reference should be made to the part number which is stamped on the side of the nozzle (figure 16).

INJECTION NOZZLE REPLACEMENT

Remove or Disconnect (Figure 17)

Tool Required: J-29873, Nozzle Socket

1. Negative battery cable.
2. Fuel line clip.
3. Fuel return hose.
4. Fuel injection line.
 - Cap the nozzle and lines.

NOTICE: When removing an injection nozzle, use J-29873. Remove the nozzle using the 30 mm hex portion (figure 16). Failure to do so will result in damage to the injection nozzle.

5. Injection nozzle using J-29873.

Install or Connect (Figure 17)

Tool Required: J-29873, Nozzle Socket

NOTICE: When installing an injection nozzle, use J-29873. Install the nozzle using the 30 mm hex portion (figure 16). Failure to do so will result in damage to the injection nozzle.

1. Injection nozzle using J-29873.

Tighten

- Nozzle to 70 N·m (50 ft. lbs.).
2. Fuel injection line.

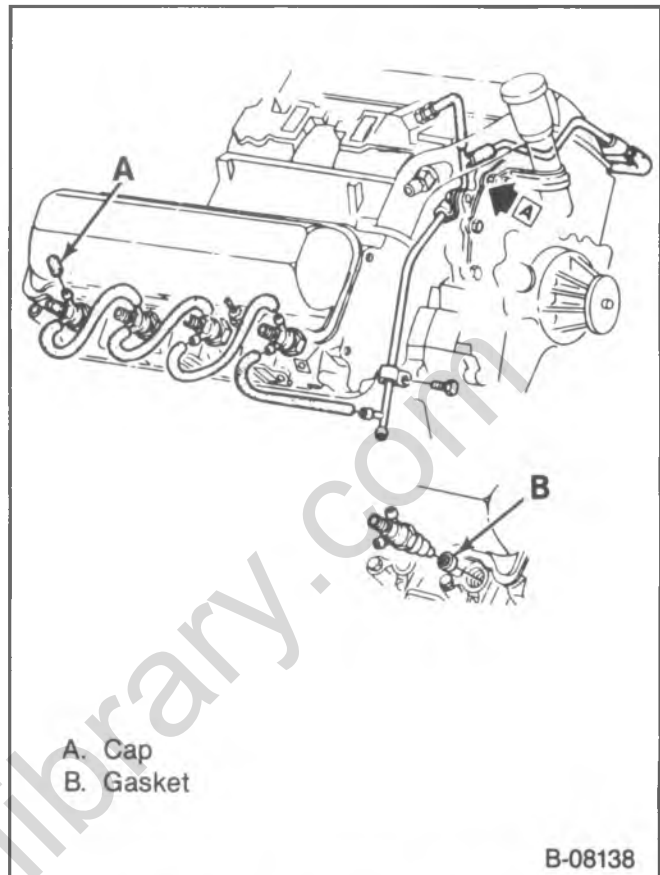

Figure 17—Injection Nozzles

Tighten

- Nut to 25 N·m (20 ft. lbs.).
3. Fuel return hose.
 4. Fuel line clip.
 5. Negative battery cable.

INJECTION NOZZLE TESTS

Nozzle testing is comprised of the following checks:

- Nozzle opening pressure
- Leakage
- Chatter
- Spray pattern

Each test should be considered independent of the others (for example, when checking opening pressure, do not check for leakage).

If all of the above tests are satisfied, the nozzle holder assembly can be re-used. If any one of the tests is not satisfied, the complete nozzle holder assembly must be replaced. The nozzle holder will then be checked and repaired at a centralized location.

- Test Lines - 6 × 2 × 400 mm (1.5 mm bore).
- Test Fluid - per ISO 4113 (Example: Shell V 1399, Viscosity 1487C or equivalent).
- Kinetic Viscosity at 40° - per ISO 3104: 2.45 - 2.75 mm²/second.
- Test oil temperature during test: 20 - 25°C (68°F - 77°F).

- Refer to the equipment manufacturers instructions for exact test procedures.
1. Connect the nozzle holder assembly to the test line.
 2. Place clear plastic tubes on overflow connections to prevent leakoff from being confused with actual leak.
 3. Close the shutoff valve to the pressure gage.

CAUTION: When testing nozzles, do not place your hands or arms near the tip of the nozzle. The high pressure atomized fuel spray from a nozzle has sufficient penetrating power to puncture flesh and destroy tissue and may result in blood poisoning. The nozzle tip should always be enclosed in a receptacle, preferably transparent, to contain the spray.

4. Fill and flush the nozzle holder assembly with test oil by activating the lever briskly and repeatedly. This will apply test oil to all functionally important areas of the nozzle and purge it of air.

OPENING PRESSURE TEST

1. Open the shutoff valve at the pressure gage one-quarter turn.

CAUTION: When testing nozzles, do not place your hands or arms near the top of the nozzle. The high pressure atomized fuel spray from a nozzle has sufficient penetrating power to puncture flesh and destroy tissue and may result in blood poisoning. The nozzle tip should always be enclosed in a receptacle preferably transparent, to contain the spray.

2. Depress the tester lever slowly. Note at what pressure the needle of the pressure gage stopped. The maximum observed pressure is the opening pressure.
 - Some nozzles may pop while other nozzles may drip down (this is not leakage).
3. The opening pressure should not fall below the lower limit of 105 bar (1500 psi) on used nozzles.
4. Replace nozzles which fall below the lower limit.

LEAKAGE TEST

1. Further open the shutoff valve at the pressure gage $\frac{1}{2}$ to 1 $\frac{1}{2}$ turns).
2. Blow-dry the nozzle tip.

CAUTION: When testing nozzles, do not place your hands or arms near the top of the nozzle. The high pressure atomized fuel spray from a nozzle has sufficient penetrating power to puncture flesh and destroy tissue and may result in blood poisoning. The nozzle tip should always be enclosed in a receptacle preferably transparent, to contain the spray.

3. Depress the lever of the manual test stand slowly until the gage reads a pressure of 95 bar (1400 psi). Observe the nozzle tip. A drop may form on the end of the nozzle but should not drop off within a period of 10 seconds.
4. Replace the nozzle assembly if a drop falls during the 10 seconds.

CHATTER TEST

When testing for chatter, it should be noted that the sound (chatter) for new and used nozzles may vary. This is due to carbonized fuel deposits on the pintle and nozzle tip of used nozzles. With some used nozzles, chatter is difficult to detect during slow actuation of the hand lever.

Some nozzles may chatter louder than others. As long as there is chatter, the nozzle is acceptable.

1. Close the shutoff lever at the pressure gage.

CAUTION: When testing nozzles, do not place your hands or arms near the top of the nozzle. The high pressure atomized fuel spray from a nozzle has sufficient penetrating power to puncture flesh and destroy tissue and may result in blood poisoning. The nozzle tip should always be enclosed in a receptacle preferably transparent, to contain the spray.

2. Depress the lever of the test stand slowly and note whether chatter noise can be heard.
3. If no chatter is heard, move the lever faster until it chatters. At fast lever movement, the nozzle may make a "hissing" or "squealing" sound rather than the normal chatter. This is acceptable.
4. These sounds indicate that the nozzle needle moves freely and that the nozzle seat, guide, and pintle are OK.
5. Replace nozzles that do not chatter.

SPRAY PATTERN

This nozzle features a longer nozzle overlap, greater pintle to body clearance, greater needle to body clearance, and an internal wave washer between the nozzle nut and the nozzle. These features make objective spray pattern testing difficult.

A pop tester will not deliver fuel fast enough for proper spray pattern analysis. Based on this, this type of nozzle should not be rejected for spray pattern.

INJECTION PUMP ON-VEHICLE SERVICE

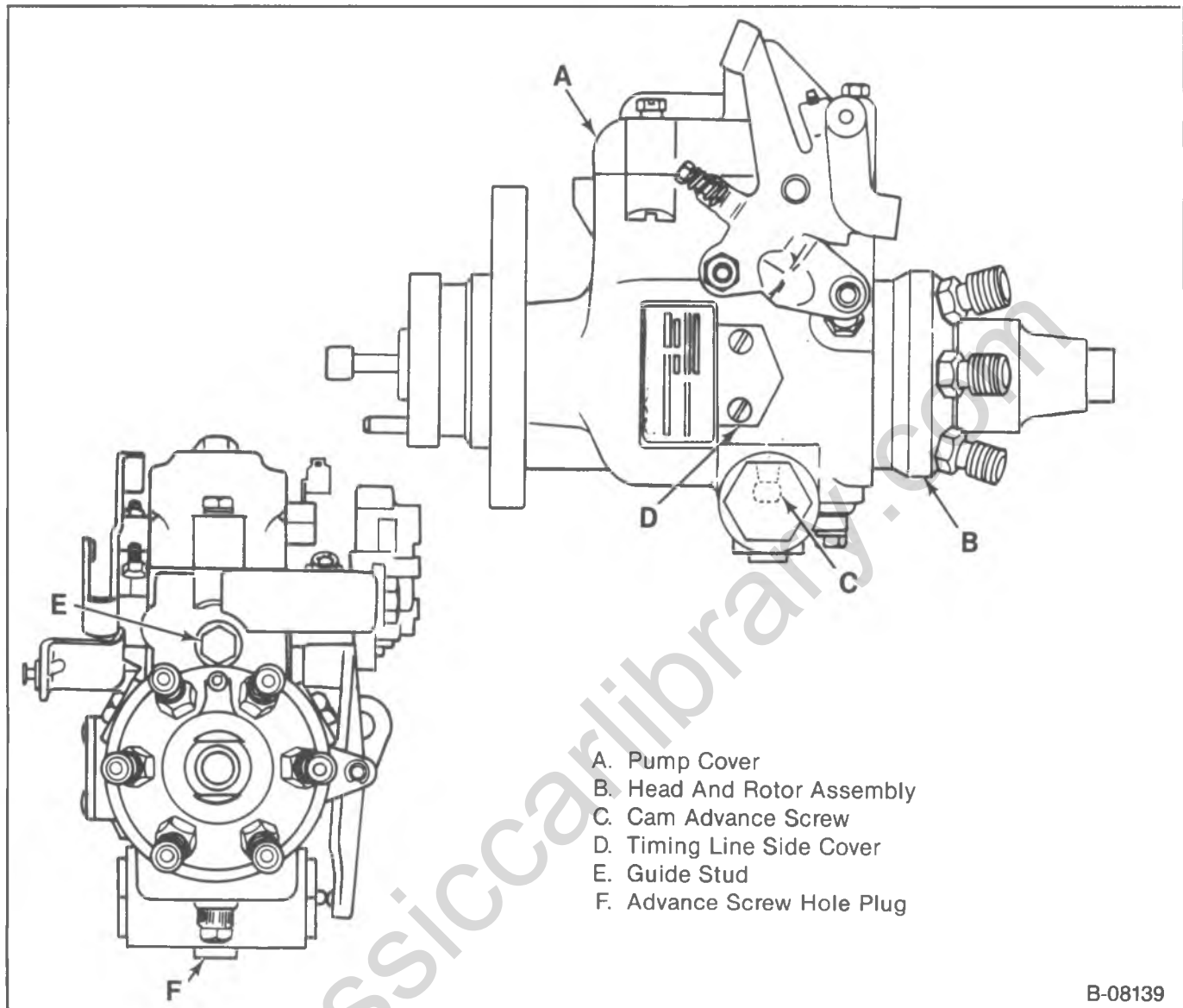

Figure 18—Injection Pump Components Location

Refer to figure 18 for injection pump components location.

PUMP COVER SEAL AND/OR GUIDE STUD SEAL REPLACEMENT

↔ Remove or Disconnect

Tool Required: J-29664, Manifold Cover Set

1. Negative battery cables.
2. Air cleaner and intake manifold.
 - Install J-29664 in the cylinder heads.
3. Injection pump fuel solenoid wire.
4. Housing pressure cold advance wire.
5. Fuel return line.
6. Top attaching bolt and loosen the lower attaching bolt on the fast idle solenoid. Move the solenoid aside.

7. Injection pump cover screws.



Clean

- Injection pump cover.
- Upper portion of the pump.
- The guide stud area.
- Place several rags in the engine valley to catch fuel.

NOTICE: Extreme care must be used to keep foreign material out of the pump when the cover is off. If any objects are dropped into the pump, they must be removed before the engine is started or injection pump and engine damage could occur.

8. Injection pump cover.
9. The guide stud and washer.
 - Note location of parts prior to removal.

B-08139

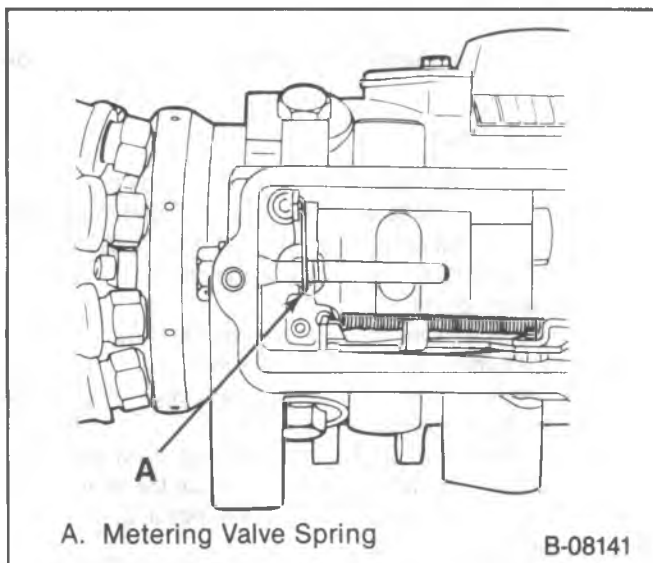

A. Metering Valve Spring

B-08141

Figure 19—Metering Valve Spring Position

- Observe the position of the metering valve spring over the top of the guide stud (figure 19). This position must be exactly duplicated during assembly.

10. Pump cover seal from the pump cover.

↔ Install or Connect

1. The guide stud with a new washer.
 - Make sure that the upper extension of the metering valve spring rides on top of the guide studs.

⌚ Tighten

- The guide stud to 9.5 N·m (85 in. lbs.).
 - Overtightening the guide stud may strip the aluminum threads in the housing.
2. New pump cover seal in the pump cover.
 3. The pump cover.
 - The screws should not be in the pump cover.
 - Position the cover about 6 mm (1/4-inch) forward (toward the shaft end) and about 3 mm (1/8-inch) above the pump (figure 20).
 - Move the cover rearward and downward into position, being careful not to cut the seal.
 - Hold throttle in the idle position.

4. The cover screws.
 - Be careful not to drop or lose the flat washer and spring washer on each screw.
 - The flat washer must be against the pump cover.

⌚ Tighten

- Screws to 3.7 N·m (33 in. lbs.).

5. Battery negative cables.

🔍 Inspect

- Turn the ignition switch to the run position and touch the pink wire to the solenoid connector. A clicking noise should be heard as the wire is connected and disconnected. If this clicking is not heard, the linkage may be jammed in the wide open throttle position and the engine **MUST NOT BE STARTED**. If clicking is not heard,

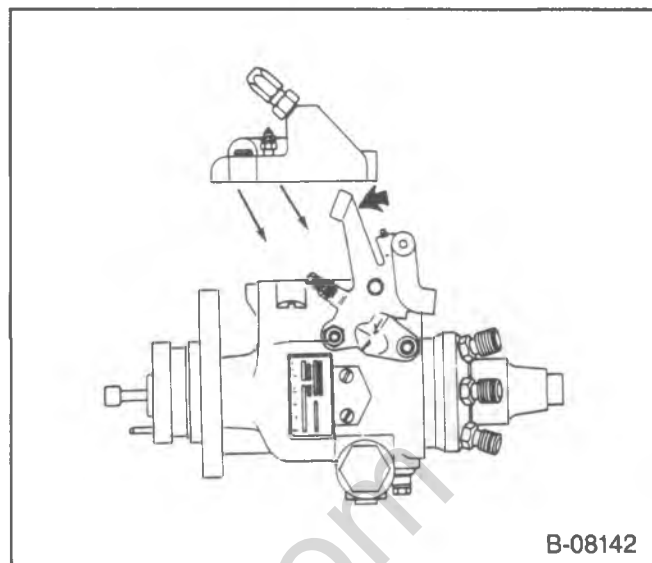

B-08142

Figure 20—Installing the Injection Pump Cover

remove the cover and ground the solenoid lead (opposite the hot lead) and connect the pink wire. With the ignition switch in the run position, the solenoid in the cover should move the linkage. If not, the solenoid must be replaced. Minimum voltage across the terminals must be 12.0. Install the cover and repeat the inspection.

6. Fuel return line, throttle cable, and the return springs.
7. Fast idle solenoid.
8. Housing pressure cold advance wire.
9. Injection pump fuel solenoid wire.
 - Start the engine and check for leaks.
 - Idle roughness may be observed due to air in the pump. Engine idling will allow the air to purge.
 - It may be necessary to shut the engine down for several minutes to allow air bubbles to rise to the top of the pump.
10. Intake manifold and air cleaner.
 - Remover J-29664.

MINIMUM-MAXIMUM GOVERNOR REPLACEMENT

↔ Remove or Disconnect (Figure 21)

Tool Required:
J-29664, Manifold Cover Set

1. Negative battery cables.
2. Air cleaner and intake manifold.
 - Install J-29664 in the cylinder heads.
3. Injection pump fuel solenoid wire.
4. Housing pressure cold advance wire.
5. Fuel Return line.
6. Fast idle solenoid top attaching bolt.
 - Loosen the lower bolt, and move the solenoid aside.
7. Injection pump cover screws.

🧼 Clean

- Injection pump cover.
- Upper portion of the pump.
- The guide stud area.

6C2-14 DIESEL FUEL INJECTION

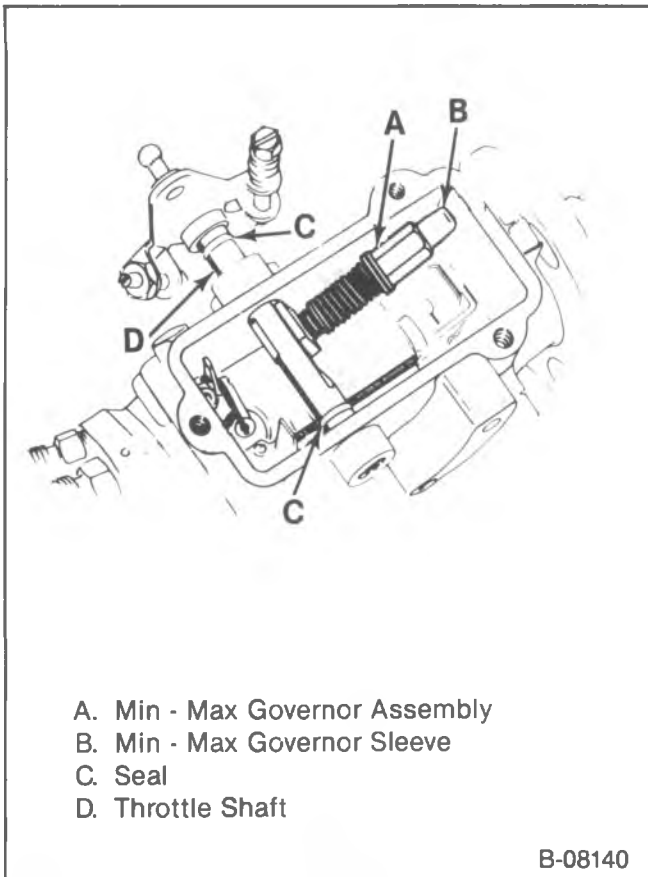

Figure 21—Injection Pump Cover Removed

- Place several rags in the engine valley to catch the fuel.

NOTICE: Extreme care must be used to keep foreign material out of the pump when the cover is off. If any objects are dropped into the pump, they must be removed before the engine is started or injection pump and engine damage could occur.

8. Injection pump cover.
9. The guide stud and washer.
 - Note the location of parts prior to removal.
 - Observe the position of the metering valve spring over the top of the guide stud (figure 19). This position must be exactly duplicated during assembly.
10. Pump cover seal from the pump cover.
11. Minimum-Maximum governor assembly.
 - Rotate the throttle shaft and the governor assembly until the governor clears the housing.
 - Governor assembly from the throttle shaft.

Install or Connect (Figure 21)

1. Minimum-Maximum governor assembly.
 - Rotate throttle shaft to full throttle.
 - Place the slotted portion of the governor assembly onto the throttle shaft slot.
 - Rotate the throttle shaft with governor assembly into the housing.
2. The guide stud with a new washer.

- Make sure that the upper extension of the metering valve spring rides on top of the guide stud.

Tighten

- The guide stud to 9.5 N·m (85 in. lbs.).
 - Overtightening the guide stud may strip the aluminum threads in the housing.
3. New pump cover seal in the pump cover.
 4. The pump cover.
 - The screws should not be in the pump cover.
 - Position the cover about 6 mm (1/4-inch) forward (toward the shaft end) and about 3 mm (1/8-inch) above the pump (figure 20).
 - Move the cover rearward and downward into position, being careful not to cut the seal.
 - Hold throttle in the idle position.
 5. The cover screws.
 - Be careful not to drop or lose the flat washer and spring washer on each screw.
 - The flat washer must be against the pump cover.

Tighten

- Screws to 3.7 N·m (33 in. lbs.).

6. Battery negative cables.

Inspect

- Turn the ignition switch to the run position and touch the pink wire to the solenoid connector. A clicking noise should be heard as the wire is connected and disconnected. If this clicking is not heard, the linkage may be jammed in the wide open position and the engine **MUST NOT BE STARTED**. If clicking is not heard, remove the cover and ground the solenoid lead (opposite the hot lead) and connect the pink wire. With the ignition switch in the run position, the solenoid in the cover should move the linkage. If not, the solenoid must be replaced. Minimum voltage across the terminals must be 12.0. Install the cover and repeat the inspection.
7. Fuel return line, throttle cable, and the return springs.
 8. Fast idle solenoid.
 9. Housing pressure cold advance wire.
 10. Injection pump fuel solenoid wire.
 - Start the engine and check for leaks.
 - Idle roughness may be observed due to air in the pump. Engine idling will allow the air to purge.
 - It may be necessary to shut the engine down for several minutes to allow air bubbles to rise to the top of the pump.
 11. Intake manifold and air cleaner.
 - Remove J-29664.

THROTTLE SHAFT SEAL REPLACEMENT

Remove or Disconnect

Tools Required:

J-29601, Injection Pump Timing Adapter
J-29664, Manifold Cover Set

1. Negative battery cables.

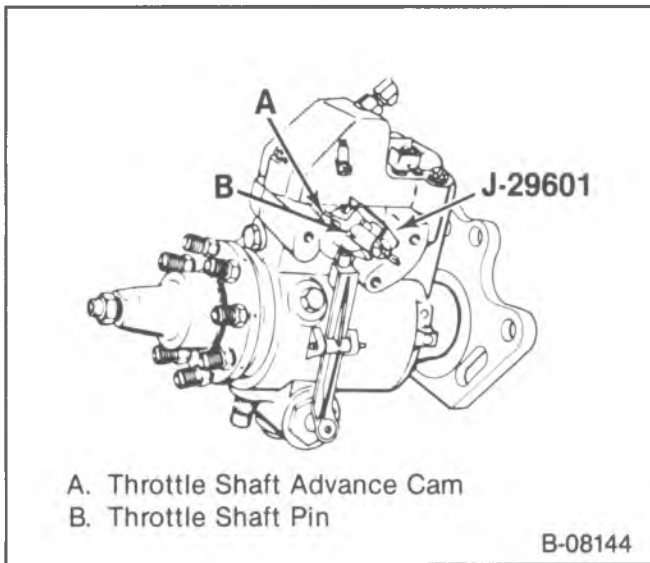

Figure 22—J-29601 Installed on Pump

2. Air cleaner and intake manifold
 - Install J-29664 in the cylinder heads.
3. Injection pump fuel solenoid, housing pressure cold advance wires, and the fuel return line.
4. Throttle rod and the return springs.
 - Mark the position of the TPS switch or VRV for installation.
5. Top attaching bolt on the fast idle solenoid. Move the solenoid aside.
6. Throttle cable bracket.
7. Throttle shaft advance cam and fiber washer.
 - Install J-29601 over the throttle shaft with the slots on the tool engaging the pin (figure 22). Put the spring clip over the throttle shaft advance cam and tighten the wing nut. Pull the tool off of the shaft without loosening the wingnut This provides proper advance cam alignment for assembly.
 - Loosen the face cam screw.
 - Drive the pin from the throttle shaft.
8. Any burrs from the throttle shaft that may have resulted from pin removal.
9. Injection pump cover screws.



Clean

- Injection pump cover.
- Upper portion of the pump.
- The guide stud area.
- Place several rags in the engine valley to catch fuel.

NOTICE: Extreme care must be used to keep foreign material out of the pump when the cover is off. If any objects are dropped into the pump, they must be removed before the engine is started or injection pump and engine damage could occur.

10. Injection pump cover.
11. The guide stud and washer.
 - Note location of parts prior to removal.

- Observe the position of the metering valve spring over the top of the guide stud (figure 19). This position must be exactly duplicated during assembly.
12. Min - max governor assembly (figure 21).
 - Rotate the assembly up to provide clearance.
 - If the idle governor spring becomes disengaged from the throttle block, it must be reinstalled with the tightly wound coils toward the throttle block.
 13. The throttle shaft assembly.



Inspect

- Throttle shaft for unusual wear or damage.
 - Throttle shaft bushings for damage or unusual wear or leaks.
 - Remove the pump and send it to the local Stanadyne dealer if bushing replacement is necessary.
14. The throttle shaft seals.
 - Do not attempt to cut the seals, as nicks in the seal seat will cause leakage.



Install or Connect

Tools Required:

J-29601, Injection Pump Timing Adapter
J-33198, Synkut Oil Seal Lubricant

1. New throttle shaft seals.
 - Use care not to cut the seal on the sharp edges of the shaft.
 - Apply J-33198 or a light coating of clean chassis grease to the seals.
2. The throttle shaft to the point where the min - max governor assembly will slide back onto the shaft.
3. Throttle shaft and governor into position.
 - Rotate the min - max governor assembly downward (figure 21).
4. New mylar washer, the throttle shaft advance cam, and a new throttle shaft drive pin (figure 22).
 - Do not tighten the cam screw.
5. J-29601 over the throttle shaft with the pin in the slots and the spring clip over the advance cam.
6. A 0.005-inch feeler gage between the white washer on the throttle shaft and the pump housing (figure 23).



Tighten

- Cam screw to 3.1 N·m (30 in. lbs.).
 - Squeeze the throttle shaft.
 - Secure the screw with Loctite 290 or equivalent.
 - Remove J-29601.
7. The guide stud with a new washer.
 - Make sure that the upper extension of the metering valve spring rides on top of the guide stud.



Tighten

- The guide stud to 9.5 N·m (85 in. lbs.).
 - Overtightening the guide stud may strip the aluminum threads in the housing.
8. New pump cover seal in the pump cover.
 9. The pump cover.
 - The screws should not be in the pump cover.

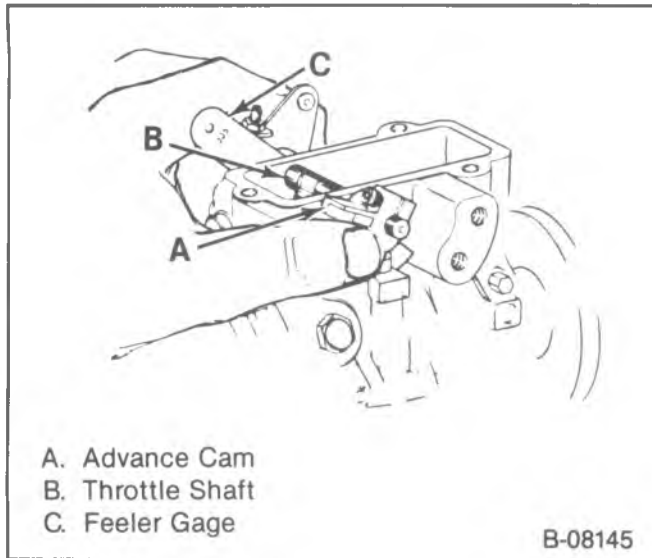

Figure 23—Setting Advance Cam to Housing Clearance

- Position the cover about 6 mm (1/4-inch) forward (toward the shaft end) and about 3 mm (1/8-inch) above the pump (figure 22).
 - Move the cover rearward and downward into position, being careful not to cut the seal.
10. The cover screws.
- Be careful not to drop or lose the flat washer and spring washer on each screw.
 - The flat washer must be against the pump cover.



Tighten

- Screws to 3.7 N·m (33 in. lbs.).

11. TPS switch or VRV.
12. Battery negative cables.



Inspect

- Turn the ignition switch to the run position and touch the pink wire to the solenoid connector. A clicking noise should be heard as the wire is connected and disconnected. If this clicking is not heard, the linkage may be jammed in the wide open throttle position and the engine **MUST NOT BE STARTED**. If clicking is not heard, remove the cover and ground the solenoid lead (opposite the hot lead) and connect the pink wire. With the ignition switch in the run position, the solenoid in the cover should move the linkage. If not, the solenoid must be replaced. Minimum voltage across the terminals must be 12.0. Install the cover and repeat the inspection.
13. Fuel return line, throttle cable, and the return springs.
14. Fast idle solenoid.
15. Housing pressure cold advance wire.
16. Injection pump fuel solenoid wire.
- Start the engine and check for leaks.
 - Idle roughness may be observed due to air in the pump. Engine idling will allow the air to purge.
 - It may be necessary to shut the engine down for several minutes to allow air bubbles to rise to the top of the pump.
17. Intake manifold and air cleaner.
- Remove J-29664.

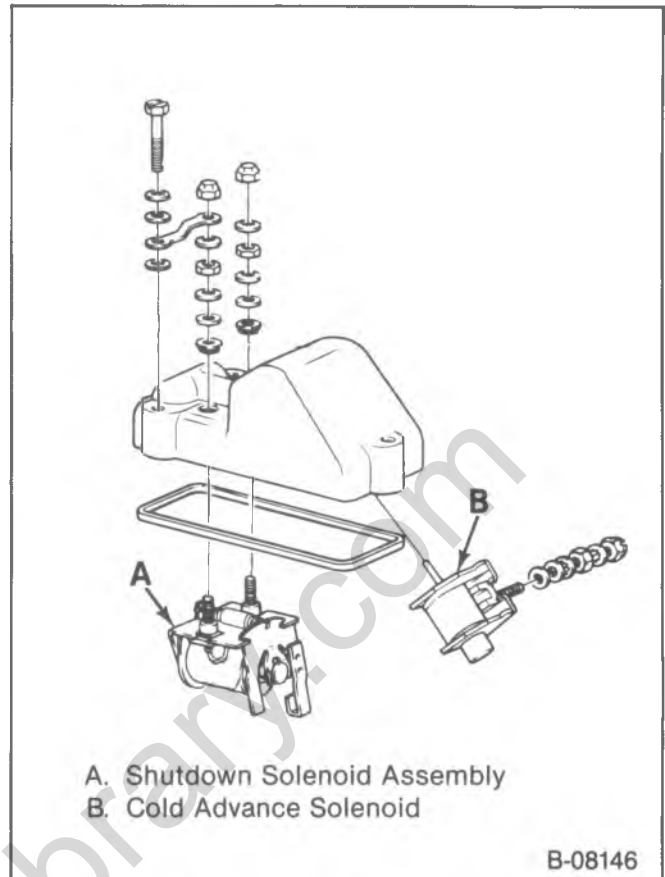

Figure 24—Cold Advance and Shutdown Solenoids

SHUTDOWN AND/OR COLD ADVANCE SOLENOID REPLACEMENT



Remove or Disconnect (Figure 24)

- Pump cover.
 - Refer to "Pump Cover Seal And/Or Guide Stud Seal Replacement."
- Terminal contact nuts.
- Solenoid.
 - Note the positions of the insulating washers.



Install or Connect (Figure 24)

- Solenoid in the pump cover.
 - On the shutdown solenoid, make sure that the linkage is free.
 - On the cold advance solenoid, make sure that the plunger is centered so that it will contact the check ball in the fitting.
- Insulating washers on the terminal studs (where used).
- Terminal nuts.



Tighten

- Nuts to 1.2 N·m (12 in. lbs.).
- Pump cover.
 - Refer to "Pump Cover Seal And/Or Guide Stud Seal Replacement."



Inspect

- Solenoid operation prior to installing the pump cover. Use a 12 V DC power source.

SIDE COVER GASKET REPLACEMENT

↔ Remove or Disconnect (Figure 25)

1. The two screws (40).
2. Cover (41).
3. Gasket (42).

→← Install or Connect (Figure 25)

1. Gasket.
2. Cover.
3. Screws.



Tighten

- Screws to 2 N·m (18 in. lbs.)

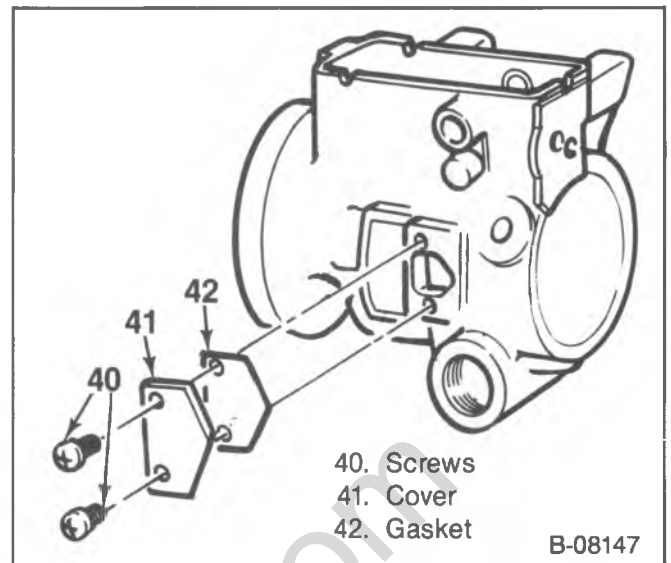

Figure 25—Side Housing and Drive Group

INJECTION PUMP OFF-VEHICLE SERVICE

Refer to "Injection Pump Replacement." Off-vehicle service operations require a leak test after the repair has been made. Refer to "Pressure Testing The Injection Pump."

ADVANCE PIN HOLE PLUG SEAL REPLACEMENT

↔ Remove or Disconnect (Figure 26)

1. Injection pump.
2. Plug (50).
 - Tap the plug lightly with a hammer to loosen it.
3. Seal (51).

→← Install or Connect (Figure 26)

1. New seal.
 - Lubricate the seal.
2. Plug.



Tighten

- Plug to 10 N·m (90 in. lbs.).
3. Injection pump.

ADVANCE PISTON SEALS REPLACEMENT

↔ Remove or Disconnect (Figure 26)

1. Injection pump.
2. Spring side advance piston hold plug (52).
3. Seal (53).
4. Power side advance piston hold plug (55).
5. Seal (54).

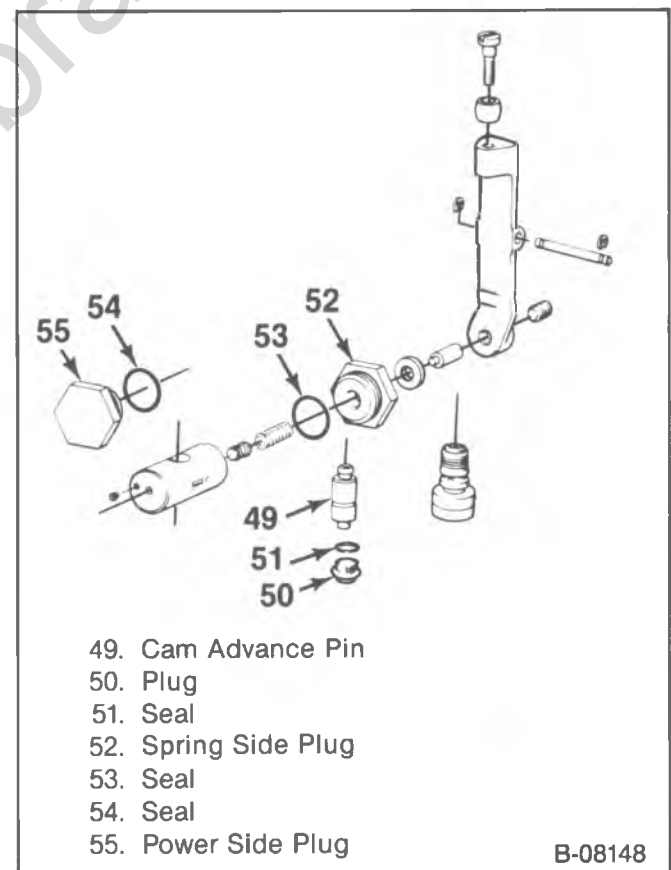

Figure 26—Advance Piston Group



Install or Connect (Figure 26)

1. New seal (54).
 - Lubricate the seal.
2. Plug (55).
3. New seal (53).

6C2-18 DIESEL FUEL INJECTION

4. Plug (52).
5. Injection pump.

ADVANCE PISTON REPLACEMENT

↔ Remove or Disconnect (Figure 26)

1. Injection pump.
2. Advance piston hold plugs (52 and 55).
3. Cam advance pin plug (50).
4. Cam advance pin (49).
5. Advance piston.

↔ Install or Connect (Figure 26)

1. Advance piston.
2. Cam advance pin (49).
3. Cam advance pin plug (50) using a new seal (51).
4. Advance piston hold plugs (52 and 55) using new seals (54 and 53).
5. Injection pump.

HYDRAULIC HEAD SEAL REPLACEMENT

↔ Remove or Disconnect

1. Injection pump.
2. Throttle shaft and seals.
 - Refer to "Throttle Shaft Seal Replacement."
3. Metering valve (figure 27)
4. Housing vent wire screw assembly (figure 28).
5. Cam advance pin hold plug (50) (figure 26).
6. Seal from the plug.
7. Cam advance pin (49) (figure 26).
8. Head locking screws (figure 29).
 - Locate the pump assembly so the rear of the pump is sloping down.
9. Head locating screw and seal (figure 30).
10. Hydraulic head assembly using a twisting motion.
11. O-ring seal.

↔ Install or Connect

1. New o-ring seal to the hydraulic head.
 - Lubricate the seal.
2. Hydraulic head assembly into the pump housing.
3. Head locking screws loosely (figure 29).
 - Lubricate the screws.
4. New seal on the head locating screw.
5. Head locating screw (figure 30).
 - Turn the pump upside down.

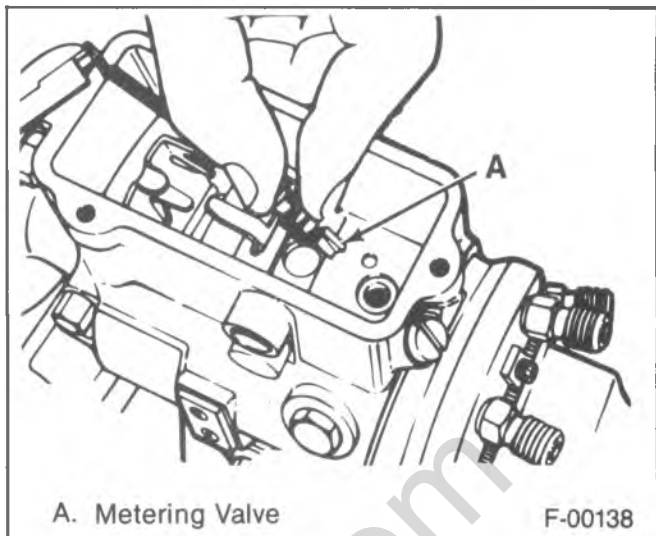

Figure 27—Metering Valve



Figure 28—Vent Wire Assembly

Tighten

- Screw to 23 N·m (17 ft. lbs.).
6. The advance pin (49) (figure 26).
 7. New seal on the advance pin hole plug.
 - Lubricate the seal.
 8. The advance pin hold plug.

Tighten

- Plug to 10 N·m (90 in lbs.).
9. Housing vent wire screw assembly (figure 28).

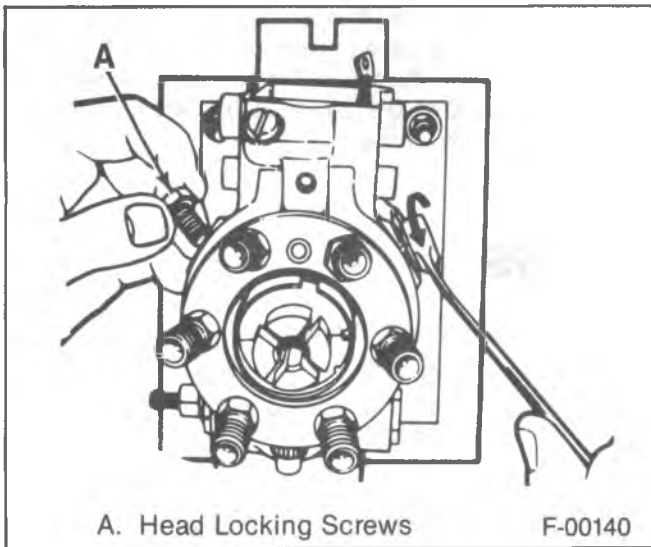

Figure 29—Head Locking Screws

10. Metering valve (figure 27).
11. Throttle shaft and seals.
 - Refer to "Throttle Shaft Seal Replacement."
12. Injection pump.

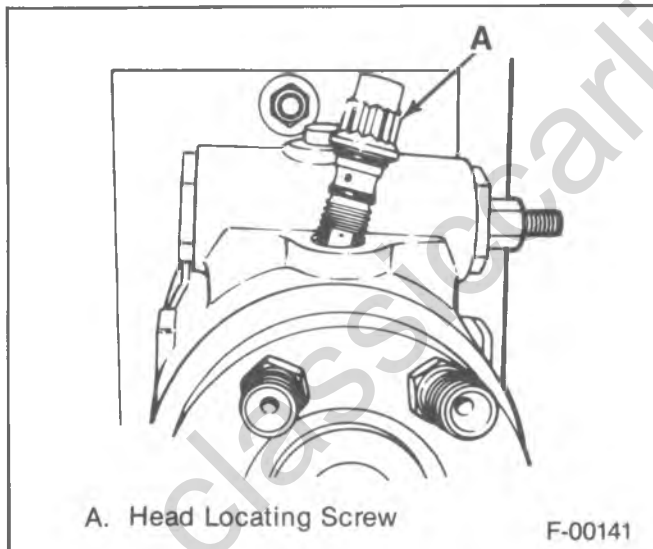

Figure 30—Head Locating Screw

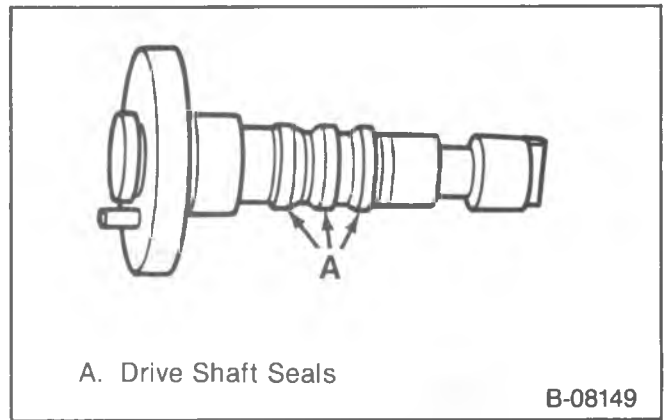

Figure 31—Drive Shaft Seals

DRIVE SHAFT SEAL REPLACEMENT

↔ Remove or Disconnect (Figure 31)

Tool Required: J-29692-B, Holding Fixture

1. Injection pump.
2. Fast idle solenoid bracket.
 - Mount the pump in J-29692-B and tilt it.
3. The drive shaft from the pump using a rotating motion (alignment pin at the top).
 - The shaft is retained by an o-ring.
 - Make sure that no pieces of the o-ring have broken off in the pump.
4. The drive shaft seals.

→← Install or Connect (Figure 31)

Tools Required:

J-29692-B, Holding Fixture
 J-29745-A, Shaft Seal Protector
 J-33198, Synkut Lubricating Oil

1. One black seal on the shaft using J-29745-A.
 - Lubricate the seal protector with J-33198 or equivalent.
2. The red seal using J-29745-A.
 - Lubricate the seal protector with J-33198 or equivalent.
3. The other black seal using J-29745-A.
 - Lubricate the seal protector with J-33198 or equivalent.
4. New o-ring retaining clip on the shaft.
5. Drive shaft into the pump.
 - Make sure the drill points on the drive shaft end match up with the rotor.
6. Fast idle solenoid bracket.
7. Injection pump.

PRESSURE TESTING THE INJECTION PUMP

1. Drain all fuel from the pump.
2. Connect an air line to the pump inlet connection.
 - Make sure the air supply is clean and dry.
3. Completely immerse the pump in a bath of clean test oil.
 - Seal off the return line fitting.

6C2-20 DIESEL FUEL INJECTION

4. Raise the air pressure in the pump to 137.9 kPa (20 psi). Keep the pump immersed in the oil for 10 minutes to allow any trapped air to escape.
5. Watch for leaks after the ten minutes. If the pump is not leaking, reduce the air pressure to 13.8 kPa (2 psi) for 30 seconds. If there is still no leakage, increase the pressure to 137.9 kPa (20 psi). If there are no leaks, the pump is ready for use.

SPECIFICATIONS

Fasteners

Torque

Injection Line Fittings	25 N·m	20 ft. lbs.
Intake Manifold Bolts	40 N·m	30 ft. lbs.
Injection Pump Mounting Nuts	40 N·m	30 ft. lbs.
Injection Pump Drive Gear Bolts	25 N·m	20 ft. lbs.
Injection Nozzles	70 N·m	50 ft. lbs.
Injection Pump Cover Screws	3.7 N·m	33 in. lbs.
Injection Pump Guide Stud	9.5 N·m	85 in. lbs.
Solenoid Terminal Nuts	1.2 N·m	12 in. lbs.
Side Cover Screws	2 N·m	18 in. lbs.
Advance Pin Hole Plug	10 N·m	90 in. lbs.
Head Locating Screw	23 N·m	17 ft. lbs.

SPECIAL TOOLS

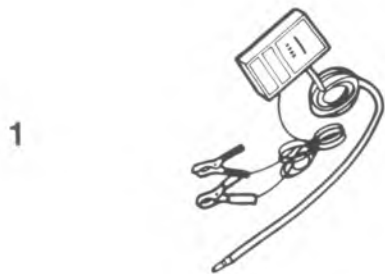

J-26925



J-36142

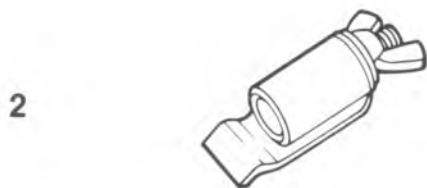

J-29601

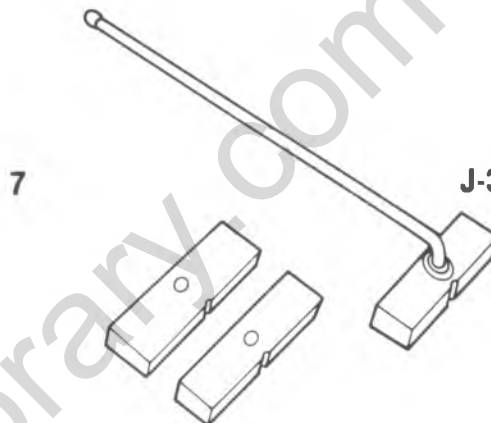

J-33198

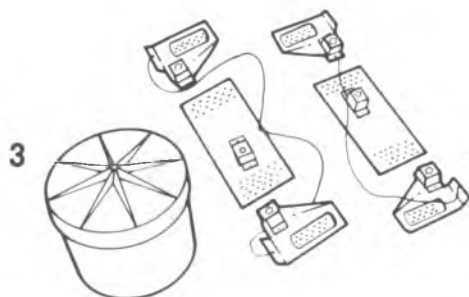

J-29664



J-29692-B



J-33042



J-29745-A



J-33043-A



J-29873

- 1. Tachometer
- 2. Injection Pump Timing Adapter
- 3. Protective Covers
- 4. Holding Fixture
- 5. Shaft Seal Protector

- 6. Nozzle Socket
- 7. Timing Fixture
- 8. Gage Block
- 9. Synkut Lubricating Oil
- 10. Switch Gage Tool

classiccarylbrary.com

SECTION 6D

ENGINE ELECTRICAL

CONTENTS

<u>SUBJECT</u>	<u>PAGE</u>
Electrical System	6D- 2
Battery	6D- 2
Description	6D- 2
General Information	6D- 3
Diagnosis of Battery	6D- 4
Visual Inspection	6D- 4
Hydrometer Test	6D- 4
Load Test	6D- 4
Battery On-Vehicle Service	6D- 5
Battery Charging Procedures	6D- 5
Current Drain Test	6D- 5
Battery Cables	6D- 6
Battery Replacement	6D- 6
Charging System	6D- 7
Description	6D- 7
Diagnosis of Charging System	6D-10
Noisy Generator	6D-10
Electrical Tests	6D-10
SI Charging System	6D-10
CS-130 Charging System	6D-12
Generator On-Vehicle Service	6D-14
Generator Replacement	6D-14
Diesel Glow Plug Electrical System	6D-15
Description	6D-15
Diagnosis of Glow Plug Electrical System	6D-16
Circuit Check	6D-16
Glow Plug Inhibit Switch	6D-16
Glow Plug System	6D-19
Glow Plug Afterstart	6D-19
Glow Plug On-Vehicle Service	6D-19
Cranking System	6D-19
Description	6D-19
Diagnosis of Cranking System	6D-22
Cranking Circuit	6D-22
Starter Motor Noise	6D-24
Diagnosis of Starter Motor Noise	6D-27
Cranking System On-Vehicle Service	6D-27
Maintenance	6D-27
Starter Motor	6D-27
Starter Motor Replacement	6D-27
Engine Block Heaters	6D-28
Description	6D-28
On-Vehicle Service	6D-28
Ignition System	6D-33
Description	6D-33
Distributor	6D-33
Engines with TBI	6D-33
Spark Plug Wires	6D-35
Spark Plugs	6D-35
Diagnosis of Ignition System	6D-36
Distributor/Timing System for TBI-Equipped Engines	6D-36
Ignition System for Carbureted Engines	6D-36
Diagnosis of Spark Plugs	6D-39

CONTENTS (Contd.)

SUBJECT	PAGE
Ignition System On-Vehicle Service	6D-40
Service Precautions	6D-40
Distributor Replacement	6D-41
Ignition Timing	6D-41
Spark Plug Wires	6D-42
Spark Plug Wire Replacement	6D-42
Engine Wire Harness	6D-52
Specifications	6D-77
Special Tools	6D-80

ELECTRICAL SYSTEM

Engine electrical system diagnosis includes the battery, charging system (generator and related wiring), cranking system (starter and related wiring), ignition system (distributor, spark plugs and wiring) and the glow plug system (diesel electrical).

Light duty emission vehicles are equipped with an electronic computer command control system. These vehicles

have a "Check Engine" or "Service Engine Soon" lamp on the instrument panel. Refer to the Fuel and Emissions Service Manual for a detailed description of the lamp's operation and use as a diagnostic indicator.

Some vehicles sold in Canada may have variations in electrical components. Refer to the appropriate Canadian Service Manual Supplement.

BATTERY

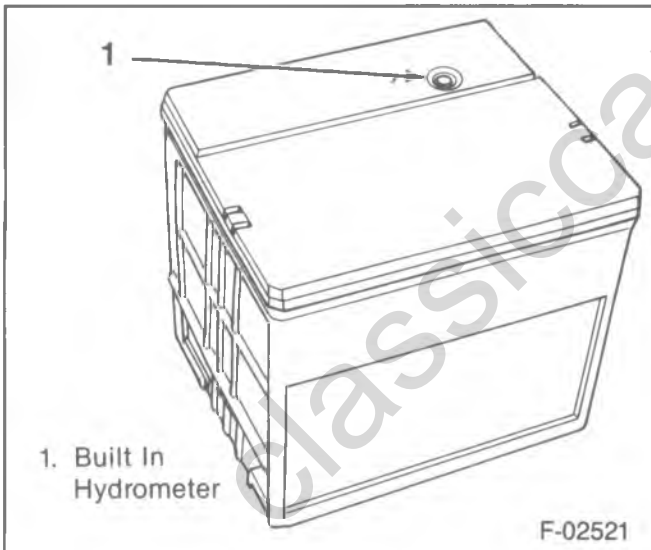

Figure 1—Sealed Battery with Side Terminals

DESCRIPTION

The battery has three major functions in the electrical system: first, it provides a source of energy for cranking the engine; second, it acts as a voltage stabilizer for the electrical system; and third, it can, for a limited time, provide energy when the electrical load used exceeds the output of the generator.

The sealed battery as shown in figure 1 is standard. Water never needs to be added. There are no filler caps in the cover. The battery is sealed, except for small vent holes in the cover. The vents allow what small amount of

gasses that are produced in the battery to escape. The special chemical composition inside the battery reduces gassing to a very small amount at normal charging voltages. Besides reducing gassing, the special chemistry greatly reduces the possibility of overcharge damage.

Keep the battery in an upright position to prevent electrolyte leakage. Tipping the battery beyond a 45 degree angle in any direction can allow a small amount of electrolyte to leak out the vent hole.

Do not exceed this 45 degree angle when carrying or installing the battery.

Evidence of electrolyte leakage does not always mean the battery is defective.

RATINGS

Batteries are rated according to their reserve capacity in minutes and their cold cranking power in amperes. Both methods involve measuring the battery terminal voltage after a specified time period and discharge current.

The "reserve capacity" is defined as the maximum length of time it is possible to travel at night with minimum electrical load and no generator output. Expressed in minutes, it is the time required for a fully charged 12-volt battery, at a temperature of 27° C (80° F), being discharged at a constant current of 25 amperes, to reach a terminal voltage of 10.5 volts.

The "cold cranking ampere" (CCA) test measures the amperage delivered by the battery at -18° C (0° F) for 30 seconds.

Refer to "Specifications" at the end of this section for battery ratings.

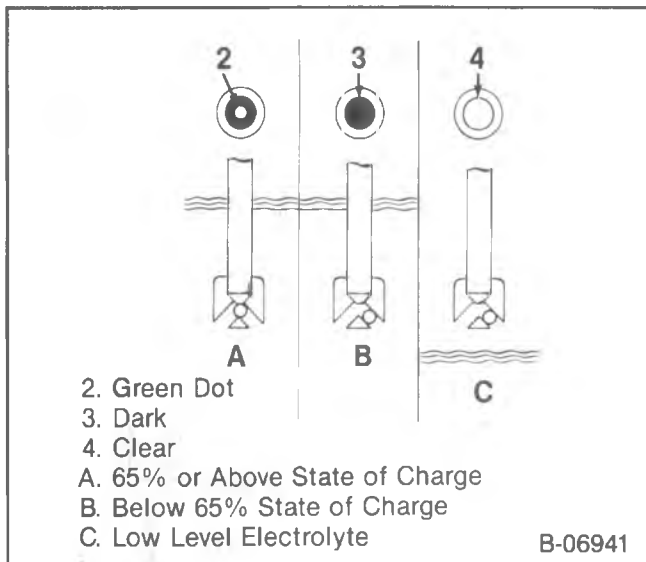

Figure 2—Built-In Hydrometer

BUILT-IN HYDROMETER

The sealed battery has a special temperature compensated hydrometer built into the cover to show at a glance the battery's state-of-charge. The hydrometer has a green ball within a cage which is attached to a clear plastic rod. The green ball will float at a predetermined specific gravity of the electrolyte. When the green ball floats, it rises within the cage and positions itself under the rod. Visually a green dot then shows in the center of the hydrometer (figure 2). The built-in hydrometer provides a guide for battery testing and charging.

When looking at the hydrometer, make sure that the battery has a clean top. A lamp may be needed in some poorly-lit areas.

1. **GREEN DOT VISIBLE:** The state of charge is 65 percent or more of the full charge.
2. **DARK; GREEN DOT NOT VISIBLE:** The state of charge is below 65 percent. Charge the battery until the green dot appears. (Shake the battery slightly to make the green dot appear after charging).
3. **CLEAR OR LIGHT YELLOW:** The fluid level has dropped below the bottom of the hydrometer. This can be caused by a broken case, tipping of the

battery, normal wearout, or overcharging because of a problem in the electrical system. Check the system and replace the battery.

GENERAL INFORMATION

COMMON CAUSES OF MALFUNCTION

If testing shows the battery to be in good condition but the battery doesn't perform satisfactorily, check for the following:

1. Vehicle accessories left on overnight.
 2. Extended slow-speed driving with many accessories turned on.
 3. The vehicle electrical load is more than the generator output, particularly with the addition of aftermarket equipment.
 4. Problems in the charging system such as shorts, slipping fan belt, or worn generator or regulator parts.
 5. Loose or poor battery cable-to-post connections, previous improper charging of a rundown battery, or loose hold-downs.
 6. High-resistance connections in the cranking system.
 7. Electronic devices draining the battery when the vehicle is parked for a long period of time.
- Disconnect the negative cable if the vehicle will be stored for more than 30 days.

Electrolyte Freezing

The freezing point of electrolyte depends on its specific gravity. Since freezing may ruin a battery, protect it against freezing by keeping it in a charged condition.

Carrier And Hold-Down

The carrier and hold-down should be clean and free from corrosion before battery installation.

The carrier should be in a sound mechanical condition so that it will support the battery securely and keep it level. Make certain there are no foreign objects in the carrier before installation.

To prevent the battery from shaking in its carrier, tighten the hold-down bolts. However, do not tighten the bolts to where the battery case or cover is placed under a severe strain.

DIAGNOSIS OF BATTERY

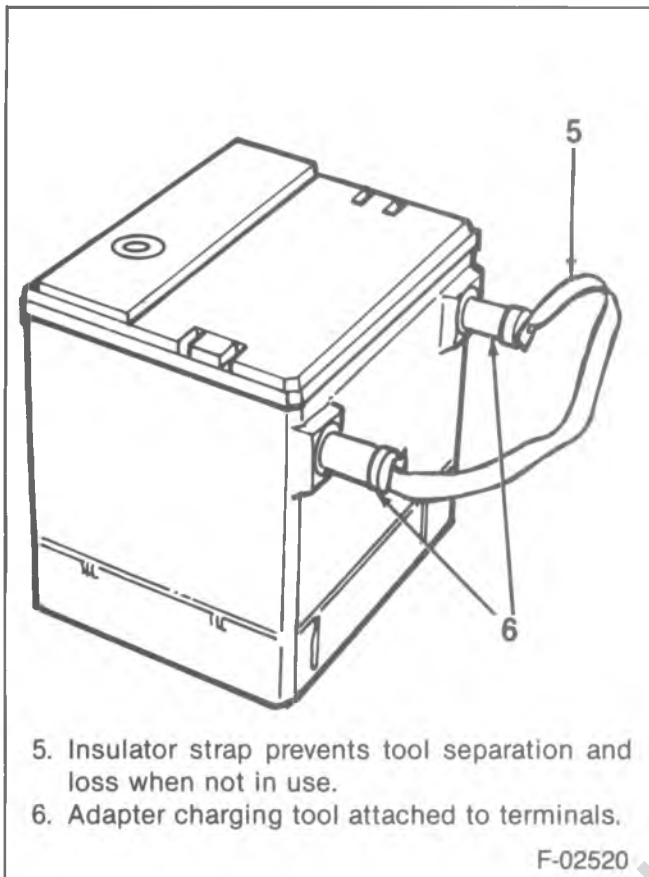

Figure 3—Testing and Charging Terminal Adapter

In a diesel-equipped vehicle, check and test each battery separately.

VISUAL INSPECTION

Check for obvious damage such as a cracked or broken case or cover that could permit loss of electrolyte. If damaged, replace the battery. Determine the cause of the damage and correct.

HYDROMETER TEST

GREEN DOT VISIBLE: If the hydrometer has a GREEN DOT visible the battery is ready for testing. Proceed to "Load Test".

DARK; GREEN DOT NOT VISIBLE: Charge the battery as outlined under the heading "Battery Charging Procedure" later in this section.

LIGHT OR BRIGHT INDICATOR: Do not charge, test, or jump start the battery. Replace the battery.

LOAD TEST

If the battery is in the vehicle, make sure the engine control switch is off. If there is more than one battery, check each separately.

1. Disconnect the battery cables from the terminals.
2. Install adapter AC-Delco ST 1201 or equivalent (figure 3).

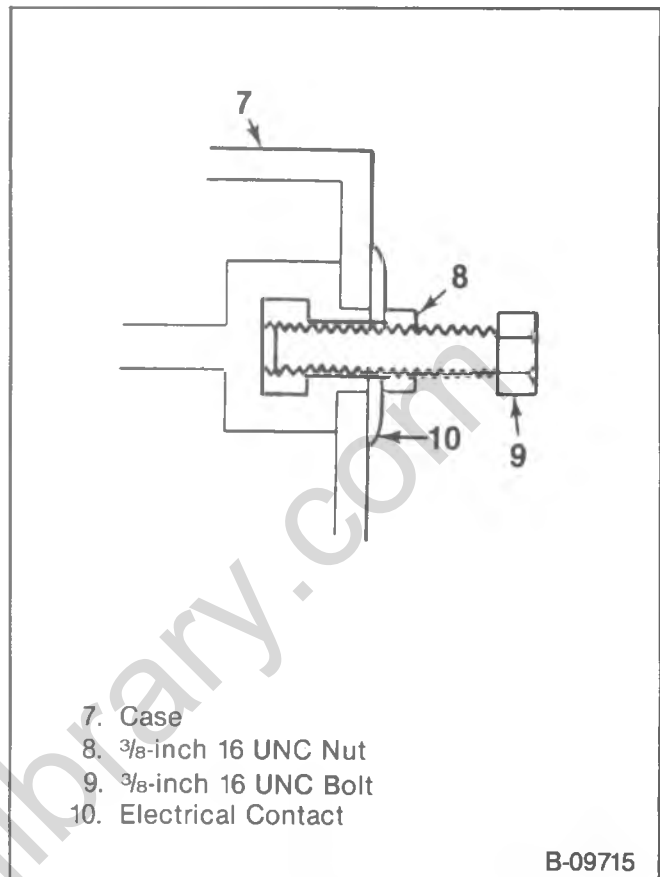

Figure 4—Testing and Charging Using Bolt and Nut

Side Terminal Batteries:

3. If adapters are not available, use a 3/8-inch 16 UNC bolt and stainless steel nut (figure 4). Finger tighten. Contact must be made through the lead pads at the face of the terminals, not through the threads of the bolt.

Top Terminal Batteries:

4. Attach terminal hex nuts, AC Delco # 7802, or equivalent (figure 5).
5. Attach the alligator clamps of the tester or charger between the terminal nuts and the load pads of the terminal studs (figure 5).
 - If the tester clamps cannot be attached between the nuts and the lead pads of the terminals, the ampere load for the load test may change. Refer to "Specifications" at the end of this section.
6. Install a voltmeter and battery load tester to the adapters.
7. Remove the surface charge from recently charged batteries by applying a 300-ampere load across the adapters for 15 seconds.
8. Do not remove the surface charge from batteries which have been in storage.
9. Turn the load off and wait 15 seconds for the battery to recover.

10. Apply the specified load selected from the chart in "Specifications". Observe the battery voltage after 15 seconds with the load connected, then turn off the load.
11. If the battery voltage does not drop below the minimum voltage as shown in the "Voltage and Temperature Chart" following, the battery is good and should be returned to service. (The battery temperature must be estimated by feel and by the temperature the battery has been exposed to for the preceding few hours.) If the battery voltage drops below the minimum voltage listed, replace the battery.

Voltage And Temperature Chart

TEMPERATURE	MINIMUM VOLTAGE
21° C (70° F & Above)	.96
10° C (50° F)	.94
-1° C (30° F)	.91
-10° C (15° F)	.88
-18° C (0° F)	.85

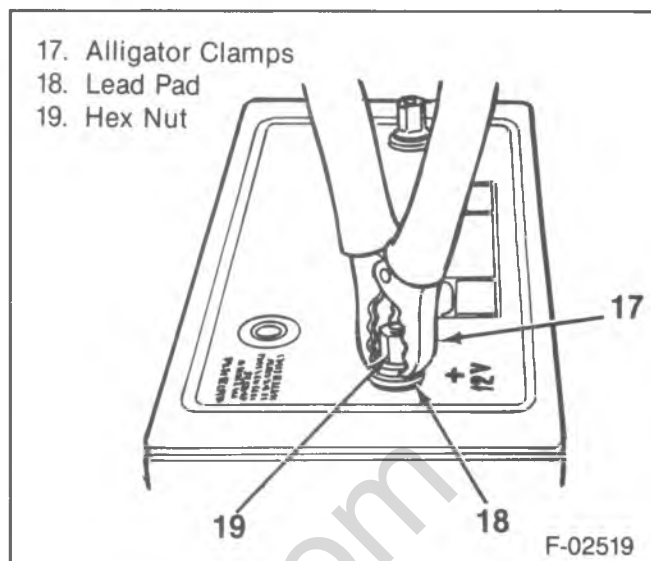

Figure 5—Testing and Charging Using Top Terminal Adapter

BATTERY ON-VEHICLE SERVICE

BATTERY CHARGING PROCEDURES

The following basic rules apply to any sealed battery charging situation:

1. Do not charge a battery if the hydrometer is clear or light yellow— replace the battery.
2. Charge rates between 3 and 50 amperes are satisfactory as long as spewing of electrolyte does not occur or the battery does not feel over 52° C, (125° F). If spewing occurs or temperature exceeds 52° C (125° F), the charging rate must be reduced or temporarily halted to permit cooling.

Estimate battery temperature by touching or feeling the battery case.

3. The battery is sufficiently charged when the green dot in the built-in hydrometer is visible. No further charging is required. Shake or tilt the batter at hourly intervals during charging to mix the electrolyte and see if the green dot appears.
4. Battery charging consists of a charge current in amperes for a period of time in hours. Thus a 25-ampere charging rate for 2 hours would be 50 ampere-hour charge to the battery. In most cases, batteries whose load test values are less than 200 amperes will have the green dot visible after at least a 50 ampere-hour charge. Most batteries whose load test values are greater than 200 amperes will have the green dot visible after at least a 75 ampere-hour charge. In the event that the green dot does not appear after this amount of charging, continue charging for another 50 or 75 ampere-hours. If the green dot still does not appear, replace the battery.

5. The time required for a charge will vary according to:

- a. Size of battery — Example: A discharged large heavy-duty battery requires more than twice the recharging as a discharged small passenger car battery.
- b. Temperature — Example: A longer time will be needed to charge any battery at -18° C (0° F) than at 27° C (80° F). When a fast charger is connected to a cold battery, the current accepted by the battery will be very low at first; then, as the battery warms, it will accept a higher rate.
- c. State-of-charge — Example: A discharged battery requires more than twice as much charge as a one-half-charged battery. Because the electrolyte is nearly pure water and therefore a poor conductor, the current accepted is low at first. Later, as the charging current causes the electrolyte acid content to increase, the charging current will likewise increase.
- d. Charger Capacity — Example: A charger which can supply only 5 amperes will require a much longer period of charging than a charger that can supply 30 amperes or more.

CURRENT DRAIN TEST

If a battery needs recharging and no cause is evident, check the vehicle for excessive current drain.



Remove or Disconnect

- Negative battery cable (both negative cables on diesels).

6D-6 ENGINE ELECTRICAL

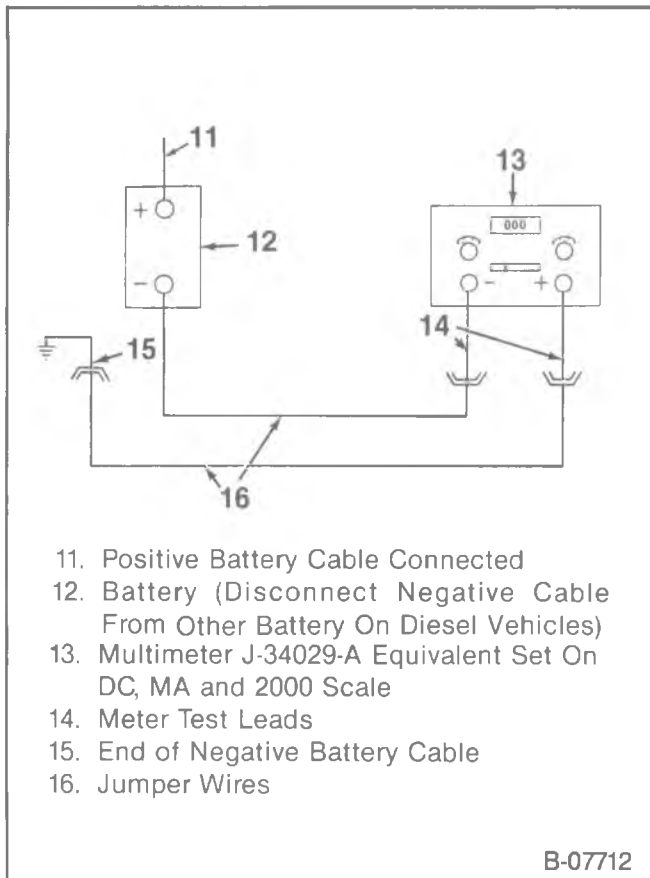

Figure 6—Battery Drain Test Circuit

Install or Connect

Tool Required:
J-34029-A Multimeter.

1. Battery side terminal adapter in the negative terminal or nut and bolt as described earlier in this section.
2. A $\frac{3}{8}$ -inch 16 UNC nut on the negative battery cable terminal attaching screw.
3. Clip of a jumper wire to the negative battery terminal adapter (figure 6).
4. Clip at the other end of the jumper wire to digital multimeter J-34029-A or equivalent.
5. Clip from the second jumper wire to the end of the negative battery cable.
6. Clip at the other end of the wire to the multimeter.
 - Set the multimeter on the DC, MA and 2000 scale.
 - Take the reading with the engine control switch and all accessories off.
7. If current draw is more than 50 milliamps, check the system for causes such as a shorted wire or a compartment lamp that does not shut off when it should.

BATTERY CABLES

Excessive resistance caused by poor terminal connections and partial short circuits through worn cable insulation will result in an abnormal voltage drop in the starter cable. Low voltage at the starter will prevent normal starter operation and cause hard starting.

CAUTION: To prevent possible personal injury from a moving vehicle or operating engine do the following before performing the checks:

1. Engage the parking brakes and block the wheels.
 2. Place the manual transmission in the neutral position or the automatic transmission in park.
 3. On gas engines disconnect the battery feed at the distributor. On diesel engines disconnect the battery feed at the engine shutoff (ESO) solenoid.
1. Check the voltage drop between ground (negative battery terminal) and the vehicle frame. Place one prod of the test voltmeter on the grounded battery post (not on the cable clamp) and the other on the frame. Operate the starter and note the voltage reading.
 2. Check the voltage drop between the positive battery terminal and starter terminal stud with starter operating.
 3. Check the voltage drop between the starter housing and frame with the starter operating.
 4. If the voltage drop in any of the above is more than 1.0 volt, there is excessive resistance in the circuit. To eliminate resistance, the cables should be disconnected and connections cleaned. If cables are frayed or the clamps corroded, the cables should be replaced. When selecting new cables, be sure they are at least as large as the ones being replaced.

BATTERY REPLACEMENT

When handling a battery, observe the following safety precautions.

1. Hydrogen gas is produced by the battery. A flame or spark near the battery may cause the gas to ignite.
2. Battery fluid is highly acidic. Avoid spilling on clothing or skin. Any spilled electrolyte should be flushed with large quantities of water and cleaned immediately.

Remove or Disconnect

1. Negative cable from the negative battery terminal.
2. Positive cable from the positive battery terminal.
3. Battery hold-down clamp.
4. Battery.

Inspect

1. Battery for damage.
2. Cables and connectors.
3. Carrier for damage or foreign objects.
 - If damage is noted, find and correct the cause.

Install or Connect

1. Battery into cleaned carrier.
2. Hold-down retainer or top bar, as equipped.

 **Tighten**

1. Retainer to 17 N·m (13 ft. lbs.).
2. Top bar to 3.5 N·m (30 in. lbs.) on batteries with side terminals.
3. Top bar to 6.8 N·m (60 in. lbs.) on batteries with top terminals.
3. Battery terminals.

 **Tighten**

- Top terminals to 17 N·m (13 ft. lbs.).
 - Side terminals to 15 N·m (11 ft. lbs.).
4. Positive cable to the positive terminal.
 5. Negative cable to the negative terminal.

CHARGING SYSTEM

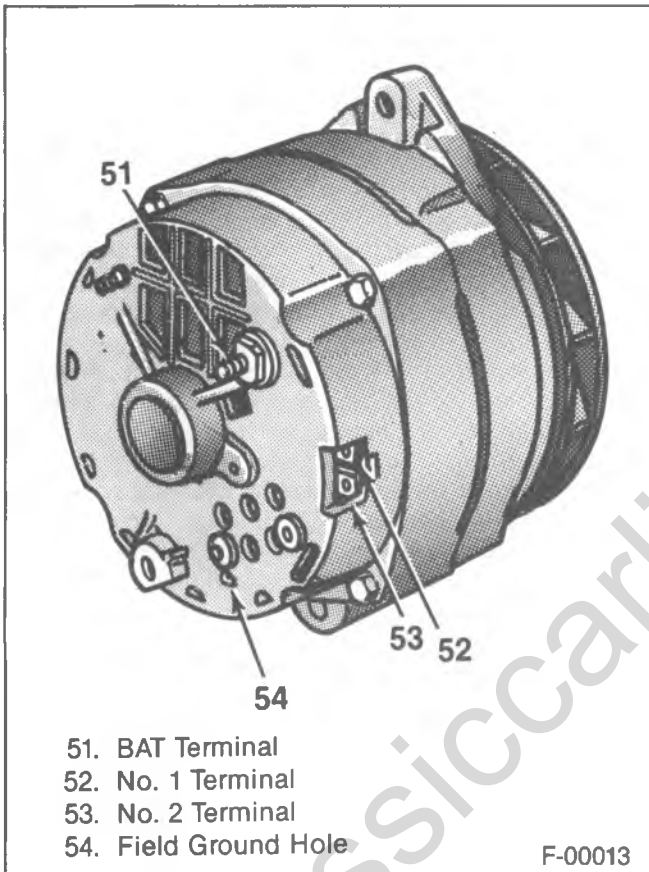

Figure 7—12-SI Series 100 Generator

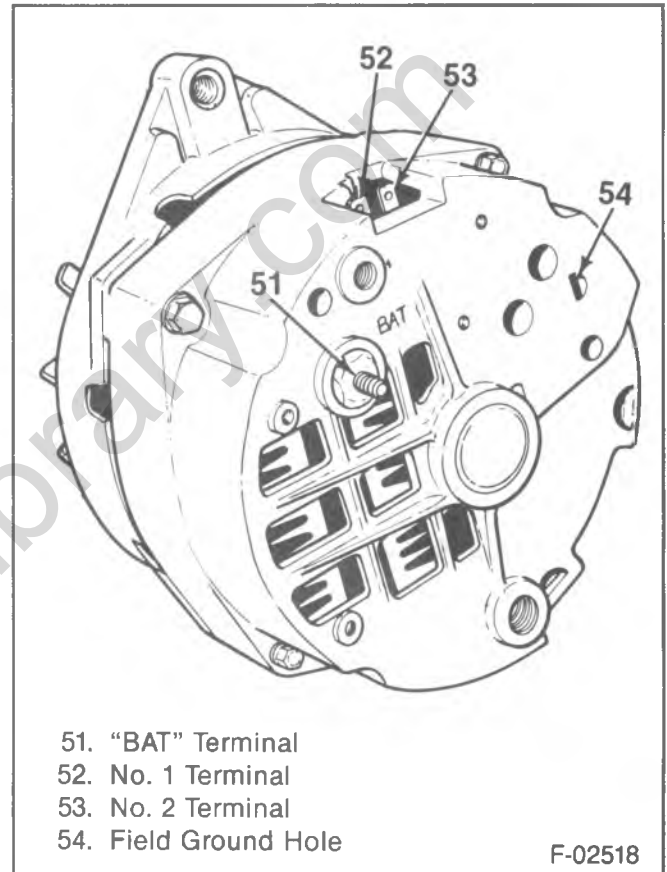

Figure 8—17-SI Series 100 Generator

DESCRIPTION

The charging system consists of the battery, the generator, the regulator, and the charging system indicator lamp circuitry. The generator supplies electrical power for charging the battery and operating accessories.

Two types of generators are used on these vehicles, the SI generator with an external 2-terminal connector on the regulator, and the CS generator with an external 4-terminal connector on the regulator. The diagnostic tests for these generators are different.

12-SI 100 AND 17-SI 100 GENERATORS (Figures 7, 8 and 9)

These generators are of the "Systems Integral" series (generator with built-in regulator).

The solid state regulator components are enclosed into a solid mold, and this unit, along with the brush holder assembly, is attached to the slip ring end frame. The regulator voltage setting cannot be adjusted.

The generator rotor bearings contain enough grease to eliminate the need for periodic lubrication. Two brushes carry current through the two slip rings to the field coil mounted on the rotor, and under normal conditions will provide long periods of attention-free service.

The stator windings are assembled on the inside of a laminated core that forms part of the generator frame. The 12-SI has a "Y" stator and the 17-SI has a delta-wound stator. A rectifier bridge connected to the stator windings contains six diodes, and electrically changes the stator AC voltages to a DC voltage which appears at the generator output (BAT) terminal. Generator field current is supplied through a diode trio which also is connected to the stator windings. A capacitor or condenser, mounted in the end frame, protects the rectifier bridge and diode trio from high voltages, and suppresses radio noise.

No periodic adjustments or maintenance of any kind is required on the entire generator assembly.

6D-8 ENGINE ELECTRICAL

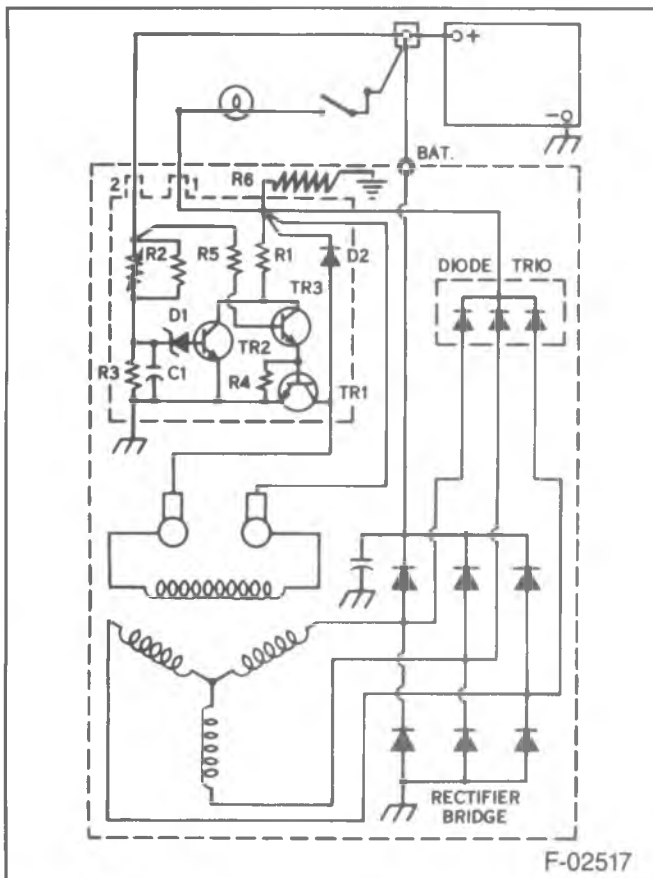

Figure 9—12-SI Series 100 Generator Schematic

CIRCUIT OPERATION

When the engine control switch is turned to "Run" or "Start", the switch closes and current from the battery flows through the charging system indicator lamp, the number 1 terminal, the regulator, ground, and back to the battery. Current also flows through the generator field coil and back to the battery. The charge indicator lamp then turns on.

With the generator operating, direct current (DC) voltage is applied to the battery through the "BAT" terminal. Some of the output flows through the diode trio

to the field coil, then through the wire at terminal number 1 to the charge indicator lamp. The lamp goes out since approximately the same voltage is present at both sides of the lamp. On vehicles with gages a voltmeter indicates voltage.

CS-130 GENERATORS (Figures 10, 11 and 12)

These generators feature a high ampere output per pound of weight. The CS stands for charging system and 130 is the measurement in millimeters of the outside diameter of the stator laminations.

This generator with integral regulator does not have a diode trio. The delta stator, rectifier bridge, and rotor with slip rings and brushes are electrically similar to other generators. A conventional fan and pulley are used, and an internal fan cools the slip rings, end frame, rectifier bridge and regulator.

The charge indicator lights when the engine control switch is closed, and goes out when the engine is running. If the charge indicator is on with the engine running, a charging system problem is indicated. The indicator will glow at full brilliance, not half lit, if any charging problem occurs or if the system voltage is too high or too low.

The regulator voltage setting varies with temperature, and limits system voltage by controlling rotor field current. It switches rotor field current on and off at a fixed frequency of about 400 cycles per second. By varying the on-off time, correct average field current for proper system voltage control is obtained. At high speeds, the on-time may be 10 percent and the off-time 90 percent. At low speeds, with high electrical loads, on-off time may be 90 percent and 10 percent respectively.

The regulator has four terminals, "P," "L," "I," and "S" (figure 12). The use of the "P," "L," and "S" terminals is optional. The "P" terminal is connected to the stator, and may be wired to a tachometer or other device. The "S" terminal may be wired to the battery to sense voltage to be controlled. The "L" and "I" terminals serve to turn on the regulator and allow field current to flow when the switch is closed. The "I" terminal may be connected directly to the switch, or through a resistor. Both are illustrated. The "I" circuit may be used with or without the "L" circuit; that is, with or without anything connected to the "L" circuit. Refer to the Light Duty Truck Wiring Diagrams for specific application.

The generator is not serviceable, and no periodic maintenance is required.

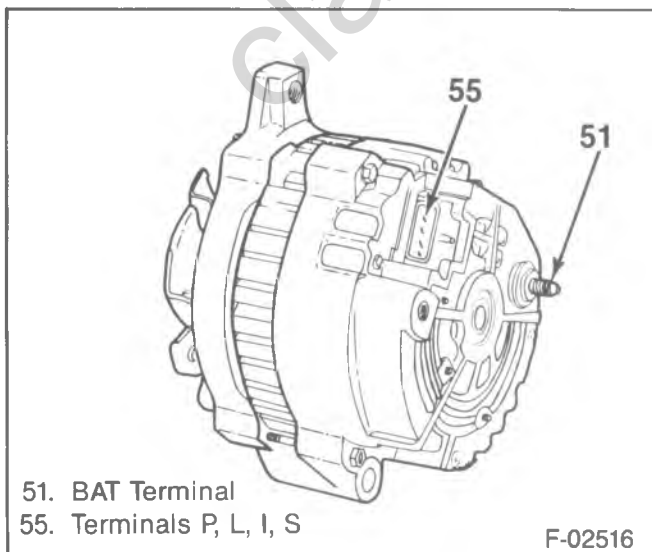

Figure 10—CS-130 Generator

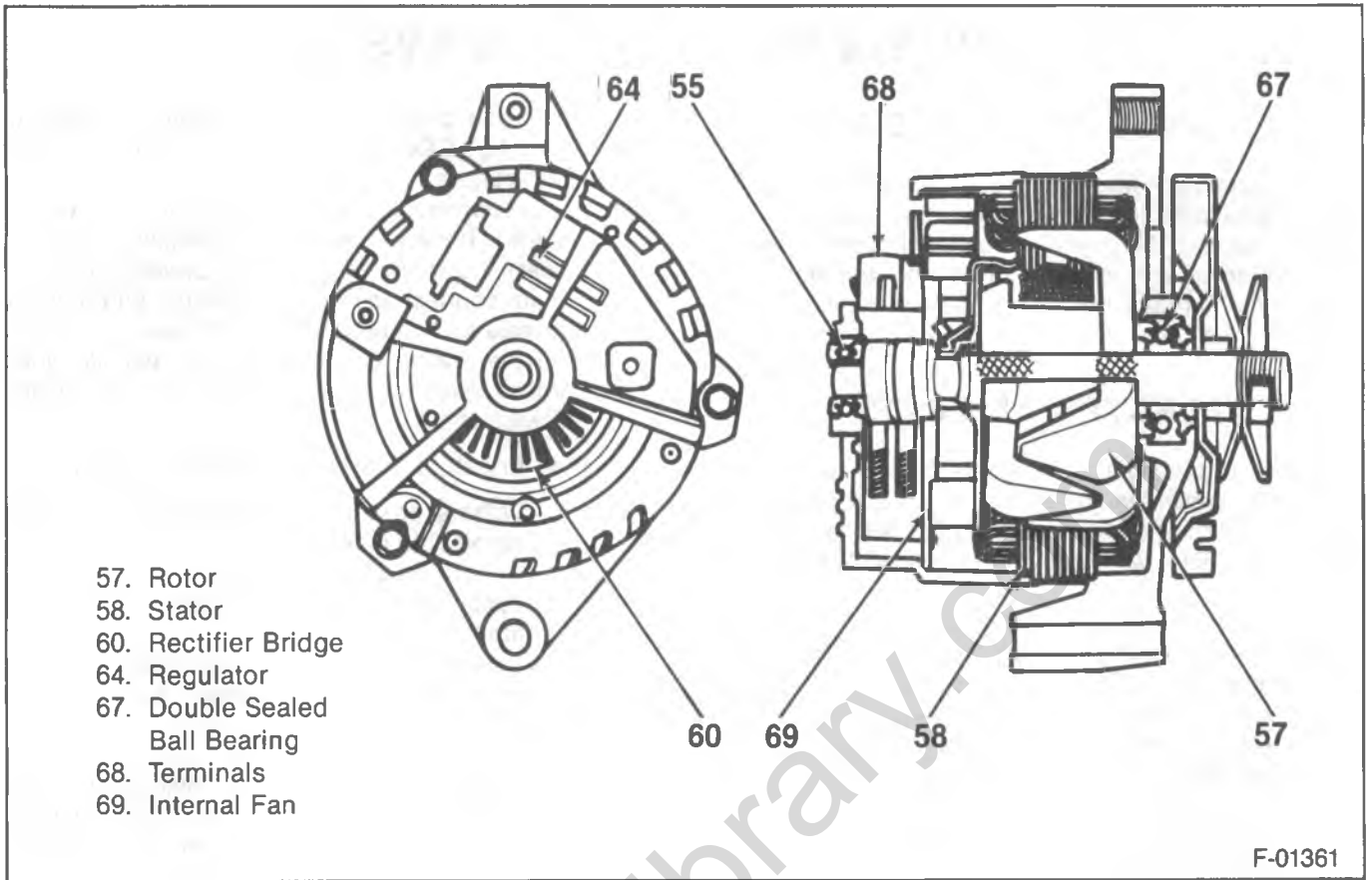

Figure 11—CS Series Generator

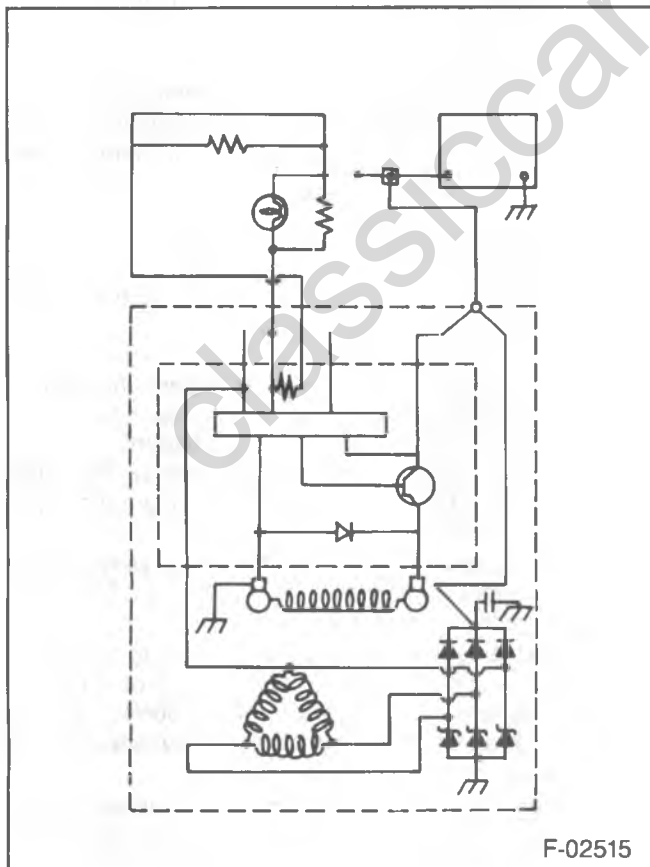

Figure 12—CS Generator Schematic

DIAGNOSIS OF CHARGING SYSTEM

NOISY GENERATOR

Noise from a generator may be caused by a loose drive pulley, loose mounting bolts, worn or dirty bearings, worn diode or stator. If the pulley and mounting bolts are snug and the noise continues, remove the generator for inspection and repair. Refer to "Generator Replacement" later in this section.

ELECTRICAL TESTS

Before performing the diagnosis procedures on the vehicle, be certain that the system wiring is good and the generator belt is not slipping. Also, the battery must be fully charged for a valid test of the charging system.

NOTICE: To avoid damage to the vehicle electrical system, observe the following precautions:

- Do not polarize the generator.
- Do not short across or ground any of the terminals in the charging circuit except as specifically instructed herein.
- NEVER operate the generator with the output terminal open-circuited.
- Make sure the generator and battery have the same ground polarity.
- When connecting a charger or booster battery to the vehicle battery, connect negative to negative and positive to positive.

Trouble in the charging system will show up as one or more of the following conditions:

1. On vehicles without gages, unusual operation of the charging indicator lamp.
2. An undercharged battery, indicated by slow cranking or a dark battery hydrometer.
3. An overcharged battery, indicated by spewing of electrolyte from the vents.

SI CHARGING SYSTEM

CHARGING SYSTEM INDICATOR LAMP OPERATION

Check the indicator lamp for normal operation in the "Charging System Diagnosis," (figure 13). If lamp operation is normal, proceed to "Undercharged Battery".

UNDERCHARGED BATTERY

Slow cranking or a dark battery hydrometer can be caused by one or more of the following conditions even though the indicator lamp may be operating normally. The following procedures also apply to vehicles equipped with a voltmeter.

1. Check that the undercharged condition has not been caused by accessories having been left on for extended periods.

2. Check the drive belt for proper tension. Refer to ENGINE COOLING (SEC. 6B) for belt specifications.
3. If you suspect the battery is bad, do a load test. Refer to "Battery" earlier in this section.
4. Inspect the wiring for cracks or breaks. Check all circuit connections, cable clamps and battery terminals for tightness and cleanliness.
5. With the engine control switch on and all wiring harness leads connected, use a voltmeter for the following checks:

Install or Connect (Figures 7 and 8)

1. Voltmeter from the generator battery terminal to ground.
 - Should read 12 volts.
2. Voltmeter from the number 1 terminal to ground.
 - Should read one volt or more.
3. Voltmeter from the number 2 terminal to ground.
 - Should read 12 volts.

A zero reading on any of the above indicates an open between the voltmeter connection and the battery. If checks 1 through 5 are normal perform the generator output test.

OVERCHARGED BATTERY

If the battery feels hot, is spewing electrolyte, or lamps seem too bright when turned on, an overcharged condition may exist.

To check the voltage, install a voltmeter across the battery. Run the engine at moderate speed with all accessories off. If the voltage reads 15.5 or more, remove the generator for repair.

GENERATOR OUTPUT TEST (Figure 14)

1. Disconnect the battery ground cable.
2. Connect an ammeter in the circuit at the battery terminal of the generator.
3. Reconnect battery ground cable.
4. Turn on the radio, windshield wipers, headlamps (high beam) and blower motor high speed.
5. Connect a carbon pile across the battery.
6. Run the engine at moderate speed (about 2,000 rpm) and adjust the carbon pile to obtain maximum current output.
7. If the ampere output is within 10 amperes of the rated output as stamped on the generator frame, the generator is probably all right.
8. If the vehicle is equipped with a charging system indicator lamp, and the lamp remains on while the engine runs, and ampere output is normal, remove the generator for repair. Check the diode trio and rectifier bridge.
9. If the ampere output is not within 10 percent of the rated output in amperes, see if the test hole is accessible (figure 15). If it is not accessible go to step 14.
10. Ground the field winding by inserting a screwdriver into the test hole.

CHARGING SYSTEM INDICATOR LAMP OPERATION

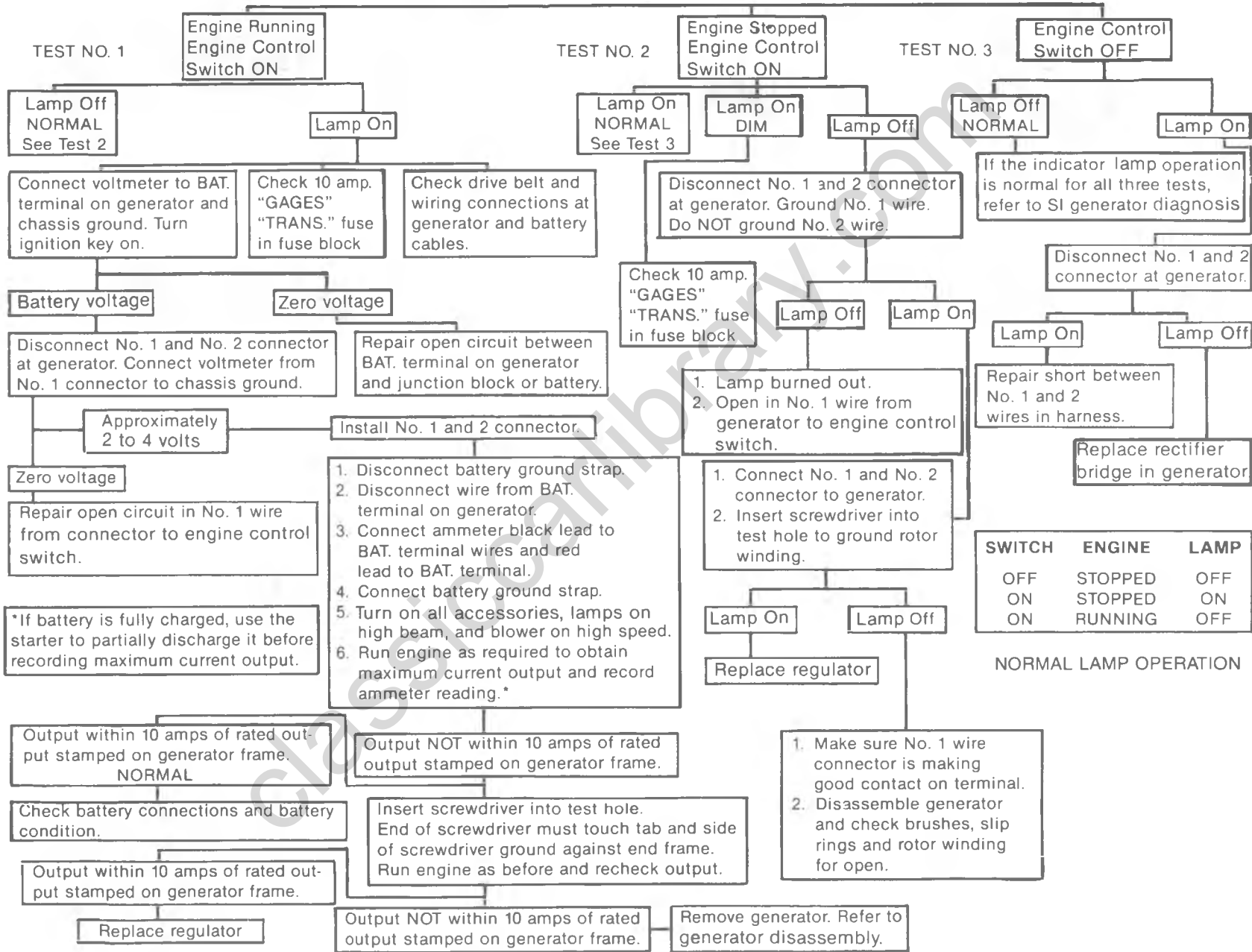
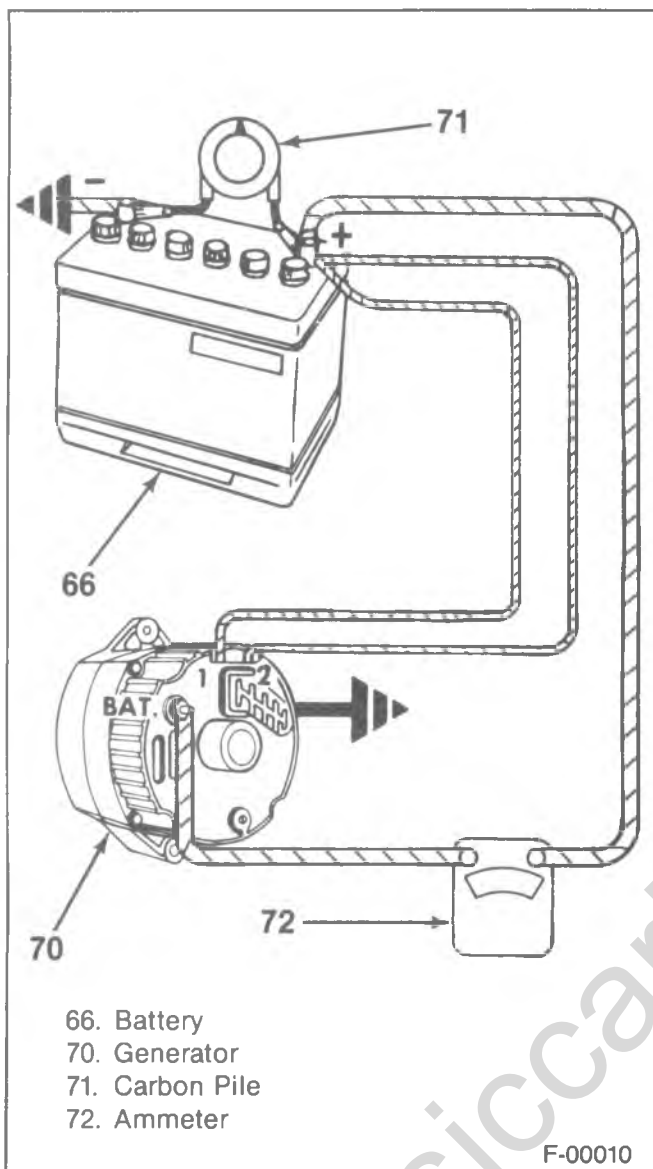

Figure 13—Charging System Diagnosis

B-09173

6D-12 ENGINE ELECTRICAL



66. Battery
70. Generator
71. Carbon Pile
72. Ammeter

F-00010

Figure 14—Connections for Generator Output Test

NOTICE: The tab is within 19 mm ($\frac{3}{4}$ inch) of the casting surface. Do not force the screwdriver deeper than 25 mm (1 inch) into the end frame or the generator may be damaged.

11. Run the engine at moderate speed and adjust the carbon pile to get maximum current output.
12. If the output is within 10 amperes of the rated output, remove the generator for repair. Refer to the Light Duty Truck Unit Repair Manual to check the field winding and regulator.
13. If the output is not within 10 amperes of rated output, remove the generator and check the field winding, diode trio, rectifier bridge and stator.
14. If the test hole is not accessible, remove the generator for repair.

GENERATOR DIAGNOSTIC TESTER INDICATIONS

If a tester is available, check the generator following the tester manufacturer's instructions. It will indicate about 98 percent of the charging system problems.

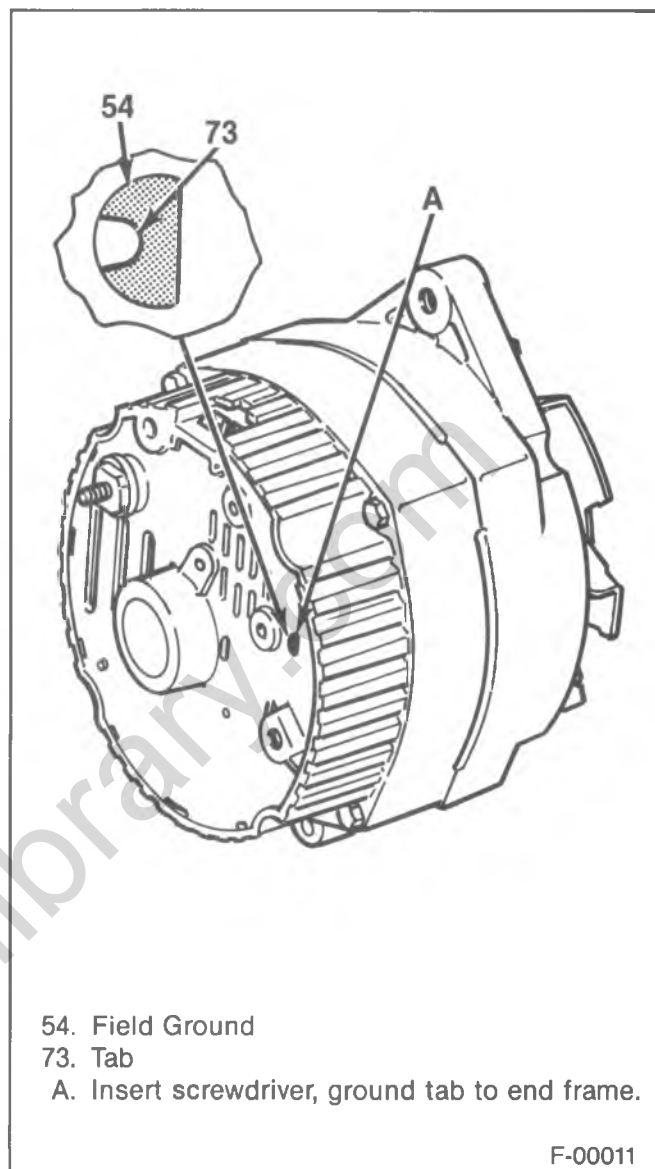

54. Field Ground
73. Tab
A. Insert screwdriver, ground tab to end frame.

F-00011

Figure 15—Generator Field Ground Tab

TRANSISTORIZED VOLTAGE REGULATOR TEST

Connect a fast charger and a voltmeter to the battery as shown in figure 16. With the engine control switch on "run" and the engine off, slowly increase the charge rate. The charging system indicator lamp (on vehicles without gages) will dim at the voltage regulator setting. The setting should be at a minimum of 13.5 volts and a maximum of 16.0 volts.

This test works if the rotor circuit is good, even if the stator, rectifier bridge or diode trio is bad.

CS-130 CHARGING SYSTEM

CIRCUIT DIAGNOSIS

Trouble in the charging system will show up as one or more of the following conditions:

- Abnormal indicator lamp operation.
- An undercharged battery as evidenced by slow cranking or dark hydrometer.
- An overcharged battery as evidenced by excessive spewing of electrolyte from the vents.

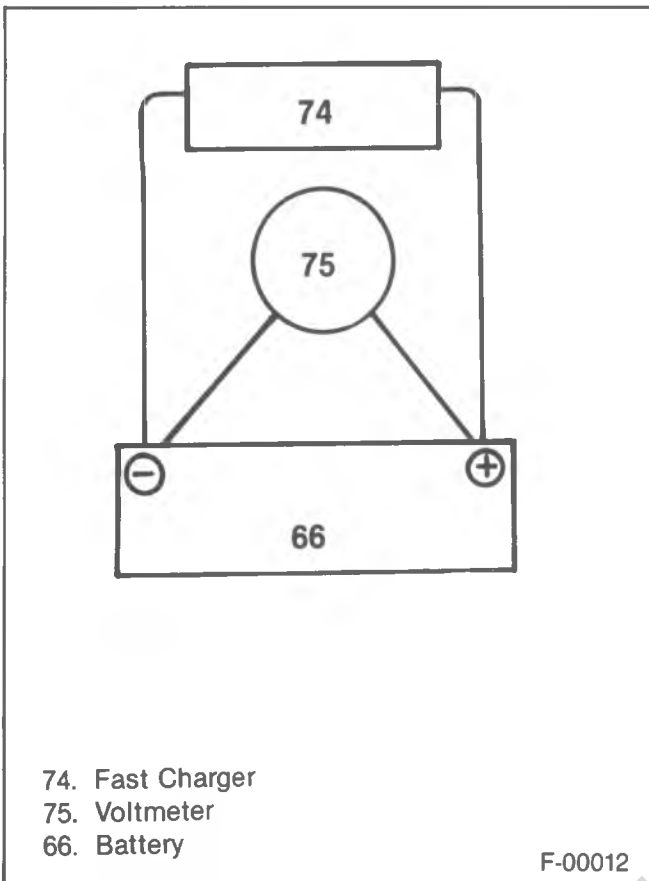

Figure 16—On-Vehicle Regulator Test

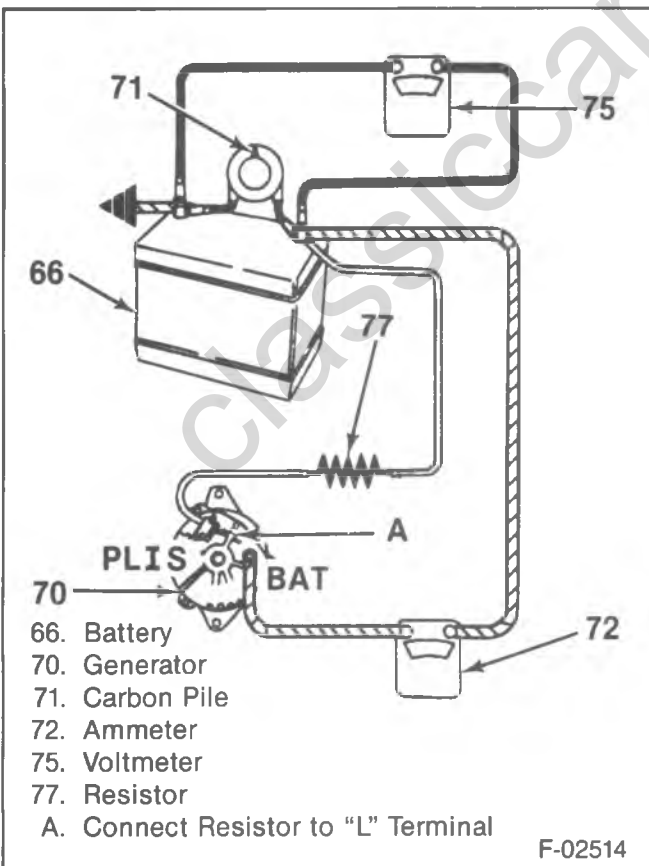

Figure 17—Connections for Generator Output Test

A basic wiring diagram for the charging system is shown in figure 12. When the system is operating normally, the indicator lamp (on vehicles so equipped) will come on when the engine control switch is turned on and go out when the engine starts. If the lamp operates abnormally, or if an undercharged or overcharged battery condition occurs, the following procedure may be used to diagnose the charging system. Remember that an undercharged battery is often caused by accessories being left on overnight, or by a switch stuck closed which allows a lamp, such as a trunk or glove box lamp, to stay on.

This generator does not have a test hole.

DIAGNOSTIC TEST FOR CS-130

1. Check belt for wear and tension. Refer to ENGINE COOLING (SEC. 6B) for belt tension. Check wiring.
2. Go to Step 5 for vehicles without a charge indicator lamp.
3. With the engine control switch on and the engine stopped, the lamp should be on. If not, detach the wiring harness at the generator and ground the "L" terminal lead.
 - If the lamp lights, replace the generator.
 - If the lamp does not light, locate the open circuit between the grounding lead and the engine control switch. The lamp may be open.
4. With the switch on, and the engine running at moderate speed, the lamp should be off. If not, detach the wiring harness at the generator.
 - If the lamp goes out, replace the generator.
 - If the lamp stays on, check for a grounded "L" terminal wire in the harness.
5. If the battery is undercharged or overcharged:
 - Detach the wiring harness connector from the generator.
 - With the switch on the engine not running, connect a voltmeter from ground to the "L" terminal in the wiring harness, and to the "I" terminal, if used. The wiring harness may connect to either "I" or to both.
 - A zero reading indicates an open circuit between the terminal and the battery. Correct as required.
 - Connect the harness connector to the generator and run the engine at moderate speed with accessories off.
 - Measure the voltage across the battery. If above 16 volts, replace the generator.
 - Connect an ammeter at the generator output terminal, turn on the accessories and load the battery with a carbon pile to obtain maximum amperage. Maintain voltage at 13 volts or above.
 - If the output is within 15 amperes of the rated output, the generator is OK. (Refer to "Specifications" at the end of this section.)
 - If the output is not within 15 amperes of the rated output, replace the generator.

6D-14 ENGINE ELECTRICAL

GENERATOR BENCH CHECK

1. Make connections as shown in figure 17, except leave the carbon pile disconnected. The ground polarity of the generator and battery must be the same. The battery must be fully charged. Use a 30 to 500 ohm resistor between the battery and the "L" terminal.
2. Slowly increase generator speed and observe the voltage.
3. If the voltage is uncontrolled and increases above 16 volts, the rotor field is shorted, the regulator is not working properly, or both. A shorted rotor field coil can cause problems in the regulator.
4. If the voltage is below 16 volts, increase speed and adjust the carbon pile to obtain maximum amperage output. Maintain the voltage above 13 volts.
5. If the output is within 15 amperes of the rated output, the generator is good.
6. If the output is not within 15 amperes of the rated output, replace the generator.

GENERATOR ON-VEHICLE SERVICE

GENERATOR REPLACEMENT

The removal and installation instructions serve only as a guide. Additional operations may be required on some vehicles to remove other equipment to gain access to the generator, drive belts and brackets.

CAUTION: Failure to observe Step 1 in this procedure may result in an injury from the hot battery lead at the generator.

Remove or Disconnect

1. Negative battery cable at the battery.
2. Terminal plug and battery lead from the back of the generator.
 - Loosen the upper mounting/adjusting bolt on the generator mounting.
 - Loosen the belt tensioner (serpentine belt only).
3. Drive belt.
4. Lower mounting bolt.

5. Upper mounting bolt.
6. Generator.

Install or Connect

1. Generator to the top bracket with the bolt.
 - Do not tighten.
2. Lower mounting bolt to the bracket.
3. Generator drive belt.

Tighten

- Lower mounting bolt. Refer to "Specifications" at the end of this section.
 - Drive belt. Refer to ENGINE COOLING (SEC. 6B) for belt specifications.
 - Upper generator mounting bolt. Refer to "Specifications" at the end of this section.
5. Terminal plug and battery lead to the back of the generator.
 6. Negative battery cable to the battery.
- Refer to the Light Duty Truck Unit Repair Manual for off-vehicle service.

DIESEL GLOW PLUG ELECTRICAL SYSTEM

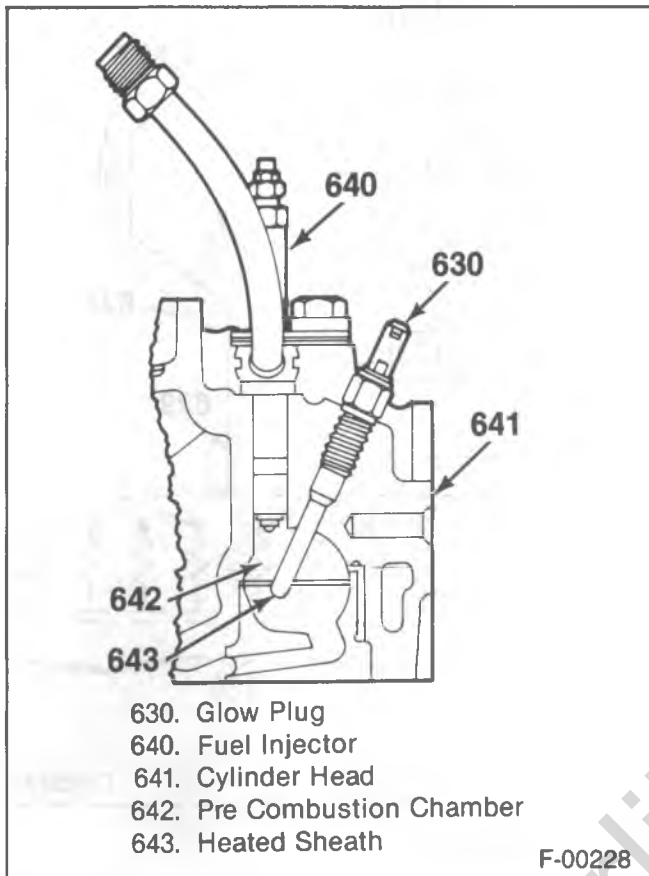

Figure 18—Diesel Engine Glow Plug Location

DESCRIPTION

In the diesel engine, air alone is compressed in the cylinder; then after the air has been compressed a charge of fuel is sprayed into the cylinder and ignition occurs due to the heat of compression. Eight glow plugs are used to preheat the chamber as an aid to starting (figure 18).

The diesel glow plug system consists of an integral-electronic control/glow plug relay assembly, 6-volt glow plugs, a glow plug inhibit temperature switch and a "GLOW PLUGS" lamp.

GLOW PLUGS

These are 6-volt heaters (operated at 12 volts) that turn on when the engine control switch is turned to the run position prior to starting the engine. They remain pulsing a short time after starting, then automatically turn off.

INSTRUMENTATION

Vehicles with the diesel engine have special instrumentation indicators to permit the operator to properly apply the starting procedure. A "GLOW PLUGS" lamp on the instrument panel provides this information on engine starting conditions.

Vehicles equipped with diesel engines have a "WATER IN FUEL" lamp and "LOW COOLANT" lamp. Refer to the engine fuel and engine cooling sections for information on these systems.

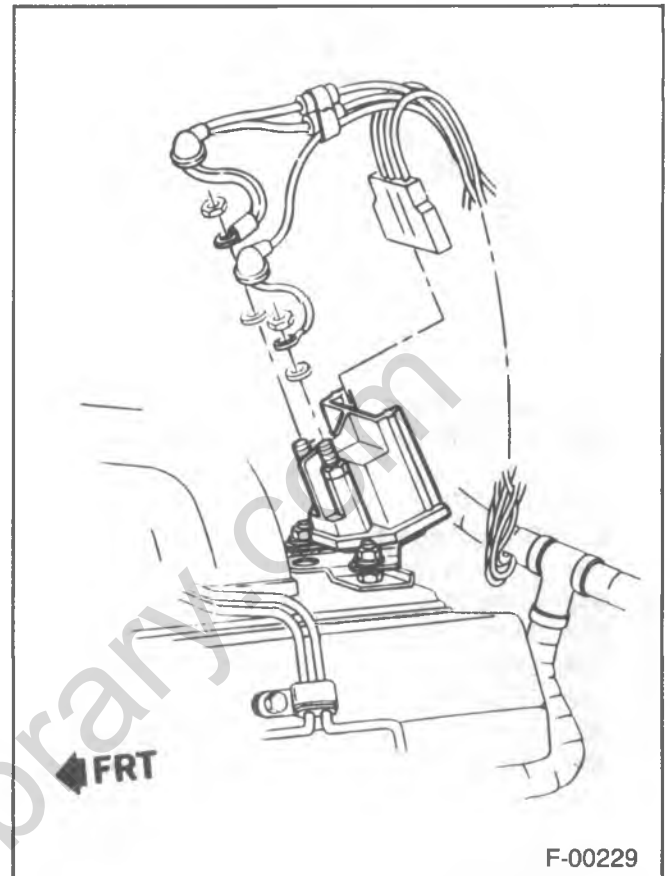

Figure 19—Glow Plug Controller

ELECTRONIC CONTROLLER/GLOW PLUG RELAY ASSEMBLY (Figures 19 and 20)

The assembly contains the circuitry which monitors and controls glow plug relay operation. Information is received at pins B and C which is used by the controller to determine glow plug operating requirements. Pin B senses voltage at the starting motor solenoid. Pin C senses glow plug voltage through the glow plug inhibit switch which is wired in series with the glow plug voltage sense lead to the glow plugs. The controller is mounted at the rear of the left cylinder head on two 10 mm studs.

GLOW PLUG INHIBIT SWITCH

The switch is temperature controlled and opens above 51.5° C (125° F) to prevent glow plug operation above this temperature. It is mounted at the rear of the right cylinder head on the P truck and G van, and in the water crossover near the front of the engine on the RV truck.

CIRCUIT OPERATION

A normal functioning system operates as follows:

- A. Key on - Engine not running and at room temperature.
1. Glow plugs ON for 4 to 6 seconds, then OFF for about 4.5 seconds.
 2. Then cycle; ON for about 1.5 seconds, OFF for about 4.5 seconds, and continue to cycle 1.5 ON/4.5 OFF, for a total duration (including the initial 4 to 6 seconds) of about 20 seconds.

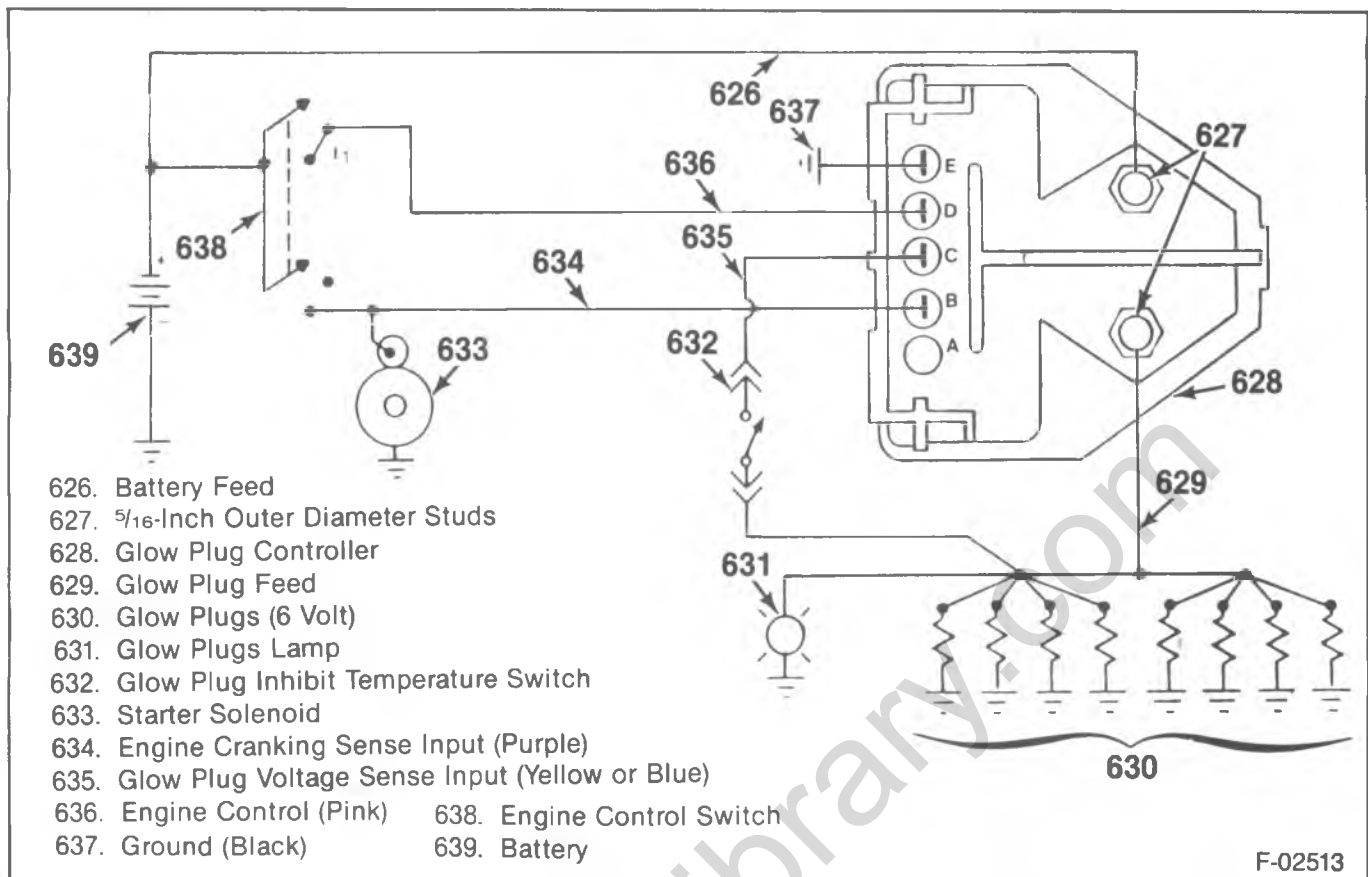

Figure 20—Electronic Glow Plug System

B. If the engine is cranked during or after the above sequence, the glow plugs will cycle ON/OFF for a total duration of 25 seconds after the engine control switch is returned from the crank position, whether the engine starts or not. The engine does not have to be running to terminate the glow plug cycling.

All the times shown above are approximate because they vary with initial engine temperature. The initial ON time and cycling ON/OFF times vary also with system voltage and/or temperature. Lower temperatures cause longer duration of cycling.

DIAGNOSIS OF GLOW PLUG ELECTRICAL SYSTEM

CIRCUIT CHECK

If the system does not operate as described, check the following:

Inspect

1. All connectors.
2. Engine harness ground connection to the engine.

Tighten

- Nut to 11 N·m (8 ft. lbs.).
3. Four-wire connector at controller. It must be fully seated and latched.
 4. Both controller copper stud upper nuts.

Tighten

- Nuts to 5 N·m (48 in. lbs.).
- Do not tighten lower nuts.

5. Temperature switch connector at top rear right cylinder head on the P and G truck, and in the water crossover near the front of the engine on the RV truck.
6. "GLOW PLUG" lamp on instrument panel for tight connection and operation.

GLOW PLUG INHIBIT SWITCH

Check the temperature-controlled switch to make sure it is closed at low temperatures and open at high temperatures.

1. Remove the connector from the inhibit switch when the engine temperature is below 38°C (100°F).
2. Set the ohmmeter on a low range or use a self-powered test lamp.
3. Test across the terminals.
4. The switch should be closed (test lamp on or a reading of less than 0.1 ohm on the meter).

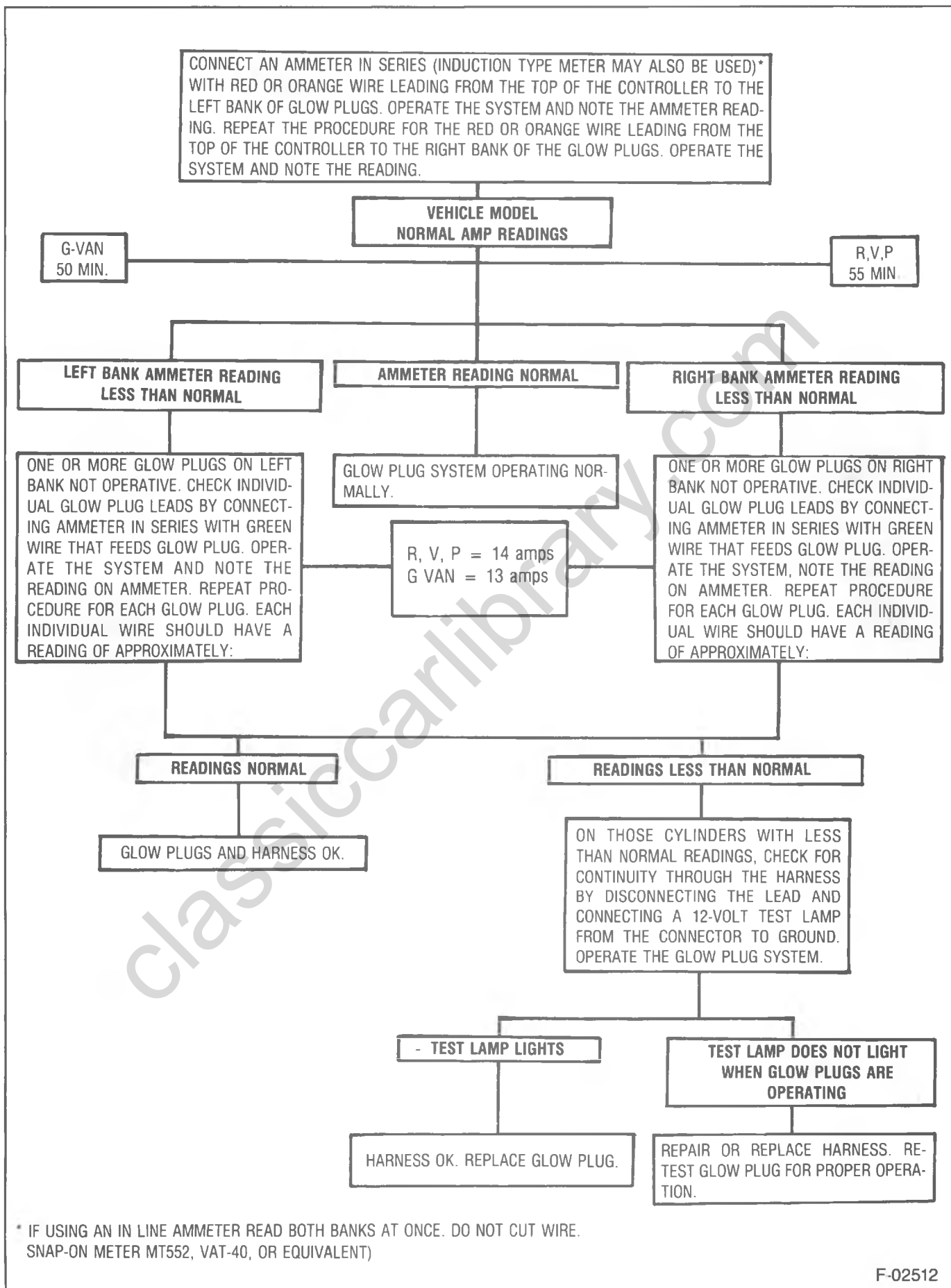

Figure 21—Preliminary Diagnosis with an Ammeter

6.2 LITER DIESEL ELECTRICAL SYSTEM DIAGNOSIS

ENGINE DOES NOT START COLD - "GLOW PLUGS" LAMP MAY OR MAY NOT COME ON.

1. FUEL SYSTEM CHECKED AND IS OK.
2. BATTERY VOLTAGE IS 12.4 VOLTS OR MORE WITH ENGINE CONTROL SWITCH OFF.
3. CRANKING SPEED OK (100 RPM OR MORE).
4. REFER TO ELECTRONIC GLOW PLUG SYSTEM FIGURE FOR WIRING HARNESS TERMINAL IDENTIFICATION.

CONNECT 12-VOLT TEST LAMP TO GROUND. TOUCH TEST LAMP TO BATTERY STUD (SINGLE RED WIRE) ON GLOW PLUG CONTROLLER.

TEST LAMP ON

WITH THE ENGINE CONTROL SWITCH OFF TOUCH THE TEST LAMP TO THE GLOW PLUG FEED STUD (TWO ORANGE OR RED WIRES) ON GLOW PLUG CONTROLLER.

TEST LAMP OFF

LOCATE AND REPAIR OPEN CIRCUIT FROM BATTERY TO GLOW PLUG CONTROLLER.

TEST LAMP OFF

DISCONNECT HARNESS FROM ALL GLOW PLUGS. CONNECT TEST LAMP TO 12-VOLT SOURCE AND TOUCH EACH GLOW PLUG TERMINAL. LAMP SHOULD BE ON. REPLACE GLOW PLUG IF LAMP IS OFF. RECONNECT ALL GLOW PLUGS BEFORE CONTINUING WITH DIAGNOSIS.

TEST LAMP ON

RELAY CONTACTS SHORTED. REPLACE GLOW PLUG CONTROLLER AND ALL GLOW PLUGS.

WITH ENGINE CONTROL SWITCH IN "RUN" CONNECT 12-VOLT TEST LAMP TO GROUND. REMOVE CONTROLLER CONNECTOR AND CHECK FOR ENGINE CONTROL SWITCH VOLTAGE AT HARNESS CONNECTOR TERMINAL "D."

TEST LAMP ON

CONNECT TEST LAMP TO 12-VOLT SOURCE AND CHECK FOR GROUND AT HARNESS TERMINAL "E" OF CONNECTOR.

TEST LAMP OFF

REPAIR OPEN CIRCUIT IN ENGINE CONTROL SWITCH FEED TO CONTROLLER.

TEST LAMP ON

CONNECT TEST LAMP TO 12-VOLT SOURCE AND CHECK HARNESS TERMINAL "C" OF CONNECTOR.

TEST LAMP OFF

REPAIR OPEN IN GROUND WIRE TO CONNECTOR TERMINAL "E."

TEST LAMP OFF

REMOVE TEMPERATURE INHIBIT SWITCH CONNECTOR AND CHECK FOR CONTINUITY THROUGH THE SWITCH. SWITCH OPEN ABOVE 51.5°C (125°F).

TEST LAMP ON

REPLACE GLOW PLUG CONTROLLER.

CONTINUITY

REPAIR OPEN CIRCUIT IN HARNESS BETWEEN GLOW PLUGS AND CONTROLLER TERMINAL "C."

NO CONTINUITY

REPLACE TEMPERATURE INHIBIT SWITCH.

F-02511

Figure 22—Diesel Electrical System Diagnosis

5. Test terminals to ground with a test lamp or the ohmmeter on a high range. The lamp should be off or the meter show greater than 1.0 megohm.
6. Replace the switch if it tests open across the terminals or if either terminal is closed to ground.
7. Disconnect the plug from the switch terminals when the engine is above 52° C (125° F).
8. Set the ohmmeter on the highest scale or use a self-powered test lamp.
9. Test across the terminals.
10. Test from each terminal to ground.
11. Switch should be open (test lamp off or high ohm reading of greater than 1 megohm on the meter).
12. Replace the switch if it is closed.
13. When installing the switch, use a socket wrench.



Tighten

- Switch to 23 N·m (17 ft. lbs.).

GLOW PLUG SYSTEM

If all connections are intact, but the glow plug system does not operate as stated, do the system diagnosis shown in figure 21. It provides a fast way to find if the glow plug system is working properly. Use this procedure whenever there is doubt about correct system operation. Then refer to the diagnostic chart in figure 22 to pinpoint the condition.

NOTICE: Do not manually bypass the relay in the glow plug controller. Do not jump start with more than a 12-volt system. The glow plugs could be damaged.

GLOW PLUG ON-VEHICLE SERVICE

Check the system and its components on the vehicle. None of the components are serviceable. When installing new components and making connections, be

sure that connections are tight and torque values are used. Torque the glow plugs to 17 N·m (12 ft. lbs.) when installed.

CRANKING SYSTEM

DESCRIPTION

CRANKING CIRCUIT

The basic cranking circuit consists of the battery, starter motor, engine control switch, neutral sensing or neutral start switch, and related electrical wiring (figure 23).

STARTER MOTOR

Two types of starter motors are used in the vehicles covered in this manual (figures 24 and 25). Both have the shift lever mechanism and the solenoid plunger enclosed in the drive housing to protect them from exposure to dirt, icing conditions and splash.

GLOW PLUG AFTERSTART

The glow plug controller provides glow plug operation after starting a cold engine. This after-start operation is initiated when the engine control switch is returned to "RUN" from the "START" position. While loss of this function may not cause a cold start complaint, it may result in excessive white smoking and/or poor idle quality after start. To check for proper operation of this circuit proceed as follows:

1. With the engine cold 27° C (80° F), turn the engine control switch to the RUN position and let the glow plugs cycle.
2. After 2 minutes crank the engine for 1 second. (It is not important that the engine starts.) Return the engine control switch to RUN. Glow plugs should cycle at least once after cranking.
3. If the plugs do not turn on, disconnect the controller connector, and check the connector harness terminal B with a grounded 12-volt test lamp. The lamp should be off with the engine control switch in RUN, and on when the engine is cranked.
4. If the lamp does not operate as just described, repair a short or open in the engine harness purple wire.
5. If the lamp works right, but the afterstart glow plug feature does not, replace the controller.

In the basic circuit (figure 23), the solenoid windings are energized when the switch is closed (in the "Start" position). The resulting plunger and shift lever movement causes the pinion to mesh with the engine flywheel ring gear and the solenoid main contacts to close, and engine cranking takes place. When the engine starts, pinion overrun protects the armature from excessive speed until the switch is opened, at which time the return spring causes the pinion to disengage. To prevent excessive overrun, open the engine control switch (release from the "Start" position) immediately when the engine starts.

6D-20 ENGINE ELECTRICAL

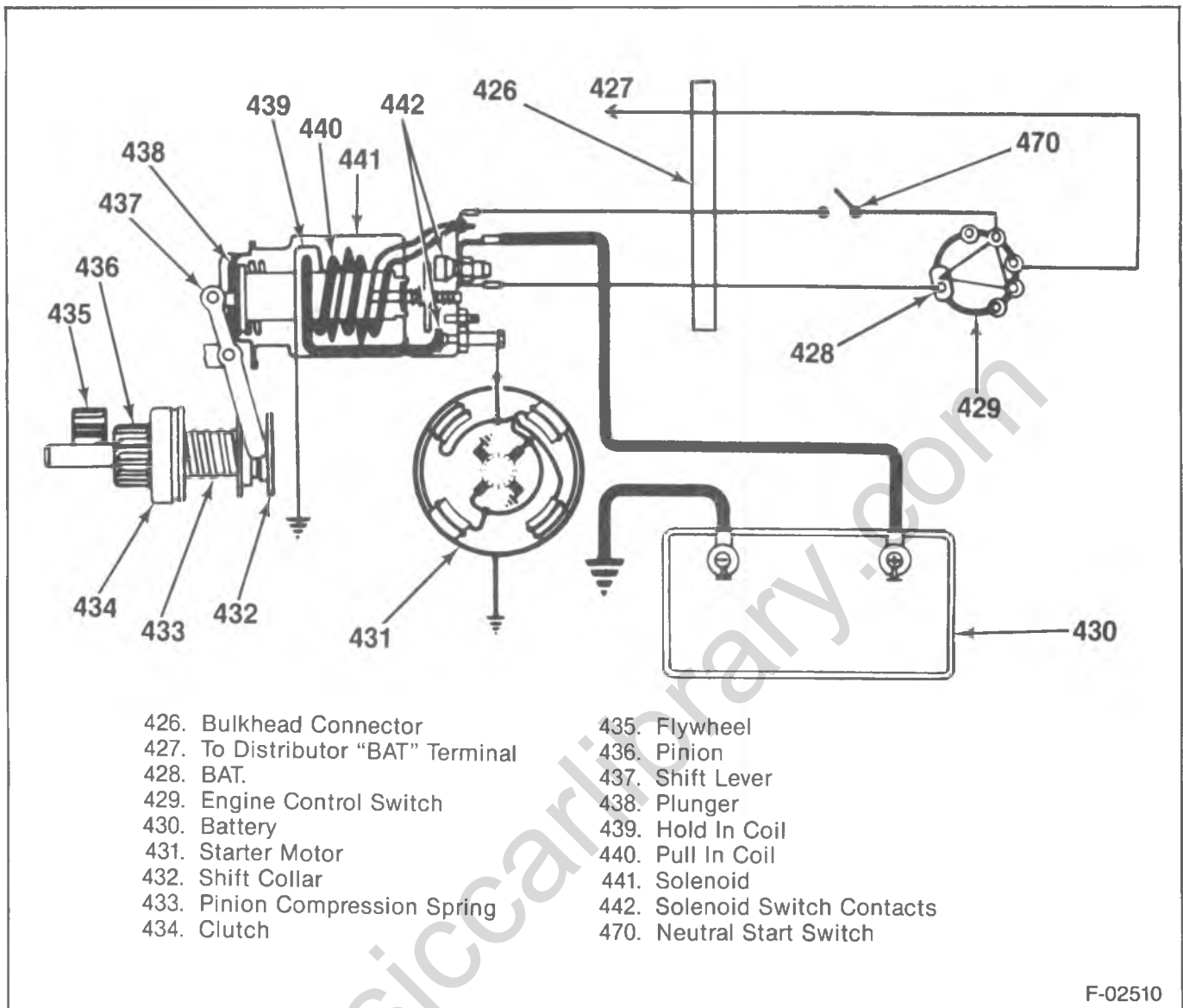

Figure 23—Cranking Circuit

F-02510

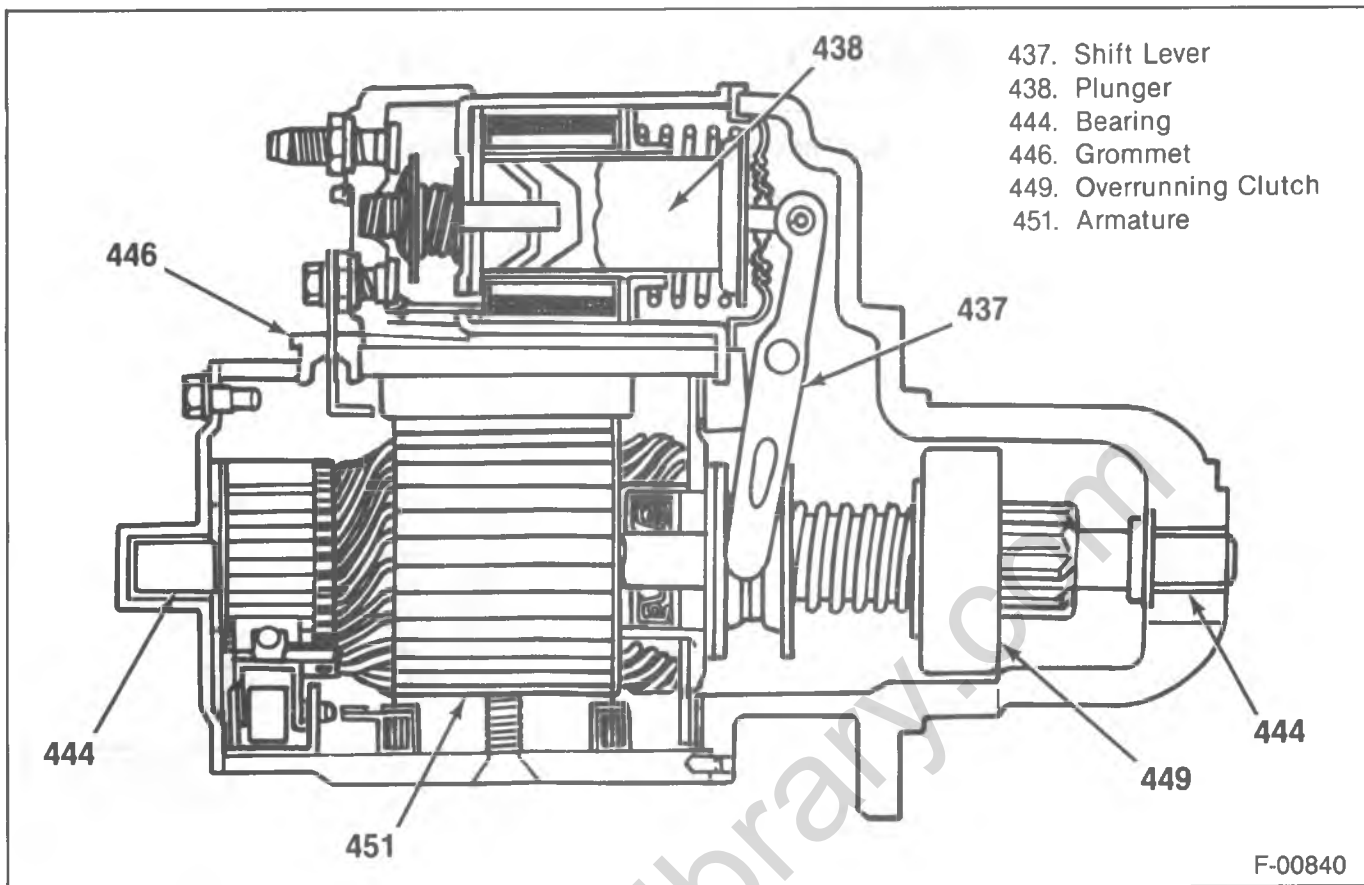

Figure 24—10MT Starting Motor

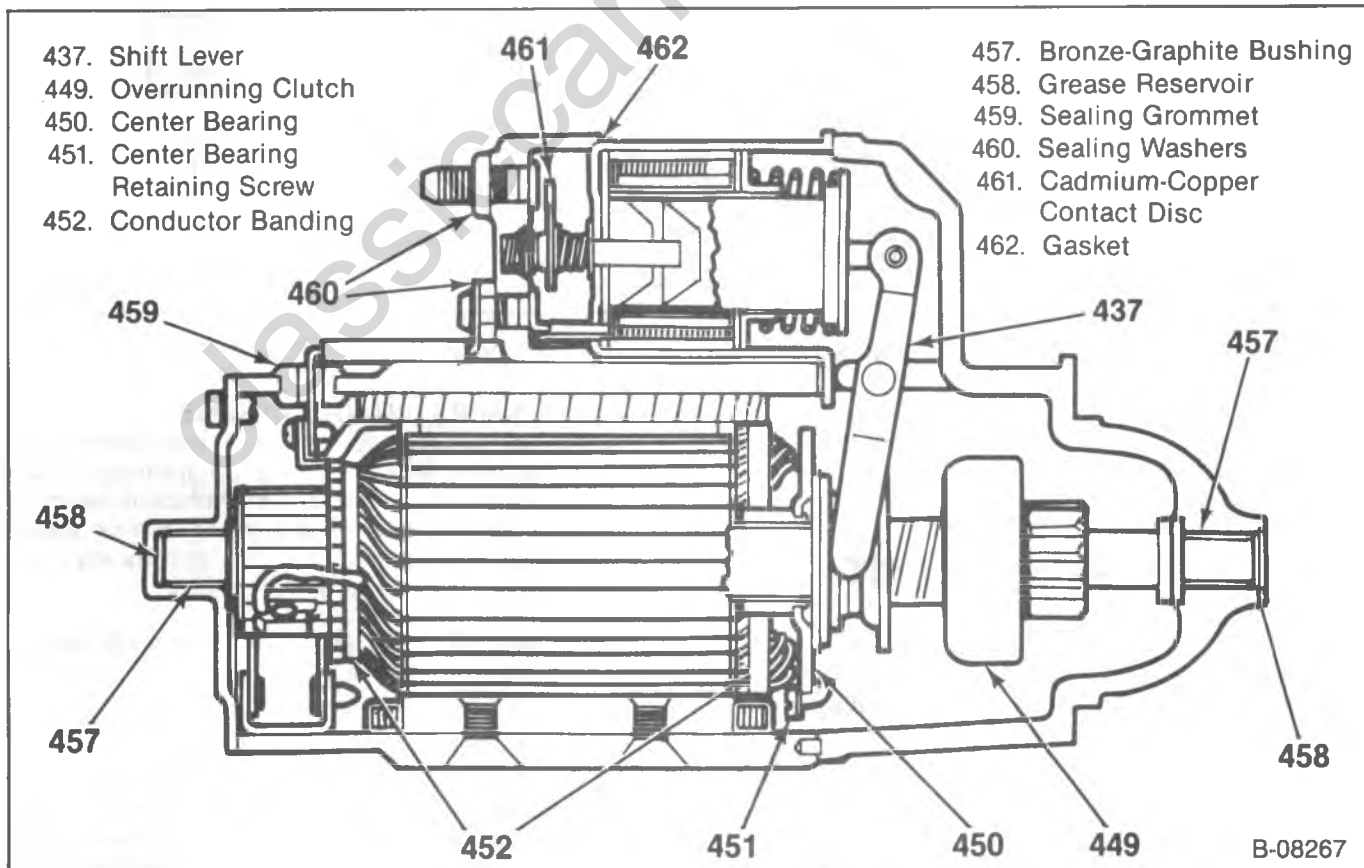

Figure 25—27MT Starting Motor

DIAGNOSIS OF CRANKING SYSTEM

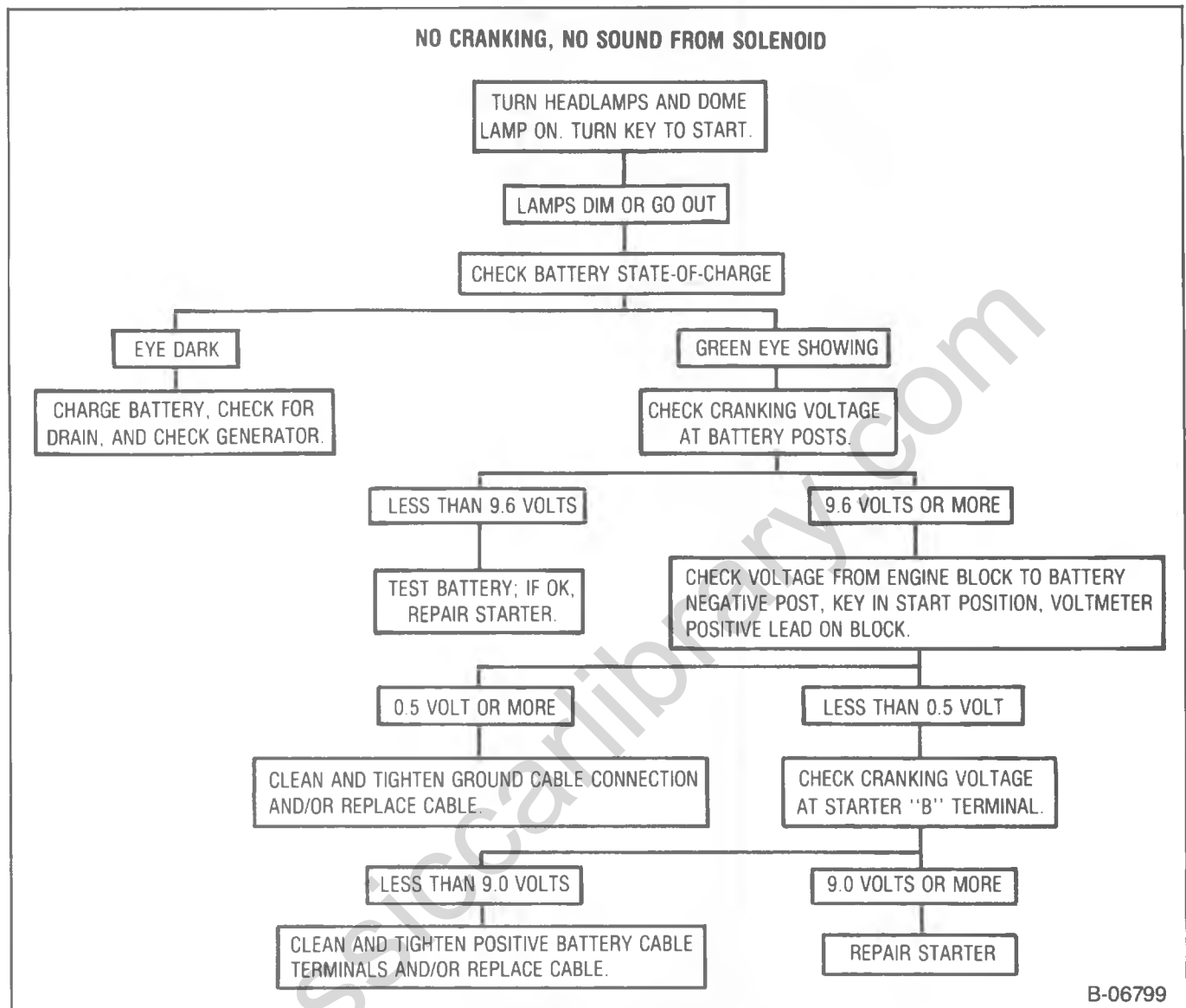

Figure 26—Cranking System Diagnosis

Refer to figures 26, 27 and 28 for a diagnosis of the cranking system. Before removing any unit in the system for repair, make the following checks.

CRANKING CIRCUIT

BATTERY

Determine the condition of the battery. Refer to "Battery" earlier in this section for battery diagnosis and testing.

WIRING

Inspect the circuit wiring for damage. Inspect all connections to the starter motor, solenoid, engine control switch, and battery, including all ground connections. Clean and tighten all connections as required.

SOLENOID AND CONTROL SWITCHES

Check all switches to determine their condition. A vehicle equipped with an automatic transmission has a neutral start switch which allows the vehicle to be started in Park or Neutral. It is located on the steering column near the floor. A vehicle with a manual transmission has a neutral start switch attached to the clutch.

The P truck with a 7.4L engine has a magnetic switch in the cranking circuit (figure 29).

Magnetic Switch Check (Figure 30)

To operate properly, the switch requires at least 11 volts. Connect a voltmeter across the winding. Close the engine control switch. If the voltmeter reads less than 11 volts, locate and repair the problem in the engine control switch, battery, or wiring. If the voltage reads 11 volts or above, yet the voltage does not seem to be reaching the starter, replace the magnetic switch.

NO CRANKING, NO SOUND FROM SOLENOID

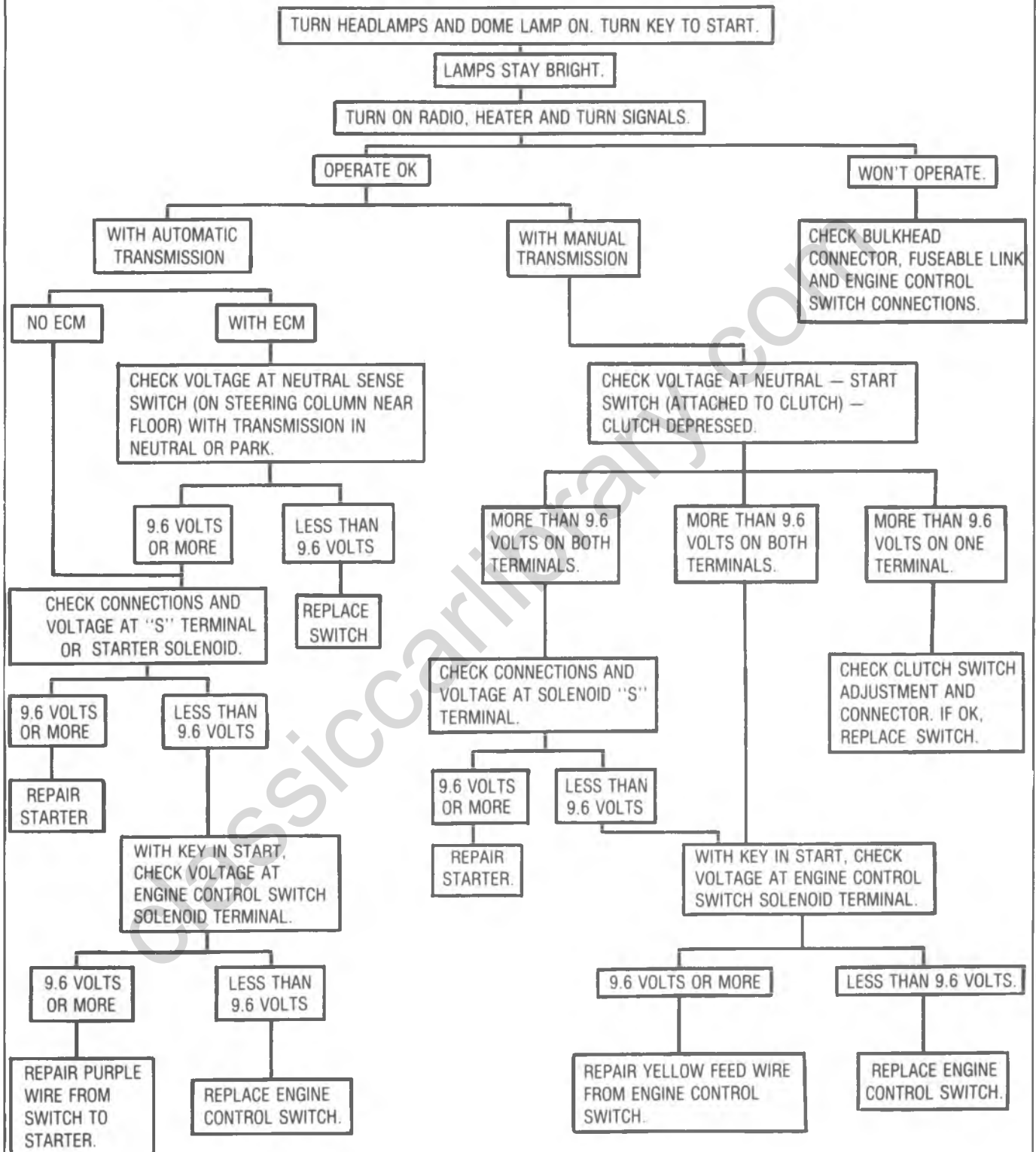

F-00249

Figure 27—Cranking System Diagnosis

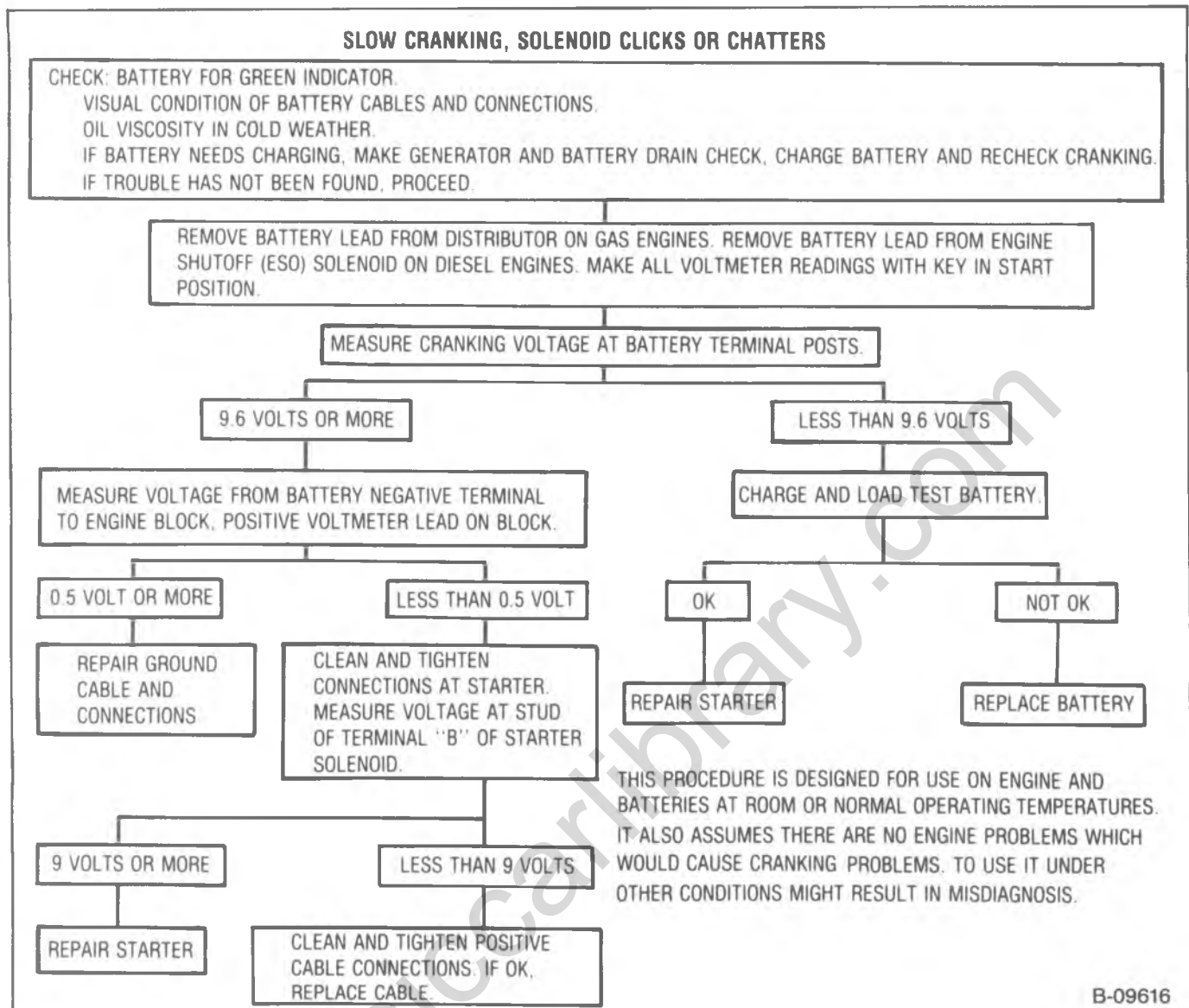

Figure 28—Cranking System Diagnosis

STARTER MOTOR NOISE

Refer to the starter noise diagnostic chart. Starter shims are shown in figure 31 and 32.

PINION CLEARANCE

1. Remove the lower flywheel housing cover.
2. Inspect the flywheel for signs of unusual wear such as chipped or missing gear teeth or the flywheel being bent. If the flywheel needs replacing, refer to "Engine Mechanical" earlier in this manual.
3. Start the engine and gently touch the outside diameter of the rotating flywheel ring gear with chalk or crayon to show the high point of tooth runout after the engine is turned off. Turn the engine off and rotate the flywheel so that the marked teeth are in the area of the starter pinion gear.
4. Disconnect the negative battery cable to prevent accidental cranking of the engine.
5. Insert a screwdriver in the small hole in the bottom of the starter (shown by the arrow in figure 33) and move the starter pinion and clutch assembly so that

the pinion teeth and flywheel teeth are meshed. If necessary, rotate the flywheel so that a pinion tooth is directly in the center of two flywheel teeth and on the centerline of the two gears (figure 34).

6. Measure the clearance between the top of the pinion tooth and the bottom of the flywheel tooth using the width of the wire gage (figure 34). Normal clearance is 0.5 to 1.5 mm (0.02 to 0.06-inch).
7. If the clearance is less than 0.5 mm (0.02-inch) and the starter whines after firing, shim the starter away from the flywheel.
 - Diesel engine (figure 31):
Add shims as required. Total shim stack must not exceed 4.0 mm (0.16-inch). If starter shims are not available, washers made of shim stock can be used.
 - Gas engines (figure 32):
Add 1.0 mm (0.04-inch) shims, one at a time, to both long bolts between starter mounting pads and engine until noise problem is corrected. Do not use more than 2 shims total.

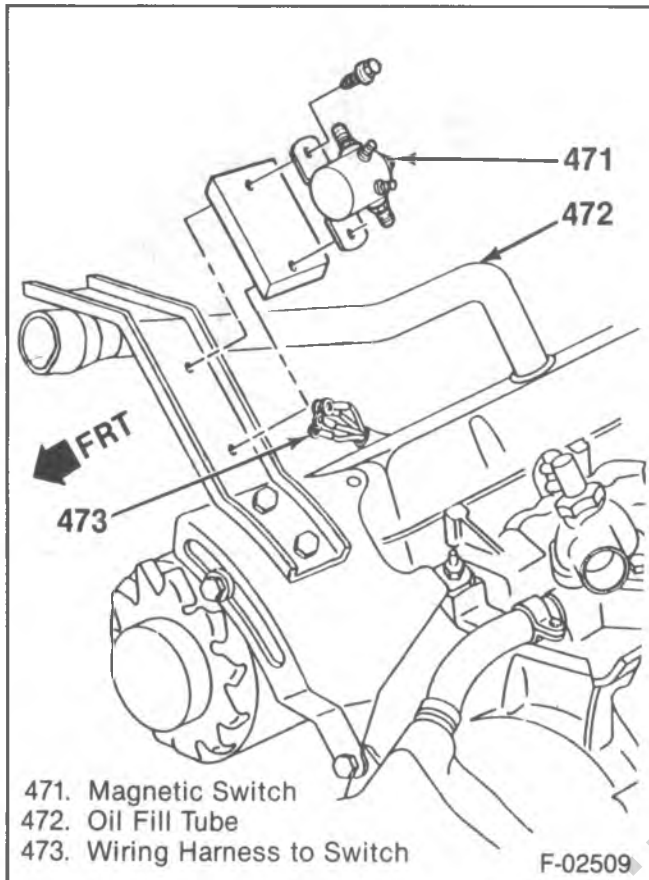

Figure 29—Magnetic Switch on P Truck

8. If the pinion clearance is more than 1.5 mm (0.06 inch) and the starter whines during cranking, shim the starter towards the flywheel.

- Diesel engine (figure 31):

Add a 1.0 mm (0.04-inch) shim between the starter motor mounting pad and the engine. If a starter shim is not available, a washer made of shim stock can be used.

- Gas engines (figure 32):

Add 0.38 mm (0.015 inch) shims between the outboard starter mounting pad and engine mount until the noise stops. Do not add more than 4 shims total.

9. When shimming is done, torque the mounting bolts.

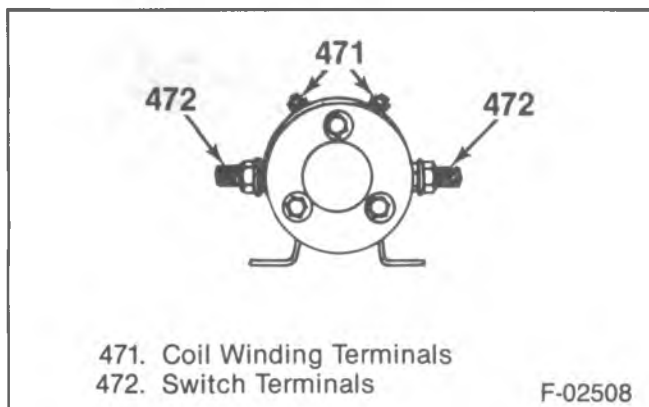

Figure 30—Magnetic Switch

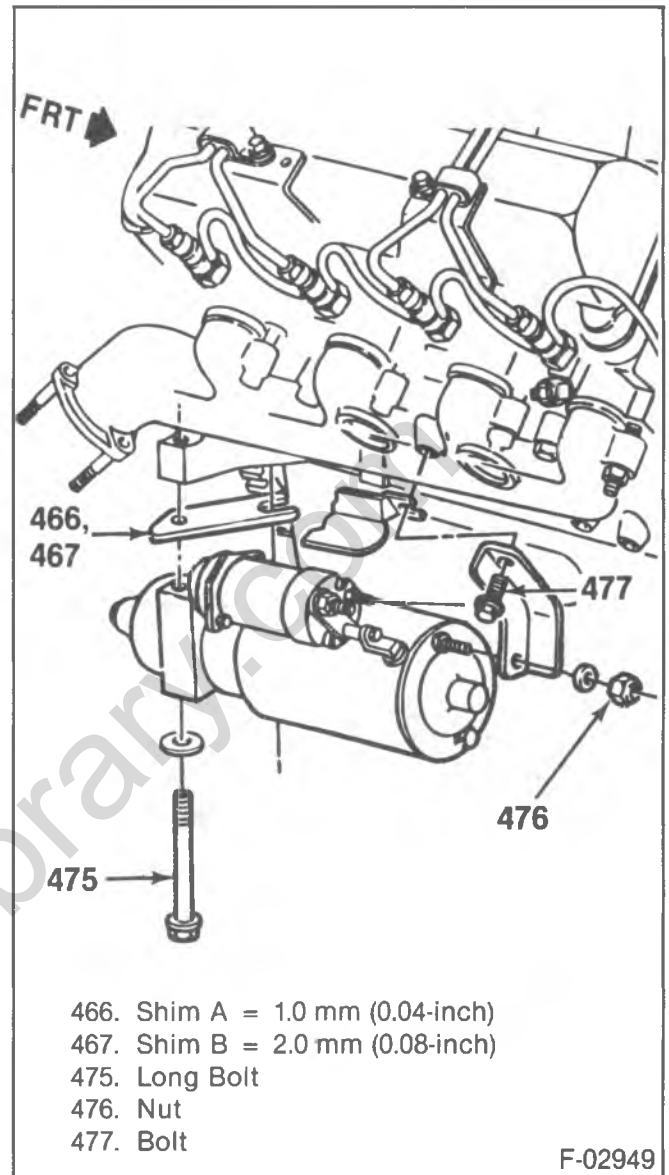

Figure 31—Shimming Diesel Engine Starter Motors

 **Tighten**

1. Gas engine starter motor mounting bolts to 38 N·m (28 ft. lbs.) (figure 34).
2. Diesel engine starter motor (figure 31):
 - Through bolt to 38 N·m (28 ft. lbs.).
 - Nut to 10 N·m (90 in. lbs.).
 - Bolt to 32 N·m (24 ft. lbs.).

6D-26 ENGINE ELECTRICAL

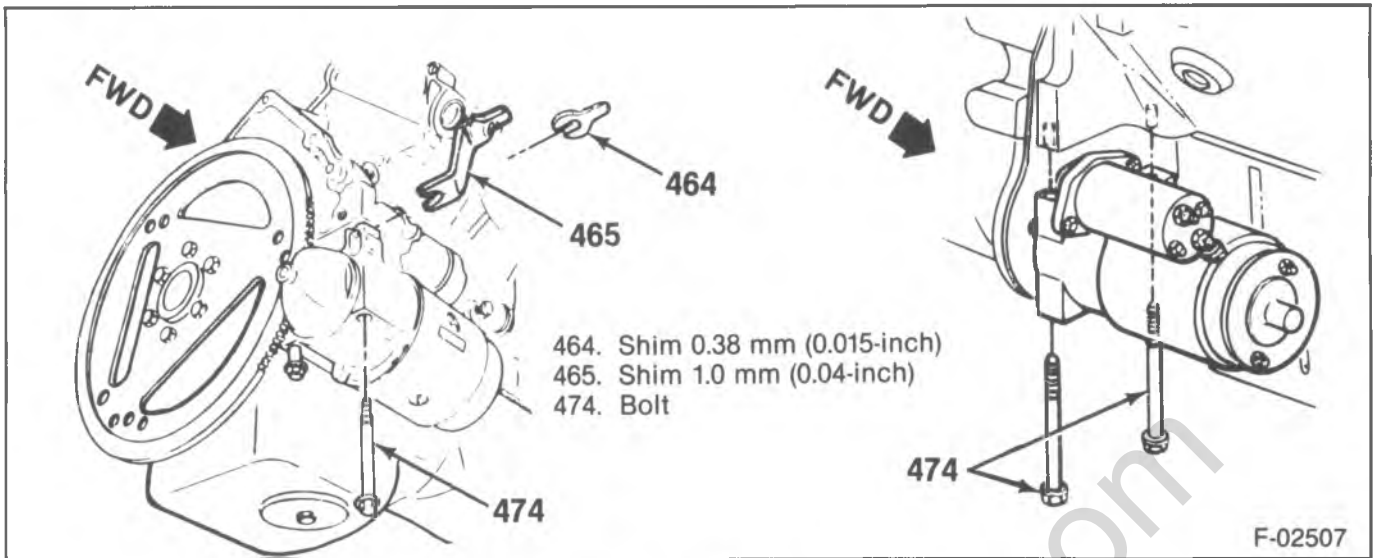

Figure 32—Shimming Gas Engine Starter Motors

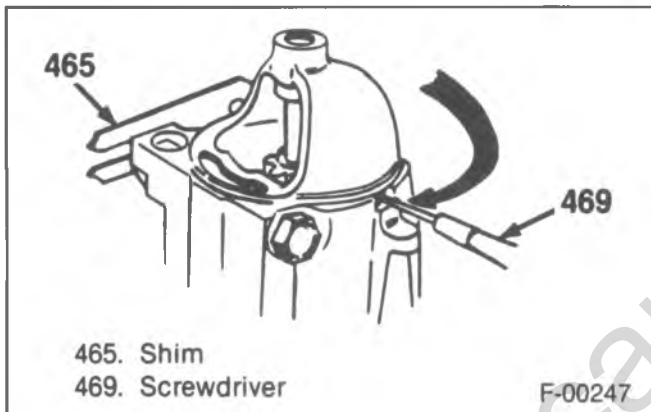

Figure 33—Meshing Starter and Flywheel Teeth

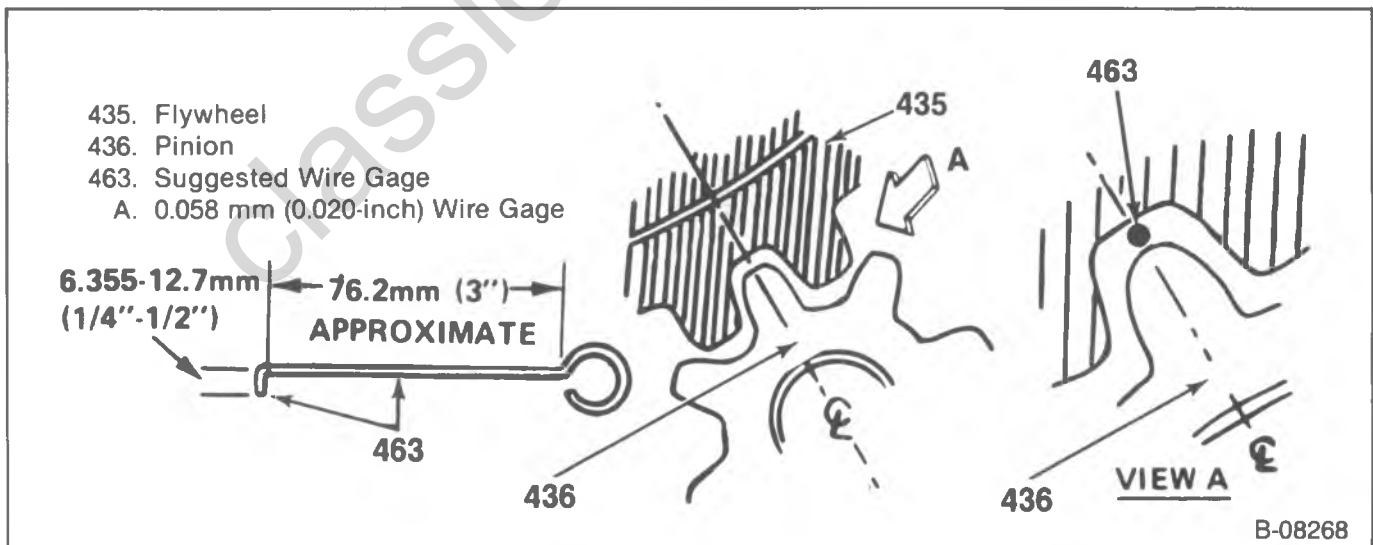

Figure 34—Flywheel to Pinion Clearance

DIAGNOSIS OF STARTER MOTOR NOISE

PROBLEM	POSSIBLE CAUSE	CORRECTION
High-pitched whine during cranking (before engine fires) but engine cranks and fires normally.	Distance too great between starter pinion and flywheel.	Remove shims at the starter mount. Refer to "Starter Motor Noise".
High-pitched whine after the engine fires as key is being released. The engine cranks and fires normally. This complaint is often diagnosed as "starter hang-in" or "solenoid weak".	Distance too small between starter pinion and flywheel. Flywheel runout contributes to the intermittent nature of the problem.	Add shims at the starter mount. Refer to "Starter Motor Noise".
A loud "whoop" after the engine fires but while the starter is still held engaged. Sounds like a siren if the engine is revved while the starter is engaged.	Usually due to a worn starter motor clutch.	Remove the starter motor and check the clutch. Refer to the Light Duty Truck Unit Repair Manual.
A "rumble" "growl" or (in severe cases) a "knock" as the starter is coasting down to a stop after starting the engine.	Usually due to a bent or unbalanced starter armature.	Remove the starter motor and check the armature. Refer to the Light Duty Truck Unit Repair Manual.

CRANKING SYSTEM ON-VEHICLE SERVICE

MAINTENANCE

Keep starter terminals and all other terminals in the electrical system clean and tight. A loose or corroded connection or terminal will cause excessive resistance in the system which will result in hard starting.

At regular intervals, inspect the starting system to locate and correct potential causes of trouble before the system performance is affected.

Starting motors do not require lubrication except during overhaul.

STARTER MOTOR

If the battery, wiring and switches are in satisfactory condition, and the engine is functioning properly, remove the motor and refer to the Light Duty Truck Unit Repair Manual.

Never operate the starter motor more than 30 seconds at a time without pausing to allow it to cool for at least two minutes. Overheating, caused by excessive cranking, will damage the motor.

STARTER MOTOR REPLACEMENT

↔ Remove or Disconnect

1. Negative battery cable.
2. Starter braces or shields if equipped.
3. Wires from the starter solenoid.
 - Raise the vehicle.
4. Two bolts, nuts, washers and shims holding the starter to the engine.
5. Starter from the engine.

↔ Install or Connect

1. Two bolts, nuts, washer and shims through the starter to the engine.

⌚ Tighten

- Bolts to 38 N·m (28 ft. lbs.).
 - Lower the vehicle.
2. Wires to the solenoid terminals.
 3. Braces or shields, if equipped.
 4. Negative battery terminal.

ENGINE BLOCK HEATERS

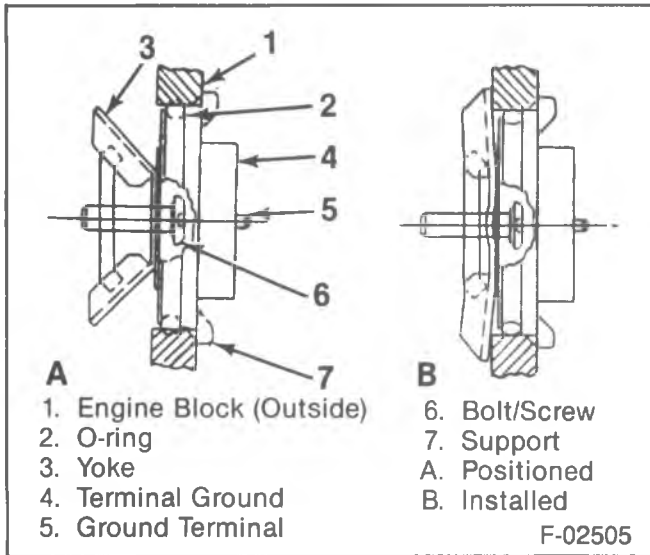

Figure 35—Engine Block Heater

DESCRIPTION

The optional engine block heater is used to preheat engine coolant for cold weather starting. The unit consists of a heating coil that fits into the engine block. It has an attached electrical cord with a plug. If the element fails to heat the coolant, check the cord and connections before replacing the element.

ON-VEHICLE SERVICE

REMOVAL

↔ Remove or Disconnect

1. Coolant. Refer to ENGINE COOLING (SEC. 6B).
2. Plug end from the heater.
 - Loosen the bolt/screw.
3. Heater from the engine block.

INSTALLATION (Figures 35, 36 and 38)

1. Apply a coating of lubricant to the O-ring and to the cleaned surface of the plug opening in the block.
2. Install the hairpin end of the heating coil into the opening and push the support in as far as it will go.
3. Position the block heater as shown for the engine in figure 38.



Tighten

- Bolt/screw to 1.8 N·m (16 in. lbs.).
4. Route the heater cord so that it does not touch the engine, hot pipes, manifold, or any moving parts. Refer to figures 37, 39, 40 and 41.
 5. Coolant. Refer to ENGINE COOLING (SEC. 6B).

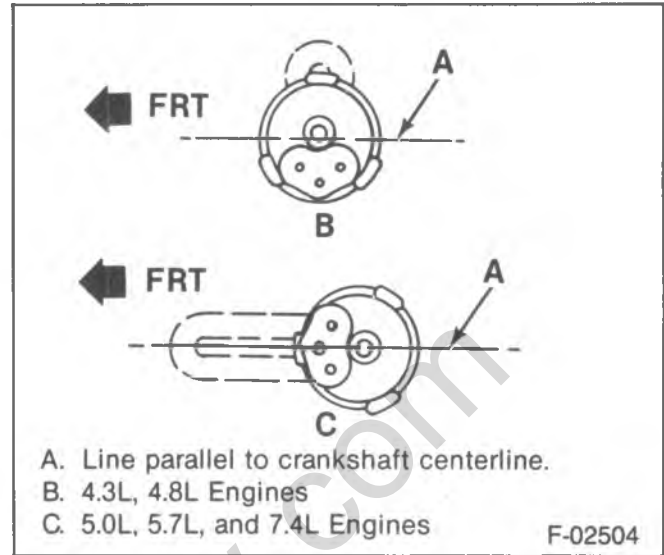

Figure 36—Element Position

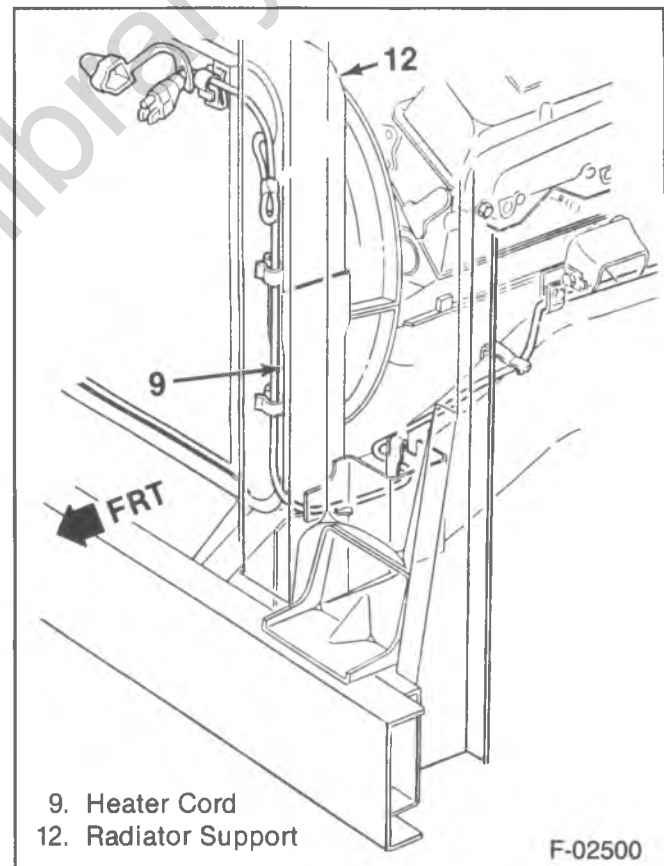
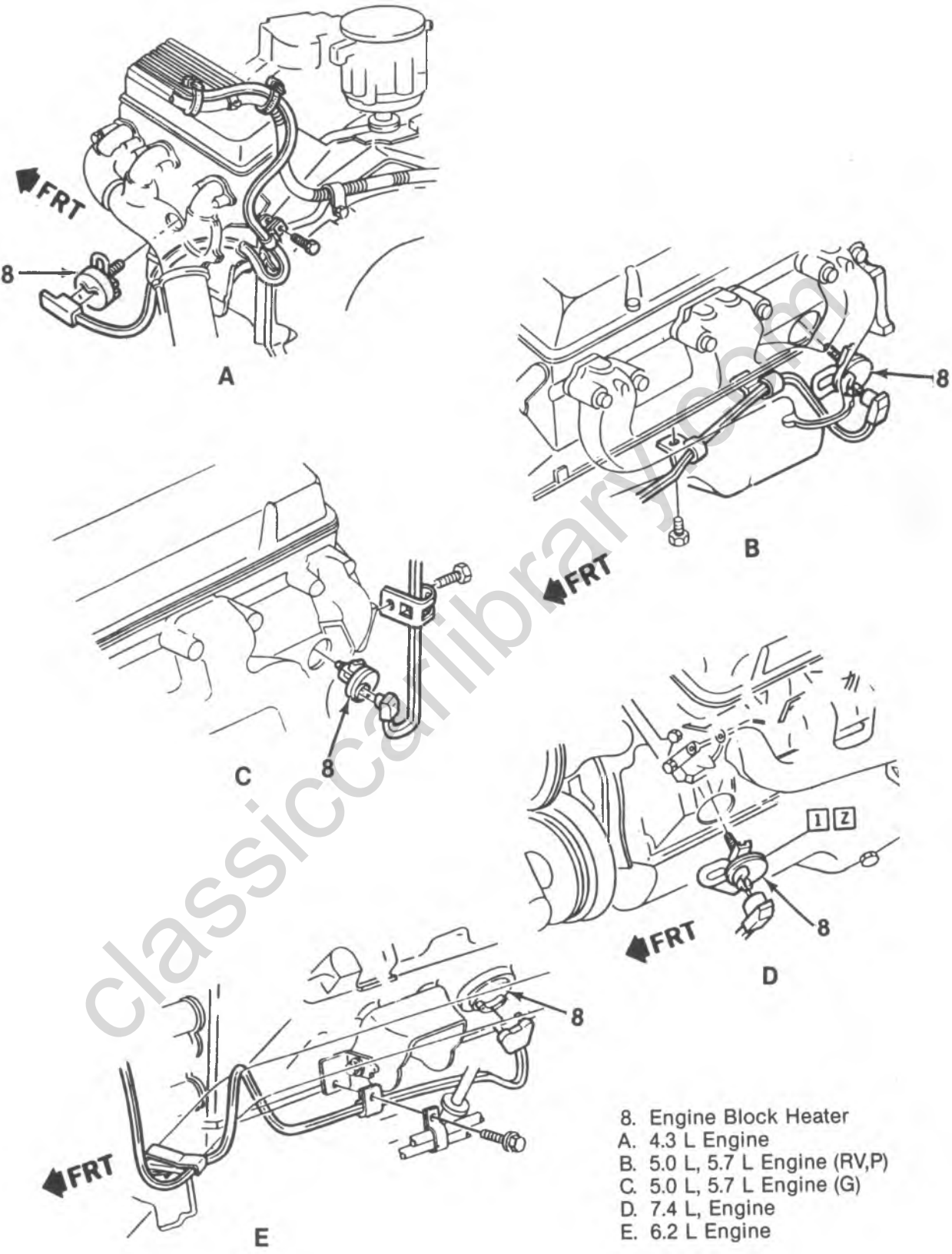

Figure 37—Heater Cord Wiring,
5.7 L, 7.4 L Engines, P Truck



- 8. Engine Block Heater
- A. 4.3 L Engine
- B. 5.0 L, 5.7 L Engine (RV,P)
- C. 5.0 L, 5.7 L Engine (G)
- D. 7.4 L, Engine
- E. 6.2 L Engine

Figure 38—Heater Location

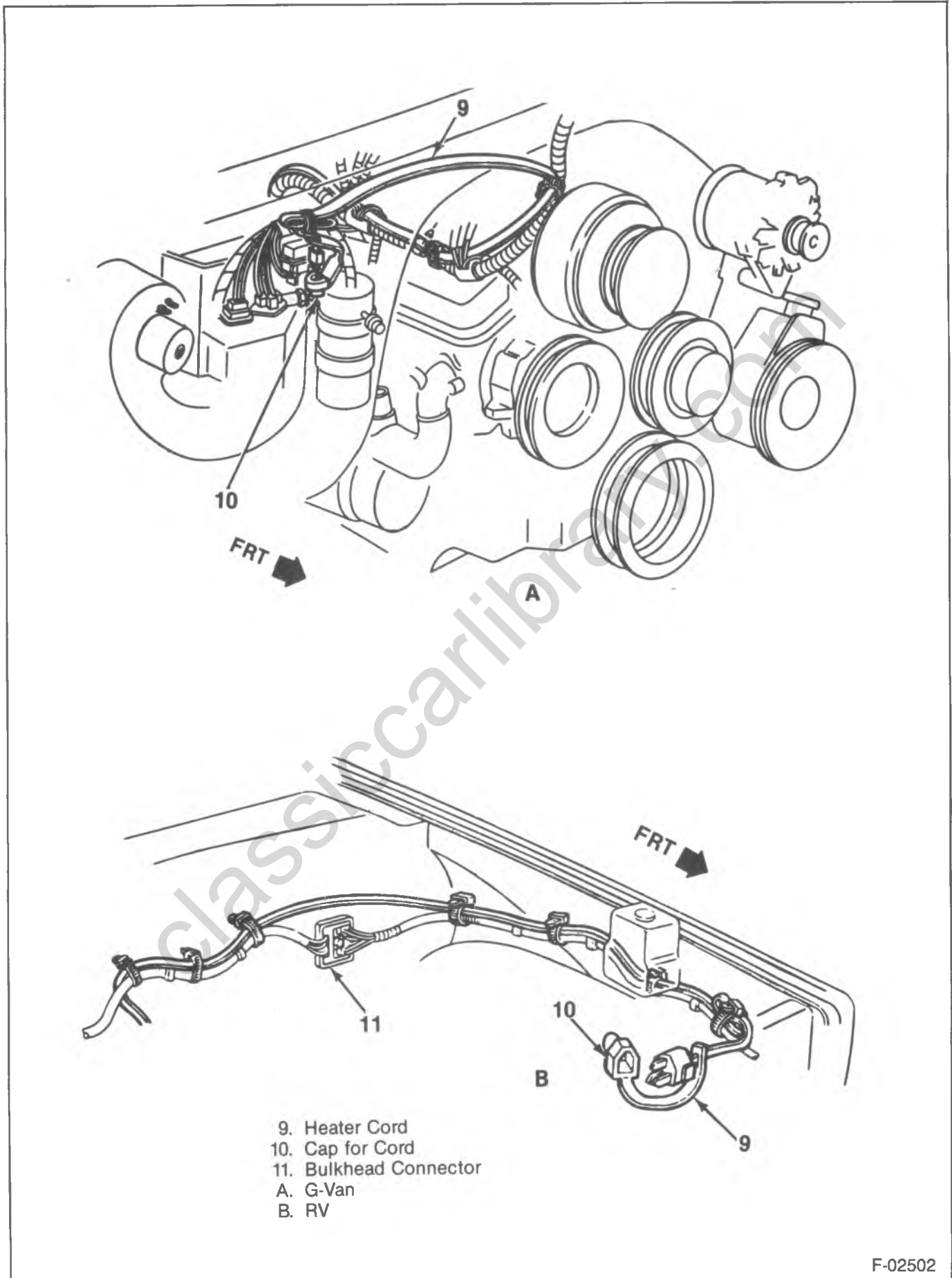
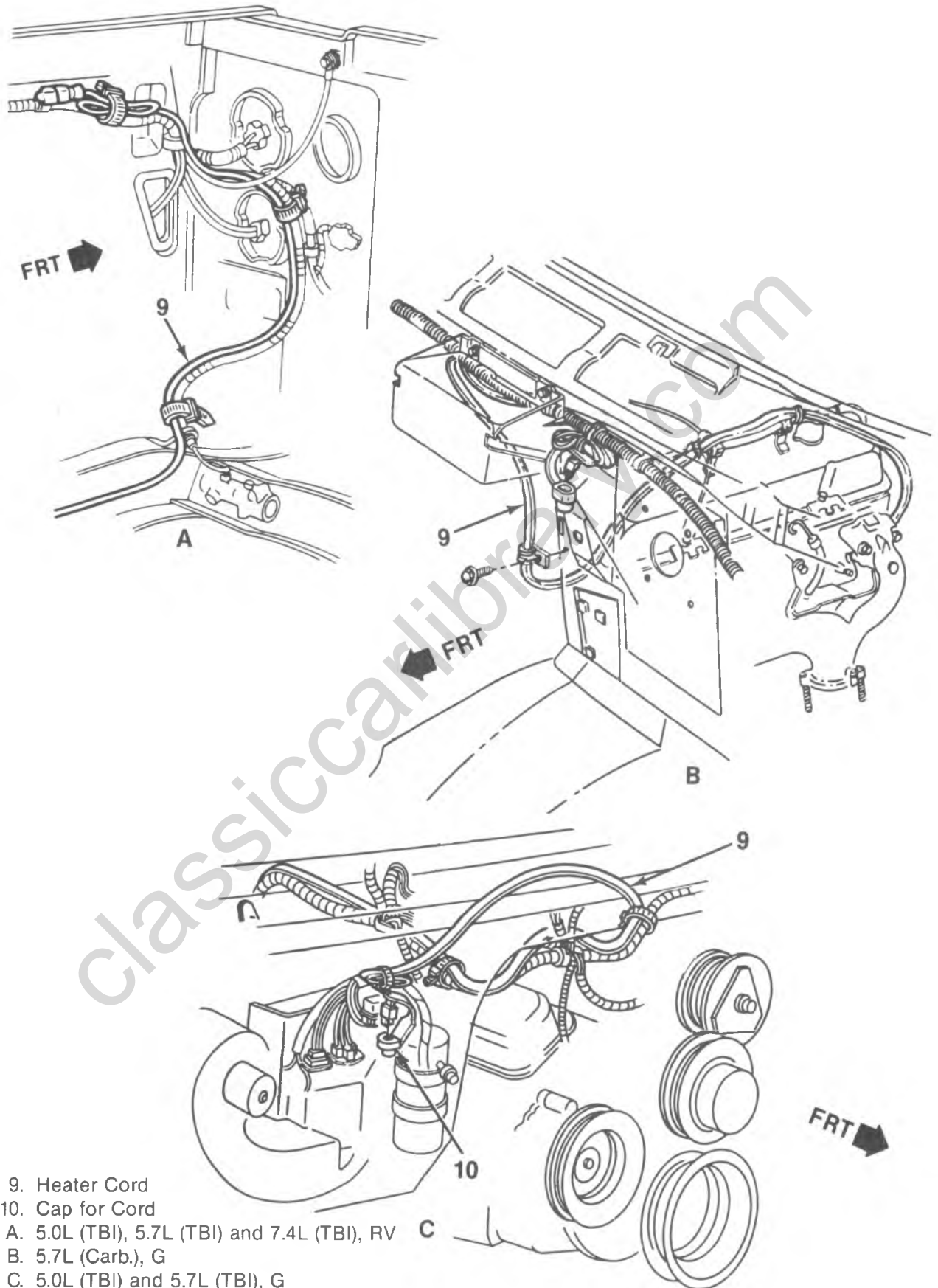
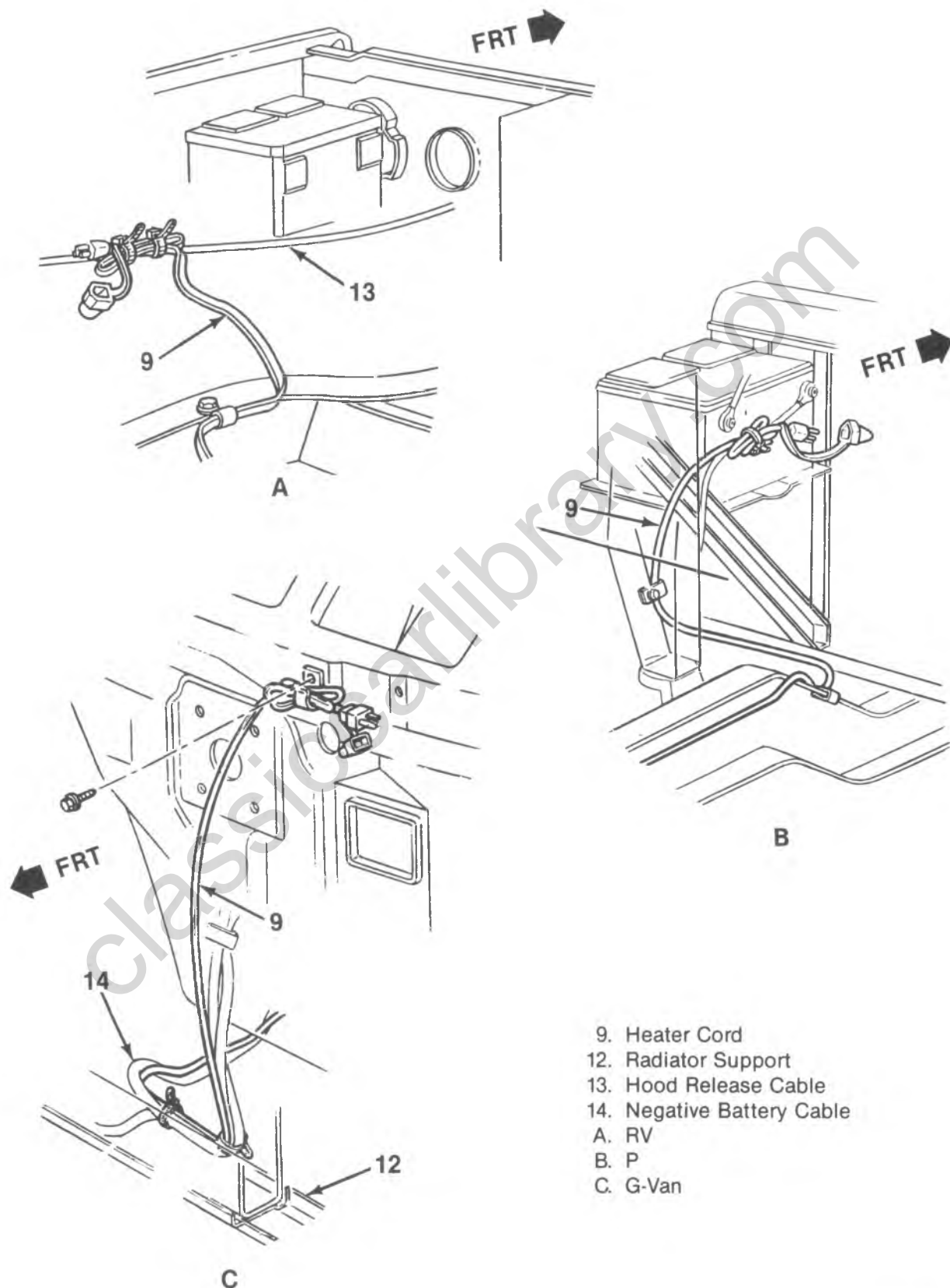

Figure 39—Heater Cord Routing, 4.3L Engine



- 9. Heater Cord
- 10. Cap for Cord
- A. 5.0L (TBI), 5.7L (TBI) and 7.4L (TBI), RV
- B. 5.7L (Carb.), G
- C. 5.0L (TBI) and 5.7L (TBI), G

Figure 40—Heater Cord Routing, 5.0L, 5.7L, 7.4L Engines



- 9. Heater Cord
- 12. Radiator Support
- 13. Hood Release Cable
- 14. Negative Battery Cable
- A. RV
- B. P
- C. G-Van

Figure 41—Heater Cord Routing, 6.2L Engine

IGNITION SYSTEM

DESCRIPTION

All ignition systems include a battery, a distributor, an engine control switch, spark plugs, and the primary and secondary wiring. Information on the battery is located earlier in this section. Refer to CAB ELECTRICAL (SEC. 8A) for information on the engine control switch.

There are two different ignition systems used on these vehicles. If the vehicle has a carbureted engine, spark is controlled by the module inside the distributor with an integral coil. If the vehicle engine is equipped with throttle body injection (TBI), the ignition system includes a knock sensor, an electronic spark control module, a computer (ECM), and a distributor with a separate coil.

DISTRIBUTOR

The distributor with an integral coil combines all ignition components in one unit (figures 42 and 43). The coil is in the cap and connects through a resistance brush to the rotor. On a distributor with a separate coil the coil connects to the rotor through a high tension wire (figure 44).

The distributor has an internal magnetic pick-up assembly which contains a permanent magnet, a pole piece with internal teeth and a pick-up coil. When the teeth of the timer core, rotating inside the pole piece, line up with the teeth of the pole piece, an induced voltage in the pick-up coil signals the electronic module to trigger the coil primary circuit. The primary current decreases and a high voltage of up to 35,000 volts is induced in the ignition coil secondary winding. This voltage is directed through the rotor and secondary leads to fire the spark plugs. The capacitor in the distributor is for radio noise suppression.

The magnetic pick-up assembly is mounted over the main bearing on the distributor housing. On carbureted engines without computers, the assembly is made to rotate by the vacuum control unit, thus providing vacuum advance. The distributor shaft is mounted on the camshaft at the rear of the engine, and rotates at one-half the rpm of the engine. The force of rotation moves the advance weights against the springs, and provides centrifugal advance to the timer core.

ENGINES WITH TBI

On engines with TBI, spark timing changes are determined electronically by the ECM (computer), which monitors information from various engine sensors, computes the desired spark timing, and signals the distributor.

The distributor does not contain centrifugal weights, springs, or a vacuum advance unit.

Each TBI equipped engine also has a knock sensor mounted in the engine block and connected by a blue wire to a spark control module (called a "half-function box") (figure 45). In response to engine knock, a signal is sent from the sensor to the module and then to the ECM,

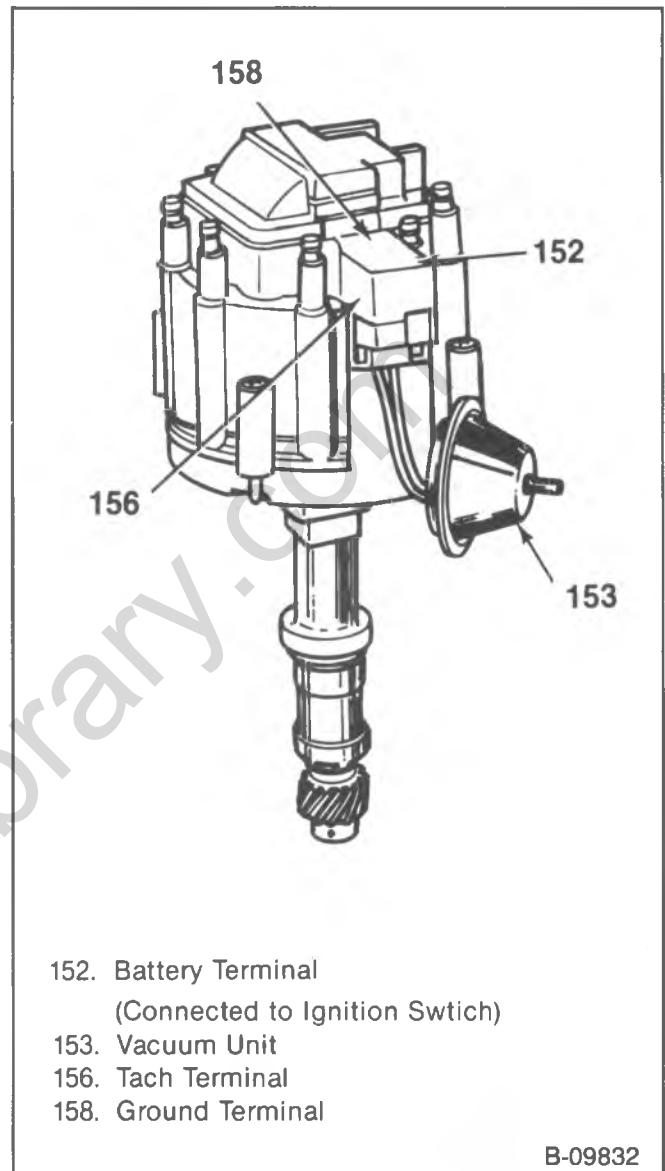

Figure 42—Distributor with Integral Coil

which computes how much to retard spark timing to reduce knock. A retard command is then sent to the distributor.

Information on TBI and the computer controlled ignition system, system components and their locations, and diagnostic charts are located in the Light Duty Truck Fuel and Emissions Service Manual.

IGNITION TIMING

Timing specifications for each engine are listed on the Vehicle Emissions Control Information label on the radiator support. Always follow Vehicle Emissions Control Information label procedures when adjusting timing. When using a timing light, connect an adapter between the number 1 spark plug and the number 1 spark plug wire, or use an inductive type pick-up. Do not pierce the plug lead. Once the insulation of the spark plug cable has been broken, voltage will jump to the nearest ground, and the spark plug will not fire properly.

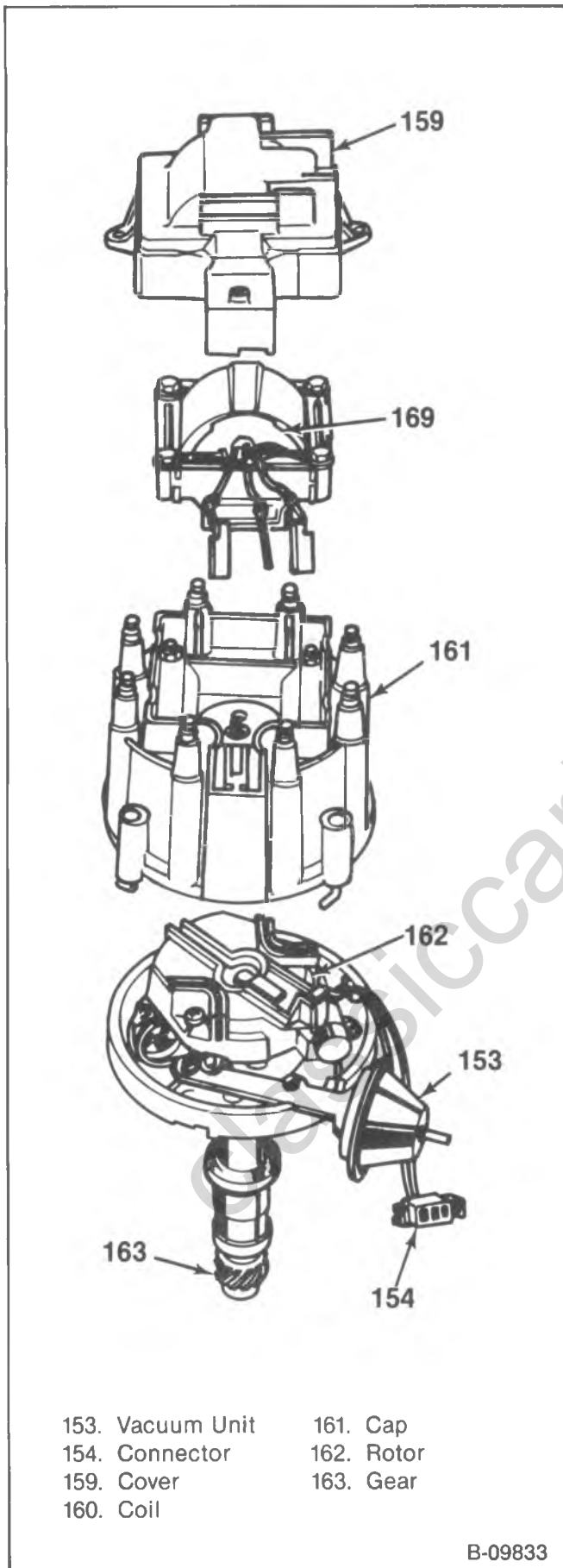

Figure 43—Distributor Components

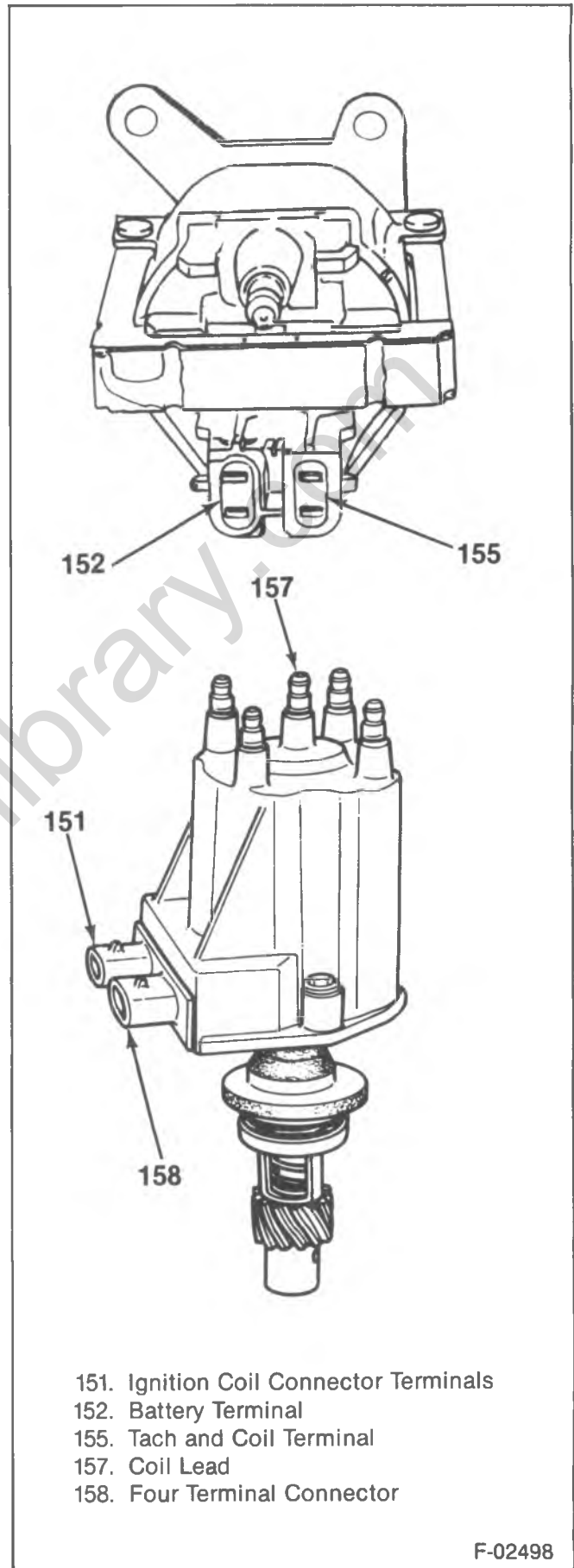

Figure 44—Distributor with Sealed Module Connectors and Separate Coil

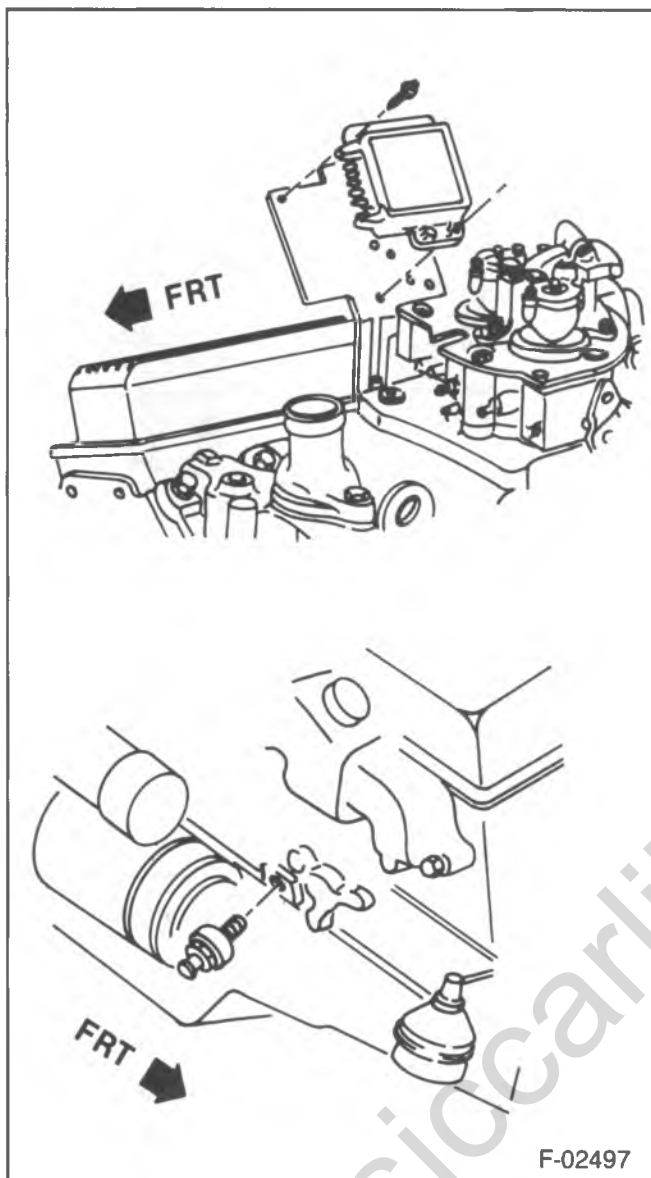

Figure 45—Knock Sensor and Spark Control Module on P Truck

Some engines incorporate a magnetic timing probe for use with special electronic timing equipment. Consult manufacturer's instructions for use of this equipment.

SPARK PLUG WIRES

The spark plug wiring is a carbon impregnated cord conductor encased in an 8mm diameter rubber jacket. The silicone spark plug boots form a tight seal on the plugs. Refer to "Spark Plug Wires" later in this section for service precautions.

SPARK PLUGS

Resistor type, tapered seat spark plugs are used on all engines. No gasket is used on these tapered seat plugs. Refer to figures 46 and 47 for an explanation of letter coding on spark plugs. Refer to the Vehicle Emissions Control Information label on the radiator support for correct gap information.

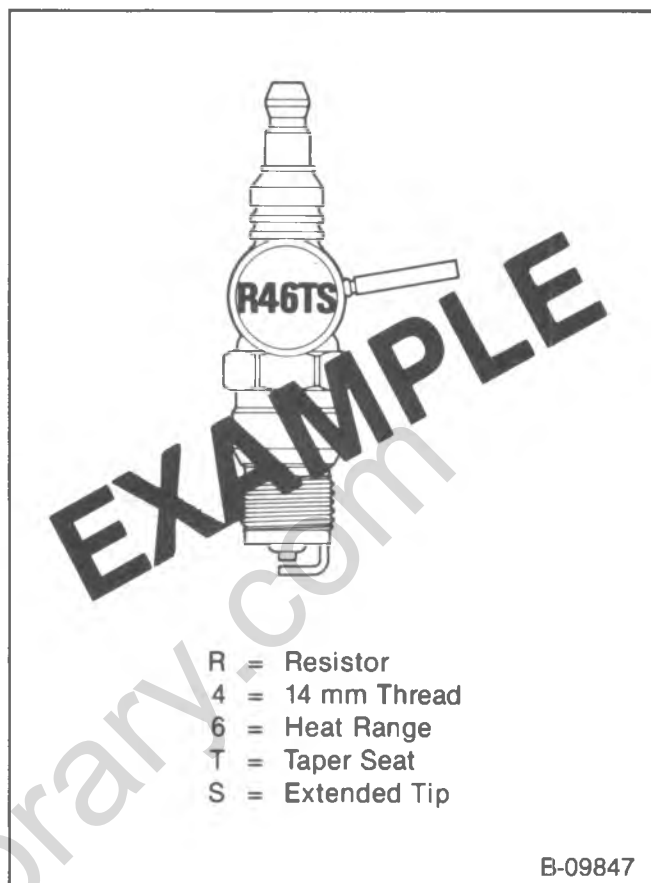

Figure 46—Spark Plug Coding

Normal or average service is assumed to be a mixture of idling, slow speed, and high speed operation with some of each making up the daily total driving. Occasional or intermittent high-speed driving is essential to good spark plug performance as it provides increased and sustained combustion heat that burns away any excess deposits of carbon or oxide that may have accumulated from frequent idling or continual stop-and-go or slow-speed driving. Spark plugs are protected by an insulating nipple made of special heat-resistant material which covers the spark plug terminal and extends downward over a portion of the plug insulator. These nipples prevent flash-over with resultant missing of engine, even though a film is allowed to accumulate on exposed portion of plug porcelains.

Do not mistake corona discharge for flash-over or a shorted insulator. Corona is a steady blue light appearing

Numbers relate to thread size as follows:	
1st number denotes THREAD SIZE	
4 = 14 mm	2 = 1/2-inch taper
8 = 18 mm	5 = 1/2-inch
10 = 10 mm	6 = 3/4-inch
12 = 12 mm	7 = 7/8-inch
2nd number denotes HEAT RANGE	
0-1-2-3-4-5-6-7-8-9	
COLD ----- HOT	

F-02496

Figure 47—Spark Plug Coding Chart

6D-36 ENGINE ELECTRICAL

around the insulator, just above the shell crimp. It is the visible evidence of a high-tension field, and has no effect on ignition performance. Usually it can be detected only in darkness. This discharge may repel dust particles, leaving a clear ring on the insulator just above the shell. This ring is sometimes mistakenly regarded as evidence that combustion gases have blown out between shell and insulator.

TEST FOR SEPARATELY MOUNTED COIL

1. Disconnect the distributor lead and wiring from the coil.
2. Connect an ohmmeter as shown in figure 48, step 1. Use the high scale. The reading should be infinite. If not, replace the coil.
3. Connect the ohmmeter as shown in step 2. Use the low scale. The reading should be very low or zero. If not, replace the coil.
4. Connect the ohmmeter as shown in step 3. Use the high scale. The meter should not read infinite. If it does, replace the coil.
5. Reconnect the distributor lead and wiring to the coil.

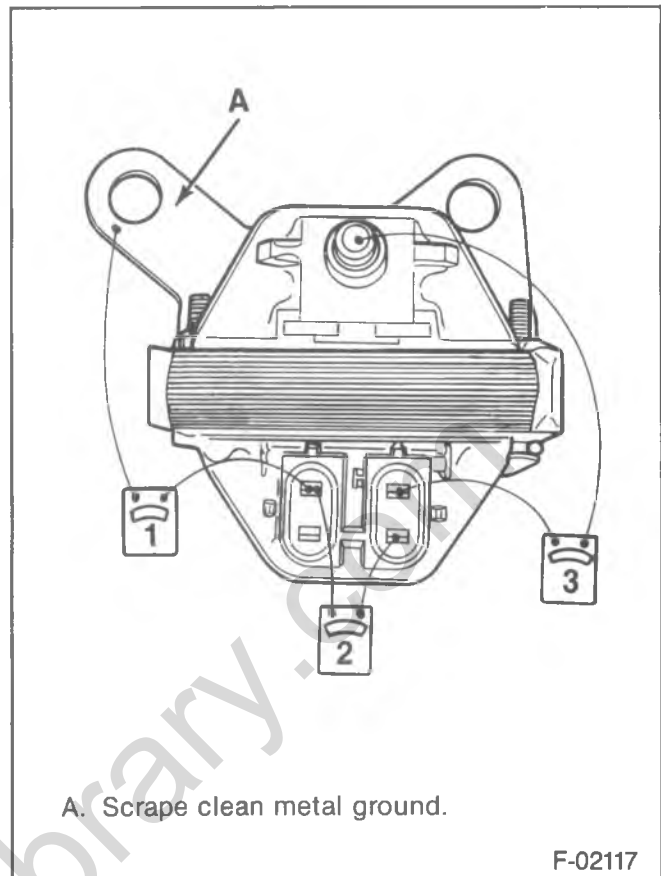

Figure 48—Testing the Ignition Coil

DIAGNOSIS OF THE IGNITION SYSTEM

DISTRIBUTOR/TIMING SYSTEM FOR TBI-EQUIPPED VEHICLES

CAUTION: To prevent possible personal injury from a moving vehicle or operating engine do the following before performing the checks:

1. Engage the parking brake and block the wheels.
 2. Place the automatic transmission in park or the manual transmission in neutral.
1. Refer to the Fuel and Emissions Service Manual for information on the computerized ignition system, including the diagnostic use of the "Check Engine" or "Service Engine Soon" lamp.
 2. Refer to the Light Duty Truck Unit Repair Manual for distributor component checks.

IGNITION SYSTEM FOR CARBURETED ENGINE

CAUTION: To prevent possible personal injury from a moving vehicle or operating engine do the following before performing the checks:

1. Engage the parking brake and block the wheels.
 2. Place the automatic transmission in park or the manual transmission in neutral.
1. Refer to figure 49, 50 and 51 for system diagnosis.
 2. Refer to the Light Duty Truck Unit Repair Manual for distributor component checks.

ENGINE CRANKS, BUT WILL NOT START
(DISTRIBUTOR WITH INTEGRAL COIL)

IF A TACHOMETER IS CONNECTED TO THE TACHOMETER TERMINAL, DISCONNECT IT BEFORE PROCEEDING WITH THE TEST.

1. CHECK SPARK AT PLUG WITH ST-125 WHILE CRANKING (VIEW A, B, FIGURE 44). IF NO SPARK ON ONE WIRE, CHECK A SECOND WIRE. A FEW SPARKS AND THEN NOTHING IS CONSIDERED NO SPARK.

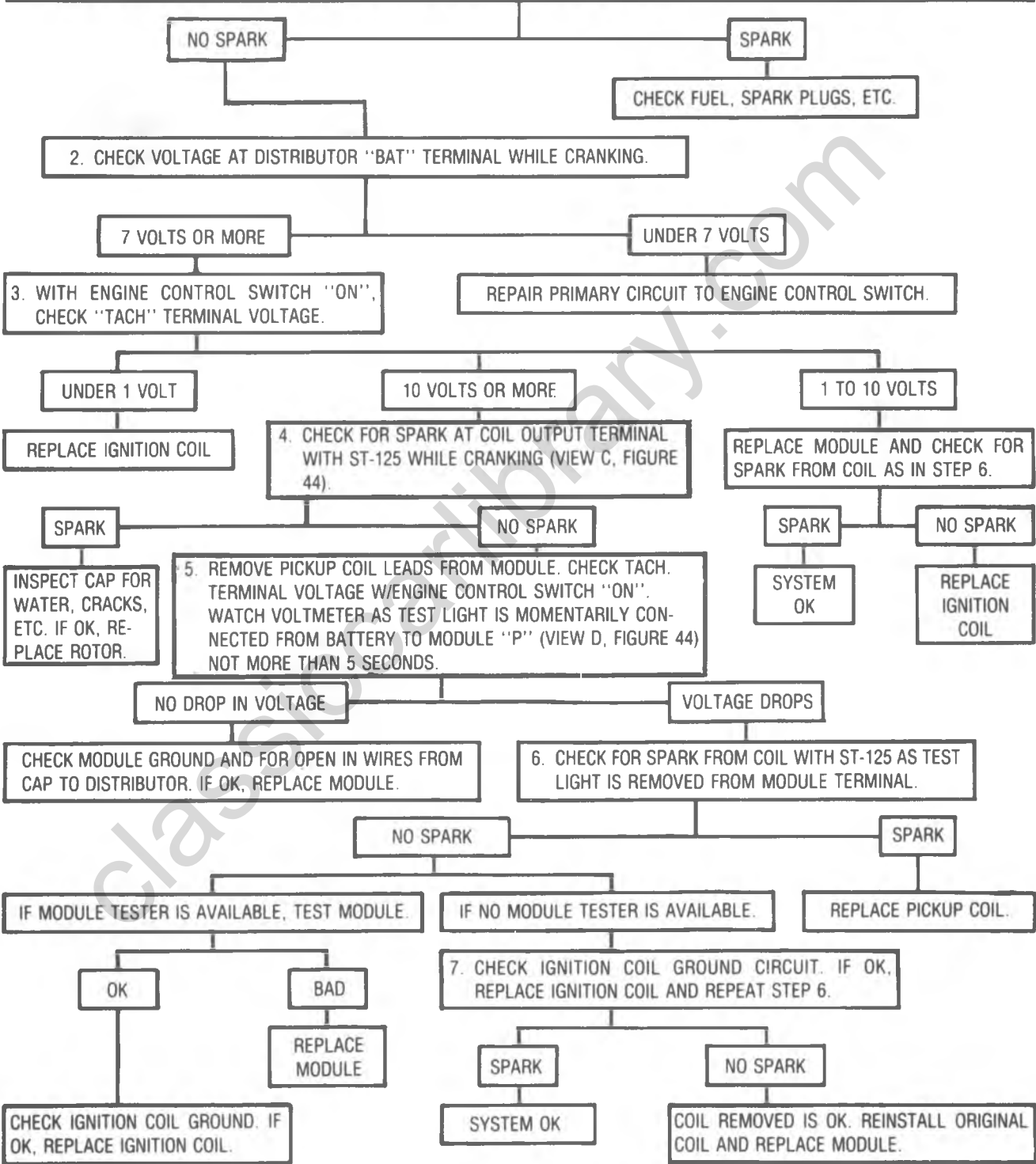
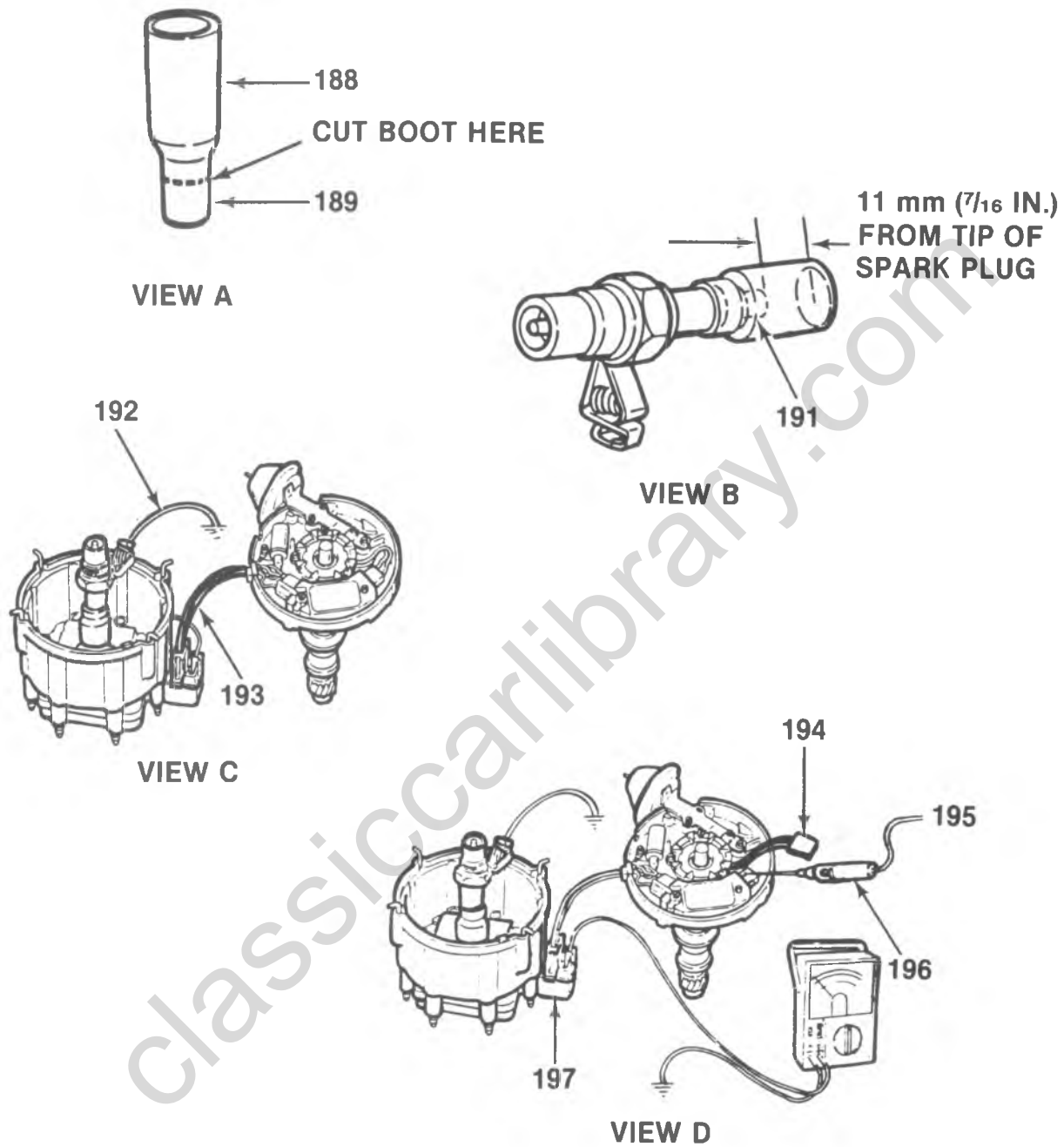

Figure 49—Ignition System Diagnosis



- 188. Spark Plug Boot
- 189. Discard
- 191. Insert Boot Over Porcelain End Of ST-125
- 192. Connect To Ground
- 193. Leave Harness Connected
- 194. Remove Leads To Module
- 195. To BAT +
- 196. Test Light
- 197. Connect Voltmeter And Tach Terminal To Ground

Figure 50—Ignition System Diagnosis

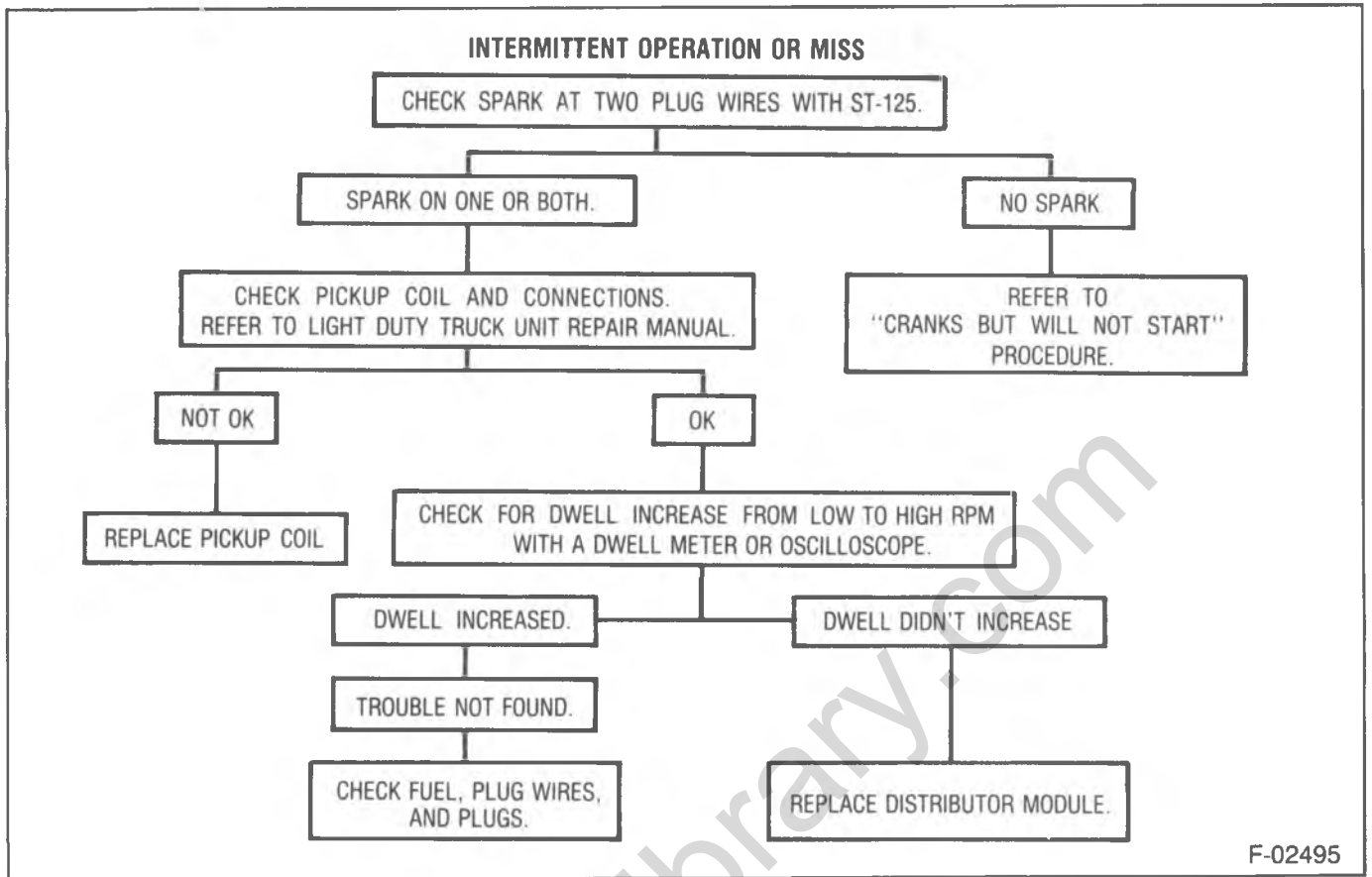

Figure 51—Ignition System Diagnosis

DIAGNOSIS OF SPARK PLUGS

PROBLEM	POSSIBLE CAUSE	CORRECTION
Brown to grayish-tan deposits and slight electrode wear.	Normal wear.	Clean, regap, reinstall.
Dry, fluffy black carbon deposits.	<ol style="list-style-type: none"> 1. Carburation is too rich. 2. Sticking EFE valve or manifold heat valve. 3. Sticking automatic choke. 4. Poor ignition output. 	<ol style="list-style-type: none"> 1. Check the fuel mixture. Replace the air cleaner if clogged. 2. Replace if necessary. 3. Refer to CARUBRETORS (SEC. 6C1). 4. Check the distributor coil connections and cables (discussed in this section). Refer to the Fuel and Emission Service Manual.
Wet, oily deposits with very little electrode wear.	<ol style="list-style-type: none"> 1. "Break-in" of new or recently overhauled engine. 2. Excessive valve stem guide clearances. 3. Worn intake valve seals. 	<ol style="list-style-type: none"> 1. Degrease, clean and reinstall the plugs. 2. Refer to ENGINE (SEC. 6A). 3. Replace the seals.
Red, brown, yellow and white colored coatings on insulator. Engine misses intermittently under severe operating conditions.	By-products of combustion.	Clean, regap, and reinstall. If heavily coated, replace.

DIAGNOSIS OF SPARK PLUGS (CONT.)

PROBLEM	POSSIBLE CAUSE	CORRECTION
Colored coatings heavily deposited on portion of the plug projecting into the chamber and on the side facing the intake valve.	Leaking seals if the condition is found in only one or two cylinders.	Check the seals. Replace if necessary. Clean, regap, and reinstall the plugs.
Shiny yellow glaze coating on the insulator.	Melted by-products of combustion.	Avoid sudden acceleration with wide-open throttle after long periods of low speed driving. Replace the plugs.
Burned or blistered insulator tips and badly eroded electrodes.	Overheating.	<ol style="list-style-type: none"> 1. Check the cooling system. 2. Check for sticking heat riser valves. Refer to ENGINE (SEC. 6A). 3. Check the air-fuel mixture. May be too lean. Refer to the Fuel and Emissions Service Manual for TBI engines or CARBURETORS (SEC. 6C1) in this manual for carbureted engines. 4. Check the heat range of the plugs. May be too hot. 5. Check the ignition timing. May be over-advanced. 6. Check the torque value of the plugs to ensure good plug-engine seat contact.
Broken or cracked insulator tips.	Heat shock from sudden rise in the tip temperature under severe operating conditions. Improper gapping of the plugs.	Replace the plugs. Gap correctly.

IGNITION SYSTEM ON-VEHICLE SERVICE

SERVICE PRECAUTIONS

Some service tachometers and electronic diagnostic equipment may NOT be compatible with these ignition systems. Consult your representative of such equipment to update your equipment for compatibility with these systems.

1. When making compression checks, disconnect the engine control switch feed wire at the distributor. When disconnecting this connector release the locking tab while pulling downward on the connector body; do not use a screwdriver or tool to release the locking tab as it may break the tab.
2. No periodic lubrication is required. Engine oil lubricates the lower bushing and an oil-filled reservoir provides lubrication for the upper bushing.

NOTICE: *the tachometer terminal must NEVER be allowed to touch ground, as damage to the module and/or ignition coil can result.*

3. On integral coil distributors, the tachometer (TACH) terminal is next to the engine control switch (BAT) connector on the distributor cap. On distributors with separate coils, the TACH terminal is at the coil (figure 44).
4. There is no dwell adjustment since this is controlled by the module.
5. The material used to construct the spark plug wires is very pliable and soft. This wire will withstand more heat and carry a higher voltage. Due to the more pliable wire, scuffing and cutting become easier. Route the spark plug wires correctly to prevent chaffing or cutting. When removing a spark plug wire from a spark plug, twist the boot on the spark plug and pull on the boot to remove the wire.

DISTRIBUTOR REPLACEMENT

Some components, such as the engine cover or air cleaner, may need to be removed to reach the distributor.

DISTRIBUTOR WITH INTEGRAL COIL

↔ Remove or Disconnect

1. Engine control switch battery feed wire from the distributor cap.
2. Tachometer lead (if equipped) from the cap.
3. Ignition coil connector from the cap.
 - Do not use a screwdriver or tool to release the locking tabs.
4. Distributor cap by pressing down on the four spring-loaded screws and turning the latches to the left.
5. Vacuum hose from the vacuum advance unit (if equipped).
6. Distributor clamp bolt and hold-down clamp from the engine.
 - Note the position of the rotor, then pull the distributor up until the rotor just stops turning to the left and again note the position of the rotor.
7. Distributor.

↔ Install or Connect

To ensure correct timing of the distributor it must be installed with the rotor correctly positioned as noted in Step 7 of the removal procedure.

If the engine was accidentally cranked after the distributor was removed, the following procedure can be used for installation:

- Remove the number 1 spark plug.
 - Place finger over the number 1 spark plug hole and crank the engine slowly until compression is felt.
 - Align the timing mark on the pulley to "0" on the engine timing indicator.
 - Turn the rotor to point between number 1 and number 8 spark plug towers on the distributor cap on V8 engines and between number 1 and number 6 on 6 cylinder engines.
1. Distributor.
 - If the distributor shaft won't drop into the engine, first insert a screwdriver into the hole for the distributor and turn the oil pump drive shaft.
 2. Distributor hold-down clamp and clamp bolt.
 3. Vacuum hose to the vacuum unit (if equipped).
 4. Cap on the distributor.
 - The aligning tab on the cap should engage with the notch in the housing.
 5. Four hold-down spring latches.
 6. Ignition coil connector to the cap.
 7. Engine control switch battery feed wire.
 8. Tachometer lead (if equipped).
 - Set ignition timing as described later in this section.

DISTRIBUTOR WITH SEPARATE COIL

↔ Remove or Disconnect

1. Negative battery cable.
2. Wiring harness connectors at the side of the distributor cap.
3. Distributor cap and move it out of the way.
 - Scribe a mark on the engine in line with the rotor.
 - Note the position of the distributor housing in relation to the engine.
4. Distributor hold-down nut and clamp.
5. Distributor.

↔ Install or Connect

- To ensure correct timing of the distributor it must be installed with the rotor correctly positioned as noted in step 3 of the removal procedure.
 - If the distributor shaft won't drop into the engine, insert a screwdriver into the hole for the distributor and turn the oil pump driveshaft.
1. Distributor.
 2. Hold-down nut and clamp.
 3. Distributor cap.
 4. Wiring harness connector at the side of the cap.
 5. Engine cover and console.
 6. Negative battery cable.

COIL REPLACEMENT

↔ Remove or Disconnect

1. Negative battery cable.
2. Engine control switch and tachometer terminals at the coil.
3. Coil to distributor lead at the coil.
4. Nuts holding the coil bracket and coil to the engine bracket.
5. Coil bracket and coil.
 - Drill and punch out the two rivets holding the coil to the bracket.
6. Coil from bracket.

↔ Install or Connect

1. Coil to the bracket with two screws.
2. Coil bracket to the engine bracket with studs and nuts.
3. Coil to the distributor lead at the coil.
4. Engine control switch and tachometer connectors to the coil.
5. Negative battery cable.

IGNITION TIMING

1. Refer to the Vehicle Emissions Control Information label located on the radiator support. Follow all instructions on the label.
2. Refer to the Fuel and Emissions Service Manual for timing information for engines equipped with TBI.
3. With the engine control switch off, connect the pick-up lead of a timing light to the number 1 spark plug. Use a jumper lead between the wire and plug or an inductive type pick-up. DO NOT pierce the wire

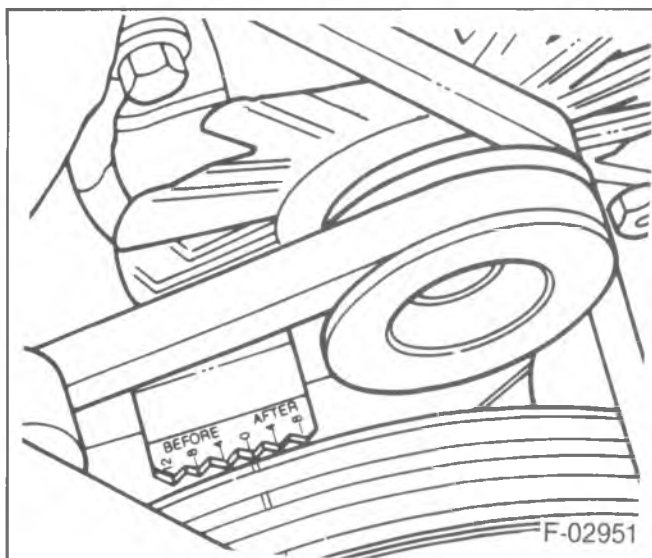

Figure 52—Timing Mark

or attempt to insert a wire between the boot and the wire. Connect the timing light power leads according to the manufacturer's instructions.

4. Disconnect the vacuum hose from the distributor if so equipped.
5. Start the engine and aim the timing light at the timing mark (figure 52). The line on the balancer or pulley will line up at the timing mark. If a change is necessary, loosen the distributor hold-down clamp bolt at the base of the distributor. While observing the mark with the timing light, slowly rotate the distributor until the line indicates the correct timing. Tighten the hold-down bolt, and re-check the timing.
6. Turn off the engine and remove the timing light. Reconnect the number 1 spark plug wire, if removed.
7. Connect the vacuum hose to the distributor if so equipped.

SPARK PLUG WIRES

PRECAUTIONS

1. Twist boots 1/2 turn before removing.
2. When removing the boot, do not use pliers or other tools that could tear the boot.
3. Do not force anything between the wire and the boot, or through the silicone jacket of the wire.
4. Do not pull on the wires to remove the boot. Pull on the boot, or use a tool designed for this purpose.
5. Special care should be exercised when installing spark plug boots to assure that the metal terminal within the boot is fully seated on the spark plug terminal and that the boot has not moved on the wire. If boot to wire movement has occurred, the boot will give a false visual impression of being fully seated. A good check to assure that boots have been properly assembled is to push sideways on the installed boots. If they have been correctly installed, a stiff boot with only slight looseness will be noted. If the terminal has not been properly seated on the spark plug, only the resistance of the rubber boot will be felt when pushing sideways.

SPARK PLUG WIRE REPLACEMENT

Wire routings must be kept intact during service, and followed exactly when wires have been disconnected, or when replacement of the wires is necessary. Failure to route the wires properly can lead to radio ignition noise and crossfiring of the plugs, or shorting of the leads to ground. For the correct wiring routing for each engine, refer to figures 53 through 61.

Some distributors have spark plug wire retainer harness assemblies with the engine firing order marked on them. If the firing order is not indicated, install the plug wires according to the firing order as shown in figures 62, 63 and 64. When the wiring is completed, the plug wire from cylinder number 1 should lead to the distributor tower at the front and on the same side of the engine as cylinder number 1. The plug wire from cylinder number 6 (in 6 cylinder engines) or from cylinder number 8 (in V8 engines) should lead to the distributor tower at the front of the engine next to the number 1 tower.

Be sure to position all plug boots perpendicular to the centerline of the engine.

On the LE8 (7.4 L V8) engine, the spark plug harness assembly and a dielectric paper insulator are fitted to a shield which is installed over the spark plug (figure 65). The insulator grounds the shield to the engine block. If the assembly is removed from the shield, make sure that the insulator is present and undamaged before reinstallation.

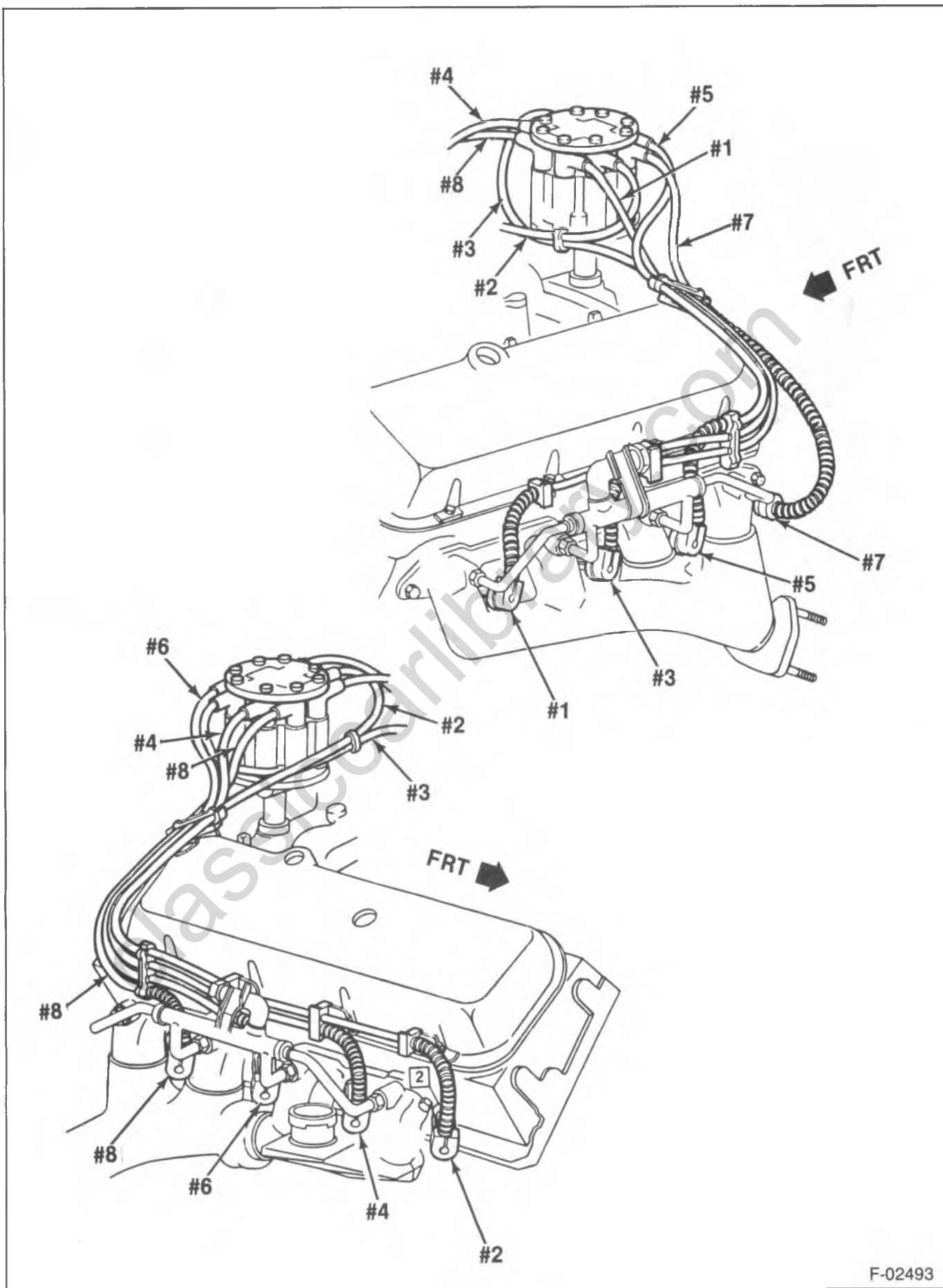
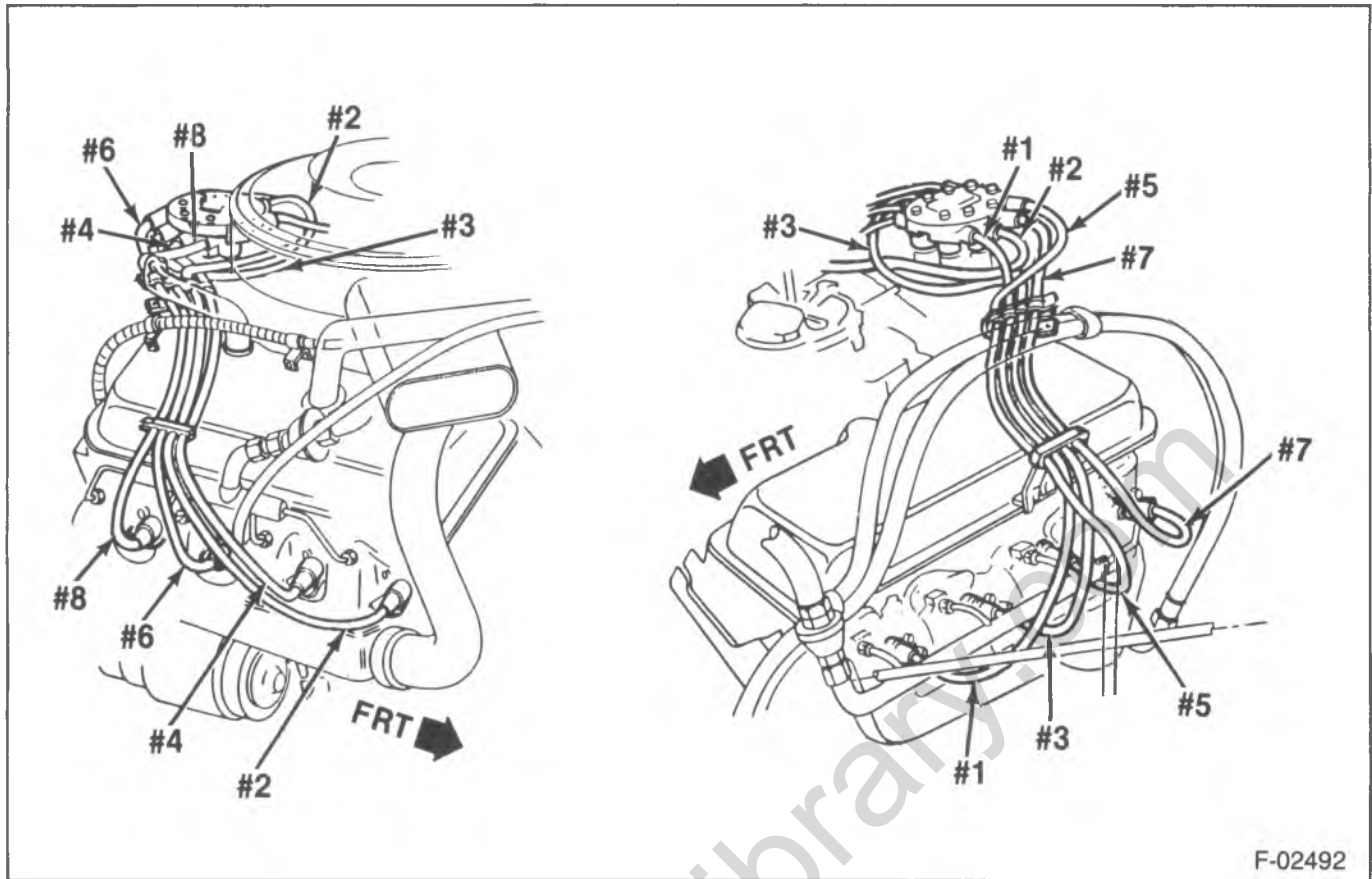

Figure 53—Spark Plug Wire Routing for the 7.4L (Carb.) Engine - P Truck (Federal)

6D-44 ENGINE ELECTRICAL



F-02492

Figure 54—Spark Plug Wire Routing for the 7.4L (Carb.) Engine - P Truck (California)

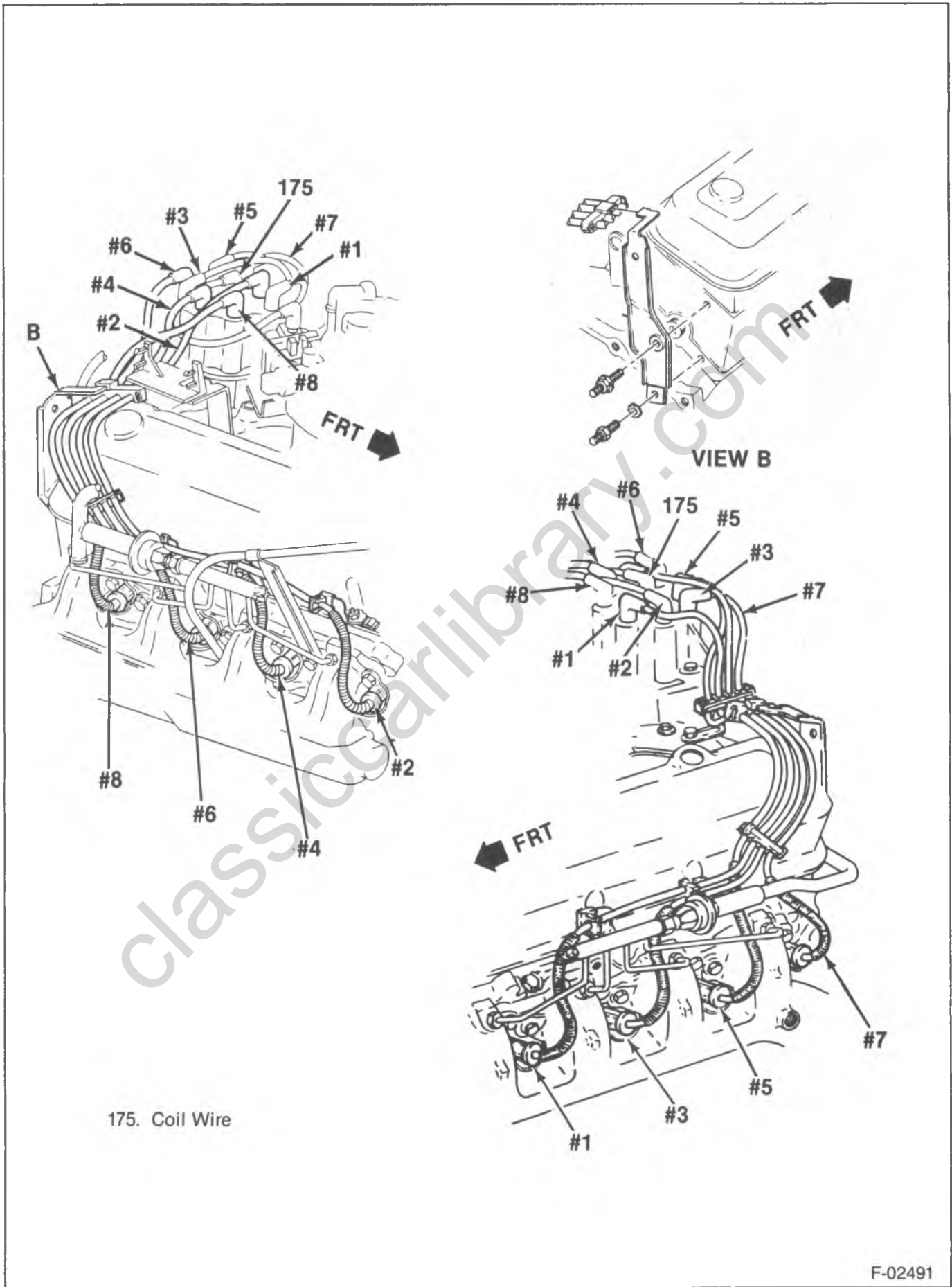

175. Coil Wire

Figure 55—Spark Plug Wire Routing for the 7.4L (TBI) Engine

6D-46 ENGINE ELECTRICAL

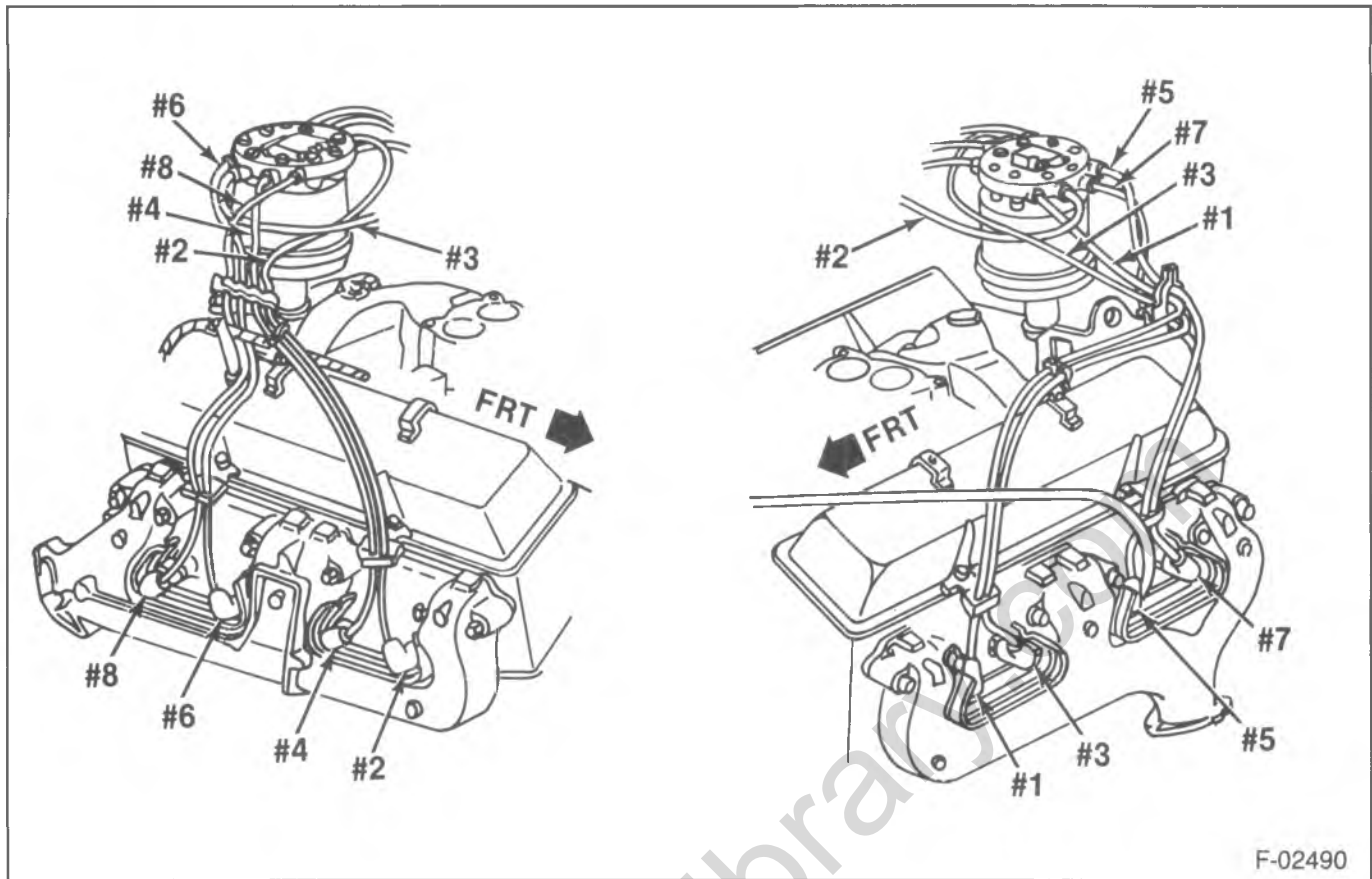

Figure 56—Spark Plug Wire Routing for the 5.7L (Carb.) Engine - P Truck (California)

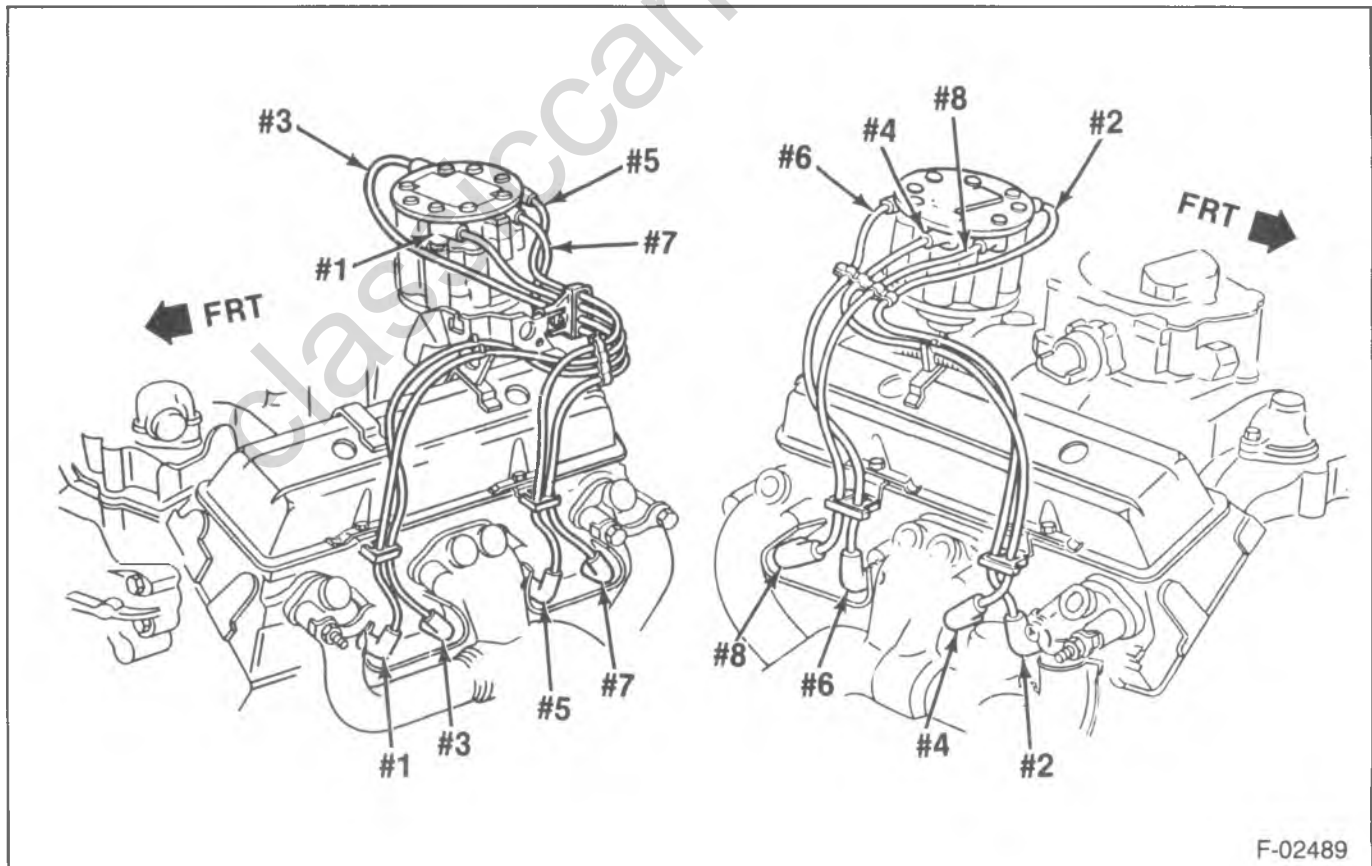
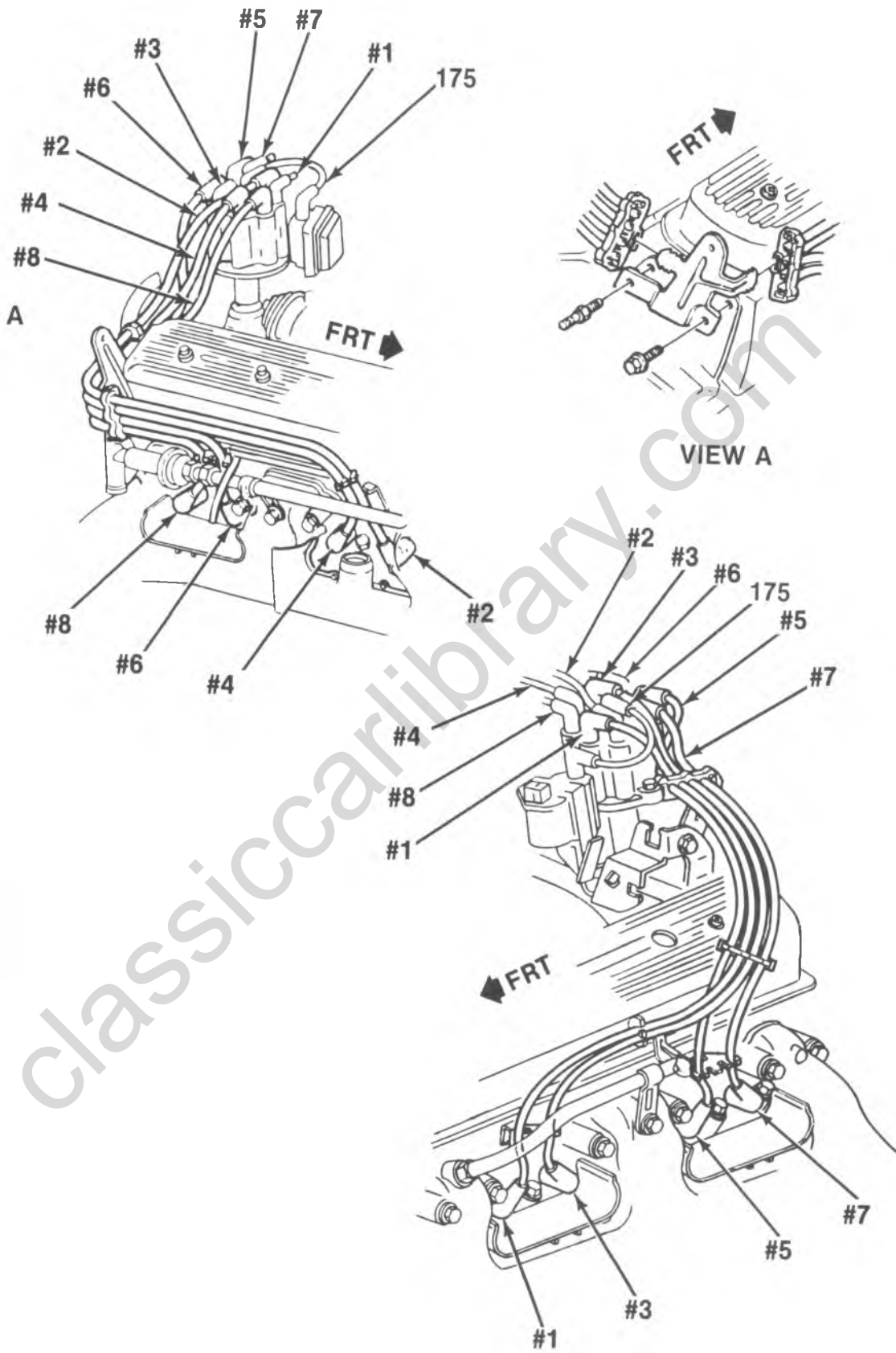

Figure 57—Spark Plug Wire Routing for the 5.7L (Carb.) Engine - G Van, P Truck (Federal)



175. Coil Wire

Figure 58—Spark Plug Wire Routing for the 5.7L (TBI) Engine - P Truck

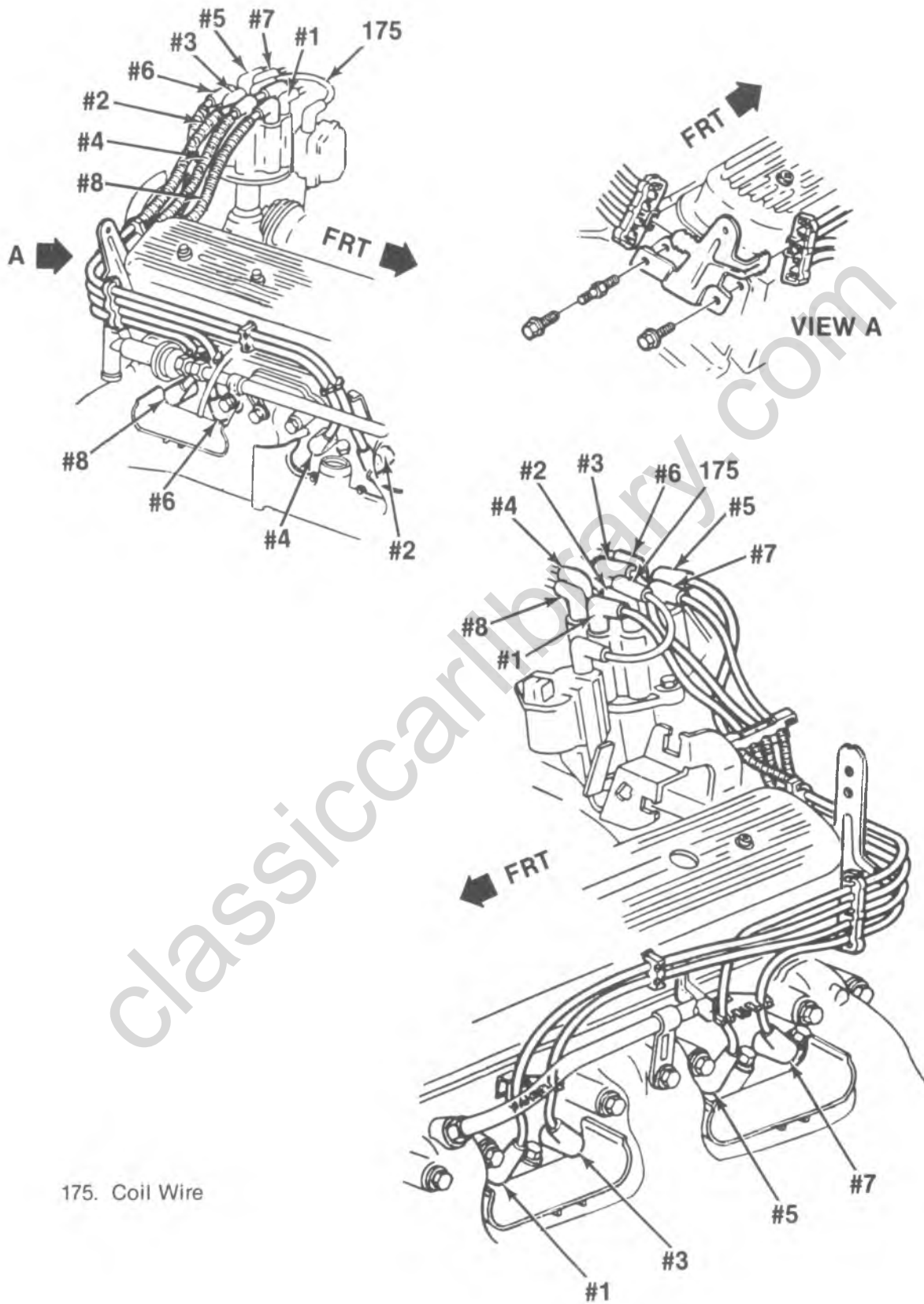
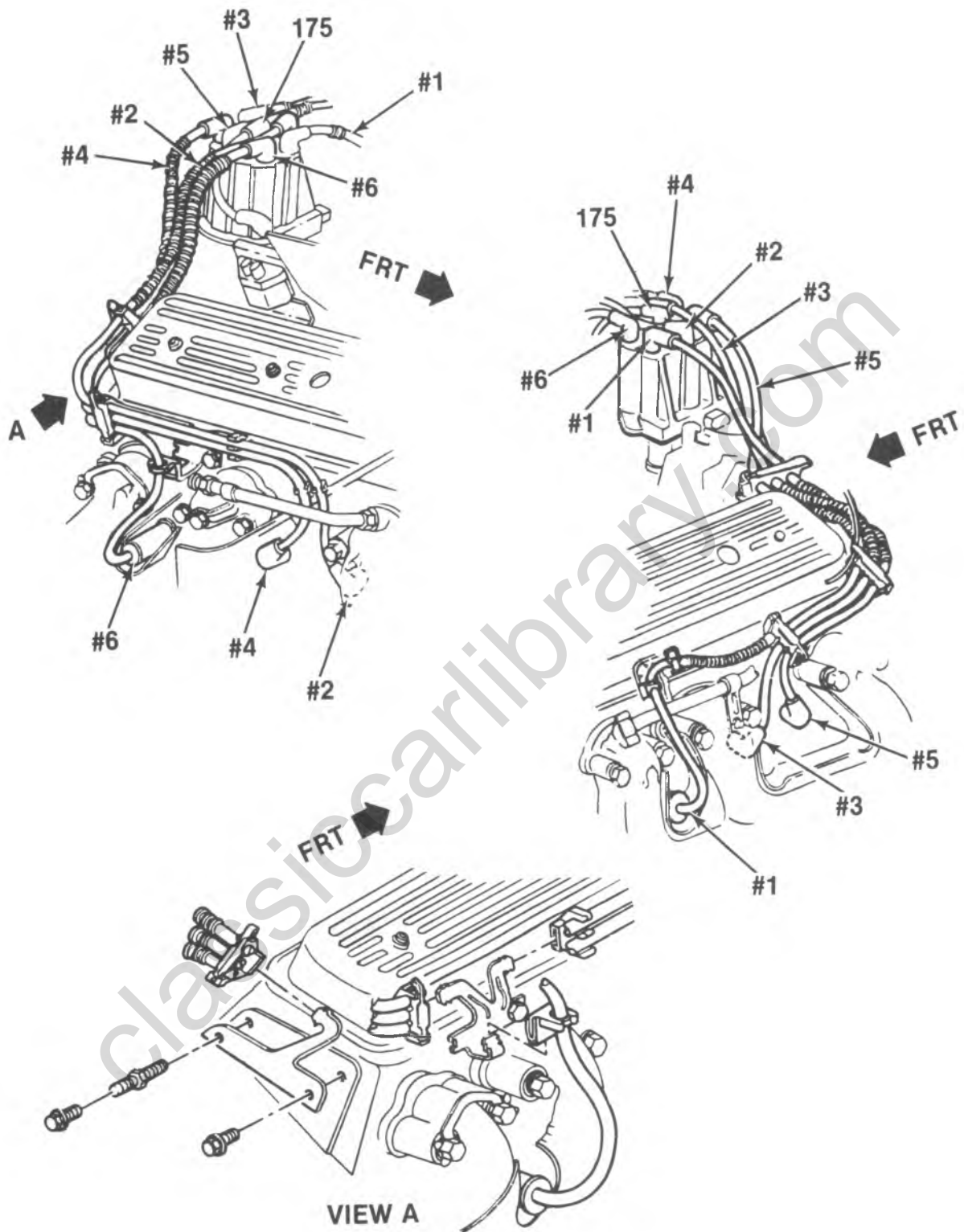

Figure 59—Spark Plug Wire Routing for the 5.0L (TBI) and 5.7L (TBI) Engine - RV,G



175. Coil Wire

F-02486

Figure 60—Spark Plug Wire Routing for the 4.3L (TBI) Engine - G Van

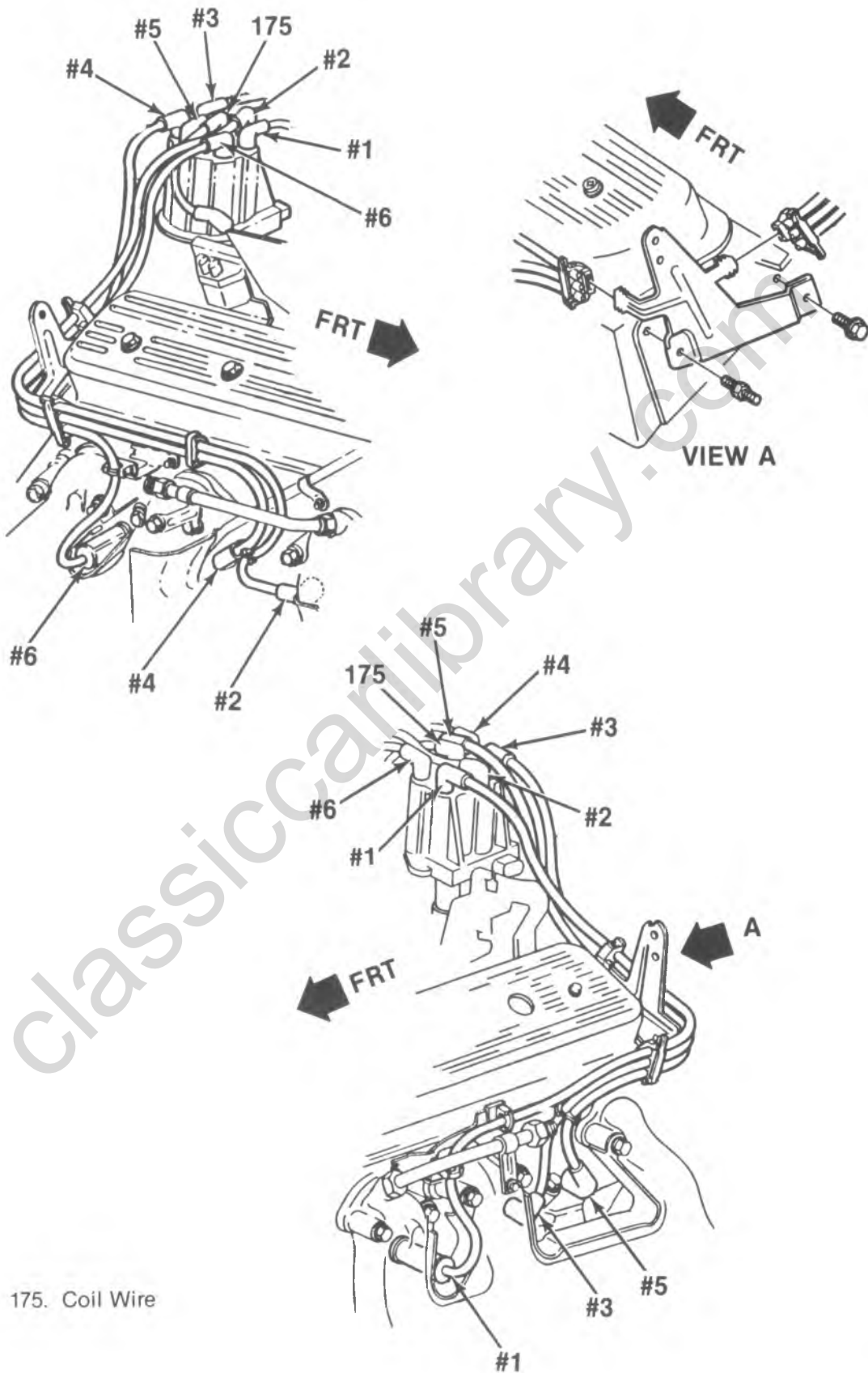

175. Coil Wire

Figure 61—Spark Plug Wire Routing for the 4.3L (TBI) Engine - RV

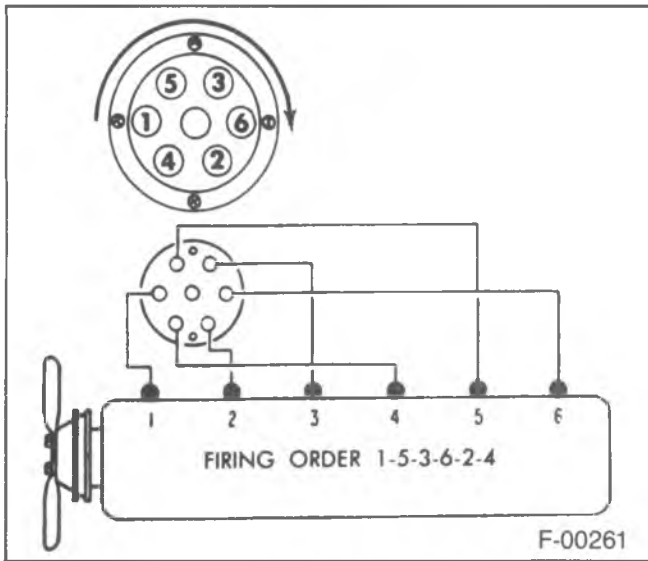

Figure 62—Spark Plug Wire Schematic (L6 Engines)

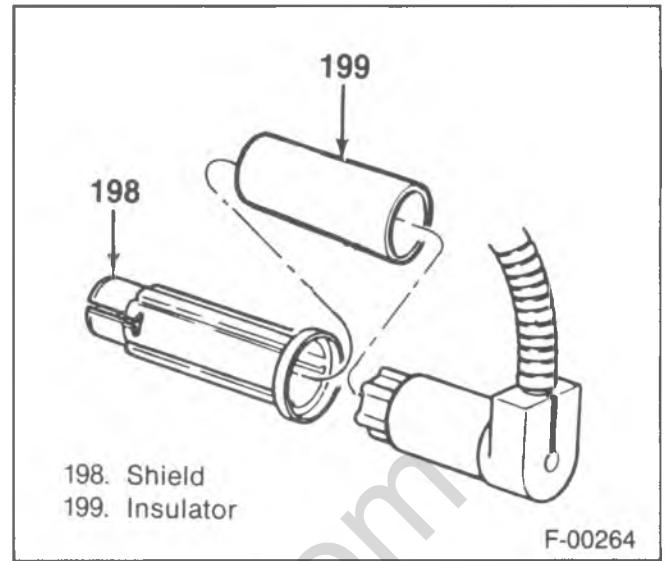

Figure 65—Spark Plug Shield for the LE8 Engine

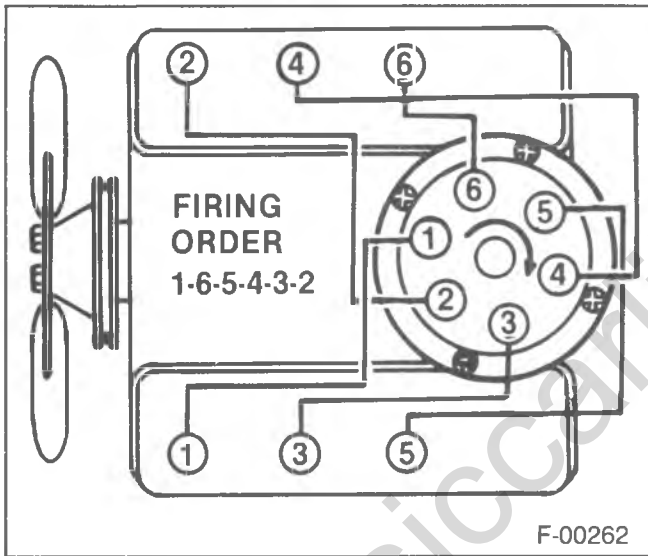

Figure 63—Spark Plug Wire Schematic (V6 Engines)

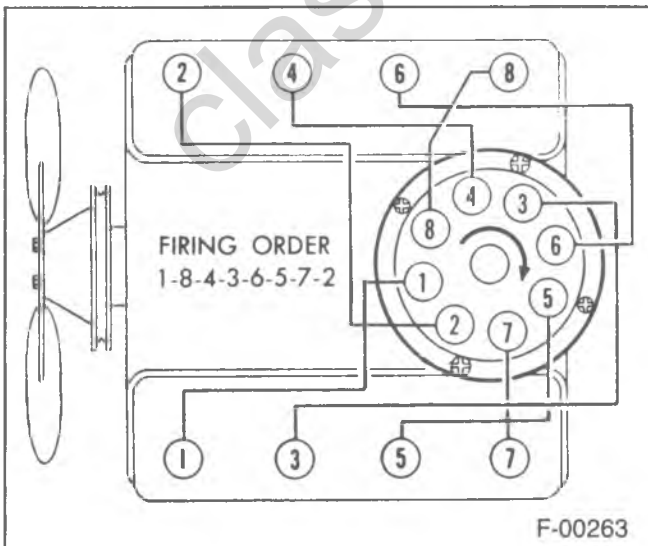
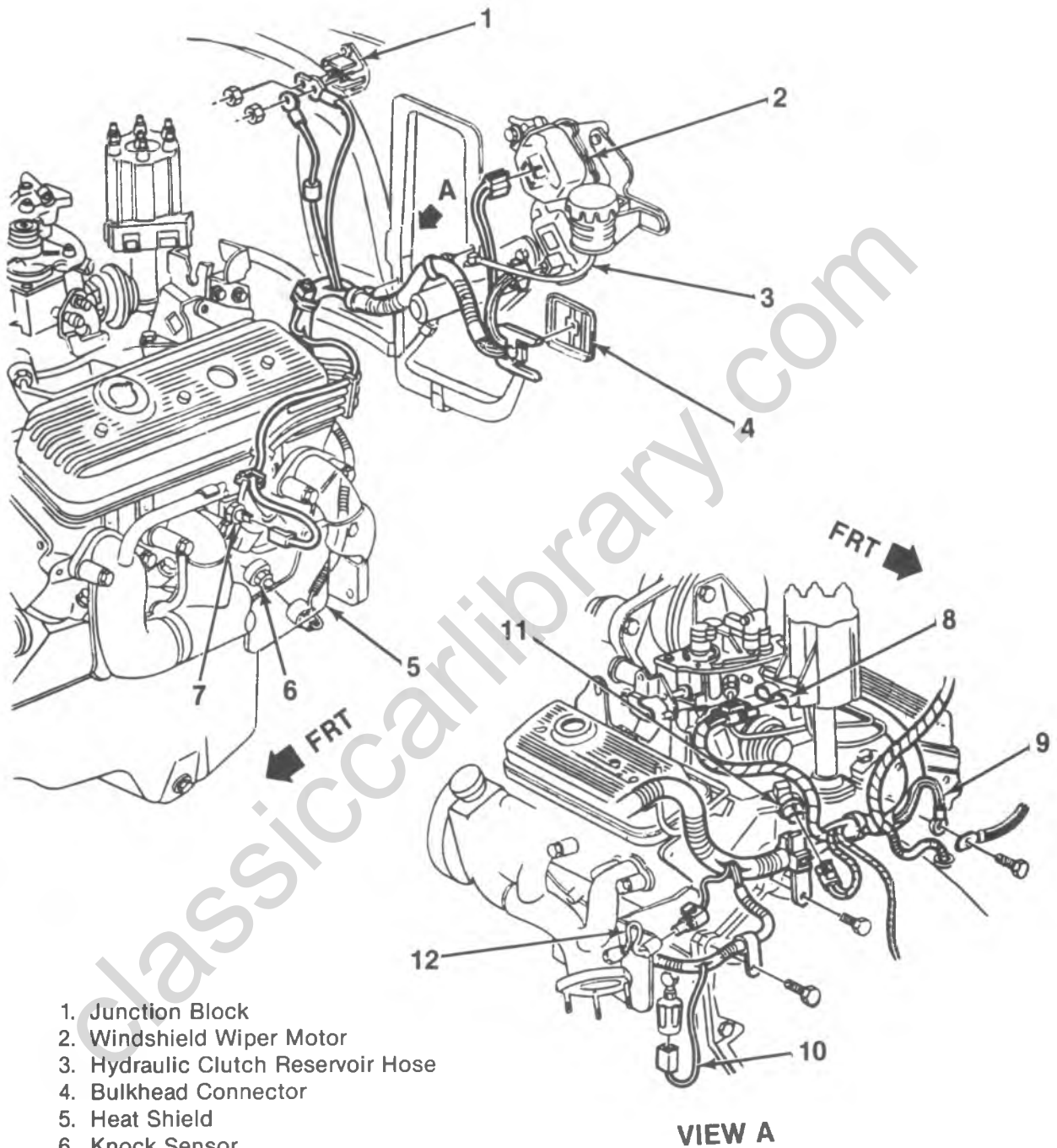

Figure 64—Spark Plug Wire Schematic (V8 Engines)

ENGINE WIRE HARNESS

When it necessary to move any of the wiring, whether to lift wires away from their harnesses or move harnesses to reach some component, take care that all wiring is replaced in its original position and all harnesses routed correctly. If clips or retainers break, replace them. Electrical problems can result from wiring or harnesses becoming loose and moving from their original positions or from being rerouted. Refer to figures 66 through 94 for the correct routing of engine wiring.

classiccarylbrary.com



1. Junction Block
2. Windshield Wiper Motor
3. Hydraulic Clutch Reservoir Hose
4. Bulkhead Connector
5. Heat Shield
6. Knock Sensor
7. Water Temp. Switch/Sensor
8. Distributor
9. Ground
10. Oil Pressure Sensor
11. Oil Pressure Switch/Sensor
12. O₂ Sensor

VIEW A

Figure 66—Engine Wiring for the 4.3L (TBI) - RV - Left Side

6D-54 ENGINE ELECTRICAL

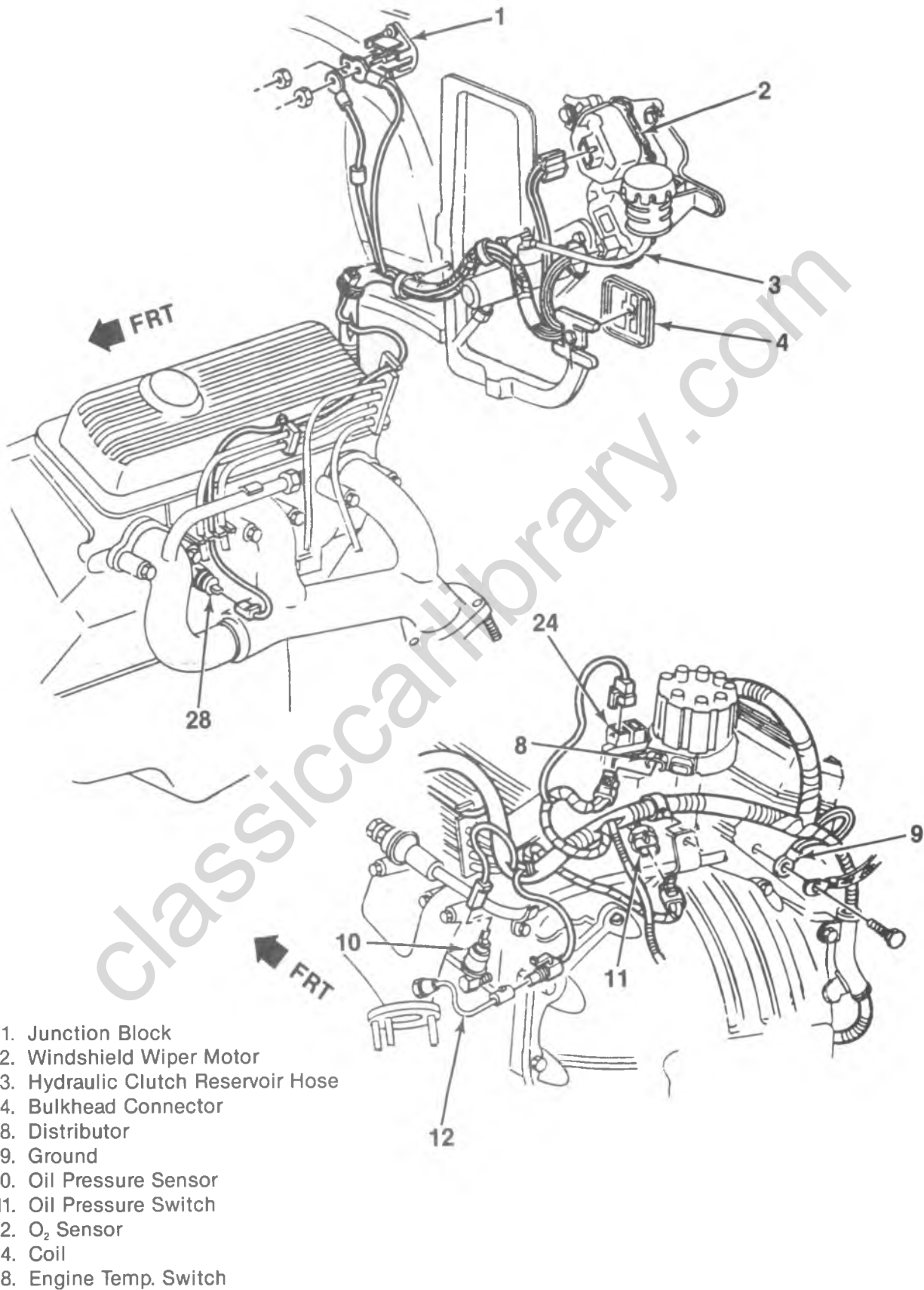

B-07749

Figure 67—Engine Wiring for the 5.0L (TBI) and 5.7L (TBI) - RV - Left Side

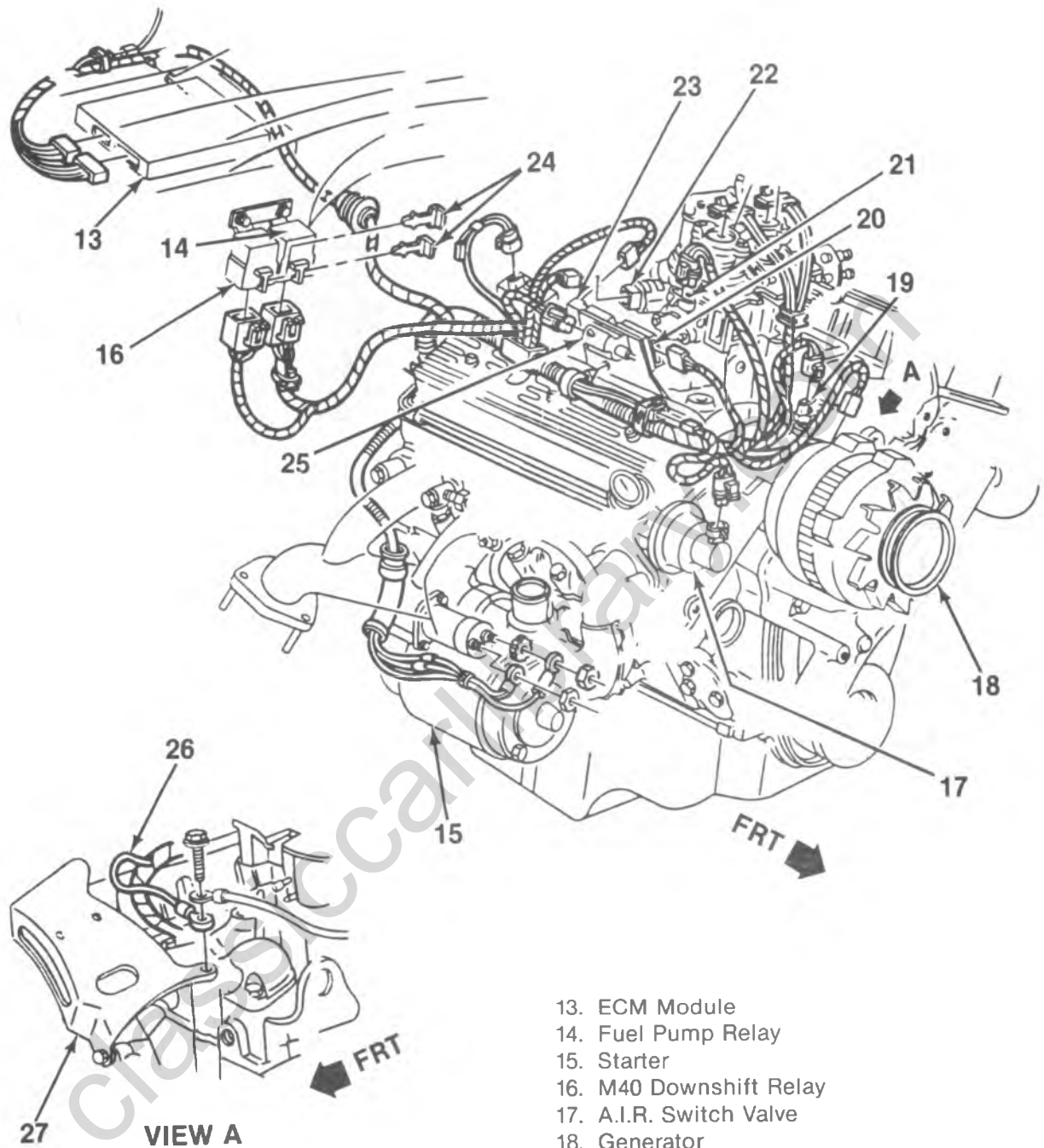

- 13. ECM Module
- 14. Fuel Pump Relay
- 15. Starter
- 16. M40 Downshift Relay
- 17. A.I.R. Switch Valve
- 18. Generator
- 19. Coolant Temp. Sensor
- 20. ESC Half Function Box
- 21. Throttle Position Sensor
- 22. I.A.C. Activator
- 23. MAP Sensor
- 24. Coil
- 25. EGR Solenoid
- 26. Ground Wire
- 27. Generator Mounting Bracket

B-07751

Figure 68—Engine Wiring for the 4.3L (TBI) - RV - Right Side

6D-56 ENGINE ELECTRICAL

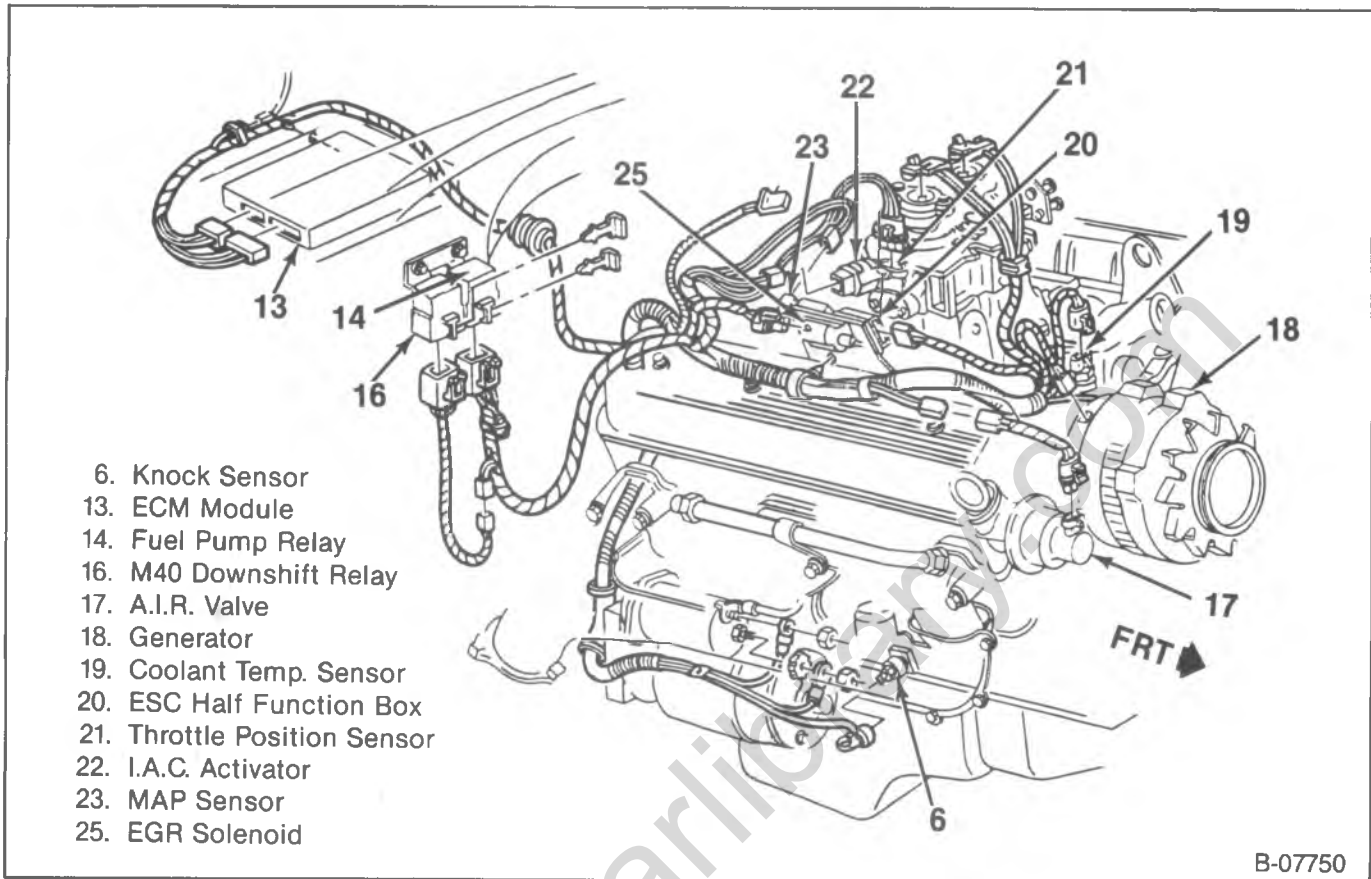

Figure 69—Engine Wiring for the 5.0L (TBI) and 5.7L (TBI) - RV - Right Side

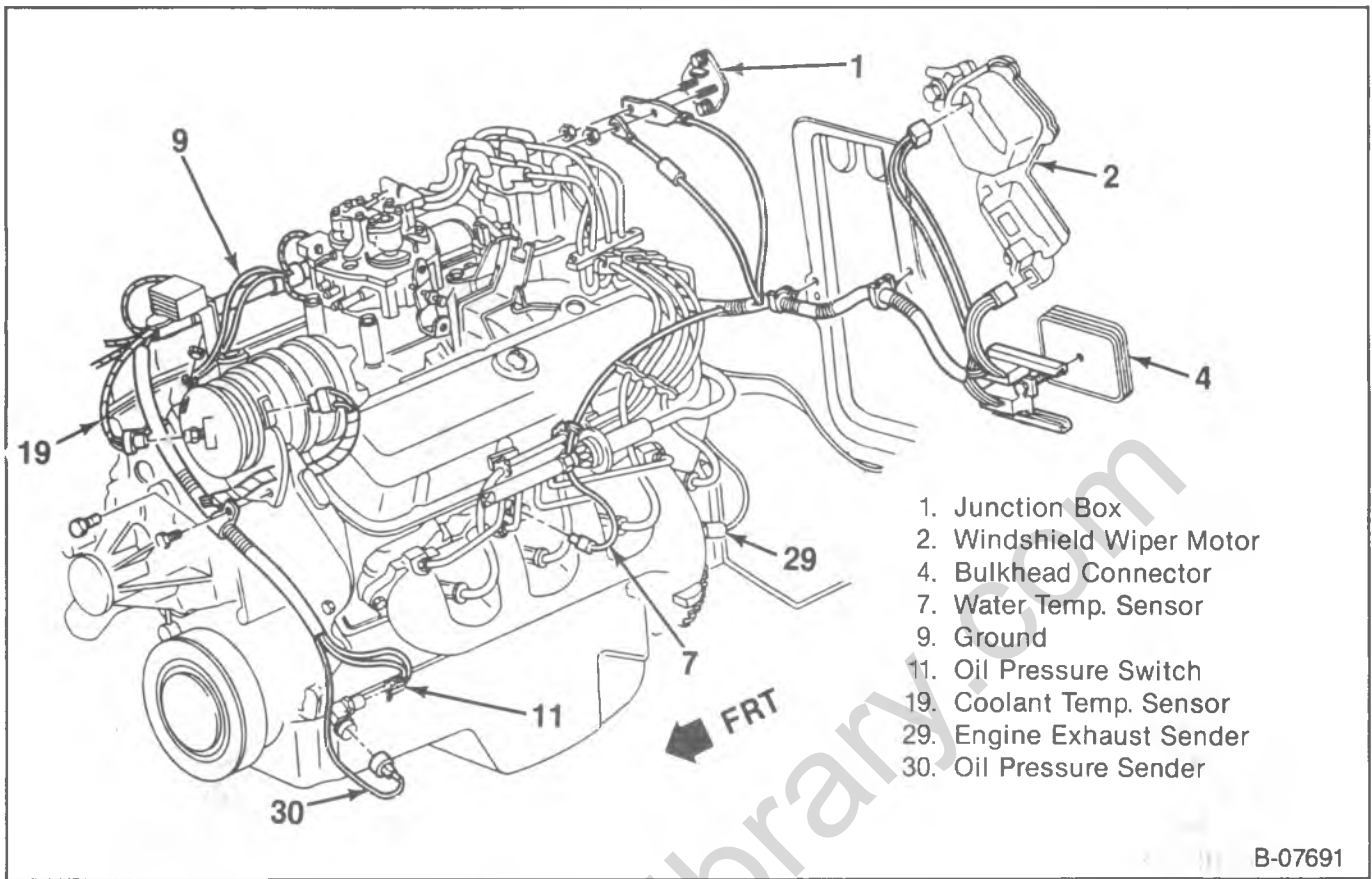

Figure 70—Engine Wiring for the 7.4L (TBI) - RV - Left Side

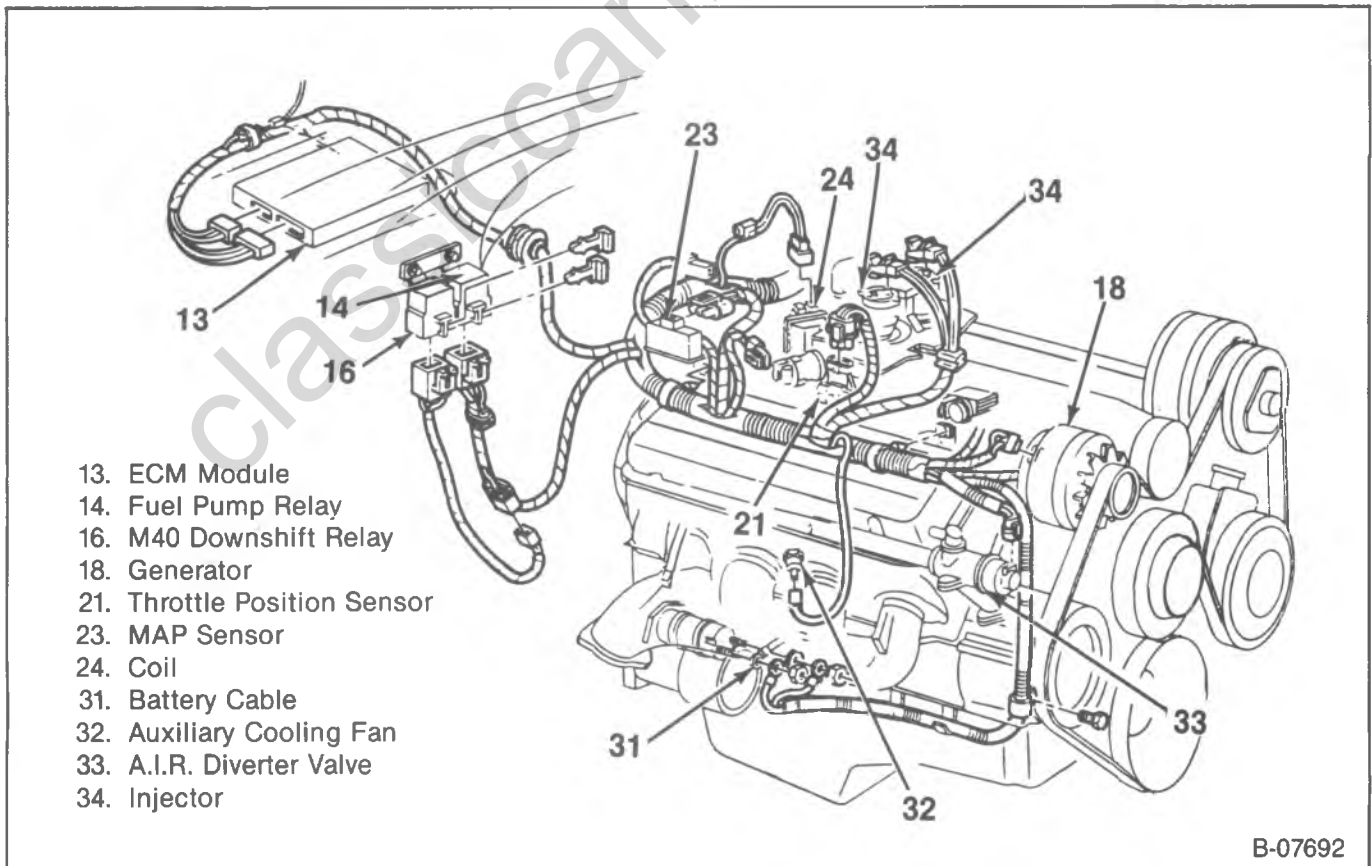
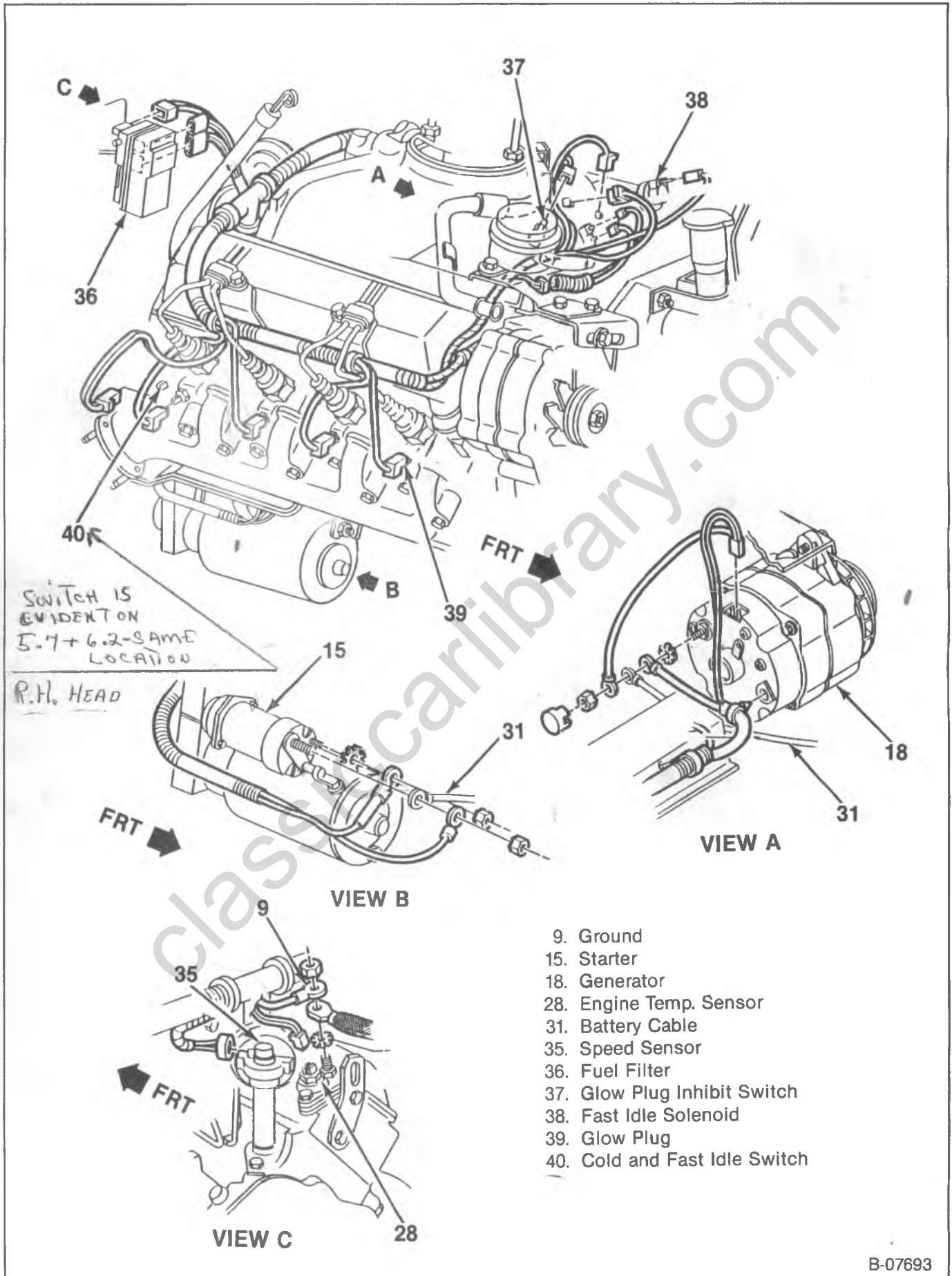

Figure 71—Engine Wiring for the 7.4L (TBI) - RV - Right Side

6D-58 ENGINE ELECTRICAL



B-07693

Figure 72—Engine Wiring for the 6.2L Diesel - RV - Right Side

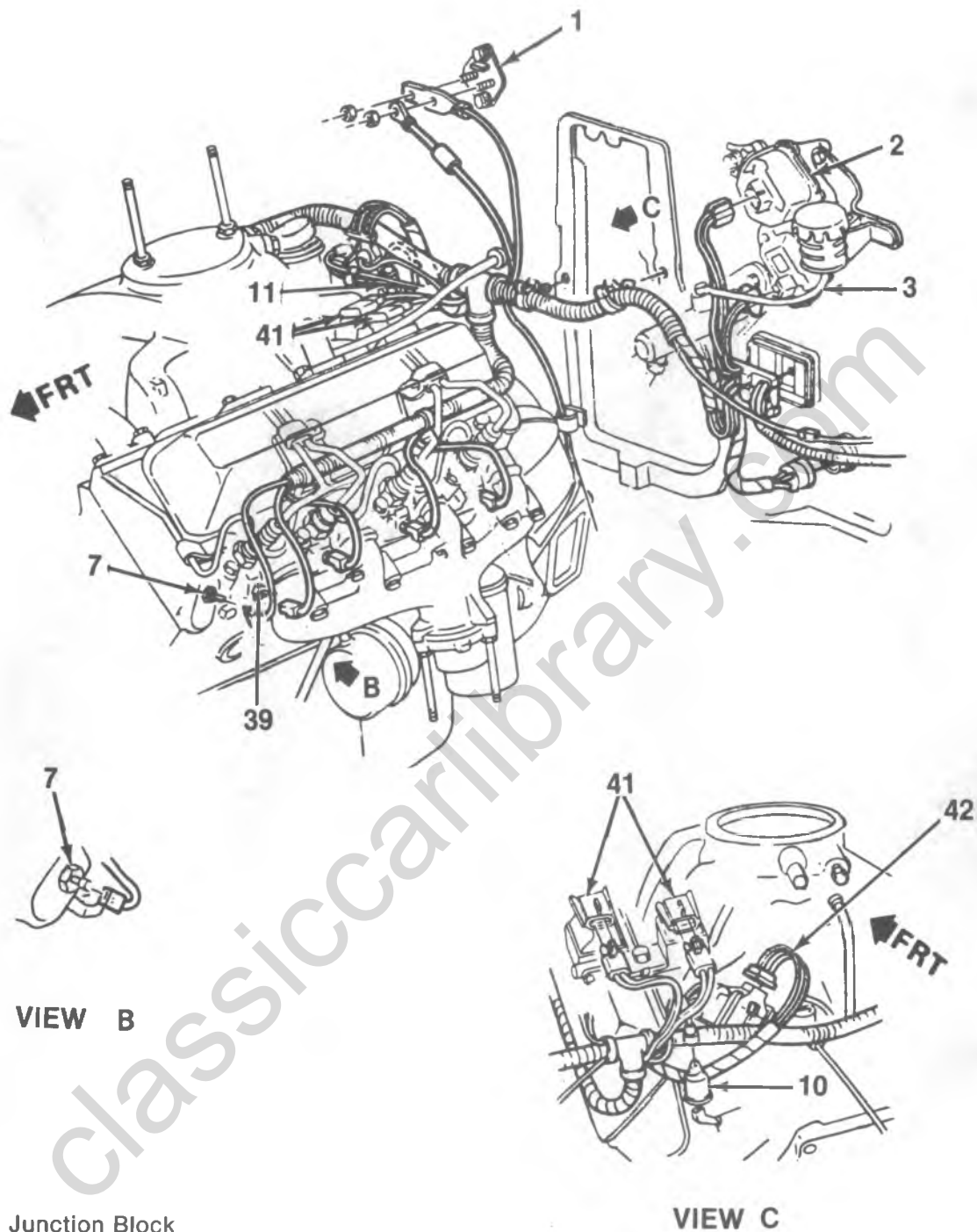

- 1. Junction Block
- 2. Windshield Wiper Motor
- 3. Hydraulic Clutch Reservoir Hose
- 7. Water Temp. Switch/Sensor
- 10. Oil Pressure Sensor
- 11. Oil Pressure Switch
- 39. Glow Plug
- 41. EGR/EPR Solenoid
- 42. Glow Plug Controller Connector

B-07694

Figure 73—Engine Wiring for the 6.2L Diesel - RV - Left Side

6D-60 ENGINE ELECTRICAL

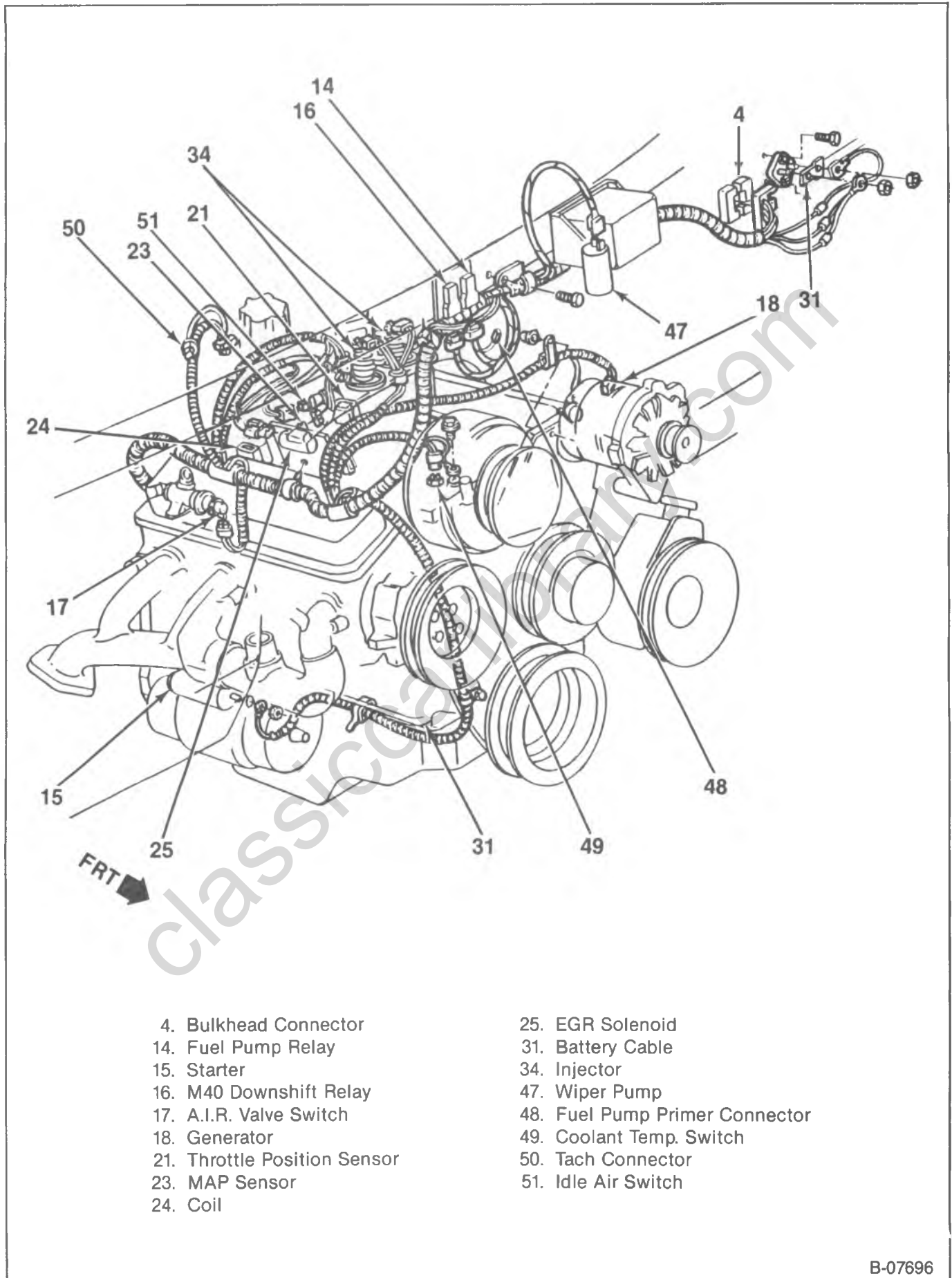

Figure 74—Engine Wiring for the 4.3L (TBI) - G Van - Left Side

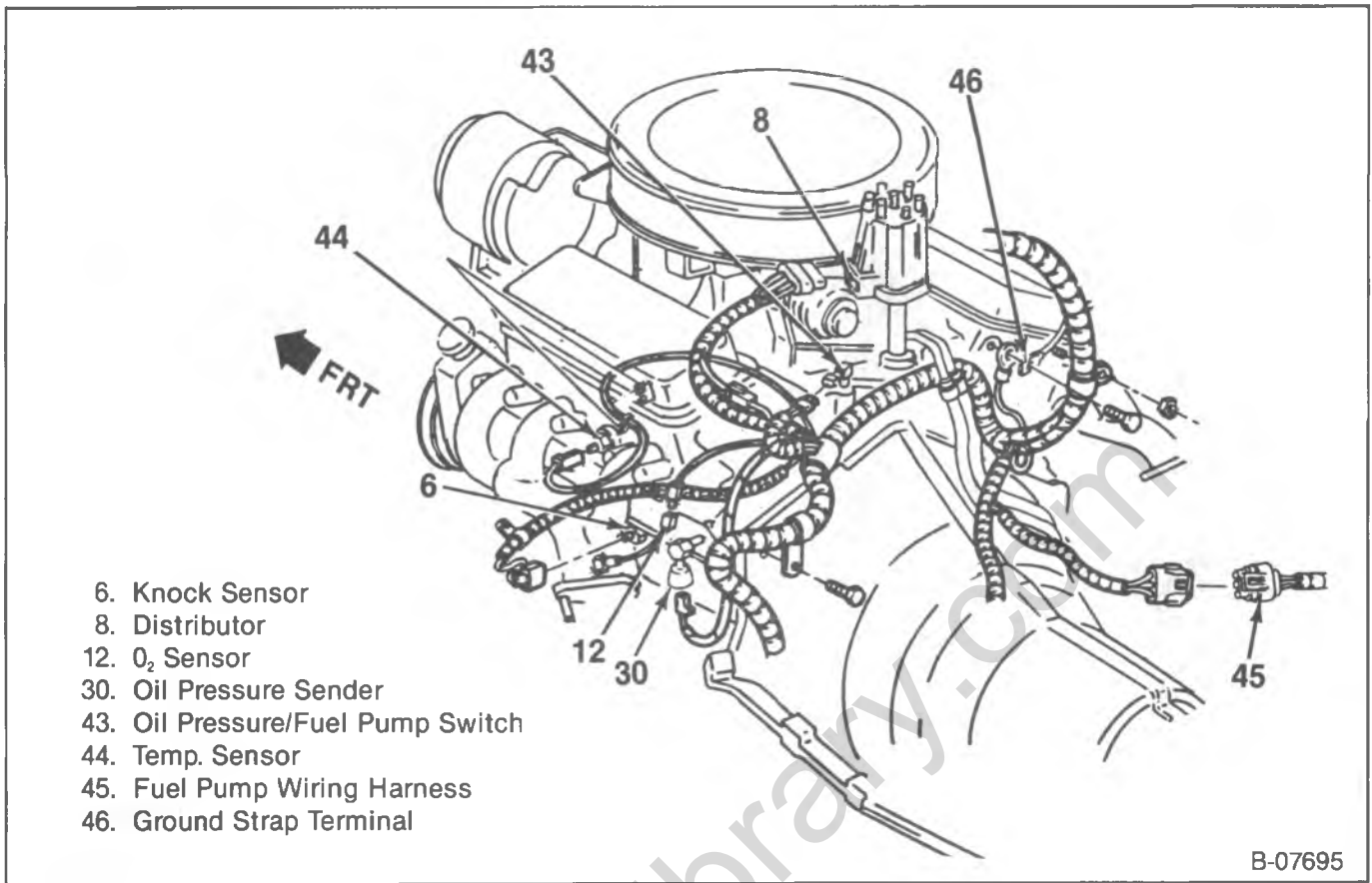

Figure 75—Engine Wiring for the 4.3L (TBI) - G Van - Left Side

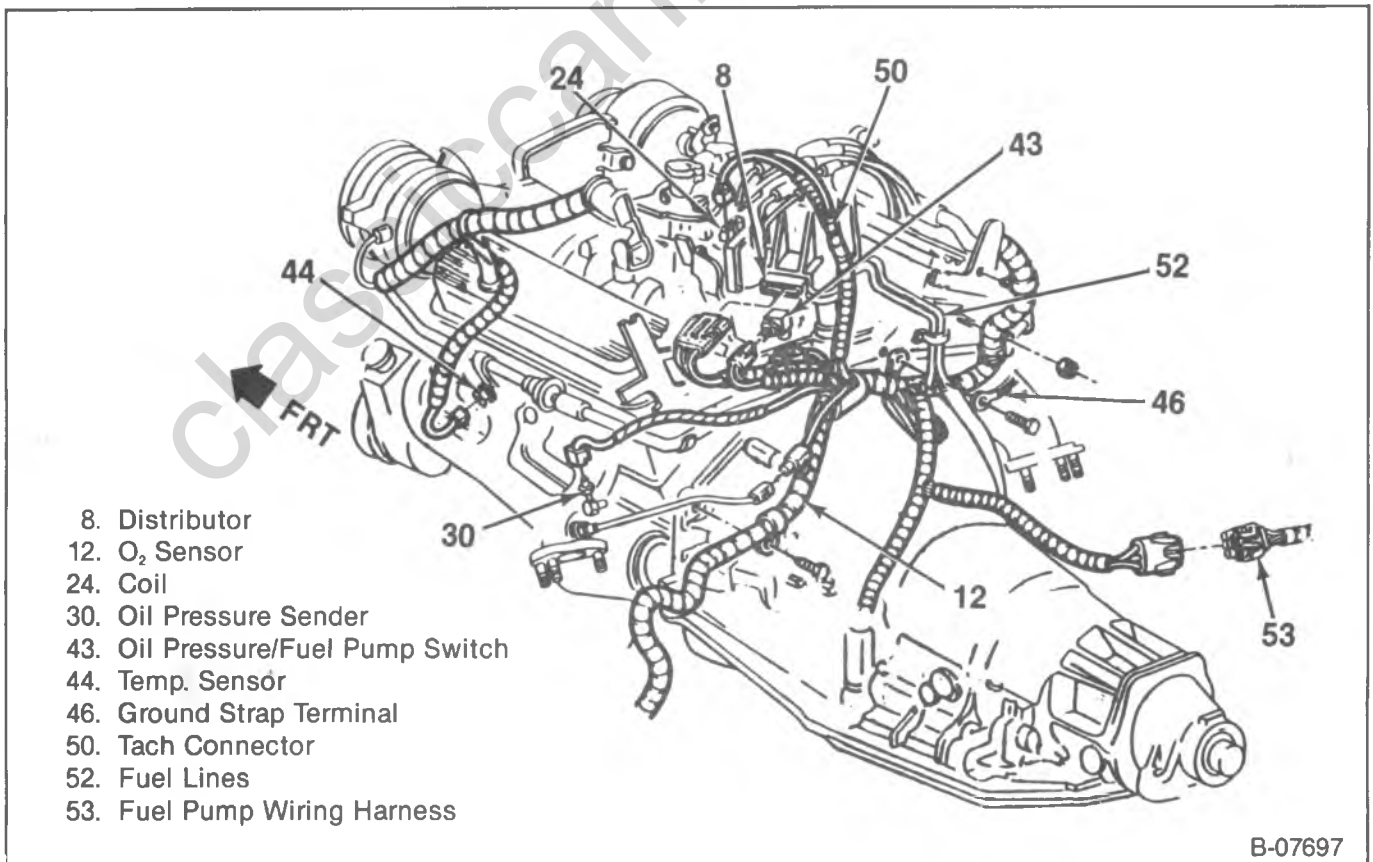

Figure 76—Engine Wiring for the 5.0L (TBI) and 5.7L (TBI) - G Van - Left Side

6D-62 ENGINE ELECTRICAL

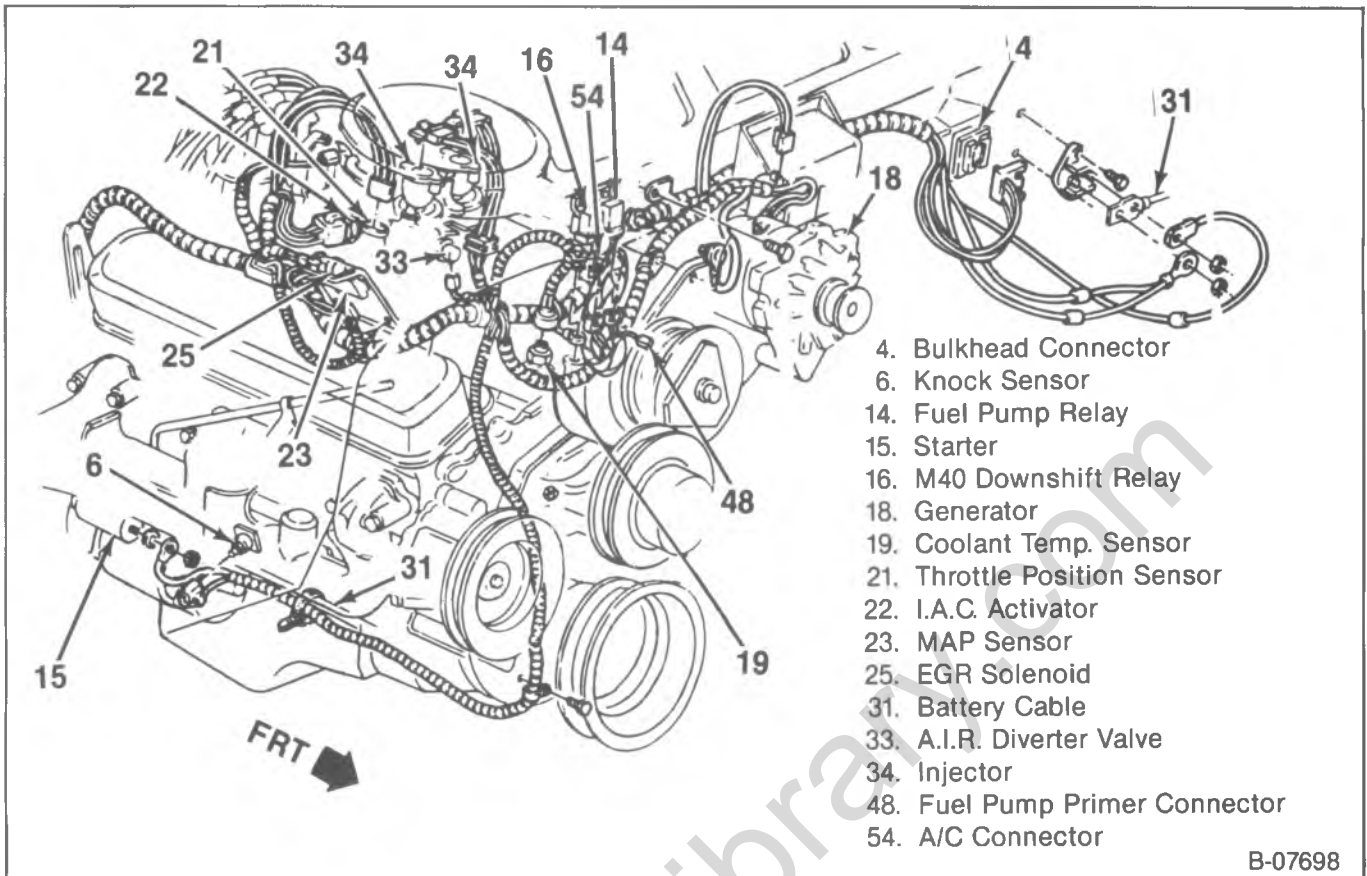
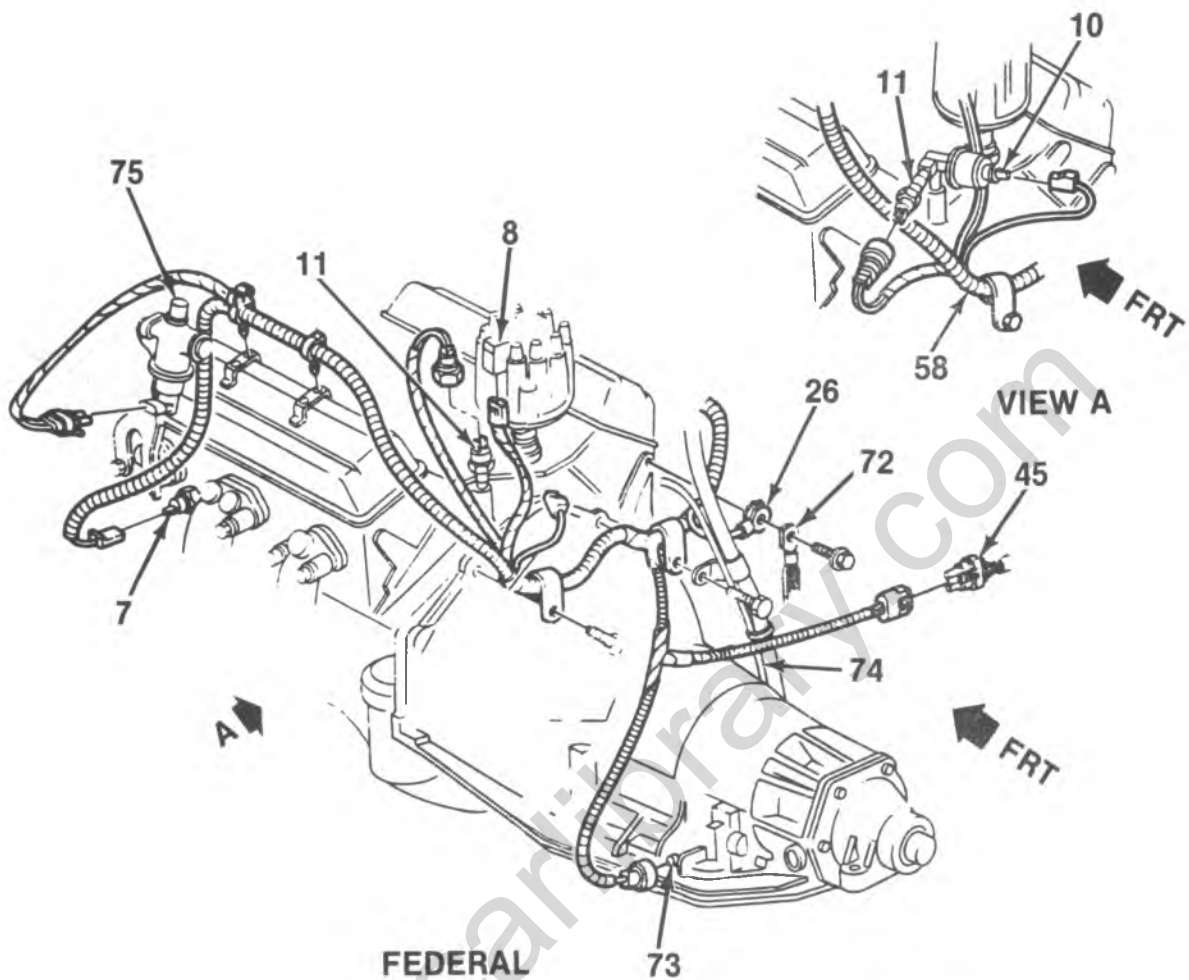
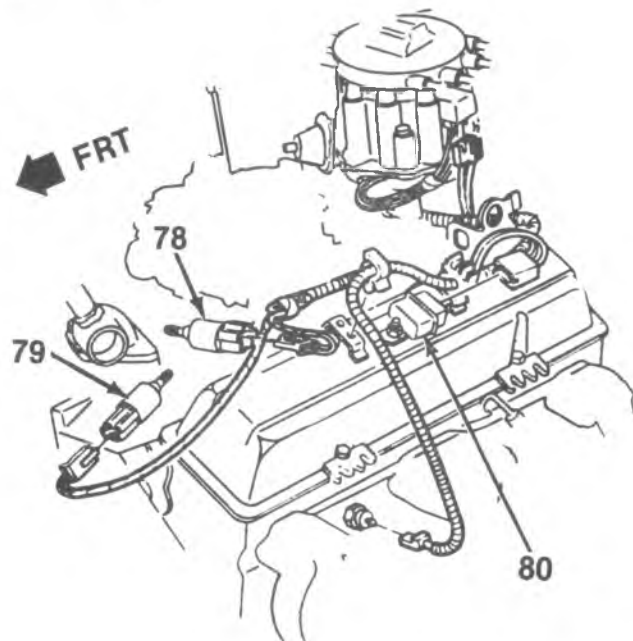

Figure 77—Engine Wiring for the 5.0L (TBI) and 5.7L (TBI) - G Van - Right Side



FEDERAL



CALIFORNIA

- 7. Water Temp. Switch
- 8. Distributor
- 10. Oil Pressure Sensor
- 11. Oil Pressure Switch
- 26. Ground Wire
- 45. Fuel Pump Wiring Harness
- 58. Engine Harness
- 72. Ground Strap
- 73. Transmission Switch
- 74. Vacuum Pipe
- 75. High Flow Air Valve
- 78. Throttle Valve (Without A/C)
- 79. Throttle Valve (A/C)
- 80. Speed Switch Relay

Figure 78—Engine Wiring for the 5.7L (Carb.) - G Van - Left Side

6D-64 ENGINE ELECTRICAL

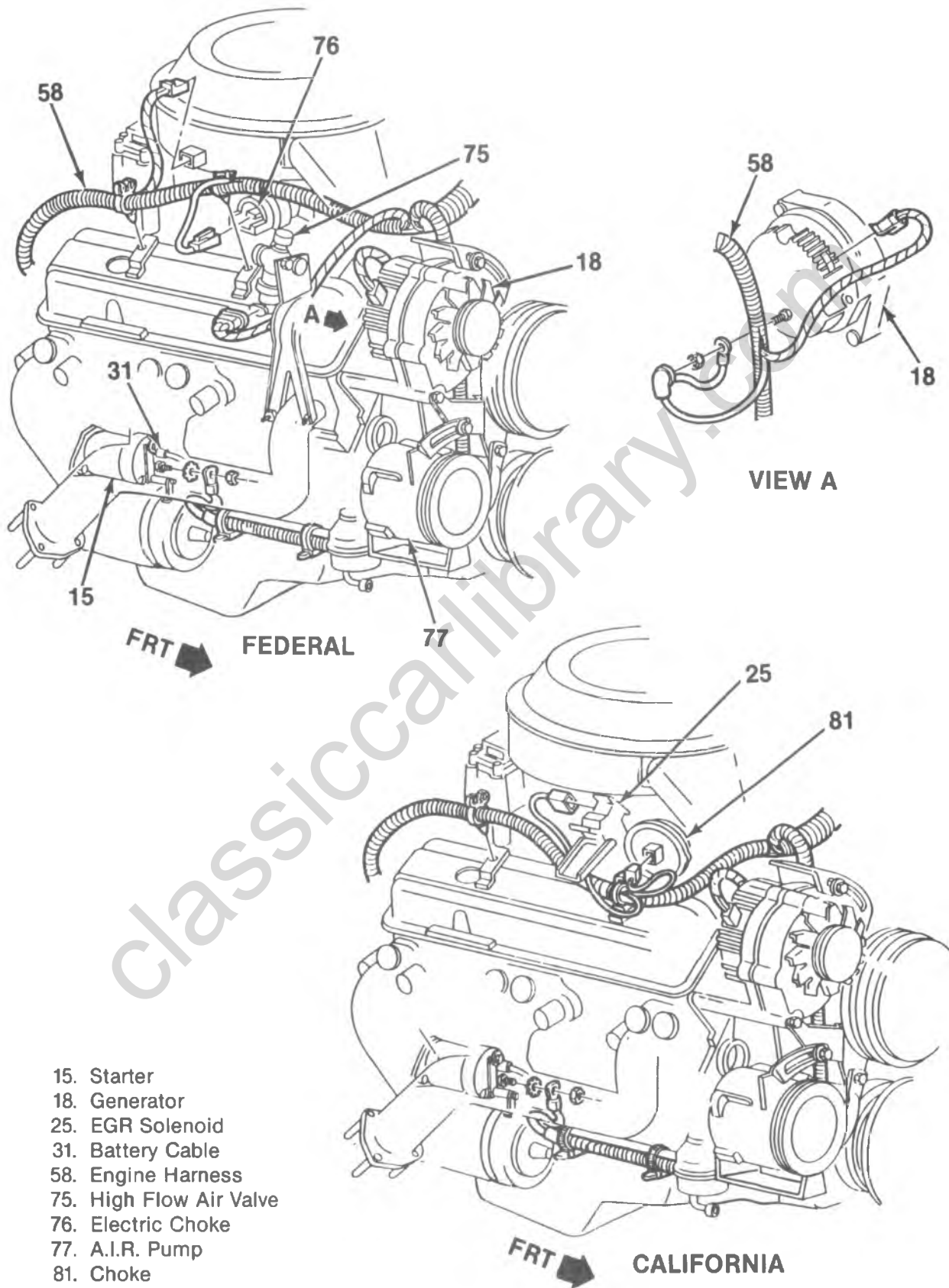

- 15. Starter
- 18. Generator
- 25. EGR Solenoid
- 31. Battery Cable
- 58. Engine Harness
- 75. High Flow Air Valve
- 76. Electric Choke
- 77. A.I.R. Pump
- 81. Choke

B-07700

Figure 79—Engine Wiring for the 5.7L (Carb.) - G Van - Right Side

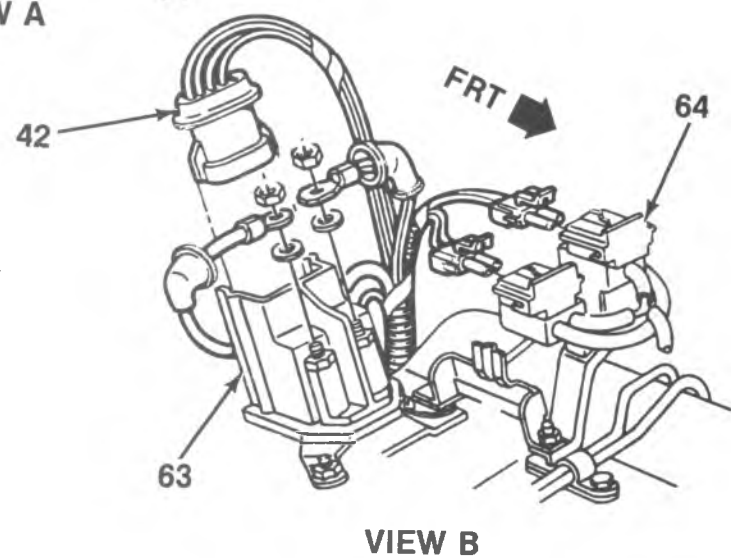
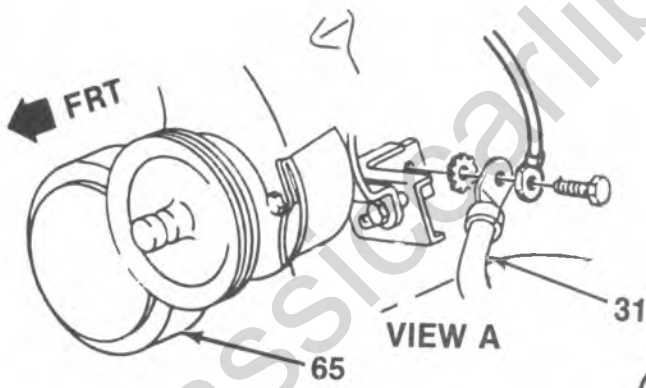
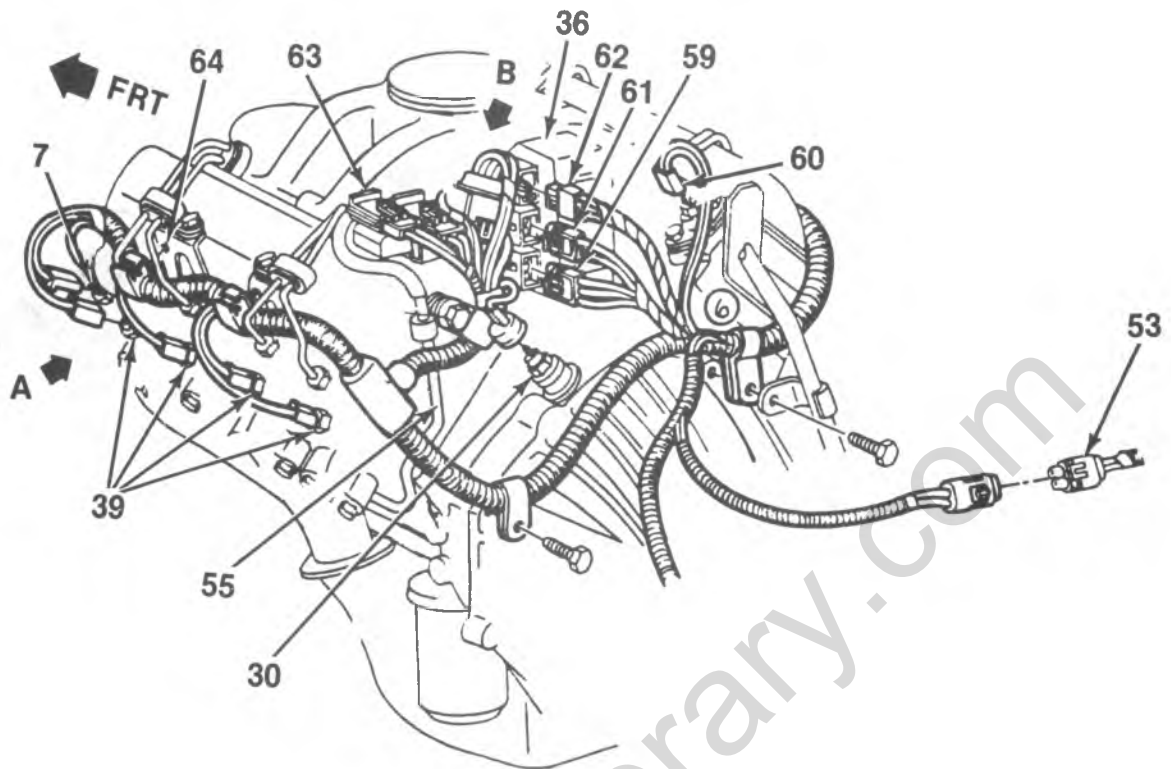

- 7. Water Temp Switch
- 30. Oil Pressure Sender
- 31. Battery Cable
- 36. Fuel Filter
- 39. Glow Plug
- 42. Glow Plug Controller Connector
- 53. Fuel Pump Wiring Harness
- 55. EPR Vacuum Pipe
- 59. Water Sensor Connector
- 60. Temp. Switch
- 61. Fuel Pressure Connector
- 62. Fuel Heater Connector
- 63. Glow Plug Controller
- 64. EPR Solenoid
- 65. Hydro-Booster Bracket

B-07701

Figure 80—Engine Wiring for the 6.2L Diesel - G Van - Left Side

6D-66 ENGINE ELECTRICAL

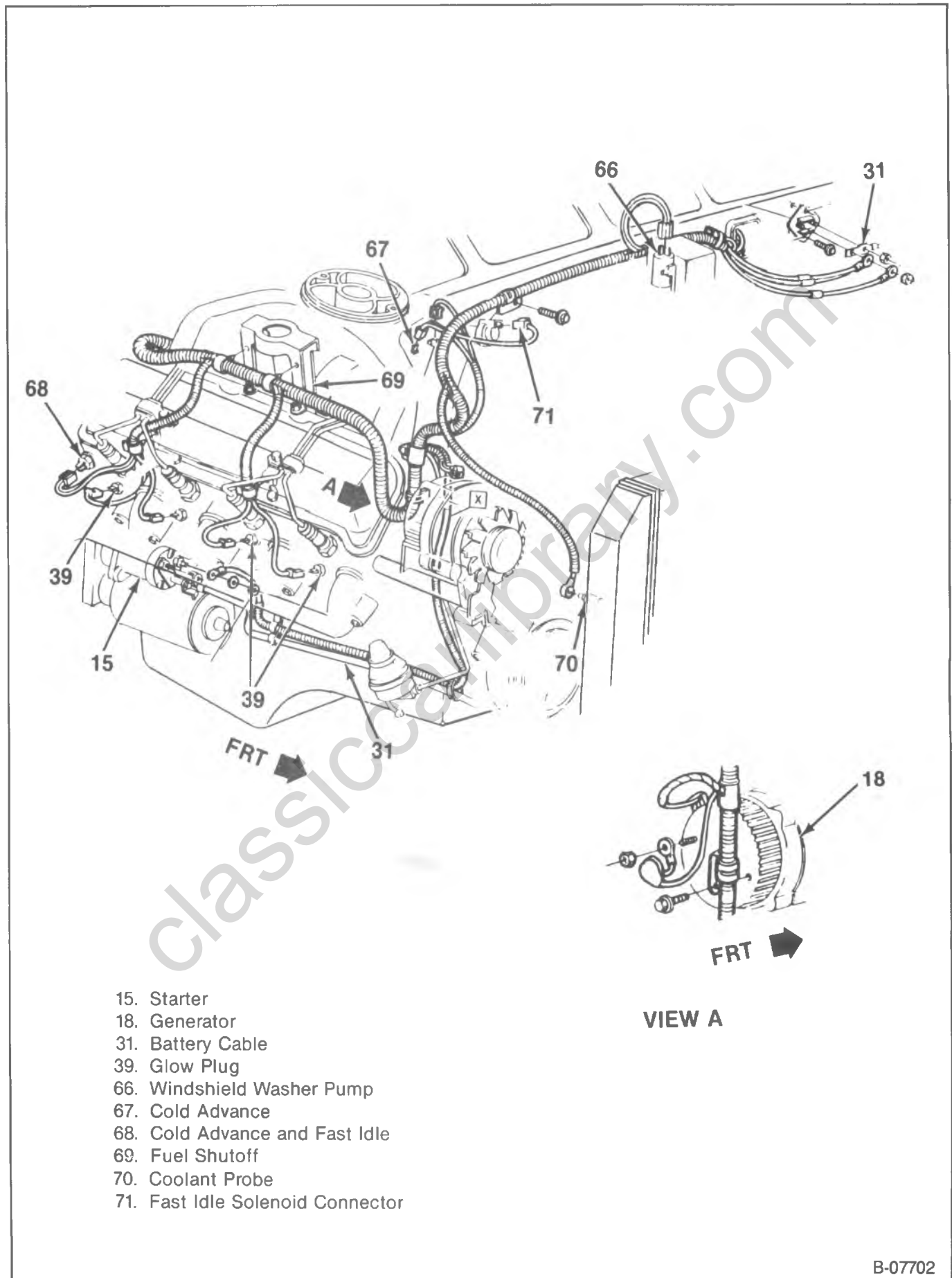

B-07702

Figure 81—Engine Wiring for the 6.2L Diesel - G Van - Right Side

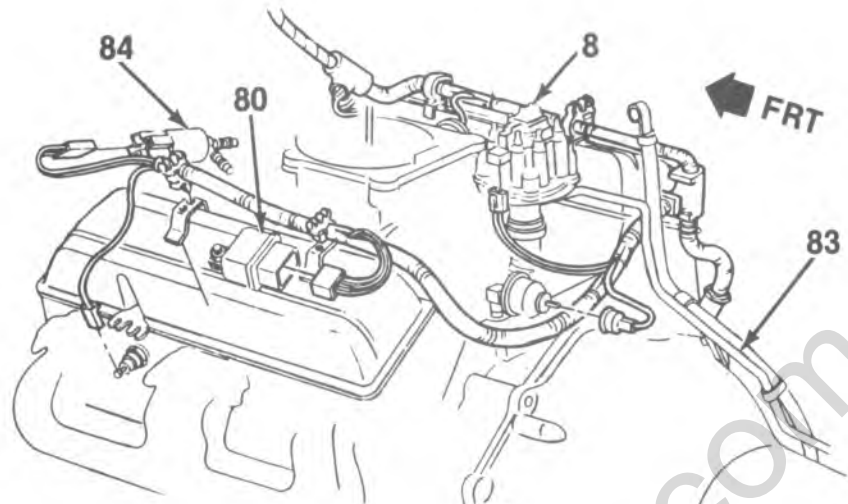

CALIFORNIA

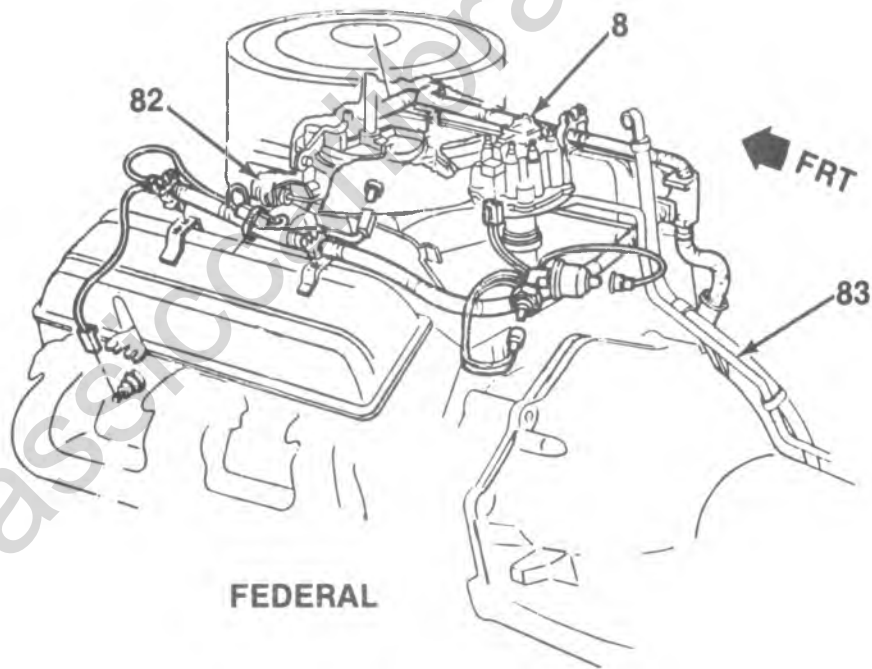

FEDERAL

- 8. Distributor
- 80. Speed Switch Relay
- 82. Anti-Diesel Solenoid
- 83. Modulator Pipe
- 84. Throttle Return Valve

Figure 82—Engine Wiring for the 5.7L (Carb.) - P Truck - Left Side

6D-68 ENGINE ELECTRICAL

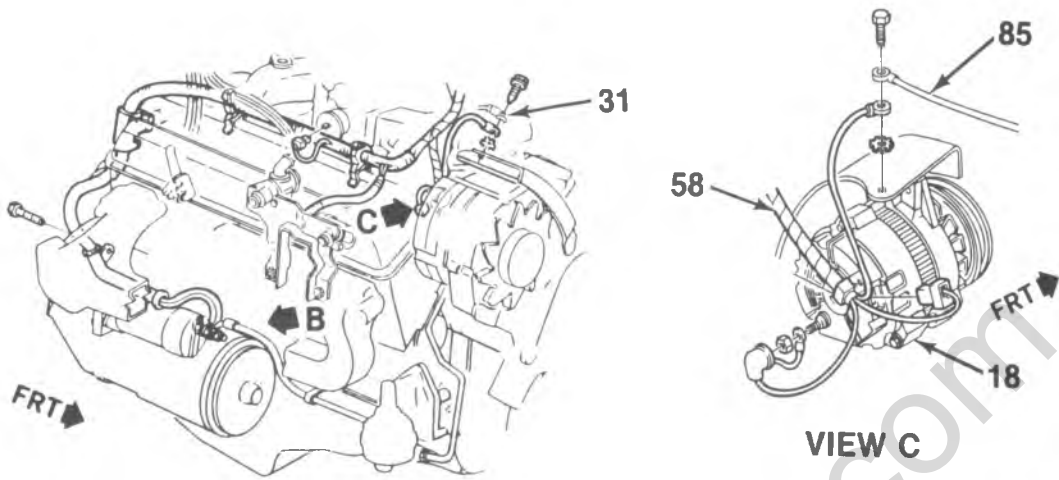

FEDERAL

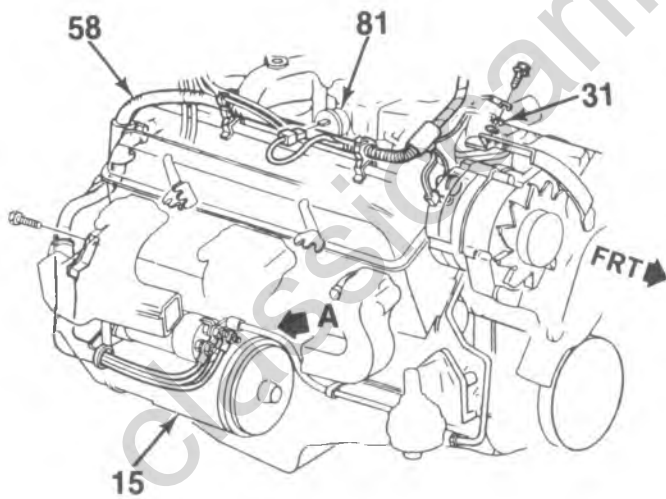

CALIFORNIA

- 15. Starter
- 18. Generator
- 31. Battery Cable
- 58. Engine Harness
- 81. Choke
- 85. Negative Battery Cable

B-07648

Figure 83—Engine Wiring for the 5.7L (Carb.) - P Truck - Right Side

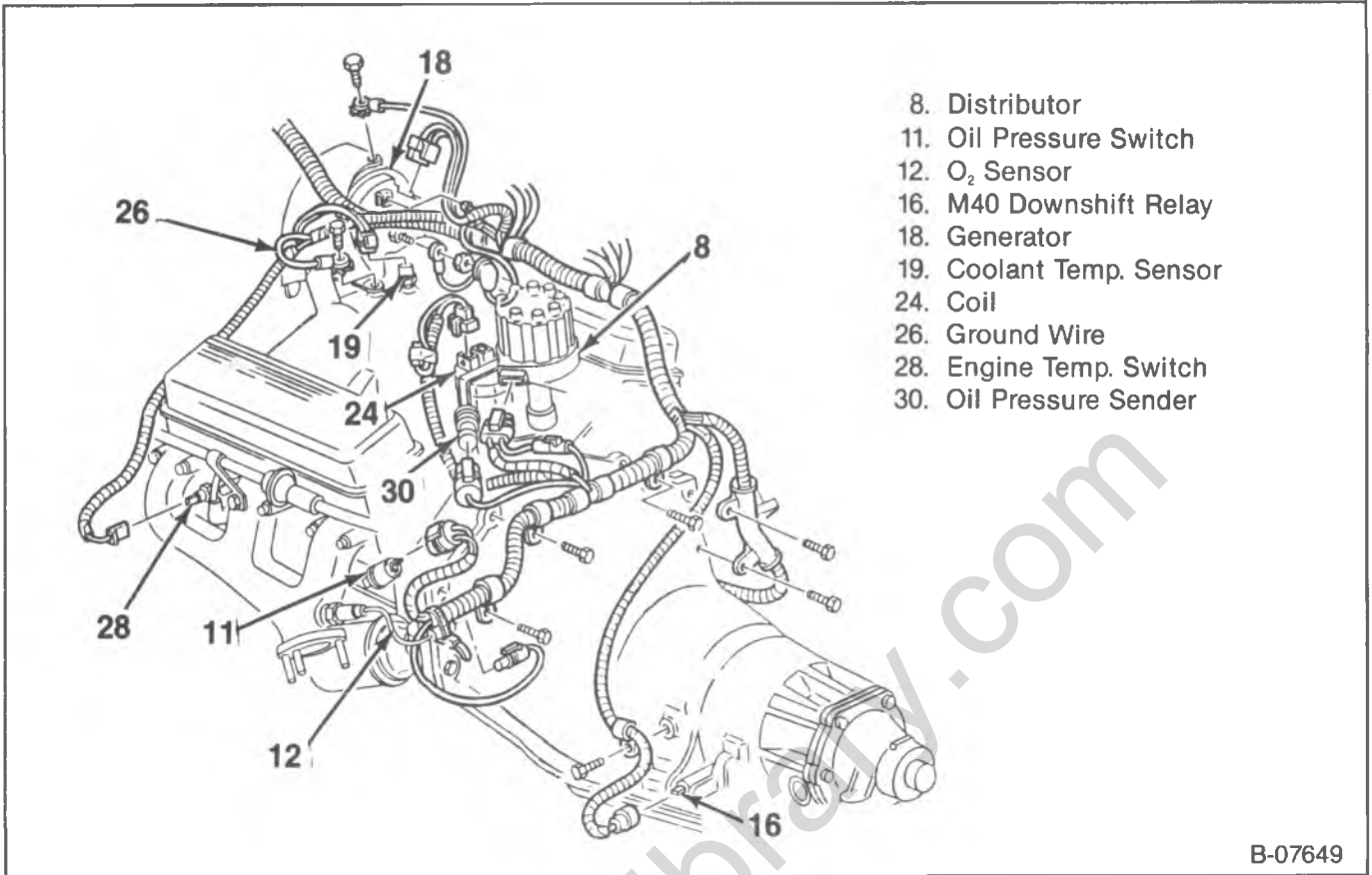

Figure 84—Engine Wiring for the 5.7L (TBI) - P Truck - Left Side

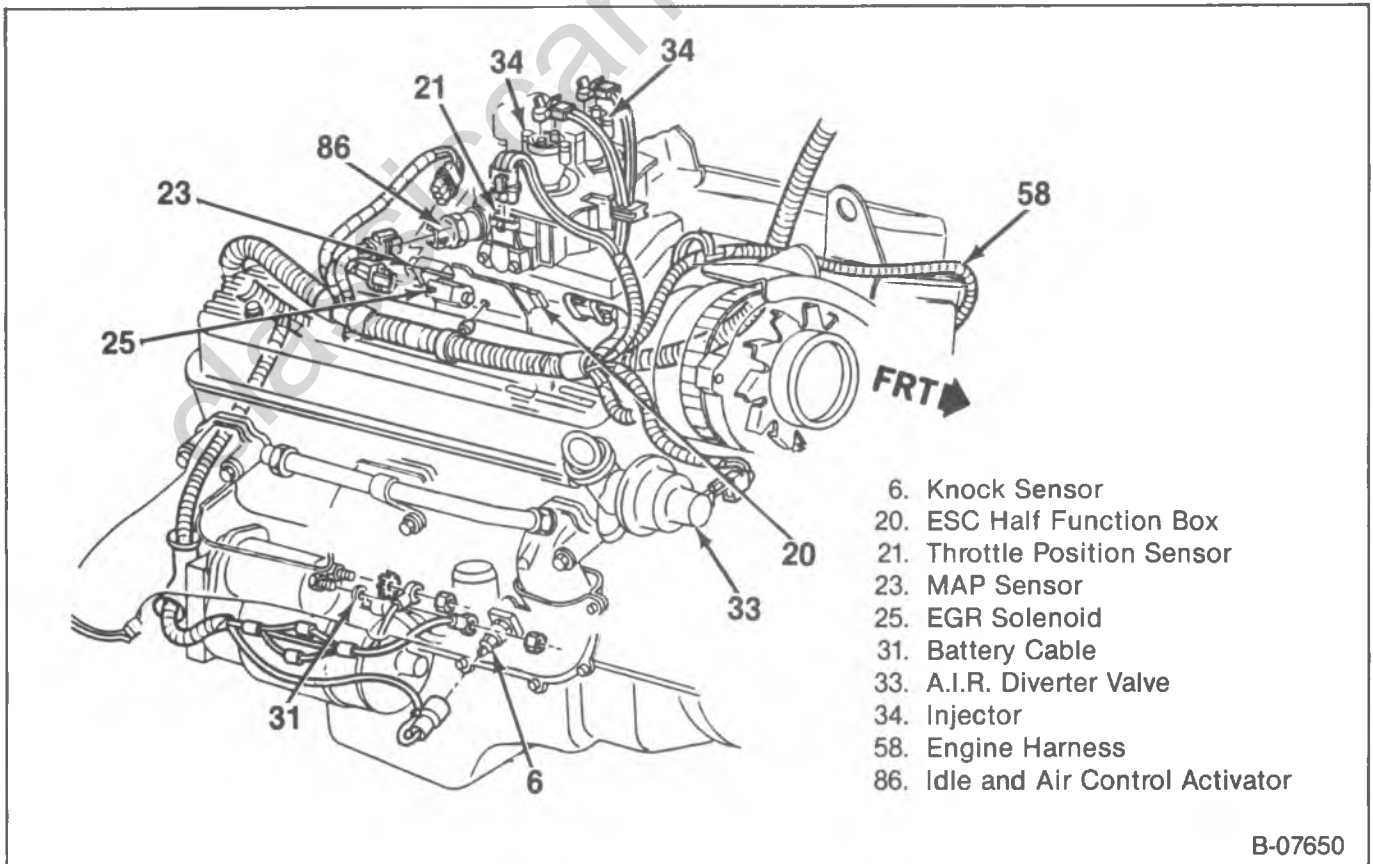
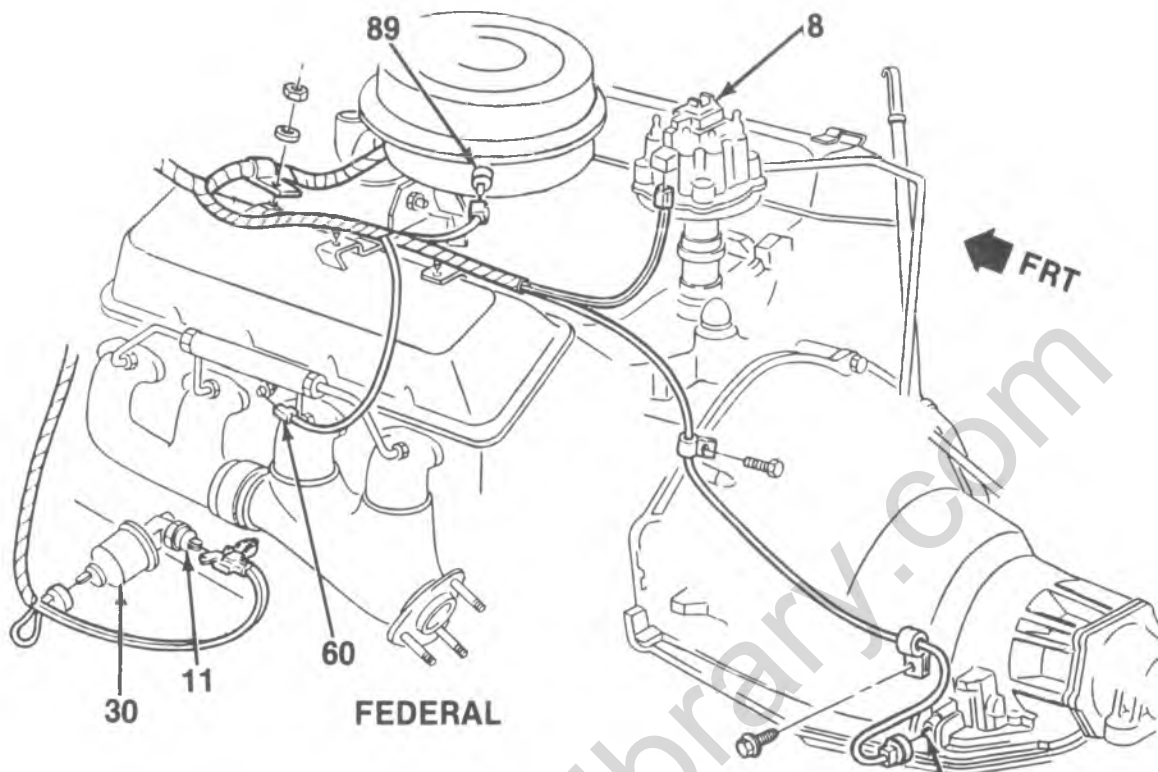
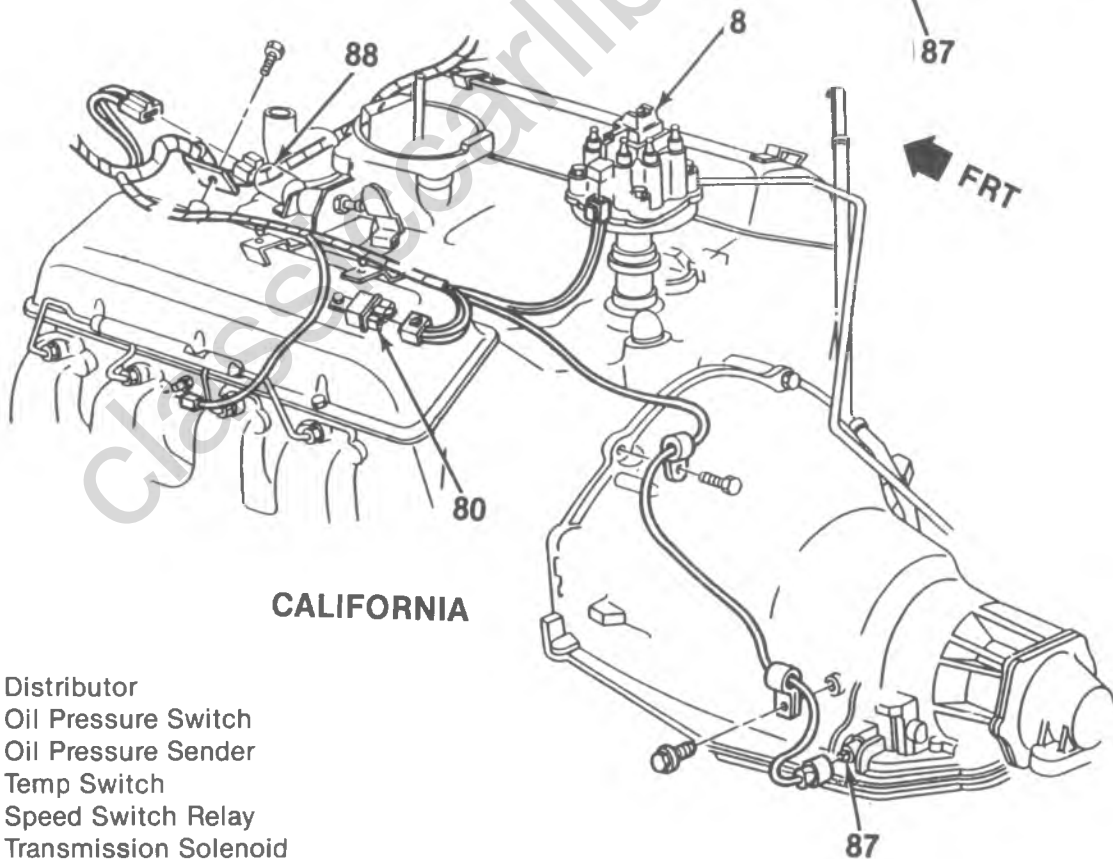

Figure 85—Engine Wiring for the 5.7L (TBI) - P Truck - Right Side

6D-70 ENGINE ELECTRICAL



FEDERAL



CALIFORNIA

- 8. Distributor
- 11. Oil Pressure Switch
- 30. Oil Pressure Sender
- 60. Temp Switch
- 80. Speed Switch Relay
- 87. Transmission Solenoid
- 88. Engine Speed Switch Solenoid
- 89. Air Cleaner Sensor

B-07652

Figure 86—Engine Wiring for the 7.4L (Carb.) - P32 Truck - Left Side

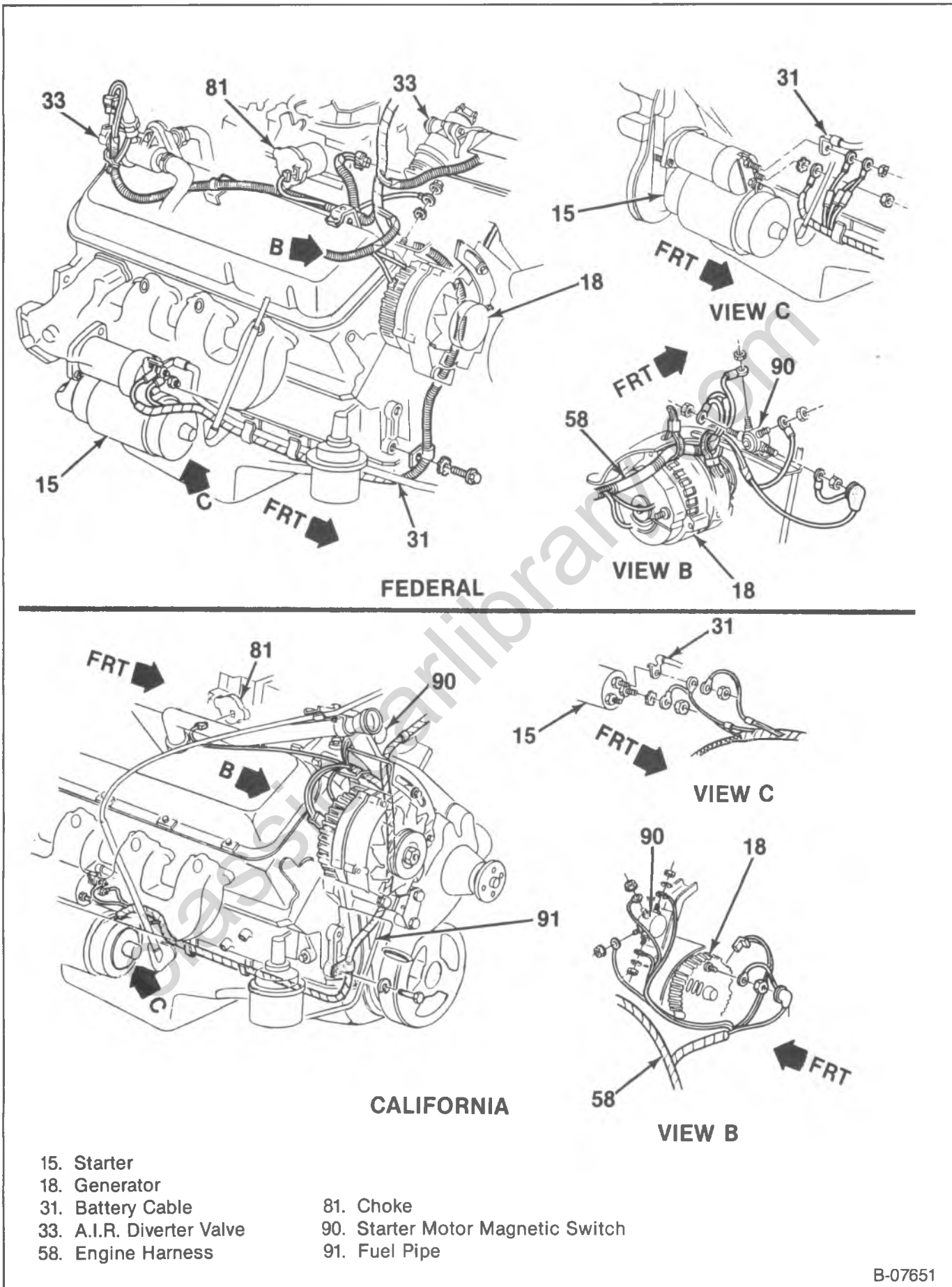

Figure 87—Engine Wiring for the 7.4L (Carb.) - P32 Truck - Right Side

6D-72 ENGINE ELECTRICAL

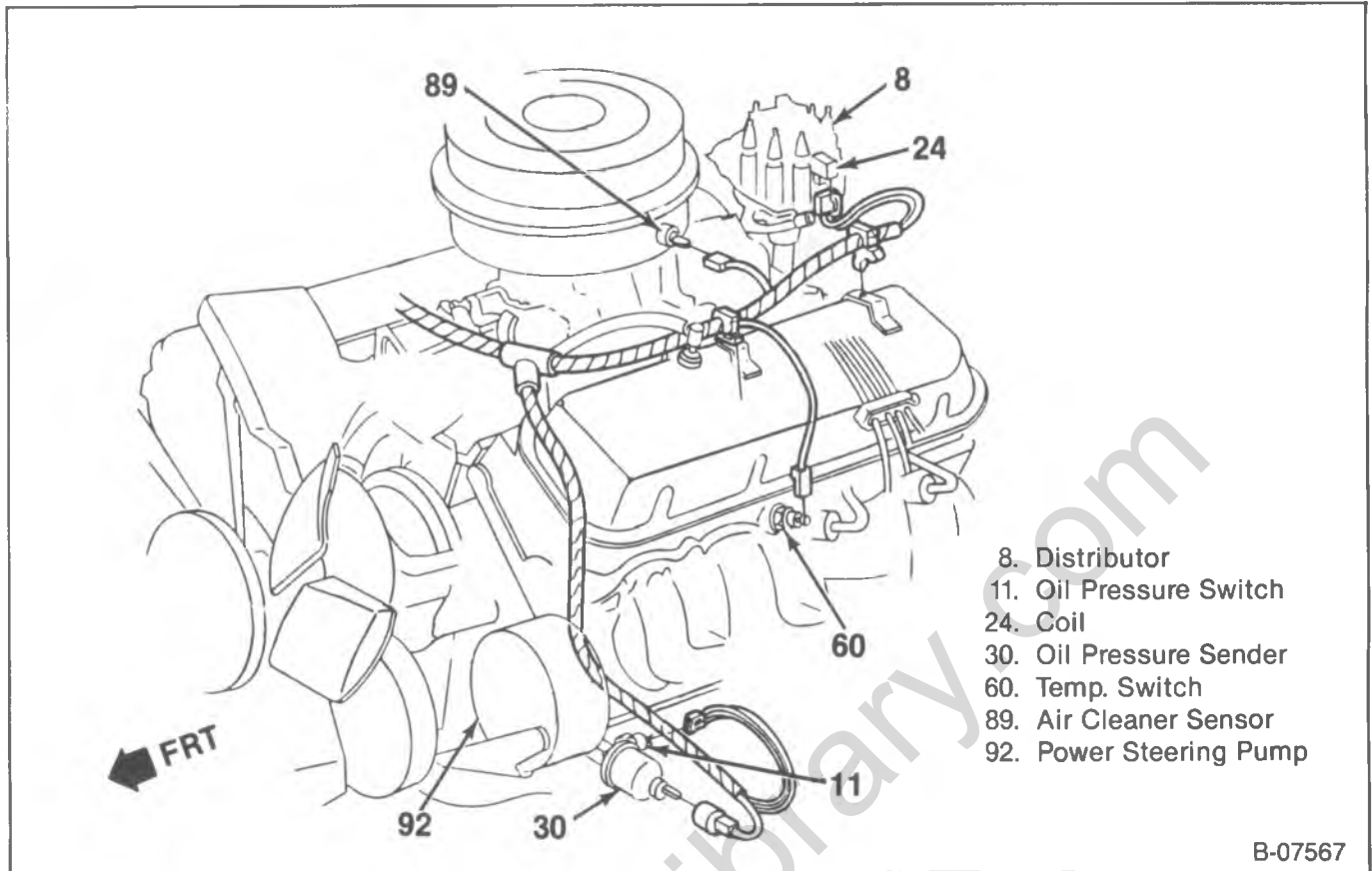

Figure 88—Engine Wiring for the 7.4L (Carb.) - P42 Truck - Left Side

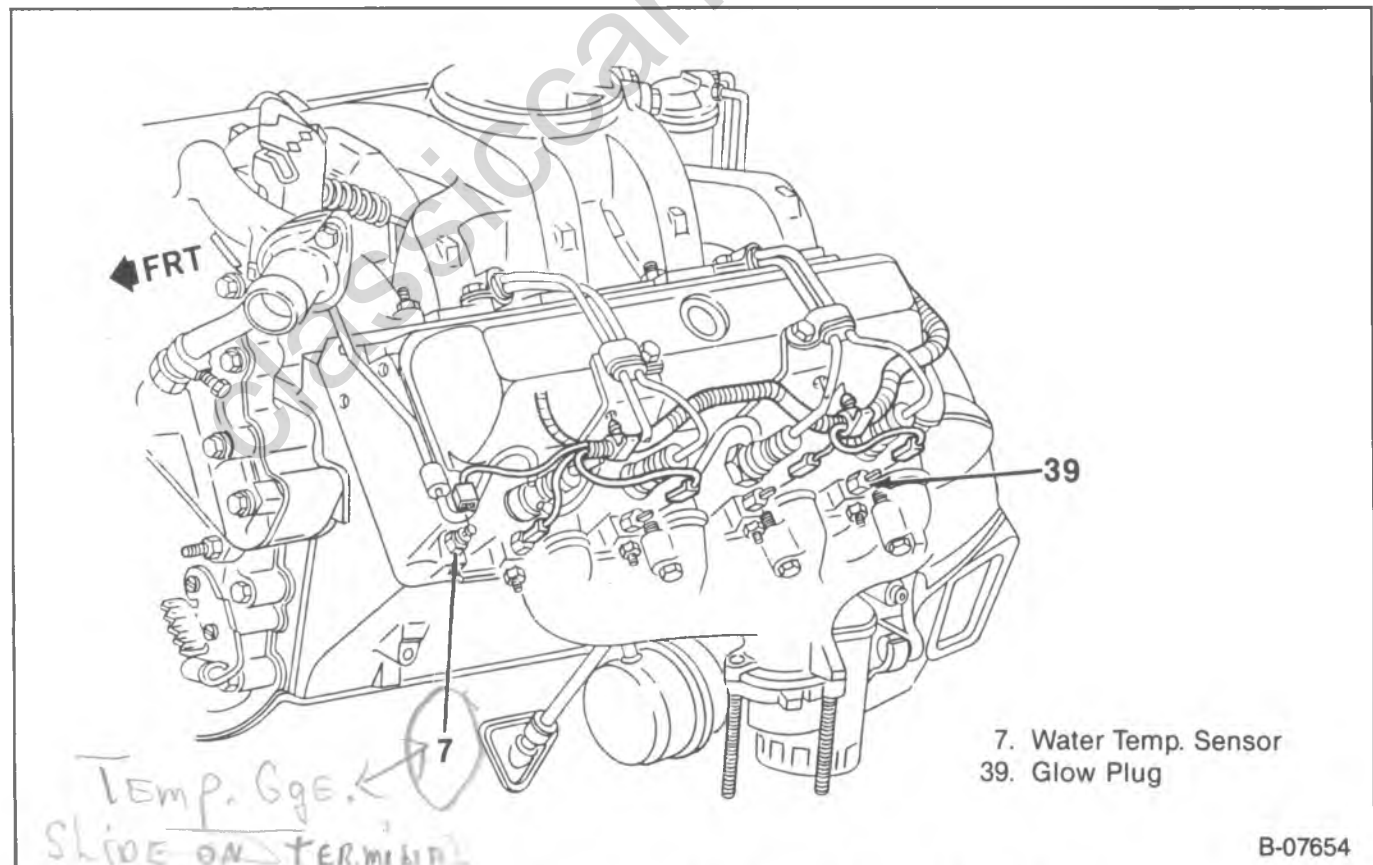
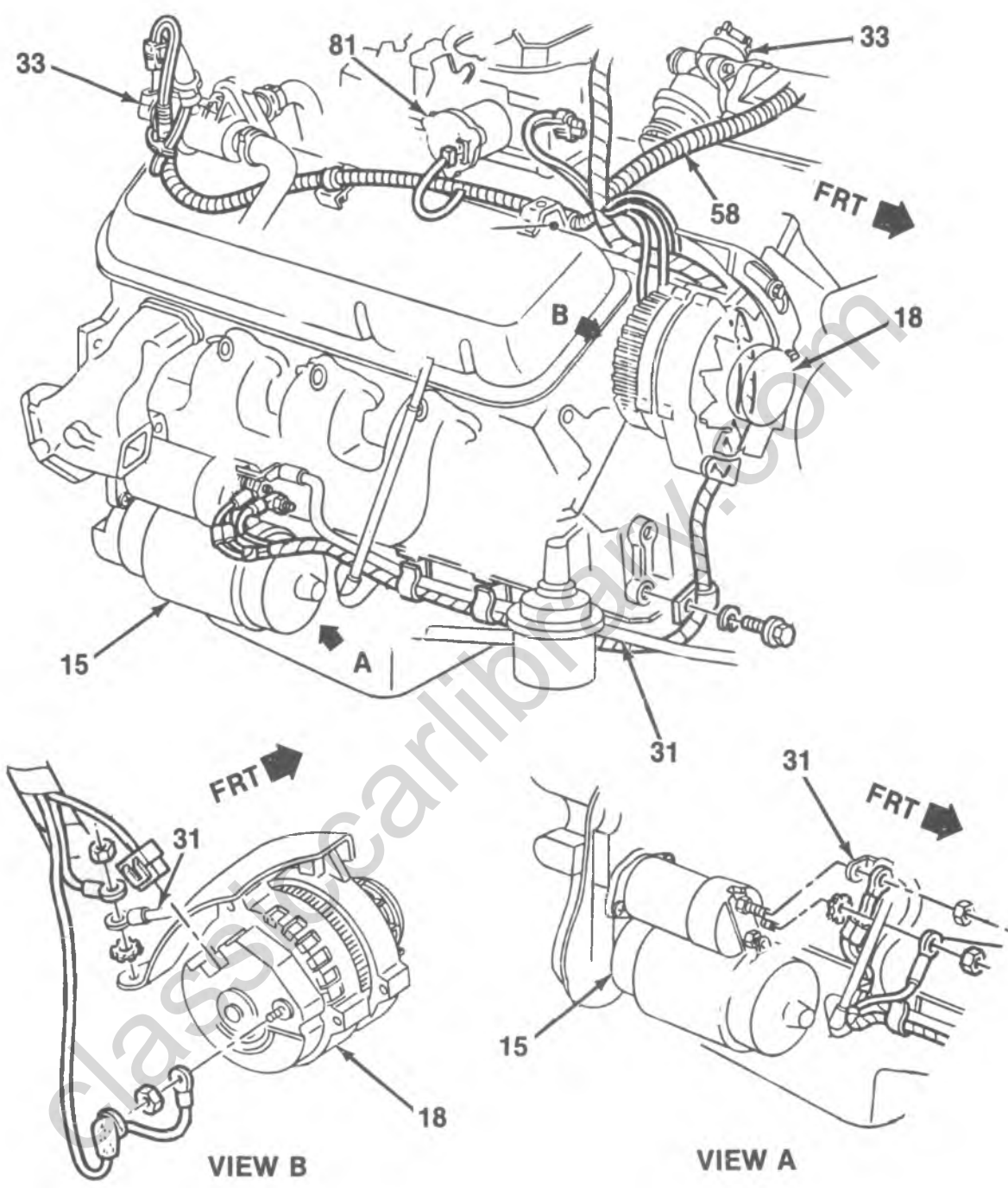

Figure 89—Engine Wiring for the 6.2L Diesel - P Truck - Left Side

DU 350 OLD ENG.



- 15. Starter
- 18. Generator
- 31. Battery Cable
- 33. A.I.R. Diverter Valve
- 58. Engine Harness
- 81. Choke

B-07653

Figure 90—Engine Wiring for the 7.4L (Carb.) - P42 Truck - Right Side

6D-74 ENGINE ELECTRICAL

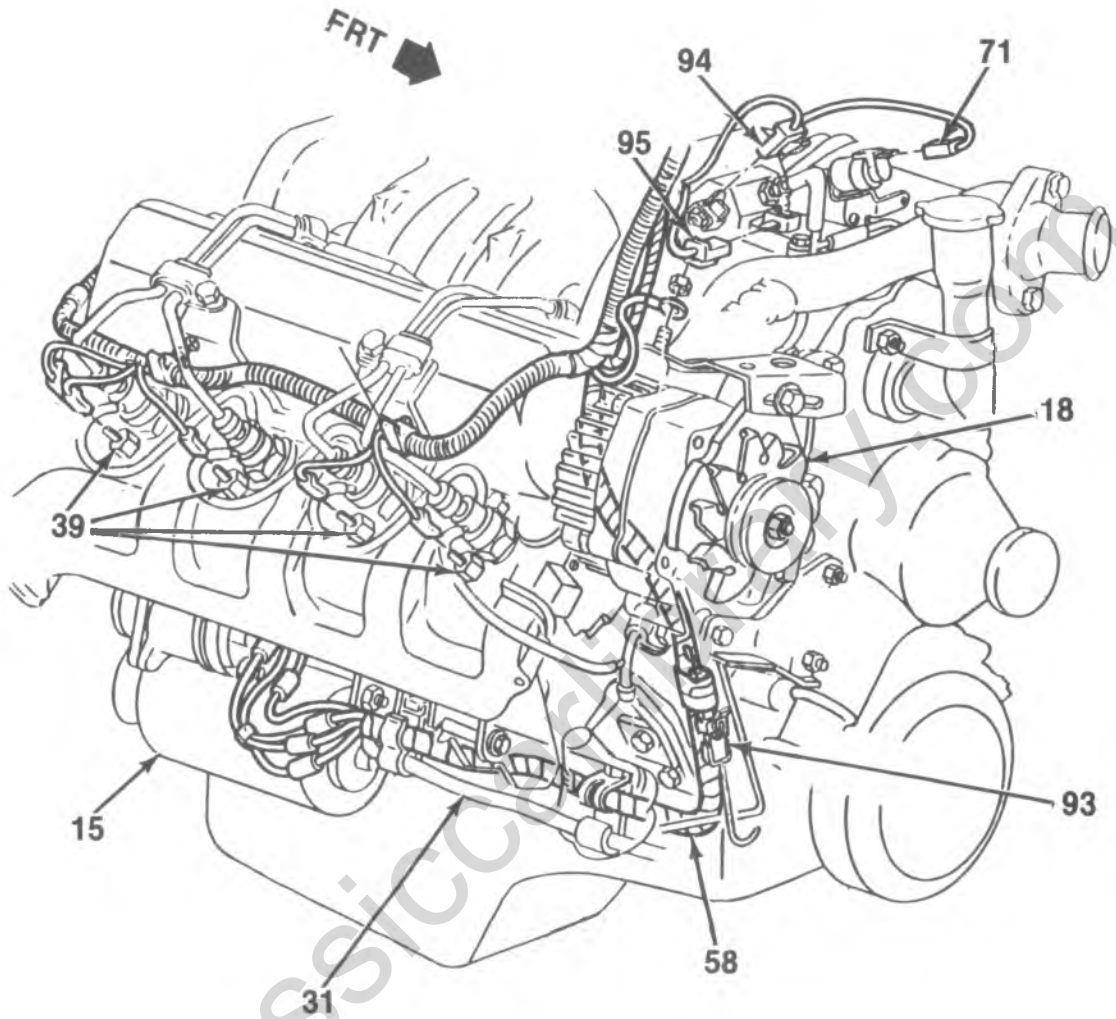

- 15. Starter
- 18. Generator
- 31. Battery Cable
- 39. Glow Plug
- 58. Engine Harness
- 71. Fast Idle Solenoid Connector
- 93. Heater Connector
- 94. Cold Advance Connector
- 95. Fuel Shutoff Valve Connector

B-07703

Figure 91—Engine Wiring for the 6.2L Diesel - P Truck - Right Side

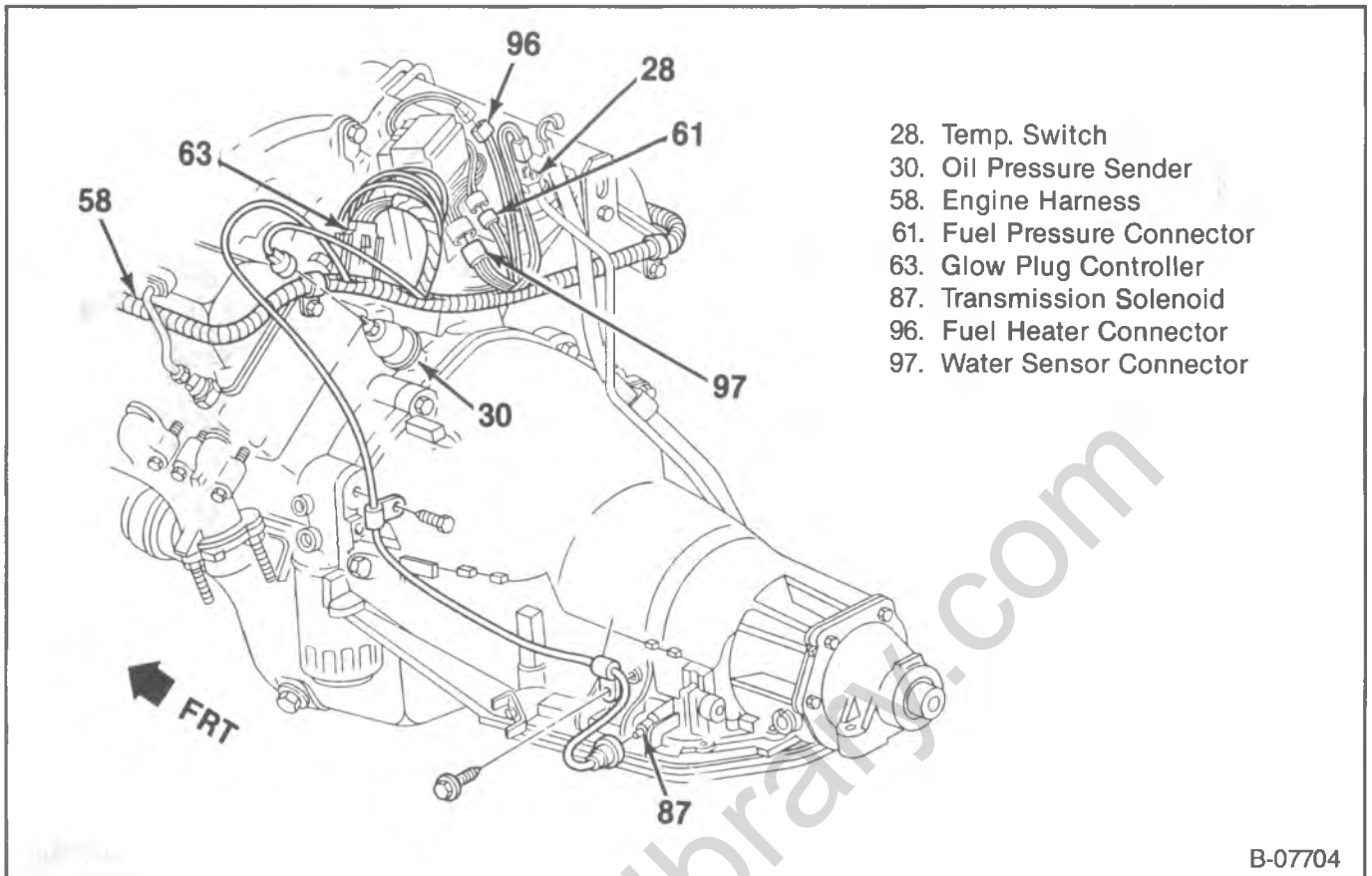

Figure 92—Engine Wiring for the 6.2L Diesel - P32 Truck - Back of Engine

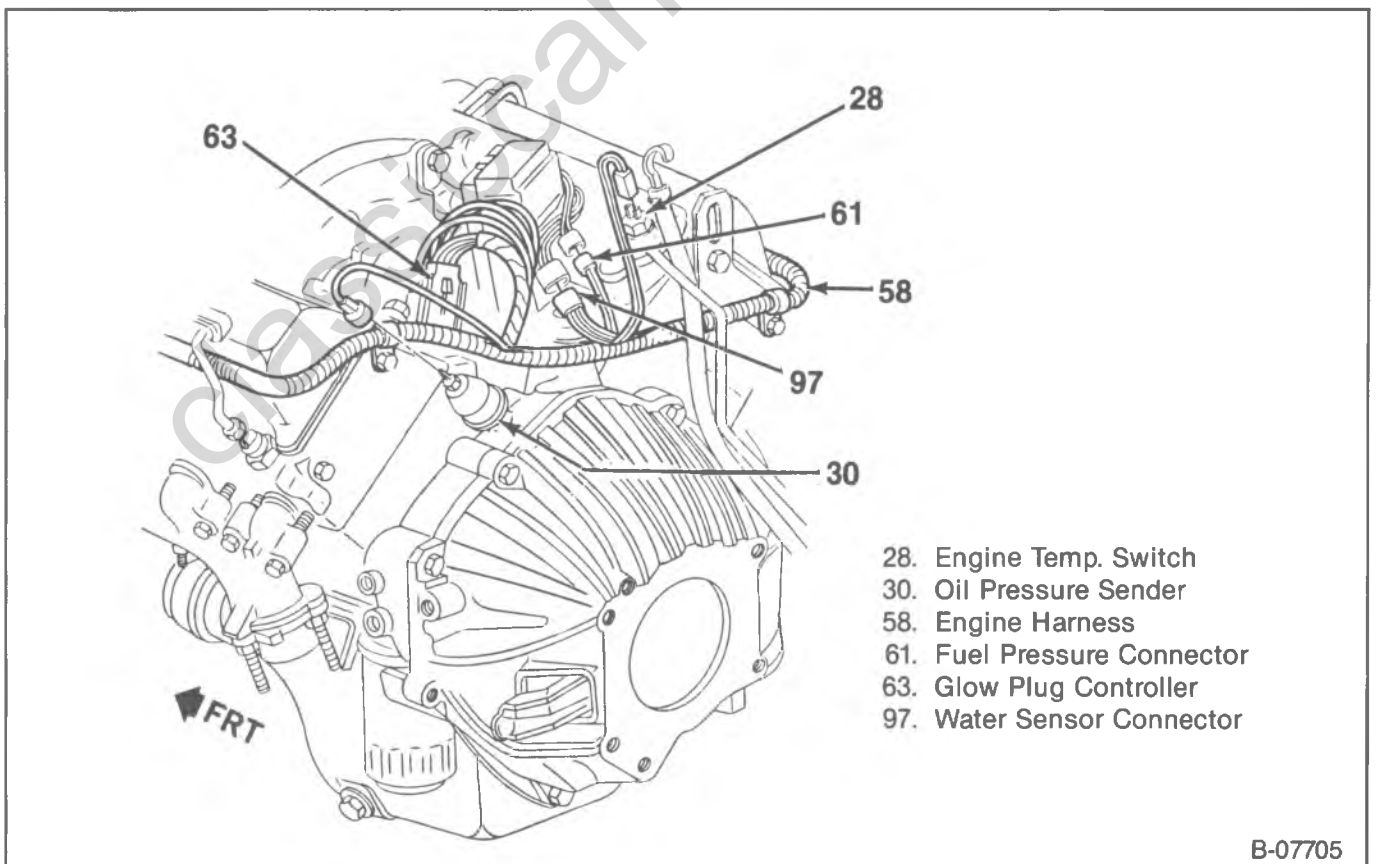

Figure 93—Engine Wiring for the 6.2L Diesel - P42 Truck - Back of Engine

6D-76 ENGINE ELECTRICAL

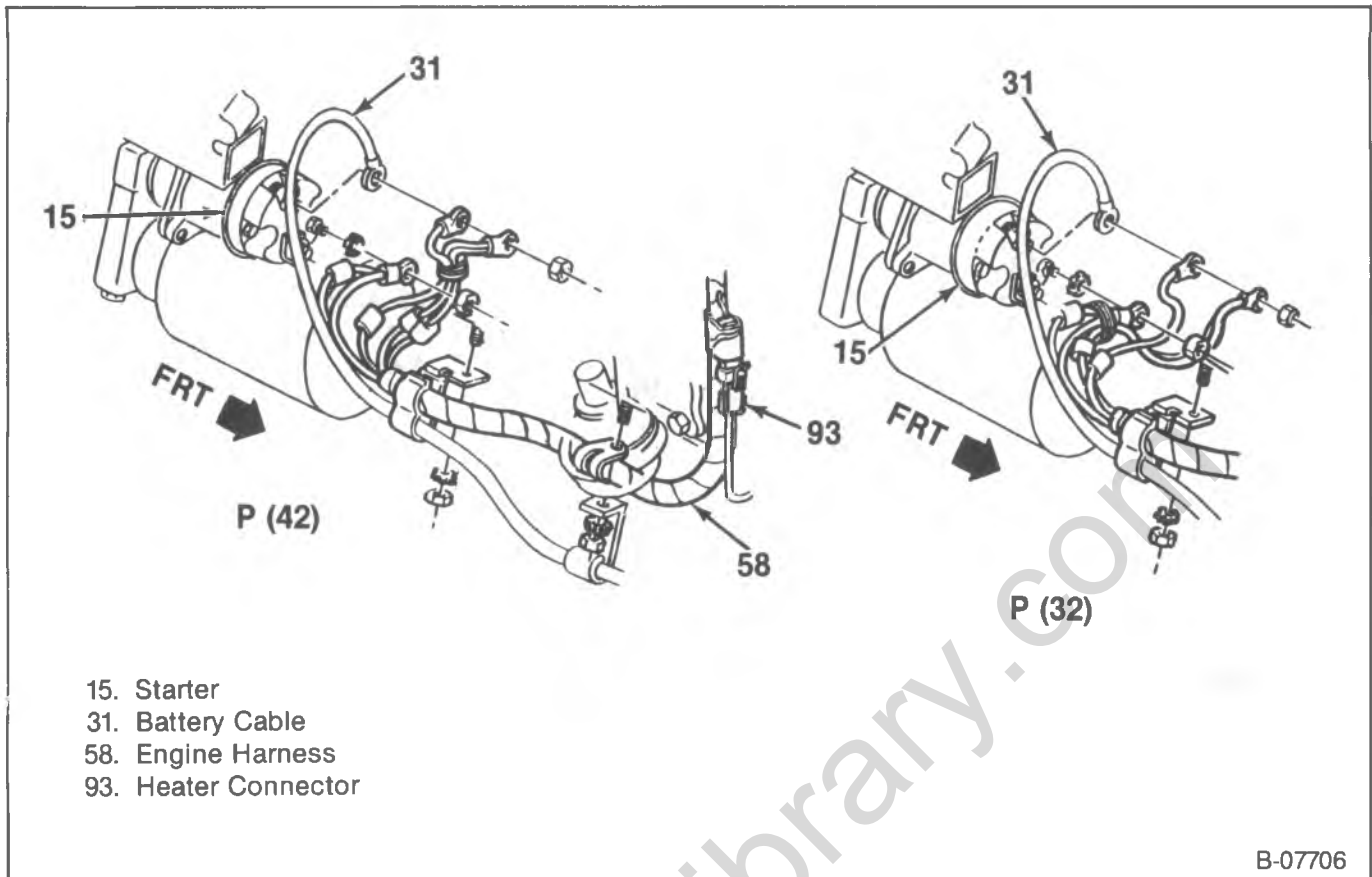

Figure 94—Engine Wiring Starter Motor for the 6.2L Diesel - P32 and P42 Truck

SPECIFICATIONS

BATTERY SPECIFICATIONS

Part No.	Application	Catalogue Replacement Number	Volts	Cold Cranking Amperes Rating @ -18 C (0° F)	Reserve Capacity (Minutes at 25 Amps)	Load Test (Amperes)
1980337	P	1200	12	550	130	270
1980474	P	1110	12	625	160	310*
1981729	RV, G	729	12	430	90	210
1981730	RV, G, P	730	12	525	40	260
1981733	RV, G, P	733	12	540	115	270
1981734	RV, G, P	734	12	630	115	310

* Battery tester cable clamps should be between terminal nuts and lead pads of terminals. If not possible, load value should be 275 amperes.

GENERATOR SPECIFICATIONS

Part No.	Series (Type 100)	Rotation Viewing Dr. End	Field Current @ 12 Volts 27°C (80°F) AMPS	Cold Output				Hot Output
				AMPS	RPM	AMPS	RPM	AMPS
1100207	12 SI	CW	4.5-5.0	23	1600	70	6500	66
1101205	17-SI	CW	1.7-2.1	50	1600	120	6500	120
1101240	12 SI	CW	4.2-5.0	30	1600	94	6500	94
1101241	12 SI	CW	4.2-5.0	30	1600	94	6500	94
1101242	12 SI	CW	4.5-5.0	23	1600	66	6500	66
1101243	12 SI	CW	4.2-5.0	23	1600	66	6500	66
1101244	12 SI	CW	4.0-5.0	23	1600	66	6500	66
1101245	12 SI	CW	4.2-5.0	30	1600	94	6500	94
1105628	12 SI	CW	4.5-5.0	30	1600	81	6500	78
1105632	12 SI	CW	4.5-5.0	23	1600	70	6500	66
1105661	CS 130	CW	6.0-7.5	42	1600	105	6500	105
1105688	CS 130	CW	6.0-7.5	36	1600	100	6500	100
1105710	CS 130	CW	4.8-5.7	30	1600	85	6500	85
1105711	CS 130	CW	6.0-7.5	36	1600	100	6500	100
1105712	CS 130	CW	4.8-5.7	30	1600	85	6500	85
1105718	CS 130	CW	6.0-7.5	42	1600	105	6500	85
1105720	CS 130	CW	6.0-7.5	42	1600	105	6500	105

SPECIFICATIONS (CONT.)

GENERATOR APPLICATIONS

Engine	Generator	Part Number	Mounting Torque			
			Top Bracket Bolt		Bottom Bracket Bolt	
			N·m	Ft. Lbs.	N·m	Ft. Lbs.
RV 4.3L (TBI)	K22	1101241	25	18	47	35
	K81	1101242	25	18	47	35
5.0L (TBI)	K22	1101240	25	18	47	35
	K68	1105720	25	18	47	35
	K81	1101243	25	18	47	35
5.7L (TBI)	K22	1101240	25	18	47	35
	K68	1105720	25	18	47	35
	K81	1101243	25	18	47	35
6.2L (Diesel)	K64	1105628	27	20	43	32
	K81	1105632	27	20	43	32
7.4L (TBI)	K68	1105661	25	18	50	37
	K81	1101244	25	18	50	37
	K22	1101245	25	18	50	37
G Van 4.3L (TBI)	K60	1105711	25	18	50	37
	K99	1105710	25	18	50	37
5.0L (TBI)	K60	1105711	25	18	50	37
	K99	1105710	25	18	50	37
5.7L (TBI)	K60	1105711	25	18	50	37
	K99	1105710	25	18	50	37
5.7L (Carb.)	K68	1105720	25	18	47	35
6.2L (Diesel)	K81	1105632	27	20	43	32
P Truck 5.7L (Carb. and TBI)	K68	1105720	25	18	47	35
	K99	1105718	25	18	47	35
6.2L (Diesel)	K09	1101215	27	20	43	32
	K81	1105632	27	20	43	32
7.4L (Carb.)	K68	1105661	25	18	50	37
4.8L (Carb.)	K81	1100207	25	18	24	17

SPECIFICATIONS (CONT.)

STARTER SPECIFICATIONS

Truck Model	Engine Application	Starter			No Load Test @ 10 Volts			
					AMPS		RPM	
		Part No.	Series	Type	Minimum	Maximum	Minimum	Maximum
R,V,G,P	6.2 L Diesel	1113589	27MT	136	120	210	9000	13400
V	6.2L Diesel	1113590	27MT	136	120	210	9000	13400
P	4.3 L (Carb.)	1998559	10MT	101	60	90	6500	10500
V	5.0L (TBI), 5.7L (TBI)	1998560	10MT	101	70	110	6500	10700
R,V,G	5.0L (TBI), 5.7L (TBI)	1998561	10MT	101	70	110	6500	10700
P	5.7L (TBI)	1998561	10MT	101	70	110	6500	10700
R,V	4.3L (TBI), 5.0L (TBI), 5.7L (TBI), 7.4L (TBI)	1998562	10MT	101	70	110	6500	11070
G	4.3L (TBI), 5.0L (TBI), 5.7L (TBI), 5.7L (Carb.)	1998562	10MT	101	70	110	6500	11070
P	7.4L (Carb.), 5.7L (Carb.), 5.7L (TBI)	1998562	10MT	101	70	110	6500	11070
V	4.3L (TBI), 5.0L (TBI), 7.4L (TBI), 5.7L (TBI)	1998565	10MT	101	70	110	6500	10700
P	5.7L (Carb.)	1998565	10MT	101	70	110	6500	10700

STARTER SHIMS

Gas Engines		Diesel Engines	
Shim	Part No.	Shim	Part No.
0.38 mm (0.015-inch)	1246249	1.0 mm (0.04-inch)	23500396
1.0 mm (0.04-inch)	14036090	2.0 mm (0.08-inch)	23500397

TORQUE VALUES

	N-m	Ft. Lbs.	In. Lbs.
Battery Retainer	17	13	
Top Bar of Hold-Down:			
Side Terminal Batteries	3.5		30
Top Terminal Batteries	6.8		60
Battery Terminals:			
Top Terminals	17	13	
Side Terminals	15	11	
Glow Plug Controller Upper Nuts	5.0		48
Glow Plug Temperature Switch	23	17	
Glow Plugs	17	12	
Diesel Engine Starter Mounts:			
Through Bolt	38	28	
Nut	10		90
Bolt	32	24	
Gas Engine Starter Mounting Bolts	38	28	
Engine Block Heater Screw	1.8	—	16

SPECIAL TOOLS

1.

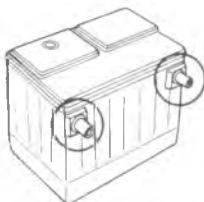

ST-1201

3.

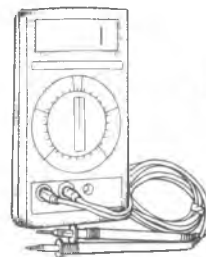

J-34029-A

2.

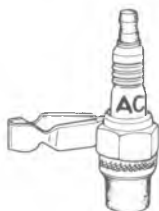

ST-125

- 1. Battery Terminal Adapters
- 2. Spark Plug Tester
- 3. Digital Multimeter

B-07709

classiccarslibrary.com

SECTION 6E
EMISSIONS
CONTENTS

<u>SUBJECT</u>	<u>PAGE</u>
Drivability and Emissions - Carbureted6E8- 1
Drivability and Emissions - Diesel6E9- 1

For information on vehicles with Throttle Body Injection (TBI), refer to the Fuel and Emissions Service Manual.

classiccarlibrary.com

classiccarylbrary.com

SECTION 6E8

**DRIVEABILITY AND EMISSIONS —
CARBURETED**

This section applies to:
4.8 L L25 ENGINE CODE "T"
5.7 L LT9 ENGINE CODE "M"
7.4 L LE8 ENGINE CODE "W"

CONTENTS

<u>SUBJECT</u>	<u>PAGE</u>
General Information	6E8- 2
Driveability	6E8- 2
Emissions	6E8- 2
Maintenance Schedule	6E8- 2
Vehicle Emission Control Information Label	6E8- 2
Visual Underhood Inspection	6E8- 2
Introduction	6E8- 4
General Description	6E8- 4
Component Location	6E8- 5
Driveability Symptoms	6E8- 8
Won't Start — Engine Cranks OK	6E8- 8
Hard Start — Cold	6E8- 9
Hard Start — Hot	6E8- 9
Stall After Start — Cold	6E8-10
Stall After Start — Hot	6E8-10
Hesitation/Sag, Stumble	6E8-10
Surges and/or Chuggle	6E8-11
Lack of Power, Sluggish or Spongy	6E8-11
Backfire	6E8-12
Misses/Cuts Out	6E8-12
Rough, Unstable or Incorrect Idle, Stalling	6E8-13
Won't Idle	6E8-13
Poor Fuel Economy	6E8-13
Dieseling, Run On	6E8-14
Detonation/Spark Knock	6E8-14
Excessive Exhaust Emissions (Odors)	6E8-14
Restricted Exhaust Check	6E8-15
Evaporative Emission Control System (EECS)	6E8-16
General Description	6E8-16
Diagnosis of EECS	6E8-17
On-Vehicle Service — EECS	6E8-18
Air Injection Reaction (AIR) System	6E8-19
General Description	6E8-19
Diagnosis of AIR	6E8-20
On-Vehicle Service — AIR	6E8-21
Exhaust Gas Recirculation (EGR) System	6E8-32
General Description	6E8-32
Diagnosis of EGR	6E8-33
On-Vehicle Service — EGR	6E8-33

CONTENTS (CONT.)

<u>SUBJECT</u>	<u>PAGE</u>
Early Fuel Evaporation System (EFE).....	6E8-35
General Description	6E8-35
Diagnosis of EFE	6E8-35
On-Vehicle Service — EFE.....	6E8-36
Positive Crankcase Ventilation (PCV)	6E8-39
General Description	6E8-39
Diagnosis of PCV	6E8-39
On-Vehicle Service — PCV	6E8-39
Thermostatic Air Cleaner (THERMAC)	6E8-40
General Description	6E8-40
Diagnosis of THERMAC	6E8-41
On-Vehicle Service — THERMAC	6E8-42
Throttle Return Control (TRC) System.....	6E8-43
General Description	6E8-43
Diagnosis of TRC	6E8-43
On-Vehicle Service — TRC	6E8-44

GENERAL INFORMATION

DRIVEABILITY

The driveability diagnosis procedures apply to various systems in current GM vehicles. The procedures assume that the vehicle worked right at one time and the problem is due to time, wear, dirt or other causes. Start with the introduction that follows. This will describe a systematic diagnostic procedure.

Any system disconnected during diagnosis should be reconnected. This includes wires, hoses, linkage, etc. When removing air cleaner, plug hose fittings that could cause an air leak.

EMISSIONS

The exhaust emission control systems used on General Motors engines perform a specific function to lower exhaust emissions while maintaining good fuel economy and driveability.

MAINTENANCE SCHEDULE

Refer to the General Motors Maintenance Schedule in Section 0B of this Service Manual for the maintenance service that should be performed to retain emission control performance.

VEHICLE EMISSION CONTROL INFORMATION LABEL

The Vehicle Emissions Control Information label (Fig. 1) contains important emission specifications and setting procedures. In the upper left corner is exhaust emission information which identifies the year, the manufacturing division of the engine, the displacement in liters of the engine, the class of vehicle and type of fuel metering. Also there is an illustrated emission component and vacuum hose schematic. This label is located in the engine compartment of every General Motors Corporation vehicle. If the label has been removed, it can be ordered from the parts division. (WDDGM)

VISUAL/PHYSICAL UNDERHOOD INSPECTION

One of the most important checks that must be done as part of any diagnostic procedure is a careful visual/physical underhood inspection. This can often lead to fixing a problem without further steps. Inspect all vacuum hoses for correct routing, pinches, cuts, or disconnects. Be sure to inspect hoses that are difficult to see beneath the air cleaner, compressor, generator, etc. Inspect all the wires in the engine compartment for correct and good connections, burned or chaffed spots, pinched wires, or contact with sharp edges or hot exhaust manifolds. This visual/physical inspection is very important. It must be done carefully and thoroughly.

6E8-4 DRIVEABILITY AND EMISSIONS — CARBURETED

ALL NEW GENERAL MOTORS VEHICLES ARE CERTIFIED BY THE UNITED STATES ENVIRONMENTAL PROTECTION AGENCY AS CONFORMING TO THE REQUIREMENTS OF THE REGULATIONS FOR THE CONTROL OF AIR POLLUTION FROM NEW MOTOR VEHICLES. THIS CERTIFICATION IS CONTINGENT ON CERTAIN ADJUSTMENTS BEING SET TO FACTORY STANDARDS. IN MOST CASES, THESE ADJUSTMENT POINTS EITHER HAVE BEEN PERMANENTLY SEALED AND/OR MADE INACCESSIBLE TO PREVENT INDISCRIMINATE OR ROUTINE ADJUSTMENT IN THE FIELD. FOR THIS REASON, THE FACTORY PROCEDURE FOR TEMPORARILY REMOVING PLUGS, CAPS, ETC., FOR PURPOSES OF SERVICING THE PRODUCT, MUST BE STRICTLY FOLLOWED AND, WHEREVER PRACTICABLE, RETURNED TO THE ORIGINAL INTENT OF THE DESIGN.

INTRODUCTION

GENERAL DESCRIPTION

The engine has controls to reduce exhaust emissions while maintaining good driveability and fuel economy.

The following emission controls are on all engines:

- Positive Crankcase Ventilation (PCV)
- Exhaust Gas Recirculation (EGR)
- Thermostatic Air Cleaner (THERMAC)
- Air Injection Reaction (AIR)
- Early Fuel Evaporation (EFE)
- Evaporative Emission Control (EECS)
- Throttle Return Control (TRC)
- Deceleration Control

Positive Crankcase Ventilation (PCV)

All engines have closed Positive Crankcase Ventilation System to provide more complete scavenging of crankcase vapors.

Ventilation air is drawn from the dirty air side of the air cleaner, through a hose, down into the crankcase, up through the ventilator valve, through a hose and into the intake manifold. Intake manifold vacuum draws any fumes from the crankcase to be burned in the engine.

EXHAUST GAS RECIRCULATION (EGR)

The Exhaust Gas Recirculation system is used on all engines. It meters exhaust gas into the induction system for recirculation through the combustion cycle to reduce oxides of nitrogen emissions.

The EGR valve remains closed during periods of engine idle and deceleration to prevent rough idle from excessive exhaust gas dilution in the idle air/fuel mixtures. It also remains closed at wide open throttle to prevent power loss.

Thermostatic Air Cleaner (THERMAC)

The Thermostatic Air Cleaner is designed to keep air entering the carburetor at approximately 100°F. Keeping the air at 100°F, or more, improves engine warm-up driveability, and will help minimize carburetor icing.

Air Injection Reaction (AIR)

The Air Injection Reaction system provides additional oxygen to the exhaust gases to continue the combustion process.

EARLY FUEL EVAPORATION (EFE)

The EFE system is used to provide a source of rapid heat to the engine induction system during cold driveaway. Rapid heating is desirable because it provides for quick fuel evaporation and more uniform fuel distribution to aid cold driveability.

Evaporative Emission Control

This system has a canister which stores fuel vapor from the fuel tank and the carburetor. The fuel vapor is removed from the canister and consumed in the normal combustion process when the engine is running.

Throttle Return Control (TRC)

The Throttle Return Control system helps to prevent an over-rich condition on deceleration. The vacuum operated Throttle Kicker will not allow the throttle to close fully until the engine speed falls below a specified RPM. By holding the throttle open slightly, more air is allowed to enter the engine to maintain a more efficient air/fuel ratio.

Deceleration Control

The deceleration control uses a deceleration valve to control emissions and back-fire on deceleration. When deceleration causes a sudden rise in manifold vacuum, the deceleration valve will open to admit fresh air to the inlet manifold. After a calibrated time delay, the valve will close. The system is mainly used with manual transmission equipped vehicles.

'G' SERIES

RPO:LT9

VIN CODE:M

5.7L V8 4BBL

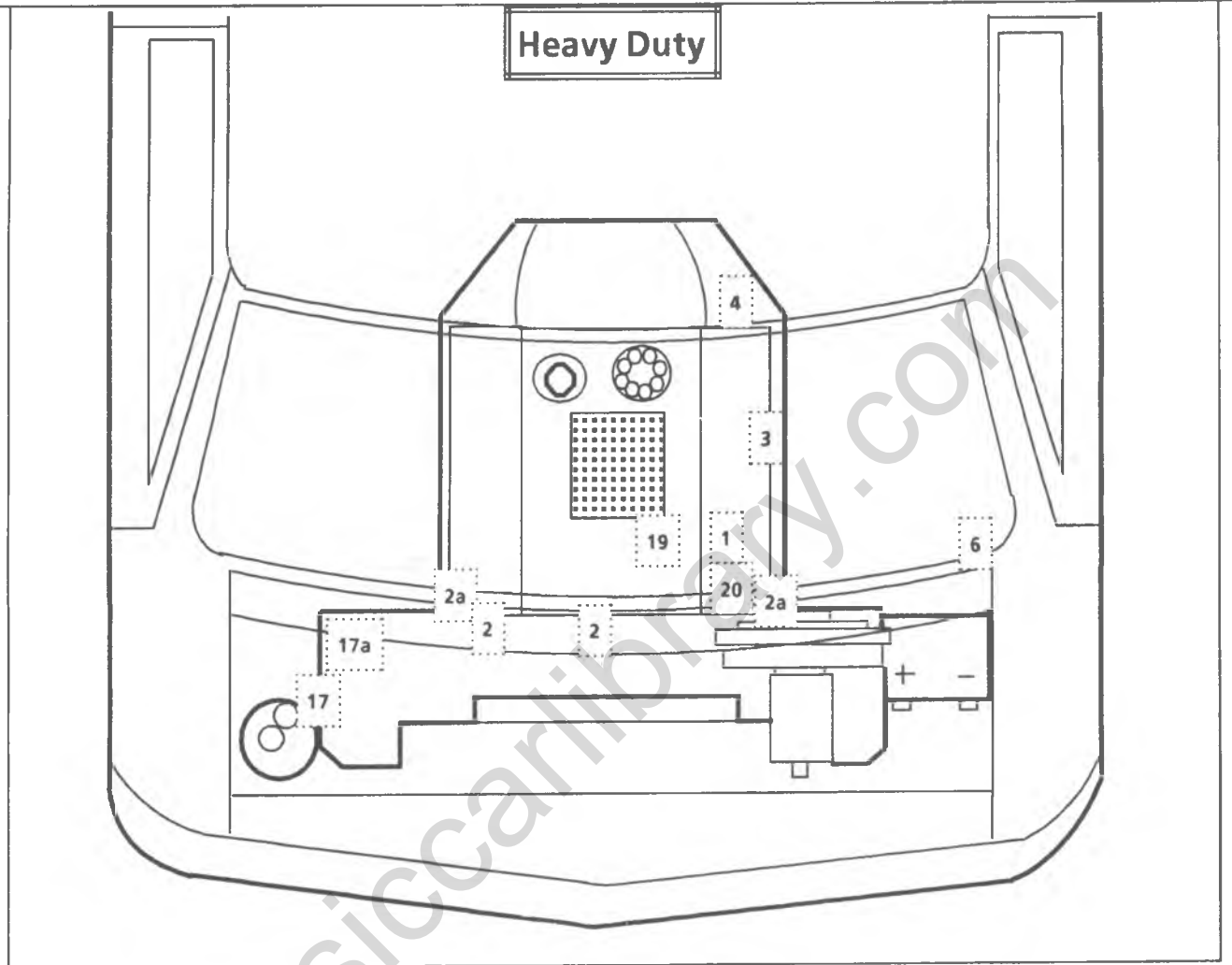

 EMISSIONS DEVICES

- 1 Crankcase vent valve (PCV)
- 2 Air injection pump
- 2a Air injection divert valve
- 3 Deceleration valve
- 4 EFE valve
- 6 Fuse panel
- 17 Fuel vapor canister
- 17a Fuel vapor canister solenoid
- 19 Throttle return control
- 20 Throttle valve relay
-  Exhaust Gas Recirculation valve

Figure 2—Component Locations — 5.7 L (G-Series)

'P' SERIES

RPO:LT9

VIN CODE:M

5.7L V8 4BBL

Heavy Duty

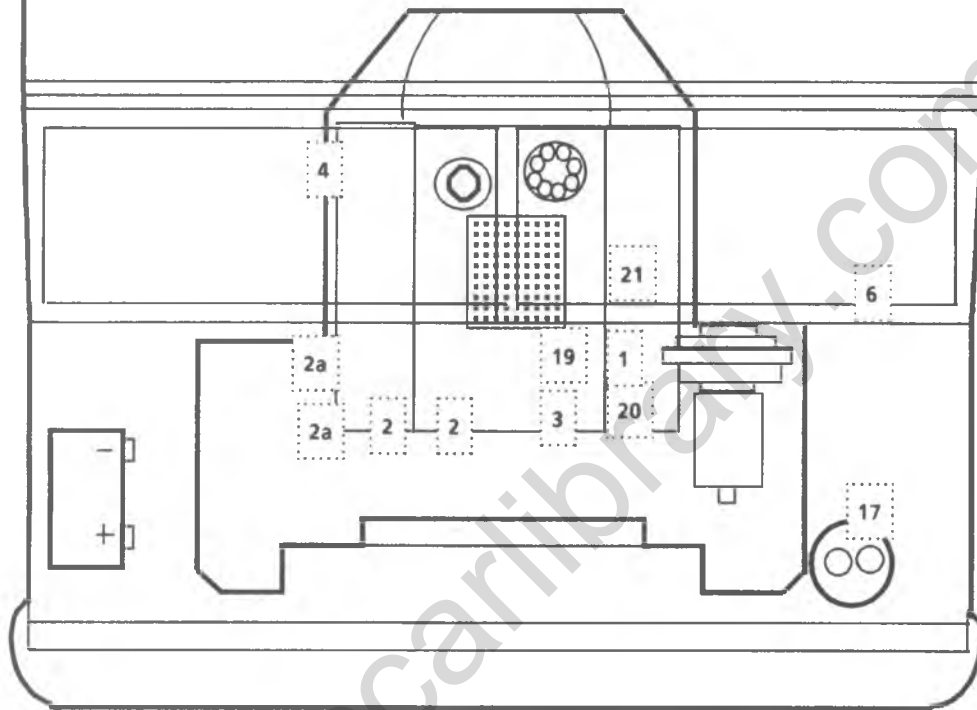

EMISSIONS DEVICES

- 1 Crankcase vent valve (PCV)
- 2 Air injection pump
- 2a Air injection divert valve
- 3 Deceleration valve
- 4 EFE valve
- 6 Fuse panel
- 17 Fuel vapor canister solenoid
- 19 Throttle return control
- 20 Throttle valve relay
- 21 Engine speed relay

 Exhaust Gas Recirculation valve

Figure 3—Component Locations — 5.7 L (P-Series)

'P' SERIES

RPO:LE8

VIN CODE:W

7.4L V8 4BBL

Heavy Duty

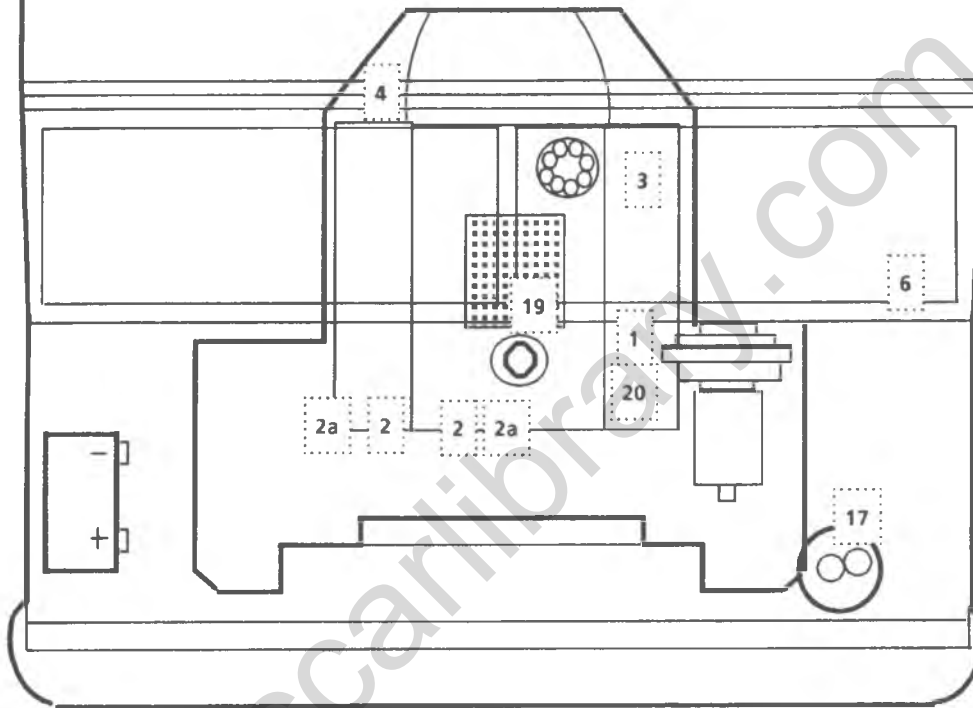

EMISSIONS DEVICES

- 1 Crankcase vent valve (PCV)
 - 2 Air injection pump
 - 2a Air injection divert valve
 - 3 Deceleration valve
 - 4 EFE valve
 - 6 Fuse panel
 - 17 Fuel vapor canister
 - 19 Throttle return control
 - 20 Throttle valve relay
-  Exhaust Gas Recirculation valve

Figure 4—Component Locations — 7.4 L (P-Series)

DRIVEABILITY SYMPTOMS

BEFORE STARTING

Verify the customer complaint, and locate the correct symptom below. Check the items indicated under that symptom.

If the ENGINE CRANKS BUT WILL NOT RUN, see "No Start — Engine Cranks OK" below.

DISTRIBUTOR INFORMATION

Refer to Section 6D, Engine Electrical, for Ignition System including distributor information.

CARBURETOR ADJUSTMENT

Carburetor adjustment and specifications can be found in Section 6C1, Carburetors.

VISUAL CHECK

Several of the symptom procedures below call for a careful visual check. This check should include:

- Vacuum hoses for splits, kinks, and proper connections, as shown on Emission Control Information label.
- Air leaks at carburetor mounting and intake manifold.
- Ignition wires for cracking, hardness, proper routing, and carbon tracking.
- Wiring for proper connections, pinches, and cuts.

The importance of this step cannot be stressed too strongly — it can lead to correcting a problem without further checks and can save valuable time.

WON'T START — ENGINE CRANKS OK

Definition: Engine cranks OK, but does not start. May fire a few times.

- Make sure proper starting procedure is being used. See Owner's Manual.
- Visual check:
 - Vacuum hoses for splits, kinks and proper connections, as shown on Vehicle Emission Control Information label.
 - Ignition wires for cracking, hardness and proper connections at both distributor cap and spark plugs.
- Remove air cleaner:
 - Check carburetor choke valve, vacuum break(s), linkage and unloader operation. See Section 6C. Set to specifications. Choke valve should move smoothly and be closed when cold, and open when hot.
- Check for presence of fuel by noting carburetor accelerator pump operation. Look for gas squirt in carburetor bore while quickly opening throttle lever.
 - If no pump squirt:
 - Check for fuel in tank.
 - Check carburetor fuel inlet filter. Replace if dirty or plugged.
 - Check fuel pump capacity.
 - If fuel pump checks OK, check float needle for sticking in seat, or binding float.
 - If there is a pump squirt:
 - Crank engine and check for flooding.
 - If not flooding, see "Ignition System Diagnosis," Section 6D.
- Remove spark plugs. Check for wet plugs, cracks, wear, improper gap, burned electrodes, or heavy deposits. Repair or replace as necessary.
- Visually check distributor cap inside and out for moisture, dust, cracks, burns, and arcing to coil mounting screws.
- Try to turn distributor shaft by hand. Drive pin may be broken.
- Very cold temperatures:
 - Check that the proper viscosity oil is being used, and crank case oil is not contaminated with gasoline.

HARD START — COLD

Definition: Engine cranks OK, but does not start for a long time. Does eventually run. If the engine starts but immediately dies (as soon as key is released from start position), see "No Start, Engine Cranks OK" symptom.

- Make sure driver is using correct starting procedure. See Owner's Manual.
- Visual check:
 - Vacuum hoses for splits, kinks and proper connections, as shown on Vehicle Emission Control Information label.
 - Air leaks at carburetor mounting and intake manifold.
 - Ignition wires for cracking, hardness, and proper connections, at both the distributor cap and spark plugs.
 - Wiring for proper connections, pinches and cuts.
- Check the choke valve, throttle and fast idle cam for sticking. Replace any malfunctioning parts. If caused by foreign material and gum, clean with suitable non-oil base solvent. See Section 6C.
- Check choke and vacuum break operation and adjustment. Choke should be closed cold. See Section 6C.
- Check EGR system for sticky operation that could cause valve to stick open.
- Check float level using external float gage. Adjust float to specification if required. See Section 6C.
- Check carburetor fuel inlet filter. Replace if dirty or plugged.
- Check ignition system — see Section 6D. Check distributor for:
 - Worn shaft.
 - Bare and shorted wires.
 - Pick-up coil resistance and connections.
 - Loose ignition coil ground.
 - Moisture in distributor cap.
- Remove spark plugs; check for wet plugs, wear, improper gap, burned electrodes or heavy deposits. Repair or replace as necessary.
- Check ignition timing per Vehicle Emission Control Information label.
- Verify proper engine oil viscosity per recommendations in Maintenance Schedule.
- Check fuel pump volume, pressure and vacuum.

HARD START — HOT

Definition: Engine cranks OK, but does not start for a long time. Does eventually run. If the engine starts but immediately dies (as soon as key is released from start position), see Ignition System Diagnosis, Section 6D.

- Visual (physical) check:
 - Vacuum hoses for splits, kinks, and proper connections, as shown on Vehicle Emission Control Information label.
 - Ignition wires for cracking, hardness, and proper connections, at the distributor cap and spark plugs.
 - Wiring for proper connections, pinches and cuts.
- Make sure driver is using correct starting procedure. See Owner's Manual.
- Check choke valve, throttle linkage and fast idle cam for sticking.
- Check choke and vacuum break operation and adjustment. Choke should be open hot. See Section 6C.
- Check for carburetor flooding.
- Check fuel inlet filter. If plugged replace.
- Check float level using external float gage. Adjust float to proper specification if required. See Section 6C.
- Check fuel pump volume, pressure and vacuum.
- Check fuel line routing.
- Check EFE valve. EFE valve should be open.
- Check EGR for sticky operation that could cause valve to stick open.
- Check for obvious overheating problems:
 - Low coolant.
 - Loose water pump belt.
 - Restricted air flow to radiator, or restricted water flow through radiator.
- Check ignition system, Section 6D. Check distributor for:
 - Worn shaft.
 - Bare and shorted wires.
 - Intermittent pickup coil or connections, module, ignition coil ground and condenser. Repair or replace as necessary.
- Remove spark plugs. Check for cracks, wear, improper gap, burned electrodes, heavy deposits. Repair or replace as necessary.
- Check ignition timing. See Vehicle Emission Control Information label.

STALL AFTER START — COLD

Definition: Engine at room or outside temperature, within three minutes after start. (1) Stalls after brief idle; (2) dies as soon as any load is placed on engine (such as A/C turned "ON" or transmission engaged); or (3) Dies on initial driveaway.

If symptom is present cold and hot, go to symptom "Stall After Start — Hot."

- Visual (physical) check:
 - Vacuum hoses for splits, kinks and proper connections, as shown on Vehicle Emission Control Information label.
 - Make sure hot air tube is connected to air cleaner.
 - Check proper operation of THERMAC.
 - Check carburetor choke valve, throttle linkage and fast idle cam for sticking.
 - With engine running, visually check vacuum break linkage for movement while removing and re-installing vacuum hoses to vacuum breaks. If the linkage does not move and vacuum is at hose, check for binding linkage. If linkage OK, replace vacuum break unit.
- With engine "OFF," check all choke adjustments, including vacuum breaks and TVS if used. See Section 6C.
- Check fast idle speed setting and curb idle speed.
- Check carburetor accelerator pump operation.
- Check EFE valve for proper operation. EFE valve should be closed cold. See Chart C-9C.
- Check EGR valve for proper operation. See Chart C-7C.
- Check engine timing. See Vehicle Emission Control Information label.
- Poor or contaminated gasoline. Suggest owner try different brand.

STALL AFTER START — HOT

Definition: The engine starts OK, but (1) dies after brief idle; (2) dies as soon as any load is placed on engine (such as A/C turned "ON" or transmission engaged); (3) dies on initial driveaway.

- Visual (physical) check:
 - Vacuum hoses for splits, kinks and proper connections, as shown on Vehicle Emission Control Information label.
 - Make sure hot air tube is connected to air cleaner.
 - Check proper operation of THERMAC.
 - Check carburetor choke and vacuum breaks for proper operation. See Section 6C for check procedure.
 - Check float level using external float gage. See Section 6C.
- Check carburetor accelerator pump operation.
- Check EGR valve for proper operation — Chart C-7C.
- Check for overcharged A/C System.
- Check for obvious overheating problems:
 - Low coolant.
 - Loose water pump belt.
 - Restricted air flow to radiator or restricted water flow through radiator.

HESITATION/SAG, STUMBLE

Definition: Momentary lack of response as the accelerator is pushed down. Can occur at all vehicle speeds. Usually most severe when first trying to make vehicle move, as from a stop sign. May cause the engine to stall if severe enough.

- Visual (physical) check:
 - Vacuum hoses for splits, kinks and proper connections, as shown on Vehicle Emission Control Information label.
 - Ignition wires for cracking, hardness, and proper connections, at both distributor and spark plugs.
 - Wiring for proper connections, pinches and cuts.
- Make sure hot air tube is connected to air cleaner.
- Check proper operation of THERMAC. See diagnosis of THERMAC.
- Note: Cold engine only — check the following for sticking or faulty operation:
 - Carburetor choke, including vacuum breaks, throttle linkage and fast idle cam.
 - Check all choke adjustments, including vacuum breaks.
- Check float level using external float gage. See Section 6C.
- Check carburetor accelerator pump operation.
- Check EGR valve operation — Chart C-7C.
- Check canister purge system for proper operation. See Evaporative Emission Control System Diagnosis.
- Check for open ignition coil ground and for intermittent ECM ground.
- Check engine timing. See Vehicle Emission Control Information label.
- Poor or contaminated gasoline. Try a different brand of gasoline.

SURGES AND/OR CHUGGLE

Definition: Engine power variation under steady throttle or cruise. Feels like the car speeds up and slows down with no change in the accelerator pedal.

- Visual (physical) check:
 - Vacuum hoses for splits, kinks and proper connections, as shown on Vehicle Emission Control Information label.
 - Ignition wires for cracking, hardness, and proper connections, at both distributor and spark plugs.
 - Wiring for proper connections, pinches and cuts.
- Have driver read explanation of transmission converter clutch and A/C compressor operation in Owner's Manual.
- Make sure hot air tube is connected to air cleaner.
- Check proper operation of THERMAC. See diagnosis of THERMAC.
- Check for intermittent open, or short to ground in TCC circuit.
- Check for proper operation of EGR. See Chart C-7C.
- Check carburetor fuel inlet filter, replace if dirty or plugged.
- Check carburetor float level using external float gage. See Section 6C.
- Test fuel pump capacity. See Section 6C.
- Remove spark plugs, check for cracks, wear, improper gap, burned electrodes or heavy deposits.
- Check condition of distributor cap, rotor and spark plug wires.
- Check for arcing to coil attaching screws in distributor cap.
- Check for intermittent ground connection on integral ignition coil.
- Poor or contaminated gasoline. Try a different brand of gasoline.

LACK OF POWER, SLUGGISH OR SPONGY

Definition: Engine delivers less than expected power, little or no increase in speed when accelerator pedal is pushed down part way.

- Visual check:
 - Vacuum hoses for splits, kinks and proper connections, as shown on Vehicle Emission Control Information label.
 - Ignition wires for cracking, harness, and proper connections, at both the distributor cap and spark plugs.
 - Wiring for proper connections, pinches and cuts.
- Compare customer's vehicle to similar unit. Make sure the customer's vehicle has an actual problem. Was the customer's old vehicle much more powerful?
- Make sure hot air tube is connected to air cleaner.
- Remove air cleaner and check air filter for dirt.
- Check for proper operation of THERMAC. See diagnosis of THERMAC.
- Check for full throttle valve opening in carburetor by depressing accelerator pedal to floor.
- Check carburetor float level using external float gage.
- Check for proper operation of carburetor air valve. See Section 6C.
- Check ignition timing. See Vehicle Emission Control Information label.
- Check transmission for proper downshift and TCC operation.
- Check EGR operation. See Chart C-7C.
- Check EFE Valve.
- Remove spark plugs. Check for cracks, wear, improper gap, burned electrodes, heavy deposits. Repair or replace as necessary.
- Check for an exhaust system restriction:
 1. With engine at normal operating temperature, connect a vacuum gage to any convenient vacuum port on intake manifold.
 2. Run engine at 1000 rpm and record vacuum reading.
 3. Increase rpm slowly to 2500 rpm. Note vacuum reading at steady 2500 rpm.
 4. If vacuum at steady 2500 rpm is more than 3 inches lower than 1000 rpm, exhaust system should be inspected for restrictions. See Chart B-1.
- Check engine valve timing and compression.
- Check engine for proper or worn camshaft, see Section 6A.
- Poor or contaminated fuel. Try a different brand of gasoline.

BACKFIRE

Definition: Fuel ignites in intake manifold, or exhaust system, making a loud popping noise.

- Visual check:
 - Vacuum hoses for splits, kinks and proper connections, as shown on Vehicle Emission Control Information label.
 - Ignition wires for cracking or hardness proper connection, at both the distributor cap and spark plugs.
 - Chaffed wiring harness by pulleys or metal edges.
- Make sure hot air tube is connected to air cleaner.
- Check proper operation of THERMAC. See diagnosis of THERMAC.
- Note: Cold engine only — check the following for sticking or faulty operation:
 - Carburetor choke, including vacuum break and throttle linkage.
- Check EFE Valve.
- Check carburetor accelerator pump operation.
- Check for proper operation of EGR valve.
- Perform a compression check — look for sticking or leaking valves.
- Check for restricted exhaust system. See Chart B-1.
- Check output voltage of ignition coil. See Ignition System Diagnosis, Section 6D.
- Check operation of decel (gulp) valve if so equipped.
- Check for crossfire between spark plugs, distributor cap, spark plug wires and proper routing of plug wires. Wires for cylinders which fire in sequence on the same side of the engine should not be routed next to each other; i.e., 8 and 4, and 5 and 7. See Section 6D.
- Check for intermittent condition in ignition system.
 - Pick-up coil.
 - Ignition coil ground on integral coil.
 - Ignition coil primary connections.
- Check for proper valve timing.

MISSES (CUTS OUT)

Definition: Pulsation or jerking that follows engine speed, usually more pronounced as engine load increases. The exhaust may have a steady spitting sound at idle or low speed. Not normally felt above 1500 rpm or 30 rpm (48 km/h).

- Visual (physical) check:
 - Vacuum hoses for splits, kinks and proper connections, as shown on Vehicle Emission Control Information label.
 - Ignition wires for cracking, hardness and proper connections at both distributor cap and spark plugs.
 - Wiring for proper connections, pinches and cuts.
- Check spark plug wire routing for correct firing order.
- Check for misfiring at spark plugs:
 1. Disconnect and plug air cleaner and EGR vacuum hoses.
 2. Check spark at all plug wires with J26792 (ST-125).
 - If there is no spark on any cylinder, see "Ignition System Diagnosis," Section 6D.
 - Spark at all cylinders.
- Visually check distributor cap inside and out for moisture, dust, cracks, burns and check for coil arcing to mounting screws. With engine running, spray cap and plug wires with fine water mist to check for shorts.
- Check for poor ground on integral ignition coil.
- Check EGR valve for sticking partially open.
- Remove spark plugs and check for cracks, wear, improper cap, burned electrodes and heavy deposits.
- Check pickup coil in distributor with ohmmeter, and check for proper connections at module. Pickup coil should be 500–1500 ohms and not grounded. See Sec. 6D.
 - If pickup coil checks OK,
 - Check for ignition dwell increase from low to high rpm by connecting dwell meter to distributor "TACH" terminal. If dwell doesn't increase, replace ECM.
- Remove rocker covers, check for bent pushrods, worn rocker arms, broken valve springs, worn camshaft lobes. Repair as necessary. See Section 6A.

ROUGH, UNSTABLE OR INCORRECT IDLE; STALLING

Definition: The engine runs unevenly at idle. If bad enough, the car may shake. Also, the idle speed may vary (called "hunting"). Either condition may be bad enough to cause stalling. Engine idles at incorrect speed.

- Visual (physical) check:
 - Vacuum hoses for splits, kinks and proper connections as shown on Vehicle Emission Control Information label.
 - Ignition wires for cracking, hardness, or proper connections, at both distributor cap and spark plugs.
- Check throttle linkage for sticking or binding.
- Check carburetor for flooding.
- Check float level using external float gage. See Section 6C.
- Check engine idle speed. See Vehicle Emission Control Information label.
- Check EGR System. See Chart C-7C. There should be no EGR at idle.
- If rough idle occurs hot, perform these additional checks:
 - Check PCV valve for proper operation by placing finger over inlet hole in valve end several times. Valve should snap back. If not, replace valve.
 - Check canister purge and bowl vent control system. See Evaporative Emission Control System Diagnosis.
 - Remove carbon with top engine cleaner. Follow instructions on can.
 - Check for proper spark plug gap.
 - Run a cylinder compression check. See Section 6.
- Check ignition timing. See Vehicle Emission Control Information label.
- Check for exhaust system restriction. See Chart B-1.

WON'T IDLE

Definition: Engine starts OK, but dies at idle. Will run if accelerator pedal is held at part throttle.

- Visual (physical) check:
 - Vacuum hoses for splits, kinks and proper connections as shown on Vehicle Emission Control Information label.
 - Air leaks at carburetor mounting and intake manifold.
- Check carburetor float level using external float gage. See Section 6C.
- Check for carburetor flooding. See Section 6C.
- Check EGR system. See Chart C-7C. Check for a loose valve or sticking EGR plunger. If sticking operation is found, clean or replace valve. There should be no EGR at idle. It may be necessary to remove the valve to check for leaking.
- Check engine idle speed. See Vehicle Emission Control Information label.
- Check carburetor idle adjustment. If unable to adjust, check carburetor idle system. See Section 6C.
- Check spark plug condition and gap.
- Check for exhaust system restriction. See Chart B1.

POOR FUEL ECONOMY

Definition: Fuel economy, as measured by an actual road test, is noticeably lower than expected. Also, economy is noticeably lower than it was on this car at one time, as previously shown by an actual road test.

- Check owner's driving habits.
 - Is A/C on full time (defroster mode on)?
 - Are tires at correct pressure?
 - Are excessively heavy loads being carried?
 - Is acceleration too much, too often?
 - Suggest driver read "Important Facts on Fuel Economy" in Owner's Manual.
- Check air cleaner damper door operation (THERMAC).
- Check air cleaner element (filter) for dirt or being plugged.
- Check for proper calibration of speedometer.
- Visual check:
 - Vacuum hoses for splits, kinks and proper connections as shown on Vehicle Emission Control Information label.
 - Ignition wires for cracking, hardness and proper connections.
- Check ignition timing. See Vehicle Emission Control Information label.
- Remove spark plugs. Check for cracks, wear, improper gap, burned electrodes or heavy deposits. Repair or replace as necessary.
- Check compression. See Section 6A.
- Check TCC for proper operation.
- Check for dragging brakes.
- Suggest owner fill fuel tank and recheck fuel economy.
- Check for exhaust system restriction. See Chart B-1.

DIESELING, RUN-ON

Definition: Engine continues to run after key is turned "OFF," but runs very roughly. If engine runs smoothly, check ignition switch and adjustment.

- Visual check:
 - Vacuum hoses for splits, kinks and proper connections as shown on Vehicle Emission Control Information label.
 - Carburetor choke, throttle linkage and fast idle cam for sticking.
- Check carburetor choke, vacuum break linkage, throttle linkage and fast idle cam for proper adjustment. See Section 6C.
- Check cruise control for proper adjustment.
- Check engine idle speed.
- Check ignition timing. See Vehicle Emission Control Information label.
- Remove carbon with top engine cleaner. Follow instructions on can.
- Check for engine overheating. Normal coolant temperature is 85°C–100°C (185°F–215°F).
 - Low coolant.
 - Loose water pump belt.
 - Restricted air flow to radiator, or restricted water flow through radiator.
 - Inoperative fan clutch.

DETONATION/SPARK KNOCK

Definition: A mild to severe ping, usually worse under acceleration. The engine makes sharp metallic knocks that change with throttle opening. Sounds like popcorn popping.

- Check EGR System for proper operation. See Chart C-7C.
- Check ignition timing. See Vehicle Emission Control Information label.
- Check for obvious overheating problems. 85°C–100°C (185°C–215°F) is normal.
 - Low coolant.
 - Loose water pump belt.
 - Restricted air flow to radiator, or restricted water flow through radiator.
 - Inoperative fan clutch.
- Check for air leaks at carburetor mounting and intake manifold.
- Check for poor fuel quality, proper octane rating.
- Remove carbon with top engine cleaner. Follow instructions on can.
- If excessive carbon in cylinders, check for leaking valve seals.
- Check for improper operation of transmission (i.e., linkage adjustment) and TCC.
- Check for incorrect basic engine parts, such as cam, heads, pistons, etc.

EXCESSIVE EXHAUST EMISSIONS (ODORS)

Definition: Car fails an emission test. May also have excessive "rotten egg" smell (hydrogen sulfide).

- If test shows excessive CO and HC (also has excessive odors):
 - Check items which cause car to run rich.
 - Make sure engine is at normal operating temperature.
 - Visually check hoses for splits, kinks and proper connections, as shown on Vehicle Emission Control Information label.
 - Remove air cleaner and check air filter for dirt or being plugged. Replace as necessary.
 - Check for misadjusted idle mixture if plugs are removed.
 - Check choke valve and linkage for sticking of faulty operation.
 - Check choke, vacuum breaks and fast idle adjustments.
 - Check for stuck PCV valve or obstructed hose.
 - Check for lead contamination of catalytic converter. Check for absence of filler neck restrictor.
 - Check operation of air management system. See appropriate C-6HD Chart in Air Injection Reaction section.
 - Check carburetor for flooding.
 - Check float level using external float gage. See Section 6C.
 - Check canister for loading and check purge system for proper operation. See Evaporative Emission Control System Diagnosis.
 - Check for incorrect idle speed.
 - Check for incorrect timing. See Vehicle Emission Control Information label.
 - Check condition of spark plugs, plug wires and distributor cap.
- If test shows excessive NOx:
 - Check items which cause vehicle to run lean, or to run too hot.
 - Check EGR valve for not opening. See Chart C-7C in Section C.
 - Check for vacuum leaks.
 - Check for inoperative THERMAC.

- Check coolant system and cooling fan for proper operation.
- Remove carbon with top engine cleaner. Follow instructions on can.
- Check ignition timing for excessive base advance. See Vehicle Emission Control Information label.

Proper diagnosis for a restricted exhaust system is essential before any components are replaced. The following diagnostic procedure is recommended:

1. Remove the rubber hose at the exhaust manifold A.I.R. pipe check valve. Remove check valve.
2. Connect a fuel pump pressure gage to a hose and nipple from a Propane Enrichment Device (J26911) (see illustration).
3. Insert the nipple into the exhaust manifold A.I.R. pipe.
4. With the engine at normal operating temperature and running at 2500 rpm, observe the exhaust system backpressure reading on the gage.
5. If the backpressure exceeds 2 3/4 psi, 19 kPa a restricted exhaust system is indicated.
6. Inspect the entire exhaust system for a collapsed pipe, heat distress, or possible internal muffler failure.
7. If there are no obvious reasons for the excessive backpressure, a restricted catalytic converter should be suspected, and replaced using current recommended procedures.

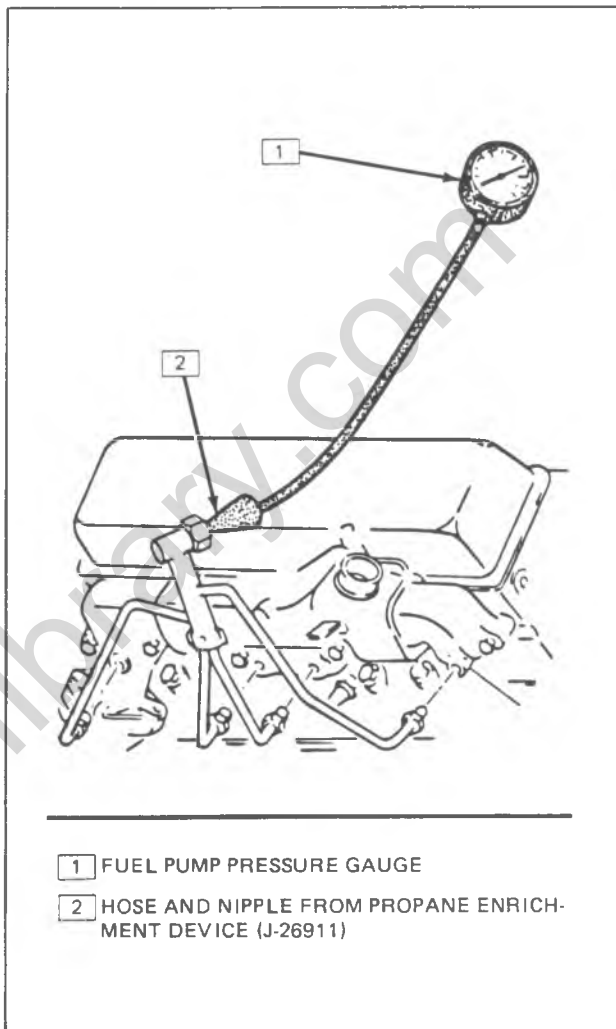

4S-1168

Chart B-1—Restricted Exhaust System Check

EVAPORATIVE EMISSION CONTROL SYSTEM (EECS)

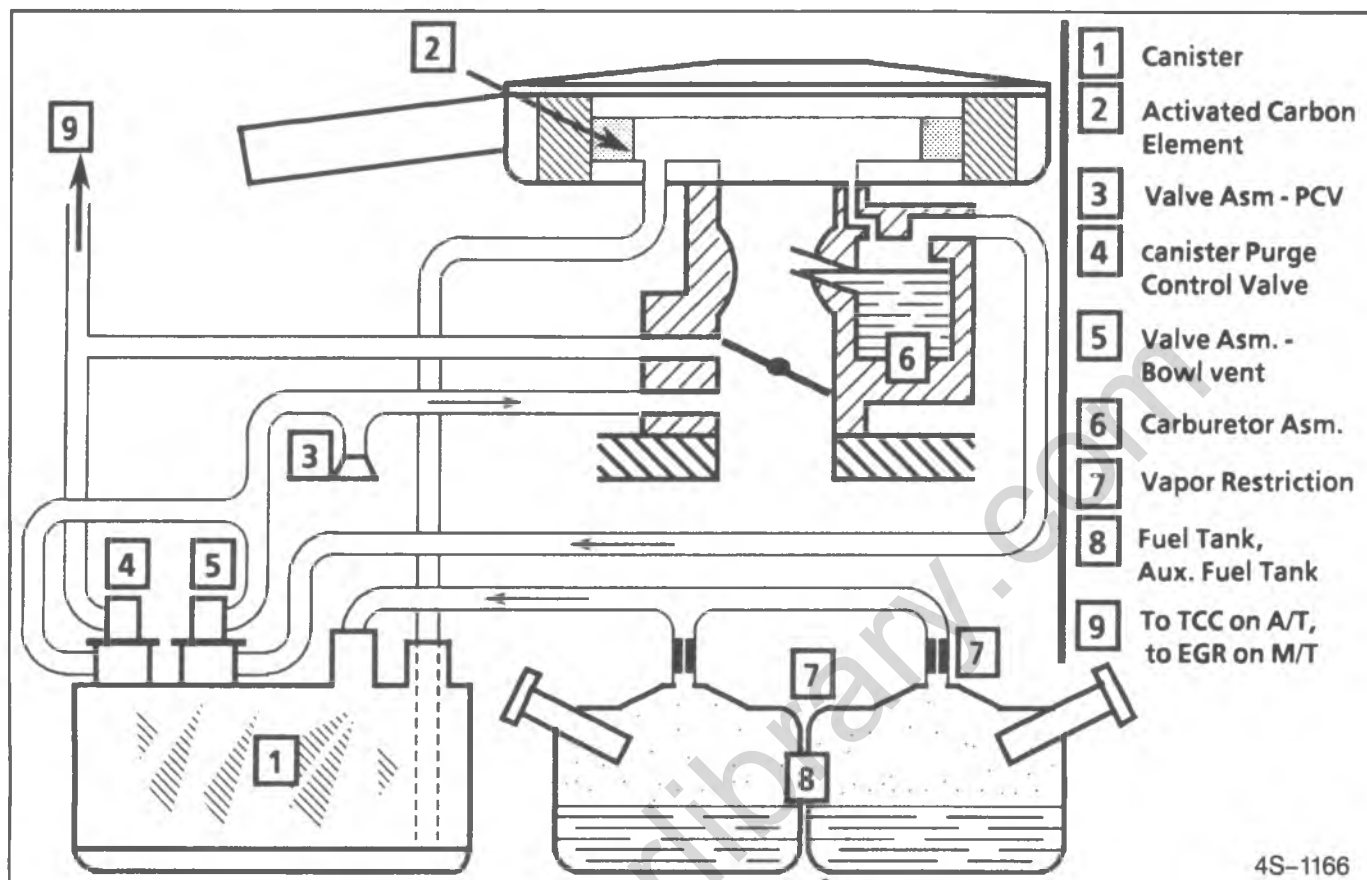

Figure 5—Evaporative Emissions System

GENERAL DESCRIPTION

PURPOSE

The Evaporative Emission Control System (EECS) (Figure 5) limits fuel vapor into the atmosphere. The system traps fuel vapor from the fuel tank and carburetor float bowl into a fuel vapor canister. The fuel tank has a non-vented fuel cap and a single vent pipe to the canister. The canister absorbs and stores the fuel vapor in a carbon element until it can be removed and burned during the normal combustion process. When the engine is running, a thermostatic vacuum switch determines when the fuel vapor is purged into the intake air flow.

OPERATION (Figure 5)

This system uses the following control valves:

- Purge control valve mounted on the canister.
- Vapor vent valve mounted on the canister.
- A thermal bowl vent valve (some applications).
- A thermostatic vacuum switch (TVS) installed in the intake manifold to sense engine coolant temperature.

When the engine is shut off, manifold vacuum is lost at the vapor vent valve. The spring loaded valve in the vapor vent valve now connects the carburetor bowl vent to the canister. Carburetor float chamber vapors now pass into the canister for storage. When the engine is restarted, manifold vacuum draws the vapor vent controlling valve against spring pressure, closing off the bowl vent. Ported

vacuum from the carburetor is connected to the TVS. When the TVS opens, ported vacuum opens the purge control valve. When the valve opens, manifold vacuum draws vapors from the canister into the intake manifold.

The thermal bowl vent valve (TBVV) is located in the section of hose that connects the carburetor bowl vent fitting to the canister control valve.

The TBVV will close and prevent vapor movement at 32°C (90°F) and below. The TBVV will open at 49°C (120°F) to permit vapor flow to the canister control valve.

FUEL VAPOR CANISTER, PRIMARY (Figure 6)

The basic large size, two chamber closed bottom canister is used on all systems and operates as follows:

Gasoline vapors from the fuel tank flow into the tube labeled "Fuel Tank," and vapors from the carburetor float bowl flow into the tube labeled "CARB BOWL," and are absorbed by the carbon. The canister is purged when the engine is running above idle speed. The closed bottom design keeps water from entering the bottom of the canister, freezing, and restricting purge air flow. During purge, air is drawn from the clean side of the air cleaner, to the tube on the canister labeled "AIR CLNR," through the carbon and into the intake manifold to be burned. Some closed bottom canisters draw purge air directly from the atmosphere.

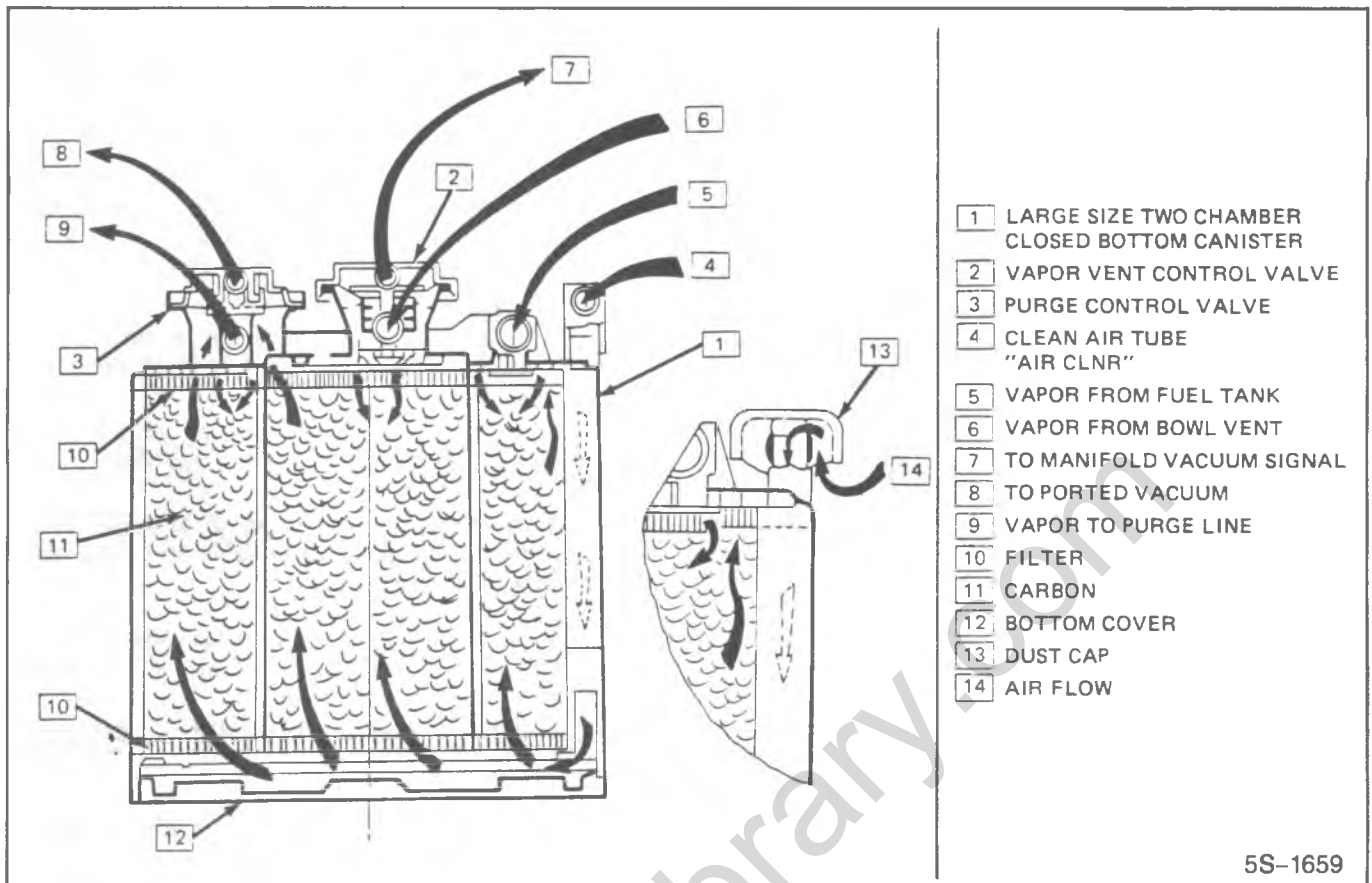

5S-1659

Figure 6—Fuel Vapor Canister

CANISTER PURGE CONTROL VALVE (Figure 6)

The Canister Purge Control Valve is a spring-biased diaphragm valve, normally closed, which allows or prevents purging of the canister. When the engine is off or idling, the spring holds the valve closed, preventing canister purge. When the engine is off-idle, however, timed manifold vacuum pulls the diaphragm upward, opening the valve and allowing the canister to be purged.

VAPOR VENT CONTROL VALVE (Figure 6)

The vapor vent control valve prevents venting of the carburetor float bowl during engine operation. A spring-biased diaphragm valve, normally open, allows (or prevents) fuel vapors from the float bowl to enter the canister. When the engine is off, spring tension holds the valve open, allowing normal venting.

When the engine is turned on, however, manifold vacuum pulls the diaphragm up to close the valve.

FUEL VAPOR CANISTER, AUXILIARY (Figure 7)

An Auxiliary Fuel Vapor Canister is added to a primary closed bottom canister to increase capacity when a dual (aux.) fuel tank is used. On the bottom is a hose which connects to the primary canister's purge air inlet. On top is a purge air inlet. Vapor overflowing from the primary canister is stored in the auxiliary canister. During purge, vapor flows through the auxiliary canister, the primary canister and into the intake manifold for burning during combustion.

DIAGNOSIS OF EECS

SYSTEM DIAGNOSIS

- Poor idle, stalling and poor driveability can be caused by:
 - Inoperative vapor vent valve.
 - Inoperative purge control valve.
 - Damaged canister.
 - Hoses split, cracked and, or, not connected to the proper tubes.

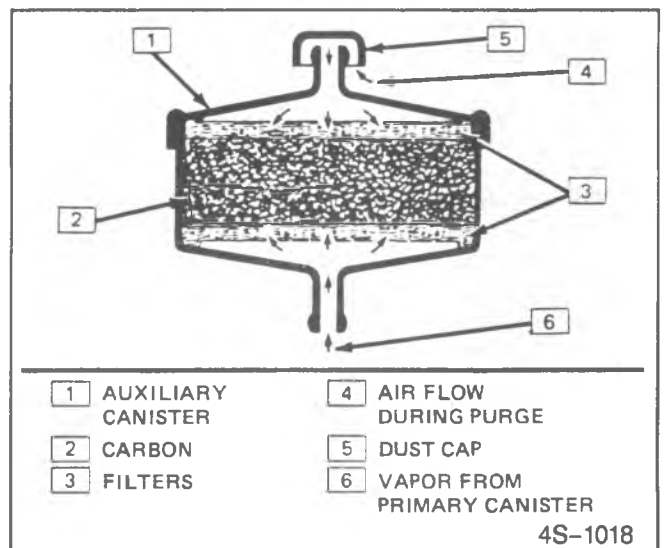

4S-1018

Figure 7—Auxiliary Vapor Canister

6E8-18 DRIVEABILITY AND EMISSIONS — CARBURETED

- Evidence of fuel loss or fuel vapor odor can be caused by:
 - Liquid fuel leaking from fuel lines, fuel pump or carburetor.
 - Cracked or damaged canister.
 - Inoperative bowl vapor vent valve.
 - Inoperative purge control valve.
 - Disconnected, misrouted, kinked, deteriorated or damaged vapor hoses, or control hoses.
 - Bowl vent hose misrouted.
 - Air cleaner or air cleaner gasket improperly seated.

FUEL VAPOR CANISTER

Visually check canister and replace if cracked, damaged or saturated with fuel. Apply a short length of hose to the carburetor bowl vapor tube of the canister (lower tube), and blow into it, to determine that air will pass the vapor vent valve into the canister. If not possible to blow into the canister, it must be replaced.

VAPOR VENT CONTROL VALVE

Functional Test

Apply a short length of hose to the carburetor bowl vapor tube of the canister (lower tube), and blow into it to determine that air will pass the vapor vent valve into the canister. If not possible to blow into the canister, it must be replaced.

With a hand vacuum pump, apply vacuum 51 kPa (15" Hg) to the vacuum signal tube on the diaphragm assembly cover. The diaphragm should hold vacuum for at least 20 seconds. If it does not, diaphragm is leaking, and the canister must be replaced.

With vacuum still applied to the vacuum signal tube, again attempt to blow into the carburetor bowl vapor tube of the canister. Now air should not pass the vapor vent valve into the canister, indicating that the valve is sealing properly. If air does enter the canister past the vapor vent valve, the valve is not functioning properly, and the canister must be replaced.

PURGE CONTROL VALVE

Functional Test

Apply a short length of hose to the PCV tube of purge valve assembly (lower tube), and attempt to blow through it. Little or no air should pass into the canister. (A small amount of air will pass if the canister has a constant purge hole.)

With a hand vacuum pump, apply vacuum 51 kPa (15" Hg) through the control vacuum signal tube to the purge valve diaphragm. If the diaphragm does not hold vacuum for at least 20 seconds, the diaphragm is leaking, and the canister must be replaced.

If the diaphragm holds vacuum, again try to blow through the hose connected to the PCV tube while vacuum is still being applied. An increased flow of air should be observed. If not, the canister must be replaced.

THERMOSTATIC VACUUM SWITCH (TVS) REPLACEMENT

Thermal vacuum switches opens, closes, or switches vacuum source when the calibration temperature is reached. The following general checking procedures can

be used for all thermal vacuum switches. Refer to number stamped on base of valve or switch for calibration temperature.

1. Allow TVS to cool below calibration temperature.
2. Inspect switch to make sure it is in good condition.
3. Connect hand vacuum pump(s) to output port(s) of the TVS. (See vacuum hose schematic on Vehicle Control Emission Information label.)
4. Apply 51 kPa (15" Hg) vacuum.
5. Heat TVS to a temperature above the calibration temperature. Never apply a torch or open flame directly to the TVS.
6. Compare vacuum gage reading to the correct reading indicated on switch or valve base.

NOTICE: Leakage of up to 7 kPa (2" Hg) vacuum in 2 minutes is allowable and does not mean a defective part.

7. If operation is satisfactory, reinstall valve or switch. If valve or switch is defective, replace with a new part.

ON-VEHICLE SERVICE — EECS

SYSTEM HOSES

Refer to Vehicle Emission Control Information label for routing of system hoses.

When replacing hoses, use hose identified with the word "Fluoroelastomer."

VAPOR PIPE

The vapor pipe is secured to the underbody with clamp and screw assemblies. Flexible hoses are connected at the fuel tank and the fuel vapor canister. The pipe should be inspected occasionally for leaks, kinks or dents and repaired as required.

Repair

Repair vapor pipe in sections using brazed seamless steel tubing meeting GM Specification 123M or its equivalent or hose identified with the word "Fluoroelastomer." Hose not so marked could cause early failure or failure to meet emission standard.

- Do not use copper or aluminum tubing to replace steel tubing. Those materials do not have satisfactory durability to withstand normal vehicle vibrations.
 - Do not use rubber hose within 4 inches (100 mm) of any part of the exhaust system or within 10 inches (254 mm) of the catalytic converter. Hose inside diameter must match steel tubing outside diameter.
1. In repairable areas, cut a piece of fuel hose 4 inches (100 mm) longer than portion of the line removed. If more than a 6-inch (152 mm) length of pipe is removed, use a combination of steel tubing and hose so that hose lengths will not be more than 10 inches (254 mm). Follow the same routing as the original pipe.
 2. Cut ends of pipe remaining on vehicle square with a tube cutter. Using the first step of a double flaring tool, form a bead on the end of both pipe sections. If pipe is too corroded to withstand bead operation

without damage, the pipe should be replaced. If a new section of pipe is used, form a bead on both ends of it also.

3. Use screw type hose clamp, Part Number 2494772, or equivalent. Slide clamps onto pipe and push hose 2 inches (51 mm) onto each portion of fuel pipe. Tighten clamps on each side of repair.
4. Pipes must be properly secured to the frame to prevent chafing.

FUEL CAP

If a fuel tank filler cap requires replacement, use only a cap with the same features. Failure to use the correct cap can result in a malfunction of the system.

CANISTER REPLACEMENT

1. Disconnect hoses from canister. Mark hoses for installation on new canister. Also refer to the Vehicle Emission Control Information label.
2. Remove screw from bracket and remove canister.
3. Install canister and bracket screw.
4. Connect hoses to canister.

AUXILIARY VAPOR CANISTER

Replacement

1. Disconnect hose from canister.
2. Remove screw from bracket and remove canister.
3. Install canister and connect hose.

THERMOSTATIC VACUUM SWITCH

1. Drain coolant below level of switch.
2. Disconnect vacuum hoses.
3. Remove switch.
4. Apply a soft setting sealant to the threads of thermostatic vacuum switch. Sealant should not be on the end of the switch.
5. Install switch, tighten to 14 N·m (120 in. lbs.) and then turn clockwise as required to align with hoses.
6. Connect hoses.
7. Add coolant as required.

PARTS INFORMATION

PART NAME.....	GROUP
Canister, Fuel Vapor	3,130
Solenoid, Fuel Vapor Canister	3,140

AIR INJECTION REACTION (AIR) SYSTEM

GENERAL DESCRIPTION

The heavy duty emission engines with vehicle weight over 8500 GVW have an AIR System with increased air flow. The system is used to reduce carbon monoxide (CO), and hydrocarbon (HC) emissions. The air injection reaction (AIR) system provides additional oxygen to continue the combustion process after the exhaust gases leave the combustion chamber. The system diverts air from the exhaust manifold at increased engine speed or when an electrical malfunction is detected in the system.

The system used on a 4.8 L engine consists of an air pump, air filter, air control valve, check valve, silencer, air temperature switch, control module, and necessary plumbing.

The system used on a 5.7 L or 7.4 L engine consists of two AIR pumps, an air filter, two air control valves, two check valves, a control module and necessary plumbing. The 7.4 L engine also uses a control relay to operate the "SERVICE ENGINE SOON" light.

AIR OPERATION

- The air pump(s) is belt driven on the front of the engine and supplies the air to the system.
- Intake air passes through an external air filter to the air pump(s).
- Air flow from the pump(s) passes through a control valve(s) and an AIR pipe(s) and into the exhaust manifold.
- The check valve prevents back flow of exhaust into the pump in the event of an exhaust backfire or pump drive belt failure.

AIR CONTROL VALVE (HFEAC) (Figure 8)

This valve is a high flow electric air control (HFEAC) valve that has an electric solenoid to combine electronic control with normal diverter valve function.

With ignition "ON," the solenoid is energized through the control module and the air control valve operates like a standardized diverter valve. With the solenoid energized, air is directed to the exhaust manifold. During an engine decel, when there is a rise in the manifold vacuum signal, air is directed to the air cleaner or silencer even though the solenoid is energized. The solenoid is de-energized when there is high engine speed over a prolonged period or a malfunction of the electrical circuit.

"SERVICE ENGINE SOON" LIGHT

If there is a malfunction in the control module, wiring harness or solenoid(s), an amber "SERVICE ENGINE SOON" light will illuminate on the instrument panel. The "SERVICE ENGINE SOON" light is "ON" with the ignition key "ON" and the engine not running as a bulb check (except 7.4 L). When the engine is started, the light will remain on for three to six seconds and then turn off. On a 7.4 L system, with ignition "ON" and the engine not running, the "SERVICE ENGINE SOON" light will come "ON" and stay "ON" for 1-2 seconds and then go "OFF" as a bulb check.

DECELERATION CONTROL (Figure 9)

To help prevent backfiring during high vacuum conditions a deceleration (gulp) valve is used with these AIR systems. The high vacuum draws the deceleration valve diaphragm down and opens the valve allowing air from the air cleaner to flow into the intake manifold. This air enters the air/fuel mixture to lean the rich condition created by high vacuum when the throttle valve closes on deceleration.

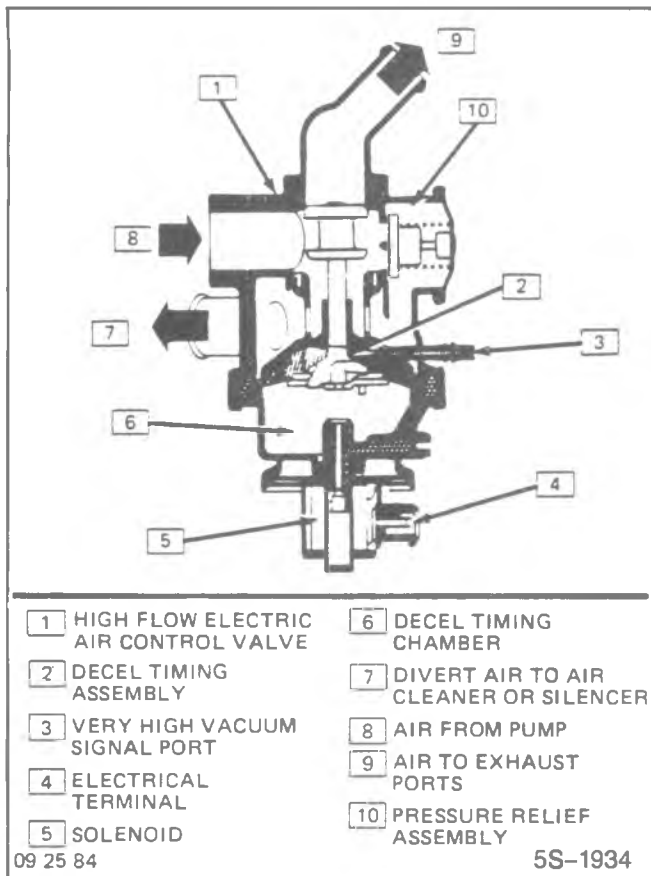

Figure 8—Air Control Valve

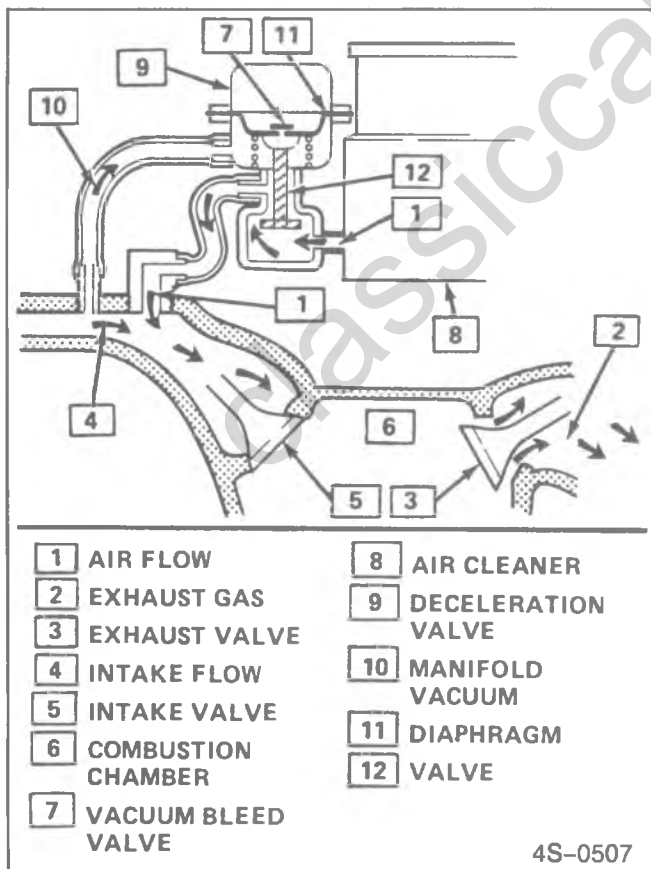

Figure 9—Deceleration Control

The vacuum draws the deceleration valve diaphragm down and opens the valve allowing air from the air cleaner to flow into the intake manifold.

DIAGNOSIS OF AIR

AIR SYSTEM

NOTICE: If the engine or under hood compartment is to be cleaned with steam or high-pressure detergent, the intake air filter should be masked off to prevent liquids from entering the pump.

The AIR System is not completely noiseless. Under normal conditions, noise rises in pitch as engine speed increases. To determine if excessive noise is the fault of the Air Injection Reactor System, operate the engine with the pump drive belt removed. If excessive noise does not exist with the belt removed, check for the following:

- A seized air pump.
- Improper mounting and bolt torque of pump.
- Improper routing and connections of hoses.

CAUTION: Do not oil air pump.

- Replace pump if none of the above conditions exist.

“SERVICE ENGINE SOON” LIGHT

If the “SERVICE ENGINE SOON” light is on with the engine running, refer to the proper C-6HD Chart for diagnosis.

AIR PUMP

The air pump is permanently lubricated and requires no periodic maintenance.

Accelerate engine and observe air flow from hose(s). If air flow increases as engine is accelerated, pump is operating satisfactorily. If air flow does not increase or is not present, proceed as follows:

Inspect

1. For proper drive belt tension.
2. For a leaky pressure relief valve. Air may be heard leaking with the pump running.

AIR CONTROL VALVE

Air pump should be working properly. Disconnect solenoid connector at valve. With ignition “ON,” check for 12 volts at the connector. If there is no voltage, refer to the proper C-6HD Chart for diagnosis. Start engine. Air should go to the air cleaner or silencer. Connect the solenoid connector and air should go to the exhaust ports. Check for manifold vacuum signal at valve with engine idling. Vacuum should be 10” Hg (34 kPa). During decel and high vacuum signal, air should go to the air cleaner and silencer. Replace valve if any of the conditions are not correct.

CHECK VALVE

Inspect

1. A check valve should be inspected whenever the hose is disconnected from a check valve or whenever check valve failure is suspected. (A pump

that had become inoperative and had shown indications of having exhaust gases in the pump would indicate check valve failure).

2. Blow through the check valve (toward the cylinder head), then attempt to suck back through the check valve. Flow should only be in one direction (toward the exhaust manifold). Replace valve which does not operate properly.

HOSE AND PIPES



Inspect

1. Hose or pipe for deterioration or holes.
2. All hoses or pipe connections, and clamp tightness.
3. Hose or pipe routing. Interference may cause wear.
4. If a leak is suspected on the pressure side of the system or if a hose or pipe has been disconnected on the pressure side, the connections should be checked for leaks with a soapy water solution. With the pump running, bubbles will form if a leak exists.

CONTROL MODULE

Refer to the proper C-6HD Chart for diagnosis of the control module.

DECELERATION VALVE

1. Remove air cleaner, plug air cleaner vacuum source and connect tachometer.
2. With the engine running at specified idle speed, remove the small deceleration valve signal hose from the manifold vacuum source.
3. Reconnect the signal hose and listen for air flow through the ventilation pipe and into the deceleration valve. There should also be a noticeable speed drop when the signal hose is reconnected.
4. If the air flow does not continue for at least one second or the engine speed does not drop noticeably, check the deceleration valve hoses for restrictions or leaks.
5. If no restrictions or leaks are found, replace the deceleration valve.

ON-VEHICLE SERVICE — AIR

AIR WIRING DIAGRAM

Refer to the proper C-6HD Chart for the wiring diagram.

DRIVE BELT

Inspect the drive belt for wear, cracks or deterioration and replace if required. When installing new belt, it must be seated and fully secured in grooves of A/C compressor, AIR pump, generator, and crankshaft pulleys.

AIR INJECTION PUMP (Figures 10 through 13)



Remove or Disconnect

1. Hold pump pulley from turning by compressing drive belt, then loosen pump pulley bolts.
2. Loosen bolt, holding pump to mounting brackets, release tension on drive belts. Remove belt from pulley.
3. Disconnect hoses at rear of pump.

4. Disconnect vacuum and electrical connections if control valve is attached to the pump.
5. Remove pump pulley.
6. Remove pump.
7. Remove control valve if attached.



Install or Connect

1. Install pump with control valve if attached.
2. Connect vacuum and electrical connections if control valve is attached to pump.
3. Connect hoses at rear of pump.
4. Install pump pulley bolts and tighten equally to 15 N·m (10 ft. lbs.). Tighten again within 10 minutes to 15 N·m (10 ft. lbs.) using a click wrench, port-a-torque or other equivalent tool.
6. Install pump drive belt and adjust tension.

AIR CONTROL VALVE (Figures 10 through 13)



Remove or Disconnect

1. Electrical connector from solenoid.
2. Air outlet hoses from valve.
3. Manifold vacuum hose.
4. Air control valve, gaskets and adapter.



Install or Connect

1. Gaskets, adapter and air control valve.
2. Manifold vacuum hose.
3. Air outlet hoses to valve with clamps.
4. Electrical connector to solenoid.

CHECK VALVE (Figures 10 through 13)



Remove or Disconnect

1. Any parts required for access to valve.
2. Release clamp and disconnect air hoses from check valve.
3. Valve from bracket.
4. Unscrew check valve from air injection pipe.



Install or Connect

1. Screw check valve onto air injection pipe.
2. Valve to bracket.
3. Position air hose on check valve and secure with clamp.
4. Any parts removed for access.

AIR INJECTION PIPE ASSEMBLY (Figures 10 through 13)



Remove or Disconnect

1. Hose from check valve.
2. Check valve.
3. Nuts attaching pipes-to-manifold.
4. Pipe assembly.



Install or Connect

1. Nuts attaching pipes-to-manifold.
2. Check valve.
3. Hose to check valve with clamp.

6E8-22 DRIVEABILITY AND EMISSIONS — CARBURETED

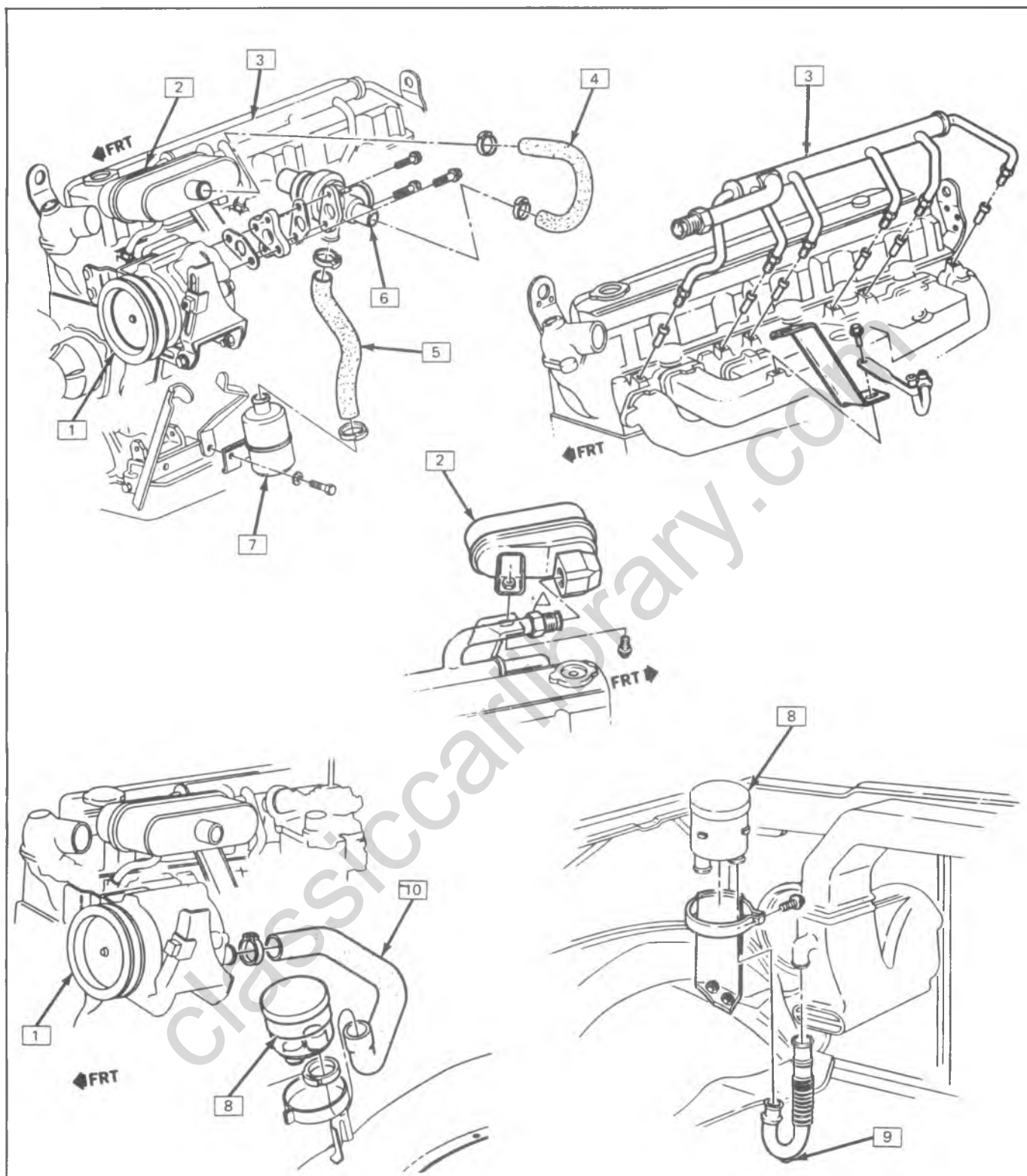

- | | |
|---|--|
| <p>1 A.I.R. PUMP—TIGHTEN MOUNTING SCREWS TO 25 N·m (18 FT. LBS.)</p> <p>2 CHECK VALVE—TIGHTEN NUT TO 35 N·m (26 FT. LBS.)</p> <p>3 AIR INJECTION PIPE—TIGHTEN NUTS TO 28 N·m (20 FT. LBS.)</p> <p>4 HOSE—AIR CONTROL VALVE TO CHECK VALVE</p> | <p>5 HOSE—SILENCER TO AIR CONTROL VALVE</p> <p>6 HIGH FLOW ELECTRIC AIR CONTROL VALVE—TIGHTEN ATTACHING BOLTS TO 10 N·m (94 IN. LBS.)</p> <p>7 SILENCER</p> <p>8 FILTER</p> <p>9 DUCT (DRAIN HOLE MUST POINT DOWNWARD)</p> <p>10 HOSE—FILTER TO PUMP</p> |
|---|--|

5S-1958

Figure 10—AIR System — 4.8 L Engine

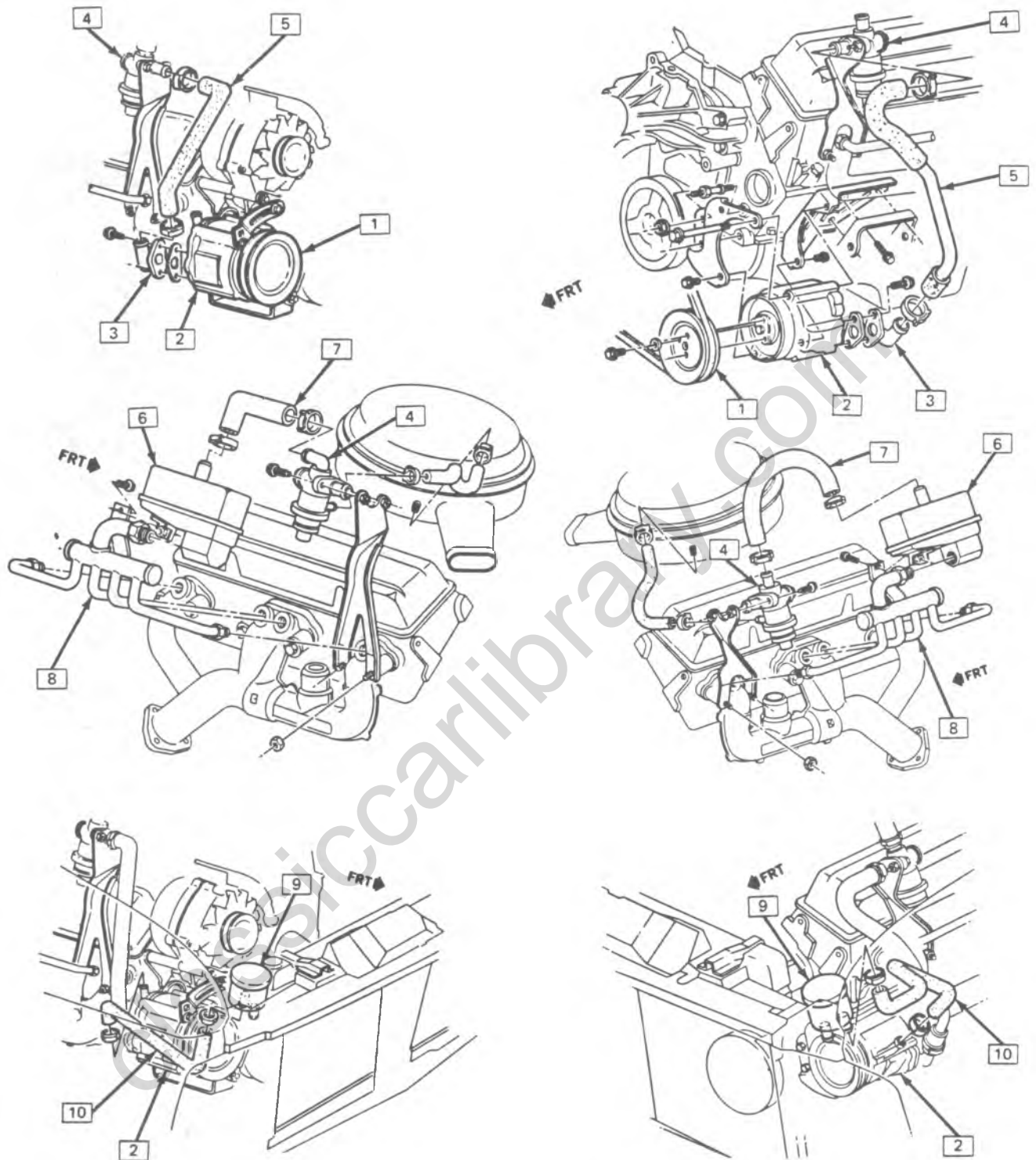

- 1 PULLEY—TIGHTEN SCREWS TO 15 N·m (10 FT. LBS.).
TIGHTEN AGAIN WITHIN 10 MINUTES TO 15 N·m
(10 FT. LBS.).
- 2 A.I.R. PUMP—TIGHTEN MOUNTING
SCREWS TO 25N·m (18FT.LBS).
- 3 ADAPTER—TIGHTEN SCREWS TO 25 N·m
(18 FT. LBS.)
- 4 AIR CONTROL VALVE—TIGHTEN SCREWS TO
25 N·m (18 FT. LBS.)

- 5 HOSE—PUMP TO AIR CONTROL VALVE
- 6 CHECK VALVE—TIGHTEN NUT TO 35 N·m
(26 FT. LBS.)
- 7 HOSE—AIR CONTROL VALVE TO CHECK VALVE
- 8 AIR INJECTION PIPE—TIGHTEN NUTS TO 28 N·m
(20 FT. LBS.)
- 9 FILTER—DRAIN HOLE IN INLET HOSE MUST
POINT DOWNWARD
- 10 HOSE—FILTER TO PUMP

5S-1960

Figure 11—AIR System — 5.7 L (G)

6E8-24 DRIVEABILITY AND EMISSIONS — CARBURETED

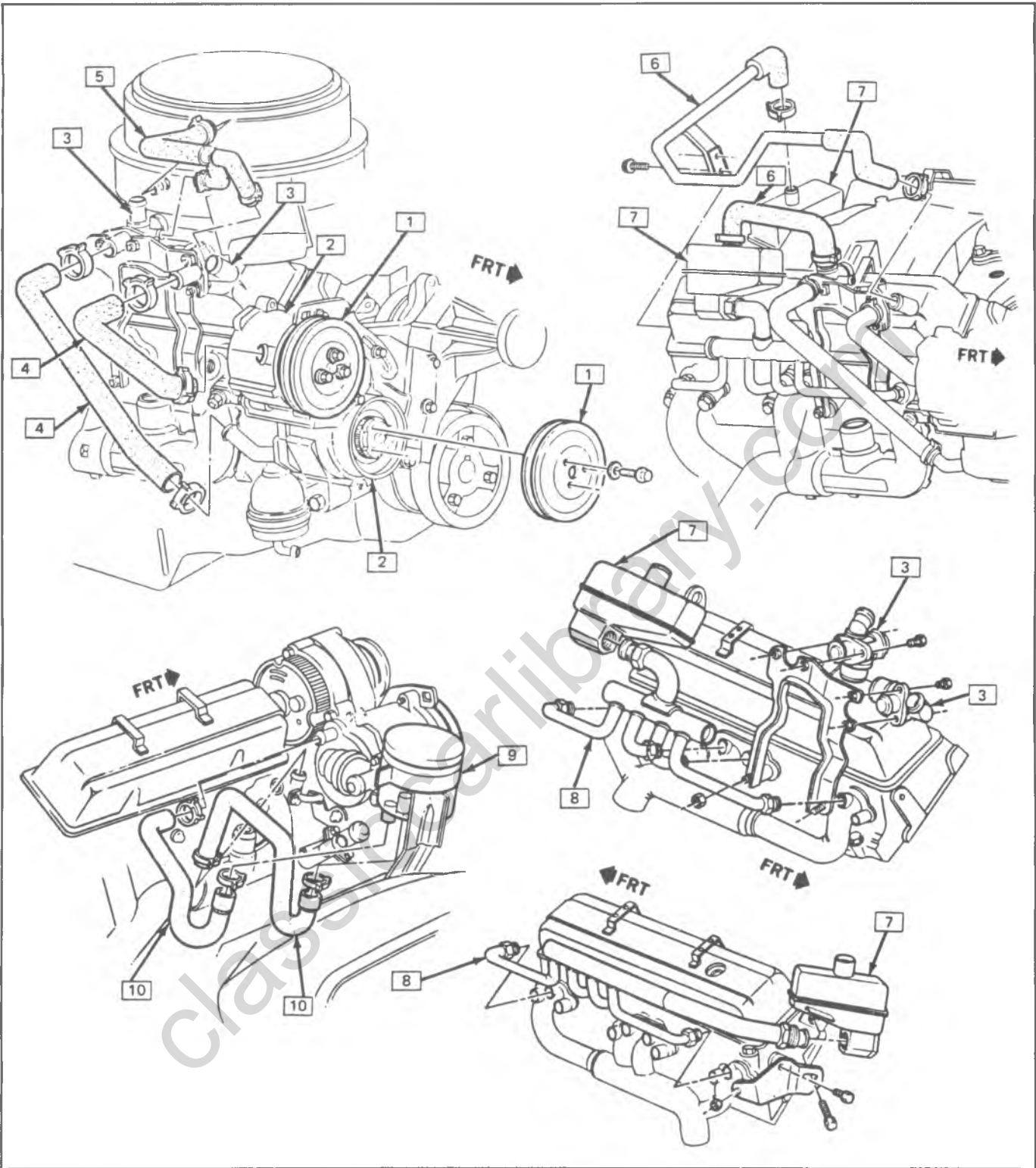

- 1** PULLEY—TIGHTEN SCREWS TO 15 N·m (10 FT. LBS.)
TIGHTEN AGAIN WITHIN 10 MINUTES TO 15 N·m
(10 FT. LBS.)
- 2** A.I.R. PUMP—TIGHTEN MOUNTING SCREWS TO
50 N·m (36 FT. LBS.)
- 3** AIR CONTROL VALVE—TIGHTEN SCREWS
TO 25 N·m (18 FT. LBS.)
- 4** HOSE—PUMP TO AIR CONTROL VALVE
- 5** HOSE—AIR CONTROL VALVES TO AIR CLEANER

- 6** HOSE—AIR CONTROL VALVE TO CHECK VALVE
- 7** CHECK VALVE—TIGHTEN NUT TO 35 N·m
(26 FT. LBS.)
- 8** AIR INJECTION PIPE—TIGHTEN NUTS TO 28 N·m
(20 FT. LBS.)
- 9** FILTER—DRAIN HOLE ON INLET HOSE MUST
POINT DOWNWARD
- 10** HOSE—FILTER TO PUMP

Figure 12—AIR System — 5.7 L (P)

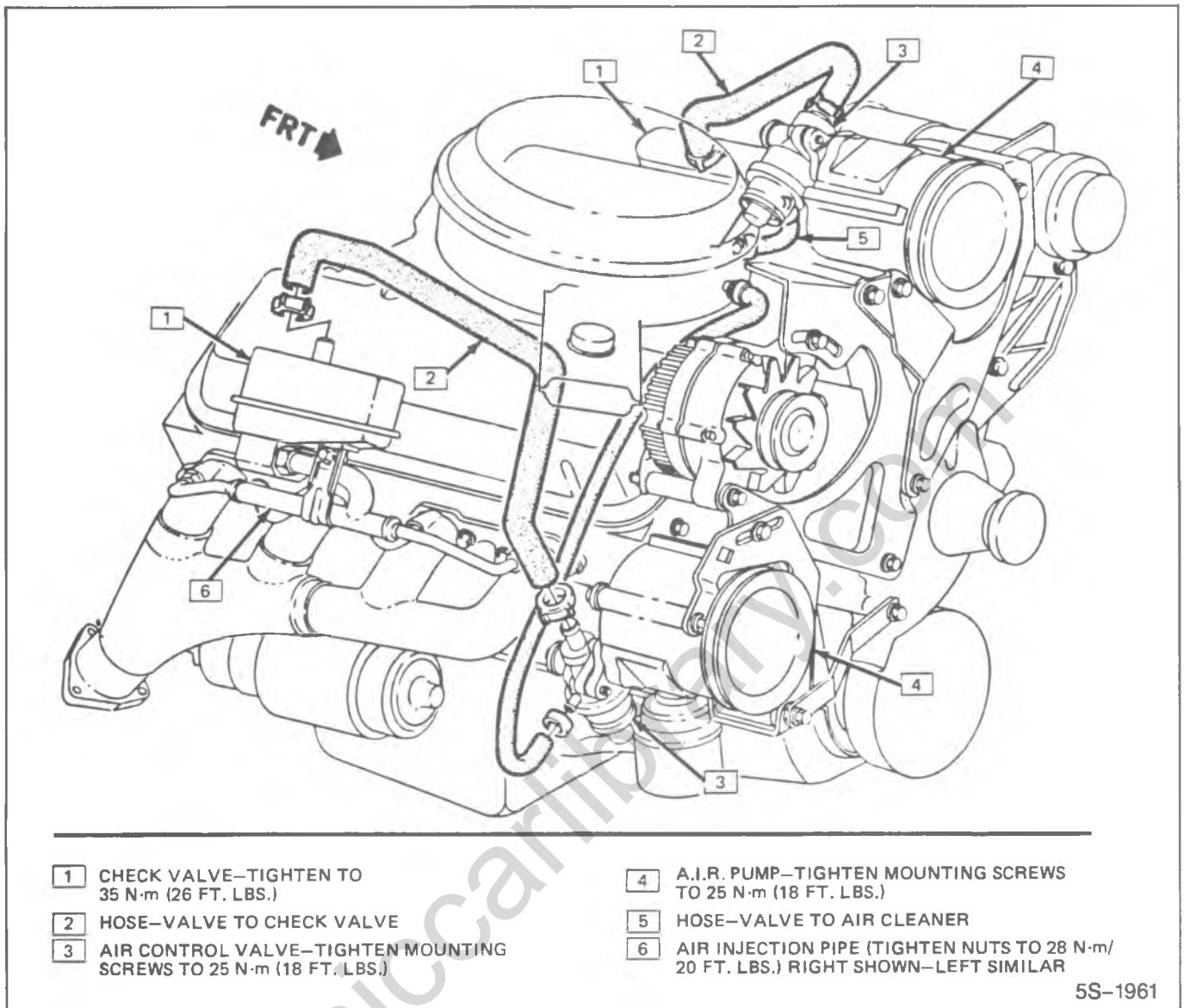

Figure 13—AIR System — 7.4 L Engine

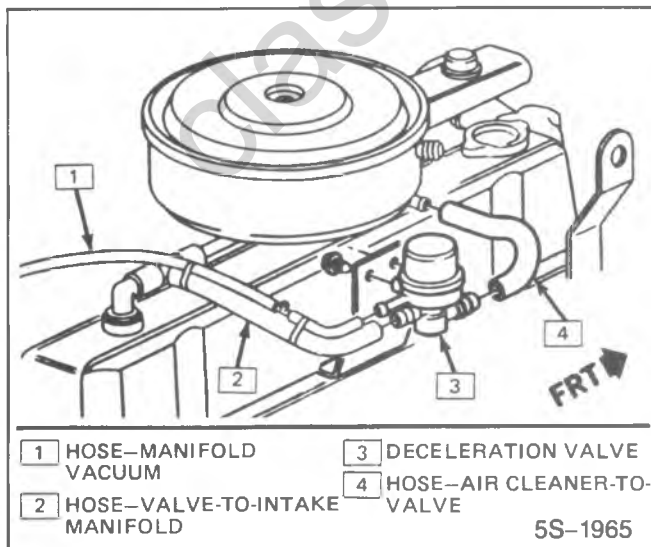

Figure 14—Deceleration Valve — 4.8 L Engine

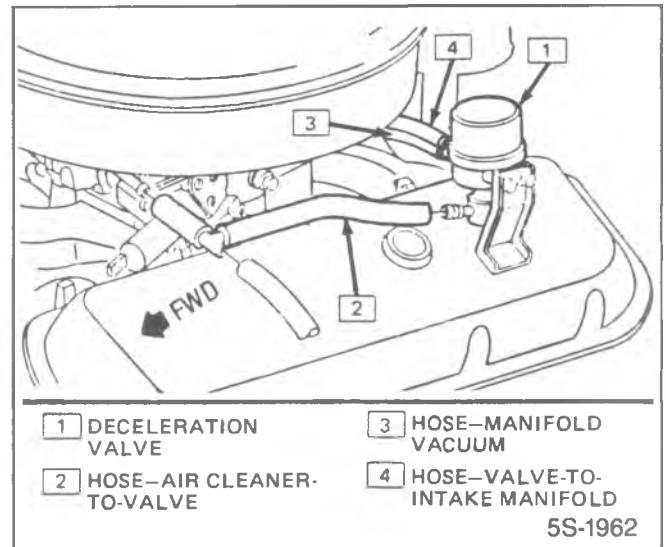

Figure 15—Deceleration Valve — 7.4 L Engine

6E8-26 DRIVEABILITY AND EMISSIONS — CARBURETED

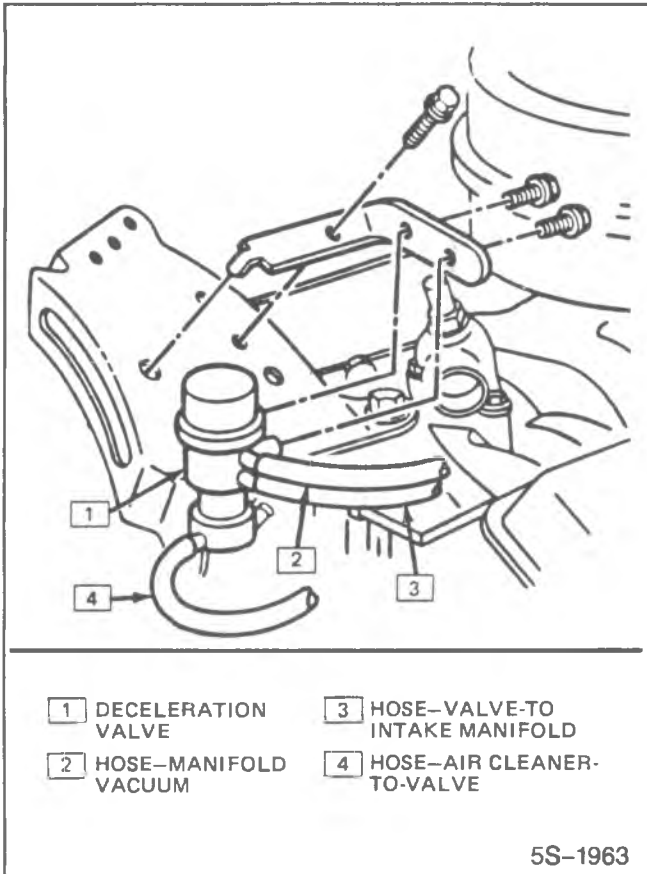

Figure 16—Deceleration Valve — 5.7 L Engine

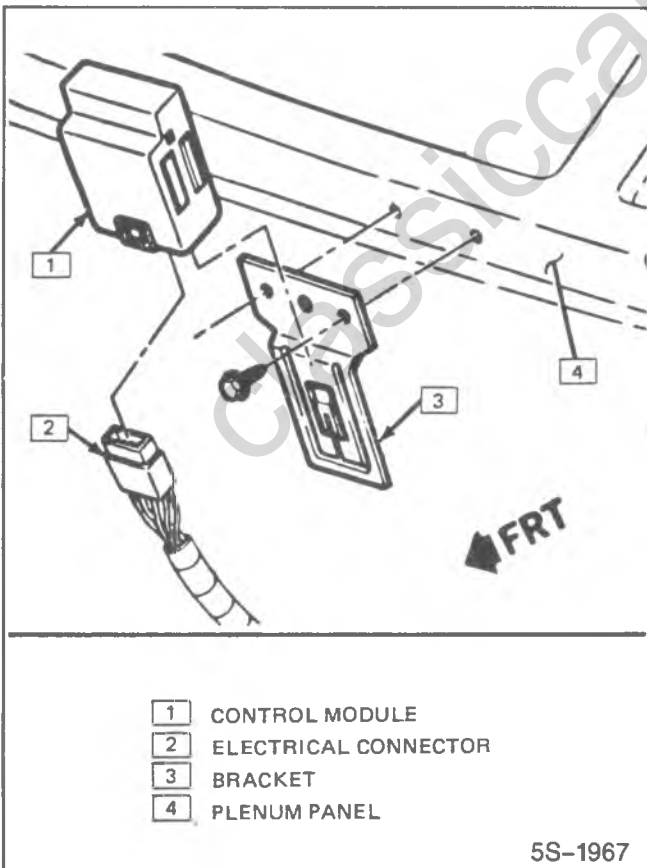

Figure 17—Control Module — 5.7 L (G)

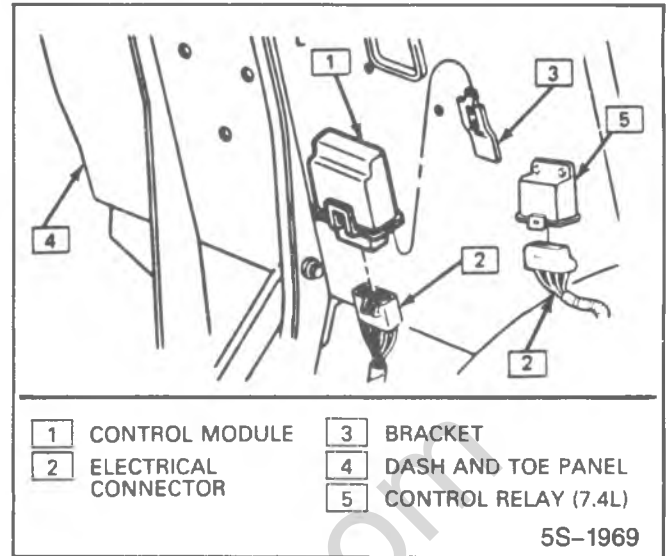

Figure 18—Control Module — 5.7 L/7.4 L (P42)

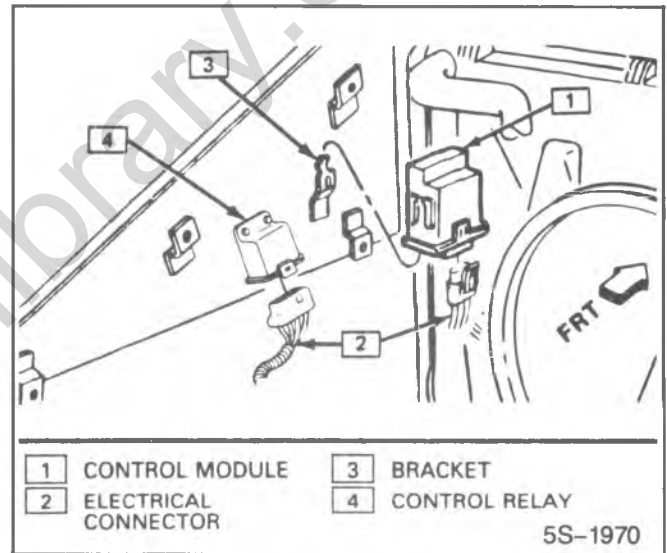

Figure 19—Control Module — 7.4 L (P32)

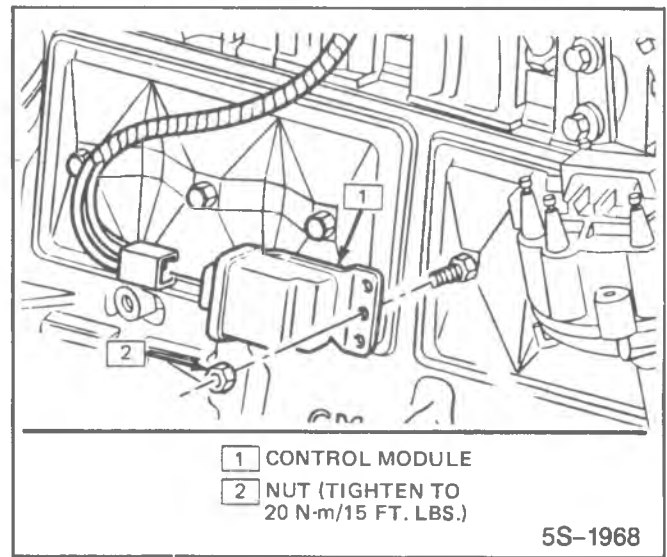

Figure 20—Control Module — 4.8 L Engine

FILTER (Figures 10 through 13)

Remove or Disconnect

1. Filter from bracket.
2. Hose from air intake and pump.

Install or Connect

1. Hose from air intake and pump.
2. Filter to bracket.

SILENCER - 4.8 L ENGINE (Figure 10)

Remove or Disconnect

1. Hose from the silencer.
2. Silencer from the bracket.

Install or Connect

1. Silencer to the bracket.
2. Hose to silencer.

DECELERATION VALVE (Figures 15 and 16)

Remove or Disconnect

1. Vacuum hoses from valve.
2. Screws securing valve to bracket.
3. Deceleration valve.

Install or Connect

1. Deceleration valve.
2. Screws securing valve to bracket.
3. Vacuum hoses to valve.

CONTROL MODULE (Figures 17 through 20)

Remove or Disconnect

1. Electrical connector.
2. Control module.

Install or Connect

1. Control module.
2. Electrical connector.

CONTROL RELAY (7.4 L ONLY) Figures 18 and 19

Remove or Disconnect

1. Electrical connector.
2. Control module.

Install or Connect

1. Control module.
2. Electrical connector.

“SERVICE ENGINE SOON” LIGHT IS “ON”

The illumination of the “SERVICE ENGINE SOON” light indicates that there is a malfunction in the solenoid, control module, or wiring. Check solenoid and module connectors for proper connection.

1. Disconnect air temperature switch and install a jumper wire across the terminals.
2. With ignition on, disconnect each solenoid connector and with a test light, check for a light from the pink/black wire to ground.
 - If light does not illuminate, check for an open in circuit 39 to the solenoid.
 - If light illuminates, check for a light across terminals. Circuit is OK if there is a light. Check solenoid coil resistance and if less than 20 ohms, replace solenoid and valve. If there is no light, check for an open in circuit 900 to the air temperature switch, an open in circuit 436 or faulty control module.
3. Connect solenoid connectors and disconnect both connectors at control module. Check for a light between terminals “A” and “B” of the 5 pin connector.
 - If the test light does not illuminate, check for an open circuit to the module.
 - If the test light illuminates, check for a light between 5 pin connector harness terminals “A” and “D.”
 - If the test light illuminates, check for a short to ground in circuit 419.
 - If the test light does not illuminate, check for an open in circuit 900 between the solenoid terminal “B” and the module 2 pin connector terminal “A.” If circuit 900 is not open, replace the control module.

6E8-28 DRIVEABILITY AND EMISSIONS — CARBURETED

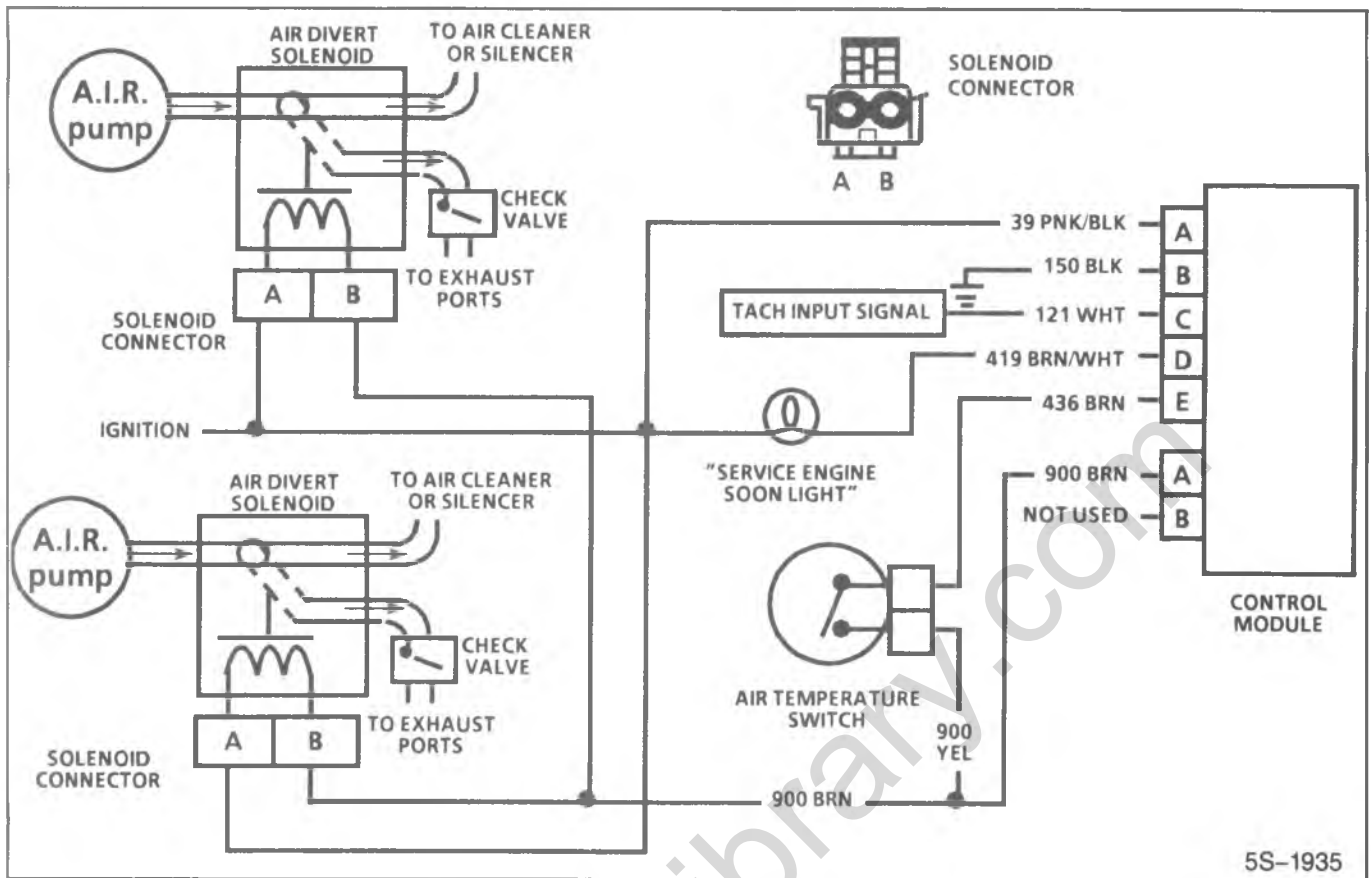

Chart C-6HD-1 Air Management System 5.7 L Engine

classiccarrlibrary.com

“SERVICE ENGINE SOON” LIGHT IS “ON”

The illumination of the “SERVICE ENGINE SOON” light indicates that there is a malfunction in the solenoid, control module, control relay, or wiring. Before diagnosis, check solenoid and module connectors for proper connection.

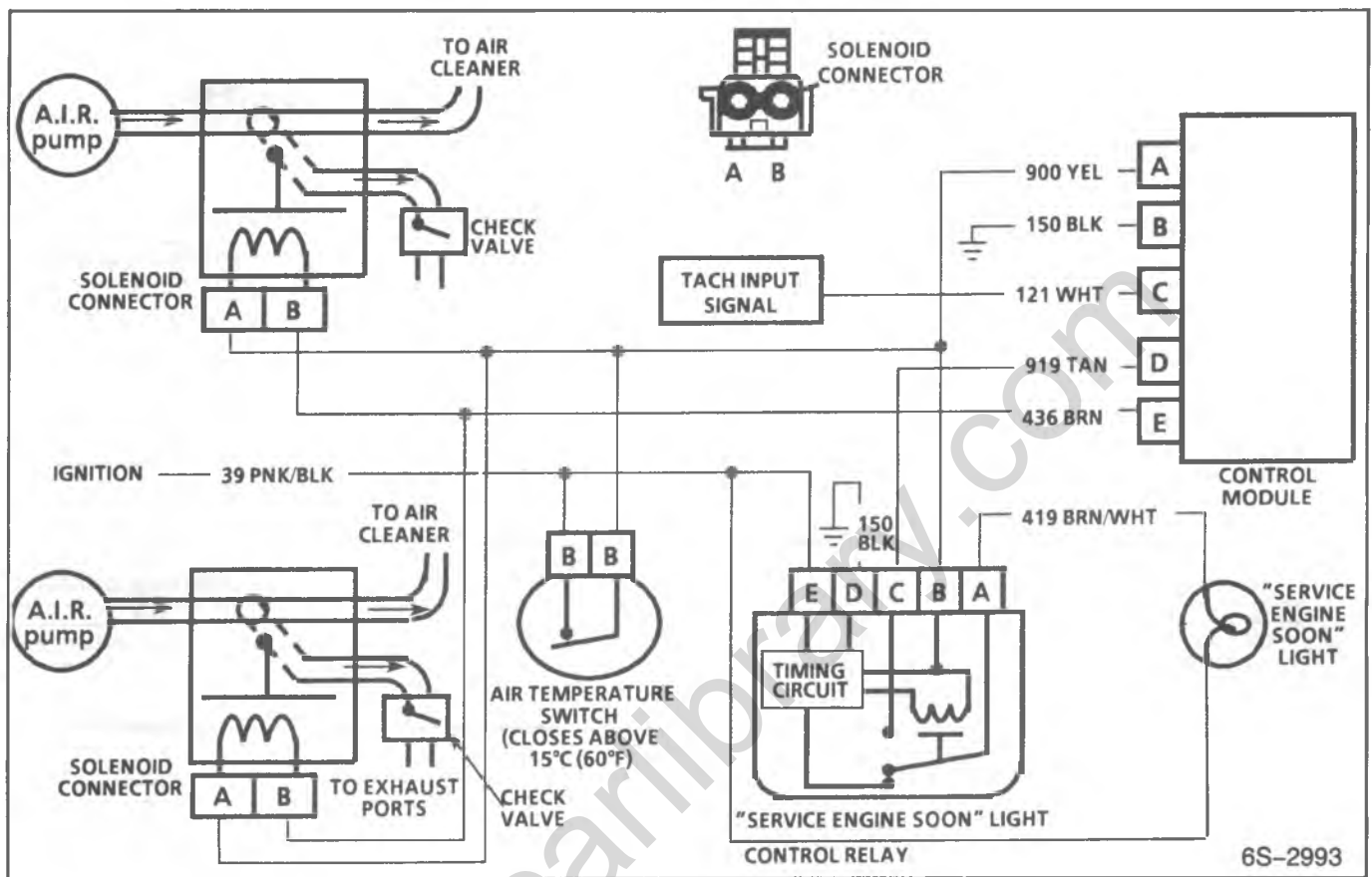
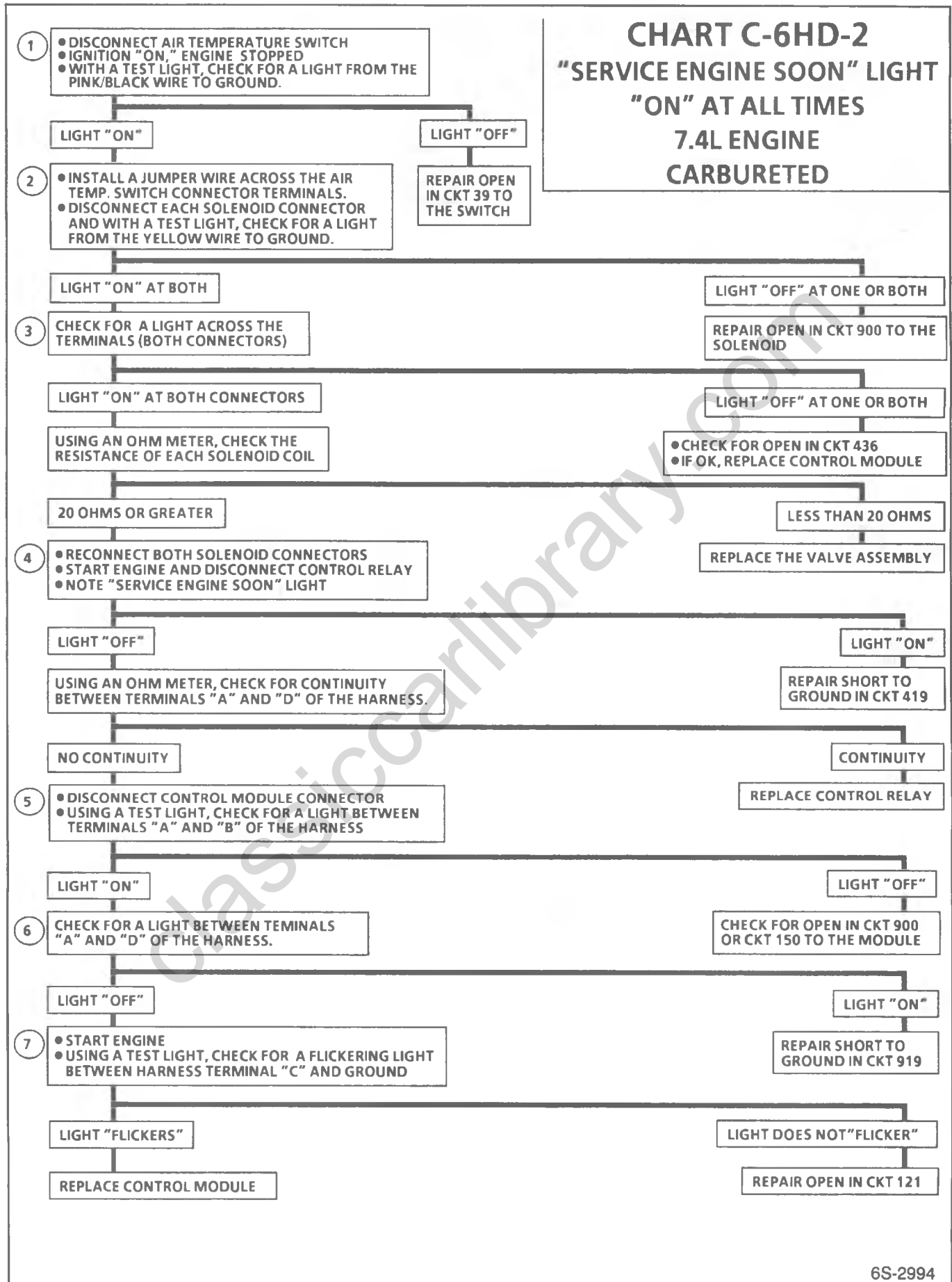

Chart C-6HD-2 Air Management System 7.4 L Engine

1. This step is to determine if there is power to the air temperature switch.
2. This step will insure that there is power to the circuit by eliminating the air temperature switch. This step will also check the wiring between the air temperature switch and the solenoids.
3. This step will check the wiring between the solenoids and ground, including the circuit inside the control module.
4. This step will determine if the problem is a short to ground in the “SERVICE ENGINE SOON” light circuit or a malfunction in the air management system.
5. This step checks for Bat. (+) at “A” and a ground at “B,” to power up the control module.
6. This step will determine if a ground signal is sent to the relay because CKT919 is grounded outside the module.
7. This step checks for a tach signal to the control module.

CHART C-6HD-2
"SERVICE ENGINE SOON" LIGHT
"ON" AT ALL TIMES
7.4L ENGINE
CARBURETED



“SERVICE ENGINE SOON” LIGHT IS “ON”

The illumination of the “SERVICE ENGINE SOON” light indicates that there is a malfunction in the solenoid, control module, or wiring. Check solenoid and module connectors for proper connection.

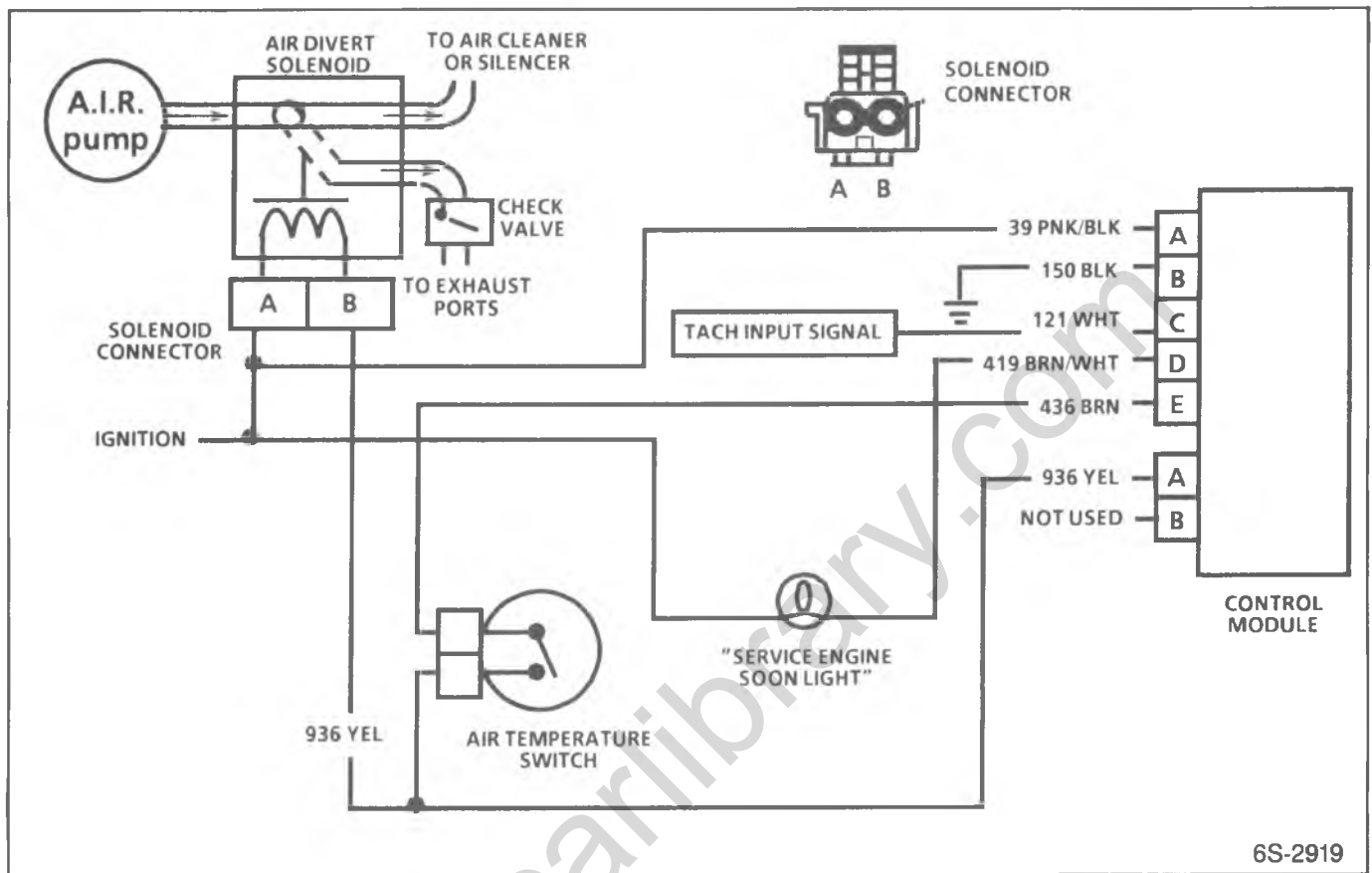

Chart C6HD-3

1. Disconnect the air temperature switch and install a jumper wire across the terminals.
2. With the ignition on, disconnect the solenoid connector and with a test light, check for a light from the pink/black wire to ground.
 - If the light does not illuminate, check for an open in circuit 39 to the solenoid.
 - If the light illuminates, check for a light across the terminals. The circuit is OK if there is a light. Check the solenoid coil resistance and if less than 20 ohms, replace the solenoid and valve. If there is no light, check for an open in circuit 936 to the air temperature switch, an open in circuit 436 or a faulty control module.
3. Connect the solenoid connector and disconnect both connectors at the control module. Check for a light between terminals “A” and “B” of the 5 pin connector.
 - If the test light does not illuminate, check for an open circuit to the module.
 - If the test light illuminates, check for a light between the 5 pin connector harness terminals “A” and “D.”
 - If the test light illuminates, check for a short to ground in circuit 419.
 - If the test light does not illuminate, check for an open in circuit 936 between the solenoid terminal “B” and the module 2 pin connector terminal “A.” If circuit 936 is not open, replace the control module.

EXHAUST GAS RECIRCULATION (EGR) SYSTEM

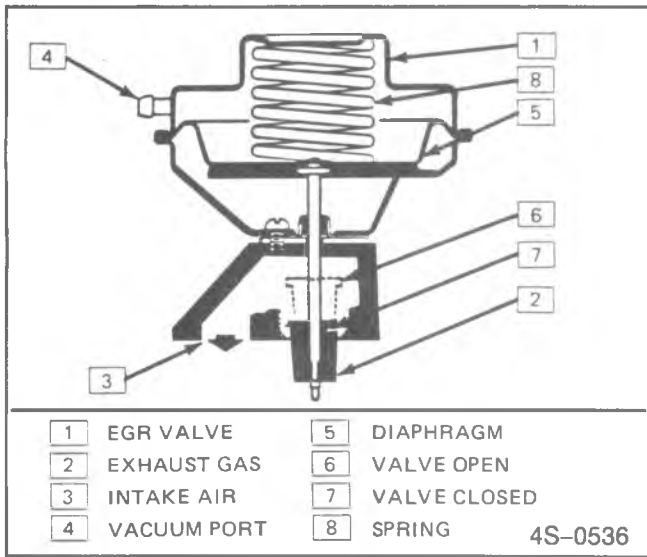

Figure 21—EGR Valve

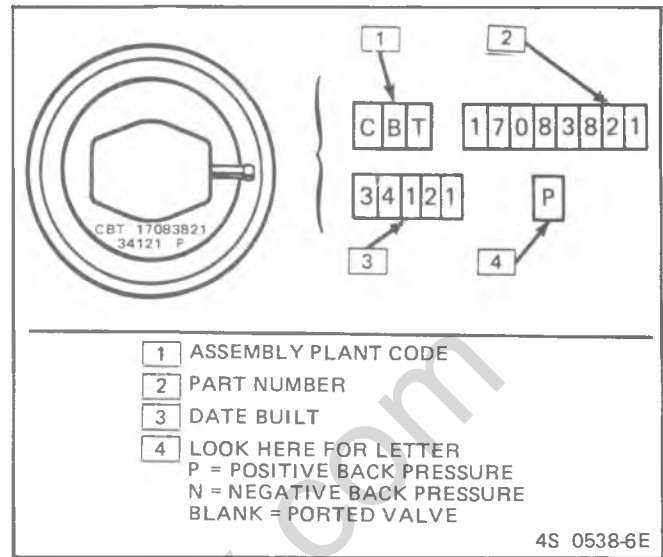

Figure 23—EGR Valve Identification

GENERAL DESCRIPTION

PURPOSE

The EGR system is used to lower NO_x (oxides of nitrogen) emission levels caused by high combustion temperatures. It does this by decreasing combustion temperature.

The EGR system has a ported EGR valve (figure 21), hose from a ported manifold vacuum source and a method to control the vacuum source.

A coolant temperature TVS is used to control the vacuum source.

OPERATION

The thermostatic vacuum switch (TVS) blocks vacuum to the EGR valve during cold engine operation (figure 22).

When the engine is warm, the TVS opens, which opens the vacuum source to the EGR valve. At idle or wide-open throttle, there is little or no vacuum from the vacuum

source, the EGR pintle is closed and there is no exhaust gas recirculation. When the throttle valves are opened, vacuum is applied through the exposed vacuum signal port(s) to the vacuum diaphragm in the EGR valve through a connection tube. When the vacuum reaches a pre-determined level, the diaphragm moves upward against calibrated spring tension, pulling the pintle with it. The pintle rises off the seat, allowing exhaust gas to flow from the exhaust manifold to the intake manifold and into the engine cylinders.

Exhaust gas will be recirculated during periods of normal intake manifold vacuum, when the throttle is open beyond idle.

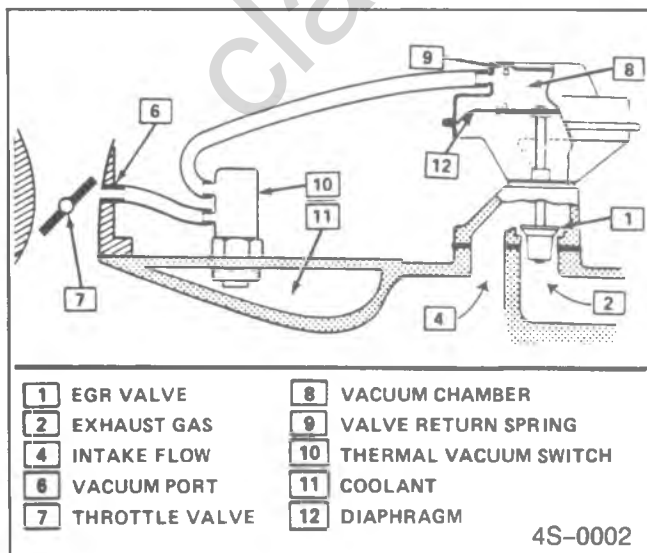

Figure 22—EGR System with TVS

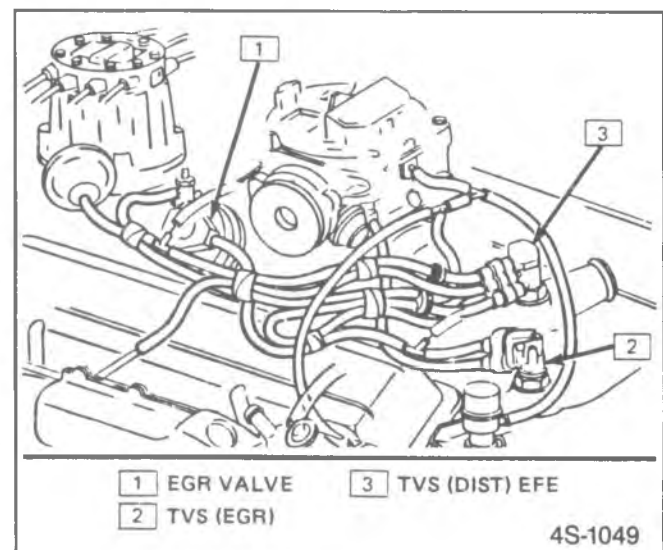

Figure 24—TVS Location, 5.7 L-LT9

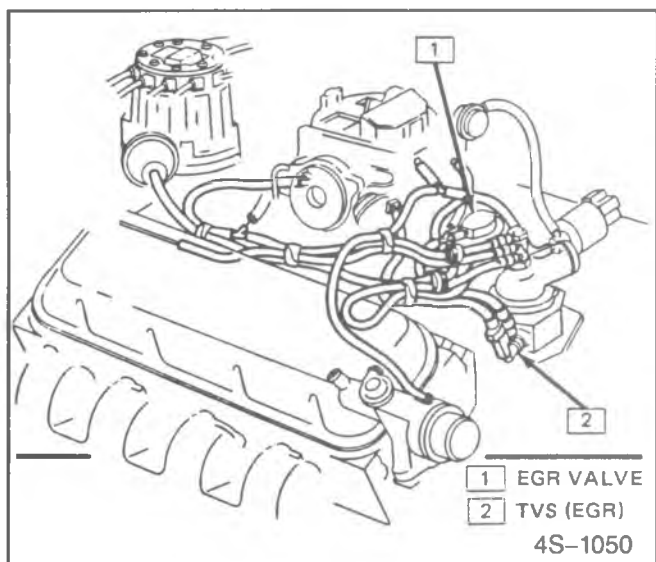

Figure 25—TVS Location, 7.4 L-LE8

DIAGNOSIS OF EGR

EGR SYSTEM

Too much EGR flow tends to weaken combustion, causing the engine to run roughly or stop. With too much EGR flow at idle, cruise, or cold operation, any of the following conditions may happen:

- Engine stops after cold start.
- Engine stops at idle after deceleration.
- Vehicle surges during cruise.
- Rough idle.

If the EGR valve should stay open all of the time, the engine may not idle.

Too little or no EGR flow allows combustion temperatures to get too high during acceleration and load conditions. This could cause:

- Spark knock (detonation).
- Engine overheating.
- Emission test failure.

System Check

Diagnosis of the EGR system is covered in the chart at the end of this section.

EGR VALVE

Refer to EGR System Check at the end of this section for diagnosis of the EGR valve.

The valve will open if vacuum is applied with the engine not running.

THERMOSTATIC VACUUM SWITCH

A thermal vacuum switch opens, closes, or switches vacuum source when the calibration temperature is reached. The following general checking procedures can be used for all thermal vacuum switches. Refer to number stamped on base of valve or switch for calibration temperature.

1. Allow TVS to cool below calibration temperature.
2. Inspect switch to make sure it is in good condition.
3. Connect vacuum gage(s) to output port(s) of the TVS. (See vacuum hose schematic on Vehicle Control Emission Information label).

4. Compare vacuum gage reading(s) with the procedures and in the TVS descriptions given under each valve name.
5. Heat TVS to a temperature above the calibration temperature. Never apply a torch or open flame directly to the TVS.
6. Compare vacuum gage reading to the correct reading indicated on switch or valve base.

NOTICE: Leakage of up to 7 kPa (2" Hg) vacuum in 2 minutes is allowable and does not mean a defective part.

7. If operation is satisfactory, re-install valve or switch. If valve or switch is defective, replace with a new part.

ON-VEHICLE SERVICE — EGR

CLEANING MANIFOLD PASSAGE

Inspect

If EGR passages in the inlet manifold indicate excessive build-up of deposits, the passages should be cleaned. Care should be taken to insure that all loose particles are completely removed to prevent them from clogging the EGR valve or from being ingested into the engine.

Do not wash EGR valve in solvents or degreaser — permanent damage to valve diaphragm may result. Also, sand blasting of the valve is not recommended since this can affect the operation of the valve.

SYSTEM HOSES

Refer to Vehicle Emission Control Information label for routing of system hoses.

When replacing hoses, use hose identification with the word "Fluoroelastomer."

EGR VALVE

Refer to figure 23 to identify the EGR valve.

Remove or Disconnect

1. Air cleaner.
2. EGR valve vacuum hose at valve.
3. Bolts.
4. EGR valve from manifold.

Install or Connect

1. EGR valve to manifold (use new gasket).
2. Bolts.
3. Vacuum hose to EGR valve.
4. Air cleaner.

THERMOSTATIC VACUUM SWITCH (Figures 24 and 25)

Replacement

1. Drain coolant below level of thermostatic vacuum switch (TVS).
2. Disconnect vacuum hoses.
3. Remove TVS.

CHART C-7C
EGR SYSTEM CHECK
 ALL ENGINES
 WITHOUT ECM
 CARBURETED

• HOLD TOP OF EGR VALVE AND TRY TO ROTATE TOP OF VALVE BACK AND FORTH.

NO LOOSENESS FELT

• PLACE TRANSMISSION IN P/N.
 • RUN WARM ENGINE AT IDLE, ENGINE TEMP. ABOVE 91° C/195°F.
 • PUSH UP ON UNDERSIDE OF EGR VALVE DIAPHRAGM. RPM SHOULD DROP.

RPM DROPS

• CHECK FOR MOVEMENT OF EGR VALVE DIAPHRAGM AS RPM IS CHANGED FROM APPROX. 2000 RPM TO IDLE.

DOESN'T MOVE

• CHECK VACUUM AT EGR VALVE AS ENGINE RPM IS CHANGED TO APPROXIMATELY 2000 RPM.

UNDER 20 kPa (6 INCHES HG)

• CHECK VACUUM HOSES FOR RESTRICTIONS, LEAKS, AND CONNECTIONS.

OK

• CHECK TVS OPERATION.
 • REMOVE CARB. TO TVS SWITCH HOSE FROM SWITCH AND CONNECT HOSE TO VACUUM GAGE.
 • CHECK VACUUM AT APPROX. 2000 RPM.

UNDER 33 kPa (10 INCHES HG)

CHECK FOR PLUGGED HOSE OR CARBURETOR PASSAGE.

IF LOOSENESS IS FELT

REPLACE EGR VALVE

NO RPM CHANGE

CLEAN EGR PASSAGES OR REPLACE VALVE AS NEEDED

MOVES

NO TROUBLE FOUND

OVER 20 kPa (6 INCHES HG)

REPLACE EGR VALVE

NOT OK - REPAIR

OVER 33 kPa (10 INCHES HG)

REPLACE TVS

Chart C-7C

4. Install replacement TVS with soft setting sealant applied to male threads. Sealant should not be on end of TVS.
5. Tighten TVS to 14 N·m (120 in. lbs.), then turn clockwise as required to align with hoses.
6. Connect vacuum hoses.
7. Add coolant as required.

PARTS INFORMATION

PARTS NAME	GROUP
Valve	3,670
Gasket, EGR Valve (15)	3,680

EARLY FUEL EVAPORATION SYSTEM (EFE) ALL ENGINES EXCEPT 4.8 L

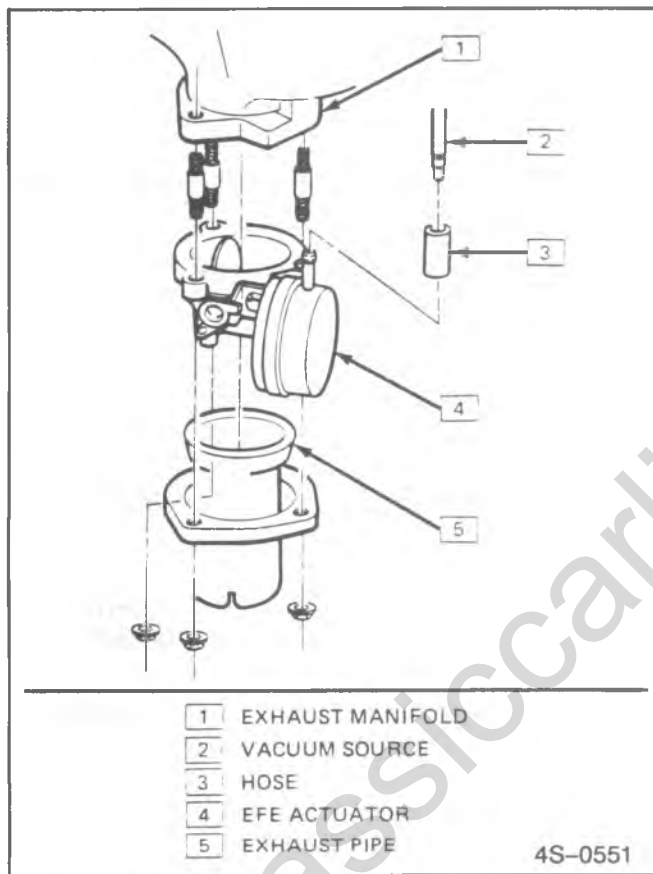

Figure 26—EFE System — Vacuum Servo Type

GENERAL DESCRIPTION

PURPOSE

The EFE system used on all engines provides a source of rapid heat to the engine induction system during cold driveaway. Rapid heating is desirable because it provides quick fuel evaporation and more uniform fuel distribution to aid cold driveability. It also reduces the length of time carburetor choking is required, so it reduces exhaust emissions.

OPERATION

The EFE system is a Vacuum Servo type that uses a valve and vacuum actuator which increases the exhaust gas flow under the intake manifold during cold engine operation. The valve is located in the exhaust and the vacuum actuator is vacuum operated (figure 26) by a

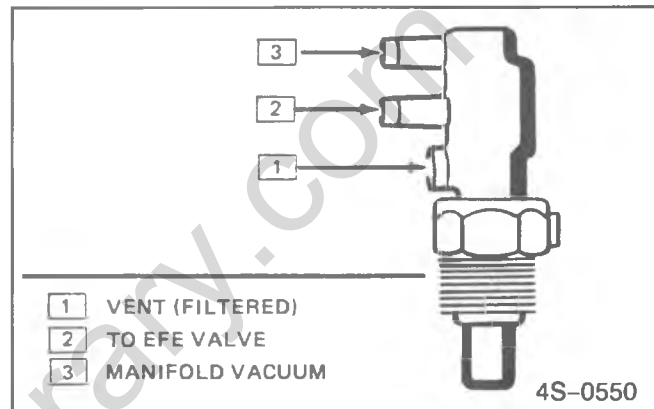

Figure 27—Thermal Vacuum Switch

thermal vacuum switch (TVS) (figure 27). When vacuum is applied to the actuator, the valve closes, causing the intake manifold to heat up.

When coolant temperature increases, the TVS stops vacuum to the actuator.

Results of Incorrect EFE Operation

No EFE when cold:

- Engine may stumble and stall during warm-up.
- Engine takes longer time to warm up.
- Choke may heat up and be off before engine is warm.

EFE stays on:

- Poor performance.
- Lack of power when warm due to superheated gases.
- Engine may overheat.

DIAGNOSIS OF EFE

GENERAL

The operation of the EFE system is to be checked at regular maintenance intervals. Refer to Section 0B for maintenance interval information.

VACUUM SERVO EFE DIAGNOSIS

- TVS controlled. See Chart C-9C.

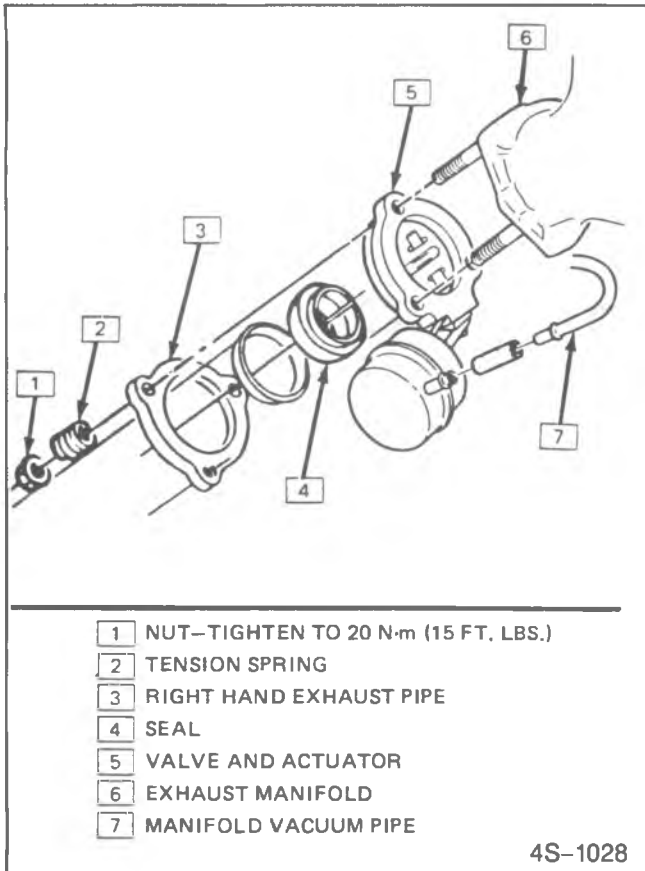

Figure 28—Valve and Actuator — 7.4 L

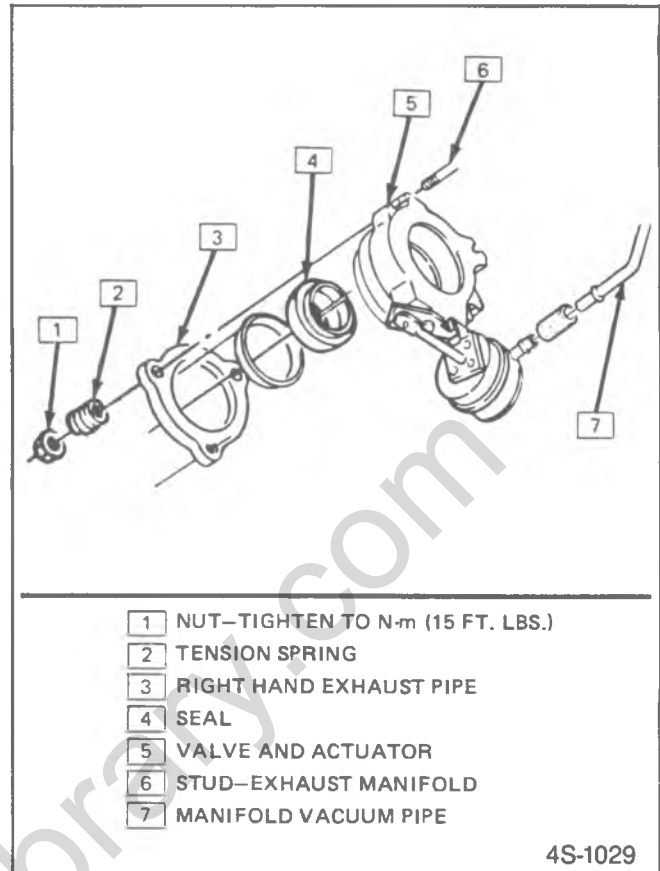

Figure 29—Valve and Actuator — 5.7 L

ON-VEHICLE SERVICE — EFE

VALVE AND ACTUATOR (Figures 28 or 29)

↔ Remove or Disconnect

1. Vacuum hose at EFE valve.
2. Exhaust pipe to manifold nuts, and tension springs.
3. Lower right hand exhaust (crossover) pipe and seal — complete removal of pipe is not always necessary.
4. EFE valve and actuator.

↔ Install or Connect

1. EFE valve (replace seals and gaskets if used).
2. Exhaust (crossover) pipe and seal.
3. Exhaust pipe to manifold nuts and tension springs. Tighten nuts to 20 N·m (15 ft. lbs.).
4. Vacuum hose at EFE valve.

COOLANT THERMAL VACUUM SWITCH (TVS) (Figure 30)

The TVS is located on the engine coolant outlet housing.

↔ Remove or Disconnect

1. Drain coolant below level of engine coolant outlet housing.
2. Hoses at TVS ports.
3. TVS. Refer to number stamped on base of TVS for calibration temperature.

↔ Install or Connect

1. Apply a soft setting sealant uniformly on replacement TVS male threads. No sealant should be applied to sensor end of TVS.
2. TVS. Tighten to 14 N·m (120 in. lbs.) and then hand torque clockwise as required to align TVS to accommodate hoses.
3. Hoses to TVS ports.
4. Coolant as required.

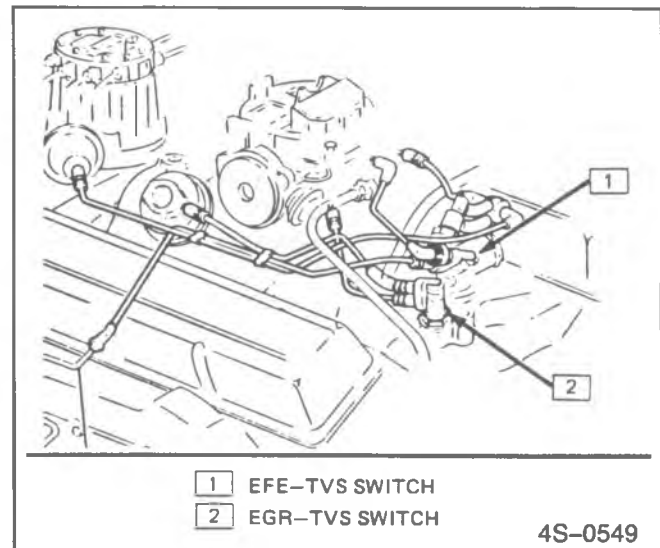
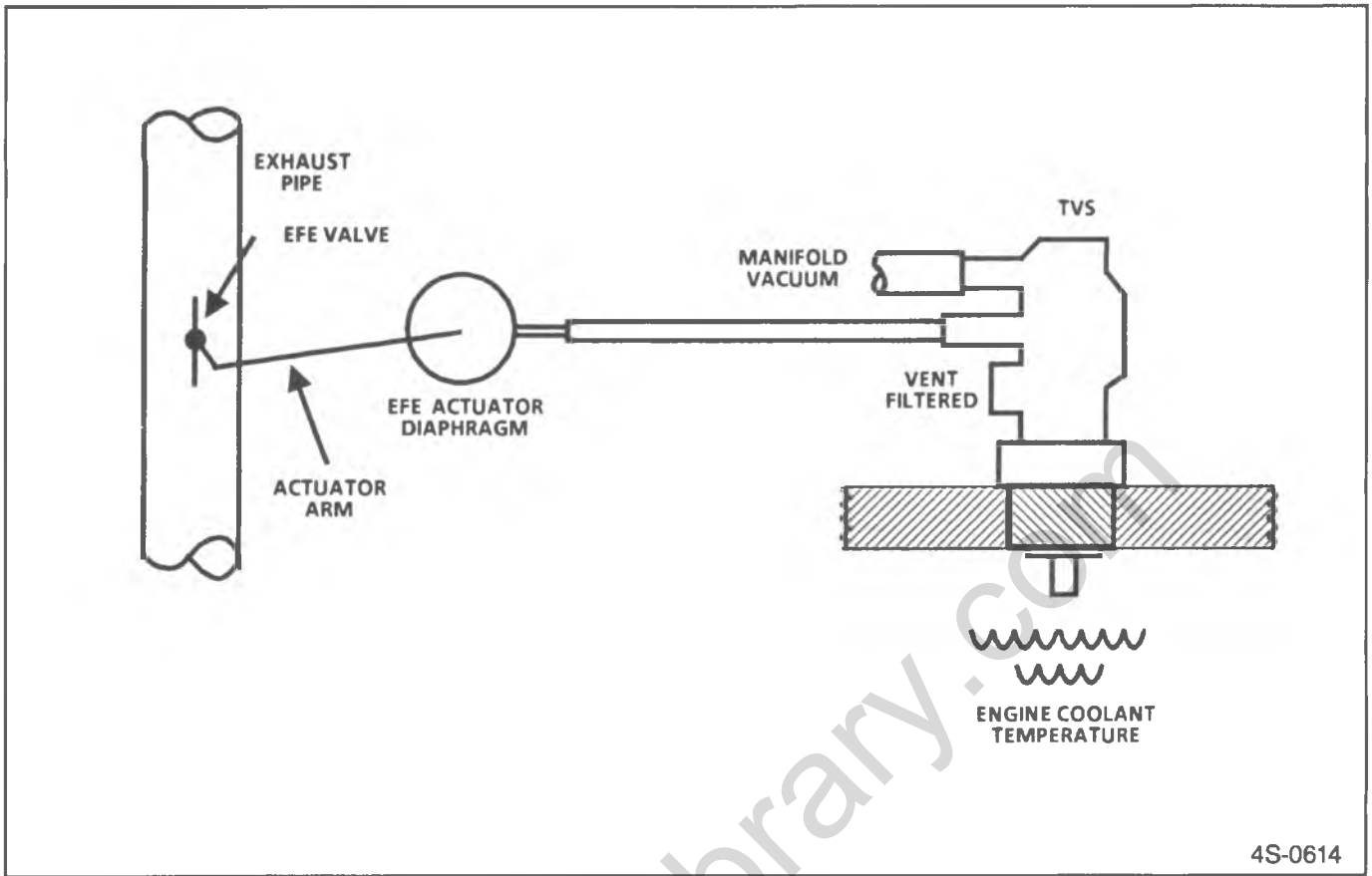

Figure 30—EFE Coolant TVS



4S-0614

Chart C-9C

1. Engine coolant temperature should be below 40°C (105°F).
2. EFE valve should open above 40°C (105°F).
3. There should be at least 34 kPa (10" Hg) vacuum available to EFE actuator diaphragm.
4. Valve may be seized up. It may be freed up by using heat valve lubricant (part #1052627 or equivalent). If valve does not free up, it must be replaced.

CHART C-9C
VACUUM ACTUATED EFE SYSTEM
CHECK
5.0L
CARBURETED

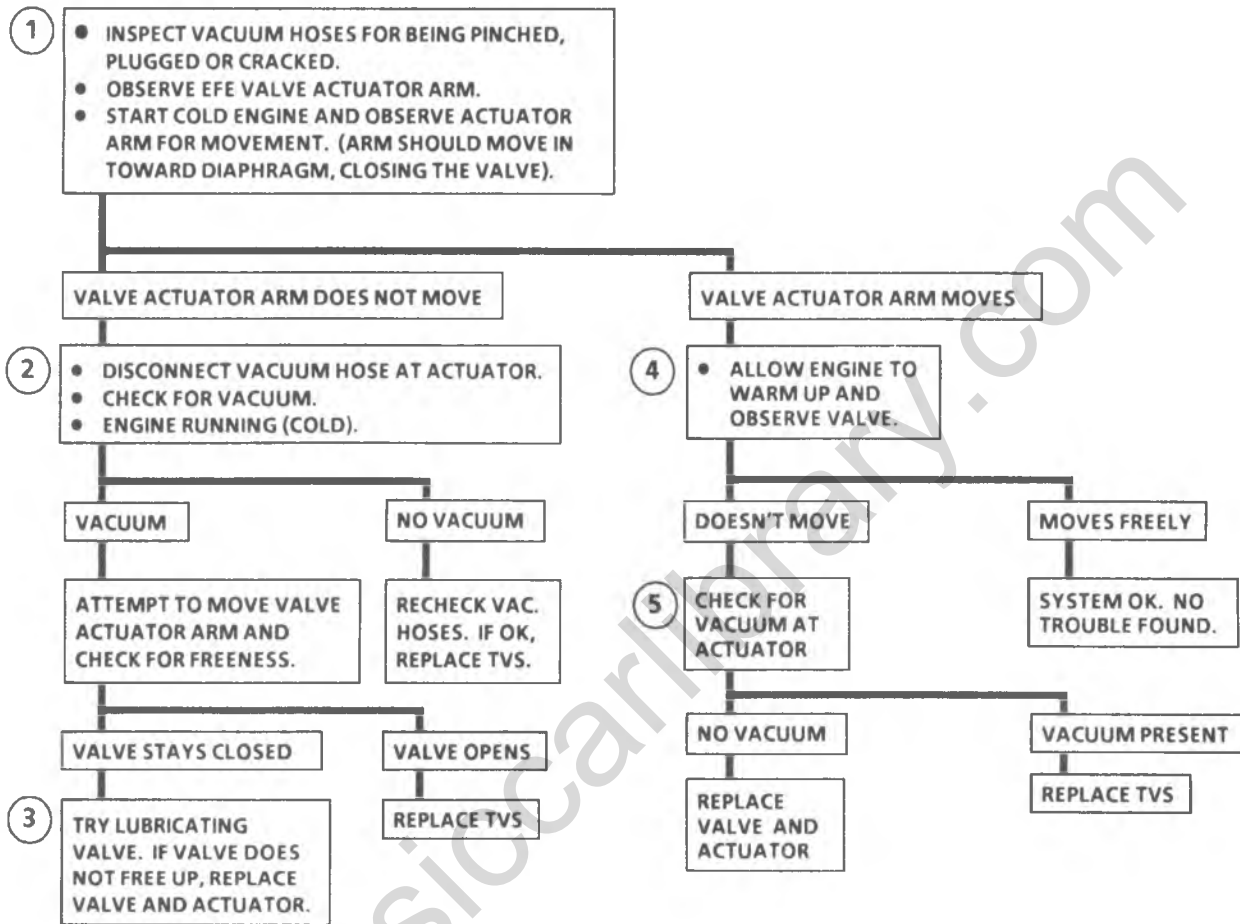

POSITIVE CRANKCASE VENTILATION (PCV)

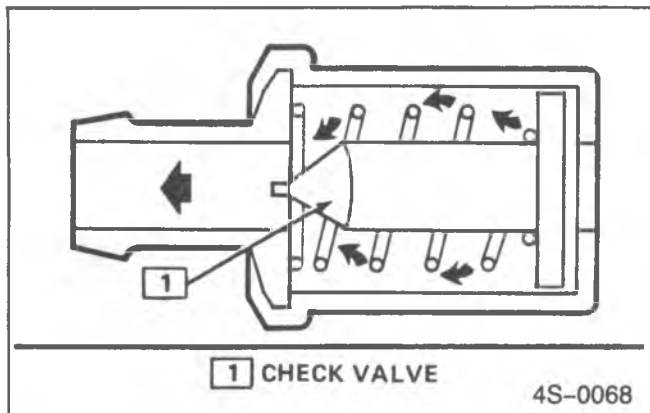

Figure 31—PCV Valve Cross Section

GENERAL DESCRIPTION

PURPOSE

A Positive Crankcase Ventilation (PCV) system is used to provide more complete scavenging of crankcase vapors.

OPERATION

Fresh air from the air cleaner is supplied to the crankcase, mixed with blow-by gases and then passed through a positive crankcase ventilation (PCV) valve into the intake manifold (figure 32). The primary control is through the PCV valve (figure 31) which meters the flow at a rate depending on manifold vacuum.

To maintain idle quality, the PCV valve restricts the flow when intake manifold vacuum is high. If abnormal operating conditions arise, the system is designed to allow excessive amounts of blow-by gases to back flow through the crankcase vent tube into the air cleaner to be consumed by normal combustion.

Results of Incorrect PCV Operation

- A plugged valve or hose may cause:
 - Rough idle.
 - Stalling or slow idle speed.
 - Oil leaks.
 - Oil in air cleaner.
 - Sludge in engine.
- A leaking valve or hose would cause:
 - Rough idle.
 - Stalling.

DIAGNOSIS OF PCV

If an engine is idling rough, check for a clogged PCV valve or plugged hose. Replace as required. Use the following procedure:

1. Remove PCV valve from rocker arm cover.
2. Run the engine at idle.
3. Place your thumb over end of valve to check for vacuum. If there is no vacuum at valve, check for plugged hoses or manifold port, or PCV valve. Replace plugged or deteriorated hoses.

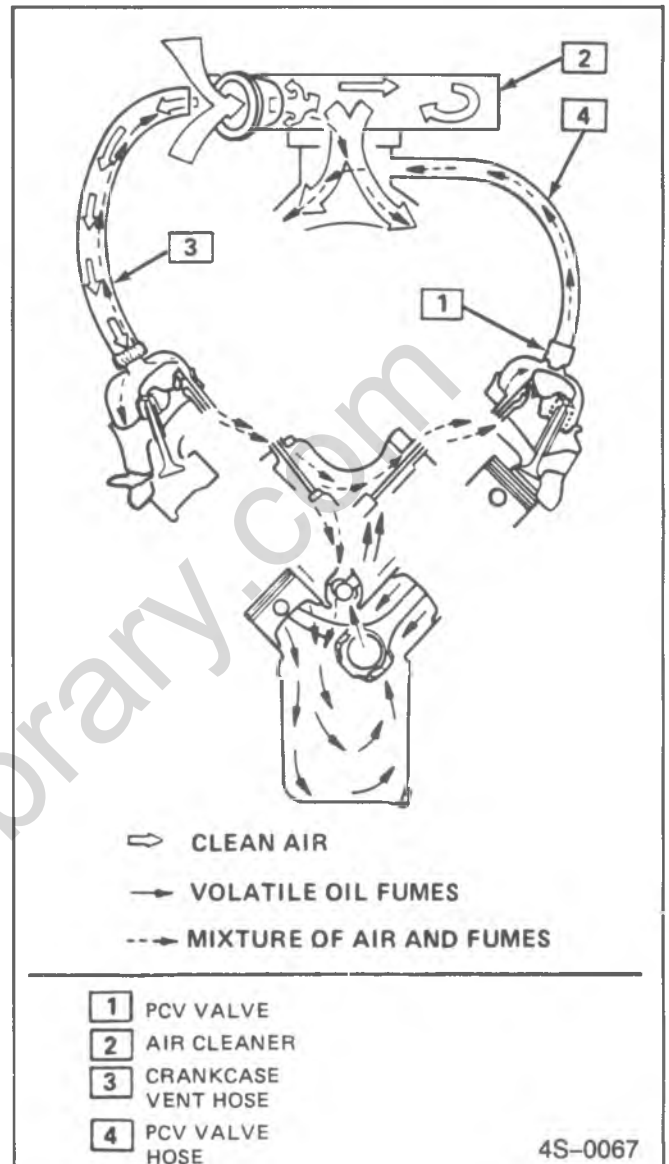

Figure 32—PCV Flow

4. Turn off the engine and remove PCV valve. Shake valve and listen for the rattle of check needle inside the valve. If valve does not rattle, replace valve.

With this system, any blow-by in excess of the system capacity (from a badly-worn engine, sustained heavy load, etc.) is exhausted into the air cleaner and is drawn into the engine.

Proper operation of the PCV System (figure 33) is dependent upon a sealed engine. If oil sludging or dilution is noted, and the PCV System is functioning properly, check engine for possible cause and correct to insure that system will function as intended.

ON-VEHICLE SERVICE — PCV

See figure 33 for replacement of PCV system components.

An engine which is operated without any crankcase ventilation can be damaged. Therefore, it is important to

6E8-40 DRIVEABILITY AND EMISSIONS — CARBURETED

replace the PCV valve and air cleaner breather at intervals shown in Section 0B.

Periodically, inspect the hoses and clamps and replace any showing signs of deterioration.

PARTS INFORMATION

PART NAME	GROUP
Air Cleaner	3,402
Tube, C/Case Vent	1,762
Hose, C/Case Vent Vlv	1,762

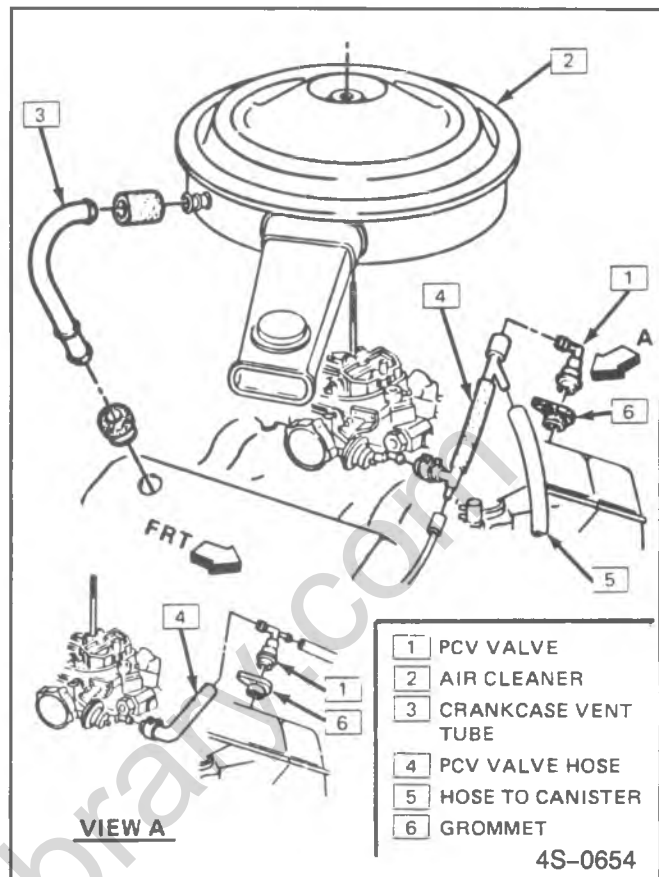

Figure 33—Positive Crankcase Ventilation System

THERMOSTATIC AIR CLEANER (THERMAC)

GENERAL DESCRIPTION

PURPOSE

A heated intake air system is used to give good driveability under varying climatic conditions. By having a uniform inlet temperature, the fuel system can be calibrated to reduce exhaust emissions and to eliminate throttle blade icing.

OPERATION

The THERMAC air cleaner operates by heated air and manifold vacuum (figure 34). Air can enter the air cleaner from outside the engine compartment or from a heat stove built around the exhaust manifold. A vacuum diaphragm motor, built into the air cleaner snorkel, moves a damper door, to admit hot air from the exhaust manifold, outside air, or a combination of both. Inside the air cleaner is a temperature sensor that reacts to air intake temperature and controls the amount of vacuum going to the motor.

- Hot Air Delivery Mode. When the temperature is below 86°F (30°C), the sensor allows vacuum to the motor and the damper door will be up, shutting off outside air and allowing only heated air from the exhaust manifold to enter the air cleaner.
- Regulating Mode. Between 86°F (30°C) and 131°F (55°C) the damper door allows both heated and outside air to enter the air cleaner.

- Outside Air Delivery Mode. When the temperature is above 131°F (55°C), the damper door drops down and only outside air enters the air cleaner.

THERMAC DELAY VALVE

Some applications use a delay valve on the hose connecting the vacuum motor to the temperature sensor (figure 35). When vacuum in this hose drops for any reason, the check valve will bleed off the vacuum to the vacuum motor slowly.

Results of Incorrect THERMAC Operation

- Hesitation during warm-up can be caused by:
 - Heat stove tube disconnected.
 - Vacuum diaphragm motor inoperative (open to snorkel).
 - No manifold vacuum.
 - Damper door does not move.
 - Missing air cleaner to carburetor seal.
 - Missing air cleaner cover seal or loose cover.
 - Loose air cleaner.
- Lack of power, sluggish or spongy, on a hot engine can be caused by:
 - Damper door does not open to outside air.
 - Temperature sensor doesn't bleed off vacuum.

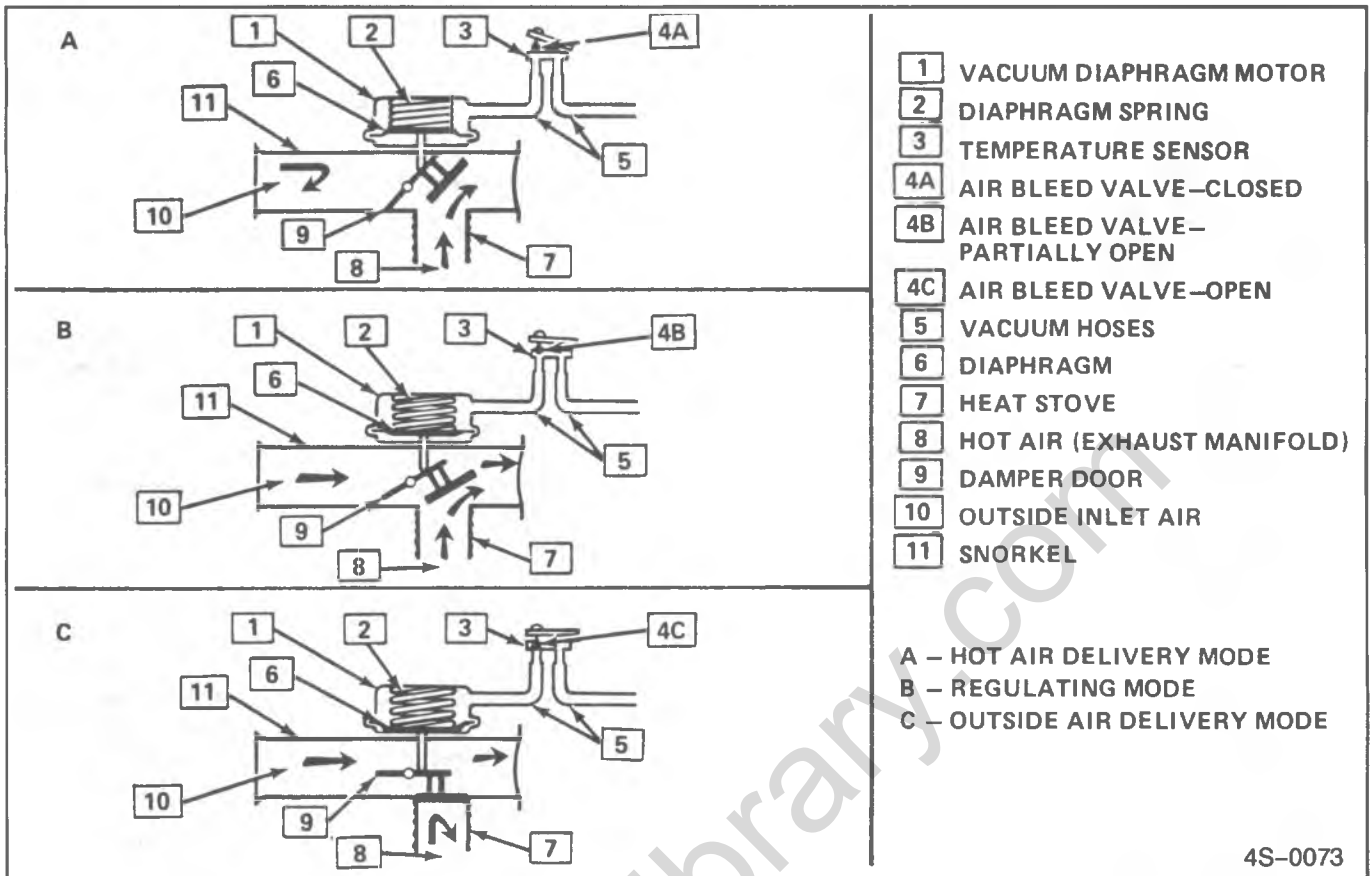

Figure 34—THERMAC Operation

DIAGNOSIS OF THERMAC

THERMAC AIR CLEANER CHECK

1. Inspect system to be sure all hoses and heat stove tube are connected. Check for kinked, plugged or deteriorated hoses.
2. Check for presence and condition of air cleaner-to-carburetor gasket seal.
3. With air cleaner assembly installed, damper door should be open to outside air.
4. Start engine. Watch damper door in air cleaner snorkel. When engine is first started, damper door should move and close off outside air. As air cleaner warms up, damper door should open slowly to outside air.

5. If the air cleaner fails to operate as described above, perform vacuum motor check. If it operates, the door may not be moving at the right temperature. If the driveability problem is during warm-up, make the temperature sensor check below.

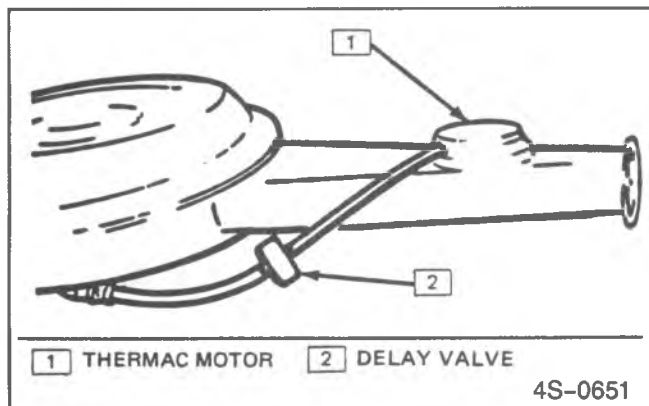

1 THERMAC MOTOR 2 DELAY VALVE

4S-0651

Figure 35—THERMAC Delay Valve

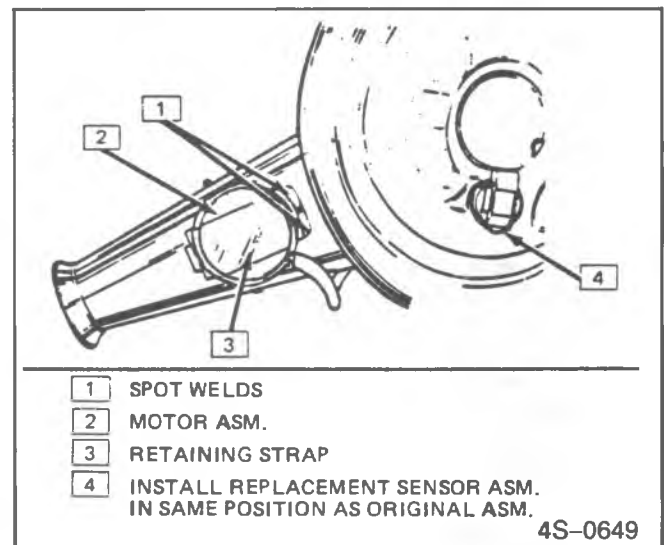

- 1 SPOT WELDS
- 2 MOTOR ASM.
- 3 RETAINING STRAP
- 4 INSTALL REPLACEMENT SENSOR ASM. IN SAME POSITION AS ORIGINAL ASM.

4S-0649

Figure 36—Replacing Vacuum Diaphragm Motor

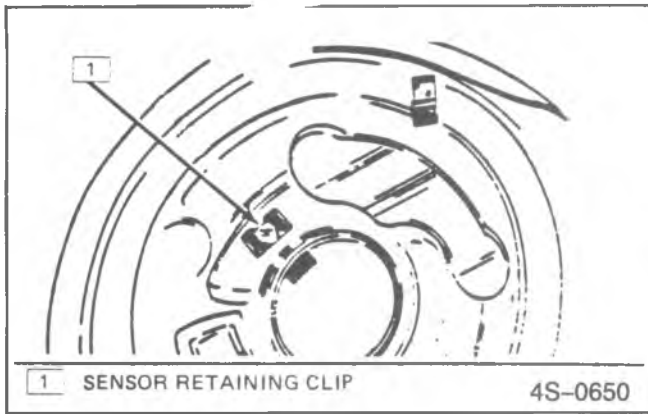

Figure 37—Replacing THERMAC Sensor Retaining Clip

VACUUM MOTOR CHECK

1. With engine off, disconnect vacuum hose at vacuum diaphragm motor.
2. Apply at least 23 kPa (7 in. Hg) of vacuum to the vacuum diaphragm motor. Damper door should completely block off outside air when vacuum is applied. If not, check to see if linkage is hooked up correctly.
3. With vacuum still applied, trap vacuum in vacuum diaphragm motor by bending hose. Damper door should remain closed. If not, replace vacuum diaphragm motor assembly. (Failure of the vacuum diaphragm motor assembly is more likely to be caused from binding linkage or a corroded snorkel than from a failed diaphragm. This should be checked first before replacing the diaphragm.)
4. If vacuum motor checks OK, check vacuum hoses and connections. If OK, replace the temperature sensor.

TEMPERATURE SENSOR CHECK

1. Start test with air cleaner temperature below 30°C (86°F). If engine has been run recently, remove air cleaner cover and place thermometer as close as possible to the sensor. Let air cleaner cool until thermometer reads below 30°C (86°F) about 5 to 10 minutes. Reinstall air cleaner on engine and continue to Step 2.
2. Start and idle engine. Damper door should move to close off outside air immediately if engine is cool enough. When damper door starts to open the snorkel passage (in a few minutes), remove air cleaner cover and read thermometer. It must read about 55°C (131°F).
3. If the damper door is not open to outside air at temperature indicated, temperature sensor is malfunctioning and must be replaced.

ON-VEHICLE SERVICE — THERMAC

AIR CLEANER ELEMENT

- ↔** Remove or Disconnect
1. Air cleaner.
 2. Old element.

↔ Install or Connect

1. New element.
2. Air cleaner cover. Do not over-torque nut (install finger-tight).

VACUUM DIAPHRAGM MOTOR (Figure 36)

↔ Remove or Disconnect

1. Air cleaner.
2. Vacuum hose from motor.
3. Drill out the two spot welds with a 1.6 mm (1/16-inch) drill, then enlarge as required to remove the retaining strap. Do not damage the snorkel tube.
4. Motor retaining strap.
5. Lift up motor, cocking it to one side to unhook the motor linkage at the control damper assembly.

↔ Install or Connect

1. Drill a 2.8 mm (7/64-inch) hole in snorkel tube at center of vacuum motor retaining strap.
2. Vacuum motor linkage into control damper assembly.
3. Use the motor retaining strap and sheet metal screw provided in the motor service package to secure motor to the snorkel tube. Make sure the screw does not interfere with the operation of the damper assembly. Shorten screw if required.
4. Vacuum hose to motor and install air cleaner.

SENSOR (Figure 37)

↔ Remove or Disconnect

1. Air cleaner.
2. Hoses at sensor.
3. Pry up tabs on sensor retaining clip. Remove clip and sensor from air cleaner. Note position of sensor for installation.

PARTS INFORMATION

PART NAME	GROUP
Air Cleaner	3,402
Element (Paper)	3,410
Nut, A/CI	3,403
Seal, Air Cleaner	3,403
Sensor, A/CI	3,415
Motor, A/CI Vac Diaph	3,415
Tube, Eng Air Heat Stove	3,417
Stove, Eng Air Heat	3,417

THROTTLE RETURN CONTROL (TRC) SYSTEM

GENERAL DESCRIPTION

PURPOSE

The TRC system (figure 38), used on V8 heavy duty emission vehicles, consists of three major components:

- Throttle Lever Actuator — Mounted as part of the carburetor assembly, this device opens the primary throttle plates a preset amount in excess of curb idle, when engine vacuum is applied to it. This actuating vacuum is controlled by a separate solenoid vacuum control valve.
- Solenoid Vacuum Control Valve — Mounted separately from the carburetor, this off-on valve is held open, above a preset nominal engine speed, by a signal from an engine speed sensor. The valve, when open, allows a vacuum signal to be applied to the throttle lever actuator as long as the preset engine speed is exceeded.
- Engine Speed Switch — Mounted separately from the solenoid vacuum control valve, this switching device monitors engine speed at the distributor and supplies a continuous electrical signal to the solenoid vacuum control valve as long as the preset engine speed is exceeded.

DIAGNOSIS OF TRC

Check hoses for cracking, abrasion, or deterioration and replace as necessary. Check for shorted or broken wires and be sure that electrical connectors are fully engaged at the distributor, speed switch, and control valve. Check system function for proper operation and adjust as necessary.

1. Connect precision tachometer (capable of resolving 10 rpm) to the distributor "TACH" terminal.
2. Start engine and advance throttle to indicated 1890 rpm. Throttle lever actuator should be extended at this speed.
3. Reduce throttle opening to indicated 1700 rpm. Throttle lever actuator should be retracted at this speed.
4. If the throttle lever actuator operates outside of the 1700 to 1890 rpm limits, the speed switch is out of calibration and should be replaced.
5. If the actuator does not operate at any speed, proceed with the following steps.
 - a. With a voltmeter, check for voltage at the control valve and speed switch. This is accomplished by connecting the negative probe of the voltmeter to the engine "ground" and inserting the positive probe in the connector cavity of the voltage source wire. A voltage of 12–14 volts should be measured at this terminal on both the valve and speed switch. When making this measurement, it is not necessary to unplug the connector from its component. The voltmeter probe can be inserted in the connector body on the wire side of the connector to contact the metal terminal.

- b. If voltage is present at one device and not the other, repair the engine wiring harness as required.
- c. If voltage is not present at either device, check the engine harness connections at the distributor and/or bulkhead connector. Repair as required.
- d. If the proper voltage exists at each device, to check for proper solenoid valve operation, "ground" the valve-to-switch connecting wire terminal at the solenoid connector, using a jumper wire. The throttle lever actuator should extend (engine running).
- e. If it does not extend, remove the hose from the solenoid side port that connects to the actuator hose. Visually, check the orifice in this port for plugging. Clear the orifice as required. If not plugged, replace the solenoid vacuum control valve.
- f. If the actuator extends in Step D, ground the valve-to-switch wire terminal at the speed switch. If it does not extend, repair the wire connecting the speed switch and valve. If it does extend, check the speed switch ground wire for "ground" — it should read 0 volts when checked with a voltmeter, with the engine running, check the speed switch-to-distributor wire for proper connection. With both the ground and distributor wires properly connected, and if the actuator does not extend when operating above 1890 rpm, replace the speed switch.

THROTTLE LEVER ACTUATOR — CHECKING PROCEDURE

1. Disconnect valve to actuator hose at valve and connect to an external vacuum source equipped with a vacuum gage.
2. Apply 68 kPa (20" Hg) vacuum to the actuator and seal off the vacuum source. If the vacuum gage reading drops, then the actuator is leaking and must be replaced.
3. To check the actuator for proper operation:
 - a. Check the throttle lever, shaft, and linkage to be sure that they operate freely without binding or sticking.
 - b. Start engine and run until warmed up and idle is stable. Note idle rpm.
 - c. Apply 68 kPa (20" Hg) vacuum to the actuator. Manually, open the throttle slightly and allow to close against the extended actuator plunger. Note the engine rpm.
 - d. Release and reapply 68 kPa (20" Hg) vacuum to the actuator and note the rpm to which the engine speed increased (do not assist the actuator).
 - e. If the rpm obtained in Step D is not within 150 rpm of that obtained in Step C, then the actuator plunger may be binding due to dirt, corrosion, varnish, etc., or the actuator

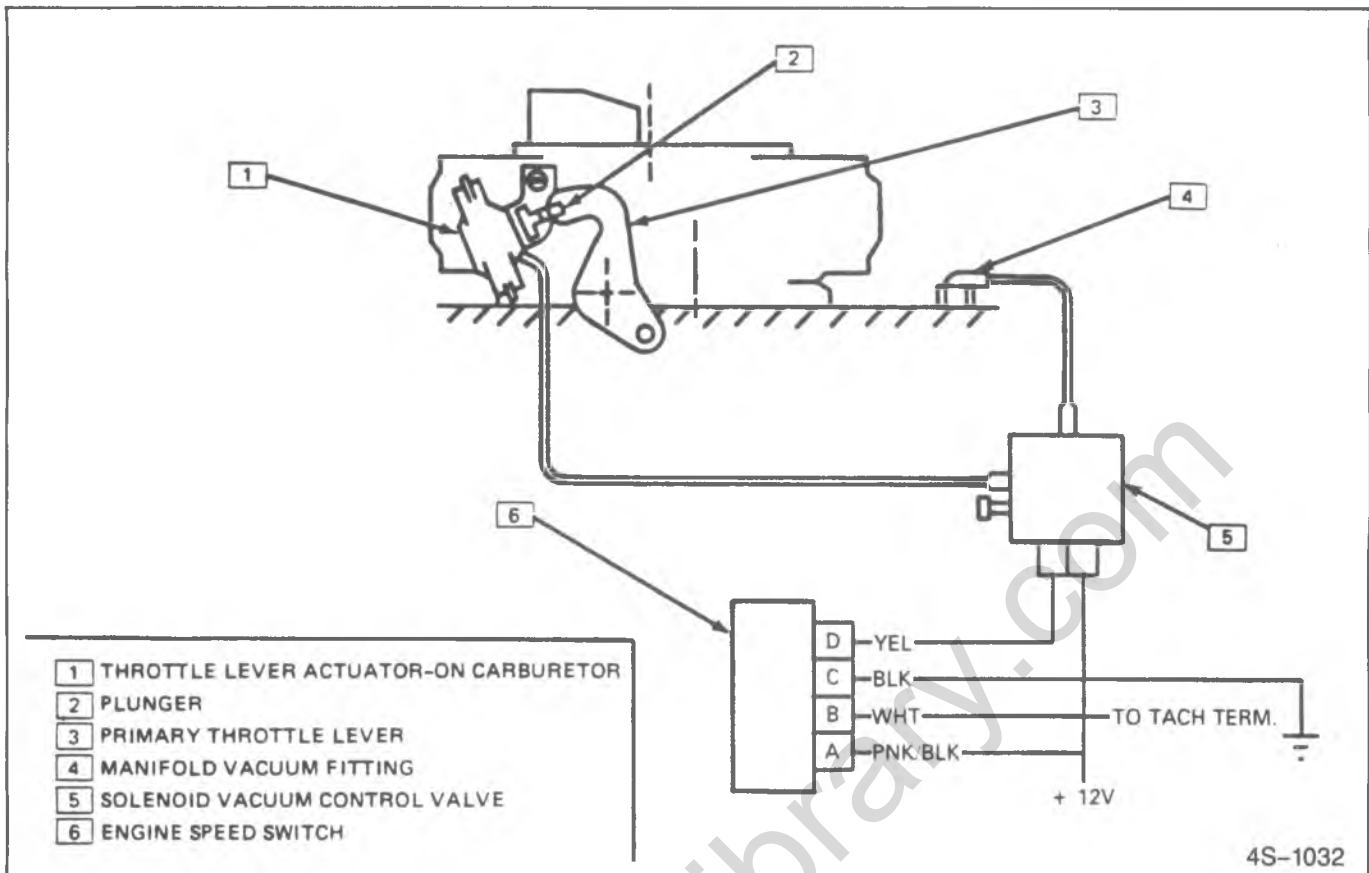

Figure 38—Throttle Return Control System

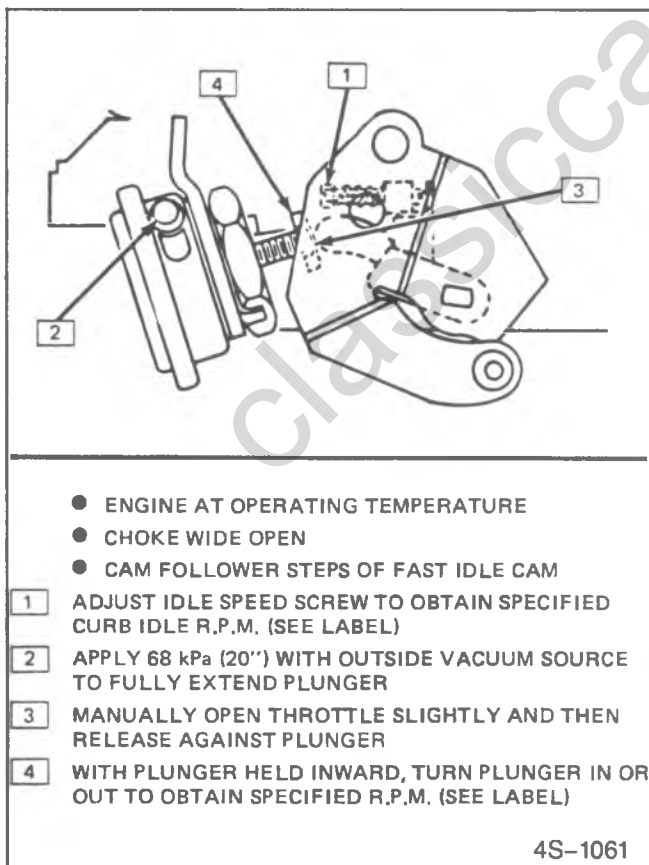

Figure 39—Throttle Lever Actuator Adjustment

diaphragm may be too weak. If binding is not indicated, or cannot be corrected, then the actuator must be replaced.

- f. Release the vacuum from the actuator and the engine speed should return to within 50 rpm of the idle speed noted in Step 2. If it does not, the plunger may be binding due to dirt, corrosion, varnish, etc. If the problem cannot be corrected, the actuator must be replaced.
- g. If the engine rpm noted in Step 3 is not within the specified TRC speed range, the TRC actuator must be adjusted. Refer to figure 39 and Vehicle Emission Control Information label for adjustment of the throttle lever actuator.

ON-VEHICLE SERVICE — TRC

THROTTLE KICKER

 **Adjust.**

Refer to figure 38 and Vehicle Emission Control Information label for adjustment of the throttle kicker.

 **Remove or Disconnect(Figure 40)**

1. Vacuum hose.
2. Bracket and throttle kicker.
3. Tab locking washer.
4. Throttle kicker.

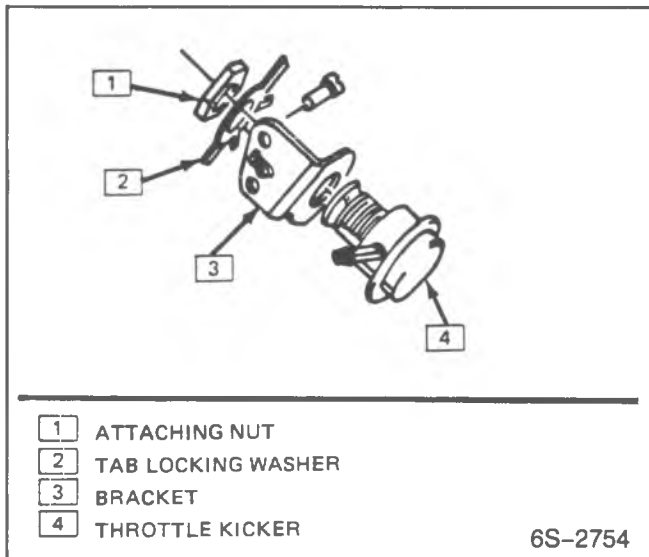

Figure 40—Throttle Kicker

↔ Install or Connect

1. Throttle kicker.
2. Tab locking washer — do not lock.
3. Bracket and throttle kicker.
4. Adjust throttle kicker.
5. Lock tab washer.
6. Vacuum hose.

ENGINE SPEED SWITCH (Figure 41)

↔ Remove or Disconnect

1. Electrical connector.
2. Engine speed switch,

↔ Install or Connect

1. Engine speed switch.
2. Electrical connector.

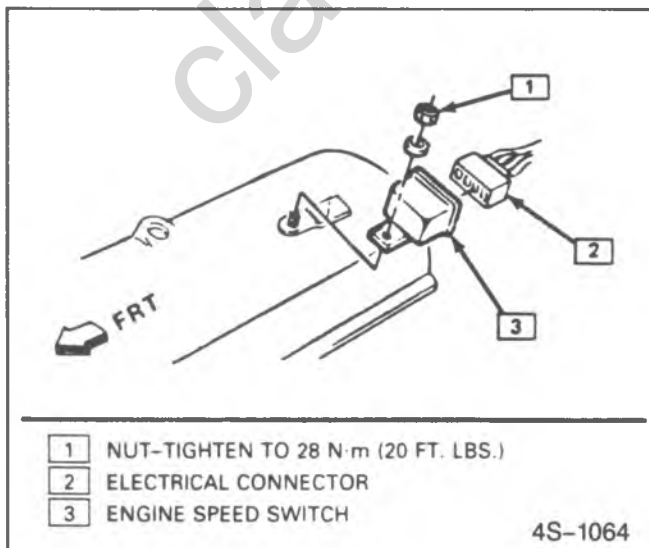

Figure 41—Engine Speed Switch

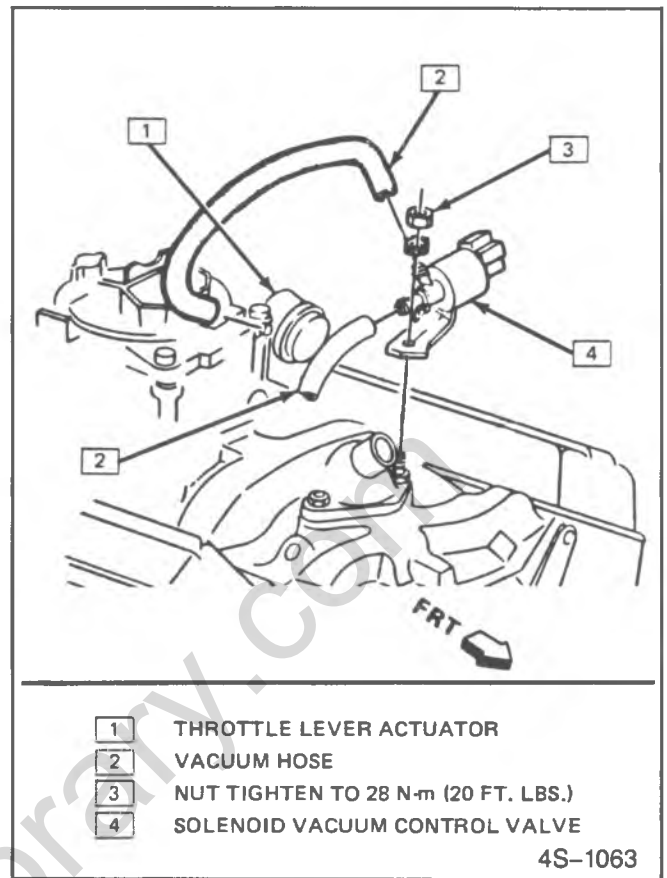

Figure 42—Solenoid Vacuum Control Valve

SOLENOID VACUUM CONTROL VALVE (Figure 42)

↔ Remove or Disconnect

1. Electrical connector.
2. Vacuum hoses.
3. Solenoid vacuum control valve.

↔ Install or Connect

1. Solenoid vacuum control valve.
2. Vacuum hoses.
3. Electrical connector.

PARTS INFORMATION

PART NAME	GROUP
Throttle Kicker.....	Carb. Chart
Engine Speed Switch.....	3,440
Solenoid Vacuum Control Valve.....	3,440

classiccarylbrary.com

SECTION 6E9

DRIVABILITY AND EMISSIONS—DIESEL

CONTENTS

<u>SUBJECT</u>	<u>PAGE</u>
Description6E9- 2
Crankcase Ventilation System6E9- 4
CDR Valve Check6E9- 4
CDR Valve Replacement6E9- 5
Exhaust Gas Recirculation System6E9- 5
EGR System Check6E9- 6
EGR Valve Replacement6E9- 7
EPR Vacuum Actuator Replacement6E9- 7
EPR/EGR Solenoid Replacement6E9- 7
Throttle Position Switch Adjustment6E9- 8
Vacuum Regulator Valve6E9- 9
VRV Adjustment6E9- 9
Specifications6E9-10
Special Tools6E9-10

All new General Motors vehicles are certified by the United States Environmental Protection Agency as conforming to the requirements of the regulations for the control of air pollution from new motor vehicles. This certification is contingent on certain adjustments being set to factory standards. In most cases, these adjustment points either have been permanently sealed and/or made inaccessible to prevent indiscriminate or routine adjustment in the field. For this reason, the factory procedure for temporarily removing plugs, caps, etc., for purposes of servicing the product must be strictly followed and, wherever practicable, returned to the original intent of the design.

For vehicles sold in Canada, also refer to the appropriate Canadian Service Manual Supplement.

DESCRIPTION

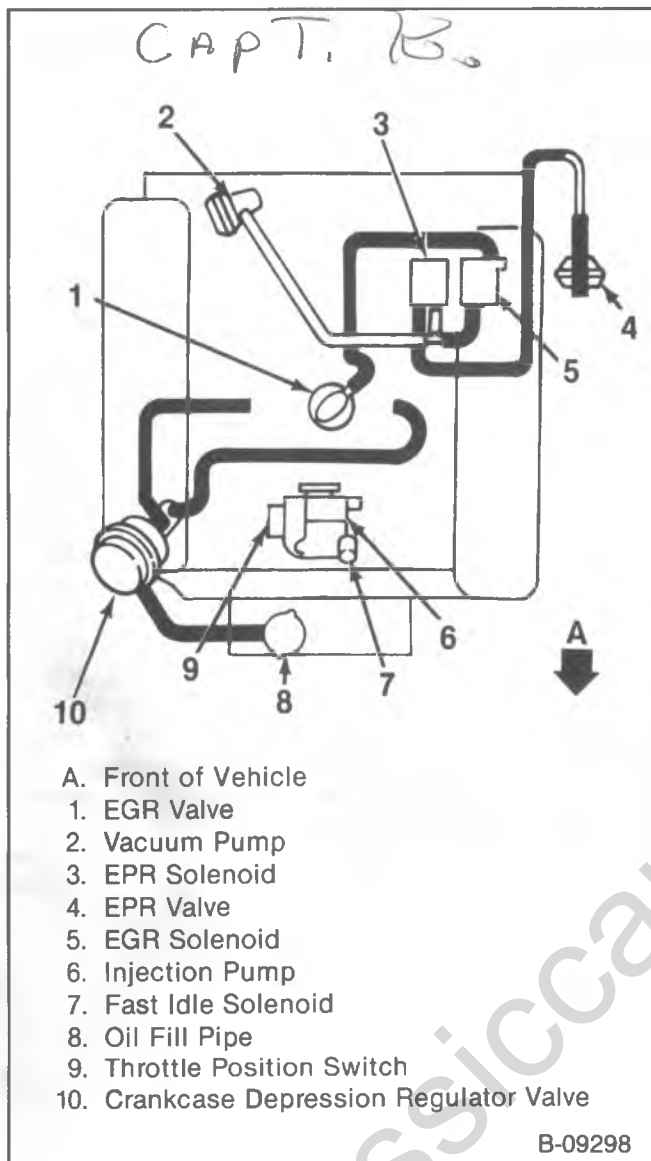

Figure 1—R-V Emission System with Light Duty Emissions

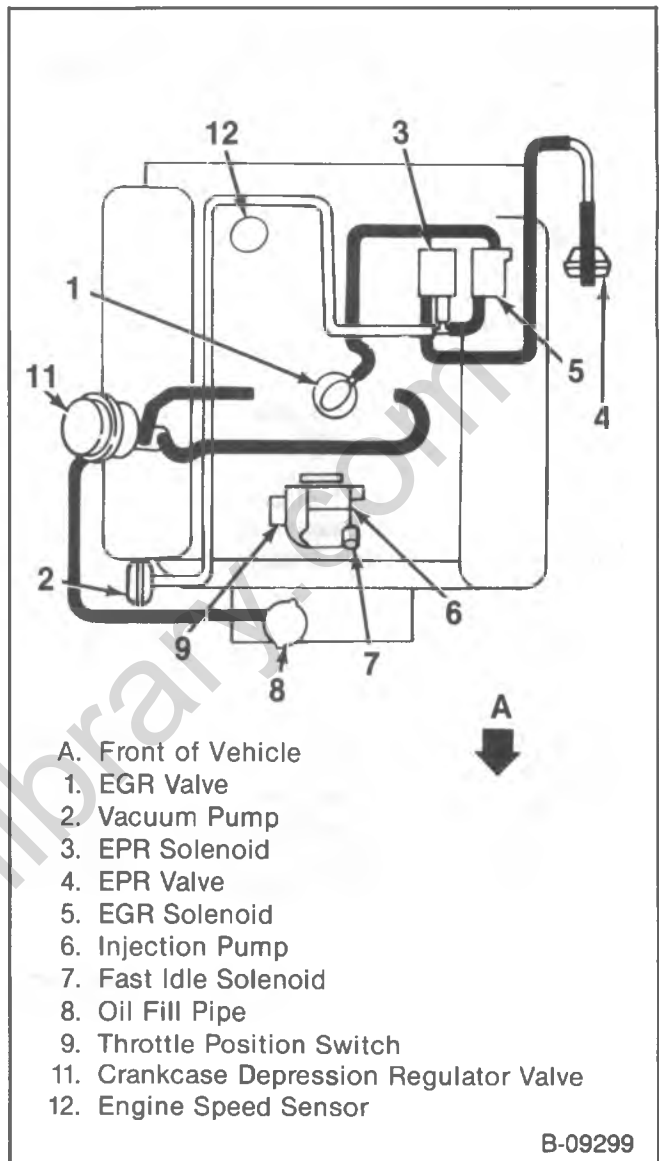

Figure 2—G-Van Emission System with Light Duty Emissions

The 6.2L diesel engine has controls to reduce exhaust emissions while maintaining good drivability and fuel economy. The light duty emission engine (RPO LH6) has Crankcase Ventilation and Exhaust Gas Recirculation

(figures 1 and 2). The heavy duty emission engine (RPO LL4) has Crankcase Ventilation and a Vacuum Regulator Valve (figure 3).

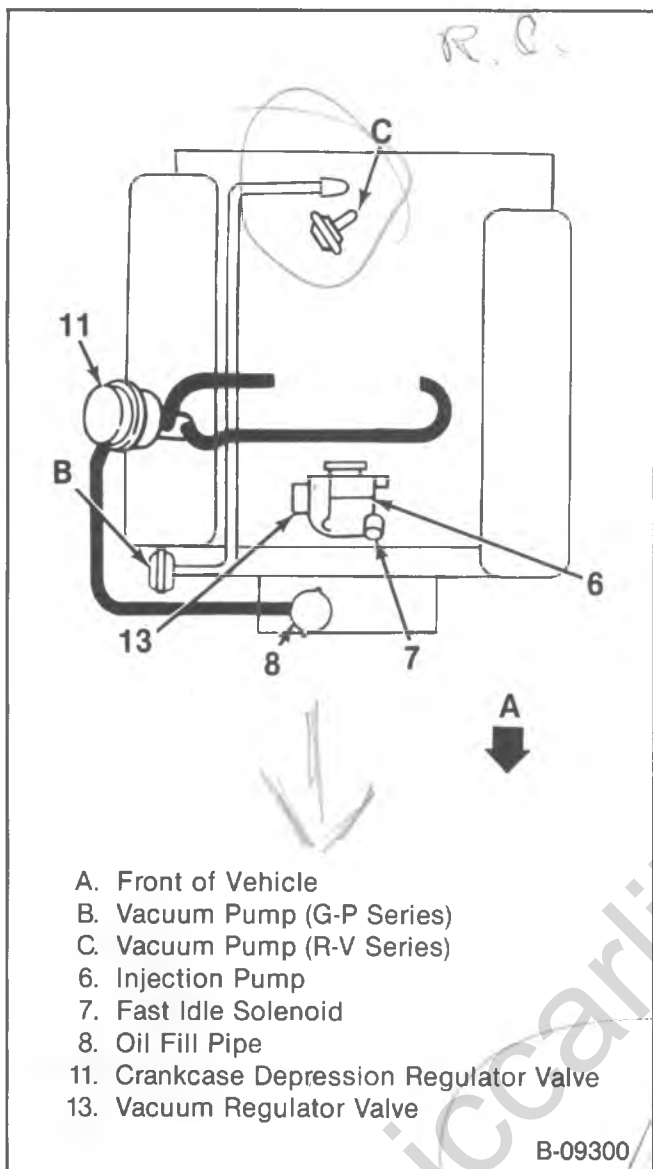

Figure 3—Heavy Duty Emission System

CRANKCASE VENTILATION SYSTEM

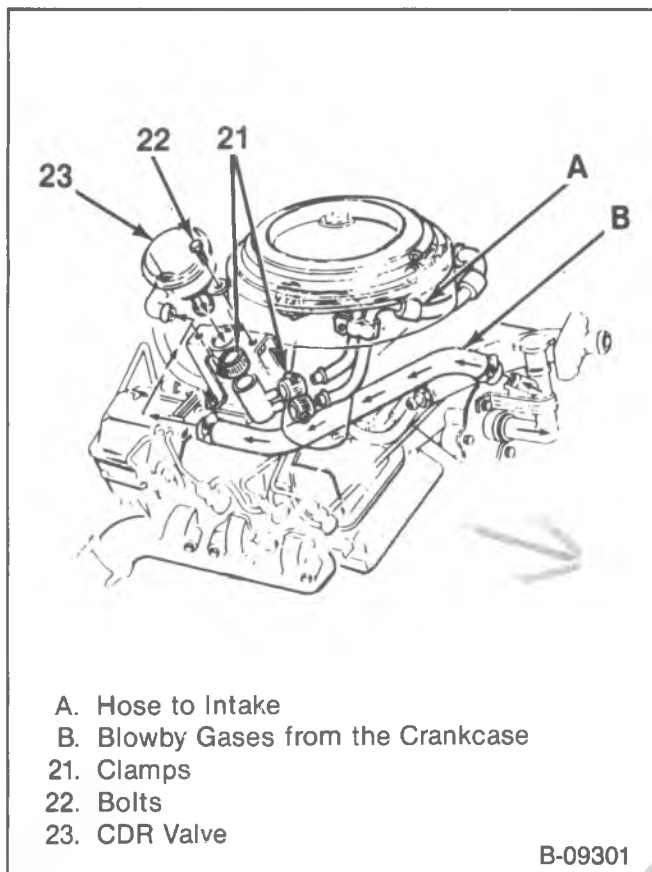

Figure 4—Crankcase Ventilation System

The crankcase ventilation system is used on all 6.2L diesel engines to reduce crankcase pressure at idle (figure 5). This reduced pressure reduces engine oil leaks. The system consists of connecting hoses and a Crankcase Depression Regulator (CDR) valve located at the front right cylinder head.

The CDR valve is used to regulate the flow of crankcase gases back into the engine. The valve limits vacuum in the crankcase as the gases are drawn from the oil fill pipe and into the intake manifold.

Intake manifold vacuum acts against a spring loaded diaphragm to control the flow of crankcase gases (figure 5). Higher intake vacuum pulls the diaphragm closer to the top of the outlet tube. This reduces the amount of gases being drawn from the crankcase and also decreases the vacuum in the crankcase. As the intake vacuum decreases, the spring pushes the diaphragm away from the top of the outlet tube. This allows more crankcase gases to flow to the intake manifold.

Refer to MAINTENANCE AND LUBRICATION (SEC. 0B) for diesel crankcase ventilation system maintenance requirements.

CDR VALVE CHECK

The purpose of the CDR valve is to maintain 0.75-1.0 kPa (3-4 inches of water) vacuum in the crankcase. Too little vacuum may force oil leaks while too much vacuum will pull oil into the air crossover.

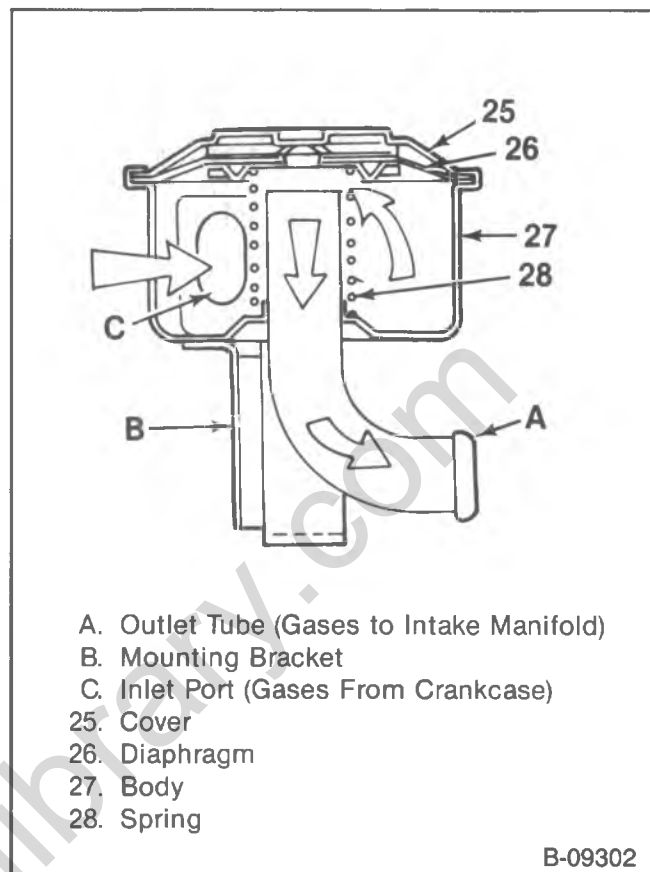

Figure 5—CDR Valve Operation

The CDR valve is checked with a water manometer. The U-tube manometer indicates pressure or vacuum by the difference in the height of the two columns of the fluid (figure 6).

Inspect

1. Connect one end of the manometer to the oil dipstick hole.
 - The other end of the manometer is vented to atmosphere.
2. Run the engine at idle.
3. The reading should be about 0.25 kPa (1-inch of water) pressure at idle to 0.5-1.25 kPa (2-5 inches of water) vacuum at full load.
 - Add the amount that the manometer column travels up to the amount the other column travels down to get the total pressure or vacuum.

As an example; 12.7 mm (one-half inch) above zero plus 12.7 mm (one-half inch) below zero gives a 25.4 (one-inch) vacuum reading (figure 6).

CDR VALVE REPLACEMENT

↔ Remove or Disconnect (Figure 4)

1. Clamps (21) from the hoses.
2. Hoses.
3. Bolts (22).
4. CDR valve (23).

↔ Install or Connect (Figure 4)

1. CDR valve to the bracket.
2. Bolts.
3. Hoses.
4. Clamps.

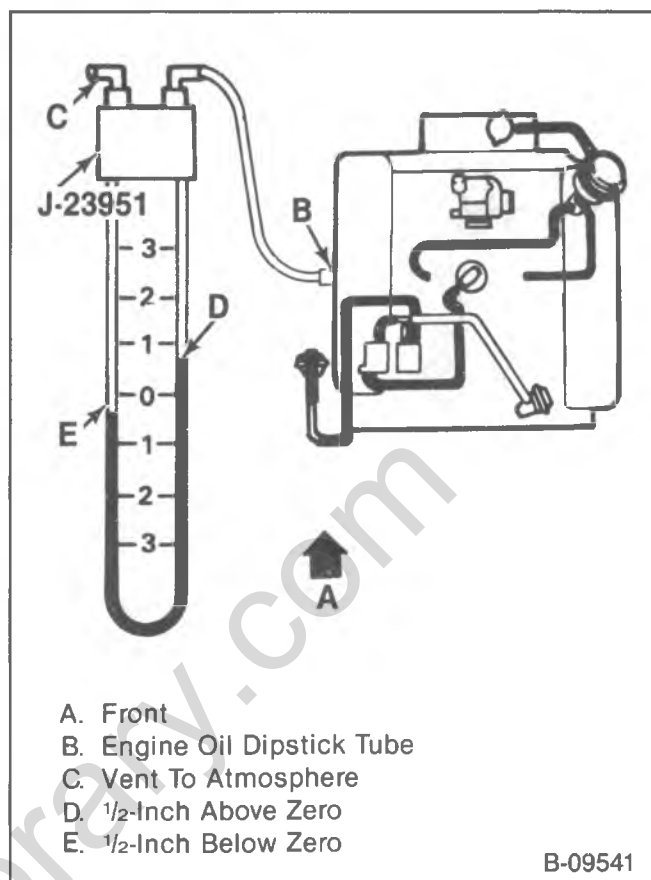

Figure 6—CDR Valve Test

EXHAUST GAS RECIRCULATION SYSTEM

The Exhaust Gas Recirculation (EGR) system is used on 6.2 L diesel engines with Federal light duty emissions. The EGR system (figure 7) consists of:

- EGR valve.
- Exhaust Pressure Regulator (EPR).
- EGR solenoid.
- EPR solenoid.
- Throttle Position Switch (TPS).
- Vacuum Pump.

Nitrogen oxides (NOx) are formed at high combustion temperatures. The purpose of the EGR system is to reduce these emissions.

Exhaust gases are introduced into the intake manifold through the EGR valve (figure 8). These exhaust gases act as an inert (non-combustible) ingredient in the combustion chamber. This reduces NOx through lower combustion temperatures.

The EPR valve is located between the exhaust manifold and the exhaust pipe (figure 9). It increases exhaust backpressure during idle to increase exhaust flow through the EGR system. The EPR valve is normally open.

The TPS is mounted on the throttle shaft of the injection pump. As the throttle is opened, one switch contact opens a circuit and another switch closes a circuit at calibrated throttle angles.

At idle, the EPR solenoid is energized through the TPS, allowing vacuum to close the EPR valve. This increases exhaust backpressure. At a calibrated throttle angle, the EPR solenoid is de-energized and the EPR valve is opened.

At idle, the EGR solenoid is de-energized, allowing vacuum to open the EGR valve. At a calibrated throttle angle, the EGR solenoid is energized. This cuts off vacuum to the EGR valve and the valve closes.

The EPR solenoid is normally de-energized and the EGR solenoid is normally energized. The EPR solenoid is de-energized before, or at the same time that the EGR solenoid is energized.

There are three different cams used to change the time when the EPR valve opens and the EGR valve closes.

- Blue Cam — 0 degree difference.
- Black Cam — 5 degree difference.
- Red Cam — 10 degree difference.

Refer to figure 10 for a summary of EGR and EPR operation.

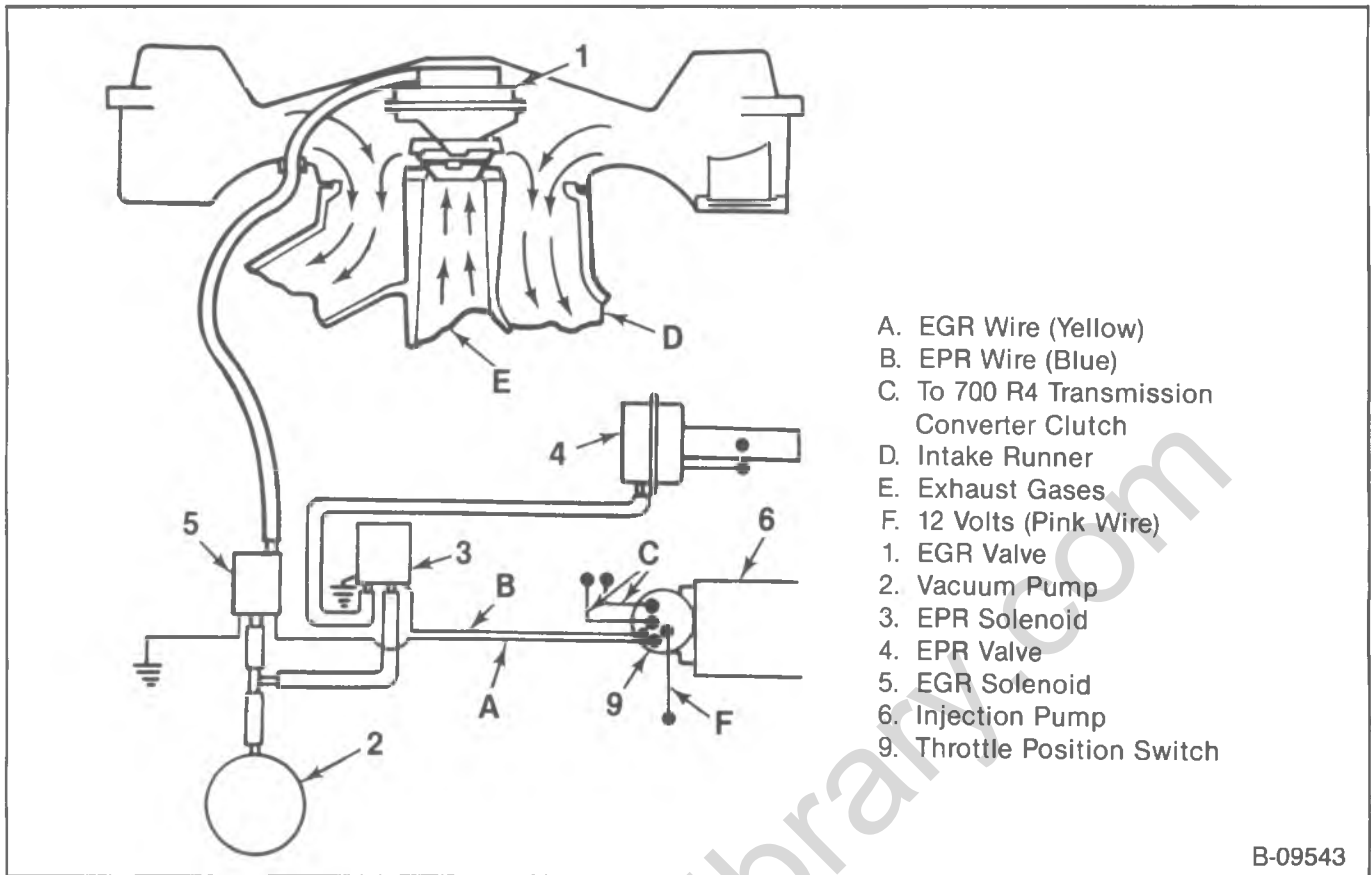

B-09543

Figure 7—EGR System

EGR SYSTEM CHECK

Heavy black exhaust smoke during acceleration usually indicates a problem in the system.

1. Start the engine and bring it to operating temperature.
2. Remove the air cleaner cover to observe EGR valve operation.
3. With the engine at idle, the EGR valve should be open (valve head in the up position and noticeable exhaust noise). If not, check and correct any

electrical and hose connection which may be loose and/or disconnected.

4. Remove the vacuum hose from the EGR valve. The valve head should drop with a noticeable reduction in noise. Connect the hose.
5. The hose to the EGR valve should have 67.5 kPa (20-inches of Hg) vacuum at idle. If vacuum is not present, check the output of the vacuum pump at the pump. The pump should produce a minimum of 67.5 kPa (20-inches of Hg) vacuum.
6. If vacuum is present at the EGR valve, but the valve does not operate as the hose is put on and taken off, the EGR valve is stuck and should be checked and replaced if necessary.
7. Manually operate the throttle lever at the injection pump through about 15 to 20 degrees of travel. The EGR valve should close when the TPS reaches the calibrated point.
8. Check the pink wire to the TPS for 12 volts (key on). If 12 volts is not present, check for loose connections, open wires, or a blown fuse.
9. With the key on, the blue wire from the TPS should also have 12 volts. The blue wire feeds the EPR solenoid. If the pink wire has 12 volts at idle, but the blue wire does not, the TPS is inoperative and should be changed.
10. With the engine off and the key on, operate the throttle through 20 degrees of travel. At about 15 degrees, the TPS will stop sending 12 volts to the blue wire (EPR). At about 20 degrees, the TPS will supply 12 volts to the yellow wire (EGR). If not, the TPS is inoperative.

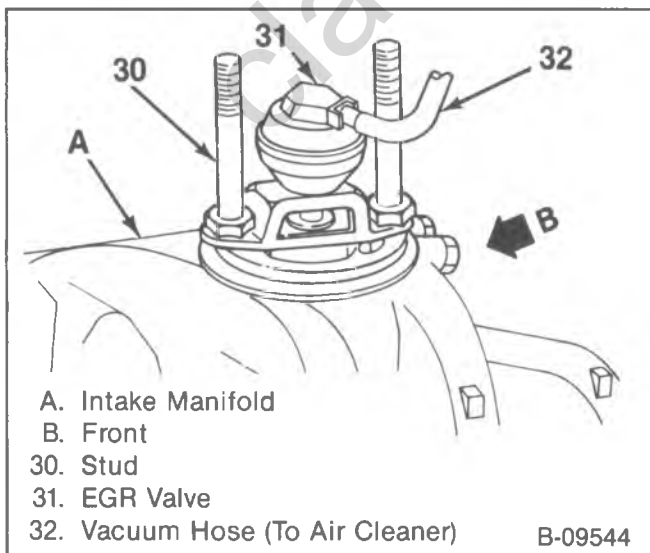

B-09544

Figure 8—EGR Valve

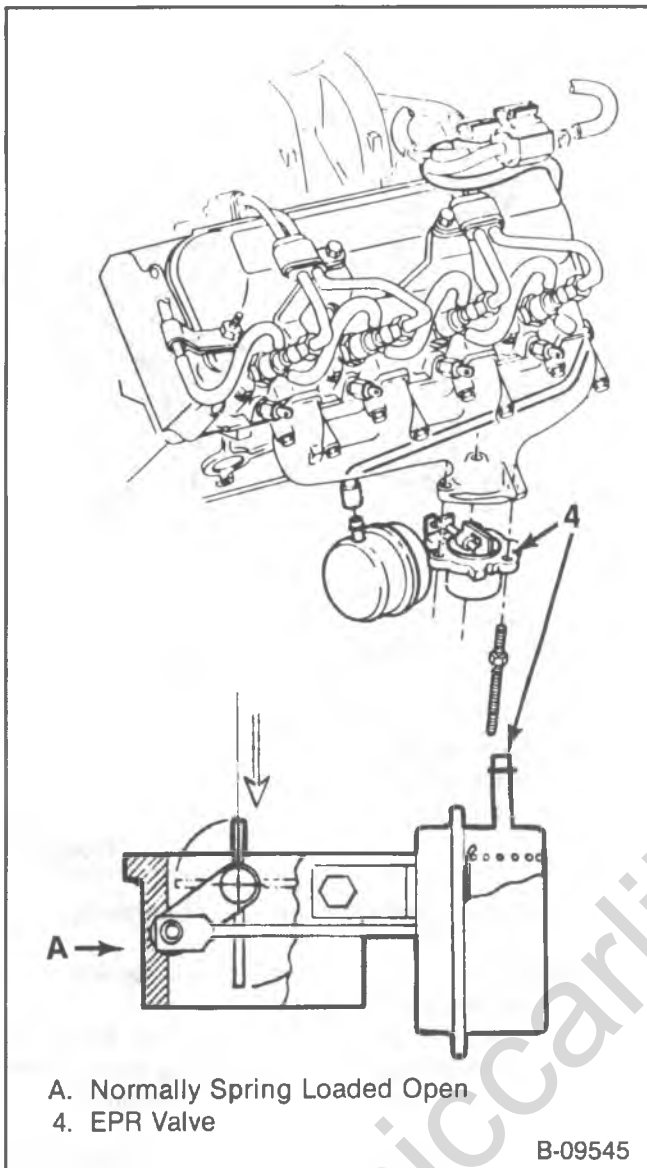

Figure 9—EPR Valve

Throttle Position	EGR Valve	EGR Solenoid	EPR Valve	EPR Solenoid
Idle to 15° Throttle	Open	Not Energized (Vacuum to Valve)	Closed	Energized (Vacuum To Valve)
15° to 20° Throttle	Open	Not Energized (Vacuum to Valve)	Open	Not Energized (No Vacuum to Valve)
20° to Full Throttle	Closed	Energized (No Vacuum to Valve)	Open	Not Energized (No Vacuum to Valve)

F-00001

Figure 10—EGR System Operation

11. Make sure the electrical connections are made at the EGR/EPR solenoid assembly and that the hoses are routed correctly.
12. If there is vacuum at the solenoid assembly and the solenoids are receiving the proper electrical signal but operation of the TPS does not operate the EGR and/or EPR valve(s), the solenoid assembly is inoperative and should be replaced.

EGR VALVE REPLACEMENT

↔ Remove or Disconnect (Figure 8)

1. Air cleaner cover.
2. Vacuum hose from the EGR valve.
3. Studs.
4. EGR valve.

↔ Install or Connect (Figure 8)

1. EGR valve.
2. Studs.
 - Seal the studs with Loctite 272 or equivalent.
3. Vacuum hose.
4. Air cleaner cover.

EPR VACUUM ACTUATOR REPLACEMENT

↔ Remove or Disconnect (Figure 9)

1. The vacuum hose from the actuator.
2. Clip from the valve lever.
3. Bolt holding the actuator to the valve.
4. Actuator from the EPR valve.

↔ Install or Connect (Figure 9)

1. Actuator to the EPR valve.
2. Bolt.
3. Clip.
4. The vacuum hose.

EPR/EGR SOLENOID REPLACEMENT

↔ Remove or Disconnect (Figure 11)

1. The vacuum hoses.
 - Observe the hose routings for proper installation.
2. Electrical connectors.
3. Bolt (35).
4. Solenoid assembly.

↔ Install or Connect (Figure 11)

1. Solenoid assembly.
2. Bolt (35).
3. Electrical connectors.
4. The vacuum hoses.

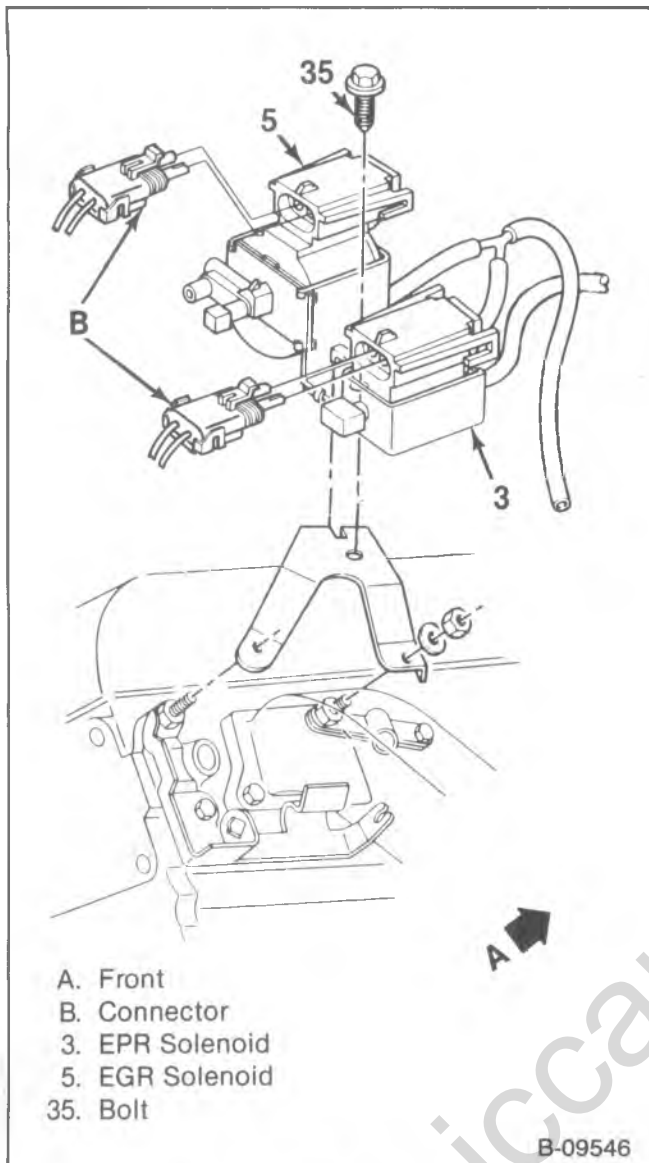

Figure 11—EGR/EPR Solenoid Assembly

THROTTLE POSITION SWITCH ADJUSTMENT

Tool Required:
J-33043, Gage Block.

1. Disconnect the throttle position switch (TPS) connector.
2. Loosen the mounting screws that hold the TPS.
3. Connect an ohmmeter or test light to the IGN (pink) and EGR (yellow) terminals of the TPS (figure 12).
4. Insert the proper "switch closed" gage block between the gage boss on the injection pump and the wide open stop screw on the throttle shaft (figure 13).
 - Refer to the Emission Control Information label for correct gage block size.
5. Rotate the throttle lever and hold the wide open stop screw against the gage block.
6. Rotate the TPS until there is continuity between the terminals.
7. Hold the TPS and tighten the mounting screws to 6 N·m (53 in. lbs.).

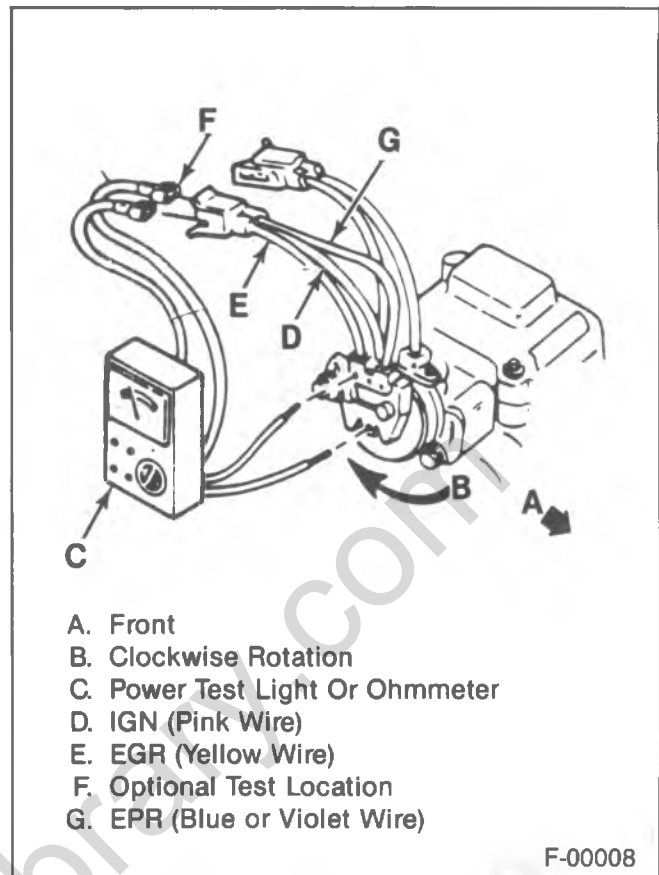

Figure 12—Testing the TPS for Continuity

8. Return the throttle lever to the idle position and remove the gage block.
9. Insert the proper "switch open" gage block and rotate the throttle lever against the block. There should be no continuity. If there is continuity, repeat steps 1 through 9.
 - Refer to the Emission Control Information label for correct gage block size.
10. Remove the gage block and ohmmeter.
11. Connect the TPS connector.

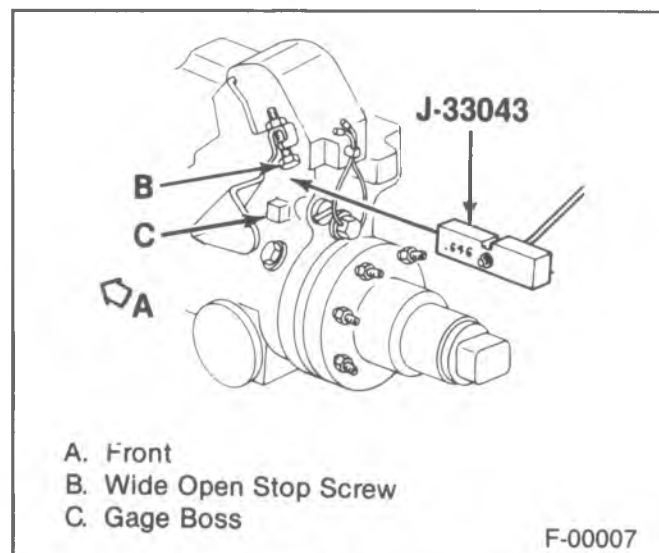

Figure 13—TPS Adjustment Block

VACUUM REGULATOR VALVE

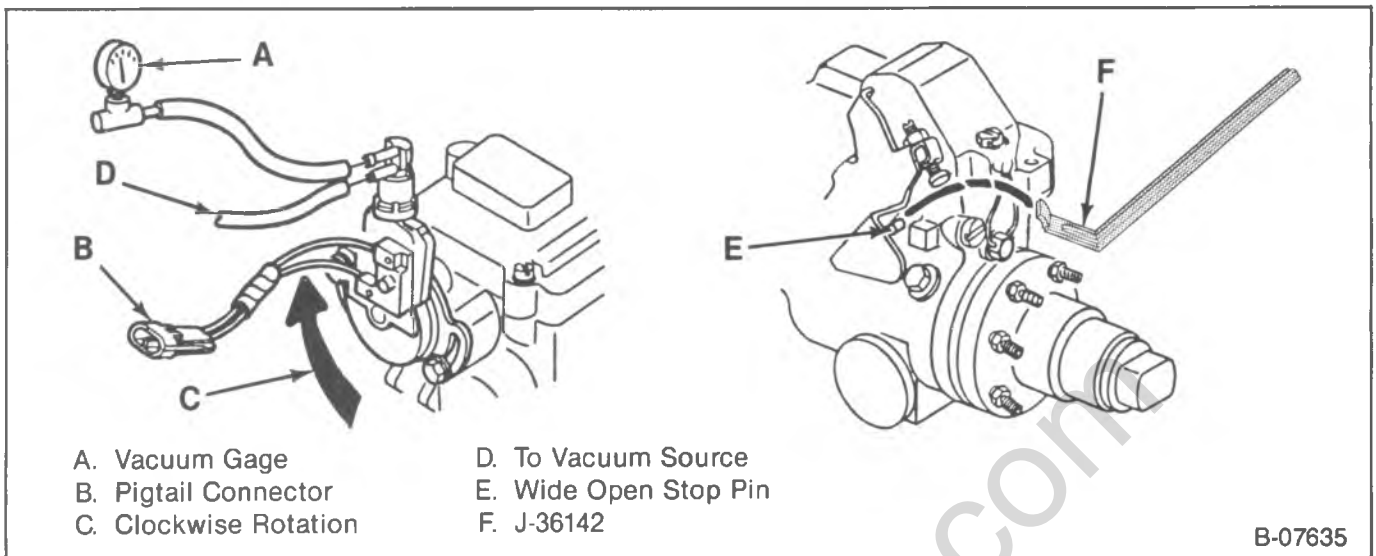

Figure 14—Vacuum Regulator Valve Adjustment

A vacuum regulator valve is used on engines with heavy duty emissions and automatic transmission. The valve regulates the vacuum signal to the vacuum modulator of a 400 automatic transmission. The valve is mounted to the injection pump and vacuum is supplied by the vacuum pump.

VRV ADJUSTMENT

Tool Required:

J-36142, Gage Block.

1. Loosen the vacuum regulator valve so it is free to rotate on the pump.
2. Attach a vacuum source of 67 ± 5 kPa (20-inches Hg. \pm 1.5-inch Hg.) to the bottom vacuum port.
3. Attach a vacuum gage to the top vacuum port (figure 14).
4. Insert the proper gage block between the gage boss on the injection pump and the wide open stop screw on the throttle lever (switch on position) (figure 13).
 - Refer to the Emission Control Information label for correct gage block size.
5. Rotate the throttle shaft and hold it against the gage block.

NOTICE: Valve must be set while rotating the valve body clockwise only.

6. Slowly rotate the vacuum regulator valve body clockwise (facing the valve) until the vacuum gage reads 38.8 ± 2 kPa (11.5 ± 0.6 inches Hg.) Hold the valve body at this position and tighten the mounting screws to 6 N·m (54 in. lbs.).
7. Check by allowing the throttle shaft to return to the idle stop position. Then rotate the throttle shaft back against the gage block and read the vacuum gage. The gage should read 38.8 ± 2 kPa (11.5 ± 0.6 inches Hg). If vacuum is outside of limits, reset the valve.

8. With the valve vacuum set, confirm the detent switch point by reading the resistance between the ignition terminal (pink with black stripe) and the detent terminal (orange).
9. Insert J-36142 between the wide open stop pin and the wide open stop screw on the throttle lever.
10. Rotate the throttle lever against the tool. There should be no continuity (infinite resistance).
11. Release the throttle lever and remove the switch gage tool.
12. Rotate the throttle lever to wide open throttle (the lever stop screw touching the pump stop pin).
13. Check the switch for continuity. The switch must have continuity (1 to 0 ohms) before the throttle reaches the wide open throttle position. If the switch does not meet these specifications, reset the assembly by returning to step 1 and repeating the entire procedure.

SPECIFICATIONS

TPS or VRV Screws.....6 N·m(53 in. lbs.)

SPECIAL TOOLS

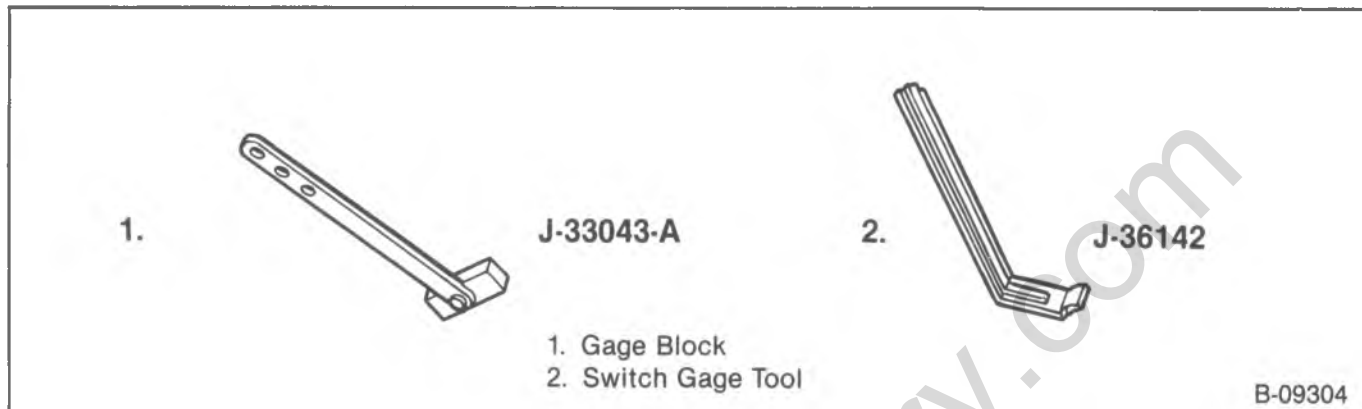

SECTION 6F

EXHAUST

CONTENTS

<u>SUBJECT</u>	<u>PAGE</u>
Description6F- 1
Diagnosis of Exhaust System6F- 2
On-Vehicle Service6F- 2
Inspection6F- 2
Installing Exhaust Parts6F- 2
Catalytic Converter Replacement6F- 4
Specifications6F-10

DESCRIPTION

Exhaust system designs will vary according to model designation and intended use of the vehicle.

The exhaust pipe(s), muffler(s) and tailpipe(s) are standard equipment. The exhaust system uses a ball joint coupling to secure the exhaust pipe to the engine manifold. The ball joint will allow angular movement for alignment purposes. The other connections use a slip joint coupling design with a clamp and U-bolt.

The exhaust system is suspended by hangers attached to the frame members. This will permit some movement of the exhaust system, but should not permit the transfer of noise and vibration into the vehicle.

Heat shields are used to protect both the vehicle and the environment from the high temperatures developed from the exhaust system, especially the catalytic converter.

The catalytic converter is an emission control device added to the gasoline engine exhaust system to reduce hydrocarbon and carbon monoxide pollutants from the exhaust gas stream. The converter contains beads which are coated with a catalytic material containing platinum and palladium. The catalytic converter for the computer command control emission system will also contain rhodium to reduce the level of nitrogen oxides. The catalyst in the converter is not serviceable.

THE CATALYTIC CONVERTER REQUIRES THE USE OF UNLEADED FUEL ONLY.

The diesel engine does not use a catalytic converter, and uses only diesel fuel.

DIAGNOSIS OF EXHAUST SYSTEM

Exhaust system performance complaints, such as excessive back pressure, are noticeable by their effect on engine performance. However, other malfunctioning vehicle components have similar effects on engine performance and are characterized by the same symptoms or complaints. Therefore, it is necessary to refer to the engine diagnosis procedure when attempting to diagnose this type of problem.

NOTICE: Replacement of exhaust system parts **MUST** be OEM standard.

PROBLEM	POSSIBLE CAUSE	CORRECTION
Vibrating or Rattling From Exhaust System	Loose and/or misaligned components.	Align, then tighten connections. Check for damaged hanger or mounting brackets and clamps.
Restricted Exhaust System	<ol style="list-style-type: none"> 1. "Kinked" exhaust tubing. 2. Restriction within the muffler. 3. End of tail pipe obstruction. 4. Plugged catalytic converter (may result from serious engine malfunction). 	<ol style="list-style-type: none"> 1. If possible, repair the damaged condition, otherwise replace the component. 2. If restriction is suspected, remove the muffler and visually check it. Replace muffler if condition is doubtful. 3. Remove the obstruction, or if end is crimped, straighten outlet. 4. Replace the catalytic converter.
Exhaust Leakage and/or Noise	<ol style="list-style-type: none"> 1. Leakage at exhaust component joints and couplings. 2. Improperly installed or misaligned. 3. Exhaust manifold cracked or broken. 4. Leak between exhaust manifold and cylinder head. 5. Damaged or worn seals or packing. 6. Burned or rusted out exhaust pipe heat tube extension. 7. Burned or rusted out exhaust pipe. 8. Burned or blown out muffler. 9. Broken or loose clamps and/or brackets. 	<ol style="list-style-type: none"> 1. Tighten clamps or couplings to specified torque. 2. Align, then tighten connections. 3. Replace the manifold. 4. Tighten the manifold to cylinder head nuts and bolts to specifications. 5. Replace the seals or packing as necessary. 6. Replace the heat tube extensions as required. 7. Replace the exhaust pipe. 8. Replace the muffler assembly. 9. Repair or replace as necessary.

ON-VEHICLE SERVICE

INSPECTION

Inspect exhaust pipes, catalytic converters (if equipped), mufflers and tailpipes for cracked joints, broken welds and corrosion damage that would result in a leaking exhaust system. Inspect the clamps, brackets and insulators for cracks and stripped or corroded bolt threads.

The exhaust system, including heat shields, must be free of leaks, binding, grounding and excessive vibration. These conditions are usually caused by damaged or loose flange bolts, heat shields, brackets or pipes. If any of these conditions exist, check the exhaust system components and alignment. Align and replace as necessary.

INSTALLING EXHAUST PARTS

When installing a new exhaust pipe or muffler and tailpipe, on any model, check for proper alignment. Rattles and noise vibrations in the exhaust system are usually caused by misalignment of parts. When aligning the system, leave all bolts or nuts loose until all parts are properly aligned, then tighten, working from the front to the rear.

Exhaust system hangers, hanger brackets, and clamps which are damaged should be replaced to maintain exhaust system alignment.

 **Important**

- When jacking or lifting the vehicle from the frame side rails, be certain lift pads do not contact the

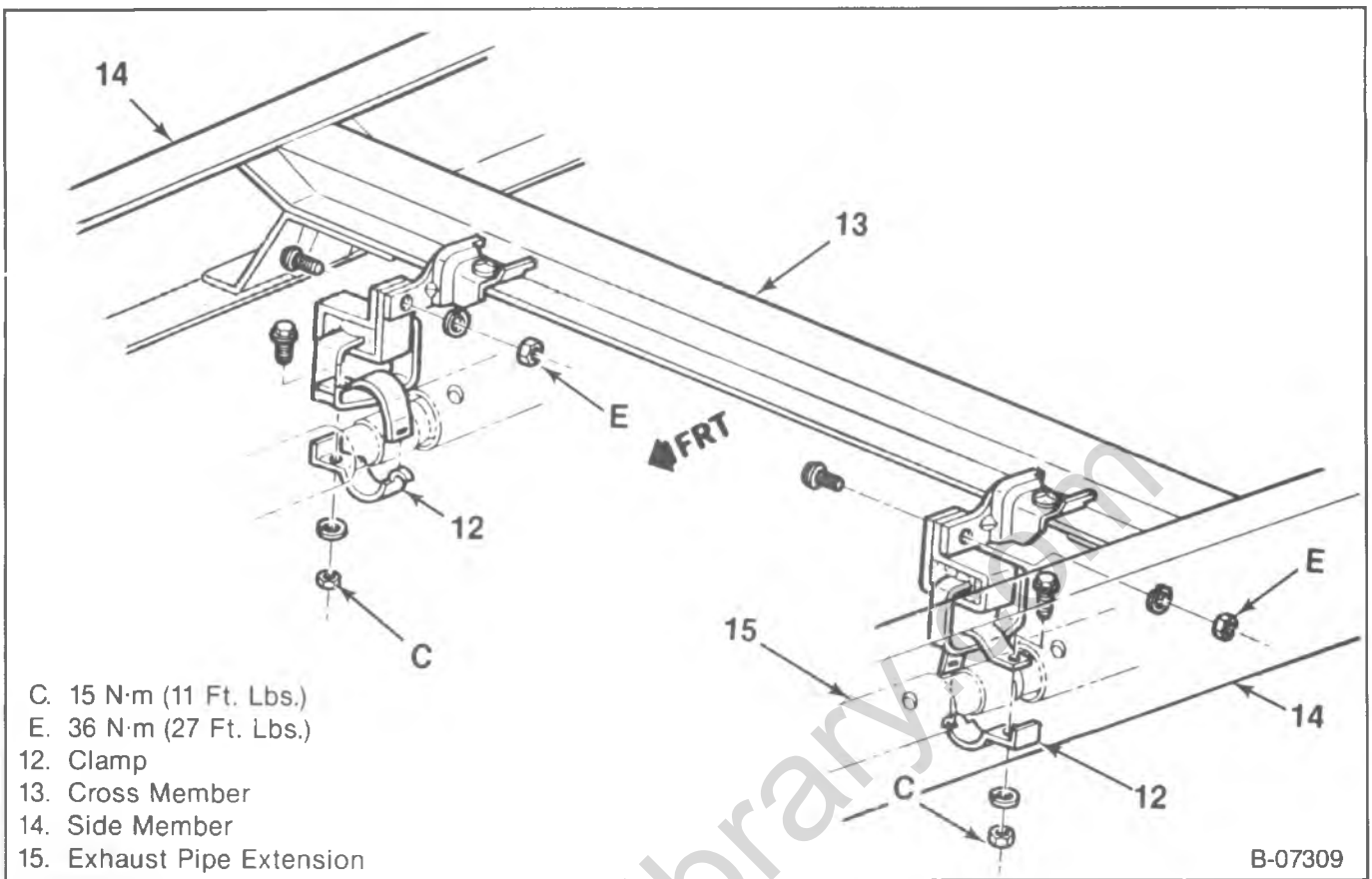

Figure 1—Exhaust Pipe Extension Hanger P-Model

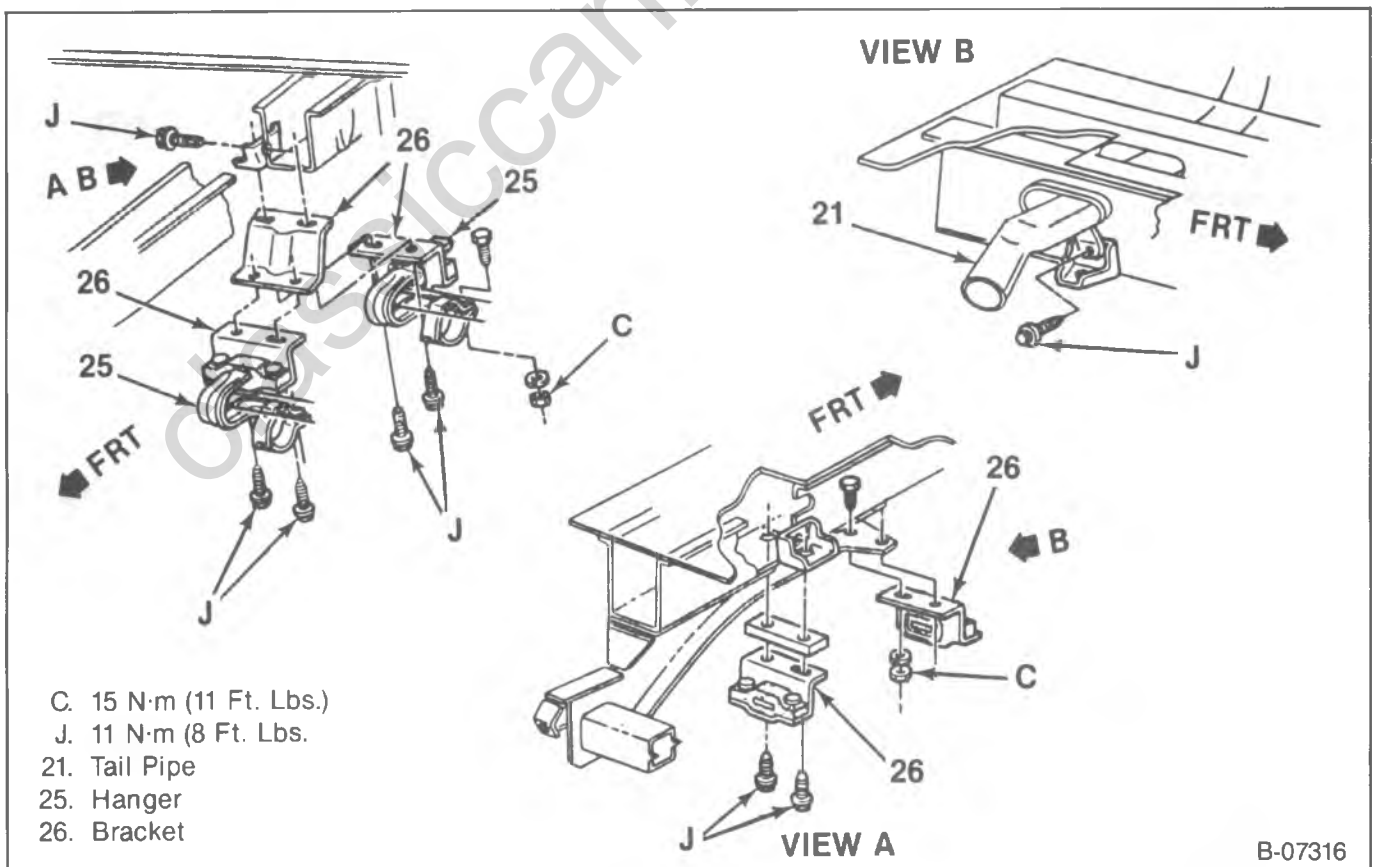

Figure 2—Tail Pipe Hanger (Typical) G-Model

6F-4 EXHAUST

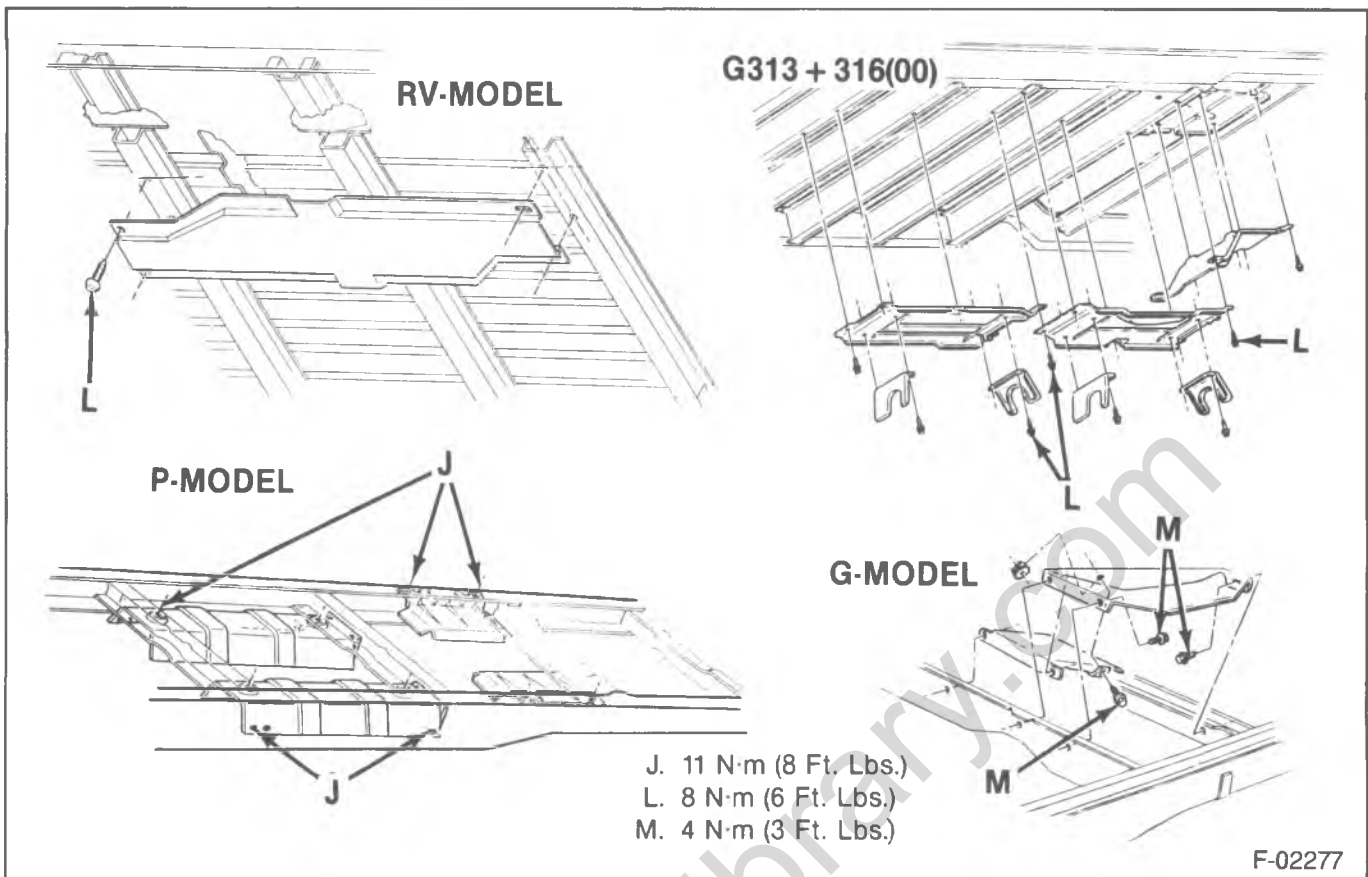

Figure 3—Exhaust Heat Shields (Typical)

catalytic converter as damage to the converter will result.

- Sealer 9985020 or equivalent is to be applied to all slip joint connections.
- When replacing a muffler, the tailpipe should also be replaced.
- When installing the exhaust pipe to the engine manifold, always use new packings and nuts. Clean the engine manifold stud threads with a wire brush before installing the new nuts.

Refer to figures 1 through 16 for component replacement of the engine exhaust system.

CATALYTIC CONVERTER REPLACEMENT

↔ Remove or Disconnect (Figure 7)

- Raise the vehicle on a hoist.
 1. Heat shield.
 2. Clamps at the front and rear of the converter.
 3. Converter pipe-to-front-exhaust pipe and converter pipe-to-rear-exhaust pipe.

↔ Install or Connect (Figure 7)

- Apply sealer 9985020 or equivalent at the slip joint connection.
 1. New catalytic converter into the exhaust pipe.
 2. New U-bolts and clamps at the front and rear of the converter.
- Check for clearance and alignment.

⊞ Tighten

- Clamps and support to 40 N·m (30 ft. lbs.).
 3. Heat shield.
 4. Lower the vehicle.

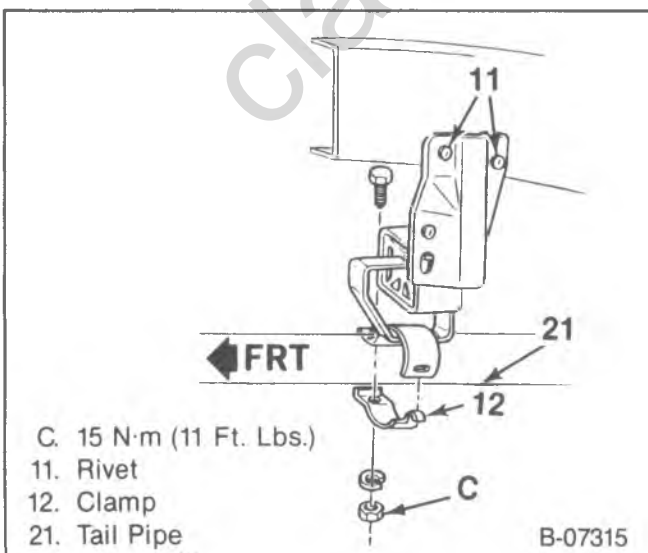

Figure 4—Tail Pipe Hanger (Typical) RV-Model

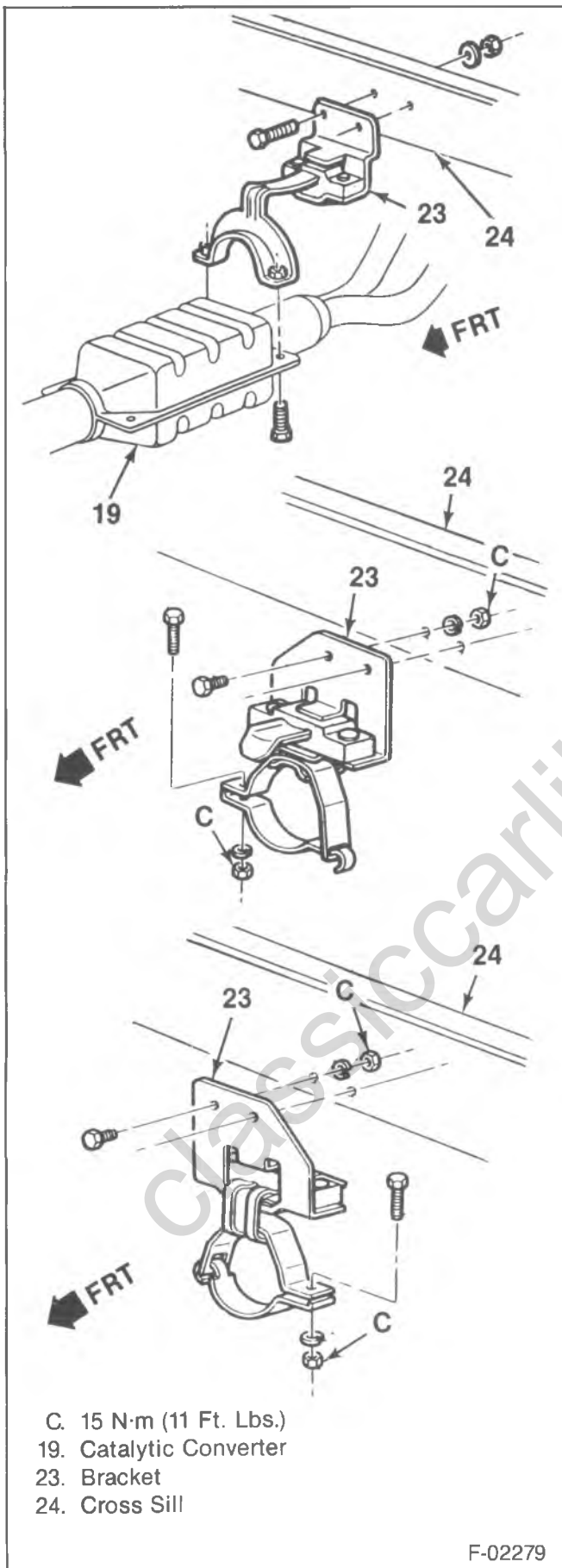

Figure 5—Front and Rear Muffler Hangers (Typical) G-Model

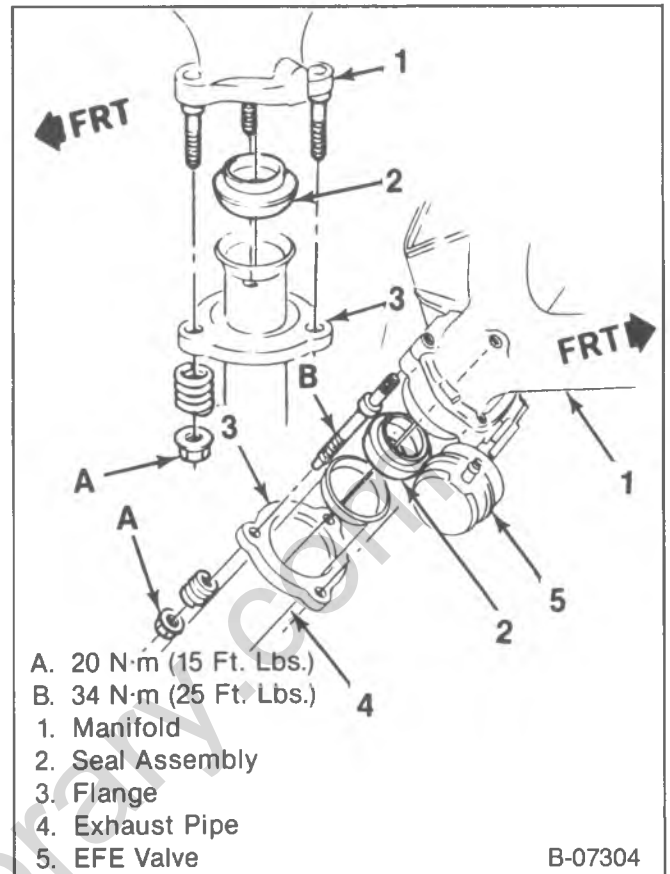

Figure 6—Exhaust Pipe to Manifold (Typical) RV-Model

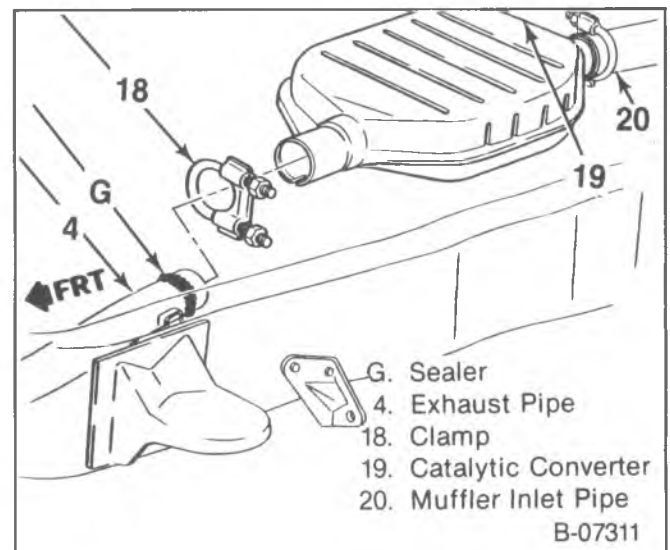

Figure 7—Catalytic Converter Clamping (Typical) RV Model

6F-6 EXHAUST

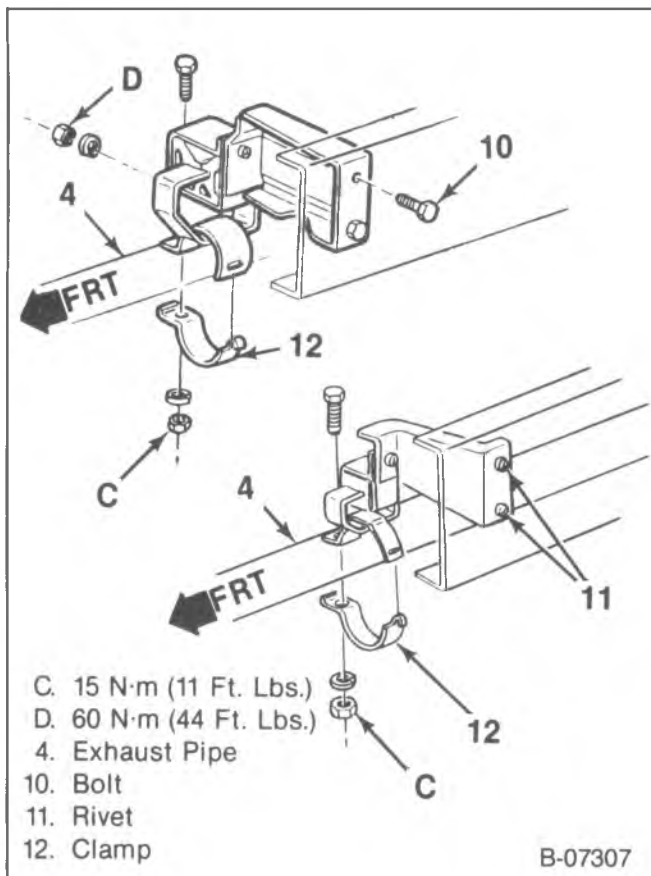

Figure 8—Exhaust Pipe Hangers (Typical)
RV-Model

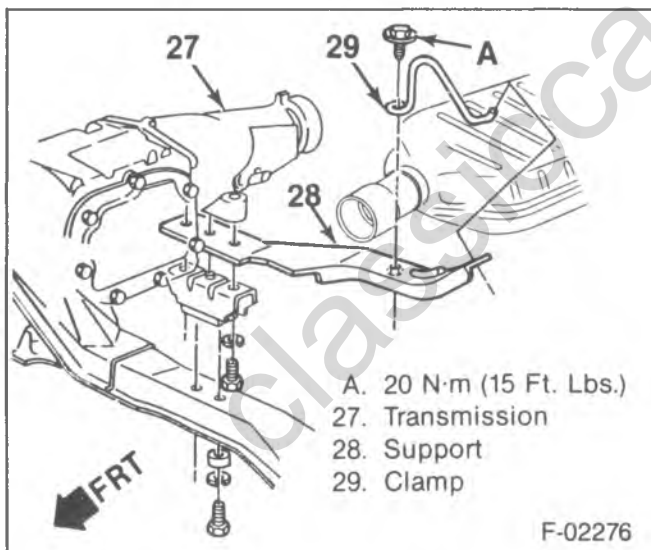

Figure 9—Catalytic Converter Support R-Model

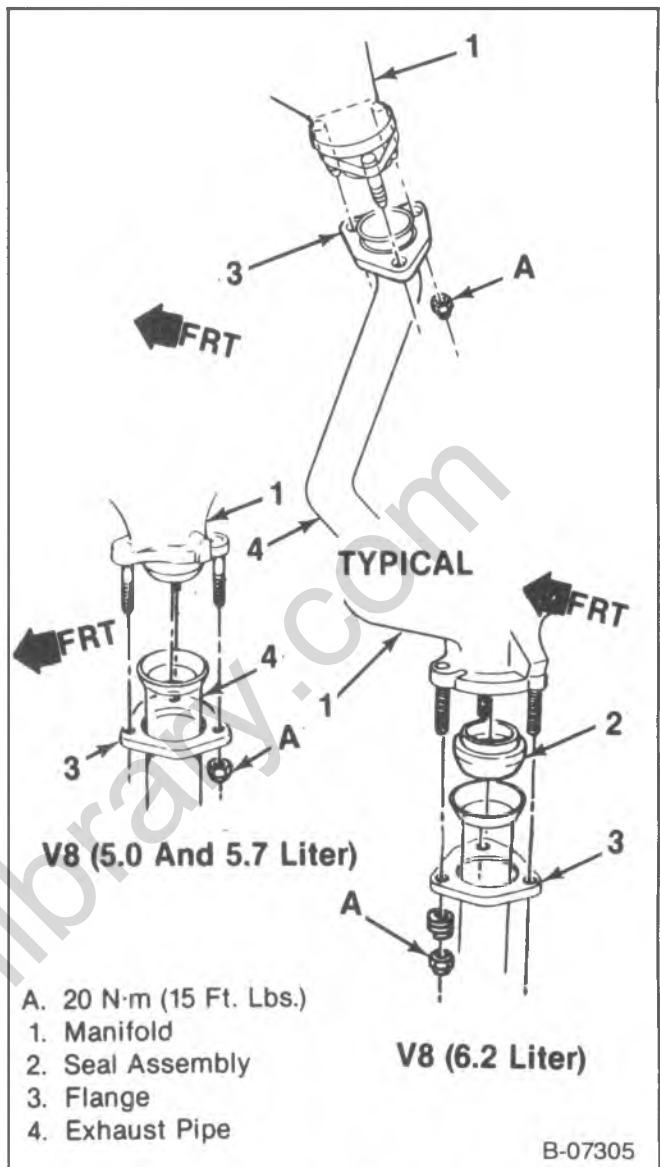

Figure 10—Exhaust Pipe to Manifold G-Model

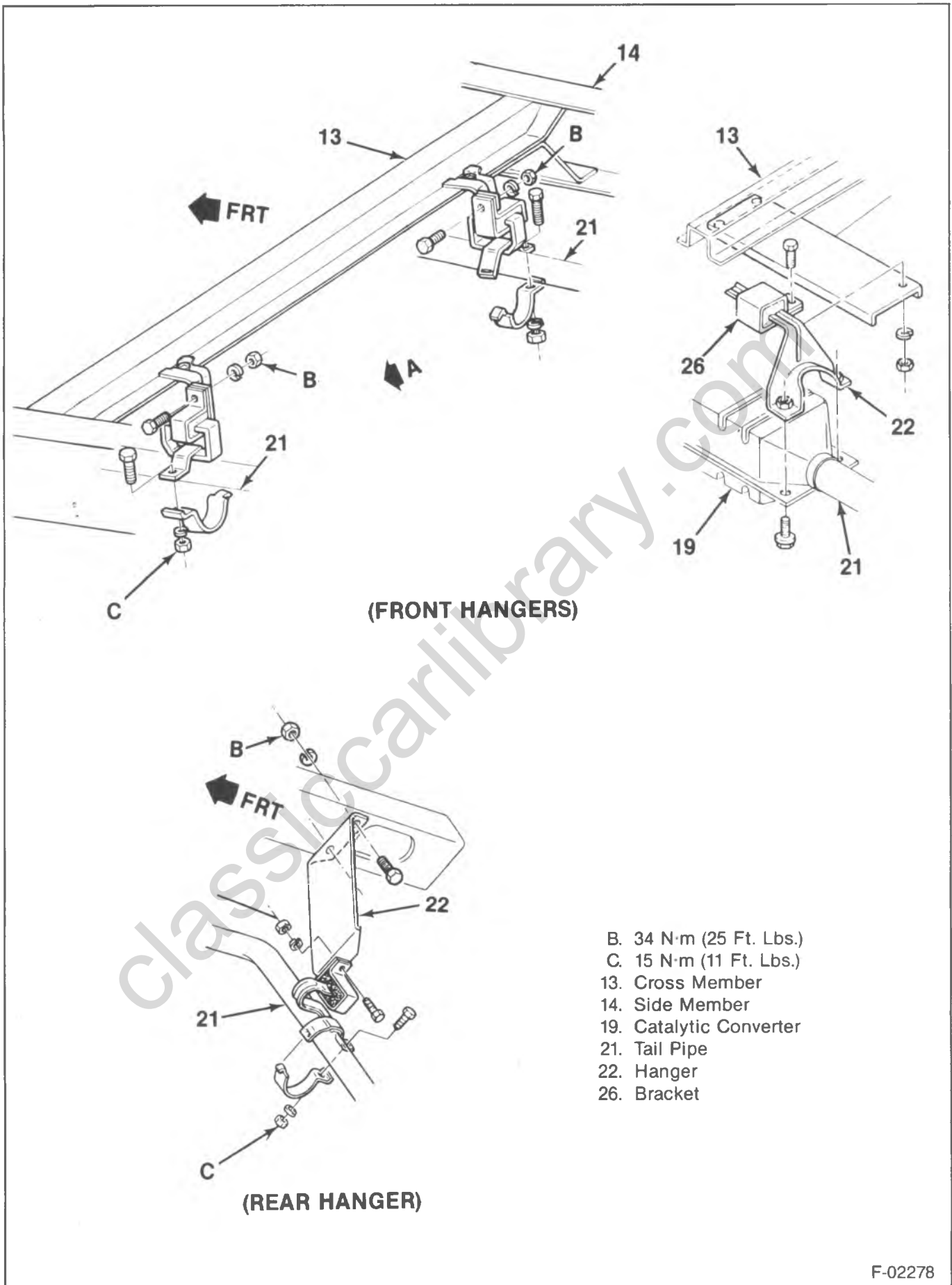
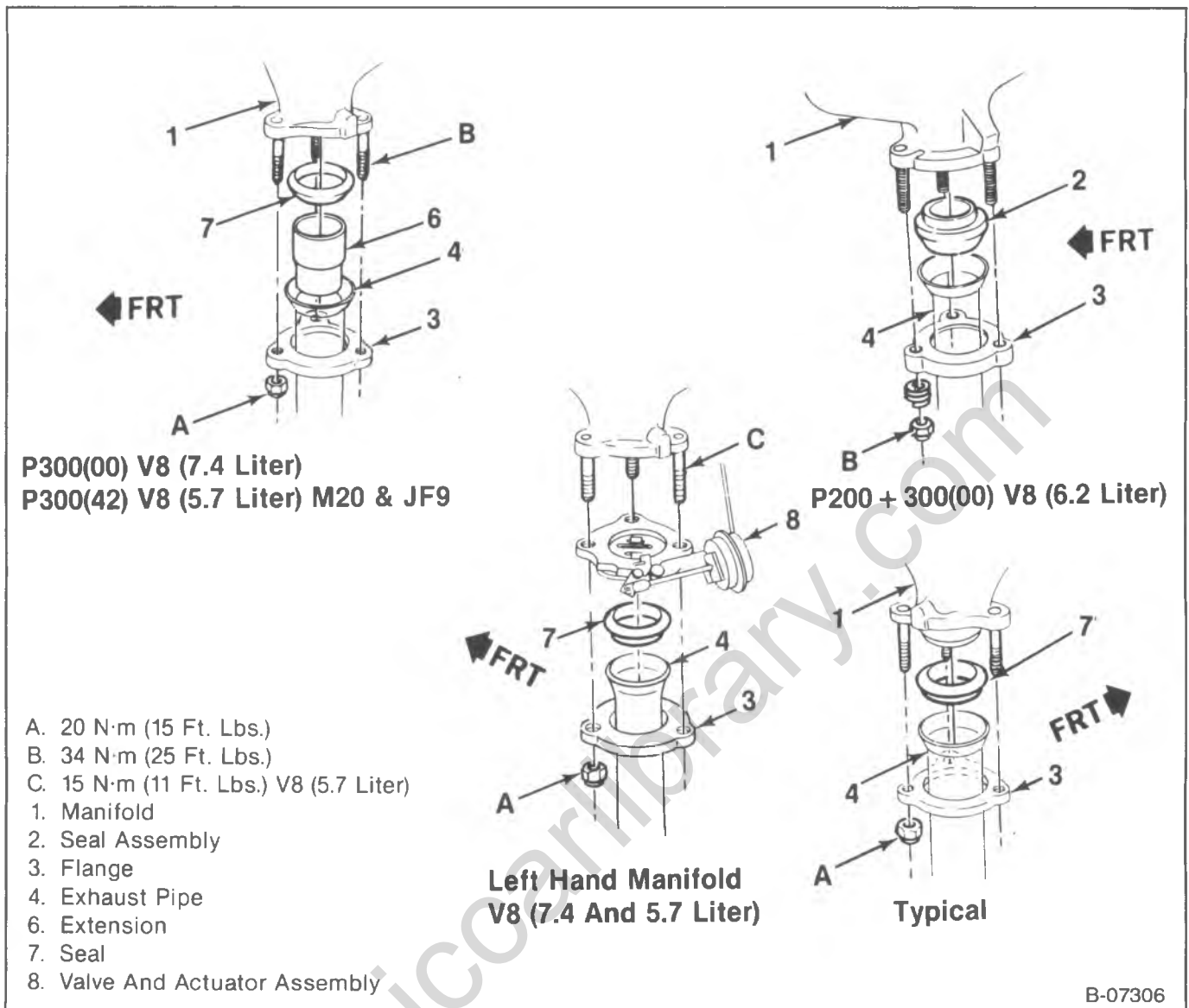

Figure 11—Tail Pipe Hanger (Typical) P-Model

6F-8 EXHAUST



B-07306

Figure 12—Exhaust Pipe to Manifold P-Model

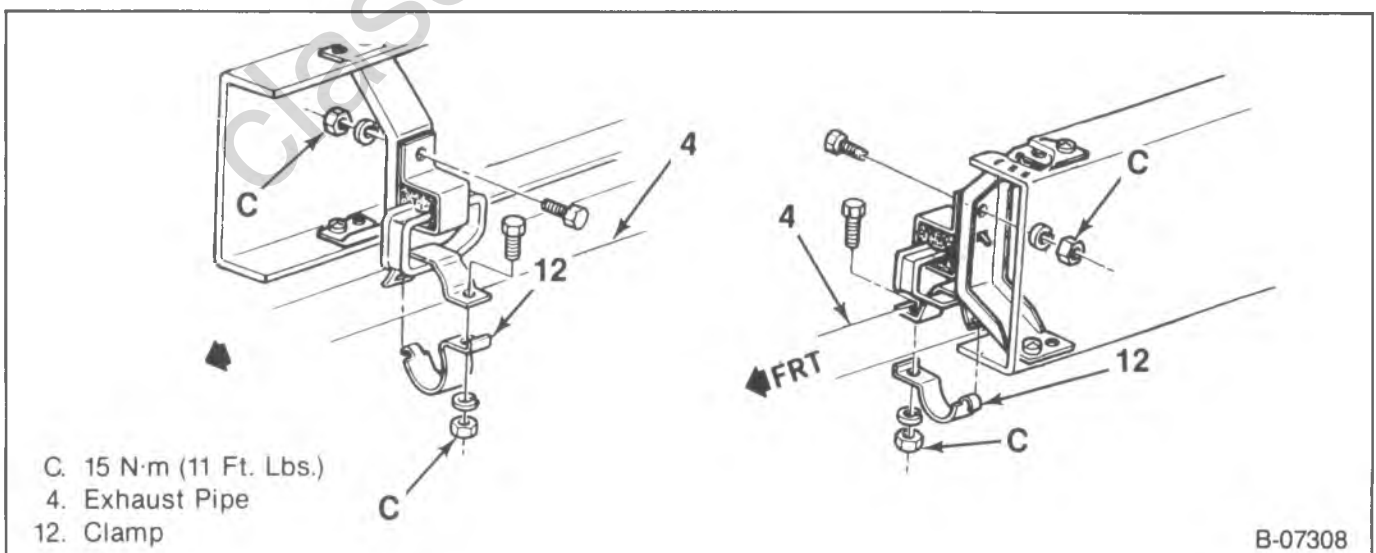

B-07308

Figure 13—Exhaust Pipe Hangers (Typical) P-Model

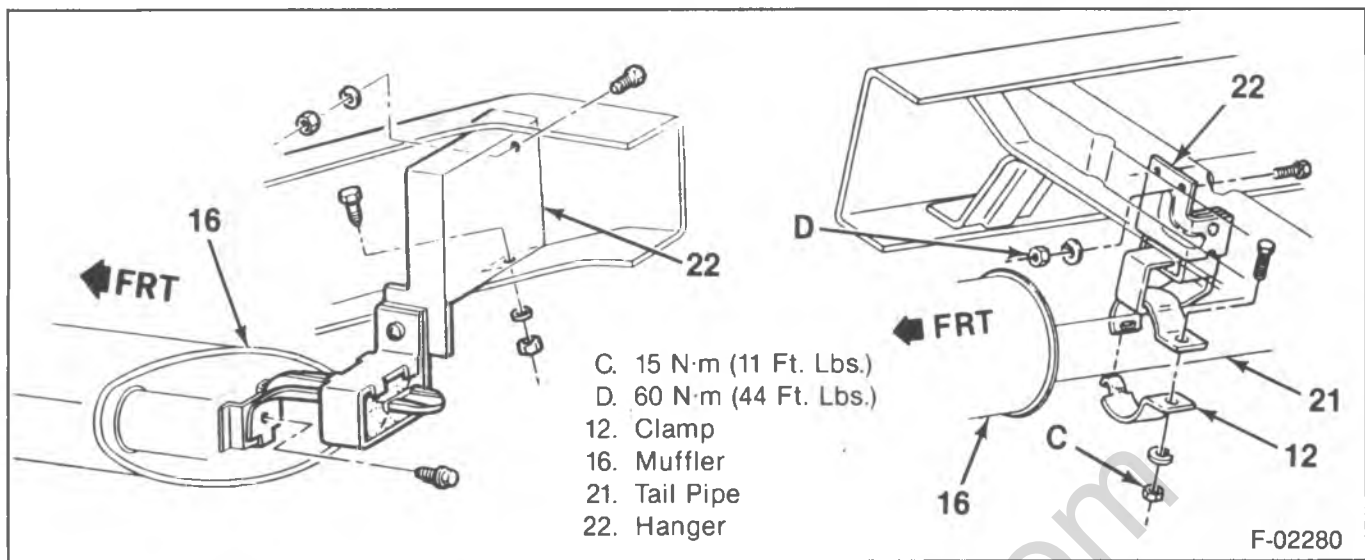

Figure 14—Muffler Hangers (Typical) RV-Model

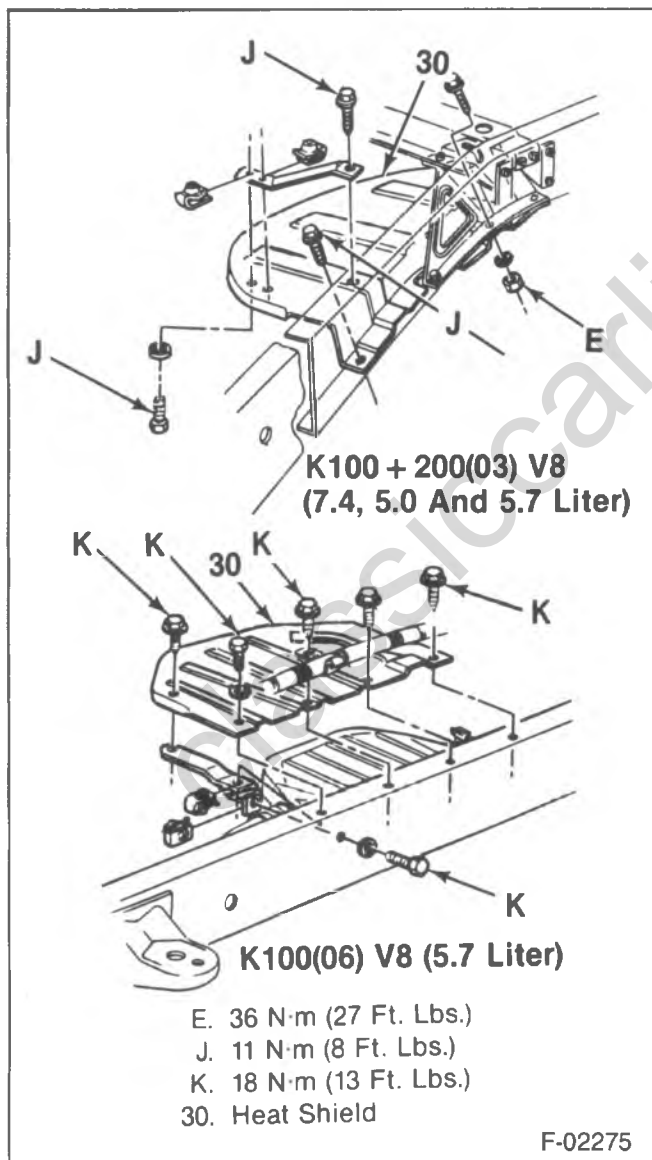

Figure 15—Converter Heat Shield V-Model

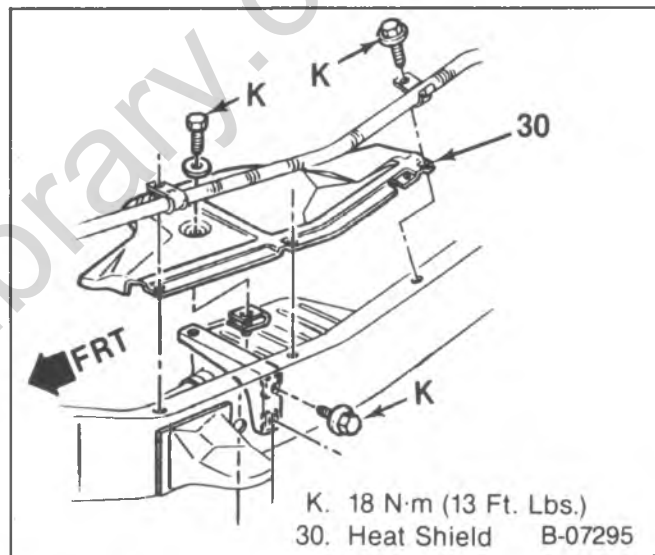

Figure 16—Converter Heat Shield (Typical) R-Model

SPECIFICATIONS**TORQUE SPECIFICATIONS**

	N·m	Ft. Lbs.
Exhaust Pipe to Manifold	20	15
Exhaust Pipe Hanger Clamp	15	11
Exhaust Pipe Hanger Bracket to Frame (RV-Model)	60	44
Exhaust Pipe Extension Hanger to Bracket (P-Model)	36	27
Exhaust Pipe Clamp	40	30
Catalytic Converter Clamp	40	30
Muffler Hanger Clamp	15	11
Muffler Hanger to Frame	60	44
Tail Pipe Hanger Clamp	15	11
Tail Pipe Hanger to Bracket/Side Member (P-Model)	34	25
Catalytic Converter Support (R-Model)	20	15
Catalytic Converter Heat Shield	18	13
Heat Shield Attachment	11	8
Heat Shield Attachment (RV200(00))	60	44
Exhaust Heat Shields (RV-Model)	8	6
Exhaust Heat Shields (G-Model)	4	3
Exhaust Heat Shields (P-Model)	11	8

SECTION 6H

VACUUM PUMPS

CONTENTS

<u>SUBJECT</u>	<u>PAGE</u>
General Description.....	.6H-1
Belt Driven Vacuum Pump.....	.6H-1
Gear Driven Vacuum Pump.....	.6H-1
Diagnosis of Vacuum Pump.....	.6H-1
On-Vehicle Service.....	.6H-4
Belt Driven Pump Replacement.....	.6H-4
Gear Driven Pump Replacement.....	.6H-5
Specifications.....	.6H-6
Special Tools.....	.6H-7

GENERAL DESCRIPTION

The vacuum pump is mounted on diesel engines and supplies power for operating emission controls, transmission modulators, cruise control, and air conditioning controls. It may be belt driven or gear driven. Refer to "Specifications" at the end of this section for model breakdown. The pump is a diaphragm pump which does not require periodic maintenance.

BELT DRIVEN VACUUM PUMP

The belt driven model is bracket mounted at the right front of the engine. It has a pulley attached which is driven by the generator belt. With the exception of the pulley, the vacuum pump is replaced as an assembly.

GEAR DRIVEN VACUUM PUMP

The gear driven model is mounted at the top rear of the engine. It is driven by a cam inside the drive assembly to which it mounts. The drive housing assembly has a drive gear on the lower end which meshes with the camshaft gear in the engine. This drive gear causes the cam in the drive housing to rotate. The drive gear also powers the engine oil lubricating pump.

DIAGNOSIS OF VACUUM PUMP

Refer to figures 1 and 2 for diagnosis of the vacuum pump.

6H-2 VACUUM PUMPS

AUTOMATIC TRANSMISSION (VACUUM MODULATED) WILL NOT SHIFT OUT OF FIRST (LOW) GEAR. BLOCK WHEELS, APPLY PARKING BRAKE AND PLACE TRANSMISSION SELECTOR LEVER IN "PARK" OR "NEUTRAL" BEFORE STARTING ENGINE.

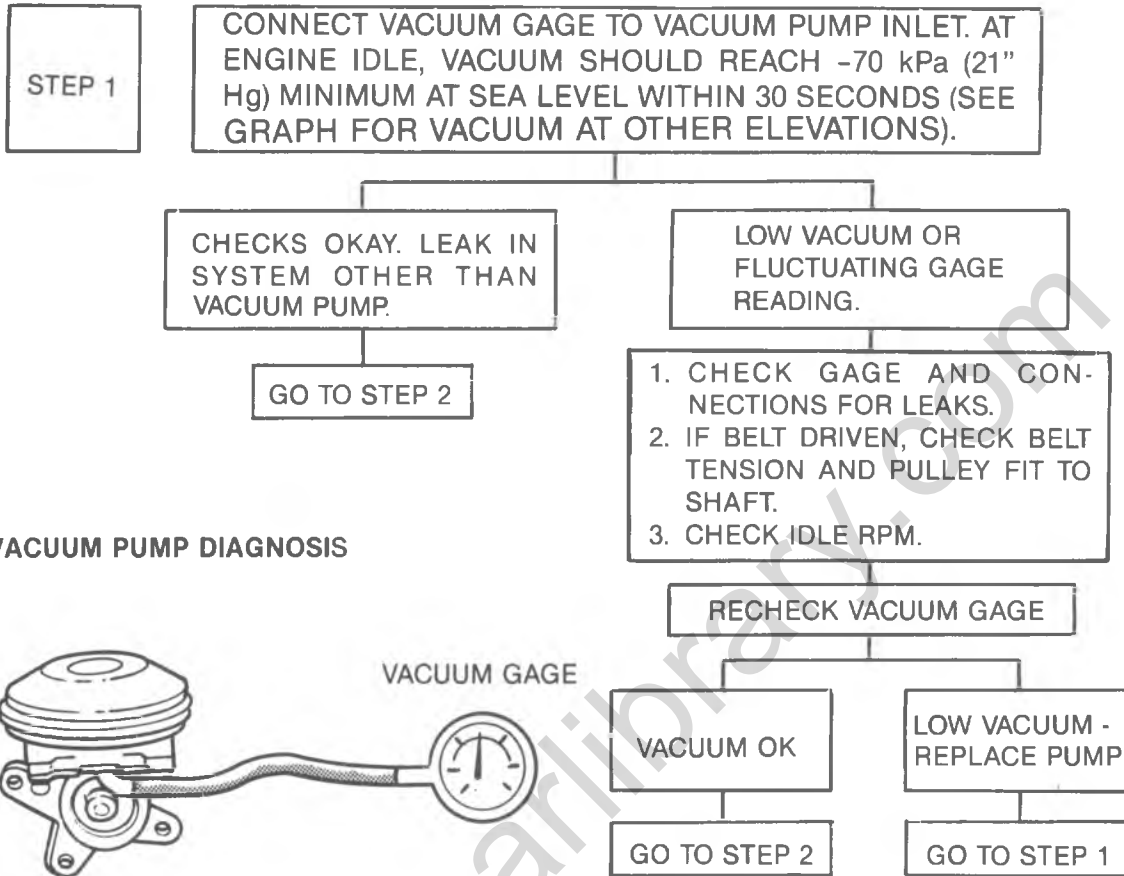

VACUUM PUMP DIAGNOSIS

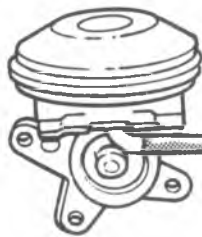

VACUUM PUMP

VACUUM GAGE



MINIMUM ACCEPTABLE vs ALTITUDE

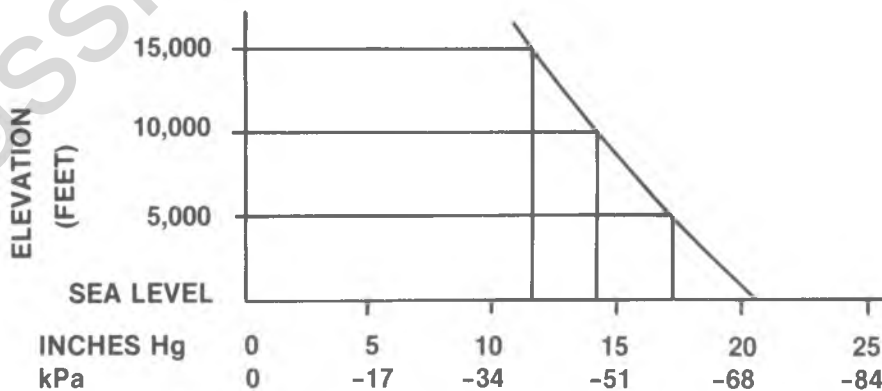
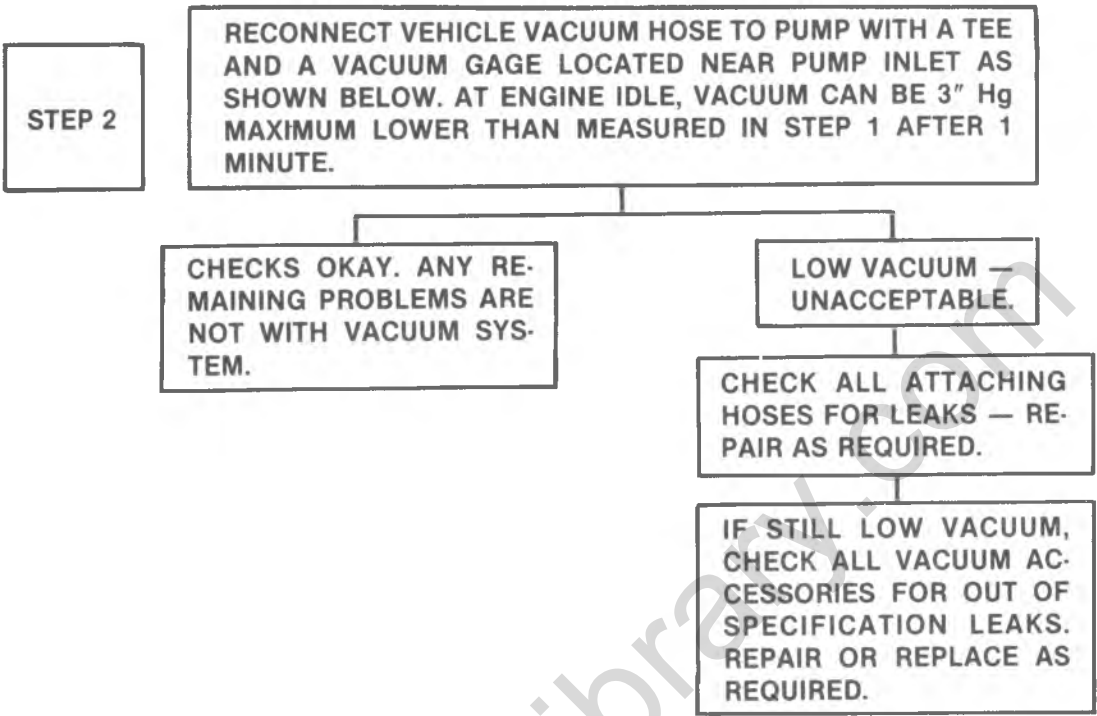

Figure 1—Diagnosis of Vacuum Pump



VEHICLE VACUUM SYSTEM DIAGNOSIS

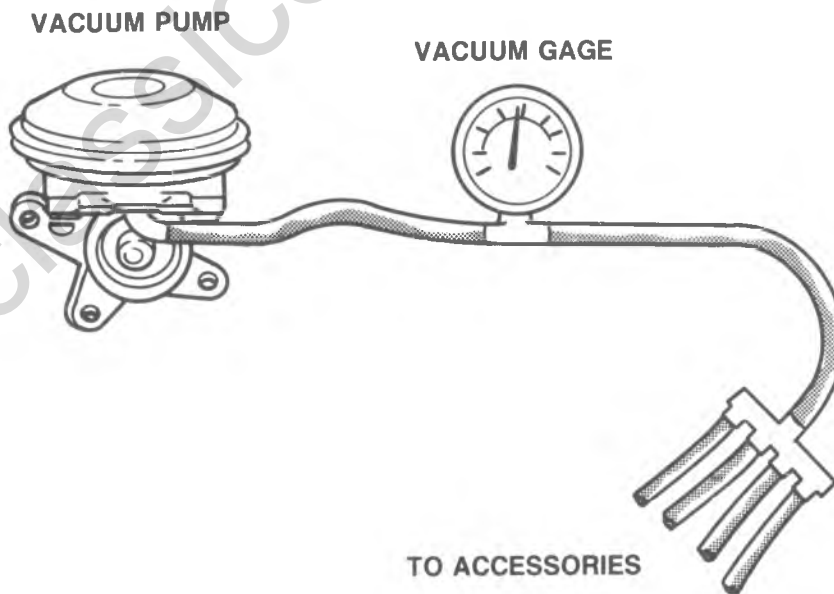
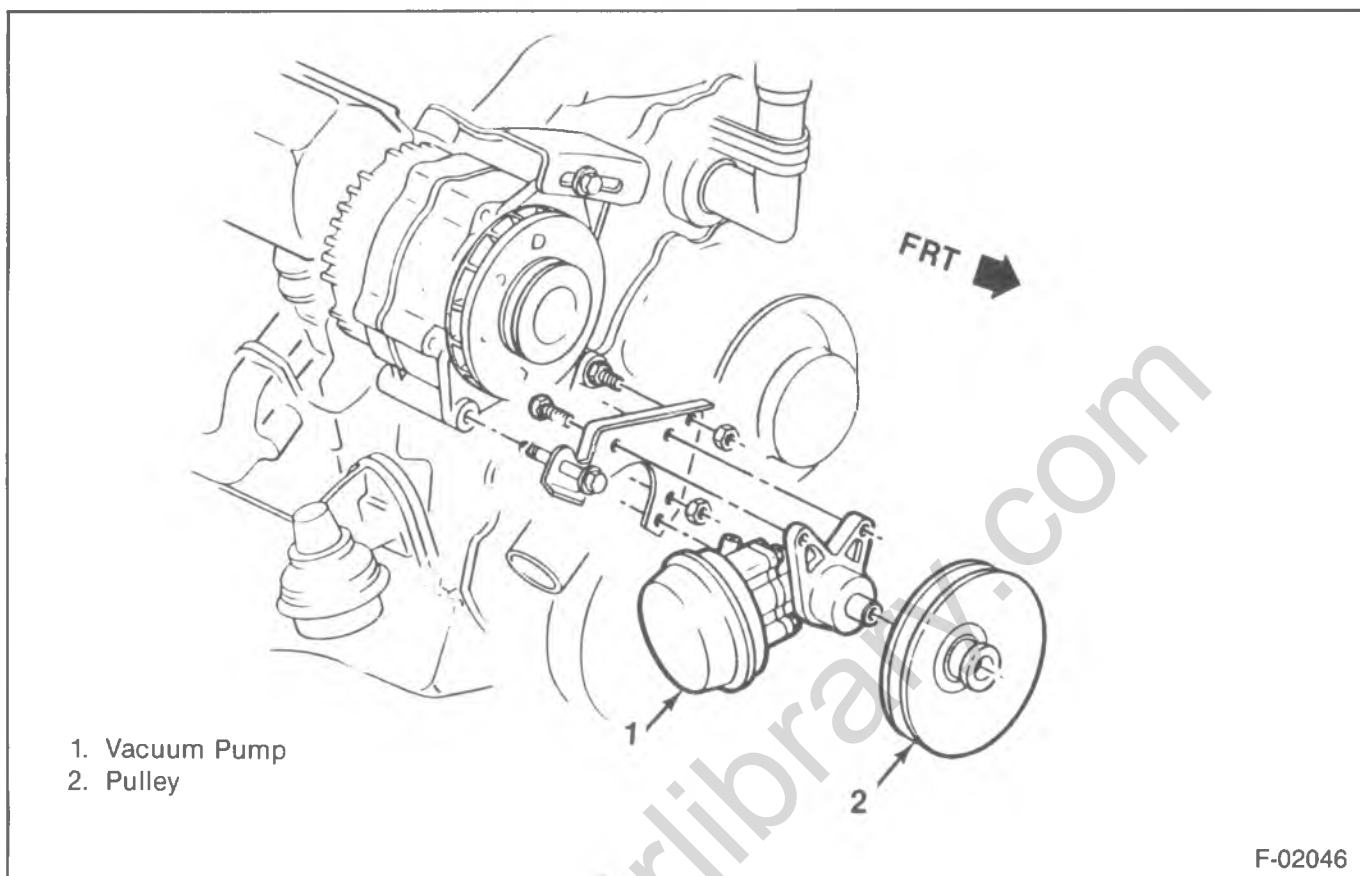

Figure 2—Diagnosis of Vacuum Pump

ON-VEHICLE SERVICE



F-02046

Figure 3—Belt Driven Vacuum Pump Assembly

BELT DRIVEN PUMP REPLACEMENT

↔ Remove or Disconnect (Figure 3)

1. Negative battery cable.
2. Generator belt.
3. Upper vacuum pump attaching bolts.
 - Raise the vehicle.
4. Engine coolant.
5. Lower radiator hose.
6. Vacuum hose.
7. Lower vacuum pump attaching bolt.
8. Vacuum pump including the pulley.

⊠ Disassemble (Figure 4)

Tool Required:

- J-25034-B Pump Pulley Remover
- Pulley from the pump with J-25034-B.

NOTICE: Do not pry from the back of the pulley. Damage could occur to the pulley or pump.

⊠ Assemble (Figure 5)

Tool Required:

- J-25033-B Pump Pulley Installer

- Pulley to the pump with J-25033-B until the pulley is flush with the end of the shaft.

NOTICE: Do not tap pulley back onto pump shaft. The pump could be damaged.

↔ Install or Connect (Figure 3)

1. Vacuum pump assembly to the engine.
2. Vacuum pump lower attaching bolt.

⊠ Tighten

- Bolts to 27 N·m (20 ft. lbs.)
3. Vacuum hose.
 4. Bottom radiator hose.
 - Lower the vehicle.
 5. Upper vacuum pump attaching bolts.
 6. Generator belt and tighten it.
 - Refer to ENGINE COOLING (SEC. 6B) for belt specifications.
 7. Battery cable.
 8. Engine coolant.

GEAR DRIVEN PUMP REPLACEMENT

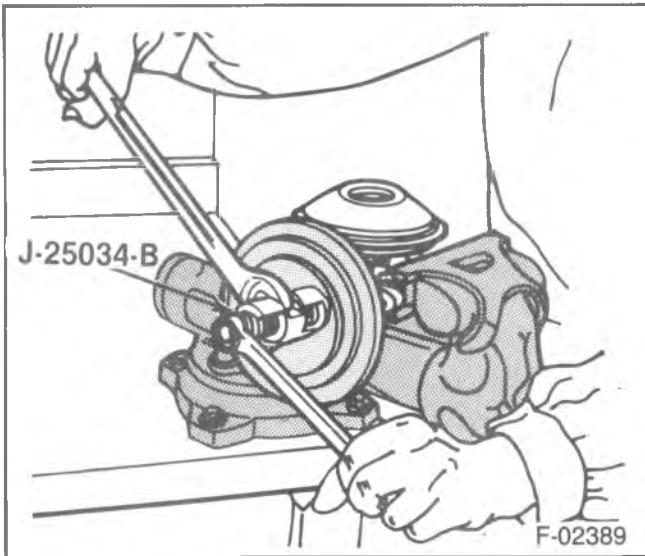

Figure 4—Removing the Pulley

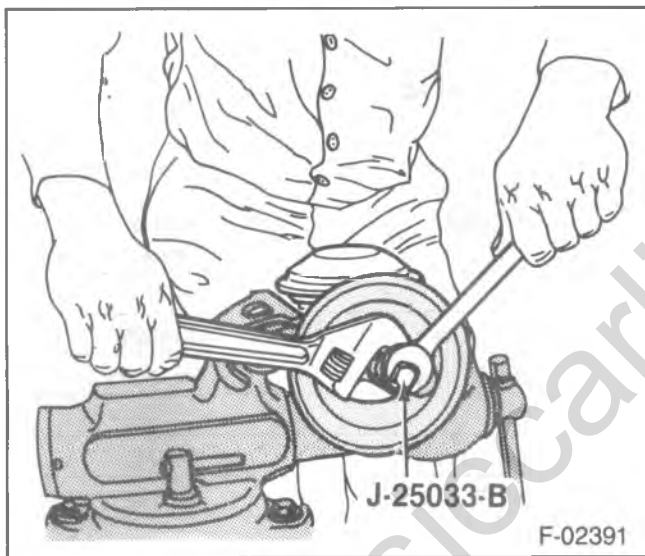

Figure 5—Installing the Pulley

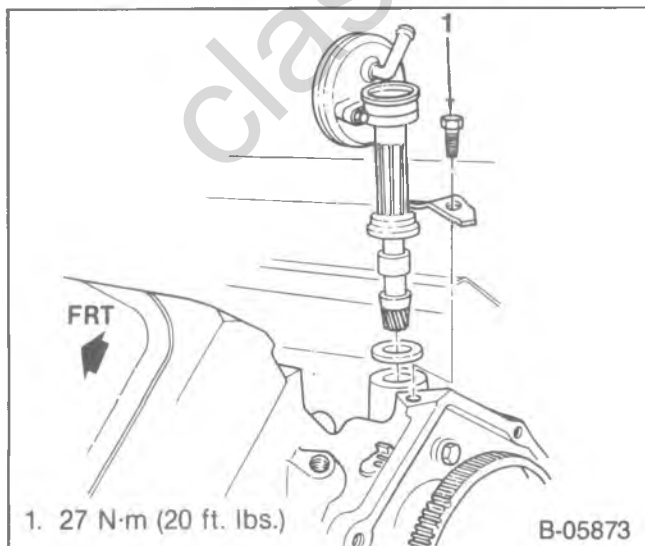

Figure 6—Gear Driven Vacuum Pump Assembly

↔ Remove or Disconnect (Figure 6)

Tool Required:

J-29664 Manifold Cover Set

1. Air cleaner.

! Important

Cover the air intake with J-29664 to prevent foreign material from falling into the manifold.

2. Vacuum hose from the pump inlet.
3. Bolt and bracket holding the drive assembly to the engine block.
4. Pump and drive assembly.

NOTICE: Do not run the engine without the vacuum pump installed. Since the oil pump is powered by the vacuum pump drive gear, no oil would circulate through the engine. The engine could be damaged.

🔍 Inspect

- Gasket on the pump assembly. Replace if necessary.

↔ Install or Connect (Figure 6)

1. New pump assembly making sure that the gear on the drive assembly meshes with the gear on the engine camshaft.

🔑 Adjust (Figure 7)

- Rotate the pump so the inlet tube faces the front of the engine.
- Pump should be on a 20-degree angle (figure 7).

2. Bolt and bracket.

🔩 Tighten

- Bolt to 27 N·m (20 ft. lbs.)
3. Vacuum hose to the inlet port.
 4. Air cleaner.
 - Remove J-29664 from the air cleaner inlet.
 - Install the air cleaner.

6H-6 VACUUM PUMPS

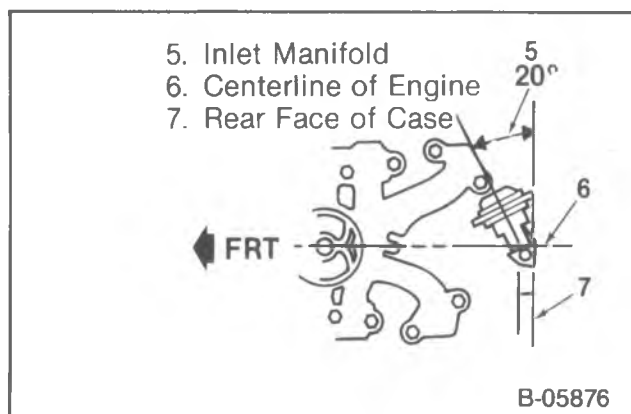

Figure 7—Vacuum Pump Positioned

SPECIFICATIONS

VACUUM PUMP APPLICATIONS

Model Designation	6.2 L V8 (379 Cu. In.) Diesel Engine	Vacuum Pump Type	Pump P/N
RV Series			
Federal	LH6, LL4	Gear Driven	7849302
California	LL4	Gear Driven	7849302
G Series			
Federal	LH6, LL4	Belt Driven	7841746
California	LL4	Belt Driven	7841746
P Series			
Federal	LL4	Belt Driven	7841746
California	LL4	Belt Driven	7841746

SPECIAL TOOLS

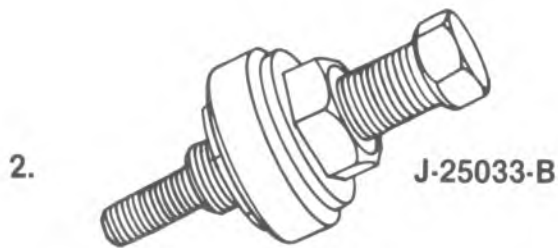
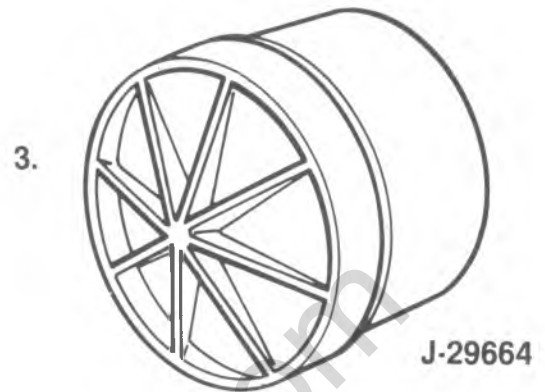
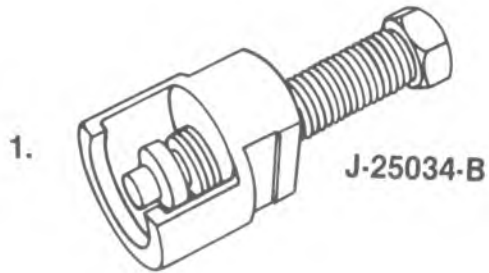

- 1. Pump Pulley Remover
- 2. Pump Pulley Installer
- 3. Manifold Cover

F-02390

classiccarlibrary.com

SECTION 7

TRANSMISSION

CONTENTS

<u>SUBJECT</u>	<u>PAGE</u>
Automatic Transmission7A-1
Manual Transmission7B-1
Clutch7C-1
Transfer Case7D-1

SECTION 7A

AUTOMATIC TRANSMISSION

CONTENTS

<u>SUBJECT</u>	<u>PAGE</u>
Description7A- 2
Torque Converter7A- 2
Torque Converter Clutch (TCC)7A- 2
Transmission Identification7A- 2
THM 400 (RPO M40)7A- 4
THM 700-R4 (RPO MD8)7A- 4
Transmission Diagnosis7A- 6
Transmission Definitions7A- 6
Preliminary Checking Procedure7A- 6
Transmission Fluid Information7A- 6
Noise and Vibration7A- 7
Fluid Leaks7A- 7
Vacuum Modulator7A- 9
Diagnosis of Torque Converter7A-11
Diagnosis of Torque Converter Clutch (TCC)7A-12
THM 400 Preliminary Checking7A-14
Road Test7A-15
Diagnosis of THM 4007A-16
Oil Circuits7A-25
THM 700-R4 Preliminary Checking7A-31
Road Test7A-33
Diagnosis of THM 700-R47A-35
Oil and Wiring Circuits7A-43
On Vehicle Service7A-62
Parts Cleaning, Inspection and Replacement7A-62
Oil Cooler Lines7A-63
Checking and Adding Fluid7A-63
Shift Linkage7A-63
TV Cable7A-65
TV Cable Adjustment7A-65
Changing the Fluid and Filter7A-66
Detent Switch (THM 400)7A-67
Vacuum Modulator (THM 400)7A-67
Speedometer Driven Gear/Vehicle Speed Sensor7A-67
Governor7A-68
2-4 Servo (THM 700-R4)7A-71
Rear Extension Oil Seal7A-73
Transmission Replacement7A-74
Specifications7A-76
Fastener Torque7A-76
Lubrication7A-76
Special Tools7A-77

DESCRIPTION

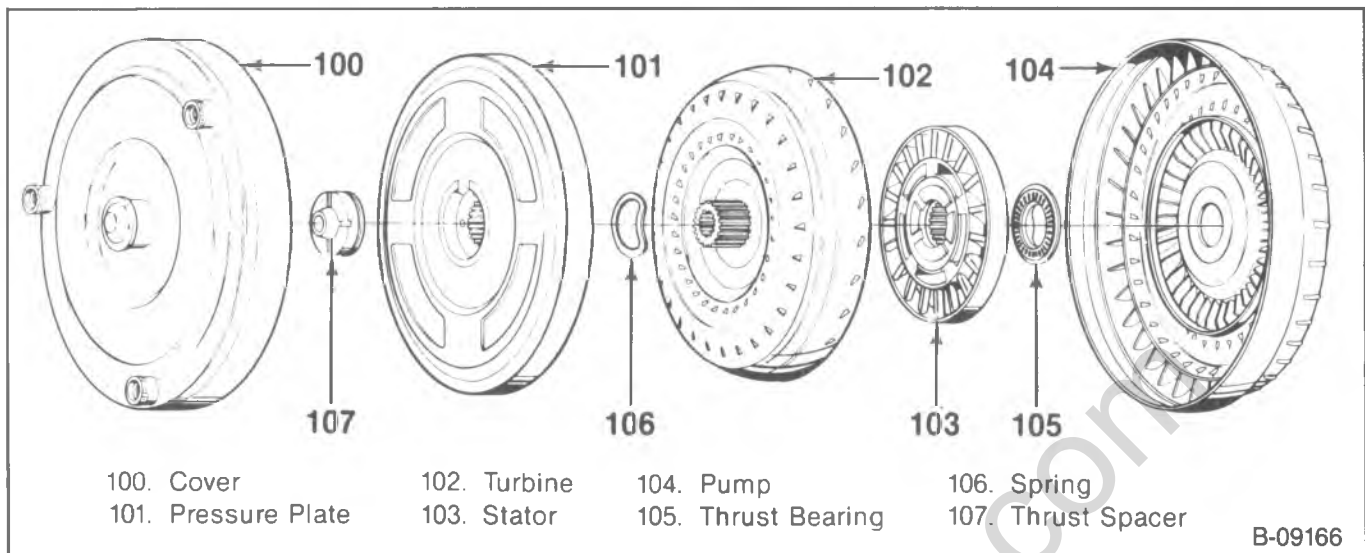

Figure 1—Torque Converter Components

TORQUE CONVERTER

The torque converter is of welded construction and is serviced as an assembly. The unit is made up of two vaned sections, or halves, that face each other in an oil filled housing. The pump half of the converter is connected to the engine and the turbine half is connected to the transmission.

When the engine makes the converter pump revolve, it sends oil against the turbine, making it revolve also. The oil then returns in a circular flow back to the converter pump, continuing this flow as long as the engine is running.

The converter also has a smaller vaned section, called a stator, that funnels oil back to the converter pump through smaller openings, at increased speed. The speeded up oil directs additional force to the engine-driven converter pump, thereby multiplying engine torque (figure 1).

TORQUE CONVERTER CLUTCH (TCC)

The converter clutch assembly consists of a 3-element torque converter with the addition of a converter clutch. The converter clutch is splined to the turbine assembly, and when operated applies against the converter cover providing a mechanical direct drive coupling of the engine to the transmission planetary gears. When the converter clutch is released, the assembly operates as a conventional torque converter (figure 1).

The Torque Converter Clutch (TCC) system uses controls that are internal as well as external to the transmission.

The internal controls are:

- TCC Solenoid Assembly — Energizes to redirect transmission fluid to the converter clutch apply valve in the auxiliary control valve assembly.

- Third Gear Switch — Closes when the transmission is in third gear to complete electrical circuit of TCC solenoid to the Electronic Control Module.

The external controls are:

- Brake Release Switch — To avoid stalling the engine when braking, the converter clutch is released any time the brakes are applied.
- Electronic Control Module — Receives input signals and grounds TCC solenoid to apply the clutch when proper operating conditions are met.
- Throttle Position Sensor — Sends throttle position information to the Electronic Control Module.
- Vacuum Sensor — Sends engine vacuum (load) information to the Electronic Control Module.
- Vehicle Speed Sensor — Sends vehicle speed information to the Electronic Control Module.
- Coolant Temperature Sensor — Sends engine coolant temperature information to the Electronic Control Module.

TRANSMISSION IDENTIFICATION

All automatic transmissions have a metal identification nameplate attached to the case exterior. The location of this name plate is shown in figure 2. The information on the nameplate will assist in the servicing and determination of replacement parts when ordered through a GM Parts Catalog.

Additional transmission identification is provided on the Service Parts Identification Label. This label contains information on the regular production options (RPO) as well as standard and mandatory options. This label is affixed to the inside of each vehicle at the assembly plant. Refer to Section 0A of this Service Manual for label location and information.

M — INDICATES TRANSMISSION TYPE IN OPTION LIST. (SPECIFIC MODEL CODE IS FOUND ON THE TRANSMISSION NAMEPLATE)	MX — DESIGNATES AUTOMATIC TRANSMISSION
SERVICE PARTS IDENTIFICATION	DO NOT REMOVE
1 G 3 A R 4 7 Y X E 5 1 0 0 0 0 1	
C90 C95 DF3 D3C D33 D 8 E Z E D FFL F40 GG1 GW9 G60 GU2 G89	
JA1 JA4 K05 K22 K99 LV2 MW9 MX0 NA5 NB1 NK1 NK3 N33 N67 GJW	
T87 UJ3 U23 U35 VQ8 V10 WC3 WG2 YT9 Y56 O1L 6SC 42B 421 42Q	
42T 409 7SB 8WT 9WT 11A 90A	
PRINTED IN U.S.A.	PART NO. 14065987

SERVICE PARTS IDENTIFICATION LABEL

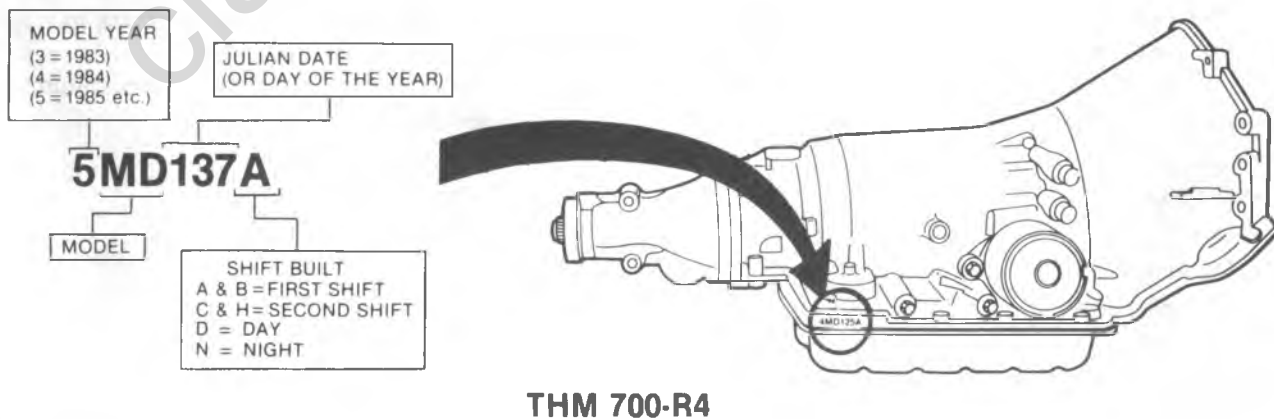
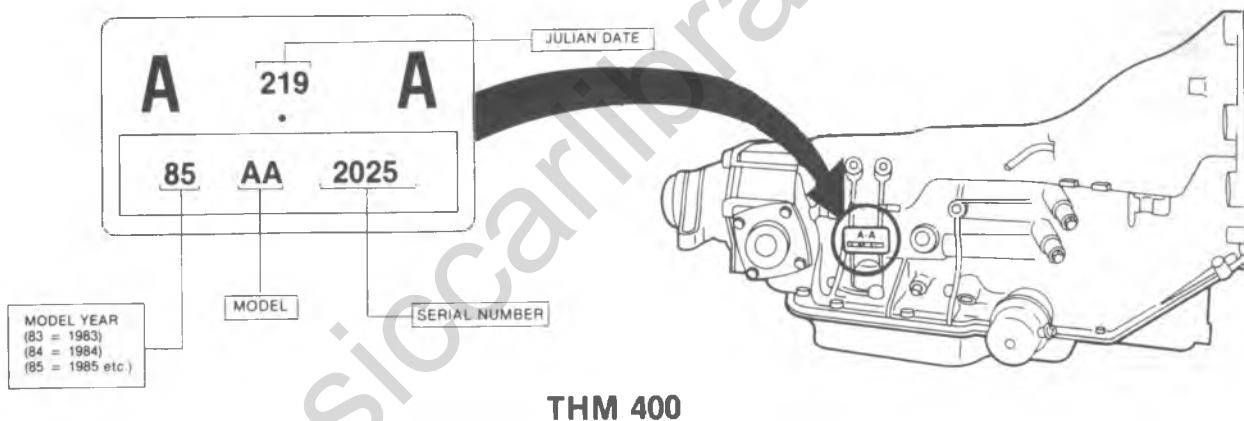

F-02661

Figure 2—Transmisison Identification

7A-4 AUTOMATIC TRANSMISSION

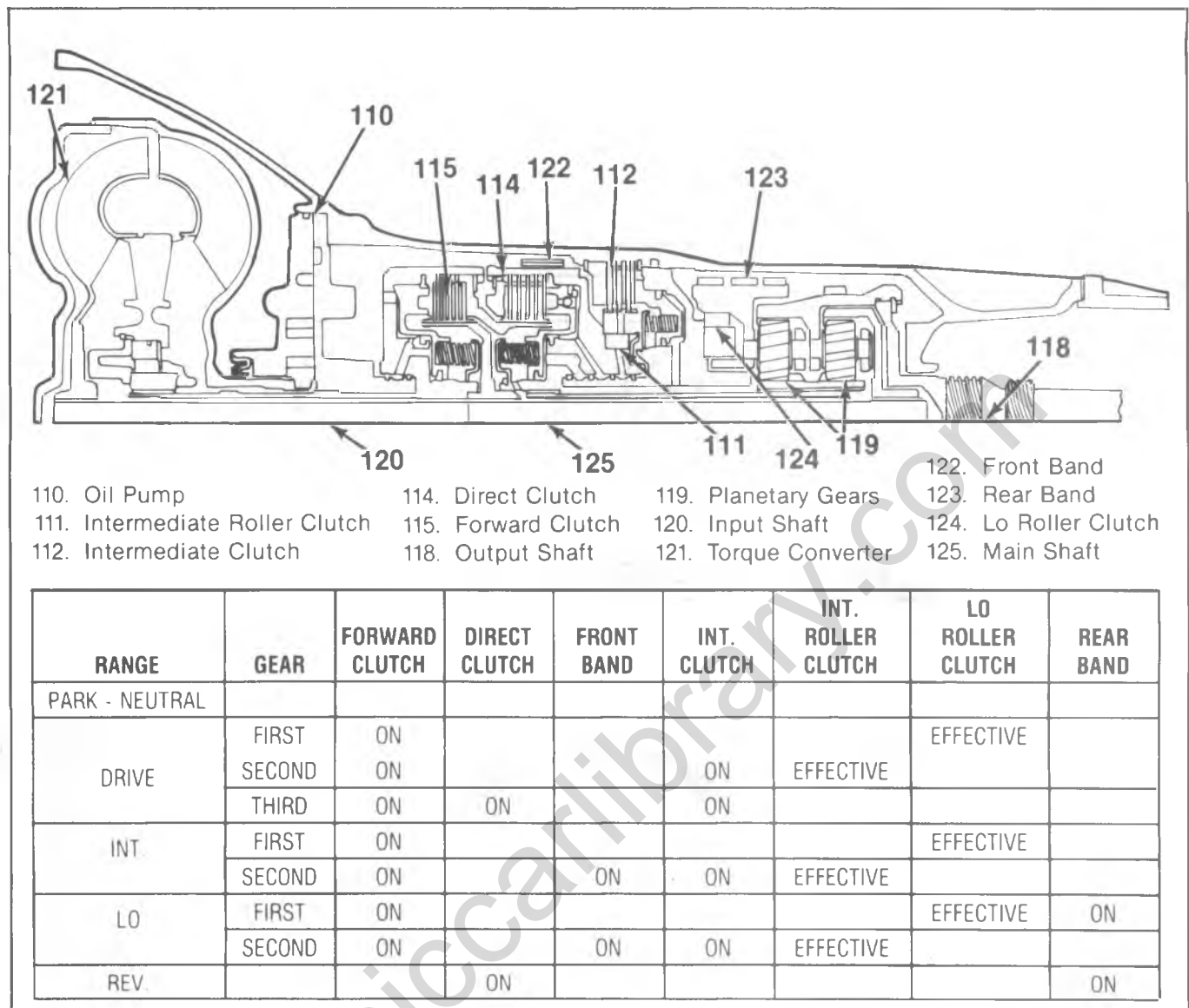

Figure 3—THM 400 Clutches and Operation

THM 400 (RPO M 40)

The THM 400 is a fully automatic transmission for rear wheel drive vehicles which provides three forward gear ranges and a reverse (figure 3).

The major components of this transmission are:

- Torque Converter.
- Gear Type Oil Pump.
- Two Bands.
- Three Multiple Disc Clutches.
- Two Planetary Gear Sets.
- Two Roller Clutches.
- Valve Body Assembly.

External control connections to the transmission are:

- Manual Linkage — To select the desired operating range.
- Engine Vacuum — To operate the vacuum modulator.
- 12 Volt Electrical Signals — To operate an electrical detent solenoid.

THM 700-R4 (RPO MD8)

The THM 700-R4 is a fully automatic transmission for rear wheel drive vehicles which provides four forward gear ranges and a reverse (figure 4).

The major components of this transmission are:

- Clutch Type Torque Converter.
- Vane Type Oil Pump.
- 2-4 Band Assembly.
- Five Multiple Disc Clutches.
- Two Planetary Gear Sets.
- One Sprag Clutch.
- One Roller Clutch.
- Valve Body Assembly.

External control connections to the transmission are:

- Manual Linkage — To selected the desired operating range.
- Throttle Valve (TV) Cable — To control shift points by throttle opening.

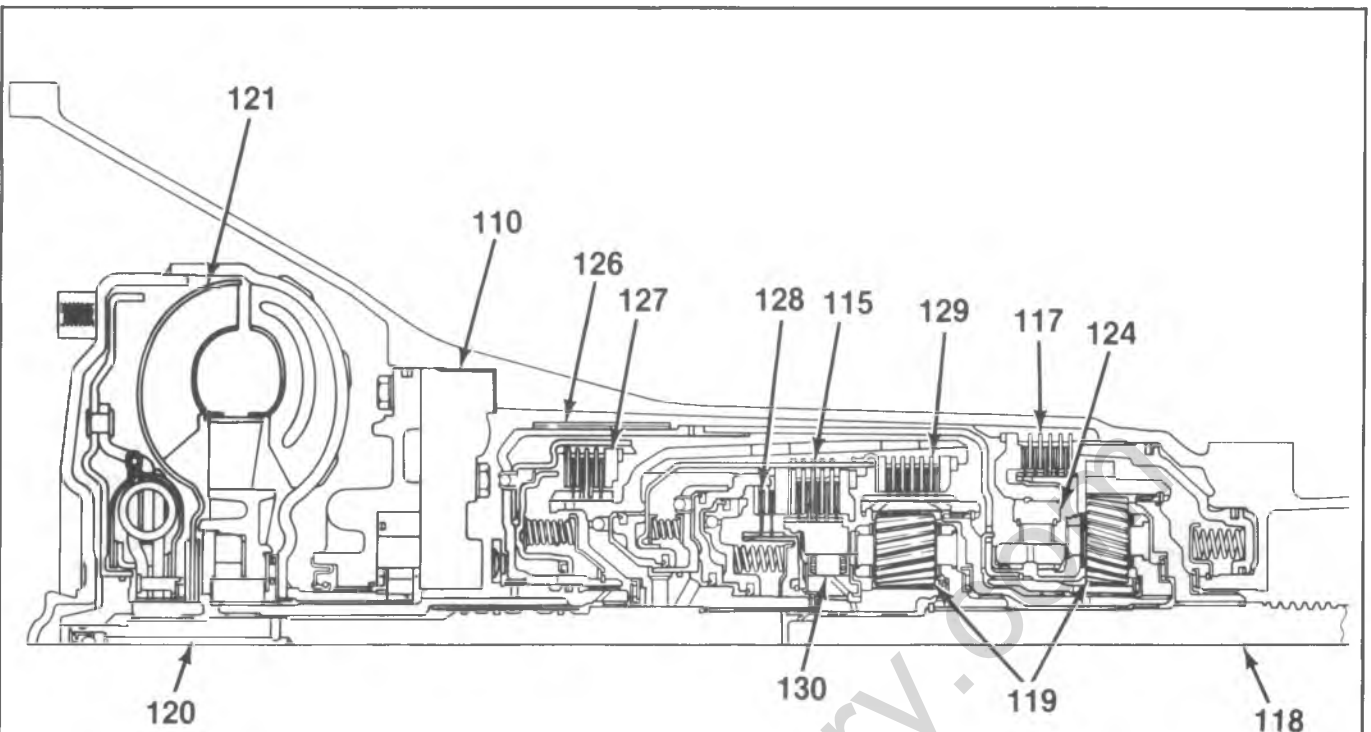

- 110. Oil Pump
- 115. Forward Clutch
- 117. Lo And Reverse Clutch
- 118. Output Shaft
- 119. Planetary Gears
- 120. Input Shaft
- 121. Torque Converter
- 124. Lo Roller Clutch
- 126. 2-4 Band
- 127. Reverse Input Clutch
- 128. Overrun Clutch
- 129. 3-4 Clutch
- 130. Forward Sprag Clutch

GEAR RANGE	2-4 BAND	REVERSE INPUT CLUTCH	OVERRUN CLUTCH	FORWARD CLUTCH	FORWARD SPRAG CL. ASSEMBLY	3-4 CLUTCH	LO ROLLER CLUTCH	LO-REV. CLUTCH
1ST DR4				ON	ON		ON	
2ND DR4	ON			ON	ON			
3RD DR4				ON	ON	ON		
4TH DR4	ON			ON		ON		
3RD DR3			ON	ON	ON	ON		
2ND DR2	ON		ON	ON	ON			
1ST LO			ON	ON	ON		ON	ON
REV.		ON						ON

Figure 4—THM 700-R4 Clutches and Operation

TRANSMISSION DIAGNOSIS

TRANSMISSION DEFINITIONS

The following definitions are being provided to establish a common language and assist the user in describing transmission related conditions. Some of these terms or conditions are used in the transmission sections of this Service Manual.

Throttle Positions

- Minimum Throttle — the least amount of throttle opening required for an upshift.
- Light Throttle — approximately $\frac{1}{4}$ of accelerator pedal travel.
- Medium Throttle — approximately $\frac{1}{2}$ of accelerator pedal travel.
- Heavy Throttle — approximately $\frac{3}{4}$ of the accelerator pedal travel.
- Wide Open Throttle (WOT) — full travel of the accelerator pedal.
- Full Throttle Detent Downshift — a quick apply of the accelerator pedal to its full travel, forcing a downshift.
- Zero Throttle Coastdown — a full release of the accelerator pedal while the vehicle is in motion and in drive range.
- Engine Braking — a condition where the engine is used to slow the vehicle by manually downshifting during a zero throttle coastdown.

Shift Conditions

- Bump — a sudden and forceful apply of a clutch or band.
- Chuggle — a bucking or jerking condition that may be engine related. May be most noticeable when the converter clutch is engaged. Similar to the feel of towing a trailer.
- Delayed — a condition where a shift is expected but does not occur for a period of time. Samples of this condition could be described as clutch or band engagement does not occur as quickly as expected during a part throttle or wide open throttle apply of the accelerator or, when manually downshifting to a lower range.
Also defined as "LATE" or, "EXTENDED."
- Double Bump ("Double Feel") — two sudden and forceful applies of a clutch or band.
- Early — a condition where the shift occurs before the vehicle has reached a proper speed and tends to labor the engine after the upshift.
- End Bump — a firmer feel at the end of a shift as compared to the feel at the start of the shift. Also defined as "END FEEL" or, "SLIP BUMP."
- Firm — a noticeable quick apply of a clutch or band that is considered normal with a medium to heavy throttle shift. Should not be confused with "HARSH" or "ROUGH."
- Flare — a quick increase in engine rpm accompanied with a momentary loss of torque. This most generally occurs during a shift. Also defined as "SLIPPING."
- Harsh ("Rough") — a more noticeable apply of a clutch or band as compared to "FIRM." This condition is considered undesirable at any throttle position.

- Hunting — a repeating quick series of upshifts and downshifts that causes a noticeable change in engine rpm. An example could be described as a 4-3-4 shift pattern. Also defined as "BUSYNESS."
- Initial Feel — a distinct firmer feel at that start of a shift as compared to the finish of the shift.
- Late — a shift that occurs when the engine is at a higher than normal rpm for a given amount of throttle.
- Shudder — a repeating jerking sensation similar to "CHUGGLE" but more severe and rapid in nature. This condition may be most noticeable during certain ranges of vehicle speed. May also be used to define the condition after converter clutch engagement.
- Slipping — a noticeable increase in engine rpm without a vehicle speed increase. A slip usually occurs during or after initial clutch or band engagement.
- Soft — a slow, almost unnoticeable clutch apply with very little shift feel.
- Surge — a repeating engine related feeling of acceleration and deceleration that is less intense than "CHUGGLE."
- Tie-Up — a condition where two opposing clutches are attempting to apply at the same time causing the engine to labor with a noticeable loss of engine rpm.

Noise Conditions

- Gear Noise — a whine, most noticeable in first gear and reverse that is related to vehicle speed. A gear noise condition may become less noticeable or go away after an upshift.
- Pump Noise — a high pitch whine that increases in intensity with engine rpm. This condition may also be noticeable in PARK and NEUTRAL operating ranges with the vehicle stationary.

PRELIMINARY CHECKING PROCEDURE

This condition of an automatic transmission not operating properly may be influenced by one, or a combination of the following items:

- Fluid level high/low.
- Engine performance.
- T.V. cable adjustment.
- Manual linkage adjustment.
- Internal fluid leaks.
- Electrical system.
- Transmission or other mechanical component.
- Vacuum modulator.

TRANSMISSION FLUID INFORMATION

Checking fluid level, color and condition at regular intervals will provide early diagnosis information about the transmission. This information may then be used to correct a condition that, if not corrected early, could result in major transmission repairs.

When adding or changing fluid, use only DEXRON® II, or equivalent. Refer to Section 0B of this Service Manual for maintenance information and servicing intervals.

- Fluid level should be checked when it reaches normal operating temperatures of 88-93°C (190-200°F). This temperature is reached after approximately 24 km (15 miles) of highway driving (figure 5).
- Fluid color:
 - Should be dark red (may be dark green) (figure 5).
- Inaccurate fluid level readings will result if checked immediately after the vehicle has been operated:
 - In high ambient temperatures above 32°C (90°F).
 - At sustained high speeds.
 - In heavy city traffic during hot weather.
 - As a towing vehicle.
 - In commercial service (taxi or police use).

NOISE AND VIBRATION

A noise or vibration that is noticeable when the vehicle is in motion, MAY NOT be the result of the transmission.

If noise or vibration is noticeable in "Park" (P) and "Neutral" (N) with engine at idle, but is less noticeable as RPM's increase, the cause may be from poor engine performance.



Inspect

- Tires for
 - Uneven wear.
 - Imbalance.
 - Mixed sizes.
 - Mixed radial and bias ply.
- Suspension components for
 - Alignment and wear.
 - Loose fasteners.
- Engine/Transmission mounts for
 - Damage.
 - Loose bolts.
- Transmission case mounting holes for:
 - Missing bolts, nuts, studs.
 - Stripped threads.
 - Cracks.
- Flexplate for:
 - Missing or loose bolts.
 - Cracks.
 - Imbalance.
- Torque converter for:
 - Missing or loose bolts or lugs.
 - Missing or loose balance weights.
 - Imbalance.

VIBRATION TEST PROCEDURE

1. Start the engine.
2. With the engine at idle speed and the transmission in "Park" (P) or "Neutral" (N), observe the vibration.
3. Shut off the engine.



Inspect

- Converter shield attaching bolts.
- Flexplate to torque converter attaching bolts.

- Rotate torque converter 120° (1/3 turn).
- Flexplate to torque converter attaching bolts.



Tighten

- Bolts to 42 N·m (31 ft. lbs.).
- Converter shield bolts.



Tighten

- Bolts to 13 N·m (10 ft. lbs.)

4. Start the engine and check for vibration. Repeat this procedure until the best possible balance is obtained.



Important

- Some engine/transmission combinations cannot be balanced in this manner due to limited clearances between the torque converter bolts and engine. Be sure bolts do not bottom out in lug nuts or the torque converter cover could be dented and cause internal damage.

FLUID LEAKS

The cause of most external leaks can generally be located and repaired with the transmission in the vehicle.

METHODS FOR LOCATING LEAKS

General Method

1. Verify that the leak is transmission fluid.
2. Thoroughly clean the suspected leak area.
3. Operate the vehicle for about 15 miles or until normal operating temperatures are reached.
4. Park the vehicle over clean paper or cardboard.
5. Shut off the engine and look for fluid spots on the paper.
6. Make the necessary repairs.

Powder Method

1. Thoroughly clean the suspected leak area with solvent.
2. Apply an aerosol type powder (foot powder) to the suspected leak area.
3. Operate the vehicle for about 15 miles or until normal operating temperatures are reached.
4. Shut off the engine.
5. Inspect the suspected leak area and trace the leak path through the powder to find the source.
6. Make necessary repairs.

Dye And Black Light Method

A fluid dye and black light kit is available from various tool manufacturers.

1. Follow the manufacturer's recommendations for the amount of dye to be used.
2. Detect the leak with the black light.
3. Correct cause of leak.

REPAIRING THE LEAK

Once the leak has been pinpointed and traced back to its source, the cause of the leak must be determined in order for it to be repaired properly. If a gasket is replaced, but the sealing flange is bent, the new gasket will not repair the leak. The bent flange must be repaired also.

7A-8 AUTOMATIC TRANSMISSION

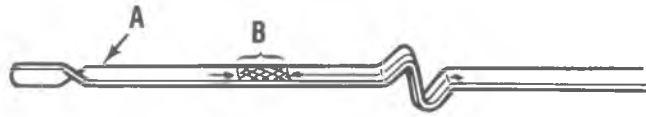

- A. FLUID LEVEL INDICATOR
- B. LEVEL TO BE IN CROSS-HATCHED AREA ON FLUID LEVEL INDICATOR BLADE.
CHECK AT OPEARTING TEMPERATURE.

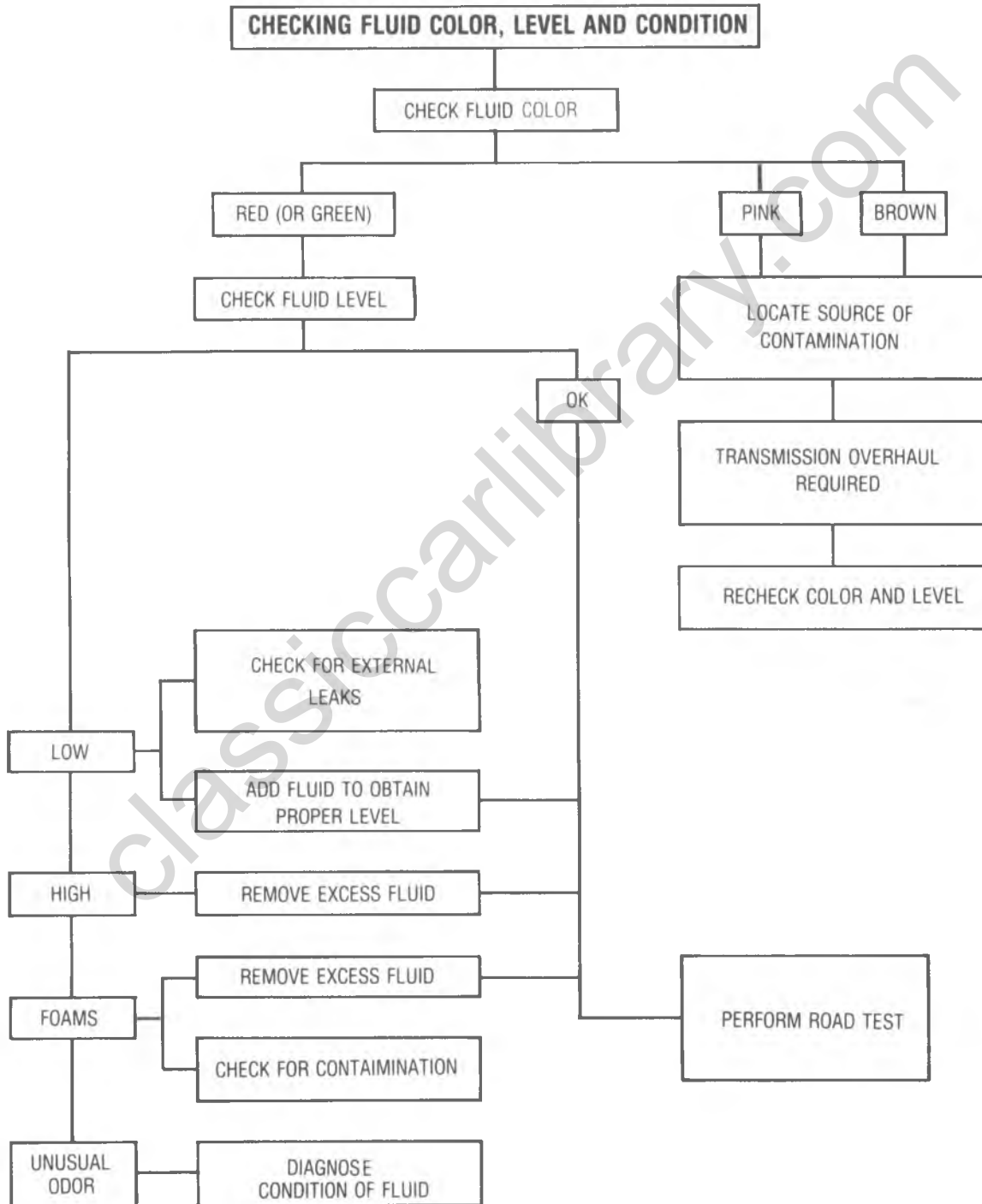

F-02662

Figure 5—Checking Fluid Level, Color and Condition

Before attempting to repair a leak, check to be sure that the following conditions are correct as they may cause a leak.

Gaskets

1. Fluid level/pressure is too high.
2. Plugged vent or drain-back holes.
3. Improperly torqued fasteners or dirty/damaged threads.
4. Warped flanges or sealing surface.
5. Scratches, burrs or other damage to the sealing surface.
6. Damaged or worn gasket.
7. Cracking or porosity of the component.
8. Improper sealant used (where applicable).

Seals

1. Fluid level/pressure is too high.
2. Plugged vent or drain-back holes.
3. Damaged seal bore (scratched, burred or nicked).
4. Damage or worn seal.
5. Improper installation.
6. Cracks in component.
7. Manual or output shaft surface scratched, nicked or damaged.
8. Loose or worn bearing causing excess seal wear.

POSSIBLE POINTS OF FLUID LEAKS (Figure 6)

1. Transmission oil pan or side cover:
 - Attaching bolts not correctly torqued.
 - Improperly installed or damaged gasket.
 - Oil pan or mounting face not flat.
2. Case leak:
 - Filler pipe "multi-lip seal" damaged or missing.
 - Filler pipe bracket mislocated.
 - T.V. cable "multi-lip" seal missing, damaged or improperly installed.
 - Governor cover or gasket damaged or missing.
 - Speedometer driven gear/speed sensor seal damaged.
 - Manual shaft seal damaged.
 - Oil cooler connector fittings loose or damaged.
 - Parking pawl shaft cup plug loose (if equipped).
 - Line pressure pipe plug loose.
 - Porous casting.
3. Leak at converter end:
 - Converter seal damaged.
 - Seal lip cut. (Check converter hub for damage).
 - Bushing moved forward and damaged.
 - Garter spring missing from seal.
 - Converter leak in weld area. (Refer to Torque Converter.)
 - Porous casting (case, pump).
4. Fluid comes out the vent pipe or fill tube:
 - Over-filled.
 - Water or coolant in fluid. Fluid will appear milky.
 - Case porous.
 - Incorrect fluid level indicator.
 - Plugged vent.
 - Drain back holes plugged.
 - Mispositioned oil pump to case gasket (if equipped).

CASE POROSITY REPAIR

1. Clean the leak area with solvent and air dry.

CAUTION: Epoxy cement may cause skin irritations and eye damage. Read and follow all information on the container label as provided by the manufacturer.

2. Mix a sufficient amount of epoxy cement, GM 1360016, or equivalent, following the manufacturer's recommendations.
3. While the transmission case is hot, apply the epoxy cement with a clean, dry soldering acid brush.
4. Allow the epoxy cement to cure for three hours before starting the engine.
5. Repeat the fluid leak diagnosis procedures.

VACUUM MODULATOR

A vacuum modulator can cause one or more of the following complaints.

1. Harsh upshifts and downshifts.
2. Delayed upshifts.
3. Soft upshifts and downshifts.
4. Slips in low, drive and reverse.
5. Transmission overheating.
6. Engine burning transmission oil.

If any one of the above complaints are encountered, the modulator must be checked.

CAUSES OF IMPROPER VACUUM AT MODULATOR

1. Engine.
 - a. Tune up.
 - b. Loose vacuum fittings or improperly routed hoses/lines.
 - c. Vacuum operated accessory leak (hoses, vacuum valve, etc.).
 - d. Engine exhaust system restricted.
 - e. Diesel—Vacuum Regulator Valve adjustment. (Refer to DIESEL FUEL INJECTION, SEC. 6C6).
2. Vacuum line to the modulator.
 - a. Leak.
 - b. Loose fitting.
 - c. Restricted orifice or incorrect orifice size.
 - d. Carbon build up at modulator vacuum fitting.
 - e. Pinched line.
 - f. Grease in pipe (delayed or no upshift-cold).

VACUUM DIAPHRAGM CHECK

1. Raise the vehicle and disconnect the vacuum line at the modulator.
2. Turn the modulator so the vacuum line stem points downward.
3. If transmission oil comes out, the modulator must be replaced.
4. If gasoline and/or water vapor are found in a vehicle which may be exposed to -12°C (10°F) temperatures or below, the modulator must be changed.
5. If oil is not found in the vacuum side of the modulator, but the transmission oil level is continually low, and no external leaks are found, there is a possibility that a pin hole leak exists in the diaphragm and the modulator should be replaced.

7A-10 AUTOMATIC TRANSMISSION

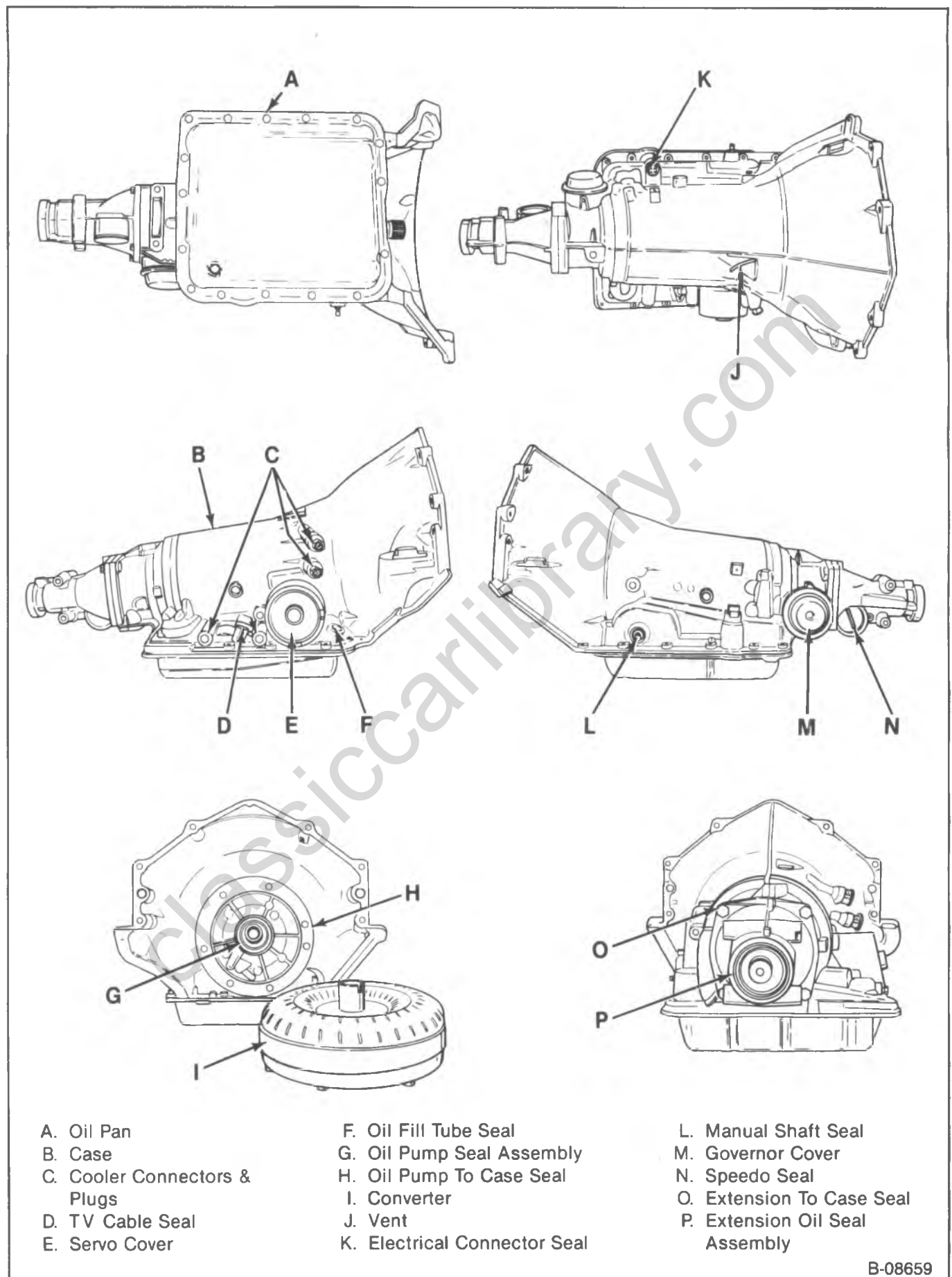

A. Oil Pan

B. Case

C. Cooler Connectors & Plugs

D. TV Cable Seal

E. Servo Cover

F. Oil Fill Tube Seal

G. Oil Pump Seal Assembly

H. Oil Pump To Case Seal

I. Converter

J. Vent

K. Electrical Connector Seal

L. Manual Shaft Seal

M. Governor Cover

N. Speedo Seal

O. Extension To Case Seal

P. Extension Oil Seal Assembly

B-08659

Figure 6—Possible Leak Points

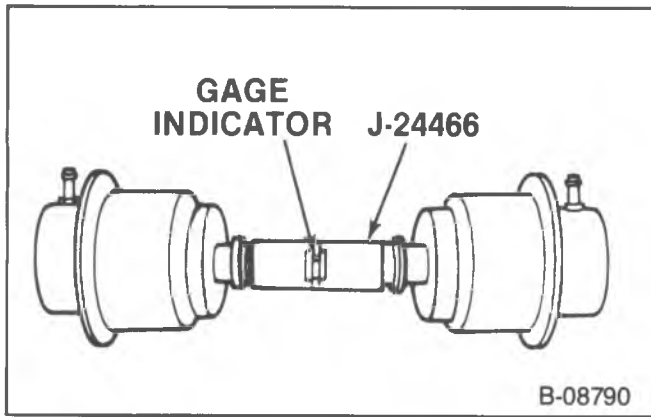

Figure 7—Checking the Modulator

ATMOSPHERIC LEAK CHECK

1. Apply a thick coating of soap bubble solution to the vacuum connector pipe seam and the crimped upper to lower housing seam.
 2. Using a short piece of rubber hose, apply air pressure to the vacuum pipe by blowing into the tube.
 3. If bubbles appear, replace the modulator.
- Do not use any method other than human lung power for applying air pressure, as pressures over 41.37 kPa (6 psi) may damage the modulator.

LOAD CHECK

1. Install a modulator that is known to be good on either end of tool J-24466.
2. Install the modulator in question on the opposite end of the gage (figure 7).
3. Holding the modulators in a horizontal position, bring them slowly together under pressure. If the modulator in question is bad, the gage line will remain blue. If the modulator is good, the gage line will be white. When making the comparison, make sure that both modulators are of the same type. The part numbers are stamped on the dome of the modulator.

SLEEVE ALIGNMENT CHECK

1. Roll the main body of the modulator on a flat surface.
 2. If the sleeve is not concentric to the can, replace the modulator.
 3. If the plunger is not free, replace the modulator.
- The following items should also be checked as a possible cause of the problem.
1. Check freeness of modulator valve in transmission case.
 2. Check the vacuum line from the manifold or vacuum pump to modulator for holes, cracks or dents. Check the rubber hose connection at the modulator and at the intake manifold or vacuum pump for leaks.

DIAGNOSIS OF TORQUE CONVERTER

PROBLEM	POSSIBLE CAUSE	CORRECTION
Converter Shudder	<ol style="list-style-type: none"> 1. Torque converter assembly. 2. Valve body. 3. Oil pump assembly. 4. Oil filter. 5. Miscellaneous. 6. Input housing and shaft assembly. 	<ol style="list-style-type: none"> 1. Internal damage. 2. Converter clutch shift valve stuck. 3. a. Converter clutch apply valve stuck. b. Restricted oil passage. 4. a. Crack in filter body. b. Flash restricting filter neck. c. Seal cut or damaged. 5. a. Low oil pressure. b. Engine not tuned properly. 6. a. Turbine shaft seal cut or damaged. b. Turbine shaft retainer and ball assembly damaged.
No Converter Clutch Release	<ol style="list-style-type: none"> 1. Solenoid 2. Converter. 3. Oil pump assembly. 	<ol style="list-style-type: none"> 1. External ground. 2. Internal damage. 3. Converter clutch apply valve stuck.

DIAGNOSIS OF TORQUE CONVERTER (CONT.)

PROBLEM	POSSIBLE CAUSE	CORRECTION
<p>No Converter Clutch Apply</p>	<ol style="list-style-type: none"> 1. Electrical. 2. Converter. 3. Oil pump assembly. 4. Valve body assembly. 5. Input housing and shaft. 	<ol style="list-style-type: none"> 1. <ol style="list-style-type: none"> a. 12 volts not supplied to transmission. b. Outside electrical connector damaged. c. Inside electrical connector, wiring harness or solenoid damaged. d. Electrical short (pinched solenoid wire). e. Solenoid not grounded. f. Incorrect or damaged pressure switches. 2. Internal damage. 3. <ol style="list-style-type: none"> a. Converter clutch apply valve stuck or assembled backwards. b. Converter clutch apply valve retaining ring mispositioned. c. Pump to case gasket mispositioned. d. Orifice cup plug plugged. e. Solenoid seal cut or damaged. f. Orifice cup plug omitted from cooler in passage. g. High or uneven bolt torque (pump body to cover). 4. Valves stuck. <ol style="list-style-type: none"> a. Converter clutch shift valve. b. Throttle valve. 5. <ol style="list-style-type: none"> a. Turbine shaft seal cut or damaged. b. Turbine shaft retainer and ball assembly plugged.

STATOR ASSEMBLY FREEWHEELS

If the stator roller clutch becomes ineffective, the stator assembly freewheels at all times in both directions. With this condition, the vehicle tends to have poor acceleration from a standstill. At speeds above 48 to 56 km/h (30-35 mph), the vehicle may act normal. If poor acceleration problems are noted, it should first be determined that the exhaust system is not blocked, the engine is running properly and the transmission is in first (1st) gear when starting out.

If the engine will free accelerate to high rpm in Neutral (N), it can be assumed that the engine and exhaust system are normal.

STATOR ASSEMBLY REMAINS LOCKED UP

If the stator assembly remains locked up at all times, the engine rpm and vehicle speed will tend to be limited or restricted at high speeds. The vehicle performance when accelerating from a standstill will be normal. Engine overheating may be noted. Visual examination of the converter may reveal a blue color from the overheating that will result.

DIAGNOSIS OF TORQUE CONVERTER CLUTCH (TCC)

To properly diagnose the Torque Converter Clutch (TCC) system perform all electrical testing first and then the hydraulic testing.

**TORQUE CONVERTER CLUTCH (T.C.C.)
ELECTRICAL DIAGNOSIS**

**MECHANICAL CHECKS, SUCH AS LINKAGE, OIL LEVEL, ETC.,
SHOULD BE PERFORMED PRIOR TO USING THIS CHART.**

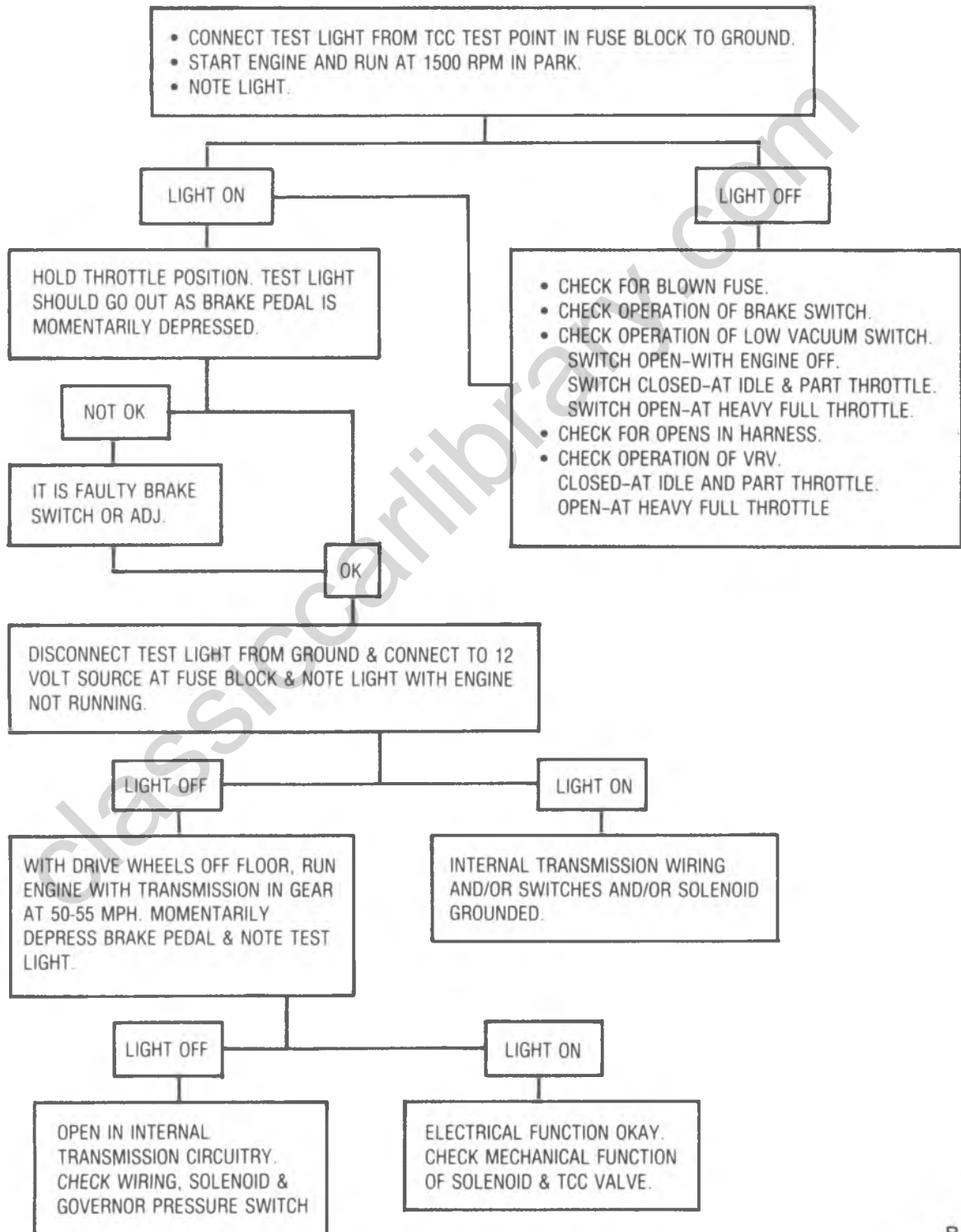

B-08583

Figure 8—TCC Diagnosis

THM 400 PRELIMINARY CHECKING

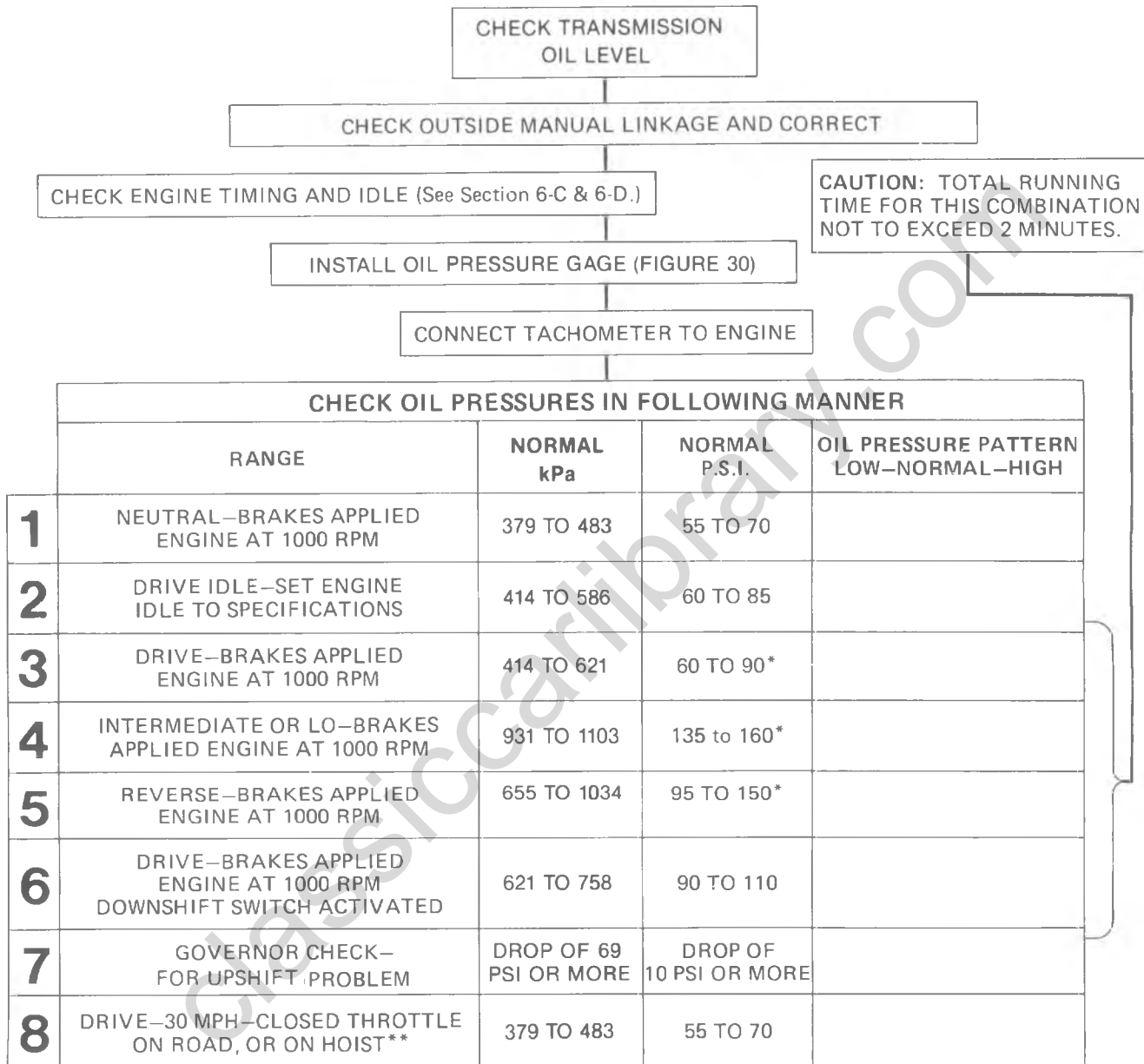

* IF HIGH LINE PRESSURES ARE EXPERIENCED, REFER TO "CAUSES OF HIGH LINE PRESSURE" IN THIS SECTION.

** VEHICLE ON HOIST, DRIVING WHEELS OFF GROUND, SELECTOR IN DRIVE, BRAKES RELEASED, RAISE ENGINE TO 3000 R.P.M., CLOSE THROTTLE AND READ PRESSURE BETWEEN 2000 AND 1200 R.P.M.

B-08660

Figure 9—Preliminary Checking Procedure

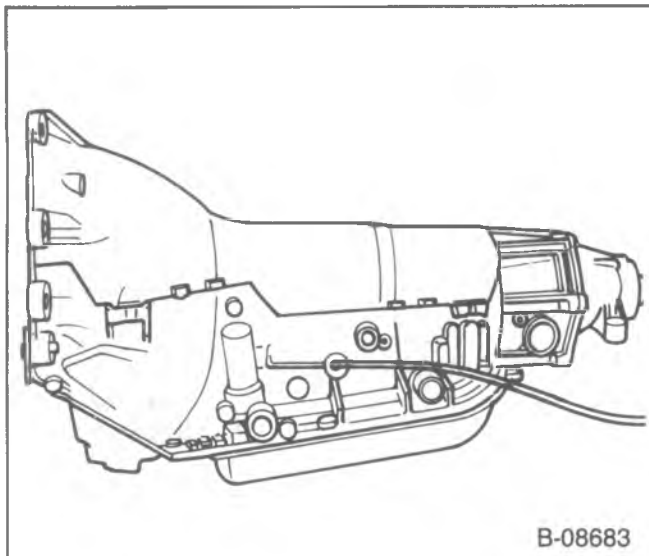

Figure 10—THM 400 Pressure Tap Location

ROAD TEST

1. Connect a portable tachometer to the engine. Engine rpm will identify the shift points.
2. Place the selector in "Drive" position and accelerate the vehicle from a rest at a minimum throttle opening. The specifications for the shifts points are:
 Downshifts should occur (3-2 and 2-1) as the vehicle speed decreases to 0 mph. Stop the vehicle.
3. Place the selector in "Intermediate" position and accelerate the vehicle from a rest. A 1-2 shift should occur at all throttle openings. No 2-3 shift can be obtained in this range. Stop the vehicle.
4. Place the selector in "Low". No upshift should occur in this range regardless of the throttle opening.
5. Position the selector in "Drive" and accelerate the vehicle to 35 mph and move the selector to "Intermediate". A 3-2 downshift should occur, increasing the engine rpm and an engine braking effect should be noticed on deceleration.
6. With the selector in "Intermediate" at approximately 25 mph, but not over 40 mph, at closed throttle, move the selector to "Low." A 2-1 downshift should occur, increasing the engine rpm and an engine braking effect should be noticed on deceleration. Stop the vehicle.

UPSHIFT	MINIMUM
1-2	15 MPH
2-3	30 MPH
UPSHIFT	MAXIMUM
1-2	44-48 MPH
2-3	77-83 MPH
DETENT DOWNSHIFT	MINIMUM
3-2	68-73 MPH
2-1	28-32 MPH

B-08325

Figure 11—THM 400 Shift Points

7. Place the selector in "Reverse" and check for reverse operation.

CAUSES OF LOW LINE PRESSURE

1. Low transmission oil level.
2. Modulator Assembly.
3. Filter.
 - Blocked or restricted. (There is no approved service procedure for checking or cleaning the filter. If the filter is suspected or being plugged or restricted, it must be replaced).
 - Seal on intake pipe and/or grommet omitted or damaged.
 - Split or leaking intake pipe.
 - Wrong filter assembly.
4. Pump.
 - Pressure regulator or boost valve stuck.
 - Gear clearance, damaged, worn. (Pump will become damaged if drive gear is installed backwards, or if converter pilot does not enter crankshaft freely).
 - Pressure regulator spring, too weak.
 - Not enough spacers in pressure regulator.
 - Pump to case gasket mispositioned.
 - Malfunctioning pump body and/or cover.
 - Mismatched pump cover/pump body.
5. Internal circuit leaks.
 - Forward clutch leak (pressure normal in neutral and reverse-pressure low in drive).
 - Check pump rings.
 - Check forward clutch seals.
 - Direct clutch leak (pressure normal in neutral, low, intermediate, and drive—pressure low in reverse).
 - Check center support oil seal rings.
 - Check direct clutch outer seal for damage.
 - Check rear servo and front accumulator pistons and rings for damage or missing.
6. Case assembly.
 - Porosity in intake bore area.
 - Check case for intermediate clutch plug leak or missing plug.
 - Lo-reverse check ball mispositioned or missing (this will cause no reverse and no overrun braking in Lo range).

CAUSES OF HIGH LINE PRESSURE

1. Vacuum leak.
 - Full leak (vacuum line disconnected).
 - Partial leak in the line from the engine modulator.
 - Improper engine vacuum.
 - Vacuum operated accessory leak. (Hoses, vacuum advance, etc.).
2. Damaged modulator.
 - Stuck valve.
 - Water in the modulator.
 - Not operating properly.
3. Detent system.
 - Detent switch actuated (plunger stuck) or shorted.
 - Detent wiring shorted.
 - Detent solenoid stuck open.
 - Detent feed orifice in the spacer plate blocked.
 - Detent solenoid loose.

DIAGNOSIS OF THM 400

	1	2	3	4	5	6	7	8	
Malfunction	Neutral Brakes Applied 1000 rpm	Drive Idle	Drive Left — Brakes Applied 1000 rpm	Drive-R Brakes Applied 1000 rpm	Reverse Brakes Applied 1000 rpm	Drive Left — Brakes Applied 1000 rpm Downshift Switch Activated	Pressure Drop Occurs while Engine rpm Increases from 1000 to 3000 rpm Wheels Free to Move*	Drive 30 mph Closed Throttle	Possible Cause of Malfunction
	Oil Pressure	Oil Pressure	Oil Pressure	Oil Pressure	Oil Pressure	Oil Pressure		Oil Pressure	
No 1-2 Upshift and/or Delayed Upshift	Normal	Normal	Normal	Normal	Normal	Normal	10 psi Drop or More	Normal	Malfunction in Control Valve Assembly
	Normal	Normal	Normal	Normal	Normal	Normal	Less than 10 psi Drop	Normal	Malfunction in Governor or Governor Feed System
	Normal	High	High	Normal	Normal	Normal		High	Malfunction in Detent System
	High	High	High	Normal	High	—	—	—	Malfunction in Modulator or Vacuum Feed System to Modulator
Slipping-Reverse	Normal	Normal	Normal	Normal	Low	Normal		Normal	Oil Leak in Feed System to the Direct Clutch
Slipping-1st Gear	Normal	Low to Normal	Low to Normal	Low to Normal	Normal	Low to Normal	—	Low to Normal	Oil Leak in Feed System to the Forward Clutch
Downshift with Zero Throttle and No Engine Braking in Drive	Normal	High	Normal	Normal	Normal	—	—	High	Stator and Detent Wires Switched
No Detent Downshifts	Normal	Normal	Normal	Normal	Normal	Low		Normal	Malfunction in Detent System

*Drive range, vacuum line disconnected from modulator.

A dash (—) in the above chart means that the oil pressure reading has no meaning under the test condition. Pressures obtained by the Preliminary Checking procedure

Figure 12—THM 400 Oil Pressure Check Chart

DIAGNOSIS OF THM 400

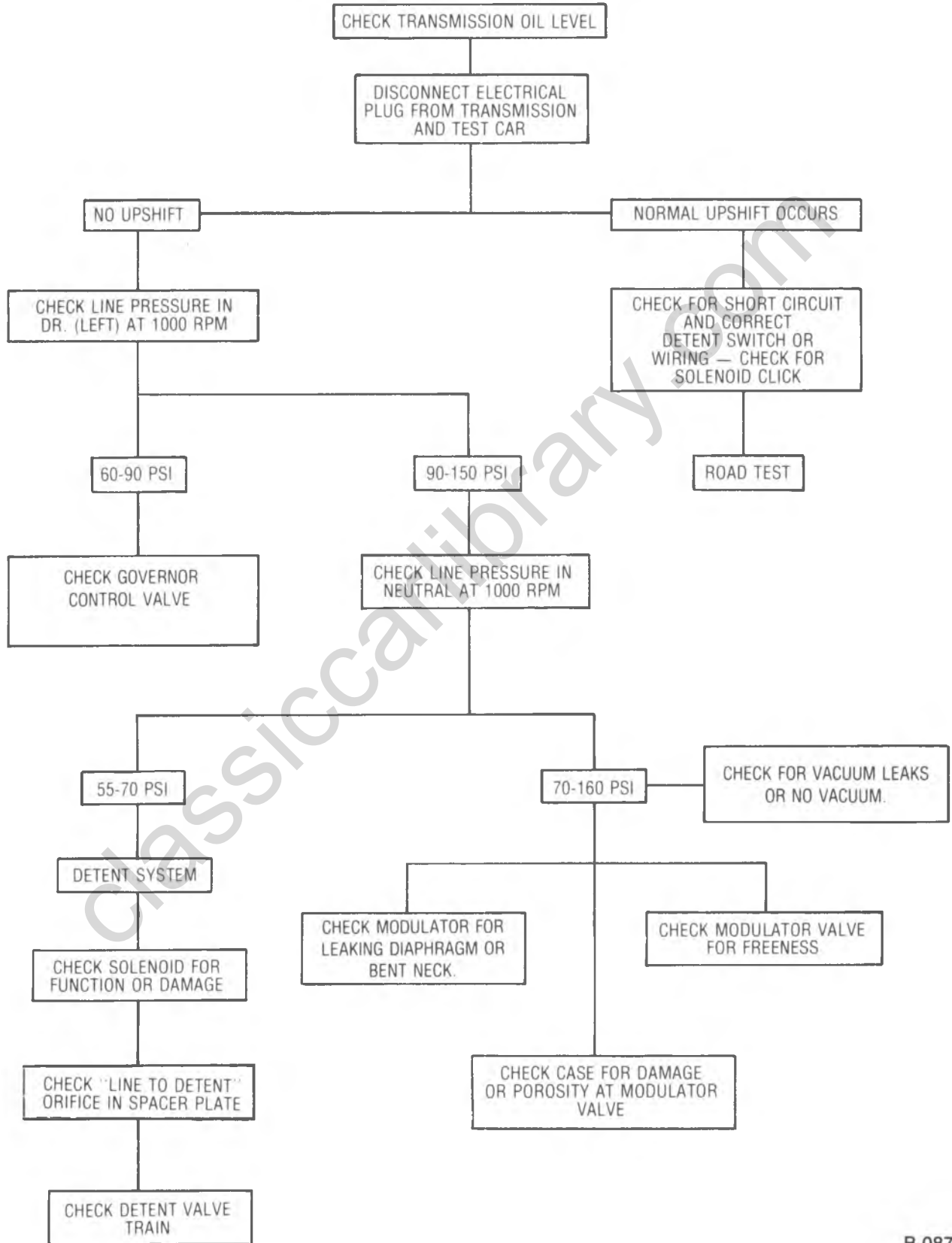

B-08739

Figure 13—No 1-2 Upshift and/or Delayed Upshift

DIAGNOSIS OF THM 400 (CONT.)

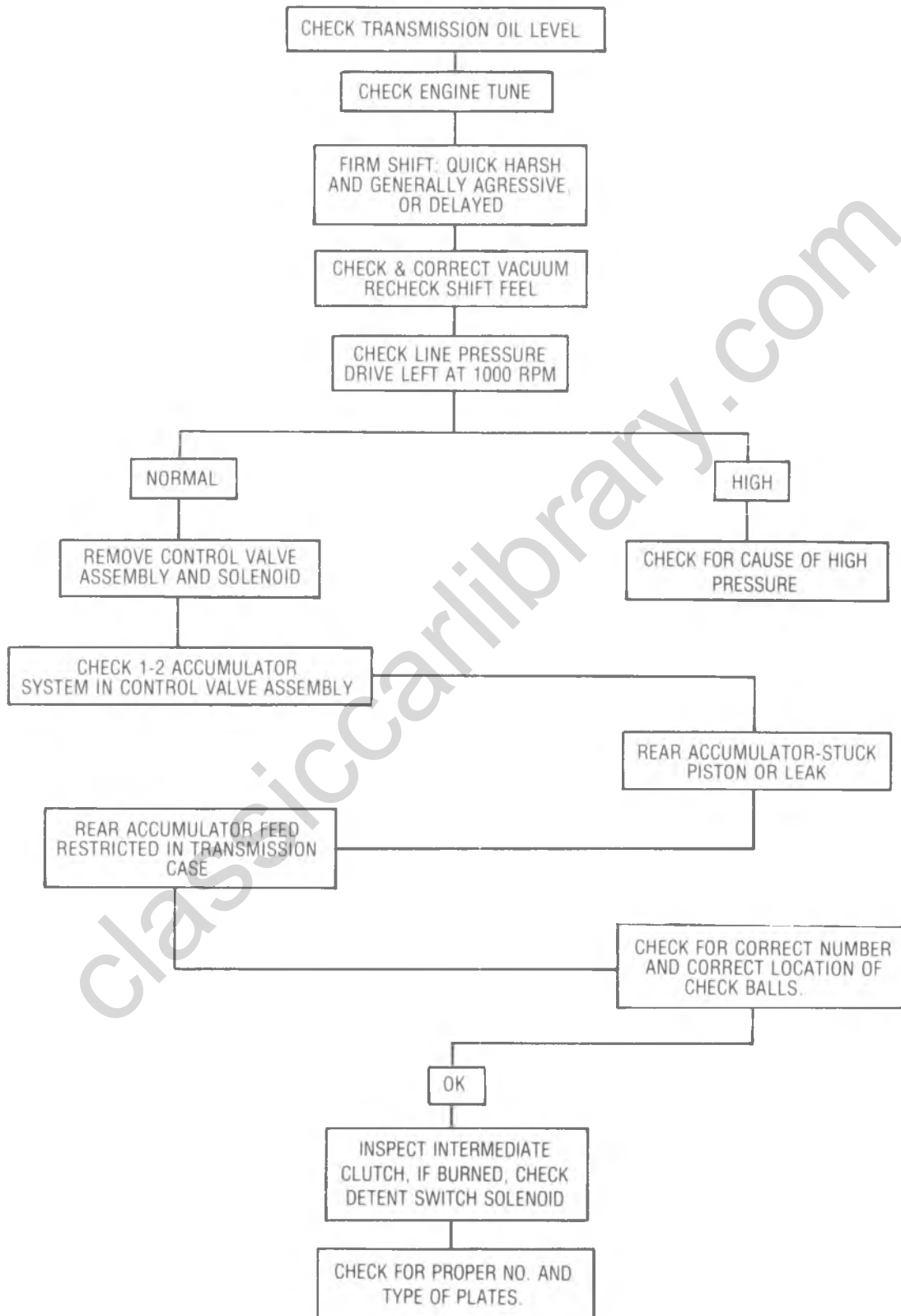

B-08737

Figure 14-1-2 Shift Feel Complaint — Firm Shift

DIAGNOSIS OF THM 400 (CONT.)

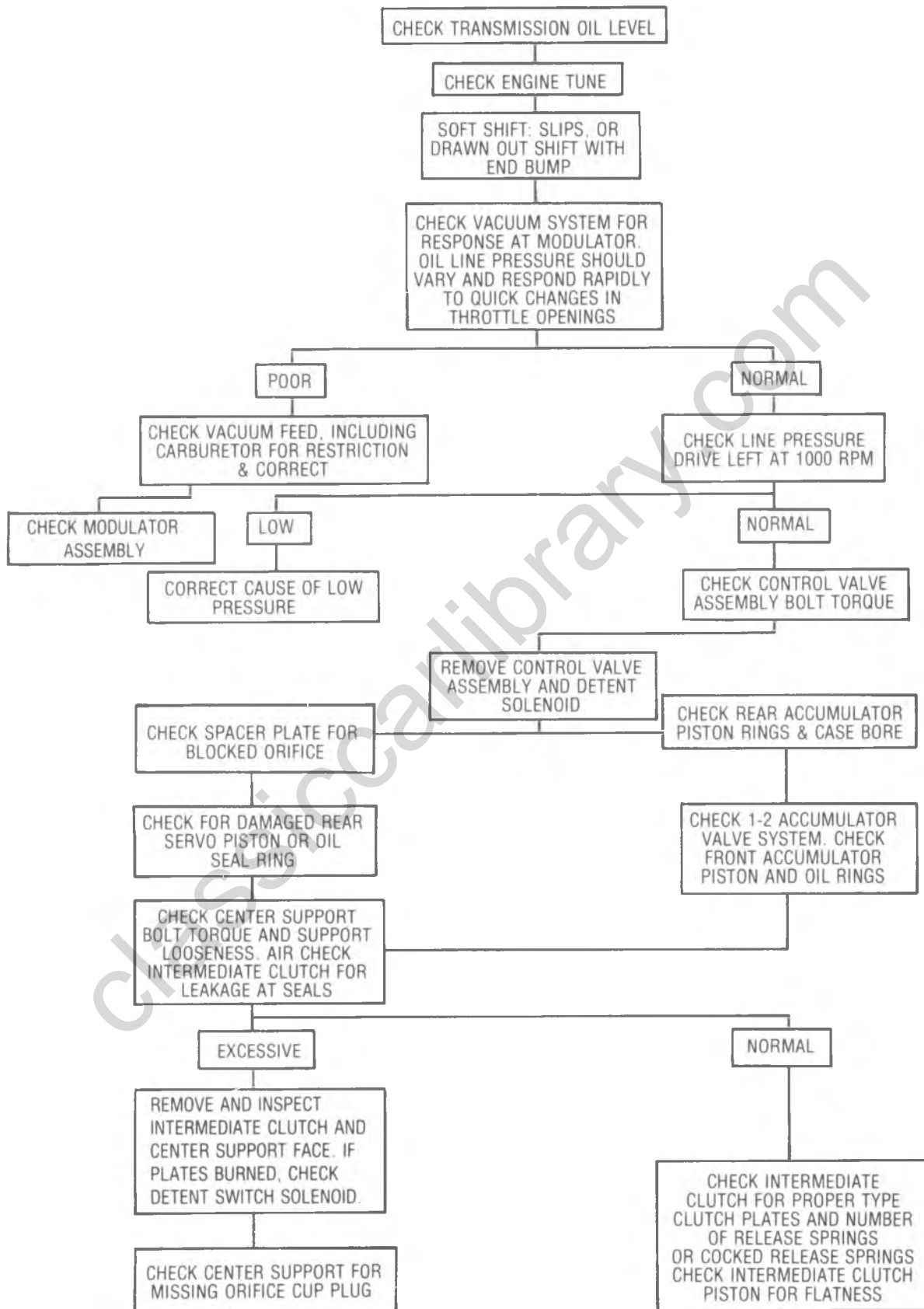

B-08735

Figure 15—1-2 Shift Feel Complaint — Firm Shift

DIAGNOSIS OF THM 400 (CONT.)

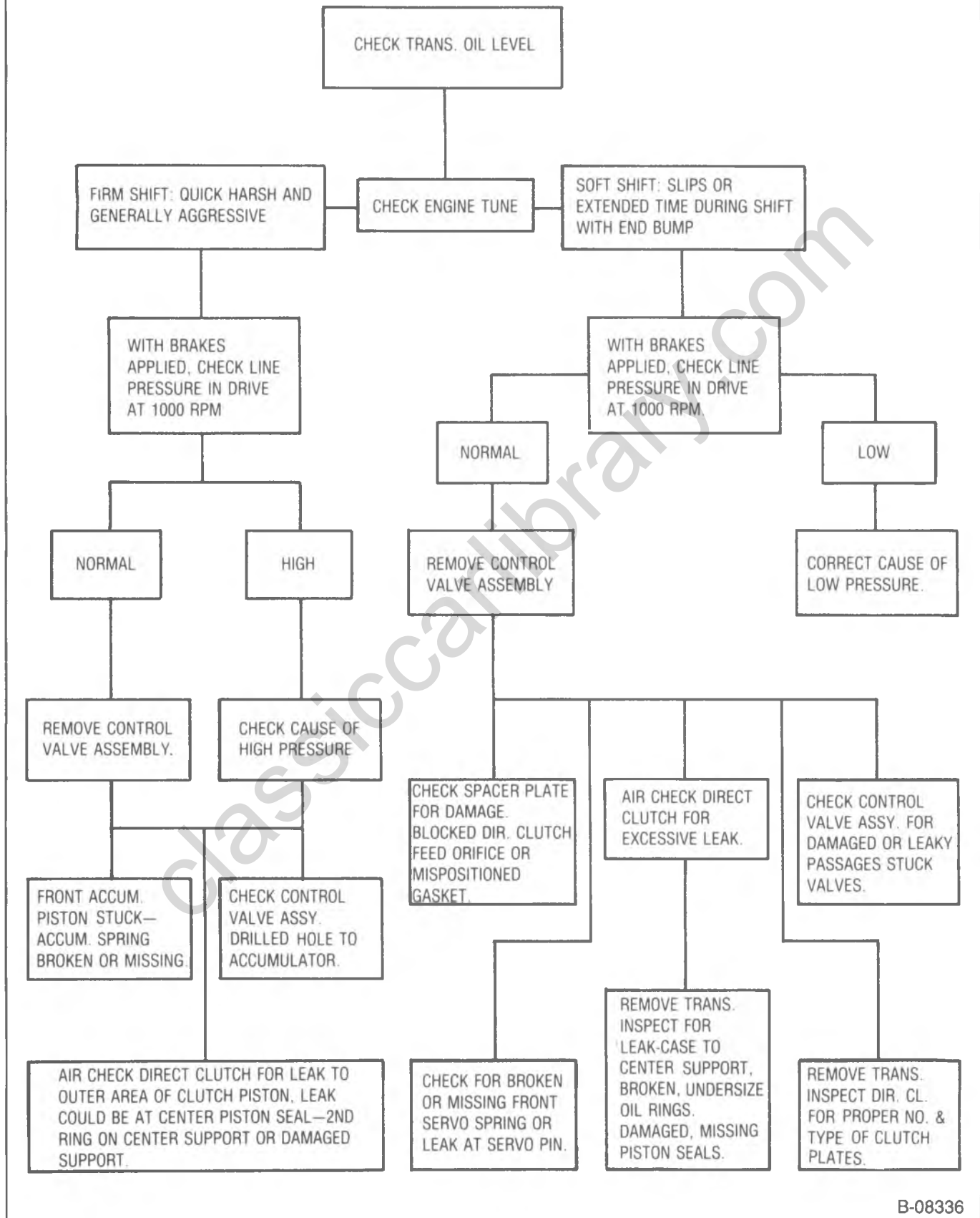

B-08336

Figure 16—2-3 Shift Complaint

DIAGNOSIS OF THM 400 (CONT.)

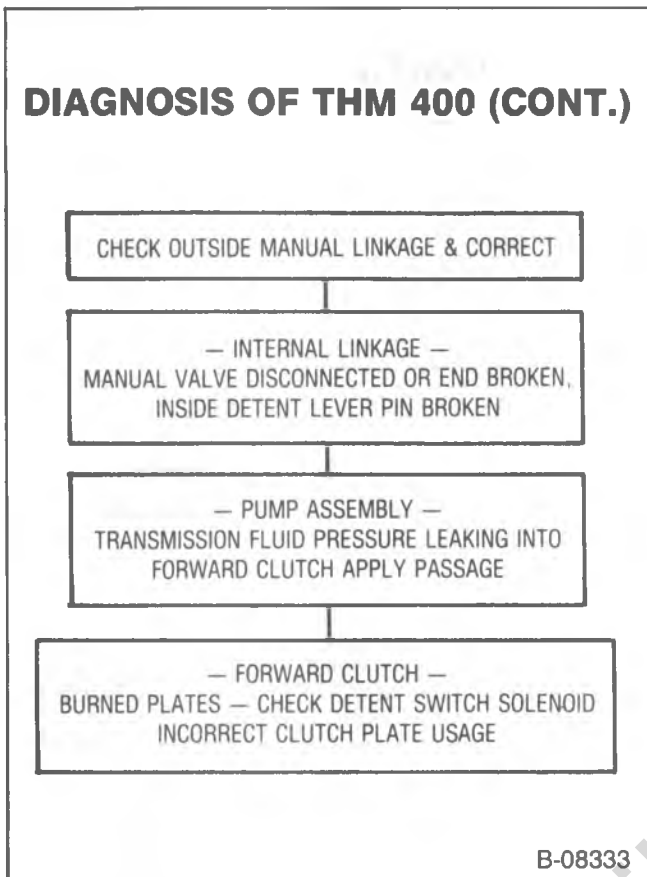

B-08333

Figure 17—Drive In Neutral

- Detent valve bore plug damaged.
 - Detent regulator valve pin short.
4. Pump.
- Pressure regulator and/or boost valve stuck.
 - Incorrect pressure regulator spring.
 - Too many pressure regulator valve spacers.
 - Pump casting bad.
 - Pressure boost valve installed backwards or malfunctioning.

DIAGNOSIS OF THM 400 (CONT.)

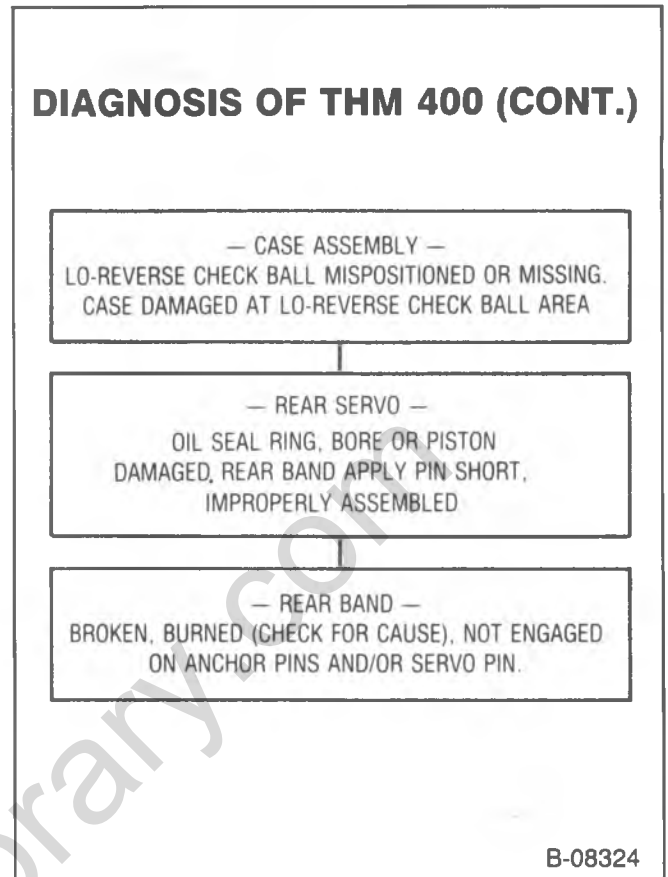

B-08324

Figure 19—No Engine Braking — Lo Range — 1st Gear

CONTROL VALVE ASSEMBLY—GOVERNOR LINE PRESSURE CHECK

1. Install an oil pressure test gage.
2. Install a tachometer.
3. Disconnect the vacuum line to the modulator.
4. With the vehicle on a hoist driving wheels off the ground, foot off the brake, in drive, check the line pressure at 1000 rpm.
5. Slowly increase the engine rpm to 3000 rpm and determine if a line pressure drop occurs (69 kPa [10 psi] or more).
6. If pressure drop of 69 kPa (10 psi) or more occurs, disassemble, clean and inspect the control valve assembly.

CHECK OUTSIDE MANUAL LINKAGE & CORRECT

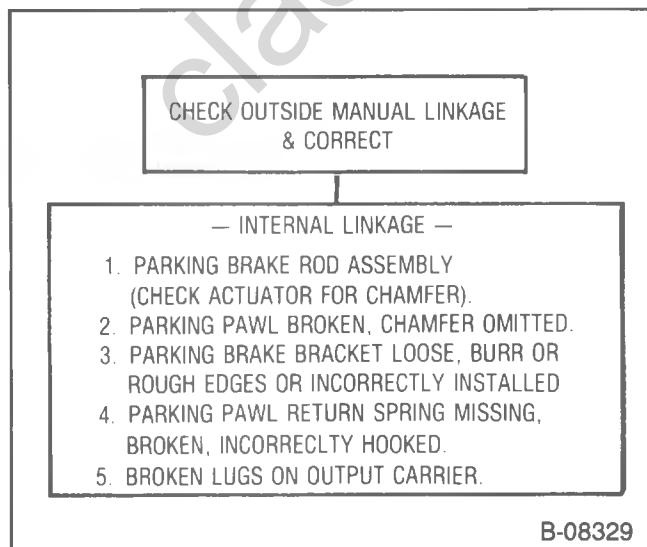

B-08329

Figure 18—Will Not Hold in Park or Will Not Release From Park

- FRONT SERVO & ACCUMULATOR -
OIL RINGS AND/OR BORES LEAKING OR FRONT SERVO PISTON COCKED OR STUCK

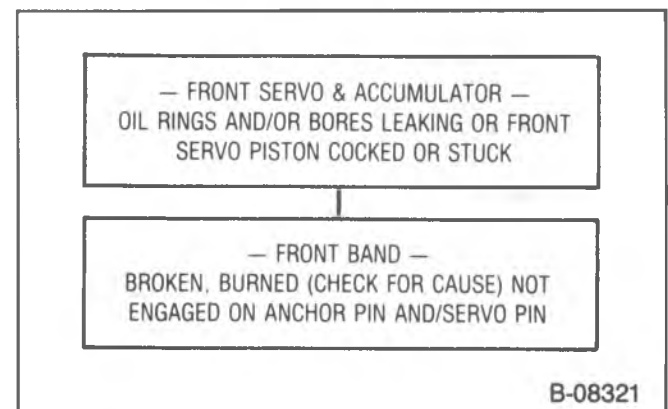

B-08321

Figure 20—No Engine Braking — Intermediate Range — 2nd Gear

7A-22 AUTOMATIC TRANSMISSION

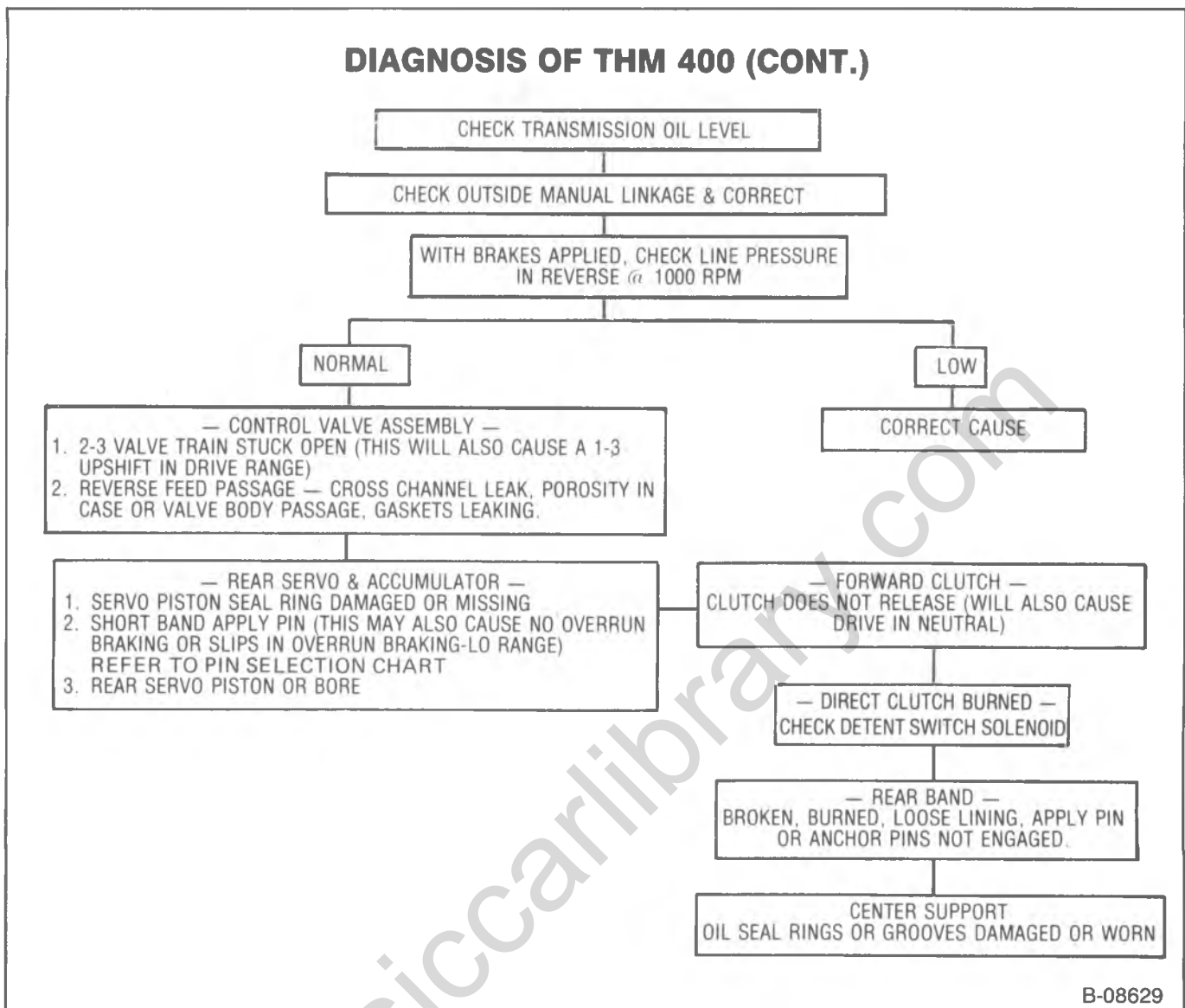

Figure 21—No Reverse or Slips in Reverse

7. If the pressure drop is less than 69 kPa (10 psi):

- Inspect the governor.
 - Stuck valve.
 - Weight freeness.
 - Restricted orifice in the governor valve.

- Check the governor valve entry and exhaust (0.50 mm [0.20-in.] min.).
- Governor feed system.
 - Check the screen in the control valve assembly or case.
 - Check for restrictions in the governor pipe.
 - Check for fit of the governor pipes in the case holes.

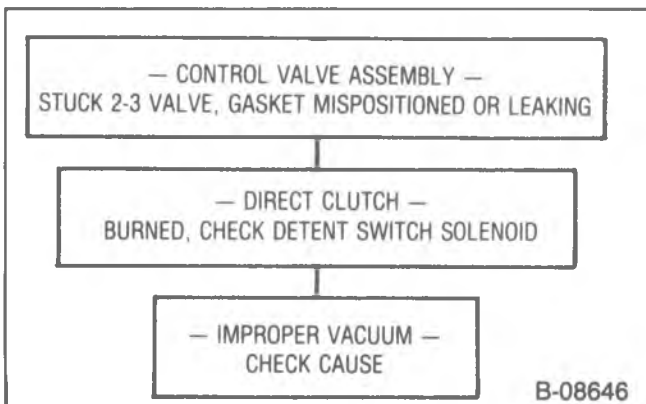
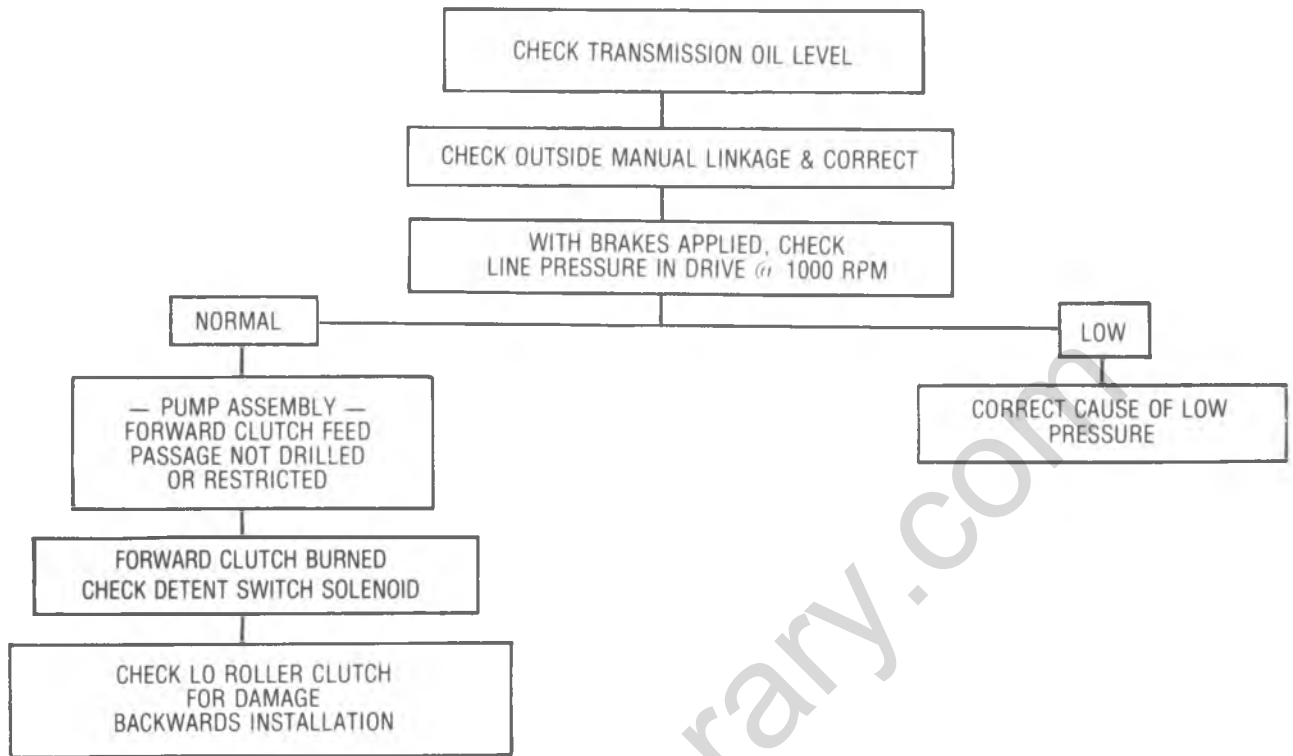

Figure 22—No 2-3 Upshift, 1st and 2nd Speeds Only

DIAGNOSIS OF THM 400 (CONT.)



B-08680

Figure 23—No Drive in Drive Range

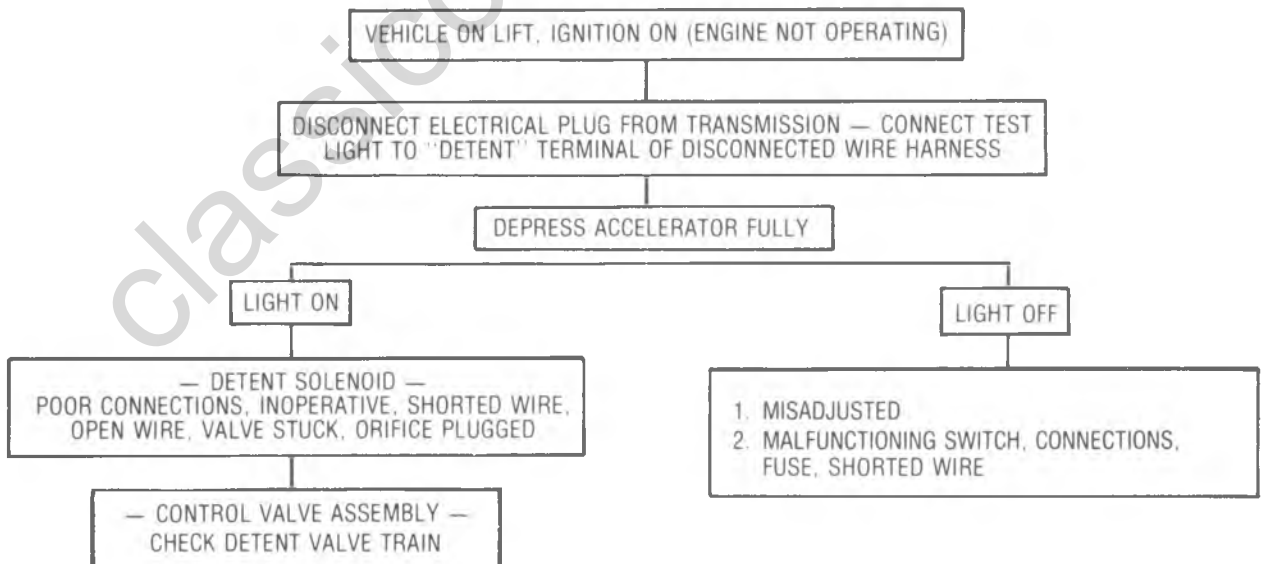

B-08675

Figure 24—No Detent Downshift

7A-24 AUTOMATIC TRANSMISSION

DIAGNOSIS OF THM 400 (CONT.)

NOTE: BEFORE CHECKING TRANSMISSION FOR WHAT IS BELIEVED TO BE "TRANSMISSION NOISE," MAKE CERTAIN THE NOISE IS NOT FROM THE WATER PUMP, GENERATOR, AIR CONDITIONER, POWER STEERING, ETC. THESE COMPONENTS CAN BE ISOLATED BY REMOVING THE PROPER BELT AND RUNNING THE ENGINE NO MORE THAN TWO MINUTES AT ONE TIME.

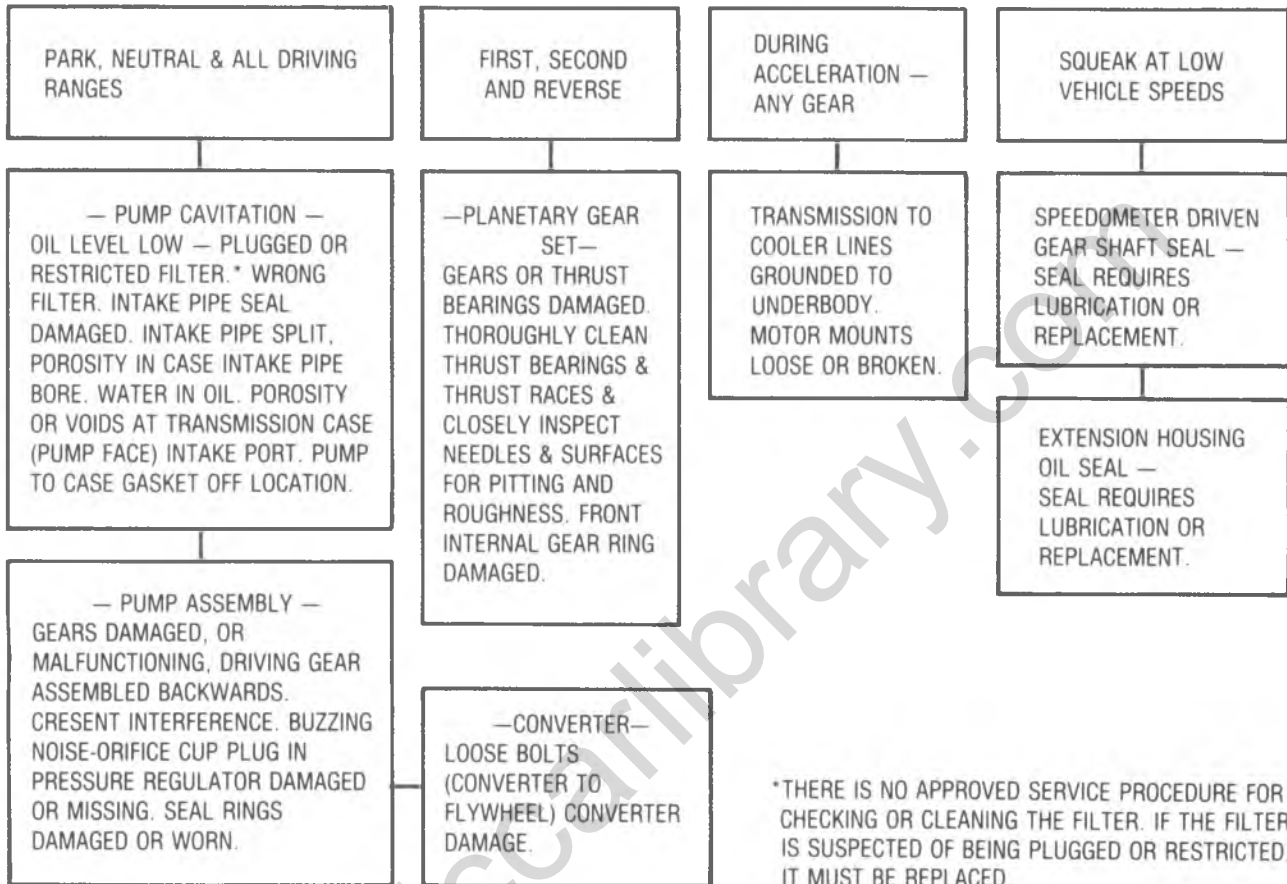

*THERE IS NO APPROVED SERVICE PROCEDURE FOR CHECKING OR CLEANING THE FILTER. IF THE FILTER IS SUSPECTED OF BEING PLUGGED OR RESTRICTED, IT MUST BE REPLACED.

B-08669

Figure 25—Transmission Noisy

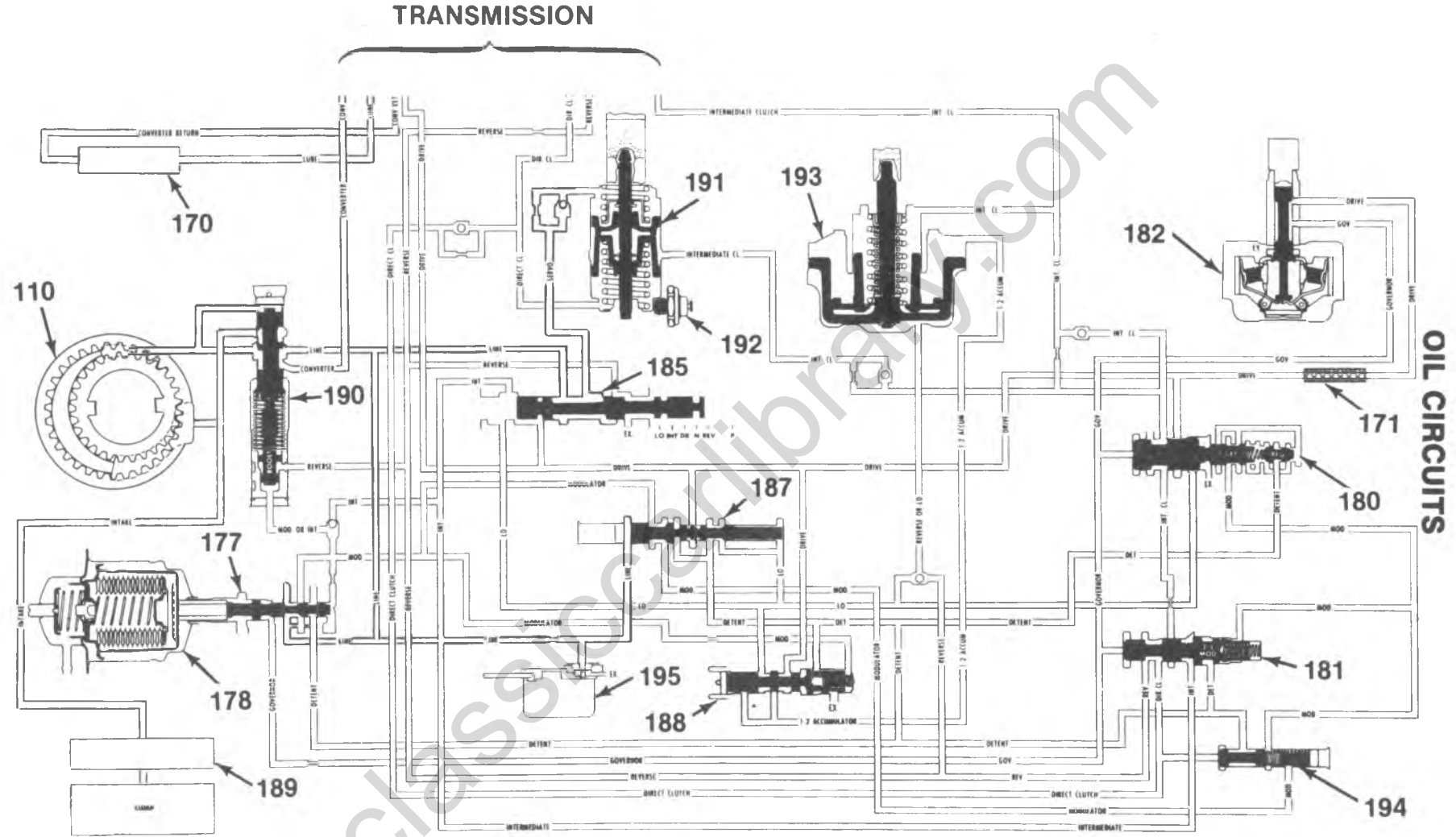

TRANSMISSION

OIL CIRCUITS

- | | | |
|-----------------------|--------------------------------|-------------------------|
| 110. Oil Pump | 181. 2-3 Shift Valve | 190. Pressure Regulator |
| 170. Oil Cooler | 182. Governor | 191. Front Servo |
| 171. Screen | 185. Manual Valve | 192. Pressure Switch |
| 177. Modulator Valve | 187. Detent Pressure Regulator | 193. Rear Servo |
| 178. Vacuum Modulator | 188. 1-2 Accumulator | 194. 3-2 Shift Valve |
| 180. 1-2 Shift Valve | 189. Filter | 195. Detent Solenoid |

Figure 26—THM 400 Oil Circuits

B-08656

7A-26 AUTOMATIC TRANSMISSION

THM 400 CLUTCH PLATE APPLICATION CHART FORWARD CLUTCH						
MODELS	THICKNESS	NO. OF FLAT STEEL PLATES		NO. OF WAVED STEEL PLATES	NO. OF DISHED PLATES	NO. OF COMPOSITION PLATES
		2.32 MM (.0915")	1.97 MM (.0775")	1.54 MM (.0605")	1.37 MM (.054")	
EV, FI, FS, HR, MA		5				5
FG, RC, RR, RT, RV, ZD, ZV		5			1	5
ALL OTHERS			4	1		5

THM 400 CLUTCH PLATE APPLICATION CHART DIRECT CLUTCH						
MODELS	THICKNESS	NO. OF FLAT STEEL PLATES		NO. OF WAVED STEEL PLATES	NO. OF DISHED PLATES	NO. OF COMPOSITION PLATES
		2.32 MM (.0915")	1.97 MM (.0775")	1.54 MM (.0605")	1.37 MM (.054")	
FA, FB, FC, FD, FF, FJ, FK, FM FN, FP, FR, FT, FV, FW, FX, FZ		5				5
FG, ZD, ZV		2	3		1	5
EV, FT, FS, HR, MA, RV		6				6
FL, FQ, HZ, RC, RR		4		1		5
LR, LS		3		1		4
RT		5		1		6

THM 400 CLUTCH PLATE APPLICATION CHART INTERMEDIATE CLUTCH				
MODELS	THICKNESS	NO. OF FLAT STEEL PLATES	NO. OF WAVED STEEL PLATES	NO. OF COMPOSITION PLATES
		2.51 MM (.099")	1.74 MM (.0685")	
EV, FG, FI, FS, HR, MA RV, ZD, ZV		3		3
ALL OTHERS		2	1	3

F-02663

Figure 27—THM 400 Clutch Usage Chart

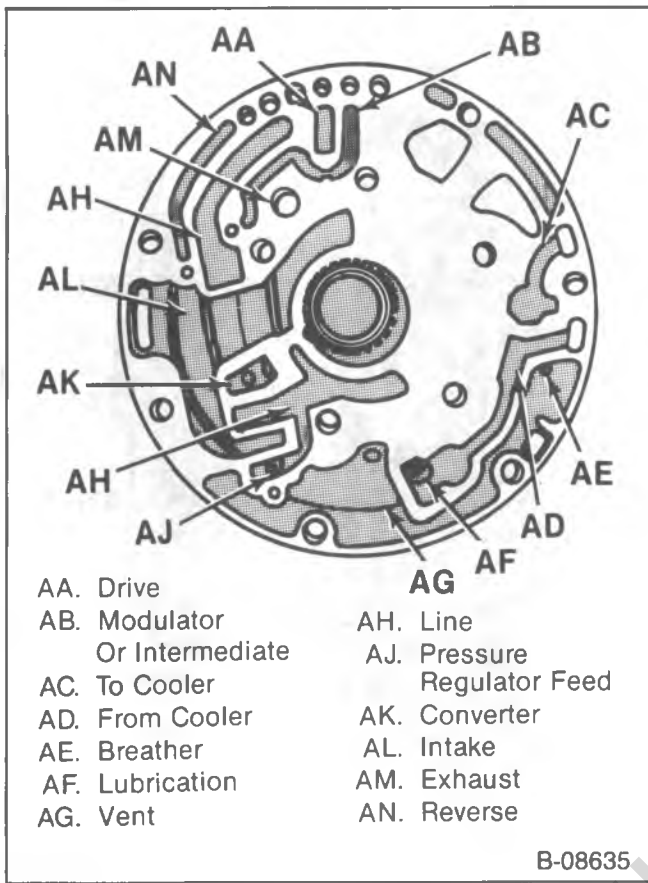

Figure 28—THM 400 Pump Cover Oil Passages

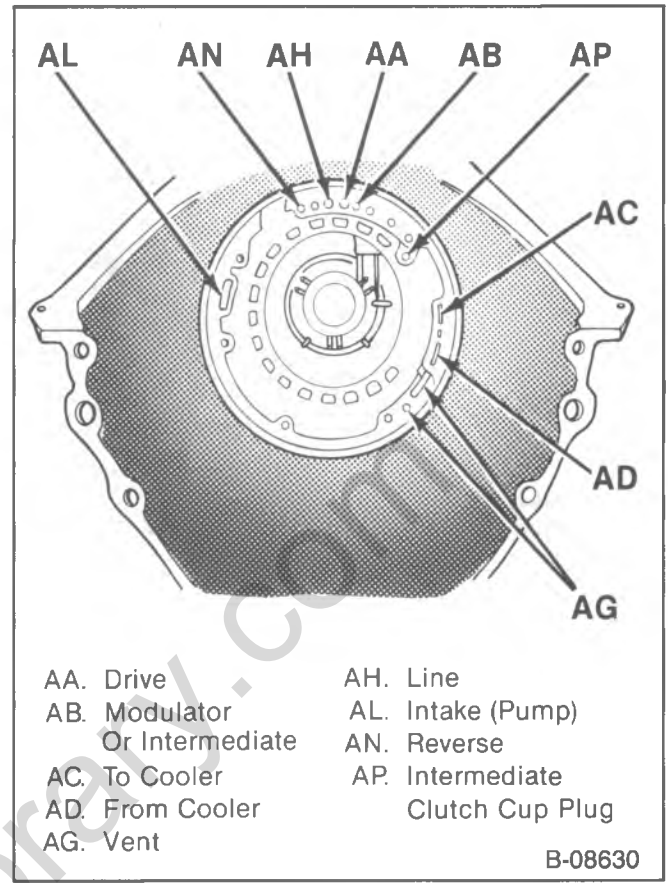

Figure 30—THM 400 Case Oil Passages

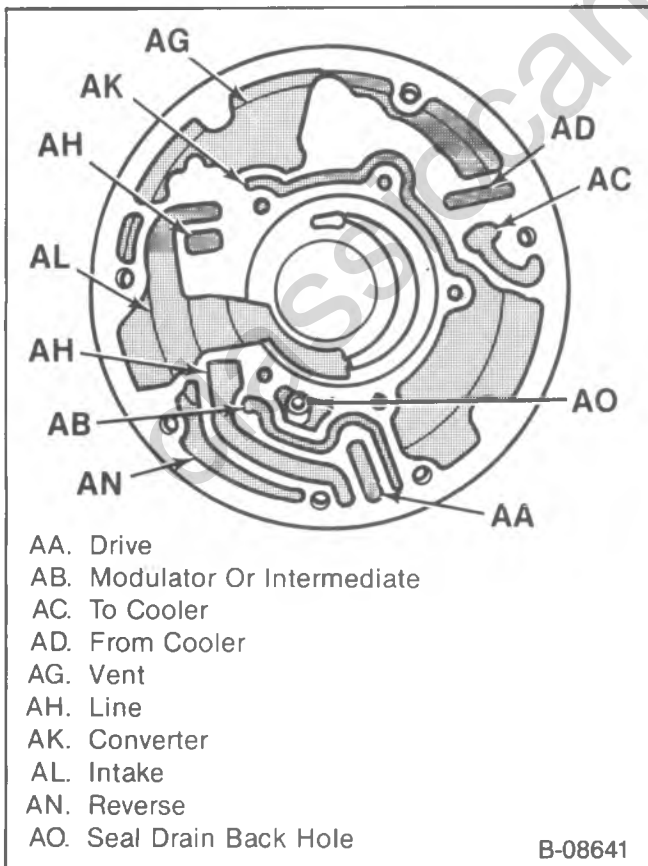

Figure 29—THM 400 Pump Body Oil Passages

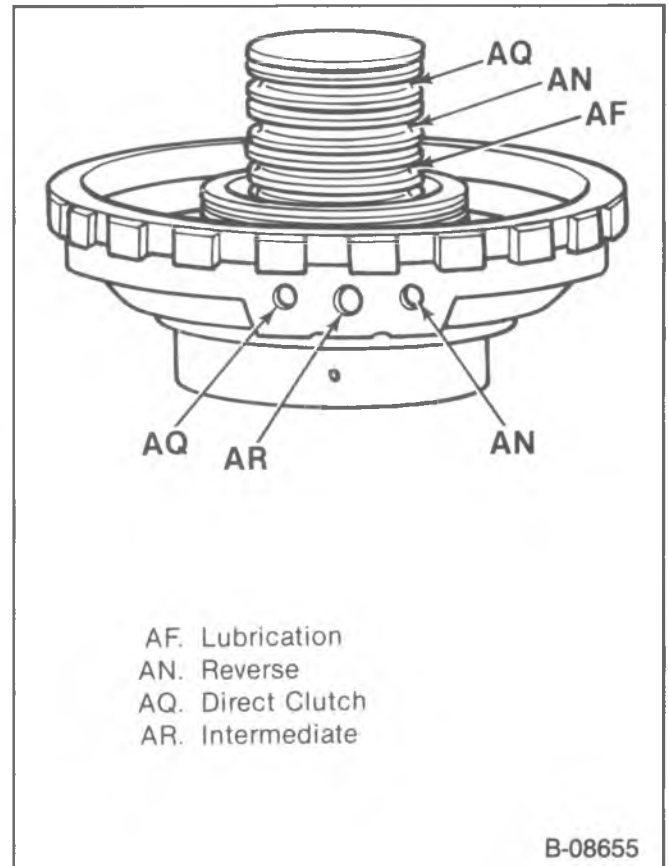

Figure 31—THM 400 Center Support Oil Passages

7A-28 AUTOMATIC TRANSMISSION

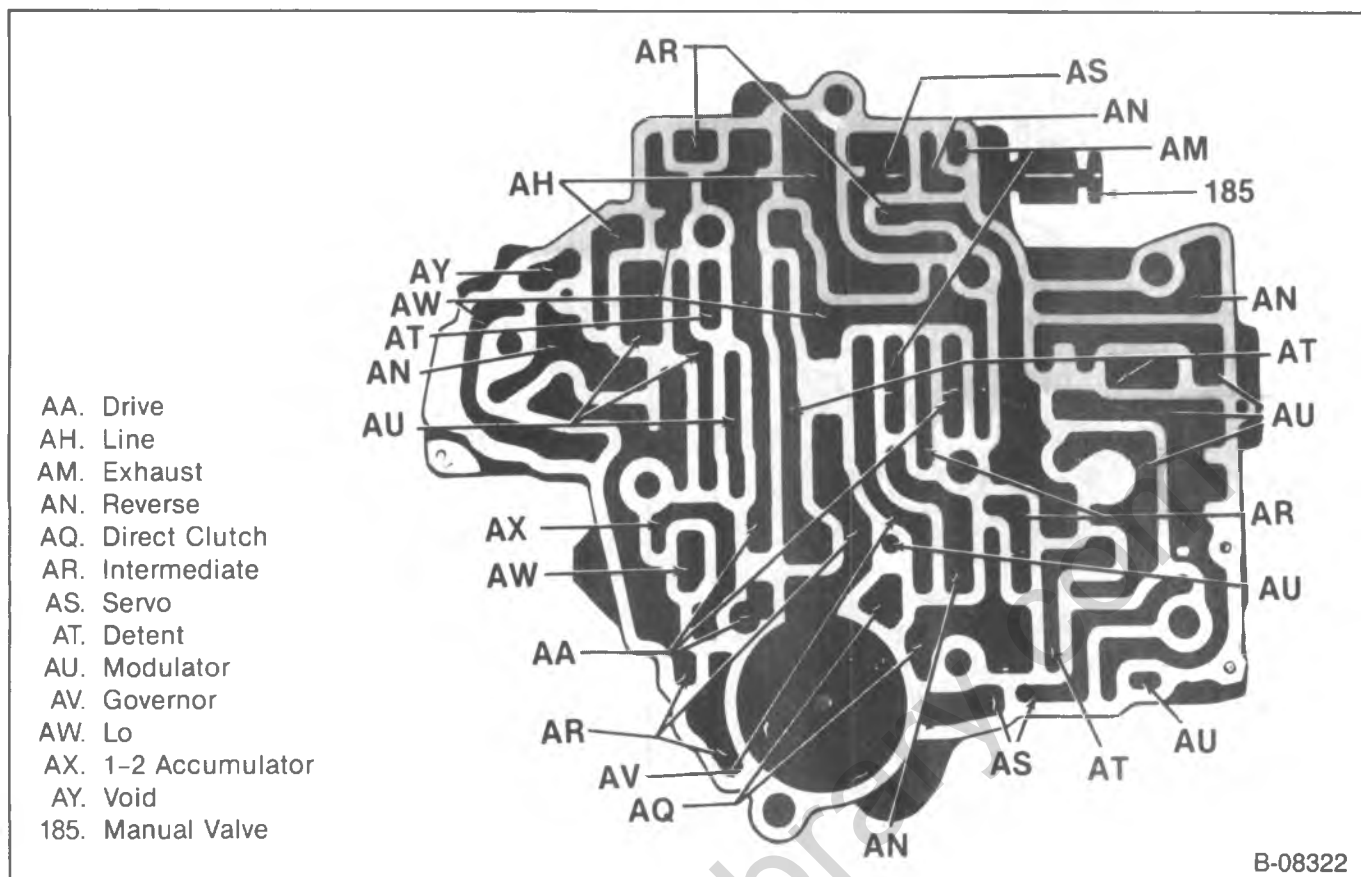
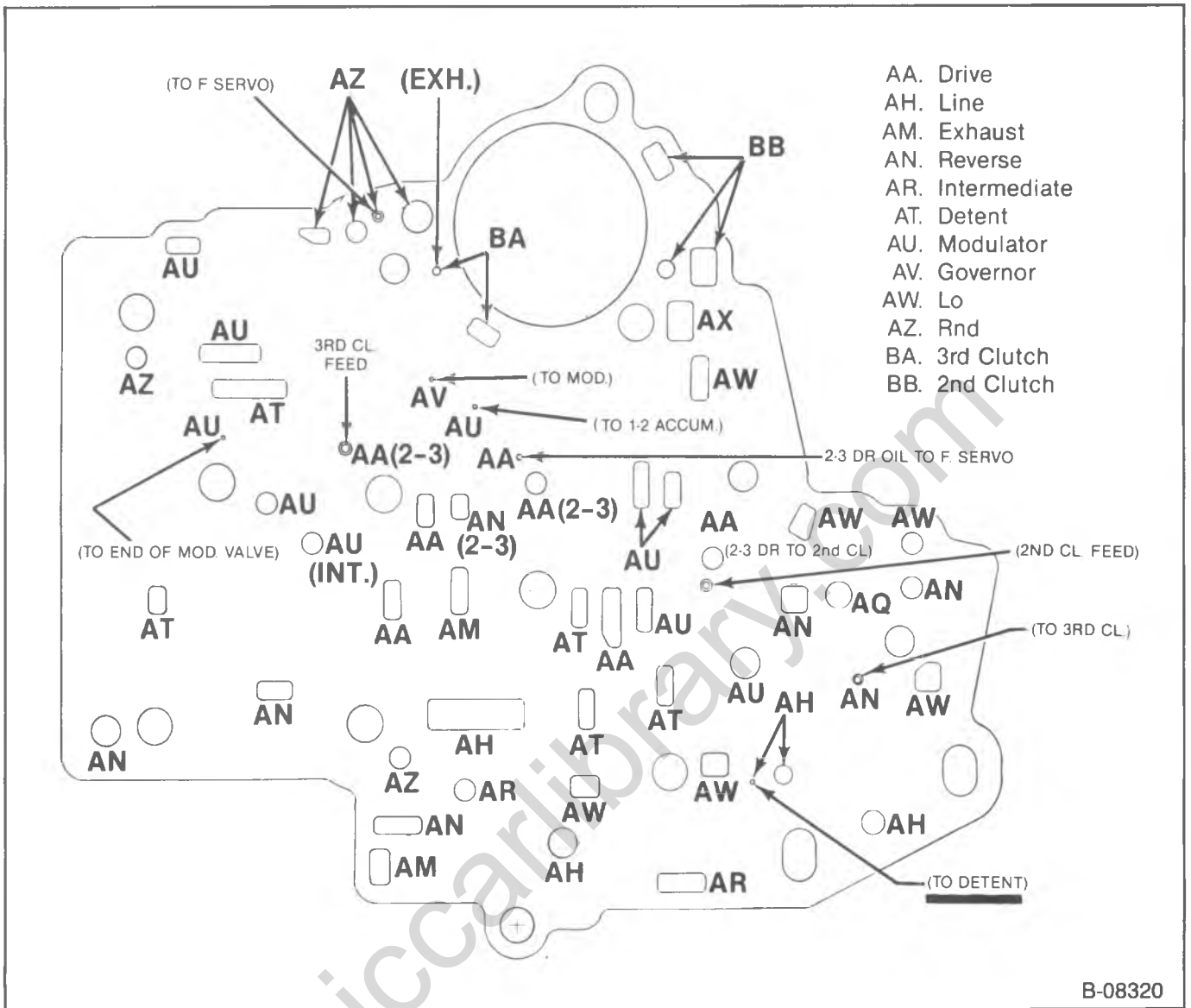
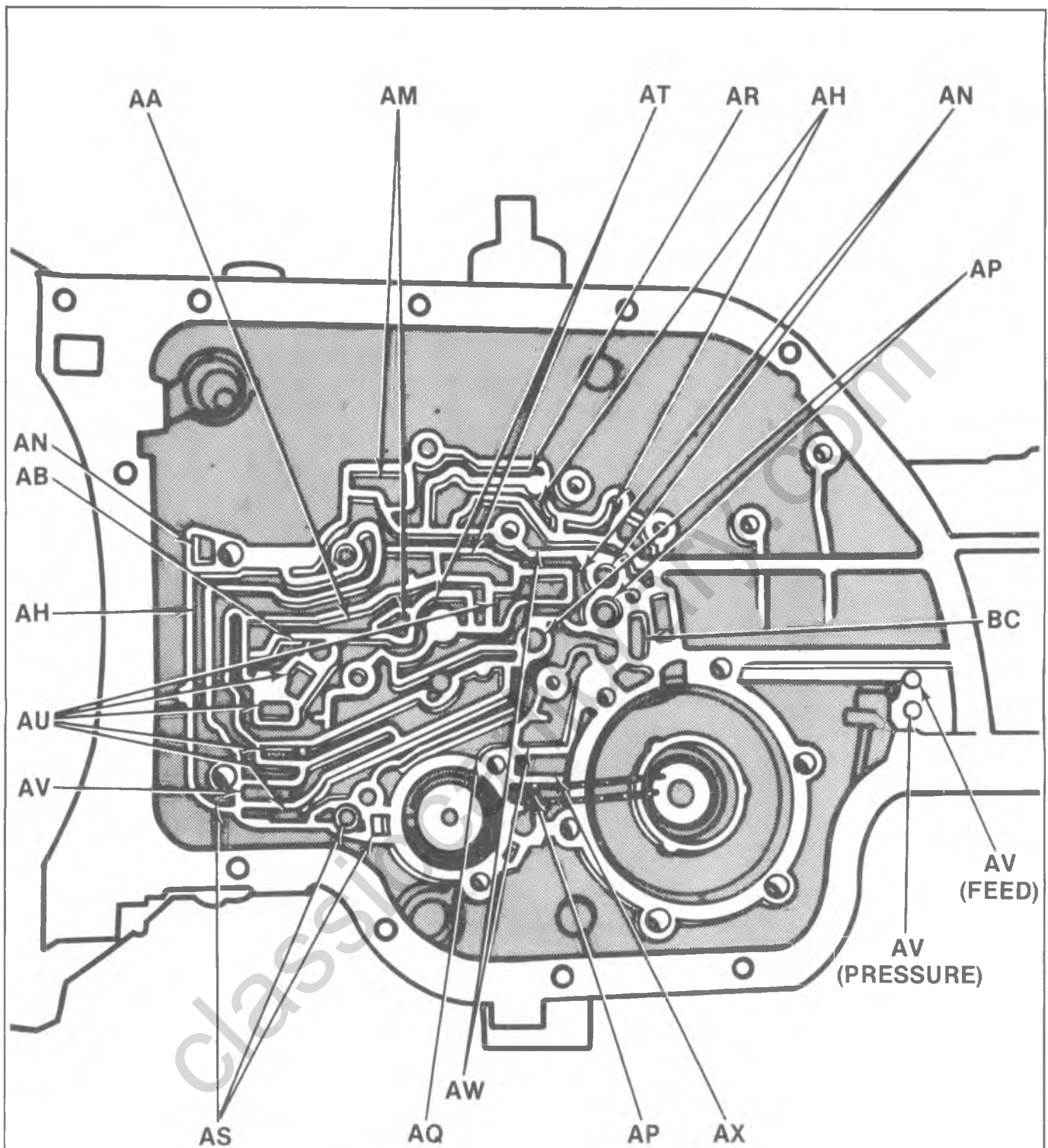

Figure 32—THM 400 Valve Body Oil Passages



B-08320

7A-30 AUTOMATIC TRANSMISSION



- | | |
|-------------------------------|---------------------|
| AA. Drive | AS. Servo |
| AB. Modulator or Intermediate | AT. Detent |
| AH. Line | AU. Modulator |
| AM. Exhaust | AV. Governor |
| AN. Reverse | AW. Lo |
| AP. Intermediate Clutch | AX. 1-2 Accumulator |
| AQ. Direct Clutch | BC. Reverse or Lo |
| AR. Intermediate | |

B-08323

Figure 34—THM 400 Case Oil Passages (Bottom View)

THM 700-R4 PRELIMINARY CHECKING

- CHECK TRANSMISSION OIL LEVEL
- CHECK AND ADJUST T V CABLE
- CHECK OUTSIDE MANUAL LINKAGE AND CORRECT
- CHECK ENGINE TUNE
- INSTALL OIL PRESSURE GAGE (FIGURE 57)
- CONNECT TACHOMETER TO ENGINE
- CHECK OIL PRESSURE AS FOLLOWS:

***NOTICE** Total running time for this combination not to exceed 2 minutes.

CAUTION Brakes must be applied at all times.

Minimum T V Line Pressure Check

Set the T V cable to specification; and with the brakes applied, take the line pressure readings in the ranges and at the engine r.p.m.'s indicated in the chart below.

Full T V Line Pressure Check

Full T V line pressure readings are obtained by tying or holding the T V cable to the full extent of its travel; and with the brakes applied, take the line pressure readings in the ranges and at the engine r.p.m.'s indicated in the chart below.

AUTOMATIC TRANSMISSION OIL PRESSURES					
Range	Model	Normal Oil Pressure At Minimum T.V.		Normal Oil Pressure At Full T.V.	
		kPa	PSI	kPa	PSI
PARK, NEUTRAL, OVERDRIVE & MANUAL 3RD @ 1000 RPM	YLM, YTM	385- 444	56- 64	818-1040	119-151
	YMM	451- 515	66-75	1115-1430	162-207
	YXM	451-515	65-75	840-1053	122-153
	MCM, MHM, PAM, TAM, YFM, MTM, PRM, TNM, TRM, PBM, TBM	451-515	65-75	844-1068	122-155
	TJM, TKM, MWM, MZM, TUM, TXM, FAM, MDM, MPM, MAM, MSM, MMM, MRM, MXM, MKM, MUM	451-515	65-75	851-1063	123-154
	YPM	384-444	56-64	876-1333	127-193
	YKM	384-444	56-64	883-1129	128-164
	TSM	384-444	56-64	962-1237	139-179
	YAM, YCM, YWM, YZM, YDM	384-444	56-64	1049-1359	152-197
REVERSE @ 1000 RPM @ 2000 RPM	YTM	632-729	92-106	* 1345-1710	195-248
	YMM	742-846	108-123	*1834-2351	266-341
	YLM	632-729	92-106	*1380-1782	200-258
	YXM	742-847	108-123	*1381-1731	200-251
	MCM, MHM, PAM, TAM, YFM, MTM, PRM, TNM, TRM, PBM, TBM	742-847	108-123	*1388-1755	201-254
	TJM, TKM, MWM, MZM, TUM, TXM, FAM, MDM, MPM, MAM, MSM, MMM, MRM, MXM, MKM, MUM	742-847	108-123	*1399-1747	203-253
	YPM	632-730	92-106	*1441-2191	209-318
	YKM	632-730	92-106	*1452-1856	211-269
	TSM	632-730	92-106	*1581-2034	229-295
YAM, YCM, YWM, YZM, YDM	632-730	92-106	*1724-2234	250-324	
MANUAL 2ND & MANUAL LO @ 1000 RPM	TSM, YAM, YCM, YKM, YLM, YPM, YTM, YWM, YZM, YDM FAM, MCM, MDM, MHM, MPM, PAM, TAM, YFM, YMM, YXM, MAM, MSM, MMM, MRM, MXM, MTM, PRM, MKM, MUM, TJM, TKM, TNM, TRM, MWM, MZM, TUM, TXM, PBM, TBM	1120-1293 1127-1286	162-187 163-186	1120-1293 1127-1286	162-187 163-186

Line pressure is basically controlled by pump output and the pressure regulator valve. In addition, line pressure is boosted in Reverse, Second and Lo by the reverse boost valve.

Also, in the Neutral, Drive, Intermediate and Reverse positions of the selector lever, the line pressure should increase with throttle opening because of the T V system. The pressure is controlled by the T V cable, the throttle lever and bracket assembly and the T V link, as well as the control valve assembly.

The main line pressure tap plug is located on the left side of the transmission above the outside manual lever.

Figure 35—Oil Pressure Check Procedure

DIAGNOSIS OF THM 700-R4



IMPORTANT

As a diagnosis aid, you can check the oil pressure differential between line pressure and the 2nd, 3rd, and 4th clutch pressure while driving the vehicle. If the pressure differential between line pressure and any of the clutch circuits is more than 70 kPa (10 psi) (provided your gages are accurate), there is a possible leak in that clutch oil circuit.

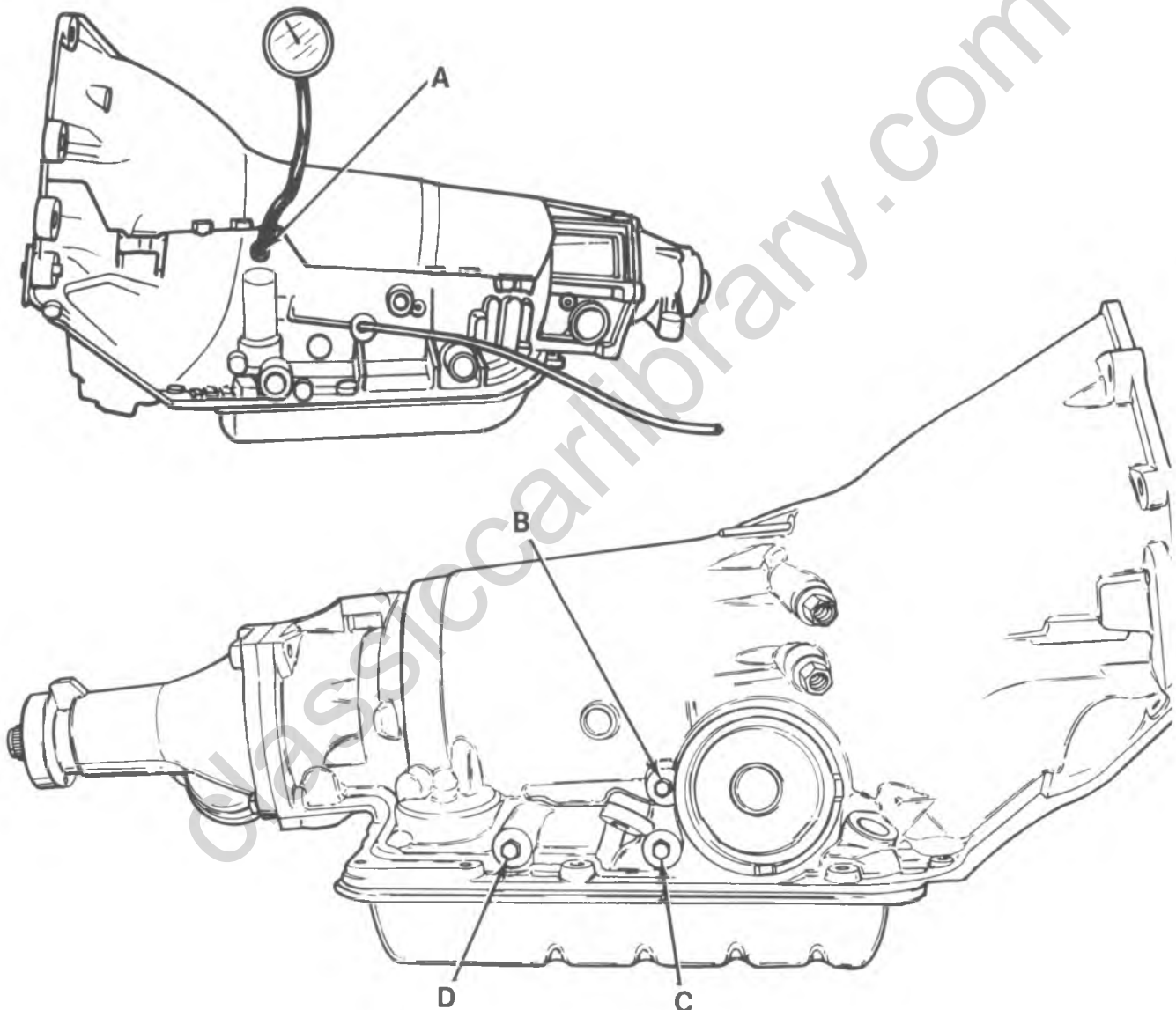

- A. Line Pressure
- B. Third Pressure
- C. Fourth Pressure
- D. Second Pressure

B-08331

Figure 36—THM 700-R4 Pressure Tap Locations

ROAD TEST

- Perform the road test following the sequence given.
- KPH (MPH) shift points will vary with actual throttle position and driver habits.
- Compare the results of the test with speed shift chart information. Use these results with the diagnosis information to evaluate the transmission (figure 37).
- This test should only be performed when traffic and road conditions permit.
- Observe all traffic safety regulations.

GARAGE SHIFT CHECK

1. Start engine.
2. Depress brake pedal.
3. Move gear selector:
 - "Park" (P) to "Reverse" (R).
 - "Reverse" (R) to "Neutral" (N) to "Drive" (D). Gear selections should be immediate and not harsh.

UPSHIFTS AND TORQUE CONVERTER CLUTCH (TCC) APPLY

With gear selector in "Overdrive" (D).

1. Accelerate using a steady increasing throttle pressure.
2. Note the shift speed point gear engagements for:
 - 2nd gear.
 - 3rd gear.
 - Overdrive.
3. Note the speed shift point to TCC apply. This should occur while in third gear or overdrive. If the apply is not noticed, refer to the Preliminary Torque Converter Clutch Diagnosis information contained in this section of the Service Manual.



Important

- The torque converter clutch will not engage if engine coolant has not reached a minimum operating temperature of approximately 54°C (130°F).

PART THROTTLE DETENT DOWNSHIFT

At vehicle speeds of 40-55 MPH (64-88 KPH) quickly depress the accelerator to a half open position and observe:

- TCC releases.
- Transmission downshift to 3rd gear immediately.

FULL THROTTLE DETENT DOWNSHIFT

At vehicle speeds of 40-55 MPH (64-88 KPH) quickly depress the accelerator to a wide open position and observe:

- TCC releases.
- Transmission downshifts to 3rd gear immediately.

MANUAL DOWNSHIFT

1. At vehicle speeds of 40-55 MPH (64 to 88 KPH) release the accelerator pedal while moving the gear selector to "Third" gear (D) and observe:
 - TCC release.
 - Transmission downshift to 3rd gear should be immediate.
 - Engine should slow vehicle down.

2. Move gear selector to "Overdrive (D) and accelerate to 40-45 MPH (64-72 KPH). Release the accelerator pedal while moving the gear selector to "Second" gear (2) and observe.
 - TCC release.
 - Downshift to second gear should be immediate.
 - Engine should slow vehicle down.

3. Move gear selector to "Overdrive" (D) and accelerate to 25 MPH (40 KPH). Release the accelerator pedal while moving the gear selector to "First" gear (1) and observe:
 - TCC release.
 - Transmission downshift to 1st gear should be immediate.
 - Engine should slow vehicle down.

COASTDOWN DOWNSHIFT

1. With the gear selector in "Overdrive" (D) accelerate to 4th gear with TCC applied.
2. Release the accelerator pedal and lightly apply the brake to observe:
 - TCC release.
 - Shift points for downshifts.

MANUAL GEAR RANGE SELECTION

MANUAL THIRD (D)

1. With vehicle stopped, place gear selector in "Third" (D) and accelerate to observe:
 - The first to second gear shift point.
 - The second to third gear shift point.

MANUAL SECOND (2)

1. With vehicle stopped, place gear selector in "Second" (2) and accelerate to observe:
 - The first to second gear shift point.
2. Accelerate to 25 MPH (40 KPH) and observe:
 - That a second to third gear shift does not occur.
 - That TCC does not engage.

MANUAL FIRST (1)

1. With vehicle stopped, place gear selector in "First" (1) and accelerate to 15 MPH (24 KPH) and observe:
 - That no upshift occurs.
 - That TCC does not engage.

REVERSE

1. With vehicle stopped, place gear selector in "Reverse" (R) and slowly accelerate to observe reverse gear operation. All possible throttle positions and corresponding MPH shift point information has not been provided.

7A-34 AUTOMATIC TRANSMISSION

1987 "THM 700-4R" SPEED SHIFT CHART

Model	1-2 Min Throt	2-3 Min Throt	3-4 Min Throt	4-3 Part Throt	3-2 Part Throt	4-3 Coast Down	3-2 Coast Down	2-1 Coast Down
FAM	12-15	20-30	33-55 +	55 +	38-55 +	28-54	17-28	11-14
MDM	13-16	22-30	37-55 +	55 +	42-55 +	32-55	19-27	12-14
MHM	9-11	17-24	28-47	55 +	27-45	25-44	14-22	8-10
MPM	11-14	19-26	33-51	55 +	37-55	28-49	16-24	10-13
NTM	13-19	23-38	46-55 +	55 +	44-55 +	38-55 +	19-31	12-17
PAM	9-11	17-24	28-47	55 +	27-45	25-44	14-22	8-10
TAM	9-11	15-22	23-51	55 +	27-51	20-47	11-20	8-10
TSM	8-10	16-22	25-53	55 +	26-55	23-48	13-20	7- 9
YMM	9-10	13-19	24-44	55 +	22-52	18-38	10-16	8- 9
YTM	12-14	19-25	36-55	55 +	38-55 +	31-53	15-23	11-13
YWM	8- 9	12-17	24-44	55 +	23-53	19-39	9-14	7- 9
YXM	10-12	16-27	35-52	55 +	36-54	30-49	13-23	9-11
YZM	11-13	13-24	34-46	55 +	10-20	30-44	10-20	13-24
YLM	10-12	16-23	32-37	55 +	31-47	28-45	12-19	16-23
YKM	10-12	19-25	31-48	55 +	31-52	27-45	15-23	19-25
YFM	11-14	18-25	31-54	55 +	28-51	26-51	15-23	10-13
YCM	11-12	15-22	32-55 +	55 +	30-55 +	24-51	12-18	9-11
YAM	9-10	13-18	27-48	55 +	25-55 +	21-43	10-16	8- 9
YPM	11-13	19-26	28-43	55 +	35-55	25-41	16-24	10-12

NOTES:

1. All speeds indicated are in miles per hour. Conversion to KPH = MPH × 1.609
2. Shift points will vary slightly due to engine loads and vehicle options
3. Speeds listed with + exceed 55 mph

F-02665

Figure 37—THM 700-R4 Speed Shift Charts

DIAGNOSIS OF THM 700-R4

PROBLEM	POSSIBLE CAUSE	CORRECTION
<p>Oil Pressure High Or Low (Check With Gage - Check Oil Level & Engine Tune)</p>	<ol style="list-style-type: none"> 1. Oil pump assembly. 2. Oil filter. 3. TV exhaust ball. 4. Throttle lever and bracket assembly. 5. Throttle link. 6. Valve body. 7. Case. 	<ol style="list-style-type: none"> 1. <ol style="list-style-type: none"> a. Pressure regulator valve stuck. b. Pressure regulator valve spring damaged. c. Rotor guide missing or misassembled. d. Rotor cracked or broken. e. TV valve, reverse boost valve or bushing stuck, damaged or incorrectly assembled. f. Orifice hole in pressure regulator valve plugged. g. Sticking slide or excessive rotor clearance. h. Pressure relief ball not seated or damaged. j. Porosity in pump cover or body. k. Wrong pump cover. l. Pump faces not flat. 2. <ol style="list-style-type: none"> a. Intake pipe restricted by casting flash. b. Cracks in filter body or intake pipe. c. Seal missing, cut or damaged. 3. Stuck or damaged. 4. Misassembled, binding or damaged. 5. Misassembled, binding or damaged. 6. <ol style="list-style-type: none"> a. Manual valve scored or damaged. b. Spacer plate or gaskets incorrect, misassembled or damaged. c. Face not flat. d. Throttle valve sticking. e. Throttle valve sleeve rotated in bore or retaining pin not seated. f. TV limit valve sticking. g. Modulated downshift valve stuck. h. Line bias valve stuck. j. 2-3 shift valve stuck. k. Check balls missing or misassembled. 7. Case to valve body face not flat.
<p>High Or Low Shift Points</p>	<ol style="list-style-type: none"> 1. TV cable. 2. TV exhaust ball. 3. Throttle lever and bracket assembly. 4. Oil pump assembly. 5. Valve body assembly. 	<ol style="list-style-type: none"> 1. Binding or not correctly adjusted. 2. Stuck or damaged. 3. Misassembled, binding or damaged. 4. <ol style="list-style-type: none"> a. Stuck pressure regulator valve or TV boost valve. b. Sticking pump slide. 5. <ol style="list-style-type: none"> a. Sticking throttle valve or plunger. b. Modulated TV up or down valves sticking. c. TV limit valve sticking. d. Spacer plate or gaskets misassembled, damaged or incorrect.

DIAGNOSIS OF THM 700-R4 (CONT.)

PROBLEM	POSSIBLE CAUSE	CORRECTION
1st Gear Range Only — No Upshift	1. Governor assembly. 2. Valve body. 3. Case. 4. 2-4 servo assembly. 5. 2-4 band assembly.	1. a. Governor valve sticking. b. Governor driven gear loose or damaged. c. Governor driven gear retaining pin missing. d. Nicks or burrs on output shaft. e. Nicks or burrs on governor sleeve or case bore. f. Governor support pin in case too long or short. g. Governor weights or springs missing binding or damaged. 2. a. 1-2 shift valve sticking. b. Spacer plate or gaskets mispositioned or damaged. 3. a. Case to valve body face not flat or damaged. b. Governor screen restricted or damaged. 4. a. Restricted or blocked apply passages in case. b. Nicks or burrs on servo pin or pin bore in case. c. Missing or damaged piston or pin seals. d. 4th servo piston in backwards. 5. a. 2-4 band worn or damaged. b. Band anchor pin not engaged.
Slips In 1st Gear	1. Forward clutch assembly. 2. Input housing and shaft assembly. 3. Valve body. 4. TV cable.	1. a. Clutch plates worn. b. Porosity or damage in forward clutch piston. c. Forward clutch piston inner and outer seals missing, cut or damaged. d. Input housing to forward clutch housing seal missing, cut or damaged. e. Damaged forward clutch housing. f. Forward clutch housing retainer and ball assembly not sealing or damaged. 2. Turbine shaft seals missing, cut or damaged. 3. a. Accumulator valve stuck. b. Face not flat, damaged lands or interconnected passages. c. Spacer plate or gaskets incorrect, mispositioned or damaged. 4. Binding or broken.

DIAGNOSIS OF THM 700-R4 (CONT.)

PROBLEM	POSSIBLE CAUSE	CORRECTION
Slips In 1st Gear (Continued)	5. 1-2 accumulator piston assembly. 6. Oil pressure. 7. 2-4 servo assembly.	5. a. Porosity in piston or 1-2 accumulator cover and pin assembly. b. Damaged ring grooves on piston. c. Piston seal missing, cut or damaged. d. 1-2 accumulator cover gasket missing or damaged. e. Leak between piston and pin. f. Broken 1-2 accumulator spring. 6. Refer to Causes of High or Low Oil Pressure. 7. 4th servo piston in backwards.
1-2 Shift Speed — High Or Low	1. TV cable. 2. Governor assembly. 3. Throttle lever and bracket assembly. 4. Valve body. 5. Oil pump assembly or case.	1. a. Binding or broken. b. Not correctly adjusted. 2. Refer to 1st Gear Range Only — No Upshift. 3. a. Misassembled, binding or damaged. b. TV link missing, binding or damaged. 4. a. TV exhaust check ball stuck. b. TV plunger sticking. c. Face not flat. 5. Face not flat.
Slipping Or rough 1-2 Shift	1. Throttle lever and bracket assembly. 2. Valve body assembly. 3. 2-4 service assembly. 4. 2nd Accumulator. 5. 2-4 band. 6. Oil pump assembly or case.	1. a. Incorrectly installed or damaged. b. TV cable broken or binding. 2. a. Throttle valve sticking. b. TV bushing turned in its bore. c. 1-2 shift valve train stuck. d. Gaskets or spacer plate incorrect, mispositioned or damaged. e. Line bias valve stuck. f. Accumulator valve stuck. g. TV limit valve stuck. h. Face not flat. 3. a. Apply pin too long or too short. b. Servo seals missing, cut or damaged. c. Restricted or missing oil passages. d. Servo bore in case damaged. 4. a. Porosity in 1-2 accumulator housing or piston. b. Piston seal or groove damaged. c. Nicks or burrs in 1-2 accumulator housing. d. Missing or restricted oil passage. 5. Worn or mispositioned. 6. Faces not flat.

DIAGNOSIS OF THM 700-R4 (CONT.)

PROBLEM	POSSIBLE CAUSE	CORRECTION
<p>No 2-3 Shift Or 2-3 Shift Slipping, Rough Or Hunting</p>	<ol style="list-style-type: none"> 1. Converter. 2. Governor assembly. 3. Oil pump. 4. Valve body. 5. Input housing assembly. 6. Case. 7. 2-4 servo assembly. 	<ol style="list-style-type: none"> 1. Internal damage. 2. <ol style="list-style-type: none"> a. Valve stuck. b. Drive gear retaining pin missing or loose. c. Governor weights binding. d. Governor drive gear damaged. e. Governor support pin in case too long or too short. 3. Stator shaft sleeve scored or off location. 4. <ol style="list-style-type: none"> a. 2-3 valve train stuck. b. Accumulator valve stuck. c. Spacer plate or gaskets incorrect, mispositioned or damaged. d. Throttle valve stuck. e. TV limit valve stuck. 5. <ol style="list-style-type: none"> a. Clutch plates worn (3-4 or forward). b. Excessive clutch plate travel. c. Cut or damaged piston seals (3-4 or forward). d. Porosity in 3-4 clutch housing or piston. e. 3-4 piston check ball stuck, damaged or not sealing. f. Restricted apply passages. g. Forward clutch piston retainer and ball assembly not seating. h. Sealing balls loose or missing. 6. 3rd accumulator retainer and ball assembly not seating. 7. <ol style="list-style-type: none"> a. 2nd apply piston seals missing, cut or damaged. b. Servo pin seals missing, cut or damaged.
<p>No. 3-4 Shift/Slipping Or Rough 3-4 Shift</p>	<ol style="list-style-type: none"> 1. Governor. 2. Oil pump assembly. 	<ol style="list-style-type: none"> 1. <ol style="list-style-type: none"> a. Governor weights binding. b. Governor valve stuck. c. Governor drive gear retaining pin missing or loose. d. Governor drive gear damaged. e. Governor support pin in case too long or too short. 2. <ol style="list-style-type: none"> a. Faces not flat. b. Pump cover retainer and ball assembly missing or damaged.

DIAGNOSIS OF THM 700-R4 (CONT.)

PROBLEM	POSSIBLE CAUSE	CORRECTION
<p>No 3-4 Shift/Slipping Or Rough 3-4 Shift (Continued)</p>	<p>3. Valve body assembly.</p> <p>4. 2-4 servo assembly.</p> <p>5. Case.</p> <p>6. Input housing assembly.</p> <p>7. 2-4 band assembly.</p>	<p>3. a. Valves stuck. -2-3 shift valve train. -Accumulator valve. -Throttle valve. -TV limit valve. -1-2 shift valve train. -3-2 control valve.</p> <p>b. Manual valve link bent or damaged.</p> <p>c. Spacer plates or gaskets incorrect, mispositioned or damaged.</p> <p>4. a. Incorrect band apply pin. b. Missing or damaged servo seals. c. Porosity in pistons, cover or case. d. Damaged piston seal grooves. e. Plugged or missing orifice cup plug.</p> <p>5. a. 3rd accumulator retainer and ball assembly leaking. b. Porosity in 3-4 accumulator piston or bore. c. 3-4 accumulator piston seal or seal grooves damaged. d. Plugged or missing orifice cup plug. e. Restricted oil passage.</p> <p>6. Refer to Slipping 2-3 Shift.</p> <p>7. Worn or misassembled.</p>
<p>No Reverse Or Slips In Reverse</p>	<p>1. Input housing assembly.</p> <p>2. Manual linkage.</p> <p>3. Oil pump assembly.</p> <p>4. Valve body assembly.</p>	<p>1. a. 3-4 apply ring stuck in applied position. b. Forward clutch not releasing. c. Turbine shaft seals missing, cut or damaged.</p> <p>2. Not adjusted.</p> <p>3. a. Retainer and ball assembly missing or damaged. b. Stator shaft seal rings or ring grooves damaged. c. Stator shaft sleeve scored or damaged. d. Reverse boost valve stuck, damaged or misassembled. e. Cup plug missing. f. Restricted oil passage. g. Faces not flat. h. Converter clutch apply valve stuck.</p> <p>4. a. 2-3 shift valve stuck. b. Manual linkage not adjusted. c. Spacer plate and gaskets incorrect, mispositioned or damaged.</p>

DIAGNOSIS OF THM 700-R4 (CONT.)

PROBLEM	POSSIBLE CAUSE	CORRECTION
No Reverse Or Slips In Reverse (Continued)	5. Reverse input clutch. 6. Lo and reverse clutch. 7. Case.	5. a. Clutch plates worn. b. Reverse input housing and drum assembly cracked at weld. c. Clutch plate retaining ring out of groove. d. Return spring assembly retaining ring out of groove. e. Piston deformed or dished. f. Seals cut or damaged. g. Retainer and ball assembly not sealing. h. Restricted apply passage. 6. a. Clutch plates worn. b. Clutch plate retaining ring mispositioned. c. Porosity in piston. d. Seals damaged. e. Return spring assembly retaining ring mispositioned. f. Restricted apply passage. 7. a. Cover plate gasket missing or damaged. b. Cover plate not torqued correctly. c. Porosity.
No Part Throttle Or Delayed Downshifts	1. External linkage. 2. 2-4 servo assembly. 3. Governor assembly. 4. Valve body assembly.	1. Not adjusted. 2. a. Apply pin seal cut or damaged. b. Servo cover retaining ring missing or misassembled. c. 4th apply piston damaged or misassembled. d. Servo inner housing damaged or misassembled. 3. a. Governor weights binding. b. Governor valve stuck. 4. a. Valves stuck. -Throttle valve. -3-2 control valve. -TV modulated downshift. b. TV sleeve turned in bore. c. 4-3 sequence valve body channel blocked. d. #5 check ball missing from valve body.
No Overrun Braking — Manual 3-2-1	1. External linkage. 2. Valve body assembly.	1. Not adjusted properly. 2. a. Valves stuck. -4-3 sequence valve. -Throttle valve. b. Check ball #3 mispositioned. c. Spacer plate and gaskets incorrect, damaged or mispositioned.

DIAGNOSIS OF THM 700-R4 (CONT.)

PROBLEM	POSSIBLE CAUSE	CORRECTION
<p>No Overrun Braking — Manual 3-2-1 (Continued)</p>	<p>3. Input clutch assembly.</p>	<p>3. a. Turbine shaft oil passages plugged or not drilled. b. Turbine shaft seal rings damaged. c. Turbine shaft sealing balls loose or missing. d. Porosity in forward or overrun clutch position. e. Overrun piston seals cut or damaged. f. Overrun piston check ball not sealing.</p>
<p>No Converter Clutch Apply</p>	<p>1. Electrical. 2. Converter. 3. Oil pump assembly. 4. Valve body assembly. 5. Input housing and shaft.</p>	<p>1. a. 12 volts not supplied to transmission. b. Outside electrical connector damaged. c. Inside electrical connector, wiring harness or solenoid damaged. d. Electrical short (pinched solenoid wire). e. Solenoid not grounded. f. Incorrect or damaged pressure switches. 2. Internal damage. 3. a. Converter clutch apply valve stuck or assembled backwards. b. Converter clutch apply valve retaining ring mispositioned. c. Pump to case gasket mispositioned. d. Orifice cup plug plugged. e. Solenoid "O" ring seal cut or damaged. f. Orifice cup plug omitted from cooler in passage. g. High or uneven bolt torque (pump body to cover). 4. Valves stuck. —Converter clutch shift valve. —Throttle valve. 5. a. Turbine shaft "O" ring seal cut or damaged. b. Turbine shaft retainer and ball assembly plugged.</p>
<p>Converter Shudder</p>	<p>1. Torque converter assembly. 2. Valve body. 3. Oil pump assembly. 4. Oil filter.</p>	<p>1. Internal damage. 2. Converter clutch shift valve stuck. 3. a. Converter clutch apply valve stuck. b. Restricted oil passage. 4. a. Crack in filter body. b. Flash restricting filter neck. c. Seal cut or damaged.</p>

DIAGNOSIS OF THM 700-R4 (CONT.)

PROBLEM	POSSIBLE CAUSE	CORRECTION
Converter Shudder (Continued)	5. Miscellaneous. 6. Input housing and shaft assembly.	5. a. Low oil pressure. b. Engine not tuned properly. 6. a. Turbine shaft seal cut or damaged. b. Turbine shaft retainer and ball assembly damaged.
No Converter Clutch Release	1. Solenoid. 2. Converter. 3. Oil pump assembly.	1. External ground. 2. Internal damage. 3. Converter clutch apply valve stuck.
Drives In Neutral	1. Forward clutch. 2. Manual linkage. 3. Case.	1. Not releasing. 2. a. Incorrectly adjusted. b. Disconnected. 3. a. Face not flat. b. Internal leakage.
2nd Gear Start (Drive Range)	1. Governor assembly. 2. Forward sprag clutch.	1. a. Valve stuck. b. Governor support pin too long or missing. 2. Sprag assembly installed backwards.
No Park	1. Parking linkage.	1. a. Acuator rod assembly bent or damaged. b. Actuator rod spring binding or improperly crimped. c. Actuator rod not attached to inside detent lever. d. Parking bracket damaged or not torqued properly. e. Inside detent lever not torqued properly. f. Detent roller mispositioned or not torqued properly. g. Parking pawl binding or damaged.
Racheting Noise	Parking pawl.	Parking pawl return spring weak, damaged or misassembled.
Oil Out The Vent	1. Oil pump. 2. Valve body.	1. Chamfer in pump body rotor pocket too large. 2. TV Imiit valve stuck.
Vibration In Reverse And Whining Noise In Park	Oil pump.	Broken vane rings.

OIL AND WIRING CIRCUITS

TRANSMISSION

TRANSMISSION

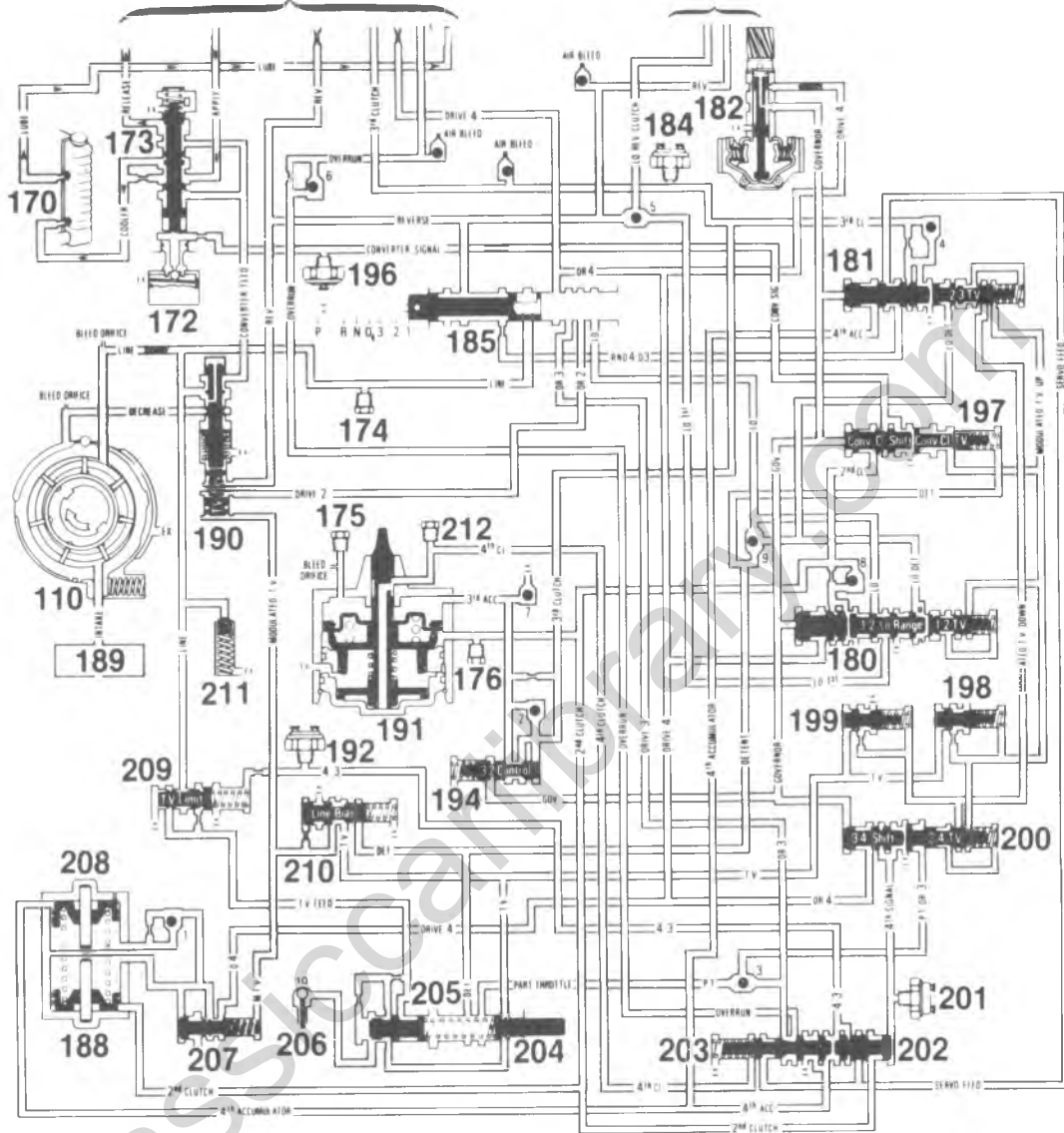

- | | | | |
|-----------------------------------|---------------------------------|---------------------------------|------------------------------|
| 110. Oil Pump | 184. 3rd Clutch Pressure Switch | 197. TCC Shift Valve Train | 205. Throttle Valve (TV) |
| 170. Oil Cooler | 185. Manual Valve | 198. MTV Up Valve Train | 206. TV Exhaust Lifter |
| 172. TCC Solenoid | 188. 1-2 Accumulator | 199. MTV Down Valve Train | 207. Accumulator Valve Train |
| 173. TCC Apply Valve | 189. Filter | 200. 3-4 Shift Valve Train | 208. 3-4 Accumulator |
| 174. Line Pressure Tap | 190. Pressure Regulator | 201. 4th Clutch Pressure Switch | 209. TV Limit Valve Train |
| 175. 3rd Accumulator Pressure Tap | 191. 2-4 Servo | 202. 3-4 Relay Valve | 210. Line Bias Valve Train |
| 176. 2nd Clutch Pressure Tap | 192. 4-3 Downshift Switch | 203. 4-3 Sequence Valve | 211. Pressure Relief Valve |
| 180. 1-2 Shift Valve Train | 194. 3-2 Control Valve Train | 204. TV Plunger | 212. 4th Clutch Pressure Tap |
| 181. 2-3 Shift Valve Train | 196. TCC Signal Switch | | ● Check Balls |
| 182. Governor | | | |

B-08461

Figure 38—THM 700-R4 Oil Circuits

7A-44 AUTOMATIC TRANSMISSION

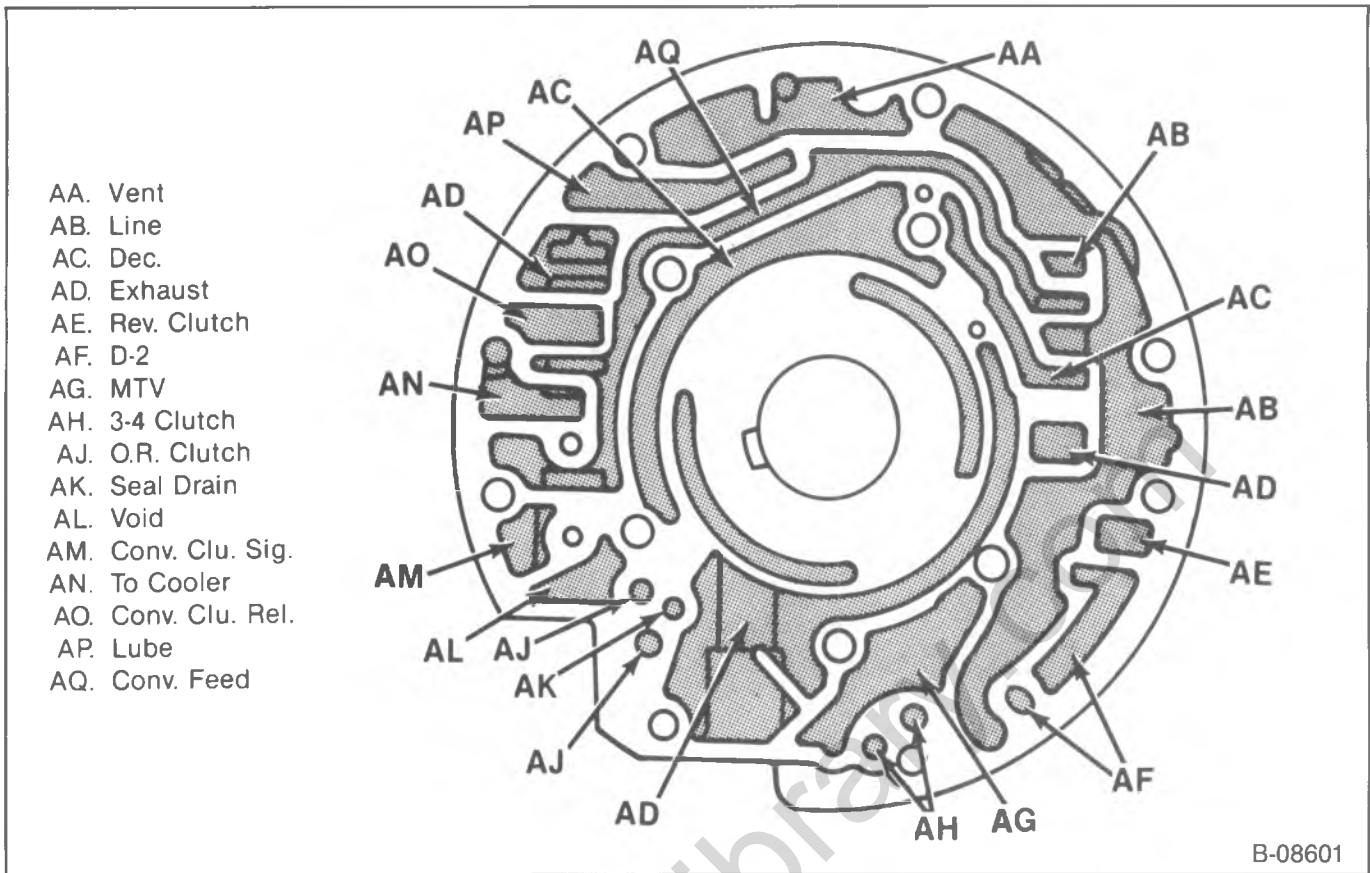

Figure 39—THM 700-R4 Pump Cover Oil Passages

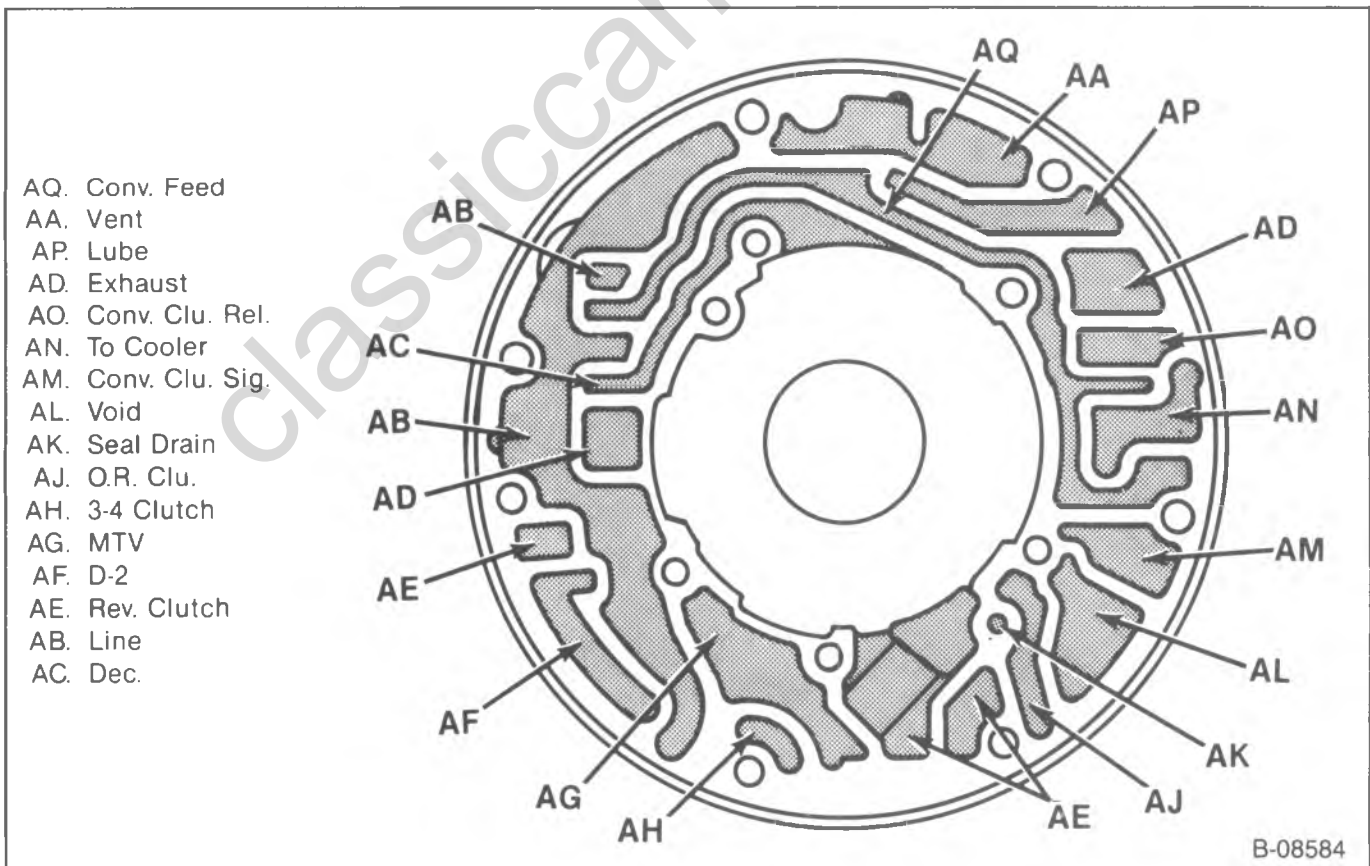
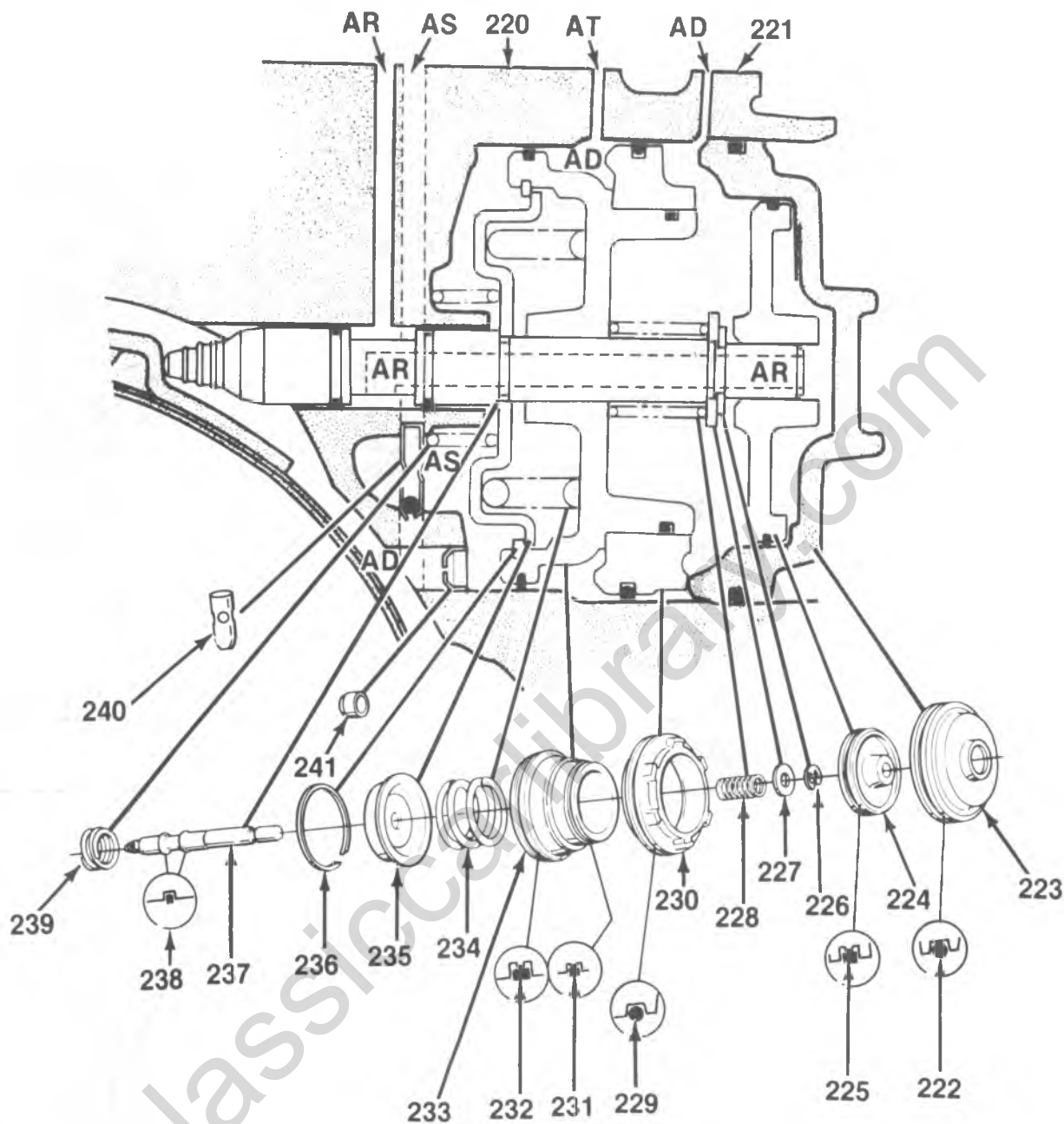

Figure 40—THM 700-R4 Pump Body Oil Passages



- | | |
|--|--|
| AD. Exhaust | 229. Seal, "O" Ring |
| AR. 4th Oil | 230. Housing, Servo Piston Inner |
| AS. 3rd Accumulator Oil | 231. Ring, Oil Seal Inner (2nd Apply Piston) |
| AT. 2nd Oil | 232. Ring, Oil Seal Outer (2nd Apply Piston) |
| 220. Valve Body Face | 233. Piston, 2nd Apply |
| 221. Oil Pan Flange | 234. Spring, Servo Cushion |
| 222. Seal, "O" Ring (2-4 Servo Cover) | 235. Retainer, Servo Cushion Spring |
| 223. Cover, 2-4 Servo | 236. Ring, Retainer (2nd Apply Piston) |
| 224. Piston, 4th Supply | 237. Pin, 2nd Apply Piston |
| 225. Ring, Oil Seal Outer (4th Apply Piston) | 238. Seal, 2nd Apply Piston Pin |
| 226. Ring, Retainer (Apply Pin) | 239. Spring, Servo Return |
| 227. Washer, Servo Apply Pin | 240. Retainer & Ball Assembly, 3rd Accum. |
| 228. Spring, Servo Apply Pin | 241. Plug, Case Servo |

B-08561

Figure 41—THM 700-R4 Servo Assembly

7A-46 AUTOMATIC TRANSMISSION

- AE. Reverse
- AF. D-2
- AU. Lo
- AV. Lo-1
- AW. D-4
- AX. Governor
- AY. Lo Reverse
- AS. 3 Accumulator
- AZ. TV
- AH. 3-4 Clutch
- AG. MTV
- AH. Accumulator (4th) •#1
- BA. 4th Signal
- AL. Void
- BB. 3-4 Accumulator
- AD. TV-Ex
- AB. Line
- BC. Part Throttle-Drive 3 •#3
- AT. 2nd (1-2) •#8
- BD. TVF
- AR. 4th
- AM. Conv. Clu. Sig.
- BE. MTV Down
- BF. MTV Up
- AJ. O.R. Clutch

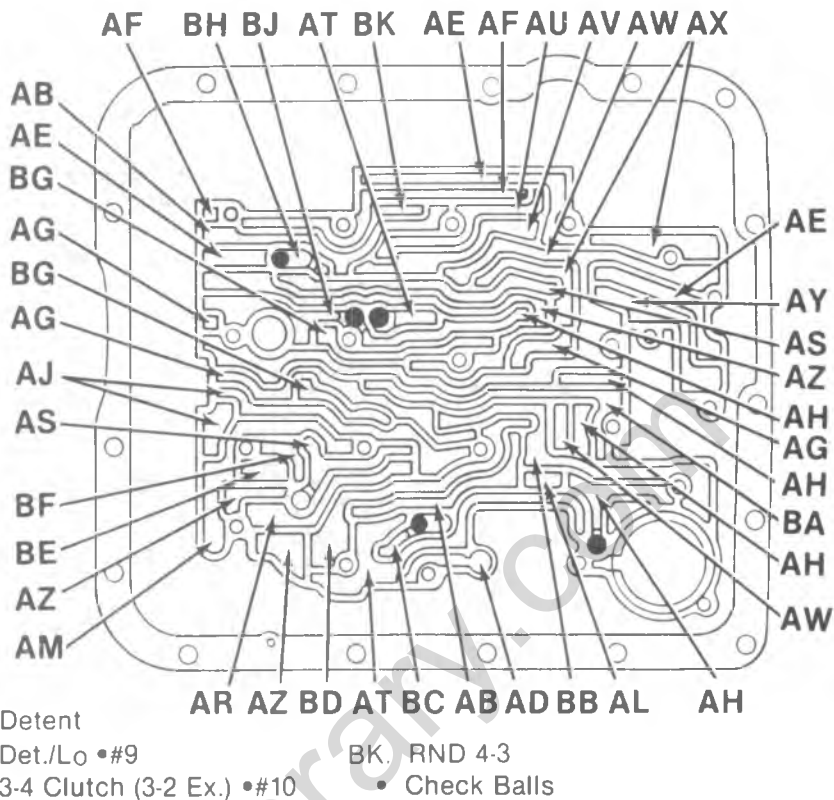

B-08462

Figure 42—THM 700-R4 Case Oil Passages and Check Ball Locations

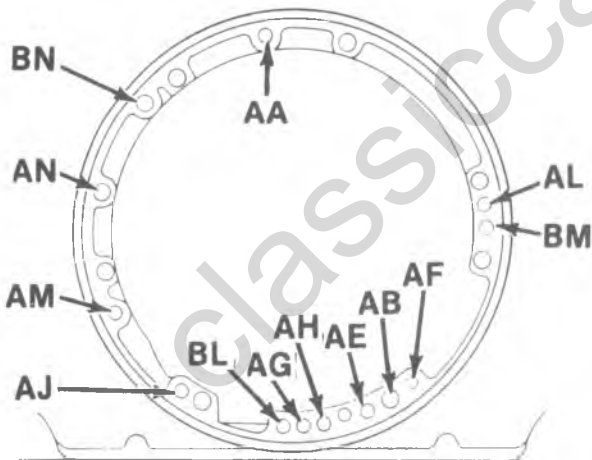

- BL. Fwd. Clutch
- AG. MTV
- AH. 3-4 Clutch
- AE. Reverse
- AB. Line
- AF. D-2
- BM. Pressure Tap
- AL. Void
- AA. Vent
- BN. From Cooler
- AN. To Cooler
- AM. Conv. Clu. Sig.
- AJ. O.R. Clutch

B-08465

Figure 43—THM 700-R4 Pump Case Oil Passages

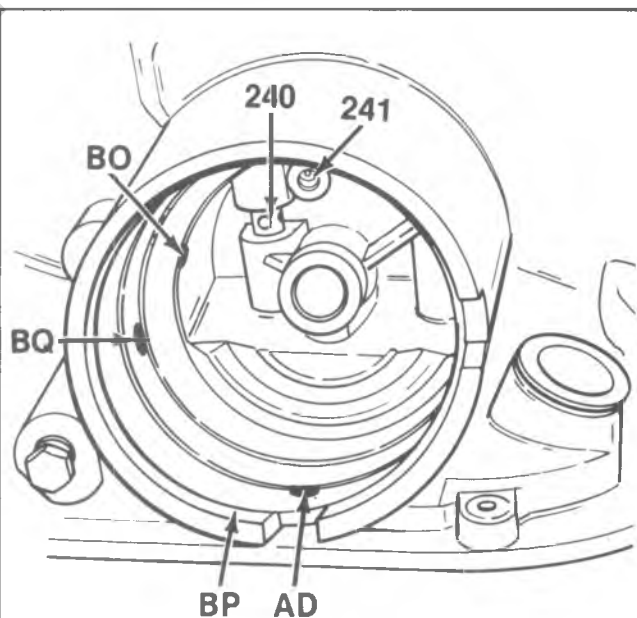

- AD. Servo Exhaust Hole
- BO. 3rd Accumulator Pressure Tap Passage
- BP. 2-4 Servo Bore
- BQ. 2nd & 4th Band Apply Passage
- 240. Retainer & Ball Assembly, 3rd Accum.
- 241. Plug, Case Servo

B-08464

Figure 44—THM 700-R4 Servo Oil Passages

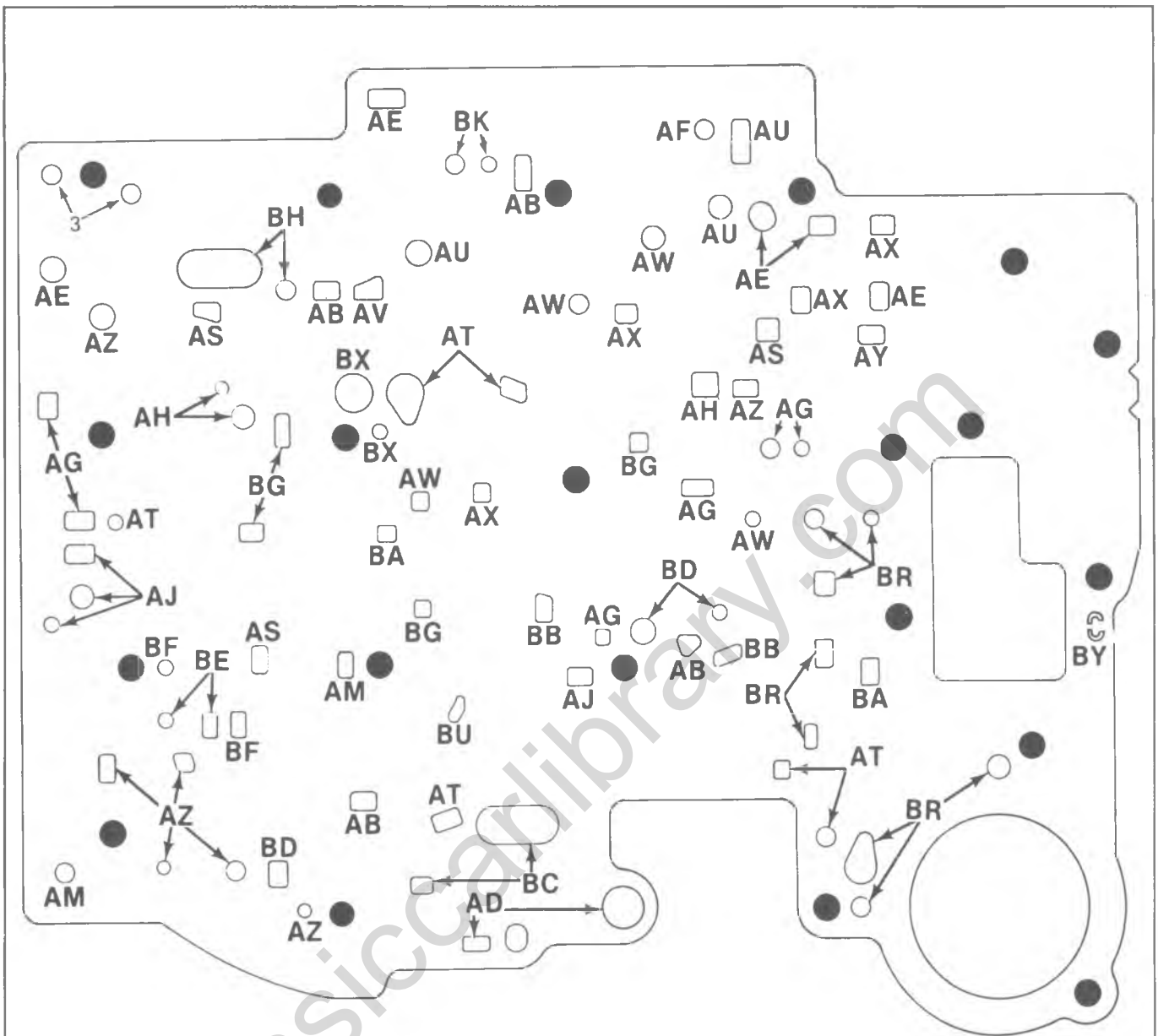

- | | | |
|---------------------|-----------------------|---------------------|
| AB. Line | ● Bolt Holes | BU. 4th Clutch |
| AW. D4 | BR. Accumulator | AM. Conv. Clu. Sig. |
| AE. Reverse | BA. 4th Signal | BF. MTV Up |
| AF. D2 | AT. 2nd Clutch | BE. MTV Down |
| AU. Lo | BB. 3-4 Accumulator | BG. Detent |
| AV. Lo-1 | BD. TVF | AH. 3-4 Clutch |
| AX. Governor | AJ. Overrun Clutch | BH. Detent/Lo |
| AY. Lo/Reverse | AD. TV Ex. | BK. Rnd. 4-3 |
| AS. 3rd Accumulator | BC. DC3/Part Throttle | BX. 3rd Clutch |
| AZ. TV | BS. Part throttle | By. Identification |
| AG. MTV | BT. D3 | |

B-08831

Figure 45—THM 700-R4 Spacer Plate to Case Gasket

7A-48 AUTOMATIC TRANSMISSION

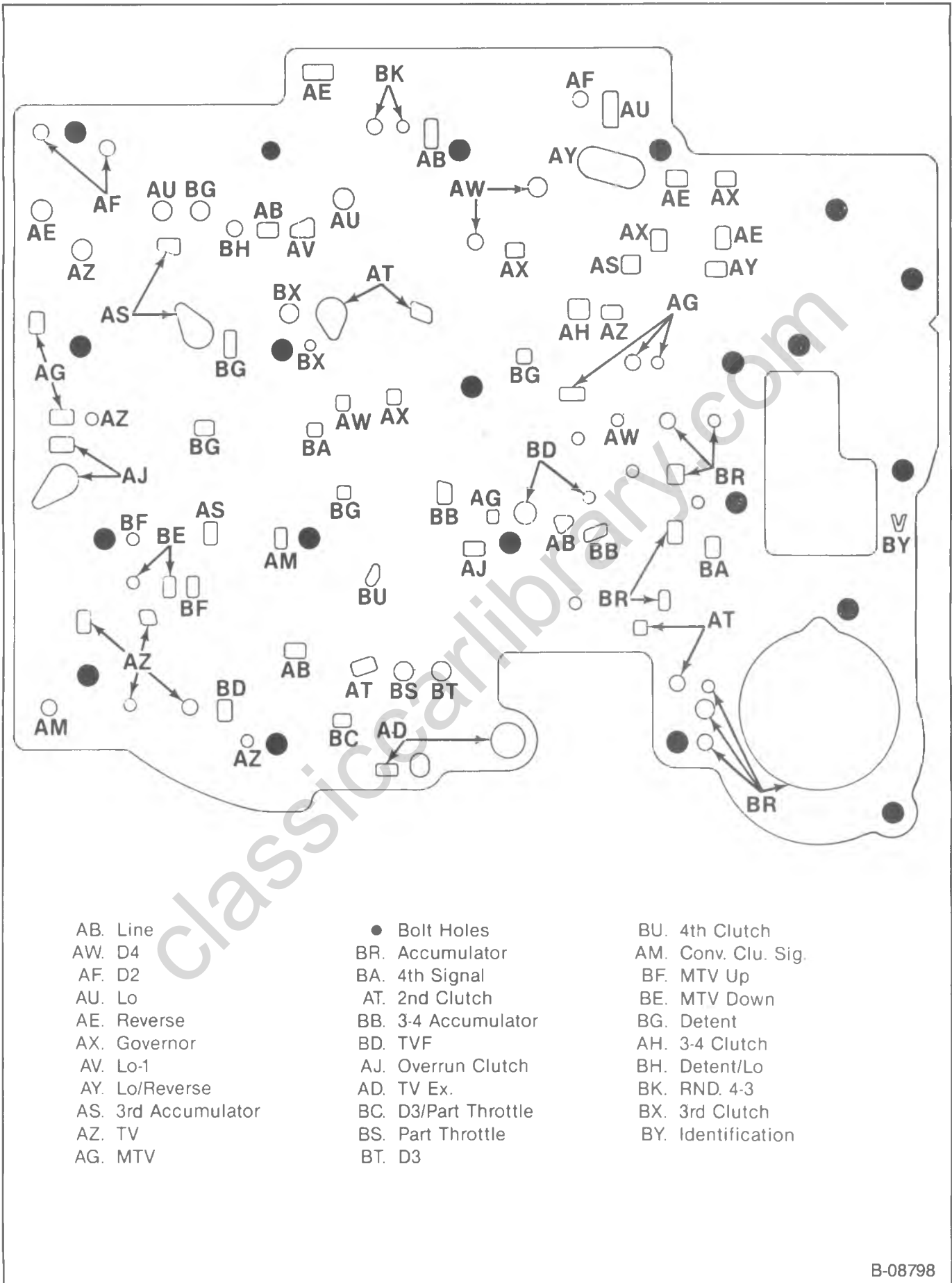

Figure 46—THM 700-R4 Spacer Plate to Valve Body Gasket

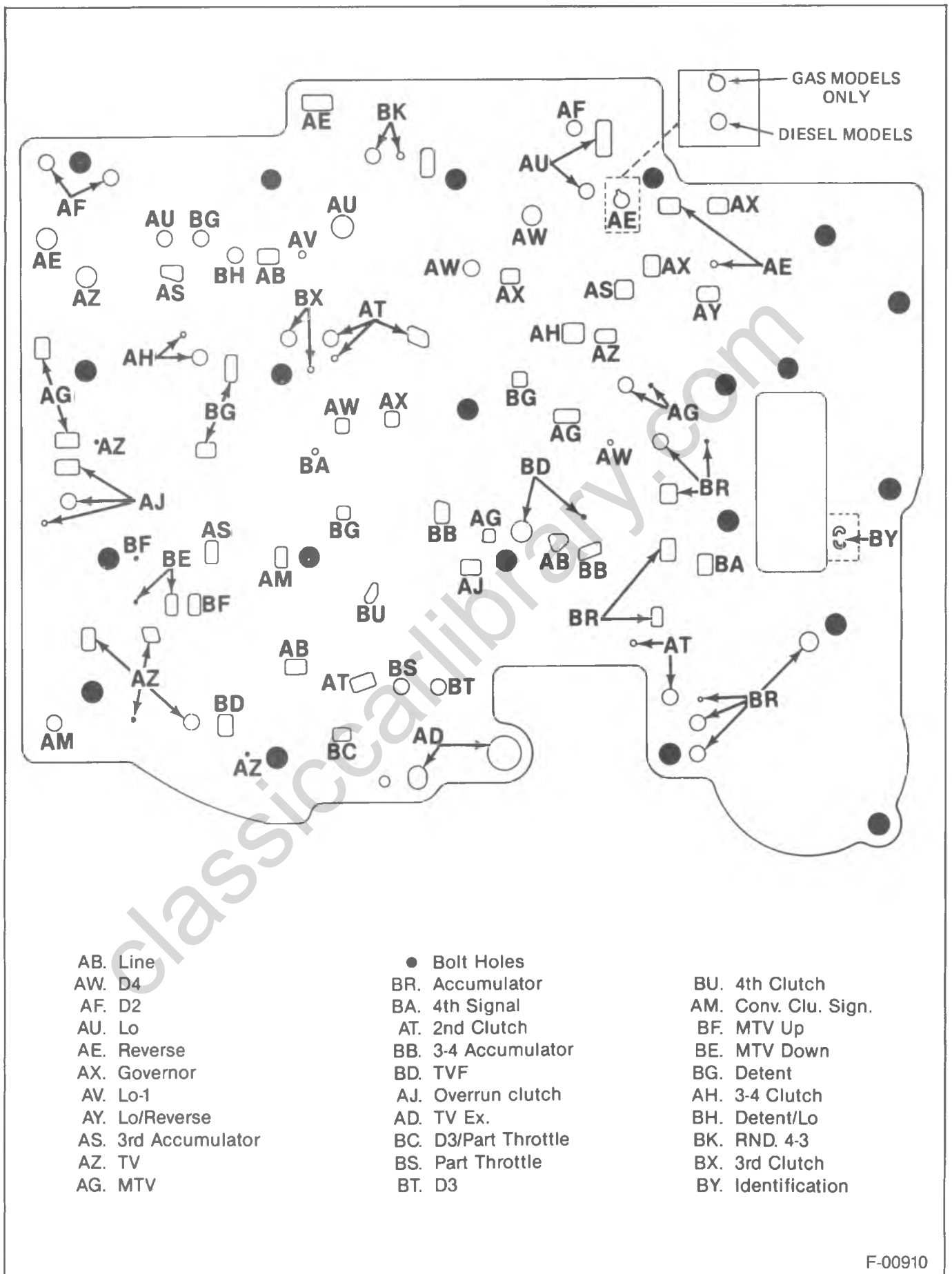
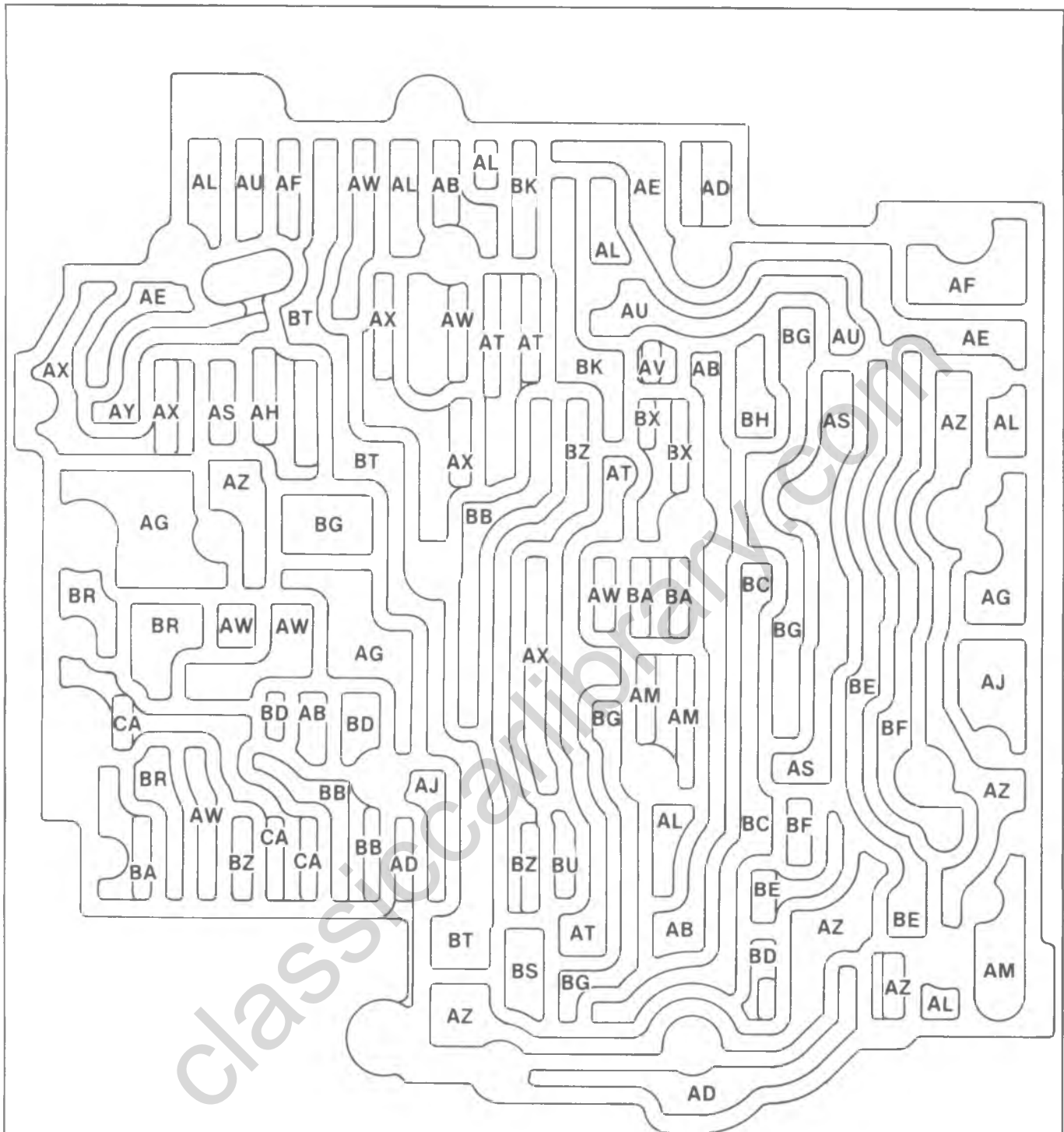

Figure 47—THM 700-R4 Spacer Plate (Typical)

7A-50 AUTOMATIC TRANSMISSION



- | | | | |
|---------------------|---------------------|----------------------|--------------------|
| AB. Line | AZ. TV | BC. D3/Part Throttle | BH. Detent/Lo |
| AW. D4 | AG. MTV | BS. Part Throttle | BK. Rnd. 4-3 |
| AF. D2 | BR. Accumulator | BT. D3 | BX. 3rd clutch |
| AU. Lo | BA. 4th Signal | BU. 4th Clutch | BY. Identification |
| AE. Reverse | AT. 2nd Clutch | AM. Conv. Clu. Sig. | AL. Void |
| AX. Governor | BB. 3-4 Accumulator | BF. MTV Up | AD. Exhaust |
| AV. Lo-1 | BD. TVF | BE. MTV Down | BZ. SF |
| AY. Lo/Reverse | AJ. Overrun Clutch | BG. Detent | CA. 4-3 |
| AS. 3rd Accumulator | AD. TV Ex. | AH. 3-4 Clutch | |

B-08520

Figure 48—THM 700-R4 Valve Body Oil Passages

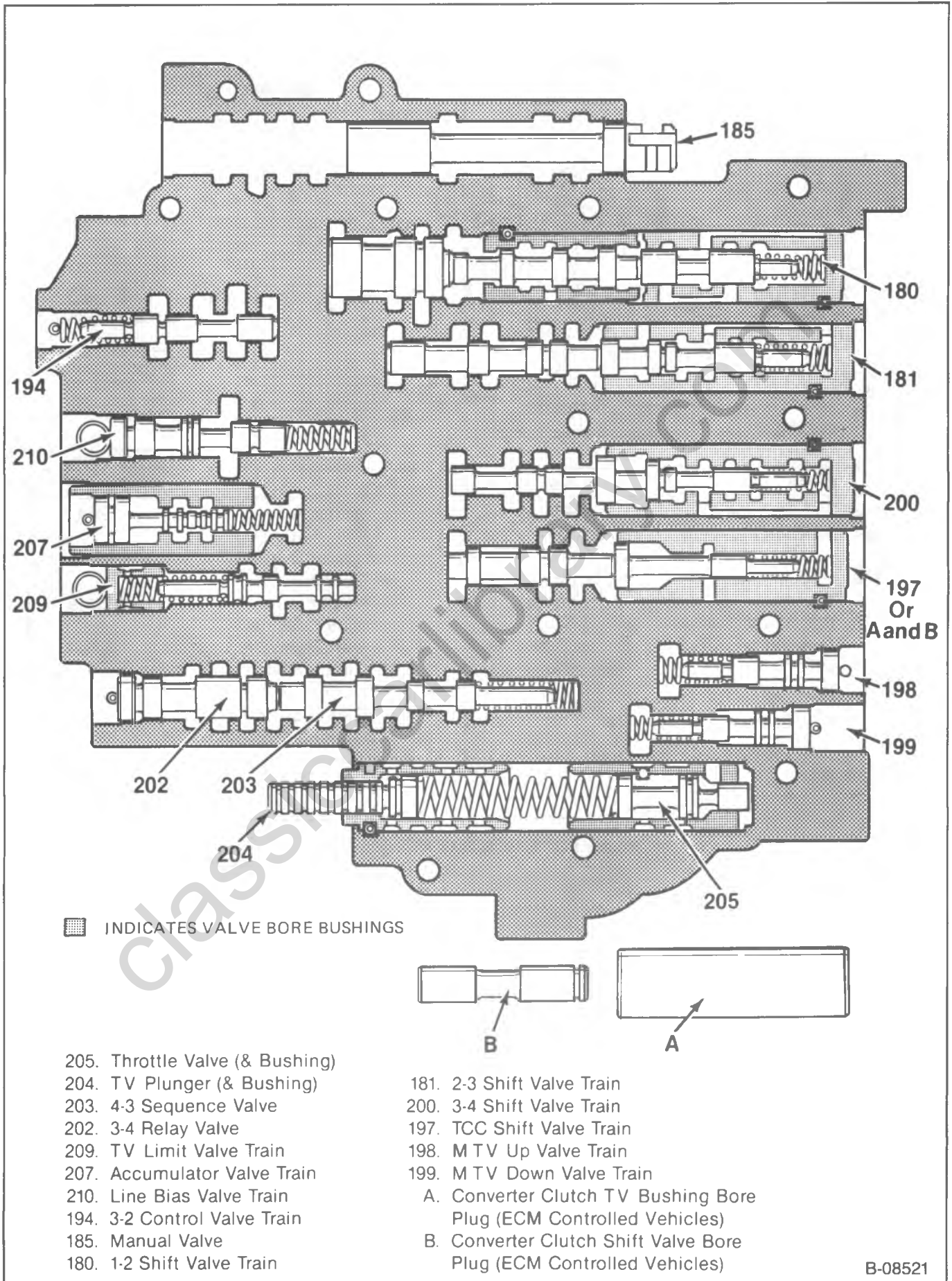

B-08521

Figure 49—THM 700-R4 Valve Trains

7A-52 AUTOMATIC TRANSMISSION

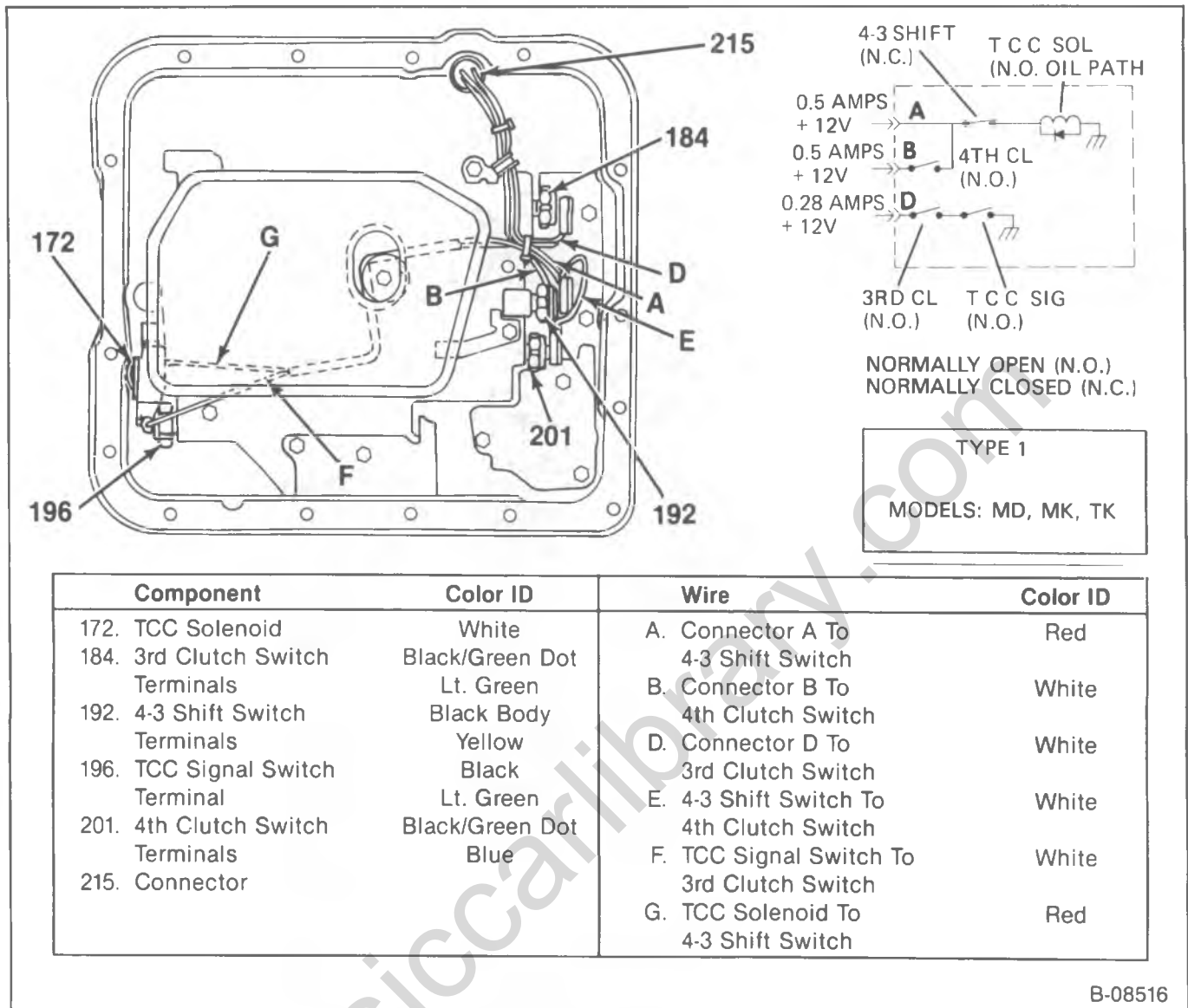

B-08516

Figure 50—THM 700-R4 Wiring — Type 1

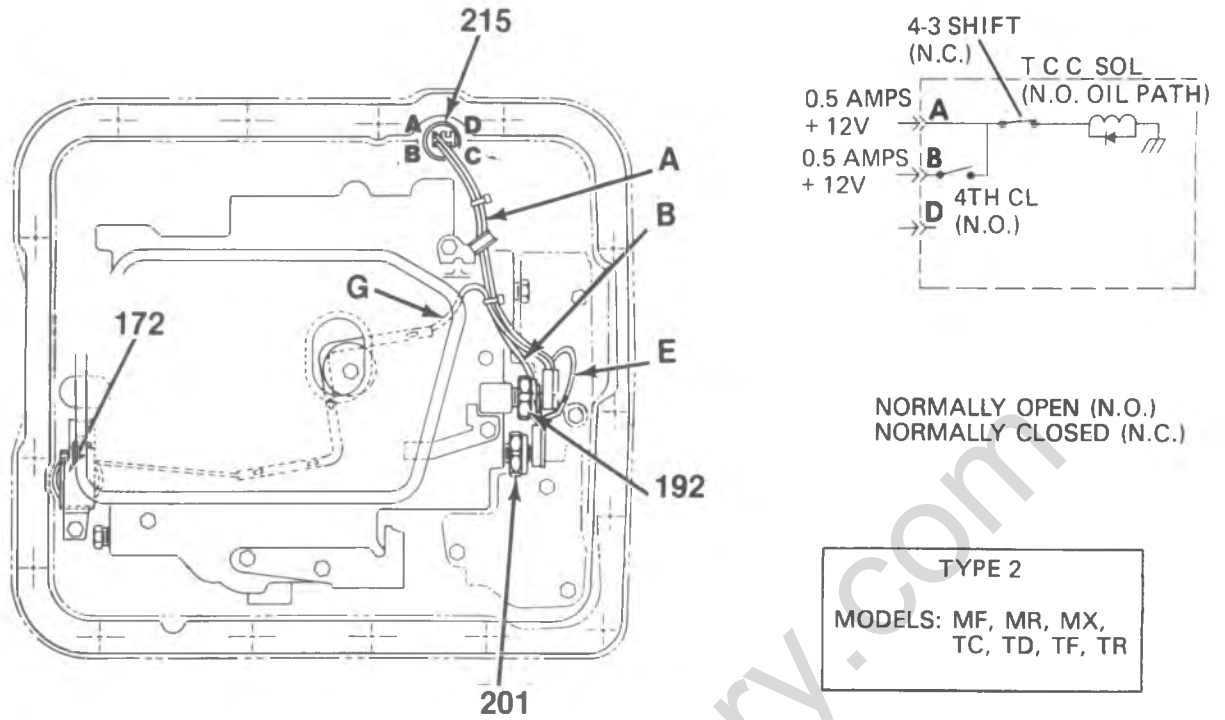

Component	Color ID	Wire	Color ID
172. TCC Solenoid	Yellow	A. Connector A To	Red
192. 4-3 Shift Switch	Black	4-3 Shift Switch	
Terminal	Yellow	B. Connector B To	White
201. 4th Clutch Switch	Black/Green Dot	4th Clutch Switch	
Terminals	Blue	E. 4-3 Shift Switch To	White
215. Connector		4th Clutch Switch	
		G. TCC Solenoid To	Red
		4-3 Shift Switch	

B-08517

Figure 51—THM 700-R4 Wiring — Type 2

7A-54 AUTOMATIC TRANSMISSION

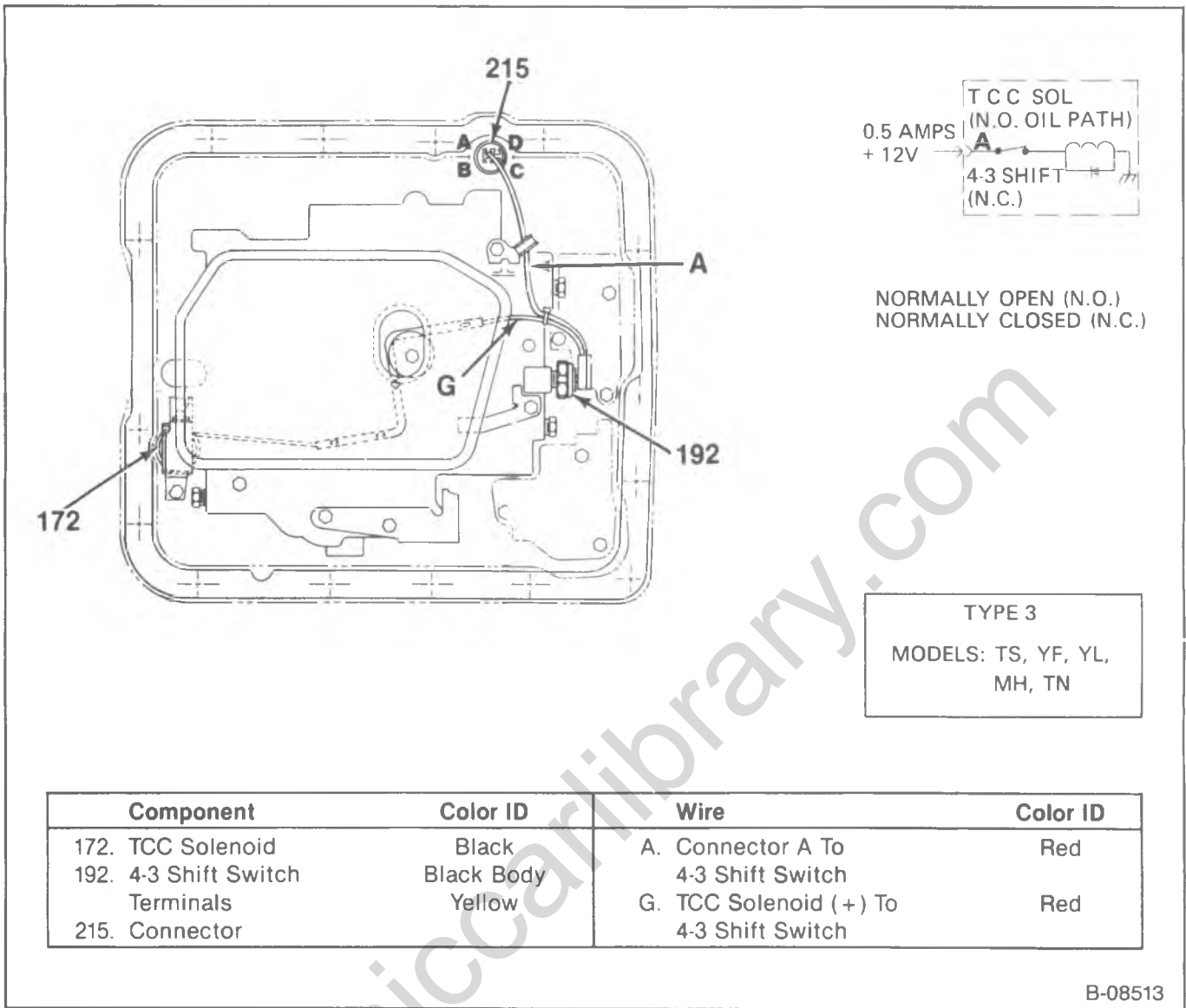

B-08513

Figure 52—THM 700-R4 Wiring — Type 3

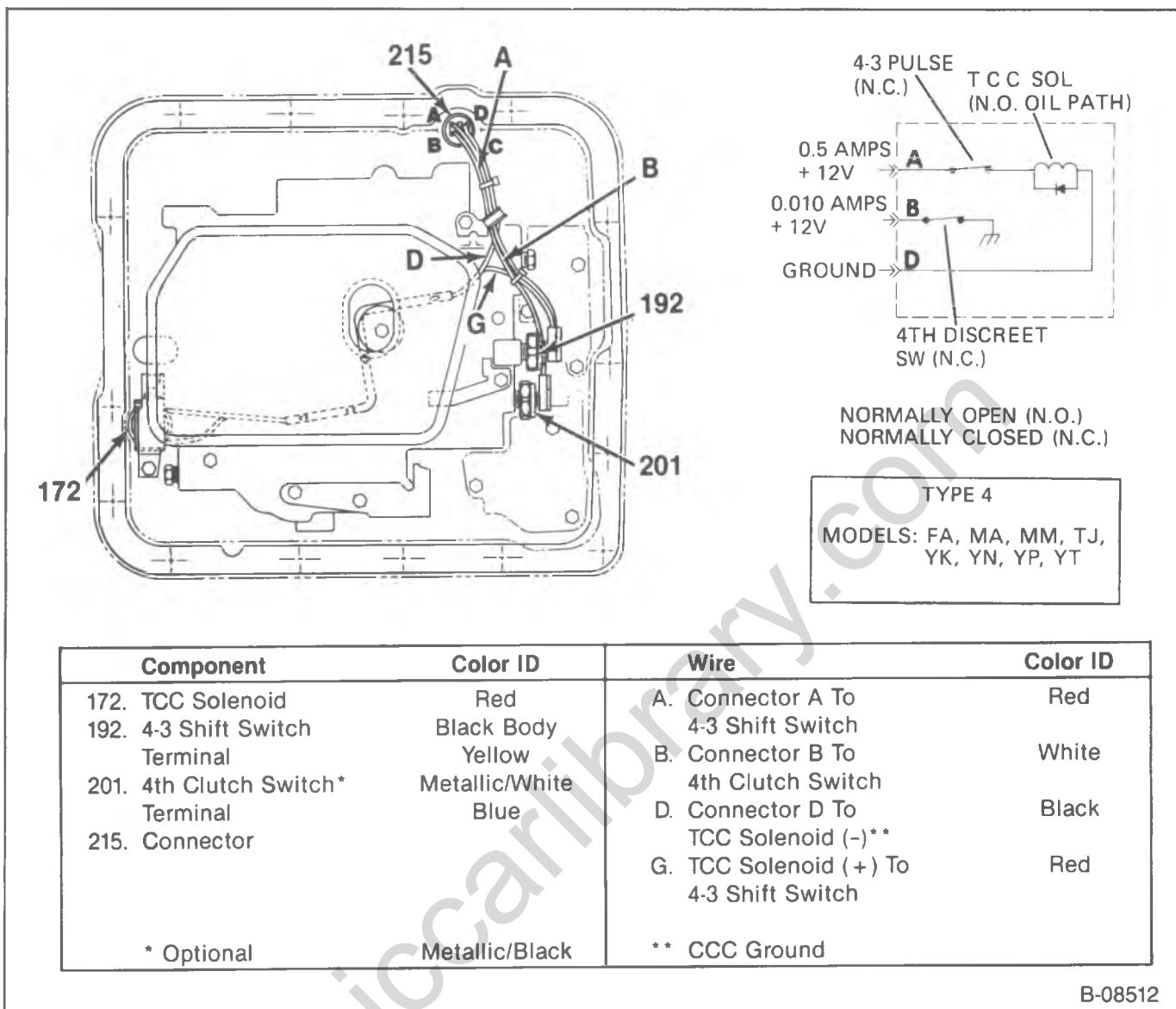

B-08512

Figure 53—THM 700-R4 Wiring — Type 4

7A-56 AUTOMATIC TRANSMISSION

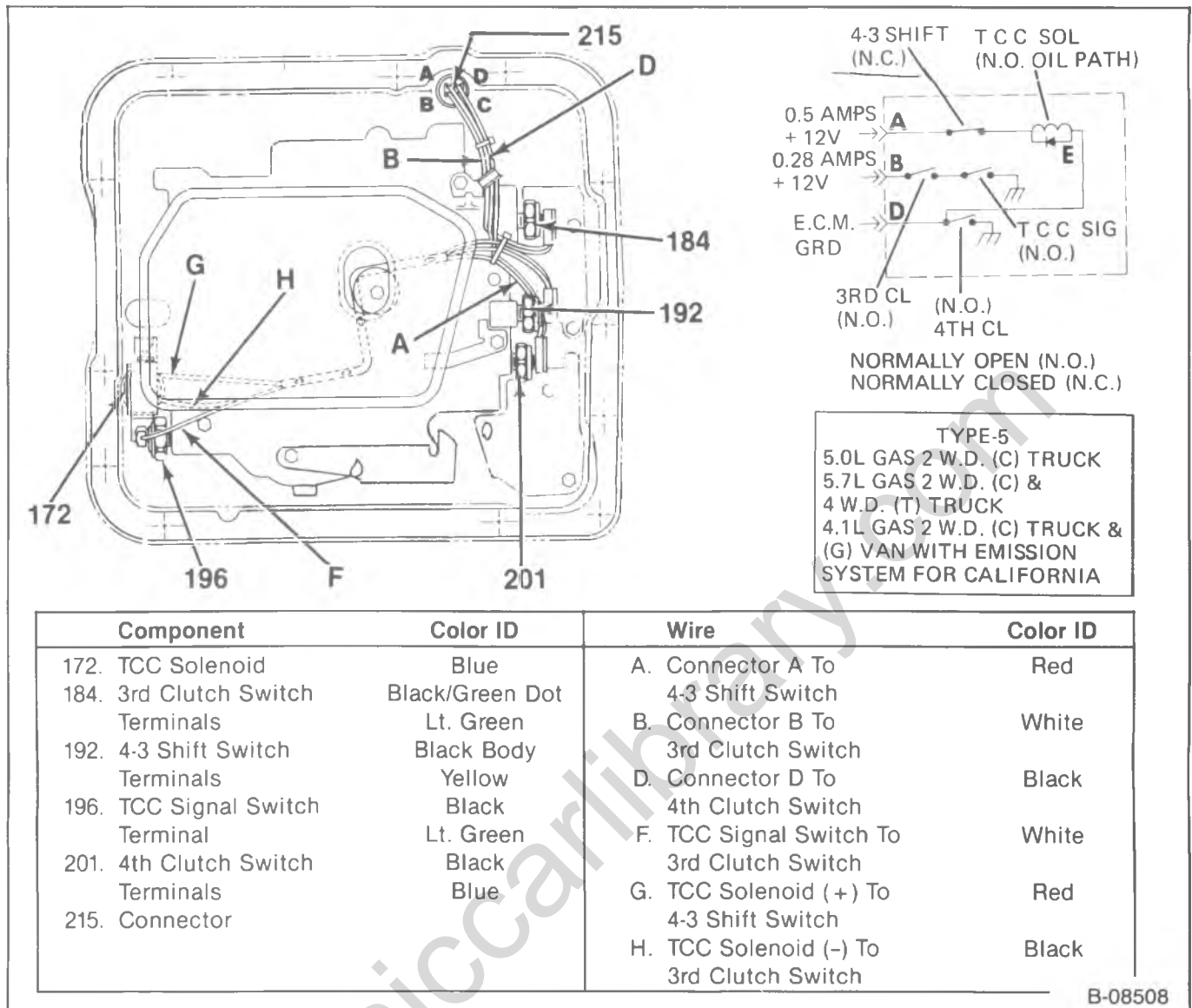

B-08508

Figure 54—THM 700-R4 Wiring — Type 5

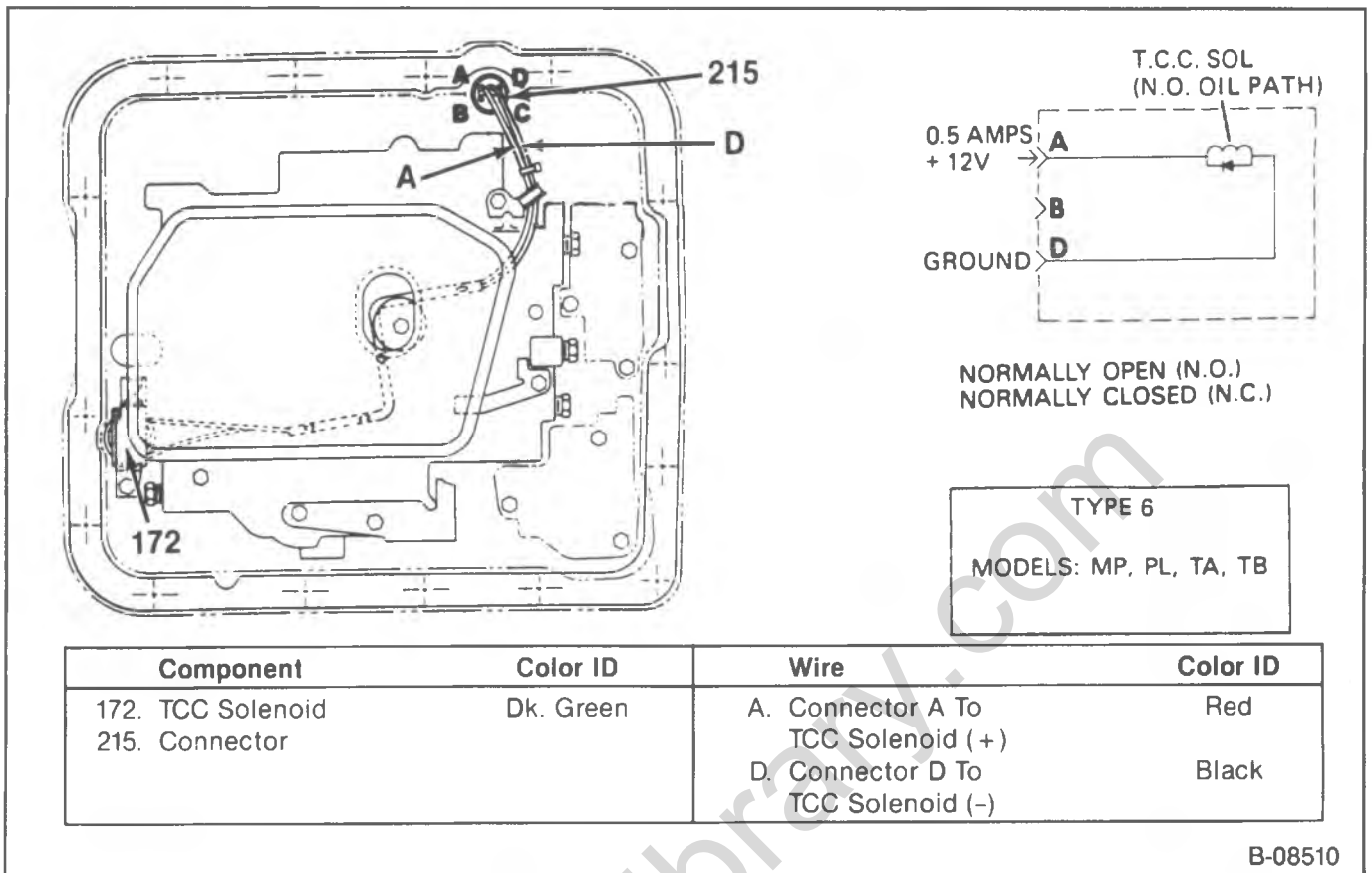

B-08510

Figure 55—THM 700-R4 Wiring — Type 6

classiccarrbro.com

7A-58 AUTOMATIC TRANSMISSION

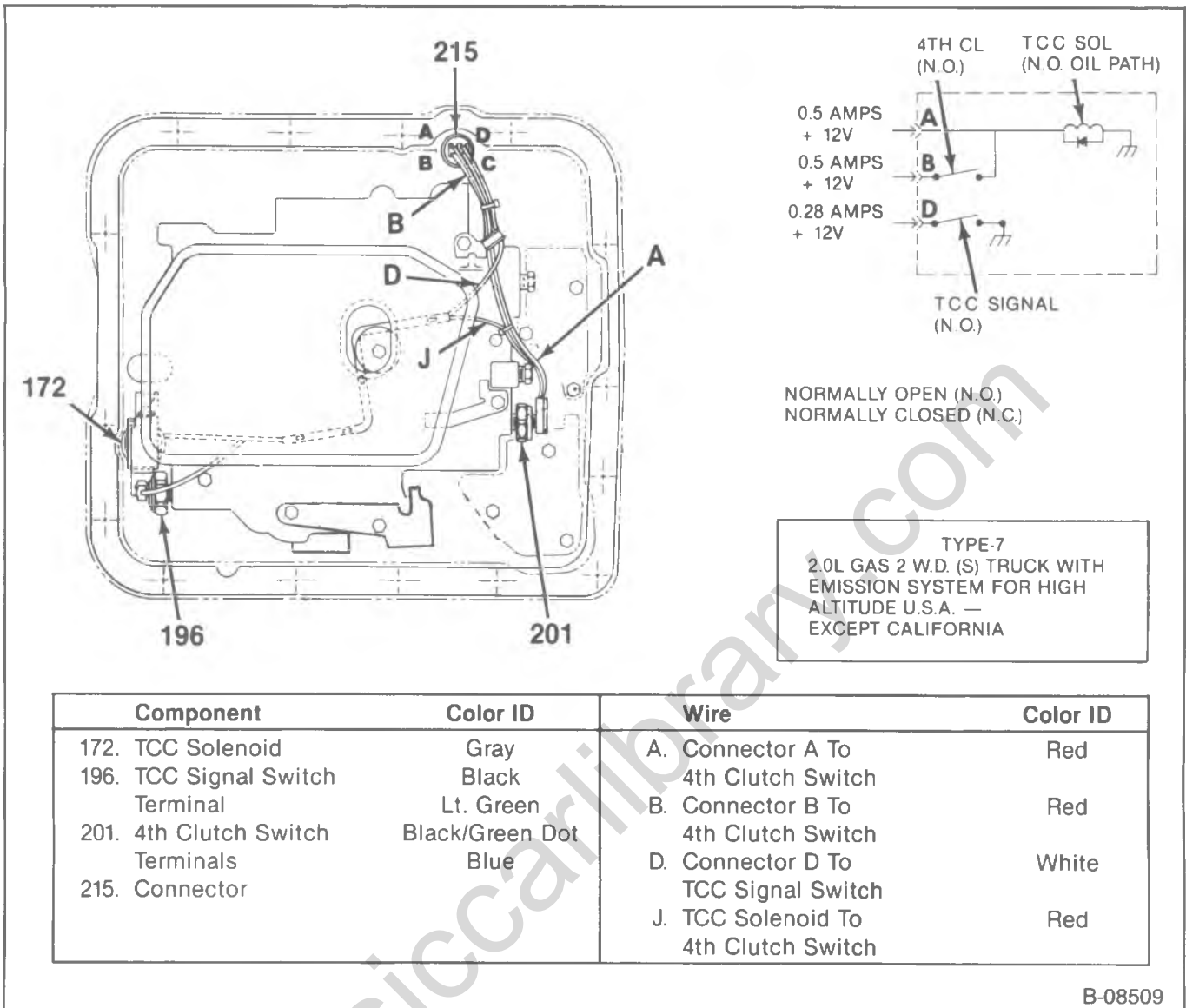

B-08509

Figure 56—THM 700-R4 Wiring — Type 7

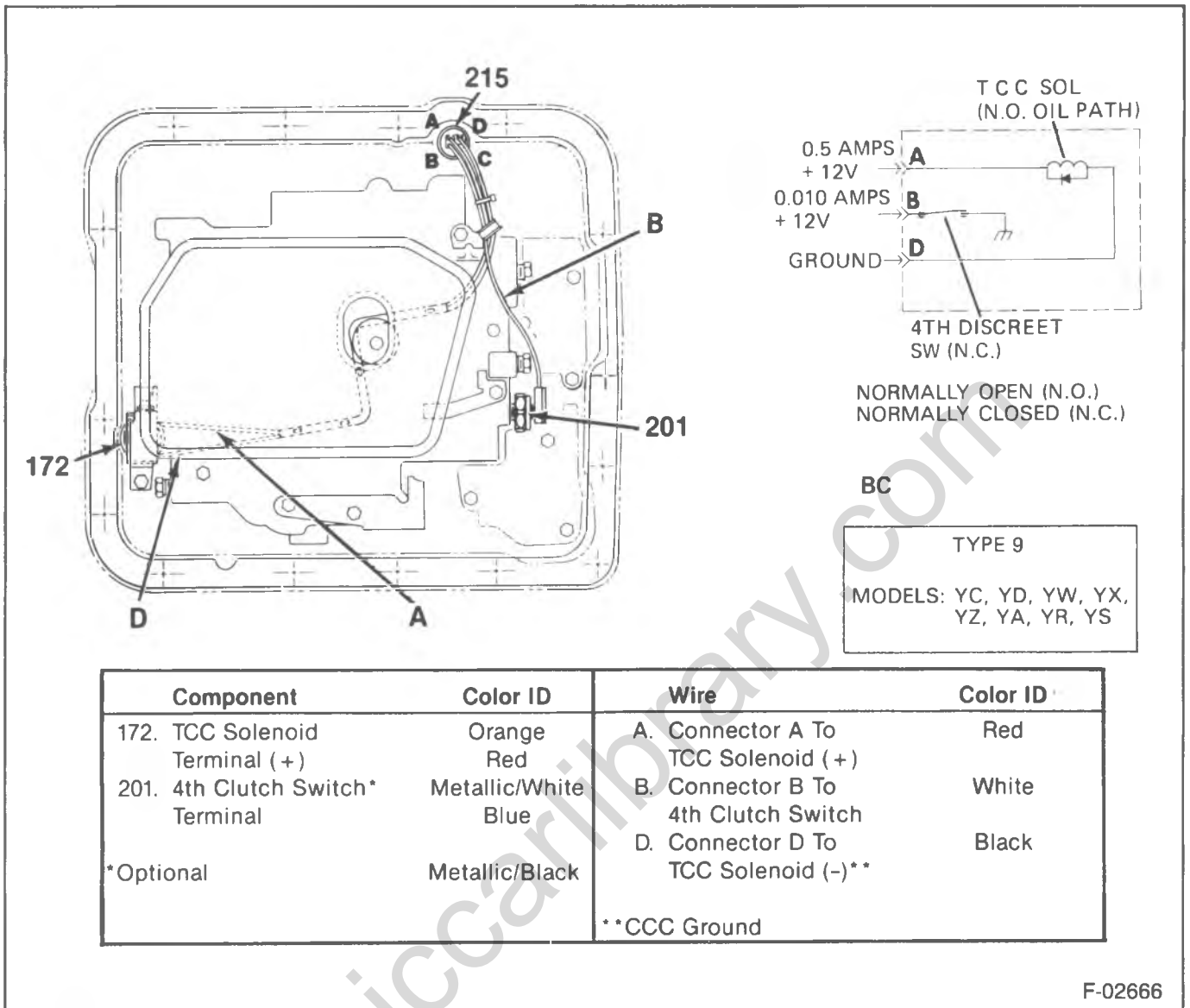

F-02666

Figure 57—THM 700-R4 Wiring — Type 9

7A-60 AUTOMATIC TRANSMISSION

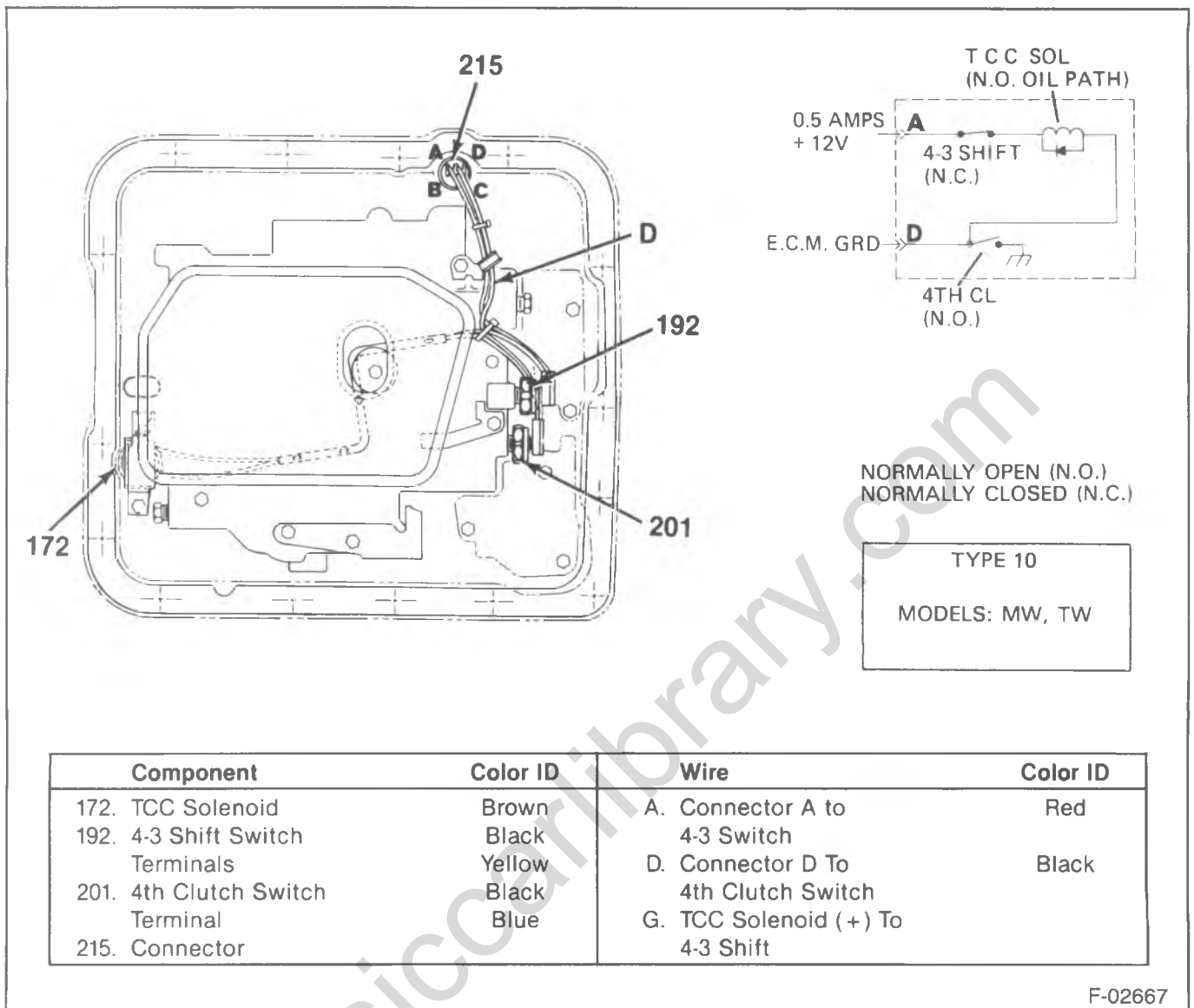

F-02667

Figure 58—THM 700-R4 Wiring — Type 10

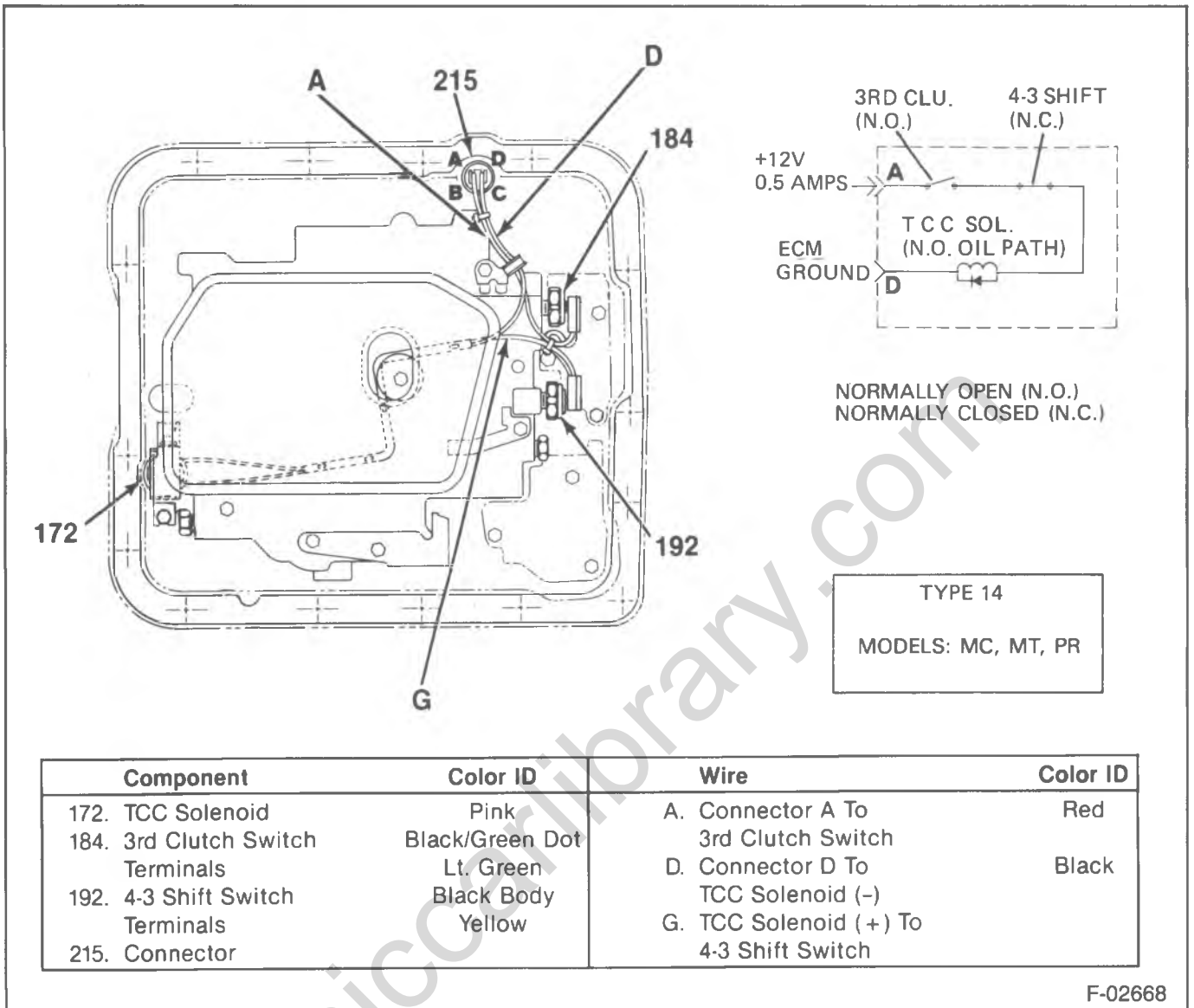

F-02668

Figure 59—THM 700-R4 Wiring — Type 14

7A-62 AUTOMATIC TRANSMISSION

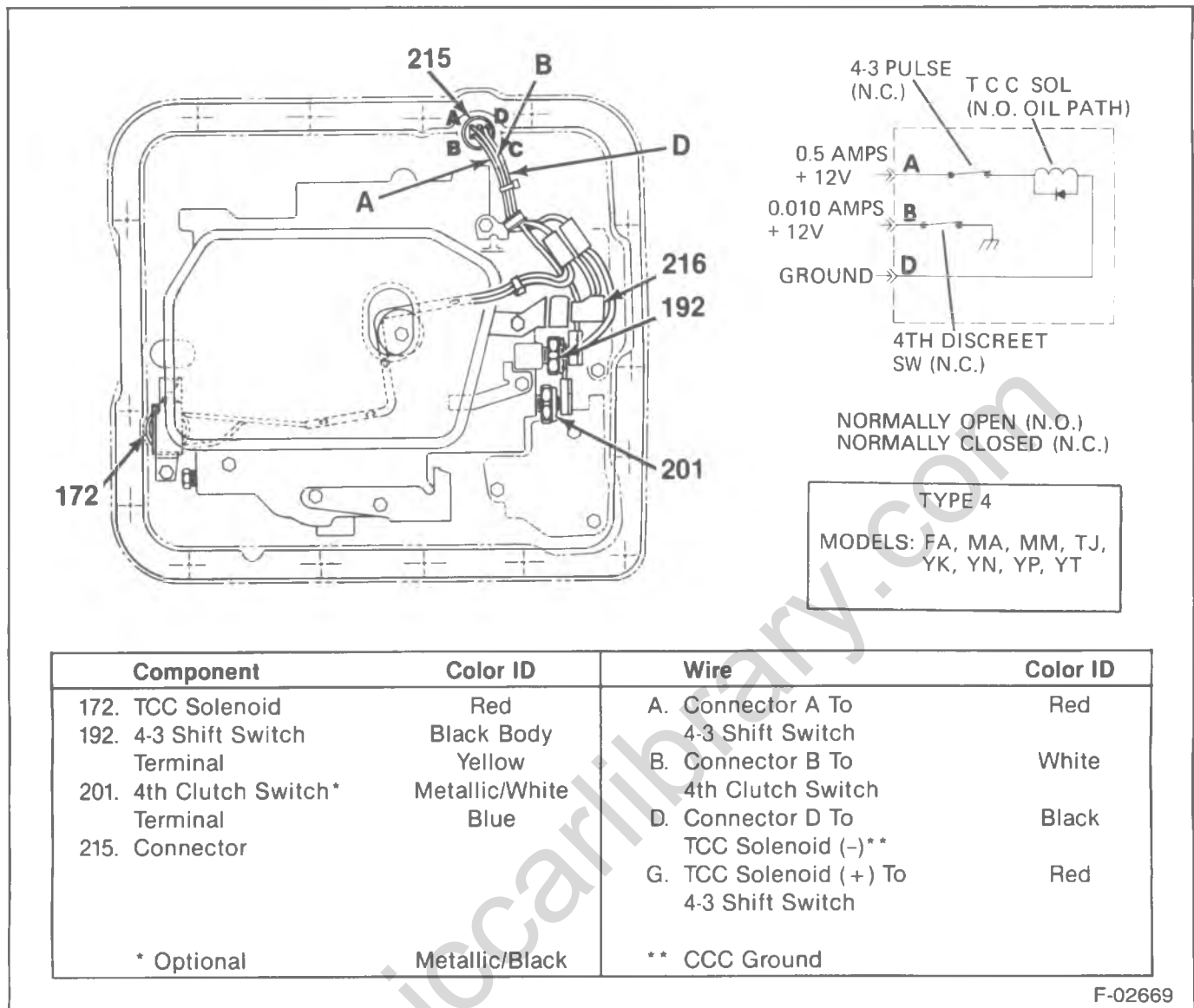

Figure 60—THM 700-R4 Wiring — Type 15

ON VEHICLE SERVICE

PARTS CLEANING, INSPECTION AND REPLACEMENT

- Use appropriate safety equipment such as:
 - Safety glasses.
 - Safety shoes.
 - Gloves.
- Keep work area and tools clean.
- Clean the transmission exterior before removing parts.
- Do not use wipe cloths or rags.
- Do not use solvents on:
 - Rubber seals.
 - Plastic/Teflon® thrust washers.
- Blow out all passages with compressed air.
- Clean out small passages with fine wire.
- Handle parts carefully to prevent damage.
- Lubricate all internal parts with transmission fluid during assembly.
- When installing screws, bolts or studs into aluminum always dip the threads in transmission fluid.
- Always use a torque wrench for proper torque.
- Recondition damaged or stripped aluminum threads with thread inserts.
- Replace all gaskets and seals.
 - Do not use gasket cement or sealers.
- Replace Teflon® and rubber lip seals only when necessary and install them using the appropriate seal protector.

Inspect

- Manual linkage for:
 - Wear at pivoting points.
 - Bent or broken links and rods.

F-02669

2. All seals, gasket and mating surfaces for:
 - Nicks.
 - Cuts.
 - Damage.
3. Snap rings for:
 - Expansion or compression.
 - Distortion.
 - Nicks.
 - Proper ring to groove fit.
4. Bearings and thrust surfaces for:
 - Wear.
 - Scoring.
 - Pitting.

OIL COOLER LINES

If replacement of transmission steel tubing cooler lines is required, use only double wrapped and brazed steel tubing meeting GM specification 123M or equivalent. Under no condition use copper or aluminum tubing to replace steel tubing. Those materials do not have satisfactory fatigue durability to withstand normal vehicle vibrations. Steel tubing should be flared using the double flare method.

COOLER LINE FLUSHING

In a major transmission failure, where particles of metal have been carried with the oil throughout the units of the transmission, it will be necessary to flush out the oil cooler and connecting lines. To flush the oil cooler and lines, use the following procedure:

1. Disconnect both cooler lines from the transmission.
2. Place a hose over the end of the cooler inlet line (from the bottom of the cooler) and insert the hose into an empty container.
3. Flush clean oleum solvent or equivalent through the return line (from the top of the cooler) using an oil suction gun until clean solvent comes out of the hose. This will "back flush" the cooler.
4. Remove the hose from the inlet cooler line and place it on the return line.
5. Flush clean oleum solvent or equivalent through the inlet line until clean solvent comes out the return line. Remove remaining solvent from cooler with compressed air applied to the return line and flush with transmission fluid.
6. Reconnect oil cooler lines and torque nuts to 17 N·m (12 ft. lbs.).

CHECKING AND ADDING FLUID

The automatic transmission is designed to operate at the "FULL HOT" mark on the dipstick at normal operating temperatures of 88°C–93°C (190°F–200°F), and should be checked under these conditions (figure 61).

The normal operating temperature is obtained only after at least 24 km (15 miles) of highway type driving.

If the vehicle has recently been operated for an extended period at high speed or in city traffic in hot weather or the vehicle is being used to pull a trailer, an accurate fluid level cannot be determined until the fluid has cooled down, usually about 30 minutes after the vehicle has been parked.

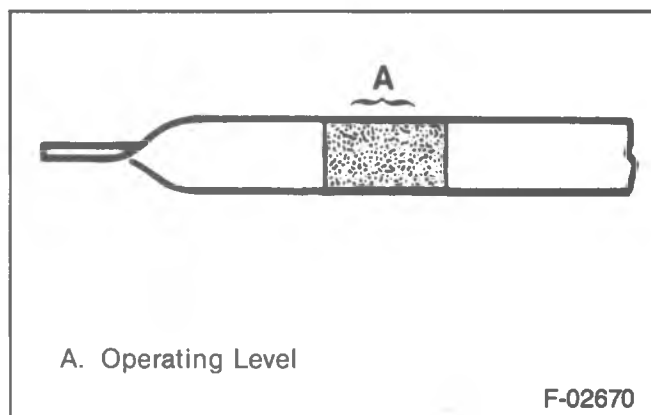

Figure 61—Transmission Dipstick



Inspect

1. Park vehicle on level ground.
2. Apply parking brake and block wheels.
3. Start engine and operate vehicle for 15 minutes or until a normal operating temperature is reached.
4. Move gear selector through all gear positions.
5. Move gear selector to "Park" (P).
6. Check fluid level, color and condition. Refer to "Transmission Fluid Information" in this section.



Important

DO NOT OVERFILL.

Overfilling can cause foaming and loss of fluid through the vent. Slippage and transmission failure can result.

Fluid level too low can cause slipping, particularly, when the transmission is cold or the vehicle is on a hill.

SHIFT LINKAGE



Remove or Disconnect (Figure 62)

- Apply the parking brake.
1. Retaining pin (226).
 2. Rod (240) from the column lever.
 - Note the position of any washers, spacers and insulators removed.
 3. Rod (240) from the equalizer lever (238).
 - R, V and P Models.
 - Screw (242) and the washer.
 - Swivel (232).
 - G Models.
 - Nut (236), washers and the insulator.
 - Swivel (232).
 - Spacer and the retainer.
 4. Retaining pin (227) and the equalizer lever (238).
 - Insulator, washer and the spring.



Clean

- Metal parts using solvent. Wipe dry using a clean, dry rag.
- Rubber or nylon parts using soapy water. Wipe dry using a clean, dry rag.



Install or Connect (Figure 62)

1. Equalizer lever (238) and a new retaining pin (227).
 - Spring, washer and the insulator.

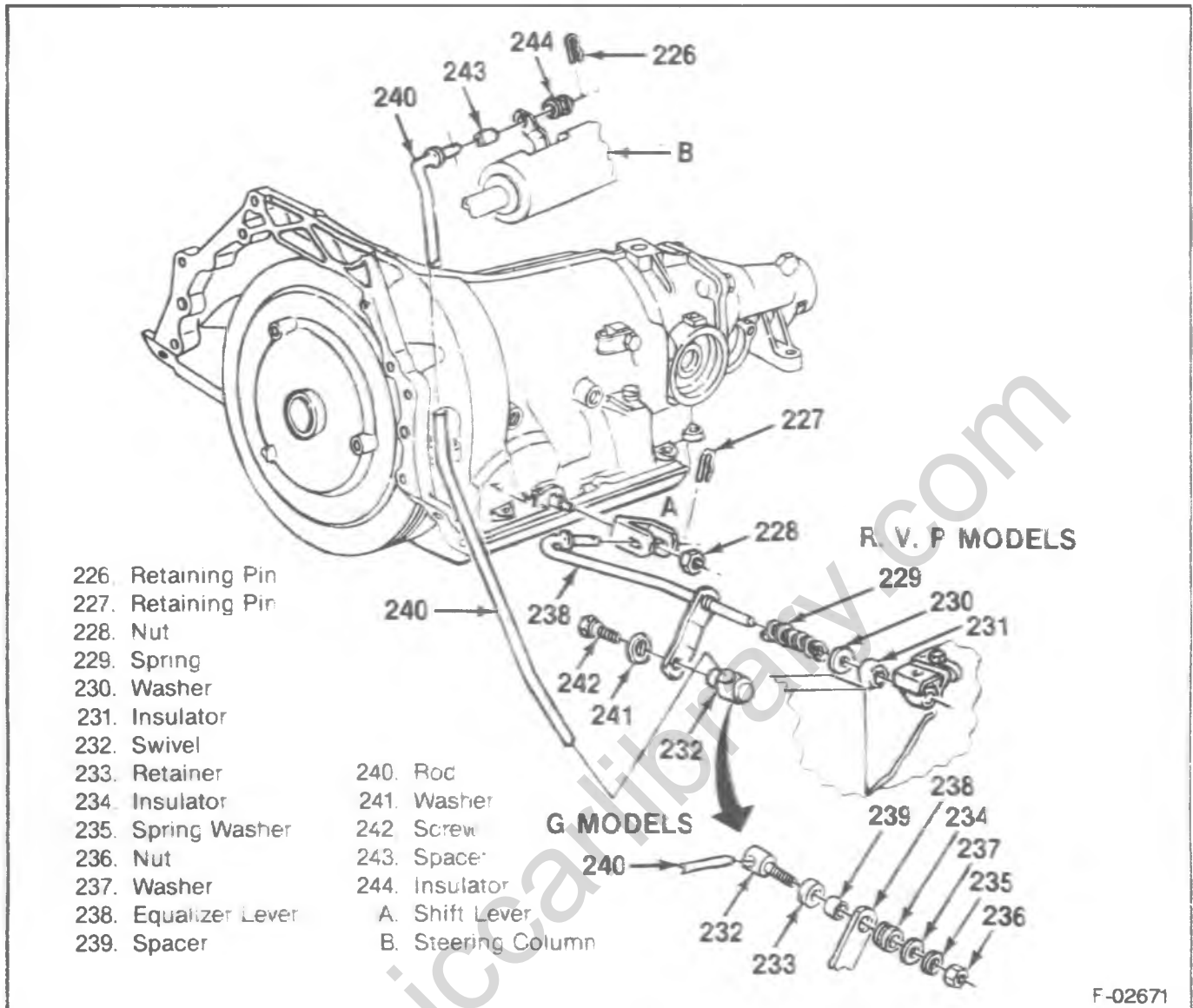

Figure 62—Shift Linkage

2. Rod (240) to the equalizer lever (238)
 - R, V and P Models
 - Swivel (232).
 - Washer and the screw (242)
 - G Models.
 - Retainer and the spacer
 - Swivel (232)
 - Insulator, washers and the nut (236).
3. Rod (240) to the column lever
 - Insulators, spacers and washers in the positions they were removed from.
4. New retaining pin (226).

 **Adjust**

- Apply the parking brake.
1. Loosen the screw (242) or the nut (236), as used.
 2. Put the column selector lever in the "N" (Neutral) position.
 - Put the lever into the neutral gate, do not use the indicator to find the neutral position.
 3. Put the transmission in neutral.

- Move the shift lever (A) to the forward position, the back to the second detent. (Figure 63).

4. Hold the rod (240) tightly in the swivel (232)

 **Tighten**

- Nut (236) or the screw (242), to 23 N·m (17 ft. lb.).
5. Put the column selector lever in the "P" (Park) position.
 6. Check the adjustment.
 - The column selector lever must go into all positions
 - The engine must start in the "P" (Park) or "N" (Neutral) positions only. Adjust if needed, refer to "Neutral Start Switch" in this section.

CAUTION: With the selector lever in the "Park" position, the parking pawl should freely engage within the rear (reaction) internal gear lugs or output ring gear lugs and prevent the vehicle from rolling, which could cause personal injury.

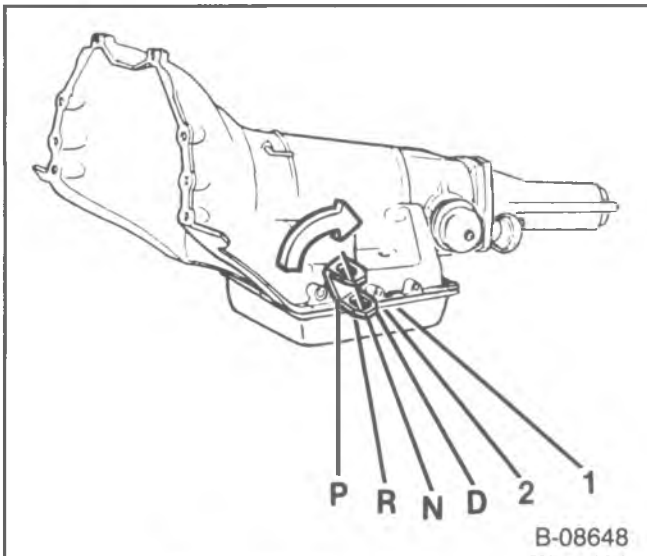

Figure 63—Shift Positions

- Align the indicator, if needed.
- Release the parking brake.

TV CABLE

The TV Cable used with the THM 700-R4 transmission should not be thought of as an automatic downshift cable. The TV cable used on the THM 700-R4 controls line pressure, shift points, shift feel, part throttle downshifts and detent downshifts. The function of the cable is similar to the combined functions of a vacuum modulator and a detent cable.

The TV cable operated the TV link (144) and bracket in the transmission (figure 64).

The TV bracket assembly serves two (2) basic functions:

1. The primary function of this assembly is to transfer the carburetor throttle plate movement to the TV plunger in the control valve assembly as related by the TV cable and linkage. This causes TV pressure and line pressure to increase according to engine throttle opening and also controls part throttle and detent downshifts. The proper adjustment of the TV cable is based on the TV plunger being fully depressed to flush with the TV bushing at engine wide open throttle.
2. The second function of the assembly involves a TV exhaust ball. The function of this system is to prevent the transmission from operating at low (idle position) pressures, if the TV cable should become broken or disconnected. If the cable is not connected or broken, the TV lifter rod will not move from its normal spring loaded up position which holds the TV exhaust check ball off its seat. The TV lifter rod will drop down to allow the TV exhaust ball to seat only if the cable is broken, disconnected or extremely out of adjustment. With the transmission pan removed, it should be possible to pull down on the TV exhaust valve lifter rod and the springs should return the rod to its normal up position. If the throttle lever and bracket assembly or lifter rod binds or sticks so that the TV lifter rod cannot lift the exhaust ball off its seat, high line pressures and delayed shifts will result.

↔ Remove or Disconnect (Figure 64)

1. Air cleaner.
2. Cable terminal (225) from the throttle lever (140).
3. Cable housing (141) from the bracket while compressing locking tangs (B).
4. Routing clips or straps.
5. Screw (252) and the washer.
6. Cable (142) from the transmission link (144).
 - Pull up on cable cover at the transmission until the cable is visible.
7. Seal (254).

→ Install or Connect (Figure 64)

1. New seal (254) into the transmission case hole.
2. Cable (142) to the transmission link.
3. Screw (252) and the washer.

⤵ Tighten

- Screw (252) to 10 N·m (7 ft. lbs.).
4. Cable routing clips or straps.
 5. Cable (142) through the engine bracket and engage locking tangs (B) of the cable on the bracket.

! Important

- Avoid damaging or kinking the cable.
6. Cable terminal (255) to the throttle lever (140).
 - Pull on upper end of cable. It should travel a short distance with light resistance caused by the small return spring on the TV lever. When releasing the upper end of the TV cable, it should return to the zero TV position.
 7. Adjust the TV cable. Refer to "TV Cable Adjustment" in this section.

TV CABLE ADJUSTMENT

Adjustment of the TV cable must be made by rotating the throttle lever at the carburetor or throttle body. Do not use the accelerator pedal to rotate the throttle lever.

🔧 Adjust (Figure 64)

1. Stop the engine.
2. Depress and hold down the metal re-adjust tab (250) at the engine end of the TV cable (142).
3. Move the slider (251) until it stops against the fitting.
4. Release the readjustment tab (250).
5. Rotate the throttle lever (140) to its "full travel position."
6. The slider (251) must move (ratchet) toward the lever when the lever is rotated to its "full travel position."
 - Check that cable moves freely. The cable may appear to function properly with the engine stopped and cold. Recheck after the engine is hot.
7. Road test the vehicle.

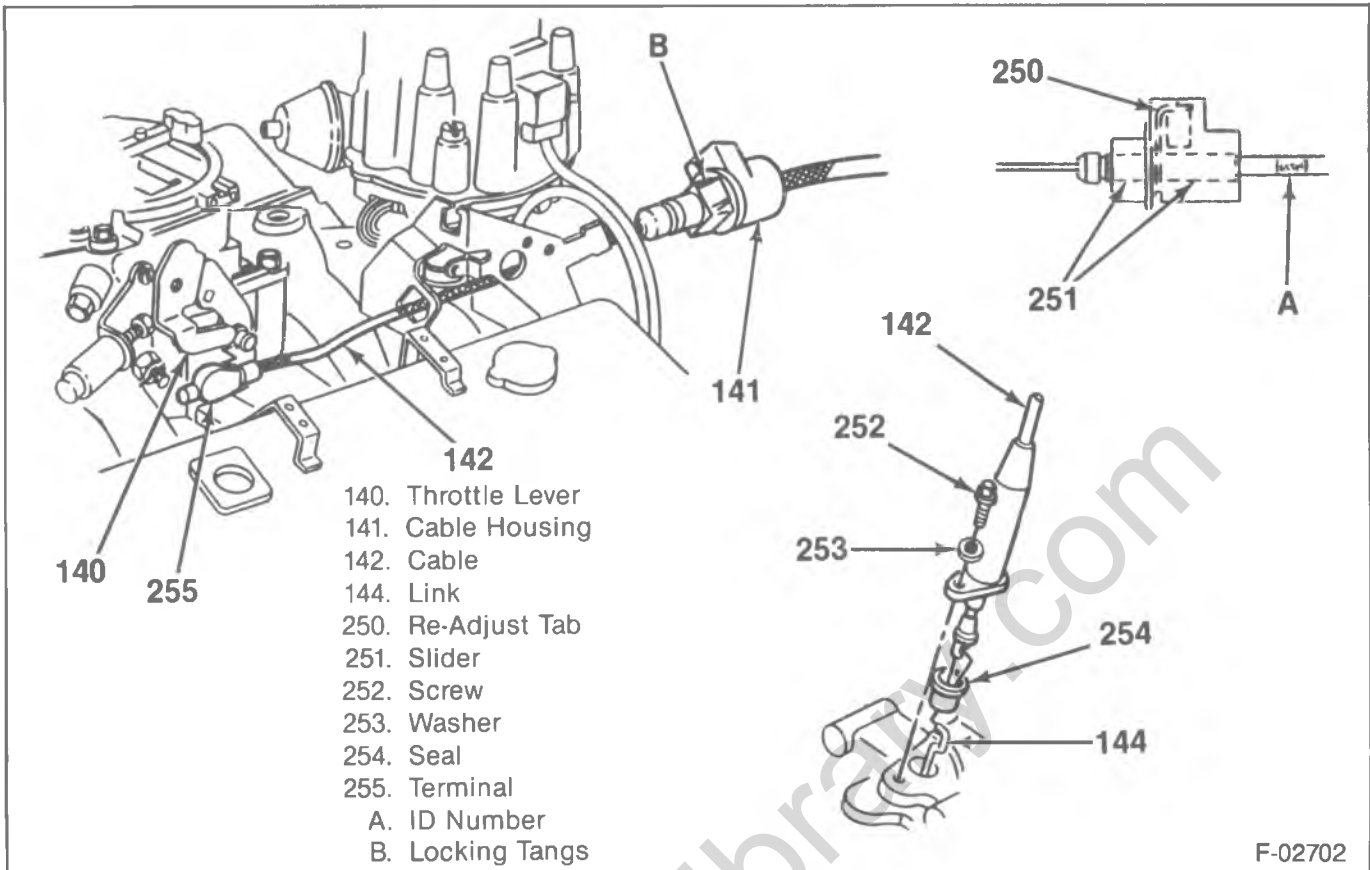

Figure 64—TV Cable (THM 700-R4)

CHANGING THE FLUID AND FILTER

↔ Remove or Disconnect (Figure 65)

- Raise the vehicle and support it using suitable safety stands.
- Place a drain pan under transmission oil pan.

- Oil pan screws (222) from the front and sides only.
 - Loosen the rear oil pan screws approximately 4 turns.

NOTICE: Do not damage the transmission case or oil pan sealing surfaces.

- Lightly tap the oil pan (221) with a rubber mallet or pry down to allow the fluid to drain.
 - Inspect the fluid color, refer to "Transmission Fluid Information" in this section.
- Remaining oil pan screws (222), oil pan and the gasket (220).
- Oil filter (189) and the seal (223).

 - The seal may be stuck in the case.

🧼 Clean

- Transmission case and oil pan gasket surfaces with solvent and air dry.
 - All traces of old gasket material must be removed.

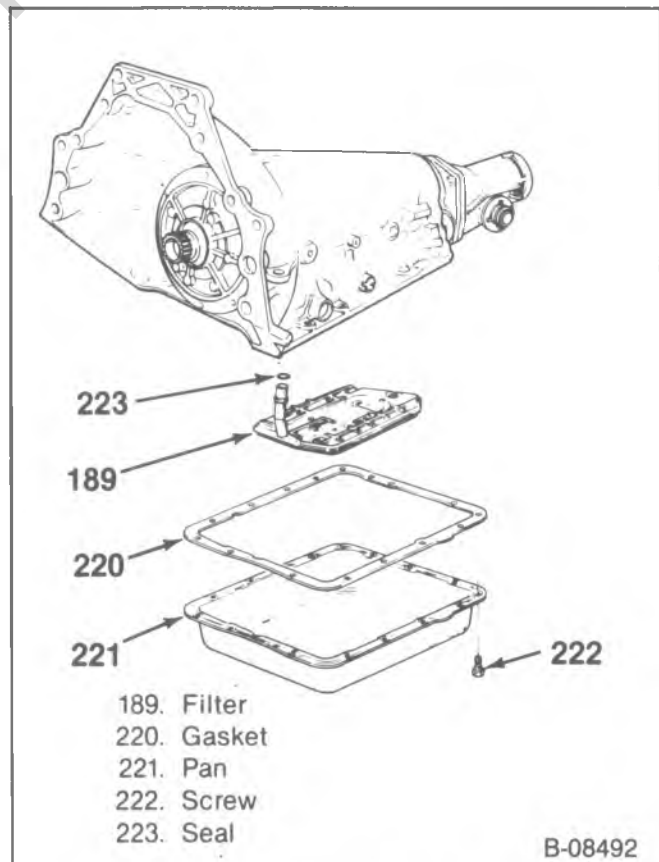

Figure 65—Transmission Filter and Pan

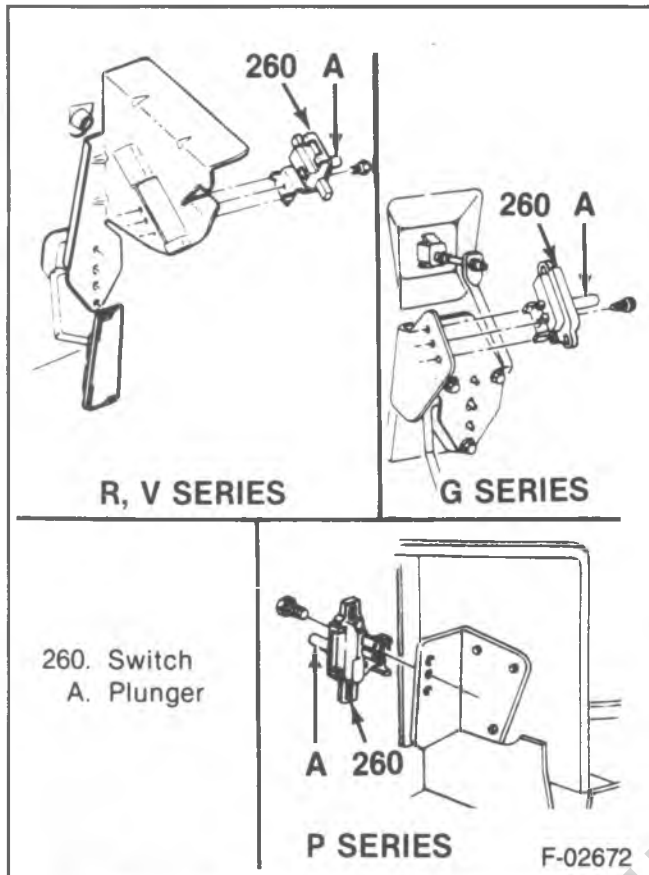

Figure 66—Detent Switch (THM 400)

↔ Install or Connect (Figure 65)

- Coat a new seal (223) with a small amount of petrolatum.
- 1. New seal (223) onto a new filter (189).
- 2. New filter (189) into the case.
- 3. Oil pan (221) and a new gasket (220).
- 4. Screws (222).

⊞ Tighten

- Screws (222) to 20 N·m (15 ft. lbs.).
- 5. New transmission fluid.
 - Lower the vehicle.
 - Fill the transmission to the proper level with DEXRON® II fluid or equivalent. Refer to "Checking and Adding Fluid" in this section.

! Important

- Do not overfill.
- 6. Check the oil pan gasket for leaks.

DETENT SWITCH (THM 400)

↔ Remove or Disconnect (Figure 66)

1. Wire connector.
2. Screw.
3. Switch (260).

↔ Install or Connect (Figure 66)

1. Switch (260).
2. Screw.

3. Wire connector.

⊞ Adjust (Figure 66)

1. Press the plunger (A) as far forward as possible.
2. Press the accelerator pedal to the floor.

VACUUM MODULATOR (THM 400)

↔ Remove or Disconnect (Figure 67)

- Raise the vehicle.
- 1. Pipe (267) from the modulator port.
 - Hose.
- 2. Vacuum modulator (178).
 - Screw and the retainer.
 - Seal.
- 3. Pipe (267) if needed.
 - Hose.
 - Note the position of the pipe and any clips.

⊞ Clean

- All parts using soapy water. Air dry.

⊞ Inspect

- Modulator and pipe for kinks, cracks and damage.
- Hoses for cracks, wear and dry rot.

↔ Install or Connect (Figure 67)

1. Pipe (267) if removed.
 - Seat the pipe against the manifold fitting.
 - The pipe must be routed in the position it was removed from.
2. Vacuum modulator (178).
 - New seal.
 - Retainer and the screw.
3. Pipe (267) onto the modulator port.

! Important

- The pipe must not be twisted or bent.
- 4. Transmission fluid if needed. Refer to "Checking and Adding Fluid" in this section.

SPEEDOMETER DRIVEN GEAR—VEHICLE SPEED SENSOR

↔ Remove or Disconnect (Figure 68)

- Apply the parking brake.
- 1. Speedometer cable (277).
- 2. Screw and the retainer.
- 3. Sleeve and the seal.
- 4. Driven gear or speed sensor (280), as used.

⊞ Inspect

- Gear teeth for nicks and burrs.
- All parts for wear and damage.

↔ Install or Connect (Figure 68)

1. Driven gear or speed sensor (280) as used.
2. New seal and the sleeve.
3. Retainer and the screw.
4. Speedometer cable (277).

7A-68 AUTOMATIC TRANSMISSION

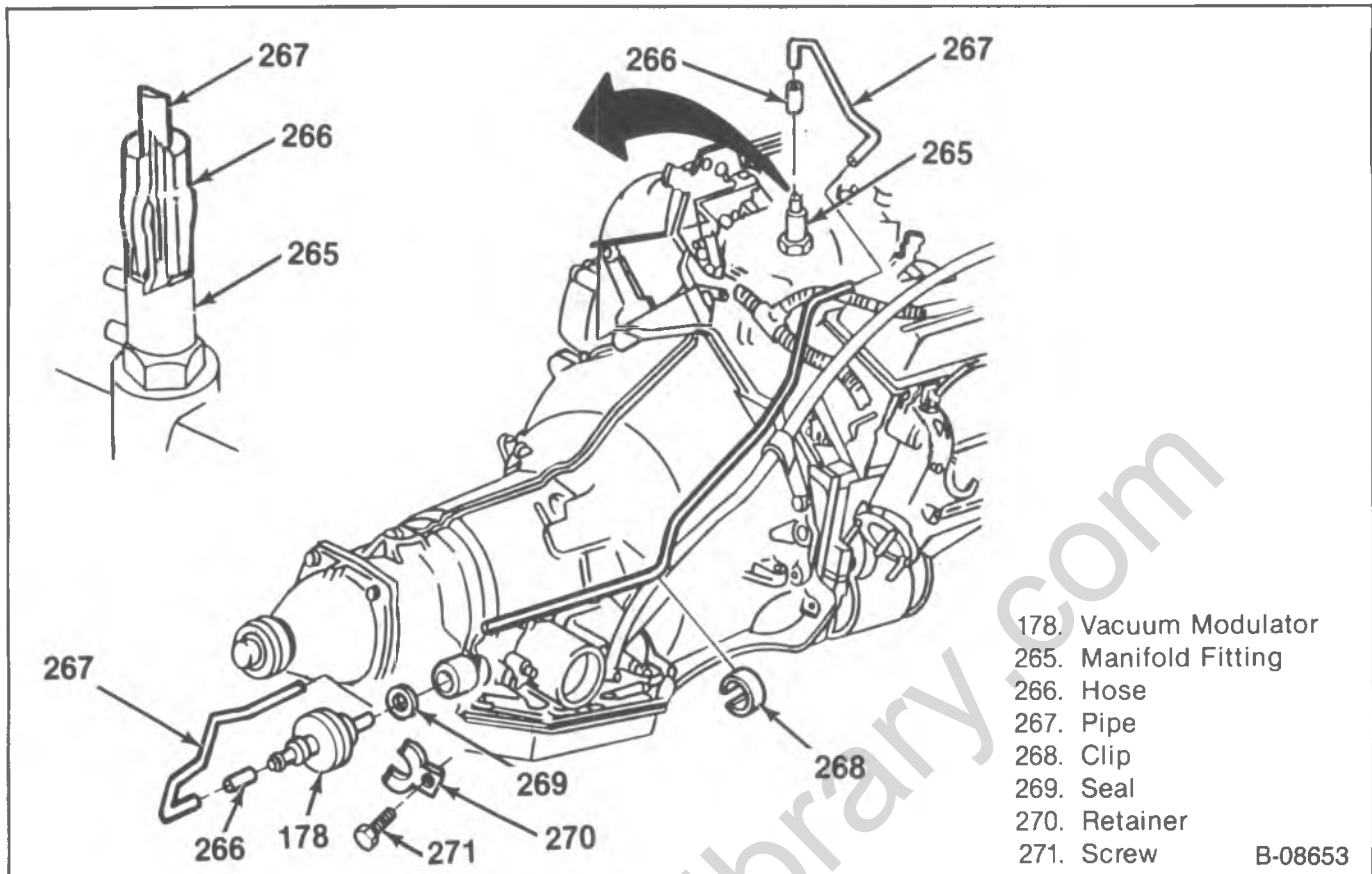

Figure 67—Vacuum Modulator (THM 400)

- Release the parking brake.
5. Transmission fluid if needed. Refer to "Checking and Adding Fluid" in this section.

GOVERNOR

↔ Remove or Disconnect (Figure 69)

- Raise the vehicle.
- Lower the transmission if needed for clearance, refer to "Transmission Replacement" in this section.

1. Governor cover (287) and the seal or gasket as used.

- THM 700-R4
 - Tap around the cover flange with a punch.
- THM 400
 - Remove the screws.

! Important

- Do not damage the governor cover. If the cover is damaged it must be replaced.

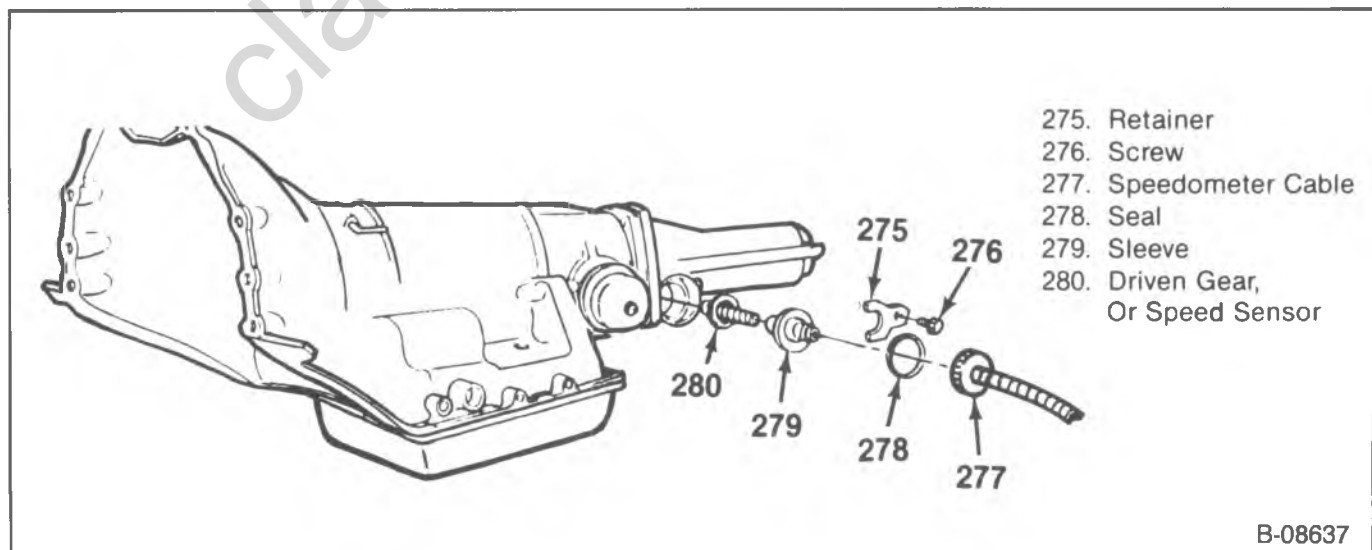

Figure 68—Speedometer Driven Gear

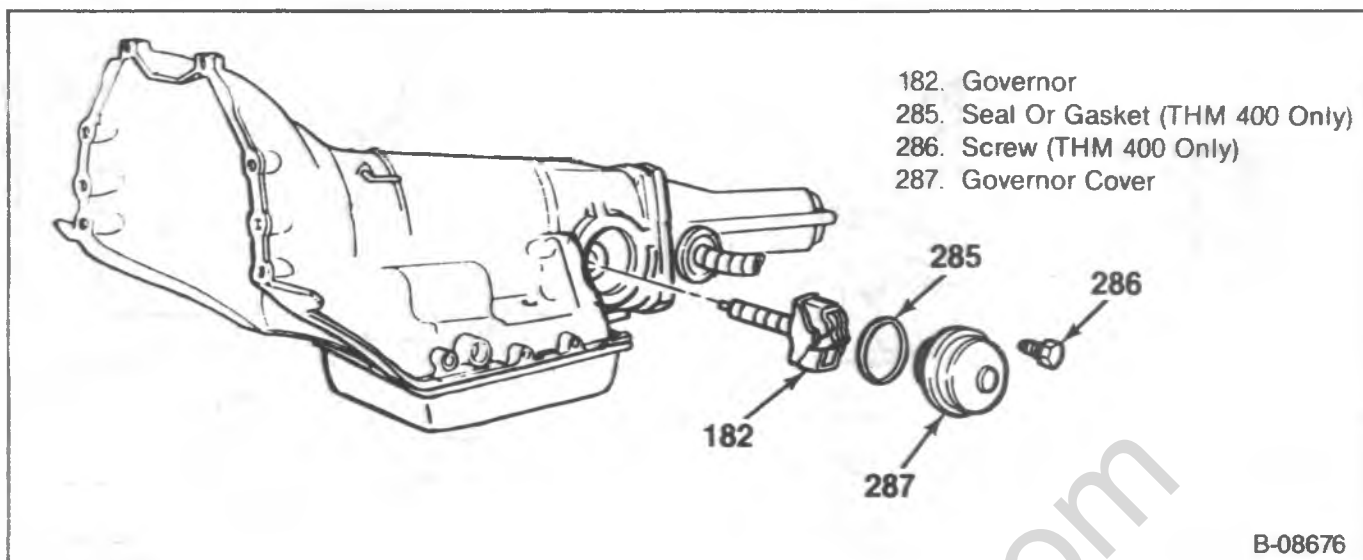

Figure 69—Governor

2. Governor (182).



Clean

- Governor using solvent. Air dry and blow out all passages using dry compressed air.



Inspect

- All parts for nicks, burrs, scoring and galling.
- Governor sleeve for binding.
- Governor valve for binding.
- Driven gear for loose fit.
- Weight springs for kinks or damage.
- Weights for binding.
- Valve entry opening. With the weights held all the way outward, the opening should be 5.1 mm (0.020 in.) (Figure 70).
- Valve exhaust opening. With the weights held all the way inward, the opening should be 5.1 mm (0.020 in.) (Figure 71).

- If the weights, sleeve, or valve do not operate freely, disassemble and clean the governor.
- If the driven gear must be replaced, the governor must be disassembled.



Important

- All the governor parts are a select fit. Except for the driven gear, the governor must be replaced as an assembly if repair is needed.



Disassemble (Figures 72 and 73)

1. Remove the governor weight pins (310).
 - Cut off one end of each pin to remove them.
2. Remove the thrust cap (317), the weights (315 and 316) and the springs (314).
3. Remove the valve (311) from the sleeve.
4. Remove the driven gear, if needed.
 - Drive out the retaining pin using a punch or 1/8 in. drill.

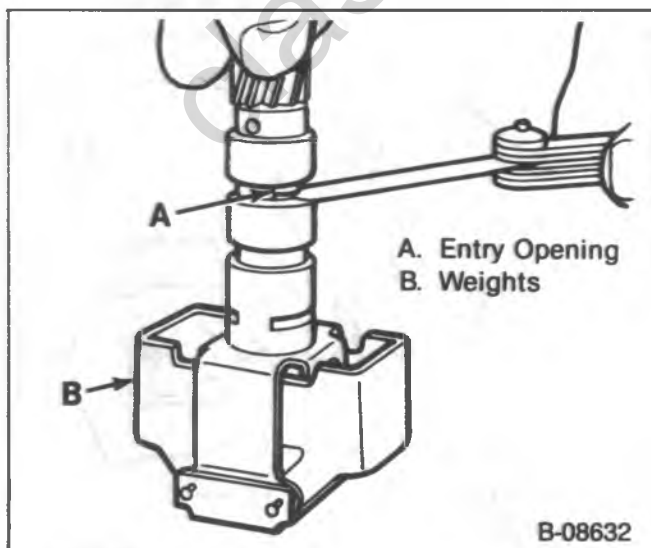

Figure 70—Measuring the Governor Valve Entry Opening

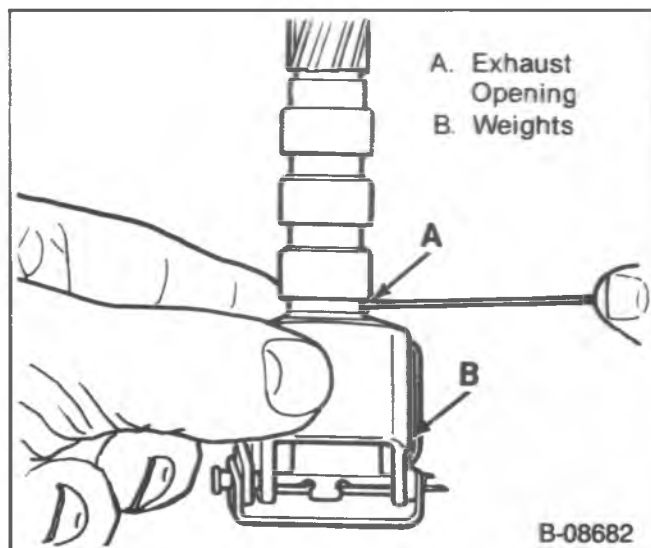

Figure 71—Measuring the Governor Valve Exhaust Opening

7A-70 AUTOMATIC TRANSMISSION

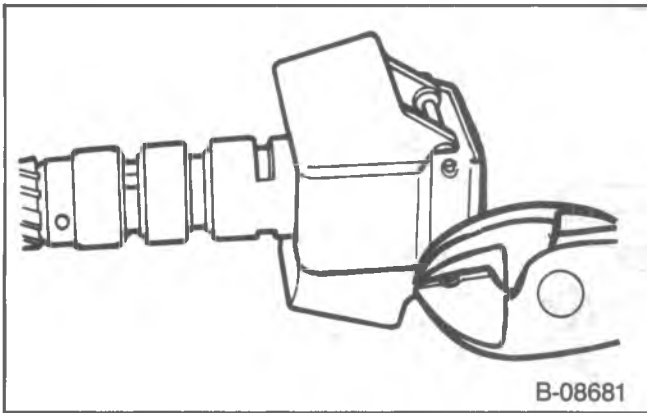
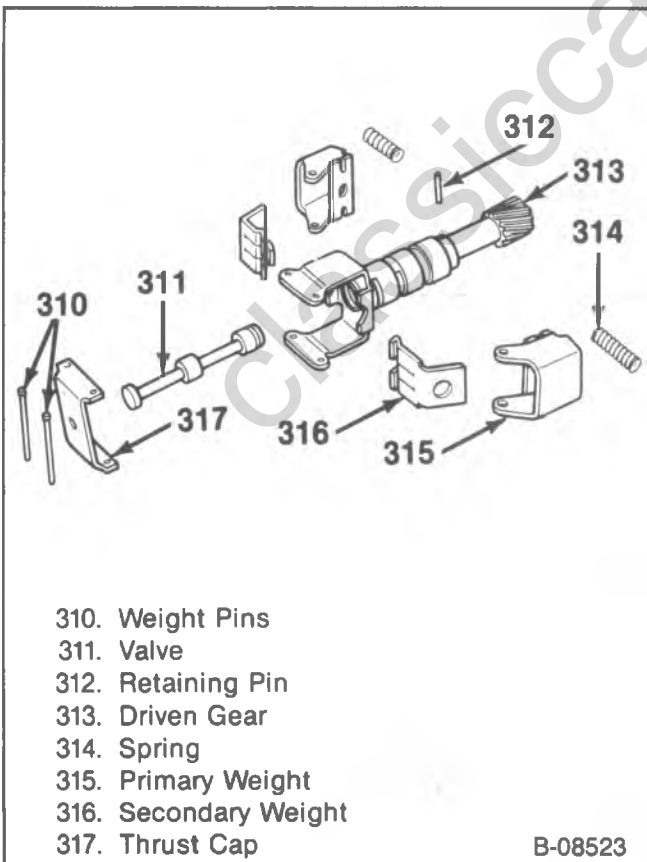

Figure 72—Removing the Governor Weight Pins

- Press the gear out of the sleeve using a punch, with the gear supported in a press with two 2.778 mm ($7/64$ in.) plates in the exhaust slots.
5. Clean the governor parts and inspect for damage.

Assemble (Figures 73, 74 and 75)

1. New driven gear into the sleeve, if needed.
 - Press the gear in until it is almost seated using a socket with the governor supported in a press with two 2.778 mm ($7/64$ in.) plates in the exhaust slots.
 - Remove any shavings from the gear hub and press the gear in until it is seated.
 - Drill a new pin hole 90° from the old one using a $1/8$ in. drill in a press.



310. Weight Pins
 311. Valve
 312. Retaining Pin
 313. Driven Gear
 314. Spring
 315. Primary Weight
 316. Secondary Weight
 317. Thrust Cap

Figure 73—Governor Components

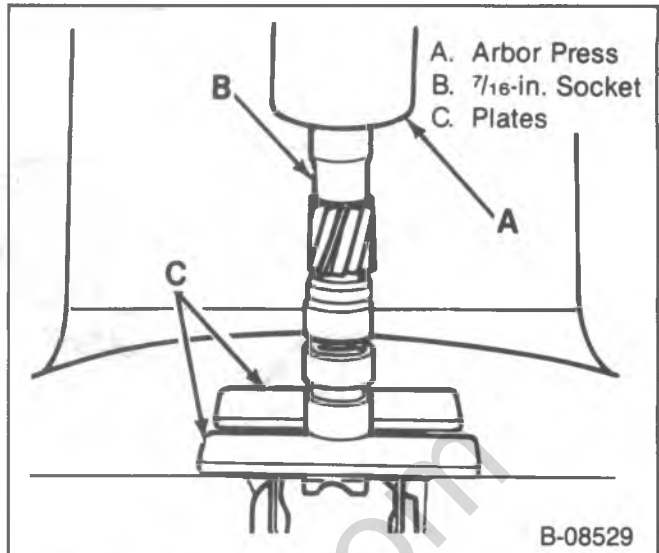

Figure 74—Installing the Driven Gear

- New retaining pin through the new pin hole so the ends are just below the top of the hole.
 - Stake both ends of the pin hole in two places, and wash the governor.
2. Valve (311) into the sleeve.
 3. Springs (314), the weights (315 and 316) and the thrust cap (317) onto the governor, aligning the pin holes.
 4. New weight pins (310) and crimp both ends of each pin.

Install or Connect (Figure 69)

1. Governor (182).
2. Governor cover (287) and a new seal or gasket as used.
 - THM 700-R4.
 - Put a thin coat of Loctite Cup Plug Sealant II, or equivalent, on the cover.
 - Tap the cover into place using a brass drift.
 - THM 400.
 - Screws.
- Raise the transmission if needed. Refer to "Transmission Replacement" in this section.

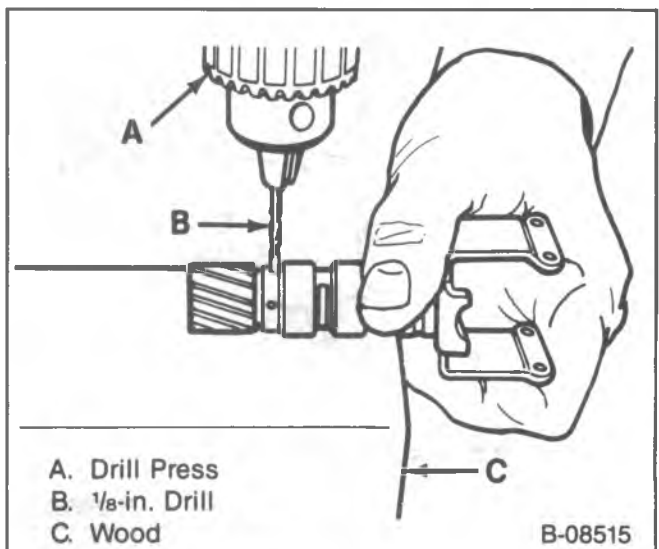

Figure 75—Drilling the Driven Gear

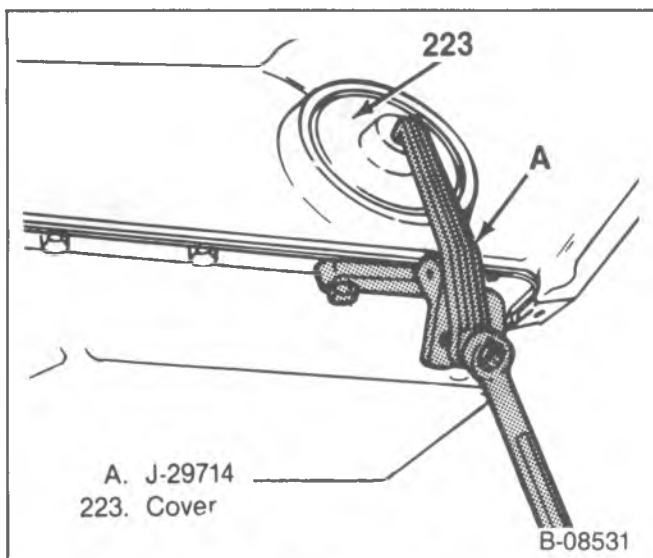

Figure 76—Removing the Servo Cover (THM 700-R4)

- Lower the vehicle.
3. Transmission fluid if needed. Refer to "Checking and Adding Fluid" in this section.

2-4 SERVO (THM 700-R4)

↔ Remove or Disconnect (Figures 76 and 77)

Tool Required:
J-29714 Servo Cover Compressor.

- Raise the vehicle.
 - Lower the transmission if needed for clearance. Refer to "Transmission Replacement" in this section.
1. Retaining ring and the cover (223) using J-29714.
 2. Seal from the cover.
 3. 4th apply piston (224).
 4. 2nd apply piston assembly (301).
 5. Spring (239).

⊠ Disassemble (Figures 78 and 79)

Tool Required:
J-22269-01 Piston Compressor.

1. Housing (230) from the piston (233).
 - Seal from the housing.
2. Retainer ring from the pin (237).
 - Washer and the spring.
3. Pin (237).
 - Seals from the pin.
4. Retainer ring from the piston (233) using J-22269-01.
 - Retainer and the spring.
 - Seals from the piston.

🧼 Clean

- All parts using solvent. Air dry.

👁 Inspect

- Pistons for porosity and damage.
- Seal grooves for damage.
- Cover for porosity and damage.
- Seals for nicks and cuts and binding in the seal grooves.

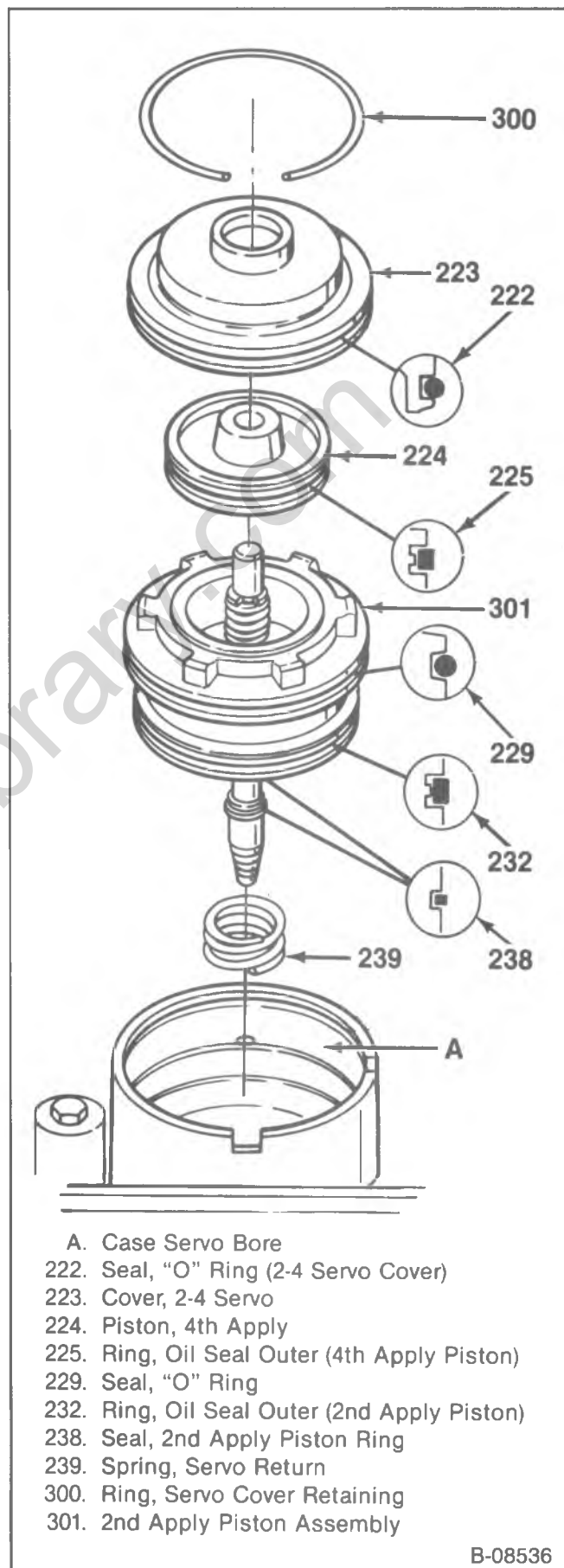

- A. Case Servo Bore
- 222. Seal, "O" Ring (2-4 Servo Cover)
- 223. Cover, 2-4 Servo
- 224. Piston, 4th Apply
- 225. Ring, Oil Seal Outer (4th Apply Piston)
- 229. Seal, "O" Ring
- 232. Ring, Oil Seal Outer (2nd Apply Piston)
- 238. Seal, 2nd Apply Piston Ring
- 239. Spring, Servo Return
- 300. Ring, Servo Cover Retaining
- 301. 2nd Apply Piston Assembly

B-08536

Figure 77—2-4 Servo (THM 700-R4)

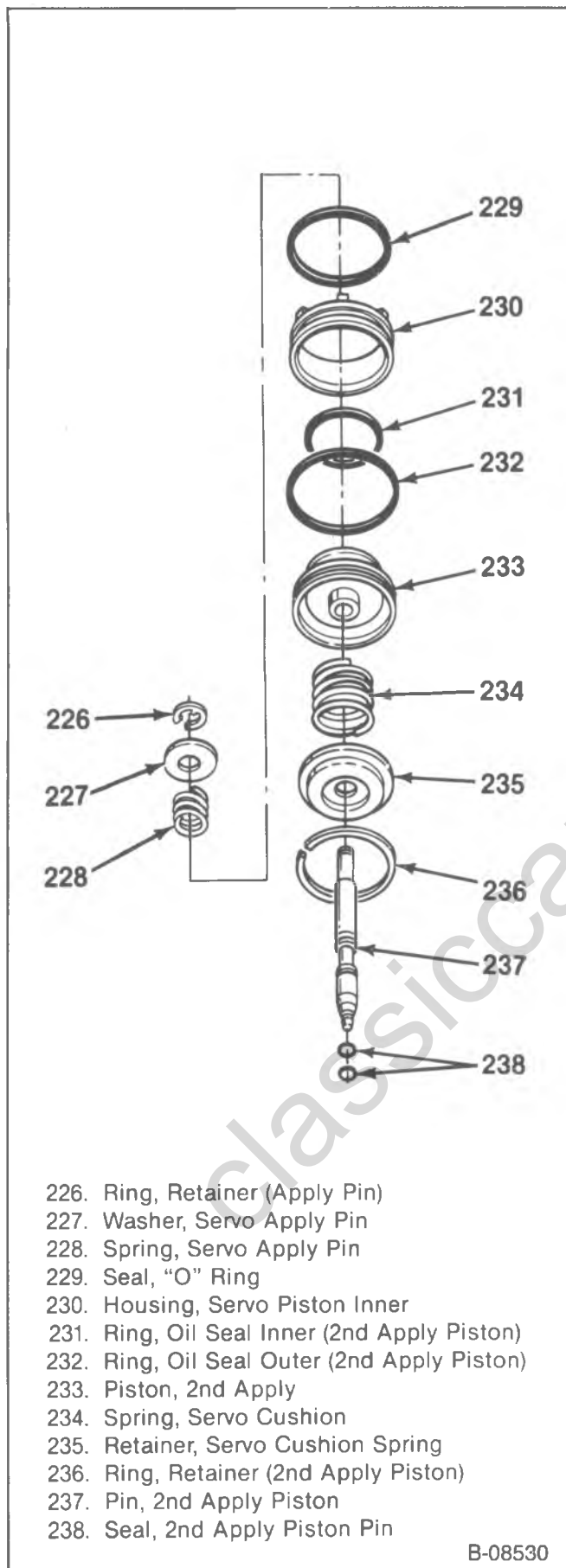

- 226. Ring, Retainer (Apply Pin)
- 227. Washer, Servo Apply Pin
- 228. Spring, Servo Apply Pin
- 229. Seal, "O" Ring
- 230. Housing, Servo Piston Inner
- 231. Ring, Oil Seal Inner (2nd Apply Piston)
- 232. Ring, Oil Seal Outer (2nd Apply Piston)
- 233. Piston, 2nd Apply
- 234. Spring, Servo Cushion
- 235. Retainer, Servo Cushion Spring
- 236. Ring, Retainer (2nd Apply Piston)
- 237. Pin, 2nd Apply Piston
- 238. Seal, 2nd Apply Piston Pin

B-08530

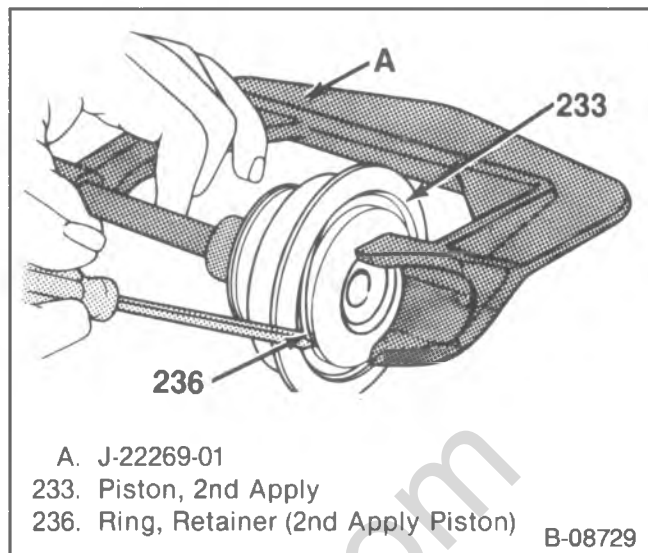

- A. J-22269-01
 - 233. Piston, 2nd Apply
 - 236. Ring, Retainer (2nd Apply Piston)
- B-08729

Figure 79—Removing the Retainer Pin (THM 700-R4)

— If damage is found, check for the cause of the damage.

- Springs for kinks and bending.
- Pin for wear and burrs.

! Important

- Check the case servo bore for damage and sharp edges.

📏 Measure (Figures 80 and 81)

Tools Required:

- J-33037 Band Apply Pin Tool
- Vernier calipers or micrometer

1. Servo pin length (Figure 80).
 - Install pin and J-33037 as shown.
 - Apply 11.0 N·m (110 in. lbs.) torque and check the gage slot (A).
 - If the white line is seen in the slot, the pin is correct.
 - If the white line is not seen in the slot, replace the pin using the chart.
 - Remove the pin and J-33037.
2. Piston and housing dimension (figure 81).
 - Measure the piston dimension (C).
 - Measure the housing dimension (D).
 - Check the chart for the proper dimensions.

⚙ Assemble (Figures 78 and 79)

Tool Required:

- J-22269-01 Piston Compressor

1. Retainer and the spring in the piston (233).
 - New seals on the piston.
 - Retainer ring using J-22269-01.
2. Pin (237).
 - New seals on the pin.
3. Retainer ring on the pin.
 - Spring and the washer.
4. Housing (230) on the piston (233).
 - New seal on the housing.

Figure 78—2nd Apply Piston Assembly (THM 700-R4)

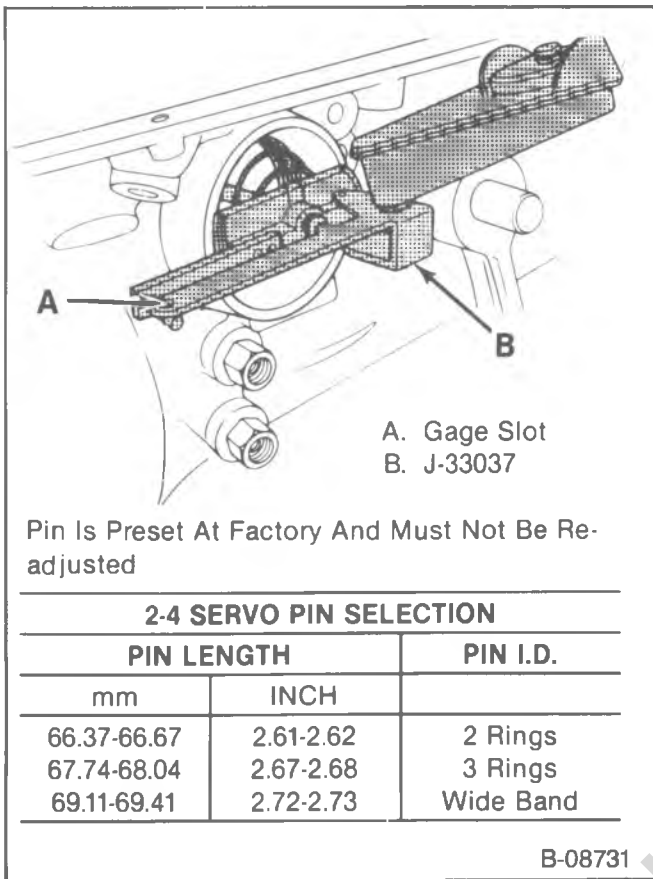

Figure 80—Measuring the Servo Pin Length (THM 700-R4)

! Important

- Be sure the proper seals are in the proper positions (Figure 77).

↔ Install or Connect (Figures 76 and 77).

Tool Required:

J-29714 Servo Cover Compressor

1. Spring (239).
2. 2nd apply piston assembly (301).
3. 4th apply piston (224).
4. New seal on the cover.
5. Cover (223) and the retaining ring using J-29714.
 - Raise the transmission if needed. Refer to "Transmission Replacement" in this section.
 - Lower the vehicle.
6. Transmission fluid if needed. Refer to "Checking and Adding Fluid" in this section.

REAR EXTENSION OIL SEAL

↔ Remove or Disconnect (Figure 82)

- Raise the vehicle.
1. Transmission fluid.
 2. Propeller shaft. Refer to PROPELLER SHAFT (SEC. 4A).
 3. Seal.

2ND APPLY PISTON & HOUSING APPLICATION

MODEL	PISTON DIMENSION *A	HOUSING DIMENSION **B
YT, Y6, YK	63.10 mm (2.48")	64.00 mm (2.52")
YC, YX	44.64 mm (1.78")	45.54 mm (1.79")
ALL OTHERS	57.85 mm (2.28")	58.74 mm (2.31")

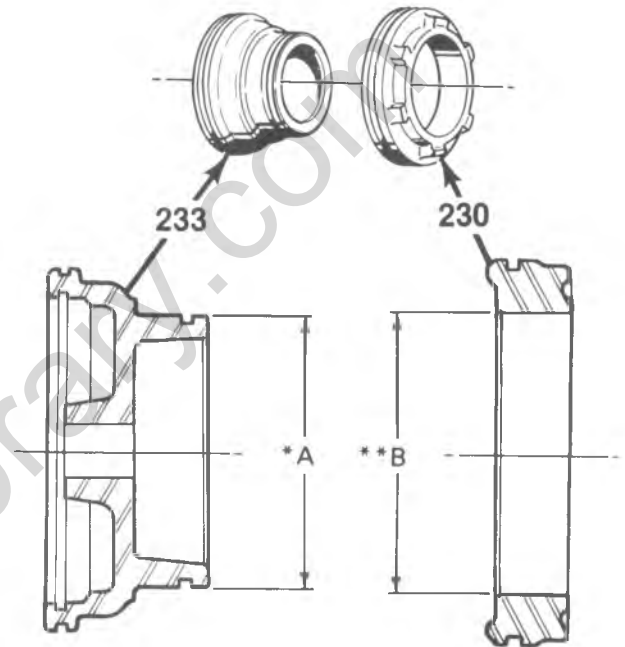

- 230. Housing, Servo Piston (Inner)
- 233. Piston, 2nd Apply

B-08730

Figure 81—2nd Apply Piston and Housing Dimensions (THM 700-R4)

↔ Install or Connect (Figure 82)

Tool Required:

J-21426 Extension Housing Oil Seal Installer (THM 700-R4)

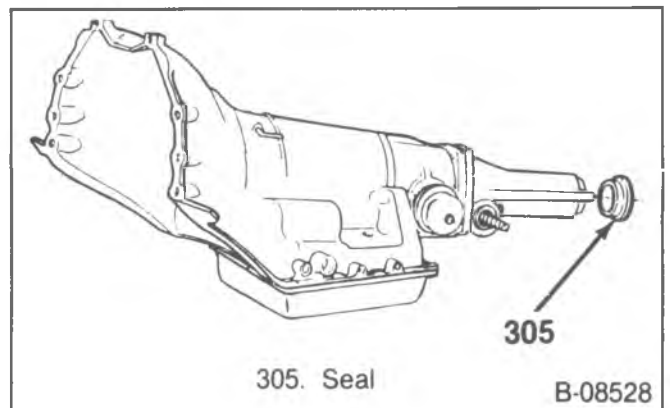

Figure 82—Rear Extension Oil Seal

J-24057 Extension Housing and Pump Oil Seal Installer (THM 400)

1. New seal using J-21426 or J-24057 as needed.
 - Coat the outer edge of the seal case with a non hardening sealer.
2. Propeller shaft. Refer to PROPELLER SHAFT (SEC. 4A).
 - Lower the vehicle.
3. New transmission fluid. Refer to "Specifications" for the proper amount.

TRANSMISSION REPLACEMENT

If the transmission is being lowered for clearance, do steps 1-8 only.

Remove or Disconnect (Figure 83)

Tool Required:

J-21366 Converter Holding Strap

1. Negative battery cable.
2. Air cleaner, and the TV cable from the throttle linkage, if the transmission is being removed.
 - Raise the vehicle.
3. Transmission fluid.
4. Shift linkage.
5. Propeller shaft, refer to PROPELLER SHAFT (SEC. 4A).
 - Front propeller shaft, if used, from the transfer case.
6. The support bracket at the catalytic converter.
 - Any other components as needed for clearance.
 - Support the transmission, and the transfer case, if used, with a transmission jack.
7. Transmission crossmember.

Important

- Do not stretch or damage any cables, wires or other components when lowering the transmission.
8. Transmission far enough for clearance to reach other components.
 9. Dipstick tube (221) and the seal.
 - Cover the opening in the transmission.
 10. Speedometer cable.
 11. Vacuum modulator line, if used.
 12. Electrical connectors from the transmission.
 13. Cooler lines (223).
 - Cap all openings in the transmission and the lines.
 14. Transfer case shifter and move it aside, refer to TRANSFER CASE (SEC. 7D).
 15. Dampener and the support, if used.
 16. Transmission support braces (222).
 - Note the location of the braces, they must be installed in the same positions.
 17. Converter housing cover (228).
 - Mark the flywheel and the torque converter alignment.
 18. Screws (230).

Important

- Support the engine with a jack or hoist before disconnecting the transmission.

19. Screws (226).
 - Note the location of any brackets or clips and move them aside.
 - Slide the transmission straight back off the locating pins (A) and install J-21366.
20. Transmission (225) from the vehicle.



Clean

- Transmission case using a solvent dampened cloth, do not allow solvent to enter the transmission. Air dry.
- All hardware and flywheel cover using solvent. Air dry.



Inspect

- All parts for wear and damage.
- All seals and fittings for signs of leakage.
- Torque converter for stripped or broken weld nuts or screw holes.
- Transmission case for porosity.



Install or Connect (Figure 83)

Tool Required:

J-21366 Converter Holding Strap

- If the transmission was lowered for clearance only, do steps 13-20.
1. Transmission (225).
 - Be sure the torque converter is seated properly and that J-21366 is in place.
 - Support the transmission, and the transfer case if used, with a transmission jack.
 - Raise the transmission into place and remove J-21366.
 - Slide the transmission straight onto the locating pins (A) while lining up the marks on the flywheel and the torque converter.



Important

- The torque converter must be flush onto the flywheel and rotate freely by hand.
2. Screws (226).
 - All brackets, clips and harnesses must be in the positions they were removed from.
 - Do not install the dipstick tube or the transmission support brace screws.
 3. Screws (230).



Tighten

- Screws finger tight to insure proper converter seating.
 - Screws to 65 N·m (50 ft. lbs.).
 - Remove the engine hoist or jack.
4. Converter housing cover (228).
 - Hook the cover under the lip of the engine oil pan.
 5. The support and dampener, if used.
 6. Transmission support braces (222).
 - The braces must be installed in the positions they were removed from.
 7. Transfer case shifter, refer to TRANSFER CASE (SEC. 7D).

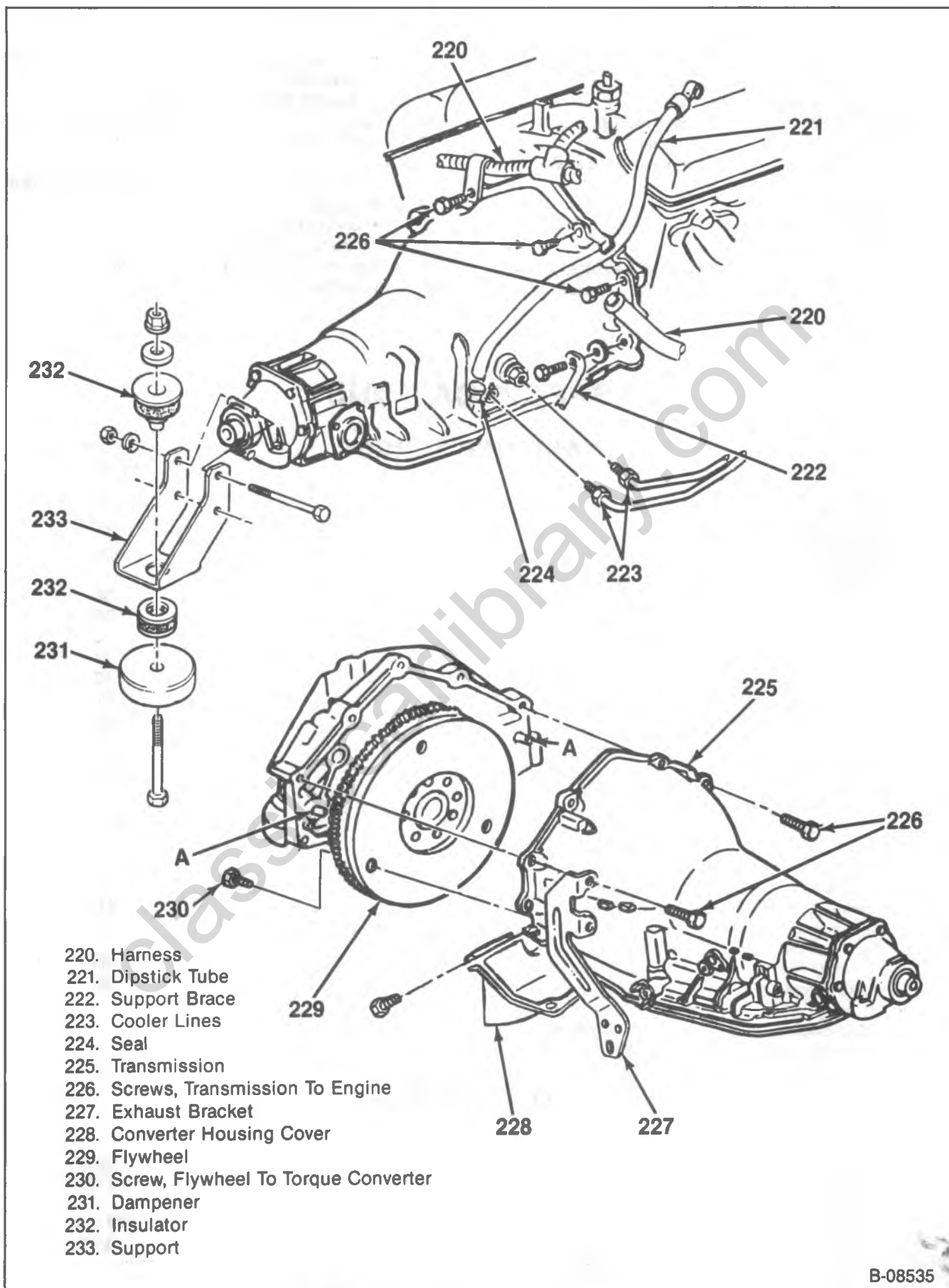



Figure 83—Transmission and Components (Typical)

7A-76 AUTOMATIC TRANSMISSION

8. Cooler lines (223).
 - Uncover the openings.
 - Do not twist or bend the lines.
9. Vacuum modulator line, if used.
10. Speedometer cable.
11. Electrical connectors to the transmission.
12. Dipstick tube (221) with a new seal.
 - Uncover the opening and install the seal first.
 - Screw (226).
13. Transmission into place.

Important

 - Do not pinch or damage any cables, wires or other components when raising the transmission.
14. Transmission crossmember and the transmission mount.
 - Any components that were removed for clearance.
 - Remove the transmission jack.
15. The support bracket at the catalytic converter.
16. Propeller shaft, refer to PROPELLER SHAFT (SEC. 4A).
 - Front propeller shaft to the transfer case, if used.
17. Shift linkage.
 - Lower the vehicle.
18. New transmission fluid.
19. Air cleaner, and the TV cable, if removed.
20. Negative battery cable.

SPECIFICATIONS

FASTENER TORQUE

	N·m	Ft. Lbs.
Shift Linkage	25	19
TV Cable	10	7
Cooler Lines to Transmission	22	16
Cooler Lines to Radiator	27	20
Dipstick Tube to Alternator Bracket (G models)		
—Except with LBI Engine	43	32
—With LBI Engine	3.5	2.5
Transmission Support Braces		
—R and V Models	95	70
—G Models (to Engine)	57	42
(to Transmission)	37	27
Dampener Support	41	30
Dampener to Support	87	65
Converter Housing Cover		
—R and G Models Except with LBI Engine	10	7
With LBI Engine	35	25
—V Models		
Except 30/3500 with L25 Engine	35	25
30/3500 with L25 Engine	10	7
—P Models	10	7
Transmission to Engine	47	34.5
Converter to Flywheel	65	50
Crossmember to Frame		
—R, G and P Models	85	63
—V Models	70	52

Note:

- LBI Engine - 4.3L (262 CID V6) Carbureted
- L25 Engine - 4.8L (292 CID L6)

LUBRICATION

Capacity

—Pan Removal		
THM 400	4 l.	9 pts.
THM 700-R4	4.7 l.	10 pts.
—Overhaul		
THM 400	10 l.	22 pts.
THM 700-R4	10.9 l.	23 pts.

Type Recommended DEXRON® II or equivalent

Note: DO NOT OVERFILL. Refer to "Checking And Adding Fluid" in this section.

SPECIAL TOOLS



J-21366

4. 

J-24057



J-21426

5. 

J-29714



J-22269-01

6. 

J-33037

- 1. Converter Holding Strap
- 2. Extension Housing Oil Seal Installer (THM 700-R4)
- 3. Piston Compressor (THM 700-R4)
- 4. Extension Housing Oil Seal Installer (THM 400)
- 5. Servo Cover Compressor (THM 700-R4)
- 6. Band Apply Pin Tool (THM 700-R4)

F-02673

classiccarlibrary.com

SECTION 7B

MANUAL TRANSMISSION

CONTENTS

<u>SUBJECT</u>	<u>PAGE</u>
Description	7B- 1
Inspection	7B- 1
Control Linkages	7B- 1
Transmission Shift Effort	7B- 2
Diagnosis of Manual Transmission	7B- 2
On Vehicle Service	7B- 3
Drian and Fill	7B- 3
Rear Oil Seal	7B- 3
Speedometer Driven Gear	7B- 3
Shift Linkage	7B- 5
Shift Linkage Adjustment	7B- 6
Shift Control	7B- 7
Side Cover	7B- 8
Transmission Replacement	7B-10
Specifications	7B-11
Fastener Torque	7B-11
Lubrication	7B-11
Special Tools	7B-12

DESCRIPTION

Manual transmissions are identified by: (A) the number of forward gears, and (B) the measured distance between centerlines of the mainshaft and the countergear.

3-SPEED 76MM

The three speed Muncie 76mm transmissions (RPO's M62 and M64) are in constant mesh and fully synchronized in all forward speeds with two sliding synchronizer sleeves.

Gearshift levers are either a floor-type or a steering column-type shift lever.

4-SPEED O.D. 89MM

The four speed New Process 89mm transmission (RPO MY6) is an overdrive unit and is fully synchronized in all forward speeds.

The countershaft is not a press fit and is sealed in the front of the case with an expansion plug.

Gear shifting is done with a floor mounted shift control.

4-SPEED 117MM

The four speed Muncie 117mm transmission (RPO M20) uses a constant mesh first gear and synchronized second, third and fourth gears.

Gear shifting is done with a transmission cover mounted shift lever. The cover has a ball pin type interlock which stops the transmission from being shifted into two gears at one time.

INSPECTION

- Before repairing the transmission, check the clutch and shifting linkages to be sure the problem is in the transmission.
- If a hydraulic clutch is used, there are no adjustments for linkage or clutch pedal.
- 3. Check the shift linkage for worn swivels, mounting brackets or damaged cordon shaft.
- 4. Check the shift linkage adjustment and adjust as necessary.

CONTROL LINKAGES

1. Check the clutch and shift linkage for dirt, wear, or damage.
2. Check clutch free pedal travel adjustment and adjust as necessary. Refer to CLUTCH (SEC. 7C).

STEERING COLUMN SHIFT CONTROL

1. Remove the shift control rods from the column levers.
2. Check shift effort at the shift control lever knob.
3. If the effort is more than 9 N (2 lb.), adjust the steering column lower bearing. Refer to STEERING (SEC. 4B).
4. Lubricate all rod and swivel connections and recheck shift effort.

7B-2 MANUAL TRANSMISSION

5. If shift linkage is free from binding, check for 0.13mm (0.005 in.) end play between the column levers and control lever.
6. Connect the control rods and check the steering column control levers for alignment. In neutral, the column control lever tangs should line up with the slot in the relay lever.

CLUTCH SPIN DOWN TIME

1. Run the engine at a normal idle with the transmission in neutral and the clutch engaged.
2. Disengage the clutch, wait nine seconds and shift the transmission into reverse.
3. If a grinding noise is heard, check the clutch for the problem. Refer to CLUTCH (SEC. 7C).

TRANSMISSION SHIFT EFFORT

1. Remove the shift rods at the transmission.
2. Line up the problem gear by shifting into the gear and back to neutral.
3. Check the effort needed to shift into the problem gear using a torque wrench.
4. If the shift effort is more than 5 N·m (50 in. lbs.) and the shift lever shaft is clean and not damaged, add an anti-chatter lubricant, (positraction additive) to the transmission.
5. If the shift effort is still high, repair the transmission as needed.

DIAGNOSIS OF MANUAL TRANSMISSION

The following diagnosis information is to be used only as a guide to locating a transmission problem.

PROBLEM	POSSIBLE CAUSE	CORRECTION
Leaks Lubricant	<ol style="list-style-type: none"> 1. Lubricant level too high. 2. Main drive bearing retainer or gasket loose or damaged. 3. Side cover or gasket loose or damaged. 4. Rear extension seal damaged. 5. Countershaft loose in case. 	<ol style="list-style-type: none"> 1. Drain to correct level. 2. Tighten or replace. 3. Tighten or replace. 4. Replace. 5. Replace case.
Hard Shifting, Column Shift — Refer to "Transmission Shift Effort" 7B-2	<ol style="list-style-type: none"> 1. Levers binding — dirty or damaged. 2. Lever end play more than 0.13mm (0.005 in.). 	<ol style="list-style-type: none"> 1. Clean and lubricate or replace. 2. Adjust. Refer to STEERING COLUMN (SEC. 3B4).
Noisy Shifting	<ol style="list-style-type: none"> 1. Shift linkage out of adjustment or damaged. 2. Clutch linkage out of adjustment or damaged. 3. Synchronizers or gears worn or damaged. 	<ol style="list-style-type: none"> 1. Adjust or replace. 2. Adjust or replace. Refer to CLUTCH (SEC. 7C). 3. Repair the transmission.
Noisy Neutral	<ol style="list-style-type: none"> 1. Shift linkage out of adjustment or damaged. 2. Pilot bearing worn or damaged. 3. Main drive gear or countergear bearings worn or damaged. 	<ol style="list-style-type: none"> 1. Adjust or replace. 2. Replace. Refer to CLUTCH (SEC. 7C). 3. Repair the transmission.
Noisy Operation	<ol style="list-style-type: none"> 1. Lubricant level low. 2. Shift linkage damaged. 3. Synchronizers worn or damaged. 4. Bearings worn or damaged. 5. Gears worn or damaged. 	<ol style="list-style-type: none"> 1. Fill to correct level. 2. Replace. 3. Repair the transmission. 4. Repair the transmission. 5. Repair the transmission.
Slips Out Of Gear	<ol style="list-style-type: none"> 1. Shift lever seal stiff. 2. Shift linkage out of adjustment or binding. 3. Pilot bearing loose or damaged. 4. Dirt between the clutch housing and transmission. 5. Transmission loose. 6. Main drive gear retainer loose or damaged. 7. Transmission not aligned. 	<ol style="list-style-type: none"> 1. Replace. 2. Adjust or replace. 3. Replace. Refer to CLUTCH (SEC. 7C). 4. Clean the mating surfaces. 5. Tighten. 6. Tighten or replace. 7. Align.

ON VEHICLE SERVICE

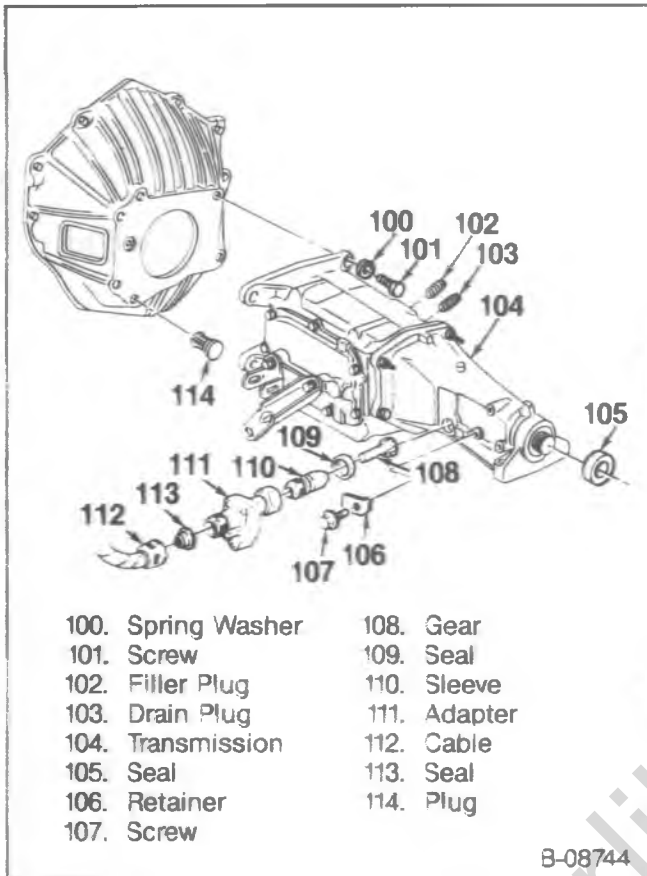

Figure 1—Transmission and Components (3 Speed/
4 Speed O.D. — Typical)

DRAIN AND FILL

Remove or Disconnect (Figures 1 and 2)

1. The filler plug (102).
2. The drain plug (103).
3. Transmission oil.
 - Catch the oil in a pan.

Install or Connect (Figures 1 and 2)

1. The drain plug (103).
2. New transmission oil.
 - Fill to the level of the filler plug hole. Refer to "Lubrication" in this section.
3. The filler plug (102).

REAR OIL SEAL

REAR EXTENSION SEAL (3 SPEED AND 4 SPEED O.D.)

Remove or Disconnect (Figure 1)

- Raise the vehicle.
1. Transmission oil.
 2. Propeller shaft. Refer to PROPELLER SHAFT (SEC. 4A).
 3. Seal (105).

Install or Connect (Figure 1)

Tool Required:

J-21426, Rear Extension Seal Installer.

1. Locking compound on the outside of a new seal (105).
2. New seal (105), use J-21426 (figure 3).
 - Fill between the seal lips with chassis grease.
3. Propeller shaft. Refer to PROPELLER SHAFT (SEC. 4A).
4. New transmission oil. Refer to "Drain and Fill" in this section.
 - Lower the vehicle.

REAR RETAINER SEAL (4 SPEED)

Remove or Disconnect (Figure 2)

- Raise the vehicle.
1. Transmission oil.
 2. Propeller shaft. Refer to PROPELLER SHAFT (SEC. 4A).
 3. Parking brake if used. Refer to BRAKES (SEC. 5).
 4. Speedometer cable (112) and the seal (113).
 5. Nut (123) and the flange (122).
 6. Transmission mount.
 - Support the transmission with jack.
 7. Screws (125) and the retainer (121).
 8. Gasket (120).
 - Scrape all gasket material from the retainer and the case.
 9. Seal (105).

Install or Connect (Figure 2)

Tool Required:

J-22834, Rear Retainer Seal Installer

1. Locking compound on the outside of a new seal (105).
2. New seal (105), use J-22834-2 (figure 4).
 - Use J-22834-1 if a parking brake is used.
 - Fill between the seal lips with chassis grease.
3. New gasket (120).
4. Retainer (121) and the screws (125).
5. Transmission mount.
 - Remove the jack.
6. Flange (122) and the nut (123).
7. New seal (113) and the speedometer cable (112).
8. Parking brake if used. Refer to BRAKES (SEC. 5).
9. Propeller shaft. Refer to PROPELLER SHAFT (SEC. 4A).
10. New transmission oil. Refer to "Drain and Fill" in this section.
 - Lower the vehicle.

SPEEDOMETER DRIVEN GEAR

Remove or Disconnect (Figures 1 and 2)

- Raise the vehicle.
1. Speedometer cable (112) and the seal (113).
 2. Adapter (111) if used.
 3. Retainer (106) and the screw (107) if used.
 4. Sleeve (110).

7B-4 MANUAL TRANSMISSION

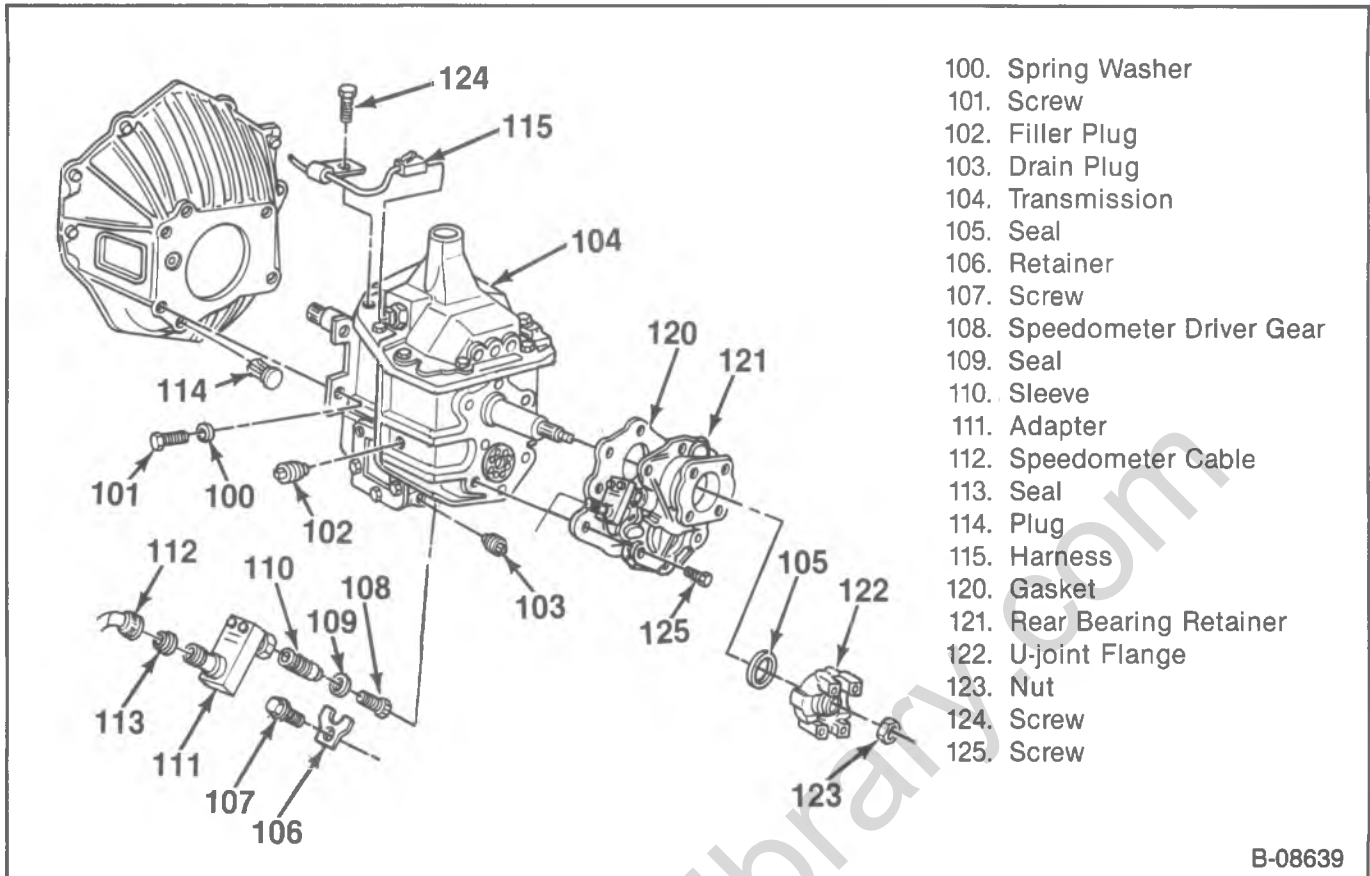

Figure 2—Transmission and Components (4 Speed)

- 5. Seal (109).
- 6. Gear (108).

Install or Connect (Figures 1 and 2)

- Put a thin coat of transmission oil on the gear and the seal.
- 1. Gear (108).
- 2. New seal (109) onto the sleeve (110).
- 3. Sleeve (110).
- 4. Retainer (106) and the screw (107) if used.

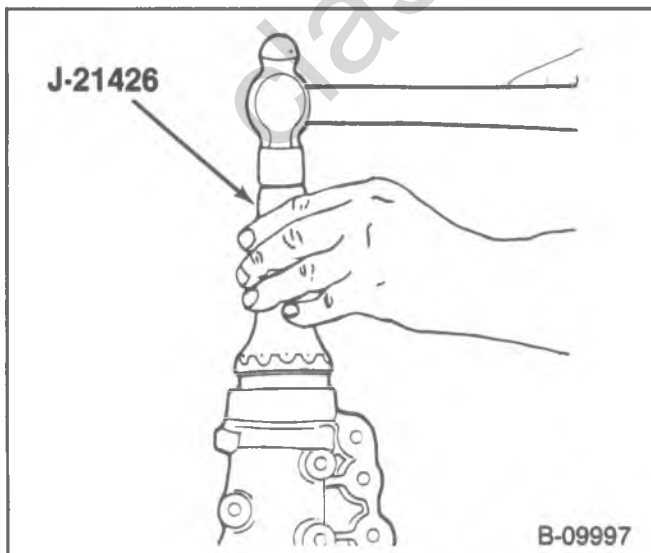

Figure 3—Rear Extension Seal Installation (3 Speed/4 Speed O.D.)

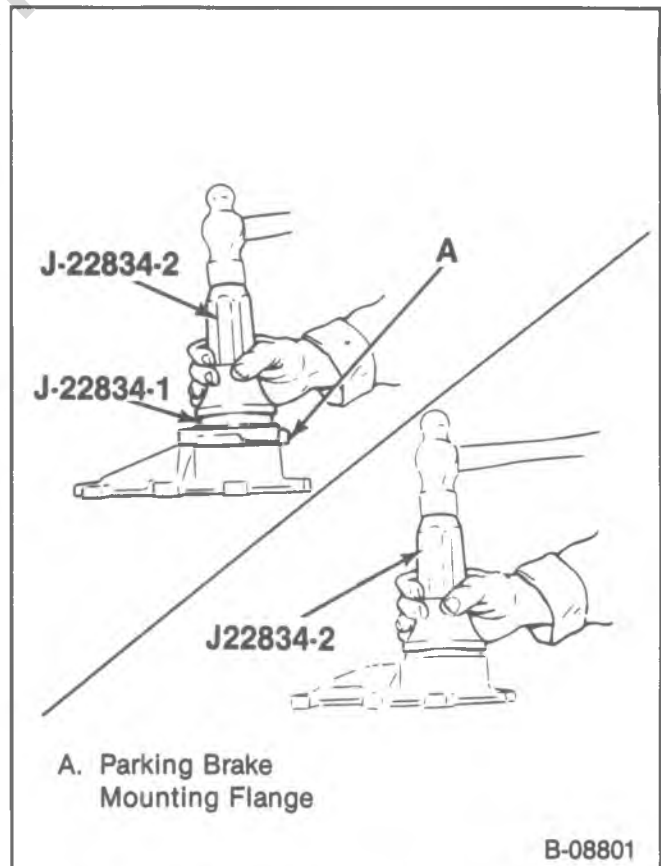
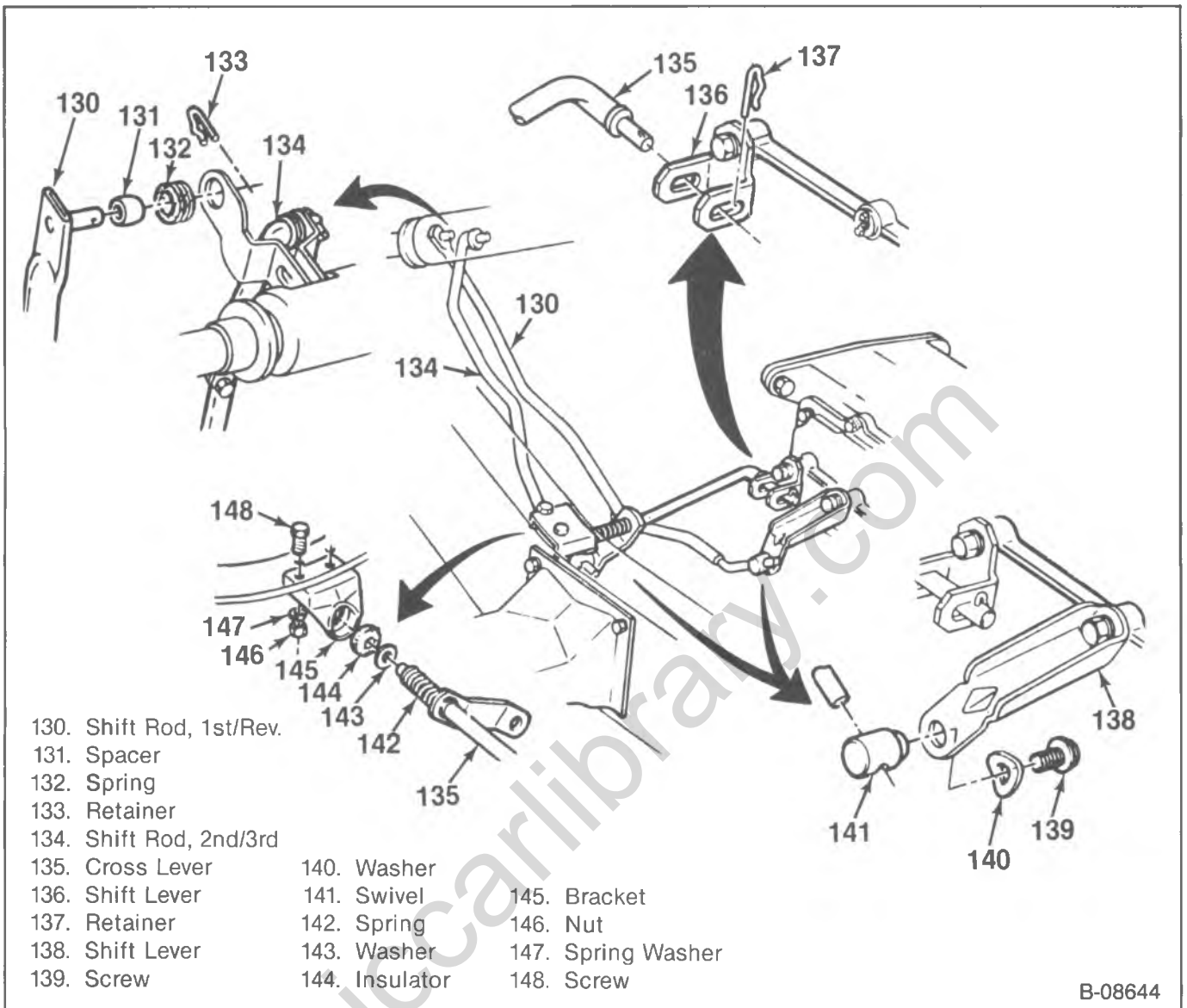

Figure 4—Retainer Seal Installation (4 Speed)



B-08644

Figure 5—Column Shift Linkage

5. Adapter (111) if used.
6. New seal (113) and the speedometer cable (112).
 - Lower the vehicle.

11. Cross lever (135).

Install or Connect (Figure 5)

- Put a thin coat of grease on the insulator.
1. Cross lever (135).

SHIFT LINKAGE

STEERING COLUMN LINKAGE

Remove or Disconnect (Figures 5 and 6)

- Raise the vehicle.
1. Retainer (133).
 2. Shift rod from the column.
 3. Spring (132) and the spacer (131).
 4. Screw (139) and the washer (140).
 5. Shift rod and the swivel (141) from the shift lever (138).
 6. Swivel (141).
 7. Retainer (137).
 8. Nuts (146), the spring washers (147) and the screws (148).
 9. Bracket (145).
 10. Insulator (144), the washer (143) and the spring (142).

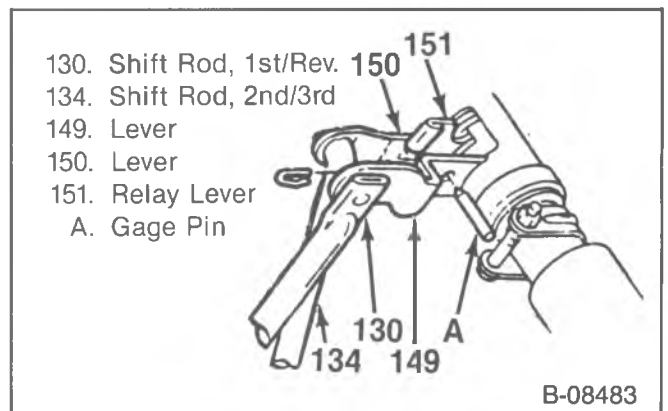

B-08483

Figure 6—Column Linkage Adjustment

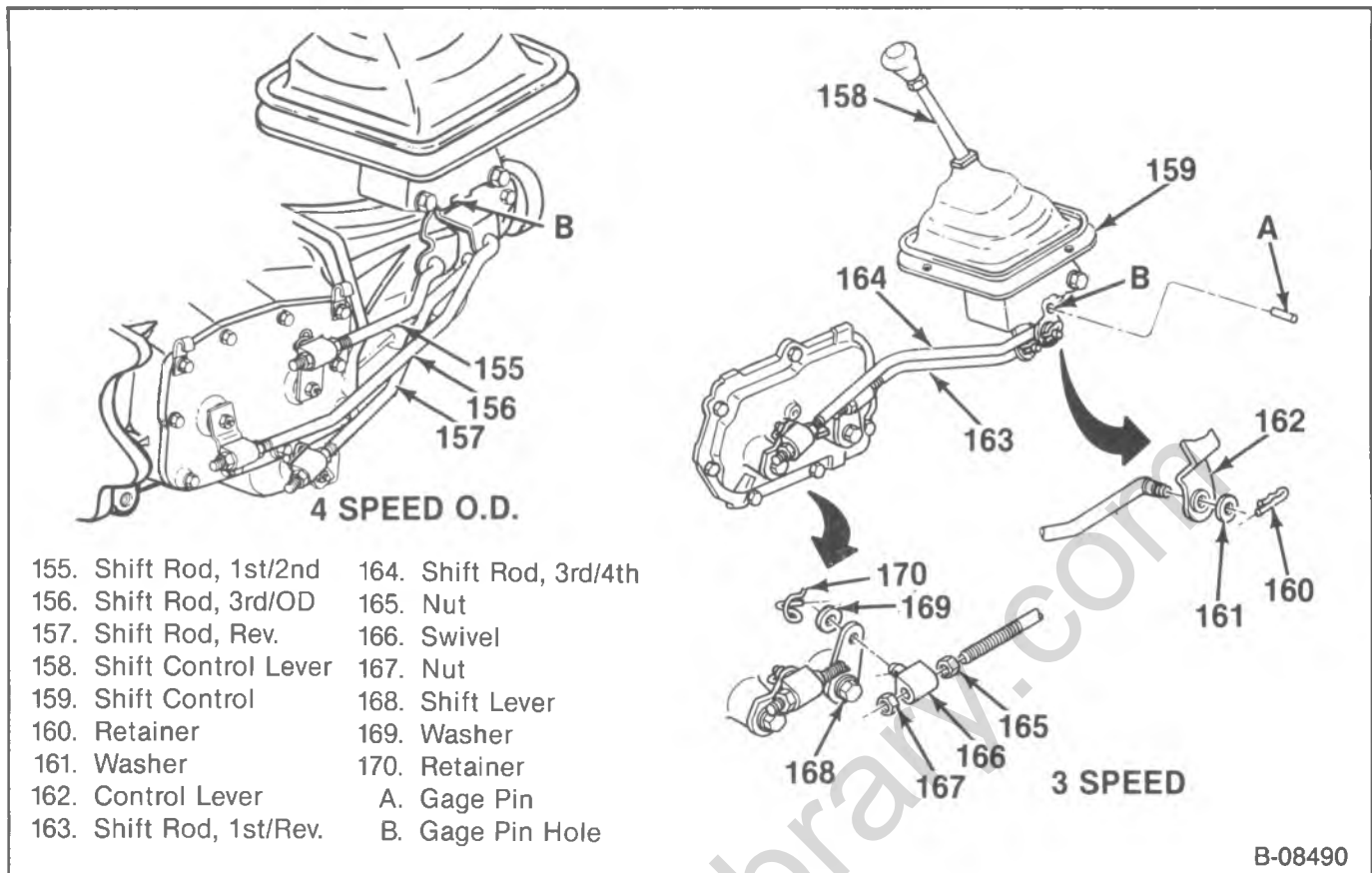

Figure 7—Floor Shift Linkage (3 Speed/4 Speed O.D.)

2. The spring (142), the washer (143) and the insulator (144).
3. Bracket (145).
4. Screws (148), new spring washers (147) and the nuts (146).
5. New retainer (137).
6. Swivel (141) onto the shift rod.
7. Shift rod and the swivel (141) to the shift lever (138).
8. Washer (140) and the screw (139) loosely.

! Important

- The washer must stand off the lever as shown.
9. Spacer (131) and the spring (132).
 10. Shift rod to the column.
 11. New retainer (133).
 - Adjust the shift linkage.

FLOOR SHIFT LINKAGE

↔ Remove or Disconnect (Figure 7)

1. Retainer (160).
2. Washer (161).
3. Shift rod from the control lever (162).
4. Retainer (170).
5. Washer (169).
6. Shift rod from the shift lever (168).
7. Nuts (165 and 167) and the swivel (166).

↔ Install or Connect (Figure 7)

1. Nuts (165 and 167) and the swivel (166).
 - Do not tighten.
2. Shift rod to the shift lever (168).

3. Washer (169).
4. New retainer (170).
5. Shift rod to the control lever (162).
6. Washer (161).
7. New retainer (160).
 - Adjust the shift linkage.

SHIFT LINKAGE ADJUSTMENT

COLUMN SHIFT LINKAGE

🔧 Adjust (Figures 5 and 6)

- The first and reverse shift rod (130) must be adjusted before the second and third shift rod (134).
1. Loosen the screw (139) if needed.
 2. Put the transmission lever in place.
 - For shift rod (130), move the shift lever (128) to the front detent (Reverse).
 - For shift rod (134), move the shift lever to the front detent then back one, (neutral).
 3. Put the column lever in place.
 - For shift rod (130), move the column lever into "Reverse" and lock the steering column.
 - For shift rod (134), move the column lever into "Neutral" and put a 0.249-0.250 in. gage pin through the levers (149 and 150) and the relay lever (151) (figure 6).
 4. Hold the shift rod (130 or 134) down tightly in the swivel (141) and tighten the screw (139).

B-08490

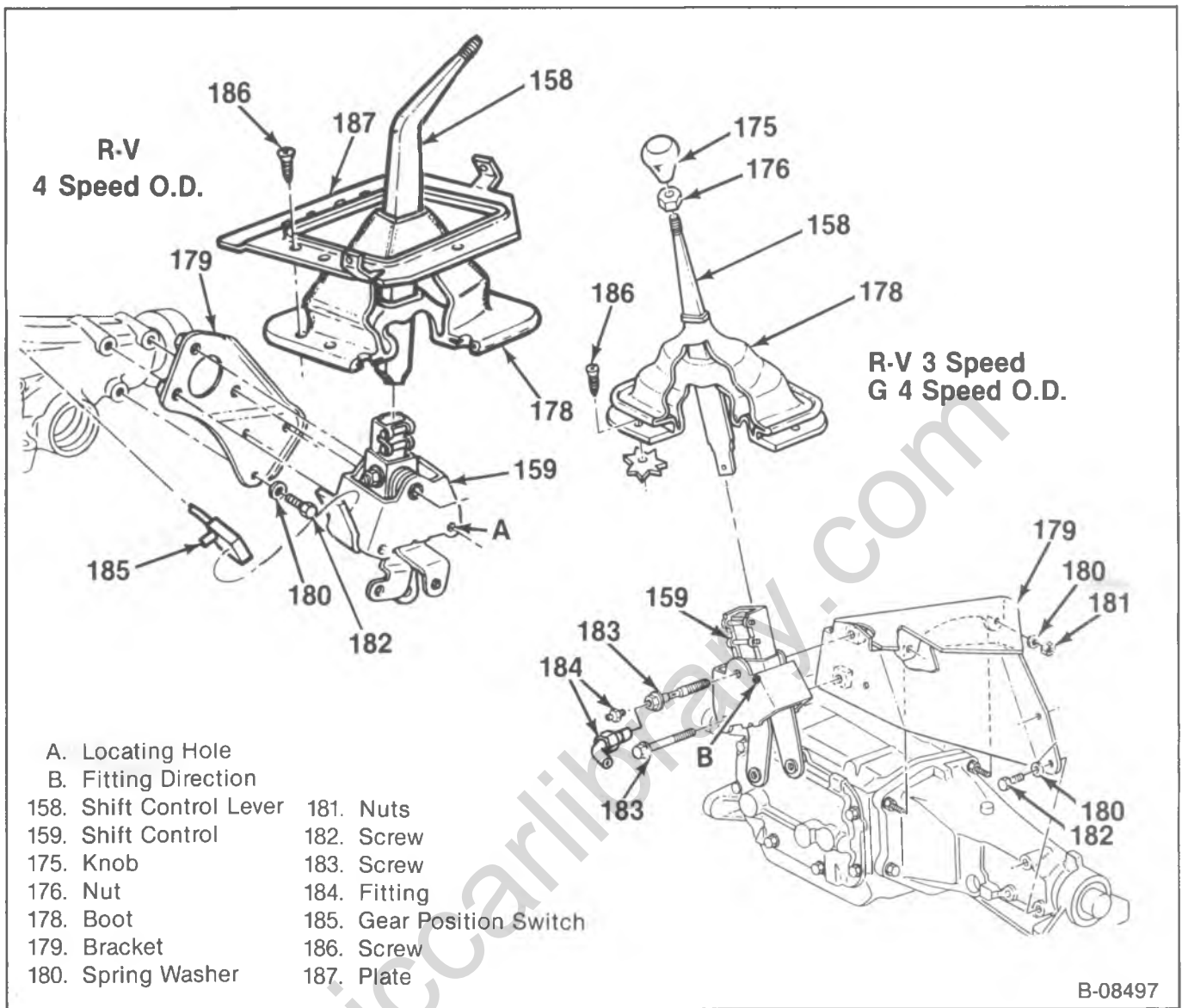

R-V
4 Speed O.D.

R-V 3 Speed
G 4 Speed O.D.

- | | |
|--------------------------|---------------------------|
| A. Locating Hole | 181. Nuts |
| B. Fitting Direction | 182. Screw |
| 158. Shift Control Lever | 183. Screw |
| 159. Shift Control | 184. Fitting |
| 175. Knob | 185. Gear Position Switch |
| 176. Nut | 186. Screw |
| 178. Boot | 187. Plate |
| 179. Bracket | |
| 180. Spring Washer | |

B-08497

Figure 8—Floor Shift Control (3 Speed/4 Speed O.D.)

- Unlock the steering column, or take the gage pin out.

5. Lubricate all rod and swivel connections. Refer to MAINTENANCE AND LUBRICATION (SEC. 0B).

FLOOR SHIFT LINKAGE

 **Adjust (Figure 7)**

1. Loosen the nuts (165 and 167) if needed.
2. Move the shift control lever (158) into "Neutral".
3. Move the shift levers (162) to the front detent then back one, (neutral).
4. Put a 0.249-0.250 in. gage pin through the control levers (158).
5. Hold the shift rods forward tightly in the swivels (166) and tighten the nuts (165 and 167).
6. Remove the gage pin and lubricate the shift control. Refer to MAINTENANCE AND LUBRICATION (SEC. 0B).

SHIFT CONTROL

FLOOR SHIFT CONTROL

 **Remove or Disconnect (Figure 8)**

1. Knob (175) and the nut (176).
2. Screws (186) and the boot (178).
 - Plate (187) if used.
3. Shift control lever (158).
 - Slide a piece of shim stock between the lever and the control to release the lever.
4. Shift rods at the control (figure 7).
 - Gear position switch (185) if used.
5. Screws (183) and the fitting (184).
6. Shift control (159).
7. Screws (182) and the spring washers (180).
8. Nuts (181) and the spring washers (180), if used.
9. Bracket (179).

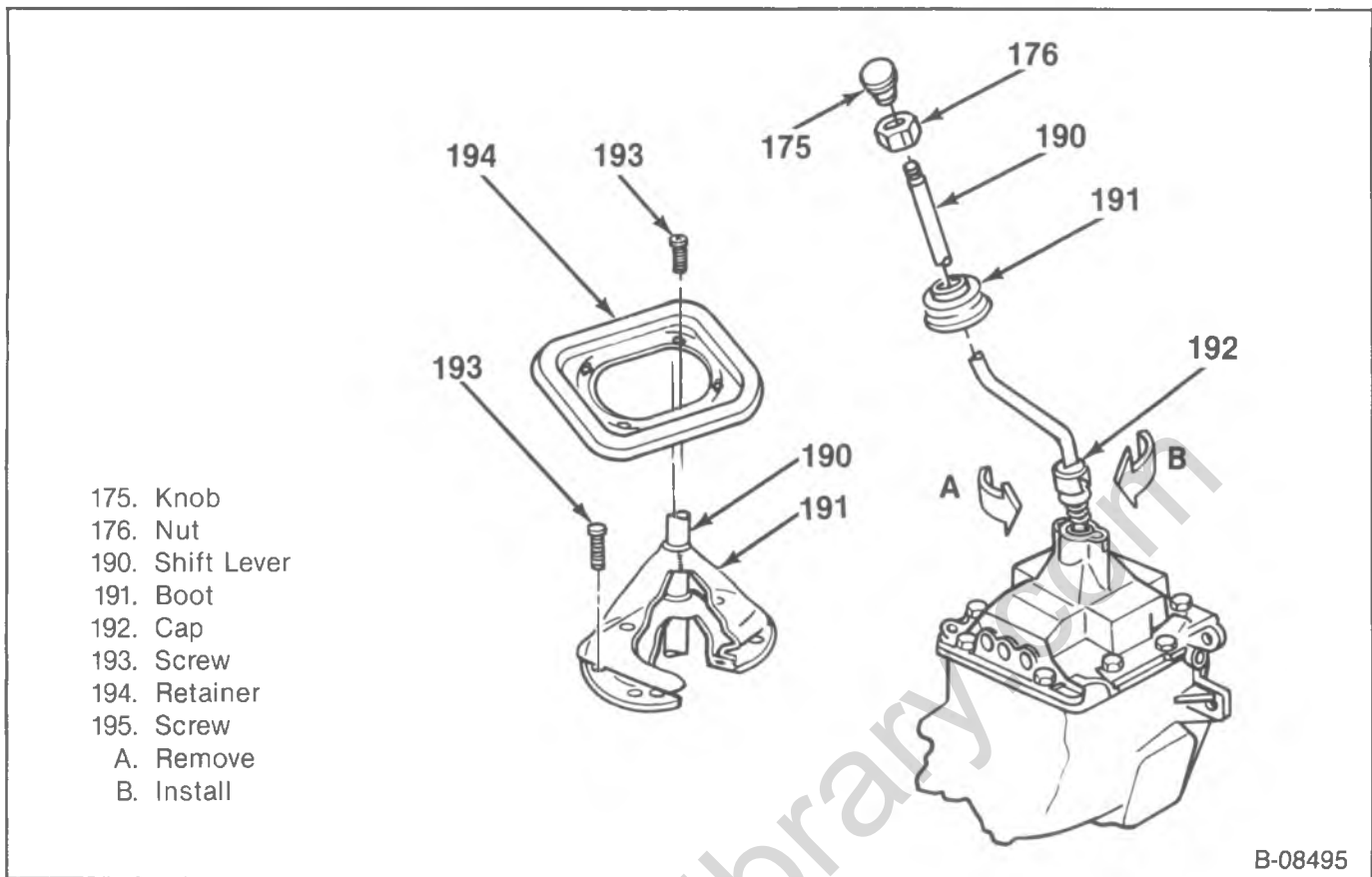

Figure 9—Shift Control Lever (4 Speed)

Install or Connect (Figure 8)

1. Bracket (179).
2. New spring washers (180) and the nuts (181), if used.
3. New spring washers (180) and the screws (182).
4. Shift control (159).
5. Fitting (184) and the screws (183).

! Important

- The screw with the large shoulder is a locating screw and must be installed in the rear-center hole (A).
 - The screw with the lubrication fitting must go into the top hole.
 - The lubrication fitting must point in the direction shown (B).
6. Shift rods at the control (figure 7).
 - Gear position switch (185), if used.
 7. Shift control lever (158).
 - Wipe the lever with a damp rag before sliding it into place.
 8. Boot (178) and the screws (186).
 - Plate (187), if used.
 9. Nut (176) and the knob (175).
 10. Lubricate the shift control and the shift linkage. Refer to MAINTENANCE AND LUBRICATION (SEC. 0B).
 - Adjust the shift linkage.

SHIFT CONTROL LEVER (4 SPEED)

Remove or Disconnect (Figure 9)

1. Transfer case shift lever boot if used, refer to TRANSFER CASE (SEC. 7D).
2. Screws (193) and the retainer (194) if used.
3. Screws (193) if used.
4. Boot (191).
5. Lever (190).
 - Push the cap (192) down and turn counter-clockwise (A).

Install or Connect (Figure 9)

1. Lever (190).
 - Push the cap (192) down and turn clockwise (B).
2. Boot (191).
3. Screws (193) if used.
4. Retainer (194) and the screws (193) if used.
5. Transfer case shift lever boot if used. Refer to TRANSFER CASE (SEC. 7D).

SIDE COVER

Remove or Disconnect (Figure 10)

- Raise the vehicle.
1. Transmission oil.
 2. Harnesses (206) as used.
 3. Shift rods (figure 7).
 - Move the shift levers into neutral.

B-08495

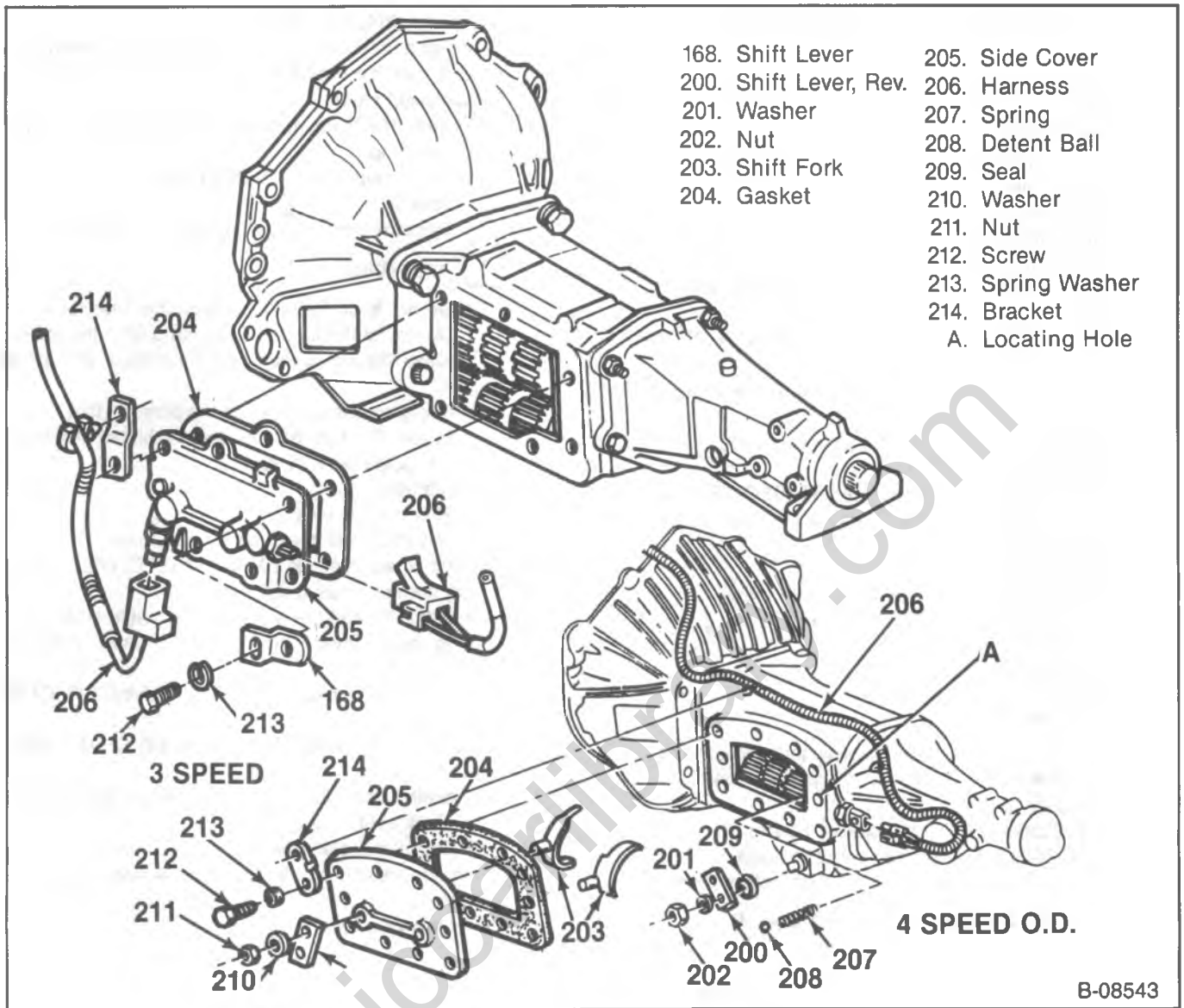

B-08543

Figure 10—Side Cover (3 Speed/4 Speed O.D.)

4. Nut (202), the washer and the reverse shift lever (200), (4 speed O.D.).
 - Seal (209).
5. Screws (212), spring washers (213) and the brackets (214).
6. Side cover (205).

! Important

- Note the positions of the shift forks while removing.
7. Reverse detent ball (208) and the spring (207), (4 speed O.D.).
 8. Gasket (204).
 - Scrape all gasket material from the cover and the case.

↔ Install or Connect (Figure 10)

1. New gasket (204).
2. Reverse detent spring (207) and the ball (208), (4 speed O.D.).
3. Side cover (205).

- | | |
|------------------------|--------------------|
| 168. Shift Lever | 205. Side Cover |
| 200. Shift Lever, Rev. | 206. Harness |
| 201. Washer | 207. Spring |
| 202. Nut | 208. Detent Ball |
| 203. Shift Fork | 209. Seal |
| 204. Gasket | 210. Washer |
| | 211. Nut |
| | 212. Screw |
| | 213. Spring Washer |
| | 214. Bracket |
| | A. Locating Hole |

- Lift the reverse interlock lever to seat the cover, (4 speed O.D.).
 - The shift levers must be in neutral.
4. Brackets (214), new spring washers (213) and the screws (212).

! Important

- The screw with the large shoulder is a locating screw and must be installed in the rear-center hole (A).
5. Reverse shift lever (200), the washer and the nut (202), (4 speed O.D.).
 - New seal (209).
 6. Shift rods (figure 7).
 7. Harnesses (206) as used.
 8. New transmission oil. Refer to "Drain and Fill" in this section.
 - Lower the vehicle and adjust the shift linkage.

TRANSMISSION REPLACEMENT

↔ Remove or Disconnect (Figures 1 and 2)

Tool Required:

J-1126, Transmission Guide Pin (4 speed)

- Raise the vehicle.
1. Transmission oil.
 2. Shift control and rods if used, (3 speed/4 speed O.D.).
 - Shift lever, (4 speed).
 3. Propeller shaft. Refer to PROPELLER SHAFT (SEC. 4A).
 4. Transfer case if used. Refer to TRANSFER CASE (SEC. 7D).
 5. Parking brake and controls if used. Refer to BRAKES (SEC. 5).
 6. Speedometer cable (112) and the seal (113).
 7. Wiring harnesses as used.
 8. Exhaust pipes. Refer to EXHAUST (SEC. 6F).
 - Support the transmission with a jack.
 9. Any parts if needed for clearance.
 10. Crossmember.
 11. Screws (101) and the spring washers (100).
 - Remove the top two first and install guide pins J-1126, (4 speed).
 12. Transmission (104).



Important

- Do not let the transmission hang from the clutch.
 - Pull the transmission straight back on the clutch hub splines.
 - Support the clutch release bearing.
13. Plugs (114), if they are loose or damaged.
 - Note the location of the plugs before removing.

↔ Install or Connect (Figures 1 and 2)

Tool Required:

J-1126, Transmission Guide Pin (4 speed)

1. New plugs (114) if needed.
 - Put a thin coat of high temperature grease on the main drive gear splines.
2. Transmission (104).
 - Shift the transmission into high gear before installing.
 - Install guide pins J-1126 in the top two holes (4 speed).
 - Remove the clutch release bearing support.



Important

- Do not force the transmission into the clutch.
 - Do not let the transmission hang from the clutch, leave the jack under the transmission to support it.
3. New spring washers (100) and the screws (101).
 - Install the two bottom screws before removing the guide pins, (4 speed).
 4. Crossmember.
 - Remove the jack.
 5. Any parts that were removed for clearance.
 6. Exhaust pipes. Refer to EXHAUST (SEC. 6F).
 7. Wiring harnesses as used.
 8. New seal (113) and the speedometer cable (112).
 9. Parking brake lever and controls if used. Refer to BRAKES (SEC. 5).
 10. Transfer case if used. Refer to TRANSFER CASE (SEC. 7D).
 11. Propeller shaft. Refer to PROPELLER SHAFT (SEC. 4A).
 12. Shift control and rods if used, (3 speed/4 speed O.D.).
 - Shift lever (4 speed).
 - Adjust the shift linkage.
 13. New transmission oil. Refer to "Drain and Fill" in this section.
 - Lower the vehicle.

SPECIFICATIONS

TRANSMISSION	3 SPEED		4 SPEED	4 SPEED O.D.
RPO	M62	M64	M20	MY6
Make	Muncie	Muncie	Muncie	New Process
Case Material	Cast Iron	Cast Iron	Cast Iron	Cast Iron/Alum.
Torque Rating (Ft. Lb.)	246	246	290	260
Ratio (:1)				
1st Gear	2.85	3.50	6.55	3.09
2nd Gear	1.68	1.89	3.58	1.67
3rd Gear	1.00	1.00	1.70	1.00
4th Gear	—	—	1.00	0.73
5th Gear	—	—	—	—
Reverse	2.95	3.62	6.09	3.00
Shafts Center Distance	76 mm (3.0 inch)	76 mm (3.0 inch)	117 mm (4.5 inch)	89 mm (3.5 inch)
Clutch Plate Diameter	279 mm (11.0 inch)	279 mm (11.0 inch)	279 mm* (11.0 inch)	302 mm (12.0 inch)

*302 mm (12.0 inch) with Diesel Engine

FASTENER TORQUE

	N·m	Ft. Lbs.
Plug, Drain and Fill.....	23	17
Cross Lever Bracket Screw.....	25	18
Shift Rod Swivel Screw (Column Shift).....	14	10
Shift Rod Swivel Screw (Floor Shift)		
3 Speed.....	25	18
4 Speed O.D.....	25	18
Control Bracket Screw.....	33	24
Control Mounting Screw		
3 Speed.....	32	23
4 Speed.....	45	33
Control Lubrication Screw.....	45	33
Side Cover Screw.....	20	15
U-joint Flange Nut.....	135	100
Rear Retainer Screw-4 Speed		
Top.....	27	20
Bottom.....	40	30
Transmission to Clutch Housing Screw.....	100	74
Transmission to Mount Screw		
3 Speed/4 Speed.....	47	35
4 Speed O.D.....	54	40
Crossmember to Mount Screw.....	54	40
Crossmember to Frame Screw.....	75	55

LUBRICATION

Capacity		
3 Speed.....	1.5 L	1.6 qts.
4 Speed/4 Speed O.D.....	4.0 L	4.2 qts.
Type Recommended		
3 Speed/4 Speed.....	API GL5 SAE 80W90	
4 Speed O.D.....	Dexron II Automatic Transmission Fluid	

SPECIAL TOOLS

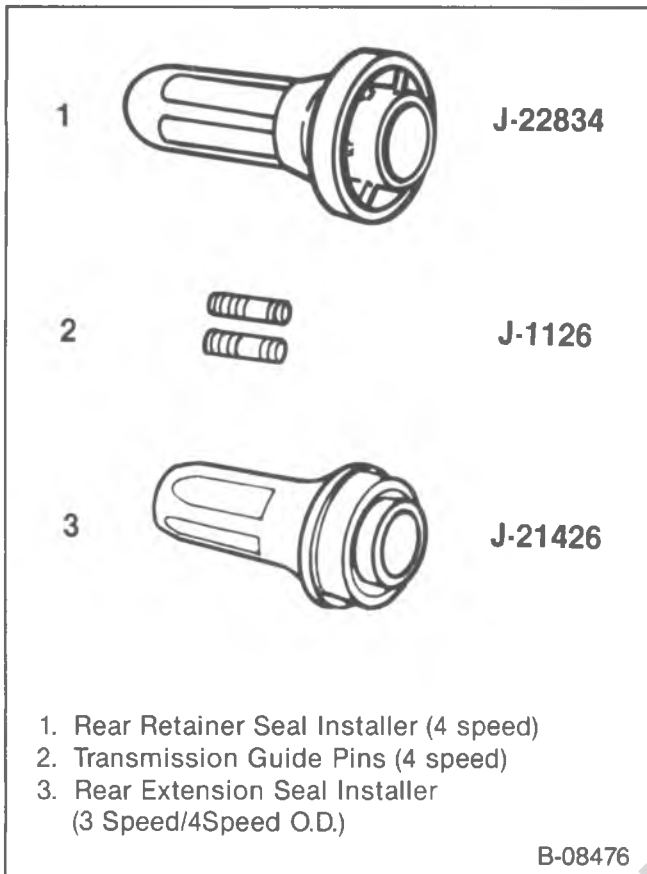

classiccarlibrary.com

SECTION 7C

CLUTCH

CONTENTS

<u>SUBJECT</u>	<u>PAGE</u>
Description.....	7C- 2
Clutch	7C- 2
Clutch Controls	7C- 2
Inspection.....	7C- 2
Linkage	7C- 2
Clutch Pedal	7C- 2
Release Bearing	7C- 2
Hydraulic Clutch.....	7C- 2
Diagnosis of Clutch.....	7C- 3
On-Vehicle Service	7C- 4
Hydraulic Clutch Pedal	7C- 4
Mechanical Clutch Pedal	7C- 4
Master Cylinder and Reservoir	7C- 5
Secondary (Slave) Cylinder and Hydraulic Line	7C- 6
Clutch Linkage	7C- 7
Cross Lever	7C- 8
Hydraulic Clutch Bleeding.....	7C- 9
Clutch Pedal Free Travel Adjustment	7C- 9
Clutch Assembly and Pilot Bearing	7C-11
Specifications	7C-15
Fastener Torque.....	7C-15
Clutch Pedal Free Travel.....	7C-15
Lubrication	7C-15
Special Tools	7C-16

DESCRIPTION

CLUTCH

The principal components on a clutch are the driven plate, pressure plate, diaphragm-type spring and a release bearing.

The driven plate is splined on the transmission clutch shaft so that it can move back and forth when the clutch is disengaged, and can turn the shaft when the clutch is engaged. The driven plate has friction pads riveted to both sides of it, and a flexible center with springs to absorb vibration.

The pressure plate has a machined surface that fits against the driven plate and a diaphragm-type spring mounted in a cover on the pressure plate. The spring holds the pressure plate and driven plate together against the engine flywheel when the clutch is engaged.

The release bearing is a ball-thrust bearing on a sleeve that pushes in on the center of the diaphragm spring, releasing pressure on the pressure plate and driven plate to disengage the clutch.

CLUTCH CONTROLS

HYDRAULIC CONTROLS - R-V MODELS

The hydraulic clutch has a master cylinder with a separate reservoir. The clutch pedal moves the master cylinder push rod and a secondary cylinder at the clutch housing moves the clutch fork and the release bearing.

MECHANICAL CONTROLS - G AND P MODELS

G models have a pull rod from the clutch pedal that moves a cross lever. The cross lever moves the clutch fork and the release bearing with an adjustable rod.

P models have an upper pull rod from the clutch pedal to a bell crank lever and a lower pull rod from the bell crank lever to a cross lever. The cross lever moves the clutch fork and the release bearing with an adjustable rod.

INSPECTION

Before repairing the clutch, check the transmission and shift linkage, and the engine mounts to be sure the problem is in the clutch.

LINKAGE

1. Check the clutch rods for bending and damage.
2. Check for worn swivels and loose or damaged mounting brackets.
3. Check the clutch lever for bending, wear and damage.
 - Be sure there is some clearance between the clutch lever and the mounting brackets and ball studs.
4. Lubricate the clutch linkage.

- Move the shift lever from first gear to reverse gear and back several times.
- If the shift is smooth, the clutch is disengaging fully.
- Adjust the clutch linkage and repeat, if needed.

CLUTCH PEDAL

1. Check the bushings for dirt, wear and damage.
2. Check the clutch release.
 - Hold the clutch pedal 12.7 mm ($\frac{1}{2}$ in.) above the floor mat with the engine running and the parking brake on.

RELEASE BEARING

1. Check the clutch fork for dirt, wear and damage.
2. Check the clutch fork for proper installation and lubrication.
3. Check the release bearing and clearance between the spring fingers and the transmission.

HYDRAULIC CLUTCH

1. Check the hoses for cracks and wear.
2. Check the cylinders for loose mounting screws and signs of leakage.
3. Check the clutch pedal travel, it should be 210.8 mm (8.3 in).
4. Check the secondary push rod travel at the clutch fork, it should be at least 25.4 mm (1.0 in).
5. Bleed the controls and repeat as needed.

DIAGNOSIS OF CLUTCH

PROBLEM	POSSIBLE CAUSE	CORRECTION
Will Not Disengage (Pedal to the floor and hard to shift into reverse).	<ol style="list-style-type: none"> 1. Linkage loose or out of adjustment. 2. Air in the hydraulic system. 3. Master or secondary hydraulic cylinder seals worn. 4. Not enough pedal travel. 5. Release bearing worn or damaged. 6. Driven plate worn or damaged. 7. Clutch fork off the ball stud. 8. Driven plate binding. 9. Driven plate run-out more than 5.08 mm (0.20 in.). 	<ol style="list-style-type: none"> 1. Tighten or adjust. 2. Bleed and check for damage. 3. Repair. 4. Adjust the linkage or trim the pedal bumper. 5. Replace. 6. Replace. 7. Install correctly and lubricate. 8. Repair or replace the plate or clutch gear. 9. Replace.
Slipping.	<ol style="list-style-type: none"> 1. Linkage out of adjustment. 2. Driven plate friction pads worn or oil soaked. 3. Pressure plate or flywheel warped. 4. Diaphragm spring weak. 5. Driven plate overheated or not seated. 	<ol style="list-style-type: none"> 1. Adjust. 2. Replace. Check for leaks as needed. 3. Replace as needed. 4. Replace. 5. Allow to cool and make 30-40 normal starts - DO NOT OVERHEAT.
Grabbing (Chattering).	<ol style="list-style-type: none"> 1. Engine mounts loose or damaged. 2. Driven plate friction pads oil soaked. 3. Pressure plate or flywheel warped. 4. Driven plate friction pad material burned or smeared onto the pressure plate or flywheel. 5. Clutch gear worn. 	<ol style="list-style-type: none"> 1. Tighten or replace. 2. Replace and check for leaks. 3. Replace as necessary. 4. Clean off or replace as needed. 5. Repair the transmission.
Rattling (Transmission Click).	<ol style="list-style-type: none"> 1. Diaphragm spring weak. 2. Clutch fork loose or off the ball stud. 3. Driven plate springs weak or oil in the damper. 	<ol style="list-style-type: none"> 1. Replace the pressure plate. 2. Replace the retaining spring or install the fork correctly. 3. Replace and check for leaks as needed.
Release Bearing Noisy With The Clutch Engaged	<ol style="list-style-type: none"> 1. Linkage out of adjustment. 2. Release bearing binding. 3. Clutch fork off the ball stud or loose spring tension. 4. Linkage return springs weak. 	<ol style="list-style-type: none"> 1. Adjust. 2. Clean, or replace if damaged, and lubricate. 3. Install, and lubricate. 4. Replace.
Noisy.	<ol style="list-style-type: none"> 1. Release bearing worn or damaged. 2. Clutch fork off the ball stud. 3. Pilot bearing loose. 	<ol style="list-style-type: none"> 1. Replace. 2. Install correctly and lubricate. 3. Replace. Refer to ENGINE (SEC. 6A).
Pedal Stays On The Floor When Disengaged.	<ol style="list-style-type: none"> 1. Linkage or release bearing binding. 2. Diaphragm spring weak. 3. Return springs being over traveled. 	<ol style="list-style-type: none"> 1. Free up (or replace) and lubricate. 2. Replace the pressure plate. 3. Adjust the linkage or replace the pedal bumper if worn.
Pedal Is Hard To Push.	<ol style="list-style-type: none"> 1. Linkage binding. 2. Hydraulic line blocked or crimped. 3. Master or secondary cylinders binding. 4. Driven plate worn. 	<ol style="list-style-type: none"> 1. Free up (or replace) and lubricate. 2. Clean out or replace. 3. Repair or replace as needed. 4. Replace.

ON-VEHICLE SERVICE

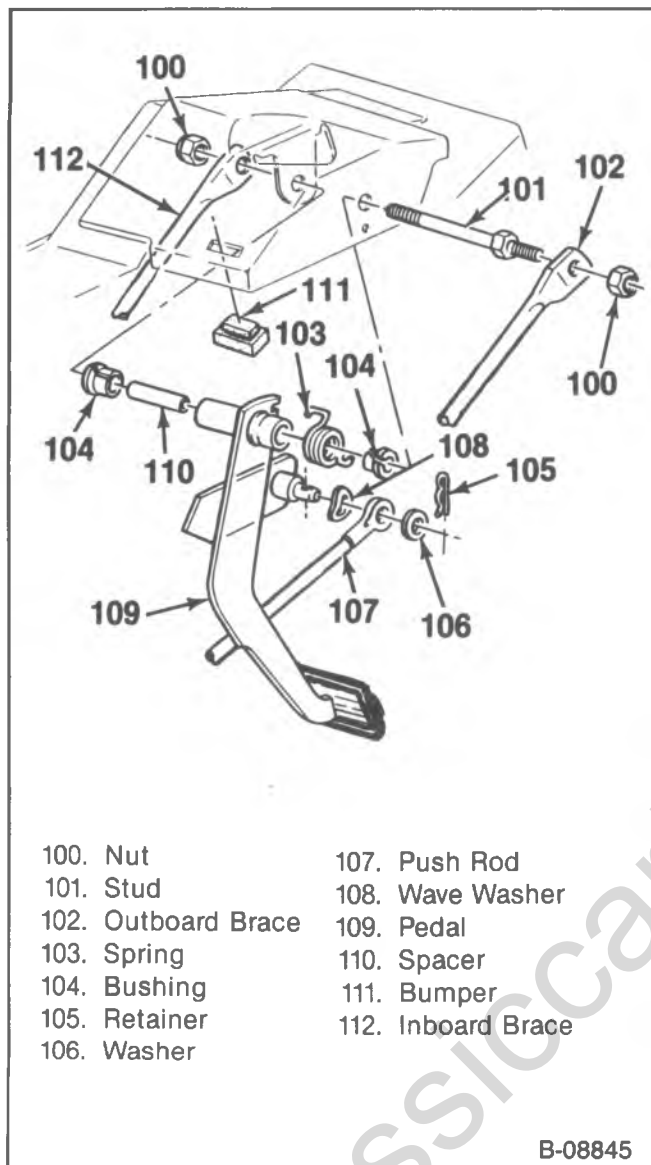

- | | |
|---------------------|--------------------|
| 100. Nut | 107. Push Rod |
| 101. Stud | 108. Wave Washer |
| 102. Outboard Brace | 109. Pedal |
| 103. Spring | 110. Spacer |
| 104. Bushing | 111. Bumper |
| 105. Retainer | 112. Inboard Brace |
| 106. Washer | |

B-08845

Figure 1—Hydraulic Clutch Pedal Components

HYDRAULIC CLUTCH PEDAL

Remove or Disconnect (Figure 1)

- Negative battery cable.
- The lower steering column covers.
- The lower left side air conditioning duct if used.
- Neutral start switch.
- Retainer (105) and the washer (106).
- Push rod (107) and the wave washer (108).
- Nuts (100).
- Braces (102 and 112).
- Stud (101), the pedal (109) and the spring (103).
 - Slide a long screw or rod into the bracket while removing the stud.
- Bushings (104) and the spacer (110).
- Bumper (111) if it is worn or damaged.

Install or Connect (Figure 1)

- New bumper (111) if needed.
- New spacer (110) and new bushings (104).
 - Coat with grease before installing.
- Spring (103), the pedal (109) and the stud (101).
 - Remove the long screw or rod while installing the stud.

Important

- The stud must be installed in the direction shown.
- Braces (102 and 112).
 - Nuts (100).
 - New wave washer (108) and the push rod (107).
 - The washer must stand off the pedal as shown.
 - Washer (106) and the retainer (105).
 - Neutral start switch.
 - The lower left side air conditioning duct, if used.
 - The lower steering column covers.
 - Negative battery cable.
 - Lubricate the clutch pedal. Refer to MAINTENANCE AND LUBRICATION (SEC. 0B).

MECHANICAL CLUTCH PEDAL

Remove or Disconnect (Figure 2)

- Negative battery cable.
- Cotter pin (132) and the washer (131).
- Wave washer (130).
- Neutral start switch (125).
 - Note the direction the switch is mounted in.
- Nut (120) and the spring washer (121).
- Screw (133) and the washer (136).
 - Note the direction the screw is mounted in.
 - Remove the washer (134) if used.
- Arm (135) and the wave washer (122).
- Pedal rod (128) and the bushing (129).
- Spring (127).
 - Push the pedal down, move it to the side and let it up to release the spring.
- Pedal (126).
 - Slide a long screw or rod through the bracket while removing the pedal to keep the brake pedal in place.
- Bushings (123).
- Bumper (124) if it is worn or damaged.

Clean (Figure 2)

- Metal parts with solvent. Wipe dry.
- Plastic and rubber parts with a dry rag.

Inspect (Figure 2)

- Pedal (126) for wear and bending.
- Bushings (123 and 129) for cracks and wear.

Install or Connect (Figure 2)

- New bumper (124) if needed.
- Bushings (123).
 - Coat the bushings with petroleum jelly.

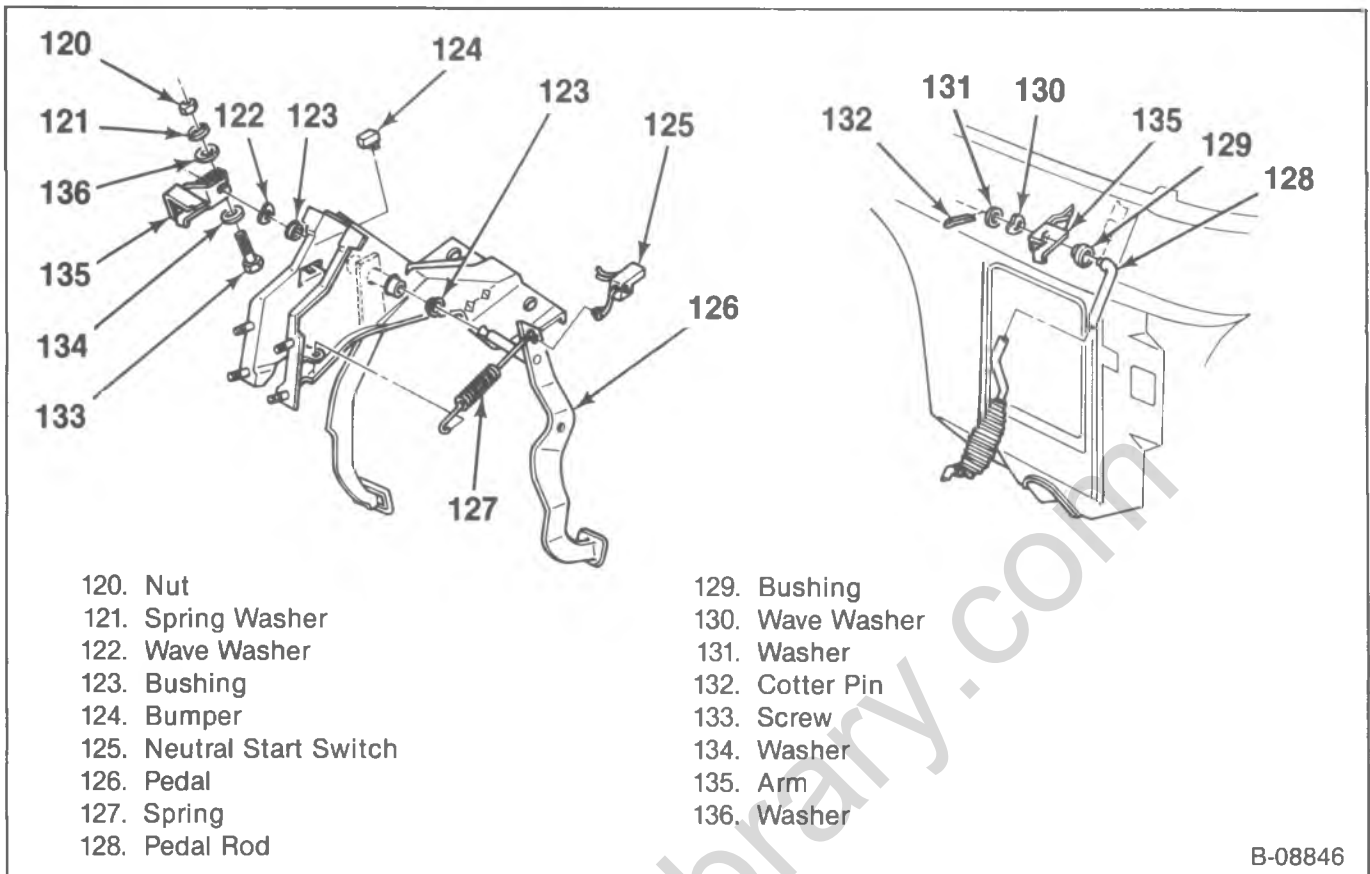

Figure 2—Mechanical Clutch Pedal Components

3. Pedal (126).
 - Slide the screw or rod out while installing the pedal.
4. Spring (127).
 - Hold the pedal up, next to the pedal stop to hook the spring.
 - Push the pedal down, slide it to the side and let it up against the pedal stop.
5. Bushing (129) and the pedal rod (128).
6. New wave washer (122) and the arm (135).
7. Washer (136) and the screw (133).
 - Install the washer (134) if used.
 - Install the screw in the direction it was removed from.
8. New spring washer (121) and the nut (120).
9. Neutral start switch (125).
 - Install the switch in the position it was removed from.
10. New wave washer (130).
11. Washer (131) and a new cotter pin (132).
12. Negative battery cable.
 - Adjust the clutch linkage. Refer to "Free Travel Adjustment" in this section.
 - Lubricate the clutch pedal. Refer to MAINTENANCE AND LUBRICATION (SEC. 0B).

MASTER CYLINDER AND RESERVOIR

↔ Remove or Disconnect (Figure 3)

1. Negative battery cable.
2. The lower steering column covers.
3. The lower left side air conditioning duct, if used.
4. Retainer (105) and the washer (106).
5. Push rod (107) and the wave washer (108).
6. Reservoir hose (145).
7. Secondary cylinder hydraulic line (142) from the master cylinder (144).
8. Nuts (143) and the master cylinder (144).
9. Gasket (141).
 - Scrape all gasket material from the master cylinder and the cowl.
10. Screws (146) and the reservoir (140).

⊠ Disassemble (Figure 4)

1. Remove the adapter (221) and the seal (220).
2. Pull the dust cover (228) back and remove the snap ring (227).
3. Shake the push rod (107) and the plunger (224) out.
4. Remove the seal (226). Remove the spring (230), the support (222), the seal (225) and the shim (223).

🧼 Clean (Figure 4)

- All parts with clean brake fluid.

7C-6 CLUTCH

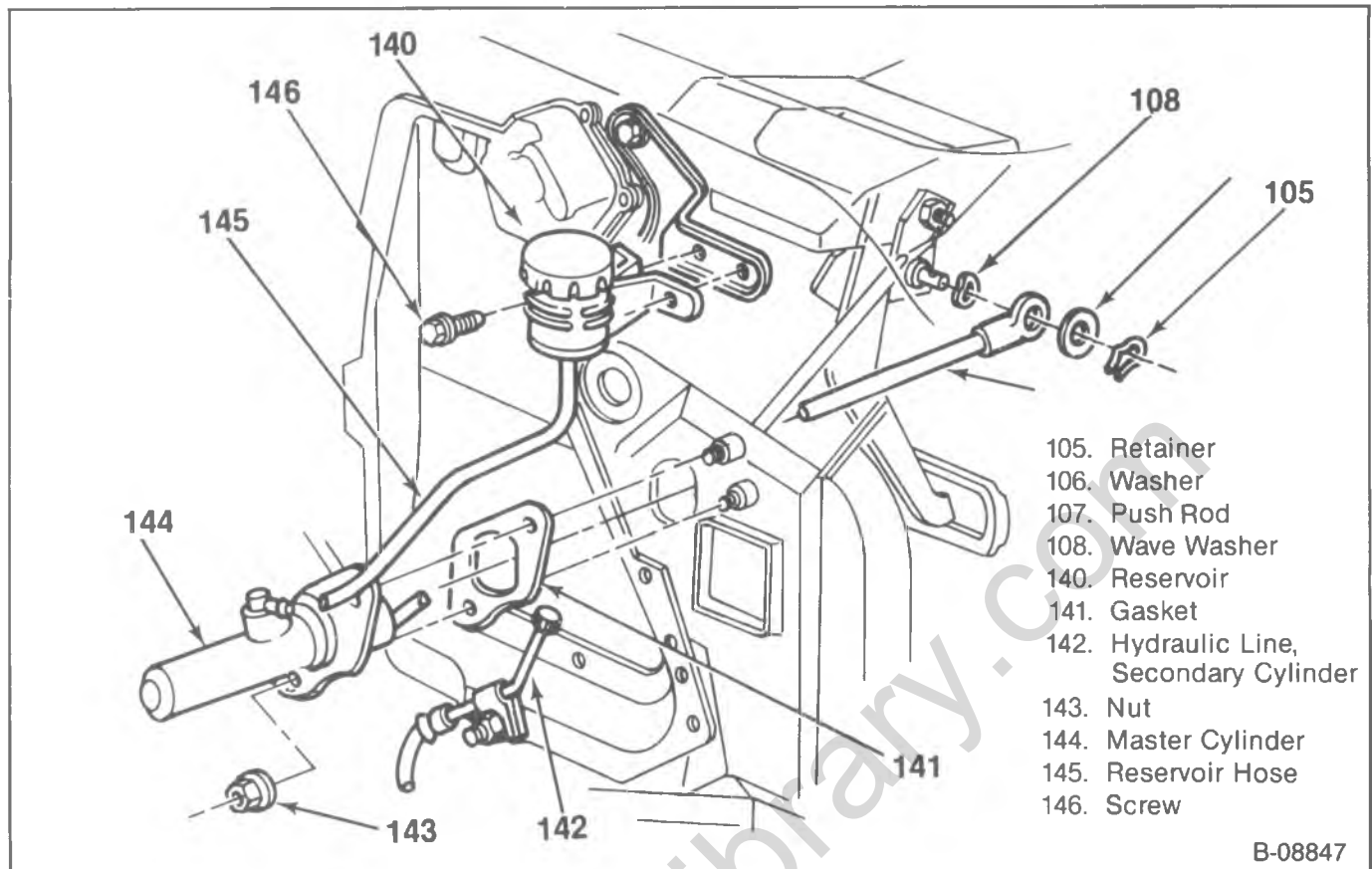

Figure 3—Master Cylinder and Reservoir

Inspect (Figure 4)

- The cylinder bore and the plunger for scratches, ridges, and pitting.
- The dust cover for wear and cracking.

Assemble (Figure 4)

- Lubricate all seals with clean brake fluid.
1. Install the shim (223) and a new seal (225) with the flat against the shim (223). Install the support (222) and the spring (230).
 2. Install a new seal (226).
 3. Coat the cylinder bore with clean brake fluid and slide the plunger (224) and the push rod (107) in.
 4. Push the push rod (107) in and install the snap ring (227). Coat the inside of the dust cover (228) with grease and slide it into place.
 5. Install a new seal (220) and the adapter (221).

Install or Connect (Figure 3)

1. Reservoir (140) and the screws (146).
2. New gasket (141).
3. Master cylinder (144) and the nuts (143).
4. Secondary cylinder hydraulic line (142) to the master cylinder (144).
5. Reservoir hose (145).
6. New wave washer (108) and the push rod (107).
7. Washer (106) and the retainer (105).
8. The lower left side air conditioning duct, if used.
9. The lower steering column covers.
10. Negative battery cable.

- Fill the reservoir. Refer to “Specifications” in this section.
- Bleed the clutch system. Refer to “Hydraulic Clutch Bleeding” in this section.

SECONDARY (SLAVE) CYLINDER AND HYDRAULIC LINE

Remove or Disconnect (Figure 5)

1. Negative battery cable.
 - Raise the vehicle.
2. Hydraulic line (142) from the secondary cylinder (153).
3. Nuts (151) and the secondary cylinder (153).
4. Hydraulic line (142).
 - Hydraulic line (142) from the master cylinder (144).
 - Nut (150) and the hydraulic line (142).
 - Install the nut (150) to hold the speedometer cable (B) in place.

Important

- Cover all hydraulic line openings to keep dirt and moisture out of the components.

Disassemble (Figure 6)

1. Remove the push rod (241) and the dust cover (240).
2. Remove the snap ring (238) and shake the plunger (239) out.
3. Remove the spring (242) and the seal (237).

B-08847

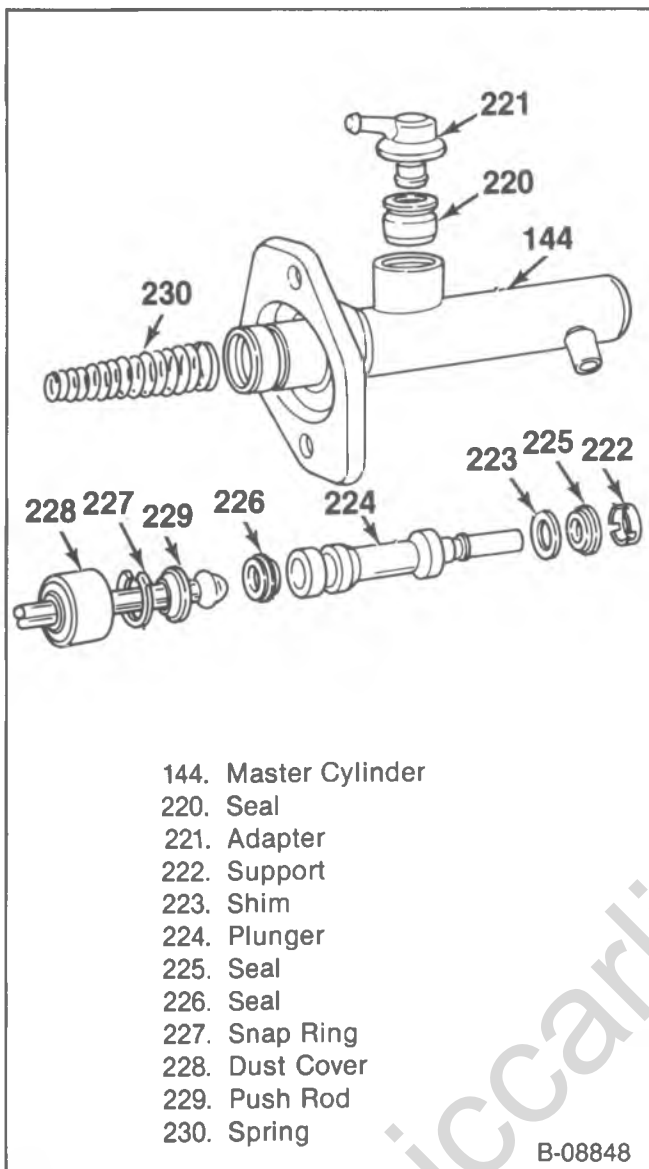

- 144. Master Cylinder
- 220. Seal
- 221. Adapter
- 222. Support
- 223. Shim
- 224. Plunger
- 225. Seal
- 226. Seal
- 227. Snap Ring
- 228. Dust Cover
- 229. Push Rod
- 230. Spring

B-08848

Figure 4—Master Cylinder Components



Clean (Figure 6)

- All parts with clean brake fluid.



Inspect (Figure 6)

- The cylinder bore and the plunger for scratches ridges and pitting.
- The dust cover for wear and cracking.



Assemble (Figure 6)

1. Coat a new seal (237) with clean brake fluid and slide it into place and install the spring (242).
2. Coat the cylinder bore with clean brake fluid and slide the plunger (239) in.
3. Push the plunger (239) in and install the snap ring (238).
4. Coat the inside of the dust cover (240) with grease and slide it into place. Install the push rod (241).



Install or Connect (Figure 5)

- Uncover the hydraulic line openings.

 1. Hydraulic line (142).

- Remove the nut (150).
- Hydraulic line (142) onto the master cylinder (144).
- Hydraulic line (142) and the nut (150).



Important

- The hydraulic line must be upright, as shown.

 2. Secondary cylinder (153) and the nuts (151).
 3. Hydraulic line (142) onto the secondary cylinder (153).
 - Lower the vehicle.
 4. Negative battery cable.

 - Bleed the clutch system. Refer to "Hydraulic Clutch Bleeding" in this section.

CLUTCH LINKAGE



Remove or Disconnect (Figures 7 and 8)

1. Negative battery cable.
2. Cotter pins (132), the washers (131) and the wave washers (130).
3. Pedal rod (128) and the bushing (129).
 - Note the direction the rod was removed from.
4. Screws (172) and the boot (171).
5. The lower pedal rod (163), (P models only).
 - Cotter pins (160), the washers (161) and the wave washers (162).
6. The pull back spring (166).
 - Retaining spring (164) if used.
7. Cotter pin (167), the washer (168) and the wave washer (169).
 - The nut (165), if used.
8. Adjusting rod (170).
 - Note the direction the rod was removed from.



Clean (Figures 7 and 8)

- All metal parts with solvent. Wipe dry.
- All nylon and rubber parts with a clean, dry rag.



Inspect (Figures 7 and 8)

- All metal parts for wear, damage and bending.
- All nylon and rubber parts for wear and cracks.



Install or Connect (Figures 7 and 8)

1. Adjusting rod (170).
 - Install the rod in the direction it was removed from.
2. New wave washer (169), the washer (168) and a new cotter pin (167).
 - The jam nut (165), if used.
3. The pull back spring (166).
 - The retaining spring (164), if used.
4. The lower pedal rod (163), (P models only).
 - New wave washers (162), the washers (161) and new cotter pins (160).
5. The boot (171) and the screws (172).
 - The dimple must face the rear of the vehicle, (P models only).
6. The bushing (129) and the pedal rod (128).
 - Install the rod in the direction it was removed from.
7. New wave washers (130), the washers (131) and new cotter pins (132).

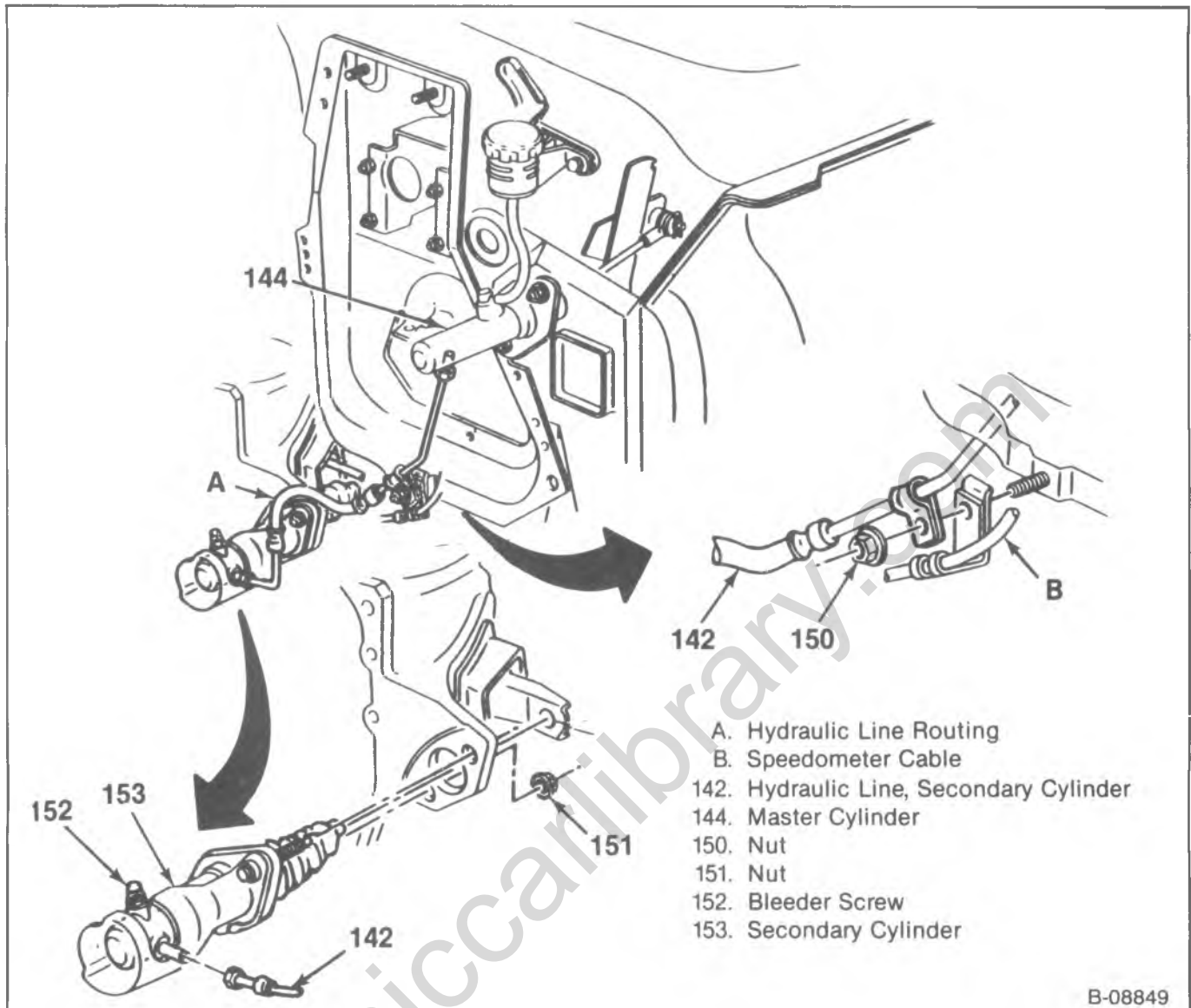

B-08849

Figure 5—Secondary (Slave) Cylinder and Hydraulic Line

8. Negative battery cable.
 - Adjust the clutch, if needed. Refer to "Free Travel Adjustment" in this section.
 - Lubricate the clutch linkage. Refer to MAINTENANCE AND LUBRICATION (SEC. 0B).

CROSS LEVER

↔ Remove or Disconnect (Figure 9)

1. Negative battery cable.
2. Springs and the adjusting rod (170), (Figures 7 and 8).
3. Pedal rod (128) or the lower pedal rod (163), (figures 7 and 8).
4. Screws (185) and the spring washers (189).
 - Nuts (190), (P models only).
5. Bracket (186) and the cross lever (191).
6. Ball stud (181), the nut (188) and the star washer (187) from the bracket (186).
7. Engine side ball stud (181) if it is worn or damaged.

🧼 Clean (Figure 9)

- All metal parts with solvent. Wipe dry.
- All nylon and plastic parts with a clean, dry rag.

🔍 Inspect (Figure 9)

- All metal parts for wear, damage and bending.
- All nylon and plastic parts for wear and cracks.

↔ Install or Connect (Figure 9)

1. Engine side ball stud (181) if needed.
2. New star washer (187), the nut (188) and the ball stud (181) onto the bracket (186).
3. Cross lever (191) and the bracket (186).
4. New spring washers (189) and the screws (185).
 - Nuts (190), (P models only).
5. Pedal rod (128) or the lower pedal rod (163), (figures 7 and 8).

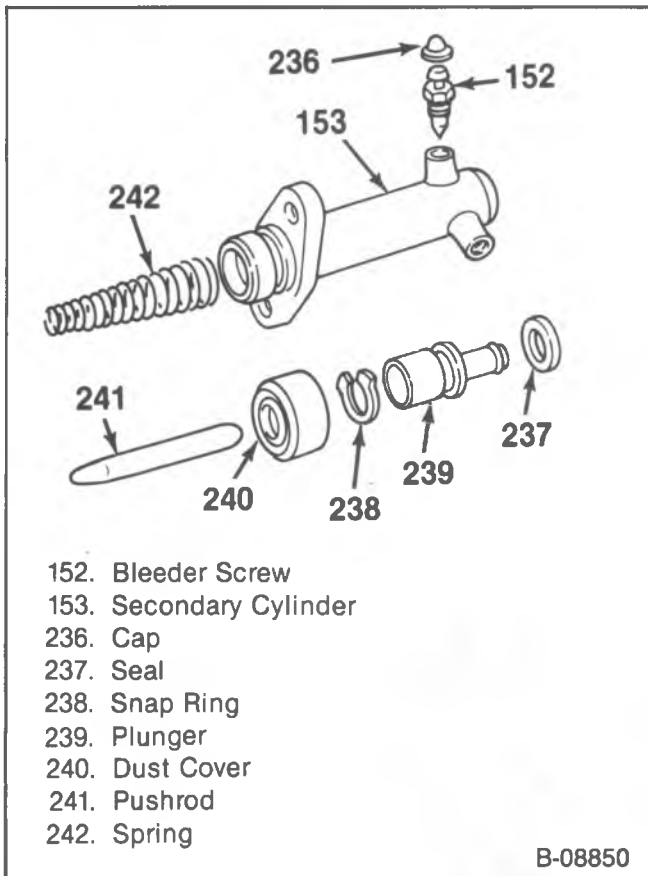

- 152. Bleeder Screw
- 153. Secondary Cylinder
- 236. Cap
- 237. Seal
- 238. Snap Ring
- 239. Plunger
- 240. Dust Cover
- 241. Pushrod
- 242. Spring

B-08850

Figure 6—Secondary (Slave) Cylinder Components

6. Adjusting rod (170) and the springs, (figures 7 and 8).
 - Adjust the clutch linkage. Refer to "Free Travel Adjustment" in this section.
 - Lubricate the clutch linkage. Refer to MAINTENANCE AND LUBRICATION (SEC. 0B).

HYDRAULIC CLUTCH BLEEDING

R-V MODELS

Bleed (Figures 3 and 5)

1. Fill the reservoir (140) with new DOT 3 brake fluid to the level of the diaphragm.

NOTICE: Never, under any circumstances, use fluid which has been bled from a system to fill the reservoir, as it may be aerated, have too much moisture content and possibly be contaminated.

2. Remove the secondary (slave) cylinder (153) and tip it so the bleeder screw (152) is up.
3. Hold the clutch pedal down, open the bleeder screw (152) to let air and fluid escape, and close the bleeder screw (152). Let the clutch pedal up.
4. Repeat step 3 until all air is out of the system.



Important

- Check and refill the reservoir as needed while bleeding so that air is not drawn into the system.

5. Install the secondary cylinder (153) and refill the reservoir (140) if needed.

CLUTCH PEDAL FREE TRAVEL ADJUSTMENT

P MODELS



Adjust (Figures 7 and 10)

1. Remove the pull back spring (166).
2. Loosen the nut (201) at the swivel (202).
 - Take the swivel (202) out of the cross lever (191), (models without JF9).
3. Move the clutch fork (200) back until the clutch spring pressure is felt, and adjust the rod length.

Models without JF9.

- Hold the clutch pedal against the bumper.
- Turn the nut (201) until the swivel (202) fits into the gage hole (A), then remove all lash.
- Install the swivel (202) with a new wave washer (169) and cotter pin (167).

Models with JF9.

- Hold the clutch pedal against the bumper.
 - Loosen the nut (165) and turn the nut (203) until it is 7.37mm (0.29-in.) from the rod shoulder (B).
 - Tighten the nut (165) and turn the nut (201) to remove all lash.
4. Install the pull back spring (166).
 5. Check the clutch pedal free travel and re-adjust if needed. Refer to "Clutch Pedal Free Travel" in this section.
 6. Lubricate the clutch linkage. Refer to MAINTENANCE AND LUBRICATION (SEC. 0B).

G MODELS



Adjust (Figures 8 and 10)

1. Remove the pull back spring (166).
2. Loosen the nut (203).
3. Move the clutch fork (200) back until the clutch spring pressure is felt.
4. Hold the clutch pedal against the bumper and turn the nut (201) until it is 7.11 mm (0.28-in.) from the cross lever (191).
5. Tighten the nut (203) against the cross lever (191).
6. Install the pull back spring (166).
7. Check the clutch pedal free travel and re-adjust if needed. Refer to "Clutch Pedal Free Travel" in this section.
8. Lubricate the clutch linkage. Refer to MAINTENANCE AND LUBRICATION (SEC. 0B).

7C-10 CLUTCH

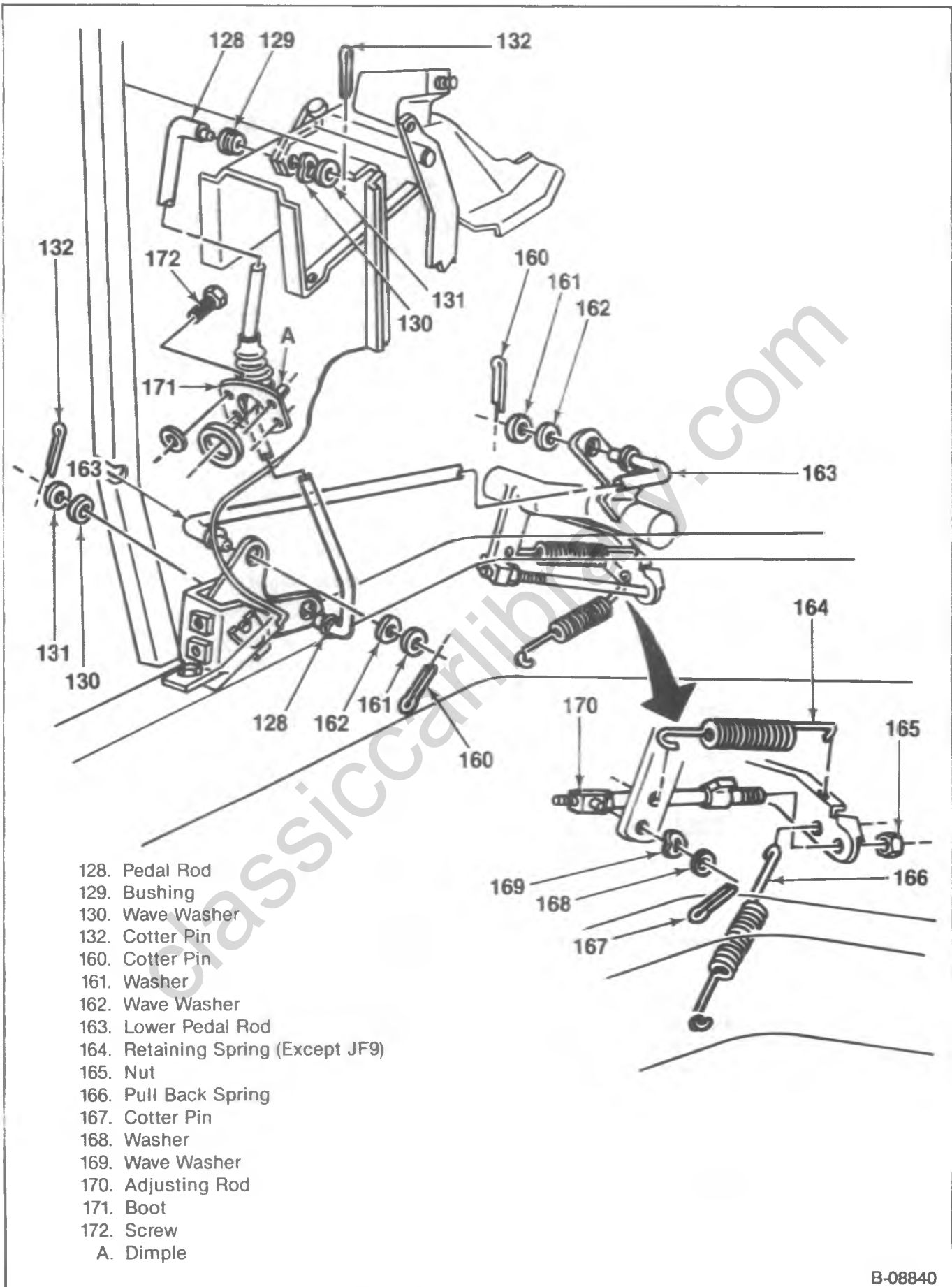
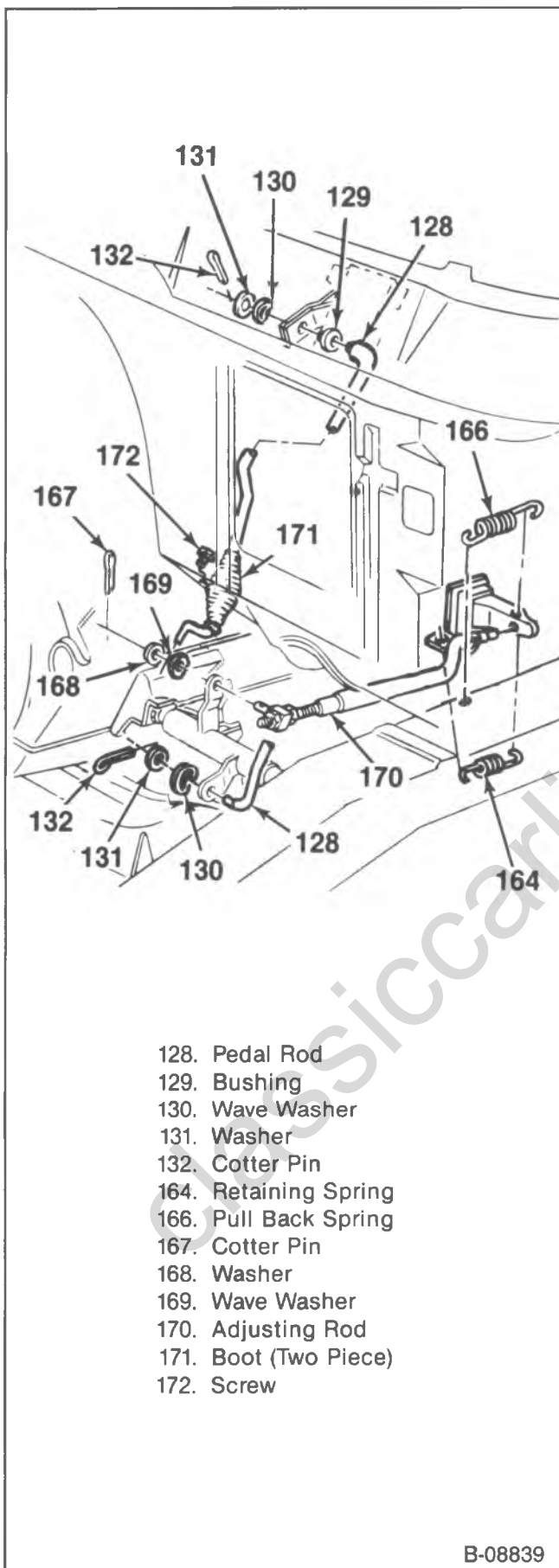

Figure 7—Clutch Linkage — P Models

B-08840

CLUTCH ASSEMBLY AND PILOT BEARING

CAUTION: When servicing clutch parts, do not create dust by grinding or sanding clutch disc or by cleaning parts with a dry brush or with compressed air. (A water dampened cloth—NOT SOAKED—should be used). The clutch disc contains asbestos fibers which can become airborne if dust is created during servicing. Breathing dust containing asbestos fibers may cause serious bodily harm.



- 128. Pedal Rod
- 129. Bushing
- 130. Wave Washer
- 131. Washer
- 132. Cotter Pin
- 164. Retaining Spring
- 166. Pull Back Spring
- 167. Cotter Pin
- 168. Washer
- 169. Wave Washer
- 170. Adjusting Rod
- 171. Boot (Two Piece)
- 172. Screw

B-08839

Figure 8—Clutch Linkage — G Models

↔ Remove or Disconnect (Figure 11)

Tool Required:

J-5824-01 Clutch Alignment Tool

J-1448 Pilot Bearing Puller (Gas Engine Only)

J-23907 Pilot Bearing Puller (6.2 L Diesel Only)

1. Transmission. Refer to TRANSMISSION (SEC. 7B).
2. Adjusting rod (170) or the secondary cylinder (153), (figures 5, 7 or 8).
 - Pull back spring (166) if used.
 - Retaining spring (164) if used.
3. Screws (216) and the cover (215).
4. Screws (208) and the flywheel housing (207).
5. Boot (210), the clutch fork (200) and the release bearing (212).
 - Pry the clutch fork (200) off the ball stud (209).
 - Pry the retainer (211) out of the clutch fork (200) if it is worn or damaged.
6. Ball stud (209).
7. Screws (206) and the spring washers (205).

! Important

- Install J-5824-01 clutch alignment tool or a used clutch drive gear to support the clutch.
 - Mark the flywheel, clutch cover and a pressure plate lug for alignment when installing.
 - Loosen each screw one turn at a time to avoid warping the clutch cover.
8. Cover assembly (213) and the driven plate (214).
 - Remove the clutch alignment tool.
 9. Pilot bearing (217) if it is worn or damaged. Use J-1448 or J-23907 as needed (figure 12).

✦ Disassemble (Figure 11)

1. Remove the screws (218) and straps (219).
 - Note the location of the retracting springs.
2. Remove the pressure plate (220).

✦ Clean (Figure 11)

- All parts with a clean, water dampened cloth to remove any asbestos fibers.
- Clutch fork (200), the flywheel housing (207) and the ball stud (209) with solvent. Wipe dry.

NOTICE: The release bearing is permanently packed with lubricant and should not be soaked in cleaning solvent as this will dissolve the lubricant.

7C-12 CLUTCH

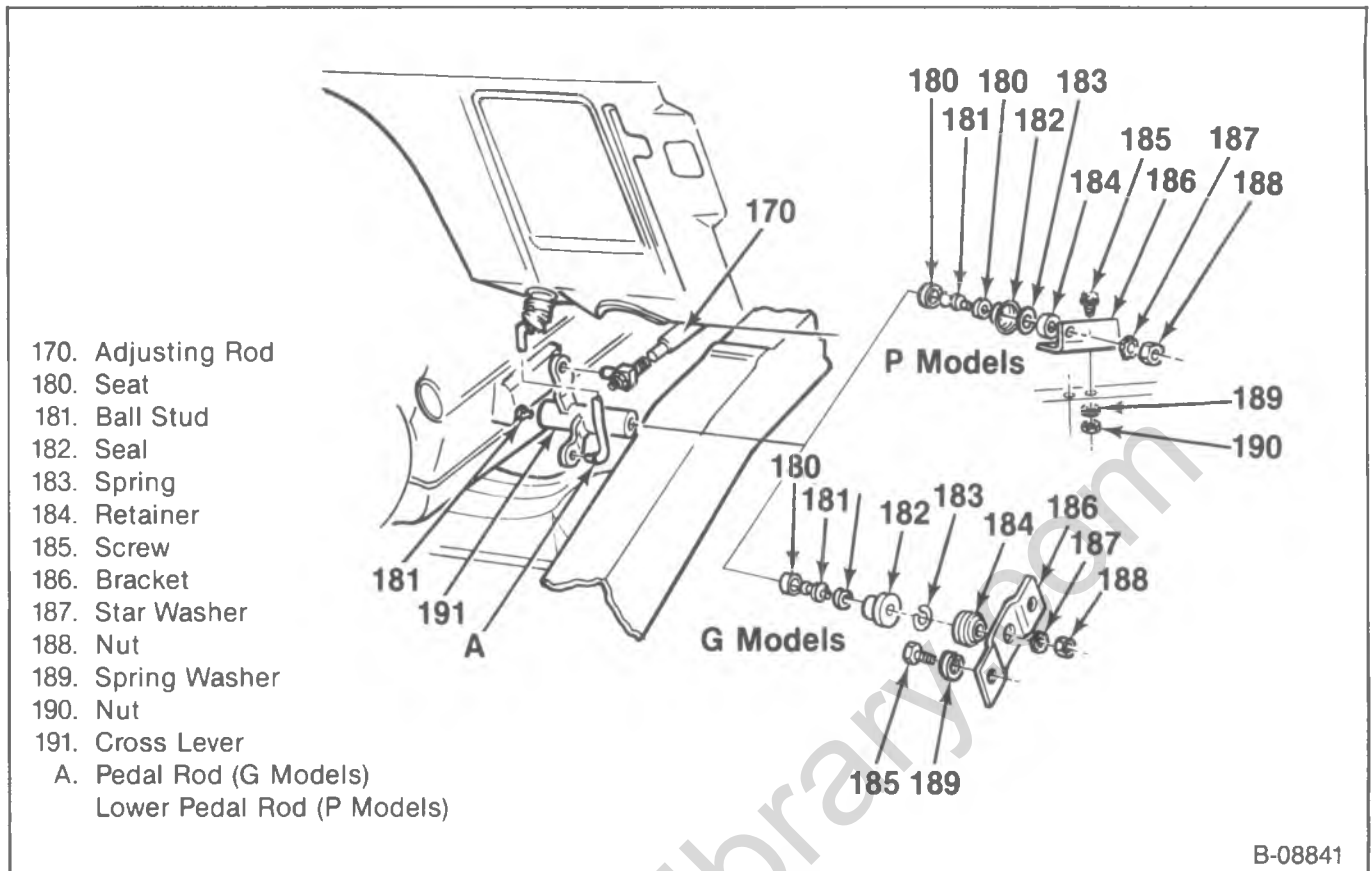

Figure 9—Cross Lever

Inspect (Figure 11)

- All parts for wear and damage.
- Contact surfaces for scoring, and flatness with a straight edge. Driven plate run-out must not be more than 5.08 mm (0.20-in.).
- Friction pads for scoring, gouges, and loose rivets. Check to see if they are oil soaked.
- All splines for nicks, burrs and sliding fit.
- All springs for bending and breaks.
- Boot for tears and brittleness.

Measure (Figure 11)

- Transmission pilot hole in the clutch housing for run out using a dial indicator. Run out should not be more than 0.380 mm (0.015-in.).

Assemble (Figure 11)

1. Install the pressure plate (220).

Important

- Line up the marks made during removal.

2. Straps (219) and the screws (218).

- Install the retracting springs in the positions they were removed from.

Install or Connect (Figure 11)

Tool Required:

- J-5824-01 Clutch Alignment Tool
- J-1522 Pilot Bearing Driver (Gas Engine Only)
- J-34140 Pilot Bearing Driver (6.2 L Diesel Only)

1. New pilot bearing (217) if needed. Use J-1522 or J-34140 as needed to drive the bearing in until the tool bottoms out.

— Gas Engine

Lubricate the bearing with a few drops of machine oil.

— 6.2 L Diesel Engine

The bearing is sealed and does not need any lubrication.

2. Driven plate (214) and the cover assembly (213).

Important

- Install J-5824-01 clutch alignment tool or a used clutch drive gear to support the clutch.
- Align the marks made during removal.

3. New spring washers (205) and the screws (206).

- Remove the clutch alignment tool.

Important

- Tighten each screw one turn at a time to avoid warping the clutch cover.

NOTICE: Be careful not to use too much lubricant. Excessive lubricant may get on clutch fingers and cause slippage or damage may result to the clutch.

4. Ball stud (209).

- Pack the seat with high temperature grease.

5. Coat the rounded end of the ball stud (209) with high temperature grease.

B-08841

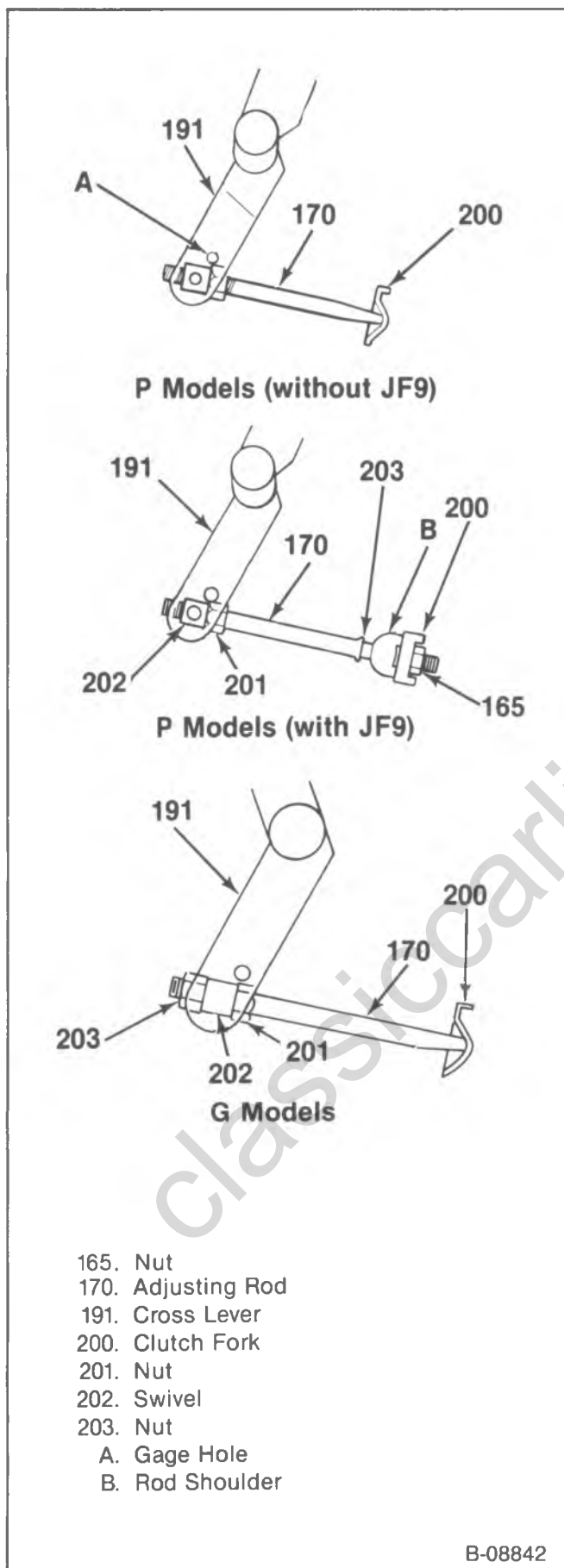

- 165. Nut
- 170. Adjusting Rod
- 191. Cross Lever
- 200. Clutch Fork
- 201. Nut
- 202. Swivel
- 203. Nut
- A. Gage Hole
- B. Rod Shoulder

- Pack the ball stud seat from the lubrication fitting (A) on the flywheel housing (207) (R-V models only).
6. New retainer (211) if needed.
 - The retainer must be installed so the fingers and tabs fit into the release bearing groove and the retainer wraps around the flat side of the ball stud head.
 7. Release bearing (212), the clutch fork (200) and the boot (210).
 - Pack the inside recess (A) and the outside groove (B) of the release bearing (212) with high temperature grease as shown, (figure 13).
 8. Flywheel housing (207) and the screws (216).
 9. Cover (215) and the screws (216).
 10. Adjusting rod (170) or the secondary cylinder (153) as needed. (Figures 5, 7 or 8).
 - Retaining spring (164) if used.
 - Pull back spring (166) if used.
 11. Transmission. Refer to TRANSMISSION (SEC. 7B).
 12. Adjust the clutch linkage as needed.

B-08842

Figure 10—Clutch Linkage Adjustment

7C-14 CLUTCH

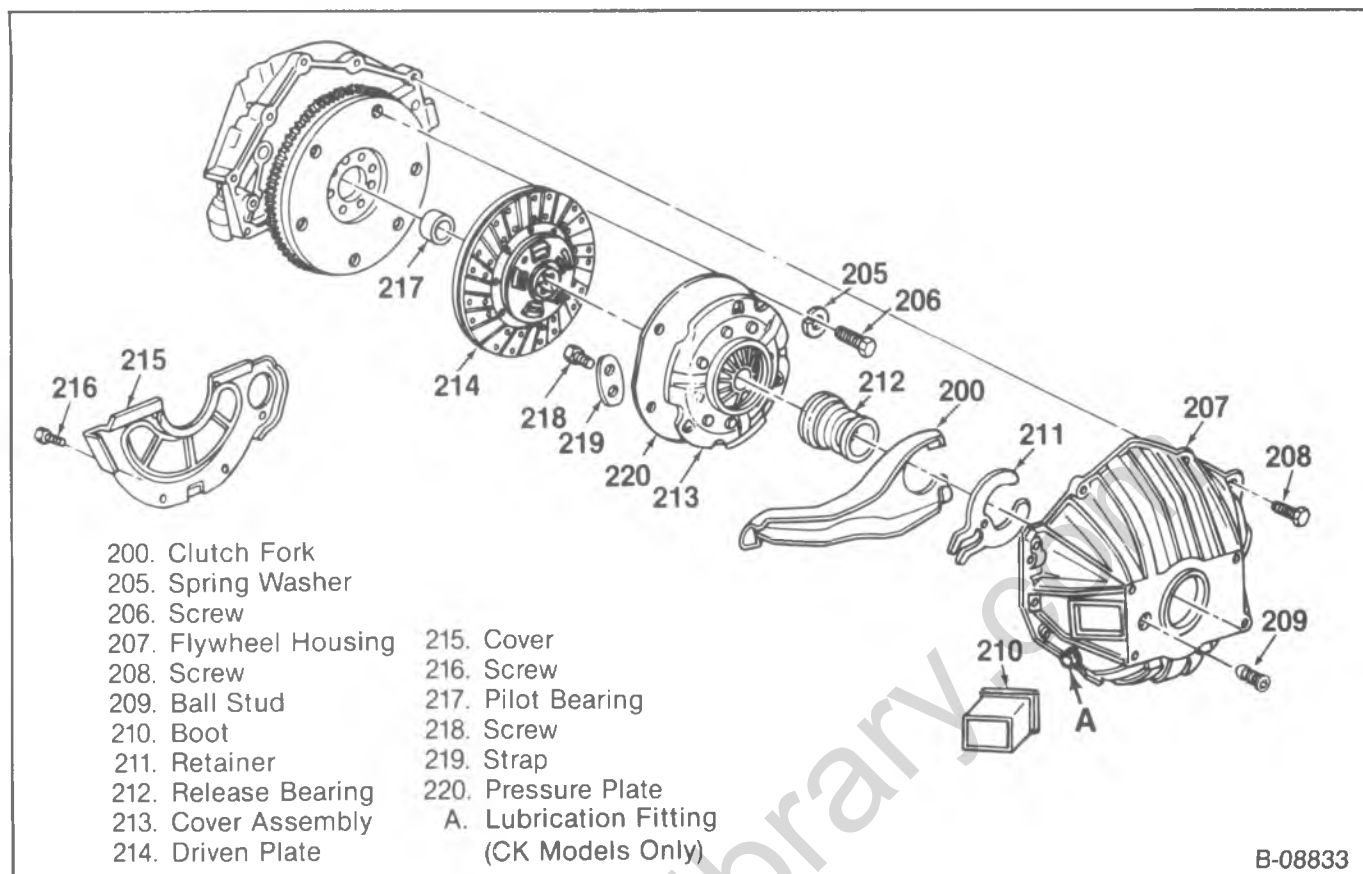

Figure 11—Clutch Assembly and Pilot Bearing

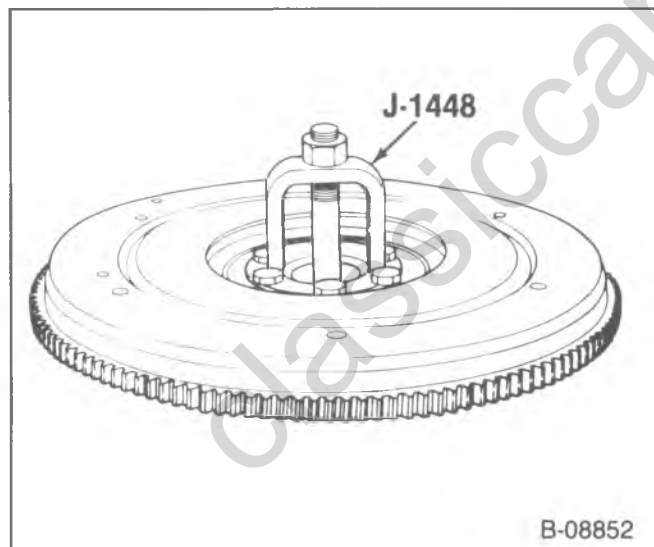

Figure 12—Removing the Pilot Bearing

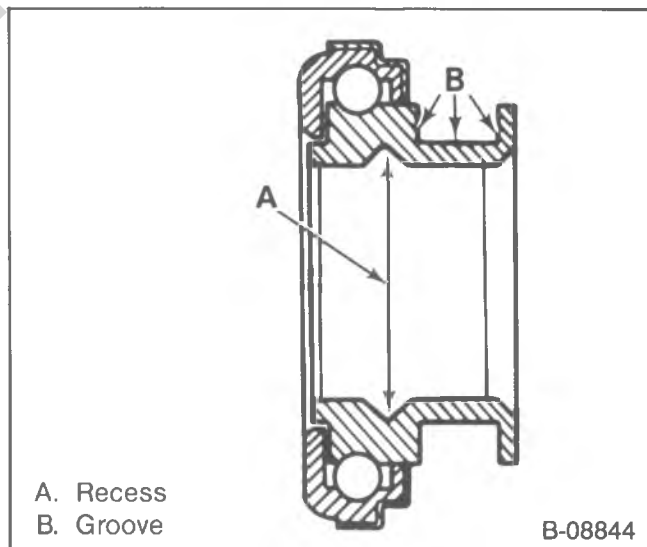

Figure 13—Release Bearing

SPECIFICATIONS

FASTENER TORQUE

	N·m	Ft. Lbs.
Flywheel Housing to Engine	54	40
Clutch Pedal Stud	39	29
Master Cylinder	18	13
Secondary (Slave) Cylinder	18	13
Cross Lever Ball Stud -		
Bracket Side	27	20
Engine Side (G Models)	54	40
(P Models)	46	34
Adjusting Rod Swivel (G Models)	43	32
(P Models)	27	20

CLUTCH PEDAL FREE TRAVEL

	mm	in.
G Models	34	1.375
P Models (Without JF9)	34	1.375
P Models (With JF9)	38	1.500

LUBRICATION

Hydraulic Clutch -	
Capacity	Fill to level of diaphragm.
Type recommended	Brake fluid meeting DOT 3.

SPECIAL TOOLS

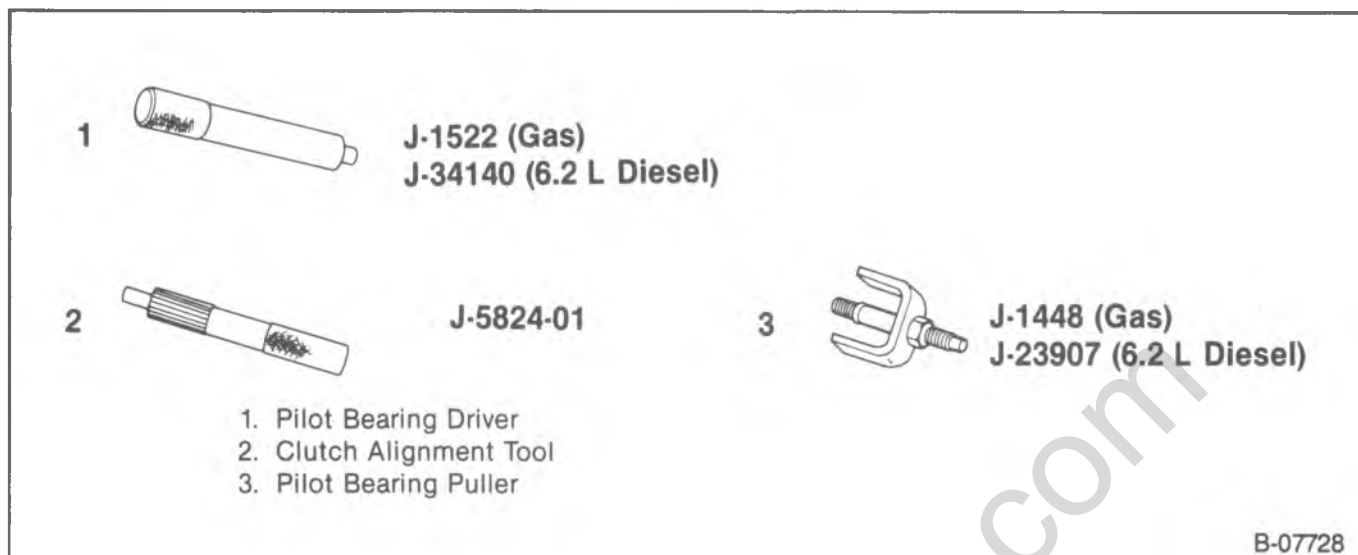

Figure 14—Special Tools

classiccarlibrary.com

SECTION 7D1

205 TRANSFER CASE

CONTENTS

SUBJECT	PAGE
Description	7D1-1
Maintenance and Adjustment	7D1-2
Diagnosis of the Transfer Case	7D1-2
On-Vehicle Service	7D1-3
Transfer Case Replacement	7D1-3
Specifications	7D1-5

DESCRIPTION

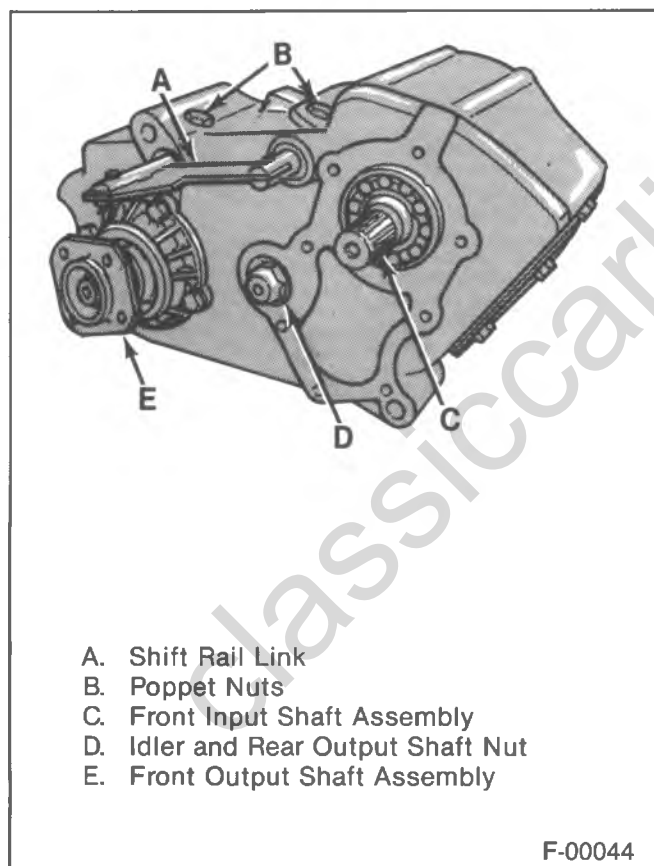

Figure 1—Front View

The 205 transfer case mounts behind the transmission and allows drive torque to be transmitted in a proportional split to both the front axle and the rear axle, resulting in four-wheel drive (figures 1 and 2).

The shift control lever for the transfer case is floor-mounted in the passenger compartment.

The model 205 is a two-speed unit, which offers two-wheel or four-wheel direct drive (1:1 ratio), is

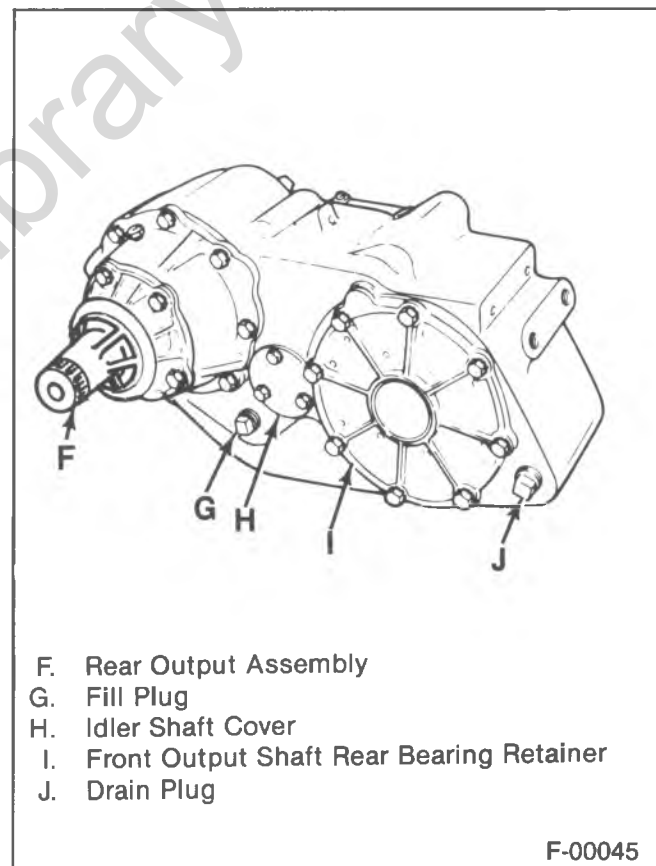

Figure 2—Rear View

available in two modes: 2H for two-wheel drive or 4H for four-wheel drive. Gear reduction (1.96:1 ratio) is used in the 4L position. This unit uses constant mesh helical gears to connect the input shaft, idler gear and two output gears, thus allowing gear selection to match driving conditions.

When driving in a four-wheel mode (4L or 4HI), turn the hubs on the front wheels to the "Locked" position.

MAINTENANCE AND ADJUSTMENT

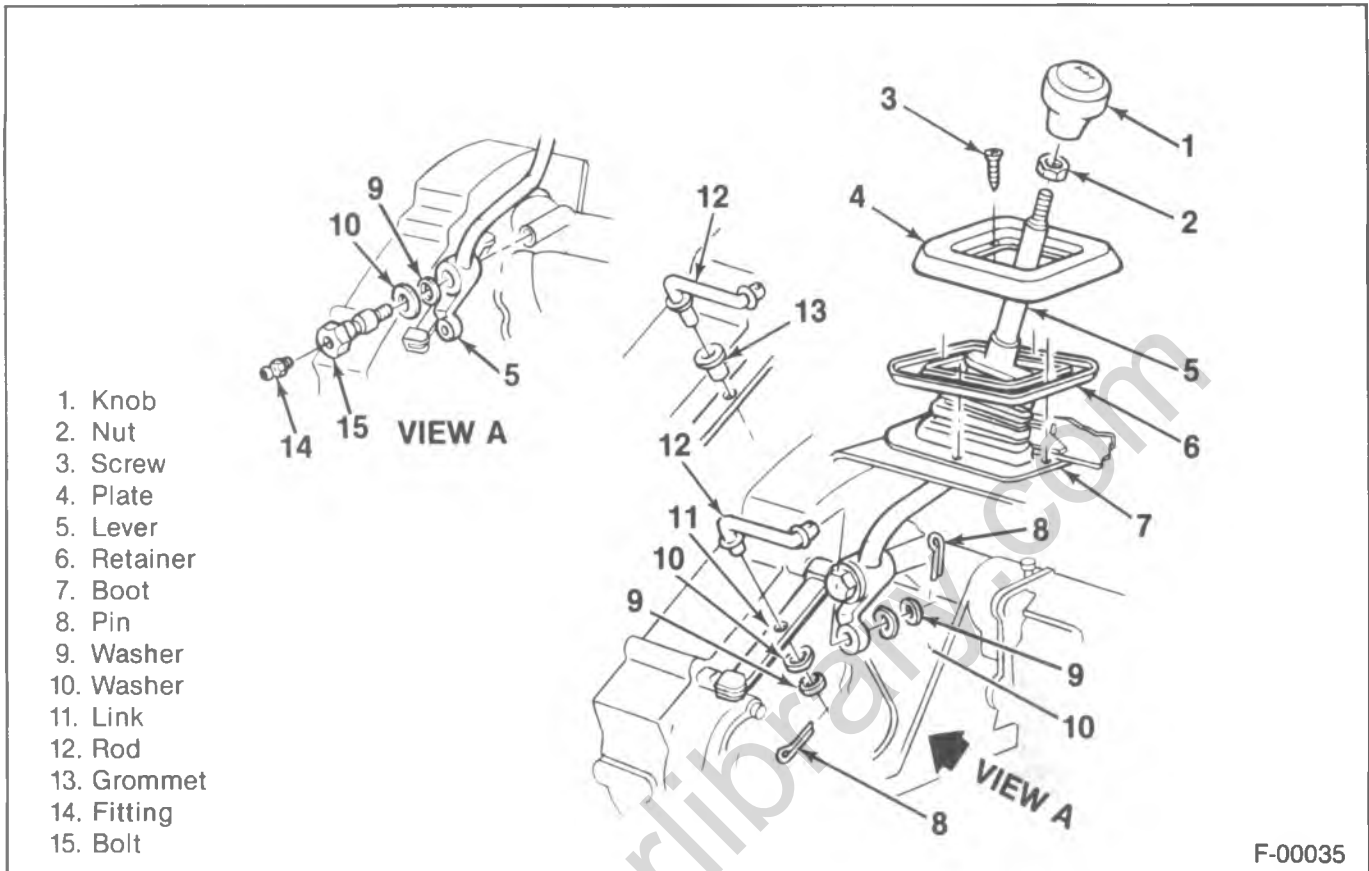

Figure 3—Shift Control Component View

LUBRICATION INFORMATION

Refer to Section 0B for information on intervals and types of lubricant.

LINKAGE ADJUSTMENT AND INSPECTION

Periodically inspect the linkage system for freedom of operation, proper engagement, loose attaching bolts, foreign material, etc. Adjust, clean and tighten as necessary (figure 3).

DIAGNOSIS OF THE TRANSFER CASE

Before servicing a malfunction, check the front hubs, axles, propeller shafts, wheels and tires, transmission or clutch.

PROBLEM	POSSIBLE CAUSE	CORRECTION
Excessive Noise	<ol style="list-style-type: none"> 1. Lubricant level low. 2. Worn or damaged bearings. 3. Misalignment of propeller shafts or universal joints. 4. Flange bolts loose. 5. Loose adapter bolts. 	<ol style="list-style-type: none"> 1. Fill as required. 2. Replace. 3. Align. 4. Refer to Specifications. 5. Refer to Specifications.
Shift Lever Difficult To Move	Binding inside the transfer case.	Repair as required.
Shifter Lever Disengages From Position	<ol style="list-style-type: none"> 1. Gears worn or damaged. 2. Shift rod bent. 3. Missing detent ball or spring. 	<ol style="list-style-type: none"> 1. Replace. 2. Replace. 3. Replace.
Lubricant Leaking	<ol style="list-style-type: none"> 1. Excessive lubricant in case. 2. Leaking seals or gaskets. 3. Loose bolts. 4. Scored flange in seal contact area. 	<ol style="list-style-type: none"> 1. Adjust level. 2. Replace. 3. Tighten 4. Refinish or replace.

ON-VEHICLE SERVICE

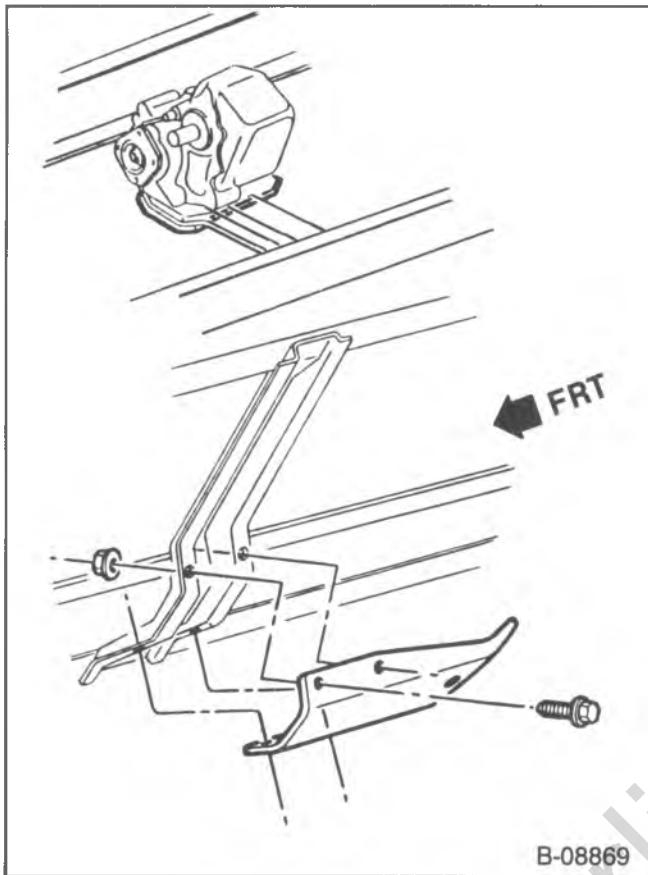

Figure 4—Skid Plate

TRANSFER CASE REPLACEMENT

↔ Remove or Disconnect

- Raise and support the vehicle on a suitable hoist.
- Drain the transfer case.
- 1. Speedometer cable.
- 2. Skid plates and crossmembers (figure 4).
- 3. Strut rod (automatic transmissions) (figure 5).
- 4. Rear propshaft from the case.
 - Mark propshaft for assembly reference.
 - Tie it up and move it away from the work area.
- 5. Shift lever rod from the shift rail link.
- 6. Bolts attaching the transfer case to the transmission adapter (figure 6).
 - Support the transfer case with a suitable stand.
- 7. Transfer case.
 - Move the transfer case to the rear until the input shaft clears the adapter.

→→ Install or Connect

- Support the transfer case in a suitable stand and position the case to the transmission adapter.
- 1. Bolts attaching the case to the adapter (figure 6).

Tighten

- Bolts to 61 N·m (45 ft. lbs.).
- Remove the stand.

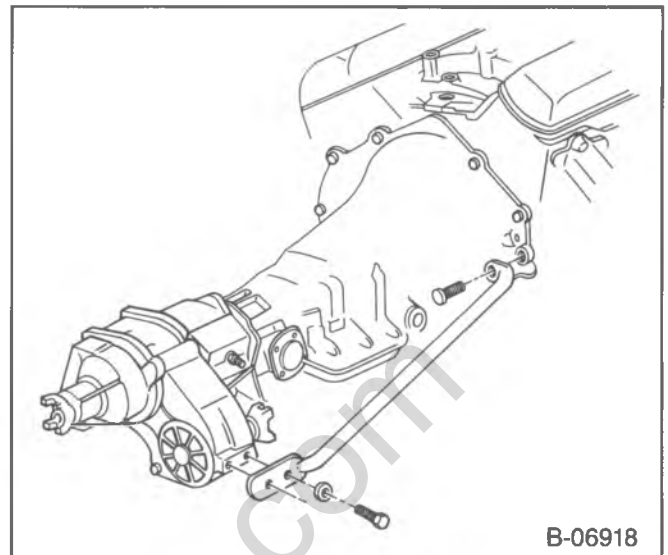

Figure 5—Strut Rod Support
(Automatic Transmissions)

- 2. Connecting rod to the shift rail link or connect the shift lever to transfer case as required (figure 3).

Tighten

- Nuts to 17 N·m (12 ft. lbs.).

- 3. Front propshaft to the transfer case front output flange or yoke.

Tighten

- Bolts to 102 N·m (75 ft. lbs.).

- 4. Rear propshaft to the transfer case rear output yoke.

Tighten

- Bolts to 20 N·m (15 ft. lbs.).

- 5. Crossmember support and skid plate, if removed (figure 4).

Tighten

- Bolts to 63 N·m (46 ft. lbs.).

- 6. Strut rod (automatic transmission) (figure 5).

Tighten

- Transmission end bolts to 47 N·m (35 ft. lbs.).
- Transfer case end bolts to 175 N·m (129 ft. lbs.).

- 7. Speedometer cable.

- 8. Fill the transfer case to the proper level with lubricant. Refer to Section 0B.

- 9. Filler plug.

Tighten

- Plug to 44 N·m (32 ft. lbs.).

- Lower and remove the vehicle from hoist.

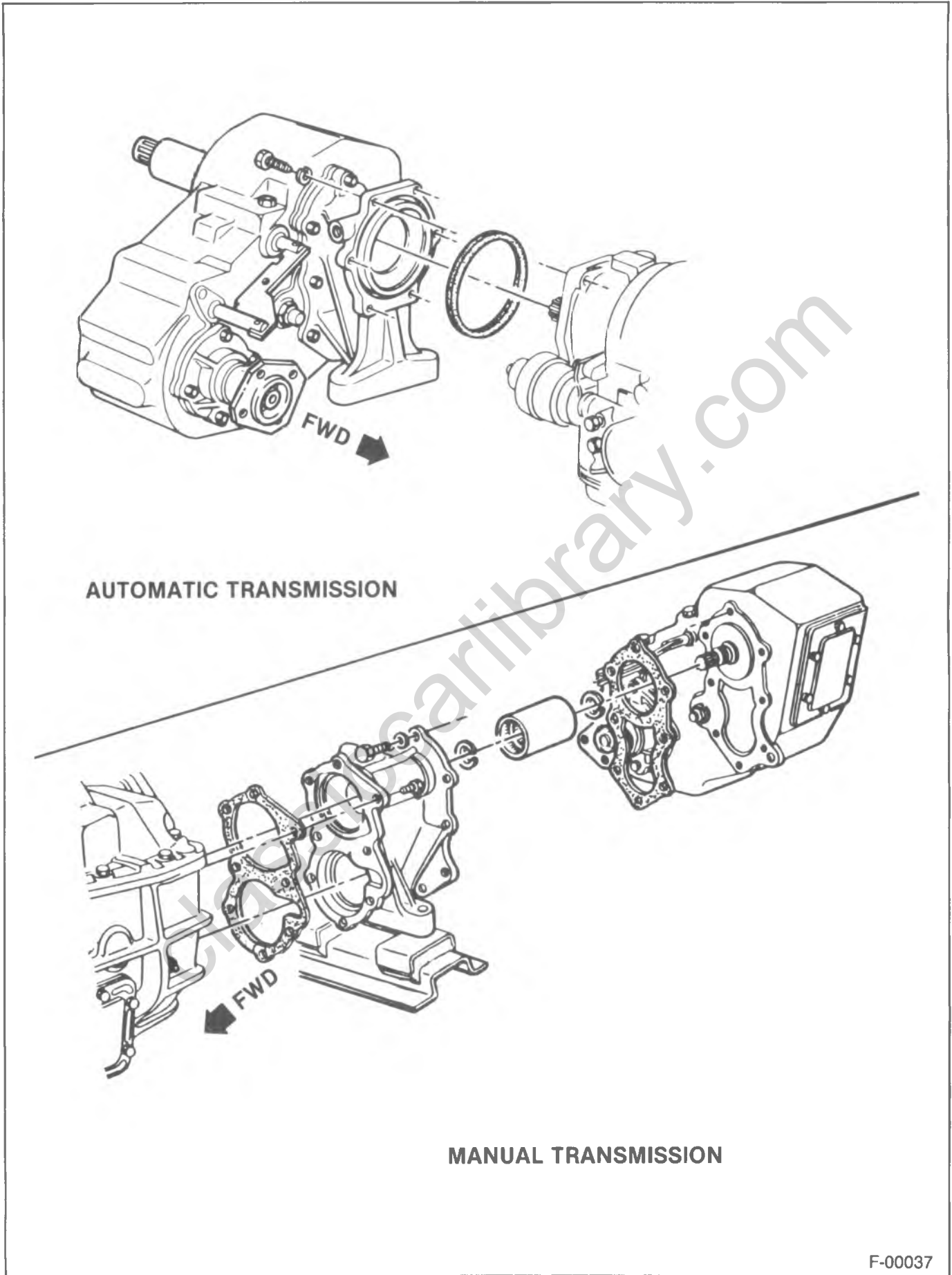

Figure 6—Transmission Adapters

SPECIFICATIONS

	N·m	Ft. Lbs.	In. Lbs.
Nut, Shift Lever-To-Shifter Assembly	23	17	
Nut, Knob Assembly-To-Shift Lever	33	24	
Bolt, Shifter Assembly-To-Transfer Case	135	100	
Nut, Shift Arms-To-Case	17	13	
Screw, Shift Lever Boot Retainer	2.7		31
Bolt, Adapter-To-Transmission	33	24	
Bolt, Adapter-To-Transfer Case	33	24	
Drain Plug	44	32	
Filler Plug	44	32	
Bolts P.T.O. Cover	22	16	
Nut, Skid Plate-To-Crossmember	63	46	
Bolt, Support Strut Rod			
—Transmission End	47	35	
—Transfer Case End	175	129	
Propeller Shaft			
—Transfer Case (Front)	75	55	
—Transfer Case (Rear)	15	11	

MODEL NO.	205 (PART TIME)
AVAILABILITY	All K30 Series
RATIOS: Hi Range Lo Range	1.00 To 1 1.96 To 1
LEVER POSITIONS	4-Lo (All Wheel Underdrive) N (Neutral) 2-Hi (Rear Wheel Drive) 4-Hi (All Wheel Direct Drive)
LEVER LOCATION	Rear Of Transmission Shift Lever
POWER TAKE-OFF DATA: Opening and Location	SAE 6-Bolt; Left Side
LUBRICANTS: Oil Capacity	5.2 Pints*
Type, Grade	Dexron® II

*To Be Filled Within One Inch Of Fill Plug.

classiccarlibrary.com

SECTION 7D2

208 TRANSFER CASE

CONTENTS

<u>SUBJECT</u>	<u>PAGE</u>
Description	7D2-1
Diagnosis of the Transfer Case	7D2-3
On-Vehicle Service	7D2-4
Maintenance and Adjustment	7D2-4
Transfer Case Replacement	7D2-5
Specifications	7D2-8

DESCRIPTION

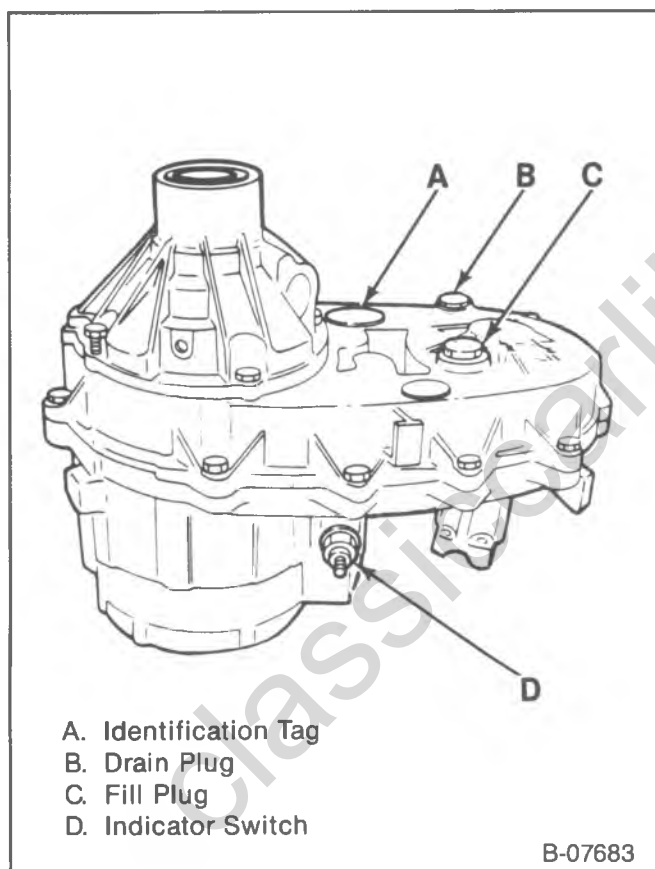

Figure 1—Indicator Switch, Identification, Tag and Drain and Fill Plug Location

The Model 208 transfer case is an aluminum case, chain driven, four position unit providing four-wheel drive high and low ranges, a two-wheel high range and a neutral position. The model 208 is a part-time four-wheel drive unit. Torque input in four-wheel high and low ranges is the same (figure 1).

A two-piece aluminum case contains front and rear output shafts, two drive sprockets, a shift mechanism and a planetary gear assembly. The drive sprockets are connected and operated by the drive chain. The planetary assembly, which consists of a four pinion carrier and an

annulus gear, provides the four-wheel drive low range when engaged. Reduction ratio is 2.61:1 in this range.

SHIFT CONSOLE AND LEVER CONTROLS

A floor mounted shift lever is used to select the operating range (figure 2). The shift lever is located on the floorpan transmission tunnel adjacent to the transmission gearshift lever. The shift pattern is not in a straight line for 208 models (figure 3).

FOUR-WHEEL DRIVE INDICATOR LAMP

An indicator lamp mounted in the instrument panel, alerts the driver whenever the vehicle is being operated in four-wheel range. An indicator switch in the transfer case controls the light (Figure 2).

The switch is a ball and plunger unit activated by the range selector when four-wheel range is selected.

IDENTIFICATION

For servicing, an identification tag attached to the rear half of the transfer case provides the transfer case model number, low range reduction ratio and assembly number. If the tag is removed or becomes dislodged during service operations, reattach using an adhesive sealant such as Loctite 312 or equivalent (figure 1).

LUBRICATION

Change the lubricant at the intervals specified in the Maintenance Schedule. When adding lubricant or refilling the transfer case after servicing, use Dexron® II. Refer to the maintenance and adjustments section for lubricant change procedures and fill level.

7D2-2 208 TRANSFER CASE

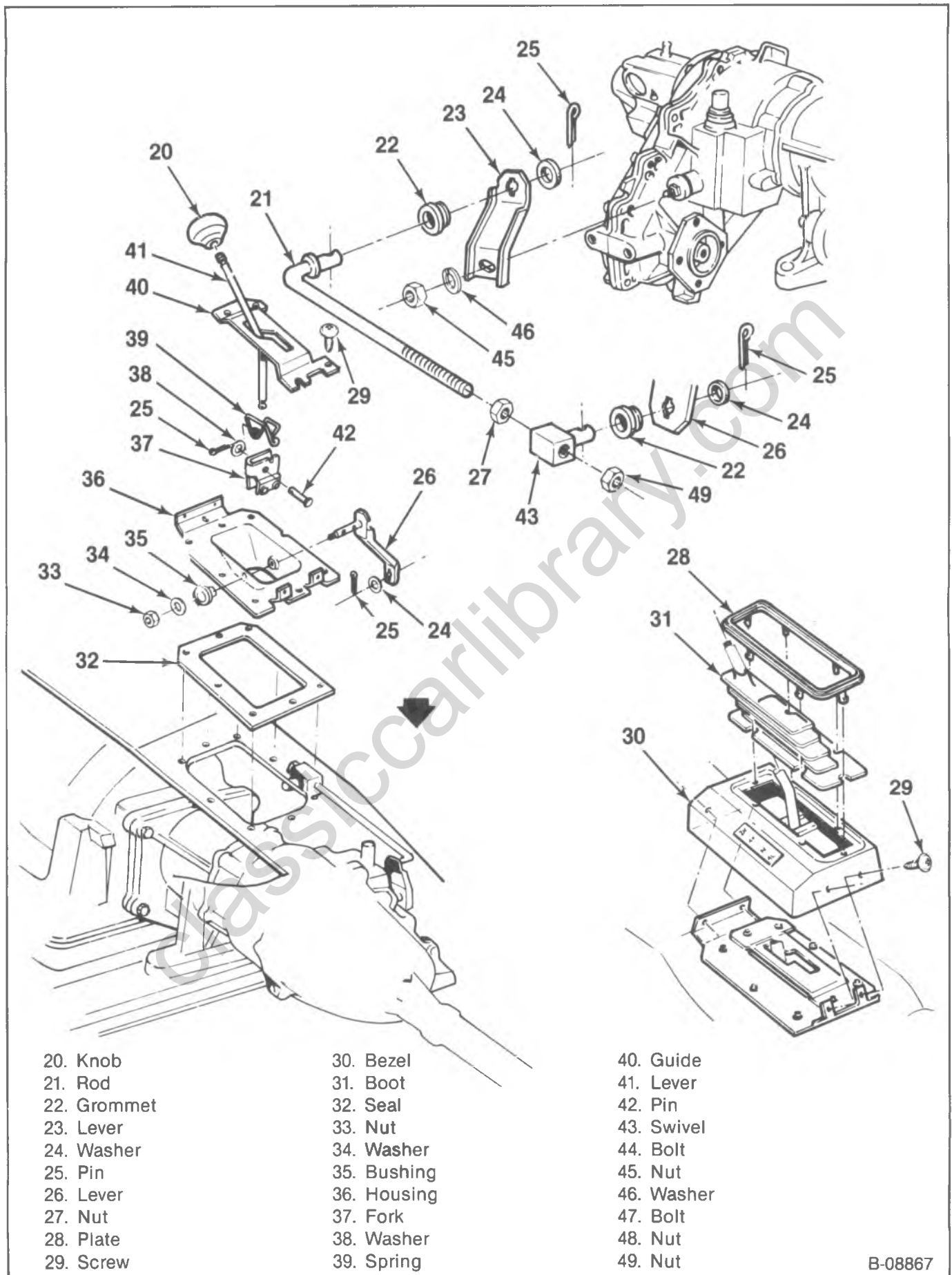

Figure 2—Console and Shift Control Component View

B-08867

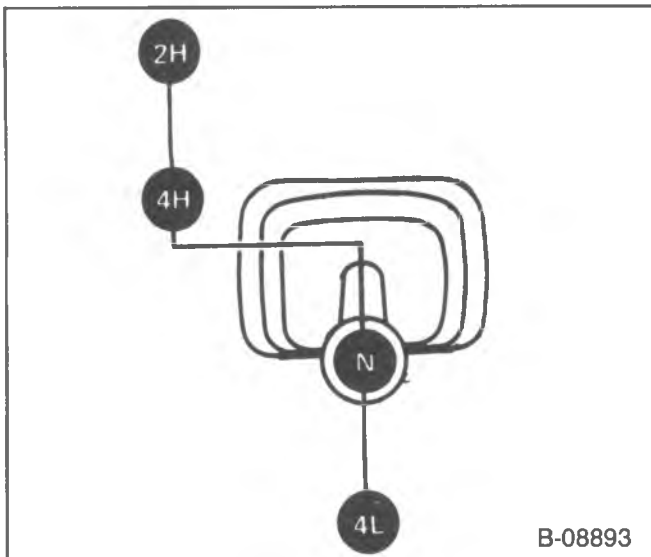

Figure 3—Shift Lever

DIAGNOSIS OF THE TRANSFER CASE

Before repairing a suspected transfer case problem check the driveline components. The problem may be related to the front hubs, axles, propeller shafts, wheels and tires, transmission or clutch.

PROBLEM	POSSIBLE CAUSE	CORRECTION
Transfer Case Difficult To Shift Or Will Not Shift Into Desired Range	<ol style="list-style-type: none"> 1. Vehicle speed is too great to permit shifting. 2. If the vehicle was operated for extended period in the 4H mode on dry paved surface, driveline torque load may cause difficult shifting. 3. Transfer case external shift linkage is binding. 4. Insufficient or incorrect lubricant. 5. Internal components binding, worn or damaged. 	<ol style="list-style-type: none"> 1. Stop the vehicle and shift into the desired range. Or reduce the speed to 2-3 mph (3-4 km/h) before attempting to shift. 2. Stop the vehicle, shift the transmission to neutral, shift the transfer case to 2H mode and operate the vehicle in 2H on dry paved surfaces. 3. Lubricate, repair or replace linkage, or tighten loose components as necessary. 4. Drain and refill to the edge of the fill hole with DEXRON® II. 5. Disassemble the unit and replace worn or damaged components as necessary.
Transfer Case Noisy In All Drive Modes	<ol style="list-style-type: none"> 1. Insufficient or incorrect lubricant. 	<ol style="list-style-type: none"> 1. Drain and refill to the edge of the fill hole with DEXRON® II. Check for leaks and repair if necessary. If unit is still noisy after draining and refilling, disassemble and inspect to locate the source of the noise.
Noisy In — Or Jumps Out Of Four Wheel Drive Low Range	<ol style="list-style-type: none"> 1. Transfer case is not completely engaged in 4L position. 2. Shift linkage is loose or binding. 3. Range Fork cracked, inserts worn, or fork is binding on shift rail. 4. Annulus gear or lockplate is worn or damaged. 	<ol style="list-style-type: none"> 1. Stop the vehicle, shift the transfer case into Neutral, then shift back into the 4L position. 2. Tighten, lubricate or repair linkage as necessary. 3. Disassemble the unit and repair as necessary. 4. Disassemble the unit and repair as necessary.

DIAGNOSIS OF THE TRANSFER CASE (CONT.)

PROBLEM	POSSIBLE CAUSE	CORRECTION
Lubricant Leaking From Output Shaft Seals Or From Vent	<ol style="list-style-type: none"> 1. Transfer case overfilled. 2. Vent closed or restricted. 3. Output shaft seals damaged or installed incorrectly. 	<ol style="list-style-type: none"> 1. Drain to the correct level. 2. Clear or replace the vent if necessary. 3. Replace seals. Be sure seal lip faces interior of case when installed. Also be sure flange seal surfaces are not scored or nicked. Remove scores, nicks with fine sandpaper or replace the flange if necessary.
Abnormal Tire Wear	<ol style="list-style-type: none"> 1. Extended operation on dry hard surface (paved) roads in 4H range. 	<ol style="list-style-type: none"> 1. Operate in 2H on hard surface (paved) roads.

ON-VEHICLE SERVICE

MAINTENANCE AND ADJUSTMENT

CASE-OIL CHANGE

↔ Remove or Disconnect

- Raise the vehicle.
- Position a drain pan under the transfer case.
- Drain and fill plugs.
- Drain the lubricant.

→ Install or Connect

1. Drain plug.

Tighten

- Plug to 24 N·m (18 ft. lb.).
- Remove the drain pan.
- Fill the transfer case to the edge of fill plug opening with DEXRON® II.

2. Fill plug.

Tighten

- Plug to 24 N·m (18 ft. lb.).
- Lower the vehicle.

INSPECTION

Periodically inspect the linkage system for freedom of operation, proper engagement, loose attaching bolts and foreign material.

LINKAGE ADJUSTMENTS

Adjust (Figures 1 and 4)

1. Put the transfer case lever into the 4H detent (Figure 4).
2. Push the lower shifter lever (26) forward into the 4H detent.
3. Install the rod swivel (21) into the shift lever hold.

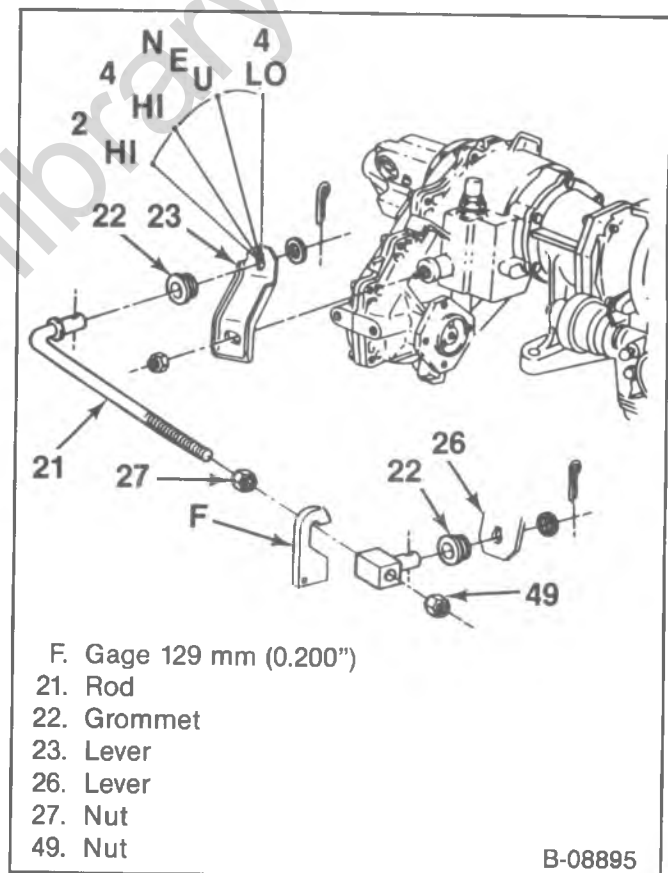

Figure 4—Linkage Adjustment

4. Hang a 129 mm (0.200) gage (F) with a 6 mm (0.25 inch) radius over the rod behind the swivel.
5. Run the rear rod nut (27) against the gage with the shifter against the 4H detent.
6. Remove the gage and push the swivel rearward against the nut (27).
7. Run the front rod nut (49) against the swivel and tighten.

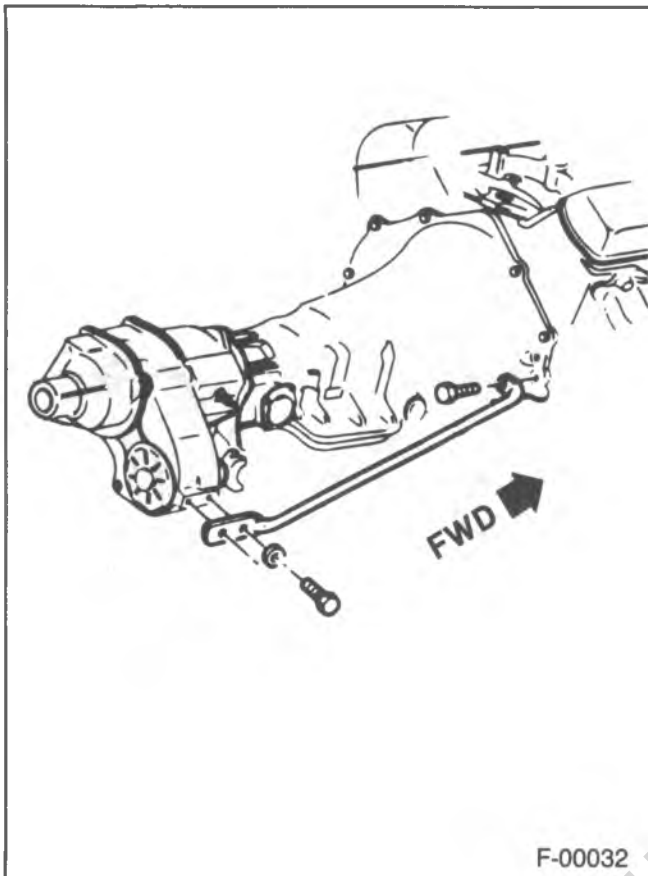

Figure 5—Strut Rod Support—Automatic Transmission

TRANSFER CASE REPLACEMENT

↔ Remove or Disconnect (Figures 2, 5, 6 and 7)

- Place the transfer case in 4H detent.
 - Raise the vehicle.
 - Drain the lubricant from the transfer case.
1. Cotter pin from the shift lever swivel (figure 2).
 2. Speedometer cable.
 3. Indicator switch wire.
 4. Front and rear propeller shafts.
 - Mark the shafts and flange for assembly alignment reference.
 5. Parking brake cable guide from the pivot located on the right frame rail.
 6. Engine strut rod on automatic transmission models (figure 5).
 7. Transfer case-to-transmission adapter bolts (figure 6).
 - Support the transfer case with a suitable stand.
 8. Skid plate (figure 7).
 9. Case.
 - Move the transfer case rearward until it is free of the transmission output shaft.
 10. Gasket material.

→ Install or Connect (Figures 5, 6 and 7)

- Place the transfer case in 4H detent.
 - Place the transfer case in a support stand.
1. Gasket to the transmission (figure 6).
 2. Output shaft.

- Rotate the transfer case output shaft (turn flange) until the output shaft gear engages the transfer case input shaft.
- Move the transfer case forward until the case seats against the transmission.

NOTICE: Place the transfer case flush against the transmission. The case can be damaged if the attaching bolts are tightened when the case is cocked or in a bind.

3. Attaching bolts.

⌚ Tighten

- Bolts to 41 N·m (30 ft. lbs.)

4. Speedometer cable.

5. Front and rear propeller shafts.

⌚ Tighten

- Front flange bolts to 100 N·m (75 ft. lbs.).

! Important

- Line up the reference marks made during removal.

6. Skid plate (figure 7).

⌚ Tighten

- Bolts to 63 N·m (46 ft. lbs.).

- Remove the support stand from under the transfer case.

7. Parking brake cable if disconnected.

8. Cotter pin to the shift lever swivel (figures 2 and 4).

9. Strut rod support to the transfer case on automatic transmissions (figure 5).

⌚ Tighten

- Transmission bolts to 47 N·m (35 ft. lbs.).

- Transfer case bolts to 175 N·m (129 ft. lbs.).

10. Fill the transfer case with DEXRON® II.

- Lower the vehicle.

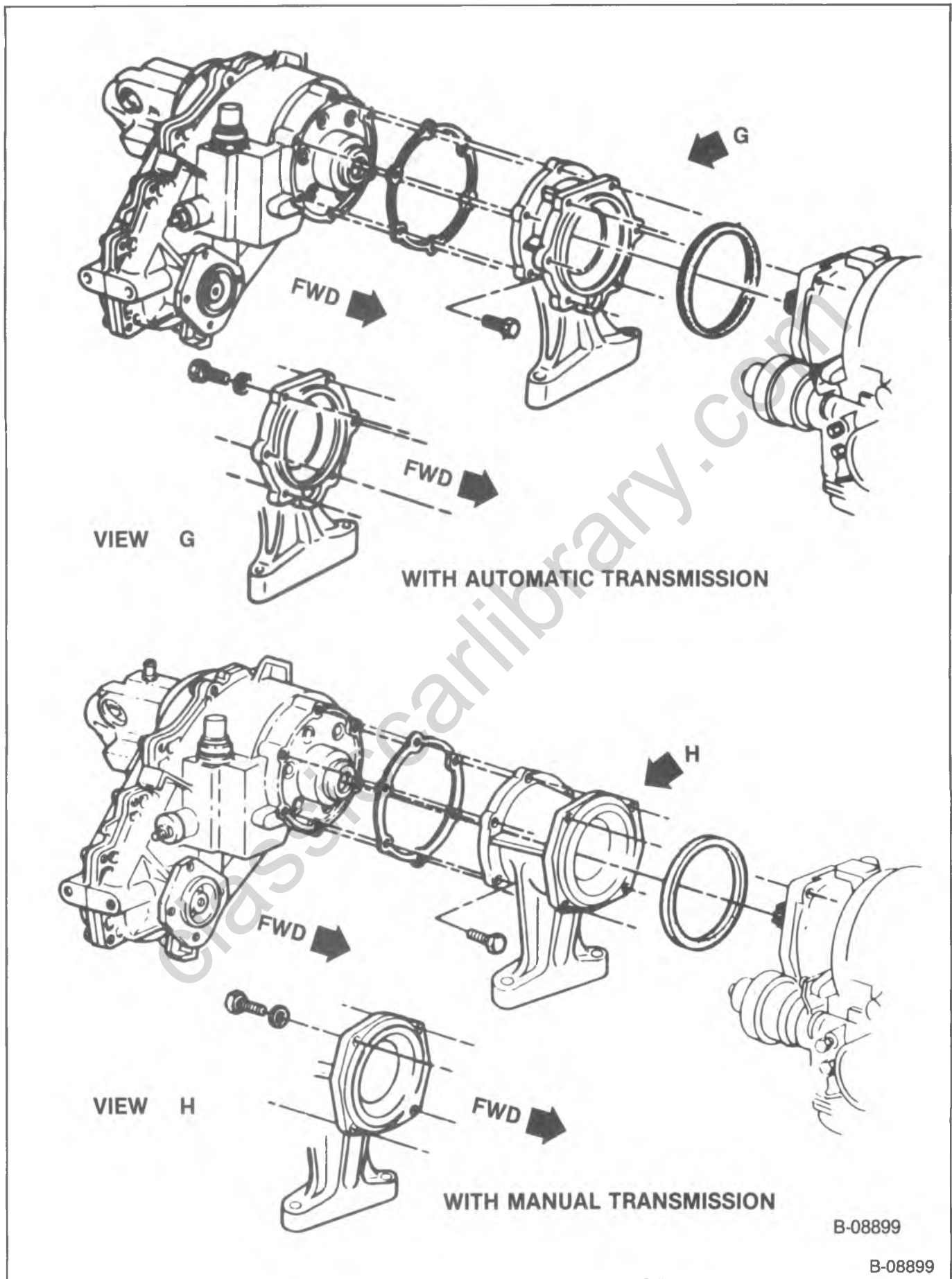

Figure 6—Transmission Adapters

B-08899

B-08899

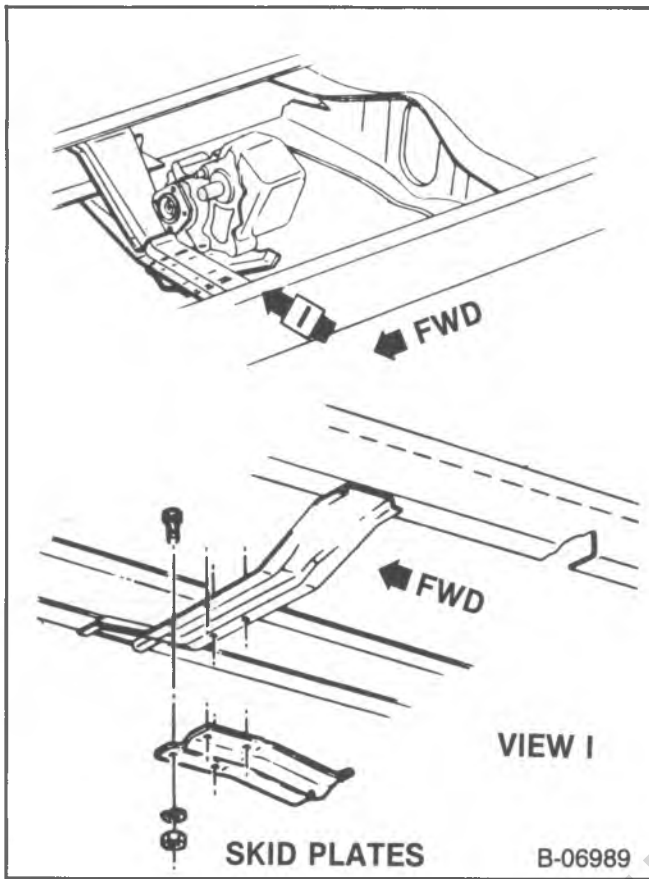

Figure 7—Skid Plate Installation

classiccarlibrary.com

7D2-8 208 TRANSFER CASE

SPECIFICATIONS

	N·m	Ft. Lbs.
Nut, Shift Lever-To-Shifter Assembly	23	17
Nut, Knob Assembly-To-Shift Lever	33	24
Bolt, Shifter Assembly-To-Transfer Case	130	96
Nut, Shift Arms-To-Case	17	13
Screw, Shift Lever Boot Retainer	2.7	24*
Bolt, Detent Retainer	31	23
Switch, Indicator	149	111
Bolt, Adapter-To-Transmission	33	24
Bolt, Adapter-To-Transmission Case	33	24
Filler Plug	47	35
Nut, Skid Plate-To-Crossmember	63	47
Bolt, Support Strut Rod		
— Transmission End	47	35
— Transfer Case End	175	129
Bolts, Front Propeller Shaft Flange	100	74
Transfer Case, Front	75	55
Transfer Case, Rear	15	11

* Inch Pounds

Model No.	208 (Part Time)
Ratios: Hi Range Lo Range	2.61 to 1
Lever Positions	4-Lo (All Wheel Underdrive) 2-Hi (Rear Wheel Drive) 4-Hi (All Wheel Drive)
Lever Location	Rear of Trans. Shift Lever
Lubricant: Oil Capacity Type, Grade	10 Pints* DEXRON® II

*Fill To The Edge Of The Plug Hole.

SECTION 8 ELECTRICAL

CONTENTS

<u>SUBJECT</u>	<u>PAGE</u>
Cab Electrical	8A- 1
Chassis Electrical.....	8B- 1
Instrument Panel	8C- 1

SECTION 8A CAB ELECTRICAL

CONTENTS

<u>SUBJECT</u>	<u>PAGE</u>
Basic Electrical.....	8A- 2
Circuits	8A- 2
Wire Size Conversion Table	8A- 4
Circuit Malfunctions.....	8A- 4
Circuit Diagnosis	8A- 4
Diagnostic Tools.....	8A- 4
Circuit Maintenance and Repair	8A- 6
Cab Electrical Systems	8A- 9
RV Cab Harness Routings	8A- 9
RV Fuse Block	8A-14
G Van Cab Harness Routings	8A-15
G Van Fuse Block.....	8A-17
Power Door Lock System	8A-17
Diagnosis of Power Door Lock System	8A-23
On-Vehicle Service.....	8A-24
Power Window System	8A-24
Diagnosis of Power Window System	8A-24
On-Vehicle Service.....	8A-26
Windshield Wiper—RV and G Models	8A-26
Description	8A-26
Diagnosis of Windshield Wiper	8A-26
On-Vehicle Service.....	8A-26
Windshield Washer—RV and G Models.....	8A-34
Description	8A-34
Windshield Washer Diagnosis	8A-35
On-Vehicle Service.....	8A-36
Wiper Motor Unit Repair	8A-36
Replacement of Components	8A-36
Windshield Wiper Delay Circuit	8A-38
Description	8A-38
Diagnosis of the Wiper Delay Circuit	8A-38
On-Vehicle Service.....	8A-38
Windshield Wiper and Washer—P Models	8A-40
Description	8A-40
Diagnosis.....	8A-41

CONTENTS (CONT.)

SUBJECT	PAGE
Diagnosis of the Wiper—On-Vehicle8A-43
Diagnosis of the Wiper—Off-Vehicle8A-43
Diagnosis of the Washer System8A-44
On-Vehicle Service8A-45
Unit Repair8A-45
Wiper Motor Disassembly8A-45
Inspection8A-45
Wiper Motor Assembly8A-46
Windshield Washer Disassembly8A-47
Windshield Washer Assembly8A-48
Heater System Circuits8A-48
Description8A-48
Diagnosis8A-48
On-Vehicle Service8A-48
Air Conditioning Electrical System8A-48
Description8A-48
Diagnosis8A-48
On-Vehicle Service8A-48
Special Tools8A-49

BASIC ELECTRICAL

CIRCUITS

An electrical circuit starts from a supply of electricity, conducts the electricity back to the supply of electricity. There should be a device to open and close the circuit, and a protective device to open the circuit in case too much current flows in the circuit.

Electrical circuits can be set up as series circuits or parallel circuits. The circuits in trucks are usually parallel circuits.

SERIES CIRCUITS (Figure 1)

In series circuits, each electrical device is connected in the circuit so that the current can only go along one path as it flows from the power supply, around the circuit and back to the power supply.

PARALLEL CIRCUITS (Figure 1)

In parallel circuits, the electrical devices are connected by parallel wires that are joined at the start of the circuit. The current divides: part of it flows into one device, part into another.

With circuits in parallel, each circuit can be switched on and off by itself since each circuit receives electricity directly from the power supply.

CIRCUIT COMPONENTS (Figure 2)

The usual circuit path starts at the power supply which is the battery/generator system. Next in the circuit is the circuit protection component which can be a fusible link, a fuse, or a circuit breaker. Then the circuit goes to the circuit controller which can be a switch or a relay. From

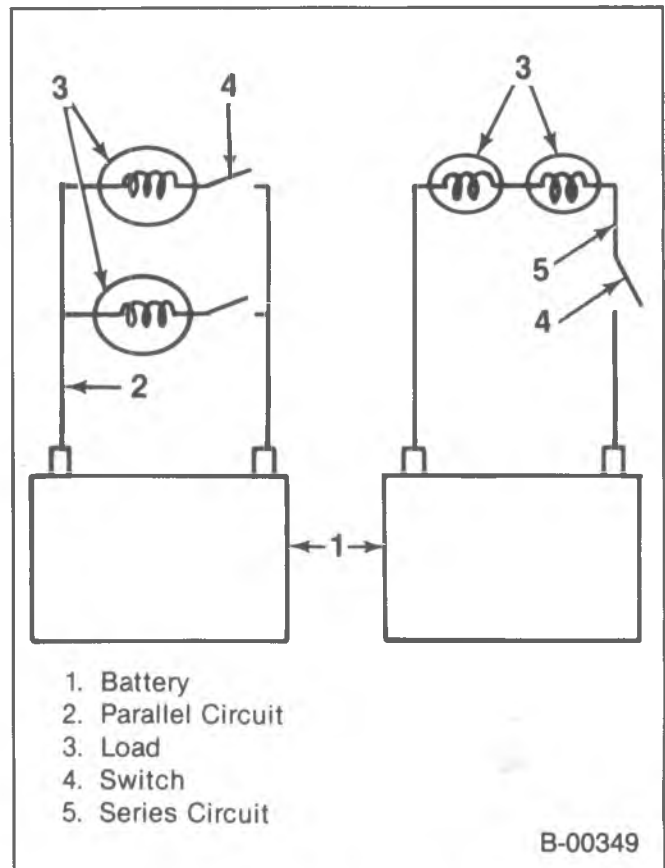

Figure 1—Basic Circuits

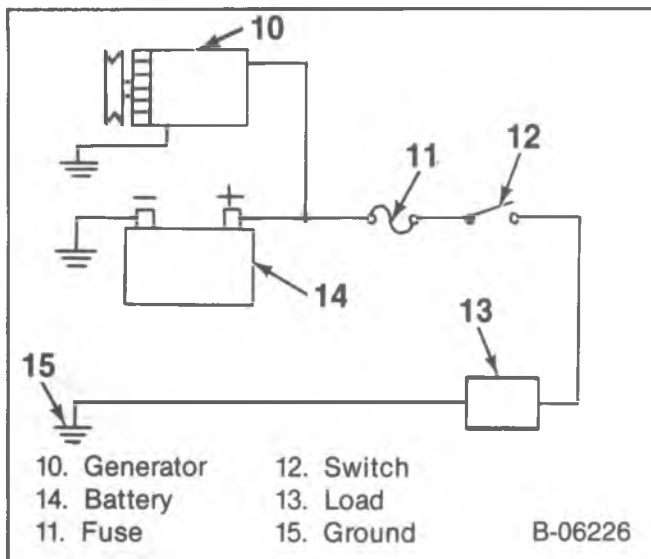

Figure 2—Circuit Components

the circuit controller the circuit goes into the circuit load. The circuit load can be one light or many lights in parallel, an electric motor or a solenoid. After the electricity has passed through the load it must return to the power supply via the ground path. The ground path can be a wire in the harness or it could be through the load housing into the body or frame, thus returning the electricity to the power supply. The body and frame are connected by flexible ground straps.

FUSIBLE LINK

A fusible link is a section of wire that is usually four gage sizes smaller than the circuit it protects. A special insulation is used that swells when heated by the wire. Fusible links are usually found in the engine compartment harnesses. The function of the fusible link is to melt open when an overload occurs, thus preventing any damage to the circuit.

FUSES

The most common protector in the vehicle circuit is a fuse. A fuse consists of a fine wire or strip of metal inside a glass tube or plastic housing. The strip melts and interrupts the flow of current in the circuit when there is an overload caused by an unwanted short or ground. The fuse is designed to melt before the wiring or electrical components in a circuit can be damaged. Naturally, the cause must be located and corrected before the fuse is replaced or the new fuse will also blow.

Since different circuits handle different amounts of current, fuses of various ratings are used. Fuses are rated in amperes. Be sure to replace a blown fuse with a fuse of the connecting rating.

CIRCUIT BREAKERS

Circuit breakers are another form of circuit protector. There are two types of circuit breakers; automatic reset and remote reset.

The automatic reset breaker opens when excess current heats a bimetallic strip, causing the strip to bend and open a set of contacts. Then the strip cools and

closes the contacts. So the circuit breaker opens and closes until the excess current condition is corrected or the circuit is disconnected from the power supply.

The remote reset circuit breaker has a heating wire wound around the bimetallic strip. When an excess current happens, the strip heats, bends, and opens the contacts. Then a small current flows through the heat wire, keeping the strip hot and the contacts open. This type of breaker will stay open until either the power supply is disconnected from the circuit or the breaker is removed from the circuit. Then the breaker can cool and reset.

CIRCUIT CONTROLLERS

Circuit controllers consist of switches or relays. Switches are usually operated by a mechanical means such as a hand or lever. Switches are usually at the beginning of a circuit but can be used to control a ground path. For example, the switch controlling the headlights is at the power end of the circuit while the door switch controlling the domelight completes the ground path.

Relays are remotely controlled switches. They are used in high current circuits and in circuits controlled by sensors.

Relays are designed so that a small current circuit will be able to control a large current circuit.

WIRING HARNESS AND WIRES

Every wire is a specific size with colored or striped insulation that is indicated on the wiring diagrams. Insulation colors help to trace circuits and to make proper connections. Abbreviations and symbols used for indicating wire insulation colors and patterns are as follows:

BLK.	Black	PPL.	Purple
BRN.	Brown	TR.	Tracer
CHK.	Check	YEL.	Yellow
CR.	Cross	//.	Parallel
GRN.	Green	WHT.	White
NAT.	Natural	BLU.	Blue
SGL.	Single	STR.	Stripe
ORN.	Orange	PNK.	Pink
GR.	Gray	DK.	Dark

Some wires are grouped and taped together or encased in a split plastic casing. This grouping of wires is called a harness. For some purposes, it is more practical to use a single wire protected by a braided tubing called a loom.

Wiring harnesses are joined by using a multiple plug and receptacle connector block, or a terminal post chassis junction block. In the instrument panel area plastic insulated blade-type connectors and screw-type terminals are used.

Each harness or wire must be held securely in place by clips or other holding devices to prevent chafing of the insulation.

WIRE SIZE

Wire size in a circuit is determined by the amount of current, the length of the circuit and the voltage drop allowed. Wire size is specified using the metric gage. The metric gage describes the wire size directly in cross section area measured in square millimeters.

8A-4 CAB ELECTRICAL

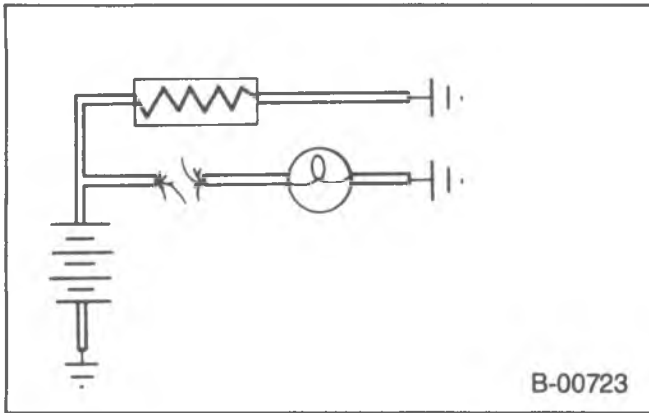

B-00723

Figure 3—Open Circuit

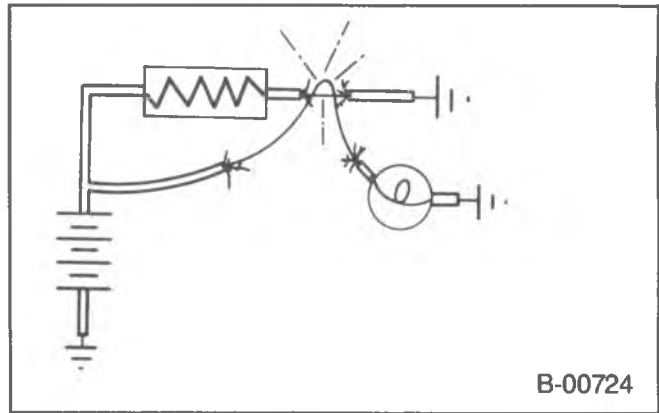

B-00724

Figure 4—Short Circuit

WIRE SIZE CONVERSION TABLE

METRIC SIZE (mm) ²	AWG SIZE
0.22	24
0.5	20
0.8	18
1.0	16
2.0	14
3.0	12
5.0	10
8.0	8
13.0	6
19.0	4
32.0	2
40.0	1
50.0	0
62.0	00

CIRCUIT MALFUNCTIONS

There are three electrical conditions that can cause a nonworking circuit; an "Open Circuit," a "Short Circuit," and a "Ground Circuit."

OPEN CIRCUIT (Figure 3)

An open circuit occurs whenever there is a break in the circuit. The break can be corrosion at the connector, a wire broken off in a device, or a wire that burned open from too much current.

SHORT CIRCUIT (Figure 4)

A short circuit happens when the current bypasses part of the normal circuit. This bypassing is usually caused by wires touching, salt water in or on a device such as a switch or a connector or solder melting and bridging conductors in a device.

GROUNDING CIRCUIT (Figure 5)

A ground circuit is like a short circuit but the current flows directly into a ground circuit that is not part of the original circuit. This may be caused by a wire rubbing against the frame or body. Sometimes a wire will break and fall against metal that is connected electrically to the ground side of the power supply. A ground circuit may

also be caused by deposits of oil, dirt and moisture around connections or terminals, which provide a good path to ground.

CIRCUIT DIAGNOSIS

A clear understanding of the circuit and a wiring diagram are needed for effective diagnosis. Use a logical sequence of testing to find the trouble. Use the diagnostic tools. After the trouble is fixed, make sure the circuit works correctly.

DIAGNOSTIC TOOLS

UNPOWERED TEST LAMP

This tool consists of a 12 volt lamp with leads. The ends of the leads usually have alligator clamps, but various kinds of probes, terminal spades, and special connectors are used also.

The unpowered test lamp is used on an open circuit. One lead of the test lamp is grounded and the other lead is moved around the circuit to find the open. Depending on the physical layout of the circuit, sometimes it will be easier to start at the power supply and other times it is easier to start at the circuit load or ground circuit.

POWER TEST LAMP

This lamp is a pencil shaped unit with a self contained battery, a 1.5 vol lamp bulb, a sharp probe and a ground lead fitted with an alligator clip.

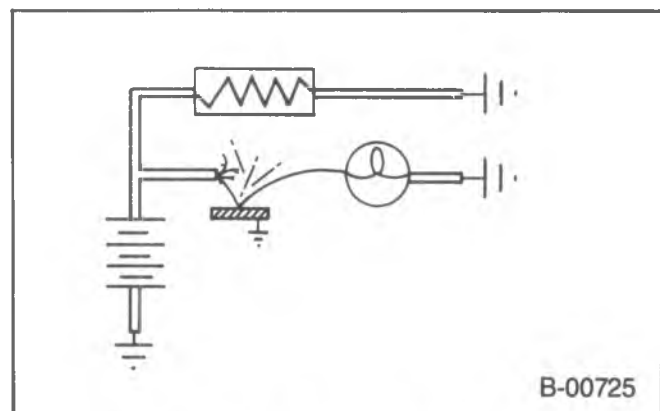

B-00725

Figure 5—Grounded Circuit

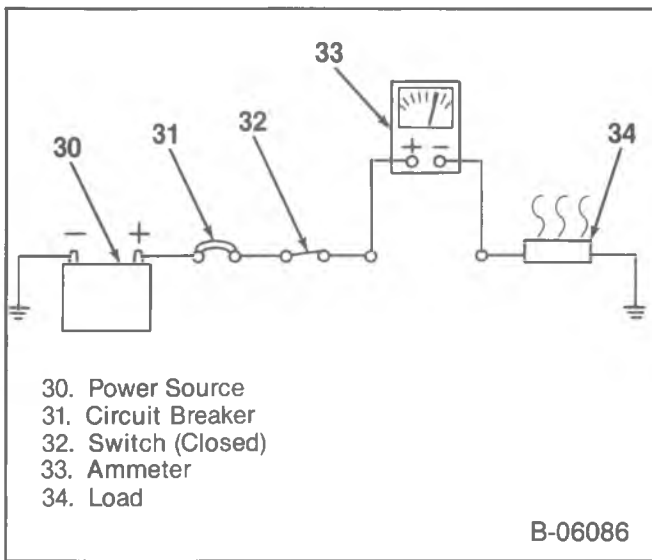

Figure 6—Ammeter Circuit

This test lamp is used mainly for testing components that are disconnected from the vehicle power supply. The power test lamp is also useful for testing suspected high resistance points in a circuit such as connectors and ground circuits that are corroded or loose.

JUMPER

The jumper is usually a long wire with alligator clamps. A version of the jumper has a fuse holder in it with a 10 Amp fuse. This will prevent damaging the circuit if the jumper is connected in the wrong way.

The jumper is used to locate opens in a circuit. One end of the jumper is attached to a power source and then the other end is attached to the load in the circuit, i.e.; lamp, motor. If the load works, try "jumping" to circuit points that are progressively closer to the power supply. When the circuit load stops working, the open has been located.

The jumper is also used to test components in the circuit such as connectors, switches, and suspected high resistance points.

NOTICE: The following instruments: Ammeter, Voltmeter, and Ohmmeter, each have a particular application for trouble shooting electrical circuits.

When using an ammeter or voltmeter, and the value being tested is unknown, always use the highest scale first and work downward to a midscale reading whenever possible. This will avoid damage to the instrument.

Never use an ohmmeter in a power circuit, or as a substitute for a voltmeter or ammeter, as damage to the instrument will result.

AMMETER (Figure 6)

Disconnect the circuit from the power source before connecting the ammeter. The ammeter measures the amount of electrical current, amperes, moving through a conductor. The ammeter must be placed in series with the circuit being tested. Be sure that the ammeter's positive

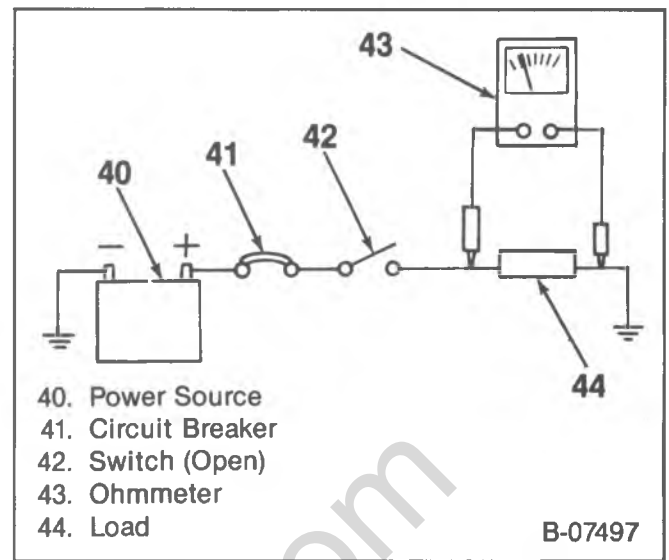

Figure 7—Ohmmeter Circuit

terminal is connected to the positive (battery) side of the circuit and the ammeter's negative terminal is connected to the negative (ground) side of the circuit.

OHMMETER (Figure 7)

The ohmmeter is an instrument designed to indicate resistance in ohms. It is used to test the condition of a unit disconnected from the circuit.

Ohmmeter Calibration

When the ohmmeter probes are connected together, a circuit is completed causing the meter needle to deflect. The needle should read ZERO ohms, if it does not, rotate the CAL or ADJ knob to ZERO the needle.

When the probes are held apart, the needle moves to the maximum (infinite) resistance side of the scale.

The meter is now ready for use.

VOLTMETER (Figure 8)

The voltmeter (properly observed) will give the technician more information than the ammeter, ohmmeter and test lamp combined. Its application for

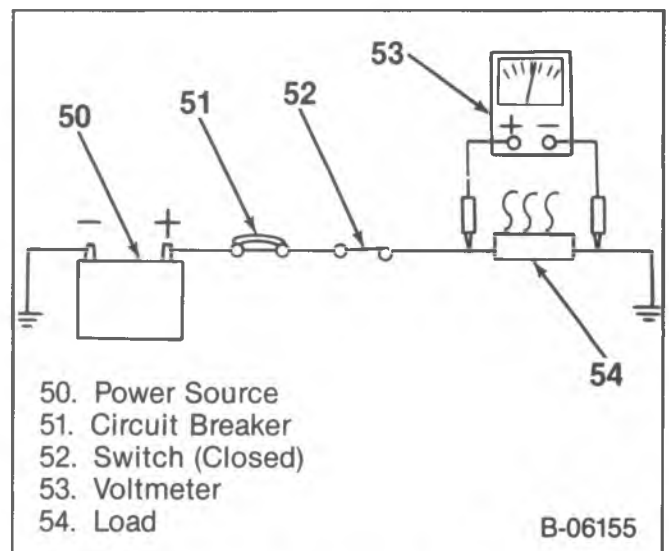

Figure 8—Voltmeter Circuit

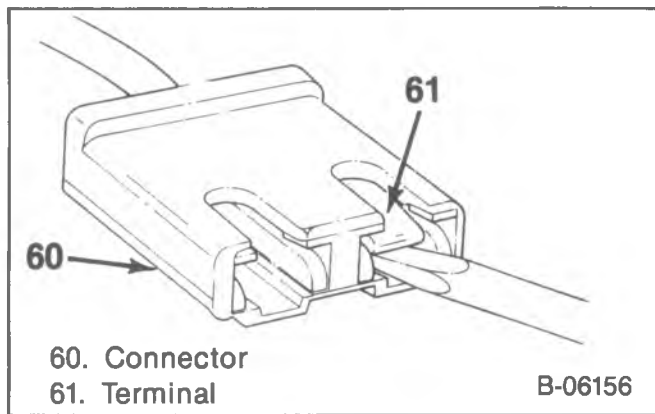

Figure 9—Removing Terminal

troubleshooting here is to measure the electrical pressure (voltage) drop in a resistance circuit.

To use a voltmeter for troubleshooting an electrical problem, connect it in parallel with the existing circuit. If the voltmeter is connected in series with the circuit being tested, the nature of the circuit would be changed and the reading would have no particular value or use. Connect the meter terminals according to polarity as shown.

The dash mounted voltmeter (in the vehicle) should also be observed for monitoring proper operation of the generator battery cranking motor, and cranking circuit. In this application, battery voltage drop can be monitored while the engine is cranking; and after the engine is running, generator output voltage can be monitored. This can be a valuable first step prior to diagnosing other electrical problems.

CIRCUIT MAINTENANCE AND REPAIR

MAINTENANCE AND REPAIR

All electrical connections must be kept clean and tight. Loose or corroded connections may cause a discharged battery, difficult starting, dim lamps, and possible damage to the generator and regulator. Wires must be replaced if insulation becomes burned, cracked, or deteriorated.

To splice a wire or repair one that is frayed or broken, always use rosin flux solder to bond the splice and insulating tape to cover all splices or bare wires.

When replacing wire, it is important that the correct size wire be used as shown on applicable wiring diagrams or parts book. Each harness or wire must be held securely in place to prevent chafing or damage to the insulation due to vibration.

Never replace a wire with one of a smaller size or replace a fusible link with a wire of a larger size.

WIRING CONNECTOR TERMINAL REPLACEMENT (BLADE TYPE)

Remove or Disconnect (Figure 9)

1. Terminal lock tang.
2. Terminal (61).

Install or Connect (Figure 10)

1. Pry up on the tang (70).
2. Terminal into the connector.

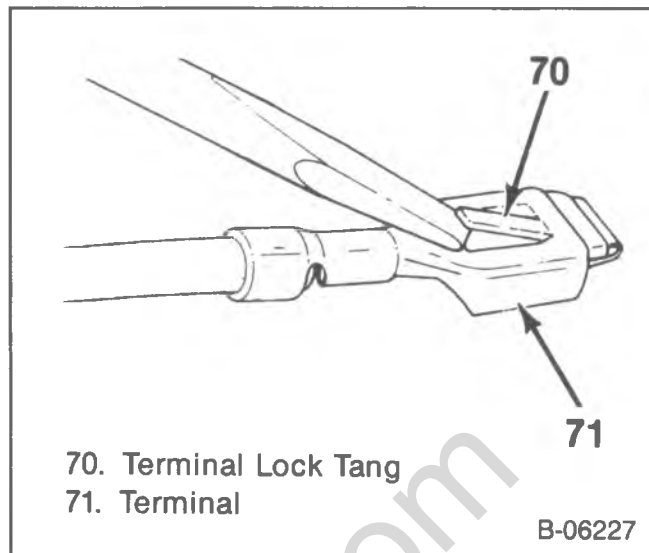

Figure 10—Resetting the Lock Tang

WIRING CONNECTOR TERMINAL REPLACEMENT (TWIN LOCK TYPE)

Remove or Disconnect (Figure 11)

Tool Required:

J-22727 Terminal Remover

1. Connector lock tangs.
2. Terminal locks using J-22727.
3. Terminal.

Install or Connect

1. Pry out the tangs.
2. Terminal into the connector.

METRI-PACK CONNECTOR REPLACEMENT

Remove or Disconnect (Figure 12)

Tool Required:

J-35689-A Terminal Remover

1. Primary lock (121) by lifting.

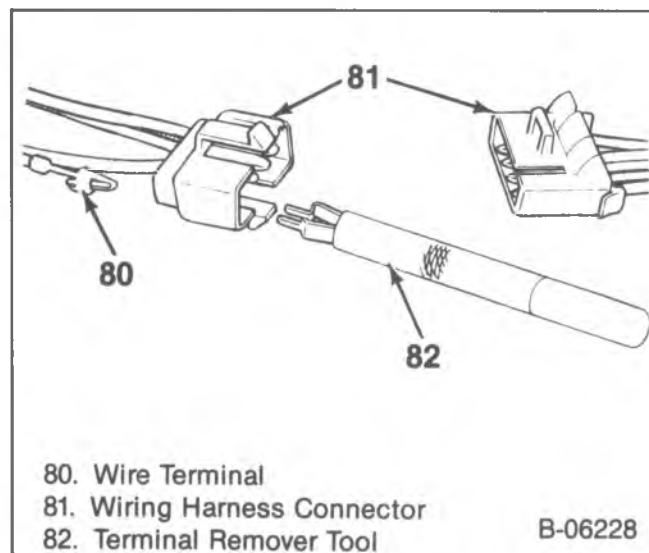
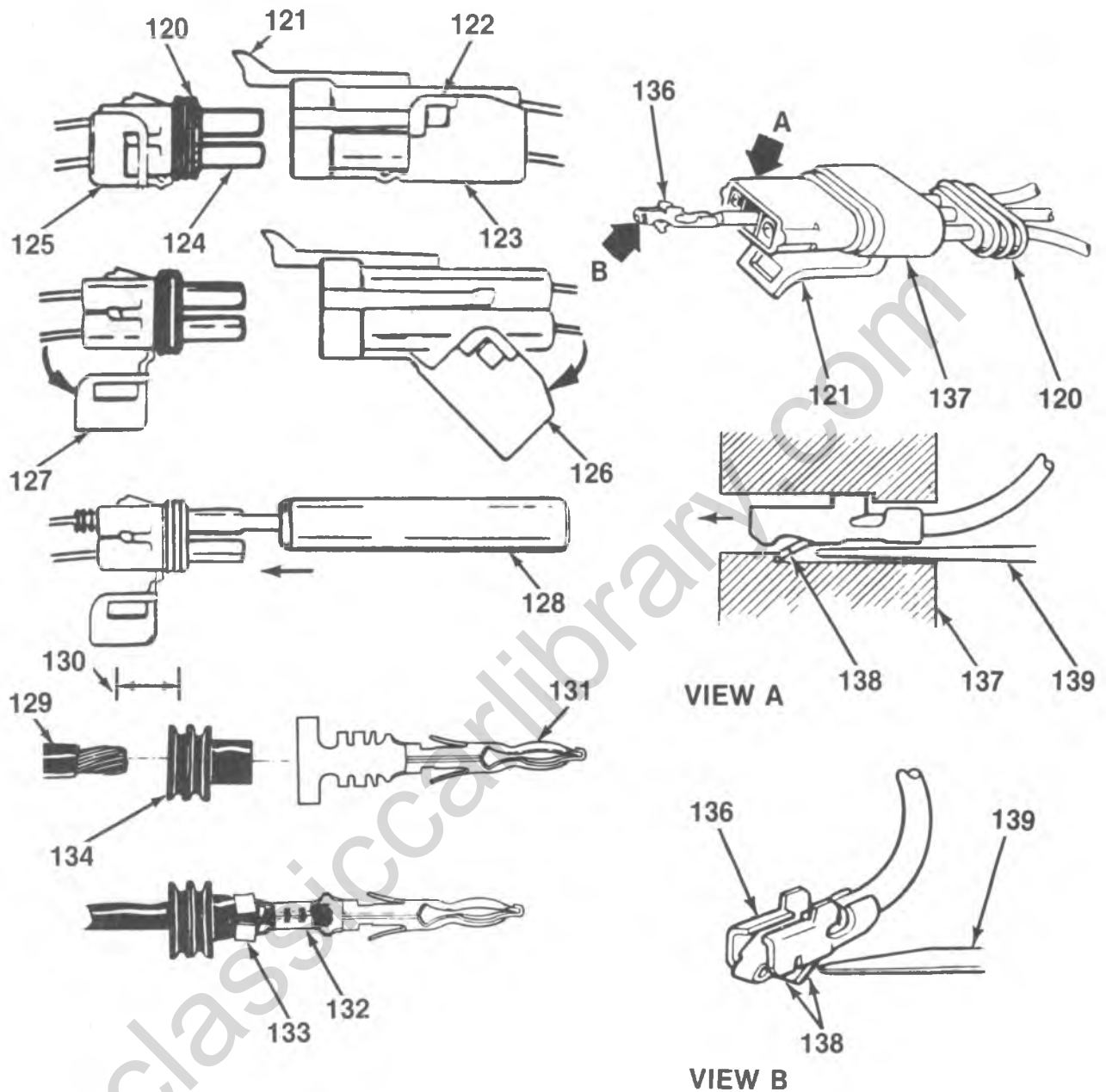

Figure 11—Twin Lock Connector Terminal



- | | |
|-------------------------------|--|
| 120. Connector Seal | 130. 5 mm (0.2 inch) |
| 121. Primary Lock | 131. Terminal |
| 122. Secondary Lock Staple | 132. Roll Crimp |
| 123. Secondary Lock | 133. Roll Crimp |
| 124. Terminal Barrel | 134. Terminal Insulator |
| 125. Secondary Lock | 136. Metri-Pack Series 150 Female Terminal |
| 126. Lock Opened | 137. Connector Body |
| 127. Lock Opened | 138. Locking Tang |
| 128. J-28742 Terminal Remover | 139. J-35689 Terminal Remover |
| 129. Wire | |

Figure 12—Weather-Pack and Metri-Pack Connectors

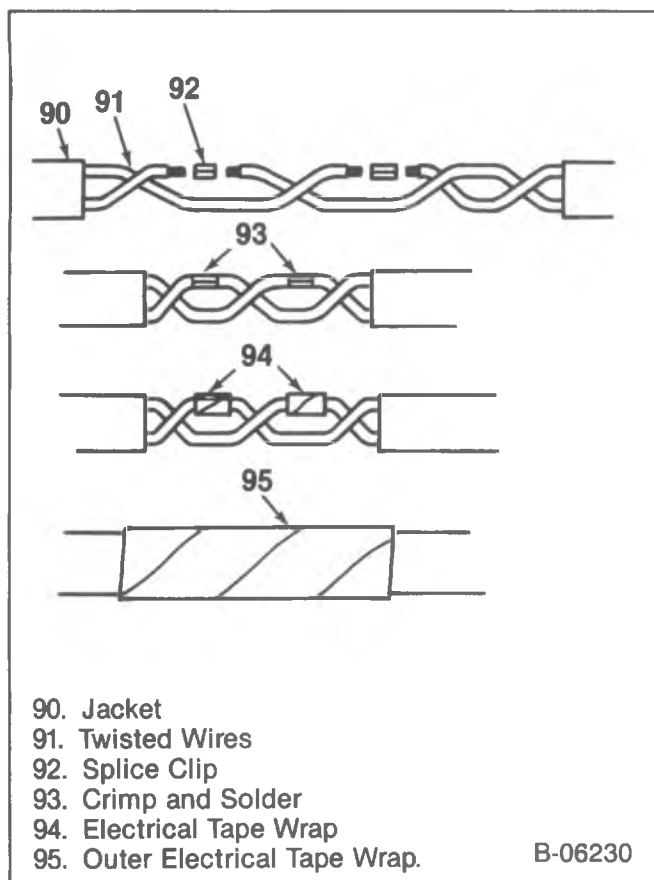

Figure 13—Twisted Lead Repair

2. Connector body (137).
3. Connector seal (120) by pulling the seal back onto the wires away from the connector body (137).
4. Terminal (136) by inserting J-35689 (139) into the connector body (137) to depress the locking tang (138), then push the wire and terminal through the connector body (Figure 12).
 - Snip off the old terminal unless the terminal is to be reused, reshape the locking tang.
5. 5 mm (0.2-inch) of the wire insulation (130).



Clean

- Terminal cavity of the connector body.



Install or Connect (Figure 12)

1. Terminal (136) on the wire.
 - Crimp and solder the terminal.
2. Terminal (136) into the connector cavity by pulling the wire on the seal side of the connector until the locking tang (138) is fully seated.
3. Seal (120) by pressing the seal into the connector body (137) until it is fully seated.
4. Connector until the primary lock (121) engages.

WEATHER-PACK CONNECTORS (Figure 12)

Special connectors known as Weather-Pack connectors require a special tool J-28742 for servicing. This special tool is required to remove the pin and sleeve terminals. If removal is attempted with an ordinary pick, there is a good chance that the terminal will be bent or deformed. Unlike standard blade-type terminals, these terminals cannot be straightened once they are bent.

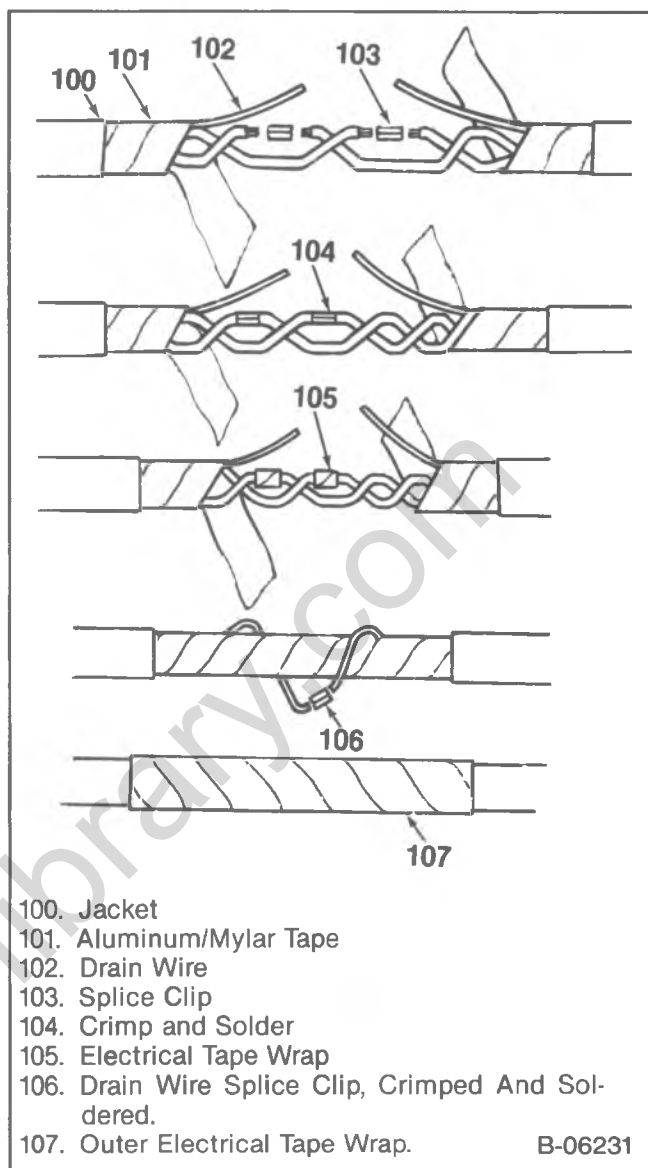

Figure 14—Twisted/Shielded Lead Repair

Make sure that the connectors are properly seated and all of the sealing rings are in place when connecting the leads. The hinge-type flap provides a back-up, or secondary locking feature for the terminals. They are used to improve the connector reliability by retaining the terminals if the small terminal lock tangs are not positioned properly.

Molded-on-connectors require complete replacement of the connection. This means splicing a new connector assembly into the harness. Environmental connections cannot be replaced with standard connections. Instructions are provided with the Weather-Pack connector and terminal packages.

With the low current and voltage levels found in some circuits, it is important that the best possible bond at all wire splices be made by soldering the splices.

Use care when probing the connections or replacing terminals in them, it is possible to short between opposite terminals. If this happens to the wrong terminal part, it is possible that damage may be done to certain

components. Always use jumper wires between connectors for circuit checking. Never probe through the Weather-Pack seals.

When diagnosing for possible open circuits, it is often difficult to locate them by sight because oxidation or terminal misalignment are hidden by the connectors. Merely wiggling a connector on a sensor or in the wiring harness may correct the open circuit condition. This should always be considered when an open circuit is indicated while troubleshooting. Intermittent problems may also be caused by oxidized or loose connections.

 **Remove or Disconnect (Figure 12)**

Tool Required:

J-28742 Terminal Remover

1. Primary lock (121) by lifting.
2. Connector sections.
3. Secondary lock (125) by spreading the sides of the hasp, thus clearing the staples and rotating the hasp (127).
4. Terminal (131) by using J-28742 (128).
 - Snip off the old terminal assembly.
5. 5 mm of the wire insulation (130).



Clean

- Terminal Barrel (124).

 **Install or Connect (Figure 12)**

1. Terminal insulator (134) on the wire. Slide the insulator back on the wire about 8 cm (3 inches).
2. Terminal (131) on the wire.
 - Roll crimp (132) and solder the terminal.
3. Terminal insulator (134) and roll crimp (133).
4. Terminal into the connector.
5. Secondary lock (125).
6. Connector sections until the primary lock (121) engages.

WIRING REPAIR

The wire repair is very important for the continued reliable operation of the vehicle. This repair must be done as described in the following procedures.

Twisted Leads (Figure 13)

 **Remove or Disconnect**

1. Jacket (90).
2. Twisted wires (91).
3. Insulation from the wire.

 **Install or Connect**

1. Splice clip (93).
 - Crimp.
 - Solder.
2. Electrical tape wrap (94) on wires.
3. Outer electrical tape wrap (95).

Twisted Leads/Shielded Cable (Figure 14)

 **Remove or Disconnect**

1. Jacket (100).
2. Unwrap aluminum/mylar tape (101).
3. Drain wire (102).
4. Leads.
5. Insulation on the leads.

 **Remove or Disconnect**

1. Splice clips (103).
2. Crimp and solder the splice clips (104).
3. Electrical tape (105) on the splices.
4. Aluminum/mylar tape by wrapping and taping.
5. Drain wire with a splice clip (106). Crimp and solder the splice clip.
6. Outer jacket electrical tape wrap (107).

CAB ELECTRICAL SYSTEMS

RV CAB HARNESS ROUTINGS

There are several wiring harnesses routed throughout the cab which provide continuity between the electrical components. These harnesses consist of: the instrument panel harness, the power door locks and power window harness, the radio harness, the heater harnesses, the air conditioning harnesses and the interior lighting harnesses.

INSTRUMENT PANEL HARNESS (Figure 15)

This harness is located along the upper back edge of the instrument panel. It starts from the fuse panel which is located at the left side of the dash panel, and goes up to the left side of the instrument panel and across the instrument panel to the right side of the cab.

As the instrument panel harness is routed across the instrument panel, various circuits branch off to the switches, indicators, and the instrument panel. The harness is held in place with bendable clips.

Other harnesses are carried in the same supports as the instrument panel harness. These harnesses consist of the power door locks, power window, radio, heater and air conditioning.

POWER DOOR LOCKS AND POWER WINDOWS HARNESS (Figures 16 and 17)

This harness starts at the fuse block and routes to the left and right along the instrument panel. At the middle of the instrument panel, the harness branches off to the relay assembly. The relay assembly is located on the inside of the dash panel, just above the steering column. The harness then goes to a set of connectors on the inner wheel housing. From the connectors the harness passes through a grommet in the front door opening trim panel and then through a flexible coupling to the door. Inside the door the harness branches off to the control switches, the door lock motors, and the power window motors. The harness connectors are fastened to the control switches with retaining nuts.

8A-10 CAB ELECTRICAL

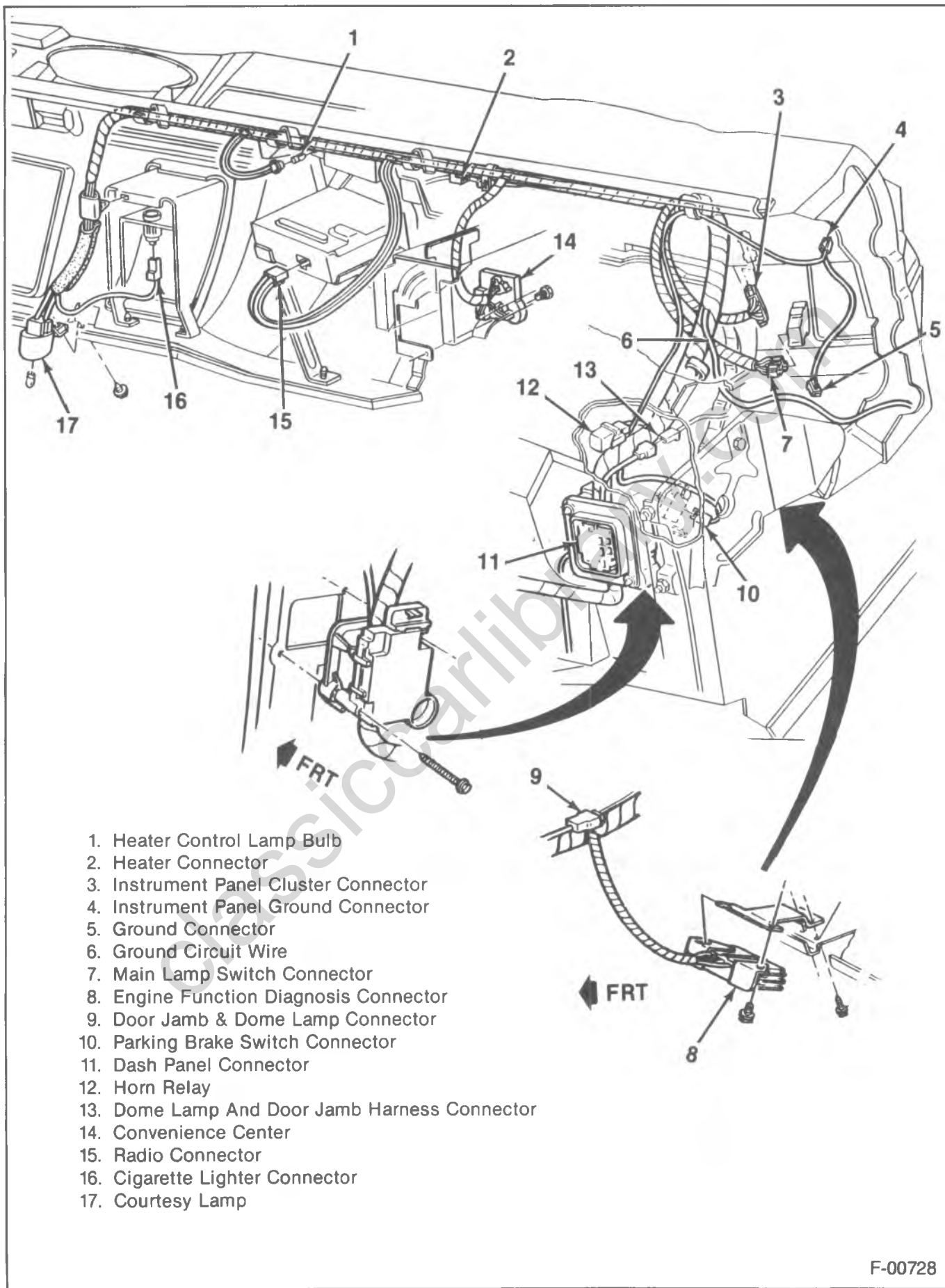

1. Heater Control Lamp Bulb
2. Heater Connector
3. Instrument Panel Cluster Connector
4. Instrument Panel Ground Connector
5. Ground Connector
6. Ground Circuit Wire
7. Main Lamp Switch Connector
8. Engine Function Diagnosis Connector
9. Door Jamb & Dome Lamp Connector
10. Parking Brake Switch Connector
11. Dash Panel Connector
12. Horn Relay
13. Dome Lamp And Door Jamb Harness Connector
14. Convenience Center
15. Radio Connector
16. Cigarette Lighter Connector
17. Courtesy Lamp

F-00728

Figure 15—RV Instrument Panel Harness

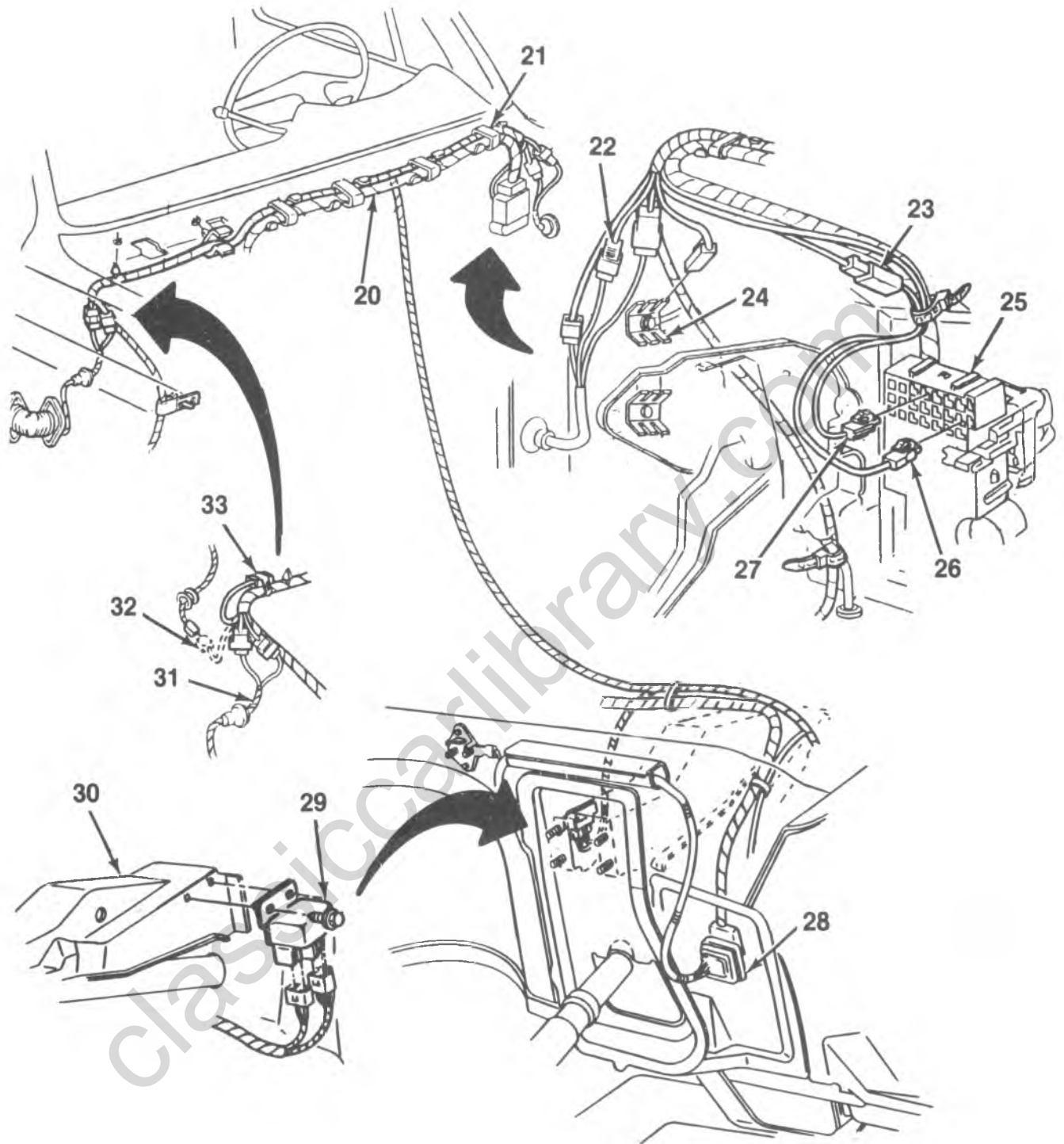

- 20. Instrument Panel Harness
- 21. Power Lock And Window Harness
- 22. Door Harness Connector
- 23. Power Window Connector
- 24. Ground
- 25. Fuse Block
- 26. Power Lock Connector

- 27. Power Window Connector
- 28. Dash Panel Connector
- 29. Power Door Lock Relay
- 30. Brake Pedal Bracket
- 31. Side Front Door Harness
- 32. Rear Panel Door Harness Connector
- 33. Rear Panel Door Power Lock Connector

F-00729

Figure 16—RV Power Door Locks and Window Harnesses

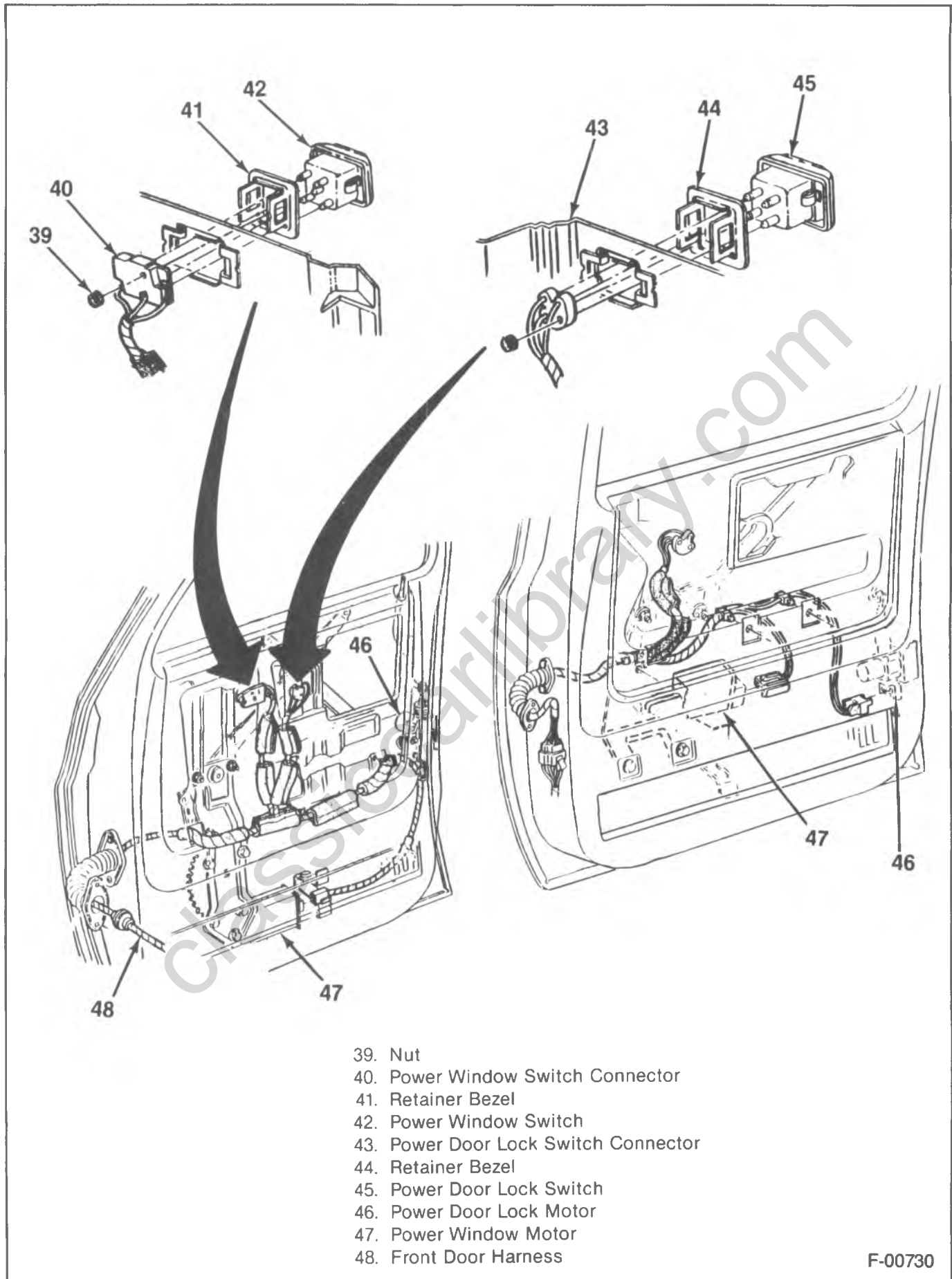

F-00730

Figure 17—RV Door Wiring

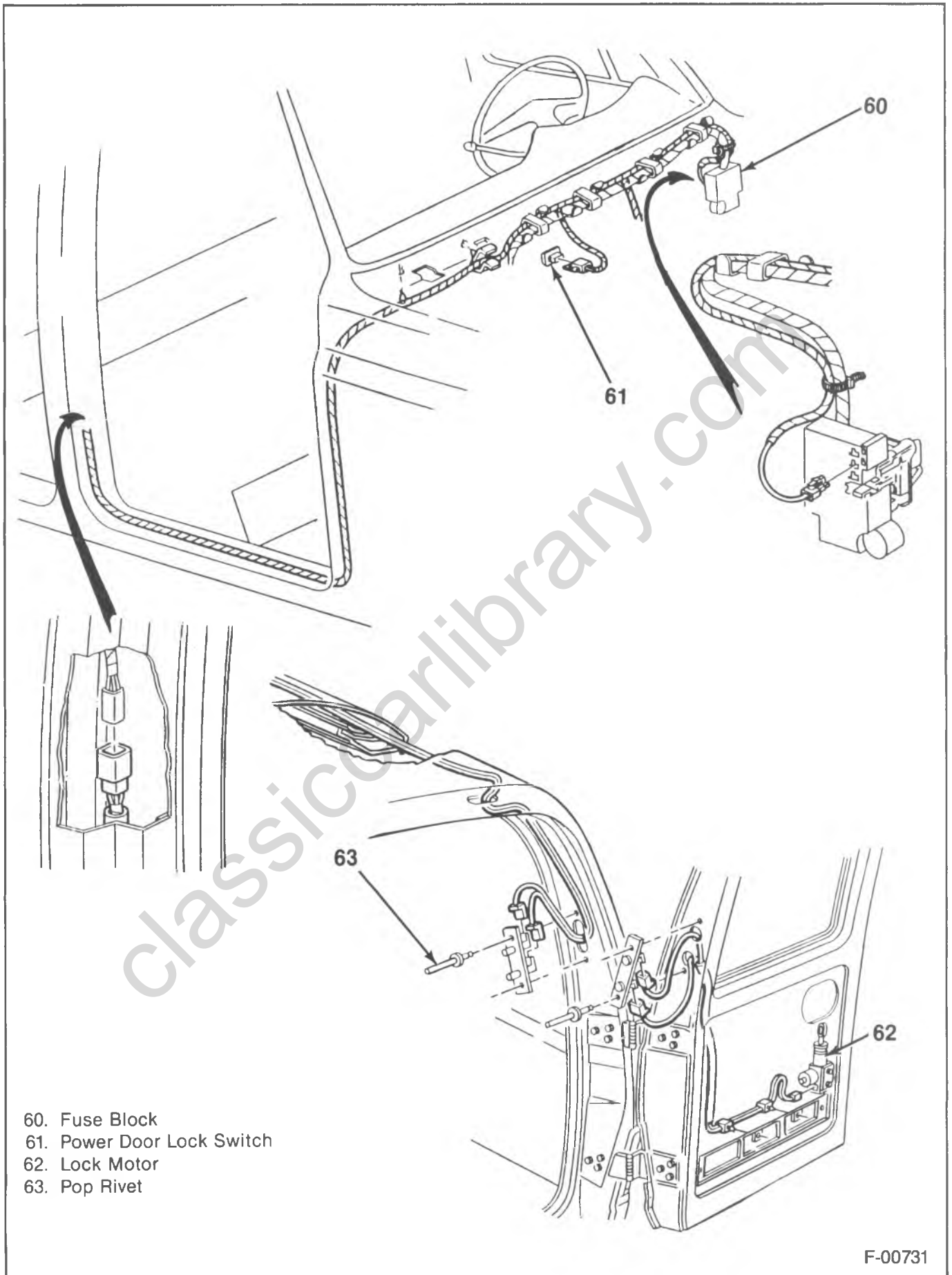
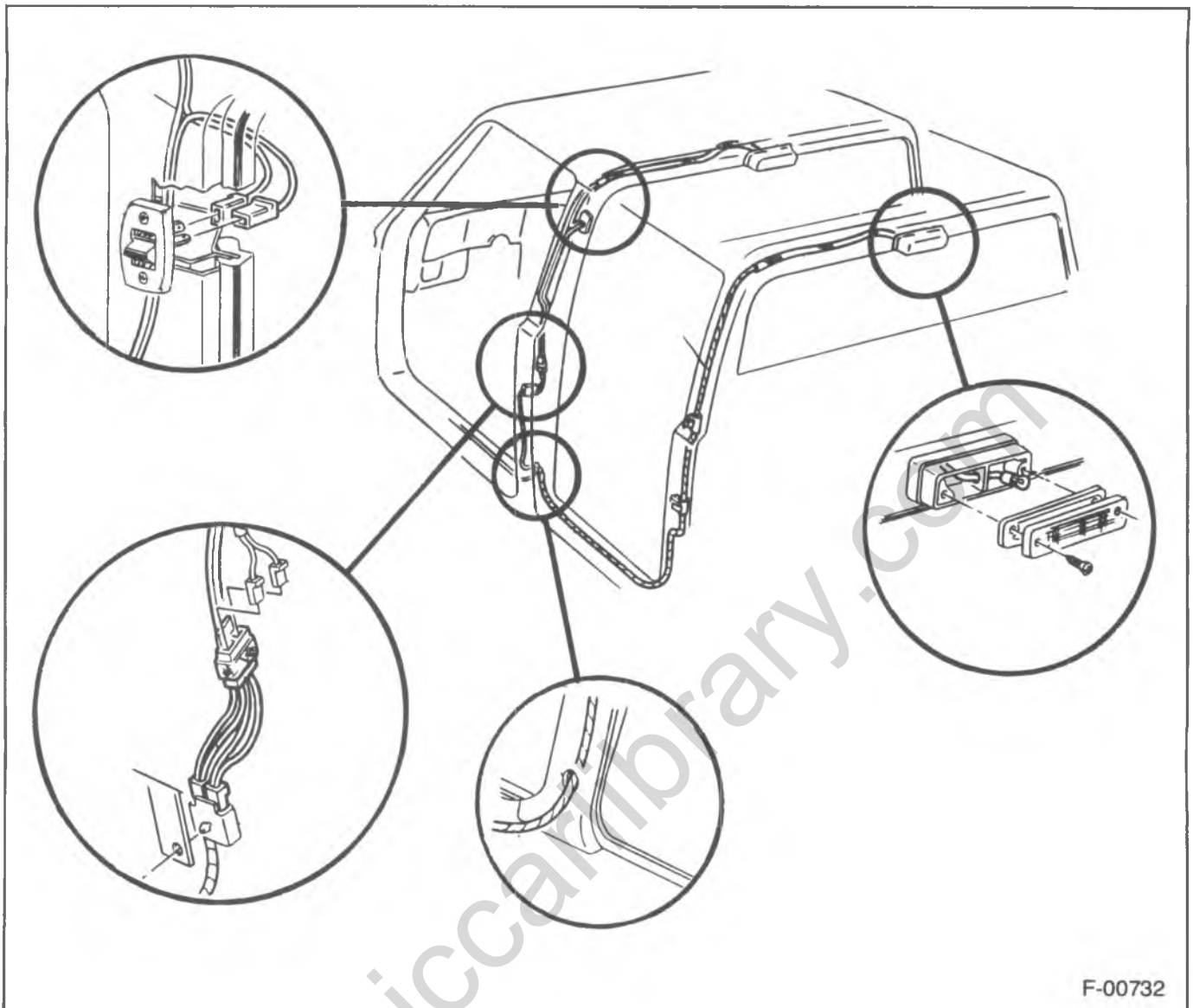

Figure 18—RV Rear Door Lock Harness



F-00732

Figure 19—Cargo Lamp Harness

REAR DOOR POWER LOCK HARNESS (Figure 18)

The rear doors power lock harness starts at a connector in the fuse block. The harness is routed along the instrument panel harness, with a branch going to the power door lock switch assembly in the instrument panel. The harness then drops down the right front door hinge frame and routes back along the right door sill to the right front door latch frame. The harness then travels up the right front door latch frame to its midpoint where a connector is located. The harness then goes to the roof halo panel and back to the rear door frame.

At the rear door frame, the harness is connected to a contact assembly on the right rear door frame. This contact assembly is aligned with a contact assembly mounted on the right rear door. From the contact assembly on the door, the harness then goes to the lock motor.

CARGO LAMP HARNESS (Figure 19)

The harness starts from the instrument panel harness and routes under the left front door sill. The harness then goes up the left front door latch frame, through a connector, and into a control switch.

From the control switch, the harness goes down the left front door frame, back along the rear door sill and then up the rear door latch frame. From the top of the frame the harness goes to the cargo lamp.

RV FUSE BLOCK

The fuse block holds the fuses and circuit breakers that protect the circuits. The fuse block is located on the left side of the dash panel and is fastened to the dash panel connector block with two screws. The fuse panel connects to the engine compartment harness. Power leads from the various circuits plug into the fuse block.

The fuses are encased in plastic and have twin blade connectors. The fuses are printed and color coded with the amperage rating. Refer to Figure 20.

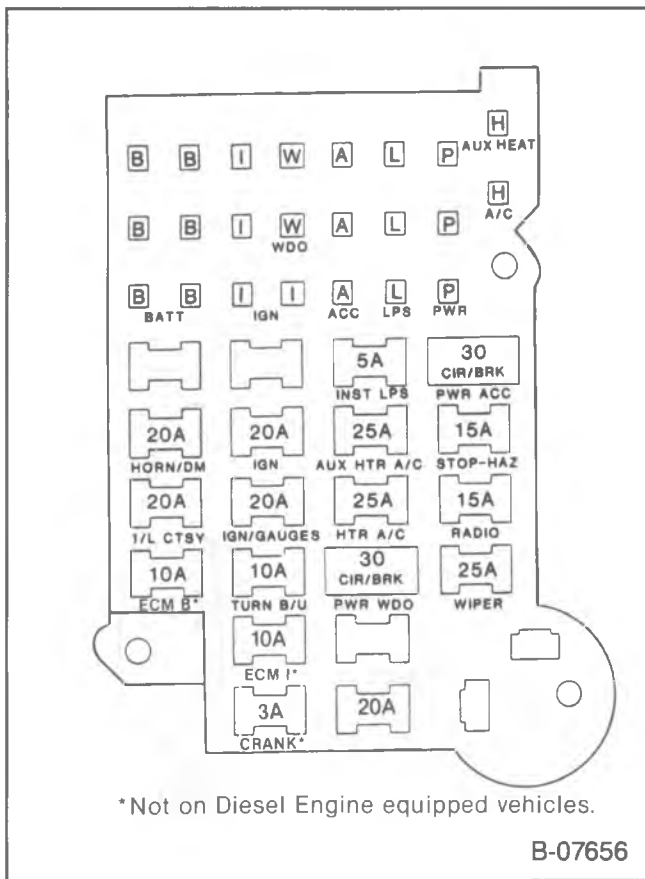

Figure 20—RV Fuse Block

G VAN CAB HARNESS ROUTINGS

INSTRUMENT PANEL HARNESS (Figure 21)

The instrument panel harness in the G van includes the circuits for the instrument panel gages, indicators, main light switch, windshield wiper and washer, and the steering column controls. The harness is held in place with clips that plug into brackets which are mounted on the instrument panel.

FRONT DOOR POWER LOCK SYSTEM (Figure 22 and 23)

The harness starts from the fuse block, which is located under the far left side of the instrument panel. The left branch of the harness has a connector at the left door hinge frame. Then the harness passes into the frame and routes down to a flexible conduit to the door. Inside the door, the harness branches; one branch going down to the door lock motor, and the other branch going up to the door lock switch.

The right branch of the harness routes across the top of the instrument panel to the right door hinge frame. The harness passes through a connector and continues into the door frame. The harness routes down to a flexible conduit. The harness passes through the flexible conduit into the door. Inside the door, the harness branches; one branch going up to the door lock switch, and the other branch going to the door lock.

SIDE DOOR POWER LOCK CIRCUIT (Figure 24)

The side door power lock circuit branches off from the left roof halo harness just behind the front door latch frame. It goes across the roof frame and down the right

front door latch frame, where it connects to the door frame contact assembly. The door frame contact assembly aligns with the door contact assembly so that electrical contact is made when the door is closed. In this way, electricity is conducted to the side door power lock motor.

REAR DOOR POWER LOCK CIRCUIT (Figure 25)

The rear power door lock harness is routed from the connector on the left front door hinge frame. The harness goes up the frame to the roof, rearward along the roof halo panel and then crosses over to the right rear corner, using the rear roof halo panel. The harness goes down the right rear corner to a connector just below the upper door hinge. The harness then passes through grommets and into the right rear door. Inside the door the harness connects to the power lock motor.

POWER WINDOW SYSTEM (Figures 22, 23, 24 and 25)

This harness starts at the fuse block and routes to the left and right along the instrument panel. The harness then routes into the left and right front doors. At the left door hinge pillar, the harness routes up to the left roof halo panel, back to the first roof frame, branches to the right side of the van and rearward to the rear door. The branch that went to the right side routed down the side door hinge pillar and into the side door.

INTERIOR LIGHTING SYSTEM (Figures 26 and 27)

This circuit starts at the fuse block and routes to the body harness connector. The standard harness is then routed up the left front door hinge frame and back along the left roof halo panel. The harness branches at the first and third roof frames, with connectors located next to the left roof halo panel. The harnesses then go to the roof lamps and terminate in bulb clips. The standard harness also branches off to the door switches.

The optional harness is routed from the body harness connector to a control switch on the instrument panel. The harness then goes from the switch to the left front door hinge frame, up the frame, and back along the left roof halo panel.

When the harness reaches the first roof frame, it goes into a connector. There are two branches coming out of the connector. One branch goes to the center lamp assembly in the roof. This branch, after connecting to the center lamp assembly, continues on to the right side of the roof, where it goes into a connector. From this connector, one lead goes to the side door grounding switch. The other leads are routed down the right front door lock frame to the stepwell lamp assembly.

The other branch, coming out of the roof frame connector, goes back along the left roof halo panel, across the rear halo panel and terminates at the rear door ground switch. Also coming from this connector is a branch that goes down the left front door lock frame to the left stepwell lamp assembly.

8A-16 CAB ELECTRICAL

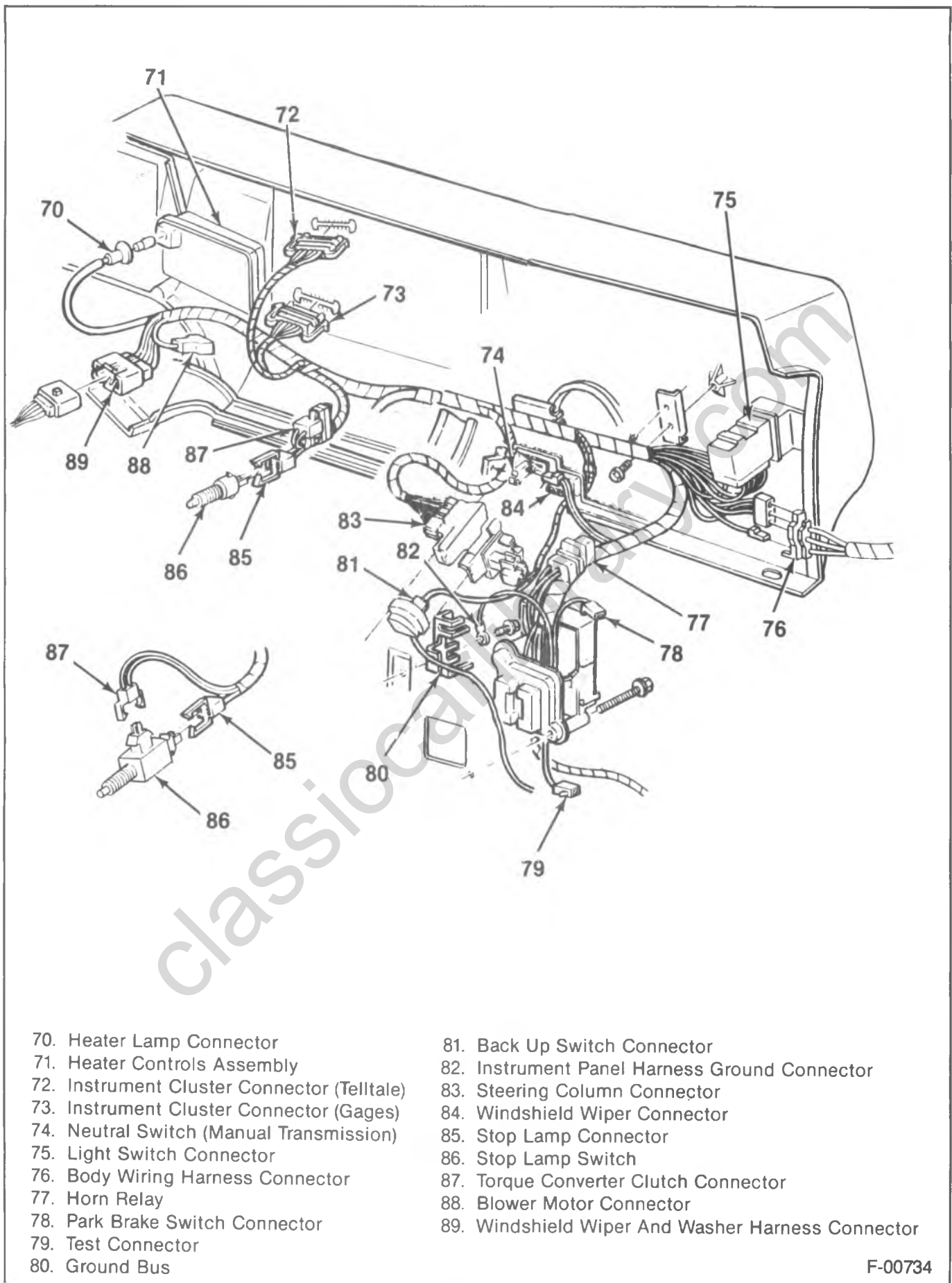

Figure 21—Van Instrument Panel Harness

F-00734

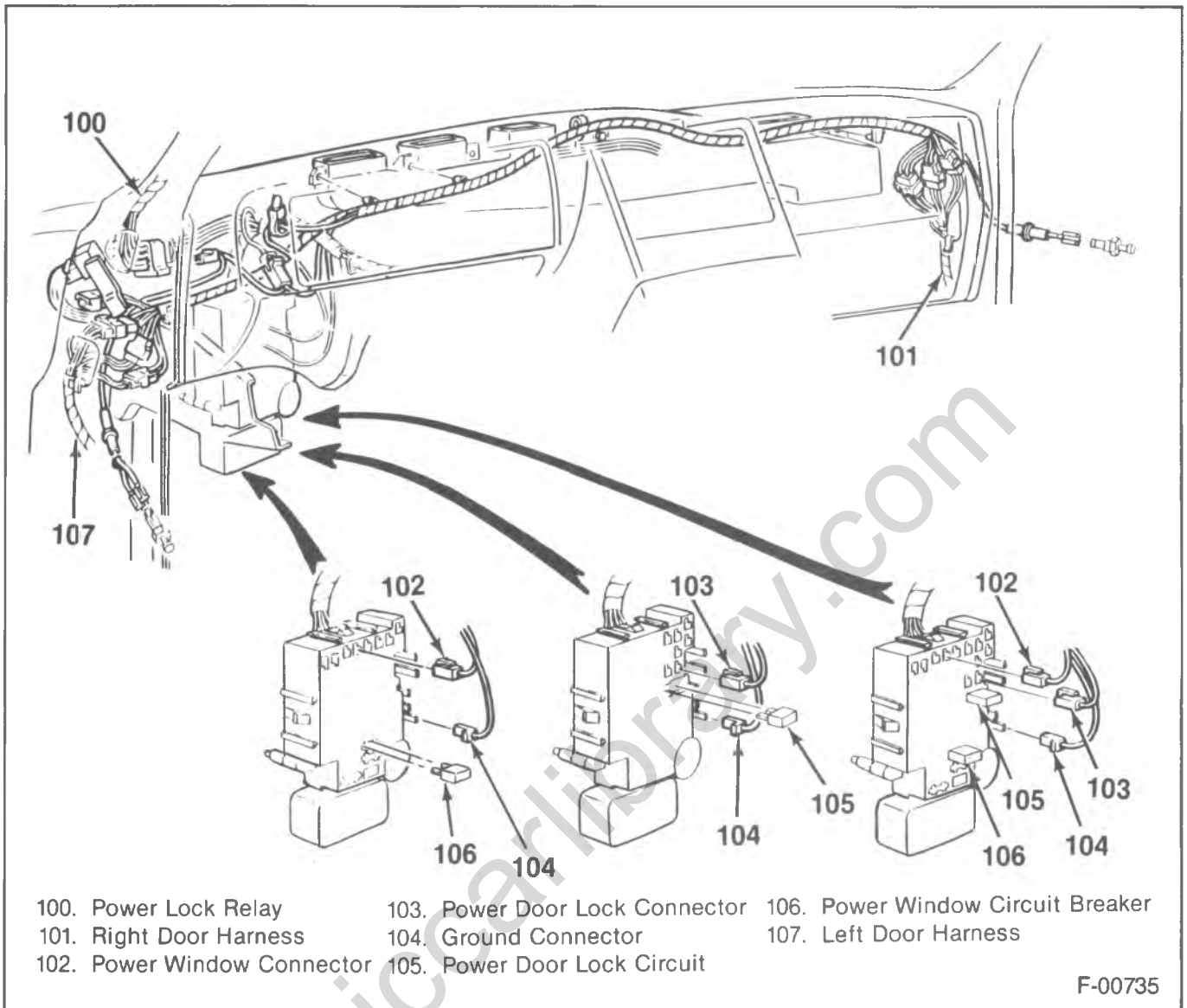

Figure 22—Van Power Door Lock and Window Harness

G VAN FUSE BLOCK

The fuse block holds the fuses and circuit breakers that protect the circuits. The fuse block is located on the left side of the dash panel and is fastened to the dash panel connector block with two screws. The fuse block connects to the engine compartment harness. Power leads from the various circuits plug into the fuse block.

The fuses are encased in plastic and have twin blade connectors. The fuses are printed and color coded with the amperage rating. Refer to Figure 28.

POWER DOOR LOCK SYSTEM

DESCRIPTION

Individual motors operate each door lock. The direction the motor turns depends on the polarity of the supply voltage. The door lock switches control the supply voltage polarity. Each switch will lock all the doors.

Each motor has a self-resetting circuit breaker built in. Voltage is present at the door lock switches at all times. Voltage is also present on the open contacts of the door lock relay at all times.

When a door switch is moved to "Lock," current flows through the switch and lock relay coil to ground. The relay closes, causing current to flow through the lock relay contacts, door lock motor, the unlock relay contacts, and then to ground.

When a door lock switch is moved to "Unlock," current flows through the switch, the unlock relay contacts, the door lock motor, the lock relay contacts, and to ground. This causes the lock motor to unlock the door.

For RV models, the door lock relay is located on the dash panel, above the steering column. For G van models the door lock relay is located on front left door hinge pillar.

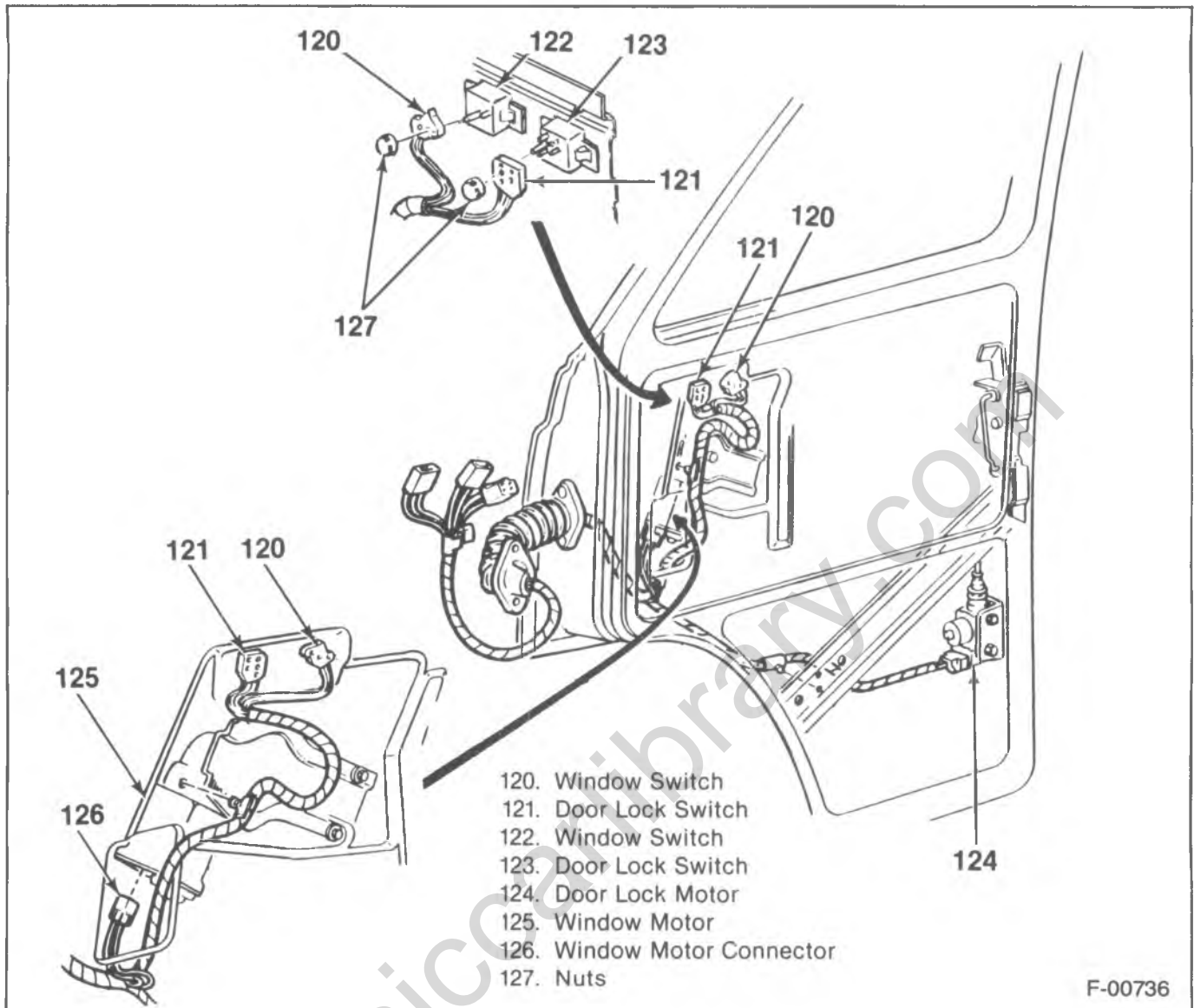

F-00736

Figure 23—Van Front Door Harness

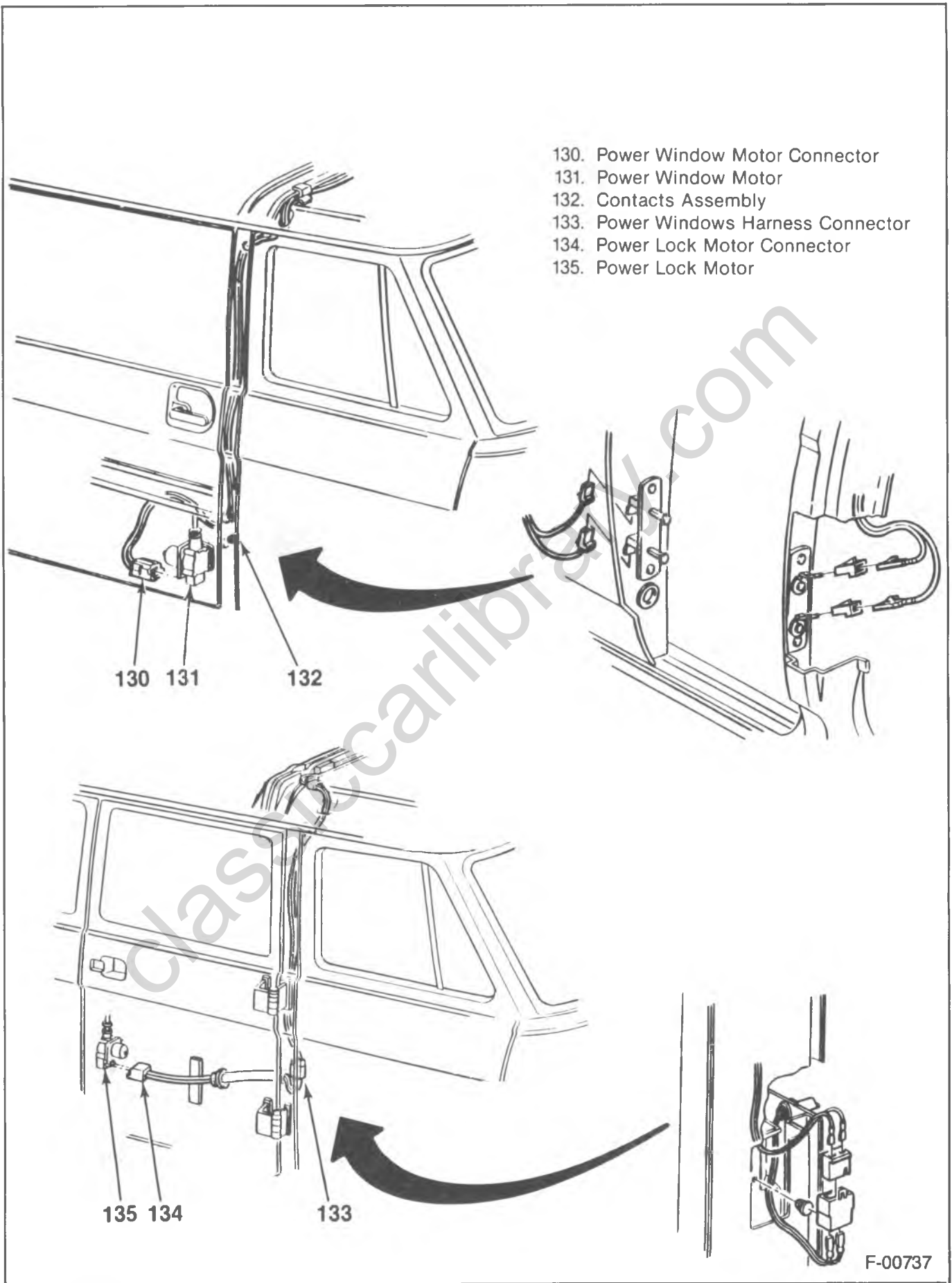
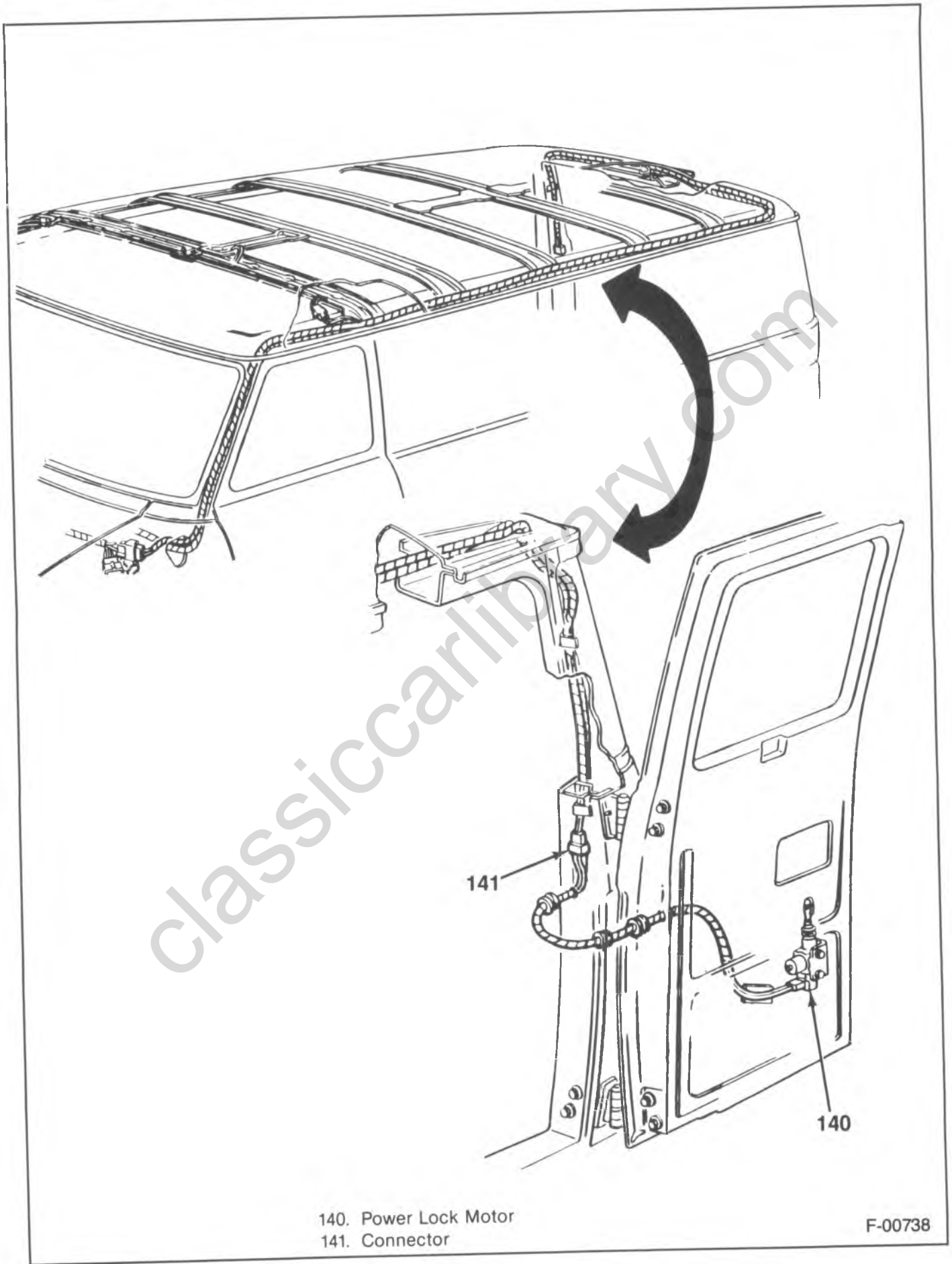

Figure 24—Van Side Door Harness



- 140. Power Lock Motor
- 141. Connector

F-00738

Figure 25—Van Rear Door Harness

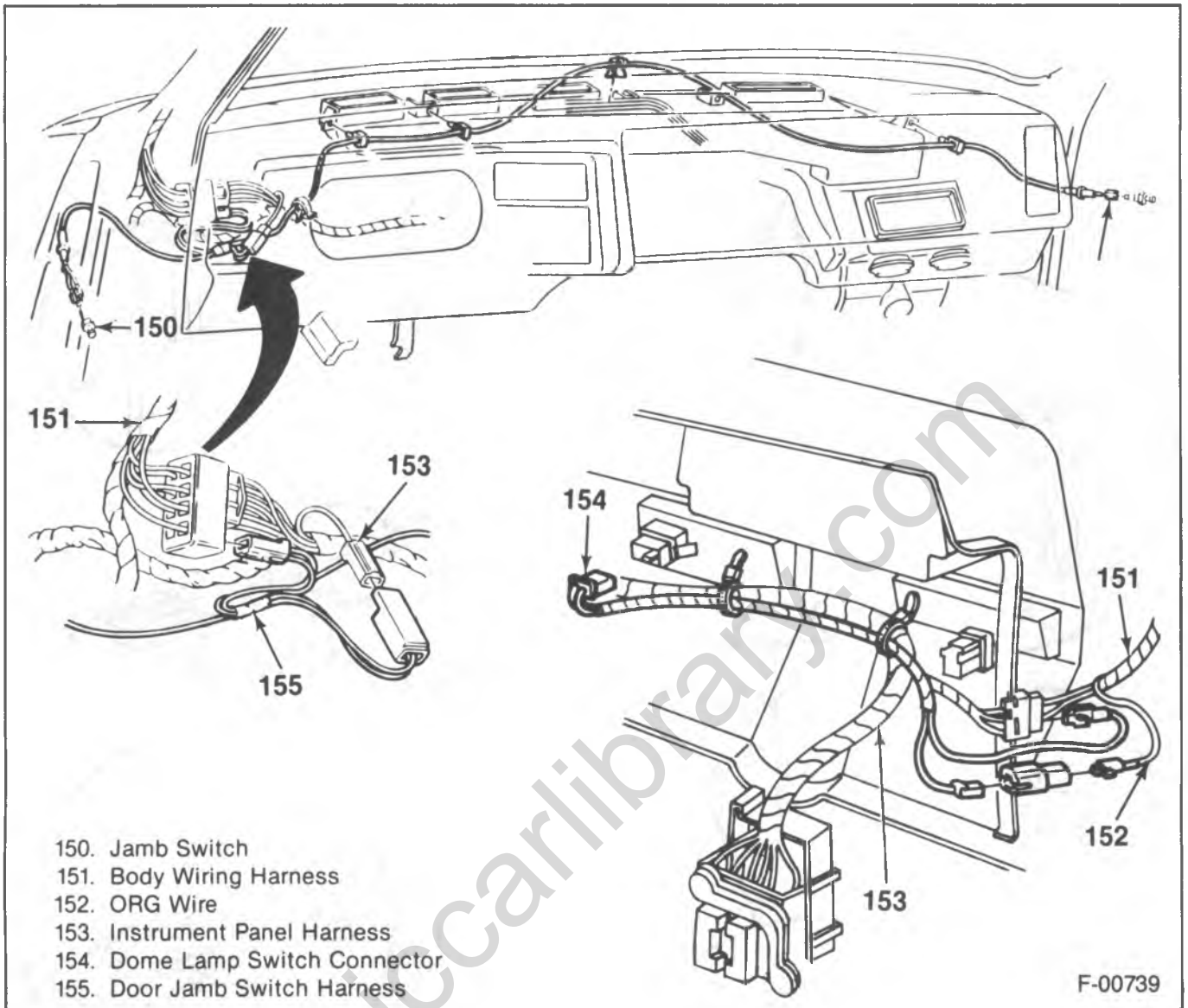

Figure 26—Van Door Jamb Switch and Dome Lamp

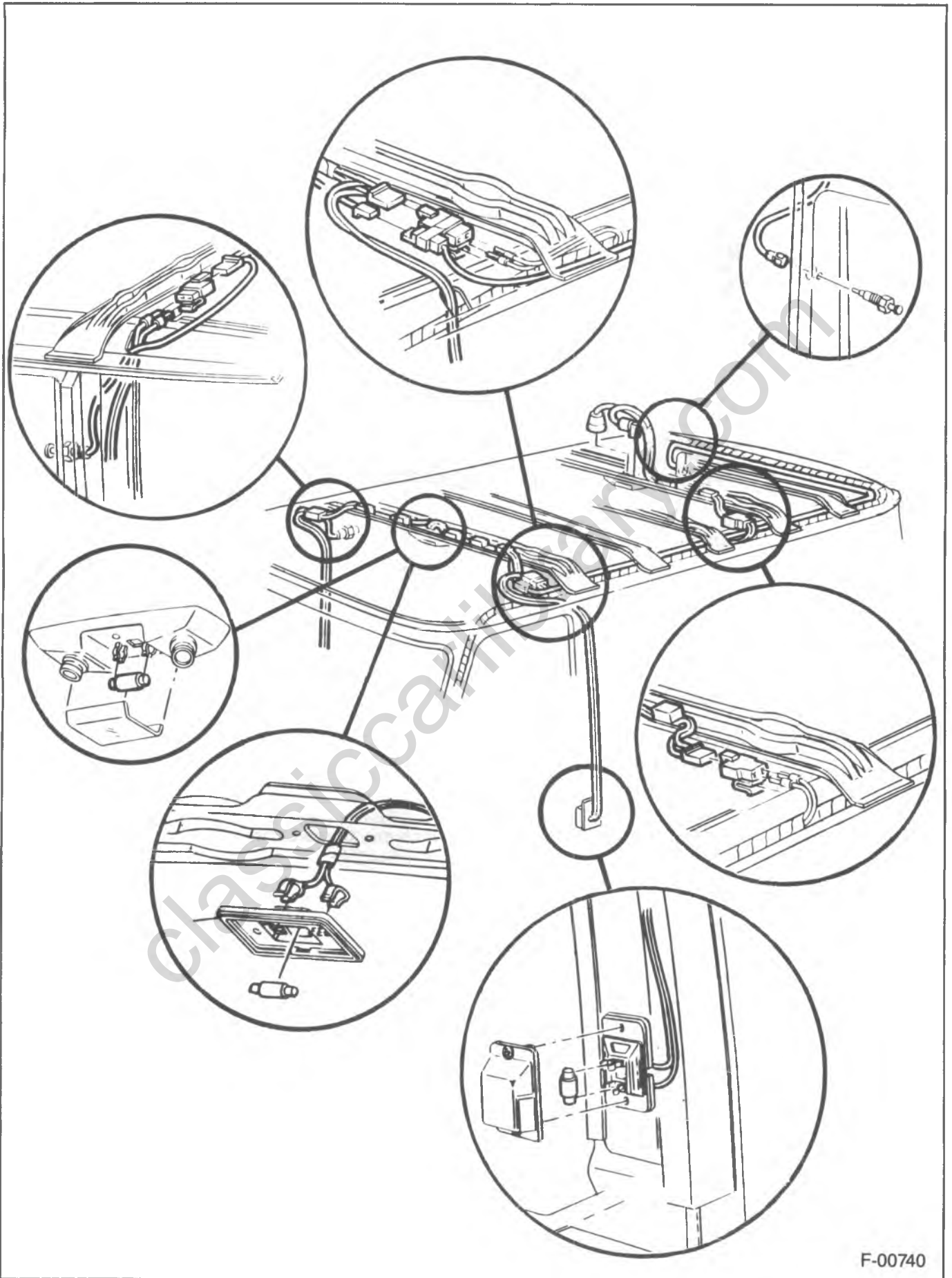

Figure 27—Van Interior Lighting Harness

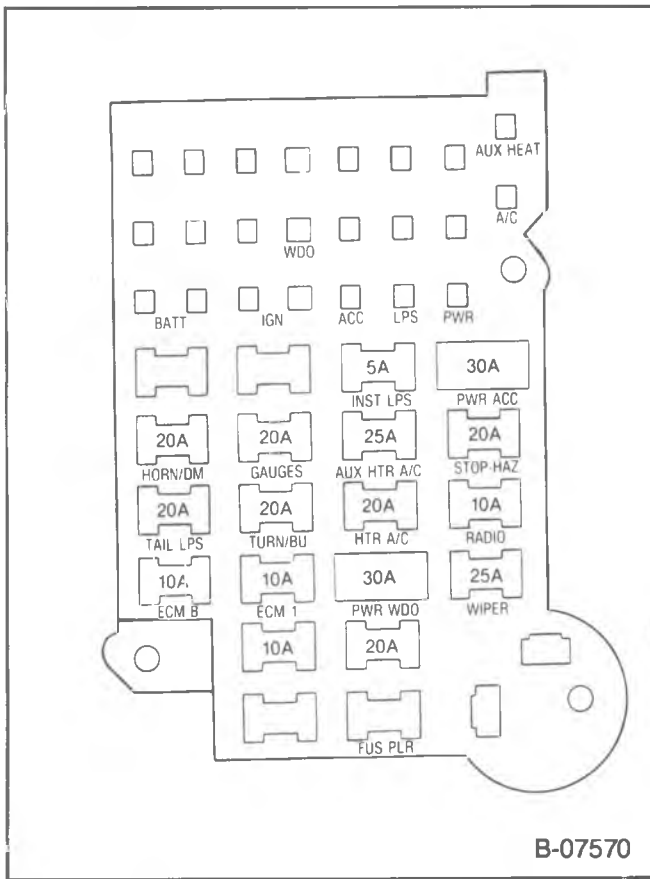

Figure 28—Van Fuse Block

DIAGNOSIS OF POWER DOOR LOCK SYSTEM

PROBLEM	POSSIBLE CAUSE	CORRECTION
One Door Lock Will Not Work.	<ol style="list-style-type: none"> 1. No power at lock motor. 2. Open ground circuit between the motor and the relay. 	<ol style="list-style-type: none"> 1. Check for voltage at the lock motor. If no voltage at lock motor, check for voltage at the connector which is located at the front door hinge pillar. If there is no voltage at the connector, check for an open between the connector and the door lock relay. 2. Move a door switch to "Lock." Backprobe the TAN wire at the motor. If there is voltage, find the open between the motor and the relay.
None of the Door Locks Function; All Switches Tried.	<ol style="list-style-type: none"> 1. No power. 2. Relay not working. 	<ol style="list-style-type: none"> 1. Check for power at the fuse block (ORN/BLK). Check for power at the door lock relay (ORN/BLK). If power is present at the fuse block but not present at the relay, find the open in the harness. 2. Hold a switch to "Lock." Backprobe the LT BLU wire at the relay. If there is no voltage, find the open in the harness. If there is voltage, check the relay case to ground path. If the ground is OK, check the relay coil for conduction. If the relay coil is OK, check for voltage on the TAN wire. If there is no voltage, replace the relay. If there is voltage, find the open in the harness.

DIAGNOSIS OF POWER DOOR LOCK SYSTEM (CONT.)

PROBLEM	POSSIBLE CAUSE	CORRECTION
One Switch Won't Lock the Doors.	<ol style="list-style-type: none"> 1. No power to the switch. 2. Switch has internal open. 	<ol style="list-style-type: none"> 1. Check for voltage on the ORN wire at the switch. If there is no voltage, find the open between the switch and the fuse block. 2. Move the switch to "Lock." Check for voltage on the LT BLU wire at the switch. If there is no voltage, replace the switch.

ON-VEHICLE SERVICE

POWER DOOR LOCK MOTOR REPLACEMENT

↔ Remove or Disconnect

1. Battery ground cable from the battery.
2. Door trim panel.
3. Motor. Refer to DOORS (SEC. 10A1).

↔ Install or Connect

1. Motor. Refer to DOORS (SEC. 10A1)
2. Door trim panel.
3. Battery ground cable.

SWITCH REPLACEMENT

↔ Remove or Disconnect

1. Battery ground cable from the battery.
2. Door trim panel.
3. Switch connector. The connector is secured with a retaining nut.
4. Switch. Press in both retaining tabs at the same time.

↔ Install or Connect

1. Switch.
2. Switch connector.
3. Retaining nut.
4. Door trim panel.
5. Battery ground cable.

POWER WINDOW SYSTEM

DESCRIPTION

Each power window is moved by a single permanent magnet motor. The direction the motor turns depends on the polarity of the supply voltage. The control switches control the supply voltage polarity.

Switches for controlling all the power windows are located at the driver's door. Each passenger's window switch controls only the window at that passenger's position.

The motors have a self resetting circuit breaker built in. The circuit breaker allows the motor to be stalled without damage. There are no travel-limit switches.

When a window switch is moved to "UP," current flows through the circuit breaker, the window switch, the DK BLU wire, the motor, the circuit breaker, the BRN wire, the "DN" contacts in the switch, and into the BLK wire which goes to ground.

DIAGNOSIS OF POWER WINDOW SYSTEM

PROBLEM	POSSIBLE CAUSE	CORRECTION
Passenger Window Will Not Work, Using Either Passenger Switch or Driver Switch.	<ol style="list-style-type: none"> 1. No power at the passenger switch. 2. Passenger switch is not working. 	<ol style="list-style-type: none"> 1. Ignition switch at RUN or ACC. Check for voltage at the PNK wire on the passenger switch. If there is no voltage, find the open between the switch and the fuse block. 2. With the voltage on the PNK wire at the switch, move the switch to "UP." There should be voltage on the DK BLU wire at the switch. If there is no voltage on the DK BLU wire, replace the switch.

DIAGNOSIS OF POWER WINDOW SYSTEM (CONT.)

PROBLEM	POSSIBLE CAUSE	CORRECTION
<p>Passenger Window Will Not Work, Using Either Passenger Switch or Driver Switch (Continued)</p>	<p>3. Motor has an internal open.</p>	<p>3. With the window switch moved to the "UP" position, check for voltage on the DK BLU wire at the motor. If there is no voltage, find the open between the switch and the motor. If there is voltage on the DK BLU wire, backprobe a jumper ground at the BRN wire at the motor. If the motor does not run, replace the motor. If the motor does run, find the open in the ground circuit. Note: the ground circuit does run back through the passenger window "DN" contacts and the driver window switch "DN" contacts before reaching ground.</p>
<p>Passenger Window Will Not Work Using the Passenger Switch. The Window Will Work Using the Driver Switch</p>	<p>1. No power at the passenger switch. 2. Switch has internal open.</p>	<p>1. Check for voltage on the PNK wire at the passenger switch. If voltage is not present, find the open in the circuit between the switch and the I.P. harness connector. 2. If voltage is present, replace the switch.</p>
<p>Passenger Window Won't Work Using the Driver Switch.</p>	<p>1. No power. 2. Open in driver switch. 3. Open in harness.</p>	<p>1. Check driver window action. If the driver window works, power is at the switch. 2. With the driver switch moved to "UP," check for voltage on the DK BLU wire at the driver switch. If voltage is not present, replace the switch. 3. With voltage present on the DK BLU wire at the driver switch, find the open between the driver switch and the passenger switch.</p>
<p>Driver Window Won't Work. Passenger Window Works.</p>	<p>1. Switch won't work. 2. Motor has internal open. 3. Motor ground circuit is open.</p>	<p>1. Switch moved to "UP." Check for voltage at the DK BLU wire at the switch. If voltage is not present, replace the switch. 2. Switch moved to "UP." Check for voltage on the DK BLU wire at the motor. If voltage is present, backprobe a jumper ground at the BRN wire at the motor. If the motor won't run, replace the motor. 3. Backprobe a jumper ground at the BRN wire at the motor. Move the driver switch to "UP." If the motor runs, find the open in the ground circuit.</p>

ON-VEHICLE SERVICE

POWER WINDOW MOTOR REPLACEMENT

↔ Remove or Disconnect

1. Battery ground cable from the battery.
2. Door trim panel.
3. Motor. Refer to DOORS (SEC. 10A1).

↔ Install or Connect

1. Motor. Refer to DOORS (SEC. 10A1).
2. Door trim panel.
3. Battery ground cable.

SWITCH REPLACEMENT

↔ Remove or Disconnect

1. Battery ground cable from the battery.
2. Door trim panel.
3. Switch connector. The connector is secured with a retaining nut.
4. Switch. Press in both retaining tabs at the same time.

↔ Install or Connect

1. Switch.
2. Switch connector.
3. Retaining nut.
4. Door trim panel.
5. Battery ground cable.

WINDSHIELD WIPER—RV AND G MODELS

DESCRIPTION

A permanent magnet type wiper is used on RV and G Series. The motor parts—field magnets, armature, drive gear etc. are enclosed in a two piece sheet metal housing. For purposes of explanation the housing halves are referred to as upper and lower housings. The two housings are attached to each other by ten extrusions which are staked over.

The wiper motor is protected by an automatic reset type circuit breaker located on the motor brush holder assembly. A fuse located in the fuse block protects the vehicle wiring.

The wiper motor can be operated only when the ignition switch is in the "run" or "accessory" position.

The wiper motor has three brushes; the "common," the low speed, and the high speed. When the ignition switch is "ON," power is applied to the common brush. The low speed and high speed brushes are connected to their respective ground via the control switch. When the control switch is positioned at "HI" or "LO" speed, a ground path is connected to the high or low speed brush in the motor. The motor runs at the switch selected speed.

In order to have the wiper blades stop in their normal park position and the wiper motor shut off properly, the motor must run in LO speed. When the control switch is moved to the OFF position, the low speed brush circuit goes through a park switch located in the gear housing and then to ground at the control switch. The park switch is normally closed and this allows the wiper to keep running. When the wiper blades reach their park position, cam on the gear opens the normally closed park switch, which turns off the wiper. Refer to Figures 29 and 30.

DIAGNOSIS OF WINDSHIELD WIPER

Refer to Figures 31 through 35.

ON-VEHICLE SERVICE

WIPER MOTOR REPLACEMENT

RV Truck

↔ Remove or Disconnect (Figure 36)

- Wiper motor must be in the Park position.
1. Ground cable from the battery.
 2. Electrical harness (38) from the wiper motor.
 3. Drive rod (34) from the wiper motor crank arm (36).
 - Reach down through the access hole (32) in the plenum and loosen the wiper drive rod attaching nuts (33) before removing the drive rod (34).
 4. Wiper motor to dash panel attaching screws (40).
 5. Wiper motor.

↔ Install or Connect (Figure 36)

1. Wiper motor.
2. Wiper motor to dash panel attaching screws (40).
3. Drive rod (34) to the wiper motor crank arm (36).
 - Lubricate wiper motor crank arm pivot ball (35) prior to installing the drive rod (34).
4. Electrical harness (38) to the wiper motor.
5. Ground cable to the battery.

G Van

↔ Remove or Disconnect (Figure 37)

- Wiper motor must be in Park position.
1. Ground cable from the battery.
 2. Wiper arms.
 3. Cowl panel cover.
 4. Drive arm (34) to the wiper motor crank arm (36).
 - Loosen nuts (33) holding the drive bar (34) to the wiper motor crank arm (36) removing the drive bar (34).
 5. Electrical harness (38) from the wiper motor.
 6. Left dash defroster outlet from the flex hose.

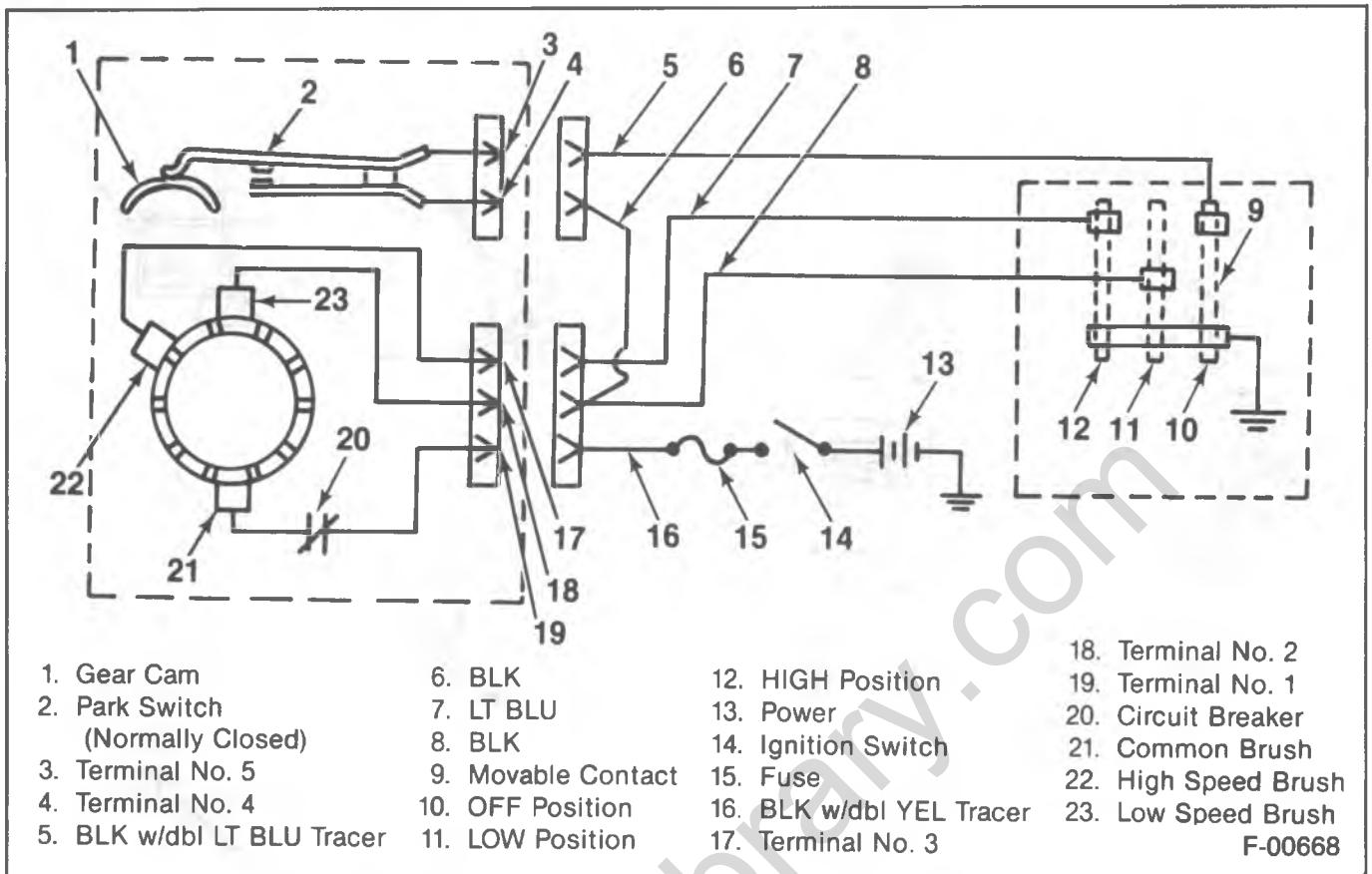

Figure 29—RV Windshield Wiper Diagram

7. Screw securing the left hand heater duct to the engine cover shroud.
8. Heater duct down and out.
9. Three screws (30) securing the wiper motor to the cowl.
10. Wiper motor.

→← Install or Connect (Figure 37)

1. Wiper motor.
2. Three screws (30) securing the wiper motor to the cowl.
3. Heater duct in and up.

4. Screw securing the left hand heater duct to the engine cover shroud.
5. Left dash defroster outlet to the flex hose.
6. Electrical harness (38) to the wiper motor.
7. Drive bar (34) to the wiper motor crank arm (36).
 - Lubricate the wiper motor crank arm pivot ball (35).
8. Cowl panel cover.
9. Wiper arms.
10. Ground cable to the battery.

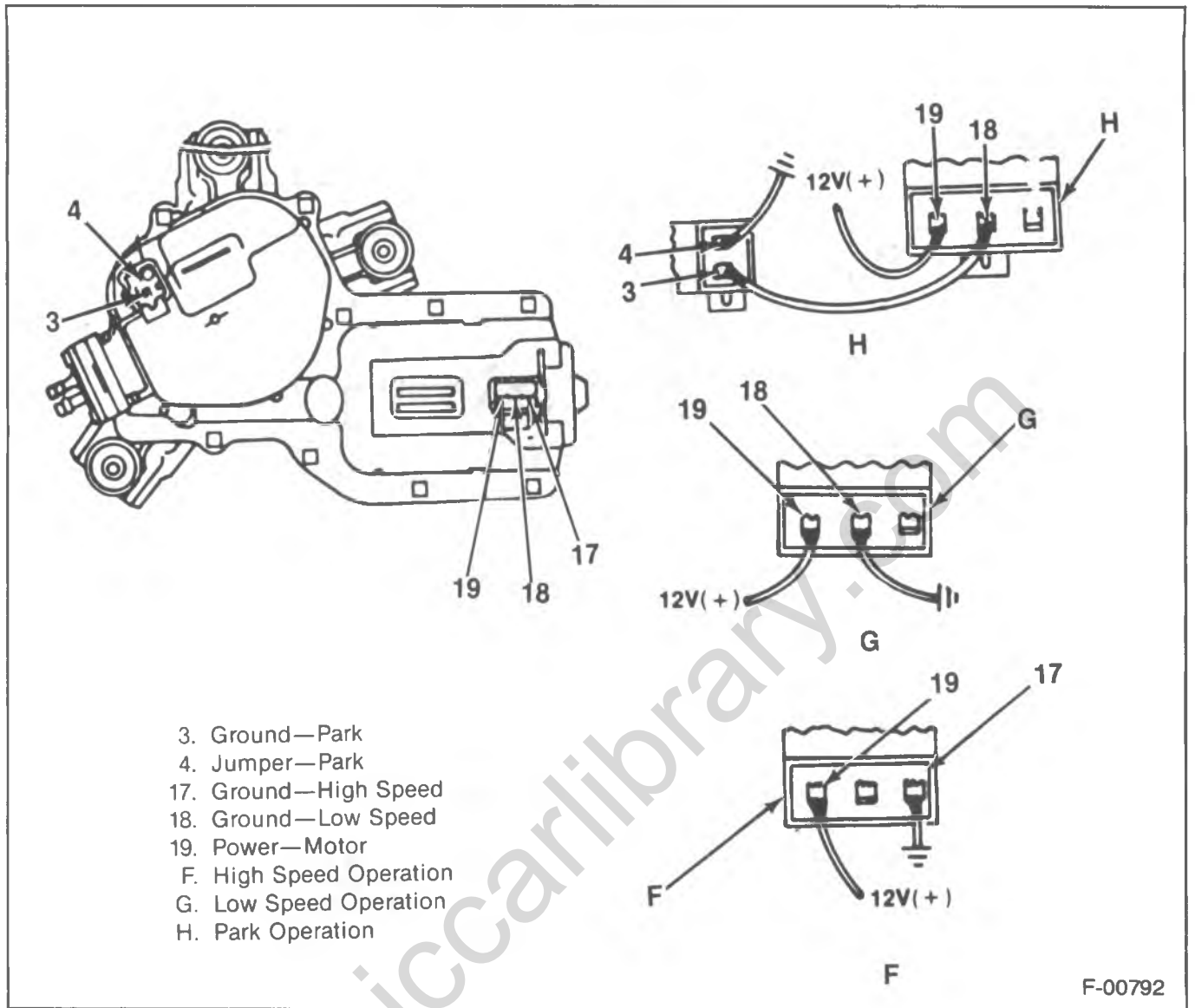
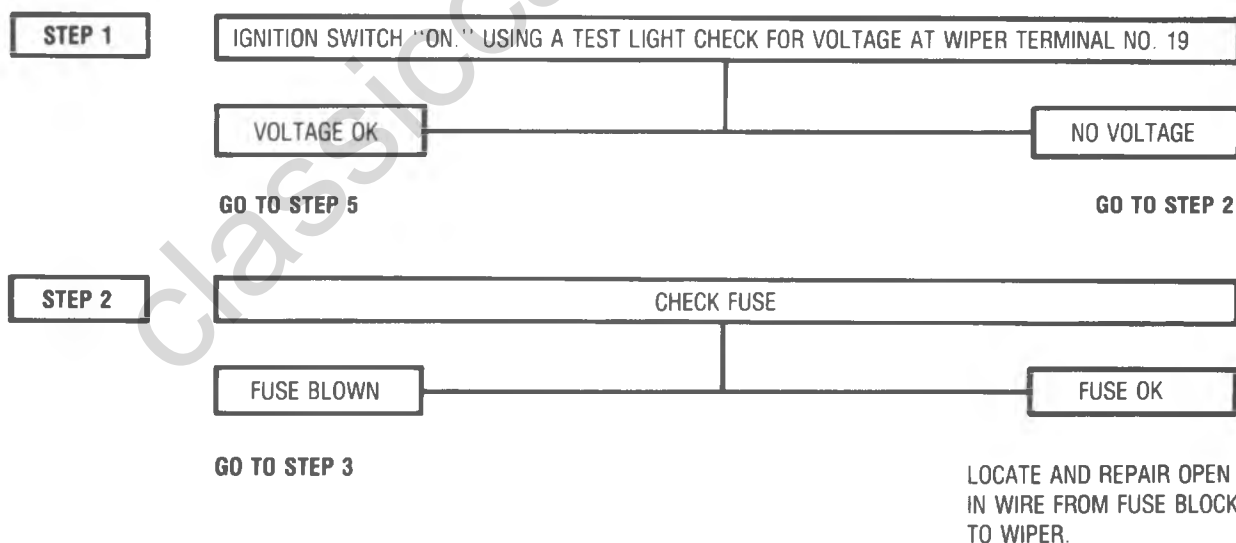

Figure 30—Diagnosis Connection

DIAGNOSIS CHART

SYMPTOM	PROCEDURE NO.
1) WIPER INOPERATIVE—BOTH LOW AND HIGH SPEED	1
2) LOW SPEED ONLY—INOPERATIVE IN HIGH SPEED	2
3) HIGH SPEED ONLY—INOPERATIVE IN LOW SPEED	3
4) ONE SPEED—SAME IN BOTH LOW AND HIGH SPEED	4
5) BLADES STOP AT RANDOM POSITIONS WHEN WIPER IS TURNED OFF. (DO NOT RETURN TO PARK POSITION.)	5
6) WIPER WILL NOT SHUT OFF	6
7) INTERMITTENT OPERATION	7
8) WIPER MOTOR RUNS BUT BLADES DON'T MOVE	8

PROCEDURE 1 (WIPER INOPERATIVE)



F-00715

Figure 31—Wiper Diagnosis

PROCEDURE 1 (CONT.)

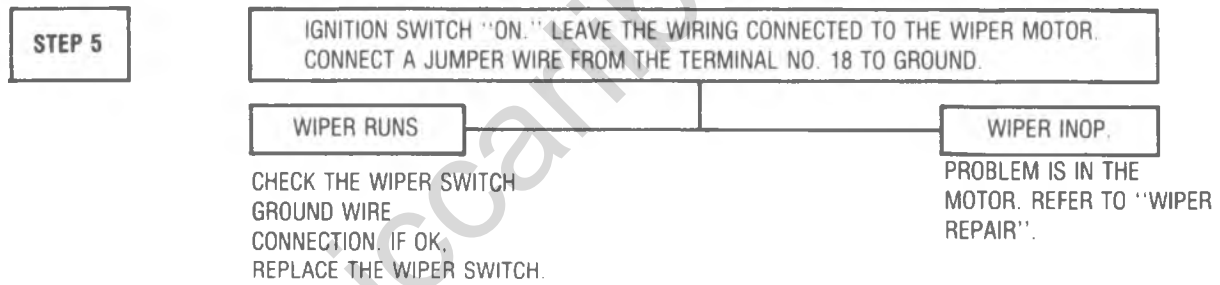
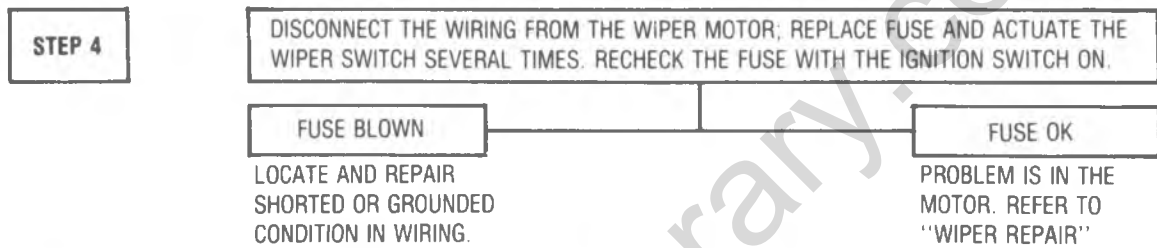
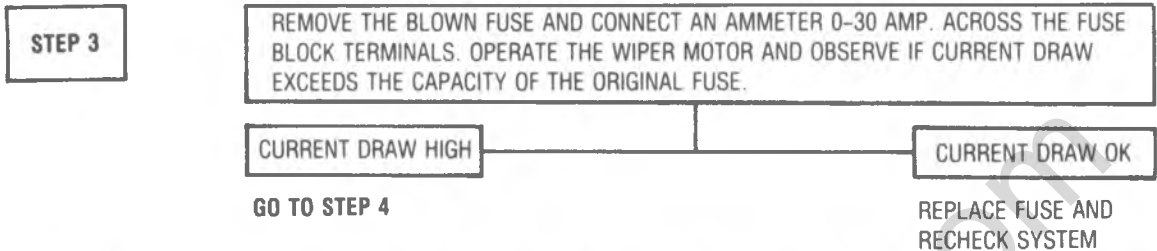

PROCEDURE 2 (LO SPEED ONLY) (INOP IN HI)

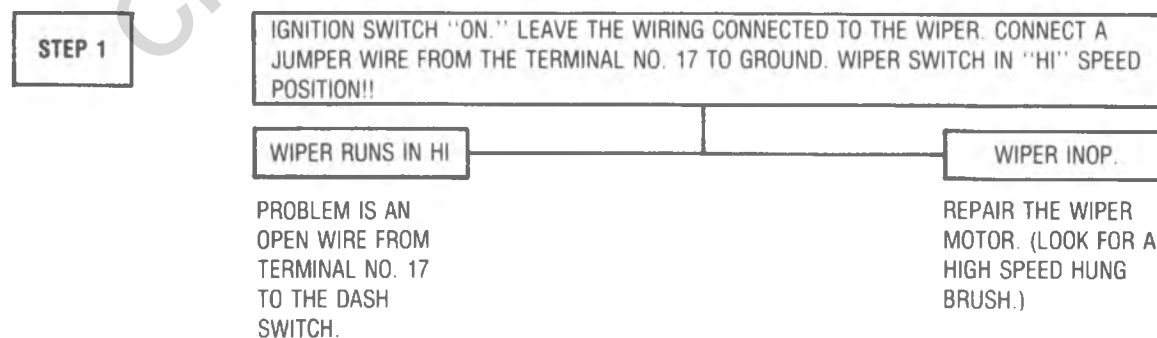
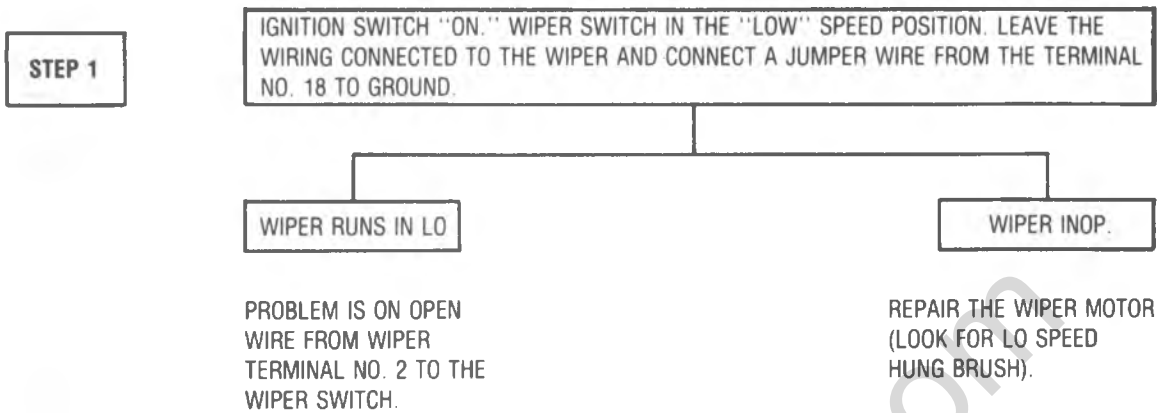
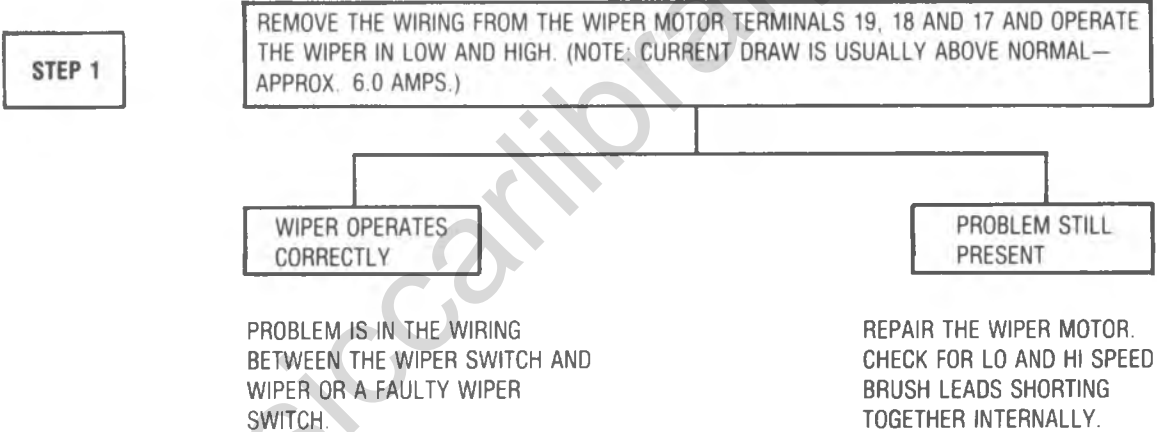

Figure 32—Wiper Diagnosis

PROCEDURE 3 ('HI' SPEED ONLY) (INOP IN LO)



PROCEDURE 4 (ONE SPEED—SAME IN BOTH LO AND HI).



PROCEDURE 5 (WIPER SHUTS OFF BUT BLADES DON'T RETURN TO PARK POSITION)

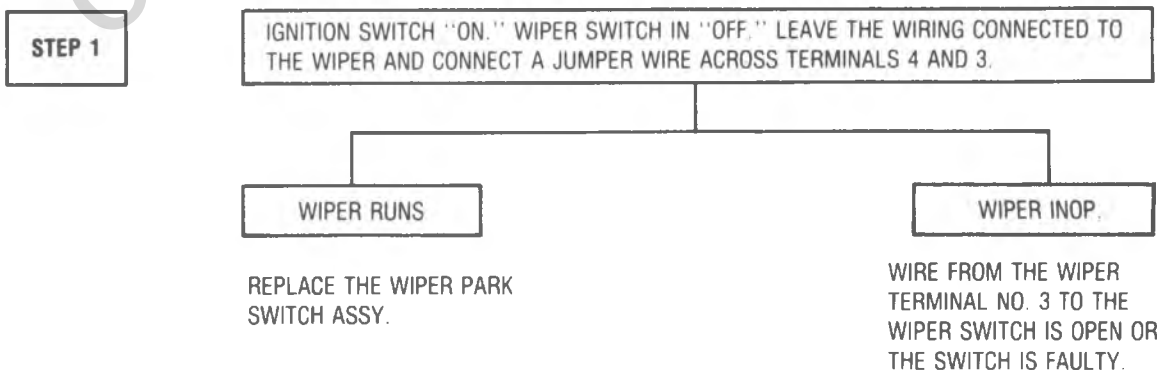

F-00743

Figure 33—Wiper Diagnosis

PROCEDURE 6 (WIPER WILL NOT SHUT OFF)

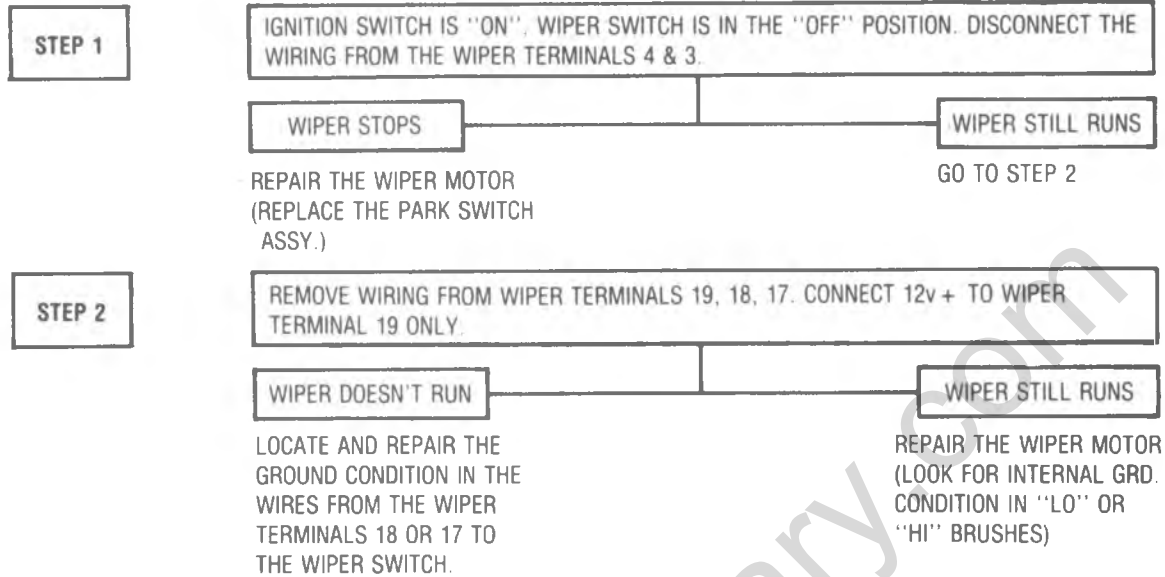

**PROCEDURE 7 (INTERMITTENT OPERATION)
(WIPER HAS BOTH SPEEDS)**

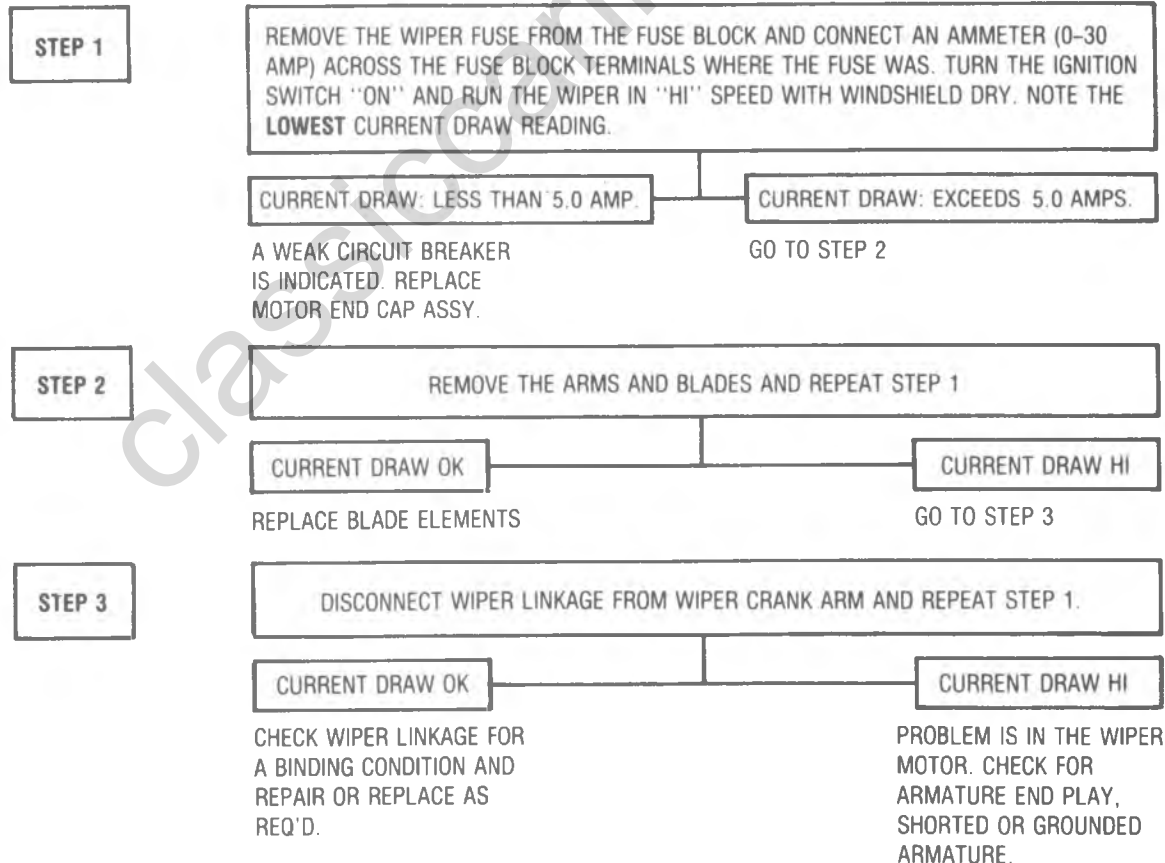

F-00744

Figure 34—Wiper Diagnosis

PROCEDURE 8 (WIPER RUNS BUT BLADES DON'T MOVE)

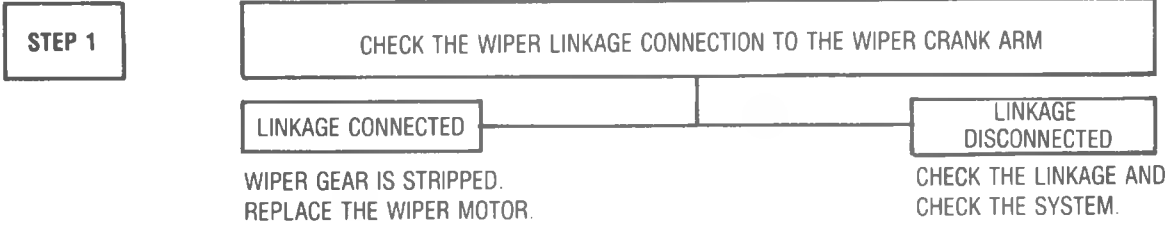

F-00745

Figure 35—Wiper Diagnosis

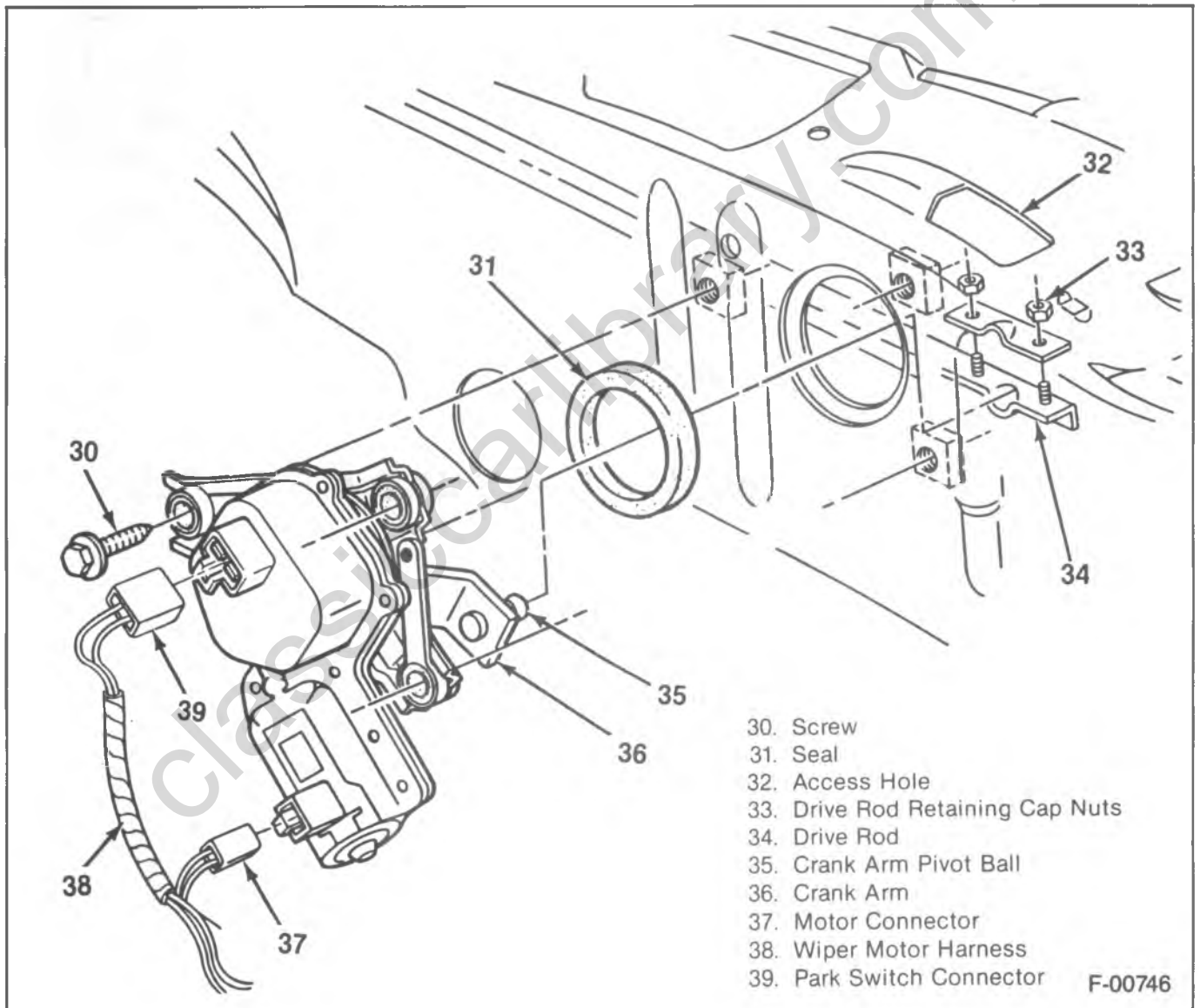

F-00746

Figure 36—RV Wiper Motor Mounting

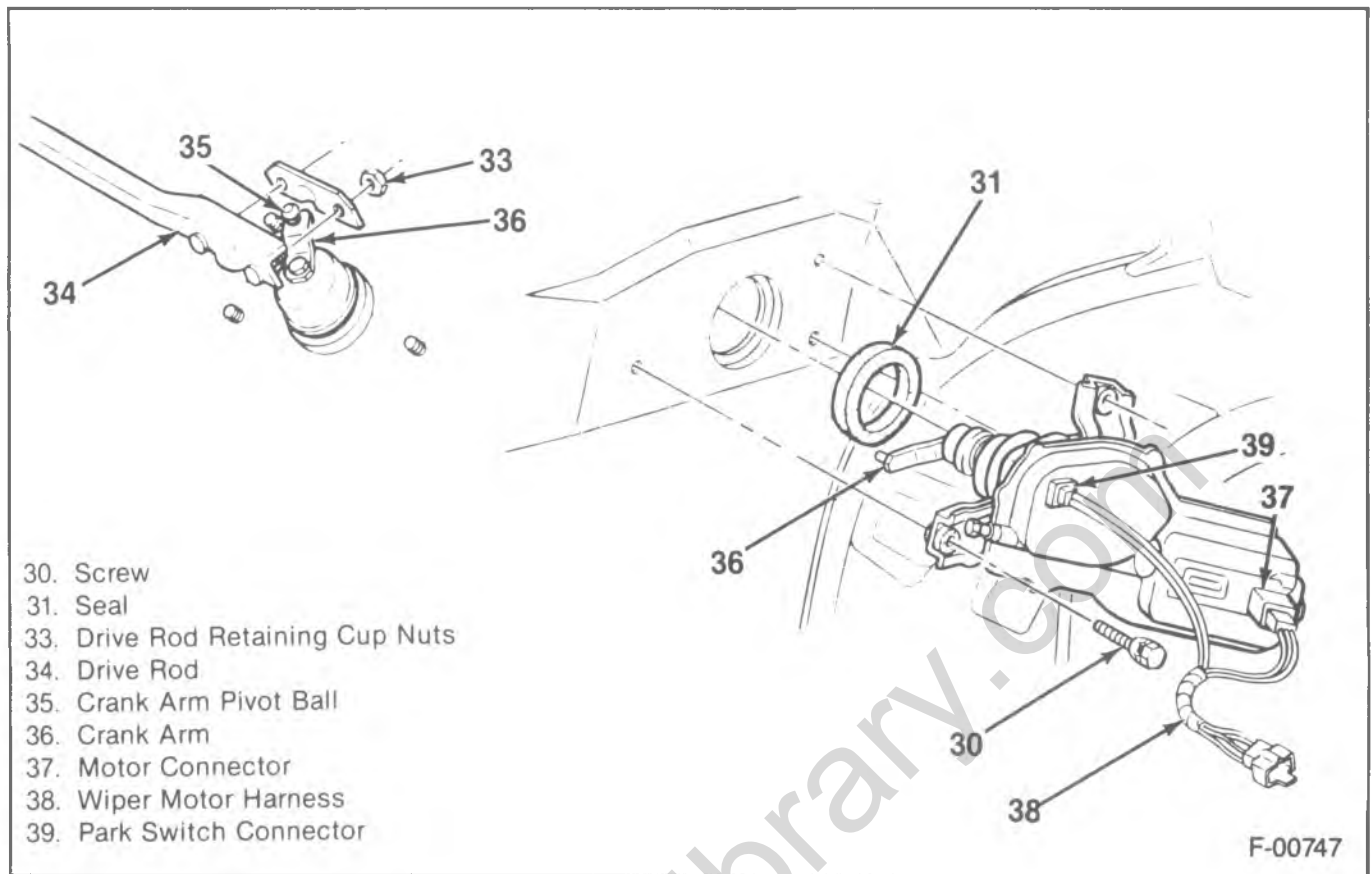

Figure 37—Van Wiper Motor Mounting

WINDSHIELD WASHER—RV AND G MODELS

DESCRIPTION

The washer motor is located in the bottom of the windshield washer fluid reservoir. The washer is controlled by a washer switch, which is located on the turn signal and multi-function lever. Two wires go to the washer. The white wire is power coming from the fuse box. The same fuse that protects the washer motor also protects the wiper motor. The pink wire is the ground circuit that goes through the washer switch to ground. Refer to figures 38 and 39.

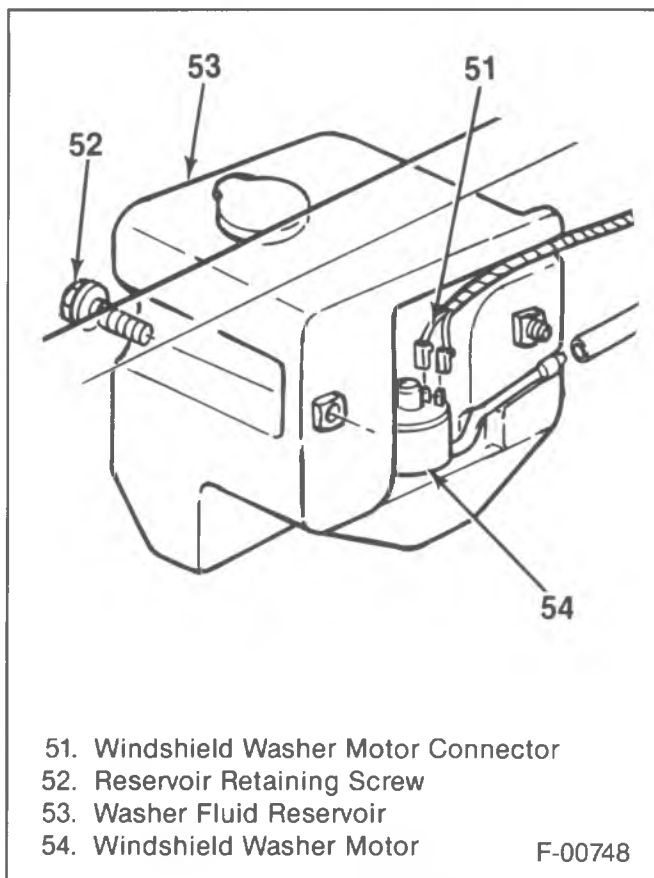

Figure 38—RV Windshield Washer

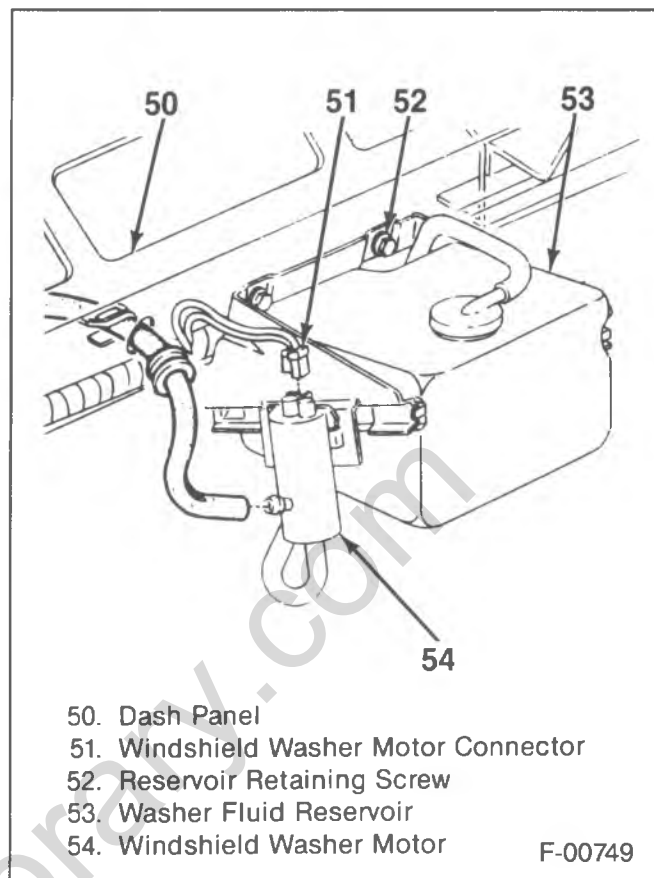

Figure 39—Van Windshield Washer

WINDSHIELD WASHER DIAGNOSIS

PROBLEM	POSSIBLE CAUSE	CORRECTION
Washer Fluid Does Not Spray on the Windshield	<ol style="list-style-type: none"> 1. No fluid. 2. Clogged jets. 3. Clogged filter in the reservoir. 4. Washer motor is not running. 	<ol style="list-style-type: none"> 1. Check the fluid reservoir. Refill, if necessary. 2. Using a fine pin, carefully clear the jets. 3. Remove the filter and back flush it. Also clean the reservoir. 4. Check for power on the WHT wire at the motor. If there is no power, and the wipers work, find the open in the power circuit. If there is power, check the PNK wire at the washer motor for ground. If the ground circuit is good, replace the washer motor.

ON-VEHICLE SERVICE

WASHER MOTOR REPLACEMENT

RV Models

↔ Remove or Disconnect

1. Battery ground cable from the battery.
2. Two reservoir retaining screws.
3. Reservoir.
4. Electrical connector at the motor.
5. Fluid tube at the motor.
6. Motor from the reservoir.

→← Install or Connect (Figure 38)

1. Motor to the reservoir.
2. Fluid tube at the motor.
3. Electrical connector at the motor.

4. Reservoir.
5. Two reservoir retaining screws.
6. Battery ground cable to the battery.

G Van

↔ Remove or Disconnect (Figure 39)

1. Battery ground cable from the battery.
2. Electrical connector at the motor.
3. Fluid tubes from the motor.
4. Motor from the bracket.

↔ Install or Connect (Figure 39)

1. Motor onto the bracket.
2. Fluid tubes to the motor.
3. Electrical connector to the motor.
4. Battery ground cable to the battery.

WIPER MOTOR UNIT REPAIR

REPLACEMENT OF COMPONENTS

PARK SWITCH

↔ Remove or Disconnect (Figure 40)

1. Cover
2. Park switch.
 - Depress tang (61).

→← Install or Connect (Figure 40)

1. Park switch.
2. Cover.

END CAP-BRUSH HOLDER, ARMATURE ASSEMBLY

↔ Remove or Disconnect

1. Retainer tabs.
2. End cap assembly.
 - Rotate crank arm clockwise.
3. Armature.

→← Install or Connect (Figure 41 and 42)

1. Armature in the end cap assembly.
 - Release the brush spring tension (65).
 - Slide the brushes back in the brush holders.
 - Put the armature in the end cap assembly.
 - Reposition the brush spring legs behind their respective notches (66).
 - Tie the armature to the end cap assembly with small wire.
2. Armature in the wiper housing.
3. End cap into the slot area of the wiper housing.
 - Remove the wire.
4. End cap assembly into the housing until it bottoms.
5. Retainer tabs.

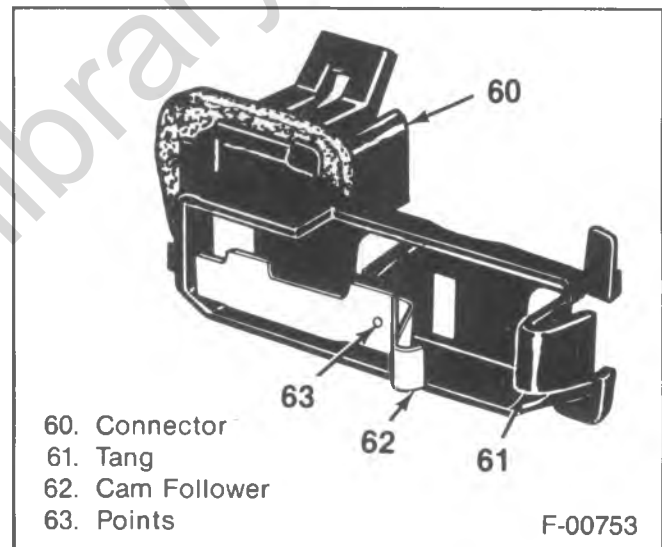

Figure 40—Park Switch

CRANK ARM, SPACER, SEAL

↔ Remove or Disconnect (Figure 43)

1. Crank arm retaining nut (71).
 - Have the crank arm clamped in a vise.
2. Crank arm (70).
3. Shaft seal (72).
4. Spacer (73).

↔ Install or Connect (Figure 43, 44 and 45)

1. Spacer (73).
2. Shaftseal (72).
3. Crank arm (70).
 - Be sure the wiper motor is in "Park."
 - Install the crank arm according to figure 44 or 45, depending on the vehicle model.
4. Crank arm retaining nut (71).

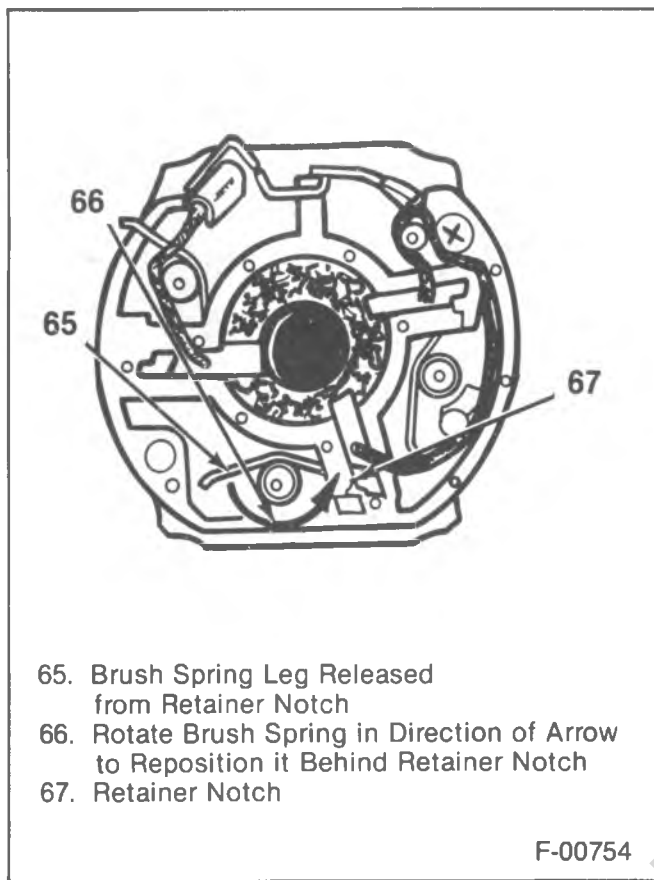

Figure 41—Brush Spring Release Position

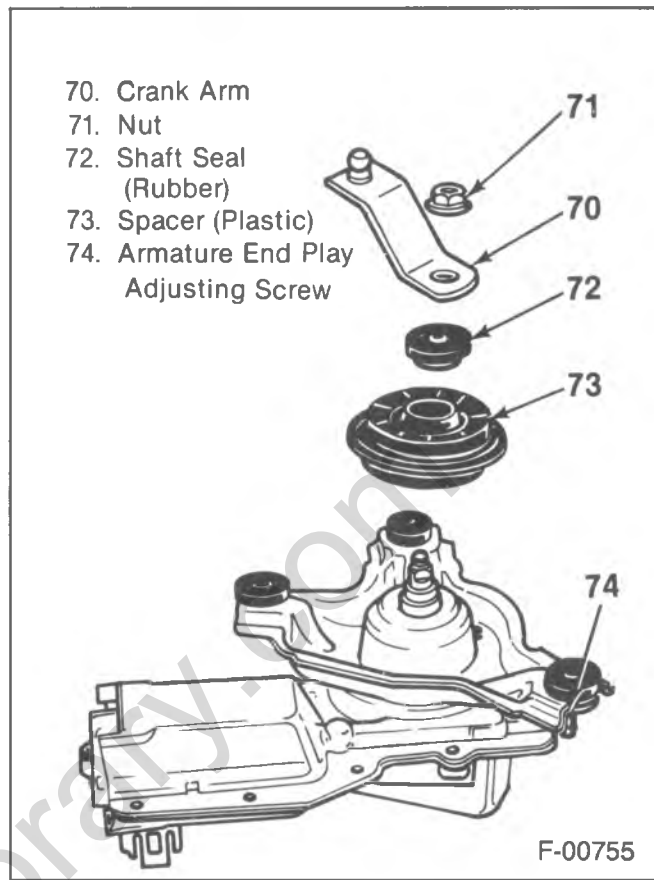

Figure 43—Crank Arm, Spacer and Seal

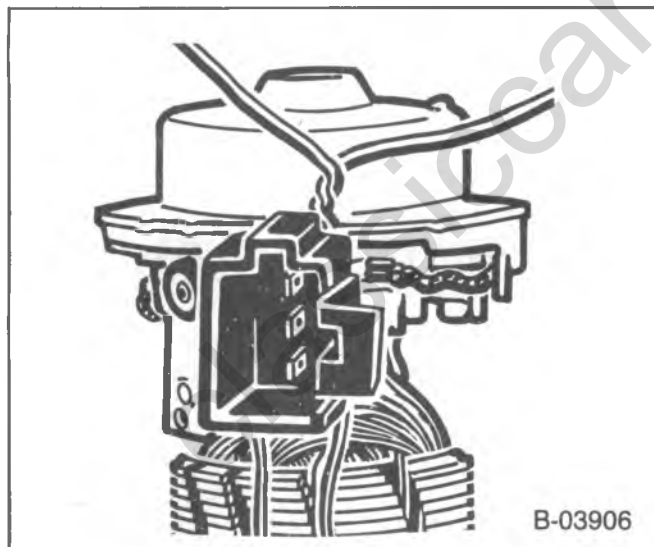

Figure 42—End Cap Assembly

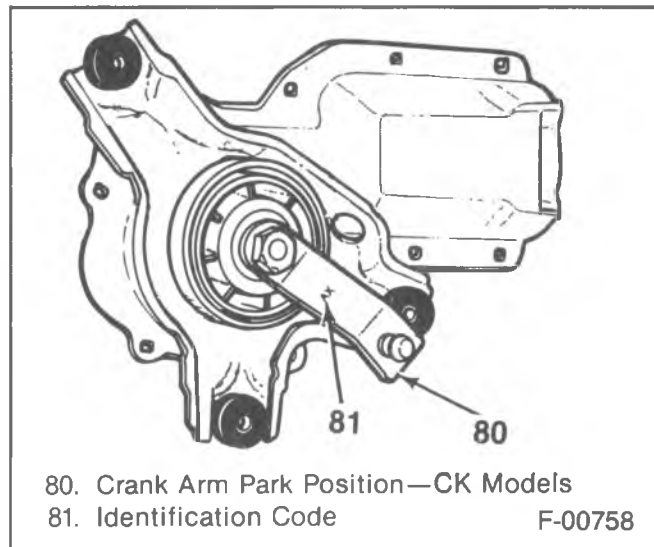

Figure 44—Crank Arm Position — RV Models

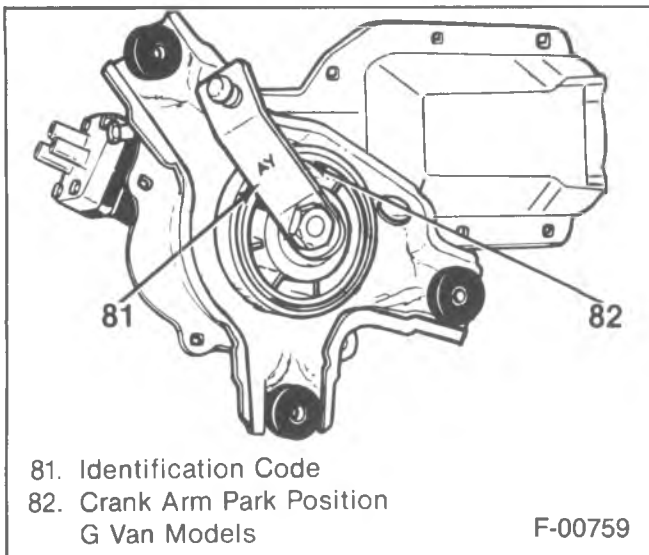

Figure 45—Crank Arm Position — Van

WINDSHIELD WIPER DELAY CIRCUIT

DESCRIPTION

The wiper pulse control circuit is an option on RV and G models. This option allows the wiper to operate at a slower rate than the low speed setting on the standard control.

The optional module is inserted into the harness under the steering column. Refer to figure 46.

DIAGNOSIS OF WIPER DELAY CIRCUIT

Refer to Figure 47.

ON-VEHICLE SERVICE

REPLACEMENT OF THE MODULE

↔ Remove or Disconnect (Figure 46)

1. Harness connectors.
2. Module (91) by sliding it off the bracket.

↔ Remove or Disconnect

1. Module (91).
2. Harness connectors.

REPLACEMENT OF THE SWITCH.

Refer to STEERING COLUMN (SEC. 3B4).

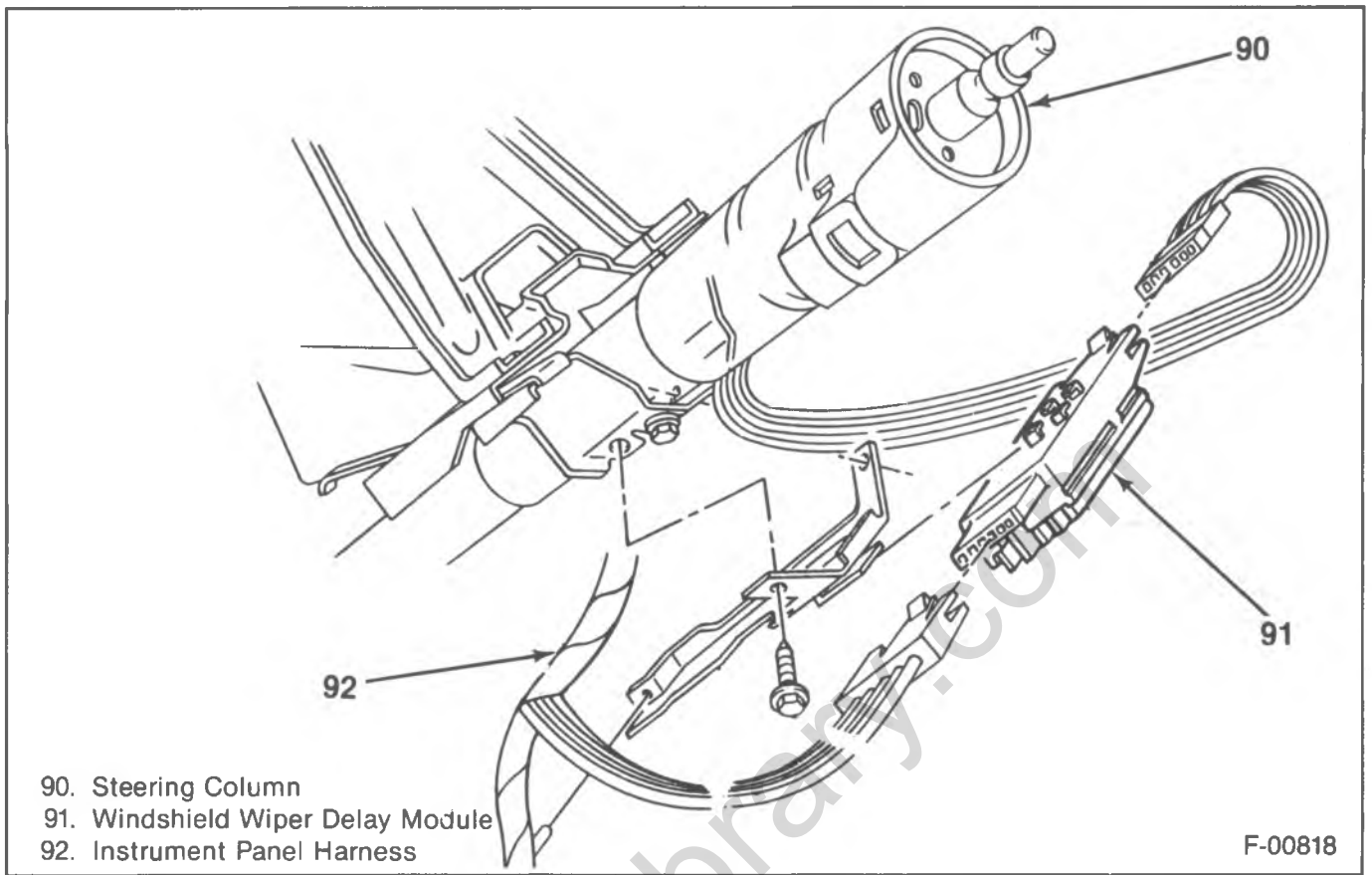

Figure 46—Wiper Pulse Module

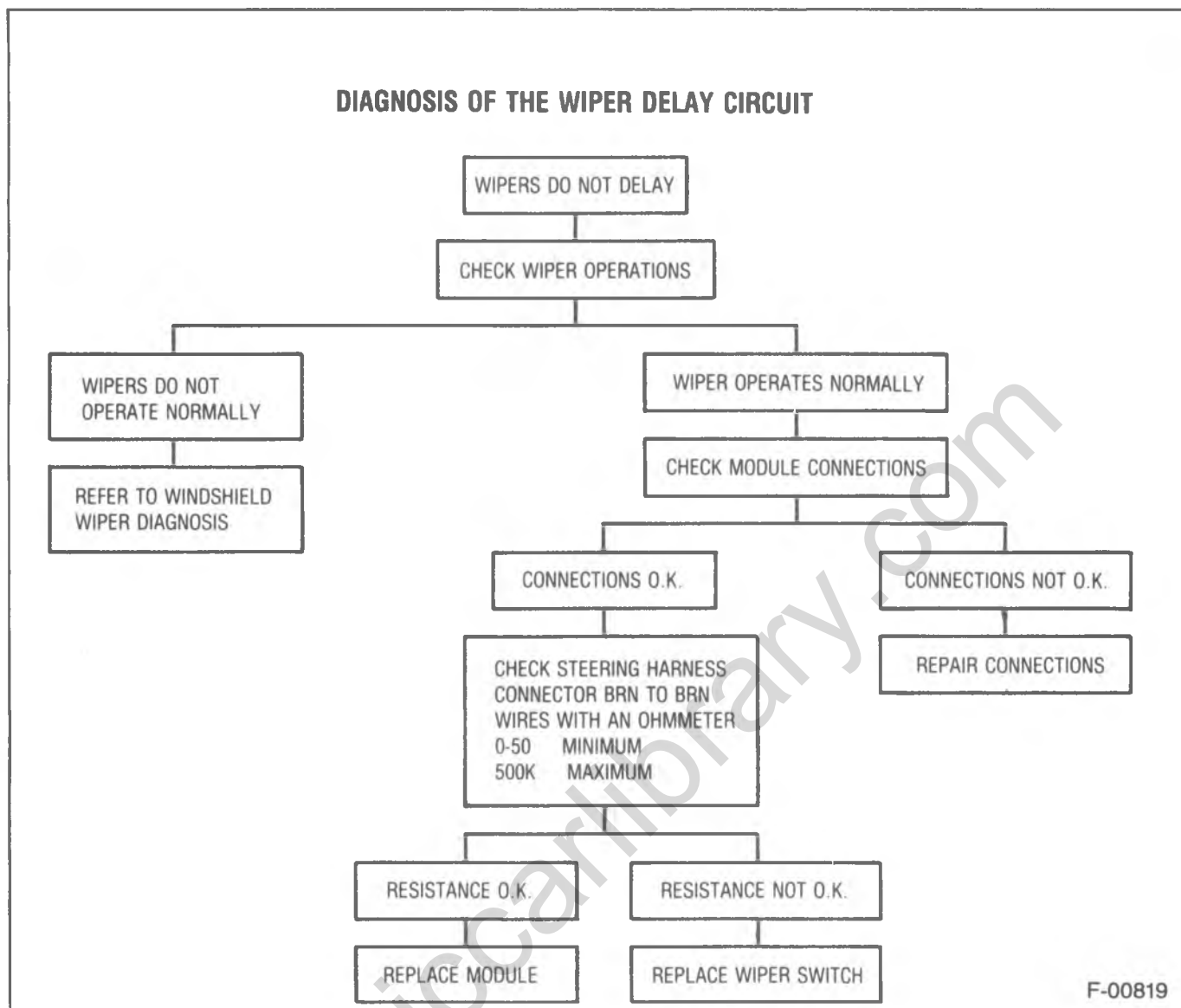

Figure 47—Diagnosis of the Wiper Delay Module

WINDSHIELD WIPER AND WASHER P MODELS

DESCRIPTION

The system consists of a compound wound rectangular-shaped motor attached to a gear box containing a parking switch in addition to the gear train. The gear train consists of a motor armature helical gearshaft which drives an intermediate gear and pinion assembly. The pinion gear of the intermediate gear and pinion drives an output gear and shaft assembly.

Turning the wiper switch to the LO speed position completes the circuits from the wiper terminals 1 and 3 to ground (Figure 48). Current then flows from the battery via wiper terminal No. 2 through the series field and divides; (1) part passes through the armature to ground via wiper terminal No. 1 to the wiper switch and (2) the second part

passes through the shunt field to ground through wiper terminal No. 3 to the wiper switch. The wiper switch must be securely grounded to body metal.

Moving the wiper switch to the HI speed position opens the shunt field circuit to ground at the switch. However, the shunt field is connected to a 20 ohm resistor which is connected across wiper terminals 1 and 3. The shunt field current then flows via terminal No. 3 through the resistor to terminal No. 1 to the switch, to ground.

The parking circuit covers that portion of wiper operation when the wiper switch is turned "off" and the wiper blades have not reached the park position.

When the wiper blades are not in the normal park position, the parking switch contacts are still closed. The wiper will continue to operate until the wiper output gear

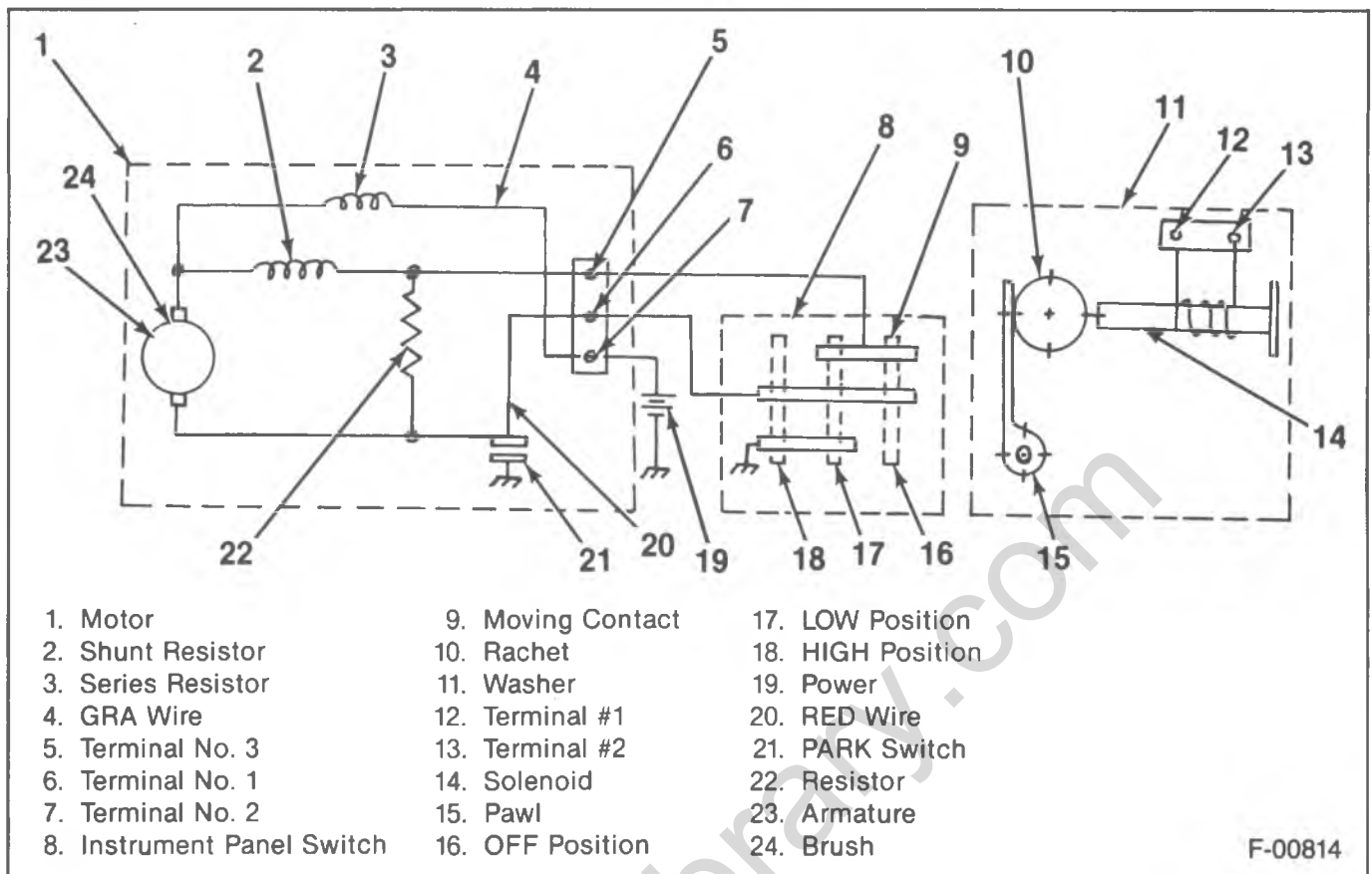

Figure 48—P-Model Wiper Diagram

is turned to a position where its cam opens the park switch. The wiper motor circuits are completed to ground through the parking switch.

The wiper motor must be securely grounded to body metal.

The shunt field circuit is completed from terminal No. 3 via the switch to terminal No. 1 through the parking switch to ground. The series field and armature circuit is also completed from terminal No. 1 through the parking switch to ground.

The shunt field is connected direct to ground, by-passing the resistor. This results in LO speed operation during the parking operation.

When the output gear cam opens the park switch contacts, the wiper is OFF.

DIAGNOSIS

WIPER SYSTEM CHECKS

1. Inspect for the following items:

- a. Wiring harness is securely connected to wiper and switch.

b. Wiper motor is securely grounded to body.

c. Wiper switch is securely mounted and grounded.

d. Check fuse.

2. If items in Step 1 check out, try operating wiper in both "LO" and "HI" speeds, then turn wiper off (blades should return to park position). If wiper fails to operate correctly, proceed to Step 3.

3. Disconnect wiring harness from wiper and try operating wiper as shown in Figures 49, 50, and 51.

4. If wiper operates correctly independently of switch and vehicle wiring, refer to "DIAGNOSIS — WIPER ON VEHICLE."

5. If wiper still fails to operate correctly in Step 3, disconnect wiper linkage from motor crank arm and try operating wiper again. If wiper operates correctly independently of linkage, check linkage for cause of wiper malfunction.

6. If wiper fails to operate correctly independently of linkage, remove wiper motor from vehicle and refer to "DIAGNOSIS — WIPER OFF VEHICLE."

8A-42 CAB ELECTRICAL

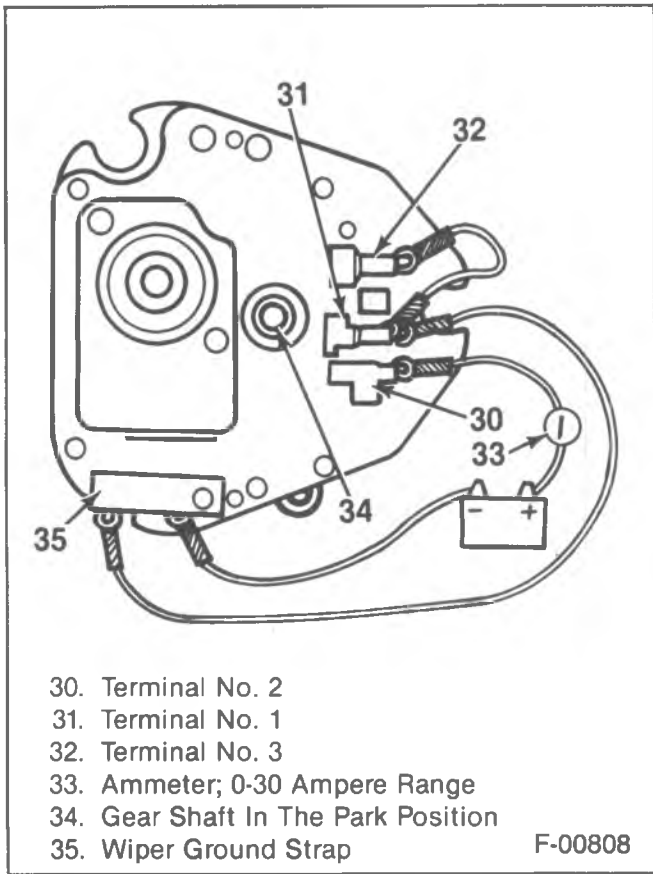

Figure 49—Jumper Connections — Low Speed

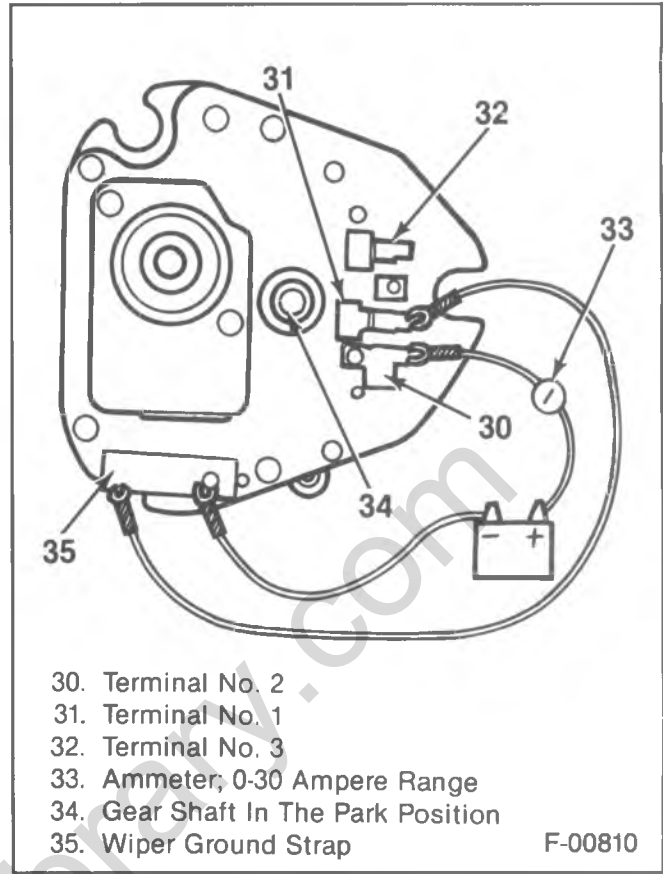

Figure 51—Jumper Connections — Off

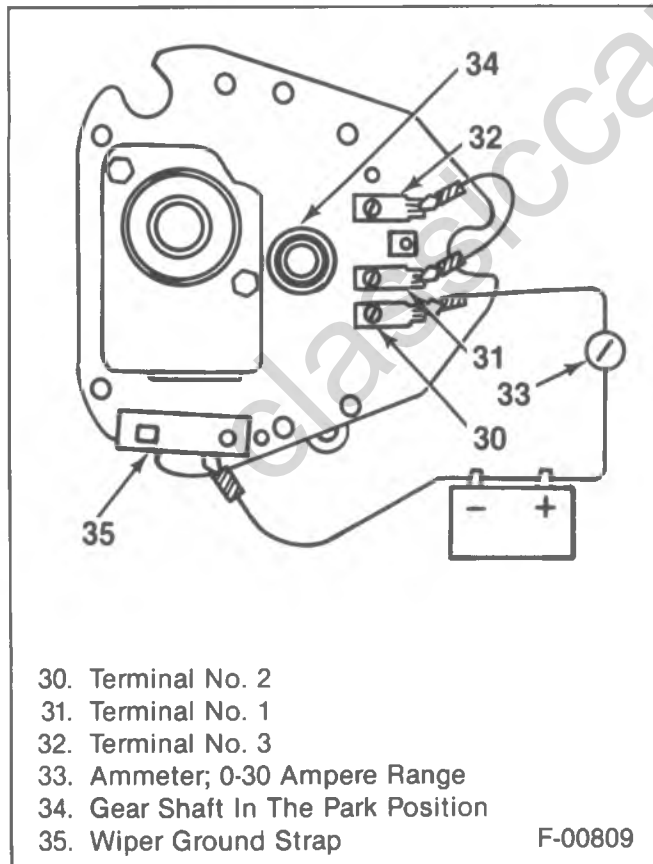

Figure 50—Jumper Connections — High Speed

DIAGNOSIS OF THE WIPER—ON VEHICLE

PROBLEM	POSSIBLE CAUSE	CORRECTION
Wiper Not Working or Intermittent	<ol style="list-style-type: none"> 1. Blown fuse 2. Open circuit in feed wire (No. 2 terminal on wiper motor) 3. Loose mounting of wiper switch. 4. Faulty wiper switch. 5. Open circuit in wire to wiper switch (No. 1 terminal on wiper motor) 	<ol style="list-style-type: none"> 1. Locate short circuit and repair. Replace fuse. 2. Locate broken wire and repair. 3. Tighten switch mounting. 4. Replace switch. 5. Locate broken wire and repair.
Wiper Will Not Shut Off. Wiper has Both "Lo" and "Hi" Speeds	Grounded wire (No. 1 terminal on wiper motor) to wiper switch.	Locate short circuit and repair.
Wiper Will Not Shut Off. Wiper Has "Lo" Speed Only.	<ol style="list-style-type: none"> 1. Defective wiper switch. 2. Grounded wire (No. 3 terminal on wiper motor) to wiper switch. 	<ol style="list-style-type: none"> 1. Replace wiper switch. 2. Locate and repair short circuit.
Wiper Will Not Shut Off. Wiper has "Hi" Speed Only	<ol style="list-style-type: none"> 1. Defective wiper switch. 2. Open circuit in wire (No. 3 terminal on wiper motor) to wiper switch. 	<ol style="list-style-type: none"> 1. Replace wiper switch. 2. Locate and repair broken wire.
Wiper Has "Hi" Speed Only	Open circuit in wire (No. 3 terminal on wiper motor) to wiper switch.	Locate broken wire and repair.
Wiper Has "Lo" Speed Only	<ol style="list-style-type: none"> 1. Grounded wire (No. 3 terminal on wiper motor) to wiper switch. 2. Defective wiper switch. 	<ol style="list-style-type: none"> 1. Locate short circuit and repair. 2. Replace wiper switch.
Blades Do Not Return To Full Park Position	Loose wiper ground strap connection.	Tighten strap connection.

DIAGNOSIS OF THE WIPER — OFF VEHICLE

PROBLEM	POSSIBLE CAUSE	CORRECTION
Wiper Not Working or Intermittent	<ol style="list-style-type: none"> 1. Broken or damaged gear train (only if not working). 2. Poor solder connections at terminal board. 3. Loose splice joints at brush plate. 4. Brushes binding in brush holder. 5. Open circuit in armature. 	<ol style="list-style-type: none"> 1. Replace gears as required. 2. Resolder wires at terminals. 3. Recrimp or solder splice joints. 4. Clean holder or replace brush, spring or brush plate assembly. 5. Replace armature.
Wiper Will Not Shut-Off. Wiper Has Normal "Hi" and "Lo" Speed	<ol style="list-style-type: none"> 1. Faulty part switch. 2. Grounded red lead wire. 	<ol style="list-style-type: none"> 1. Replace terminal board assembly. 2. Repair short circuit in red wire.

DIAGNOSIS OF THE WIPER — OFF VEHICLE (CONT.)

PROBLEM	POSSIBLE CAUSE	CORRECTION
Wiper Will Not Shut Off. Wiper Has "Lo" Speed Only	<ol style="list-style-type: none"> 1. Grounded shunt field coil. 2. Grounded black wire. 	<ol style="list-style-type: none"> 1. Replace frame and field assembly. 2. Repair short circuit in black wire.
Wiper Will Not Shut Off. Wiper Has "Hi" Speed Only	<ol style="list-style-type: none"> 1. Open circuit in shunt field coil. 2. Open circuit in black wire. 	<ol style="list-style-type: none"> 1. Replace frame and field assembly. 2. Repair broken wire or poor solder connection.
Wiper Shuts Off—But Not In Park Position	Park switch defective or contacts dirty.	Replace terminal board assembly or clean contacts.
"Hi" Speed Too Fast	Resistor defective.	Replace terminal board assembly.

DIAGNOSIS OF THE WASHER SYSTEM

PROBLEM	POSSIBLE CAUSE	CORRECTION
Washers Inoperative	<ol style="list-style-type: none"> 1. Inadequate quantity of washer solution. 2. Hoses damaged or loose. 3. Plugged screen at end of jar cover hose. 4. Loose electrical connection to washer pump or wiper switch. 5. Open circuit in feed wire to ratchet relay coil. 6. Wiper switch faulty. 7. Ratchet relay coil defective. 8. Washer nozzles plugged. 9. Ratchet wheel tooth missing. 10. Ratchet pawl spring missing. 11. Faulty pump valve assembly. 	<ol style="list-style-type: none"> 1. Add washer solution. 2. Cut short length off end of hose to insure air tight connection or replace hose. 3. Clean screen. 4. Check electrical connections and repair if necessary. 5. Locate open circuit and repair. 6. Replace wiper switch. 7. Replace ratchet relay. 8. Clean washer nozzles. 9. Replace ratchet wheel. 10. Replace ratchet pawl spring. 11. Replace pump valve assembly.
Washer Pumps Continuously When Wipers Are Operating	<ol style="list-style-type: none"> 1. Grounded wire from ratchet relay to switch. 2. Wiper switch faulty. 3. Ratchet wheel tooth missing. 4. Ratchet wheel dog broken or not contacting ratchet wheel teeth. 5. Lock-out tang broken or bent on piston actuating plate. 	<ol style="list-style-type: none"> 1. Locate grounded wire and repair. 2. Replace wiper switch. 3. Replace ratchet wheel. 4. Replace or repair ratchet wheel dog. 5. Replace piston actuating plate.

ON-VEHICLE SERVICE

WIPER MOTOR

Wiper motor replacement procedures are not included here since installation is performed by the individual body manufacturers; however, disassembly of the unit will be covered in "Unit Repair."

UNIT REPAIR

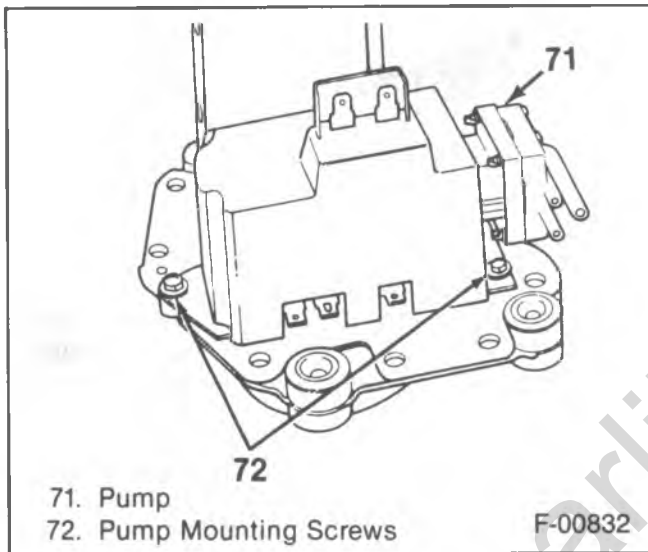

Figure 52—Washer Pump Mounting Screws

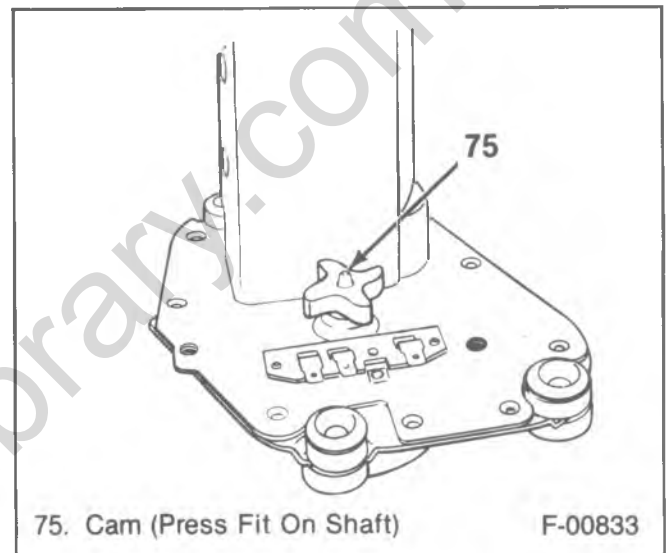

Figure 53—Drive Cam

WIPER MOTOR DISASSEMBLY

GEAR BOX AND MOTOR

↔ Remove or Disconnect (Figure 52, 53, and 54)

1. Two washer pump mounting screws (72).
2. Pump (71) from the gear box cover.
3. Washer pump drive cam (75).
 - Wedge off the cam and the plate using two screwdrivers.
4. Crank arm retaining nut (58).
 - Clamp the crank arm (57) in a vise before removing the nut (58).
5. Crank arm (57).
6. Seal cap (56).
7. Retaining ring (55).
8. Spacer (54).
9. Gear box cover retaining rivets.
 - Drill out the rivets.
10. Gear box cover (53).
11. Output gear and shaft assembly (52).
12. Intermediate gear and pinion assembly off the shaft (51).
13. Terminal board and park switch assembly, if necessary.
 - Unsolder the motor leads from the terminals.

- Label the motor leads.
- Drill out the rivets securing the terminal board and the park switch ground strap to the mounting plate.

14. Motor through bolts (42).
15. Motor from the mounting plate.
 - Tap motor frame lightly.
16. Brush spring tension (61).
17. Armature (46) and end plate (43) from the motor frame (44).
18. End plate (43) from the armature (46).
 - There is a thrust plug (45) between the armature shaft and the end plate.
19. End play adjusting washers (47 and 41) from the armature.
 - Note the washers positions.

INSPECTION

Inspect all the parts for wear or damage. All the parts can be replaced individually except the motor frame and field, which is serviced as an assembly. Service kits provide screws, nuts and washers to replace the gear cover and terminal board rivets.

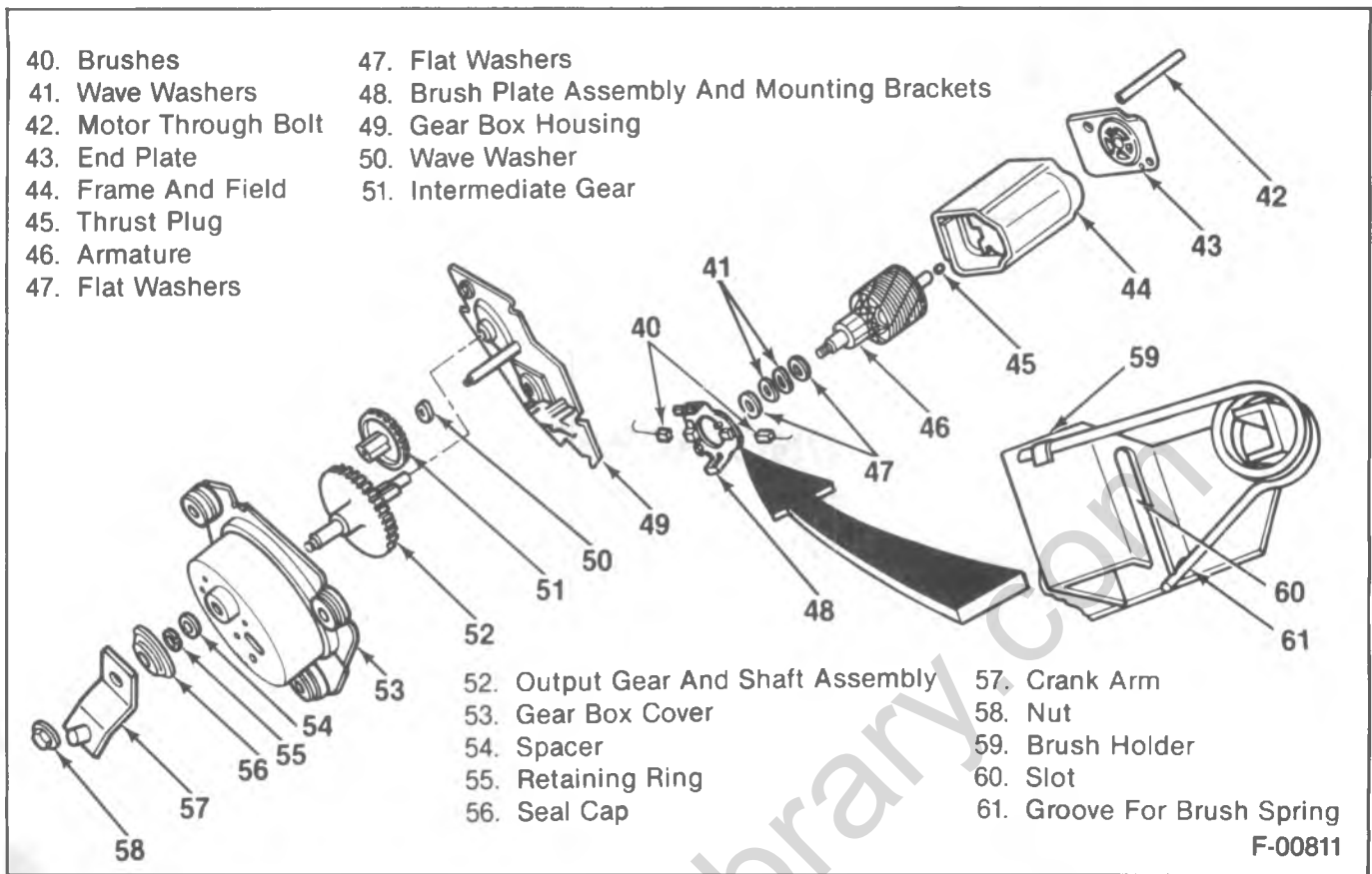

Figure 54—Motor Assembly

WIPER MOTOR ASSEMBLY

GEAR BOX AND MOTOR

↔ Install or Connect (Figure 52, 53, 54, and 55)

1. End play adjusting washers (41 and 47) on the armature (46).
2. End plate (43) on the armature (46).
 - Make sure the thrust plug (45) is between the armature shaft and the endplate.
 - Lubricate the bearing with light machine oil.
3. Armature and the end plate assembly on the motor frame (44).
4. Brush spring tension (60).
5. Motor to the mounting plate (49).
6. Motor through bolts (42).
7. Terminal board and park switch assembly, if removed.
 - Secure the terminal board and park switch with the screws, washers and nuts supplied in the rebuild kits.
 - Solder the motor leads to the terminals.
8. Intermediate gear and pinion assembly on the shaft (51).
 - Lubricate the gear teeth with Delco Cam and Ball Bearing Grease (or equivalent).
9. Output gear and shaft assembly (52).
10. Gear box cover (53).
11. Gear box cover screw, washers, and nuts.
12. Spacer (54).
13. Retaining ring (55).

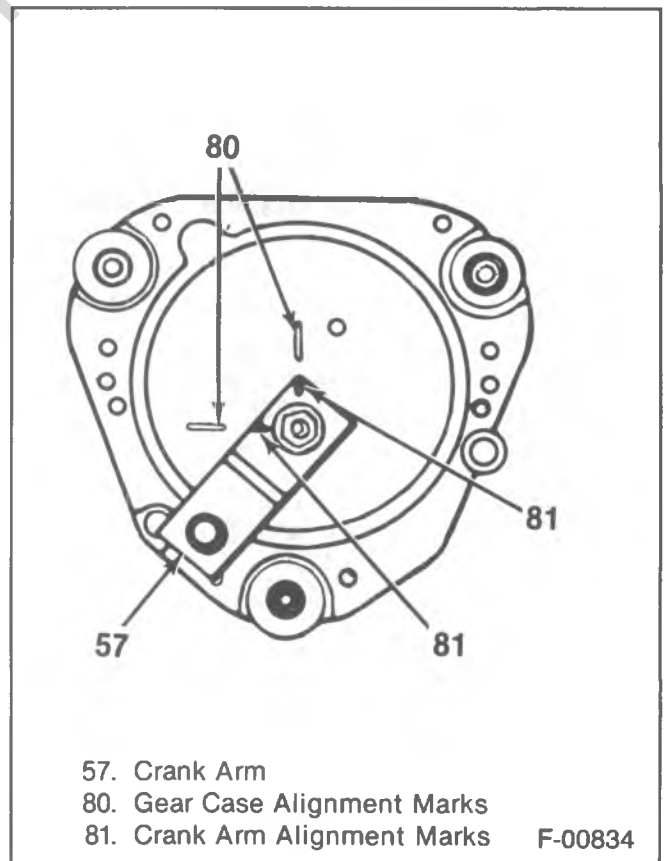
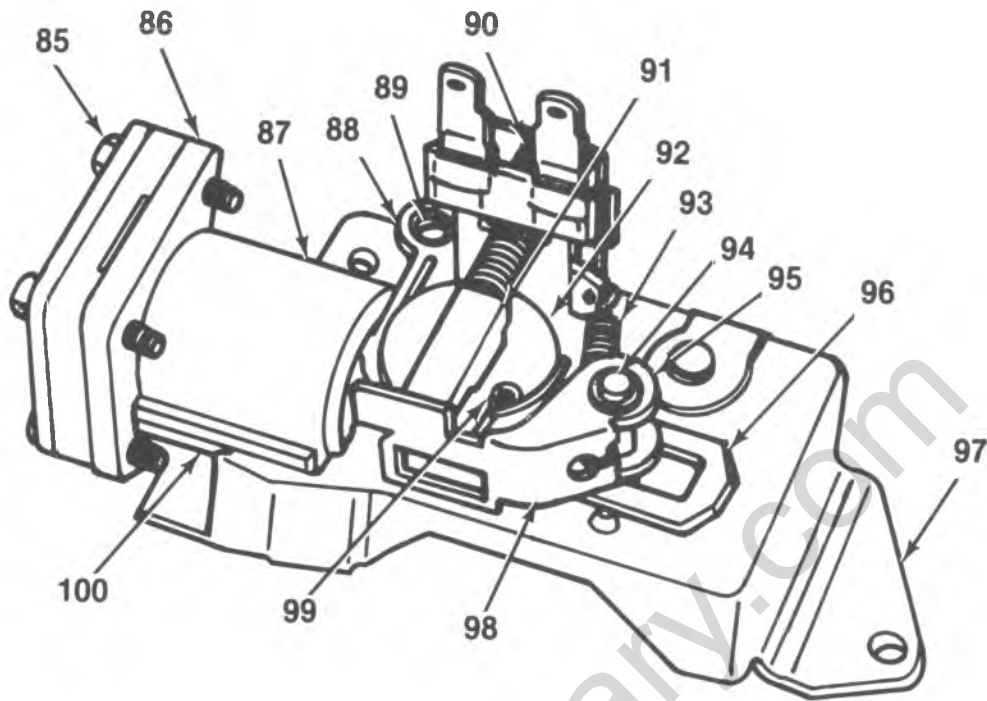

Figure 55—Park Alignment



- | | |
|-----------------------------------|----------------------------|
| 85. Valve Assembly Mounting Screw | 93. Ratchet Pawl Spring |
| 86. Valve Assembly | 94. Cam Follower Upper Pin |
| 87. Pump | 95. "E" Ring |
| 88. Ratchet Dog | 96. Cam Follower |
| 89. Ratchet Dog Retaining Screw | 97. Frame |
| 90. Solenoid Coil | 98. Ratchet Pawl |
| 91. Solenoid Plunger | 99. Ratchet Wheel Spring |
| 92. Ratchet Wheel | 100. Retaining Groove |

F-00835

Figure 56—Washer Pump Assembly

14. Seal cap (56).
 15. Crank arm (57).
 - Place the wiper in the park position.
 - Install the crank arm on the output shaft.
 - Rotate the crank so that the alignment marks line up with those on the cover (80 and 81).
 16. Crank arm retaining nut (58).
 - Clamp the crank arm in a vise before tightening the retaining nut.
 17. Washer pump drive cam (75).
 - Press the cam on the shaft.
 18. Pump on the gear box cover.
 19. Two pump mounting screws (72).
-
- ### WINDSHIELD WASHER DISASSEMBLY
- ↔ Remove or Disconnect (Figure 56)**
1. Washer pump cover
 2. Ratchet dog retaining screw (89).
 3. Solenoid assembly (90) and ratchet dog (88) off the pump frame (97).
 - Hold the spring loaded solenoid plunger (91) in position while lifting the solenoid assembly.
 4. Ratchet pawl spring (93).
 5. Ratchet pawl retaining ring (94).
 6. Ratchet pawl (98) from the cam follower Upper Pin.
 7. Ratchet wheel spring (99) out of the shaft groove.
 8. Ratchet wheel (92) from the shaft.
 9. Pump and actuator plate assembly.
 - Pull the pump housing away from the drive cam until the housing grooves (100) clear the frame.
 - Lift the cam follower (96) from the ratchet wheel and cam follower shafts.
 10. Four valve assembly screws (85).
 11. Valve assembly (86) from the pump housing.

WINDSHIELD WASHER ASSEMBLY

Install or Connect (Figure 56)

1. Valve assembly (86). To the pump housing (87).
 - Be sure that the seal between the pump housing and the valve plate is properly positioned in the pump housing and valve plate grooves.
 - Be sure that the triple seal is properly installed between the valve body and the pipe assembly.
2. Four valve assembly screws (85).
3. Pump (87) and cam follower (96) assembly to the frame (97).
4. Ratchet wheel (92) to the shaft.
5. Ratchet wheel spring (99) into the shaft groove.
6. Ratchet pawl (98) onto the cam follower upper pin (94).
7. Ratchet pawl retaining "E" ring (95).
8. Ratchet pawl spring (93).
9. Solenoid assembly (90) and ratchet dog (88) on the pump frame (97).
 - Hold the spring loaded solenoid plunger (91) in position while installing the solenoid assembly.
10. Ratchet dog retaining screw (89).
11. Washer pump cover.

HEATER SYSTEM CIRCUITS

DESCRIPTION

The heater blower motor is controlled by the blower switch. The blower switch is a four position switch; off, low, medium, and high. This switch controls the speed of the blower motor by connecting different resistances into the motor circuit, thereby dropping the voltage available to the motor.

The blower switch is located on the control assembly. The harness from the switch goes to the dash panel connector and into the engine compartment. The harness is then routed to the resistor block, which is located on the blower housing. From the resistor block, the harness then goes to the blower motor. The wire colors

can be found in the wiring diagrams which are at the back of this manual.

DIAGNOSIS

For diagnosis of the heater blower circuit, refer to HEATING AND VENTILATION (SEC. 1A).

ON-VEHICLE SERVICE

For on-vehicle service of the heater blower circuit, refer to HEATING AND VENTILATION (SEC. 1A).

AIR CONDITIONING ELECTRICAL SYSTEM

DESCRIPTION

The compressor electro-magnetic clutch is turned on and off by the pressure sensing switch. When refrigerant pressure drops below a certain predetermined level, the switch opens the compressor clutch circuit, which causes the refrigeration system to stop working. The pressure sensing switch is located near the top of the accumulator.

DIAGNOSIS

For diagnosis of the A/C electrical system, refer to AIR CONDITIONING (SEC. 1B).

ON-VEHICLE SERVICE

For on-vehicle service of the air conditioning, refer to AIR CONDITIONING (SEC. 1B).

SPECIAL TOOLS

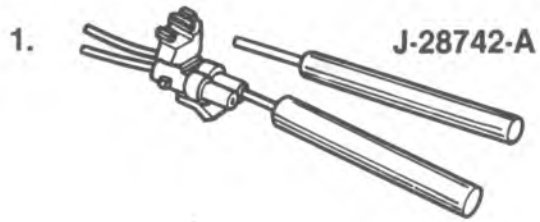

1. Terminal Remover (Weather Pack)
2. Terminal Remover (Metri-Pack)

B-07589

classiccarlibrary.com

classiccarlibrary.com

SECTION 8B

CHASSIS ELECTRICAL

CONTENTS

<u>SUBJECT</u>	<u>PAGE</u>
Front Lighting System8B- 1
Headlamp System8B- 1
Diagnosis Of Headlamp8B- 6
On-Vehicle Service8B- 7
Front Parking Lamps System8B- 8
Diagnosis Of The Front Parking Lamps8B- 8
On-Vehicle Service8B- 9
Front Side Marker Lamp System8B-10
Diagnosis Of The Front Side Marker Lamps8B-10
On-Vehicle Service8B-11
Rear Lighting Systems8B-11
Rear Running Lamps And Marker Lamps8B-11
Rear Park Lamps8B-11
Rear Turn, Stop And Hazard Systems8B-11
Back-Up Lamp System8B-12
Rear Lamp Harness Layouts8B-12
Diagnosis Of The Rear Side Marker Lamps8B-17
Diagnosis Of The Running, Park And License Lamps8B-18
Diagnosis Of The Turn Signal And Hazard Systems8B-19
Diagnosis Of The Stoplamp System8B-20
Diagnosis Of The Back Up Lamp System8B-20
On-Vehicle Service8B-21
Fuses, Circuit Breakers Specifications8B-27
Lamp Specifications8B-29

FRONT LIGHT SYSTEMS

The front lighting system includes the headlamps, the front parking lamps, and the front side marker lamps. The circuit starts at the fuse block and goes to the light switch in the instrument panel. From the light switch the circuit goes to the dash panel connector and then to the front lamps.

HEADLAMP SYSTEM

The headlamp system has two options. One option is two headlamps, each headlamp having a parking lamp located under it. The other option is four headlamps, with the parking lamps located in the grill. On the four headlamp option, when the low beam circuit is energized, only the upper headlamps will be on. When the high beam circuit is energized, only the lower headlamps will be on. Refer to figures 1, 2, 3, and 4.

8B-2 CHASSIS ELECTRICAL

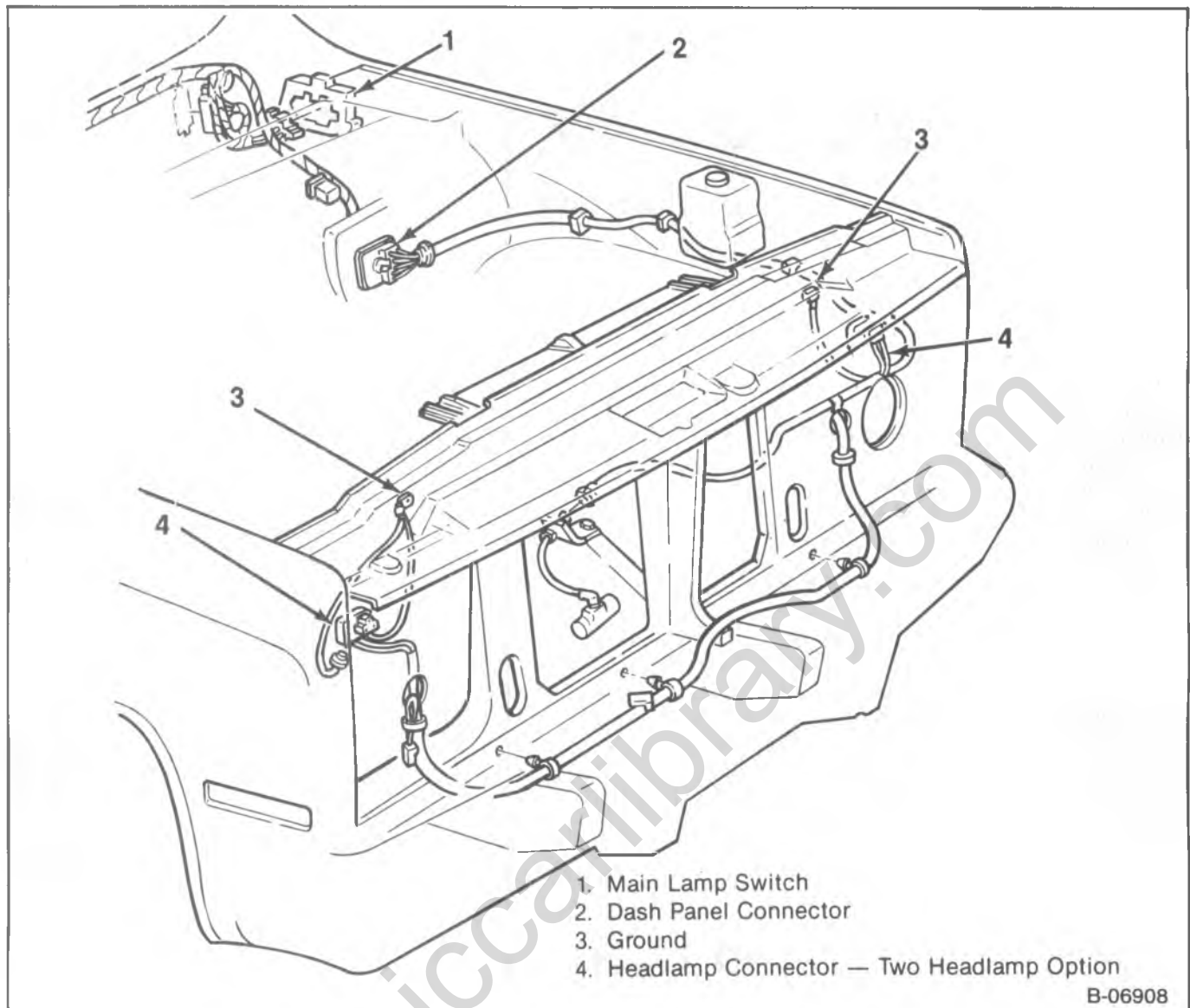

Figure 1—RV Two Headlamp Wiring Harness

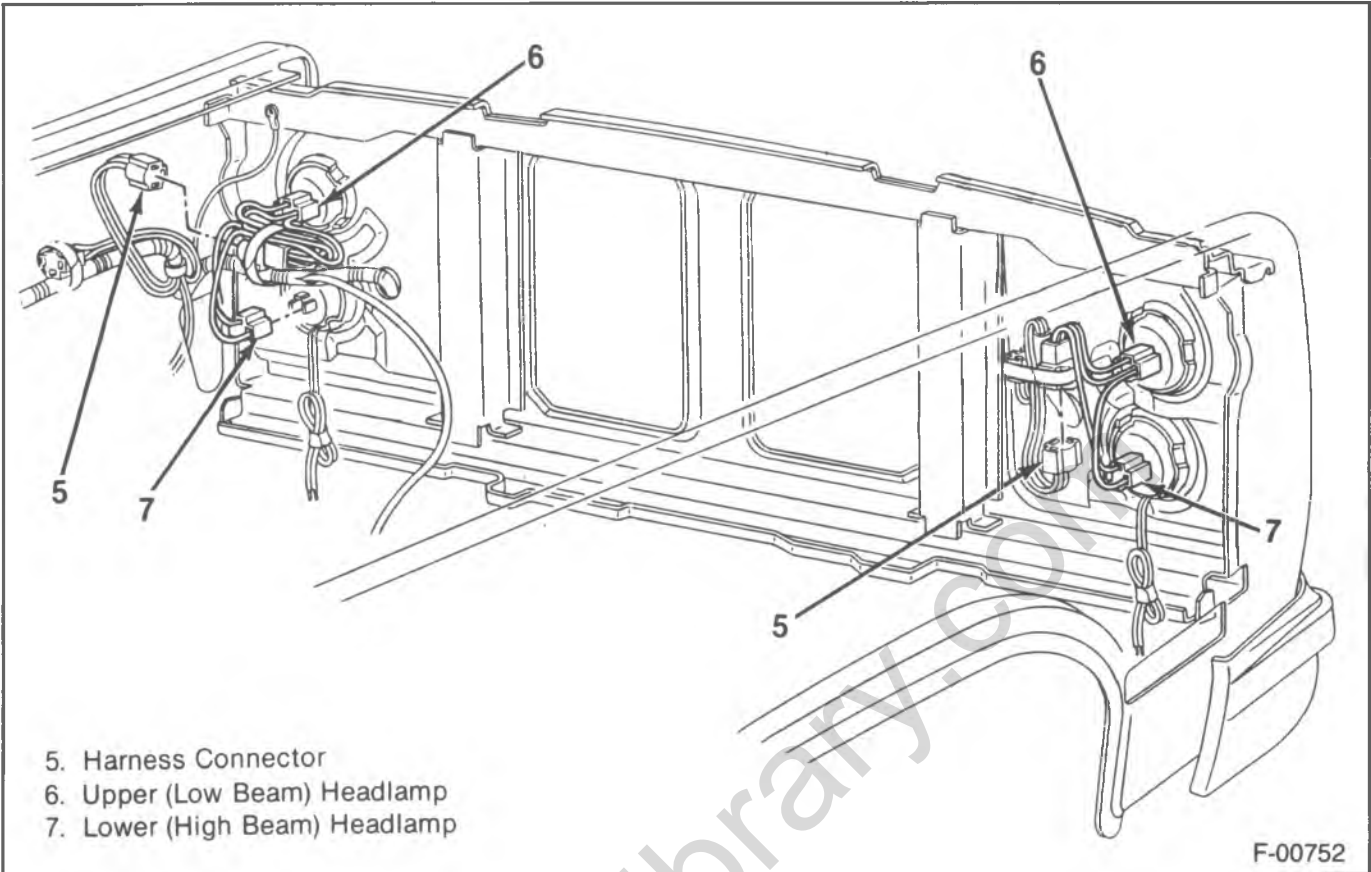

Figure 2—RV Four Headlamp Wiring Harness

8B-4 CHASSIS ELECTRICAL

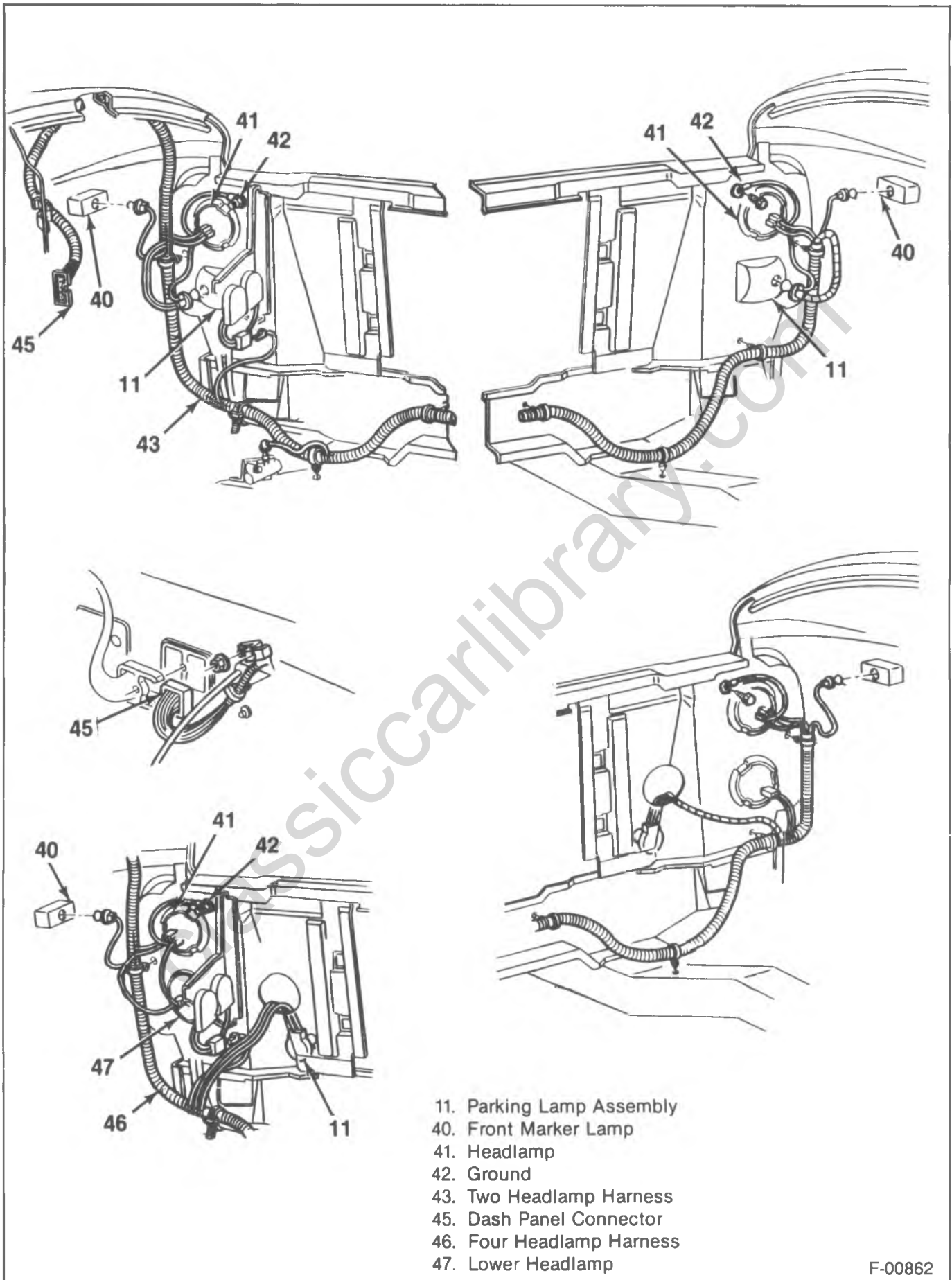

Figure 3—G Van Front Lighting Harness

F-00862

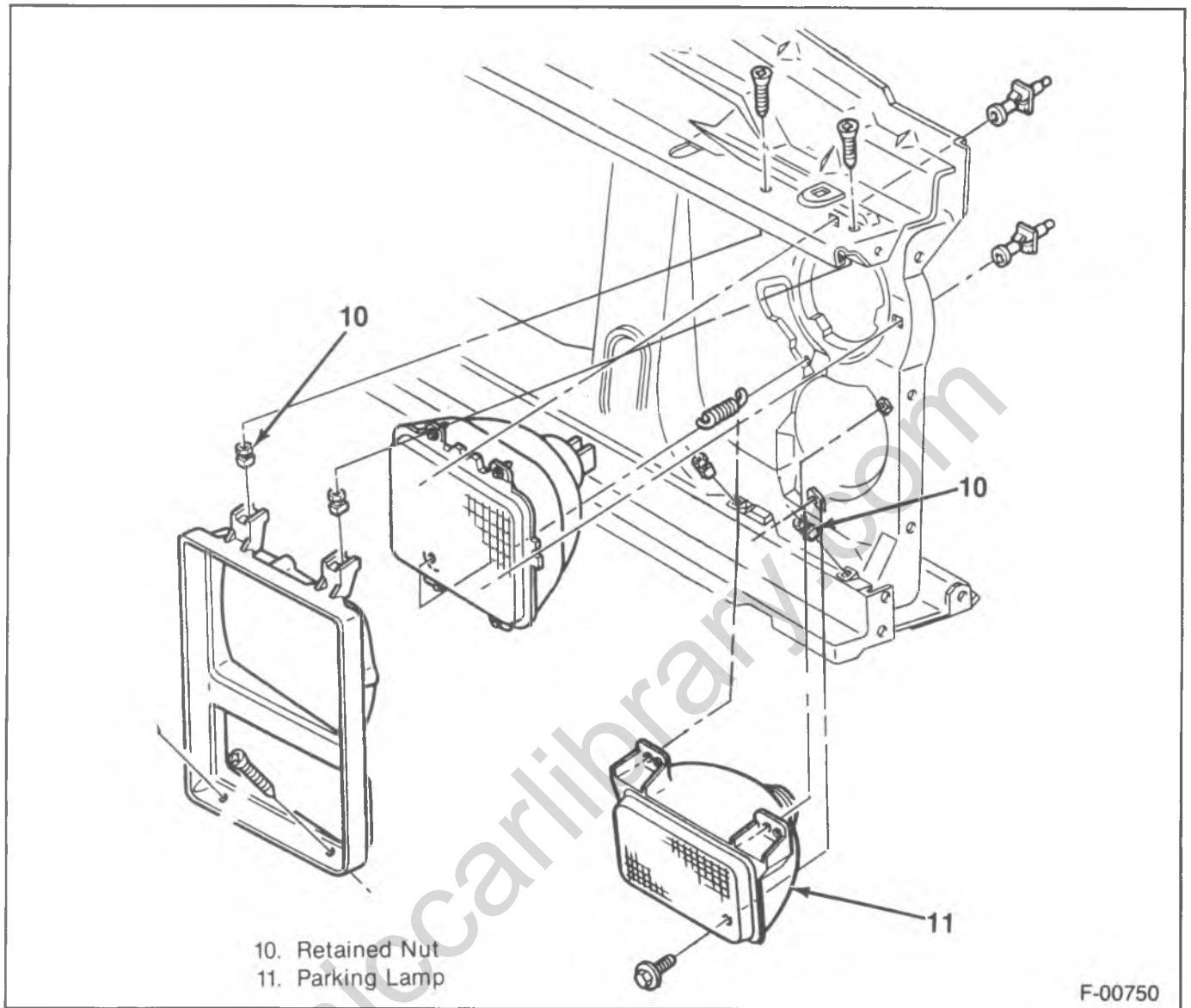
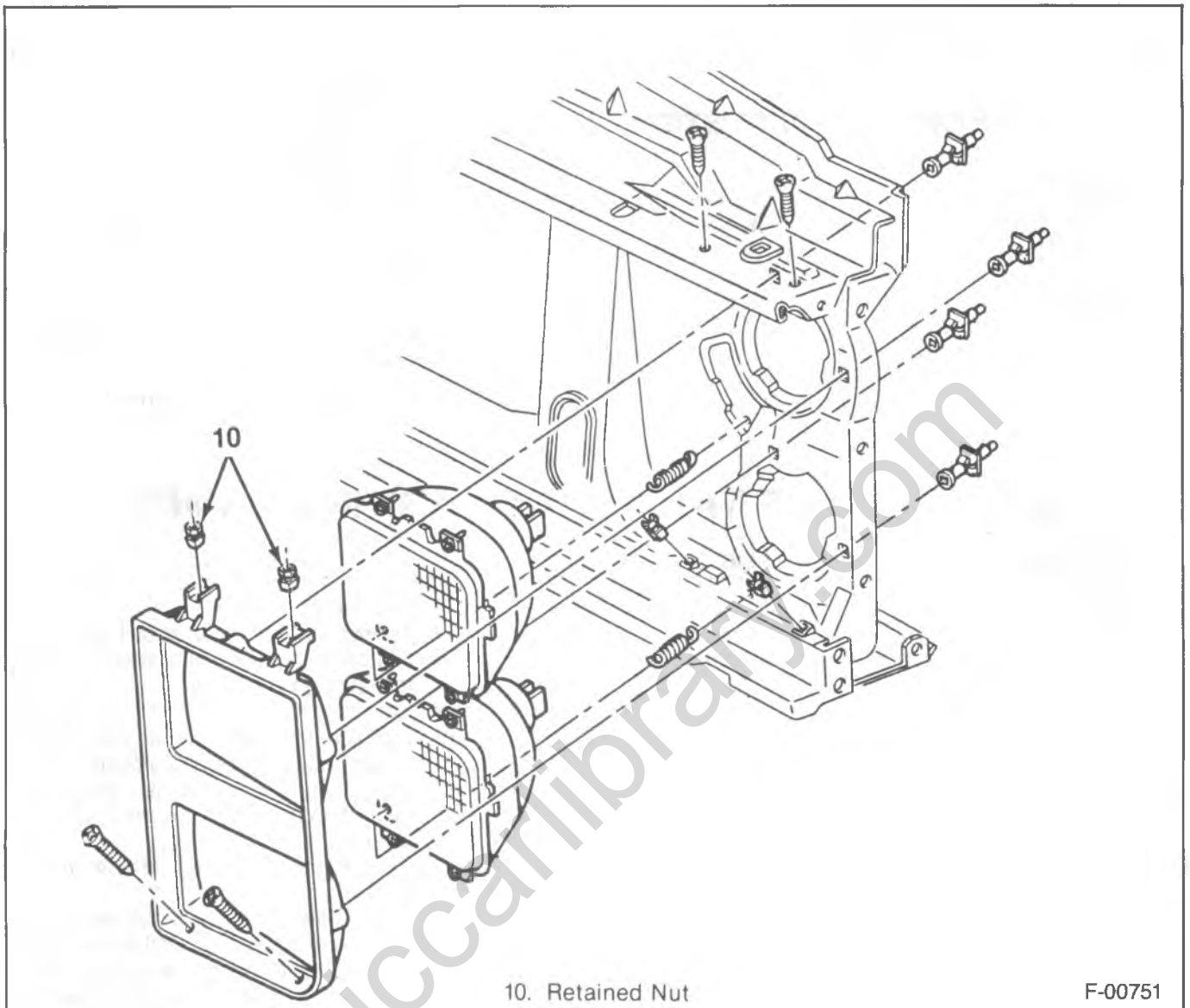

Figure 4—Two Headlamp Assembly

DIAGNOSIS OF HEADLAMP

PROBLEM	POSSIBLE CAUSE	CORRECTION
One Headlamp Inoperative Or Intermittent.	<ol style="list-style-type: none"> 1. Loose connection. 2. Defective sealed beam unit. 	<ol style="list-style-type: none"> 1. Secure the connections to the headlamp including the ground (black wire). 2. Replace the headlamp.
One Or More Headlamps Are Dim.	<ol style="list-style-type: none"> 1. Open ground connection at the headlamp. 2. Black ground wire mislocated in the headlamp connector (three-wire, hi-lo, connector only). 	<ol style="list-style-type: none"> 1. Repair the black wire connection between headlamp and the body ground. 2. Relocate the black wire in the connector.
One Or More Headlamps Short Life.	Charge circuit problem.	Refer to ENGINE ELECTRICAL (SEC. 6D), charging system diagnosis.
All Headlamps Inoperative Or Intermittent.	<ol style="list-style-type: none"> 1. Loosen connection. 2. Defective dimmer switch. 3. Open wiring—lamp switch to the dimmer switch. 4. Open wiring—lamp switch to the battery. 5. Shorted ground circuit. 6. Defective switch. 	<ol style="list-style-type: none"> 1. Check and secure the connections at the dimmer switch and the lamp switch. 2. Check the voltage at the dimmer switch with a test lamp. Refer to CAB ELECTRICAL (SEC. 8A) for the test points. 3. Check the yellow wire with a test lamp. If the bulb lamps at the lamp switch yellow wire terminal but not at the dimmer switch, repair the open wire. 4. Check the red wire terminal at the lamp switch with a test lamp. If the bulb does not lamp, repair the open red wire circuit to the battery (possible open fusible link). 5. If, after a few minutes operation, the headlamps flicker "ON" and "OFF" and/or a thumping noise can be heard from the lamp switch (circuit breaker opening and closing), repair the short to ground in the circuit between the lamp switch and the headlamps. After repairing the short, check for headlamp flickering after one minute operation. If flickering occurs, the circuit breaker has been damaged and the lamp switch must be replaced. 6. Check the red and yellow wire terminals at the lamp switch with test. If the bulb lamps at the red wire terminal but not at the yellow terminal, replace the lamp switch.
Upper Or Lower Beam Will Not Light Or Intermittent.	<ol style="list-style-type: none"> 1. Open connection or defective dimmer switch. 2. Short circuit to ground. 	<ol style="list-style-type: none"> 1. Check the dimmer switch terminals with a test lamp. If the bulb lights at the light green or tan wire terminals, repair the open wiring between the dimmer switch and the headlamps. If the bulb will not light at either of these terminals, depending upon switch position, replace the dimmer switch. 2. Follow the diagnosis above (all headlamps inoperative or intermittent).



10. Retained Nut

F-00751

Figure 5—Four Headlamp Assembly

ON-VEHICLE SERVICE

HEADLAMP UNIT REPLACEMENT

↔ Remove or Disconnect (Figure 4 and 5)

1. Battery ground cable from the battery.
2. Headlamp bezel retaining screws.
3. Bezel.
4. Retaining ring screws. Be careful not to move the adjustment screws.
5. Retaining ring spring, using a hooked tool.
6. Retaining ring from the mounting ring.
7. Headlamp unit.
8. Headlamp electrical connector.

↔ Install or Connect (Figure 4 and 5)

1. Headlamp electrical connector.
 - On the dual headlamp option, the 2A1 headlamp is the upper unit and the 1A1 headlamp is the lower unit.
2. Headlamp.
3. Retaining ring.

4. Retaining ring screws. Make sure that the headlamp is properly seated.
5. Retaining ring spring.
6. Bezel.
7. Bezel retaining screws.
8. Battery ground cable to the battery.

HEADLAMP ADJUSTMENT (Figure 6)

Horizontal and vertical aiming of each headlamp is done by two (2) adjusting screws which move the mounting ring against the tension of the coil spring.

Some state and local authorities have specific requirements for aiming headlamps and these requirements should be followed.

Replacement of a headlamp will normally not require aiming adjustment. However, do check the aim.

Use the safety aimer J-6878-01 or equivalent. Instructions for using the safety aimer are supplied by the instrument manufacturer.

DIMMER SWITCH REPLACEMENT

Refer to STEERING COLUMNS (SEC. 3B4).

8B-8 CHASSIS ELECTRICAL

LAMP SWITCH REPLACEMENT

Refer to "Rear Lighting Systems."

FRONT PARKING LAMPS SYSTEM

DESCRIPTION

The front parking lamps circuit is in the headlamp harness. The circuit starts from the fuse block, goes to the lamp switch, and then forward to the front parking lamps. The circuit also includes the rear parking lamps, which are covered later in this section. The parking lamp system is turned on when the lamp switch is pulled out to the first detent.

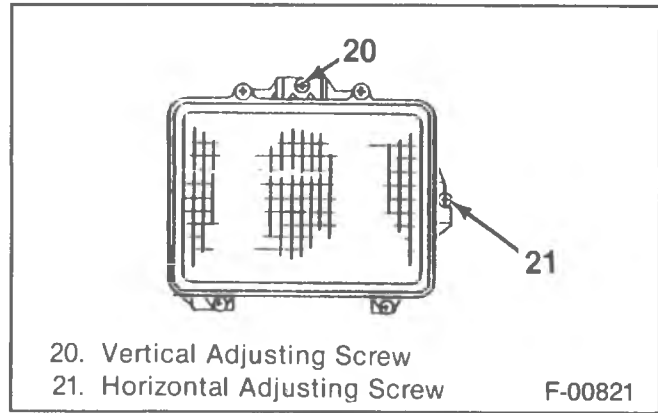

Figure 6—Headlamp Aiming Screws

DIAGNOSIS OF THE FRONT PARKING LAMPS

PROBLEM	POSSIBLE CAUSE	CORRECTION
One Side Not Working.	<ol style="list-style-type: none">1. Bulb burnt out.2. Open connection at the bulb socket or the ground wire terminal.	<ol style="list-style-type: none">1. Replace the bulb.2. Jumper the bulb base socket connection to ground. If the bulb lamps, repair the open ground circuit.
Both Sides Not Working.	<ol style="list-style-type: none">1. Fuse blown.2. Loose connection.3. Open wiring.4. Multiple bulb burnout.5. Defective lamp switch.	<ol style="list-style-type: none">1. Replace the fuse. If the new fuse blows, repair the short to ground in the brown wire circuit between the fuse panel through the lamp switch to the lamps.2. Secure the connector at the lamp switch.3. Using a test lamp, check the circuit on both sides of the fuse. If the test bulb does not lamp on either side, repair the open circuit between the fuse panel and the battery (possible open fusible link). If the test bulb lamps at the lamp switch brown wire terminal, repair the open wiring between the lamp switch and the lamps.4. If the test bulb lamps at the lamp socket brown wire terminal, replace the bulb(s).5. If the test bulb lamps at the lamp switch orange wire but not at the brown wire, replace the defective lamp switch.

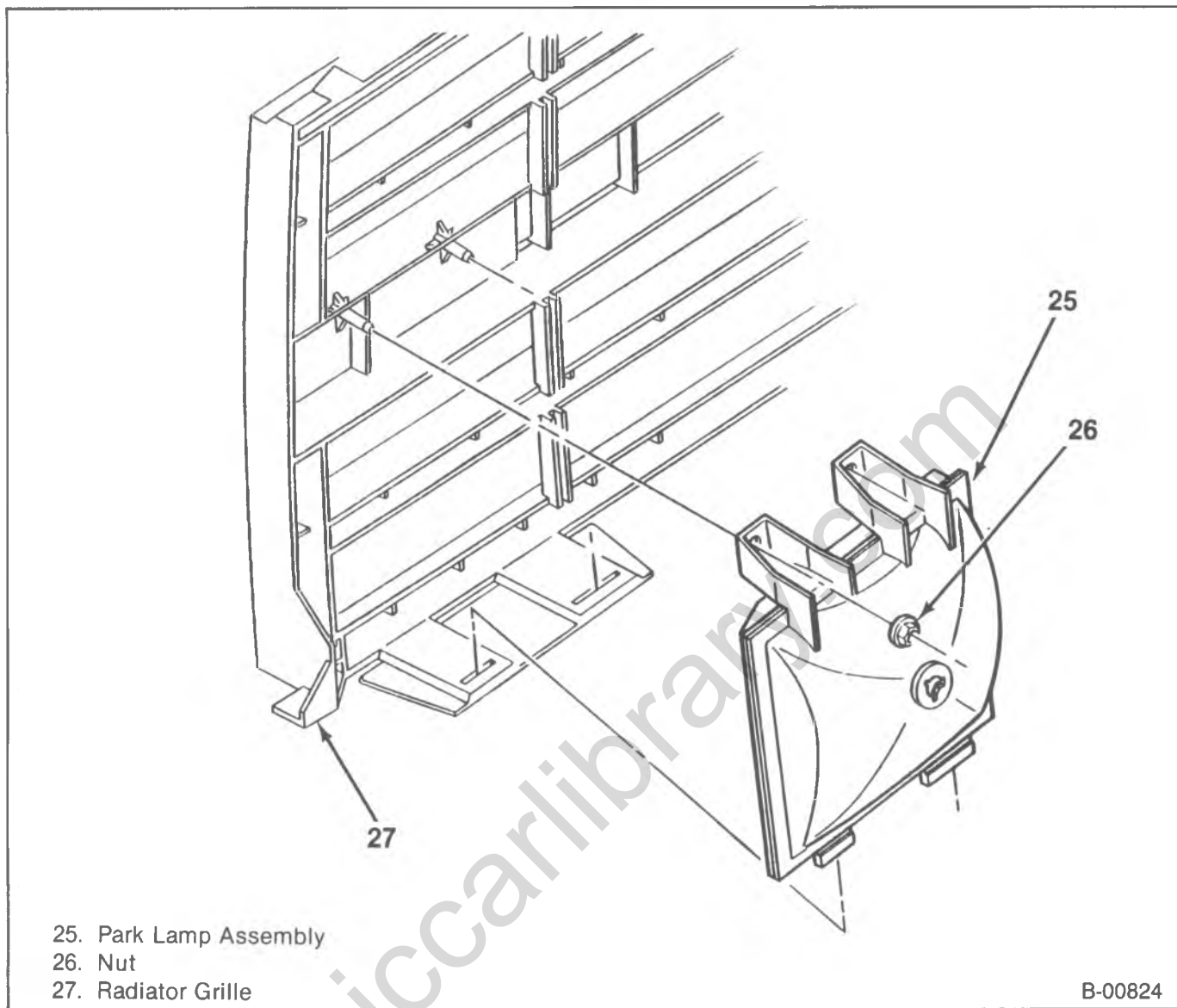

Figure 7—Parking Lamp Assembly

ON-VEHICLE SERVICE

REPLACEMENT OF THE LAMP SWITCH

Refer to INSTRUMENT PANEL (SEC. 8C).

REPLACEMENT OF THE FRONT PARKING LAMP

RV and G Models—Two Headlamp Option

↔ Remove or Disconnect (Figures 3 and 4)

1. Battery ground cable from the battery.
2. Four bezel retaining screws.
3. Bezel.
4. Three park lamp retaining screws.
5. Parking lamp.
6. Electrical connector from the parking lamp.

↔ Install or Connect (Figures 3 and 4)

1. Electrical connector to the parking lamp.
2. Parking lamp.
3. Three parking lamp retaining screws.
4. Bezel.

5. Four bezel retaining screws.

6. Battery ground cable to the battery.

RV and G Models—Four Headlamp Option

↔ Remove or Disconnect (Figure 7)

1. Radiator grille (27). Refer to SHEET METAL (SEC. 2B).
2. Electrical connector from the parking lamp.
3. Two nuts (26) at the top of the housing (25).
4. Housing by lifting it up from the radiator grille.

↔ Install or Connect (Figure 7)

1. Park lamp housing (25) on the radiator grille (27).
2. Two nuts (26) at the top of the housing (25).
3. Electrical connector into the parking lamp.
4. Radiator grille (27). Refer to SHEET METAL (SEC. 2B).

FRONT SIDE MARKER LAMP SYSTEM

DESCRIPTION

The front side marker lamp circuit is included in the headlamp harness. The circuit starts at the lamp switch. It goes to the dash panel connector and out to the front side marker lamps. The circuit also branches at the lamp switch and goes to the rear side marker lamps. This part of the circuit is covered later in this section.

DIAGNOSIS OF THE FRONT SIDE MARKER LAMPS

PROBLEM	POSSIBLE CAUSE	CORRECTION
One Lamp Won't Work	<ol style="list-style-type: none">1. Turn signal bulb burnt out (front lamp).2. Side marker bulb burnt out.3. Loose connection or open in wiring.	<ol style="list-style-type: none">1. Switch turn signals on. If the signal bulb does not light, replace the bulb. (Bulb filament provides ground path for marker lamp bulb through the dark blue or brown wires.)2. Replace the bulb.3. Using a test lamp, check the brown wire terminal at the bulb socket. If the test bulb lights, repair the open ground circuit. If the bulb does not light, repair the open in the brown wire circuit.
Front or Rear Lamps Won't Work	<ol style="list-style-type: none">1. Loose connection or open ground circuit.2. Multiple bulbs burnt out.	<ol style="list-style-type: none">1. If the associated tail or park lamps do not operate, check all the connectors in the brown wire circuit. If the park and turn lamps are not working, repair the open ground connections.2. Replace the burnt out bulbs.
All Lamps Won't Work	<ol style="list-style-type: none">1. Blown fuse.2. Loose connection.3. Open in wiring.4. Defective lamp switch.	<ol style="list-style-type: none">1. If the park and tail lamps do not operate, replace the blown fuse. If the new fuse blows, check for a short to ground between the fuse panel and the lamps.2. Secure the connector to the lamp switch.3. Check the tail lamp fuse with a test lamp. If the test bulb lights, repair the open wiring between the fuse and the light switch. If not, repair the open wiring between the fuse and the battery. (Possible open fusible link.)4. Check the lamp switch with a test light. If the test bulb lights at the orange wire but not at the brown wire, replace the lamp switch.

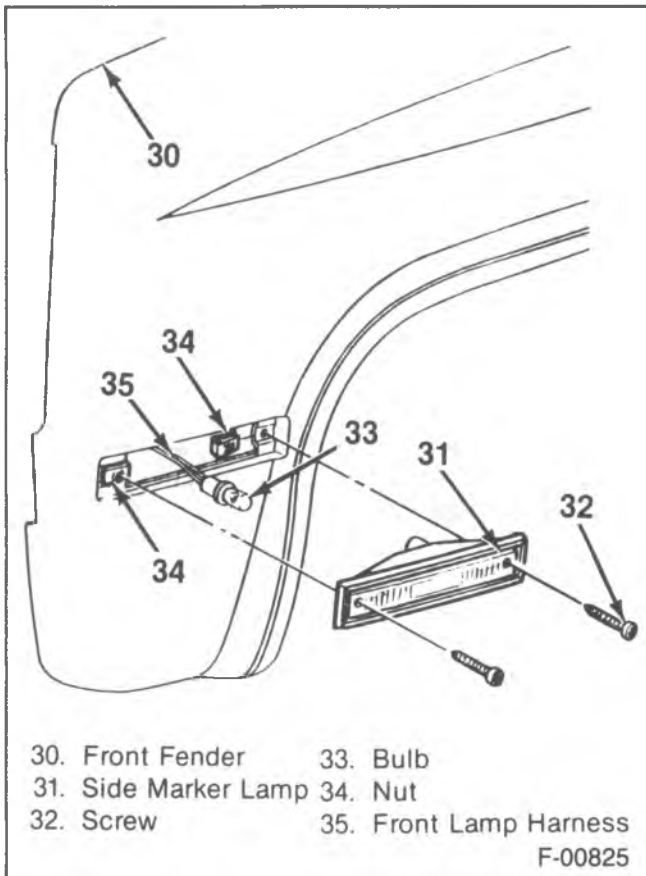

Figure 8—RV Model Front Side Marker Lamp

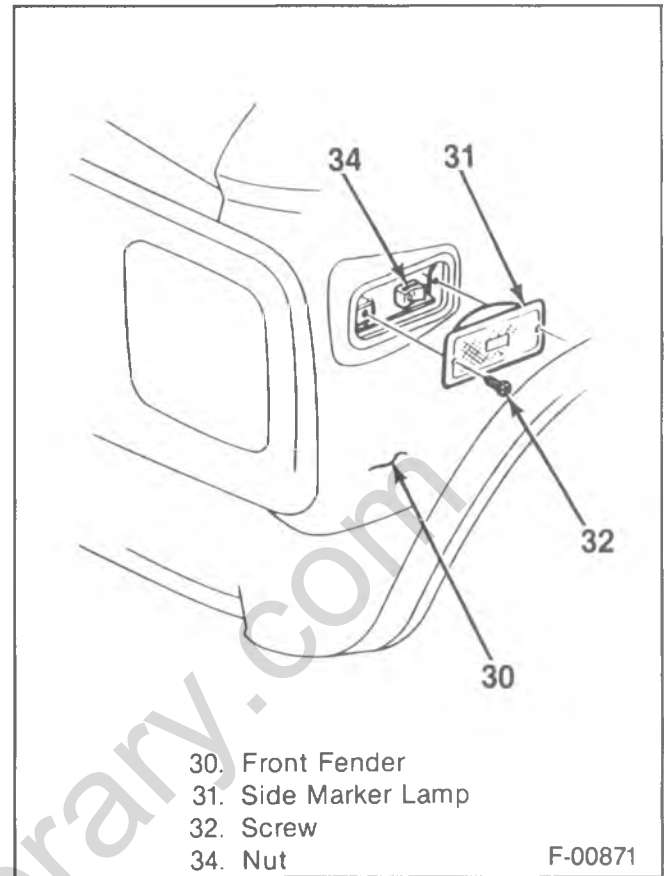

Figure 9—G Van Front Side Marker Lamp

ON-VEHICLE SERVICE

REPLACEMENT OF THE FRONT SIDE MARKER LAMP

↔ Remove or Disconnect (Figures 8 and 9)

1. Two screws (32).
2. Side marker lamp (31).
3. Bulb (33) from the lamp (31).

→ Install or Connect (Figures 8 and 9)

1. Bulb (33) the lamp (31).
2. Side marker lamp (31) into the fender (30).
3. Two screws (32).

REAR LIGHTING SYSTEMS

The rear lighting systems contain the circuits for the running, park, turn, stop and license lamps. One bulb may function for more than one circuit. The harness for the rear lighting systems starts at the fuse block, goes to the various switches and then back along the left frame to the various lamps.

REAR RUNNING LAMPS AND MARKER LAMPS

This circuit starts at the lamp switch. The lamps will be on when the lamp switch is in the first and second detents. The front park lamps and front marker lamps will also be on when the lamp switch is in the first detent.

REAR PARK LAMPS

These lamps will be on when the lamp switch is in the first detent. The front park lamps will also be on. The side marker lamps will also be on.

REAR TURN, STOP, AND HAZARD SYSTEMS

These three systems use the same bulb in the rear lamps. When the rear turn system is turned on, a thermal oscillator is turned on, which causes the system to flash. The front park lamps are also a part of the turn system.

The stop lamp system is turned on by a brake switch closing. The two rear bright lamps are then turned on.

The hazard system is turned on by the hazard switch. The hazard system thermal oscillator is then turned on

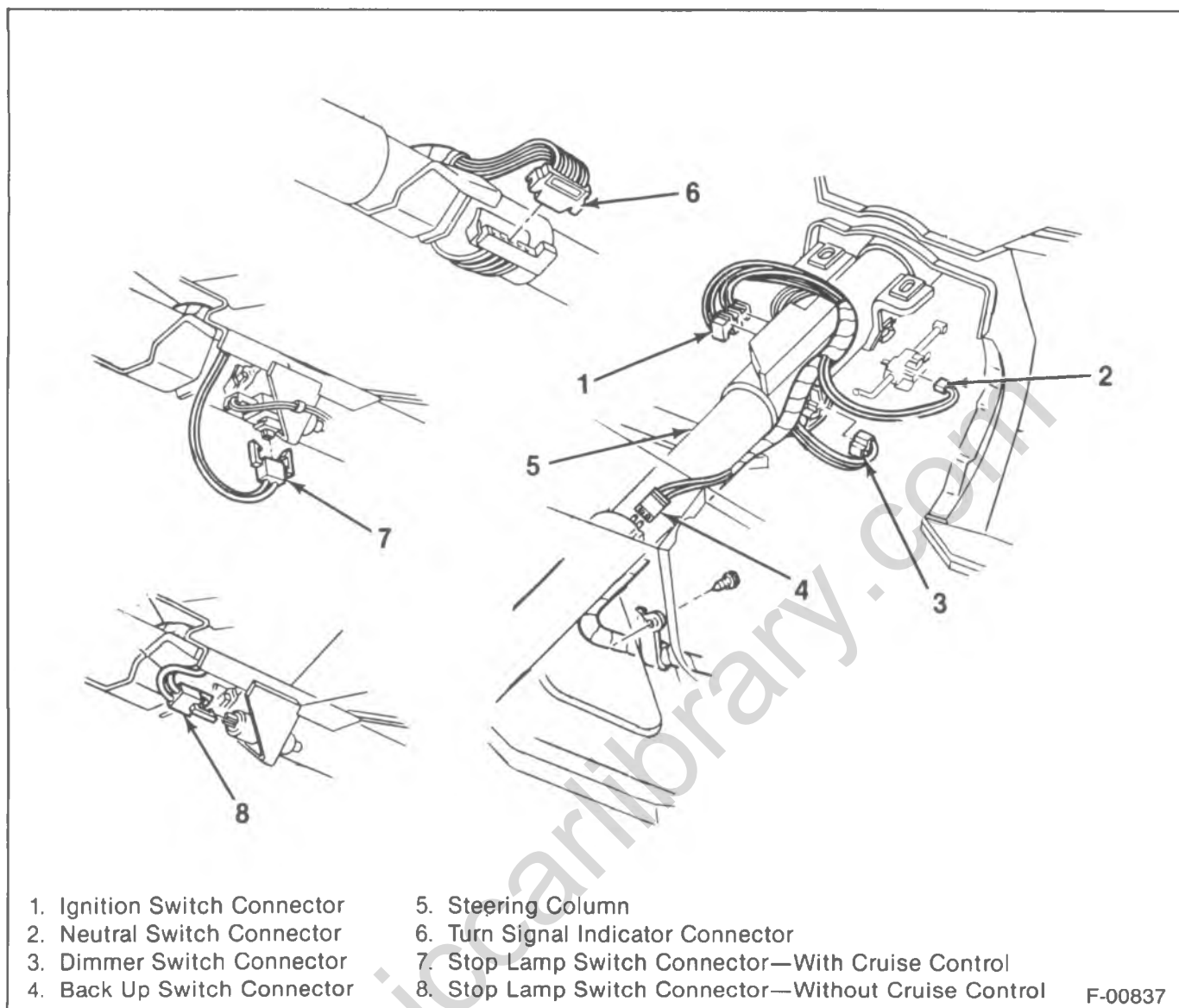

Figure 10—Steering Column Connectors — RV Models

which causes the front park lamps and the rear bright lamps to flash.

BACKUP LAMP SYSTEM

This circuit is turned on when the transmission is shifted into reverse. The backup switch is closed, thus turning on the backup lamps. The backup lamps are located in the rear lamp assemblies.

REAR LAMP HARNESS LAYOUTS

Refer to Figures 10, 11, 12, 13, 14, 15, 16, 17, 18 and 19.

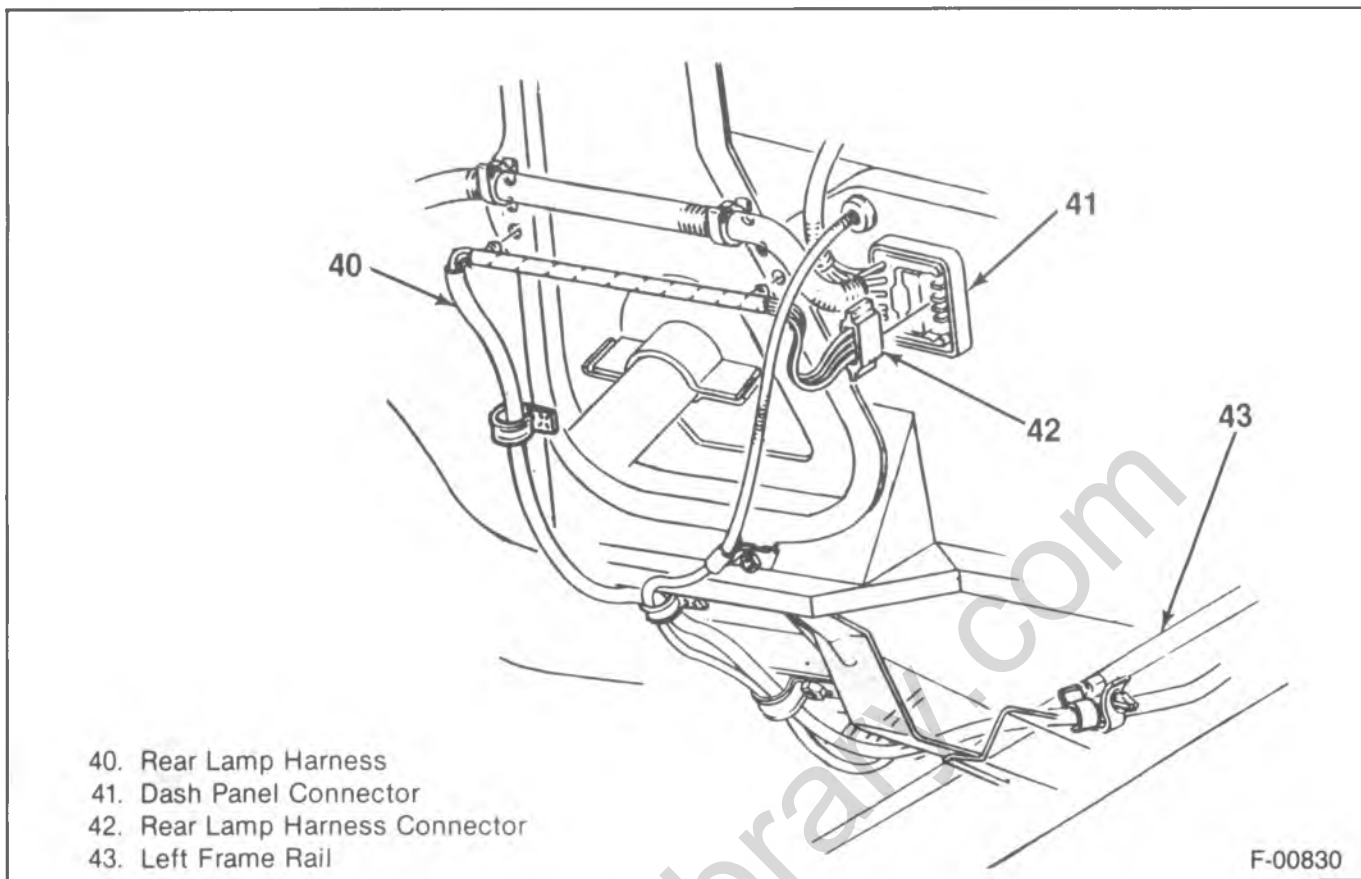

Figure 11—Rear Lamp Harness at the Dash — RV Models

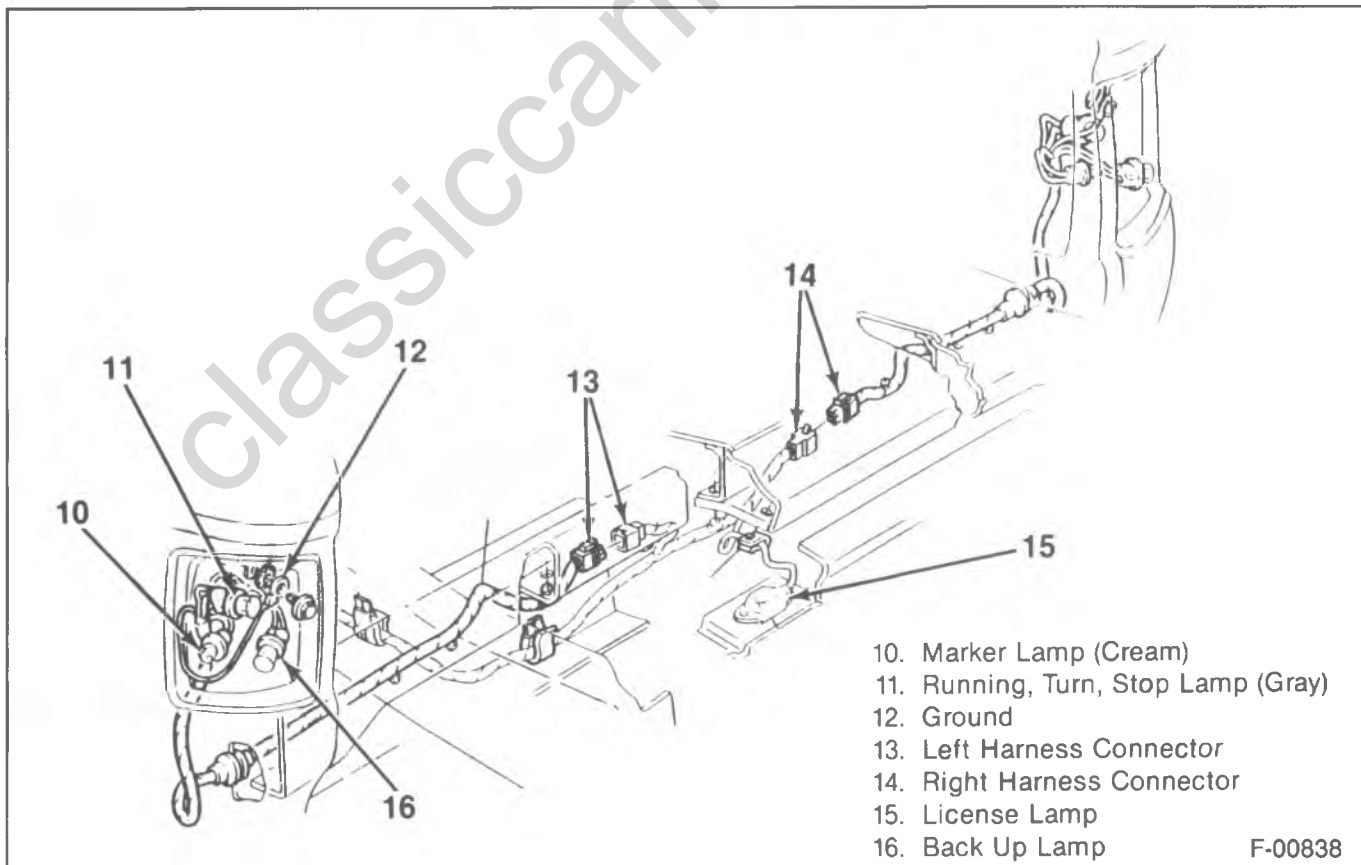

Figure 12—Rear Lamp Harness — Suburban

8B-14 CHASSIS ELECTRICAL

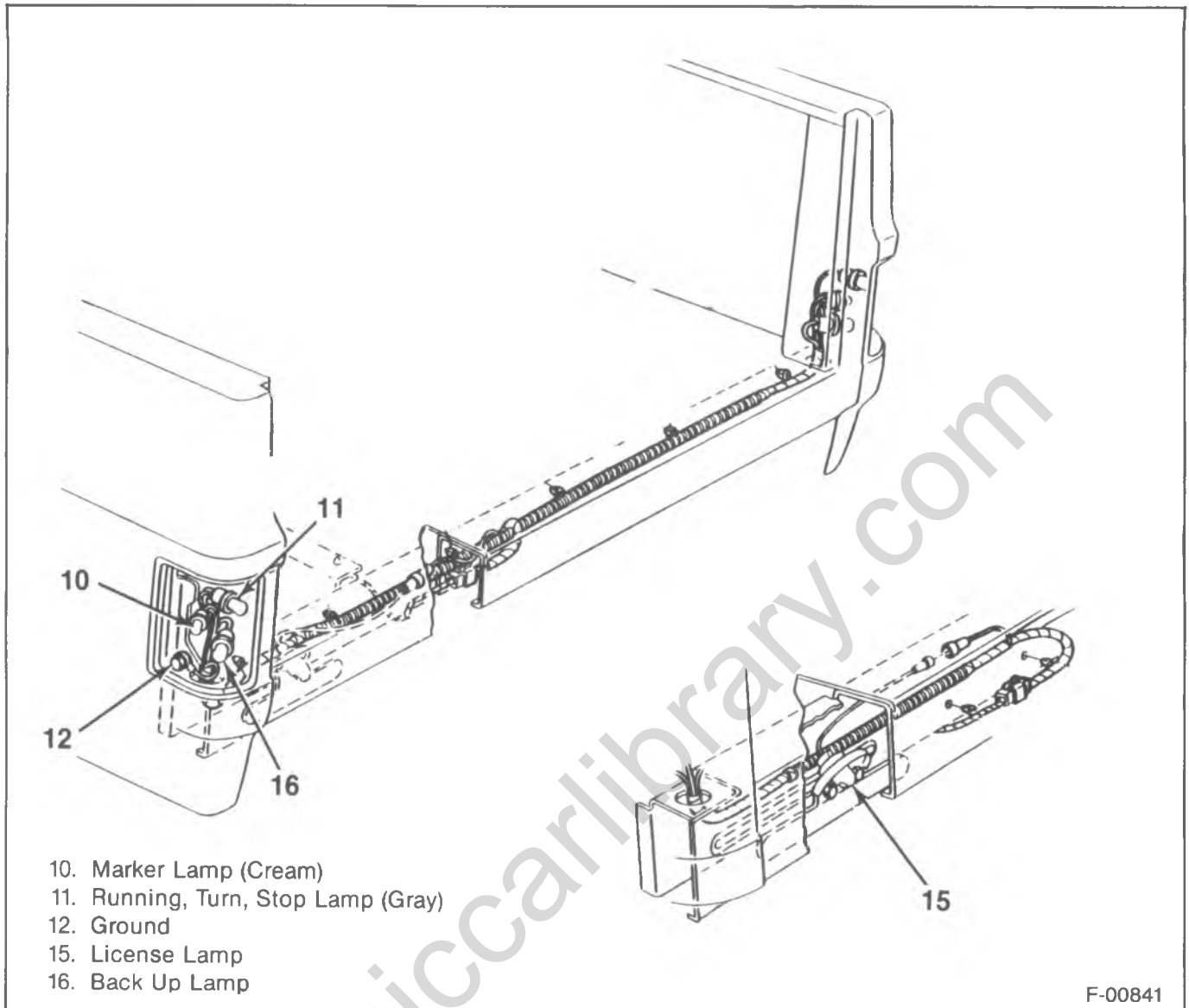

Figure 13—Rear Lamp Harness — Fleetside

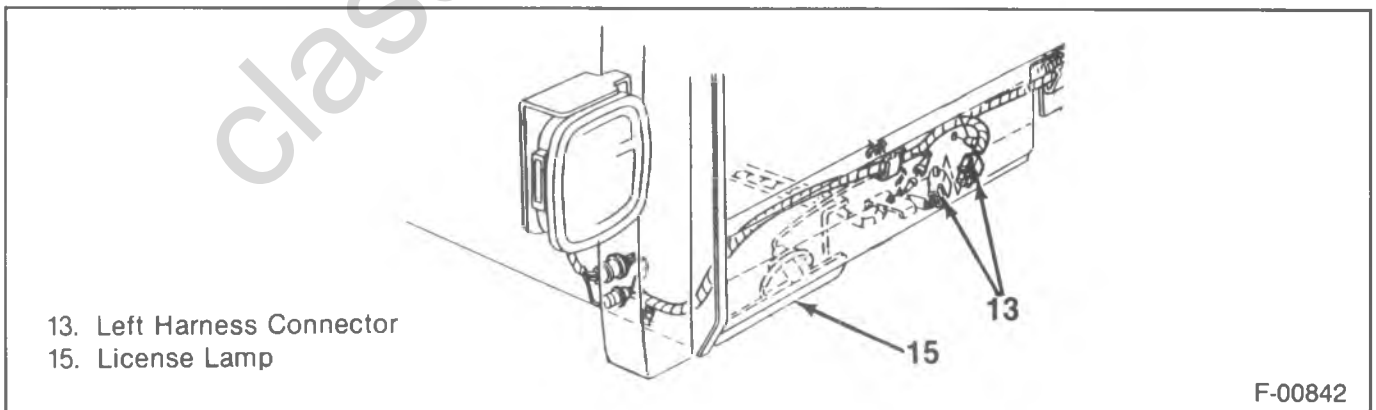

Figure 14—Rear Lamp Harness — Stepside

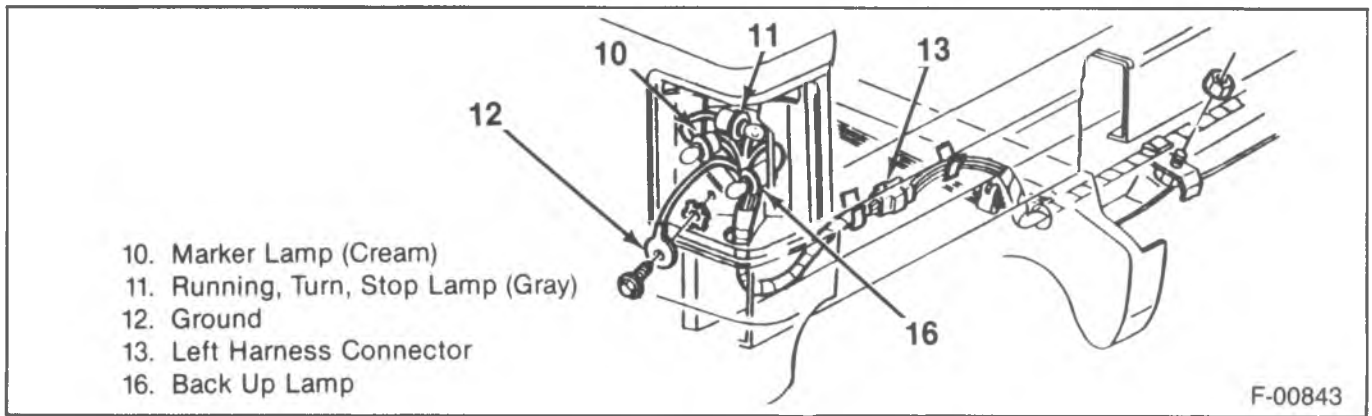

Figure 15—Rear Lamp Harness — Utility Vehicle

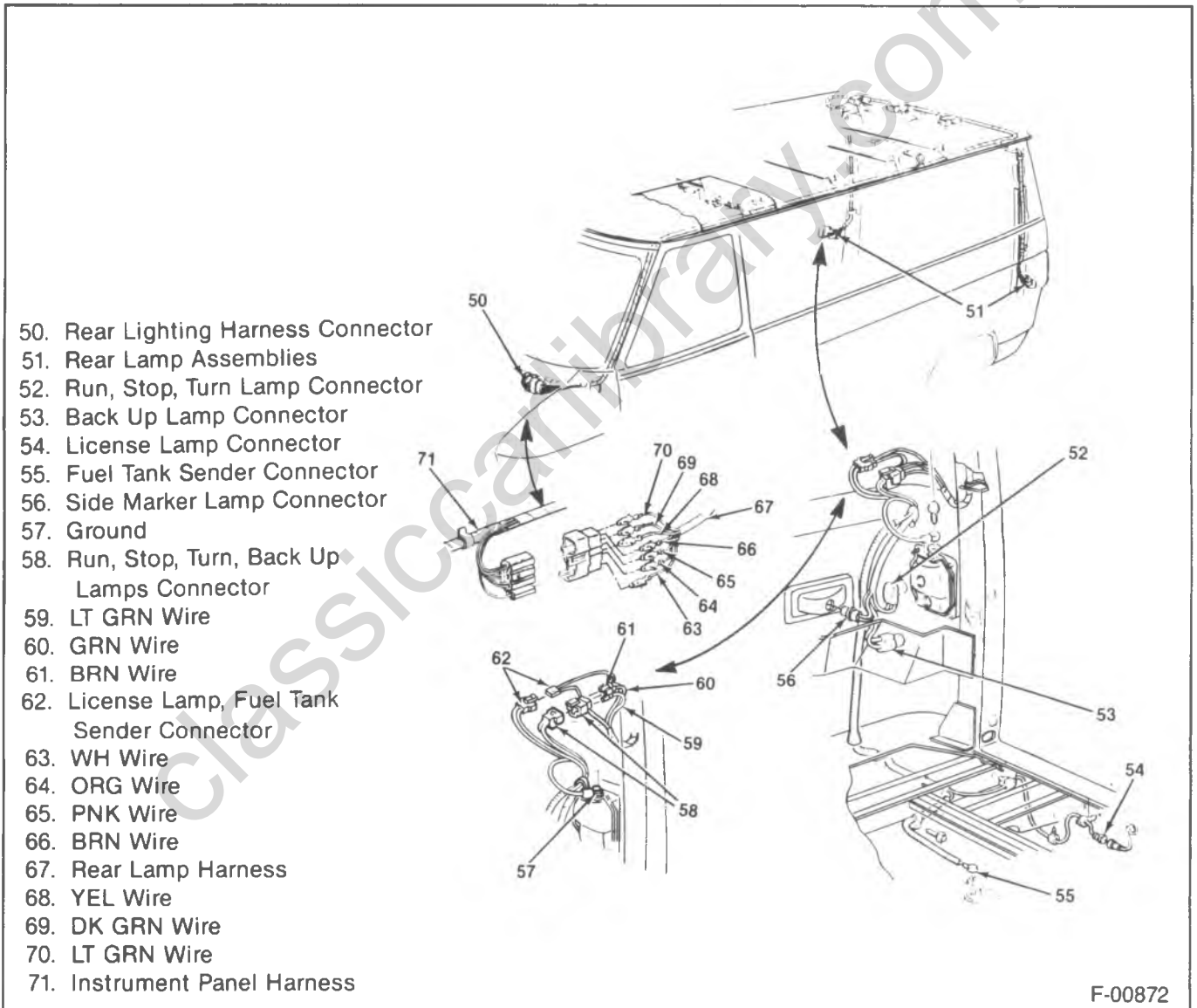
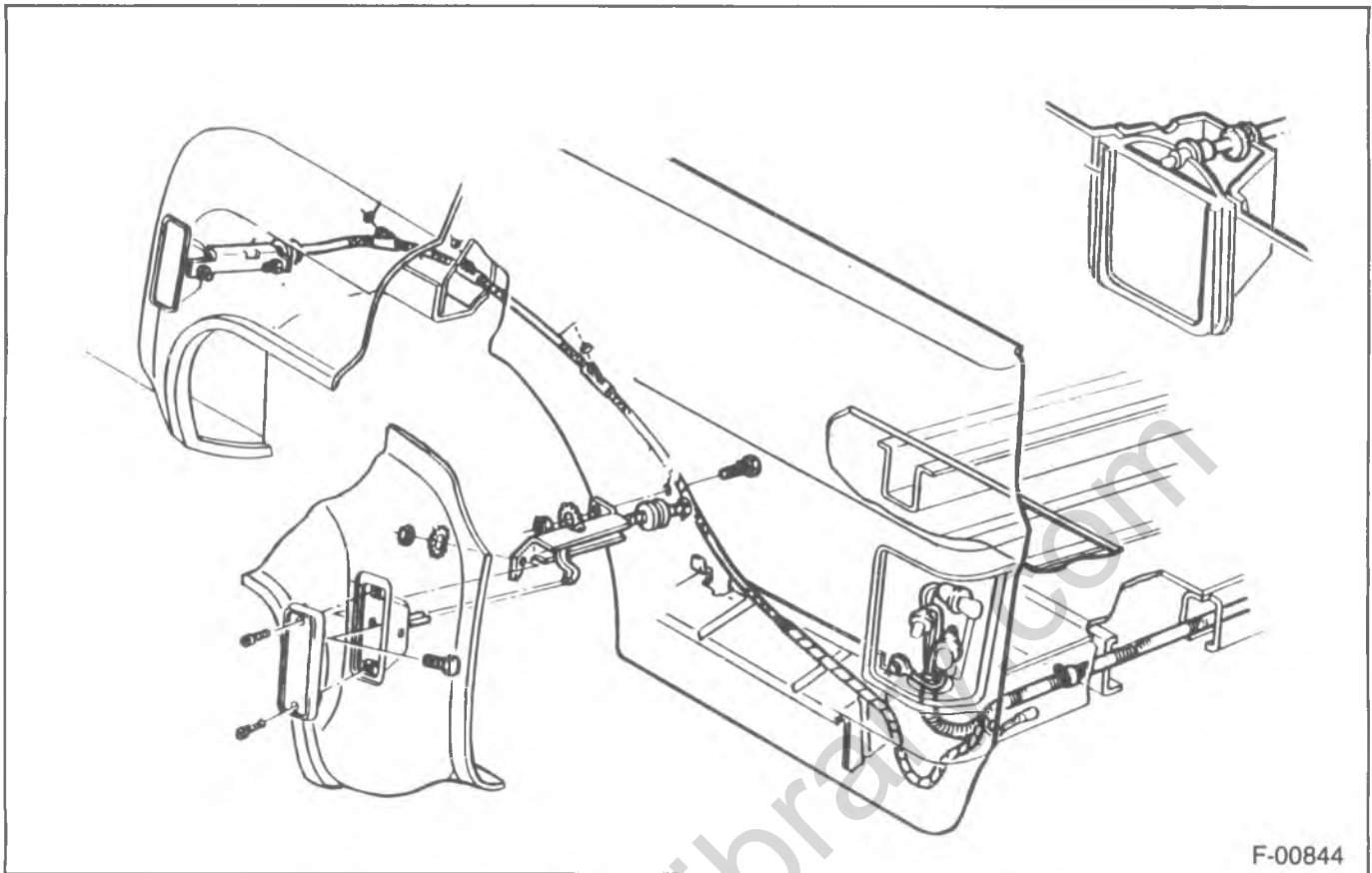
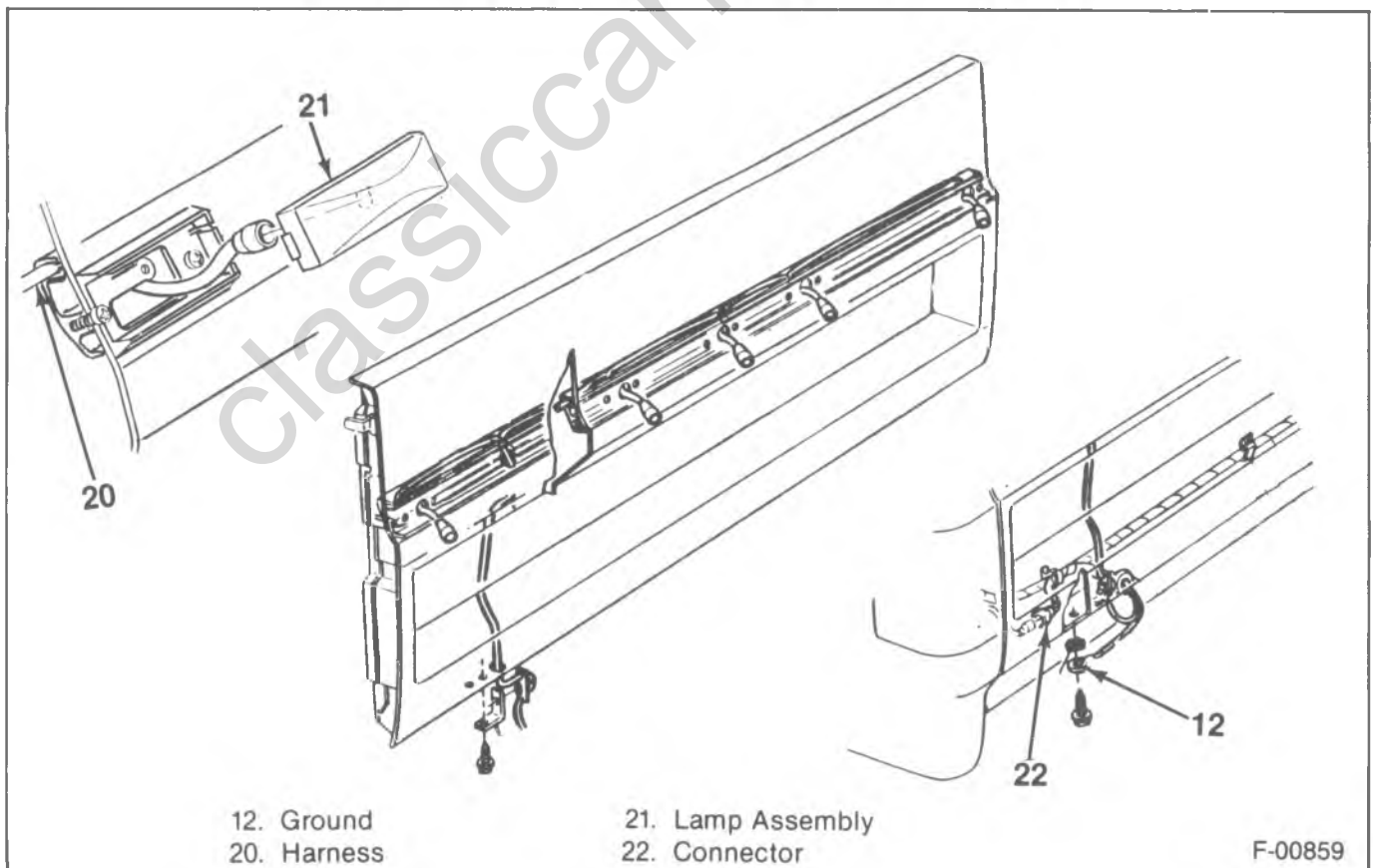

Figure 16—Rear Lamp Harness — Van



F-00844

Figure 17—Rear Side Marker Lamp Wiring Harness — RV Models



12. Ground
20. Harness

21. Lamp Assembly
22. Connector

F-00859

Figure 18—Tailgate Lamp Wiring Harness

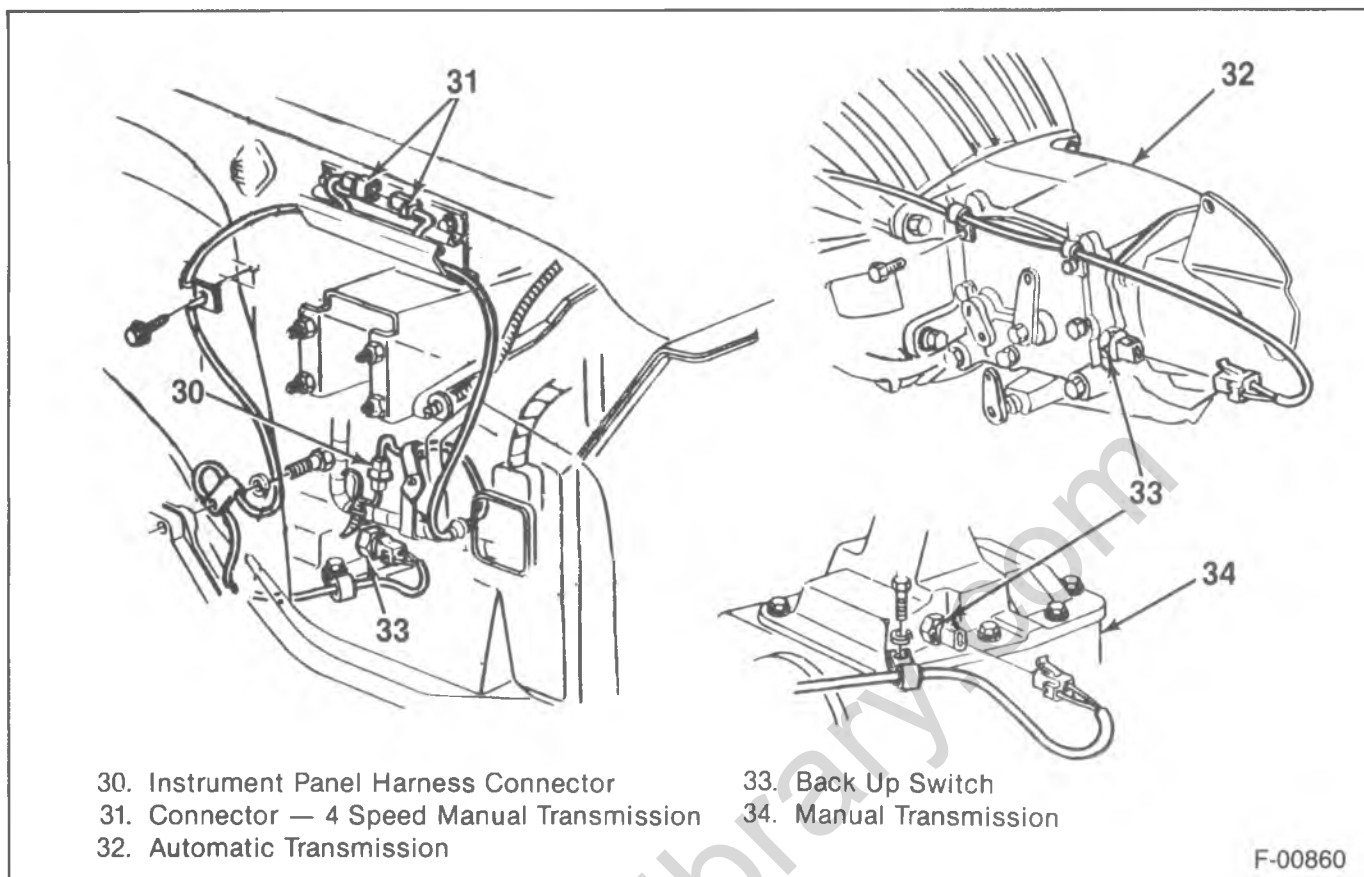

Figure 19—RV Model Backup Lamp Switch and Wiring

DIAGNOSIS OF THE REAR SIDE MARKER LAMPS

PROBLEM	POSSIBLE CAUSE	CORRECTION
One Lamp Won't Work	<ol style="list-style-type: none"> 1. Turn signal bulb burnt out (front lamp). 2. Side marker bulb burnt out. 3. Loose connection or open in wiring. 	<ol style="list-style-type: none"> 1. Switch turn signals on. If the signal bulb does not light, replace the bulb. (Bulb filament provides ground path for marker lamp bulb through the dark blue or brown wires.) 2. Replace the bulb. 3. Using a test lamp, check the brown wire terminal at the bulb socket. If the test bulb lights, repair the open ground circuit. If the bulb does not light, repair the open in the brown wire circuit.
Front Or Rear Lamps Won't Work	<ol style="list-style-type: none"> 1. Loose connection or open ground circuit. 2. Multiple bulbs burnt out. 	<ol style="list-style-type: none"> 1. If the associated tail or park lamps do not operate, check all the connectors in the brown wire circuit. If the park and turn lamps are not working, repair the open ground connections. 2. Replace the burnt out bulbs.

DIAGNOSIS OF THE REAR SIDE MARKER LAMPS (CONT.)

PROBLEM	POSSIBLE CAUSE	CORRECTION
<p>All Lamps Won't Work</p>	<ol style="list-style-type: none"> 1. Blown fuse. 2. Loose connection. 3. Open in wiring. 4. Defective lamp switch. 	<ol style="list-style-type: none"> 1. If the park and tail lamps do not operate, replace the blown fuse. If the new fuse blows, check for a short to ground between the fuse panel and the lamps. 2. Secure the connector to the lamp switch. 3. Check the taillamp fuse with a test lamp. If the test bulb lights, repair the open wiring between the fuse and the lamp switch. If not, repair the open wiring between the fuse and the battery. (Possible open fusible link.) 4. Check the lamp switch with a test lamp. If the test bulb lights at the orange wire but not at the brown wire, replace the light switch.

DIAGNOSIS OF THE RUNNING, PARK AND LICENSE LAMPS

PROBLEM	POSSIBLE CAUSE	CORRECTION
<p>One Side Not Working</p>	<ol style="list-style-type: none"> 1. Bulb burnt out. 2. Open connection at the bulb socket or the ground wire terminal. 	<ol style="list-style-type: none"> 1. Replace the bulb. 2. Jumper the bulb base socket connection to ground. If the bulb lights, repair the open ground circuit.
<p>Both Sides Not Working</p>	<ol style="list-style-type: none"> 1. Tail lamp fuse blown. 2. Loose connection. 3. Open wiring. 4. Multiple bulb burnout. 5. Defective lamp switch. 	<ol style="list-style-type: none"> 1. Replace the fuse. If the new fuse blows, repair the short to ground in the brown wire circuit between the fuse panel through the lamp switch to the lamp. 2. Secure the connector at the lamp switch. 3. Using a test lamp, check a circuit on both sides of the fuse. If the test bulb does not light on either side, repair the open circuit between the fuse panel and the battery (possible open fusible link). If the test bulb lights at the lamp switch brown wire terminal, repair the open wiring between the lamp switch and the lamps. 4. If the test bulb lights at the lamp socket brown wire terminal, replace the bulb(s). 5. If the test bulb lights at the lamp switch orange wire but not at the brown wire, replace the defective lamp switch.

DIAGNOSIS OF THE TURN SIGNAL AND HAZARD SYSTEMS

PROBLEM	POSSIBLE CAUSE	CORRECTION
Turn Signals Not Working On One Side	<ol style="list-style-type: none"> 1. Bulb(s) burnt out (flasher cannot be heard). 2. Open wiring or loose ground connector. 3. Improper bulb or defective turn signal switch. 4. Short to ground. (Flasher can be heard, no bulbs operate). 	<ol style="list-style-type: none"> 1. Turn the hazard warning system "ON." If one or more bulbs are inoperative, replace the bulbs as necessary. 2. Turn the hazard warning system on. If one or more bulbs are inoperative, use the test lamp and check the circuit at the bulb socket. If the test bulb lights, repair the open ground connection. If not, repair the open wiring between the bulb socket and the turn signal switch. 3. Turn the hazard warning system on. If all the front lamps and rear lamps operate, check for an improper bulb (see bulb chart). If the bulbs are OK, replace the defective turn signal switch. 4. Locate and repair the short to ground by disconnecting the front and rear circuits separately.
Turn Signals Not Working	<ol style="list-style-type: none"> 1. Blown turn signal fuse. 2. Defective flasher (located in convenience center near steering column). 3. Loose connection. 	<ol style="list-style-type: none"> 1. Turn the hazard warning system on. If all the lamps operate, replace the blown fuse. If the new fuse blows, repair the short to ground between the fuse and the lamps. 2. If the turn signal fuse is OK and the hazard warning system will operate the lamps, replace the defective turn signal flasher. 3. Secure the steering column connector.
Hazard Warning Not Working	<ol style="list-style-type: none"> 1. Blown stop-hazard fuse. 2. Faulty hazard warning flasher. (Located in the convenience center). 3. Open in the wiring or a defective turn signal switch. 	<ol style="list-style-type: none"> 1. Switch the turn signals "ON." If the lights operate, replace the stop-hazard fuse if blown. If the new fuse blows, repair the short to ground. (Could be in stop lamp circuit). 2. If the stop-hazard fuse is OK, switch the turn signals on. If the lamps operate, replace the defective hazard flasher. 3. Using the test lamp, check the brown wire in the turn signal steering column connector. If the test bulb does not light, repair the open circuit between the flasher and the connector. If the test lamp indicates power on the brown wire and connection is good, use a test lamp to check the output terminals (lt. blue, blue, yellow and dark green wires).

DIAGNOSIS OF THE STOPLAMP SYSTEM

PROBLEM	POSSIBLE CAUSE	CORRECTION
One Bulb Not Working	Bulb burnt out.	Replace the bulb.
One Side Not Working (Multi-Bulb Design)	<ol style="list-style-type: none"> 1. Loose connection, open wiring or faulty bulbs. 2. Faulty directional signal switch or cancelling cam. 	<ol style="list-style-type: none"> 1. Turn on the directional signal. If lamp does not operate, check the bulbs. If the bulbs are OK, check all connections. If the lamp still does not operate, use the test lamp and check for open wiring. 2. If the lamp will operate by turning the directional signal on, the switch is not centering properly during the cancelling operation. Replace faulty cancelling cam or directional signal switch.
All Stoplamps Inoperative	<ol style="list-style-type: none"> 1. Stop-hazard fuse is blown. 2. Open in the wire from the fuse to the stop-switch. 3. Stop-switch misadjusted or faulty. 	<ol style="list-style-type: none"> 1. Replace the fuse. If the new fuse blows, repair the short to ground in the circuit between the fuse and the lamps. 2. Check for power at the brown wire at the stop-switch and at the fuse. If there is power at the fuse but not at the switch, check for an open in the brown wire. 3. With the brake pedal pressed, check the white wire terminal in the steering column connector with a test lamp. If the bulb does not light, check the stop switch for proper adjustment. If the adjustment is OK, jumper the stop switch. If the stop lamps operate, replace the stop switch.
Will Not Turn Off	Stop switch misadjusted or faulty.	Readjust the switch. If the switch still malfunctions, replace the switch.

DIAGNOSIS OF THE BACKUP LAMP SYSTEM

PROBLEM	POSSIBLE CAUSE	CORRECTION
One Lamp Not Working Or Intermittent	<ol style="list-style-type: none"> 1. Loose or burnt out bulb. 2. Loose connection. 3. Open ground connections. 	<ol style="list-style-type: none"> 1. Secure or replace the bulb. 2. Tighten the connectors. 3. Repair the bulb ground circuit.
Both Lamps Not Working Or Intermittent	<ol style="list-style-type: none"> 1. Gear selector switch is misadjusted (open when shifter lever is in reverse position). 2. Loose connection or open circuit. 3. Blown fuse. 	<ol style="list-style-type: none"> 1. Readjust the gear selector switch. 2. Check all connectors. If OK, check the continuity of the circuit from the fuse to the lamp on either side of the fuse. Correct the open circuit from the battery to the fuse. 3. Replace the fuse. If the new fuse blows, repair the short to ground in the circuit from the fuse through the gear selector or from the fuse through the gear selector or the backup lamp switch to the backup lamps.

DIAGNOSIS OF THE BACKUP LAMP SYSTEM (CONT.)

PROBLEM	POSSIBLE CAUSE	CORRECTION
Both Lamps Not Working Or Intermittent (Continued)	4. Faulty gear selector or backup lamp switch. 5. Faulty ignition switch.	4. With the ignition "ON," check the switch terminals in the backup position with the test lamp. If the test bulb lights at the dark blue wire terminal but not at the light green wire terminal, replace the switch. 5. If the test bulb lights at the ignition switch battery terminal, but not at the output terminal, replace the ignition switch.
Lamp Will Not Turn Off	Gear selector switch misadjusted (closed when the shift lever is not in the reverse position).	Readjust the gear selector switch.

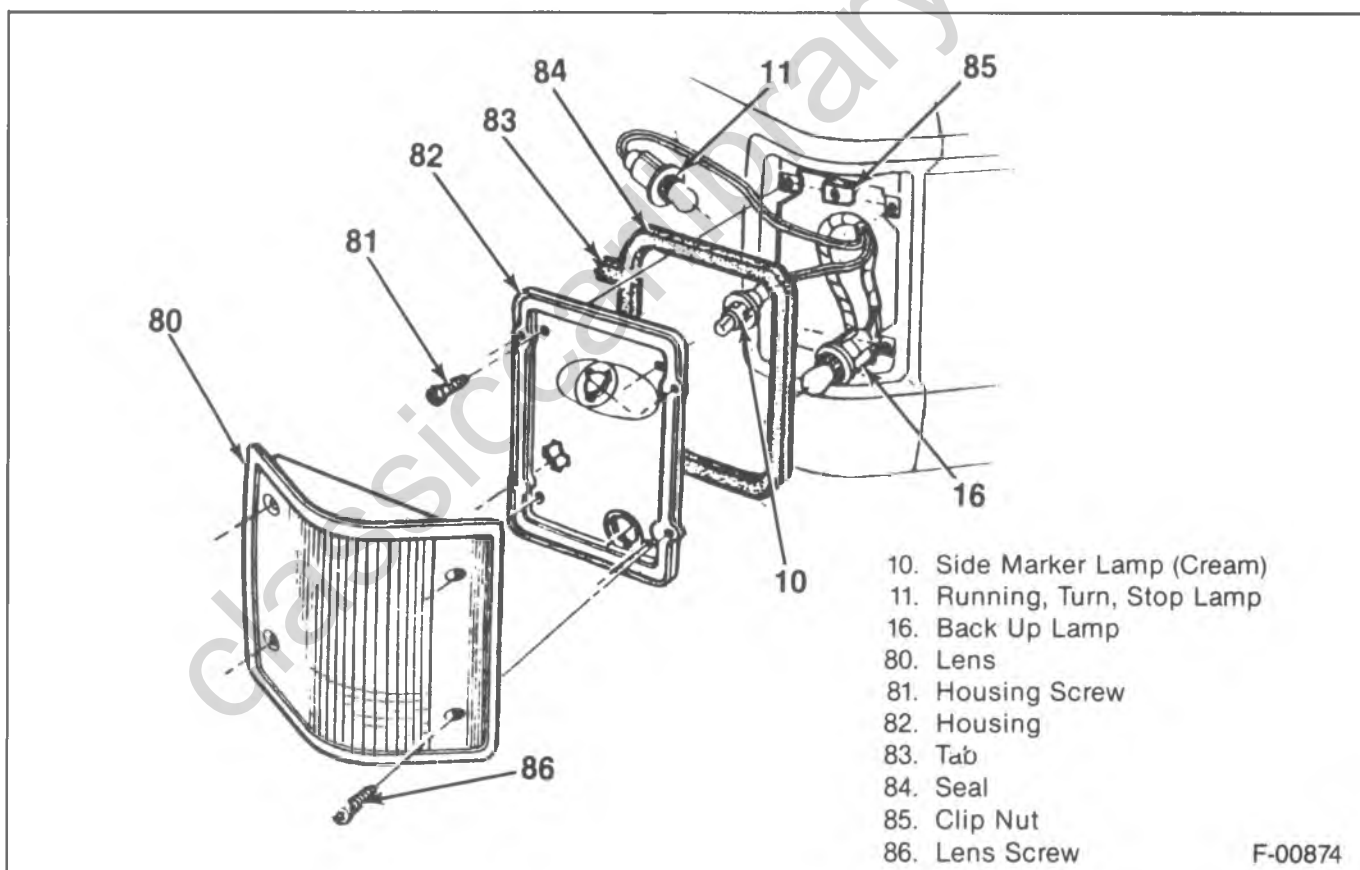

Figure 20—RV Model Rear Lamp Assembly

ON-VEHICLE SERVICE

REAR LAMP BULB REPLACEMENT—RV MODELS

←→ Remove or Disconnect (Figure 20)

1. Battery ground cable from the battery.
2. Lens retaining screws (86).
3. Lens (80).

→← Install or Connect (Figure 20)

4. Bulb (10, 11 or 16).
1. Bulb (10, 11 or 16).
2. Lens (80).
3. Lens retaining screws (86).
4. Battery ground cable to the battery.

8B-22 CHASSIS ELECTRICAL

REAR LAMP HOUSING AND SEAL REPLACEMENT—RV MODELS

↔ Remove or Disconnect (Figures 20)

1. Battery ground cable from the battery.
2. Lens retaining screws (86).
3. Lens (80).
4. Housing retaining screws (81).
5. Housing (82).
6. Lamps (10, 11 and 16).
7. Seal (84).

→← Install or Connect (Figure 20)

1. Seal (84).
 - Install the seal with the tabs (83) pointed forward.
 - Apply adhesive at the four corners of the seal in order to hold the seal in place.
2. Lamps (10, 11 and 16).
3. Housing (82).
4. Housing screws (81).
5. Lens (80).
6. Lens screws (86).
7. Battery ground cable to the battery.

LICENSE LAMP REPLACEMENT—RV MODELS

↔ Remove or Disconnect (Figure 21)

1. Battery ground cable from the battery.
2. Housing retaining screws (92) or bolts (97).
3. Lens.
4. Bulb.

→← Install or Connect (Figure 21)

1. Bulb.
2. Lens.
3. Housing retaining screws (92) or bolts (97).
4. Battery ground cable from the battery.

REAR LAMP BULB REPLACEMENT—G VAN

↔ Remove or Disconnect (Figures 22 and 16)

1. Battery ground cable from the battery.
2. Lens housing retaining screws (101).
3. Lamp housing (100).
4. Bulb socket (52 and 53) by squeezing the retention lock and rotating the socket counterclockwise.
5. Bulb from the bulb socket (52 and 53).

→← Install or Connect

1. Bulb into the bulb socket.
2. Bulb socket (52 and 53) into the housing.
3. Lamp housing (100).
4. Lens housing retaining screws (101).
5. Battery ground cable to the battery.

REAR MARKER LAMP BULB REPLACEMENT—G VAN

↔ Remove or Disconnect (Figure 23)

1. Battery ground cable from the battery.
2. Housing retaining screws (113).

3. Housing (112).
4. Bulb socket (56).
5. Bulb.

→← Install or Connect

1. Bulb.
2. Bulb socket (56) into the housing (112).
3. Housing (112).
4. Housing retaining screws (113).
5. Battery ground cable from the battery.

LIGHT SWITCH REPLACEMENT

RV Models

↔ Remove or Disconnect (Figures 24 and 25)

1. Battery ground cable from the battery.
2. Knob assembly (131).
 - Push in retainer pin on the switch body.
 - Pull out the knob assembly.
3. Trim panel screws (121).
4. Trim panel (120).
5. Bezel (132).
6. Light switch harness (130).
7. Light switch (133).

→← Install or Connect (Figures 24 and 25)

1. Light switch (133).
2. Light switch harness (130).
3. Bezel (132).
4. Trim panel (120).
5. Trim panel screws (121).
6. Knob assembly (131).
7. Battery ground cable to the battery.

G-Van

↔ Remove or Disconnect (Figures 26 and 27)

1. Battery ground cable from the battery.
2. Knob assembly (141).
 - Press the knob assembly retaining pin on the switch.
 - Pull out the knob assembly.
3. Trim plate retaining screws (142).
4. Trim plate (140).
5. Bezel (143).
6. Light switch (144).
7. Light switch harness (145)

→← Install or Connect

1. Light switch harness (145) from the light switch (144).
2. Light switch (144).
3. Bezel (143).
4. Trim plate (140).
5. Trim plate retaining screws (142).
6. Knob assembly (141) into the switch (144).
7. Battery ground cable to the battery.

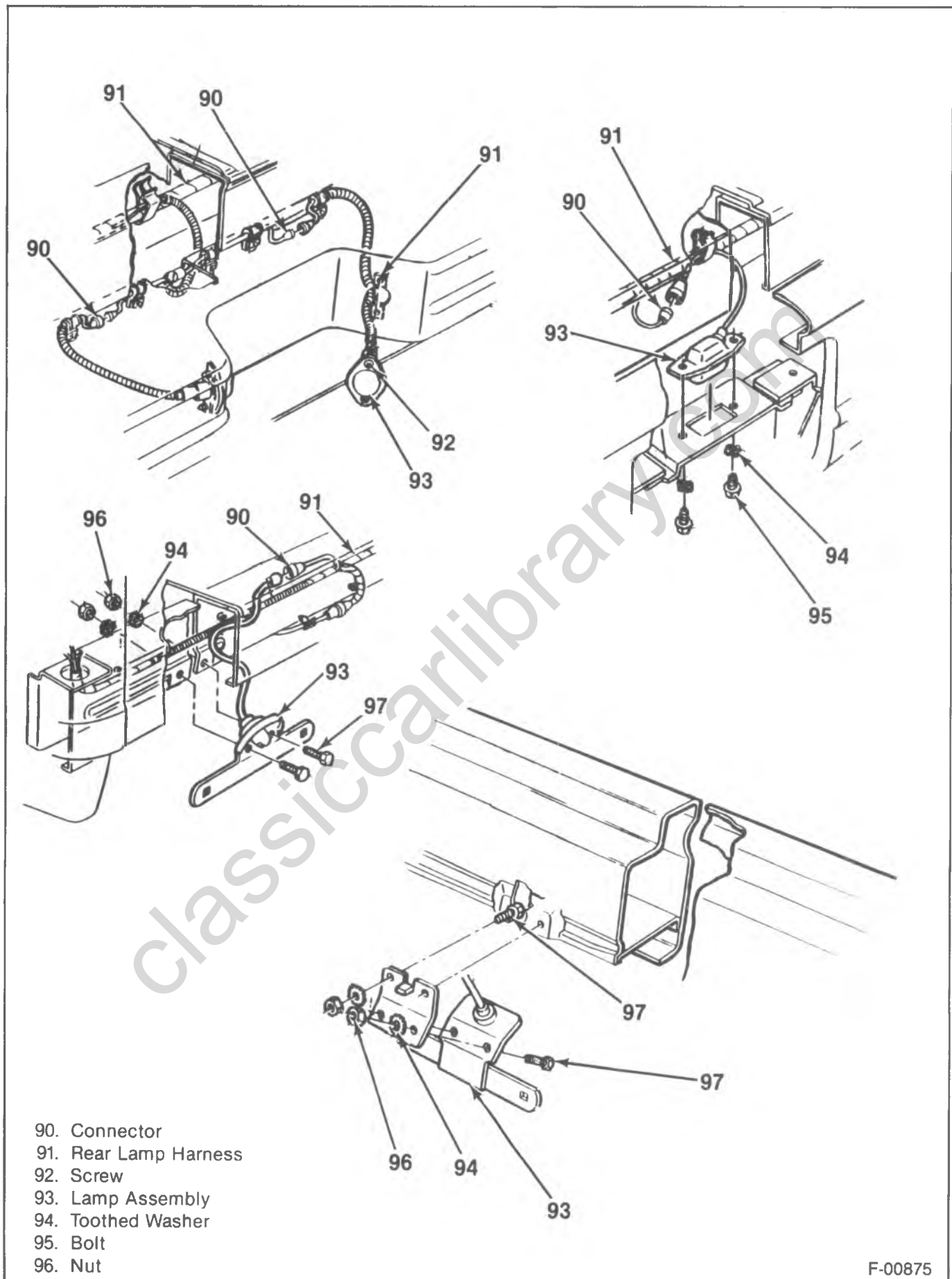

Figure 21—RV Model License Lamp

8B-24 CHASSIS ELECTRICAL

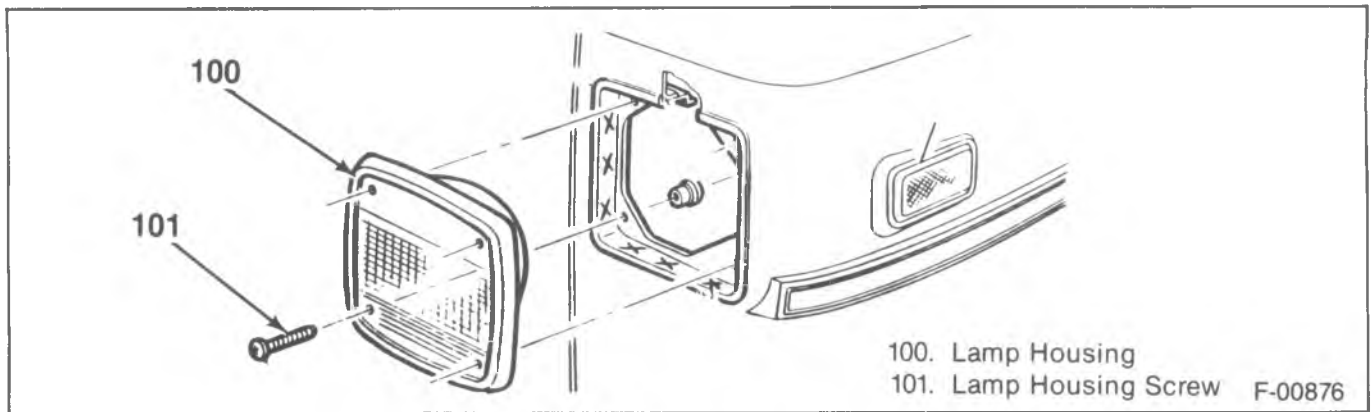

Figure 22—Van Rear Lamp

BARK UP SWITCH REPLACEMENT

Manual Transmission

↔ Remove or Disconnect (Figure 28)

1. Battery ground cable from the battery.
2. Backup switch harness (164).
3. Backup switch (163).
4. Seal (162).

↔ Install or Connect (Figure 28)

1. Seal (162).
2. Backup switch (163).
3. Backup switch harness (164).
4. Battery ground cable to the battery.

Automatic Transmission

↔ Remove or Disconnect (Figure 28)

1. Battery ground cable from the battery.
2. Switch assembly harness.
3. Switch assembly.
 - Place gear selector in neutral.
 - Squeeze the switch tangs (151) together.
 - Lift out the switch assembly (152).

↔ Install or Connect

1. Switch assembly.
 - Place gear selector in neutral.
 - Align the actuator (157) with the cutout (159) in the steering column jacket (158).
 - Insert the tangs (151) into the rectangular holes (150).
 - Push down on the switch assembly (152).

🔧 Adjust

- Switch by moving the gear selector to park. The actuator will ratchet, providing proper switch adjustment.
2. Switch assembly harness.

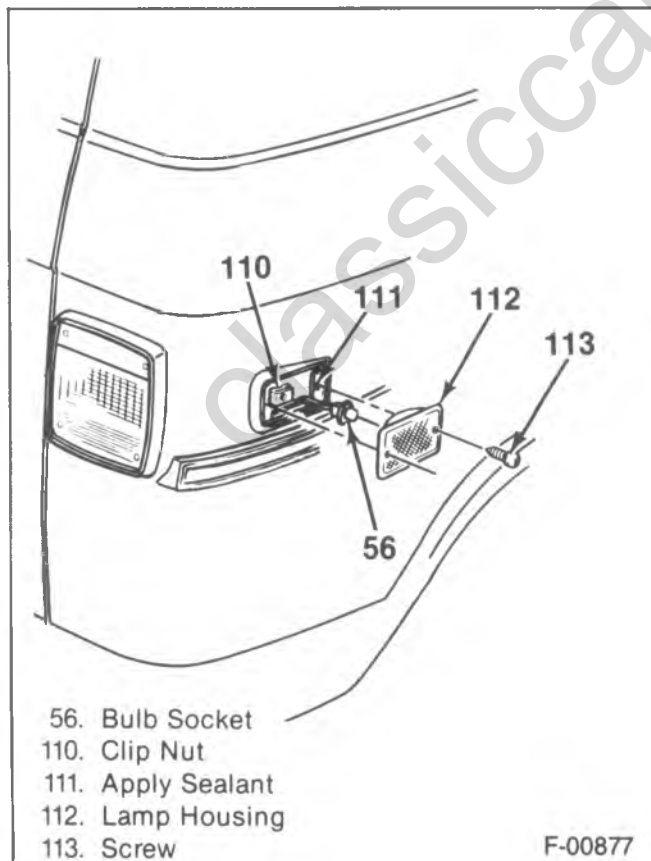

Figure 23—Van Rear Marker Lamp

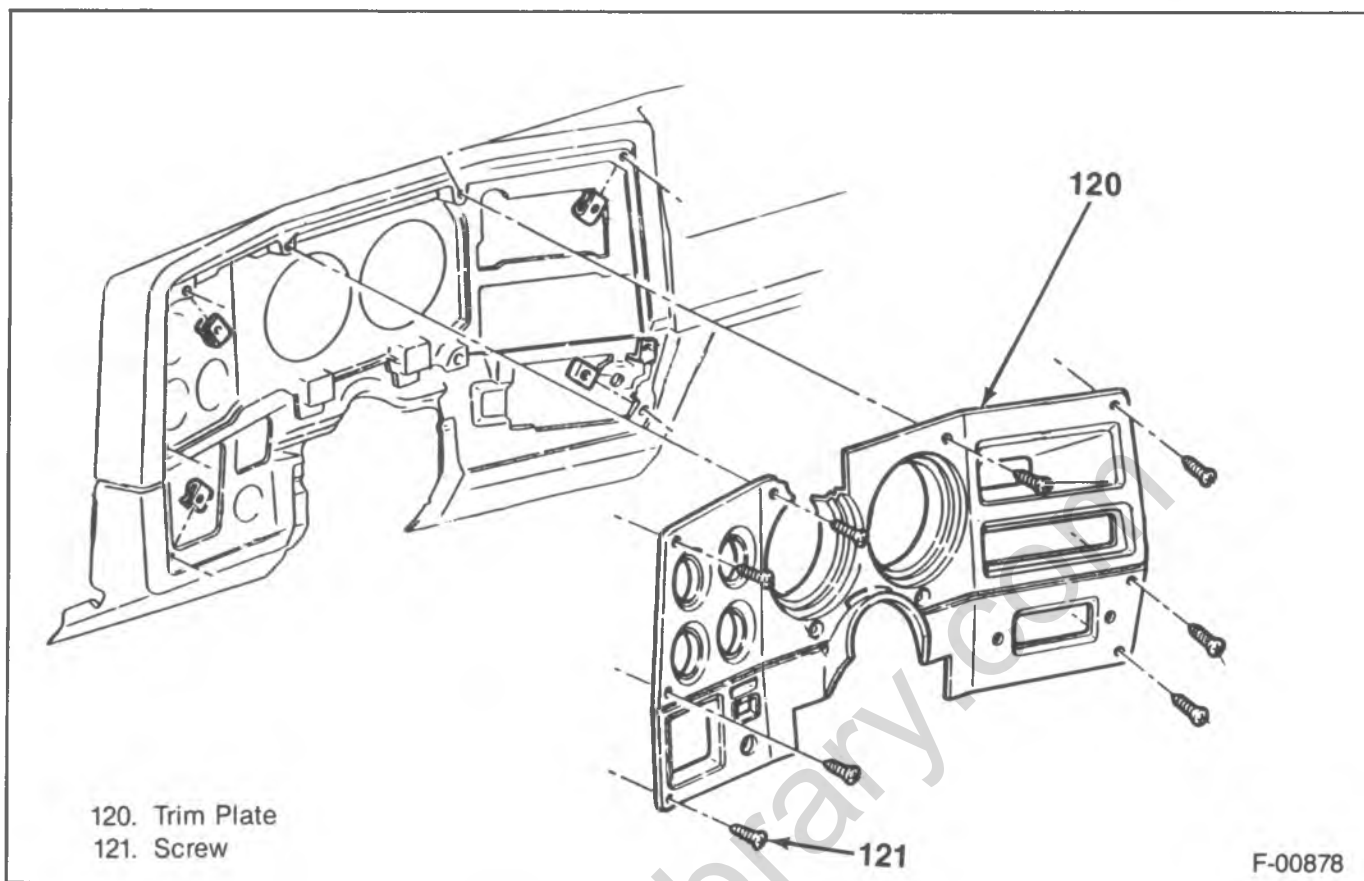

Figure 24—RV Model Instrument Panel Trim Plate

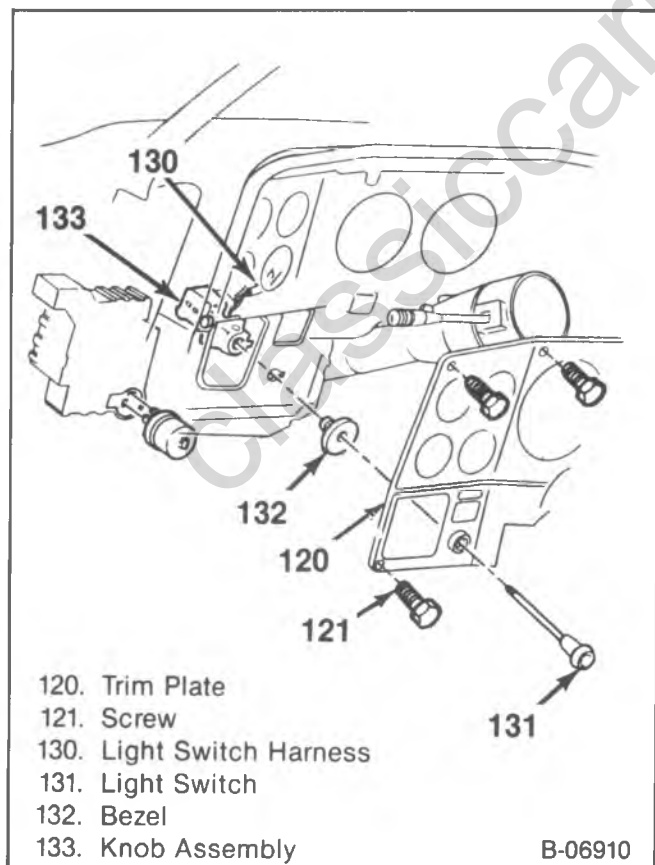

Figure 25—RV Model Light Switch

8B-26 CHASSIS ELECTRICAL

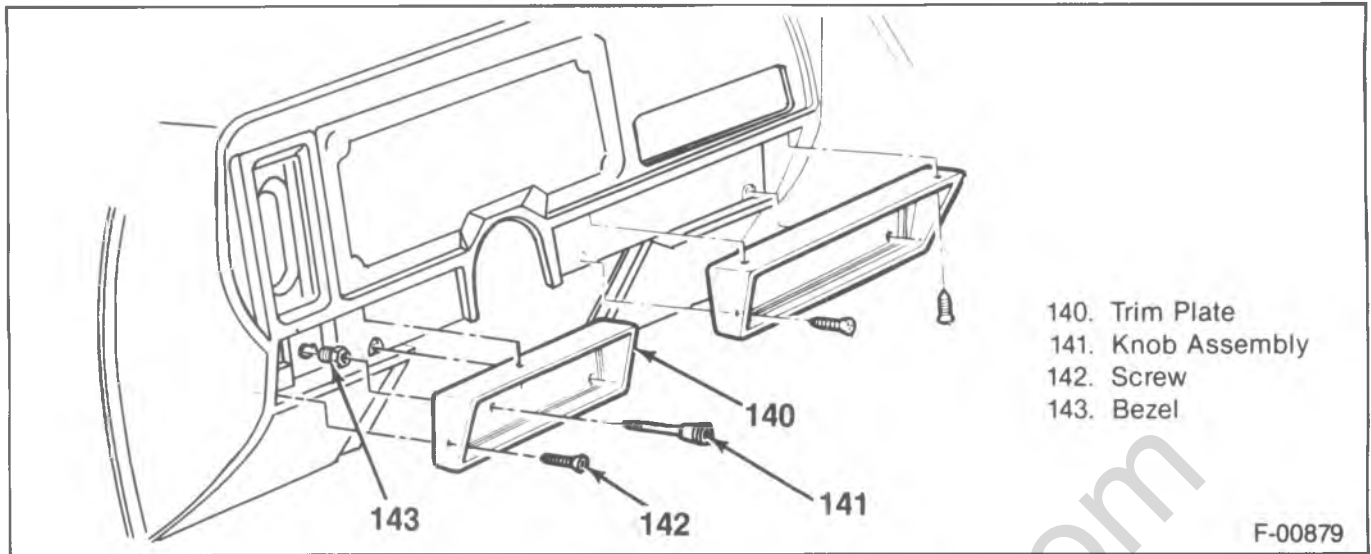

Figure 26—Van Instrument Panel Trim Plate

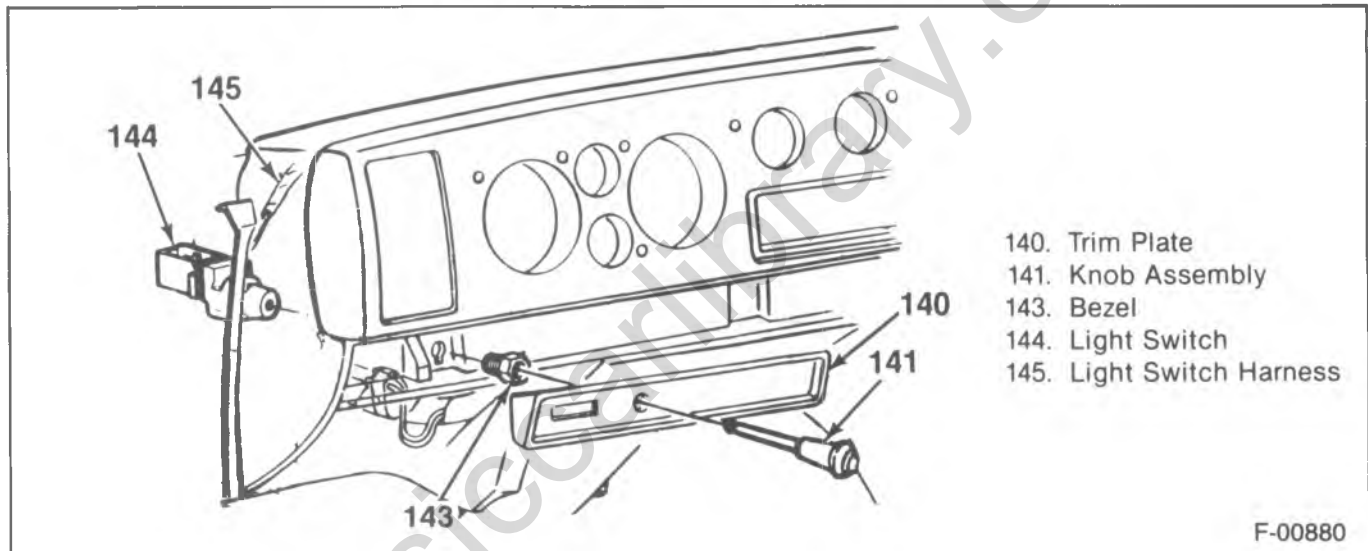
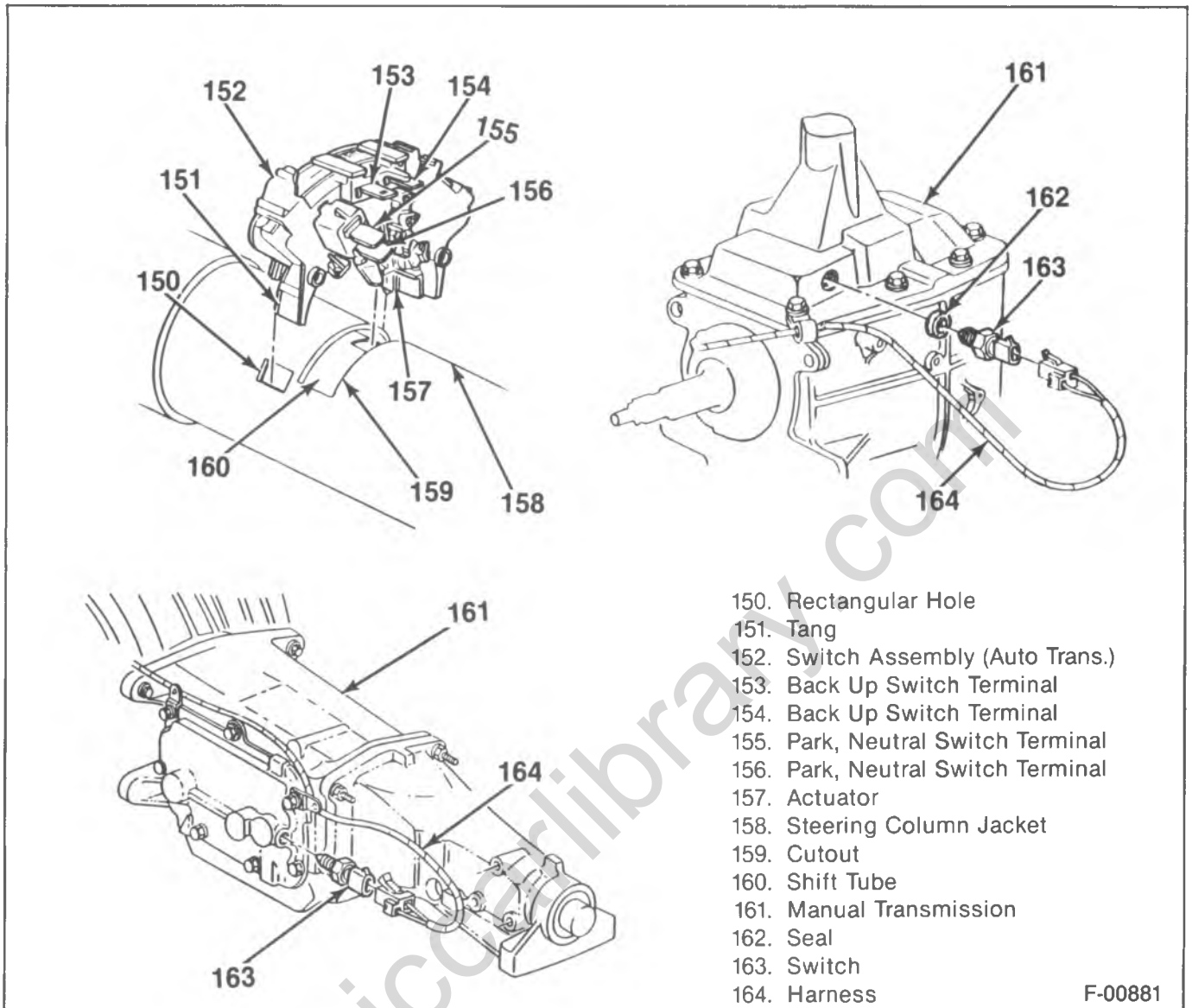

Figure 27—Van Light Switch



- 150. Rectangular Hole
- 151. Tang
- 152. Switch Assembly (Auto Trans.)
- 153. Back Up Switch Terminal
- 154. Back Up Switch Terminal
- 155. Park, Neutral Switch Terminal
- 156. Park, Neutral Switch Terminal
- 157. Actuator
- 158. Steering Column Jacket
- 159. Cutout
- 160. Shift Tube
- 161. Manual Transmission
- 162. Seal
- 163. Switch
- 164. Harness

F-00881

Figure 28—Van Backup Lamp Switch

FUSES—CIRCUIT BREAKERS SPECIFICATIONS

The wiring circuits are protected from short circuits by a combination of fuses, circuit breakers, and fusible thermal links in the wiring itself. This greatly reduces the hazard of electrically caused fires in the vehicles.

The headlamp circuits are protected by a circuit breaker in the light switch. An electrical overload on the breaker will cause the lamps to go on and off, or in some cases to remain off.

In addition to a fuse, the windshield wiper motor is also protected by a circuit breaker. If the motor overheats, due to overloading caused by heavy snow, etc., the wipers will remain stopped until the motor cools.

Fuses located in the Junction Block beneath the dash on the drivers side are:

RV TRUCK

Heater, Front A/C, Generator Warning Lamp20 Amp

Idle Stop Solenoid, Aux. Battery, Radio, Time Delay Relay, Emission Control Solenoid, Transmission Downshift (M40)15 Amp
 Cigarette Lighter, Clock, Dome Lamp, Cargo Lamp20 Amp
 Fuel Gage, Brake Warning Lamp, Temperature Warning Lamp, Oil Pressure Warning Lamp4 Amp
 Courtesy Lamp, Roof Marker Lamp, License Plate Lamp, Parking Lamp, Side Marker Lamp, Tail Lamp, Clearance Lamp20 Amp
 Directional Signal Indicator Lamp, Stop Lamp, Traffic Hazard15 Amp
 Instrument Cluster Lamp, Heater Dial Lamp, Radio Dial Lamp, Cruise Control Lamp, Windshield Wiper Switch Lamp4 Amp

8B-28 CHASSIS ELECTRICAL

Windshield Wiper/Washer25 Amp
 Cruise Control, Rear Window Aux.,
 Fuel Tank, Tachometer, Back-up Lamp,
 Directional Signal Indicator Lamp,
 Directional Signal Lamp, Headlamp
 Buzzer15 Amp

P TRUCK

Heater*, Air Conditioning*25 Amp
 Instrument Cluster Lamp, Windshield
 Wiper Switch Lamp3 Amp
 Directional Signal Indicator Lamp, Stop
 Lamp, Traffic Hazard15 Amp
 Fuel Gage, Brake Warning Lamp3 Amp
 License Plate Lamp, Parking Lamp,
 Side Marker Lamp, Tail Lamp,
 Clearance Lamp, Identification Lamp15 Amp
 Windshield Washer/Wiper25 Amp
 Cigarette Lighter*, Clock*, Courtesy*,
 Dome Lamp*15 Amp
 Auxiliary Battery*, Back-up Lamp,
 Radio15 Amp
 Idle Stop Solenoid, Cruise Control*,
 Directional Signal Lamp, Time Delay
 Relay, Emission Control Solenoid,
 Transmission Downshift (M40)10 Amp
 In-line fuses are located in the auxiliary heater circuits
 (C-K-P models) and underhood lamp, front and rear A/C
 circuits (C-K models).

*When incorporated by body builder.

Do not use fuses of higher amperage than those recommended above.

The following wiring harnesses are protected by a "fusible link" which is a special wire incorporated in the circuit headlamp hi-beam indicator, horn, air conditioning high blower, ignition circuits (RV-P models) starter solenoid (pull-in and hold) circuit (RV models). Should an electrical overload occur, this wire will fail and prevent damage to the major harness.

G TRUCK

Heater, A/C25 Amp
 Idle Stop Solenoid, Cruise Control,
 Directional Signal Lamp, Directional
 Signal Indicator Lamp, Transmission
 Downshift (M-40)10 Amp

Cigarette Lighter, Dome Lamp, Spot Lamp15 Amp
 Fuel Gage, Brake Warning Lamp,
 Temperature Warning Lamp, Generator
 Warning Lamp, Oil Pressure Warning Lamp3 Amp
 Stop Lamp, Traffic Hazard15 Amp
 Auxiliary Battery, Backing Lamp,
 Radio Dial Lamp, Radio15 Amp
 Instrument Cluster Lamp, Heater Dial
 Lamp, Transmission Control Lamp
 with Tilt Wheel, Cruise Control
 Lamp, W/S Wiper Switch Lamp,
 Headlamp Buzzer3 Amp
 License Lamp, Parking Lamp, Side
 Marker Lamp, Tail Lamp15 Amp
 Windshield Wiper25 Amp
 An in-line fuse is located in the Ammeter and the
 auxiliary heater circuits.

Do not use fuses of higher amperage rating than those recommended above.

The following wiring harnesses are protected by a "fusible link" which is a special wire incorporated in the circuit, ignition, horn and headlamp hi-beam indicator circuits, air conditioning high blower. Should an electrical overload occur, this wire will fail and prevent damage to the major harness.

CIRCUIT BREAKERS

DEVICE OR CIRCUIT PROTECTED	MODELS	AMPS.	LOCATION
Headlamp and parking lamp circuit	RV-P-G	15	Lamp switch
Tailgate window motor	RV	30	Dash (forward side)
Rear A/C (C69 overhead)	G	35	Dash (forward side)

LAMP SPECIFICATIONS

LAMP BULB DATA RV-P TRUCK

USED IN	QUAN.	TRADE #	POWER
Dome Lamps:			
Cab	1	1004	15 CP
Utility & Suburban	1	211-2	12 CP
Oil Pressure indicator lamp ¹	1	168	3 CP
Generator indicator lamp ¹	1	168	3 CP
Instrument cluster lamps ²	5	168	3 CP
Headlamp beam indicator lamp	1	168	3 CP
Lamp assembly—tail & stop lamp	2	1157	3-32 CP
License Lamp ⁴	1	67	4 CP
Directional signal (front park lamps) ⁵	2	1157	3-32 CP
Head Lamps	2	6014	50-60 W
Temperature indicator lamp	1	168	3 CP
Directional signal indicator lamp	2	168	3 CP
Clearance and marker lamps	4	168	3 CP
Roof marker lamps ⁵	5	194	2 CP
Brake warning indicator lamp	1	168	3 CP
Transmission control (auto)	1	1445	0.7 CP
Backing lamp (exc. motor home)	2	1156	32 CP
Backing lamp (motor home)	2	1295	50 CP
Heater or A/C Illum. lamp	1	161	1 CP
Corner marker lamps (platform)	7	67	4 CP
Cargo lamp (RV cab)	1	1142	21 CP
Radio dial lamp — AM	1	216	1 CP
—AM/FM	1	216	1 CP
Courtesy lamp	1	1003	15 CP
Windshield wiper switch lamp	1	161	1 CP
Clock lamp	1	168	3 CP
Rear identification ⁷ lamp	10	1895	2 CP
Underhood lamp	1	93	15 CP
Seat belt warning lamp	1	168	3 CP
Cargo/dome lamp	2	211-2	12 CP
Four wheel drive indicator lamp	1	161	1 CP
Choke heater indicator lamp	1	168	3 CP

LAMP BULB DATA G TRUCK

USED IN	QUAN.	TRADE #	POWER
Dome lamps	2	211-2	12 CP
Oil pressure indicator lamp	1	161	1 CP
Generator indicator lamp	1	194	2 CP
Instrument cluster lamps ¹¹	1	161	1 CP
Headlamp beam indicator lamp	1	161	1 CP
Park, directional signal lamps	2	1157	3-32 CP
Tail, stop lamps	2	1157	3-32 CP
License lamp	1	67	4 CP
Head lamps ¹²	2	6014	50-60 W
Temperature indicator lamp	1	194	2 CP
Directional signal indicator lamp	2	194	2 CP
Marker lamps	4	168	3 CP
Brake warning indicator lamp	1	194	2 CP
Back-up lamp	2	1156	32 CP
Radio dial lamp	1	1893	2 CP
Heater or A/C Illum. lamp	1	194	2 CP
Transmission control w/tilt wheel Illum. lamp	1	1445	0.7 CP
W/S wiper switch lamp	1	161	1 CP
Transmission control Illum. lamp	1	73	.3 CP
Choke heater indicator lamp	1	1893	2 CP
Seat belt warning lamp	1	194	2 CP
Instrument cluster lamps ⁹	5	194	2 CP
Instrument cluster lamps ¹⁰	1	168	3 CP

¹On RV instrument clusters only.

²3 lamps used on instrument cluster on P models or RV w/o gages.

³Double filament sealed beam 60W high beam, 50W low beam.

⁴2 lamps used with step bumper and P models.

⁵4 required on P models.

⁶1157 NA, 2.2-24 CP on RV models.

⁷Wideside Pickup.

⁸P' truck only.

⁹G' model w/o gages; 1 lamp with gages.

¹⁰G' model w/o gages; 3 lamps with gages.

¹¹G' model with gages only.

¹²Double filament sealed beam 60W high beam, 50W low beam.

classiccarlibrary.com

SECTION 8C

INSTRUMENT PANEL

CONTENTS

<u>SUBJECT</u>	<u>PAGE</u>
Description8C- 2
Speedometer8C- 2
Fuel Gage8C- 2
Oil Pressure Gage8C- 2
Temperature Gage8C- 2
Ignition Switch8C- 2
Lamp Switch8C- 2
Diagnosis Of Speedometer System8C- 3
Diagnosis Of The Fuel Gage8C- 4
Diagnosis Of The Oil Pressure Gage8C- 5
Diagnosis Of The Temperature Gage8C- 6
On Vehicle Service8C- 7
Speedometer Replacement8C- 7
Speedometer Cable Core Replacement8C- 7
Fuel Gage Replacement8C- 9
Fuel Sender Unit Replacement8C-11
Temperature Gage Replacement8C-11
Temperature Gage Sensor Replacement8C-13
Oil Pressure Gage Replacement8C-13
Oil Pressure Gage Sensor Replacement8C-14
Voltmeter Replacement8C-14
Instrument Cluster Replacement8C-15
Laminated (Printed) Circuit Replacement8C-16
Ignition Switch Replacement8C-16
Lamp Switch Replacement8C-16
Special Tools8C-16

DESCRIPTION

SPEEDOMETER

The speedometer on the instrument panel is a mechanical type that is driven by a cased cable which is connected to the transmission. The speedometer is located in the center of the instrument panel. Refer to figure 1 for diagnosis.

FUEL GAGE

The fuel gage is an electrical, current sensing type of indicator. It has two coils in it. One coil sets up a constant magnetic field. The other coil has a varying magnetic field which is varied by the reostat attached to a float in the fuel tank. A magnet, attached to a pointer, is located between the two coils. The magnet will establish a position which is controlled by the magnetic fields of the two coils. Refer to figure 2 for diagnosis.

OIL PRESSURE GAGE

The oil pressure gage displays the engine oil pressure. The gage is electrical. The sender is a variable resistance which controls the current passing through the gage. Refer to figure 3 for diagnosis.

TEMPERATURE GAGE

This gage displays the temperature of the engine coolant. It is an electrical gage. The gage's sender is a variable resistance that controls the current passing through the gage. Refer to figure 4 for diagnosis.

ENGINE CONTROL IGNITION SWITCH

On the RV and G models, the ignition switch is located in the steering column on the right hand side just below the steering wheel. The electrical switching portion of the assembly is separate from the key and lock cylinder. However, both are synchronized and work in conjunction with each other through the action of the actuator rod assembly.

For a complete explanation of the key and lock cylinder, and the actuator rod assembly, refer to STEERING COLUMN, (Sec. 3B4).

The ignition and starting switch is key operated through the actuator rod assembly to close the ignition primary circuit and to energize the starting motor solenoid for cranking.

On the P models the ignition switch is located on the instrument panel. The switch controls the engine run and start functions, and the accessories.

The connections to the ignition switch are shown in the Wiring Diagrams Booklet. The charts included on the diagrams show how the switches are internally connected in each switch position.

LAMP SWITCH

The lamp switch controls the headlamps, marker lamps, running lamps and parking lamps. The switch also controls the dome lamps and the light level of the instrument illumination lamps.

DIAGNOSIS—SPEEDOMETER SYSTEM

PROBLEM	POSSIBLE CAUSE	CORRECTION
Noisy	Kinked, pinched or burned casings.	Replace both the cable and casing. Recheck for noise.
"	Bent cable tips.	Replace both the cable and casing. Recheck for noise.
"	Improper or insufficient lubrication of cable.	Lubricate cable core with P/N 6478535 or equivalent. Pack ferrule with grease.
"	Faulty driven gear or rough drive gear.	Remove driven gear assembly from transmission. Check for free rotation of gear in sleeve. Check for burrs, flash or unusual worn spots. If gears appear faulty, replace and recheck for noise.
Whine	Oversize driven gear stem in transmission binds with adapter.	Replace driven gear and stem.
Buzzing sound with manual transmission.	Shift linkage vibration.	Adjust transmission shift linkage.
Tick or ringing sound with jumpy pointer between 0 and 30 MPH.	Faulty cable.	Replace cable.
Sticky speedometer pointer.	Speedometer pointer is bent and rubs.	Remove speedometer cluster or lens and straighten pointer. Recheck speedometer operation.
Incorrect calibration.	Wrong transmission adapter, drive gear or sleeve.	Check speedometer gear reference for correct application and replace if necessary.
"	Oversize or undersize tires.	Check calibration using correct tire size.
"	Faulty speedometer head.	Remove speedometer for repair.

F-00930

Figure 1—Diagnosis of the Speedometer

8C-4 INSTRUMENT PANEL

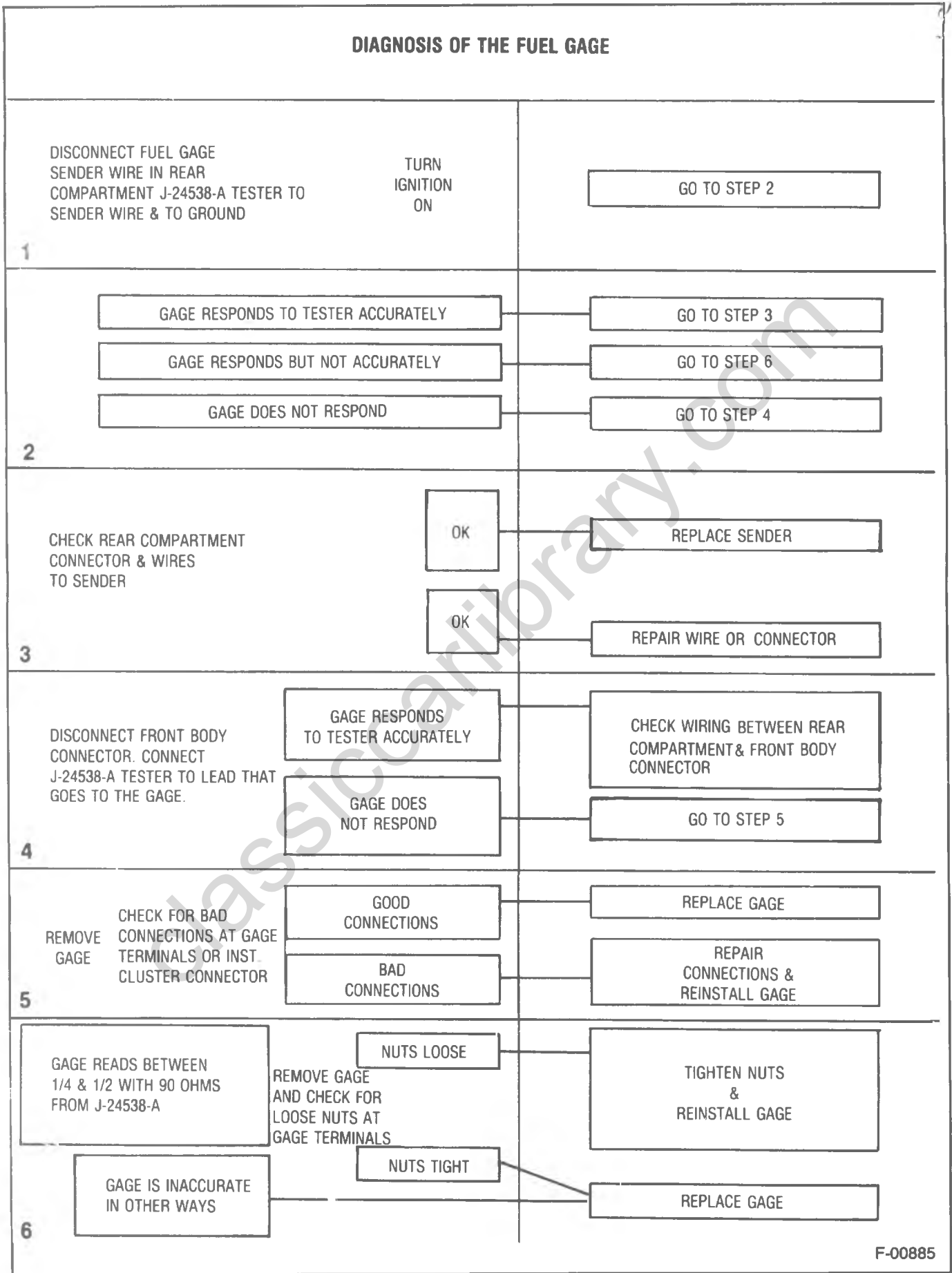

F-00885

Figure 2—Diagnosis of the Fuel Gage

DIAGNOSIS OF THE OIL PRESSURE GAGE

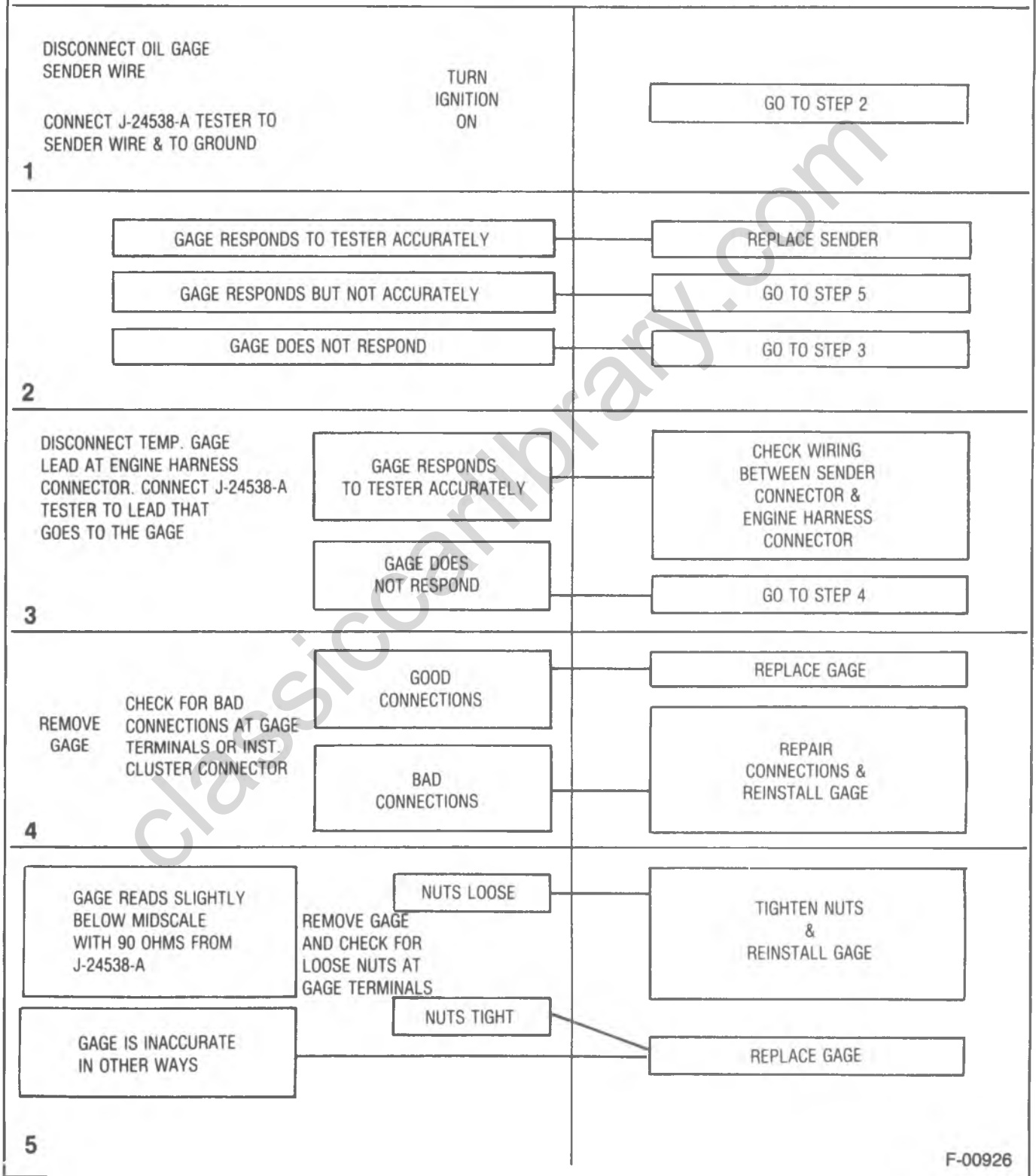

F-00926

Figure 3—Diagnosis of the Oil Pressure Gage

DIAGNOSIS OF THE TEMPERATURE GAGE

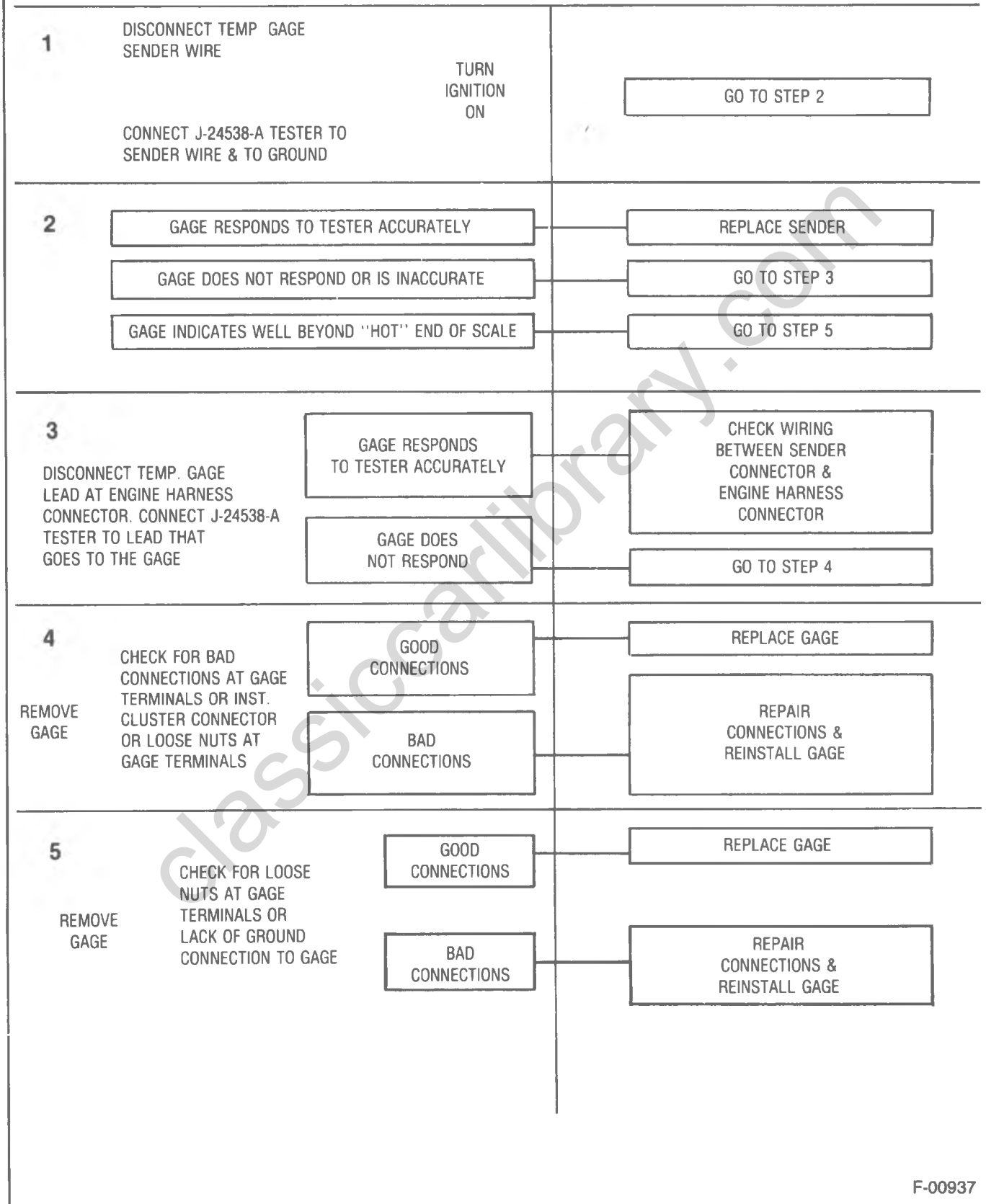

Figure 4—Diagnosis of the Temperature Gage

ON VEHICLE SERVICE

SPEEDOMETER REPLACEMENT

Servicing of the speedometer assembly should only be performed by trained technicians having the proper test equipment.

When replacing a speedometer or odometer assembly, the law requires the odometer reading of the replacement unit to be set to register the same mileage as the prior odometer. If the same mileage cannot be set, the law requires the replacement odometer be set to zero and a label be installed on the driver's door frame to show the previous odometer reading and the date of replacement.

RV MODELS

Remove or Disconnect (Figures 5 and 6)

1. Battery ground cable from the battery.
2. Headlamp switch knob assembly. Refer to CHASSIS ELECTRICAL (SEC. 8B).
3. Radio control knobs.
4. Clock adjuster stem.
5. Instrument cluster bezel (43).
6. Steering column cover.
7. Instrument cluster lens (42).
8. Transmission shift indicator (41).
9. Retainer (44).
10. Speedometer cable.
 - Depress spring clip (30).
 - Remove cable and case from the speedometer (36).

Install or Connect (Figures 5 and 6)

1. Speedometer (36).
2. Speedometer cable assembly.
 - Push the cable assembly into the speedometer head, rotating the cable assembly, until the spring clip engages.
3. Retainer (44).
4. Transmission shift indicator (41).
5. Instrument cluster lens (42).
6. Steering column cover.
7. Instrument cluster bezel (43).
8. Clock adjuster stem.
9. Radio control knobs.
10. Headlamp switch knob assembly.
11. Battery ground cable to the battery.

G MODELS

Remove or Disconnect (Figure 7)

1. Battery ground cable from the battery.
2. Instrument cluster. Refer to "Instrument Cluster Replacement" in this section.
3. Speedometer dial retaining screws.
4. Two hex head screws and rubber grommets securing the speedometer assembly to the cluster cover.
5. Speedometer cable assembly from the speedometer.
6. Speedometer (80).

Install or Connect

1. Speedometer (80).
2. Speedometer cable assembly.
3. Two hex head screws and rubber grommets that hold the speedometer assembly to the cluster cover.
4. Speedometer dial retaining screws.
5. Instrument cluster. Refer to "Instrument Cluster Replacement" in this section.
6. Battery ground cable to the battery.

P MODELS

Remove or Disconnect

1. Battery ground cable from the battery.
2. Instrument cluster. Refer to "Instrument Cluster Replacement" in this section.
3. Lamp socket assemblies.
4. Laminated circuit retaining nuts.
5. Laminated circuit.
6. Cluster case retaining screws.
7. Cluster case from the bezel.
8. Speedometer retaining bolts.
9. Speedometer from the cluster case.

Install or Connect

1. Speedometer to the cluster case.
2. Speedometer retaining bolts.
3. Cluster case to the bezel.
4. Cluster case retaining screws.
5. Laminated circuit.
6. Laminated circuit retaining nuts.
7. Lamp socket assemblies.
8. Instrument cluster. Refer to "Instrument Cluster Replacement" in this section.
9. Battery ground cable from the battery.

SPEEDOMETER CABLE CORE REPLACEMENT

ALL VEHICLES

Remove or Disconnect (Figures 5, 8,, 9, and 10)

1. Battery ground cable from the battery.
2. Speedometer cable assembly from the speedometer.
 - Compress the spring clip (30).
 - Pull the cable assembly from the speedometer.
3. Cable core.
 - Pull the core out of the speedometer end of the casing. If the cable core is broken, remove the lower piece of the core from the transmission end of the casing.

Install or Connect (Figures 5, 8, 9, and 10)

1. Lubricant in the casing and on the core.
2. Core into the speedometer end of the casing. Turn the core to engage the drive gear in the transmission.

8C-8 INSTRUMENT PANEL

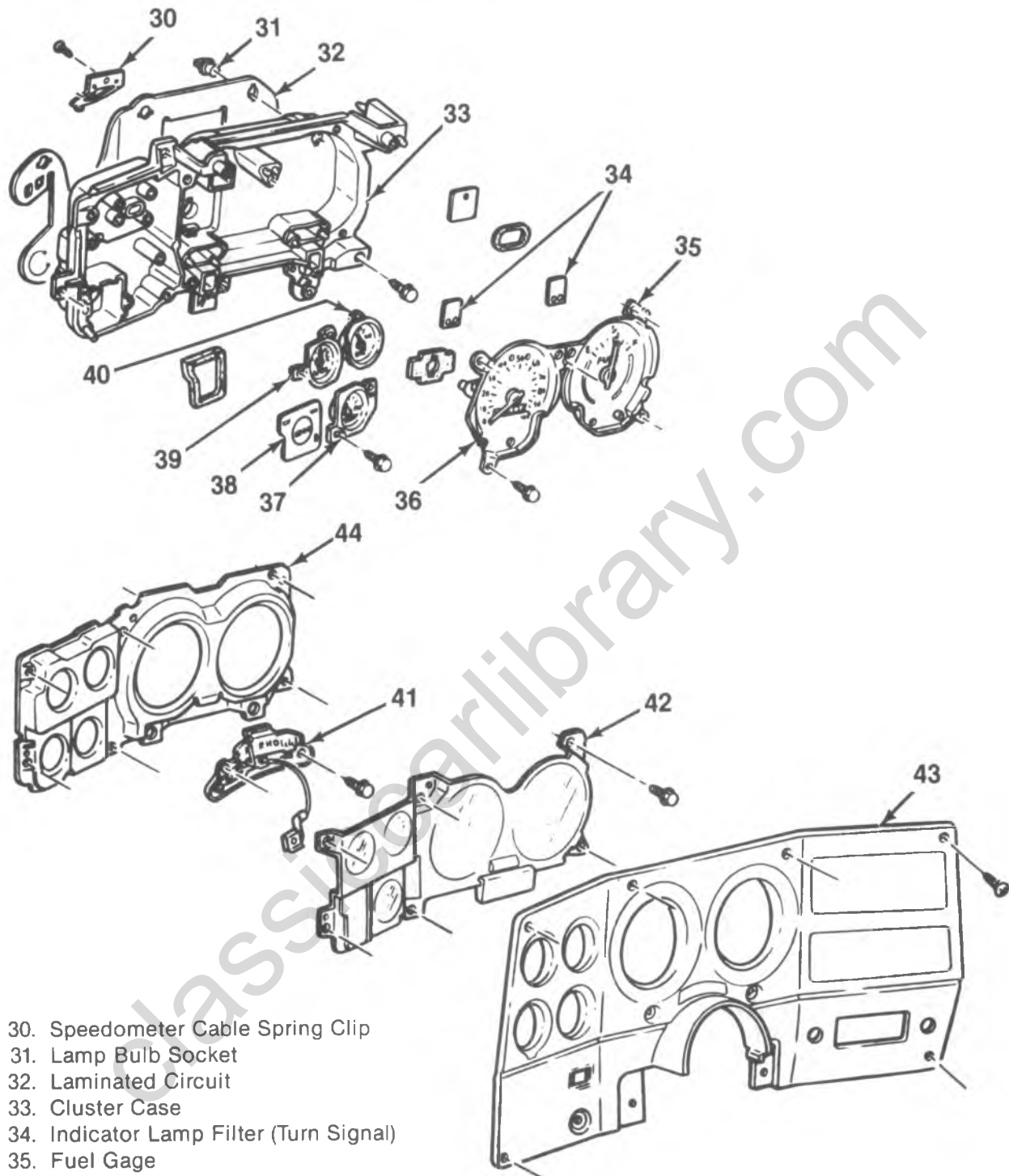

- 30. Speedometer Cable Spring Clip
- 31. Lamp Bulb Socket
- 32. Laminated Circuit
- 33. Cluster Case
- 34. Indicator Lamp Filter (Turn Signal)
- 35. Fuel Gage
- 36. Speedometer
- 37. Temperature Gage
- 38. Brake Warning Lamp Filter
- 39. Ammeter
- 40. Oil Pressure Gage
- 41. Transmission Shift Indicator
- 42. Instrument Cluster Lens
- 43. Instrument Cluster Bezel
- 44. Retainer

F-00945

Figure 5—RV Model Instrument Panel

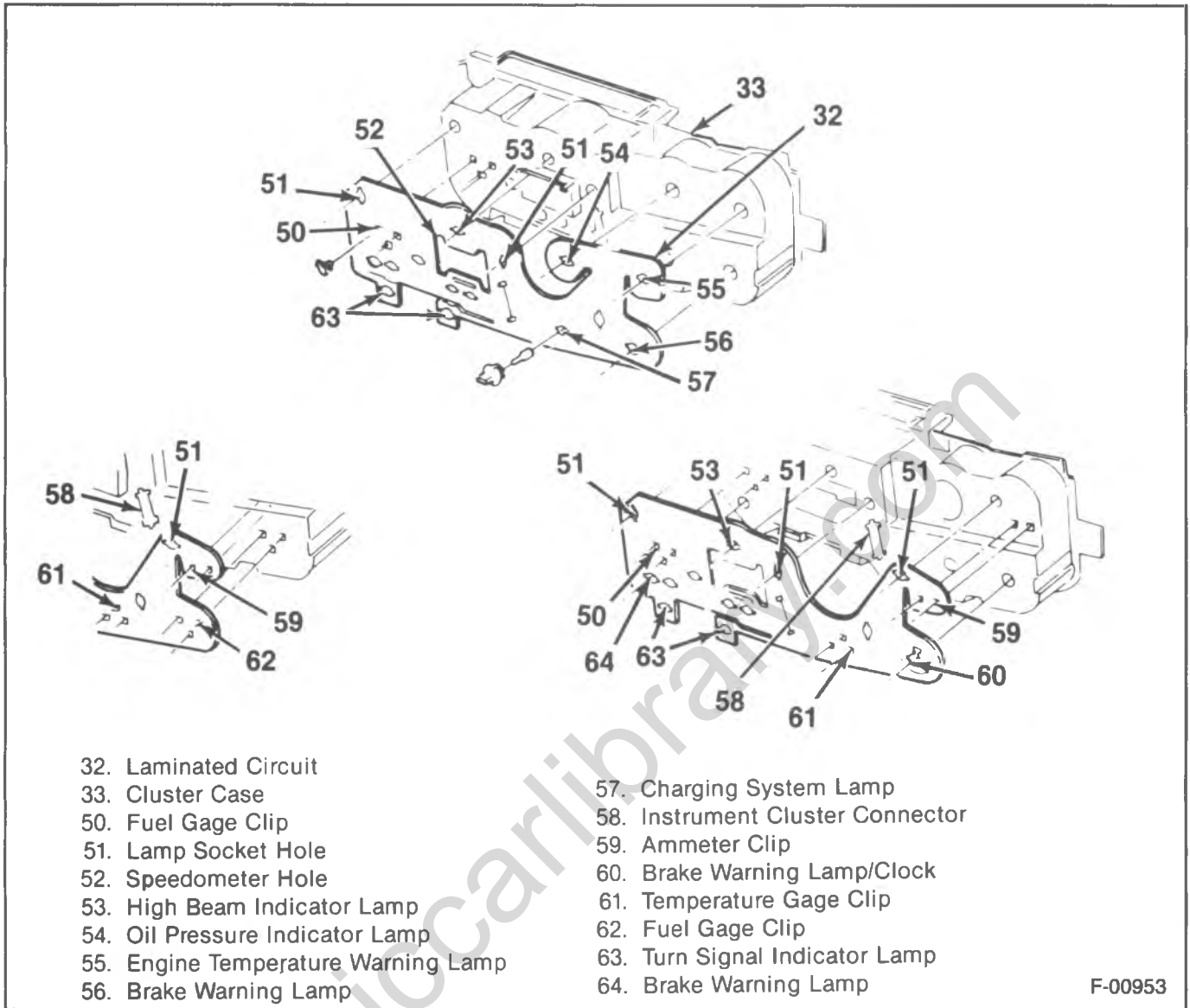

Figure 6—RV Model Laminated Circuit

3. Speedometer cable assembly into the speedometer head until the spring clip (30) engages.
4. Battery ground cable to the battery.

FUEL GAGE REPLACEMENT

Remove or Disconnect (Figures 5 and 6)

1. Battery ground cable from the battery.
2. Headlamp switch knob assembly. Refer to CHASSIS ELECTRICAL (SEC. 8B).
3. Radio control knobs.
4. Clock adjuster stem.
5. Instrument cluster bezel (43).
6. Steering column cover.
7. Instrument cluster lens (42).
8. Transmission shift indicator (41).
9. Case front cover (44).
10. Fuel gage attaching screws.
11. Fuel gage (35).

Install or Connect (Figures 5 and 6)

1. Fuel gage (35).
2. Fuel gage attaching screws.
3. Case front cover (44).
4. Transmission shift indicator (41).
5. Instrument cluster lens (42).
6. Steering column cover.
7. Instrument cluster bezel (43).
8. Clock adjuster stem.
9. Radio control knobs.
10. Headlamp switch knob assembly. Refer to CHASSIS ELECTRICAL (SEC. 8B).
11. Battery ground cable to the battery.

G MODELS

Remove or Disconnect (Figure 7)

1. Battery ground cable from the battery.
2. Instrument cluster assembly. Refer to "Instrument Cluster Replacement" in this section.
3. Lens (83).

F-00953

8C-10 INSTRUMENT PANEL

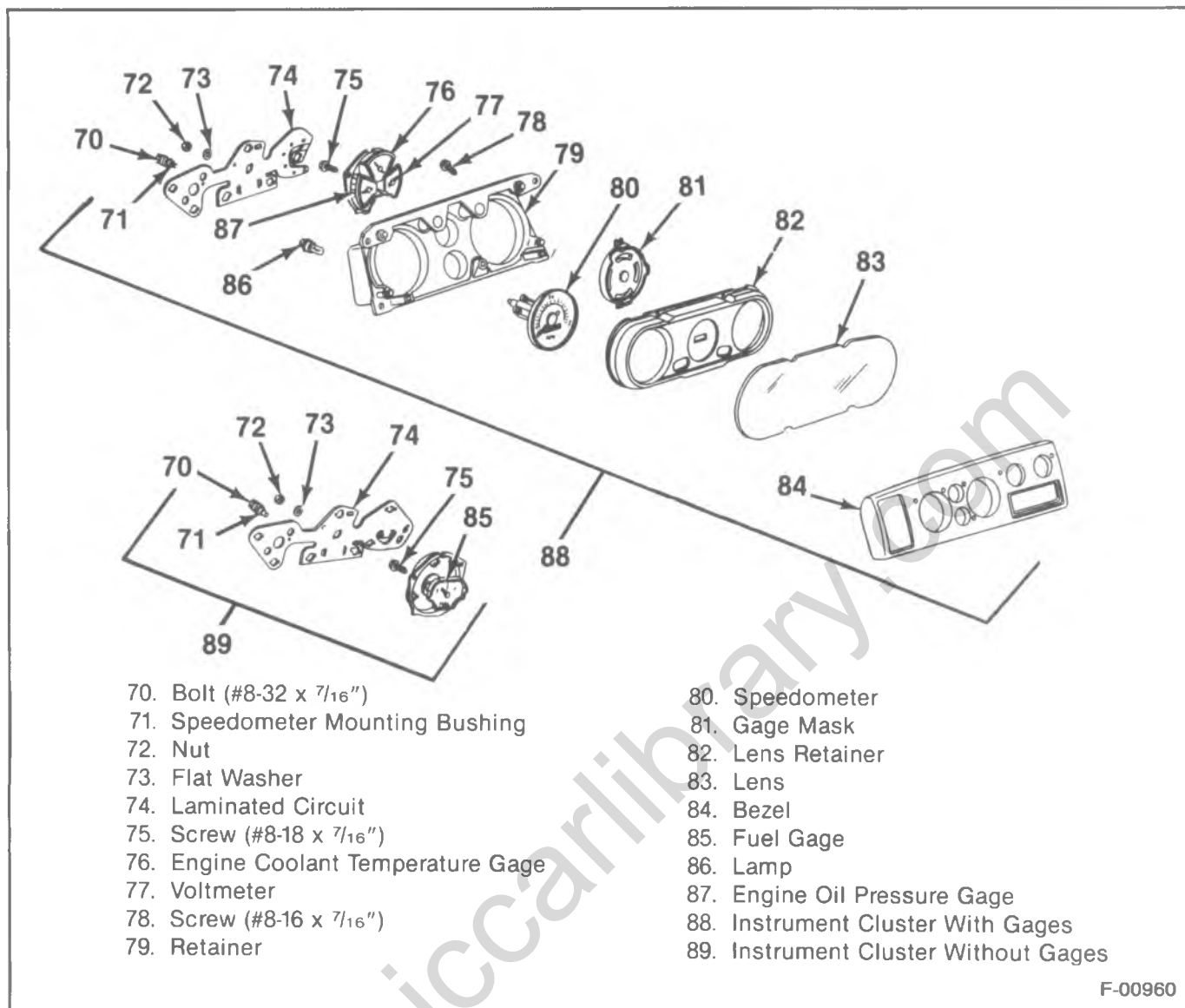

F-00960

Figure 7—Van Instrument Panel

4. Lens retainer (82).
5. Laminated circuit retaining nuts.
6. Laminated circuit (74) from the retainer (79).
7. Fuel gage retaining nuts (72).
8. Fuel gage.

Install or Connect (Figure 7)

1. Fuel gage to the laminated circuit.
2. Fuel gage retaining nuts (72).
3. Laminated circuit (74) to the retainer (79).
4. Laminated circuit retaining nuts.
5. Lens retainer (82).
6. Lens (83).
7. Instrument cluster assembly. Refer to "Instrument Cluster Replacement" in this section.
8. Battery ground cable to the battery.

P MODELS

Remove or Disconnect

1. Battery ground cable from the battery.
2. Instrument cluster. Refer to "Instrument Cluster Replacement" in this section.
3. Lamp socket assemblies.
4. Laminated circuit retaining nuts.
5. Laminated circuit.
6. Cluster case retaining screws.
7. Cluster case from the bezel.
8. Fuel gage retaining bolts.
9. Fuel gage from the cluster case.

Install or Connect

1. Fuel gage to the cluster case.
2. Fuel gage retaining bolts.
3. Cluster case to the bezel.
4. Cluster case retaining screws.
5. Laminated circuit.
6. Laminated circuit retaining nuts.

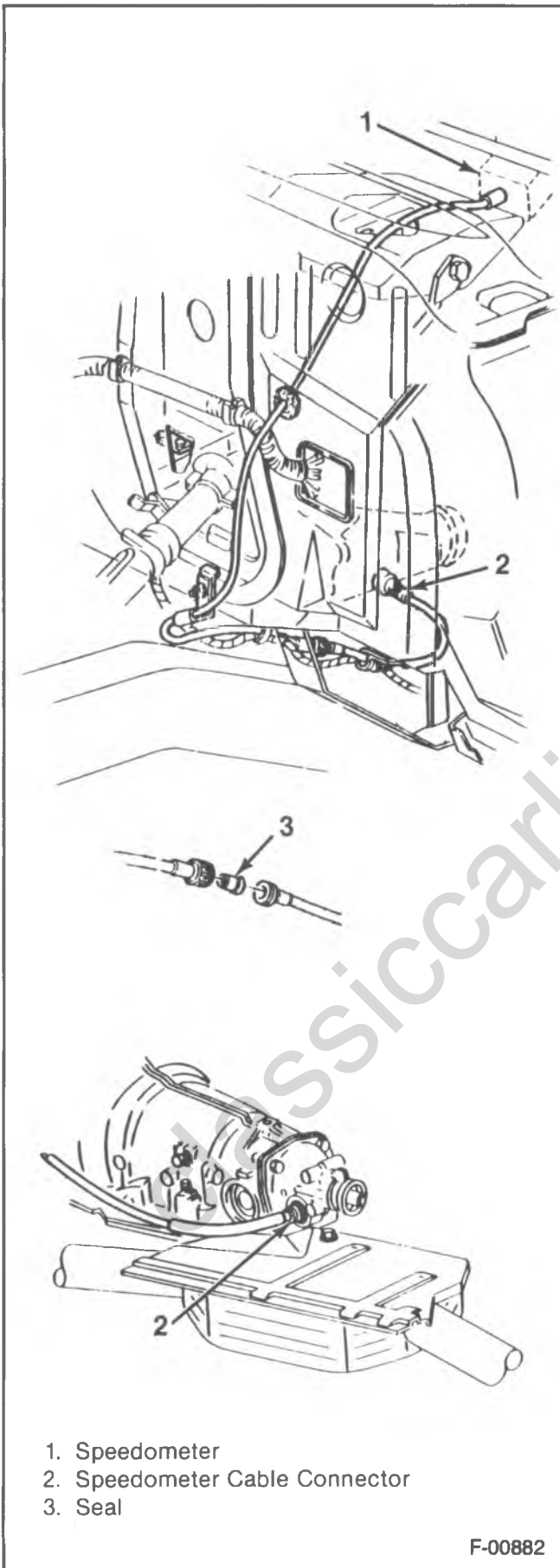

- 1. Speedometer
- 2. Speedometer Cable Connector
- 3. Seal

F-00882

Figure 8—Speedometer Cable—Two Wheel Drive

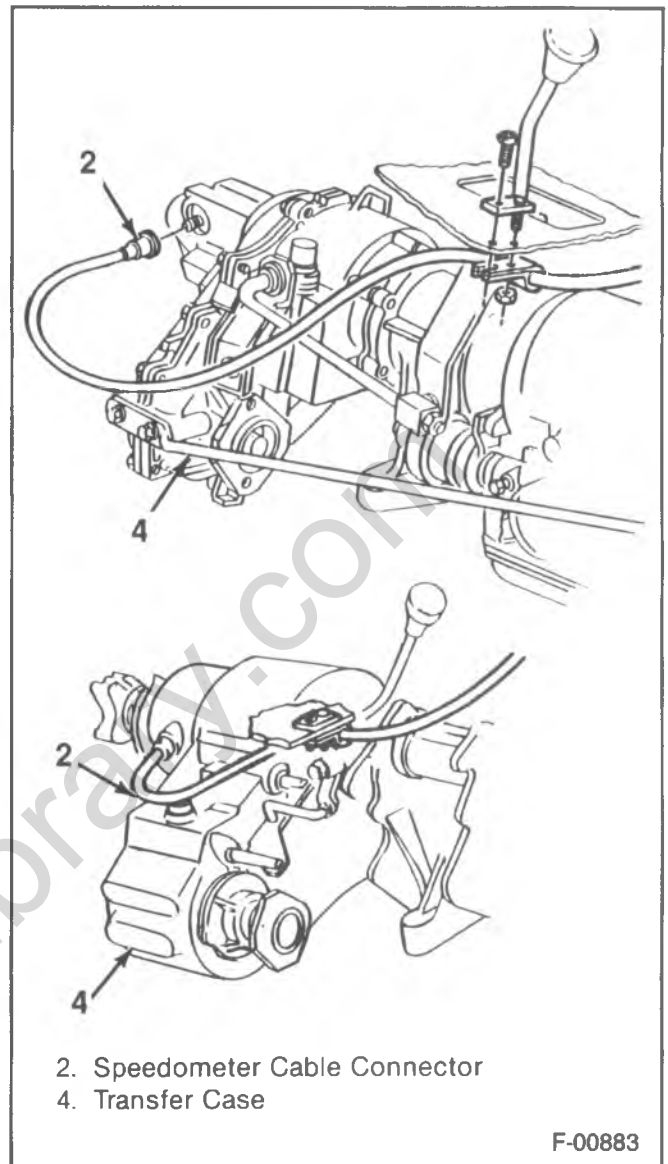

- 2. Speedometer Cable Connector
- 4. Transfer Case

F-00883

Figure 9—Speedometer Cable—Four Wheel Drive

- 7. Lamp socket assemblies.
- 8. Instrument cluster. Refer to "Instrument Cluster Replacement" in this section.
- 9. Battery ground cable from the battery.

FUEL SENDER UNIT REPLACEMENT

ALL MODELS

Refer to FUEL SYSTEMS (SEC. 6C) or the FUEL AND EMISSIONS Manual (TBI vehicles).

TEMPERATURE GAGE REPLACEMENT

RV MODELS



Remove or Disconnect (Figure 5)

- 1. Battery ground cable from the battery.
- 2. Headlamp switch knob assembly. Refer to CHASSIS ELECTRICAL (SEC. 8B).

8C-12 INSTRUMENT PANEL

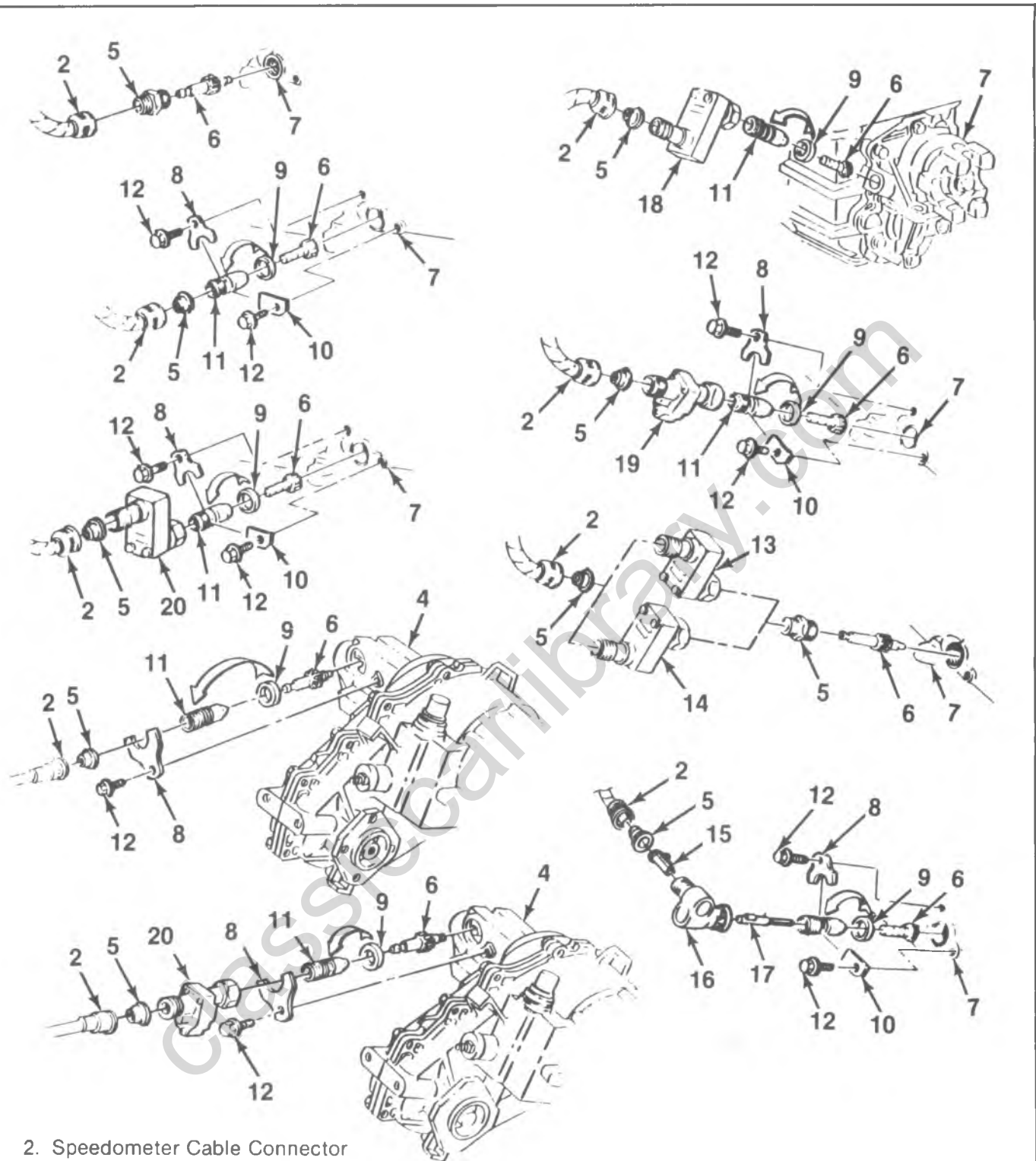

- 2. Speedometer Cable Connector
- 4. Transfer Case
- 5. Sleeve
- 6. Gear
- 7. Transmission
- 8. Retainer
- 9. Seal
- 10. Retainer
- 11. Sleeve Assembly
- 12. Bolt
- 13. Adapter Assembly—Position for All Transmissions Except SM465
- 14. Adapter Assembly—Position For SM465 Transmission
- 15. Output Key
- 16. Adapter Assembly—Right Angle
- 17. Adapter Assembly
- 18. In-Line Adapter Assembly (With SM465 Transmission)
- 19. Parallel Adapter Assembly (Except SM465 Transmission)
- 20. In-Line Adapter

F-00884

Figure 10—Speedometer Adapter Assemblies

3. Radio control knobs.
4. Clock adjuster stem.
5. Instrument cluster bezel (43).
6. Steering column cover.
7. Instrument cluster lens (42).
8. Transmission shift indicator (41).
9. Retainer (44).
10. Temperature gage attaching screws.
11. Temperature gage (37).

↔ Install or Connect (Figure 5)

1. Temperature gage (37).
2. Temperature gage attaching screws.
3. Retainer (44).
4. Transmission shift indicator (41).
5. Instrument cluster lens (42).
6. Steering column cover.
7. Instrument cluster bezel (43).
8. Clock adjuster stem.
9. Radio control knobs.
10. Headlamp switch knob assembly. Refer to CHASSIS ELECTRICAL (SEC. 8B).
11. Battery ground cable to the battery.

G MODELS

↔ Remove or Disconnect (Figure 7)

1. Battery ground cable from the battery.
2. Instrument cluster assembly. Refer to "Instrument Cluster Replacement" in this section.
3. Lens (83).
4. Lens retainer (82).
5. Laminated circuit retaining nuts.
6. Laminated circuit (74) from the retainer (79).
7. Temperature gage retaining nuts (72).
8. Temperature gage (76).

↔ Install or Connect (Figure 7)

1. Temperature gage (76) to the laminated circuit.
2. Temperature gage retaining nuts (72).
3. Laminated circuit (74) to the retainer (79).
4. Laminated circuit retaining nuts.
5. Lens retainer (82).
6. Lens (83).
7. Instrument cluster assembly. Refer to "Instrument Cluster Replacement" in this section.
8. Battery ground cable to the battery.

P MODELS

↔ Remove or Disconnect

1. Battery ground cable from the battery.
2. Instrument cluster. Refer to "Instrument Cluster Replacement" in this section.
3. Lamp socket assemblies.
4. Laminated circuit retaining nuts.
5. Laminated circuit.
6. Cluster case retaining screws.
7. Cluster case from the bezel.
8. Temperature gage retaining bolts.
9. Temperature gage from the cluster case.

↔ Install or Connect

1. Temperature gage to the cluster case.
2. Temperature gage retaining bolts.
3. Cluster case to the bezel.
4. Cluster case retaining screws.
5. Laminated circuit.
6. Laminated circuit retaining nuts.
7. Lamp socket assemblies.
8. Instrument cluster. Refer to "Instrument Cluster Replacement" in this section.
9. Battery ground cable from the battery.

TEMPERATURE GAGE SENSOR REPLACEMENT

ALL MODELS

CAUTION: Do not remove cap with the engine hot. Allow the vehicle to cool off first.

↔ Remove or Disconnect

1. Radiator cap.
 - Loosen the cap to the first stop. This will relieve the cooling system pressure.
 - Tighten the cap. This will minimize the loss of coolant when replacing the temperature sender.
2. Sensor harness connector.
3. Sensor.
 - Have the new sender ready to install or close the sender hole with a cork in order to minimize coolant loss.

↔ Install or Connect

1. Sensor.
2. Sensor harness connector.
3. Coolant to return the coolant level to the proper level.

OIL PRESSURE GAGE REPLACEMENT

RV MODELS

↔ Remove or Disconnect (Figure 5)

1. Battery ground cable from the battery.
2. Headlamp switch knob assembly. Refer to CHASSIS ELECTRICAL (SEC. 8B).
3. Radio control knobs.
4. Clock adjuster stem.
5. Instrument cluster bezel (43).
6. Steering column cover.
7. Instrument cluster lens (42).
8. Transmission shift indicator (41).
9. Retainer (44).
10. Oil pressure gage attaching screws.
11. Oil pressure gage (40).

↔ Install or Connect

1. Oil pressure gage (40).
2. Oil pressure gage attaching screws.

8C-14 INSTRUMENT PANEL

3. Retainer.
4. Transmission shift indicator (41).
5. Instrument cluster lens (42).
6. Steering column cover.
7. Instrument cluster bezel (43).
8. Clock adjuster stem.
9. Radio control knobs.
10. Headlamp switch knob assembly. Refer to CHASSIS ELECTRICAL (SEC. 8B).
11. Battery ground cable to the battery.

G MODELS

↔ Remove or Disconnect (Figure 7)

1. Battery ground cable from the battery.
2. Instrument cluster assembly. Refer to "Instrument Cluster Replacement" in this section.
3. Lens (83).
4. Lens retainer (82).
5. Laminated circuit retaining nuts.
6. Laminated circuit (74) from the retainer (79).
7. Oil pressure gage retaining nuts (72).
8. Oil pressure gage (87).

↔ Install or Connect (Figure 7)

1. Fuel gage (87) to the laminated circuit.
2. Fuel gage retaining nuts (72).
3. Laminated circuit (74) to the retainer (79).
4. Laminated circuit retaining nuts.
5. Lens retainer (82).
6. Lens (83).
7. Instrument cluster assembly. Refer to "Instrument Cluster Replacement" in this section.
8. Battery ground cable to the battery.

P MODELS

↔ Remove or Disconnect

1. Battery ground cable from the battery.
2. Instrument cluster. Refer to "Instrument Cluster Replacement" in this section.
3. Lamp socket assemblies.
4. Laminated circuit retaining nuts.
5. Laminated circuit.
6. Cluster case retaining screws.
7. Cluster case from the bezel.
8. Oil pressure gage retaining bolts.
9. Oil pressure gage from the cluster case.

↔ Install or Connect

1. Oil pressure gage to the cluster case.
2. Oil pressure gage retaining bolts.
3. Cluster case to the bezel.
4. Cluster case retaining screws.
5. Laminated circuit.
6. Laminated circuit retaining nuts.
7. Lamp socket assemblies.
8. Instrument cluster. Refer to "Instrument Cluster Replacement" in this section.
9. Battery ground cable from the battery.

OIL PRESSURE GAGE SENSOR REPLACEMENT

ALL MODELS

↔ Remove or Disconnect

1. Battery ground cable from the battery.
2. Wiring harness connector from the sensor.
 - L-6 engines — the sensor is located in the block above the starter.
 - V-6 and V-8 engines — the sensor is located at the left front side of the distributor.
 - V-8 (454) engines — the sensor is located at the rear left side of the block.
 - Diesel engines — Left side, above the flywheel housing.
3. Sensor.
 - Use Tool J-21757.

↔ Install or Connect

1. Sensor.
 - Use Tool J-21757.
2. Wiring harness connector to the sender.
3. Battery ground cable to the battery.

VOLTMETER REPLACEMENT

RV MODELS

↔ Install or Connect (Figure 5)

1. Battery ground cable from the battery.
2. Headlamp switch knob assembly. Refer to CHASSIS ELECTRICAL (SEC. 8B).
3. Radio control knobs.
4. Clock adjuster stem.
5. Instrument cluster bezel (43).
6. Steering column cover.
7. Instrument cluster lens (42).
8. Transmission shift indicator (41).
9. Retainer (44).
10. Voltmeter attaching screws.
11. Voltmeter.

↔ Install or Connect (Figure 5)

1. Voltmeter.
2. Voltmeter attaching screws.
3. Retainer (44).
4. Transmission shift indicator (41).
5. Instrument cluster lens (42).
6. Steering column cover.
7. Instrument cluster bezel (43).
8. Clock adjuster stem.
9. Radio control knobs.
10. Headlamp switch knob assembly.
11. Battery ground cable to the battery.

G MODELS

↔ Remove or Disconnect (Figure 7)

1. Battery ground cable from the battery.
2. Instrument cluster assembly. Refer to "Instrument Cluster Replacement" in this section.
3. Lens (83).
4. Lens retainer (82).
5. Laminated circuit retaining nuts.
6. Laminated circuit (74) from the retainer (79).
7. Voltmeter retaining nuts (72).
8. Voltmeter.

→← Install or Connect (Figure 7)

1. Voltmeter to the laminated circuit.
2. Voltmeter retaining nuts (72).
3. Laminated circuit (74) to the retainer (79).
4. Laminated circuit retaining nuts.
5. Lens retainer (82).
6. Lens (83).
7. Instrument cluster assembly. Refer to "Instrument Cluster Replacement" in this section.
8. Battery ground cable to the battery.

P MODELS

↔ Remove or Disconnect

1. Battery ground cable from the battery.
2. Instrument cluster. Refer to "Instrument Cluster Replacement" in this section.
3. Lamp socket assemblies.
4. Laminated circuit retaining nuts.
5. Laminated circuit.
6. Cluster case retaining screws.
7. Cluster case from the bezel.
8. Voltmeter retaining bolts.
9. Voltmeter from the cluster case.

→← Install or Connect

1. Voltmeter to the cluster case.
2. Voltmeter retaining bolts.
3. Cluster case to the bezel.
4. Cluster case retaining screws.
5. Laminated circuit.
6. Laminated circuit retaining nuts.
7. Lamp socket assemblies.
8. Instrument cluster. Refer to "Instrument Cluster Replacement" in this section.
9. Battery ground cable from the battery.

INSTRUMENT CLUSTER REPLACEMENT

RV MODELS

↔ Remove or Disconnect (Figure 5)

1. Battery ground cable from the battery.
2. Headlamp switch knob assembly.
3. Radio control knobs.
4. Four steering column cover retaining screws.
5. Steering column cover.
6. Eight instrument bezel retaining screws.

7. Instrument bezel (43).
8. Speedometer drive cable.
 - Press the spring clip (30) at the speedometer (36).
 - Pull the cable from the speedometer head.
9. Four cluster retaining screws.
10. Cluster harness connector.
11. Cluster.

→← Install or Connect (Figure 5)

1. Cluster.
2. Cluster harness connector.
3. Four cluster retaining screws.
4. Speedometer drive cable.
5. Instrument bezel (43).
6. Eight instrument bezel retaining screws.
7. Steering column cover.
8. Four steering column cover retaining screws.
9. Radio control knobs.
10. Headlamp switch knob assembly.
11. Battery ground cable to the battery.

G MODELS

↔ Remove or Disconnect (Figure 7)

1. Battery ground cable from the battery.
2. Speedometer drive cable.
 - Press in the tang on the speedometer head.
 - Pull out the drive cable.
3. Clock set stem knob.
4. Instrument cluster bezel retaining screws.
5. Instrument bezel (84).
6. Two lower cluster retaining screws.
7. Cluster.
 - Pull the top of the cluster away from the instrument panel.
 - Lift out the bottom of the cluster.
8. Instrument cluster harness connector.

→← Install or Connect (Figure 7)

1. Cluster harness connector into the cluster.
2. Cluster.
3. Two lower cluster retaining screws.
4. Instrument bezel (84).
5. Instrument cluster bezel retaining screws.
6. Clock set stem knob.
7. Speedometer drive cable.
8. Battery ground cable to the battery.

P MODELS

↔ Remove or Disconnect

1. Battery ground cable from the battery.
2. Speedometer drive cable.
 - Press in the tang on the speedometer head.
 - Pull out of the drive cable.
3. Instrument cluster harness connector.
4. Instrument cluster bezel screws.
5. Instrument cluster from the dash panel.

→← Install or Connect

1. Instrument cluster to the dash panel.
2. Instrument cluster bezel screws.
3. Instrument cluster harness connector.

8C-16 INSTRUMENT PANEL

4. Speedometer drive cable.
5. Battery ground cable from the battery.

LAMINATED (PRINTED) CIRCUIT REPLACEMENT

ALL MODELS

Remove or Disconnect (Figures 5, 6, and 7)

1. Instrument cluster assembly. Refer to "Instrument Cluster Replacement" in this section.
2. Instrument cluster lamp bulb assemblies (57).
3. Laminated circuit retaining screws.
4. G and P models.
 - Fuel gage terminal nuts.
 - Temperature gage terminal nuts.
 - Ammeter terminal nuts.
5. Laminated circuit from the cluster case (33).

Install or Connect (Figures 5, 6, and 7)

1. Laminated circuit (51) to the cluster case (33).
2. Laminated circuit retaining screws.
3. G and P models.
 - Fuel gage terminal nuts.
 - Ammeter terminal nuts.
4. Instrument cluster lamp bulb assemblies (57).
5. Instrument cluster assembly. Refer to "Instrument Cluster Replacement" in this section.

IGNITION SWITCH REPLACEMENT

Refer to STEERING COLUMN (SEC. 3B4).

LAMP SWITCH REPLACEMENT

Refer to CHASSIS ELECTRICAL (SEC. 8B).

SPECIAL TOOLS

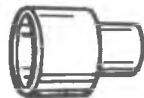

J-21757-03

Oil Pressure
Sending Unit Socket
Wrench

B-07667

Figure 11—Special Tool

SECTION 9

ACCESSORIES

CONTENTS

<u>SUBJECT</u>	<u>PAGE</u>
Cruise Control	9- 1
Description	9- 1
Diagnosis	9- 3
On-Vehicle Service	9- 6
Vacuum Release Valve Replacement	9- 6
Clutch Release Switch Replacement	9- 6
Cruise Control Modul Replacement	9- 8
Multi-Function Switch Replacement	9-10
Servo Replacement	9-11
Radio	9-16
Description	9-16
Diagnosis	9-16
Accessory Noise	9-16
Chart 1 — System Diagnosis and Analysis	9-17
Chart 2 — Noisy Part 1	9-18
Chart 3 — Noisy Part 2	9-19
Chart 4 — ECM or Digital Dash Noise	9-20
Chart 5 — Ignition Noise	9-21
Chart 6 — Antenna Noise Part 1	9-22
Chart 7 — Antenna Noise Part 2	9-23
Chart 8 — Weak	9-24
Chart 9 — Alternator Whine	9-25
Chart 10 — Dead	9-26
Chart 11 — Tape	9-27
Diagnostic RF Sniffer	9-30
Radio Receiver Replacement	9-30
RV Models	9-30
G Van	9-30
Antenna Replacement	9-32
RV Models	9-32
G Van	9-32
Speaker Replacement	9-32
RV Models	9-32
G Van	9-35

CRUISE CONTROL

DESCRIPTION

Cruise control is a speed control system which maintains a desired vehicle speed under normal driving conditions. However, steep grades up or down may cause variations in the selected speeds. The electronic cruise control system has the capability to cruise coast, resume speed, accelerate, and "tap-up" and "tap-down" (figure 1).

The main parts of the cruise control system are the mode control switches, controller (module), servo unit, speed sensor, vacuum supply, electrical and vacuum release switches, and electrical harness.

The cruise control system uses vacuum to operate a throttle servo unit. The servo unit maintains a desired

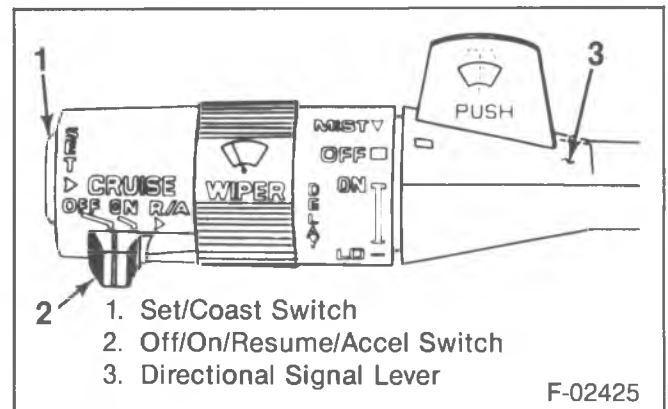

Figure 1—Multi-Function Lever

9-2 ACCESSORIES

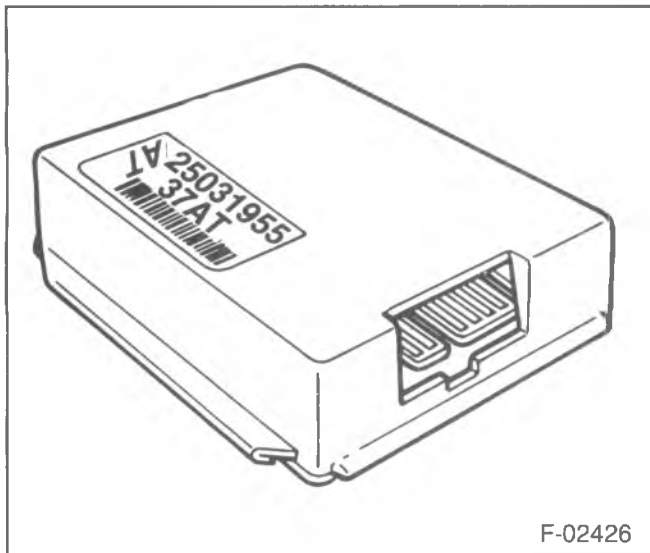

Figure 2—Controller Module

vehicle speed by trapping vacuum in the servo unit at the proper servo position. The controller monitors vehicle speed and servo position and operates the vacuum and vent valves in the servo to maintain desired speed. The controller contains a low speed limit which will prevent system engagement below a minimum speed, about 25 mph. The operation of the controller is controlled by mode control switches located in the end of the directional signal lever. To disengage the system, two release switches are provided. An electrical release switch mounted on the brake pedal bracket (and clutch pedal bracket on vehicles equipped with manual transmission) disengages the system electrically when the brake pedal (or clutch pedal) is depressed. A vacuum release valve, mounted on the brake pedal bracket, vents the trapped vacuum in the servo to atmosphere when the brake pedal is depressed, allowing the servo unit to quickly return the throttle to idle position.

ELECTRONIC CONTROLLER (MODULE)

The controller interprets the position of the servo, the position of the mode control switches and the output of the speed sensor. In response to these inputs, the controller electrically signals the opening or closing of the vent and vacuum solenoid valves in the servo (figure 2).

The controller is usually mounted on the accelerator pedal bracket. For mounting location, refer to the On-Vehicle Service portion of this section.

SERVO UNIT (Figure 3)

The servo consists of a vacuum operated diaphragm, a normally open solenoid valve to vent the diaphragm chamber to atmosphere, a normally closed solenoid valve to connect the diaphragm chamber to the vacuum source, and a variable inductance position sensor. The servo operates the throttle in response to signals from the electronic controller as follows:

- **Steady Cruise State** (system engaged and operating) — Both vacuum and vent valves are closed or sealed. The servo has a constant vacuum on the diaphragm and places no-flow requirements on the vacuum source. Vacuum is trapped in diaphragm chamber.

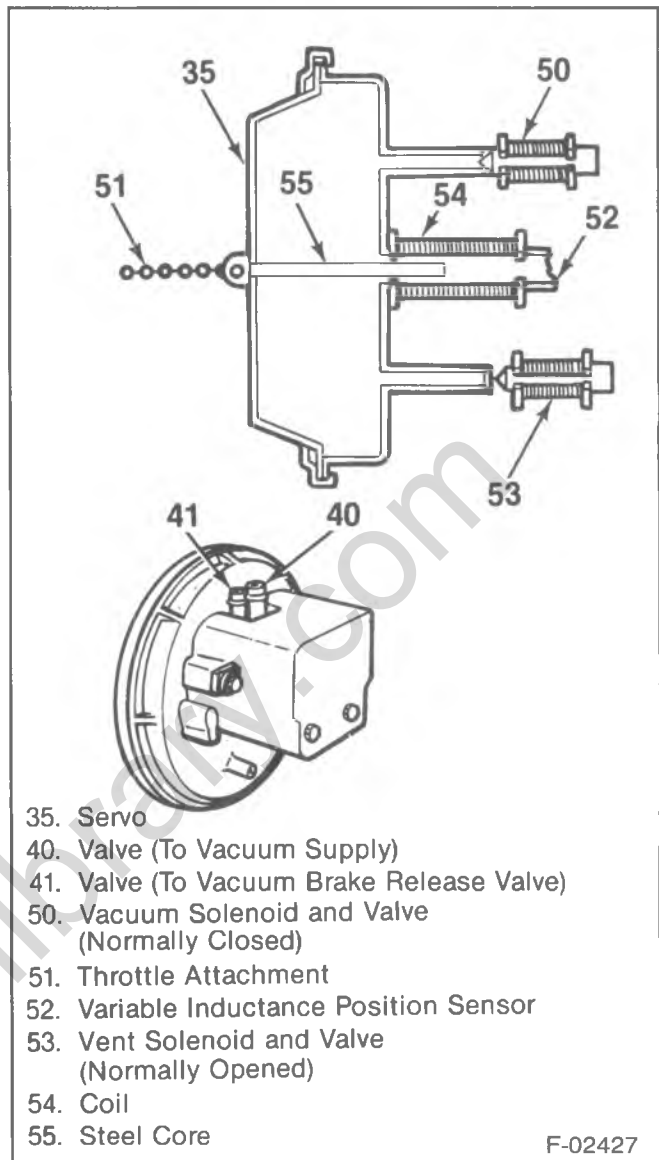

Figure 3—Servo Unit

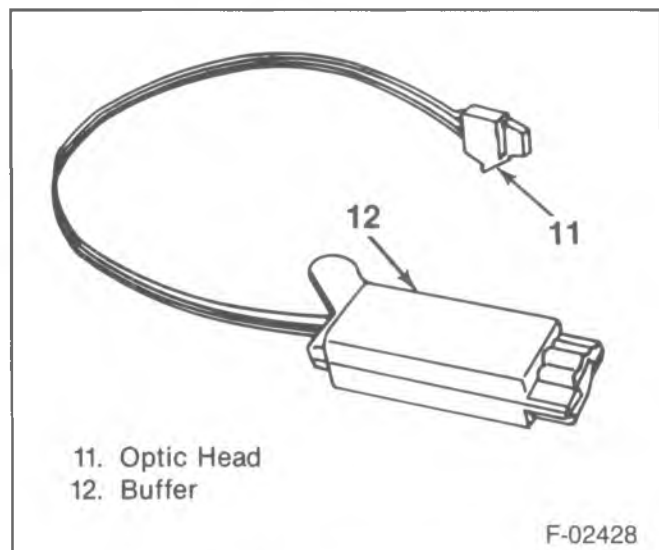

Figure 4—VSS (Vehicle Speed Sensor)

- **Vehicle Losing Speed** (due to steep grades or driver wishes to increase speed by operating mode control switches) — The controller energizes the vacuum solenoid to open the vacuum valve to the vacuum source. This increases the vacuum level in the servo to increase the throttle opening. The vent remains closed.
- **Vehicle Gaining Speed** (due to steep grades or driver wishes to decrease speed by operating mode control switches) — The controller de-energizes the vent solenoid to open the vent valve to the atmosphere which reduces vacuum in the servo and allows the throttle return spring to decrease the throttle opening. The vacuum valve remains closed.

When the cruise system is engaged and operating (without any interference from the driver via the mode control switches), no speed correction will be made until the vehicle exceeds approximately $\pm 1/4$ mph of set speed.

When the controller senses an over or underspeed condition it will pulse the opening of the vent or vacuum valve. The average duration of one pulse will be 10 milliseconds. The pulse will be repeated, as required, until the speed correction required brings the vehicle to the set speed. From any set speed, under normal road load conditions, the vacuum valve will remain in a completely open position when vehicle speed has dropped 5 mph below set speed. Likewise, when vehicle speed has exceeded 3 mph over the set speed, such as down a steep grade, the vent will go into constant open position.

The servo incorporates a steel core which moves within a coil. Its resulting variable inductance provides a continuous (voltage) servo position signal to the controller. This voltage signal is constantly compared to the vehicle speed signal. This comparison determines if the pulses issued have corrected the speed error or if additional pulses are required. This comparison is also used to lengthen the average pulse when it is not enough to compensate for the speed error, such as a steep grade.

The servo will go into an open vent valve position under the following conditions:

- When the brake (or clutch) pedal is depressed.

- An open variable inductance position sensor coil in the servo.
- A loss of electrical power to the system.
- The ignition is turned off.

SPEED SENSORS

VSS Buffer Amplifier (Figure 4)

This is the device that will supply the vehicle speed input to the controller. The optic head portion of the vehicle speed sensor (VSS) is located in the speedometer frame. A reflective blade is attached to the speedometer cable/head assembly. The reflective blade spins like a propeller, with its blades passing through a light beam from a L.E.D. in the optic head. As each blade enters the L.E.D. light beam, light is reflected back to a photocell in the optic head causing a low power speed signal to be sent to a buffer for amplification and signal conditioning. This amplified signal is then sent to the controller.

VACUUM SUPPLY

The vacuum supply to operate the cruise control system is routed to the servo. This can be done by routing manifold vacuum straight to the servo or from manifold through a vacuum storage tank.

ELECTRICAL AND VACUUM RELEASE SWITCHES

These switches are used to disengage the cruise control system. An electrical release switch mounted on the brake pedal bracket (and clutch pedal bracket on vehicles equipped with manual transmission) disengages the system electrically when the brake (or clutch) pedal is depressed. This is done by interrupting the flow of current to the controller. A vacuum release valve, mounted on the brake pedal bracket vents the trapped vacuum in the servo to atmosphere when the brake pedal is depressed, allowing the servo unit to more quickly retain the throttle to idle position. This is done by routing a separate hose directly to the servo from the normally closed vacuum switch. These two types of switches will also sometimes be combined with stop light switch, TCC (Torque Converter Clutch) switch, etc. Refer to Automatic Transmission (Sec. 7A) On-Vehicle Service in this section.

DIAGNOSIS OF CRUISE CONTROL SYSTEM

PROBLEM	POSSIBLE CAUSE	CORRECTION
Inoperative System (Electrical)	1. No power to module terminals "G" and "A" (figure 5).	1. Check, repair, adjust or replace the fuse, brake and clutch switches, turn signal lever, wires in the steering column.

DIAGNOSIS OF CRUISE CONTROL SYSTEM (CONT.)

PROBLEM	POSSIBLE CAUSE	CORRECTION
Inoperative System (Electrical) (Cont.)	<ol style="list-style-type: none"> 2. Open ground circuits to the module, servo or buffer. Module terminal J, H and servo terminal C. 3. Open leads to or at the servo terminals "B" and "D" (servo position sensor). 4. Open leads to or at servo terminals "A" and "E" (vent and vacuum circuits). 5. No high and low voltage signal at the module speed sender terminal "D." 6. Incorrect input signals to the module, Set/Coast or Resume/Accelerate terminals (figure 8). 7. Poor connections at the module. 8. Cruise control module. 	<ol style="list-style-type: none"> 2. Check the ground circuits for loose or broken connections. Clean and repair as needed. 3. Repair the leads or replace the servo (figures 6 and 7). 4. Repair the leads or replace the servo. 5. Check, repair, replace: open leads, bad printed circuit foil at the cluster, bad buffer amplifier, terminal "B" of servo to "B" of buffer, ground for buffer, foreign material or grease in speedometer head. 6. Check, repair, replace: open leads, open connector, bad turn signal lever and terminal in the proper cavity. 7. Clean, repair the module connector as needed. 8. Replace the module.
Inoperative System (Mechanical)	<ol style="list-style-type: none"> 1. No vacuum at the small hose to the servo. 2. Cocked servo position rod and spring. Leaky servo, broken fittings, and/or inoperative valves. 3. Disconnected servo linkage. 4. Misadjusted or leaky vacuum release valve or hose. 	<ol style="list-style-type: none"> 1. Check for plugged, pinched, disconnected vacuum hoses, incorrectly positioned 3-port or 2-port check valve, restricted engine vacuum fitting. 2. Replace the servo. Replace the servo. 3. Reconnect. 4. Check for leak in vacuum release hose or valve or misadjusted vacuum dump switch.
Vehicle Surges (Electrical)	<ol style="list-style-type: none"> 1. Intermittent ground. 2. Intermittent open in the vacuum, vent, SPS (Servo Position Sensor) leads or connectors or terminals or servo. 3. Spikes on the positive battery line (Transient). 4. Turn signal, radio or other electrical device interference. 5. Wrong module part number. 6. Crossed vacuum and vent electrical leads between the module and servo. 	<ol style="list-style-type: none"> 1. Check for poor grounding to the servo module, VSS (Vehicle Speed Sensor) buffer. If chassis ground is suspect, attach a new ground strap between the cowl and engine block. Retorque all ground connections. 2. Do a physical and an electrical inspection as shown in the test charts. 3. Check for any hot wires intermittently making contact with chassis ground. Repair as required. 4. Reposition electrical leads away from cruise or VSS (Vehicle Speed Sensor) buffer leads. Check for poor grounds. If no defect is found, replace the module. 5. Replace the module with a correct part number. 6. Rewire.

DIAGNOSIS OF CRUISE CONTROL SYSTEM (CONT.)

PROBLEM	POSSIBLE CAUSE	CORRECTION
Vehicle Surges (Mechanical)	<ol style="list-style-type: none"> 1. Excess slack in servo linkage. 2. Servo valve sticking. 3. Misadjusted or leaky vacuum release valve or hose. 4. Dry or overlubed speedo cable. 5. Speedometer pointer shake: <ul style="list-style-type: none"> — Due to misrouted speedometer cable and casing assembly. — Transmission speedometer drive or driven gear. 6. Restricted (kinked or leaking) vacuum supply hose to accumulator or servo. 7. Binding servo linkage due to interference, rust, etc. 8. Misadjusted or leaky vacuum release valve or hose. 9. Grease or foreign material in speedo head. 10. Torque converter clutch cutting in and out, or transmission shifting. 11. Engine cuts in and out due to mixture ignition problem. 12. Incorrectly positioned 3 port or 2 port check valve. 	<ol style="list-style-type: none"> 1. Adjust to requirements outlined in the On-Vehicle Service portion in this section. 2. Replace the servo. 3. Check for leak in vacuum release hose, or valve, or misadjusted vacuum dump valve. 4. Lubricate to specifications. 5. Reroute or replace the cable and assembly. <ul style="list-style-type: none"> — Replace component. 6. Inspect hoses and reposition as required. 7. Repair or replace. 8. Check for leak in the vacuum release hose or valve, or misadjusted vacuum dump switch. 9. Clean or replace. 10. (Not a cruise problem.) Check TV cable adjustment on the transmission. Refer to section 7A. 11. Repair and/or adjust as required. 12. Make correction.
Cruise Set Speed	<ol style="list-style-type: none"> 1. Excess slack in servo linkage. 2. Incorrect module part number usage. 	<ol style="list-style-type: none"> 1. Adjust to requirements outlined in the On-Vehicle Service portion in this section. 2. Install a modual with the correct part number. 3. Replace.
No Resume Function	<ol style="list-style-type: none"> 1. Incorrect operator technique. (If R/A is held down for more than 1 second, the system reverts to the accelerator mode. The speed at the time of release is the new cruise speed). 2. Open connection at terminal "A" of the module or the terminal is in the wrong cavity. 3. Cruise control module. 4. Intermittent On/Off Switch. 	<ol style="list-style-type: none"> 1. Advise the operator. 2. Repair. 3. Replace. 4. Replace.
No "Tap Down" Function	<ol style="list-style-type: none"> 1. Incorrect operator technique. (Set/Coast switch held down in excess of .4 seconds resets speed when the Set/Coast is released). 	<ol style="list-style-type: none"> 1. Advise operator.

DIAGNOSIS OF CRUISE CONTROL SYSTEM (CONT.)

PROBLEM	POSSIBLE CAUSE	CORRECTION
Unwanted Cruise or Acceleration	<ol style="list-style-type: none"> 1. Crossed vacuum and vent wires. 2. Defective or intermittent turn signal mode control switches. 3. Sticking valves in the servo. 4. Binding throttle linkage due to interference, rust or other contaminants. 5. Grease in the speedometer head. 6. Floor mat interference. 7. Loose retainer on the bail of the servo. 8. Ground circuit. 9. Speed sensor buffer. 10. Incorrect module. 	<ol style="list-style-type: none"> 1. Rewire. 2. Replace the lever. 3. Replace servo. 4. Correct as required. 5. Service speedometer. 6. Reposition as required. 7. Replace servo. 8. Clean and repair as required. 9. Replace. 10. Replace.
Cruise Disengages While Tapping Down	Cruise control module.	Replace module.
Occasional Missed Cruise "Sets"	Cruise control module.	Replace module.

ON-VEHICLE SERVICE

VACUUM RELEASE VALVE REPLACEMENT

CLUTCH RELEASE SWITCH REPLACEMENT

↔ Remove or Disconnect (Figure 9)

1. Instrument panel harness connector (8).
2. Vacuum lines (10).
3. Retainer (12). Turn the retainer counterclockwise to unseat it.
4. Vacuum release valve.

→← Install or Connect (Figure 9)

1. Retainer (12). Turn the retainer clockwise to seat it.
2. Vacuum release valve (9 or 11) until it is seated on the retainer, with the brake pedal in the depressed position.
 - Note that audible "clicks" can be heard as the threaded portion of the valve is pushed through the retainer toward the brake pedal.
 - Pull the brake pedal fully rearward against the pedal stop, until the audible "click" sounds can no longer be heard.
 - Release the brake pedal and repeat step 2 to assure that no audible "click" sounds remain.
3. Vacuum lines (10).
4. Instrument panel harness connector (8).

↔ Remove or Disconnect (Figure 10)

1. Connector (98).
2. Retainer (102). Turn the retainer counterclockwise to unseat it.
3. Clutch release switch (99).

→← Install or Connect (Figure 10)

1. Retainer (102). Line up the notches on the clutch pedal bracket (101) to the retainer.
2. Clutch release switch (99) until it is seated on the retainer, with the brake pedal in the depressed position.
 - Note that audible "clicks" can be heard as the threaded portion of the valve is pushed through the retainer toward the brake pedal.
 - Pull the brake pedal fully rearward against the pedal stop, until the audible "click" sounds can no longer be heard.
 - Release the brake pedal and repeat step 2 to assure that no audible "click" sounds remain.
3. Connector (98).

VOLTAGE CHECK — MODULE CONNECTED

TEST	TERMINAL	FUNCTION	SPECIFIED VOLTAGE TO GROUND	CONDITIONS
V ₁	G	Brake Input	12V 0V	Brake/Clutch Not Applied Brake/Clutch Applied
V ₂	A	Cruise On-Off Input	12V 0V	Slider Switch On Slider Switch Off, Set/Coast Depressed or Normal
V ₃	M	Resume/Accel Input	12V 0V 0V	Slider Switch in R/A Position Slide Switch On, Set/Coast Depressed or Normal Slider Switch Off, Set/Coast Depressed or Normal
V ₄	L	Set/Coast Input	12V 0V	Slider Switch On, Set/Coast Depressed Slider Switch Off, Set/Coast Normal
V ₅	B	Cruise Lamp	12V	Cruise Engaged
V ₆	D	Speed Signal	Greater than 4V High, Near 0V Low	Drive Wheels Rotating on Applications Listed

RESISTANCE CHECK — MODULE DISCONNECTED

TEST	TERMINAL	FUNCTION	SPECIFIED RESISTANCE	CONDITIONS
R ₆	C to Ground	Vent Valve Control	30-55 Open Circuit	Measured to Ground, Servo Connected Measured to Ground, Servo Disconnected
R ₂	F to H F to Ground H to Ground	SPS High, SPS Low	15-25 Open Circuit	Measured F to H, Servo Connected Measured F and H to Ground, Servo Disconnected
R ₃	K to Ground	Vacuum Valve Control	30-55 Open Circuit	Measured to Ground, Servo Connected Measured to Ground, Servo Disconnected
R ₄	J to Ground	Ground	0	Measured to Vehicle Ground

Figure 5—Control Module Validation Test

• SERVO CONNECTOR DISCONNECTED • MEASURE AT SERVO PINS

PIN	FUNCTION	RESISTANCE	CONDITIONS
D to B	SPS	15-25 Ω	MEASURED BETWEEN PINS D AND B (IF MEASURED RESISTANCE IS NOT STATED VALUE, REPLACE SERVO)
A to C	VENT VALVE	30-55 Ω	MEASURED BETWEEN PINS A AND C (IF MEASURED RESISTANCE IS NOT STATED VALUE, REPLACE SERVO)
E to C	VACUUM VALVE	30-55 Ω	MEASURED BETWEEN PINS E AND C (IF MEASURED RESISTANCE IS NOT STATED VALUE, REPLACE SERVO)

4. Multi-meter
5. Servo
6. Servo Connector

B-07644

Figure 6—Servo Resistance Measurement

CRUISE CONTROL MODULE REPLACEMENT

→ Install or Connect (Figure 11)

1. Module assembly (116).
2. Harness connector (121).

← Remove or Disconnect (Figure 11)

1. Harness connector (121).
2. Module assembly (116) by prying back the retaining clip on the bracket and sliding the module out.

Test	Action	Reaction
1	Apply 12 volts to A and E, then ground C (A-C closes the normally open vent valve — E-C opens the normally closed vacuum valve).	Servo should full stroke. If not, check vacuum hoses to the vacuum supply.
2	Remove voltage from E	The servo should hold a full stroke. If not, go to the next step. If servo holds, go to step 4.
3	Disconnect the vacuum brake release at the servo and plug the servo. Momentarily apply 12 volts to E to allow the servo to full stroke.	If the servo holds its position, adjust the brake vacuum release valve or replace the valve. See On-Vehicle Service in this section.
4	<ul style="list-style-type: none"> • Turn Ignition "ON" • Turn Ignition "OFF" and disconnect vacuum valve connector at the valve. Turn Ignition "ON." 	<ul style="list-style-type: none"> • Vacuum release valve should engage. • With a properly adjusted brake switch, battery voltage should be present across the (2) connector terminals. No battery voltage indicates an open circuit.

F-02436

Figure 7—Vacuum Servo Test

SET/COAST (S/C) SW	POSITION SLIDER	1-2 C-B	1-3 C-D	1-4 C-A	2-3 B-D	2-4 B-A	3-4 D-A
Normal	Off	O	O	O	O	O	O
Normal	On	O	O	O	O	C	O
Normal	R/A	C	O	C	O	C	O
Depressed	Off	O	O	O	C	O	O
Depressed	On	O	O	O	C	C	C
Depressed	R/A	C	C	C	C	C	C

C — Closed
O — Open

- A. Blue
- B. Green
- C. Yellow
- D. Red

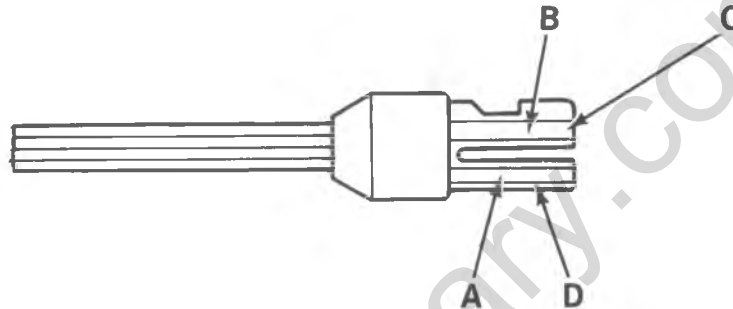

F-02437

Figure 8—Mode Control Test

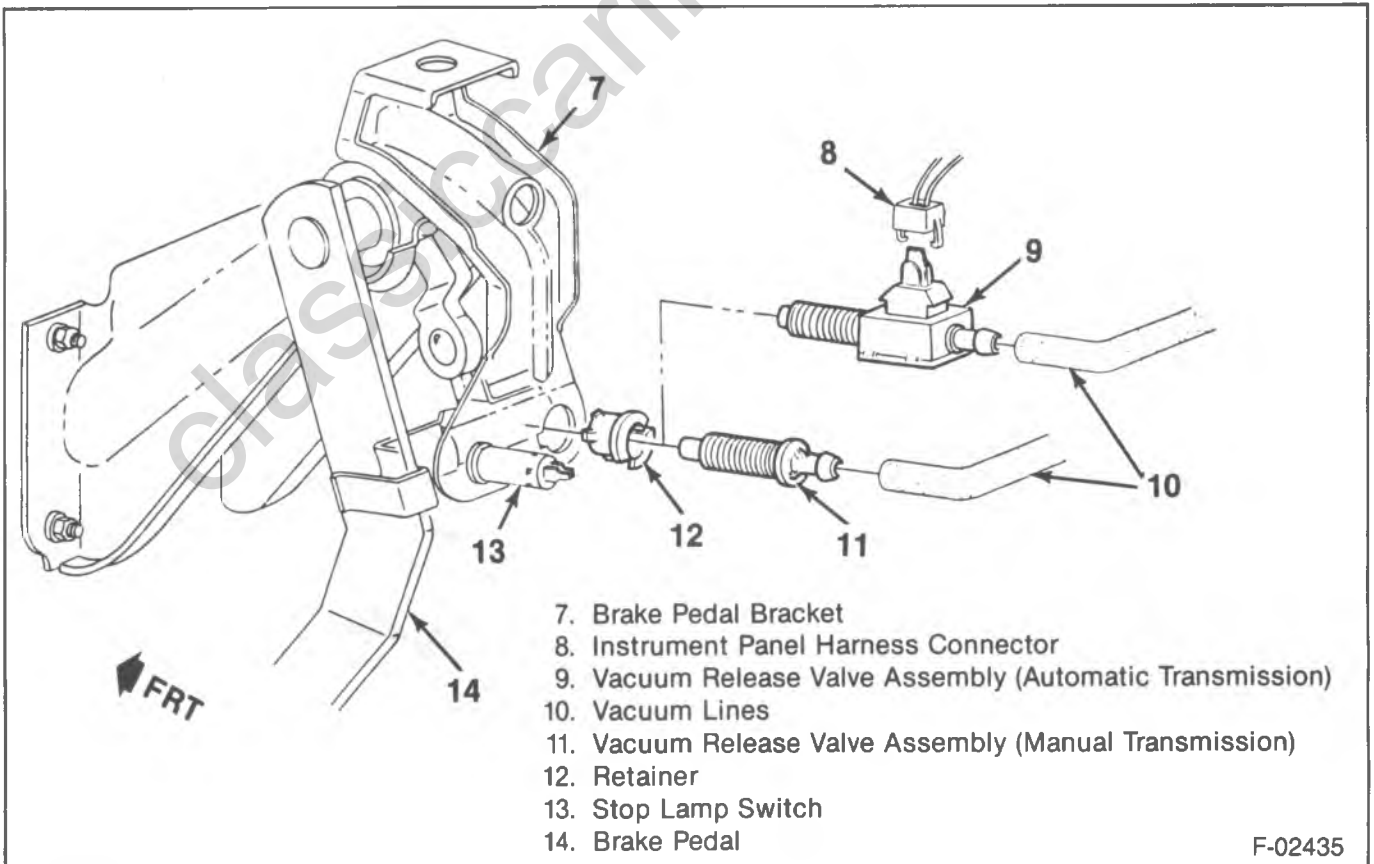

- 7. Brake Pedal Bracket
- 8. Instrument Panel Harness Connector
- 9. Vacuum Release Valve Assembly (Automatic Transmission)
- 10. Vacuum Lines
- 11. Vacuum Release Valve Assembly (Manual Transmission)
- 12. Retainer
- 13. Stop Lamp Switch
- 14. Brake Pedal

F-02435

Figure 9—Vacuum Release Valve

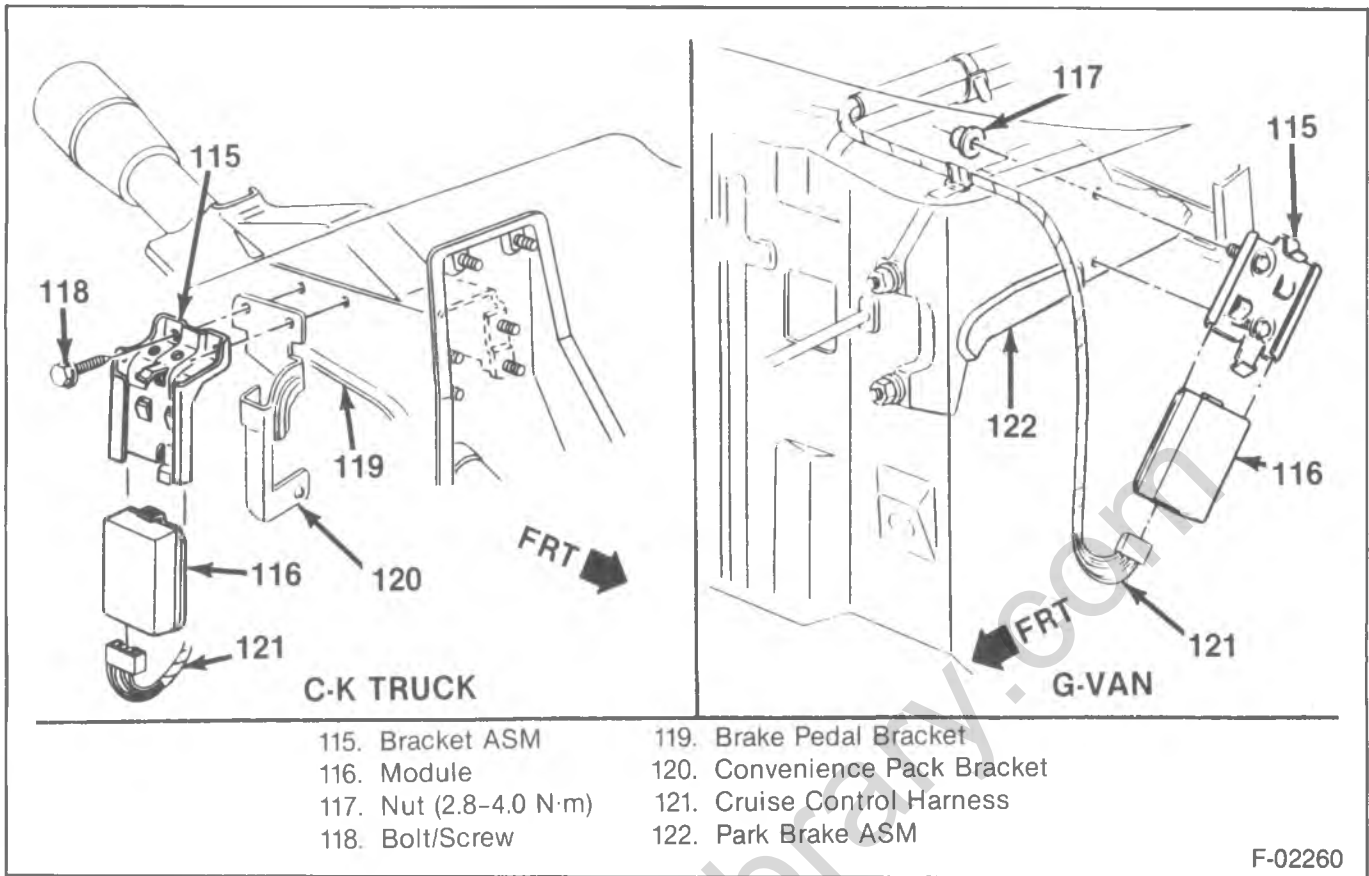

Figure 10—Clutch Release Switch

MULTI-FUNCTION SWITCH REPLACEMENT

↔ Remove or Disconnect (Figure 12)

1. Protector cover (26).
2. Multi-function switch (24).
3. Cruise control wire (27).

↔ Install or Connect (Figure 12)

1. Cruise control wire (27) with the use of a piano wire.
2. Multi-function switch (24).
3. Protector cover (26).

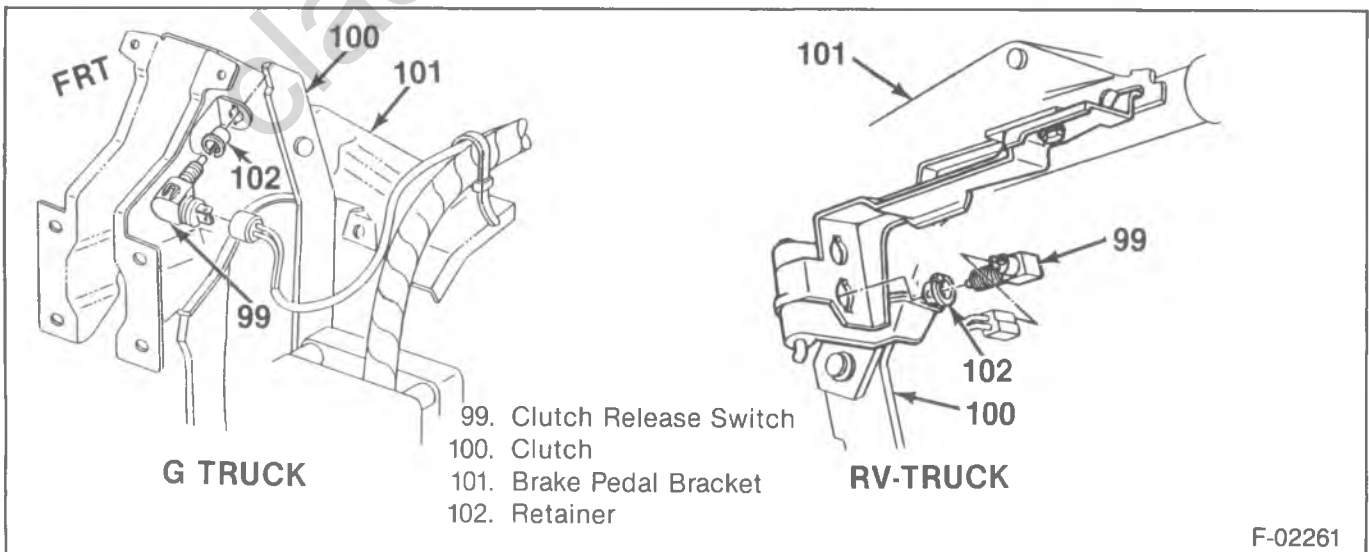

Figure 11—Controller Module Mounting

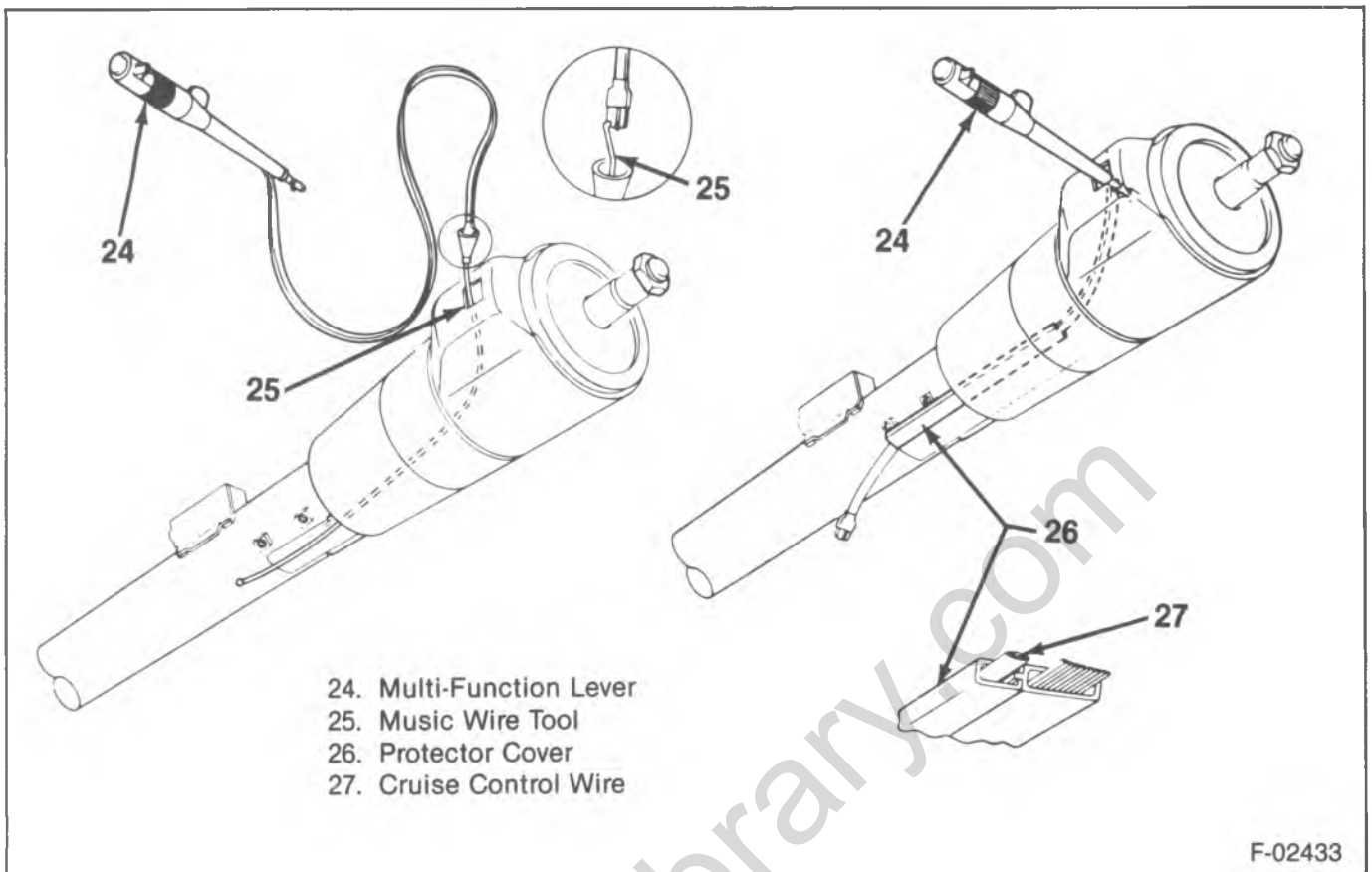

Figure 12—Multi-Function Lever Replacement

SERVO REPLACEMENT

↔ Remove or Disconnect (Figures 13 through 16)

1. Vacuum hoses (39) and hose assembly (49).
2. Retainer (34).
3. Rod (33).
4. Cruise cable assembly (50) (figure 16).
5. Bolts (36) and servo (35).

NOTICE: Flexible components (hoses, wires, conduits, etc.) must not be routed within 50 mm (2 inches) of moving parts of the accelerator linkage forward of the servo assembly unless routing is positively controlled.

→ Install or Connect (Figures 13 through 16)

1. Servo (35).
2. Bolts (36).
 - Ignition and fast idle cam should be off and the throttle should be fully closed before starting the adjustment procedure.
3. Cruise cable assembly (50).
4. Rod (33).

🔑 Adjust

- Rod (33) so that it assembles over stud (32) (figure 14).
 - Cruise cable assembly (50) to the third ball on the servo chain (figure 16).
 - Jam nut (53) until the cable sleeve at the throttle lever is tight but not holding the throttle open (figure 16).
5. Retainer (34).
 6. Vacuum hoses (39) and hose assembly (49). Refer to figures 17 through 20 for hose routings.

9-12 ACCESSORIES

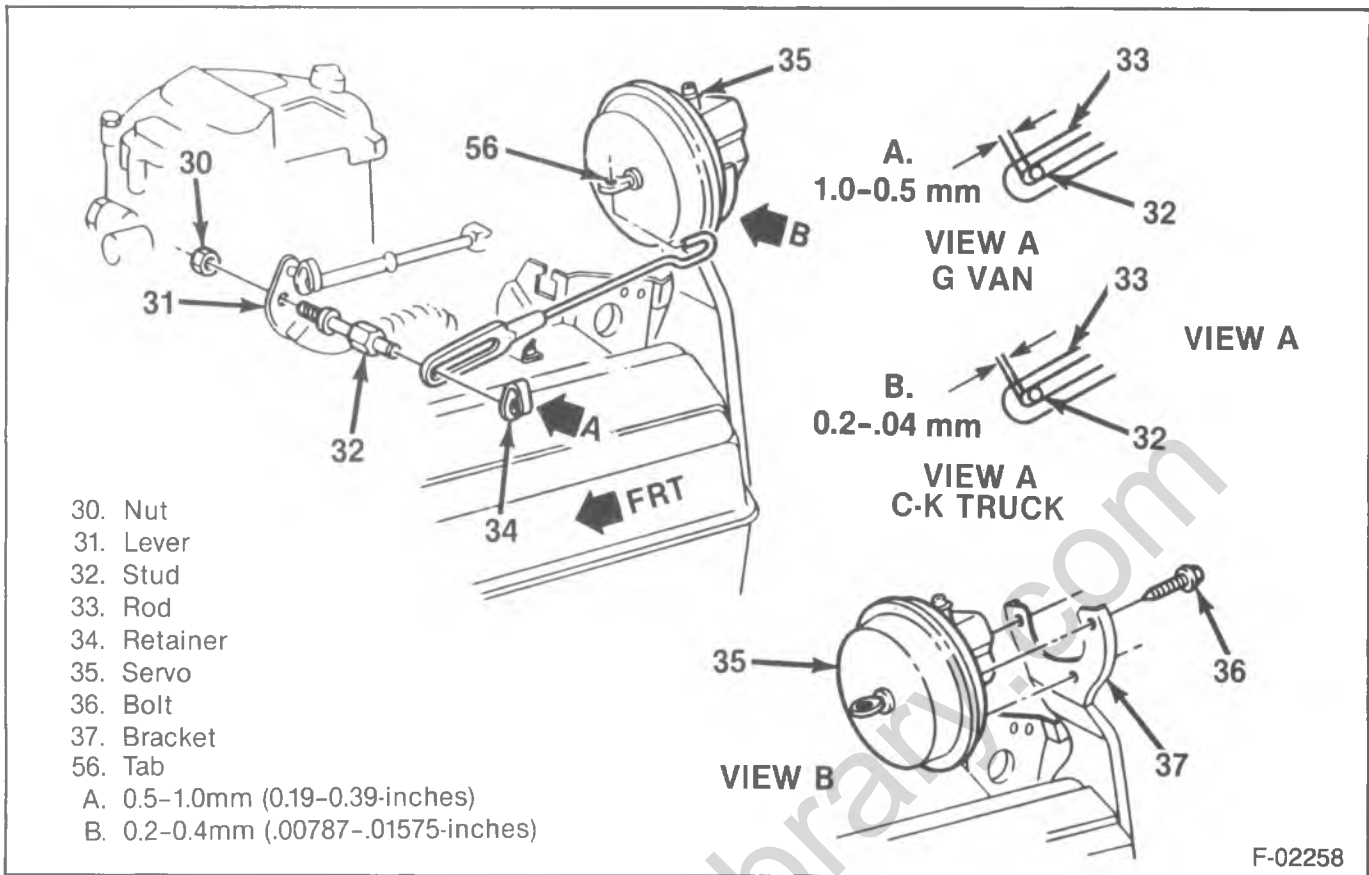

Figure 13—Servo Mounting (V6 Gas)

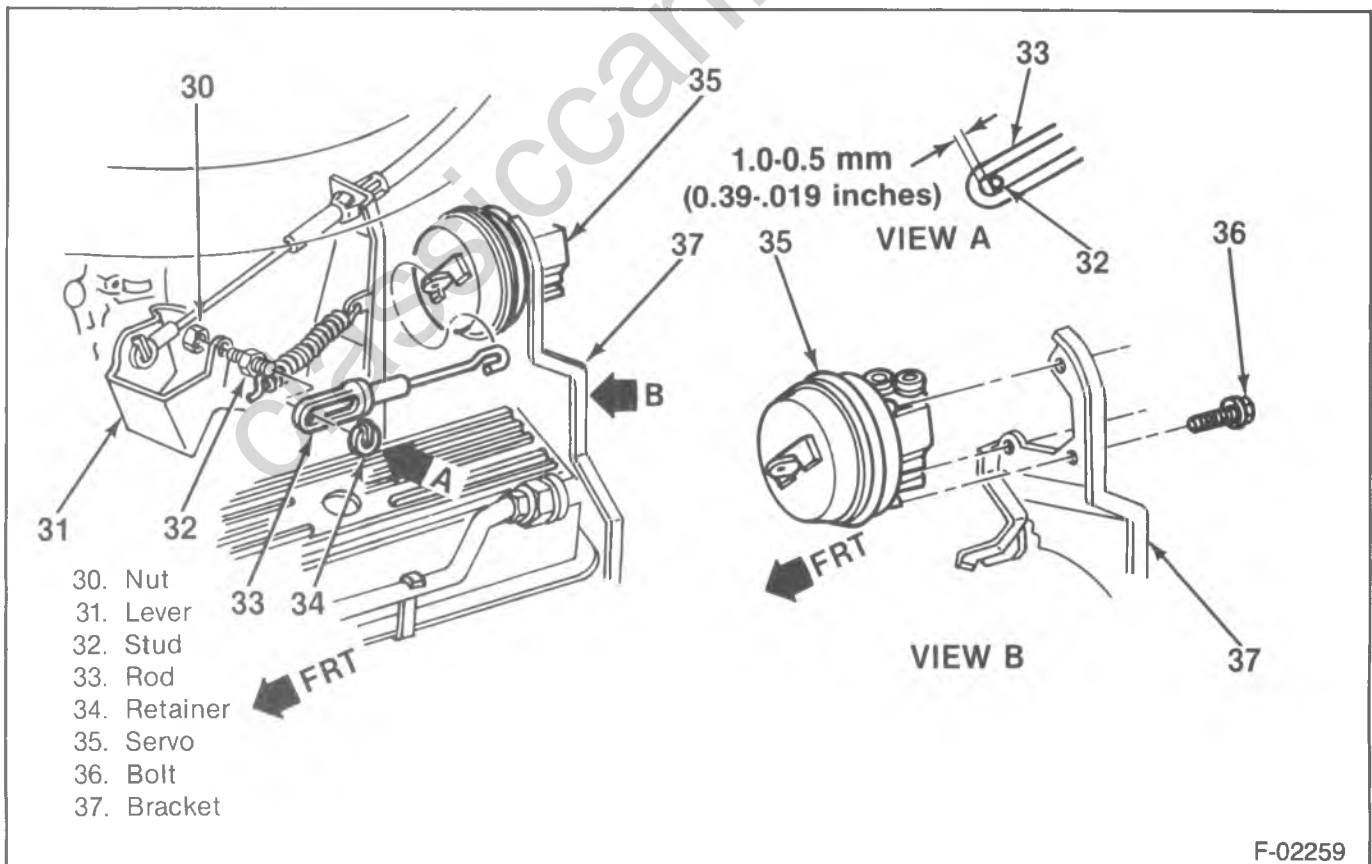

Figure 14—Servo Mounting (V8 Gas)

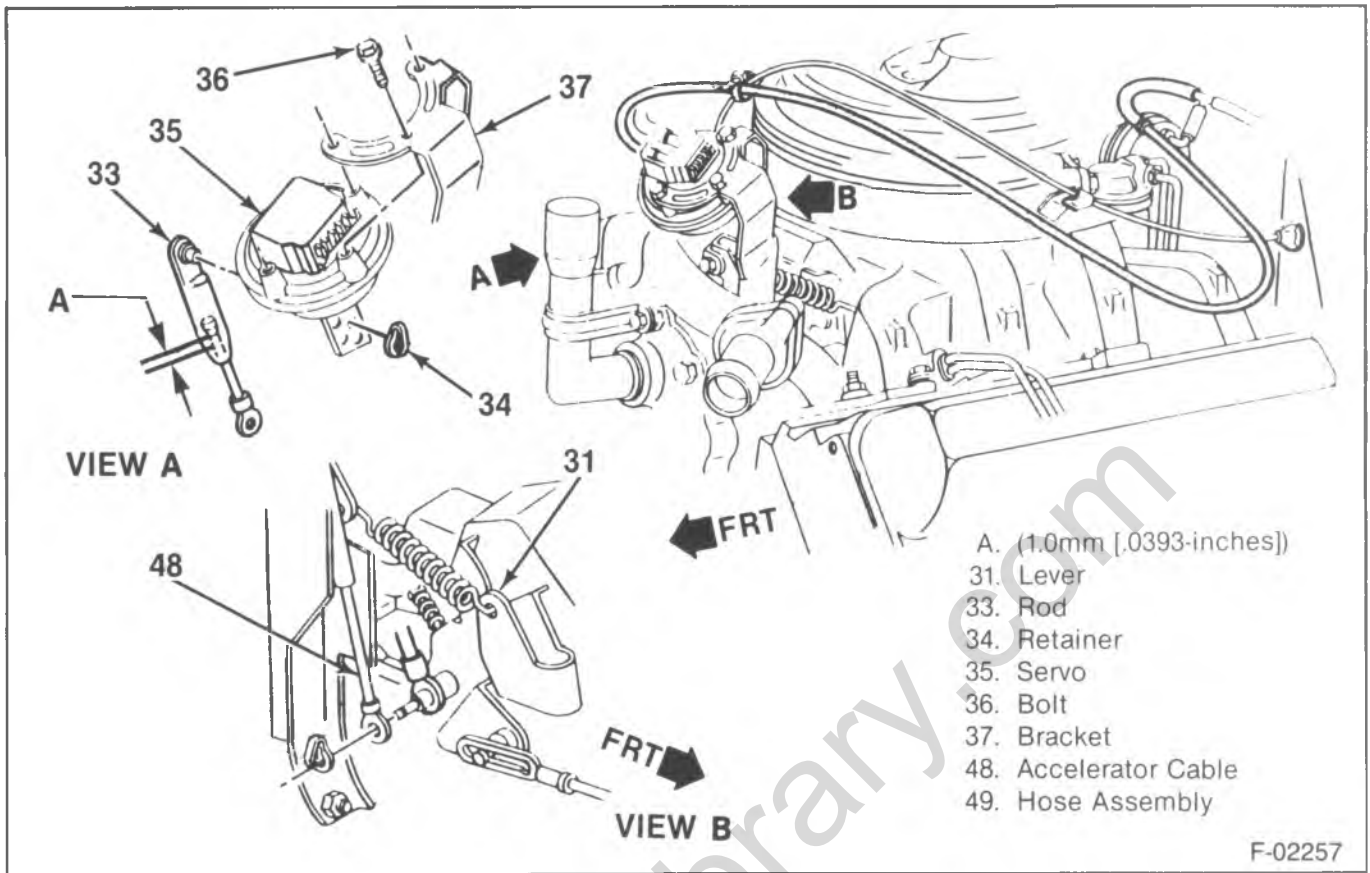

Figure 15—Servo Mounting (RV Diesel)

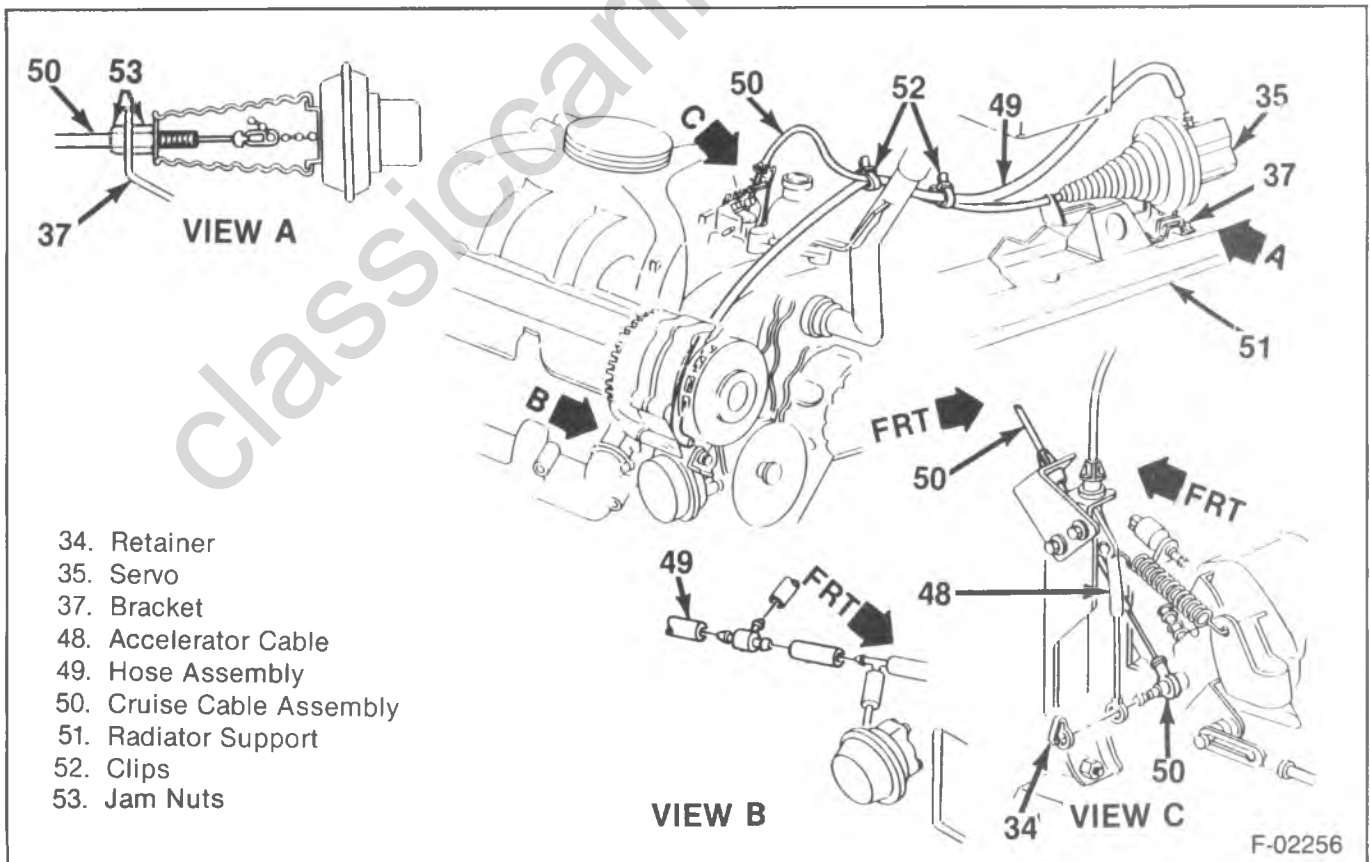

Figure 16—Servo Mounting (G-Van Diesel)

9-14 ACCESSORIES

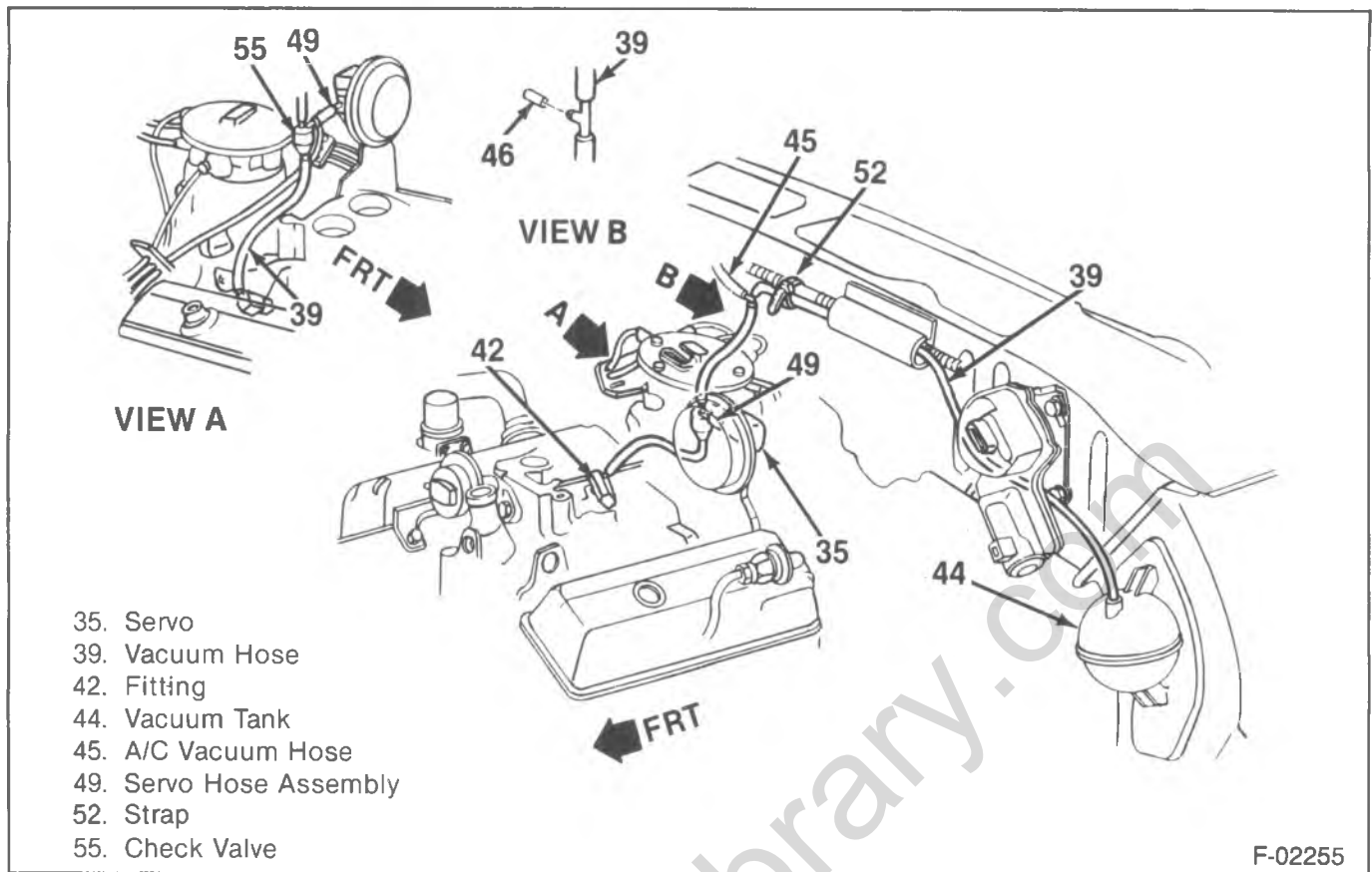

Figure 17—Vacuum Hose Routing (RV-Truck V6)

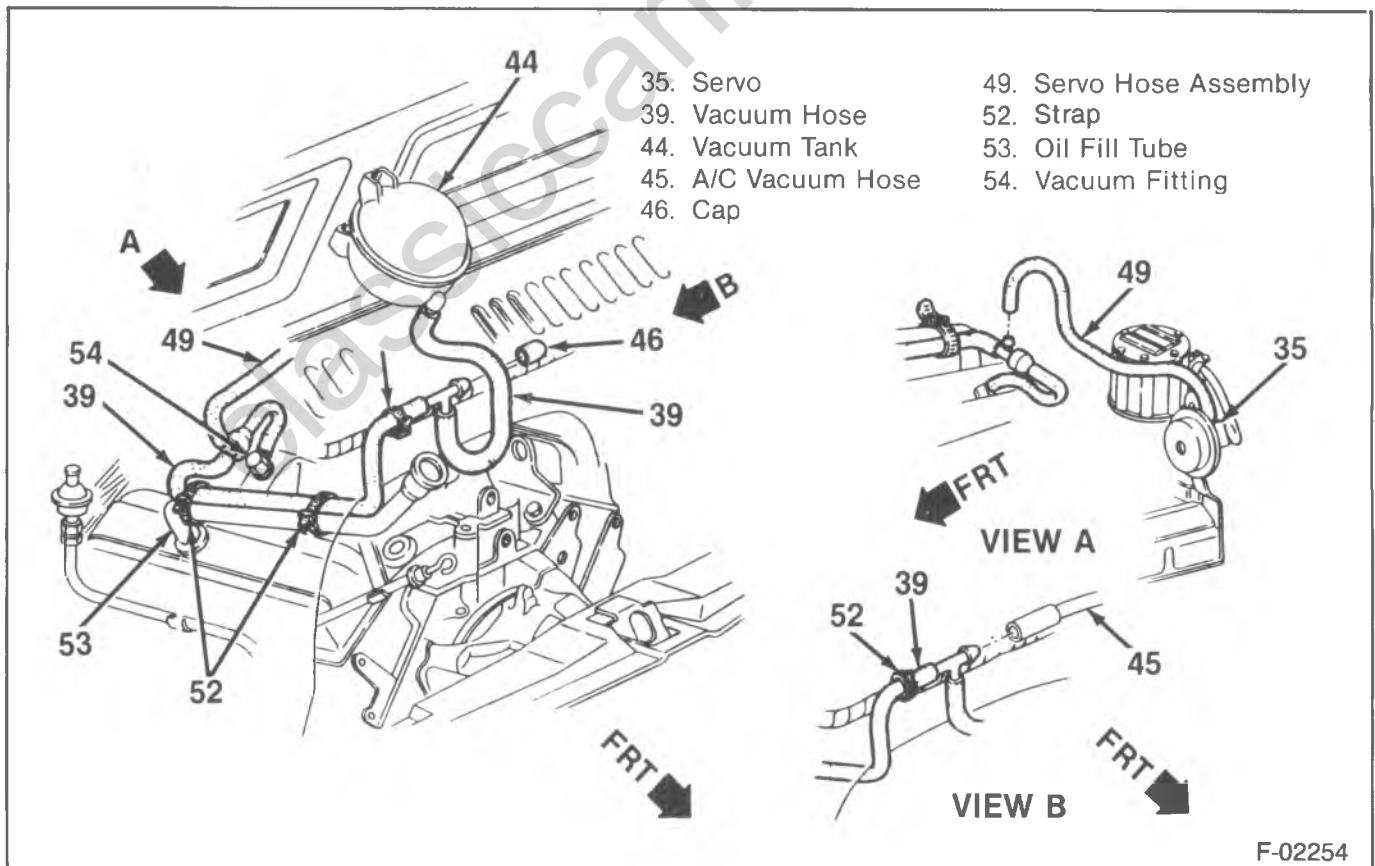
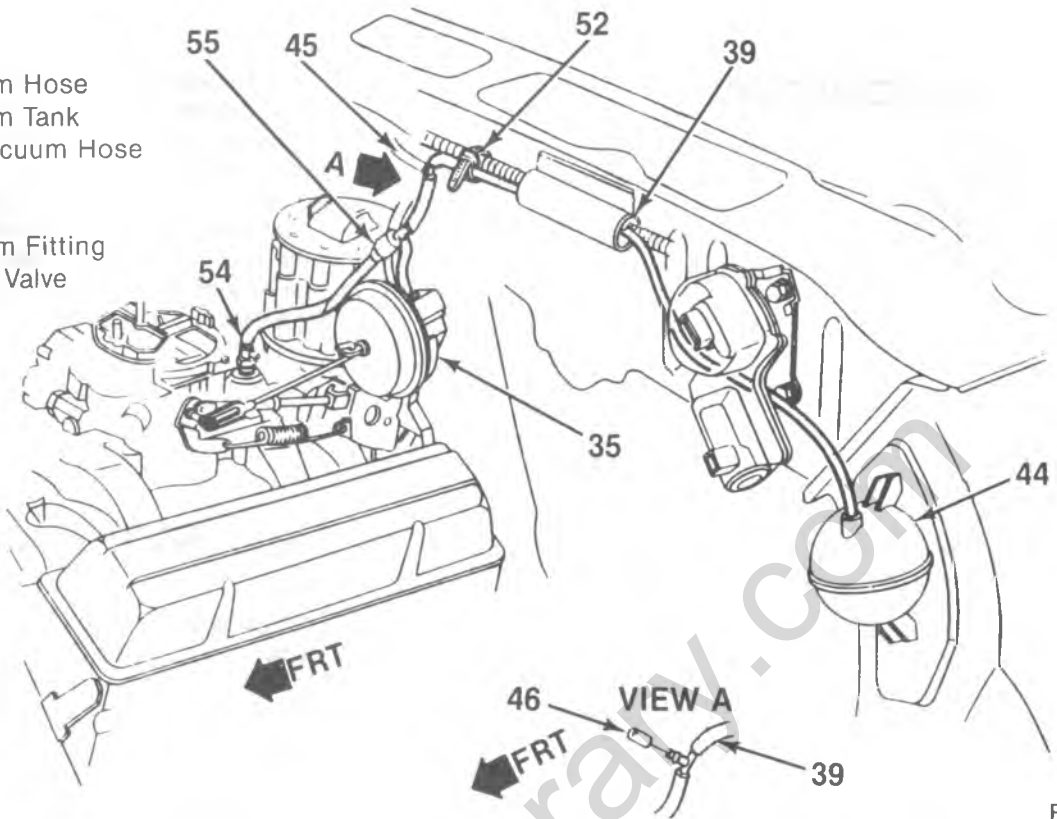

Figure 18—Vacuum Hose Routing (G-Van V6)

- 35. Servo
- 39. Vacuum Hose
- 44. Vacuum Tank
- 45. A/C Vacuum Hose
- 46. Cap
- 52. Strap
- 54. Vacuum Fitting
- 55. Check Valve



F-02400

Figure 19—Vacuum Hose Routing RV-Truck (V8 Gas)

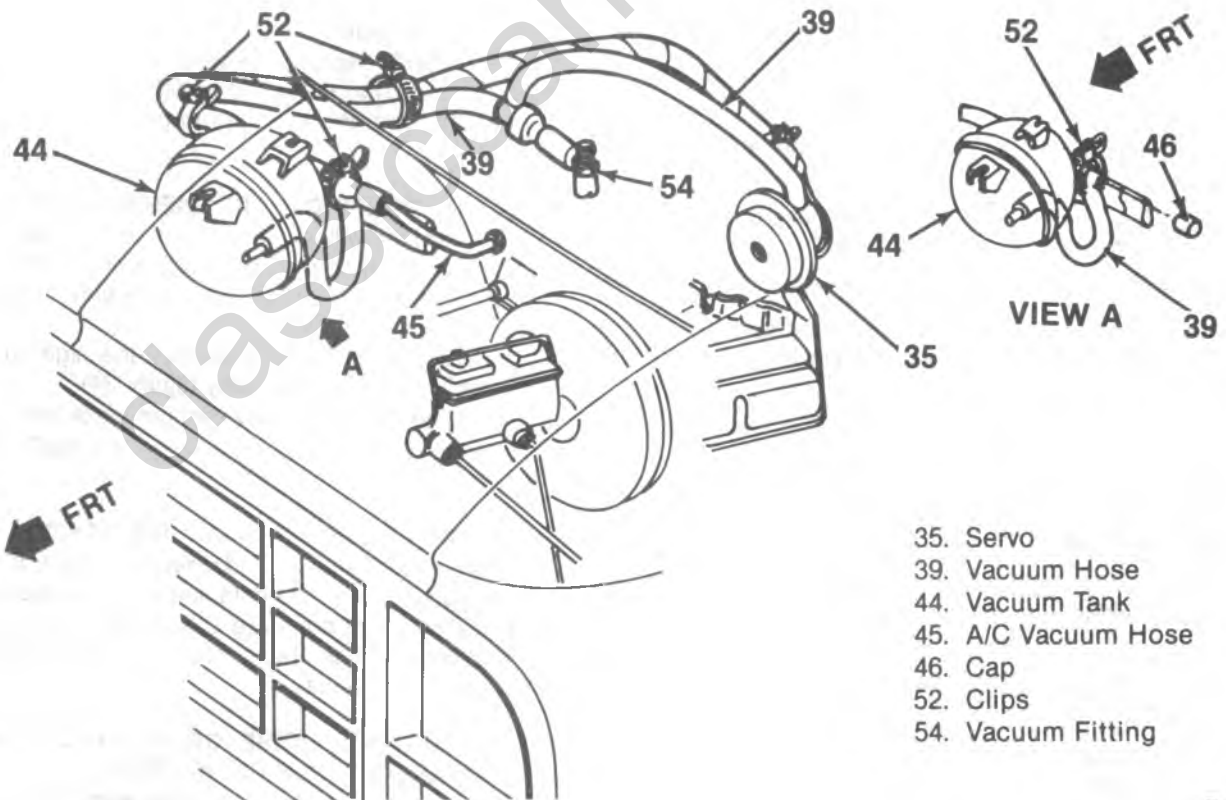

- 35. Servo
- 39. Vacuum Hose
- 44. Vacuum Tank
- 45. A/C Vacuum Hose
- 46. Cap
- 52. Clips
- 54. Vacuum Fitting

F-02541

Figure 20—Vacuum Hose Routing G-Van (V8 Gas)

RADIO

DESCRIPTION

For operation of the factory installed standard and optional radios available, refer to the Owner's Manual or radio supplement supplied with the vehicle.

The receiver is mounted using the front support tubes surrounding the control shafts, and a rear support

bracket. The front support tubes are secured with nuts. The rear support bracket is secured with a screw.

The power, antenna, and speaker harnesses connect to the rear of the receiver.

Depending on the system, the speakers can be mounted at the center or end of the dash, in the side panels or in the rear corners of the cab.

The antenna may be mounted in the windshield, or on the right front corner of the vehicle.

DIAGNOSIS

Since radio problems are most often repaired at authorized warranty repair stations, the tendency is to remove the set when a problem is reported, without any preliminary diagnosis. This results in a large number of radios showing up as "NO TROUBLE FOUND" units when received by the warranty repair stations. Many times, when this is the case, the trouble usually could have been corrected without removal of the radio, such as noise complaints.

The inconvenience of driving without a radio, while the set is being serviced at a warranty repair station, can frequently be avoided if the following quick checks are used to eliminate external radio system problems before removing the radio for repair:

- Test the radios outside, with the hood down.
- Most noise can be found on weak "AM" stations near the low frequency and end of the band
- Ignition noise on FM indicates a possible faulty HEI system.
- If a test antenna is used, ground the base to the car body and **DO NOT HOLD THE MAST.**
- 90% of the noises enter via the antenna.
- A small amount of ignition noise may be normal when the HEI is located near the cowl (windshield antennas only).
- Coated screws or bolts **CAN** act as a poor ground.
- Windshield antennas are more prone to noise and station directivity.
- Most hoses are conductive unless they have a white stripe.
- When shielding the dash, wire, hose, etc., use foil or screen and ground it.
- Weak or fading "AM" is often caused by improperly adjusted antenna trimmer (when present).

Always determine the exact nature of the radio problem as an aid to diagnosis. Knowing whether the condition is intermittent or constant, whether it occurs with engine off or running, and whether it occurs with car stationary or moving, will help to pinpoint the problem. Use Chart 1 to isolate radio problems, then proceed to the diagnostic charts.

ACCESSORY NOISE

BLOWER MOTOR NOISE (Figure 32)

Install a blower motor feed through capacitor. Attach one end to the blower motor and the other end to the hot lead from the blower motor switch. Also, ground the capacitor ground tab.

BLOWER SWITCH POP (HIGH SETTING TO OFF)

Install a diode (diode number IN4001, or the equivalent diode to withstand a 50V inverse peak voltage) from the high speed switch wire (orange) to ground on the high speed blower relay under the hood.

BRAKE SWITCH POP

Install a 0.5 MFD capacitor between the two wires going to the brake switch at the brake pedal. Also, install a 0.5 MFD capacitor from the 14V lead to ground at the brake switch.

CLICKING OR POPPING NOISE (DIESEL ENGINE)

- 1) The problem will sound similar to ignition noise. However, it won't vary with engine speed. Also the noise will most likely be noticeable only in the idle condition.
- 2) The noise is being generated by the high vacuum switch in the EGR assembly (figure 34).
- 3) Check the system for any vacuum leaks and repair.
- 4) If the noise still remains, change the EGR control assembly.

CRUISE CONTROL POP (TRANSDUCER TYPE)

For cruise control engage and disengage pops, install a 0.5 MFD capacitor from the hold line at the transducer to ground. If disengage pops are still present, splice a 0.5 MFD capacitor across the contacts of the disengage switch at the brake pedal.

HORN BLOW-THRU NOISE OR HASH (STATIC IN RADIO SPEAKERS WHEN USING HORN)

Splice blower motor capacitors into each lead. Install the capacitors as close to the horn as possible. Ground the case of the capacitor to chassis ground using the metal ground tab on the capacitor. The technician should solder all connections instead of using quick connects.

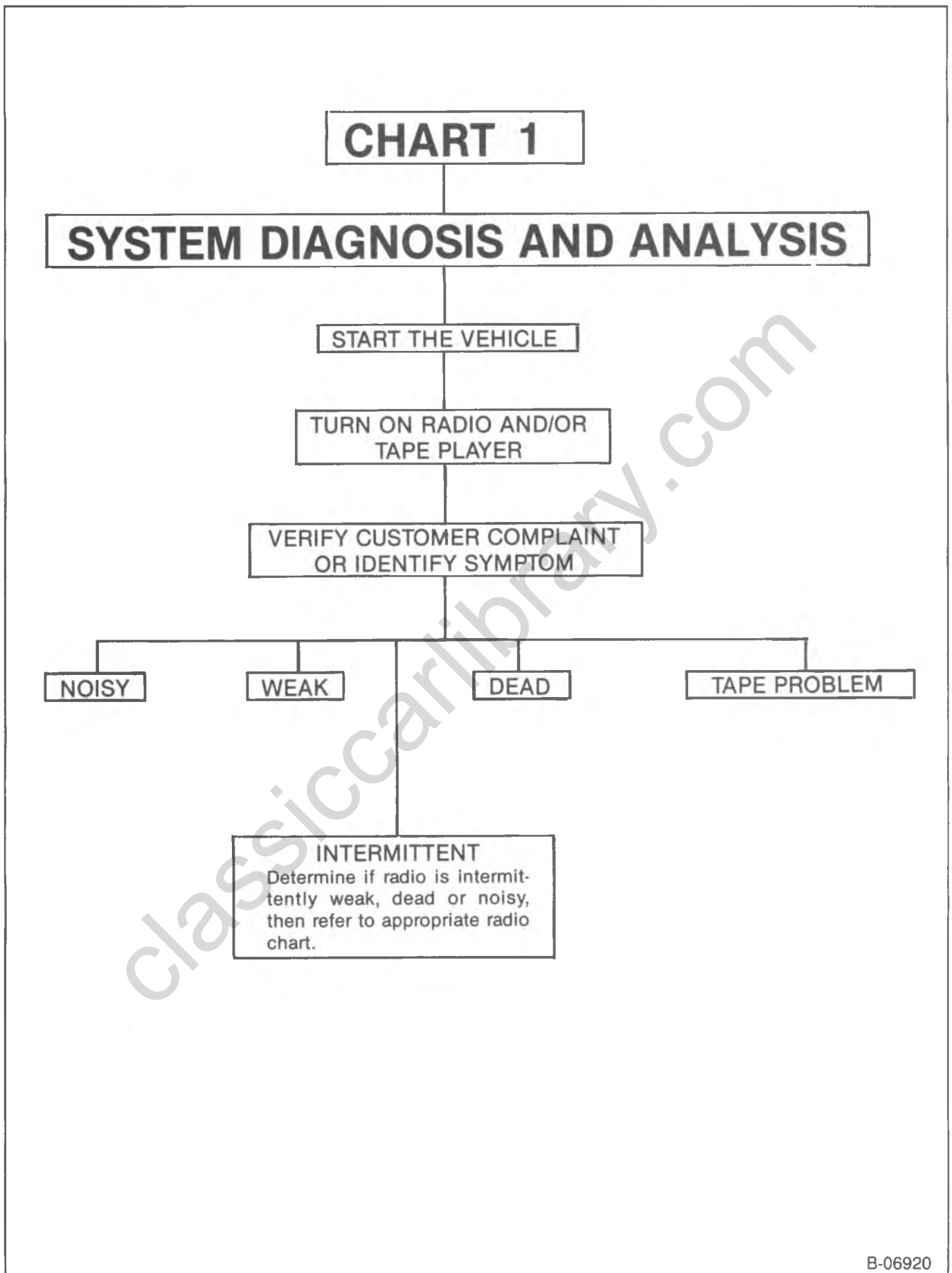

B-06920

Figure 21—Chart 1 (System Diagnosis & Analysis)

CHART 2

NOISY - PART 1

Check for the noise in each of the following three positions:

1. Accessory (all electrical accessories OFF)
2. Ignition on (engine NOT running)
3. Engine started

If the noise is ONE switch pop, go immediately to the ACCESSORY NOISE chart. For MORE THAN one switch pop, go to the ANTENNA chart.

If the noise occurs in position 1, substitute a known good radio. If it plays fine, send the faulty unit to an authorized repair shop.

If the noise occurs in position 2, it is possibly related to the ECM or digital dash. Go to the ECM OR DIGITAL DASH NOISE chart.

If the noise occurs in position 3, continue on this chart.

Measure the ground from the case of the radio to the accelerator mounting bracket, using the LOWEST scale on a digital ohmmeter.

Less than 0.2 Ohms

Greater than 0.2 Ohms

Good Ground

Noise Remains

Unplug antenna from the back of the radio and check for the noise.

Noise Eliminated

Noise Remains

A poor ground exists. Cut the ground (black) wire from the black plug at the back of the radio. Attach a braided ground strap from the case of the radio steering column

Noise eliminated.

Go to the ANTENNA Chart.

(Next Page)

Figure 22—Chart 2 (Noisy Part 1)

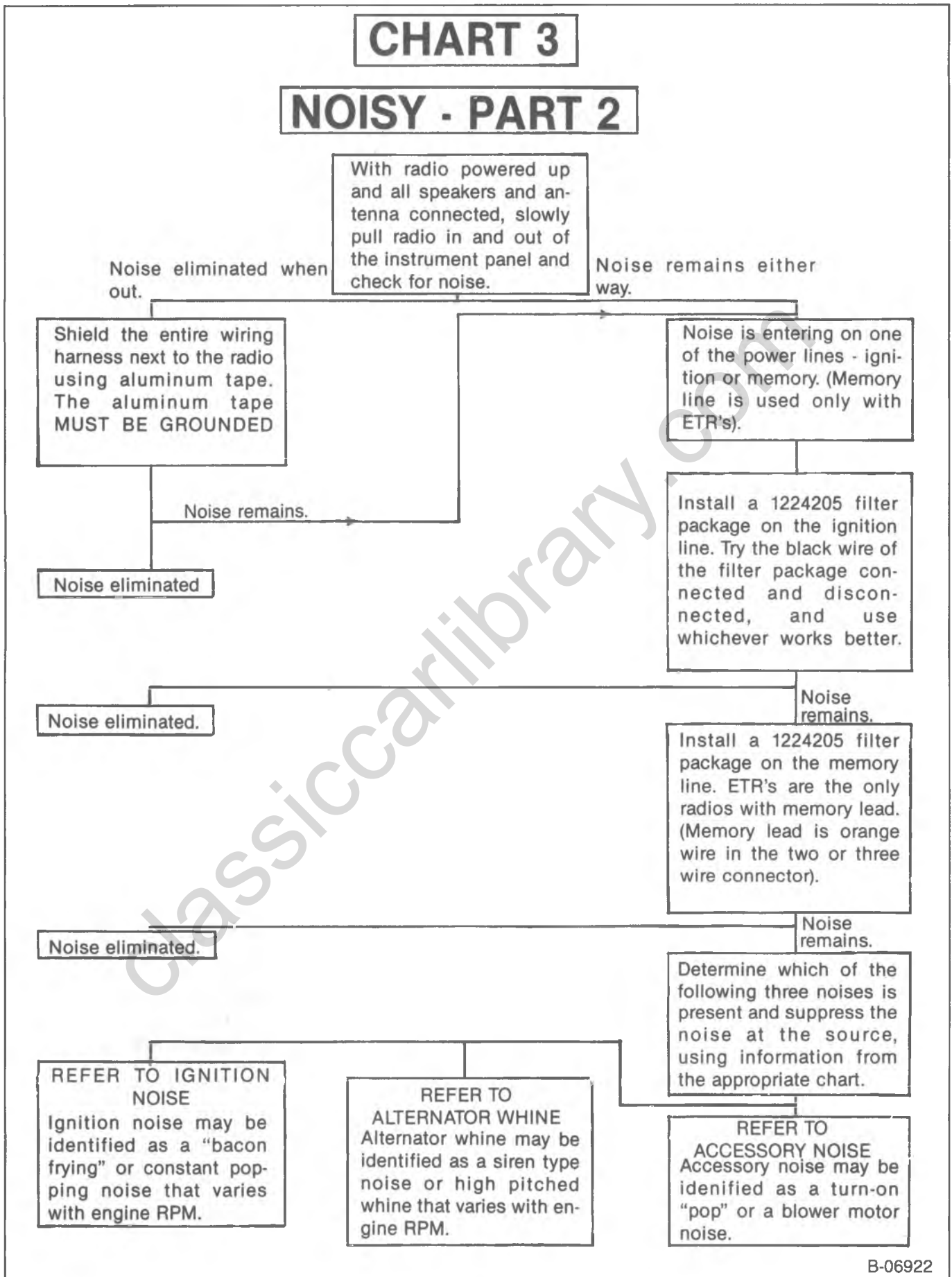
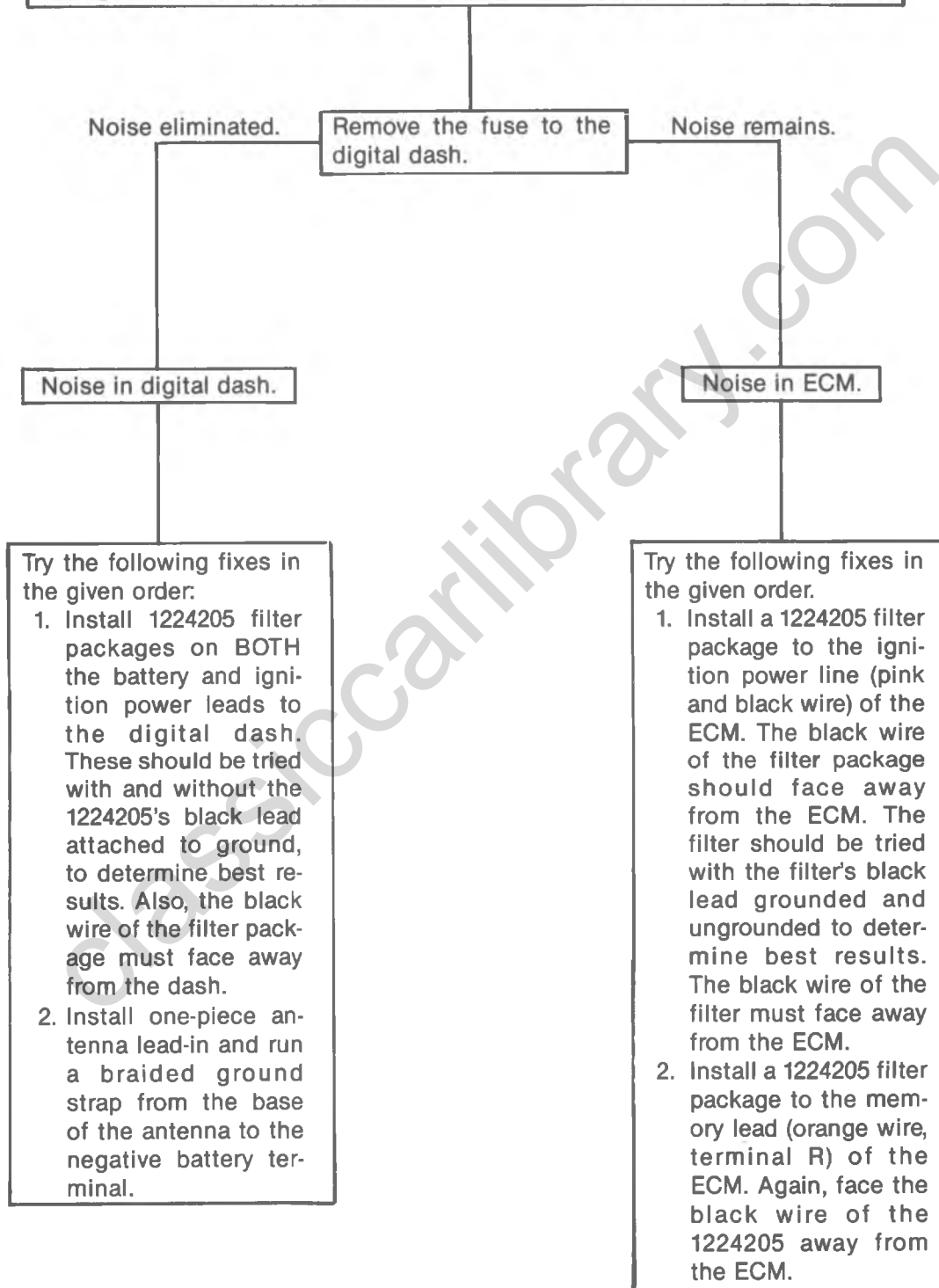

Figure 23—Chart 3 (Noisy Part 2)

CHART 4

ECM OR DIGITAL DASH NOISE



B-06923

Figure 24—Chart 4 (ECM or Digital Dash Noise)

CHART 5**IGNITION NOISE**

Determine the source of the ignition noise.

1 or 2 cylinders.

All cylinders.

Try the following fixes in the given order:

1. Check for loose or defective spark plug wire.
2. Reroute spark plug wires laying against anything that could possibly transmit noise to the radio (wiring or sensor leads that travel into the passenger compartment).
3. Check for faulty spark plug.
4. Replace distributor cap and rotor.

Try the following fixes in the given order:

1. Check the ground from engine to bulkhead; install a braided ground strap if necessary.
2. Install a braided ground strap on the hood.
3. Check heater core ground; clean or install braided ground strap if necessary.
4. Check air conditioner accumulator ground; clean or install a braided ground strap if necessary.
5. Move all wiring away from HEI and spark plug wires.
6. Inspect HEI for the following and replace if necessary:
 - Distributor cap carbon ball eroded away, or cracked or loose cap.
 - A rotor with burned black spot on wiper or pits in wiper surface.
 - A faulty coil.
 - An oily film on some of the lead terminals or inside the cap.
 - Faulty HEI module; can cause ignition noise on FM only.

B-06924

Figure 25—Chart 5 (Ignition Noise)

CHART 6

ANTENNA NOISE - PART 1

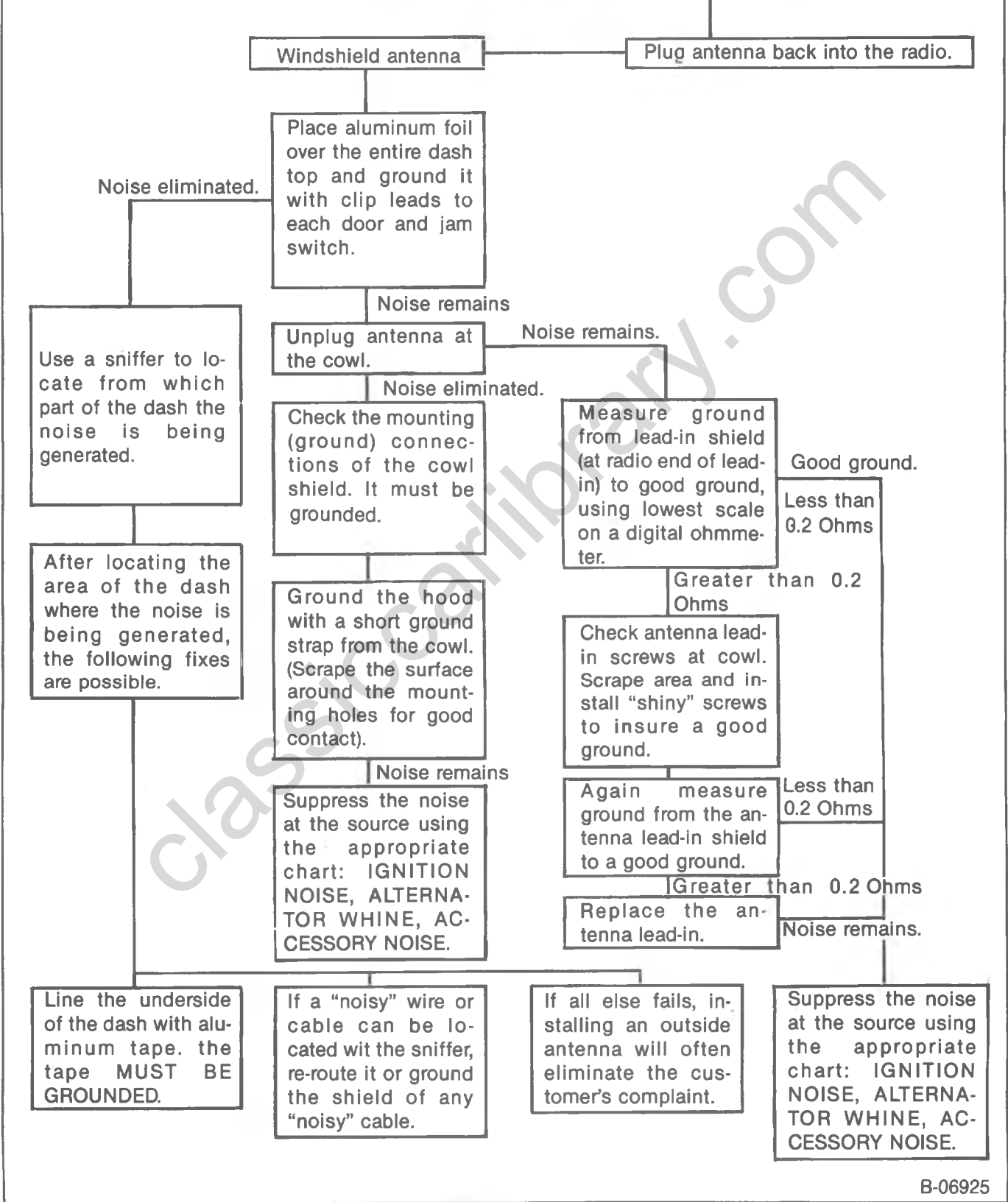

B-06925

Figure 26—Chart 6 (Antenna Noise Part 1)

CHART 7

ANTENNA NOISE - PART 2

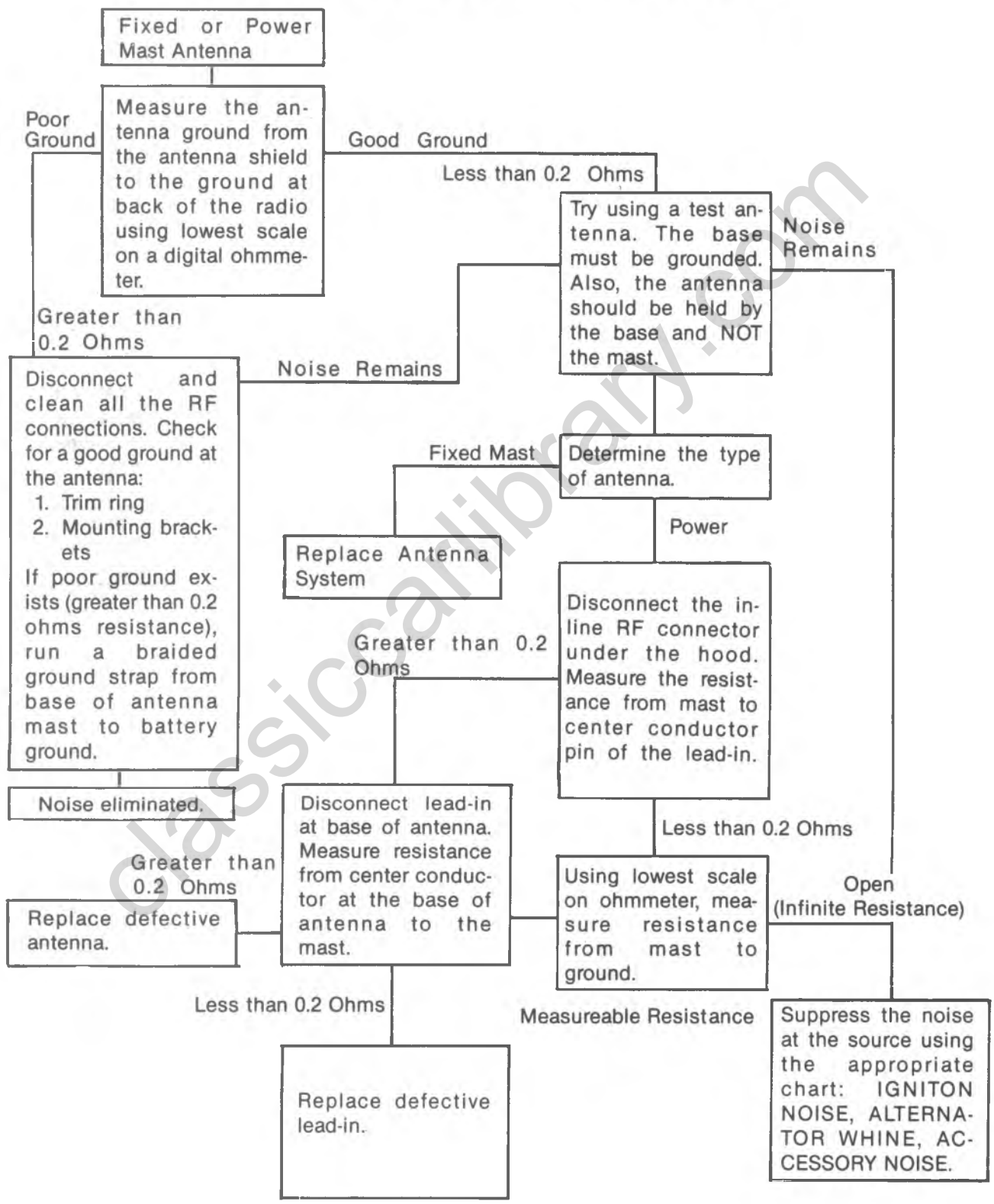
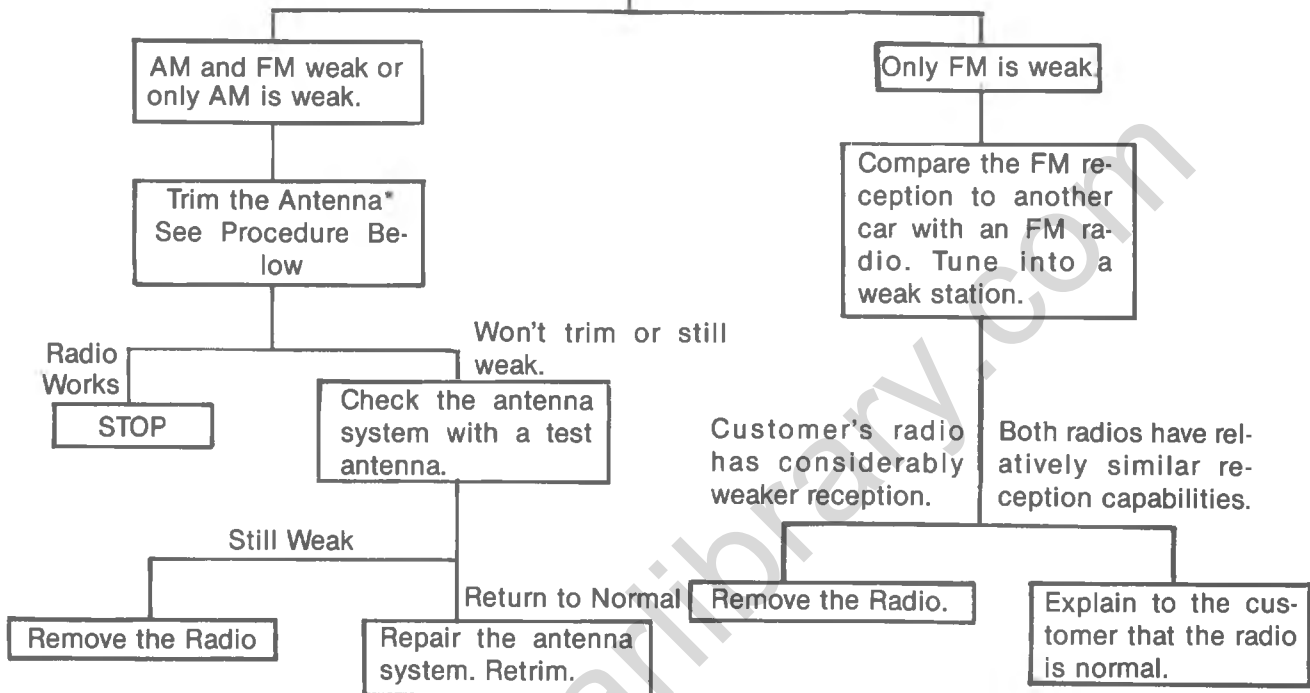

Figure 27—Chart 7 (Antenna Noise Part 2)

CHART 8

WEAK



*ETR and 2000 series radios do not have an antenna trimmer. Try a substitute antenna.

ANTENNA TRIMMER ADJUSTMENT

The antenna trimmer adjustment matches the antenna coil in the radio to the antenna. Only AM radios, or the AM part of AM/FM radios, need this adjustment. (ETR models and all 2000 series radios use "self adjusting" circuits, and do not have an antenna trimmer).

1. Tune the radio to a weak AM station or noise near 1400 kHz. Turn the volume all the way up. You should barely hear the station.
2. Remove the right inner and outer knobs.
3. Use a small screwdriver to adjust the trimmer screw. Adjust the screw for the loudest volume.
4. Reinstall the control knobs.

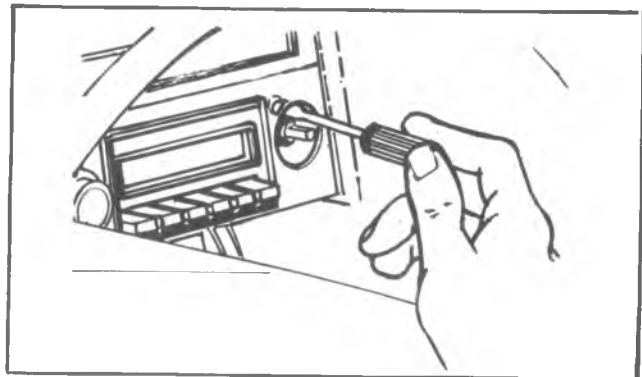

B-06927

Figure 28—Chart 8 (Weak)

CHART 9

ALTERNATOR WHINE

Noise Remains

Unplug antenna
from the back of the
radio.

Noise Eliminated

Try the following fixes in the given order:

1. Install a 250 MFD, 100V capacitor on the alternator output lead and/or the brown field wire of the alternator to ground.
2. Exchange radio with a known good radio. If this eliminates the noise, send the faulty radio to an authorized repair shop.
3. Dedicated ground for the radio receiver. Cut the black wire of the black plug in back of the radio. Attach a braided ground strap from the case of the radio to a good chassis.
4. Run a wire directly from the positive battery terminal to the alternator.
5. Replace the alternator.

Try the following fixes in the given order:

1. Install a 250 MFD, 100V capacitor on the alternator output lead and/or the brown field wire at the alternator.
2. Install a 1224205 filter package on the existing ground wire for the radio.
3. Exchange the radio with a known good radio. If this eliminates the noise, send the faulty radio to an authorized repair shop.
4. Replace the alternator.

B-06928

Figure 29—Chart 9 (Alternator Whine)

CHART 10

DEAD

Check the radio.
Check to see if all speakers are dead.
(Use fader to check.)

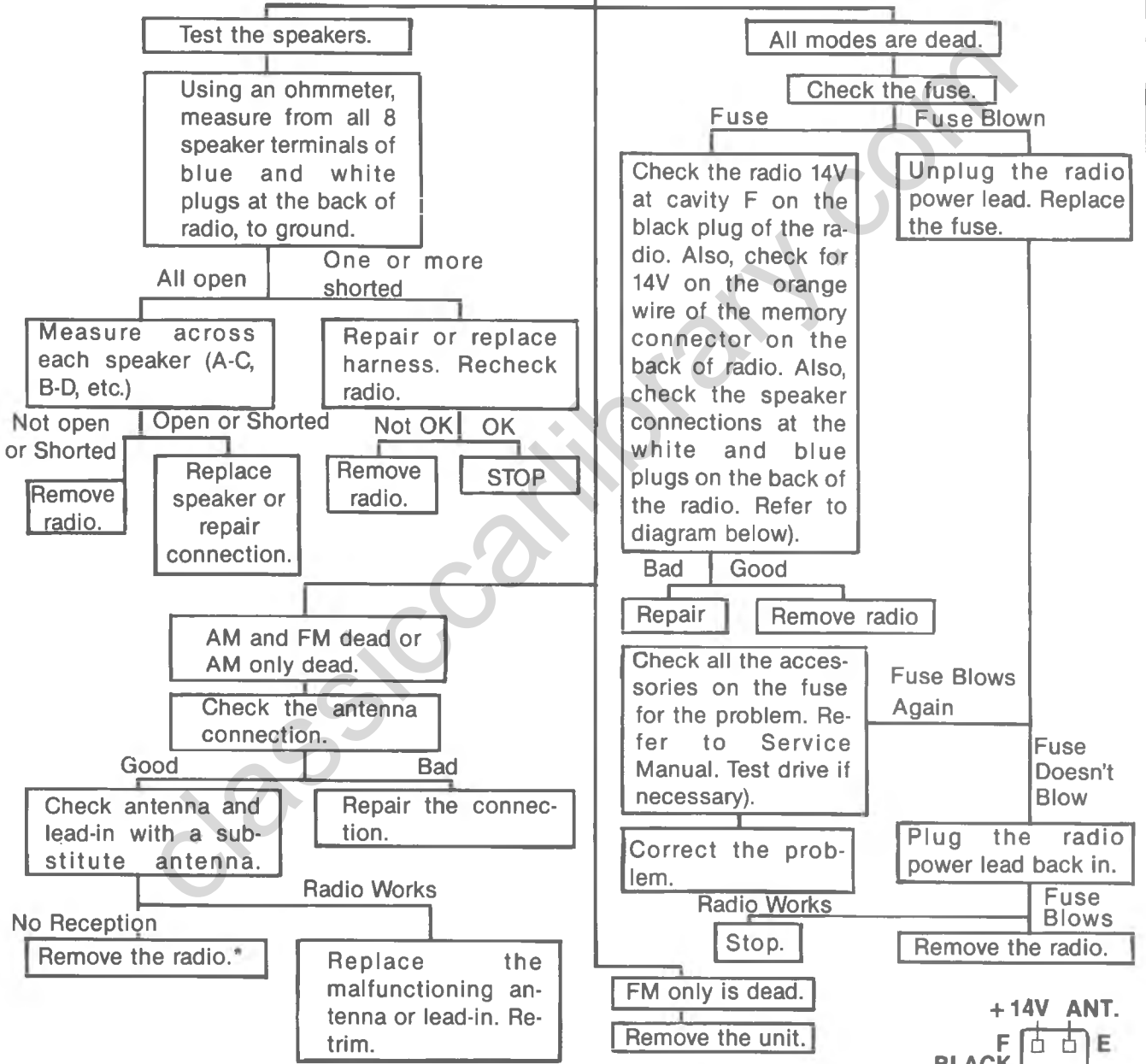

*When radio has been determined to be defective, be sure to describe the symptoms to aid the radio technician.

Front and rear speaker harnesses, and power plug connector pin views.

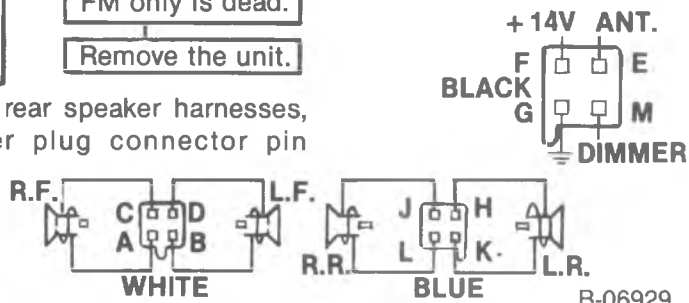

B-06929

Figure 30—Chart 10 (Dead)

CHART 11

TAPE

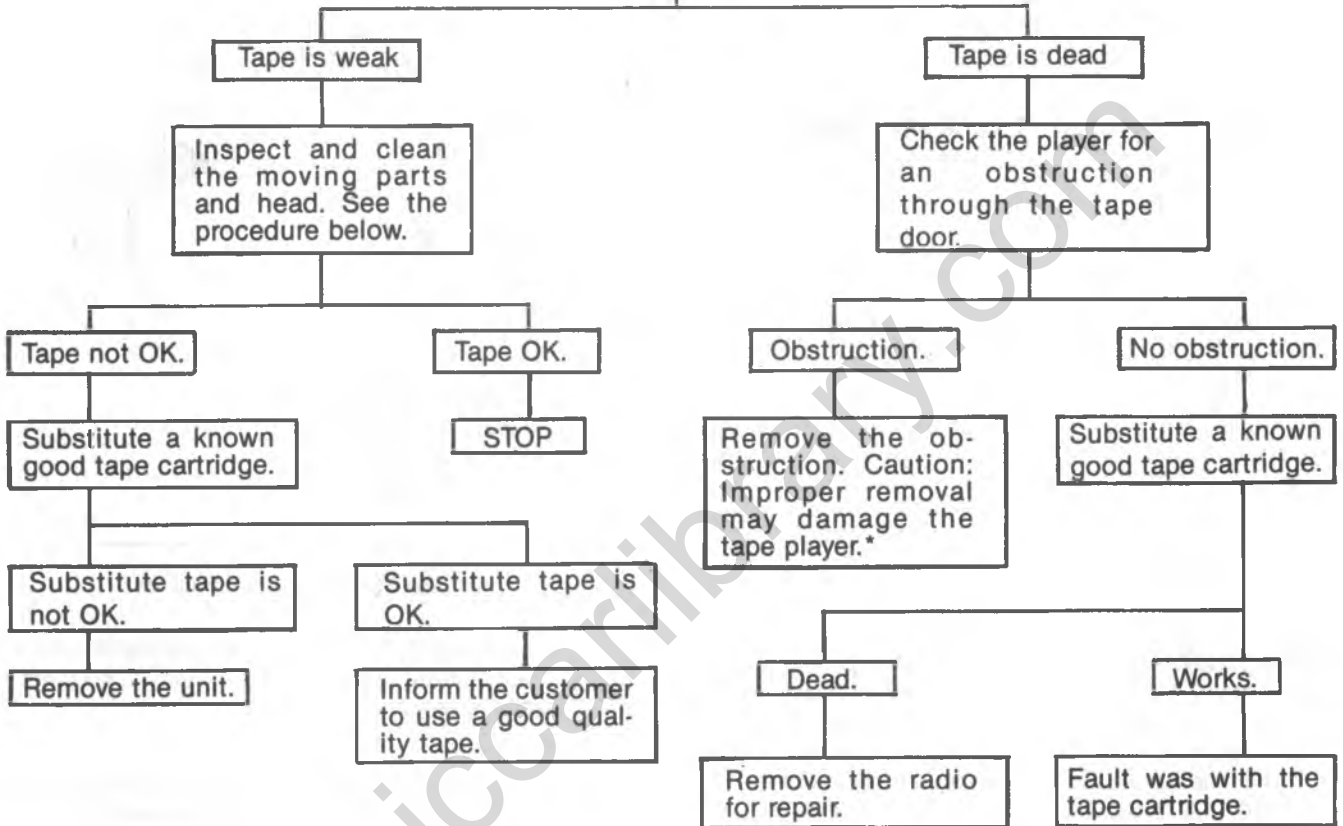

*NOTE: Jammed tape cannot be removed from the search and repeat tape deck. Send the radio to authorized repair shop.

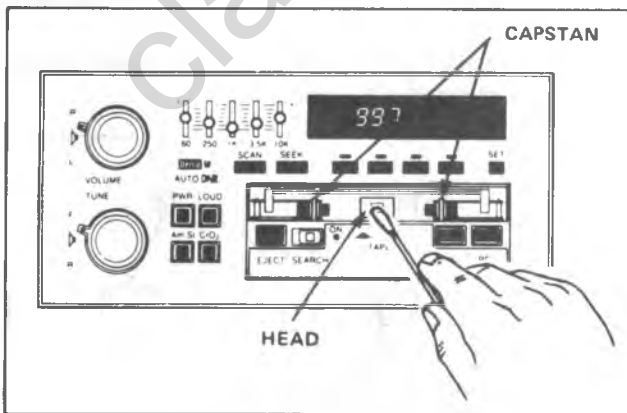

CLEANING PARTS OF TAPE PLAYER TO REDUCE TAPE NOISE

There are two parts that you clean on a tape player; the head and the capstan. Since you can reach them through the tape door, you can leave the tape player in the car.

To clean the head and capstan, use a cotton swab dipped in ordinary rubbing alcohol. Wipe the head and capstan as shown.

B-06930

Figure 31—Chart 11 (Tape)

9-28 ACCESSORIES

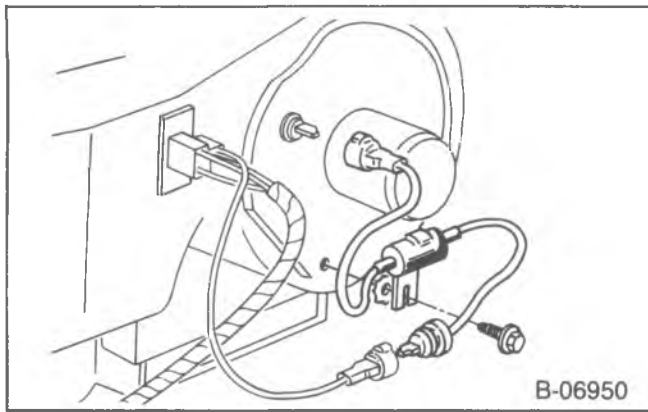

Figure 32—Blower Motor Noise Capacitor

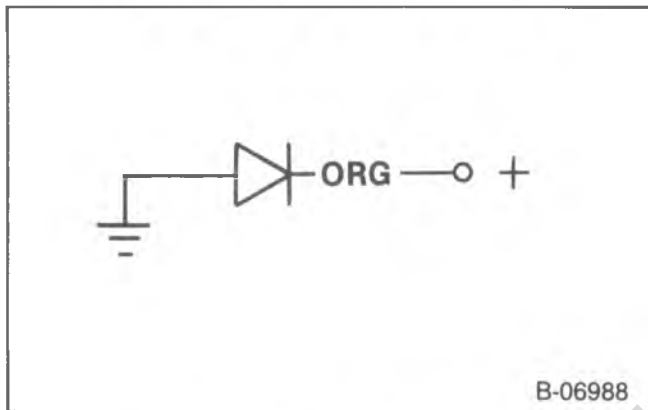

Figure 33—Diode IN4001

HORN SWITCH POPS (Figure 36 and 37)

- 1) Install a 0.5 MFD capacitor between the switched 14 volt lead and horn lead at the horn delay.
- 2) If pop persists, install a 0.5 MFD capacitor from the switched 14 volt lead of the horn relay to ground and a 0.5 MFD capacitor from the horn lead to ground.

MIXTURE CONTROL SOLENOID POPPING

Complaint:

A popping noise which sounds like ignition noise occurring on the AM band. This noise will NOT vary with

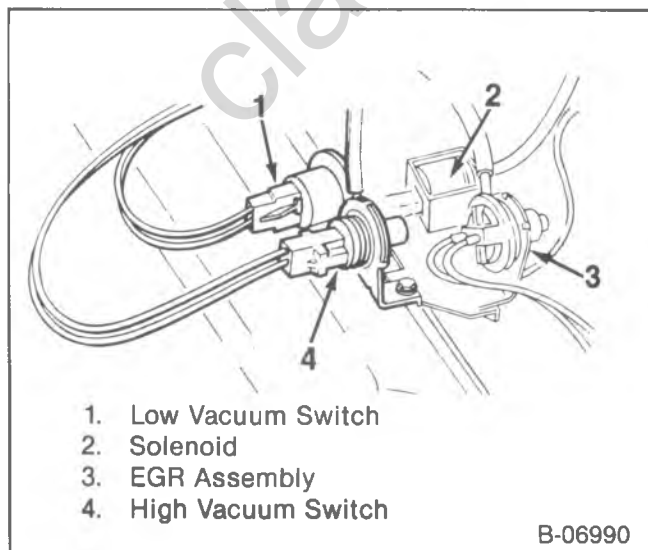

Figure 34—Diesel EGR High Vacuum Switch

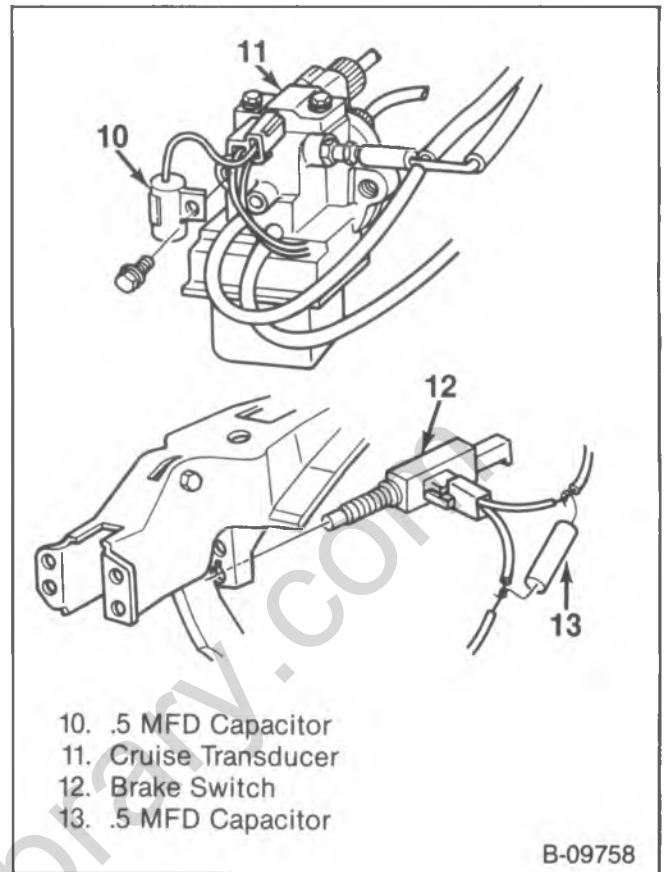

Figure 35—Cruise Transducer

engine speed. Also this noise should be noticeable with the ignition "on", and engine "off", but not in "accessory" position.

Problem:

Noise is being radiated from the mixture control solenoid duty cycle lead to the ALDL connector.

Fix:

- 1) Located the breakout harness extending from the main harness, about six inches from the ECM harness connector.
- 2) Located the light blue wire. It should connect to Pin D on the 15 pin breakout connector.
- 3) Cut the light blue wire on the vehicle side of the connector at the connector.

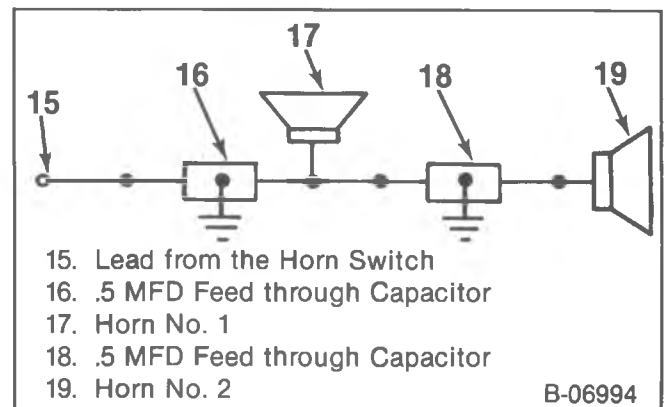

Figure 36—Horn Capacitor

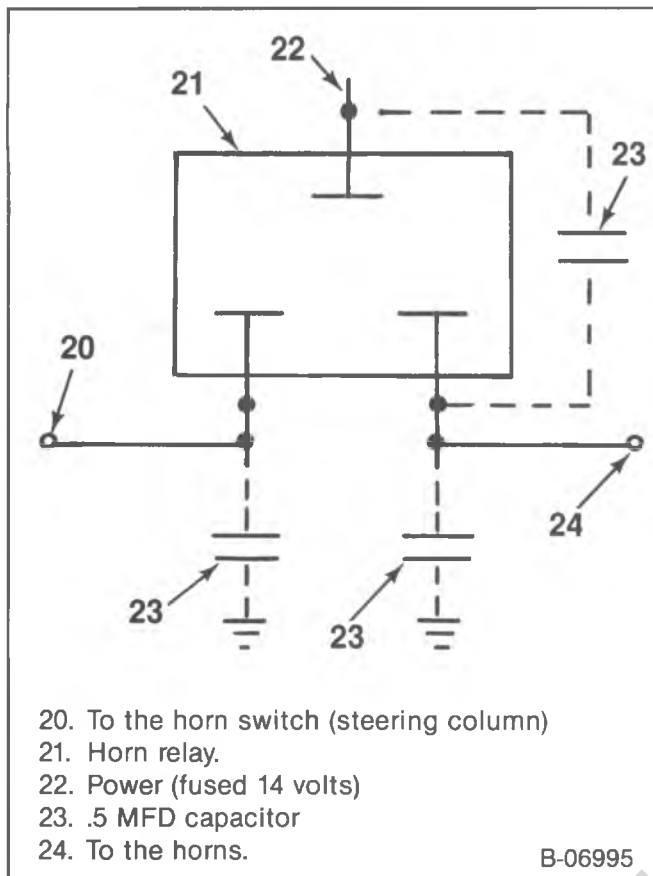

Figure 37—Horn Switch Capacitor

REAR DEFOGGER NOISE OR HASH

A broken grid in the defogger in the rear glass may cause a "hash" in the radio. Repairing this break will eliminate the noise. A break in the rear defogger grid can be found by touching each "line" of the grid while the rear defogger is on. The cold grid is the one broken.

TACHOMETER NOISE

Locate the wire from the distributor cap to the tachometer and shield the wire by wrapping it with aluminum tape. The tape must also be connected to a good ground.

TORQUE CONVERTER LOCK-UP NOISE

Model:
 Diesel Engines
 Complaint:
 Hash or popping noise on "AM" band after torque converter "lock-up" (35-45 mph).
 Fix:
 1) Install a 1224205 filter package in series with green lead on the VRV switch (see the instructions in filter package). For this application, connect the ground lead in the filter package to the blue lead on the VRV switch, instead of to ground.
 Install a capacitor (0.5 MFD) from the blue lead on VRV switch to ground.

Fix:
 2) Install a 220 MFD capacitor rated at 50 VDC across the VRV switch between the green and blue wires.

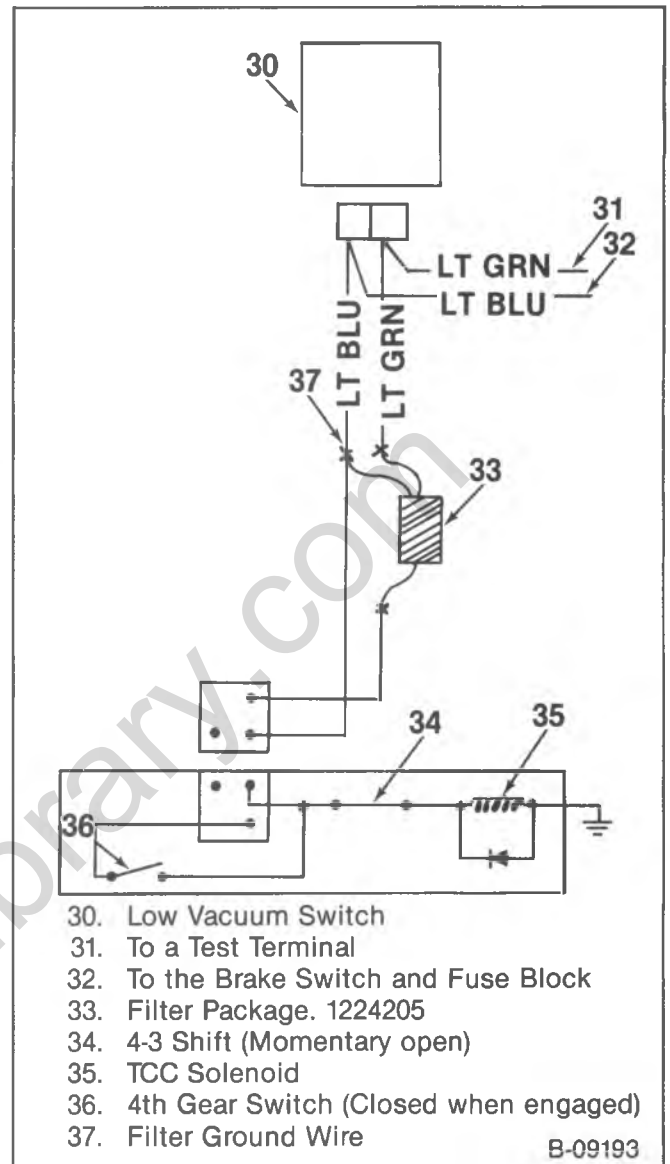

Figure 38—Torque Converter Lock Up Noise

WIPER SWISH WINDSHIELD ANTENNA

The swish sound encountered when the wipers pass over the windshield antenna is due to a static buildup between the windshield and the wiper. Try cleaning the windshield with Opticlean or add a tablespoon of dish soap to the washer bottle.

OTHER ELECTRIC MOTOR NOISES (POWER WINDOWS, BLOWER MOTORS)

Install a 0.5 MFD capacitor rated at 50 VDC across each motor.

OTHER SWITCH POPS (BLOWER SWITCHES, POWER LOCKS, POWER MIRRORS, PARK - NEUTRAL SWITCH, POWER WINDOWS, WIPERS, REAR WINDOW DEFOGGER)

Install a 0.5 MFD capacitor rated at 50 VDC across the contacts of the switch, from the hot side of the switch to ground or both.

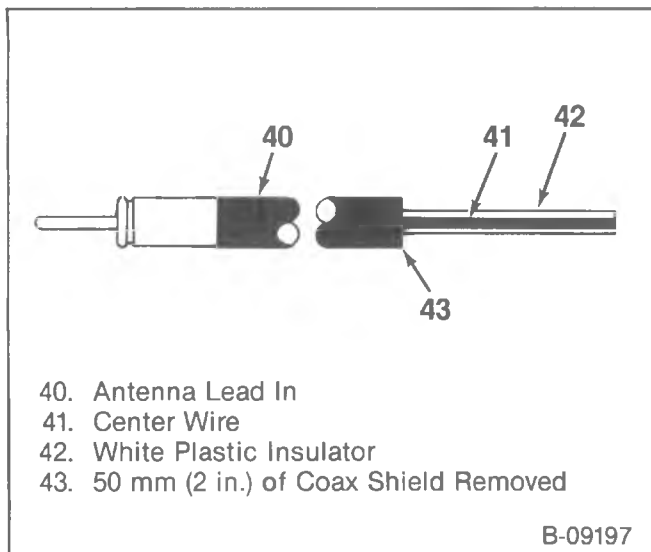

Figure 39—RF Sniffer

DIAGNOSTIC RF SNIFFER

The antenna sniffer can be used along with the car's radio to locate "Hot Spots" which are generating radio noise interference. These "Hot Spots" will be found in the harnesses, in the upper part of the dash or even between the hood and windshield.

The sniffer is made from an old piece of antenna lead-in from a mast or power antenna. The longer the lead-in the better, since it will make the sniffer more flexible as a diagnostic tool.

Make the sniffer as shown in figure 39. The 50 mm (2 inch) section with the black coating and braided shield stripped back becomes the antenna when the sniffer is plugged into the radio's antenna socket. It can then be used to probe and search out "Hot Spots".

Procedure:

1. While listening to the complaint noise, disconnect the antenna and plug the sniffer into the antenna socket.
2. Turn the radio volume up.
3. When searching for the noise source, keep fingers off of the probe, otherwise erroneous results will be received.

When checking for noise on a wire, the best results will be achieved when the sniffer is placed parallel to the wire.

The sniffer can also be used to determine from what area of the dash the noise is being generated onto a windshield antenna.

The sniffer can also be used to locate "Hot Spots" between the windshield and the hood that may be directing noise onto the windshield antenna.

It must be noted that the sniffer will also locate "normal" hot spots. However, the technician who becomes familiar with the sniffers capabilities will find it the most useful diagnostic tool in noise suppression work.

RADIO RECEIVER REPLACEMENT

RV MODELS

↔ Remove or Disconnect (Figure 40)

1. Battery ground cable
2. Control knobs (54)
3. Knob bezels (53)
4. Nuts (52) from the support tubes (51)
5. Support bracket retainer screws (55)
6. Harnesses
 - Lift up the rear edge of the receiver.
 - Push the receiver forward until the control shafts clear the instrument panel.
 - Lower the control shafts.
 - Remove the power feed, speaker and antenna connectors.
7. Receiver (50)

↔ Install or Connect (Figure 40)

1. Receiver (50)
 - Position the receiver under the instrument panel.
 - Connect the power, speaker and antenna leads.
 - Lift the rear of the receiver into place.
 - Move the receiver rearward so that the control shafts slide through the control shaft holes in the instrument panel.

2. Support bracket screws (55)
3. Nuts (52) on the support tubes (51)
4. Knob bezels (53)
5. Control knobs (54)
6. Battery ground cable

G VAN

↔ Remove or Disconnect (Figure 40)

1. Battery ground cable
2. Engine cover
3. Air cleaner cover
4. Air cleaner element
5. Control knobs (54)
6. Knob bezels (53)
7. Retaining nuts (52)
8. Rear mounting bracket screws (55)
9. Power, speaker and antenna leads
 - Push receiver forward.
 - Lower receiver.
 - Disconnect leads.
10. Receiver (50)

↔ Install or Connect (Figure 40)

1. Power, speaker and antenna leads.
2. Receiver (50)
 - Raise receiver into place.

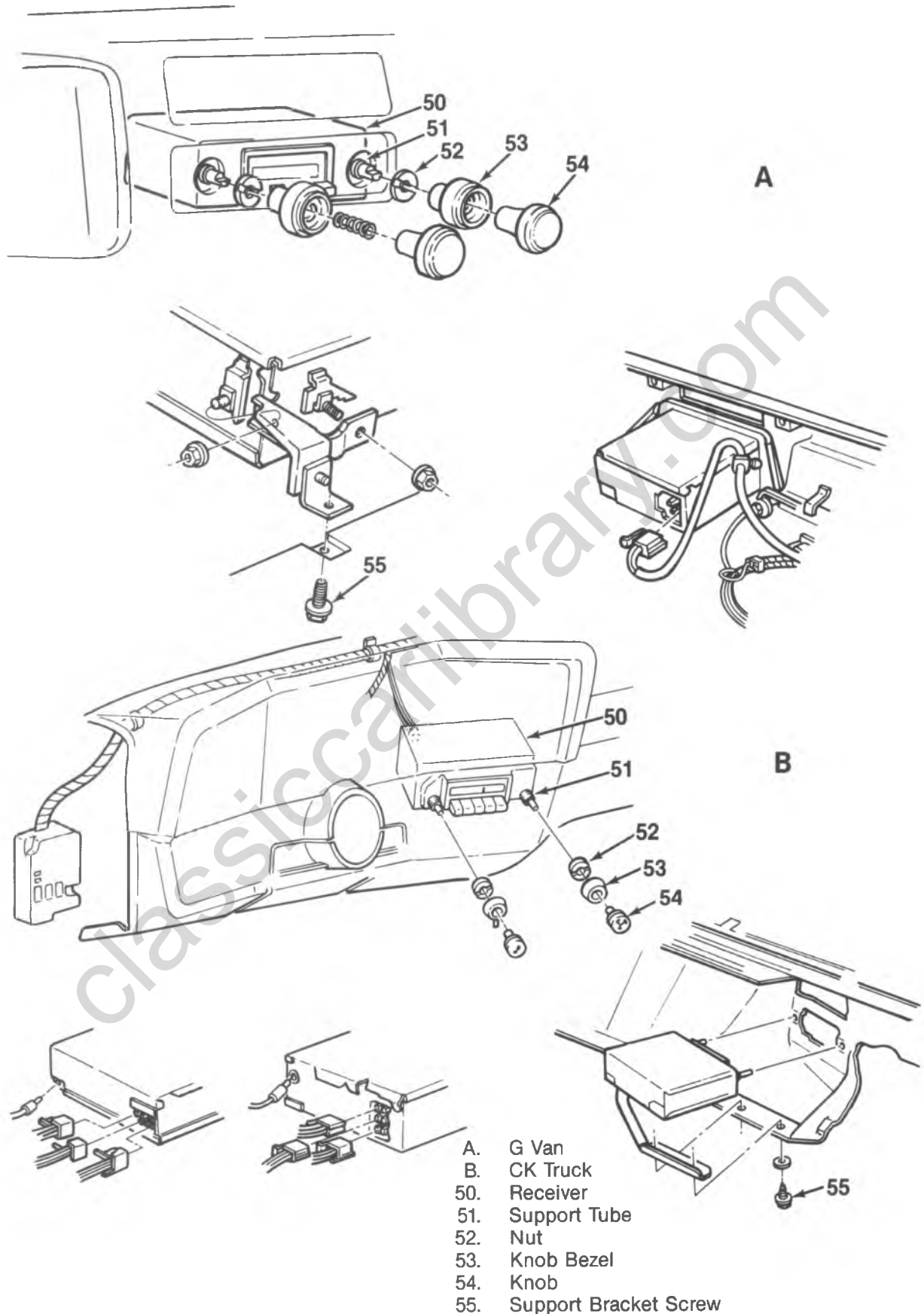

B-06949

Figure 40—Receiver Installation

9-32 ACCESSORIES

- Move receiver rearward so that the control shafts are in the mounting holes.
3. Rear mounting bracket screws (55).
 4. Retaining nuts (52) on the supporting tubes (51).
 5. Knob bezel (53).
 6. Control knobs (54).
 7. Air cleaner element.

8. Air cleaner cover.
9. Engine cover.
10. Battery ground cable.

NOTICE: Always connect the speaker wiring harness to the receiver before applying power to the receiver in order to prevent receiver damage.

ANTENNA REPLACEMENT

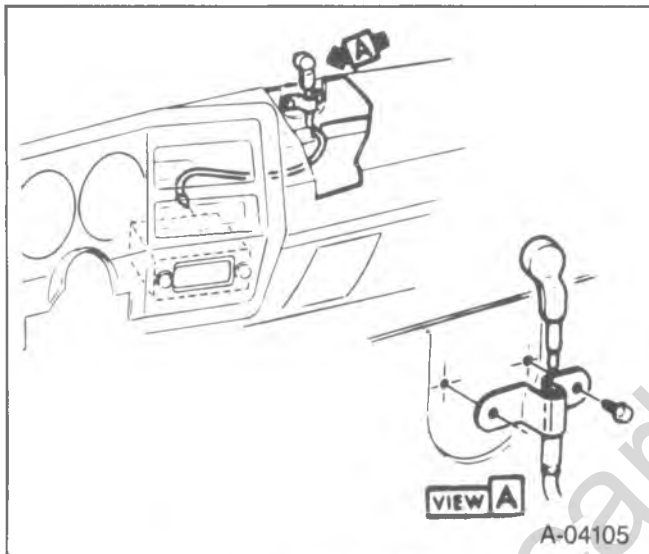

Figure 41—Antenna Cable RV

RV MODELS

↔ Remove or Disconnect (Figure 41)

1. Battery ground cable
2. Antenna cable connector
3. Window. Refer to Sec. 10 "Windshield Replacement".

↔ Install or Connect (Figure 41)

1. Window. Refer to Sec. 10 "Windshield Replacement".
2. Antenna cable connector
3. Battery ground cable

G VAN

↔ Remove or Disconnect (Figure 42)

1. Battery ground cable
2. Mast retaining nut (56)
3. Mast (57)
4. Nut (55)
5. Seal (54) and bezel (53)
6. Seal (52)
7. Body and cable assembly (50)
8. Washer (51)

↔ Install or Connect

1. Washer (51)
2. Body and cable assembly (50)
3. Seal (52)
4. Seal (54) and bezel (53)
5. Nut (55)
6. Mast (57)
7. Mast retaining nut (56)
8. Battery ground cable

SPEAKER REPLACEMENT

RV MODELS

FRONT SPEAKER

↔ Remove or Disconnect (Figures 43 and 44)

1. Battery ground cable
2. Instrument cluster bezel upper four screws
3. Instrument panel pad screws
4. Pad (70)
5. Speaker to dash panel screws (72)
6. Speaker harness
 - Lift up speaker (71)
7. Speaker (71)

↔ Install or Connect (Figures 43 and 44)

1. Speaker harness to speaker (71)
2. Speaker (71)
3. Speaker to dash panel screws (72)
4. Pad (70)
5. Instrument panel pad screws
6. Instrument cluster bezel upper four screws
7. Battery ground cable

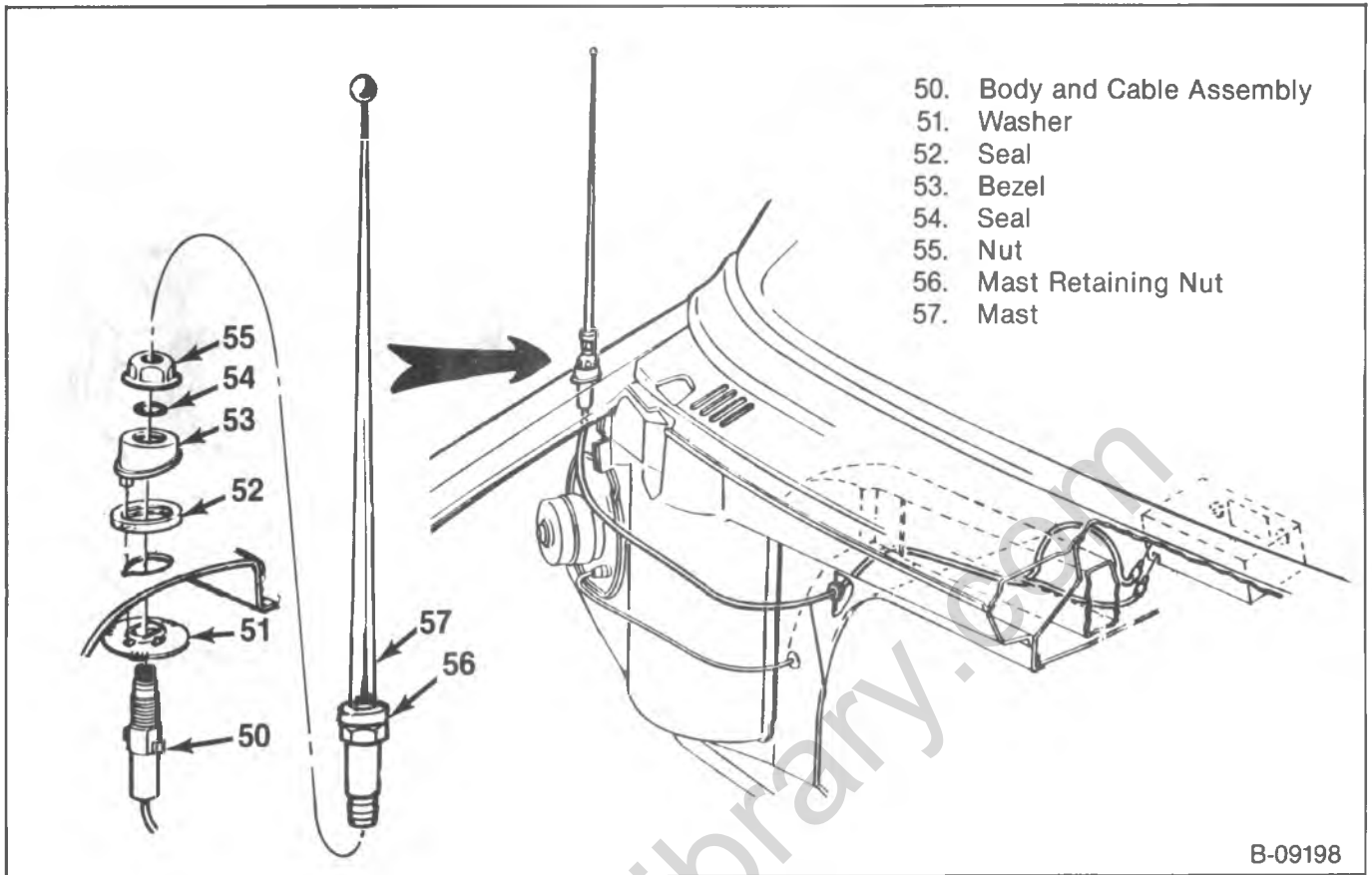

Figure 42—Antenna System G-Van

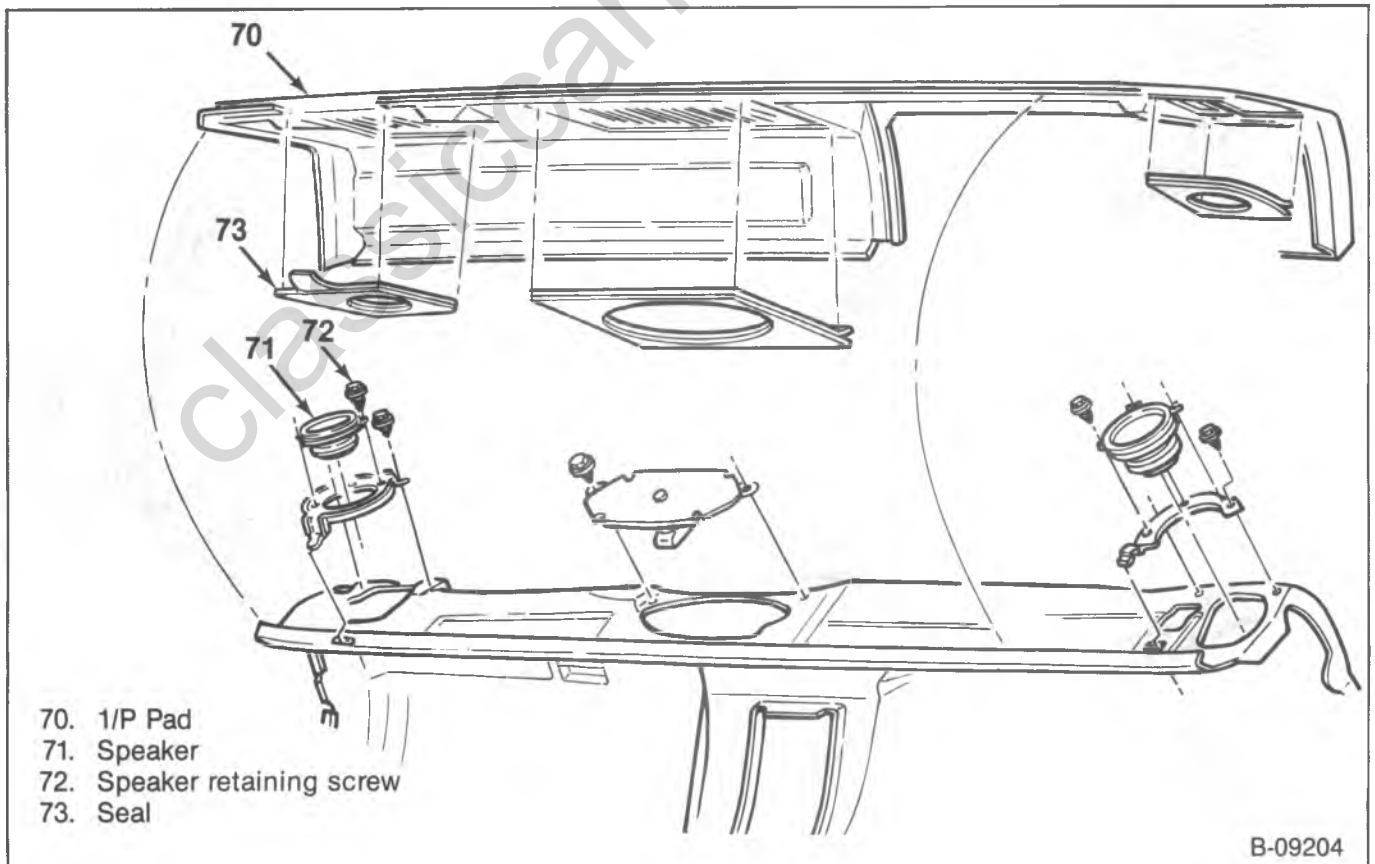
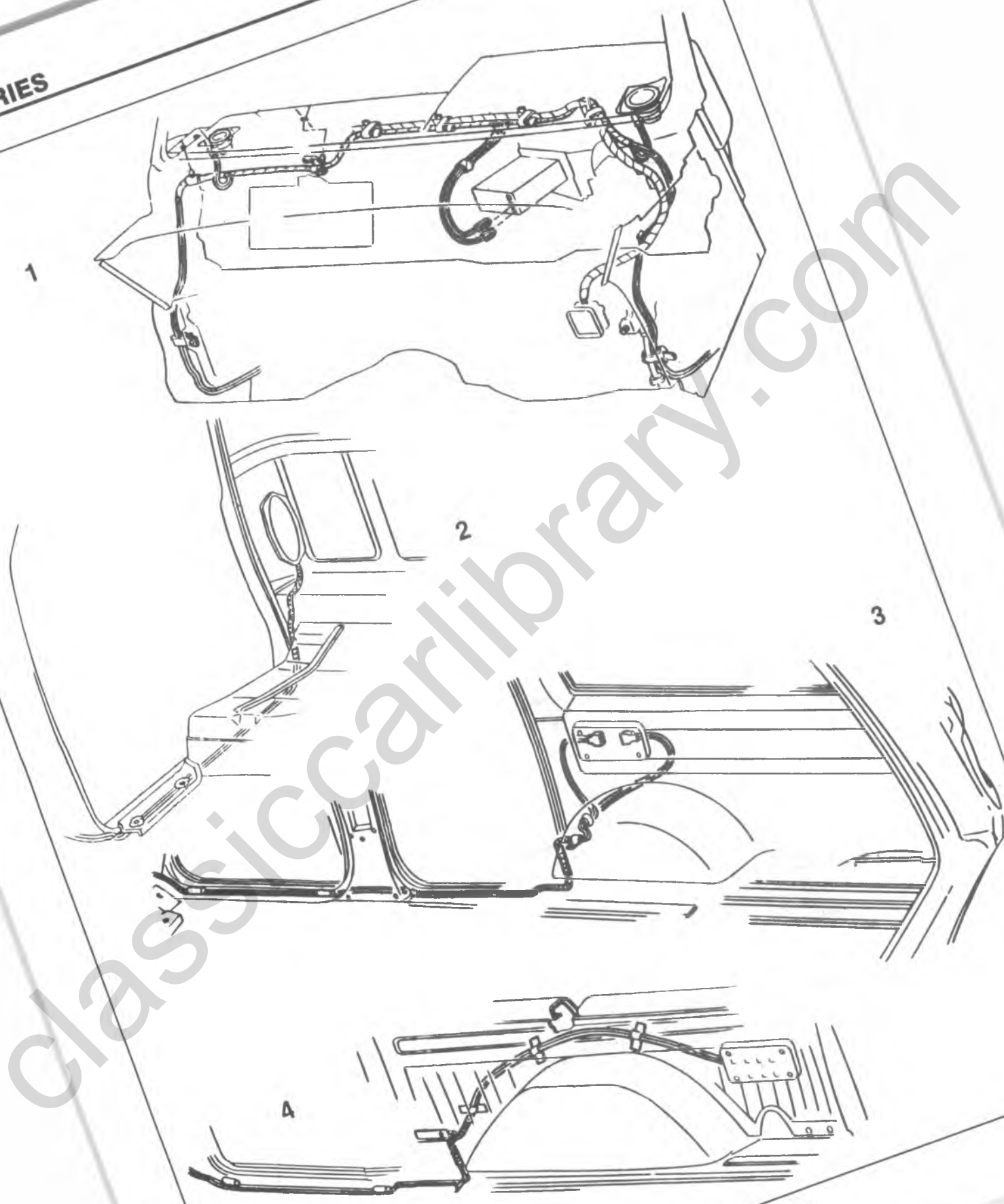

Figure 43—Front Speakers RV

9-34 ACCESSORIES



- 1. All CK Models
- 2. Pickup
- 3. Suburban
- 4. Utility

Figure 44—Speaker Harness RV

B-06878

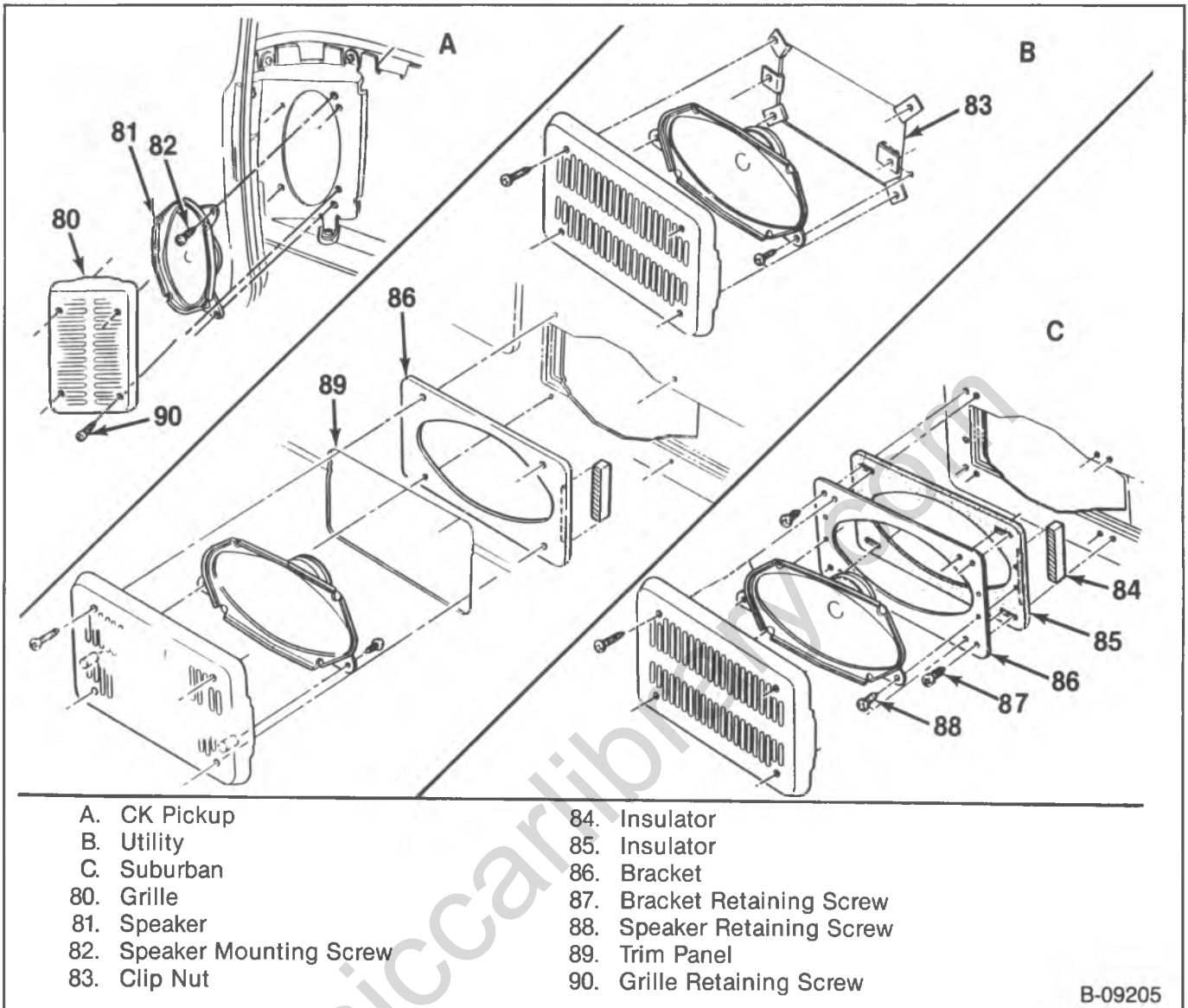

B-09205

Figure 45—Rear Speakers RV

REAR SPEAKER

↔ Remove or Disconnect (Figure 45)

1. Battery ground cable
2. Grill retaining screws (90)
3. Grill (80)
4. Speaker retaining screws (82)
5. Speaker harness from the speaker (81)
6. Speaker (81)

→ Install or Connect (Figure 45)

1. Speaker harness to the speaker
2. Speaker (81)
3. Speaker retaining screws (82)
4. Grill (80)
5. Grill retaining screws (82)
6. Battery ground cable

G VAN

FRONT SPEAKER

↔ Remove or Disconnect (Figure 46)

1. Battery ground cable
2. Instrument panel bezel
3. Instrument cluster
4. Speaker screws (102)
5. Speaker connector (101)
6. Speaker (100)

→ Install or Connect (Figure 46)

1. Speaker connector (101) to the speaker (100)
2. Speaker (100)
3. Speaker screws (102)
4. Instrument cluster
5. Instrument panel bezel
6. Battery ground cable

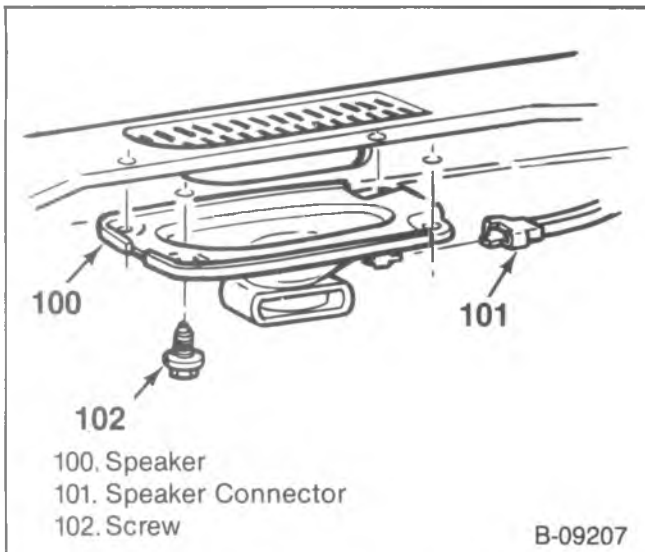

Figure 46—Front Speakers G-Van

REAR CORNER SPEAKER

↔ Remove or Disconnect (Figure 47)

1. Battery ground cable.
2. Lower corner trim panel (114).
3. Lower edge screws of the upper corner trim panel (110).
4. Trim strip (115) screws.
5. Rear door upper molding (113) screws.
6. Upper corner trim panel (110) upper screws.
7. Upper corner trim panel assembly (110).
8. Horns connector from the speaker.
9. Insulation retaining screws.
10. Insulation (112).
11. Speaker retaining screws.
12. Speaker (111) from the upper corner trim panel (110).

→↔ Install or Connect (Figure 47)

1. Speaker (111) to the upper corner trim panel (110).
2. Speaker retaining screws.
3. Insulation (112).
4. Insulation retaining screws.
5. Harness connector to the speaker.
6. Upper corner trim panel assembly (110).
7. Upper corner trim panel screws.
8. Rear door upper molding (113) screws.
9. Trim strip (115).
10. Trim strip (115) screws.
11. Lower corner trim panel (114).
12. Battery ground cable.

REAR SIDE SPEAKER

↔ Remove or Disconnect (Figure 48 and 49)

1. Battery ground cable.
2. Four forward lower screws retaining the rear trim panel.
 - Pull the trim panel out to reach the speaker.

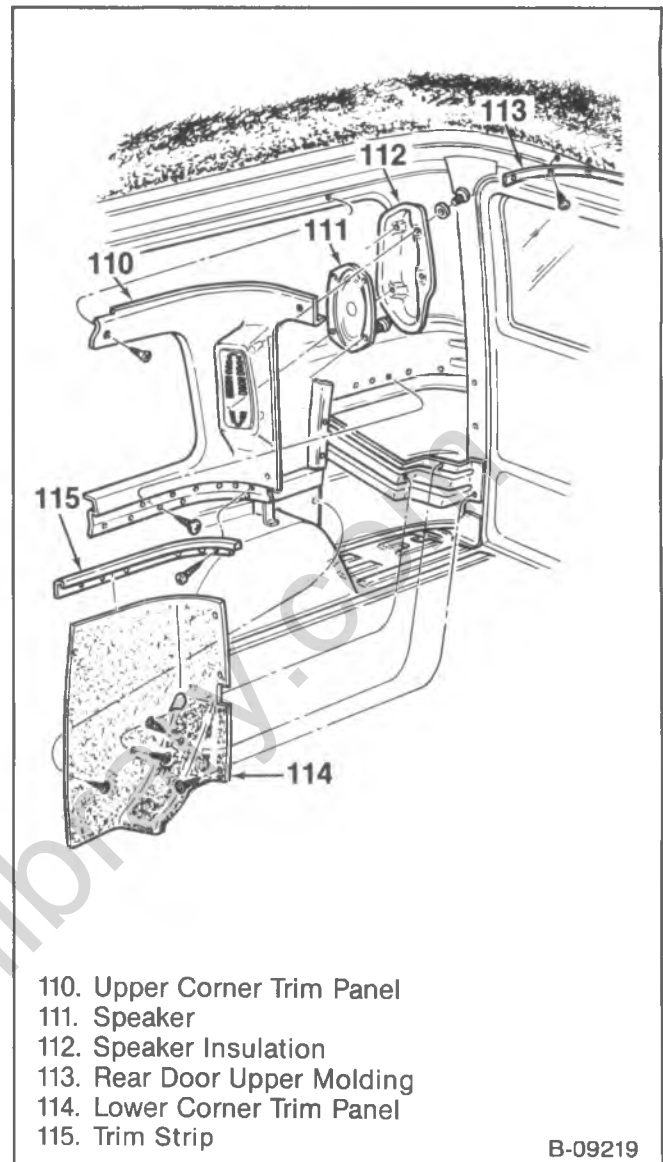

Figure 47—Rear Corner Speakers G-Van

3. Harness connector from the speaker.
4. Speaker retaining nuts.
5. Speaker.

→↔ Install or Connect (Figure 48 and 49)

1. Speaker.
2. Speaker retaining nuts.
3. Harness connector to the speaker.
4. Rear trim panel screws.
5. Battery ground cable.

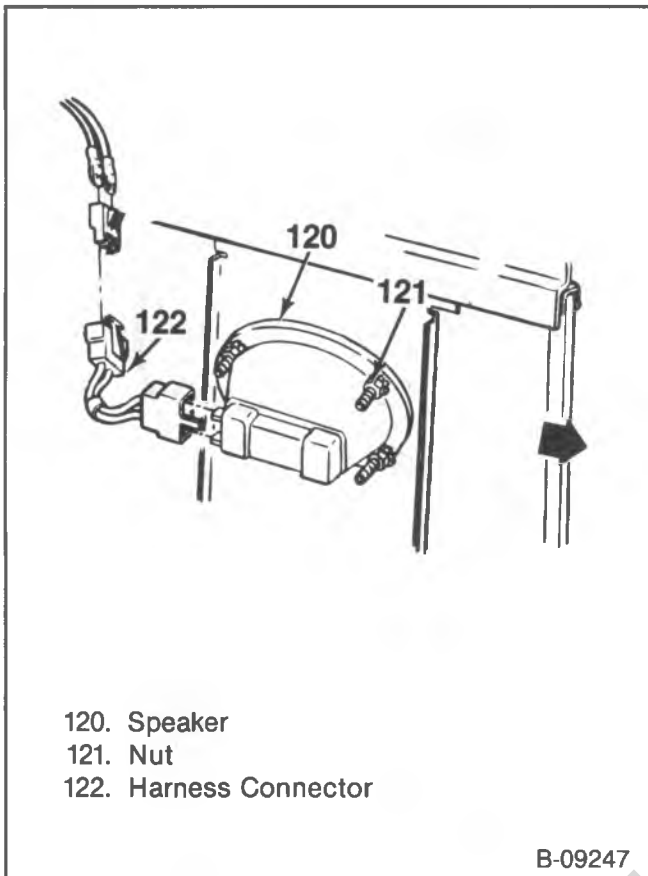
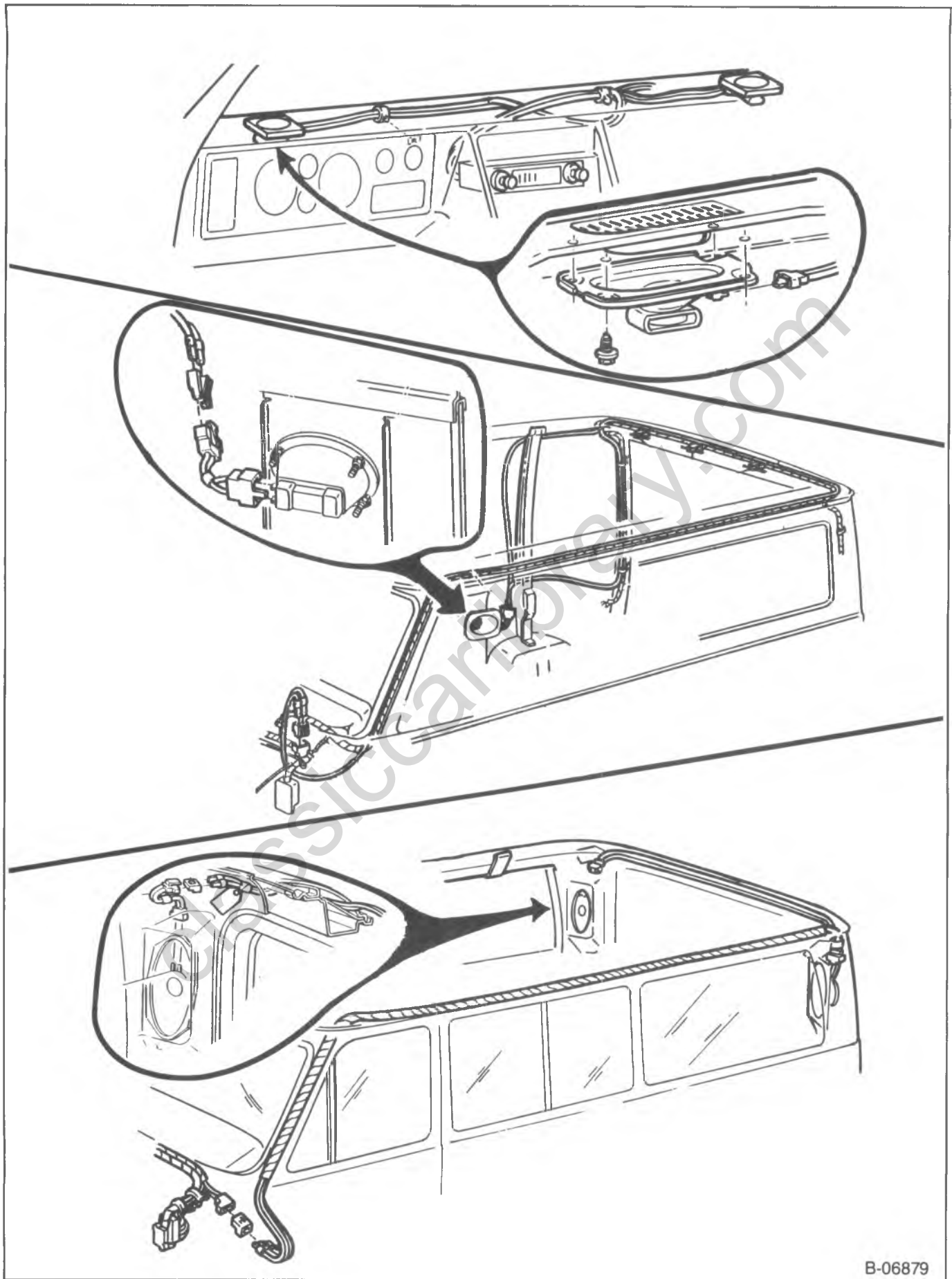

Figure 48—Rear Side Speakers

classiccarlibrary.com



B-06879

Figure 49—Speaker Harness G-Van

SECTION 10

BODY

CONTENTS

<u>SUBJECT</u>	<u>PAGE</u>
Doors	10A1-1
Seats	10A2-1
Glass	10A3-1
Interior Trim	10A4-1
End Gate	10A5-1

SECTION 10A1

DOORS

NOTICE: Door lock striker system fasteners are important attaching parts in that they could affect the performance of vital parts and systems, and/or could result in major repair expense. They must be replaced with one of the same part number or with an equivalent part if replacement becomes necessary. Do not use a replacement part of lesser quality or substitute design. Torque values must be used as specified during reassembly to assure proper retention of these parts.

CONTENTS

<u>SUBJECT</u>	<u>PAGE</u>
RV Model Side Front Door	10A1- 4
Door And Hinge Replacement	10A1- 4
Door Adjustment	10A1- 4
Door Trim Panel Replacement	10A1- 4
Door Vent/Window Run Channel Assembly Replacement	10A1- 5
Vent Glass Replacement	10A1- 6
Vent Window Adjustment	10A1- 7
Door Window Replacement	10A1- 7
Inner Window Weatherstrip Replacement	10A1- 8
Outer Window Weatherstrip Replacement	10A1- 8
Rear Glass Run Channel Replacement	10A1- 8
Window Regulator Replacement	10A1- 9
Door Lock Replacement	10A1-10
Power Door Lock Motor Replacement	10A1-10
Door Outside Handle Replacement	10A1-11
Door Lock Cylinder Replacement	10A1-11
Door Inside Handle Replacement	10A1-12
Door Weatherstrip Replacement	10A1-12
Outside Rear View Mirror Replacement	10A1-13
Below Eyeline Outside Rear View Mirror Replacement	10A1-13
West Coast Outside Rear View Mirror Replacement	10A1-13
Door Air Valve Replacement	10A1-13
RV Model Side Rear Doors	10A1-14
Door And Hinge Replacement	10A1-14
Door Adjustment	10A1-15
Door Trim Panel Replacement	10A1-16

10A1-2 DOORS

CONTENTS (CONTINUED)

<u>SUBJECT</u>	<u>PAGE</u>
RV Model Side Rear Doors (Continued)	
Stationary Glass/Window Run Channel Assembly Replacement	10A1-16
Door Window Replacement	10A1-17
Inner Window Weatherstrip Replacement	10A1-17
Outer Window Weatherstrip Replacement	10A1-18
Front Glass Run Channel Replacement	10A1-19
Window Regulator Replacement	10A1-19
Door Lock Replacement	10A1-20
Power Door Lock Motor Replacement	10A1-20
Door Outside Handle Replacement	10A1-21
Door Inside Handle Replacement	10A1-21
Remote Control Replacement	10A1-21
Door Weatherstrip Replacement	10A1-22
Door Air Valve Replacement	10A1-22
RV Model Rear Doors	10A1-23
Door And Hinge Replacement	10A1-23
Door Adjustment	10A1-23
Striker Replacement	10A1-23
Bumper Wedge Replacement	10A1-25
Door Trim Panel Replacement	10A1-25
Window Replacement	10A1-25
Right Door Lower Latch Replacement	10A1-26
Right Door Upper Latch Replacement	10A1-27
Right Door Control Assembly Replacement	10A1-28
Door Outside Handle Replacement	10A1-28
Left Door Lower Latch Replacement	10A1-28
Check Strap Replacement	10A1-29
Right Door Weatherstrip Replacement	10A1-29
Left Door Weatherstrip Replacement	10A1-29
Secondary Weatherstrip Replacement	10A1-30
G Model Side Front Door	10A1-32
Door And Hinge Replacement	10A1-32
Door Adjustment	10A1-32
Door Trim Panel Replacement	10A1-33
Door Vent/Window Run Channel Assembly Replacement	10A1-34
Vent Glass Replacement	10A1-35
Vent Window Adjustment	10A1-36
Door Window Replacement	10A1-36
Window Stop Assembly Adjustment	10A1-37
Inner Window Weatherstrip Replacement	10A1-37
Outer Window Weatherstrip Replacement	10A1-37
Rear Glass Run Channel Replacement	10A1-37
Window Regulator Replacement	10A1-38
Door Lock Replacement	10A1-39
Power Door Lock Motor Replacement	10A1-40
Door Outside Handle Replacement	10A1-40
Door Lock Cylinder Replacement	10A1-40
Door Lock Control Assembly Replacement	10A1-41
Door Weatherstrip Replacement	10A1-41
Below Eycline Outside Rear View Mirror Replacement	10A1-41
G Model Intermediate Doors	10A1-42
Door And Hinge Replacement	10A1-42
Door Adjustment	10A1-42

CONTENTS (CONTINUED)

<u>SUBJECT</u>	<u>PAGE</u>
G Model Intermediate Doors (Continued)	
Bumper Wedge Replacement	10A1-44
Door Trim Panel Replacement	10A1-44
Window Replacement	10A1-45
Intermediate Front Door Lock Replacement	10A1-46
Intermediate Front Door Lock Control Replacement	10A1-47
Door Lock Cylinder Replacement	10A1-47
Door Outside Handle Replacement	10A1-47
Intermediate Rear Door Lower Latch Replacement	10A1-49
Intermediate Rear Door Upper Latch Replacement	10A1-49
Intermediate Rear Door Control Assembly Replacement	10A1-50
Power Door Lock Motor Replacement	10A1-50
Intermediate Front Door Weatherstrip Replacement	10A1-50
Intermediate Rear Door Weatherstrip Replacement	10A1-51
G Model Sliding Side Door	10A1-53
Door Replacement	10A1-53
Hinge Assembly Replacement	10A1-53
Lower Roller Assembly Replacement	10A1-54
Upper Front Roller Replacement	10A1-54
Door Adjustment	10A1-54
Door Trim Panel Replacement	10A1-58
Window Replacement	10A1-58
Front Lock Replacement	10A1-59
Rear Lock Replacement	10A1-61
Lock Cylinder Replacement	10A1-61
Sliding Side Door Weatherstrip Replacement	10A1-61
G Model Rear Doors	10A1-63
Door And Hinge Replacement	10A1-63
Door Adjustment	10A1-64
Striker Replacement	10A1-64
Door Trim Panel Replacement	10A1-64
Bumper Wedge Replacement	10A1-66
Window Replacement	10A1-66
Swing Out Window	10A1-67
Left Door Lower Latch Replacement	10A1-67
Right Door Lower Latch Replacement	10A1-67
Right Door Upper Latch Replacement	10A1-69
Right Door Control Assembly Replacement	10A1-69
Door Outside Handle Replacement	10A1-70
Door Lock Cylinder Replacement	10A1-70
Check Strap Replacement	10A1-70
Check Assembly Replacement	10A1-71
Left Door Weatherstrip Replacement	10A1-71
Right Door Weatherstrip Replacement	10A1-72
Power Door Lock Motor Replacement	10A1-72
Special Tools	10A1-74

RV MODEL SIDE FRONT DOOR

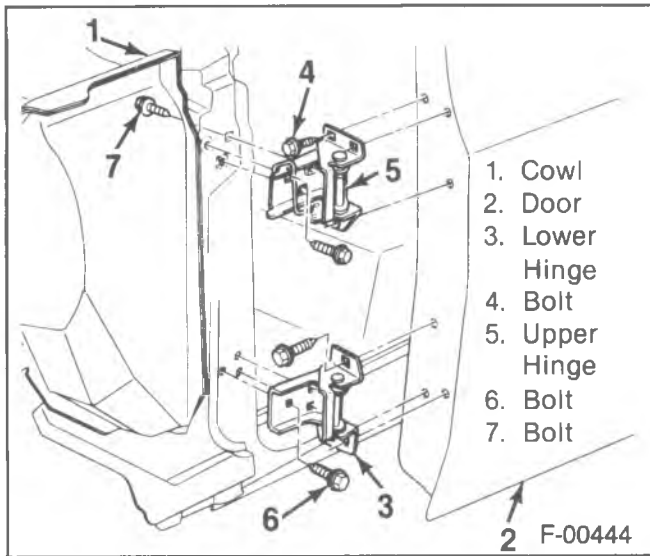

Figure 1—Door Hinge Components

DOOR AND HINGE REPLACEMENT

↔ Remove or Disconnect (Figure 1)

- Open the door.
- 1. Electrical wiring harness (if equipped).
 - Refer to "Door Trim Panel Replacement," for access to the wiring harness.
- Mark the position of the hinges on the door.
- 2. Door hinge to door bolts (4).
- 3. Door from the vehicle.
 - Mark the position of the hinges on the body side pillar.
- 4. Hinge to door pillar bolts (6).
- 5. Door pillar to hinge bolt (7).
- 6. Hinges from the vehicle.

↔ Install or Connect (Figure 1)

1. Hinges to the vehicle.
 - Align the hinges to the marks on the body side pillars.
2. Hinge to door pillar bolts (6).
3. Door pillar to hinge bolt (7).
4. Door to the vehicle.
 - Align the marks on the door to the hinges.
5. Door hinge to door bolts (4).
6. Electrical wiring harness (if equipped).
 - Refer to "Door Trim Panel Replacement," for access to the wiring harness.

DOOR ADJUSTMENT

↔ Remove or Disconnect (Figures 2 and 3)

Tools Required:

- J-22585-01 Door Hinge Bolt Wrench.
- J-23457-A Wrench.

- Door striker bolt using J-23457-A.
- Use tool J-22585-01 when loosening the door hinge to body side pillar bolts. The rear fender bolts may need to be loosened for access to these bolts.

🔑 Adjust

- The door up or down, forward or rearward, and in or out, at the door hinges.
- 1. Adjust the door to obtain a gap of 6 mm ± (0.24-inch ± 0.09-inch) between the rocker panel and the door.
- 2. The gap between the door and the roof panel should be 5 mm ± 2 mm (0.19-inch ± 0.09-inch).
- 3. Adjust the door to obtain a gap of 5 mm ± 2 mm (0.19-inch ± 0.09-inch) between the doors rear edge and the rear door pillar.
- 4. The gap between the door and the windshield pillar should be 2 mm ± 1.5 mm (0.08-inch ± 0.06-inch).
- 5. The door surface should be flush with the other panels within ± 1.5 mm (± 0.06-inch) except for the door to roof panel surface which should be flush within + 1.5 mm (+ 0.06-inch).
- 6. Tighten the hinge bolts.

↔ Install or Connect (Figures 2 and 3)

NOTICE: Refer to "Notice" on page 10A1-1 of this section.

1. Door striker bolt.

🔑 Adjust

- Bolt to properly engage the door lock.
- 2. Tighten the striker bolt.

🔧 Tighten

- Striker bolt to 63 N·m (46 ft. lbs.).

DOOR TRIM PANEL REPLACEMENT

↔ Remove or Disconnect (Figures 4 and 5)

Tools Required:

- J-9776-01 Door Handle Clip Remover.
- J-24595-B Door Trim Pad Clip Remover.

1. Window regulator handle using J-9886-01.
2. Lock knob.
3. Arm rest to arm rest bracket screws (77).
4. Arm rest from the door.
5. Strap assembly covers (if equipped).
6. Strap assembly screws (24) (if equipped).
7. Strap assembly (if equipped).
8. Door trim panel to door screws (22).
9. Door trim panel to door retainers using J-24595-B.
10. Door trim panel from the door.
 - Pry the top of the panel away from the door side window seal clips.

↔ Install or Connect (Figures 4 and 5)

- Check that all the trim retainers are securely fastened, and are not damaged. Replace any damaged fasteners.

1. Door trim panel onto the door side window seal clips.
2. Door trim retainers into the door panel.
3. Door trim panel to door screws (22).

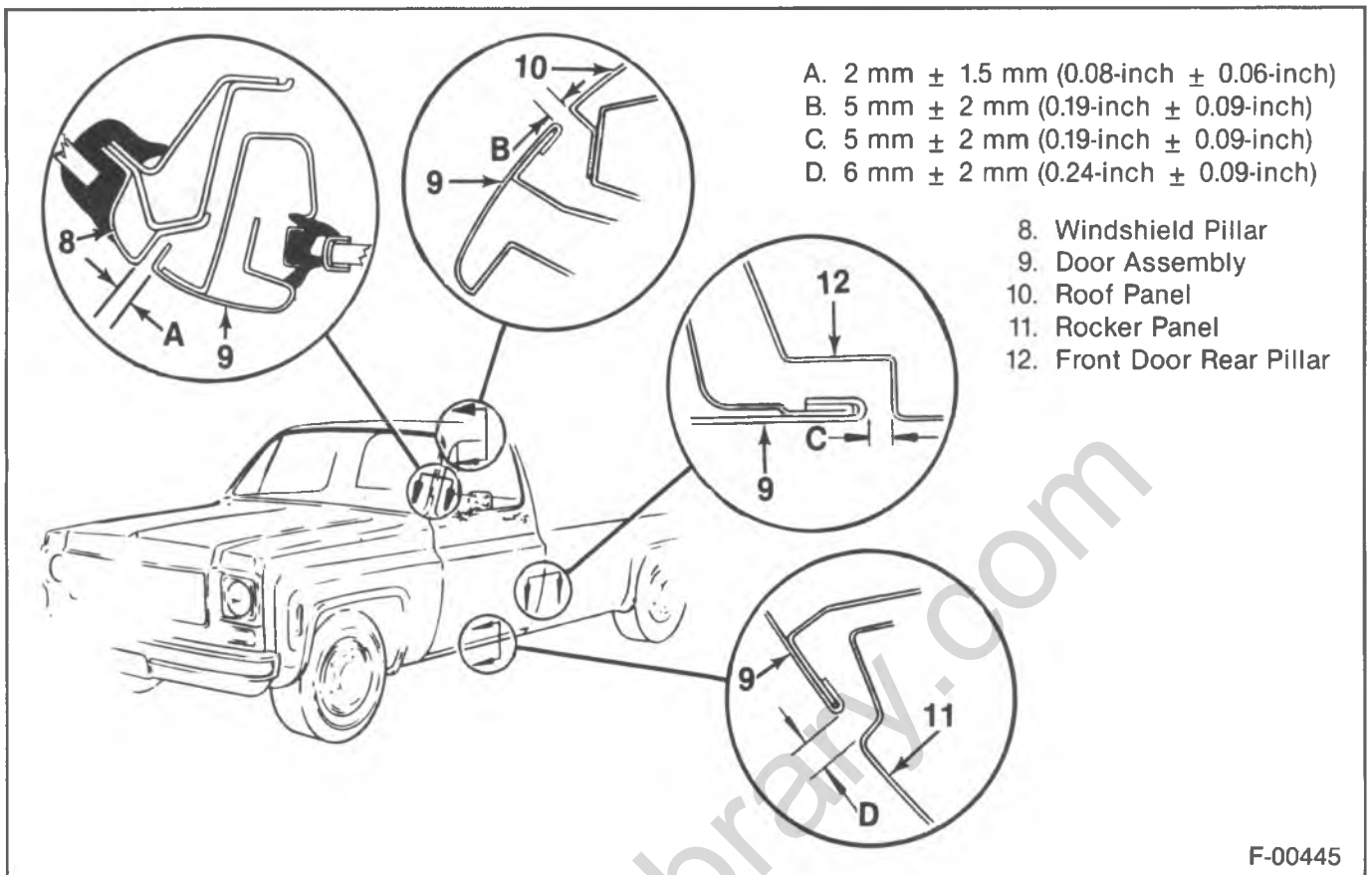

F-00445

Figure 2—Door Adjustments

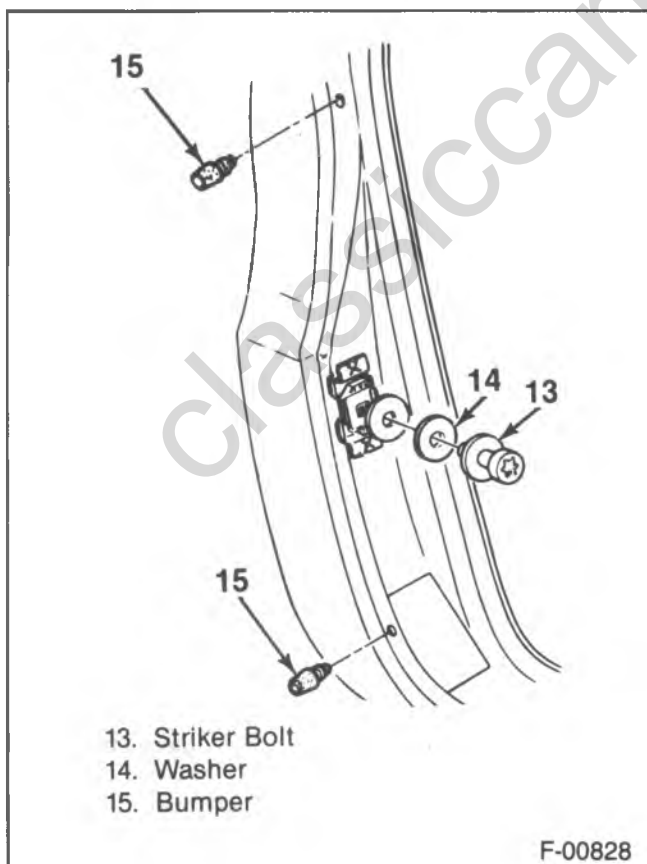

- 13. Striker Bolt
- 14. Washer
- 15. Bumper

F-00828

Figure 3—Door Striker

- 4. Strap assembly onto the door (if equipped).
- 5. Strap assembly screws (if equipped).
- 6. Strap assembly covers (if equipped).
- 7. Arm rest to the door.
- 8. Arm rest to arm rest bracket screws (77).
- 9. Lock knob.
- 10. Window regulator handle.

DOOR VENT/WINDOW RUN CHANNEL ASSEMBLY REPLACEMENT

The door vent and the front window run channel are one assembly. This assembly is fit into the front of the door frame.

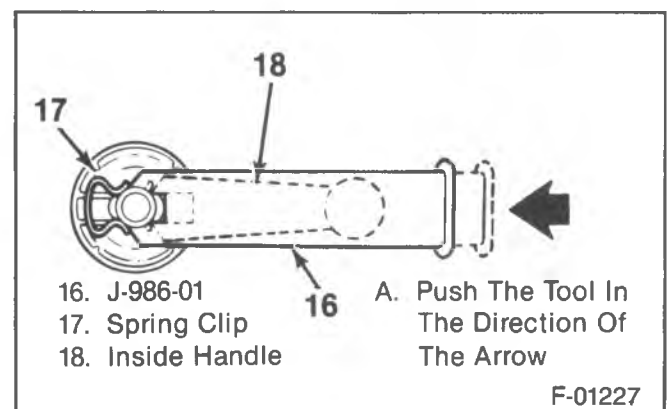

- 16. J-986-01
- 17. Spring Clip
- 18. Inside Handle
- A. Push The Tool In The Direction Of The Arrow

F-01227

Figure 4—Handle Clip Remover

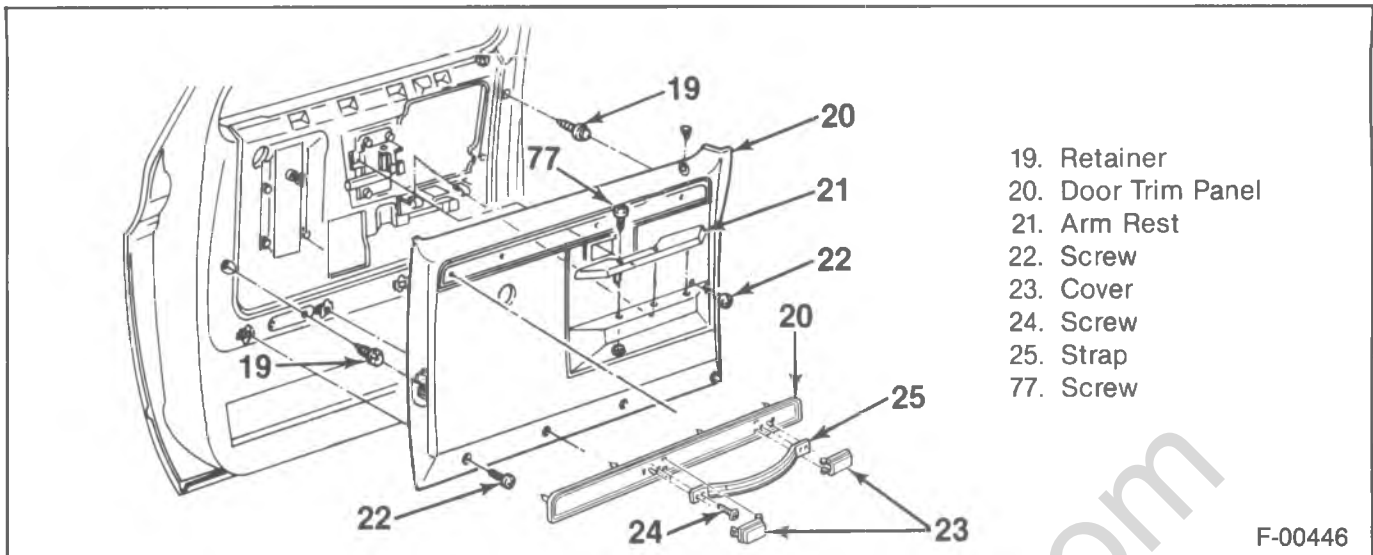

- 19. Retainer
- 20. Door Trim Panel
- 21. Arm Rest
- 22. Screw
- 23. Cover
- 24. Screw
- 25. Strap
- 77. Screw

F-00446

Figure 5—Trim Panel Components

↔ Remove or Disconnect (Figure 6)

- Place the window in the lowered position.
- 1. Door trim panel. Refer to "Door Trim Panel Replacement."
- 2. Run channel molding.
 - Pull the molding out of the vent assembly only.
- 3. Door panel to run channel bolt (31).
- 4. Door to ventilator screws (26) and spacers (27).

- 5. Door vent/window run channel assembly from the vehicle.
 - Pull the top of the vent backwards away from the door frame.
 - Lift and rotate the assembly out of the door.

↔ Install or Connect (Figure 6)

- 1. Door vent/window run channel assembly to the vehicle.
 - Rotate the vent assembly into the door.
 - Fit the assembly into the door frame.
- 2. Door to ventilator screws (26) and spacers (27).
 - Start with the screw at the top of the door, and work downward.
- 3. Door panel to run channel bolts (31).
- 4. Run channel molding.
 - Seat the clip into the vent, then push the remainder of the molding into the run channel.
- 5. Door trim panel. Refer to "Door Trim Panel Replacement."

VENT GLASS REPLACEMENT

CAUTION: Always wear heavy gloves when handling glass to minimize the risk of injury.

REMOVAL (Figure 6)

1. Open the vent window.
2. Squirt solvent on the tar-paper-like filler all around the glass channel, on both sides of the glass.
3. When the filler and sealer soften, pull the glass and the old filler from the channel.

INSTALLATION (Figure 6)

1. Thoroughly clean the inside of the glass channel with sandpaper to remove all rust and foreign matter.
2. Cut the new piece of glass channel filler 51 mm (2-inches) longer than required.
3. Position the filler (soap stoned side away from the glass) evenly around and over the edge of the glass that will be inserted in the channel. Press the filler firmly onto the edge of the glass to ensure a good

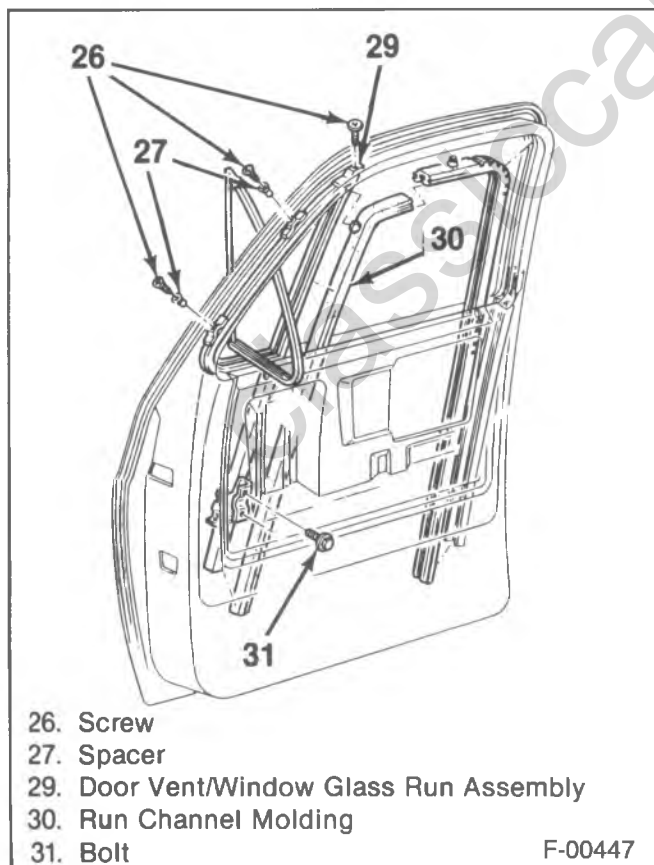

- 26. Screw
- 27. Spacer
- 29. Door Vent/Window Glass Run Assembly
- 30. Run Channel Molding
- 31. Bolt

F-00447

Figure 6—Door Vent/Window Run Channel Components

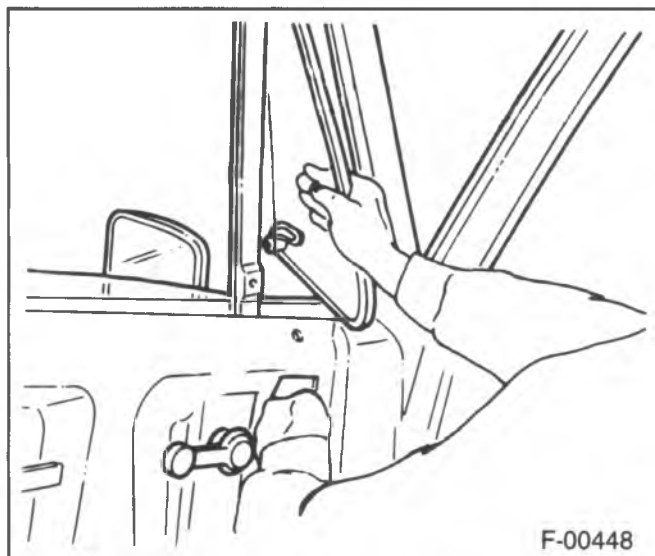

Figure 7—Vent Window Adjustment

- bond. (Usually this is done with a mechanical window press.) Squeeze together the doubled ends of the filler which project beyond the edge of the glass.
- Brush the inner channel with soap solution. DO NOT USE GREASE OR OIL.
 - Press the glass and the filler into the channel until firmly seated.
 - Trim off excess filler material around, and at the end of the channel.

VENT WINDOW ADJUSTMENT

Adjust (Figure 7)

- Remove the door trim panel. Refer to "Door Trim Panel Replacement."
- Bend the tabs on the adjustment nut away from the nut.
- Adjust the vent by placing a wrench on the adjusting nut, and then turning the vent window to the proper tension.
- Bend the tabs over the adjustment nut.
- Install the door trim panel. Refer to "Door Trim Panel Replacement."

DOOR WINDOW REPLACEMENT

Remove or Disconnect (Figure 8)

CAUTION: Always wear heavy gloves when handling glass to minimize the risk of injury.

- Lower the glass to the bottom of the door.
- Door trim panel. Refer to "Door Trim Panel Replacement."
 - Door vent/window run channel assembly. Refer to "Door Vent/Window Run Channel Assembly Replacement."
 - Mask or cover any sharp edges that could scratch the glass.
 - Door window glass.

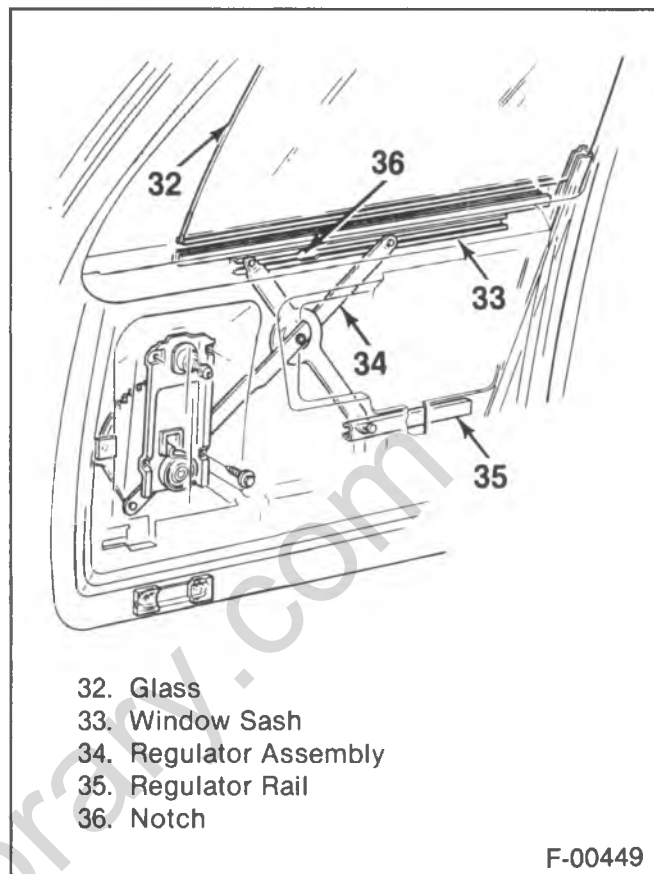

- Glass
- Window Sash
- Regulator Assembly
- Regulator Rail
- Notch

F-00449

Figure 8—Window Assembly Components

- Slide the glass forward until the front roller is in line with the notch in the sash channel. Disengage the roller from the channel.
- Push the window forward, then tilt it up until the rear roller is disengaged.
- Place the window in a level position, and raise it straight up and out of the door.

Install or Connect (Figure 8)

- Door window glass.
 - Lower the window into the door frame.
 - Push the window forward, then tilt it up, and slide the rear roller into the sash channel.
 - Slide the glass backward until the front roller is in line with the notch in the sash channel. Engage the roller to the sash channel.
 - Slide the glass rearward into the glass run channel.
- Remove any masking or covering.
- Door vent/window run channel assembly. Refer to "Door Vent/Window Run Channel Assembly Replacement."
- Door trim panel. Refer to "Door Trim Panel Replacement."

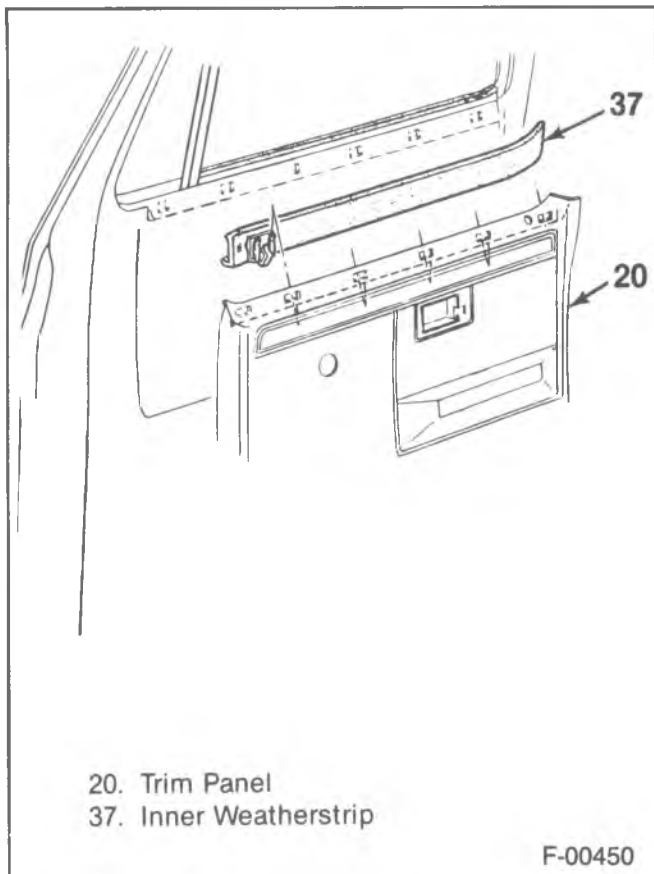

Figure 9—Inner Window Weatherstrip

INNER WINDOW WEATHERSTRIP REPLACEMENT

↔ Remove or Disconnect (Figure 9)

1. Door trim panel. Refer to "Door Trim Panel Replacement."
2. Weatherstrip (37) from the trim panel.
 - Pry the clips on the weatherstrip from the trim panel shoulder.

→ Install or Connect (Figure 9)

1. Weatherstrip (37) to the trim panel.
 - Push the weatherstrip clips onto the trim panel shoulder.
2. Door trim panel. Refer to "Door Trim Panel Replacement."

OUTER WINDOW WEATHERSTRIP REPLACEMENT

↔ Remove or Disconnect (Figure 10)

- Lower the window.
- Weatherstrip (38) from the door.
 - Pry the weatherstrip clips from the door panel.

→ Install or Connect (Figure 10)

- Weatherstrip (38) to the door.
 - Push the weatherstrip clips onto the door panel.

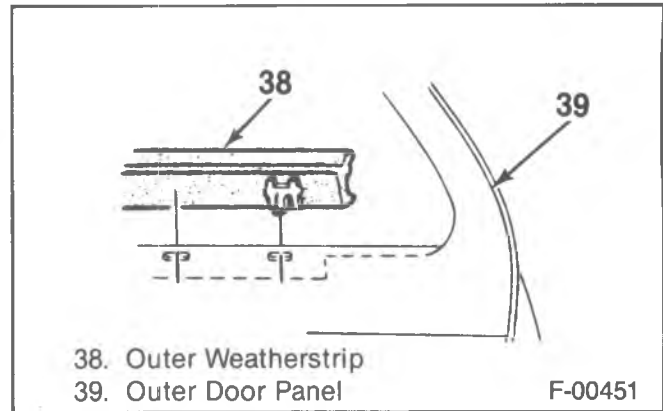

Figure 10—Outer Window Weatherstrip

REAR GLASS RUN CHANNEL REPLACEMENT

↔ Remove or Disconnect (Figure 11)

1. Door trim panel. Refer to "Door Trim Panel Replacement."
 - Lower the window completely.
2. Inner and outer window weatherstrips.
3. Door to run channel bolts (41).
4. Run channel from the vehicle.
 - Pull the run channel upwards while twisting to clear the lower bracket.

→ Install or Connect (Figure 11)

1. Run channel to the vehicle.
 - Work the run channel into the door frame. Be certain that the glass is in the channel.
2. Lower door to run channel bolt (41).
- Raise the window completely.
3. Upper door to run channel bolt (41).
4. Inner and outer window weatherstrips.
5. Door trim panel. Refer to "Door Trim Panel Replacement."

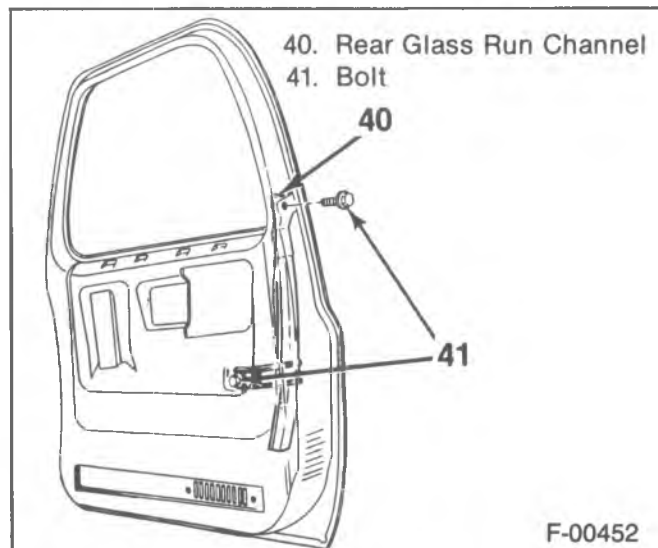
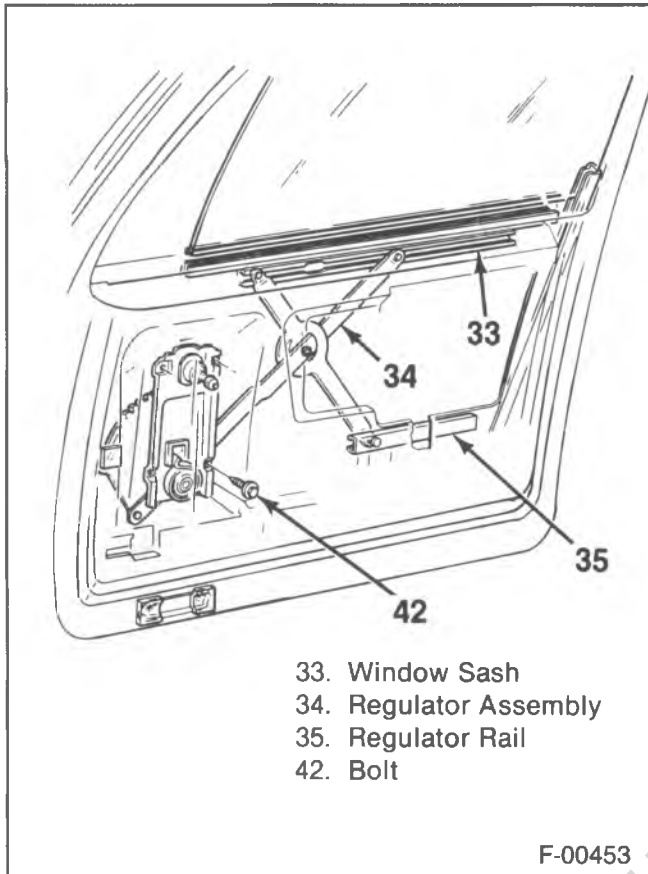

Figure 11—Rear Glass Run Channel Components



- 33. Window Sash
- 34. Regulator Assembly
- 35. Regulator Rail
- 42. Bolt

F-00453

Figure 12—Manual Window Regulator

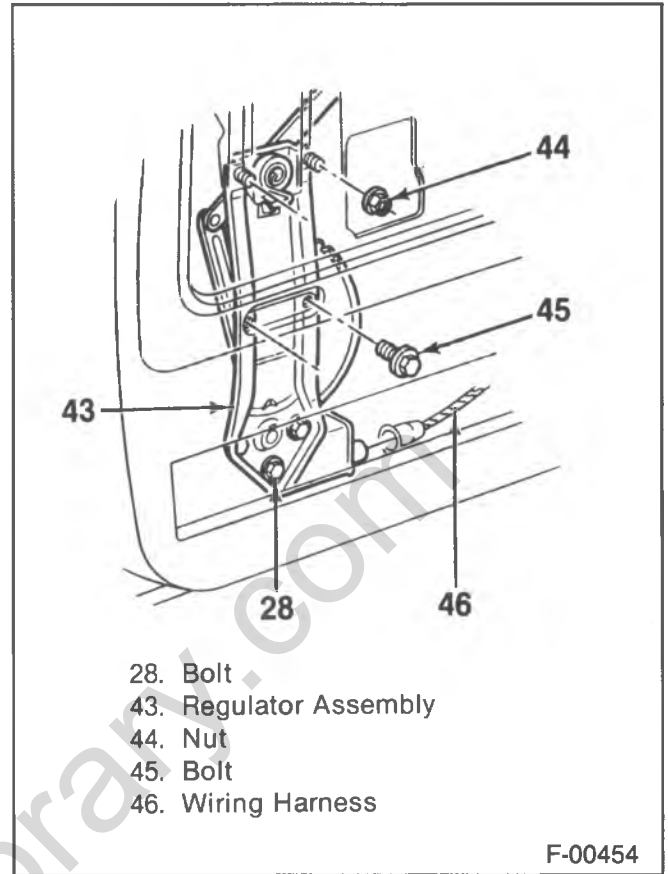

- 28. Bolt
- 43. Regulator Assembly
- 44. Nut
- 45. Bolt
- 46. Wiring Harness

F-00454

Figure 13—Power Window Regulator

WINDOW REGULATOR REPLACEMENT

MANUAL REGULATOR

↔ Remove or Disconnect (Figure 12)

- Raise the window and tape the glass in the full up position using cloth body tape.
1. Door trim panel. Refer to "Door Trim Panel Replacement."
 2. Door panel to regulator bolts (42).
 3. Window regulator.

- Slide the regulator rearward to disengage the rear roller from the sash channel. Also disengage the lower roller from the regulator rail.
- Disengage the forward roller from the sash channel at the notch in the sash channel.
- Collapse the regulator, and remove it through the access hole in the door.

↔ Install or Connect (Figure 12)

- Lubricate the regulator and the sash and regulator rails with lubriplate or equivalent.
1. Window regulator.
 - Collapse the regulator, and insert it through the access hole in the door.
 - Unfold the regulator, and engage the forward roller to the sash channel at the sash channel notch.

- Slide the regulator rearward to engage the rear roller to the sash channel. Also engage the lower roller to the regulator rail.
 - Slide the regulator into its proper position, and insert the regulator drive through the door panel.
2. Door panel to regulator bolts (42).
 3. Door trim panel. Refer to "Door Trim Panel Replacement."
- Remove the tape from the window.

POWER REGULATOR

For the diagnosis of power window circuits, refer to CAB ELECTRICAL (SEC. 8A).

↔ Remove or Disconnect (Figures 12 and 13)

- Raise the window and tape the glass in the full up position using cloth body tape.
1. Battery ground cable.
 2. Door trim panel. Refer to "Door Trim Panel Replacement."
 3. Remove control to door trim panel bolts.
 - Lay the control aside.
 4. Regulator to door panel bolts (45) and nuts (44).
 5. Wiring harness from the regulator.
 6. Window regulator.
 - Slide the regulator rearward to disengage the rear roller from the sash channel. Also disengage the lower roller from the regulator rail.
 - Disengage the forward roller from the sash channel at the notch in the sash channel.
 - Collapse the regulator, and remove it through the access hole in the door.

10A1-10 DOORS

CAUTION: The next step must be performed when the regulator is removed from the door. The regulator lift arms are under tension from the counterbalance spring and can cause serious injury if the motor is removed without locking the sector gear in position.

- Drill a hole through the regulator sector gear and back plate. Drill the hole at least 12.7 mm (1/2-inch) away from the edge of the sector gear or back plate. Install a pan head sheet metal tapping screw at least 19 mm (3/4-inch) long into the drilled hole to lock the sector gear in place.
7. Motor to regulator attaching bolts (28).
 8. Motor from the regulator.

Install or Connect (Figures 12 and 13)

- Lubricate the motor drive gear and regulator sector teeth.
1. Regulator motor to regulator.
 - The motor pinion gear teeth must mesh properly with the sector gear teeth before installing the motor to regulator screws.
 2. Regulator motor to regulator bolts (28).
 - Remove the sheet metal screw from the back plate and sector gear.
 3. Window regulator to the door.
 - Collapse the regulator, and insert it through the access hole in the door.
 - Unfold the regulator, and engage the forward roller to the sash channel at the sash channel notch.
 - Slide the regulator rearward to engage the rear roller to the sash channel. Also engage the roller to the regulator rail.
 - Slide the regulator into its proper position.
 4. Wiring harness to the regulator.
 5. Regulator to door panel bolts (45) and nuts (44).
 6. Remote control to door trim panel bolts.
 7. Door trim panel. Refer to "Door Trim Panel Replacement."
 8. Battery ground cable.
 - Remove the tape from the window.

DOOR LOCK REPLACEMENT

Remove or Disconnect (Figure 14)

- Raise the window completely.
1. Door trim panel. Refer to "Door Trim Panel Replacement."
 2. Inside door handle to lock rod clips (49).
 - Using a flat bladed screwdriver, push on the top of the clip where it is connected to the rod. Pivot the clip away from the rod.
 3. Inside door handle to lock rod from the lock.
 4. Outside door handle to lock rod clip.
 - Use the procedure given under step 2.
 5. Outside door handle to lock rod from the lock.
 6. Inside door lock knob.
 7. Door to lock assembly screws (52).
 8. Lock assembly from the door.

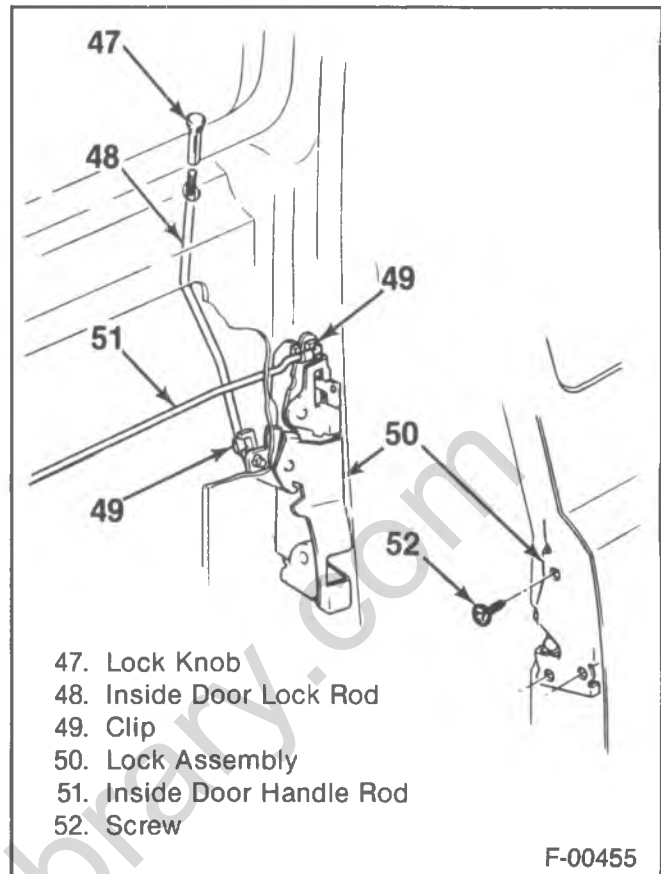

Figure 14—Door Lock Components

- Tilt the lock assembly away from the outside lock cylinder. Pull the lock assembly downward to make clearance for the inside lock rod.

Install or Connect (Figure 14)

1. Lock assembly to the door.
 - Align the inside lock rod to the hole in the door panel. Tilt the lock assembly onto the outside lock cylinder.
2. Door to lock assembly screws (52).
3. Inside door lock knob.
4. Outside door handle to lock rod onto the lock assembly.
5. Clip onto the lock rod.
 - Pivot the clip up and onto the lock rod.
6. Inside door handle to lock rod onto the lock assembly.
7. Clip onto the lock rod.
 - Pivot the clip up and onto the lock rod.
8. Door trim panel. Refer to "Door Trim Panel Replacement."

POWER DOOR LOCK MOTOR REPLACEMENT

Refer to CAB ELECTRICAL (SEC. 8A) for electrical diagnosis of the door lock motor.

Remove or Disconnect (Figure 15)

1. Battery ground cable.
2. Door trim panel. Refer to "Door Trim Panel Replacement."

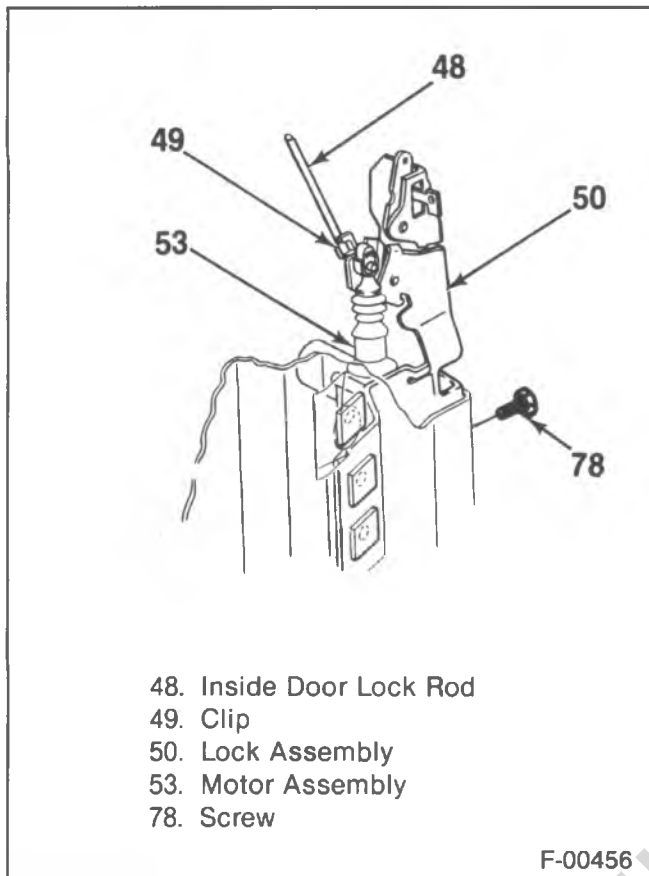

48. Inside Door Lock Rod
49. Clip
50. Lock Assembly
53. Motor Assembly
78. Screw

F-00456

Figure 15—Power Door Lock Motor

3. Electrical connector from the motor.
4. Door to motor screws (78).
5. Motor from the lock rod.
 - Slide the rubber mount at the top of the motor off of the door lock rod.
6. Motor from the door.

Install or Connect (Figure 15)

1. Motor into the door.
2. Motor to the lock rod.
 - Slide the rubber mount at the top of the motor onto the door lock rod.
3. Door to motor screws (78).
4. Electrical connector to the motor.
5. Door trim panel. Refer to "Door Trim Panel Replacement."
6. Battery ground cable.

DOOR OUTSIDE HANDLE REPLACEMENT

Remove or Disconnect (Figure 16)

- Raise the window completely.
1. Door trim panel. Refer to "Door Trim Panel Replacement."
 2. Outside door handle to lock rod clip.
 - Using a flat bladed screwdriver, push on the top of the clip where it is connected to the rod. Pivot the clip away from the rod.
 3. Outside door handle to lock rod from the lock.
 4. Door to outside handle screws (54).

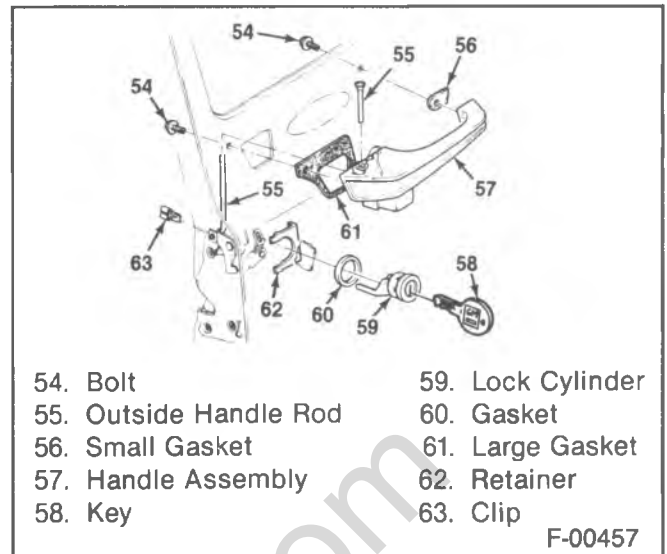

54. Bolt
55. Outside Handle Rod
56. Small Gasket
57. Handle Assembly
58. Key
59. Lock Cylinder
60. Gasket
61. Large Gasket
62. Retainer
63. Clip

F-00457

Figure 16—Outside Handle and Lock Cylinder Components

5. Handle with the control rod from the door.
6. Gaskets from the door.

Install or Connect (Figure 16)

1. Large gasket over the lock rod and onto the handle.
2. Handle with the lock rod onto the door.
3. Door to outside handle screw (54) to the push button side of the handle.
 - Do not tighten.
4. Small gasket between the door and the handle.
5. Door to outside handle screw (54) to the other side of the handle.
 - Tighten both screws.
6. Outside door handle to lock rod to the lock assembly.
7. Clip onto the lock rod.
 - Pivot the clip up and onto the lock rod.
8. Door trim panel. Refer to "Door Trim Panel Replacement."

DOOR LOCK CYLINDER REPLACEMENT

Remove or Disconnect (Figure 16)

- Raise the window completely.
1. Door trim panel. Refer to "Door Trim Panel Replacement."
 2. Lock cylinder retaining clip (62) from the cylinder.
 - Slide the clip off the cylinder with a screwdriver.
 3. Lock cylinder and gasket from the door.

Install or Connect (Figure 16)

1. Lock cylinder with gasket to the door.
 - The cylinder rod must engage the lock assembly lever.
2. Lock cylinder (62) retaining clip onto the cylinder.
3. Door trim panel. Refer to "Door Trim Panel Replacement."

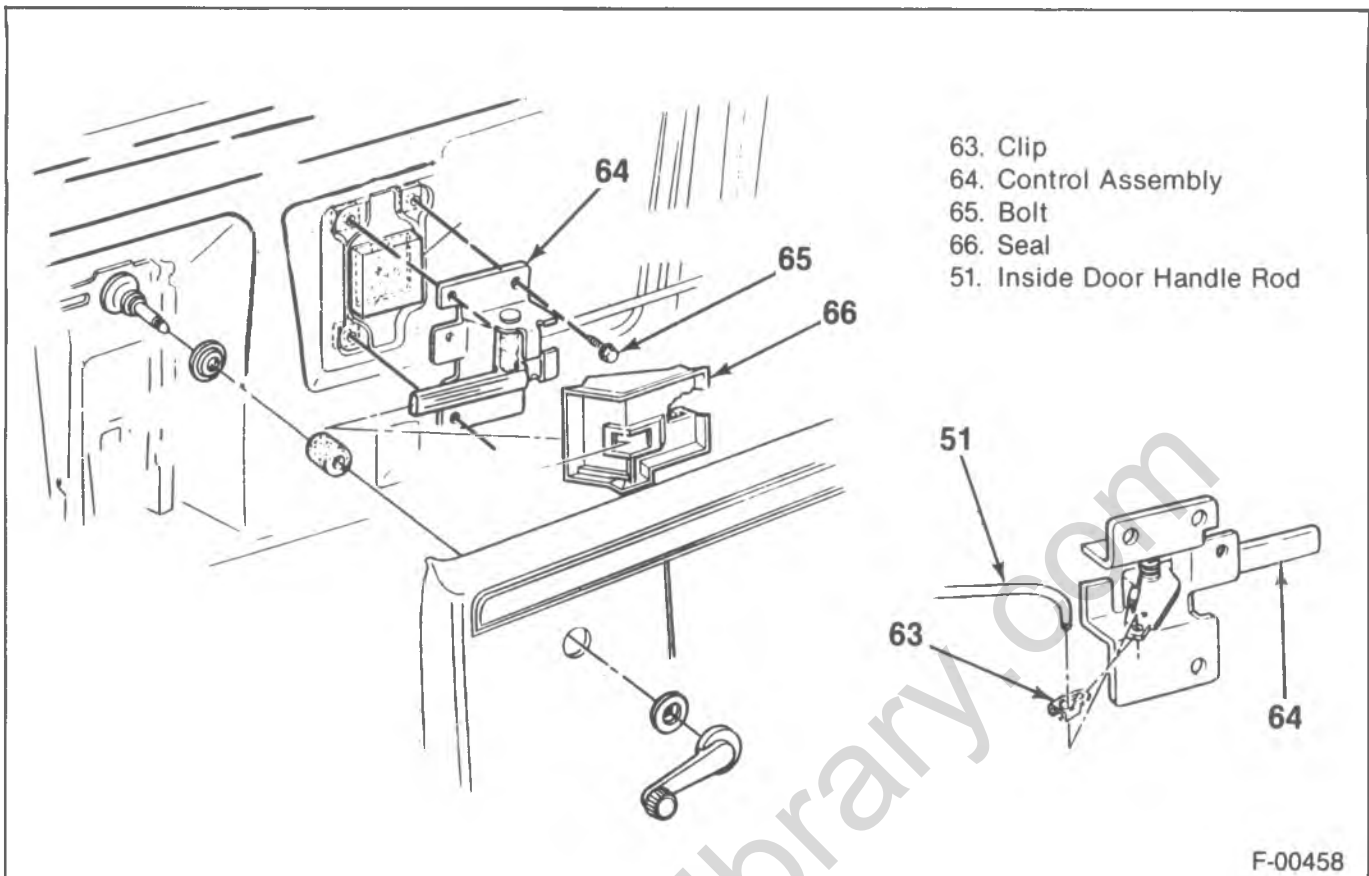

Figure 17—Door Inside Handle

DOOR INSIDE HANDLE REPLACEMENT

↔ Remove or Disconnect (Figure 17)

1. Door trim panel. Refer to "Door Trim Panel Replacement."
2. Door handle seal.
3. Handle to door screws (65).
4. Control rod from the inside handle.
 - Slide the clip so that the large diameter slot is in line with the lock rod. Then, pull the rod from the handle.
5. Inside handle from the door.

→ Install or Connect (Figure 17)

1. Control rod to the inside handle.
 - Place the rod into the clip and the lever. Slide the clip so that the small diameter slot is in line with the lock rod.
2. Handle to door screws (65).
3. Door handle seal.
4. Door trim panel. Refer to "Door Trim Panel Replacement."

DOOR WEATHERSTRIP REPLACEMENT

↔ Remove or Disconnect (Figure 18)

- Open the door.
1. Sill plate from the vehicle.
 2. Weatherstrip from the pinchweld flange.
 - Pull the weatherstrip away from the flange.

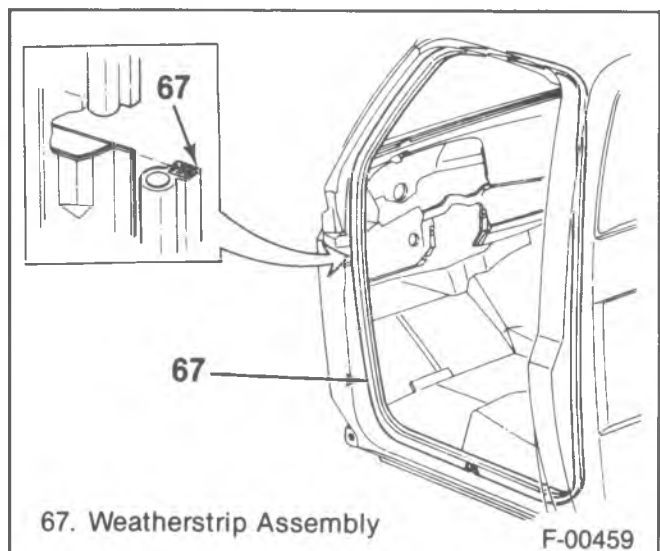

Figure 18—Front Door Weatherstrip

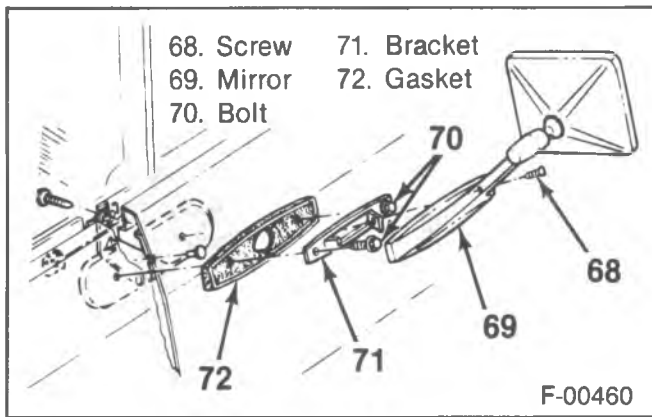

Figure 19—Outside Rear View Mirror Components

Install or Connect (Figure 18)

- Weatherstrip to the pinchweld flange.
 - Start at the bottom center of the door opening.
 - Trim the weatherstrip, and butt the ends together.
- Sill plate to the vehicle.

OUTSIDE REAR VIEW MIRROR REPLACEMENT

Remove or Disconnect (Figure 19)

- Mirror to bracket screw.
- Mirror from the door.
- Bracket to door bolts.
- Bracket and gasket from the vehicle.

Install or Connect (Figure 19)

- Bracket and gasket to the vehicle.
- Bracket to door bolts.
- Mirror to the bracket.
- Mirror to bracket screw.

BELOW EYELINE OUTSIDE REAR VIEW MIRROR REPLACEMENT

Remove or Disconnect (Figure 20)

- Mirror cover screw.
 - Lift the cover, and pivot the mirror towards the window.
- Mirror to door bolts.
- Mirror and seal from the door.

Install or Connect (Figure 20)

- Mirror and seal to the door.
- Mirror to door bolts.
 - Pivot the mirror away from the window, and lower the mirror cover.
- Mirror cover screw.

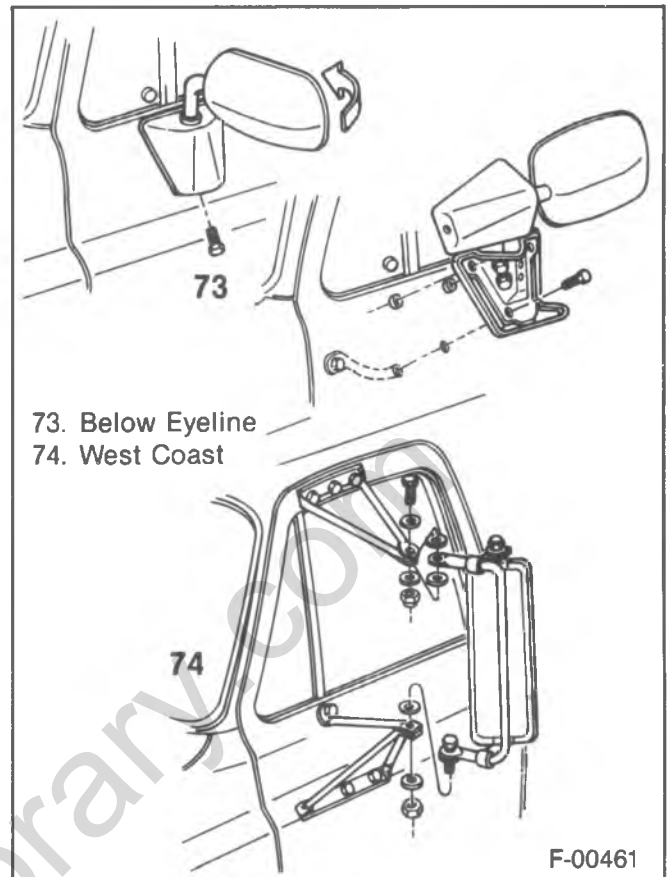

Figure 20—Below Eyeline and West Coast Style Mirrors

WEST COAST OUTSIDE REAR VIEW MIRROR REPLACEMENT

Remove or Disconnect (Figure 20)

- Mirror bracket to door bracket nuts, bolts, and bushings.
- Mirror bracket from the vehicle.
- Door bracket nuts and bolts.
- Brackets from the door.

Install or Connect (Figure 20)

- Door brackets to the door.
- Door bracket nuts and bolts.
- Mirror bracket to the door brackets.
- Mirror bracket to door bracket nuts, bolts, and bushings.

DOOR AIR VALVE REPLACEMENT

Remove or Disconnect (Figure 21)

- Door trim panel. Refer to "Door Trim Panel Replacement."
- Door to air valve screws.
- Air valve from the door.

10A1-14 DOORS

Install or Connect (Figure 21)

1. Air valve to the door.
2. Door to air valve screws.
3. Door trim panel. Refer to "Door Trim Panel Replacement."

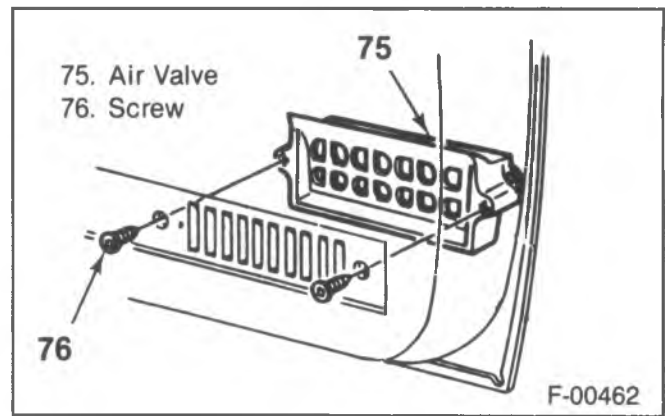

Figure 21—Door Air Valve

RV MODEL SIDE REAR DOORS

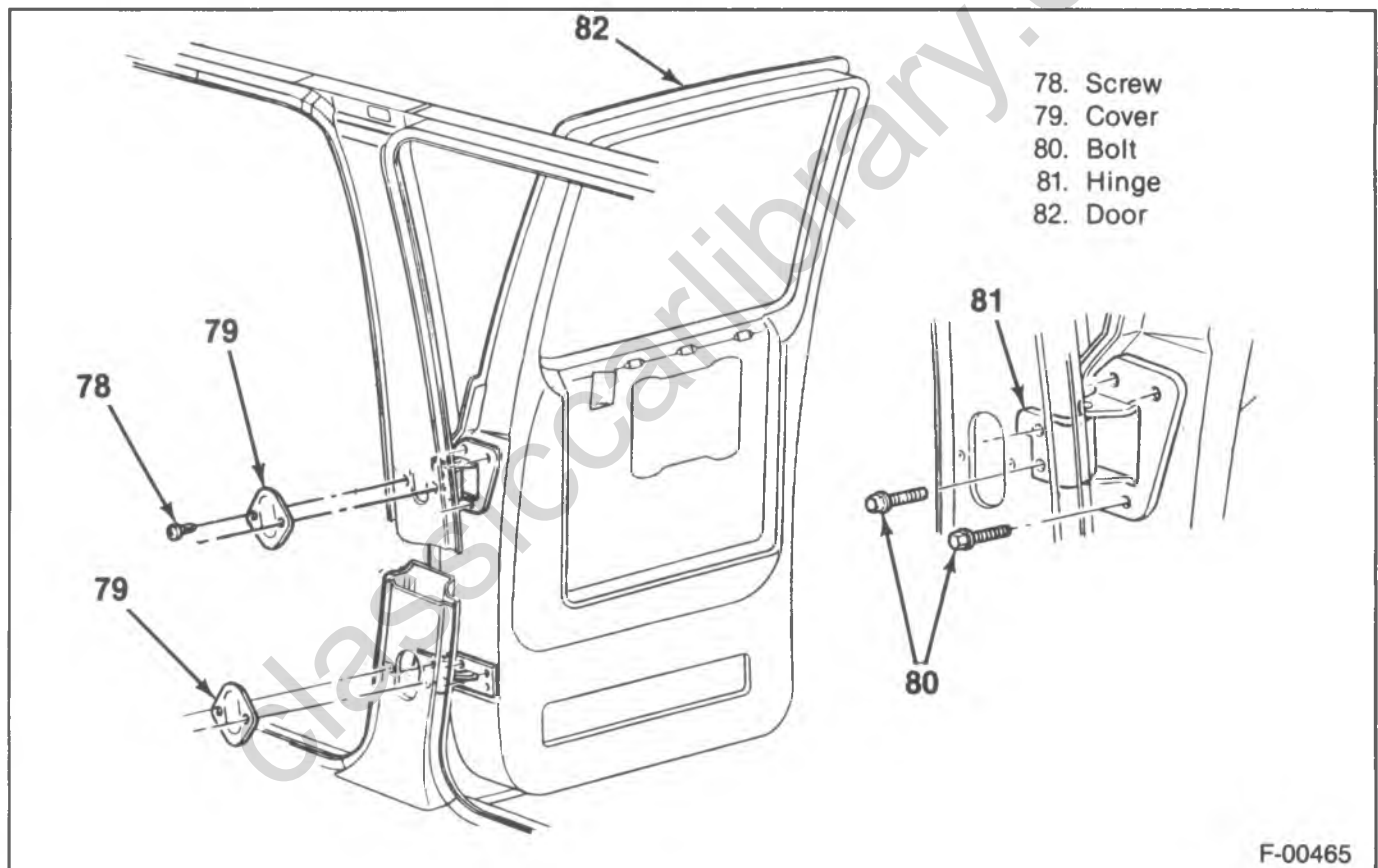

Figure 22—Door Hinge Components

DOOR AND HINGE REPLACEMENT

Remove or Disconnect (Figure 22)

- Open the door.
1. Electrical wiring harness (if equipped).
 - Refer to "Door Trim Panel Replacement" for access to the wiring harness.
 2. Inner hinge pillar cover screws (78) and covers (79).

Install or Connect (Figure 22)

1. Hinges to the door.
 - Align the hinges with the previously made marks.

3. Hinge to door pillar bolts (80).
4. Door from the vehicle.
5. Hinge to door bolts (80).
6. Hinges from the door.

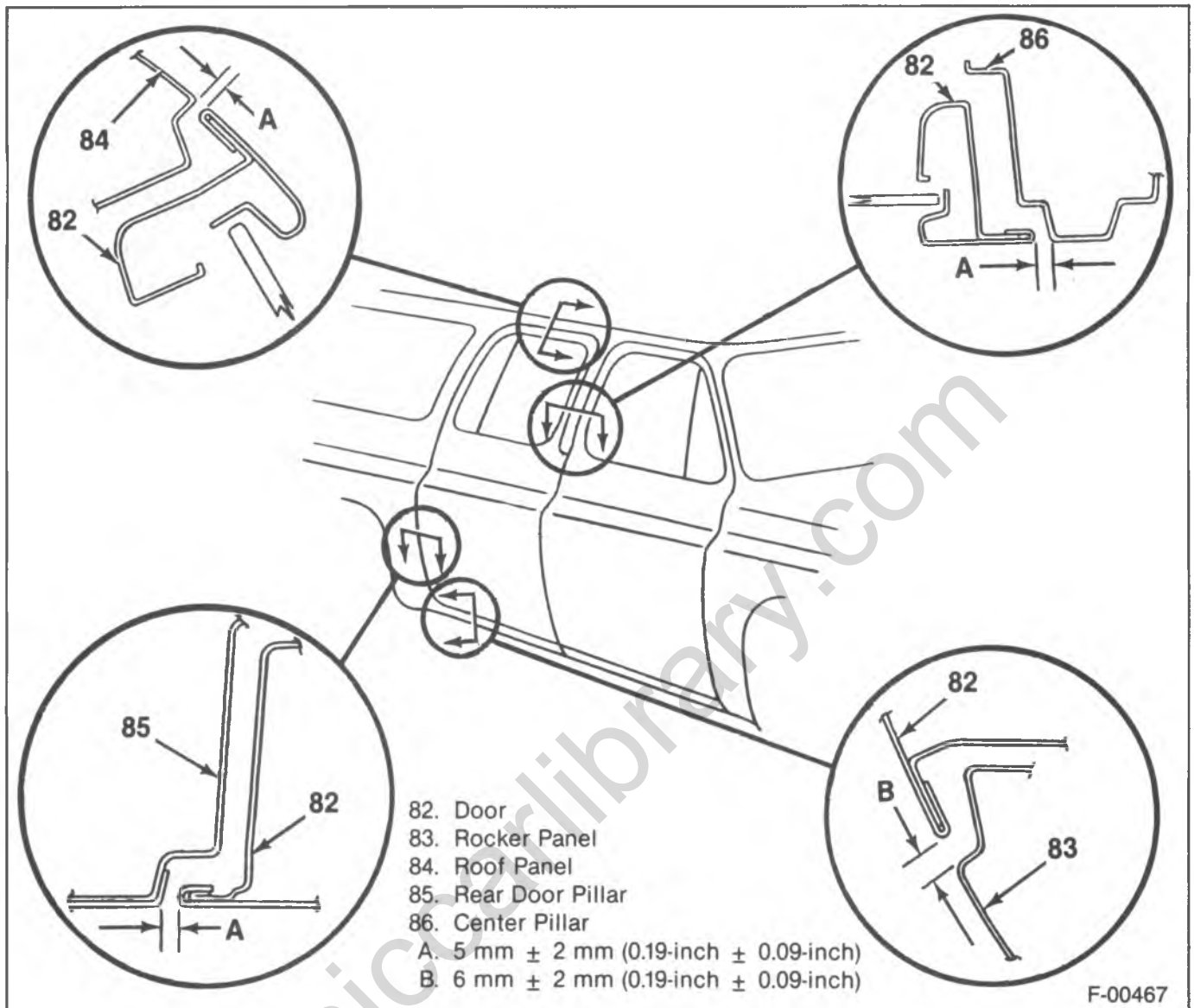

Figure 23—Door Adjustments

2. Hinge to door bolts (80).
 3. Door to the vehicle.
 - Align the hinges with the previously made marks.
 4. Hinge to door pillar bolts (80).
 5. Inner hinge pillar covers (79) and screws (78).
 6. Electrical wiring harness (if equipped).
 - Refer to "Door Trim Panel Replacement" for access to the wiring harness.
1. Adjust the door to obtain a gap of 6 mm ± 2 mm (0.24-inch ± 0.09-inch) between the rocker panel and the door.
 2. The gap between the door and the roof panel should be 5 mm ± 2 mm (0.19-inch ± 0.09-inch).
 3. Adjust the door to obtain a gap of 5 mm ± 2 mm (0.19-inch ± 0.09-inch) between the doors rear edge and the rear door pillar.
 4. The gap between the door and the center pillar should be 5 mm ± 2 mm (0.19-inch ± 0.09-inch).
 5. The door surface should be flush with the other panels within ± 1.5 mm (± 0.06-inch) except for the door to roof panel surface which should be flush within + 1.5 mm (+ 0.06-inch).

DOOR ADJUSTMENT

↔ Remove or Disconnect

Tool Required:

J-23457-A Wrench.

- Door striker bolt using J-23457-A.



Adjust (Figure 23)

- The door up or down, forward or rearward, and in or out, at the door hinges.

→← Install or Connect

NOTICE: Refer to "Notice" on page 10A1-1 of this section.

- Door striker bolt.

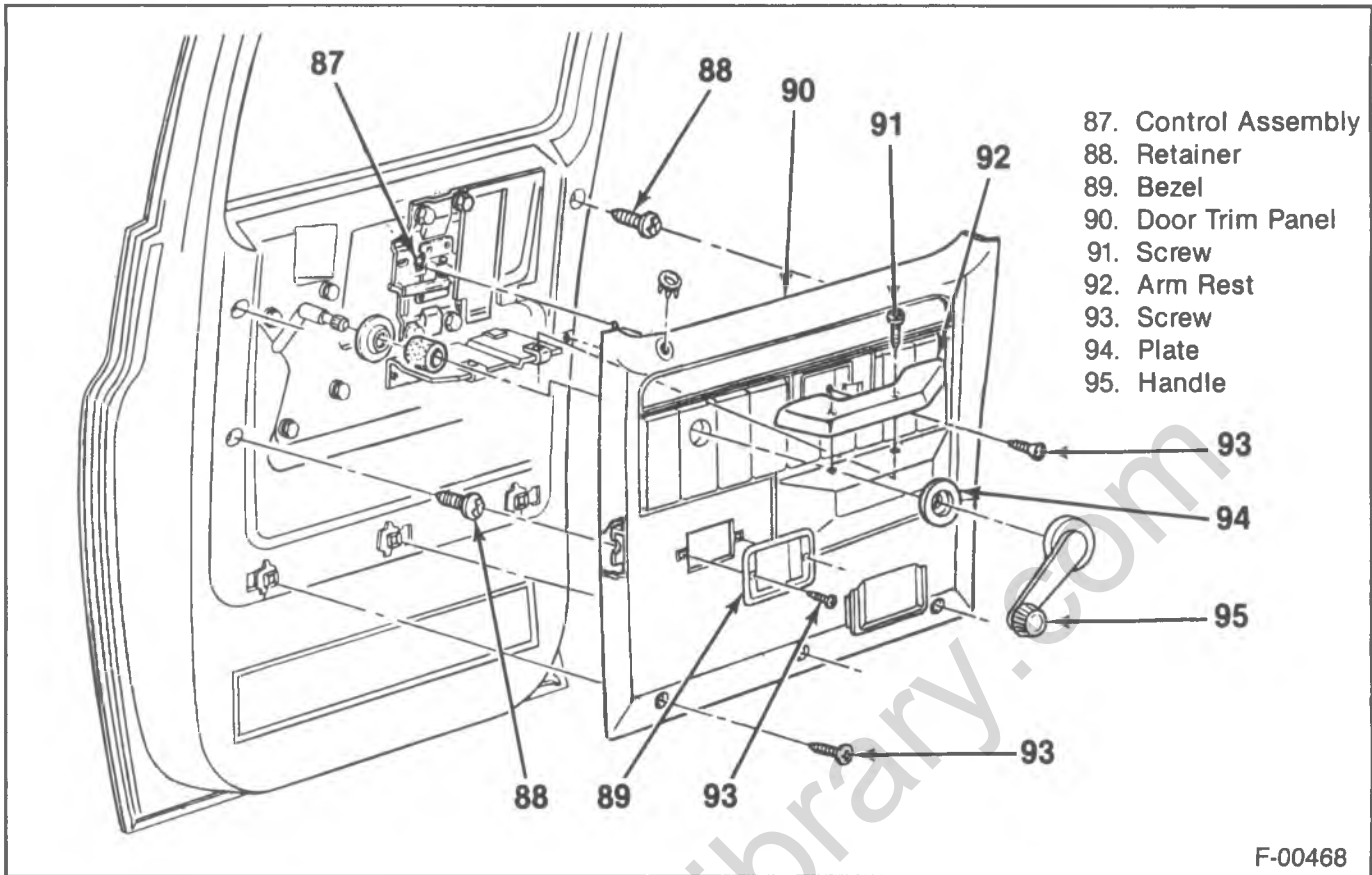

Figure 24—Door Trim Panel Components



Adjust

- Bolt to properly engage the door lock.



Tighten

- Striker bolt to 63 N·m (46 ft. lbs.).

DOOR TRIM PANEL REPLACEMENT



Remove or Disconnect (Figure 24)

Tools Required:

- J-9886-01 Door Handle Clip Remover.
- J-24595-B Door Trim Pad Clip Remover.

1. Window regulator handle using J-9886-01.
2. Lock knob.
3. Arm rest to arm rest bracket screws (91).
4. Arm rest from the door.
5. Strap assembly covers (if equipped).
6. Strap assembly screws (if equipped).
7. Strap assembly (if equipped).
8. Door trim panel to door screws (93).
9. Door trim panel to door retainers using J-24595-B.
10. Door trim panel from the door.
 - Pry the top of the panel away from the door side window seal clips.



Install or Connect (Figure 24)

- Check that all the trim retainers are securely fastened, and are not damaged. Replace any damaged fasteners.

1. Door trim panel onto the door side window seal clips.
2. Door trim retainers into the door panel.
3. Door trim panel to door screws (93).
4. Strap assembly onto the door (if equipped).
5. Strap assembly screws (if equipped).
6. Strap assembly covers (if equipped).
7. Arm rest to the door.
8. Arm rest to arm rest bracket screws (91).
9. Lock knob.
10. Window regulator handle.

STATIONARY GLASS/WINDOW RUN CHANNEL ASSEMBLY REPLACEMENT

The stationary glass and the rear window run channel are one assembly. This assembly fits into the rear of the door frame.



Remove or Disconnect (Figure 25)

- Place the window in the lowered position.
1. Door trim panel. Refer to "Door Trim Panel Replacement."
 2. Run channel molding (96).
 - Pull the molding out of the run channel only.
 3. Door panel to run channel bolt (99).
 4. Door frame to run channel screw (97).
 5. Stationary glass/window run channel assembly from the door.
 - Pull the top of the channel backwards away from the door frame.

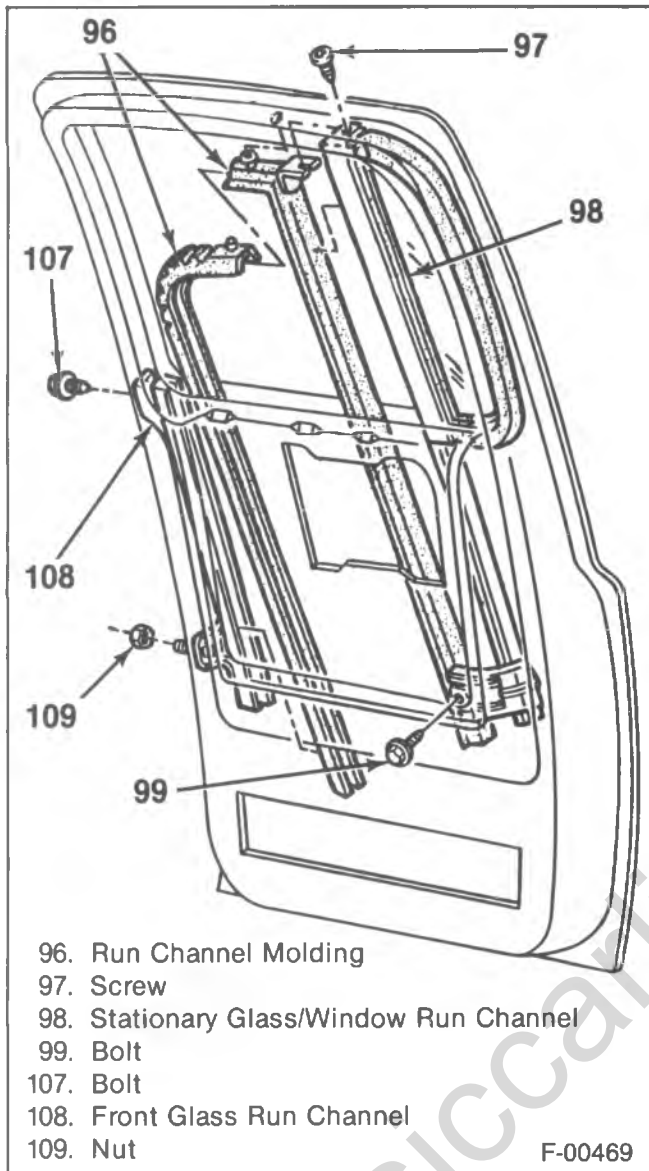

96. Run Channel Molding
 97. Screw
 98. Stationary Glass/Window Run Channel
 99. Bolt
 107. Bolt
 108. Front Glass Run Channel
 109. Nut

F-00469

Figure 25—Stationary Glass/Window Run Channel Components

- Lift and rotate the assembly out of the door.

→→ Install or Connect (Figure 25)

1. Stationary glass/window run channel assembly to the door.
 - Rotate the vent assembly into the door.
 - Fit the assembly into the door frame.
2. Run channel molding.
 - Push the molding into the run channel. The slot at the top of the molding must be on top of the run channel.
3. Door frame to run channel screw (97).
 - The screw must pass through the run channel molding slot.
4. Door panel to run channel bolt (99).
5. Door trim panel. Refer to "Door Trim Panel Replacement."

DOOR WINDOW REPLACEMENT

↔ Remove or Disconnect (Figure 26)

CAUTION: Always wear heavy gloves when handling glass to minimize the risk of injury.

- Lower the window to the bottom of the door.
1. Door trim panel. Refer to "Door Trim Panel Replacement."
 2. Stationary glass/window run channel assembly. Refer to "Stationary Glass/Window Run Channel Assembly Replacement."
- Mask or cover any sharp edges that could scratch the glass.
3. Door window glass (100).
 - Slide the glass rearward until the rear roller is in line with the notch in the sash channel. Disengage the roller from the channel.
 - Push the window rearward, then tilt it up until the front roller is disengaged.
 - Place the window in a level position, and raise it straight up and out of the door.

→→ Install or Connect (Figure 26)

1. Door window glass (100).
 - Lower the window into the door frame.
 - Push the window rearward, then tilt it up, and slide the front roller into the sash channel.
 - Slide the glass forward until the rear roller is in line with the notch in the sash channel. Engage the roller to the sash channel.
 - Slide the glass forward into the glass run channel.
- Remove any masking or covering.
2. Stationary glass/window run channel assembly. Refer to "Stationary Glass/Window Run Channel Assembly Replacement."
3. Door trim panel. Refer to "Door Trim Panel Replacement."

INNER WINDOW WEATHERSTRIP REPLACEMENT

↔ Remove or Disconnect (Figure 27)

1. Door trim panel. Refer to "Door Trim Panel Replacement."
2. Weatherstrip from the trim panel.
 - Pry the clips on the weatherstrip from the trim panel shoulder.

→→ Install or Connect (Figure 27)

1. Weatherstrip to the trim panel.
 - Push the weatherstrip clips onto the trim panel shoulder.
2. Door trim panel. Refer to "Door Trim Panel Replacement."

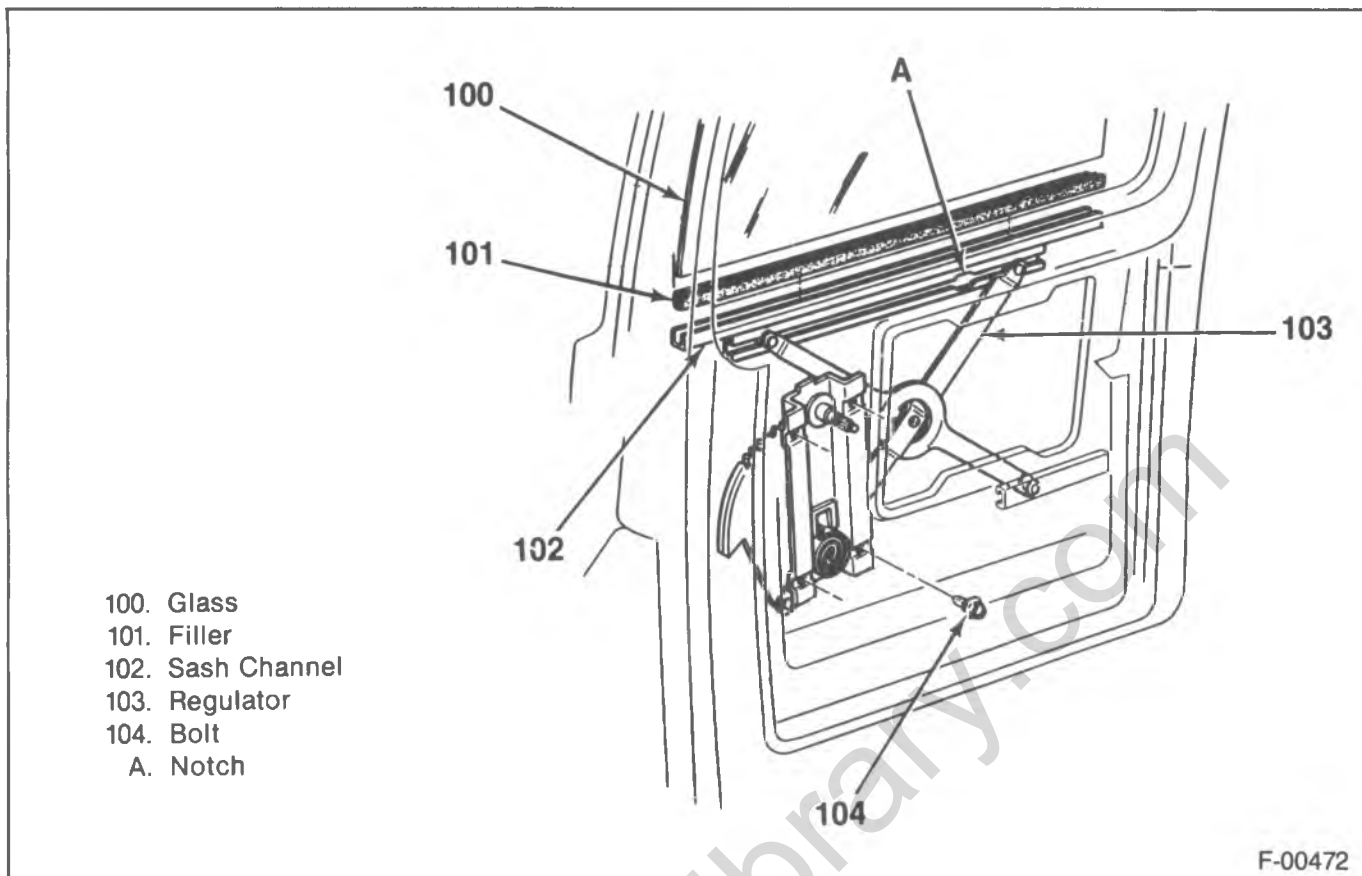

Figure 26—Window Assembly Components

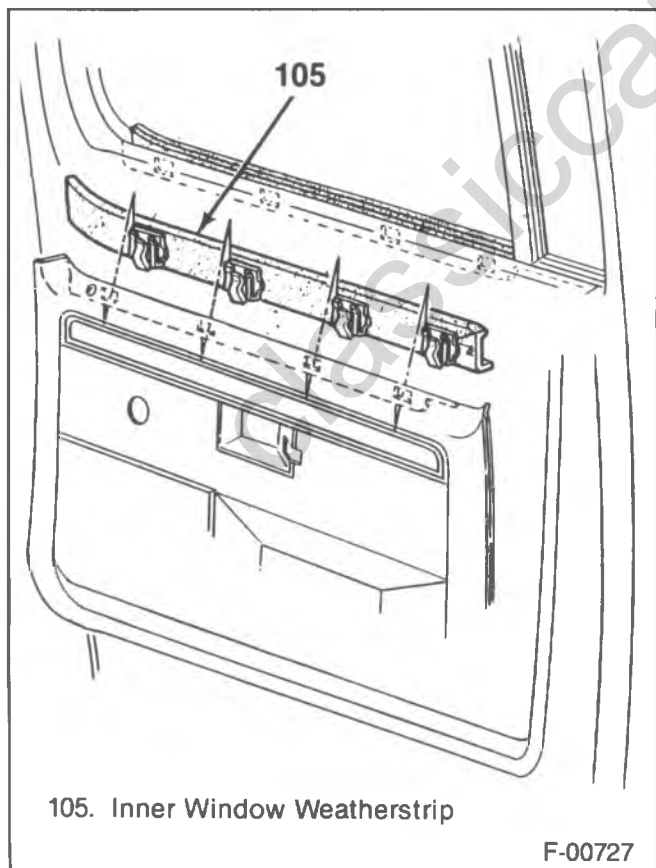

Figure 27—Inner Window Weatherstrip

OUTER WINDOW WEATHERSTRIP REPLACEMENT

←→ Remove or Disconnect (Figure 28)

- Lower the window.
- 1. Weatherstrip from the door.
 - Pry the weatherstrip clips from the door panel.

←→ Install or Connect (Figure 28)

- 1. Weatherstrip to the door.
 - Push the weatherstrip clips onto the door panel.

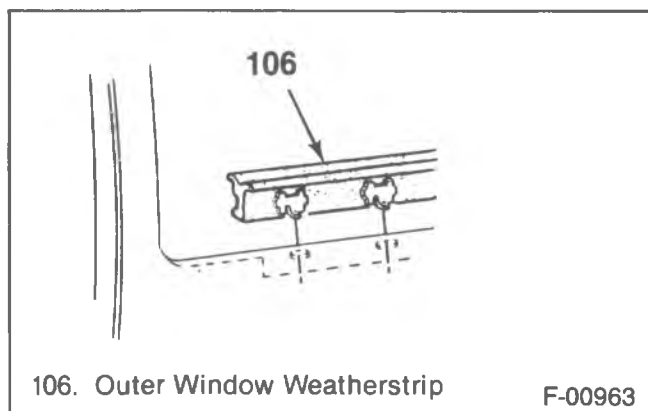

Figure 28—Outer Window Weatherstrip

FRONT GLASS RUN CHANNEL REPLACEMENT

↔ Remove or Disconnect (Figure 25)

- Lower the window completely.
- 1. Outer window weatherstrip.
- 2. Door to run channel bolt (107) and nut (109).
- 3. Run channel from the vehicle.
 - Pull the run channel upwards while twisting to clear the lower bracket.

↔ Install or Connect (Figure 25)

- 1. Run channel to the vehicle.
 - Work the run channel into the door frame. Be certain that the glass is in the channel.
- 2. Door to run channel bolt (107) and nut (109).
- 3. Outer window weatherstrip.

WINDOW REGULATOR REPLACEMENT

MANUAL REGULATOR

↔ Remove or Disconnect (Figure 26)

- 1. Door trim panel. Refer to "Door Trim Panel Replacement."
- 2. Door window. Refer to "Door Window Replacement."
- 3. Door panel to regulator bolts (104).
- 4. Window regulator.
 - Collapse the regulator, and remove it through the access hole in the door.

↔ Install or Connect (Figure 26)

- Lubricate the regulator and the sash and regulator rails with lubriplate or equivalent.
- 1. Window regulator.
 - Collapse the regulator, and insert it through the access hole in the door.
- 2. Door panel to regulator bolts (104).
- 3. Door windows. Refer to "Door Window Replacement."
- 4. Door trim panel. Refer to "Door Trim Panel Replacement."

POWER REGULATOR

For the diagnosis of power window circuits, refer to CAB ELECTRICAL (SEC. 8A).

↔ Remove or Disconnect (Figure 29)

- 1. Battery ground cable.
- 2. Door trim panel. Refer to "Door Trim Panel Replacement."
- 3. Door window. Refer to "Door Window Replacement."
- 4. Regulator to door panel bolts (110) and nuts (112).
- 5. Wiring harness from the regulator.
- 6. Window regulator.
 - Collapse the regulator, and remove it through the access hole in the door.

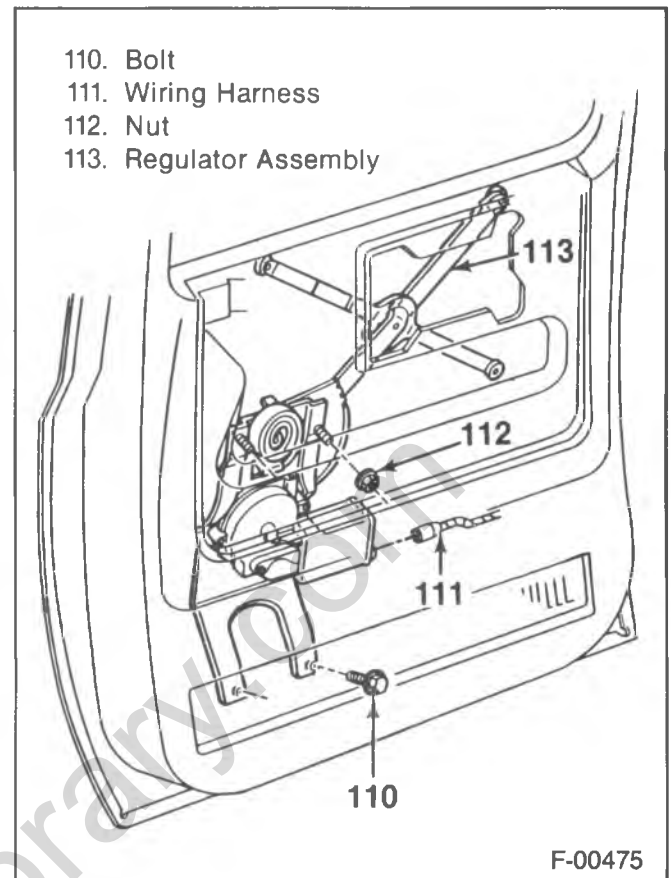

Figure 29—Power Regulator

CAUTION: The next step must be performed when the regulator is removed from the door. The regulator lift arms are under tension from the counterbalance spring and can cause serious injury if the motor is removed without locking the sector gear in position.

- Drill a hole through the regulator sector gear and back plate. Drill the hole at least 12.7 mm (1/2-inch) away from the edge of the sector gear or back plate. Install a pan head sheet metal tapping screw at least 19 mm (3/4-inch) long into the drilled hole to lock the sector gear in place.
- 7. Motor to regulator attaching screws.
- 8. Motor from the regulator.

↔ Install or Connect (Figure 29)

- Lubricate the motor drive gear and regulator sector teeth.
- 1. Regulator motor to regulator.
 - The motor pinion gear teeth must mesh properly with the sector gear teeth before installing the motor to regulator screws.
- 1. Regulator motor to regulator screws.
- Remove the sheet metal screw from the back plate and sector gear.
- 3. Window regulator to the door.
 - Collapse the regulator, and insert it through the access hole in the door.
- 4. Wiring harness to the regulator.
- 5. Regulator to door panel bolts (110) and nuts (112).
- 6. Door window. Refer to "Door Window Replacement."

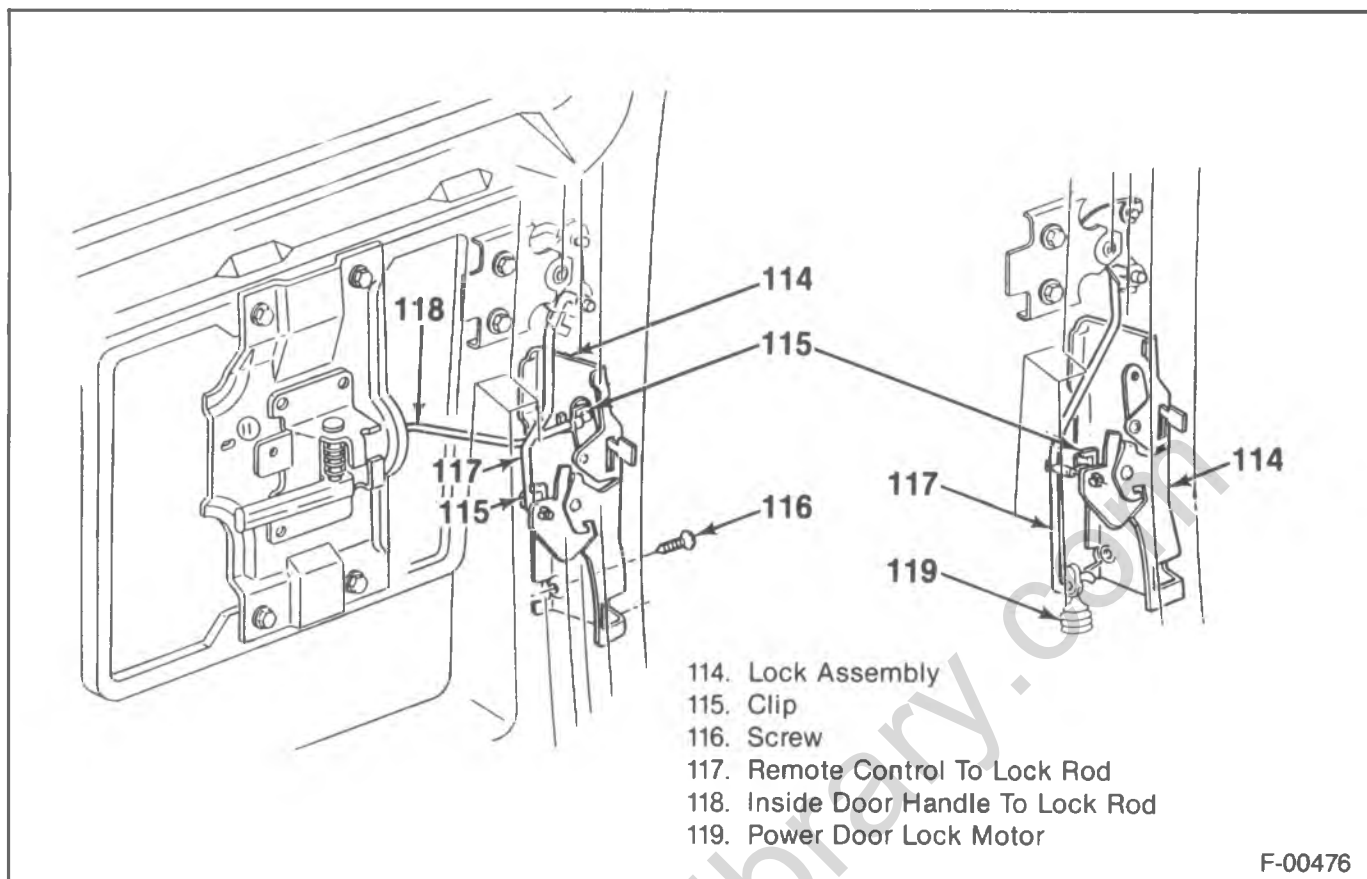

Figure 30—Door Lock Components

7. Door trim panel. Refer to "Door Trim Panel Replacement."
8. Battery ground cable.

DOOR LOCK REPLACEMENT

↔ Remove or Disconnect (Figure 30)

- Raise the window completely.
1. Door trim panel. Refer to "Door Trim Panel Replacement."
 2. Inside door handle to lock rod clip (115).
 - Using a flat bladed screwdriver, push on the top of the clip where it is connected to the rod. Pivot the clip away from the rod.
 3. Inside door handle to lock rod from the lock.
 4. Outside door handle to lock rod clip.
 - Use the procedure given under step 2.
 5. Outside door handle to lock rod from the lock.
 6. Remove control to lock assembly clip and rod.
 7. Door to lock assembly screws (116).
 8. Lock assembly from the door.
 - Tilt the lock assembly away from the outside lock cylinder. Pull the lock assembly downward to make clearance for the inside lock rod.

↔ Install or Connect (Figure 30)

1. Lock assembly to the door.
 - Tilt the lock assembly onto the outside lock cylinder.
2. Door to lock assembly screws (116).
3. Remote control to lock assembly rod and clip.

4. Outside door handle to lock rod onto the lock assembly.
5. Clip onto the lock rod.
 - Pivot the clip up and onto the lock rod.
6. Inside door handle to lock rod onto the lock assembly.
7. Clip onto the lock rod.
 - Pivot the clip up and onto the lock rod.
8. Door trim panel. Refer to "Door Trim Panel Replacement."

POWER DOOR LOCK MOTOR REPLACEMENT

Refer to CAB ELECTRICAL (SEC. 8A) for electrical diagnosis of the door lock motor.

↔ Remove or Disconnect (Figure 30)

1. Battery ground cable.
2. Door trim panel. Refer to "Door Trim Panel Replacement."
3. Electrical connector from the motor.
4. Door to motor screws.
5. Motor from the lock rod.
 - Slide the rubber mount at the top of the motor off of the door lock rod.
6. Motor from the door.

↔ Install or Connect (Figure 30)

1. Motor into the door.
2. Motor to the lock rod.

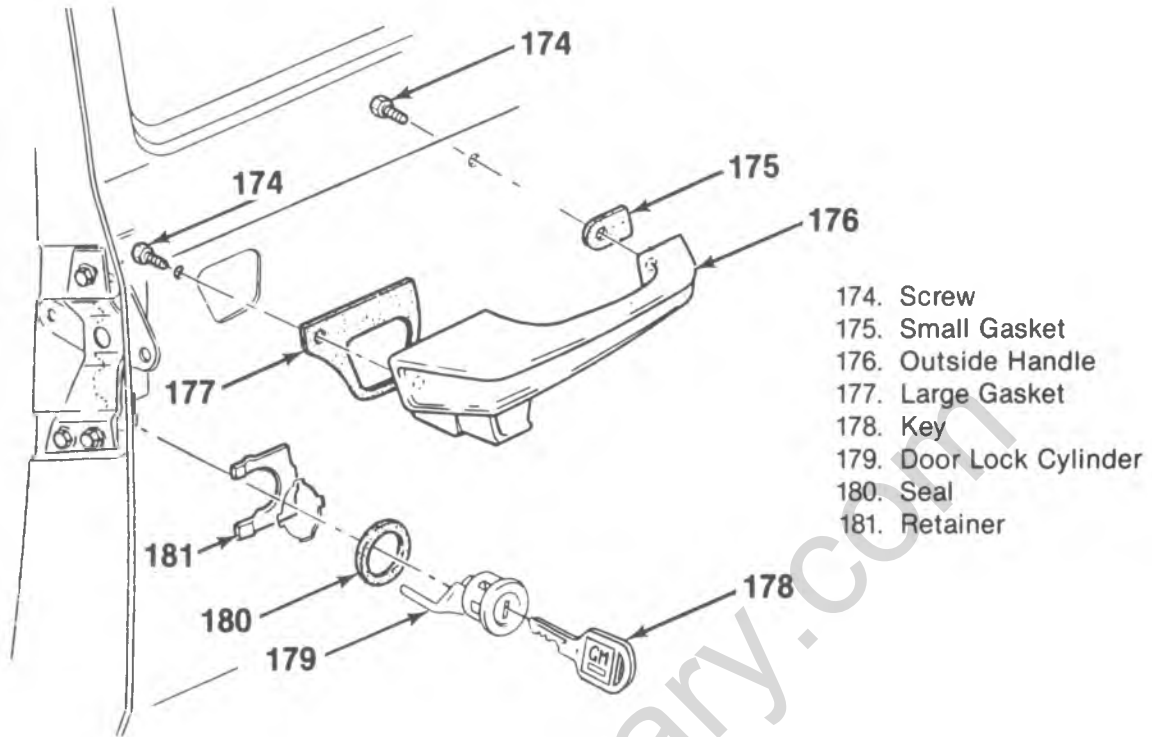

- 174. Screw
- 175. Small Gasket
- 176. Outside Handle
- 177. Large Gasket
- 178. Key
- 179. Door Lock Cylinder
- 180. Seal
- 181. Retainer

F-00477

Figure 31—Door Outside Handle Components

- Slide the rubber mount at the top of the motor onto the door lock rod.
3. Door to motor screws.
 4. Electrical connector to the motor.
 5. Door trim panel. Refer to "Door Trim Panel Replacement."
 6. Battery ground cable.

DOOR OUTSIDE HANDLE REPLACEMENT

↔ Remove or Disconnect (Figure 31)

- Raise the window completely.
1. Door trim panel. Refer to "Door Trim Panel Replacement."
 2. Outside door handle to lock rod clip.
 - Using a flat bladed screwdriver, push on the top of the clip where it is connected to the rod. Pivot the clip away from the rod.
 3. Outside door handle to lock rod from the lock.
 4. Door to outside handle screws (120).
 5. Handle with the control rod from the door.
 6. Gaskets from the door.

↔ Install or Connect (Figure 31)

1. Large gasket over the lock rod and onto the handle.
2. Handle with the lock rod onto the door.
3. Door to outside handle screw (120) to the push button side of the handle.
 - Do not tighten.
4. Small gasket between the door and the handle.

5. Door to outside handle screw (120) to the other side of the handle.
 - Tighten both screws.
6. Outside door handle to lock rod to the lock assembly.
7. Clip onto the lock rod.
 - Pivot the clip up and onto the lock rod.
8. Door trim panel. Refer to "Door Trim Panel Replacement."

DOOR INSIDE HANDLE REPLACEMENT

↔ Remove or Disconnect (Figure 32)

1. Door trim panel. Refer to "Door Trim Panel Replacement."
2. Door handle seal.
3. Handle assembly to door screws (131).
4. Control rod from the inside handle.
 - Slide the clip so that the large diameter slot is in line with the lock rod. Then, pull the rod from the handle.
5. Inside handle from the door.

↔ Install or Connect (Figure 32)

1. Control rod to the inside handle.
 - Place the rod into the clip and the lever. Slide the clip so that the small diameter slot is in line with the lock rod.
2. Handle assembly to door screws (131).
3. Door handle seal.
4. Door trim panel. Refer to "Door Trim Panel Replacement."

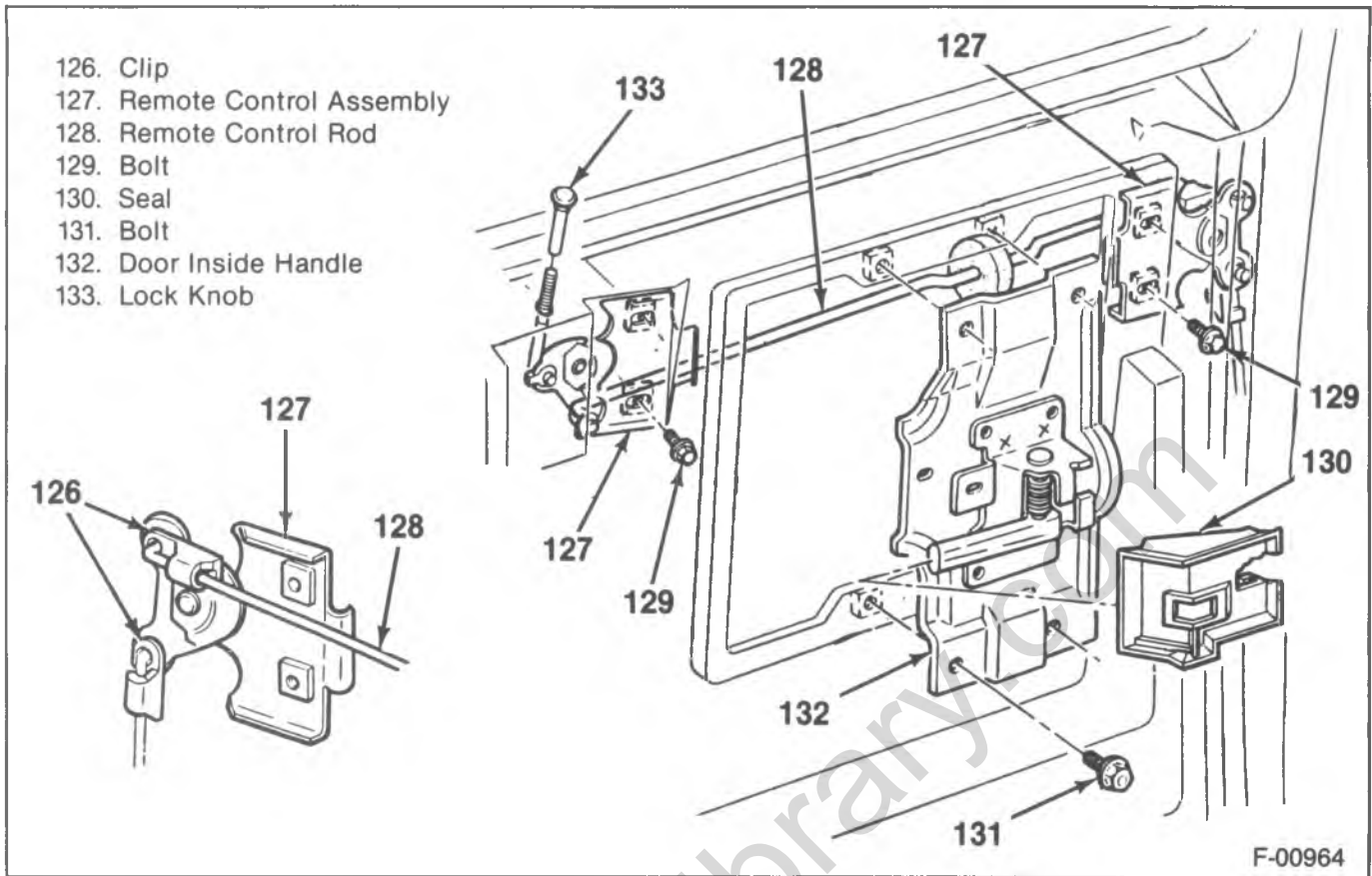

Figure 32—Door Inside Handle Components

REMOTE CONTROL REPLACEMENT

↔ Remove or Disconnect (Figure 32)

1. Door trim panel. Refer to "Door Trim Panel Replacement."
2. Remote control to lock assembly rod.
 - Using a flat bladed screwdriver, push on the top of the clip where it is connected to the rod. Pivot the clip away from the rod.
 - Pull the rod from the remote control.
3. Door panel to remote control bolts (129).
4. Remote control levers and rods through the access hole.

↔ Install or Connect (Figure 32)

1. Remote control levers and rods through the access hole.
2. Door panel to remote control bolts (129).
3. Remote control to lock assembly rod.
 - Pivot the clip up and onto the lock rod.
4. Door trim panel. Refer to "Door Trim Panel Replacement."

DOOR WEATHERSTRIP REPLACEMENT

↔ Remove or Disconnect (Figure 33)

- Open the door.

 1. Sill plate from the vehicle.
 2. Weatherstrip from the pinchweld flange.

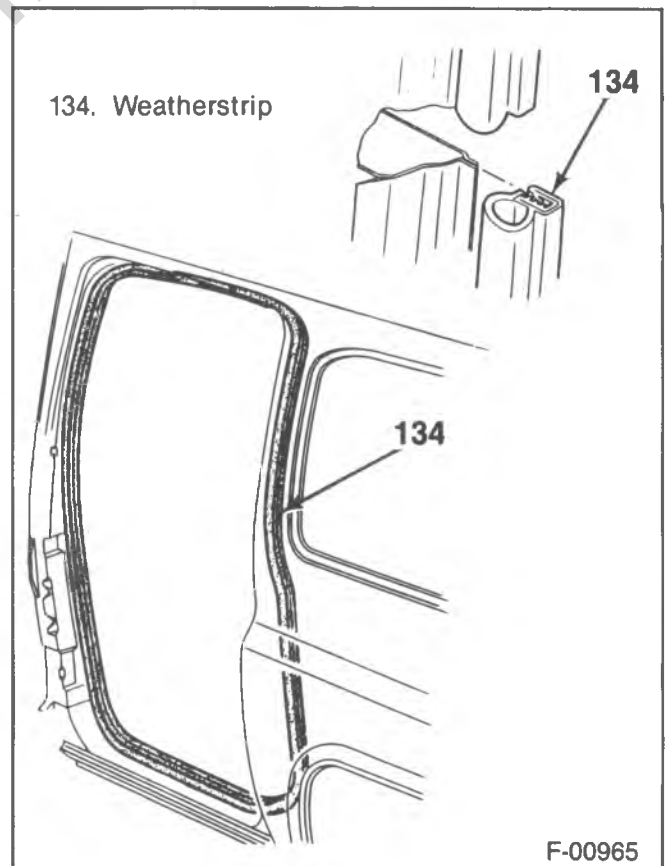

Figure 33—Door Weatherstrip

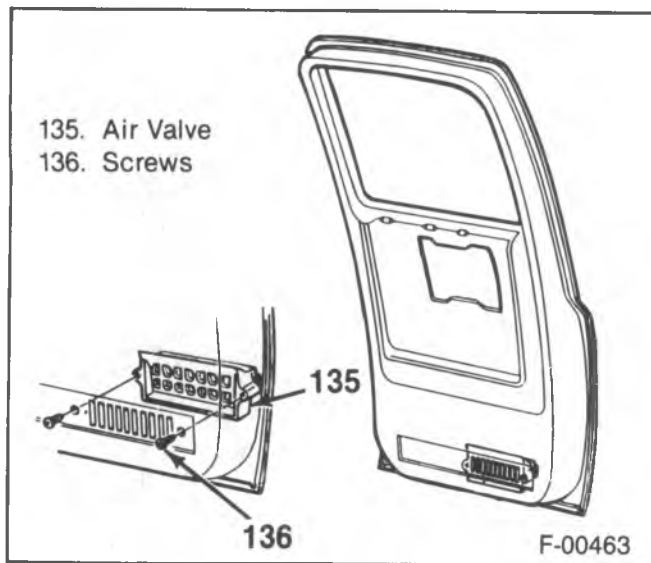

Figure 34—Door Air Valve

↔ Install or Connect (Figure 33)

- Weatherstrip to the pinchweld flange.
 - Start at the bottom center of the door opening.
 - Trim the weatherstrip, and butt the ends together.
- Sill plate to the vehicle.

DOOR AIR VALVE REPLACEMENT

↔ Remove or Disconnect (Figure 34)

- Door trim panel. Refer to "Door Trim Panel Replacement."
- Door to air valve screws.
- Air valve from the door.

↔ Install or Connect (Figure 34)

- Air valve to the door.
- Door to air valve screws.
- Door trim panel. Refer to "Door Trim Panel Replacement."

RV MODEL REAR DOORS

DOOR AND HINGE REPLACEMENT

↔ Remove or Disconnect (Figure 35)

- Mark the position of the door and the door opening on the hinges.
- Strap pin.
 - Electrical wiring harness (if equipped).
 - Refer to "Door Trim Panel Replacement" for access to the wiring harness.
 - Rear door hinge access plug screw, and the access plug (if equipped).
 - Door to hinge bolts (139).
 - Door from the vehicle.
 - Door opening to hinge bolts (137).
 - Hinges from the door opening.

↔ Install or Connect (Figure 35)

- Hinges to the door opening.
 - Align the hinge with the previously made mark.
- Door opening to the hinge bolts (137).
- Door to the vehicle.
 - Align the hinge with the previously made mark.
- Door to hinge bolts (139).
- Rear door hinge access plug and screw (if equipped).
- Electrical wiring harness (if equipped).
 - Refer to "Door Trim Panel" for access to the wiring harness.
- Strap pin.

DOOR ADJUSTMENT

Each of the two doors must first be adjusted in the door opening before adjusting the door to door clearance.

🔑 Adjust (Figure 36)

- The door height so that there is a gap of 5 mm \pm 2.3 mm (0.190-inch \pm 0.09-inch) between the roof panel and the rear door panel.
- The gap between the bottom of the door panel (not the bottom of the outer panel) and the platform panel should be 7 mm (0.280-inch). This measurement should be taken on each door individually from the side of the door. The door should be in its normal closed position. (The outer rear door panel is 14 mm \pm 1.5 mm (0.560-inch \pm 0.06-inch) away from the rear platform panel when normally closed).
- The rear door outer panel to the body side outer panel gap to 5 mm \pm 2.3 mm (0.190-inch \pm 0.09-inch).
- The door to door clearance between the left and right outer door panels should be 5 mm \pm 2.3 mm (0.190-inch \pm 0.09-inch).

STRIKER REPLACEMENT

↔ Remove or Disconnect (Figure 37)

- Striker to door frame bolts (150).
- Striker from the door frame.
- Spacer (if equipped).

↔ Install or Connect (Figure 37)

- Spacer (as required).
- Striker to the door frame.
- Striker to door frame bolts (150).

10A1-24 DOORS

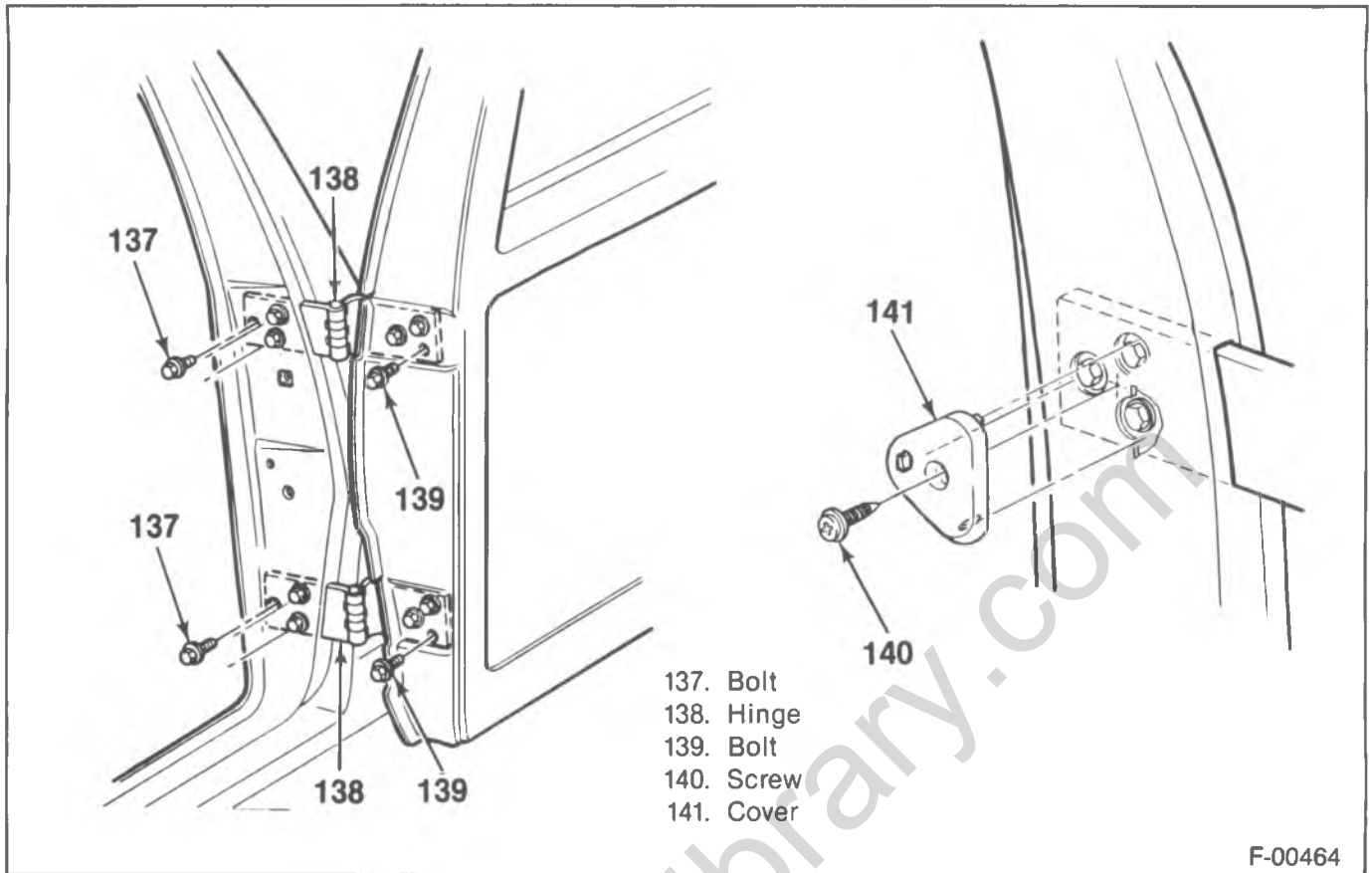

Figure 35—Hinge Components

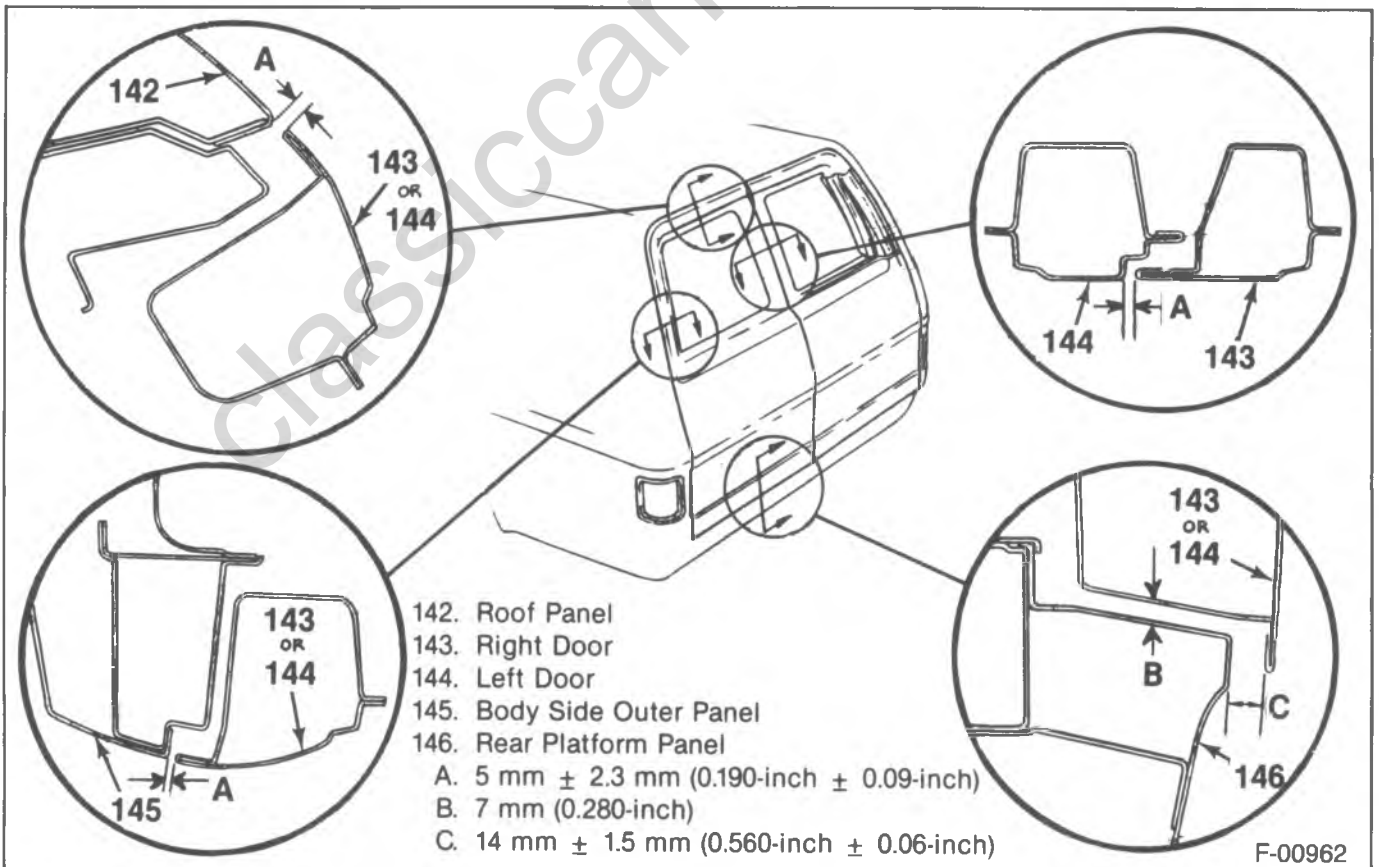

Figure 36—Door Adjustments

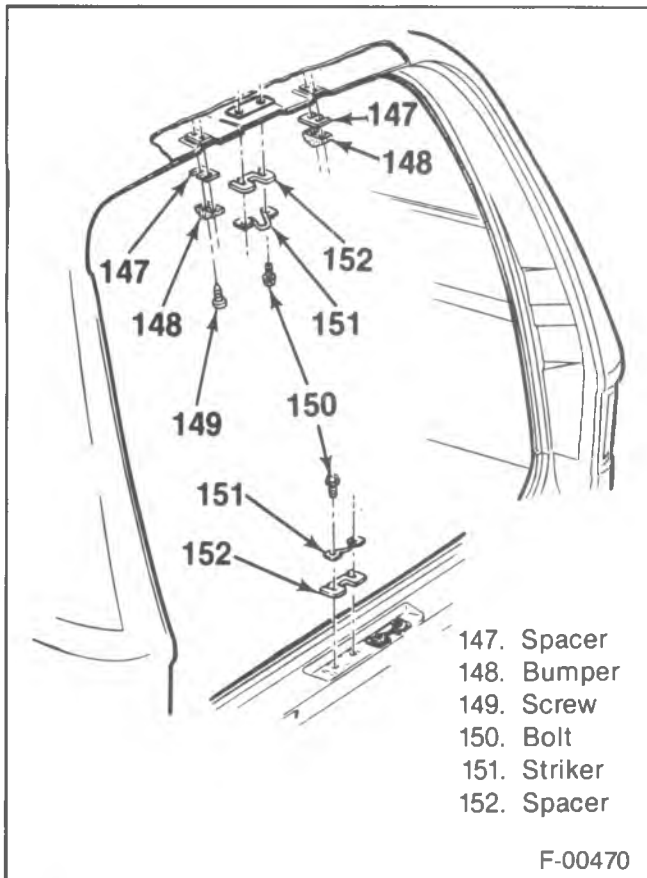

Figure 37—Striker Components

Adjust (Figure 38)

- The striker to door latch clearance so that there are 4.4 mm (0.172-inch) between the striker and the door latch when the door is in the secondary latched position. (The door is latched but not fully closed.) An 1¹/₆₄-inch diameter drill bit may be used to gage this clearance.

BUMPER WEDGE REPLACEMENT

Remove or Disconnect (Figure 37)

1. Bumper to upper door frame screws (149).
2. Bumper and spacer.

Install or Connect (Figure 37)

1. Spacer (as required).
2. Bumper.
3. Bumper to upper door frame screws (149).

Adjust

- The bumper to door clearance so that there is 1 mm (0.04-inch) between the bumper and the door when the door is in the secondary position. (The door is latched but not fully closed).

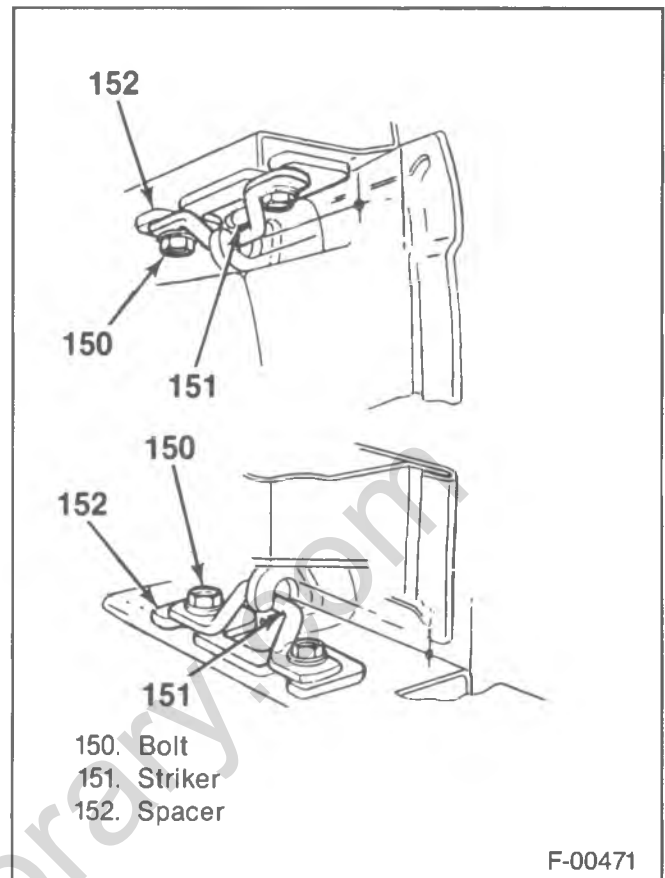

Figure 38—Striker Adjustment

DOOR TRIM PANEL REPLACEMENT

Remove or Disconnect (Figure 39)

1. Lower garnish molding to door screws (158).
2. Lower garnish molding.
3. Check strap from the door.
4. Door trim panel to door screws (156).
5. Door trim panel.
6. Upper garnish molding to door screws (153).
7. Upper garnish molding.

Install or Connect (Figure 39)

1. Upper garnish molding.
2. Upper garnish molding to door screws (153).
3. Door trim panel.
4. Door trim panel to door screws (156).
5. Check strap to the door.
6. Lower garnish molding.
7. Lower garnish molding to door screws (158).

WINDOW REPLACEMENT

If a glass is cracked but still intact, it should be crisscrossed with masking tape to reduce the risk of injury and/or damage to the vehicle. If a crack extends to the edge of the glass, mark the door with a piece of chalk at the point where the crack meets the weatherstrip. Later, when examining the flange of the opening for a cause of the crack, start at the point marked.

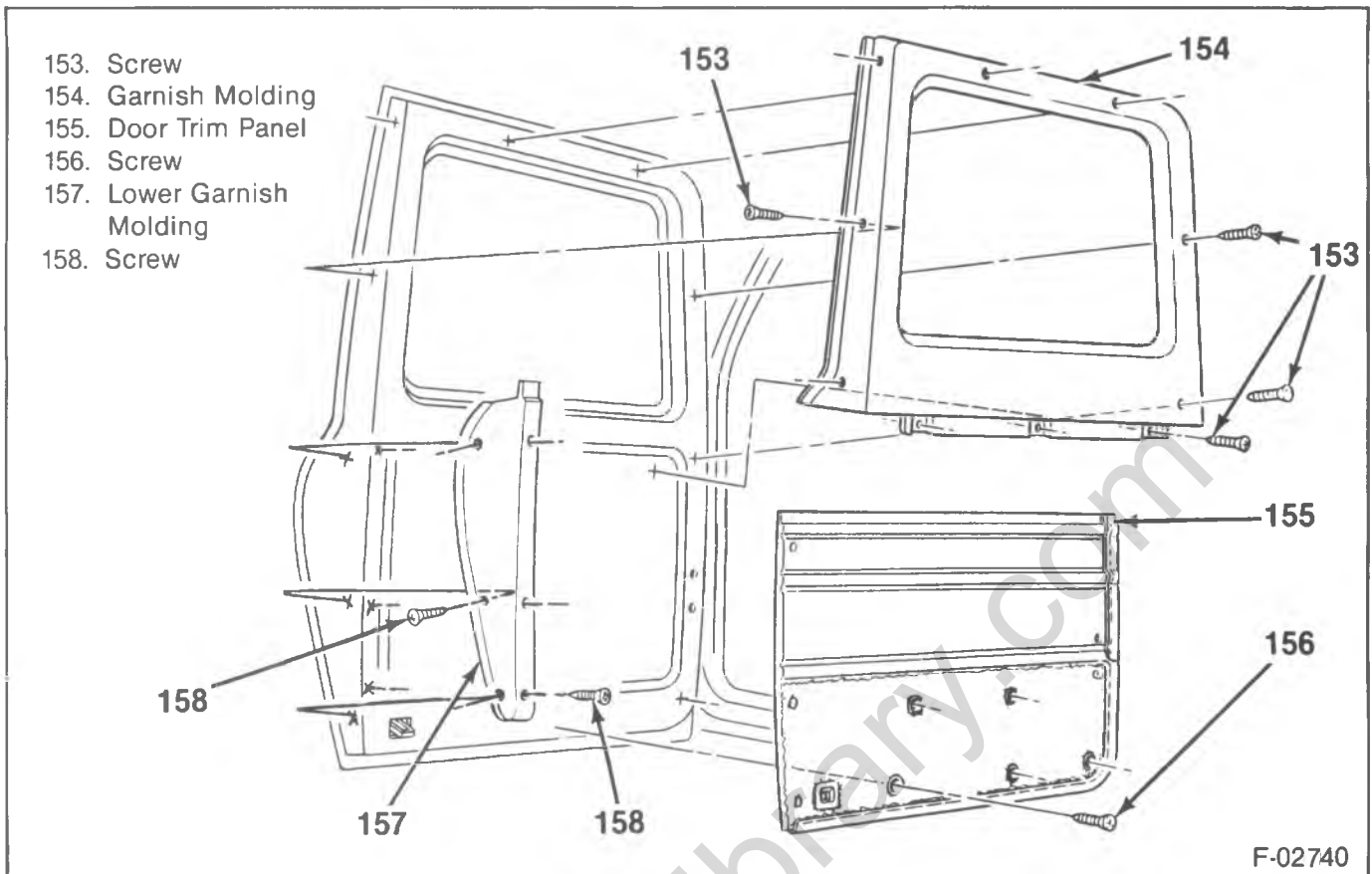

Figure 39—Door Trim Panel Components

It is important that the cause of the crack be determined and the condition corrected, before the new glass is installed. The cause of the crack may be an obstruction or high spot somewhere around the flange of the opening; cracking may not occur until pressure from the high spot or obstruction becomes particularly high due to winds, extremes of temperature, or rough terrain.

- Have an assistant pull the cord from inside the cab to seat the lip of the weatherstrip on the flange.

RIGHT DOOR LOWER LATCH REPLACEMENT

↔ Remove or Disconnect (Figure 40)

CAUTION: Always wear heavy gloves when handling glass to minimize the risk of injury.

1. Weatherstrip seal by running a putty knife between the flange and the weatherstrip (inside and outside the door).
 - Have an assistant outside the cab by the window.
2. Weatherstrip and glass from the flange.
 - Force the weatherstrip from the flange from the inside with a putty knife.
3. Window from the weatherstrip.

→ Install or Connect (Figure 40)

1. Weatherstrip to the glass.
2. A six mm (1/4-inch) cord in the weatherstrip groove. The ends should overlap about 5 cm (6-inches) at the window bottom.
3. Window and weatherstrip on the flange from outside the cab.
 - Brush soapy water on the flange.

↔ Remove or Disconnect (Figure 41)

1. Door trim panel. Refer to "Door Trim Panel Replacement."
2. Door lock access cover.
3. Lower latch to control assembly rod from the control assembly.
 - Using a flat bladed screwdriver, push on the top of the clip where it is connected to the rod. Pivot the clip away from the rod.
4. Lower latch to door screws (165).
5. Lower latch with the rod from the door.

→ Install or Connect

1. Lower latch with the rod to the door.
2. Lower latch to door screws (165).
3. Lower latch to control assembly rod into the control assembly.
 - Pivot the clip onto the rod.
4. Door lock access cover.
5. Door trim panel. Refer to "Door Trim Panel Replacement."

F-02740

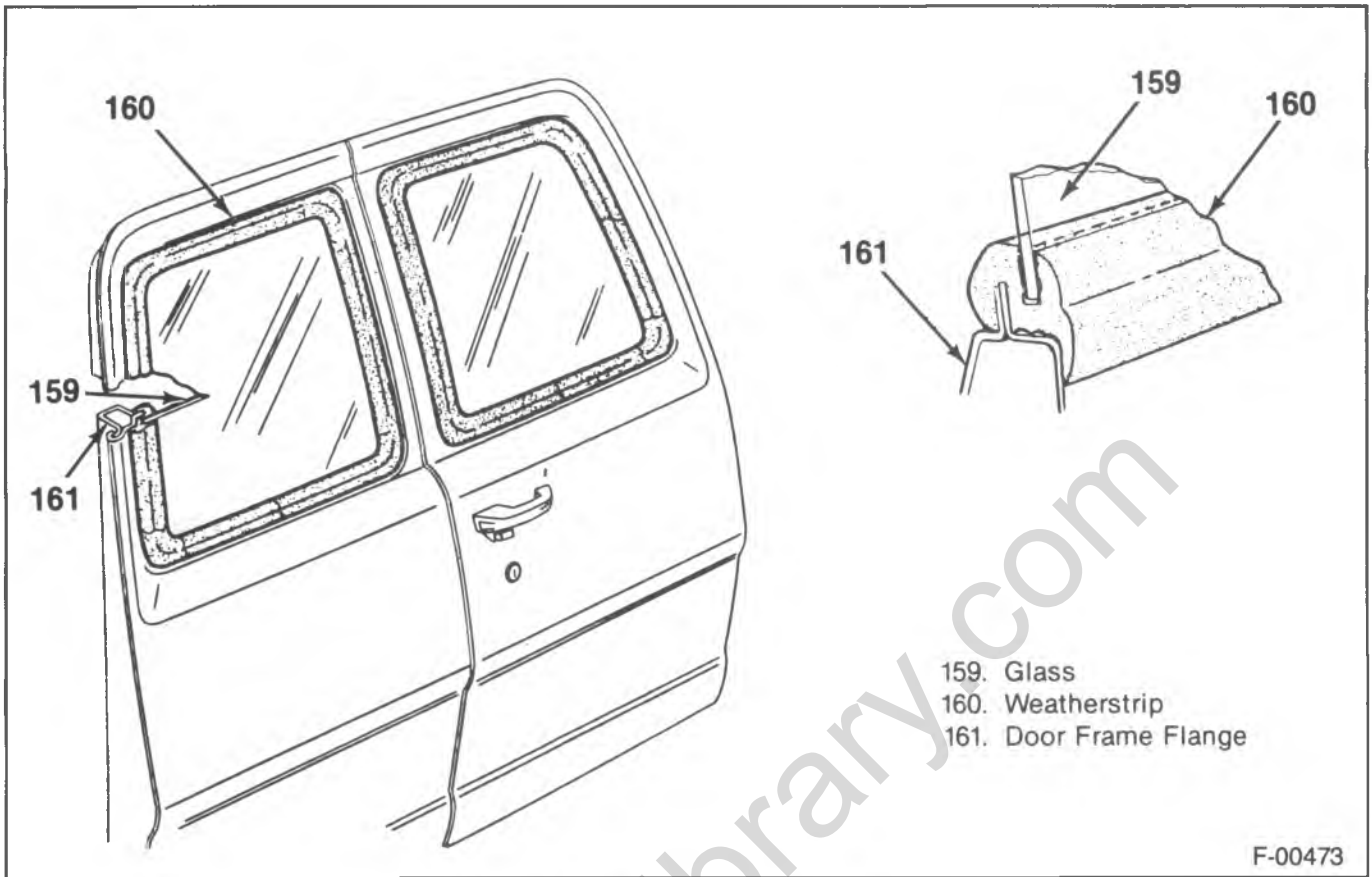

Figure 40—Window Components

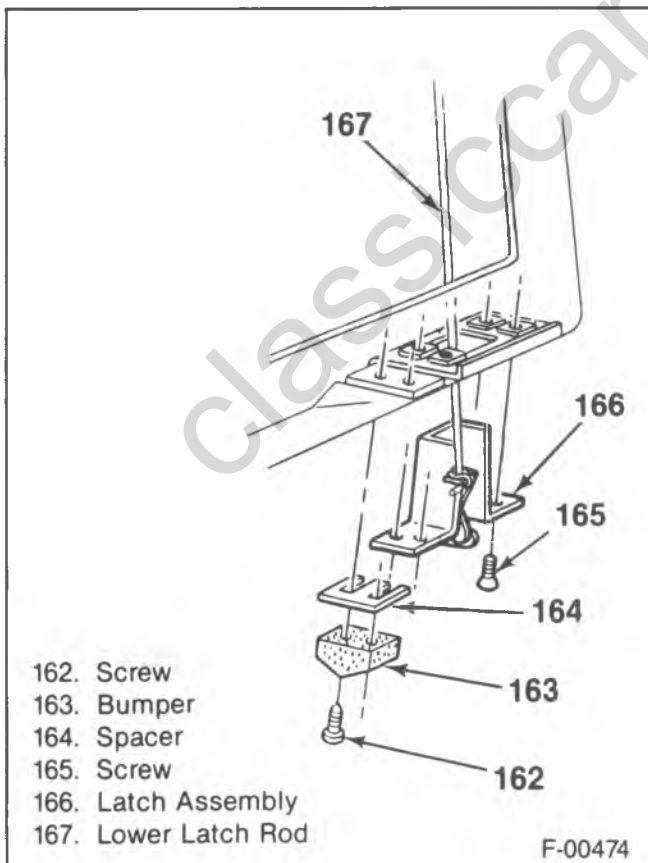

Figure 41—Right Door Lower Latch

RIGHT DOOR UPPER LATCH REPLACEMENT



Remove or Disconnect (Figure 42)

1. Door trim panel. Refer to "Door Trim Panel Replacement."
2. Door lock access cover.
3. Upper latch to control assembly rod from the control assembly.

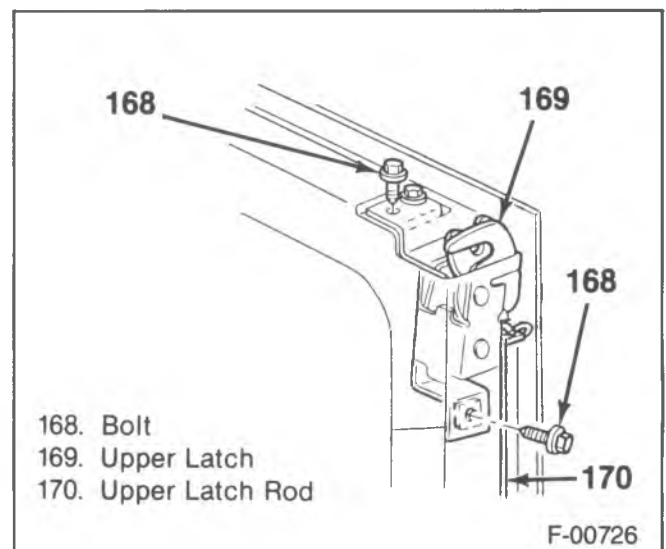

Figure 42—Right Door Upper Latch

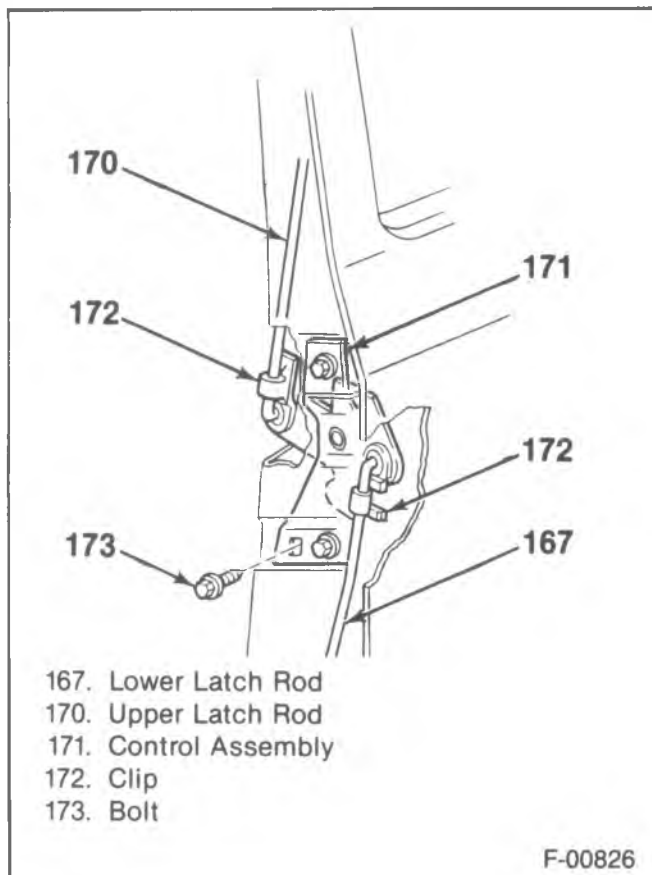

Figure 43—Right Door Control Assembly

- Using a flat bladed screwdriver, push on the top of the clip where it is connected to the rod. Pivot the clip away from the rod.

4. Upper latch to door bolts (168).
5. Upper latch with the rod from the door.

Install or Connect

1. Upper latch with the rod to the door.
2. Upper latch to door bolts (168).
3. Upper latch to control assembly rod into the control assembly.
 - Pivot the clip onto the rod.
4. Door lock access cover.
5. Door trim panel. Refer to "Door Trim Panel Replacement."

RIGHT DOOR CONTROL ASSEMBLY REPLACEMENT

Remove or Disconnect (Figure 43)

1. Door trim panel. Refer to "Door Trim Panel Replacement."
2. Door lock access cover.
3. Upper and lower door latch rods from the control assembly.
 - Using a flat bladed screwdriver, push on the top of the clip where it is connected to the rod. Pivot the clip away from the rod.
4. Electric door actuator (if equipped).
5. Door to control assembly bolts (173).
6. Control assembly through the access hole.

Install or Connect (Figure 43)

1. Control assembly through the access hole.
2. Door to control assembly bolts (173).
3. Electrical door actuator (if equipped).
4. Upper and lower door latch rods to the control assembly.
 - Pivot the clips onto the rods.
5. Door lock access cover.
6. Door trim panel. Refer to "Door Trim Panel Replacement."

DOOR OUTSIDE HANDLE REPLACEMENT

Remove or Disconnect (Figure 44)

1. Door trim panel. Refer to "Door Trim Panel Replacement."
2. Door lock access cover.
3. Outside door handle to lock rod clip.
 - Using a flat bladed screwdriver, push on the top of the clip where it is connected to the rod. Pivot the clip away from the rod.
4. Outside door handle to lock rod from the lock.
5. Door to outside handle screws (174).
6. Handle with the control rod from the door.
7. Gaskets from the door.

Install or Connect

1. Large gasket over the lock rod and onto the handle.
2. Handle with the lock rod onto the door.
3. Door to outside handle screw (174) to the push button side of the handle.
 - Do not tighten.
4. Small gasket between the door and the handle.
5. Door to outside handle screw (174) to the other side of the handle.
 - Tighten both screws.
6. Outside door handle to lock rod to the lock assembly.
7. Clip onto the lock rod.
 - Pivot the clip up and onto the lock rod.
8. Door lock access cover.
9. Door trim panel. Refer to "Door Trim Panel Replacement."

LEFT DOOR LOWER LATCH REPLACEMENT

Remove or Disconnect (Figure 45)

- Open the door.
1. Latch to door screws (182).
 2. Latch from the door.

Install or Connect (Figure 45)

1. Latch to the door.
2. Latch to door screws (182).

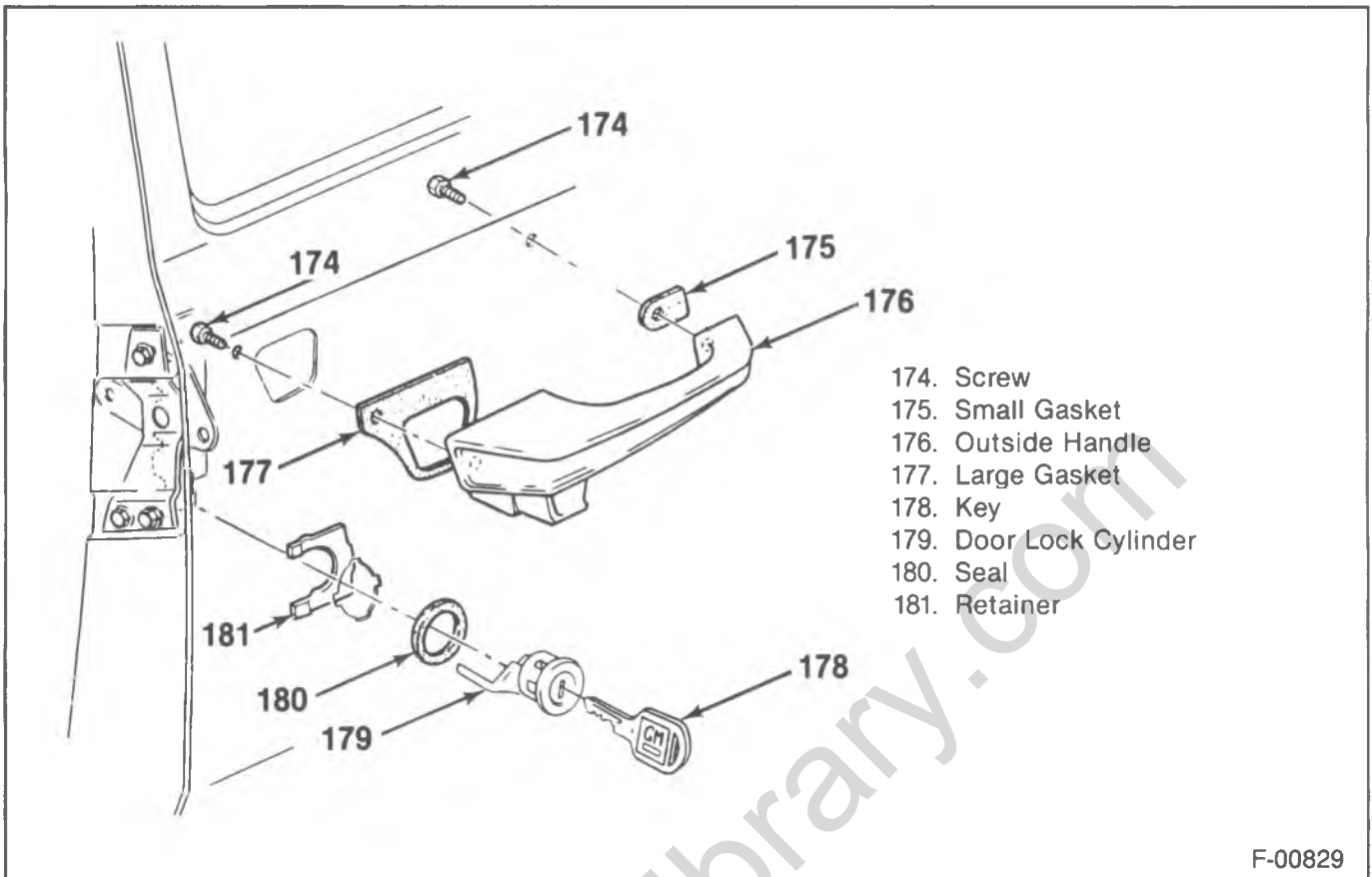

Figure 44—Door Outside Handle Components

CHECK STRAP REPLACEMENT

↔ Remove or Disconnect (Figure 46)

1. Pin.
2. Strap to door bolts (184).
3. Strap.
4. Bracket to inner panel bolts (187).
5. Bracket.

↔ Install or Connect (Figure 46)

1. Bracket.
2. Bracket to inner panel bolts (187).
3. Strap to the door.
4. Strap to door bolts (184).
5. Pin.

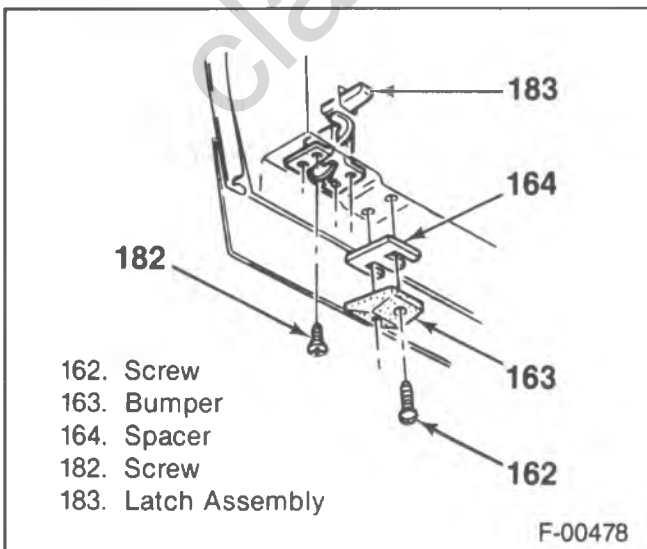

Figure 45—Left Door Lower Latch

RIGHT DOOR WEATHERSTRIP REPLACEMENT

↔ Remove or Disconnect (Figure 47)

1. Weatherstrip from the door using 3M Release Agent (or equivalent).

🧼 Clean

- The door and weatherstrip of all the old cement.

↔ Install or Connect (Figure 47)

1. Weatherstrip to the door using 3M Weatherstrip Adhesive (or equivalent).

LEFT DOOR WEATHERSTRIP REPLACEMENT

↔ Remove or Disconnect (Figure 48)

Tool Required:

J-24595-B Door Trim Pad Clip Remover.

1. Weatherstrip to door fasteners using J-24595-B.

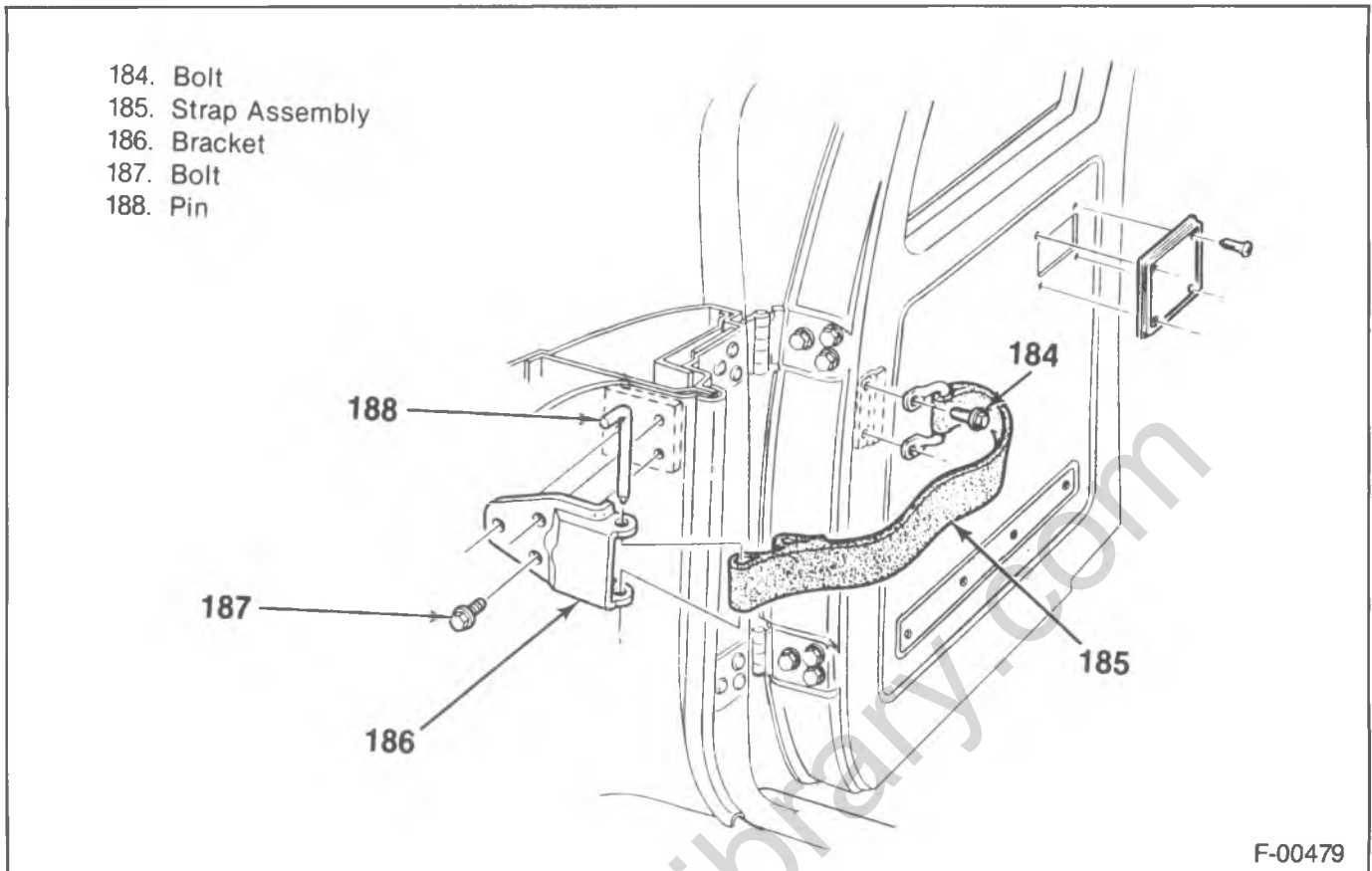
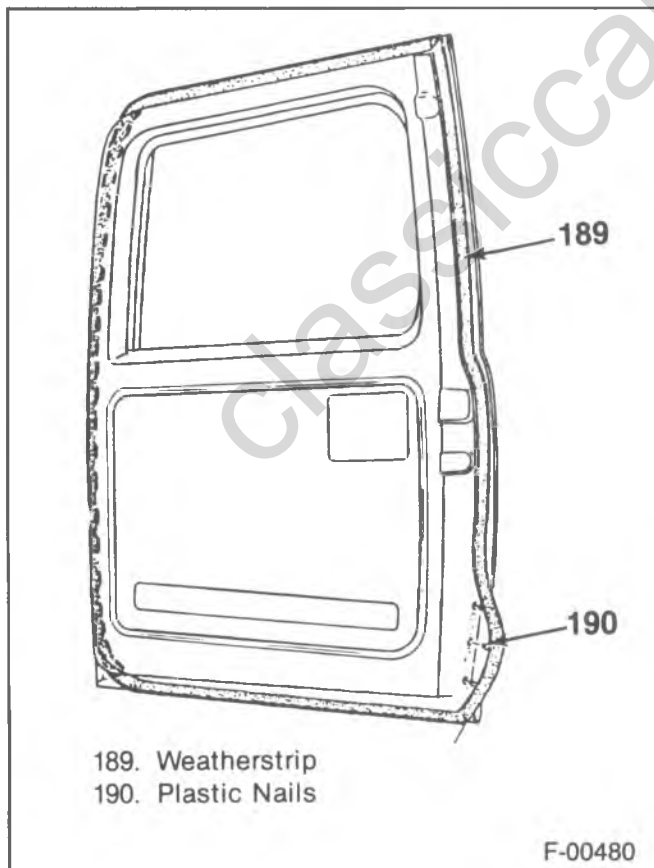

Figure 46—Check Strap Components



- 189. Weatherstrip
- 190. Plastic Nails

F-00480

Figure 47—Right Door Weatherstrip

2. Weatherstrip from the door using 3M Release agent (or equivalent).



Clean

- The door and weatherstrip of all the old cement.



Install or Connect (Figure 48)

1. Weatherstrip to the door using 3M Weatherstrip Adhesive (or equivalent).
2. Weatherstrip to door fasteners.

SECONDARY WEATHERSTRIP REPLACEMENT



Remove or Disconnect (Figure 49)

1. Weatherstrip from the door using 3M Release Agent (or equivalent).



Clean

- The door and weatherstrip of all the old cement.



Install or Connect (Figure 49)

1. Weatherstrip to the door using 3M Weatherstrip Adhesive (or equivalent).

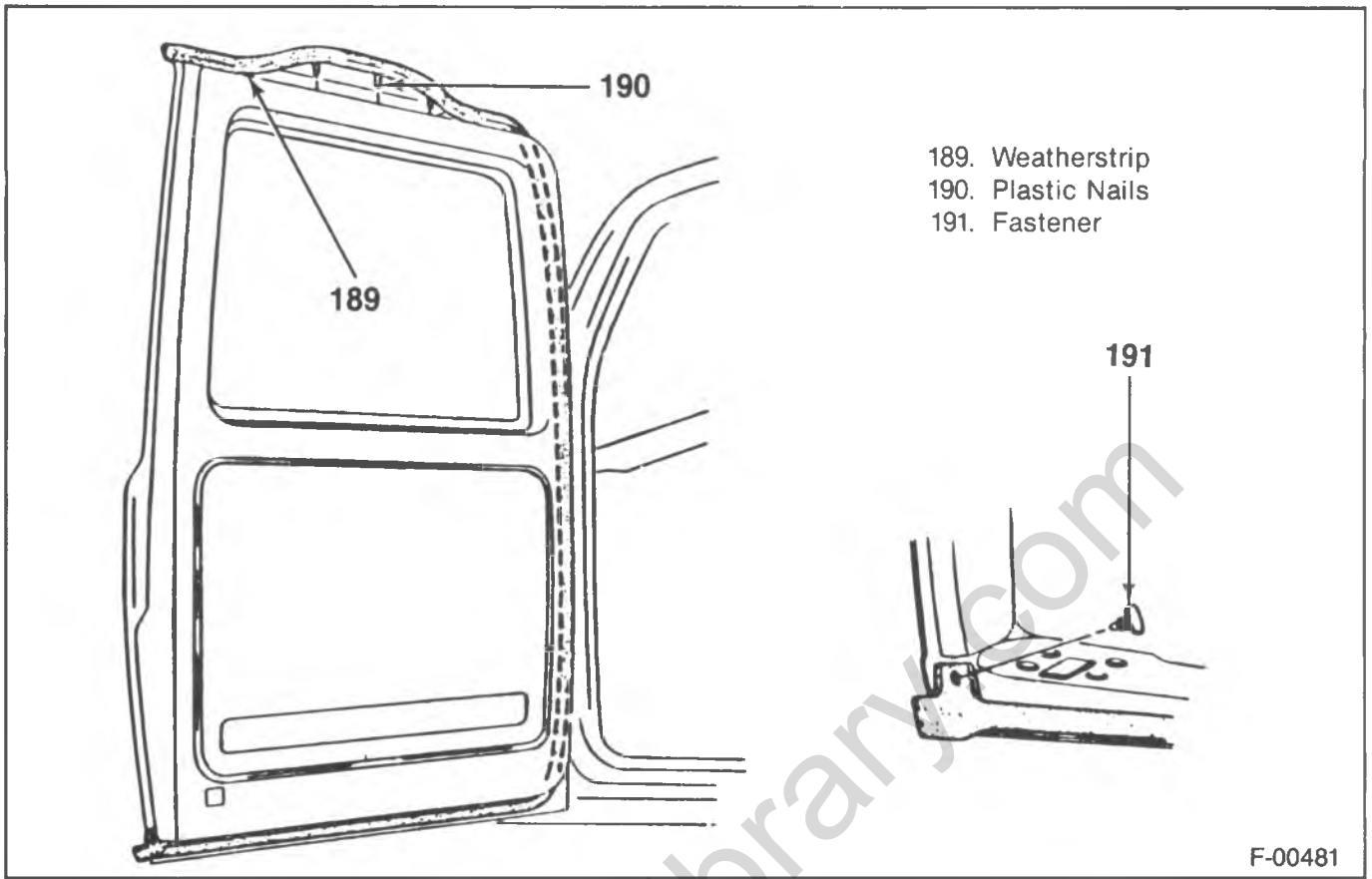

Figure 48—Left Door Weatherstrip

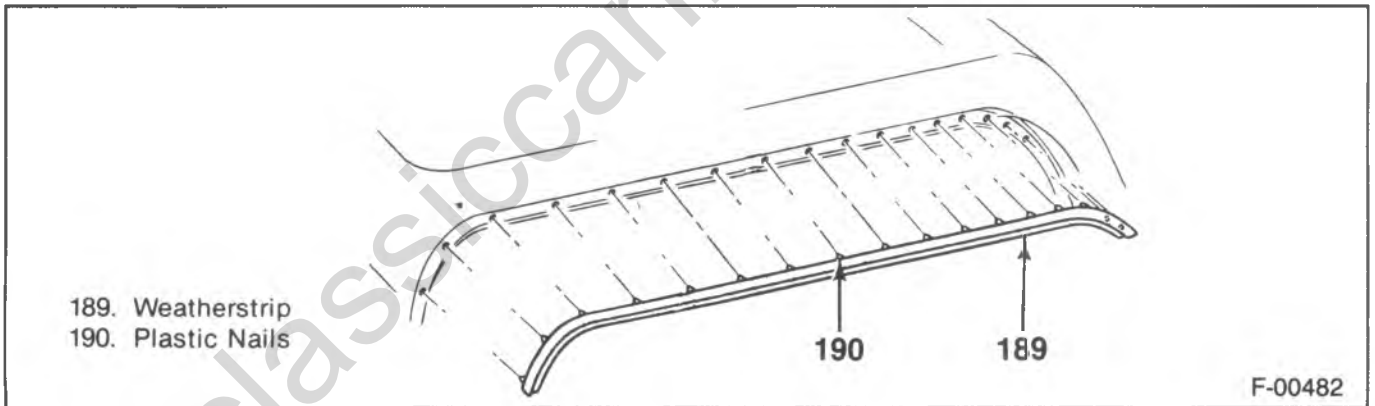

Figure 49—Door Secondary Weatherstrip

G MODEL SIDE FRONT DOORS

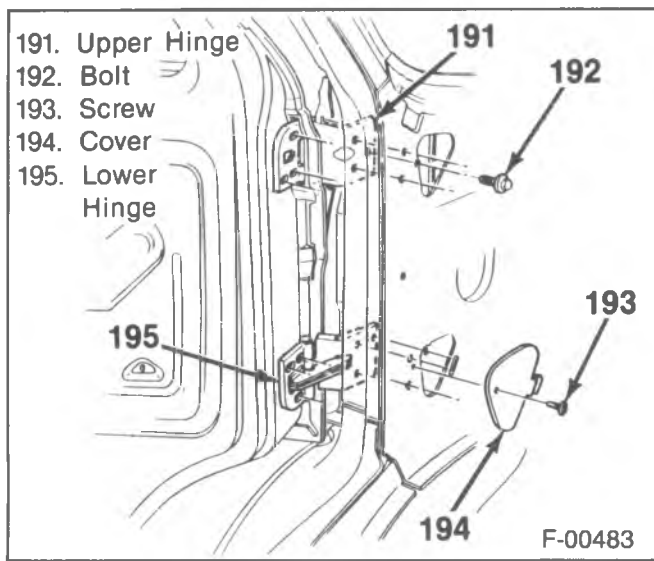

Figure 50—Door Hinge Components

DOOR AND HINGE REPLACEMENT

↔ Remove or Disconnect (Figure 50)

1. Electrical wiring harness from the door (if equipped).
 - Refer to "Door Trim Pad Replacement" for access to the wiring harness.
2. Kick panel (if equipped).
3. Hinge bolt cover screw (193).
4. Hinge bolt cover.
 - Mark the position of the hinges on the door and door pillar.
 - Support the door.
5. Door frame to hinge bolts (192).
6. Door from the vehicle.
7. Hinge to door bolts.
8. Hinges from the door.

↔ Install or Connect (Figure 50)

1. Hinges to the door.
2. Hinge to door bolts.
 - Align the hinges to the previously made mark.
3. Door to the vehicle.
 - Align the hinges with the previously made mark.
- Support the door.
4. Door frame to hinge bolts (192).
5. Hinge bolt cover.
 - Place the tab on the cover into the slot.
6. Hinge bolt cover screws (193).
7. Kick panel (if equipped).
8. Electrical wiring harness to the door (if equipped).
 - Refer to "Door Trim Panel Replacement" for access to the wiring harness.

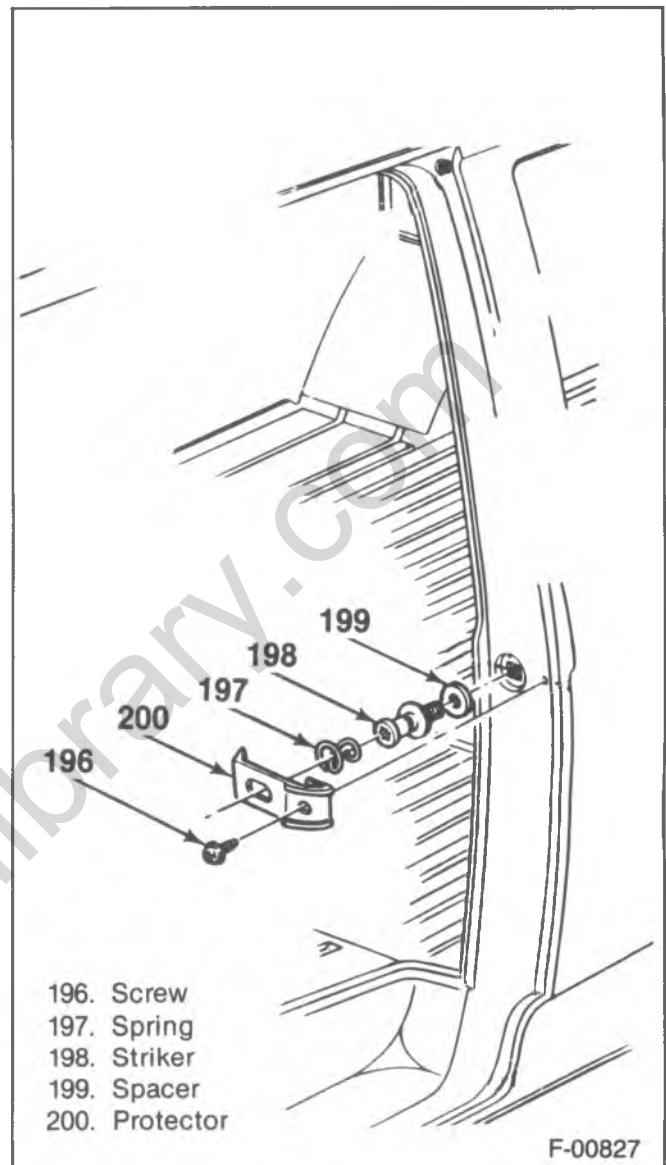

Figure 51—Striker Components

DOOR ADJUSTMENT

↔ Remove or Disconnect (Figure 51)

Tool Required:

J-23457-A #50 Torx Wrench.

1. Lock striker protector screw (196).
2. Lock striker protector.
3. Spring.
4. Door striker using J-23457-A.
5. Spacer.
6. Kick panel (if equipped).
7. Hinge bolt cover screw (193).
8. Hinge bolt cover.
 - Loosen the door hinge bolts as needed to adjust the door.

🔑 Adjust (Figure 52)

- The door up or down, forward or rearward and in or out, at the door hinges.

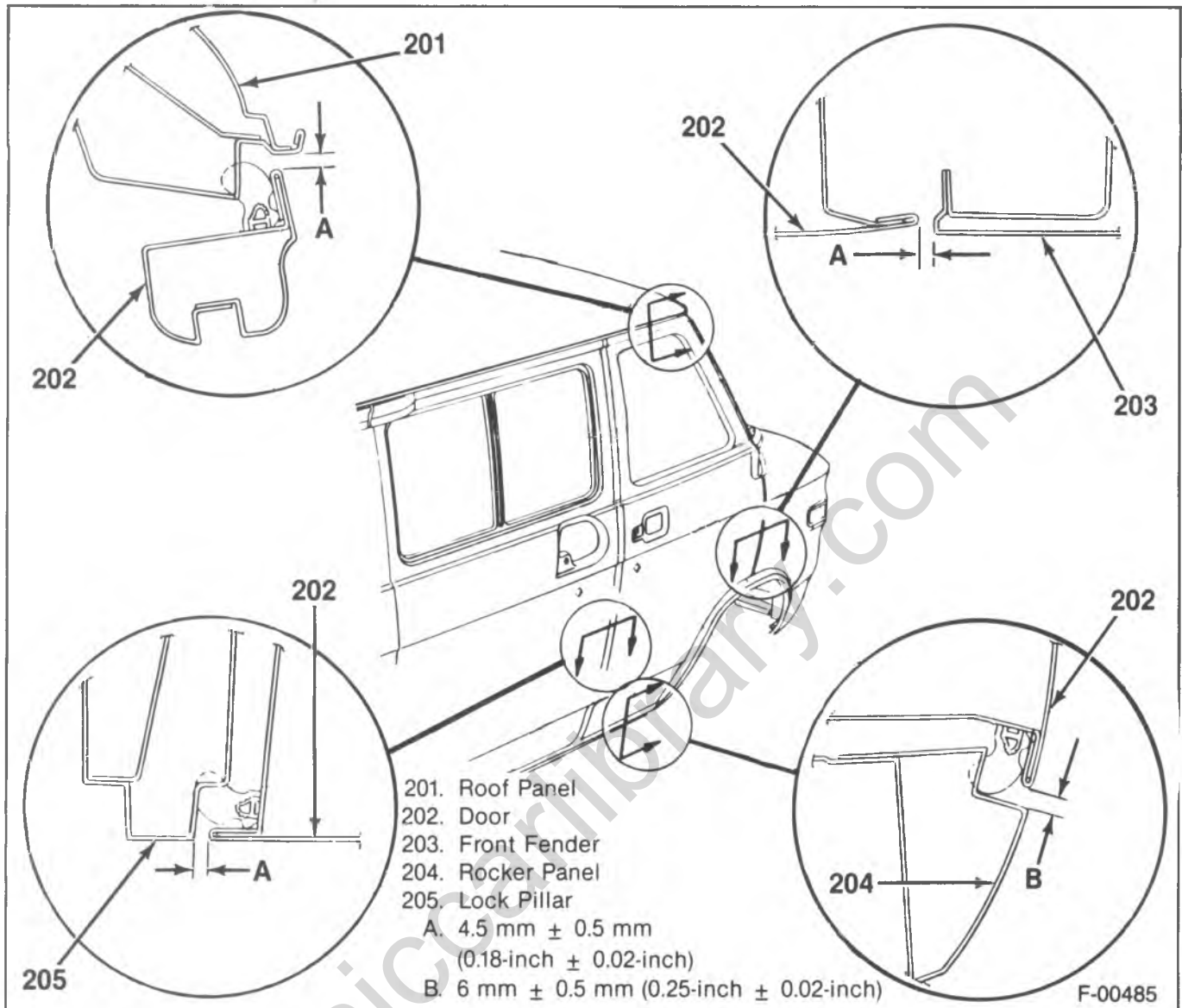

Figure 52—Door Adjustments

1. Adjust the door to obtain a gap of 4.5 mm \pm 0.5 mm (0.18-inch \pm 0.02-inch) between the front door and the roof panel.
2. The gap between the rocker panel and the front door at its base should be 6 mm \pm 0.5 mm (0.25-inch \pm 0.02-inch).
3. Adjust the door to obtain a gap of 4.5 mm \pm 0.5 mm (0.18-inch \pm 0.02-inch) between the doors rear edge and the rear door pillar.
4. The gap between the doors front edge and the rear edge of the fender should be 4.5 mm \pm 0.5 mm (0.18-inch \pm 0.02-inch).

- Tighten the door hinge bolts that were loosened.

Install or Connect (Figure 51)

1. Hinge bolt cover.
 - Place the tab on the cover into the slot.
2. Hinge bolt cover screw (193).
3. Kick panel (if equipped).
4. Spacer to the door striker.

NOTICE: Refer to "Notice" on page 10A1-1 of this section.

5. Door striker.
6. Spring.
7. Lock striker protector.
8. Lock striker protector screw (196).

DOOR TRIM PANEL REPLACEMENT

Remove or Disconnect (Figures 53 and 54)

Tool Required:

J-9886-01 Door Handle Clip Remover.

1. Window regulator handle using J-9886-01.
2. Window regulator handle bezel.
3. Door lock control assembly handle using J-9886-01.
4. Control assembly handle bezel.
5. Assist handle (if equipped).
6. Arm rest (if equipped) (figure 55).
7. Door trim outer panel screws (if equipped).

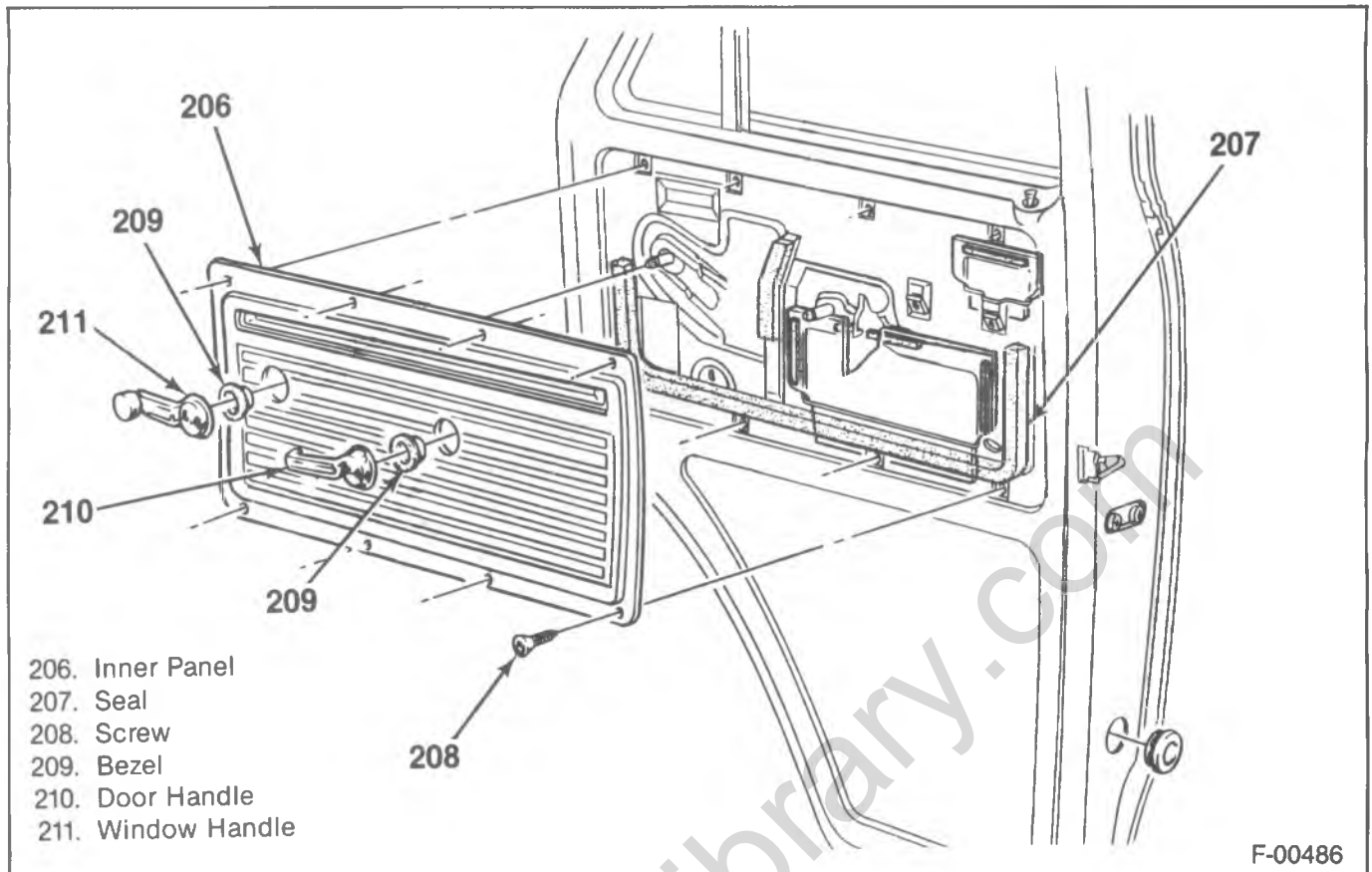

Figure 53—Door Trim Inner Panel

8. Door trim outer panel (if equipped).
 - Pull the panel away from the retainers.
9. Door trim inner panel screws.
10. Door trim inner panel.

→← Install or Connect (Figures 53 and 54)

1. Door trim inner panel.
2. Door trim inner panel screws.
3. Door trim outer panel (if equipped).
 - Push the panel into the retainer.
4. Door trim outer panel screws (if equipped).
5. Arm rest (if equipped) (figure 55).
6. Assist handle (if equipped).
7. Control assembly handle bezel.
8. Window regulator handle bezel.
9. The clips to the window regulator handle and the door lock control assembly handle.
10. Window regulator handle.
 - Push the handle onto the shaft.
11. Door lock control assembly handle.
 - Push the handle onto the shaft.

DOOR VENT/WINDOW RUN CHANNEL ASSEMBLY REPLACEMENT

The door vent and the front window run channel are one assembly. This assembly is fit into the front of the door frame.

↔ Remove or Disconnect (Figure 56)

- Place the window in the lowered position.
1. Door trim panel. Refer to "Door Trim Panel Replacement."
 2. Run channel molding.
 - Pull the molding out of the vent assembly only.
 3. Door panel to run channel bolt (228).
 4. Door to ventilator screws (223).
 5. Door vent/window run channel assembly from the vehicle.
 - Pull the top of the vent backwards away from the door frame.
 - Lift and rotate the assembly out of the door.

→← Install or Connect (Figure 56)

1. Door vent/window run channel assembly to the vehicle.
 - Rotate the vent assembly into the door.
 - Fit the assembly into the door frame.
2. Door to ventilator screws (223).
 - Start with the screw at the top of the door, and work downward.
3. Door panel to run channel bolt (228).
4. Run channel molding.
 - Push the corner of the molding into the run channel.
5. Door trim panel. Refer to "Door Trim Panel Replacement."

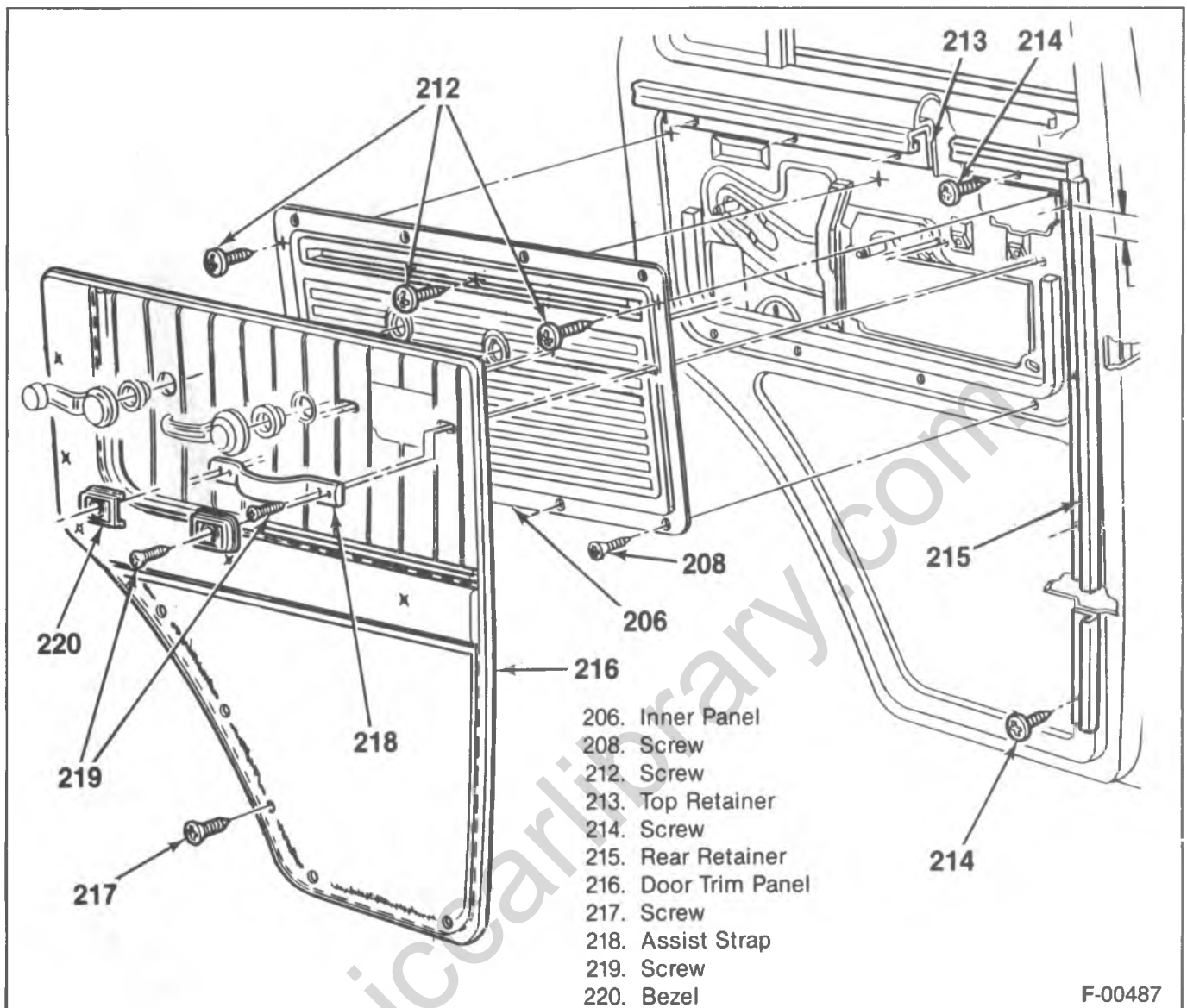

F-00487

Figure 54—Door Trim Outer Panel

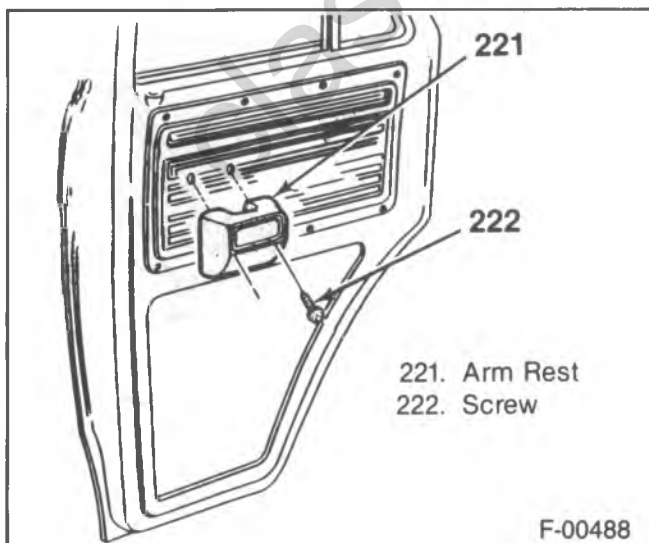

F-00488

Figure 55—Arm Rest

VENT GLASS REPLACEMENT

CAUTION: Always wear heavy gloves when handling glass to minimize the risk of injury.

REMOVAL (Figure 57)

1. Open the vent window.
2. Squirt solvent on the tar-paper-like filler all around the glass channel, on both sides of the glass.
3. When the filler and sealer soften, pull the glass and the old filler from the channel.

INSTALLATION

1. Thoroughly clean the inside of the glass channel with sandpaper to remove all rust and foreign matter.
2. Cut the new piece of glass channel filler 51 mm (2-inches) longer than required.
3. Position the filler (soap stoned side away from the glass) evenly around and over the edge of the glass that will be inserted in the channel. Press the filler

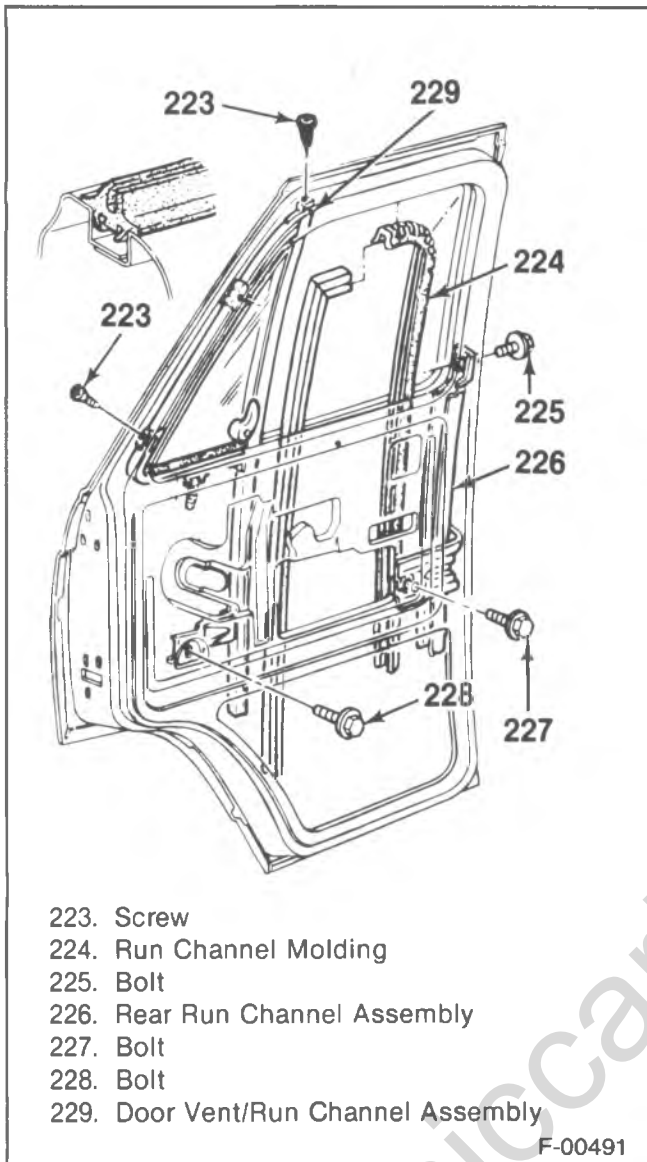

Figure 56—Door Run Channel Assemblies

firmly onto the edge of the glass to ensure a good bond. (Usually this is done with a mechanical window press.) Squeeze together the doubled ends of the filler which project beyond the edge of the glass.

4. Brush the inner channel with soap solution. DO NOT USE GREASE OR OIL.
5. Press the glass and the filler into the channel until firmly seated.
6. Trim off excess filler material around, and at the end of the channel.

VENT WINDOW ADJUSTMENT

Adjust (Figure 58)

- Remove the door trim panel. Refer to "Door Trim Panel Replacement."
- Bend the tabs on the adjustment nut away from the nut.
- Adjust the vent by placing a wrench on the adjusting nut, and then turning the vent window to the proper tension.
- Bend the tabs over the adjustment nut.

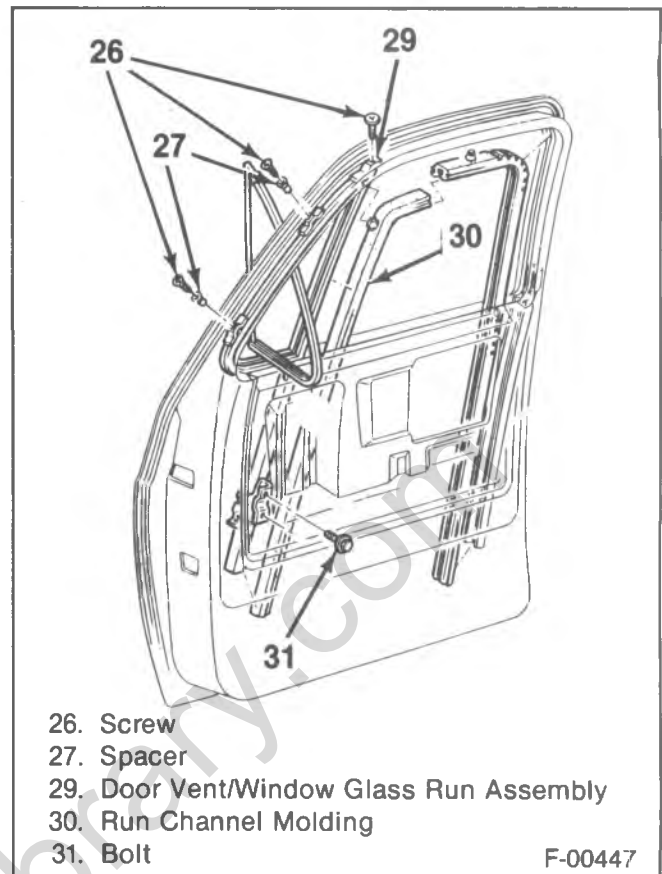

Figure 57—Door/Vent Window Run Channel Components

- Install the door trim panel. Refer to "Door Trim Panel Replacement."

DOOR WINDOW REPLACEMENT

Remove or Disconnect (Figure 59)

CAUTION: Always wear heavy gloves when handling glass to minimize the risk of injury.

- Lower the glass to the bottom of the door.



Figure 58—Vent Window Adjustment

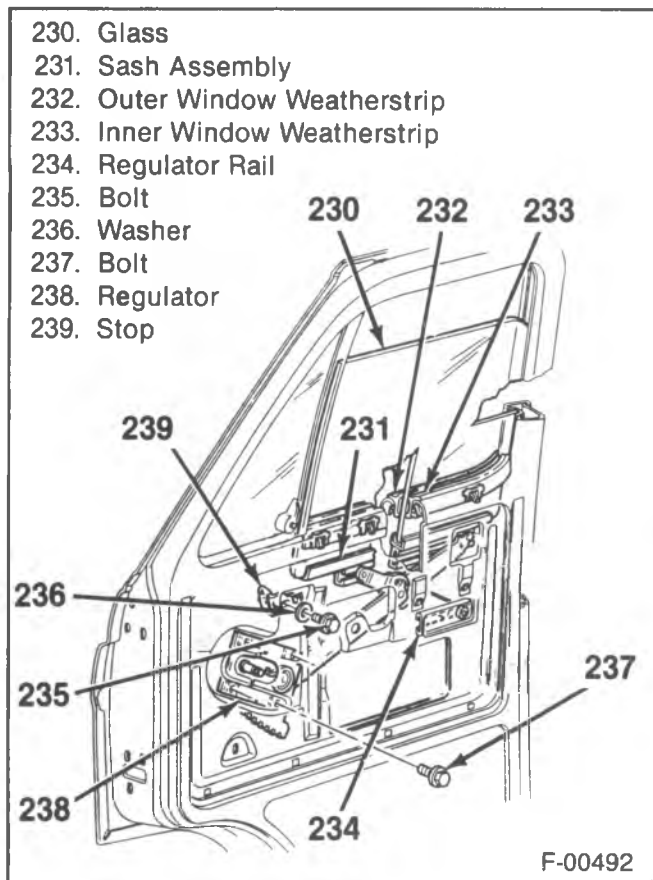

Figure 59—Door Window Components

1. Door trim panel. Refer to "Door Trim Panel Replacement."
2. Door vent/window run channel assembly. Refer to "Door Vent/Window Run Channel Assembly Replacement."
 - Mask or cover any sharp edges that could scratch the glass.
3. Door window glass (230).
 - Slide the glass forward until the front roller is in line with the notch in the sash channel. Disengage the roller from the channel.
 - Push the window forward, then tilt it up until the rear roller is disengaged.
 - Place the window in a level position, and raise it straight up and out of the door.

→→ Install or Connect (Figure 59)

1. Door window glass (230).
 - Lower the window into the door frame.
 - Push the window forward, then tilt it up, and slide the rear roller into the sash channel.
 - Slide the glass backward until the front roller is in line with the notch in the sash channel. Engage the roller to the sash channel.
 - Slide the glass rearward into the glass run channel.
- Remove any masking or covering.
2. Door vent/window run channel assembly. Refer to "Door Vent/Window Run Channel Assembly Replacement."
3. Door trim panel. Refer to "Door Trim Panel Replacement."

WINDOW STOP ASSEMBLY ADJUSTMENT

1. Remove the door trim panel. Refer to "Door Trim Panel Replacement."
2. Lower the window until it is flush with the window sill.
3. Loosen the glass stop bolt, and adjust the stop until the glass is completely flush with the window sill (figure 59).
4. Tighten the bolt.
5. Install the trim pad. Refer to "Door Trim Panel Replacement."

INNER WINDOW WEATHERSTRIP REPLACEMENT

↔ Remove or Disconnect (Figure 59)

- Lower the window.
1. Weatherstrip from the door.
 - Pry the weatherstrip clips from the door panel.

→← Install or Connect (Figure 59)

1. Weatherstrip to the door.
 - Push the weatherstrip clips onto the door panel.

OUTER WINDOW WEATHERSTRIP REPLACEMENT

↔ Remove or Disconnect (Figure 59)

- Lower the window.
1. Weatherstrip from the door.
 - Pry the weatherstrip clips from the door panel.

→← Install or Connect (Figure 59)

1. Weatherstrip to the door.
 - Push the weatherstrip clips onto the door panel.

REAR GLASS RUN CHANNEL REPLACEMENT

↔ Remove or Disconnect (Figure 56)

1. Door trim panel. Refer to "Door Trim Panel Replacement."
- Lower the window completely.
2. Inner and outer window weatherstrips.
3. Door to run channel bolts (225 and 227).
4. Run channel from the vehicle.
 - Pull the run channel upwards while twisting to clear the lower bracket.

→← Install or Connect (Figure 56)

1. Run channel to the vehicle.
 - Work the run channel into the door frame. Be certain that the glass is in the channel.
2. Lower door to run channel bolt (227).
 - Raise the window completely.
3. Upper door to run channel bolt (225).
4. Inner and outer window weatherstrips.
5. Door trim panel. Refer to "Door Trim Panel Replacement."

WINDOW REGULATOR REPLACEMENT

MANUAL REGULATOR

↔ Remove or Disconnect (Figure 59)

- Raise the window and tape the glass in the full up position using cloth body tape.
1. Door trim panel. Refer to "Door Trim Panel Replacement."
 2. Door panel to regulator bolts (237).
 3. Window regulator (238).
 - Slide the regulator rearward to disengage the rear roller from the sash channel. Also disengage the lower roller from the regulator rail.
 - Disengage the forward roller from the sash channel at the notch in the sash channel.
 - Collapse the regulator, and remove it through the access hole in the door.

→← Install or Connect

- Lubricate the regulator and the sash and regulator rails with lubriplate or equivalent.
1. Window regulator (238).
 - Collapse the regulator, and insert it through the access hole in the door.
 - Unfold the regulator, and engage the forward roller to the sash channel at the sash channel notch.
 - Slide the regulator rearward to engage the rear roller to the sash channel. Also engage the lower roller to the regulator rail.
 - Slide the regulator into its proper position, and insert the regulator drive through the door panel.
 2. Door panel to regulator bolts (237).
 3. Door trim panel. Refer to "Door Trim Panel Replacement."
 - Remove the tape from the window.

POWER REGULATOR

For the diagnosis of power window circuits, refer to CAB ELECTRICAL (SEC. 8A).

↔ Remove or Disconnect (Figure 60)

- Raise the window and tape the glass in the full up position using cloth body tape.
1. Battery ground cable.
 2. Door trim panel. Refer to "Door Trim Panel Replacement."
 3. Remote control to door trim panel bolts.
 - Lay the control aside.
 4. Regulator to door panel bolts (244) and nuts (245).
 5. Wiring harness from the regulator.
 6. Window regulator (246).
 - Slide the regulator rearward to disengage the rear roller from the sash channel. Also disengage the lower roller from the regulator rail.
 - Disengage the forward roller from the sash channel at the notch in the sash channel.
 - Collapse the regulator, and remove it through the access hole in the door.

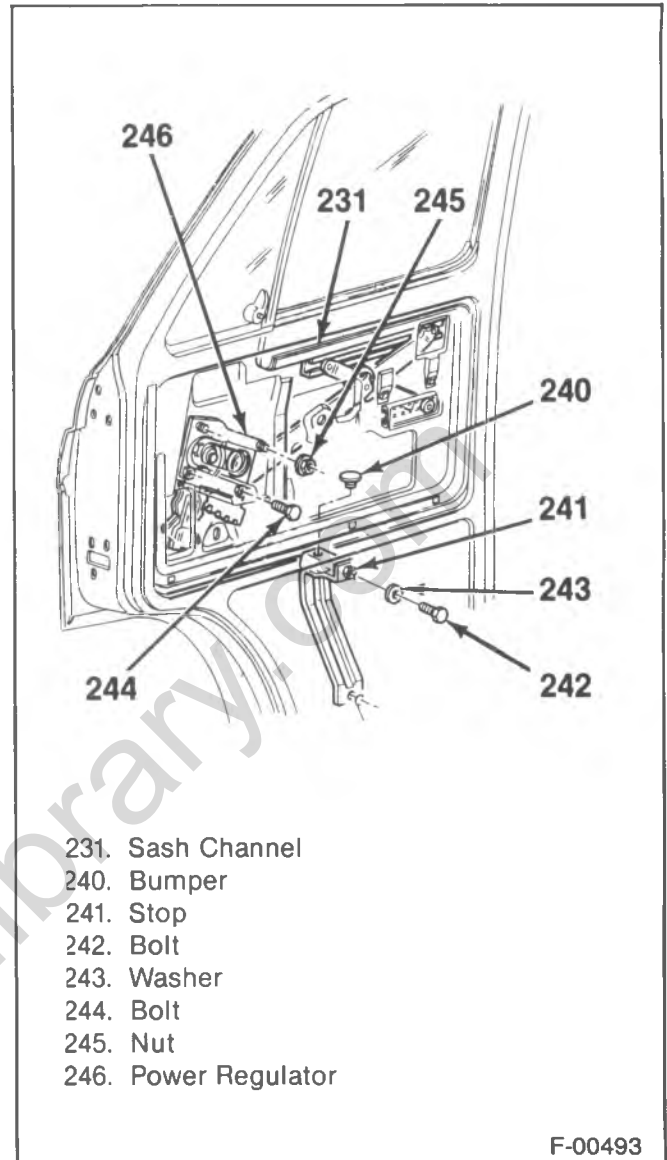

Figure 60—Power Window Regulator

CAUTION: The next step must be performed when the regulator is removed from the door. The regulator lift arms are under tension from the counterbalance spring and can cause serious injury if the motor is removed without locking the sector gear in position.

- Drill a hole through the regulator sector gear and back plate. Drill the hole at least 12.7 mm (1/2-inch) away from the edge of the sector gear or back plate. Install a pan head sheet metal tapping screw at least 19 mm (3/4-inch) long into the drilled hole to lock the sector gear in place.
7. Motor to regulator attaching screws.
 8. Motor from the regulator.

→← Install or Connect (Figure 60)

- Lubricate the motor drive gear and regulator sector teeth.
1. Regulator motor to regulator.

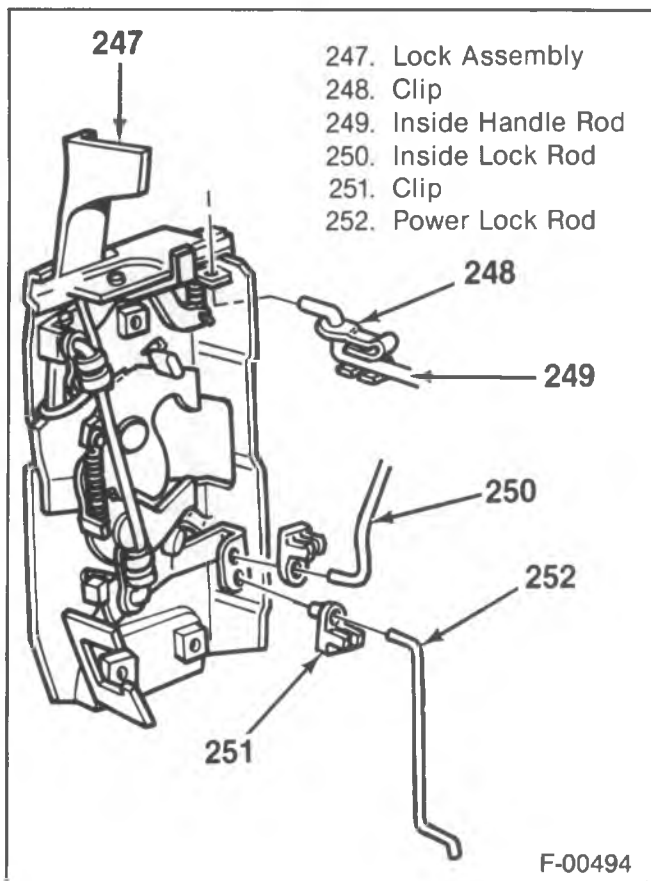

Figure 61—Door Lock With Lock Rods

- The motor pinion gear teeth must mesh properly with the sector gear teeth before installing the motor to regular screws.
2. Regulator motor to regulator screws.
 - Remove the sheet metal screw from the back plate and sector gear.
 3. Window regulator to the door.
 - Collapse the regulator, and insert it through the access hole in the door.
 - Unfold the regulator, and engage the forward roller to the sash channel at the sash channel notch.
 - Slide the regulator rearward to engage the rear roller to the sash channel. Also engage the lower roller to the regulator rail.
 - Slide the regulator into its proper position.
 4. Wiring harness to the regulator.
 5. Regulator to door panel bolts (244) and nuts (245).
 6. Remote control to door trim panel bolts.
 7. Door trim panel. Refer to "Door Trim Panel Replacement."
 8. Battery ground cable.
 - Remove the tape from the window.

DOOR LOCK REPLACEMENT

↔ Remove or Disconnect (Figures 61 and 62)

- Raise the window completely.
1. Door trim panel. Refer to "Door Trim Panel Replacement."
 2. Door lock knob.

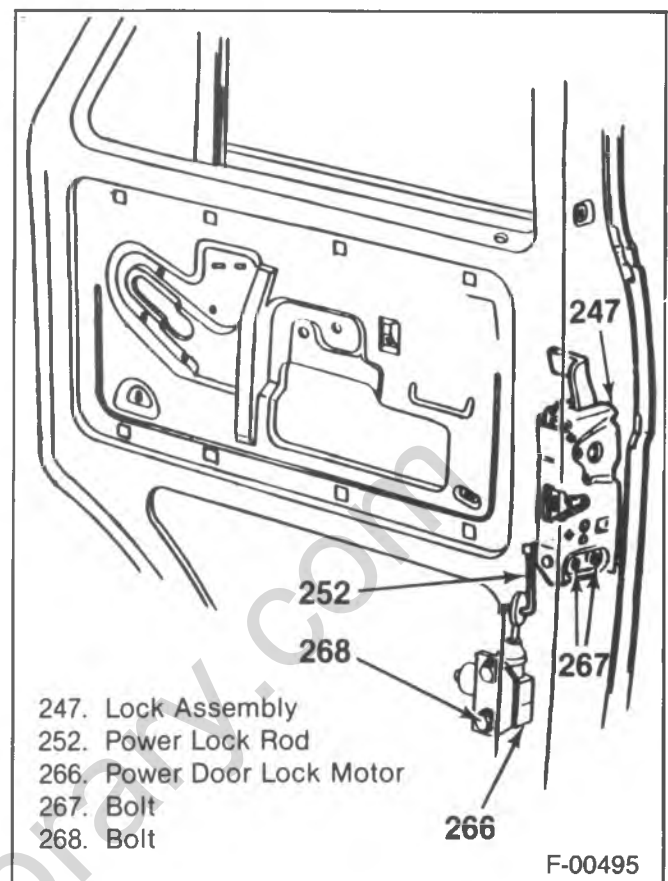

Figure 62—Door Lock Attachments

3. Remove control assembly. Refer to "Remote Control Replacement."
4. Rear glass run channel. Refer to "Rear Glass Run Channel Replacement."
5. Door to lock screws (267).
6. Lock from the door.
 - Lower the lock in the door far enough to provide clearance for the inside lock rod.

→ Install or Connect (Figures 61 and 62)

1. Lock to the door.
 - Align the lock rod with the hole in the top of the door panel.
2. Door to lock screws (267).
3. Rear glass run channel. Refer to "Rear Glass Run Channel Replacement."
4. Remote control assembly. Refer to "Remote Control Assembly."
5. Door lock knob.
6. Door trim panel. Refer to "Door Trim Panel Replacement."

POWER DOOR LOCK MOTOR REPLACEMENT

Refer to CAB ELECTRICAL (SEC. 8A) for electrical diagnosis of the door lock motor.

↔ Remove or Disconnect (Figure 62)

1. Battery ground cable.
2. Door trim panel. Refer to "Door Trim Panel Replacement."
3. Electrical connector from the motor.
4. Door to motor screws (268).
5. Motor from the lock rod.
 - Slide the rubber mount at the top of the motor off of the door lock rod.
6. Motor from the door.

↔ Install or Connect (Figure 62)

1. Motor into the door.
2. Motor to the lock rod.
 - Slide the rubber mount at the top of the motor onto the door lock rod.
3. Door to motor screws (268).
4. Electrical connector to the motor.
5. Door trim panel. Refer to "Door Trim Panel Replacement."
6. Battery ground cable.

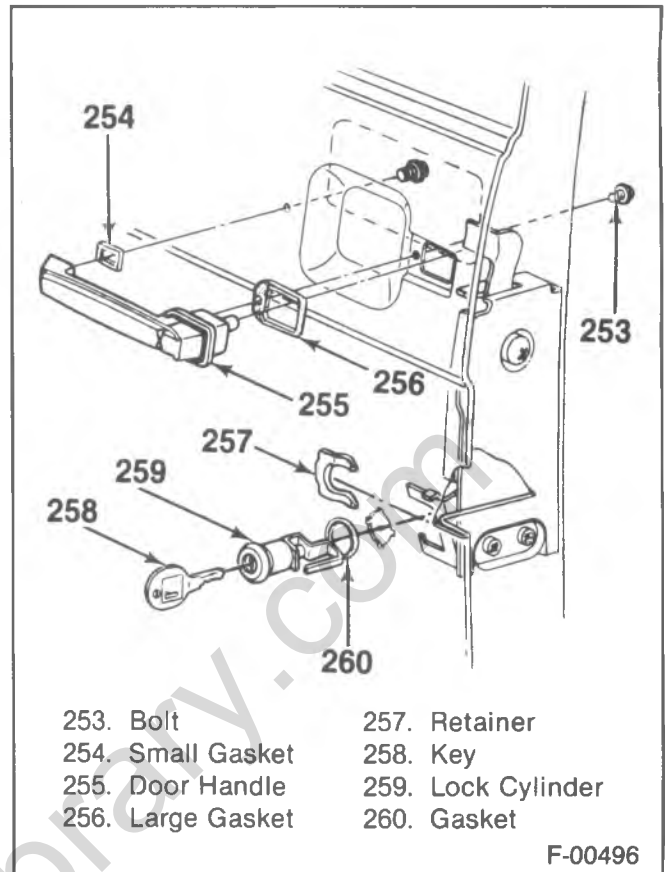

Figure 63—Outside Handle and Lock Cylinder Components

DOOR OUTSIDE HANDLE REPLACEMENT

↔ Remove or Disconnect (Figure 63)

- Raise the window completely.
1. Door trim panel. Refer to "Door Trim Panel Replacement."
 2. Door to outside handle screws (253).
 3. Handle from the door.
 4. Gaskets from the door.

↔ Install or Connect (Figure 63)

1. Large gasket onto the handle.
2. Door to outside handle screw (253) to the push button side of the handle.
 - Do not tighten.
3. Small gasket between the door and the handle.
4. Door to outside handle screw (253) to the other side of the handle.
 - Tighten both screws.
5. Door trim panel. Refer to "Door Trim Panel Replacement."

DOOR LOCK CYLINDER REPLACEMENT

↔ Remove or Disconnect (Figure 63)

- Raise the window completely.
1. Door trim panel. Refer to "Door Trim Panel Replacement."
 2. Lock cylinder retaining clip from the cylinder.
 - Slide the clip off the cylinder with a screwdriver.
 3. Lock cylinder and gasket from the door.

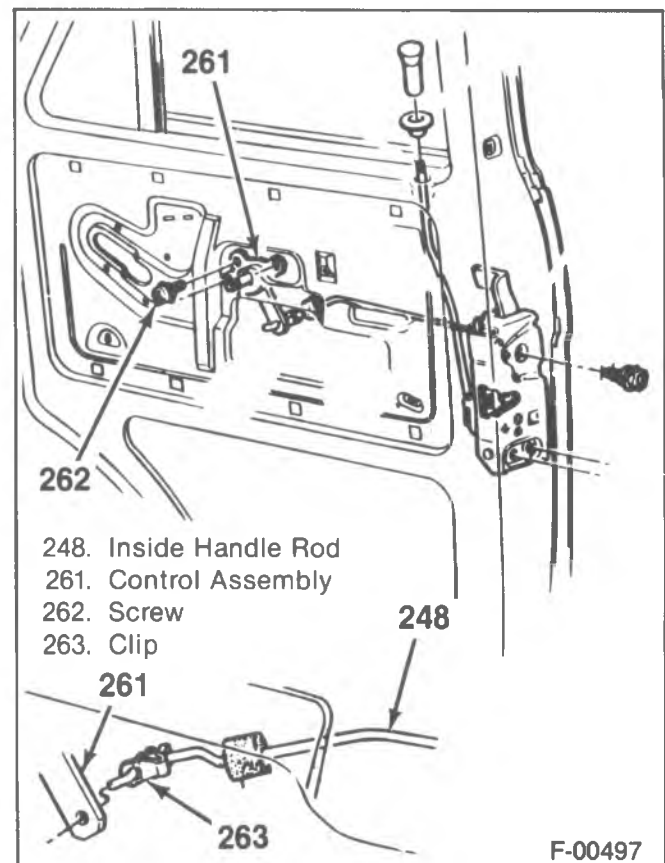

Figure 64—Door Lock Control

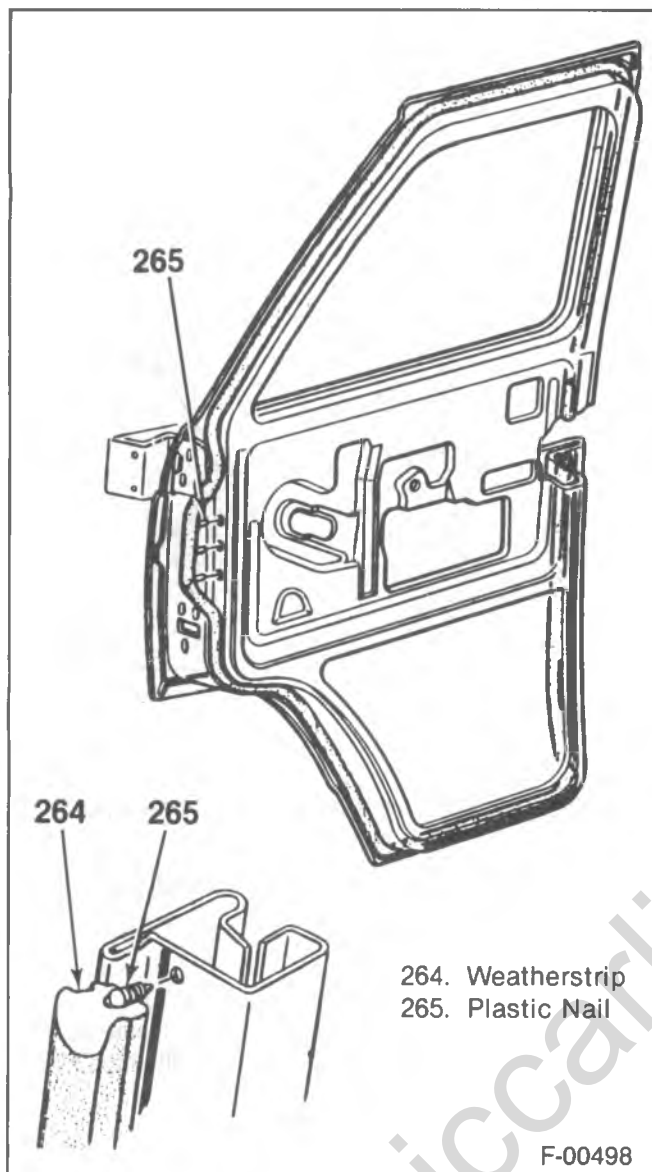

Figure 65—Door Weatherstrip

Install or Connect (Figure 63)

1. Lock cylinder with gasket to the door.
 - The cylinder rod must engage the lock assembly lever.
2. Lock cylinder retaining clip onto the cylinder.
3. Door trim panel. Refer to "Door Trim Panel Replacement."

DOOR LOCK CONTROL ASSEMBLY REPLACEMENT

Remove or Disconnect (Figure 64)

1. Door trim panel. Refer to "Door Trim Panel Replacement."
2. Door panel to control assembly screws (262).
3. Control assembly from the lock assembly rod.
 - Pivot the clip away from the rod at the control assembly.
 - Twist the control assembly off the rod.
4. Control from the vehicle.

Install or Connect (Figure 64)

1. Control to the vehicle.
2. Control assembly to the lock assembly rod.
 - Twist the control assembly (with clip) onto the rod.
 - Pivot the clip onto the rod.
3. Door panel to control assembly screws (262).
4. Door trim panel. Refer to "Door Trim Panel Replacement."

DOOR WEATHERSTRIP REPLACEMENT

Remove or Disconnect (Figure 65)

1. Weatherstrip from the door using 3M Release Agent (or equivalent).
2. Plastic nails from the door.

Clean

- The door of all the old cement.

Install or Connect (Figure 65)

1. Weatherstrip adhesive to the door. Use 3M Weatherstrip Adhesive (or equivalent).
2. Weatherstrip to the door.
 - Locate the weatherstrip part number, and place it at the top of the vent window.
 - Press the plastic nails into the door.

BELOW EYELINE OUTSIDE REAR VIEW MIRROR REPLACEMENT

Remove or Disconnect (Figure 20)

1. Mirror cover screw.
 - Lift the cover, and pivot the mirror towards the window.
2. Mirror to door bolts and nut.
3. Mirror and seal from the door.

Install or Connect (Figure 20)

1. Mirror and seal to the door.
2. Mirror to door bolts and nut.
 - Pivot the mirror away from the window, and lower the mirror cover.
3. Mirror cover screw.

G MODEL INTERMEDIATE DOORS

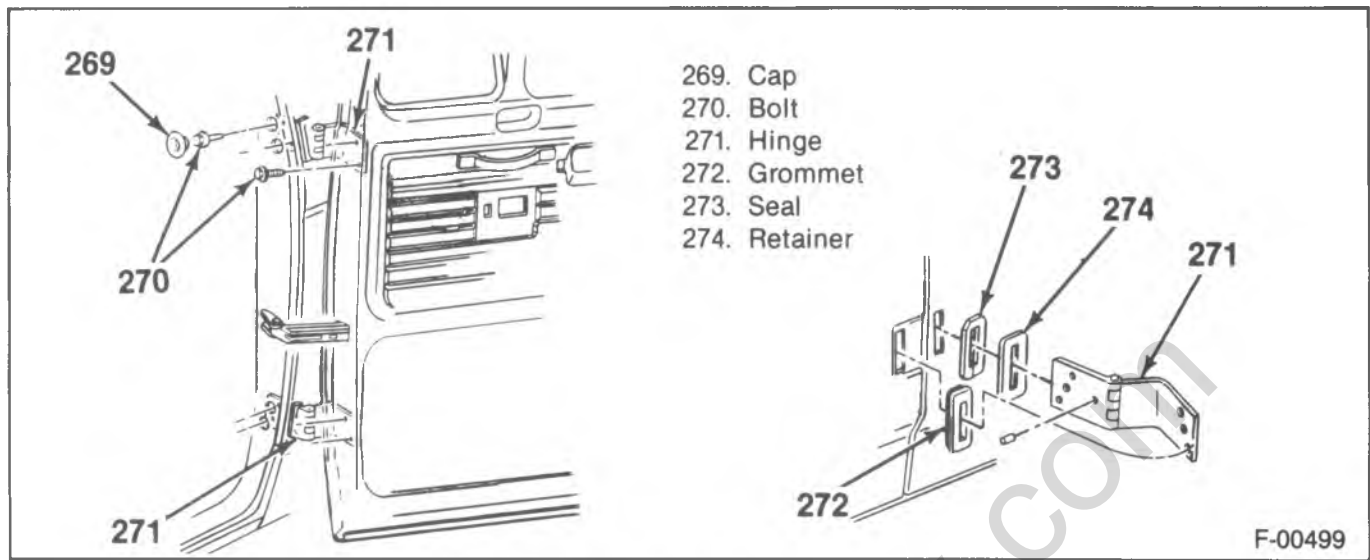

Figure 66—Door Hinge Components

DOOR AND HINGE REPLACEMENT

↔ Remove or Disconnect (Figures 66 and 67)

- Open the door.
- 1. Electrical wiring harness (if equipped).
 - Refer to “Door Trim Panel Replacement” for access to the wiring harness.
- Mark the position of the door on the hinges using a wax pencil.
- 2. Hinge hole plugs on the body side pillar.
- 3. Strap pin (275) from the bracket.
 - Remove the snap ring from the pin, and pull the pin.
- Support the door.
- 4. Hinge to the body pillar bolts (270).
- 5. Door from the vehicle.
- 6. Hinge to door bolts (270).

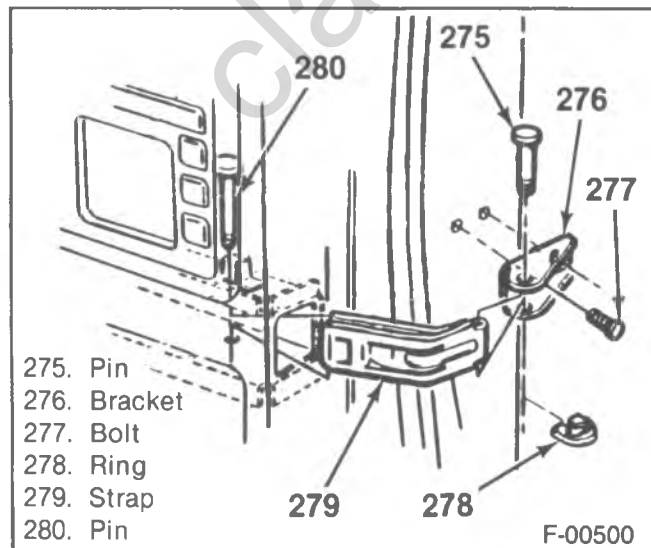

Figure 67—Check Strap Components

↔ Install or Connect (Figures 66 and 67)

1. Grommet to the door.
2. Hinge to the door.
3. Hinge to door bolts (270).
 - Align the hinge to the previously made mark.
4. The seals and retainers to the body half of the hinge.
5. Door to the vehicle.
 - Support the door.
6. Hinge to body pillar bolts (270).
 - Align the hinge to the previously made mark.
7. Strap pin (275) to the bracket.
8. Snap ring to the pin.
9. Hinge hole plugs on the body side pillar.
10. Electrical wiring harness (if equipped).
 - Refer to “Door Trim Panel Replacement” for access to the wiring harness.

DOOR ADJUSTMENT

↔ Remove or Disconnect (Figure 68)

Tool Required:

J-23457-A Wrench.

1. Door lock striker from the rear intermediate door using J-23457-A.
2. Upper and lower rear intermediate door strikers.
 - Loosen the hinge bolts as necessary to adjust the doors.

🔧 Adjust

- Each of the two doors must first be adjusted in the door opening before adjusting the door to door clearance.
- The door up or down, forward or rearward, and in or out, at the door hinges.

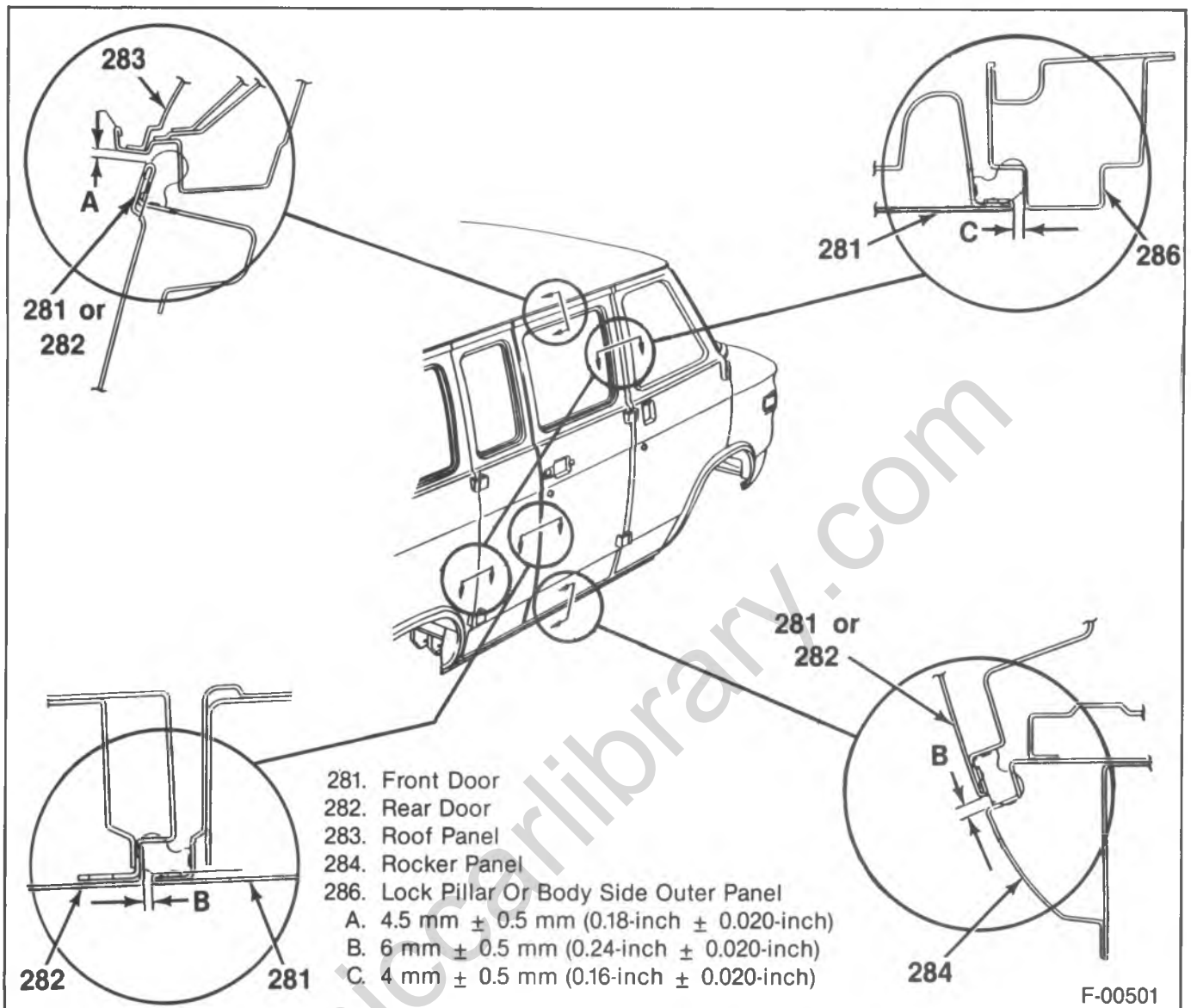

Figure 68—Door Adjustments

1. The door height so that there is a gap of 4.5 mm \pm 0.5 mm (0.18-inch \pm 0.020-inch) between the doors and the roof panel.
 2. The gap between the door and the rocker panel to 6 mm \pm 0.5 mm (0.24-inch \pm 0.020-inch).
 3. The gap between the doors and the body at the hinge pillars to 4 mm \pm 0.5 mm (0.16-inch \pm 0.020-inch).
 4. The gap between the front and rear intermediate doors to 6 mm \pm 0.5 mm (0.25-inch \pm 0.020-inch).
- Tighten the hinge bolts that were loosened.

Install or Connect

1. Upper and lower rear intermediate door strikers to the body.
2. Door lock striker to the rear intermediate door using J-23457-A.

Adjust (Figure 69)

- The upper and lower rear intermediate door striker to door clearance so that there is 4.4 mm (0.172-inch) between the striker and the door latch when the door is

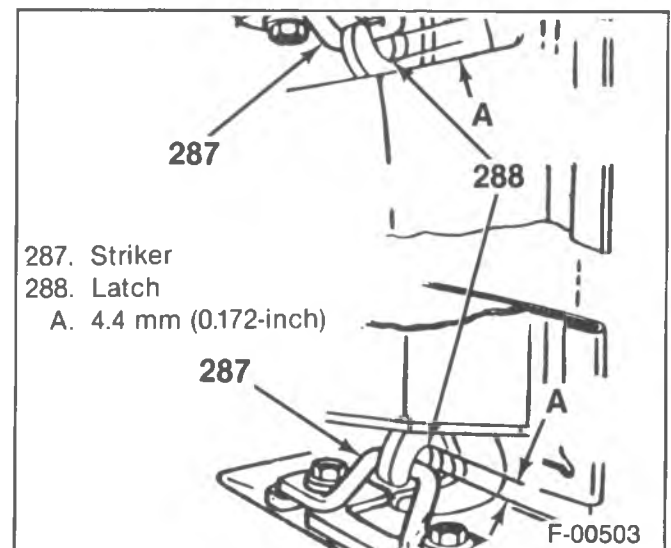

Figure 69—Striker Adjustments

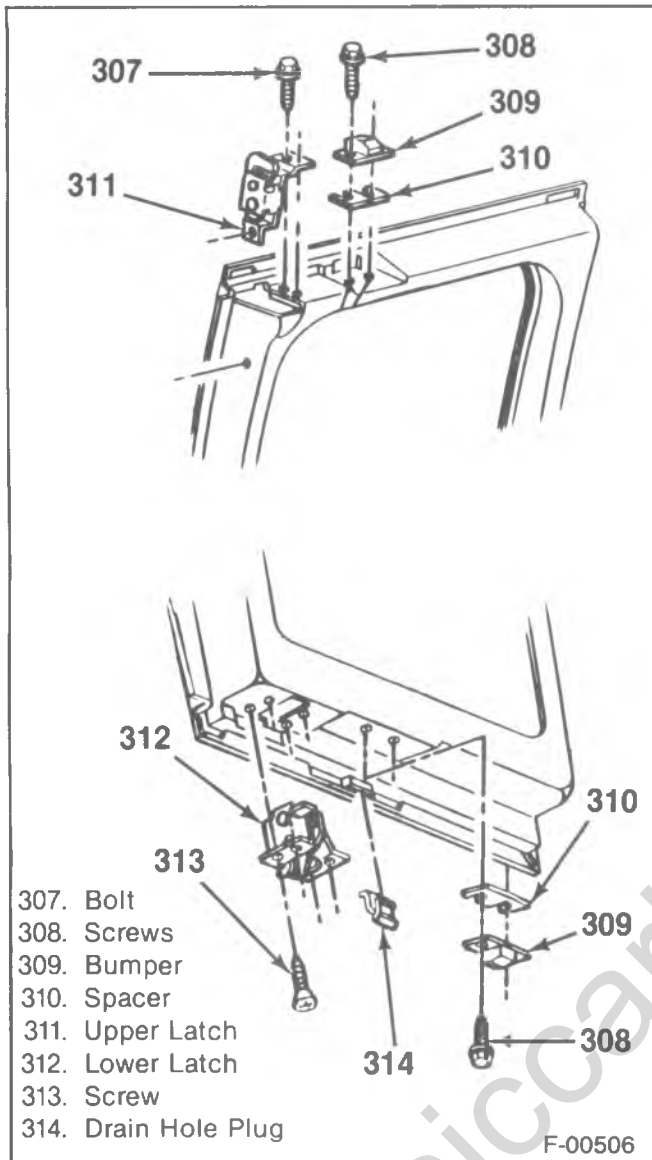

Figure 70—Bumper Wedge Components

in the secondary latched position. (The door is latched but not fully closed.) An $1\frac{1}{64}$ -inch diameter drill bit may be used to gauge this clearance.

- The front intermediate striker on the rear door. Adjust it so that the front door lock properly engages the rear door, and so the front door is flush with the rear door.

BUMPER WEDGE REPLACEMENT

↔ Remove or Disconnect (Figure 70)

1. Bumper to upper and lower door frame screws (308).
2. Bumper and spacer.

→← Install or Connect (Figure 70)

1. Spacer (as required).
2. Bumper.
3. Bumper to upper and lower door frame screws (308).

🔧 Adjust

- The bumper to door clearance so that there is 1 mm (0.04-inch) between the bumper and the door when the door is in the secondary position. (The door is latched but not fully closed).

DOOR TRIM PANEL REPLACEMENT

INTERMEDIATE FRONT DOOR

↔ Remove or Disconnect (Figure 71)

1. Door strap.
 - Pry the lock knob off of the lock rod, when the knob is in the unlocked position.
2. Door handle bezel screws.
3. Bezel and lock knob from the vehicle.
4. Door trim panel to door screws (295).
5. Door trim panel.
 - Pull the panel from the retainers.
6. Retainer to door screws (293).
7. Retainers from the door.
8. Door garnish molding screws (289).
9. Door garnish molding from the doors.

→← Install or Connect (Figure 71)

1. Door garnish molding to the door.
2. Door garnish molding screws (289).
3. Retainers to the door.
4. Retainer to door screws (293).
5. Door trim panel.
 - Push the edge of the panel into the retainers.
6. Door trim panel to door screws (295).
7. Door handle bezel and lock knob to the vehicle.
 - Place the lock knob onto the lock rod.
8. Door handle bezel screws.
9. Door strap.

INTERMEDIATE REAR DOORS

↔ Remove or Disconnect (Figure 72)

1. Door trim panel to door screws (305).
2. Door trim panel.
 - Pull the panel from the retainers.
3. Side door garnish molding screws (304) and bolt (302).
4. Side door garnish molding from the door.
5. Retainer to door screws (301).
6. Retainer from the door.
7. Upper door garnish molding screws (298).
8. Upper door garnish molding from the door.

→← Install or Connect (Figure 72)

1. Upper door garnish molding to the door.
2. Upper door garnish molding screws (298).
3. Retainer to the door.
4. Retainer to door screws (301).
5. Side door garnish molding to the door.
6. Side door garnish molding screws (304) and bolt (302).
7. Door trim panel.
 - Push the edge of the panel into the retainer.
8. Door trim panel to door screws (305).

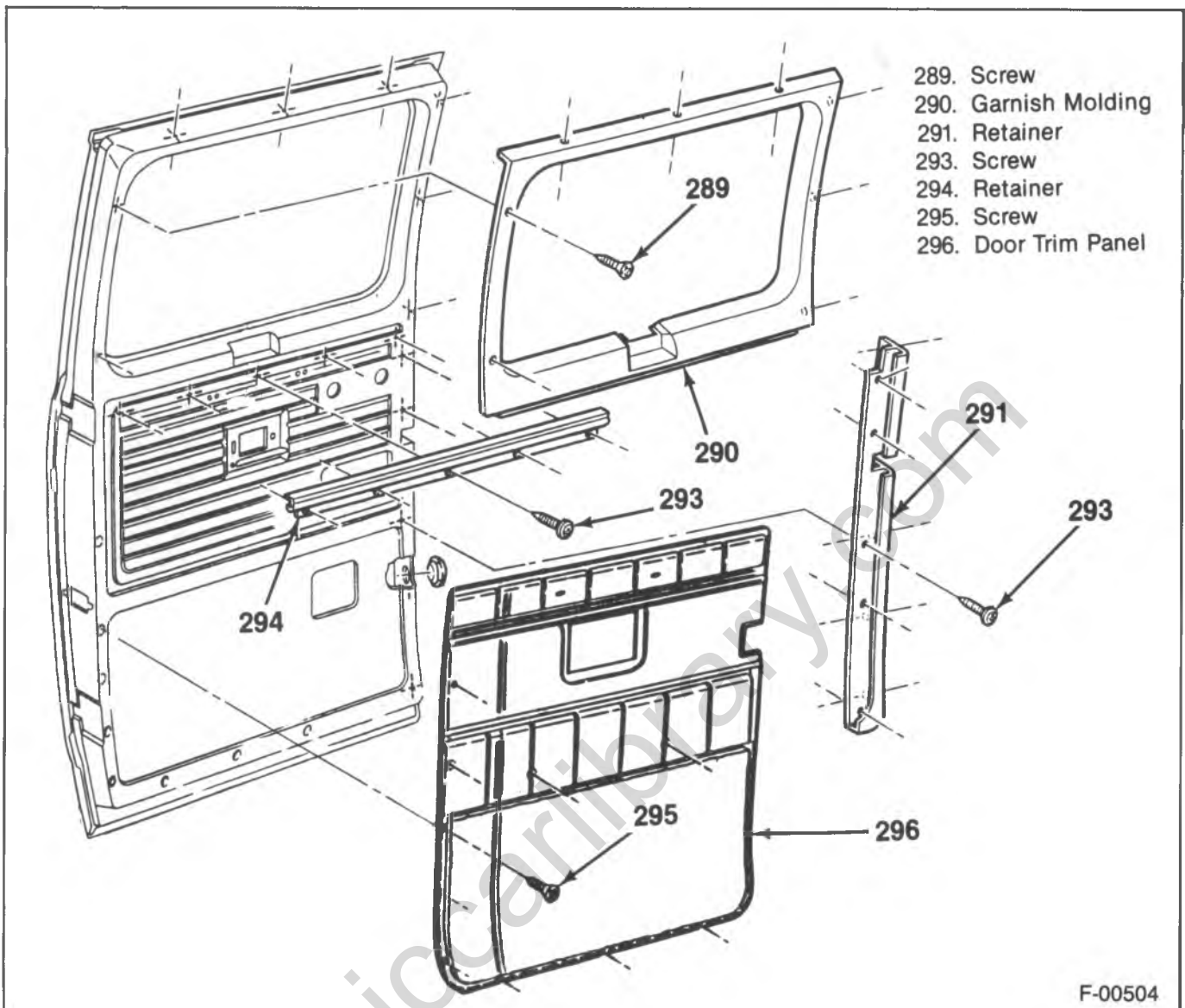

F-00504

Figure 71—Intermediate Front Door Trim Panel

WINDOW REPLACEMENT

If a glass is cracked but still intact, it should be crisscrossed with masking tape to reduce the risk of injury and/or damage to the vehicle. If a crack extends to the edge of the glass, mark the door with a piece of chalk at the point where the crack meets the weatherstrip. Later, when examining the flange of the opening for a cause of the crack, start at the point marked.

It is important that the cause of the crack be determined and the condition corrected, before the new glass is installed. The cause of the crack may be an obstruction or high spot somewhere around the flange of the opening; cracking may not occur until pressure from the high spot or obstruction becomes particularly high due to winds, extremes of temperature, or rough terrain.

STATIONARY GLASS

↔ Remove or Disconnect (Figure 73)

CAUTION: Always wear heavy gloves when handling glass to minimize the risk of injury.

1. Weatherstrip seal by running a putty knife between the flange and the weatherstrip (inside and outside the door).
 - Have an assistant outside the cab by the window.
2. Weatherstrip and glass from the flange.
 - Force the weatherstrip from the flange from the inside with a putty knife.
3. Window from the weatherstrip.



Install or Connect (Figure 73)

1. Weatherstrip to the glass.
 - The seam of the weatherstrip must be located at the bottom centerline of the glass.
2. A six mm (1/4-inch) cord in the weatherstrip groove. The ends should overlap about 5 cm (6-inches) at the window bottom.
3. Window and weatherstrip on the flange from outside the cab.
 - Brush soapy water on the flange.
 - Have an assistant pull the cord from inside the cab to seat the lip of the weatherstrip on the flange.

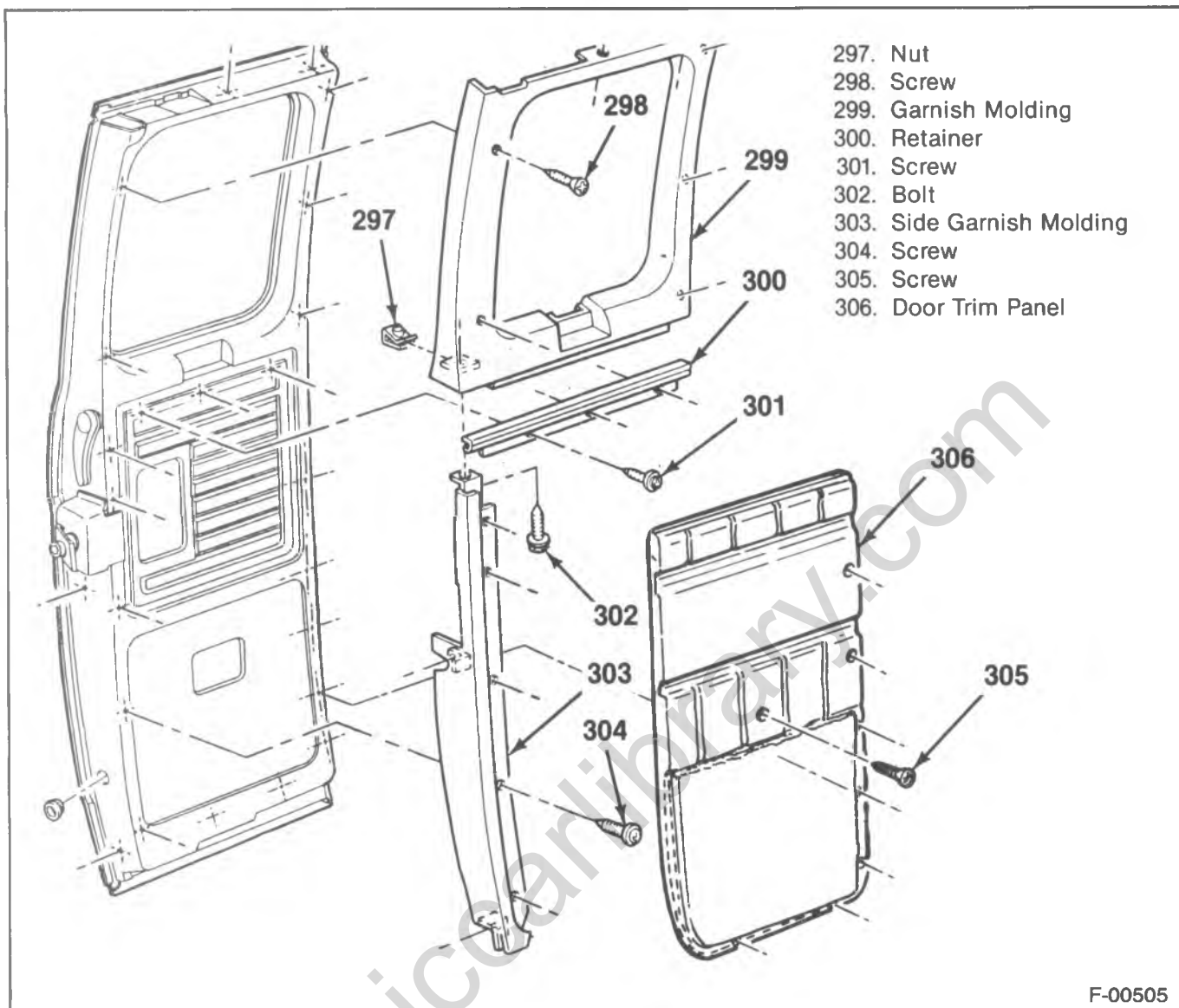

- 297. Nut
- 298. Screw
- 299. Garnish Molding
- 300. Retainer
- 301. Screw
- 302. Bolt
- 303. Side Garnish Molding
- 304. Screw
- 305. Screw
- 306. Door Trim Panel

F-00505

Figure 72—Intermediate Rear Door Trim Panel

SWING OUT WINDOW

↔ Remove or Disconnect (Figures 74 and 75)

CAUTION: Always wear heavy gloves when handling glass to minimize the risk of injury.

1. Window latch to door screws (327).
2. Window latch from the window.
 - Twist the latch 1/4 of a turn to release the latch components from the window.
 - Lift the window for access to the hinge screws.
3. Hinge to door screws (320).
4. Hinge from the door.
5. Hinge seal from the door.

↔ Install or Connect (Figures 74 and 75)

1. Hinge and hinge seal to the door.
2. Hinge to door screws (320).
3. Window latch to the window.
 - Place the cover and spacer through the window.
 - Place the washer and spring onto the cover.

- Twist the latch onto the cover with 1/4 of a turn.
- 4. Window latch to door screws (327).

INTERMEDIATE FRONT DOOR LOCK REPLACEMENT

↔ Remove or Disconnect (Figure 76)

1. Door trim panel. Refer to "Door Trim Panel Replacement."
2. Door lock control. Refer to "Door Lock Control Replacement."
3. Power door lock motor (if equipped). Refer to "Power Door Lock Motor Replacement."
4. Door to remote control screws (330).
5. Door to lock screws (331).
6. Lock and remote control with rods from the door.

↔ Install or Connect (Figure 76)

1. Lock and remote control with rods to the door.
2. Door to lock screws (331).
3. Door to remote control screws (330).

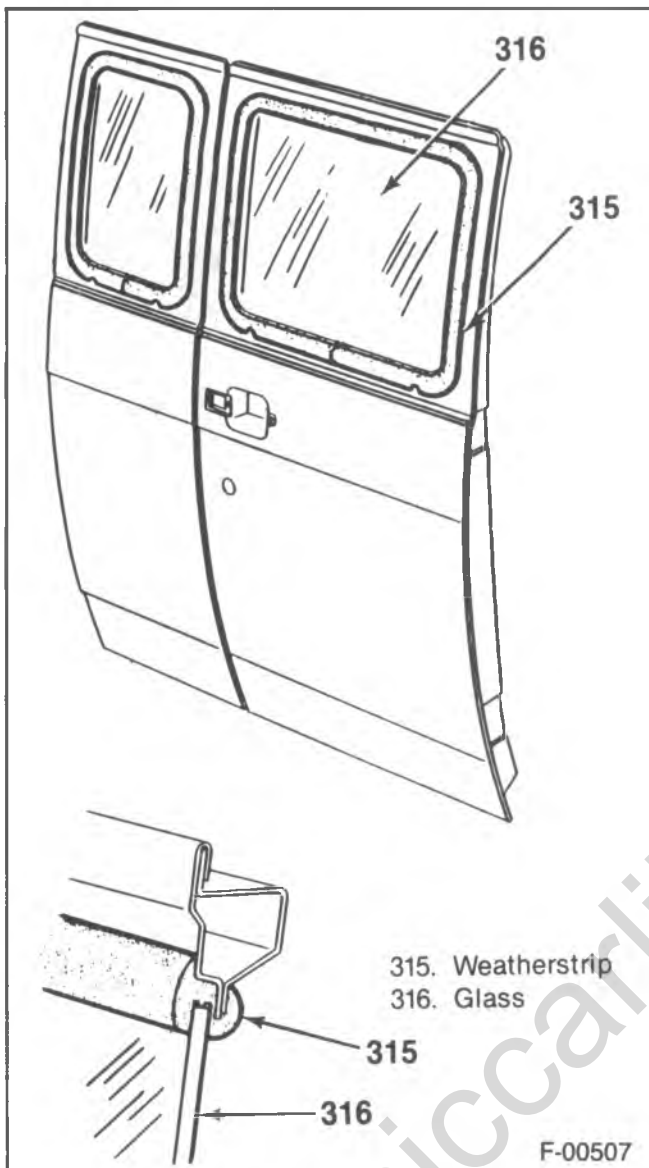

Figure 73—Window Components

4. Power door lock motor (if equipped). Refer to "Power Door Lock Motor Replacement."
5. Door lock control. Refer to "Door Lock Control Replacement."
6. Door trim panel. Refer to "Door Trim Panel Replacement."

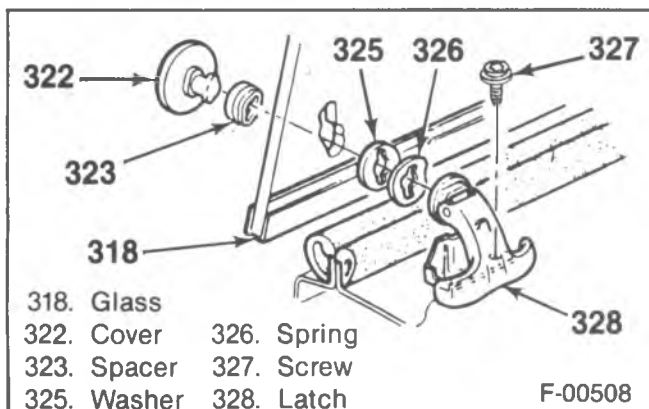

Figure 74—Swing Out Latch Components

INTERMEDIATE FRONT DOOR LOCK CONTROL REPLACEMENT

↔ Remove or Disconnect (Figure 77)

1. Door trim panel. Refer to "Door Trim Panel Replacement."
2. Lock control to door screw (337).
3. Lock control from the door.
 - Slide the control towards the front of the door.
4. Lock rod from the lock control.
 - Slide the clip so that the large diameter slot is in line with the lock rod. Then, pull the rod from the control.

↔ Install or Connect (Figure 77)

1. Lock rod to the lock control.
 - Place the rod into the clip and the lever. Slide the clip so that the small diameter slot is in line with the lock rod.
2. Lock control to the door.
 - Slide the control towards the rear of the door.
3. Lock control to door screws (337).
4. Door trim panel. Refer to "Door Trim Panel Replacement."

DOOR LOCK CYLINDER REPLACEMENT

↔ Remove or Disconnect (Figure 78)

1. Door trim panel. Refer to "Door Trim Panel Replacement."
2. Lock cylinder retaining clip from the cylinder.
 - Slide the clip off the cylinder with a screwdriver.
3. Lock cylinder and gasket from the door.

↔ Install or Connect (Figure 78)

1. Lock cylinder with gasket to the door.
 - The cylinder rod must engage the lock assembly lever.
2. Lock cylinder retaining clip onto the cylinder.
3. Door trim panel. Refer to "Door Trim Panel Replacement."

DOOR OUTSIDE HANDLE REPLACEMENT

↔ Remove or Disconnect (Figure 78)

- Raise the window completely.
1. Door trim panel. Refer to "Door Trim Panel Replacement."
 2. Door to outside handle screws (341).
 3. Handle from the door.
 4. Gaskets from the door.

↔ Install or Connect (Figure 78)

1. Large gasket onto the handle.
2. Door to outside handle screw (341) to the push button side of the handle.
 - Do not tighten.

10A1-48 DOORS

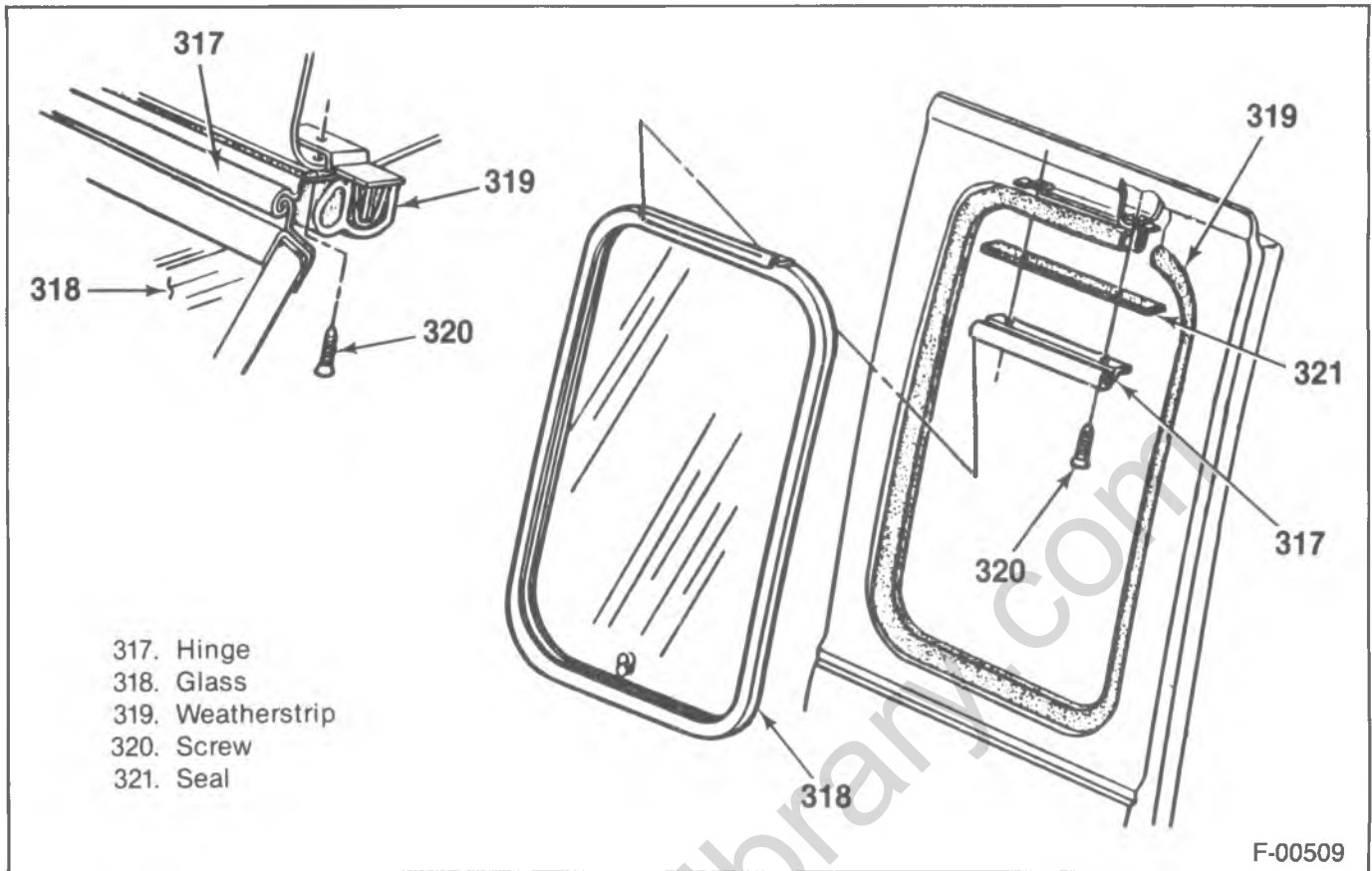

Figure 75—Swing Out Window Attachment

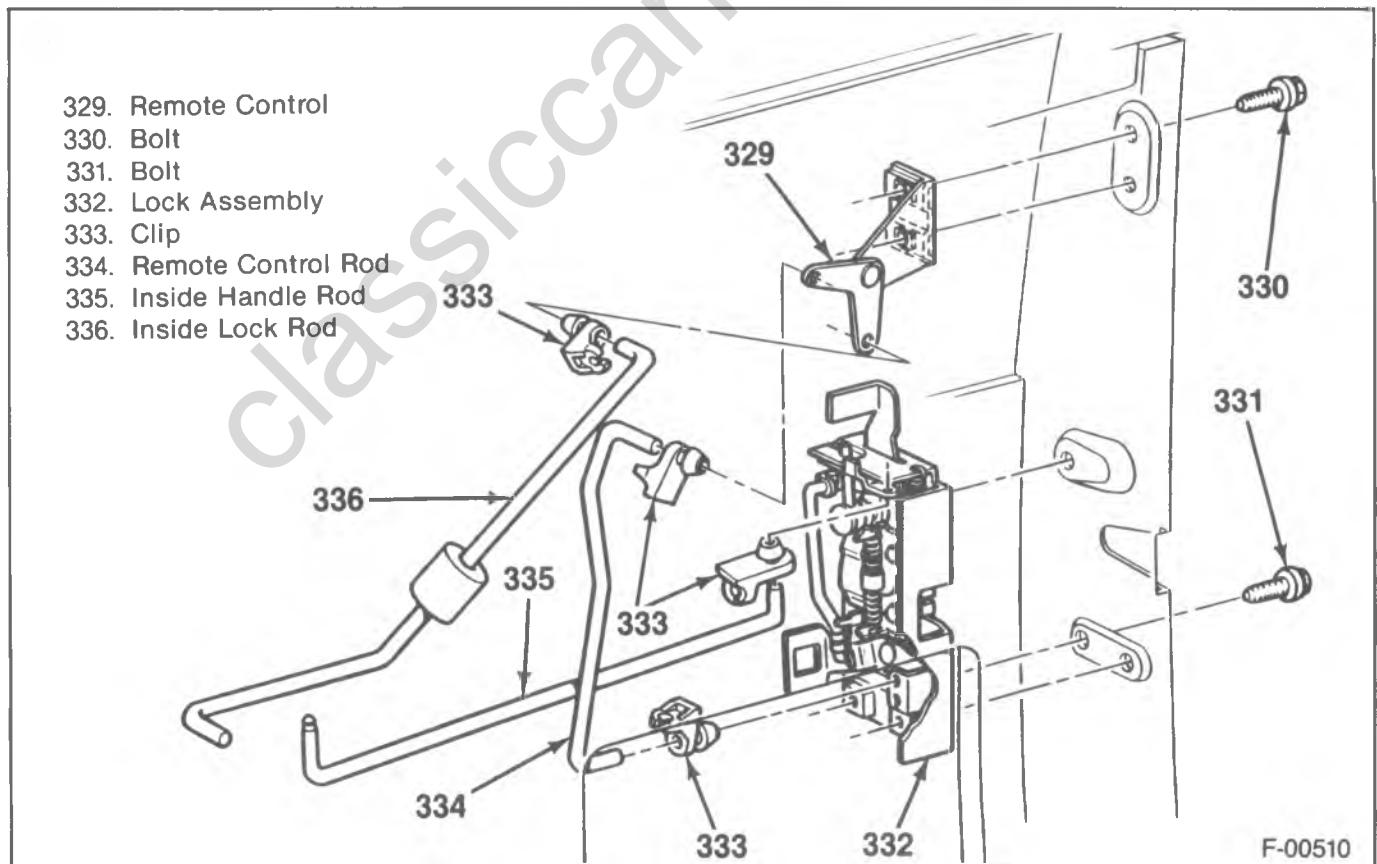

Figure 76—Intermediate Front Door Lock Components

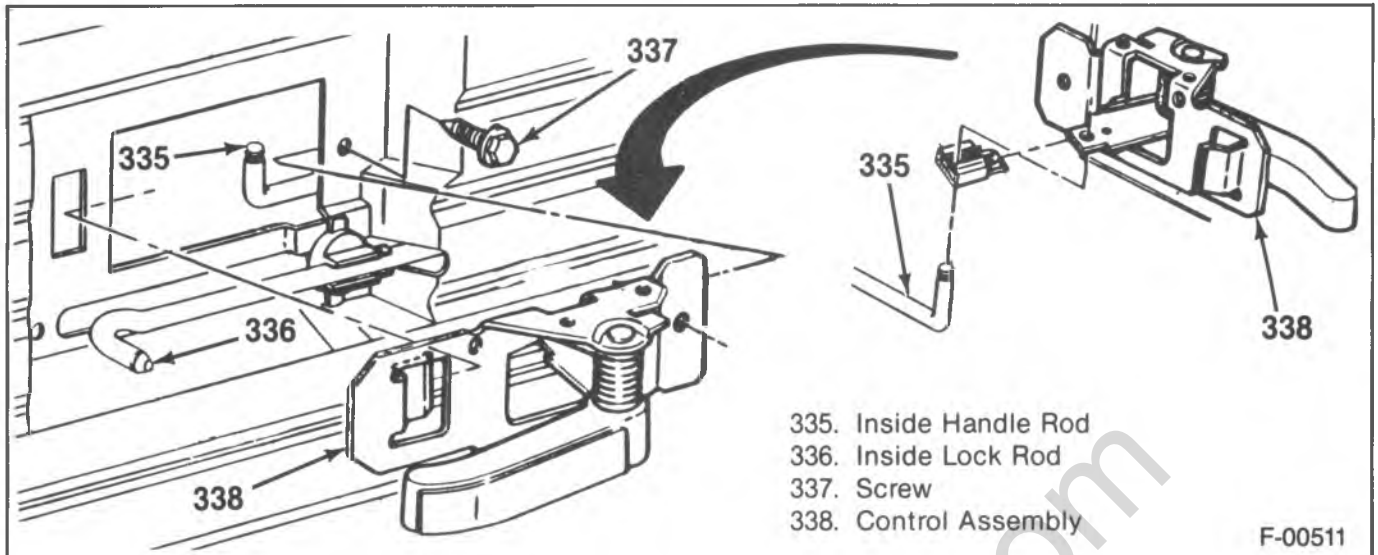

Figure 77—Intermediate Front Door Lock Control

3. Small gasket between the door and the handle.
4. Door to outside handle screw (341) to the other side of the handle.
 - Tighten both screws.
5. Door trim panel. Refer to "Door Trim Panel."

INTERMEDIATE REAR DOOR LOWER LATCH REPLACEMENT

↔ Remove or Disconnect (Figure 79)

1. Door trim panel. Refer to "Door Trim Panel Replacement."
2. Lower latch to control assembly rod from the control assembly.
 - Using a flat bladed screwdriver, push on the top of the clip where it is connected to the rod. Pivot the clip away from the rod.
3. Lower latch to door screws (349).
4. Lower latch with the rod from the door.

↔ Install or Connect (Figure 79)

1. Lower latch with the rod to the door.
2. Lower latch to door screws (349).
3. Lower latch to control assembly rod into the control assembly.
 - Pivot the clip onto the rod.
4. Door trim panel. Refer to "Door Trim Panel Replacement."

INTERMEDIATE REAR DOOR UPPER LATCH REPLACEMENT

↔ Remove or Disconnect (Figure 80)

1. Door trim panel. Refer to "Door Trim Panel Replacement."
2. Upper latch to control assembly rod from the control assembly.
 - Using a flat bladed screwdriver, push on the top of the clip where it is connected to the rod. Pivot the clip away from the rod.

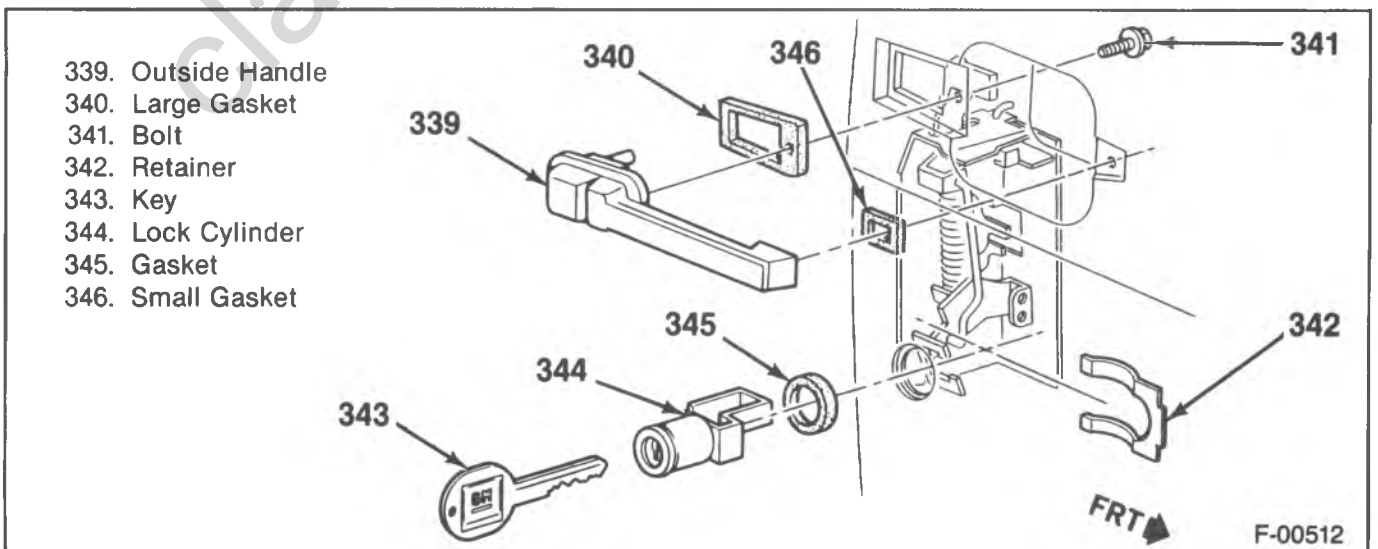

Figure 78—Outside Handle And Lock Cylinder Components

10A1-50 DOORS

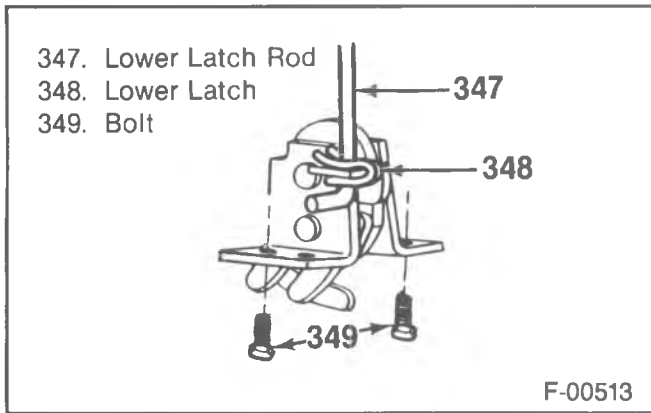

Figure 79—Intermediate Rear Door Lower Latch

3. Upper latch to door bolts (350).
4. Upper latch with the rod from the door.

↔ Install or Connect (Figure 80)

1. Upper latch with the rod to the door.
2. Upper latch to door bolts (350).
3. Upper latch to control assembly rod into the control assembly.
 - Pivot the clip onto the rod.
4. Door trim panel. Refer to "Door Trim Panel Replacement."

INTERMEDIATE REAR DOOR CONTROL ASSEMBLY REPLACEMENT

↔ Remove or Disconnect (Figure 81)

1. Door trim panel. Refer to "Door Trim Panel Replacement."
2. Upper and lower door latch rods from the control assembly.
 - Using a flat bladed screwdriver, push on the top of the clip where it is connected to the rod. Pivot the clip away from the rod.
3. Electric door actuator (if equipped).
4. Lock knob (356).
5. Rear door inside handle screw (364) and handle (365).
6. Rear door lock rod clip at the door panel.
 - Pivot the clip away from the rod.
7. Door to control assembly bolts (363).

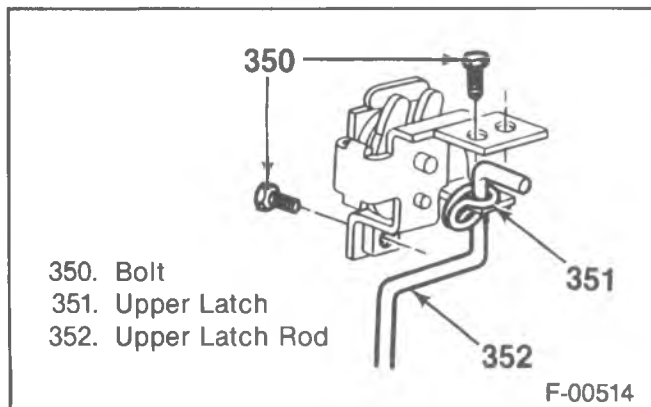

Figure 80—Intermediate Rear Door Upper Latch

8. Control assembly with lock rod through the access hole.

↔ Install or Connect (Figure 81)

1. Control assembly with lock rod through the access hole.
2. Door to control assembly bolts (363).
3. Rear door lock rod clip at the door panel.
 - Pivot the clip onto the rod.
4. Rear door inside handle (365) and screw (364).
5. Lock knob (356).
6. Electric door actuator (if equipped).
7. Upper and lower door latch rods to the control assembly.
 - Pivot the clip onto the rod.
8. Door trim panel. Refer to "Door Trim Panel Replacement."

POWER DOOR LOCK MOTOR REPLACEMENT

Refer to CAB ELECTRICAL (SEC. 8A) for electrical diagnosis of the door lock motor.

↔ Remove or Disconnect (Figure 82)

1. Battery ground cable.
2. Door trim panel. Refer to "Door Trim Panel Replacement."
3. Electrical connector from the motor.
4. Door to motor screws (370).
5. Motor from the lock rod.
 - Slide the rubber mount at the top of the motor off of the door lock rod.
6. Motor from the door.

↔ Install or Connect (Figure 82)

1. Motor into the door.
2. Motor to the lock rod.
 - Slide the rubber mount at the top of the motor onto the door lock rod.
3. Door to motor screws (370).
4. Electrical connector to the motor.
5. Door trim panel. Refer to "Door Trim Panel Replacement."
6. Battery ground cable.

INTERMEDIATE FRONT DOOR WEATHERSTRIP REPLACEMENT

↔ Remove or Disconnect (Figure 83)

1. Weatherstrip from the door using 3M Release Agent (or equivalent).
2. Plastic nails from the door.

🧼 Clean

- The door of all the old cement.

↔ Install or Connect (Figure 83)

1. Weatherstrip adhesive to the door. Use 3M Weatherstrip Adhesive (or equivalent).
2. New weatherstrip to the door.
 - Press the plastic nails into the door.

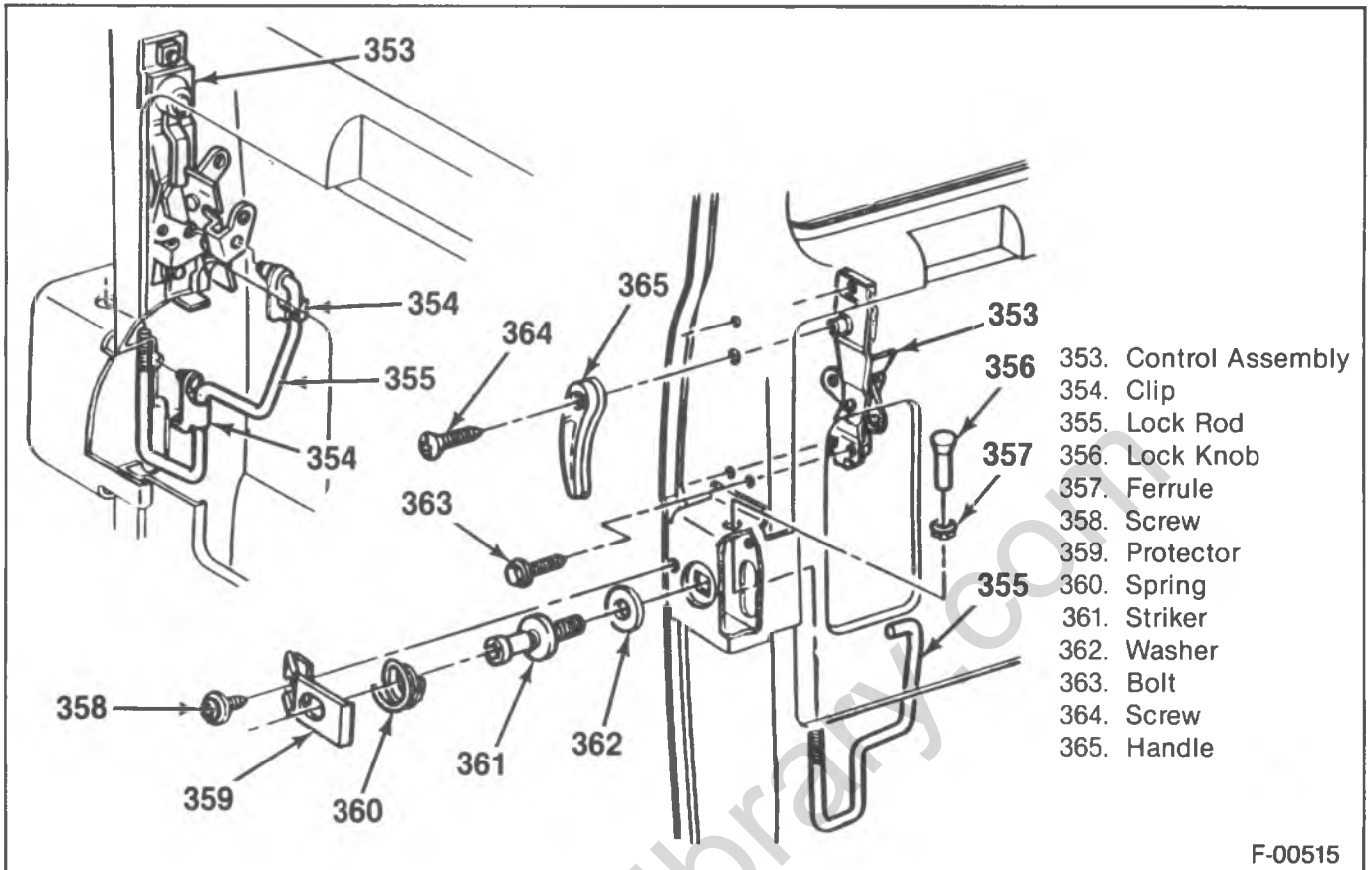

Figure 81—Intermediate Rear Door Control Assembly

INTERMEDIATE REAR DOOR WEATHERSTRIP REPLACEMENT

←→ Remove or Disconnect (Figure 84)

1. Weatherstrip to door panel screws (375).
2. Weatherstrip from the door using 3M Release Agent (or equivalent).
3. Plastic nails from the door.

Clean

- The door of all the old cement.

→← Install or Connect (Figure 84)

1. Weatherstrip adhesive to the door. Use 3M Weatherstrip adhesive (or equivalent).
2. New weatherstrip to the door.
 - Press the plastic nails into the door.
3. Weatherstrip to door panel screws (375).

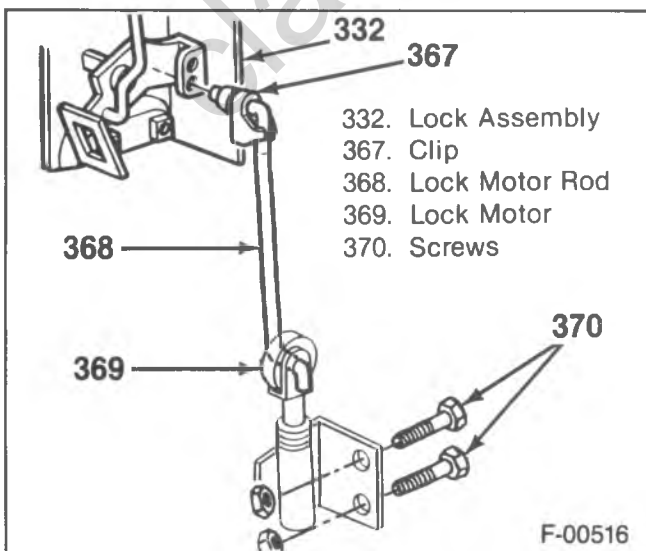

Figure 82—Power Door Lock Motor Attachments

10A1-52 DOORS

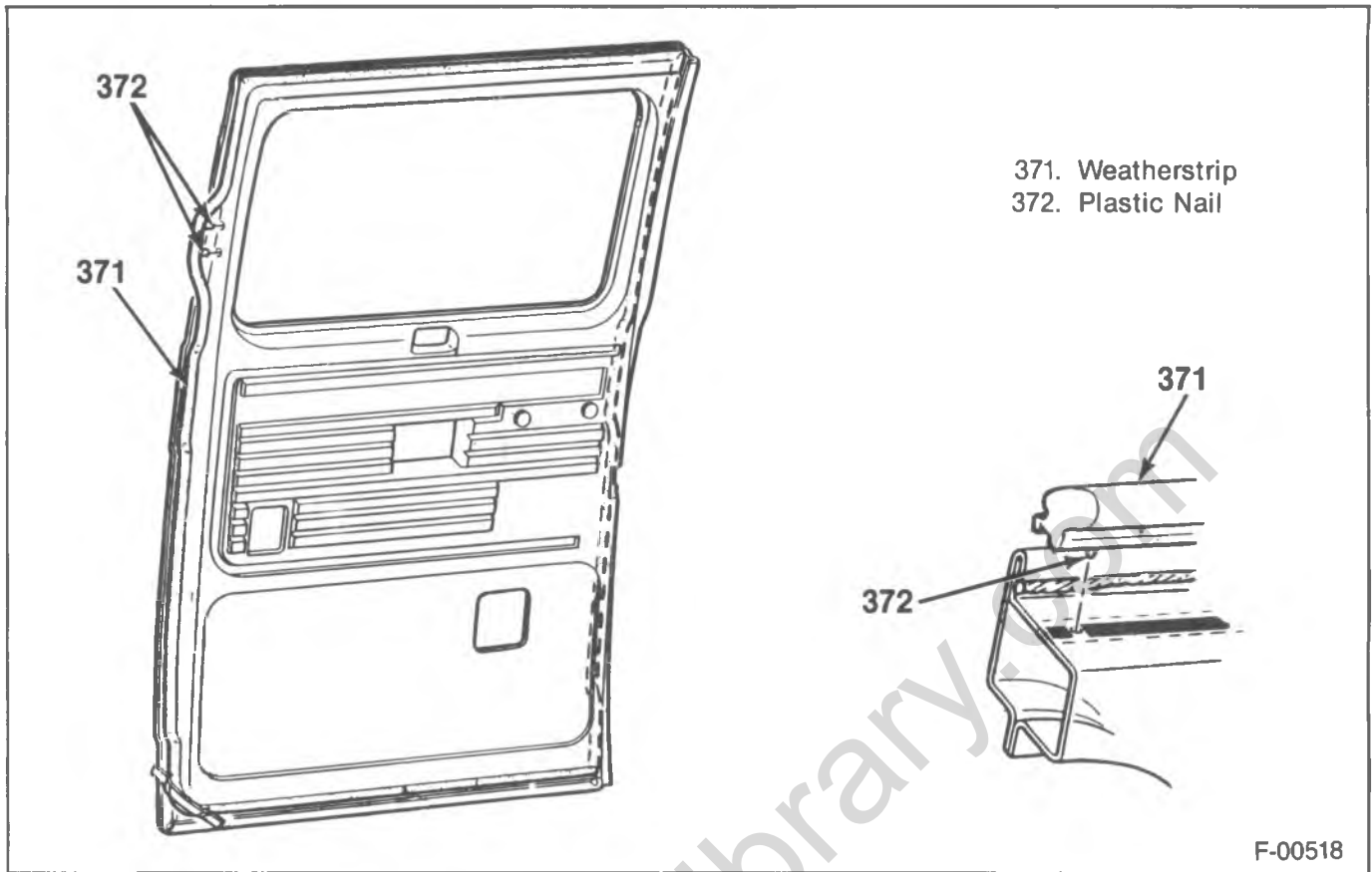

Figure 83—Intermediate Front Door Weatherstrip

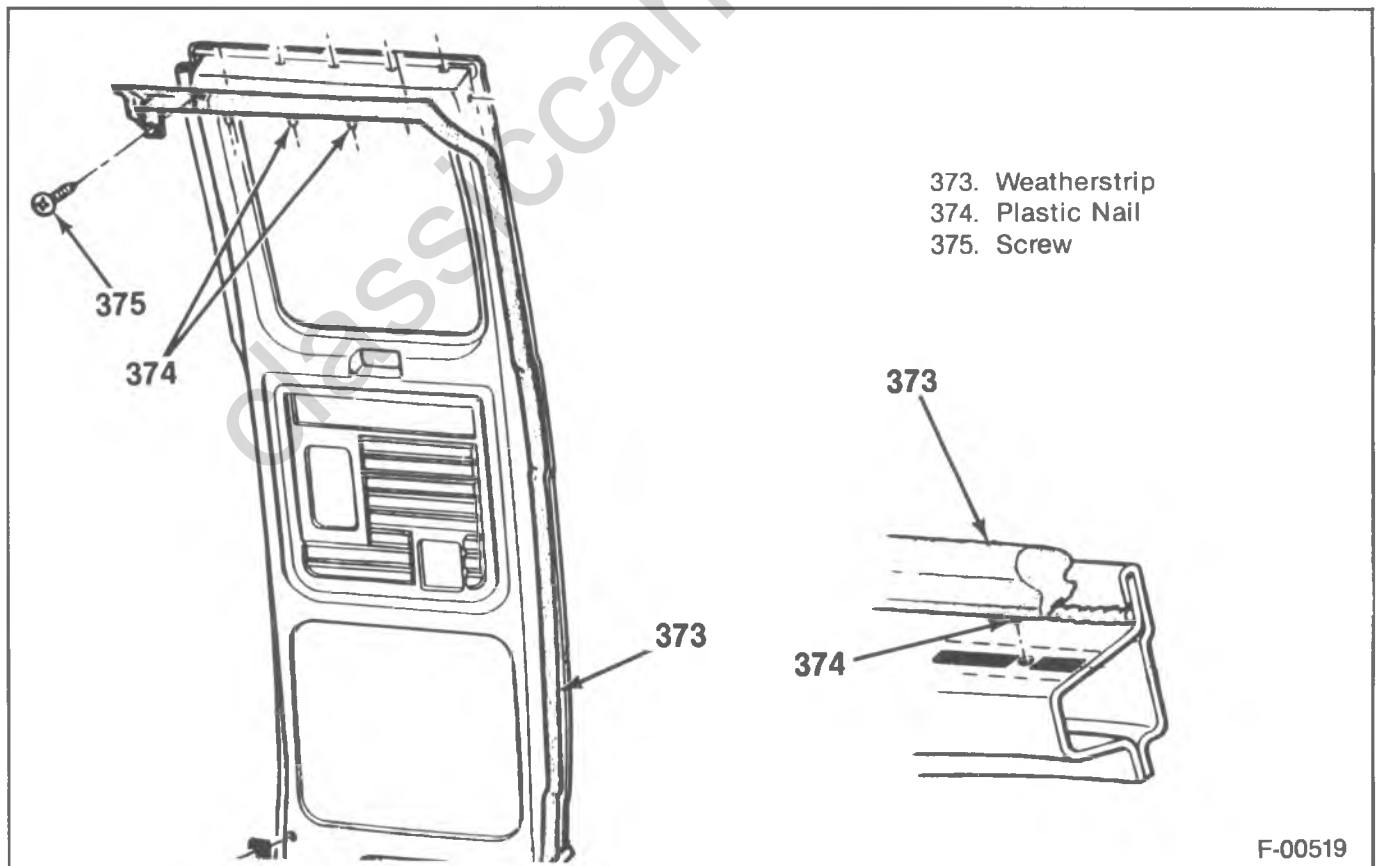

Figure 84—Intermediate Rear Door Weatherstrip

G MODEL SLIDING SIDE DOOR

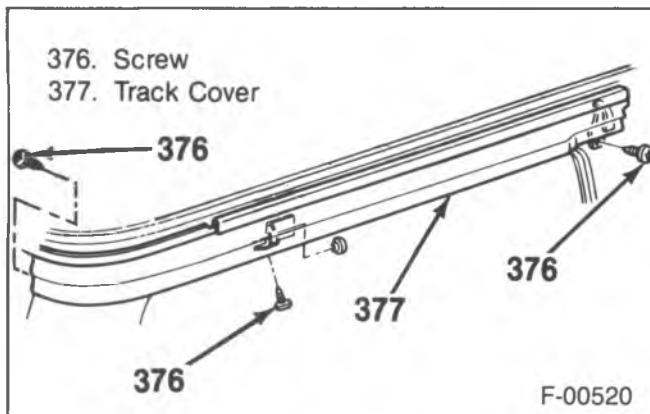

Figure 85—Upper Track Cover

DOOR REPLACEMENT

↔ Remove or Disconnect (Figures 85 through 89)

- Upper rear track cover and hinge cover.
 - Open the door completely.
- Upper front roller assembly (381) from the door.
 - Mark the position of the roller assembly on the door.
- Upper rear hinge retainer (393) from the hinge.
- Upper rear hinge (394) from the upper rear track.
 - Lift the hinge off of the track.
- Lower front roller (398) from the track.
 - Pivot the door away from the vehicle to disengage the rollers.
- Door from the vehicle.

↔ Install or Connect (Figures 85 through 89)

- Door to the vehicle.
- Lower front roller (398) to the track.
 - Pivot the door away from the vehicle to engage the rollers to the track. Then pivot the door towards the vehicle.
- Upper rear hinge (394) to the upper rear track.

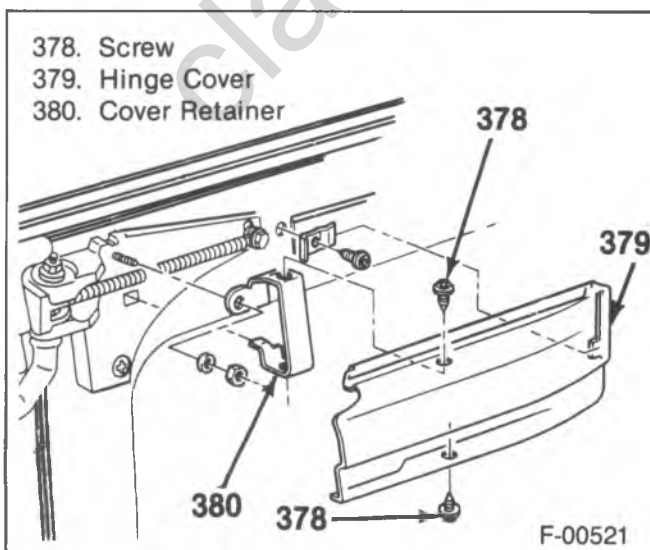
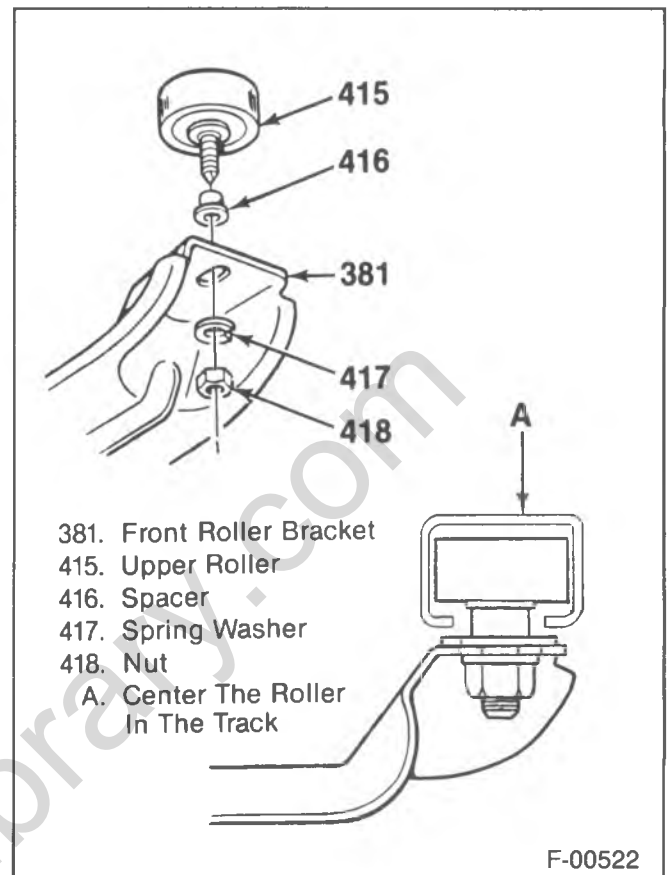

Figure 86—Upper Hinge Cover



381. Front Roller Bracket
 415. Upper Roller
 416. Spacer
 417. Spring Washer
 418. Nut
 A. Center The Roller In The Track

F-00522

Figure 87—Upper Front Roller Components

- Lift the hinge roller onto the track.
- Upper rear hinge retainer (393) to the hinge.
 - Upper front roller assembly (381) to the door.
 - Align the roller assembly to the previously made mark.
 - Upper rear track cover and hinge cover.

HINGE ASSEMBLY REPLACEMENT

↔ Remove or Disconnect (Figure 88)

- Close the door completely.
- Hinge cover (figure 85).
 - Track cover (figure 86).
 - Hinge retainer plate (393).
 - Mark the position of the hinge on the door.
 - Nut (390), washer (389), and retainer (380).
 - Hinge to door screw (391).
 - Hinge to door bolt (388).
 - Hinge from the vehicle.

↔ Install or Connect (Figure 88)

- Hinge to the vehicle.
 - Place the roller on the track.
 - Align the hinge to the previously made mark.
- Hinge to door bolt (388).
- Hinge to door screw (391).
- Retainer (380), washer (389) and nut (390).

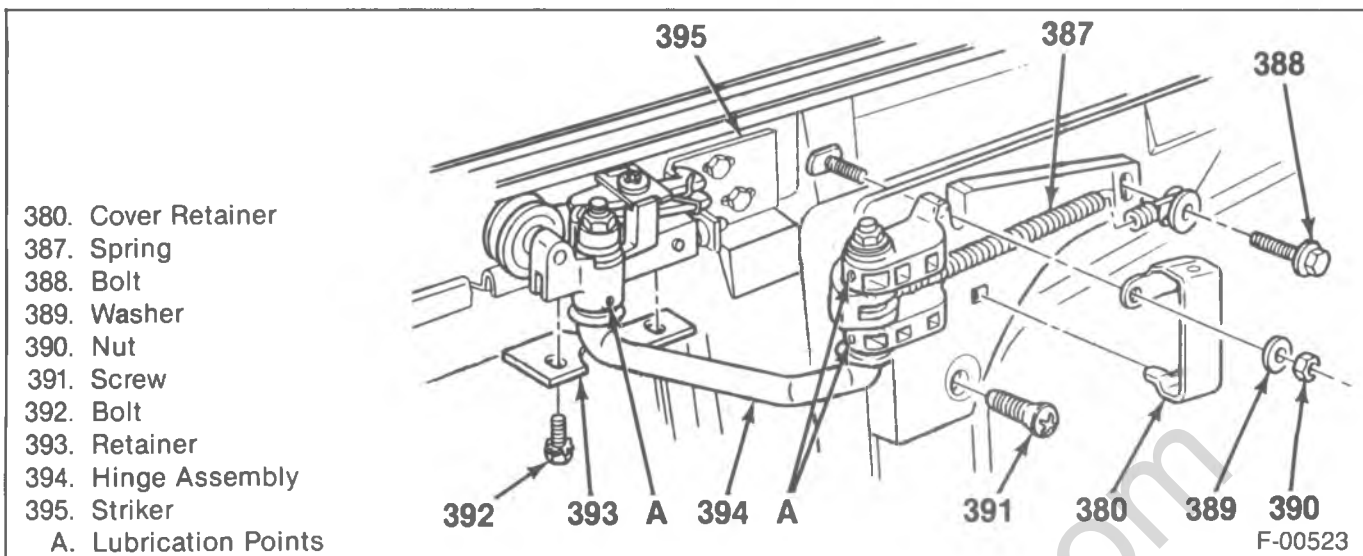

Figure 88—Upper Rear Hinge Components

5. Hinge retainer plate (393).
6. Track cover (figure 86).
7. Hinge cover (figure 85).

LOWER ROLLER ASSEMBLY REPLACEMENT

↔ Remove or Disconnect (Figure 89)

- Mark the position of the assembly to the bracket on the roller assembly.
1. Roller assembly to door bracket bolts (401).
 2. Catch clip (400) and rod from the catch.
 3. Pivot the roller assembly out of the lower door track.

↔ Install or Connect (Figure 89)

1. Pivot the roller assembly into the lower door track.
2. Roller assembly to door bracket bolts (401).
 - Align the roller assembly to the previously made mark.
3. Catch clip (400) and rod to the catch.

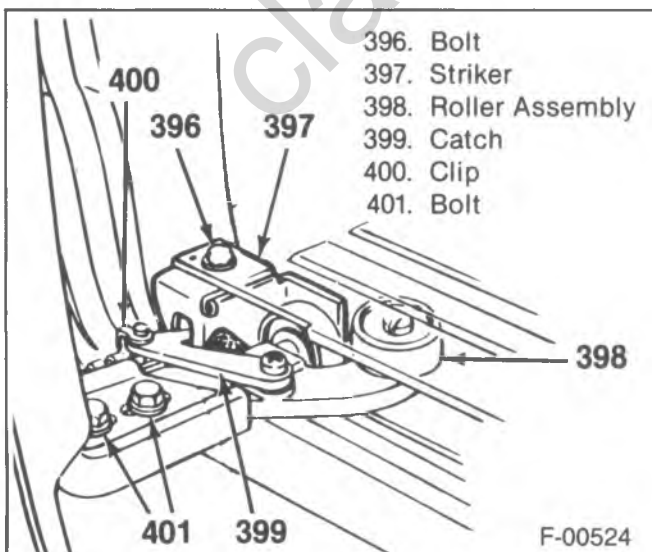

Figure 89—Lower Front Roller Assembly

UPPER FRONT ROLLER REPLACEMENT

↔ Remove or Disconnect (Figure 87)

1. Roller molding (if equipped).
2. Plastic cap (if equipped).
3. Bracket to door bolts (386).
4. Roller from the track.

↔ Install or Connect (Figure 87)

1. Roller into the track.
2. Bracket to door bolts (386).
3. Plastic cap (if equipped).
4. Roller molding (if equipped).

DOOR ADJUSTMENT

UP AND DOWN ADJUSTMENT

↔ Remove or Disconnect (Figure 90)

Tool Required:

J-23457 #50 Torx Wrench.

1. Upper rear hinge cover.
2. Front lock striker (404).
3. Rear lock striker (405) using J-23457.
4. Rear door wedge assembly (407).

⚙ Adjust (Figure 91)

1. The rear edge of the door to obtain a gap of $4.5 \text{ mm} \pm 0.5 \text{ mm}$ ($0.18\text{-inch} \pm 0.02\text{-inch}$) between the top of the door and the roof side rail. This adjustment should provide a gap of $6 \text{ mm} \pm 0.5 \text{ mm}$ ($0.25\text{-inch} \pm 0.02\text{-inch}$) between the bottom of the door and the rocker panel. To accomplish this adjustment, loosen the upper rear hinge to door bolts (figure 88), and align the rear edge of the door up or down. Next, tighten the upper rear hinge to door bolts (figure 88).

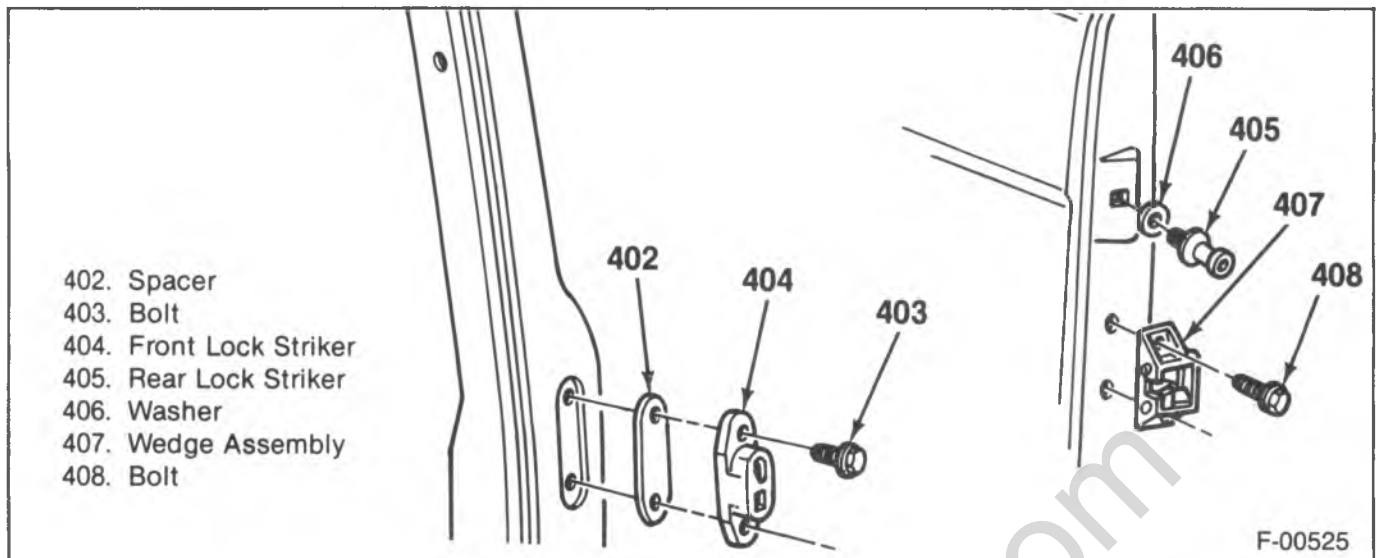

Figure 90—Front and Rear Lock Striker

- The front edge of the door by loosening the upper front roller bracket to door bolts (figure 87) and the lower hinge to door bolts (figure 89). Align the door to obtain the same gap as in step 1, then tighten the lower hinge to door bolts (figure 89).
- The upper front roller bracket up or down so that the roller is centered in the track. The roller must not touch the top or bottom of the track. Tighten the upper front roller bracket to door bolts (figure 92).

↔ Install or Connect (Figure 90)

- Rear door wedge assembly (407).
- Rear lock striker (405) using J-23457.
- Front lock striker (404).
- Upper rear hinge cover.

IN AND OUT ADJUSTMENT (Figures 90 through 92)

- Remove the front lock striker (404).
- Loosen the nut (418) retaining the upper front roller (415) to the upper roller bracket (381).
- Loosen the lower front roller assembly to roller assembly bracket bolts (figure 89).
- Loosen the rear door lock striker.
- Adjust the door in or out until the surface of the door is flush with the surface of the body.
- Tighten the rear door lock striker.
- Tighten the lower front roller assembly to roller assembly bracket bolts (figure 89).
- Tighten the nut (418) retaining the upper front roller (415) to the upper roller bracket (381).
- Install the front lock striker.

FORWARD AND REARWARD ADJUSTMENT

- Mark the position of the front and rear latch strikers on the body pillars.
- Remove the front (404) and rear (405) lock strikers (figure 90).
- Remove the upper front track over.
- Loosen the upper rear hinge striker (figure 88).
- Adjust the door forward or rearward to obtain a gap of $4.5 \text{ mm} \pm 0.5 \text{ mm}$ (0.18-inch \pm 0.02-inch) between the left and right door edge and the door pillars (figure 91).
- Tighten the upper rear hinge striker (figure 88).

- Install the upper front track cover.
- Install the front (404) and rear (405) lock strikers at the position previously marked (figure 90).

FRONT STRIKER ADJUSTMENT (Figure 90)

- Loosen the front latch striker bolts (403).
- Slide the door towards the striker.
- The guide on the door must fit snugly into the rubber lined opening in the striker assembly.
- Check that the latch fully engages the striker. Add or delete shims behind the striker to accomplish this adjustment.
- Tighten the striker bolts (403).

REAR STRIKER ADJUSTMENT (Figure 90)

Tool Required:

J-23457 Wrench.

- Loosen the striker using J-23457.
- Loosen the rear wedge assembly.
- Center the striker vertically so that the striker properly engages the door lock. Mark the vertical position of the striker.
- Adjust the striker in or out to align the surface of the door flush with the body surface. Mark the position of the striker.
- Tighten the striker using J-23457.
- Open the door, and apply grease to the striker.
- Close the door to make an impression of the lock on the striker.
- Open the door and measure the distance from the rear of the striker head to the impression. The distance should be between 5 mm and 8 mm (0.20-inch and 0.30-inch).
- Adjust the striker by adding or deleting shims. Align the striker to the previously made marks.
- Tighten the striker using J-23457.

UPPER REAR HINGE ADJUSTMENT (Figure 93)

- The lower hinge lever (419) should have a gap of 2.5 mm to 4 mm (0.10-inch to 0.16-inch) between the outer edge of the lower lever and the striker latch edge. This adjustment is made by adding an equal amount of

10A1-56 DOORS

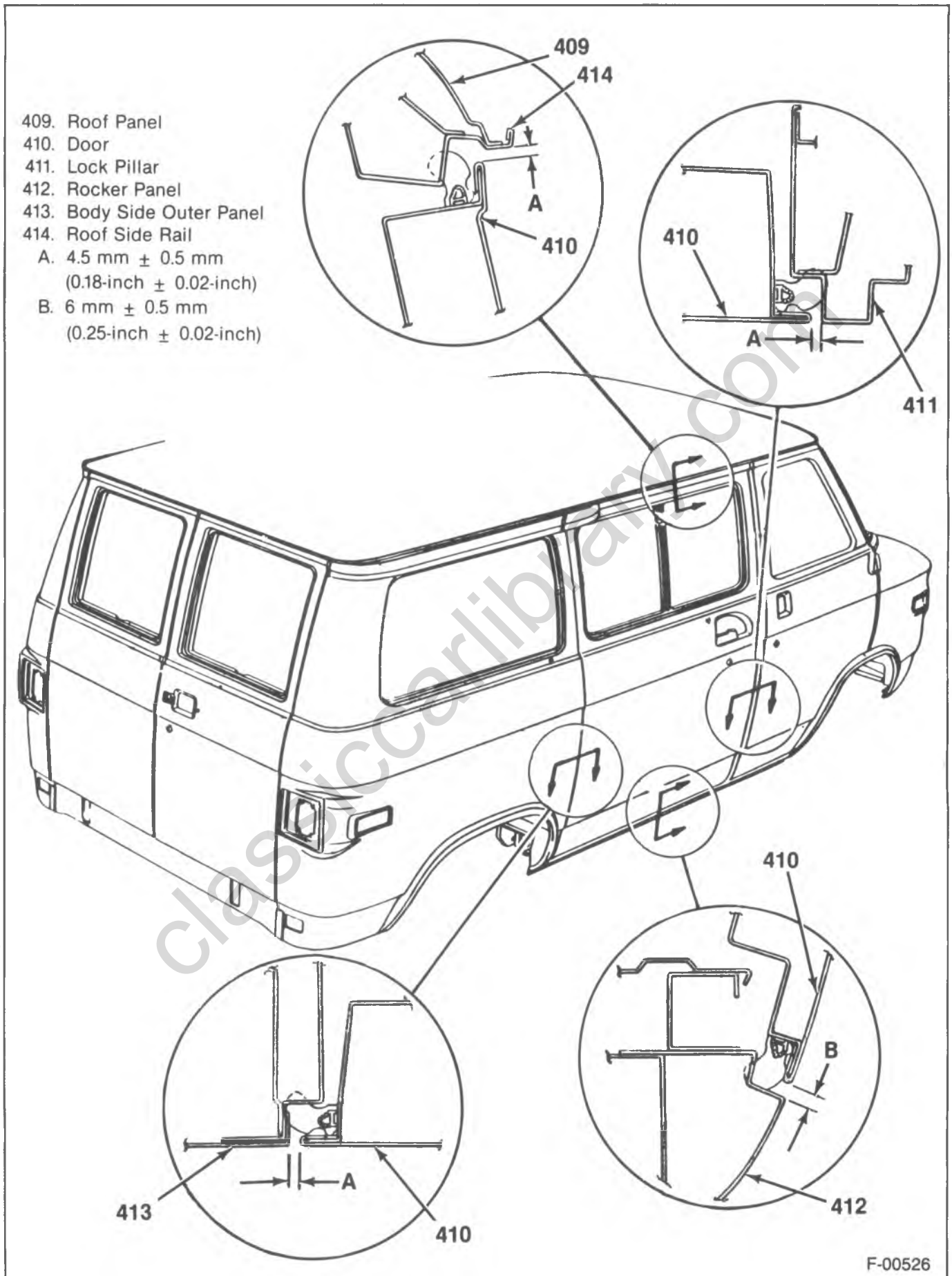

F-00526

Figure 91—Door Adjustments

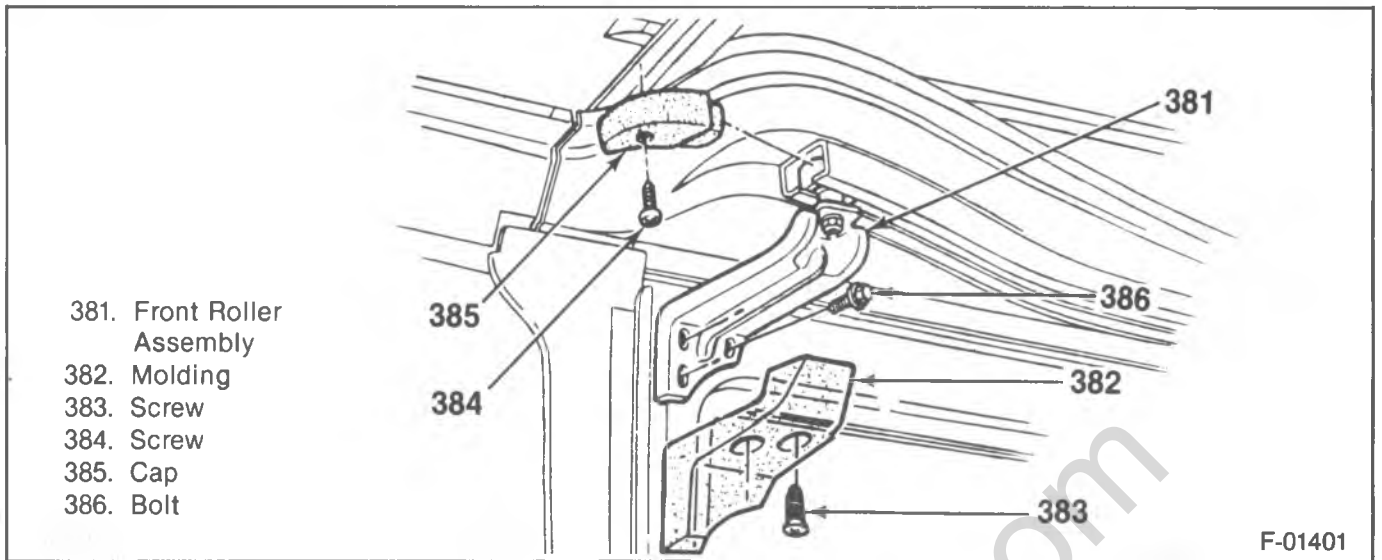

- 381. Front Roller Assembly
- 382. Molding
- 383. Screw
- 384. Screw
- 385. Cap
- 386. Bolt

F-01401

Figure 92—Upper Front Roller Adjustment

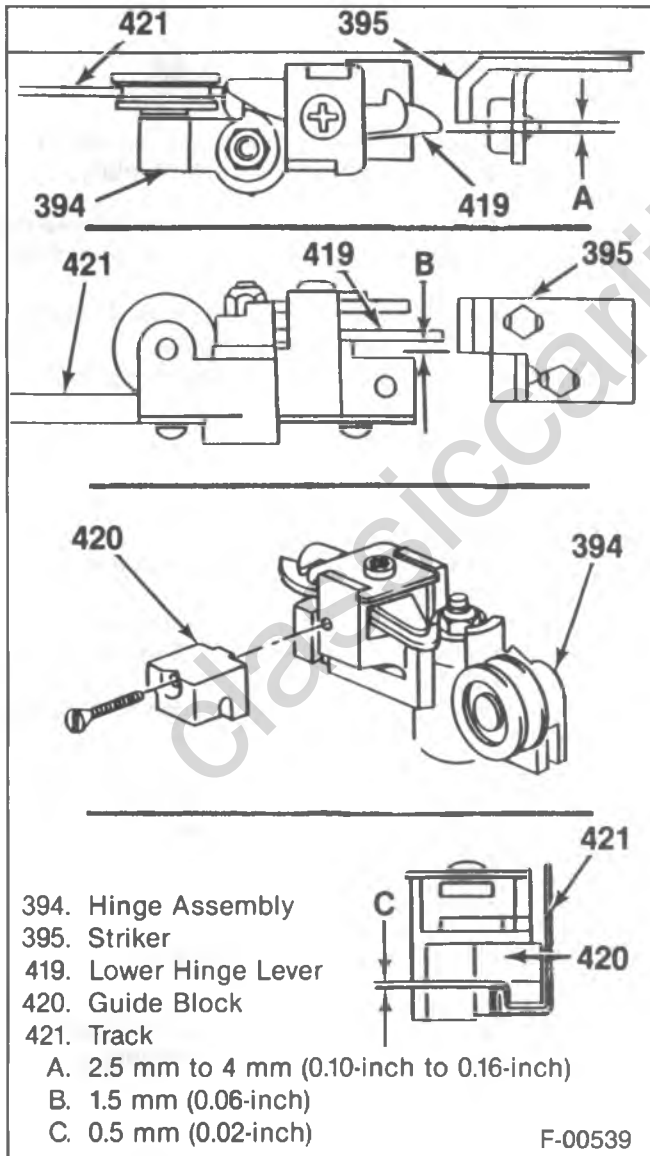

- 394. Hinge Assembly
 - 395. Striker
 - 419. Lower Hinge Lever
 - 420. Guide Block
 - 421. Track
- A. 2.5 mm to 4 mm (0.10-inch to 0.16-inch)
 B. 1.5 mm (0.06-inch)
 C. 0.5 mm (0.02-inch)

F-00539

Figure 93—Upper Rear Hinge Adjustments

shims between the guide block (420) and the hinge assembly, and between the roller and the hinge assembly.

2. Adjust the striker up or down to obtain a gap of 1.5 mm (0.06-inch) between the lower edge of the striker plate (395) and the lower edge of the lower hinge lever (419).
3. Adjust the guide up or down to obtain a gap of 0.5 mm (0.02-inch) between the track and the guide.

DOOR HOLD OPEN CATCH ADJUSTMENT (Figure 89)

1. Mark the position of the lower roller assembly to the bracket.
2. Loosen the lower roller assembly bolts (401).
3. Pivot the lower roller assembly to properly engage the latch striker.
4. Tighten the lower roller assembly bolts (401).

REAR WEDGE ASSEMBLY ADJUSTMENT (Figure 94)

1. Loosen the rear wedge assembly screws (408).
2. Completely close the door.
3. From inside the vehicle, center the wedge assembly (407) onto the door wedge.
4. Mark the position of the wedge assembly.
5. Open the door, and move the wedge assembly forward 4.7 mm (3/16-inch).
6. Tighten the rear wedge assembly screws (408).

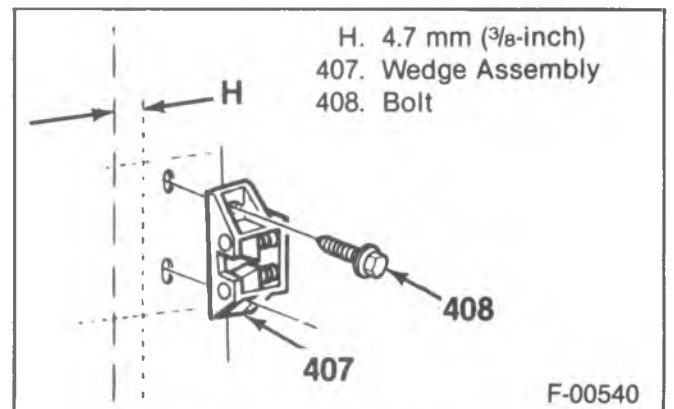

- H. 4.7 mm (3/16-inch)
- 407. Wedge Assembly
- 408. Bolt

F-00540

Figure 94—Rear Wedge Adjustment

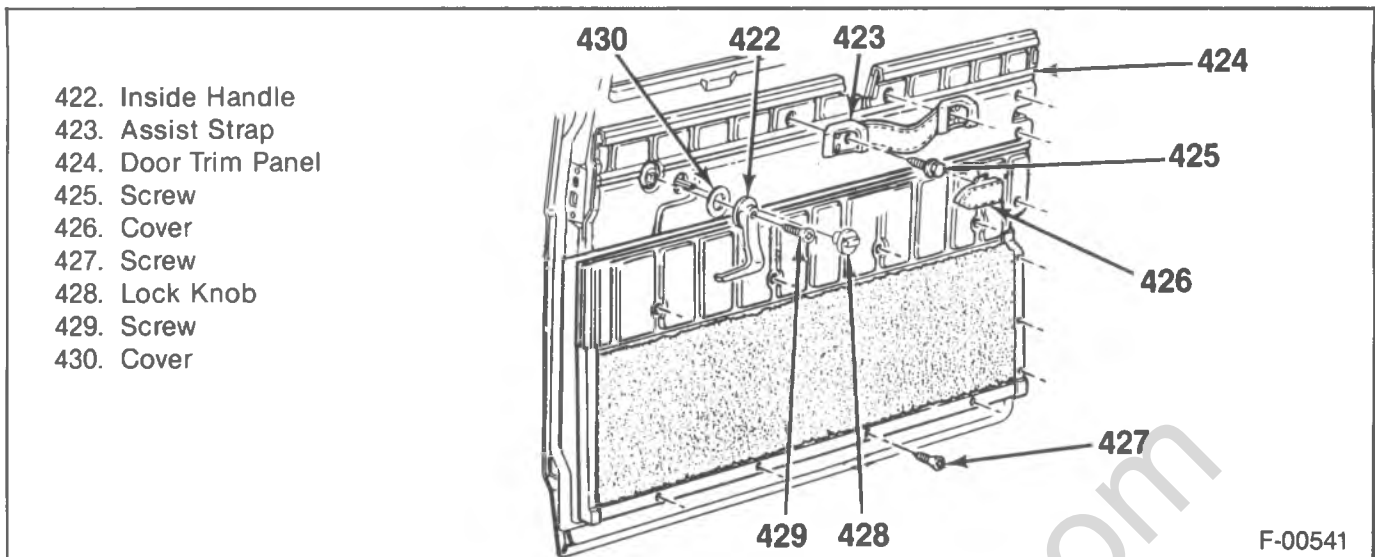

- 422. Inside Handle
- 423. Assist Strap
- 424. Door Trim Panel
- 425. Screw
- 426. Cover
- 427. Screw
- 428. Lock Knob
- 429. Screw
- 430. Cover

F-00541

Figure 95—Door Trim Panel Components

DOOR TRIM PANEL REPLACEMENT

↔ Remove or Disconnect (Figure 95)

1. Inside door handle screw (429).
2. Inside door handle (422).
3. Inside door handle cover (430).
4. Lock knob (428).
 - Pull the knob from the door.
5. Door assist strap screws (425), and assist strap (423).
6. Trim panel to door screws (427).
7. Trim panel from the door.

→ Install or Connect (Figure 95)

1. Trim panel to the door.
2. Trim panel to door screws (427).
3. Door assist strap (423) and assist strap screws (425).
4. Lock knob (428).
5. Inside door handle cover (430).
6. Inside door handle (422).
7. Inside door handle screw (429).

WINDOW REPLACEMENT

If a glass is cracked but still intact, it should be crisscrossed with masking tape to reduce the risk of injury and/or damage to the vehicle. If a crack extends to the edge of the glass, mark the door with a piece of chalk at the point where the crack meets the weatherstrip. Later, when examining the flange of the opening for a cause of the crack, start at the point marked.

It is important that the cause of the crack be determined and the condition corrected, before the new glass is installed. The cause of the crack may be an obstruction or high spot somewhere around the flange of the opening; cracking may not occur until pressure from the high spot or obstruction becomes particularly high due to winds, extremes of temperature, or rough terrain.

STATIONARY GLASS

↔ Remove or Disconnect (Figure 96)

CAUTION: Always wear heavy gloves when handling glass to minimize the risk of injury.

1. Weatherstrip seal by running a putty knife between the flange and the weatherstrip (inside and outside the door).
 - Have an assistant outside the cab by the window.
2. Weatherstrip and glass from the flange.
 - Force the weatherstrip from the flange from the inside with a putty knife.
3. Window from the weatherstrip.

→ Install or Connect

1. Weatherstrip to the glass.
 - The seam of the weatherstrip must be located at the bottom of the glass.
2. A six mm (1/4-inch) cord in the weatherstrip groove. The ends should overlap about 5 cm (6-inches) at the window bottom.
3. Window and weatherstrip on the flange from outside the cab.
 - Brush soapy water on the flange.
 - Have an assistant pull the cord from inside the cab to seat the lip of the weatherstrip on the flange.

SWING OUT WINDOW

↔ Remove or Disconnect (Figure 97)

CAUTION: Always wear heavy gloves when handling glass to minimize the risk of injury.

1. Window latch to door screws (441).
2. Window latch from the window.
 - Twist the latch 1/4 of a turn to release the latch components from the window.
- Lift the window for access to the hinge screws.
3. Hinge to door screws (435).

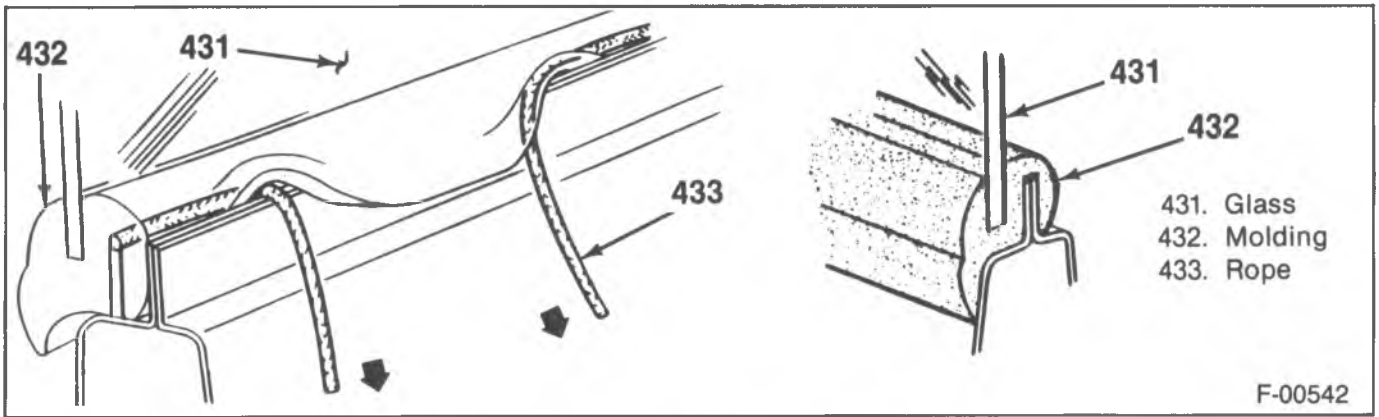

F-00542

Figure 96—Window Components

4. Hinge from the door.
5. Hinge seal from the door.

↔ Install or Connect (Figure 97)

1. Hinge and hinge seal to the door.
2. Hinge to the door screws (435).
3. Window latch to the window.
 - Place the cover and spacer through the window.
 - Place the washer and spring onto the cover.
 - Twist the latch onto the cover with 1/4 of a turn.
4. Window latch to door screws (441).

FRONT LOCK REPLACEMENT

↔ Remove or Disconnect (Figures 98 and 99)

1. Door trim panel. Refer to "Door Trim Panel Replacement."
2. Lock access panel screws (445) and the panel (444).
 - Pull the panel upwards to disengage the clips.
3. Outside door handle (422).
4. Lock to door screws (449 and 451).
5. Rear door lock rods from the front lock.
 - Pivot the clips from the rods, and pull the rods from the lock.
6. Lower latch rod from the lock.
 - Pivot the clip from the rod and pull the rod from the lock.

- | | |
|-------------------|-------------|
| 434. Glass | 439. Spacer |
| 435. Screw | 440. Washer |
| 436. Hinge | 441. Screw |
| 437. Weatherstrip | 442. Latch |
| 438. Cover | 443. Spring |

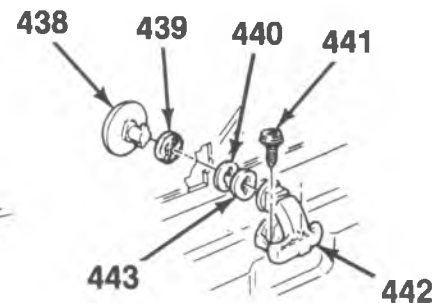
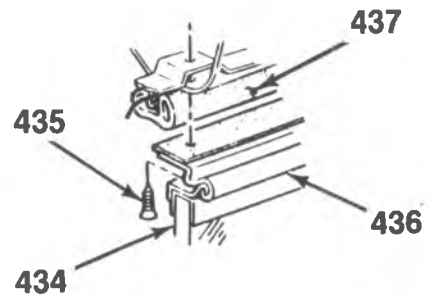
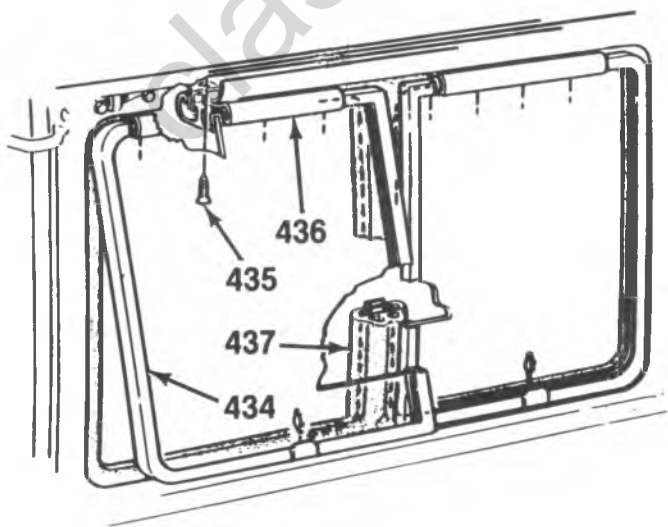

F-00543

Figure 97—Swing Out Window Components

10A1-60 DOORS

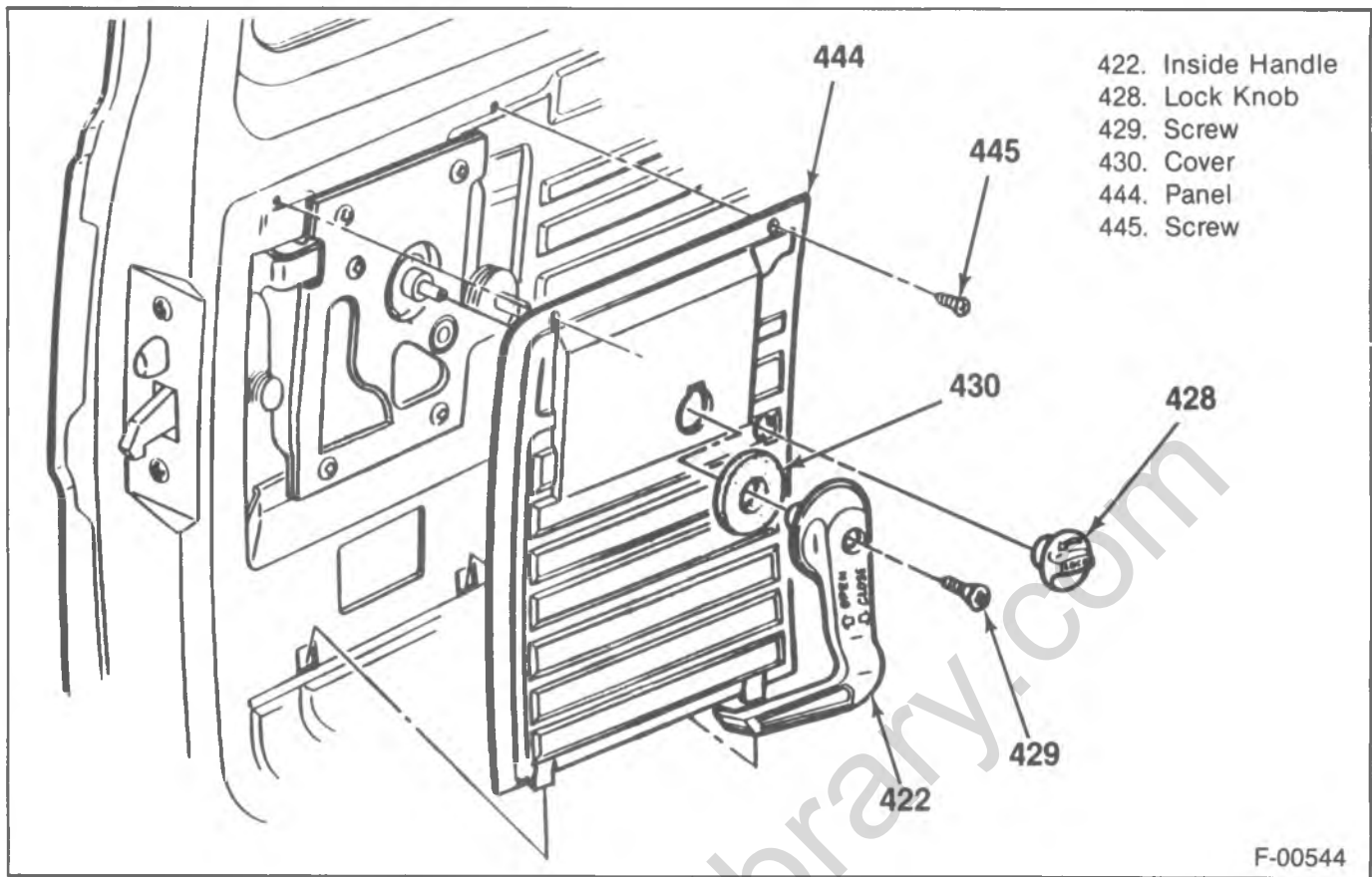

Figure 98—Door Lock Access Panel

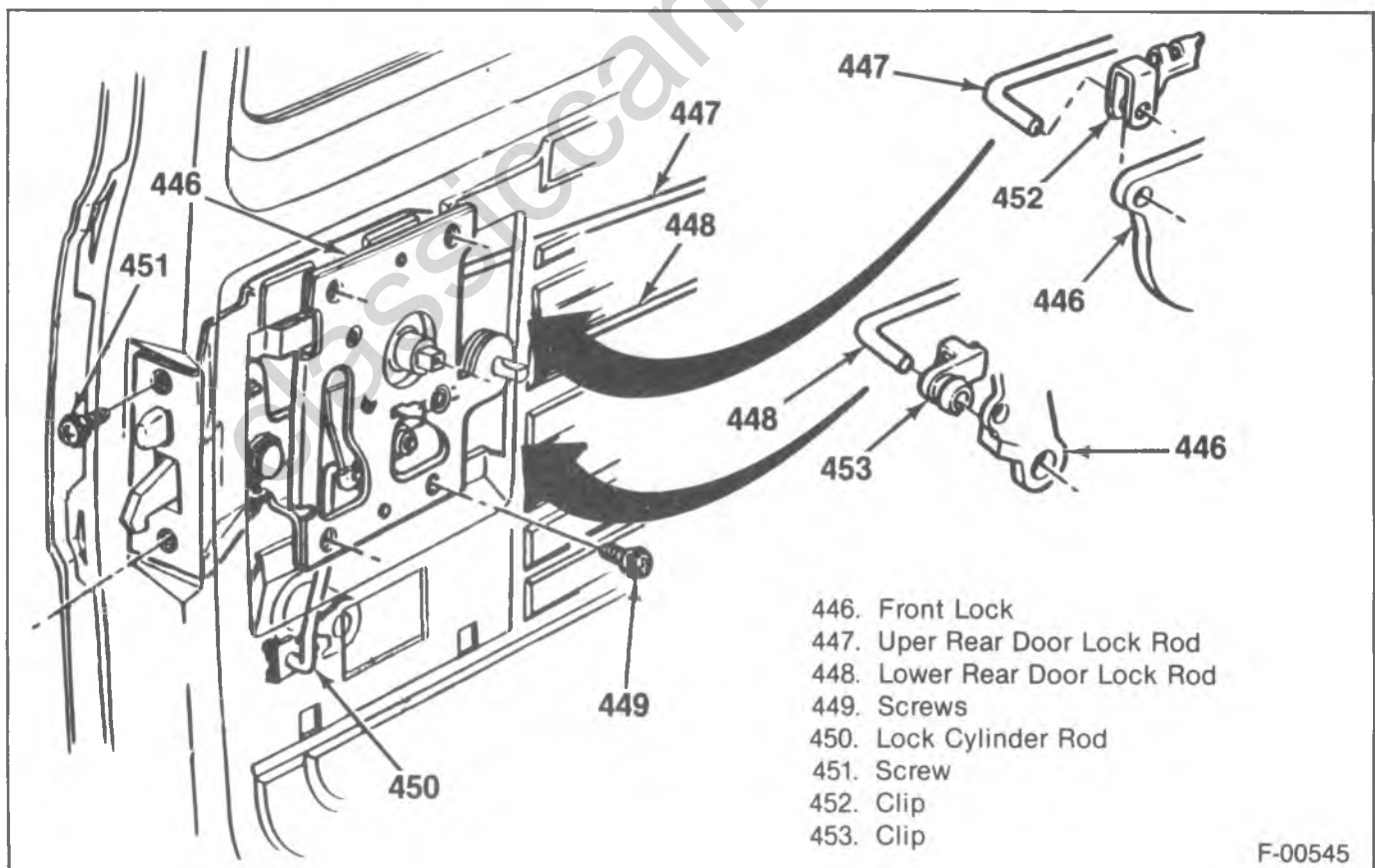

Figure 99—Door Lock Attachment

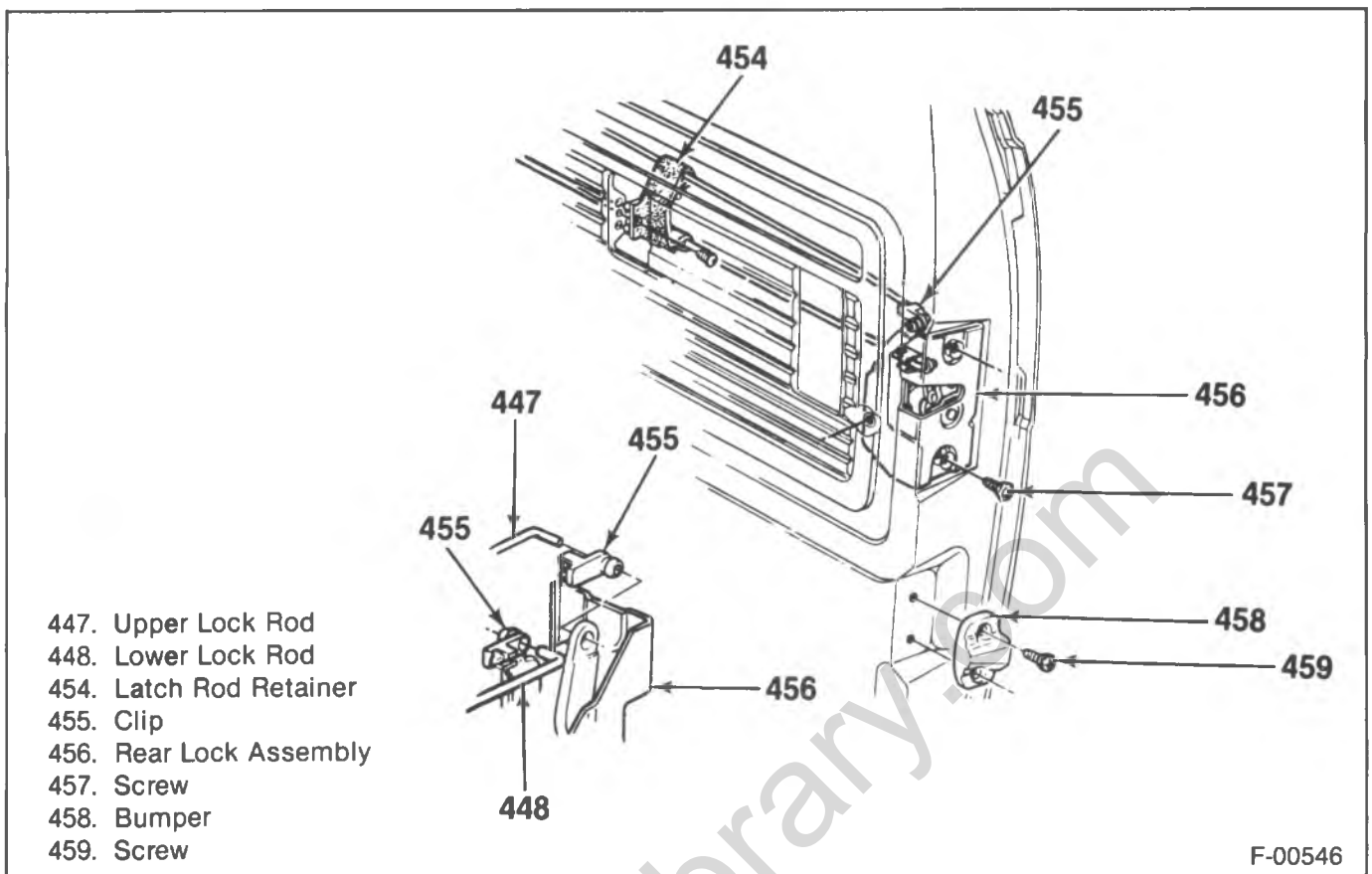

Figure 100—Rear Lock Attachment

7. Lock cylinder rod clips.
 - Slide the clip to release the rod.
8. Lock assembly from the door.

↔ Install or Connect (Figures 98 and 99)

1. Lock assembly to the door.
2. Lock cylinder rod clip.
3. Lower latch rod to the lock.
 - Pivot the clip onto the rod.
4. Rear door lock rods to the front lock.
 - Pivot the clip onto the rod.
5. Lock to door screws (449 and 451).
6. Outside door handle (422).
7. Lock access panel (444) and panel screws (445).
8. Door trim panel. Refer to "Door Trim Panel Replacement."

REAR LOCK REPLACEMENT

↔ Remove or Disconnect (Figure 100)

1. Lock rods from the lock.
 - Pivot the clip from the rod, and pull the rod from the lock.
2. Lock to door screws (457).
3. Lock from the door through the access hole.

↔ Install or Connect (Figure 100)

1. Lock to the door through the access hole.
2. Lock to door screws (457).
3. Lock rods to the lock.
 - Pivot the clip onto the rod.

LOCK CYLINDER REPLACEMENT

↔ Remove or Disconnect (Figure 101)

1. Door trim panel. Refer to "Door Trim Panel Replacement."
2. Door lock cylinder rod (450).
3. Cylinder retainer (462).
 - Pry the retainer from the lock.
4. Cylinder (464) and seal (463) from the door.

↔ Install or Connect (Figure 101)

1. Cylinder (464) and seal (463) to the door.
2. Cylinder retainer (462).
 - Push the retainer onto the cylinder.
3. Door lock cylinder rod (450).
4. Door trim panel. Refer to "Door Trim Panel Replacement."

SLIDING SIDE DOOR WEATHERSTRIP REPLACEMENT

↔ Remove or Disconnect (Figure 102)

1. Weatherstrip from the door using 3M Release Agent (or equivalent).
2. Plastic nails from the door.

🧼 Clean

- The door of all the old cement.

10A1-62 DOORS

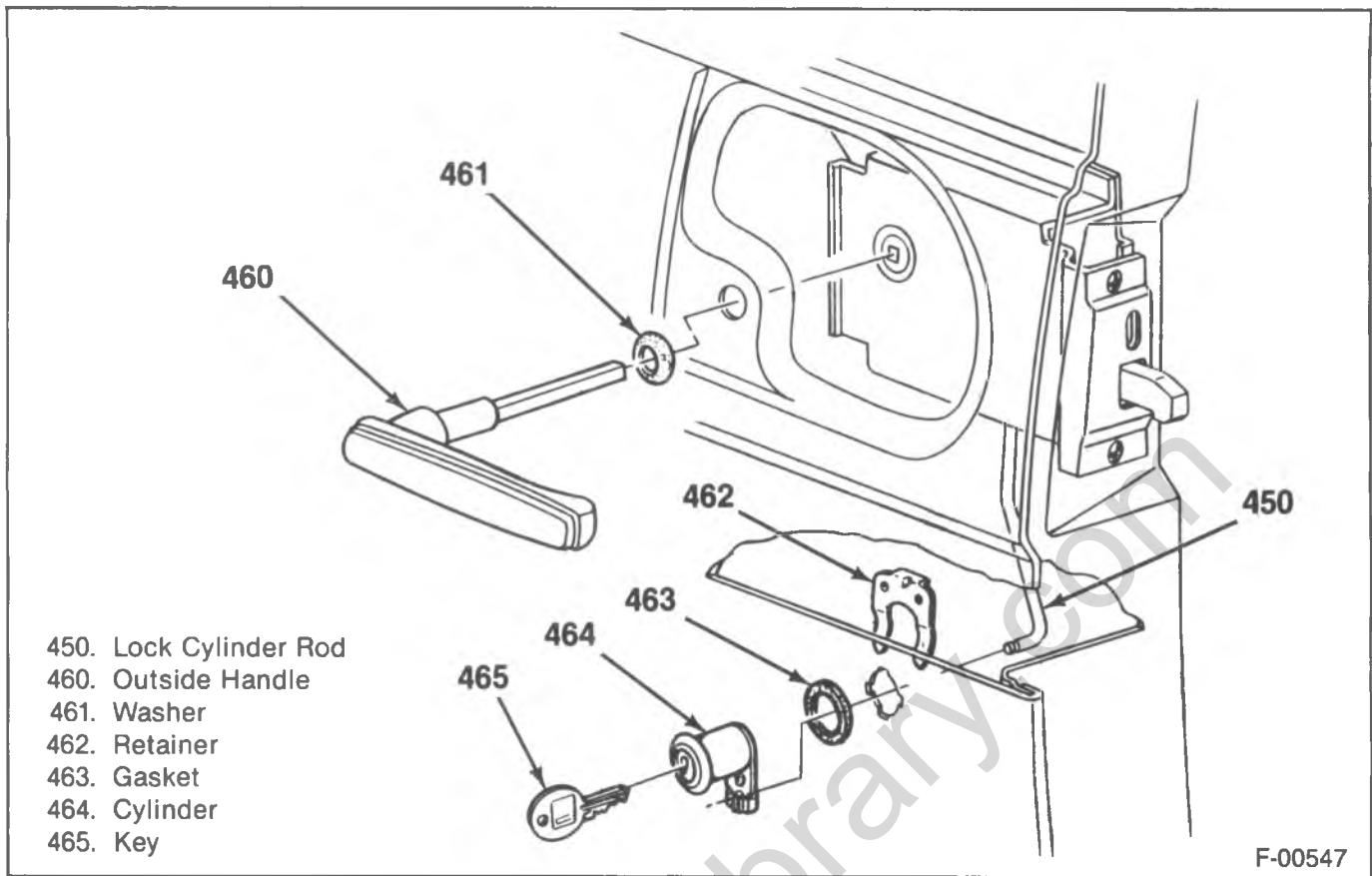

Figure 101—Outside Handle and Lock Cylinder Attachments

Install or Connect (Figure 102)

1. Weatherstrip adhesive to the door. Use 3M Weatherstrip Adhesive (or equivalent).
2. New weatherstrip to the door.
 - Press the plastic nails into the door.

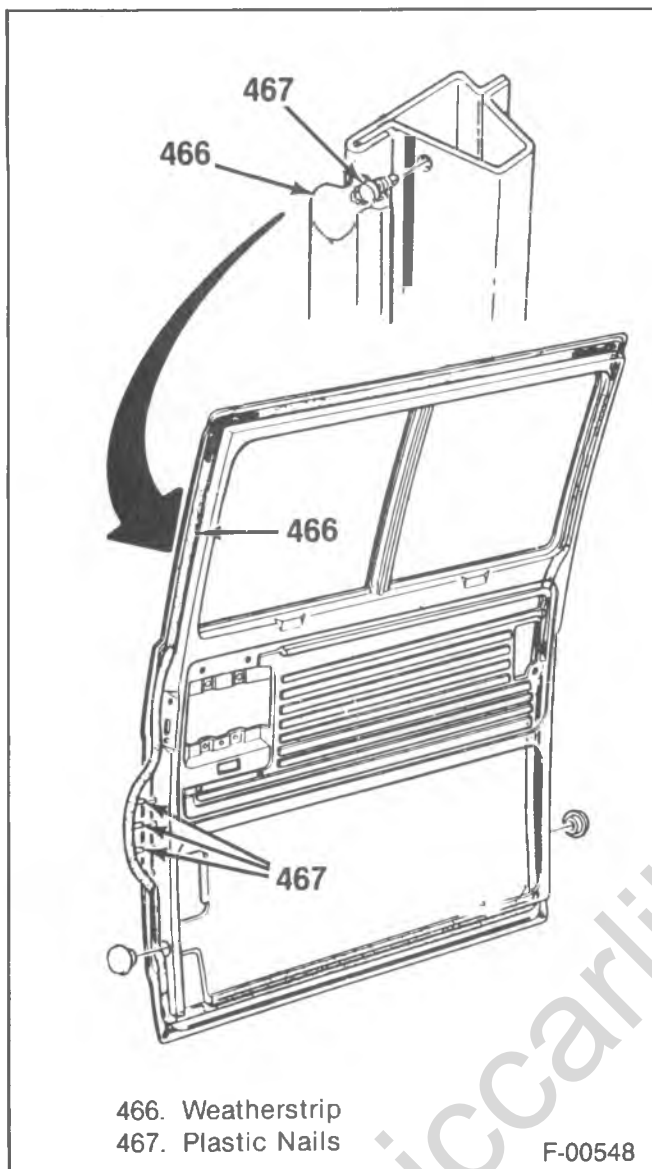

Figure 102—Sliding Side Door Weatherstrip

G MODEL REAR DOORS

DOOR AND HINGE REPLACEMENT

↔ Remove or Disconnect (Figure 103)

- Open the doors.
- 1. Electrical wiring harness (if equipped). Refer to "Door Trim Panel Replacement" for access to the wiring harness.
- Mark the position of the door on the hinges using a wax pencil.
- 2. Strap pin (469).
 - Support the door.
- 3. Hinge to body pillar bolts (475).
- 4. Door from the vehicle.
- 5. Hinge to door bolts (470).
- 6. Hinges from the door.

- 7. Retainers (478), seals (477), and grommets (479) from the door or the hinges.

↔ Install or Connect (Figure 103)

1. Grommet to the door.
2. Hinge to the door.
3. Hinge to door bolts (470).
 - Align the hinge to the previously made mark.
4. The seals and retainers to the body half of the hinge.
5. Door to the vehicle.
 - Support the door.
6. Hinge to body pillar bolts (475).
 - Align the hinge to the previously made mark.
7. Strap pin (469).
8. Electrical wiring harness.
 - Refer to "Door Trim Panel Replacement" for access to the wiring harness.

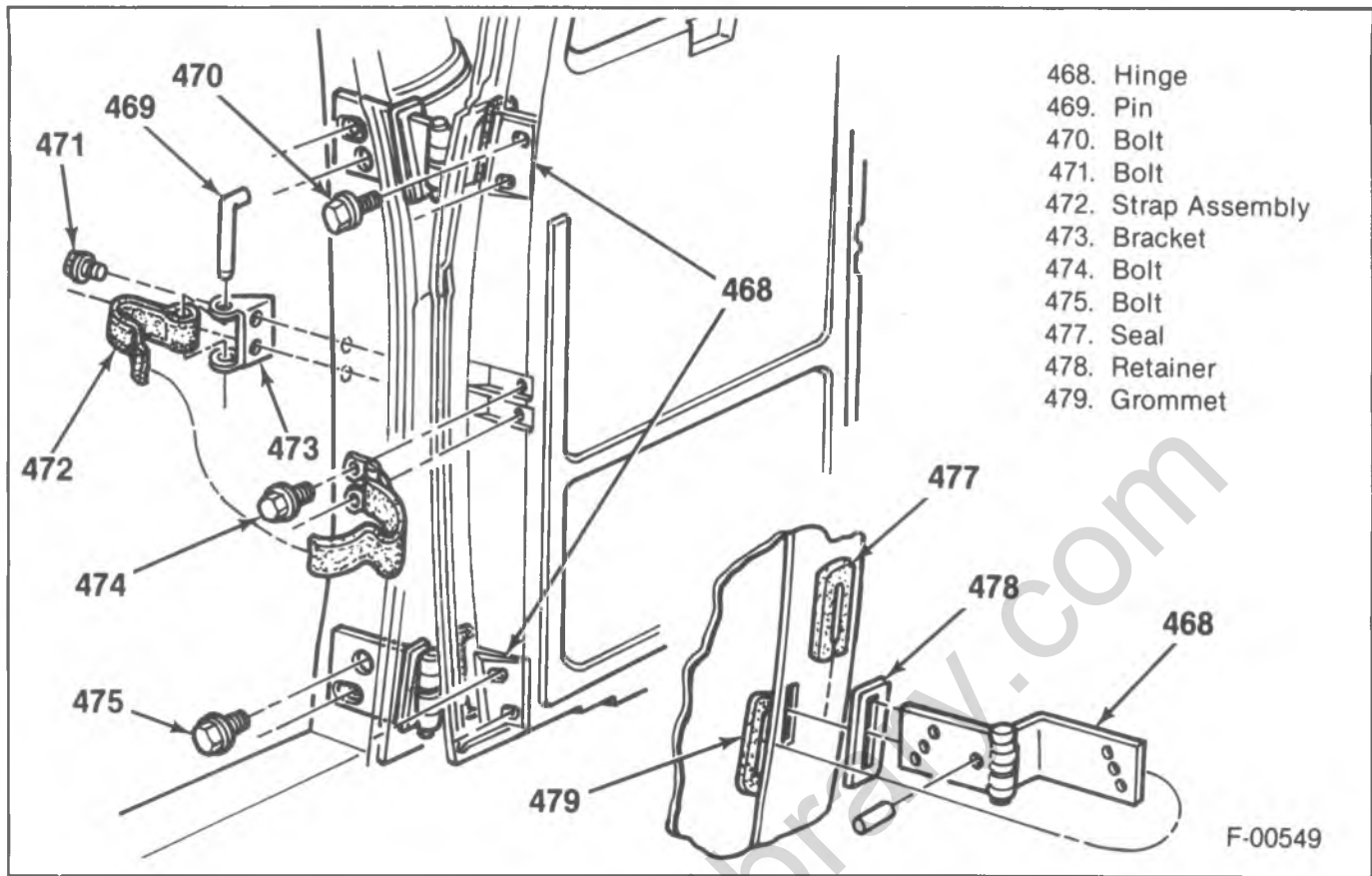

Figure 103—Hinge Components

DOOR ADJUSTMENT

Each of the two doors must first be adjusted in the door opening before adjusting the door to door clearance.

Adjust (Figure 104)

1. The door height so that there is a gap of 6 mm \pm 0.5 mm (0.25-inch \pm 0.02-inch) between the roof panel and the rear door panel.
2. The gap between the bottom of the door panel (not the bottom of the outer panel) and the platform panel should be 6 mm \pm 0.5 mm (0.25-inch \pm 0.02-inch). This measurement should be taken on each door individually from the side of the door. The door should be in its normal closed position. (The outer rear door panel is 15.25 mm \pm 0.5 mm (0.60-inch \pm 0.02-inch) away from the rear platform panel when normally closed).
3. The rear door outer panel to the body side outer panel gap to 4 mm \pm 0.5 mm (0.16-inch \pm 0.02-inch).
4. The door to door clearance between the left and right outer door panels should be 6 mm \pm 0.5 mm (0.25-inch \pm 0.02-inch).

STRIKER REPLACEMENT

Remove or Disconnect (Figure 105)

1. Striker to door frame bolts (486).
2. Striker from the door frame.
3. Spacer (if equipped).

Install or Connect (Figure 105)

1. Spacer (as required).
2. Striker to the door frame.
3. Striker to door frame bolts (486).

Adjust (Figure 106)

- The striker to door latch clearance so that there are 4.4 mm (0.172-inch) between the striker and the door latch when the door is in the secondary latched position. (The door is latched but not fully closed.) An $1\frac{1}{64}$ -inch diameter drill bit may be used to gage this clearance.

DOOR TRIM PANEL REPLACEMENT

Remove or Disconnect (Figure 107)

1. Door trim panel to door screws (489).
2. Door trim panel from the vehicle.
 - Slide the panel out of the retainers.

Install or Connect (Figure 107)

1. Door trim panel to the vehicle.
 - Slide the panel into the retainers.
2. Door trim panel to door screws (489).

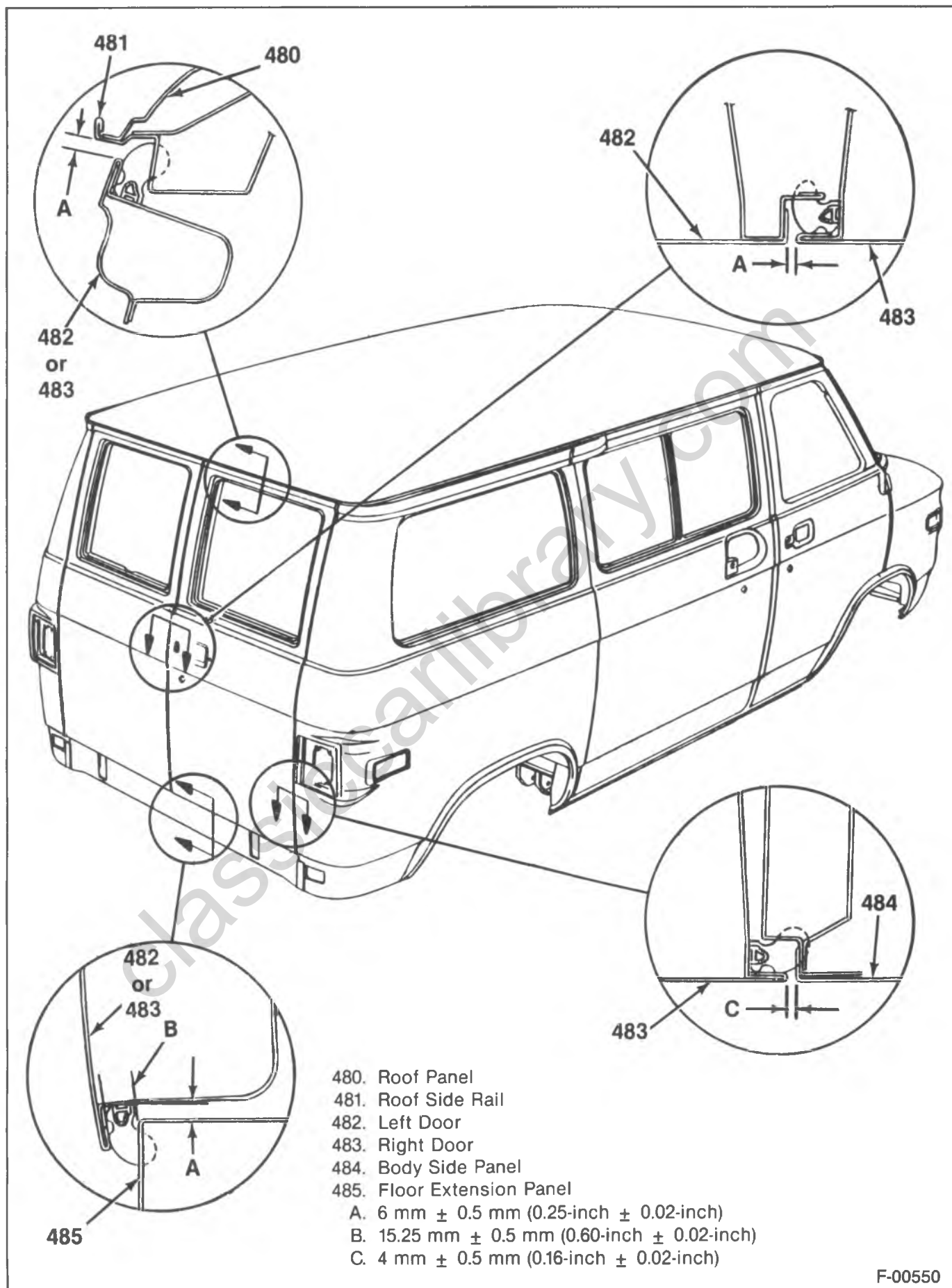

F-00550

Figure 104—Door Adjustments

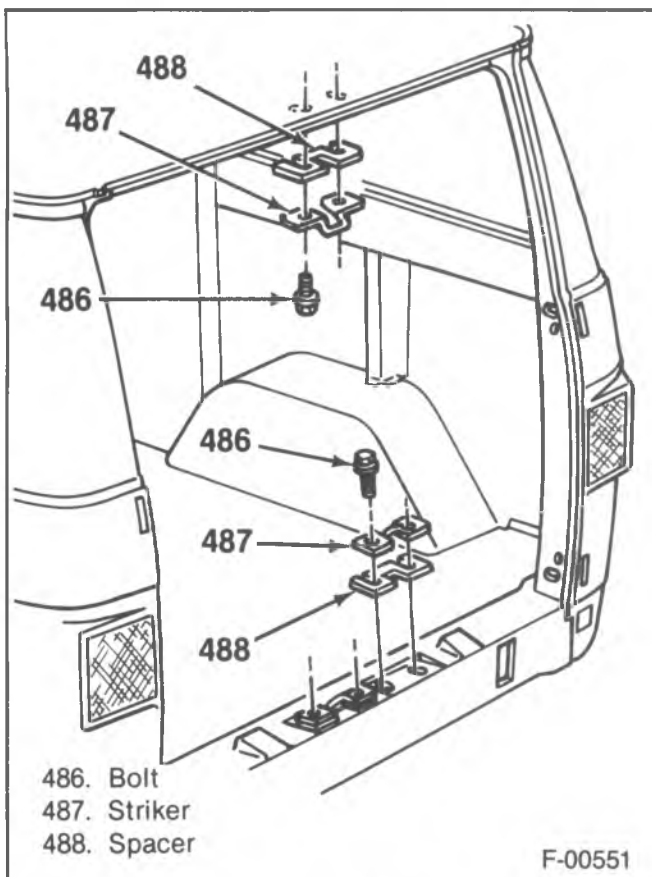

Figure 105—Striker Components

BUMPER WEDGE REPLACEMENT

↔ Remove or Disconnect (Figure 108)

1. Bumper to upper door frame screws (495).
2. Bumper and spacer.

↔ Install or Connect (Figure 108)

1. Spacer (as required).
2. Bumper.

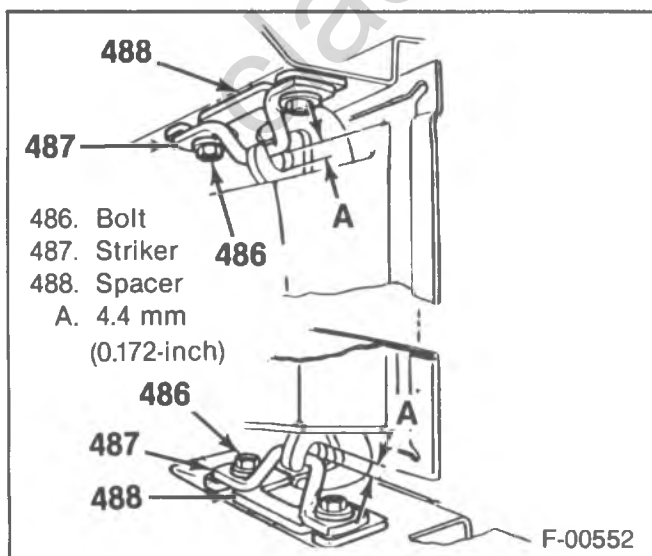

Figure 106—Striker Components

3. Bumper to upper door frame screws (495).

🔧 Adjust

- The bumper to door clearance so that there is 1 mm (0.04-inch) between the bumper and the door when the door is in the secondary position. (The door is latched but not fully closed).

WINDOW REPLACEMENT

If a glass is cracked but still intact, it should be crisscrossed with masking tape to reduce the risk of injury and/or damage to the vehicle. If a crack extends to the edge of the glass, mark the door with a piece of chalk at the point where the crack meets the weatherstrip. Later, when examining the flange of the opening for a cause of the crack, start at the point marked.

It is important that the cause of the crack be determined and the condition corrected, before the new glass is installed. The cause of the crack may be an obstruction or high spot somewhere around the flange of the opening; cracking may not occur until pressure from the high spot or obstruction becomes particularly high due to winds, extremes of temperature, or rough terrain.

↔ Remove or Disconnect (Figure 109)

CAUTION: Always wear heavy gloves when handling glass to minimize the risk of injury.

1. Using a $\frac{3}{16}$ -inch drill bit, drill the rivets from the weatherstrip (if equipped).
2. Weatherstrip seal by running a putty knife between the flange and the weatherstrip (inside and outside the door).
 - Have an assistant outside the cab by the window.
3. Weatherstrip and glass from the flange.
 - Force the weatherstrip from the flange from the inside with a putty knife.
4. Window from the weatherstrip.

↔ Install or Connect (Figure 109)

1. Weatherstrip to the glass.
2. A six mm ($\frac{1}{4}$ -inch) cord in the weatherstrip groove. The ends should overlap about 5 cm (6-inches) at the window bottom.
3. Window and weatherstrip on the flange from outside the cab.
 - Brush soapy water on the flange.
 - Have an assistant pull the cord from inside the cab to seat the lip of the weatherstrip on the flange.
4. Rivets (if equipped) to the weatherstrip with a rivet gun.
 - Use $\frac{3}{16}$ -inch blind rivets.

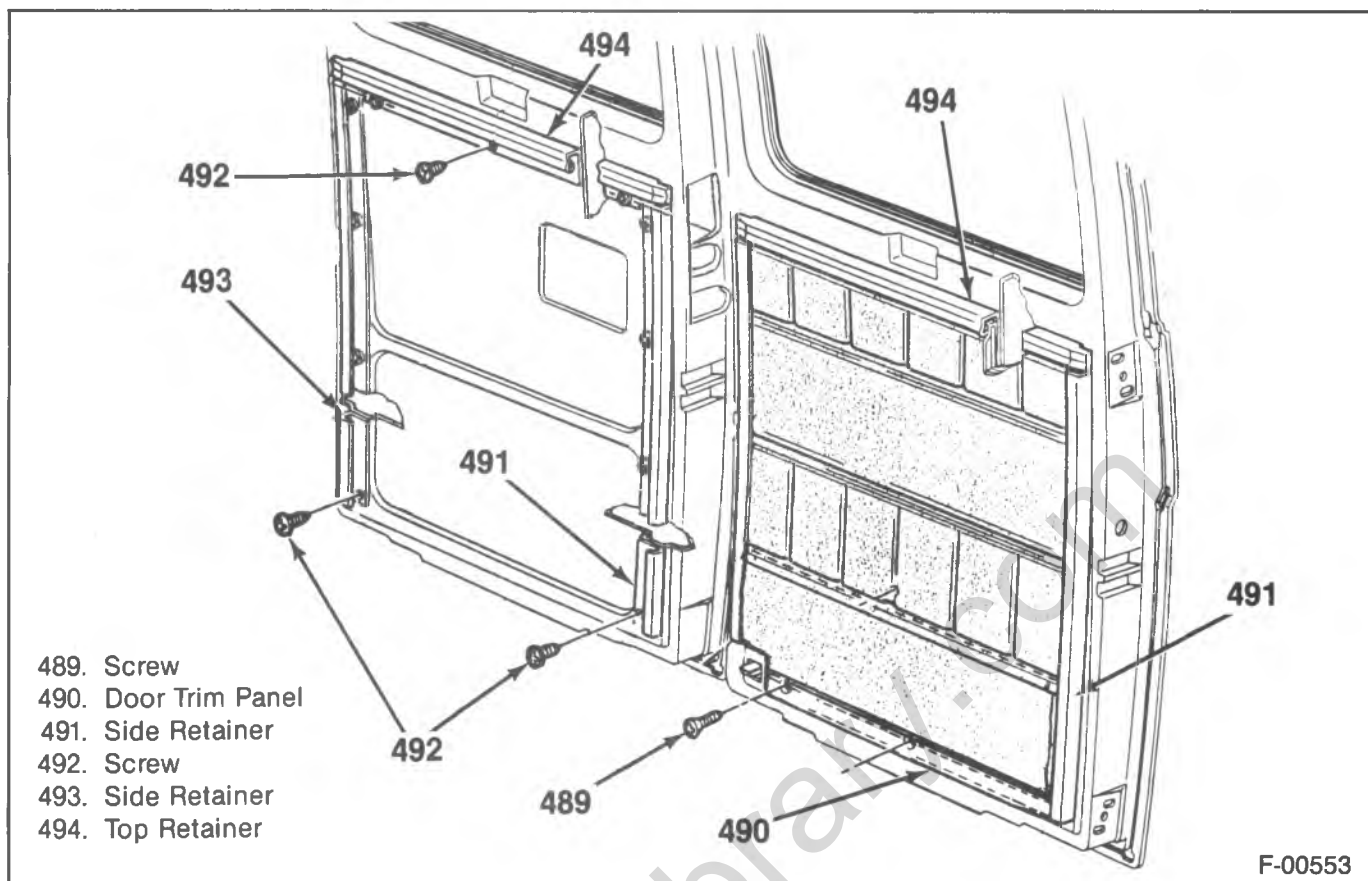

Figure 107—Door Trim Panel Components

SWING OUT WINDOW

Install or Connect (Figure 110)

CAUTION: Always wear heavy gloves when handling glass to minimize the risk of injury.

1. Window latch to door screws (509).
2. Window latch from the window.
 - Twist the latch $\frac{1}{4}$ of a turn to release the latch components from the window.
- Lift the window for access to the hinge screws.
3. Hinge to door screws (502).
4. Hinge from the door.
5. Hinge seal from the door.

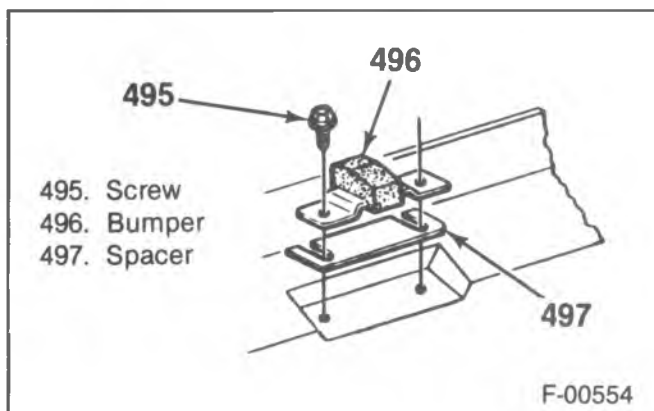

Figure 108—Bumper Wedge Components

Install or Connect (Figure 110)

1. Hinge and hinge seal to the door.
2. Hinge to door screws (502).
3. Window latch to the window.
 - Place the cover and spacer through the window.
 - Place the washer and spring onto the cover.
 - Twist the latch onto the cover with $\frac{1}{4}$ of a turn.
4. Window latch to door screws (509).

LEFT DOOR LOWER LATCH REPLACEMENT

Remove or Disconnect (Figure 111)

- Open the door.
1. Latch to door screws (511).
 2. Latch from the door.

Install or Connect (Figure 111)

1. Latch to the door.
2. Latch to door screws (511).

RIGHT DOOR LOWER LATCH REPLACEMENT

Remove or Disconnect (Figure 112)

1. Door trim panel. Refer to "Door Trim Panel Replacement."
2. Lower latch to control assembly rod from the control assembly.

10A1-68 DOORS

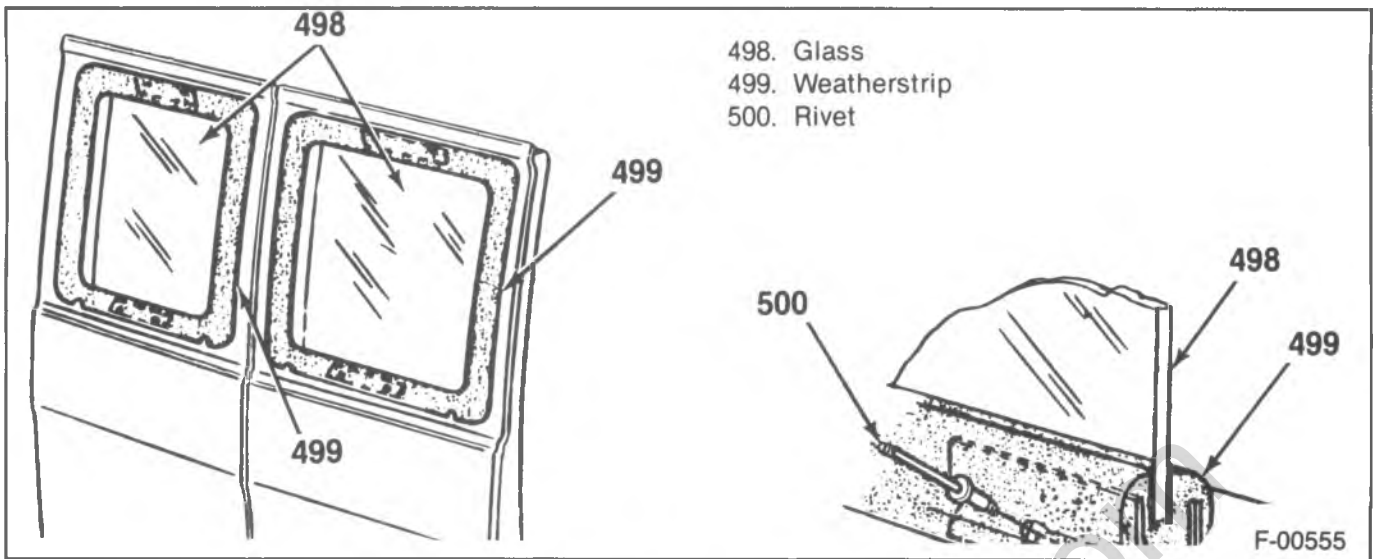

Figure 109—Window Components

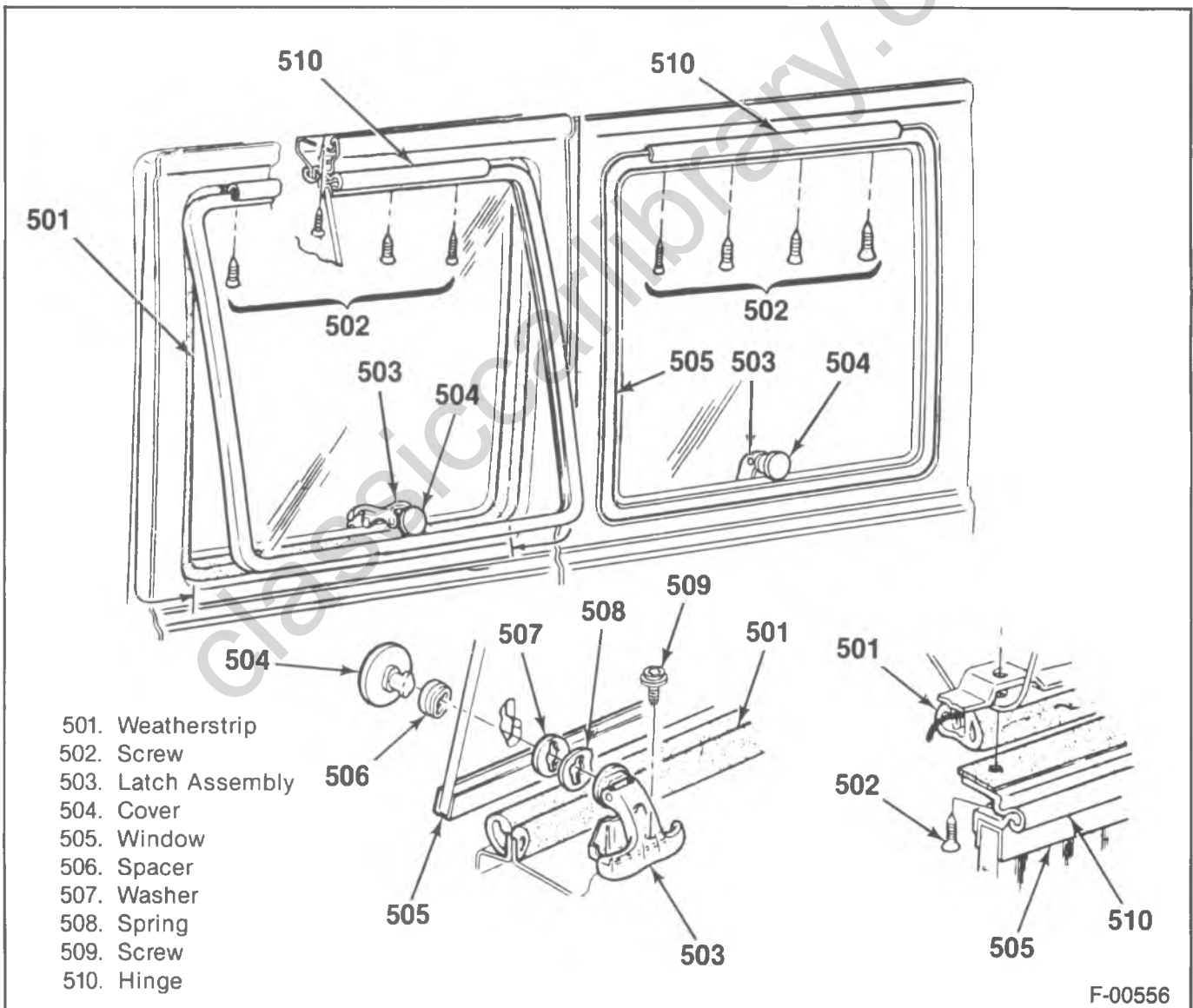

Figure 110—Swing Out Window Components

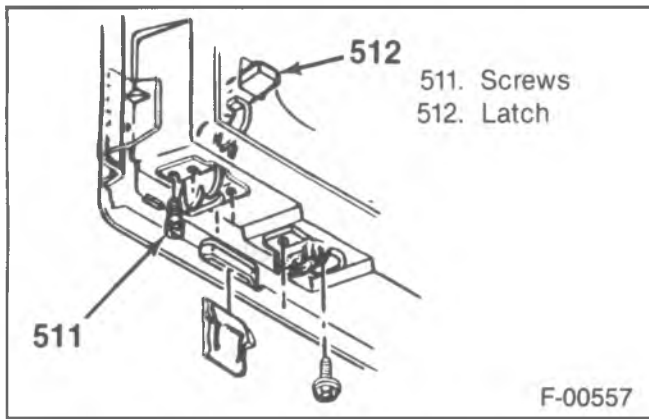

Figure 111—Left Door Latch Components

- Using a flat bladed screwdriver, push on the top of the clip where it is connected to the rod. Pivot the clip away from the rod.
3. Lower latch to door screws (513).
 4. Lower latch with the rod from the door.

↔ Install or Connect (Figure 112)

1. Lower latch with the rod to the door.
2. Lower latch to door screws (513).
3. Lower latch to control assembly rod into the control assembly.
 - Pivot the clip onto the rod.
4. Door trim panel. Refer to "Door Trim Panel Replacement."

RIGHT DOOR UPPER LATCH REPLACEMENT

↔ Remove or Disconnect (Figure 113)

1. Door trim panel. Refer to "Door Trim Panel Replacement."
2. Upper latch to control assembly rod from the control assembly.
 - Using a flat bladed screwdriver, push on the top of the clip where it is connected to the rod. Pivot the clip away from the rod.

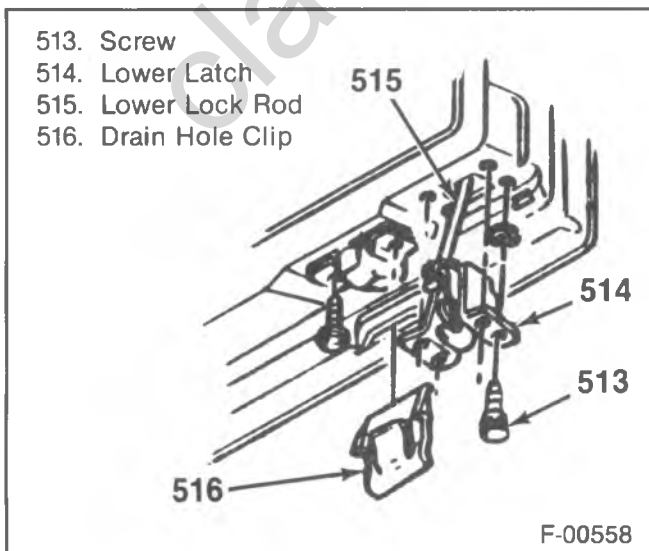

Figure 112—Right Door Lower Latch

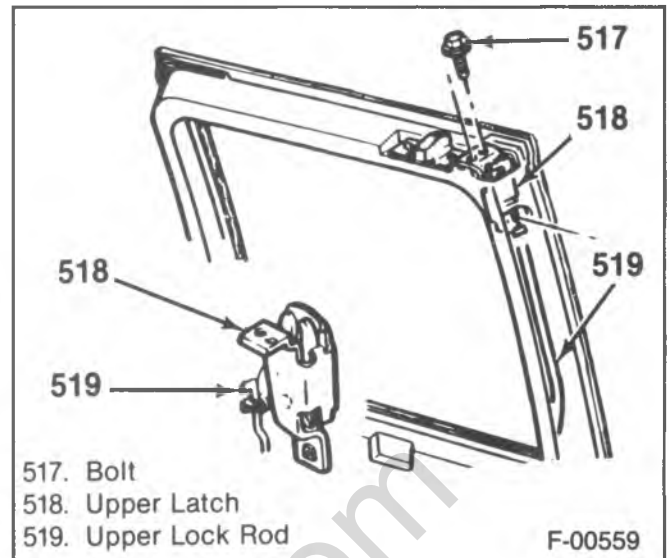

Figure 113—Right Door Upper Latch

3. Upper latch to door bolts (517).
4. Upper latch with the rod from the door.

↔ Install or Connect (Figure 113)

1. Upper latch with the rod to the door.
2. Upper latch to door bolts (517).
3. Upper latch to control assembly rod into the control assembly.
 - Pivot the clip onto the rod.
4. Door trim panel. Refer to "Door Trim Panel Replacement."

RIGHT DOOR CONTROL ASSEMBLY REPLACEMENT

↔ Remove or Disconnect (Figure 114)

1. Door trim panel. Refer to "Door Trim Panel Replacement."
2. Upper and lower door latch rods from the control assembly.
 - Using a flat bladed screwdriver, push on the top of the clip where it is connected to the rod. Pivot the clip away from the rod.
3. Electric door actuator (if equipped).
4. Door to control assembly bolts (520).
5. Control assembly through the access hole.

↔ Install or Connect (Figure 114)

1. Control assembly through the access hole.
2. Door to control assembly bolts (520).
3. Electrical door actuator (if equipped).
4. Upper and lower door latch rods to the control assembly.
 - Pivot the clips onto the rods.
5. Door trim panel. Refer to "Door Trim Panel Replacement."

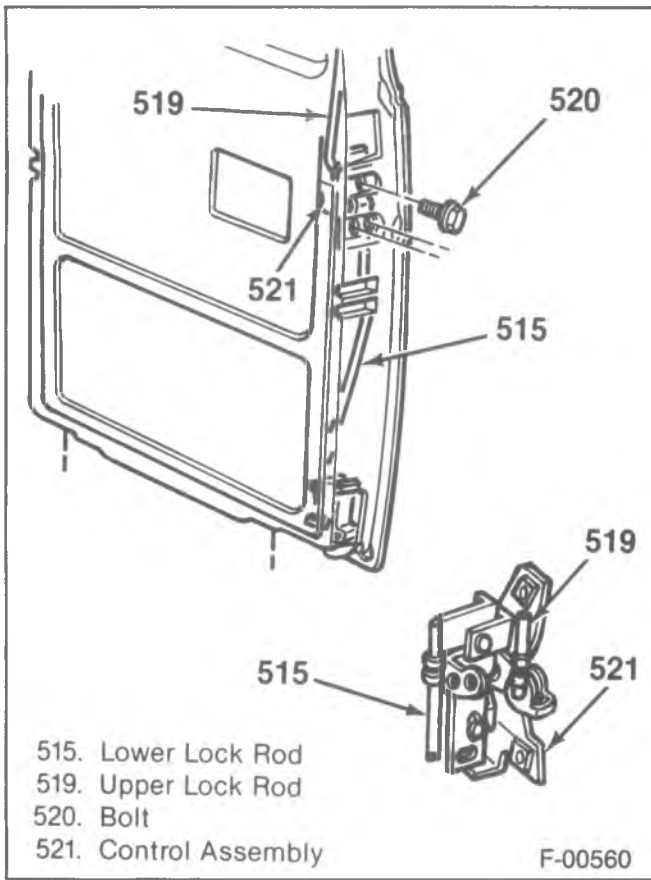

Figure 114—Right Door Control Assembly Attachment

DOOR OUTSIDE HANDLE REPLACEMENT

↔ Remove or Disconnect (Figure 115)

1. Door trim panel. Refer to "Door Trim Panel Replacement."
2. Door to outside handle screws (502).
3. Handle from the door.
4. Gaskets from the door.

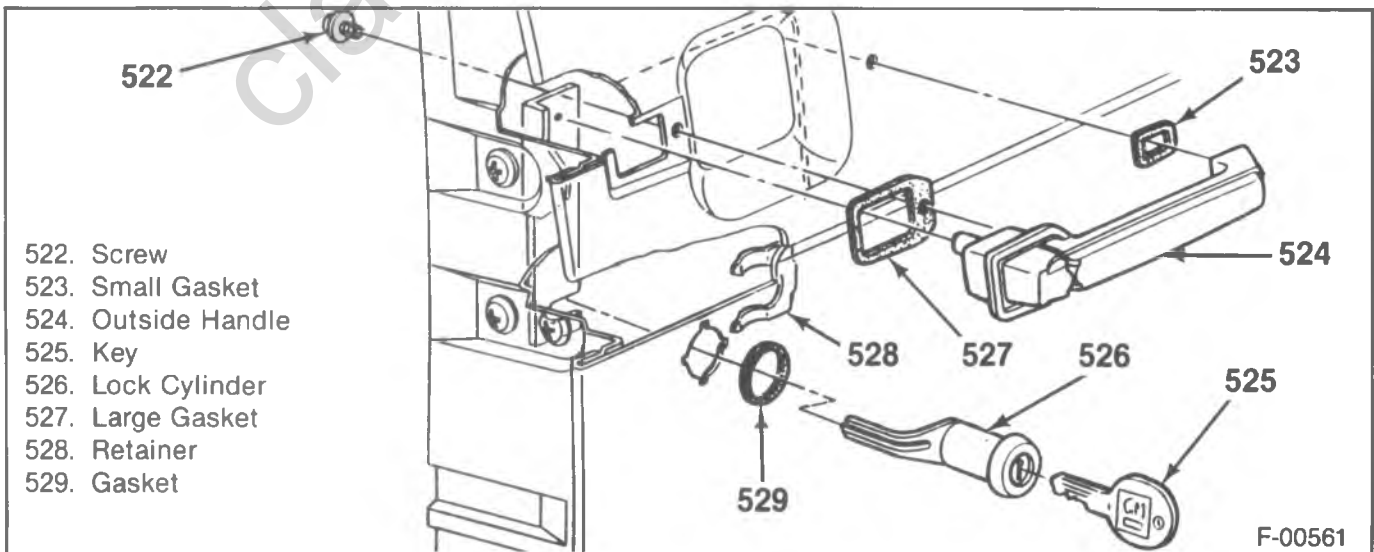

Figure 115—Outside Handle and Lock Cylinder Attachments

↔ Install or Connect (Figure 115)

1. Large gasket onto the handle.
2. Door to outside handle screw (502) to the push button side of the handle.
 - Do not tighten.
3. Small gasket between the door and the handle.
4. Door to outside handle screw (522) to the other side of the handle.
 - Tighten both screws.
5. Door trim panel. Refer to "Door Trim Panel."

DOOR LOCK CYLINDER REPLACEMENT

↔ Remove or Disconnect (Figure 115)

1. Door trim panel. Refer to "Door Trim Panel Replacement."
2. Lock cylinder retaining clip from the cylinder.
 - Slide the clip off the cylinder with a screwdriver.
3. Lock cylinder and gasket from the door.

↔ Install or Connect (Figure 115)

1. Lock cylinder with gasket to the door.
 - The cylinder rod must engage the lock assembly lever.
2. Lock cylinder retaining clip onto the cylinder.
3. Door trim panel. Refer to "Door Trim Panel Replacement."

CHECK STRAP REPLACEMENT

↔ Remove or Disconnect (Figure 103)

1. Pin (469).
2. Strap to door bolts (474).
3. Strap (472).
4. Bracket to inner panel bolts (471).
5. Bracket (473).

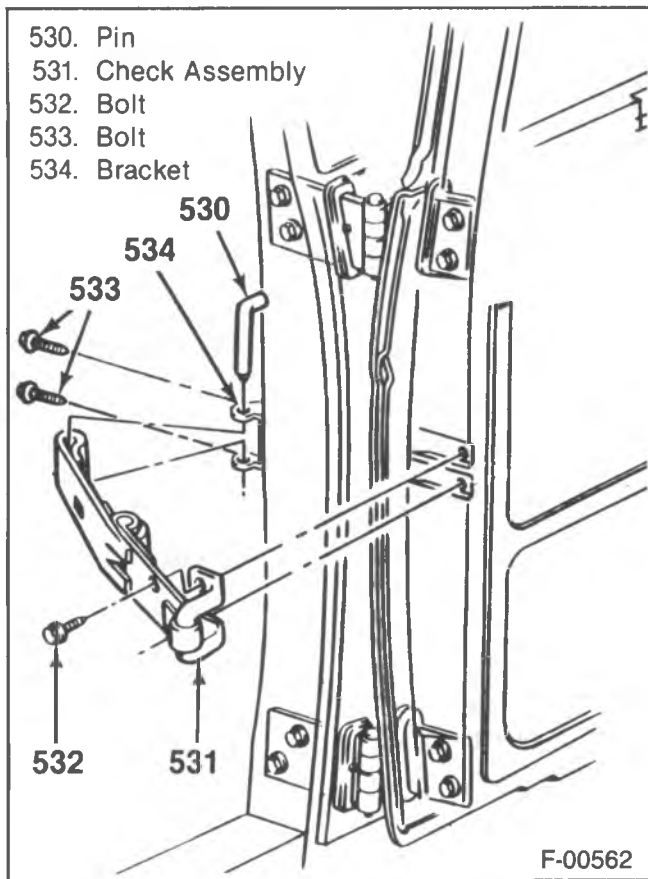

F-00562

Figure 116—Check Assembly Components

Install or Connect (Figure 103)

1. Bracket (473).
2. Bracket to inner panel bolts (471).
3. Strap to the door.
4. Strap to door bolts (474).
5. Pin (469).

CHECK ASSEMBLY REPLACEMENT

Remove or Disconnect (Figure 116)

1. Pin (530).
2. Check assembly to door bolts (532).
3. Check assembly (531).
4. Bracket to inner panel bolts (533).
5. Bracket (534).

Install or Connect (Figure 116)

1. Bracket (534).
2. Bracket to inner panel bolts (533).
3. Check assembly (531).
4. Check assembly to door bolts (532).
5. Pin (530).

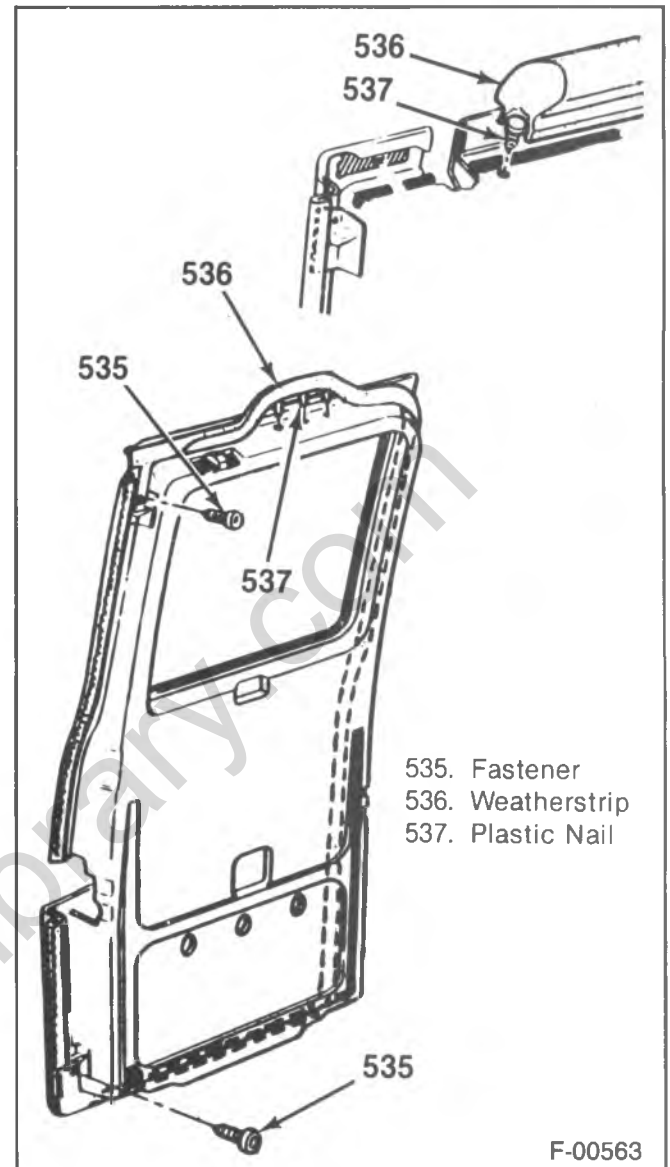

F-00563

Figure 117—Left Door Weatherstrip

LEFT DOOR WEATHERSTRIP REPLACEMENT

Remove or Disconnect (Figure 117)

Tool Required:

J-24595-B Door Trim Pad Clip Remover.

1. Weatherstrip to door fasteners using J-24595-B.
2. Weatherstrip from the door using 3M Release Agent (or equivalent).
3. Plastic nails from the door frame.

Clean

- The door and weatherstrip of all the old cement.

Install or Connect (Figure 117)

1. New weatherstrip to the door using 3M Weatherstrip Adhesive (or equivalent).
 - Push the plastic nails into the door frame.
2. Weatherstrip to door fasteners.

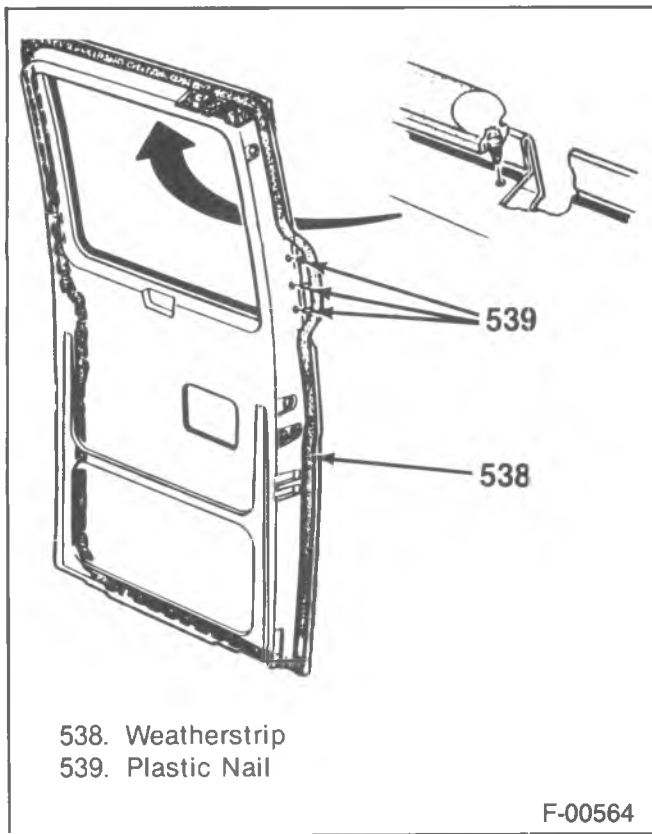

Figure 118—Right Door Weatherstrip

RIGHT DOOR WEATHERSTRIP REPLACEMENT

↔ Remove or Disconnect (Figure 118)

1. Weatherstrip from the door using 3M Release Agent (or equivalent).
2. Plastic nails from the door frame.

🧼 Clean

- The door and weatherstrip of all the old cement.

→← Install or Connect (Figure 118)

1. New weatherstrip to the door using 3M Weatherstrip Adhesive (or equivalent).
- Push the plastic nails into the door frame.

POWER DOOR LOCK MOTOR REPLACEMENT

↔ Remove or Disconnect (Figure 119)

1. Battery ground cable.
2. Door trim panel. Refer to "Door Trim Panel Replacement."
3. Electrical connector from the motor.
4. Door to motor screws (540).
5. Motor from the lock rod.
 - Slide the rubber mount at the top of the motor off of the door lock rod.
6. Motor from the door.

→← Install or Connect (Figure 119)

1. Motor into the door.
2. Motor to the lock rod.
 - Slide the rubber mount at the top of the motor onto the door lock rod.
3. Door to motor screws (540).
4. Electrical connector to the motor.
5. Door trim panel. Refer to "Door Trim Panel Replacement."
6. Battery ground cable.

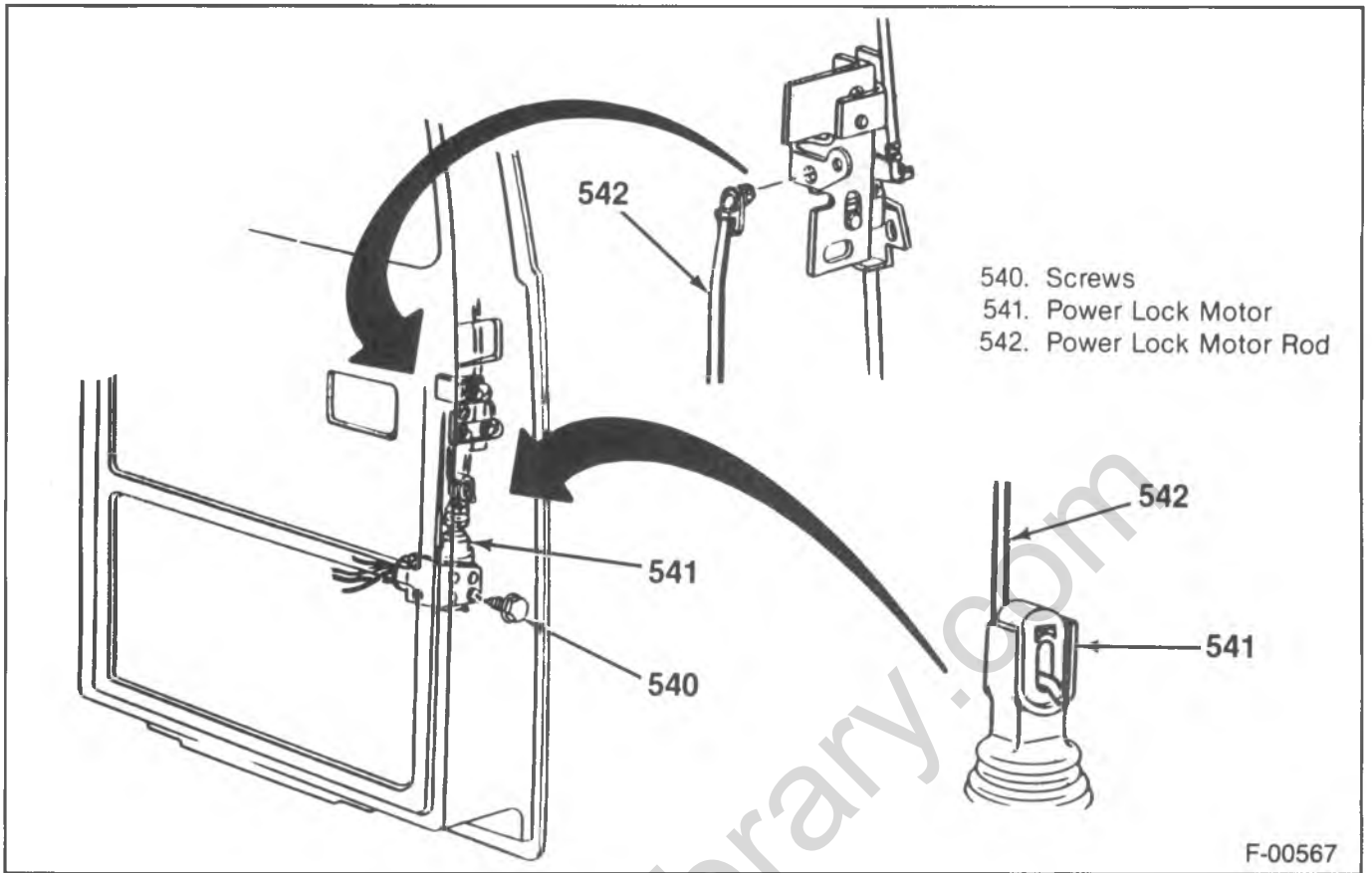

Figure 119—Power Door Lock Motor Attachment

classiccarlibrary.com

SPECIAL TOOLS

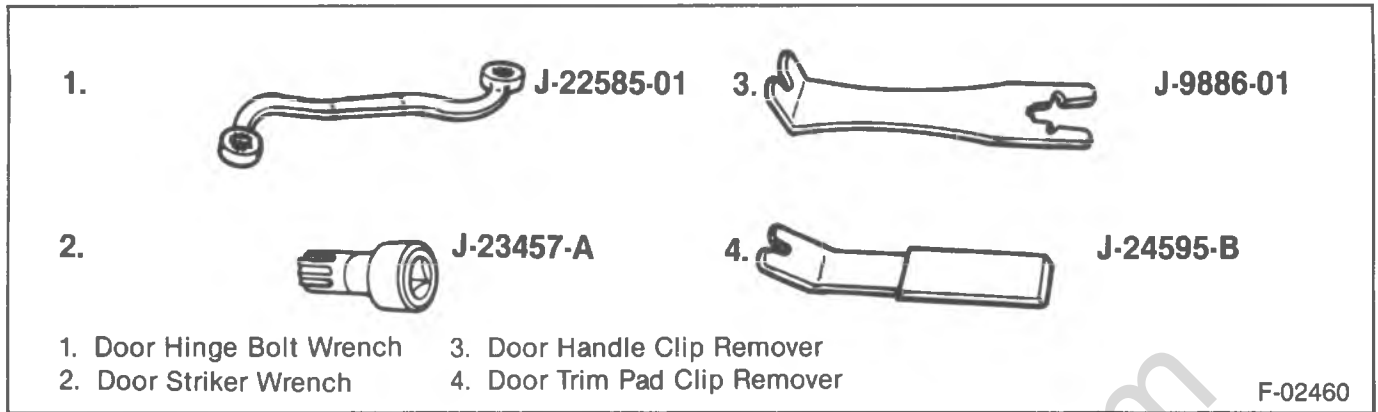

Figure 120—Special Tools

classiccarslibrary.com

SECTION 10A2

SEATS

The following "Notice" applies to one or more steps in the assembly procedure of components in this portion of the manual as indicated at appropriate locations by the terminology "NOTICE: See 'Notice' on page 10A2-1 of this section."

NOTICE: All seat belt fasteners are important attaching parts in that they could affect the performance of all vital parts and systems, and/or could result in major repair expense. They must be replaced with one of the same part number or with an equivalent part if replacement becomes necessary. Do not use a replacement part of lesser quality or substitute design. Torque values must be used as specified during reassembly to assure proper retention of all parts.

CONTENTS

<u>SUBJECT</u>	<u>PAGE</u>
Diagnosis Of Manual Seat Adjuster	10A2- 2
Seat Adjuster Adjustment	10A2- 3
RV Model Front Seat	10A2- 3
Front Seat And Seat Adjuster Replacement	10A2- 3
Utility Vehicle Passenger Front Bucket Seat Replacement	10A2- 3
Front Pivot Bracket Disassembly	10A2- 3
Bench Seatback And Catch Replacement	10A2- 5
Seat Belt Replacement	10A2- 6
High Back Bucket Seat Belt Replacement	10A2- 7
RV Model Suburban Center Seat	10A2- 8
Center Seatback Replacement	10A2- 8
Center Seat Bottom Replacement	10A2- 8
Center Seat Bottom Support Bracket Replacement	10A2- 8
Center Seatback Bumper And Striker Replacement	10A2- 9
Center Seat Bottom Striker Replacement	10A2- 9
Center Seatback Latch Replacement	10A2- 9
Center Seat Bottom Latch Replacement	10A2- 9
Center Seat Belt Replacement	10A2-11
RV Model Rear Seats	10A2-13
Crew Cab Rear Seat Replacement	10A2-13
Crew Cab Rear Seatback And Catch Replacement	10A2-13
Crew Cab Rear Seat Belt Replacement	10A2-13
Utility Vehicle Rear Seat Replacement	10A2-14
Utility Vehicle Rear Seat Cover Rod Replacement	10A2-14
Utility Vehicle Rear Seat Storage Strut Replacement	10A2-14
Utility Vehicle Rear Seat Belt Replacement	10A2-14
Utility Vehicle And Suburban Seatback And Hinge Replacement	10A2-16
Utility Vehicle And Suburban Latch And Support Assembly Replacement	10A2-16
Suburban Rear Seat Replacement	10A2-17
Suburban Rear Seat Belt Replacement	10A2-18
RV Model Top Strap Belt Anchor Installation	10A2-19
Pickup And Crew Cab Models	10A2-19
Utility Vehicle Rear Seat	10A2-19
Suburban Front Seat	10A2-19
Suburban Second Seat	10A2-21
Suburban Third Seat	10A2-21
G Model Front Seat	10A2-23
Front Seat Replacement	10A2-23
Front Seat Disassembly	10A2-23
Front Seat Belt Replacement	10A2-23

CONTENTS (CONTINUED)

<u>SUBJECT</u>	<u>PAGE</u>
G Model Center And Rear Seats	10A2-26
Center And Rear Seat Replacement	10A2-26
Center And Rear Seat Disassembly	10A2-26
Center And Rear Seat Armrest Replacement	10A2-27
Center And Rear Seat Belt Replacement	10A2-27
G Model Top Strap Belt Anchor Installation	10A2-30
Vehicles With A 125-Inch Wheelbase	10A2-30
Vehicles With A 110-Inch Wheelbase	10A2-31
Specifications	10A2-34

DIAGNOSIS OF MANUAL SEAT ADJUSTER

PROBLEM	POSSIBLE CAUSE	CORRECTION
Adjuster Will Not Lock	<ol style="list-style-type: none"> 1. Locking wire too tight. 2. Adjuster lock bar spring disconnected or broken. 3. Adjuster lock bar sticking or binding. 	<ol style="list-style-type: none"> 1. Loosen the locking wire tension enough to provide full engagement of the lock bar in the locking slots of the adjuster lower channel. Refer to "Seat Adjuster Adjustment." 2. Connect the spring or install a new spring. 3. Lubricate the lock bar pivot. If the bar is binding, eliminate the cause of binding or replace the adjuster.
Adjuster Will Not Unlock	<ol style="list-style-type: none"> 1. Locking wire too loose or disconnected. 2. Adjuster lock bar sticking or binding. 	<ol style="list-style-type: none"> 1. Tighten the locking wire enough to allow the lock bar to disengage from the locking slots in the adjuster lower channel when the lock control lever is activated. Refer to "Seat Adjuster Adjustment." 2. Lubricate the lock bar pivot. If the bar is binding, eliminate the cause of binding or replace the adjuster.
When The Left Adjuster Locks, The Right Adjuster Is Between Lock Positions	<ol style="list-style-type: none"> 1. Right adjuster either rearward or forward of the left adjuster. 	<ol style="list-style-type: none"> 1. Loosen the adjuster to floor pan bolts or nuts — move one adjuster forward or rearward as far as possible and the other adjuster in the opposite direction. Refer to "Seat Adjuster Adjustments."
Seat Hard To Move Forward Or Rearward	<ol style="list-style-type: none"> 1. Adjusters new, not broken in. 2. Adjuster(s) improperly lubricated. 3. Adjuster(s) binding due to bent or damaged channels. 4. Adjusters not in parallel alignment with each other. 	<ol style="list-style-type: none"> 1. Operate the seat to the full forward and full rearward positions several times to work the new tightness out of the channels. 2. Lubricate the adjuster channels with Lubriplate or equivalent. 3. Replace the adjuster. 4. Loosen the floor pan attaching bolts or nuts, align the adjusters parallel on the floor pan and tighten nuts. Refer to "Seat Adjuster Adjustments."

SEAT ADJUSTER ADJUSTMENT



Adjust

- Remove the seat. Refer to "Front Seat and Seat Adjuster Replacement."
 - Leave the adjuster on the seat.
- Loosen the adjuster to seat bolts.
- 1. The adjuster rails forward or rearward so that both rails are the same distance from the front of the seat.
- 2. The adjuster rails so they are parallel to each other.
 - Tighten the adjuster to seat bolts.
- 3. Wire assembly tension. Three holes on the secondary adjuster rail allow for tension adjustment of the wire assembly (figure 1).
 - Slide the spring off of the hook.
 - Open the hook, and remove it from the hole.
 - Move the hook to a forward hole to loosen the wire, move the hook to a rearward hole to tighten it.

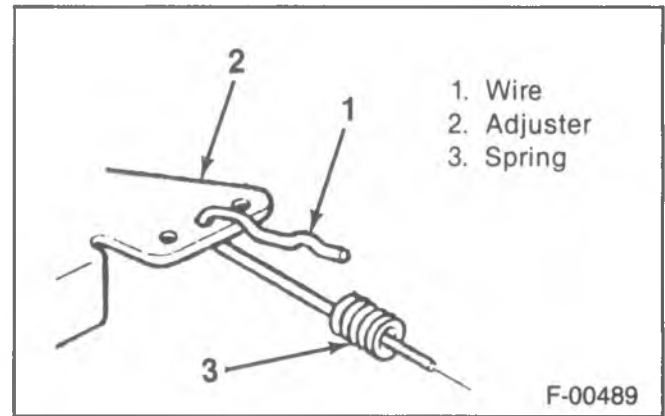

Figure 1—Adjustment Points

- Close the hook, and slide the spring over the hook.
- Install the seat. Refer to "Front Seat and Seat Adjuster Replacement."

RV MODEL FRONT SEATS

FRONT SEAT AND SEAT ADJUSTER REPLACEMENT

This procedure applies to all RV Model front seats, whether bench or bucket type with the exception of the utility vehicle passenger front bucket seat. Refer to "Utility Vehicle Passenger Front Bucket Seat Replacement" for information on this type of seat.

↔ Remove or Disconnect (Figures 2 and 3)

1. Bolt cover (5) (if equipped).
2. Seat adjuster to floor panel bolts (7).
3. Seat (10) with adjuster (2) from the vehicle.
4. Adjuster to seat bolts (8).
5. Adjuster (2) from the seat (10).

↔ Install or Connect (Figures 2 and 3)

1. Adjuster (2) to the seat (10).
2. Adjuster to seat bolts (8).
3. Seat (10) with adjuster (2) to the vehicle.
4. Seat adjuster to floor panel bolts (7).
5. Bolt cover (5) (if equipped).

UTILITY VEHICLE PASSENGER FRONT BUCKET SEAT REPLACEMENT

↔ Remove or Disconnect (Figure 4)

- Place the seat in its forward position.
- 1. Restraint cable (19) to the floor panel bolt (22).
 - Allow the seat to tip forward.
- 2. Spring retaining bracket bolts (12) and the bracket (13).
- 3. Lower seat bracket (23) to the floor panel bolts (20).
- 4. Seat from the vehicle.
- 5. Upper seat bracket bolts (15).
- 6. Seat brackets (14) from the seat.

7. Latch assembly to seat bolts.
8. Latch assembly from the seat.

↔ Install or Connect (Figure 4)

1. Latch assembly to the seat.
2. Latch assembly to seat bolts.
3. Seat brackets (14) to the seat.
4. Upper seat bracket bolts (15).
5. Seat to the vehicle.
6. Lower seat bracket (22) to the floor panel bolts (20).
7. Spring retaining bracket (13) onto the springs (21), and the spring retaining bracket bolts (12).
8. Restraint cable (19) to the floor panel bolts (22).

FRONT PIVOT BRACKET DISASSEMBLY

This procedure applies only to Utility Vehicle passenger front bucket seats.

↔ Remove or Disconnect (Figure 4)

1. Seat. Refer to "Utility Vehicle Passenger Front Bucket Seat Replacement."
2. Nut (18).
3. Washer (17).
4. Pivot stud (25).
5. Sleeve (24).
6. Springs (21).
7. Upper bracket (14) from the lower bracket (23).

↔ Install or Connect (Figure 4)

1. Upper bracket (14) to the lower bracket (23).
2. Springs (21) onto the sleeve (24).
3. Brackets (14 and 16) to the sleeve.
4. Pivot stud (25).
5. Washer (17).
6. Nut (18).
 - Tighten each nut until it bottoms out.

10A2-4 SEATS

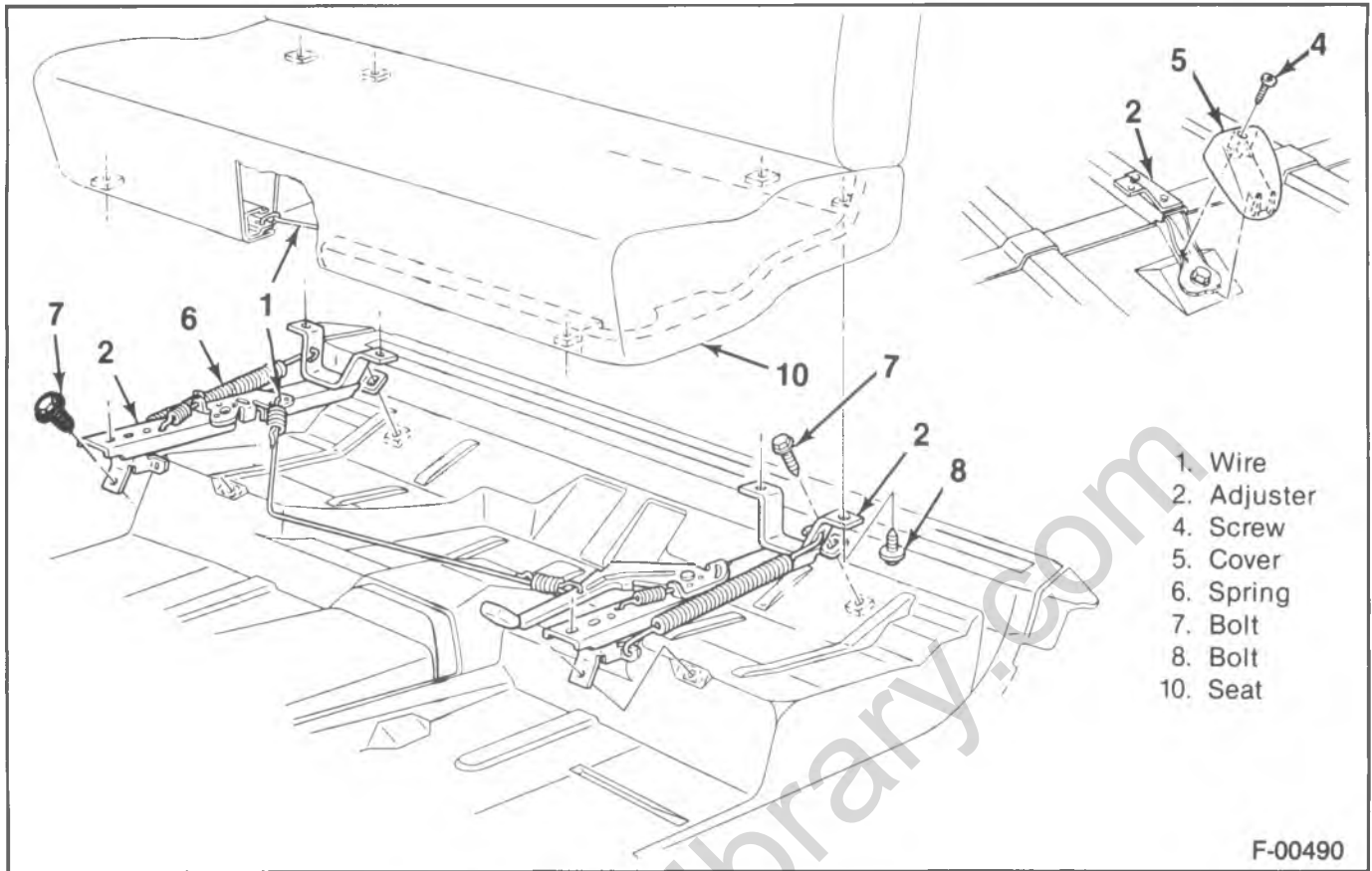

Figure 2—Bench Seat Components

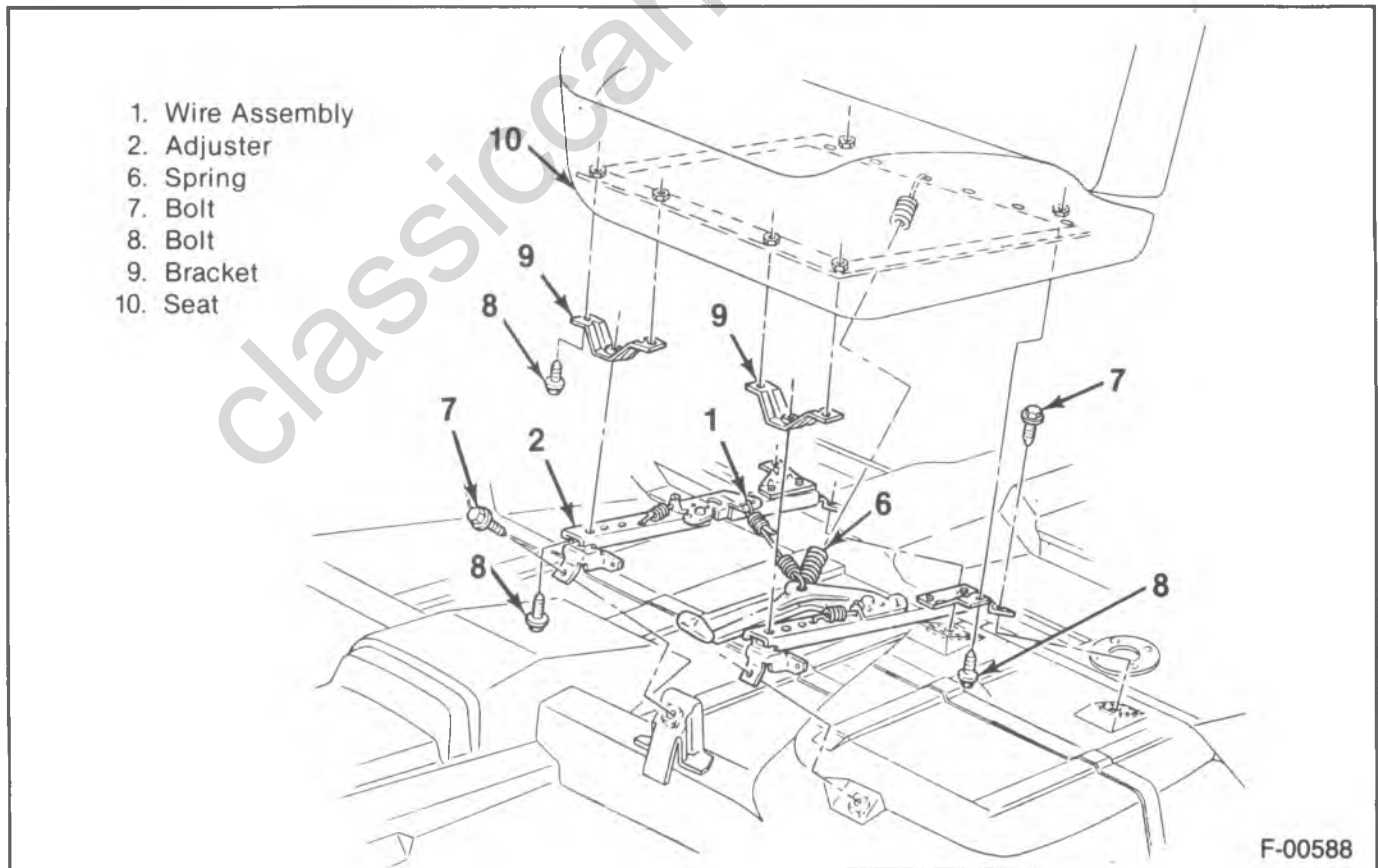

Figure 3—Bucket Seat Components

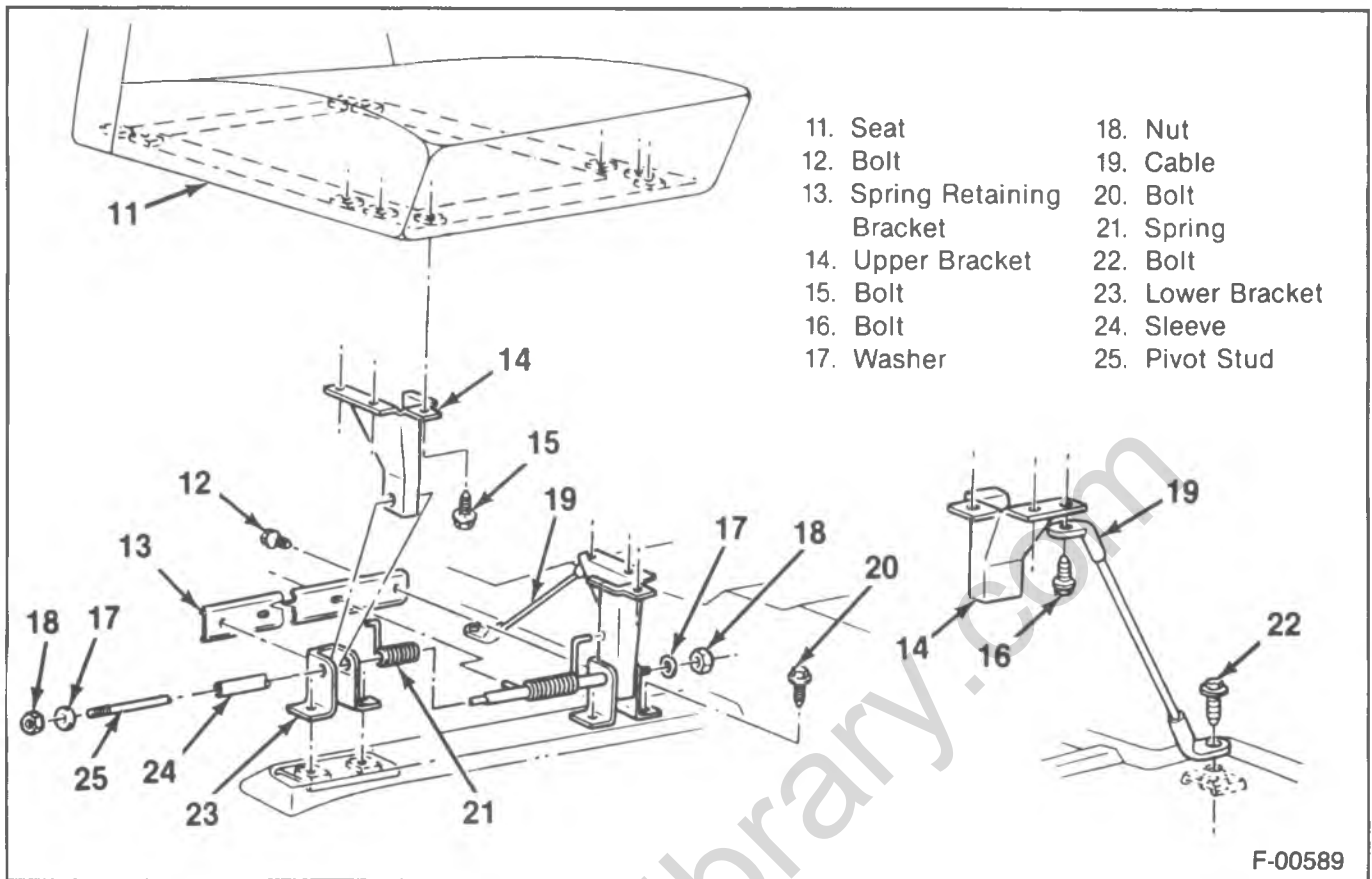

Figure 4—Utility Vehicle Passenger Seat Components

7. Seat. Refer to "Utility Vehicle Passenger Front Bucket Seat Replacement."

BENCH SEATBACK AND CATCH REPLACEMENT

↔ Remove or Disconnect (Figure 5)

1. Seat back trim cover (32).
2. Striker (27).
3. Catch (28) with bushing (29).

4. Washer (30).
5. Seatback to seat base bolt (26).
6. Washer (30).
7. Seatback from the vehicle.

↔ Install or Connect (Figure 5)

1. Seatback to the vehicle.
2. Washer (30) between the seat base and the seatback frame.
3. Seatback to seat base bolt (26).

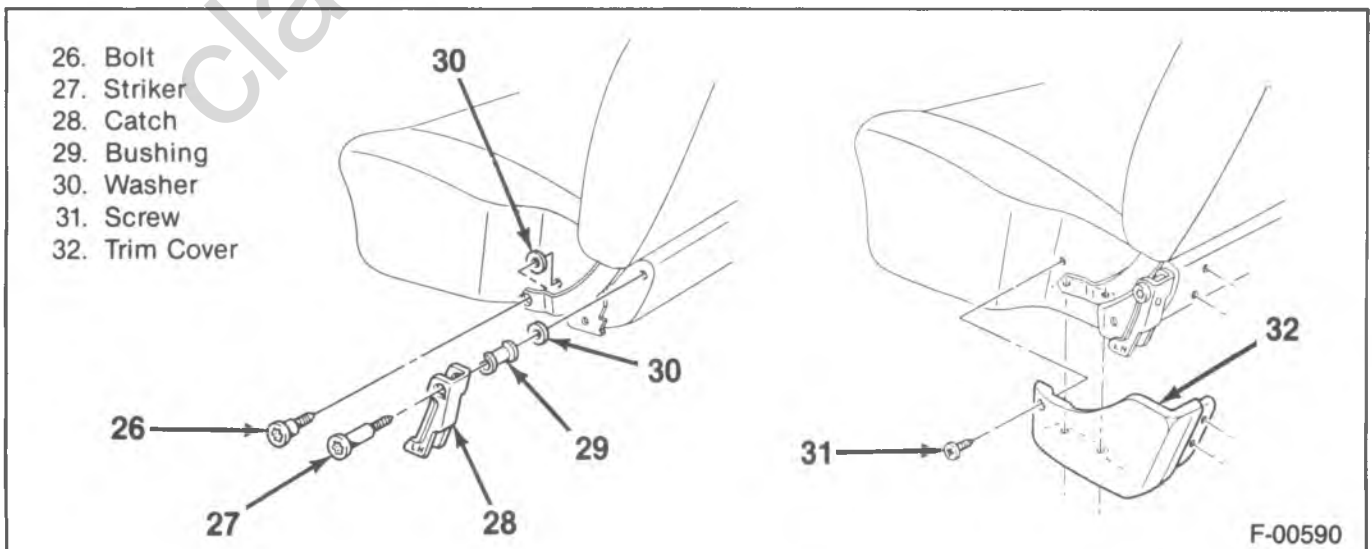

Figure 5—Seat Back Catch Components

10A2-6 SEATS

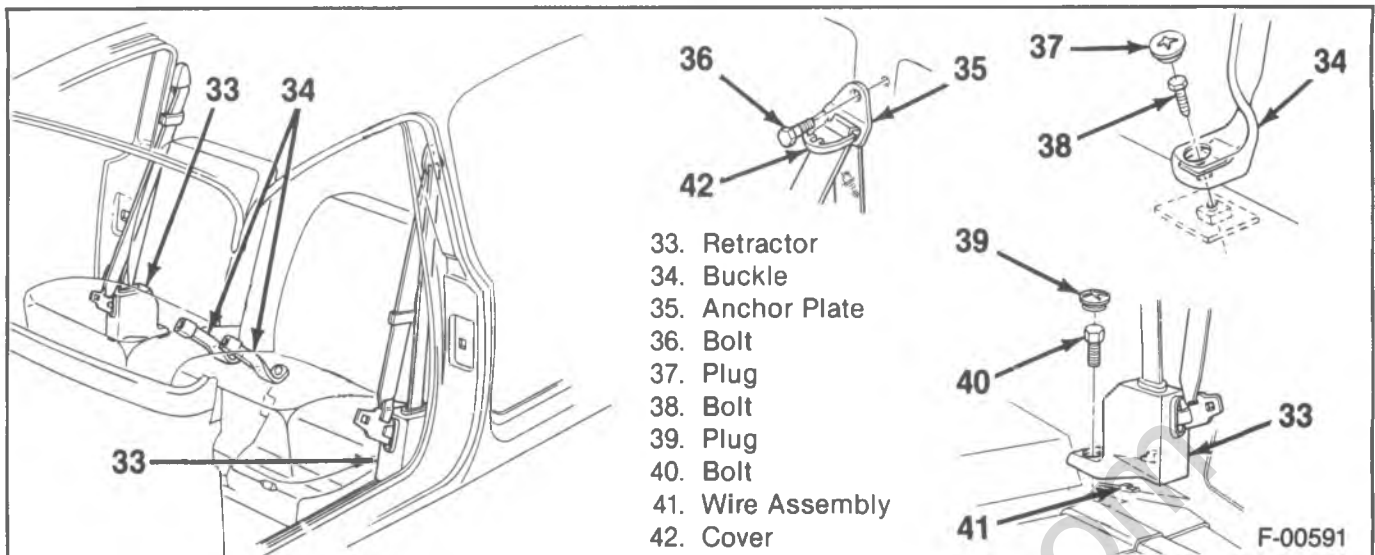

Figure 6—Bucket Seat Belt Components

4. Washer (30).
5. Catch (28) with bushing (29).
6. Striker (27).
7. Seat back trim cover (32).

9. Buckle (34) to floor bolt (38).
10. Buckle from the floor.

NOTICE: For steps 2, 6, and 9 see "Notice" on page 10A2-1 of this section.

SEAT BELT REPLACEMENT

This procedure covers belts for all seats except high back bucket seats.

↔ Remove or Disconnect (Figures 6 and 7)

1. Upper seat belt anchor plate cover (42).
 - Pry the top of the cover away from the anchor plate.
2. Anchor plate bolt (36).
3. Anchor plate (35).
4. Plug (39) (except regular cab).
5. Retractor (33) to floor bolt (40).
6. Seat belt wire (left side only).
7. Retractor from the vehicle.
8. Plug (37).

↔ Install or Connect

1. Buckle (38) to the floor.
2. Buckle to floor bolt (38).

⤵ Tighten

- Bolt to 50 N·m (37 ft. lbs.).
3. Plug (37).
 4. Retractor to the vehicle.
 5. Seat belt wire (left side only).
 6. Retractor to floor bolt (40).

⤵ Tighten

- Bolt to 50 N·m (37 ft. lbs.).
7. Plug (39) (except regular cab).

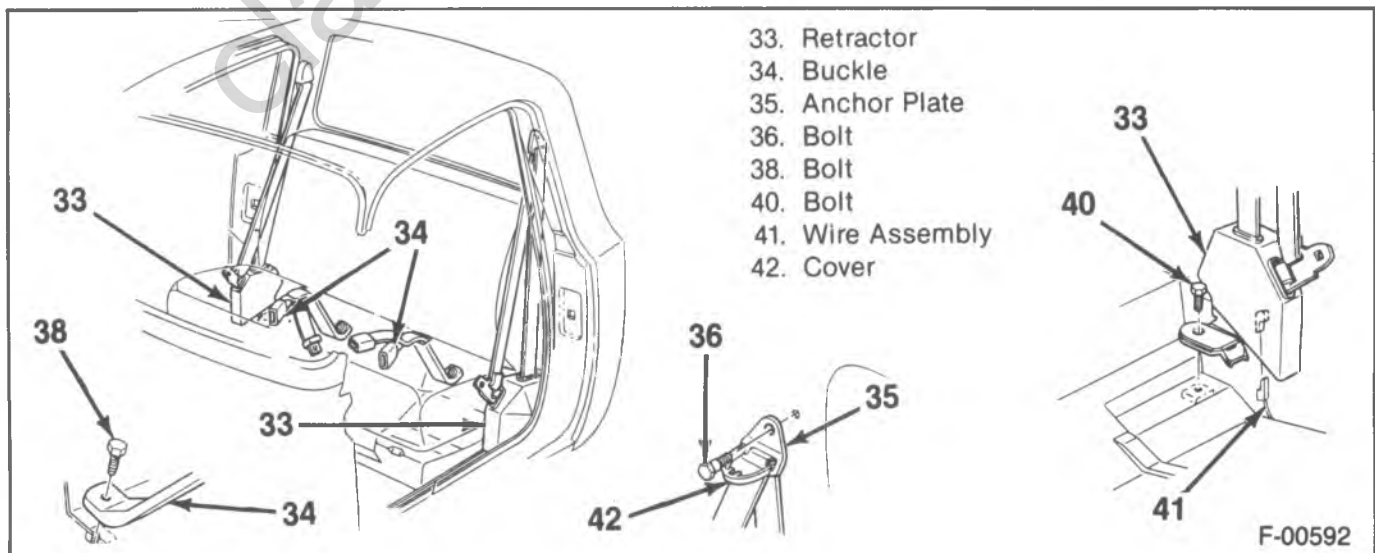

Figure 7—Bench Seat Belt Components

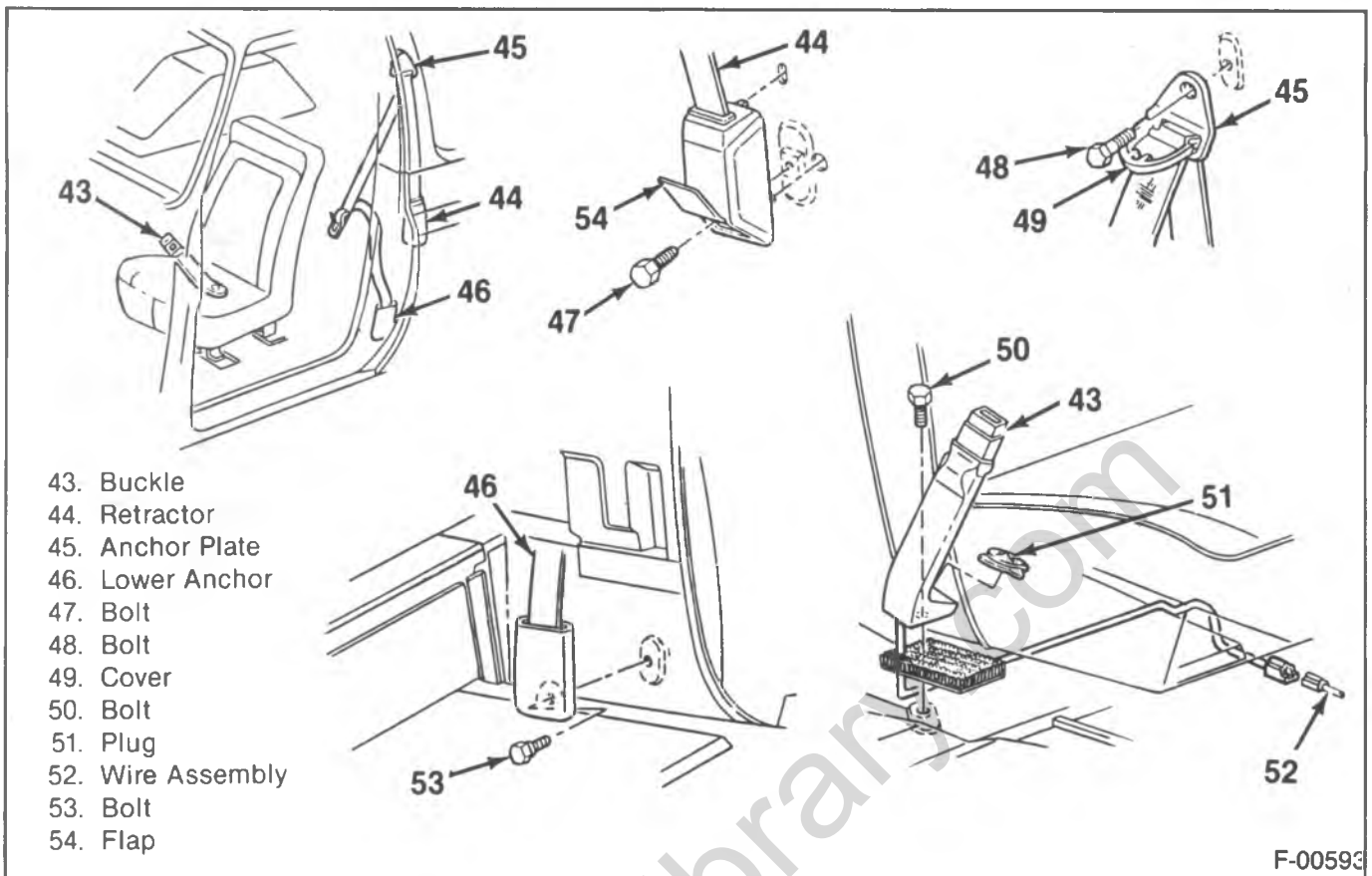

Figure 8—High Back Bucket Seat Belt Components

8. Anchor plate (35) to the door pillar.
9. Anchor plate bolt (36).

Tighten

- Bolt to 50 N·m (37 ft. lbs.).
10. Upper seat belt anchor plate cover (42).
 - Pivot the cover upwards, and press it into place.

HIGH BACK BUCKET SEAT BELT REPLACEMENT

Remove or Disconnect (Figure 8)

1. Upper seat belt anchor plate cover (49).
 - Pry the top of the cover away from the anchor plate.
2. Anchor plate bolt (48).
3. Anchor plate (45).
4. Retractor lower flap (54).
5. Retractor (44) to pillar bolt (47).
6. Lower anchor bolt (53).
7. Lower anchor (46).
8. Retractor from the vehicle.
9. Plug (51).
10. Buckle (43) to floor bolt (50).
11. Seat belt wire (left side only).
12. Buckle from the floor.

Install or Connect

1. Buckle to the floor.
2. Seat belt wire (left side only).
3. Buckle (43) to floor bolt (50).

Tighten

- Bolt to 50 N·m (37 ft. lbs.).
4. Plug (51).
 5. Retractor to the vehicle.
 6. Lower anchor (46) to the pillar.
 7. Lower anchor bolt (53).

Tighten

- Bolt to 50 N·m (37 ft. lbs.).
8. Retractor (44) to pillar bolt (47).

Tighten

- Bolt to 50 N·m (37 ft. lbs.).
9. Retractor lower flap.
 10. Anchor plate (45).
 11. Anchor plate bolt (48).

Tighten

- Bolt to 50 N·m (37 ft. lbs.).
12. Upper seat belt anchor plate cover (49).

NOTICE: For steps 3, 7, 8 and 11 see "Notice" on page 10A2-1 of this section.

F-00593

RV MODEL — SUBURBAN CENTER SEAT

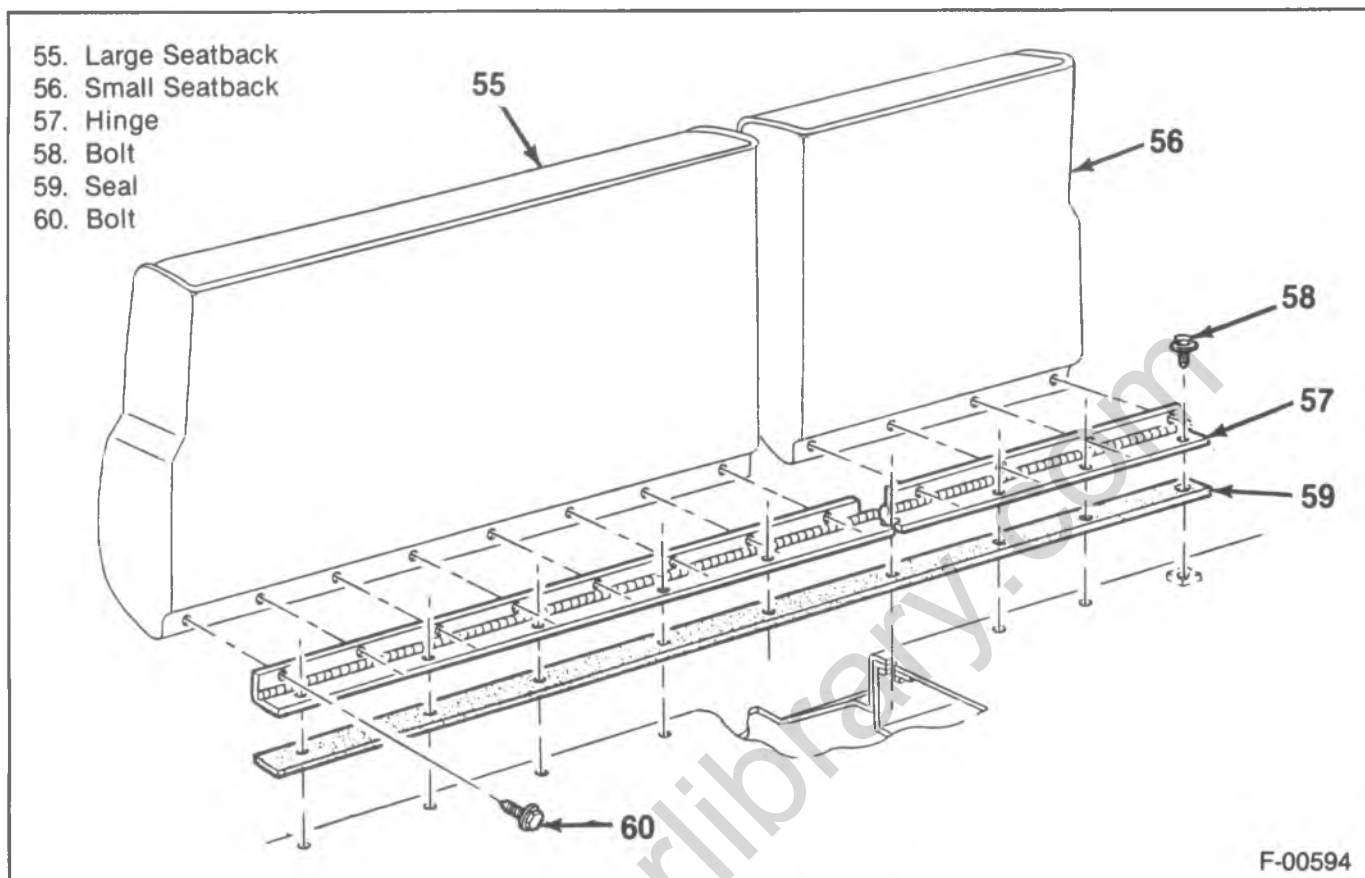

Figure 9—Center Seat Back Mounting

CENTER SEATBACK REPLACEMENT

↔ Remove or Disconnect (Figure 9)

- Fold the seatback forward.
- 1. Hinge (57) to floor panel bolts (58).
- 2. Seatback (55 or 56) from the vehicle.
- 3. Seal (59).
- 4. Hinge (57) to seatback bolts (60).
- 5. Hinge (57) from the seatback (55 or 56).

↔ Install or Connect (Figure 9)

1. Hinge (57) to the seatback (55 or 56).
2. Hinge (57) to seatback bolts (60).
3. Seal (59).
4. Seatback (55 or 56) to the vehicle.
5. Hinge (57) to floor panel bolts (58).

CENTER SEAT BOTTOM REPLACEMENT

↔ Remove or Disconnect (Figure 10)

- Fold the seat bottom forward.
- 1. Bracket (105) to floor panel bolts (61).
- 2. Seat bottom (55 or 56) from the vehicle.
- 3. Center stop bracket bolts (103) and bracket (64).
- 4. Side stop bracket bolts (104) and brackets (63).

↔ Install or Connect

1. Side stop bracket (63) and bolts (104).
2. Center stop bracket (64) and bolts (103).
3. Seat bottom (55 or 56) to the vehicle.
4. Bracket (105) to floor panel bolts (61).

CENTER SEAT BOTTOM SUPPORT BRACKET REPLACEMENT

↔ Remove or Disconnect (Figure 11)

- Fold the seat bottom forward.
- 1. Trim panel bolts (69) and the panel (68).
- 2. Bracket to seat bolts (67).
- 3. Bracket to floor panel bolts.
- 4. Bracket (105) from the vehicle.

↔ Install or Connect (Figure 11)

1. Bracket (105) to the vehicle.
2. Bracket to floor panel bolts.
3. Bracket to seat bolts (67).
4. Trim panel (68) and bolts (69) to the seat.

F-00594

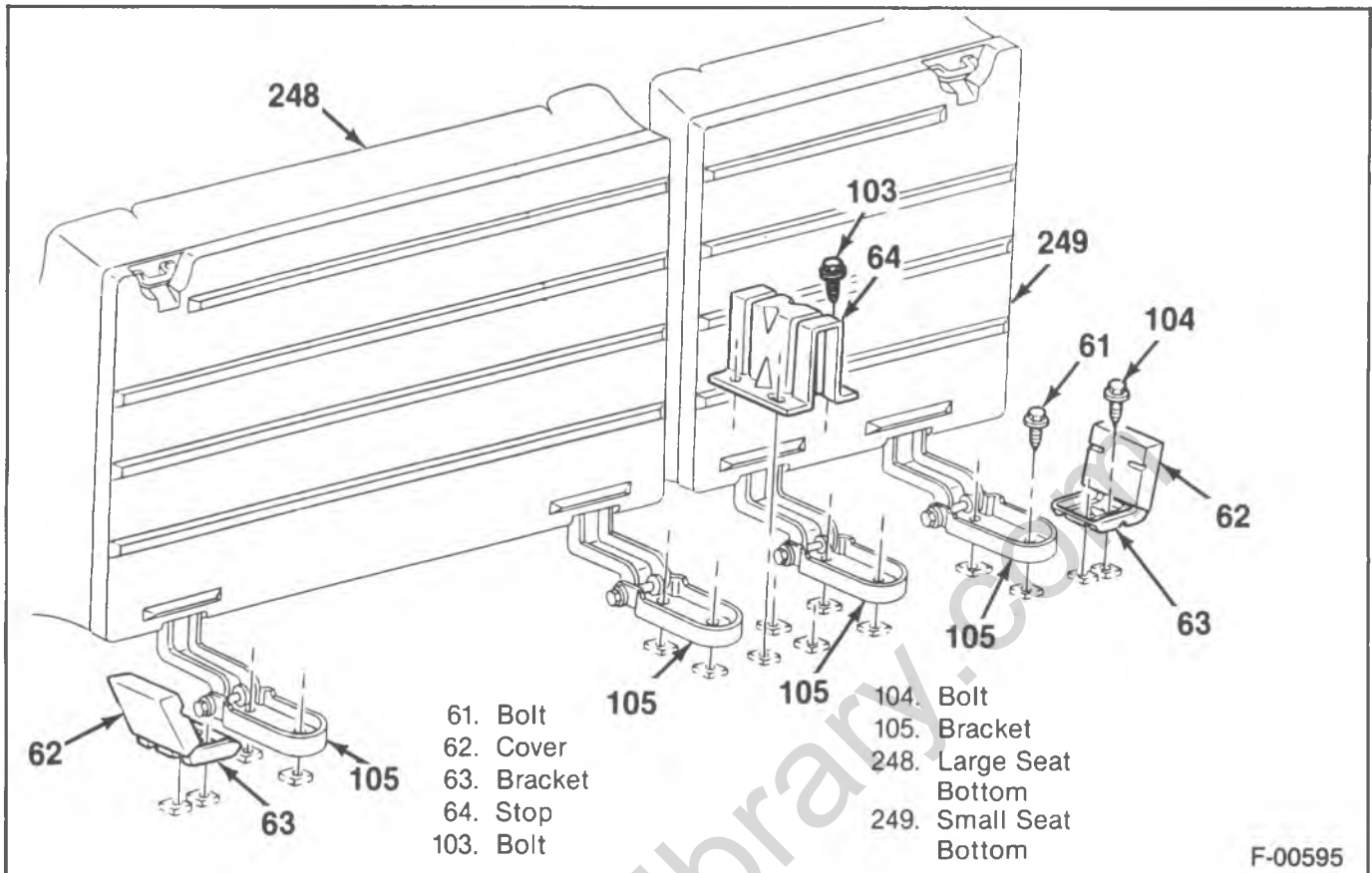

Figure 10—Center Seat Body Mounting

CENTER SEATBACK BUMPER AND STRIKER REPLACEMENT

↔ Remove or Disconnect (Figure 12)

- Fold the seatback forward.

1. Bumper covers (73).
2. Bumper (75) to seat bolts (74).
3. Bumpers (75).
4. Striker bolts (76).
5. Striker (77).
6. Spacer (78).
7. Plate (79).

↔ Install or Connect (Figure 12)

1. Plate (79).
2. Spacer (78) as required.
3. Striker (77).
4. Striker bolts (76).
5. Bumpers (75).
6. Bumper (75) to seat bolts (74).
7. Bumper covers (73).

CENTER SEAT BOTTOM STRIKER REPLACEMENT

↔ Remove or Disconnect (Figure 11)

- Fold the seat bottom forward.
1. Striker (65) to seat bolts (66).
 2. Striker (65) from the seat.

↔ Install or Connect (Figure 11)

1. Striker (65) to the seat.
2. Striker (65) to seat bolts (66).

CENTER SEATBACK LATCH REPLACEMENT

↔ Remove or Disconnect (Figure 13)

- Fold the seatback forward.
1. Latch bolts (83).
 2. Latch from the vehicle.

↔ Install or Connect (Figure 13)

1. Latch to the vehicle.
2. Latch bolts (83).

CENTER SEAT BOTTOM LATCH REPLACEMENT

↔ Remove or Disconnect (Figure 14)

- Fold the seat bottom forward.
1. Latch to floor panel bolts (89).
 2. Latch (88) from the vehicle.

↔ Install or Connect

1. Latch (88) to the vehicle.
2. Latch to floor panel bolts (89).

10A2-10 SEATS

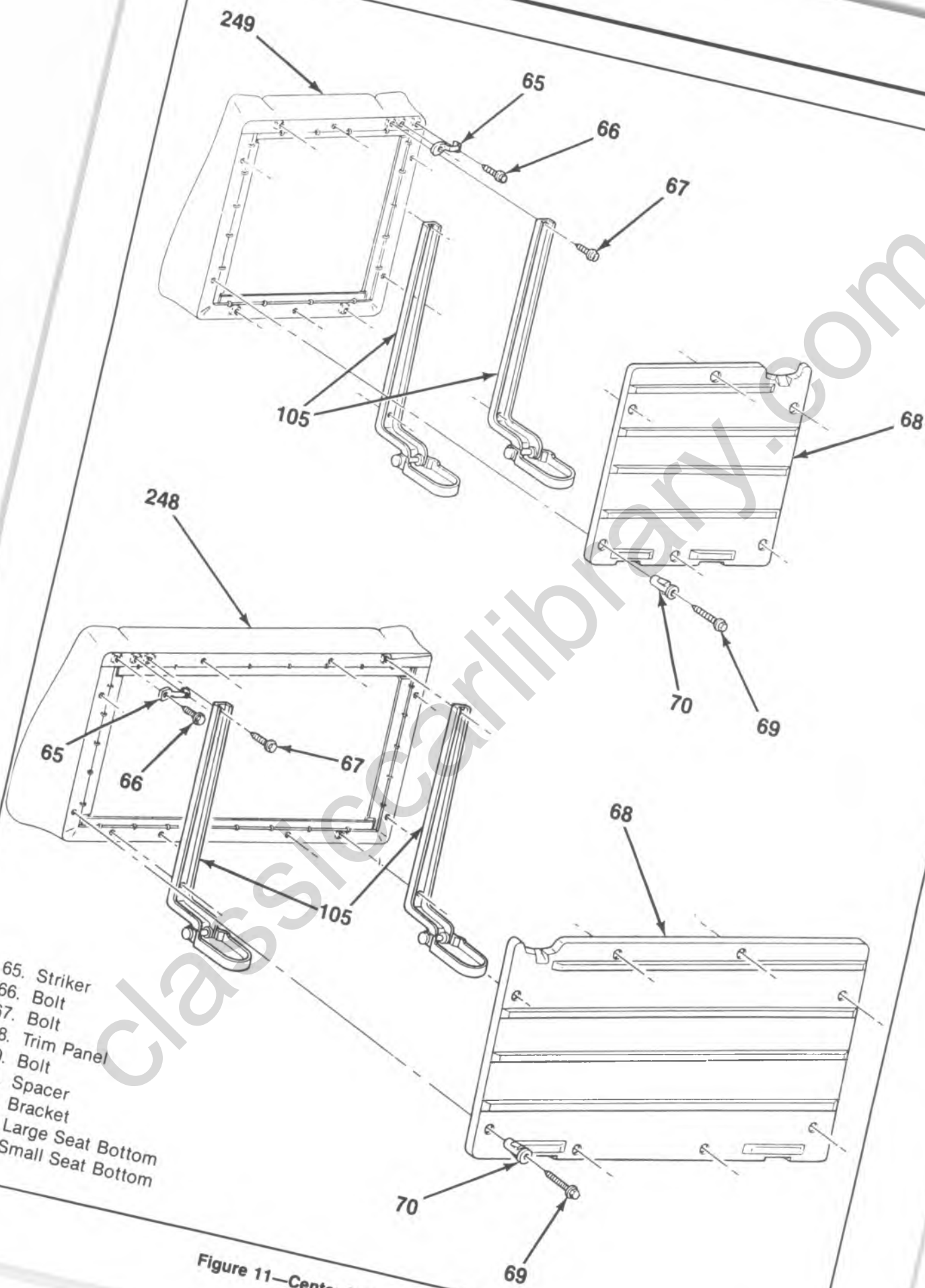
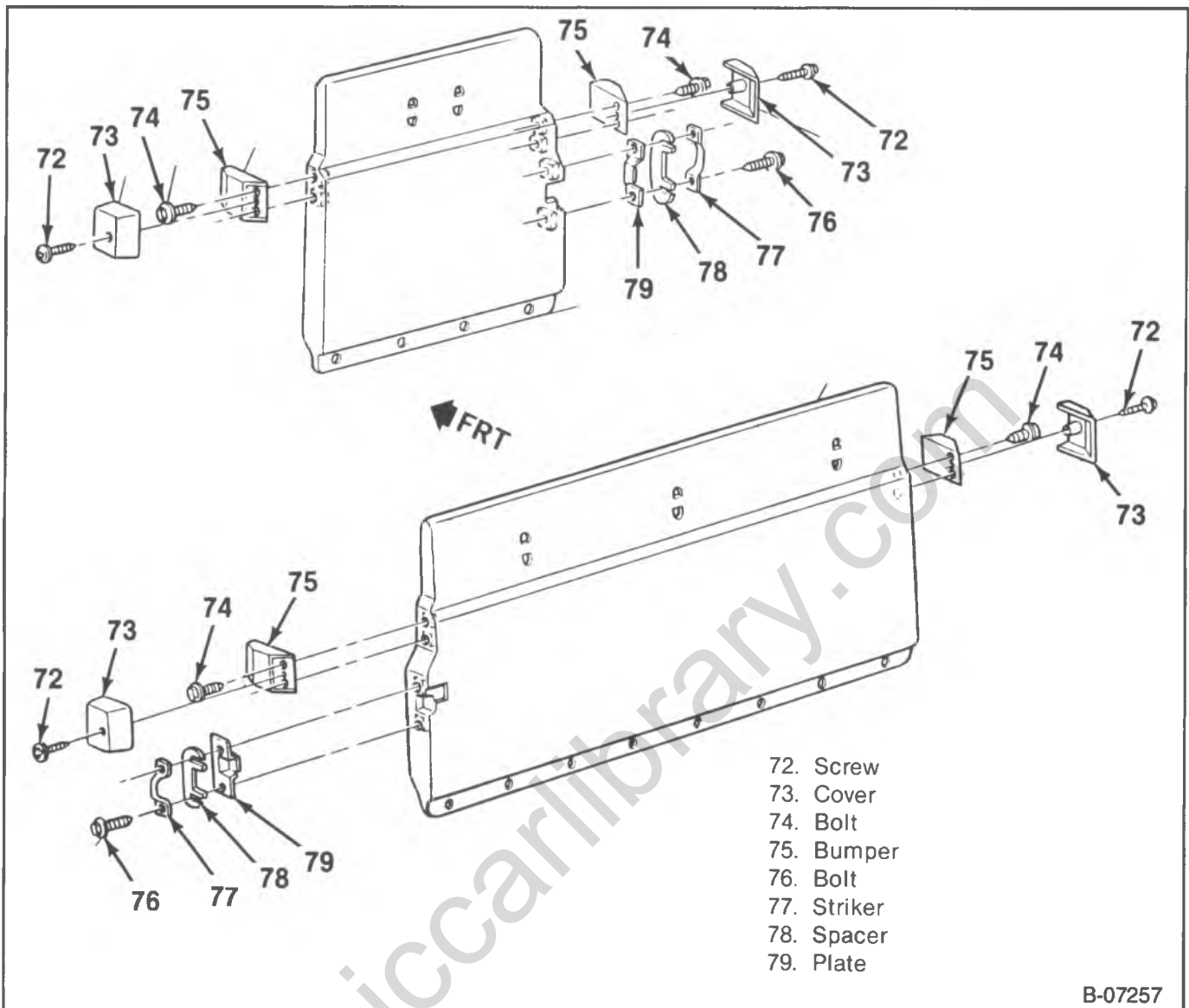

Figure 11—Center Seat Bottom Brackets

F-00596



B-07257

Figure 12—Center Seatback Bumper and Striker Components

CENTER SEAT BELT REPLACEMENT

↔ Remove or Disconnect (Figure 15)

- Fold the seat bottoms forward.
 - Note the position of the belts.
1. Retractor flaps (94).
 2. Retractor bolts (93).
 3. Retractor (92) from the vehicle.
 4. Guide assembly bolts (97) and the guides (96).
 5. Buckle (95) and latch plate (99) assembly bolts (98).
 6. Buckle and latch plate assemblies from the vehicle.

↔ Install or Connect (Figure 15)

NOTICE: For steps 2 and 5 see "Notice" on page 10A2-1 of this section.

1. Buckle and latch plate assemblies to the vehicle.
2. Buckle and latch plate assembly bolts (98).

Tighten

- Bolts to 50 N·m (37 ft. lbs.).
3. Guide assemblies (96) and guide bolts (97).
 4. Retractor (92) to the vehicle.
 5. Retractor bolts (93).

Tighten

- Retractor bolts to 50 N·m (37 ft. lbs.).
6. Retractor flaps (94).

10A2-12 SEATS

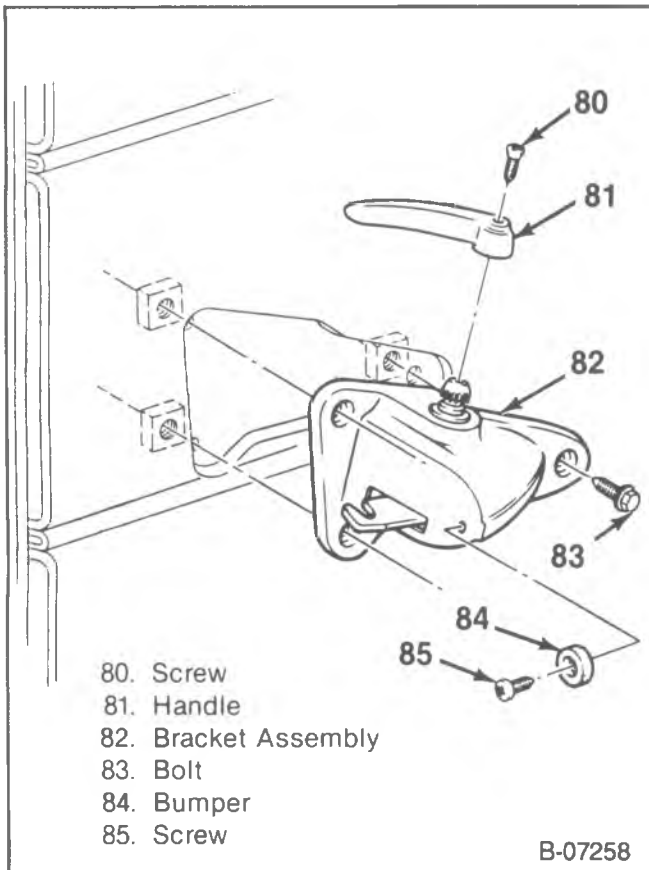

Figure 13—Center Seatback Latch

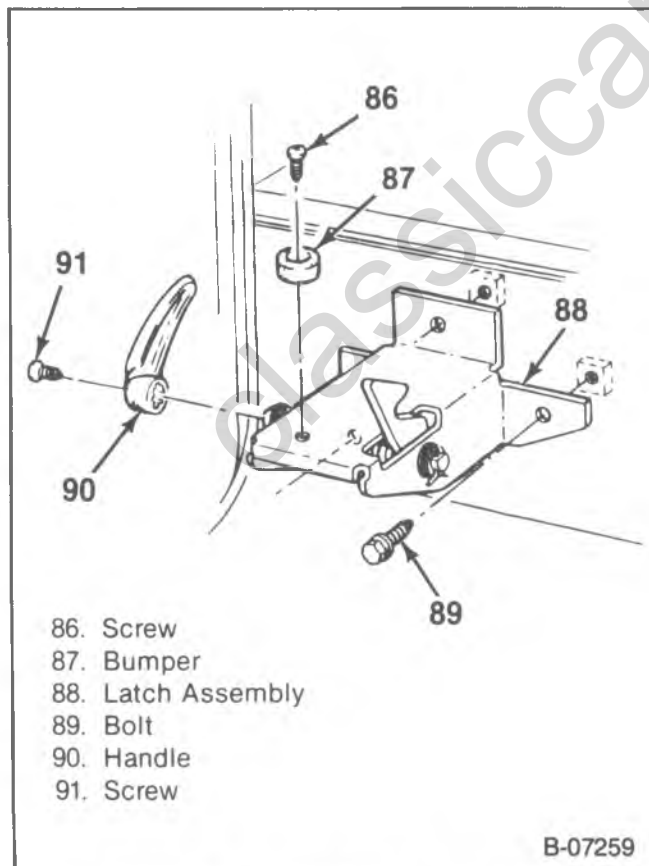

Figure 14—Center Seat Bottom Latch

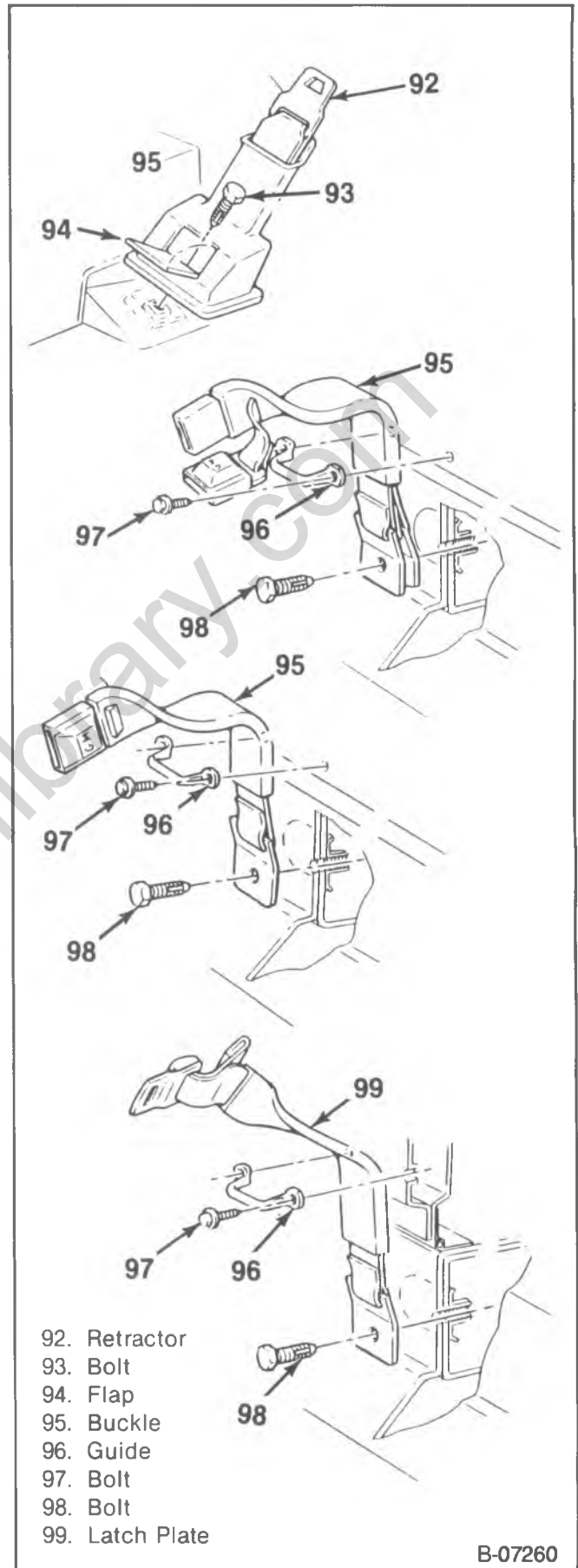

Figure 15—Center Seat Belt Components

RV MODEL REAR SEATS

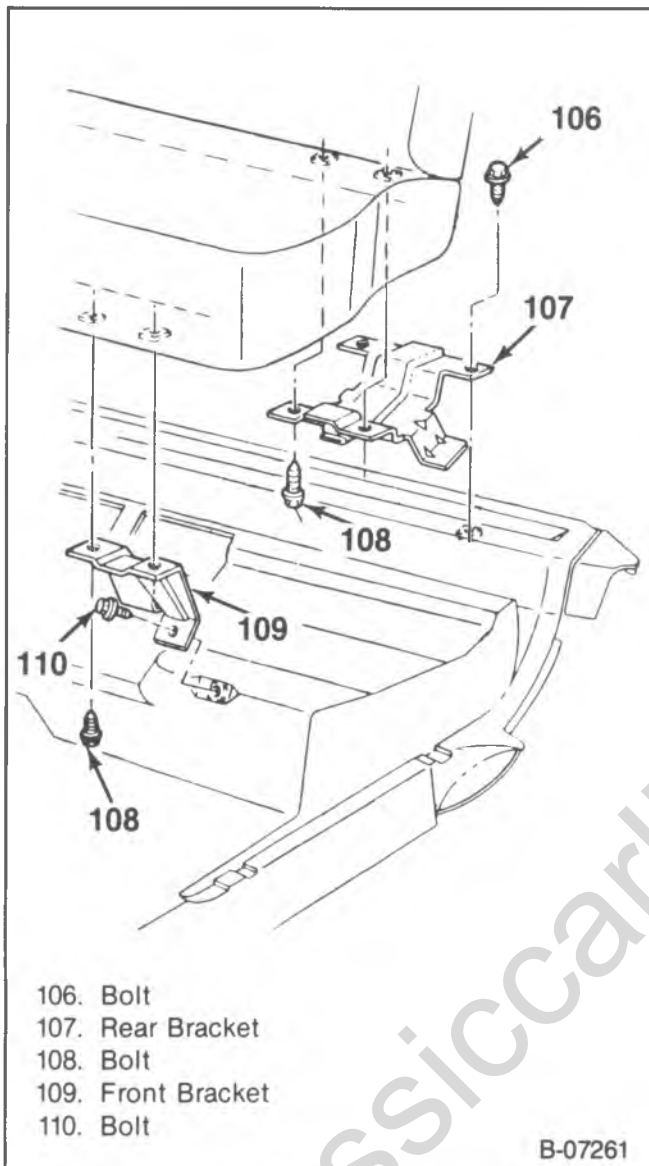

Figure 16—Crew Cab Rear Seat Components

CREW CAB REAR SEAT REPLACEMENT

↔ Remove or Disconnect (Figure 16)

1. Rear bracket (107) to floor bolts (106).
2. Front bracket (109) to floor bolts (110).
3. Seat from the vehicle.
4. Front and rear bracket to seat bolts (108).
5. Rear bracket (107).
6. Front bracket (109).

→ Install or Connect (Figure 16)

1. Front bracket (109) and bolts (108).
2. Rear bracket (107) and bolts (108).
3. Seat to the vehicle.
4. Front bracket (109) to floor bolts (110).
5. Rear bracket (107) to floor bolts (106).

CREW CAB REAR SEATBACK AND CATCH REPLACEMENT

↔ Remove or Disconnect (Figure 5)

1. Seat back trim cover (32).
2. Striker (27).
3. Catch (28) with bushing (29).
4. Washer (30).
5. Seatback to seat base bolt (26).
6. Washer (30).
7. Seatback from the vehicle.

→ Install or Connect (Figure 5)

1. Seatback to the vehicle.
2. Washer (30) between the seat base and the seatback frame.
3. Seatback to seat base bolt (26).
4. Washer (30).
5. Catch (28) with bushing (29).
6. Striker (27).
7. Seat back trim cover (32).

CREW CAB REAR SEAT BELT REPLACEMENT

RETRACTOR REPLACEMENT

↔ Remove or Disconnect (Figure 17)

1. Retractor to floor panel bolts (115).
2. Retractor (112).

→ Install or Connect (Figure 17)

1. Retractor (112) to the floor panel.

NOTICE: See "Notice" on page 10A2-1 of this section.

2. Retractor to floor panel bolts (115).

⊞ Tighten

- Bolts to 50 N·m (37 ft. lbs.).

CENTER BUCKLE AND LATCH PLATE REPLACEMENT

↔ Remove or Disconnect (Figure 17)

1. Seat. Refer to "Crew Cab Rear Seat Replacement."
 - Note the position of the belts.
2. Belt to floor panel bolts (114).
3. Left belt (113) and right belt (113) from the vehicle.

→ Install or Connect (Figure 17)

1. Left belt (113) and right belt (113) to the vehicle.

NOTICE: See "Notice" on page 10A2-1 of this section.

2. Belt to floor panel bolts (114).

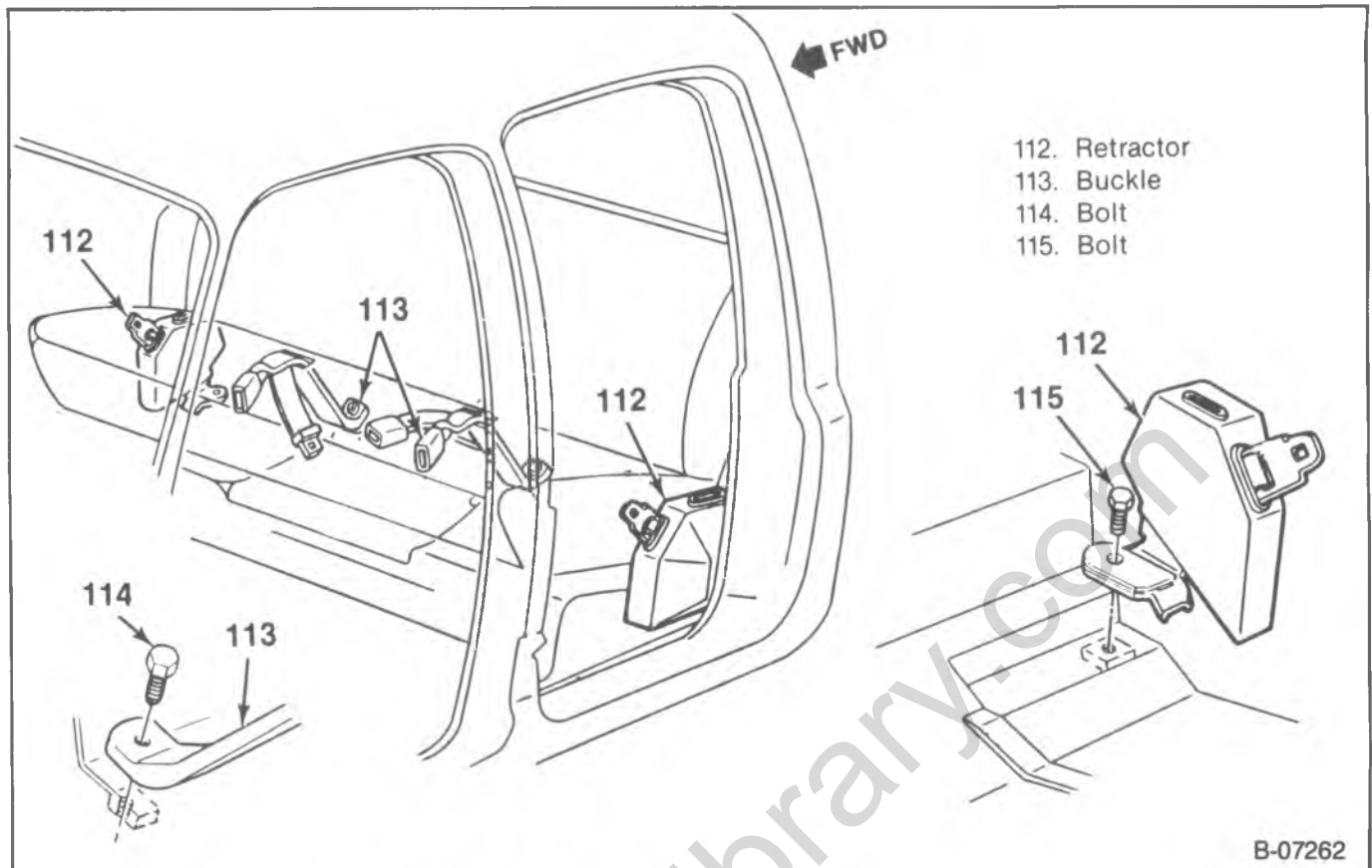

B-07262

Figure 17—Crew Cab Rear Seat Belt Components



Tighten

- Bolts to 50 N·m (37 ft. lbs.).

3. Seat. Refer to "Crew Cab Rear Seat Replacement."

UTILITY VEHICLE REAR SEAT REPLACEMENT



Remove or Disconnect (Figure 18)

- Fold the seat forward.
1. Hinge to floor bolt (116) and spring washer (117).
 2. Seat from the vehicle.



Install or Connect (Figure 18)

1. Seat to the vehicle.
2. Spring washer (117) and bolt (116).

UTILITY VEHICLE REAR SEAT COVER ROD REPLACEMENT



Remove or Disconnect (Figure 19)

1. Actuator rod clip (123).
2. Actuator rod (124).



Install or Connect (Figure 19)

1. Actuator rod (124).
2. Actuator rod clip (123).

UTILITY VEHICLE REAR SEAT STORAGE STRUT REPLACEMENT



Remove or Disconnect (Figure 20)

- Tilt the seat forward.
1. Strut (125) to floor bolts (126).
 2. Strut (125) to seat bolts (127).
 3. Strut from the vehicle.



Install or Connect (Figure 20)

1. Strut (125) to the vehicle.
2. Strut (125) to seat bolts (127).
3. Strut (125) to floor bolts (126).

UTILITY VEHICLE REAR SEAT BELT REPLACEMENT



Remove or Disconnect (Figure 21)

- Fold the seat forward.
1. Side latch plate (128) to floor panel bolts (129).
 2. Side latch plate (128) from the vehicle.
 3. Rear seat cover rod.
 4. Latch and support assembly from the seat. Refer to "Utility Vehicle and Suburban Latch and Support Assembly Replacement."
 5. Seat belt (130) to latch bolts (131).
 6. Seat belts from the latch.

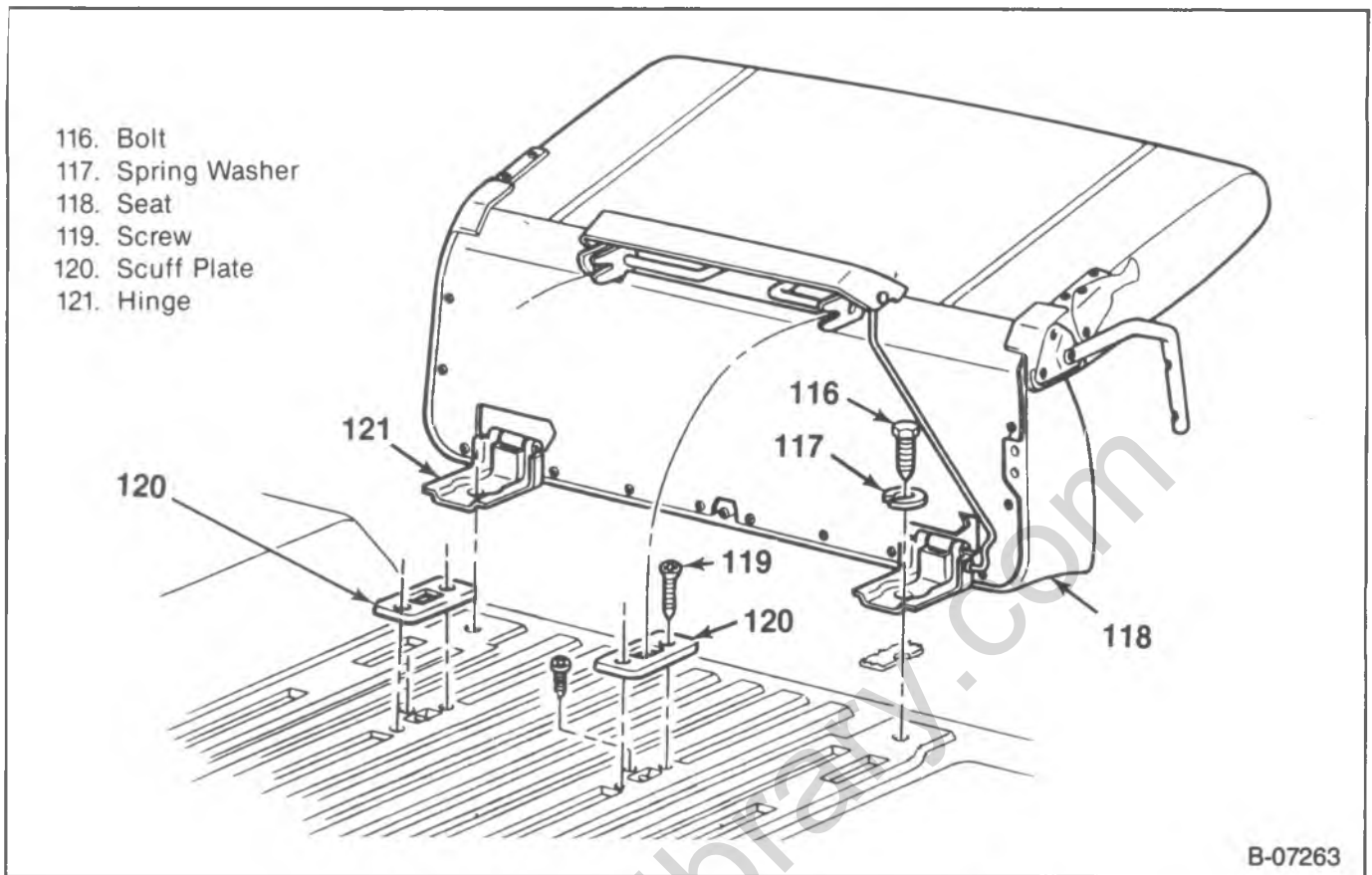

Figure 18—Utility Vehicle Rear Seat Components

NOTICE: For steps 2 and 6 see "Notice" on page 10A2-1 of this section.

Install or Connect (Figure 21)

1. Seat belts (130) to the latch.
2. Seat belts (130) to latch bolts (131).

Tighten

- Bolts to 50 N·m (37 ft. lbs.).

3. Latch and support assembly to the seat. Refer to "Utility Vehicle and Suburban Latch and Support Assembly Replacement."

4. Rear seat cover rod.
5. Side latch plate (128) to the vehicle.
6. Side latch plate (128) to floor panel bolts (129).

Tighten

- Bolts to 50 N·m (37 ft. lbs.).

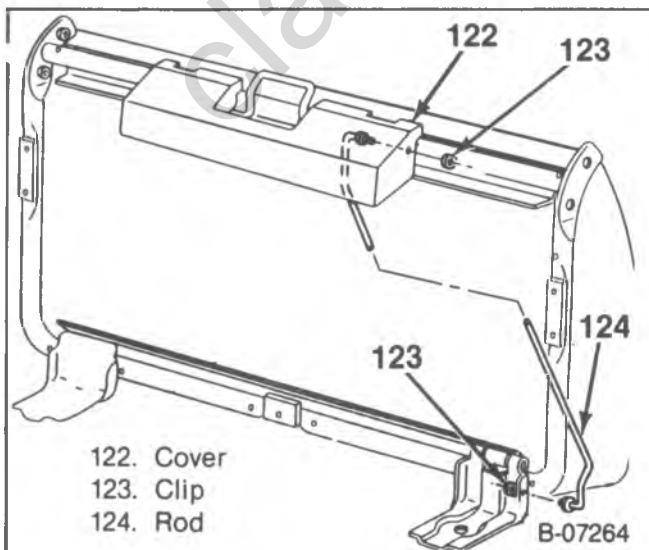

Figure 19—Utility Vehicle Cover Rod

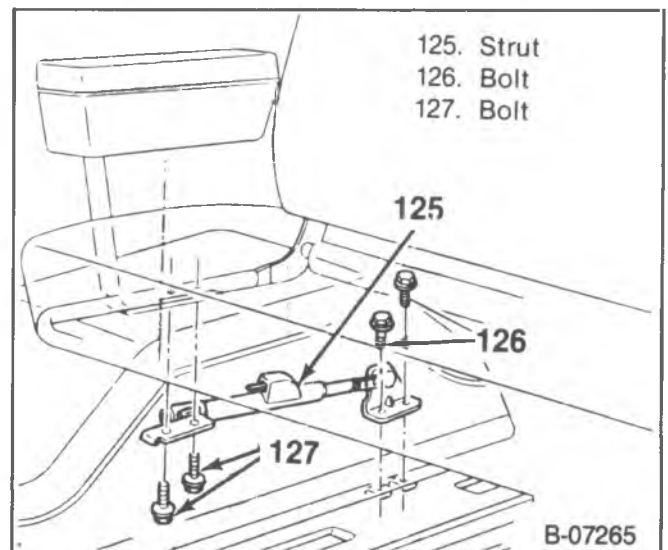

Figure 20—Utility Vehicle Storage Strut

10A2-16 SEATS

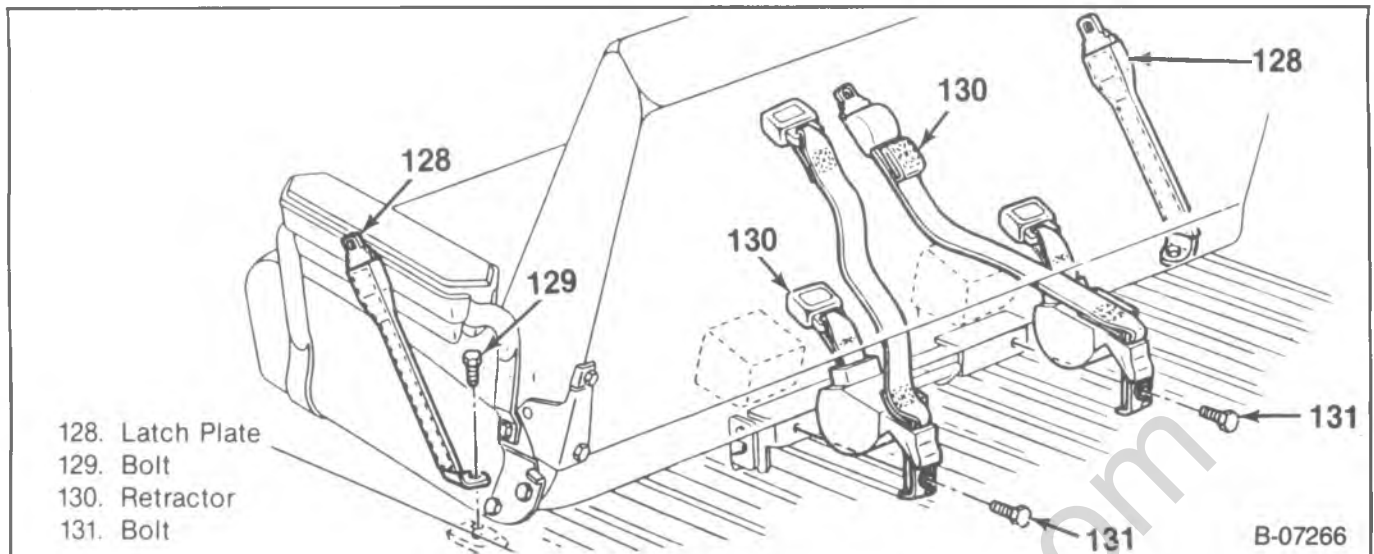

Figure 21—Utility Vehicle Rear Seat Belts

UTILITY VEHICLE AND SUBURBAN SEATBACK AND HINGE REPLACEMENT

↔ Remove or Disconnect (Figures 22 and 23)

1. Seatback to hinge bolts (139).
2. Seatback (154) from the vehicle.
3. Hinge (153) to seat bottom bolts (137).
4. Hinge from the vehicle.
5. Armrest to hinge bolt (136).
6. Armrest support (138) from the hinge.

→ Install or Connect

1. Armrest (133) to the hinge.
2. Armrest to hinge bolt (136).
3. Hinge to the vehicle.
4. Hinge (153) to seat bottom bolts (137).
5. Seatback (154) to the vehicle.
6. Seatback to hinge bolts (139).

UTILITY VEHICLE AND SUBURBAN LATCH AND SUPPORT ASSEMBLY REPLACEMENT

↔ Remove or Disconnect (Figures 24 and 25)

- Fold the seat forward (Utility vehicle only).
1. The seat (Suburban only). Refer to "Suburban Seat Replacement."
 2. Latch cover rod (Utility vehicle only).
 3. Latch cover (Suburban only) (141).
 4. Latch to seat bolts (145).
 5. Latch (144) from the seat.
 6. Latch cover (143) (Utility vehicle only).

→ Install or Connect

1. Latch cover (141) to the seat (Utility vehicle only).
2. Latch (144) to the seat.
3. Latch to seat bolts (145).

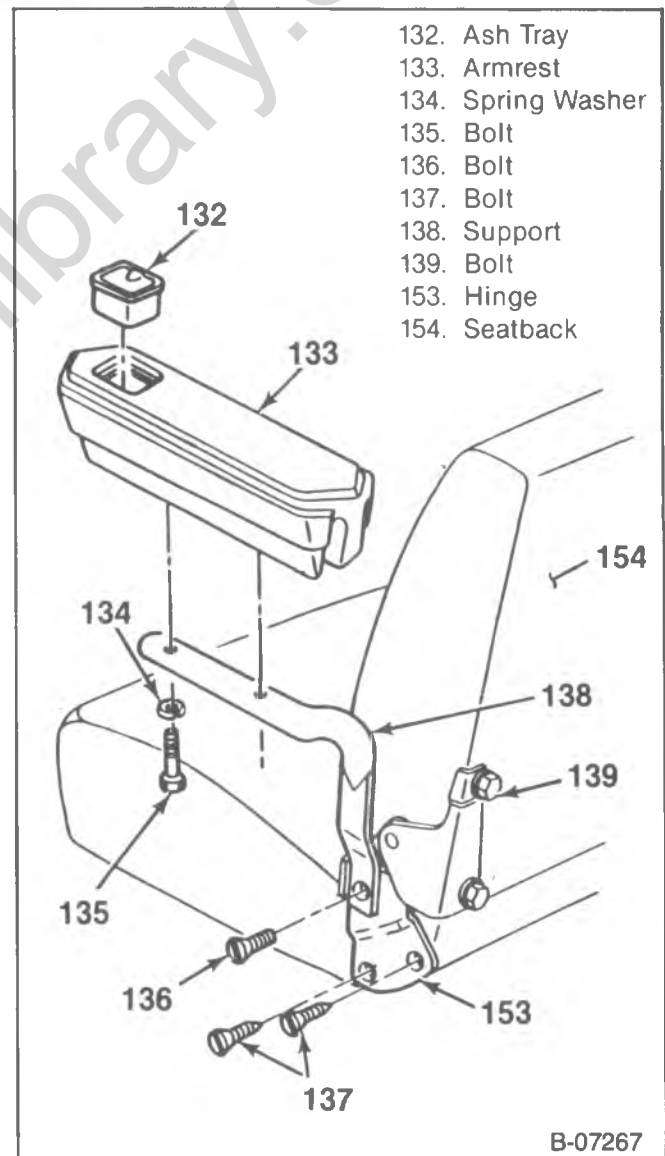

Figure 22—Left Seatback Hinge

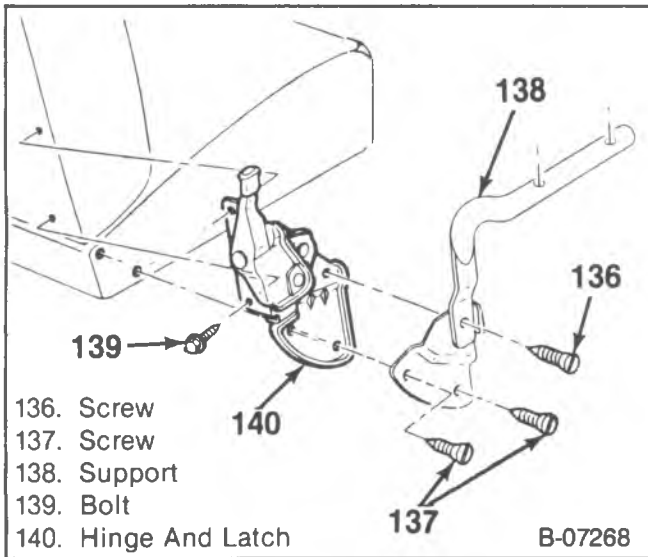

Figure 23—Right Seatback Hinge

4. Latch cover (Suburban only).
5. Latch cover rod (Utility vehicle only).
6. The seat (Suburban only). Referr to "Suburban Seat Replacement."

SUBURBAN REAR SEAT REPLACEMENT

REMOVAL

1. Unlatch the seat, and pull towards the rear of the vehicle.
2. Remove the seat from the vehicle.

INSTALLATION

1. Place the seat in the vehicle.
2. Place the hooked retainers onto the anchor pins.

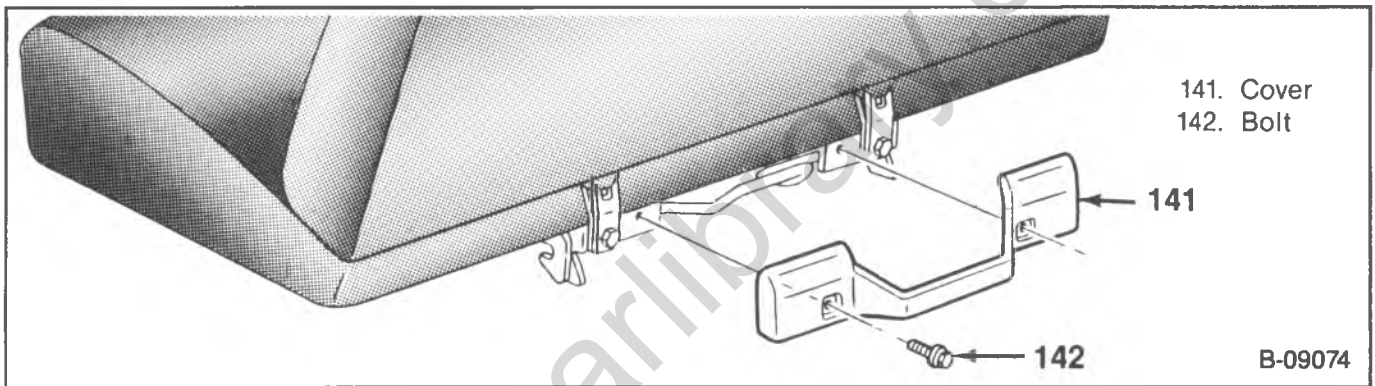

Figure 24—Suburban Rear Seat Latch Cover

10A2-18 SEATS

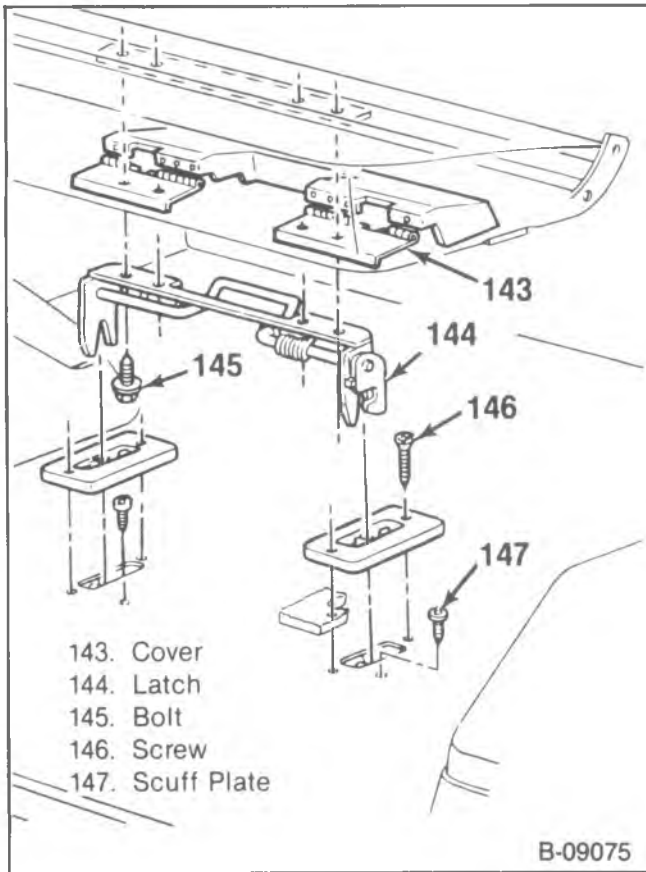

Figure 25—Rear Seat Latch Components

3. Latch the seat.
4. Push back and forth on the seat to be sure it is latched.

SUBURBAN REAR SEAT BELT REPLACEMENT

↔ Remove or Disconnect (Figure 26)

1. Rear seat latch cover (figure 24).
2. Seat belts (151 and 152) to latch bolts (150).
3. Seat belts from the seat.

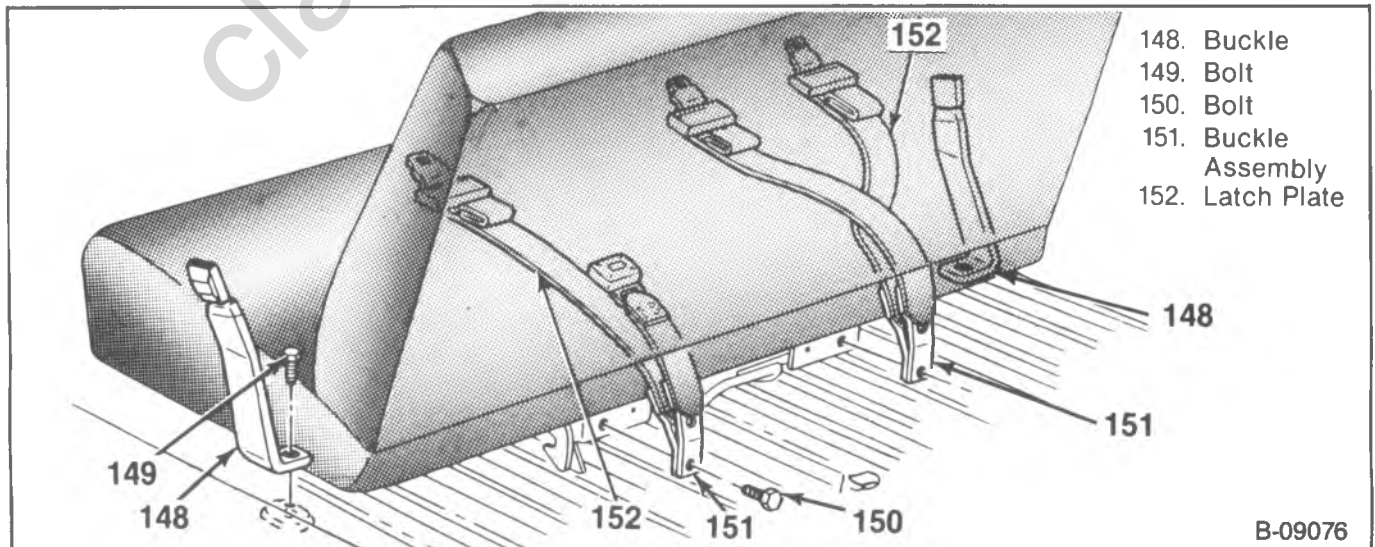

Figure 26—Suburban Rear Seat Belts

4. Side buckle (148) to floor panel bolts (149).
5. Buckle (148) from the vehicle.

NOTICE: For steps 2 and 4 see "Notice" on page 10A2-1 of this section.

↔ Install or Connect

1. Buckle (148) to the vehicle.
2. Buckle (148) to floor panel bolts (149).

⌚ Tighten

- Bolts to 50 N·m (37 ft. lbs.).

3. Seat belts (151 and 152) to the seat.
4. Seat belt to latch bolts (150).

⌚ Tighten

- Bolts to 50 N·m (37 ft. lbs.).

5. Rear seat latch cover (figure 24).

RV MODEL TOP STRAP BELT ANCHOR INSTALLATION

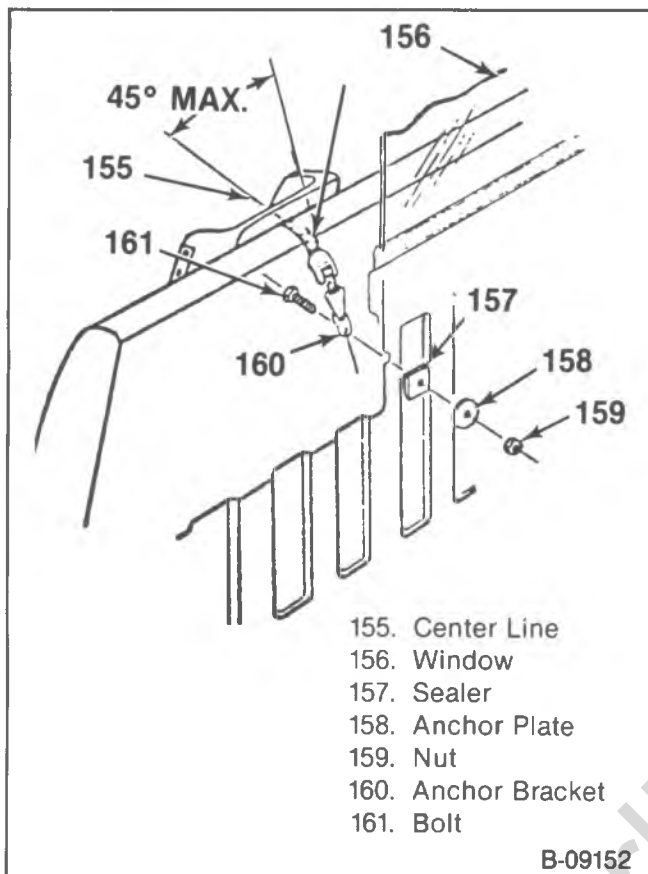

Figure 27—Pickup Top Strap Belt Components

All hardware discussed in this procedure should be supplied or available from the child seat manufacturer. Be sure the child seat position does not conflict with any additional requirements provided by its manufacturer, or with any recommendations in the Child Restraint section of the Owner's Manual.

The child seat may be used only in a forward facing seating location.

PICKUP AND CREW CAB MODELS

1. Place the Child Seat in the front seating position (rear seating position on crew cab models) (figure 27).
2. Secure the vehicle lap belt over the armrests of the Child Seat in the position which the Child Seat will be used.
3. Select a suitable anchor bracket mounting location on the cab back panel. The location must be:
 - Located near the rear window reinforcement. The angle between the Child Seat top strap and horizontal should not exceed 45°.
 - As close to the center line of the Child Seat as possible, but in no case more than 50 mm (2-inches) towards the passenger side of the cab, and 150 mm (6-inches) towards the drivers side of the cab.
 - In a position clear of the fuel tank, fuel lines, brake lines, exhaust systems, etc.
4. Drill an 8 mm ($\frac{5}{16}$ -inch) diameter hole through the cab panel at the selected location.

NOTICE: See "Notice" on page 10A2-1 of this section.

5. Install the bolt (161), anchor bracket (160), anchor plate (158), and lock nut (159) to the hole with an appropriate sealant.
6. Tighten the nut to 31 N·m (23 ft. lbs.).
Use the Child Seat only in the seating position for which the anchor bracket has been installed, latching the Child Seat top strap hook to the anchor bracket as shown.

CAUTION: In the event that the Child Seat anchorage assembly is removed, the 8 mm ($\frac{5}{16}$ -inch) diameter hole must be properly resealed to prevent toxic exhaust fumes from entering the cab.

UTILITY VEHICLE REAR SEAT

1. Determine the location for the anchor by measuring 140 mm (5½-inches) forward from the rear edge of the floor pan (figure 28). Make this measurement in the center of one of the depressed floor pan ribs. Next, measure 1330 mm (52.25-inches) inboard of the right quarter inner panel. Mark the position where these measurements meet.
2. Drill an 8 mm ($\frac{5}{16}$ -inch) hole at the mark.
3. To insure proper sealing of the hole, remove any dirt or foreign matter from around the hole on the underside of the floor pan where the sealer is to be applied.

NOTICE: See "Notice" on page 10A2-1 of this section.

4. Place sealer on the hole from the underside of the vehicle and assembly the bolt (162), anchor plate (163), washer (165), and lock nut (166) to the floor pan.
5. Tighten the nut to 31 N·m (23 ft. lbs.). Use the Child Seat only in the seating position for which the anchor bracket has been installed.

NOTICE: In the event the Child Seat anchorage assembly is removed, the 8 mm ($\frac{5}{16}$ -inch) diameter hole must be properly resealed.

SUBURBAN FRONT SEAT

This procedure applies to vehicles not equipped with a second seat or vehicles with the second seat in the down position.

1. Determine the location for the anchor by measuring 51 mm (2-inches) rearward from the rear edge of the kick up molding. Make this measurement in the center of one of the depressed floor pan ribs (figure 29).
 - A. Measure 360 mm (14.6-inches) inboard of the right quarter inner panel for the right seating position.

10A2-20 SEATS

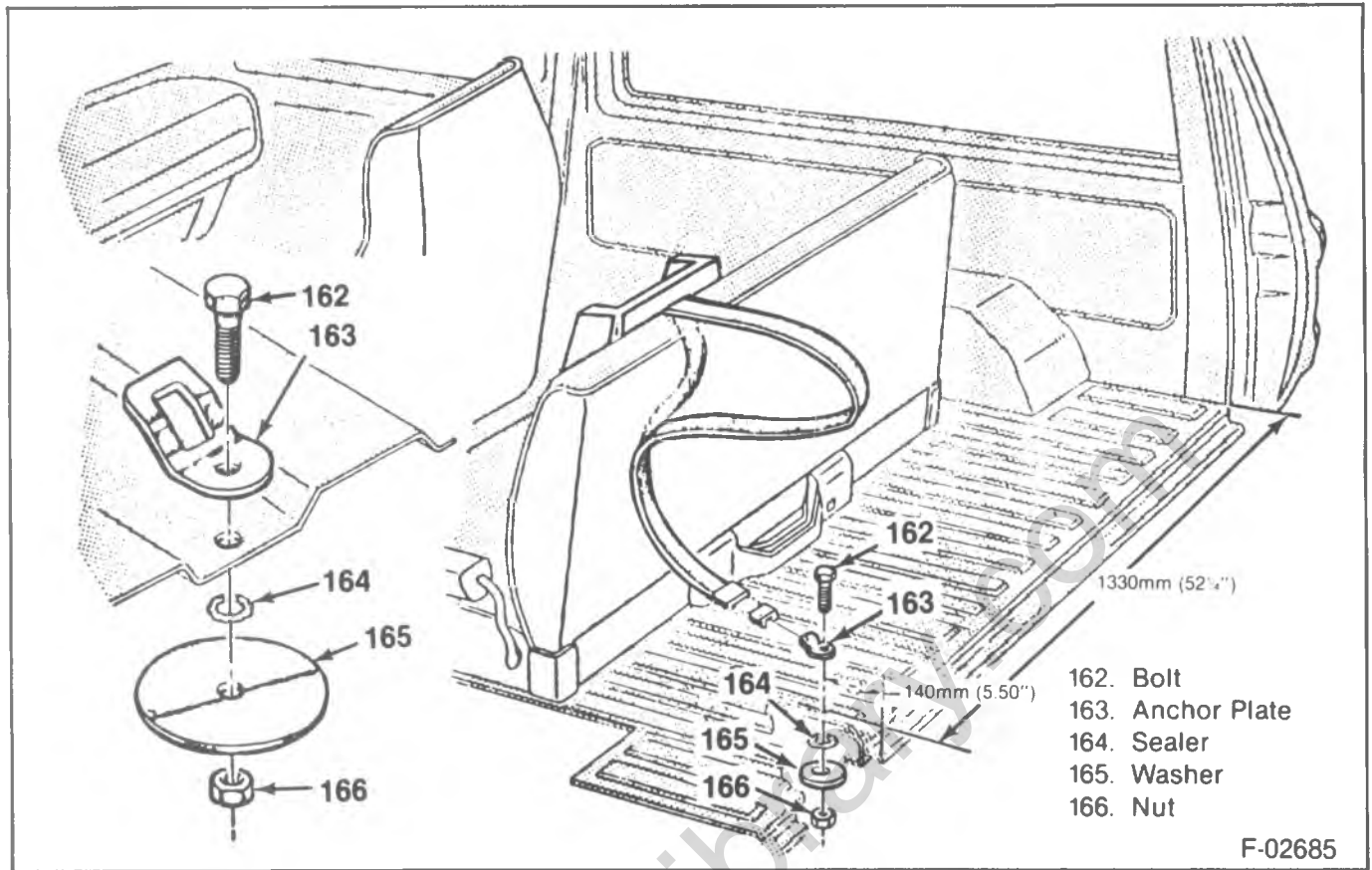

Figure 28—Utility Vehicle Second Seat Top Strap Belt Components

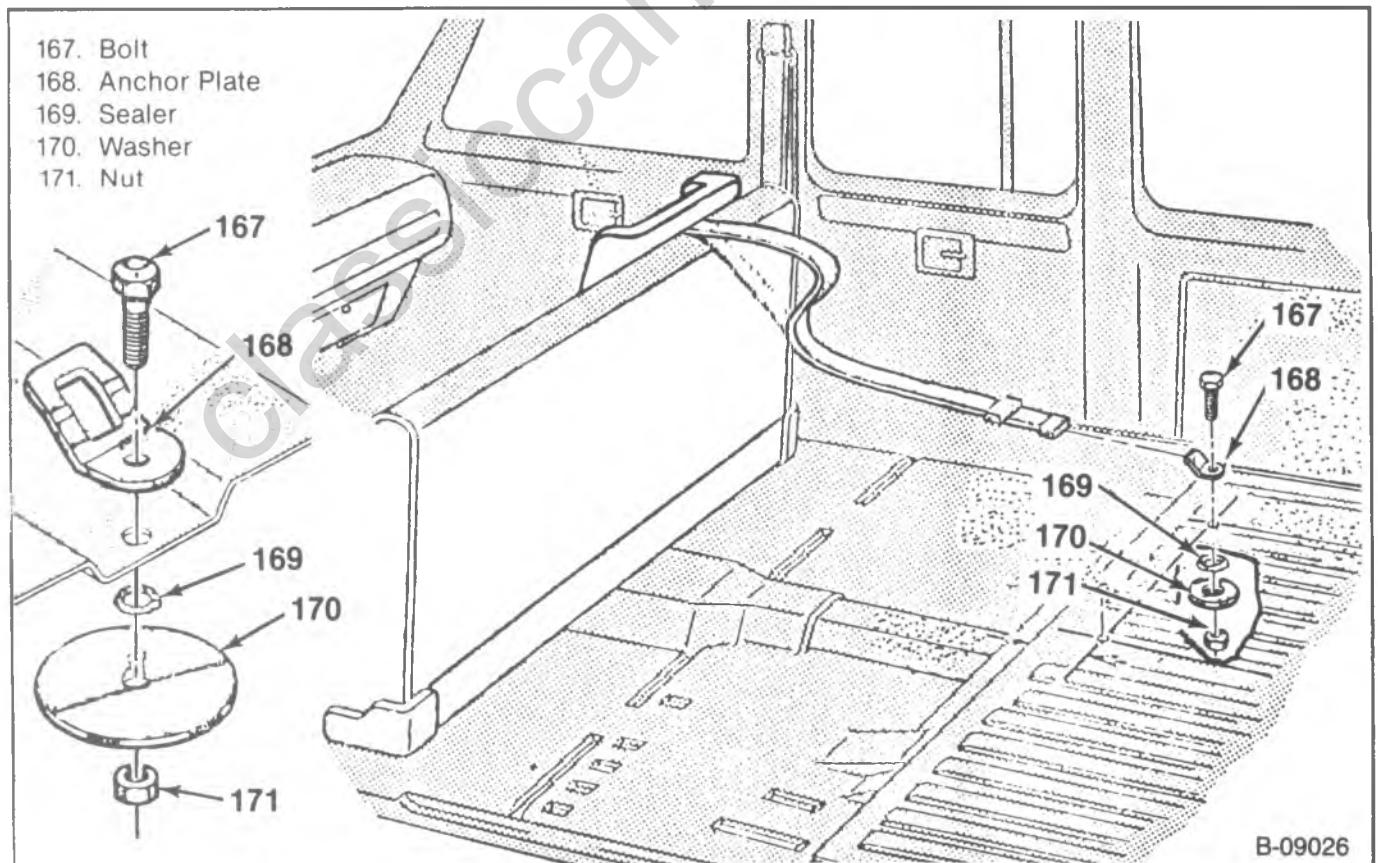

Figure 29—Suburban Front Seat Top Strap Belt Components

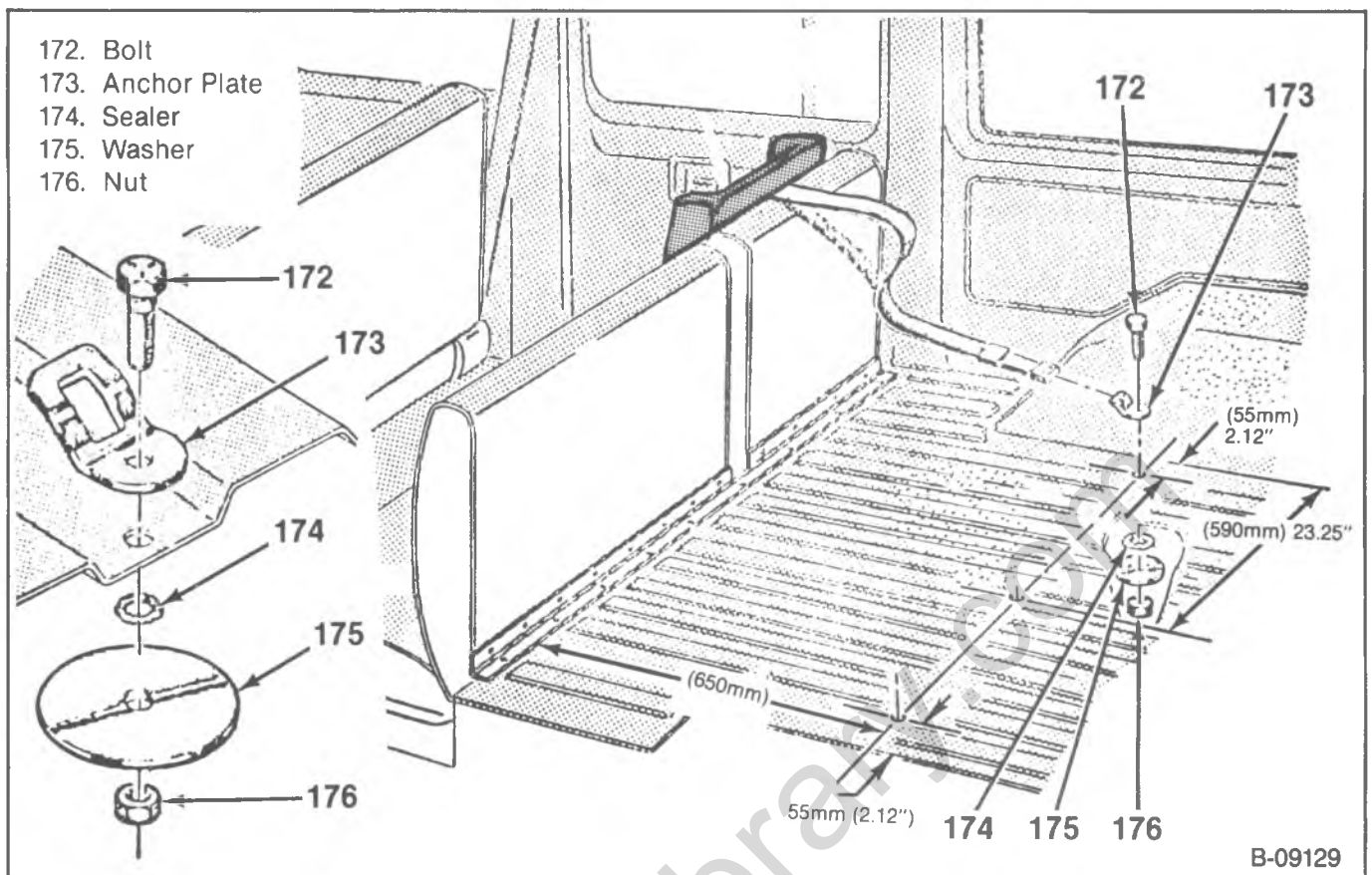

Figure 30—Suburban Second Seat Top Strap Belt Components

B. Measure 895 mm (35.25-inches) inboard of the right quarter inner panel for the center seating position.

Mark the position where the measurements meet.

2. Drill an 8 mm ($\frac{5}{16}$ -inch) hole at the mark.
3. To insure proper sealing of the hole, remove any dirt or foreign matter from around the hole on the underside of the floor pan where the sealer is to be applied.

NOTICE: See "Notice" on page 10A2-1 of this section.

4. Place sealer on the hole from the underside of the vehicle and assemble the bolt (167), anchor plate (168), washer (170), and lock nut (171) to the floor pan.
5. Tighten the nut to 31 N·m (23 ft. lbs.). Use the Child Seat only in the seating position for which the anchor bracket has been installed.

NOTICE: In the event the child seat anchorage assembly is removed, the 8 mm ($\frac{5}{16}$ -inch) diameter hole must be properly resealed.

SUBURBAN SECOND SEAT

1. Determine the location for the anchor by measuring 650 mm (25½-inches) rearward from the rear edge of the kick-up molding (figure 30). Next:
 - A. Measure 55 mm (2.12-inches) inboard of the right wheelhouse for the right seating position.

B. Measure 590 mm (23.25-inches) inboard of the right wheelhouse for the center seating position.

C. Measure 55 mm (2.12-inches) inboard of the left wheelhouse for the left seating position.

Mark the position where the measurements for the desired seating position meet.

2. Drill an 8 mm ($\frac{5}{16}$ -inch) hole at mark.
3. To insure proper sealing of the hole, remove any dirt or foreign matter from around the hole on the underside of the floor pan where the sealer is to be applied.

NOTICE: See "Notice" on page 10A2-1 of this section.

4. Place sealer on the hole from the underside of the vehicle and assemble the bolt (172), anchor plate (173), washer (175), and lock nut (176) to the floor pan.
5. Tighten the nut to 31 N·m (23 ft. lbs.). Use the Child Seat only in the second seat seating position for which the anchor bracket has been installed.

NOTICE: In the event the child seat anchorage assembly is removed, the 8 mm ($\frac{5}{16}$ -inch) diameter hole must be properly resealed.

SUBURBAN THIRD SEAT

1. Determine the location for the anchor by measuring 127 mm (5-inches) forward from the rear edge of the floor pan. Make this measurement in the center of one of the depressed floor pan ribs (figure 31).

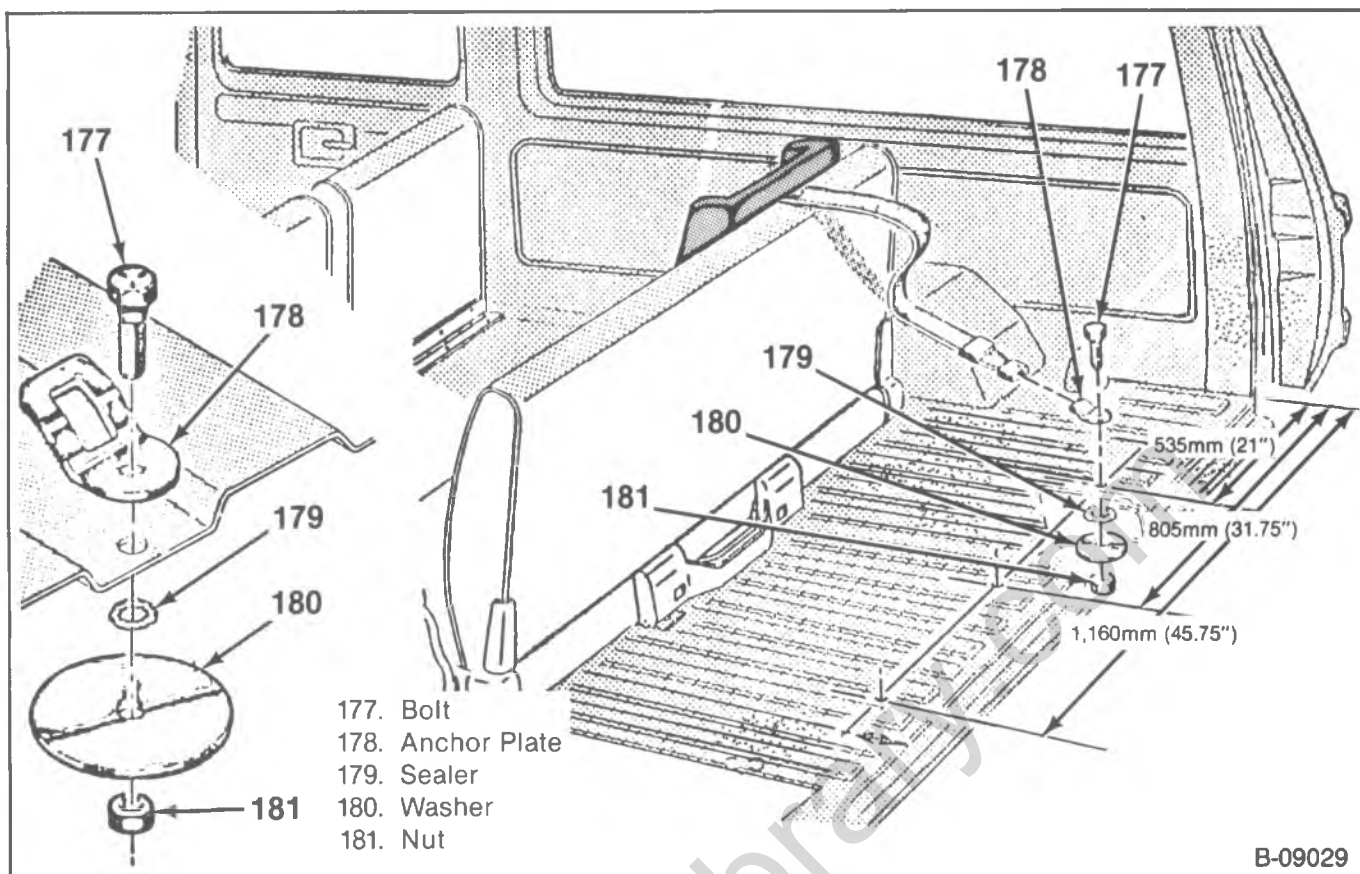

Figure 31—Suburban Third Seat Top Strap Belt Components

Next:

- A. Measure 535 mm (21-inches) inboard of the right quarter inner panel for the right seating position.
 - B. Measure 805 mm (31.75-inches) inboard of the right quarter inner panel for the center seating position.
 - C. Measure 1,160 (45.75-inches) inboard of the right quarter inner panel for the left seating position.
2. Drill an 8 mm ($\frac{5}{16}$ -inch) hole at the mark.
 3. To insure proper sealing of the hole, remove any dirt or foreign matter from around the hole on the underside of the floor pan where the sealer is to be applied.

NOTICE: See "Notice" on page 10A2-1 of this section.

4. Place sealer on the hole from the underside of the vehicle and assemble the bolt (177), anchor plate (178), washer (180), and lock nut (181) to the floor pan.

5. Tighten the nut to 31 N·m (23 ft. lbs.). Use the Child Seat only in the third seat seating position for which the anchor bracket has been installed.

NOTICE: In the event the Child Seat anchorage assembly is removed, the 8 mm ($\frac{5}{16}$ -inch) diameter hole must be properly resealed.

NOTICE: If the hole penetrates to the exterior of the vehicle, apply a sealant between the anchor bolt washer and the sheet metal to prevent carbon monoxide from entering the vehicle. Suitable sealers include silicone, butyl or acrylic type caulking.

In the event that the child seat anchorage assembly is removed, all bolt holes penetrating to the exterior of the vehicle must be resealed to prevent exhaust fumes from entering the vehicle.

G MODEL FRONT SEAT

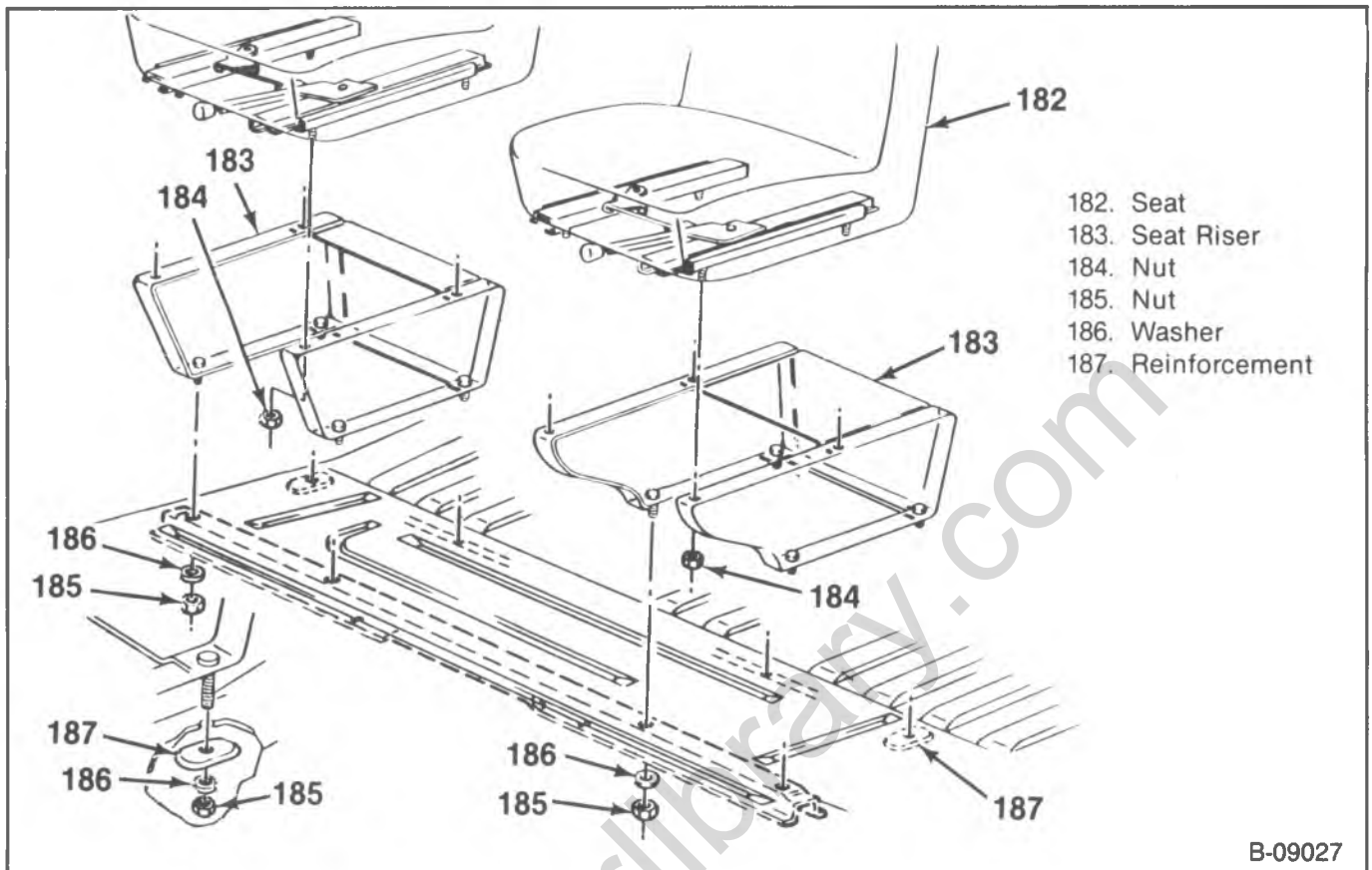

Figure 32—Front Bucket Seat Components

FRONT SEAT REPLACEMENT

↔ Remove or Disconnect (Figure 32)

1. Seat belts. Refer to "Seat Belt Replacement."
 - Raise and support the vehicle.
2. Seat riser (183) to floor panel nuts (185), washers (186), and reinforcements (187) from underneath the vehicle.
3. Seat from the vehicle.

↔ Install or Connect (Figure 32)

1. Seat (182) to floor panel nuts (185), washers (186), and reinforcements (187) to the underside of the vehicle.
 - Lower the vehicle.
3. Seat belts. Refer to "Seat Belt Replacement."

FRONT SEAT DISASSEMBLY

↔ Remove or Disconnect (Figures 32 and 33)

1. Seat. Refer to "Front Seat Replacement."
2. Seat riser to adjuster nuts (184).
3. Seat (182) and adjuster (190) from the riser (183).
4. Adjuster to seat bolts (193) and spacers (191).
5. Adjuster (190) from the seat (182).

↔ Install or Connect (Figures 32 and 33)

1. Adjuster (190) to the seat (182).
2. Adjuster to seat spacers (191) and bolts (193).
3. Seat (182) and adjuster (190) to the riser (183).

4. Seat riser to adjuster nuts (184).
5. Seat. Refer to "Seat Replacement."

FRONT SEAT BELT REPLACEMENT

↔ Remove or Disconnect (Figure 34)

1. Anchor plate (194) to the roof side rail bolt (198).
2. Anchor plate (194).
3. Seat belt warning wire (left side only).
4. Retractor (195) to seat riser bolt (199).
5. Retractor (195) and anchor plate (194) from the vehicle.
6. Plug (200).
7. Buckle (196) to seat riser bolt (201) and washer (202).
8. Buckle (196) from the vehicle.

NOTICE: For steps 2, 5, and 7 see "Notice" on page 10A2-1 of this section.

↔ Install or Connect (Figure 34)

1. Buckle (196) to the vehicle.
2. Buckle (196) to seat riser washer (202) and bolt (201).

⌚ Tighten

- Bolt to 60 N·m (44 ft. lbs.).
3. Plug (200).
 4. Retractor (195) and anchor plate (194) to the vehicle.

10A2-24 SEATS

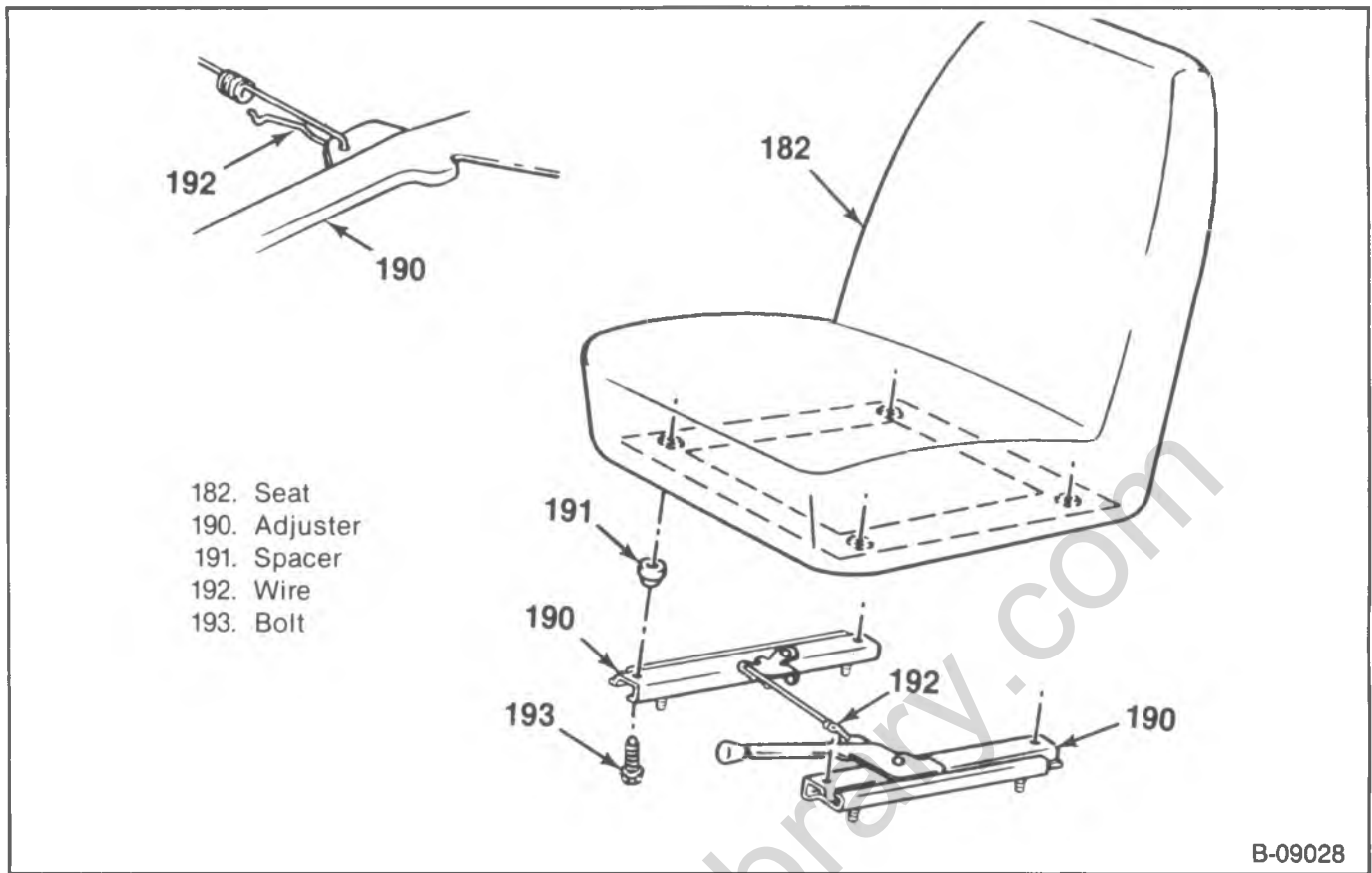

Figure 33—Bucket Seat Adjusters

5. Retractor (195) to seat riser bolt (199).

 **Tighten**

- Bolt to 60 N·m (44 ft. lbs.).

6. Seat belt warning wire (left side only).

7. Anchor plate (194) to the roof side rail.

8. Anchor plate bolt (198).

 **Tighten**

- Bolt to 60 N·m (44 ft. lbs.).

classiccarlibrary.com

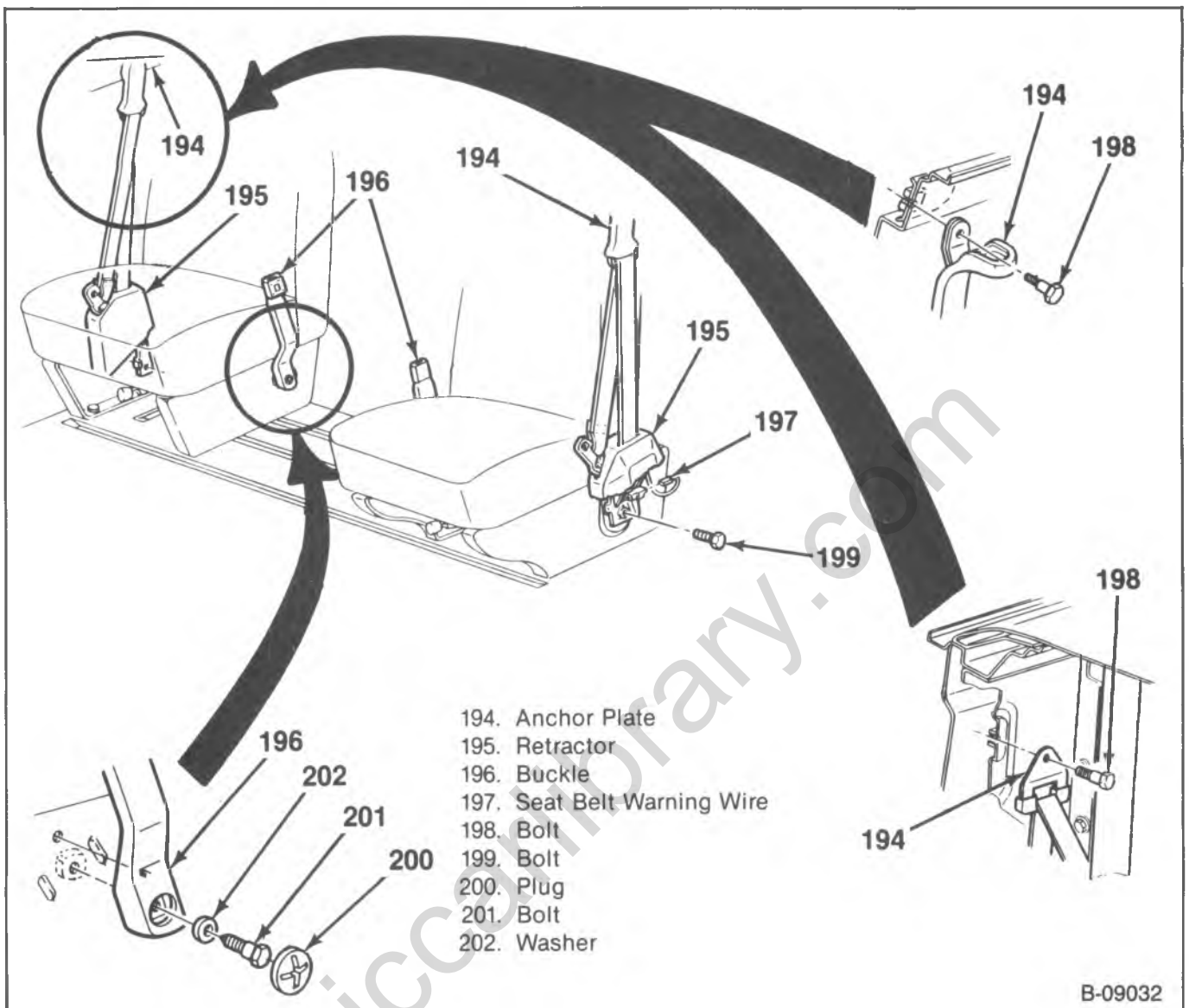

B-09032

Figure 34—Bucket Seat Belt Components

G MODEL CENTER AND REAR SEATS

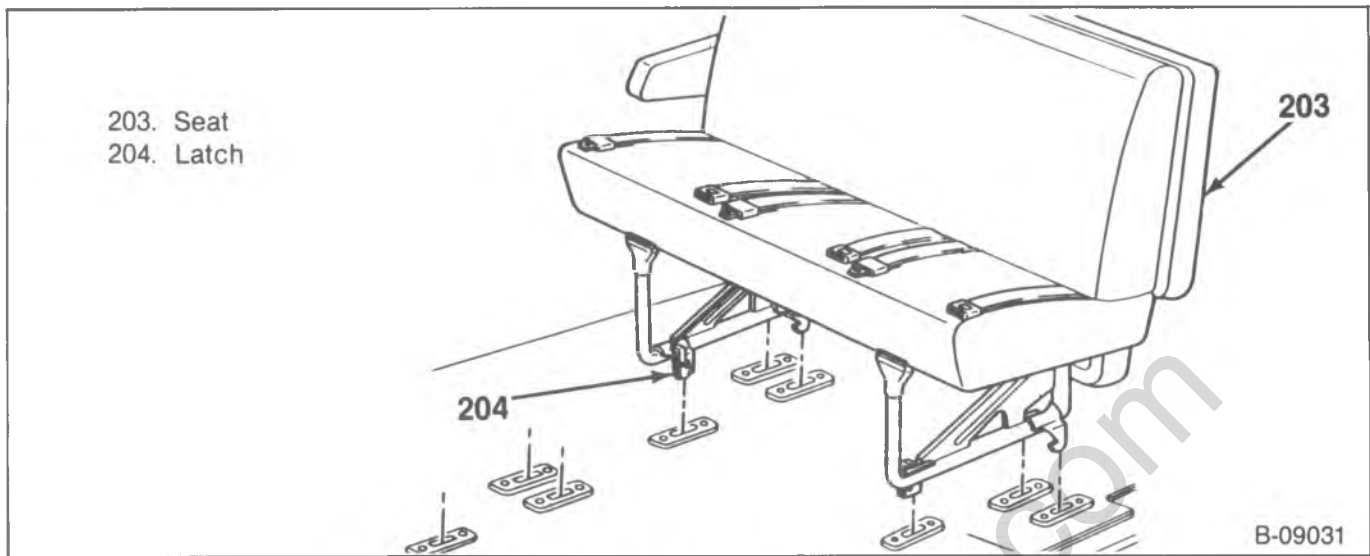

Figure 35—Rear Seat Mounting

CENTER AND REAR SEAT REPLACEMENT

REMOVAL (Figure 35)

1. Unlatch the seat, and pull towards the rear of the vehicle.
2. Remove the seat from the vehicle.

INSTALLATION (Figure 35)

1. Place the seat in the vehicle.
2. Place the hooked retainers onto the anchor pins.
3. Latch the seat.
4. Push back and forth on the seat to be sure it is latched.

CENTER AND REAR SEAT DISASSEMBLY

↔ Remove or Disconnect (Figures 36 and 37)

1. Seat from the vehicle. Refer to "Center and Rear Seat Replacement."
2. Support (210) and leg assembly (209) to seat bolts (207 and 208).
3. Support assembly (210) to leg assembly (209), bolts (206) and spring washers (205).
4. Support assembly (210) from the legs (209).

→← Install or Connect (Figures 36 and 37)

1. Support assembly (210) to the legs (209).
2. Support assembly (210) to leg assembly (209), springs washers (205) and bolts (206).

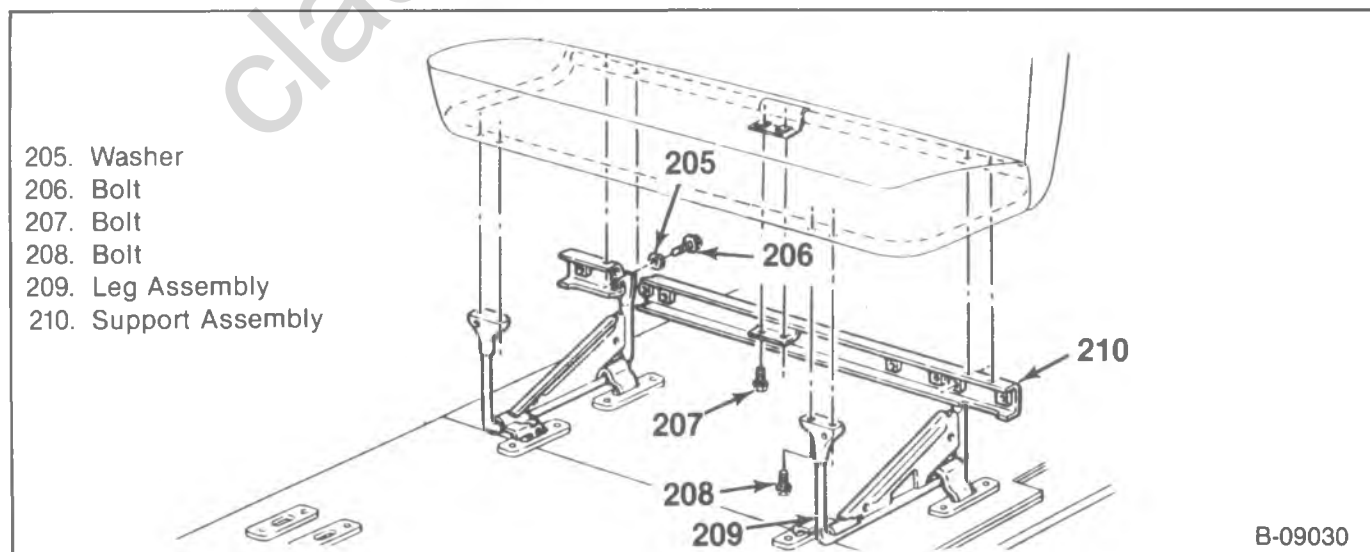

Figure 36—Center Seat Components

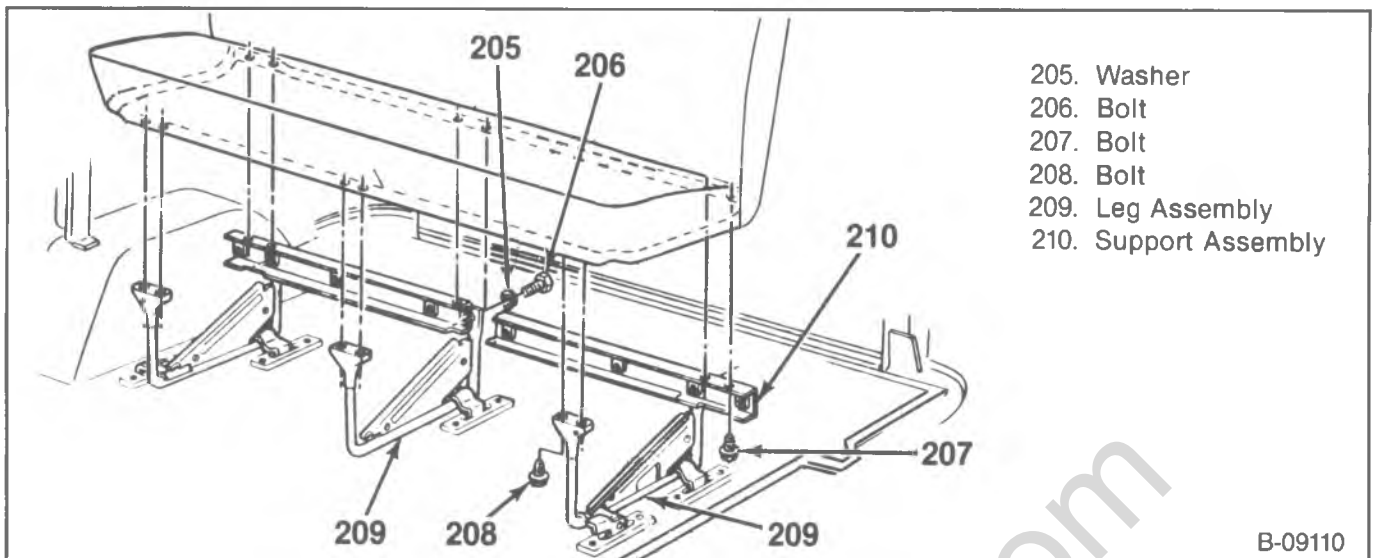

Figure 37—Rear Seat Components

Tighten

- Bolts to 155 N·m (114 ft. lbs.).
3. Support (210) and leg assembly (209) to seat bolts (207 and 208).
 4. Seat to the vehicle. Refer to "Center and Rear Seat Replacement."

CENTER AND REAR SEAT ARMREST REPLACEMENT

Remove or Disconnect (Figures 38 and 39)

1. Armrest bracket (217) to seat bolts (216).
2. Armrest to seatback bolts (213).
3. Armrest cover (218) (if equipped).
4. Armrest bracket (217) to armrest nuts (215) and washers (214).
5. Armrest bracket (217) from the armrest (212).

Install or Connect

1. Armrest bracket (217) to the armrest (212).
2. Armrest bracket (217) to armrest washers (214) and nuts (215).
3. Armrest cover (218) (if equipped).
4. Armrest to seatback bolts (213).
5. Armrest bracket (217) to seat bolts (216).

CENTER AND REAR SEAT BELT REPLACEMENT

Remove or Disconnect (Figures 40, 41, and 42)

1. Retractor to support assembly bolts (221).
2. Retractor (220) from the seat.
3. Buckle (219) and latch plate (225) (if equipped) to support assembly bolts (222).
4. Buckle (219) and latch plate (225) (if equipped) from the seat.

NOTICE: For steps 2 and 4 see "Notice" on page 10A2-1 of this section.

1. Buckle (219) and latch plate (225) (if equipped) to the seat.
2. Buckle (219) and latch plate (225) (if equipped) bolts (222).
 - The shoulder of the bolt must bottom on the weld nut.

Tighten

- Bolts to 50 N·m (37 ft. lbs.).
3. Retractor (220) to the seat.
 4. Retractor to support assembly bolts (221).

Tighten

- Bolts to 50 N·m (37 ft. lbs.).

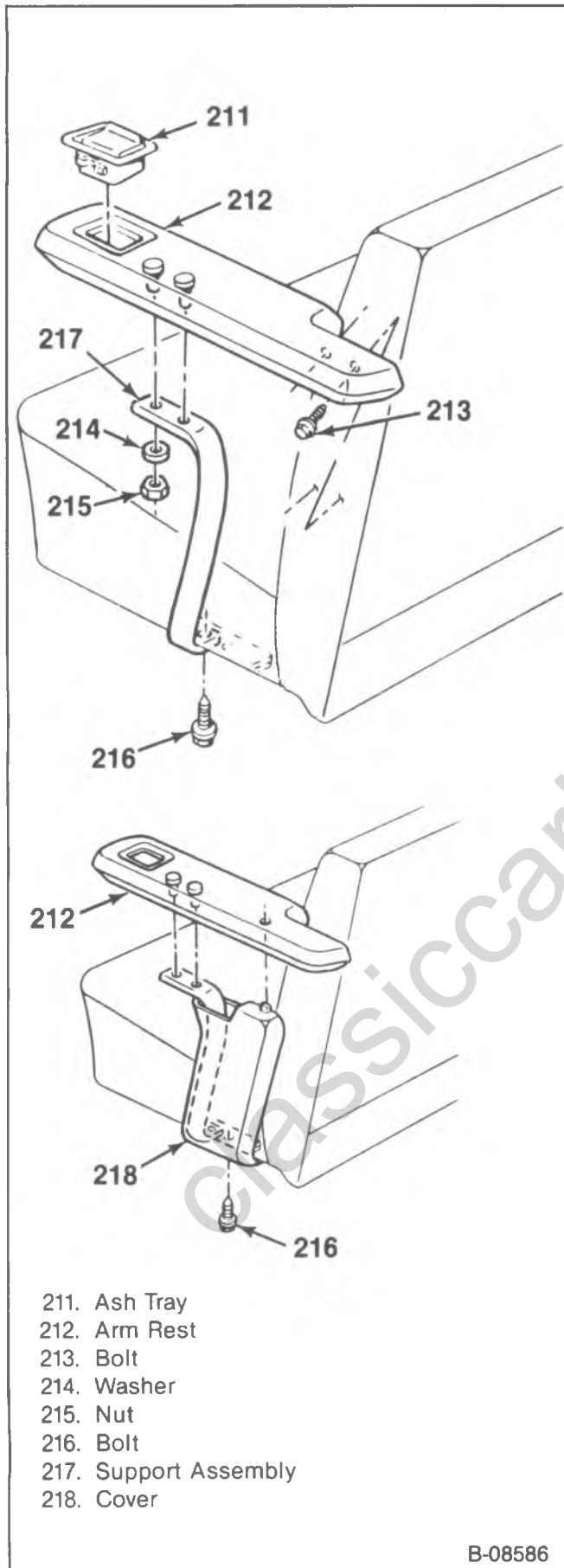

Figure 38—Center Seat Armrest

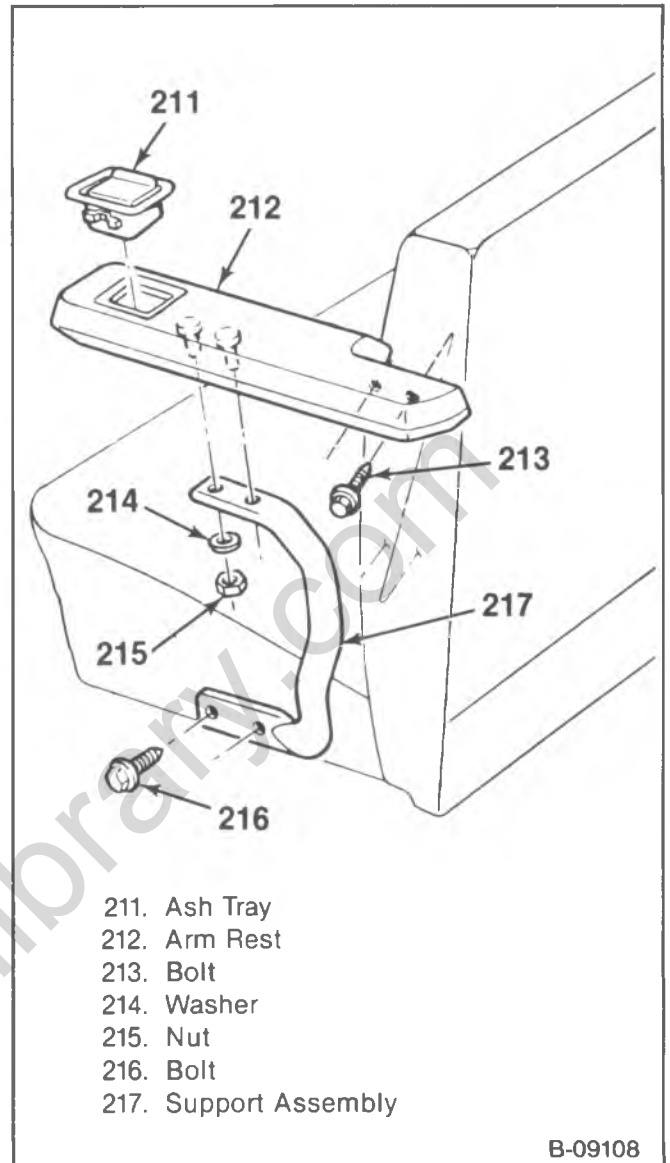

Figure 39—Rear Seat Armrest

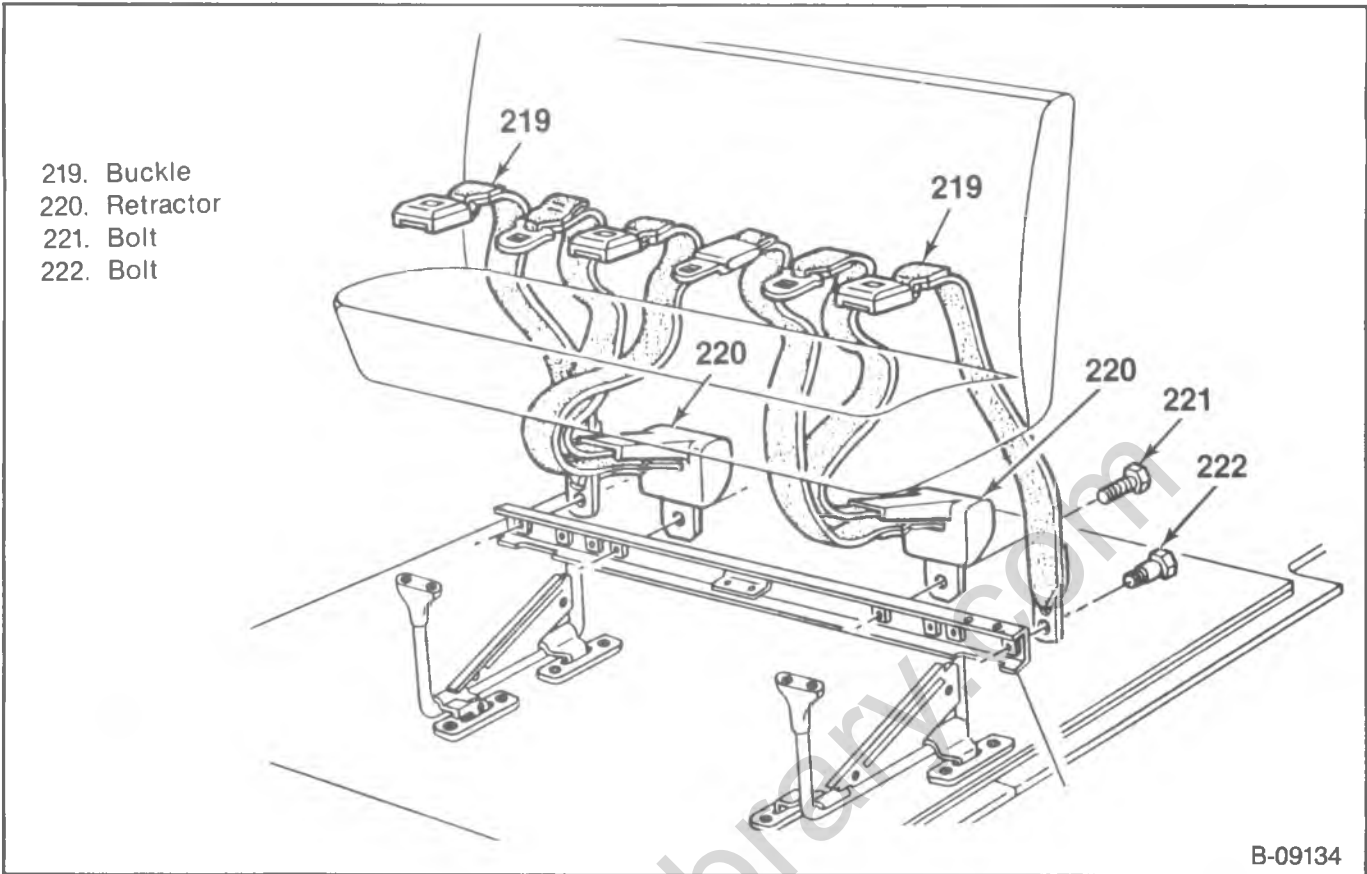

Figure 40—Center Seat Belt Components

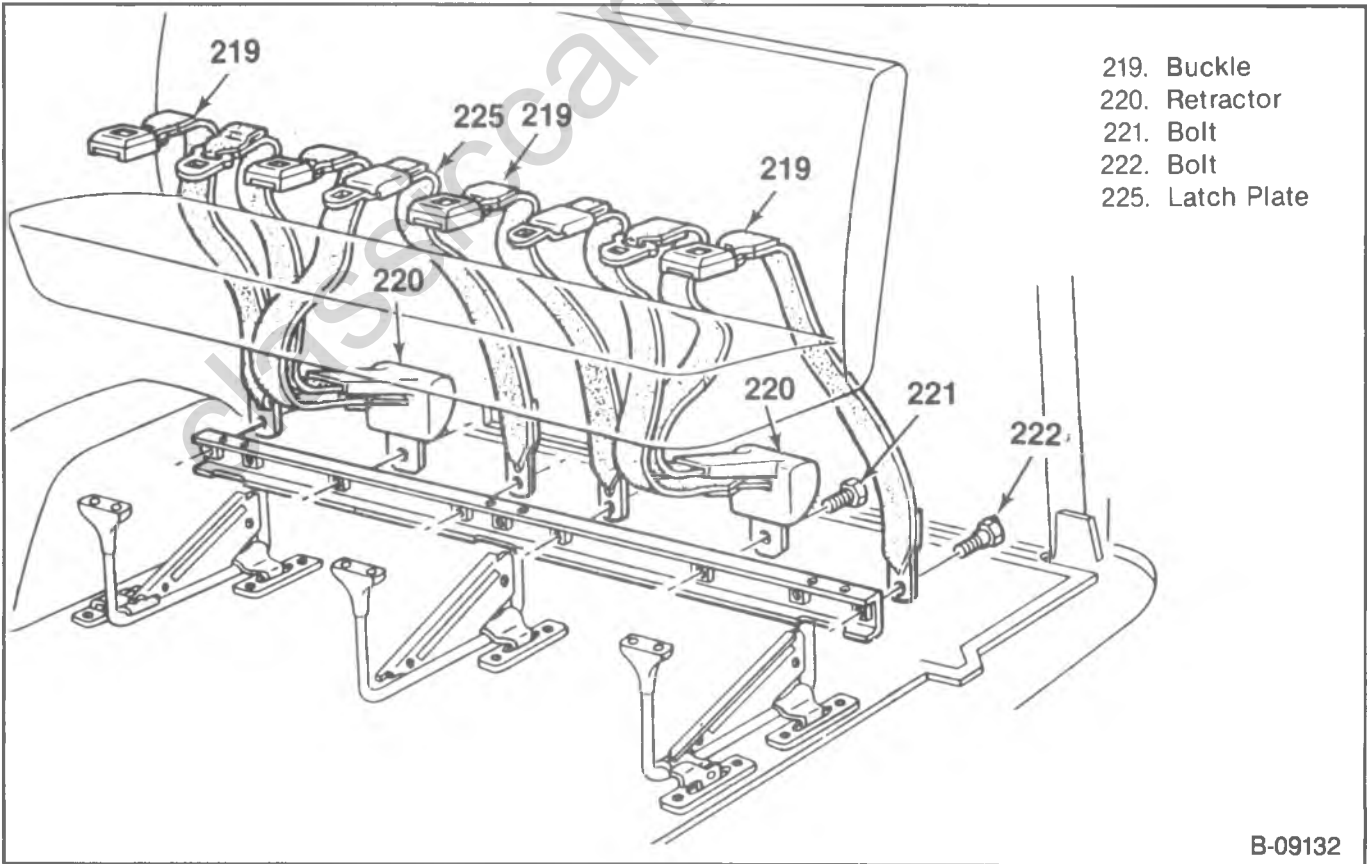

Figure 41—Rear Seat Belt Components

10A2-30 SEATS

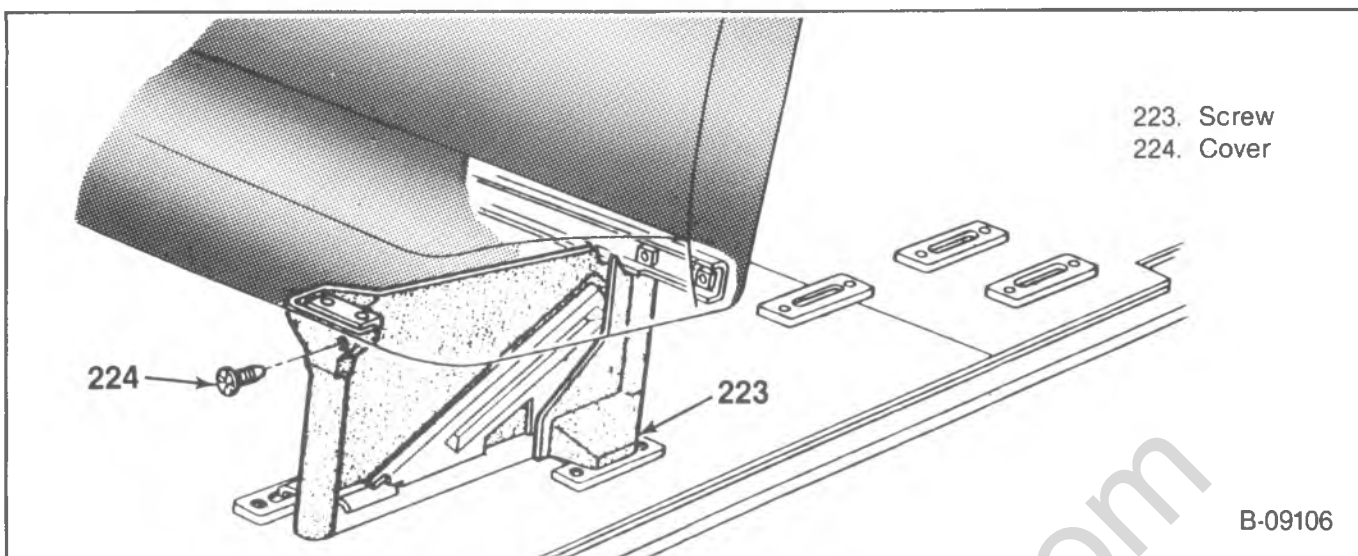

Figure 42—Seat Leg Cover

G MODEL TOP STRAP BELT ANCHOR INSTALLATION

All hardware discussed in this procedure should be supplied or available from the child seat manufacturer. Be sure the child seat position does not conflict with any additional requirements provided by its manufacturer, or with any recommendations in the Child Restraint section of the Owner's manual.

The child seat may be used only in a forward facing seating location.

Installation of top strap belts is not recommended in the front passenger seat of "G" Vans. The second seat offset which allows passenger entry does not position a second seat lap belt within the recommended zone for attachment to the top strap hook. Also, a floor anchorage is impractical since the top strap length is insufficient to directly connect the restraint to the floor with high back bucket seats.

VEHICLES WITH A 125-INCH WHEELBASE

SECOND SEAT LEFT SEATING POSITION

This procedure is for vehicles not having a third seat.

1. Determine the location for the anchor by measuring 76 mm (3-inches) rearward from the front edge of the left wheelhouse. Measure 60 mm ($2\frac{3}{8}$ -inches) inboard from the left wheelhouse. Mark the position on top of the rib where these measurements meet (figure 43).
2. Drill an 8 mm ($\frac{5}{16}$ -inch) hole at the mark.
3. To insure proper sealing of the hole, remove any dirt or foreign matter from around the hole on the underside of the floor pan where sealer is to be applied.

NOTICE: See "Notice" on page 10A2-1 of this section.

4. Place sealer on the hole from the underside of the vehicle and assemble the bolt (227), anchor bracket

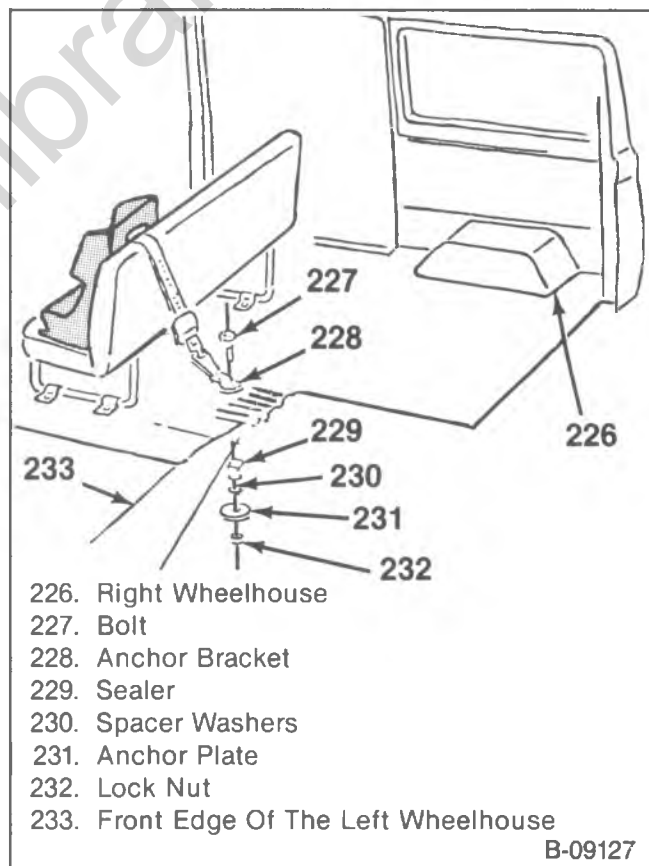

Figure 43—Second Seat Top Strap Components—
Left Position

(228), two 35 mm ($1\frac{3}{8}$ -inch) outside diameter spacer washers (230), anchor plate (231) and lock nut (232) to the floor pan.

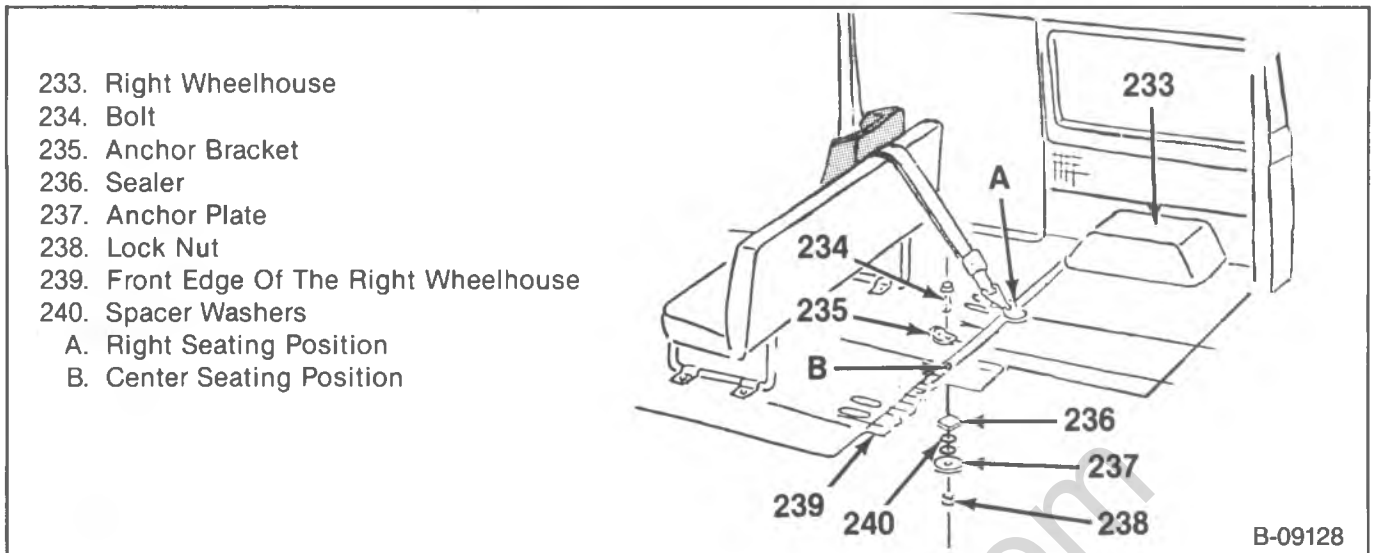

Figure 44—Second Seat Top Strap Components—Center and Right Position

5. Tighten the nut to 31 N·m (23 ft. lbs.). Use the Child Seat only in the seating position for which the anchor bracket has been installed.

NOTICE: In the event the Child Seat anchorage assembly is removed, the 8 mm ($5/16$ -inch) diameter hole must be properly resealed.

SECOND SEAT—CENTER OR RIGHT SEATING POSITIONS

This procedure is for vehicles not having a third seat.

1. Determine the location for the anchor by measuring 35 mm ($1\frac{3}{8}$ -inch) rearward from the front edge of the left wheelhouse (figure 44). Next:
 - A. Measure 580 mm ($22\frac{7}{8}$ -inches) inboard from the right wheelhouse for the center seating position.
 - B. Measure 395 mm ($15\frac{1}{2}$ -inches) inboard of the right wheelhouse for the right seating position.

Mark the position where the measurements for the desired seating positions meet.

2. Drill an 8 mm ($5/16$ -inch) hole at the mark.
3. To insure proper sealing of the hole, remove any dirt or foreign matter from around the hole on the underside of the floor pan where sealer is to be applied.

NOTICE: See "Notice" on page 10A2-1 of this section.

4. Place sealer on the hole from the underside of the vehicle and assemble the bolt (234), anchor bracket (237), two 35 mm ($1\frac{3}{8}$ -inch) outside diameter spacer washers (240), anchor plate (237) and lock nut (238) to the floor pan.
5. Tighten the nut to 31 N·m (23 ft. lbs.). Use the Child Seat only in the seating position for which the anchor bracket has been installed.

NOTICE: In the event the Child Seat anchorage assembly is removed, the 8 mm ($5/16$ -inch) diameter hole must be properly resealed.

THIRD SEAT

It is recommended that only the left seating position be used for the third seat.

1. Determine the location for the anchor by measuring 76 mm (3-inches) rearward from the left wheelhouse. Measure 10 mm ($3/8$ -inch) inboard from the left wheelhouse. Mark the position where those measurements meet (figure 45).
2. Drill an 8 mm ($5/16$ -inch) hole at the mark.
3. To insure proper sealing of the hole, remove any dirt or foreign matter from around the hole on the underside of the floor pan where sealer is to be applied.

NOTICE: See "Notice" on page 10A2-1 of this section.

4. Place sealer on the hole from the underside of the vehicle and assemble the bolt (241), anchor bracket (242), anchor plate (244) and lock nut (245) to the floor pan.
5. Tighten the nut to 31 N·m (23 ft. lbs.). Use the Child Seat only in the seating position for which the anchor bracket has been installed.

NOTICE: In the event the Child Seat anchorage assembly is removed, the 8 mm ($5/16$ -inch) diameter hole must be properly resealed.

VEHICLES WITH A 110-INCH WHEELBASE

SECOND SEAT

This procedure is for vehicles without a third seat (figures 46 and 47).

1. Determine the location of the anchor by:
 - A. Measuring 457 mm (18-inches) rearward from the front edge of the left wheelhouse. Measure 50 mm (2-inches) inboard of the left wheelhouse for the left seating position.
 - B. Measuring 546 mm ($21\frac{1}{2}$ -inches) rearward from the front edge of the left wheelhouse. Make this measurement in the center of one of the

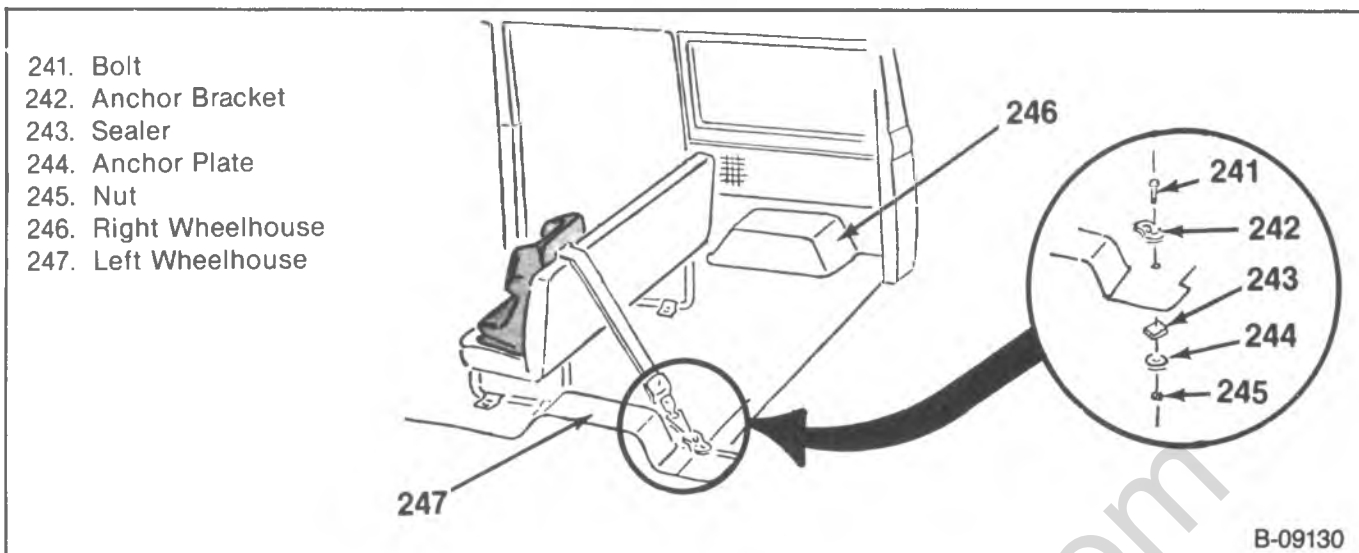

Figure 45—Third Seat Top Strap Components—Left Position

depressed floor pan ribs. Next, measure 580 mm (22⁷/₈-inches) inboard of the left wheelhouse for the center seating position.

C. Measure 546 mm (21¹/₂-inches) rearward from the front edge of the right wheelhouse. Next, measure 395 mm (15¹/₂-inches) inboard from the right wheelhouse for the right seating position.

Mark the position where the measurements for the desired seatings positions meet.

2. Drill an 8 mm (5/16-inch) hole at the mark.

3. To insure proper sealing of the hole, remove any dirt or foreign matter from around the hole on the underside of the floor pan where sealer is to be applied.

NOTICE: See "Notice" on page 10A2-1 of this section.

4. Place sealer on the hole from the underside of the vehicle and assemble the bolt (248), anchor bracket (249), anchor plate (251) and lock nut (252) to the floor pan.

5. Tighten the nut to 31 N·m (23 ft. lbs.). Use the Child Seat only in the second seat seating position for which the anchor bracket has been installed.

NOTICE: In the event the Child Seat anchorage assembly is removed, the 8 mm (5/16-inch) diameter hole must be properly resealed.

SECOND SEAT — VEHICLES EQUIPPED WITH A THIRD SEAT

Use the Child Seat as directed in the usage instructions furnished with the Child Seat, in any second seating position. Latch the Child Seat top strap hook to the third seat lap belt tongue located most directly behind the Child Seat.

THIRD SEAT

The Child Seat is not recommended for use in the third seat of a 110-inch wheelbase model.

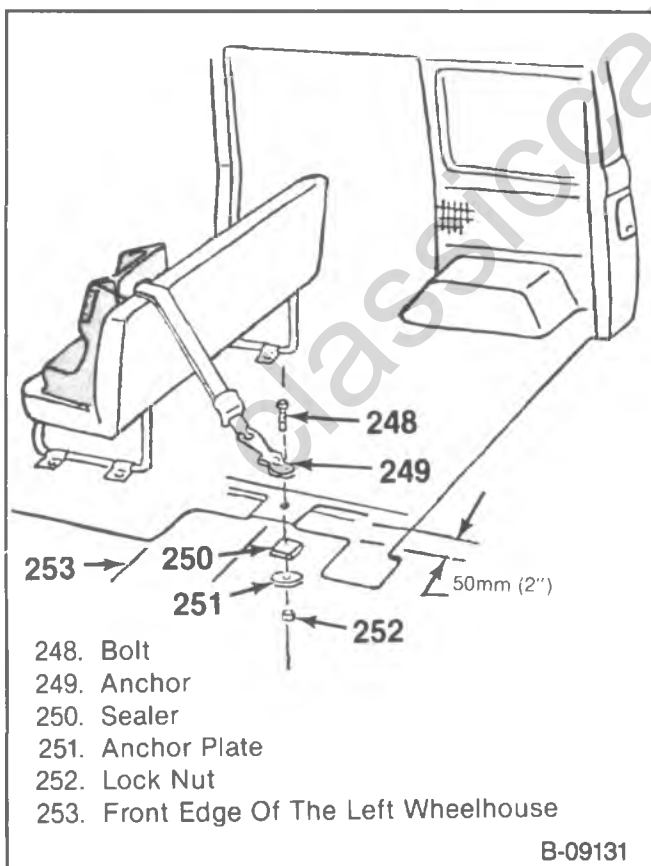

- 248. Bolt
- 249. Anchor
- 250. Sealer
- 251. Anchor Plate
- 252. Lock Nut
- 253. Front Edge Of The Left Wheelhouse

B-09131

Figure 46—Second Seat Top Strap Components—Left Position

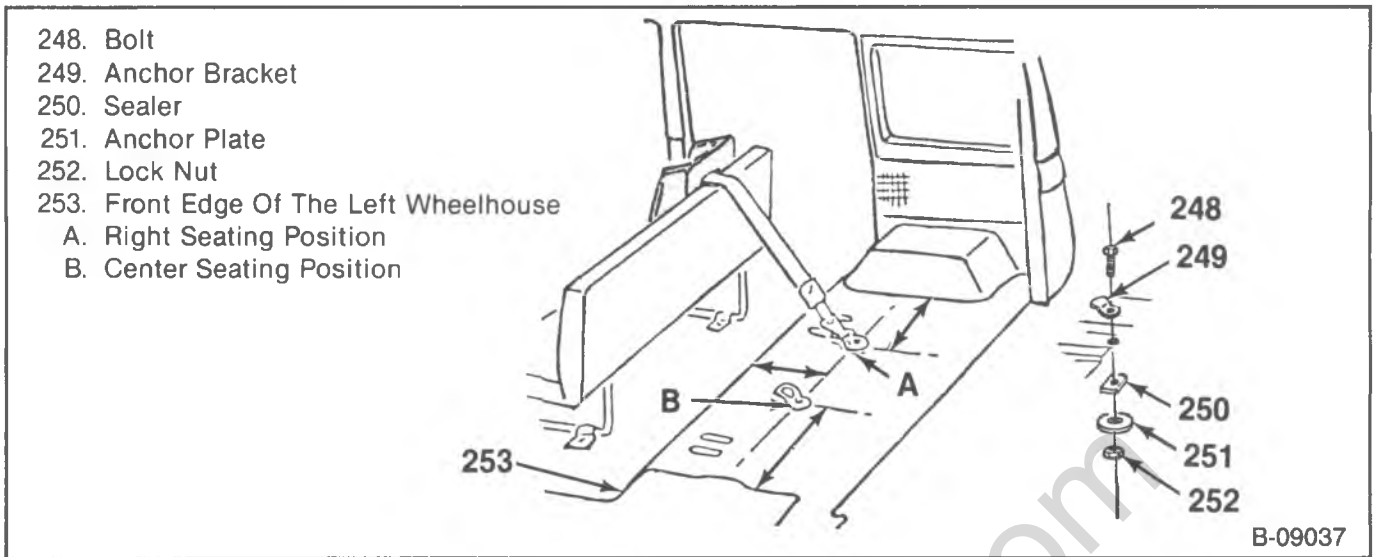

Figure 47—Second Seat Top Strap Components—Center and Right Position

SPECIFICATIONS

ITEM	TORQUE	
	N·m	FT. LBS.
RV Models		
All Seat Belt Fasteners — Except Top Strap	50	37
G Models		
Front Seat Belt Fasteners	60	44
Center And Rear Seat Belt Fasteners — Except Top Strap	50	37
Top Strap Fasteners		
All Models	31	23

classiccarlibrary.com

SECTION 10A3

GLASS

NOTICE: If a glass is cracked but still intact, it should be crisscrossed with masking tape to reduce the risk of damage to the vehicle. If a crack extends to the edge of the glass, mark the cab with a piece of chalk at the point where the crack meets the cab.

CONTENTS

<u>SUBJECT</u>	<u>PAGE</u>
RV Models	10A3- 1
Windshield Replacement.....	10A3- 1
Stationary Glass Replacement	10A3- 3
G Models	10A3- 6
Windshield Replacement.....	10A3- 6
Stationary Glass Replacement	10A3-10
All Models.....	10A3-11
Glass Polishing	10A3-11
Special Tools	10A3-12

RV MODELS

WINDSHIELD REPLACEMENT

When replacing a cracked windshield, it is important that the cause of the crack be determined and the condition corrected, before a new glass is installed. The cause of the crack may be an obstruction or high spot somewhere around the flange of the opening; cracking may not occur until pressure from the high spot or obstruction becomes particularly high due to winds, extremes of temperature, or rough terrain. Suggestions of what to look for are described later in this section under "Inspection".

If a crack extends to the edge of the glass, mark the point where the crack meets the weatherstrip. (Use a piece of chalk and mark the point on the cab, next to the weatherstrip.) Later, when examining the flange of the opening for a cause of the crack start at the point marked.

The higher the temperature of the work area, the more pliable the weatherstrip will be. The more pliable the weatherstrip, the more easily the windshield can be removed.

 Remove or Disconnect (Figures 1 and 2)

CAUTION: Always wear heavy gloves when handling glass to avoid the risk of injury.

Tool Required:

J-24402-A, Glass Sealant Removal Knife

- Place protective coverings around the glass removal area.
- 1. Reveal molding cap.
- 2. Reveal molding.

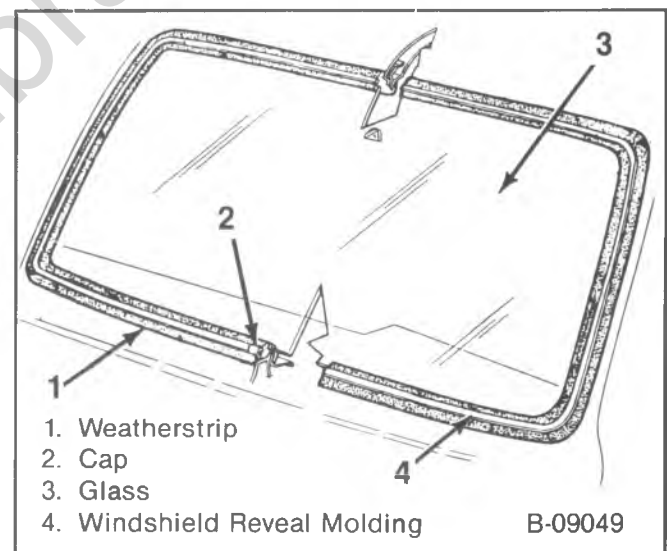

Figure 1—Windshield Components

- From inside the cab, apply a firm controlled pressure to the edge of the glass while forcing the weatherstrip from the flange with a flat-blade tool.

NOTICE: See "Notice" on page 10A3-1 of this section.

3. Windshield glass.
 - With the aid of a helper from outside the vehicle, remove windshield from opening.
4. Excess urethane and remaining weatherstrip from the pinchweld flange.

10A3-2 GLASS

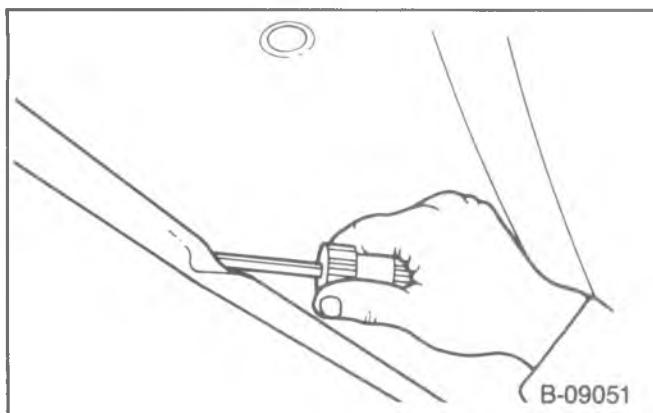

Figure 2—Forcing the Weatherstrip Over the Flange



Clean

- Pinchweld with a dry cloth.

INSPECTION

An inspection of the flange of the windshield opening, the weatherstrip, and the glass may reveal the cause of a broken windshield. This can help prevent future breakage. If there is no apparent cause of breakage, the weatherstrip should be removed from the flange of the opening and the flange inspected. Look for high weld or solder spots, hardened spot weld sealer, or any other obstruction or irregularity in the flange. Check the weatherstrip for irregularities or obstructions in it.

Check a windshield that is to be installed to make sure it does not have any chipped edges. Chipped edges can be ground off, restoring a smooth edge to the glass, and minimizing concentrations of pressure that cause breakage. Remove no more than necessary, in an effort to maintain the original shape of the glass and the proper clearance between it and the flange of the opening. See "Glass-To-Opening Clearance Check" later in this section.

GLASS-TO-OPENING CLEARANCE CHECK

Before installing a windshield, the clearance between the edge of the glass and the flange of the opening should be checked. On RV Models the glass and flange overlap by 5 mm (0.2-inch). If the windshield is too big, rework the metal flange or grind off the edge of the glass. If the glass is to be ground off, place a strip of tape on the glass and use the edge of the tape as a guide.

If there is too much clearance between the glass and the flange of the opening, the flange can be built up. Braze a piece of 3 mm (1/8-inch) diameter wire to the edge of the flange. Usually, building up one side and half way around one corner will be enough. Taper off the ends of the wire to avoid an abrupt change in contour which could result, later, in a broken windshield.

SERVICE KIT

To replace a urethane adhered windshield, GM adhesive service kit No. 9636067 contains some the materials needed, and must be used to insure the original integrity of the windshield design. Materials in the kit include:

1. One tube of adhesive material.
2. One dispensing nozzle.
3. Steel music wire.

4. Rubber cleaner.
5. Rubber primer.
6. Pinchweld primer.
7. Blackout primer.
8. Filler strip (for use on windshield installations for vehicles equipped with embedded windshield antenna).
9. Primer applicators.

Other materials are required for windshield installation which are not included in the service kit. These include:

1. GM Rubber lubricant No. 1051717.
2. Alcohol for cleaning the edge of the glass.
3. Adhesive dispensing gun J-24811 or
4. A standard household cartridge type gun reworked as follows:
 - a. Widen the end slot to fit the diameter of the dispensing nozzle of the adhesive tube.
 - b. Reduce the diameter of the plunger disc so that the disc will enter the large end of the adhesive tube.
5. Commercial type razor knife (for cutting along the edge of the glass).
6. Weatherstrip Tool J-2189-02.

Windshield installation requires a number of timed steps because of the cure times involved with the primers, solvents, and adhesives used in this procedure. This timing is important and must be followed.



Install or Connect (Figures 3 and 4)

Tools Required:

J-24811 Adhesive Dispensing Gun
J-2189-02 Weatherstrip Tool

1. Pinchweld primer.
 - Primer must be thoroughly stirred and agitated.
 - Allow to cure for 30 minutes.
2. Rubber cleaner to both channels of rubber weatherstrip.
 - Wait 5 minutes before wiping the channels with a clean dry cloth.
3. Rubber primer to both channels of the weatherstrip.
 - Wait 30 minutes for curing.



Clean

- Inner surface of glass with a clean alcohol dampened cloth. Allow the glass to air dry.
4. Blackout primer to the inside face of the glass.
 - Start 10 mm (.40-inch) from the edge and work the primer outward to the edge.
 - Allow the primer to dry.
5. Urethane adhesive bead with a diameter of 6 mm (.25-inch) to the center of the pinchweld flange around the entire windshield opening.
 - Glass must be installed within 20 minutes of performing this step.
 - Spray a mist of water to the urethane bead, wetting it fully.
6. Rubber weatherstrip to the pinchweld flange.
7. Urethane adhesive bead with a 4.5 mm (.18-inch) diameter to the rubber weatherstrip glass channel (figure 3).
8. Glass to the window opening.
9. Rubber lubricant to the lockstrip channel.
 - Glass must be seated before the lubricant is applied.

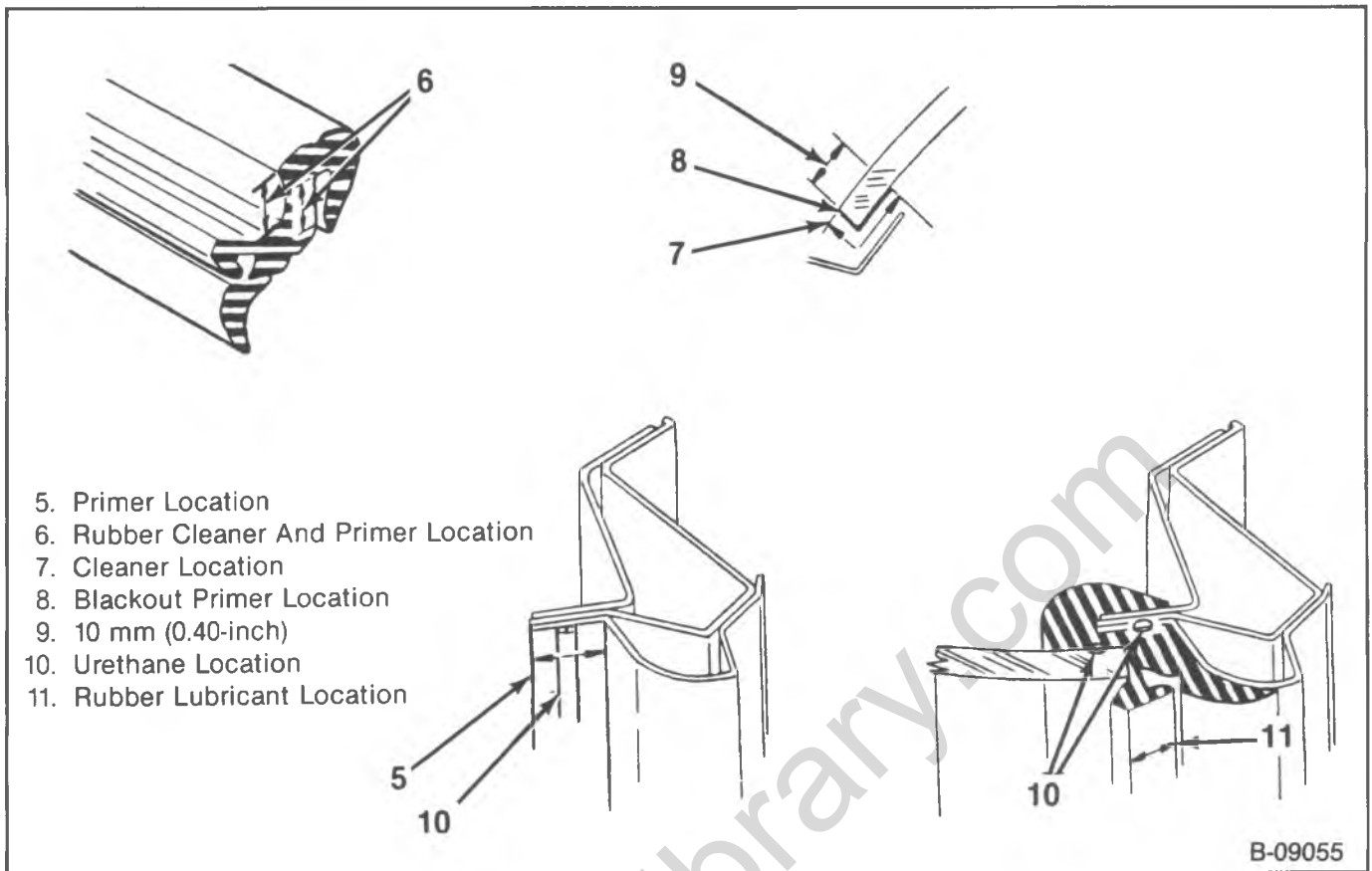

Figure 3—Primer and Adhesive Application Locations

- 10. Reveal molding to the weatherstrip using J-2189-02 (figure 4).
- 11. Reveal molding cap at the joint.

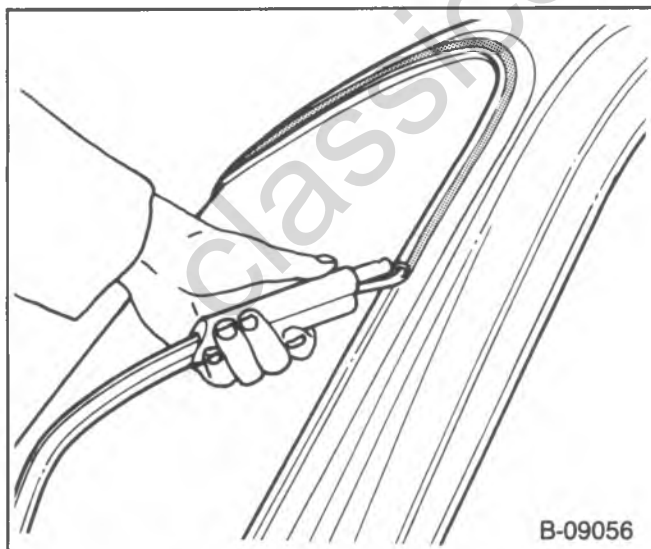

Figure 4—Installing the Reveal Molding

STATIONARY GLASS REPLACEMENT

↔ Remove or Disconnect (Figures 5 through 9)

CAUTION: Always wear heavy gloves when handling glass to avoid the risk of injury.

1. Reveal molding.
 - Push the clip to one side to free the ends.

NOTICE: Refer to "Notice" on page 10A3-1 of this section.

2. Window glass.
 - Insert a putty knife between the glass and the weatherstrip and run the knife around the entire edge of the window.

NOTICE: Refer to "Notice" on page 10A3-1 of this section.

- With a helper standing outside the vehicle, push the glass from the weatherstrip from inside the cab while the helper removes the glass.

↔ Install or Connect (Figures 5 through 9)

Tool Required:

J-2189-02 Weatherstrip Tool

10A3-4 GLASS

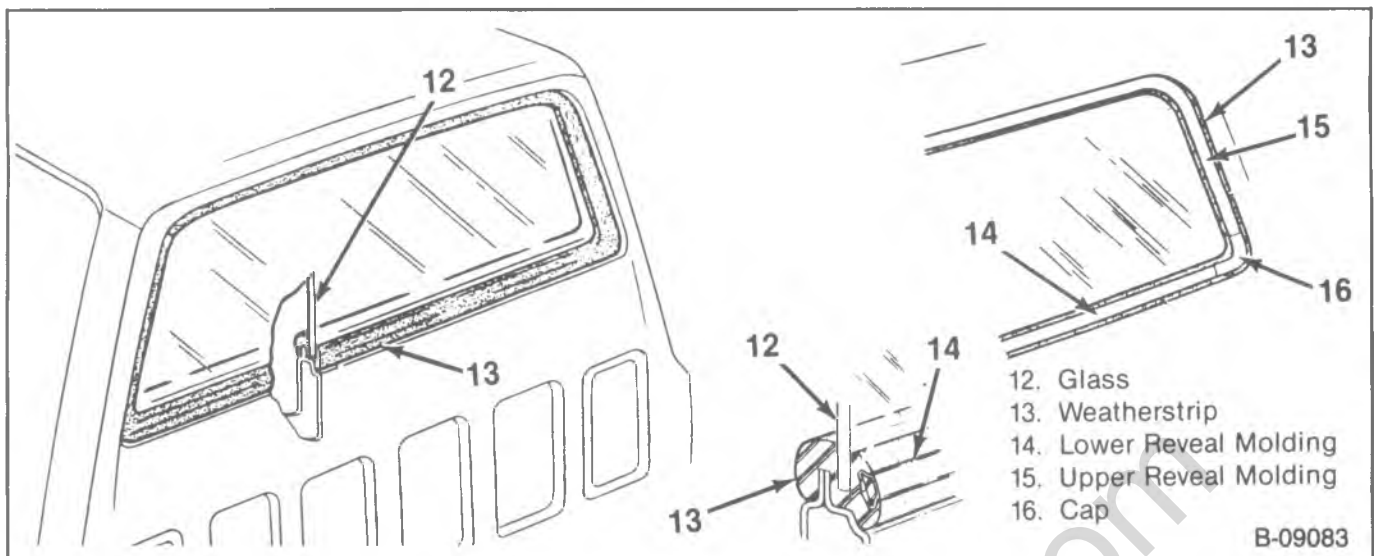

Figure 5—Back Window Components

CAUTION: Always wear heavy gloves when handling glass to avoid risk of injury.

1. Sealing tape on the outside upper corners of the opening, 120 mm (1/6-inch) wide.

2. Weatherstrip at the center of the bottom edge of the opening and work around the entire opening of the flange.

- Brush the weatherstrip with soapy water.

Inspect

- Glass for cracks or chips on the edge. If the glass is chipped, it should be ground smooth.
3. Glass in place on the weatherstrip.
- Insert the hook end of tool J-2189-02 between the weatherstrip and the edge of the glass.
 - Pull the tool around the glass to slip the edge of the glass into the groove of the weatherstrip.
4. Reveal molding.

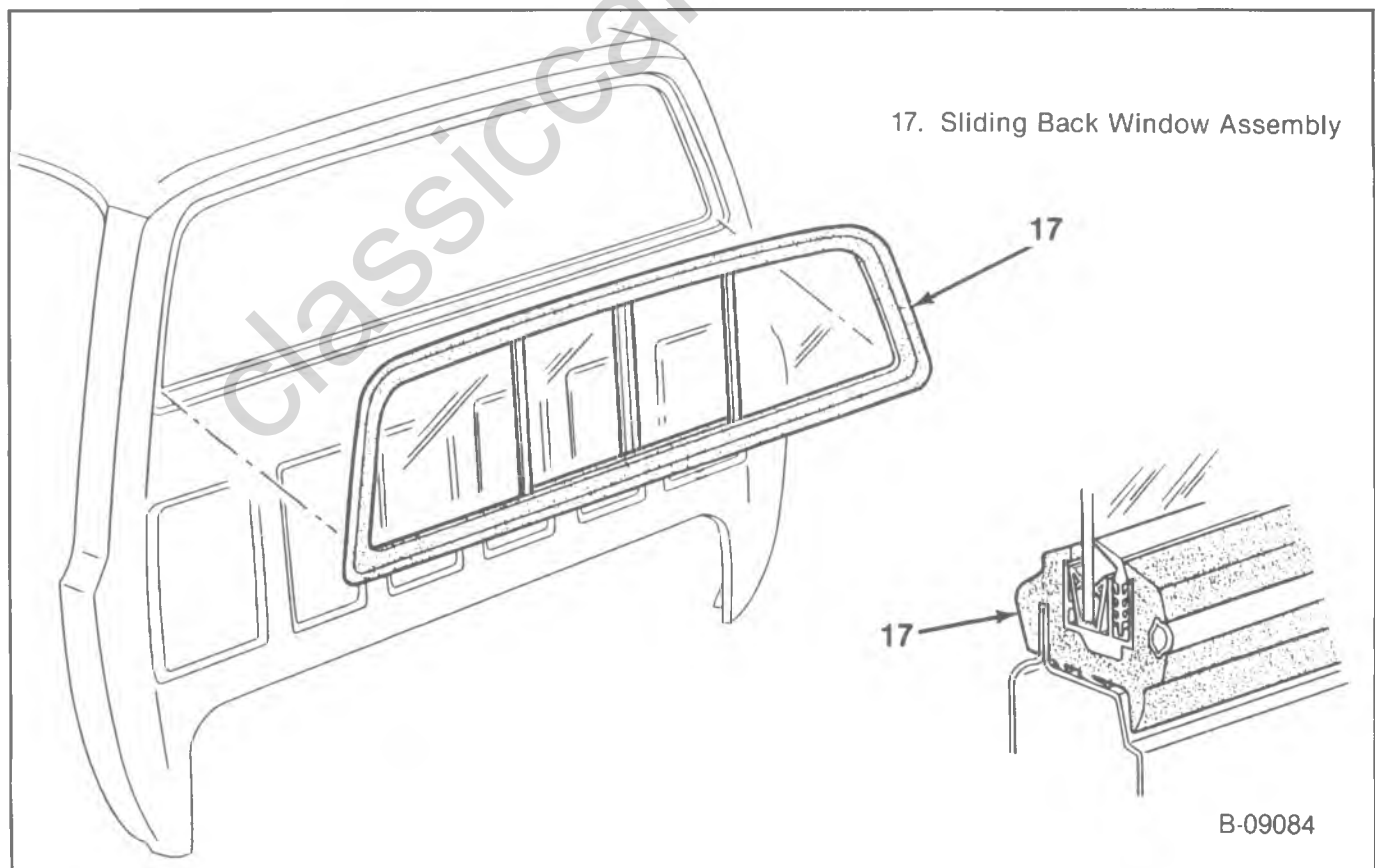

Figure 6—Sliding Back Window Components

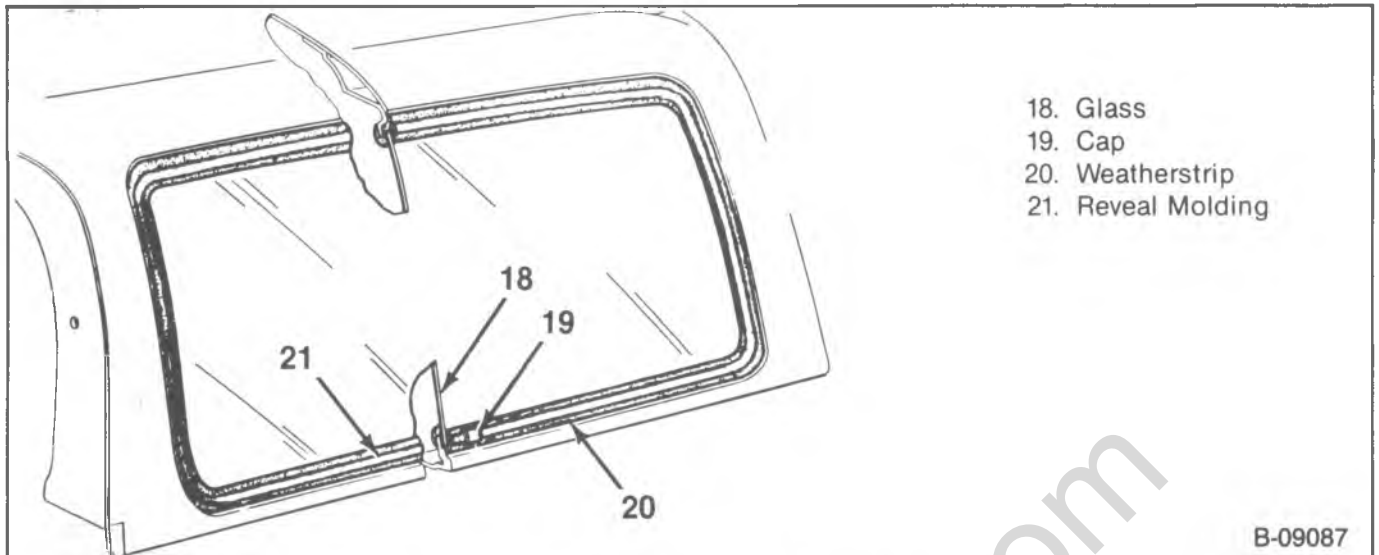

Figure 7—Body Side Window Components

- Thread the end of the molding through the handle of tool J-2189-02.
 - Push the end of the molding into the groove of the weatherstrip at the center of the bottom edge (figure 4).
 - Move the tool around the window while feeding the molding. Use a hitching motion to avoid stretching the molding.
 - Cut any excess molding leaving the ends to overlap by 25 mm (1-inch).
5. Retaining clip over one end of the molding.
 - Butt the ends of the molding together and secure them with the clip.
 6. Ends of the molding, with the clip in place, into the groove of the weatherstrip.

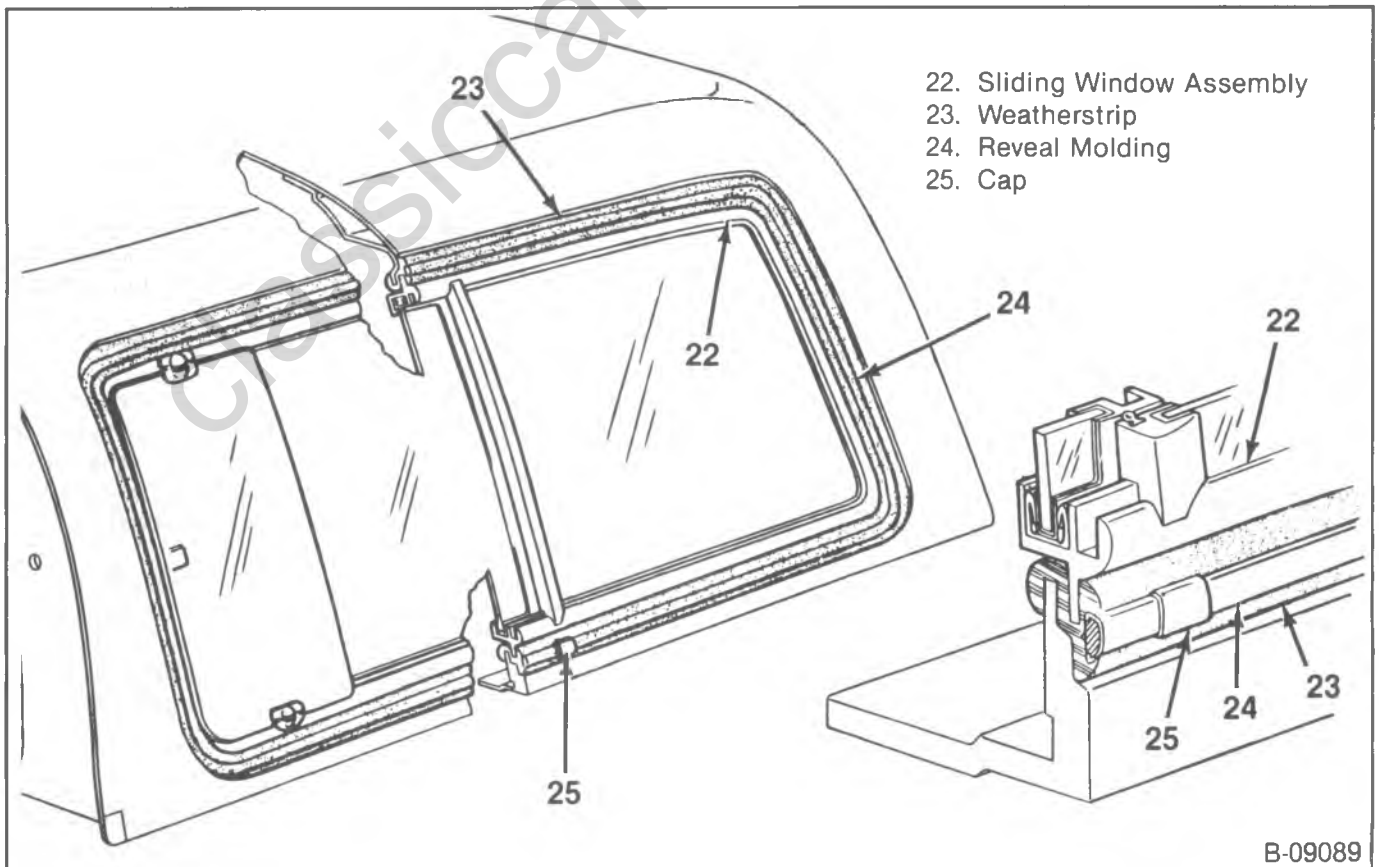

Figure 8—Sliding Body Side Window Components

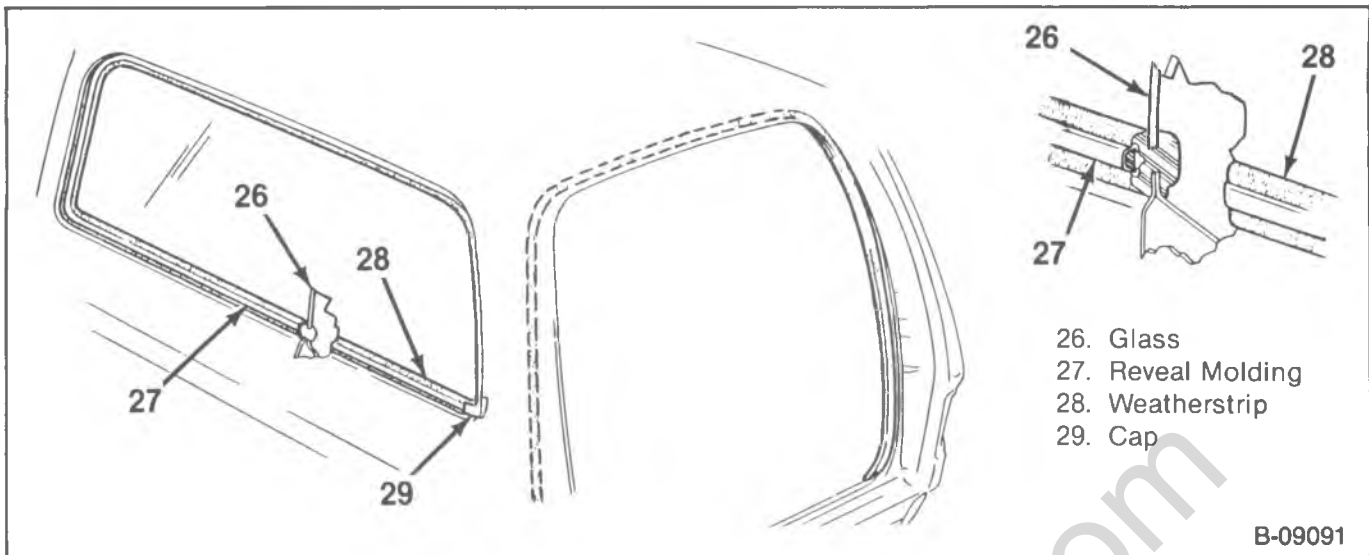

Figure 9—Suburban Rear Stationary Window Components

G MODELS

WINDSHIELD REPLACEMENT

When replacing a cracked windshield, it is important that the cause of the crack be determined and the condition corrected, before a new glass is installed. The cause of the crack may be an obstruction or high spot somewhere around the flange of the opening; cracking may not occur until pressure from the high spot or obstruction becomes particularly high due to winds, extremes of temperature, or rough terrain. Suggestions of what to look for are described later in this section under "Inspection".

If a crack extends to the edge of the glass, mark the point where the crack meets the weatherstrip. (Use a piece of chalk and mark the point on the cab, next to the weatherstrip.) Later, when examining the flange of the opening for a cause of the crack start at the point marked.

The higher the temperature of the work area, the more pliable the weatherstrip will be. The more pliable the weatherstrip, the more easily the windshield can be removed.

NOTICE: When cleaning windshield glass, avoid contacting the edge of the plastic laminate material (on the edge of the glass) with volatile cleaner. Contact may cause discoloration and deterioration of the plastic laminate by wicking action. Do not use a petroleum based solvent such as kerosene or gasoline. The presence of oil will prevent adhesion of new material.

↔ Remove or Disconnect (Figures 10 and 11)

CAUTION: Always wear heavy gloves when handling glass to minimize the risk of injury.

Tool Required:

J-24402-A, Glass Sealant Removal Knife

- Place protective coverings around the glass removal area.
- 1. Windshield wiper arms.
- 2. Interior garnish moldings.
- 3. Reveal molding cap.
- 4. Reveal molding.
- 5. Interior support molding.

NOTICE: Refer to "Notice" on page 10A3-1 of this section.

6. Windshield from the flange.
 - Use J-24709-1 or J-24402-A to cut the glass from the urethane adhesive. Keep the cutting edge of the knife against the glass, and cut the sealant from the windshield.
 - With the aid of an assistant, remove the windshield.

Two methods of glass replacement may be used. The first of these methods is called the short method. This method can be used when the original adhesive is left on the window opening pinchweld flange after the glass has been removed. The old adhesive serves as a base for the new glass.

The second method, is the extended method. This is used when the original adhesive cannot be used as a base for the new glass. The original adhesive is removed and replaced with new adhesive. When repair to the sheet metal or window opening is required, the extended method must be used.

INSPECTION

An inspection of the flange of the windshield opening, the weatherstrip, and the glass may reveal the cause of a broken windshield. This can help prevent future breakage. If there is no apparent cause of breakage, the

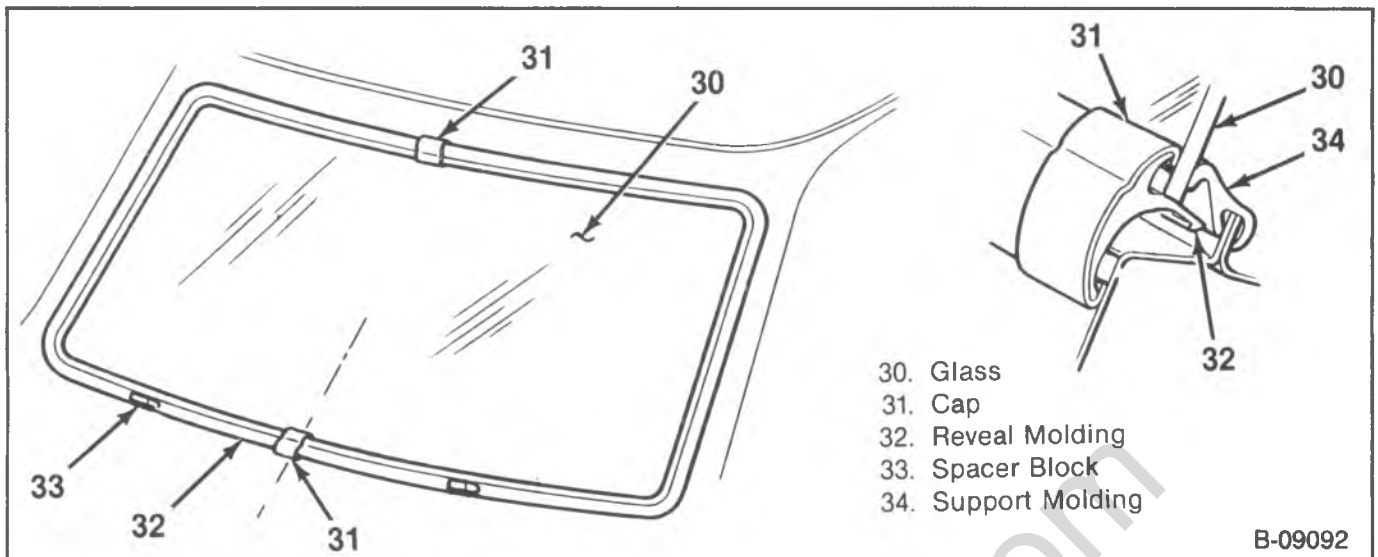

Figure 10—Windshield Components

weatherstrip should be removed from the flange of the opening and the flange inspected. Look for high weld or solder spots, hardened spot weld sealer, or any other obstruction or irregularity in the flange. Check the weatherstrip for irregularities or obstructions in it.

Check a windshield that is to be installed to make sure it does not have any chipped edges. Chipped edges can be ground off, restoring a smooth edge to the glass, and minimizing concentrations of pressure that cause breakage. Remove no more than necessary, in an effort to maintain the original shape of the glass and the proper clearance between it and the flange of the opening.

SERVICE KIT (Figures 12 through 16)

To replace a urethane adhered windshield, GM adhesive service kit No. 9636067 contains some of the materials needed, and must be used to insure the original integrity of the windshield design. Materials in the kit include:

1. One tube of adhesive material.
2. One dispensing nozzle.
3. Steel music wire.
4. Rubber cleaner.
5. Rubber primer.
6. Pinchweld primer.
7. Blackout primer.

8. Filler strip (for use on windshield installations for vehicles equipped with embedded windshield antenna).
9. Primer applicators.

Other materials are required for windshield installation which are not included in the service kit. These include:

1. GM Rubber lubricant No. 1051717.
2. Alcohol for cleaning the edge of the glass.
3. Adhesive dispensing gun J-24811 or
4. A standard household cartridge type gun reworked as follows:

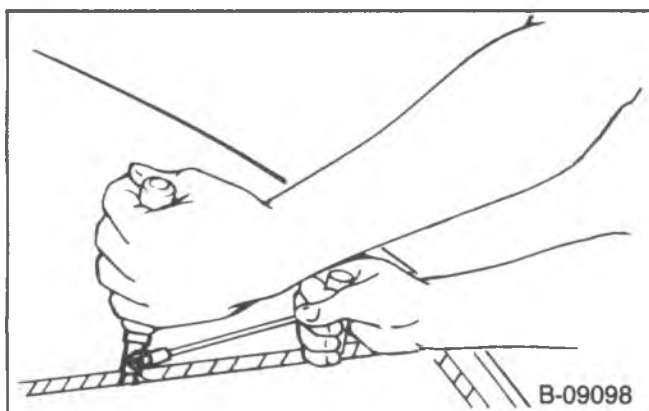

Figure 11—Cutting the Glass from the Adhesive

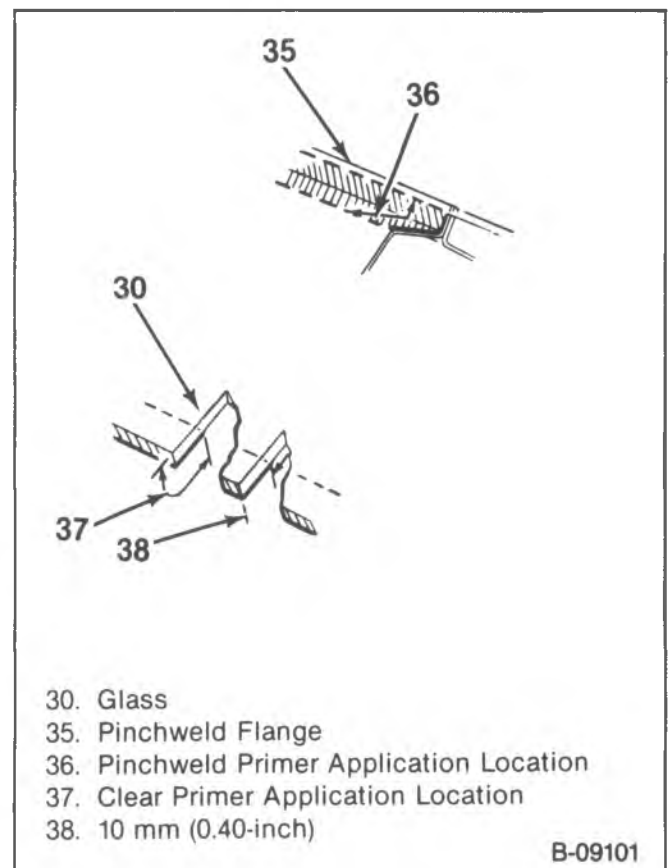

Figure 12—Primer Applications Locations

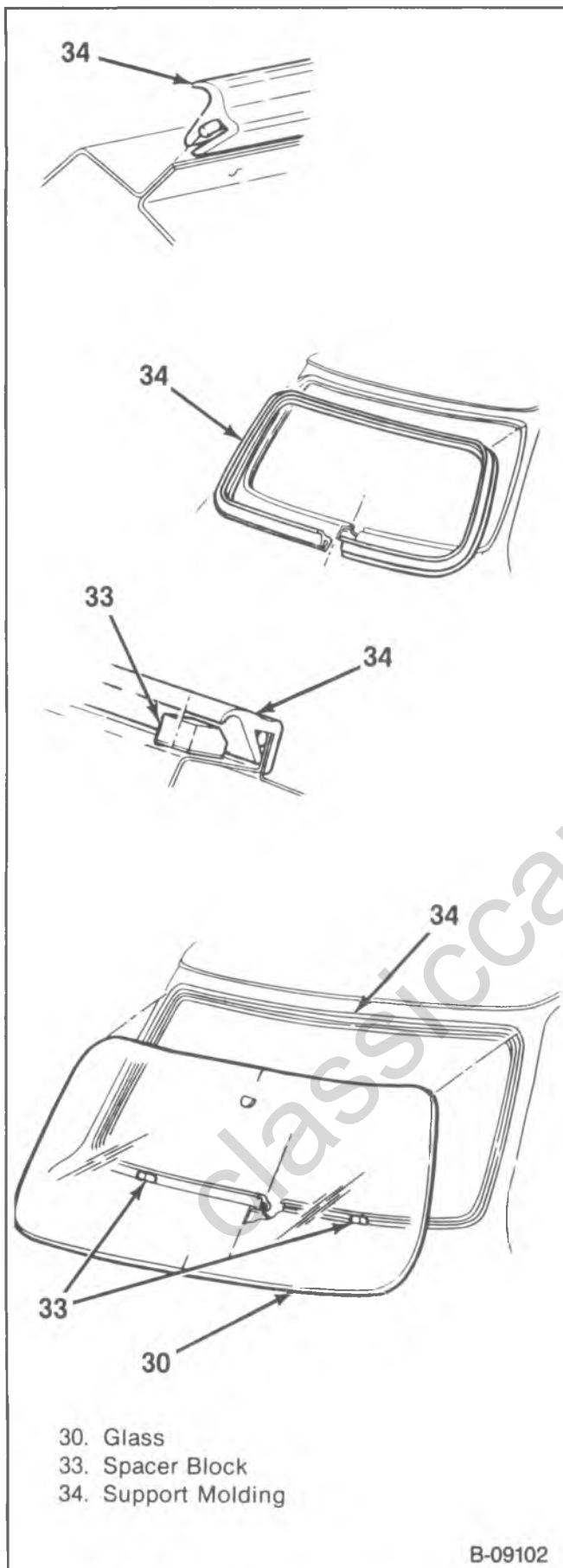

Figure 13—Windshield Components Locations

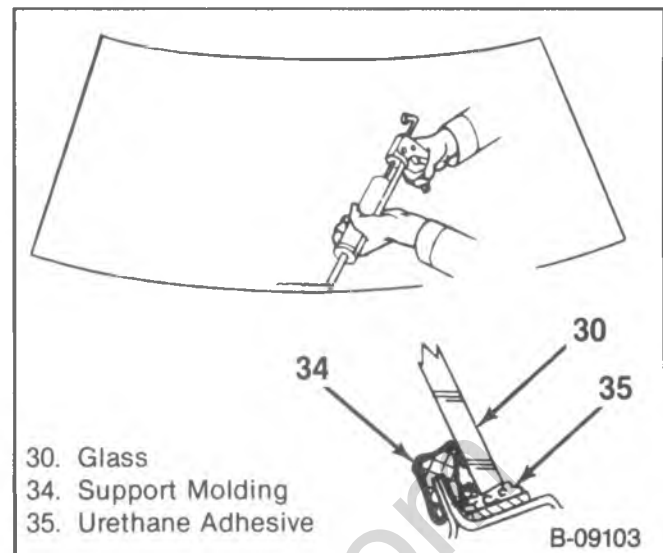

Figure 14—Urethane Application

- a. Widen the end slot to fit the diameter of the dispensing nozzle of the adhesive tube.
 - b. Reduce the diameter of the plunger disc so that the disc will enter the large end of the adhesive tube.
5. Commercial type razor knife (for cutting along the edge of the glass).
 6. Weatherstrip Tool J-2189-02.

Windshield installation requires a number of timed steps because of the cure times involved with the primers, solvents, and adhesives used in this procedure. This timing is important and must be followed.

SHORT METHOD



Clean

1. Loose material from the glass frame opening.
2. Edge of the glass with alcohol or equivalent.



Install or Connect (Figures 12 through 16)

1. Support molding onto the pinchweld flange from inside the vehicle.
 - Locate the joint of the molding at the bottom center of the molding.
2. Clear glass primer to the inner edge of the windshield from the edge of the glass inward 10 mm (.40-inch), and around the entire perimeter of the glass.
 - Allow 30 minutes to cure.
3. Blackout primer to the glass in the same area as the clear primer.
 - Allow to dry to the touch.
4. Windshield.
 - Place two rubber blocks onto the base of the pinchweld flange. Place the blocks in line with the last screw on either side of the cowl grille cover.
 - With the aid of a helper, left the glass into the opening. Center the glass in the opening, on top of the support molding.
 - Check the fit of the reveal molding. If necessary, remove the glass and cut away additional urethane to give the proper windshield height. Place the glass in the window opening.

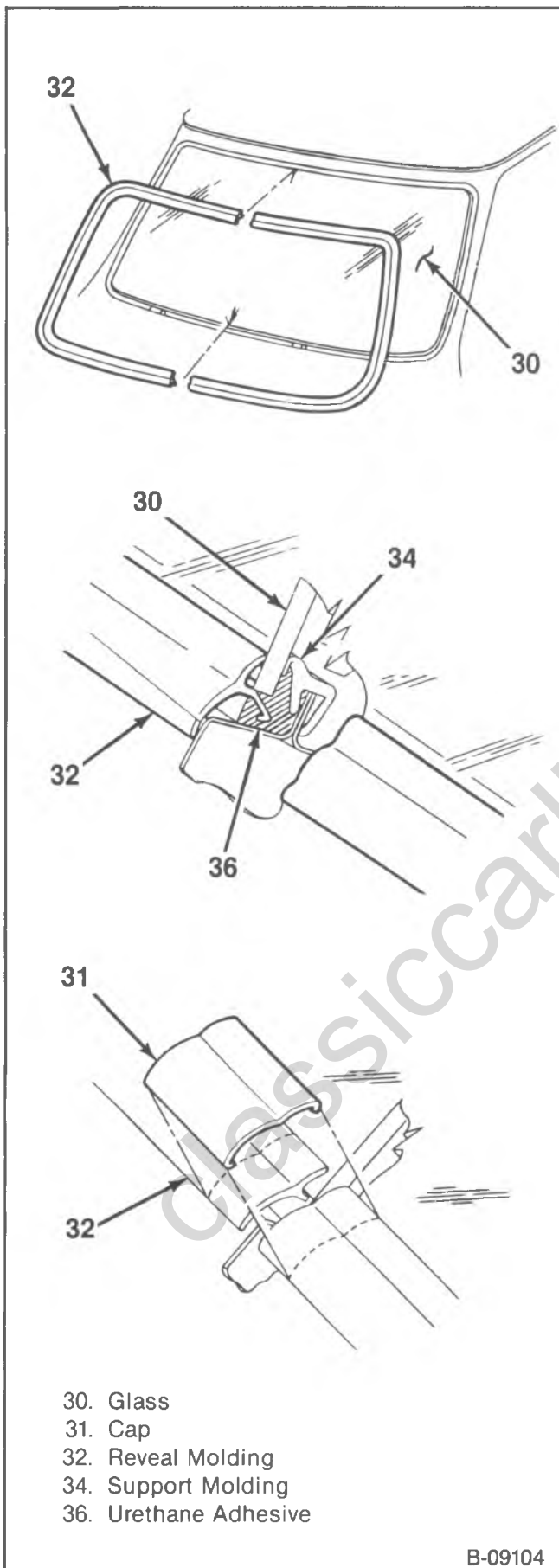
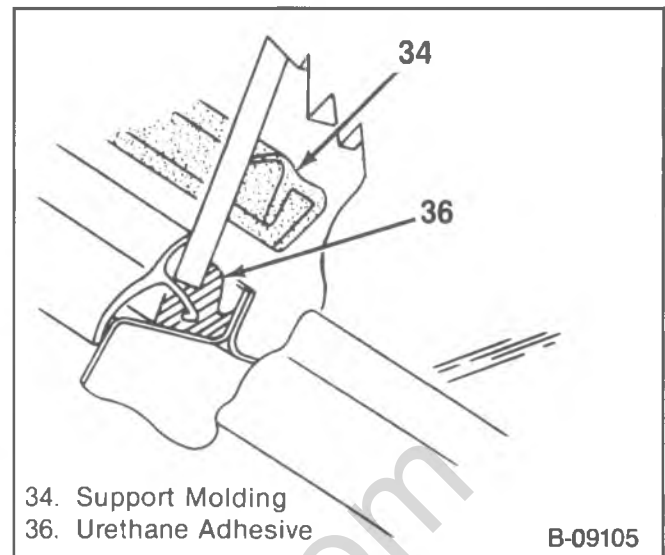

Figure 15—Reveal Molding

Figure 16—Windshield Support Molding—
Short Method

- Cut the tip of the adhesive cartridge approximately 5 mm ($\frac{3}{16}$ -inch) from the end of the tip.
- Apply the adhesive first in and around the spacer blocks. Apply a smooth continuous bead of adhesive into the gap between the glass edge and the sheet metal. Use a flat-bladed tool to paddle the material into position if necessary. Be sure that the adhesive contacts the entire edge of the glass, and extends to fill the gap between the glass and the primed sheet metal (extended method) or solidified urethane base (short method).
- Spray a mist of water onto the urethane. Water will assist in the curing process. Dry the area where the reveal molding will contact the body or glass.

5. New reveal moldings.

- Remove the protective tape covering the butyl adhesive on the underside of the molding.
- Push the molding caps onto each end of one of the reveal moldings.
- Press the lip of the molding into the urethane adhesive while holding it against the edge of the windshield. Take care to seat the molding in the corners. The lip must fully contact the adhesive and the gap must be entirely covered by the crown of the molding.
- Slide the molding caps onto the adjacent moldings.
- Use tape to hold the molding in position until the adhesive cures.

6. Wiper arms.

7. Interior garnish moldings.

- Allow the vehicle to sit for six hours before driving.

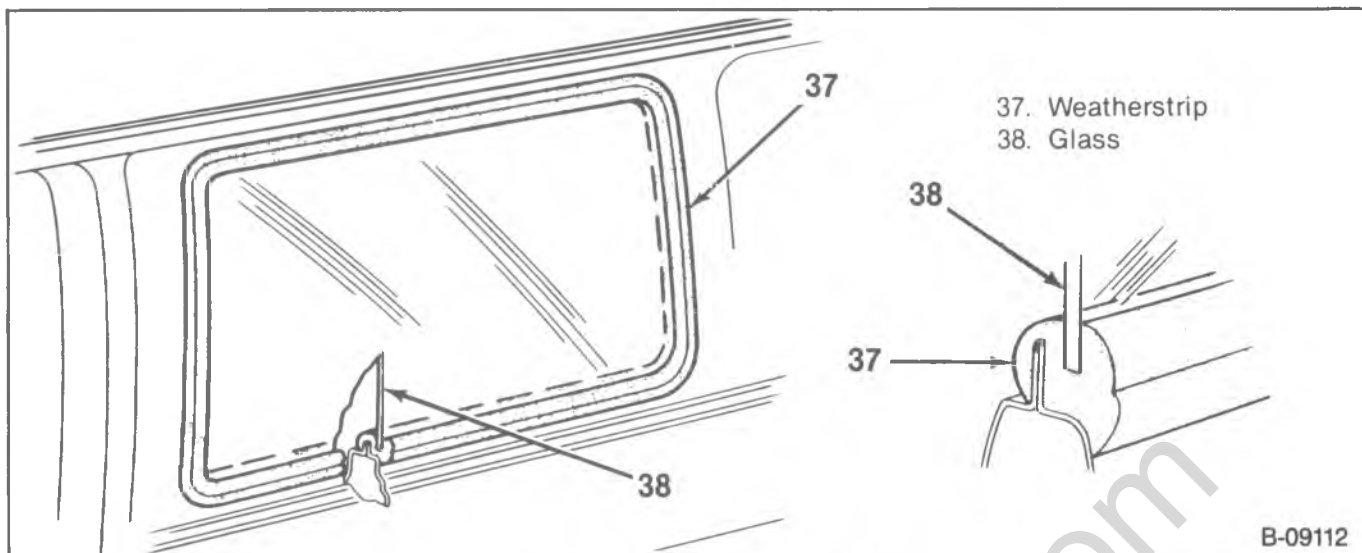

Figure 17—Body Side Front Window

EXTENDED METHOD

Clean

- The old adhesive from the pinchweld flange using a sharp scraper or chisel.

Install or Connect (Figure 12)

- Pinchweld primer to the pinchweld area.
 - Do not allow primer to touch exposed paint.
 - Allow 30 minutes to dry.
- Follow the steps as listed under "Short Method" in this section for the rest of this procedure.

STATIONARY GLASS REPLACEMENT

Remove or Disconnect (Figures 17, 18 and 19)

CAUTION: Always wear heavy gloves when handling glass to avoid the risk of injury.

1. Rivets (if equipped) using a 5 mm (⁹/₁₆-inch) drill bit.

NOTICE: Refer to "Notice" on page 10A3-1 of this section.

2. Window glass and weatherstrip.
 - Run a putty knife around the edge of the window, between the weatherstrip and the cab panels (inside and outside the cab).

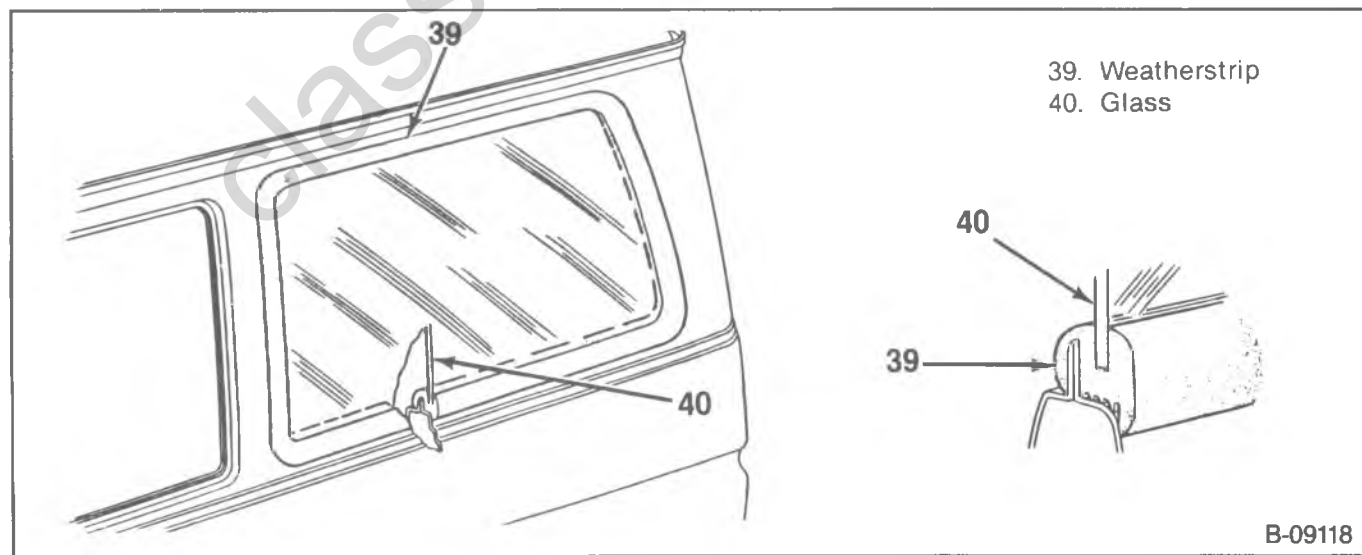

Figure 18—Body Side Rear Window

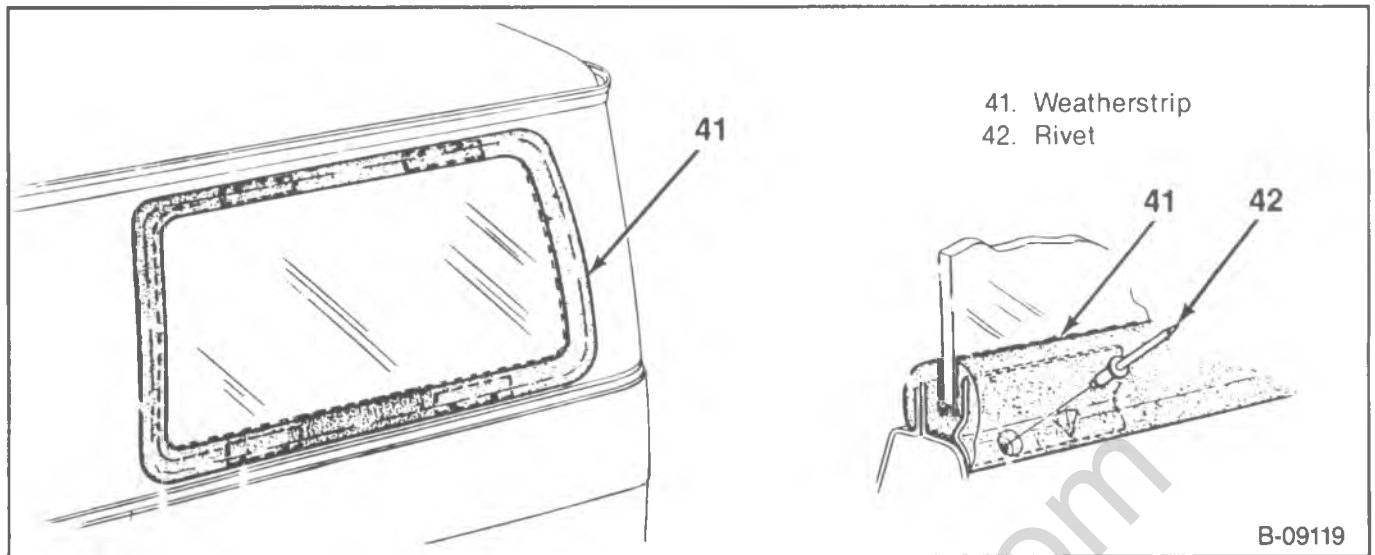

Figure 19—Body Side Rear Window — Riveted

- Have a helper stand outside the cab next to the window.
- Use a putty knife, or other blunt tool, to force the edge of the weatherstrip off the flange of the opening inside the cab, while pushing out on the glass.
- Continue around the window, forcing the weatherstrip off the flange, until the glass and weatherstrip are free of the opening.
- Have the helper remove the glass and weatherstrip from the outside of the vehicle.

Inspect

- Flange.
- Weatherstrip.
- New glass.

Install or Connect (Figures 17, 18 and 19)

- To ease installation, the weatherstrip can be heated with a non-flame source. Do not heat above 52°C (125°F), or for more than 1½ hours.

1. Weatherstrip around the edge of the replacement glass.
 - Place a length of cord about 6 mm (¼-inch) thick in the groove of the weatherstrip where the flange of the opening will fit.
 - Overlap the ends of the cord about 152 mm (6 inches) and locate at the bottom of the window.
 - Brush a soapy solution of water around the outside edge of the cab opening.
2. Glass and weatherstrip to flange.
 - Have a helper hold the glass and weatherstrip (with the cord around it) up to the window opening from the outside of the cab; with the ends of the cord placed through the opening and hang loosely inside the cab.
 - While the helper holds the glass firmly in place, pull one end of the cord, forcing the lip of the weatherstrip up and over the flange.
 - Pull the cord out from around the weatherstrip.
3. Rivets (if equipped) to the weatherstrip and the side panel with a rivet installing gun.

ALL MODELS

GLASS POLISHING

MINOR SCRATCH AND ABRASION REMOVAL

Minor scratches and abrasions can be removed or reduced by following the procedure outlined below. Precautions must be taken, however, to prevent distortions of vision; double vision may result if an attempt is made to remove deep scratches. Deep scratches should not be removed from an area in the driver's line of vision; in such cases, the glass should be replaced.

The procedure that follows was developed using a cerium oxide compound. Follow manufacturer's directions if other materials are used.

Recommended Equipment

1. A low speed (600-1300 rpm) rotary polisher.

2. A wool, felt, rotary polishing pad 76 mm (three-inches) in diameter and 51 mm (two-inches) thick.
3. Powdered cerium oxide mixed with water. This is the abrasive compound.
4. A wide mouth container to hold the abrasive compound.

Polishing Procedure (Figure 20)

1. Mix at least 44 ml (1.5 oz.) of cerium oxide with enough water to obtain a creamy consistency. (If the mixture is too thick it will cake on the felt pad more quickly. If it is too runny, more polishing time will be needed.)
2. Draw a circle around the scratches on the opposite side of the glass with a marking crayon, or equivalent.
3. Draw a line directly behind the scratch(es) to serve as a guide for locating the scratch while polishing.
4. Cover the surrounding area with masking paper to catch the drippings or spattered polish.

10A3-12 GLASS

5. Dip the felt pad attached to the polisher into the mixture. Do not submerge the pad or allow the pad to stay in the mixture as it may loosen the bond between the pad and the metal plate.

NOTICE: Never hold the tool in one spot or operate the tool on the glass any longer than 30 to 45 seconds. If the glass becomes hot to touch, let it air cool before proceeding further. Cooling with cold water may crack heated glass. Avoid excessive pressure. It may cause overheating of the glass.

6. Polish the scratched area, but note the following:
 - a. Agitate the mixture as often as needed to maintain the creamy consistency of the compound.
 - b. Use moderate but steady pressure.
 - c. Hold the pad flat against the glass.
 - d. Use a feathering-out motion.
 - e. Dip the pad into the mixture every 15 seconds to ensure that the wheel and the glass are always wet during the polishing operation. (A dry pad causes excessive heat to develop.)
 - f. Keep the pad free of dirt and other foreign substances.
7. After removing the scratch, wipe the area clean of any polish.
8. Clean the polishing pad.

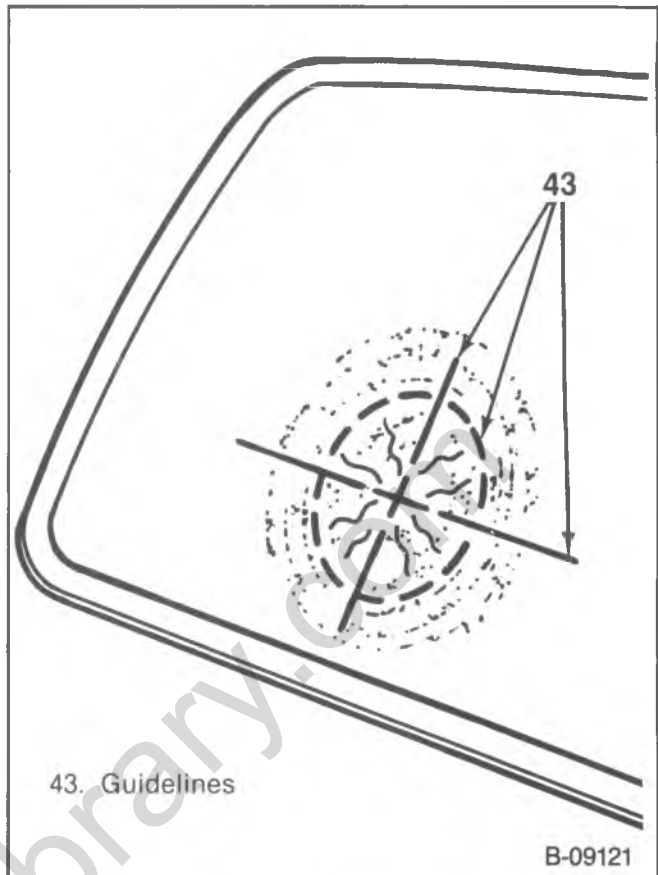

Figure 20—Glass Polishing Guidelines

SPECIAL TOOLS

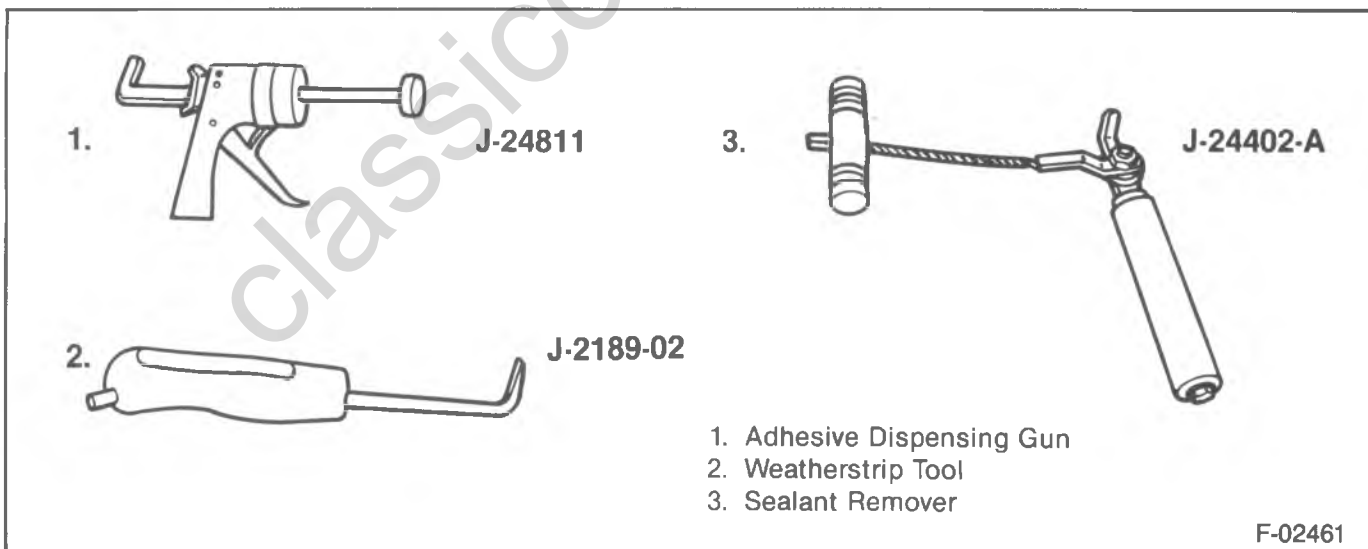

Figure 21—Special Tools

SECTION 10A4

INTERIOR TRIM

CONTENTS

SUBJECT	PAGE
RV Model Interior Trim	10A4- 1
Front Trim Replacement	10A4- 1
Pick Up Models	10A4- 3
Carpet Replacement	10A4- 3
Headliner And Trim Replacement	10A4- 3
Bonus Cab Models	10A4- 5
Carpet Replacement	10A4- 5
Headliner And Trim Replacement	10A4- 6
Utility Vehicle Models	10A4- 8
Carpet Replacement	10A4- 8
Headliner And Trim Replacement	10A4- 8
Front Floor Compartment Replacement	10A4- 8
Suburban Models	10A4-13
Carpet Replacement	10A4-13
Headliner And Trim Replacement	10A4-13
Roof Rear Header Trim Panel Replacement	10A4-14
G Model Interior Trim	10A4-18
Carpet Replacement	10A4-18
Headliner Replacement	10A4-18
Interior Trim Replacement	10A4-19
Engine Cover Replacement	10A4-21

RV MODEL INTERIOR TRIM

The following procedure covers the trim located at the front of the cab, and applies to all RV models.

FRONT TRIM REPLACEMENT

↔ Remove or Disconnect (Figures 1 through 4)

1. Sill plate screws (1).
2. Sill plate (2).
3. Kick panel screws (3).
4. Kick panel (4).
5. Instrument panel outer filler screws (5).
6. Instrument panel outer filler (6).
7. Upper garnish molding screws (7).
8. Upper garnish molding (8).
9. Windshield side garnish molding screws (9).
10. Windshield side garnish molding (10).

↔ Install or Connect (Figures 1 through 4)

1. Windshield side garnish molding (10).
2. Windshield side garnish molding screws (9).
3. Upper garnish molding (8).
4. Upper garnish molding screws (7).
5. Instrument panel outer filler (6).
6. Instrument panel outer filler screws (5).

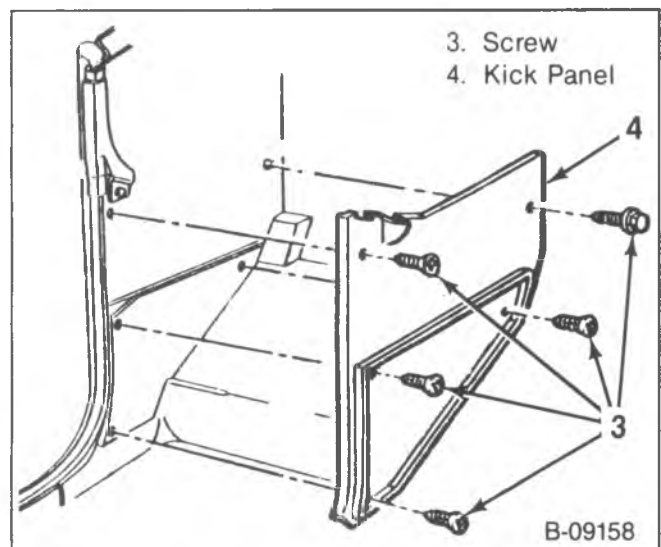

Figure 1—Kick Panel

7. Kick panel (4).
8. Kick panel screws (3).
9. Sill plate (2).
10. Sill plate screws (1).

10A4-2 INTERIOR TRIM

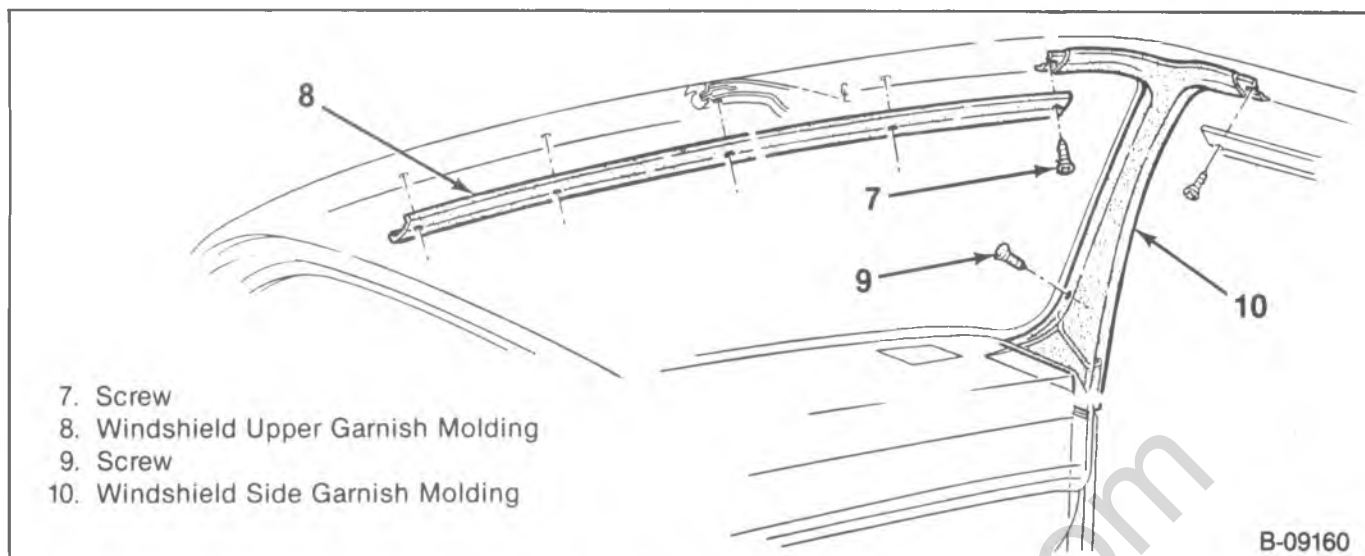

Figure 2—Windshield Garnish Moldings

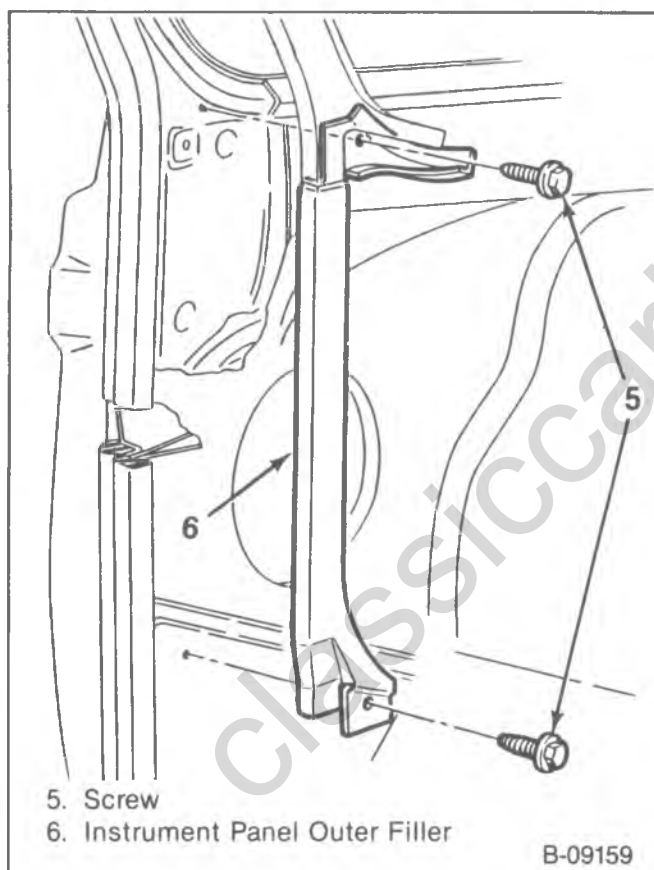

Figure 3—Instrument Panel Outer Filler

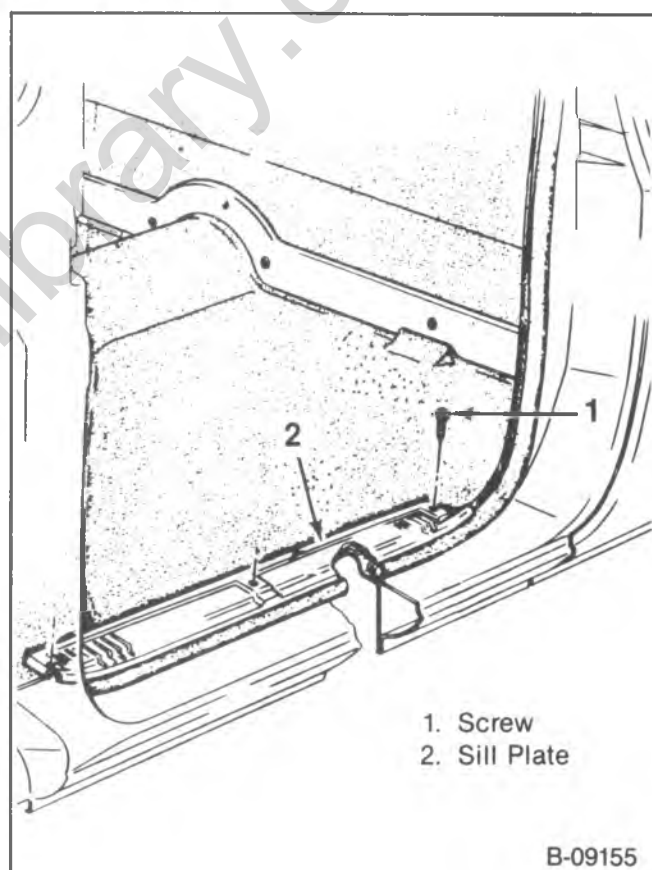
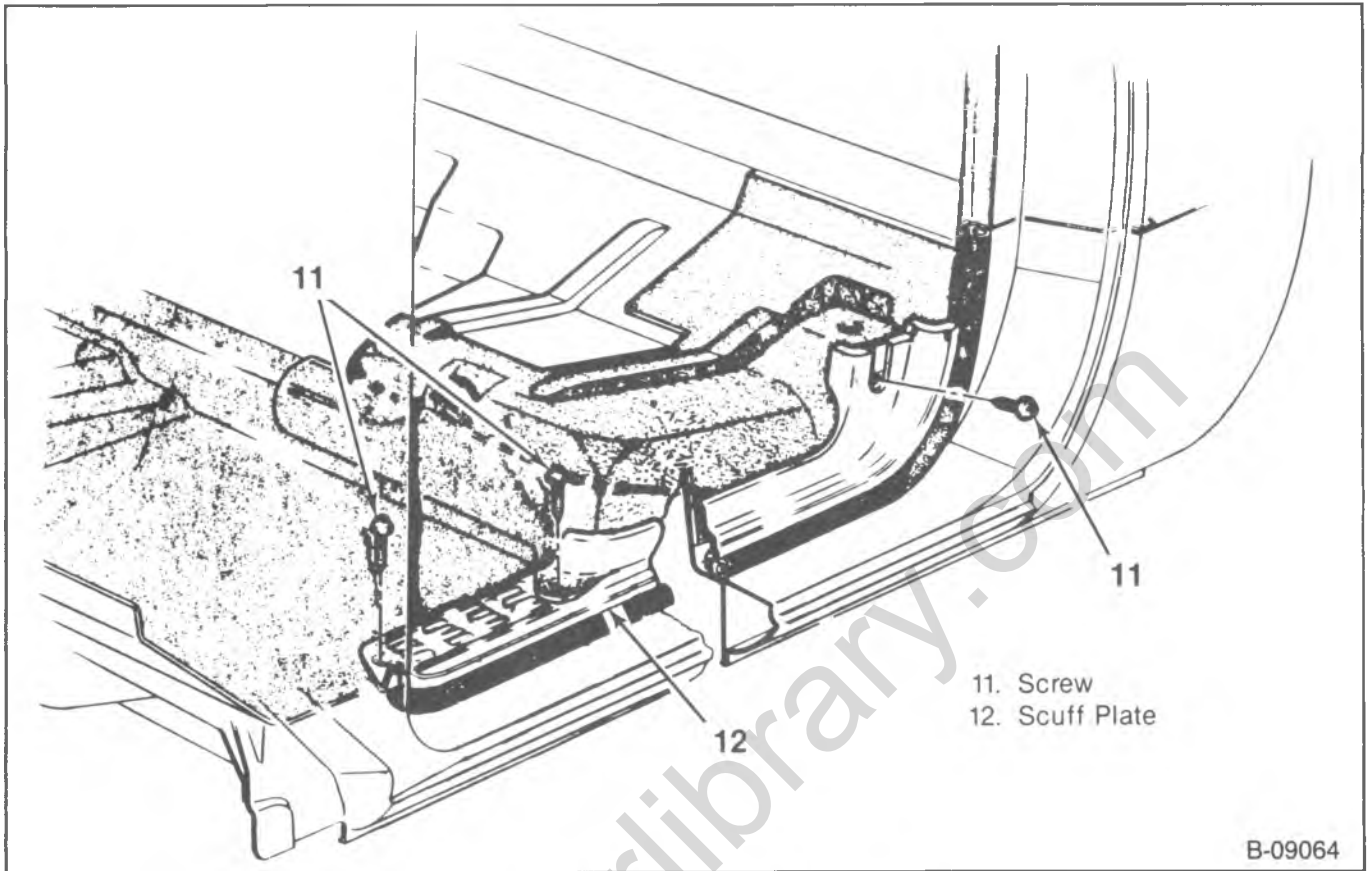

Figure 4—Sill Plate

PICK UP MODEL



B-09064

Figure 5—Front Door Sill Plate

CARPET REPLACEMENT

↔ Remove or Disconnect (Figures 5 through 8)

1. Seats and seat belts. Refer to SEATS (SEC. 10A2).
2. Kick panel.
3. Front door scuff plate (12).
4. Rear panel nails (13).
 - Pull the nails from the panel.
5. Rear panel (14).
6. Dash panel retainers (15).
7. Carpet (16) from the vehicle.

↔ Install or Connect (Figures 5 through 8)

1. Carpet (16) to the vehicle.
2. Dash panel retainers (15).
3. Rear panel (14).
4. New rear panel nails (13).
 - Push the nails through the panel and into the body panels.
5. Front door scuff plate (12).
6. Kick panel.
7. Seats and seat belts. Refer to SEATS (10A2).

HEADLINER AND TRIM REPLACEMENT

↔ Remove or Disconnect (Figure 9)

1. Windshield upper garnish molding screws (23).
2. Windshield upper garnish molding (17).
3. Side window garnish molding screws (21).
4. Side window garnish molding (22).
5. Windshield garnish molding screws.
6. Windshield garnish molding (24).
7. Back window garnish molding screws.
8. Back window garnish molding (25).
9. Headliner (20).

↔ Install or Connect (Figure 9)

1. Headliner (20).
2. Back window garnish molding (25).
3. Back window garnish molding screws.
4. Windshield garnish molding (24).
5. Windshield garnish molding screws.
6. Side window garnish molding (22).
7. Side window garnish molding screws (21).
8. Windshield upper garnish molding (17).
9. Windshield upper garnish molding screws (23).

10A4-4 INTERIOR TRIM

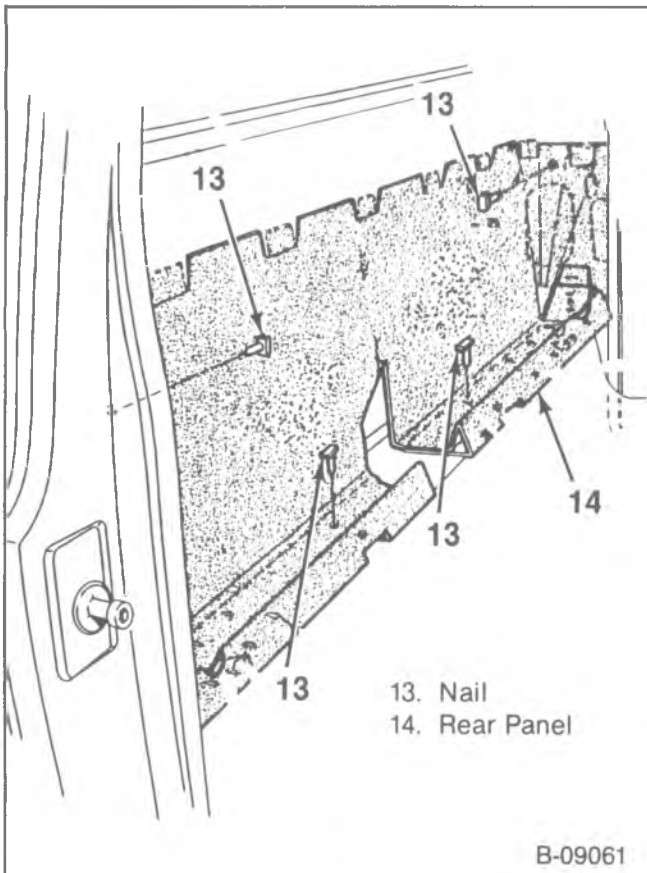

Figure 6—Rear Panel

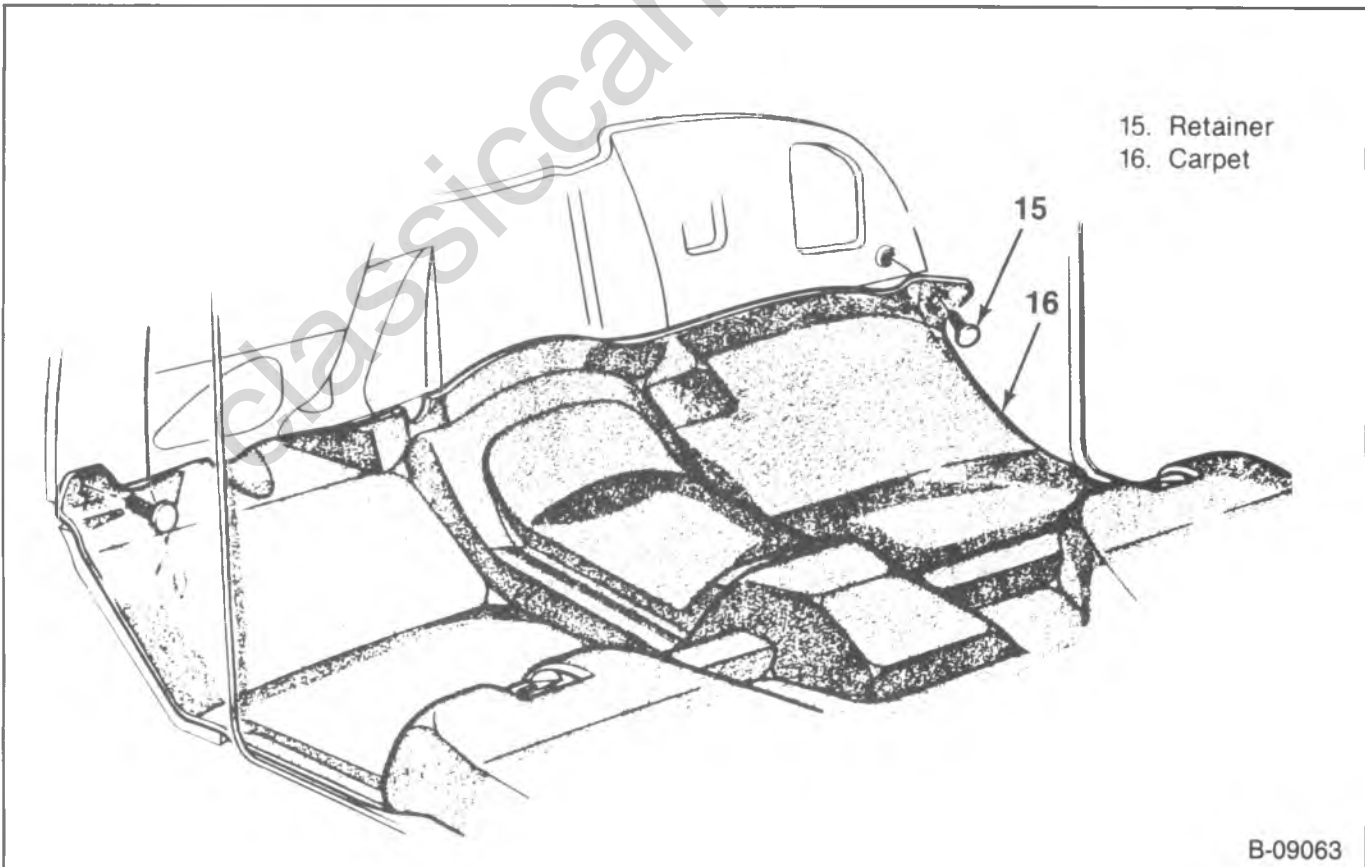

Figure 7—Carpet Retainers

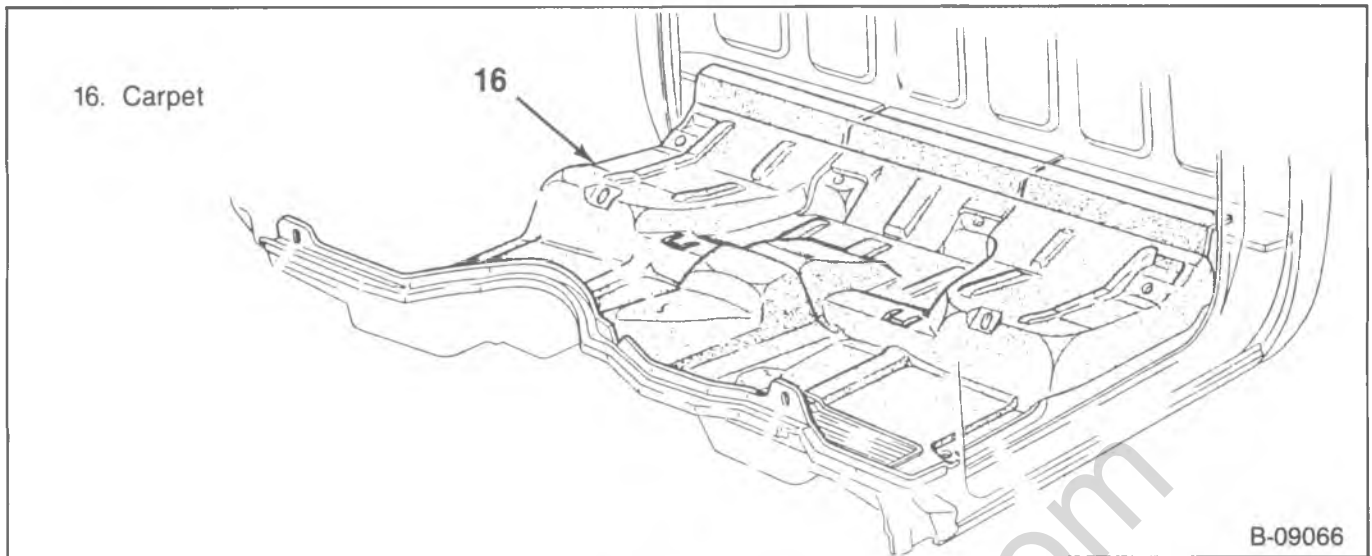

Figure 8—Carpet

B-09066

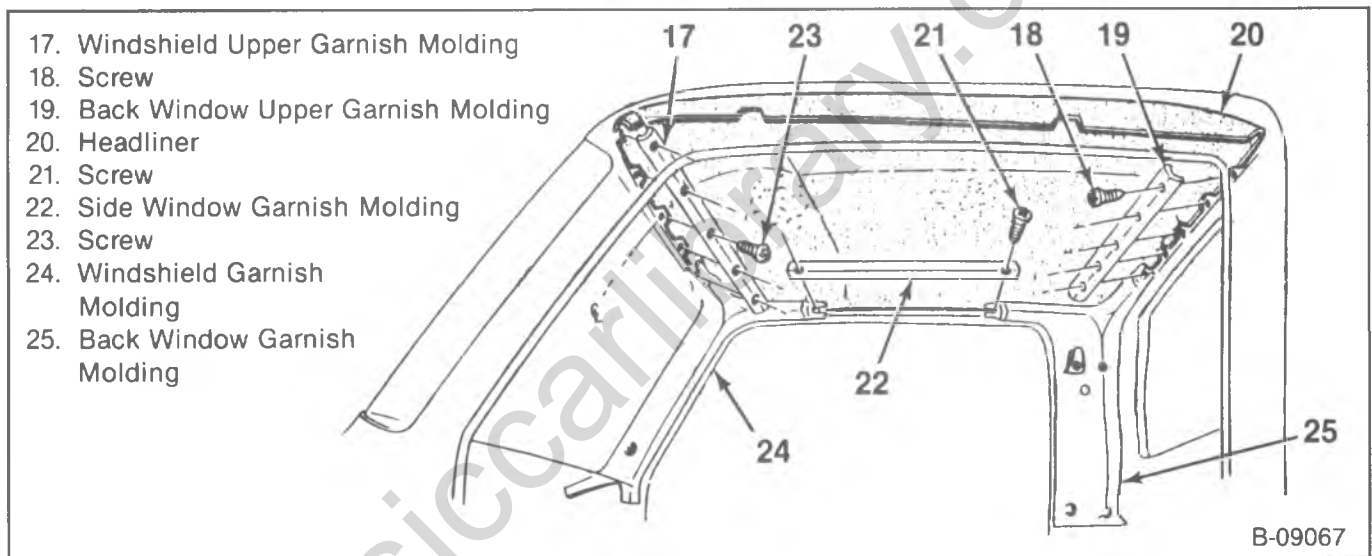

Figure 9—Headliner and Interior Trim

B-09067

BONUS CAB MODELS

CARPET REPLACEMENT

↔ Remove or Disconnect (Figures 10 through 12)

1. Seats and seat belts. Refer to SEATS (Sec. 10A1).
2. Kick panel.
3. Front and rear door scuff plates (27).
4. Rear panel nails (figure 6).
 - Pull the nails from their panel.
5. Rear panel (figure 6).
6. Dash panel retainers (figure 7).
7. Lock pillar garnish molding screws (41) and the molding (42).
8. Carpet to floor panel bolts (28) (if equipped).
9. Carpet (29) from the vehicle.

→ Install or Connect (Figures 10 through 12)

1. Carpet (29) to the vehicle.
2. Carpet to floor panel bolts (28) (if equipped).
3. Lock pillar garnish molding (42) and the screws (41).
4. Dash panel retainers (figure 7).
5. Rear panel (figure 6).
 - Push the nails through the panel and into the body panels.
6. Rear panel nails (figure 6).
7. Front and rear door scuff plates (27).
8. Kick panel.
9. Seats and seat belts. Refer to SEATS (SEC. 10A1).

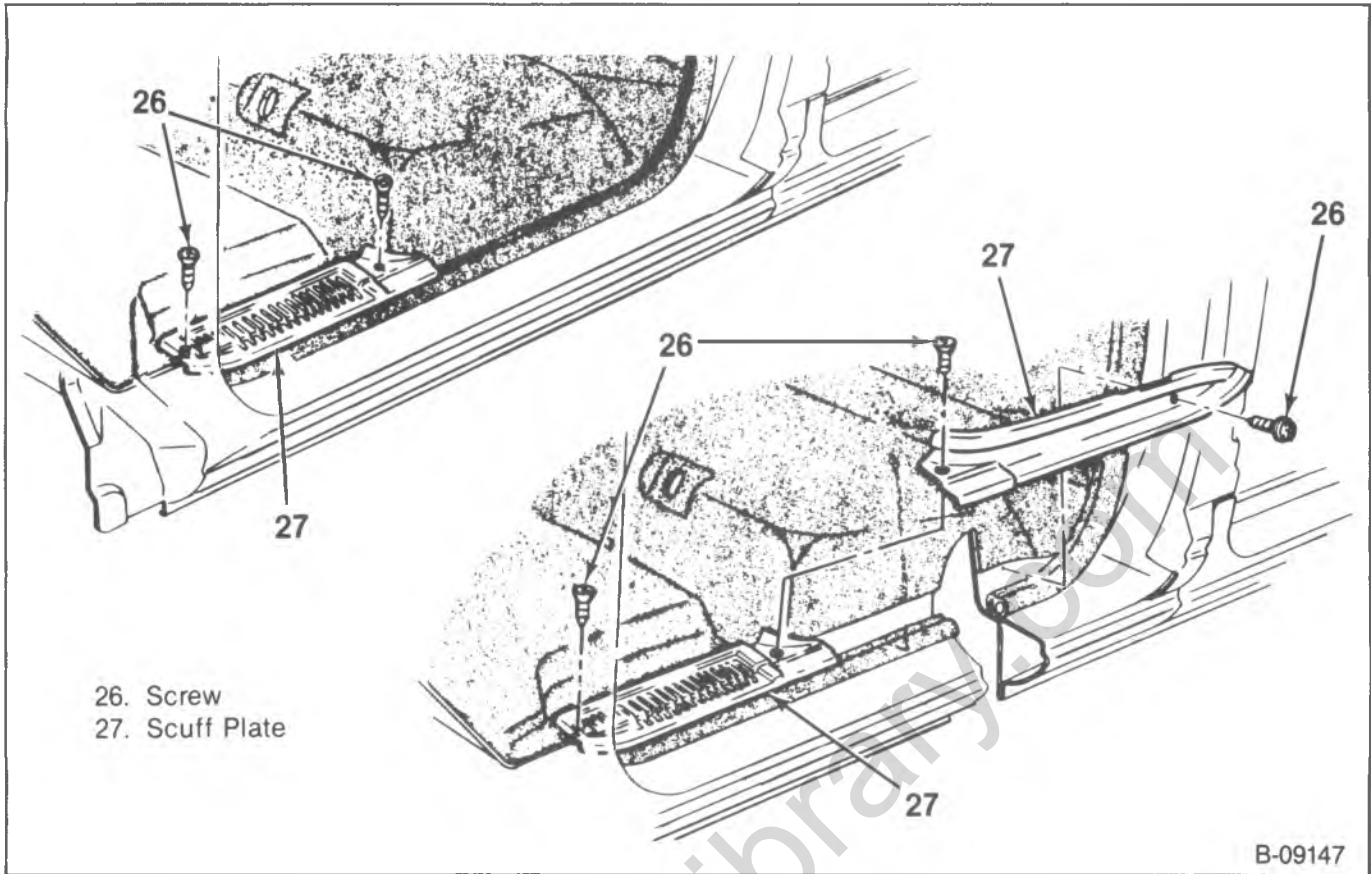

Figure 10—Front Door Sill Plate

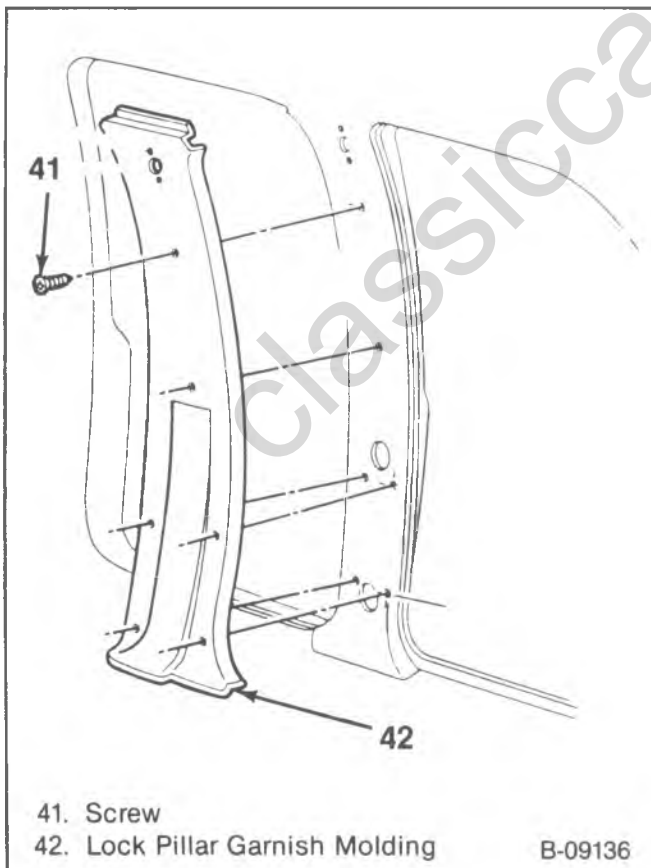

Figure 11—Lock Pillar Garnish Molding

HEADLINER AND TRIM REPLACEMENT

↔ Remove or Disconnect (Figures 13 and 14)

1. Windshield upper garnish molding screws (39) and the molding (31).
2. Side window garnish molding screws (40) and the molding (38).
3. Windshield garnish molding screws and the molding (30).
4. Back window garnish molding screws and the molding (35).
5. Lock pillar garnish molding screws and the molding.
6. Sunshade screws (44) and sunshade (43).
7. Headliner (32) from the vehicle.

↔ Install or Connect (Figures 13 and 14)

1. Headliner (32) to the vehicle.
2. Sunshade (43) and screws (44).
3. Lock pillar garnish molding and screws.
4. Back window garnish molding (35) and screws.
5. Windshield garnish molding (30) and screws.
6. Side window garnish molding (38) and screws (40).
7. Windshield upper garnish molding (31) and screws (39).

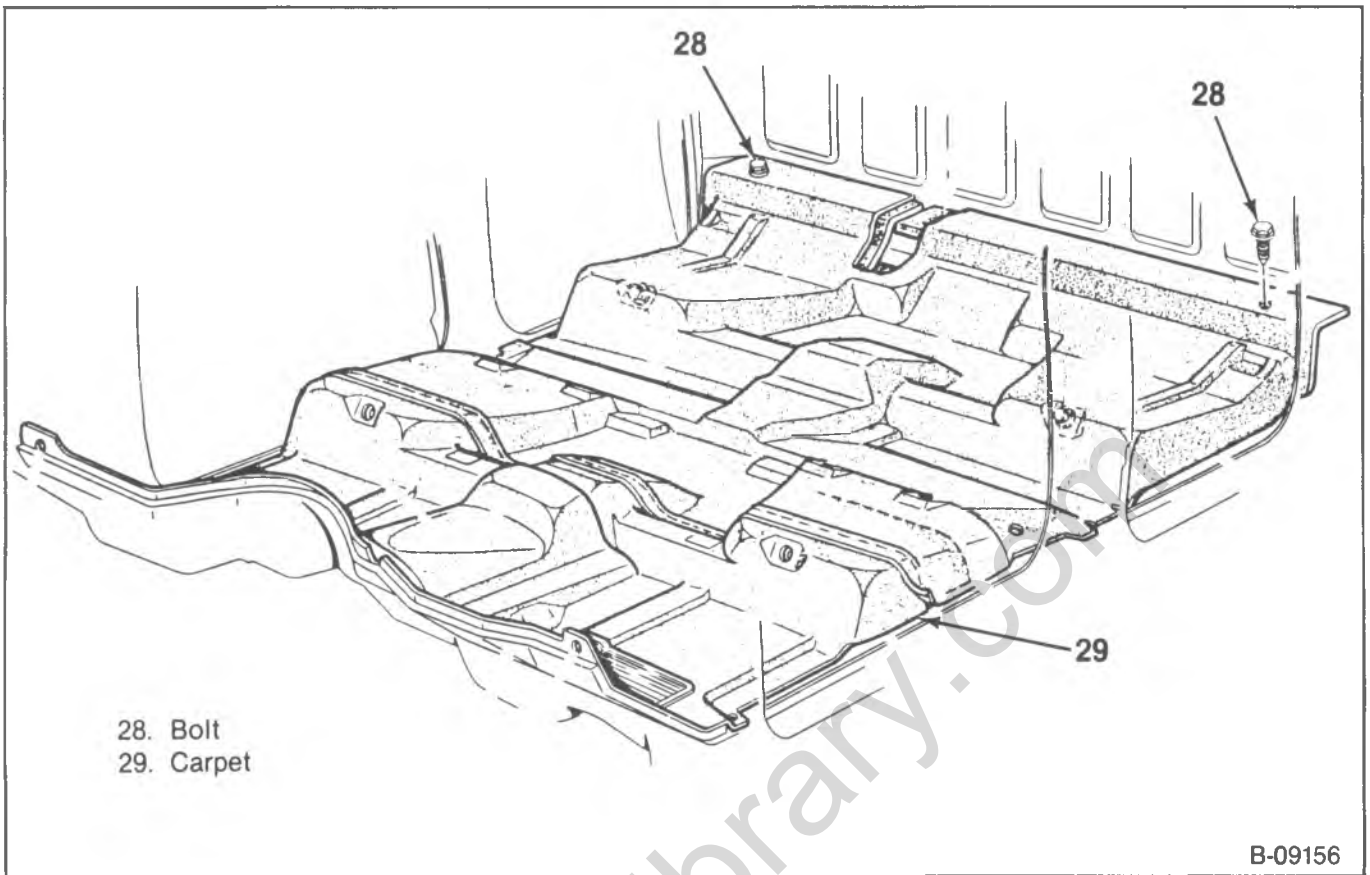

Figure 12—Carpet

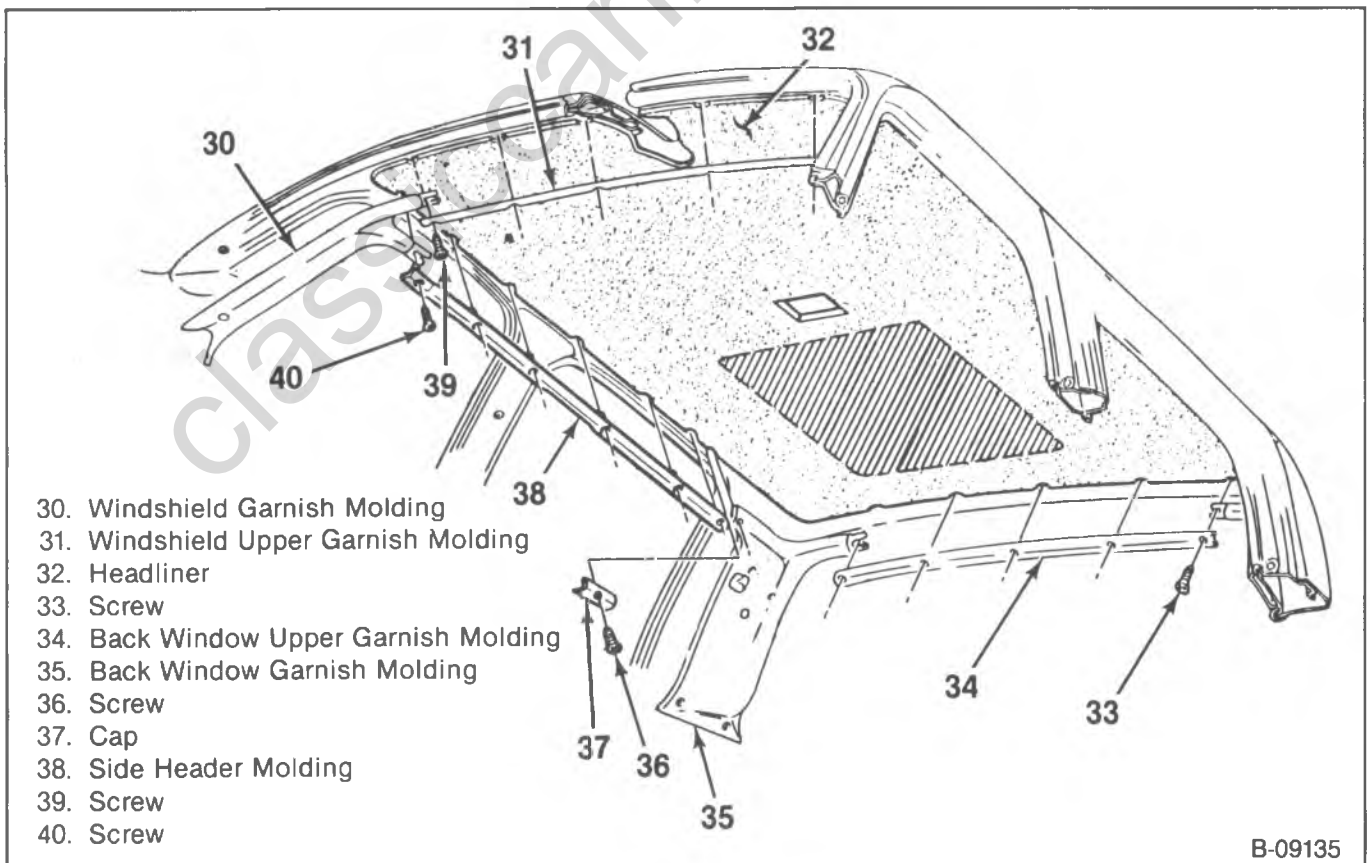

Figure 13—Headliner and Interior Trim

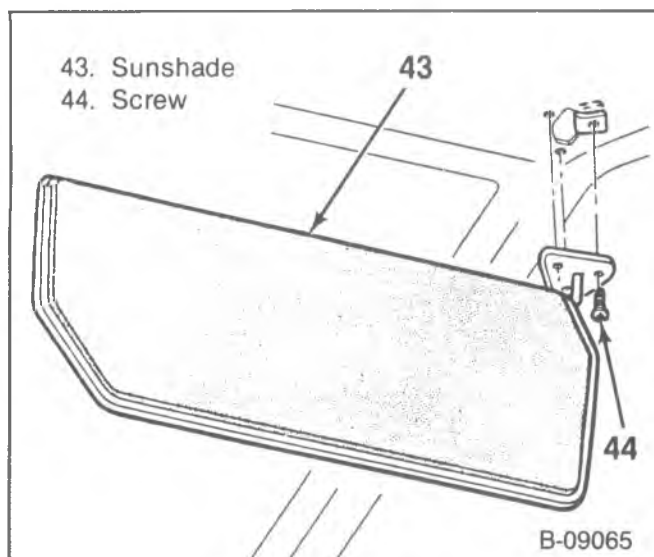

Figure 14—Sunshade

UTILITY VEHICLE MODELS

CARPET REPLACEMENT

↔ Remove or Disconnect (Figures 15 through 19)

1. Seats and seat belts. Refer to SEATS (SEC. 10A2).
2. Kick panel.
3. Front door scuff plate.
4. Side trim carpet panel screws (45) and the panel (46).
5. Side trim panel screws (47) and the panel (48).
6. Floor panel trim plate screws (49) and the trim plate (50).
7. Rear scuff plate screws (51) and the plate (52).
8. Dash panel retainers (figure 7).
9. Carpet (53) from the vehicle.

↔ Install or Connect (Figures 15 through 19)

1. Carpet (53) to the vehicle.
2. Dash panel retainers (figure 7).
3. Rear scuff plate (52) and screws (51).
4. Floor panel trim plate (50) and screws (49).
5. Side trim panel (48) and screws (47).
6. Side trim carpet panel (46) and screws (45).
7. Front door scuff plate.
8. Kick panel.
9. Seats and seat belts. Refer to SEATS (Sec. 10A2).

HEADLINER AND TRIM REPLACEMENT

↔ Remove or Disconnect (Figure 20)

1. Windshield upper garnish molding screws (56) and the molding (55).
2. Side window garnish molding screws (58) and the molding (59).
3. Windshield garnish molding screws and the molding (57).

4. Roof rear header molding screws (60) and the molding (53).
5. Lock pillar garnish molding screws and the molding (61).
6. Sunshade screws and sunshade (figure 14).
7. Headliner (54) from the vehicle.

↔ Install or Connect (Figure 20)

1. Headliner (54) to the vehicle.
2. Sunshade and screws (figure 14).
3. Lock pillar garnish molding (61) and screws.
4. Roof rear header molding (53) and screws (60).
5. Windshield garnish molding (57) and screws.
6. Side window garnish molding (59) and screws (58).
7. Windshield upper garnish molding (55) and screws (56).

FRONT FLOOR COMPARTMENT REPLACEMENT

↔ Remove or Disconnect (Figure 21)

- Open the compartment door.

 1. Compartment to floor bolts (74).
 2. Compartment from the vehicle.

↔ Install or Connect (Figure 21)

1. Compartment to the vehicle.
2. Compartment to the floor bolts (74).

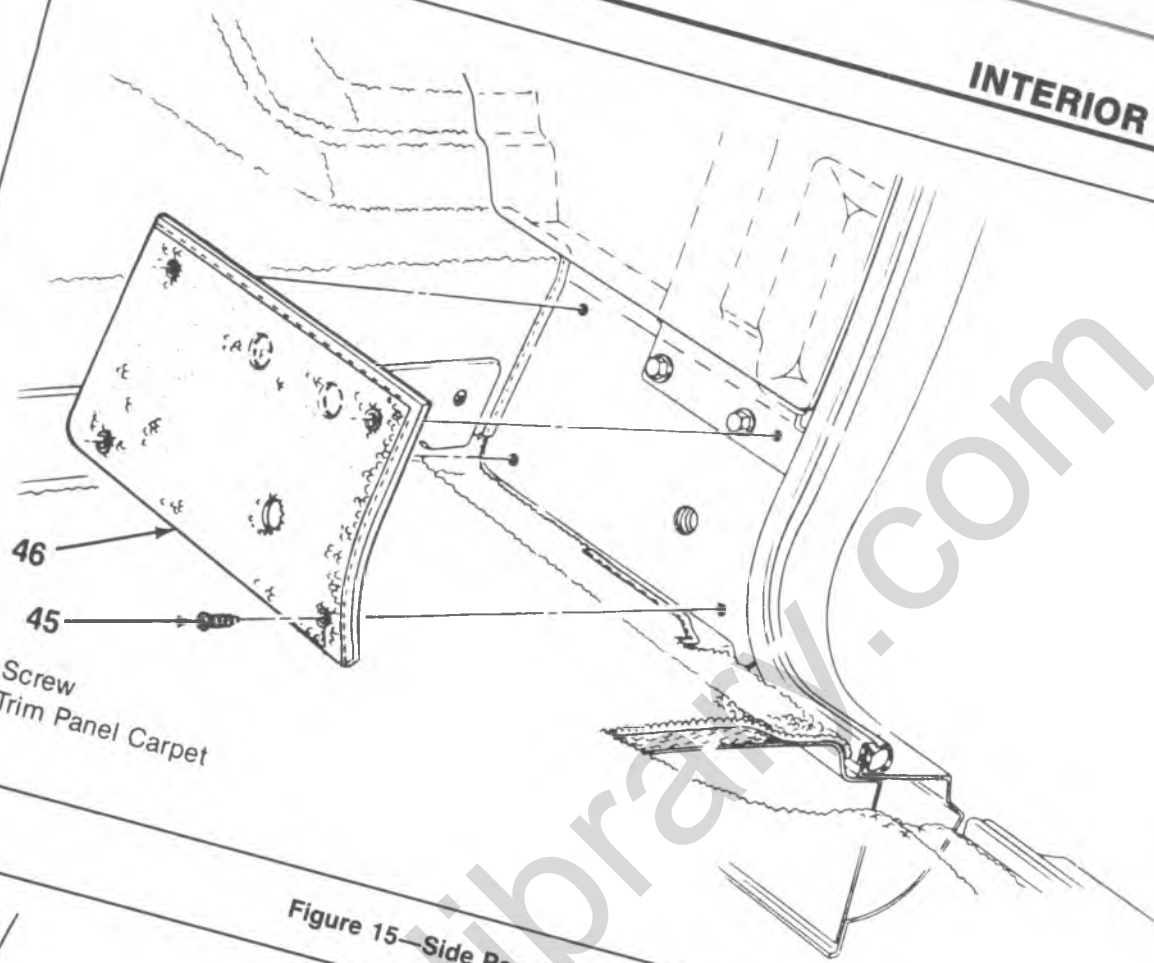

- 45. Screw
- 46. Trim Panel Carpet

Figure 15—Side Panel Trim Carpet

B-09144

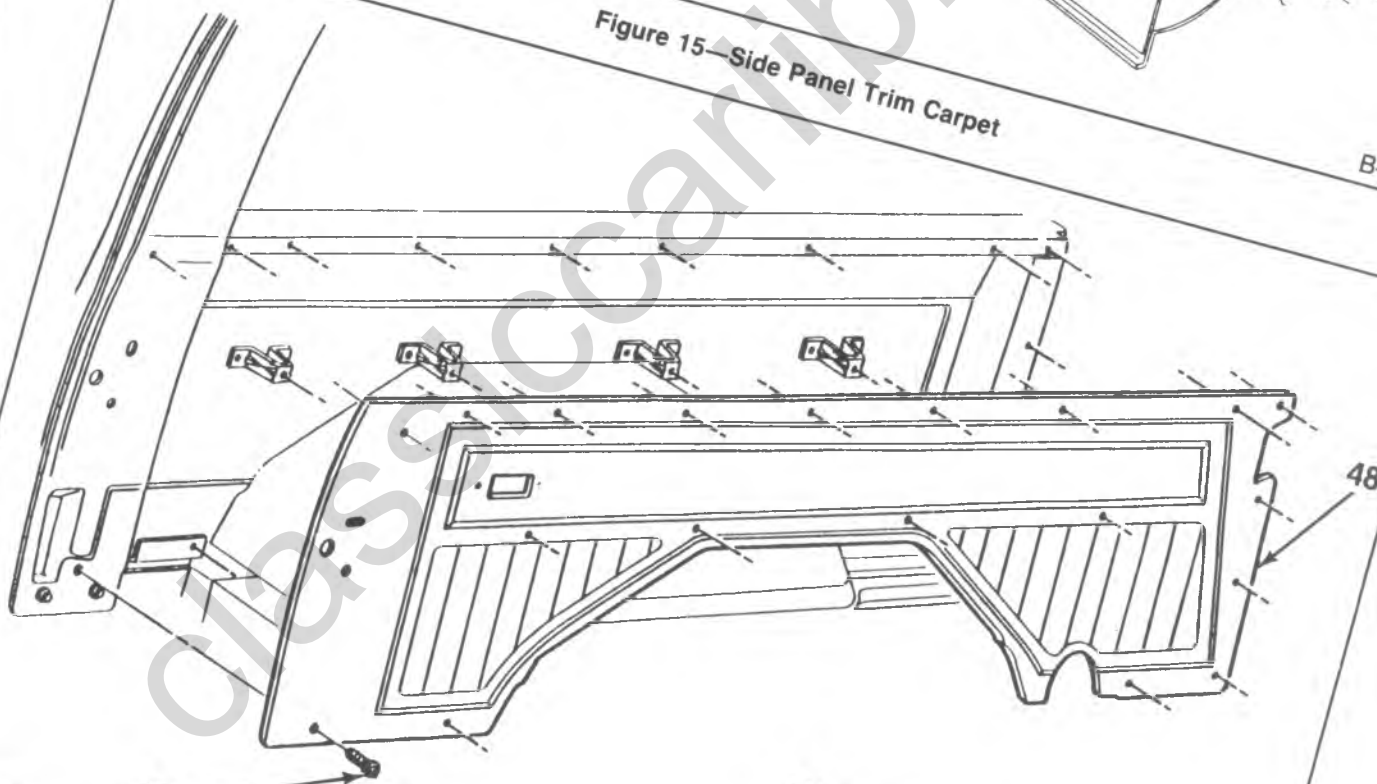

- 47. Screw
- 48. Side Trim Panel

Figure 16—Side Trim Panel

B-09111

10A4-10 INTERIOR TRIM

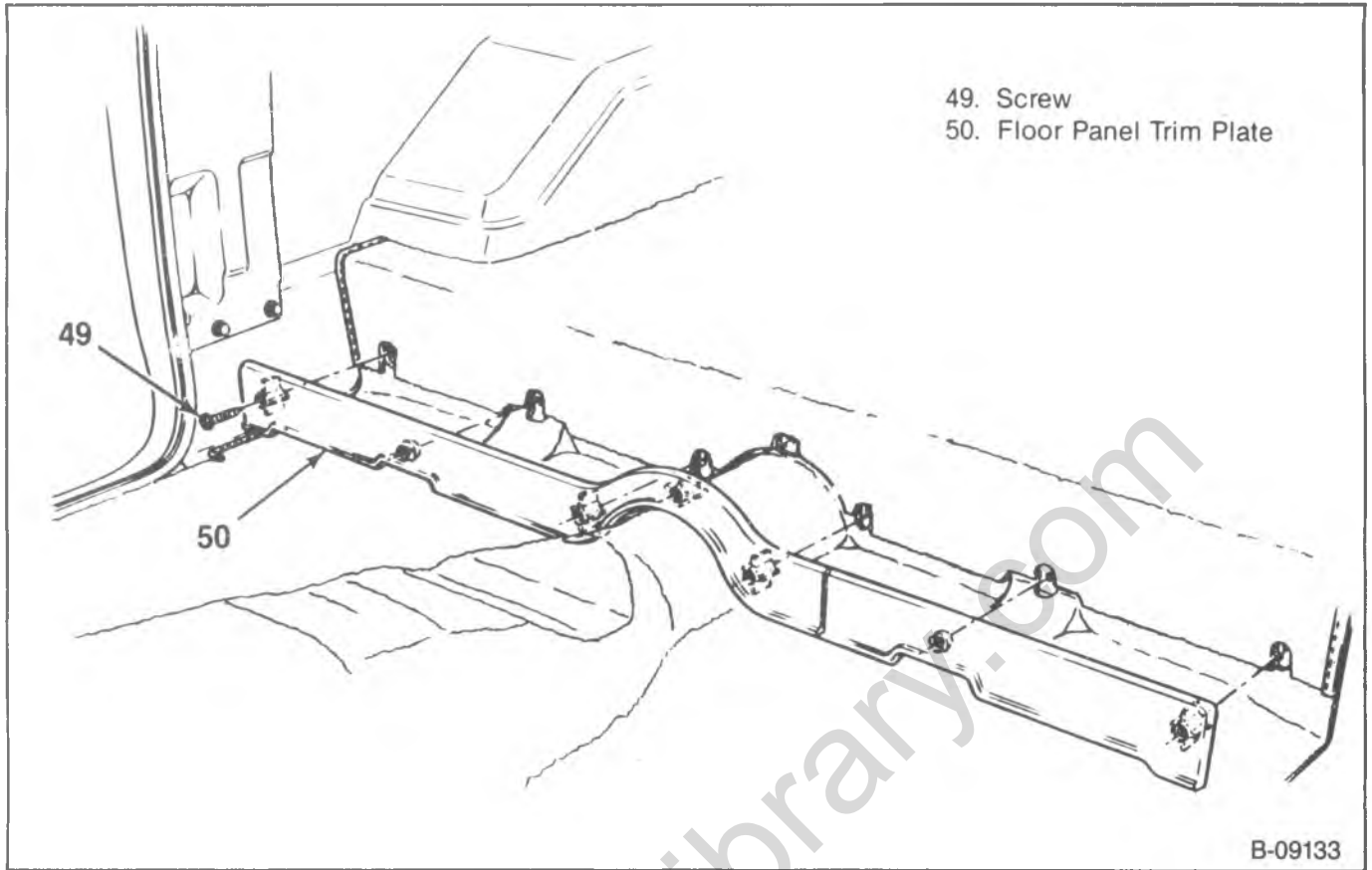

Figure 17—Floor Panel Trim Panel

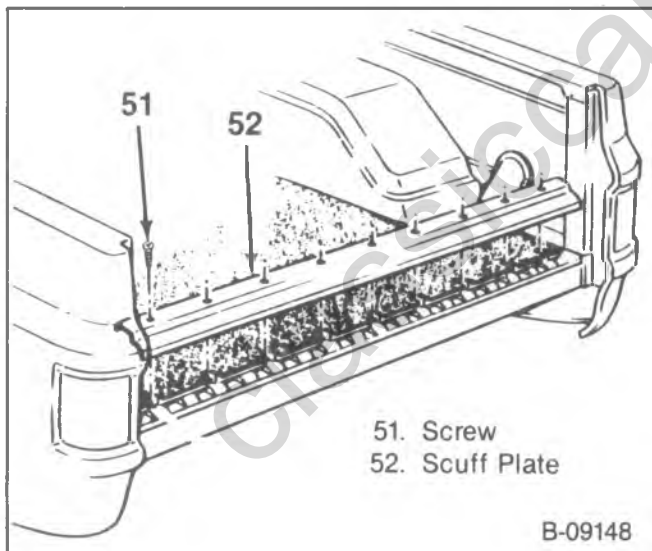

Figure 18—Rear Scuff Plate

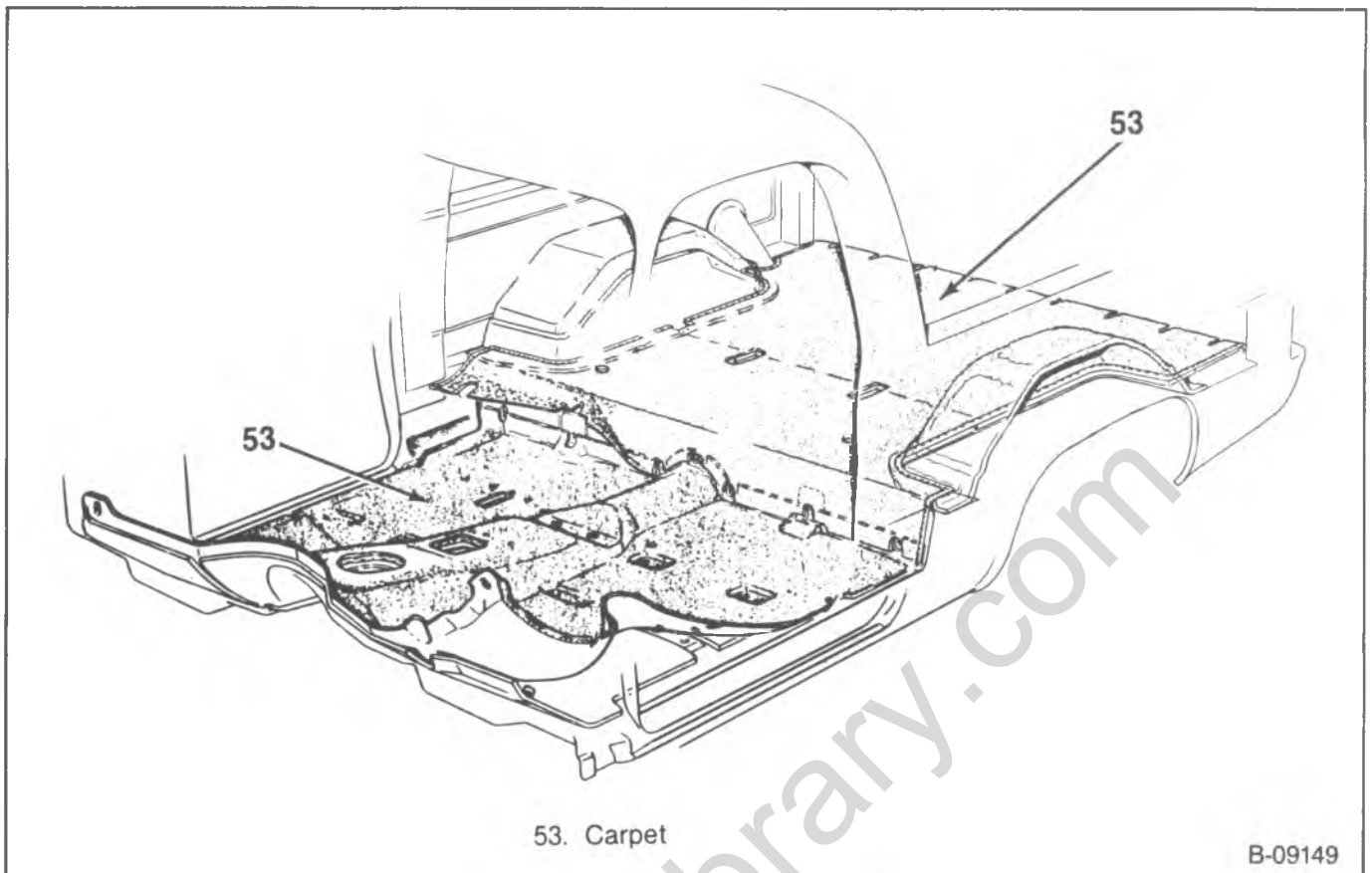

Figure 19—Carpet Assemblies

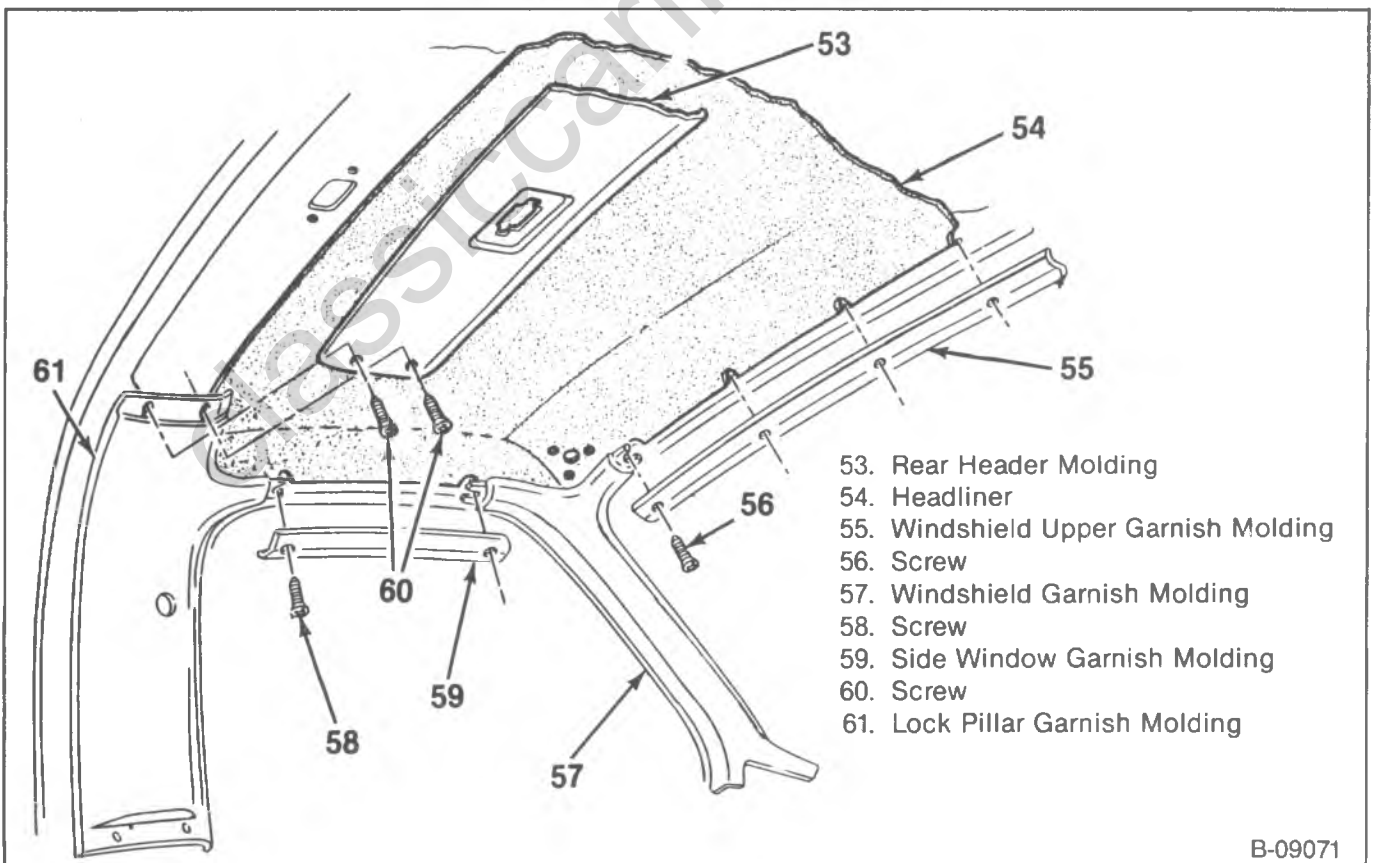
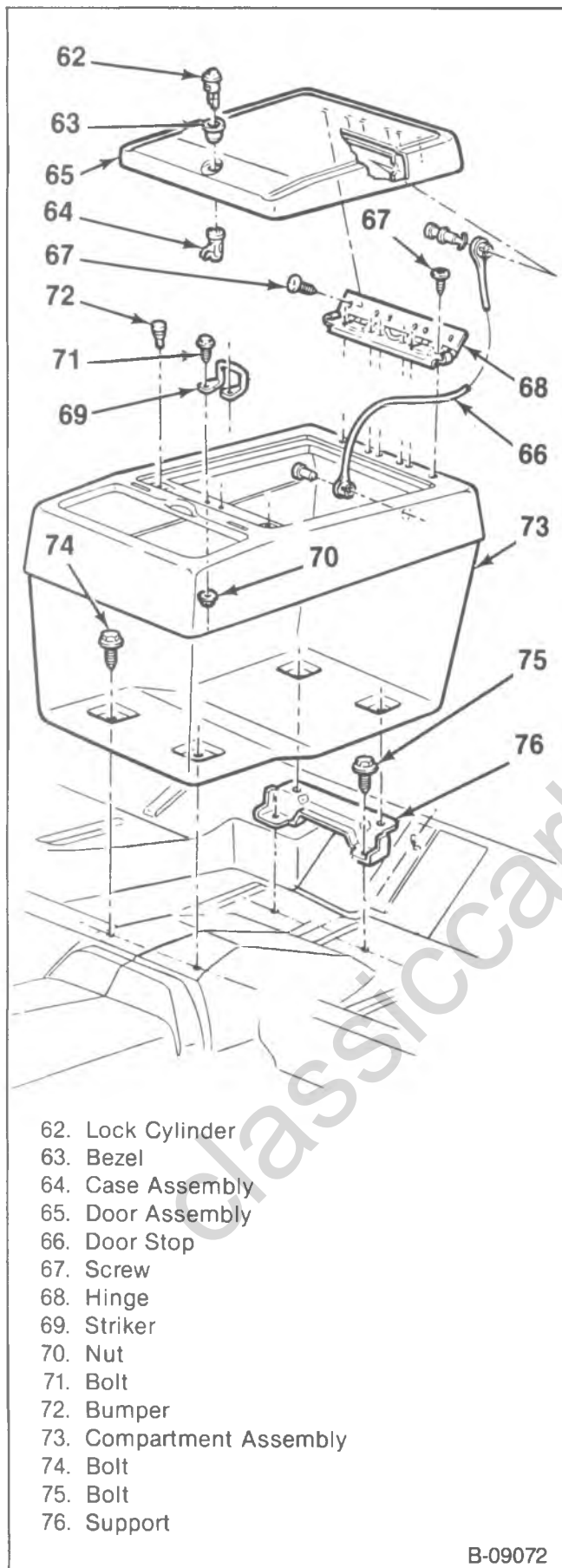

Figure 20—Headliner and Interior Trim

10A4-12 INTERIOR TRIM



- 62. Lock Cylinder
- 63. Bezel
- 64. Case Assembly
- 65. Door Assembly
- 66. Door Stop
- 67. Screw
- 68. Hinge
- 69. Striker
- 70. Nut
- 71. Bolt
- 72. Bumper
- 73. Compartment Assembly
- 74. Bolt
- 75. Bolt
- 76. Support

B-09072

Figure 21—Floor Compartment

SUBURBAN MODEL

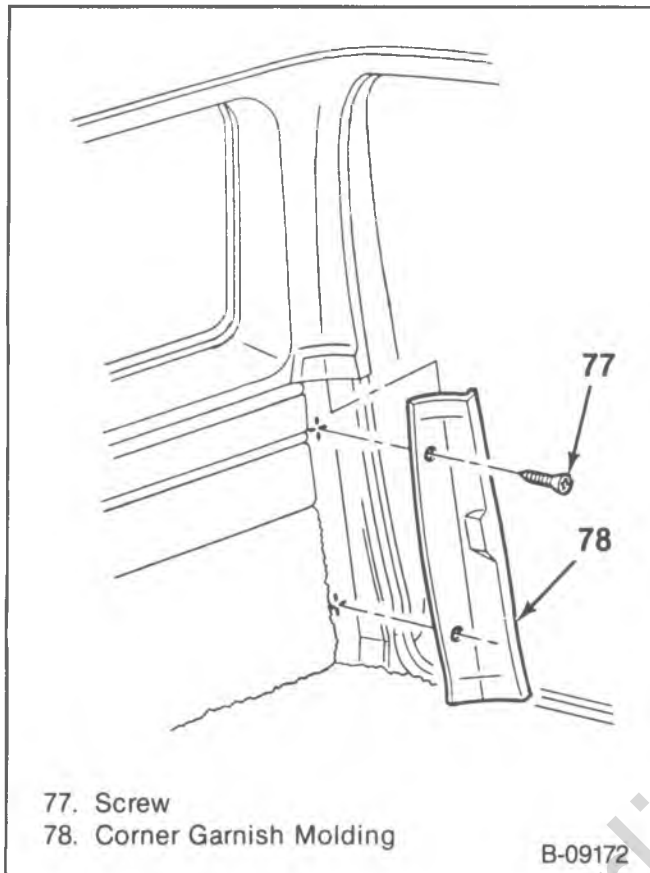

Figure 22—Corner Garnish Molding

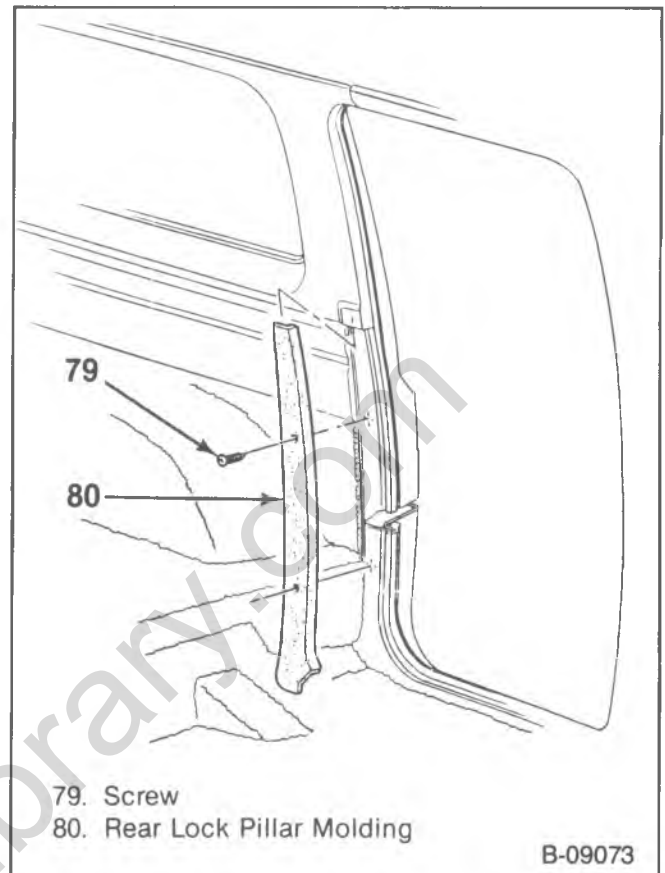

Figure 23—Rear Lock Pillar Molding

CARPET REPLACEMENT

↔ Remove or Disconnect (Figures 22 through 27)

1. Seats and seat belts. Refer to SEATS (SEC. 10A1).
2. Front and rear door scuff plates (figure 5).
3. Kick panel.
4. Rear corner garnish molding screws (77) and the molding (78).
5. Rear lock pillar garnish molding screws (79) and the molding (80).
6. Front lock pillar garnish molding screws (81) and the molding (82).
7. Body side trim panel screws (83) and the panel (84).
8. Front scuff plate screws (85) and the plate (86).
9. Rear scuff plate screws (87) and the plate (88).
10. Dash panel retainers (figure 7).
11. Carpet (89) from the vehicle.

↔ Install or Connect (Figures 22 through 27)

1. Carpet (89) to the vehicle.
2. Dash panel retainers (figure 7).
3. Rear scuff plate (88) and the screws (87).
4. Front scuff plate (86) and the screws (85).
5. Body side trim panel (84) and the screws.
6. Front lock pillar garnish molding (82) and the screws (81).
7. Rear lock pillar garnish molding (80) and the screws (79).

8. Rear corner garnish molding (78) and the screws (77).
9. Kick panel.
10. Front and rear door scuff plates (figure 5).
11. Seats and seat belts. Refer to SEATS (SEC. 10A1).

HEADLINER AND TRIM REPLACEMENT

↔ Remove or Disconnect (Figures 28 and 29)

1. Windshield upper garnish molding screws (90) and the molding (91).
2. Side header garnish molding screws (92) and the molding (93).
3. Windshield garnish molding screws and the molding (94).
4. Rear roof header molding screws (95) and the molding (96).
5. Side header rear garnish molding screws (97) and the molding (98) (if equipped).
6. Upper side garnish molding screws (99) and the molding (100) (if equipped).
7. Roof inner trim panel screws (101) and the panel (102).
8. Headliner (103) from the vehicle.

↔ Install or Connect (Figures 28 and 29)

1. Headliner (103) to the vehicle.
2. Roof inner trim panel (102) and screws (101).

ROOF REAR HEADER TRIM PANEL

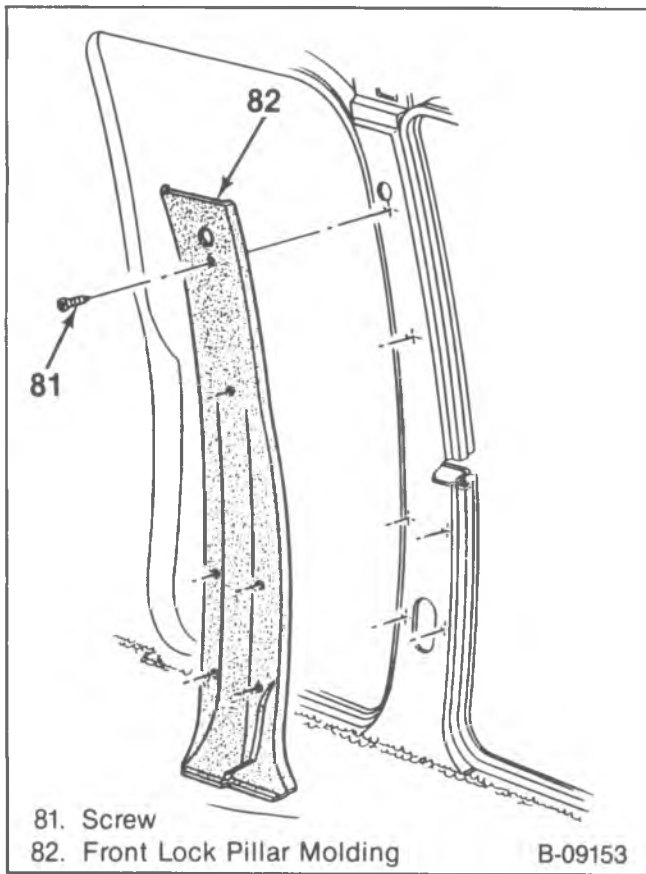

↔ Remove or Disconnect (Figures 30 and 31)

1. Lower trim panel screws (104) and the lower panel (105).
2. Upper trim panel screws (106) and the upper panel (107).

→ Install or Connect (Figures 30 and 31)

1. Upper trim panel (107) and the screws (106).
2. Lower trim panel (105) and the screws (104).

Figure 24—Front Lock Pillar Molding

3. Upper side garnish molding (100) and screws (99) (if equipped).
4. Side header rear garnish molding (98) and screws (97) (if equipped).
5. Rear roof header molding (96) and screws (95).
6. Windshield garnish molding (94) and screws.
7. Side header garnish molding (93) and screws (92).
8. Windshield upper garnish molding (91) and screws (90).

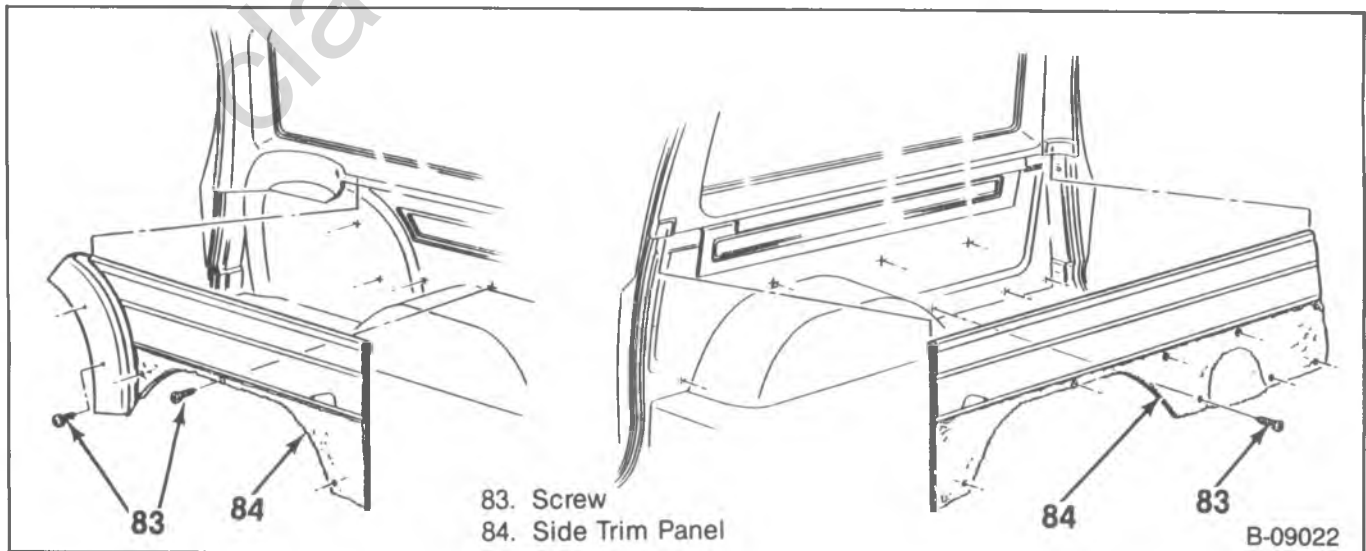

Figure 25—Side Trim Panel

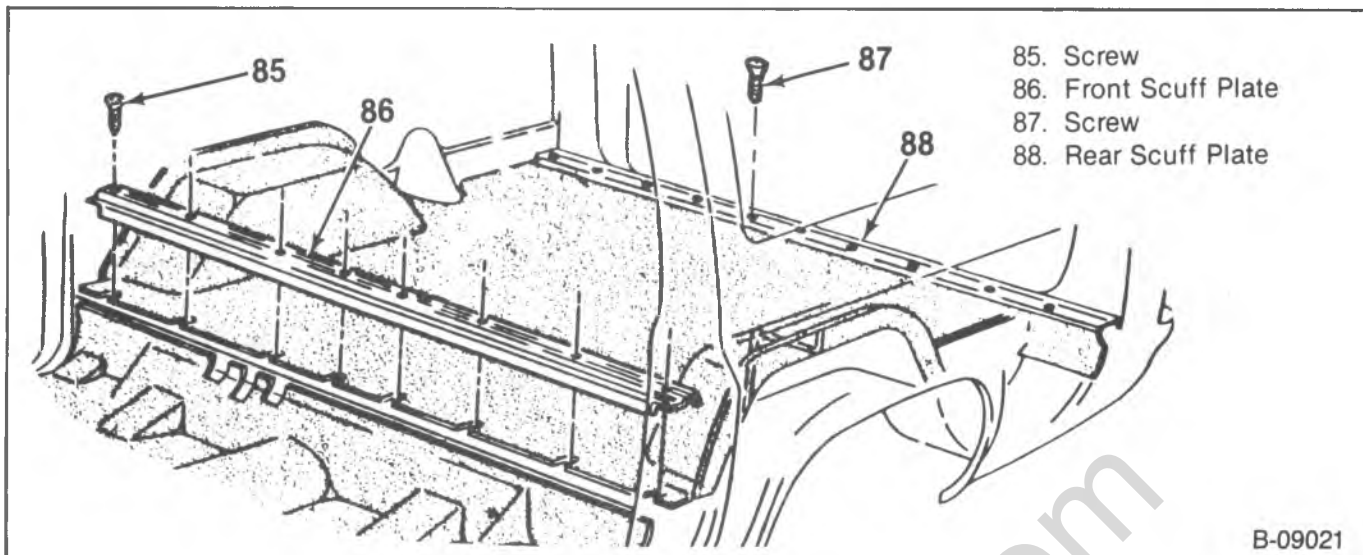

Figure 26—Scuff Plates

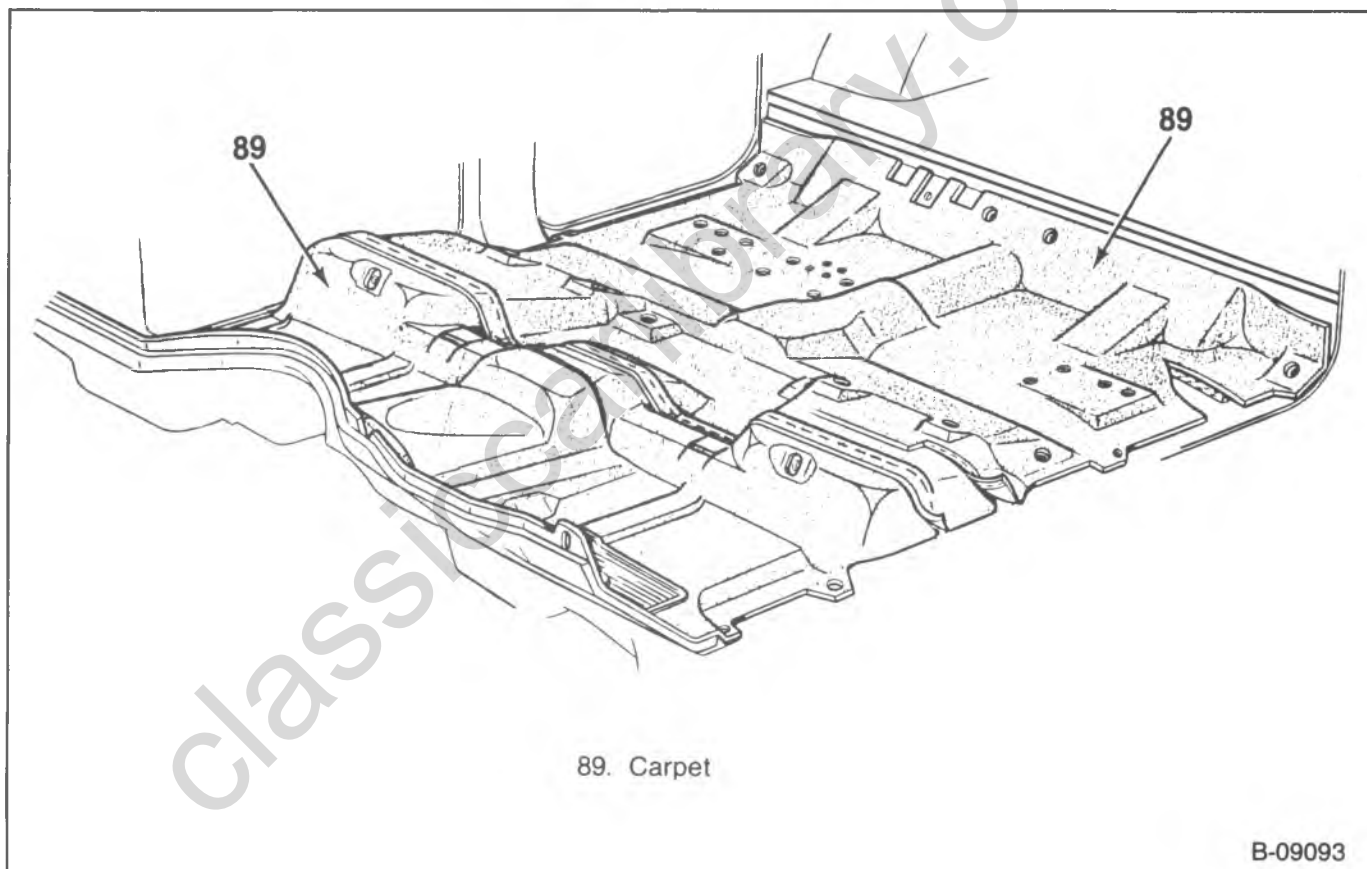

Figure 27—Carpet

10A4-16 INTERIOR TRIM

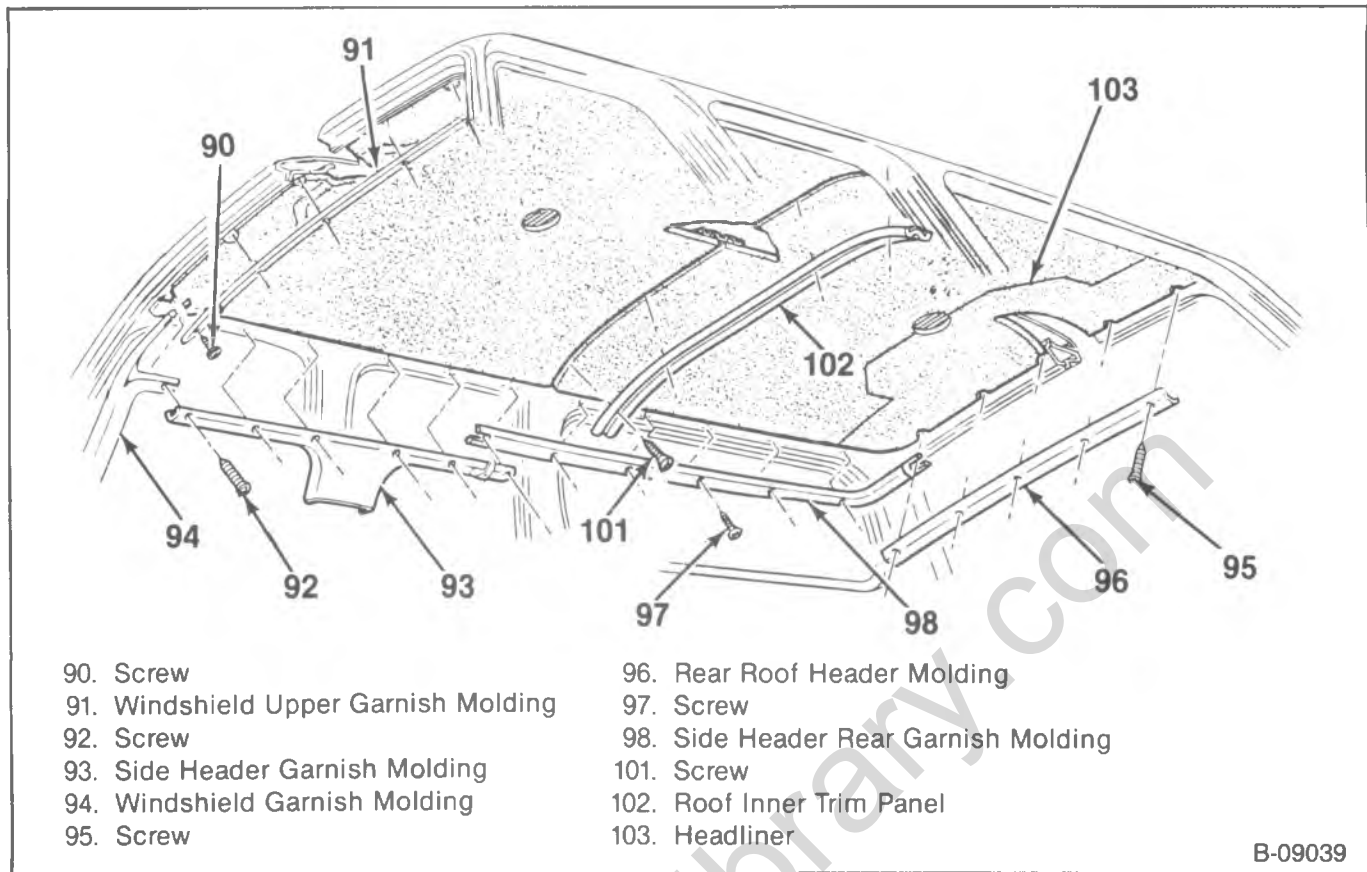

Figure 28—Headliner and Interior Trim

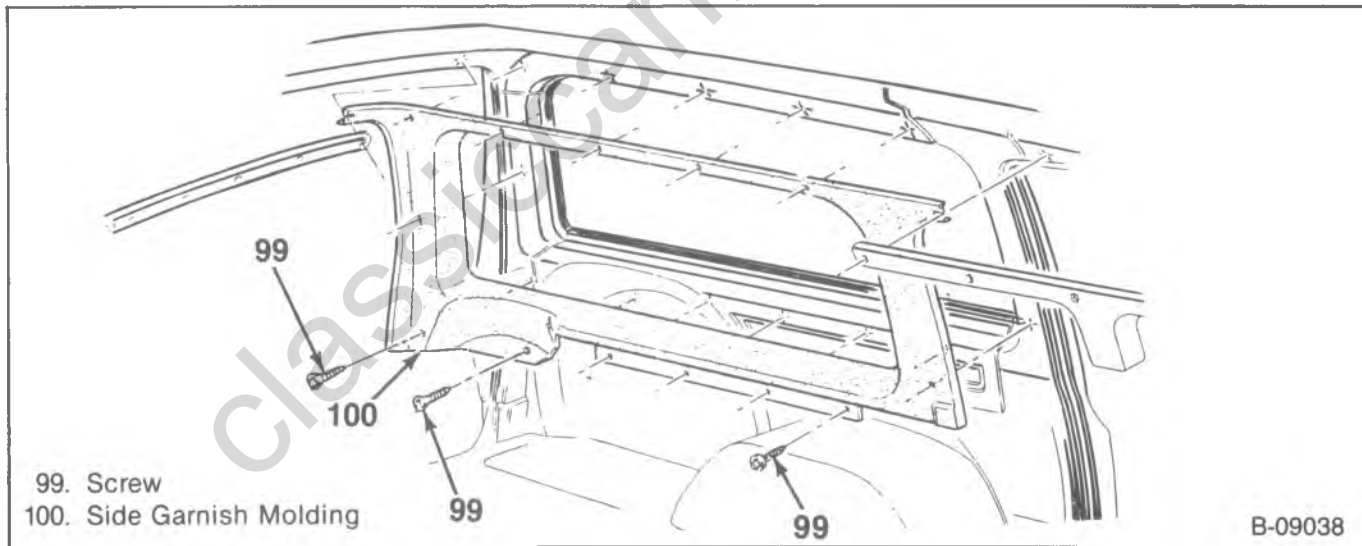

Figure 29—Side Garnish Molding

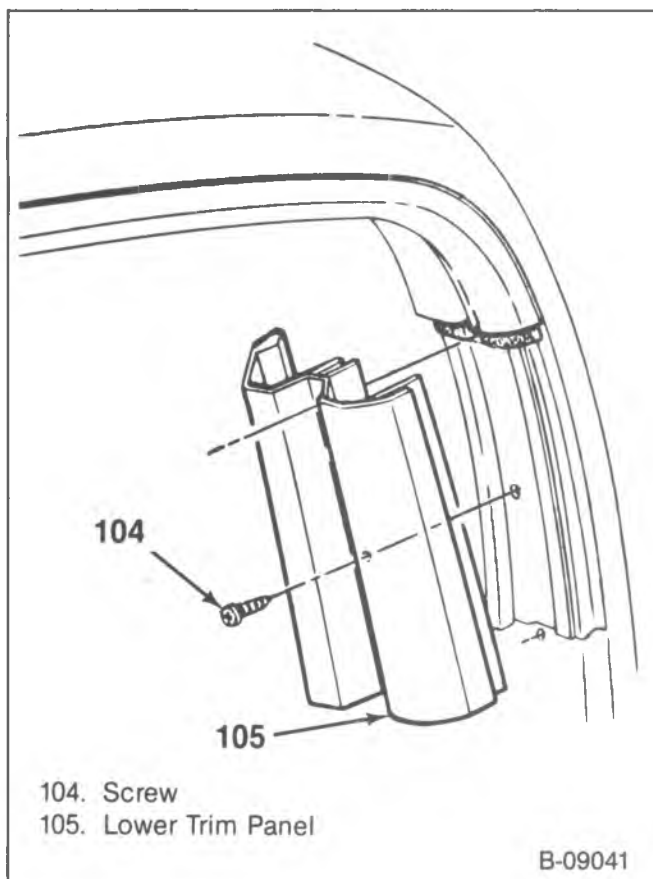

Figure 30—Rear Header Lower Trim Panel

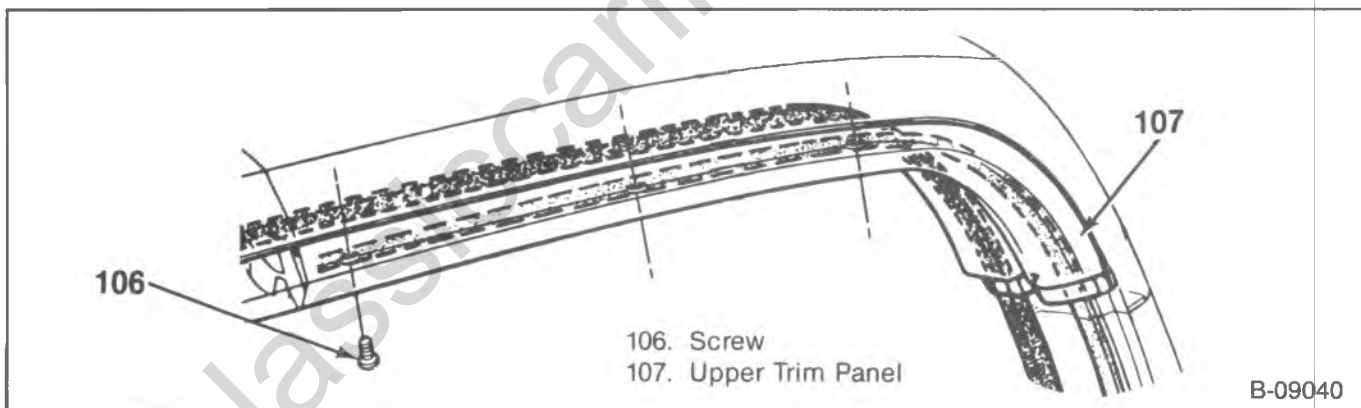

Figure 31—Rear Header Upper Trim Panel

G MODEL INTERIOR TRIM

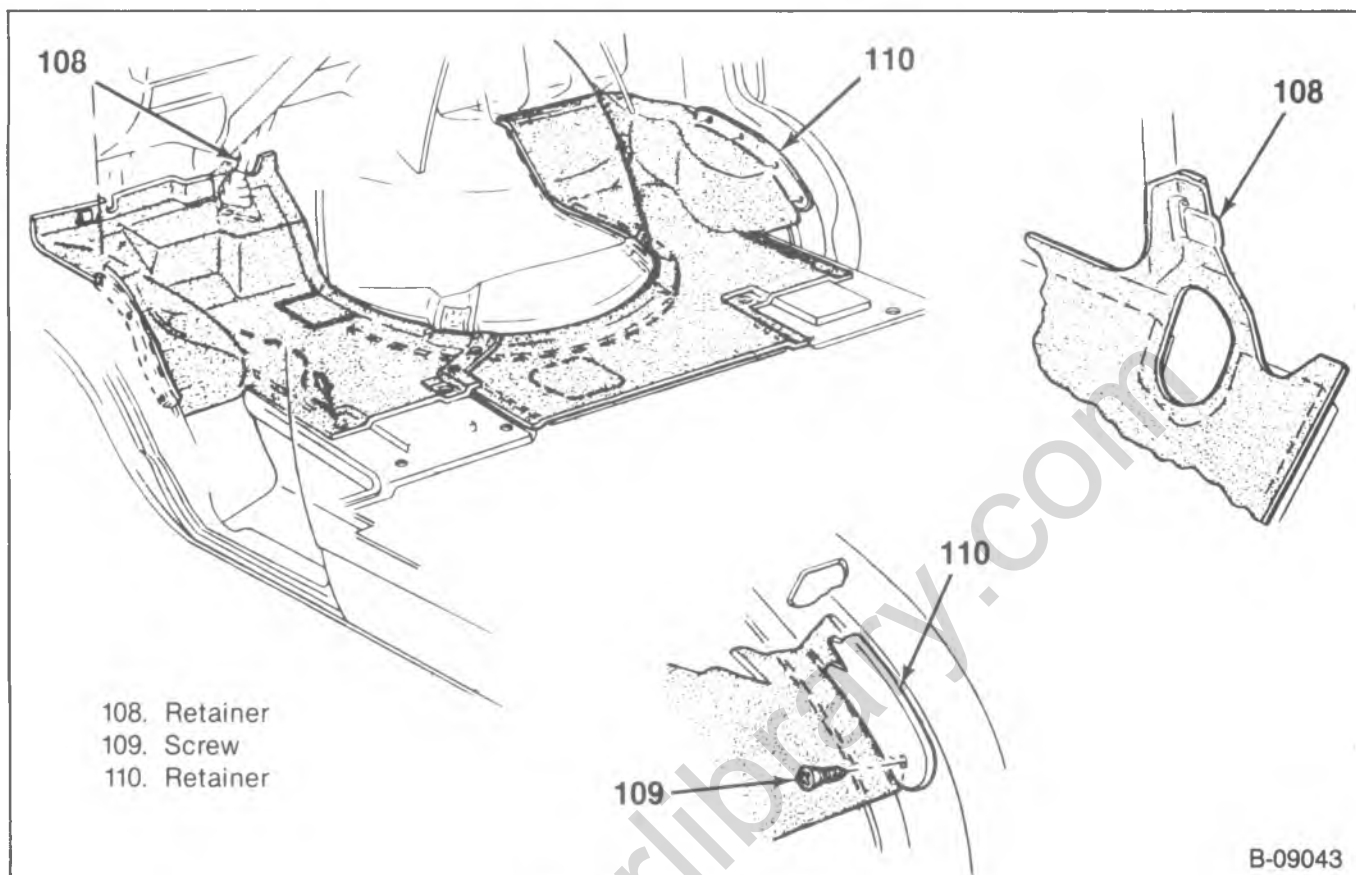

Figure 32—Carpet Retainers

CARPET REPLACEMENT

↔ Remove or Disconnect (Figures 32 through 41)

1. Seats. Refer to SEATS (SEC. 10A2).
2. Front carpet retainer (110).
3. Front door scuff plate (112).
4. Front step panel mat (if equipped) (114).
5. Carpet from the dash retainers (108).
 - Bend the retainers away from the dash.
6. Front carpet (115) from the vehicle.
7. Side door scuff plate (116).
8. Side door mat (if equipped) (118).
9. Carpet to side door screws (119).
10. Rear door scuff plate (121).
11. Front trim panel (123).
12. Rear trim panel (125).
13. Rear corner panel (127).
14. Rear carpet from the vehicle.

↔ Install or Connect (Figures 32 through 41)

1. Rear carpet to the vehicle.
2. Rear corner panel (127).
3. Rear trim panel (125).
4. Front trim panel (123).
5. Rear door scuff plate (121).
6. Carpet to side door screws (119).
7. Side door mat (if equipped) (118).

8. Side door scuff plate (116).
9. Front carpet (115) to the vehicle.
10. Carpet to the dash retainers (108).
 - Bend the retainers over the carpet.
11. Front step panel mat (if equipped) (114).
12. Front door scuff plate (112).
13. Front carpet retainer (110).
14. Seats. Refer to SEATS (SEC. 10A2).

HEADLINER REPLACEMENT

↔ Remove or Disconnect (Figure 42)

1. Upper window trim that supports the headliner. Refer to "Interior Trim Replacement."
2. Headliner retainer bow (if equipped).
 - Pull the bow (128) from the retainer.
3. Retainer bolts (129) and the retainers (130).
4. Headliner (131) from the vehicle.
 - Shift the headliner from side to side to disengage the headliner from the clips.

↔ Install or Connect (Figure 42)

1. Headliner (131) to the vehicle.
 - Place the headliner into the roof clips.
2. Retainers (130) to the headliner, and the retainer bolts (129).
3. Headliner retainer bow (if equipped).

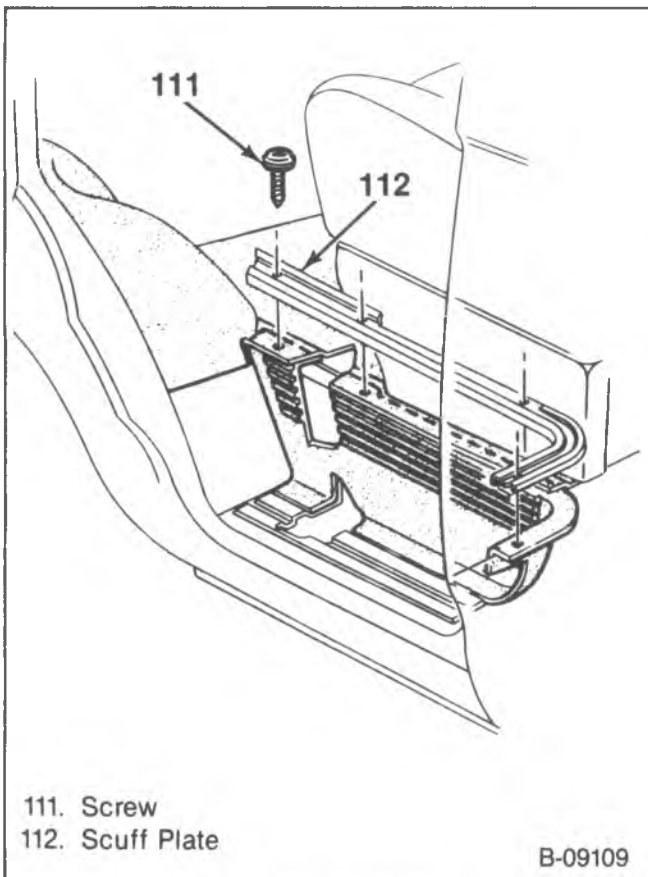

Figure 33—Scuff Plate

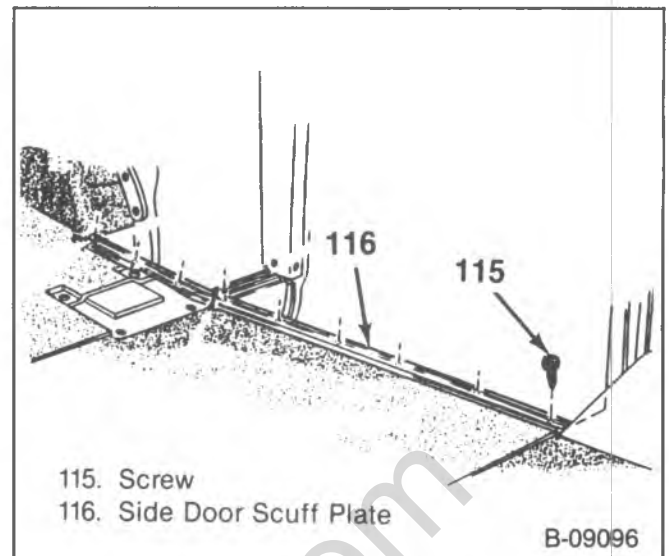

Figure 35—Side Door Scuff Plates

- Push the bow (128) onto the retainer.
- 4. Upper window trim that supports the headliner. Refer to "Interior Trim Replacement."

INTERIOR TRIM REPLACEMENT

↔ Remove or Disconnect

1. Lock pillar garnish molding screws and the lock pillar garnish molding (figure 43).
2. Front door hinge pillar molding screws and the front door hinge pillar molding (figure 44).
3. Sunshade screws and the sunshade (figure 45).
4. Front header garnish molding screws and the front header garnish molding (figure 46).
5. Roof side rail garnish molding (figure 47). For vehicles with intermediate doors only.
6. Roof side header garnish molding (figure 48). For vehicles with the sliding side door only.
7. Lower lock pillar garnish molding screws and the molding (figure 49).
8. Body side front garnish molding screws and the molding (figure 49).
9. Roof rear header garnish molding screws and the molding (figure 50).
10. Body rear corner garnish molding screws and the molding (figure 51).
11. Body side rear garnish molding screws and the molding (figure 52).
12. Body side front trim panel screws and the trim panel (figure 39).
 - Pull the panel from the retainers.
13. Body side rear trim panel screws and the trim panel (figure 40).
 - Pull the panel from the retainers.
14. Body side trim rear corner panel screws and the panel (figure 41).
 - Pull the panel from the retainers.

→ Install or Connect

1. Body side trim rear panel and screws (figure 41).
2. Body side rear trim panel and screws (figure 40).

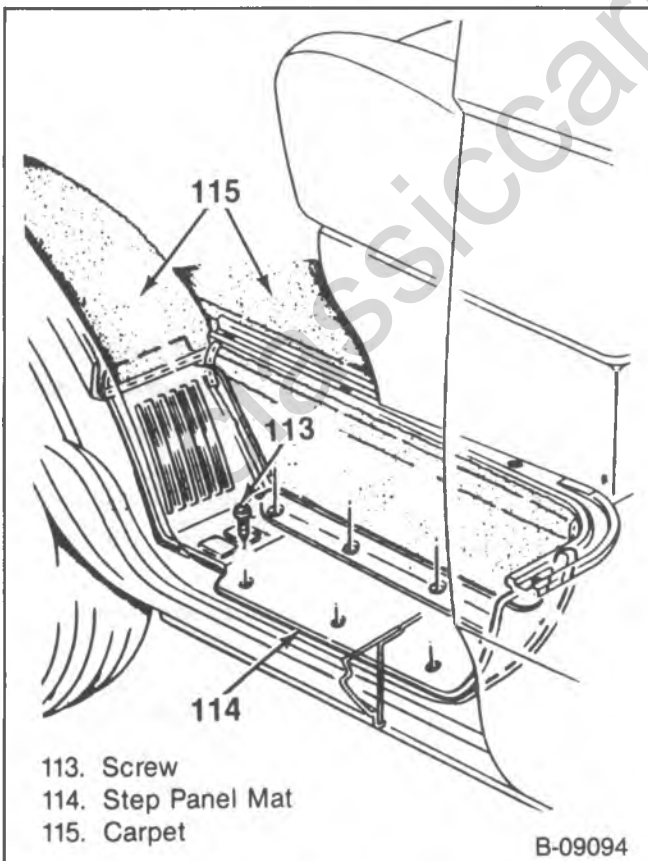

Figure 34—Step Panel Mat

10A4-20 INTERIOR TRIM

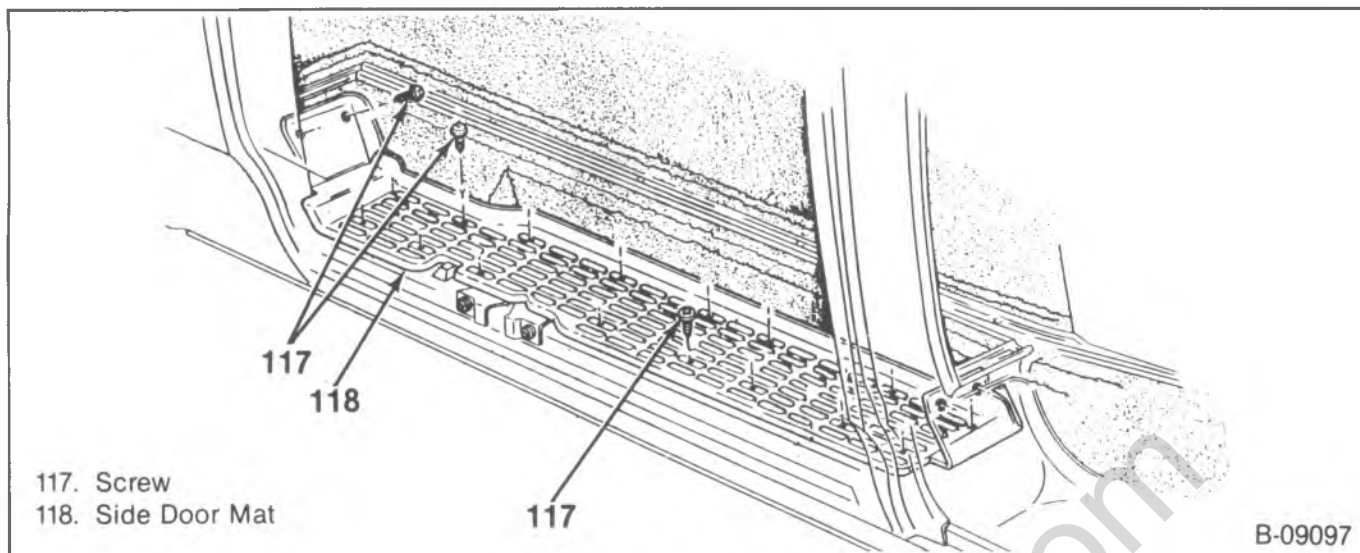

Figure 36—Side Door Mat

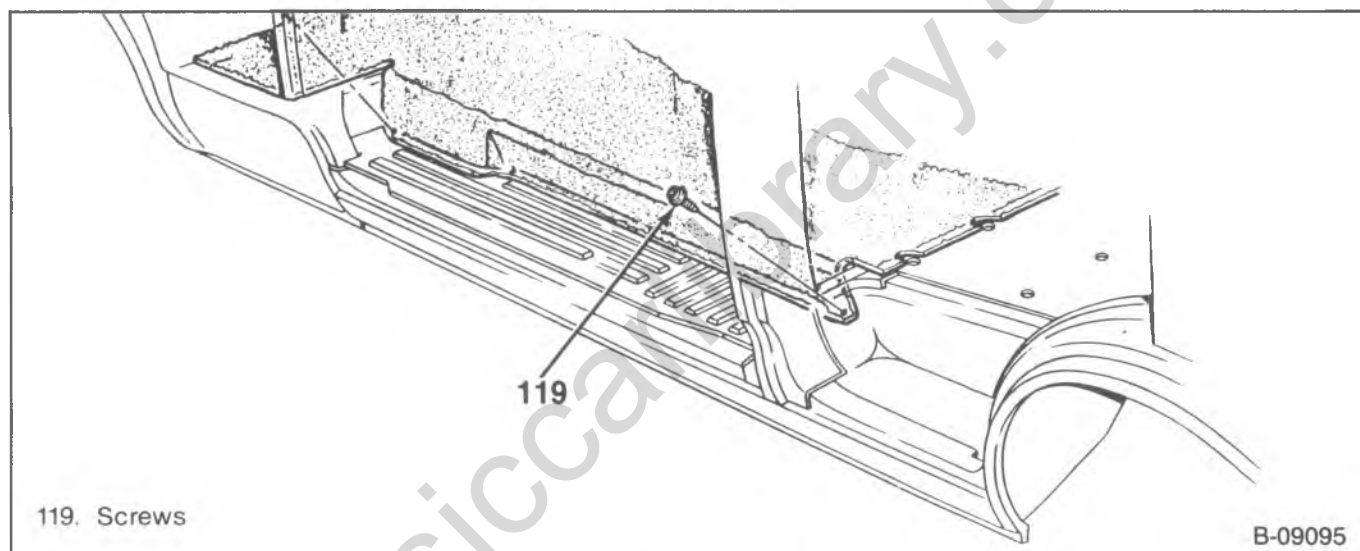

Figure 37—Floor Carpet Bolts

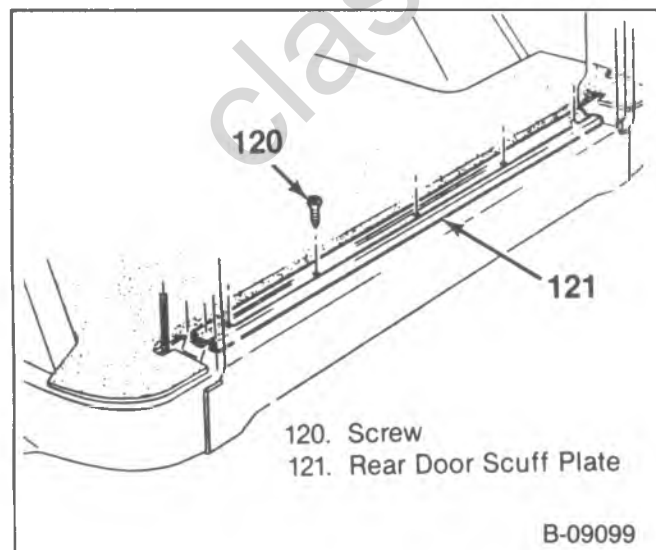

Figure 38—Rear Door Scuff Plates

3. Body side front trim panel and screws (figure 39).
4. Body side rear garnish molding and screws (figure 52).
5. Body rear corner garnish molding and screws (figure 51).
6. Roof rear head garnish molding and screws (figure 50).
7. Body side front garnish molding and screws (figure 49).
8. Lower lock pillar garnish molding and screws (figure 49).
9. Roof side header garnish molding and screws (figure 48). For vehicles with the sliding side door only.
10. Roof side rail garnish molding and screws (figure 47). For vehicles with intermediate doors only.
11. Front header garnish molding and screws (figure 46).
12. Sunshade and screws (figure 45).
13. Front door hinge pillar molding and screws (figure 44).
14. Lock pillar garnish molding and screws (figure 43).

ENGINE COVER REPLACEMENT

↔ Remove or Disconnect (Figures 53 and 54)

1. Instrument panel lower extension screws (150), washers (151), and shims (152).
2. Instrument panel lower extension (153).
3. Engine cover (158) to floor panel bolts (156).
4. Clamp (157) from the pin (155).
5. Engine cover (158) from the vehicle.

↔ Install or Connect (Figures 53 and 54)

1. Engine cover (158) to the vehicle.
2. Clamp (157) to the pin (155).
3. Engine cover (158) to floor panel bolts (156).
4. Instrument panel lower extension (153).
5. Instrument panel lower extension screws (150), washers (151) and shims (152).

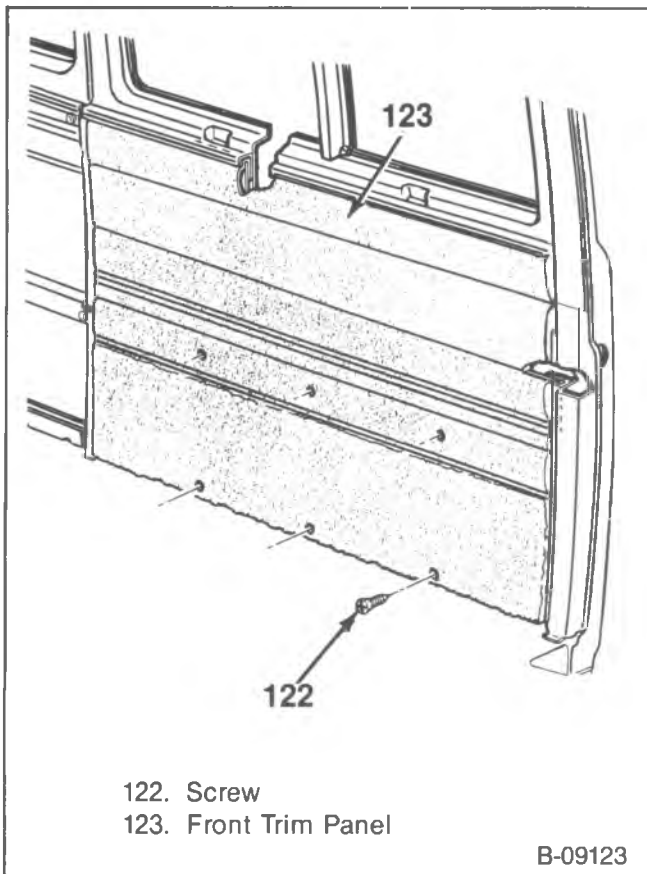

122. Screw
123. Front Trim Panel

B-09123

Figure 39—Front Trim Panel

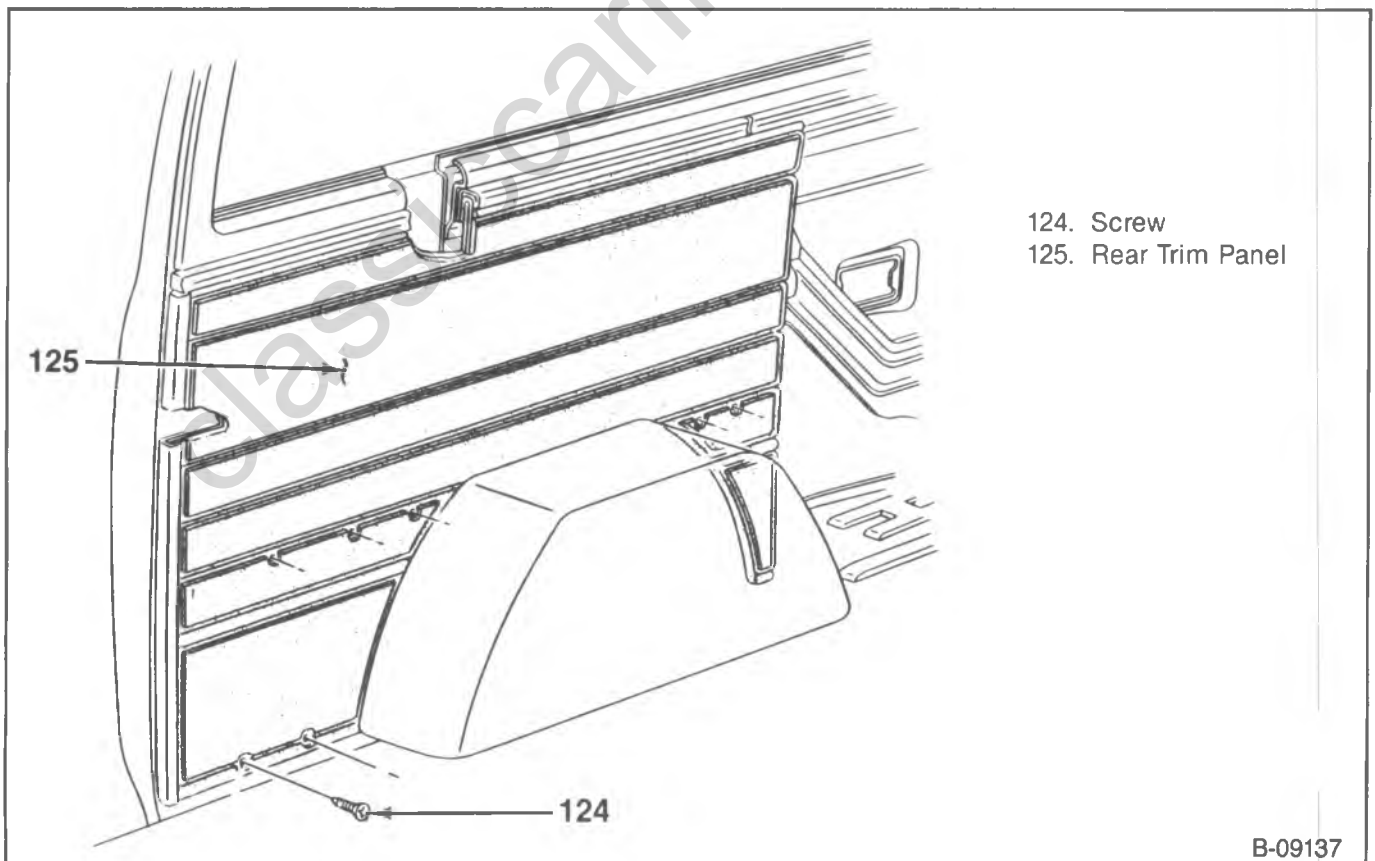

124. Screw
125. Rear Trim Panel

B-09137

Figure 40—Rear Trim Panel

10A4-22 INTERIOR TRIM

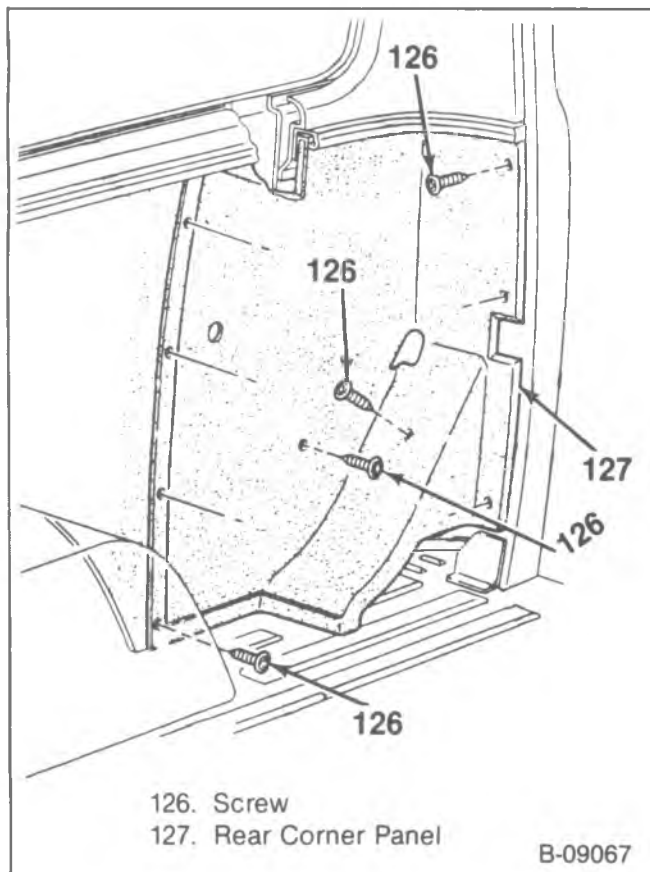

Figure 41—Rear Corner Panel

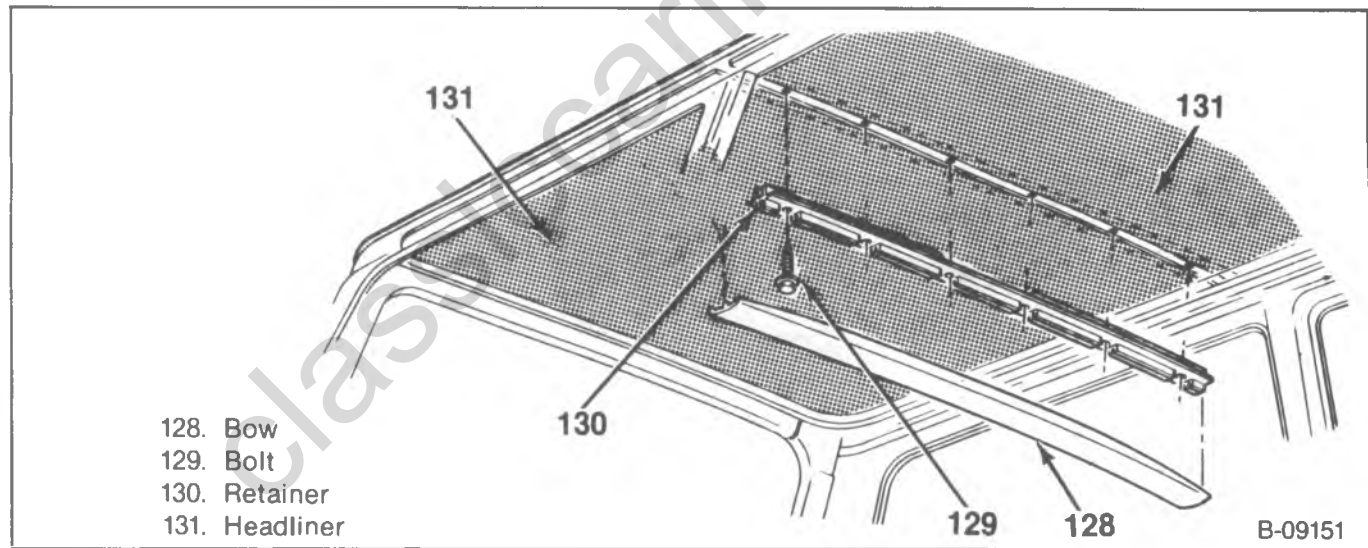

Figure 42—Headliner Retainer

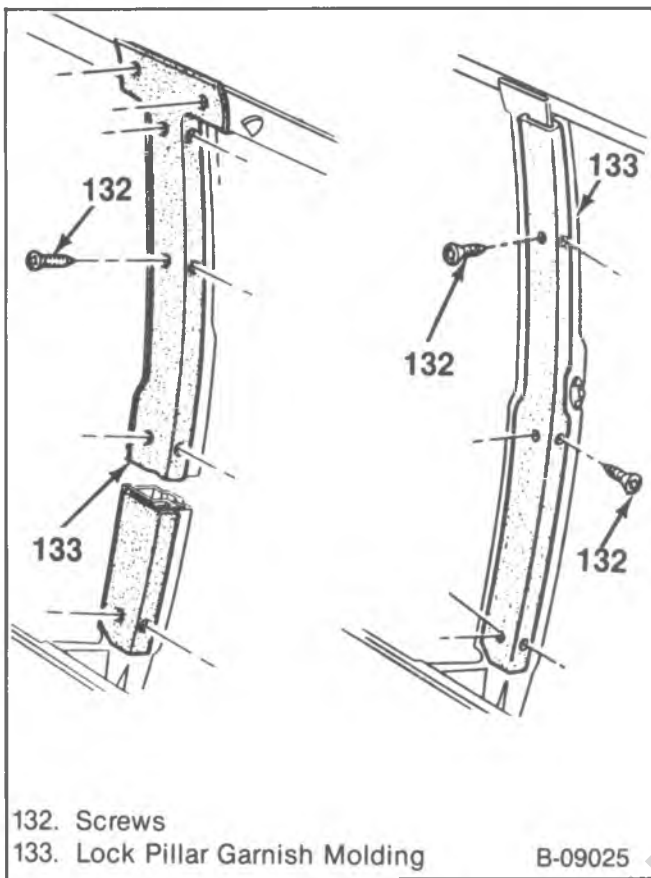

Figure 43—Lock Pillar Garnish Molding

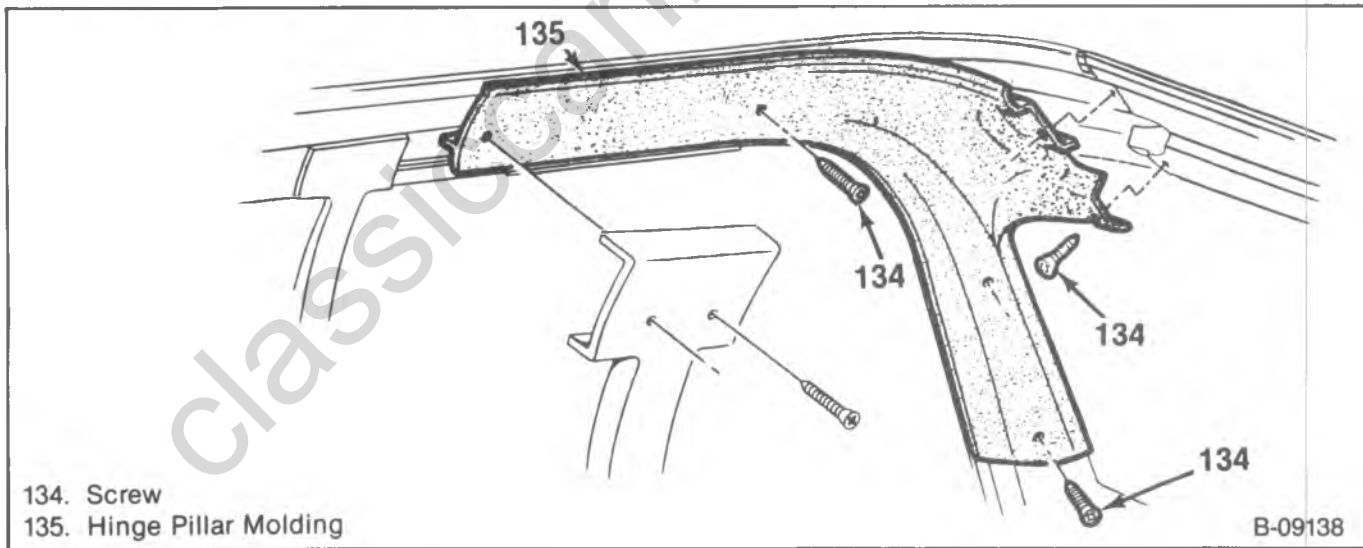

Figure 44—Hinge Pillar Molding

10A4-24 INTERIOR TRIM

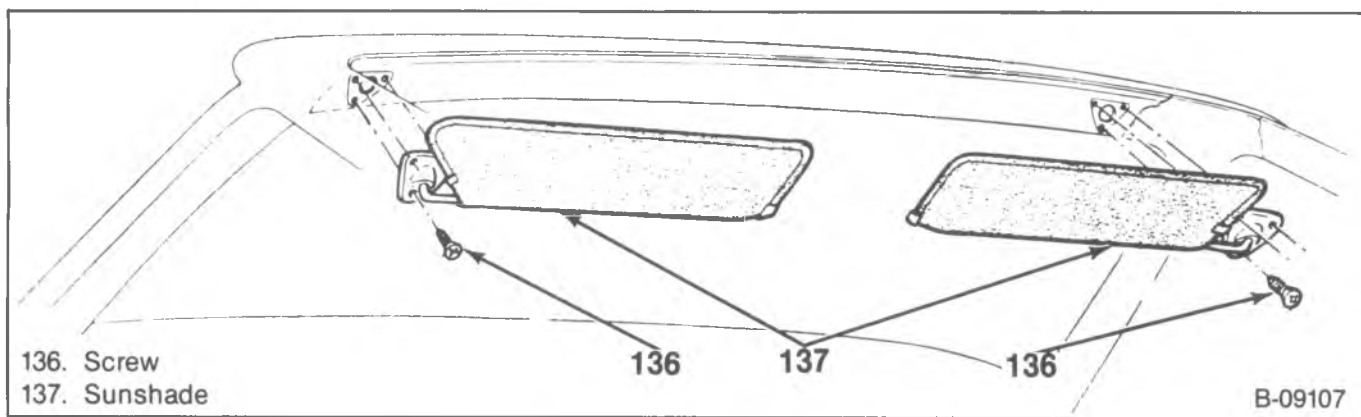

Figure 45—Sunshade

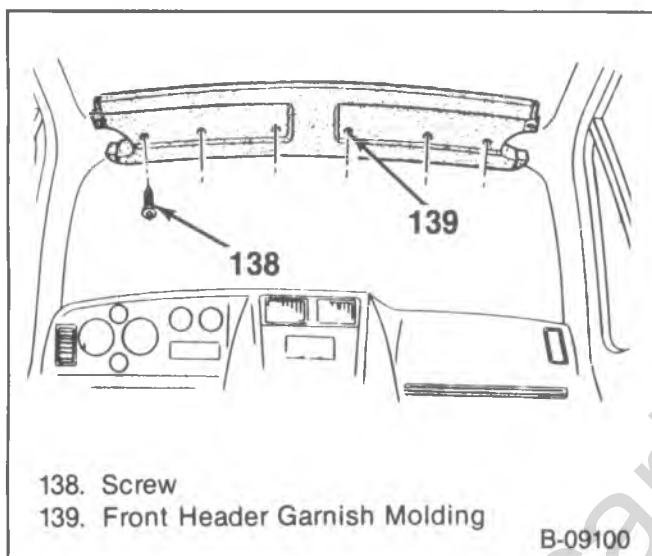

Figure 46—Front Header Garnish Molding

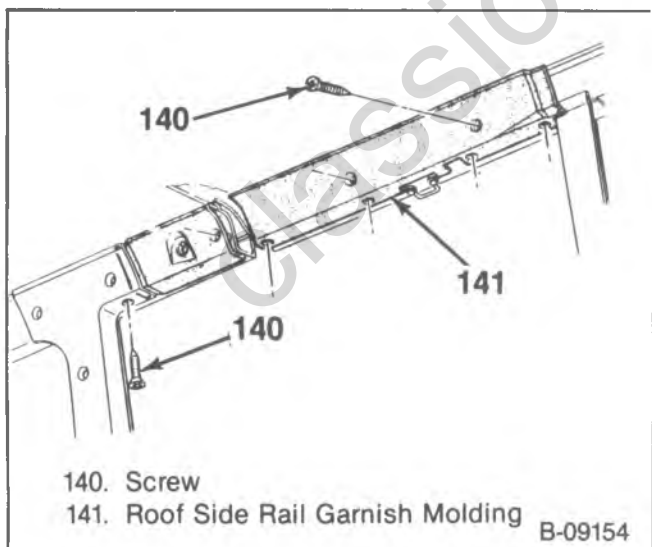

Figure 47—Roof Rear Rail Garnish Molding

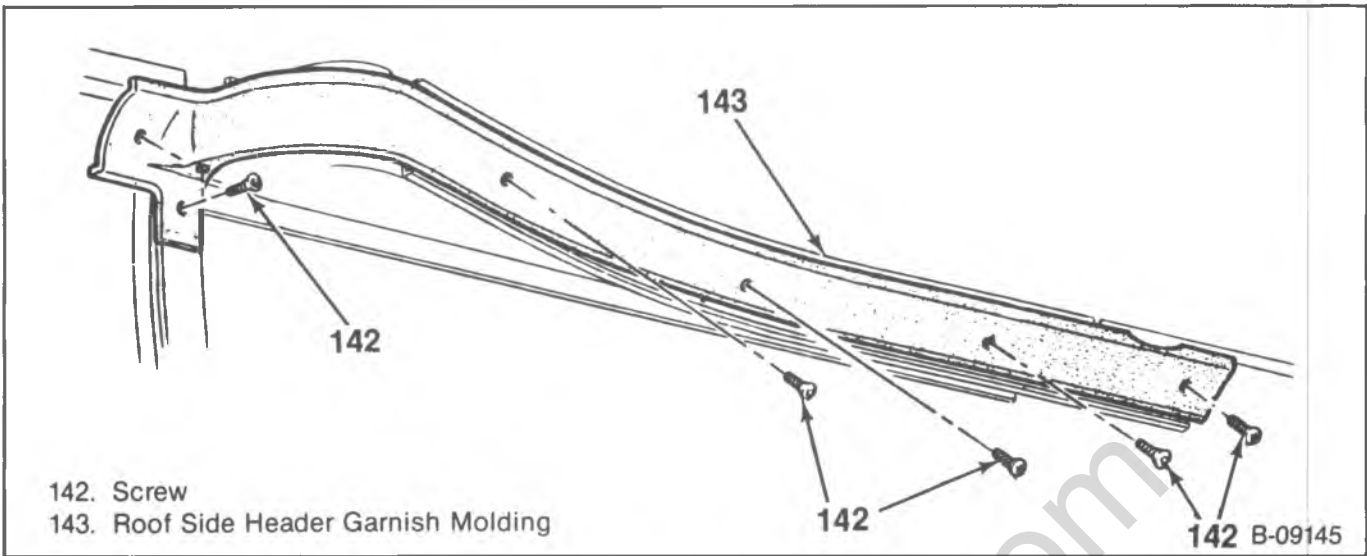

Figure 48—Roof Side Header Garnish Molding

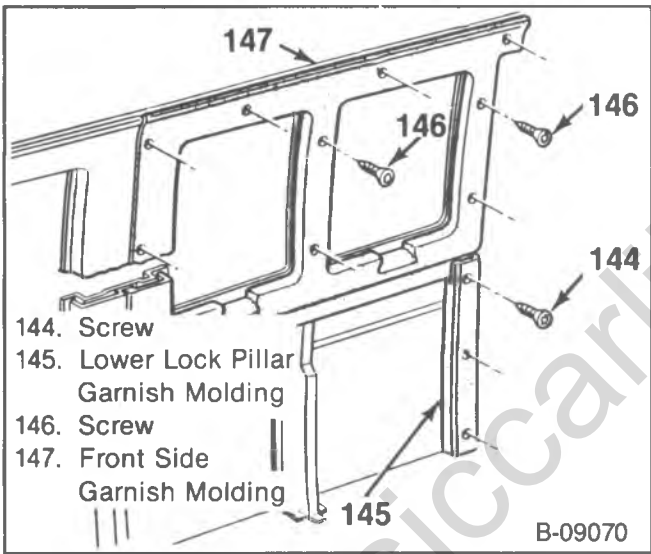

Figure 49—Front Garnish Moldings

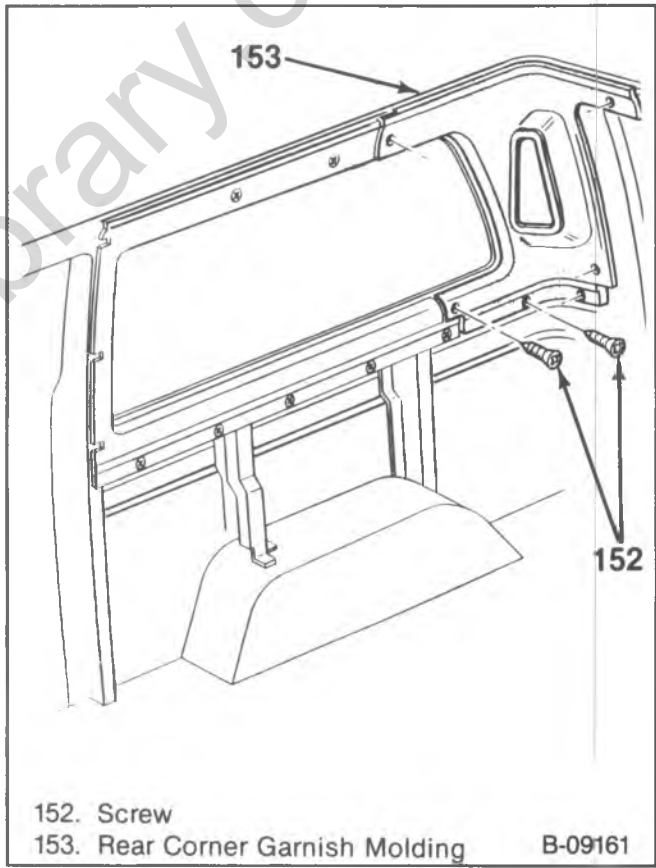

Figure 51—Rear Corner Garnish Molding

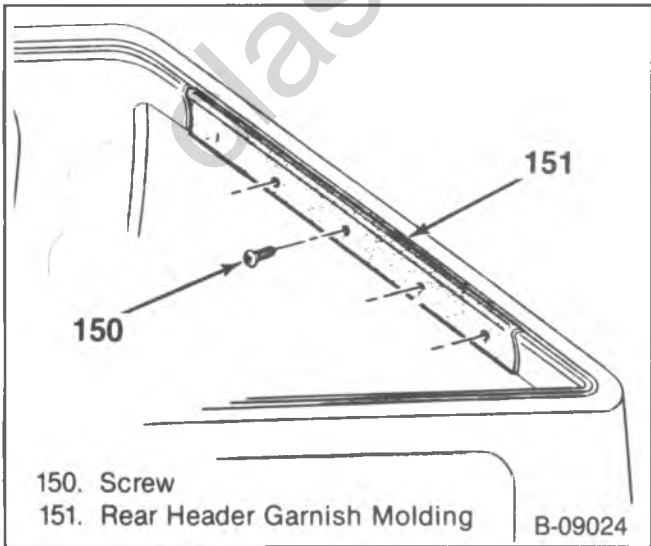

Figure 50—Rear Header Garnish Molding

10A4-26 INTERIOR TRIM

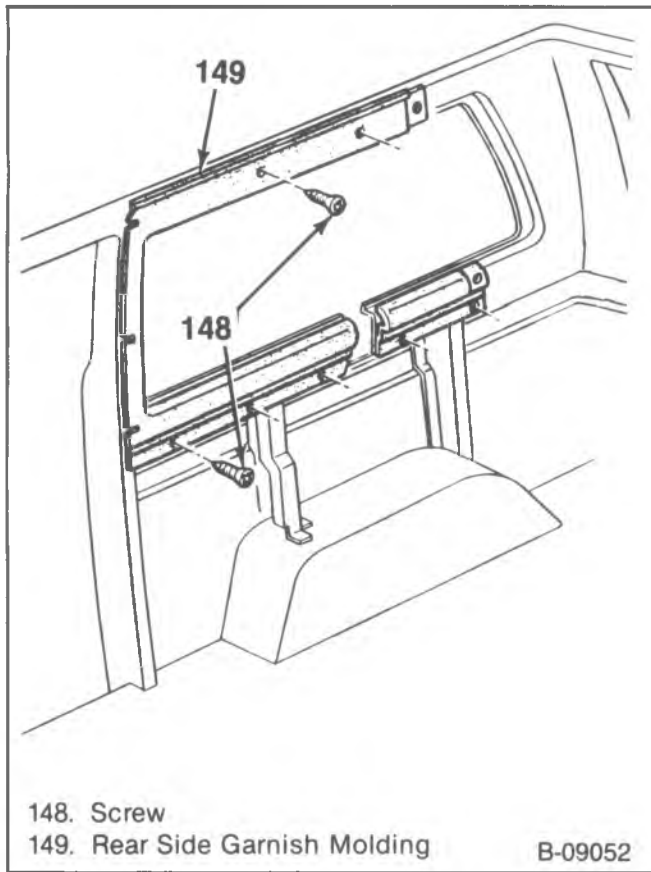

Figure 52—Rear Side Garnish Molding

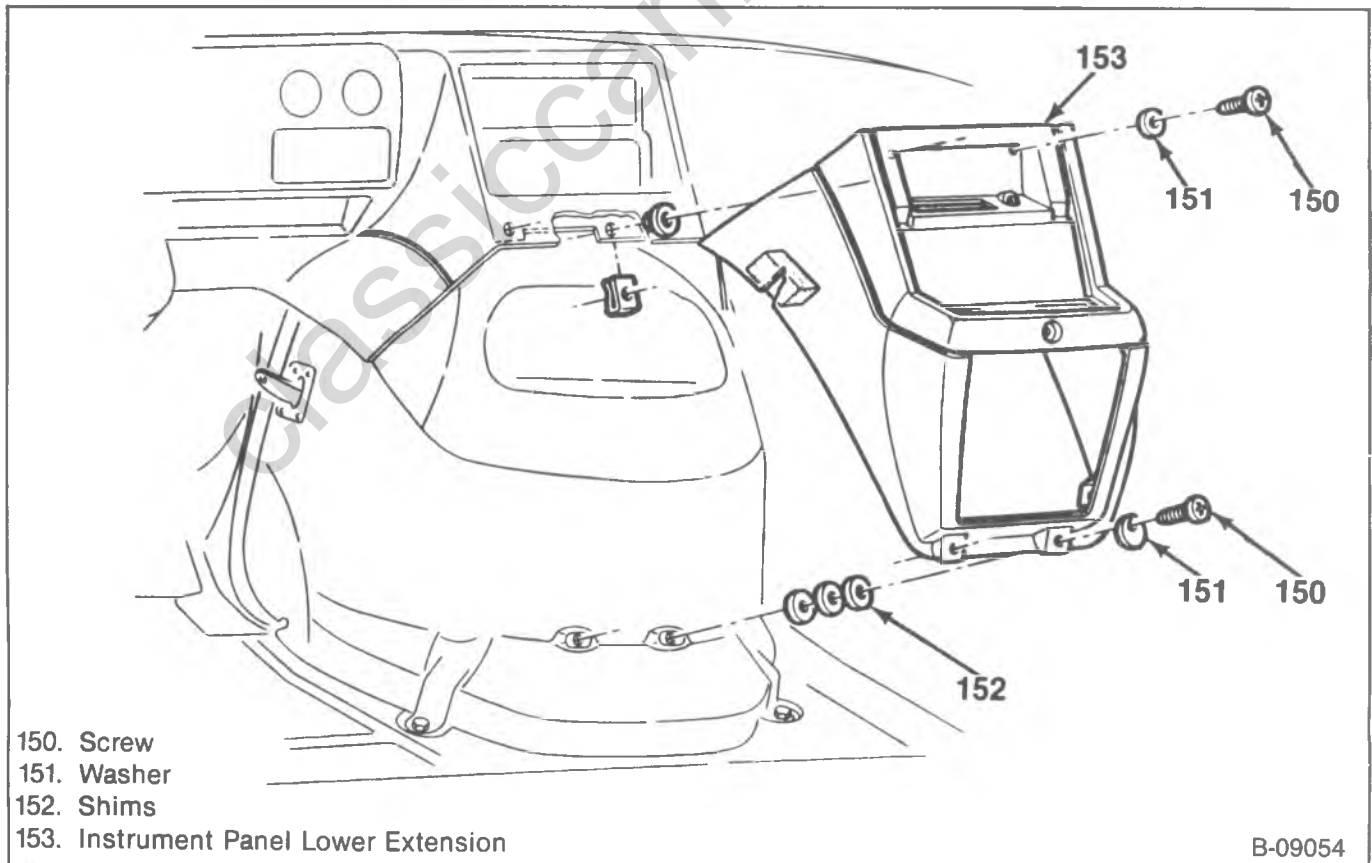

Figure 53—Instrument Panel Lower Extension

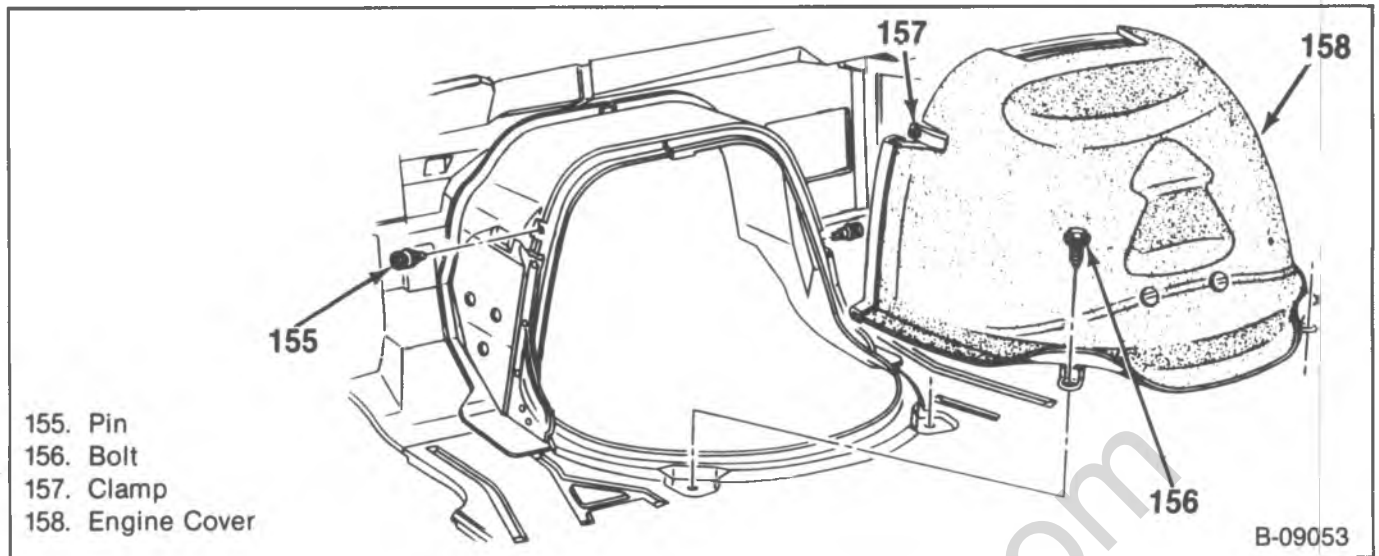

Figure 54—Engine Cover

classiccarlibrary.com

classiccarylbrary.com

SECTION 10A5

END GATE

CONTENTS

<u>SUBJECT</u>	<u>PAGE</u>
Fender Side Models	10A5- 2
End Gate Replacement	10A5- 2
Fleet Side Models	10A5- 2
End Gate Replacement	10A5- 2
Handle And Latch Replacement	10A5- 2
Utility Vehicle Models	10A5- 4
End Gate Replacement	10A5- 4
Torque Rod Replacement	10A5- 5
Hinge Replacement	10A5- 6
End Gate Cover Replacement	10A5- 6
Handle And Control Assembly Replacement	10A5- 6
Latch Replacement	10A5- 7
Regulator Replacement	10A5- 8
Window Motor And Blockout Switch Replacement	10A5- 9
Sash Assembly Replacement	10A5-10
Run Channel Replacement	10A5-11
End Gate Outside Crank Replacement	10A5-11
Window Glass Seal Replacement	10A5-11
Weatherstrip Replacement	10A5-11
Utility Vehicle Removable Top	10A5-12
Removable Top Replacement	10A5-12
Suburban Models	10A5-13
End Gate Replacement	10A5-13
Torque Rod Replacement	10A5-13
Hinge Replacement	10A5-13
End Gate Trim And Cover Panel Replacement	10A5-15
Handle And Control Assembly Replacement	10A5-15
Latch Replacement	10A5-16
Regulator Replacement	10A5-16
Blockout Switch Replacement	10A5-17
Sash Assembly Replacement	10A5-17
Run Channel Replacement	10A5-17
End Gate Outside Crank Replacement	10A5-17
Window Glass Seal Replacement	10A5-17
Weatherstrip Replacement	10A5-18

FENDER SIDE MODELS

END GATE REPLACEMENT

↔ Remove or Disconnect (Figure 1)

- Open the end gate and support it with a table or other suitable support.
- 1. Fender to end gate bolt (6) and washer (7).
- 2. End gate (4), and bushing (5) from the vehicle.
- 3. Chain (3) to fender nut (1), washer (2), and eye bolt.

↔ Install or Connect (Figure 1)

1. Chain (3) with eye bolt to the fender.
2. Washer (2) and nut (1) to the eye bolt.
3. End gate (4) and bushing (5) to the vehicle.
4. Fender to end gate washer (7), and bolt (6).
 - Anti-rattle bumper must seat fully against vertical surface of tab (159).

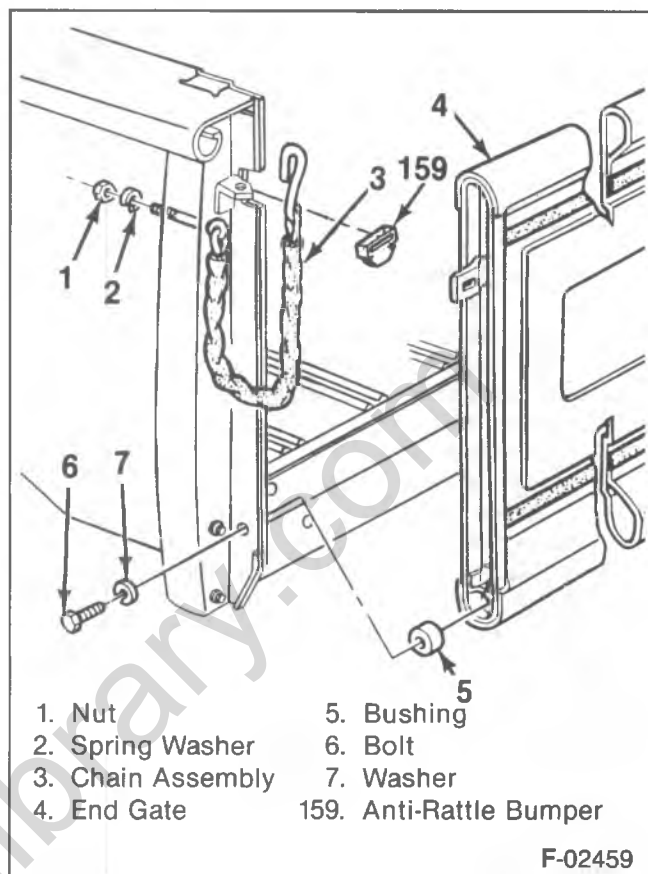

Figure 1—Fender Side End Gate Components

FLEET SIDE MODELS

END GATE REPLACEMENT

↔ Remove or Disconnect (Figure 2)

- Open the end gate and support it with a table or other suitable support.
- 1. Link and striker plate (8) to fender bolts (17).
- 2. Link and striker (8) from the end gate.
 - Rotate the link until it aligns with the tab (9) on the end gate, and pull it from the end gate.
- 3. Hinge (14) to end gate bolts (13).
- 4. End gate (12) from the vehicle.
- 5. Inner hinge half (A).
- 6. Hinge (14) to fender bolts (16).
- 7. Outer hinge half (B).
- 8. Bumper (10) to fender screws (11).
- 9. Bumpers (10) from the vehicle.

↔ Install or Connect (Figure 2)

1. Bumpers (10) to the vehicle.
2. Bumper (10) to fastener screws (11).
3. Outer hinge half (B).
4. Hinge (14) to fender bolts (16).
5. Inner hinge half (A).
6. End gate (12) to the vehicle.
7. Hinge (14) to end gate bolts (13).

8. Link and striker (8) to the end gate.
 - Place the slot on the link in line with the tab (9) on the end gate, and place the link onto the end gate. Pivot the link into its proper position.
9. Link and striker to the fender.
10. Link and striker to fender bolts (17).

HANDLE AND LATCH REPLACEMENT

↔ Remove or Disconnect (Figure 3)

- Lower and support the end gate with a table or other suitable support.
- 1. Latch rods (19) from the clips (20).
- 2. End gate to handle bolts (22).
- 3. Handle (21) from the end gate.
- 4. Link from the end gate.
 - Refer to "End Gate Replacement."
- 5. Latch (18) to end gate bolts (23).
- 6. Latch (18) from the vehicle.

↔ Install or Connect (Figure 3)

1. Latch (18) to the vehicle.
2. Latch (18) to end gate bolts (23).

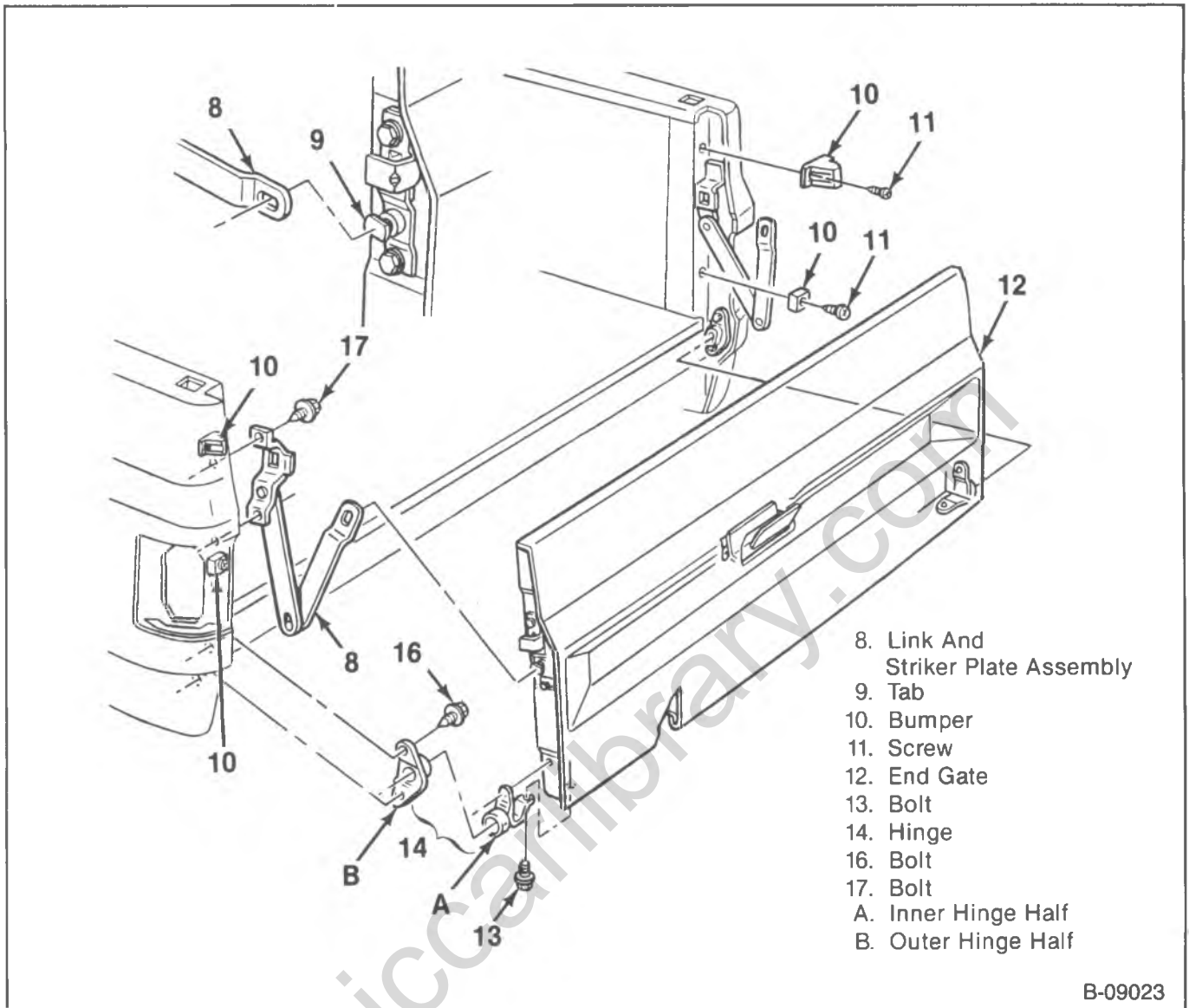

B-09023

Figure 2—Fleet Side End Gate Components

3. Link to the end gate.
 - Refer to "End Gate Replacement."
4. Handle (21) to the end gate.
5. End gate to handle bolts (22).
6. Latch rods (19) to the clips (20).

10A5-4 END GATE

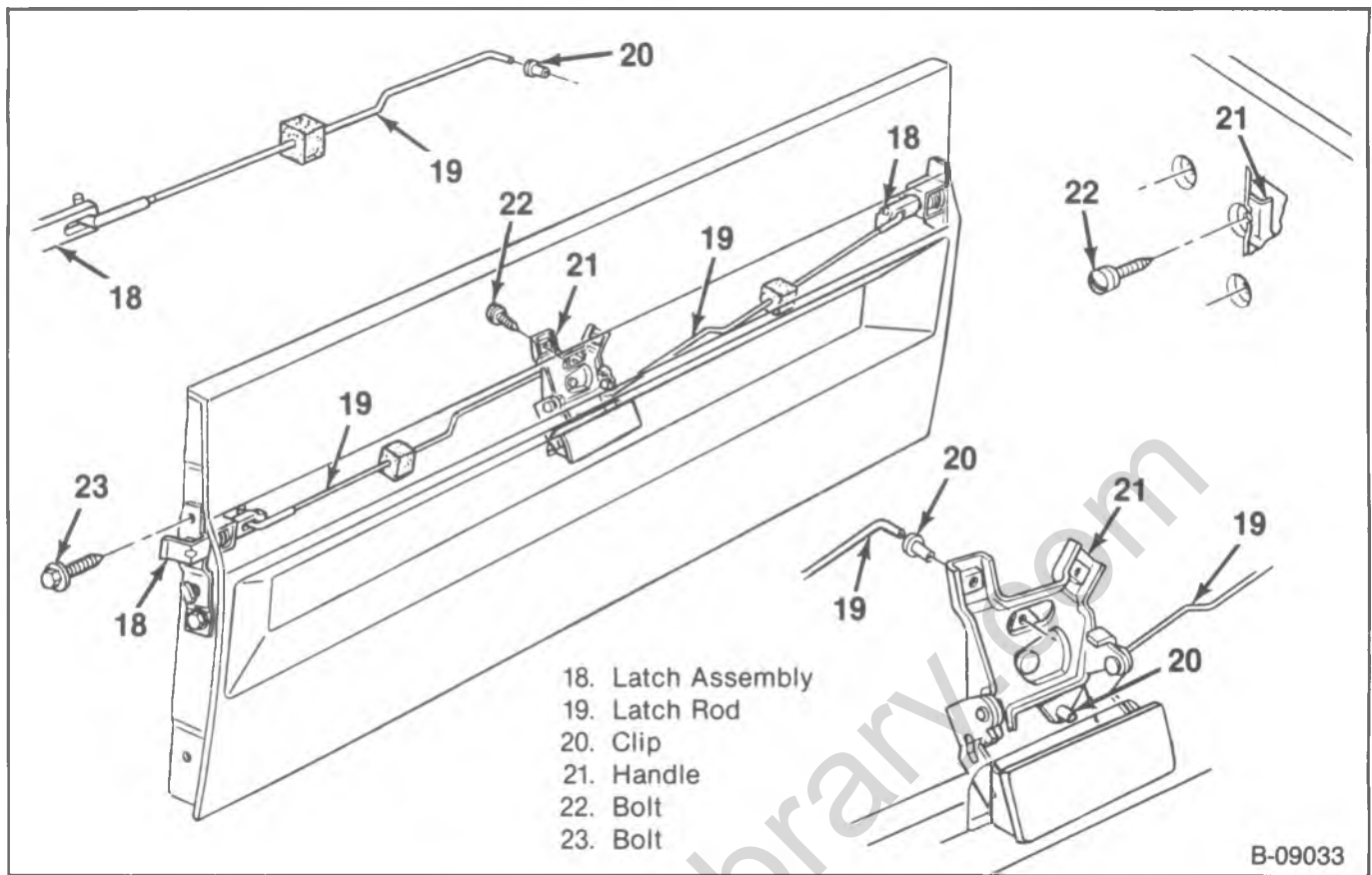

Figure 3—Handle and Latch Components

UTILITY VEHICLE MODELS

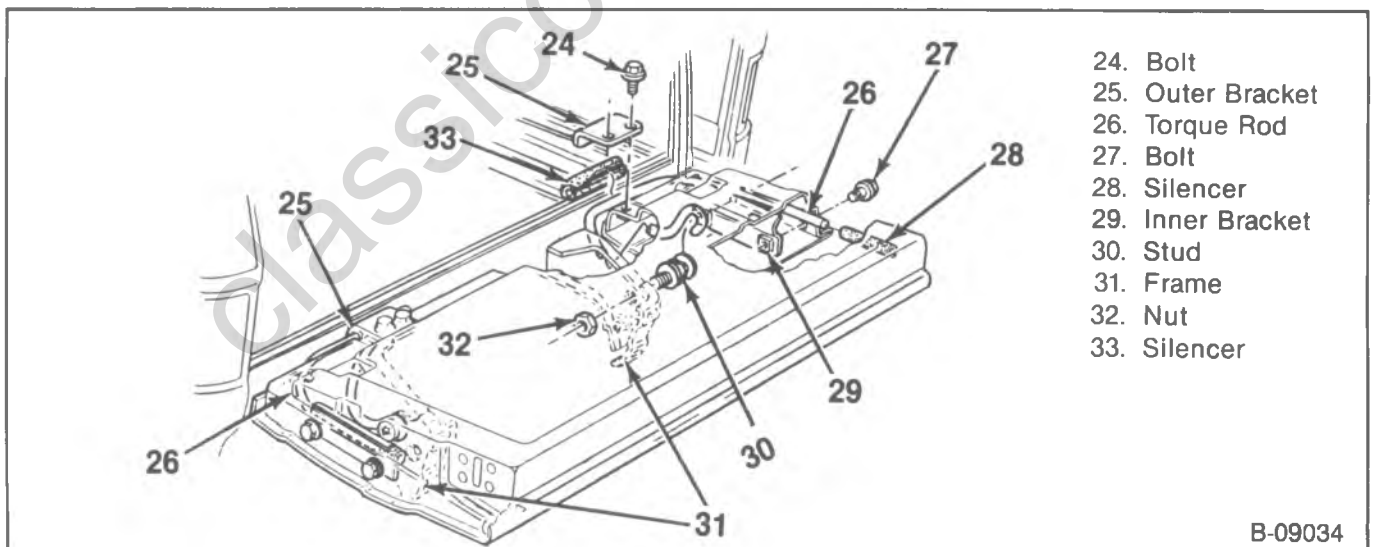

Figure 4—Utility Vehicle — Torque Rod

END GATE REPLACEMENT

↔ Remove or Disconnect (Figures 4, 5, and 6)

- The end gate must be in the closed position.
- 1. Torque rod to frame stud (30) and nut (32).
 - Allow the torque rod to swing down.

- Open the end gate, and support it with a table or other suitable support.
- 2. Electrical wiring harness (if equipped). Refer to "End Gate Cover Replacement" for access to the harness.
- 3. Cable (34) to end gate opening bolts (37), spacers (36), and washers (35).

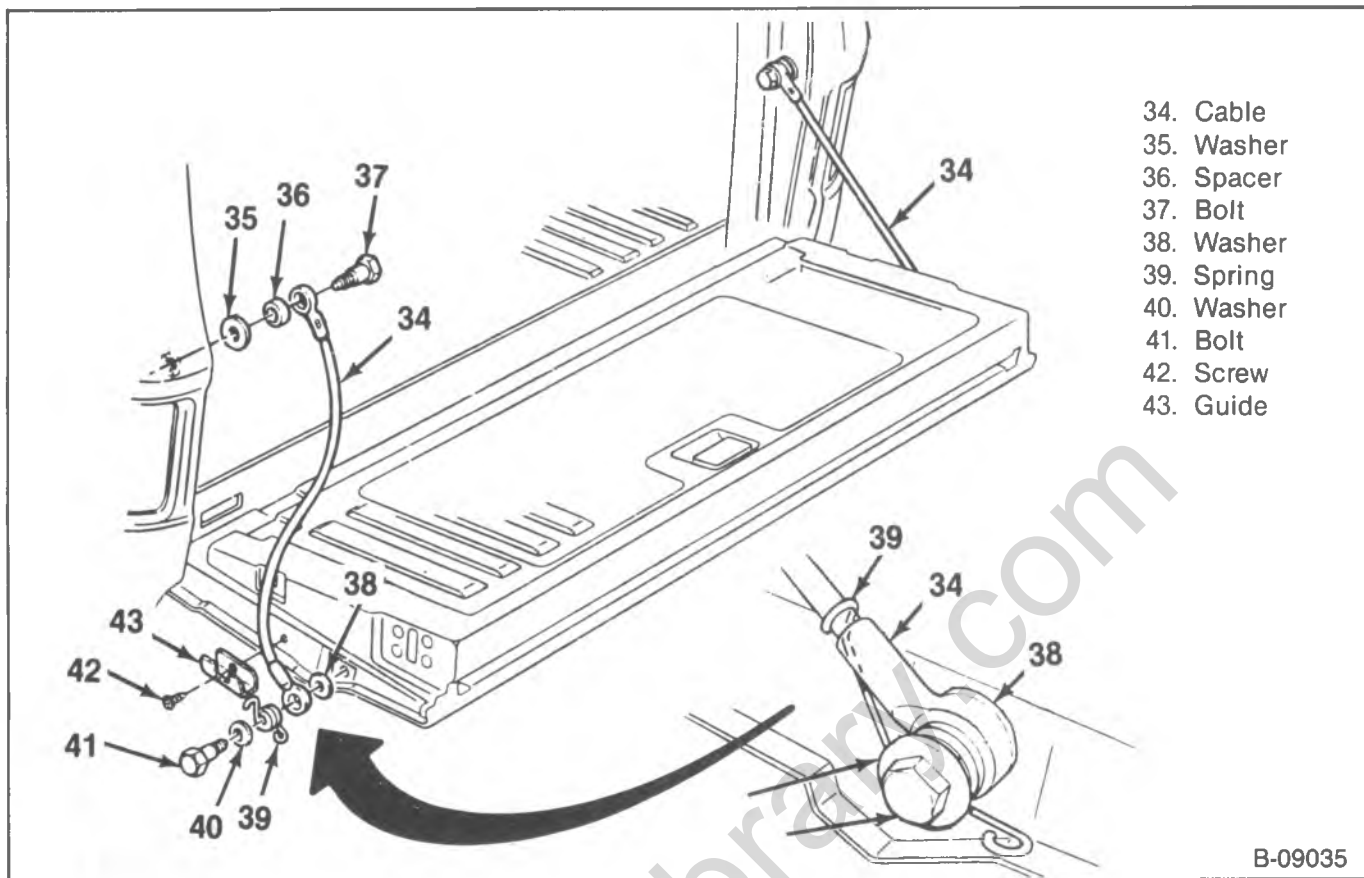

- 34. Cable
- 35. Washer
- 36. Spacer
- 37. Bolt
- 38. Washer
- 39. Spring
- 40. Washer
- 41. Bolt
- 42. Screw
- 43. Guide

B-09035

Figure 5—Cable Assembly Components

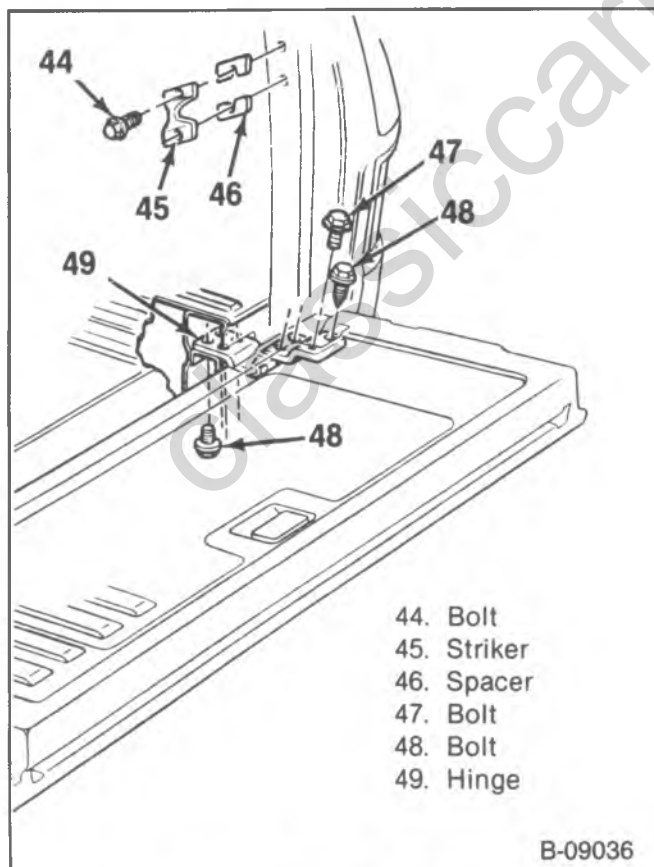

- 44. Bolt
- 45. Striker
- 46. Spacer
- 47. Bolt
- 48. Bolt
- 49. Hinge

B-09036

Figure 6—Hinge Assembly

4. Torque rod bracket bolts (24) and brackets (25).
5. Hinge (49) to floor panel bolts (48) from the under side of the vehicle.
6. End gate from the vehicle.
 - Lift the end gate from the body.
 - Guide the torque rods over the gravel deflectors to prevent damage.

⇄ Install or Connect (Figures 4, 5, and 6)

1. End gate to the vehicle.
 - Guide the torque rods over the gravel deflectors to prevent damage.
 - Insert the hinges into the floor panel slots.
2. Hinge (49) to floor pan bolts (48) to the under side of the vehicle.
3. Torque rod brackets (25) and bolts (24).
4. Cable (34) to the end gate opening with bolts (37), spacers (36), and washers (35).
5. Electrical wiring harness (if equipped). Refer to "End Gate Cover Replacement" for access to the harness.
 - Close the end gate.
6. Torque rod to frame stud (30) and nut (32).
7. Torque rods onto the studs.

TORQUE ROD REPLACEMENT

⇄ Remove or Disconnect (Figure 4)

1. End gate. Refer to "End Gate Replacement."
2. End gate cover.
3. End gate to torque rod inner bracket bolts (27).
4. Torque rod (26) with silencers (28) from the end gate.

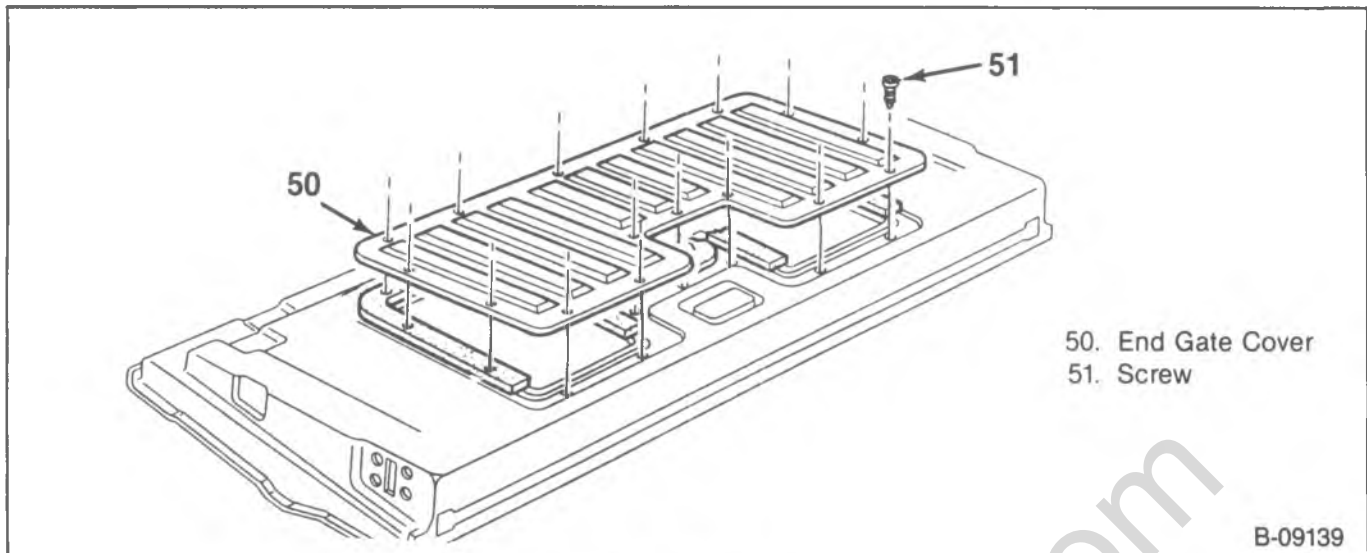

50. End Gate Cover
51. Screw

B-09139

Figure 7—End Gate Cover

5. Inner bracket (29) from the end gate.

↔ Install or Connect (Figure 4)

1. Torque rod (26) with silencers (28) to the end gate.
2. Inner bracket (29) to the torque rod.
3. End gate to torque rod inner bracket bolts (27).
4. End gate cover.
5. End gate. Refer to "End Gate Replacement."

HINGE REPLACEMENT

↔ Remove or Disconnect (Figure 6)

- Lower the end gate.
1. Hinge to body bolts (48) for the hinge to be removed only.
 - Loosen the hinge to body bolts (48) on the opposite hinge.
 2. Hinge to end gate bolts (47) for the hinge to be removed.
 - Pull the end gate away from the body several inches and remove the hinge from the body.
 - Lift the end gate slightly to allow removal of the hinge from the end gate.

↔ Install or Connect (Figure 6)

- Lift the end gate slightly and install the hinge to the end gate.
 - Pull the end gate away from the body several inches, and insert the hinge into the body.
1. Hinge to end gate bolts (47).
 2. Hinge to body bolts (48).
- Tighten the hinge to body bolts on the opposite hinge.

END GATE COVER REPLACEMENT

↔ Remove or Disconnect (Figure 7)

1. End gate cover screws (51).
2. End gate cover (50).

↔ Install or Connect (Figure 7)

1. End gate cover (50).
2. End gate cover screws (51).

HANDLE AND CONTROL ASSEMBLY REPLACEMENT

↔ Remove or Disconnect (Figure 8)

1. End gate cover.
2. Control rod (64) from the handle (61).
3. Handle to end gate screws (62).
4. Handle (61) from the end gate.
5. Right and left latch rods (65) from the control assembly.
6. Control assembly to end gate bolts (60).
7. Control assembly (55) from the end gate.
8. Window lockout rod spring (54).
9. Lockout rod (53) to end gate bolts (52).
10. Lockout rod (53) from the end gate.

↔ Install or Connect (Figure 8)

1. Lockout rod (53) to the end gate.
 - The bottom of the rod must fit into the clip at the base of the end gate.
2. Lockout rod (53) to end gate bolts (52).
3. Window lockout rod spring (54).
4. Control assembly (55) to the end gate.
5. Control assembly to end gate bolts (60).
6. Right and left latch rods (65) from the control assembly.
7. Handle (61) to the end gate.
8. Handle to end gate screws (62).
9. Control rod (64) to the handle (61).
10. End gate cover.

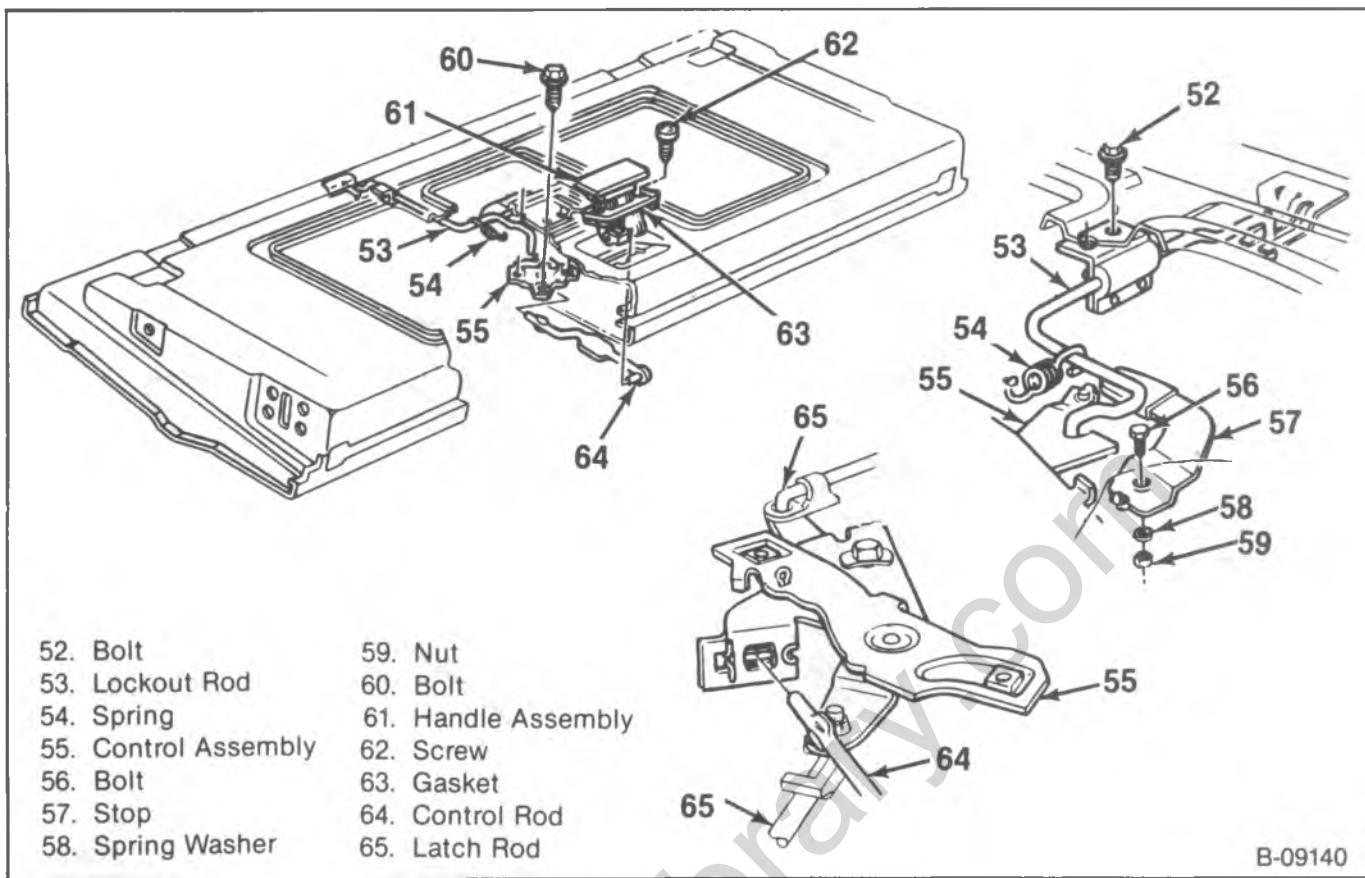

Figure 8—Handle and Control Assembly

LATCH REPLACEMENT

↔ Remove or Disconnect (Figure 9)

1. End gate cover.
2. Right or left latch rod (65) from the control assembly.
3. Latch (66) to end gate screws (67).
4. Latch (66) from the end gate.

↔ Install or Connect (Figure 9)

1. Latch (66) with rod to the end gate.
2. Latch (66) to end gate screws (67).
3. Right or left latch rod (65) to the control assembly.
4. End gate cover.

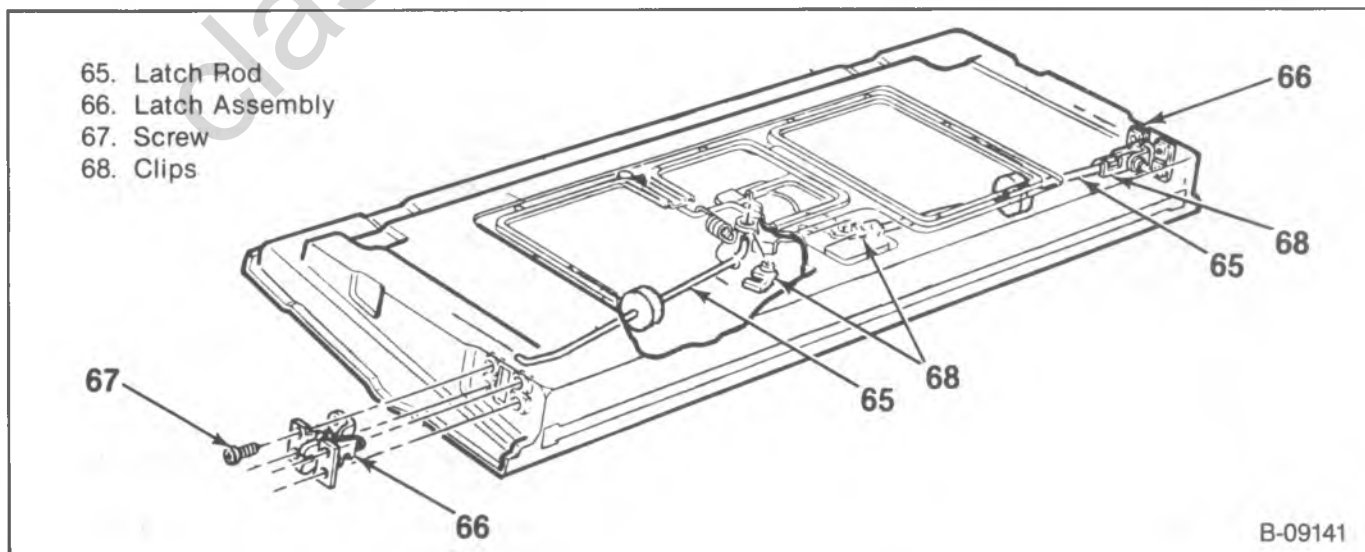

Figure 9—Latch Components

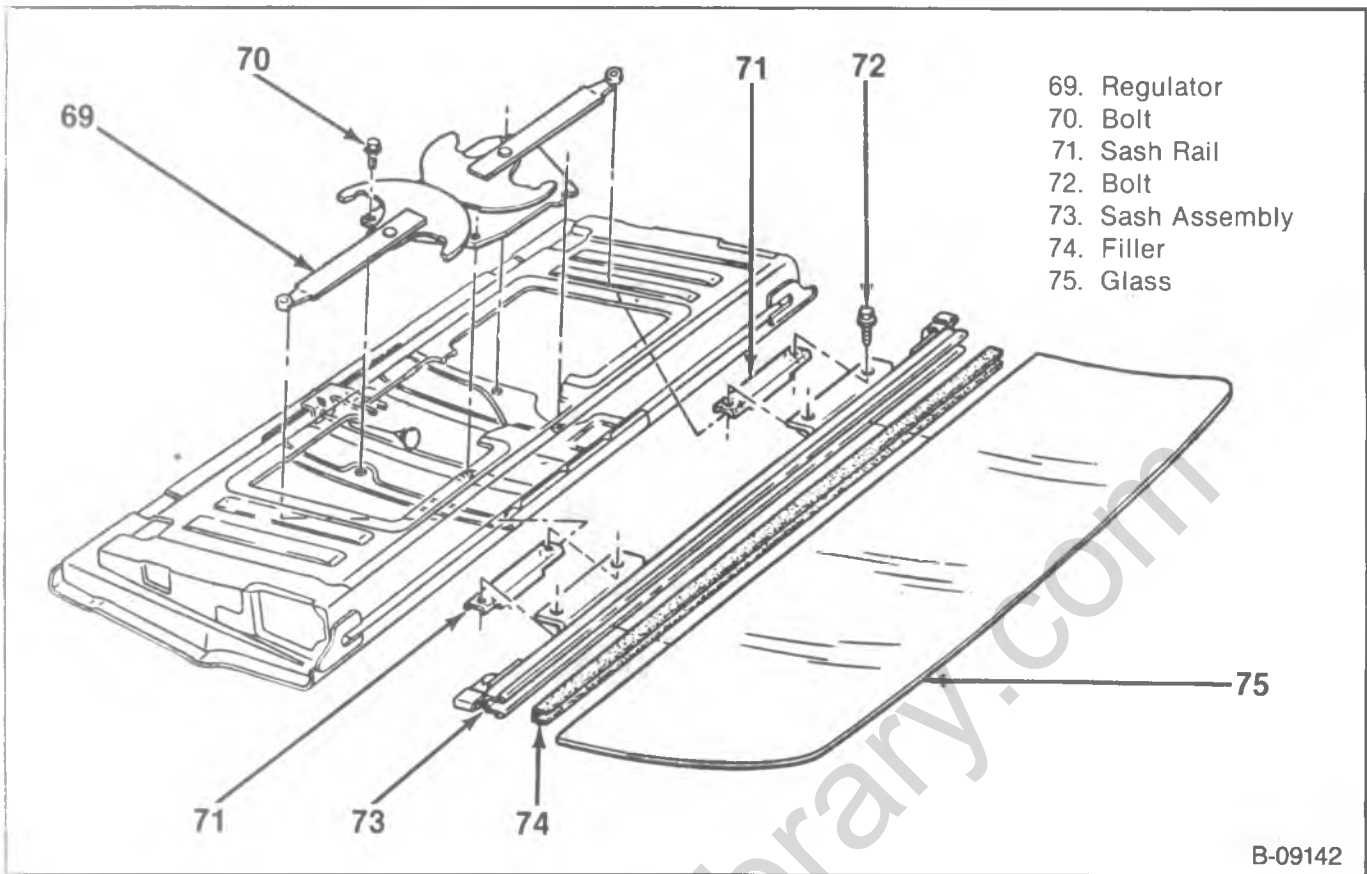

Figure 10—Regular and Sash Components

REGULATOR REPLACEMENT

MANUAL REGULATOR

↔ Remove or Disconnect (Figure 10)

1. End gate cover.
2. Control assembly. Refer to "Handle And Control Assembly Replacement."
3. Sash assembly (73). Refer to "Sash Assembly Replacement."
4. Regulator (69) to end gate bolts (70).
5. Regulator (69) from the end gate.

↔ Install or Connect (Figure 10)

1. Regulator (69) to the end gate.
2. Regulator (69) to end gate bolts (70).
3. Sash assembly (73). Refer to "Sash Assembly Replacement."
4. Control assembly. Refer to "Handle And Control Assembly Replacement."
5. End gate cover.

POWER REGULATOR

↔ Remove or Disconnect (Figures 10 and 11)

1. End gate cover.
2. Control assembly. Refer to "Handle And Control Assembly Replacement."
3. Sash assembly (73). Refer to "Sash Assembly Replacement."

CAUTION: Step 4 must be performed if the gear box is removed or disengaged from the regulator lift arms. The left arms are under tension from the counterbalance spring, and can cause injury if the gear box is removed without locking the sector gears in place.

4. Drill a 3.1 mm (1/8-inch) diameter hole through the sector gear and back plate. Install a sheet metal tapping screw into the hole to lock the sector gears in position.
5. Drive cable (77) at regulator (76).
6. Regulator (76) to end gate bolts (78).
7. Regulator (76) from the end gate.
8. Gear assembly (80) to regulator bolts.
9. Gear assembly (80) from the regulator (76).

↔ Install or Connect (Figures 10 and 11)

1. Gear box (80) to the regulator (76).
2. Gear box (80) to regulator bolts.
3. Regulator (76) to the end gate.
4. Regulator (76) to end gate bolts (78).
5. Drive cable (77) to the regulator (76).
 - Remove the sheet metal screw.
6. Sash assembly (73). Refer to "Sash Assembly Replacement."
7. Control assembly. Refer to "Handle and Control Assembly Replacement."
8. End gate cover.

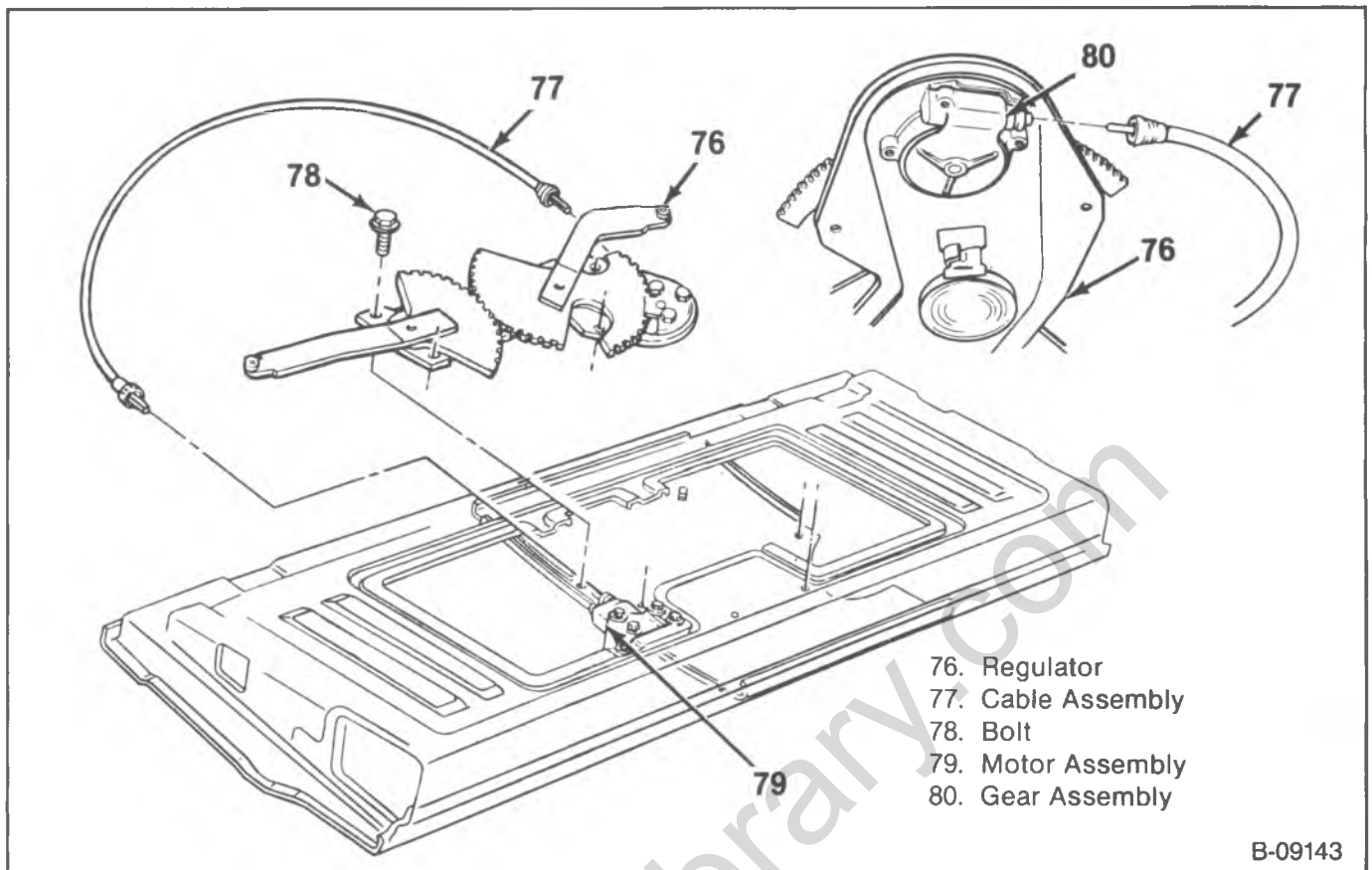

Figure 11—Power Regulator Components

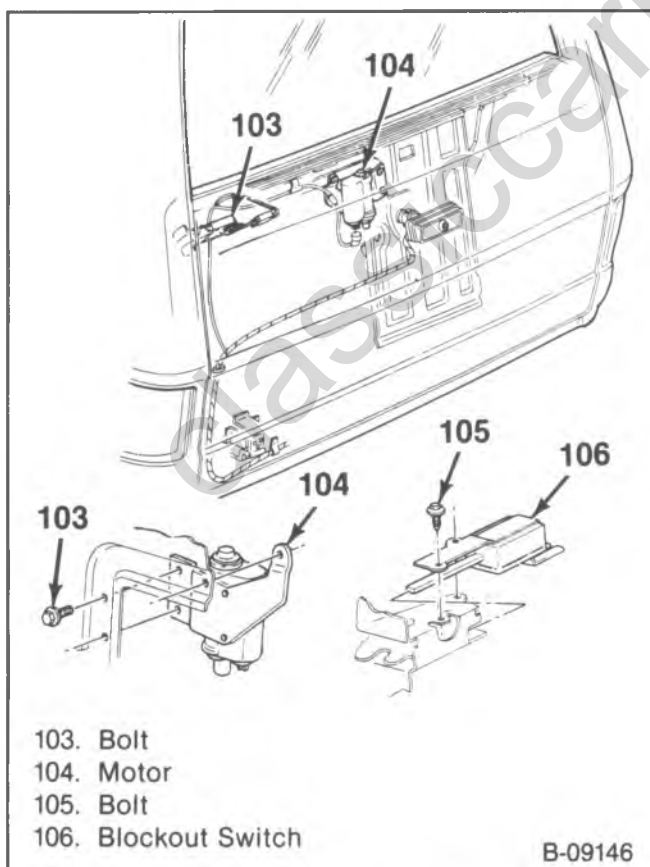

Figure 12—End Gate Electrical Components

WINDOW MOTOR AND BLOCKOUT SWITCH REPLACEMENT

↔ Remove or Disconnect (Figure 12)

1. End gate panel.
2. Wiring harness from the motor and switch.
3. Cable from the motor.
4. End gate to motor bolts (103).
5. Motor (104) from the end gate.
6. Latch containing the blockout switch from the end gate. Refer to "Latch Replacement."
7. Blockout switch (106) to latch bolts (105).
8. Blockout switch (106) from the latch.

↔ Install or Connect (Figure 12)

1. Blockout switch (106) to the latch.
2. Blockout switch (106) to latch bolts (105).
3. Latch to the end gate. Refer to "Latch Replacement."
4. Motor (104) to the end gate.
5. End gate to motor bolts (103).
6. Cable to the motor.
7. Wiring harness to the motor and the switch.
8. End gate panel.

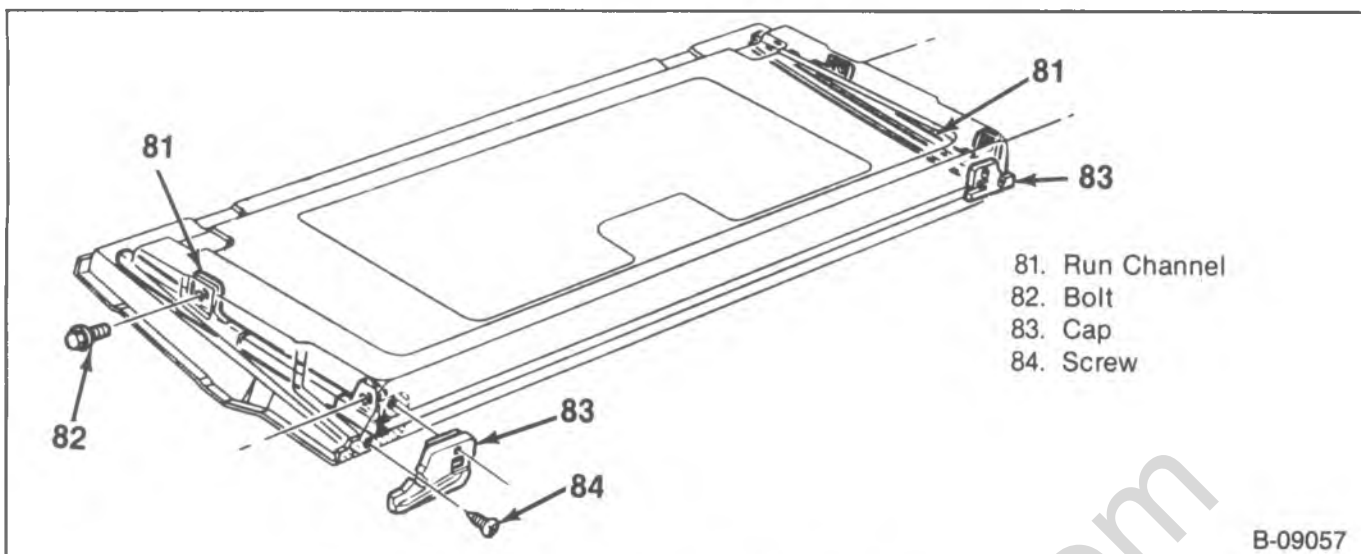

Figure 13—Run Channel Components

SASH ASSEMBLY REPLACEMENT

←→ Remove or Disconnect (Figure 10)

1. Window run channel caps (figure 13).
2. Inner and outer window glass seals. Refer to "Window Glass Seal Replacement."
3. End gate cover.
 - Regulate the window so that the sash channel bolts (72) are accessible.
4. Sash (73) to sash channel bolts (72).

5. Sash (73) with glass (75) from the end gate.
6. Sash rails (71) from the regulator (69).

→→ Install or Connect (Figure 10)

1. Sash rails (71) to the regulator (69).
2. Sash (73) with glass (75) to the end gate.
3. Sash (73) to sash channel bolts (72).
4. End gate cover.

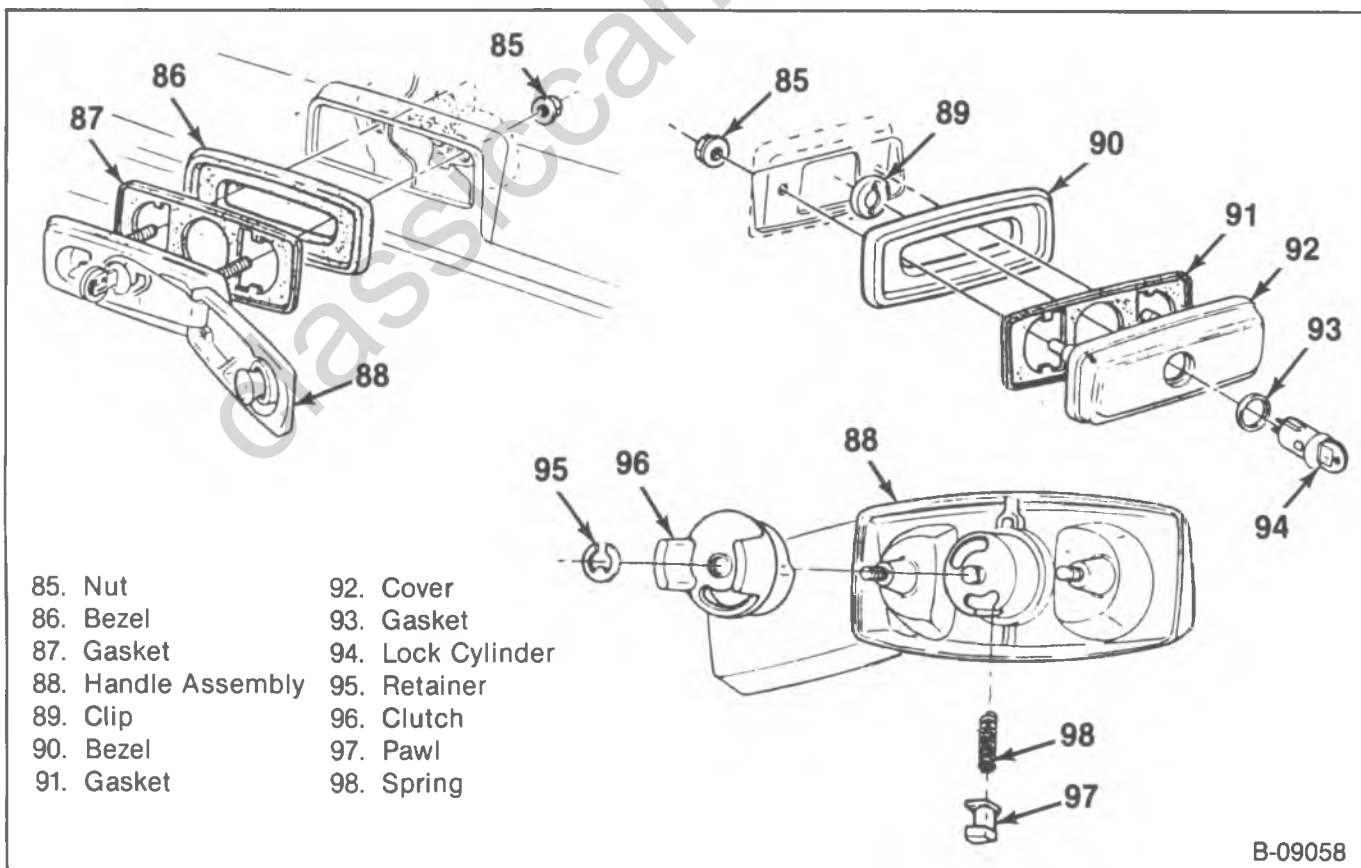

Figure 14—Window Control Components

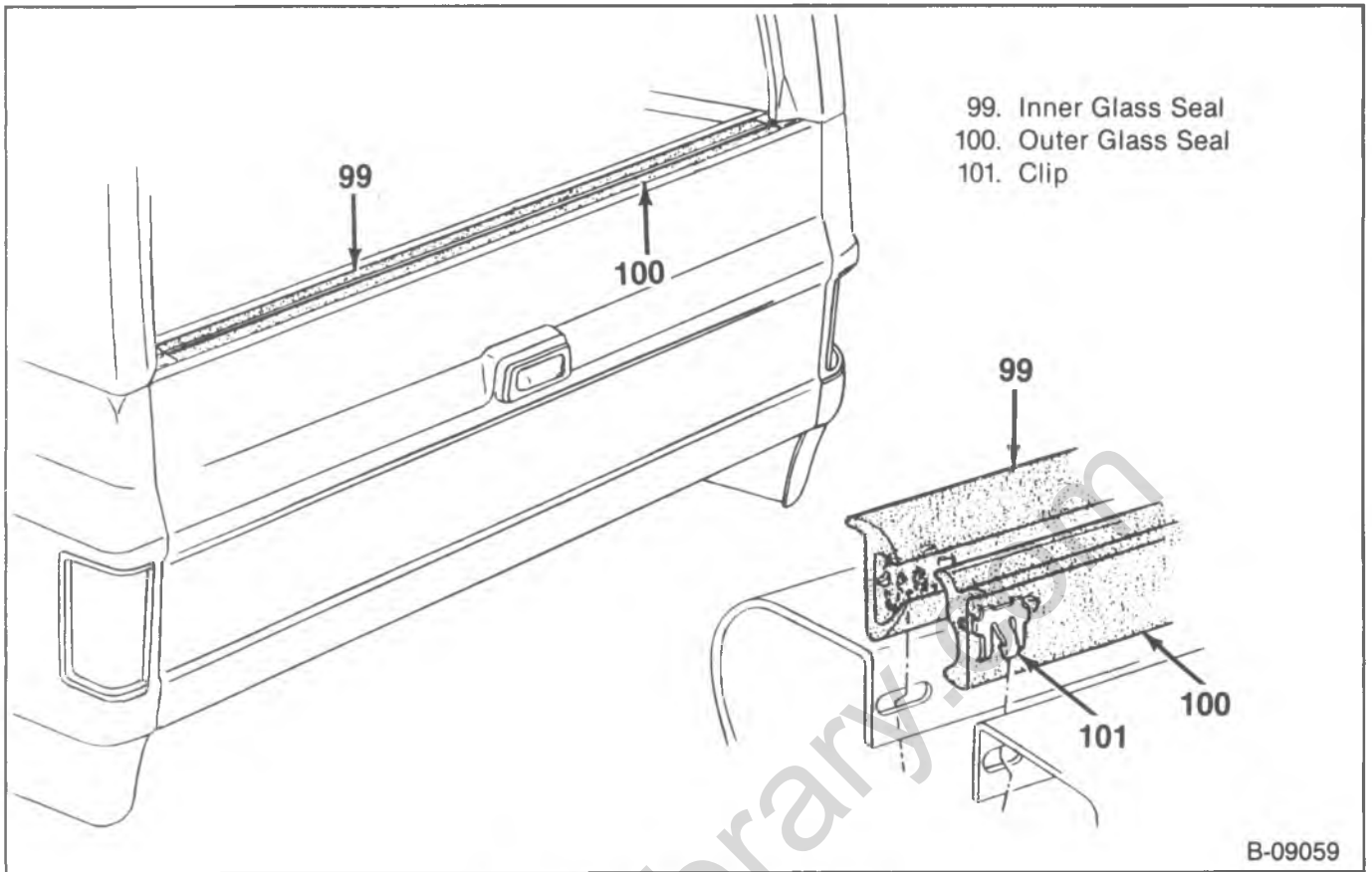

Figure 15—Window Glass Seals

5. Inner and outer window glass seals. Refer to "Window Glass Seal Replacement."
6. Window run channel caps (figure 13).

RUN CHANNEL REPLACEMENT

↔ Remove or Disconnect (Figure 13)

1. Window run-channel caps (83).
 - Completely lower the window.
2. Run-channel (81) from the end gate.
 - Pull the channel from the end gate. Twist the channel to clear the window opening.

↔ Install or Connect (Figure 13)

1. Run-channel (81) to the end gate.
 - Twist the channel into the window opening.
2. Run-channel (81) to end gate bolts (82).
3. Window run-channel caps (83).

END GATE OUTSIDE CRANK REPLACEMENT

↔ Remove or Disconnect (Figure 14)

1. Handle and control assembly. Refer to "Handle And Control Assembly Replacement."
2. Crank to end gate nuts (85).
3. Crank (88) and bezel (86) from the end gate.

↔ Install or Connect (Figure 14)

1. Crank (88) and bezel (86) to the end gate.
2. Crank to end gate nuts (85).
3. Handle and control assembly. Refer to "Handle And Control Assembly Replacement."

WINDOW GLASS SEAL REPLACEMENT

↔ Remove or Disconnect (Figure 15)

- Lower the window.
- Inner or outer seal by prying the clips from the end gate.

↔ Install or Connect (Figure 15)

- Inner or outer seal by pressing the clips into the holes in the end gate.

WEATHERSTRIP REPLACEMENT

↔ Remove or Disconnect (Figure 16)

- Weatherstrip from the end gate using 3M Release Agent (or equivalent).

↔ Install or Connect (Figure 16)

- Weatherstrip to the end gate using 3M Weatherstrip Adhesive (or equivalent).

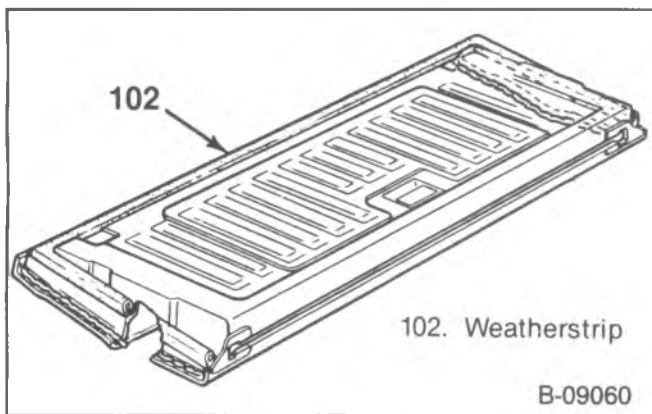

Figure 16—Weatherstrip Components

UTILITY VEHICLE REMOVABLE TOP

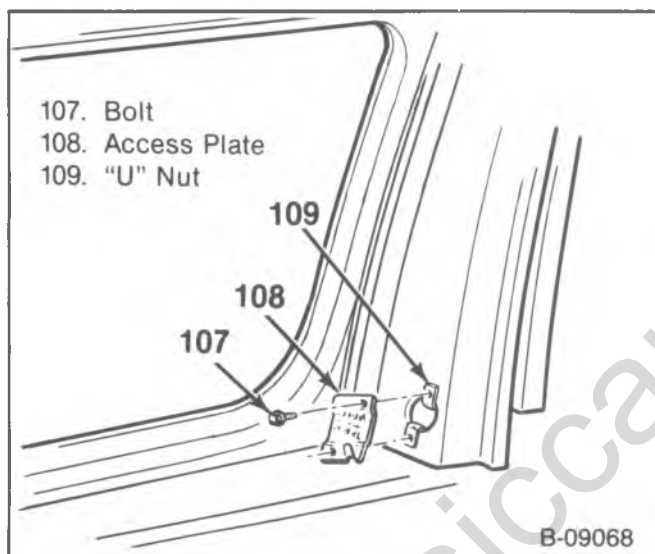

Figure 17—Removable Top—Access Plate Components

REMOVABLE TOP REPLACEMENT

←→ Remove or Disconnect (Figures 17 and 18)

1. Access plate (108) and dome lamp wiring harness.
 - Lower the end gate.
2. Top (111) to roof mounting bolts (110) and (114).
3. Top (111) to side panel mounting bolts (113) and (112).
4. Upper tire brace bolt and the upper brace.
 - Reinstall the brace after the top is removed.

5. Side trim panel rear attaching screws.
 - Remove twelve screws on the left side.
 - Remove eleven screws on the right side.
- Pull the panel away only far enough to gain access to the hidden top bolt.
6. Hidden bolts (115).
7. The removable top (111).
 - With the assistance of helpers, carefully lift the top from the vehicle. Do not allow the sides to bend.

→← Install or Connect (Figures 17 and 18)

To prevent damage to the top and to ensure proper weatherstrip sealing, the following procedure must be followed.

- Remove the upper spare tire brace.
1. The top onto the vehicle.
 - Use the two rear guide pins as locators.
 2. Top to roof mounting bolts (114).
 3. Top to side panel mounting bolts (112).
 - Start with the bolts nearest the end gate, and work towards the cab.
 - Do not install the second bolt from the rear on the right side at this time.
 - Do not install the bolts (113) nearest the cab.
 - Loosen the top (111) to roof mounting bolts (114).
 4. Top to side panel mounting bolts (113).
 5. Top to roof mounting bolts (110) and (114).
 6. Hidden bolts (115).
 7. Trim panel screws to the right and left trim panels.
 8. The upper spare tire brace with the remaining bolt.
 9. Dome lamp wiring harness, and access plate (108).

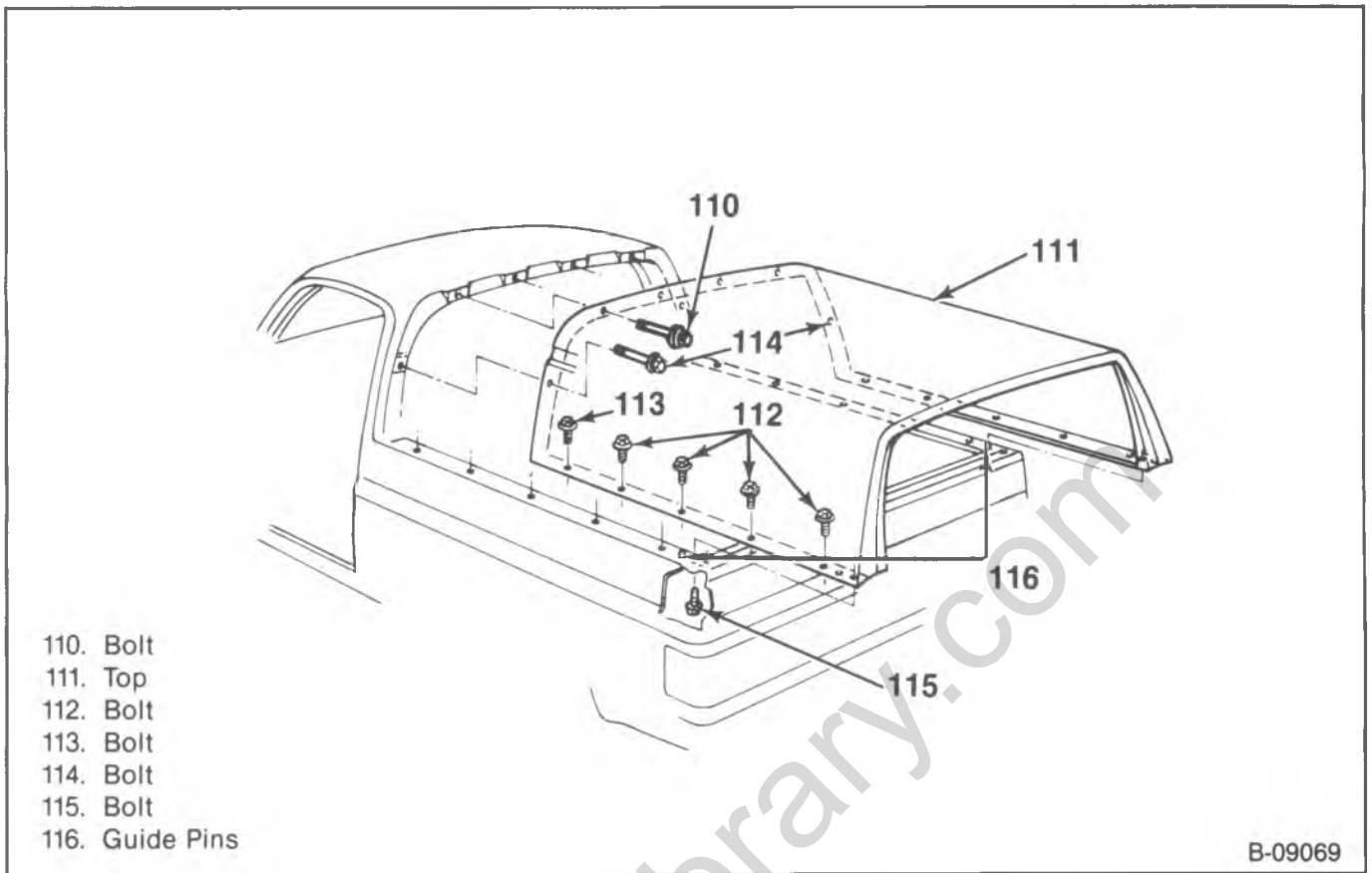

Figure 18—Removable Top Components

SUBURBAN MODELS

END GATE REPLACEMENT

↔ Remove or Disconnect (Figures 19, 20, and 21)

- Lower the end gate.
- 1. Torque rod bracket (119).
- 2. Wiring harness (if equipped). Refer to "End Gate Trim And Cover Panel Replacement" for access to the wiring harness.
- 3. Hinge access cover (131) and seal (132).
- 4. End gate to hinge bolts (133).
 - Lift the end gate to the almost closed position.
- 5. Support cable (136) to end gate bolt (142) and washer (143).
- 6. End gate with torque rod from the vehicle.

→← Install or Connect (Figures 19, 20 and 21)

1. End gate with torque rod (117) to the vehicle.
2. Support cable (136) to end gate washer (143) and bolt (142).
3. End gate to hinge bolts (133).
4. Hinge cover seal (132) and access cover (131).
5. Wiring harness (if equipped). Refer to "End Gate Trim And Cover Panel Replacement" for access to the wiring harness.
6. Torque rod bracket (119).

TORQUE ROD REPLACEMENT

↔ Remove or Disconnect (Figure 19)

1. End gate. Refer to "End Gate Replacement."
2. Trim panel (if equipped) and the cover panel.
3. End gate to torque rod inner bracket bolts (126).
4. End gate to torque rod outer bracket bolts (122).
5. Inner (118) and outer (119) brackets from the end gate.
6. Torque rod (117) from the end gate.

→← Install or Connect (Figure 19)

1. Torque rod (117) to the end gate.
2. Outer brackets (117) to the end gate.
3. Outer bracket bolts (122).
4. Inner bracket (118) to the end gate.
5. Inner bracket bolts (126).
6. The cover panel and trim panel (if equipped).
7. End gate. Refer to "End Gate Replacement."

HINGE REPLACEMENT

↔ Remove or Disconnect (Figure 20)

- Lower the end gate.
- 1. Hinge to body bolts (134) for the hinge to be removed.
- Loosen the hinge to body bolts (134) on the opposite hinge.

10A5-14 END GATE

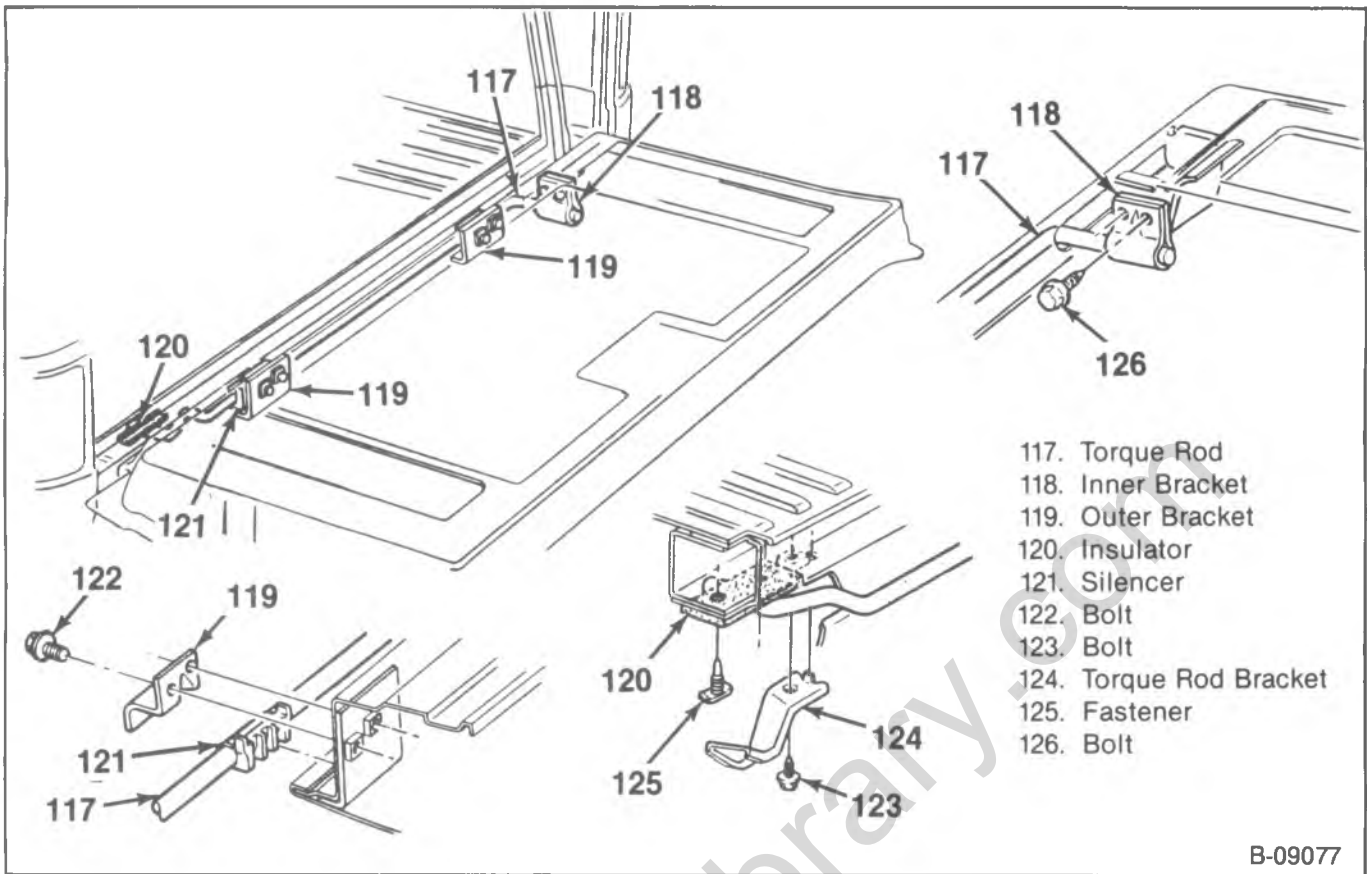

Figure 19—Suburban—Torque Rod Components

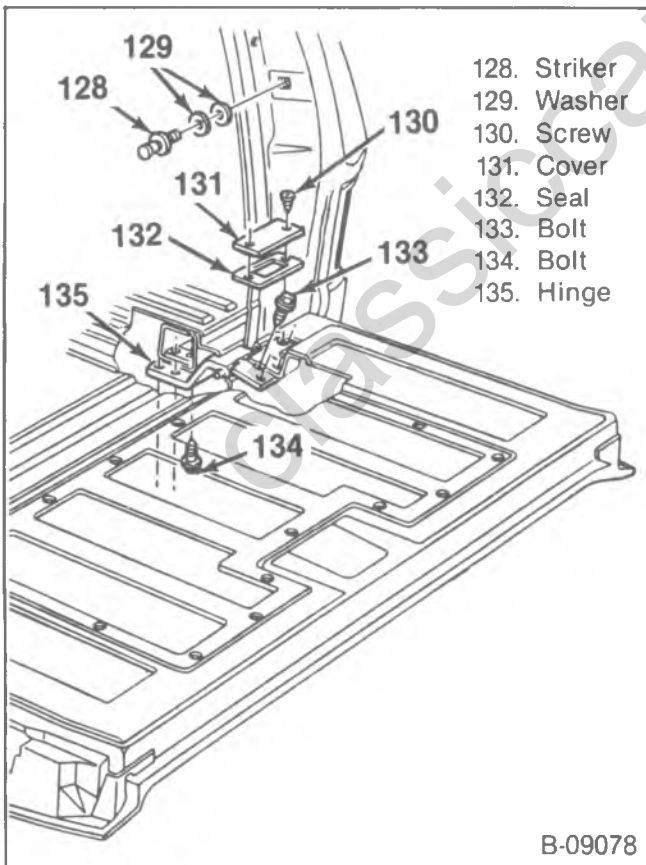

Figure 20—Hinge Components

2. Hinge cover screws (130) and covers (131).
3. Hinge to end gate bolts (133) for the hinge to be removed.
 - Pull the end gate away from the body several inches and remove the hinge from the body.
 - Lift the end gate slightly to allow removal of the hinge from the end gate.

↔ **Install or Connect (Figure 20)**

- Lift the end gate slightly and install the hinge to the end gate.
 - Pull the end gate away from the body several inches, and insert the hinge into the body.
1. Hinge to end gate bolts (133).
 2. Hinge to body bolts (134).
 - Tighten the hinge to body bolts on the opposite hinge.
 3. Hinge covers (131) and cover screws (130).

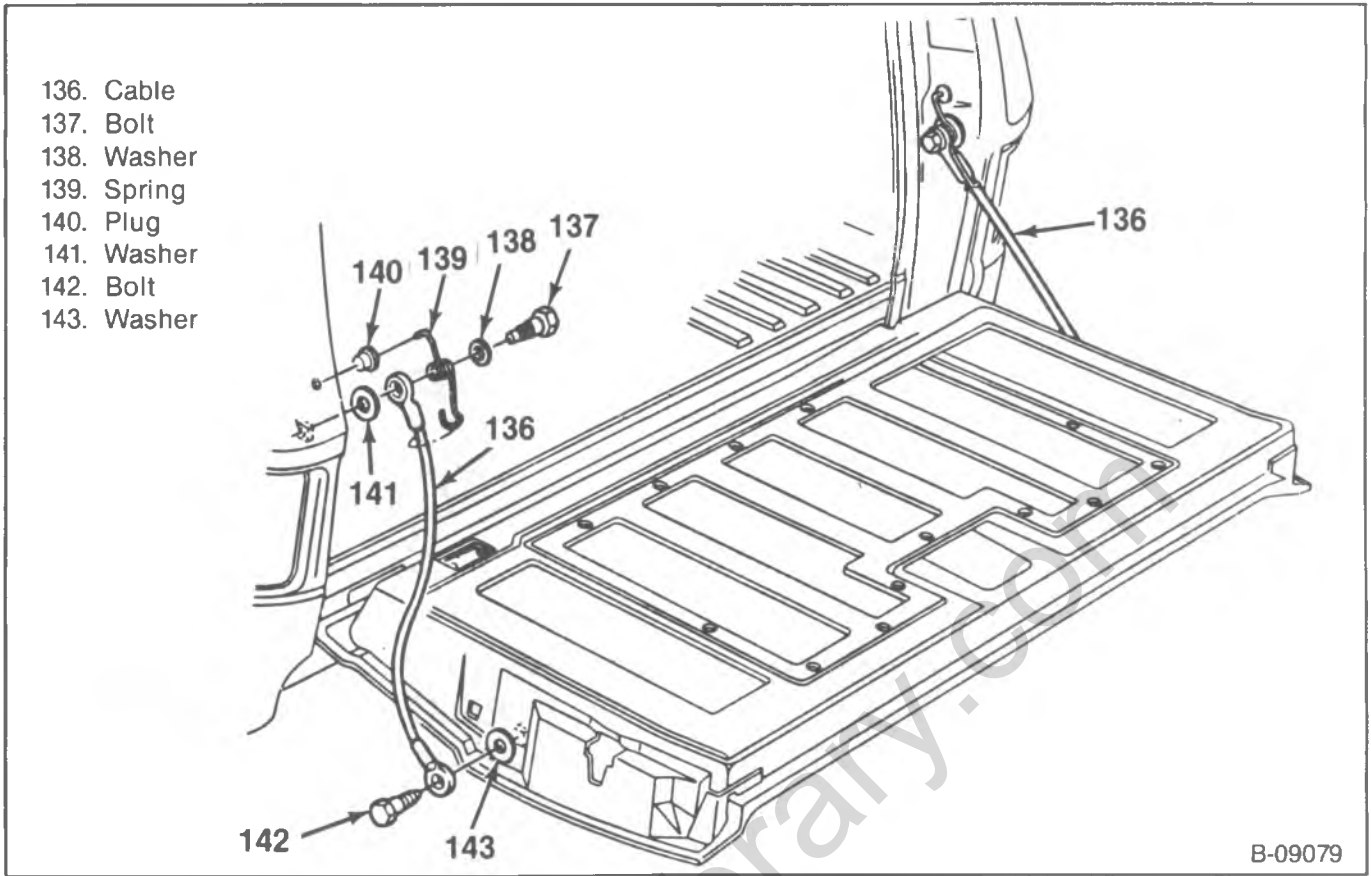

Figure 21—Cable Assembly Components

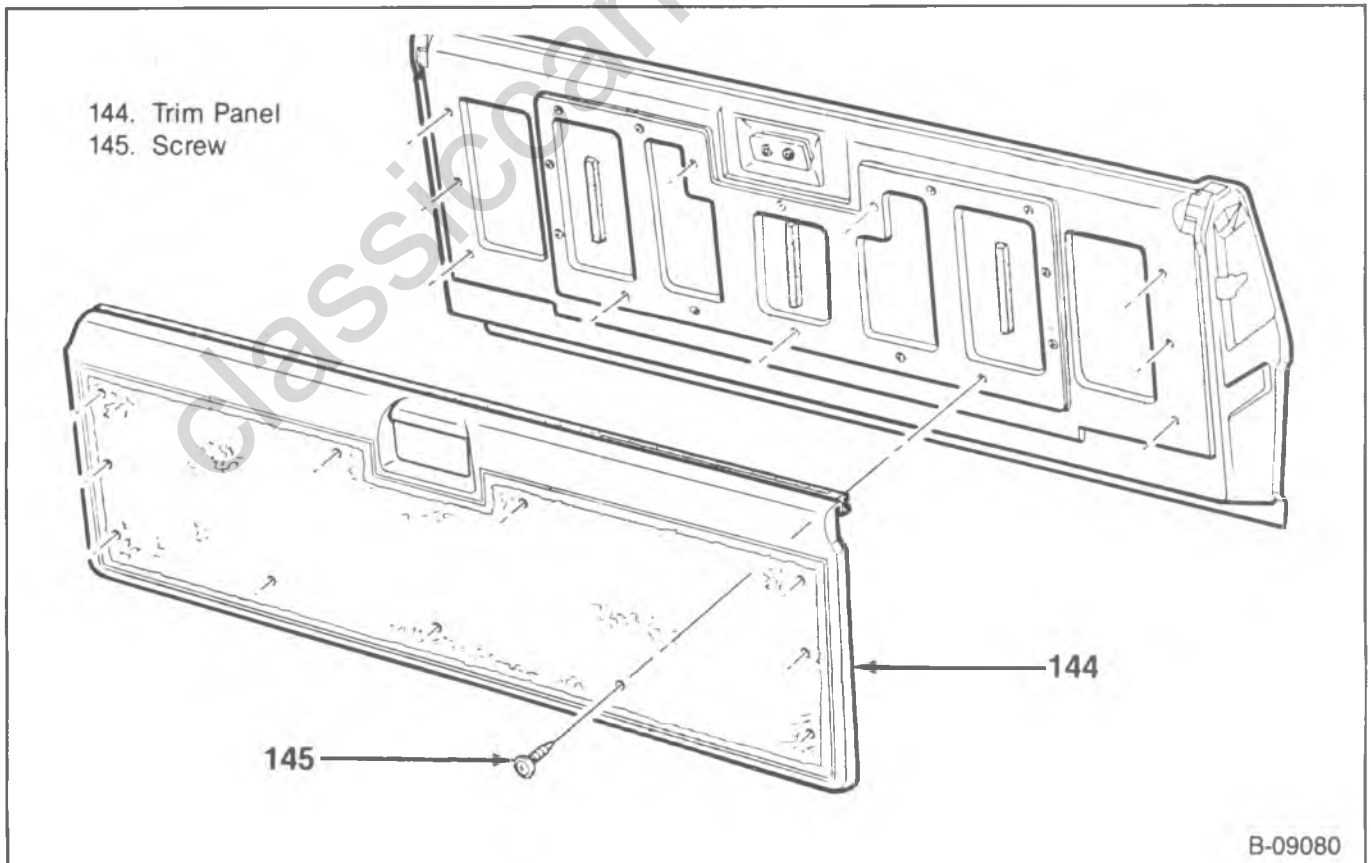

Figure 22—Trim Panel Components

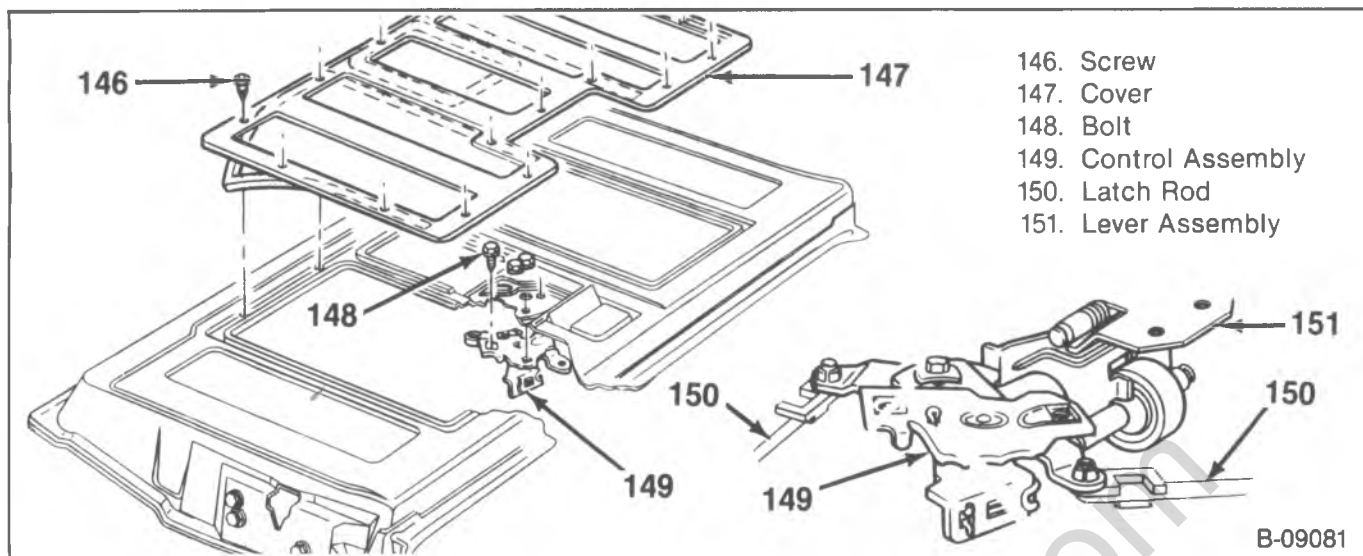

Figure 23—End Gate Cover and Control Assembly Components

END GATE TRIM AND COVER PANEL REPLACEMENT

↔ Remove or Disconnect (Figures 22 and 23)

1. Trim panel screws (145).
2. Trim panel (144).
 - Slide the panel away from the glass opening.
- Note the position of the cover panel screws. Five of the holes in the cover panel are also holes for the trim panel.
3. Cover panel screws (146).
4. Cover panel (147).

↔ Install or Connect (Figures 22 and 23)

1. Cover panel (147).
2. Cover panel screws (146).
3. Trim panel (144).
4. Trim panel screws (145).

HANDLE AND CONTROL ASSEMBLY REPLACEMENT

↔ Remove or Disconnect (Figures 23 and 24)

1. Trim panel (if equipped) and the cover panel.
2. Control rod (154) from the handle (159).
3. Handle to end gate screws (161).
4. Handle (159) from the end gate.
5. Right and left latch rods (150) from the control assembly.
6. Control assembly to end gate bolts (148).
7. Control assembly (149) from the end gate.

↔ Install or Connect (Figures 23 and 24)

1. Control assembly (149) to the end gate.
2. Control assembly to end gate bolts (148).
3. Right and left latch rods (150) from the control assembly.
4. Handle (159) to the end gate.
5. Handle to end gate screws (161).
6. Control rod (154) to the handle (159).
7. End gate cover and trim panel (if equipped).

LATCH REPLACEMENT

↔ Remove or Disconnect (Figure 24)

1. Trim panel (if equipped) and the cover panel.
2. Right or left latch rods (150) from the control assembly.
3. Latch (153) to end gate screws (152).
4. Latch (153) from the end gate.

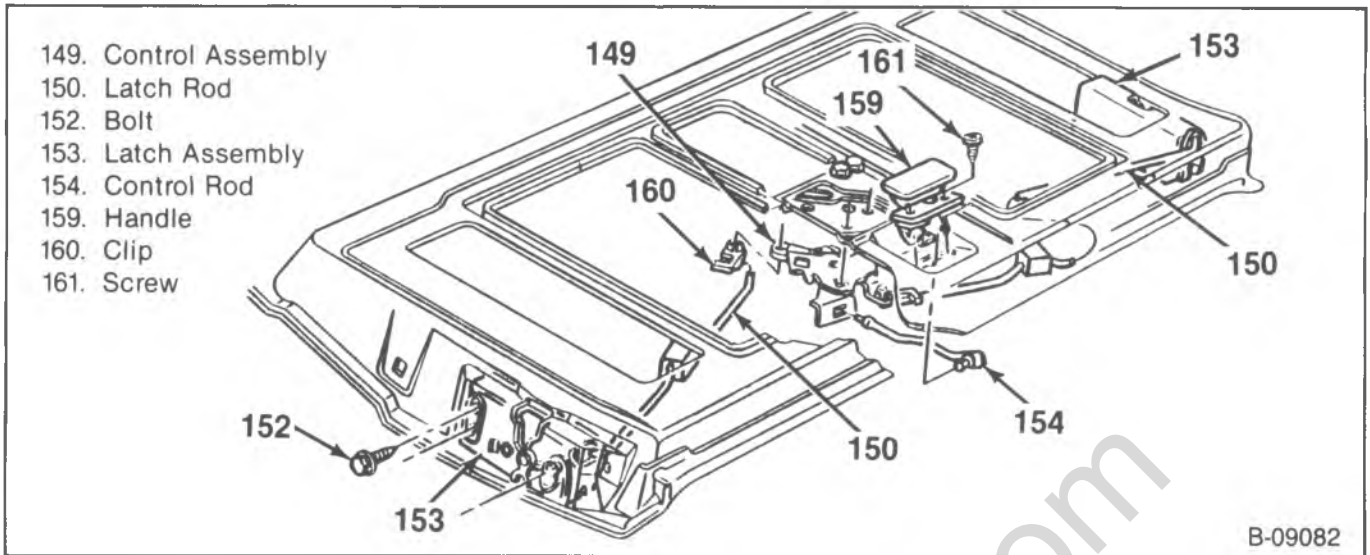

Figure 24—Handle and Latch Components

↔ Install or Connect (Figure 24)

1. Latch (153) with rod to the end gate.
2. Latch (153) to end gate screws (152).
3. Right or left latch rod (150) to the control assembly.
4. Cover panel and trim panel (if equipped).

4. Wiring harness from the motor.
5. Regulator (76) to end gate bolts (78).
6. Regulator (76) from the end gate.

CAUTION: Step 7 must be performed if the gear box is removed or disengaged from the regulator lift arms. The lift arms are under tension from the counterbalance spring, and can cause injury if the gear box is removed without locking the sector gear in place.

REGULATOR REPLACEMENT

MANUAL REGULATOR

↔ Remove or Disconnect (Figure 10)

1. Trim panel (if equipped) and cover panel.
2. Control assembly. Refer to "Handle And Control Assembly Replacement."
3. Sash assembly (73). Refer to "Sash Assembly Replacement."
4. Regulator (69) to end gate bolts (70).
5. Regulator (69) from the end gate.

7. Drill a 3.1 mm (1/8-inch) diameter hole through the sector gear and back plate. Install a sheet metal tapping screw into the hole to lock the sector gears in position.
8. Motor to regulator bolts.
9. Motor from the regulator.

↔ Install or Connect (Figure 10)

1. Regulator (69) to the end gate.
2. Regulator (69) to end gate bolts (70).
3. Sash assembly (73). Refer to "Sash Assembly Replacement."
4. Control assembly. Refer to "Handle And Control Assembly Replacement."
5. End gate cover and trim panel (if equipped).

↔ Install or Connect (Figures 10 and 11)

1. Motor to the regulator.
2. Motor to regulator bolts.
 - Remove the sheet metal screw.
3. Regulator (76) to the end gate.
4. Regulator (76) to end gate bolts (78).
5. Wiring harness to the motor.
6. Sash assembly (73). Refer to "Sash Assembly Replacement."
7. Control assembly. Refer to "Handle And Control Assembly Replacement."
8. Trim panel (if equipped) and end gate cover.

POWER REGULATOR

↔ Remove or Disconnect (Figures 10 and 11)

1. Trim panel (if equipped) and end gate cover.
2. Control assembly. Refer to "Handle And Control Assembly Replacement."
3. Sash assembly (73). Refer to "Sash Assembly Replacement."

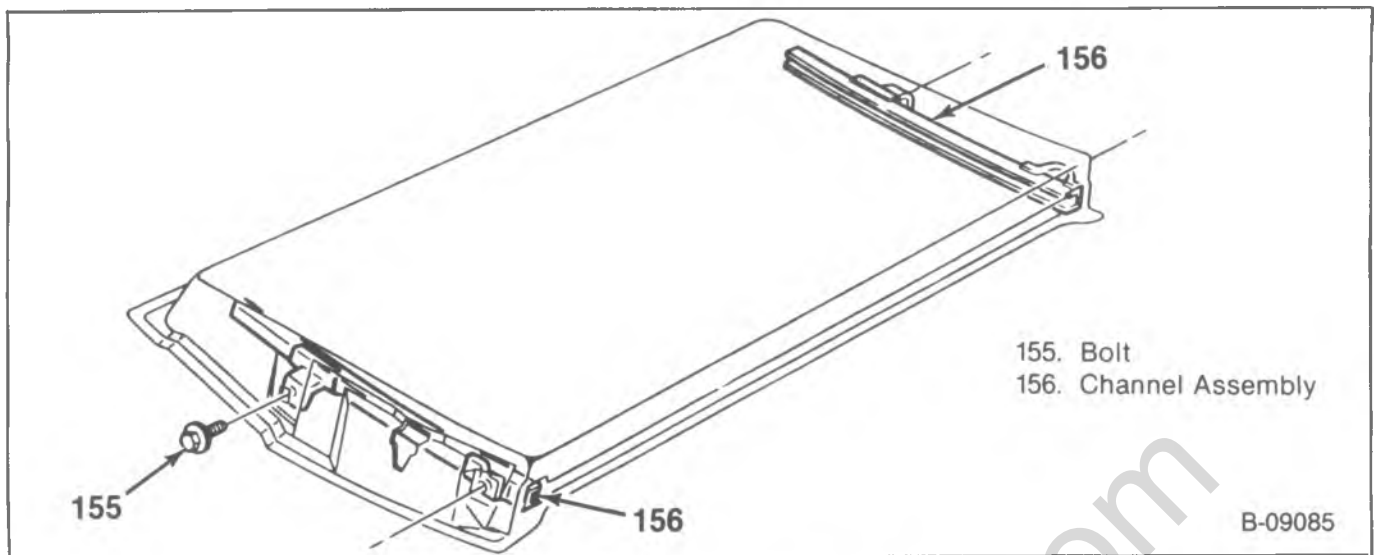

Figure 25—Run Channel Components

BLOCKOUT SWITCH REPLACEMENT

↔ Remove or Disconnect

1. Trim panel (if equipped) and the end gate cover.
2. The right latch assembly. Refer to "Latch Replacement."
3. Wiring harness from the switch.
4. Switch from the latch.

→← Install or Connect

1. Switch to the latch.
2. Wiring harness to the switch.
3. The right latch assembly to the end gate. Refer to "Latch Replacement."
4. End gate cover and trim panel (if equipped).

SASH ASSEMBLY REPLACEMENT

↔ Remove or Disconnect (Figure 10)

1. Inner and outer window glass seals. Refer to "Window Glass Seal Replacement."
2. Trim panel (if equipped) and cover panel.
 - Regulate the window so that the sash channel bolts (72) are accessible.
3. Sash (73) to sash channel bolts (72).
4. Sash (73) with glass (75) from the end gate.
5. Sash rails (71) from the regulator (69).

→← Install or Connect (Figure 10)

1. Sash rails (71) to the regulator (69).
2. Sash (73) with glass (75) to the end gate.
3. Sash (73) to sash channel bolts (72).
4. End gate cover and trim panel.
5. Inner and outer window glass seals. Refer to "Window Glass Seal Replacement."

RUN CHANNEL REPLACEMENT

↔ Remove or Disconnect (Figure 25)

- Completely lower the window.
1. Run-channel (156) to end gate bolts (155).
 2. Run-channel (156) from the end gate.
 - Pull the channel from the end gate. Twist the channel to clear the window opening.

→← Install or Connect (Figure 25)

1. Run-channel (156) to the end gate.
 - Twist the channel into the window opening.
2. Run-channel (156) to end gate bolts (155).

END GATE OUTSIDE CRANK REPLACEMENT

↔ Remove or Disconnect (Figure 14)

1. Handle and control assembly. Refer to "Handle And Control Assembly Replacement."
2. Crank to end gate nuts (85).
3. Crank (88) and gasket (87) from the end gate.

→← Install or Connect (Figure 14)

1. Crank (88) and gasket (87) to the end gate.
2. Crank to end gate nuts (85).
3. Handle and control assembly. Refer to "Handle And Control Assembly Replacement."

WINDOW GLASS SEAL REPLACEMENT

↔ Remove or Disconnect (Figure 15)

- Lower the window.
- 1. Trim panel (if equipped).
 - The inner seal is attached to the trim panel, when equipped, and replacement is not recommended.
- 2. Inner or outer seals by prying the clips from the end gate.

→ Install or Connect (Figure 15)

1. Inner or outer seal by pressing the clips into the holes in the end gate.
2. Trim panel (if equipped).

WEATHERSTRIP REPLACEMENT

↔ Remove or Disconnect (Figure 26)

1. Weatherstrip screws (158).
2. Weatherstrip from the end gate using 3M Release Agent (or equivalent).

→ Install or Connect (Figure 26)

1. Weatherstrip to the end gate using 3M Weatherstrip Adhesive (or equivalent).
2. Weatherstrip screws (158).

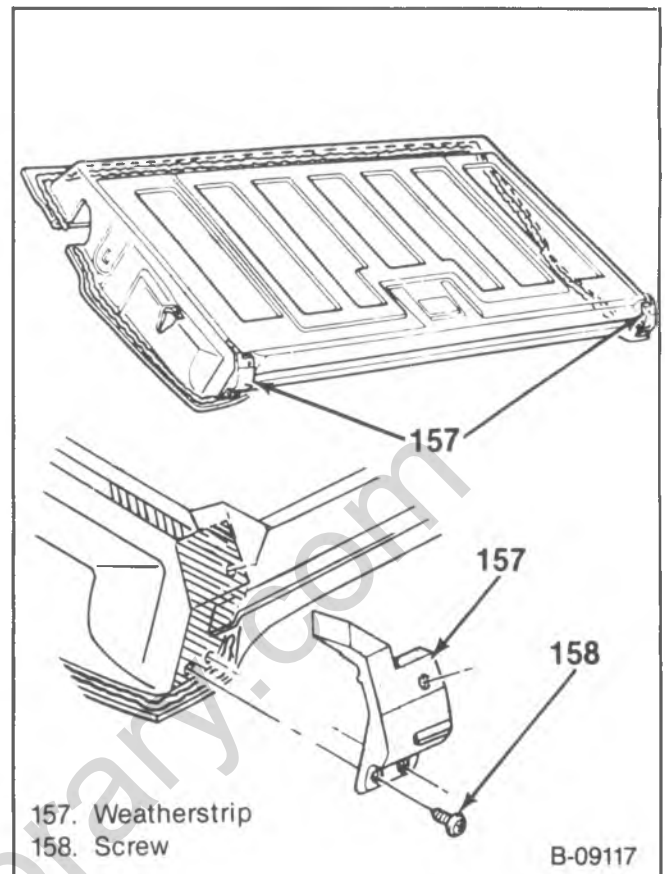

Figure 26—Weatherstrip Components

Classiccarlibrary.com

classicalibrary.com

SECTION	PAGE	SECTION	PAGE
A			
A/C Components—G Series		A/C Refrigerant-11 Flushing Procedure	1B-29
Accumulator Replacement	1B-50	A/C Refrigerant-12 Operating Characteristics	1B-9
Blower Motor Replacement	1B-54	A/C Refrigerant System Diagnosis	1B-11
Blower Switch Replacement	1B-57	A/C Special Tools	1B-67
Condenser Replacement	1B-50	A/C Specifications	1B-65
Control Assembly Replacement	1B-55	A/C System Components	1B-4
Defroster Duct Replacement	1B-57	A/C System Description	1B-3
Ductwork Replacement	1B-57	A/C System—P Series	
Evaporator Core (Diesel) Replacement	1B-53	A/C System Performance Test	1B-11
Evaporator Core Replacement	1B-53	A/C System Operation — R/V & G	1B-4
Heater Core Replacement	1B-51	A/C Temperature and Pressure Relationships	1B-9
Orifice Replacement	1B-53	A/C Testing the Refrigerant System	1B-11
Refrigerant-12 Hose Routing	1B-58	A/C Vacuum System Check	1B-26
Relay Replacement	1B-57	A/C Vacuum System Diagnosis	1B-23
Resistor Replacement	1B-57	Accelerator Controls	6C-16
Temperature Door Cable Adjustment	1B-55	Accelerator Control Cable	6C-16
Temperature Door Cable Replacement	1B-57	Accelerator Pedal	6C-16
Vacuum Lines—Engine	1B-57	A/C Electrical Circuits	8A-48
Vacuum Tank Replacement	1B-57	Advance Pin Hole Plug Seal	
A/C Components—R/V Series		Replacement (Diesel)	6C2-17
Accumulator Replacement	1B-35	Advance Piston Replacement (Diesel)	6C2-18
Actuator-Plenum Side Vent Replacement	1B-37	Advance Piston Seals Replacement (Diesel)	6C2-17
Blower Assembly Replacement	1B-35	Air Cleaner	6C-2
Blower Switch Replacement	1B-40	AIR Diagnosis	6E8-21
Condenser Replacement	1B-34	Air Filter Element Replacement	6C-2
Control Assembly Replacement	1B-39	Air Injection Reaction (AIR)	6E8-19
Evaporator Core Replacement	1B-36	Air Valve Link Adjustment	
Fuse Replacement	1B-43	(M4ME and M4MEF Models)	6C1-45
Heater Core Replacement	1B-36	Air Valve Return Spring Adjustment	
Orifice Replacement	1B-36	(M4ME and M4MEF Models)	6C1-41
Plenum Valve Replacement	1B-37	Aluminum Radiator	6B2-15
Refrigerant-12 Hose Routing	1B-43	Anaerobic Gasket Eliminator, Using	6A-2
Relay Replacement	1B-41	Auxiliary Cooling Fan Replacement	6B1-14
Resistor Replacement	1B-41	Auxiliary Heater Components — G	
Selector Duct Replacement	1B-36	Blower Motor Replacement	1A-25
Temperature Door Cable Adjustment	1B-40	Coolant-Control Valve Replacement	1A-26
Vacuum Line Replacement — Dash	1B-43	Heater Core Replacement	1A-26
Vacuum Line Replacement—Engine	1B-43	Resistor Replacement	1A-26
Vacuum Tank Replacement	1B-41	Auxiliary Heater Components — R/V	
A/C Charging Station Method	1B-26	Blower Motor Replacement	1A-17
A/C Compressor Diagnosis	1B-27	Blower Switch Replacement	1A-17
A/C Compressor Replacement (G)	1B-30	Coolant-Control Valve Replacement	1A-17
A/C Compressor Replacement (R/V)	1B-29	Heater Core Replacement	1A-17
A/C Condenser Diagnosis	1B-27	Resistor Replacement	1A-17
A/C Electrical/Vacuum Trouble Diagnosis	1B-18	Axle Joint Component Replacement	4C-4
A/C Evacuation and Charging Procedures	1B-23	Axle Shaft Replacement, Front	4C-2
A/C Evaporator Diagnosis	1B-27	Axle Shaft, Oil Seal and Bearing Replacement	
A/C Expansion Valve Diagnosis	1B-27	(8 ¹ / ₂ and 9 ¹ / ₂ -inch Ring Gear)	4B1-9
A/C Functional Test — R/V & G	1B-4	Axle Shaft Replacement Full Floating Axle	
A/C Gage Calibration	1B-26	(9 ³ / ₄ and 10 ¹ / ₂ -inch Ring Gear)	4B1-14
A/C Handling Refrigerant-12	1B-9	Axle Shaft Replacement (12-inch Ring Gear)	4B1-18
A/C Handling Refrigerant Lines and Fittings	1B-9	Axle Vent Replacement (12-inch Ring Gear)	4B1-18
A/C Maintaining Chemical Stability	1B-9		
A/C Periodic Maintenance and Servicing	1B-4	B	
A/C Pressure Sensing Switch	1B-13	Ball Joint, Lower, I.F.S.	3C-17
A/C "Quick-Check" Procedure	1B-11	Ball Joint, Upper, I.F.S.	3C-19
A/C Rear Interior Roof Mounted Systems		Ball Joints (V10/1500 and 20/2500 Models Only)	3C-48
(Suburban & G Series) Description	1B-3	Battery Cables	6D-6
A/C Rear Roof Mounted System—G Series	1B-63	Battery Charging Procedures	6D-5
A/C Refrigerant and Oil Capacity	1B-9	Battery Description	6D-2
A/C Refrigerant Drum Method	1B-26	Battery-General Information	6D-3
		Battery Replacement	6D-6

SECTION	PAGE
Bearing Adjustment Full Floating Axle (9 ³ / ₄ and 10 ¹ / ₂ -inch Ring Gear)	4B1-16
Bearing Adjustment (12-inch Ring Gear)	4B1-18
Bleeding, Hydraulic Clutch	7C-9
Bleeding the Brake Hydraulic System	5A-5
Bleeding the Hydro-Boost System	5A1-7
Blower and Air Inlet Assembly	1A-2
Brake Adjustment	5A2-10
Brake Backing Plate Replacement (8 ¹ / ₂ and 9 ¹ / ₂ -inch Ring Gear)	4B1-11
Brake Caliper Rebuilding	5A2-6
Brake Drum Service	5A2-10
Brake Lining Replacement (Drum Brakes)	5A2-9
Brake Pedal Assembly	5A-13
Brake Pedal Replacement	5A-13
Brake Pedal Rod Replacement	5A-15
Brake Pedal Travel Check	5A-13
Brake Pipes and Hoses	5A-6
Brake System Diagnosis	5A-2
Bumpers, G Model	2A-18
Bumpers, P Model	2A-15
Bumpers, R/V Model	2A-7

C

Cab Mount Replacement	2B-18
Camshaft Lobe Lift, Measuring (4.3L)	6A3-17
(Small Block)	6A4-17
(7.4L)	6A5-13
(4.8L)	6A7-14
Camshaft Replacement (4.3L)	6A3-17
(Small Block)	6A4-17
(7.4L)	6A5-13
(6.2L)	6A6-14
(4.8L)	6A7-15
Carburetor Adjustment (1MEF)	6C1-17
Carburetor, 1 BBL	6C1-15
Carburetor Diagnosis, 1 BBL	6C1-7
Carburetor, 4 BBL	6C1-37
Carburetor Diagnosis, 4 BBL	6C1-28
Carburetor Identification (M4ME and M4MEF Models)	6C1-21
Carburetor Model 1 MEF	6C1-2
Carburetor Models M4ME and M4MEF	6C1-21
Carburetor Mounting Torque (M4ME and M4MEF Models)	6C1-38
Carburetor Replacement (1 MEF)	6C1-17
Carburetor Replacement (M4ME and M4MEF)	6C1-38
Carburetor Special Tools	6C1-48
Carburetor Specifications	6C1-47
Carbureted Engine Fuel Filters	6C-2
Catalytic Converter Replacement	6F-4
CDR Valve Check	6E9-4
CDR Valve Replacement	6E9-5
Charging System — CS-130	6D-12
Charging System — SI	6D-10
Chassis Electrical	8B-1
Choke Checking Procedure (M4ME and M4MEF Models)	6C1-37
Choke Link and Fast Idle Cam Adjustment (M4ME and M4MEF Models)	6C1-42

SECTION	PAGE
Choke Stat Lever Adjustment (M3ME and M3MEF Models)	6C1-42
Circuit Check — Glow Plug System	6D-16
Circuit Diagnosis	8A-4
Circuit Repair	8A-6
Clutch Assembly and Pilot Bearing	7C-11
Clutch Diagnosis	7C-3
Clutch Inspection	7C-2
Clutch Linkage	7C-7
Clutch Pedal Free Travel Adjustment	7C-9
Clutch Pedal, Manual	7C-4
Clutch Pedal, Hydraulic	7C-4
Clutch Specifications	7C-15
Coil Springs, I.F.S.	3C-17
Combination Valve	5A-7
Compression Check Diesel Engine	6A-10
Gasoline Engine	6A-5
Connecting Rod and Piston Replacement (4.3L)	6A3-20
(Small Block)	6A4-19
(7.4L)	6A5-15
(6.2L)	6A6-21
(4.8L)	6A7-16
Control Arm, Lower, I.F.S.	3C-24
Control Arm, Upper, I.F.S.	3C-25
Control Arm Pivot Shaft and Bushings, Lower, I.F.S.	3C-20
Control Arm Pivot Shaft and Bushings, Upper, I.F.S.	3C-23
Coolant Level Indicator Diagnosis	6B1-3
Coolant Recovery System	6B2-14
Coolant Recovery Tank Replacement	6B1-6
Cooling System Capacities— Blazer/Jimmy, Suburban	0B-2
Cooling System Capacities— Forward Control	0B-3
Cooling System Capacities — G Van	0B-5
Cooling System Capacities — Pickup Models	0B-4
Cooling System Diagnosis	6B1-5
Cowl Vent Grille Replacement (G Model)	2B-15
Cowl Vent Grille Replacement (R/V Model)	2B-4
Crankcase Ventilation System (6.2L Diesel)	6E9-4
Cranking Circuit	6D-22
Cranking Speed Check (6.2L)	6A-10
Cranking System Description	6D-19
Cranking System Maintenance	6D-27
Crankshaft Gear Replacement (4.8L)	6A7-19
Crankshaft Replacement (4.3L)	6A3-23
(Small Block)	6A4-22
(7.4L)	6A5-18
(6.2L)	6A6-24
(4.8L)	6A7-20
Cross Lever, Clutch	7C-8
Current Drain Test	6D-5
Cylinder Head Replacement (4.3L)	6A3-12
(Small Block)	6A4-12
(7.4L)	6A5-7
(6.2L)	6A6-9
(4.8L)	6A7-9

SECTION	PAGE	SECTION	PAGE
D			
Deaeration Tank Replacement	6B1-6	Diesel Fuel Filter Assembly Component Replacement	6C-5
Detent Switch (THM 400)	7A-67	Diesel Fuel Filter Replacement	6C-4
Diagnosis		Diesel Fuel Injection Special Tools	6C2-21
AIR	6E8-21	Diesel Fuel Injection Specifications	6C2-20
Battery	6D-4	Diesel Fuel System Contamination	6C-8
Carburetor, 1 BBL	6C1-7	Diesel Glow Plug Electrical System Description	6D-15
Carburetor, 4 BBL	6C1-28	Diesel Idle Speed Adjustment	6C2-2
Circuit	8A-4	Diesel Throttle Position Switch Adjustment (LH6 Engine With 700 R4 Transmission)	6C2-3
Clutch	7C-3	Differential Capacities	0B-1
Cooling	6B1-2	Dipstick Tube Replacement (6.2L)	6A6-16
Diesel Engine	6A-8	Disc Brakes	5A2-1
Door Lock	8A-23	Disc Brake Lining Inspection	5A2-1
Driveline	4A-3	Disc Brake Lining Replacement	5A2-2
EECS	6E8-17	Distributor	6D-33
EFE	6E8-35	Distributor Replacement	6D-41
EGR	6E8-33	Distributor/Timing System for TBI-Equipped Vehicles	6D-36
Front Axle	4C-2	Doors (G Model Front)	
Front Side Marker	8B-10	Door and Hinge Replacement	10A1-32
Front Suspension	3C-2	Outside Handle Replacement	10A1-40
Fuel Gage	8C-4	Lock Replacement	10A1-39
Fuel Tank Selector Valve	6C-13	Power Lock Replacement	10A1-40
Gas Engine	6A-2	Trim Panel Replacement	10A1-33
Glow Plug Electrical System	6D-16	Vent Replacement	10A1-35
Headlamp	8B-6	Window Regulator Replacement	10A1-38
Heater Circuit Diagnosis	1A-8	Window Replacement	10A1-36
Heater System	1A-9	Doors (G Model Intermediate)	
Hydraulic Lifters	6A-6	Door and Hinge Replacement	10A1-42
Ignition System	6D-36	Lock Replacement	10A1-46
Insufficient Heat Diagnosis	1A-5	Power Lock Replacement	10A1-50
Marker Lamp	8B-10	Trim Panel	10A1-44
Manual Steering	3B2-2	Window Replacement	10A1-45
Oil Pressure Gage	8C-5	Doors (G Model Rear)	
Parking Lamps	8B-8	Door and Hinge Replacement	10A1-63
PCV	6E8-39	Lock Replacement	10A1-70
Power Steering	3B3-5	Outside Handle Replacement	10A1-70
Power Window	8A-24	Power Lock Replacement	10A1-72
Rear Axle	4B1-2	Trim Panel Replacement	10A1-64
Rear Lighting Systems	8B-17	Window Replacement	10A1-66
Spark Plugs	6D-39	Doors (G Model Sliding)	
Speedometer	8C-3	Door and Hinge Replacement	10A1-53
Steering Column	3B4-2	Lock Replacement	10A1-59
Steering Linkage	3B1-2	Trim Panel Replacement	10A1-58
Temperature Gage	8C-6	Window Replacement	10A1-58
THERMAC	6E8-41	Doors (RV Model Front)	10A1-4
Thermostat	6B1-3	Door and Hinge Replacement	10A1-4
Torque Converter	4C-11	Trim Panel Replacement	10A1-4
Torque Converter Clutch	7A-12	Vent/Window Replacement	10A1-5
Transmission, Automatic	7A-6	Lock Replacement	10A1-10
Transmission, Manual	7B-2	Outside Rear View Mirror Replacement	10A1-13
Transmission, THM 400	7A-16	Power Lock Motor Replacement	10A1-10
Transmission, THM 700 R-4	7A-35	Window Regulator Replacement	10A1-9
TRC	6E8-43	Doors (RV Model Side Rear)	
Vacuum Pump	6H-1	Door and Hinge Replacement	10A1-14
"Water In Fuel" Light	6C-3	Lock Replacement	10A1-20
Wheels and Tires	3E-3	Power Lock Replacement	10A1-20
Wheel Bearings	3C-3	Trim Panel Replacement	10A1-16
Windshield Washer	8A-35	Window Regulator Replacement	10A1-19
Windshield Wiper	8A-26	Window Replacement	10A1-17
Wiper Delay	8A-38	Doors (RV Model Rear)	
Diesel Engine Diagnosis	6A-8	Door and Hinge Replacement	10A1-23
Diesel Fuel Filters	6C-3		

SECTION	PAGE
Trim Panel Replacement	10A1-25
Window Replacement	10A1-25
Draining the Diesel Engine Fuel Filter	6C-3
Draining the Fuel Tank	6C-7
Drivability Symptoms	6E8-8
Drive Belt Replacement	6B1-10
Drive Pinion Oil Seal Replacement (12-Inch Ring Gear)	4B1-19
Drive Shaft Seal Replacement (Diesel)	6C2-19
Drum Brakes	5A2-9

E

Early Fuel Evaporation (EFE)	6E8-35
EECS Diagnosis	6E8-17
EFE Diagnosis	6E8-35
EGR Diagnosis	6E8-33
EGR System Check (6.2L Diesel)	6E9-6
EGR Valve Replacement (6.2L Diesel)	6E9-7
Electric Choke (1 MEF)	6C1-15
Electrical Circuits	8A-2
Electrical Systems, Cab	8A-9
Electrical Tests — Generator	6D-10
Emissions, Carb.	6E8-2
Emissions Components, Carb.	6E8-5
End Gate	
Fender Side Models	10A5-2
Fleet Side Models	10A5-2
Suburban Models	10A5-13
Utility Vehicle Models	10A5-4
Engine Block Heaters	6D-28
Engine Code Identification	0B-1
Engine Crankcase Capacities— Blazer/Jimmy, Suburban	0B-2
Engine Crankcase Capacities — Forward Control	0B-3
Engine Crankcase Capacities — G Van	0B-5
Engine Crankcase Capacities — Pickup Models	0B-4
Engine Electrical System	6D-2
Engine Electrical System Specifications	6D-77
Engine Emission Classification VIN Code	0B-8
Engine Gaskets, Replacing	6A-2
Engine Lubrication	
(4.3L)	6A3-2
(Small Block)	6A4-2
(7.4L)	6A5-3
(6.2L)	6A6-2
(4.8L)	6A7-2
Engine Replacement	
(4.3L)	6A3-24
(Small Block)	6A4-23
(7.4L)	6A5-22
(6.2L)	6A6-28
(4.8L)	6A7-21
Engine Mountings	
(4.3L)	6A3-23
(Small Block)	6A4-22
(7.4L)	6A5-19
(6.2L)	6A6-25
(4.8L)	6A7-21
Engine Wire Harness	6D-52

SECTION	PAGE
Engines with TBI	6D-33
EPR Vacuum Actuator Replacement	6E9-7
EPR/EGR Solenoid Replacement	6E9-7
Evaporator Emissions Control System (EECS)	6E8-16
Exhaust Gas Recirculation (EGR)	6E8-32
Exhaust Gas Recirculation System (6.2L Diesel)	6E9-5
Exhaust Inspection	6F-2
Exhaust Manifold Replacement	
(4.3L)	6A3-11
(Small Block)	6A4-10
(6.2L)	6A6-3
(7.4L)	6A5-7
Exhaust Parts, Installing	6F-2
Exhaust Specifications	6F-10
Exhaust System Diagnosis	6F-2
Fan and Fan Clutch Replacement	6B1-13
Fan Clutch Diagnosis	6B1-2
Fan Shroud Replacement	6B2-6
Float Adjustment (M4ME and M4MEF Models)	6C1-40
Float Level-External Check (M4ME and M4MEF Models)	6C1-37
Fluids and Lubricants	0B-24
Flushing the Brake Hydraulic System	5A-6
Flushing the Cooling System	6B1-6
Flywheel Replacement	
(4.3L)	6A3-23
(Small Block)	6A4-22
(7.4L)	6A5-18
(4.8L)	6A7-20
Frame Alignment	2A-4
Frame Diagnosis	2A-2
Frame Straightening	2A-5
Front Axle Assembly Replacement	4C-3
Front Axle Capacities — Blazer/Jimmy, Suburban	0B-2
Front Axle Capacities — Pickup Models	0B-4
Front Axle Diagnosis	4C-2
Front Axle, I-Beam	3C-34
Front Axle Specifications	4C-8
Front Cover Replacement	
(4.3L)	6A3-14
(Small Block)	6A4-14
(7.4L)	6A4-14
(6.2L)	6A6-13
(4.8L)	6A7-11
Front End Alignment	3A-2
Front End Alignment Requirements	3A-3
Front End Alignment Specifications	3A-6
Front End Panel Replacement (G Model)	2B-17
Front End Sheet Metal Cross Panel Replacement (G Model)	2B-17
Front Fender Replacement (R/V Model)	2B-6
Front Suspension, Diagnosis	3C-2
Front Suspension, Specifications	3C-51
Fuel Filter Replacement	6C-2
Fuel Filter Replacement (M4ME and M4MEF Models)	6C1-38
Fuel Gage Diagnosis	8C-4

SECTION	PAGE
(6.2L)	6A6-3
(7.4L)	6A5-5
Interior Trim	
G Models	10A4-18
R/V Models	10A4-1
Suburban Model	10A4-13

L

Lamp Switch	8C-16
Leaf Spring and Bushings, 4 W.D.	3C-49
Leaf Spring Assembly Replacement	3D-9
Leaf Spring Eye Bushing Replacement	3D-10
Leaf Springs, I-Beam	3C-34
License Plate Bracket Replacement	2A-13
Load Test — Battery	6D-4
Locking Hub Rebuild Procedure, Manual	4C-8
Locking Hub Component Replacement	4C-4
Locking Hub Replacement, Manual	4C-7
Locking Hub to the Wheel Adjustment, Automatic	4C-7
Lubrication Points—Conventional, Forward	
Control Models	0B-6
Lubrication Points—Four Wheel Drive Models	0B-6
Lubrication Points—G Van	0B-7

M

Main Bearing Replacement	
(4.3L)	6A3-22
(Small Block)	6A4-21
(7.4L)	6A5-17
(6.2L)	6A6-22
(4.8L)	6A7-18
Maintenance Schedules	0B-7
Manual Steering Gear Maintenance	3B2-3
Manual Steering Gear Specifications	3B2-7
Manual Steering System Diagnosis	3B2-2
Marker Lamp	8B-11
Marker Lamp Diagnosis	8B-10
Marking TDC on the Front Housing (Diesel)	6C2-8
Master Cylinder and Reservoir, Clutch	7C-5
Master Cylinders	5A-24
Master Cylinder Bench Bleeding	5A-26
Master Cylinder Replacement	5A-24
Minimum-Maximum Governor Replacement	
(Diesel Fuel Injection)	6C2-13

O

Oil Filter Bypass Valve Replacement	
(4.3L)	6A3-23
(Small Block)	6A4-20
(7.4L)	6A5-18
(6.2L)	6A6-24
(4.8L)	6A7-20
Oil Pan Replacement	
(4.3L)	6A3-15
(Small Block)	6A4-14
(7.4L)	6A5-10
(6.2L)	6A6-17
(4.8L)	6A7-12
Oil Pressure Gage Diagnosis	8C-5
Oil Pressure Gage Replacement	8C-13

SECTION	PAGE
Oil Pressure Gage Sensor	8C-14
Oil Pump Drive Replacement (6.2L)	6A6-12
Oil Pump Replacement	
(4.3L)	6A3-16
(Small Block)	6A4-15
(7.4L)	6A5-11
(6.2L)	6A6-18
(4.8L)	6A7-12

P

Parking Brake Adjustment	5A-22
Parking Brake Cable Replacement	5A-18
Parking Brake Pedal or Handle Replacement	5A-17
Parking Brake System	5A-17
Parking Lamp	8B-9
Parking Lamp Diagnosis	8B-8
PCV Diagnosis	6E8-39
Pinion Flange, Dust Deflector/Oil Seal Replacement	
(8 ¹ / ₂ and 9 ¹ / ₂ -inch Ring Gear)	4B1-12
Pinion Oil Seal/Companion Flange Replacement	
Full Floating Axle (9 ³ / ₄ and	
10 ¹ / ₂ -inch Ring Gear)	4B1-17
Pitman Arm Replacement	3B1-5
Pitman Shaft Seal Replacement	3B2-5
Positive Crankcase Ventilation (PCV)	6E8-39
Power Door Lock	8A-24
Power Lock Diagnosis	8A-23
Power Steering Diagnosis	3B3-5
Power Steering Flush	3B3-12
Power Steering Gear	3B3-13
Power Steering Gear Adjustments	3B3-17
Power Steering Pump	3B3-19
Power Steering System Bleeding	3B3-12
Power Steering System Test	3B3-8
Power Window	8A-26
Power Window Diagnosis	8A-24
Pressure Testing the Injection Pump	
(Diesel)	6C2-19
Primary Hood Latch Replacement (G Model)	2B-13
Primary Hood Latch Replacement (R/V Model)	2B-2
Primary Side Vacuum Break Adjustment	
(M4ME and M4MEF Models)	6C1-42
Propeller Shaft	4A-1
Propeller Shaft Balance Check	4A-5
Propeller Shaft Brake Replacement	5A-22
Propeller Shaft Replacement (Front Drive)	4A-7
Propeller Shaft Replacement (Rear Drive)	4A-6
Propeller Shaft Runout Check	4A-5
Pump Adjustment (M4ME and M4MEF Models)	6C1-41
Pump Cover Seal and/or Guide Stud Seal	
Replacement (Diesel Fuel Injection)	6C2-12
Pushrod Cover Replacement (4.8L)	6A7-6

R

Radiator Support Replacement (R/V Model)	2B-10
Rear Axle Assembly Replacement (All Axles)	4B1-8
Rear Axle Diagnosis	4B1-2
Rear Axle Specifications	4B1-20
Rear Crankshaft Seal Retainer Replacement	
(4.3L)	76A3-16
(Small Block)	6A4-16

SECTION	PAGE	SECTION	PAGE
Rear Crankshaft Oil Seal Replacement		Sheet Metal Vertical Support	
(4.3L)	6A3-16	Replacement (G Model)	2B-17
(Small Block)	6A4-15	Shift Control, Manual Transmission	7B-7
(7.4L)	6A5-11	Shift Linkage Adjustment,	
(6.2L)	6A6-18	Manual Transmission	7B-6
(4.8L)	6A7-13	Shift Linkage, Automatic Transmission	7A-63
Rear Extension Oil Seal, Automatic		Shift Linkage, Manual Transmission	7B-5
Transmission	7A-73	Shock Absorber Bench Test	3C-3
Rear Fender Replacement (R/V Model)	2B-8	Shock Absorber, I-Beam	3C-28
Rear Lighting Service	8B-21	Shock Absorber, I.F.S.	3C-8
Rear Lighting Diagnosis	8B-17	Shock Absorber, 4 W.D.	3C-36
Rear Lighting Systems	8B-11	Shock Absorber Replacement	3D-8
Rear Oil Seal, Manual Transmission	7B-3	Shutdown and/or Cold Advance Solenoid	
Rear Suspension Specifications	3D-12	Replacement (Diesel)	6C2-16
Relay Rod Replacement	3B1-4	Side Cover Gasket Replacement (Diesel)	6C2-17
Road Testing the Brakes	5A-2	Side Cover, Manual Transmission	7B-8
Rocker Arm and Pushrod Replacement		Spark Plugs	6D-35
(4.3L)	6A3-5	Spark Plug Wires	6D-35
(Small Block)	6A4-5	Spark Plug Wires — Service	6D-42
(7.4L)	6A5-3	Spark Plug Wire Replacement	6D-42
(4.8L)	6A7-4	Specifications (Engine)	
Rocker Arm Cover Replacement		(4.3L)	6A3-28
(4.3L)	6A3-5	(Small Block)	6A4-32
(Small Block)	6A4-5	(7.4L)	6A5-27
(7.4L)	6A5-3	(6.2L)	6A6-33
(6.2L)	6A6-4	(4.8L)	6A7-25
(4.8L)	6A7-4	Speedometer Cable Core Replacement	8C-7
Rocker Arm, Shaft, and Pushrod		Speedometer Diagnosis	8C-3
Replacement (6.2L)	6A6-4	Speedometer Drive Gear, Manual	
Rocker Arm Stud Replacement		Transmission	7B-3
(4.3L)	6A3-10	Speedometer Drive Gear/Vehicle	
(Small Block)	6A4-10	Speed Sensor	7A-67
(7.4L)	6A5-7	Speedometer Replacement	8C-7
(4.8L)	6A7-8	Spindle, 4 W.D.	3C-41
Rotor Servicing	5A2-6	Spring Assembly Replacement (R/V Model)	2B-2
RTV Sealer, Using	6A-2	Stabilizer Bar Replacement	3D-8
		Stabilizer Bar, I-Beam	3C-30
		Stabilizer Bar, I.F.S.	3C-8
		Stabilizer Bar, 4 W.D.	3C-36
		Starter Motor Noise	6D-24
		Starter Motor Replacement	6D-27
		Starter Motor Service	6D-27
		Steering Arm, Knuckle and Spindle, I-Beam	3C-33
		Steering Column Diagnosis	3B4-2
		Steering Column (G Model) Replacement	3B4-16
		Steering Column Lock Cylinder Replacement	
		(R, V, G Models)	3B4-17
		Steering Column Lower Bearing Adjustment	
		-P(42) Models	3B4-42
		Steering Column Lower Bearing Replacement	
		-P(42) Models	3B4-42
		Steering Column Lower Bearing Adjustment	
		(Standard)	3B4-23
		Steering Column Replacement (Standard)-	
		P(42) Models	3B4-38
		Steering Column (RV Model) Replacement	3B4-15
		Steering Column Shift Tube Adjustment-	
		P(42) Models	3B4-41
		Steering Column Special Tools	3B4-45
		Steering Column Specifications	3B4-44
		Steering Column (Standard) Unit Repair-	
		P(42) Models	3B4-42
		Steering Column Unit Repair-	
		Standard (R, V, G Models)	3B4-19

S

Seat Adjuster Diagnosis	10A2-2
Seat Belts	10A2-7
Seats	
G Model Center and Rear	10A2-26
G Model Front	10A2-23
RV Model Front	10A2-3
RV Model Rear	10A2-13
Suburban Model Center	10A2-8
Secondary Hood Latch and Spring Replacement	
(G Model)	2B-14
Secondary Hood Latch and Spring Replacement	
(RV Model)	2B-3
Secondary (Slave) Cylinder and Hydraulic	
Line, Clutch	7C-6
Secondary Side Vacuum Break Adjustment	
(M4ME and M4MEF Models)	6C1-44
Secondary Throttle Lockout Adjustment	
(M4ME and M4MEF Models)	6C1-46
Selector Valve Diagnosis	6C-13
Servo, 2-4 (THM 700-R4)	7A-71
Semi Floating Rear Axle (8 ¹ / ₂ and	
9 ¹ / ₂ Ring Gear)	4B1-9
Sheet Metal Adjustments (R/V Model)	2B-11
Sheet Metal Unit Replacement (R/V Model)	2B-11

SECTION	PAGE
Steering Column Unit Repair— Tilt (R, V, G Models)	3B4-26
Steering Column Upper Bearing Replacement— P(42) Models	3B4-39
Steering Connecting Rod Replacement (P30(32) Motorhome)	3B1-11
Steering Connecting Rod Replacement (V and P30(00) FS3 Models)	3B1-10
Steering Flexible Coupling Replacement	3B4-14
Steering Gear Adjustments, Manual	3B2-6
Steering Gear High Point Centering, Manual	3B2-7
Steering Gear Replacement, Manual	3B2-3
Steering Intermediate Shaft Replacement	3B4-13
Steering Intermediate Shaft Unit Repair— P(42) Models	3B4-43
Steering Knuckle and Arm, 4 W.D.	3C-45
Steering Knuckle, I.F.S.	3C-15
Steering Linkage Diagnosis	3B1-2
Steering Linkage Specifications	3B1-13
Steering Shock Absorber Inspection	3B1-6
Steering Shock Absorber Replacement	3B1-7
Steering Wheel Inspection	3B4-12
Stoplamp Switch	5A-16
Suspension Unit, I.F.S.	3C-26

T

Temperature Gage Diagnosis	8C-6
Temperature Gage Replacement	8C-11
THERMAC Diagnosis	6E8-41
Thermostat Diagnosis	6B1-3
Thermostat Housing Crossover Removal	6B1-8
Thermostatic Air Cleaner (THERMAC)	6E8-40
Thermostat Replacement	6B1-7
Throttle Kicker	6C1-38
Throttle Kicker Adjustment (M4ME and M4MEF Models)	6C1-40
Throttle Position Switch Adjustment (6.2L Diesel)	6E9-8
Throttle Return Control (TRC)	6E8-43
Throttle Shaft Seal Replacement (Diesel Fuel Injection)	6C2-14
Tie Rod Replacement (R, G P20 and 30(42) Models)	3B1-7
Tie Rod Replacement (V and P30(00) FS3 Models)	3B1-8
Tilt Steering Column Unit Repair— P(32) Models	3B4-38
Tilt Steering Column Replacement— P(32) Models	3B4-33
Tilt Steering Column Bearing Housing Replacement— P(32) Models	3B4-35
Timing Gear Cover Replacement (4.8L)	6A7-11
Tire Load Limits and Inflation Pressure	3E-1
Tone Alarm Switch (Steering Column) Replacement (R, V, G Models)	3B4-18
Torque Converter Clutch Diagnosis	7A-12
Torque Converter Diagnosis	7A-11
Torsional Damper and Front Crankshaft Seal Replacement	6A3-13
(4.3L)	6A4-13
(Small Block)	6A4-13

SECTION	PAGE
(7.4L)	6A5-8
(6.2L)	6A6-12
(4.8L)	6A7-10
Trailer Hitch Replacement	2A-20
Trailer Hitch Replacement (Utility Vehicle and Suburban)	2A-13
Transfer Case Capacities — Blazer/Jimmy, Suburban	0B-2
Transfer Case Capacities — Pickup Models	0B-4
Transfer Case Diagnosis (205)	7D1-3
Transfer Case Maintenance and Adjustment (205)	7D1-2
Transfer Case Replacement (205)	7D1-3
Transmission Capacities	0B-1
Transmission Diagnosis, Automatic	7A-6
Transmission Diagnosis, Manual	7B-2
Transmission Diagnosis, THM 400	7A-16
Transmission Diagnosis, THM 700 R-4	7A-35
Transmission Fluid Checking and Adding, Automatic	7A-63
Transmission Fluid and Filter Changing, Automatic	7A-66
Transmission Inspection, Manual	7B-1
Transmission Oil Circuits, THM 400	7A-25
Transmission Oil Cooler and Lines, Automatic	7A-63
Transmission Oil Drain and Fill, Manual	7B-3
Transmission Oil and Wiring Circuits, THM 700 R-4	7A-43
Transmission Preliminary Checking, THM 400	7A-14
Transmission Preliminary Checking, THM 700 R-4	7A-31
Transmission Replacement, Automatic	7A-74
Transmission Replacement, Manual	7B-10
Transmission Specifications, Automatic	7A-74
Transmission Specifications, Manual	7B-11
TRC Diagnosis	6E8-43
Turn Signal Switch Replacement— P(32) Models	3B4-33
Turn Signal Switch Replacement (R, V, G Models)	3B4-16
TV Cable	7A-65
TV Cable Adjustment	7A-65
Tune-Up Information	6A-2

U

Underbody Alignment	2A-6
Underbody, G Model	2A-6
Universal Joint	4A-1
Unloader Adjustment (M4ME and M4MEF Models)	6C1-45

V

Vacuum Boosters	5A1-3
Vacuum Booster Replacement	5A2-3
Vacuum Modulator (THM 400)	7A-67
Vacuum Pumps	6H-1
Vacuum Pump Diagnosis	6H-1
Vacuum Pump Replacement	6H-4
Vacuum Regulator Valve Adjustment (LL4 Engine with Automatic Transmission)	6C2-4
Vacuum Regulator Valve	6E9-9

SECTION	PAGE	SECTION	PAGE
Valve Adjustment			
(4.3L)6A3-6		
(Small Block)6A4-6		
(7.4L)6A5-4		
(4.8L)6A7-5		
Valve Stem Seal and Valve Spring Replacement			
(4.3L)6A3-6		
(Small Block)6A4-7		
(7.4L)6A5-4		
(6.2L)6A6-8		
(4.8L)6A7-5		
Valve Timing, Checking (4.8L)6A7-14		
Vehicle Emissions Classification0B-8		
Voltmeter Replacement8C-14		

W

"WATER IN FUEL" Light Diagnosis6C-3
Water Pump Replacement6B1-15
Welding2A-6
Weight Distribution Hitch Replacement2A-20
Weight Distribution Hitch Replacement (Suburban Only)2A-14
Weight Distribution Hitch Replacement (Utility Vehicle Only)2A-15
Wheel and Tire Balancing3E-8
Wheel and Tire Installing3E-7
Wheel and Tire Runout3E-4
Wheel Bearing Adjustment, I-Beam3C-32
Wheel Bearing Adjustment, I.F.S.3C-13
Wheel Bearing Adjustment, 4 W.D.3C-37
Wheel Bearing/Cup Replacement Full Floating Axle (9 ³ / ₄ and 10 ¹ / ₂ -inch Ring Gear)4B1-15
Wheel Bearings, Diagnosis3C-3
Wheel Bolt Replacement Full Floating Axle (9 ³ / ₄ and 10 ¹ / ₂ -inch Ring Gear)4B1-16
Wheel Cylinder Rebuilding5A2-11
Wheel Cylinder Replacement5A2-11
Wheelhouse Panel Replacement (R/V Model)2B-7
Wheel Hub Bolt, I-Beam3C-33
Wheel Hub Bolt, I.F.S.3C-15
Wheel Hub Bolt, 4 W.D.3C-41
Wheel Hub/Rotor Assembly, I-Beam3C-31
Wheel Hub/Rotor Assembly, I.F.S.3C-8
Wheel Hub/Rotor Assembly, 4 W.D.3C-36
Wheel Stud Replacement (8 ¹ / ₂ and 9 ¹ / ₂ -inch Ring Gear)4B1-11
Window Replacement (G Model)10A3-10
Window Replacement (RV Model)10A3-3
Windshield Replacement (G Model)10A3-6
Windshield Replacement (RV Model)10A3-1
Windshield Washer8A-36
Windshield Washer Diagnosis8A-35
Windshield Wiper8A-26
Windshield Wiper Diagnosis8A-26
Wiper Delay8A-38
Wiper Delay Diagnosis8A-38
Wiper Motor Repair8A-36



Automotive
Service
Educational
Program



WE SUPPORT
VOLUNTARY TECHNICIAN
CERTIFICATION THROUGH

National Institute for
**AUTOMOTIVE
SERVICE
EXCELLENCE**



classiccarlibrary.com

