

LIGHT DUTY TRUCK

SERVICE MANUAL



ST 330-80

1980 CHEVROLET

FOREWORD

This manual includes procedures for diagnosis, maintenance and adjustments, minor service operations, and removal and installation for components of Chevrolet Light Duty Trucks. Procedures involving disassembly and assembly of major components for these vehicles are contained in the 1980 Chevrolet Passenger Car and Light Duty Truck Unit Repair (Overhaul) Manual. Wiring diagrams for 1980 trucks are contained in a separate Wiring Diagram Booklet.

The Section Index on the contents page enables the user to quickly locate any desired section. At the beginning of each section containing more than one major subject is a Table of Contents, which gives the page number on which each major subject begins. An index is placed at the beginning of each major subject within the section.

Summaries of Special Tools, when required, and specifications are found at end of major sections.

When reference is made in this manual to a brand name, number, or specific tool, an equivalent product may be used in place of the recommended item.

This manual should be kept in a handy place for ready reference. If properly used, it will enable the technician to better serve the owners of Chevrolet built vehicles.

All information, illustrations and specifications contained in this literature are based on the latest product information available at the time of publication approval. The right is reserved to make changes at any time without notice.

IMPORTANT SAFETY NOTICE

Proper service and repair is important to the safe, reliable operation of all motor vehicles. The service procedures recommended and described in this service manual are effective methods for performing service operations. Some of these service operations require the use of tools specially designed for the purpose. The special tools should be used when and as recommended.

It is important to note that this manual contains various Cautions and Notices which should be carefully read in order to minimize the risk of personal injury to service personnel or the possibility that improper service methods will be followed which may damage the vehicle or render it unsafe. It also is important to understand that these Cautions and Notices are not exhaustive. The manufacturer could not possibly know, evaluate and advise the service trade of all conceivable ways in which service might be done or of the possible hazardous consequences of each way. Consequently, the manufacturer has not undertaken any such broad evaluation. Accordingly, anyone who uses a service procedure or tool which is not recommended must first satisfy himself thoroughly that neither his safety nor vehicle safety will be jeopardized by the service method he selects.

classiccarlibrary.com

1980 LIGHT DUTY TRUCK (SERIES 10-35) CHASSIS SERVICE MANUAL

CAUTION

These vehicles contains some parts dimensioned in the metric system as well as in the customary system. Some fasteners are metric and are very close in dimension to familiar customary fasteners in the inch system. It is important to note that, during any vehicle maintenance procedures, replacement fasteners must have the same measurements and strength as those removed, whether metric or customary. (Numbers on the heads of metric bolts and on surfaces of metric nuts indicate their strength. Customary bolts use radial lines for this purpose, while most customary nuts do not have strength markings.) Mismatched or incorrect fasteners can result in vehicle damage or malfunction, or possibly personal injury. Therefore, fasteners removed from the vehicle should be saved for re-use in the same locations whenever possible. Where the fasteners are not satisfactory for re-use, care should be taken to select a replacement that matches the original. For information and assistance, see your dealer.

| TABLE OF CONTENTS | SECTION |
|--|---|
| GENERAL INFORMATION General Information Maintenance and Lubrication | 0A 0B |
| HEATING AND AIR CONDITIONING Heating and Ventilation Air Conditioning | 1A 1B |
| FRAME AND BUMPERS Frame and Body Mounts Bumpers Sheet Metal Body | 2A 2B 2C 2D |
| STEERING, SUSPENSION, WHEELS AND TIRES Front Alignment Steering Linkage Manual Steering Power Steering Steering Column Front Suspension Rear Suspension Wheel and Tires | 3A 3B1 3B2 3B3 3B4 3C 3D 3E |
| AXLE Propeller Shaft and Universal Joint Rear Axle Front Wheel Drive | 4A 4B 4C |
| BRAKES | 5 |
| ENGINE Engine Mechanical In-Line 6 Small Block Mark IV 5.7L(Z) 350 Diesel Engine Cooling Fuel System - Diagnosis Model 1ME Model 2SE Model M2MC Model M4MC Fuel Supply Engine Electrical Emission Control Systems Engine Exhaust | 6A 6A1 6A4 6A5 6A6 6B 6C 6C1 6C2 6C3 6C4 6C5 6D 6E 6F |
| TRANSMISSION Automatic Manual Clutch Transfer Case | 7A 7B 7C 7E |
| ELECTRICAL — BODY AND CHASSIS Lamps and Lighting Electrical and Wiring Instrument Panel and Gages | 8A 8B 8C |
| ACCESSORIES | 9 |
| METRIC AND FASTENER INFORMATION | 10 |
| INDEX | 11 |

classicalibrary.com

SECTION 0A

GENERAL INFORMATION

CONTENTS OF THIS SECTION

| | |
|--|-----|
| General | 0-1 |
| Vehicle Identification Number | 0-1 |
| Service Parts Identification Sticker | 0-1 |
| Vehicle Loading | 0-1 |
| Engine Code Number | 0-1 |
| Unit and Serial Number Locations..... | 0-3 |

GENERAL

Information to identify the vehicle and vehicle components appears in this section. Detailed specifications on major units are given at the end of each respective section in this manual.

VEHICLE IDENTIFICATION NUMBER (VIN)

This is the legal identification of the vehicle. It appears on a plate which is attached to the left top of the instrument panel on CK and G truck and can be easily seen through the windshield from outside the vehicle (fig. 0A-1). On P10-20-30 models, the plate is attached to the front of the dash and toe panel to the left of steering column (fig. 0A-2). The VIN also appears on the Vehicle Certificates of Title and Registration.

SERVICE PARTS IDENTIFICATION STICKER

The Service Parts Identification Sticker (fig. 0A-6) is provided on all Truck models. On C and K models, the identification sticker be located on the inside of the glove box door or on G model, the sticker will be located on an inner hood panel surface. On P models, the sticker is located on a inner body panel.

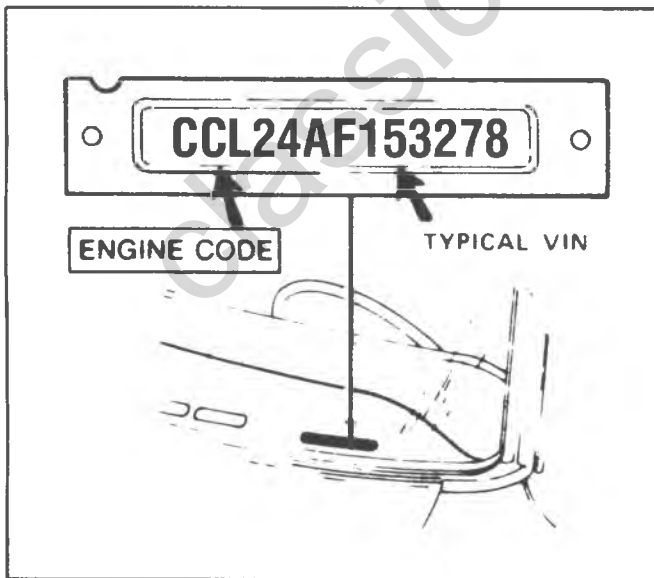


Fig. 0A-1-Vehicle Identification Number Location (CK and G)

The plate lists the vehicle identification number, wheelbase, and all Production options or Special Equipment on the vehicle when it was shipped from the factory including paint information. **ALWAYS REFER TO THIS INFORMATION WHEN ORDERING PARTS.**

VEHICLE LOADING

Vehicle loading must be controlled so weights do not exceed the numbers shown on the Vehicle Identification Number and/or Rating Plate for the vehicle.

A typical example of a truck in a loaded condition is shown in Figure 0A-7. Note that the axle or GVW capabilities are not exceeded.

ENGINE CODE NUMBER

The engine code number indicates manufacturing plant, month and day of manufacture, and transmission type. A typical engine number would be F1210TTBB, which would breakdown thus:

- F - Manufacturing Plant (F-Flint, T-Tonawanda)
- 12 - Month of Manufacture (December)
- 10 - Day of Manufacture (tenth)
- T - Truck
- TBB - Transmission and engine type

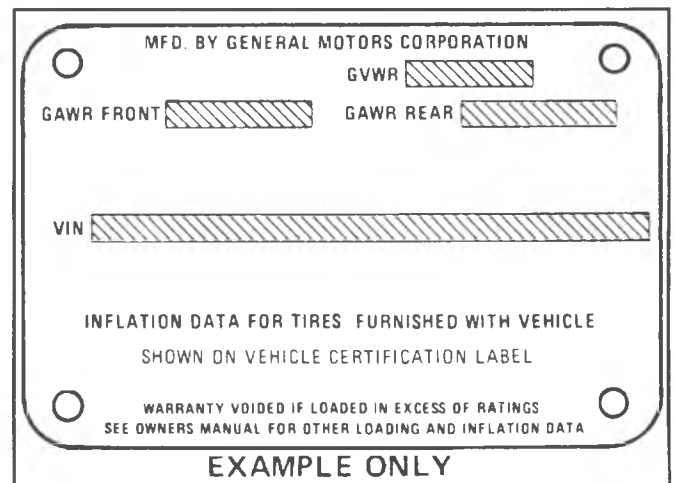


Fig. 0A-2-V.I.N. Rating Plate (P Model)

LIGHT DUTY TRUCK (EXCEPT EL CAMINO) VIN SYSTEM IDENTIFICATION

CCD13AF100007

DIVISION

C - Chevrolet
T - GMC

PLANT SEQUENTIAL NUMBER

CHASSIS TYPE

C Conventional Cab
G Chevy Van & Sport Van
K Conventional Cab 4 x 4
P Forward Control

ASSEMBLY PLANT

"A" GMAD-Lakewood GA.
"B" GMAD-Baltimore MD.
"F" CHEVROLET-Flint MI.
"J" GMAD-Janesville WI.
"S" GMAD-St. Louis MO.
"Z" GMAD-Fremont CA.
"O" GM Truck-Pontiac MI.
"1" GM of Canada-Oshawa Ont.
"3" CHEVROLET-Detroit MI.
"4" GM of Canada-Scarborough Ont.
"7" GMAD-Lordstown OH.

ENGINE

| CODE | DISPLACEMENT | | TYPE | CARB. |
|------|--------------|---------|------|--------|
| D | 4.1L | 250 cid | L6 | 2B |
| G | 5.0L | 305 cid | V8 | 2B |
| L | 5.7L | 350 cid | V8 | 4B |
| M | 5.7L | 350 cid | V8 | 4B |
| P | 5.7L | 350 cid | V8 | 2B |
| R | 6.6L | 400 cid | V8 | 4B |
| S | 7.4L | 454 cid | V8 | 4B |
| T | 4.8L | 292 cid | L6 | 1B |
| W | 7.4L | 454 cid | V8 | 4B |
| X | 6.6L | 400 cid | V8 | 4B |
| Z | 5.7L | 350 cid | V8 | Diesel |

MODEL YEAR

A for 1980

BODY STYLE

- 2 Chassis Cowl & Forward Control Chassis
- 3 Chassis Cab
- 4 Cab & Pick-Up Box or Hi-Cube Van
- 5 Chevy Van & Step Van
- 6 Sport Van & Suburban
- 7 Motor Home Chassis
- 8 Blazer

MODEL

- 1-1/2 Ton
- 2-3/4 Ton
- 3-1 Ton
- 4-1/2 Ton (W/HD Susp)

Fig. 0A-3-Vehicle Identification Number

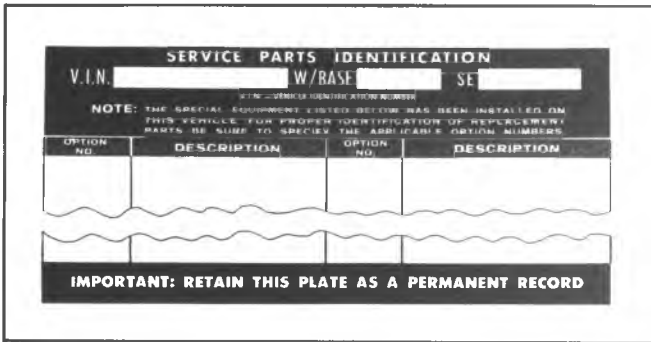


Fig. 0A-4--Service Parts Identification Plate

UNIT AND SERIAL NUMBER LOCATIONS

For the convenience of service technicians and engineers when writing up certain business papers such as Warranty Reports, Product Information Reports, or reporting product failures in any way, the location of the various unit numbers have been indicated. These unit numbers and their prefix or suffix are necessary on these papers for various reasons - such as accounting, follow-up on production, etc.

The prefixes on certain units identify the plant in which the unit was manufactured and thereby permits proper follow-up of the plant involved to get corrections made when necessary.

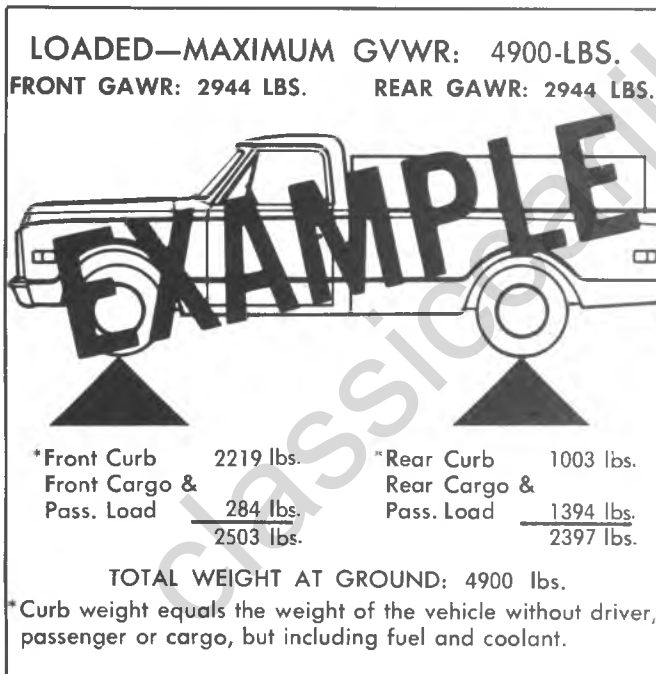


Fig. 0A-5--Typical Vehicle Loading Condition

Always include the prefix in the number.

Axles

Chevrolet Built

- On 10 Series, the Code is stamped on Top of Right Rear Axle Tube.
- On 20-30 Series, the Code is stamped on Top of the Right Rear Axle Tube.

Dana Built

- On Front Axles, code is stamped on Top Rear of Left Axle Tube.
- On Rear Axles, code is stamped on Rear Surface of Right Axle Tube.

Transmissions (Fig. 0A-6)

- On 3-Speed Transmissions (except Tremec), the Unit Number is located on Lower Left Side of Case Just Below Cover.
- On Tremec Transmissions, Unit Number is located on Upper Left Attachment Case (Top Side).
- On Muncie 4-Speeds, Unit Number is located on Rear Face of Case below Retainer.
- On New Process 205 model 4-wheel drive transfer case, a build date is on tag attached to front face of transfer case.
- On Automatic 350 Transmission, Unit Number is Located on Right Rear Vertical Surface of Oil Pan.
- On the Automatic 400 Transmission, Serial Number is Located on the Light Blue Plate on the Right Side of the Transmission.

Engines (Fig. 0A-7)

- 6-Cylinder Engine Unit Number Located on Pad at Right Hand Side of Cylinder Block at Rear of Distributor.
- 8-Cylinder Gasoline Engine Code is (305, 350, 400 CID) Located on Pad immediately forward of right hand cylinder head.
- 8-Cylinder Gasoline Engine (454 CID) Code is located on a pad of the front top center of the engine block immediately forward of the inlet manifold.
- 8-Cylinder Diesel Engine Code is on a label located on rear face of the left valve cover.

Generators

Generator Unit Serial Number is located on the Drive End Frame Below the Part Number.

Batteries

Battery Code Number is Located on Cell Cover Top of Battery.

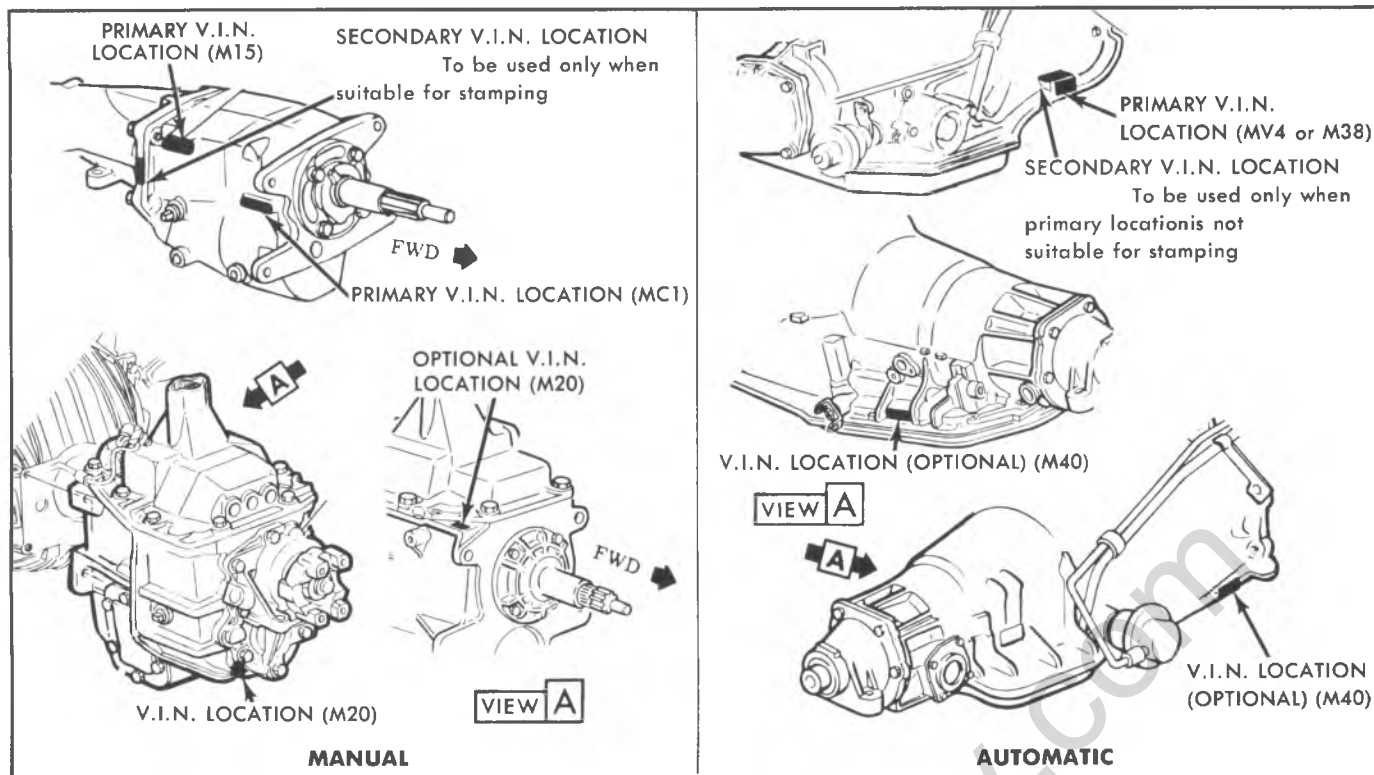


Fig. 0A-6-Transmission V.I.N. Location

Starters

Starter Serial Number and Production Date are Stamped on Outer Case, Toward Rear.

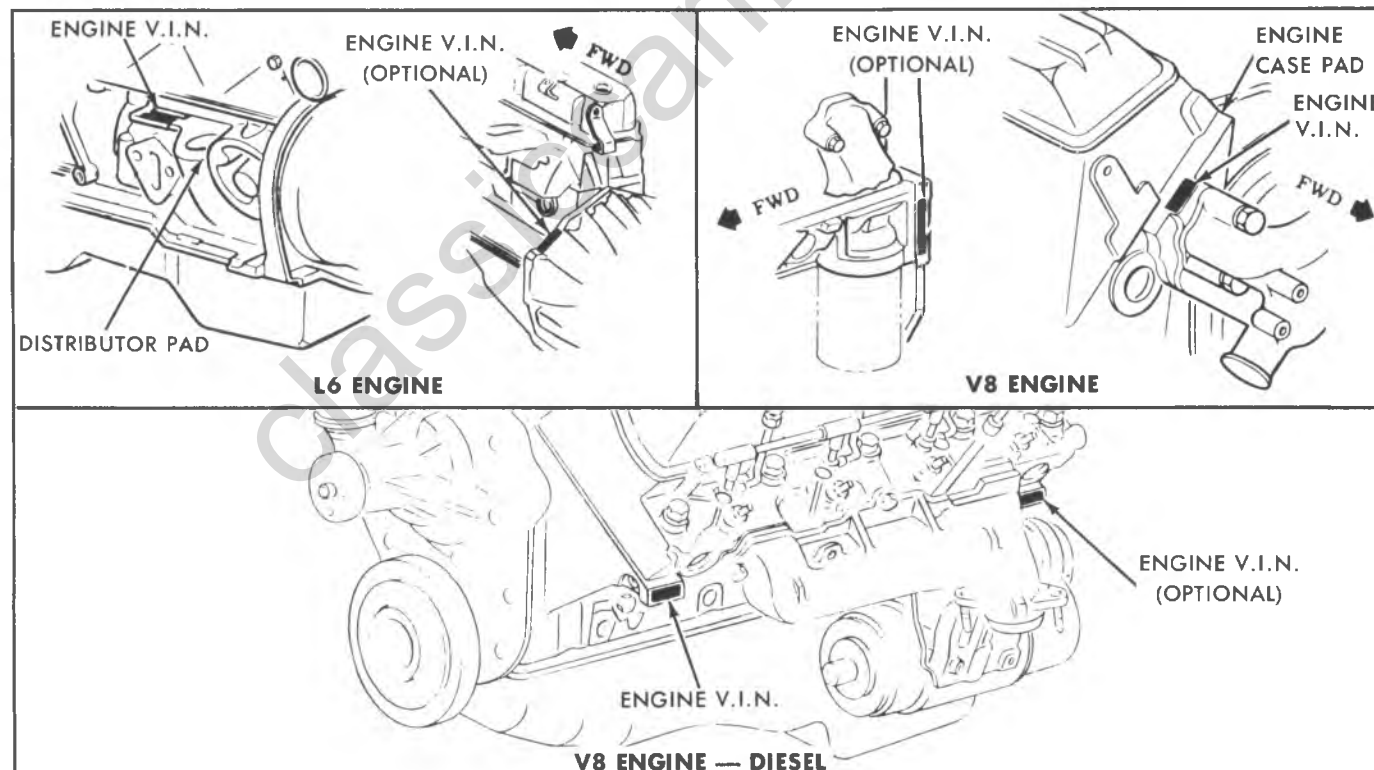


Fig. 0A-7-Engine V.I.N. Location

SECTION 0B
MAINTENANCE AND LUBRICATION

CONTENTS

| | |
|---|-------|
| General | 0B-1 |
| Maintenance Schedule | 0B-2 |
| Lubrication and General Maintenance | 0B-4 |
| Safety Maintenance | 0B-14 |
| Emission Control Maintenance | 0B-15 |
| Specifications | 0B-16 |
| Recommended Fluids and Lubricants | 0B-16 |
| Fluid Capacities..... | 0B-17 |

GENERAL

The maintenance schedule for a gasoline engine follows two formats, Light Duty Emissions and Heavy Duty Emissions (Fig. 0B-1 and 0B-2). A separate vehicle maintenance schedule is provided for those vehicles with a

V-8 diesel engine (Fig. 0B-3).

The maintenance schedule is provided in the glove box with the vehicle.

classiccarslibrary.com

**VEHICLE MAINTENANCE SCHEDULE
GASOLINE ENGINE -- LIGHT DUTY EMISSIONS**

| When To Perform Services (Months or Miles (km) Whichever Occurs First | Item No. | Services |
|---|-------------|--|
| SECTION A -- Lubrication and General Maintenance | | |
| Every 12 Months or 7,500 Miles (12 000 km) | A-1 | ▲ Fluid Levels Check |
| | A-2 | Clutch Pedal Free Travel Check/Adjust. |
| | A-3 | * Engine Oil Change |
| See Explanation | A-4 | * Oil Filter Change |
| | A-5 | ▲ Chassis Lubrication |
| | A-6 | Front Wheel Drive |
| | A-7 | Tire Rotation |
| | A-8 | Rear Axle Lubrication |
| Every 12 Months or 15,000 Miles (24 000 km) | A-9 | * Cooling System Check -- See Explanation |
| Every 30,000 Miles (48 000 km) | A-10 | Wheel Bearing Repack |
| | A-11 | Manual Steering Gear Seals Check |
| | A-12 | Clutch Cross Shaft Lubrication |
| Every 100,000 Miles (160 000 km) | A-13 | Auto. Trans. Fluid & Filter Change |
| SECTION B -- Safety Maintenance | | |
| Every 12 Months or 7,500 Miles (12 000 km) | B-1 | Owner Safety Checks |
| | B-2 | Tire, Wheel and Disc Brake Check |
| | B-3 | * Exhaust System Check |
| | B-4 | Suspension and Steering Check |
| | B-5 | Brake and Power Steering Check |
| Every 12 Months or 15,000 Miles (24 000 km) | B-6 | * Drive Belt Check |
| | B-7 | Drum Brake and Parking Brake Check |
| | B-8 | Throttle Linkage Check |
| | B-9 | Bumper Check |
| | B-10 | * Fuel Cap, Tank and Lines Check |
| SECTION C -- Emission Control Maintenance Schedule I | | |
| At First 6 Months or 7,500 Miles (12 000 km) -- Then at 18 Month/22,500 Mile (36 000 km) | C-1 | Thermo. Controlled Air Cleaner Check |
| | C-2 | Carburetor Choke Check |
| | C-3 | Engine Idle Speed Adjustment |
| | C-4 | EFE System Check |
| | C-5 | Carburetor Mounting Torque |
| | C-6 | Vacuum Advance System & Hoses Check |
| Every 15,000 Miles (24 000 km) | C-7 | Fuel Filter Replacement |
| | C-8 | PCV System Check PCV Valve & Filter Service |
| Every 22,500 Miles (36 000 km) | C-9 | Spark Plug Wires Check |
| | C-10 | Idle Stop Solenoid and/or Dashpot Check |
| | C-11 | Spark Plug Replacement |
| | C-12 | Engine Timing Adjust. & Distrib. Check |
| | C-13 | Carburetor Vacuum Break Check |
| Every 30,000 Miles (48 000 km) | C-14 | Air Cleaner Element Replacement |
| | C-15 | ECS System Check & Filter Replacement |
| SECTION C -- Emission Control Maintenance Schedule II | | |
| At first 6 Months or 7,500 Miles (12 000 km) -- Then 24-Month 30,000-Mile (48 000 km), Except C-2 and C-6, Which Require Service at 45,000 Miles (72 000 km) | C-1 | Thermo. Controlled Air Cleaner Check |
| | C-2 | Carburetor Choke & Hoses Check |
| | C-3 | Engine Idle Speed Adjustment |
| | C-4 | EFE System Check |
| | C-5 | Carburetor Mounting Torque |
| | C-6 | Vacuum Advance System & Hoses Check |
| Every 15,000 Miles (24 000 km) | C-7 | Fuel Filter Replacement |
| | C-8 | PCV System Check PCV Valve & Filter Service |
| Every 30,000 Miles (48 000 km) | C-9 | Spark Plug Wires Check |
| | C-10 | Idle Stop Solenoid and/or Dashpot Check |
| | C-11 | Spark Plug Replacement |
| | C-12 | Engine Timing Adjust. & Distrib. Check |
| | C-13 | Carburetor Vacuum Break Check (1) |
| | C-14 | Air Cleaner Element Replacement |
| | C-15 | ECS System Check & Filter Replacement |

▲ Also A Safety Service

* Also An Emission Control Service

(1) Applies only to GM Engine Family 08Y2A

Fig. OB-1--Maintenance Schedule - Gasoline - Light Duty Emissions

VEHICLE MAINTENANCE SCHEDULE
GASOLINE ENGINE – HEAVY DUTY EMISSIONS

| When To Perform Services (Months or Miles/km, Whichever Occurs First) | Item No. | Services (For Details, See Numbered Paragraphs) |
|---|-------------|--|
| SECTION A – Lubrication and General Maintenance | | |
| Every 4 months or 6,000 miles (9 600 km) | A-1 | ●Fluid Levels Check |
| | A-2 | Clutch Pedal Free Travel Check/Adjust |
| | A-3 | *Engine Oil Change |
| | A-5 | ●Chassis Lubrication |
| | A-6 | Front Wheel Drive |
| See Explanation | A-4 | *Engine Oil Filter Change |
| | A-7 | Tire Rotation |
| | A-8 | Rear Axle Lubrication |
| | A-10 | Wheel Bearings Repack |
| Every 12 months or 12,000 miles (19 200 km) | A-9 | Cooling System Check |
| Every 24,000 miles (38 400 km) | A-13 | Auto. Trans. Fluid & Filter Change |
| Every 36,000 miles (57 600 km) | A-11 | Manual Steering Gear Check |
| | A-12 | Clutch Cross Shaft Lubrication |
| SECTION B – Safety Maintenance | | |
| Every 4 months or 6,000 miles (9 600 km) | B-1 | Owner Safety Checks |
| | B-2 | Tire, Wheel and Disc Brake Check |
| | B-3 | Exhaust System Check |
| | B-4 | Suspension and Steering Check |
| | B-5 | Brakes and Power Steering Check |
| Every 12,000 miles (19 200 km) | B-6 | *Engine Drive Belts Check |
| Every 12 months or 12,000 miles (19 200 km) | B-7 | Drum Brakes and Parking Brake Check |
| | B-8 | Throttle Linkage Check |
| | B-9 | Bumpers |
| Every 24 months or 24,000 miles (38 400 km) | B-10 | *Fuel Cap, Lines and Tank Check |
| SECTION C – Emission Control Maintenance | | |
| At 1st 4 months or 6,000 miles (9 600 km) – then at 12 month/12,000 mile (19 200 km) intervals | C-3 | Engine Idle Speed Adjustment |
| | C-10 | Idle Stop Solenoid Check |
| Every 12,000 miles (19 200 km) | C-9/11 | Spark Plug Wire Check & Plug Replacement |
| | C-12 | Engine Timing Adjust. & Distributor Check |
| | C-14 | Air Cleaner Element Replacement |
| Every 12 months or 12,000 miles (19 200 km) | C-5 | Carburetor Mounting Torque |
| | C-1 | Thermo. Controlled Air Cleaner Check |
| | C-17 | Manifold Heat Valve Check |
| | C-7 | Carburetor Fuel Filter Replacement |
| | C-18 | Throttle Return Control |
| | C-8 | PCV System Check – PCV Valve & Filter Service |
| Every 24 months or 24,000 miles (38 400 km) | C-15 | ECS System Check & Filter Replacement |
| | C-16 | Engine Idle Mixture Adjust (4.8 L. L-6 only) |
| | C-4 | EFE System Check |
| | C-6 | Vacuum Advance System Check |
| | C-2 | Carburetor Choke Check |

●Also A Safety Service

*Also An Emission Control Service

Fig. 0B-2--Maintenance Schedule-Gasoline - Heavy Duty Emissions

**VEHICLE MAINTENANCE SCHEDULE
DIESEL-FUELED VEHICLE**

| When To Perform Services (Months or Miles, Whichever Occurs First) | Item No. | Services (For Details, See Numbered Paragraphs) |
|---|-------------|--|
| SECTION A — Lubrication and General Maintenance | | |
| Every 3,000 Miles (4 800 km) | A-3 | * Engine Oil Change |
| | A-6 | * Oil Filter Change |
| Every 6,000 Miles (9 600 km) | A-4 | • Chassis Lubrication |
| | A-1 | • Fluid Levels Check |
| See Explanation | A-8 | Rear Axle Lubricant Check |
| | A-7 | Tire Rotation |
| Every 12 Months or 12,000 Miles (19 200 km) | A-10 | * Cooling System Check |
| Every 15,000 Miles (24 000 km) | A-9 | Wheel Bearings Repack |
| Every 30,000 Miles (48 000 km) | A-11 | Manual Steering Gear Check |
| Every 100,000 Miles (160 000 km) | A-13 | Auto Trans. Fluid and Filter Change |
| SECTION B — Safety Maintenance | | |
| Every 12 Months or 6,000 Miles (9 600 km) | B-1 | Owner Safety Checks |
| | B-2 | Tire, Wheels and Disc Brake Check |
| | B-3 | Exhaust System Check |
| | B-4 | Suspension and Steering Check |
| | B-5 | Brakes and Power Steering Check |
| | B-6 | * Drive Belt Check |
| Every 12 Months or 15,000 Miles (24 000 km) | B-7 | Drum Brakes and Parking Brake Check |
| | B-8 | Throttle Linkage Check |
| | B-9 | Bumper Check |
| SECTION C — Emissions Control Maintenance | | |
| Every 15,000 Miles (24 000 km) | C-7 | Fuel Filter Replacement |
| Every 6,000 Miles (9 600 km) | C-19 | Crankcase Ventilation System |
| At First 3,000 Miles (4 800 km) Then at 30,000 Mile (48 000 km) Intervals | C-3 | Engine Idle Speeds Adjust |
| Every 30,000 Miles (48 000 km) | C-14 | Air Cleaner Element Replacement |

• Also a Safety Service * Also an Emission Control Service

Fig. OB-3--Maintenance Schedule - Diesel

MAINTENANCE SCHEDULE

This is an explanation of the service listed in the Vehicle Maintenance Schedule.

NORMAL VEHICLE USE-The maintenance instructions contained in the maintenance schedule are based on the assumption that the vehicle will be used as designed:

- To carry passengers and cargo within the limitations indicated on the Tire Placard located on the edge of the driver's door,
- on reasonable road surfaces within legal operating limits,
- on a daily basis, as a general rule, for at least several miles (km), and

- On unleaded gasoline (gasoline light duty emission only).

Unusual operating conditions will require more frequent vehicle maintenance as specified in the respective sections.

SECTION A

LUBE & GENERAL MAINTENANCE

A-1 Fluid Levels

Check battery and the following fluid levels:

Battery Care

The original equipment battery (two batteries on diesel engine) needs no periodic maintenance. Its top is permanently sealed (except for two small vent holes) and has no filler caps. Water will never have to be added.

The hydrometer (test indicator) in the top of the battery provides information for testing purposes only. See Section 6D for battery test procedures.

Jump Starting

CAUTION: The instructions below must be followed exactly or personal injury (particularly to eyes) or property damage may result from battery explosion, battery acid, or electrical (short circuit) burns.

- To reduce the likelihood of sparks (and thus of an explosion), and of electrical burns, be sure the jumper cables do not have loose or missing insulation.

- **THE MAJOR SAFETY PRECAUTION WHEN JUMP STARTING IS TO MAKE THE FINAL CONNECTION TO GROUND (A SOLID STATIONARY METALLIC OBJECT) ON THE ENGINE AT SOME DISTANCE FROM THE BATTERY. THIS HELPS REDUCE THE CHANCE OF AN EXPLOSION DUE TO SPARKS.**

- To lessen the chance of an explosion, never expose the battery to open flames or electric sparks. Also do not smoke near the battery. Batteries give off a gas which is flammable and explosive.

- To lessen the risk of injury in case an explosion does occur, **wear eye protection** or shield your eyes when working near any battery. Do not lean over a battery.

- Do not allow battery fluid to contact eyes, skin, fabrics, or painted, surfaces because battery fluid is a corrosive acid. **Flush any contacted area with water immediately and thoroughly. Also get medical help if eyes are affected .**

- To lessen the risk of a short circuit, remove rings, metal watch bands and other metal jewelry. Also do not allow metal tools to contact at the same time the positive battery terminal (or any metal connected to this terminal) and any other metal on the vehicle.

Make certain when attaching the jumper cable clamps to the positive terminals of the batteries that neither clamp contacts any other metal.

- The vehicle has a 12 volt battery and a negative ground electrical system. Make sure that the other vehicle also has a 12 volt battery and that the negative terminal is grounded (attached to a metal part of the vehicle). Its owner's manual may give you that information. If unsure of the other vehicle's voltage (or if the voltage and ground on the other vehicle are different from your vehicle), do not try to jump start as personal injury or severe damage to electrical and electronic parts may result.

- If the discharged battery has filler caps, check the fluid level. (Do not check with an open flame and do not smoke). Add clear drinking water to the proper level if low, and replace the caps before jump starting.

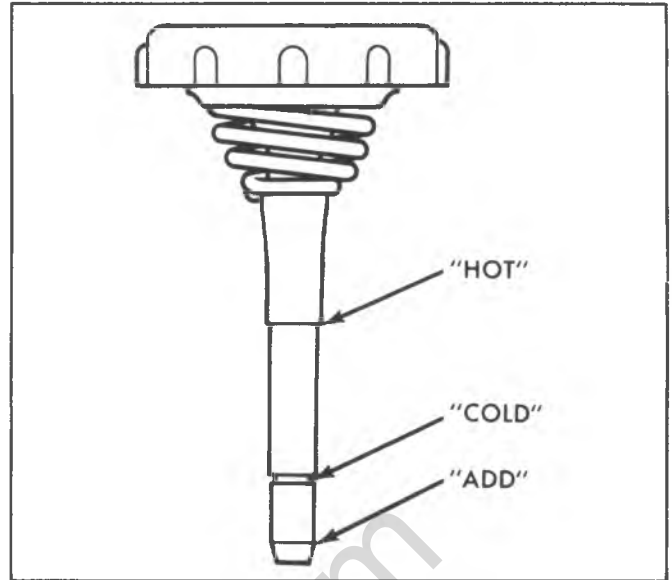


Fig. 0B-4--Power Steering Filler Cap

Brake Master Cylinder

(Also a Safety Service)

Check fluid level in each reservoir and maintain 1/4" below lowest edge of each filler opening with Delco Supreme No. 11 or DOT-3 hydraulic brake fluid, or equivalent.

A low fluid level in the brake master cylinder can indicate worn disc brake pads, and should be checked accordingly.

Hydro-boost Brake System Hydraulic Pump

1. Vehicles Equipped With Power Steering.

- On vehicles equipped with power steering, the power steering pump is also used as the Hydro-boost pump. See section on power steering system when checking fluid level or adding fluid.

2. Vehicles Equipped With Manual Steering.

- The Hydro-boost pump installed in vehicles equipped with manual steering uses power steering fluid. See section on power steering system when checking fluid level or adding fluid.

NOTICE: Power steering fluid and brake fluid cannot be mixed, since seat damage may result.

Power Steering System

(Also a Safety Service)

Check the fluid level in the power steering pump at each oil change and add GM Power Steering FLuid (GM 1050017) or equivalent as needed (Fig. 0B-4):

- If fluid is warmed up (about 150°F or 66°C--hot to the touch), it should be between "Hot" and "Cold" marks on the filler cap indicator.

- If cool (about 70°F or 21°C), fluid should be between "Add" and "Cold" marks.

Fluid does not need periodic changing.

Rear Axle (Standard) Lubricant

Check lubricant level. Add lubricant, if necessary, to fill to level of filler plug hole. Use SAE 80W GL-5 or SAE 80W-90 GL-5 or GM 1052271/1052272 gear lubricant. For those vehicles driven in Canada, use SAE 80W GL-5 gear

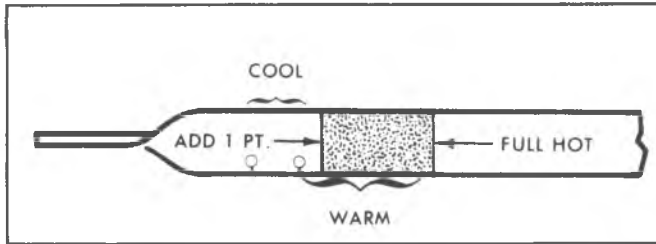


Fig. OB-5--Automatic Transmission Dipstick

lubricant.

Rear Axle (Limited-Slip) Lubricant

Check lubricant level. Add lubricant, if necessary, to fill to level of filler plug hole. Use gear lubricant GM 1052271/1052272 or equivalent.

Automatic Transmission Fluid

Use only automatic transmission fluid labeled DEXRON®-II or equivalent.

Check the automatic transmission fluid level at each engine oil change period. Overfilling can cause foaming and loss of fluid. Transmission damage can result. Low fluid level can cause slipping or loss of drive.

Automatic transmissions are often overfilled because the fluid level is checked when the fluid is cold. When cold, the dipstick shows that fluid should be added. However, the low reading is normal, the level will rise as the fluid gets warm. The fluid level will increase more than 3/4 inch (19mm) as fluid warms up from 60°F to 180°F (16°C to 82°C).

Check the transmission fluid level with the engine running, the shift lever in "Park", and the vehicle level.

If the vehicle has just been driven for a long time at high speed or in city traffic in hot weather, or if the vehicle has been pulling a trailer, the correct fluid level cannot be read. Wait until the fluid has cooled down (about 30 minutes).

Remove the dipstick. Carefully touch the wet end of the dipstick to find out if the fluid is cool, warm or hot. Wipe it clean and push it back in until cap seats. Pull out the dipstick and read the fluid level (fig. OB-5).

- If it felt cool, about room temperature, the level should be 1/8 to 3/8 inch (3 to 10mm) below the "Add" mark. The dipstick has two dimples below the "Add" mark to show this range.

- If it felt warm, the level should be close to the "Add" mark (either above or below).

- If it was too hot to hold, the level should be at the "Full" mark.

- It takes only one pint (0.5 liter) to raise level from "Add" to "Full" with a hot transmission.

Manual Transmission Lubricant

Check lubricant level. Add lubricant, if necessary, to fill to level of filler plug hole.

Use SAE 80W GL-5 or SAE 80W-90 GL-5 gear lubricant. For those vehicles driven in Canada, use SAE 80W GL-5 gear lubricant.

Windshield Washer Fluid

(Also a Safety Service)

Fill the washer jar only 3/4 full during the winter to allow for expansion if the temperature should fall low enough to freeze the solution.

- Check the washer fluid level regularly--do it often when the weather is bad.

- Use a fluid such as GM Optikleen or equivalent to help prevent freezing damage, and for better cleaning.

- Do not use radiator antifreeze in the windshield washer; it could cause paint damage.

- In cold weather, warm the windshield with the defrosters before using the washer--to help prevent icing that may block the driver's vision.

Cooling System Care

Do not remove radiator cap to check coolant level. Instead, check by looking at the "see through" coolant recovery tank. Level should be at the "Full Cold" mark on the recovery tank when the system is cold; and at the "Full Hot" mark during engine operation. Add a 50/50 mixture of a good quality ethylene glycol antifreeze and water to the recovery tank when more coolant is needed. If frequent additions are needed, cooling system.

NOTICE: If the proper quality antifreeze is used, there is no need to add extra inhibitors or additives that claim to improve the system. They may be harmful to the proper operation of the system, and are an unnecessary expense.

A-2 Manual Transmission Clutch Adjustment

Clutch adjustment should be checked and adjusted as necessary to compensate for clutch facing wear. To check, depress pedal by hand until resistance is felt. Free travel should be approximately one to one and a half inches; if very little or no free travel is evident, clutch adjustment is required.

A-3 & A-6 Engine Oil and Filter

(Also an Emission Control Service)

Engine Oil and Filter Recommendations

Gasoline

- Engine oils are labeled on the containers with various API (American Petroleum Institute) designations of quality. Use engine oils that are labeled SE, SF or SE/CC. Do not use oils labeled only SA, SB, SC, SD, CA, CB, CC or CD; or oils with the combination label SE and CD (SE/CD).

- Use only SE or SF quality engine oils (see markings on containers).

- The oil and filter change intervals for the engine is based on the use of SE-quality or SF-quality oils and high quality filters. Using oils other than SE-quality or SF-quality oils, or oil change intervals longer than listed, could reduce engine life and might affect warranty.

- The engine was filled with an SE or SF quality engine oil when it was built. You do not have to change this oil before the suggested change period.

- Change oil each 7,500 miles (12 000 km) or once a year for light duty emissions service, each 6,000 miles (9 600 km) or 4 months for heavy duty emissions service,

whichever occurs first.

- Change oil filter:

Light Duty Emissions- Replace at the first oil change and then every second oil change if mileage 7,500 miles (12 000 km) determines oil change. If time (12 months) determines oil change, or you change the oil at 3,000 miles (4 800 km) or 3 months, replace filter at each oil change.

Heavy Duty Emissions- Replace at the first oil change, and then every second oil change if mileage 6,000 miles (9 600 km) determines oil change. If time (4 months) determines oil change, or you change the oil at 3,000 miles (4 800 km) or 2 months, replace filter at each oil change.

- Change oil and filter each 3,000 miles (4 800 km) or 3 months (light duty emissions) or 2 months (heavy duty emission service) if:

- Driving in dusty areas
- Pulling a trailer
- Frequent idling or idling for long periods
- Driving 4 miles (6 km) or less in freezing weather, or other short trips in cold weather, where the engine does not thoroughly warm up.
- After driving in a dust storm, change the oil and filter as soon as possible.

Engine Oil Additives The engine should not need these extra engine oil helpers or additives if SE quality engine oil is used and changed as suggested. If you think your engine has an oil related problem, refer to Section 6A.

Diesel Engine

Use ONLY engine oils labeled with the A.P.I. (American Petroleum Institute) designations SE and CC. Do not use any other type of oil. The A.P.I. designations are listed somewhere on the oil can, usually on the top or label. The A.P.I. has several designations, such as: SC, SD, SE, CB, CC, CD.

Several Different designations may appear on the can. Be sure the oil used has both the SE and the CC designations, regardless of the order in which they appear on the oil can. Do not use an oil if the designation CD appears anywhere on the oil can. Using any type of oil other than SE/CC may affect warranty.

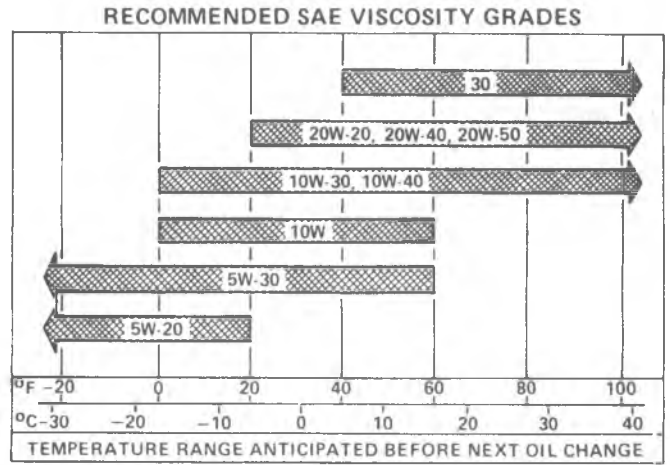
NOTICE: Do NOT use engine oils labeled only SE or only CC. These oils will not give the protection and lubrication of diesel engine needs. When reading the can, be sure not to confuse the SE designation with the letters "SAE", which may also appear on the can.

- It is VERY IMPORTANT to change the oil and filter every 3,000 miles (4 800 km). Because of the way a diesel engine operates, contaminants build up in the oil faster than in a gasoline engine which can cause engine wear and/or damage.

- Change the oil and filter soon after driving in a dust storm.

- Single viscosity grade oils (such as SAE 30) are more satisfactory than multi-viscosity oils (such as SAE 10W-30) for sustained high-speed driving.

The oil and filter change intervals for a diesel engine are based on the use of SE/CC quality oils and quality oil filters. Use of oils other than SE/CC or oil and filter change



NOTICE: Do not use SAE 5W-20 oils for continuous high-speed driving.

Fig. OB-6--Oil Viscosity Chart (Gasoline)

intervals longer than 3,000 miles (4 800 km) could reduce engine life and may affect warranty.

The diesel engine was filled with a quality engine oil when it was built. You do not have to change the oil before the recommended change interval. Keep in mind the engine may use more oil when it is new. Check the oil level more often when the engine is new.

Engine Oil Additives Do not use any supplemental additives. Using oil additives may cause engine damage and may affect warranty. If you think the engine has an oil related problem, see Section 6A.

Oil Viscosity (Figs. OB-6 and 7)

Engine oil viscosity (thickness) has an effect on fuel economy. Lower viscosity engine oils can provide increased fuel economy; however, higher temperature weather conditions require higher viscosity engine oils for satisfactory lubrication. Figures OB-6 and OB-7 lists the engine oil viscosities that will provide the best balance of fuel economy, engine life, and oil economy.

Checking Oil Level

- **Warm-** The best time to check the engine oil level is when the oil is warm, such as during a fuel stop. First, allow about 5 minutes for the oil to drain back to the oil pan. Then pull the dipstick out, wipe it clean, and push it

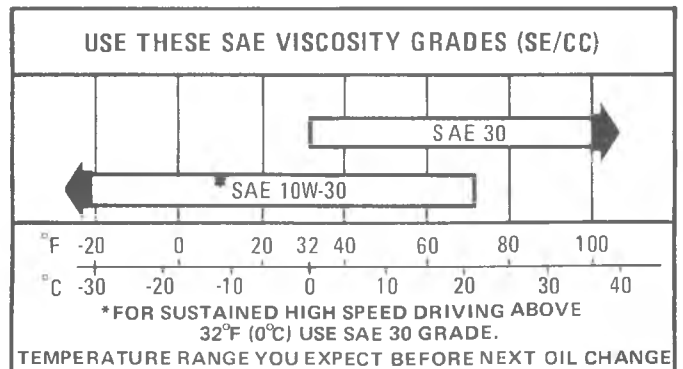


Fig. OB-7--Oil Viscosity Chart (Diesel)

back down all the way. Now pull the dipstick out and look at the oil level on the dipstick. Some dipsticks are marked with "Add" and "Full" lines. Others are marked "Add 1 Qt" and "Operating Range". **In all cases, keep the oil level above the "Add" line**. Push the dipstick back down all the way after taking the reading. Add oil if needed.

● **Cold** - If you check the oil level when the oil is cold, do not run the engine first. The cold oil will not drain back to the pan fast enough to give a true oil level.

A-4 Chassis Lubrication (Figs. 0B-8 and 9)

Large fluid loss in any of these units may point out a problem. Repair these problems promptly.

Lubricate the following system or units:

Steering Linkage and Suspension

(Also a Safety Service)

Lubrication Intervals

- a. On C20, G30 and P20, lubricate every 4 months or 6,000 miles (9 600 km).
- b. On all other vehicles, lubricate every 12 months or 7,500 miles (12 000 km).

Maintain correct front end alignment to provide easy steering, longer tire life, and driving stability.

Check control arm bushings and ball joints for wear.

Lubricate tie rods, upper and lower control arms, and ball joints at fittings with water resistant EP chassis lubricant which meets General Motors Specification GM 6031M. Lubricate every 3 months (Light Duty), 2 months (Heavy Duty and Diesel), or 3,000 miles (4 800 km) whichever occurs first, under the following conditions:

- Driving in dusty or muddy conditions.
- Extensive off-road use.

Ball joints must be at 10°F (-12°C) or more before lubricating.

Transmission Shift Linkage

(Manual and Automatic)

(Also a Safety Service)

Lubricate shift linkage and manual transmission floor controls lever contacting faces with water resistant EP chassis lubricant which meets GM specification 6031M.

Hood Latches

Lubricate hood latch assembly and hood hinge assembly as follows:

1. Wipe off any accumulation of dirt or contamination on latch parts.
2. Apply Lubriplate or equivalent to latch pilot bolts and latch locking plate.
3. Apply light engine oil to all pivot points in release mechanism, as well as primary and secondary latch mechanisms.
4. Lubricate hood hinges.
5. Make hood hinge and latch mechanism functional check to assure the assembly is working correctly.

Door Lock Cylinder

Use WD-40 or equivalent spray lubricant as necessary for free operation.

Gas Tank Filler Door Hinge

Clean area of dirt and old lubricant. Apply a few drops of engine oil to friction point of door hinge. Work door several times and wipe off excess lubricant.

Door Hinge Assembly

Wipe off dirt and apply a thin coat of engine oil. Open and close door several times to insure that the oil has worked in effectively.

Door Jam Switch

Apply a thin coat of lubriplate or equivalent to end of surface of switch plunger.

Parking Brake Pulley, Cable and Linkage

(Also a Safety Service)

Apply water resistant EP chassis lubricant which meets GM specification 6031M, to parking brake cable at cable guides and at all operating links and levers.

Accelerator Linkage

(Also a Safety Service)

Lubricate carburetor stud and carburetor lever and accelerator pedal lever at support with engine oil.

Body Lubrication

See Body Service Manual for body lubrication.

A-5 Four Wheel Drive

Most lubrication recommendations and procedures for four wheel drive-equipped vehicles are the same for corresponding components of conventional drive vehicles.

In addition, the following items require lubrication each 4 months or 6,000 miles (9 600 km).

Transfer Case

Check the transfer case level at the interval and if necessary, add lubricant as follows:

Conventional Four Wheel Drive- Add 10W-30 or 10W-40 engine oil to bring to level of filler plug hole.

Front Axle

The front axle should be checked at the interval and refilled with SAE 80W-90 GL-5 gear lubricant when necessary. With the differential at operating temperature fill to the level of filler plug hole. If differential is cold, fill to level of 1/2 inch below the filler plug hole.

Propeller Shaft Slip Joints

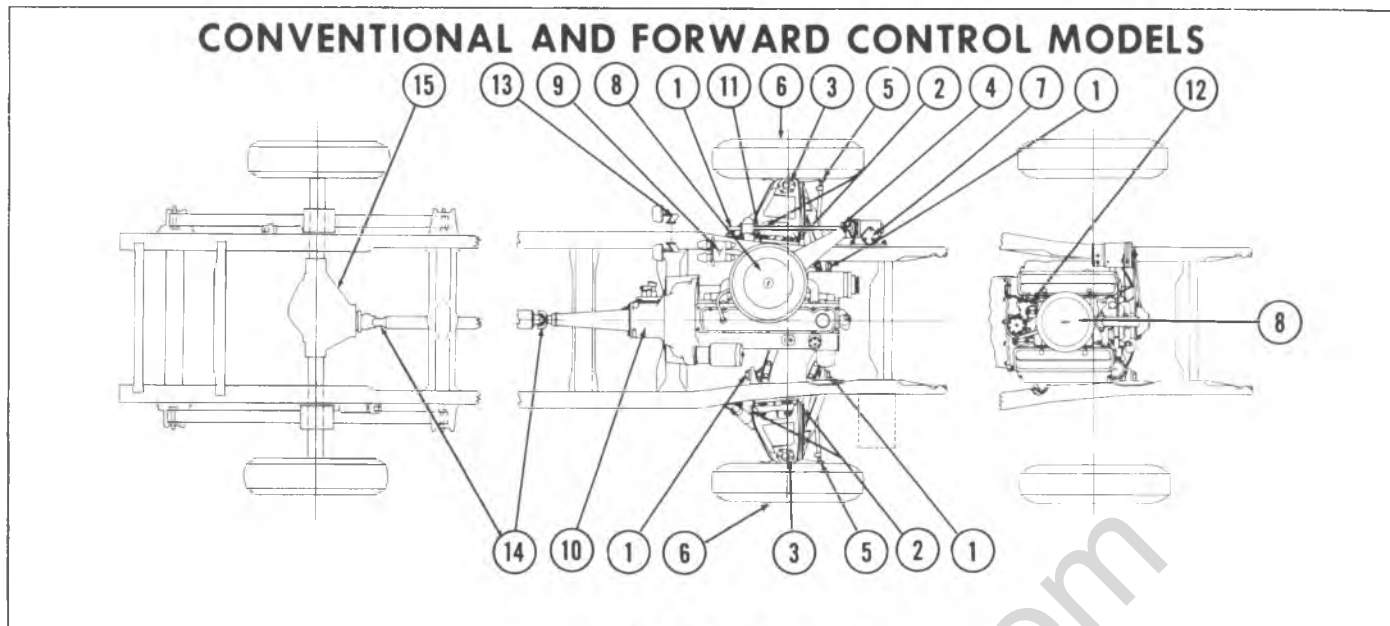
Propeller shaft slip joints should be lubricated at the interval with water resistant EP Chassis lubricant which meets General Motors Specification GM 6031M.

Constant Velocity (C/V Joint)

A C/V joint is located at the transfer case end of the front propshaft and must be lubricated at the interval with GM lubricated part no. 1052497 or equivalent. See Fig. 0B-10 showing how the fitting may be lubricated from above the C/V joint, with a special adapter on the end of a flex hose.

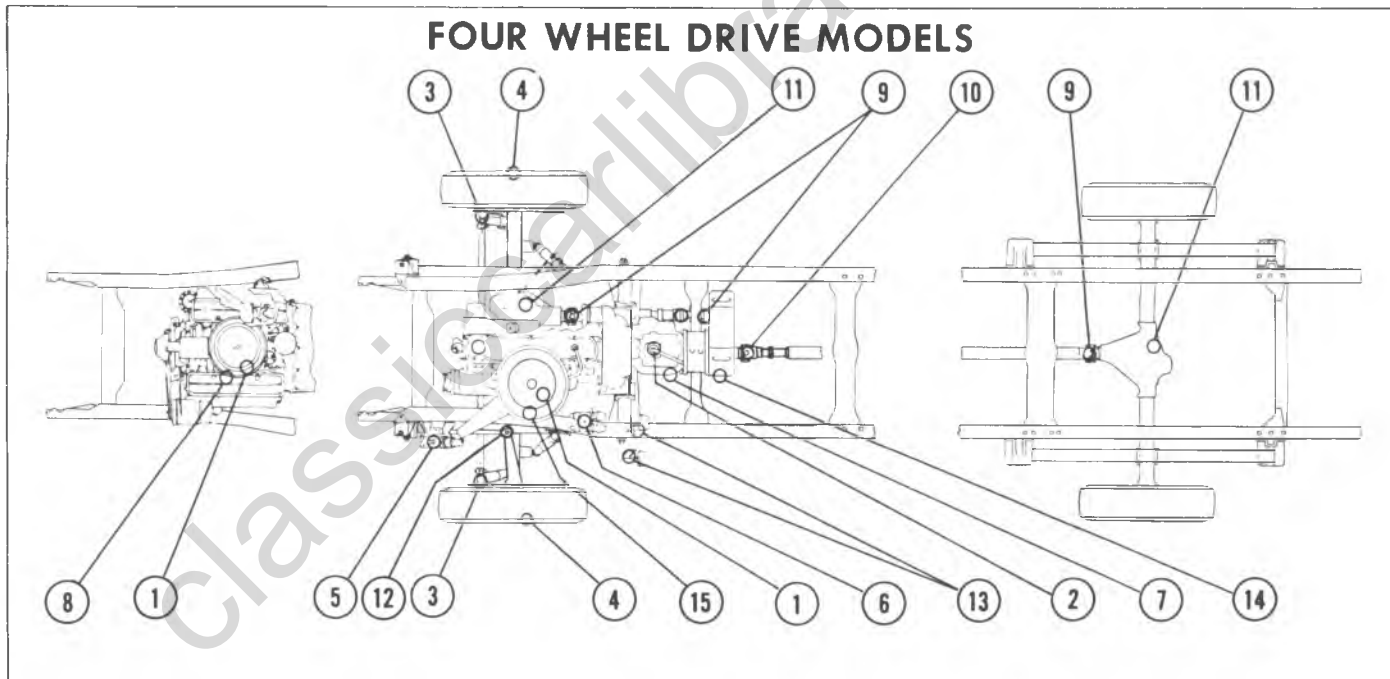
A-6 Oil Filter

Refer to item A-3 for oil filter recommendations.



LUBRICATION POINTS

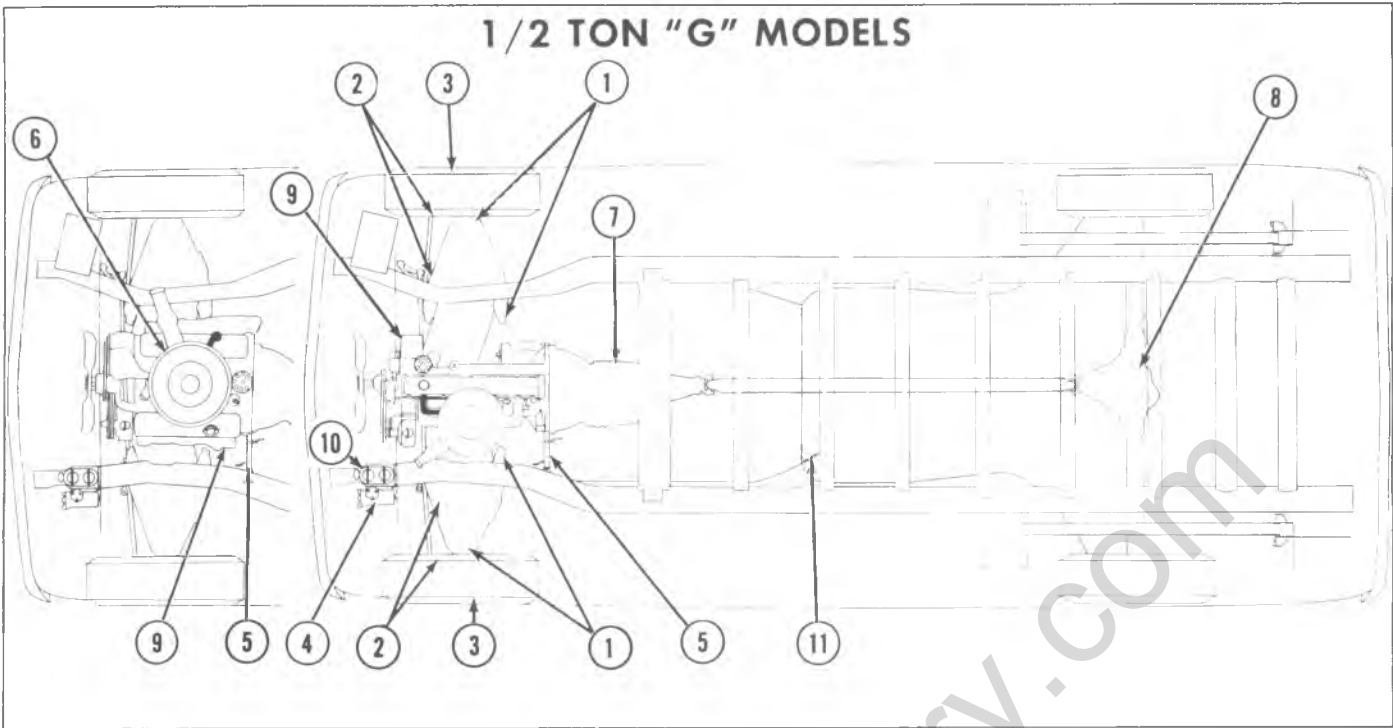
- | | | |
|---|---|-----------------------------------|
| 1 Lower Control Arms | 6 Wheel Bearings | 11 Throttle Bell Crank – L-6 |
| 2 Upper Control Arms | 7 Steering Gear | 12 Carburetor Linkage – V-8 |
| 3 Upper and Lower Control Arm Ball Joints | 8 Air Cleaner – Element | 13 Brake and Clutch Pedal Springs |
| 4 Intermediate Steering Shaft (PA10) | 9 Master Cylinder | 14 Universal Joints |
| 5 Tie Rod Ends | 10 Transmission – Manual – Automatic | 15 Rear Axle |



LUBRICATION POINTS

- | | | |
|--------------------------|--|-----------------------------------|
| 1 Air Cleaner | 6 Master Cylinder | 11 Front and Rear Axle |
| 2 Control Linkage Points | 7 Transmission – Manual – Automatic | 12 Drag Link |
| 3 Tie Rod Ends | 8 Carburetor Linkage – V-8 | 13 Brake and Clutch Pedal Springs |
| 4 Wheel Bearings | 9 Universal Joints | 14 Transfer Case |
| 5 Steering Gear | 10 Propeller Shaft Slip Joints | 15 Throttle Bell Crank – L-6 |

Fig. OB-8--Lubrication Points (Conventional and Four Wheel Drive)



LUBRICATION POINTS

- | | | |
|--|-------------------------|--------------------------|
| 1 Control Arm Bushings and Ball Joints | 5 Trans. Control Shaft | 8 Rear Axle |
| 2 Tie Rod Ends | 6 Air Cleaner - Element | 9 Oil Filter |
| 3 Wheel Bearings | 7 Transmission - Manual | 10 Brake Master Cylinder |
| 4 Steering Gear Clutch Cross-Shaft | | 11 Parking Brake Linkage |

Fig. OB-9-Lubrication Points (G Van)

A-7 Tires

Inspection and Rotation

Front and rear tires perform different jobs and can wear differently depending on the types of roads driven, driving habits, etc. To obtain maximum tire life inspect and rotate tires regularly. (Fig. OB-11) If the truck is equipped with tires having different load ratings between the front

and the rear, the tires should not be rotated front to rear. Vehicle handling could be adversely affected and the tires having the lower load rating could be overloaded.

CAUTION: Before installing wheels, remove any build up of corrosion on the wheel mounting surface and brake drum

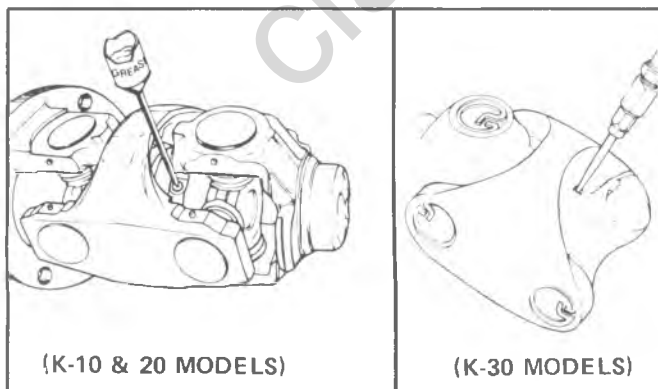


Fig. OB-10-C/V Joint Lube Fitting

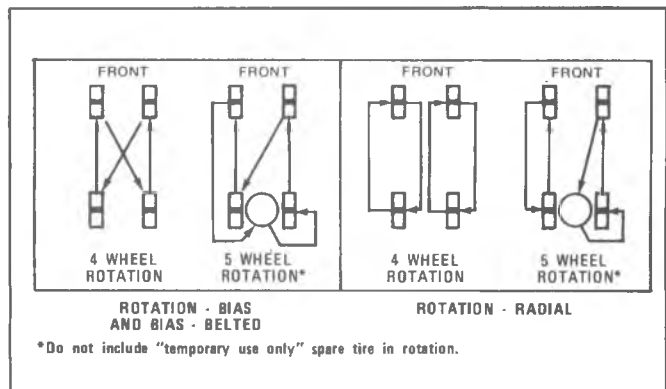


Fig. OB-11--Tire Rotation

| SERIES | DESCRIPTION | TORQUE |
|---|---|---------------------------------|
| K10 | 7/16" BOLTS (6) | 70-90 FT. LBS. 95-120 N•m |
| C10, G10, G20 AND P10 | 1/2" BOLTS (5) | 75-100 FT. LBS. 100-140 N•m |
| C20, K20, C30, G30, P20 AND P30 SINGLE WHEELS | 9/16" BOLTS (8) | 90-120 FT. LBS. 120-160 N•m |
| C30, K30, G30 AND P30 DUAL WHEELS | 9/16" BOLTS (8) | 110-140 FT. LBS. 150-190 N•m |
| | HEAVY DUTY WHEELS 5/8" BOLTS (10) | 130-180 FT. LBS. 175-245 N•m |

Fig. 0B-12--Wheel Nut Torque

or disc mounting surface by scraping and wire brushing. Installing wheel without good metal-to-metal contact at the mounting surfaces can cause the wheel nuts to loosen, which can later allow a wheel to come off while the vehicle is moving, possibly causing loss of control.

Dual Tire Operation

The outer tire of a pair on dual wheel installations generally wears faster than the inner tire. If this occurs, reverse position of the tires to equalize wear and achieve optimum tire life.

In addition, when trucks are driven continuously on high crown roads, an increase in air pressure of from 5 psi (35 kPa) to 10 psi (70 kPa) in the outside tire of each dual produces maximum tire life. Be sure not to exceed the inflation pressure limits shown in the Load and Inflation Charts in Section 3E.

Wheel Nut Torque (Fig. 0B-12)

Caution:

Trucks With Single Wheels:

As soon as possible after installing a wheel and at the intervals shown on the chart in the Maintenance Schedule have a mechanic tighten wheel nuts with a torque wrench to the correct torque listed on the chart which follows.

Trucks With Dual Wheels:

Have a mechanic tighten wheel nuts with a torque wrench as stated above for single wheels for both front and rear wheels. In addition, when the truck, or wheel, or fasteners are new, also have the torque set at the first 100, 1,000, and 6,000 miles (160, 1 600, and 9 600 km). This precaution is necessary because the clamping system used on this type of wheel in some cases needs to seat before the fasteners will hold a uniform clamp load and remain fully tightened.

For both single and dual wheels, wheel nuts should be tightened alternately and evenly to the correct torque in the sequence shown in Section 3E. Never use oil or grease on studs or nuts. Improperly tightened wheel nuts could eventually allow the wheel to come off while the vehicle is moving, possibly causing loss of control.

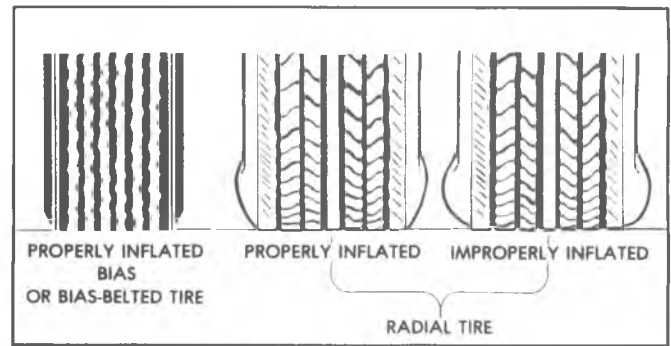


Fig. 0B-13--Properly Inflated Tire

CAUTION: This vehicle has some parts dimensioned in the metric system as well as in the customary system. Some fasteners are metric and are very close in dimension to well-known customary fasteners in the inch system. Mismatched or incorrect fasteners can result in damage to the vehicle or possibly personal injury.

Inflation Pressure (Fig. 0B-13)

The cold inflation pressures for the factory installed tires are on the label on the rear of the driver's door. The tires must be inflated to these pressures to obtain the GVWR (Gross Vehicle Weight Rating) or GAWR (Gross Axle Weight Rating). Incorrect tire inflation pressures can have adverse effects on tire life and vehicle performance. Too low an air pressure causes increased tire flexing and heat build-up. This weakens the tire and increases the chance of damage or failure and can result in tire overloading, abnormal tire wear, adverse vehicle handling, and reduced fuel mileage. Too high an air pressure can result in abnormal wear, harsh ride, and also increase the chance of damage from road hazards.

Lower inflation pressures can be used for light truck-type tires with reduced vehicle loads. After finding the load on each tire by weighing the vehicle on a scale, the minimum cold inflation pressures can be found in Section 3E.

Tire inflation pressures should be checked at least monthly (including the spare if so equipped). Always check tire inflation pressures when tires are "cold".

1. The "cold" tire inflation pressure applies to the tire pressure when a vehicle has not been driven more than one mile (1.6 km) after sitting for three hours or more.

2. It is normal for tire pressures to increase 4 to 8 pounds per square inch (30 to 60 kilopascals) or more, when the tires become hot from driving. Do not "bleed" or reduce tire inflation pressures after driving vehicle. Bleeding serves to reduce "cold" inflation pressure and increase tire flexing which can result in tire damage and failure.

Passenger-Car-Type tires:

For sustained driving at speeds of 75 mph of 85 mph (120 km/h to 140 km/h), in countries where such speeds are permitted by law, cold inflation pressures must be increased 4 psi (30 kPa) above the stated cold inflation pressures on the Certification Label. When the 4 psi (30 kPa) adjustment would require pressures greater than the maximum pressures stated for each load

range. **Sustained driving at speeds over 85 mph (140 km/h), where such speeds are permitted by law, is not advised** unless vehicle is equipped with special high speed.

Truck-Type Tires:

For sustained driving at speeds over 65 mph (100 km/h), where such speeds are permitted by law cold inflation pressures should be increased 10 psi (70 kPa) above those stated in the Tire/Wheel Load and Inflation Pressure Charts for the load being carried. Do not exceed the wheel capacity limit shown in Section 3E.

Sustained speeds over 65 mph (100 km/h) are not advised where the 10 psi (70 kPa) pressure increase would exceed the wheel capacity limit.

For special operating conditions, such as carrying slide-in campers, cold inflation pressures may be increased up to 10 psi (70 kPa) above those shown in the table. The total increase in cold inflation pressures, however, must not exceed the wheel capacity limit shown in Section 3E.

Passenger-car-type tires have a 15-inch (380 millimeter) or smaller wheel size and have no "LT" designation molded in the sidewall after the tire size. Light truck-type tires have "LT" molded in the sidewall after the tire size and/or are larger than 15 inches (380mm) in wheel size.

Passenger-Car Type Snow Tires:

When using passenger-car-type snow tires, cold inflation pressures should be increased 4 psi (30 kPa) above the stated cold inflation pressures on the Certification Label up to the maximum for each load range stated in the chart above. **Sustained speeds above 75 mph (120 km/h) are not advised.**

CAUTION: Be sure to keep tires properly inflated. A tire that is run while significantly underinflated will overheat to the point where the tire may blow out and/or catch fire, possibly resulting in damage to the vehicle and its contents and/or personal injury to its occupants and persons in the area.

Truck-Type Snow Tires:

When using truck-type snow tires, cold inflation pressures should be increased 10 psi (70 kPa) above the advised pressures for the load being carried. However, do not exceed the wheel capacity limit shown in Section 3E.

3. For proper inflation pressures when towing trailers, the following is recommended:

When towing trailers on dead-weight hitches, inflate tires to the pressures shown on the Certification Label (on either the left door latch post or the left door edge next to the driver) or, if applicable the "Tire Inflation Pressure" charts in Section 3E.

For trailers using weight-distributing hitches, increase front tire pressure 2 psi (14 kPa) above the pressure shown on the Certification Label (or "Tire Inflation Pressure" charts). This increase should never exceed the maximum pressure shown on the side of the tire.

It should be remembered that when a trailer is connected, the trailer tongue weight is part of the load being

carried by the vehicle and, therefore, is included in the GVW of the vehicle.

4. Always use a tire pressure gage (a pocket-type gage is advised) when checking inflation pressures. A visual inspection of tires for inflation pressures is not enough, especially in the case of radial tires. Underinflated radial tires may look similar to correctly inflated radial tires. If the inflation pressure on a tire quite often is found to be low, correct the cause.

5. Be sure to reinstall the tire inflation valve caps, if so equipped, to prevent dirt and moisture from getting into the valve core which could cause air leakage.

6. If an air loss occurs while driving, do not drive on the deflated tire more than is needed to stop safely. Driving even a short distance on a deflated tire can damage a tire and wheel beyond repair.

A-8 Rear Axle

Drain and refill to level of filler plug hole every 7,500 miles (12 000 km) on light duty emissions or 12,000 miles (19 200 km) on heavy duty emissions when using vehicle to pull a trailer or severe operating conditions. Use SAE 80W GL-5 or SAE 80W-90 GL-5 gear lubricant. In Canada, use SAE 80W GL-5 gear lubricant. On 20 and 30 series trucks, change lubricant every 24,000 miles (38 400 km).

A-9 Wheel Bearing

For normal application, clean and repack front wheel bearings with a high melting point wheel bearing lubricant at each front brake lining replacement or 30,000 miles (48 000 km) on light duty emissions 12,000 miles (19 200 km) on heavy duty emission or 15,000 miles (24 000 km) on diesel engine vehicles which ever comes first. For heavy duty application such as police and taxi cabs, clean and repack front wheel bearings at each front brake lining replacement or 15,000 miles (24 000 km) which ever comes first.

Use Wheel Bearing Lubricant GM Part No. 105 44 (one pound), 1052356 (35 pounds) or Exxon Ronex MP Grease or equivalent. This is a premium high melting point lubricant.

"Long fiber" or "viscous" type lubricant should not be used. Do not mix wheel bearing lubricants. Be sure to thoroughly clean bearings and hubs of all old lubricant before repacking.

NOTICE: Tapered roller bearings used in this vehicle have a slightly loose feel when properly adjusted. They must never be over tightened (preloaded) or severe bearing damage may result.

Refer to Section 3C for proper detailed adjustment procedures and specifications.

A-10 Cooling System

(Also a LD Emission Control Service)

The coolant recovery system is standard. The coolant in the radiator expands with heat, and the overflow is collected in the recovery tank. When the system cools down, the coolant is drawn back into the radiator.

The cooling system has been filled at the factory with a quality coolant that meets General Motors Specification 1899-M. The coolant is a 50/50 mixture of water and

ethylene glycol antifreeze.

Service

- Maintain cooling system freeze protection at -34°F (-37°C) to ensure protection against corrosion and loss of coolant from boiling. This should be done even if freezing temperatures are not expected.

- Add ethylene glycol base coolant that meets GM Specification 1899-M when coolant has to be added because of coolant loss or to provide added protection against freezing at temperatures lower than -34°F (-37°C).

- Alcohol or methanol base coolants or plain water alone should not be used in a vehicle at any time.

The cooling system should be serviced each year (15,000 miles, 24 000 km, on light duty emission service) (12,000 miles, 19 200 km, on heavy duty emission and diesel engine vehicle service) as follows:

1. Wash radiator cap and filler neck with clean water.
2. Check coolant level and test for freeze protection.
3. Test system and radiator cap for proper pressure holding capacity, 15 psi (105 kPa). If replacement cap is needed, use a cap designed for coolant recovery systems and specified model.
4. Tighten hose clamps and inspect all hoses. Replace hoses if swollen, "checked", or otherwise deteriorated.
5. Clean frontal area of radiator core and air conditioning condenser.

Flush and Refill

Every two years, 30,000 miles (48 000 km) on light duty emissions or 24,000 miles (38 400 km) on heavy duty emissions and diesel engine vehicles, whichever occurs first, the cooling system should be flushed and refilled as follows:

1. Remove radiator cap when engine is cool:
 - Turn cap slowly to the left until it reaches a "stop" (Do not press down while turning the cap).
 - Wait until pressure is relieved (indicated by a hissing sound); then press down on cap and continue to rotate to the left.

CAUTION: To help avoid the danger of being burned, do not remove the radiator cap while the engine and radiator are still hot. Scalding fluid and steam can be blown out under pressure if the cap is taken off too soon.

2. With radiator cap removed, run the engine until upper radiator hose is hot (this shows that the thermostat is open and the coolant is flowing through the system).
3. Stop engine and open radiator drain valve to drain coolant. (Drainage may be speeded by removing drain plugs in the block.)
4. Close drain valve (install block drain plugs, if removed). Add water until system is filled.
5. Repeat steps 3, and 4 several times until the drained liquid is nearly colorless.
6. Drain system and then close radiator drain valve tightly. (Install block drain plugs, if removed.)
7. Remove recovery tank cap, leaving hoses in place. Remove coolant recovery tank and empty fluid. Scrub and clean inside of tank with soap and water. Flush well with clean water and drain. Reinstall tank.

8. Add enough ethylene glycol solution, meeting GM Specification 1899-M, and water to provide the required cooling function as well as freezing and corrosion protection. Use a 50 percent solution, -34°F (-36°C), but no more than a 70 percent solution. Fill radiator to the base of the radiator filler neck and raise level of coolant in the recovery tank to the "Full Hot" mark. Reinstall recovery tank cap.

9. Run engine, with radiator cap removed, until radiator upper hose is hot.

10. With engine idling, add coolant to radiator until level reaches bottom of filler neck. Install cap, making sure arrows line up with overflow tube.

Radiator Pressure Cap

The radiator cap, a 15 psi (105 kPa) pressure type, must be installed tightly, otherwise coolant may be lost and damage to engine may result from overheating. Radiator pressure cap should be checked periodically for proper operation.

Thermostat

The engine coolant temperature is controlled by a thermostat. It stops coolant flow through the radiator until a pre-set temperature is reached. This thermostat is installed on the engine block. The same thermostat is used in both winter and summer. Refer to Section 6B-Engine Cooling for additional information.

A-11 Manual Steering Gear

The steering gear is factory-filled with steering gear lubricant. Seasonal change of this lubricant should not be performed and the housing should not be drained-no lubrication is required for the life of the steering gear.

Inspect for seal leakage (actual solid grease-not just oily film). If a seal is replaced or the gear is overhauled, the gear housing should be refilled only with the proper Steering Gear Lubricant as noted below.

NOTICE: Use only 1052182 (13 oz. (.38L) container) Steering Gear Lubricant which meets GM Specification 4673M, or its equivalent.

Do not use EP chassis lube, meeting GM Specification 6031M, to lubricate the gear. **DO NOT OVER-FILL** the gear housing.

A-12 Clutch Cross-Shaft

Remove the plug, install a lubrication fitting and lubricate with water resistant EP Chassis Lubricant which meets GM Specification 6031M.

A-13 Automatic Transmission Fluid

Refer to A-1 for checking automatic transmission. Change the transmission fluid and service screen every 15,000 miles (24 000 km) on light duty emissions or 12,000 miles (19 200 km) on heavy duty emission and diesel engine vehicles if the vehicle has been driven under one or more of these hot conditions:

- In heavy city traffic where the outside temperature regularly reaches 90°F (32°C).
- In hill or mountain areas.
- Frequent trailer pulling.
- Uses such as taxi, police or delivery service. If the vehicle was not used mainly under any of these conditions, change the fluid and service screen each 100,000

miles (160 000 km) on light duty emissions and diesel engine vehicle or 24,000 miles (38 400 km) on heavy duty emissions.

It takes only one pint (0.5 liter) to raise level from "Add" to "Full" with a hot transmission.

SECTION B

SAFETY MAINTENANCE

B-1 Owner or Driver Safety Checks -

The maintenance Schedule in the glove box lists items to be checked by the owner or driver.

B-2 Tires, Wheels, and Disc Brakes

During tire rotation, check disc brake pads for wear, and surface condition of rotors while wheels are removed (see Item A-7). Check tires for excessive or abnormal wear, or damage. Also check tire inflation pressures and adjust as shown on Time Placard (located on left front door). Be sure wheels are not bent or cracked and that wheel nuts have been tightened to the torque value shown Section 3E.

B-3 Exhaust System

(Also an LD Emission Control Service)

Check the complete exhaust system, including the catalytic converter. Check body areas near the exhaust system and also the tailgate. Look for broken, damaged, missing, or out-of-position parts. Also, inspect for open seams, holes, loose connections, or other conditions which could cause a heat buildup in the floor pan, or could let exhaust fumes seep into the passenger compartment. Dust or water in the passenger compartment may indicate a leak in the area. Needed repairs should be made at once. To help maintain system integrity, replace the exhaust pipes and resonators rearward of the muffler whenever a new muffler is put on.

Refer to Section 6F for exhaust system repair procedures.

B-4 Suspension and Steering

Check front and rear suspension, and steering system. Look for damaged, loose, or missing parts; also for parts showing signs of wear, or lack of lubrication. Replace questionable parts at once.

Refer to Section 3B for steering and Section 3C and 3D for suspension repair procedures.

B-5 Brakes and Power Steering

Check lines and hoses for proper hook-up, binding, leaks, cracks, chafing, etc. Any questionable parts should be replaced or repaired at once. When rubbing or wear is noted on lines or hoses, the cause must be corrected at once.

Refer to Section 5 for brakes and Section 3B for power steering repair procedures.

B-6 Engine Drive Belts

(Also an Emission Control Service)

Check belts driving the fan, AIR pump, generator, power steering pump, and the air conditioning compressor. Look for cracks, fraying, wear, and proper tension. Adjust or replace as needed.

Frayed or cracked belts should be replaced and tensioned to specifications using a strand tension gage, such as tool J-23600 or equivalent.

| ALL L6 ENGINES AND ALL V8 ENGINES EXCEPT DIESEL | | |
|---|---------------------------|--|
| GENERATOR A.I.R. PUMP P/S PUMP | 50 LB. (222 N) MIN. | ADJUST TO 75 ± 5 LBS. USED (334 ± 22 N) ADJUST TO 125 ± 5 LBS. NEW (556 ± 22 N) |
| A/C COMPRESSOR | 65 LB. (289 N) MIN. | ADJUST TO 95 ± 5 LBS. USED (423 ± 22 N) ADJUST TO 140 ± 5 LBS. NEW (623 ± 22 N) |
| 5.7L — V8 DIESEL | | |
| GENERATOR P/S PUMP A.I.R. PUMP (NON A/C) | 70 LB. (311 N) MIN. | ADJUST TO 75 ± 5 LBS. USED (334 ± 22 N) ADJUST TO 110-140 LBS. NEW (480-623 N) |
| A/C COMPRESSOR A.I.R. PUMP | 80 LB. (356 N) MIN. | ADJUST TO 90 ± 5 LBS. USED (400 ± 22 N) ADJUST TO 135-165 LBS. USED (600-734 N) |

Fig. 0B-14--Engine Drive Belt Chart

Loose belts may place an extremely high impact load on driven component bearings due to the whipping action of the belt.

An over tightened belt places unnecessary loads on the component bearings.

In the Chart (Fig. 0B-14), the minimum reading is the lowest allowable setting before the belt must be reset. When readjusting, the adjustment specification should be met. When adjusting a drive belt, it is important that the proper adjustment specification be used.

Refer to Section 6A for engine mechanical additional information.

A "Used" belt is one that has been rotated at least one complete revolution on engine pulleys. This begins the "seating" of the belt and it should never be reset to "New" belt specifications.

B-7 Drum Brakes and Parking Brake

(See Item B-2 for disc brake check.) Check drum brake linings for wear or cracks. Also inspect other brake parts at each wheel, such as drums, wheel cylinders, etc. Check parking brake adjustment also when inspecting drum brake linings.

Check brakes more often if conditions and habits result in frequent braking .

Refer to Section 5 for brake repair procedures.

B-8 Throttle Linkage

Check for damaged or missing parts, interference or binding. Fix any problems at once.

Refer to Section 6C for fuel system repair procedures.

B-9 Bumpers

Check front and rear bumper systems for proper impact protection and clearance. Check also when a bumper looks out of position or if it was struck hard--even if no damage can be seen. Refer to Section 2B for bumper repair procedures.

B-10 Fuel Cap, Fuel Lines and Fuel Tank

(Also an Emission Control Service)

Check the fuel tank, cap and lines for damage or leaks. Remove fuel cap, check gasket for an even filler neck imprint, and any damage. Replace parts as needed. Refer to Section 6C for fuel system repair procedures.

SECTION C

EMISSION CONTROL MAINTENANCE

Refer to Sections 6C or 6E for procedures needed to service the items below:

C-1 Thermostatically Controlled Air Cleaner

Check all hoses and ducts for correct hookup. Be sure valve works properly.

C-2 Carburetor Choke and Hoses

Check that choke and vacuum break work properly. Correct any binding caused by damage or gum on the choke shaft. Check hoses for proper hookup, cracks, rubbing, or decay, correct as needed (Schedule II only).

C-3 Engine Idle Speed

Adjust to the specifications shown on the underhood label. Use calibrated test equipment.

C-4 Early Fuel Evaporation (EFE) System

Check that valve works properly, correct any binding. Check that thermal vacuum switch works properly. Check hoses for cracks, rubbing, or decay. Replace parts as needed.

C-5 Carburetor Mounting

Torque mounting bolts and/or nuts at mileage shown on Maintenance Schedule.

C-6 Vacuum Advance System and Hoses

Check that system works properly. Check hoses for proper hookup, cracks, rubbing or decay. Replace parts as needed.

C-7 Fuel Filter

Replace at mileage shown on Maintenance Schedule or sooner if clogged.

C-8 PCV System

Check that system works properly each 15,000 miles (24 000 km) - Light Duty Emission or 12,000 miles (19 200 km) - Heavy Duty Emissions.

PCV Valve and Filter - Replace the valve, filter and worn or plugged hoses each 30,000 miles (48 000 km) - Light Duty Emissions or 24,000 miles (38 400 km) - Heavy Duty Emissions.

C-9 Spark Plug Wires

Clean wires. Remove corrosion on terminals. Check the wires for checks, burns, cracks or other damage. Check the boot fit at distributor cap and spark plugs. Replace wire if damaged or if corrosion cannot be cleaned.

C-10 Idle Stop Solenoid

Check that parts work properly. Replace them as needed.

C-11 Spark Plugs

Replace as shown on Schedule. Use the type listed in Owner's and Driver's Manual.

C-12 Engine Timing and Distributor Cap

Adjust timing to underhood label specifications. Check the inside and outside of the cap and rotor for cracks, carbon tracking and corrosion. Clean or replace as needed.

C-13 Carburetor Vacuum Break

(All except light duty emission engine family 08K4G)

Check that linkage works properly correct any binding. Check hoses for proper hookup and condition. Replace parts as needed. If necessary, reset vacuum break as shown in Section 6C.

C-14 Air Cleaner Element

Replace at mileage shown on Schedule. Replace more often under dusty conditions.

C-15 Evaporation Control System (ECS)

Check all fuel and vapor lines and hoses for proper hookup routing and condition. Check that bowl vent and purge valves work properly, if equipped. Remove canister, check for cracks or damage. Replace as needed. Replace canister filter.

C-16 Engine Idle Mixture (4.8L; L6 Only)

At designated intervals or in case of a major carburetor overhaul, or when poor idle quality exists, adjust mixture by a mechanical method (lean drop), following the specifications shown on the label under the hood.

C-17 Manifold Heat Valve

Some engines are equipped with a manifold heat valve which should be inspected and repaired as necessary to insure free operation.

C-18 Throttle Return Control (TRC) System

Check hoses for proper connections, cracking, abrasion, or deterioration and replace as necessary. Check for proper operation of system.

Check for shorted or broken wires and ensure electrical connectors are fully engaged at distributor, speed switch and vacuum solenoid.

C-19 Crankcase Ventilation System

(Diesel Only)

Clean breather cap and filter assemblies (both valve covers) each 6,000 miles (9 600 km).

Replace breather cap and ventilation regulator valve assembly each 30,000 miles (48 000 km).

Inspect rubber fittings and replace as required, and clean tubes each 30,000 miles (48 000 km).

SPECIFICATIONS

RECOMMENDED FLUIDS AND LUBRICANTS

| USAGE | FLUID/LUBRICANT |
|--|--|
| Power steering system and pump reservoir | GM power steering fluid Part No. 1050017 or equivalent. |
| Full time front wheel drive case | SAE-10W-30 or 10W-40 SE or SF engine oil |
| Manual steering gear | Lubricant GM Part No. 1051052 or equivalent |
| Differential — Standard or locking, Manual Transmission, Conventional transfer case | SAE-80W GL-5 or SAE-80W-90 GL-5 gear lubricant (SAE-80W — GL-5 in Canada) |
| Brake system and master cylinder | Delco Supreme 11 fluid or DOT-3 |
| Clutch Linkage (Man. Trans. only) a. Pivot points b. Push rod to clutch fork joint, and cross shaft pressure fitting | a. Engine oil b. Chassis grease meeting requirements of GM 6031-M |
| Manual Transmission Shift Linkage, column shift Propeller shaft slip joint | Chassis Grease |
| Shift Linkage, floor shift | Engine oil |
| Hood Latch Assembly a. Pivots and spring anchor b. Release pawl | a. Engine Oil b. Chassis Grease |
| Hood and Door Hinges | Engine Oil |
| Automatic Transmission Shift Linkage | Engine Oil |
| Chassis Lubrication | Chassis grease meeting requirements of GM 6031-M |
| Engine (Gasoline) | "SE" or "SF" Engine Oil conforming to GM specs GM 6136-M |
| Engine (Diesel) | "SE/CC" Engine Oil conforming to GM specs GM 6146-M |
| Constant Velocity Universal Joint | GM Lubricant Part No. 1052497 or equivalent |
| Automatic Transmission | DEXRON®-II Automatic Transmission Fluid |
| Parking Brake Cables | Chassis grease |
| Front Wheel Bearings | Wheel bearings lubricant GM Part No. 1051344 (One Pound) 1052356 (35 pounds) or Exxon Ronex MP Grease or equivalent. |
| Body door hinge pins, tailgate hinge and linkage, folding seat, fuel door hinge | Engine Oil |
| Windshield Washer Solvent | GM Optikleen washer solvent Part No. 1051515 or equivalent |
| Engine Coolant | Mixture of water and high quality Ethylene Glycol base type antifreeze conforming to GM Spec. 1899-M |
| Key Lock Cylinder | WD-40 Spray Lubricant or equivalent |

CAPACITIES

| | U.S. MEASURE | | IMPERIAL MEASURE |
|---|--------------|------------------------|------------------|
| Differential | | | |
| 8½" Ring Gear | 1.9L | 4¼ pts. | 3½ pts. |
| 8-7/8" Ring Gear | | 3½ pts. | 3 pts. |
| 10½" Ring Gear (Chev.) | 2.8L | 6½ pts. | 5½ pts. |
| 10½" Ring Gear (Dana) | 3L | 7.2 pts. | 5½ pts. |
| 9¾" Ring Gear (Dana) | 2.6L | 6.0 pts. | 5 pts. |
| 12¼" Ring Gear (Dana) | 11.7L | 26.8 pts. | 21½ pts. |
| Engine Crankcase | | | |
| 250 L6 – Drain & Refill | 3.8L | 4 qts. | 3¾ qts. |
| – w/Filter Change | 4.7L | 5 qts. | 4¼ qts. |
| 292 L6 – Drain & Refill | 4.7L | 5 qts. | 4¼ qts. |
| – w/Filter Change | 5.7L | 6 qts. | 5 qts. |
| 305 V8 } – Drain & Refill | 3.8L | 4 qts. | 3¾ qts. |
| 350 V8 } – w/Filter Change | 4.7L | 5 qts. | 4¼ qts. |
| 400 V8 } | | | |
| 454 V8 – Drain & Refill | 5.7L | 6 qts. | 5 qts. |
| – w/Filter Change | 6.6L | 7 qts. | 5¾ qts. |
| 350 V8 Diesel Including Filter | 6.6L | 7 qts. | 5¾ qts. |
| Transmission | | | |
| Automatic | | | |
| 350 – Total | 9.5L | 10 qts. | 8¾ qts. |
| – Refill | 2.8L | 3 qts. | 2½ qts. |
| 400 – Total | 10.4L | 11 qts. | 9¼ qts. |
| – Refill | 3.8L | 3.5 qts. | 3 qts. |
| Manual | | | |
| 4 Speed 117mm | 3.8L | 4 qts. | 3¾ qts. |
| 3 Speed 76mm | 1.4L | 1.5 qts. | 1¼ qts. |
| 3 Speed 77mm | 1.4L | 1.5 qts. | 1¼ qts. |
| Four Wheel Drive | | | |
| Front Axle | 2.4L | 2.5 qts. | 2 qts. |
| Transfer Case | 2.4L | 2.5 qts. | 2 qts. |
| Fuel Tank | | | |
| Pickup – C10-35, K10-25 & Crew Cab (Except 107 Models) | 76L | 20 gal. | 16.8 gal. |
| 107 Models | 60.5L | 16 gal. | 13.3 gal. |
| Auxiliary Tank | | Same as Main Fuel Tank | |
| Van – Standard | 83L | 22 gal. | 18¼ gal. |
| – Optional | 125L | 33 gal. | 27½ gal. |
| Suburban – Standard | 95L | 25 gal. | 20.8 gal. |
| – Optional | 117L | 31 gal. | 25.8 gal. |
| – Optional | 151L | 40 gal. | 33.3 gal. |
| Blazer/Jimmy – Standard | 95L | 25 gal. | 20.8 gal. |
| – Optional | 117L | 31 gal. | 25.8 gal. |
| P10, 15/20-35 | 117L | 31 gal. | 25.8 gal. |
| P30042 | 114L | 30 gal. | 25 gal. |
| P30032 | 151L | 40 gal. | 33.5 gal. |

COOLING SYSTEM

| Engine | Series | Capacity (Qts./Liters) | | Transmission | | H.D. Radiator | | Air Cond. | |
|------------------|----------------|------------------------|------------------|--------------|------|---------------|------|-----------|------|
| | | U.S. Measure | Imperial Measure | Man. | Auto | Man. | Auto | Man. | Auto |
| 250 CID L6 | C K10-15 | 15 (14L) | 12½ | X | X | X | X | X | |
| | | 15½ (14.5L) | 13 | | | | | | X |
| | C 20-25 | 15 (14L) | 12½ | X | X | X | X | | |
| | | 15½ (14.5L) | 13 | | | | | X | X |
| G10-30, 15-35 | 17 | 14¼ | X | X | X | X | X | X | |
| 292 CID L6 | C 20-25 | 15 (14L) | 12½ | X | X | X | X | | |
| | | 15½ (14.5) | 13 | | | | | X | X |
| | C K30-35 | 14½ (13.7L) | 12 | X | X | X | X | | |
| | | 15 (14L) | 12½ | | | | | X | X |
| P10-30, 15-35 | 13½ (12.7L) | 11¼ | X | X | X | | | | |
| 305CID V8 | C K10-15 | 17½ (16.5L) | 14½ | X | X | X | | X | |
| | G10-15 | 19 (18L) | 15¾ | X | X | X | X | | |
| | | 20 (19L) | 16¾ | | | X | X | X | X |
| 350 CID V8 | C K10-30 15-35 | 17½ (16.5L) | 14½ | X | | | | | |
| | | 18 (17L) | 15 | | X | X | X | X | X |
| | P20-35 | 16½ (15.6L) | 13¾ | X | X | | X | | |
| | | 17 (16L) | 14¼ | | | X | | | |
| G10-30 G15-35 | 20 (19L) | 16¾ | | X | | X | | X | |
| 400 CID V8 | K20-25 | 18 (17L) | 15 | | X | | | | |
| | | 19 (18L) | 15¾ | | | | X | | |
| | | 20 (19L) | 16¾ | | | | | | X |
| | G20-25 | 20 (19L) | 16¾ | | X | X | X | | X |
| | | 21 (20L) | 17½ | | | | X | | |
| G30-35 | 23 (21.7L) | 19¼ | X | | X | | | | |
| 454 CID V8 | C20-30 25-35 | 24 (22.7L) | 20 | | | | | | X |
| | | 24¼ (23L)* | 20¼ | | X | | | | X |
| | | P30-35 (42) | 23½ (22.2L) | 19½ | | X | | | |
| | P30-35 (32) | 23½ (22.2L) | 19½ | | X | | | | |
| | | 24½ (23L) | 20¼ | | X | | | | X |

SECTION 1A

HEATER

CONTENTS OF THIS SECTION

| | |
|------------------------|-------|
| Standard Heater | 1A-1 |
| Auxiliary Heater | 1A-15 |
| Specifications | 1A-19 |

STANDARD HEATER

INDEX

| | | | |
|---|------|---|-------|
| General Description..... | 1A-1 | Heater Hoses..... | 1A-9 |
| System Components..... | 1A-1 | Center Distributor Duct - G Models..... | 1A-9 |
| System Controls..... | 1A-3 | Defroster Duct..... | 1A-12 |
| Diagnosis..... | 1A-4 | Control Assembly..... | 1A-12 |
| On Vehicle Service | | Control Cables..... | 1A-13 |
| Blower Motor..... | 1A-8 | Blower Switch..... | 1A-13 |
| Heater Distributer and Core Assembly..... | 1A-8 | Resistor Unit..... | 1A-13 |

GENERAL DESCRIPTION

Heating components are attached to the dash panel on the right side of the vehicle. The blower and air inlet assembly and water hoses are located on the forward side of the dash panel while the heater core and distributor duct are on the passenger side.

The heater system is an air mix type system in which outside air is heated and then mixed in varying amounts with cooler outside air to attain the desired air temperature. The system consists basically of three parts: (1) the blower and air inlet assembly, (2) the heater distributor assembly and (3) the heater control assembly.

HEATER AIR FLOW SCHEMATIC

CK Series heater airflow is shown in Figure 1A-1.

BLOWER AND AIR INLET ASSEMBLY

The blower and air inlet assembly draws outside air through the outside air inlet grille located forward of the windshield reveal molding and channels the air into the heater distributor assembly. The operation of the blower motor is controlled by the FAN switch on the heater control. The motor is connected in series with the FAN switch and also the blower resistor assembly. Located in the fuse block, in series between the blower motor and the battery, is a 25 amp. fuse C-K models - a 20 amp fuse on G models.

HEATER DISTRIBUTOR ASSEMBLY

The heater distributor assembly houses the heater core and the doors necessary to control mixing and channeling of the air. Since the unit has no water valve, water circulation keeps the core hot at all times. That portion of the air passing through the core receives maximum heat from the core. Air entering the distributor assembly is channeled as follows:

C-K Models

Air entering the distributor can be directed out the purge door opening, on the right end of the distributor assembly, by the purge door. If the purge door is closed, then air is directed through and/or around the heater core by the temperature door. Air is then directed into the passenger compartment through the heater (floor) outlets and/or the defroster (dash) outlets by the defroster door. The temperature of the outlet air is dependent on the ratio of heated to unheated air (controlled by the temperature door).

G Models

Air flow is controlled by doors in the distributor assembly. The air door can be adjusted to vary airflow. If air is allowed to enter the distributor assembly, it is then directed through and/or around the heater core by the temperature door. Air is directed into the passenger compartment through the heater (floor) and/or defroster (dash) outlets by the defroster door. The temperature of the

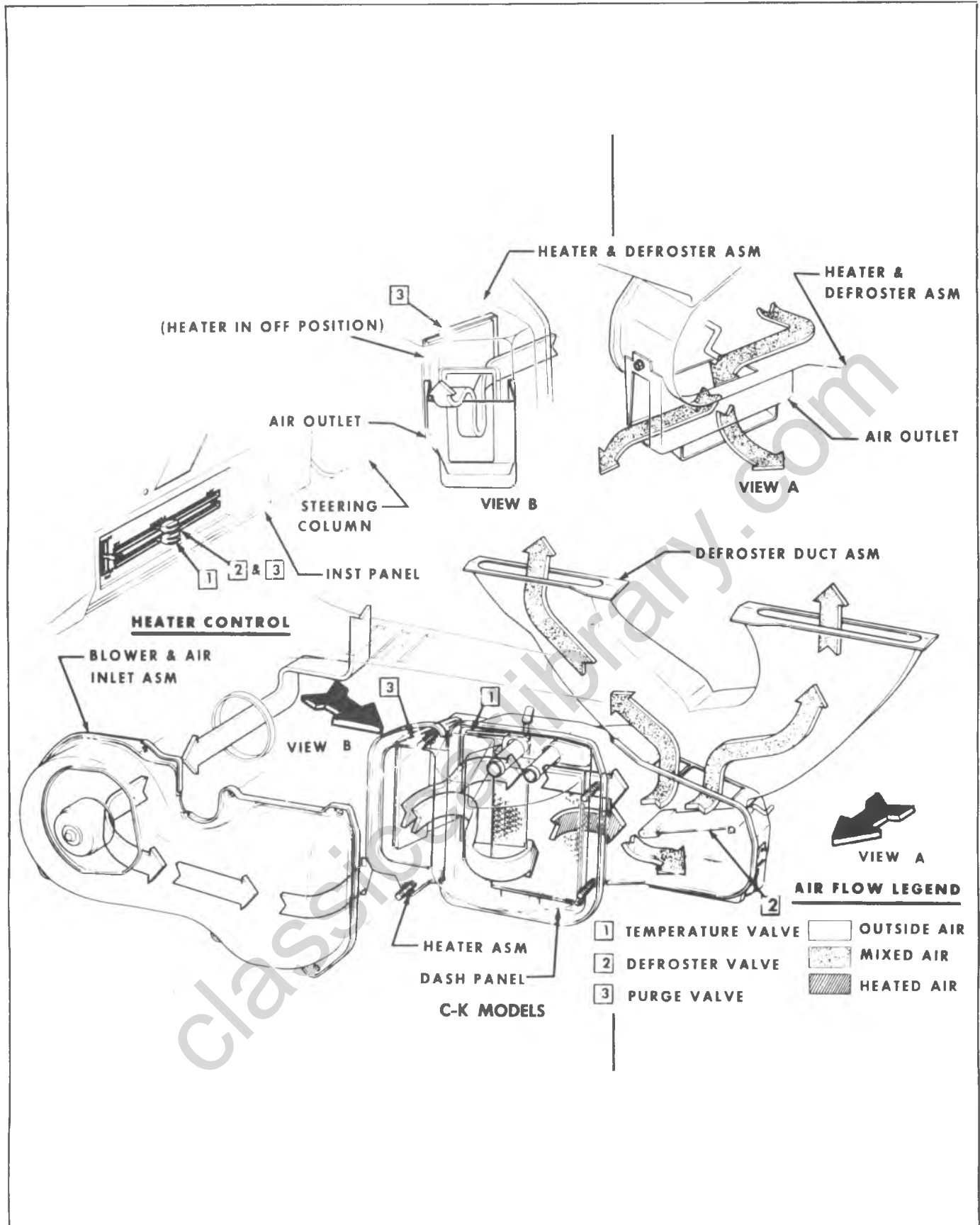


Fig. 1A-1--Heater Air Flow Schematic--C-K Models



Fig. 1A-2—Heater Control-C-K Models

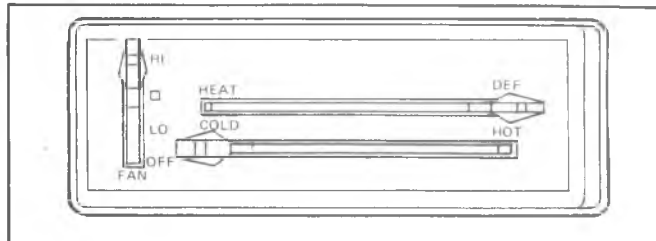


Fig. 1A-3—Heater Control-G Models

outlet air is dependent of the ratio of heated to unheated air (controlled by the temperature door).

CONTROLS

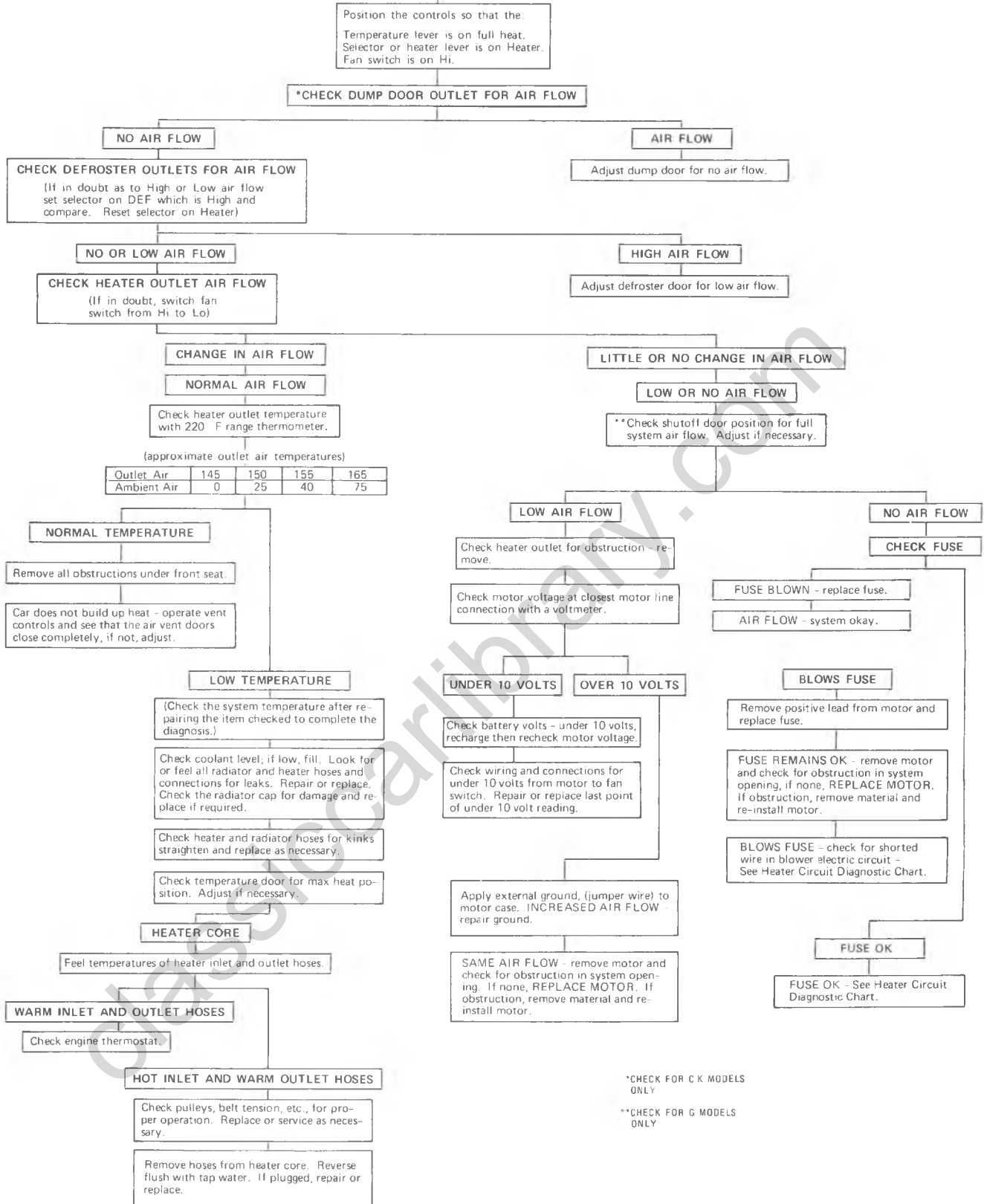
Heater controls for CK & G Models are shown in Figures 1A-2 and 1A-3.

classiccarslibrary.com

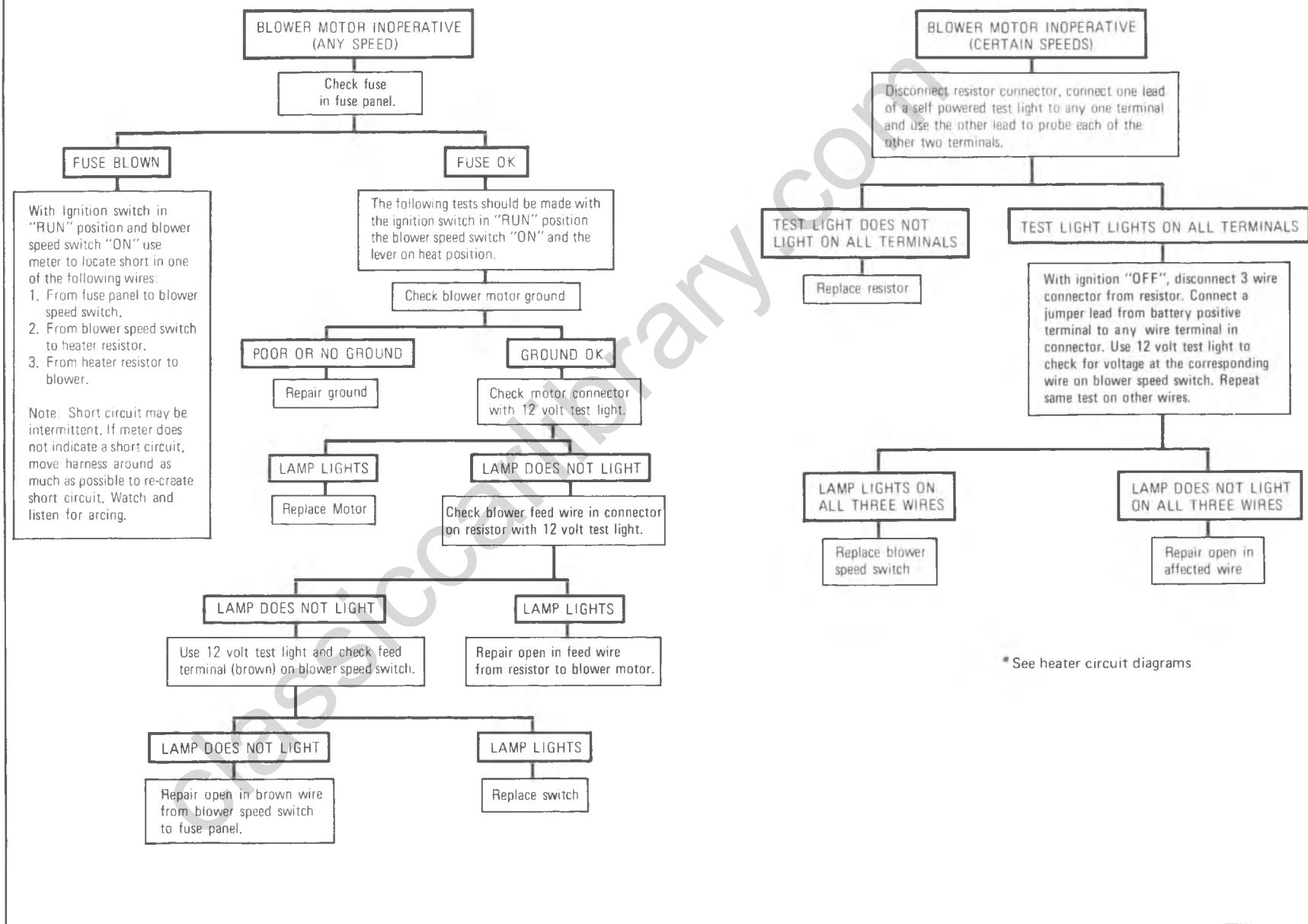
DIAGNOSIS

| TROUBLE | CAUSE AND CORRECTION |
|--|---|
| Temperature of heater air at outlets too low to heat up passenger compartment. | 1. See "Insufficient Heat Diagnostic Chart". |
| Temperature of heater air at outlets adequate but the vehicle will not build up sufficient heat. | <p>Check for body leaks such as:</p> <ol style="list-style-type: none"> 1. Floor side kick pad ventilators partially open. 2. Leaking grommets in dash. 3. Leaking welded seams along rocker panel and windshield. 4. Leaks through access holes and screw holes. 5. Leaking rubber molding around door and windows. 6. Leaks between sealing edge of blower and air inlet assembly and dash, and between sealing edge of heater distributor assembly and dash. |
| Inadequate defrosting action. | <ol style="list-style-type: none"> 1. Check that DEFROST lever completely opens defroster door in DEF position - Adjust if necessary. 2. Insure that temperature and air doors open fully - Adjust. 3. Look for obstructions in defroster ducts - Remove any obstructions. 4. Check for air leak in ducting between defroster outlet on heater assembly and defroster duct under instrument panel - Seal area as necessary. 5. Check position of bottom of nozzle to heater locating tab - Adjust. 6. Check position of defroster nozzle openings relative to instrument panel openings. Mounting tabs provide positive position if properly installed. |
| Inadequate circulation of heated air through vehicle. | <ol style="list-style-type: none"> 1. Check heater air outlet for correct installation - Reinstall. 2. Inspect floor carpet to insure that carpet lies flat under front seat and does not obstruct air flow under seat, and also inspect around outlet ducts to insure that carpet is well fastened to floor to prevent cupping of air flow - Correct as necessary. |
| Erratic heater operation. | <ol style="list-style-type: none"> 1. Check coolant level - Fill to proper level. 2. Check for kinked heater hoses - relieve kinks or replace hoses. 3. Check operation of all bowden cables and doors - Adjust as necessary. 4. Sediment in heater lines and radiator causing engine thermostat to stick open - flush system and clean or replace thermostat as necessary. 5. Partially plugged heater core - backflush core as necessary. |
| Hard operating or broken controls. | <ol style="list-style-type: none"> 1. Check for loose bowden cable tab screws or mis-adjusted bowden cables - Correct as required. 2. Check for sticking heater system door(s) - Lubricate as required using a silicone spray. |

INSUFFICIENT HEAT DIAGNOSIS



HEATER CIRCUIT DIAGNOSIS*



* See heater circuit diagrams

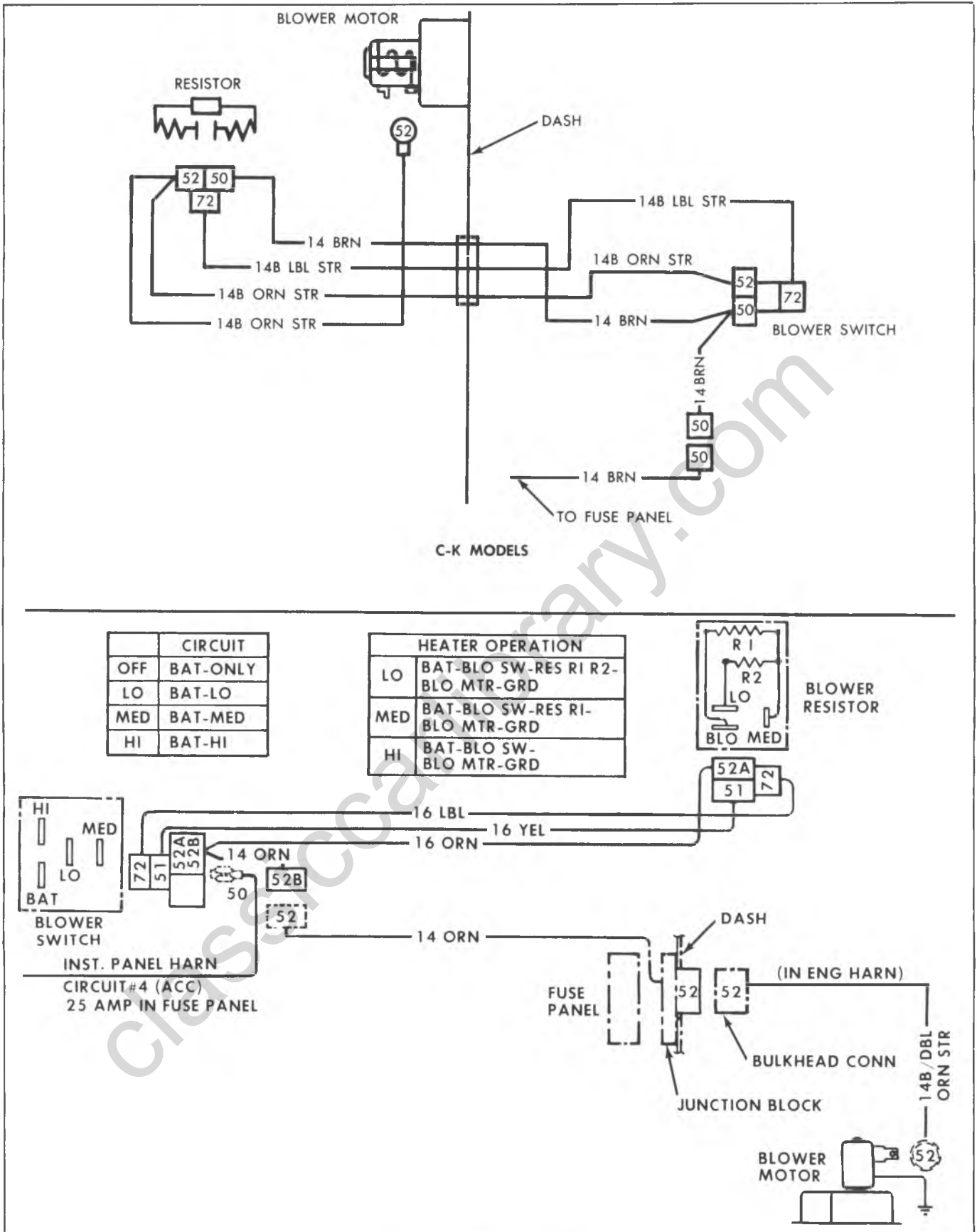


Fig. 1A-4--Heater Wiring Diagrams

ON VEHICLE SERVICE

BLOWER MOTOR

Removal (Fig. 1A-5)

1. Disconnect battery ground cable.

G Models - Remove the coolant recovery tank, and power antenna as outlined in Sections 6 and 9.

2. Disconnect the blower motor lead wire.

3. Remove the five blower motor mounting screws and remove the motor and wheel assembly. Pry gently on the blower flange if the sealer acts as an adhesive.

4. Remove the blower wheel to motor shaft nut and separate the wheel and motor assemblies.

5. To install a new motor, reverse Steps 1-4 above.

The following steps should be taken to assure proper installation:

a. Assemble the blower wheel to the motor with the open end of the wheel away from the blower motor.

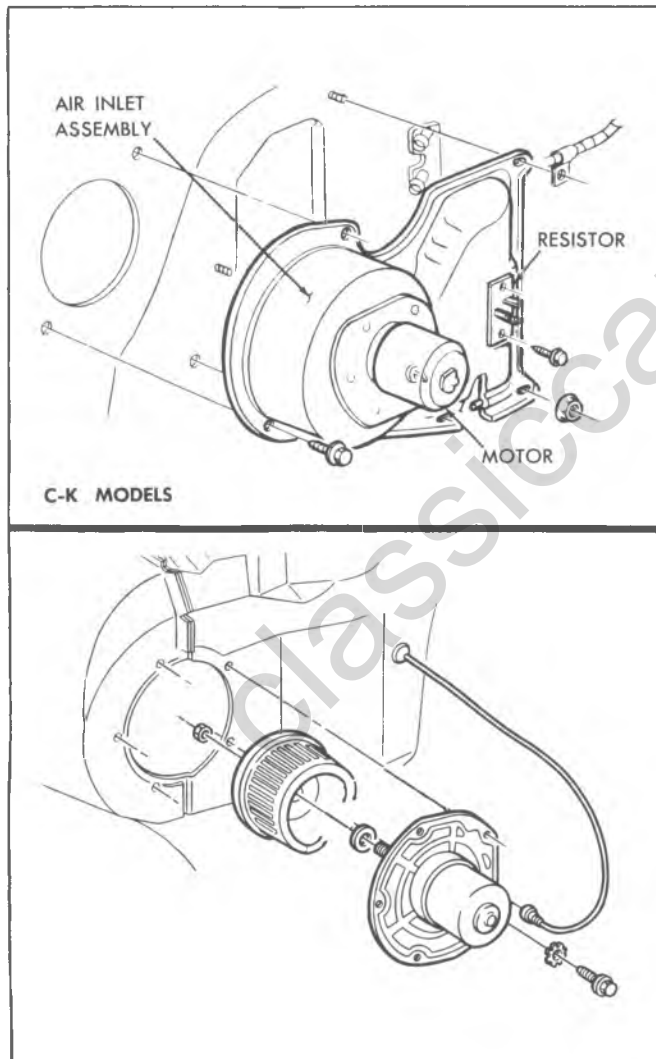


Fig. 1A-5--Blower Motor Assembly

b. If the motor mounting flange sealer has hardened, or is not intact, remove the old sealer and apply a new bead of sealer to the entire circumference of the mounting flange.

c. Check blower operations: blower wheel should rotate freely with no interference.

HEATER DISTRIBUTOR AND CORE ASSEMBLY

C-K Models

Replacement (Fig. 1A-6)

1. Disconnect the battery ground cable.

2. Disconnect the heater hoses at the core tubes and drain engine coolant into a clean pan. Plug the core tubes to prevent coolant spillage at removal.

3. Remove the nuts from the distributor duct studs projecting into the engine compartment.

4. Remove the glove box and door assembly.

5. Disconnect the Air-Defrost and Temperature door cables.

6. Remove the floor outlet and remove the defroster duct to heater distributor duct screw.

7. Remove the heater distributor to dash panel screws. Pull the assembly rearward to gain access to wiring harness and disconnect all harnesses attached to the unit.

8. Remove the heater-distributor from the vehicle.

9. Remove the core retaining straps and remove the core.

10. To install, reverse Steps 1-9 above. Be sure core to case and case to dash panel sealer is intact before assembling unit.

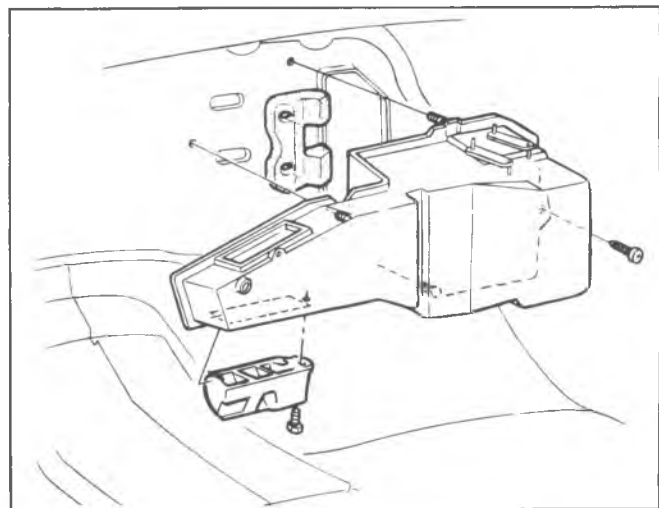


Fig. 1A-6--Heater Distributor Assembly--C-K Models

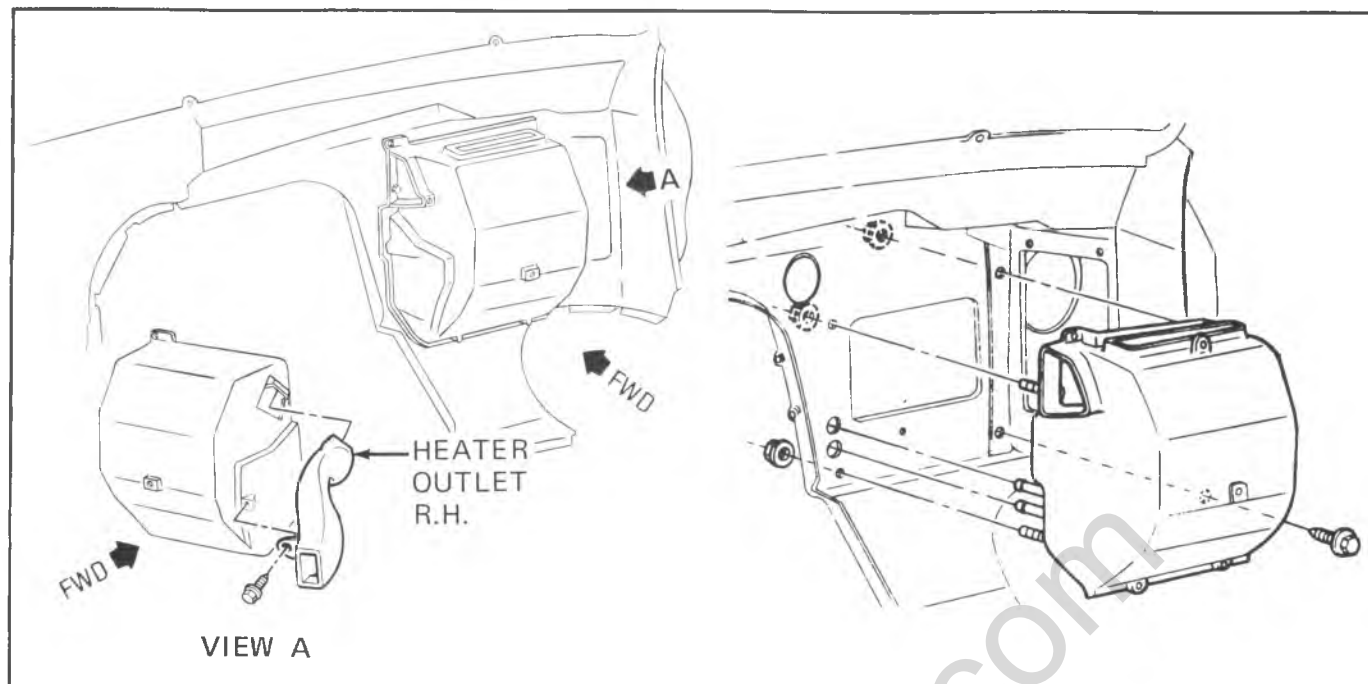


Fig. 1A-7--Heater Distributor - G Models

G Models

Replacement (Fig. 1A-7)

1. Disconnect the battery ground cable.
2. Remove coolant recovery tank and lay aside.
3. Place a clean pan under the vehicle and then disconnect the heater core inlet and outlet hoses at the core connections (see "Heater Hoses-Replacement" later in this section). Quickly plug the heater hoses and support them in a raised position. Allow the coolant in the heater core to drain into the pan on the floor.
4. Remove heater distributor duct to distributor case attaching screws and distributor duct to engine cover screw and remove duct.
5. Remove engine housing cover.
6. Remove instrument panel attaching screws: above, at windshield, all lower screws and right lower I.P. support bracket at door pillar and engine housing.
7. Lower steering column, and raise and support right side of I.P.
8. Remove defroster duct to distributor case attaching screw, and 2 screws attaching distributor to heater case.
9. Disconnect temperature door cable and fold cable back for access (See Fig. 1A-17).
10. Remove three (3) nuts at engine compartment side of distributor case and one (1) screw on passenger side.
11. Remove the heater case and core as an assembly. Tilt the case assembly rearward at the top while lifting up until the core tubes clear the dash openings.
12. Remove the core retaining strap screws and remove the core.
13. To install a new core, reverse Steps 1-10 above. Be sure core to case and case to dash panel sealer is intact before assembling unit.

HEATER HOSES

Heater hoses are routed from the thermostat housing or inlet manifold and water pump (radiator on some automatic transmission vehicles) to the core inlet and outlet pipes as shown in Figures 1A-8 thru 1A-11. Hoses are attached at each end with screw type clamps.

Replacement

The heater core can be easily damaged in the area of the core tube attachment seams whenever undue force is exerted on them. Whenever the heater core hoses do not readily come off the tubes, the hoses should be cut just forward of the core tubes. The portion of the hose remaining on the core tube should then be split longitudinally. Once the hoses have been split, they can be removed from the tubes without damage to the core.

DISTRIBUTOR DUCTS - G Models

Replacement (Fig. 1A-12)

1. Disconnect the battery ground cable.
2. Raise I.P. at right side as outlined under heater distributor removal.
3. Unsnap the engine cover front latches. Remove the two cover to floorpan screws and remove the cover.
4. Remove the heater distributor duct to case attaching screws as illustrated in Figure 1A-12.
5. Remove one (1) screw at left center of distributor duct.
6. Pull the center distributor duct to the right and remove it from the vehicle.
7. To install, reverse Steps 1-5 above. Check cable and door operation; cables should be free from kinks or binding and doors should close properly. If cable adjustment is necessary, see "Bowden Cable-Adjustment."

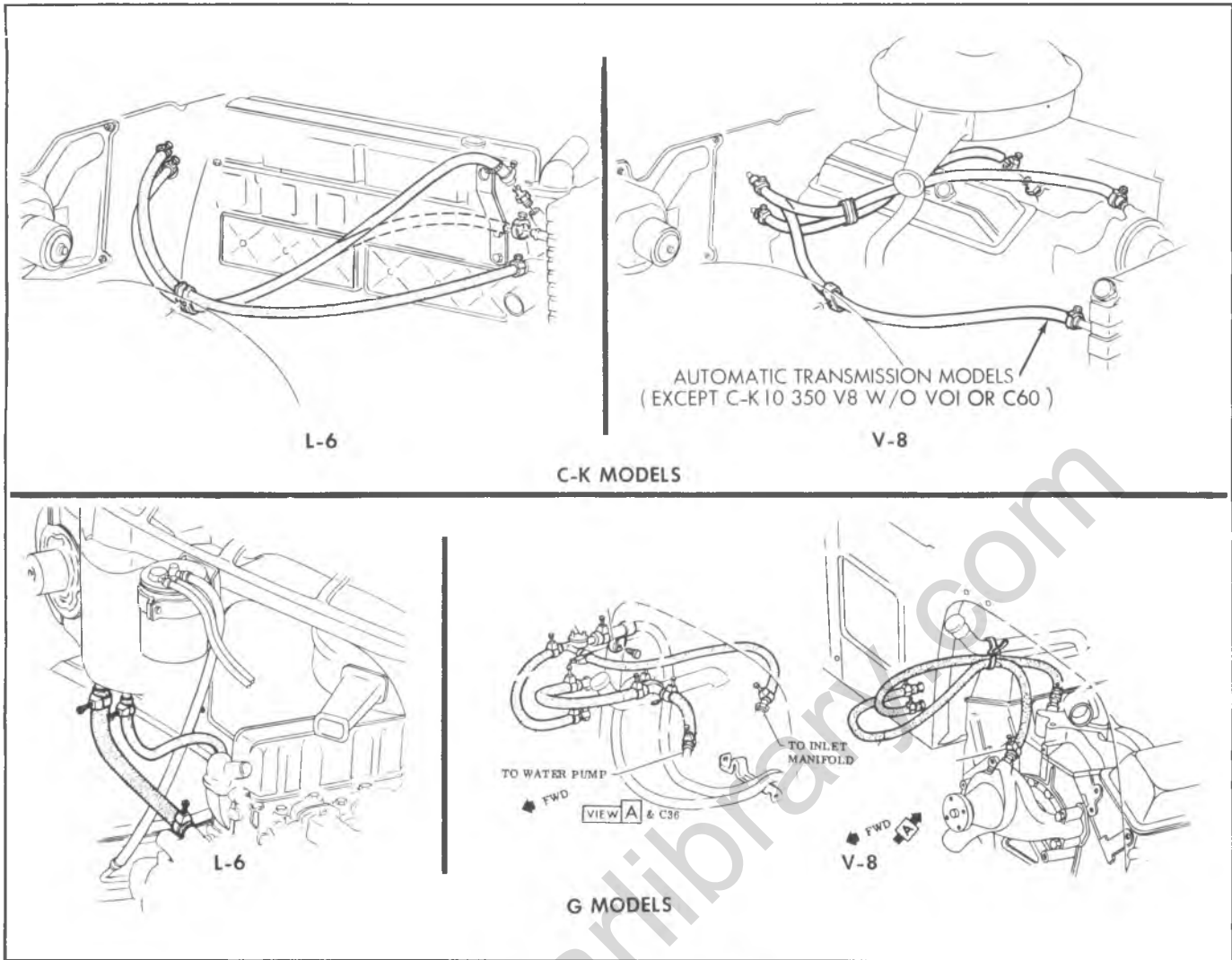


Fig. 1A-8-Heater Hose Routings

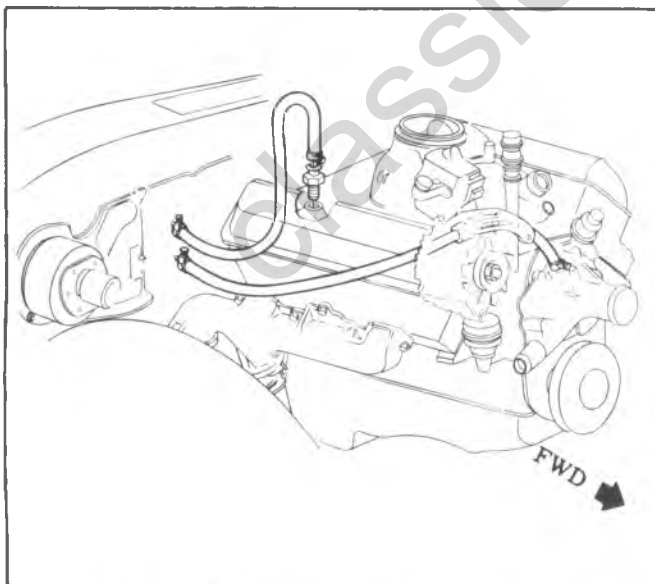


Fig. 1A-9-Heater Hose Routing-Diesel Eng

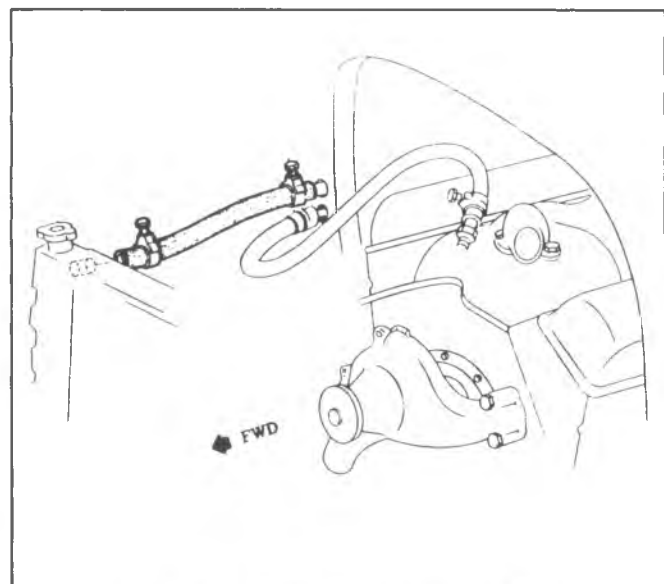
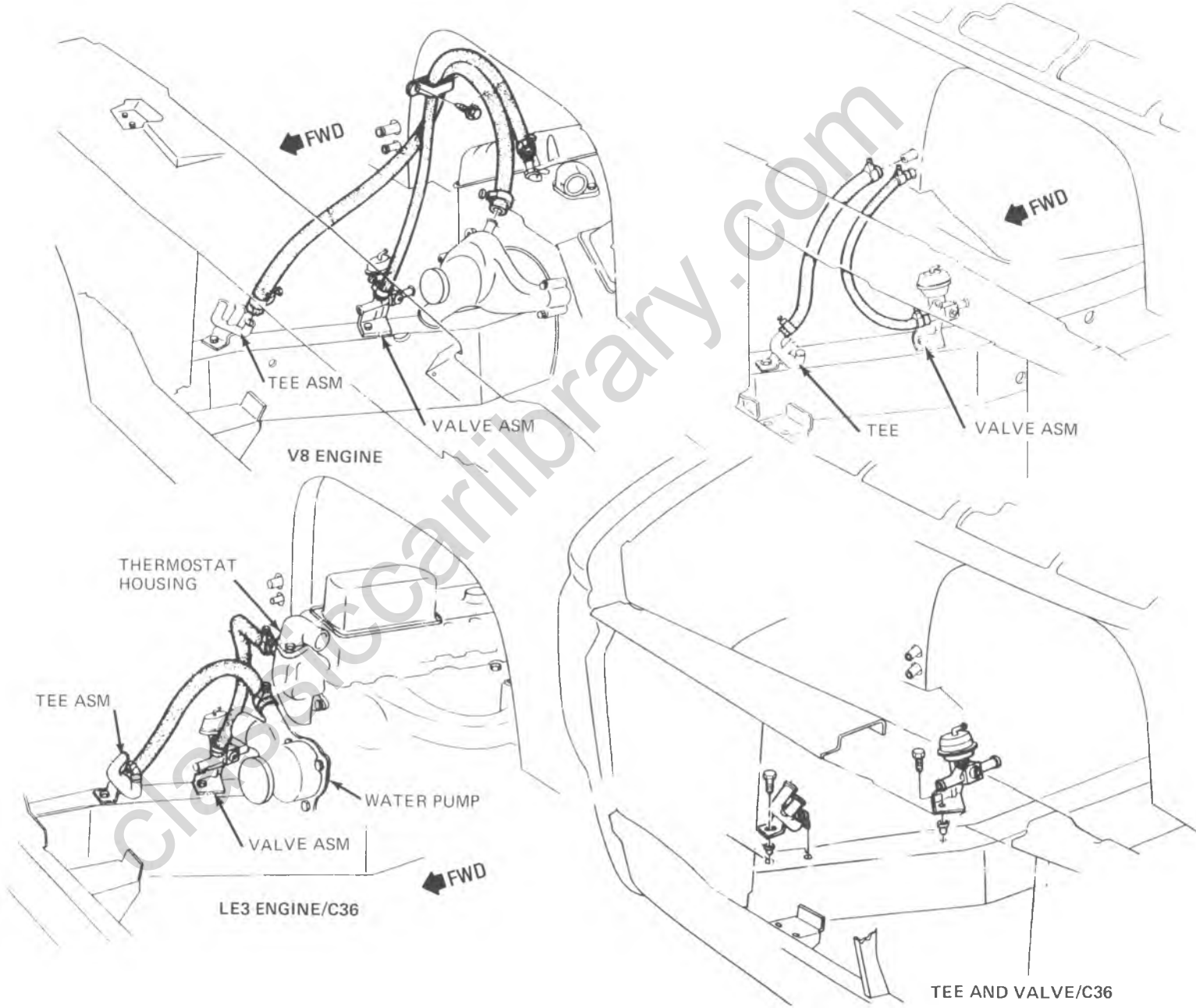


Fig. 1A-10-Heater Hose Routing V8 Eng

Fig. 1A-11-Heater Hose Routing G Series



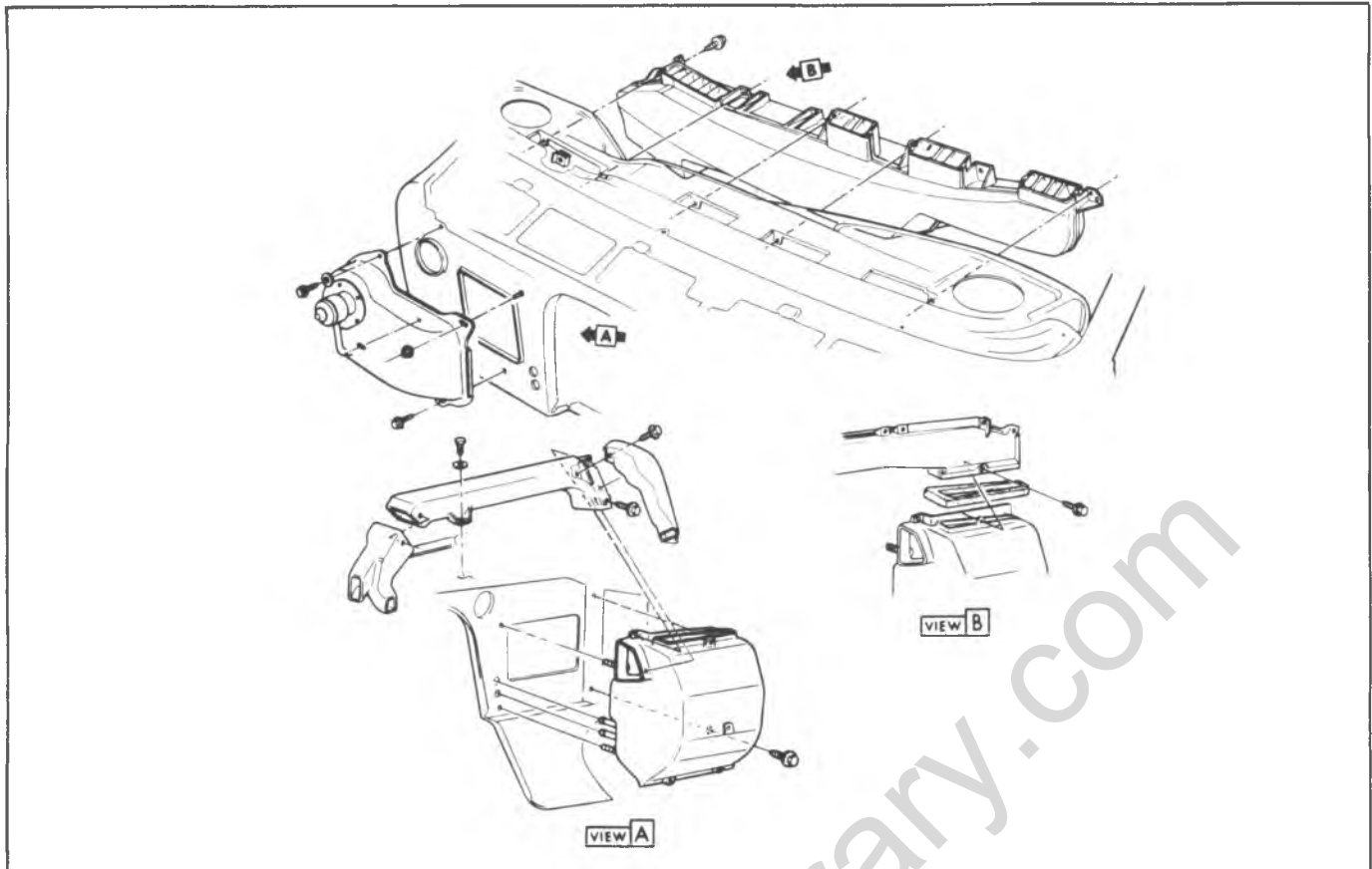


Fig. 1A-12-Distributor Ducts-G Models

DEFROSTER DUCT

Defroster assemblies attachment is illustrated in Figure 1A-13.

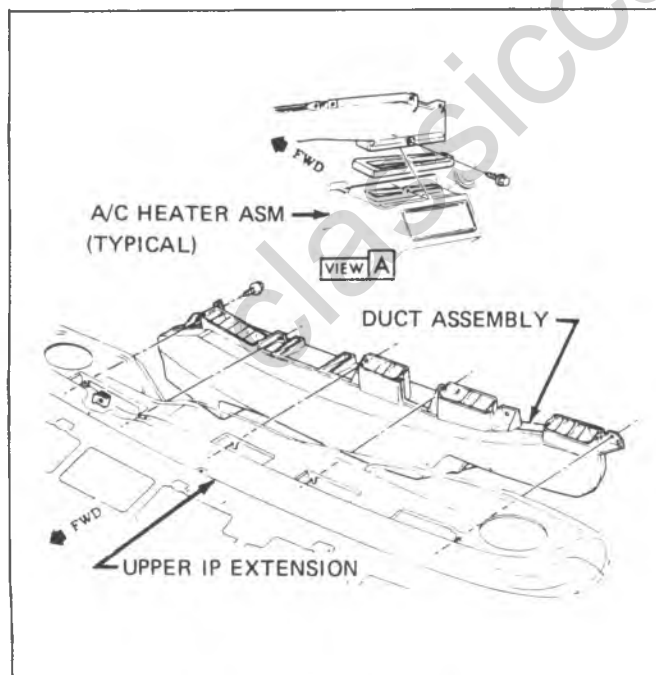


Fig. 1A-13-Defroster Outlets

CONTROL ASSEMBLY

C-K Models

Replacement (Fig. 1A-14)

1. Disconnect the battery ground cable.
2. Remove the instrument panel bezel.
3. Disconnect the bowden cables and the blower switch wiring harness. Be careful not to kink the bowden cables.

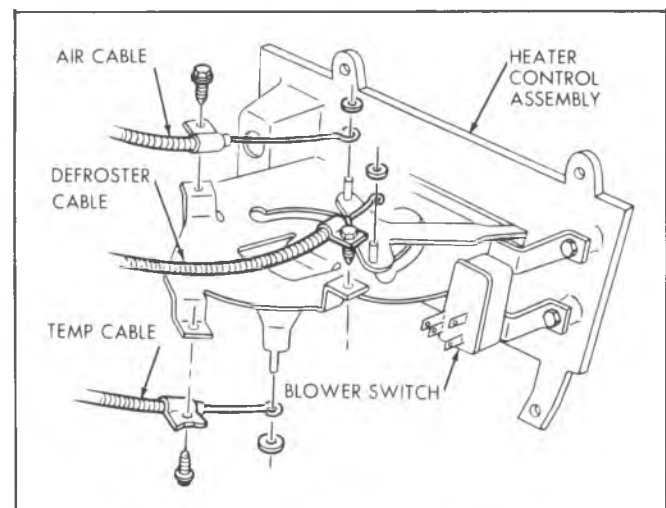


Fig. 1A-14-Control Assembly-C-K Models

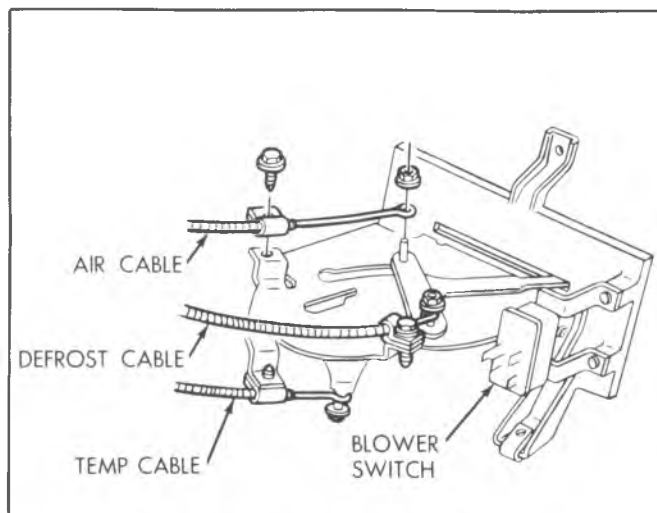


Fig. 1A-15—Control Assembly-G Models

4. Remove the control through the opening above the control.
5. If a new unit is being installed, transfer the blower switch to the new unit.
6. To reinstall, reverse Steps 1-4 above.

G Models

Replacement (Fig. 1A-15)

1. Disconnect the battery ground cable.
2. Remove I.P. bezel as outlined in Section 8C of this manual.
3. Remove the control to instrument panel mounting screws (3) and carefully pull the control rearward far enough to gain access to the bowden cable attachments. Care should be taken to prevent kinking the bowden cables while lowering the control.
4. Disconnect the bowden cables, the control illumination bulb, the blower switch connector and remove the control from the vehicle.
5. Remove the blower switch screws and remove the blower switch.
6. To install, reverse Steps 1-4 above.

CONTROL CABLES (Fig. 1A-16 & 1A-17)

C-K Models

Replacement

1. Disconnect the battery ground cable.
2. Remove the instrument panel bezel.
3. Remove the control to instrument panel screws.
4. Raise or lower control as necessary to remove cable push nuts and tab attaching screws.
5. Remove glove box and door as an assembly.
6. Remove cable push nut and tab attaching screw at door end of cable.
7. Remove cable from retaining clip and remove cable assembly.
8. To install, reverse Steps 1-7 above. Be careful not to kink the cable during installation. Be sure to route the cable as when removed. Check cable adjustment.

G Models

Replacement (Fig. 1A-17)

Heater and defroster cable routing and attachment to control and to distributor case is illustrated in Figure 1A-17. If cable adjustment is required, see below.

Adjustment - CK Series

1. Disconnect the battery ground cable.
2. Remove glove box and door as an assembly.
3. Pry off the appropriate cable eyelet clip and disconnect the cable from the door.
4. Remove the cable retaining screw.
5. While holding the cable with pliers, rotate the mounting tab on the cable to lengthen or shorten the cable, whichever is required.

NOTICE: Do not pinch the cable too tightly or damage to the cable could result.

6. Install the cable, reversing Steps 1-4 above.

Adjustment - G Van

1. Attach inner cable and sheath to I.P. Control.
2. With I.P. installed, move temperature cable to cold and attach loop on inner cable to temperature door on heater case.
3. Attach cable sheath to heater case.
4. Move temperature lever to full heat. This will require some effort due to force required to slide inner cable clip to its proper position.

BLOWER SWITCH

C-K Models

Replacement (Fig. 1A-14)

1. Disconnect the battery ground cable.
2. Remove the instrument panel bezel.
3. Remove the control to instrument panel screws and lower the control onto the radio.
4. Disconnect the switch electrical harness.
5. Remove the switch attaching screws and remove the switch.
6. To install, reverse Steps 1-5 above.

G Models

Replacement (Fig. 1A-15)

1. Disconnect the battery ground cable.
2. Disconnect the blower switch wiring harness connector at the switch.
3. Remove the two switch attaching screws and remove the switch assembly.
4. To install a new switch, reverse Steps 1-3 above.

RESISTOR

Replacement (Figs. 1A-5 and 1A-18)

1. Disconnect the wiring harness at the resistor connector.
2. Remove the two resistor mounting screws and remove the resistor.
3. To install a new resistor, reverse Steps 1 and 2 above.

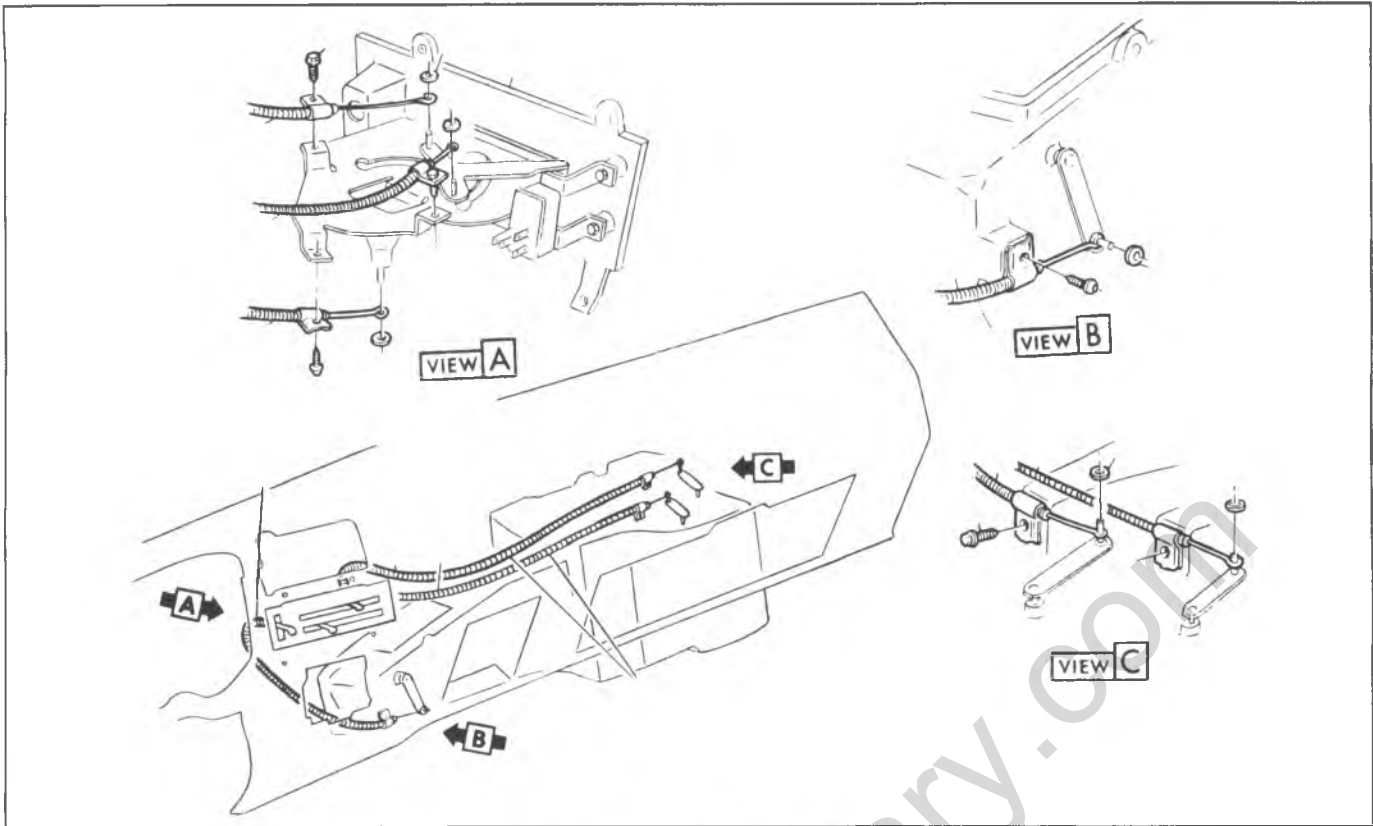


Fig. 1A-16-Control Cables - CK Series

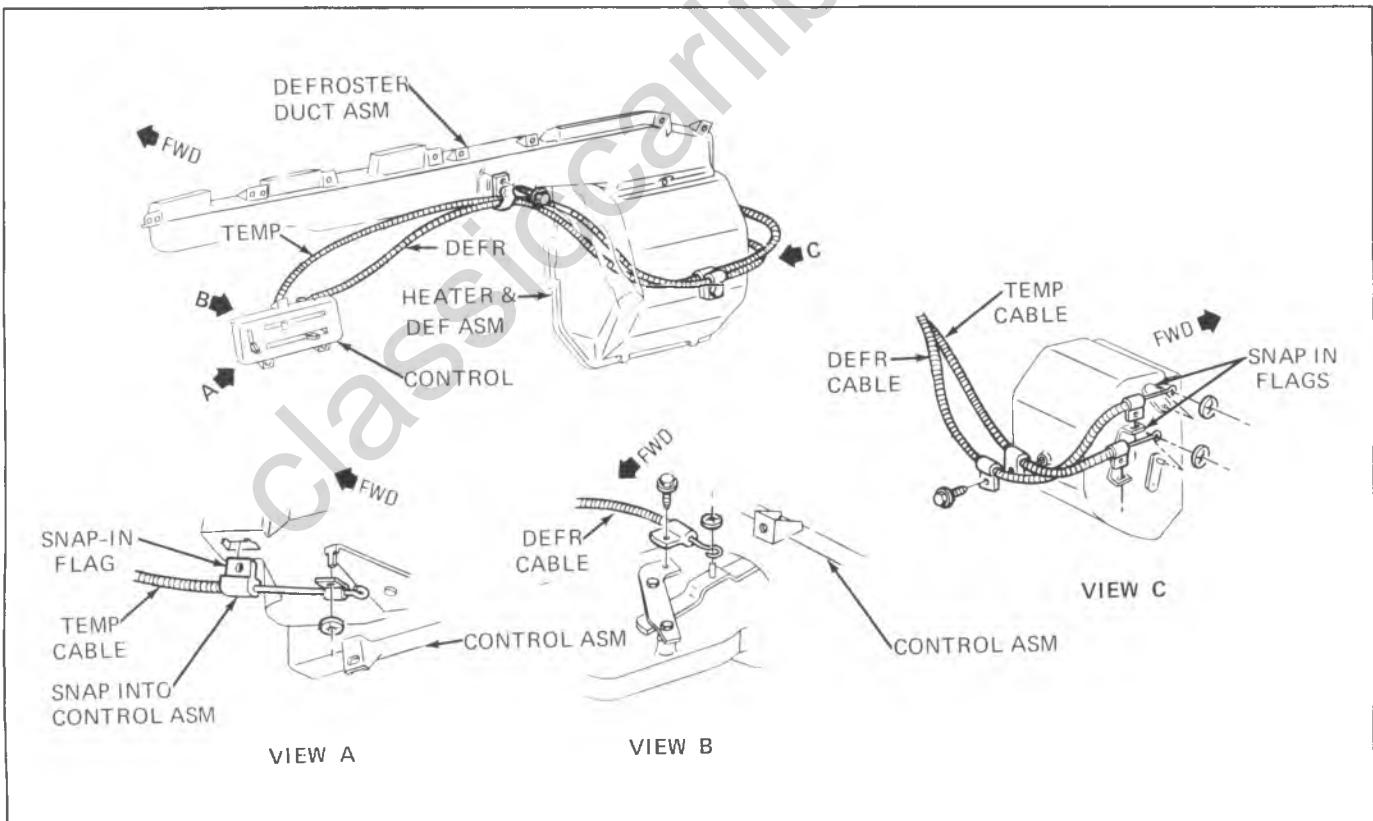


Fig. 1A-17-Control Cable Routing--G Models

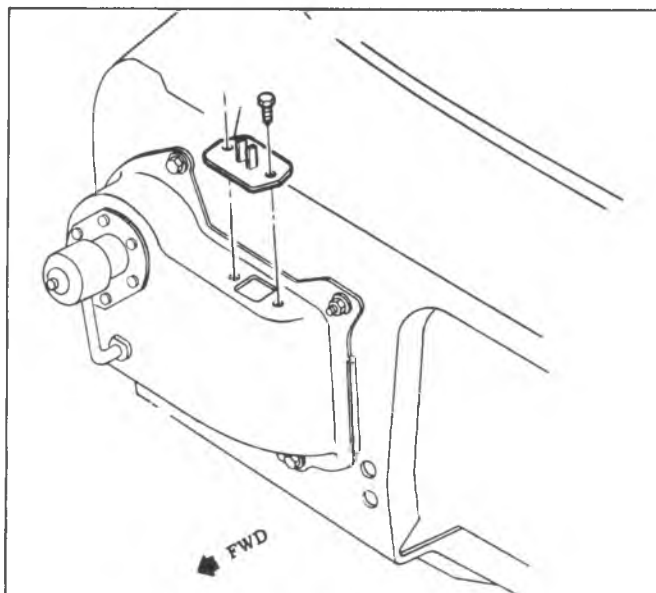


Fig. 1A-18--Resistor - G Models

AUXILIARY HEATER

INDEX

| | |
|--------------------------|-------|
| General Description..... | 1A-15 |
| Control..... | 1A-15 |
| Diagnosis | |
| On Vehicle Service..... | 1A-17 |
| Specifications..... | 1A-19 |

GENERAL DESCRIPTION

An auxiliary heater is available as a dealer installed accessory to provide additional heating capacity for the rearmost extremities of the G (05 and 06) models.

This unit operates entirely independent of the standard heater and is regulated through its own controls at the instrument panel.

This system consists of a separate core and fan unit mounted as shown in Fig. 1A-23.

Heater hoses extend from the unit to the front of the vehicle where they are connected to the standard heater hoses with "tees". An "on-off" vacuum operated water valve is installed in the heater core inlet line in the engine compartment. The purpose of the valve is to cut off coolant flow to the auxiliary core during warm weather and eliminate the radiant heat that would result.

CONTROLS

Two methods of control are employed with this system:

Water Valve (See Fig. 1A-11)

When heat is desired, and the fan switch is any position except off, a vacuum operated water valve controlled by the switch, opens the water line to permit hot water circulation through the heater core. In the OFF position the valve is closed to prevent unwanted heat during warm weather.

Fan Switch (Fig. 1A-20)

The three speed fan switch (LOW-MED-HI) is located in the instrument panel, to the right of the steering column.

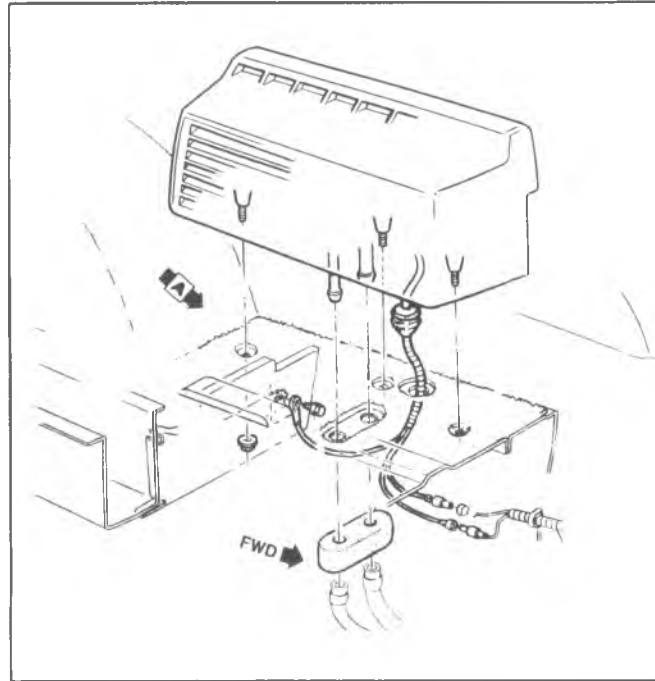


Fig. 1A-23--Auxiliary Heater - G Models

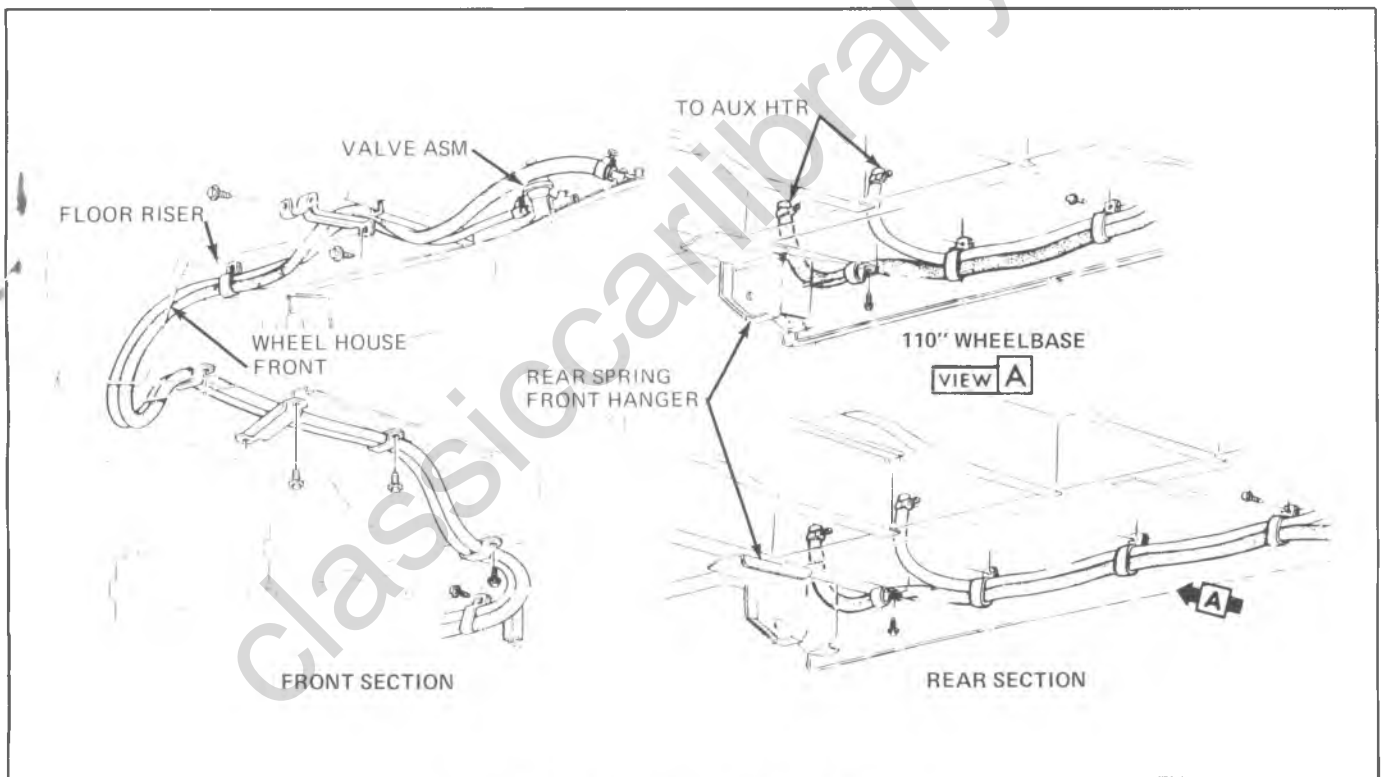


Fig. 1A-24--Auxiliary Heater Hose Routing

SPECIFICATIONS

| SECTION 1A | | | |
|------------------------|--------------|-------------------------|------------------------|
| HEATER | | | |
| | <u>Volts</u> | <u>Amps. (Cold)</u> | <u>RPM (Cold)</u> |
| Blower Motor | | | |
| C-K Models | 13.5 | 6.25 Max. | 2550 Min. 2950 Max. |
| G Models | 13.5 | 7.1 Max. | 2850 Min. 3250 Max. |
| Fuses | | | |
| C-K Models | | | 20 Amp. |
| G Models | | | 20 Amp. |
| AUXILIARY HEATER | | | |
| | <u>Volts</u> | <u>Amps. (Cold)</u> | <u>RPM (Cold)</u> |
| Blower Motor | 13.5 | 9.6 Max. | 2700 Min. |

classiccarlibrary.com

SECTION 1B

AIR CONDITIONING

NOTICE: When performing air conditioning diagnosis on Chevrolet vehicles equipped with a catalytic converter, it will be necessary to warm the engine to a normal operating temperature before attempting to idle the engine for periods greater than five (5) minutes. Once the choke is open and fast idle speed reduced to a normal idle, diagnosis and adjustments can be made.

CONTENTS

| | | | |
|---|-------|--|-------|
| General Description..... | 1B-1 | Fuse | 1B-42 |
| C60 System (C-K & G Models) | 1B-1 | C60 System--G Models..... | 1B-42 |
| Overhead Systems (C-K-G Models) | 1B-1 | Condenser..... | 1B-42 |
| Motor Home Chassis System..... | 1B-1 | A/C Air Distributor Duct | 1B-42 |
| System Control..... | 1B-5 | A/C Center and Right Dash Outlets, Heater, Air Distributor and Extension Ducts..... | 1B-42 |
| Diagnosis | 1B-11 | Heater Core Case and Core | 1B-42 |
| Leak Testing The Refrigerant System | 1B-12 | Expansion Valve..... | 1B-43 |
| Pressure Cycling System Diagnosis | 1B-15 | Blower Motor..... | 1B-43 |
| Compressor Diagnosis | 1B-15 | Evaporator Core..... | 1B-44 |
| Insufficient Cooling..... | 1B-15 | Temperature Door Cable..... | 1B-44 |
| Electrical System Diagnosis | 1B-19 | Control..... | 1B-44 |
| Evacuating and Charging Procedures..... | 1B-26 | Blower Switch | 1B-44 |
| Air Conditioning System Capacity | 1B-26 | Blower Motor Relay | 1B-44 |
| Checking Oil | 1B-27 | Resistors | 1B-44 |
| On Vehicle Service..... | 1B-26 | Blower Motor Relay | 1B-45 |
| Engine Idle Compensator | 1B-32 | Pressure Cycling Switch | 1B-47 |
| Compressor..... | 1B-32 | Vacuum Tank..... | 1B-47 |
| C60 System--C-K Models..... | 1B-34 | Circuit Breaker..... | 1B-47 |
| Condenser..... | 1B-34 | Overhead System--G Models..... | 1B-47 |
| Accumulator-All | 1B-34 | Dash Mounted System--Motor Home Units | 1B-52 |
| Blower Assembly | 1B-34 | Condenser..... | 1B-52 |
| Evaporator Core..... | 1B-35 | Receiver-Dehydrator | 1B-52 |
| Expansion Tube-All | 1B-35 | Sight Glass | 1B-53 |
| Selector Duct and Heater Core..... | 1B-35 | Blower-Evaporator Assembly | 1B-53 |
| Kick Panel Air Valve | 1B-35 | Blower Assembly | 1B-53 |
| Plenum Air Valve | 1B-35 | Expansion Valve, Evaporator Case or Core..... | 1B-53 |
| Control Assembly | 1B-35 | Thermostatic and/or Blower Switches..... | 1B-53 |
| Temperature Door Cable Adjustment | 1B-35 | Resistor..... | 1B-54 |
| Master Switch and/or Blower Switch | 1B-35 | Fuse | 1B-54 |
| Vacuum Tank..... | 1B-37 | Specifications | 1B-56 |
| Blower Resistor Unit | 1B-37 | Special Tools..... | 1B-57 |
| Blower Motor Relay | 1B-37 | | |
| Fuse | 1B-37 | | |
| Overhead System--C-K Models..... | 1B-38 | | |
| Rear Duct..... | 1B-38 | | |
| Blower Motor Resistor | 1B-38 | | |
| Blower Motor Assembly..... | 1B-38 | | |
| Expansion Valve..... | 1B-40 | | |
| Evaporator Core..... | 1B-41 | | |
| Blower Motor Switch..... | 1B-41 | | |

GENERAL DESCRIPTION

C60 A/C SYSTEM

Both the heating and cooling functions are performed by this system. Air entering the vehicle must pass through the cooling unit (evaporator) and through (or around) the heating unit, in that order, and the system is thus referred to as a "reheat" system.

The evaporator provides maximum cooling of the air passing through the core when the air conditioning system is calling for cooling.

On CK and G Series, compressor operation is controlled by a pressure sensing switch, located near the top of the accumulator. The switch responds to pressure changes to turn the compressor on or off, as required.

System operation is as follows:

Air, either outside air or recirculated air, enters the system and is forced through the system by the blower. As the air passes through the evaporator core, it receives maximum cooling if the air conditioning controls are calling for cooling. After leaving the evaporator, the air enters the Heater and Air Conditioner Selector Duct Assembly where, by means of diverter doors, it is caused to pass through or to bypass the heater core in the proportions necessary to provide the desired outlet temperature. Conditioned air then enters the vehicle through either the floor distributor duct or the dash outlets. When, during cooling operations, the air is cooled by the evaporator to below comfort level, it is then warmed by the heater to the desired temperature. During "heating only" operations, the evaporator will not be in operation and ambient air will be warmed to the desired level in the same manner.

AIR DISTRIBUTION OUTLETS

CK Series

The dash outlets are rectangular in design. The outlets can be rotated horizontally or vertically to direct air as desired. Under the left distributor duct is located a floor cooler which can be rotated to provide cooling air or shut off completely.

G-Van

The dash outlets are rectangular in design and can be rotated horizontally or vertically to direct air as desired. Foot coolers are provided on both driver and passenger side.

In the heater-defrost modes, the air conditioning outside air door is closed. The heater air door is open and outside air is allowed to pass through the heater core (receiving maximum heating) and is then directed into the passenger compartment through the heater and/or defroster outlets.

OVERHEAD SYSTEMS (C-K-G SERIES)

These systems (C69 on C-K-G Series) operate in conjunction with the C60 System--they do not operate independently. However, control of rear blower motor speed is possible even when the front system is off, thus, rear

air circulation without the refrigerant function may be had by operating the rear blower control switch.

These units are self contained, operating on inside (recirculated) air only. Air is drawn into the unit, passed through the evaporator core and then directed into the passenger compartment through the air distributor duct.

System control is through the front system. The only control on the overhead system is a three speed blower switch.

MOTOR HOME CHASSIS SYSTEM

This system performs the cooling functions only. When heating (above ambient temperatures) is desired, the vehicle heater must be used. When air conditioning is desired, the heater should be completely shut off.

This self-contained unit is bracket mounted to the dash by the body manufacturer. It operates on inside (recirculated) air only. Air is drawn into the unit, passed through the evaporator core (receiving maximum cooling) and then directed into the vehicle through adjustable outlets.

A thermostatic switch, located on the face plate is used to control compressor operation by sensing air temperature as it leaves the evaporator core.

System Components

Receiver-Dehydrator (Motor Home Chassis Models)

The receiver-dehydrator, serving as a reservoir for storage of high pressure liquid produced in the condenser, incorporates a screen sack filled with the dehydrating agent.

The receiver-dehydrator, used primarily as a liquid storage tank, also functions to trap minute quantities of moisture and foreign material which may have remained in the system after installation or service operations. A refrigerant sight glass is built into the receiver-dehydrator to be used as a quick check of the state and condition of charge of the entire system. The receiver-dehydrator is mounted near the condenser.

Sight Glass (Motor Home Chassis Models Only)

While having no real function to perform in the system, the sight glass is a valuable aid in determining whether or not the refrigerant charge is sufficient and for eliminating some guess work in diagnosing difficulties. The sight glass, is built into the receiver-dehydrator outlet connection and is designed and located so that a shortage of refrigerant at this point will be indicated by the appearance of bubbles beneath the glass. The dust cap provided should be kept in place when the sight glass is not in use.

Thermostatic Expansion Valve (Fig. 1B-2)

C-K and G Overhead, and Motor Home Chassis systems use a thermostatic expansion valve in place of a float system.

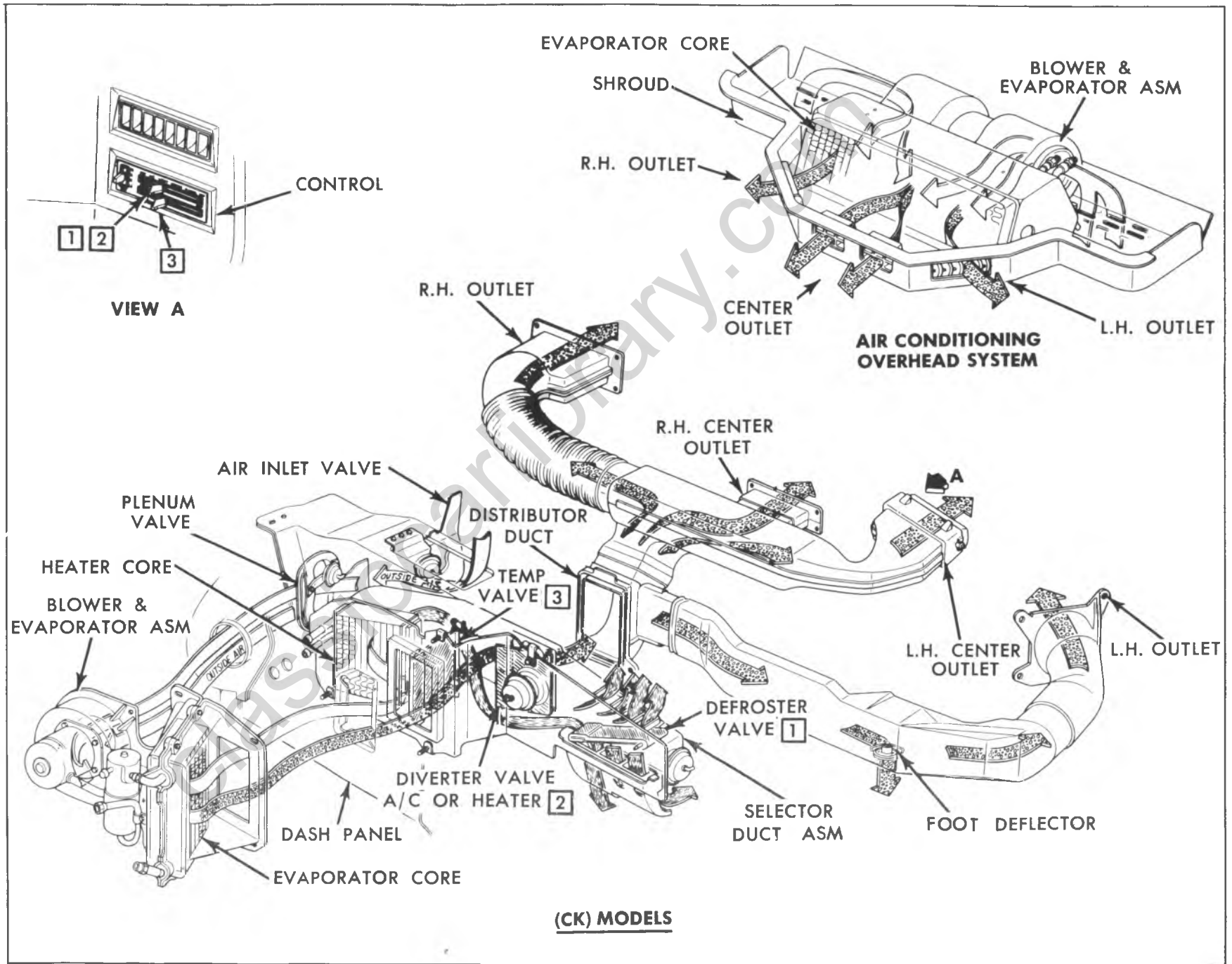


Fig. 1B-1--Airflow Chart - CK Models

(CK) MODELS

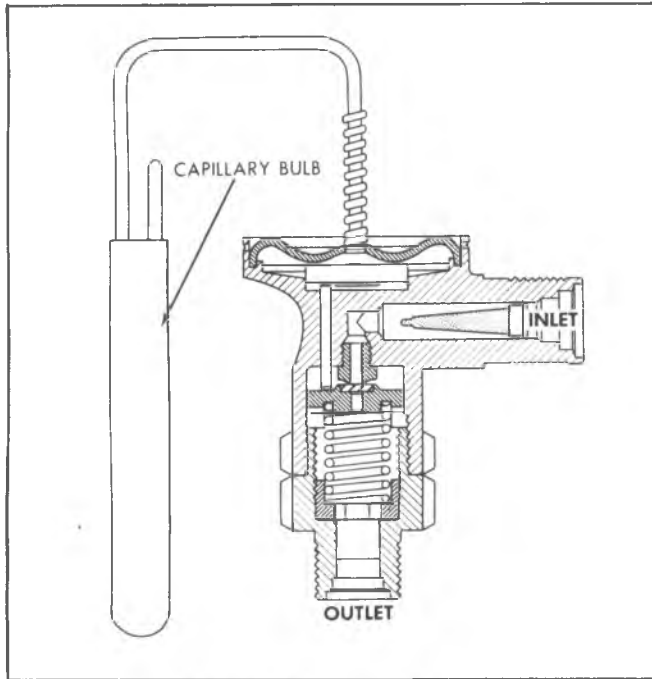


Fig. 1B-2-Expansion Valve

The valve consists primarily of the power element, body, actuating pins, seat and orifice. At the high pressure liquid inlet, is a fine mesh screen which prevents dirt, filings or other foreign matter from entering the valve orifice.

When the valve is connected in the system, high pressure liquid refrigerant enters the valve through the screen from the receiver-dehydrator or condenser and passes on to the seat and orifice. Upon passing through the orifice the high pressure liquid becomes low pressure liquid. The low pressure liquid leaves the valve and flows into the evaporator core where it absorbs heat from the evaporator core and changes to a low pressure vapor, and leaves the evaporator core as such. The power element bulb is clamped to the low pressure vapor line just beyond the outlet of the evaporator (fig. 1B-2).

Accumulator-C-K, G Series (Fig. 1B-3)

The accumulator is located at the evaporator outlet. Its most important function is not to "accumulate" although this too is important. Its primary function is to separate liquid retained from vapor, retain the liquid and release the vapor to the compressor.

Thus, in an ideal accumulator with no oil bleed hole, and in a correctly designed system, no liquid can get to the compressor.

In an actual accumulator, there is some entrained liquid in the vapor stream to the compressor.

Flow out of the accumulator to the compressor consists mostly of vapor with the addition of entrained liquid and liquid flow through the oil bleed hole.

A bag of desiccant (dehydrating agent) is located in the accumulator as a moisture collecting device.

There is no sight glass in the accumulator-clutch cycle system.

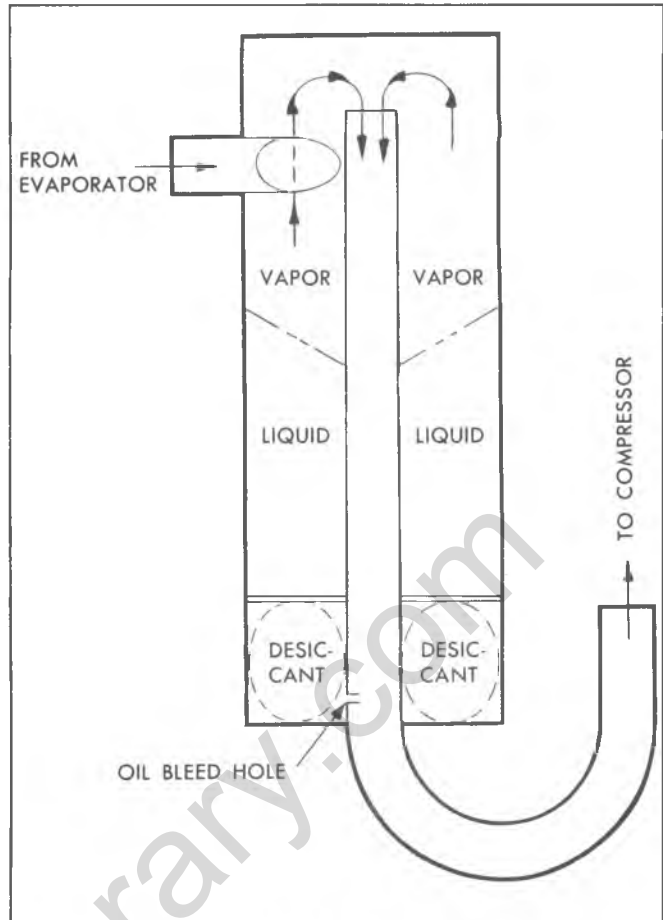


Fig. 1B-3-Accumulator-CK and G Series With C60

Expansion Tube-C-K, G Series

Expansion tube flow rate depends on pressure difference and on subcooling; however, the flow rate is more sensitive to subcooling.

The expansion tube is located in the evaporator inlet line (fig. 1B-4).

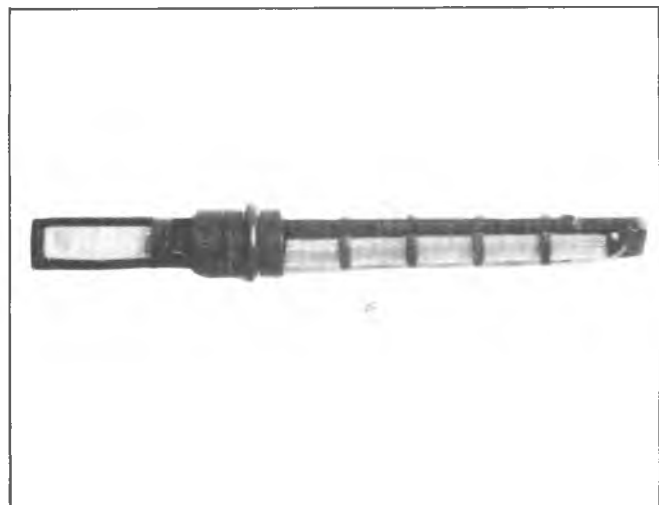


Fig. 1B-4-Expansion Tube

Thermostatic Switch - Motor Home Chassis**Units Only**

System temperature is controlled by running the compressor intermittently, automatically turning it on and off as necessary to maintain proper temperatures. The compressor is started and stopped through the use of an electro-magnetic clutch and a thermostat affected by variations in temperature.

The thermostatic switch incorporates a metallic tube which contains a highly expansive gas. This tube is located in the air stream as it leaves the evaporator. The tube leads to a bellows operated switch. As air temperature rises, the gas inside the tube expands, travels through the tube to the bellows and closes the electrical switch which engages the compressor clutch.

As soon as the compressor starts running, the temperature begins to go down. As the air being cooled gets colder, the gas in the thermostatic tube begins to reduce the pressure on the switch bellows. This allows the switch contact to open and the compressor clutch disengages.

Pressure Cycling Switch - Low Refrigerant Charge Protection System-CK&G Series

Low refrigerant charge protection is afforded by the pressure cycling switch as a secondary function. When refrigerant pressure drops below a certain predetermined level, the switch opens the compressor clutch circuit, shutting the system off.

SYSTEM CONTROLS**C60 SYSTEM (C-K and G SERIES) - FIG. 1B-5****System Operation - CK Truck**

System operation is as illustrated in Fig. 1B-6.

Vacuum Schematic - CK Truck

The CK Truck air conditioning vacuum schematic is illustrated in Figure 1B-7.

System Operation - G Models

System operation is illustrated in Fig. 1B-8.

Vacuum Schematic - G Models

G Model vacuum schematic is illustrated in Fig. 1B-9.

OVERHEAD SYSTEM (C-K and G SERIES)

This system operates in conjunction with the C60 System. Since refrigerant flow is controlled by the front system, the only control provided for on the overhead system is a three-speed fan switch (LOW, MED, HI). The fan switch is mounted in the instrument panel, to the right of the steering column (fig. 1B-10).

In the OFF position, the blower is inoperative; however, refrigerant is circulating in the system if the C60 System is ON. In any of the three blower positions (LOW, MED, HI), the blower will be operative regardless if the Four-Season System is ON.

To obtain maximum cooling, the Four-Season System should be on A/C, temperature lever on COLD, blower switch on HI and the overhead unit blower switch should be on HI.

OVERHEAD SYSTEM (G MODELS)

This system operates in conjunction with the C60 system. Since refrigerant is controlled by the C60 system, the only control provided on the rear overhead system is a three speed blower switch (fig. 1B-11).

In the OFF position, the blower is inoperative; however, refrigerant is circulating in the system if the front system is ON. To operate the rear overhead system, simply select the desired blower speed (LOW, MED, HI).

When air circulation only is desired, the rear A/C blower motor may be operated independent of the front A/C blower motor and without the cooling function.

DASH MOUNTED UNIT (MOTOR HOME CHASSIS UNITS)

This system is self contained and is mounted below the dash by the body manufacturer. System controls consist of an AIR knob and TEMP knob located in the center of the unit face plate (fig. 1B-12).

Air Knob

Turning the AIR knob clockwise operates a three speed (LOW-MED-HI) blower motor.

Temp Knob

This knob is used to control the degree of cooling desired. Fully clockwise at CITY provides maximum cooling, while turning the knob to HIWAY provided adequate cooling for highway operation.

Reduced cooling could be encountered when operating at highway speeds with the controls at the CITY setting. The heater must be fully off to obtain maximum cooling.

CCOT SYSTEM COMPONENTS

CCOT Refrigerant System components and refrigerant flow are illustrated in Figure 1B-13. Chart 1B-1 shows pressure temperature relationships of R-12.

Refrigerant and Oil Capacities

Refrigerant and oil charge is shown in Chart 1B-2.

PRECAUTIONS IN HANDLING REFRIGERANT-12

1. Do not leave drum of Refrigerant-12 uncapped.
2. Do not carry any container of Refrigerant-12 in passenger compartment of car.
3. Do not subject any container of Refrigerant-12 to high temperature.
4. Do not weld or steam clean on or near system.
5. Do not fill drum of Refrigerant-12 completely.
6. Do not discharge vapor into area where flame is exposed.
7. Do not expose eyes to liquid.

CAUTION: If Refrigerant-12 liquid should strike the eye, call a doctor immediately.

a. DO NOT RUB THE EYE. Splash the affected area with quantities of cold water to gradually get the temperature above the freezing point.

b. The use of an antiseptic oil is helpful in providing a protective film over the eyeball to reduce the possibility of infection.

CONDITIONED AIR IS DIRECTED THRU W/SHLD, I.P. & FLOOR DISTRIBUTOR OUTLETS

CONDITIONED AIR IS DIRECTED THRU I.P. OUTLETS

IN THIS MODE LEVER POSITION, MAXIMUM COOLING IS OFFERED WITH THE CONDITIONED AIR DISTRIBUTED THRU I.P. OUTLETS AT "HI" BLOWER SPEED.

LIMITED AIR FLOW DISTRIBUTED THRU I.P. OR W/SHLD. OUTLETS WHENEVER IGNITION IS IN A "RUN" OR "ON" POSITION.

A NON-COMPRESSOR OPERATING POSITION, WITH OUTSIDE AIR DELIVERED THRU I.P. OUTLETS

A NON-COMPRESSOR OPERATING POSITION, WITH OUTSIDE AIR DISTRIBUTED ABOUT 80% TO FLOOR & 20% TO W/SHLD

CONDITIONED AIR DISTRIBUTED ABOUT 80% TO W/SHLD. & 20% TO FLOOR

4 SPEED FAN CONTROL LEVER

VACUUM OPERATED SYSTEM SELECTOR (MODE) LEVER

TEMPERATURE LEVER POSITION REGULATES TEMPERATURE OF THE AIR ENTERING THE PASSENGER COMPARTMENT BY CABLE OPERATION OF THE HEATER CORE TEMPERATURE DOOR



Fig. 1B-5-C60 System Controls (C-K and G Series)

SYSTEM OPERATION - CK TRUCK

| SELECTOR LEVER POSITION | COMPRESSOR | BLOWER SPEEDS AVAIL | AIR SOURCE | AIR ENTERS VEHICLE | HEATER A/C DOOR-OPEN TO: | HEATER DEFROSTER DOOR-OPEN TO: |
|-------------------------|------------|---------------------|------------|------------------------|--------------------------|--------------------------------|
| OFF | OFF | LOW | OUTSIDE | FLOOR OUTLETS | HEATER | HEATER |
| MAX A/C | ON | HI | INSIDE% | DASH OUTLETS | A/C | HEATER |
| NORM A/C | ON | ALL | OUTSIDE | DASH OUTLETS | A/C | HEATER |
| BI-LEVEL | ON | ALL | OUTSIDE | FLOOR AND DASH OUTLETS | A/C & HEATER | HEATER |
| VENT | OFF | ALL | OUTSIDE | DASH OUTLETS | A/C | HEATER |
| HTR | OFF | ALL | OUTSIDE | FLOOR OUTLETS | HEATER | HEATER |
| DEF | ON | ALL | OUTSIDE | DEFROST OUTLETS | HEATER | DEFROST |

NOTE % 100% Inside air is not available, some bleed through of outside air is allowed.

Fig. 1B-6--System Operation - CK Truck

c. Obtain treatment as soon as possible, from a doctor or eye specialist.

Should liquid R-12 come into contact with the skin, the injury should be treated the same as (skin which has been frostbitten or frozen.

All Refrigerant-12 drums are shipped with a heavy metal screw cap. The purpose of the cap is to protect the valve and safety plug from damage. It is good practice to replace the cap after each use of the drum for the same reason.

If it is necessary to transport or carry any container of Refrigerant-12 in a car, keep it in the luggage compartment. If the drum is exposed to the radiant heat of the sun, the resultant increase in pressure may cause the safety plug to release or the drum to burst.

Welding or steam cleaning near any of the refrigerant lines or components of the air conditioning system could build up dangerous and damaging pressures in the system.

If the occasion arises to fill a small Refrigerant-12 drum from a large one, never fill the drum completely. Space should always be allowed above the liquid for

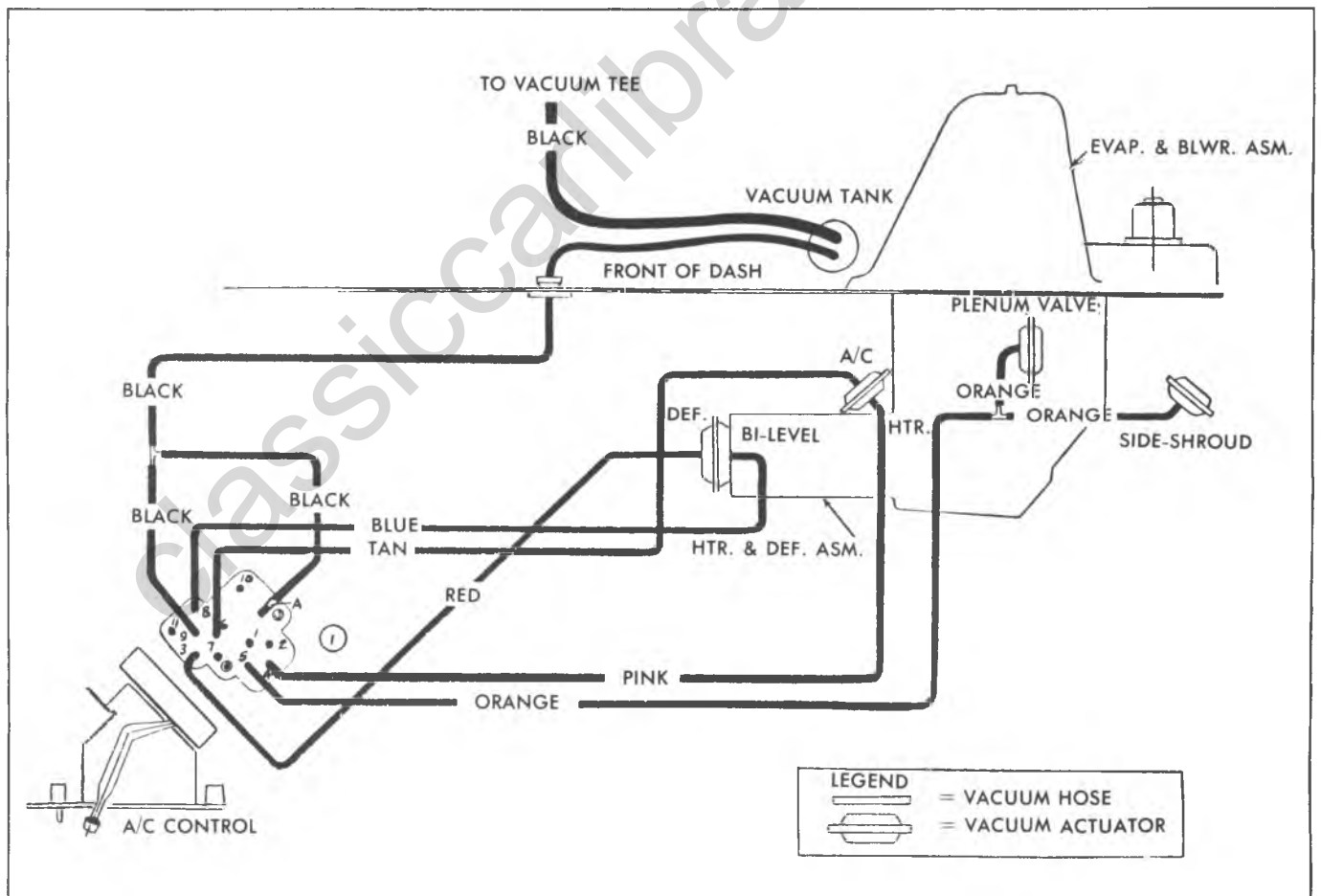


Fig. 1B-7--Air Conditioning Vacuum Schematic - CK Truck

| COMPRESSOR | | BLOWER SPEEDS AVAIL | AIR SOURCE | AIR ENTERS VEHICLE | HEATER DEFROSTER DOOR | HEATER A/C DOOR |
|------------|-----|---------------------|------------|----------------------------------|-----------------------|-----------------|
| OFF | OFF | NONE | OUTSIDE | FLOOR OUTLETS | OPEN TO | OPEN TO |
| | | | | | HEATER | HEATER-DEF |
| MAX | ON | ALL | INSIDE % | DASH OUTLETS | HEATER | A/C |
| NORM | ON | ALL | OUTSIDE | DASH OUTLETS | HEATER | A/C |
| BI LEV | ON | ALL | OUTSIDE | DASH OUTLETS FLOOR OUTLETS | HEATER | A/C & HEATER |
| VENT | OFF | ALL | OUTSIDE | DASH OUTLETS | HEATER | A/C |
| HEATER | OFF | ALL | OUTSIDE | BLEED TO DEFROST & FLOOR OUTLETS | HEATER | HEATER |
| DEFR | ON* | ALL | OUTSIDE | DEFROST OUTLETS | DEFROST | HEATER |

*PROVIDED COMPRESSOR PRESSURE SWITCH CLOSED

Fig. 1B-8--System Operation - G Models

expansion. If the R-12 drum were completely full and the temperature was increased, tremendous hydraulic force could be developed.

CAUTION: Avoid breathing smoke and fumes produced by the burning of the Refrigerant-12. Such fumes may be hazardous.

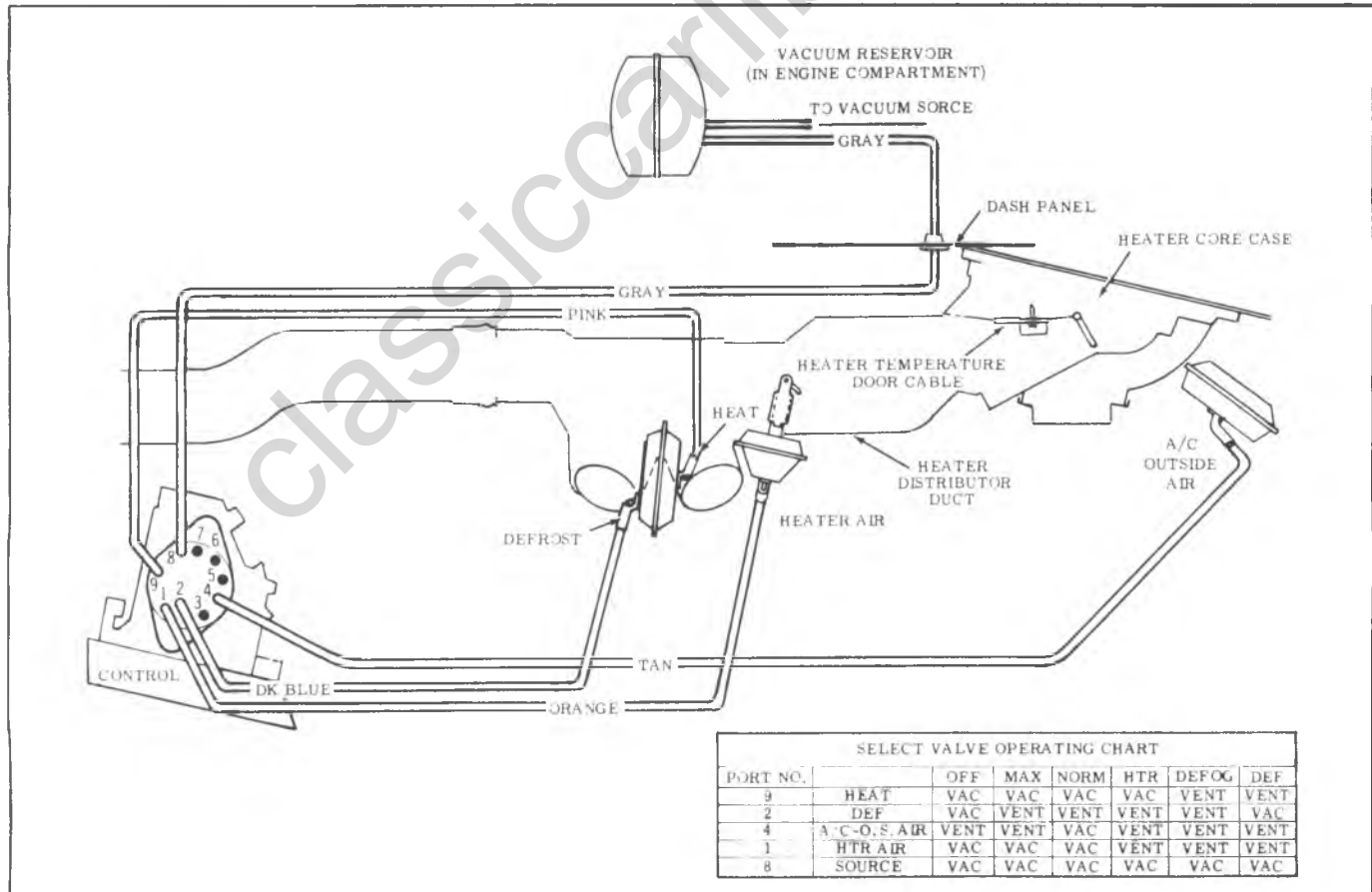


Fig. 1B-9--Vacuum Schematic - G Models



Fig. 1B-10—Overhead Unit Control (C-K Series)

One of the most important cautions concerns the eyes. Any liquid Refrigerant-12 which may accidentally escape is approximately 21°F (-6°C) below zero. If liquid R-12 should touch the eyes, serious damage could result. Always wear goggles to protect the eyes when opening refrigerant connections.

PRECAUTIONS IN HANDLING REFRIGERANT LINES AND FITTINGS

- All metal tubing lines should be free of kinks, because of the restriction that kinks will offer to the flow of refrigerant-12. The refrigeration capacity of the entire system can be greatly reduced by a single kink.
- The flexible hose lines should never be bent to a radius of less than 4 times the diameter of the hose.
- The flexible hose lines should never be allowed to come within a distance of 63.5 mm (2-1/2") of the exhaust manifold.
- Flexible hose lines should be inspected at least once a year for leaks or brittleness. If found brittle or leaking they should be replaced with new lines.
- Use only new lines that have been sealed during storage.

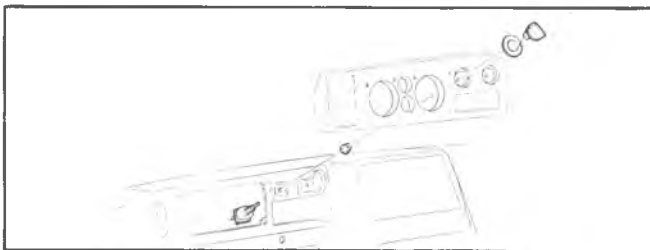


Fig. 1B-11—Overhead Unit Control (G Models)

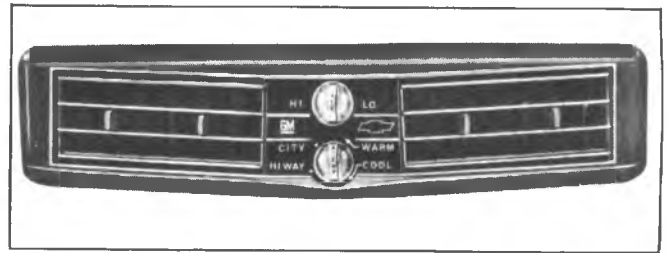


Fig. 1B-12—Motor Home Unit Control

● Always wear safety goggles when opening refrigerant lines.

● When disconnecting any fitting in the refrigeration system, the system must first be discharged of all refrigerant-12. However, proceed very cautiously regardless of gage readings. Open very slowly, keeping face and hands away so that no injury can occur if there happens to be liquid refrigerant-12 in the line. If pressure is noticed when fitting is loosened, allow it to bleed off as described under discharging, adding oil, evacuating and charging procedures for C.C.O.T. A/C systems.

● In the event any line is opened to atmosphere, it should be immediately capped or taped to prevent entrance of moisture and dirt which can cause internal compressor wear or plugged. lines, condenser and evaporator core, expansion tubes (orifice) or compressor inlet screens.

● The use of the proper wrenches when making condenser and connections on "O" ring fittings is important. The use of improper wrenches may damage the connection. The opposing fitting should always be backed up with a wrench to prevent distortion of connecting lines or components. When connecting the flexible hose connections it is important that the swaged fitting and the flare nut, as well as the coupling to which it is attached, be held at the same time using three different wrenches to prevent turning the fitting and damaging the ground seat.

● "O" rings and seats must be in perfect condition. A burr or piece of dirt may cause a refrigerant leak. Always replace the o-ring when a correction has been broken. When replacing the o-ring, first dip it in clean 525 viscosity refrigeration oil.

● Where steel to aluminum corrections are being made, use torque for aluminum tubing (see Chart 1B-9).

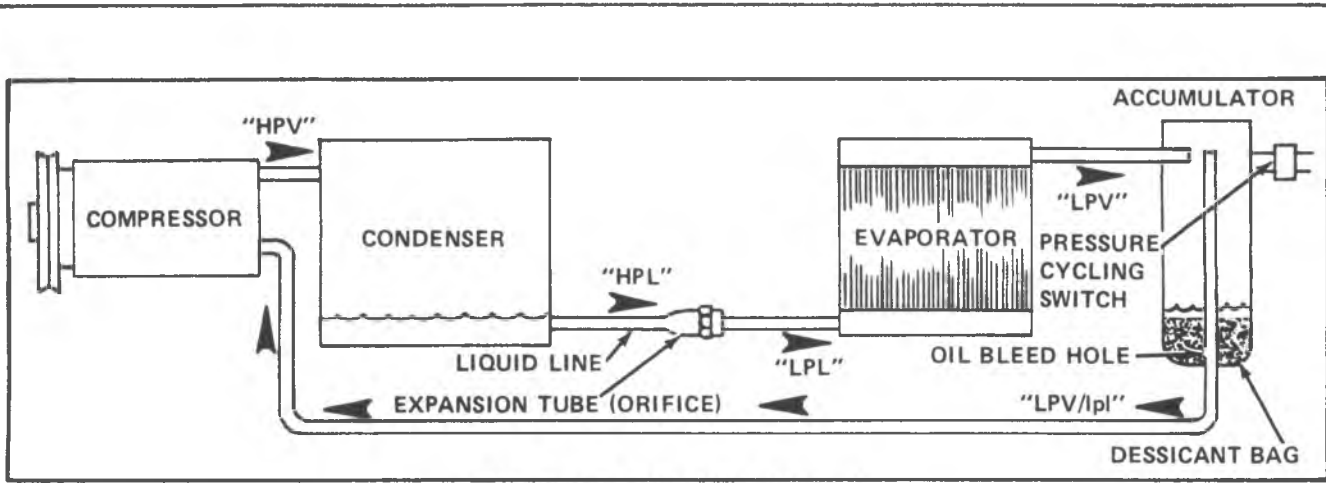
MAINTAINING CHEMICAL STABILITY IN

THE REFRIGERATION SYSTEM

The efficient operation of the air conditioning refrigeration system is dependent upon the pressure - temperature relationship of pure Refrigerant-12 (see Chart 1B-1). As long as the system contains pure R-12 (plus a certain amount of 525 Viscosity Compressor oil which mixes with the R-12, it is considered to be chemically stable.

When foreign materials, such as dirt, air or moisture are allowed to get into the system, they will change the pressure - temperature relationship of the Refrigerant-12. Thus, the system will no longer operate at the proper pressures and temperatures and the efficiency will decrease.

The following general practices should be observed to ensure chemical stability in the system:



PRESSURE CYCLING SYSTEM

- "HPV" - HIGH PRESSURE VAPOR LEAVING COMPRESSOR.
- "HPL" - VAPOR IS COOLED DOWN BY CONDENSER AIR FLOW AND LEAVES AS HIGH PRESSURE LIQUID.
- "LPL" - ORIFICE METERS THE LIQUID R-12, INTO EVAPORATOR, REDUCING ITS PRESSURE, AND WARM BLOWER AIR ACROSS EVAPORATOR CORE CAUSES BOILING OFF OF LIQUID INTO VAPOR.
- "LPV" - LEAVES EVAPORATOR AS LOW PRESSURE VAPOR AND RETURNS WITH THE SMALL AMOUNT OF . . .
- "lpl" - . . . LOW PRESSURE LIQUID THAT DIDN'T BOIL OFF COMPLETELY BACK TO THE COMPRESSOR TO BE COMPRESSED AGAIN.

Fig. 1B-13--CCOT System Components

1. Whenever it becomes necessary to disconnect a refrigerant connection, wipe away any dirt or oil at and near the connection to eliminate the possibility of dirt entering the system. Both sides of the connection should be capped, plugged or taped as soon as possible to prevent the entrance of dirt, foreign material and moisture. (It must be remembered that all air contains moisture. Air that enters any part of the refrigerant system will carry moisture with it and the exposed surfaces will collect the moisture quickly.)

2. Keep tools clean and dry. This includes the manifold Gage set and replacement parts.

3. When adding 525 viscosity refrigerant oil (see ADDING OIL in the "Discharging, Adding Oil, Evacuating and Charging Procedures for C.C.O.T. A/C Systems"), the container/transfer tube through which the oil will flow should be exceptionally clean and dry due to the fact that refrigeration oil is as moisture-free as it is possible to make it.

| REFRIGERANT — 12 | | (° F)(° C) | | (PSIG)(kPa) | | (° F)(° C) | | (PSIG)(kPa) | |
|------------------------|--|------------|--------|----------------------|-------|------------|-------|-------------|--------|
| PRESSURE — TEMPERATURE | | | | O(ATMOSPHERIC O(kPa) | | | | | |
| RELATIONSHIP | | | | PRESSURE) | | | | | |
| | | -21.7 | -29.8C | 0 | 0 | 55 | 12.7C | 52.0 | 358.5 |
| | | | | | | 60 | 15.5C | 57.7 | 397.8 |
| | | -20 | -28.8C | 2.4 | 16.5 | 65 | 18.3C | 63.7 | 439.2 |
| | | -10 | -23.3C | 4.5 | 31.0 | 70 | 21.1C | 70.1 | 482.7 |
| | | -5 | -20.5C | 6.8 | 46.9 | 75 | 23.8C | 76.9 | 530.2 |
| | | 0 | -17.7C | 9.2 | 63.4 | 80 | 26.6C | 84.1 | 579.9 |
| | | 5 | -15.0C | 11.8 | 81.4 | 85 | 29.4C | 91.7 | 632.3 |
| | | 10 | -12.2C | 14.7 | 101.4 | 90 | 32.2C | 99.6 | 686.7 |
| | | 15 | -9.4C | 17.7 | 122.0 | 95 | 35.0C | 108.1 | 745.3 |
| | | 20 | -6.6C | 21.1 | 145.5 | 100 | 37.7C | 116.9 | 806.0 |
| | | 25 | -3.8C | 24.6 | 169.6 | 105 | 40.5C | 126.2 | 870.2 |
| | | 30 | -1.1C | 28.5 | 196.5 | 110 | 43.3C | 136.0 | 937.7 |
| | | 32 | 0C | 30.1 | 207.5 | 115 | 46.1C | 146.5 | 1010.1 |
| | | 35 | 1.6C | 32.6 | 224.8 | 120 | 48.8C | 157.1 | 1083.2 |
| | | 40 | 4.4C | 37.0 | 255.1 | 125 | 51.6C | 167.5 | 1154.9 |
| | | 45 | 7.2C | 41.7 | 287.5 | 130 | 54.4C | 179.0 | 1234.2 |
| | | 50 | 10.0C | 46.7 | 322.0 | 140 | 60.0C | 204.5 | 1410.0 |

The table below indicates the pressure of Refrigerant — 12 at various temperatures. For instance, a drum of Refrigerant at a temperature of 80°F (26.6°C) will have a pressure of 84.1 PSI (579.9 kPa). If it is heated to 125°F (51.6°C), the pressure will increase to 167.5 PSI (1154.9 kPa). It also can be used conversely to determine the temperature at which Refrigerant — 12 boils under various pressures. For example, at a pressure of 30.1 PSI (207.5 kPa), Refrigerant — 12 boils at 32°F (0°C).

| Refrigerant Charge | | |
|--------------------|-----------------|-----------------|
| | Overhead System | C60 System |
| C-K Models | 5 lbs.-4 oz. | 3 Lbs. - 12 oz. |
| G Models | 5 lbs. | 3 lbs. |

4. When it is necessary to "open" an A/C system, have everything needed ready and handy so that as little time as possible will be required to perform the operation. Do not leave the A/C system open any longer than is necessary.

5. Any time the A/C system has been "opened", it should be properly Evacuated before Re-Charging with Refrigerant-12 according to the DISCHARGING, ADDING OIL, EVACUATING & CHARGING PROCEDURES FOR C.C.O.T. A/C SYSTEMS following in the Service Manual.

REFRIGERANT CHARGING PRECAUTIONS

Normally, air conditioning systems are charged

making use of the Charging Station J-23500-01 which uses the 13.60 kg (30 lb.) of Refrigerant-12. 420 ml (14 oz) Refrigerant-12 disposable cans or R-12 drums are also used. DISCHARGING, ADDING OIL, EVACUATING AND CHARGING PROCEDURES FOR C.C.O.T. SYSTEMS are described on following pages in the Service Manual.

With R-12 Drum or 14 oz. Disposable Can Charging:

- Do not Charge while compressor system is hot.
- ALWAYS CHARGE THROUGH LOW-SIDE OF A/C SYSTEM (low-side fitting is found on Accumulator).
- NEVER CONNECT ON HIGH-SIDE of A/C system or to any system having a pressure higher than indicated on the R-12 container.
- When opening valves designed for use with container, follow manufacturer's directions carefully.
- Always use pressure gages before and during Charging.
- Empty R-12 container completely before disposing.
- See Disposable Can CHARGING procedures later in Service Manual.

With J-23500-01 Charging Station:

- Follow manufacturer's directions carefully with three exceptions:
 - HI-PRESSURE VALVE OF GAGE SET SHOULD BE CLOSED AT ALL TIMES DURING CHARGING
 - DO NOT CONNECT HIGH PRESSURE LINE TO A/C SYSTEM
 - ALL EVACUATING AND CHARGING OF A/C SYSTEM MUST BE PERFORMED THROUGH LOW PRESSURE VALVE/LINE TO LOW-SIDE SERVICE FITTING ON ACCUMULATOR

DIAGNOSIS

TESTING THE REFRIGERANT SYSTEM

If a malfunction in the refrigerant system is suspected due to abnormal system pressures, check the following:

1. Check outer surfaces of radiator and condenser cores to be sure they are not plugged with dirt, leaves or other foreign material. Be sure to check between the condenser and radiator as well as the outer surfaces.
2. Restrictions or kinks in evaporator core or condenser core, hoses, tubes, etc.
3. Refrigerant leaks.
4. Check all air ducts for leaks or restrictions. Air restriction may indicate a plugged (or partially plugged) evaporator core.
5. Compressor clutch slippage.
6. Improper drive belt tension.
7. Plugged accumulator, expansion tube (orifice) or compressor suction inlet screen.
8. Excessive moisture in refrigerant system.
9. Start properly operating, tuned engine and set up A/C system according to appropriate PERFORMANCE

CONDITIONS stated in C.C.O.T. System Diagnostic Procedure (Chart 1B-3 & Chart 1B-4).

LEAK TESTING THE REFRIGERANT SYSTEM

Whenever a refrigerant leak is suspected in the system or a service operation performed which results in disturbing lines or connections, it is advisable to test for leaks. Common sense should be used in performing any refrigerant leak test, since the necessity and extent of any such test will, in general, depend upon the nature of the complaint and the type of service performed on the system.

J-6084 Leak Detector

Tool J-6084 is a propane gas-burning torch which is used to locate a leak in any part of the system. Refrigerant gas drawn into the sampling tube attached to the torch will cause the torch flame to change color in proportion to the size of the leak. Propane gas fuel cylinders used with the torch are readily available commercially throughout the country.

CAUTION: Do not use lighted detector in any place where combustible or explosive gases, dusts or vapors may be present.

Operating Detector

1. Determine if there is sufficient refrigerant in the system for leak testing.
2. Open control valve only until a low hiss of gas is heard, then light gas at opening in chimney.
3. Adjust flame until desired volume is obtained. This is most satisfactory when blue flame is approximately 3/8" above reactor plate. The reaction plate will quickly heat to a cherry red.
4. Explore for leaks by moving the end of the sampling hose around possible leak points in the system. Do not pinch or kink hose.

Since R-12 is heavier than air, it is good practice to place open end of sampling tube immediately below point being tested, particularly in cases of small leaks.

CAUTION: Do not breathe the fumes that are produced by the burning of R-12 gas in the detector flame, since such fumes can be toxic in large concentrations.

5. Watch for color changes. The color of the flame which passes through the reaction plate will change to green or yellow-green when sampling hose draws in very small leaks of R-12. Large leaks will be indicated by a change in color to a brilliant blue or purple; when the sampling hose passes the leaks, the flame will clear to an almost colorless pale-blue again. Observations are best made in a semi-

darkened area. If the flame remains yellow when unit is removed from leak, insufficient air is being drawn in or the reaction plate is dirty.

A refrigerant leak in the high pressure side of the system may be more easily detected if the system is operated for a few minutes, then shut off and checked immediately (before system pressures equalize). A leak on the low pressure side may be more easily detected after the engine has been shut off for several minutes (system pressures equalized); this applies particularly to the front seal.

PRESSURE CYCLING CCOT SYSTEM - C60, CK and G MODELS,

Compressor clutch cycling on CK&G Series C60 CCOT AC Systems is accomplished through the use of a pressure sensing switch, (See Figure 1B-21 & 1B-22) located near the top of the accumulator. The switch performs two functions in the system. In addition to cycling the compressor on and off to control refrigerant flow, the switch shuts off the compressor clutch when pressure falls to a predetermined level, indicating low refrigerant charge in the system.

When diagnosis (See Chart 1B-3 and 1B-4) indicates replacement of the switch is necessary, it should be noted that it will not normally be necessary to discharge the A/C system, as the pressure switch fitting on the accumulator is equipped with a schrader type valve.

When replacing the pressure cycling switch, a new oiled "O" ring must be installed and the switch must be torqued to 10 N·m (7.5 ft. lb.). Do not exceed this torque as the threads in the accumulator may be stripped.

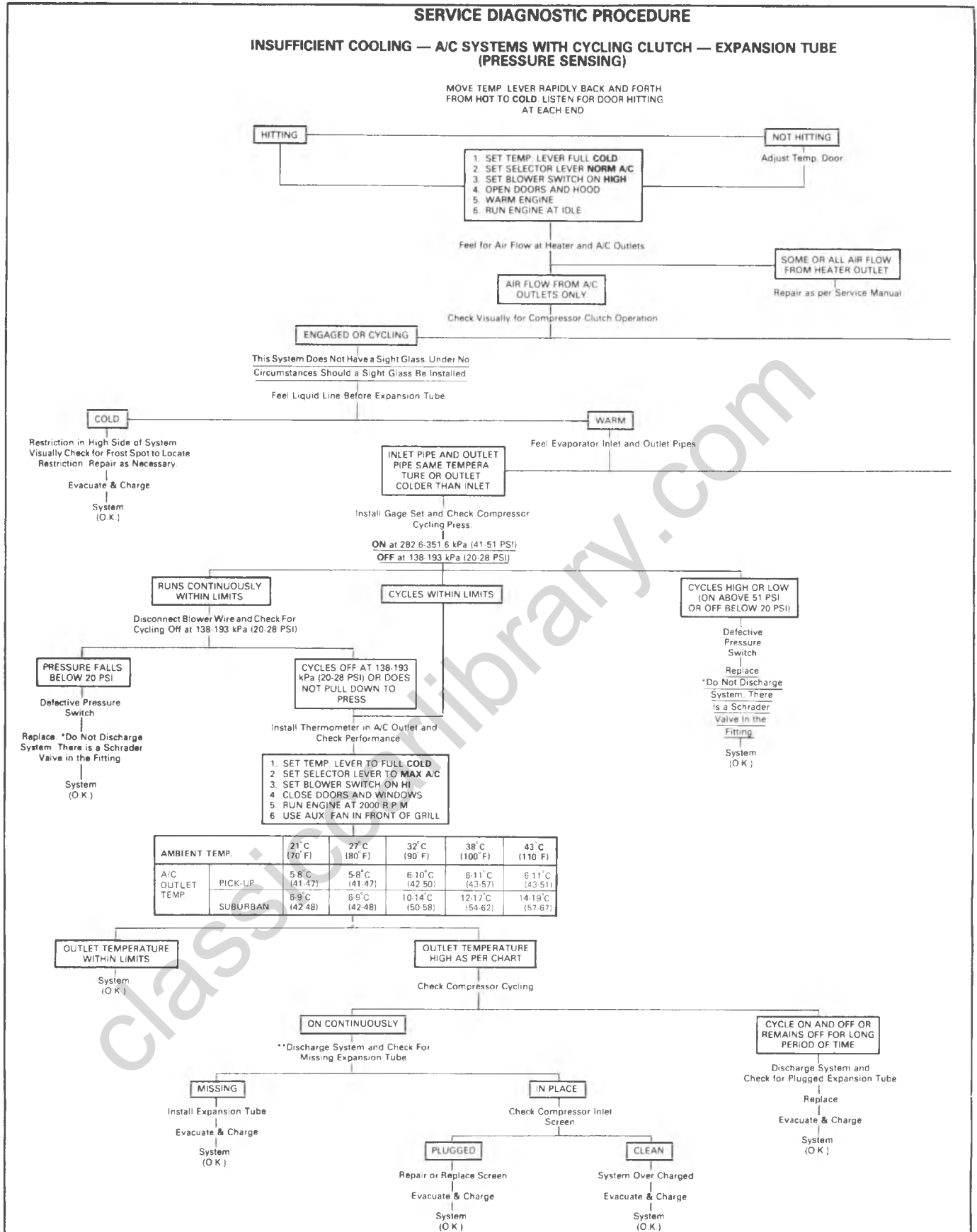


Chart 1B-3--Pressure Cycling CCOT System Diagnosis

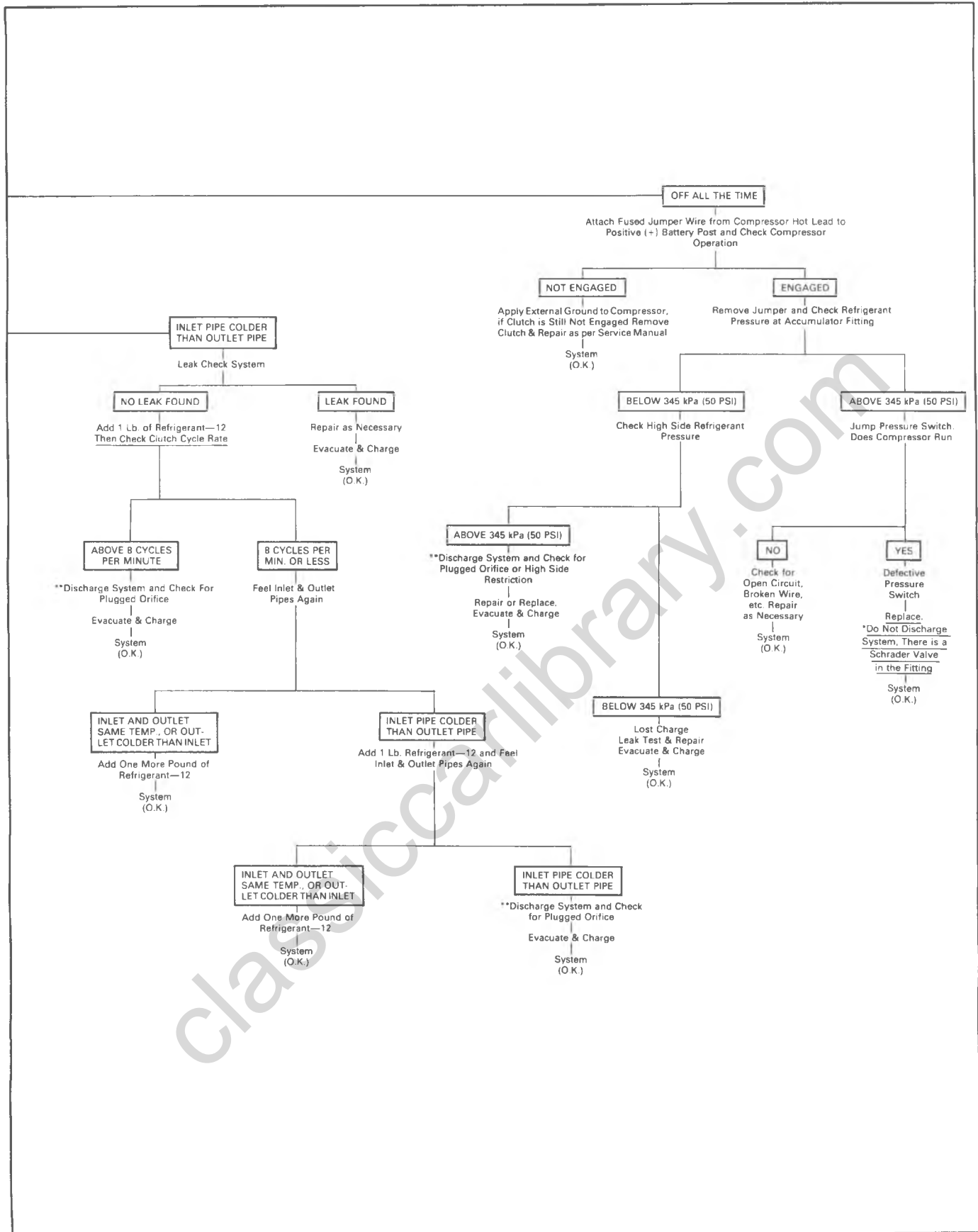


Chart 1B-4--Pressure Cycling CCOT System Diagnosis

ELECTRICAL/VACUUM TROUBLE DIAGNOSIS

When diagnosing problems in the electrical and vacuum systems of the air conditioning system, consult electrical wiring diagrams and vacuum diagrams.

Ports on rotary vacuum valves are illustrated in a manner to provide simplicity in following vacuum schematic lines but are numbered in consecutive order on the actual valve.

Operational Test

To aid in determining whether or not the air conditioning electrical, air, vacuum and refrigeration systems are operating properly and efficiently, a table of performance characteristics is shown in Chart 1B-3.

1. Operation of the air conditioning blower at all four speeds and engagement of the compressor clutch would indicate that electrical circuits are functioning properly.

2. The same hand-felt temperature of the evaporator inlet pipe AND the accumulator can surface of an operating system would indicate a properly charged Refrigeration-12 system.

3. Operation of the A/C control selector (mode) lever to distribute air from designed outlets would indicate proper vacuum and diaphragm function.

VACUUM SYSTEM DIAGNOSIS

(C-K-G C60 SYSTEM)

Start the engine and allow it to idle - move the selector lever to each position and refer to the vacuum diagrams and operational charts for proper airflow, air door functioning and vacuum circuits. If air flow is not out of the proper outlets at each selector lever position, then proceed as follows:

1. Check for good hose connections--at the vacuum actuators, control head valve, reservoir, tees, etc.

2. Check the vacuum source circuit as follows:

Install vacuum tee and gage (with restrictor) at the vacuum tank outlet (see Vacuum Diagram). Idle the engine and read the vacuum (a normal vacuum is equivalent to manifold vacuum) at all selector lever positions.

a. Vacuum Less Than Normal At All Positions -

Remove the tee and connect the vacuum gage line directly to the tank - read the vacuum. If still low, then the problem lies in the feed circuit, the feed circuit to the tank or in the tank itself. If vacuum is now normal, then the problem lies downstream.

b. Vacuum Less Than Normal at Some Positions -

If vacuum was low at one or several of the selector lever positions, a leak is indicated in these circuits.

c. Vacuum Normal at All Positions -;

If vacuum was normal and even at all positions, then the malfunction is probably caused by improperly connected or plugged lines or a defective vacuum valve or valves.

3. Specific Vacuum Circuit Check

Place the selector lever in the malfunctioning position and check for vacuum at the pertinent vacuum actuators. If vacuum exists at the actuator but the door does not move,

then the actuator is defective or the door is mechanically bound. If low or no vacuum exists at the actuator, then the next step is to determine whether the cause is the vacuum harness or the vacuum valve. Check the vacuum harness first.

4. Vacuum Harness Circuit Check

a. Disconnect the vacuum harness at the control head.

b. The black line (#1) should show engine vacuum - if not, trace back through connector to vacuum tank.

c. To check any individual circuit place the selector lever at the involved circuit position and check for vacuum presence.

VACUUM AND WIRING DIAGRAMS

Refer to Figures 1B-14 thru 1B-22.

INSUFFICIENT COOLING "QUICK-CHECK" PROCEDURE

The following C.C.O.T. "Hand-Feel" procedure can be used to quickly determine whether or not the A/C system has the proper charge of Refrigerant-12 (providing ambient temperature is above 70°F (21°C). This check can be made in a matter of minutes, simplifying system diagnosis by pinpointing the problem to the amount of R-12 charge in the system or by eliminating this possibility from the over-all checkout.

1. Engine must be warm (CHOKE OPEN and OFF FAST IDLE SPEED CAM).

2. Hood and body doors open.

3. Selector lever set at NORM.

4. Temperature lever at COLD.

5. Blower on HI.

6. Normal engine idle.

7. "Hand-Feel" temperature of evaporator inlet pipe AND accumulator can surface with compressor engaged.

a. BOTH SAME TEMPERATURE AND SOME DEGREE COOLER THAN AMBIENT--Proper condition: check for other problems (see A/C System Diagnostic Procedure).

b. INLET PIPE COOLER than accumulator surface low refrigerant charge.

● Add slight amounts (1/4 lbs.) of refrigerant UNTIL BOTH feel the same temperature. Allow stabilization time between additions.

● Then add 480 ml (14 oz.) (1 can) additional refrigerant.

c. INLET PIPE HAS FROST ACCUMULATION--Accumulator surface warmer; proceed as in Step b above.

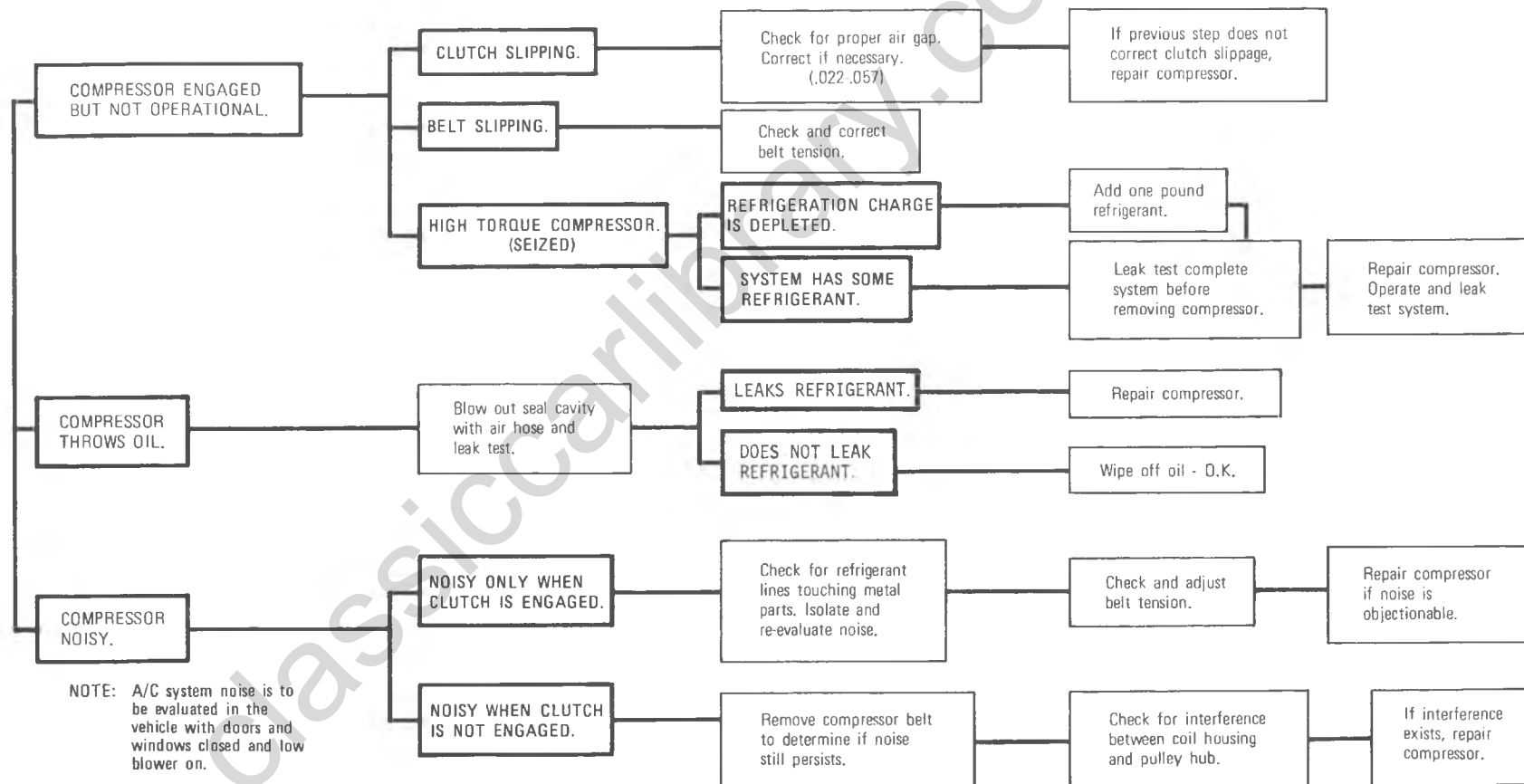
Engine Idle Compensator

On V8 Engines, with factory installed air conditioning systems, the compensator is located within the carburetor and is accessible when the engine air cleaner is removed.

All compensators are factory set and non adjustable.

A malfunctioning unit should be replaced.

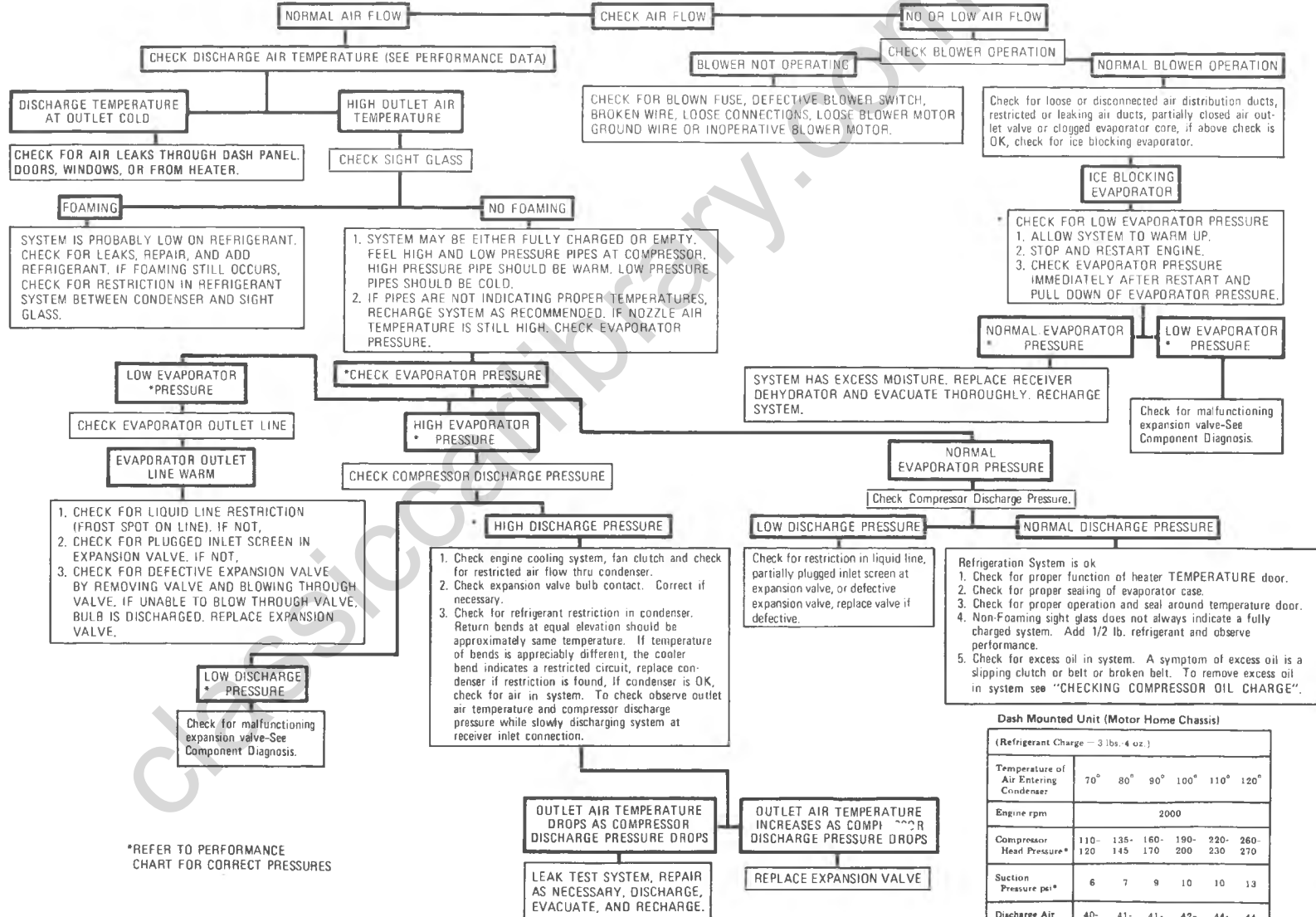
COMPRESSOR DIAGNOSIS



NOTE: A/C system noise is to be evaluated in the vehicle with doors and windows closed and low blower on.

INSUFFICIENT COOLING DIAGNOSIS CHART DASH MOUNTED UNIT (MOTOR HOME CHASSIS UNITS)

- The following procedures should be applied before performance testing an A/C System.
1. Check for proper belt installation and tension with J-23600.
 2. Check for proper clutch coil terminal connector installation.
 3. Check for clutch air Gap (.022 - .057).
 4. Check for broken, burst, or cut hoses. Also check for loose fittings on all components.
 5. Check for condenser air blockage due to foreign material.
 6. Check for proper air ducting hose connections.
 7. Check heater temperature door adjustment, adjust if incorrect.
 8. Check evaporator sealing for air leak, repair if leaking.
 9. Install pressure gages and thermometer and make performance test.

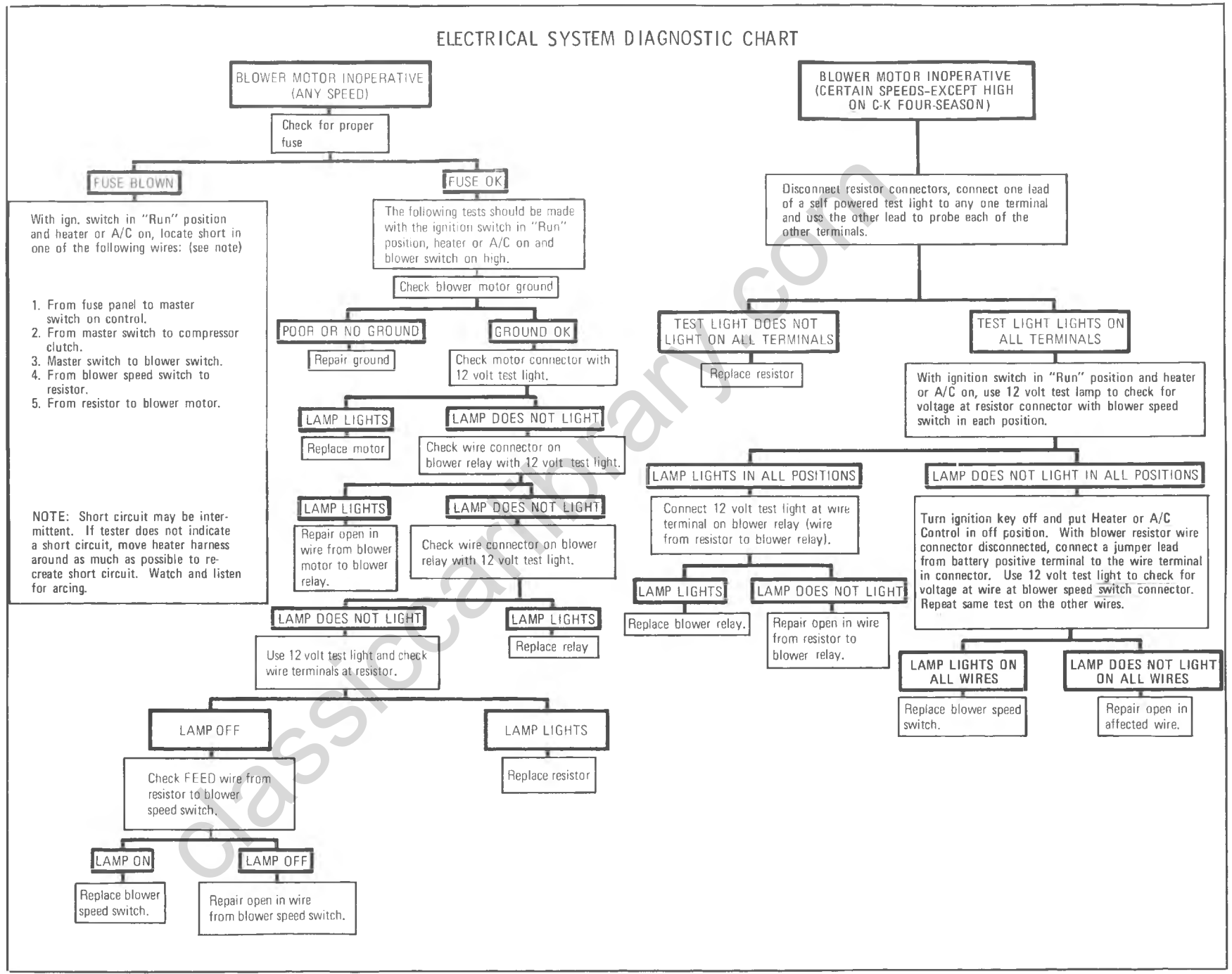


Dash Mounted Unit (Motor Home Chassis)

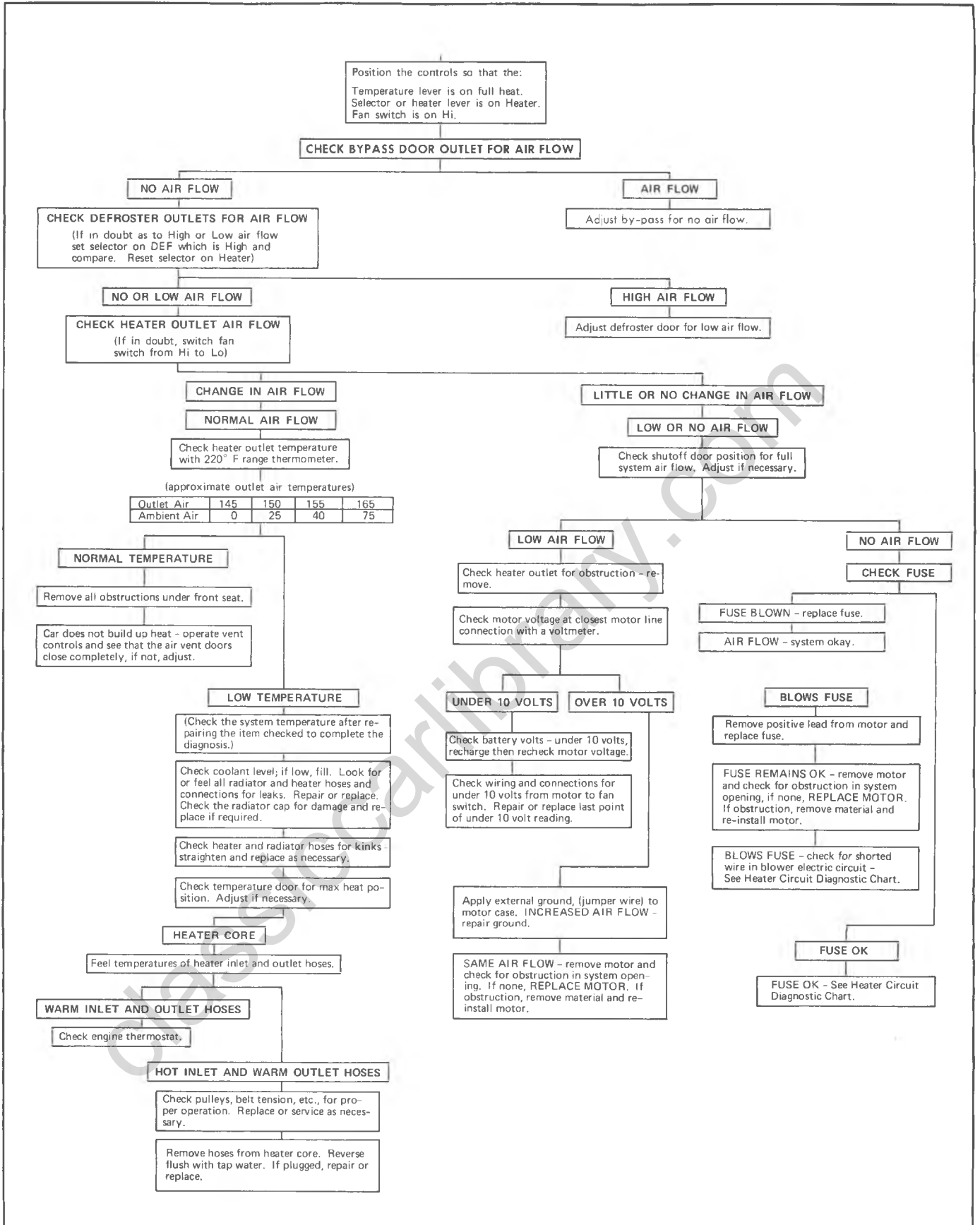
| (Refrigerant Charge - 3 lbs. 4 oz.) | | | | | | |
|---------------------------------------|---------|---------|---------|---------|---------|---------|
| Temperature of Air Entering Condenser | 70° | 80° | 90° | 100° | 110° | 120° |
| Engine rpm | 2000 | | | | | |
| Compressor Head Pressure* | 110-120 | 135-145 | 160-170 | 190-200 | 220-230 | 260-270 |
| Suction Pressure psi* | 6 | 7 | 9 | 10 | 10 | 13 |
| Discharge Air Temperature* | 40-45 | 41-46 | 41-46 | 42-47 | 44-45 | 44-49 |

*Just prior to compressor clutch disengagement.

ELECTRICAL SYSTEM DIAGNOSTIC CHART



NOTE: Short circuit may be intermittent. If tester does not indicate a short circuit, move heater harness around as much as possible to re-create short circuit. Watch and listen for arcing.



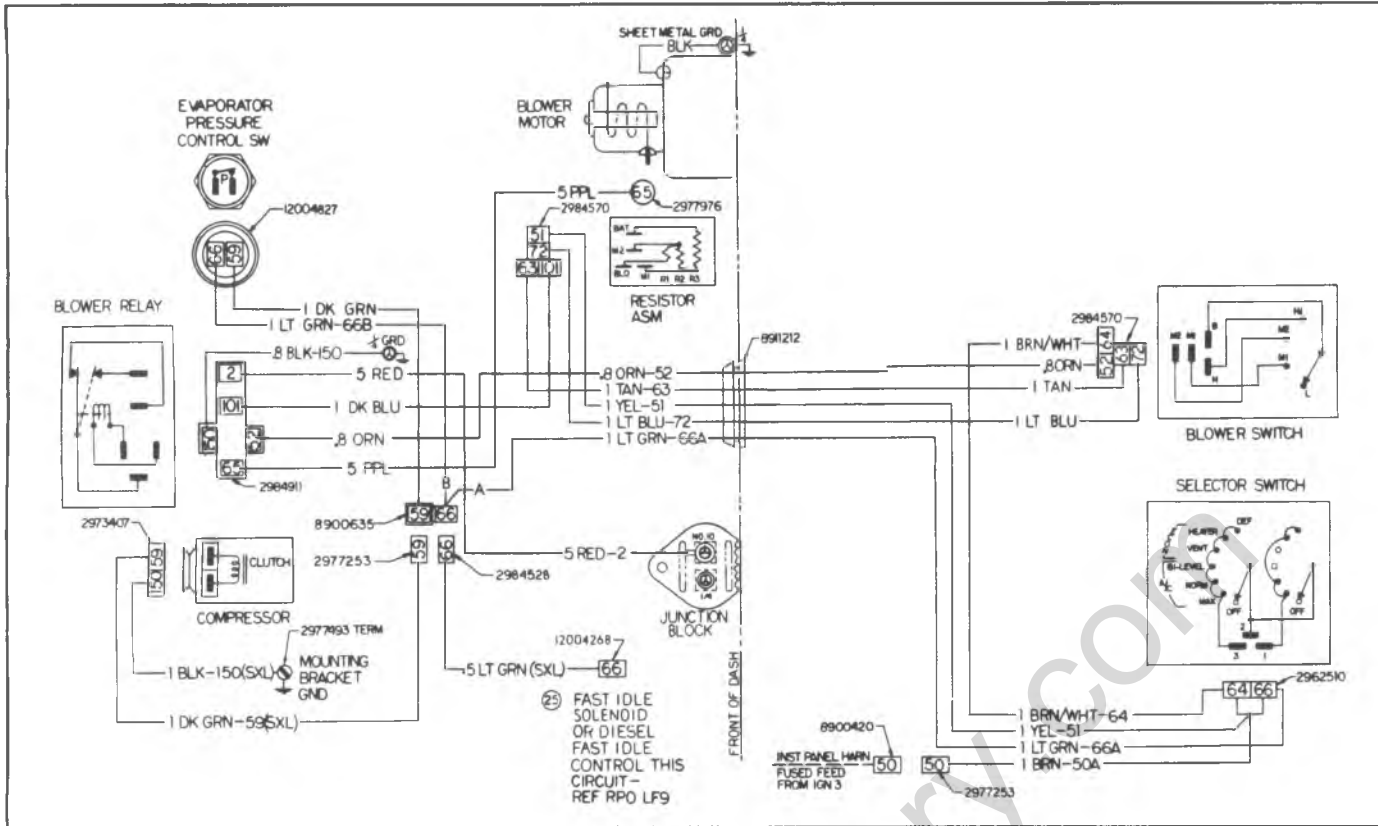


Fig. 1B-14--C60 System Wiring Diagram (C-K Series)

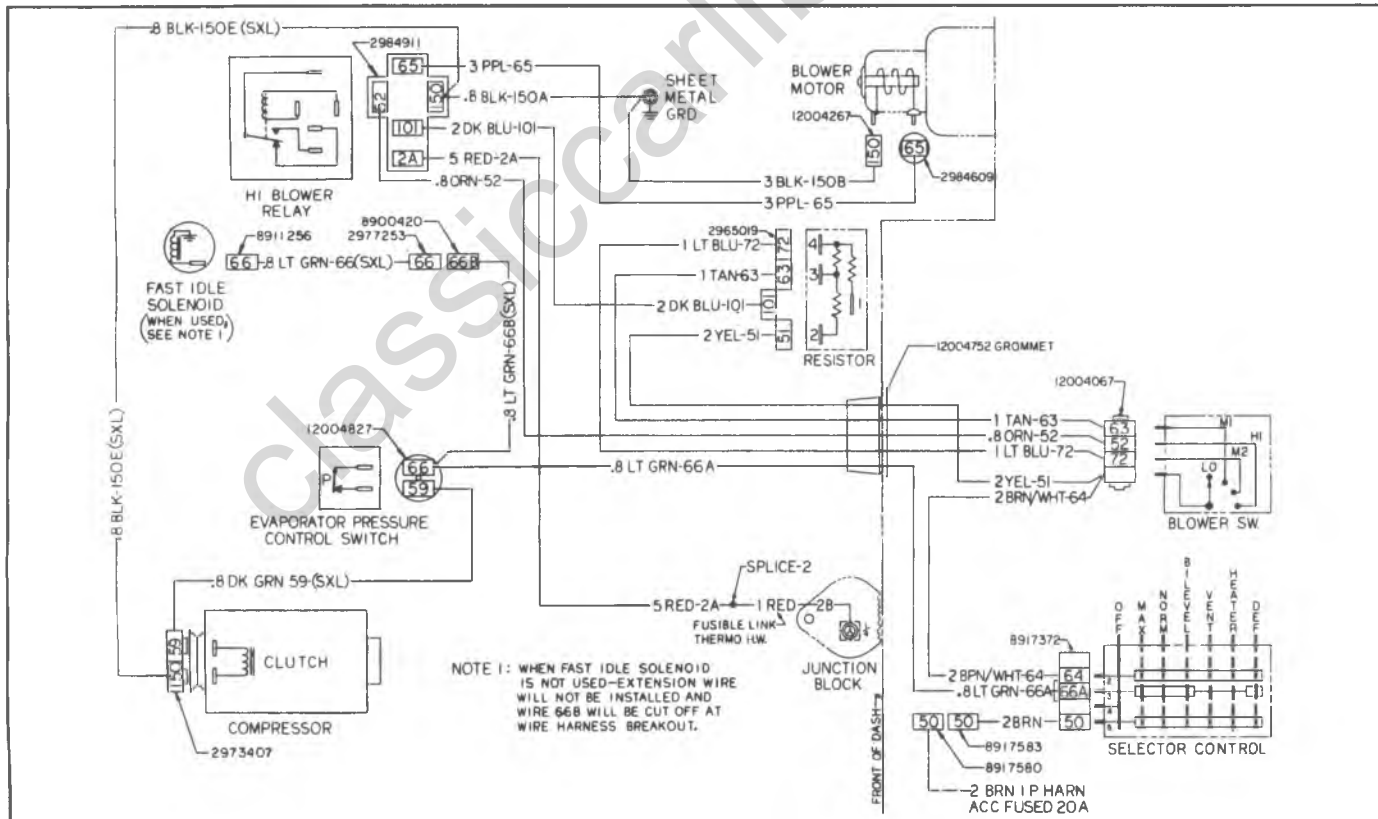
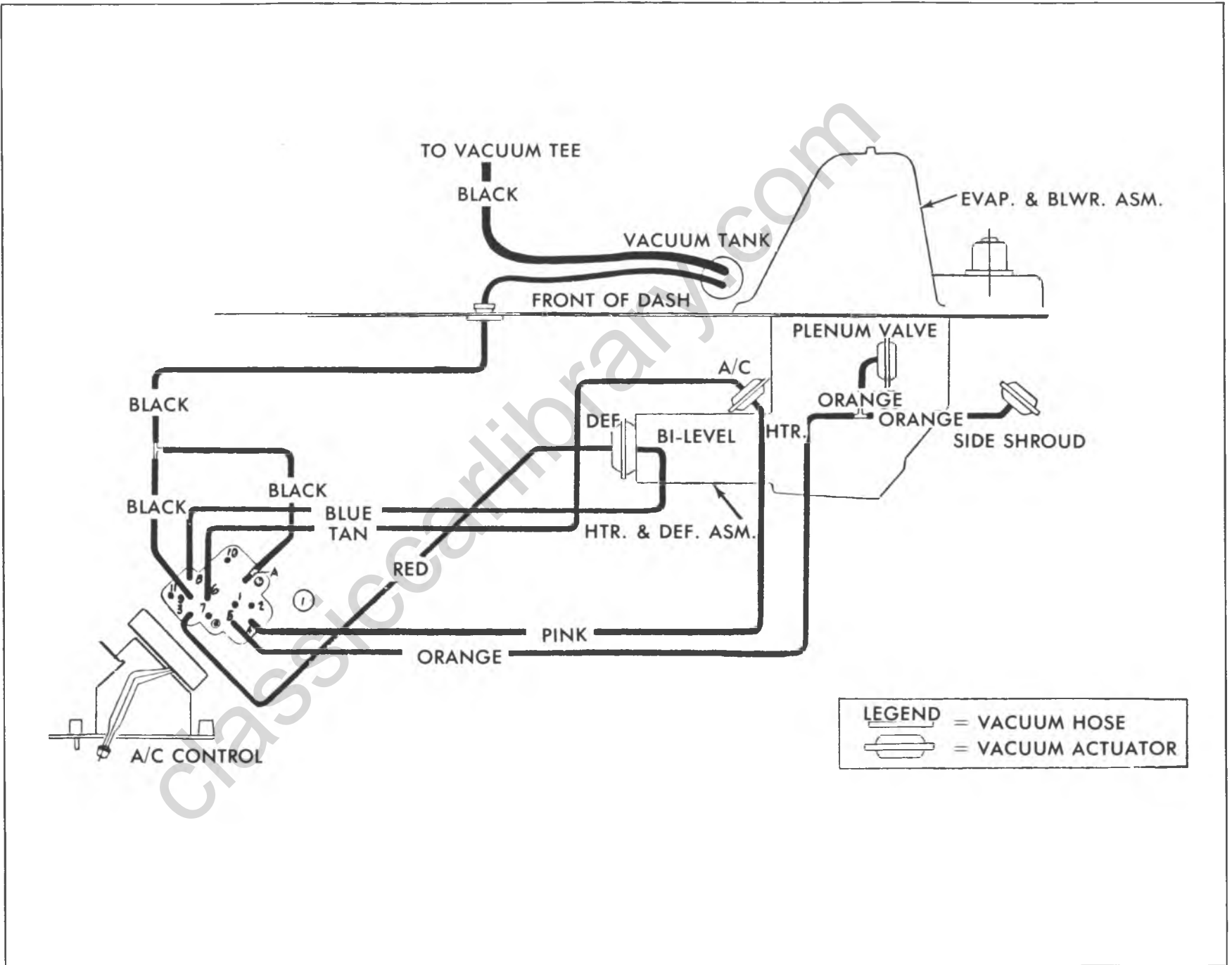


Fig. 1B-15--C60 System Wiring Diagram (G Series)

Fig. 1B-16—C60 System Vacuum Diagram (C-K Series)



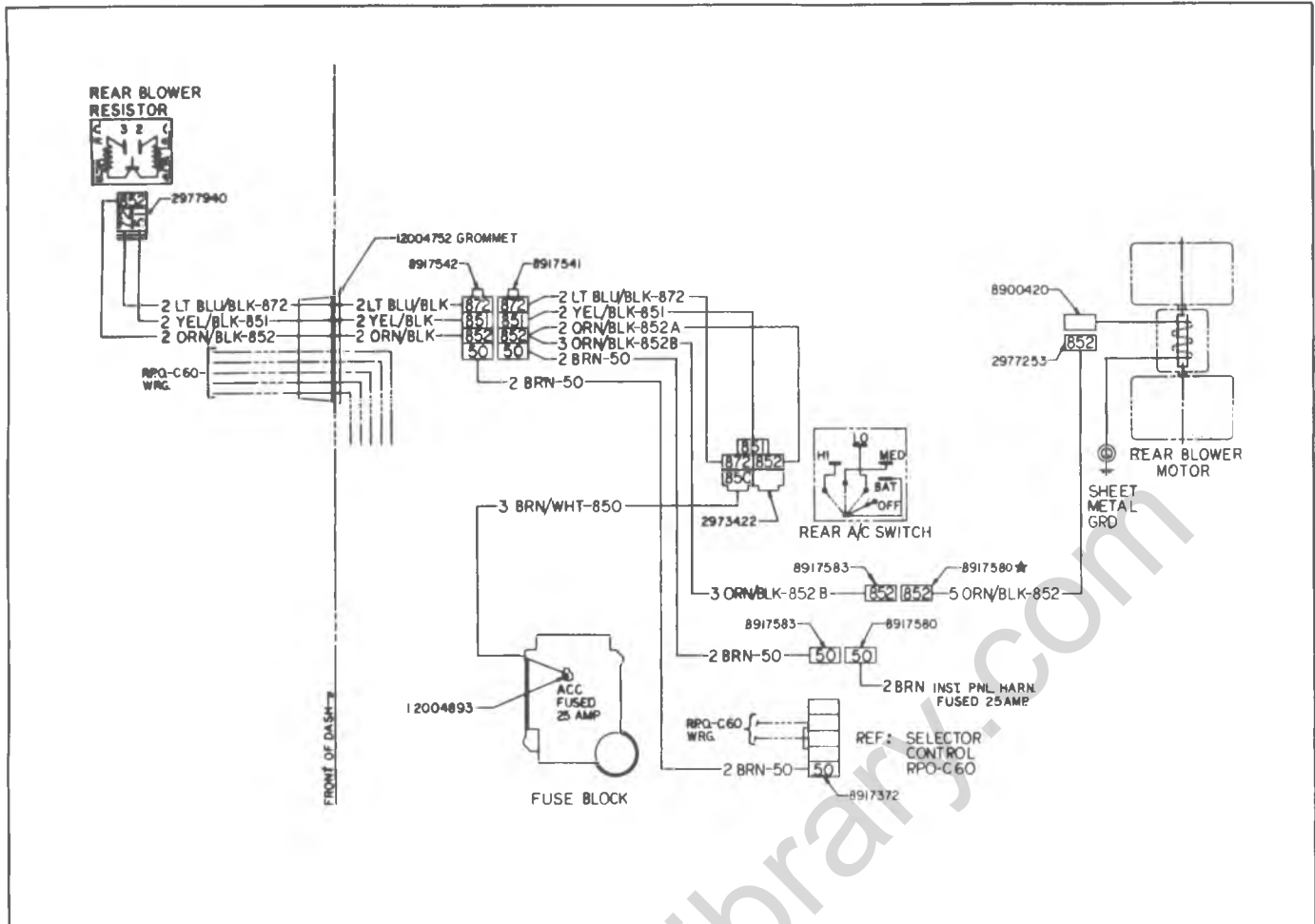


Fig. 1B-17—Overhead Systems Wiring Diagrams-All

SPECIFIC COMPONENT DIAGNOSIS

The following is a description of the type of symptom each refrigerant component will evidence if a defect occurs:

COMPRESSOR

A compressor defect will appear in one of four ways: Noise, seizure, leakage, or low discharge pressure.

NOTICE: Resonant compressor noises are not cause for alarm; however, irregular noise or rattles may indicate broken parts or excessive clearances due to wear. To check seizure, de-energize the magnetic clutch and check to see if drive plate can be rotated. If rotation is impossible, compressor is seized (See "False Compressor Seizure"). To check for a leak, refer to leak testing. Low discharge pressure may be due to a faulty internal seal of the compressor, or a restriction in the compressor.

Low discharge pressure may also be due to an insufficient refrigerant charge or a restriction elsewhere in the system. These possibilities should be checked prior to servicing the compressor. If the compressor is inoperative, but is not seized, check to see if current is being supplied to the magnetic clutch coil terminals.

CONDENSER

A condenser may be defective in two ways: it may leak, or it may be restricted. A condenser restriction will result in excessive compressor discharge pressure. If a partial restriction is present, sometimes ice or frost will form immediately after the restriction as the refrigerant expands after passing through the restriction. If air flow through the condenser or radiator is blocked, high discharge pressures will result. During normal condenser operation, the outlet pipe will be slightly cooler than the inlet pipe.

RECEIVER-DEHYDRATOR - MOTOR HOME CHASSIS

A defective receiver-dehydrator may be due to a restriction inside the body of the unit. A restriction at the inlet to the receiver-dehydrator will cause high head pressures. Outlet tube restrictions will be indicated by low head pressures and little or no cooling. An excessively cold receiver-dehydrator outlet may be indicative of a restriction.

EXPANSION VALVE

A malfunction of the expansion valve will be caused by one of the following conditions: valve stuck open, valve stuck closed, broken power element, a restricted screen or an improperly located or installed power element bulb. The first three conditions require valve replacement. The last two may be corrected by replacing the valve inlet screen and by properly installing the power element bulb.

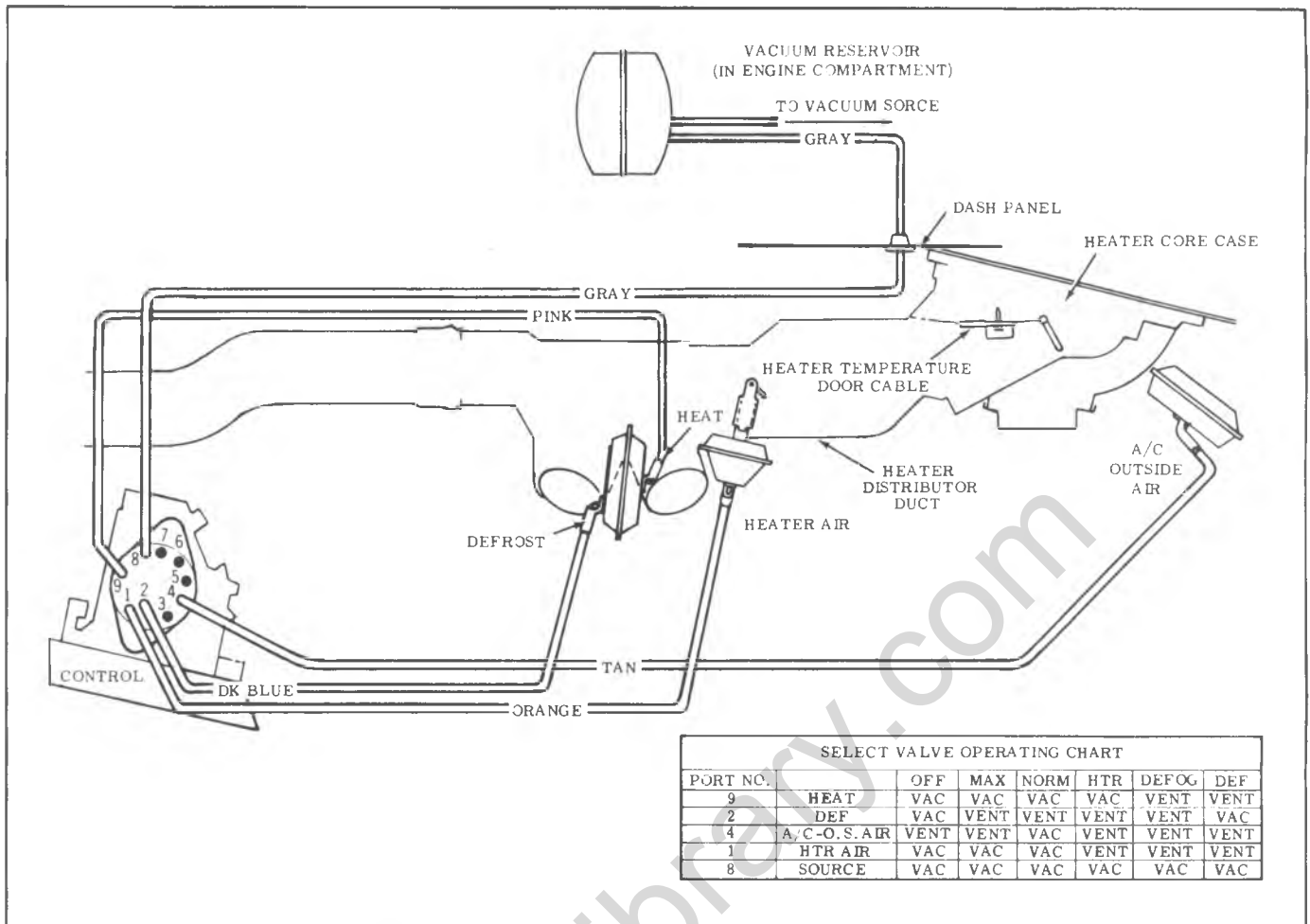


Fig. 1B-18-C60 System Vacuum Diagram (G Series)

Attachment of the expansion valve bulb to the evaporator outlet line is very critical. The bulb must be attached tightly to the line and must make good contact with the line along the entire length of the bulb. A loose bulb will result in high low side pressures and poor cooling.

Indications of expansion valve trouble are provided by Performance Tests; consult Diagnostic Charts.

VALVE STUCK OPEN

- Noisy Compressor
- No Cooling - Freeze Up.

VALVE STUCK CLOSED, BROKEN POWER ELEMENT OR PLUGGED SCREEN

- Very Low Suction Pressure.
- No Cooling.

POORLY LOCATED POWER ELEMENT BULB

- Normal Pressure.
- Poor Cooling.

Diagnosis for Defective Valve

The following procedure must be followed to determine if a malfunction is due to a defective expansion valve.

1. Check to determine if the system will meet the performance test as outlined previously. If the expansion valve is defective, the low pressure readings (evaporator pressure) will be above specifications.

2. The loss of system performance is not as evident when the compressor head pressure is below 1 379 kPa (200 psi). Therefore, it may be necessary to increase the system head pressure by partially blocking the condenser. Disconnect the blower lead wire and repeat the "performance check" to determine if the evaporator pressure can be obtained.

3. The system will also indicate a low refrigerant charge by bubbles occurring in the sight glass (Motor Home Chassis Systems).

EVAPORATOR

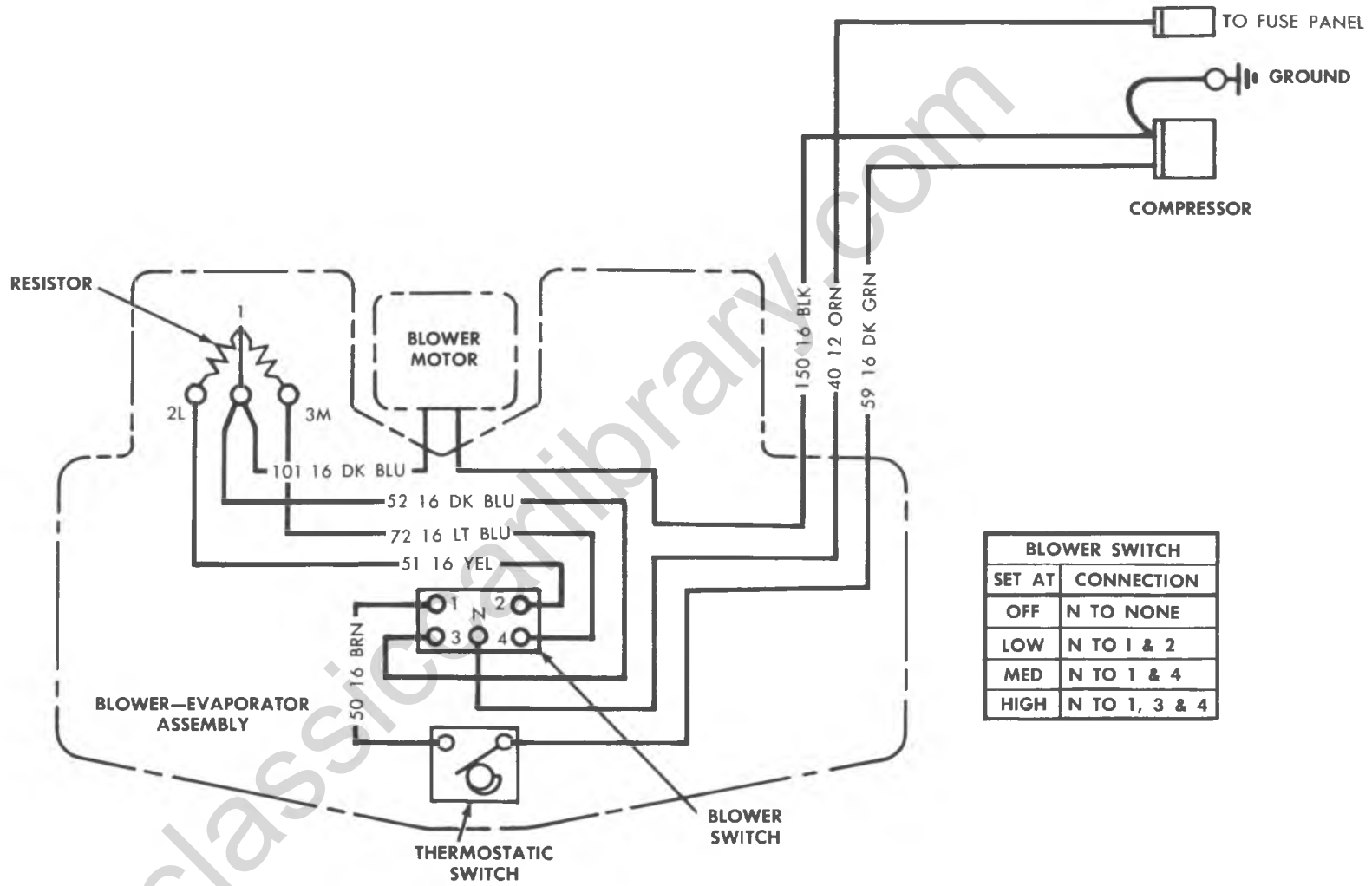
When the evaporator is defective, the trouble will show up as an inadequate supply of cool air. A partially plugged core due to dirt, a cracked case, or a leaking seal will generally be the cause.

REFRIGERANT LINE RESTRICTIONS

Restrictions in the refrigerant lines will be indicated as follows:

1. Suction Line - A restricted suction line will cause low suction pressure at the compressor, low discharge pressure and little or no cooling.
2. Discharge Line - A restriction in the discharge line generally will cause the pressure relief valve to open.
3. Liquid Line - A liquid line restriction will be evidenced by low discharge and suction pressure, and insufficient cooling.

Fig. 1B-19-C60 Motor Home Chassis Wiring Diagram



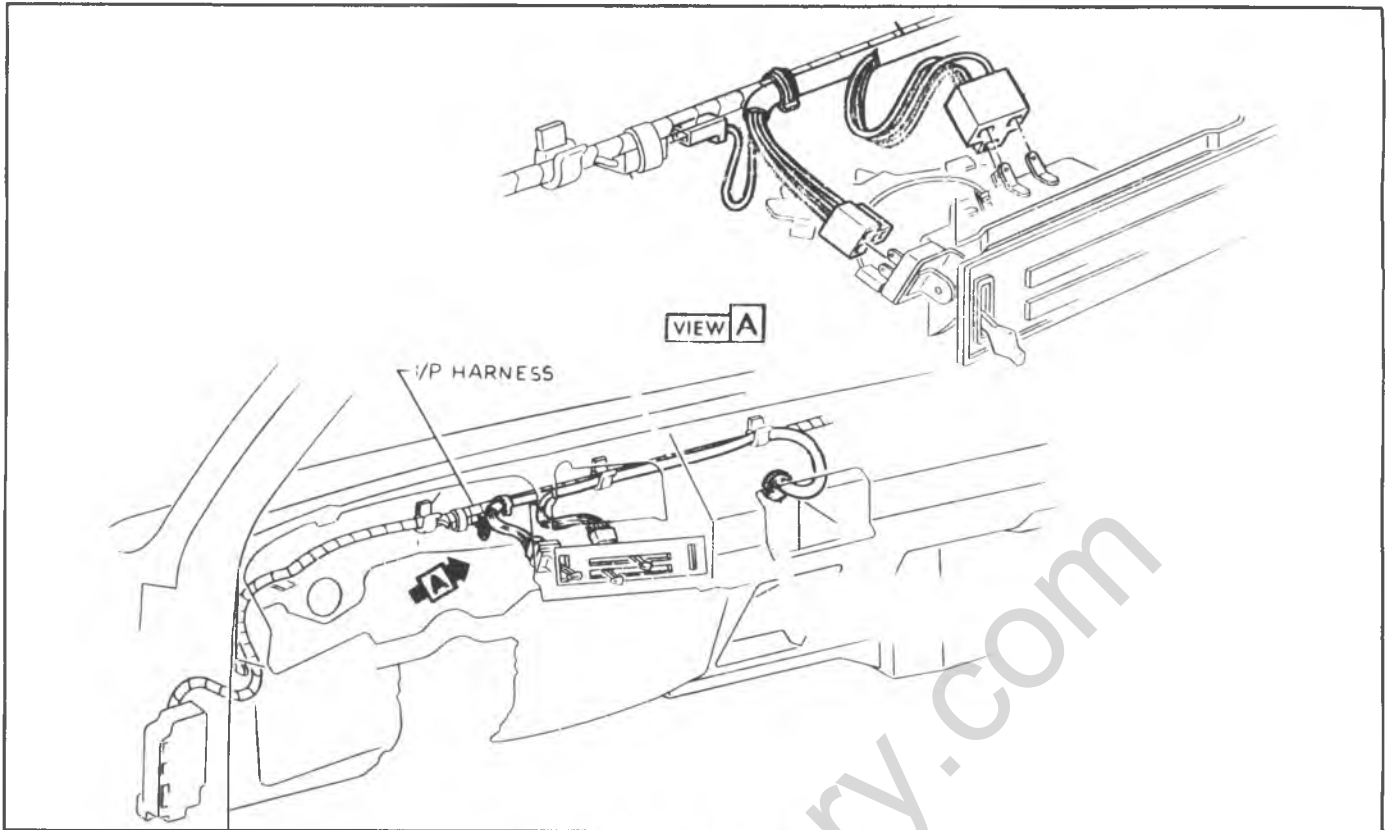


Fig. 1B-20-I.P. A/C Harness Wiring

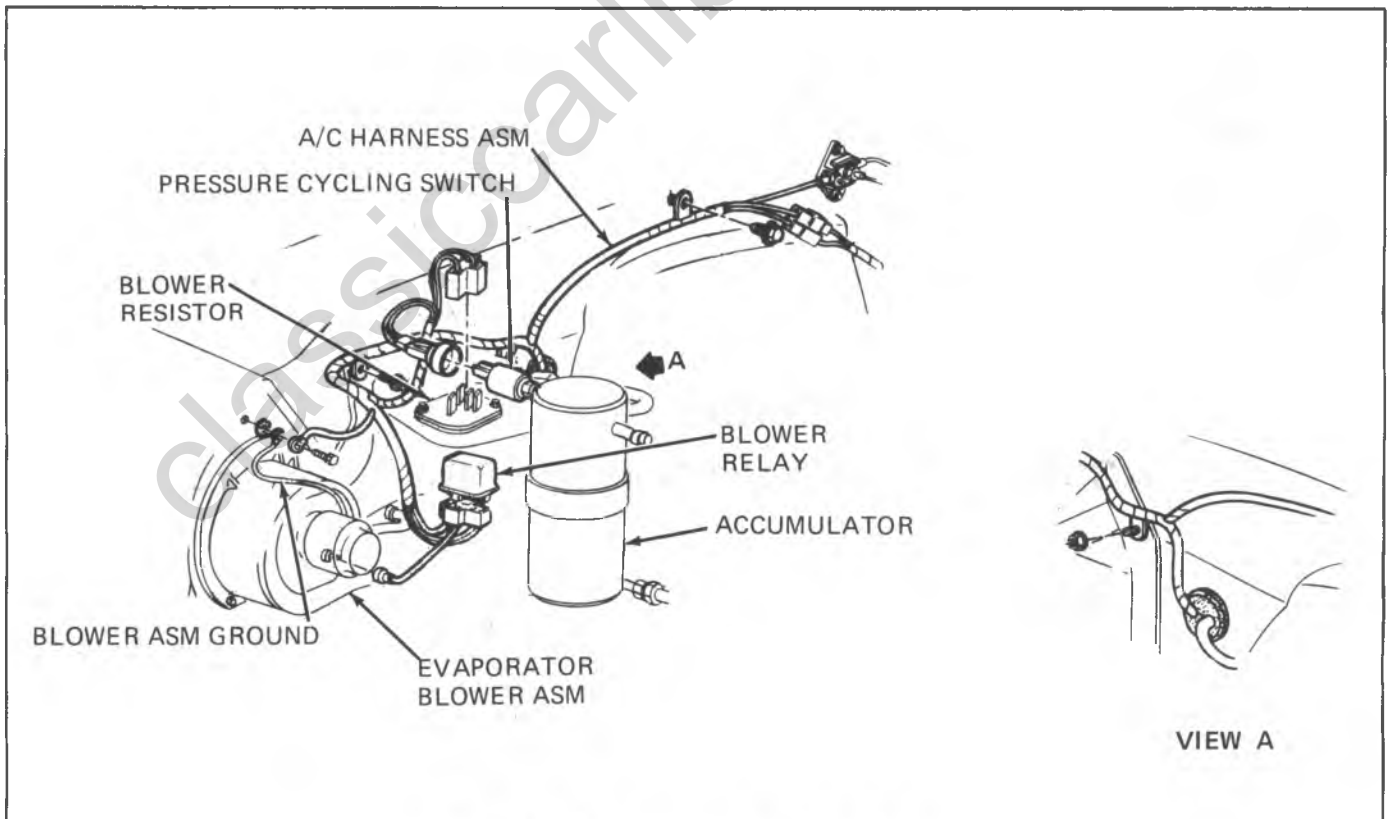


Fig. 1B-21-A/C Compressor Wiring-CK Series

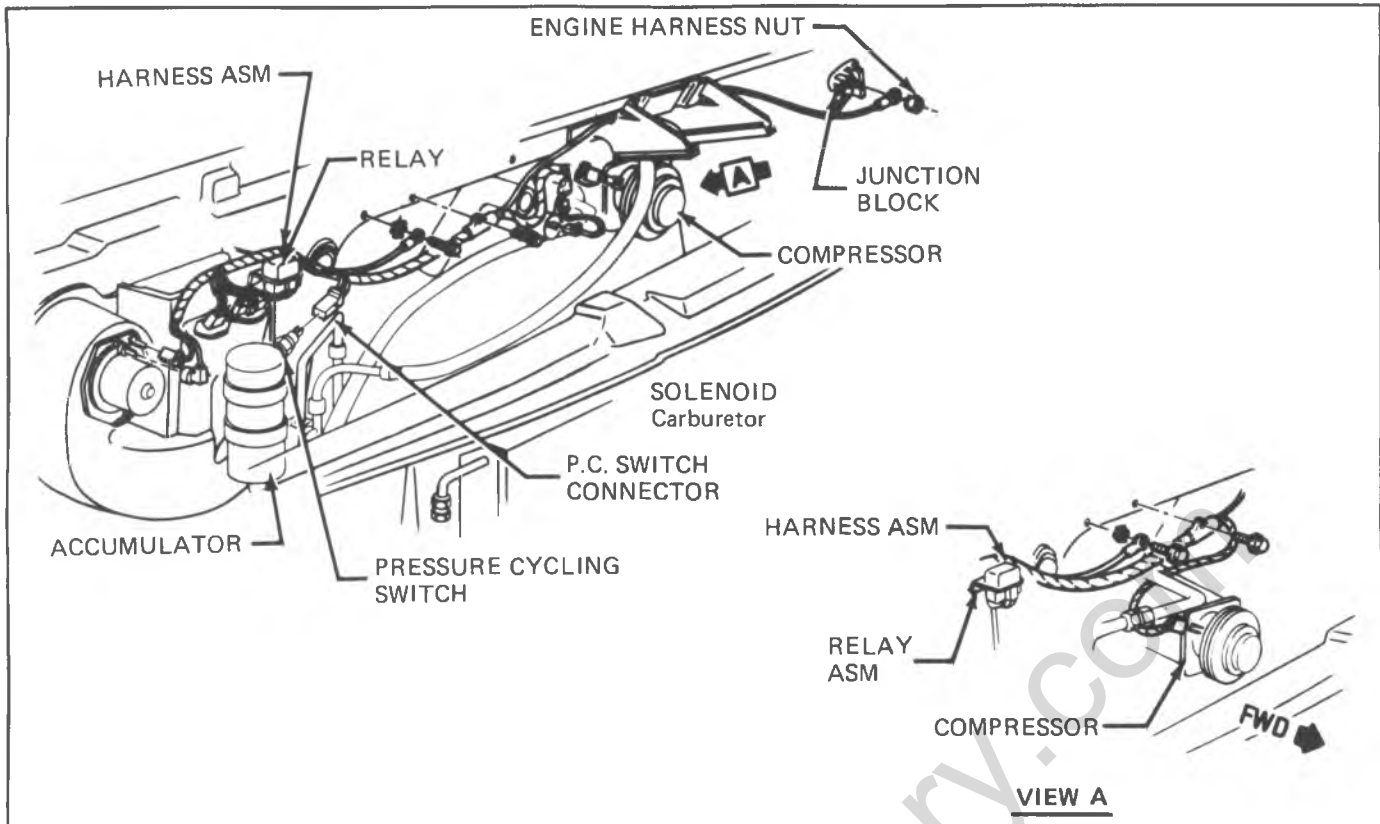


Fig. 1B-22-A/C Compressor Wiring - G Series

Sight Glass Diagnosis (Motor Home Chassis

Units)

At temperatures higher than 70°F (21°C), the sight glass may indicate whether the refrigerant charge is sufficient. A shortage of liquid refrigerant is indicated after above five minutes of compressor operation by the appearance of slow-moving bubbles (vapor) or a broken column of refrigerant under the glass. Continuous bubbles may appear in a properly charged system on a cool day. This is a normal situation. If the sight glass is generally clear and performance is satisfactory, occasional bubbles do not indicate refrigerant shortage.

If the sight glass consistently shows foaming or a broken liquid column, it should be observed after partially blocking the air to the condenser. If under this condition the sight glass clears and the performance is otherwise satisfactory, the charge shall be considered adequate.

In all instances where the indications of refrigerant shortage continues, additional refrigerant should be added in 1/4 lb. increments until the sight glass is clear. An additional charge of 1/2 lb. should be added as a reserve after the glass clears. In no case should the system be overcharged.

ON VEHICLE SERVICE EVACUATING AND CHARGING PROCEDURES

PRECAUTIONARY SERVICE MEASURES

Before any service is attempted which requires opening of refrigerant lines or components, the person doing the work should be thoroughly familiar with the information under PRECAUTIONS IN HANDLING REFRIGERANT-12 PRECAUTIONS IN HANDLING REFRIGERANT LINES AND FITTINGS MAINTAINING CHEMICAL STABILITY IN THE REFRIGERATION SYSTEM, AND REFRIGERANT CHARGING PRECAUTIONS and should follow very

carefully the DISCHARGING, EVACUATING, OIL ADDITION AND CHARGING THE REFRIGERANT SYSTEM instructions given on the following pages for the unit being serviced.

The major reasons behind these measures are safety and the prevention of dirt and moisture in the system which can restrict A/C system refrigerant flow.

The presence of moisture can also cause the formation of hydrochloric or hydrofluoric acids in the system.

| METAL TUBE OUTSIDE DIAMETER | THREAD AND FITTING SIZE | STEEL TUBING TORQUE | | ALUMINUM OR COPPER TUBING TORQUE | | NOMINAL TORQUE WRENCH SPAN |
|-----------------------------------|----------------------------|---------------------------|-------|---|-------|----------------------------------|
| | | LB. FT. | N·m | LB. FT. | N·m | |
| 1/4 | 7/16 | 10-15 | 14-20 | 5-7 | 7-9 | 5/8 |
| 3/8 | 5/8 | 30-35 | 41-48 | 11-13 | 15-18 | 3/4 |
| 1/2 | 3/4 | 30-35 | 41-48 | 15-20 | 20-27 | 7/8 |
| 5/8 | 7/8 | 30-35 | 41-48 | 21-27 | 29-37 | 1 1/16 |
| 3/4 | 1 1/16 | 30-35 | 41-48 | 28-33 | 38-45 | 1 1/4 |

All sub-assemblies are dehydrated and sealed prior to shipping. They are to remain sealed until just prior to making connections. All sub-assemblies should be at room temperature before uncapping (this prevents condensation of moisture from the air that enters the system). If, for any reason, caps are removed but the connections are not made, parts should be resealed as soon as possible.

All precautions should be taken to prevent damage to fittings or connections. Any fittings getting grease or dirt on them should be wiped clean with a cloth dampened with stoddard solvent, kerosene (or equivalent) may be used. Make sure fittings are dry prior to re-assembly. If dirt, grease or moisture get inside pipes and cannot be removed, the pipe should be replaced.

Sealing caps should be removed from sub-assemblies just prior to making connections for final assembly. Use a small amount of clean 525 viscosity refrigerant oil on all tube and hose joints. Always use new O-rings dipped in the clean refrigerant oil when assembling joints. The oil will aid in assembly and help provide a leak-proof joint. When tightening joints, use a second wrench to hold stationary part of connection so that a solid feel can be attained. This will indicate proper assembly.

NOTICE: Tighten all tubing connections as shown in torque chart (Chart 1B-9). Insufficient or excessive torque when tightening can result in loose joints or deformed joint parts. Either condition can result in refrigerant leakage.

C.C.O.T. REFRIGERANT OIL DISTRIBUTION

A-6 COMPRESSOR SYSTEM -- requires 300 ml (10 fluid ounces) of 525 viscosity oil.

R-4 COMPRESSOR SYSTEM -- requires 180 ml (6 fluid ounces) of 525 viscosity oil.

New oil quantities must be added to the system during Service component replacement and conditions stated as follows:

A. When there are no signs of excessive oil leakage, for the -

- Compressor - Remove, drain oil, measure, replace same amount of new oil plus 30 ml (1 oz.).
- Evaporator - Add 90 ml (3 fluid ounces).
- Condenser - Add 30 ml (1 fluid ounce).
- Accumulator - Remove, drain oil, measure, replace same amount of new oil **plus** 30 ml (1 oz.) to compensate for that retained by the original accumulator dessicant.

B. With signs of excessive oil leakage, for -

A-6 Compressor Systems

Remove Compressor AND Accumulator. Drain, measure and record TOTAL oil from both components. Discard old oil.

If less than 180 ml (6 ounces), add 6 ounces of new oil to system.

If more than 180 ml (6 ounces), add same amount of new oil as drained.

If a new Accumulator must be added to A-6 system, add 1 additional ounce of oil to compensate for that held/absorbed by the original accumulator dessicant.

R-4 Compressor Systems

Remove only the Accumulator. Drain, measure and record quantity of oil in Accumulator. (It is not necessary to remove and drain the R-4 Compressor because the R-4 Compressor only retains a minimum quantity of oil-it doesn't have an oil sump area.)

If less than 90 ml (3 ounces), add 90 ml (3 ounces) of new oil to system.

If more than 90 ml (3 ounces), add same amount of new oil as drained.

If a new Accumulator must be added to R-4 system, add 30 ml (1 ounce) of oil to compensate for that held/absorbed by the original Accumulator dessicant.

1. If there are no signs of excessive oil leakage, add the following amount of oil depending on component replaced:

For A-6 & R-4 Compressor Systems - Evaporator - (3 fluid ounces).

For A-6 & R-4 Compressor Systems - Condenser - (1 fluid ounce).

For R-4 Compressor System only - Accumulator (Drain oil, measure, replace same amount plus 1 oz.).

For A-6 Compressor System only - Accumulator (see Item 2 below).

2. However, on an A-6 compressor system:

● If either the accumulator or the compressor is to be replaced...

● Or if there are signs of abundant oil leakage...

THEN BOTH ACCUMULATOR AND COMPRESSOR must be removed -- oil drained -- and measured to determine correct quantity of oil replacement for the system. If the amount of oil recovered is 4 oz. or more, replace with a like amount of new oil. If less than 4 oz. are recovered, add 6 oz. of new oil.

A good A-6 system will have 6 ounces of oil found in the accumulator and/or compressor. Neither necessarily has 3 ounces - could be more or less. This is why **BOTH** have to be measured.

● **IN ADDITION** to these measure amounts, one (1) additional fluid ounce **MUST** be added to replace that amount captured in the oil desiccant of the replaced accumulator assembly.

| Refrigerant Charge | | |
|--------------------|-----------------|-----------------|
| | Overhead System | C60 System |
| C-K Models | 5 lbs.-4 oz. | 3 Lbs. - 12 oz. |
| G Models | 5 lbs. | 3 lbs. |

Chart 1B-10--R12 Charging Capacities

New service A-6 Compressors are shipped with 10 ounces of oil already inside. Therefore, when a new A-6 Compressor is installed, its oil must first be drained and measured to leave only that like amount drained and measured in the oil compressor.

3. ON AN R-4 COMPRESSOR SYSTEM WITH SIGNS OF ABUNDANT OIL LEAKAGE:

- ONLY THE ACCUMULATOR SHOULD BE REMOVED from the system, oil drained and then measured to determine correct quantity of oil replacement. If the amount drained is 2 oz. or more, replace with like amount. If less than 2 oz., replace with 2 oz. of new oil.

- IN ADDITION to this amount, add 1 oz. to replace the amount captured in the old desiccant of the replaced accumulator assembly. Because the R-4 Compressor has no oil sump, it is not necessary to remove this compressor to measure oil.

DISCHARGING EVACUATING ADDING OIL AND CHARGING PROCEDURES FOR C.C.O.T. A/C SYSTEMS

The refrigerant system may be Discharged, Evacuated and Charged using J-23500-01 air conditioning service Charging Station or the J-5725-04 Manifold and Gage Set and 14 oz. disposable cans of Refrigerant-12.

Charging lines from the Charging Station or Manifold and Gage Set require the use of gage adapters to connect to system service fittings. A straight gage Adapter J-5420 and a 90-degree angle gage Adapter J-9459 are available.

CAUTION: Always wear goggles and wrap a clean cloth around fittings and connections when doing work that involves opening the refrigerant system. If liquid refrigerant comes into contact with the skin of eyes injury can result.

DISCHARGING THE C.C.O.T. A/C SYSTEM

In replacing any of the air conditioning refrigeration components the system must be completely discharged of Refrigerant-12.

ALWAYS DISCHARGE SYSTEM AT LOW SIDE SERVICE FITTING.

1. With ignition turned OFF, remove protective cap from low-side service fitting and connect Charging Station J-23500-01 Gage Set as indicated in Figure 1B-22.

Or, with ignition turned OFF and protective cap removed from LOW-SIDE service fitting, discharge system by SLOWLY connecting a gage hose to LOW-SIDE service fitting on Accumulator and discharging into oil bottle (Fig.

1B-23). As hose is slowly tightened down onto schrader valve, Refrigerant-12 will be in to discharge from the system into the container. If no discharge occurs, check for missing or defective schrader depressor in hose fitting.

2. When the system is completely discharged (no vapor escaping with hose fully-tightened down), measure, record and discard any of the collected refrigerant oil. If this quantity is 15 ml (1/2 oz.) OR MORE, it must be added to system, plus any trapped in removed parts before Evacuation and Charging with Refrigerant-12 (see C.C.O.T. Refrigerant Oil Distribution for specific quantity instructions on oil found in removed parts).

3. With the low-side of system fully discharged, check high-side system fitting (on muffler) for remaining pressure by connecting a downward directed 36" section J-5418-36B charging line with attached J-25498 straight or J-25499 90° angle fitting adapter SLOWLY tightened down to depress the fitting valve.

4. If pressure is found on the high-side of the system, attempt to discharge high-side using same procedure as used for low-side. (This condition indicates a restriction and high-side components should be removed and/or diagnosed to determine the area restricted.)

EVACUATING, ADDING REFRIGERANT OIL AND CHARGING THE C.C.O.T. A/C SYSTEM

If the system has been opened for any repair, or the Refrigerant-12 charge lost, the system must be Evacuated prior to Charging to remove any trace of air or moisture that may have entered.

Evacuation and Charging is a combined procedure, with all lines and gauges, as well as the system, to be purged with R-12 and Evacuated just prior to Charging.

There are three standard Refrigerant-12 Evacuate and Charge procedures which include Oil Addition:

- J-23500-01 Charging Station Method
- Disposable Can Method
- Drum Method

Under no circumstances should alcohol be used in the system in an attempt to remove moisture, regardless of the successful use of alcohol in other refrigerant systems.

Prior to Evacuation, check the low pressure gage for proper calibration. With the gage disconnected from the refrigeration system, be sure that the pointer indicates to the center of "O". Lightly tap gage a few times to be sure pointer is not sticking. If necessary, calibrate as follows:

- a. Remove cover from gage.

- b. Holding gage pointer adjusting screw firmly with one hand, carefully force pointer in the proper direction in proper amount to position pointer through the center of "O" position. Tap gage a few times to be sure pointer is not sticking. Replace gage cover.

J-23500-01 CHARGING STATION METHOD

Follow Charging instructions provided with the J-23500-01 Charging Station in use with the following exceptions:

1. DO NOT CONNECT THE HIGH PRESSURE LINE TO THE AIR CONDITIONING SYSTEM.

2. KEEP THE HIGH PRESSURE VALVE ON THE CHARGING STATION CLOSED AT ALL TIMES.

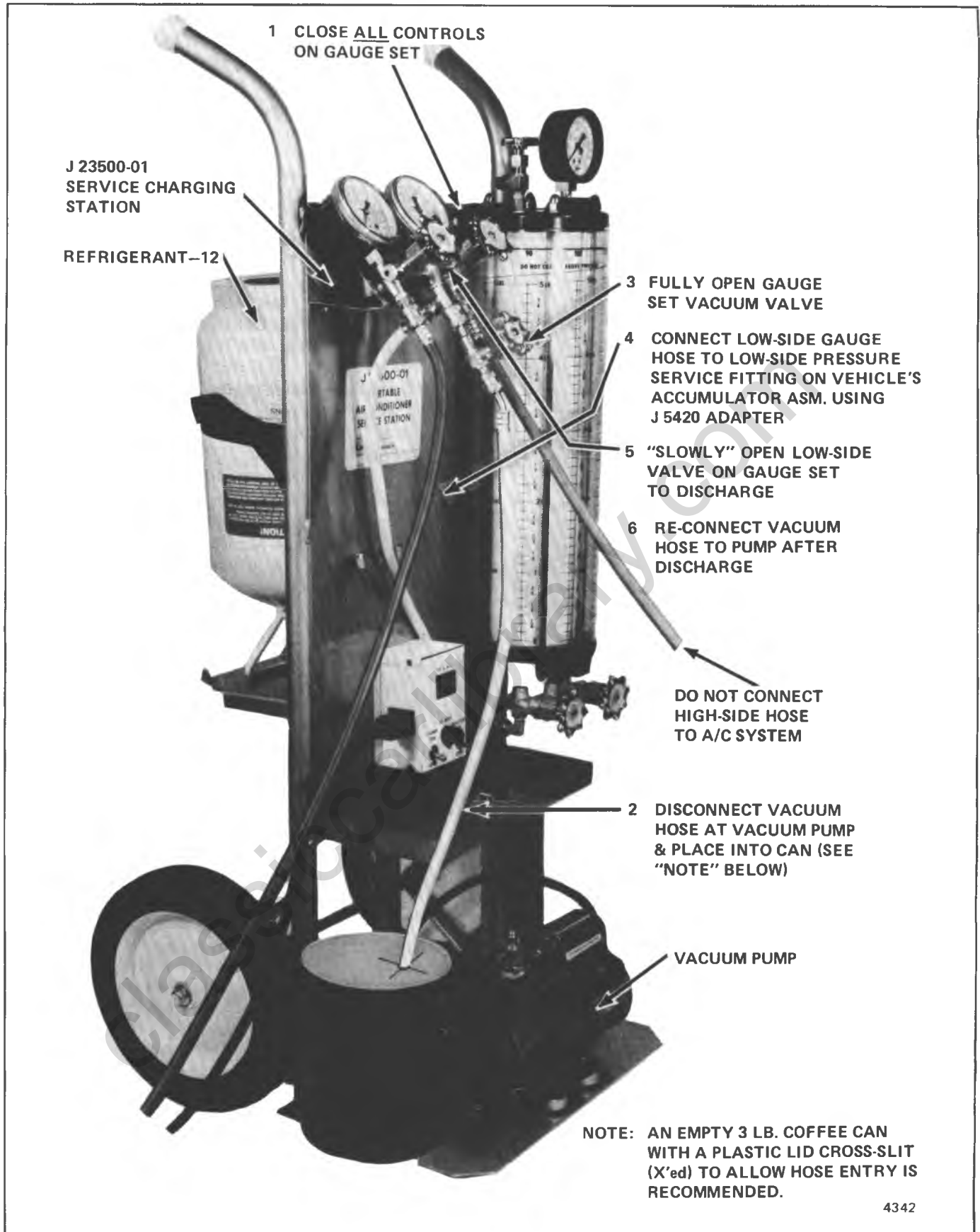


Fig. 1B-22--Discharging The C.C.O.T. System With J-23500-01 Charging Station

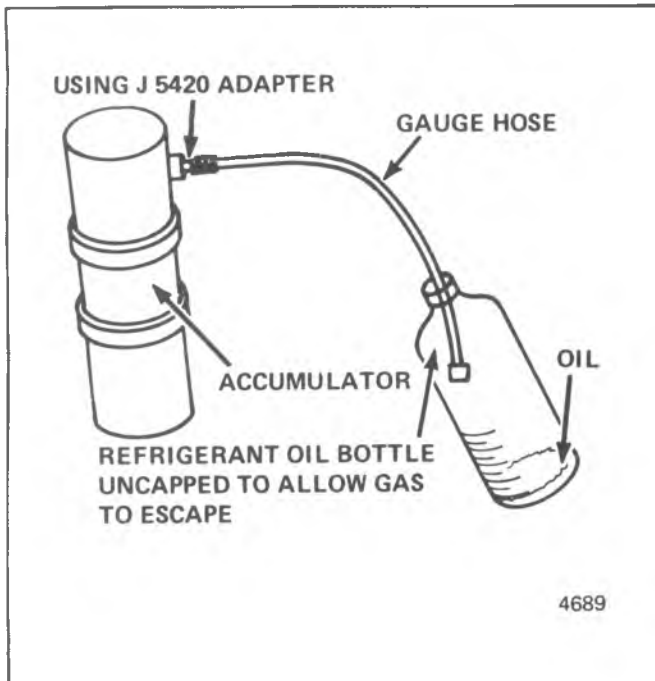


Fig. 1B-23--Discharging and Collecting Oil From System Without Charging Station J-23500-01

3. PERFORM THE ENTIRE EVACUATE AND CHARGE PROCEDURE THROUGH THE ACCUMULATOR LOW-SIDE PRESSURE SERVICE FITTING.

4. ADDING OIL TO THE C.C.O.T. A/C SYSTEM should take place AFTER Discharge AND BEFORE Evacuation procedures by removing the refrigeration suction hose at the Accumulator outlet pipe connection, pouring the correct quantity of refrigerant oil into the hose or pipe and then properly reconnecting hose to pipe (see Discharging Step No. 2 and C.C.O.T. Refrigeration Oil Distribution for specific quantity instructions).

5. Following these procedures will prevent accidental high-side vehicles system pressure being subjected to the Charging Station in the event an error is made in valve sequence during compressor operation to pull in the Refrigerant-12 charge.

DISPOSABLE CAN OR REFRIGERANT DRUM METHOD

ADDING OIL TO THE C.C.O.T. A/C SYSTEM should take place after Discharge and before Evacuation procedure by removing the refrigeration suction hose at the Accumulator outlet pipe connection, pouring the correct quantity of refrigerant oil into the hose or pipe and then properly reconnecting hose to pipe (see Discharging Step No. 2 and C.C.O.T. Refrigeration Oil Distribution for specific quantity instructions).

- If the Refrigerant-12 drum is used, place it on a scale and note the total weight before Charging. Watch the scale during Charging to determine the amount of R-12 used.

- If disposable 420 ml (14 ounce) R-12 cans are used, close the tapping valve and then attach can(s) following instructions included with the tapping valve or tapping manifold adapter.

1. Connect Manifold Gage Set J-5725-04 as shown in Figure 1B-24.

- LOW pressure gage set valve to Accumulator fitting
- Gage set center hose to Refrigerant-12 source
- High pressure gage set valve to vacuum pump

2. To begin evacuation, with Manifold Gage Set and Vacuum Pump as illustrated in Fig. 1B-24 slowly open high and low-side gage valves and begin vacuum pump operation. Pump the system for 15 minutes after low-side gage reaches 711.2-736.6 mm (28"-29") vacuum or more.

In all Evacuation procedures, the specification of 711.2-736.6 mm (28"-29") of Mercury vacuum is used. This specification can only be reached at or near sea level. For each 304.8 m (1,000 feet) above sea level, specification should be lowered by one inch of mercury vacuum. At 1524 m (5,000 feet) elevation only 711.2-736.6 mm (23"-24") of vacuum is required.

If prescribed vacuum cannot be reached, close vacuum control valve, shut off pump and look for a leak at connections or pump.

3. When the system is fully Evacuated, close the high-side gage set valve and turn OFF the vacuum pump.

4. Watch low-side gage to be sure vacuum holds for 5 (FIVE) minutes at gage set and then proceed to Charging.

5. If Vacuum Does Not Hold For 5 Minutes, charge system with 240 ml (1/2 pound) Refrigerant-12 and leak check. Discharge system again then repair leak as necessary. Repeat Evacuation procedure.

TO BEGIN CHARGING OF THE C.C.O.T. A/C SYSTEM

1. Start engine, run with choke open and fast idle speed reduced to normal idle, set A/C control lever on OFF.

2. With the Refrigerant-12 drum or 420 ml (14 oz.) can(s) inverted, open R-12 source valve(s) and allow 480 ml (one (1) pound) or 1-2 420 ml 14 oz. can(s) of liquid R-12 to flow into system through low-side Service fitting on Accumulator (see Figure 1B-31).

3. As soon as 480 ml (1 lb.) or 1-2 420 ml (14 oz.) can(s) of liquid R-12 has been added to system, immediately engage the compressor, by setting the A/C control lever to NORM and blower speed on HI, to draw in the remainder of the R-12 charge.

The Charging operation can also be speeded up by using a large volume fan to pass air over the condenser. If condenser temperature is maintained below charging cylinder temperature, Refrigerant-12 will enter system more rapidly.

4. Shut off R-12 source valve and run engine for 30 seconds to clear lines and gages.

5. With the engine running, remove the charging low-side hose adapter from the Accumulator Service fitting. Unscrew rapidly to avoid excess R-12 escape from system.

CAUTION: Never remove a gage line from its adapter when line is connected to A/C system. Always remove the line adapter from the service fitting to disconnect a line. Do not remove charging hose at set while attached to accumulator. This will result in complete discharge of system due to the depressed schrader valve in

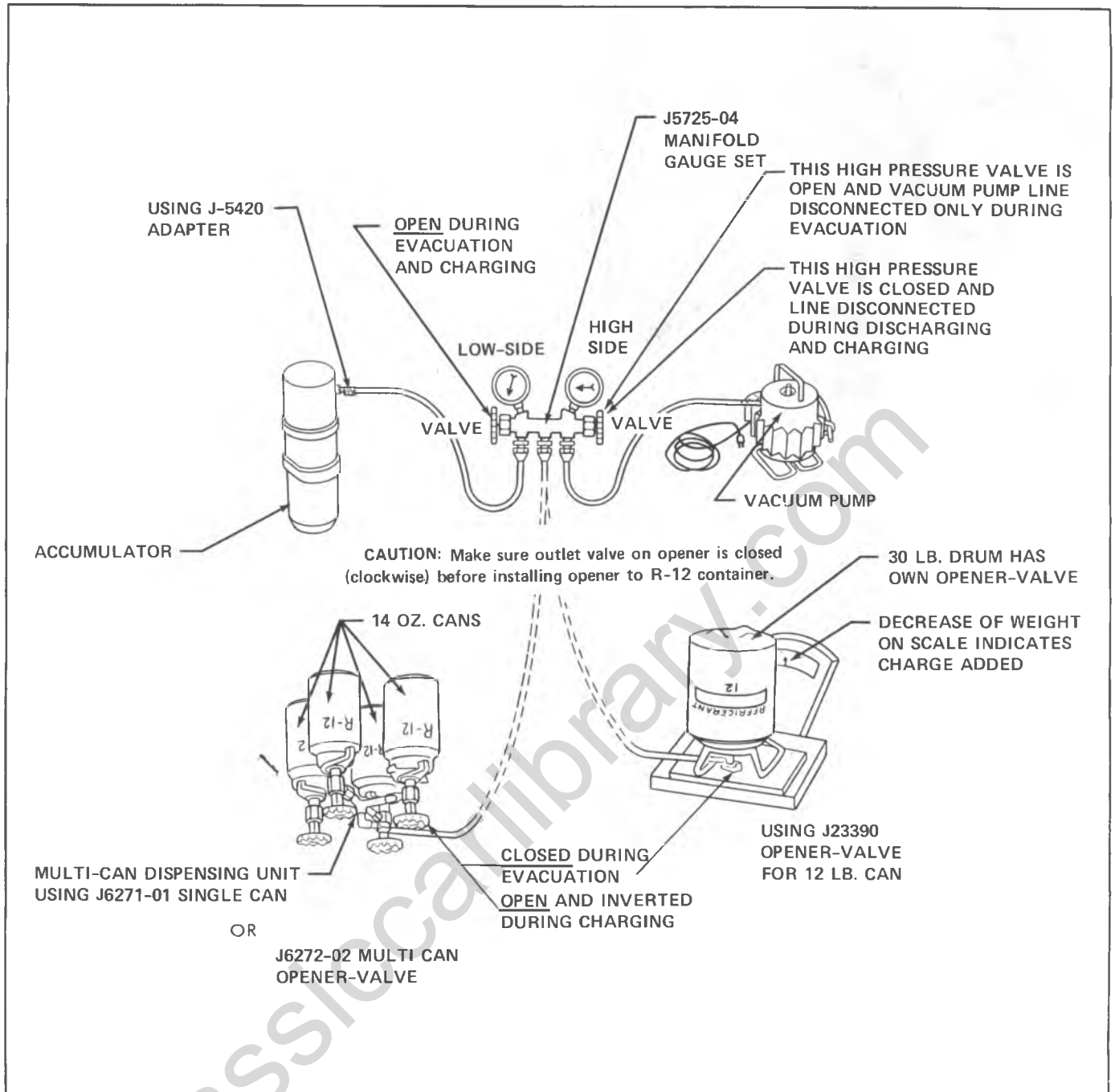


Fig. 1B-24--Charging the CCOT A/C System with Disposable Can or Refrigerant Drum.

service low-side fitting, and may cause personal injury due to escaping Refrigerant-12.

6. Replace protective cap on Accumulator fitting.
7. Leak check system with J-6084 Leak Detector.
8. With system fully Charged and leak-checked, continue to operate system and test for proper system pressures as outlined under PERFORMANCE PRESSURE-TEMPERATURE DATA -C.C.O.T. A/C SYSTEM DIAGNOSTIC PROCEDURE.

ACCUMULATOR ASSEMBLY

The accumulator assembly for the C.C.O.T. system has a service replacement which includes two O-rings (for the inlet and outlet connections). The dessicant within the shell is NOT serviced separately - it is part of the sealed accumulator assembly.

See C.C.O.T. Refrigerant oil distribution for presence of refrigerant oil and service conditions when the accumulator must be removed from the vehicle to measure the amount of oil present inside the Accumulator.

The accumulator assembly should be replaced only when:

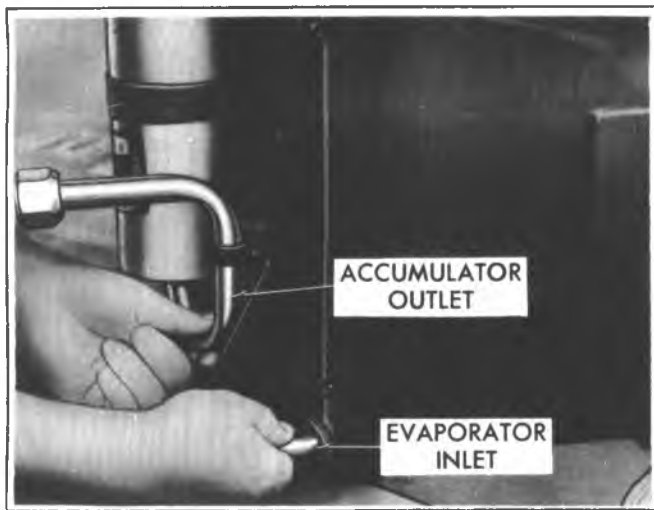


Fig. 1B-25—Checking Evaporator Inlet and Accumulator Outlet Temperatures

1. A physical perforation to the accumulator is found resulting in a leak.
2. The expansion tube (orifice) screen is plugged.
3. The compressor inlet screen is plugged.
4. An evaporator fails because of inside-out (internal) corrosion.

DO NOT REPLACE the accumulator assembly when:

1. Merely a dent is found in the outer shell of the accumulator.
2. A vehicle is involved in a collision and no physical perforation to the accumulator is found. An open refrigerant line should be capped or have a plastic bag tightly taped around it.

ENGINE IDLE COMPENSATOR

This additional aid to prevent stalling during prolonged hot weather periods is included with all air conditioned vehicles. The idle compensator is a thermostatically controlled air bleed which supplies additional air to the idle mixture. On V-8 engines, with factory installed air conditioning systems, the compensator is located within the carburetor and is accessible when the engine air cleaner is removed.

COMPRESSOR

C-K SERIES

Removal (Fig. 1B-33)

1. Discharge the system.
2. Remove connector attaching bolt and connector. Cap or plug open connections at once.
3. Disconnect electrical lead to clutch actuating coil.
4. Loosen brace and pivot bolts and detach belt.
5. Remove the nuts and bolts attaching the compressor brackets to the mounting bracket. Remove the compressor.
6. Before beginning any compressor disassembly, drain and measure oil in the compressor. Check for evidence of contamination to determine if remainder of system requires servicing. Compressor servicing information is located in the Unit Repair Manual.

Installation

1. If oil previously drained from the compressor upon removal shows no evidence of contamination, replace a like amount of fresh refrigeration oil into the compressor before reinstallation. If it was necessary to service the entire system because of excessive contamination in the oil removed, install a full charge of fresh refrigeration oil into the compressor.
2. Position compressor on the mounting bracket and install all nuts, bolts and lock washers.
3. Install the connector assembly to the compressor rear head, using new "O" rings coated with clean refrigeration oil.
4. Connect the electrical lead to the coil and install and adjust compressor belt.
5. Evacuate, charge and check the system.

G and Motor Home Chassis Models

Removal (Fig. 1B-26)

1. Disconnect battery ground cable.
2. Disconnect compressor clutch connector.
3. Purge the system of refrigerant.
4. Release the belt tension at the idler pulley and remove the belt from the compressor pulley. On some vehicles it may be necessary to remove the crankshaft pulley in order to remove the belt.
5. **G Series** --Remove the two bolts and two clamps that hold the engine cover and remove the cover.
6. Remove the air cleaner to aid access to the compressor.
7. Remove fitting and muffler assembly and cap or plug all open connections.
8. Remove the nuts and bolts attaching the compressor to the bracket.
9. Remove the engine oil tube support bracket bolt and nut from the compressor, also compressor clutch ground lead.

Before beginning any compressor disassembly, drain and measure oil in the compressor. Check for evidence of contamination to determine if remainder of system requires servicing. Compressor Servicing information is located in the Unit Repair Manual.

Installation

1. If the oil drained from the compressor showed no evidence of contamination replace a like amount of fresh refrigeration oil into the compressor before reinstallation. If it was necessary to service the entire system because of excessive contamination in the oil removed, install a full charge of fresh refrigeration oil in the compressor. (See Checking Compressor Oil Charge in the Diagnosis Section of this Service Manual.)
2. Position compressor on the mounting bracket and install all nuts, bolts, lock washers, and ground wire.
3. Install the connector assembly to the compressor rear head, using new "O" ring coated with clean refrigeration oil.
4. Connect the electrical lead to the coil and install and adjust compressor belt, using idler pulley. See "Compressor Belt Tension Adjustment."
5. Evacuate, charge and check the system.

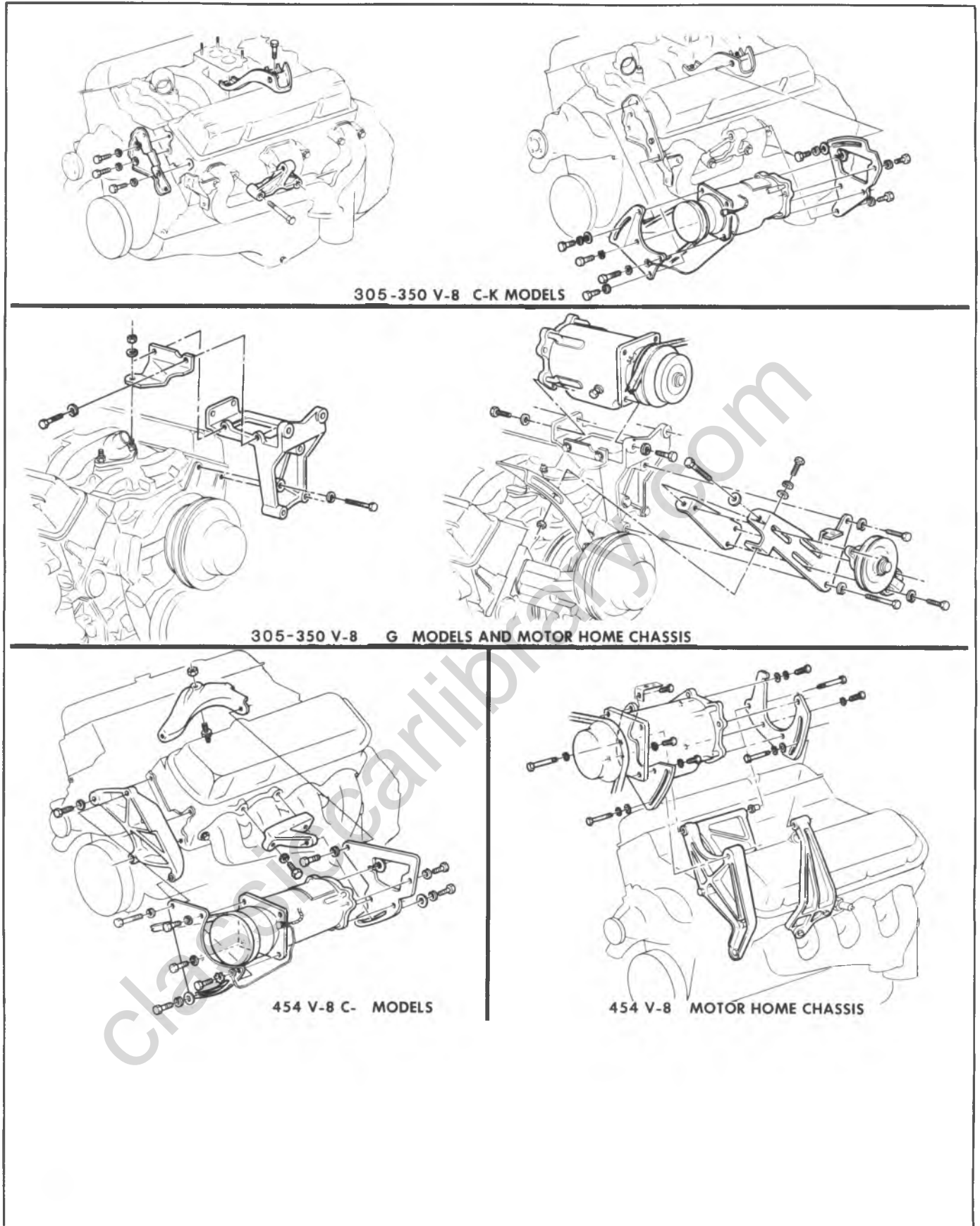


Fig. 1B-26—Compressor Mounting

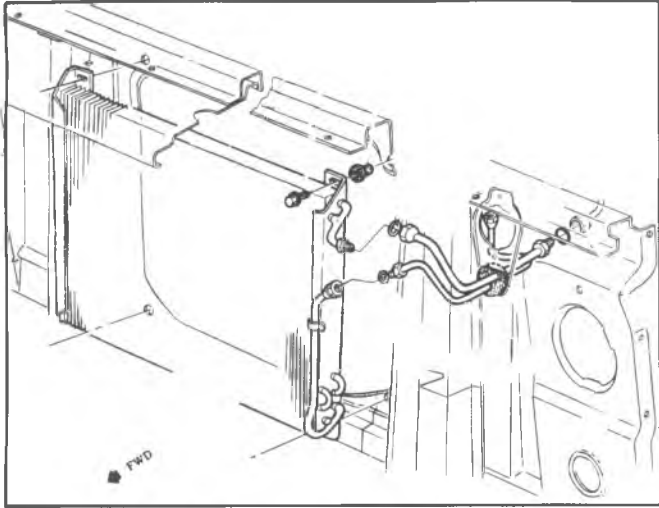


Fig. 1B-27--Condenser Installation (C-K Series)

6. Replace air cleaner. On G series, replace the engine cover.

7. Connect the battery ground cable.

Compressor Belt Tension Adjustment

Adjust the compressor belt to the specifications shown in the Engine section of the Service Manual.

On some G and Motor Home Chassis units it may be necessary to increase idler pulley slack adjustment. This may be accomplished by (1) Remove and discard the idler adjustment bolt. (2) Remove the idler backing plate and elongate all 3 adjusting slots 1/2 inch inboard or outboard as required. (3) Reinstall the idler assembly and adjust belt tension using a lever (screwdriver, etc.) to move the pulley outboard until proper belt tension is reached. If the belt is being replaced it may be necessary to remove and replace the throttle cable during the belt replacement. If so check throttle cable adjustment upon completion. It may also be necessary to remove the crankshaft pulley to install a new compressor belt.

C60 SYSTEM--C-K SERIES

CONDENSER - CK SERIES (FIG. 1B-27)

Replacement (Fig. 1B-27)

1. Disconnect battery ground cable.
2. Discharge system.
3. Remove the grille assembly.
4. Remove the radiator grille center support.
5. Remove the left grille support to upper fender support (2) screws.
6. Disconnect the condenser inlet and outlet lines and the outlet tube line at the right end of the condenser. Cap or plug all open connections at once.
7. Remove the condenser to radiator support screws.
8. Bend the left grille support outboard to gain clearance for condenser removal.
9. Remove the condenser assembly by pulling it forward and then lowering it from the vehicle.
10. To install a new condenser, reverse Steps 1-9 above. Add one fluid ounce of clean refrigeration oil to a new condenser.

Use new "O" rings, coated with clean refrigeration oil, when connecting all refrigerant lines.

11. Evacuate, charge and check the system.

ACCUMULATOR - ALL

Replacement

1. Disconnect the battery ground cable and the compressor clutch connector.
2. Discharge system.
3. Disconnect the accumulator inlet and outlet lines and cap or plug the open connections at once.
4. Remove the accumulator bracket screws and remove the accumulator from the vehicle.
5. Drain any excess refrigerant oil from the accumulator into a clean container. Measure and discard the oil.

6. If a new accumulator is being installed, add one ounce of clean refrigeration oil to the new accumulator **PLUS** an amount equal to that drained in Step 5 above.

7. To install the new accumulator, reverse Steps 1-4 above. Connect all lines using new "O" rings, coated with clean refrigeration oil.

Do not uncap the new unit until ready to fasten the inlet and outlet line to the unit.

8. Evacuate charge and check the system.

BLOWER ASSEMBLY - CK SERIES

Replacement

1. Disconnect the battery ground cable.
2. Disconnect the blower motor lead and ground wires.
3. Disconnect the blower motor cooling tube.
4. Remove the blower to case attaching screws and remove the blower assembly. Pry the blower flange away from the case carefully if the sealer acts as an adhesive.
5. Remove the nut attaching the blower wheel to the motor shaft and separate the assemblies.
6. To install, reverse Steps 1-5 above; replace sealer as necessary.

EVAPORATOR CORE

Replacement (Fig. 1B-28)

1. Disconnect the battery ground cable.
2. Discharge system.
3. Remove the nuts from the selector duct studs projecting through the dash panel.
4. Remove the cover to dash and cover to case screws and remove the evaporator case cover.
5. Disconnect the evaporator core inlet and outlet lines and cap or plug all open connectins at once.
6. Remove the expansion tube as outlined under Expansion Tube replacement.
7. Remove the evaporator core assembly.
8. To install, reverse Steps 1-7 above. Add three ounces of clean refrigeration oil to a new evaporator core. Use new "O" rings, coated with clean refrigeration oil, when connecting refrigerant lines. Be sure cover to case and dash panel sealer is intact before reinstalling cover.
9. Evacuate, charge and check the system.

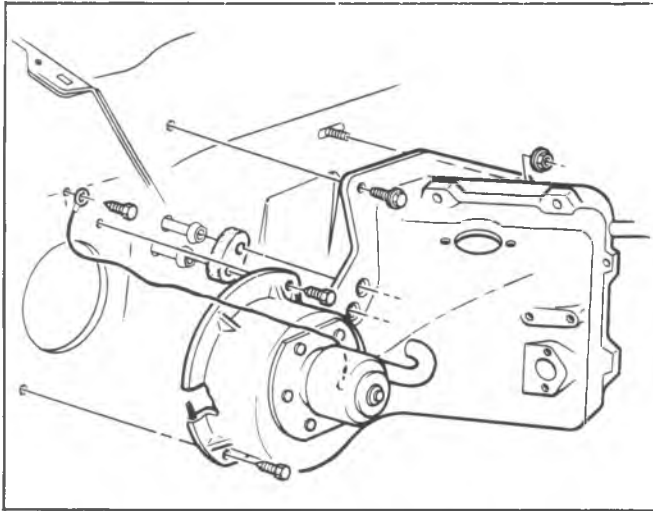


Fig. 1B-28--Blower-Evaporator (C-K Series)

EXPANSION TUBE-CK, G

The expansion tube is located in the evaporator core inlet line.

Replacement

1. Discharge system.
2. Disconnect the condenser to evaporator line at the evaporator inlet. Cap the open line at once.
3. Using needle-nose pliers, remove the expansion tube from the evaporator core inlet line.
4. Remove the expansion tube "O" ring from the core inlet line.
5. To install, reverse Steps 1-4 above.

Install the expansion tube using a new "O" ring coated with clean refrigeration oil, by inserting the short screen end of the tube into the evaporator inlet line.

6. Evacuate, charge and check the system.

SELECTOR DUCT AND HEATER CORE ASSEMBLY-CK

Replacement (Fig. 1B-30)

1. Disconnect the battery ground cable.
2. Drain the radiator and remove the heater hoses from the core tubes. Plug the core tubes to prevent coolant spillage during removal.
3. Remove the glove box and door as an assembly.
4. Remove the center duct to selector duct and instrument panel screws and remove the center lower and center upper ducts.
5. Disconnect the bowden cable at the temperature door.
6. Remove the nuts from the three selector duct studs projecting through the dash panel.
7. Remove the selector duct to dash panel screw (inside vehicle).
8. Pull the selector duct assembly rearward until the core tubes clear the dash panel. Lower the selector assembly far enough to gain access to all vacuum and electrical harnesses.
9. Disconnect the vacuum and electrical harness and remove the selector duct assembly.

10. Remove the core mounting strap screws and remove the core.

11. To install, reverse Steps 1-10 above.

12. Refill coolant system and connect the battery ground strap. Check temperature door cable adjustment.

KICK PAD VALVE - CK SERIES

Replacement (Fig. 1B-31)

1. Disconnect the vacuum hose at the actuator.
2. Unhook the valve return spring at the actuator end.
3. Remove the actuator bracket mounting screws.
4. Remove the cam to actuator arm screw and separate the actuator and bracket from the cam.
5. Remove the actuator to bracket nuts and separate the actuator and bracket.
6. To install reverse Steps 1-5 above.

PLENUM VALVE - CK SERIES

Replacement (Fig. 1B-31)

1. Raise the hood.
2. Remove the cowl plastic grille.
3. Remove the three cowl to valve assembly screws and remove the valve assembly from the vehicle.
4. Remove the actuator arm push nut.
5. Remove the actuator to valve nuts and separate the valve and actuator.
6. To install, reverse Steps 1-5 above.

CONTROL ASSEMBLY - CK SERIES

Removal (Fig. 1B-32)

1. Disconnect the battery ground cable.
2. Remove the radio as outlined in Section 8 of this manual.
3. Remove the instrument panel bezel.
4. Remove the control to instrument panel screws and lower the control far enough to gain access to the control assembly.

Be careful not to kink the bowden cable.

5. Disconnect the bowden cable, vacuum harness and electrical harness at the control.
6. Remove the control.
7. If a new unit is being installed, transfer the master blower switches to the new control.
8. To reinstall, reverse Steps 1-6 above. Check control operation.

TEMPERATURE DOOR CABLE ADJUSTMENT - CK MODELS

1. Remove glove box and door assembly.
2. Loosen the cable attaching screw at the selector duct assembly.
3. Make sure the cable is installed in the bracket on the selector duct assembly.
4. Place temperature lever in full COLD position and hold while tightening cable attaching screw.

MASTER SWITCH AND/OR BLOWER SWITCH - CK SERIES

The master switch is located on rear of the control assembly.

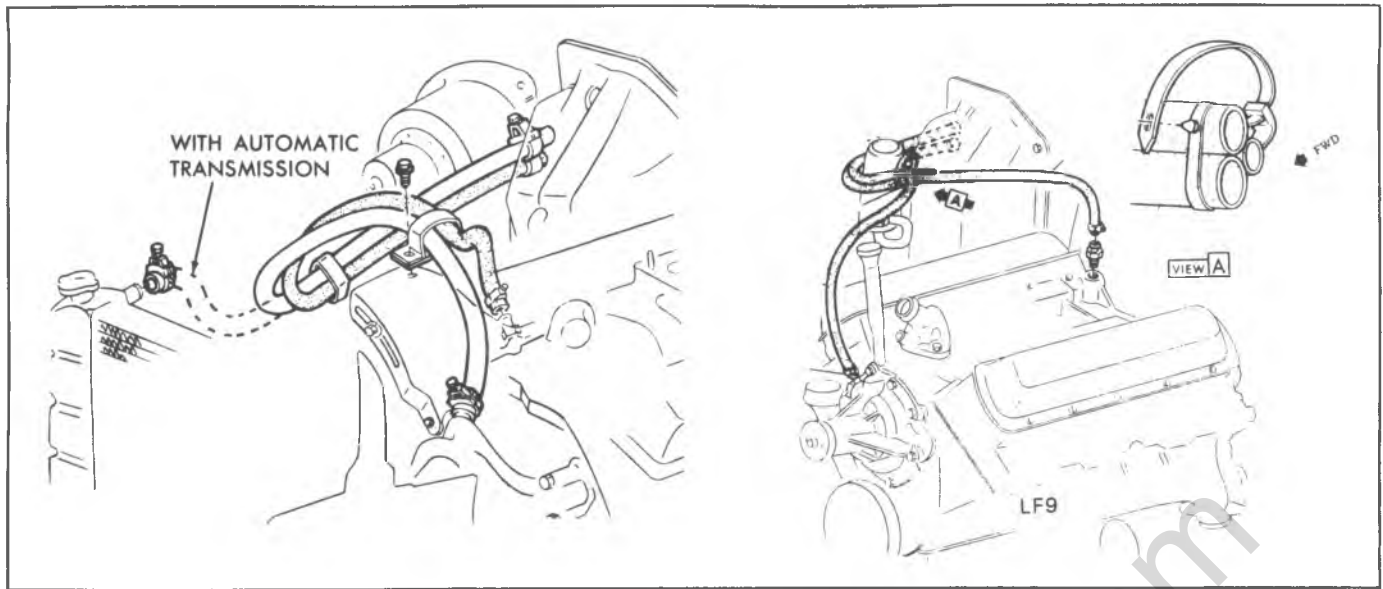


Fig. 1B-29-Heater Hose Routings (C-K Series)

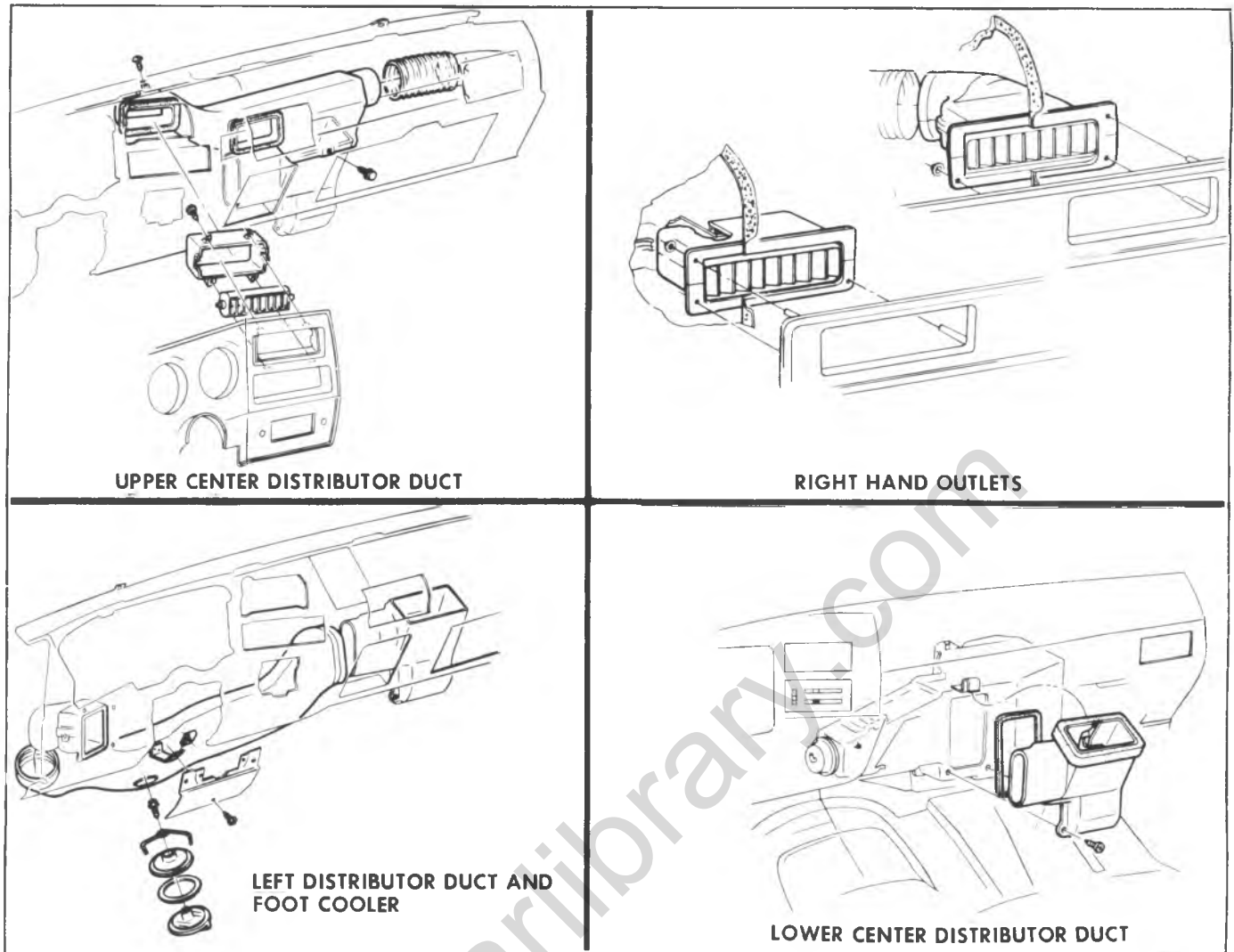


Fig. 1B-30—Air Selector and Ducts (C-K Series)

Replacement

1. Disconnect the battery ground cable.
2. Remove the instrument panel bezel.
3. Remove the control to instrument panel screws and allow control to rest on top of the radio.
4. Remove the switch to control screws, disconnect the electrical harness (and vacuum harness on master switch) at the switch and remove the switch assembly.
5. To install a new switch, reverse Steps 1-4 above.

VACUUM TANK

The vacuum tank is mounted to the engine side of the dash panel above the blower assembly (fig. 1B-33).

Replacement

1. Disconnect the vacuum lines at the tank.
2. Remove the tank to dash panel screws and remove the tank.
3. To install, reverse Steps 1 and 2 above.

BLOWER MOTOR RESISTOR

The blower motor resistor is located in the blower side of the blower-evaporator case (fig. 1B-35).

Replacement

1. Disconnect the wiring harness at the resistor.
2. Remove the resistor to case attaching screws and remove the resistor.
3. Place the new resistor in position and install the attaching screws.
4. Connect the resistor wiring harness.

BLOWER MOTOR RELAY - ALL

The blower motor relay is located on the blower side of the blower-evaporator case (fig. 35).

Replacement

1. Disconnect the wiring harness at the relay.
2. Remove the relay to case attaching screws and remove the relay.
3. Place the new relay in position and drive the mounting screws.
4. Connect the relay wiring harness.

FUSE

A 25 amp fuse, located in the junction block protects the entire air conditioning system except for the blower circuit, the fuse for the blower circuit is located in the electrical wiring between the junction block and the blower relay.

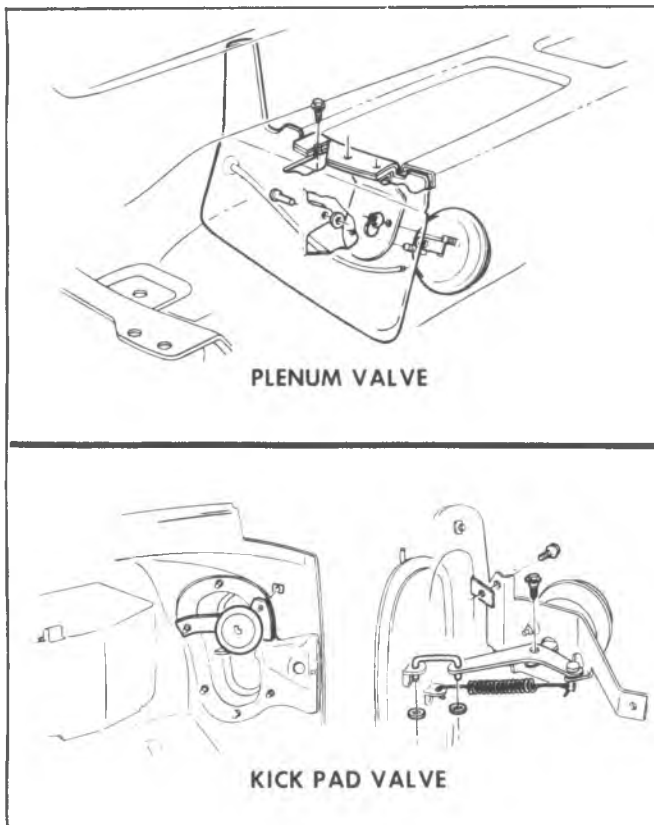


Fig. 1B-31—Air Inlet Valves (C-K Models)

OVERHEAD SYSTEM—C-K MODELS

The Overhead System is used in conjunction with the C60 System. Since replacement of C60 System components has been covered previously, only those components peculiar to the Overhead System will be covered in this section.

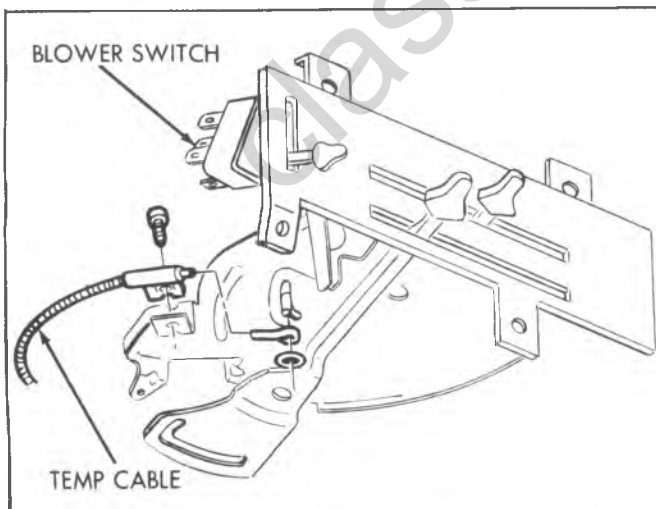


Fig. 1B-32—Control Assembly (C-K C60 System)

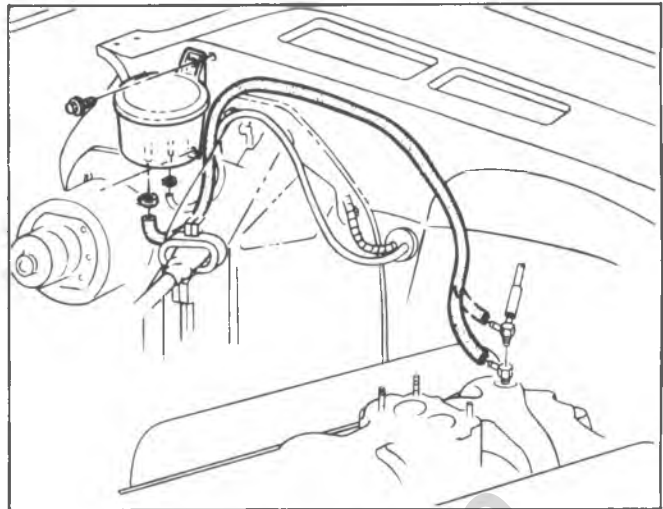


Fig. 1B-33—Vacuum Tank (C-K Series)

REAR DUCT

This duct covers the blower-evaporator assembly, at the rear of the vehicle, and incorporates four adjustable air outlets (fig. 1B-36).

Replacement

1. Disconnect the battery ground cable.
2. Disconnect the drain tube from the rear duct.
3. Remove the screws securing the duct to the roof panel and rear header brackets.
4. Remove the duct.
5. To install, reverse Steps 1-4 above.

BLOWER MOTOR RESISTOR

The blower motor resistor is located on the cover side of the C60 System blower-evaporator as shown in Figure 1B-37.

Replacement

1. Disconnect battery ground cable.
2. Disconnect the electrical harness at the resistor.
3. Remove the resistor attaching screws and remove the resistor.
4. To install a new resistor, reverse Steps 1-3 above.

BLOWER MOTOR ASSEMBLY

Removal (Fig. 1B-38)

1. Disconnect the battery ground cable.
2. Remove the rear duct as outlined previously.
3. Disconnect the blower motor ground strap.
4. Disconnect the blower motor lead wire.
5. Remove the lower to upper blower-evaporator case screws and lower the lower case and motor assembly.

NOTICE: Before removing the case screws, support the lower case to prevent damage to the case or motor assemblies.

6. Remove the motor retaining strap and remove the motor and wheels. Remove the wheels from the motor shaft.

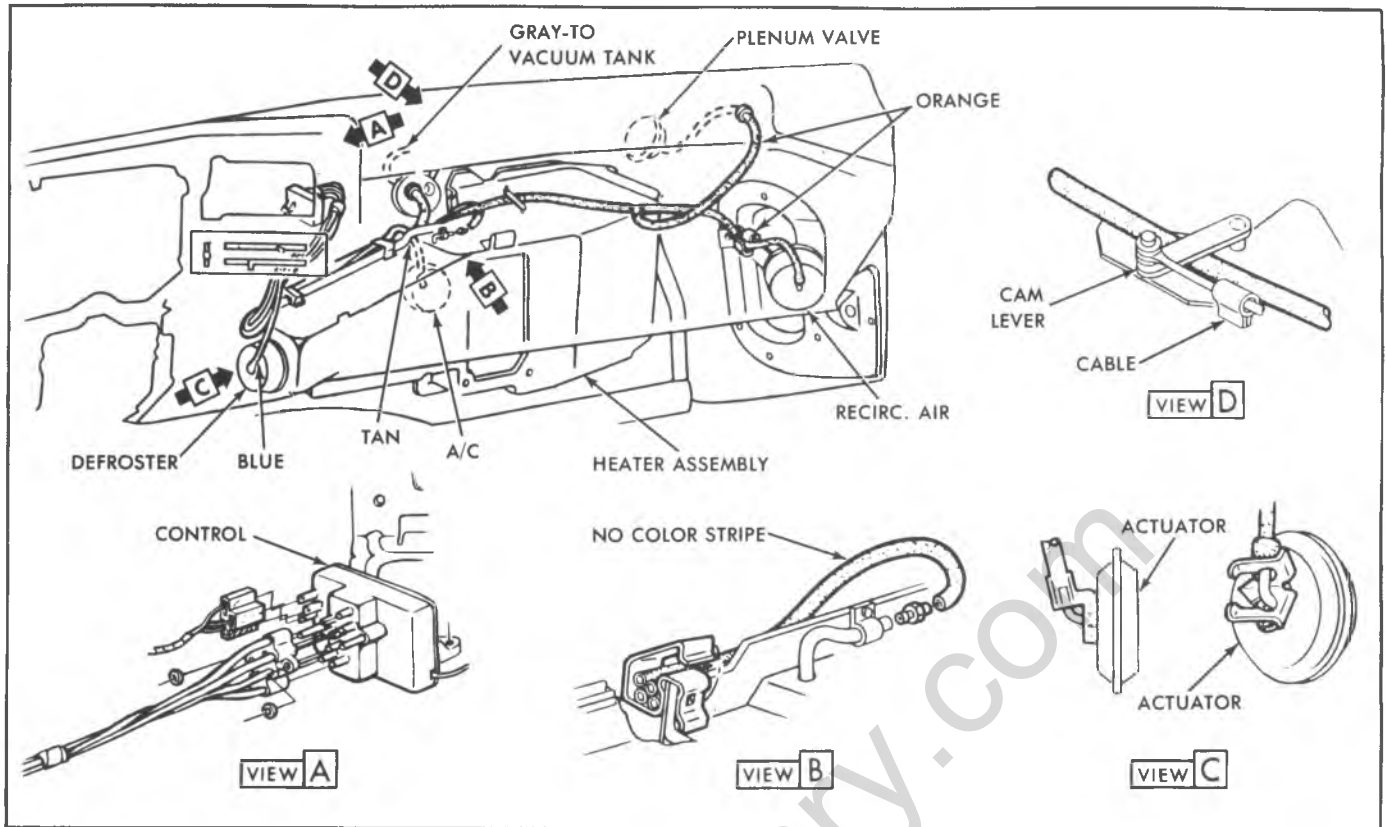


Fig. 1B-34--Vacuum Line Routing - CK Models

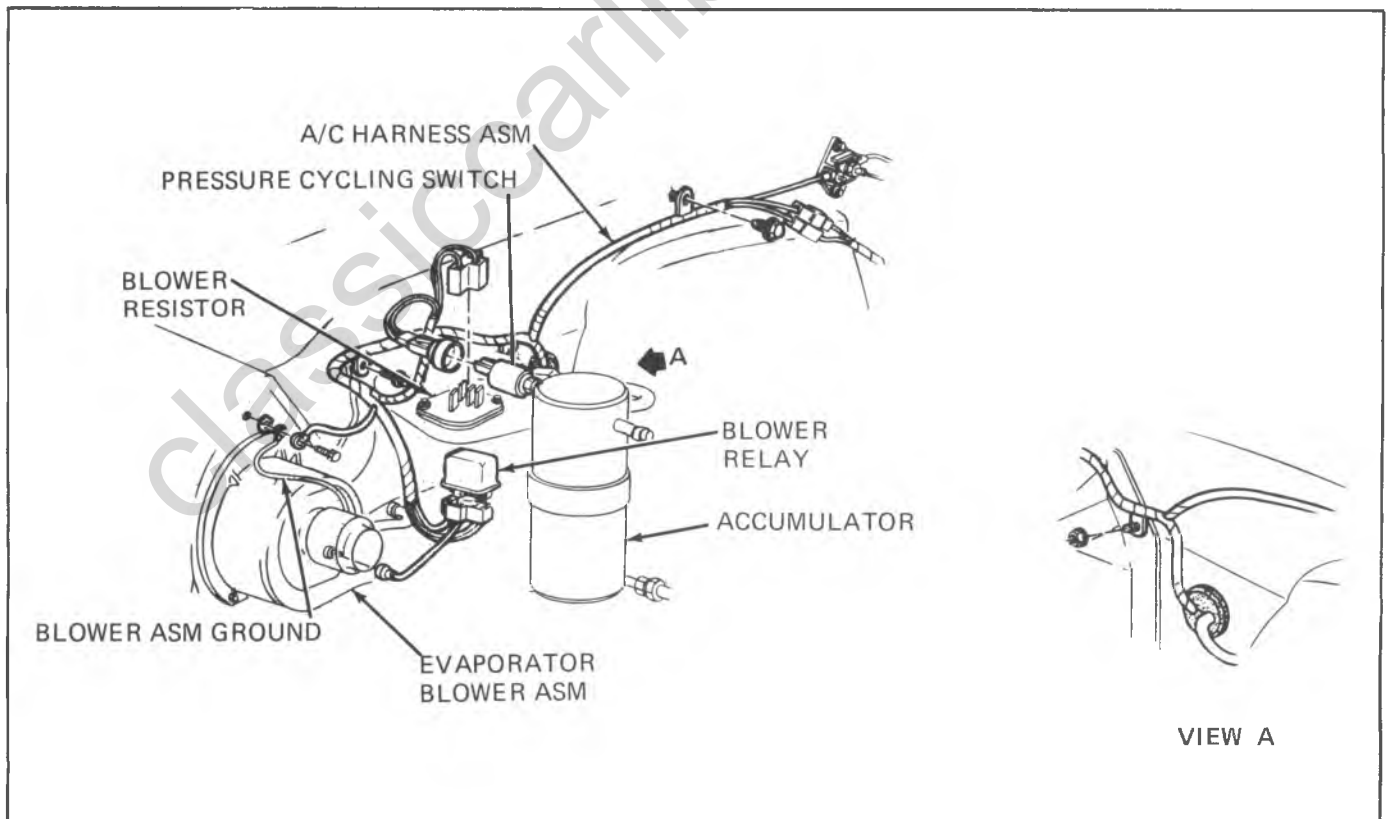


Fig. 1B-35--Engine Compartment Wiring Harness (C-K Series)

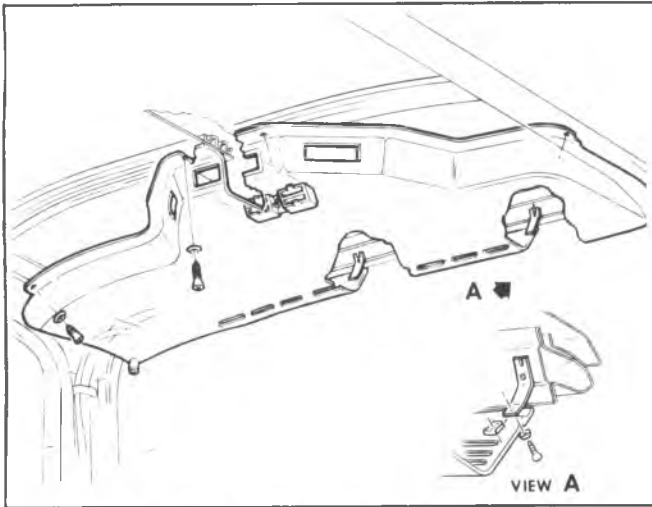


Fig. 1B-36—Rear Duct (C-K and G Overhead System)

Installation

1. Place the blower wheels onto the motor shaft making sure the wheel tension springs are installed on hub of wheels.

Be sure that the blower wheels are installed as shown in Figure 1B-39.

2. Install the blower motor retaining strap and foam.

3. Place the blower motor and wheel assembly into the lower case. Align the blower wheels so that they do not contact the case.

4. Place the lower case and blower motor assembly in position in the vehicle and install the lower to upper case screws.

NOTICE: Rotate the blower wheels to make sure that they do not rub on the case.

5. Install the center ground wire and connect the blower lead wire.

6. Install the rear duct assembly as described previously.

7. Connect the battery ground cable.

EXPANSION VALVE

This system incorporates an expansion valve which does not utilize an external equalizer line (fig. 1B-40).

Removal

1. Disconnect battery ground cable.

2. Purge the system of refrigerant.

3. Remove the rear duct as outlined previously.

4. Disconnect the blower motor lead and ground wires.

5. Remove the lower to upper blower-evaporator case screws and lower the lower case and motor assembly.

NOTICE: Before removing the case screws, support the lower case and motor assemblies to prevent damage to the case or motor assemblies.

6. Remove the expansion valve sensing bulb clamps.

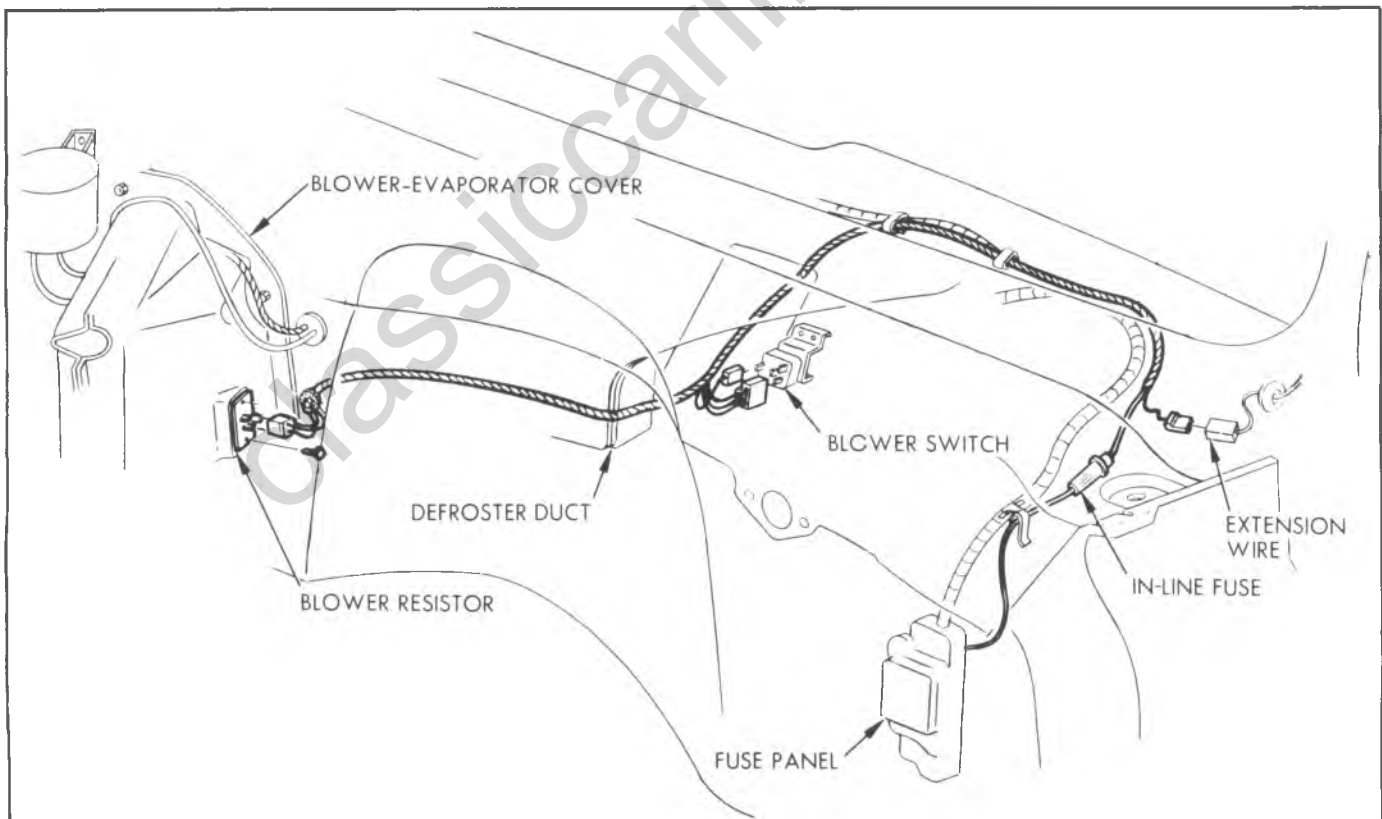


Fig. 1B-37--Overhead System Front Wiring (C-K Models)

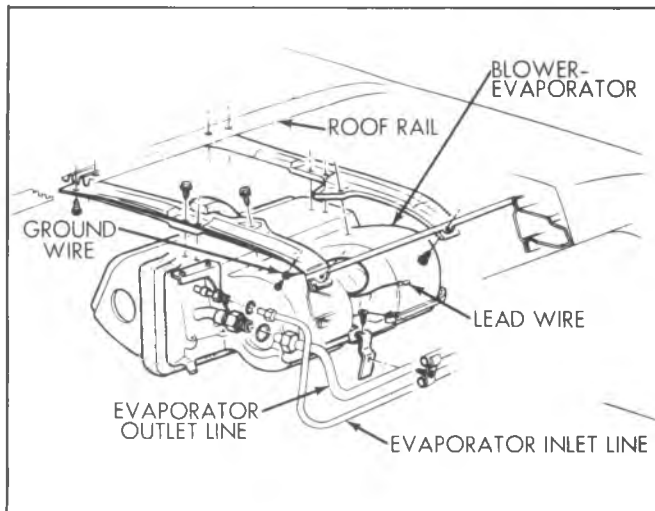


Fig. 1B-38-Blower-Evaporator (C-K Overhead System)

7. Disconnect the valve inlet and outlet lines and remove the expansion valve assembly. Cap or plug the open connections at once.

Installation

1. Remove caps or plugs from system connections and install the new valve assembly using new "O" rings coated with clean refrigeration oil.
2. Install the sensing bulb, making sure that the bulb makes good contact with the core outlet line.
3. Install the lower case and blower motor assemblies. Connect the blower motor lead and ground wires.
4. Install the rear duct as outlined previously.
5. Connect the battery ground cable.
6. Evacuate, charge and check the system.

EVAPORATOR CORE (Fig. 1B-40)

Removal

1. Disconnect the battery ground cable.
2. Purge the system of refrigerant.
3. Remove the rear duct as outlined previously.

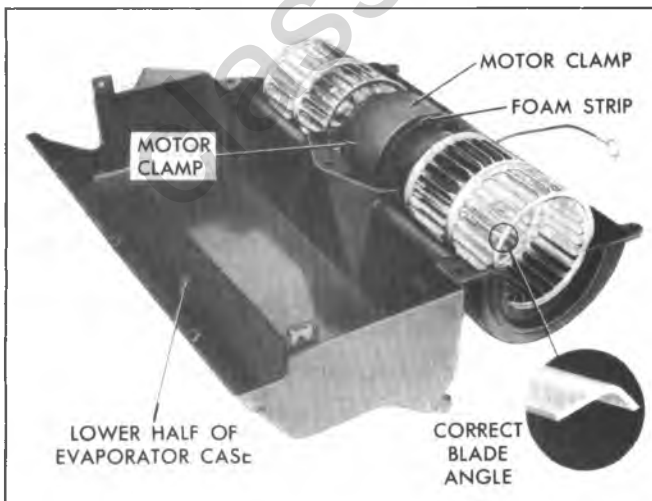


Fig. 1B-39-Blower Motor (C-K Overhead System)

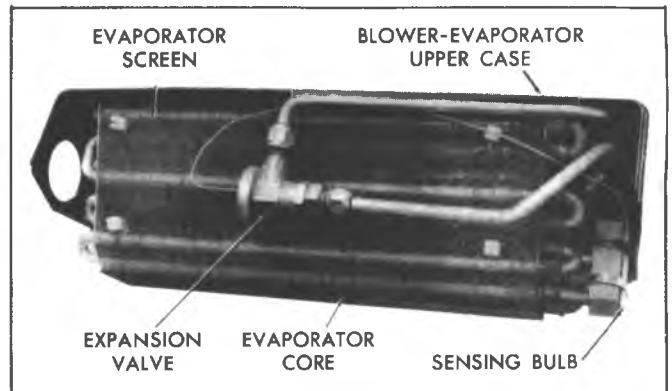


Fig. 1B-40-Expansion Valve C69 System

4. Disconnect the blower motor lead and ground wire connections.

5. Disconnect the refrigerant lines at the rear of the blower-evaporator assembly. Cap or plug the open connections at once.

6. Remove the blower-evaporator support to roof rail screws, lower the blower-evaporator assembly and place it on a work bench upside down.

7. Remove the lower to upper case screws and remove the lower case assembly. Remove the support to upper case screws and remove the upper case from the evaporator core.

8. Remove the expansion valve inlet and outlet lines and cap or plug the open connections at once. Remove the expansion valve capillary bulb from the evaporator outlet line and remove the valve.

9. Remove the plastic pins holding the screen to the core and remove the screen.

Installation

1. Install the wire screen to the front of the core and insert the plastic pins.

2. Install the expansion valve inlet and outlet lines using new "O" rings coated with clean refrigeration oil. Install the sensing bulb to the evaporator outlet line as shown in Figure 1B-44; make sure the bulb has good contact with the line.

Add 3 oz. clean refrigeration oil when installing a new core.

3. Install the upper case and supports to the core.
4. Install the lower core case and blower assembly.
5. Install the blower-evaporator assembly to the roof and install the support to roof rail screws.
6. Connect the refrigerant lines to the blower-evaporator unit using new "O" rings coated with clean refrigeration oil.
7. Connect the blower lead and ground wires.
8. Install the rear duct as outlined previously.
9. Connect the battery ground cable.
10. Evacuate, charge and check the system.

BLOWER MOTOR SWITCH

The three-speed (LO-MED-HI) blower motor switch is located in the instrument panel, just to the left of the ash tray (fig. 1B-41).



Fig. 1B-41--Blower Switch (C-K Overhead System)

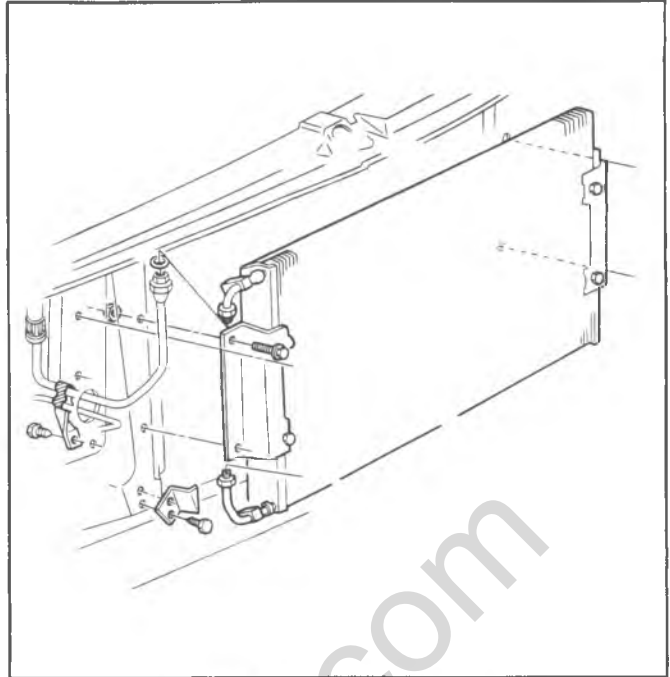


Fig. 1B-42--Condenser-G Series

Replacement

1. Disconnect the battery ground cable.
2. Remove the switch retaining screws.
3. Disconnect the wiring harness at the switch and remove the switch.
4. To install, reverse Steps 1-3 above.

FUSE

The Four Season portion of this system is protected by a 25 amp fuse in the junction block.

The rear blower high speed circuit is protected by a 20 amp in-line fuse, located between the junction block and the rear blower motor switch.

C60 SYSTEM-G SERIES**CONDENSER - G Series****Replacement (Fig. 1B-42)**

1. Disconnect battery ground cable.
2. Purge the system of refrigerant.
3. Remove grille, and hood lock and center hood lock support as an assembly.
4. Disconnect condenser inlet and outlet lines at condenser.
5. Remove screws attaching left side condenser bracket to radiator.
6. Remove screws attaching right side condenser bracket to condenser.
7. Remove condenser from vehicle.
8. Remove left hand bracket from condenser.
9. To install new condenser, reverse steps 3 thru 8 above.
10. Add 1 ounce of clean refrigeration oil to a new condenser.
11. Evacuate charge and test the system.

Refer to figures 1B-61 thru 1B-66 for condenser inlet and outlet connections, compressor refrigerant line connections, and general refrigerant line routing and connections.

HEATER AIR DISTRIBUTOR AND EXTENSION DUCT - G SERIES**Replacement (Fig. 1B-43)**

1. Disconnect battery ground cable.
2. Remove engine cover.
3. Remove evaporator-blower shield.
4. Remove shield bracket.
5. Remove left floor outlet deflector and bracket.
6. Loosen steering column to instrument panel reinforcement screws. Remove one screw. Torque both screws on installation.
7. Disconnect speedometer cable at meter.

HEATER CORE - G SERIES**Replacement**

1. Disconnect battery ground cable.
2. Remove engine cover as outlined in Section 6A of this manual.
3. Remove steering column to instrument panel attaching bolts and lower column.
4. Remove upper and lower instrument panel attaching screws and radio support bracket attaching screw.
5. Raise and support right side of instrument panel.
6. Remove right lower instrument panel support bracket.
7. Remove recirculating air door vacuum actuator. See Figure 1B-44.
8. Disconnect temperature cable and vacuum hoses at distributor case.
9. Remove heater distributor duct. (Figure 1B-45).
10. Remove 2 defroster duct to dash panel attaching screws (below windshield).
11. Working from the engine compartment, disconnect heater hoses and plug to prevent water spillage.

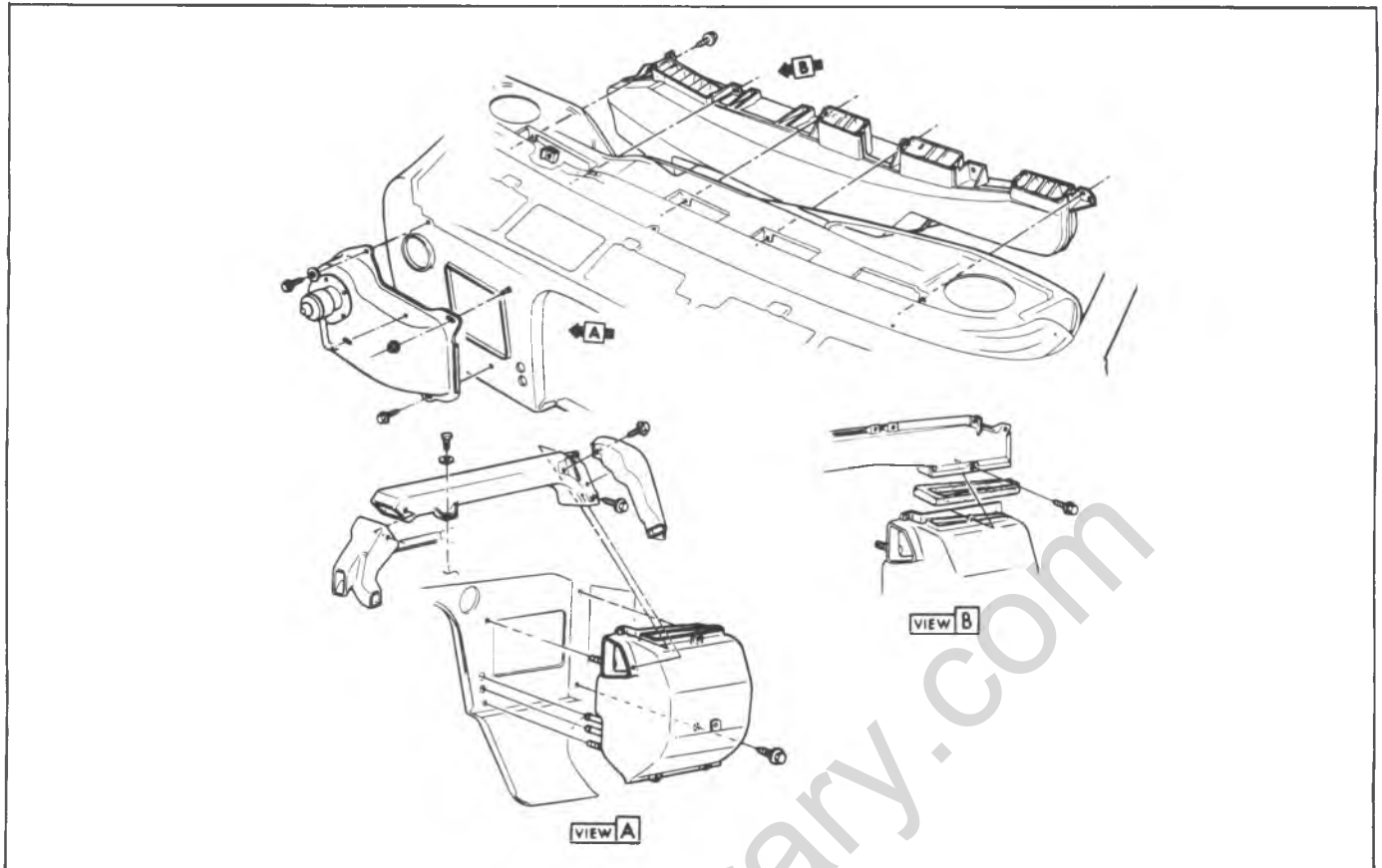


Fig. 1B-43--Heater Distributor Duct-G Series

12. Remove three (3) nuts from bolts attaching heater core case to dash panel and one (1) screw at lower right corner (inside).

13. Remove distributor assembly from vehicle.

14. Remove gasket (Fig. 1B-46) to expose screws attaching case sections together.

15. Remove temperature cable support bracket.

16. Remove case attaching screws and separate case.

17. Remove heater core.

18. To install new heater core, reverse steps 2 through 17 above.

BLOWER MOTOR - G SERIES

Replacement

1. Disconnect battery ground cable.

G Series - Remove the coolant recovery tank, and power antenna as outlined in Sections 6 and 9.

2. Disconnect the blower motor lead wire.

3. Remove the five blower motor mounting screws and remove the motor and wheel assembly. Pry gently on the blower flange if the sealer acts as an adhesive.

4. Remove the blower wheel to motor shaft nut and separate the wheel and motor assemblies.

5. To install a new motor, reverse Steps 1-4 above.

The following steps should be taken to assure proper installation:

a. Assemble the blower wheel to the motor with the open end of the wheel away from the blower motor.

b. If the motor mounting flange sealer has hardened, or is not intact, remove the old sealer and apply a new bead of sealer to the entire circumference of the mounting flange.

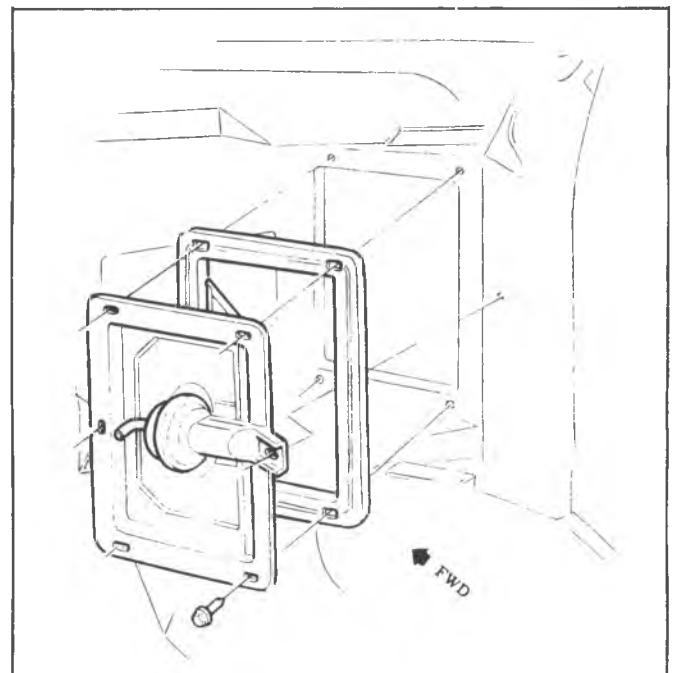


Fig. 1B-44--Recirculating Air Door Vacuum Actuator

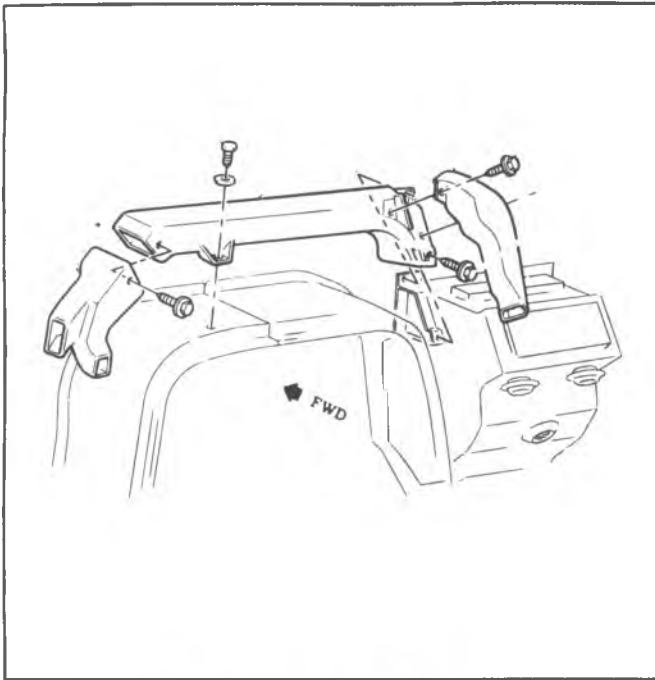


Fig. 1B-45-Heater Distributor Duct

c. Check blower operations: blower wheel should rotate freely with no interference.

EVAPORATOR CORE

Replacement (Fig. 1B-54)

1. Disconnect battery ground cable.
2. Purge system of refrigerant.
3. Remove coolant recovery tank and bracket as outlined earlier.

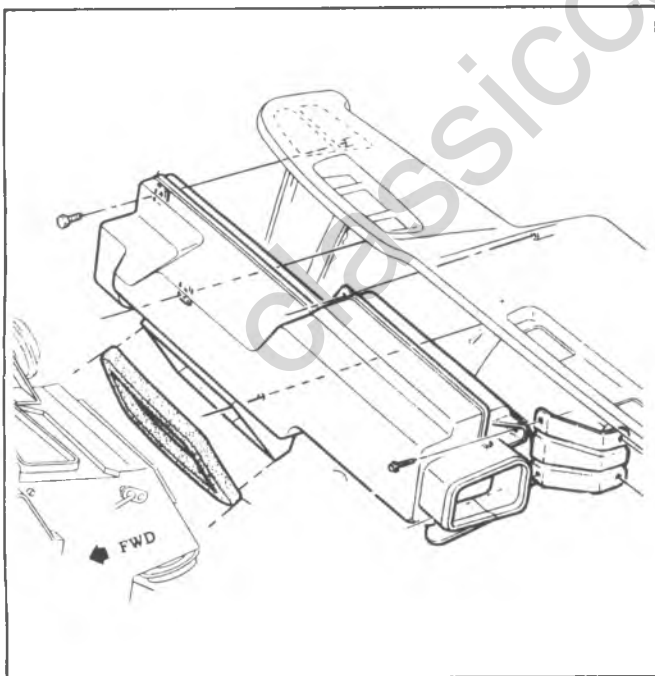


Fig. 1B-46-Distributor Gasket

4. Disconnect all electrical connectors from core case assembly.
5. Remove bracket at evaporator case.
6. Remove right hand marker lamp for access.
7. Disconnect accumulator inlet and outlet lines and 2 brackets attaching accumulator to case.
8. Disconnect evaporator inlet line.
9. Remove three (3) nuts and one (1) screw attaching module to dash panel.
10. Remove core case assembly from vehicle.
11. Remove screws and separate case sections.
12. Remove evaporator core.
13. To install new core, reverse steps 3 thru 14 above.
14. Add 3 oz. 525 viscosity refrigeration oil to a new condenser.
15. Evacuate charge and check the system.

TEMPERATURE DOOR CABLE - G SERIES

Replacement

Follow Steps 1-10 of "Heater Air Distributor and Extension Duct Replacement" procedure.

11. Disconnect temperature door control cable at heater case.
12. Disconnect temperature door control cable at control.
13. Make up new cable.
14. To reassemble, Reverse Steps 1-13.

CONTROL - G SERIES

Replacement (Fig. 1B-48)

1. Disconnect the battery ground cable.
2. Remove the headlamp switch control knob.
3. Remove the instrument panel bezel.
4. Remove the control to instrument panel attaching screws.
5. Remove the temperature cable eyelet clip and mounting tab screw.
6. Pull the control through the instrument panel opening as follows: First pull the lower right mounting tab through the opening, then the upper tab and finally the lower right tab.
7. Disconnect electrical and vacuum connections and remove the control assembly.
8. To install, reverse Steps 1-7 above. Check temperature door operation; adjust if necessary.

BLOWER SWITCH

Replacement (Fig. 1B-48)

1. Disconnect the battery ground cable.
2. Remove the left foot cooler outlet assembly at the instrument panel attachment.
3. Disconnect the switch electrical harness.
4. Remove the switch mounting screws and remove the switch.
5. To install, reverse Steps 1-4 above.

RESISTORS

Replacement (Fig. 1B-49)

1. Disconnect electrical harness at the resistor.
2. Remove the resistor mounting screws and remove the resistor.

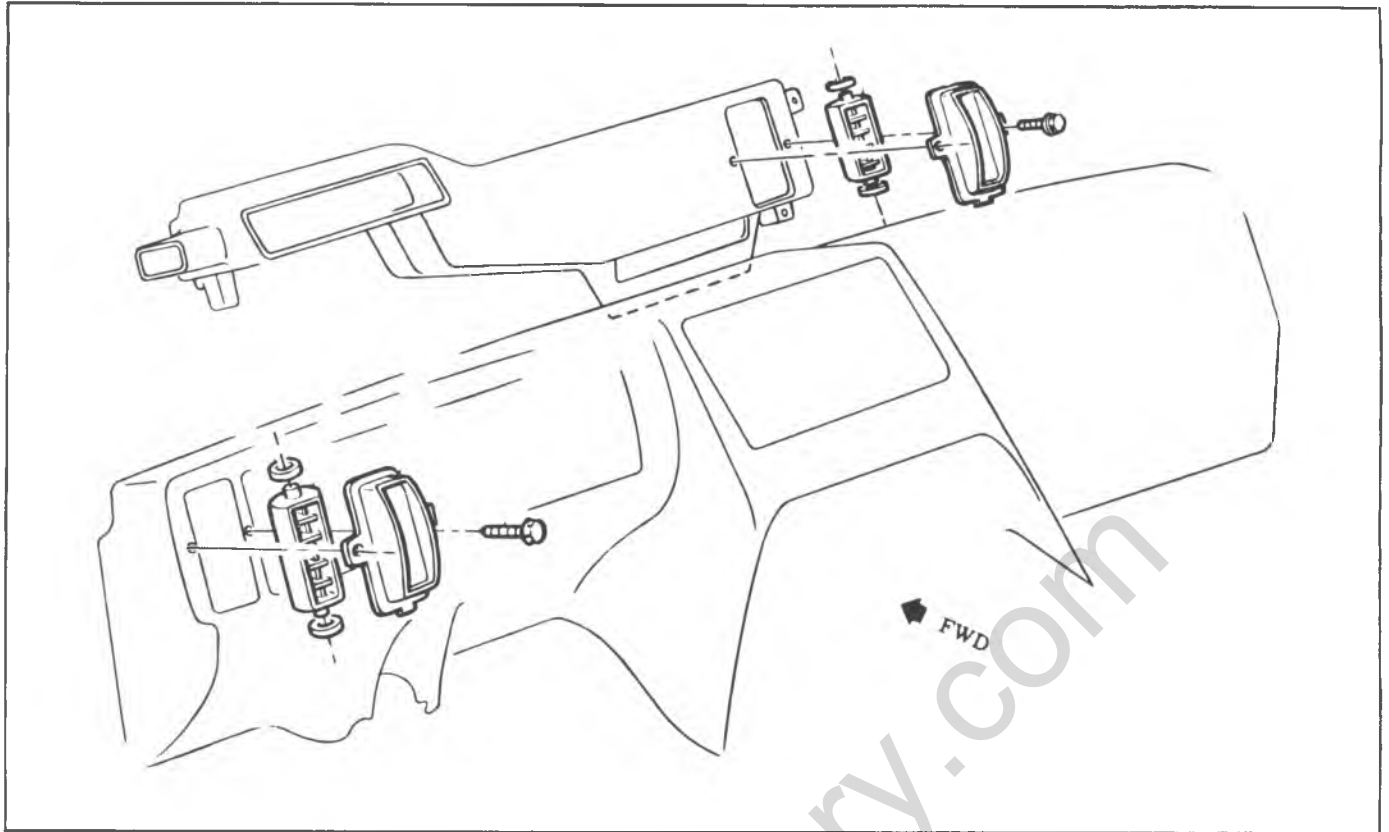


Fig. 1B-47--Air Deflector Outlets (G Series C60 System)

3. To install, reverse Steps 1-3 above.

3. To install, reverse Steps 1-3 above.

BLOWER MOTOR RELAY - G SERIES

CENTER A.C. OUTLET - G SERIES

Replacement (Fig. 1B-49)

Replacement

1. Disconnect electrical harness at the relay.
2. Remove the relay mounting screw and remove the relay.

1. Disconnect negative battery cable.
2. Remove engine cover (see Section 6A).
3. Remove steering column to I.P. attaching screw.
4. Remove radio support bracket screw.
5. Remove I.P. attaching screws.
6. Pull right side of I.P. rearward.

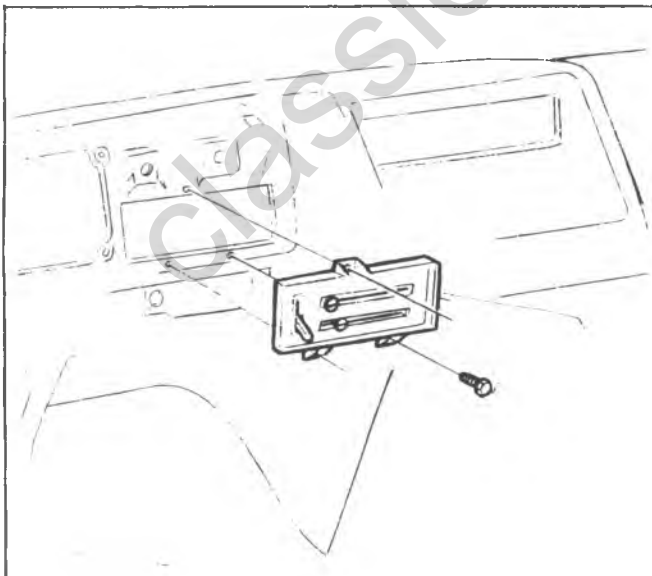


Fig. 1B-48--Control (G Series C60 System)

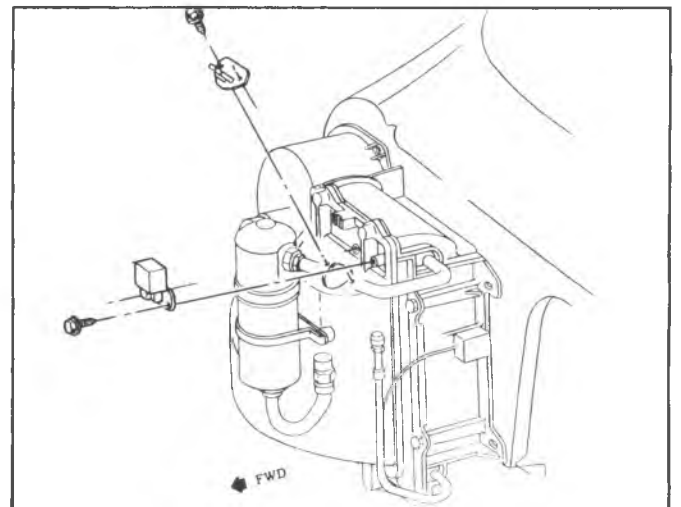


Fig. 1B-49--Blower Motor Relay

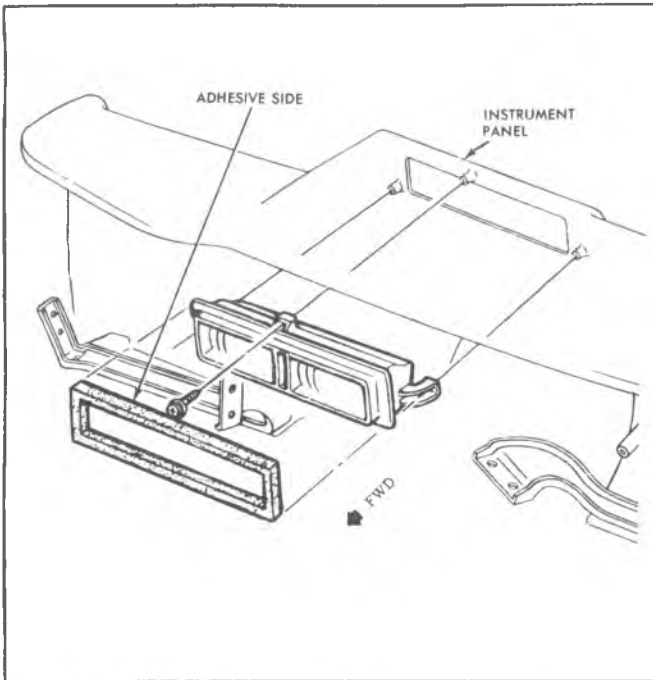


Fig. 1B-50--Center A/C Outlet Assembly-G Series

7. Remove duct (distributor) attaching screws.
8. Remove center deflector.
9. To replace, reverse steps 1 - 8 above.

VACUUM LINES-G VAN

Replacement

Vacuum line routing is illustrated in Figure 1B-52.

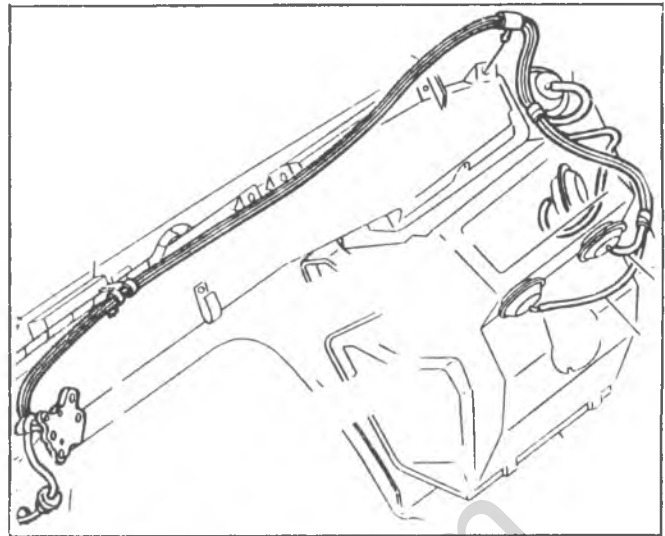


Fig. 1B-52--Vacuum Harness (G Series)

A/C DUCTWORK

Air Conditioning duct attachment is illustrated in Figure 1B-63.

DEFROSTER DUCT

Defroster duct mounting is illustrated in Figure 1B-64.

TEMPERATURE DOOR CABLE

Temperature cable attachment and routing is illustrated in Figure 1B-65.

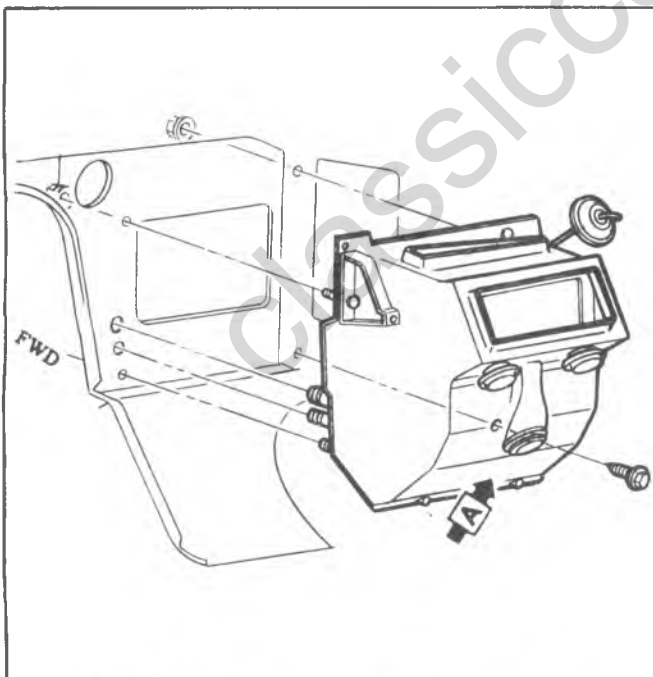


Fig. 1B-51--Heater Defroster Assembly-G Series

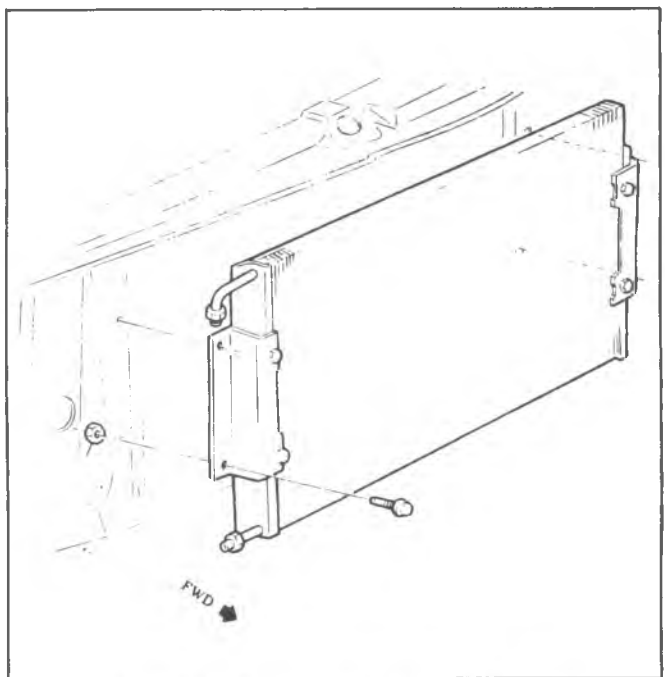


Fig. 1B-53--Condenser Installation-G Series

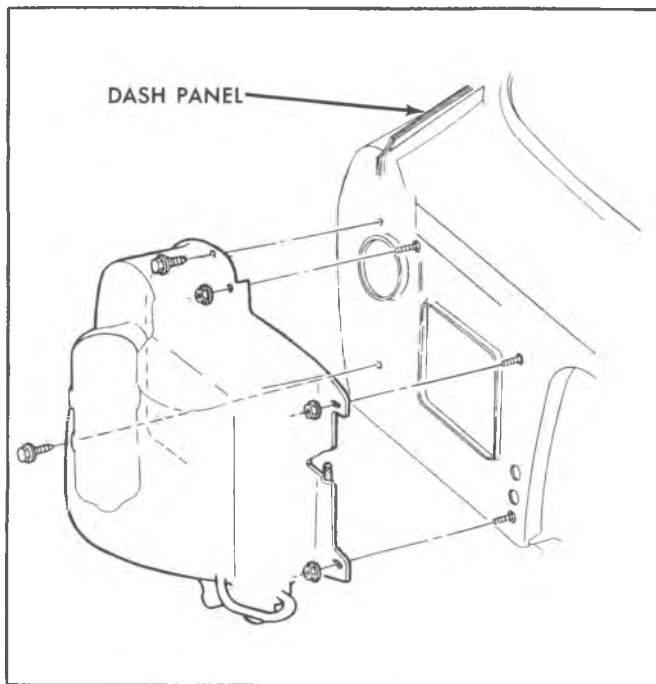


Fig. 1B-54--Evaporator Blower Assembly-G Series

VACUUM TANK - G SERIES (Figures 1B-60 & 1B-61)

Replacement

1. Raise the hood.
2. Disconnect the vacuum harness at the tank.
3. Remove the tank attaching screws and remove the tank.
4. To install, reverse Steps 1-3 above.

CIRCUIT BREAKER

The entire air conditioning system is protected by a 45 amp circuit breaker located on the left side of the dash, in the engine compartment.

OVERHEAD SYSTEM-G SERIES

This system is used in conjunction with the C60 system.

The G Van C69 system is almost identical to the CK Series overhead system. Refer to CK Series overhead system service procedures.

classiccarslibrary.com

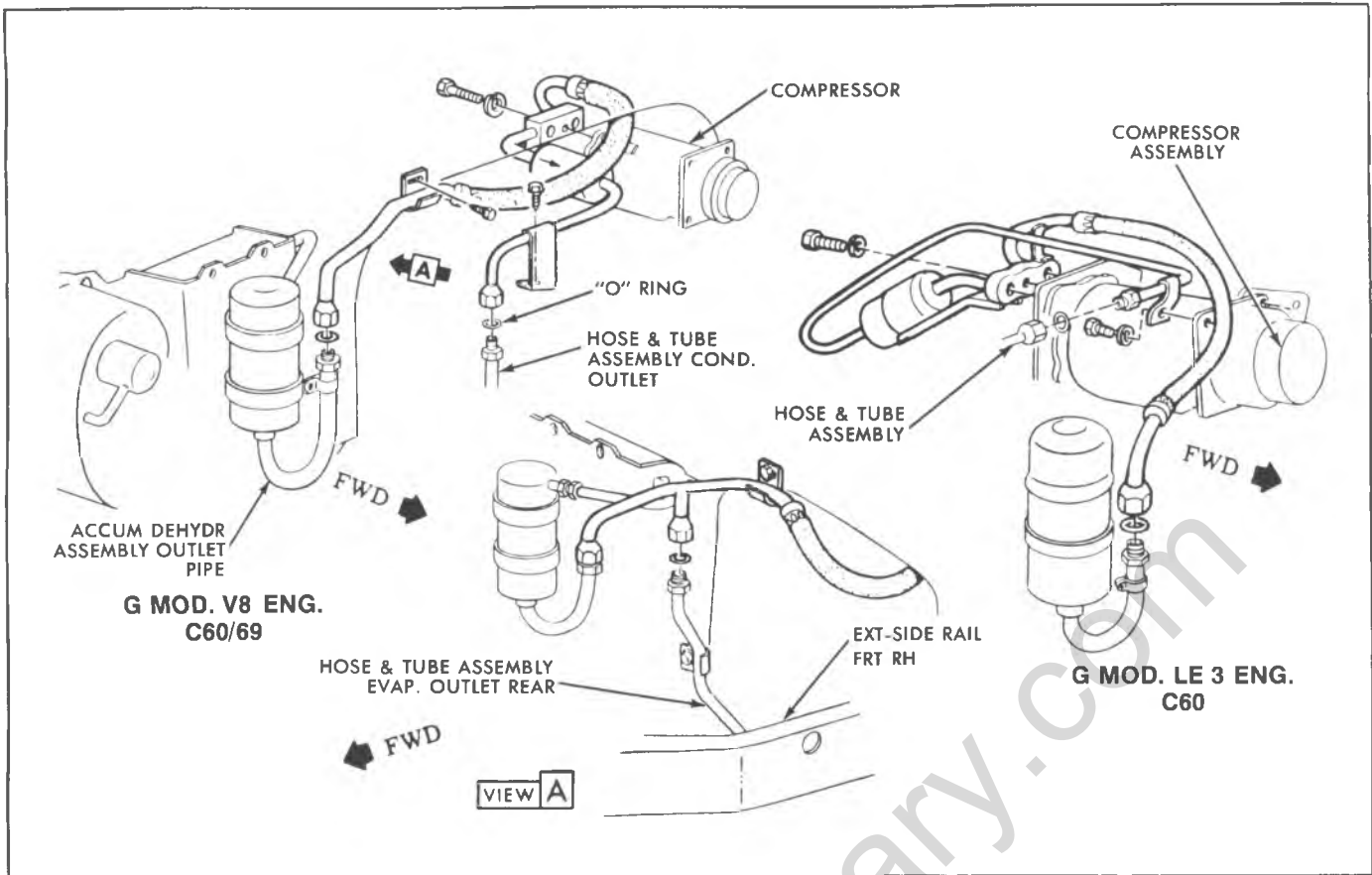


Fig. 1B-55--Refrigerant Lines - G Series

classiccarslibrary.com

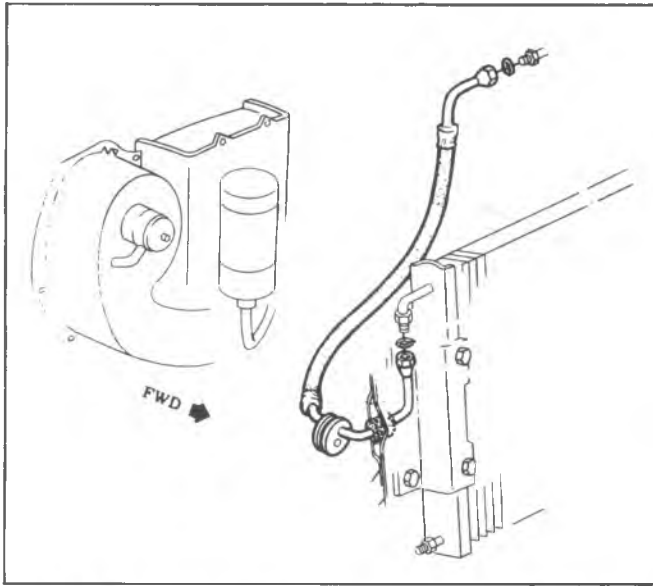


Fig. 1B-56—Refrigerant Lines—Condenser Inlet 6 Cyl Engine

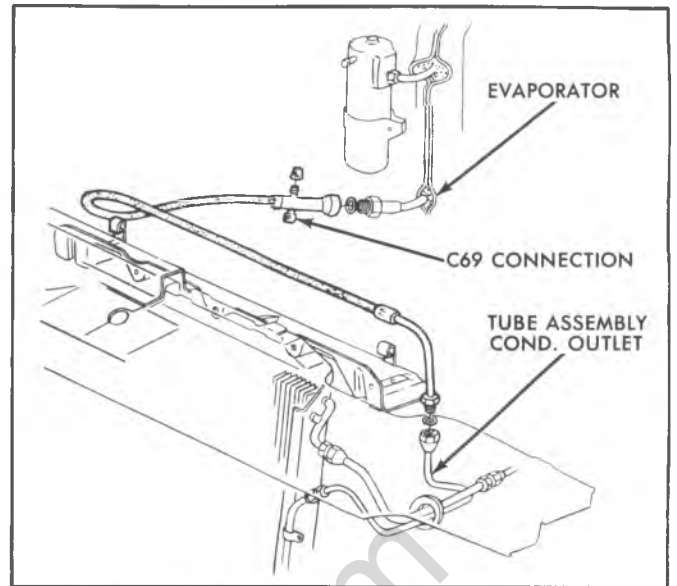


Fig. 1B-58—CK Series Refrigerant Lines—V8

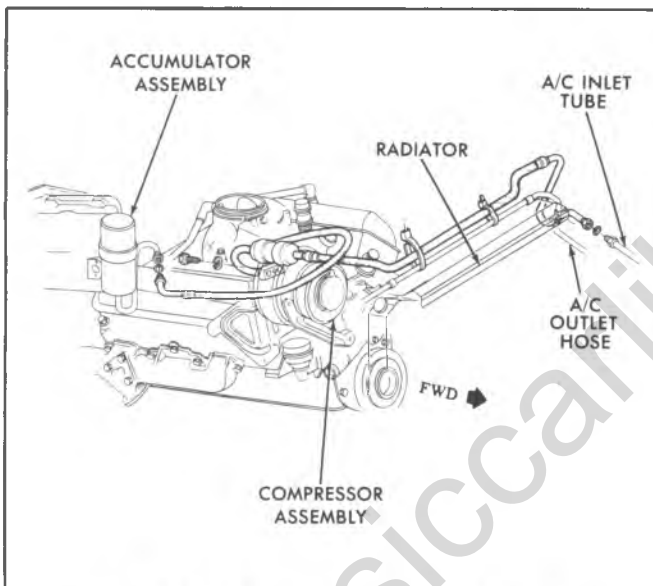


Fig. 1B-57—Refrigerant Lines—Diesel Engine

classiccarrlibrary.com

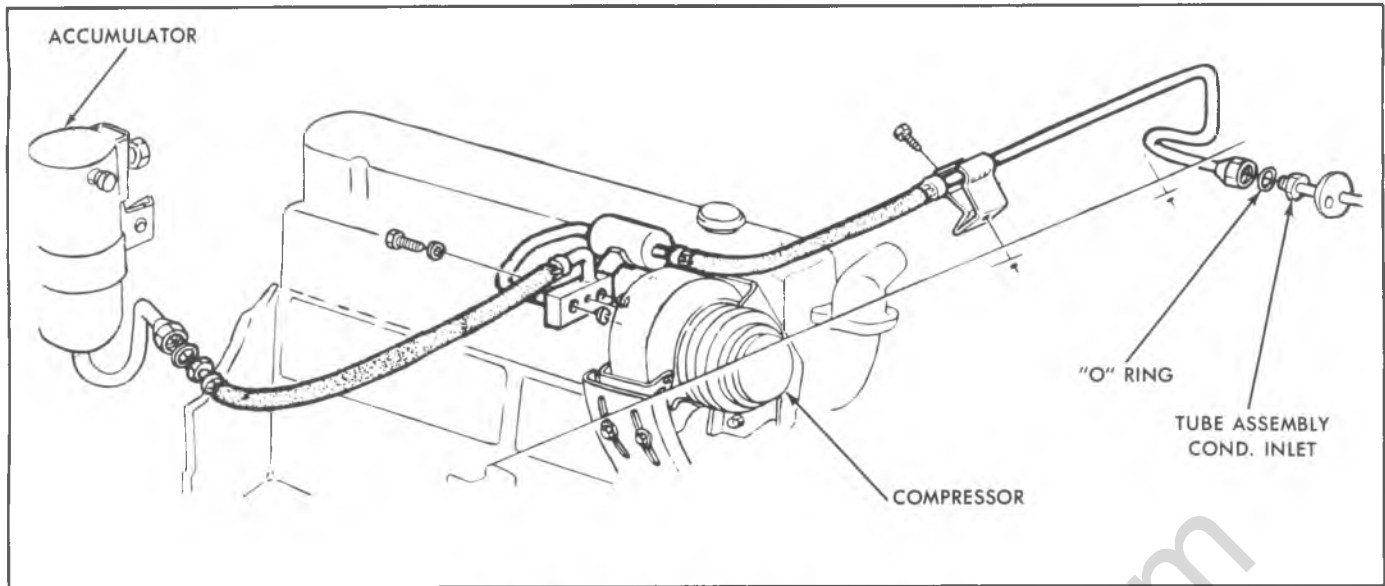


Fig. 1B-59--CK Series Refrigerant Lines-L6

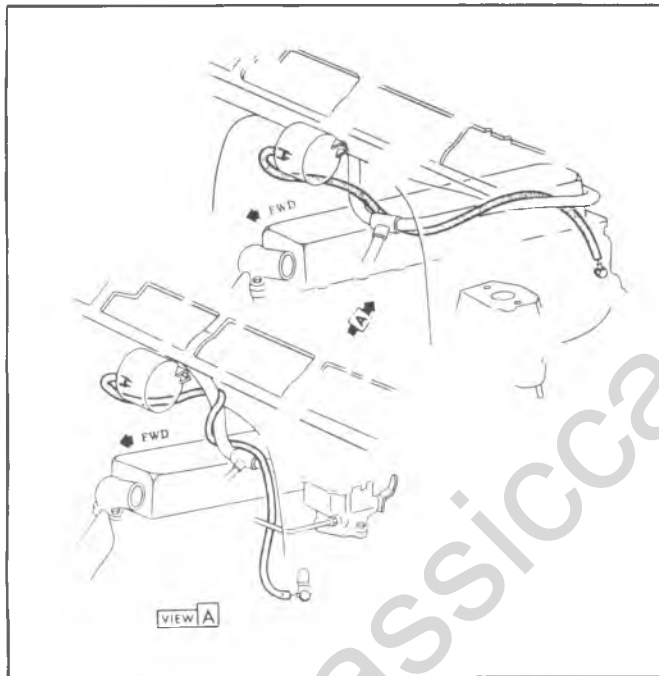


Fig. 1B-60--Vacuum Tank-G Series with 6 Cyl. Engine

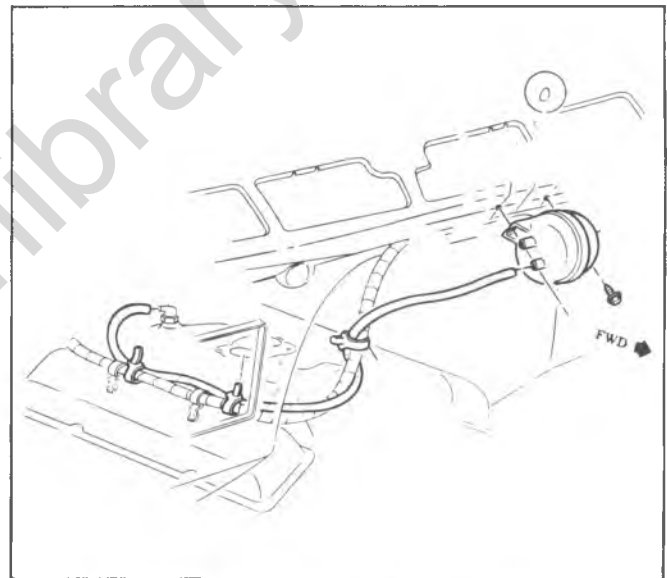


Fig. 1B-61--Vacuum Tank G Series-V8 Engine

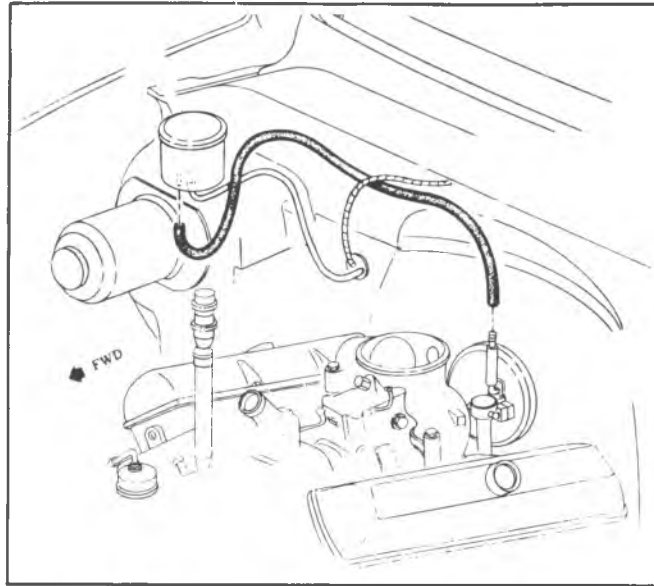


Fig. 1B-62--Vacuum Tank CK Series-Diesel Engine

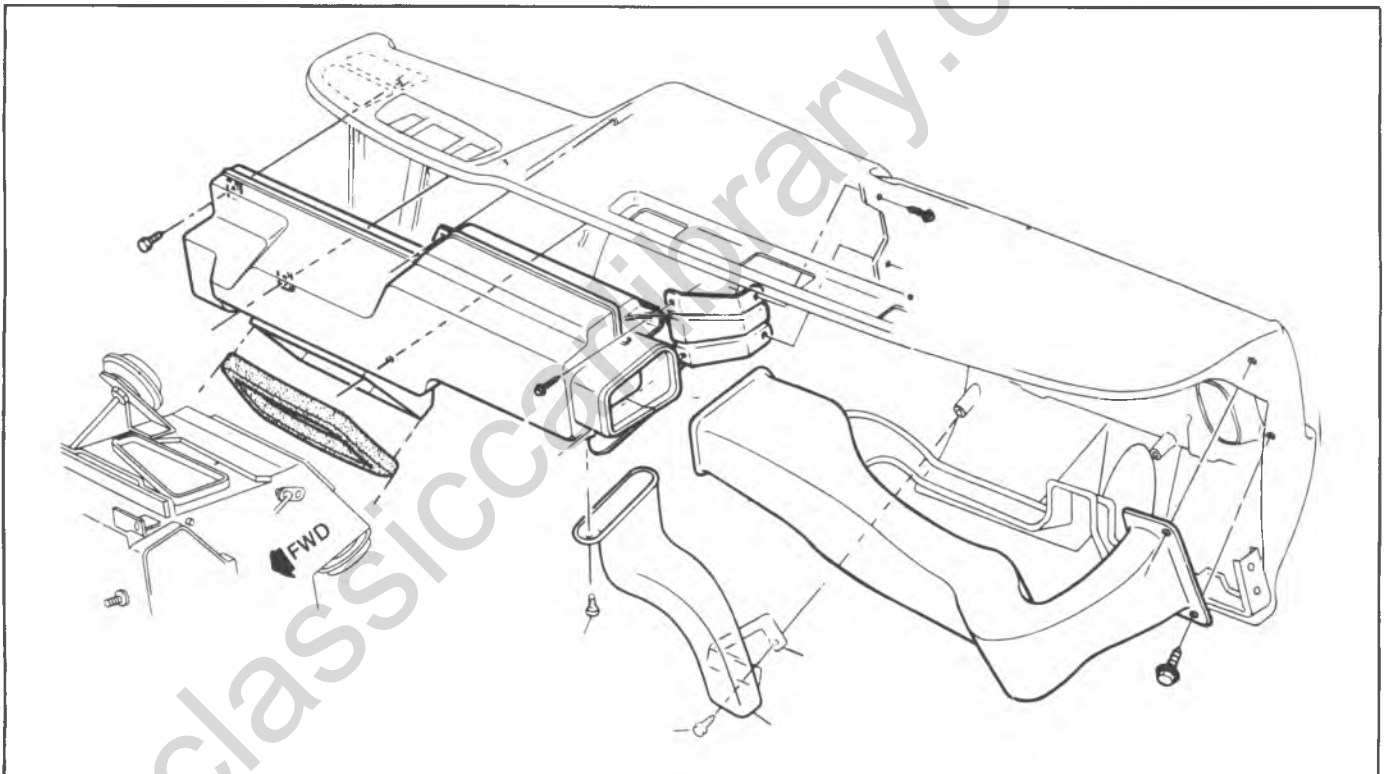


Fig. 1B-63--A/C Ducts-G Series

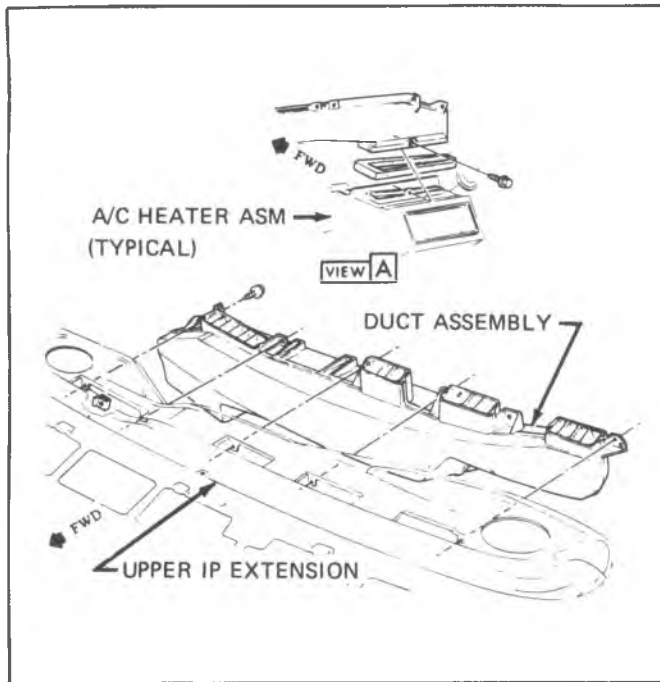


Fig. 1B-64--Defroster Duct-G Series

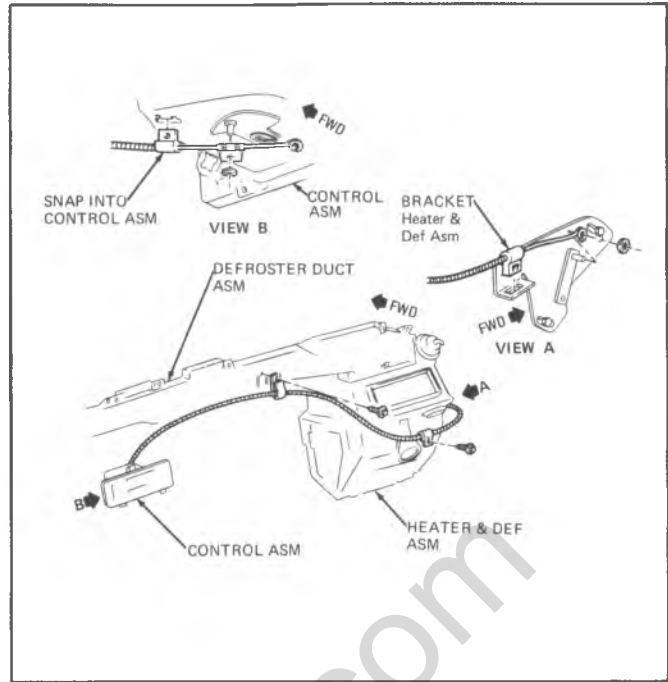


Fig. 1B-65--Temperature Cable-G Series

DASH MOUNTED SYSTEM--MOTOR HOME CHASSIS

This system is installed on the vehicle and checked at assembly. The blower-evaporator is then disconnected and shipped with the chassis unit to the body supplier. For this reason, it will only be possible to give basic replacement procedures on some components.

CONDENSER

Replacement (Fig. 1B-66)

1. Disconnect the battery ground cable.
2. Purge the system of refrigerant.
3. Disconnect the condenser inlet and outlet lines and cap or plug all open connections at once.
4. Remove the condenser to radiator support screws and remove the condenser.
5. To install a new condenser, reverse Steps 1-4 above. Add one foud ounce of clean refrigeration oil to a new condenser.

NOTICE: Use new "O" rings, coated with clean refrigeration oil, when connecting all refrigerant lines.

6. Evacuate, charge and check the system.

RECEIVER-DEHYDRATOR

Replacement (Fig. 1B-67)

1. Disconnect the battery ground cable.
2. Purge the system of refrigerant.
3. Disconnect the inlet and outlet lines at the receiver-dehydrator and cap or plug the open lines at once.

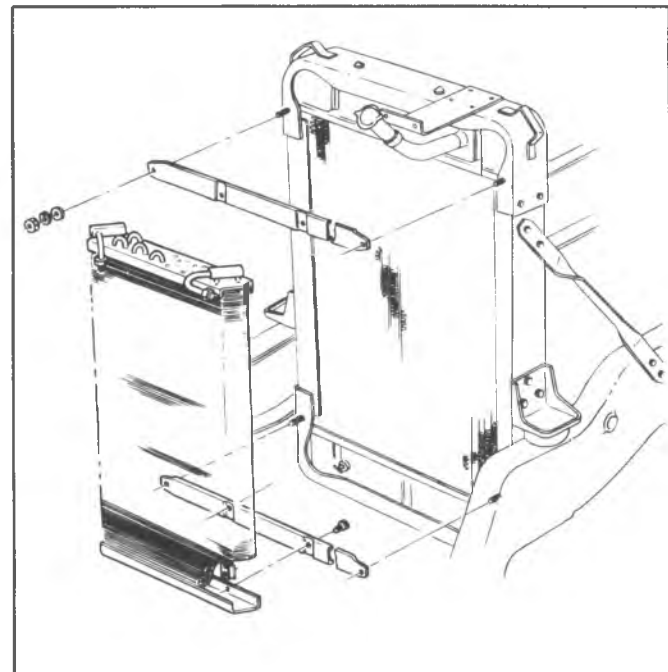


Fig. 1B-66--Condenser (Motor Home Chassis Unit)

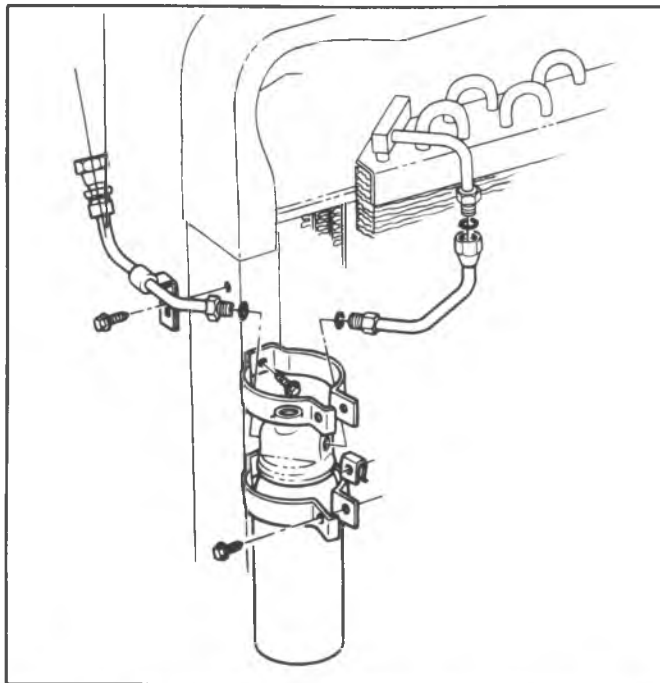


Fig. 1B-67—Receiver-Dehydrator (Motor Home Chassis Unit)

NOTICE: Use new "O" rings, coated with clean refrigeration oil, when connecting all refrigerant lines.

6. Evacuate, charge and check the system.

SIGHT GLASS REPLACEMENT

If damage to the sight glass should occur, a new sight glass kit should be installed. The kit contains the sight glass, seal and retainer. (See Figure 1B-68).

1. Purge system.
2. Remove the sight glass retainer nut using a screwdriver and remove old glass and "O" ring seal.
3. Install the new glass and seal and retainer nut, being careful not to turn the nut past the face of the housing. To do so may damage the "O" ring seal.
4. Evacuate, charge and check the system.

BLOWER-EVAPORATOR ASSEMBLY (Fig. 1B-69)

Removal

1. Disconnect battery ground cable.
2. Purge system of refrigerant.
3. Disconnect inlet and outlet refrigerant lines from the back of unit. Cap or plug all open connections at once.
4. Disconnect drain tubes from evaporator case.
5. Disconnect electrical connector from compressor. Remove the terminal (See Figure 1B-70) and allow connector to hang on ground wire.
6. Remove screws securing grommet retainer to dash panel. Remove wire from grommet through slit.
7. Disconnect electrical lead at connector.
8. Remove unit mounting bolts. Remove unit from vehicle, carefully pulling compressor electrical lead through dash panel.

Once the unit has been removed from the vehicle, continue with component replacement as follows:

BLOWER ASSEMBLY

Removal (Fig. 1B-71)

1. Remove the cover plate and separate the upper and lower case halves. Remove blower motor mounting strap screw and remove strap.
2. Remove blower assembly. Remove the wheels from the motor shaft.

Installation

1. Install the blower wheels on the motor so that the lower blades curve toward the dash panel side of the unit when the motor is placed in the case as illustrated in Figure 1B-85.
2. Place the motor in the bracket with the electrical connector side of the motor to the right side of the bracket. Attach the mounting strap. Align blower wheels so that they do not contact case.
3. Assemble the case halves and attach the cover plate.
4. Reverse Steps 1-8 on the "Blower-Evaporator Assembly" removal procedure.
5. Evacuate, charge and check the system.

EXPANSION VALVE, EVAPORATOR AND/OR EVAPORATOR CASE

Removal (Fig. 1B-72)

1. Remove the cover plate and separate upper and lower case halves.
2. Remove inlet and outlet lines from the expansion valve. Remove sensing bulb from the evaporator outlet manifold. Remove expansion valve. Cap or plug open connections at once.
3. Remove evaporator core retaining screws and remove core.
4. Remove blower motor and harness assembly from case.

Installation

1. Reverse applicable steps in the removal procedure.

NOTICE: Use new "O" rings coated with clean refrigeration oil when connecting lines. Add 3 oz. of new refrigeration oil to a new core.

2. Reverse steps 1-8 of the "Blower Evaporator Assembly" removal procedure.
3. Evacuate, charge and check the system.

THERMOSTATIC AND/OR BLOWER SWITCHES

Replacement

1. Remove the cover plate assembly from the evaporator case.
2. Remove two screws securing either switch to the cover plate and remove appropriate switch (fig. 1B-73).
3. Install replacement switch, reinstall cover plate and reverse steps 1-8 of the "Blower-EVaporator Assembly" removal procedure.

When installing thermostatic switch, be sure to position sensing capillary as when unit was removed.

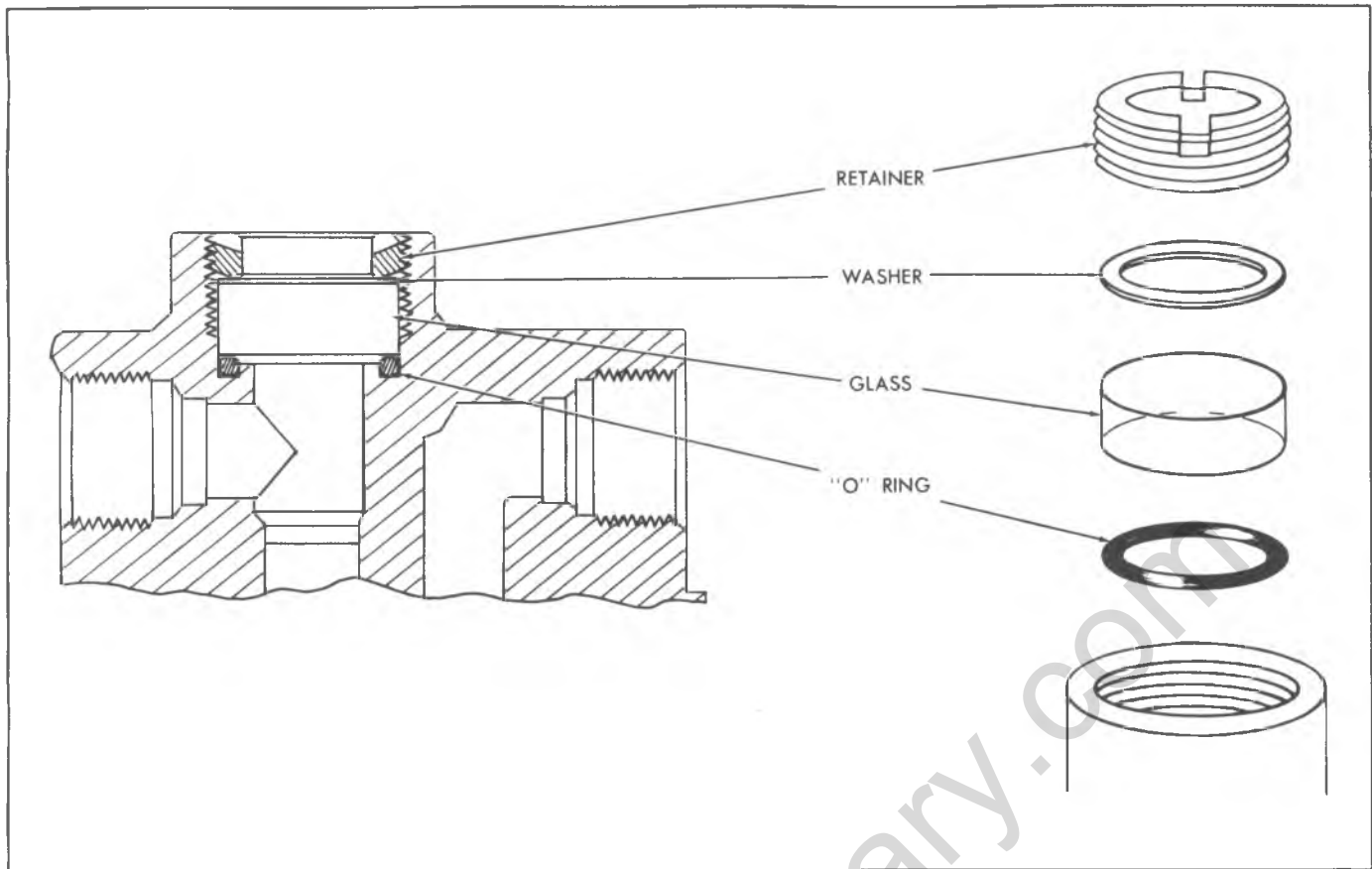


Fig. 1B-68--Sight Glass Replacement

RESISTOR

The blower motor resistor is located on the top of the unit. The entire unit must be removed to replace the resistor.

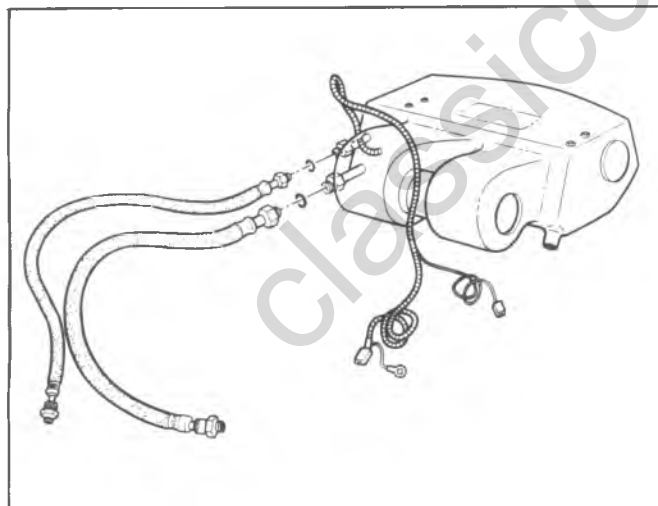


Fig. 1B-69--Blower-Evaporator (Motor Home Chassis Units)

FUSE

This Unit does not incorporate an in-line fuse. The lead wire is connected to the Heater Wiring Harness and operates off the 20 amp Heater Fuse.

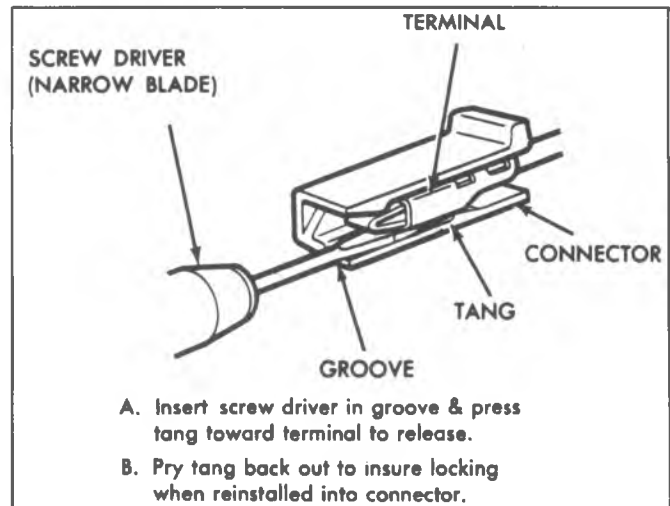


Fig. 1B-70--Terminal Removal

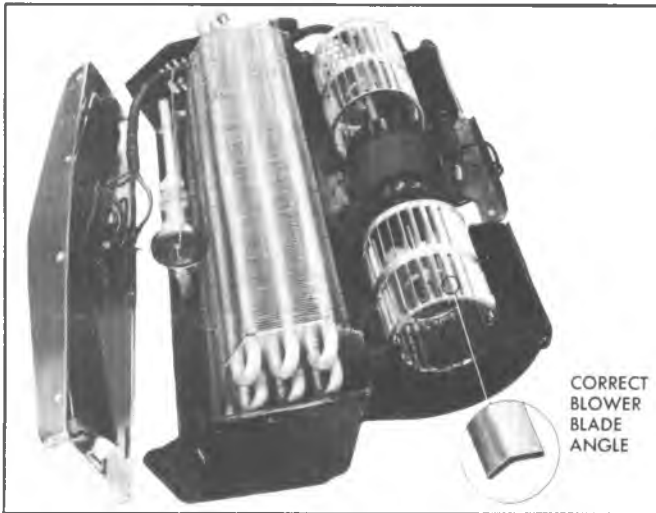


Fig. 1B-71-Blower Assembly (Motor Home Chassis Unit)

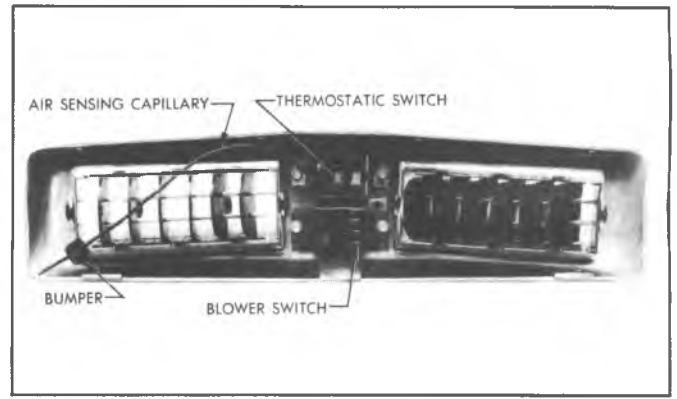


Fig. 1B-73-Thermostatic and Blower Switches

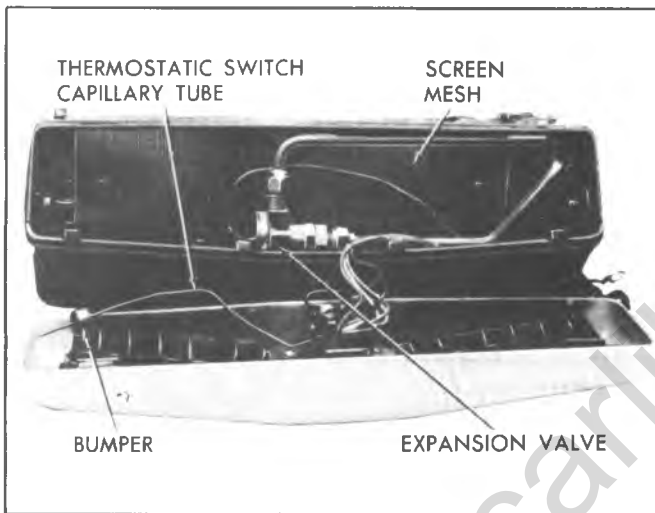


Fig. 1B-72-Expansion Valve (Motor Home Chassis Unit)

classiccarlibrary.com

SPECIFICATIONS

AIR CONDITIONING

Compressor

| | |
|------|-------------------|
| Type | 6 Cylinder Axial |
| | 4 Cylinder Radial |

Displacement

| | |
|-------------------|--------------|
| 6 Cylinder Axial | 12.6 Cu. In. |
| 4 Cylinder Radial | 10.0 Cu. In. |

| | |
|----------|-----------|
| Rotation | Clockwise |
|----------|-----------|

| | Volts | Amps. (Cold) | RPM (Cold) |
|---|-------|-----------------|---------------|
| Blower Motor | | | |
| C-K Four Season | 12.0 | 12.8 Max. | 3400 Min. |
| C-K-G Overhead, G Floor and Motor Home Units | 12.0 | 13.7 Max. | 3400 Min. |

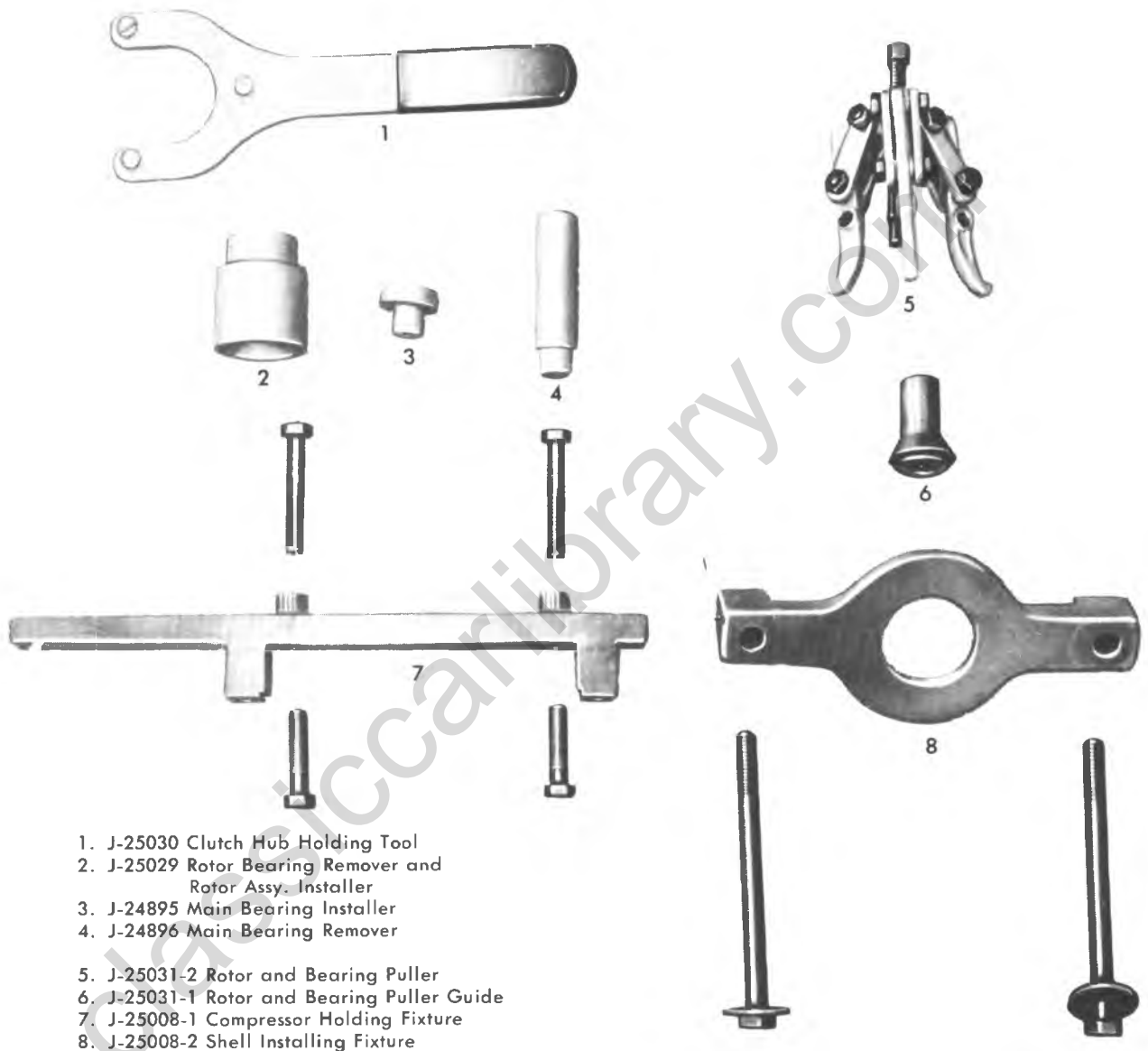
Compressor Clutch Coil

| | |
|-----------------|-----------------|
| Ohms (at 80°F) | 3.70 |
| Amps. (at 80°F) | 3.33 @ 12 volts |

Torque Specifications
Compressor Suction and Discharge

| | |
|---------------------------------------|-------------------|
| Connector Bolt | 25 ft. lbs. |
| Rear Head to Shell Stud Nuts (6 Cyl.) | 23 ft. lbs. |
| Shaft Mounting Nut (6 Cyl.) | 20 ft. lbs. |
| Shaft Mounting Nut (4 Cyl.) | 8-12 ft. lbs. |
| High Pressure Relief Valve (6 Cyl.) | 12 ft. lbs. |
| Oil Charge Screw (6 Cyl.) | 14 ft. lbs. |
| Air Gap on Clutch (6 Cyl.) | .022 to .057 in. |
| Compressor Mounting Bracket | 35 ft. lbs. |
| Compressor to Front Bracket Bolts | 25 ft. lbs. |
| Belt Tension | See Tune-Up Chart |
| Fuse Block— | |
| C-K Systems | 25 Amp. |
| Motor Home Chassis Unit | 20 Amp. |
| In-Line— | |
| C-K Systems | 25 Amp. |
| Motor Home Chassis Unit | None |
| Circuit Breaker | |
| G Model Systems | 45 Amp. |

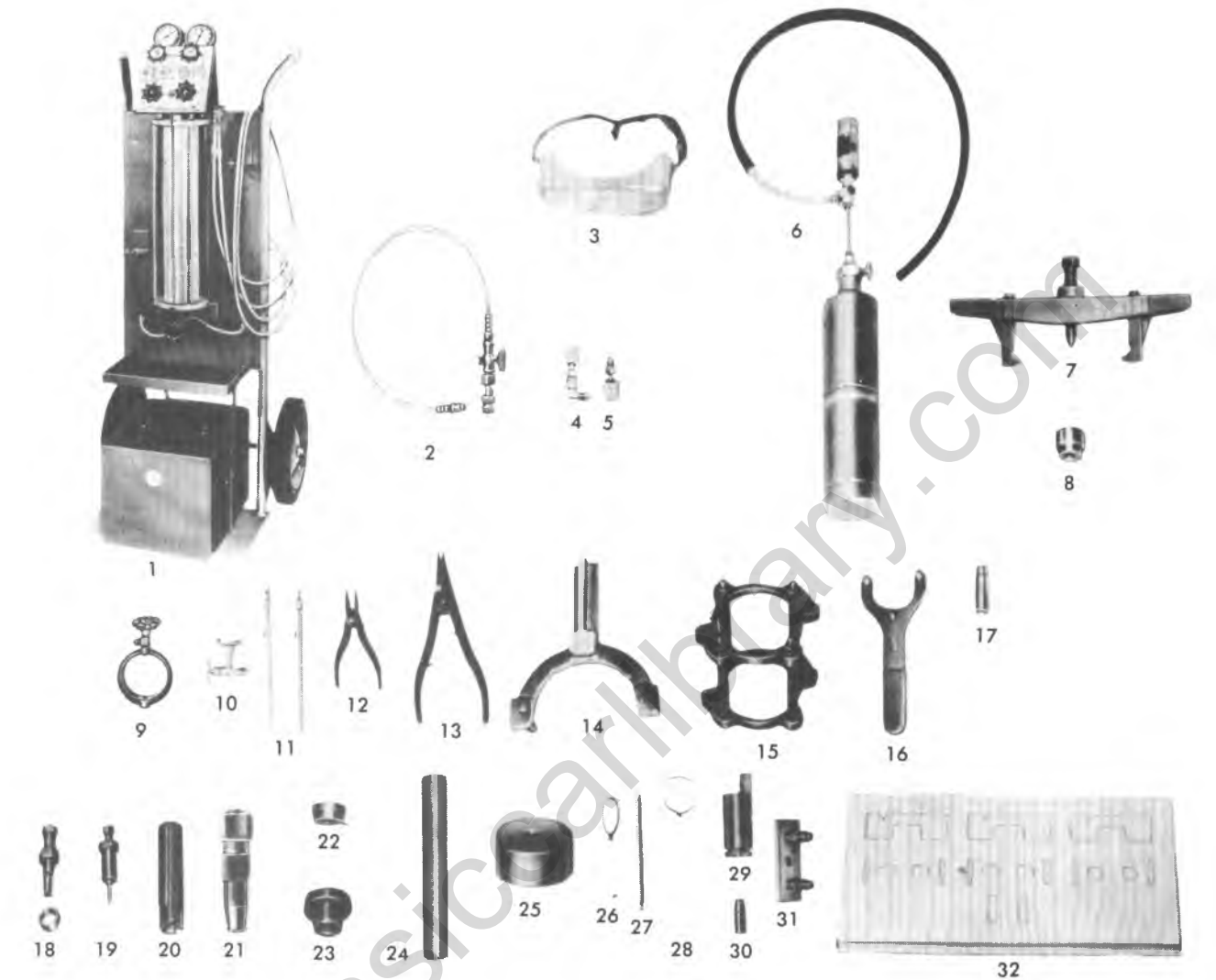
SPECIAL TOOLS



1. J-25030 Clutch Hub Holding Tool
2. J-25029 Rotor Bearing Remover and Rotor Assy. Installer
3. J-24895 Main Bearing Installer
4. J-24896 Main Bearing Remover
5. J-25031-2 Rotor and Bearing Puller
6. J-25031-1 Rotor and Bearing Puller Guide
7. J-25008-1 Compressor Holding Fixture
8. J-25008-2 Shell Installing Fixture

Fig. 1B-74--Air Conditioning Special Tools

SPECIAL TOOLS



- | | | | | | |
|---------------|----------------------------------|---------------|--|---------------|---------------------------------|
| 1. J-8393 | Charging Station | 11. J-5421-02 | Pocket Thermometers (2) | 22. J-9398 | Pulley Bearing Remover |
| 2. J-24095 | Oil Inducer | 12. J-5403 | No. 21 Snap Ring Pliers | 23. J-9481 | Pulley and Bearing Installer |
| 3. J-5453 | Goggles | 13. J-6435 | No. 26 Snap Ring Pliers | 24. J-8092 | Handle |
| 4. J-9459 | 7/16"-20 90° Gauge Line | 14. J-9396 | Compressor Holding Fixture | 25. J-21352 | Internal Assembly Support Block |
| J-25499 | 3/8"-24 Adapter | 15. J-25030 | Compressing Fixture | 26. J-5139 | Oil Pickup Tube Remover |
| 5. J-5420 | 7/16"-20 Straight Gauge Line | 16. J-9403 | Clutch Hub Holding Tool | 27. J-9432 | Needle Bearing Installer |
| J-25498 | 3/8" Adapter | 17. J-9399 | 9/16" Thin Wall Socket | 28. J-9553-01 | Seal Seat "O" Ring Remover |
| 6. J-6084 | Leak Detector | 18. J-9401 | Hub and Drive Plate Assembly Remover | 29. J-21508 | Seal Seat "O" Ring Installer |
| 7. J-8433 | Puller | 19. J-9480-01 | Hub and Drive Plate Assembly Installer | 30. J-22974 | Shaft Seal Protector |
| 8. J-9395 | Puller Pilot | 20. J-9392 | Seal Remover | 31. J-9625 | Pressure Test Connector |
| 9. J-23595 | Refrigerant Can Valve (Side-Tap) | 21. J-23128 | Seal Seat Remover | 32. J-9402 | Parts Tray |
| 10. J-6271-01 | Refrigerant Can Valve (Top-Tap) | | | | |

Fig. 1B-75--Air Conditioning Special Tools

SECTION 2A

FRAME

CONTENTS

| | |
|---------------------------------|------|
| General Description | 2A-1 |
| On Vehicle Service..... | 2A-1 |
| Maintenance and Inspection..... | 2A-1 |
| Underbody Inspection..... | 2A-1 |
| Frame Inspection | 2A-1 |
| Frame Alignment..... | 2A-1 |
| Underbody Alignment | 2A-4 |
| Excessive Body Damage..... | 2A-4 |

GENERAL DESCRIPTION

Light duty 10-30 Series frames are of the ladder channel section riveted type.

Figure 2A-1 thru 2A-4 illustrates typical light duty truck frames with crossmembers, body mounts and suspension attaching brackets. This section also includes general instructions for checking frame alignment and recommendations on frame repair.

The G-Van frame side rails, cross sills and outriggers are part of the underbody assembly which is a welded unit.

Misalignment of the underbody can affect door opening fits and also influence the suspension system, causing suspension misalignment. It is essential, therefore, that underbody alignment be exact to within $\frac{1}{16}$ in. (1.9mm) of the specified dimensions.

ON-VEHICLE SERVICE

MAINTENANCE AND INSPECTION

UNDERBODY INSPECTION

Raise the vehicle on a hoist (preferably a twin-post type).

Check for obvious floor pan deterioration.

Check for loose dirt and rust around the inside of the floor pan reinforcement member access holes. This is the first indication that corrosion may exist in hidden areas, and that repairs might be required before the final cleaning and protective treatment is performed.

Using a chisel, ensure that the drain provisions in the floor pan reinforcement members are open.

There are drain holes in the body side panels also. These holes can be opened by using a punch or drift. The side panel drain holes are in the rear section of the rocker panels, and in the lower rear quarter panels.

FRAME INSPECTION

Raise the vehicle on a hoist (preferably a twin-post type).

Check for obvious floor pan deterioration.

Check for loose dirt and rust around the inside of the frame rails, on top and at the ends where corrosion may

exist in hidden areas. Check especially in the frame box sections for accumulation of debris.

FRAME ALIGNMENT

Horizontal frame checking can be made with tramming gages applied directly to the frame or by transferring selected points of measurement from the frame to the floor by means of a plum bob and using the floor layout for measuring. Fig. 2A-2 or 2A-4 may be used as a general guide in the selection of checking points; however, selection of these points is arbitrary depending on accessibility and convenience. An important point to remember is that for each point selected on one side of the frame, a corresponding point on the opposite side of the frame must be used for vertical checks, opposite and alternate sides for horizontal checks.

Vehicle Preparation

Points to remember when preparing vehicle for frame checking:

1. Place vehicle on a level surface.
2. Inspect damaged areas for obvious frame misalignment to eliminate unnecessary measuring.

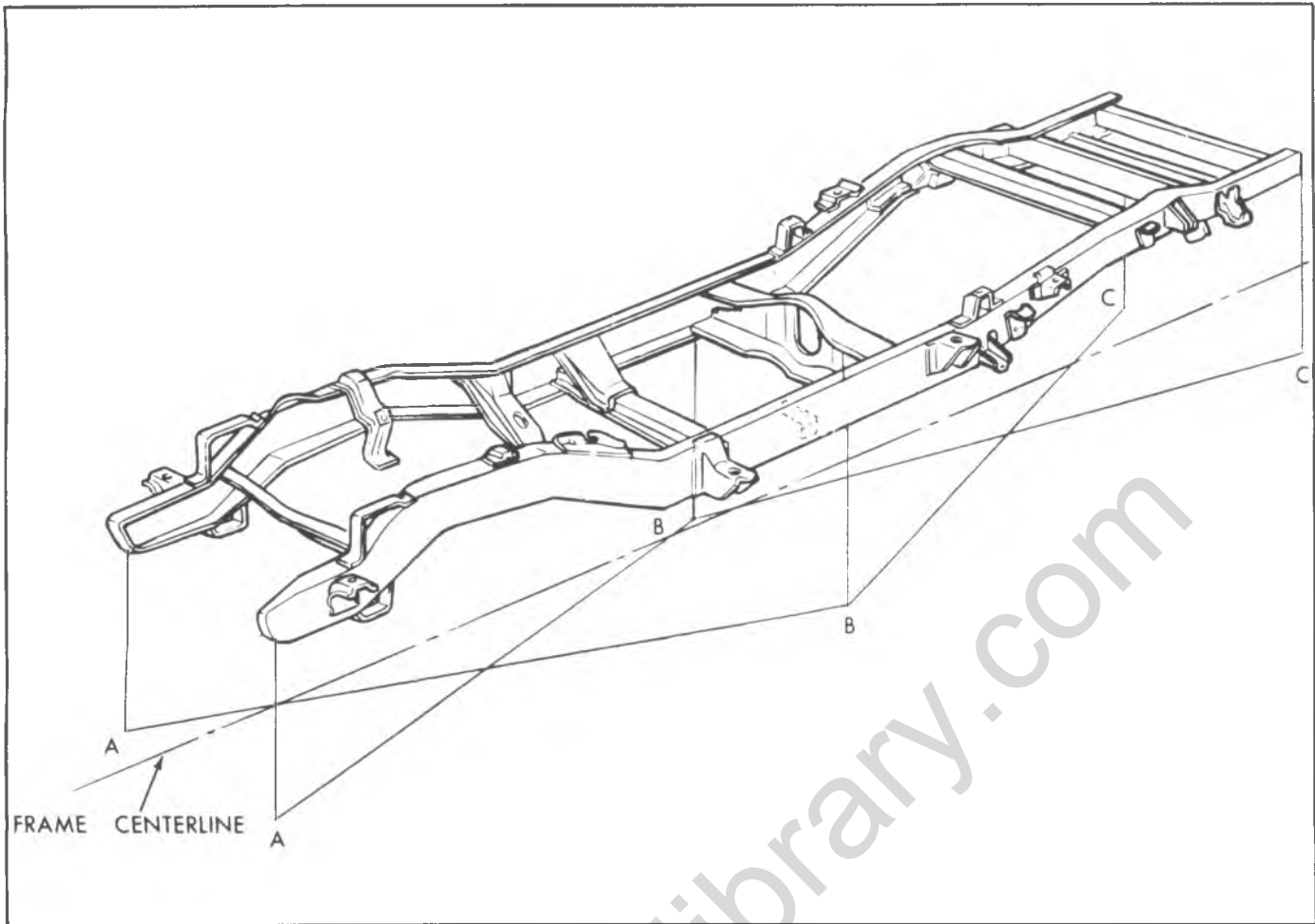


Fig. 2A-1—Frame Horizontal Checking—Typical

3. Support vehicle so that frame sidemembers are parallel to the ground.

Tramming Sequence (Fig. 2A-1)

1. Dimensions to bolts and/or holes in frame extend to dead center of the hole or bolt.
2. Dimensions must be within 3/16 in. (4.7 mm).
3. If a tram bar is used, for horizontal alignment "X" - check from opposite and alternate reference points AA, BB and CC, as illustrated by the lines in Fig. 2A-1. Error will result if a tram bar is not level and centered at the reference points.
4. Obtain vertical dimensions and compare the differences between these dimensions with the dimensions as shown in Fig. 2A-3 or 2A-4.

Horizontal Check

1. Measure frame width at front and rear. If widths correspond to specifications, draw centerline full length of vehicle halfway between lines indicating front and rear widths. If frame widths are not correct, layout centerline as shown in Step 4.
2. Measure distance from centerline to corresponding points on each side of frame layout over entire length. Opposite side measurement should correspond within 3/16 in. (4.7 mm).

3. Measure diagonals marked A, B and C. If the lengths of intersecting diagonals are equal and these diagonals intersect the centerline, frame area included between these points of measurement may be considered in alignment.

4. If front or rear end of frame is damaged and width is no longer within limits, frame centerline may be drawn through the intersection of any two previously drawn pairs of equal, intersecting diagonals.

Vertical Check

Vertical dimensions are checked with a tramming bar from indicated points on the frame (Figs. 2A-2 and 2A-4). For example, if the tram bar is set at point B with a vertical pointer length of 8-1/4 in. (206 mm), and at point E with a vertical pointer length of 5-1/4 in. (131 mm) (a height difference of 3 in. (75 mm)), the tram bar should be parallel with the frame. If the area is twisted or misaligned in any way, tram bar will not be parallel. Placing the tram bar vertical pointers on opposite sides of the frame side rail is preferable in that frame twist will show up during this vertical check. Fig. 2A-2 and 2A-4 show typical checking points, with dimensions for various frames shown in Fig. 2A-3.

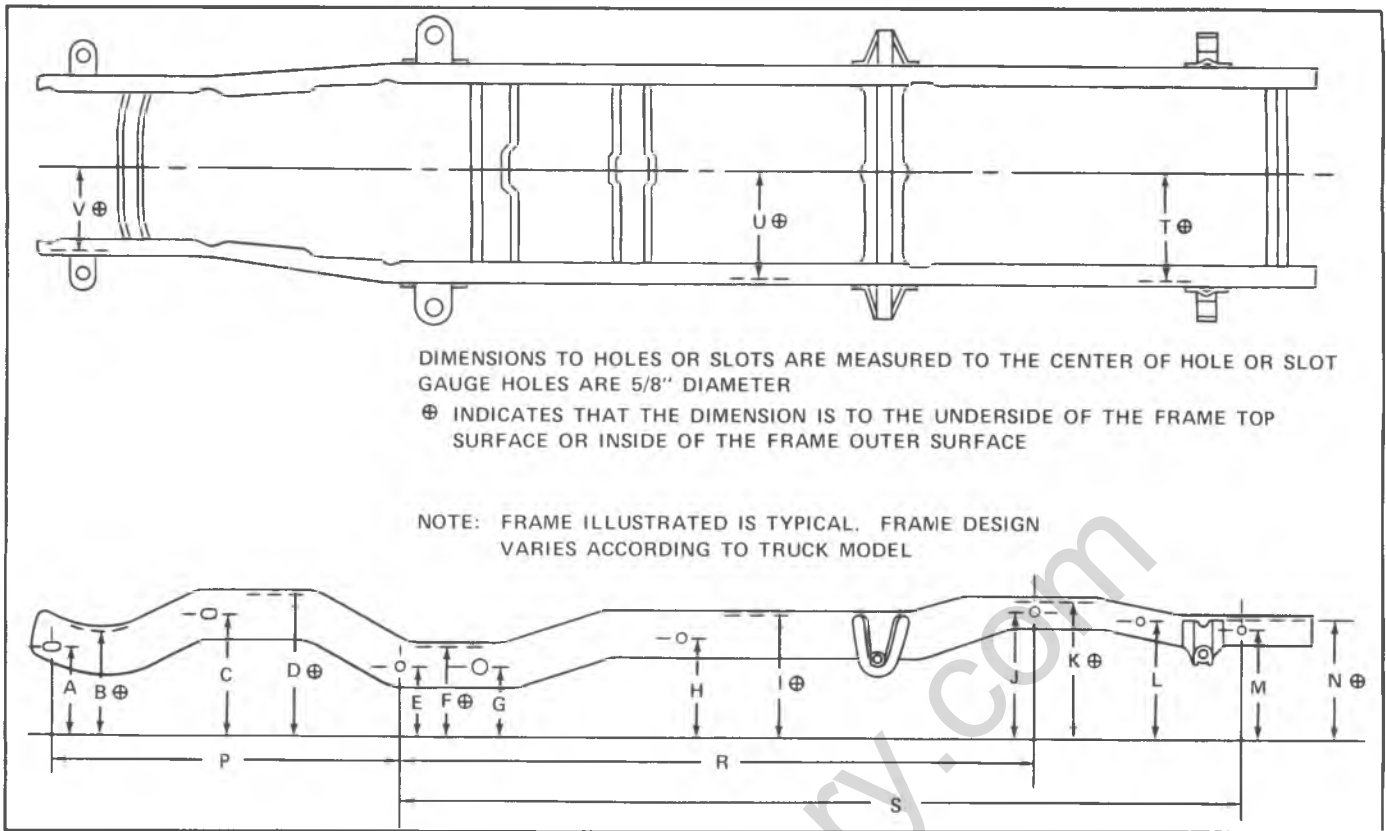


Fig. 2A-2-C-K-P Series Truck Frame

| Model | A | B | C | D | E | F | G | H | I | J | K | L | M | N | P | R | S | T | U | V |
|----------------------------------|--------|--------|--------|--------|--------|----|----|--------|--------|--------|--------|--------|--------|--------|--------|--------|----------|--------|--------|----|
| CA107 | 13-3/8 | 15-1/4 | 16 | 19-7/8 | 12 | 13 | 10 | 14 7/8 | 17-3/4 | 17-3/4 | 19-7/8 | 16-3/4 | 15-5/8 | 17-3/4 | 69-5/8 | 76-1/2 | 110 | 16-7/8 | 16-7/8 | 14 |
| CA109 | 13-3/8 | 15-1/4 | 16 | 19-7/8 | 12 | 13 | 10 | 14-7/8 | 17-3/4 | 17-3/4 | 19-7/8 | 16-3/4 | 15-5/8 | 17-3/4 | 69-5/8 | 86-1/2 | 120 | 16-7/8 | 16-7/8 | 14 |
| CA209 | 13-3/8 | 15-1/4 | 17 | 19-7/8 | 12 | 13 | 10 | 14-7/8 | 17-3/4 | 17-3/4 | 19-7/8 | 16-3/4 | 15-5/8 | 17 3/4 | 69-5/8 | 86-1/2 | 120 | 16-7/8 | 16-7/8 | 14 |
| CA ²¹⁰ ₃₁₀ | 13-3/4 | 15-1/4 | 16 | 18-1/2 | 10 | 13 | 10 | 14-1/4 | 17-3/4 | 17-3/4 | 19-7/8 | | 15-5/8 | 17-3/4 | 69-7/8 | 105 | 131 | 16-7/8 | 16-7/8 | 14 |
| CA314 | 13-3/8 | 14-7/8 | 16 | 18-1/2 | 10 | 13 | 10 | 14-1/4 | 17-3/4 | 17-3/4 | 19-7/8 | | 15-5/8 | 17-3/4 | 69-7/8 | 129 | 155-1/2 | 16-7/8 | 16 7/8 | 14 |
| KA107 | 13-3/8 | 15-1/4 | 17 | 19-7/8 | 12-1/2 | 13 | 10 | 14-7/8 | 17-3/4 | 17-3/4 | 19-7/8 | 16-3/4 | 15-5/8 | 17-3/4 | 69-5/8 | 76-1/2 | 110 | 16-7/8 | 16-7/8 | 14 |
| KA ¹⁰⁹ ₂₀₉ | 13-3/8 | 15-1/4 | 17 | 19-7/8 | 12-1/2 | 13 | 10 | 14-7/8 | 17-3/4 | 17-3/4 | 19-7/8 | 16-3/4 | 15-5/8 | 17-3/4 | 69-5/8 | 86-1/2 | 120 | 16-7/8 | 16-7/8 | 14 |
| PA100 | 7-5/8 | 9-3/8 | 11 | 14-5/8 | 9-1/2 | 13 | 10 | | | 9-1/2 | 13 | | 10-7/8 | 13 | 71-7/8 | 36 | 89 | 16-7/8 | 16-7/8 | 14 |
| PA ²⁰⁸ ₃₀₈ | 7-5/8 | 9-3/8 | 11 5/8 | 14-5/8 | 9-1/2 | 13 | 10 | 9-1/2 | 13 | 9-1/2 | 13 | | 10-7/8 | 13 | 72-1/4 | 59 | 131 | 16-7/8 | 16-7/8 | 14 |
| PA ²¹⁰ ₃₁₀ | 7-5/8 | 9-3/8 | 11-5/8 | 14-5/8 | 9-1/2 | 13 | 10 | 9-1/2 | 13 | 9-1/2 | 13 | 10-7/8 | 10-7/8 | 13 | 71-7/8 | 67 | 153 | 16-7/8 | 16-7/8 | 14 |
| PA314 | 7-5/8 | 9-3/8 | 11 5/8 | 14-5/8 | 9-1/2 | 13 | 10 | 9-1/2 | 13 | 9-1/2 | 13 | 10-7/8 | 10-7/8 | 13 | 71-7/8 | 91 | 177 | 16-7/8 | 16-7/8 | 14 |
| CA105 | 13-3/8 | 15-1/4 | 17 | 19-7/8 | 12 | 13 | 10 | | | 14-1/4 | 20 | 17-3/4 | 15-5/8 | 17-3/4 | 69-5/8 | 46 | 88 | 16-7/8 | 16-7/8 | 14 |
| KA105 | 13-3/8 | 15-1/4 | 17 | 19-7/8 | 12-1/2 | 13 | 10 | | | 14-1/4 | 20 | 17 3/4 | 15-5/8 | 17 3/4 | 69-5/8 | 46 | 88 | 16-7/8 | 16-7/8 | 14 |
| PE 31132 (137) | 9-1/8 | 11-1/2 | 10-7/8 | | 9-1/2 | 13 | 10 | 9-1/2 | 13 | 9-1/2 | 13 | 10-7/8 | 10-7/8 | 13 | 68-1/2 | 71 | 157 | 16-7/8 | 16-7/8 | 14 |
| PE 31432 (157) | 9-1/8 | 11-1/2 | 10-7/8 | | 9-1/2 | 13 | 10 | 9-1/2 | 13 | 9-1/2 | 13 | 9-7/8 | 10-7/8 | 13 | 68-1/2 | 92-1/2 | 178-1/2 | 16-7/8 | 16-7/8 | 14 |
| PE 31832 | 9-1/8 | 11-1/2 | 10-7/8 | | 9-1/2 | 13 | 10 | 9-1/2 | 13 | 9-1/2 | 13 | 10-7/8 | 10-7/8 | 13 | 68-1/2 | 112 | 240-3/16 | 16-7/8 | 16-7/8 | 14 |

Fig. 2A-3-C-K-P Series Frame Reference Dimensions

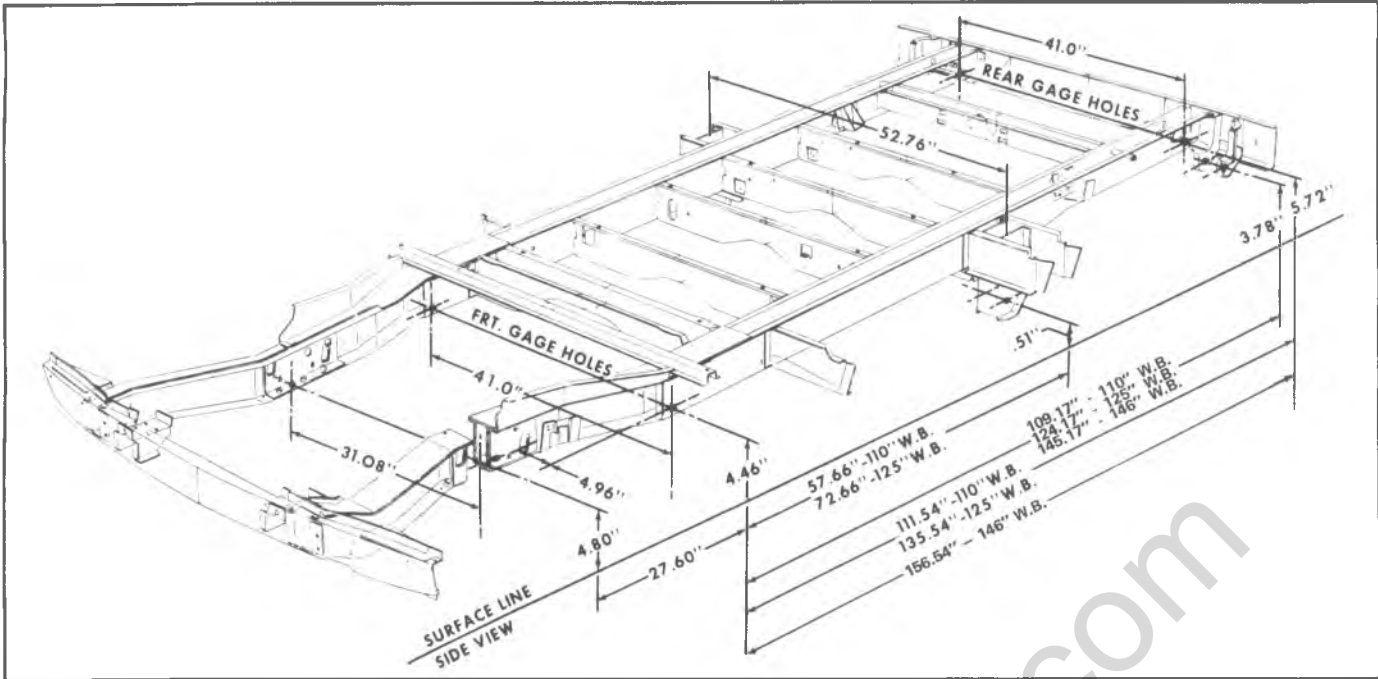


Fig. 2A-4-G Van Truck Reference Dimensions

Frame Repair

Welding

Before welding up a crack in frame, a hole should be drilled at the starting point of the crack to prevent spreading. Widen V groove crack to allow complete weld penetration.

NOTICE: Do not weld into corners of frame or along edges of side rail flanges. Welding at these points will tend to weaken the frame and encourage new cracks.

Bolting

Wherever rivets or failed bolts are replaced, bolt hole must be as near the O.D. of the bolt as possible to prevent bolt from working and wearing. Drill out and line ream hole (or holes) to the bolt O.D.

UNDERBODY ALIGNMENT

One method of determining the alignment of the underbody is with a tram gage which should be sufficiently flexible to obtain all necessary measurements up to three quarters the length of the vehicle. A good tramping tool is essential for analyzing and determining the extent of collision misalignment present in underbody construction.

MEASURING

To measure the distance accurately between any two reference points on the underbody, two specifications are

required.

1. The horizontal dimension between the two points to be trammed.
2. The vertical dimension from the datum line to the points to be trammed.

The tram bar should be on a parallel to that of the body plane. The exception to this would be when one of the reference locations is included in the misaligned area; then the parallel plane between the body and the tram bar may not prevail. After completion of the repairs, the tram gage should be set at the specified dimension to check the accuracy of the repair operation.

EXCESSIVE BODY DAMAGE

If damage is so extensive that key locations are not suitable as reference points, repair operations should always begin with the underbody area. All other components should be aligned progressively from this area. Unlike the conventional type of frame design, the unitized type of body construction seldom develops the two conditions of "twist" and "diamond" in the underbody area as a result of front or rear end collisions, therefore, there usually is an undamaged area suitable as a beginning reference point.

SECTION 2B

BUMPERS

CONTENTS

| | | | |
|--|------|---------------------------------|------|
| General Description..... | 2B-1 | Front Bumper G Series..... | 2B-2 |
| Service Procedures - 10 thru 30 series | 2B-1 | Rear Bumper G Series..... | 2B-2 |
| Front Bumper - C, K and P Models..... | 2B-1 | Rear Bumper G Series..... | 2B-2 |
| Rear Bumper - C and K Models..... | 2B-1 | Rear Step Bumper G Series | 2B-2 |
| Rear Step Bumper - C and K Models..... | 2B-1 | | |

GENERAL DESCRIPTION

All truck front and rear bumpers are of a single piece design. Bumper attachments are the standard bracket and brace to frame mountings. This section contains procedures for the removal and installation of face bar, brackets, braces and license plate brackets.

SERVICE PROCEDURES-10 THRU 30 SERIES

FRONT BUMPER-C, K AND P MODELS

Removal Fig. 2B-1, 2B-2

1. Remove bolts securing two bumper brackets to frame.
2. Remove bolts securing bumper face bar to frame, and left and right bumper braces and remove bumper from vehicle.
3. If necessary, disassemble bumper by removing bolts attaching brackets and braces to bumper face bar.
4. If equipped with bumper guards (Fig. 2B-2) remove remaining nuts and bolts.

Installation

Assemble and install front bumper following the removal procedure in reverse order.

REAR BUMPER-C AND K MODELS (FIG 2B- 3)

Removal

1. Remove bolts attaching bumper to each bumper brace. Disconnect license lamp wiring on suburban and panels and pickup.
2. Remove bolts attaching bumper to frame.
3. Remove bumper from vehicle.
4. If necessary, replace body splash shield.

Installation

Install rear bumper following removal procedure in reverse order. Connect license lamp wiring on suburban panel, and pickup models.

REAR STEP BUMPER C AND K MODELS

Removal (Fig. 2B-4)

1. Disconnect license lamp wiring.
2. Remove bolts connecting bumper to braces.
3. Remove bumper assembly.
4. Remove bolts securing bumper brace to frame and remove brace.

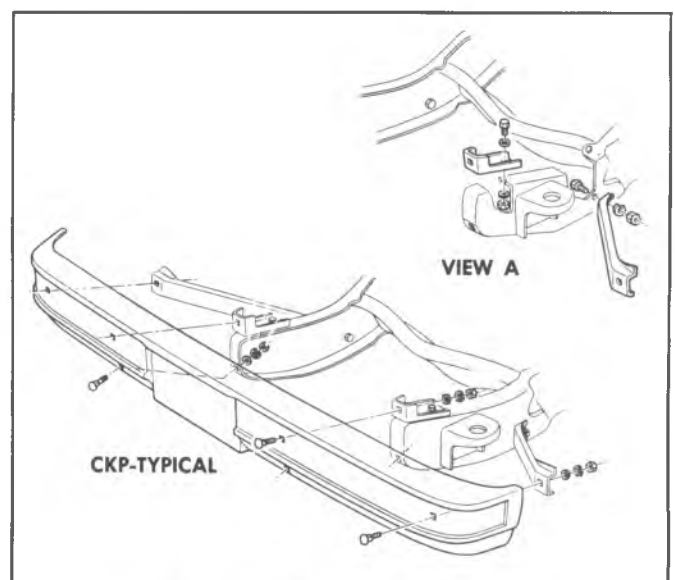


Fig. 2B-1--Front Bumper-C, K and P Models

2B-2 BUMPERS

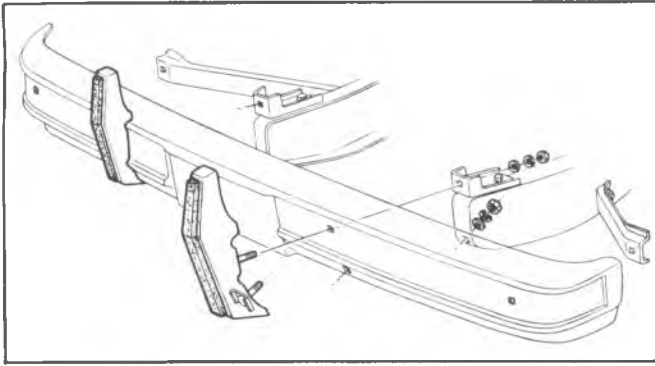


Fig. 2B-2-C, K Model Front Bumper Guards

Installation

Install rear step bumper by reversing removal procedure. Connect license lamp wiring.

FRONT BUMPER - G MODELS

Removal Fig. 2B-5, 2B-6

1. Remove nuts securing bumpers to brackets and braces from left and right side. Remove bumper.
2. If necessary to remove the braces and brackets, remove screws securing brackets and braces to sheet metal.
3. If equipped with bumper guards (Fig. 2B-6) they may be removed from the face bar at this time.

Installation

Reverse removal steps to install bumpers.

REAR BUMPER-G MODELS

Removal Fig. 2B-7, 2B-8

1. Remove nuts securing bumper to brackets and

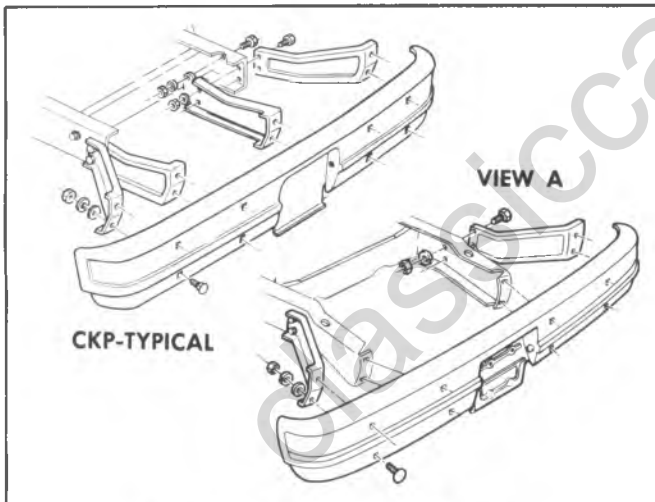


Fig. 2B-3--Rear Bumper - C, K Models

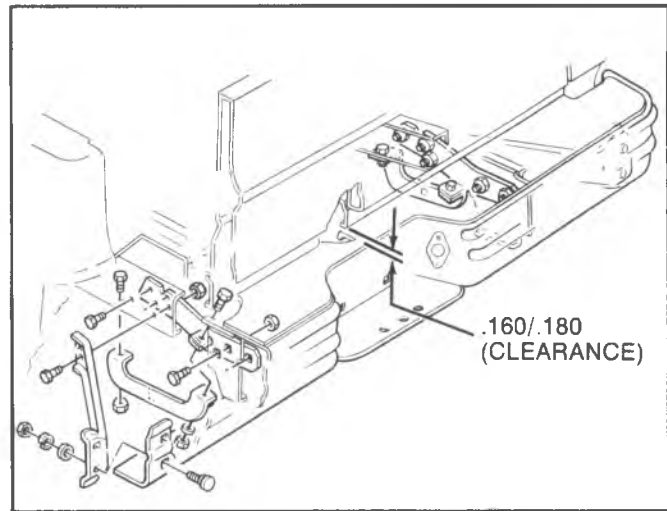


Fig. 2B-4--Rear Step Bumper C and K Models

braces and remove the bumper.

2. Remove the license plate support nut and bolts.
3. Remove brackets and braces from vehicle.

The bumper may be removed with brackets and braces attached if necessary.

Installation

Install in reverse order of removal.

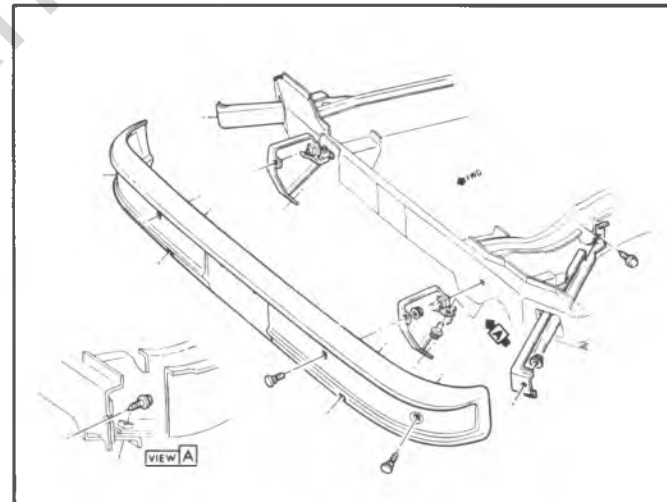


Fig. 2B-5--Front Bumper - G Models

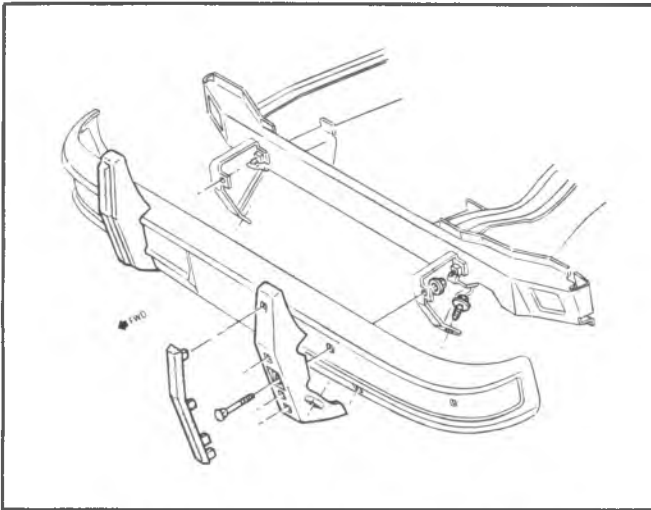


Fig. 2B-6-G-Models Front Bumper Guards

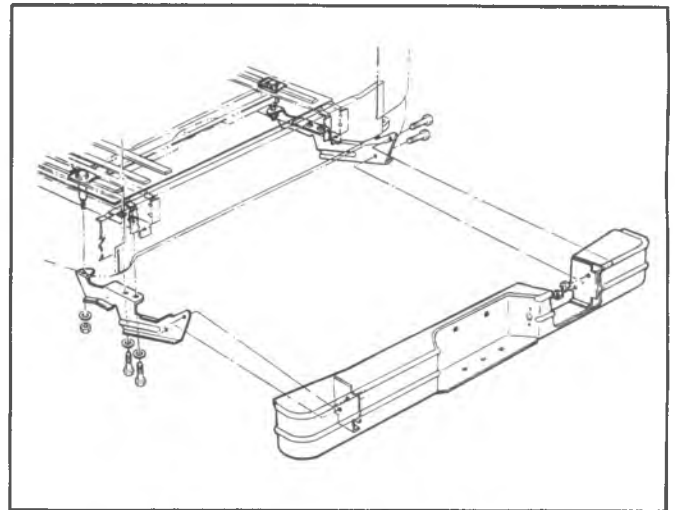


Fig. 2B-8-G-Model Rear Step Bumper

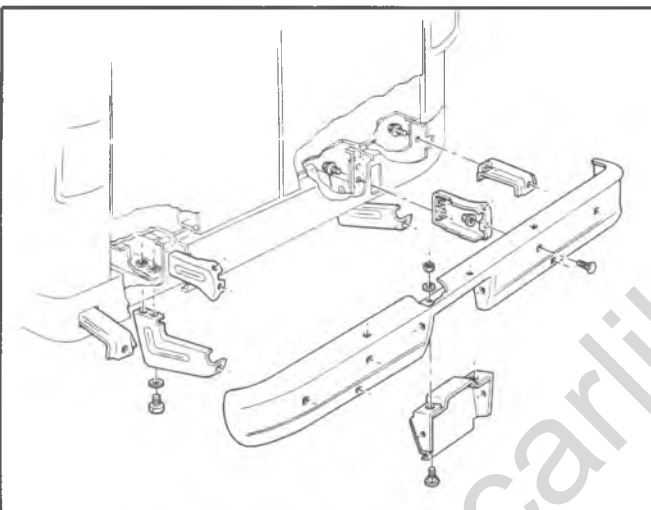


Fig. 2B-7-Rear Bumper-G Models

SPECIFICATIONS

TORQUE SPECIFICATIONS C, P AND K

| | |
|--------------------------------------|--------------|
| Front Bumper | .35 ft.-lbs. |
| Front Bumper Bracket and Brace | .70 ft.-lbs. |
| Rear Bumper to Outer Bracket | .35 ft.-lbs. |
| Rear Bumper Outer Bracket and Brace | .50 ft.-lbs. |
| License Plate Bracket | .18 ft.-lbs. |
| Gravel Deflector | .85 in.-lbs. |
| Rear Step Bumper to Bracket or Frame | .40 ft.-lbs. |

TORQUE SPECIFICATIONS G

| | |
|-----------------------------------|---------------|
| Front Face Bar to Bracket | .24 ft.-lbs. |
| Bracket to Cross Sill | .24 ft.-lbs. |
| License Plate Bracket to Face Bar | .100 in.-lbs. |
| Rear Face Bar to Brackets | .55 ft.-lbs. |
| Bracket to Floor | .55 ft.-lbs. |

Fig. 2B-ST-Specifications

classicalcarlibrary.com

SECTION 2C

CHASSIS SHEET METAL

CONTENTS

| | |
|--|--|
| <p>General Description..... 2C-1</p> <p>On Vehicle Service..... 2C-1</p> <p> Hood Assembly - CK Series 2C-1</p> <p> Hood Hinge Spring Replacement 2C-1</p> <p> Hood Hinge..... 2C-1</p> <p> Hood Lock Assembly 2C-2</p> <p> Hood Assembly 2C-3</p> <p> Hood Assembly - G Series 2C-3</p> <p> Hood Hinge..... 2C-3</p> <p> Hood Lock Assembly 2C-3</p> <p> Hood Bumper..... 2C-4</p> | <p>Front Sheet Metal - CK Series 2C-6</p> <p> Radiator Support 2C-7</p> <p> Front Fender 2C-9</p> <p> Front Fender and Skirt 2C-9</p> <p> Front Fender Skirt..... 2C-9</p> <p> Running Board..... 2C-10</p> <p>Front Sheet Metal - G Series 2C-10</p> <p> Sheet Metal Checking 2C-10</p> <p> Fender Skirt - P Series 2C-10</p> <p> Wood Grain Applique Installation Procedure 2C-10</p> <p>Specifications..... 2C-12</p> |
|--|--|

GENERAL DESCRIPTION

CK SERIES

The chassis sheet metal assembly is attached to the frame and body at adjustment points. The front of the assembly is supported by two mounts located at the frame side rails. Fore and aft and side adjustment is allowed by oversize holes at the fender rear attaching point and chassis sheet metal mounts. Special shims at the rear locations allow adjustment of the rear of the assembly. The lower rear edge of the assembly is attached to the body at the rocker panel by bolts on each side. Shims are used at this location to provide in and out adjustment at the rear of the fender. The bolts that retain the sheet metal braces must be torqued to the required torques. If these bolts are loose, the braces will not provide additional support for the sheet metal assembly.

G SERIES

The front end sheet metal design does not include the radiator support and fenders as loose items inasmuch that these items are welded together as an integral part of the body.

Front end sheet metal includes the hood assembly, hood hinges, hood lock catch and support, a hood rod assembly which supports the hood, a bolted radiator-upper tie bar, and series designation plates and hoods emblems.

ON VEHICLE SERVICE

HOOD ASSEMBLY - CK MODELS

Hood Hinge Spring Replacement

For Hinge Spring Replacement, a tool can be made to dimensions as shown in Fig. 2C-1.

1. Raise and safely support the hood in full open position.

2. As shown in Fig. 2C-2, engage hooked end of tool to spring, then carefully pull forward to engage or disengage spring from hinge assembly.

Hood Hinge (Fig. 2C-2)

Removal

1. Prop the hood in the extreme open position and place protective covering over the cowl and fenders.

2. Scribe position of hinge attachment on hood rear reinforcement and remove two bolts.

3. Remove hood hinge spring as described above.

4. Scribe position of hinge attachment on fender assembly and remove bolts.

5. Remove hinge.

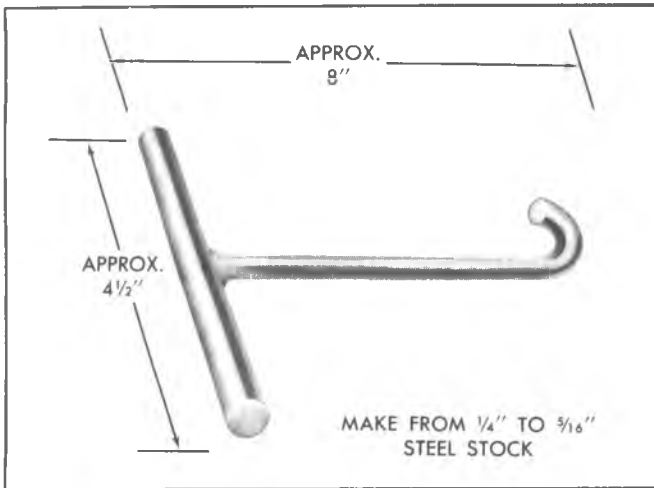


Fig. 2C-1-Hood Hinge Spring Remover/Installer

Installation

1. Install hinge assembly to fender and align within scribe marks. Install bolts.
2. Install hood hinge spring.
3. Install bolts and align hood. See Hood Alignment in this section.

Hood Lock Assembly

A bolt-type hood lock is used as shown in Fig. 2C-5. The lock bolt, located on the hood dovetails with the mounted striker plate, preventing upward or downward movement of the hood while the vehicle is in motion. Integral with the striker plate is the combination lock release lever and safety catch.

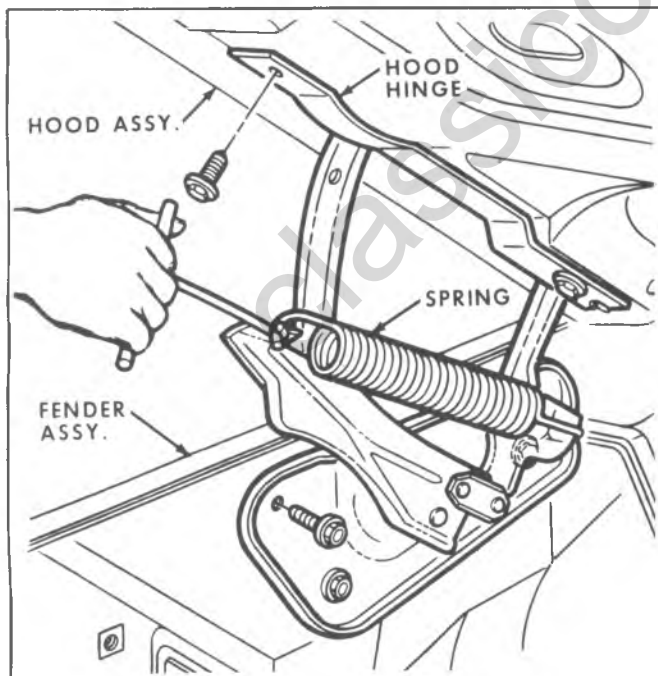


Fig. 2C-2-Hood Hinge and Spring-CK Models

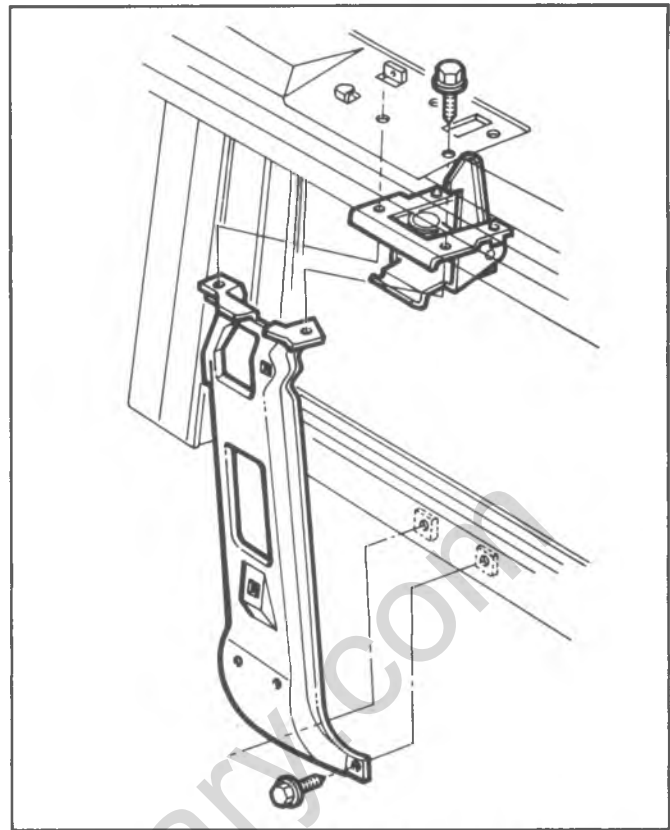


Fig. 2C-3-Hood Lock Catch and Support-CK Models

Replacement

1. Open hood and remove the four bolts holding the combination lock support and lock bolt.
If original hood lock assembly is to be replaced, scribe a line around lock for alignment on installation.
2. Place hood lock assembly in position.
3. Adjust as outlined under Adjustments.

Adjustment (Fig. 2C-5)

1. Loosen lock nut on lock bolt and adjust lock bolt approximately 2 7/16 in. (61 mm) from bottom of lock bolt to bottom of support.
2. Adjust tightness of support screws so they are just snug enough to hold support in position.
3. Adjust support fore and aft until nubbe enters center of elongated guide. Bending nubbe to accomplish this adjustment may seriously effect lock operation and safety latch engagement and is, therefore, not recommended.
4. Tighten screws to 140 in. lb. (154 N·m).
5. Adjust lock bolt to obtain a secure hood closure and reasonable lock release effort.

Hood Bumper Adjustment

Hood Bumpers must be adjusted until hood and fender line up flush at front corner. Adjust hood lock bolt to obtain a minimum load of 45 lbs. (198 N) maximum load of 55 lbs. (242 N) on each bumper after hood is firmly slammed.

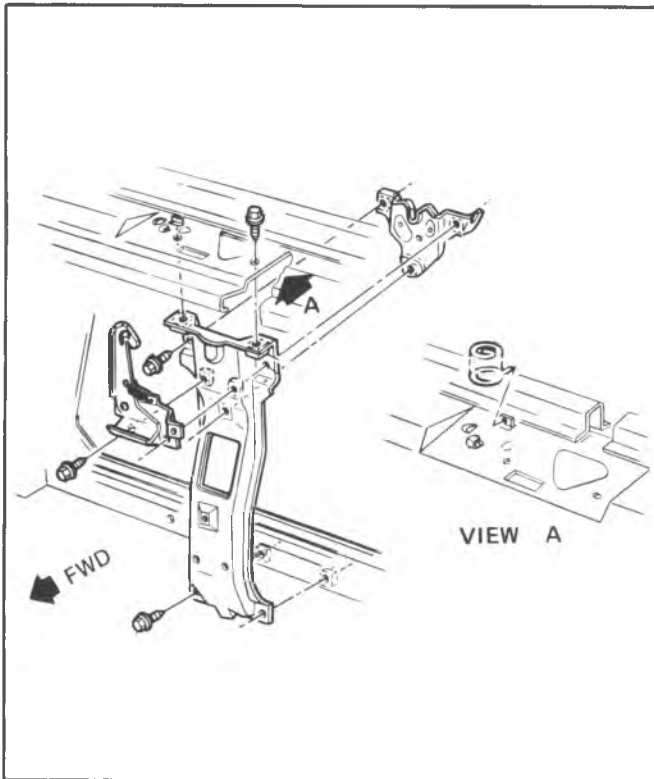


Fig. 2C-4--Hood Lock Catch and Support-CK Models with T-44

Hood Assembly

Removal

1. Open hood and prop in full open position.

If hood is to be reinstalled and present alignment is satisfactory, mark each hinge in relation to hood, to assure original alignment.

2. Remove two (2) cap screws which attach each hinge to hood; then with a helper remove hood from vehicle.

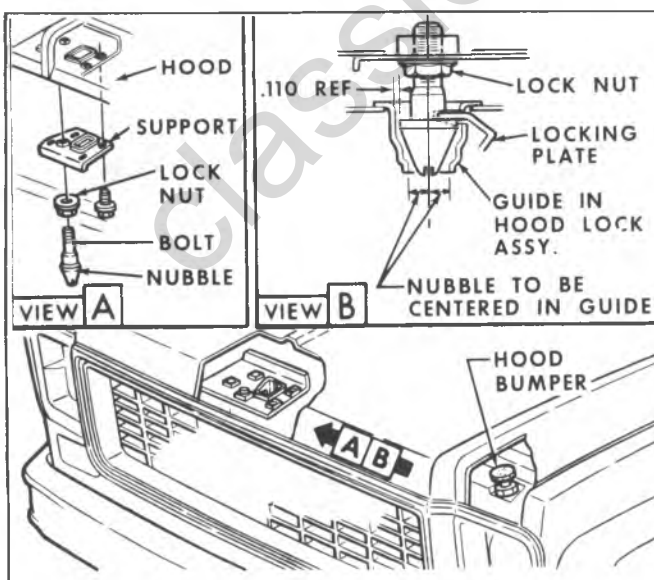


Fig. 2C-5--Hood Lock Bolt and Bumper-CK Models

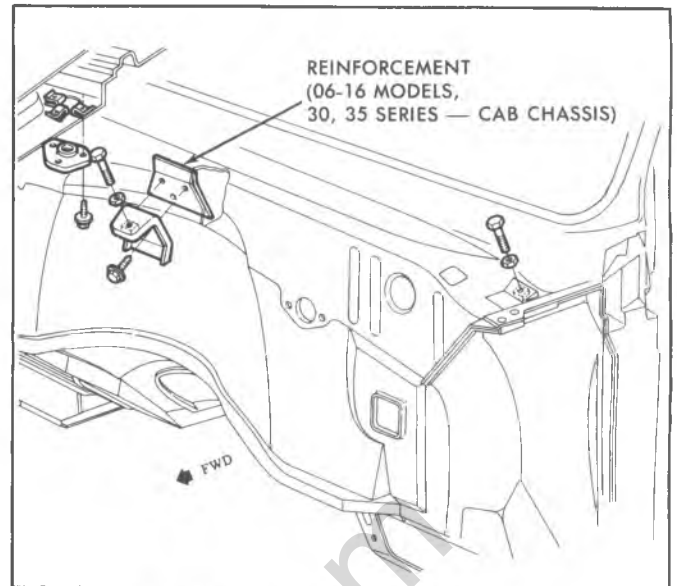


Fig. 2C-6--Hood Stop Bolt CK Models

Installation

1. If original hood is to be installed, position hood to hinges and install four cap screws snug which attach hinges to hood.

If a new hood is to be installed, perform procedures as outlined under Alignment, directly below.

2. Shift hood on hinges to location marks made before removal of hood, then tighten attaching cap screws at hinges firmly. Close hood and check fit. If necessary to align hood perform procedure as outlined under "Alignment" which follows.

Alignment

1. Loosen hood hinge bolts. Note that rear most bolt hole in hinge is slotted to allow hood trailing edge to move up and down.
2. Adjust hood rear bumper bolt so that bumper is flush with fender. Nut must be threaded completely onto bolt before torquing to maintain design height.
3. Perform hood lock adjustment as outlined in this section if necessary.

Hood Assembly - G Series

The alignment of the hood is controlled by the position of the hood hinges and the height of the two bumpers located one at each side of the radiator support. The adjustment at the hood lock must be made after the hinges and bumpers are properly adjusted (Refer to Hood Lock Adjustment Fig. 2C-9). To align the hood and lock proceed as follows:

Hood Hinge (Fig. 2C-7)

Hood Lock Assembly

A bolt-type hood lock is used as shown in Fig. 2C-9. The lock bolt, located on the hood, dovetails with the mounted striker plate, preventing upward or downward movement of the hood while the vehicle is in motion. Integral with the striker plate is the combination lock release lever and safety catch.

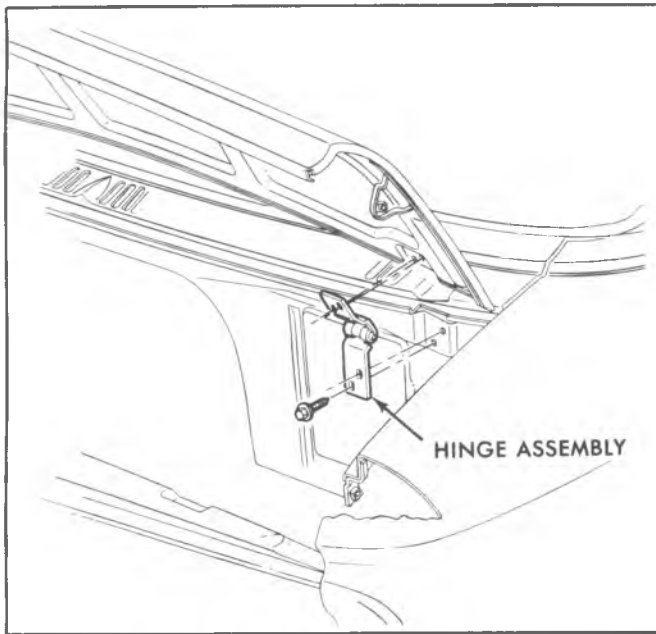


Fig. 2C-7--Hood Hinge-G Model

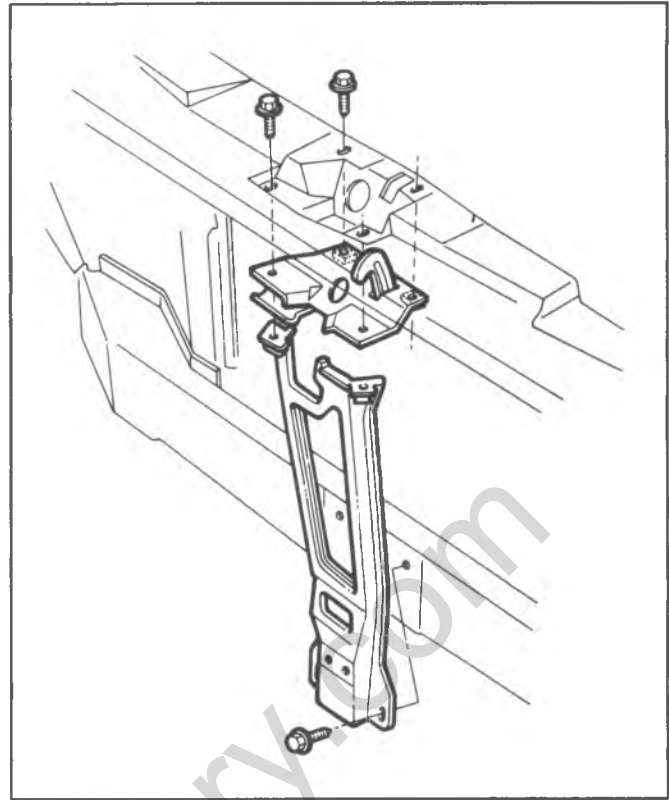


Fig. 2C-8--Hood Lock Catch Assembly-G Model

1. Scribe a line around the entire hinge plate to be repositioned.

2. Loosen the appropriate screws and shift the position of the hood into correct alignment using the scribe marks to check amount of movement. Check alignment by tightening screws and closing the hood.

Replacement

1. Open hood and remove the four bolts holding the combination lock catch and lock bolt.

If original hood lock assembly is to be replaced, scribe a line around lock for alignment on installation.

2. Place hood lock assembly in position.
3. Adjust as outlined under Adjustments.

Adjustment

Hood lock assembly to be adjusted fore and aft until hood lock bolt enters center of elongated guide. Bending bolt to accomplish this adjustment may seriously effect lock operation and safety catch engagement and is, therefore not recommended.

1. Adjust lock bolt as shown in Fig. 2C-9.
2. Open hood and adjust tightness of catch assembly so that it is just "snug" enough to hold lock bolt in position.
3. Close hood in a normal manner.
4. Raise hood again; lock bolt assembly will have shifted to operating position. Tighten bolts fully. Further adjustment may be made at lock bolt support, if necessary.
5. Adjust lock bolt to obtain a secure hood closure and reasonable lock release effort.

HOOD LATCH CABLE RELEASE - CK MODELS (FIG. 2C-10)

Replacement

1. Release the hood from below, using a suitable rod, by pressing on the hood release tab at the right side of the lock assembly.

2. Remove the cable at the lock assembly.
3. Remove hood release handle to kickpad attaching screws.
4. Remove hood release cable.
5. To install, reverse Steps 2 through 4.

HOOD EMBLEM - CK MODELS (FIG. 2C-11)

Hood Bumper

Adjust hood bumpers so that hood top surface is flush with the fender and grille top surfaces. Refer to Fig. 17 for correct sheet metal adjustment dimensions.

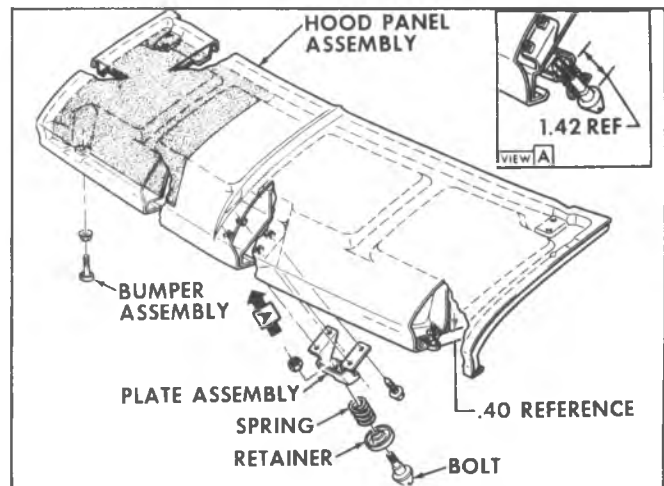


Fig. 2C-9--Hood, Bumpers and Latch-G Model

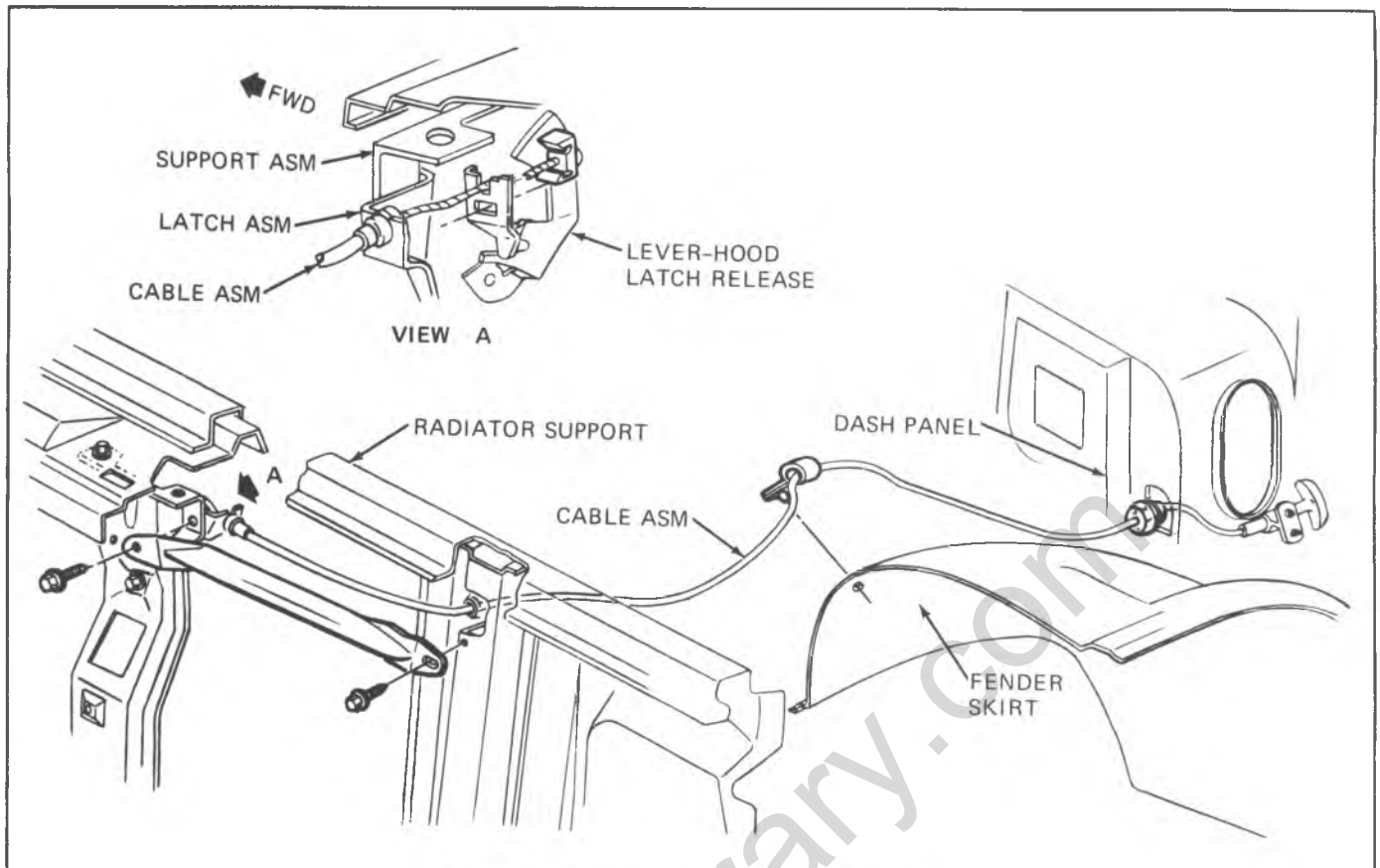


Fig. 2C-10-Hood Release Cable - CK Models

Hood Assembly-G Model (Fig. 2C-9)

Removal

1. Lay a fender cover along cowl top to prevent hood from scratching painted surfaces.

2. Open hood and prop in full open position.

If hood is to be reinstalled and present alignment is satisfactory, mark each hinge in relation to hood, to assure original alignment.

3. Remove two cap screws which attach each hinge to hood; (Fig. 2C-7) then with a helper remove hood from vehicle.

Installation

1. If original hood is to be installed, position hood to hinges with helper and install four cap screws snug which attach hinges to hood.

2. Install rod assembly. If a new hood is to be installed, perform procedures as outlined under Alignment, directly below.

3. Shift hood on hinges to location marks made before removal of hood, then tighten attaching cap screws at hinges firmly. Close hood and check fit. If necessary to align hood perform procedure as outlined under "Alignment" which follows.

Alignment

1. Loosen hood hinge bolts. Note that rear bolt holes in hinge is slotted to allow hood trailing edge to move up and down.

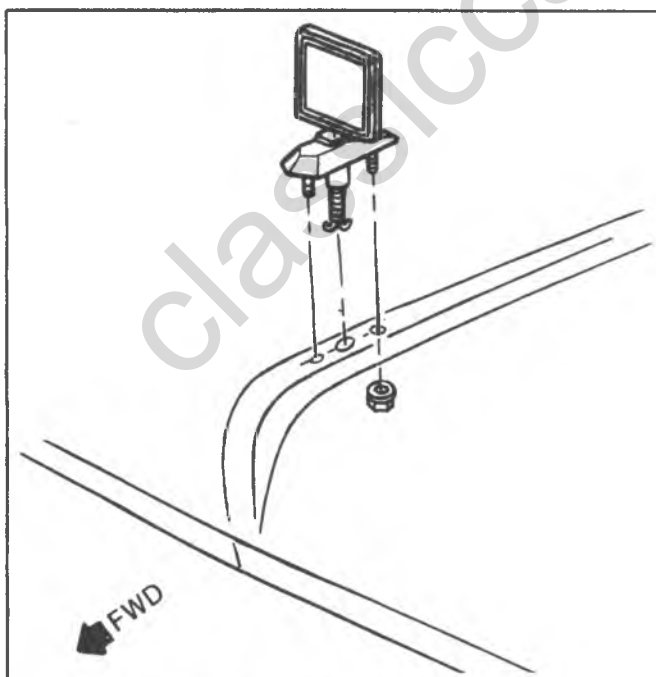


Fig. 2C-11-Hood Emblem - CK Models

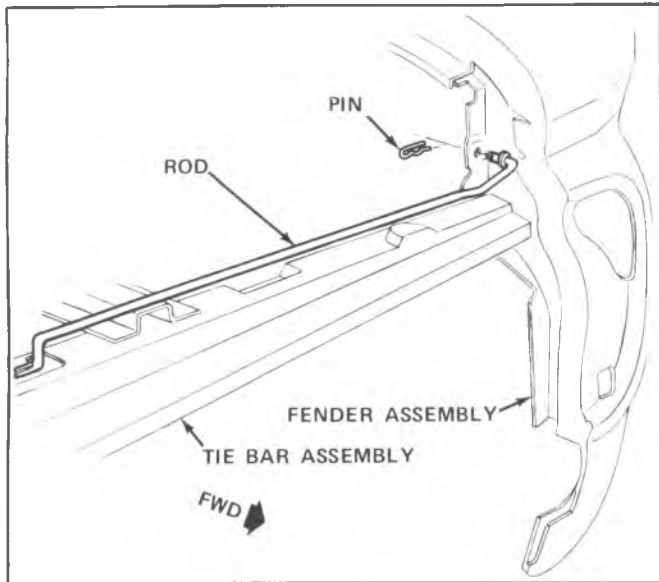


Fig. 2C-12--Hood Rod Support - G-Model

2. Adjust hood bumpers so that hood and adjacent surfaces are flush.

3. Perform hood lock adjustment as outlined in this section if necessary.

Hood Lock Assembly to be adjusted fore and aft until nubble (part of Hood Lock Bolt Support Assembly) enters center of elongated guide (Socket). Bending nubble to accomplish this adjustment may seriously effect lock operation and safety catch engagement and is, therefore, NOT RECOMMENDED.

Hood Rod Support - G-Model

Refer to Fig. 2C-12 for removal and installation of hood rod support.

CARBURETOR OUTSIDE AIR INLET SNORKELS (Fig. 2C-13)

Removal

1. Raise hood and remove carburetor air duct from air snorkel by sliding duct rearward.

2. Remove two (2) screws attaching air snorkel to radiator support and remove from vehicle.

LOWER RADIATOR GRILLE - G MODEL (FIG. 2C-14)

RADIATOR GRILLE AND BRACKETS CK, G-MODELS (FIG. 2C-15)

RADIATOR GRILLE MOLDING - CK, G MODELS (FIG. 2C-16)

FRONT SHEET METAL ASSEMBLY-CK SERIES

Removal of entire front sheet metal assembly including radiator involves disassembly of mounts, disconnecting radiator hoses and removal of front bumper. Vehicles equipped with air conditioning and/or power steering will require special handling.

Refer to appropriate sections of this manual for instructions.

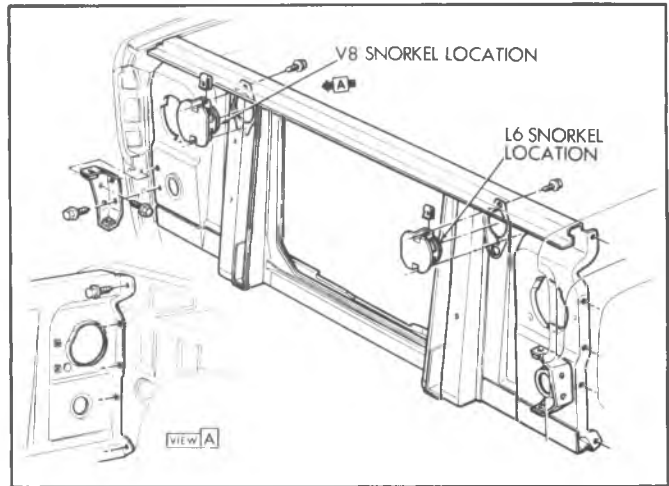


Fig. 2C-13--Carburetor Outside Air Inlet Snorkels--CK Model

Shims which are found at various locations should be recorded to ease installation of sheet metal assembly.

Refer to Fig. 2C-17 for sheet metal clearance.

Removal

1. Drain radiator and remove radiator hoses. Disconnect oil cooler lines if so equipped.

2. Disconnect wire connectors at the dash and toe panel and wire connector to horn and voltage regulator.

3. Disconnect battery and generator wires.

4. Remove front bumper bolts and remove bumper.

5. Remove bolts attaching fender upper edge to cowl door frame.

6. Remove fan shroud.

7. Working from underneath rear of fender, remove attachment from each fender at the hinge pillar.

8. Remove bolt from each radiator support mounting.

9. Remove bolts at each fender skirt to cab underbody (Fig. 2C-18).

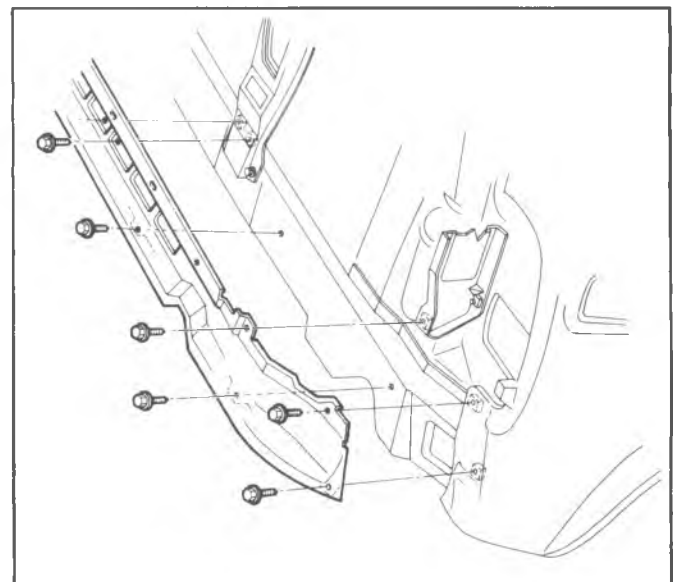


Fig. 2C-14--Lower Radiator Grille - G Models

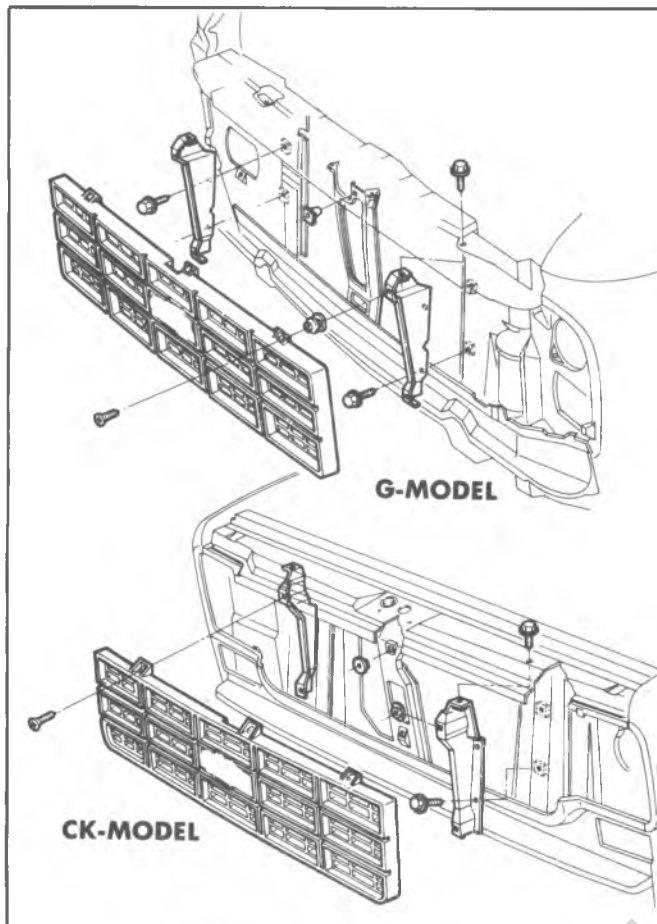


Fig. 2C-15--Radiator and Grille Brackets

10. With a helper, remove front sheet metal assembly, with radiator, battery, horn and voltage regulator attached.

Installation

1. With a helper place sheet metal assembly in position.

Install all bolts loosely to facilitate aligning after complete installation.

2. Install fender bolts at cowl.

3. Install combination bolt and flat washer assembly into each fender reinforcement while inserting shims required between fender reinforcement and body (Refer to Fig. 2C-19).

4. Install two bolts and shims required at each fender rear lower edge to hinge pillar.

5. Install bolt in each fender skirt to underbody.

6. Install bolts at steering column skirt reinforcement, final torque 25 ft. lb. (33 N·m).

7. Tighten each radiator support mounting bolt 33 ft. lb. (44 N·m).

8. Torque bolts at fender to cowl 25 ft. lb. (33 N·m)

9. Install front bumper.

10. Connect wire connectors at dash and toe panel. Attach generator and regulator wires.

11. Connect upper and lower radiator hoses. Connect oil cooler lines to the radiator on models so equipped.

12. Connect battery and fill radiator. Start engine and check for leaks.

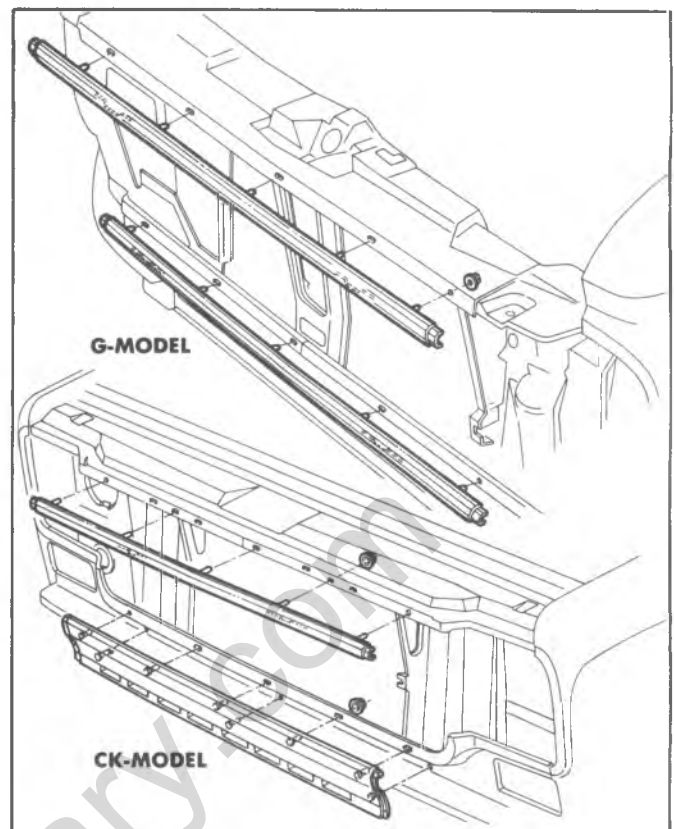


Fig. 2C-16--Radiator Grille Moldings - CK, G Models

Radiator Support

Removal

1. Remove hood as described in this section.
2. Drain radiator, saving coolant, loosen attachments and remove radiator and coolant recovery tank.
3. Disconnect and remove battery.
4. Remove battery tray with battery hanger.
5. Remove wiring from radiator support.
6. Disconnect fan shroud and lay back on engine.
7. Remove both head lamp assemblies.
8. Remove grille assembly.
9. Remove upper and lower radiator grille panels. (Fig. 2C-20).
10. Remove screws securing front fenders to radiator support.
11. Remove screws securing fender skirts to radiator support bottom. (Fig. 2C-18).
12. Remove bolt securing center grille support to radiator support.
13. Remove bolts securing hood catch assembly to radiator support.
14. Remove radiator support bolts secured to frame.
15. Tilt radiator support rearward and lift up and off.

Installation

1. Rotate radiator support into position and loosely install attachments to frame.
2. Connect center grille support to radiator support.
3. Connect hood latch plate.

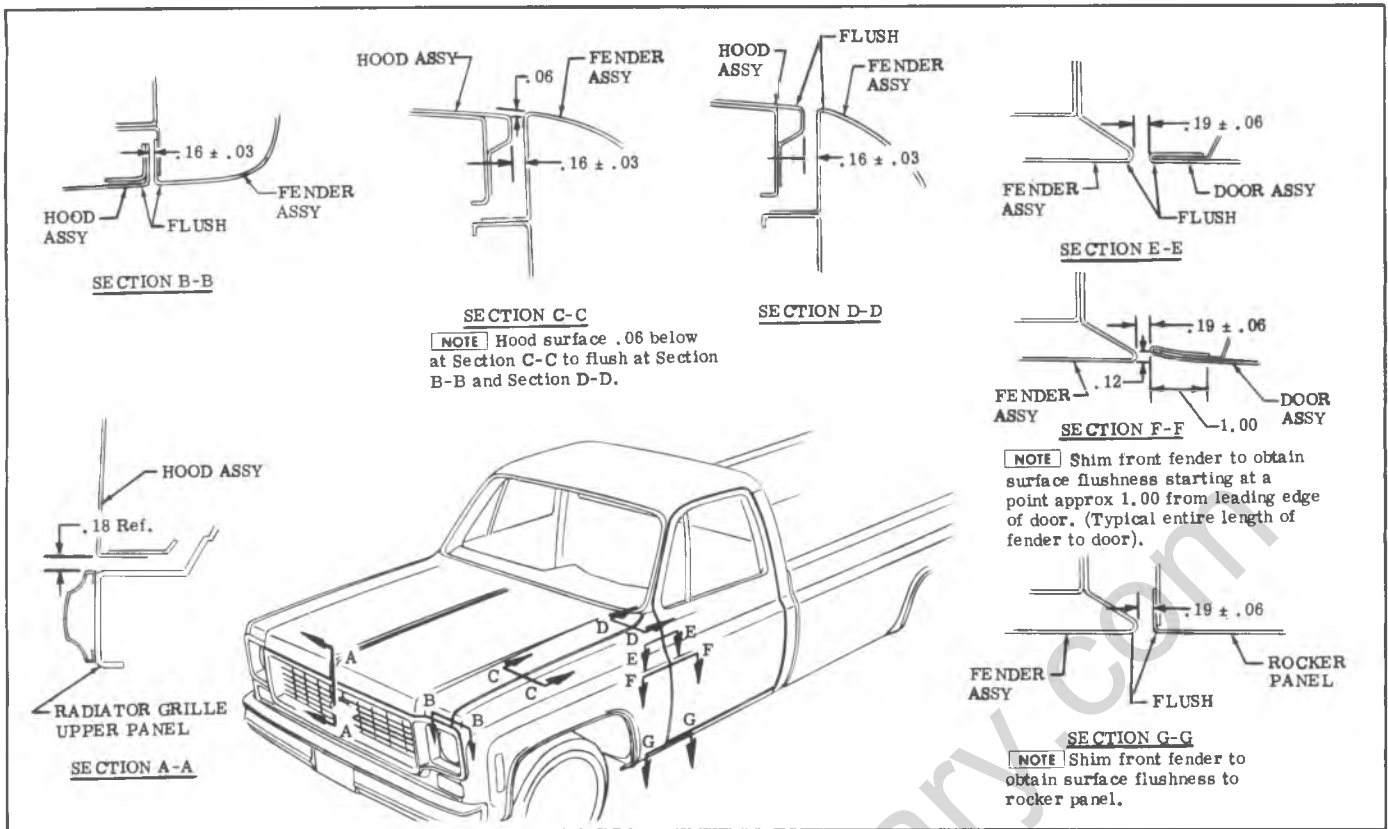


Fig. 2C-17—Sheet Metal Clearance—CK Model

4. Connect radiator support brackets to fenders.
5. Connect support to fenders.
6. Connect screws from underside of fender skirts to support bottom.
7. Attach grille upper panel to fenders loosely.
8. Attach grille lower panel to fenders.
9. Tighten radiator support bolts.
10. Place battery tray in position and fasten to radiator support.

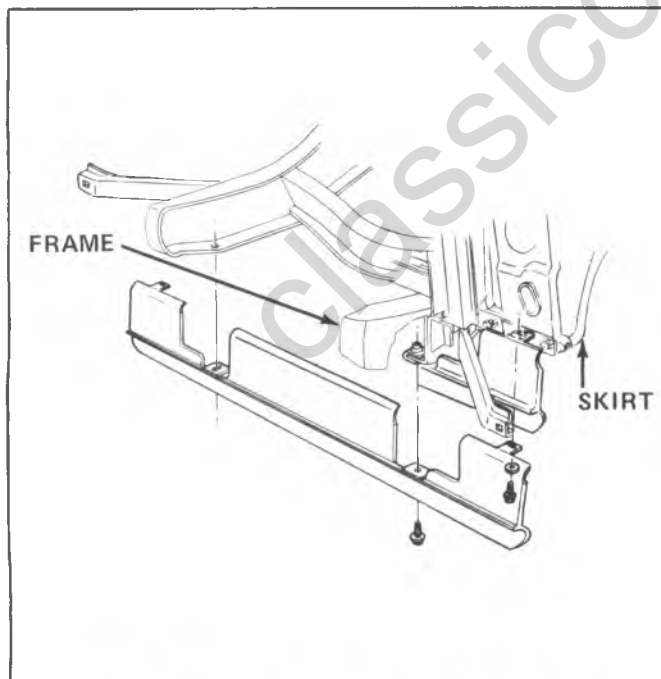


Fig. 2C-18—Fender Skirt Assembly—CK Model

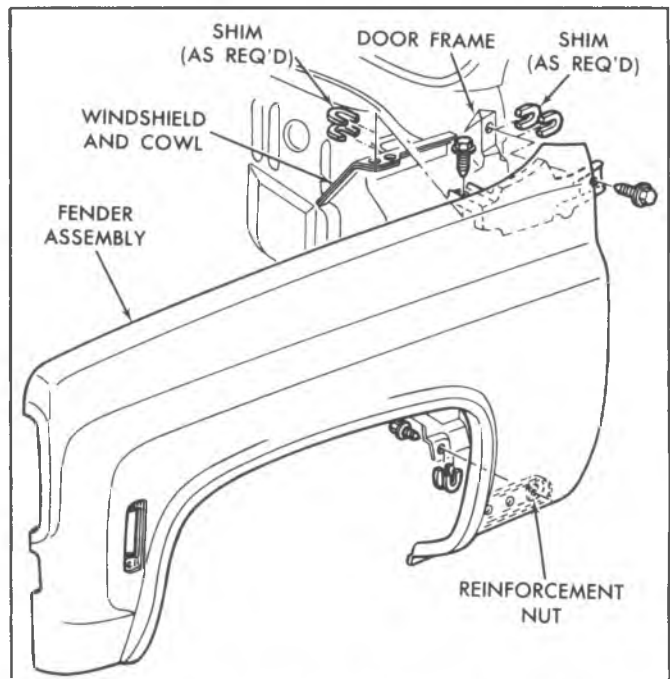


Fig. 2C-19—Front Fender Assembly—CK Model

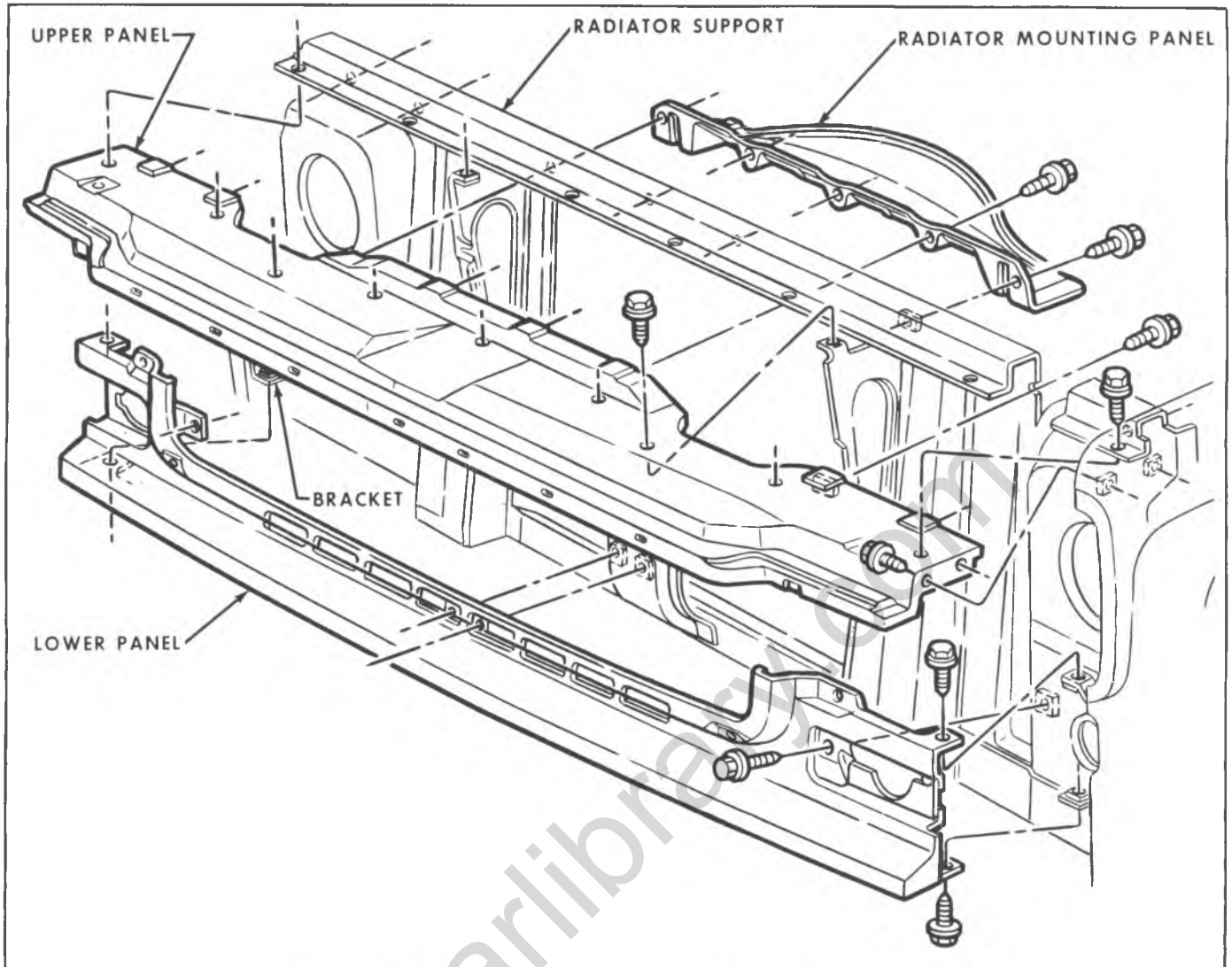


Fig. 2C-20-Radiator Upper and Lower Grille Panels-CK Models

11. Install radiator coolant recovery tank hoses and shroud.
12. Connect removed wiring to radiator support.
13. Install both head lamp assemblies.
14. Tighten all previously installed bolts and screws.
15. Install battery and connect leads and wires.
16. Install grille assembly.
17. Fill radiator with coolant as specified in Section 13.
18. Install hood on previously marked outline.

FRONT FENDER (FIG. 2C-19)

Removal

1. Remove hood and hinge assembly.
2. Remove head lamp bezel, wiring and attachments from fender.
3. Remove screws attaching upper and lower radiator grille panels.
4. Remove screws attaching fender wheel opening flange to skirt.
5. Remove skirt to fender bolts, located inboard on underside of skirt.

6. Remove two (2) screws attaching support bracket to fender.

7. Remove five (5) screws attaching radiator support to front fender.

8. Remove bolt and shim attaching trailing edge of fender to hinge pillar.

9. Remove two bolts and shims at top rear of fender attaching to cowl.

Installation

To install, reverse the removal procedure using sealing tape between filler panel and fender. Check sheet metal alignment.

FRONT FENDER AND SKIRT (FIGS. 2C-18 AND 2C-19)

Removal

1. Remove hood and hood hinge assembly.
2. Disconnect and remove battery (right side or auxiliary left side).
3. Remove head lamp bezel, wiring and attachments from fender.

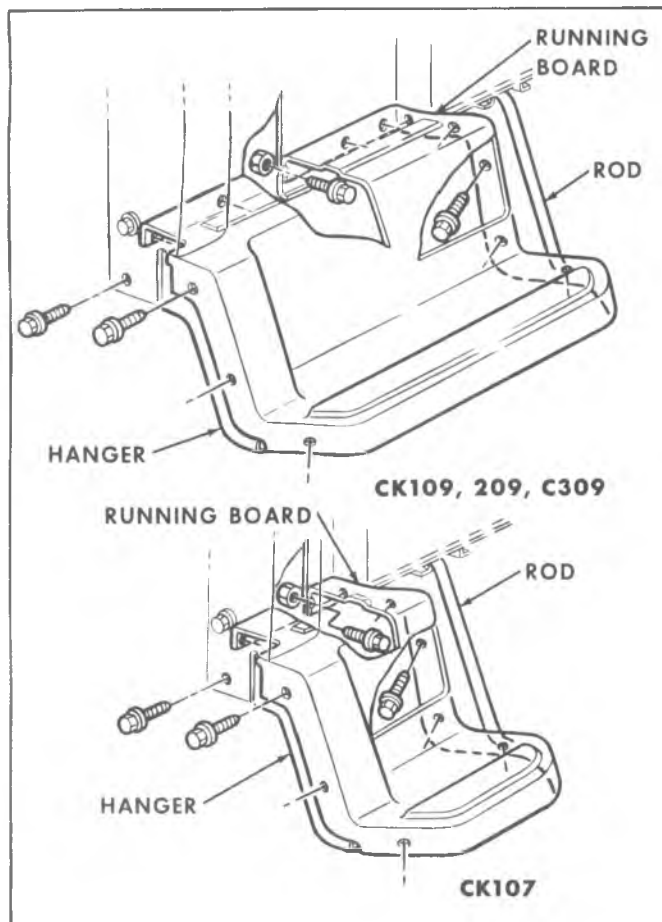


Fig. 2C-21--Running Boards--CK Models

4. Remove screws attaching upper and lower radiator grille panels.
5. Remove screws attaching skirt to radiator support.
6. Remove two (2) top rear fender bolts and shims.
7. Remove bolt and shims at bottom of fender.
8. Remove bolt and shim(s) attaching skirt to underbody.
9. Remove two (2) screw attaching support bracket to fender.
10. Remove five (5) screws attaching radiator support to front fender.
11. Lift fender and skirt from truck.

Installation

Install front fender and skirt assembly in reverse order of removal.

RUNNING BOARDS

Refer to Fig. 2C-21 for removal and installation of running boards.

SHEET METAL CHECKING--G-MODEL

Refer to the sheet metal checking as shown in Fig. 2C-22 for proper gaps and hood adjustments.

Fender Skirt - P Model

Refer to figure 2C-23 for removal and installation of fender skirt, brackets, rear supports and hangers.

WOOD GRAIN APPLIQUE (INSTALLATION PROCEDURE)

General

The wood grain applique (transfer film) is a vinyl material with a pressure sensitive adhesive backing. The transfers are serviced in precut panels. The transfers are designed with an appealing wood grain pattern and a 50 degree or semigloss finish.

Preparation of the surface to which the transfer will be applied is very important. In cases where body metal repair has been made it is necessary to prime and color coat these areas to blend with the undamaged surface. Apply the transfer film to color coated panels only, never to bare metal or primer.

The surface must be free of any imperfections that might high-light through the film. Remove dirt nibs and other foreign material in the paint by light sanding with 600 grit sandpaper.

The temperature of the body must be maintained at a moderate level between approximately 70 and 90°F (21 and 32°C). Too warm a body will cause the wood grain film to stick prematurely while too cool a body will reduce the adhesion of the wood grain film. Cool the body panel with cool water when too warm and heat the body panel with a heat gun or a heat lamp when too cold.

Transfers should not be replaced in temperatures below 65 degrees F (18°C). The transfer should not be subjected to temperature greater than 175°F (79°C) and should not be left at or near this temperature for extended periods of time.

Shelf life of the transfer material is 90 days at a temperature not to exceed 105°F (40°C).

Removal

Remove the moldings from the affected panel. The transfer film may then be removed by lifting an edge and peeling the material from the painted surface. Exercise care so as not to damage the paint. Application of heat to the transfer and the panel by means of a heat gun or heat lamp will aid in the removal.

Installation

1. With a solvent dampened sponge, clean entire surface to be covered with applique.
2. Wipe area dry with a clean cloth.
3. Prior to application of transfer, wet down the complete transfer surface of the fender with a solution of 1/4 oz. of neutral detergent cleaner (must not contain oils, perfumes, or bleaches) per gallon of clear water. It is essential that no substitute for this solution be used and that the specified proportions be maintained.
4. While entire area is still wet with solution, remove paper backing from transfer and align upper edge with pierced holes in fender and press on lightly.
5. Start at center of transfer and squeeze outboard from middle to edges removing all air bubbles and wetting solution to assure a satisfactory bond. Use teflon-backed plastic squeegee only.
6. Notch applique at fender rear contour bend areas with scissors. Also notch out front marker lamp.
7. Fold ends of applique over fender flanges using squeegee. Heat the wrap-around area of applique with a heat lamp or gun to approximately 90°F (32°C) and press with squeegee to secure entire edge surface.

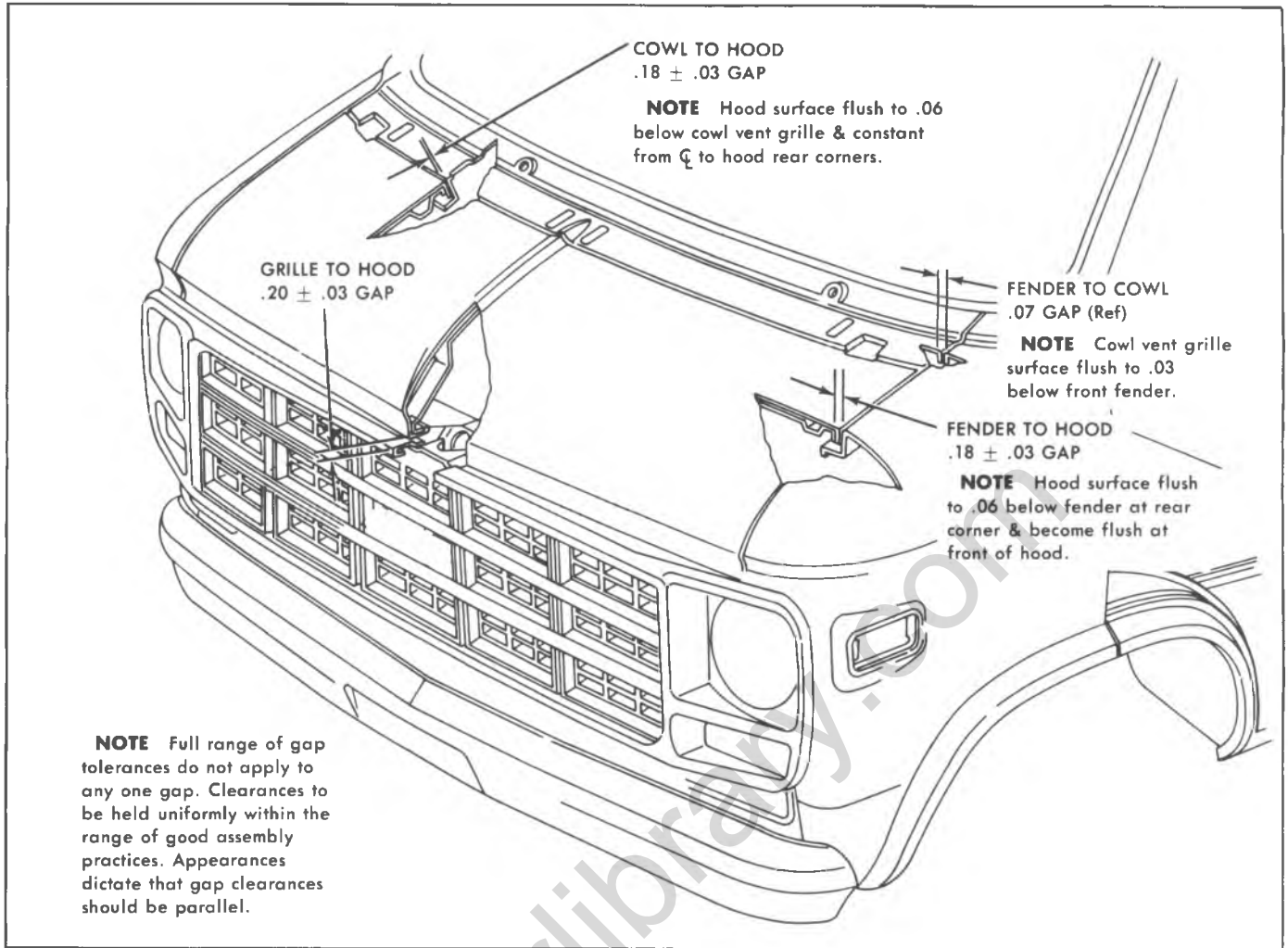


Fig. 2C-22--Front End Sheet Metal Checking--G Model

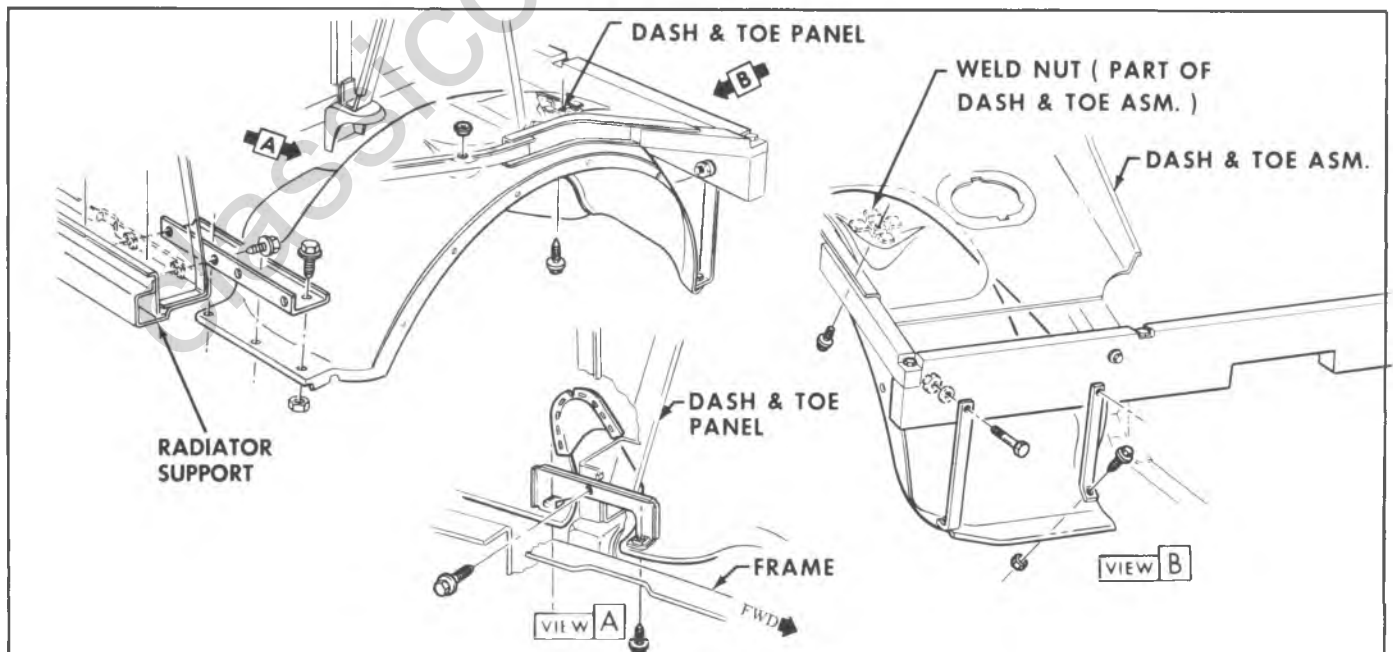


Fig. 2C-23--Fender Skirt, Dash and Toe Pan--P Series

8. If the wrap-around of the transfer has trouble sticking to fender edges, brush vinyl adhesive onto the fender or transfer area. Allow the adhesive to set for one minute then press transfer to fender for adhesion.

9. Inspect transfer installation from critical angle using adequate light reflection to detect any irregularities that may have developed during installation. Remove all air

or moisture bubbles by piercing each at an acute angle with a fine pin or needle and by pressing the bubble down.

10. Install previously removed parts and clean up vehicle as required.

SPECIFICATIONS

SHEET METAL

SECTION 2C

TORQUE SPECIFICATIONS

| | CK | G | P |
|------------------------------|--------------|--------------|--------------|
| Lock Support to Hood | 150 in. lbs. | 150 in. lbs. | |
| Lock Bolt Nut | 30 ft. lbs. | 40 ft. lbs. | |
| Bumper Bolt Nut | 85 in. lbs. | 150 in. lbs. | |
| Hood Hinge | 35 ft. lbs. | 18 ft. lbs. | |
| Hood Lock Catch | 150 in. lbs. | 18 ft. lbs. | |
| Lock Support to Rad. Support | 150 in. lbs. | 18 ft. lbs. | |
| Rad. Support to Frame | 35 ft. lbs. | | 30 ft. lbs. |
| Rad. Support to Fender | 150 in. lbs. | | |
| Fender Skirt to Fender | 150 in. lbs. | | 150 in. lbs. |
| Fender to Cowl | 35 ft. lbs. | | |
| Rad. Grille Panel Upper | 150 in. lbs. | | |
| Rad. Grille Panel Lower | 150 in. lbs. | | |

SECTION 2D

CAB AND BODY

The following notice applies to one or more steps in the assembly procedure of components in this portion of the manual as indicated at appropriate locations by the terminology "See Notice on page 1 of this Section".

NOTICE: This fastener is an important attaching part in that it could affect the performance of vital components and systems, and/or could result in major repair expense. It must be replaced with one of the same part number or with an equivalent part if replacement becomes necessary. Do not use a replacement part of lesser quality or of substitute design. Torque values must be used as specified during reassembly to assure proper retention of this part.

CONTENTS OF THIS SECTION

| | |
|--------------------------|-------|
| General Description..... | 2D-1 |
| On Vehicle Service..... | 2D-4 |
| C-K Models..... | 2D-4 |
| G Models..... | 2D-38 |
| Specifications..... | 2D-61 |
| Special Tools..... | 2D-63 |

GENERAL DESCRIPTION

On the following pages, service procedures will be given for components on all 10-20-30 series trucks in C, K and G models. Reference will be made, both in text and illustrations, to vehicle model lines and to individual model numbers within these model lines.

As an aid to identification of specific models, the following general descriptions are given.

Chassis/Cabs

All chassis cabs use "03" as the model identification. See figure 2D-1. Two-wheel drive units come in C10, C-20 and C-30 series. Four-wheel drive units may be either K-10 or K-20. Optional pickup boxes are available.

Crew Cab/Chassis

Model number "63" designates the crew cab/chassis models. See figure 2D-2. Optional pickup boxes are available.

Coach

The four-door coach model number is "06". See figure 2D-3. Base models have rear cargo doors. An optional endgate with moveable window is available.

Utility

Utility models are designated with the number "16". See figure 2D-4. An optional removable roof is also available.

Vans

G-Series Vans are available in three model number designations. See figures 2D-5 and 2D-6. Vans without body windows use number "05"; vans with body windows are "06" models; "03" vans have an open cargo area, as shown in figure 2D-6.

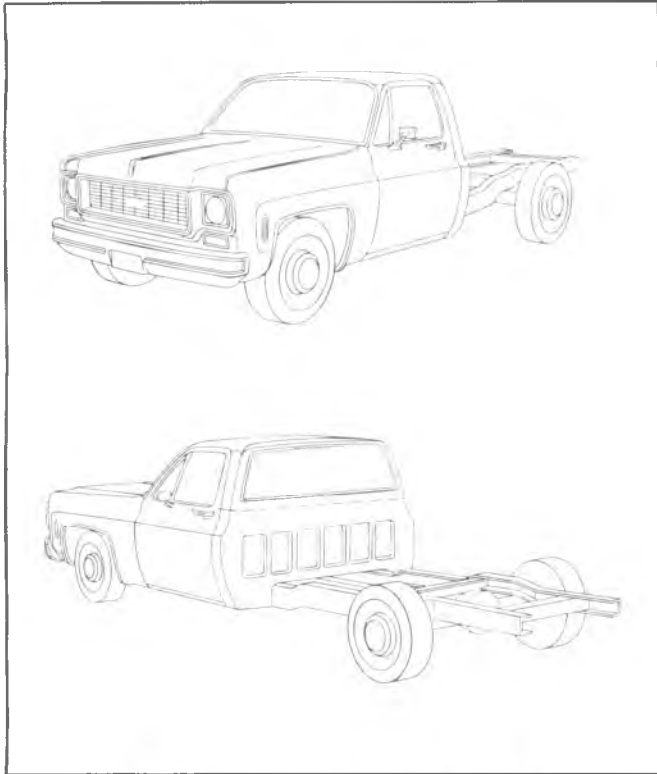


Fig. 2D-1--Typical Chassis/Cab, Model 03

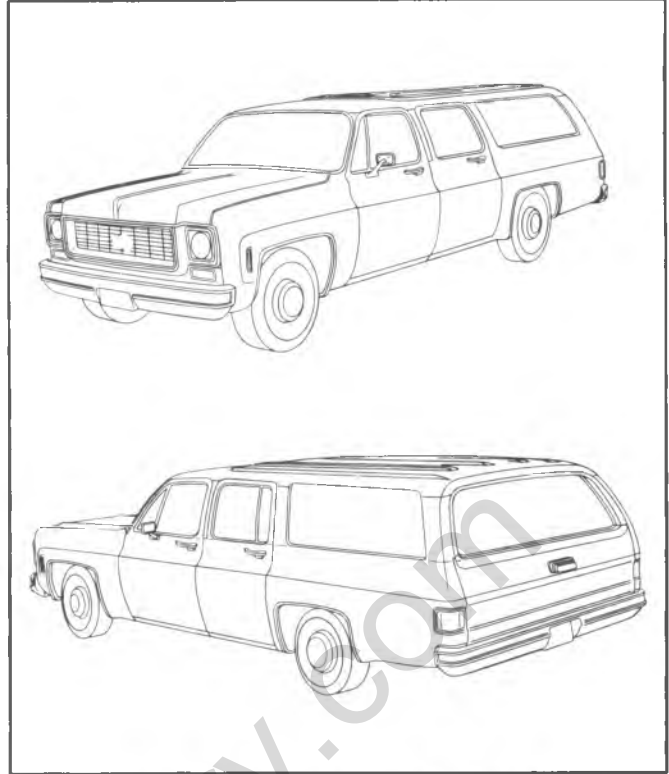


Fig. 2D-3--Typical Coach, Model 06



Fig. 2D-2--Typical Crew Cab/Chassis, Model 63



Fig. 2D-4--Typical Utility Vehicle, Model 16

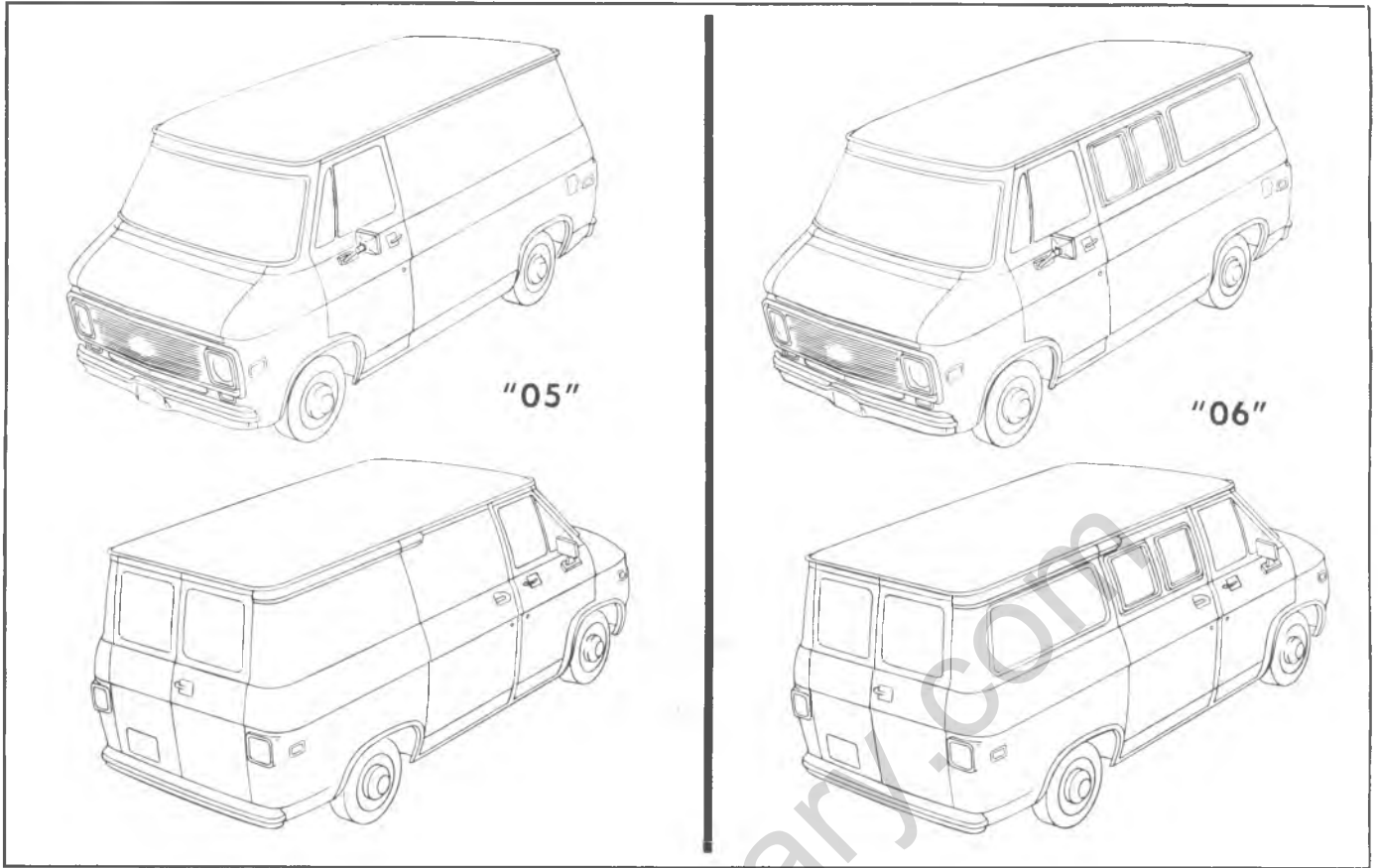


Fig. 2D-5--Typical "05" and "06" Vans

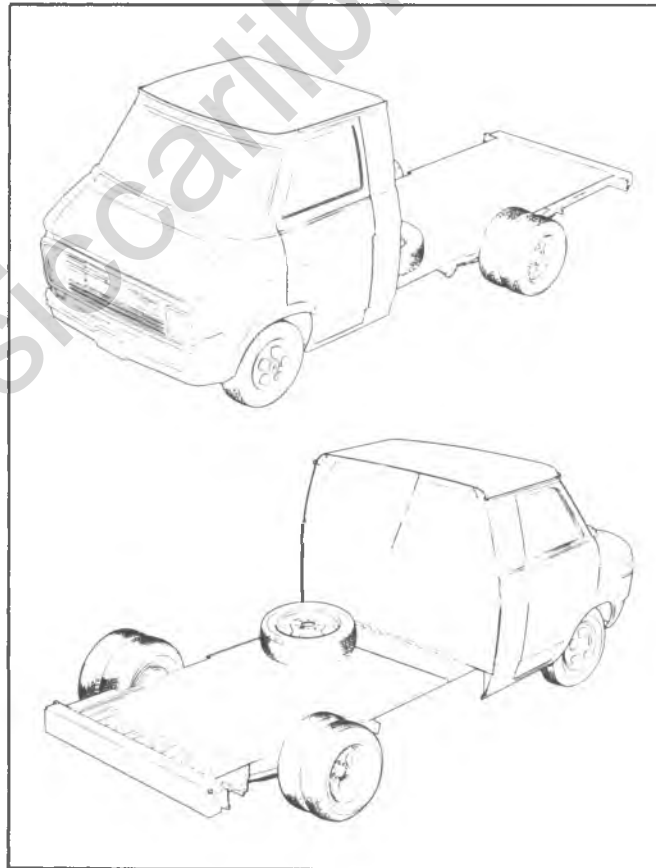


Fig. 2D-6--Typical "03" Van

ON VEHICLE SERVICE C-K MODELS

INDEX

| | | | |
|-----------------------------|-------|-------------------------------|-------|
| Front End | | Replacement | 2D-16 |
| Windshield Wipers..... | 2D-5 | Hinges | 2D-16 |
| Glove Box..... | 2D-5 | Stationary Glass | 2D-17 |
| Rear View Mirrors..... | 2D-5 | Window and Regulator..... | 2D-17 |
| Body Glass | | Locks, Handles, Rods..... | 2D-17 |
| Windshield Glass | 2D-6 | Weatherstrip | 2D-18 |
| Stationary Body Glass | 2D-9 | Rear Doors | |
| Side Doors | | Adjustments..... | 2D-18 |
| Adjustments..... | 2D-10 | Locks, Handles, Rods..... | 2D-19 |
| Front Side Door..... | 2D-11 | Hinges..... | 2D-19 |
| Replacement | 2D-11 | Gates | |
| Hinges | 2D-11 | Endgates | 2D-21 |
| Ventilator..... | 2D-12 | Tailgates..... | 2D-23 |
| Window and Regulator..... | 2D-13 | Removable Top (Utility) | 2D-27 |
| Locks, Handles, Rods | 2D-15 | Seat Belts..... | 2D-29 |
| Weatherstrip | 2D-16 | Seats..... | 2D-29 |
| Rear Side Doors..... | 2D-16 | Body Mounting..... | 2D-29 |

FRONT END

WINDSHIELD WIPERS

Windshield wiper units on all models are of the two-speed electric type. A single wiper motor unit, mounted to the left side of the dash panel inside the engine compartment, powers both wiper arms. The wiper arm operating link rods and pivot mountings on these models are located in the outside air inlet plenum chamber.

Arm Adjustment

To adjust sweep of blades, turn on wipers and note sweep of arms. If necessary, remove one or both arms as follows:

Pull outer end of arm away from glass which will trip lock spring at base of arm and release spring from undercut of pivot shaft. While holding arm in this position, pull outward on cap section at base of arm to remove arm. Arm can be reinstalled in any one of several positions due to serrations on pivot shaft and in arm cap. See figure 2D-7.

Wiper Arm Pivot Shafts and Linkage

Removal

1. Remove windshield wiper arms from pivot shafts. Procedure for removing arms is explained previously under "Arm Adjustment".

2. Remove two nut and lock washer assemblies from the connector link to motor drive arm via the plenum access hole.

3. Remove two screws from each transmission pivot shaft assembly to windshield frame. Remove wiper linkage and transmission from plenum.

Installation

1. Place wiper linkage and transmission into position. Secure assembly with two screws at each transmission.

2. Attach end of cross rod to drive arm of motor assembly. Secure rod.

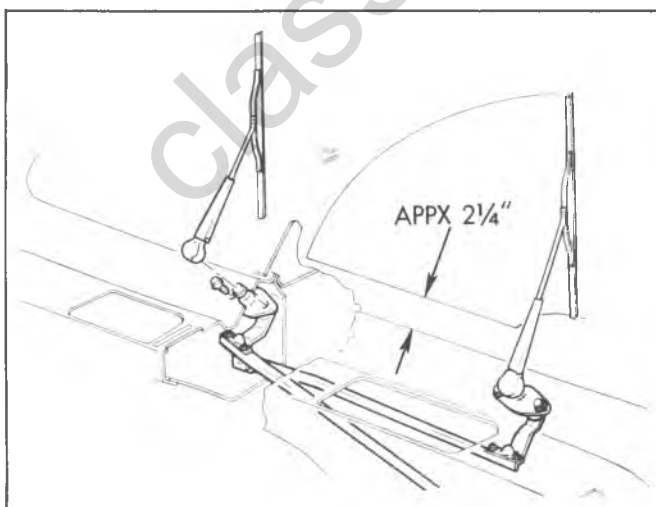


Fig. 2D-7--Windshield Wipers

3. Before installing wiper arms, operate wiper motor momentarily which should rotate pivot shafts to park position. Install arms and shafts.

INSTRUMENT PANEL COMPARTMENT AND LOCK

Replacement

Removal of the entire assembly including door may be accomplished by removing four screws which attach hinge just below box. See figure 2D-8. The outer door panel may be removed, leaving the compartment intact, by removal of four screws. Access to the door stop bumper is gained by reaching into compartment opening with door partially open.

Adjustment

Engagement of lock in striker may be adjusted by loosening striker retaining screws and moving the striker to desired position.

OUTSIDE REAR VIEW MIRRORS

Rear view mirror installations are shown in figure 2D-9, 2D-10 and 2D-11. Occasional tightening of mounting and assembly bolts and screws will sharply decrease occurrence of failure due to door slamming or road shock.

Camper mirror installation is similar to the below eyeliner mirror installation.

INSIDE REAR VIEW MIRROR - FIGURE 2D-11

Replacement

1. Remove screw retaining mirror to its glass-mounted bracket and remove mirror.

2. Install mirror into its mounting bracket. Torque screw to specifications.

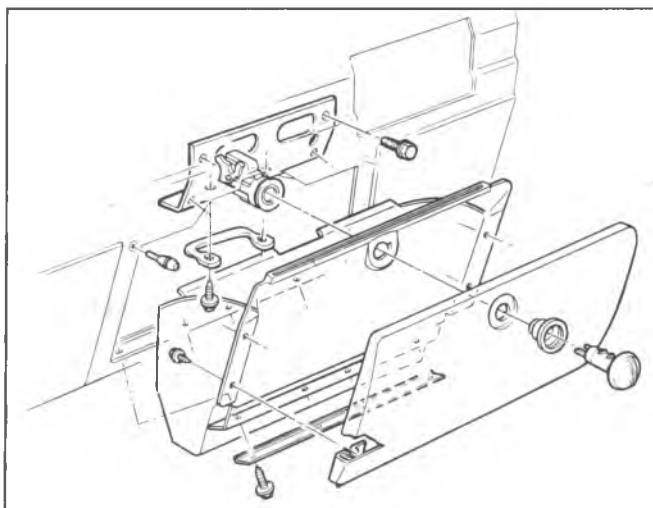


Fig. 2D-8--Glove Box

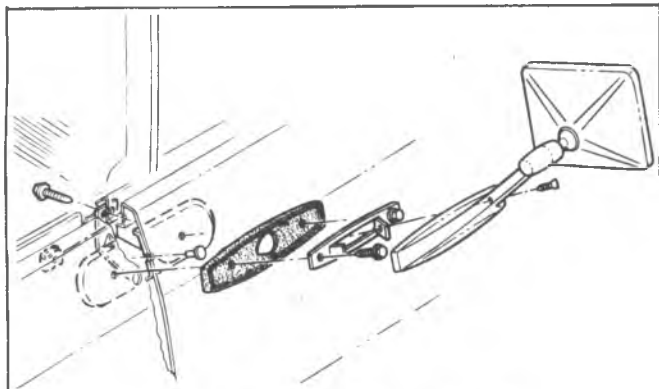


Fig. 2D-9-Rear View Mirror - Base

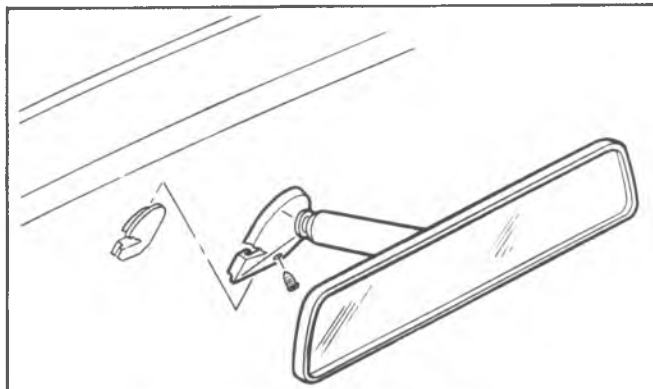


Fig. 2D-11-Inside Rear View Mirror

COWL VENT VALVE - FIGURE 2D-12

Two styles are shown in Figure 2D-12. Removing the

attaching screws allows removal of the valve from the side panels.

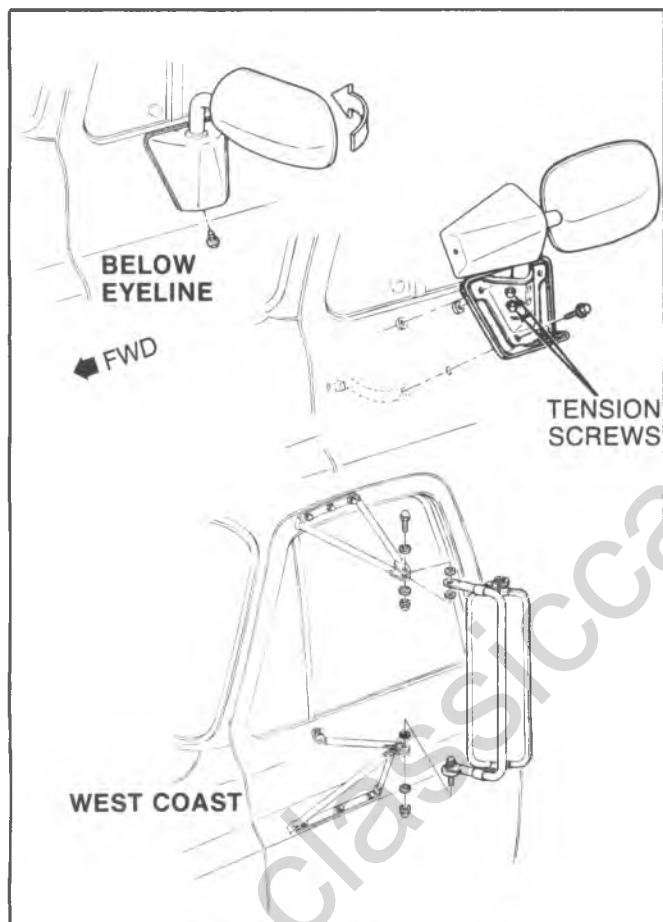


Fig. 2D-10-Rear View Mirrors

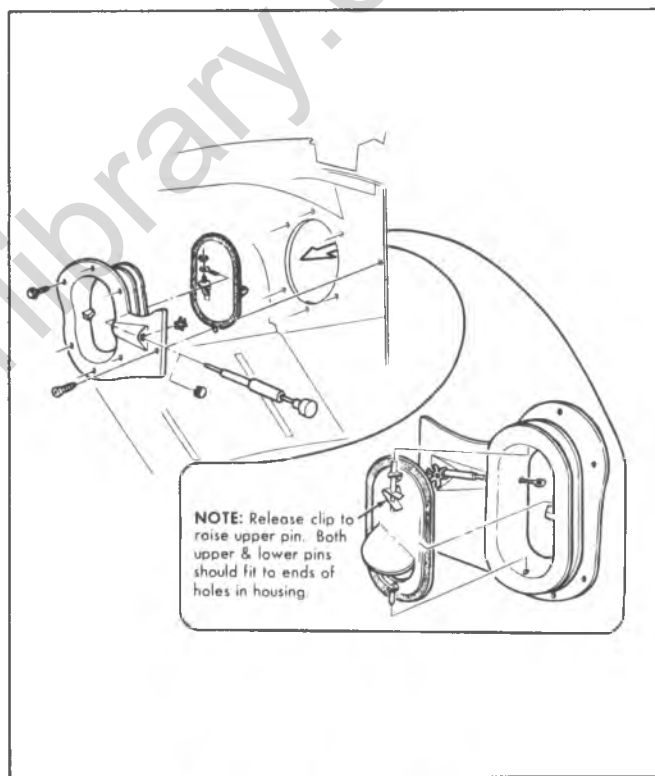


Fig. 2D-12-Cowl Vent Valves

BODY GLASS

CAUTION: Always wear gloves and eye glasses when handling glass to avoid personal injury.

CK TRUCK WINDSHIELD REPLACEMENT

The windshield is a one-piece type and is retained in the windshield opening by a urethane bonded rubber weatherstrip. See figure 2D-13.

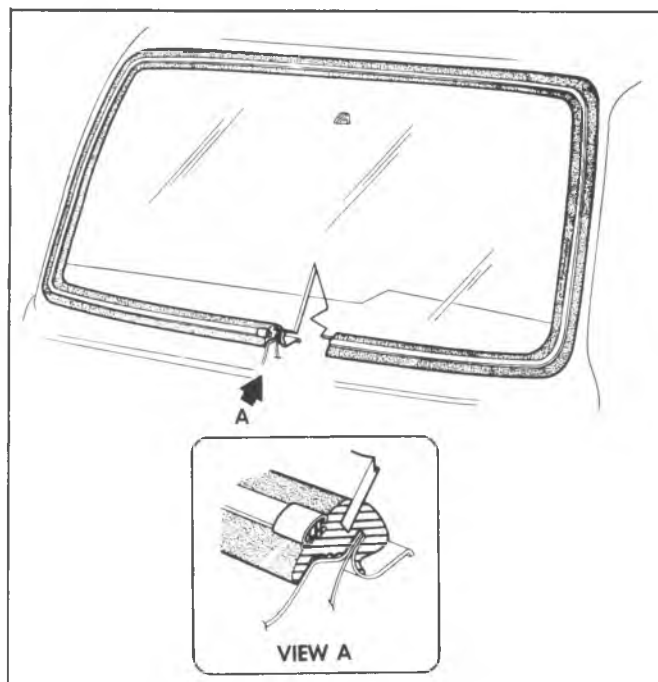


Fig. 2D-13—Typical Windshield

When replacing a cracked windshield glass, it is very important that the cause of the glass breakage be determined and the condition corrected before a new glass is installed. Otherwise, it is highly possible that a small obstruction or high spot somewhere around the windshield opening will continue to crack or break the newly installed windshield especially when the strain on the glass caused by this obstruction is increased by such conditions as wind pressures, extremes of temperature, motion of the vehicle, etc.

To replace a window installed with urethane adhesive requires replacement of the adhesive material. Adhesive service kits No. 1052420 and No. 9631000 contain some of the materials needed to remove and replace a urethane adhesive installed glass. These kits and other materials that may be required can be obtained through the service parts system. The components of glass adhesive kits (urethane) No. 1052420 and 9631000 are as follows:

1. One tube of urethane adhesive material.
2. One dispensing nozzle.
3. Steel music wire.
4. Rubber cleaner.
5. Rubber primer.
6. Pinch-weld primer.
7. Blackout primer.
8. Filler strip (for use on windshield installations on vehicles equipped with embedded windshield antenna).
9. Primer applicators.

Additional Material Required:

1. Rubber lubricant No. 1051717 (available through the service parts system).
2. Alcohol for cleaning edge of glass.
3. Adhesive dispensing gun No. J-24811 or a standard household cartridge type gun reworked as follows:



Fig. 2D-14--Applying Pressure to Windshield

- a. Widen end slot to accept dispensing end of adhesive material tube.
- b. Reduce diameter of plunger disc on rod so that disc can enter large end of adhesive material tube.
4. Commercial type razor knife (for cutting around edge of glass).
5. Weatherstrip tool set J-2189.
6. Six glass spacers J-22577 (for checking windshield glass to opening).

Removal

1. Before removing the windshield, mark the location of the break on the windshield rubber channel and the body. Protect the paint finish inside of the cab. Mask around the windshield opening and outside, lay a suitable covering across the hood and fenders.
2. Remove windshield reveal molding (lock strip) and reveal molding cap.
3. To free windshield rubber channel of weatherstrip loosen the lip of the windshield weatherstrip from the pinchweld flange along the top and at the sides by applying firm, controlled pressure to the edge of the glass. At the



Fig. 2D-15--Assisting Weatherstrip over Flange

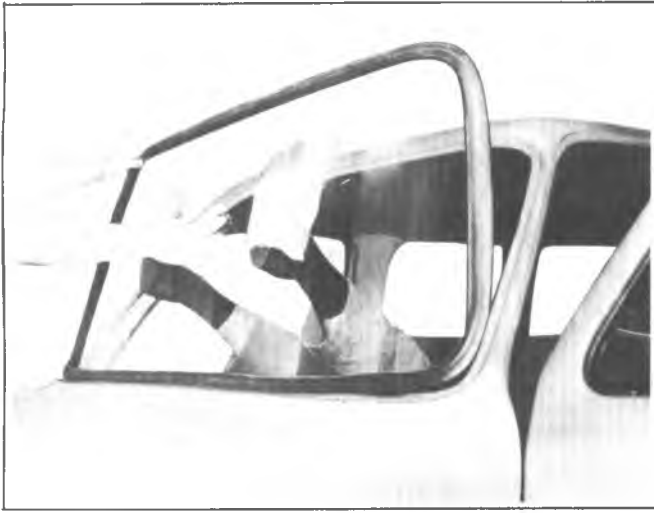


Fig. 2D-16--Removing Windshield from Opening



Fig. 2D-17--Checking Windshield Opening

same time assist the lip of the rubber weatherstrip channel over the pinchweld flange with a flat bladed tool. See figures 2D-14 and 2D-15.

4. With the aid of an assistant outside the cab, remove the windshield from the opening. See figure 2D-16.

5. Remove all excess urethane adhesive and any remaining pieces of weatherstrip from pinch-weld flange.

6. If sheet metal and paint repairs are required, refer to "Repairing and Refinishing Pinchweld Flange" of this section.

Checking Windshield Opening

Due to the expanse and contour of the windshield it is imperative in the event of a stress crack that the windshield opening be thoroughly checked before installing a replacement windshield. The replacement glass is used as a template.

1. Check for the following conditions at the previously marked point of fracture.
 - a. Chipped edges on glass.
 - b. Irregularities in body opening.
 - c. Irregularities in rubber channel weatherstrip.
2. Check flange area for solder, weld high spots, or hardened spot-weld sealer. Remove all high spots.
3. Check windshield glass to opening, by supporting glass with six spacers contained in packet J-22577. See figure 2D-17.

NOTICE: Do not strike glass against body metal. Chipped edges on the glass can lead to future breaks.

4. With the windshield supported and centered in its opening, check the relationship of the glass to the body opening flange around the entire perimeter of the glass.

5. Check the relationship of glass to opening as follows:

- a. Inside edge of glass to body flange.
 - b. Outer edge of glass to parallel body metal.
6. Mark areas of body metal or flange to be reformed. Remove glass and correct as outlined in this section.

7. Recheck windshield in its opening and if satisfactory proceed as follows:

Repairing and Refinishing Pinch-Weld Flange and/or Surrounding Areas

1. Repair all metal deformations in the windshield opening area for appearance.
2. Sand to smooth surface using No. 320 sandpaper.
3. Apply primer - surfacer (DuPont 80 S Primer - Surfacer, PPG 204-1000 Red Flash Primer or PPG 700-345 Repair Primer/or equivalent) and sand smooth for required surface.
4. Apply color coats of 9984024 acrylic enamel (or equivalent) catalyzed as indicated.

Installation (Fig. 2D-18)

Installation of the windshield requires a number of timed (cure time) steps. This timing is important and must be followed. All cure times are minimum, unless indicated otherwise. When performing a step that requires a cure time, it is not necessary to stop and wait for the cure time to elapse. Make a note of the cure time and move on to any following step that does not interfere with the timed sequence.

1. Wipe pinch-weld clean with a dry cloth. Make sure most of the previous urethane has been removed.
2. Apply pinch-weld primer with a new applicator to pinch-weld as shown in View B.

Primer must be thoroughly stirred and agitated prior to application.

Allow primer to cure for at least 30 minutes (100 hour maximum). Pinch weld flange must not exceed 160°F (38°C) at time of primer application.

3. Apply rubber cleaner with a new applicator to both channels of rubber weatherstrip as shown in View A. Allow cleaner to remain for at least 5 minutes (4 hour maximum), then wipe both channels with a clean dry cloth.

4. Apply rubber primer to both channels of rubber weatherstrip that were cleaned in the previous step and are shown in View A. Allow primer to cure for at least 30 minutes (30 day maximum).

5. Thoroughly clean surface of glass to which blackout primer will be applied (around edge of inside surface) by wiping with a clean, alcohol dampened cloth. Allow to air dry.

NOTICE: When cleaning windshield glass, avoid contacting edge of plastic laminate material (on edge of glass) with volatile cleaner. Contact may cause discoloration and deterioration of plastic laminate by wicking action. **DO NOT** use a petroleum base solvent such as kerosene or gasoline. The presence of oil will prevent adhesion of new material.

6. Apply blackout primer to the same area of the windshield glass that was cleaned in the previous step and is shown in View C. Allow to dry to touch.

7. Apply a 3/16 inch minimum diameter bead of urethane adhesive around pinch-weld flange as shown in View B. Windshield glass must be installed within 20 minutes after performing this step.

8. Apply a mist of plain water to the urethane bead on the pinch-weld flange, wetting it fully.

9. Install rubber weatherstrip to the pinch-weld flange.

10. Apply a 3/16 inch minimum diameter bead of urethane adhesive to rubber weatherstrip glass channel as shown in View D.

11. Apply a mist of lubricant to surface "C" or weatherstrip as shown in View D, wetting it fully. Install windshield within 5 minutes after performing this step.

12. On windshields equipped with embedded antenna, tape pigtail of antenna to inside surface of windshield glass in a convenient and accessible position.

13. With the aid of a helper, lift glass into window opening. Suction cups may be used but are not mandatory. Then, install glass in channel of weatherstrip.

14. Apply lubricant to lockstrip channel. Windshield must be seated prior to application of lubricant.

15. Use J-2189 weatherstrip tool set and install lockstrip in channel of weatherstrip. Install lockstrip cap at lockstrip joint.

16. Install windshield wiper arms and blades.

17. On windshields equipped with embedded antenna, connect antenna pigtail to radio antenna lead.

18. Install inside trim panels.

19. Install rear view mirror to windshield.

STATIONARY BODY GLASS

Replacement

The method used to remove the windshield glass may be applied to other stationary glass, such as shown in figures 2D-20 and 2D-21. Remember to check for cause of breakage, and to always wear gloves when handling glass. Installation procedures are similar to G-Van windshield. Refer to figures 2D-101 and 2D-103, later in this section.

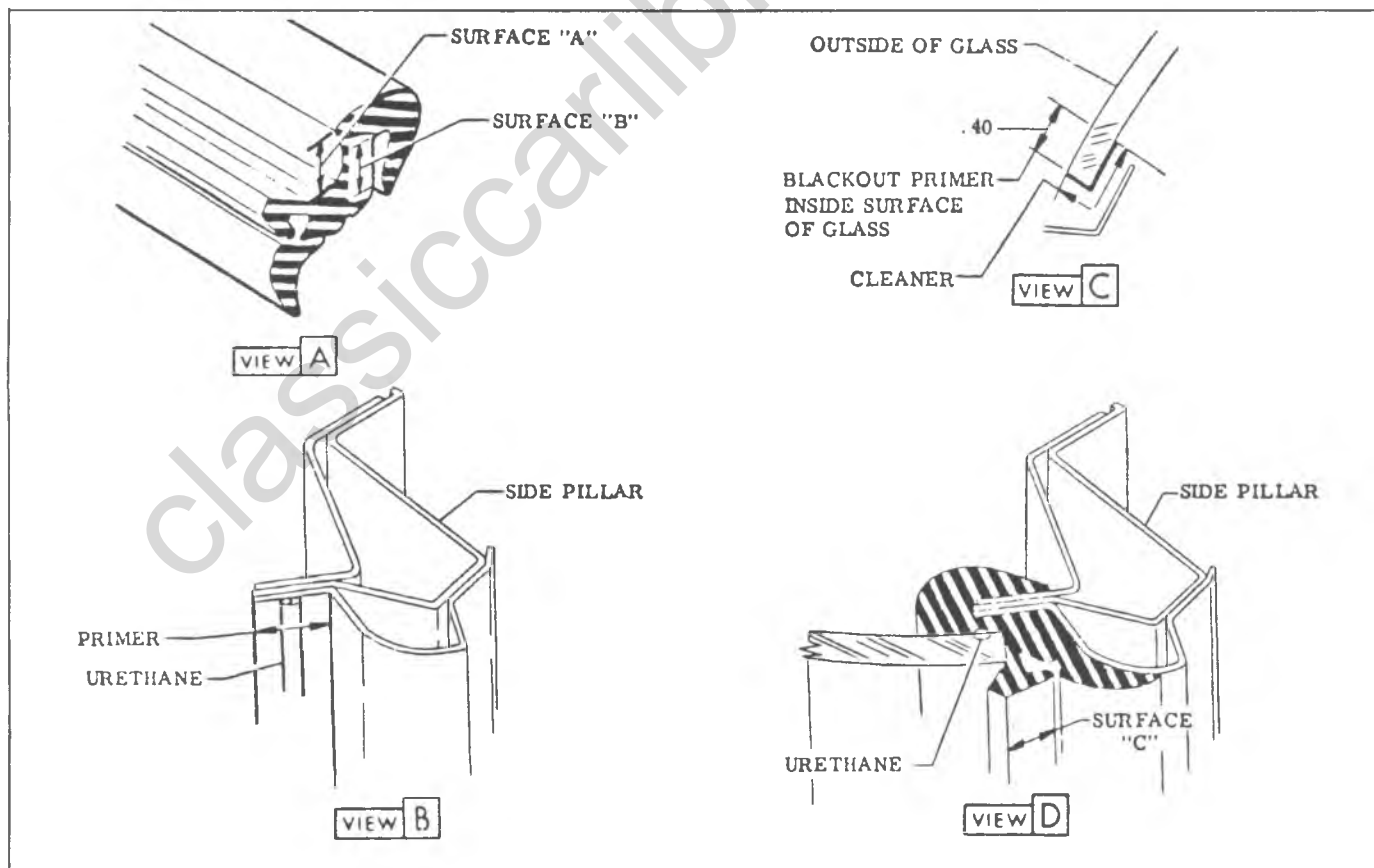


Fig. 2D-18--Windshield Installation-CK Truck



Fig. 2D-19--Installing Reveal Molding

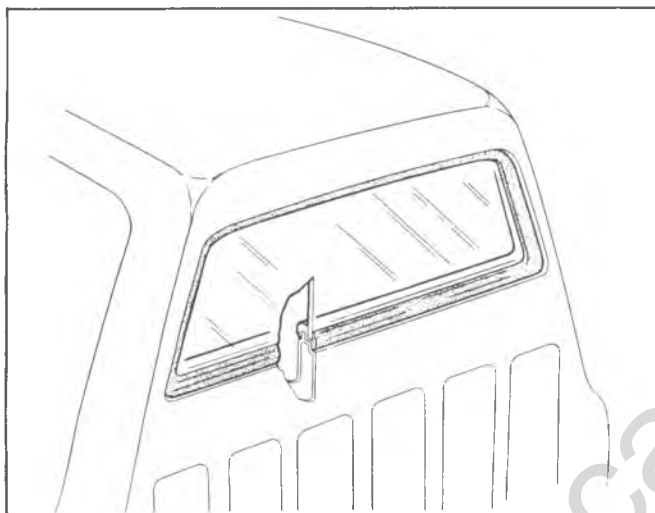


Fig. 2D-20--Back Window Glass - (03, 63)

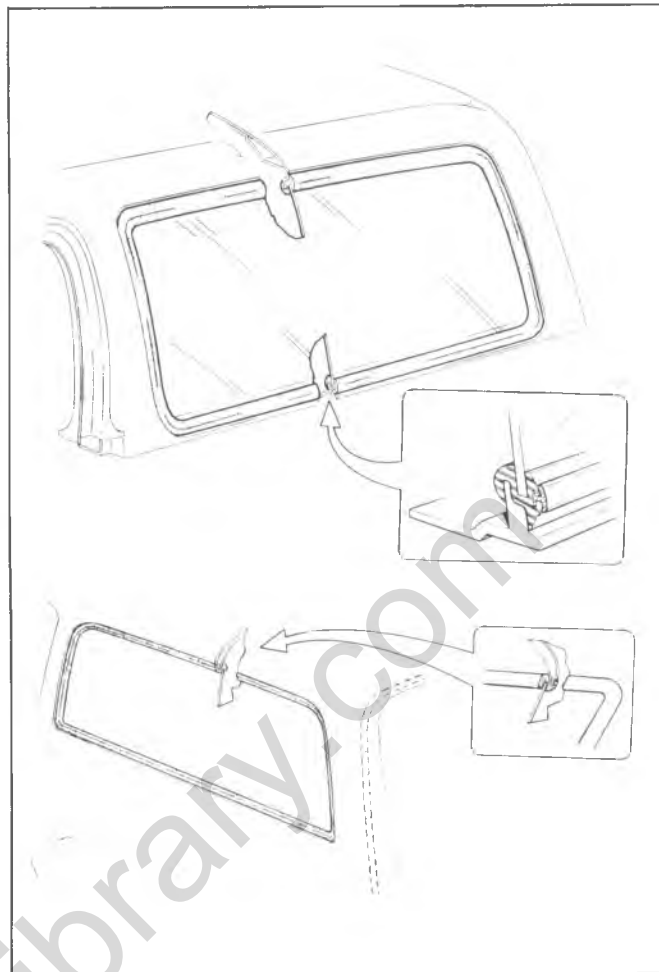


Fig. 2D-21--Body Side Window - (16 and 06)

BODY SIDE DOORS

DOOR ADJUSTMENTS

Doors can be adjusted for alignment of clearance in the cab door opening, and for proper latching. Door alignment adjustments are made at the striker bolt, and at door hinges. The door, when properly located in door opening, will have .19 inch clearance at the top and side edges, and .25 inch clearance at the bottom. The door should be adjusted in the opening so the edge of the door across the top and also at the lock side is parallel with the body opening as nearly as possible.

Hinge Adjustment

Door hinge bolt holes are oversized to make adjustment possible. Alignment adjustments can be made by loosening the proper hinge bolts, aligning door to proper position, and tightening bolts securely (fig. 2D-22).

Striker Bolt Adjustment

With the use of J-23457, shown in figure 2D-23, the striker bolt can be adjusted in any of three ways. See figure 2D-24.

1. **Up and down** - To adjust striker up or down, loosen bolt, adjust to desired height, and tighten bolt securely.

NOTICE: This adjustment is important to assure that the right proportion of door's weight will rest on striker bolt when door is closed. If bolt is positioned too high on pillar, rapid wear will occur to the lock cam; if too low, an extra load will be placed on door hinges as well as pull door downward and out of alignment.

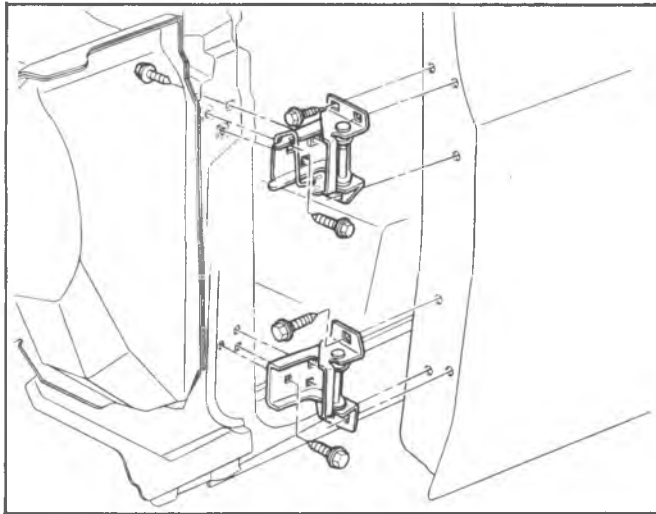


Fig. 2D-22-Door Hinge

2. **In and Out** - To adjust striker in and out, loosen bolt, adjust horizontally to desired position and tighten bolt securely.

3. **Forward and Rearward** --To make this adjustment, loosen striker bolt, shim to desired position, and tighten bolt securely.

FRONT DOOR ASSEMBLY

Replacement

Remove the door assembly from the body by removing the hinge-to-door attaching bolts.

DOOR HINGE

The door check is part of the front door upper hinge. The front door torque rod check holds the door in either of two positions between full open and closed. The front door check-hinge assembly is replaced as a complete unit as follows. See figure 2D-22.

Removal

1. Loosen front fender rear bolts.
2. With special Tool J-22585 remove 3 bolts securing front door upper hinge to cowl pillar.

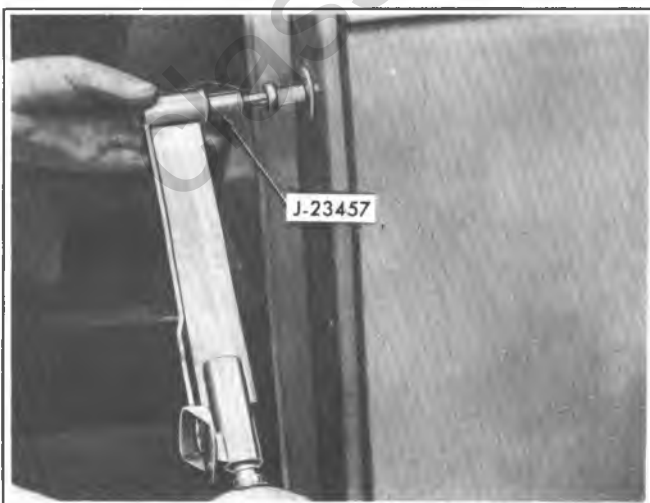


Fig. 2D-23-Loosening Striker Bolt

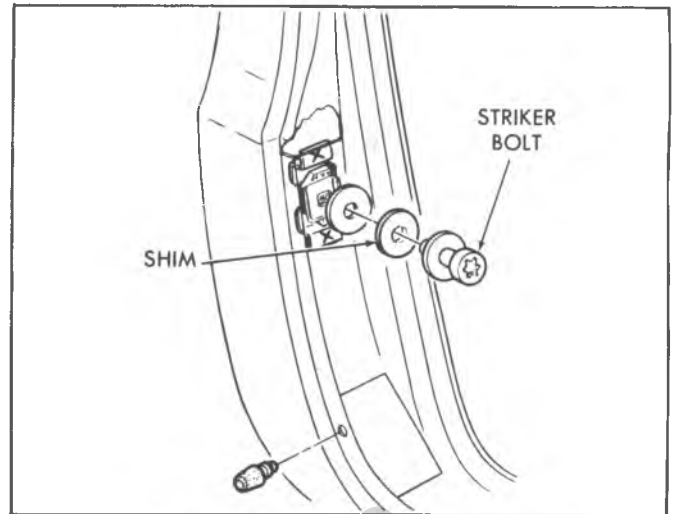


Fig. 2D-24-Typical Striker Bolt Adjustment

- a. Remove the door to upper hinge retaining bolts.
- b. With aid of an assistant to support weight of door, remove the door to lower hinge retaining bolts and remove door.

Installation

1. Install hinge snugly on pillar in same location as hinge removed.
2. With the aid of an assistant fasten the door to the hinge.
3. Adjustment of the door lock and striker plate should be made after the door is positioned in the opening.

DOOR TRIM PANELS - CK MODELS

Removal

1. Using tool J-9886-01, remove clip retaining window crank (fig. 2D-26).
2. Remove door lock knob.
3. Remove (4) screws securing lower edge of trim panel.
4. Remove (2) arm rest attaching screws and remove arm rest pad.
5. Remove (1) screw at door handle cover plate and (1) screw located under arm rest pad.
6. If equipped assist strap, remove (2) screws retaining assist strap.
7. Remove trim panel by carefully prying out at trim retainers located around perimeter of panel.

Installation

Before installing door trim assembly, check that all trim retainers are securely installed to the assembly and are not damaged.

1. To install door trim assembly, pull door inside handle inward; then position trim assembly to inner panel, inserting door handle through handle hole in panel.
2. Position trim assembly to door inner panel so trim retainers are aligned with attaching holes in panel and tap retainers into holes with a clean rubber mallet.
3. Install previously removed items.

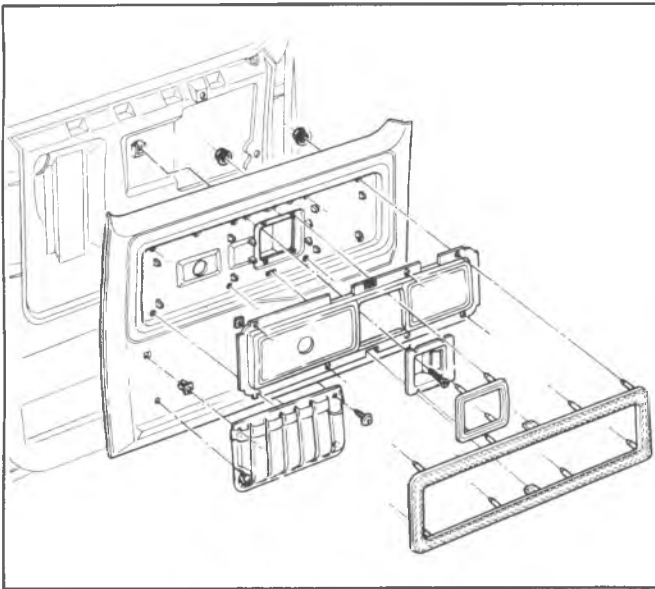


Fig. 2D-25--Door Trim Panel

DOOR VENTILATOR ASSEMBLY--Fig. 2D-28

Removal

The channel between the door window glass and door vent is removed as part of the vent assembly.

1. Regulate the door window glass to the full down position.
2. Remove clip from the window regulator handle, and knob from lock rod.
3. Remove arm rest screws and trim panel. See figure 2D-27.
4. Remove screws attaching ventilator lower assembly to door panel.
5. Remove three screws at the upper front of the door frame.
6. Pull upper portion of vent assembly rearward and raise upward while rotating counter clockwise.
7. Turn vent assembly 90° and carefully remove by guiding up and out. See figure 2D-29.

Ventilator Glass Replacement

1. Using an oil can or similar means, squirt prepsol or equivalent on the glass filler all around the glass channel or frame to soften the old seal. When the seal has softened, remove the glass from the channel.
2. Thoroughly clean the inside of the glass channel with sandpaper, removing all rust, etc.

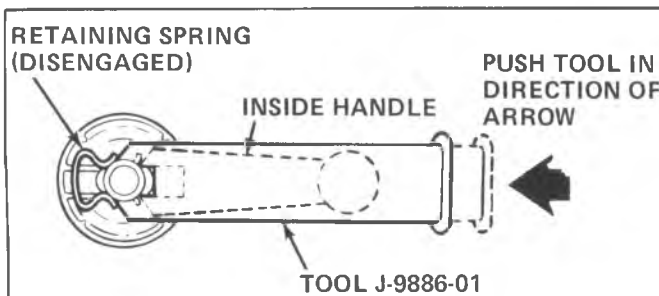


Fig. 2D-26--Clip Retained Inside Handle Removal

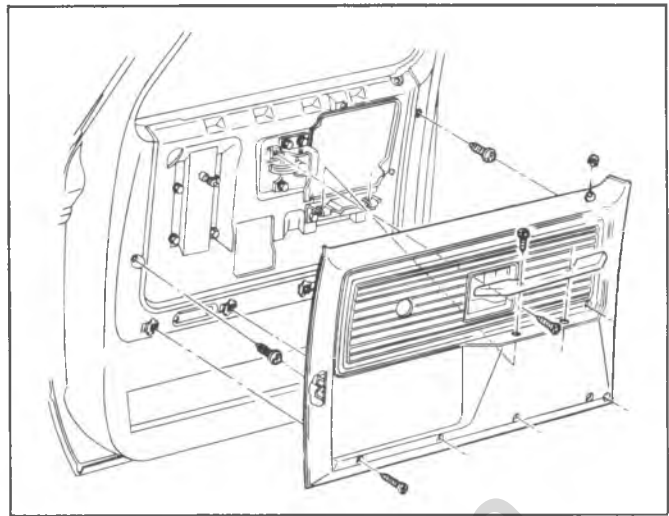


Fig. 2D-27--Door Trim Pad

3. Using new glass channel filler, cut the piece to be installed two inches longer than necessary for the channel. Place this piece of filler (soapstoned side of filler away from glass) evenly over the edge of the glass which will fit in the channel. The extra filler extending beyond the rear edge of the glass should be pinched together to hold it in place during glass installation.

One side of this filler (the outside of the roll) is soapstoned. This is the side which goes into the metal channel.

4. Brush the inside of the metal glass channel freely with ordinary engine oil. This will enable the glass and filler to slide freely into the channel. Push the glass with the filler around it into the channel until it is firmly seated. After the glass is firmly in place, the oil softens the filler, causing it to swell, thereby making a watertight seal. Trim off the excess filler material around the channel and at the ends of the channel.

Glass should be installed so that rear edge is parallel to the division post. Allow full cure before water testing.

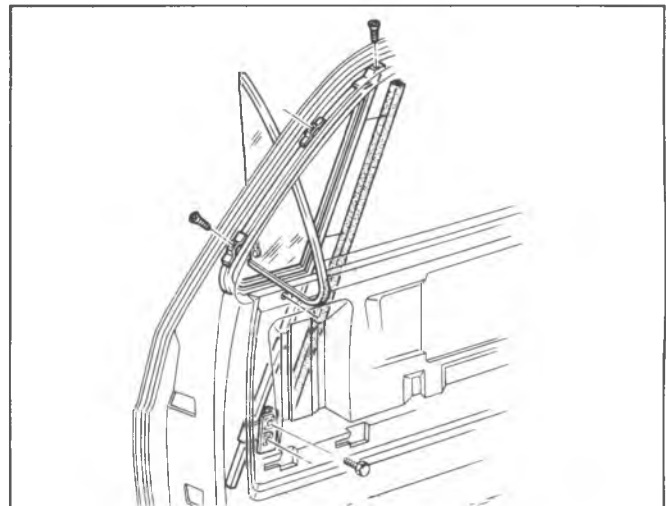


Fig. 2D-28--Door Ventilator Assembly



Fig. 2D-29--Removing Ventilator Assembly

Installation

1. Lower the ventilator assembly into the door frame.
2. Make certain the rubber lip is positioned inside the inner and outer panel before tightening screws.
3. Reinstall all screws and tighten.
4. Install and tighten the three screws at the upper front of the door.

Adjustment

1. Adjust the ventilator by placing wrench on adjusting nut thru access hole and **turning vent window** to the desired tension. See figure 2D-30.
2. After making adjustment bend tabs over the hex nut on base of assembly. See figure 2D-31.
3. Install arm rest screws and trim panel.
4. Install window regulator handle.

DOOR WINDOW ASSEMBLY--FIG. 2D-32

Replacement

1. Completely lower glass to bottom of door.
2. Remove door arm rest and trim pad as outlined in this section.

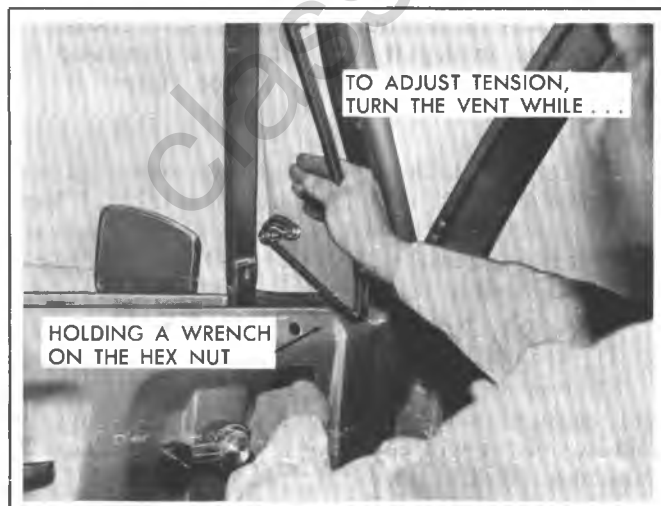


Fig. 2D-30--Adjusting Tension

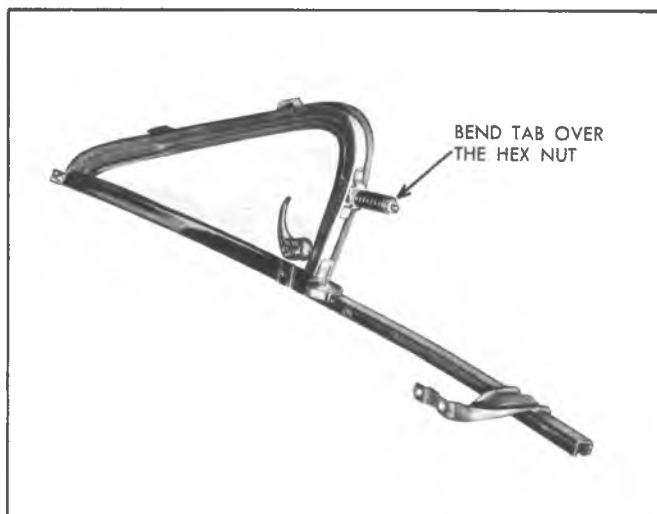


Fig. 2D-31--Bend Tabs Over Hex Nut

3. Mask or cover upper portion of door window frame. Remove ventilator assembly as previously outlined.
4. Slide glass forward until front roller is in line with notch in sash channel. Disengage roller from channel.
5. Push window forward and tilt front portion of window up until rear roller is disengaged. See figure 2D-33.
6. Put window assembly in normal position (level) and raise straight up and out.
7. Reverse above procedure for installation.

WINDOW REGULATOR-MANUAL--FIG. 2D-32

Replacement

1. Raise window and tape glass in full up position using cloth body tape.
2. Remove trim panel as outlined previously.
3. Remove screws attaching regulator to door inner panel.
4. Remove regulator by sliding regulator rearward, disengaging rollers from sash channel.

A notch is provided in the sash channel to allow disengagement of the forward roller on the window regulator (Fig. 2D-32).

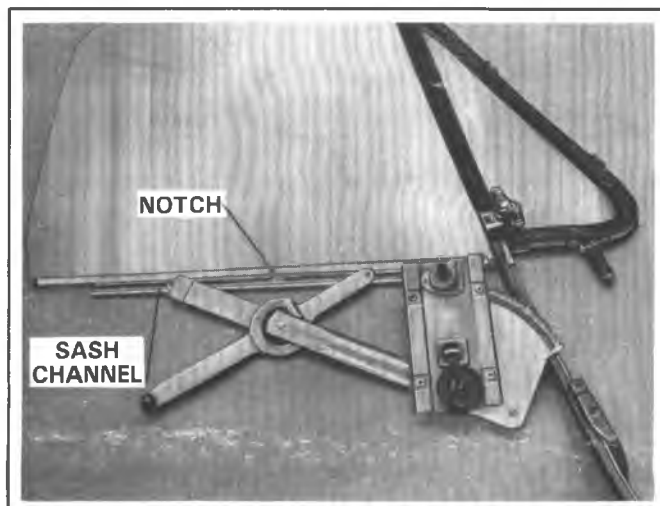


Fig. 2D-32--Door Window and Regulator

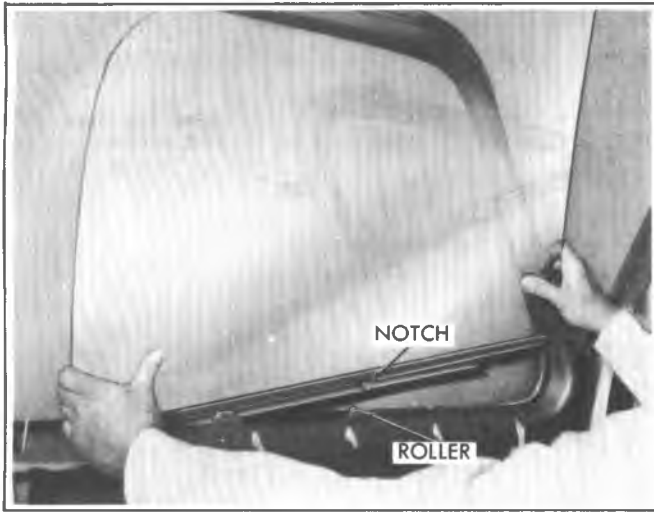


Fig. 2D-33--Removing Door Glass

5. Install regulator by reversing above steps. Lubricate regulator gear with lubriplate or equivalent.

WINDOW REGULATOR - POWER - CK MODELS

In the case that window will not operate, check electrical connections first. Figure 2D-34 illustrates location of junctions, switch, relay and circuit breaker.

Replacement

CAUTION: Electrical connectors must be removed from window lift motor before performing any operation on the regulator, or personal injury could occur. Figure 2D-35 illustrates location of regulator on door and wiring.

1. Raise glass to full up position and tape to door frame using cloth body tape.

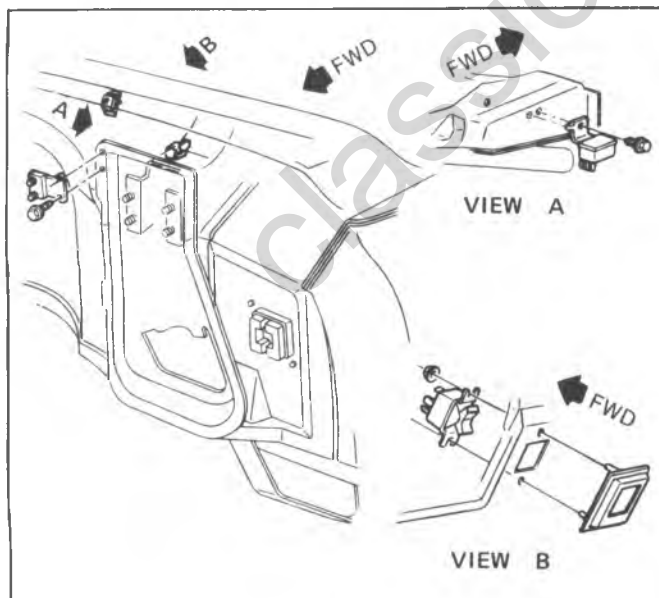


Fig. 2D-34--Power Window Switch, Relay and Breaker Assembly

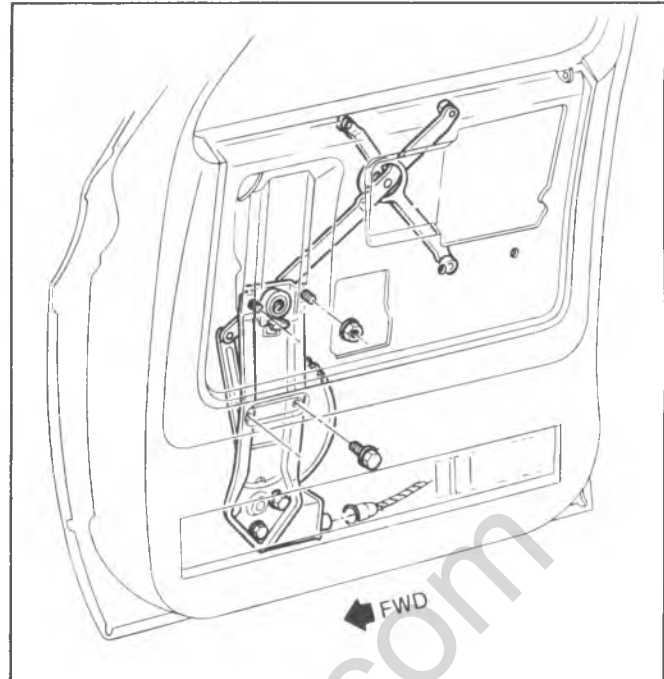


Fig. 2D-35--Power Window Regulator, Motor and Connector

2. Disconnect battery ground cable.
3. Remove door trim panel as previously outlined.
4. Remove remote control bolts and lay control assembly aside for access.
5. Remove regulator to door panel attaching screws.
6. Disconnect harness from regulator.
7. Slide regulator assembly rearward, disengaging rollers from sash channel.

A notch is provided in the sash channel to allow disengagement of the forward roller on the window regulator (fig. 2D-32).

8. Remove regulator assembly through access hole in door.

CAUTION: Step 9 must be performed when regulator is removed from door. The regulator lift arms are under tension from the counterbalance spring and can cause serious injury if the motor is removed without locking the sector gear in position.

9. Drill a hole through the regulator sector gear and back plate. DO NOT drill hole closer than 1/2" (12.7mm) to edge of sector gear or back plate. Install a pan head sheet metal tapping screw (No. 10 - 12 x 3/4) in drilled hole to lock sector gear in position.

10. Remove motor to regulator attaching screws.
11. Remove motor from regulator.
12. Prior to installation, lubricate the motor drive gear and regulator sector teeth. The lubrication used must be cold weather approved to a minimum of minus 20° Fahrenheit (-29°C).

13. Install regulator motor to regulator. Make sure the motor pinion gear teeth mesh properly with the sector gear teeth before installing the three motor attaching screws.

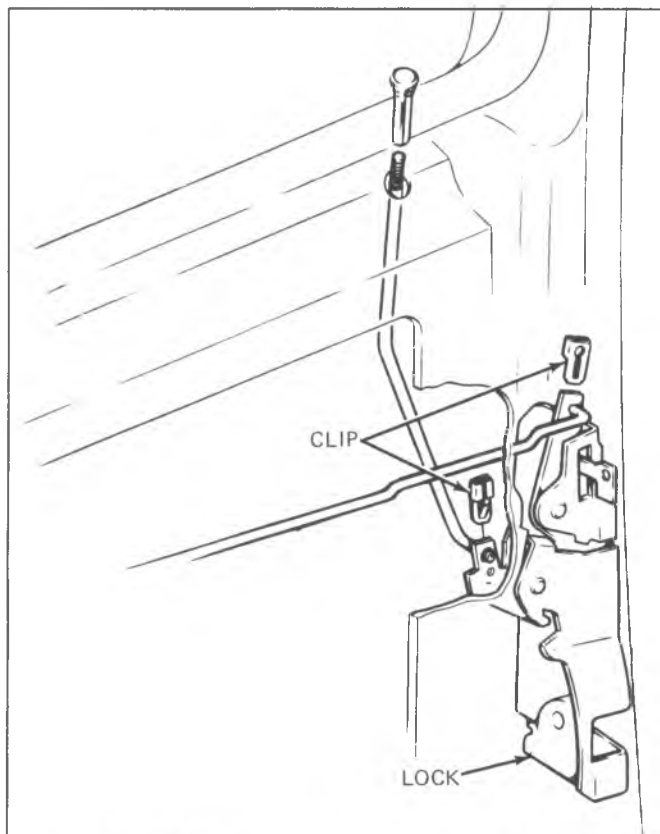


Fig. 2D-36--Door Lock Assembly and Rods

14. Remove screw locking sector gear in a fixed position.

15. Insert regulator into door in such a position that motor connector can be installed onto motor.

16. Reinstall regulator into door.

LOCKS, HANDLES AND RODS

Door Lock Assembly--Fig. 2D-36

Replacement

1. Raise window to full up position.
2. Remove trim panel as outlined in this section.
3. Remove clip from inside handle rod-to-lock.
4. Remove clip from outside handle rod-to-lock.
5. Remove screws which attach lock assembly to door panel.
6. Remove lock and remote control rod as an assembly.

7. To install lock assembly, reverse above steps. Be sure to replace all clips removed earlier.

Door Outside Handle--Fig. 2D-37

Replacement

1. Raise window to full up position.
2. Remove trim panel as outlined.
3. Remove clip from outside handle rod-to-lock.
4. Remove screws which retain outside handle to door panel.
5. Remove handle and control rod.
6. Reverse above procedures to install outside handle.

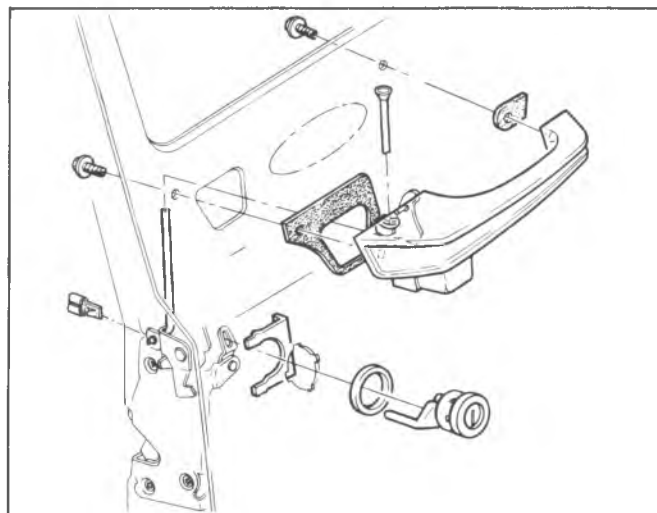


Fig. 2D-37--Outside Handle and Lock Cylinder

Door Lock Cylinder -Fig 2D-37

Replacement

1. Raise door window.
2. Remove trim panel as outlined.
3. Use a screwdriver or other suitable tool to slide the lock cylinder retaining clip out of engagement with the lock cylinder.
4. Remove lock cylinder.
5. To install, reverse the above steps.

Door Inside Handle

Replacement

1. Remove trim panel as outlined.
2. Disconnect control rod from inside handle, as shown in figure 2D-38.
3. Remove screws retaining inside handle to door.
4. Remove inside handle.
5. Reverse above steps to install.

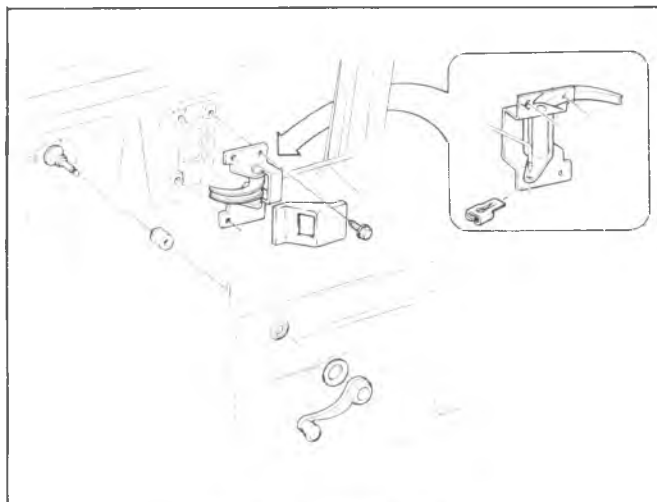


Fig. 2D-38--Inside Handle

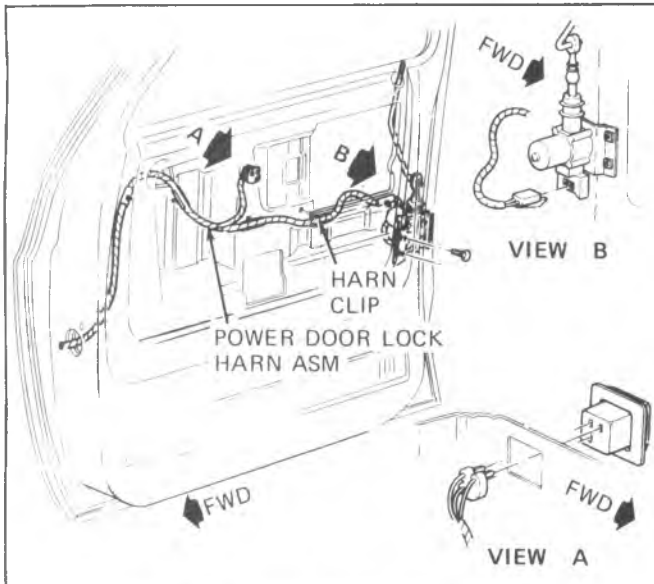


Fig. 2D-39—Power Door Lock Assembly

POWER DOOR LOCKS - CK MODELS (Fig. 2D-39)

Replacement

1. Disconnect battery ground cable.
2. Remove door trim panel to gain access to power door lock motor.
3. Disconnect electrical connector from motor.
4. Remove screws attaching motor to door inner panel.
5. Remove door lock lever from rubber mount at top of motor actuator and remove motor through access hole.
6. To install, reverse steps 1 through 5 above.

DOOR TO BODY OPENING WEATHERSTRIP—FIG. 2D-40

Side door sealing incorporates an inner seal. The inner seal is mounted on the body opening welding flange and goes completely around the periphery of the opening. The molded weatherstrip material is snapped in place. After

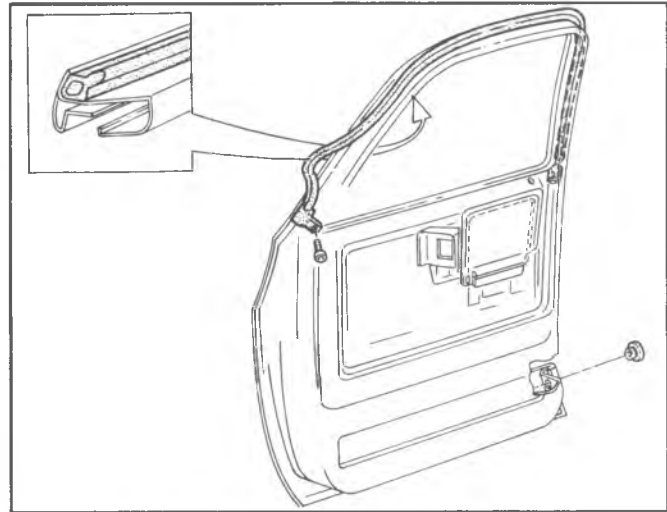


Fig. 2D-41—Door Secondary Seal

removing all foreign material from door opening surface proceed as follows:

1. Open door and block open.
2. Remove sill plate retaining screws and remove sill plate.
3. Remove side door inner weatherstrip seal.
4. Starting at the bottom center of the door opening, install seal on welded flange.
5. Trim inner weatherstrip with a notch and butt ends together.
6. Reinstall sill plate and sill plate retaining screws.

REAR SIDE DOOR (06 AND 63 ONLY)

Adjustments and Hinge Replacement

The procedures for hinge replacement, and for hinge and striker bolt adjustment are similar to those detailed in the front door adjustment procedure. Access to the hinges of the rear door is shown in figure 2D-42.

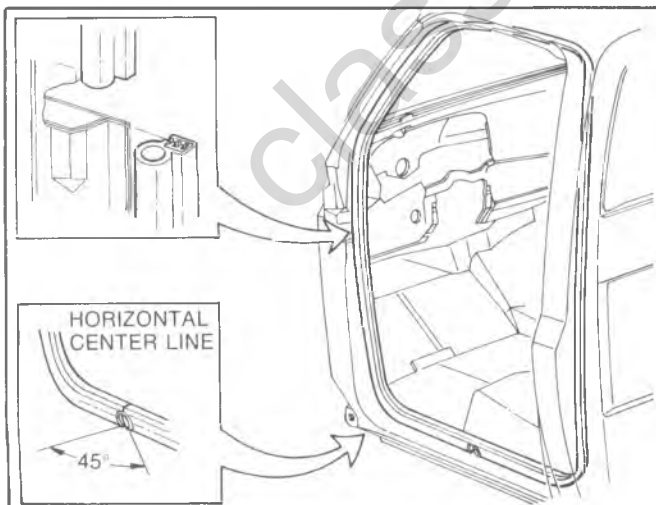


Fig. 2D-40—Door Weatherstrip CK

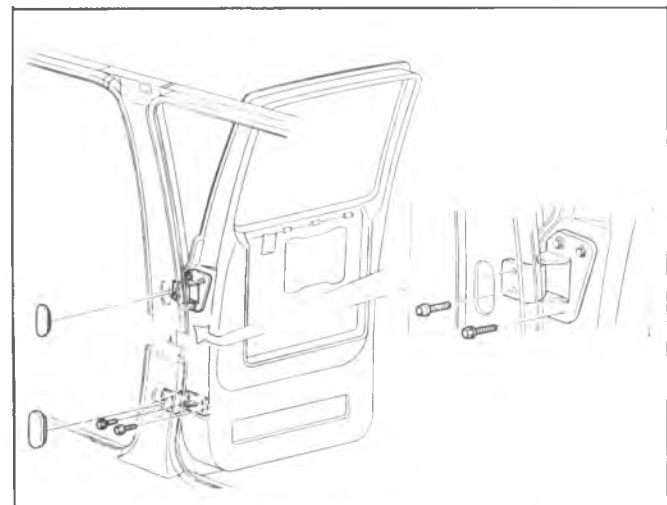


Fig. 2D-42—Rear Door Hinge Location

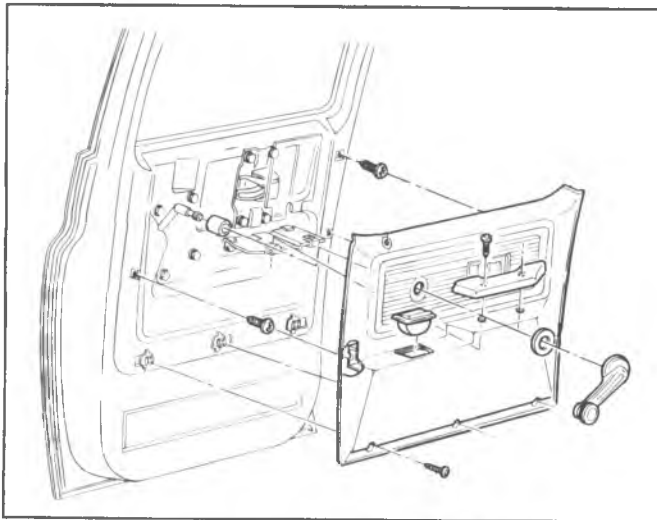


Fig. 2D-43--Side Rear Door Trim Pad

STATIONARY GLASS--REAR DOOR

Replacement

1. Lower window to full down position.
2. Remove remote control knob and window regulator handle.
3. Remove screws retaining door trim pad, and remove trim pad. See figure 2D-43.
4. Remove glass run channel by removing screws retaining channel to door. See figure 2D-44.
5. Remove stationary glass.
6. Replace glass by reversing above procedure.

Glas Run Channel Adjustment

Figure 2D-45 illustrates the front run channel. At the lower end, a slotted bracket provides for in-and-out adjustment. The screw and locknut at that bracket allow fore-and-aft adjustment. Together, this allows proper alignment of the glass to the rear glass run channel for full up and down travel.

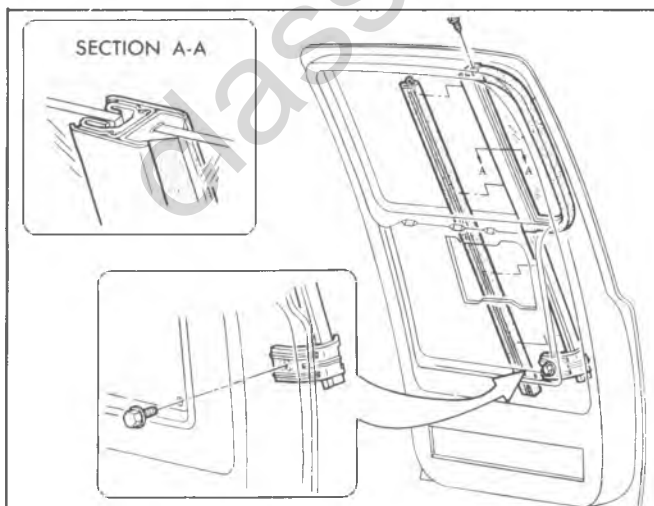


Fig. 2D-44--Glass Run Channel



Fig. 2D-45--Glass Run Channel Adjustment

WINDOW GLASS--FIG. 2D-46

Replacement

1. Lower glass to full down position.
2. Remove remote control push button knob, window regulator handle and trim pad.
3. Remove stationary glass as previously outlined. Remove screws from rear division channel, and slide channel rearward in the opening.
4. Raise glass as far as possible, then slide glass until the roller is in line with the notch in the sash channel. See figure 2D-46. Disengage roller from channel.
5. Tilt window outboard and move until other roller can be removed from channel.
6. Raise window up and out.
7. Reverse above procedure for installation.

WINDOW REGULATOR ASSEMBLY--FIG. 2D-46

Replacement

1. Remove trim pad, stationary glass, and window glass as outlined earlier.
2. Remove screws attaching regulator assembly to door inner panel.
3. Remove regulator assembly through opening in door.
4. Install regulator by reversing above procedure. Lubricate regulator gear with lubriplate or equivalent.

LOCKS HANDLES AND RODS

Lock Assembly--Fig. 2D-47

Replacement

1. Remove window regulator handle, remote control push button knob and trim pad as outlined previously.
2. Disengage three clips which retain control rods to lock assembly.

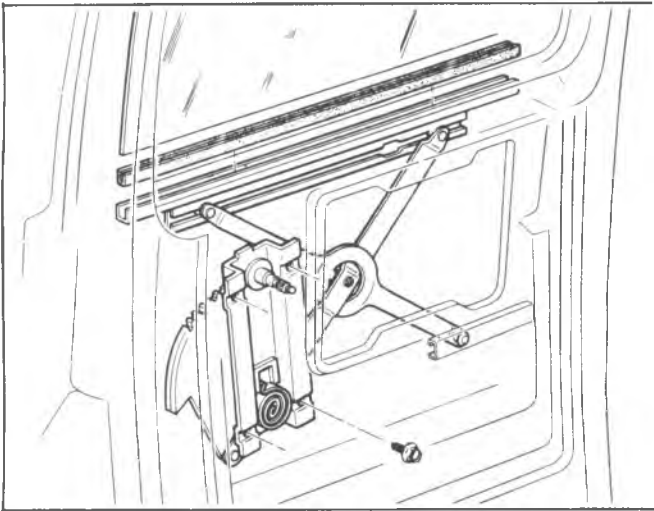


Fig. 2D-46--Window Glass and Regulator Assembly

- a. Inside handle control rod.
 - b. Remote control lower rod.
 - c. Outside handle control rod.
3. Remove screws retaining lock assembly to door panel, then remove lock assembly.
 4. Install lock by reversing above procedure. Be sure to replace all clips removed with new clips on installation.

Inside Handle--Fig. 2D-47**Replacement**

1. Remove regulator handle, remote control knob and trim pad as outlined previously.
2. Disconnect control rod from inside handle by removing clip as shown in figure 2D-47.
3. Remove inside handle by removing four screws which secure handle to door panel.
4. Replace handle by reversing above procedure.

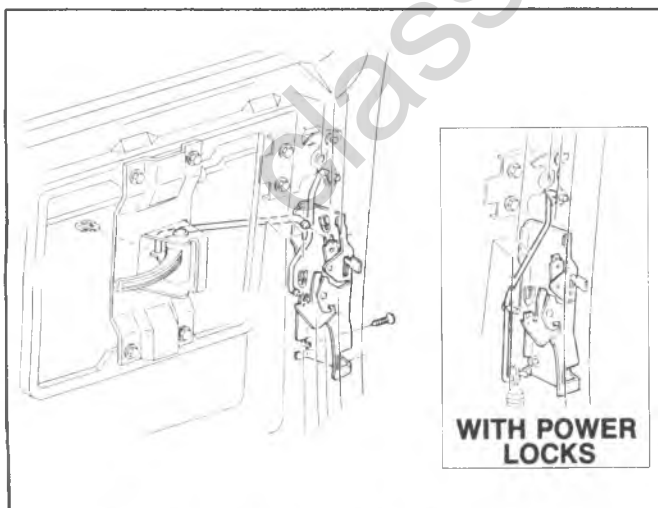


Fig. 2D-47--Lock Assembly and Inside Handle

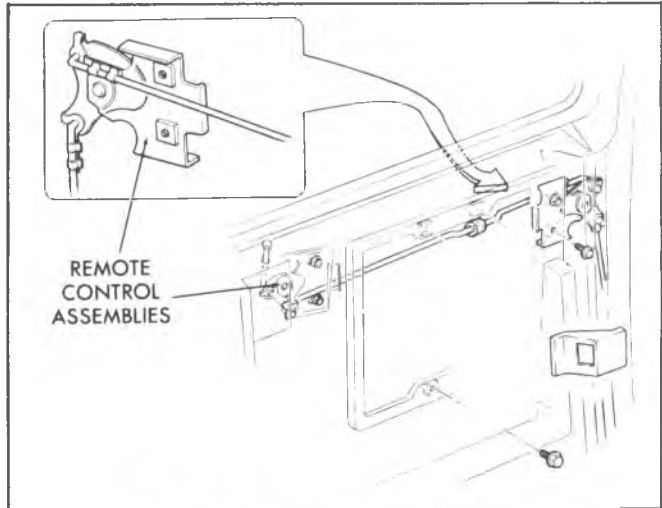


Fig. 2D-48--Remote Control Assembly

Remote Control--Fig. 2D-48**Replacement**

1. Remove regulator handle, remote control knob and trim pad.
2. Disconnect remote control lower rod from door lock assembly.
3. Remove two screws securing each remote control lever to door panel.
4. Remove remote control levers and rods through door opening.
5. Replace by reversing above procedure.

Outside Handle--Fig. 2D-49**Replacement**

1. Remove regulator handle, remote control rod and trim pad as outlined previously.
2. Disengage outside handle control rod from lock assembly by removing clip, as shown in figure 2D-49.
3. Remove two screws securing outside handle to door panel.
4. Remove handle assembly.
5. Replace by reversing above procedure.

WEATHERSTRIP--FIG. 2D-50

The procedure outlined in Front Door Weatherstrip may be applied to the Rear Side Door Weatherstrip, shown in figure 2D-50 with the following exception:

- a. Begin installation by positioning the weatherstrip "internal core" (approximately 6" long) center in the upper front corner of the door opening.
- b. Proceed as outlined previously.

REAR DOORS (06 ONLY)**Adjustments**

Rear doors may be adjusted in the body opening by loosening hinge bolts and repositioning door, then retightening bolts. See figure 2D-54 for hinge bolt location. Rear door wedges and strikers should be adjusted as shown in figure 2D-55.

Be sure that adjustments are as shown to insure proper latching of the rear doors.

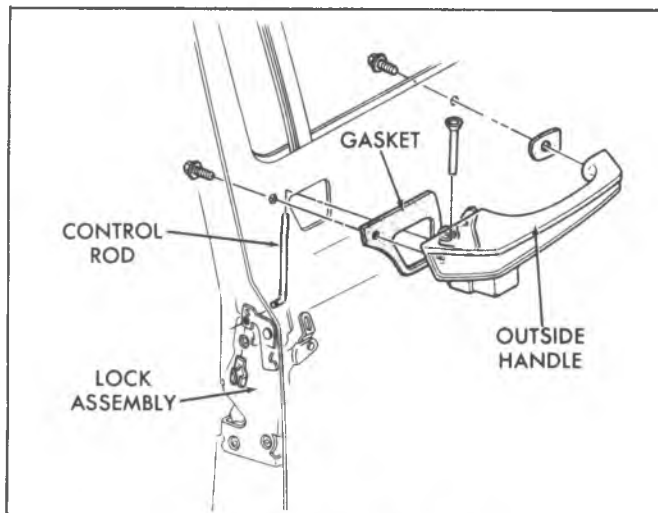


Fig. 2D-49--Outside Handle

LOCKS, HANDLES AND RODS

The rear door lock, outside handle, lock cylinder, control rods and latch are shown in figures 2D-51 and 2D-52. The rods can be disconnected from the lock, latch or handle by disengaging the retaining clips, as shown. The lock cylinder is removed in the same manner as the front side door lock cylinder.

REAR DOOR CHECK STRAP

Model 06

Figure 2D-53 shows the cloth check strap used for rear doors. The door may be completely opened by removing the strap pin from the bracket. The bracket attaches to the pillar with three screws; the strap is fastened to the door panel with two screws and an attaching bar.

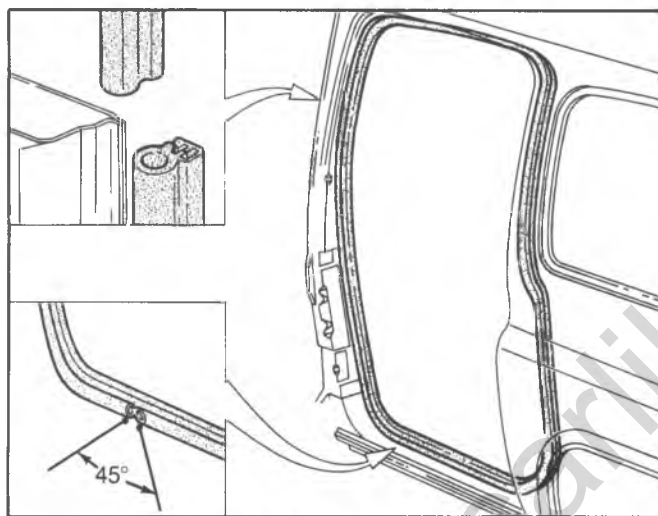


Fig. 2D-50--Side Rear Door Weatherstrip

WEATHERSTRIP

Weatherstrip installation is shown in Figs. 2D-55 and 2D-56. Proper installation is dependent on completely cleaning all foreign material from old installation and using a quality cement on the new installation.

classicroadlibrary.com

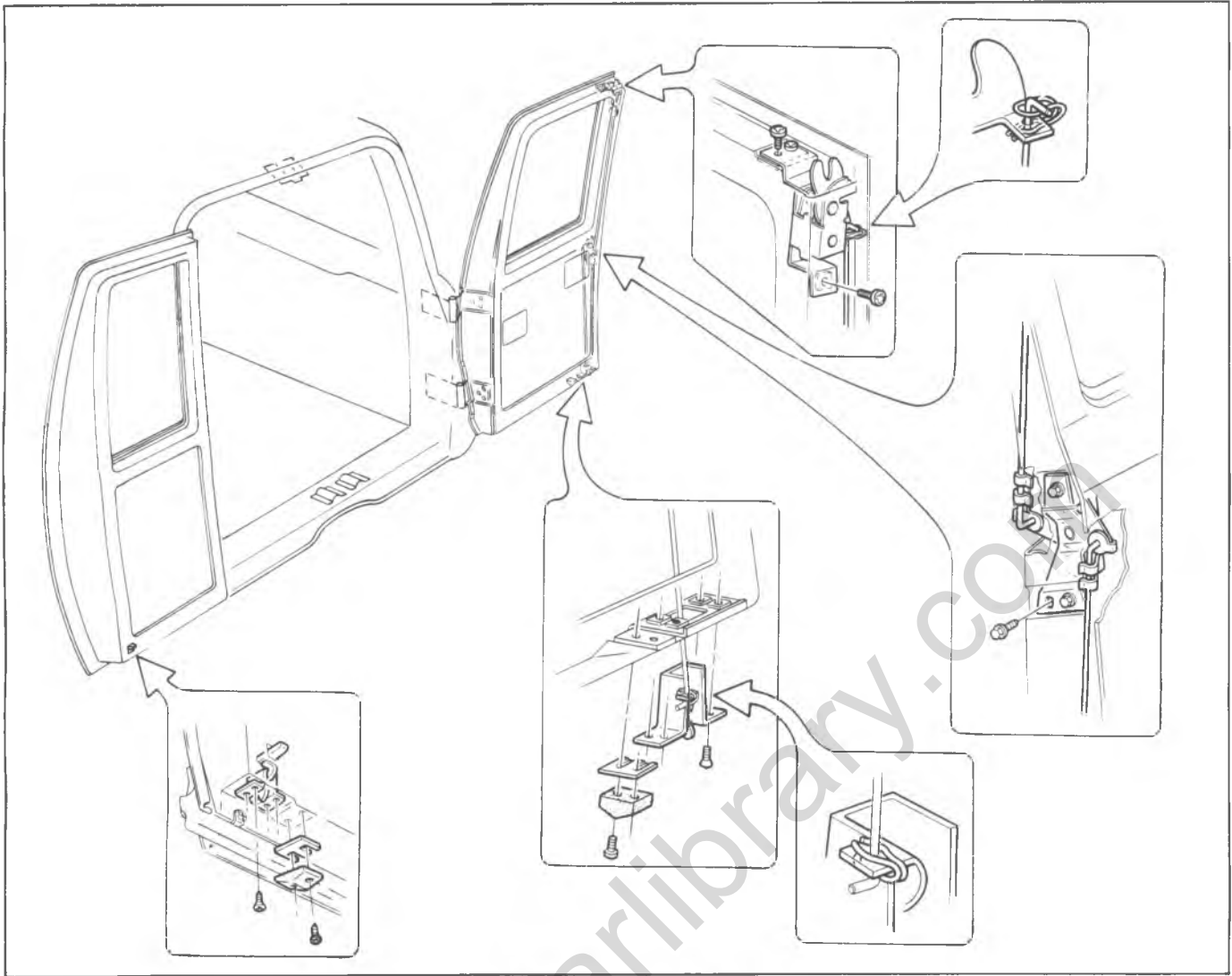


Fig. 2D-51-Rear Door Controls

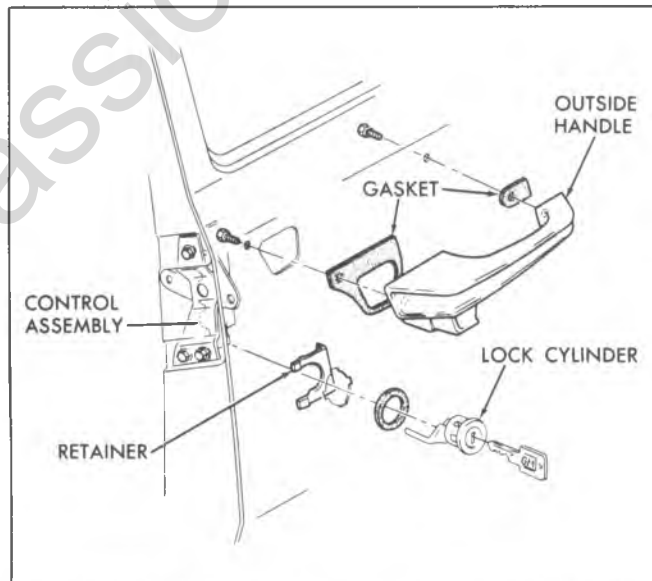


Fig. 2D-52-Rear Door Outside Handle and Lock Cylinder

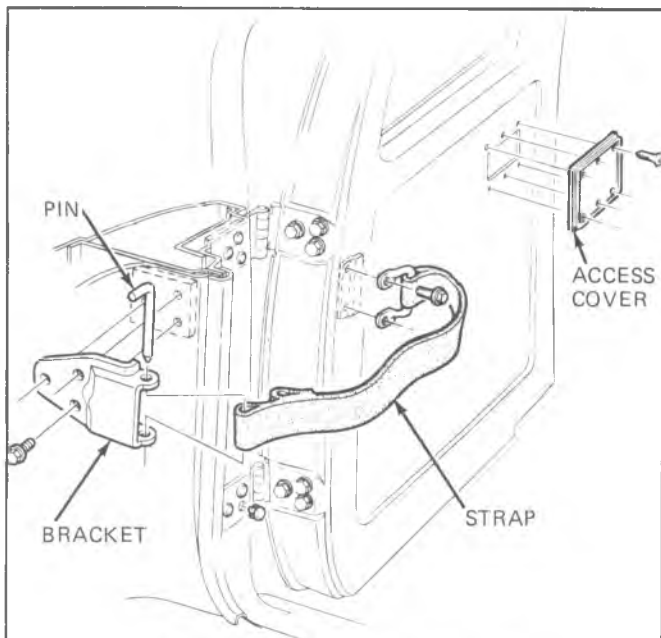


Fig. 2D-53--Rear Door Check Strap

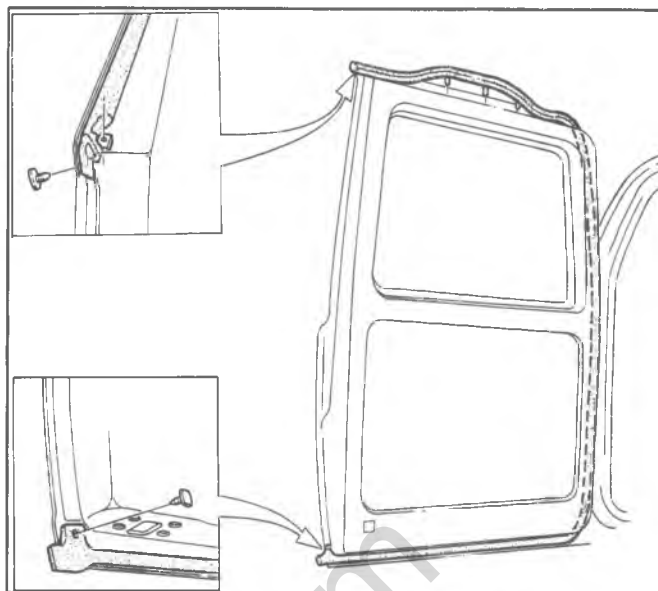


Fig. 2D-55--Weatherstrip - L.H. Rear Door

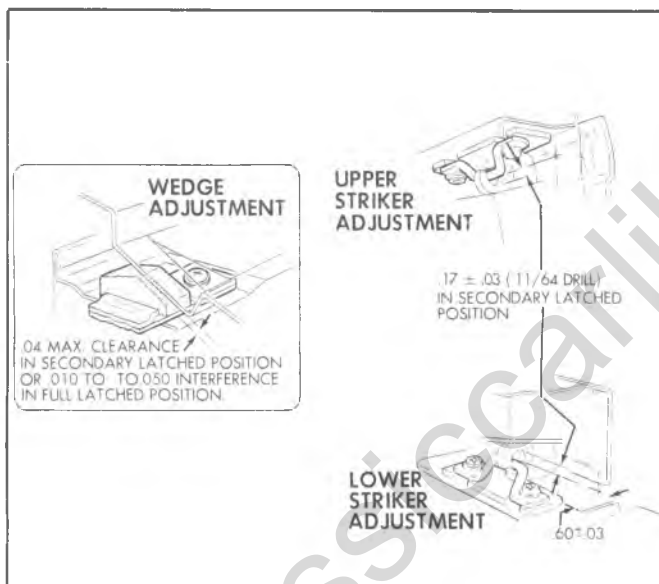


Fig. 2D-54--Wedge and Striker Adjustments

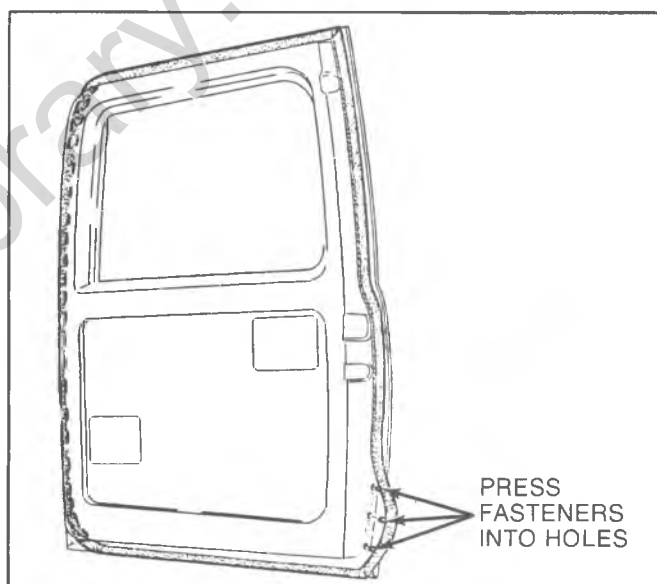


Fig. 2D-56--Weatherstrip--R.H. Rear Door

ENDGATES (06 AND 16)

Coach models (06) and utility models (16) use endgates of similar, yet distinct design. Separate procedures follow for service on each of these endgates.

ENDGATE ASSEMBLY - (06) MODELS ONLY

Replacement

1. Lower endgate, and removed hinge access covers. See figure 2D-57.

2. Remove endgate-to-hinge bolts.
3. Remove L.H. torque rod bracket, shown in figure 2D-58.
4. If equipped with electric powered window, disconnect wiring harness.
5. Lift endgate to almost closed position and remove support cables.
6. Remove endgate with torque rod.

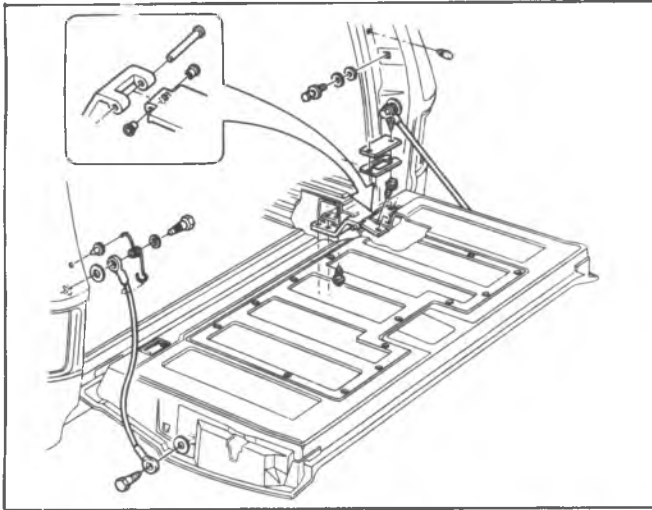


Fig. 2D-57--Endgate, Hinges and Supports--(06 Only)

7. To install, reverse removal procedure.

HINGES

Replacement

If necessary to remove hinges, remove endgate as outlined previously, and proceed as follows:

1. Remove bolts from each of the hinge assemblies on the underside of the body. See figure 2D-57.
2. Remove hinge assemblies. If the hinge pins are to be removed, note the position of bushings so they may be reinstalled in the same position.
3. Reverse procedure to install.

ENDGATE DISASSEMBLY

1. Remove access cover shown in figure 2D-59, to gain access to interior components.
2. Detach remote control rods from lock assembly by removing clips.
3. Remove bolts securing lock assembly, and remove lock assembly.
4. Remove handle assembly bolts and remove inside handle.

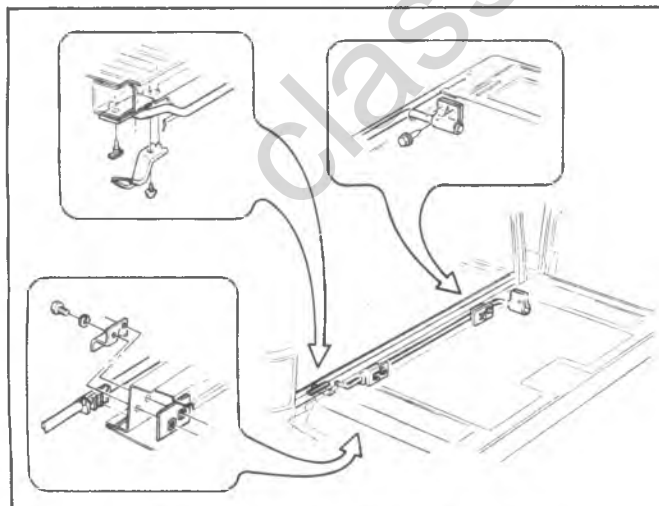


Fig. 2D-58--Torque Rod--(06 Only)

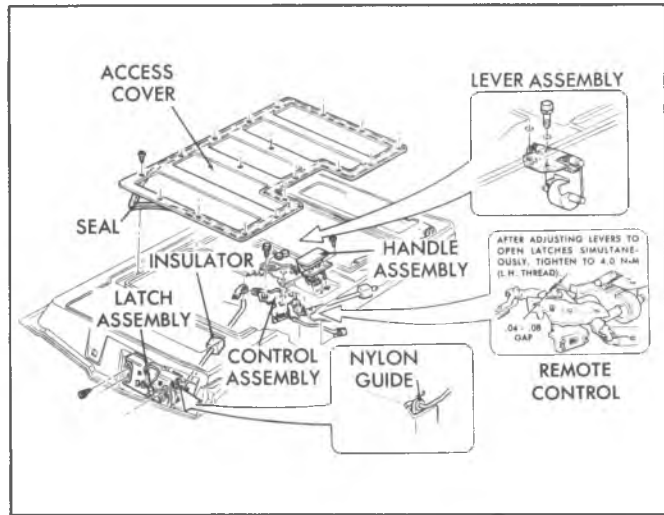


Fig. 2D-59--Latch and Remote Controls--(06 Only)

5. Remove R.H. torque rod bracket screws, figure 2D-58, then remove torque rod from endgate.
6. Remove screws connecting cam assemblies to sash assembly, figure 2D-60, then remove cam assemblies.
7. Remove glass from endgate.
8. Unclip and remove inner and outer seal assemblies.
9. Remove screws connecting window regulator assembly to endgate, figure 2D-60, and remove regulator.

CAUTION: Step 10 must be performed if the window is removed or disengaged from the regulator lift arms. The lift arms are under tension from the counterbalance spring, and can cause injury if the motor is removed without locking the sector gears in position.

10. For endgates with electric window, secure the window regulator lift arms before removing the electric motor, when the window glass has been removed or disengaged from the lift arms.

a. Drill a 1/8 (3.1mm) inch hole through the sector gear and back plate, as shown in figure 2D-60. Install a sheet metal tapping screw into the hole to lock the sector gears in position.

b. Remove the regulator motor attaching screws and remove the motor assembly.

11. From inside the endgate, remove the nuts fastening the outside handle to endgate and remove the outside handle. See figure 2D-61.

If equipped with power tailgate window, detach wiring harness from motor.

12. Remove side bolts connecting left and right glass channels to endgate and remove channels.

13. Remove side latch bolts and remove side latches with control rods. See figure 2D-59. Detach wiring harness from R.H. latch if so equipped.

14. Separate side latch from control rod by pulling control rod thru nylon guide.

15. Reverse the above procedure for reassembly and installation.

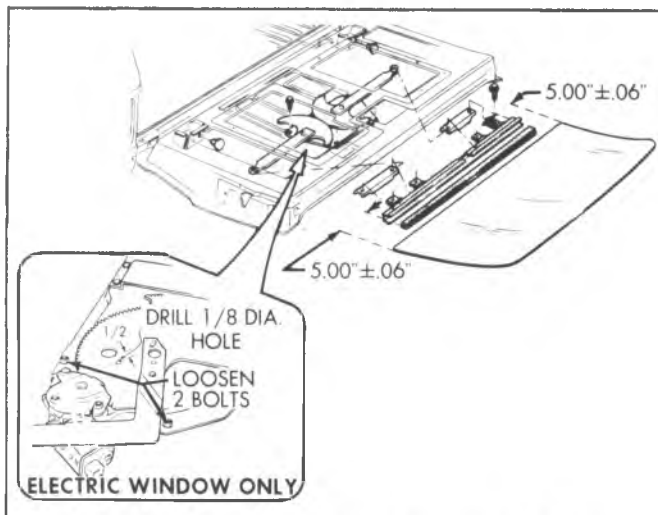


Fig. 2D-60--Window Glass and Regulator--(06 Only)

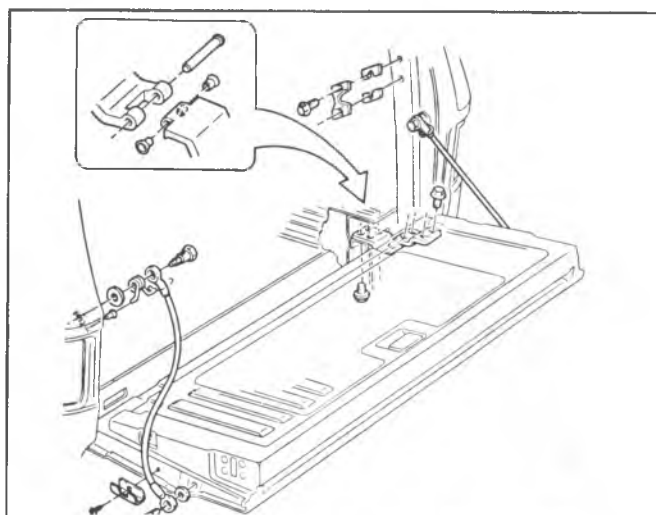


Fig. 2D-62--Endgate, Hinges and Support (16)

Adjustments

Loosen bolts, adjust at either endgate hinge position or endgate latch, then retighten bolts.

ENDGATE ASSEMBLY--(16) MODELS ONLY

Replacement

1. Lower endgate, then remove four bolts securing hinge to body on each side. See figure 2D-62. Disconnect wiring harness, if so equipped.

2. Disconnect torque rod anchor plate on each side. It is necessary to remove lower bolt only, then let plate swing down. See figure 2D-66.

3. With an assistant, raise endgate part way, then disconnect support cables from endgate. See figure 2D-62.

4. Remove endgate by pulling disconnected hinge from body, figure 2D-63, then grasping torque rod with one hand and pulling torque rod over gravel deflector, as shown in figure 2D-64.

5. Individual components may be removed from the endgate now, or after reinstallation.

6. To install endgate, reverse the above procedure.

HINGE

Replacement

1. Lower endgate and disconnect hinge to be replaced by removing hinge-to-body bolts. See figure 2D-62.

2. At the other hinge, **loosen** the hinge-to-body bolts.

3. On the hinge to be replaced, remove the hinge-to-endgate bolts.

4. Pull the endgate away from the body several inches and withdraw hinge from body. Then lift endgate slightly to allow removal of hinge from endgate. See figure 2D-63.

5. To install hinge, reverse the above procedure. Be sure to install hinge into endgate first, then into the body.

TORQUE ROD

Replacement

1. Lower endgate and remove access cover, as shown in figure 2D-65.

2. Disconnect torque rod anchor plate. It is necessary to remove the lower bolt only, then let plate swing down. See figure 2D-66.

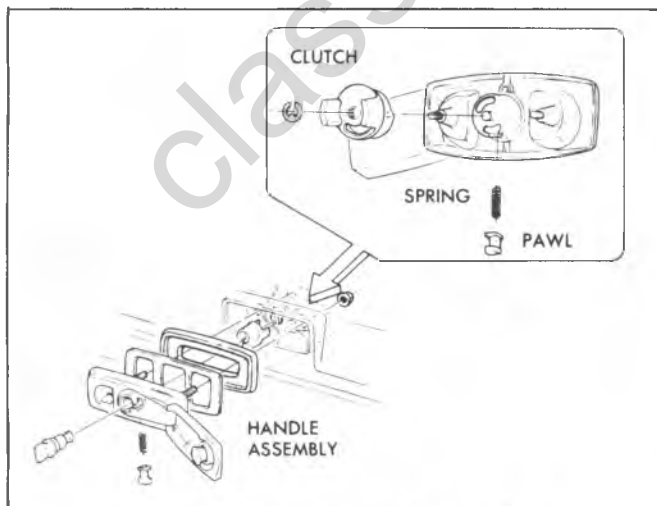


Fig. 2D-61--Outside Handle (06 and 16)

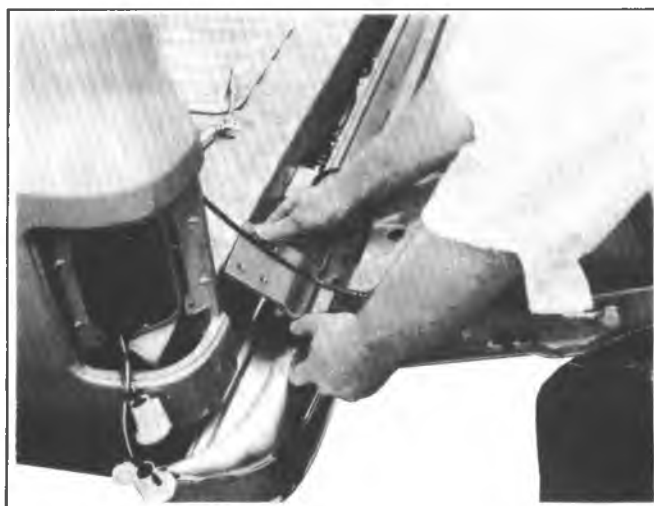


Fig. 2D-63--Pulling Hinge Away From Body (16)

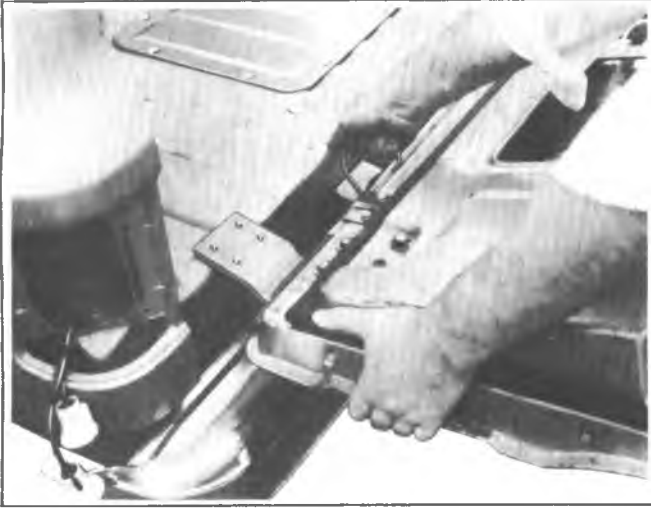


Fig. 2D-64--Grasping Torque Rod (16)

3. Loosen four bolts retaining endgate hinge to body.
4. Move endgate slightly away from body.
5. Remove torque rod retaining bracket on lower edge of endgate. See figure 2D-66.
6. Remove torque rod retaining clip on side edge of endgate.
7. Lift torque rod up and slide from endgate as shown in figure 2D-67.
8. Reverse the procedure above for installation.

ENDGATE DISASSEMBLY (16) MODELS ONLY

Manual Window

1. Lower endgate and remove access cover.
2. Disconnect side latch remote control rods from center control by removing retaining clips. See figure 2D-68.
3. Remove four screws from each side latch, and withdraw latch and control rod from endgate, as shown in figure 2D-69.
4. Disconnect control rod from latch.
5. Refer to figure 2D-70 for installation of latch control and blackout rod.



Fig. 2D-65--Removing Access Cover (16)

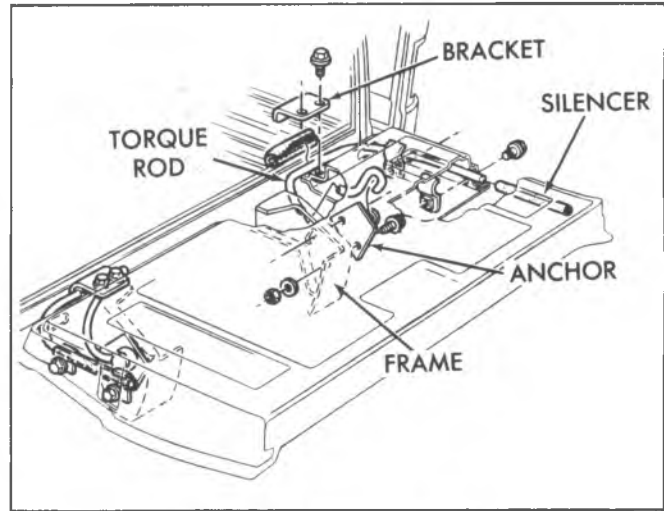


Fig. 2D-66--Torque Rod (16)

6. Disconnect blackout rod from control assembly by detaching spring and removing two screws retaining rod to inner panel.
7. Disconnect inside handle control rod from control assembly, then remove screws which secure inside handle to inner panel.
8. Remove three screws which retain remote control assembly to inner panel.
9. Remove control assembly and inside handle as shown in figure 2D-71.
10. Refer to figure 2D-72 for window and regulator installation.
11. Roll window to up position.
12. Disconnect sash from regulator as shown in figure 2D-73.
13. Remove glass from endgate.
14. Remove four regulator attaching screws and withdraw regulator from endgate as shown in figure 2D-74.
15. Remove outside handle by removing nuts from inside of outer panel. See figure 2D-61.

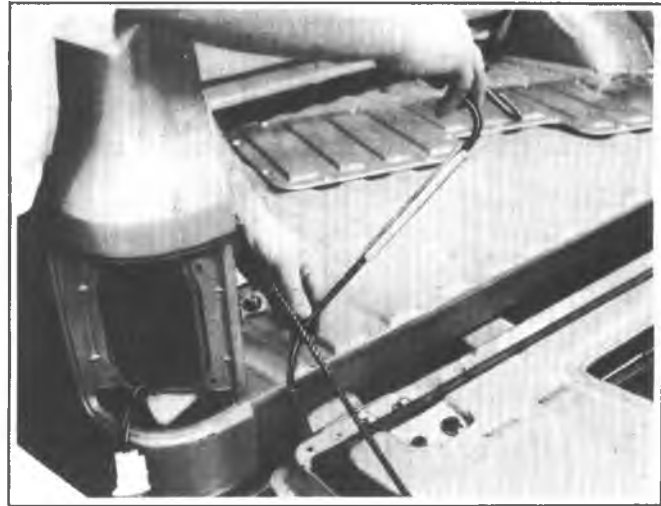


Fig. 2D-67--Removing Torque Rod (16)

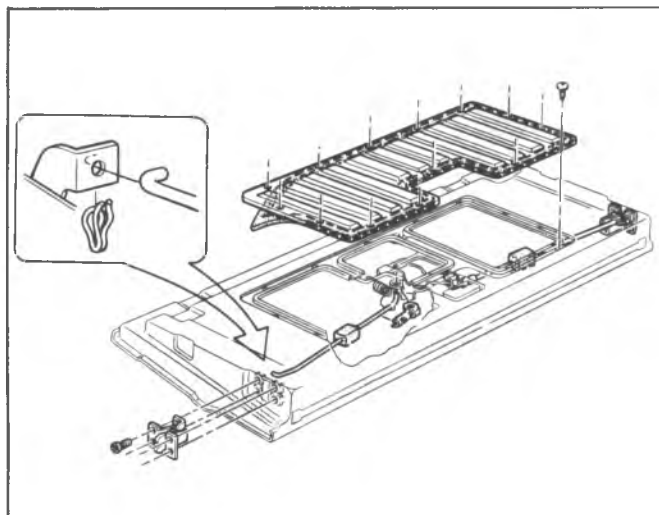


Fig. 2D-68--Latches and Rods

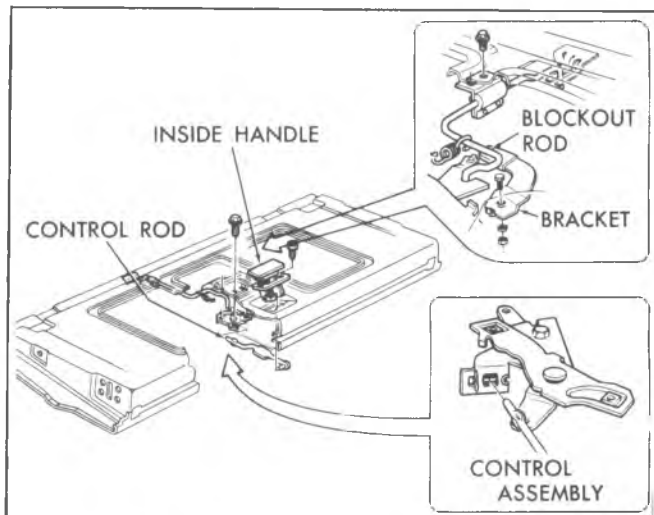


Fig. 2D-70--Control Assembly and Blockout Rod

16. Reverse the above steps for reassembly.

ELECTRIC WINDOW (16) MODELS

The window is controlled by a jackscrew mounted to the regulator, drive cable and a 12V DC reversible motor mounted to the endgate inner panel. This circuit also includes a block out switch to prevent operation of the window while the endgate is open (fig. 2D-75).

Service procedures for endgate disassembly are the same as outlined above with the following exceptions:

Drive Cable

The drive cable can be replaced by disengaging the cable from the motor and jackscrew assembly and removing the cable. Reverse removal procedure to reinstall cable.

Motor (Fig. 2D-76)

Removal

1. Disconnect drive cable from motor.
2. Disconnect wiring harness from motor.
3. Remove (3) motor attaching screws and remove motor.

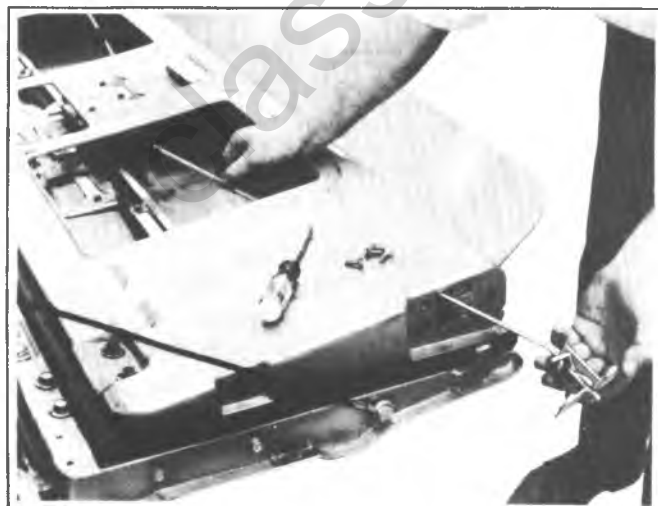


Fig. 2D-69--Removing Side Latch

4. To install, reverse removal procedure.

Blockout Switch (Fig. 2D-75)

Removal

1. Disconnect L.H. side latch remote control rod from center control by removing retaining clip.
2. Remove side latch retaining screws and disconnect blockout switch wiring.
3. Remove side latch assembly and remove screws retaining switch to side latch.
4. Reverse removal procedures for installation.

Jackscrew (Fig. 2D-76)

Removal

For endgates with electric window, secure the window regulator lift arms before removing the jackscrew when the window glass has been removed or disengaged from the lift arms.

CAUTION: Step 1 must be performed if the window is removed or disengaged from the regulator lift arms. The lift arms

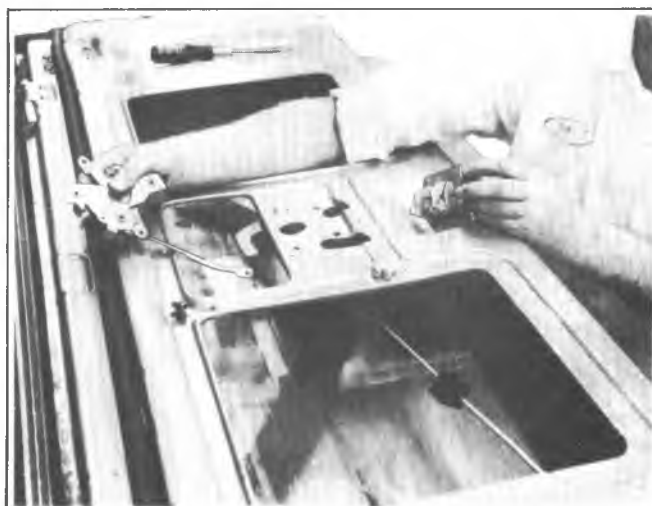


Fig. 2D-71--Removing Control Assembly and Inside Handle

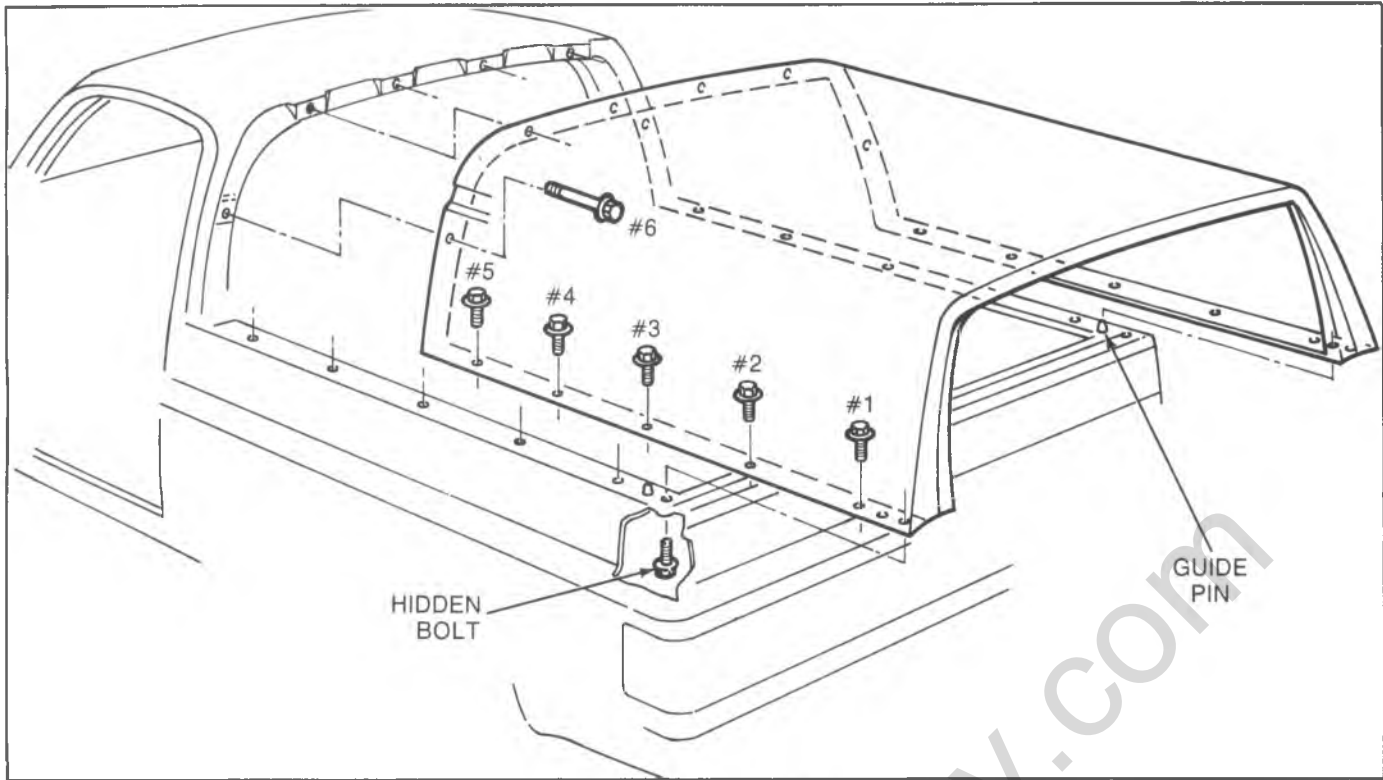


Fig. 2D-78--Removable Top

12. Finally, reconnect the courtesy light and reinstall the upper spare tire brace using 2 bolts (1 bolt being the #2 top-to-side panel bolt).

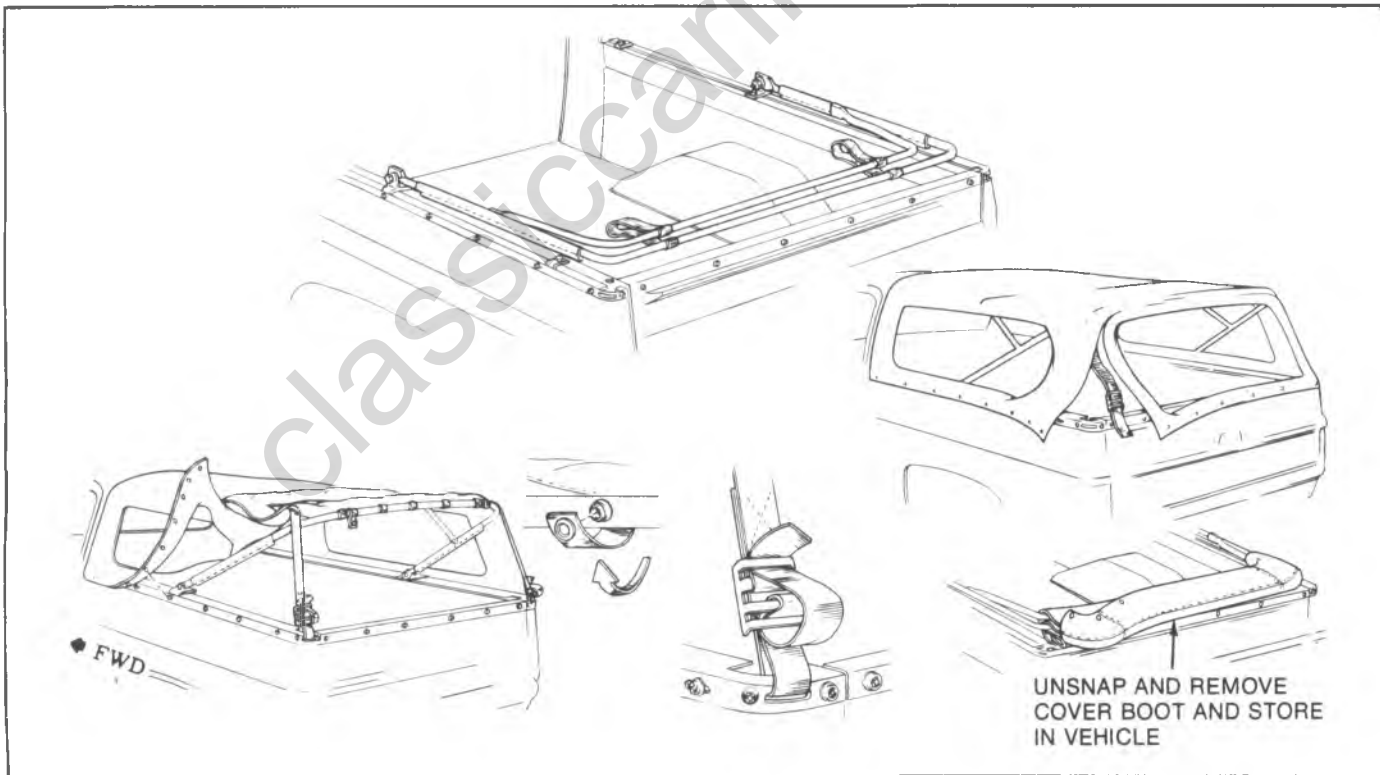


Fig. 2D-79--Folding Top Assembly

SEATS

SEAT BELTS

SERVICING LAP AND SHOULDER

BELTS - ALL MODELS

Before servicing or replacing lap and shoulder belts, including single loop belt systems, refer to the following precautionary items:

1. Lap and shoulder belts will be serviced as follows:
 - a. All belts will be serviced in complete sets.
 - b. Do not intermix standard and deluxe belts on front or rear seats.
2. Keep sharp edges and damaging objects away from belts.
3. Avoid bending or damaging any portion of the belt buckle or latch plate.
4. Do not bleach or dye belt or strap webbing (clean with a mild soap solution and water).
5. When installing lap or shoulder belt anchor bolt, start bolt by hand to assure that bolt is threaded straight.
6. Do not attempt repairs on lap or shoulder belt retractor mechanisms or lap belt retractor covers. Replace defective assemblies with new service replacement parts.
7. Do not attempt to remove seat belt retractor cover. The cover and the long rivet securing the cover to the retractor are not available as service replacement parts.

LAP BELTS AND SHOULDER BELTS

The shoulder belts and lap belts are attached to the front seat lap belt latch plate and connected to an inertia locking retractor installed to the floor or quarter inner panel above the right and left side of the front seat. The belts remain unlocked to allow occupants to move freely while the vehicle is being operated. When the vehicle decelerates or changes direction abruptly, the belts are locked in position by a pendulum that causes a locking bar to engage a cog of the retractor mechanism.

Removal and Installation

Refer to illustrations on following pages and select the appropriate illustration for removing and installing lap belts and shoulder belts.

Internal drive thread-forming anchor bolts are used to secure lap belts to the floor pan. To remove or install internal drive anchor bolts, use door lock striker and lap belt anchor bolt removal tool J-23457 or equivalent. Start bolt by hand to assure that bolt is threaded straight.

SEAT MOUNTING

Typical Seat Mounting provisions are shown in figures 2D-83 through 2D-89.

NOTICE: See NOTICE on page 1 of this section regarding fasteners used on seats and seat belts.

SEAT SEPARATOR COMPARTMENT

Figure 2D-90 illustrates assembly and installation of the CK model seat separator compartment.

BODY MOUNTING

The sequence of mounting attachments is shown in figures 2D-91 through 2D-94.

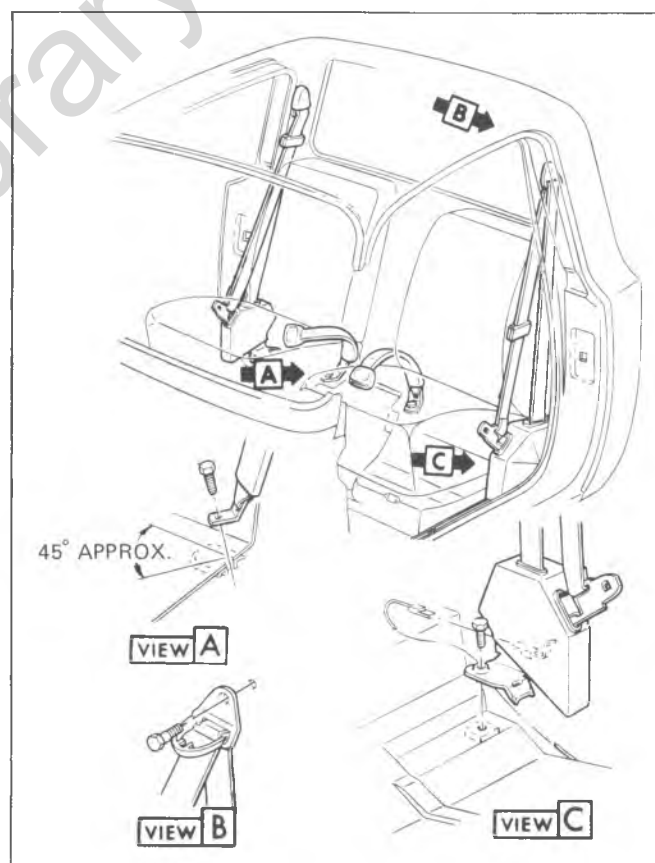


Fig. 2D-80--Seat Belt Installation (03) Models

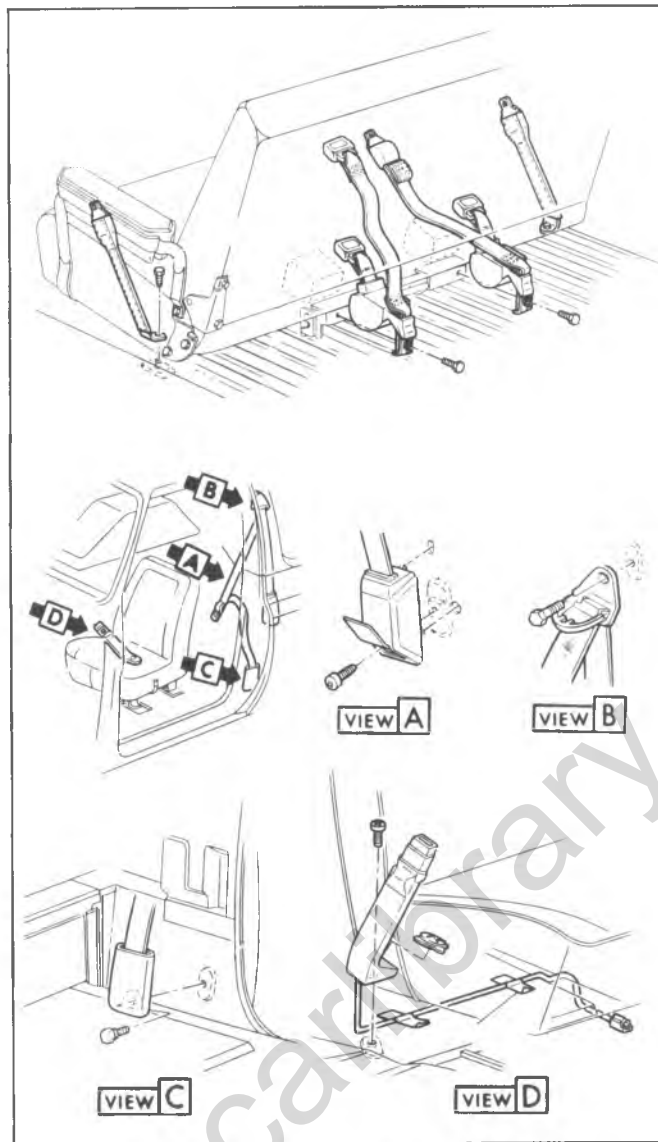


Fig. 2D-81--Seat Belt Installation (16) Models

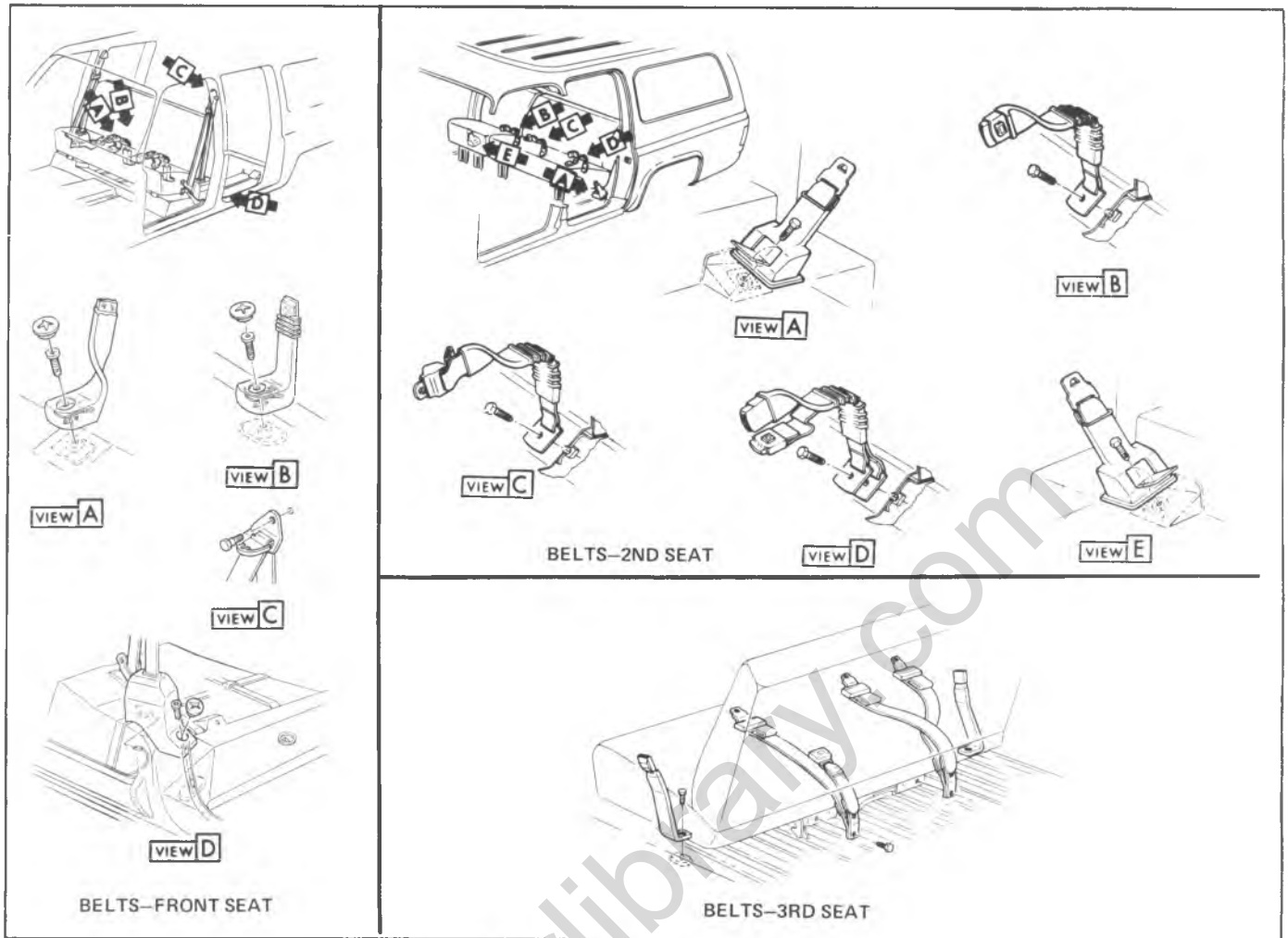


Fig. 2D-82--Seat Belt Installation (06) Models

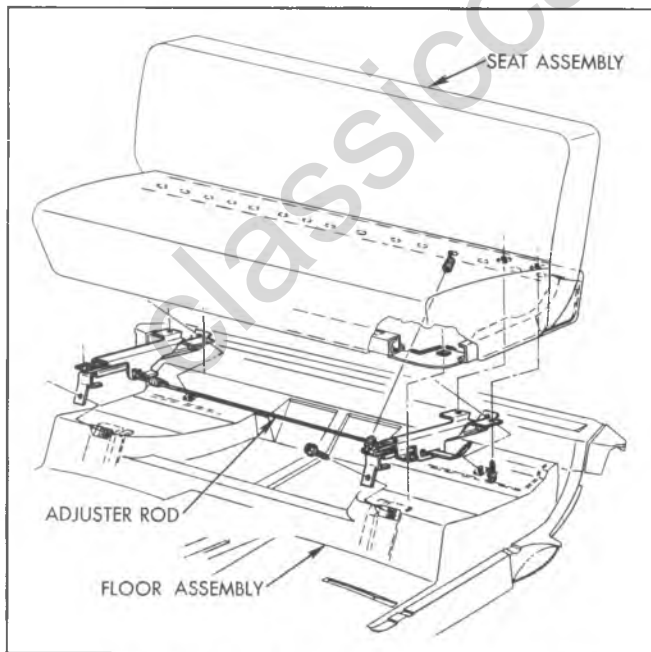


Fig. 2D-83--Front Bench Seat (03, 06 and 63)

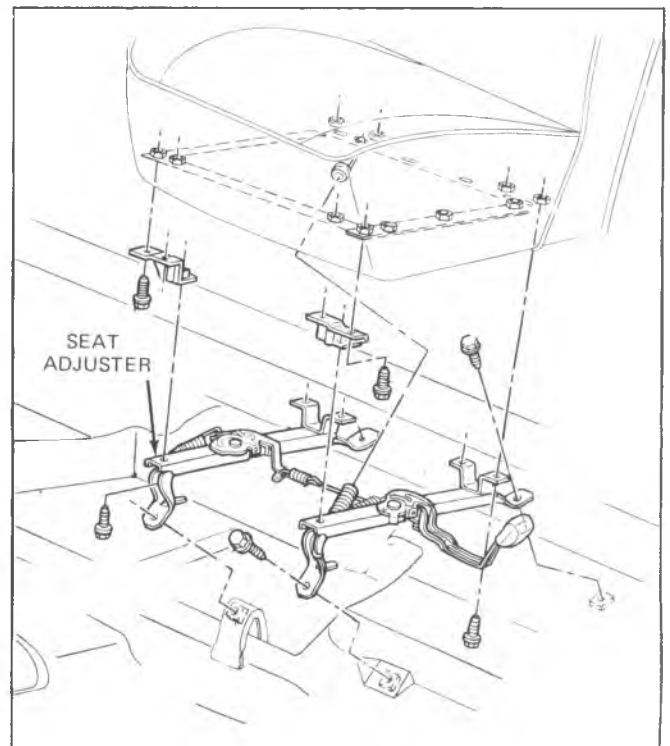


Fig. 2D-84--Driver's Bucket Seat (03 and 06)

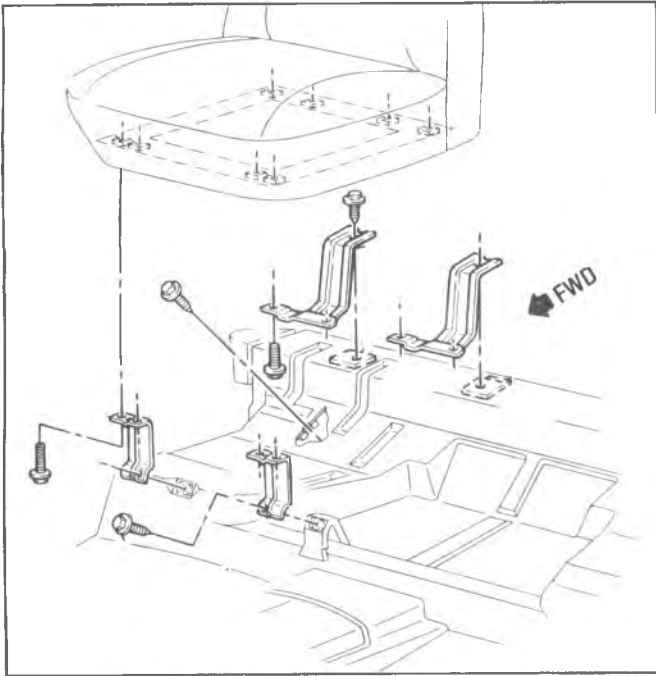


Fig. 2D-85--Passenger's Bucket Seat (03)

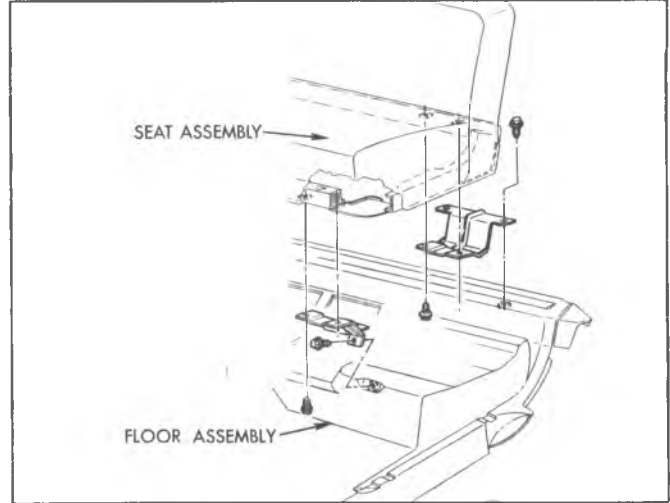


Fig. 2D-87--Rear Bench Seat (63)

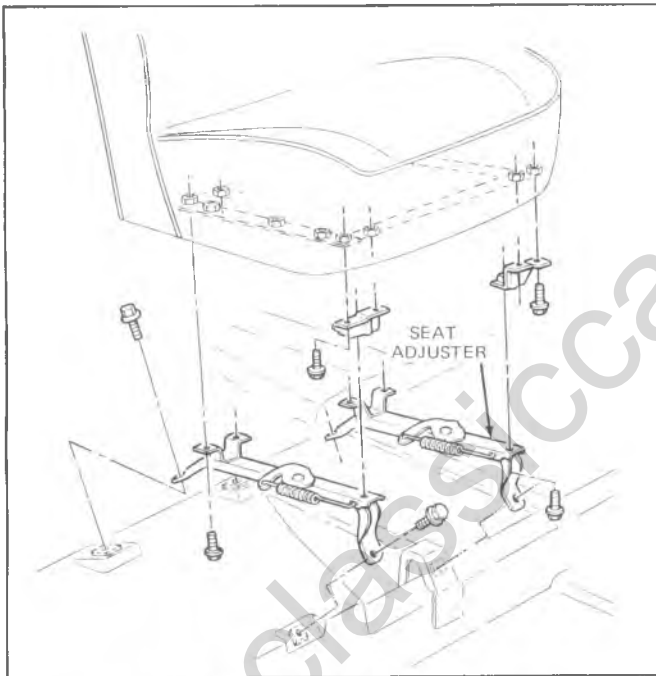


Fig. 2D-86--Passenger's Bucket Seat (06)

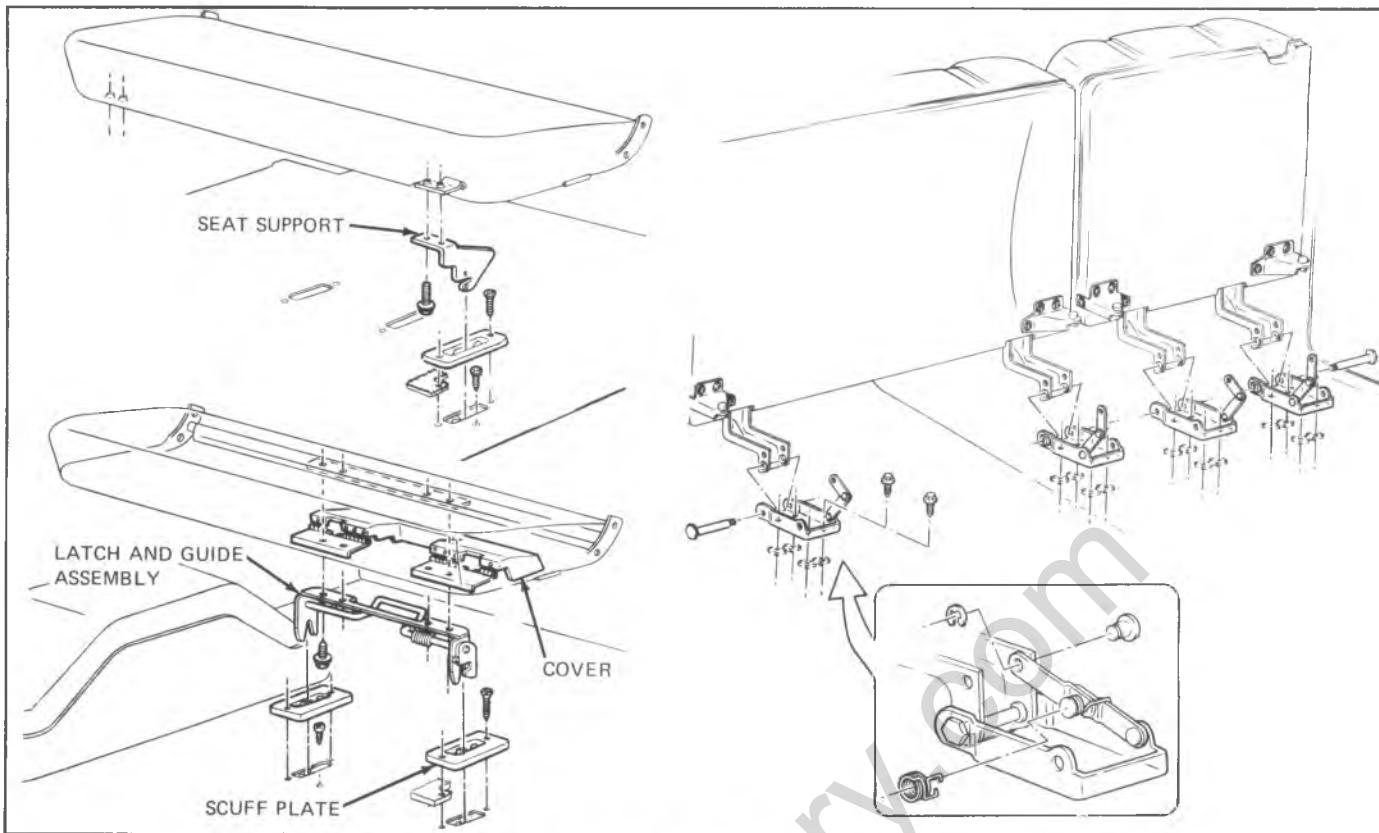


Fig. 2D-88--Rear Bench Seats (06)

classiccarlibrary.com

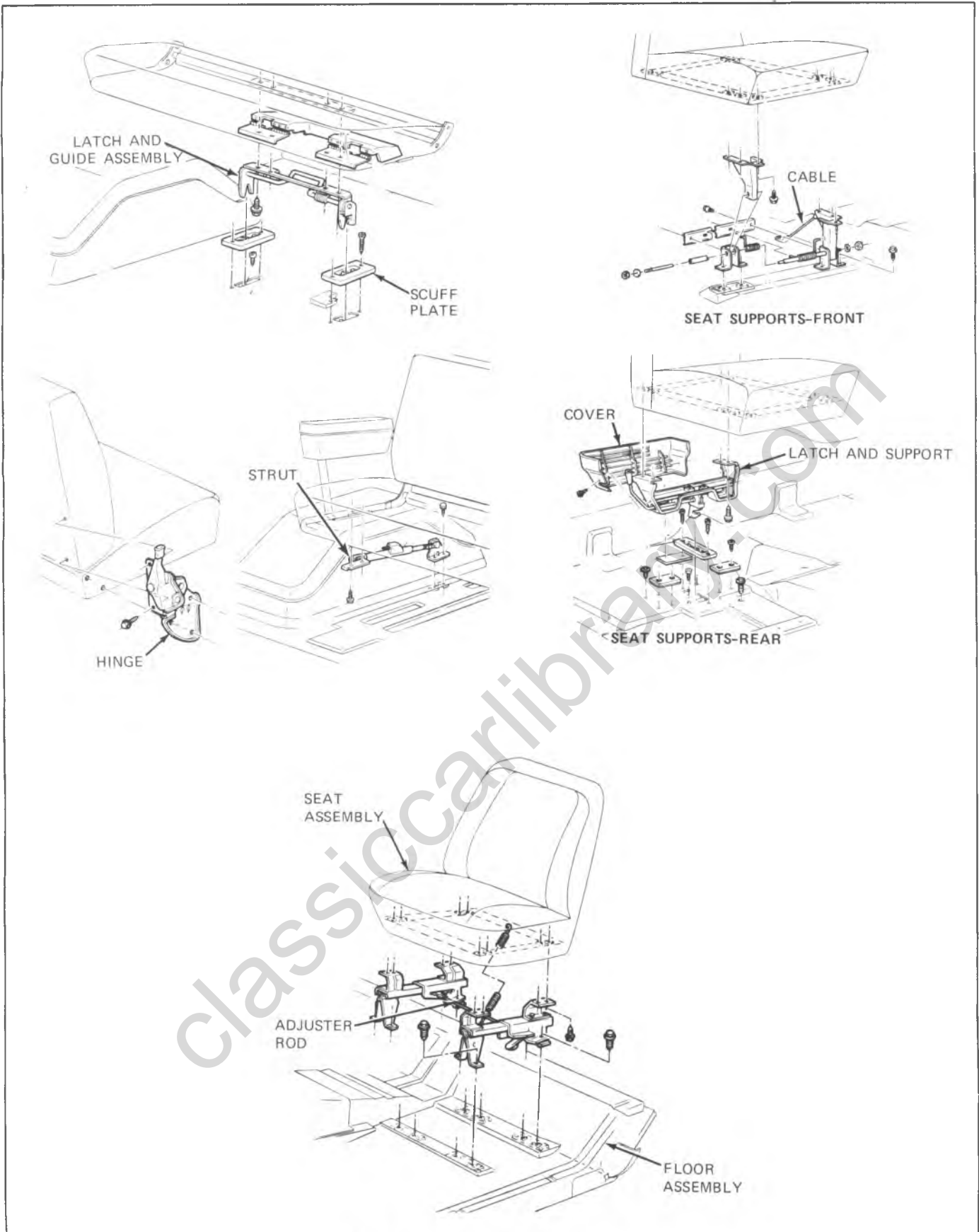


Fig. 2D-89-CK (16) Seat Attachments

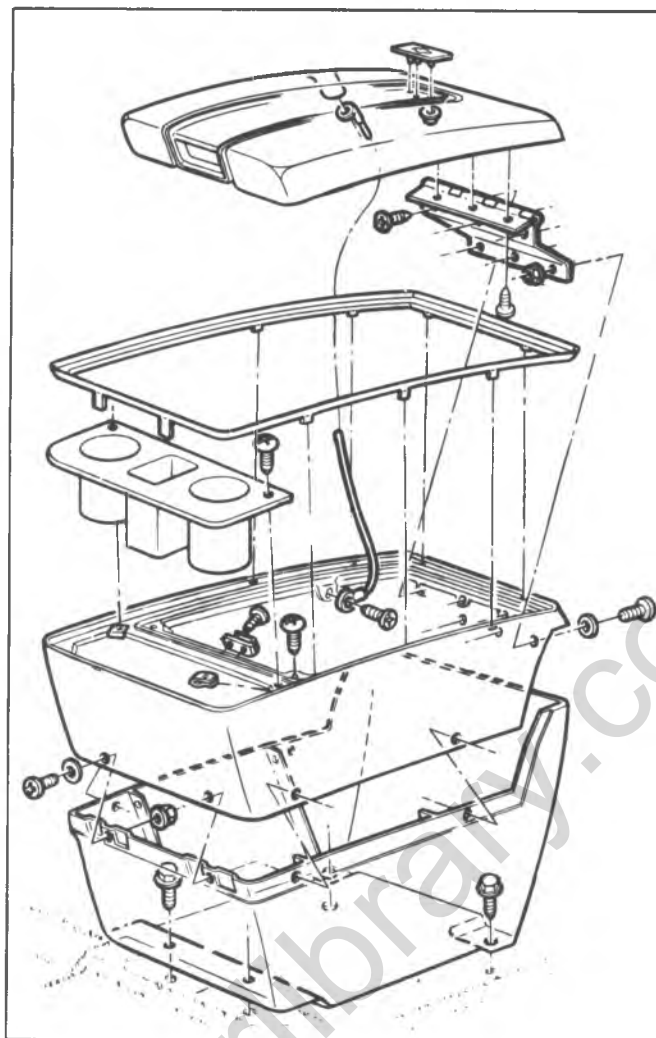


Fig. 2D-90--Seat Separator Compartment and Door--CK Models

classiccarslibrary.com

G MODELS

INDEX

| | | | |
|-----------------------------|-------|-----------------------|-------|
| Front End | | Sliding Side Door | |
| Windshield Wipers..... | 2D-38 | Description..... | 2D-48 |
| Cowl Ventilator Grille..... | 2D-39 | Adjustments..... | 2D-48 |
| Side Ventilator Valve..... | 2D-39 | Front Latch..... | 2D-50 |
| Rear View Mirror..... | 2D-39 | Rear Latch..... | 2D-51 |
| Body Glass | | Upper Rear Hinge..... | 2D-51 |
| Windshield Glass..... | 2D-40 | Strikers..... | 2D-52 |
| Stationary Glass..... | 2D-42 | Rear Door | |
| Swingout Glass..... | 2D-42 | Hinge..... | 2D-54 |
| Front Door | | Remote Control..... | 2D-54 |
| Adjustments..... | 2D-42 | Latches and Rods..... | 2D-55 |
| Replacement..... | 2D-42 | Adjustments..... | 2D-55 |
| Weatherstrip..... | 2D-42 | Seats | |
| Hinges..... | 2D-42 | Drivers Seat..... | 2D-56 |
| Ventilator..... | 2D-43 | Passenger Seat..... | 2D-56 |
| Window and Regulator..... | 2D-44 | Rear Seats..... | 2D-56 |
| Locks, Handles, Rods..... | 2D-46 | Roof Vent..... | 2D-57 |
| | | Seat Belts..... | 2D-57 |

FRONT END

WINDSHIELD WIPERS

Windshield wiper units on all models are of the two-speed electric type. A single wiper motor unit, mounted to dash panel at top and to left of engine cover inside cab, powers both wiper blades. The wiper blade operating link rods and pivot mountings on these models are located in the outside air inlet plenum chamber.

Arm Adjustment

To adjust sweep of blades turn on wipers, then note sweep of arms. If necessary, remove one or both arms as follows:

Pull outer end of arm away from glass which will trip lock spring at base of arm and release spring from undercut of pivot shaft. While holding arm in this position, pull outward on cap section at base of arm to remove arm. Arm can be reinstalled in any one of several positions due to serrations on pivot shaft and in arm cap. See figure 2D-95.

WIPER ARM PIVOT SHAFTS AND LINK ROD- FIG. 2D-96

Removal

1. Remove windshield wiper arms from pivot shafts. Procedure for removing arms is explained previously under "Arm Adjustments."

2. Remove screws which attach outside air cowl ventilator grille to cowl. Carefully remove grille from cowl.

3. At center of cowl, remove two attaching nuts which attach link rod to motor drive. Disengage link rods from pins.

4. Remove screws which attach each arm transmission pivot shaft assembly to cowl. Remove pivot shaft assembly with link rod from plenum chamber.

Installation

1. Place pivot shaft assembly with link rod into position at cowl bracket. Secure assembly to bracket with two screws.

2. Attach end of link rod to motor drive and arm. Secure rod with the two attaching nuts.

3. Install outside air cowl ventilator grille to top of cowl.

4. Before installing wiper arms, operate wiper motor momentarily which should rotate pivot shafts to park position. Install arms.

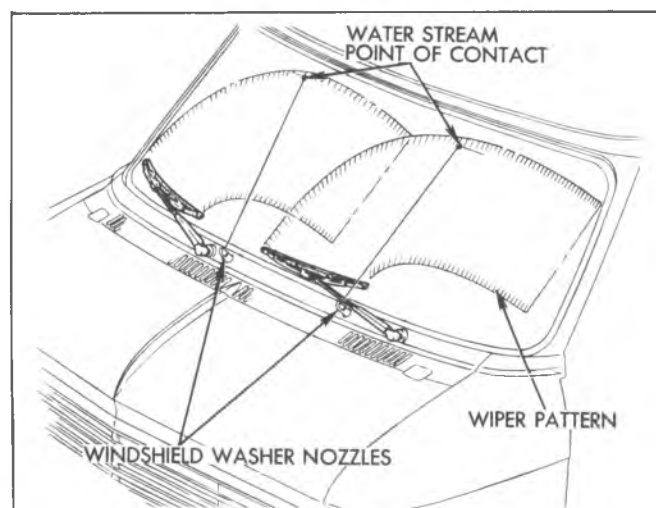


Fig. 2D-95--Wiper Pattern

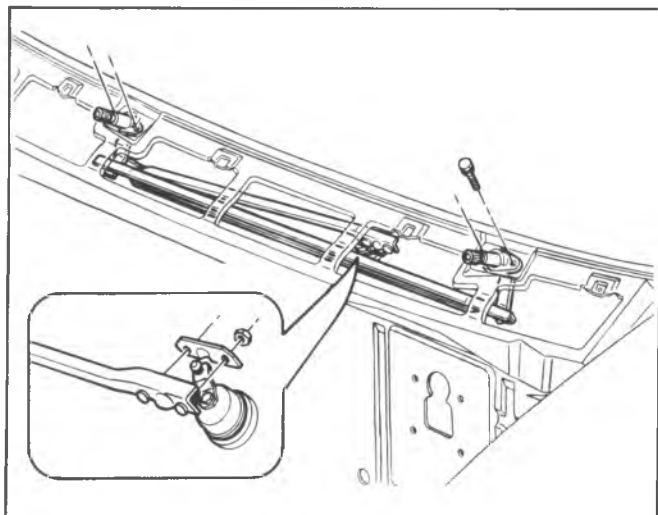


Fig. 2D-96--Windshield Wiper Linkage

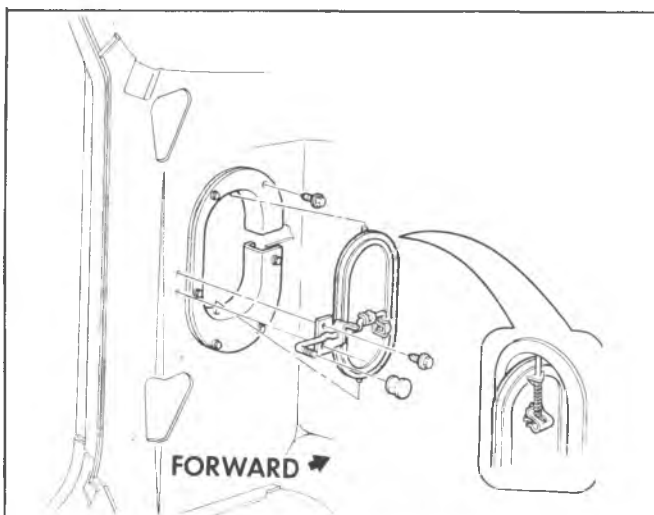


Fig. 2D-98--Side Cowl Ventilator

COWL VENTILATOR GRILLE

Replacement

1. Remove windshield wiper arms.
2. Remove screws retaining grille, figure 2D-97.
3. Remove grille and seal.
4. Reverse above steps to install grille.

SIDE COWL VENTILATOR

Replacement

1. Remove screws retaining valve guide to panel, as shown in figure 2D-98.
2. Remove valve assembly by depressing pins at top and bottom of valve.
3. Reverse the above steps for installation.

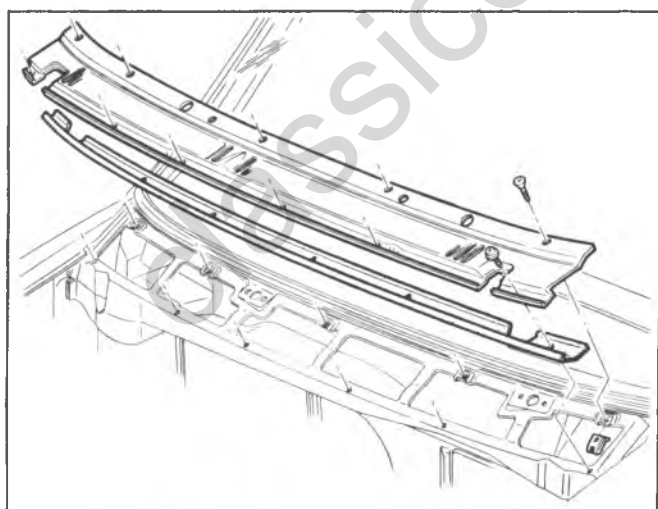


Fig. 2D-97--Cowl Ventilator Grille

REAR VIEW MIRRORS

Inside Rear View Mirror

Replacement

The inside mirror may be removed by removing screw retaining mirror to its glass-mounted bracket, and lifting mirror off bracket (fig. 2D-99).

Outside Rear View Mirrors

Outside rear view mirror installations are shown in figure 2D-100. Occasional tightening of mounting and assembly bolts and screws will sharply decrease occurrence of failure due to door slamming or road shock.

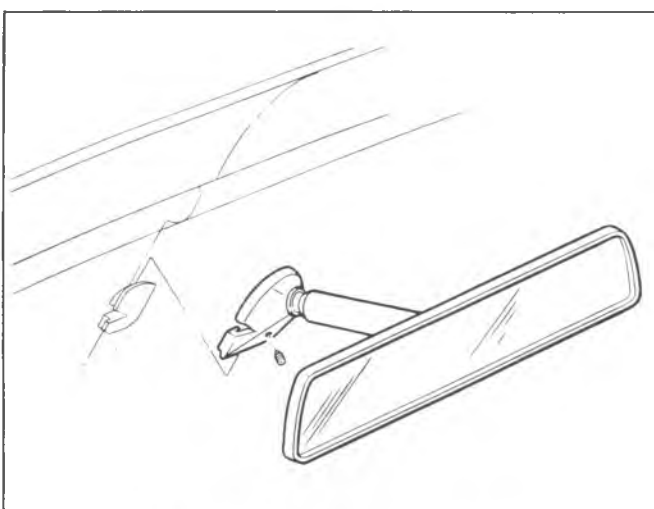


Fig. 2D-99--Inside Rear View Mirror

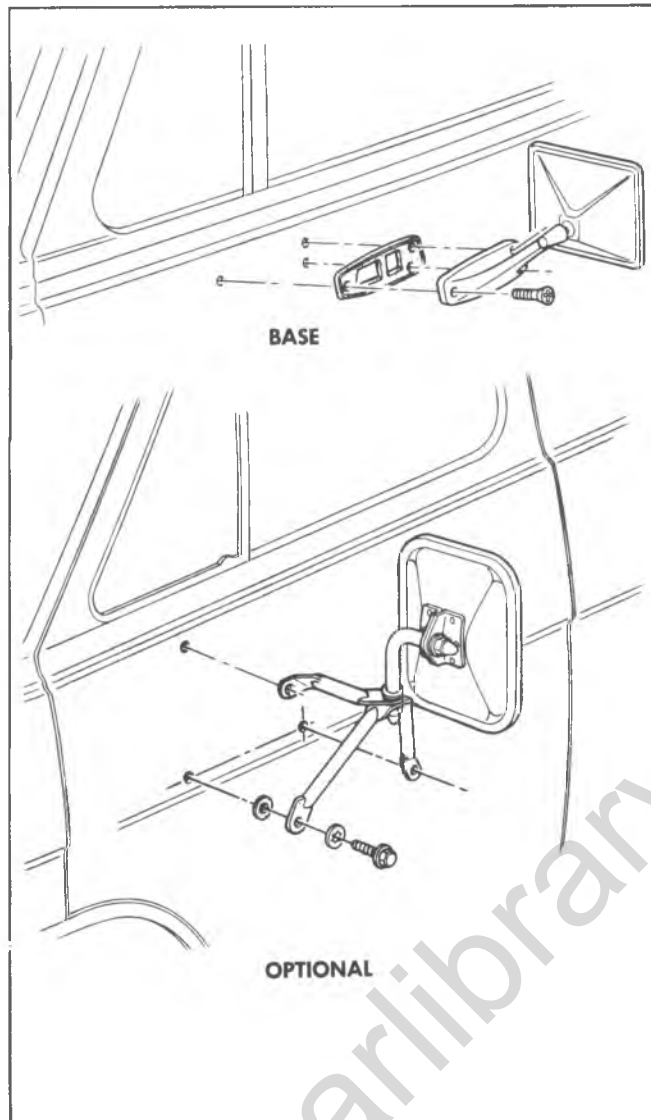


Fig. 2D-100—Outside Rear View Mirrors

BODY GLASS

CAUTION: Always wear gloves and eye glasses when handling glass to avoid personal injury.

WINDSHIELD GLASS

The windshield is a one-piece type and is retained in the windshield opening by an extruded rubber weatherstrip. This weatherstrip is sealed in the windshield opening and sealed to the windshield glass. See figure 2D-101.

When replacing a cracked windshield glass, it is very important that the cause of the glass breakage be determined and the condition corrected before a new glass is installed. Otherwise, it is highly possible that a small obstruction or high spot somewhere around the windshield opening will continue to crack or break the newly installed windshield, especially when the strain on the glass caused by this obstruction is increased by such conditions as wind

pressures, extremes of temperature, motion of the vehicle, etc.

The procedure for removal of the windshield applies to the complete windshield assembly and to other stationary glass, such as in figure 2D-104.

Removal

Refer to figures 2D-14 to 2D-16 in the "C-K Models" portion of this section for illustration of removal technique.

1. Before removing the windshield, mark the location of the break on the windshield rubber channel and the body. Protect the paint finish inside of the cab. Mask around the windshield opening and outside, lay a suitable covering across the hood and fenders.

The windshield glass rubber weatherstrip is one piece. The glass is held in a channel within the weatherstrip.

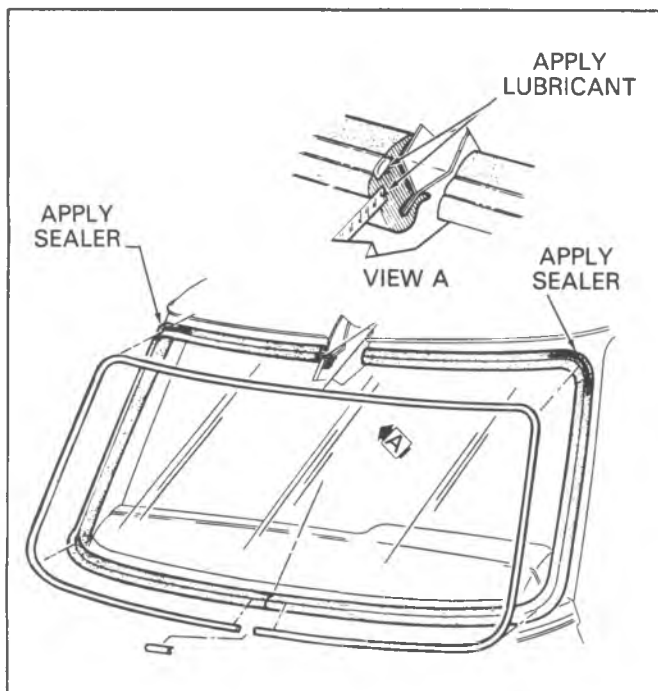


Fig. 2D-101--Windshield Glass

2. Do not try to remove reveal moldings while windshield is in body opening. Remove reveal molding from custom weatherstrip retention groove after windshield is removed from body opening.

3. To free windshield rubber channel of weatherstrip loosen the lip of the windshield weatherstrip from the pinchweld flange along the top and at the sides by applying firm, controlled pressure to the edge of the glass. At the same time assist the lip of the rubber weatherstrip channel over the pinchweld flange with a flat bladed tool.

Checking Windshield Opening

Due to the expanse and contour of the windshield it is imperative in the event of a stress crack that the windshield opening be thoroughly checked before installing a replacement windshield. The replacement glass is used as a template.

1. Check for the following conditions at the previously marked point of fracture.

- a. Chipped edges on glass.
- b. Irregularities in body opening.
- c. Irregularities in rubber channel weatherstrip.

2. Remove all sealer from flange and body around windshield opening.

3. Check flange area for solder, weld high spots, or hardened spot-weld sealer. Remove all high spots.

4. Check windshield glass to opening, by supporting glass with six spacers contained in packet J-22577, as shown in figure 2D-102.

It is necessary to modify the spacers by cutting off 3/16" from the back of the spacer with a knife, as shown in figure 2D-102.

NOTICE: Do not strike glass against body metal. Chipped edges on the glass can lead to future breaks.

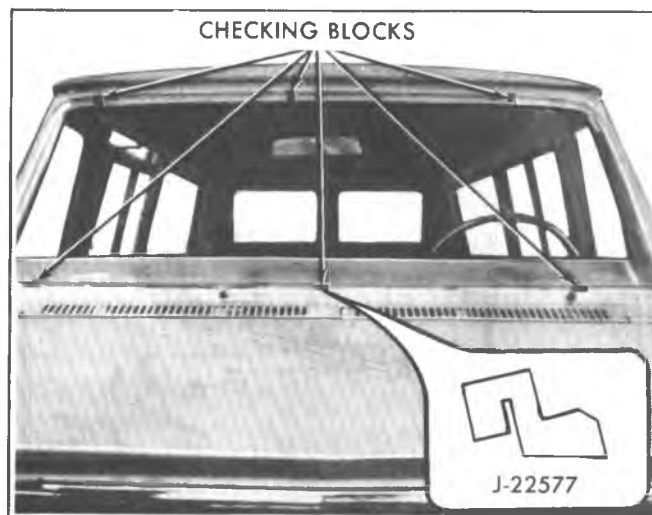


Fig. 2D-102--Checking Windshield Opening

5. With the windshield supported and centered in its opening, check the relationship of the glass to the body opening flange around the entire perimeter of the glass.

6. Check the relationship of glass to opening as follows:

- a. Inside edge of glass to body flange.
- b. Outer edge of glass to parallel body metal.

7. Mark areas of body metal or flange to be reformed, remove glass and correct as necessary.

8. Recheck windshield in its opening and if satisfactory proceed as follows:

Installation

Installation procedure is same as procedure used for CK models, with the exception of the steps relating to urethane adhesive. Refer to "CK Truck Windshield Replacement" found earlier in this section.

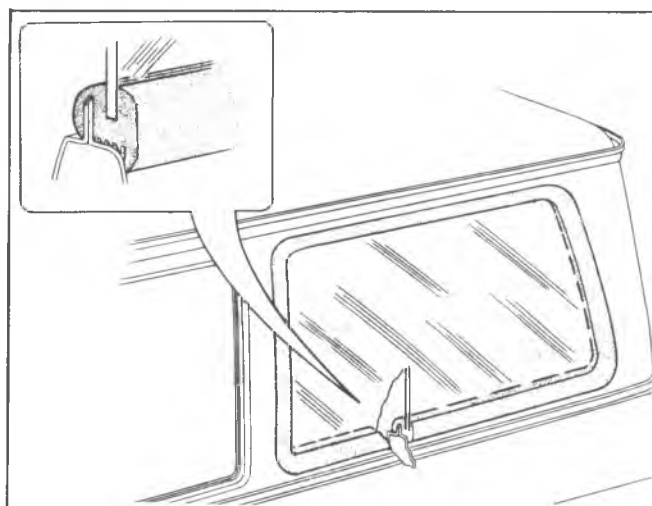


Fig. 2D-104--Body Window Glass

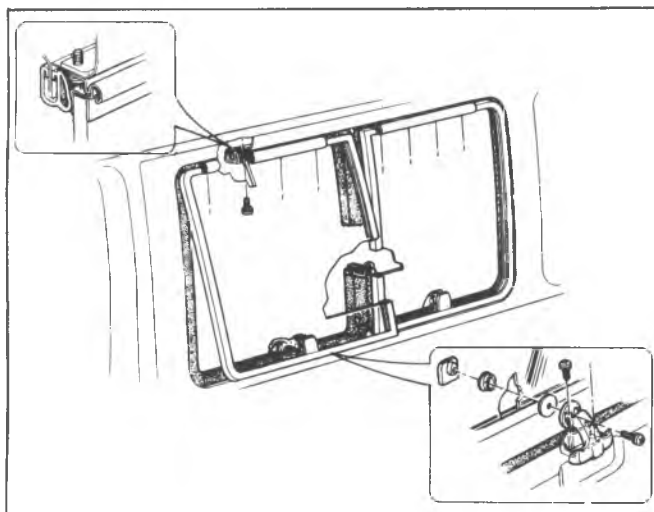


Fig. 2D-105--Swingout Window

SWINGOUT WINDOW

Replacement

1. Swing out the window. See figure 2D-105.
2. Remove screws retaining latch to body.
3. Remove window by swinging glass out, separating assembly at hinge.
4. Remove latch from glass by twisting and pulling out.
5. Reverse removal procedure to install swingout window.

LATCH SWINGOUT WINDOW

Replacement

1. Swing out the window.
2. Remove latch to body attaching screws.
3. Twist and pull latch to remove from glass.
4. Reverse above steps for installation.

FRONT DOOR

DOOR ADJUSTMENTS

Doors can be adjusted for alignment of clearance in the cab door opening, and for proper latching. Door alignment adjustments are made at the striker bolt, and at door hinges. The door, when properly located in door opening, will have equal clearance around its perimeter. The door should be adjusted in the opening so the edge of the door across the top and also at the lock side is parallel with the body opening as nearly as possible.

Hinge Adjustment

Door hinge bolt holes are oversized to make adjustment possible. Alignment adjustments can be made by loosening the proper hinge bolts, aligning door to proper position, and tightening bolts securely. See figure 2D-106, for typical adjustments.

Striker Bolt Adjustment

With the use of J-23457, shown in figure 2D-107, the striker bolt can be adjusted in any of three ways. See figure 2D-108.

1. **Up and down** -To adjust striker up or down, loosen bolt, adjust to center of lock entry, and tighten bolt securely.

NOTICE: This adjustment is important to assure that the right proportion of door's weight will rest on striker bolt when door is closed. If bolt is positioned too high on pillar, rapid wear will occur to the lock cam; if too low, an extra load will be placed on door hinges as well as pulling door downward and out of alignment.

2. **In and Out** -To adjust striker in and out, loosen bolt, adjust horizontally to match the door surface to the body surface, and tighten bolt securely.

3. **Forward and Rearward** -To make this adjustment, loosen striker bolt, shim to desired position, and tighten bolt securely.

DOOR HINGE

Remove

1. Remove hinge access hole cover from door hinge pillar.
2. If removing one hinge, support door in such a manner that weight is taken off other hinge, and that the door will not move.
3. Remove hinge screws from both body and from door and remove hinge. See figure 2D-106.

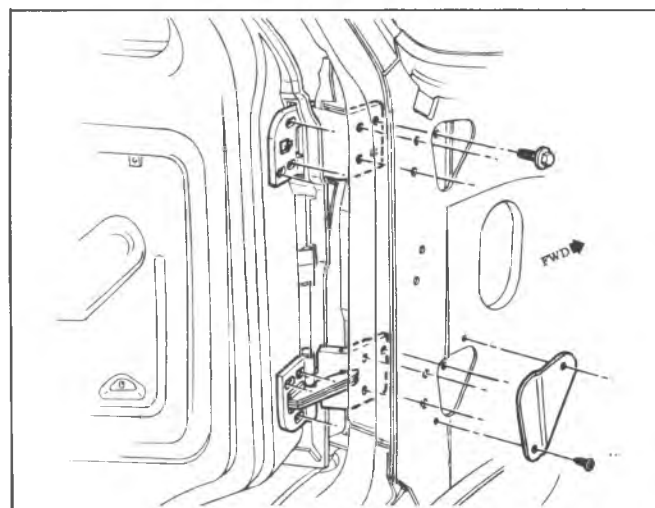


Fig. 2D-106--Door Hinge

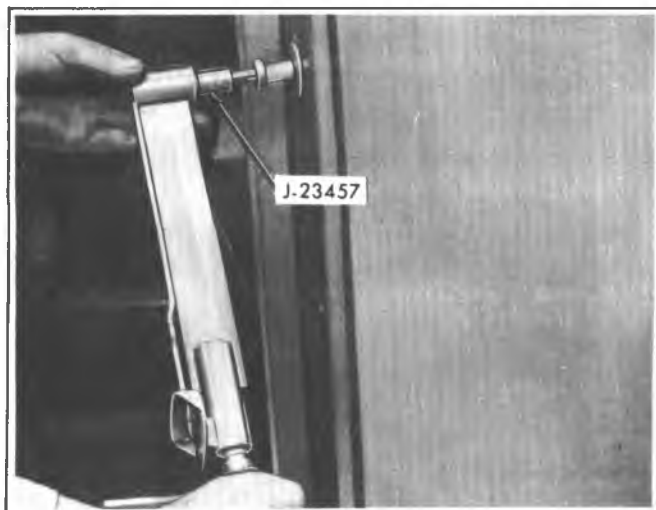


Fig. 2D-107--Loosening Striker Bolt

Installation

1. Install hinge to door and body. Snug bolts.
2. Remove door supports.
3. Adjust door as outlined under "Door Adjustment".
4. Torque bolts to specifications.
5. Install hinge access hole covers.

DOOR WEATHERSTRIP

Success of weatherstrip replacement depends entirely upon the quality of the cement used and the care with which it is applied. All rust, road dirt and grease or oil must be completely removed as should all old cement and bits of old weatherstrip. After removing all foreign material from door opening surface, wipe down with prepsol or its equivalent. Use only a good quality cement which is made specially for weatherstrip installation, following the manufacturer's directions. Proceed as follows:

1. Open door and block open.
2. Remove side door weatherstrip.
3. Remove used adhesive from door with adhesive or cement remover, and remove all plastic nails.

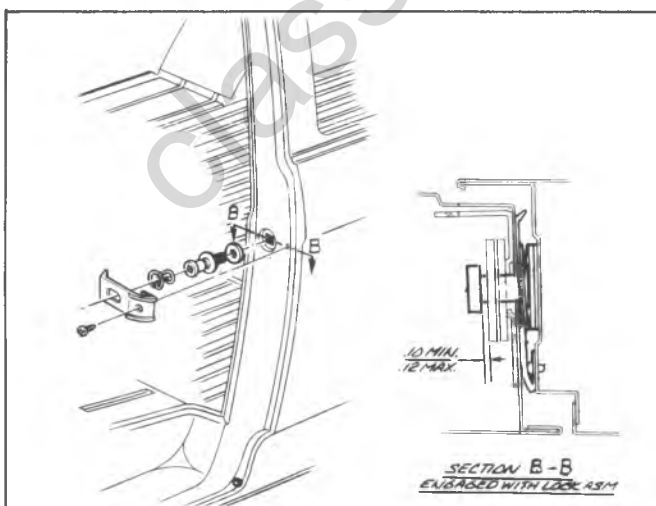


Fig. 2D-108--Typical Striker Bolt Adjustment

4. Apply adhesive to door.
5. Position weatherstrip by locating part number at top of vent window, making sure that plastic nails align with holes in door.
6. Install weatherstrip by pressing each nail into the door.

TRIM PANEL, ARM REST AND HANDLES

Removal

1. Remove screws retaining arm rest to trim panel.
2. Remove door and window handles with Tool J-9886-01 and pull from shaft.
3. Remove trim panel and water shields screws and remove panel. If seal is damaged, replace seal.

Installation

1. Install trim panel.
2. Install arm rest. Install door and window handle washers and handles.

DOOR VENTILATOR ASSEMBLY

Removal

The channel between the door window glass and door vent is removed as part of the vent assembly.

1. Regulate the door window glass to the full down position.
2. Remove door and window handles with Tool J-9886-01.
3. Remove trim panel and water shields.
4. Remove rear window run channel screws.
5. Slide door window glass rearward away from ventilator.
6. Remove three screws at the upper front of the door and lower forward channel screw, as shown in figure 2D-109.
7. Pull the upper portion of the ventilator rearward.
8. Turn the vent assembly 90° and carefully remove by guiding up and out, as shown in figure 2D-110.

Ventilator Glass Replacement

1. Using an oil can or similar means, squirt prepsol on the glass filler all around the glass channel or frame to soften the old seal. When the seal has softened, remove the glass from the channel.

2. Thoroughly clean the inside of the glass channel with sandpaper, removing all rust, etc.

3. Using new glass channel filler, cut the piece to be installed two inches longer than necessary for the channel. Place this piece of filler (soapstoned side of filler away from glass) evenly over the edge of the glass which will fit in the channel. The extra filler extending beyond the rear edge of the glass should be pinched together to hold it in place during glass installation.

One side of this filler (the outside of the roll) is soapstoned. This is the side which goes into the metal channel.

4. Brush the inside of the metal glass channel freely with ordinary engine oil. This will enable the glass and filler to slide freely into the channel.

Glass should be installed so that rear edge is parallel to the division post. Allow full cure before water testing.

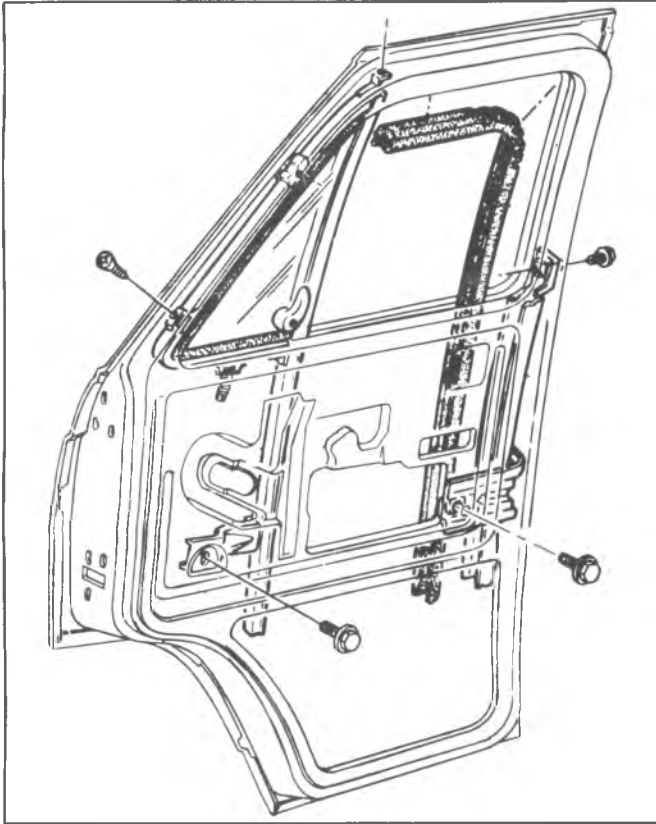


Fig. 2D-109--Ventilator Assembly

Installation

Replace the door window glass and regulate to the full down position before installing the door ventilator assembly.

1. Lower the ventilator assembly into the door frame. Center into position.
2. Make certain the rubber lip is positioned before tightening screws.
3. Slide door glass forward engaging glass in vent channel.

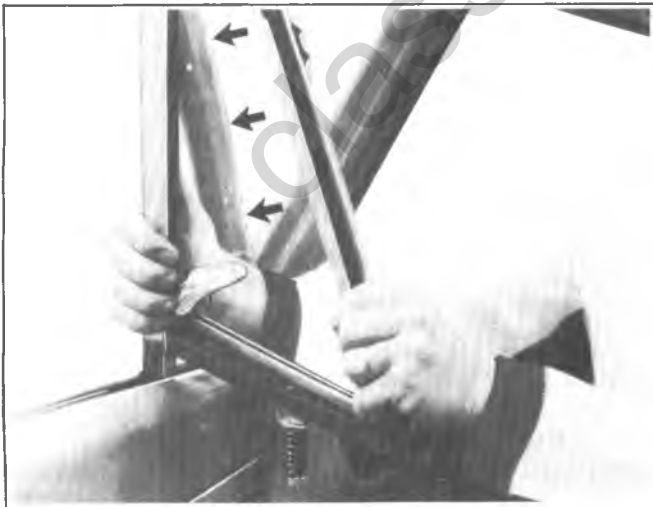


Fig. 2D-110--Removing Ventilator

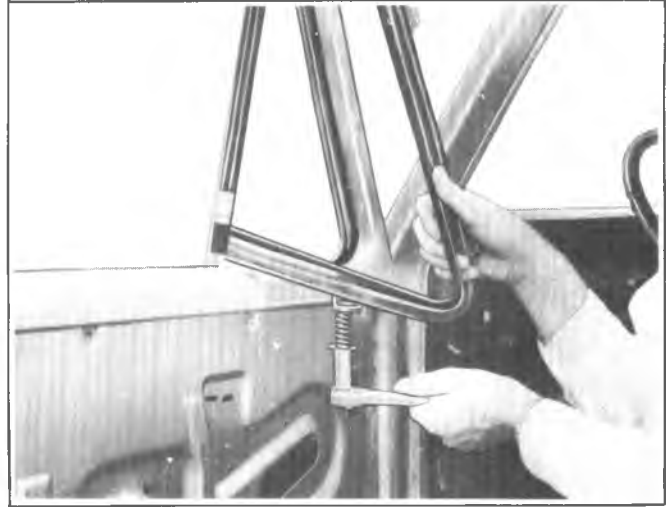


Fig. 2D-111--Adjusting Ventilator Tension

4. Reinstall all screws and tighten.

5. Install and tighten the three screws at the upper front of the door.

Adjustment

1. Adjust the ventilator adjusting nut by turning clockwise to increase operating tension, as shown in figure 2D-111.
2. After making adjustment bend tabs over the hex nut.
3. Install trim panel.
4. Install door and window regulator handles.

DOOR WINDOW ASSEMBLY

Replacement

1. Completely lower glass to bottom of door.
2. Remove door arm rest, trim pad and water shields.
3. Mask or cover upper portion of door window frame.
4. Remove ventilator assembly as previously outlined.
5. Raise window until regulator arms are level with access hole in door.
6. Slide glass forward until front roller is in line with notch in sash channel. Disengage roller from channel. See figure 2D-112.
7. Push window forward and tilt front portion of window up until rear roller is disengaged.
8. Put window assembly in normal position (level) and raise straight up and out.
9. Reverse above procedure for installation.

WINDOW REGULATOR - MANUAL

Replacement

1. Wind window all the way up.
2. Remove inside door handles with Tool J-7797.
3. Remove door trim pad.
4. Remove screws securing regulator to inner panel.
5. Push regulator out of door opening while holding rear of assembly, then slide assembly to the notches in the carrier channel and out through the door access hole.
6. Install regulator in reverse order of removal, lubricate regulator gears with lubriplate or equivalent.

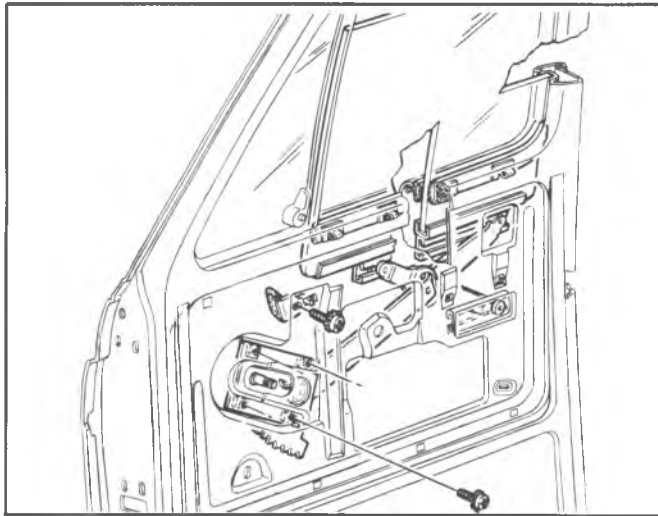


Fig. 2D-112--Window and Regulator

WINDOW REGULATOR - POWER

In the case that window will not operate, check electrical connections first. Figure 2D-113 illustrates location of junctions, switch, relay and circuit breaker.

Replacement

CAUTION: Electrical connectors must be removed from window lift motor before performing any operation on the regulator, or personal injury could occur.

1. Disconnect battery ground cable.
2. Remove door trim panel.
3. Disconnect harness from regulator.
4. Remove screws securing regulator to inner panel.
5. Push regulator out of door opening while holding rear of assembly, then slide assembly to the notches in the carrier channel and out through the door access hole.

CAUTION: Step 6 must be performed when regulator is removed from door. The regulator lift arms are under tension from the counterbalance spring and can cause serious injury if the motor is removed without locking the sector gear in position.

6. Drill a hole through the regulator sector gear and back plate. **DO NOT** drill hole closer than 1/2" (12.7mm) to edge of sector gear or back plate. Install a pan head sheet metal tapping screw (No. 10 - 12 x 3/4) in drilled hole to lock sector gear in position.

7. Remove motor to regulator attaching screws.
8. Remove motor from regulator.
9. Prior to installation, lubricate the motor drive gear and regulator sector teeth.

The lubrication used must be cold weather approved to a minimum of minus 20° fahrenheit (-29°C).

10. Install regulator motor to regulator. Make sure the motor pinion gear teeth mesh properly with the sector gear teeth before installing the three motor attaching screws.

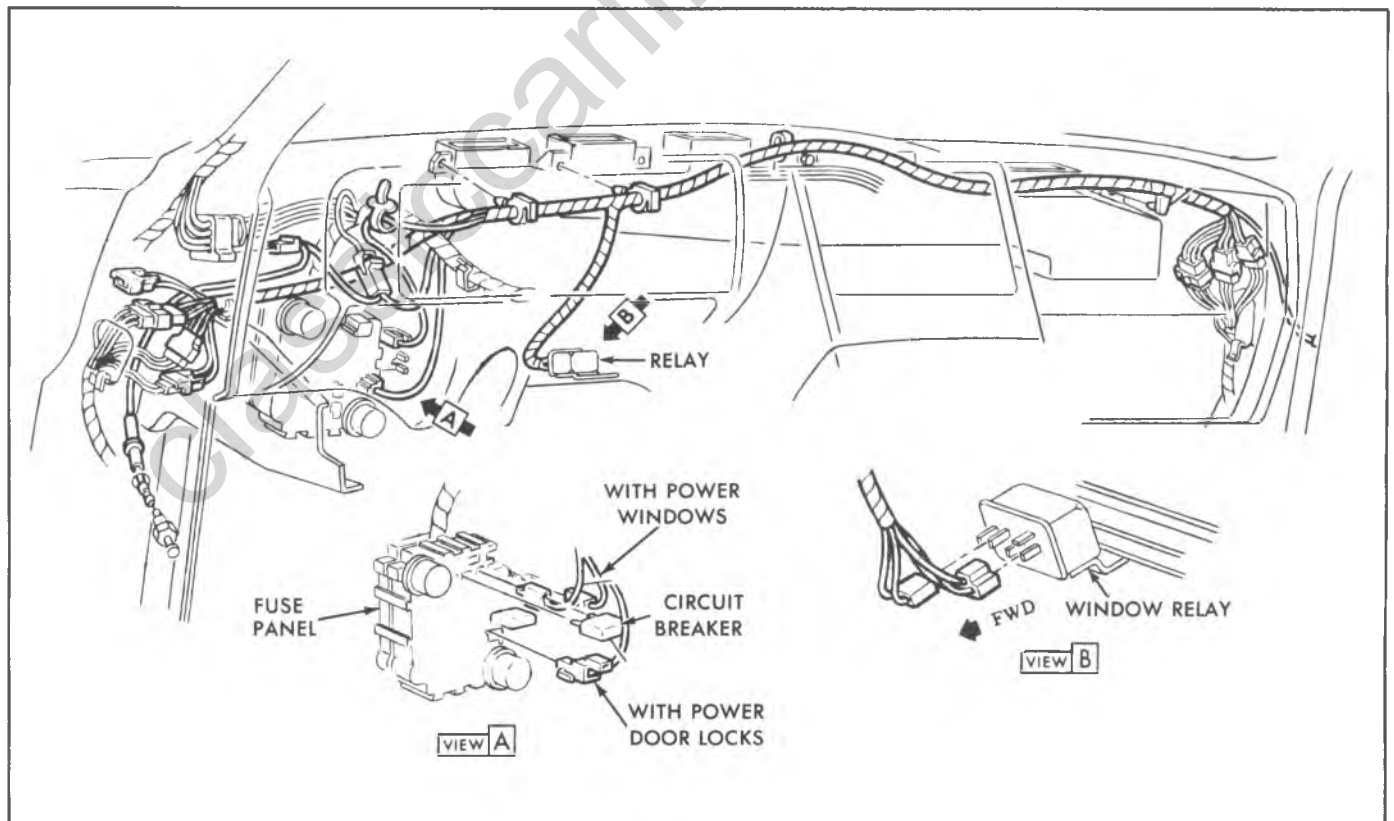


Fig. 2D-113--Power Window and Power Door Lock Wiring

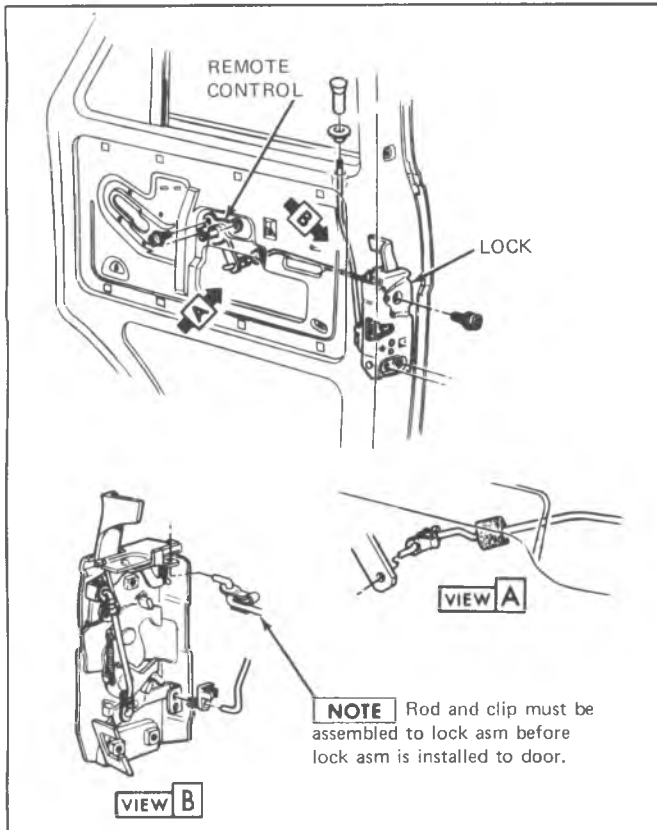


Fig. 2D-114--Lock and Remote Control Assembly

11. Remove screw locking sector gear in a fixed position.

12. Install regulator in reverse order of removal, lubricate regulator gears and rollers with lubriplate or equivalent.

DOOR LOCK—FIGURE 2D-114

Removal

1. Raise window.
2. Remove inside handles with Tool J-9886-01.
3. Remove trim panel.
4. Remove door lock knob.
5. From outside the door remove screws retaining lock to door edge and lower the lock assembly.
6. Remove screws retaining remote control.
7. Remove screws securing glass run guide channel.
8. Remove lock, push button rod and remote control rod as an assembly.

Installation

1. Transfer remote rod with clip to new lock.
2. Connect remote door handle rod to lock after lock is positioned.
3. Secure lock screws and glass run guide channel.
4. Secure remote handle.
5. Check all controls for proper operation before reinstalling trim and handles.
6. Install door lock knob.

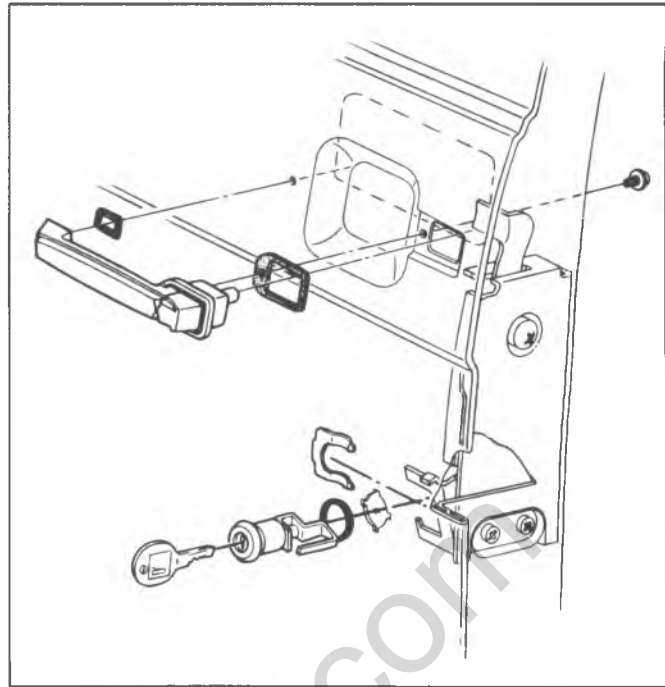


Fig. 2D-115--Lock Cylinder Assembly

REMOTE CONTROL AND CONNECTING

ROD—Fig. 2D-114

Replacement

1. Raise door window and remove door trim pad.
2. Remove bolts securing remote control to door inner panel.
3. Pivot remote inboard slightly, to disengage connecting rod, and remove remote control from door.
Connecting rod can be removed at this point by disconnecting spring clip from lock.
4. To install, reverse removal procedure.

POWER DOOR LOCKS

The power door lock system incorporates a motor actuator in each door which actuates the lock through linkage (fig. 2D-116). See Figure 2D-113 for switches, relay and wire routing.

Replacement

1. Disconnect battery ground cable.
2. Remove door trim panel to gain access to power door lock motor.
3. Disconnect electrical connector from motor.
4. Remove screws attaching motor to door inner panel.
5. Remove door lock lever from rubber mount at top of motor actuator and remove motor through access hole.
6. To install, reverse steps 1 through 5 above.

LOCK CYLINDER ASSEMBLY—FIG. 2D-115

Replacement

1. Raise door window and remove door trim pad.
2. With a screwdriver, or other suitable tool, slide lock cylinder retaining clip (on door outer panel) out of engagement and remove lock cylinder.
3. To install, reverse removal procedure.

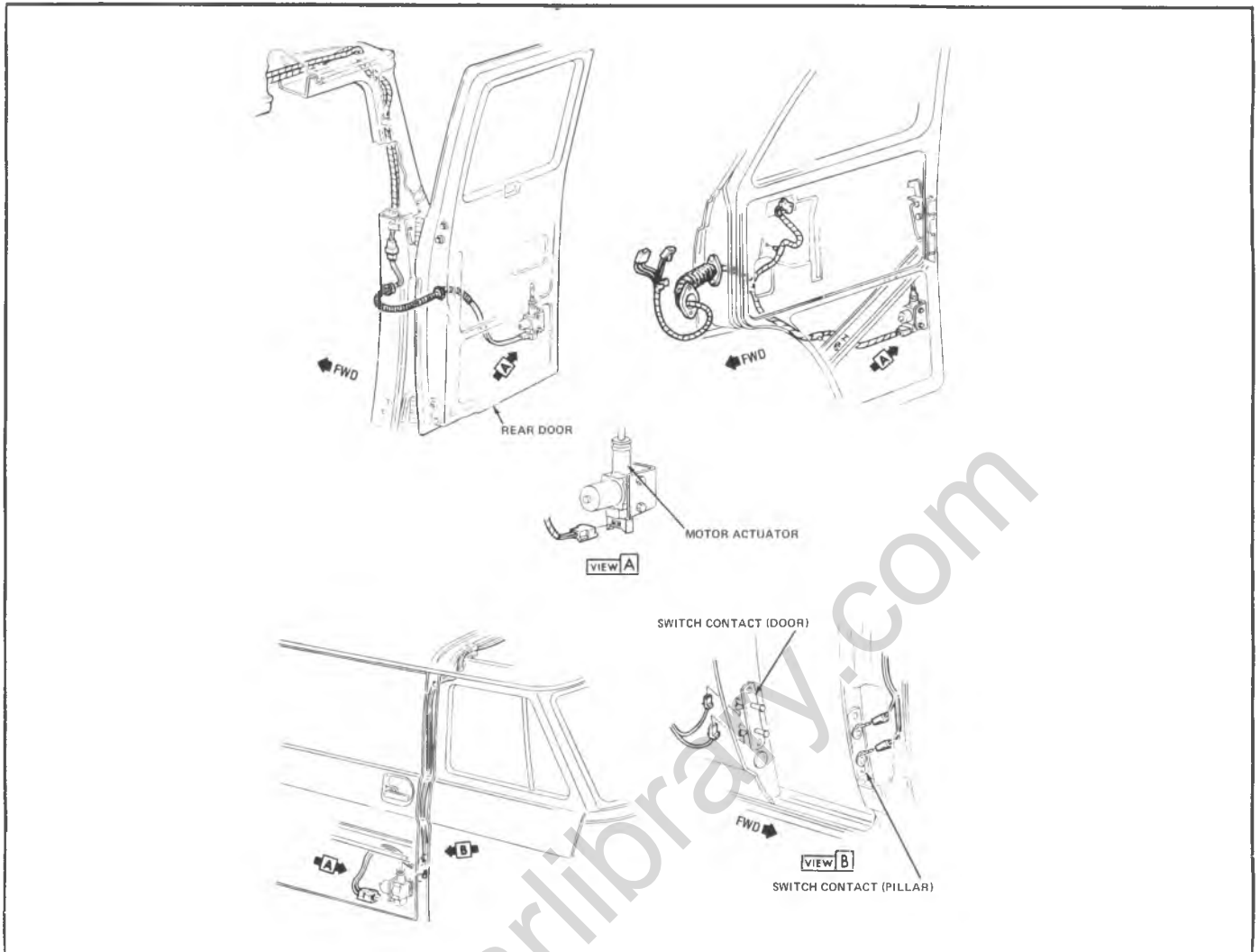


Fig. 2D-116--Power Door Lock Actuators

classiccarlibrary.com

SLIDING SIDE DOOR

DESCRIPTION

The weight of the sliding side door is supported by the upper rear hinge-and-roller assembly, and by the lower front catch-and-roller assembly. The front and rear latches retain the door in the locked position, while the rear wedge assembly restricts door vibration on rough road surfaces.

ADJUSTMENTS

NOTICE: See NOTICE on page 1 of this section regarding all sliding door fasteners and adjustments found below.

The side door can be adjusted for alignment and/or clearance in the body opening and for proper latching. When properly positioned in the body opening, the door should have equal clearances around its perimeter. Adjustments for door positioning and proper latching can be made at the locations shown in figure 2D-117.

Up and Down

Up and down adjustments are provided by means of slotted holes located at the upper front roller, view B of figure 2D-117; at the lower front catch-and-roller, view D; and at the upper rear hinge-and-roller assembly, view A. To reposition the door up or down:

1. Partially open door and loosen front latch striker on pillar.
2. Remove upper rear hinge cover, shown in figure 2D-118.
3. Loosen upper rear hinge-to-door bolts.
4. Loosen rear lock striker and door wedge assembly.
5. Align rear edge of door up or down, then tighten upper rear hinge-to-door bolts to specifications.
6. Loosen upper front roller bracket-to-door bolts.
7. Partially close door and align front edge of door up or down by loosening front lower hinge-to-door bolts. When door is correctly positioned, tighten bolts to specifications.
8. Position upper front roller in center of track, then tighten roller bracket to door.
9. Adjust front and rear strikers and rear wedge assembly as outlined in their respective procedures later in this section.

In and Out

Front in and out adjustments are provided by means of an adjustable lower roller mounting bracket, view D of figure 2D-117, and by a slotted upper bracket, view B of figure 2D-117. Rear in and out adjustment is provided by adjusting the rear latch striker, view E of figure 2D-117. To position the door in or out:

1. Loosen front latch striker.
2. Loosen upper front roller from its bracket.

3. Loosen lower front roller bracket-to-arm bolts.
4. Adjust front of door in or out, then tighten bolts to specifications.
5. Adjust door hold open catch bracket, rear wedge assembly, rear latch striker, upper front roller and front latch striker as outlined later in "Adjustments".

Fore and Aft

Fore and aft adjustment is provided at the upper rear hinge striker by means of a slotted bracket mounted to the body, view A of figure 2D-117.

1. Partially open door and remove front latch striker and rear lock striker.
2. Loosen rear wedge assembly.
3. Remove upper rear track cover.
4. Loosen upper rear hinge striker.
5. Move door assembly forward or rearward, then tighten striker bolts to specifications.
6. Reinstall upper rear track cover.
7. Reinstall front and rear latch strikers.
8. Adjust latch strikers and rear wedge assembly as outlined below.

Latch Striker Adjustments

Front Striker

1. Loosen front latch striker screws, view C of figure 2D-117.
2. Visually align latch-to-striker relationship and adjust if necessary.
3. Slide door slowly toward striker. The guide on the door, just above the latch, must fit snugly within the rubber-lined opening on the striker assembly.
4. Assure that the latch engages fully into the striker. Add or delete shims behind the striker as necessary.
5. Tighten striker screws to specified torque.

Rear Striker

1. Loosen striker with J-23457.
2. Loosen rear wedge assembly.
3. Center the striker vertically to door striker opening.
4. Adjust the striker laterally to match outer panel to the body panel surfaces, view E of figure 2D-117.
5. Apply grease to the striker.
6. Gently push the door in until the rear lock contacts the striker enough to make an impression in the grease.
7. Open the door and measure the distance from the rear of the striker head to the impression. The distance should be between .20 inch and .30 inch. Refer to view E of figure 2D-117.
8. Adjust position of striker by adding or deleting shims between the striker and the pillar.
9. Adjust rear wedge assembly as outlined later in this section, and torque all fasteners to specifications.

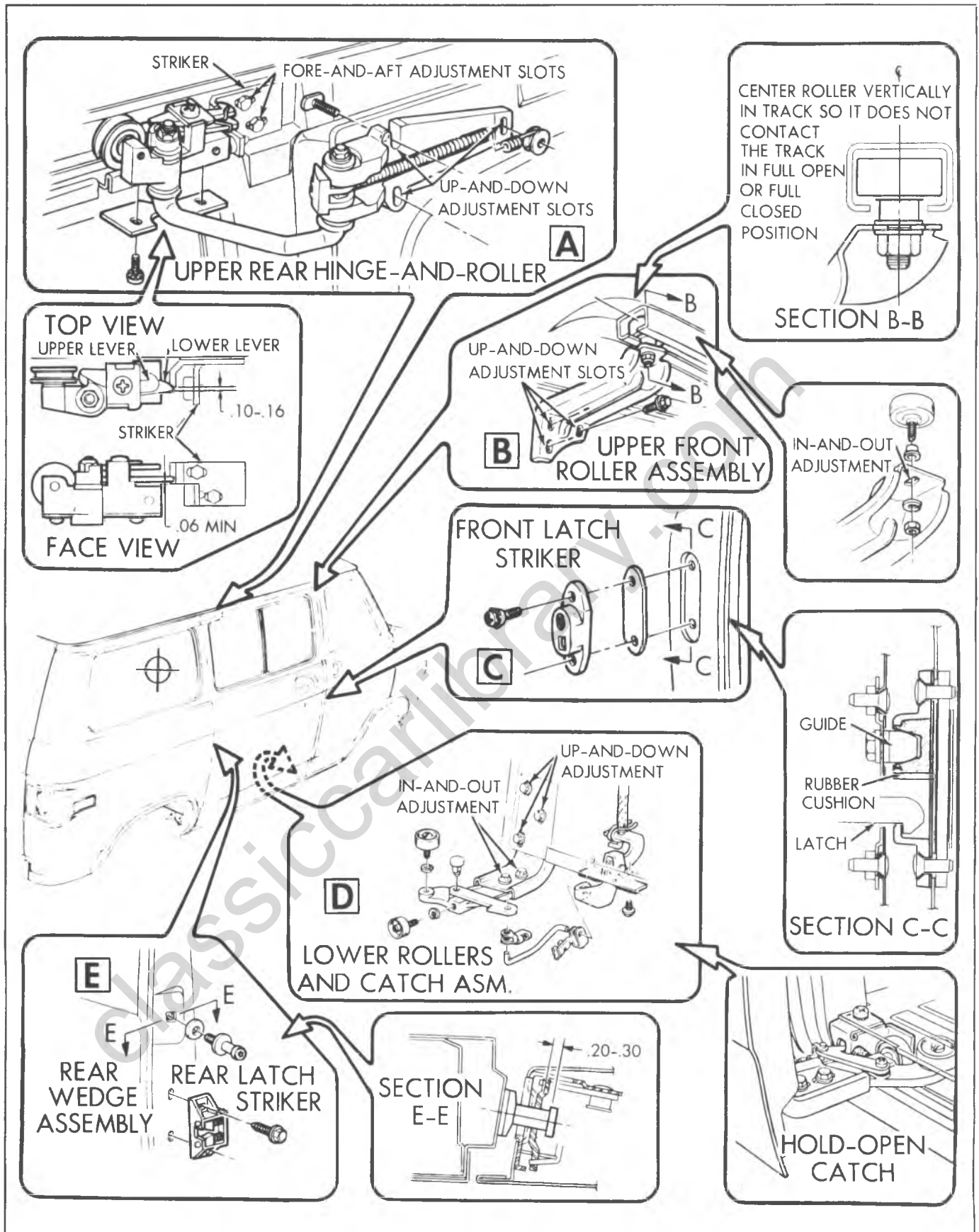


Fig. 2D-117--Sliding Side Door Adjustment Locations

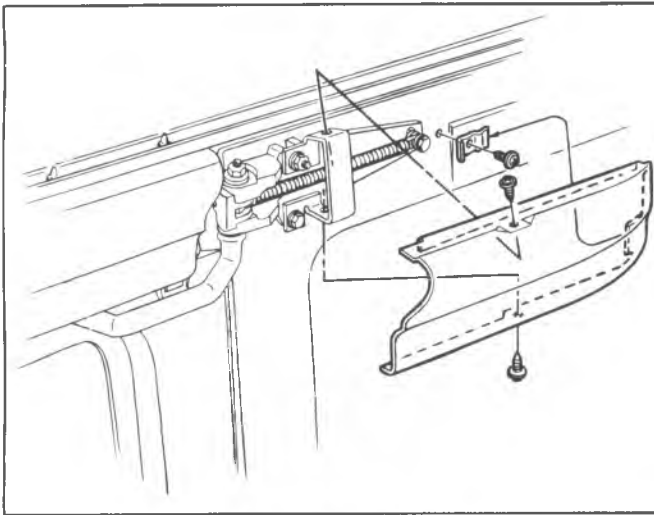


Fig. 2D-118--Hinge Cover

Upper Rear Hinge-To-Striker Adjustment

NOTICE: If door has been removed and is being reinstalled, adjust striker-to-lower hinge lever before closing door. Failure to do so may cause possible lever breakage.

The upper rear hinge must be positioned as shown in view A of figure 2D-117, in order to insure proper latching.

1. The hinge lower lever must contact the striker at least .06 inch above the lower edge of the striker tang.
2. The lower lever must extend at least .10 inch outboard of the striker tang. Add or delete shims between the striker and the body as necessary.

3. If necessary to shim roller away from guide, shims are added between the nylon block and hinge and between roller and hinge. They must be installed in pairs. For example, if one shim is added behind the nylon block another must be added behind the roller.

Door Hold-Open Catch Adjustment

This catch, mounted on the lower front roller bracket, holds the door in the full open position. See figure 2D-119. The catch engages a striker installed at the rear of the lower roller channel, view D of figure 2D-117.

1. Loosen the screws retaining the catch rod bracket to bottom of door.
2. Adjust catch-to-striker engagement by sliding the bracket laterally. Catch should fully engage striker.

Rear Wedge Assembly Adjustment

1. Loosen screws attaching rear wedge assembly to the body pillar, then close the door to the fully latched position.
2. Center the wedge assembly on the door wedge, as shown in figure 2D-120, and scribe a line around the wedge assembly.
3. Open the door, and move the wedge assembly 3/16 inch.

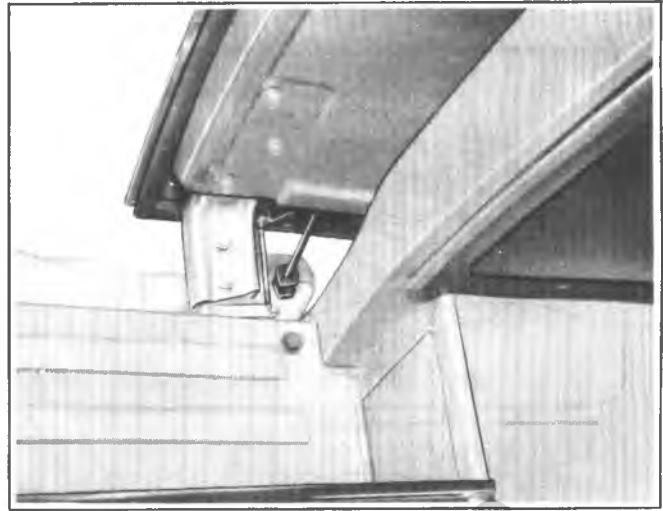


Fig. 2D-119--Hold-Open Catch

FRONT LATCH ASSEMBLY

Removal

1. Remove trim panel, if so equipped.
2. Remove access cover.
3. Unscrew door lock knob from rod.
4. Disconnect the following rods from latch, shown in figure 2D-121.
 - a. Rear latch rods.
 - b. Lock cylinder rod.
 - c. Door lock rod.
5. Remove door handle.
6. Remove screws retaining latch assembly to door.
7. Slide latch rearward and lift front of latch. Disconnect rod leading to lower hinge door catch by pushing rod out of hole and rotating rod clear of latch. See figure 2D-122.
8. Remove latch assembly from door.

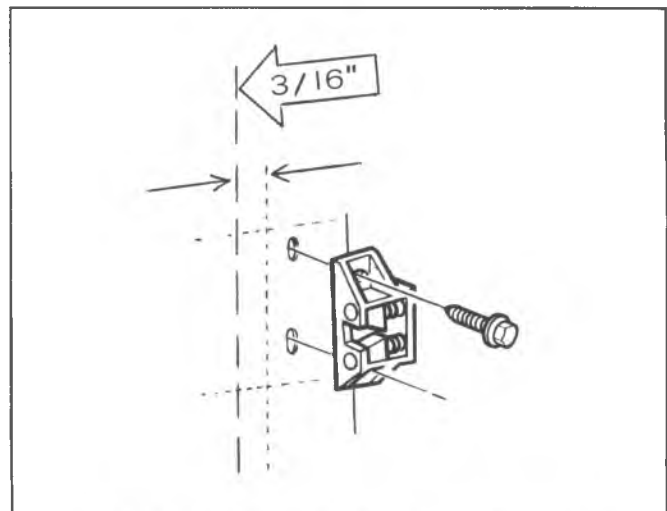


Fig. 2D-120--Adjusting the Rear Wedge Assembly

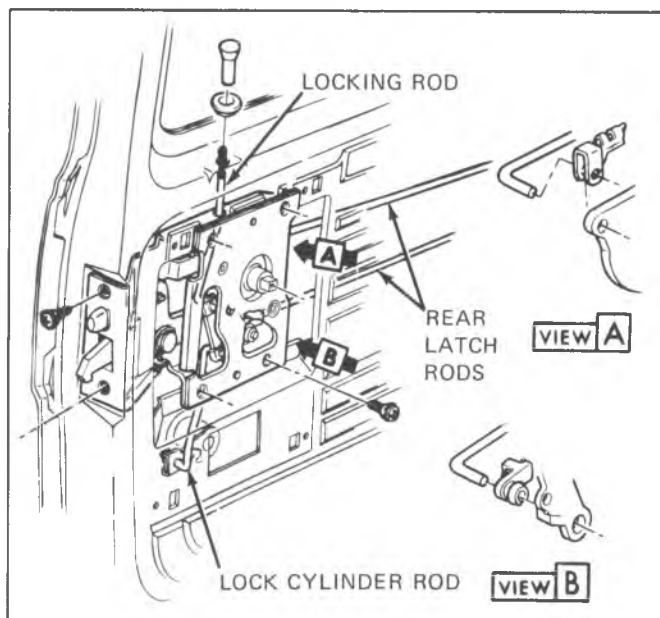


Fig. 2D-121--Sliding Door Front Latch

Installation

1. Install latch assembly into door by working latch assembly behind the lower hinge door catch.
2. Connect lower hinge door catch, lock cylinder rod, door lock rod, and both rear latch rods.
3. Install latch assembly-to-door attaching screws. Torque to specifications.
4. Install door lock knob and door handle.
5. Install access cover and trim panel.
6. Adjust door front striker as outlined earlier under "Adjustments".

REAR LATCH AND/OR LATCH ACTUATING RODS

Removal

1. Remove trim panel (if so equipped).
2. Remove front latch assembly access cover.

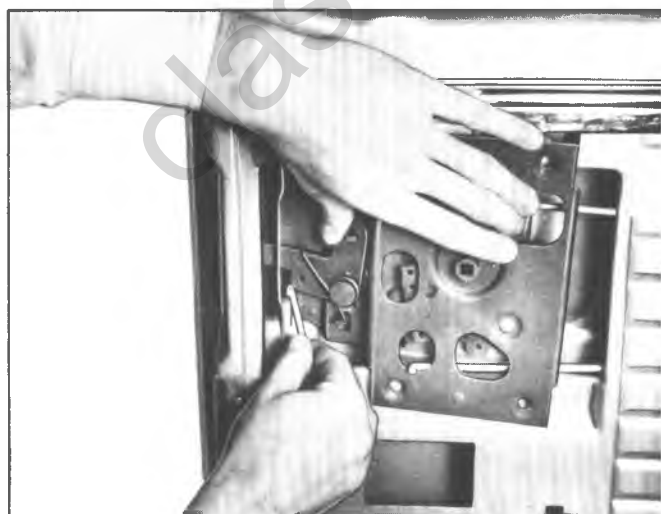


Fig. 2D-122--Disconnecting Lower Latch Rod from Latch

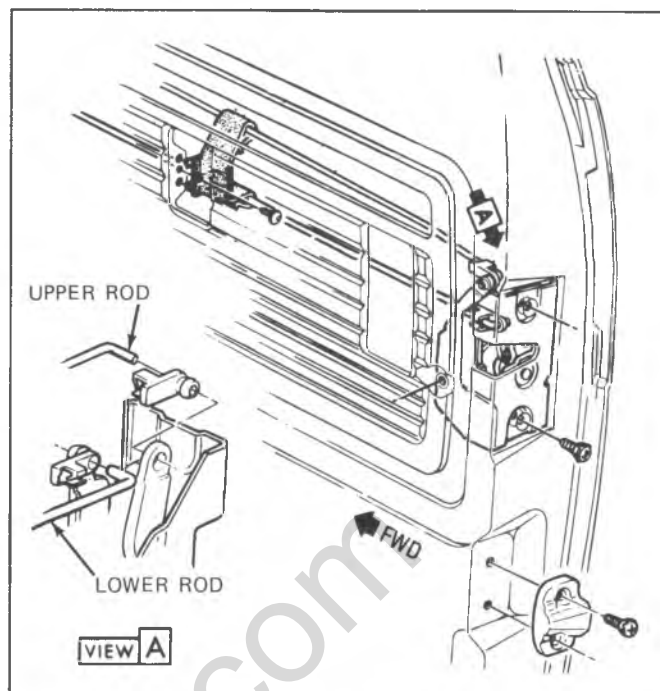


Fig. 2D-123--Sliding Door Rear Latch

3. Disconnect rear latch rods from front latch assembly, shown in figure 2D-121.
4. Remove rear latch attaching screws. See figure 2D-123.
5. Slide rear latch toward front of door until rod clips become exposed. Disconnect rod clips and remove latch from door.

Installation

1. Connect rods to latch and install latch to door. Torque screws to specifications.
2. Connect rods to front latch assembly.
3. Install access covers and trim panels (if so equipped).
4. Adjust rear latch striker as outlined earlier under "Adjustments".

UPPER REAR HINGE

Removal

1. Remove the hinge cover and rear track cover. See figures 2D-118 and 2D-124.
2. Open the door.
3. Disengage spring from bolt, using a spring removal tool.
4. Close the door.
5. Remove the hinge assembly.

Installation

When holding hinge assembly as in figure 2D-126, the lower latch must engage cam.

1. Install hinge assembly to door. Torque bolts to specifications.
2. Check and adjust latch to striker position as outlined under "Adjustments".

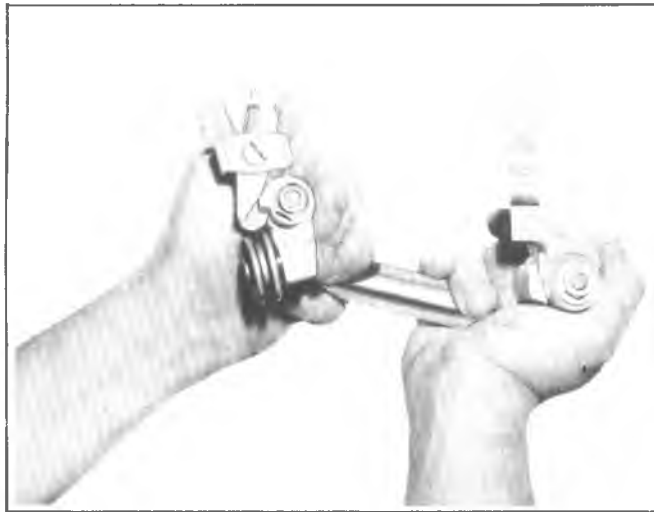


Fig. 2D-126--Checking Assembly of Hinge

REAR DOORS

REAR DOOR HINGE STRAP

Replacement

1. Remove strap release pin. See figure 2D-127.
2. Remove screws retaining strap to door.
3. Install strap to door. Torque retaining screws to specifications.

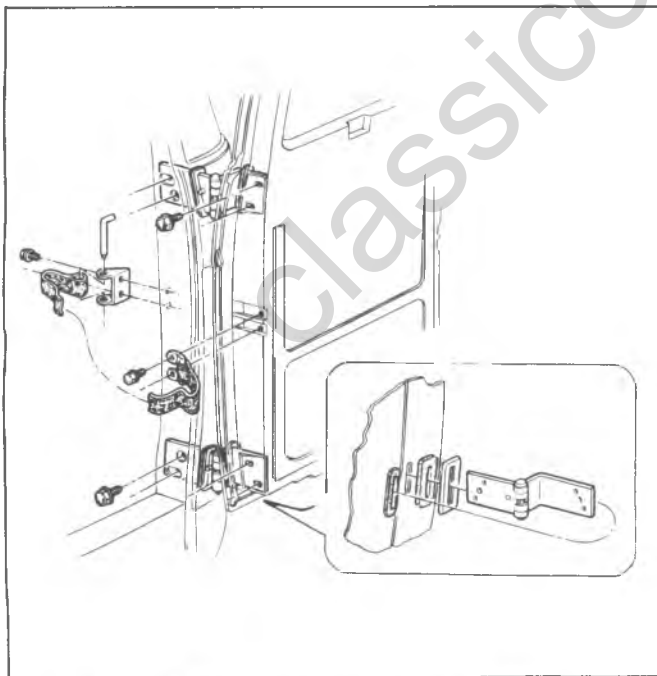


Fig. 2D-127--Rear Door Hinges and Strap

REAR DOOR HINGE

Removal

1. Open door. Support door so that when hinge screws are removed door weight will be on support.
2. Remove hinge strap release pin.
3. Remove hinge-to-door bolts and remove door assembly.
4. Remove hinge-to-body bolts and hinge.

Installation

1. Install grommet into door hinge opening (if removed).
2. Install hinge into door. Snug bolts.
3. Install seal and retainer on body half of hinge (if removed).
4. Install hinge into body opening and install bolts.
5. Take care to compress seal between body and retainer and snug bolts.
6. Install hinge strap and its retaining pin.
7. Adjust door and torque hinge bolts to specification.

REAR DOOR REMOTE CONTROL

Removal

1. Remove trim panel.
2. Disengage upper and lower latch rods from control by removing retaining clips. See figure 2D-128.
3. Remove remote control by removing its retaining screws.

Installation

1. Install remote control screws loosely.
2. Attach upper and lower control rods.
3. Rotate remote control lever clockwise, and hold in this position while torquing the screws to specifications.
4. Install the trim panel.

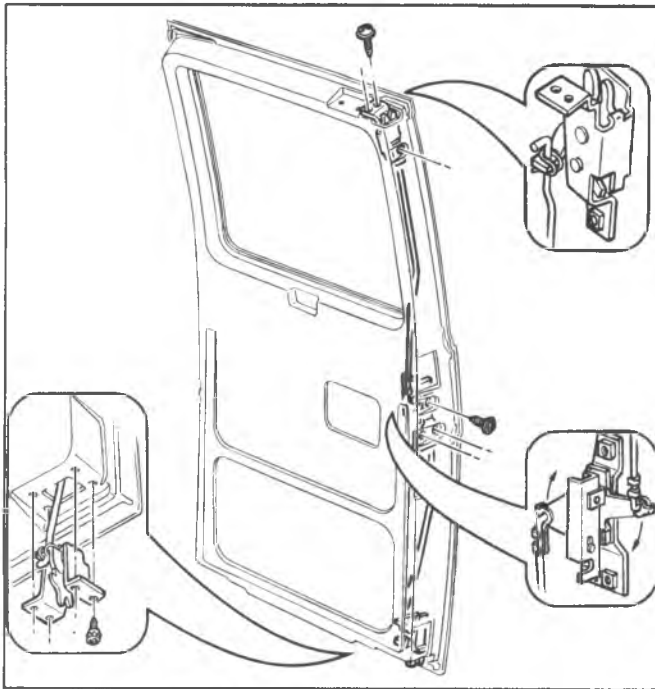


Fig. 2D-128—Remote Control and Latch

REAR DOOR UPPER OR LOWER LATCHES AND/OR LATCH RODS

Removal

1. Remove trim panel.
2. Disengage rod from remote control assembly. See figure 2D-128.
3. Remove latch retaining screws and withdraw latch and control rod.
4. Remove spring clip retaining rod to latch.

Installation

1. Install latch rod to latch.

When reinstalling the lower latch rod to control, the short straight section attaches to the latch.

2. Install latch and rod assembly into door and connect rod to remote control. Lube all moving parts.
3. Install latch retaining screws and torque to specifications.
4. Adjust latch to strikers.

REAR DOOR OUTSIDE HANDLE

Removal

1. Remove trim panel.
2. Remove door handle retaining screws, handle and gaskets. See figure 2D-129.

Installation

1. Apply grease to remote control where handle plunger makes contact.

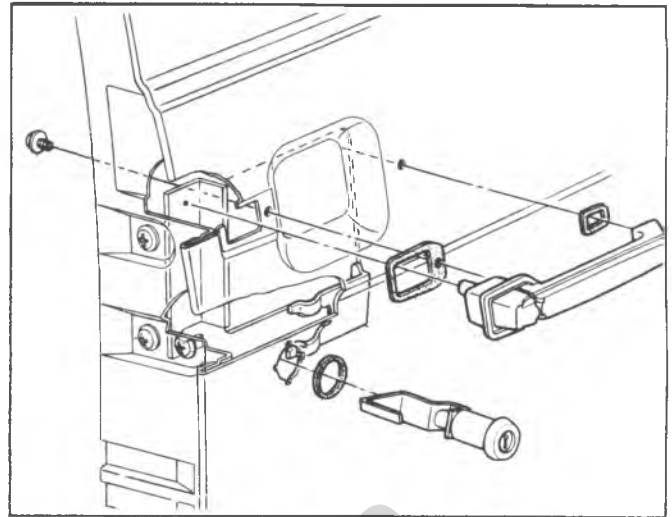


Fig. 2D-129—Outside Handle and Lock Cylinder

2. Install handle and gaskets. Torque screws to specifications.

3. Install trim panel.

REAR DOOR LOCK CYLINDER

Removal

1. Remove trim panel.
2. Remove remote control.
3. Remove lock cylinder retainer and lock cylinder.

Installation

1. Install lock cylinder and retainer.
2. Install remote control. Torque screws to specifications.
3. Install trim panel.

REAR DOOR GLASS AND WEATHERSTRIP

Removal and installation procedures are the same as for the stationary body side windows. Refer to those procedures for rear door glass and weatherstrip replacement.

REAR DOOR ADJUSTMENTS

Door adjustments are provided by slotted holes, at hinge attachment, in body and door.

1. Remove or loosen door strikers and wedges.
2. Loosen door hinge bolts and adjust door to provide equal clearances between body and door around perimeter of door.
3. Adjust door in and out so that door panel is flush with body.
4. Install door strikers and wedges and adjust as outlined under door striker adjustment.

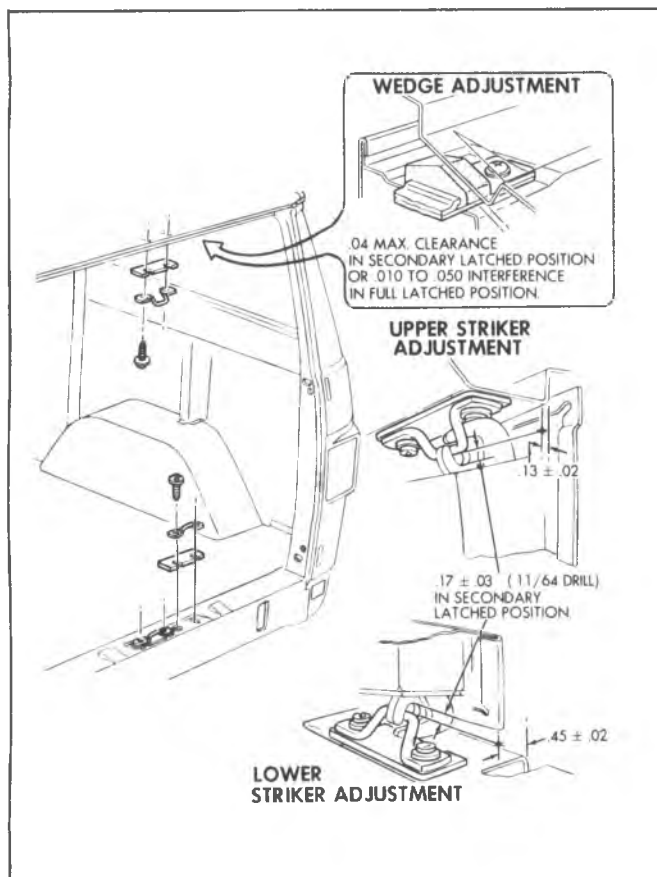


Fig. 2D-130-Rear Door Striker and Wedge Adjustment

REAR DOOR STRIKER AND WEDGE ADJUSTMENT

NOTICE: See NOTICE on page 1 of this section regarding Rear Door Striker fasteners.

1. Adjust striker by adding or deleting shims as necessary to obtain dimension as shown in figure 2D-130. This dimension can be checked by applying grease to the latch and slowly closing door until striker fully engages latch. Then open door and measure from grease impression to bottom of latch slot. Torque to specifications.

2. Adjust door wedge by adding or deleting shims as necessary so that wedge contact ramp on body when door is closed. See figure 2D-130.

SEATS

NOTICE: See NOTICE on page 1 of this section regarding fasteners used on seats and seat belts.

DRIVERS SEAT

Seat Adjuster

Replacement

1. Remove seat by removing nuts securing seat adjuster to seat riser.
2. Remove adjuster from seat. See figure 2D-131.
3. Install seat adjuster to seat. Torque bolts to specifications.
4. Install seat onto seat riser, and torque nuts to specifications.

SEAT RISER

Replacement

1. Remove seat and adjusters as an assembly by removing nuts securing seat to riser.
2. Remove nuts securing seat riser to floor.
3. Install seat riser to floor. Torque nuts to specifications.
4. Install seat and torque nuts to specifications.

PASSENGER SEAT-MOUNTING BRACKETS

Removal

1. Remove seat and brackets from seat riser. See figure 2D-132.
2. Remove brackets from seat.

Installation

1. Install brackets to seat. Torque to specifications.
2. Install seat to seat riser. Torque to specifications.

SEAT RISER

Removal

1. Remove seat and mounting bracket as an assembly.
2. Remove riser from floor.

Installation

1. Install riser to floor. Torque nuts to specifications.
2. Install seat riser. Torque nuts to specifications.

REAR BENCH SEATS

All models equipped with 2nd, 3rd and 4th bench seat assemblies feature a quick release mechanism which facilitates removal of the seats for added cargo space.

Instead of the conventional clamp and bolt method of seat retention, cam type latch assemblies and hooked retainers, which fit onto anchor pins in floor anchor plates

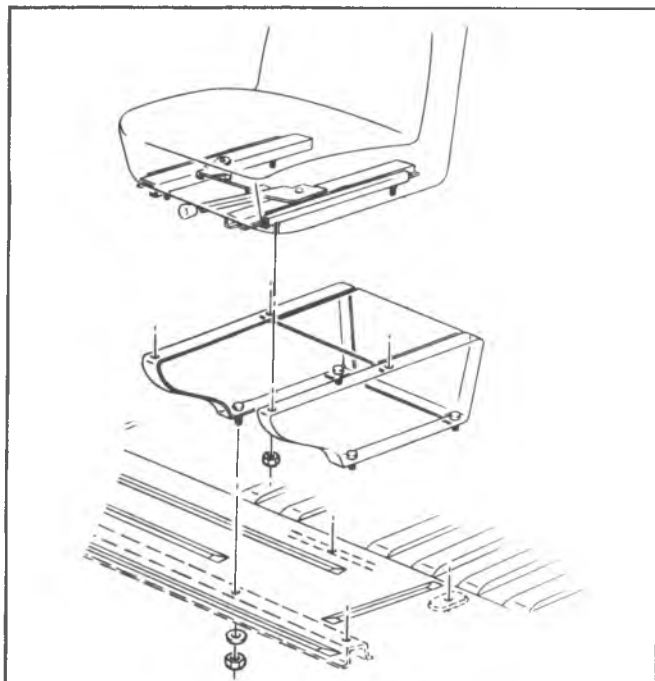


Fig. 2D-131—Driver's Seat

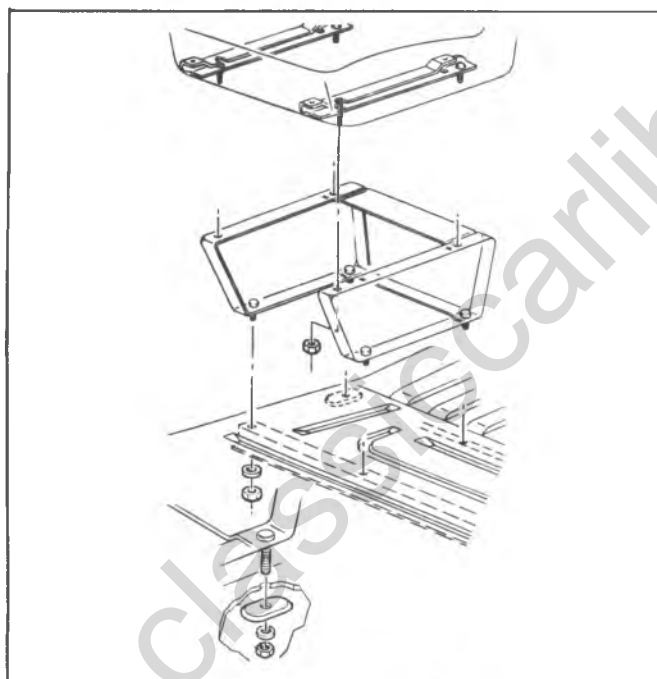


Fig. 2D-132—Passenger Seat

are used. When the latch assemblies are depressed, their cams and the hooks of the retainers are drawn tightly onto the anchor pins for secure seat attachment.

Removal is accomplished using the following procedure:

1. Pull up on quick release latches located at lower front of seat legs (right and left hand sides).
2. Tilt up front of seat and push seat rearward to clear anchor pins located beneath floor at front and rear of seat legs.
3. Lift seat up and remove from van.
4. To replace, reverse steps 1 to 3.

NOTICE: When replacing seats make sure that seat retainer hooks are fully engaged with anchor pins and latching assembly is fully depressed into place.

SWIVEL BUCKET SEATS - G MODELS

Refer to the illustration in Figure 2D-134 for swivel Bucket Seat Assembly installation.

ROOF VENT - G MODELS

Roof vent installation is illustrated in Figure 2D-135.

SERVICING LAP BELTS

Service precautionary items are outlined in the CK portion of this section.

Internal drive thread-forming anchor bolts are used to secure lap belts to the floor pan. To remove or install internal drive anchor bolts, use door lock striker and lap belt anchor bolt removal tool J-23457 or equivalent. Start bolt by hand to assure that bolt is threaded straight.

Refer to figures 2D-136 through 2D-138 and select the appropriate illustration for removing and installing lap belts.

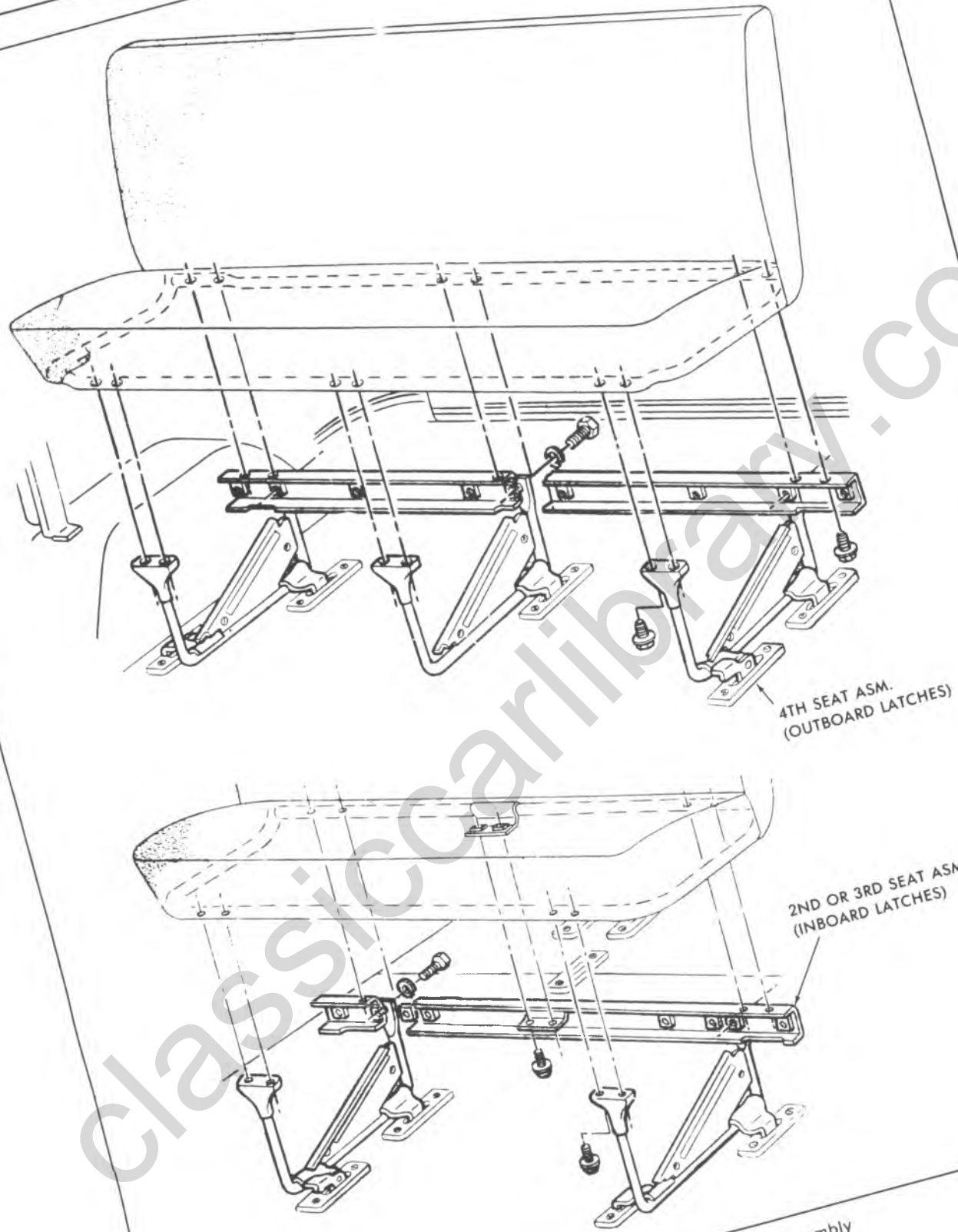


Fig. 2D-133-Quick Release Seat Assembly

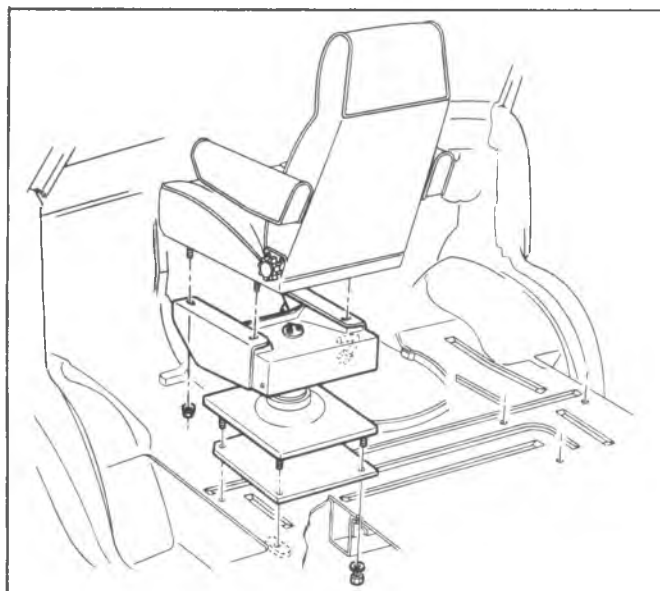


Fig. 2D-134--Swivel Bucket Seat Assembly - G Series

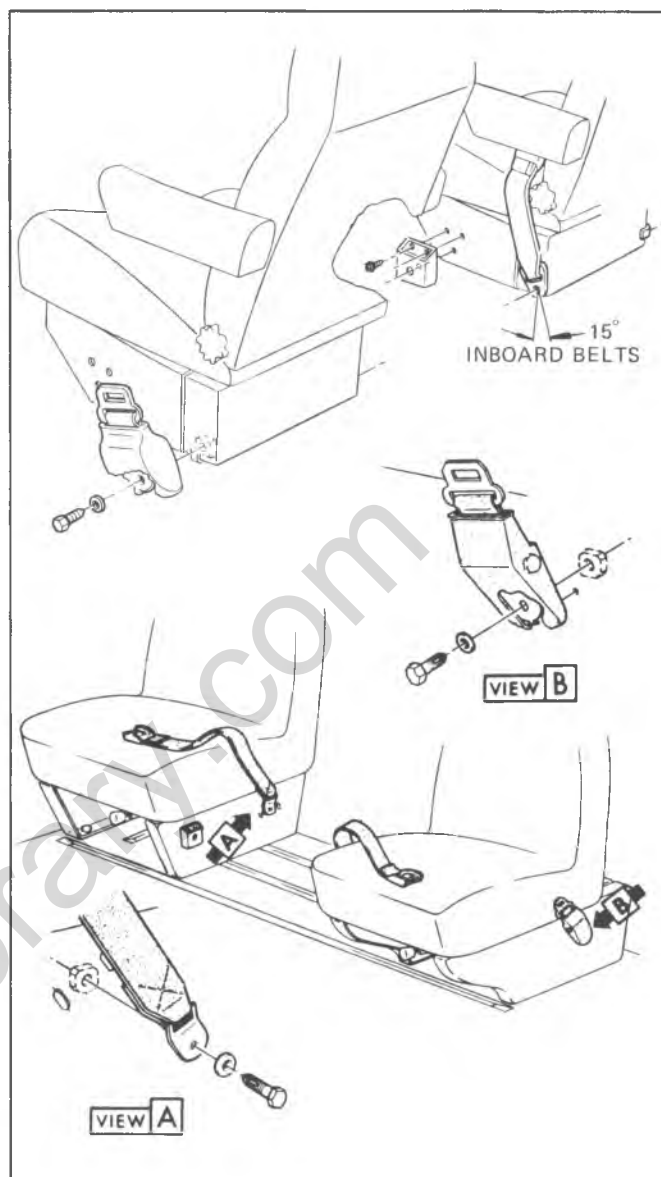


Fig. 2D-136--Front Lap Belt Installation

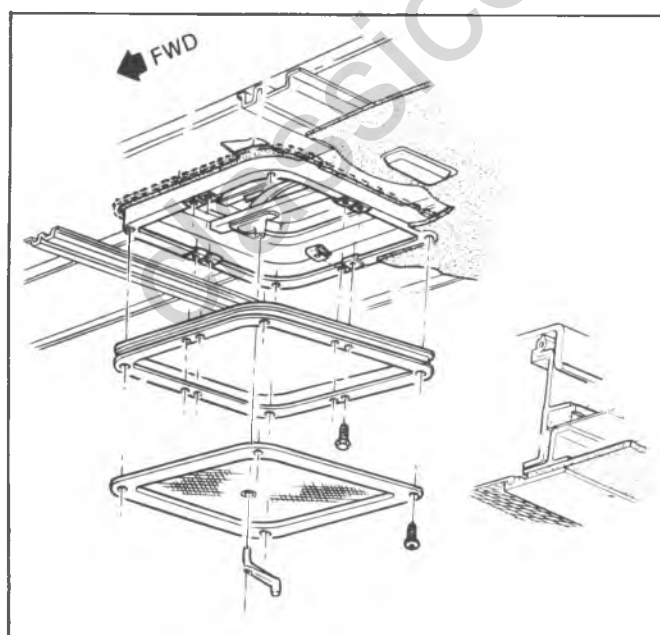


Fig. 2D-135--Roof Vent - G Series

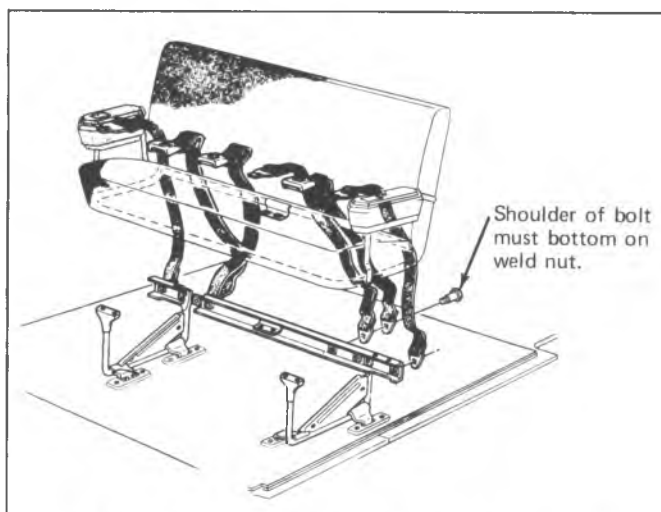


Fig. 2D-137--2nd and 3rd Seat Lap Belt Installation

BODY MOUNTING (C-K MODELS)--FT. LBS.

| Model | #1 | #2 | #3 | #4 | #5 | #6 |
|-------|----|----|----|----|----|----|
| (03) | 45 | 45 | — | — | — | — |
| (06) | 35 | 35 | — | 35 | — | 35 |
| (14) | 55 | 45 | 35 | 35 | — | — |
| (63) | 55 | 35 | 55 | — | — | — |

G MODELS

MIRRORS AND SUNSHADE

- Inside Rear View Mirror to Bracket 15 in. lb.
- Outside Rear View Mirror to Panel 40 in. lb.
- Sunshade Support to Header Panel 15 in. lb.

SIDE WINDOW (SWINGOUT)

- Latch to Body 40 in. lb.
- Latch to Glass 40 in. lb.
- Hinge to Body 40 in. lb.

FRONT SIDE DOORS

- Door Hinges 30 ft. lb.
- Door Hinge Access Hole Cover 18 in. lb.
- Door Lock Striker 45 ft. lb.
- Door Lock to Door 20 ft. lb.
- Outside Door Handle 45 in. lb.

REAR DOOR

- Hinge Strap to Door 45 in. lb.
- Hinge Strap Bracket to Body 45 in. lb.
- Hinge (to body and door) 30 ft. lb.
- Remote Control Retaining Screws 85 in. lb.
- Latch-to-Door Retaining Screws 90 in. lb.
- Door Strikers-to-Body 90 in. lb.
- Outside Door Handle 45 in. lb.

SLIDING SIDE DOOR

- Remote Control (front latch) to Door 90 in. lb.
- Rear Latch to Door 90 in. lb.
- Rear Plate to Door 90 in. lb.
- Lower Front Roller and Roller Support
 - Support-to-Door 24 ft. lb.
 - Support to Roller Bracket 24 ft. lb.
 - Roller to Roller Bracket 20 ft. lb.
 - Catch to Roller Bracket 45 in. lb.
- Upper Front Roller Bracket
 - Bracket to Door 24 ft. lb.
 - Roller to Bracket 20 ft. lb.
- Upper Left Hinge (Door Half)
 - Hinge to Door 25 ft. lb.
- Upper Left Hinge (Body Half)
 - Roller to Hinge 20 ft. lb.
 - Guide Block to Hinge 40 in. lb.
 - Lever Arm-to-Hinge Retaining Nut 120 in. lb.
 - Lever Retaining Screw 40 in. lb.
 - Striker to Body 20 ft. lb.
- Rear Striker Bolt (Body Mounted) 45 ft. lb.
- Front Striker Retaining Screws (Body Mounted) 90 in. lb.

SEATS

- Seat Belt to Seat 37 ft. lb.
- Passenger and Drivers
 - Seat to Adjuster (Mounting Bracket) 18 ft. lb.
 - Seat to Riser 18 ft. lb.
 - Seat Riser-to-Floor 50 ft. lb.
- Bench Seats
 - Seat to Seat Support 18 ft. lb.
 - Seat Support to Floor Clamps 40 ft. lb.

SPECIAL TOOLS

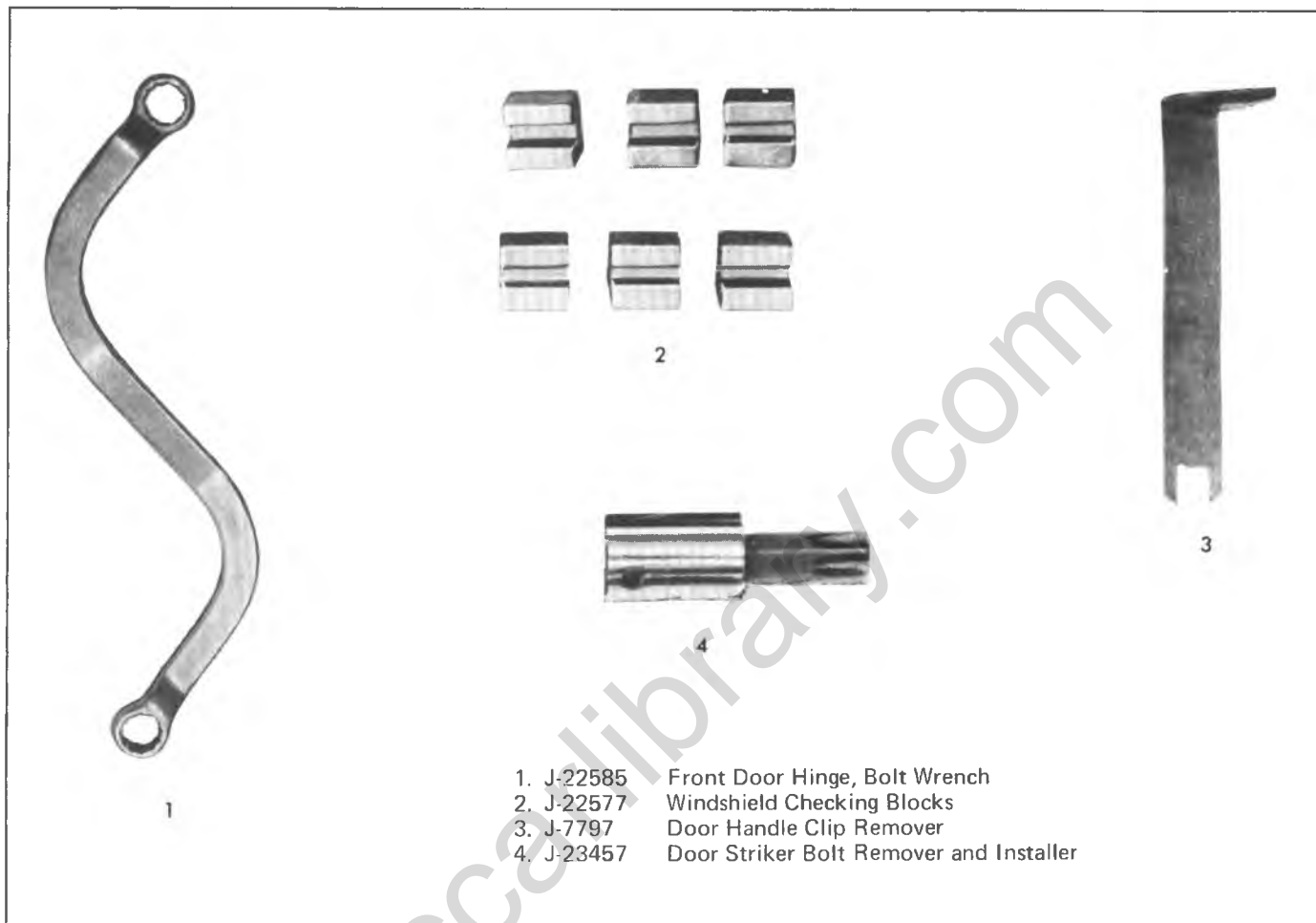


Fig. 2D-139--Special Tools

classicalcarlibrary.com

SECTION 3A

FRONT ALIGNMENT

CONTENTS

| | |
|-----------------------------------|------|
| General Description | 3A-1 |
| Maintenance and Adjustments | 3A-2 |
| Specifications | 3A-6 |

GENERAL DESCRIPTION

FRONT ALIGNMENT

The term "front alignment" refers to the angular relationships between the front wheels, the front suspension attaching parts and the ground.

The pointing in or "toe-in" of the front wheels, the tilt of the front wheels from vertical (when viewed from the front of the vehicle) and the tilt of the suspension members from vertical (when viewed from the side of the vehicle), all these are involved in front alignment. The various factors that enter into front alignment are covered here each one under its own heading.

CASTER

Caster is the tilting of the front steering axis either forward or backward from the vertical (when viewed from the side of the vehicle). A backward tilt is said to be positive (+) and a forward tilt is said to be negative (-).

On the short and long arm type suspension you cannot see a caster angle without a special instrument, but you can understand that if you look straight down from the top of the upper control arm to the ground you would find that the ball joints do not line up (fore and aft) when a caster angle other than 0° is present. If you had a positive caster angle the lower ball joint would be slightly ahead (toward the front of the vehicle) of the upper ball joint center line. In short then, caster is the forward or backward tilt of the steering axis as viewed from a side elevation. Caster is designed into the front axle assembly on all K series vehicles (four-wheel drive), and is non-adjustable. See caster copy under ADJUSTMENTS.

CAMBER

Camber is the tilting of the front wheels from the vertical when viewed from the front of the vehicle. When the wheels tilt outward at the top, the camber is said to be positive (+). When the wheels tilt inward at the top, the camber is said to be negative (-). The amount of tilt is measured in degrees from the vertical and this measurement is called the camber angle. Camber is designed into the front axle assembly of all K series vehicles and is non-adjustable. See camber copy under ADJUSTMENTS.

TOE-IN

Toe-in is the turning in of the front wheels. The actual amount of toe-in is normally only a fraction of an inch. The purpose of a toe specification is to ensure parallel rolling of the front wheels. (Excessive toe-in or toe-out will cause tire wear). Toe-in also serves to offset the small deflections of the wheel support system which occurs when the vehicle is rolling forward. In other words, even when the wheels are set to toe-in slightly when the vehicle is standing still, they tend to roll parallel on the road when the vehicle is moving. See toe-in copy under ADJUSTMENTS.

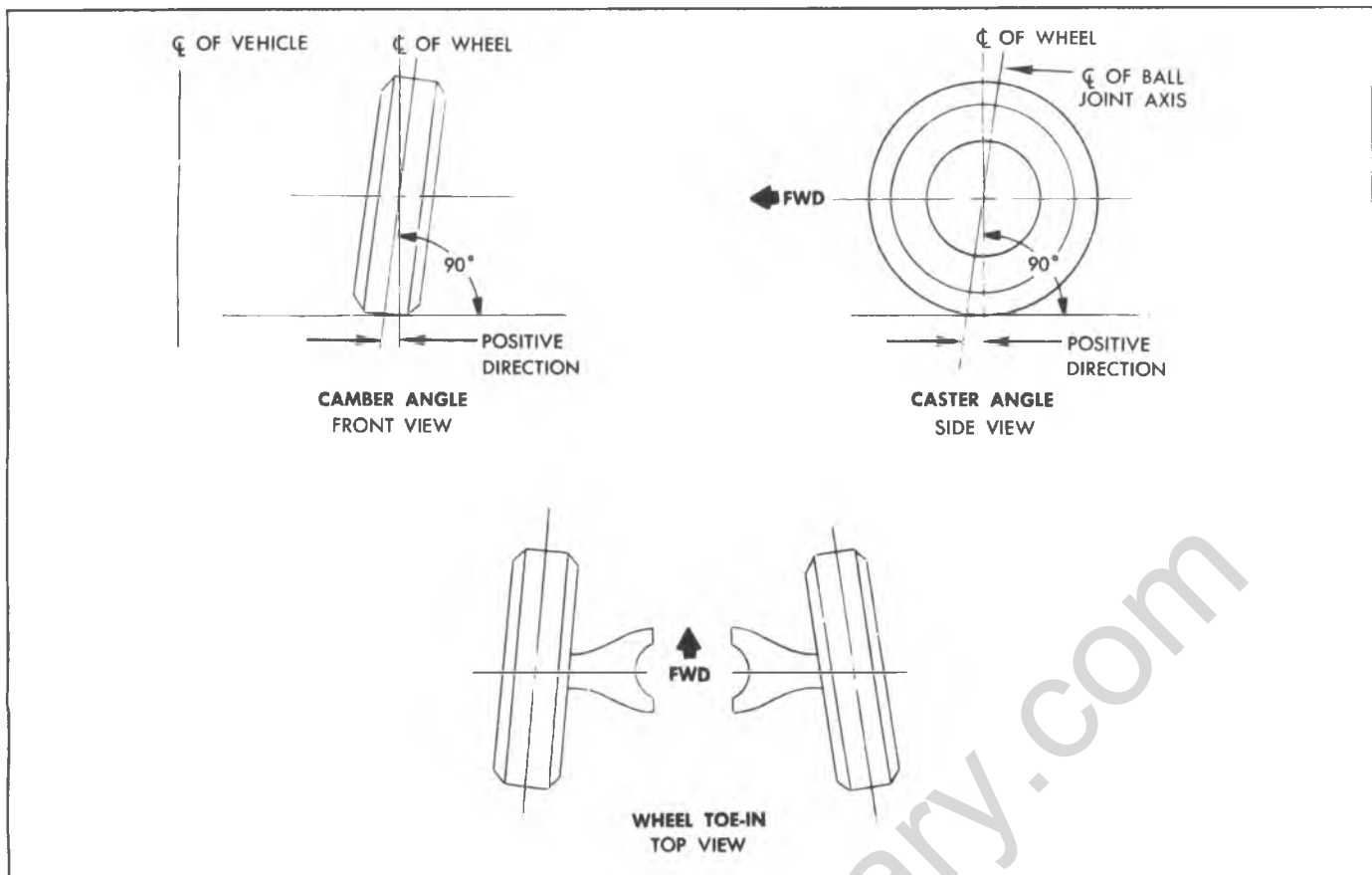


Fig. 3A-1-Caster - Camber - Toe-In

MAINTENANCE AND ADJUSTMENTS

PRELIMINARY CHECKS PRIOR TO ADJUSTING FRONT ALIGNMENT

Before making any adjustment affecting caster, camber or toe-in, the following checks and inspections should be made to insure correctness of alignment readings and alignment adjustments.

1. Check all tires for proper inflation pressures and approximately the same tread wear.
2. Check front wheel bearings for looseness (.001-.008 end play is correct) and adjust if necessary.
3. Check for looseness of ball joints, tie rod ends and steering relay rods; if excessive looseness is noted, it must be corrected before adjusting.
4. Check for run-out of wheels and tires.
5. Check vehicle trim heights; if out of specifications and a correction is to be made, the correction must be made before adjusting caster, camber or toe-in.
6. Check for steering gear looseness at frame.
7. Check for improperly operating shock absorbers.
8. Check for loose control arms.
9. Check for loose or missing stabilizer bar attachments.

10. Consideration must be given to excess loads, such as tool boxes. If this excess load is **normally** carried in the vehicle, it should remain in the vehicle during alignment checks.

11. Consider the condition of the equipment being used to check alignment and follow the manufacturer's instructions.

12. Regardless of equipment used to check alignment, the vehicle must be on a level surface both fore and aft and transversely.

13. Steering and vibration complaints are not always the result of improper alignment. An additional item to be checked is the possibility of tire lead due to worn or improperly manufactured tires. "Lead" is the deviation of the vehicle from a straight path on a level road without hand pressure on the steering wheel. Section 3E of this manual, "Wheels and Tires", contains a procedure for determining the presence of a tire lead problem.

FRONT ALIGNMENT REQUIREMENTS

Satisfactory vehicle operation may occur over a wide range of front end wheel alignment settings. Nevertheless, should settings vary beyond certain tolerances, readjustments of alignment is advisable. The specifications stated in column 1 of the chart in the specifications section

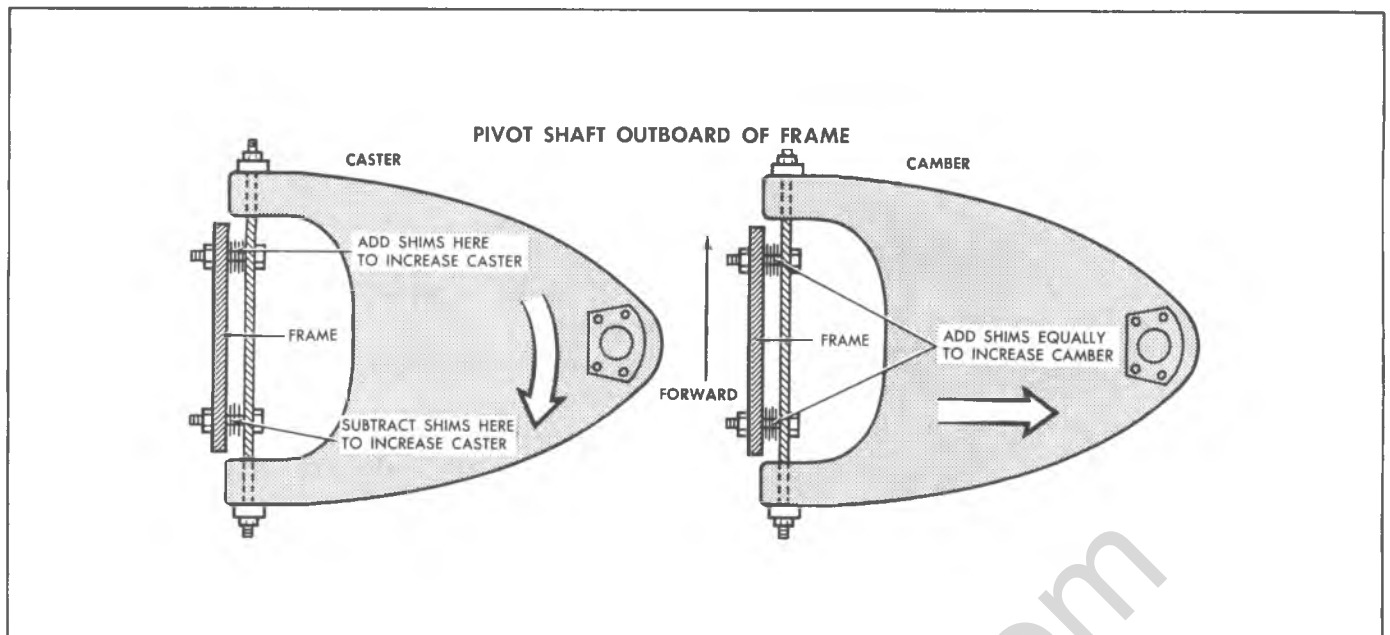


Fig. 3A-2-Caster - Camber Adjustment

of this manual should be used by owners, dealers and repairmen as guidelines in vehicle diagnosis either for repairs under the new vehicle warranty or for maintenance service at customer's request. These specifications provide an acceptable all-around operating range in that they prevent abnormal tire wear caused by wheel alignment.

Governmental Periodic Motor Vehicle Inspection programs usually include wheel alignment among items that are inspected. To provide useful information for such inspections, the specifications stated in column 2 of the wheel alignment chart are given and these are well within the range of safe vehicle operation.

In the event the actual settings are beyond the specifications set forth in column 1 or 2 (whichever is applicable), or whenever for other reasons the alignment is being reset, the specifications given in column 3 of the wheel alignment chart should be used.

It is good practice to set front end alignment to specifications while the vehicle is in its **normally loaded** condition. Trucks which are **consistently operated with heavy loads should have toe-in adjusted with the truck under heavy load**. This procedure should result in longer tire life.

ALIGNMENT ADJUSTMENTS

A normal shim pack will leave at least two (2) threads of the bolt exposed beyond the nut. If two (2) threads cannot be obtained, check for damaged control arms and related parts. The difference between front and rear shim packs must not exceed 7.62mm (.30 inches). Front shim pack must be at least 2.54mm (.10 inches).

Access to Shim Packs

G10-20 Models, C10 Models with 3/4" Nut:

With vehicle on front end rack, jack at frame and raise the wheel off the ground. This will allow the upper control arm to pivot down far enough to use a socket on the nuts and permit shim removal.

G30 Models, C20 and 30 Models with 7/8" Nut:

Remove the upper control arm bumper; then follow the same procedure as above. Reinstall the upper control arm bumper when alignment is completed.

Caster

All caster specifications are given assuming a frame angle of zero. Therefore, it will be necessary to know the angle of the frame (whether "up" in rear or "down" in rear) before a corrected caster reading can be determined. Camber and toe can be read "as is" from the alignment equipment.

How to Determine Caster (Fig. 3A-4)

All caster specifications are given assuming vehicle frame angle is zero. Therefore, it is necessary to adjust specifications when applying them to vehicles with any frame angle other than zero.

1. With vehicle on a level surface, determine frame angle (whether up or down in rear) with the use of a bubble protractor or inclinometer. Record this measurement (See Figure 4).
2. Measure dimension "A" (See Figure 4).
3. Check and record specifications for caster under that column related to dimension "A" as measured in step 2.
4. Using one of the following rules, add or subtract frame angle found in step 1 to or from specification found in step 3.
 - a. A down-in-rear frame angle must be added to a positive caster specification.
 - b. An up-in-rear frame angle must be subtracted from a positive caster specification.
 - c. A down-in-rear frame angle must be subtracted from a negative caster specification.
 - d. An up-in-rear frame angle must be added to a negative caster specification.

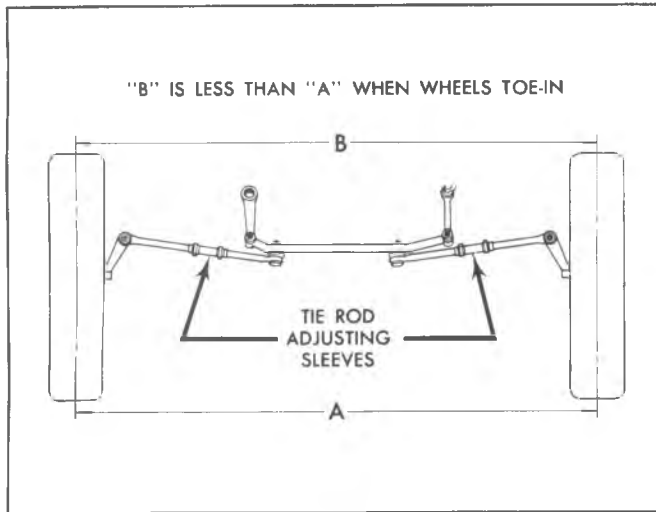


Fig. 3A-3--Toe-In Adjustment

Vehicle caster specification should be adjusted to answer arrived at in step 4.

Camber

1. Determine the camber angle from the alignment equipment.
2. Add or subtract shims from both the front and rear bolts to affect a change.

Toe-In

1. Determine the wheel toe-in from the alignment equipment.
2. Change the length of both tie rod sleeves to affect a toe change.

Toe-in can be increased or decreased by changing the length of the tie rods. A threaded sleeve is provided for this purpose.

When the tie rods are mounted ahead of the steering knuckle they must be decreased in length in order to increase toe-in. When the tie rods are mounted behind the steering knuckle they must be lengthened in order to increase toe-in.

See Section 3B for proper tie rod clamp orientation and positioning.

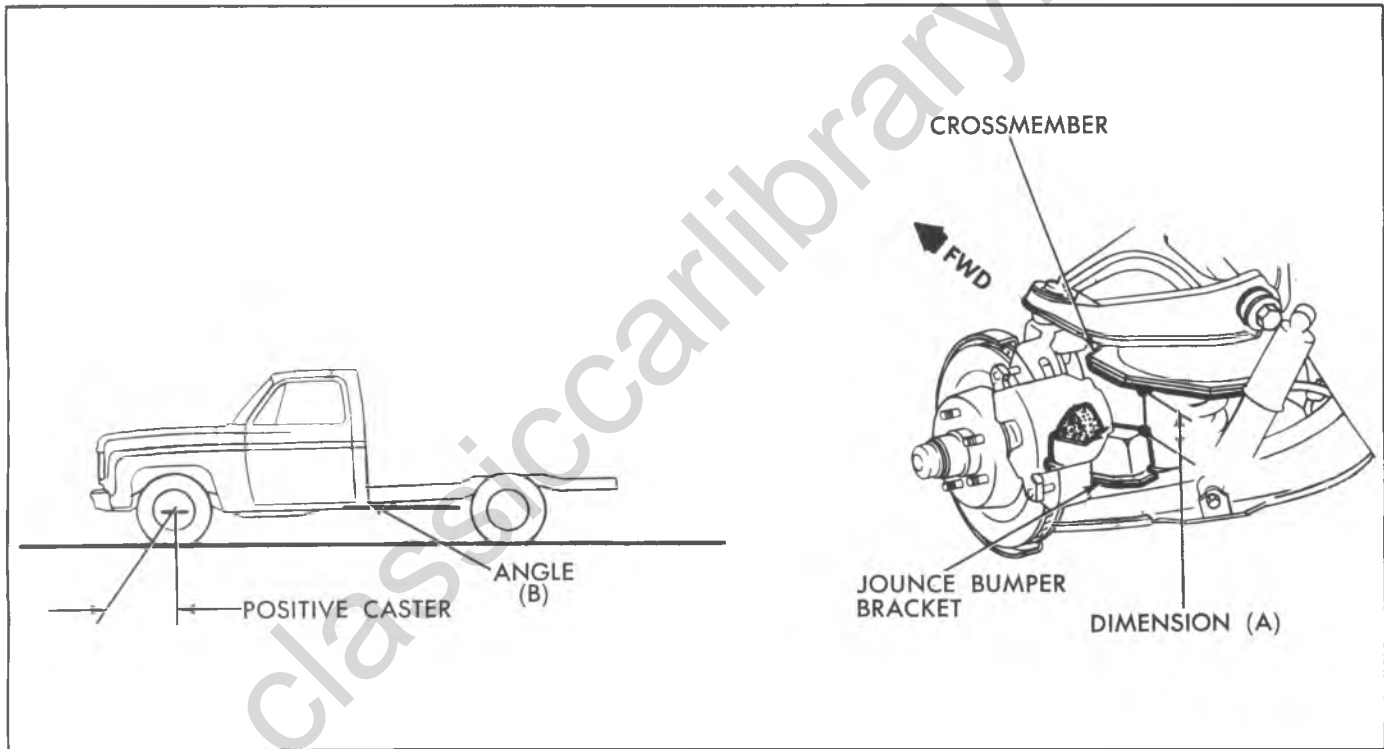


Fig. 3A-4--Determining Caster

SPECIFICATIONS

WHEEL ALIGNMENT SPECIFICATIONS CASTER

DIMENSION "A"

| | | | | | | | | | | | | |
|--|--------------------------------|------|------|------|------|------|-------|-------|-------|-------|-------|-------|
| MODELS (mm) | 2½" | 2¾" | 3" | 3¼" | 3½" | 3¾" | 4" | 4¼" | 4½" | 4¾" | 5" | |
| | 63.5 | 69.8 | 76.2 | 82.5 | 89.0 | 95.2 | 102.0 | 107.9 | 114.3 | 121.6 | 127.0 | |
| C10 | 2.4° | 2.1° | 1.8° | 1.5° | 1.2° | 1.0° | 0.7° | 0.5° | 0.2° | 0.1° | 0.3° | |
| C20, 30 | 1.5° | 1.2° | 0.9° | 0.6° | 0.3° | 0.1° | 0° | -0.1° | -0.7° | -1.0° | -1.2° | |
| K10,20,30 | (8°) (NO ADJUSTMENT PROVISION) | | | | | | | | | | | |
| (mm) | 1½" | 1¾" | 2" | 2¼" | 2½" | 2¾" | 3" | 3¼" | 3½" | 3¾" | 4" | 4¼" |
| | 38.0 | 44.4 | 51.0 | 57.1 | 63.5 | 69.8 | 76.2 | 82.5 | 89.0 | 95.2 | 102.0 | 107.9 |
| G10, 20 | 3.5° | 3.3° | 3.1° | 2.9° | 2.7° | 2.6° | 2.4° | 2.2° | 2.1° | 1.9° | 1.8° | 1.6° |
| G30 | 2.8° | 2.5° | 2.2° | 1.9° | 1.6° | 1.3° | 1.0° | .7° | .5° | .2° | 0° | -0.2° |
| (mm) | 2½" | 2¾" | 3" | 3¼" | 3½" | 3¾" | 4" | 4¼" | 4½" | 4¾" | 5" | |
| | 63.5 | 69.8 | 76.2 | 82.5 | 89.6 | 95.2 | 102.0 | 107.9 | 114.3 | 120.6 | 127.0 | |
| P10 | 2.3° | 2.0° | 1.7° | 1.5° | 1.2° | 0.9° | 0.6° | 0.4° | 0.1° | -0.1° | -0.3° | |
| (mm) | 2" | 2¼" | 2½" | 2¾" | 3" | 3¼" | 3½" | 3¾" | 4" | 4¼" | 4½" | 4¾" |
| | 51.0 | 57.1 | 63.5 | 69.8 | 76.2 | 82.5 | 89.0 | 95.2 | 102.0 | 107.9 | 114.3 | 120.6 |
| *P20, 30 | 2.9° | 2.6° | 2.3° | 2.0° | 1.7° | 1.4° | 1.2° | 0.9° | 0.6° | 0.4° | 0.2° | 0.1° |
| * ADD .3° WITH JB8 OR JF9 SUBTRACT .4° WITH R05 | | | | | | | | | | | | |
| MOTOR HOME (32) (mm) | 2½" | 2¾" | 3" | 3¼" | 3½" | 3¾" | 4" | 4¼" | 4½" | 4¾" | 5" | |
| | 63.5 | 69.8 | 76.2 | 82.5 | 89.0 | 95.2 | 102.0 | 107.9 | 114.3 | 120.6 | 127.0 | |
| | 5.5° | 5.3° | 5.0° | 4.7° | 4.4° | 4.1° | 3.8° | 3.6° | 3.3° | 3.1° | 2.9° | |

| CAMBER | |
|-----------------|--------------------------------|
| MODEL | |
| C10, 20, 30 | .2° |
| K10, 20 | 1.0° (NO ADJUSTMENT PROVISION) |
| K30 | .5° (NO ADJUSTMENT PROVISION) |
| G10, 20 | .5° |
| G30 | .2° |
| P10, 20, 30 | .2° |
| MOTOR HOME (32) | .2° |

| ALIGNMENT TOLERANCES | | | |
|----------------------|--------------------------------|---------------------|--|
| | Warranty Repair Checking | Resetting Target | Periodic Motor Vehicle Inspection |
| Caster | ± 1° | ± 0.5° | ± 2° |
| Camber | ± 0.7° | ± 0.5° | ± 1.5° |
| Toe-In | ± 1/8" (3.2 mm) | ± 1/16" (1.6 mm) | ± 3/8" (9.5 mm) |

| TOE-IN | |
|------------------------|----------------|
| C10, C20, C30 | 3/16" (4.7 mm) |
| K10, K20, K30 | 0 |
| G10, G20, G30 | 3/16" (4.7 mm) |
| P10, P20, P30 | 3/16" (4.7 mm) |
| MOTOR HOME P30 (32) | 5/16" (7.9 mm) |

Specs Page

classiccaryllibrary.com

SECTION 3B1

STEERING LINKAGE

The following notice applies to one or more steps in the assembly procedure of components in this portion of the manual as indicated at appropriate locations by the terminology "See Notice on page 1 of this Section".

NOTICE: These fasteners are important attaching parts in that they could affect the performance of vital components and systems, and/or could result in major repair expense. They must be replaced with one of the same part number or with an equivalent part if replacement

becomes necessary. Do not use a replacement part of lesser quality or substitute design. Torque values must be used as specified during reassembly to assure proper retention of these parts. For prevailing torque nut(s) and bolt(s), refer to the "Reuse of Prevailing Torque Nut(s) and Bolt(s)" chart in section 10.

CONTENTS

| | |
|-----------------------------------|-------|
| General Description | 3B1-1 |
| Diagnosis | 3B1-1 |
| Maintenance and Adjustments | 3B1-4 |
| On-Vehicle Service | 3B1-4 |
| Tie Rods | 3B1-4 |
| Relay Rod | 3B1-8 |
| Idler Arm | 3B1-8 |
| Pitman Arm | 3B1-9 |
| Steering Connecting Rod | 3B1-9 |

GENERAL DESCRIPTION

The steering linkage is located forward of the front crossmember. Refer to Fig. 3B1-1, for a typical system. Steering effort is transmitted to left and right hand adjustable tie rods through a relay rod. The relay rod is connected to an idler arm on the right and to the pitman arm on the left.

DIAGNOSIS

Reference should be made to the correct method of disassembly, repair, adjustment and reassembly. Damaged, broken or deformed parts must be replaced with the correct replacement.

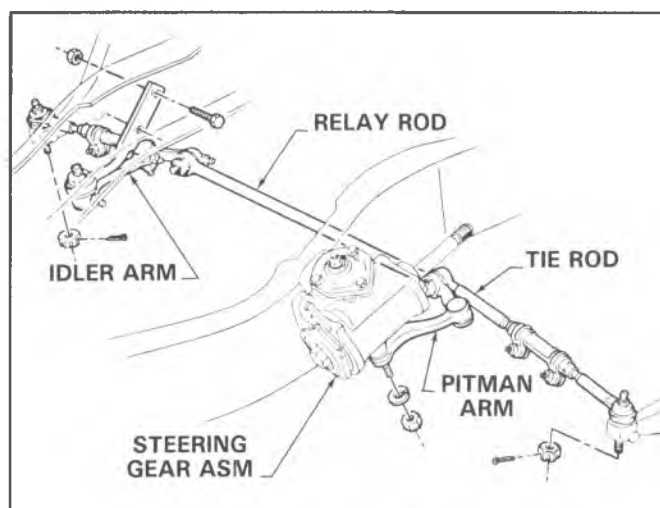


Fig. 3B1-1--Typical Steering Linkage

| CONDITION | POSSIBLE CAUSE | CORRECTION |
|--|--|--|
| <p>Excessive Play or Looseness in Steering System.</p> | <p>Front wheel bearings loosely adjusted.</p> <p>Worn steering shaft couplings.</p> <p>Worn upper ball joints.</p> <p>Steering wheel loose on shaft, loose pitman arm, tie rods, steering arms or steering linkage ball studs.</p> <p>Steering gear thrust bearings loosely adjusted.</p> <p>Excessive over-center lash in steering gear.</p> <p>Worn intermediate rod or tie rod sockets.</p> | <p>Adjust bearings to obtain proper end play.</p> <p>Replace part.</p> <p>Check and replace if necessary.</p> <p>Tighten to specified torque, or replace if necessary.</p> <p>Adjust preload to specification.</p> <p>Adjust preload to specification.</p> <p>Replace worn part.</p> |
| <p>Excessive looseness in tie rod or intermediate rod pivots, or excessive vertical lash in idler support.</p> | <p>Seal damage and leakage resulting in loss of lubricant, corrosion and excessive wear.</p> | <p>Replace damaged parts as necessary. Properly position upon reassembly.</p> |

Fig. 3B1-2--Steering Linkage Diagnosis Chart A

| CONDITION | POSSIBLE CAUSE | CORRECTION |
|---|--|---|
| <p>Hard Steering – Excessive Effort Required at Steering Wheel.</p> | <p>Low or uneven tire pressure.</p> <p>Steering linkage or bolt joints need lubrication.</p> <p>Tight or frozen intermediate rod, tie rod or idler socket.</p> <p>Steering gear to column misalignment.</p> <p>Steering gear adjusted too tightly.</p> <p>Front wheel alignment incorrect. (manual gear)</p> | <p>Inflate to specified pressures.</p> <p>Lube with specified lubricant.</p> <p>Lube replace or reposition as necessary.</p> <p>Align column.</p> <p>Adjust over-center and thrust bearing preload to specification.</p> <p>Check alignment and correct as necessary.</p> |
| <p>Poor Returnability.</p> | <p>Steering linkage or ball joints need lubrication.</p> <p>Steering gear adjusted too tightly.</p> <p>Steering gear to column misalignment.</p> <p>Front wheel alignment incorrect. (Caster)</p> | <p>Lube with specified lubricant.</p> <p>Adjust over-center and thrust bearing preload to specifications.</p> <p>Align column.</p> <p>Check alignment and correct as necessary.</p> |

Fig. 3B1-3--Steering Linkage Diagnosis Chart B

MAINTENANCE AND ADJUSTMENTS

LUBRICATION

LUBRICATION OF STEERING LINKAGE

The steering linkage under normal conditions should be lubricated with any water resistant EP type chassis lubricant every 7,500 miles (12 000 km) or six months, whichever occurs first. Lubricate every 3,000 miles (4 800 km) or two months whichever occurs first when operating in dusty or muddy conditions or if the vehicle is used "off-road". Lubrication points and additional information on the chassis lubricant recommended can be found in Section 0--General Information and Lubrication.

STEERING DAMPER CHECK

(Fig. 3B1-4)

This type of steering damper is nonadjustable, nonrefillable and is not repairable. At each lubrication interval make check #1 and #2 on the steering damper system.

1. **Inspecting Damper Mountings** : Check the damper attachments to be sure they are properly and securely installed. (Tighten, if loose). Replace the damper assembly if the rubber bushings are badly worn.

2. **Inspecting Damper For Leaks** : Inspect the damper for evidence of fluid leakage. A light film of fluid is permissible on the body of the damper near the shaft seal. A dripping damper should be replaced.

If a Functional or Noise Complaint is Reported, Make the Following Inspections:

3. **Inspecting Damper For Noise** : Disconnect the frame or axle end of the damper. Extend and compress the damper using as much travel as possible. The damper action should be smooth throughout each stroke.

4. **Inspecting Damper For Functioning**: While checking the damper in step (3) above, observe the operation of the damper for fluid leakage, effort and lag. Items from this check that require damper replacement are:

- A. Any fluid leakage during this check.
- B. Seizing or binding condition during travel of damper.
- C. A skip or lag at reversal near mid-stroke of damper.

5. Reinstall Disconnected End of Damper Using Proper Torque.

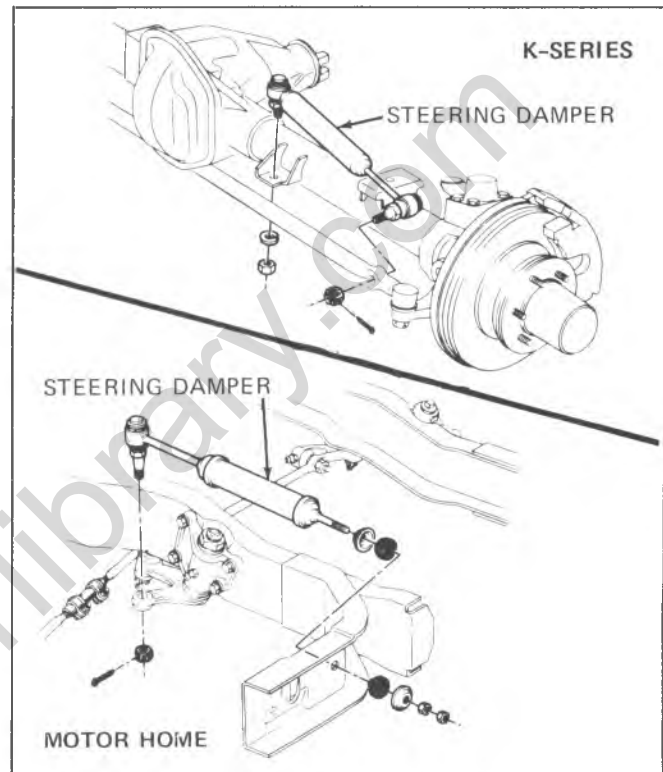


Fig. 3B1-4-Steering Dampers

ON-VEHICLE SERVICE

NOTICE: See NOTICE on page 1 of this section regarding all fasteners referred to in servicing steering linkage components.

TIE RODS

Removal

1. Raise vehicle on hoist.
2. Remove nuts from ball studs. The inner tie rod ends use crimp nuts, while the outer ends use castellated nuts and cotter pins.
3. To remove outer ball stud, tap on steering arm at tie rod end with a hammer while using a heavy hammer or

similar tool as a backing (Fig. 3B1-7).

4. Remove inner ball stud from relay rod using same procedure as described in Step 3.

5. To remove tie rod ends from tie rod, loosen clamp bolts and unscrew end assemblies.

Installation

NOTICE: See the NOTICE on page 1 of this section regarding the fasteners referred to in steps 4 and 6.

Tie rod adjuster components often become rusted in service. In such cases, it is recommended that if the torque required to remove the nut from the bolt after breakaway

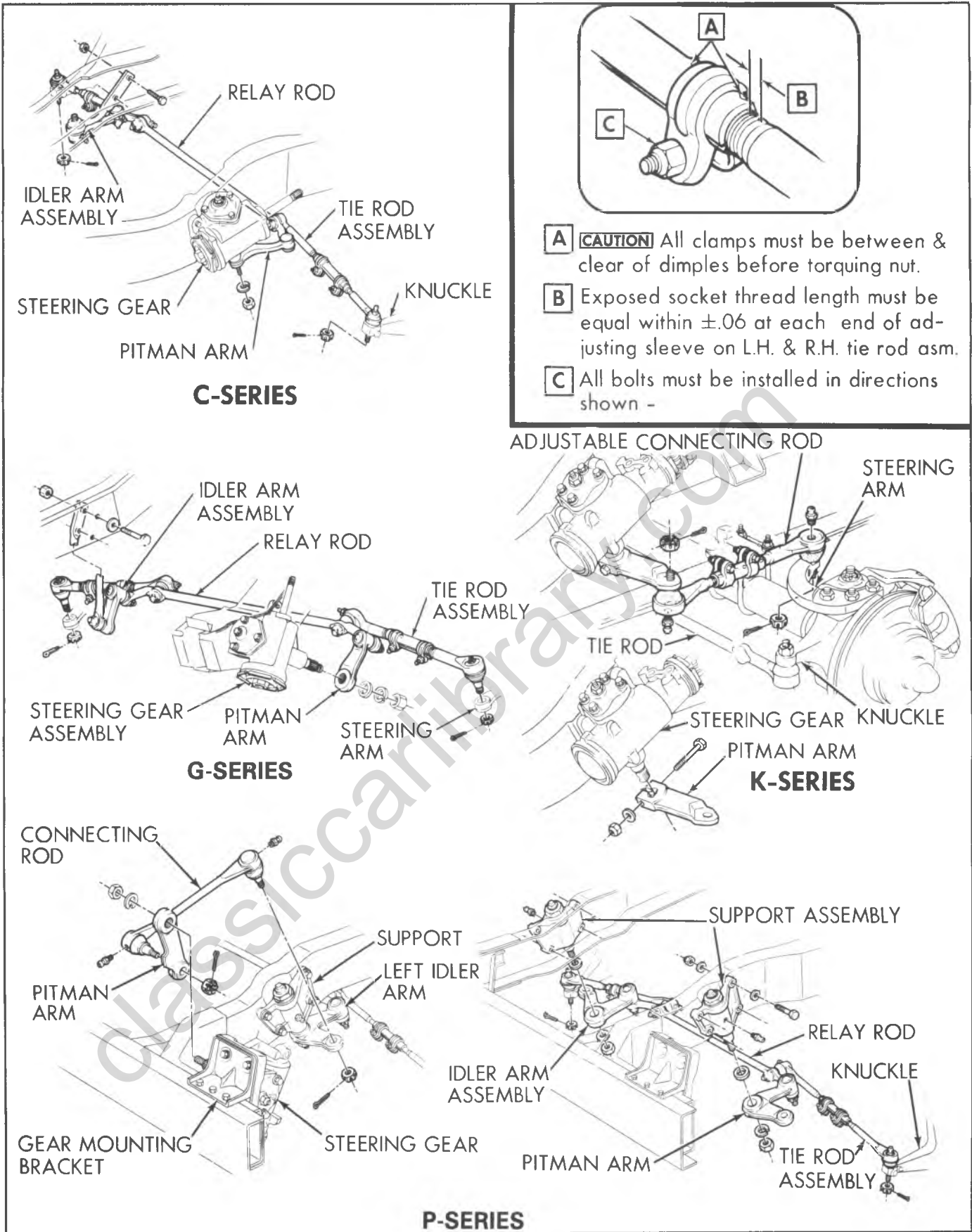


Fig. 3B1-5--Steering Linkage

3B1-8 STEERING LINKAGE

1. Check the total rotation of the tie rod assembly using the following procedure:

- a. Lubricate inner and outer tie rod ends.
- b. Attach vise grip pliers to the outer tie rod end.
- c. Rotate outer tie rod end counterclockwise (up) to maximum position. Attach bevel protractor as shown in Figure 3B1-9. Center protractor bubble indicator and record reading.

d. Rotate tie rod end clockwise (down) to maximum position. Center protractor bubble indicator and record reading.

e. Compare protractor readings obtained in Steps c and d. Total rotation of tie rod assembly should measure at least 35°.

f. If rotation is less than 35°, loosen one tie rod sleeve clamp and rotate both tie rod ends to their maximum limit **both ends must be rotated in the same direction**

g. Tighten tie rod clamp and again rotate both ends to their maximum limits, repeating Steps c and d. This recheck of total rotation will result in a minimum of 35° travel.

h. After obtaining the correct amount of rotation (35° or greater), position the outer tie rod end approximately midway in this travel.

If rotating checks, outlined above, reveal a rough or lumpy feel, the inner or outer tie rod end assembly may have excessive wear and should be replaced.

If all of the above mentioned conditions are met, proper tie rod installation is assured.

RELAY ROD

Removal

1. Raise vehicle on hoist.
2. Remove inner ends of the tie rods from relay rod as described under "Tie Rod-Removal".
3. Remove the nuts from the pitman and idler arm ball studs at the relay rod.
4. Remove the relay rod from the pitman and idler arms by tapping on the relay rod ball stud bosses with a hammer, while using a heavy hammer as a backing (Fig. 3B1-7).
5. Remove the relay rod from the vehicle.

Installation

NOTICE: See the NOTICE on page 1 of this section regarding the fasteners referred to in steps 2 and 3.

1. Make sure that threads on the ball studs and in the ball stud nuts are clean and smooth. If threads are not clean and smooth, ball studs may turn in sockets when attempting to tighten nut. Check condition of ball stud seals; replace if necessary.

2. Install the relay rod to the idler arm and pitman arm ball studs, making certain the seals are in place. Use J-23193 or J-23194 to seat the tapers, as shown in Fig. 3B1-6. A torque of 20 N·m is required. With the tapers seated, remove the tool. Install and tighten a torque prevailing to 54 N·m (40 ft. lbs.).

3. Install the tie rods to the relay rod as previously described under "Tie Rod- Installation". Lubricate the tie rod ends.

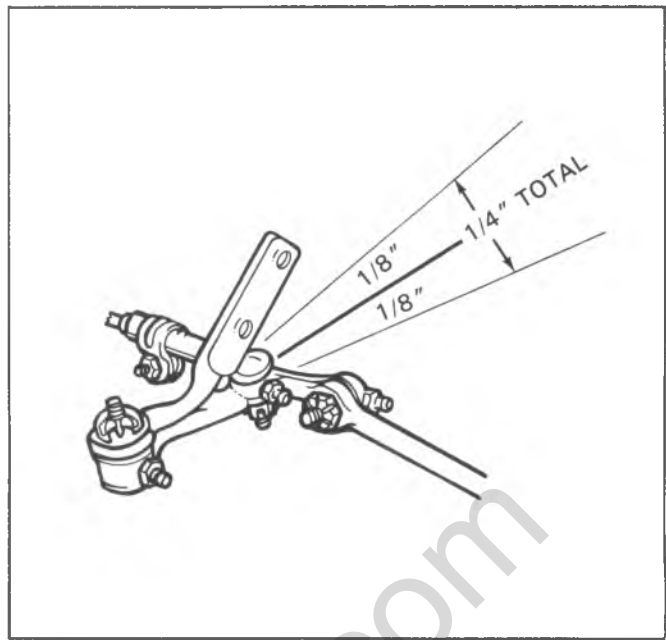


Fig. 3B1-10--Checking Idler Movement, Typical

4. Lower the vehicle to the floor.

5. Adjust toe-in (see Section 3A) and align steering wheel as described previously in Section 3B4 under "Steering Wheel Alignment and High Point Centering".

IDLER ARM

Use of the proper diagnosis and checking procedure is essential to prevent needless replacement of good idler arms.

1. Raise the vehicle in such a manner as to allow the front wheels to rotate freely and the steering mechanism freedom to turn. Position the wheels in a straight ahead position.

2. Using a push pull type spring scale located as near the relay rod end of the idler arm as possible, exert a 25 lb. force upward and then downward while noticing the total distance the end of the arm moves. This distance should not exceed $\pm 1/8$ inch for a total acceptable movement of 1/4 inch (Figure 3B1-10). It is necessary to ensure that the correct load is applied to the arm since it will move more when higher loads are applied. It is also necessary that a scale or ruler be rested against the frame and used to determine the amount of movement since observers tend to over-estimate the actual movement when a scale is not used. The idler arm should always be replaced if it fails this test.

Jerking the right front wheel and tire assembly back and forth this causing an up and down movement in the idler arm is not an acceptable method of checking since there is no control on the amount of force being applied.

Caution should be used in assuming shimmy complaints are caused by loose idler arms. Before suspecting suspension or steering components, technicians should eliminate shimmy excitation factors, such as dynamic imbalance, run-out or force variation of wheel and tire assemblies and road surface irregularities.

Removal

1. Raise vehicle on a hoist.
2. Remove the nut from ball stud at the relay rod. Remove the ball stud from the relay rod by tapping on the relay rod boss with a hammer, while using a heavy hammer as a backing (Fig. 3B1-7).
3. Remove the idler arm to frame bolt and remove the idler arm assembly.

Installation

NOTICE: See the NOTICE on page 1 of this section regarding the fasteners referred to in steps 1 and 3.

1. Position the idler arm on the frame and install the mounting bolts (special plain washers under bolt heads); torque the nuts to specifications.
2. Make sure that the threads on the ball stud and in the ball stud nut are clean and smooth. If threads are not clean and smooth, ball stud may turn in the socket when attempting to tighten nut. Check condition of ball stud seal; replace if necessary.
3. Install the idler arm ball stud in the relay rod, making certain the seal is positioned properly. Use J-29193 or J-29194 to seat the tapers, as shown in Fig. 3B1-6. A torque of 20 N·m is required. With the tapers seated, remove the tool. Install a torque prevailing nut and torque to 54 N·m (40 ft. lbs.).
4. Lower the vehicle to the floor.

PITMAN ARM**Removal**

1. Raise vehicle on hoist.
2. Remove nut from pitman arm ball stud.
3. Remove pitman arm or relay rod from ball stud by tapping on side of rod or arm (in which the stud mounts) with a hammer while using a heavy hammer or similar tool as a backing. Pull on linkage to remove from stud.
4. Remove pitman arm nut from pitman shaft or clamp bolt from pitman arm, and mark relation of arm position to shaft.
5. Remove pitman arm, using Tool J-6632 or J-5504.

Installation

NOTICE: See the NOTICE on page 1 of this section regarding the fasteners referred to in steps 3 and 4.

1. Install pitman arm on pitman shaft, lining up the marks made upon removal.

NOTICE: If a clamp type pitman arm is used, spread the pitman arm just enough, with a wedge, to slip arm onto pitman shaft. Do not spread pitman arm more than required to slip over pitman shaft with hand

pressure. Do not hammer or damage to steering gear may result. Be sure to install the hardened steel washer before installing the nut.

2. Make sure that threads on ball studs and in ball stud nuts are clean and smooth. If threads are not clean and smooth, ball studs may turn in sockets when attempting to tighten nut. Check condition of ball stud seals; replace if necessary.

3. Install pitman shaft nut or pitman arm clamp bolt and torque to specifications.

4. Position ball stud onto pitman arm or relay rod. Use J-29193 or J-29194 to seat the tapers, as shown in Fig. 3B1-6. A torque of 20 N·m is required. With the tapers seated, remove the tool. Install a torque prevailing nut and torque to 54 N·m (40 ft. lbs.).

5. Lubricate ball studs.

6. Lower the vehicle to the floor.

STEERING CONNECTING ROD (K MODELS ONLY)**Removal**

1. Remove cotter pins from ball studs, and then remove the castellated nuts.
2. Remove ball studs from steering arm and pitman arm boss with a heavy hammer and striking other side of boss with lighter hammer (similar to method shown in (Fig. 3B1-7).

Installation

NOTICE: See the NOTICE on page 1 of this section regarding the fasteners referred to in step 3.

1. Make sure that threads on ball studs and in ball stud nuts are clean and smooth. If threads are not clean and smooth, ball studs may turn in connecting rod when attempting to tighten nut. Check condition of ball stud seals-replace if necessary.

2. Install ball studs in steering arm and pitman arm. (Be sure to install the long end of the connecting rod assembly to the pitman arm, as shown in Fig. 3B1-5).

3. Install ball stud nuts and torque to specifications.

Never back off nut to align cotter pin, always tighten nut to next slot that lines up with hole in stud.

4. Install cotter pins and lubricate ball studs. For proper alignment and orientation of connecting rod clamps see Figure 3B1-11.

SPECIFICATIONS AND SPECIAL TOOLS

Refer to Specifications and Special Tools at end of Section 3B4.

| CONDITION | POSSIBLE CAUSE | CORRECTION |
|--|--|--|
| <p>Rattle or Chuck in Steering Gear.</p> | <p>Insufficient or improper lubricant in steering gear.</p> <p>Pitman arm loose on shaft or steering gear mounting bolt loose.</p> <p>Loose or worn steering shaft bearing.</p> <p>Excessive over-center lash or worm thrust bearings adjusted too loose.</p> <p>NOTE: On turns a slight rattle may occur, due to the increased lash between ball nut and pitman shaft as gear moves off the center of "high point" position. This is normal and lash must not be reduced to eliminate this slight rattle.</p> | <p>Add lube specified.</p> <p>Tighten to specified torque.</p> <p>Replace steering shaft bearing.</p> <p>Adjust steering gear to specified preloads.</p> |
| <p>Poor Returnability</p> | <p>Steering column misaligned.</p> <p>Insufficient or improper lubricant in steering gear or front suspension.</p> <p>Steering gear adjusted too tight.</p> <p>Front wheel alignment incorrect (Caster)</p> | <p>Align column.</p> <p>Lubricate as specified.</p> <p>Adjust over-center and thrust bearing preload to specifications.</p> <p>Adjust to specifications.</p> |

Fig. 3B2-2-Manual Gear Diagnosis Chart A

| CONDITION | POSSIBLE CAUSE | CORRECTION |
|--|--|--|
| <p>Excessive Play or Looseness in Steering System.</p> | <p>Front wheel bearings loosely adjusted.</p> <p>Worn upper ball joints.</p> <p>Steering wheel loose on shaft, loose pitman arm, tie rods, steering arms or steering linkage ball nuts.</p> <p>Excessive over-center lash.</p> <p>Worm thrust bearings loosely adjusted.</p> | <p>Adjust to obtain proper end play.</p> <p>Check and replace ball joints if necessary.</p> <p>Tighten to specification, replace if worn or damaged.</p> <p>Adjust over-center preload to specifications.</p> <p>Adjust worm thrust bearing preload to specifications.</p> |
| <p>Hard Steering – Excessive Effort Required at Steering Wheel</p> | <p>Low or uneven tire pressure.</p> <p>Insufficient or improper lubricant in steering gear or front suspension.</p> <p>Steering shaft flexible coupling misaligned.</p> <p>Steering gear adjusted too tight.</p> <p>Front wheel alignment incorrect. (Manual Gear)</p> | <p>Inflate to specified pressures.</p> <p>Lubricate as specified. Re-lubricate at specified intervals.</p> <p>Align column and coupling.</p> <p>Adjust over-center and thrust bearing preload to specifications.</p> <p>Adjust to specifications.</p> |

Fig. 3B2-3–Manual Gear Diagnosis Chart B

MAINTENANCE AND ADJUSTMENTS

LUBRICATION OF MANUAL STEERING GEAR

The manual steering gear is factory-filled with steering gear lubricant. Seasonal change of this lubricant should not be performed and the housing should not be drained— **no lubrication is required for the life of the steering gear** .

According to the intervals listed in Section 0B, the manual gear should be inspected for seal leakage (**actual solid grease - not just oily film**) . If a seal is replaced or the gear is overhauled, the gear housing should be refilled with **1051052 (13 oz. container) Steering Gear Lubricant which meets GM Specification GM 4673M, or its equivalent.**

NOTICE: Do not use EP Chassis Lube, which meets GM Specification GM 6031M, to lubricate the gear **DO NOT OVER-FILL** the gear housing, or damage may occur to the gear.

ADJUSTMENT OF MANUAL STEERING GEAR

NOTICE: See Notice on page one of this section regarding the fasteners referred to in steps 9d and 10.

Before any adjustments are made to the steering gear attempt to correct complaints of loose or hard steering, or other wheel disturbances, a careful check should be made of front end alignment, shock absorbers, wheel balance and tire pressure for possible steering system problems. See Diagnosis earlier in this section.

Correct adjustment of steering gear is very important. While there are but two adjustments to be made, the following procedure must be followed step-by-step in the order given.

1. Disconnect the battery ground cable.
2. Raise the vehicle.

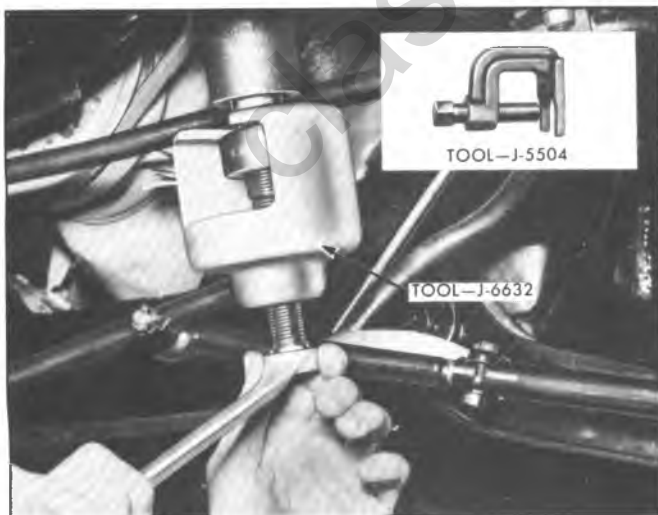


Fig. 3B2-4--Removing Pitman Arm

3. Remove the pitman arm nut. Mark the relationship of the pitman arm to the pitman shaft. Remove the pitman arm with Tool J-6632 or J-5504 as shown in Figure 3B2-4.

4. Loosen the steering gear adjuster plug locknut and back the adjuster plug off 1/4 turn (Fig. 3B2-5).

5. Remove the horn shroud or button cap.

6. Turn the steering wheel gently in one direction until stopped by the gear; then turn back one-half turn.

NOTICE: Do not turn the steering wheel hard against the stops when the steering linkage is disconnected from the gear as damage to the ball guides could result.

7. Measure and record "bearing drag" by applying a torque wrench with a socket on the steering wheel nut and rotating through a 90° arc (Fig. 3B2-6). Do not use a torque wrench having a maximum torque reading of more than 50 inch pounds.

8. Adjust "thrust bearing preload" by tightening the adjuster plug until the proper "thrust loading preload" is obtained (See specifications section). When the proper preload has been obtained, tighten the adjuster plug locknut to specifications and recheck torque. If the gear feels "lumpy" after adjustment, there is probably damage in the bearings due to severe impact or improper adjustment; the gear must be disassembled and inspected for replacement of damaged parts.

9. Adjust "over-center preload" as follows:

a. Turn the steering wheel gently from one stop all the way to the other carefully counting the total number of turns. Turn the wheel back exactly half-way, to center position.

b. Turn the lash adjuster screw clockwise to take out all lash between the ball nut and pitman shaft sector teeth and then tighten the locknut.

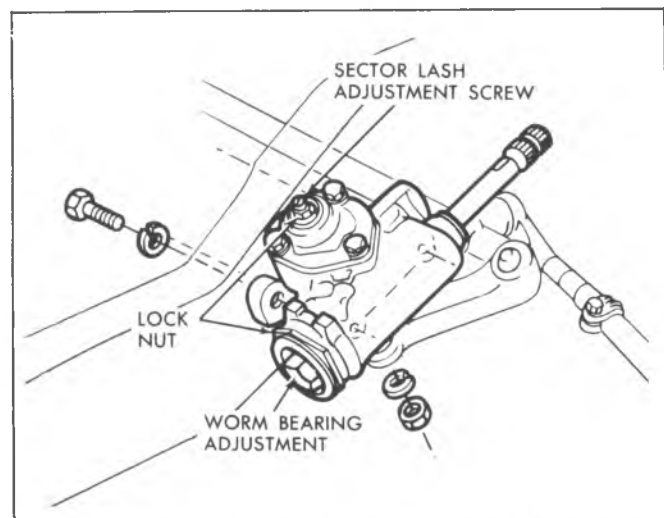


Fig. 3B2-5--Steering Gear Adjustment Points-Typical

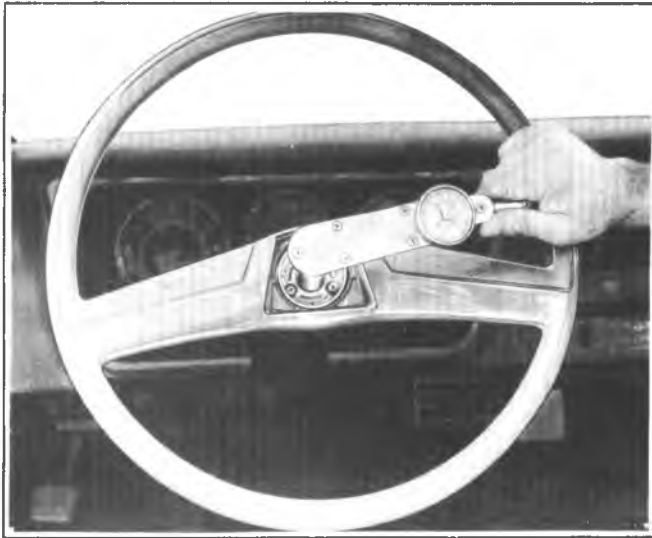


Fig. 3B2-6--Checking Torque at Steering Wheel

c. Check the torque at the steering wheel, taking the highest reading as the wheel is turned through center position. See Specifications for proper over-center preload.

d. If necessary, loosen locknut and readjust lash adjuster screw to obtain proper torque. Tighten the locknut to specifications and again check torque reading through center of travel. If maximum specification is exceeded, turn lash adjuster screw counterclockwise, then come up on adjustment by turning the adjuster in a clockwise motion.

10. Reassemble the pitman arm to the pitman shaft, lining up the marks made during disassembly. Torque the pitman shaft nut to specifications.

If a clamp type pitman arm is used, spread the pitman arm just enough, with a wedge, to slip the arm onto the pitman shaft. Do not spread the clamp more than required

to slip over pitman shaft with hand pressure. Do not hammer the pitman arm onto the pitman shaft. Be sure to install the hardened steel washer before installing the nut.

11. Install the horn button cap or shroud and connect the battery ground cable.

12. Lower the vehicle to the floor.

STEERING GEAR HIGH POINT CENTERING

1. Set front wheels in straight ahead position. This can be checked by driving vehicle a short distance on a **flat** surface to determine steering wheel position at which vehicle follows a straight path.

2. With front wheels set straight ahead, check position of mark on wormshaft designating steering gear high point. This mark should be at the top side of the shaft at 12 o'clock position and lined up with the mark in the coupling lower clamp.

3. On C, G and P series, if the gear has been moved off high point when setting wheel in straight ahead position, loosen adjusting sleeve clamps on both left and right hand tie rods. Then turn both sleeves an equal number of turns in the same direction to bring gear back on high point.

Turning the sleeves an unequal number of turns or in different directions will disturb the toe-in setting of the wheels.

4. On K series, if the gear has been moved off high point when setting wheels in straight ahead position, loosen adjusting sleeve clamps on the connecting rod. Then turn sleeve to bring gear back on high point.

5. Readjust toe-in as outlined in Section 3A (if necessary).

6. Be sure to properly orient sleeves and clamps when fastening and torquing clamps to proper specifications.

ON-VEHICLE SERVICE

STEERING GEAR

Removal

1. Set the front wheels in straight ahead position by driving vehicle a short distance on a flat surface.

2. Remove the flexible coupling to steering shaft flange bolts (C-K models) or the lower universal joint pinch bolt (P models). Mark the relationship of the universal yoke to the wormshaft.

3. Mark the relationship of the pitman arm to the pitman shaft. Remove the pitman shaft nut or pitman arm pinch bolt and then remove the pitman arm from the pitman shaft using Puller J-6632 (Fig. 3B2-9).

4. Remove the steering gear to frame bolts and remove the gear assembly.

5. **C-K Models** - Remove the flexible coupling pinch bolt and remove the coupling from the steering gear wormshaft.

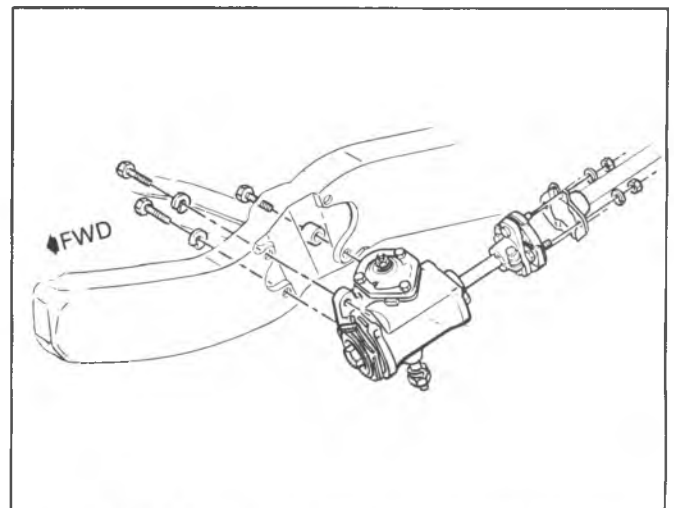


Fig. 3B2-7--Steering Gear Attachment, C-K Models

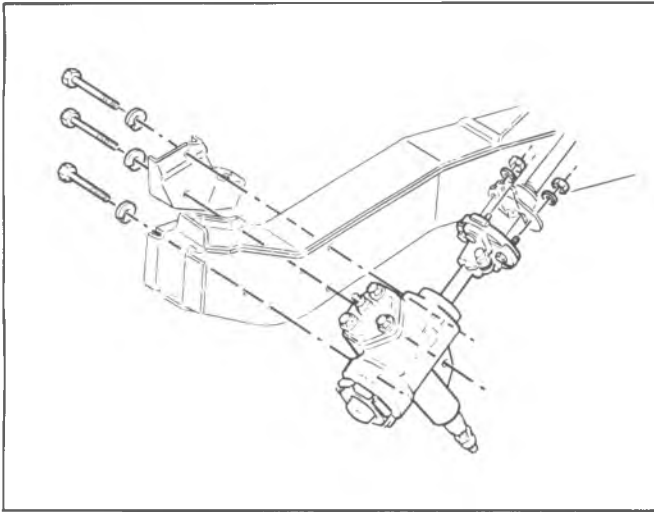


Fig. 3B2-8--Steering Gear Attachment, G-P Models

Installation

NOTICE: See NOTICE on page 1 of this section regarding the fasteners referred to in steps 1a, 1c, 1d, 1e, 2b, 2c and 3.

1. C-K Models

a. Install the flexible coupling onto the steering gear wormshaft, aligning the flat in the coupling with the flat on the shaft. Push the coupling onto the shaft until the wormshaft bottoms on the coupling reinforcement. Install the pinch bolt and torque to specifications. The coupling bolt must pass through the shaft undercut.

b. Place the steering gear in position, guiding the coupling bolt into the steering shaft flange.

c. Install the steering gear to frame bolts and torque to specifications.

d. If flexible coupling alignment pin plastic spacers were used, make sure they are bottomed on the pins, torque the flange bolt nuts to specifications and then remove the plastic spacers.



Fig. 3B2-9--Removing Pitman Arm-Typical

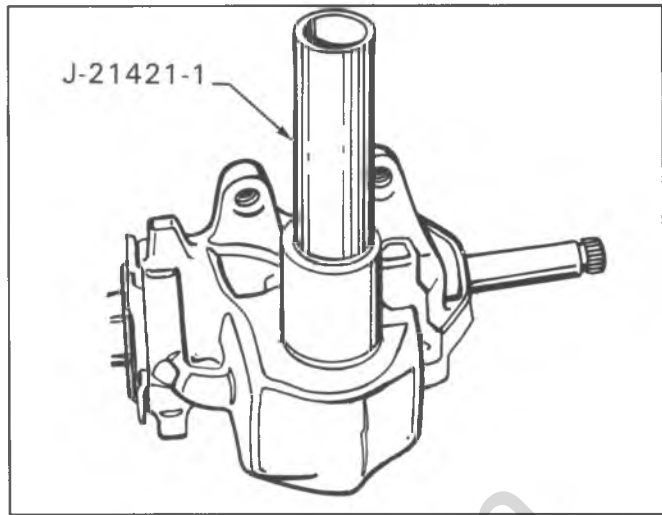


Fig. 3B2-10--Pitman Shaft Seal Replacement

e. If flexible coupling alignment pin plastic spacers were not used, center the pins in the slots in the steering shaft flange and then install and torque the flange bolt nuts to specifications.

2. P Models

a. Place the steering gear in position, guiding the wormshaft into the universal joint assembly and lining up the marks made at removal. If a new gear was installed, line up the mark on the wormshaft with the slit in the universal joint yoke.

b. Install the steering gear to frame bolts and torque to specifications.

c. Install the universal joint pinch bolt and torque to specification. The pinch bolt must pass through the shaft undercut.

3. Install the pitman arm onto the pitman shaft, lining up the marks made at removal. Install the pitman shaft nut or pitman arm pinch bolt and torque to specifications.

If a clamp type pitman arm is used, spread the pitman arm just enough, with a wedge, to slip the arm onto the pitman shaft. Do not spread the clamp more than required to slip over pitman arm onto the pitman shaft. Be sure to install the hardened steel washer before installing the nut.

PITMAN SHAFT SEAL REPLACEMENT

A faulty seal may be replaced without removal of steering gear from C, G and P trucks by removing pitman arm as outlined under Maintenance and Adjustments - Steering Gear Adjustments and proceed as follows:

On K series vehicles remove the gear from the vehicle first.

1. Rotate the steering wheel from stop to stop, counting the total number of turns. Then turn back exactly half-way, placing the gear on center (the wormshaft flat should be at the 12 o'clock position).

2. Remove the three self-locking bolts attaching side cover to the housing and lift the pitman shaft and side cover assembly from the housing.

3. Pry the pitman shaft seal from the gear housing using a screwdriver and being careful not to damage the housing bore. See Fig. 3B2-10.

NOTICE: Inspect the lubricant in the gear for contamination. If the lubricant is contaminated in any way, the gear must be removed from the vehicle and completely overhauled as outlined in the Unit Repair Manual, or damage to the gear could result.

4. Coat the new pitman shaft seal with Steering Gear Lubricant meeting GM Specification GM4673M (or equivalent). Position the seal in the pitman shaft bore and tap into position using a suitable size socket.

5. Remove the lash adjuster lock nut. Remove the side cover from the pitman shaft assembly by turning the lash adjuster screw clockwise.

6. Place the pitman shaft in the steering gear such that the center tooth of the pitman shaft sector enters the center tooth space of the ball nut.

7. Fill the steering gear housing with Steering Gear Lubricant meeting GM Specification GM4673M (or equivalent).

8. Install a new side cover gasket onto the gear housing.

9. Install the side cover onto the lash adjuster screw by reaching through the threaded hole in the side cover with a small screwdriver and turning the lash adjuster screw counter-clockwise until it bottoms and turns back in 1/4 turn.

10. Install the side cover bolts and torque to specifications.

11. Install the lash adjuster screw locknut, perform steering gear adjustment and install the pitman arm as outlined under "Maintenance and Adjustments".

On K series install the gear into the vehicle using previously outlined procedure.

SPECIFICATIONS AND SPECIAL TOOLS

Refer to Specifications and Special Tools at end of Section 3B4.

Classiccarlibrary.com

System Checks

Many factors affect power operation of the steering system, of which the most common are:

1. Fluid level and condition.
2. Drive belt tension.
3. Loose component mountings.
4. Loose pump pulley.

These factors must be checked and corrected before making any further diagnosis of the steering system. The need for proper diagnosis cannot be over-emphasized.

After the source of the problem has been found, determine the cause. For example, if the oil level in the reservoir is found to be low, refill and check the entire hydraulic system for oil leaks. Refilling the reservoir will not necessarily correct problem.

Fluid Level

1. Run engine to normal operating temperature, then shut engine off. Remove reservoir filler cap and check oil level to "hot" mark on dipstick.

2. If oil level is low, add hydraulic fluid to proper level on dipstick and replace filler cap. When adding or making a complete fluid change, always use GM power steering fluid or equivalent.

3. When checking fluid level after the steering system has been serviced, air must be bled from the system. Proceed as follows:

a. With wheels turned all the way to the left, add power steering fluid to "Cold" mark on dipstick.

b. Start engine, and running at fast idle, recheck fluid level. Add fluid if necessary to "Cold" mark on dipstick.

c. Stabilize system by turning wheels from side to side without hitting stops. Maintain fluid level just above internal pump casting. Fluid with air in it will have a light tan or red appearance. This air must be eliminated from fluid before normal steering action can be obtained.

d. Return wheels to center position and continue to run engine for two or three minutes, then shut engine off.

e. Road test car to make sure steering functions normally and is free from noise.

f. Recheck fluid level as described in steps 1 and 2, making sure fluid level is at "hot" mark on dipstick after the system has stabilized at its normal operating temperature approximately 170° to 190°F (76° to 88°C).

Belt Adjustment

When adjusting a power steering pump belt, never pry against the pump reservoir or pull against the filler neck. To increase belt tension move the pump outward by prying against the pump housing casting extension directly behind the pump drive pulley.

A belt that has been previously tensioned is considered to be a used belt and should be tightened to 75 pounds. A belt that has never been tensioned is considered to be a new belt and should be tightened to 125 pounds.

Place belt tension gage, J-23600 or equivalent midway between the pulleys on drive belt being checked. If the belt tension is incorrect proceed as follows:

a. Loosen the pump attaching bolts and adjust the belt to correct tension by moving the pump outward, away from the engine.

b. Snug all pump mounting bolts and remove pry bar.

c. Tighten all pump mounting bolts to specified torque.

d. Check belt tension and remove the belt tension gage.

Hydraulic System Checks

The following procedure outlines methods to identify and isolate power steering hydraulic circuit difficulties. The test provides means of determining whether power steering system hydraulic parts are actually faulty. This test will result in readings indicating faulty hydraulic operation, and will help to identify the faulty component.

Before performing hydraulic circuit test, carefully check belt tension, fluid level and condition of driving pulley.

Power Steering Hydraulic System Test

Engine must be at normal operating temperature. Inflate front tires to correct pressure. All tests are made with engine idling, check idle adjustment and if necessary adjust engine idle speed to correct specifications listed in Section 6C and proceed as follows:

1. With engine NOT running disconnect pressure hose from pump and install Tool J-5176 using a spare pressure hose between gauge and pump. Gauge must be between shut-off valve and pump. Open shut-off valve. See Fig. 3B3-7.

2. Remove filler cap from pump reservoir and check fluid level. Fill pump reservoir to full mark on dipstick. Start engine and, momentarily holding steering wheel against stop, check connections at Tool J-5176 for leakage.

3. Bleed system as outlined under Maintenance and Adjustments.

4. Insert thermometer (Tool J-5421) in reservoir filler opening. Move steering wheel from stop to stop several times until thermometer indicates that hydraulic fluid in reservoir has reached temperature of 150° to 170°F (66° to 76°C).

NOTICE: To prevent scrubbing flat spots on tires, do not turn steering wheel more than five times without rolling vehicle to change tire-to-floor contact area.

5. Start engine and check fluid level adding any fluid if required. When engine is at normal operating temperature, the initial pressure read on the gauge (valve open) should be in the 80-125 PSI range. Should this pressure be in excess of 200 PSI - check the hoses for restrictions and the poppet valve for proper assembly.

6. Close gate valve fully 3 times. Record the highest pressures attained each time.

NOTICE: Do not leave valve fully closed for more than 5 seconds as the pump could be damaged internally.

a. If the pressures recorded are within the listed specs and the range of readings are within 50 PSI, the pump is functioning within specs. (EX. Spec. 900 - 1500 PSI - readings - 1270 - 1275 - 1280).

b. If the pressures recorded are high, but do not repeat within 50 PSI, the flow controlling valve is sticking. Remove the valve, clean it and remove any burrs using crocus cloth

| CONDITION | POSSIBLE CAUSE | CORRECTION |
|--|--|---|
| <p>SYSTEM NOISE</p> <p>There is some noise in all power steering systems.</p> <p>Common complaints are listed as follows:</p> | | |
| Pump noise-"chirp". | Loose belt. | Adjust belt tension to specification. |
| Belt squeal. | Loose belt. | Adjust belt tension to specification. |
| Gear noise ("hissing" sound) | There is some noise in all power steering systems. One of the most common is a hissing sound most evident at standstill parking. There is no relationship between this noise and performance of the steering. "Hiss" may be expected when steering wheel is at end of travel or when slowly turning at standstill. | Do not replace valve unless "hiss" is extremely objectionable. Slight "hiss" is normal and in no way affects steering. A replacement valve will also exhibit slight noise and is not always a cure for the objection. Investigate clearance around flexible coupling rivets. Be sure steering shaft and gear are aligned so flexible coupling rotates in a flat plane and is not distorted as shaft rotates. Any metal-to-metal contacts through flexible coupling will transmit "hiss" into passenger compartment. Also, check for proper sealing between steering column and toe pan. |
| Rattle. | Pressure hose touching other parts of car. Loose pump pulley nut Pump vanes not installed properly. Pump vanes sticking in rotor slots. | Adjust hose position. Replace nut, torque to specs. Install properly. Free up by removing burrs, varnish or dirt. |
| Gear noise (rattle or chuckle). | Improper over-center adjustment NOTE: A slight rattle may occur on turns because of increased clearance off the "high point". This is normal and clearance must not be reduced below specified limits to eliminate this slight rattle. Loose pitman arm. Gear loose on frame. | Adjust to specifications. Tighten to specifications Check gear-to-frame mounting bolts. Tighten bolts to 70 foot-pounds. |
| Rattle or chuckle. | Steering linkage looseness. | Check linkage pivot points for wear. Replace if necessary. |
| Groan. | Low oil level. | Fill reservoir to proper level. |
| Groan. | Air in the oil. Poor pressure hose connection. | Bleed system by operating steering from right to left full turn. Check connections, torque to specs. |
| Growl. | Excessive back pressure caused by hoses or steering gear. (restriction) | Locate restriction and correct. Replace part if necessary. |

Fig. 3B3-2—Power Steering System Diagnosis Chart A

3B3-4 POWER STEERING SYSTEM

| CONDITION | POSSIBLE CAUSE | CORRECTION |
|--|---|---|
| Pump growl Note: Most noticeable at full wheel travel and stand still parking | Scored pump pressure plates, thrust plate or rotor. Extreme wear of pump cam ring. | Replace affected parts, flush system. Replace affected parts. |
| Swish in pump | Defective pump flow control valve | Replace valve |
| Whine in pump | Pump shaft bearing scored. | Replace housing and shaft, flush system |
| Squawk in gear (not belt) | Damper "O" ring on valve spool cut | Replace "O" ring. |
| SYSTEM OPERATION Excessive wheel kick-back or loose steering. | Backlash in steering linkage. Air in system. Excessive "over-center" lash. Loose thrust bearing preload adjustment. Worn poppet valve (Gear) Steering gear loose on frame. Steering gear flexible coupling too loose on shaft or rubber disc mounting screws loose. Steering linkage ball studs worn enough to be loose. Front wheel bearings incorrectly adjusted or worn. | Adjust parts affected or replace worn parts. Add oil to pump reservoir and bleed by operating steering. Check all connections. Adjust to specification. Adjust to specification. Replace poppet valve. Tighten attaching bolts to 70 foot-pounds. Tighten flange pinch bolts to 30 foot-pounds, if serrations are not damaged. Tighten upper flange to coupling nuts to 20 foot-pounds. Replace loose components. Adjust bearings or replace with new parts as necessary. |
| Poor return of steering. | Tires under-inflated. Lower coupling flange rubbing against steering gear adjuster plug. Steering wheel rubbing against directional signal housing. Tight or frozen steering shaft bearings. Steering linkage or ball joints binding. Steering gear to column misalignment. Tie rod pivots not centralized. Lack of lubricant in suspension ball joints and steering linkage | Inflate to specified pressure. Loosen pinch bolt and assemble properly. Adjust steering jacket. Replace bearings. Replace affected parts. Align steering column. Adjust tie rod ends as required to center pivots. Lubricate and relubricate at proper intervals |

Fig. 3B3-3—Power Steering System Diagnosis Chart B

| CONDITION | POSSIBLE CAUSE | CORRECTION |
|--|--|---|
| Poor return of steering. (Cont'd.) | Steering gear adjustments over specifications. Sticky or plugged valve spool. Rubber spacer binding in shift tube. Improper front suspension alignment. Tight steering shaft bearings. | Check adjustment with pitman arm disconnected. Readjust if necessary. Remove and clean or replace valve. Make certain spacer is properly seated. Lubricate inside diameter with silicone lubricant. Check and adjust to specifications. Replace bearings. |
| Car leads to one side or the other. (Keep in mind road condition and wind. Test car on flat road going in both directions) | Front suspension misaligned Steering shaft rubbing ID of shift tube. Unbalanced or badly worn steering gear valve. NOTE: If this is cause, steering effort will be very light in direction of lead and heavy in opposite direction. Steering linkage not level. | Adjust to specifications. Align column. Replace valve. Adjust as required. |
| Steering wheel surges or jerks when turning with engine running especially during parking. | Low oil level in pump. Loose pump belt. Sticky flow control valve. Insufficient pump pressure. Steering linkage hitting engine oil pan at full turn. | Check oil level, add as necessary Adjust tension to specification. Inspect for varnish or damage, replace if necessary. Check pump pressure. (See pump pressure test). Replace relief valve if defective. Correct clearance. |
| Momentary increase in effort when turning wheel fast to right or left. | Pump belt slipping. Low oil level in pump. High internal leakage. | Tighten or replace belt. Check oil level, add as necessary. Check pump pressure (Test) |
| Hard steering or lack of assist. | High internal leakage. (Gear or pump) Loose pump belt. Low oil level in reservoir. | Check pump pressure. (See pump pressure test). Adjust belt tension to specification. Fill to proper level. If excessively low, check all lines and joints for evidence of external leakage, torque to specs. |

Fig. 3B3-4--Power Steering Diagnosis Chart C

| CONDITION | POSSIBLE CAUSE | CORRECTION |
|--|---|---|
| <p>Hard Steering or lack of assist (Continued)</p> | <p>Lack of lubricant in suspension or ball joints.</p> <p>Tires not properly inflated.</p> <p>Steering gear to column misalignment.</p> <p>Steering gear adjusted too tight.</p> <p>Excessive friction in steering linkage.</p> <p>Lower coupling flange rubbing against steering gear adjuster plug.</p> <p>Sticky flow control valve.</p> <p>Frame bent.</p> <p>Front springs weak and sagging.</p> <p>Insufficient oil pressure.</p> | <p>Lubricate, relubricate at proper intervals.</p> <p>Inflate to recommended pressure.</p> <p>Align steering column.</p> <p>Test steering system for binding with front wheels off floor. Adjust as necessary.</p> <p>Check tie rod pivot points for excessive friction. Replace the affected pivot.</p> <p>Loosen pinch bolt and assemble properly.</p> <p>Replace or clean valve.</p> <p>Check frame for proper alignment or cracking. Repair or replace as necessary.</p> <p>Check standing height. Weak or sagging springs should be replaced with new ones.</p> <p>If above checks do not reveal cause of hard steering, diagnose hydraulic system to determine problem.</p> |
| <p>Low oil pressure due to restriction in hoses:</p> | <p>Check for kinks in hoses.</p> <p>Foreign object stuck in hose.</p> | <p>Remove kink.</p> <p>Remove hoses and remove restricting object or replace hose.</p> |
| <p>Low oil pressure due to steering gear: (See pump pressure test)</p> | <p>Pressure loss in cylinder due to worn piston ring or scored housing bore.</p> <p>Leakage at valve rings, valve body to worm seal.</p> <p>Loose fit of spool in valve body or leaky valve body.</p> <p>Damaged poppet valve.</p> | <p>Remove gear from car for disassembly and inspection of ring and housing bore. Replace affected parts.</p> <p>Remove gear from car for disassembly and replace seals.</p> <p>Replace valve.</p> <p>Replace valve.</p> |

Fig. 3B3-5--Power Steering System Diagnosis Chart D

or fine hone. If the system contains some dirt, flush it. If it is exceptionally dirty, both the pump and the gear must be completely disassembled, cleaned, flushed and reassembled before further usage.

c. If the pressures recorded are constant, but more than 100 PSI, below the low listed spec., replace the flow control valve and recheck. If the pressures are still low, replace the rotating group in the pump.

| CONDITION | POSSIBLE CAUSE | CORRECTION |
|---|--|--|
| <p>Low oil pressure due to steering pump: (See pump pressure test.)</p> <p>Note: Steering system external leakage</p> <p>Foaming milky power steering fluid, low level and possible low pressure.</p> | <p>Loose belt.</p> <p>Low oil level.</p> <p>Air in the oil.</p> <p>Defective hoses or steering gear.</p> <p>Flow control valve stuck or inoperative.</p> <p>Loose screw in end of flow control valve.</p> <p>Cracked or broken thrust or pressure plate.</p> <p>Pressure plate not flat against cam ring.</p> <p>Extreme wear of cam ring.</p> <p>Scored pressure plate, thrust plate or rotor.</p> <p>Vanes not installed properly.</p> <p>Vanes sticking in rotor slots.</p> <p>Air in the fluid, and loss of fluid due to internal pump leakage causing overflow.</p> | <p>Adjust tension to specification</p> <p>Fill reservoir to proper level.</p> <p>Locate source of leak and correct. Bleed system.</p> <p>Correct as necessary.</p> <p>Remove burrs or dirt or replace.</p> <p>Tighten.</p> <p>Replace part.</p> <p>Replace pressure plate.</p> <p>Replace parts, flush system</p> <p>Replace parts. (If rotor, replace with rotating group kit), flush system</p> <p>Install properly. Radius edge to outside.</p> <p>Free-up by removing burrs, varnish or dirt.</p> <p>Check for leak and correct. Bleed system. Extremely cold temperatures will cause system aeration should the oil level be low. If oil level is correct and pump still foams, remove pump from vehicle and separate reservoir from housing. Check welsh plug and housing for cracks. If plug is loose or housing is cracked, replace housing.</p> |

Fig. 3B3-6--Power Steering System Diagnosis Chart E

7. If the pump checks within specifications, leave the valve open and turn (or have turned) the steering wheel into both corners. Record the highest pressures and compare with the maximum pump pressure recorded. If this pressure cannot be built in either (or one) side of the gear, the gear is leaking internally and must be disassembled and repaired. See the current Unit Repair Manual.

8. Shut off engine, remove testing gauge, spare hose, reconnect pressure hose, check fluid level and/or make needed repairs.

POWER STEERING SYSTEM EXTERNAL LEAKAGE

General Procedure

1. Wipe suspected area dry.
2. Check for overfilled reservoir.

3. Check for oil aeration and overflow.
4. Check hose connections - tighten if necessary.
5. Verify exact point of leakage.

Example: Torsion bar, stub shaft and adjuster seals are close together; exact leakage point could be confused.

Example: The point oil drips from is not necessarily the leakage point - oil overflowing from reservoir for instance.

6. When service is required:
 - a. Clean leakage area upon disassembly.
 - b. Replace leaking seal.
 - c. Check component sealing surfaces for damage.
 - d. Reset bolt torque to specifications where required.

Customer Descriptions

Some of the customer complaints associated with the power steering system may be reported as:

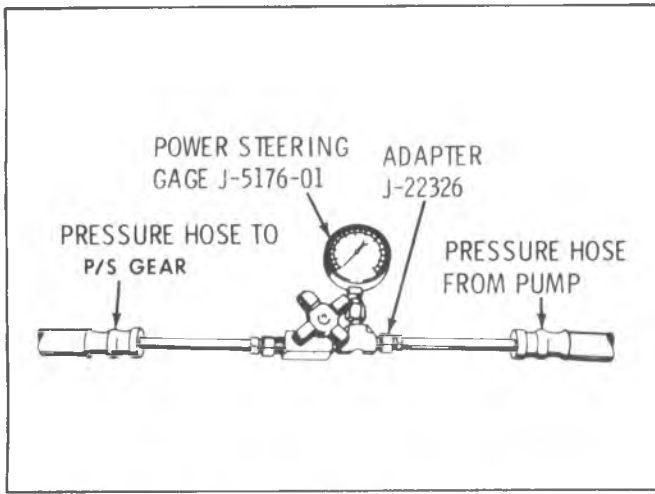


Fig. 3B3-7—Checking Power Steering Pressures

1. Oil leakage on garage floor.
2. Oil leaks visible on steering gear, pump, or anywhere else on the left side of engine compartment.
3. Growling noise especially when parking or when engine is cold.
4. Loss of power when parking.
5. Heavy steering effort.

For the purpose of trouble shooting complaints of this nature, assume that there is an external leak in the power steering system.

Leakage Diagnosis (Fig. 3B3-8)

This section is a guide, which will enable you to locate, identify, and repair leaks in the power steering system. It contains:

- A. Diagram of the complete power steering system with the areas of potential leakage identified.
- B. Recommended procedure for locating external leakage in the vehicle.
- C. Areas of leakage to be checked, which can be serviced at once.
- D. Part replacement recommendations.
- E. Diagram of the actual areas where leakage will be observed and the action recommended to repair this leakage.

Leakage Check

The purpose of the diagnostic procedure is to pin-point the location of the leak. The method outlined in this manual can be followed to locate the leak and repair it.

In some cases you will be able to locate the leak easily. However, seepage type leaks may be more difficult to isolate. For seepage leaks, the following method is recommended.

- A. With the vehicle's engine off, wipe the complete power steering system dry (gear, pump, hoses, and

connections).

B. Check oil level in pump's reservoir and adjust as directed in maintenance section.

C. Start engine and turn steering wheel from stop to stop several times. Do not hold in corner for any length of time as this can damage the power steering pump. It is easier if someone else operates the steering wheel while you search for the seepage.

D. Find the exact area of leakage.

E. Refer to the diagnostic chart to find the recommended method of repair.

Quick Fixes

The purpose of this section is to acquaint you with the types of leakage which can be repaired very easily. It contains information on reservoir oil level, the hoses and the hose connections.

An overfilled pump reservoir can be a cause for leakage complaint. The oil in the steering system expands as heated during normal usage. If overfilled the excess is forced through the breather cap hole and may be sprayed over the engine by air blast. Operate the engine and steering system until normal operating temperature is obtained. Remove the reservoir cap and check the graduated level on the dipstick. Adjust the oil level as required.

Seepage at the hose connections can be a cause for leakage complaint and can be due to loose connection nuts. If leakage is observed at the hose connections, and the nut is not cross threaded, tighten the nuts at the gear to 30 foot pounds.

The nut at the power steering pump should be tightened to 40 foot pounds. If tightening to this torque does not stop the leak, refer to the diagnostic chart.

If either the return hose or the pressure hose leaks, replace the hose.

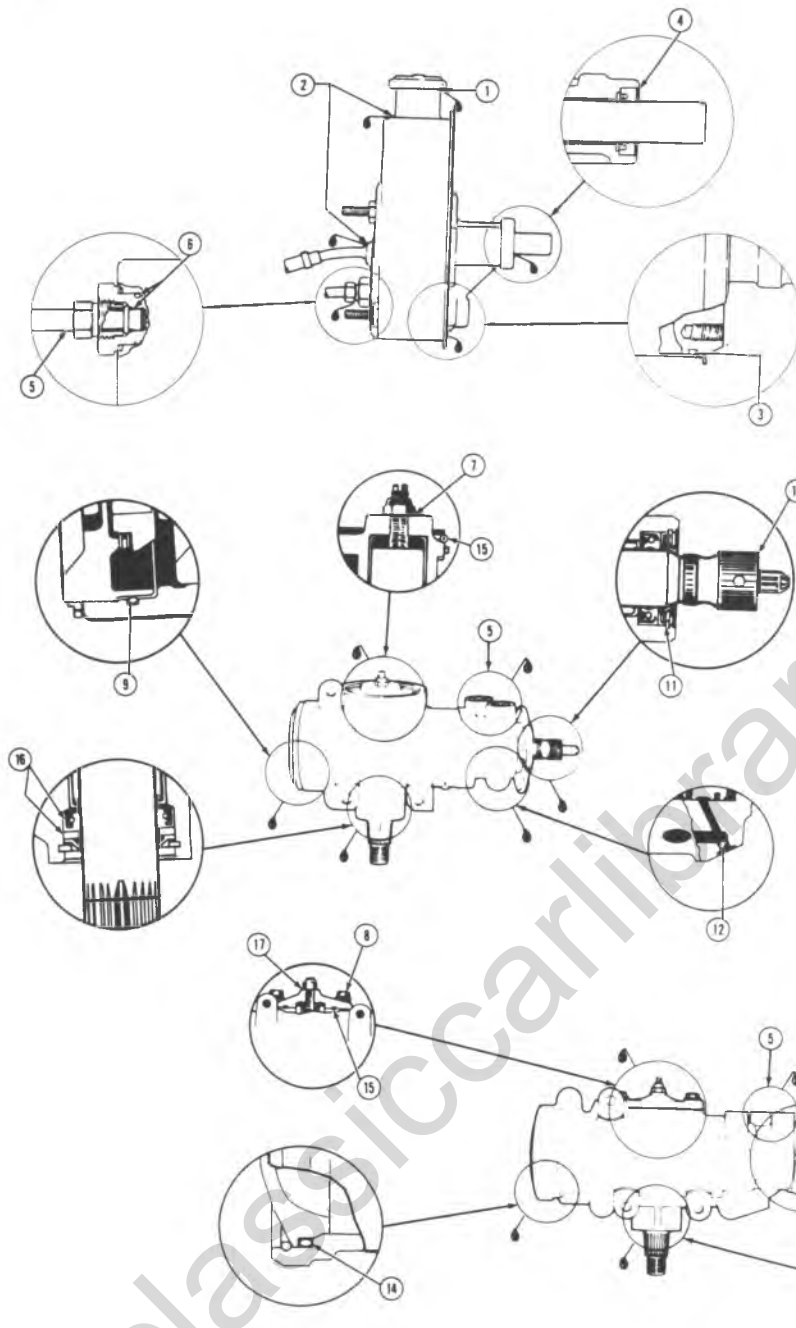
Component Replacement

Lip seals, which seal rotating shafts, require special treatment. This type of seal is used on the steering gear at the pitman shaft, at the stud shaft, and on the drive shaft of the pump. When leakage occurs in one of these areas, always replace the seal(s), after inspecting and thoroughly cleaning the sealing surfaces. Replace the shaft only if very severe pitting is found. If the corrosion in the lip seal contact zone is slight, clean the surface of the shaft with crocus cloth. Replace the shaft only if the leakage cannot be stopped by smoothing with crocus cloth first.

Housing or Cover Seepage - Both the power steering gear and pump assemblies are leakage checked before shipment. However, occasionally oil seepage may occur from the gear or pump other than the seal areas. If this type of leakage is found, replace the leaking part.

Fig. 3B3-8 has been prepared to show the potential areas of leakage. If leakage occurs in the zones shown, replace the part listed using the service manual as a guide.

GEAR AND PUMP LEAK DIAGNOSIS



START ENGINE AND TURN STEERING WHEEL FROM STOP TO STOP SEVERAL TIMES. DO NOT HOLD AT STOP FOR ANY LENGTH OF TIME AS THIS CAN DAMAGE THE POWER STEERING PUMP.

1. CHECK OIL LEVEL. IF LEAKAGE PERSISTS WITH THE LEVEL CORRECT AND THE CAP TIGHT, REPLACE CAP.
2. CRACKED OR BENT RESERVOIR, REPLACE RESERVOIR.
3. REPLACE RESERVOIR "O" RING.
4. REPLACE FRONT SEAL. MAKE CERTAIN THAT DRIVE SHAFT IS CLEAN AND FREE OF PITTING IN SEAL RIDE AREA.
5. TORQUE HOSE FITTING NUT TO 27 N·m (20 FT. LBS.). IF LEAKAGE PERSISTS, REPLACE "O" RING SEAL.
6. TORQUE FITTING TO 48 N·m (35 FT. LBS.). IF LEAKAGE PERSISTS, REPLACE BOTH "O" RING SEALS.
7. TORQUE NUT TO 27 N·m (20 FT. LBS.). REPLACE NUT IF LEAKAGE PERSISTS.
8. TORQUE SIDE COVER BOLTS TO 60 N·m (45 FT. LBS.). REPLACE SIDE COVER SEAL IF LEAKAGE PERSISTS.
9. REPLACE ADJUSTER PLUG "O" RING SEAL.
10. REPLACE ROTARY VALVE ASSEMBLY.
11. REPLACE ADJUSTER PLUG SEALS.
12. SEAT BALL FLUSH WITH PUNCH AND RESTAKE. IF SEEPAGE PERSISTS, REPLACE HOUSING.
13. REPLACE BOTH PITMAN SHAFT SEALS.
14. REPLACE END PLUG "O" RING SEAL.
15. REPLACE SIDE COVER "O" RING SEAL.
16. REPLACE DUST SEAL AND PITMAN SHAFT SEAL.
17. TORQUE NUT TO 48 N·m (35 FT. LBS.). REPLACE NUT IF LEAKAGE PERSISTS.

Fig. 3B3-8--Gear and Pump Leak Diagnosis

5. Start engine and check fluid level adding any fluid if required. When engine is at normal operating temperature, the initial pressure read on the gage (valve open) should be in the 80-125 PSI range. Should this pressure be in excess of 200 PSI - check the hoses for restrictions and the poppet valve for proper assembly.

6. Close gate valve fully 3 times. Record the highest pressures attained each time.

NOTICE: Do not leave valve fully closed for more than 5 seconds as the pump could be damaged internally.

a. If the pressures recorded are within the listed specs and the range of readings are within 50 PSI, the pump is functioning within specs. (Ex. Spec. 1250 - 1350 PSI - readings - 1270 - 1275 - 1280).

b. If the pressures recorded are high, but do not repeat within 50 PSI, the flow controlling valve is sticking. Remove the valve, clean it and remove any burrs using crocus cloth or fine hone. If the system contains some dirt, flush it. If it is exceptionally dirty, both the pump and the gear must

be completely disassembled, cleaned, flushed and reassembled before further usage.

c. If the pressures recorded are constant, but more than 100 PSI, below the low listed spec., replace the flow control valve and recheck. If the pressures are still low, replace the rotating group in the pump.

7. If the pump checks within specifications, leave the valve open and turn (or have turned) the steering wheel into both corners. Record the highest pressures and compare with the maximum pump pressures and compare with the maximum pump pressure recorded. If this pressure cannot be built in either (or one) side of the gear, the gear is leaking internally and must be disassembled and repaired. See the current Overhaul Manual.

8. Shut off engine, remove testing gauge, spare hose, reconnect pressure hose, check fluid level and/or make needed repairs.

ON-VEHICLE SERVICE

POWER STEERING GEAR

Removal

1. Disconnect hoses at gear. When hoses are disconnected, secure ends in raised position or prevent drainage of oil. Cap or tape the ends of the hoses to prevent entrance of dirt.

2. Install two plugs in gear fittings to prevent entrance of dirt.

3. Remove the flexible coupling to steering shaft flange bolts (G, C and K models) or the lower universal joint pinch bolt (P models). Mark the relationship of the universal yoke to the stub shaft.

4. Mark the relationship of the pitman arm to the pitman shaft. Remove the pitman shaft nut or pitman arm pinch bolt and then remove the pitman arm from the pitman shaft using Puller J-6632 (Fig. 3B3-13).

5. Remove the steering gear to frame bolts and remove the gear assembly.

6. G, C and K Models - Remove the flexible coupling pinch bolt and remove the coupling from the steering gear stub shaft.

Installation (Fig. 3B3-14)

NOTICE: See NOTICE on page 1 of this section regarding the fasteners referred to in steps 1, 3, 4 and 5.

1. Install the flexible coupling onto the steering gear stub shaft, aligning the flat in the coupling with the flat on the shaft. Push the coupling onto the shaft until the stub shaft bottoms on the coupling reinforcement. Install the pinch bolt and torque to specifications.

NOTICE: The coupling bolt must pass through the

shaft undercut, or damage to the components could occur.

2. Place the steering gear in position, guiding the coupling bolt into the steering shaft flange.

3. Install the steering gear to frame bolts and torque to specifications.

4. If flexible coupling alignment pin plastic spacers were used, make sure they are butted on the pins, tighten the flange bolt nuts to specifications and then remove the plastic spacers.

5. If flexible coupling alignment pin plastic spacers were not used, center the pins in the slots in the steering shaft flange and then install and torque the flange bolt nuts to specifications.



Fig. 3B3-13--Removing Pitman Arm

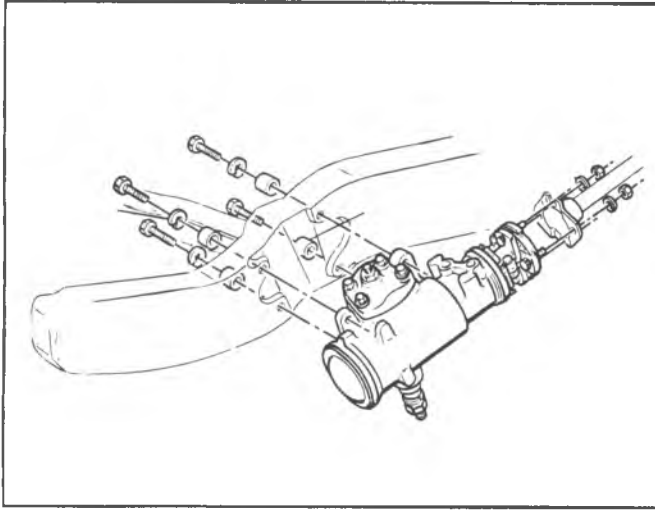


Fig. 3B3-14--Power Steering Gear Mounting-Typical

P Models

a. Place the steering gear in position, guiding the stub shaft into the universal joint assembly and lining up the marks made at removal. If a new gear was installed, line up the mark on the stub shaft with the mark on the universal yoke.

b. Install the steering gear to frame bolts and torque to specifications.

c. Install the universal joint pinch bolt and torque to specification. The pinch bolt must pass through the shaft undercut.

All Models

6. Install the pitman arm onto the pitman shaft, lining up the marks made at removal. Install the pitman shaft nut or pitman arm pinch bolt and torque to specifications.

7. Remove the plugs and caps from the steering gear and hoses and connect the hoses to the gear. Tighten the hose fittings to specified torque.

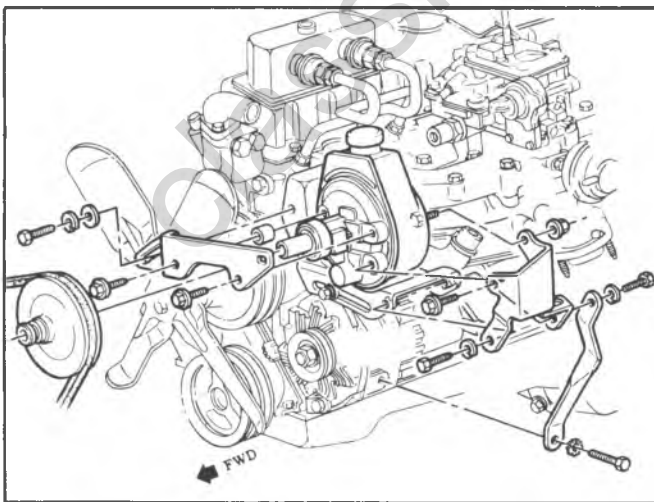


Fig. 3B3-15--P/S Pump Mounting; CK100, CK200 (03) With LE3 Engine

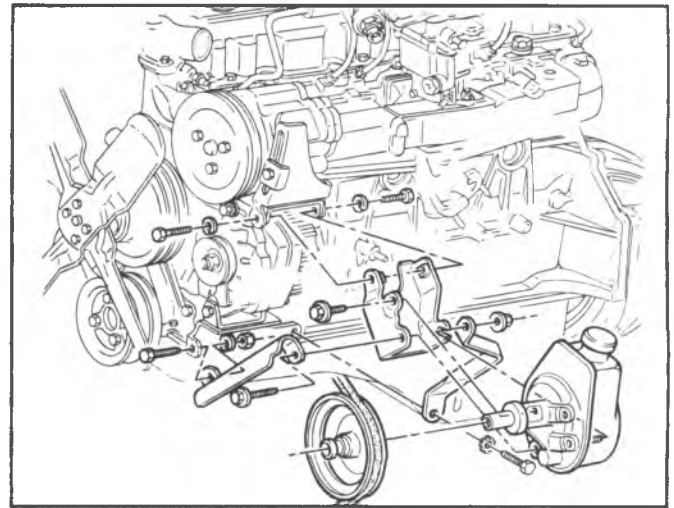


Fig. 3B3-16--P/S Pump Mounting; CK200, CK300 With L25 Engine

POWER STEERING PUMP (3B3-15 THROUGH 3B3-26)**Removal**

1. Disconnect hoses at pump. When hoses are disconnected, secure ends in raised position to prevent drainage of oil. Cap or tape the ends of the hoses to prevent entrance of dirt.

On Models with remote reservoir, disconnect reservoir hose at pump and secure in raised position. Cap hose pump fittings.

2. Install two caps at pump fittings to prevent drainage of oil from pump.

3. Loosen bracket-to-pump mounting nuts.

4. Remove pump belt.

5. Remove pump from attaching parts and remove pump from vehicle.

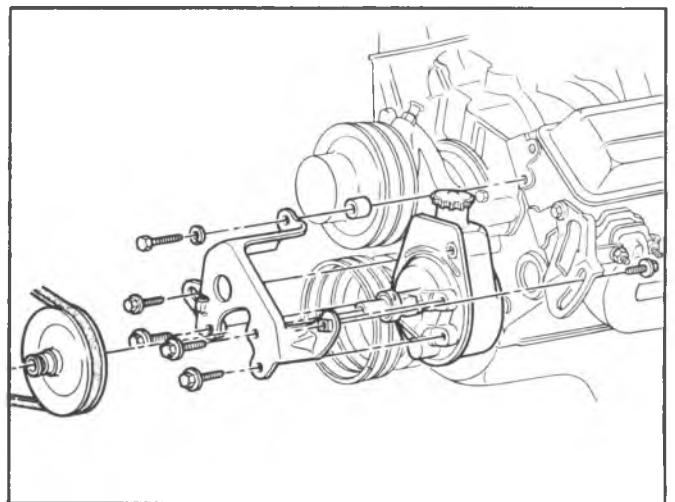


Fig. 3B3-17--P/S Pump Mounting; CK100, CK200, CK300 LE4, LG9, LS9, LT9 (Exc. C60, JB8)

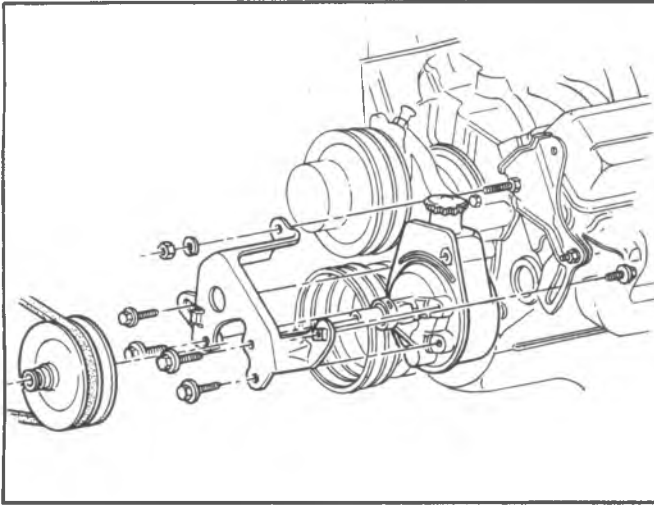


Fig. 3B3-18-P/S Pump Mounting; CK100, CK200, CK300
LE4, LG9, LS9, LT9 and C60

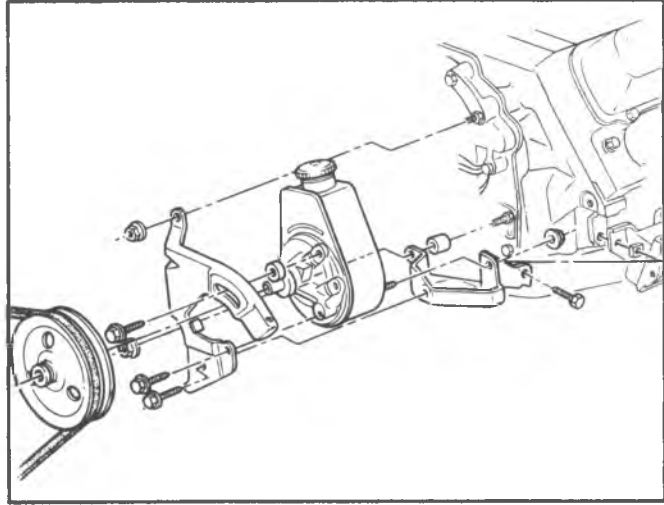


Fig. 3B3-20-P/S Pump mounting; CK100 (03)
With LF9 Engine

Installation

1. Position pump assembly on vehicle and install attaching parts loosely.
2. Connect and tighten hose fittings.
3. Fill reservoir. Bleed pump by turning pulley backward (counter-clockwise as viewed from front) until air bubbles cease to appear.
4. Install pump belt over pulley.
5. Tension belt as outlined under "Pump Belt Tension-Adjustment" in this section.
6. Bleed as outlined under "Bleeding Power Steering Systems."

SPECIFICATIONS AND SPECIAL TOOLS

Refer to Specifications and Special Tools at end of Section 3B4.

POWER STEERING HOSES

When servicing the power steering hoses be sure to align the hoses in their correct position as shown in Figs. 3B3-27 through 3B3-42.

It is important that the power steering hoses be installed correctly. Hoses installed out of position may be subjected to chafing or other abuses during sharp turns. Do not twist hoses unnecessarily during installation.

NOTICE: Do not start engine with any power steering hose disconnected, or damage to the components could occur.

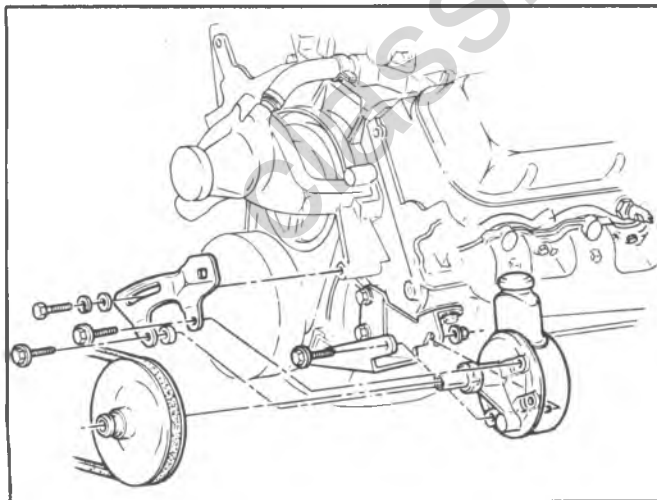


Fig. 3B3-19-P/S Pump Mounting; C100, C200, C300
With LE8 Engine

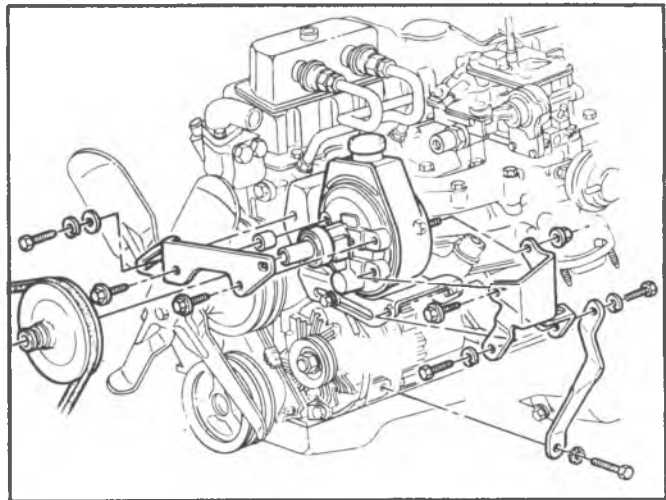


Fig. 3B3-21-P/S Pump Mounting; G100, G200, G300
With LE3 Engine

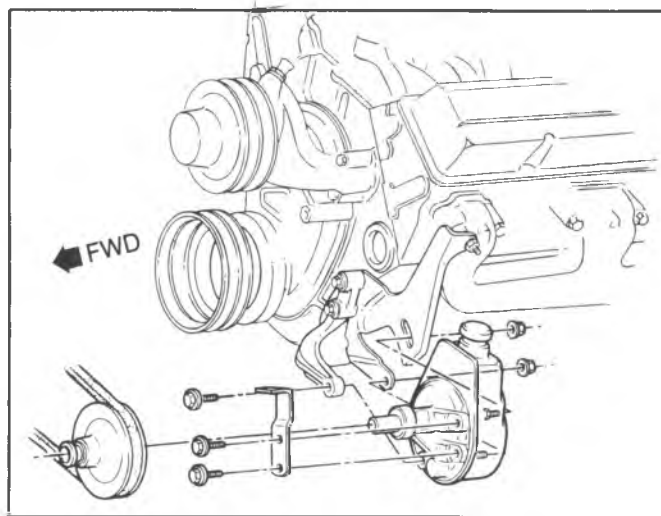


Fig. 3B3-22--P/S Pump Mounting; G100, G200, G300
LE4, LF4, LG9, LS9, LT9

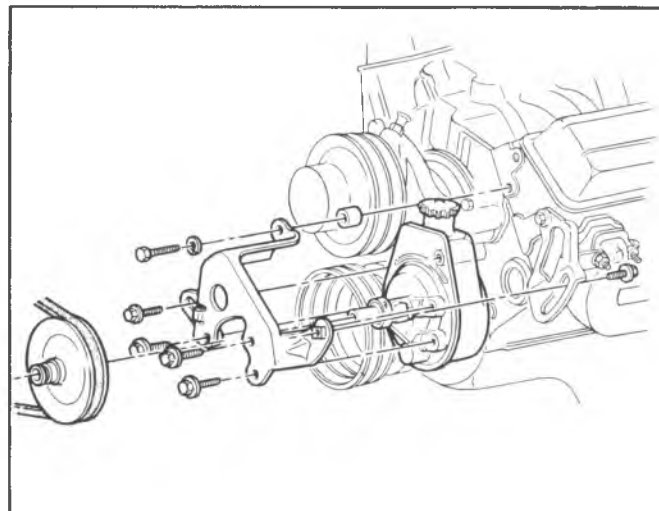


Fig. 3B3-24--P/S Pump Mounting; P200, P300 (42)
With LT9 (Exc. JB8)

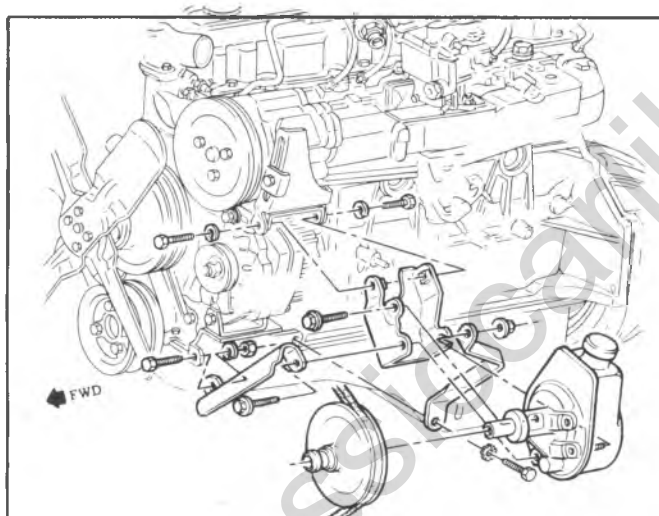


Fig. 3B3-23--P/S Pump Mounting; P200, P300 (42)
With L25 Engine

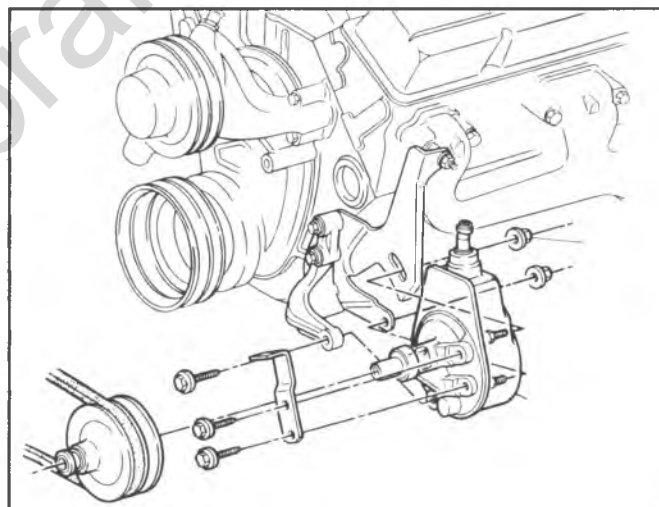


Fig. 3B3-25--P/S Pump Mounting; P200, P300 (32)
With LT9 Engine

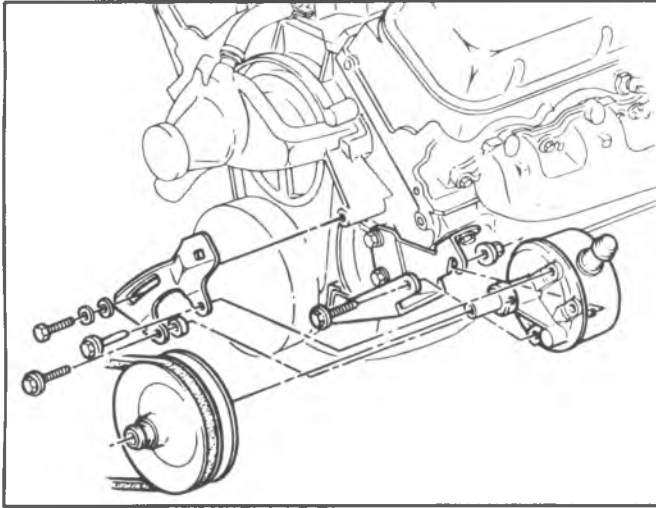


Fig. 3B3-26-P/S Pump Mounting; P300 (32)
With LE8 Engine

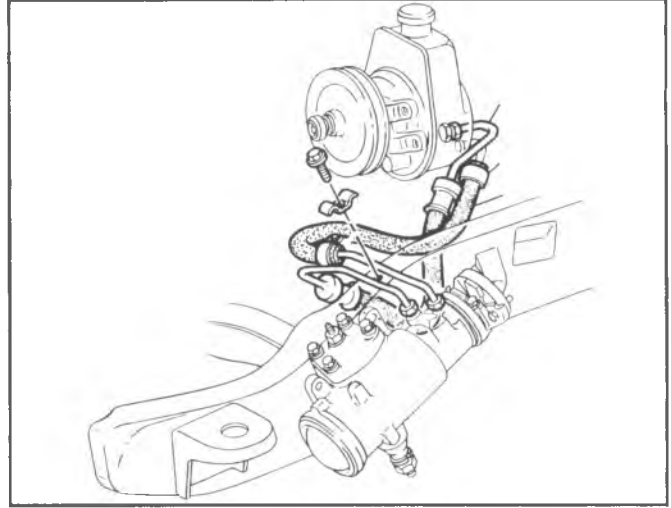


Fig. 3B3-29-P/S Hose Routing; CK100, CK 200, CK 300
LE4, LG9, LS9, LT9 (Exc. C60, JB8)

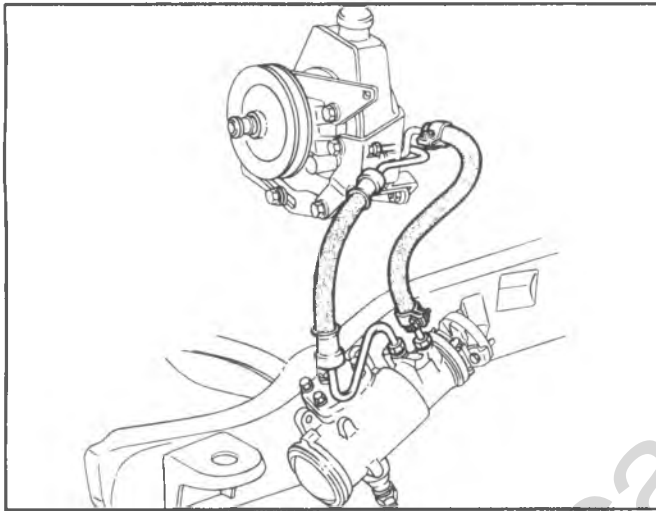


Fig. 3B3-27-P/S Hose Routing; CK100, CK200 (03)
With LE3 Engine

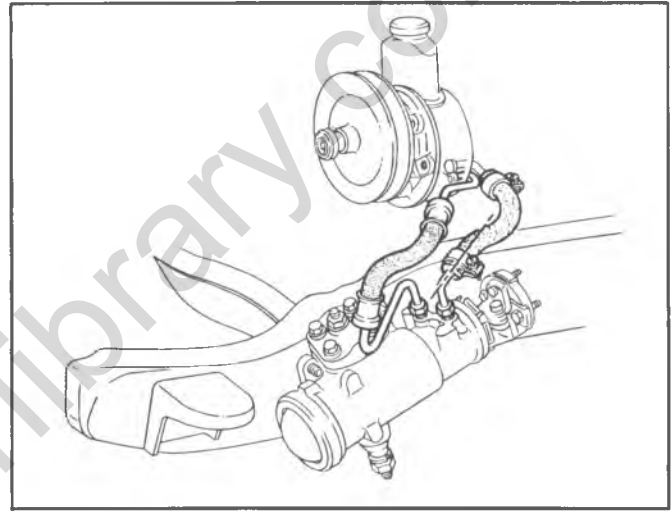


Fig. 3B3-30-P/S Hose Routing; C100, C200, C300
With LE8 Engine

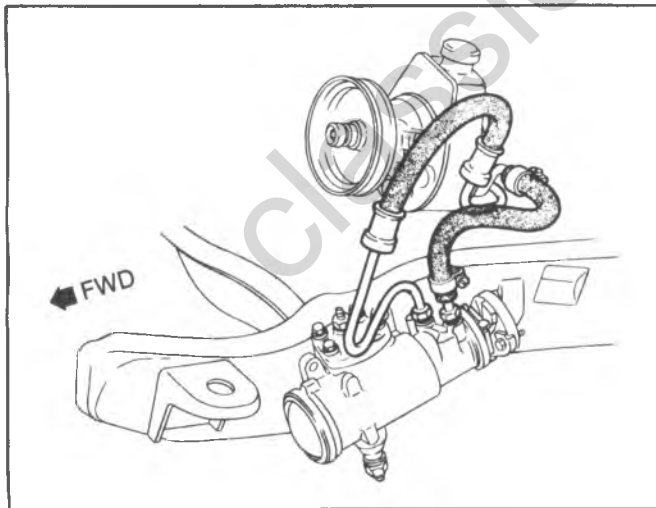


Fig. 3B3-28-P/S Hose Routing; CK200, CK300
With L25 Engine

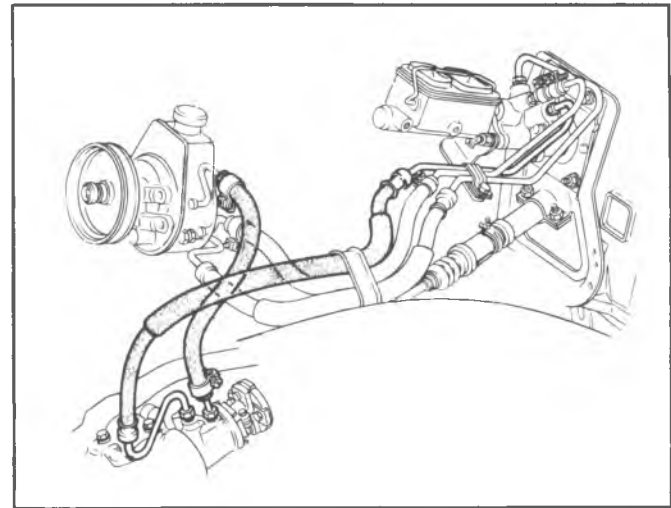


Fig. 3B3-31-P/S Hose Routing; CK300
With L25 and JB8

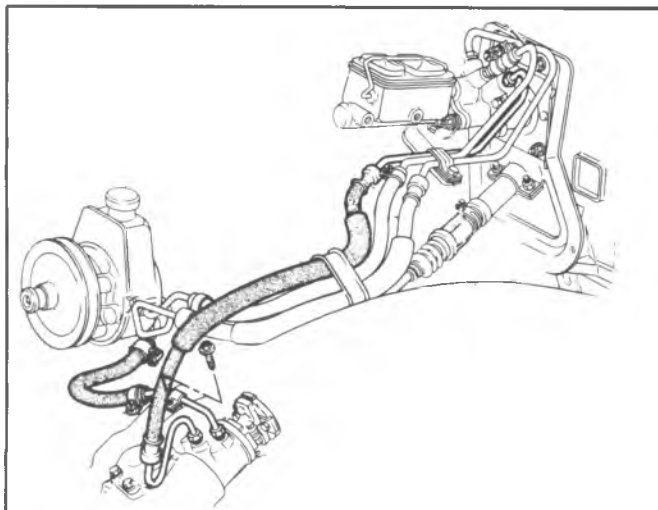


Fig. 3B3-32-P/S Hose Routing; CK300
LE4, LF5, LT9, and JB8

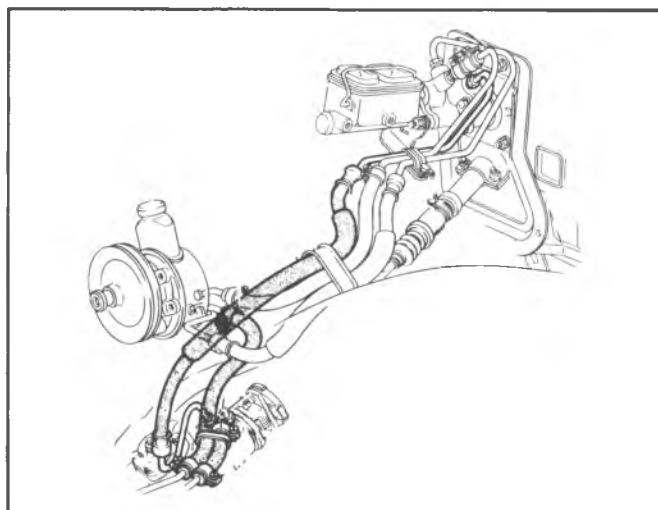


Fig. 3B3-35-P/S Hose Routing; C300
LE8 and JB8/HC4

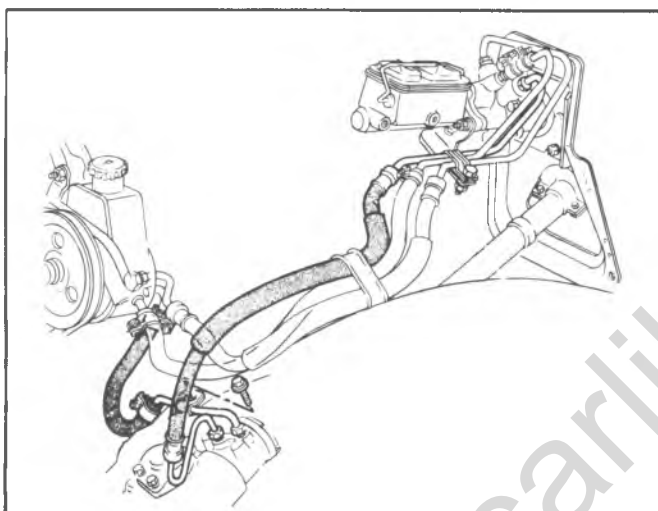


Fig. 3B3-33-P/S Hose Routing; CK 100 (03)
With LF9 Engine; and JB3, JB5

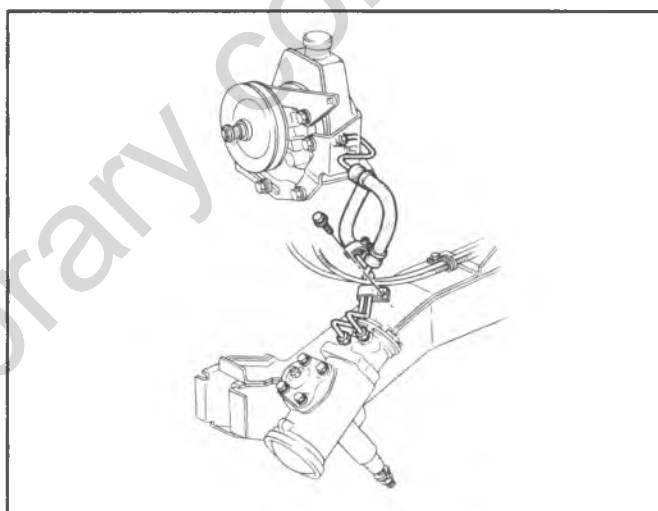


Fig. 3B3-36-P/S Hose Routing; G100, G200, G300
With LE3 Engine

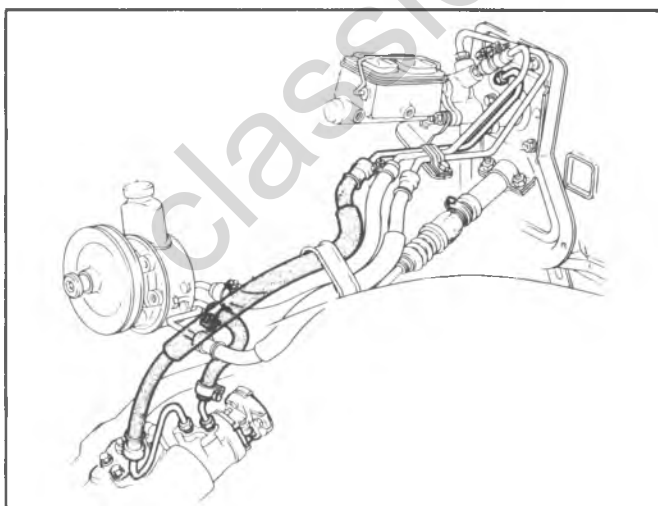


Fig. 3B3-34-P/S Hose Routing; C300
LE8 and JB8 (Exc. HC4)

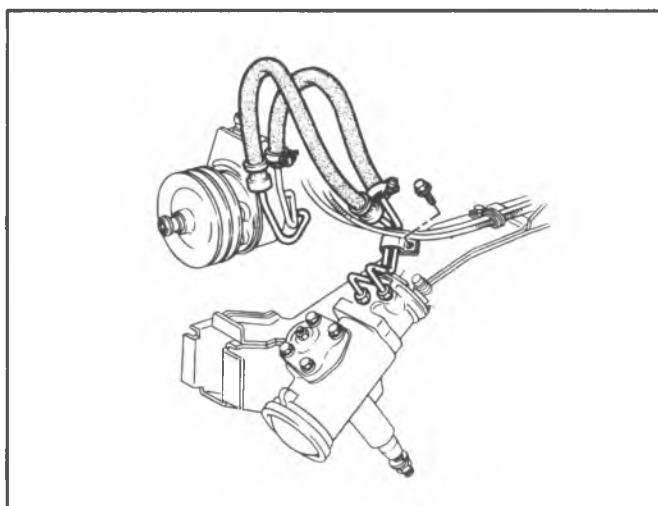


Fig. 3B3-37-P/S Hose Routing; G100, G200, G300
LE4, LG9, LF4, LS9, LT9, and JB7

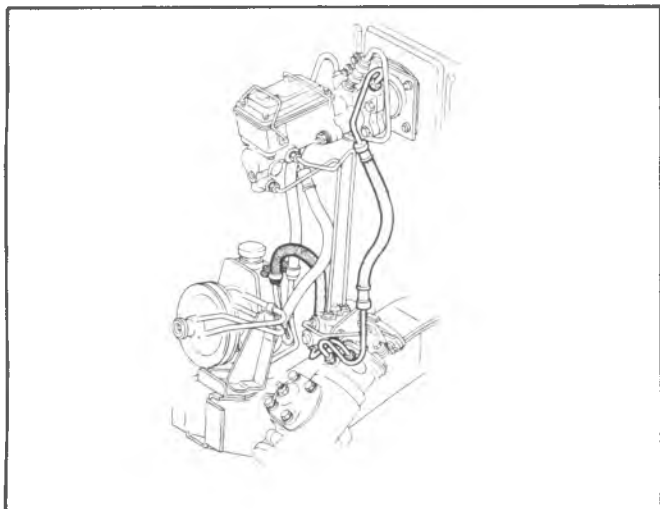


Fig. 3B3-38-P/S Hose Routing; G300
LE4, LG9, LT9, and JB8

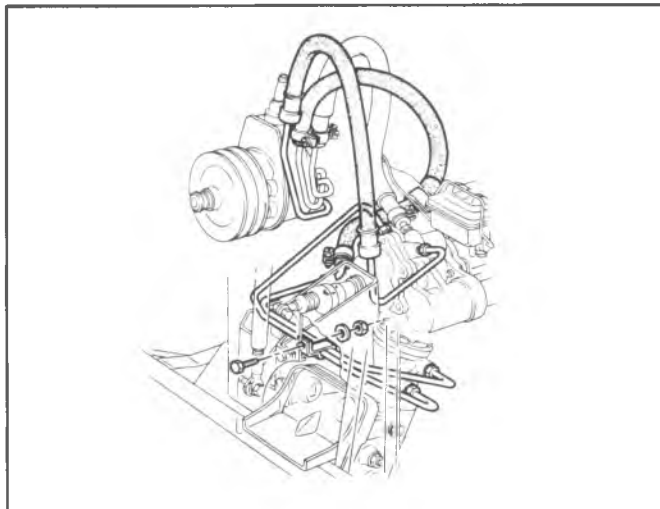


Fig. 3B3-41-P/S Hose Routing; P300 (32)
With LT9 Engine

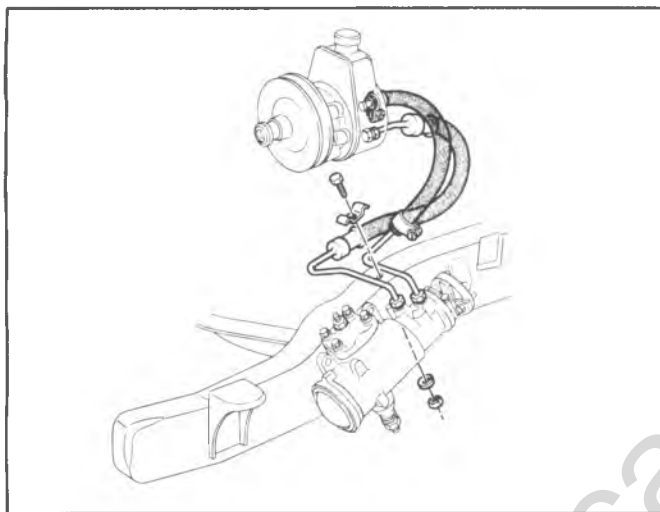


Fig. 3B3-39-P/S Hose Routing; P200, P300 (42)
With L25 Engine and JB7

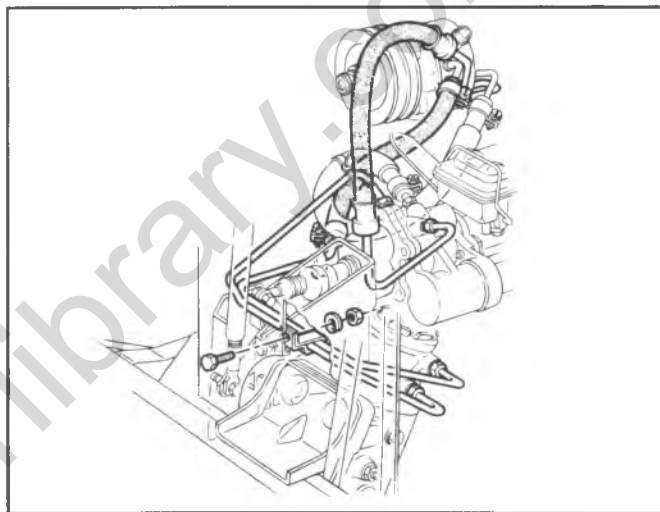


Fig. 3B3-42-P/S Hose Routing; P300 (32)
With LE8 Engine

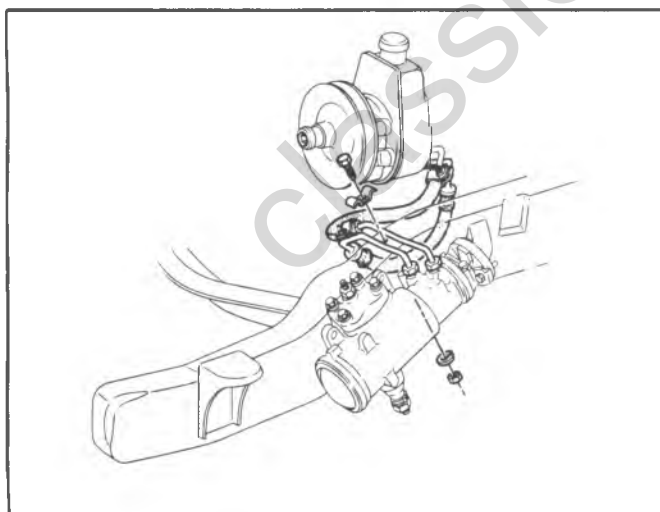


Fig. 3B3-40-P/S Hose Routing; P200, P300 (42)
With LT9 Engine and JB7

SECTION 3B4

STEERING COLUMNS

The following notice applies to one or more steps in the assembly procedure of components in this portion of the manual as indicated at appropriate locations by the terminology "See Notice on page 1 of this Section".

NOTICE: This fastener is an important attaching part in that it could affect the performance of vital components and systems, and/or could result in major repair expense. It must be replaced with one of the same part number or with an equivalent part if replacement becomes necessary. Do not use a replacement part of lesser quality or substitute design. Torque values must be used as specified during reassembly to assure proper retention of this part.

CONTENTS

| | |
|-----------------------------------|--------|
| General Description | 3B4-1 |
| Diagnosis | 3B4-2 |
| Maintenance and Adjustments | 3B4-16 |
| On-Vehicle Service | 3B4-18 |
| C-Series, K-Series | 3B4-18 |
| G-Series, P-Series | 3B4-35 |
| Specifications | 3B4-51 |
| Special Tools | 3B4-52 |

GENERAL DESCRIPTION

FUNCTION LOCKING COLUMNS

The function locking energy absorbing steering column includes three important features in addition to the steering function:

1. The column is energy absorbing, designed to compress in a front-end collision to minimize the possibility of injury to the driver of the vehicle.
2. The ignition switch and lock are mounted conveniently on the column.
3. With the column mounted lock, the ignition, steering and gearshifting operation can be locked to inhibit theft of the vehicle.

The function locking energy absorbing column may be easily disassembled and reassembled. The serviceman should be aware that it is important that only the specified screws, bolts and nuts be used as designated and that they are tightened to their specified torque. This precaution will insure the energy absorbing action of the assembly. Over-length bolts should not be used, as they may prevent a portion of the assembly from compressing under impact. Equally as important is correct torque of bolts and nuts.

Care should be taken to assure that the bolts or nuts securing the column mounting bracket to the instrument panel are torqued to the proper specification in order that the bracket will break away under impact.

When the function locking energy absorbing column assembly is installed in a vehicle, it is no more susceptible to damage through usage than an ordinary column; however, when the column is removed, special care must be taken in handling this assembly. Only the specified wheel puller should be used. When the column is removed from the vehicle, such actions as a sharp blow on the end of the steering shaft or shift lever, leaning on the column assembly, or dropping of the assembly could shear or loosen the plastic fasteners that maintain column rigidity. It is, therefore, important that the removal and installation and the disassembly and reassembly procedures be carefully followed when servicing the assembly.

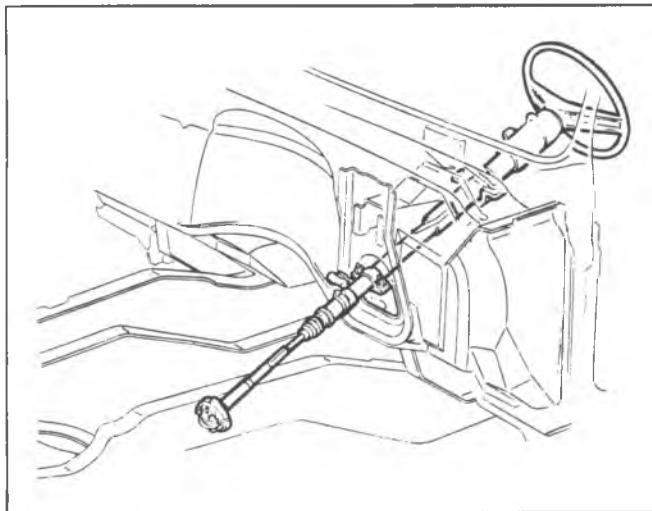


Fig. 3B4-1--Steering Column

DIAGNOSIS

GENERAL INFORMATION

This section contains diagnostic information to help locate the cause of the problem in the column. Reference should be made to the correct method of column disassembly, repair, adjustment and reassembly. Damaged, broken or deformed parts must be replaced with the correct replacement.

To perform diagnostic procedures on the steering column upper end components, it is not necessary to remove the column from the vehicle.

The steering wheel, horn components, directional signal switch, ignition switch and lock cylinder may be removed with the column remaining in the vehicle as described in the Service Manual under "Component Part Replacement".

CAUTION: The outer mast jacket shift tube, steering shaft and instrument panel mounting bracket are designed as energy absorbing units. Because of the design of these components, it is absolutely necessary to handle the column with care when performing any service operation. Avoid hammering, jarring, dropping or leaning on any portion of the column. When reassembling the column components, use only the specified screws, nuts and bolts and tighten to specified torque. Care should be exercised not to use over-length screws or bolts as they may prevent a portion of the column from compressing under impact. Personal injury could result from lack of care when servicing the steering column.

STEERING COLUMN ELECTRICAL ANALYZER J-23980

For C-Series and K-Series (Fig. 3B4-2)

Tool J-23980 will help the technician analyze the steering column wiring harness for electrical problems. The tool in actuality eliminates the steering column, related wiring and components; and replaces them with the tool itself. In this way disassembly of the column is not performed until the problem has been determined to be in the column. By moving the tester switch, (with the key in the "on" position), the various functions may be checked. The switch positions are "OFF", "HORN", "LEFT

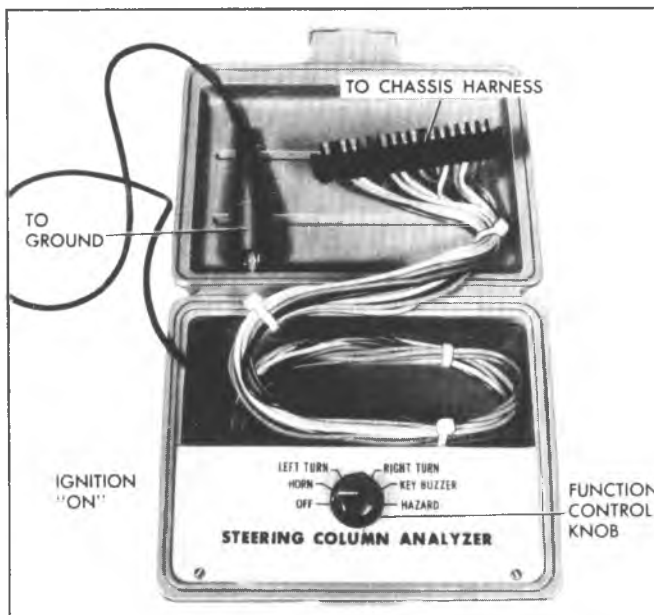


Fig. 3B4-2--Steering Column Electrical Analyzer J-23980

TURN", "RIGHT TURN", "KEY BUZZER", and "HAZARD". (Trucks do not incorporate a Key Buzzer Switch) if the systems function properly while using the tester, then the malfunction has been narrowed to the column wiring or components. When this has been determined then the column may be serviced to correct the malfunction.

To use the tool just unfasten the harmonica connector on the column and plug the harness from J-23980 into the vehicle chassis harness. The "A", "B", and "C" terminals on the tester will overhang the chassis connector. This does not affect the test results. These terminals are for vehicles with cornering lights. Connect the single black jumper to a good ground. The tester is now ready for use (Fig. 3B4-2).

COLLISION DIAGNOSIS (FIGS. 3B4-3 THROUGH 3B4-8)

To determine if the energy absorbing steering column components are functioning as designed, or if repairs are required, a close inspection should be made. An inspection is called for in all cases where damage is evident or whenever the vehicle is being repaired due to a front end collision. Whenever a force has been exerted on the steering wheel or steering column, or its components, inspection should also be made. If damage is evident, the affected parts must be replaced.

The inspection procedure for the various steering column components on C and K trucks is as follows:

Column Support Bracket

Damage in this area will be indicated by separation of the mounting capsules from the bracket. The bracket will have moved forward toward the engine compartment and will usually result in collapsing of the jacket section of the steering column.

COLUMN JACKET

Inspect jacket section of column for looseness, and/or bends.

SHIFTER SHAFT

Separation of the shifter shaft sections will be internal and cannot be visually identified. Hold lower end of the "shifter shaft" and move "shift lever" on column through its ranges and up and down. If there is little or no movement of the "shifter shaft", the plastic joints are sheared.

Steering Shaft

If the steering shaft plastic pins have been sheared, the shaft will rattle when struck lightly from the side and some lash may be felt when rotating the steering wheel while holding the rag joint. It should be noted that if the steering shaft pins are sheared due to minor collision with no appreciable damage to other components, that the vehicle can be safely steered; however, steering shaft replacement is recommended.

Because of the differences in the steering column types, be sure to refer to the set of instructions below which apply to the column being serviced.

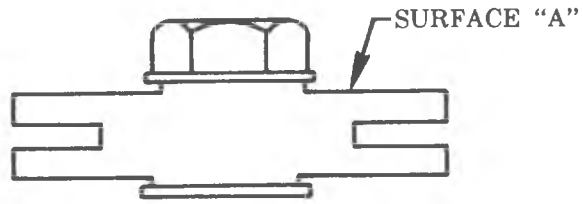
METHOD TO DETERMINE COLUMN COLLAPSE

Measure distance between top of neutral-start switch window opening and the bottom of the upper jacket. The correct value is shown below:

- a. C-Truck 5 11/16" to 5 1/2".
- b. K-Truck 5 11/16" to 5 1/2".

Instrument Panel Bracket Capsule Damage

NOTE: The bolt head must not contact surface "A". If contact is made, the capsule shear load will be increased. If this condition exists replace the bracket.



AUTOMATIC TRANSMISSION COLUMNS

LOCK SYSTEM – WILL NOT UNLOCK

| Cause | Solution |
|--|-------------------------------------|
| A. Lock bolt damaged. | A. Replace lock bolt. |
| B. Defective lock cylinder. | B. Replace or repair lock cylinder. |
| C. Damaged housing. | C. Replace housing. |
| D. Damaged or collapsed sector. | D. Replace sector. |
| E. Damaged rack. | E. Replace rack. |
| F. Shear Flange on sector shaft collapsed. | F. Replace. |

LOCK SYSTEM - WILL NOT LOCK

| Cause | Solution |
|---|------------------------------------|
| A. Lock bolt spring broken or defective. | A. Replace spring. |
| B. Damaged sector tooth, or sector installed incorrectly. | B. Replace, or install correctly. |
| C. Defective lock cylinder. | C. Replace lock cylinder |
| D. Burr or lock bolt or housing. | D. Remove Burr. |
| E. Damaged housing. | E. Replace housing. |
| F. Transmission linkage adjustment incorrect. | F. Readjust (see Sec. 7). |
| G. Damaged rack. | G. Replace rack. |
| H. Interference between bowl and coupling (tilt). | H. Adjust or replace as necessary. |
| I. Ignition switch stuck. | I. Readjust or replace. |
| J. Actuator rod restricted or bent. | J. Readjust or replace. |

LOCK SYSTEM – HIGH EFFORT

| Cause | Solution |
|--|----------------------------|
| A. Lock cylinder defective. | A. Replace lock cylinder. |
| B. Ignition switch defective. | B. Replace switch. |
| C. Rack preload spring broken or deformed. | C. Replace spring. |
| D. Burrs on sector, rack, housing, support, tang of shift gate or actuator rod coupling. | D. Remove Burr. |
| E. Bent sector shaft. | E. Replace shaft. |
| F. Distorted rack. | F. Replace rack |
| G. Misalignment of housing to cover (tilt only). | G. Replace either or both. |

Fig. 3B4-3--Automatic Transmission Column Diagnosis Chart A

| LOCK SYSTEM – HIGH EFFORT (CONT'D.) | |
|---|---|
| Cause | Solution |
| H. Distorted coupling slot in rack (tilt). I. Bent or restricted actuator rod. J. Ignition switch mounting bracket bent. | H. Replace rack. I. Straighten remove restriction or replace. J. Straighten or replace. |
| HIGH EFFORT LOCK CYLINDER – BETWEEN "OFF" AND "OFF-LOCK" POSITIONS | |
| Cause | Solution |
| A. Burr on tang of shift gate. B. Distorted rack. | A. Remove burr. B. Replace rack. |
| STICKS IN "START" POSITION | |
| Cause | Solution |
| A. Actuator rod deformed. B. Any high effort condition. | A. Straighten or replace. B. Check items under high effort section. |
| KEY CAN NOT BE REMOVED IN "OFF-LOCK" POSITION | |
| Cause | Solution |
| A. Ignition switch is not set correctly. B. Defective lock cylinder. | A. Readjust ignition switch. B. Replace lock cylinder. |
| LOCK CYLINDER CAN BE REMOVED WITHOUT DEPRESSING RETAINER | |
| Cause | Solution |
| A. Lock cylinder with defective retainer. B. Lock cylinder without retainer. C. Burr over retainer slot in housing cover. | A. Replace lock cylinder. B. Replace lock cylinder. C. Remove burr. |
| LOCK BOLT HITS SHAFT LOCK IN "OFF" AND "PARK" POSITIONS | |
| Cause | Solution |
| A. Ignition switch is not set correctly. | A. Readjust ignition switch. |
| IGNITION SYSTEM – ELECTRICAL SYSTEM WILL NOT FUNCTION | |
| Cause | Solution |
| A. Defective fuse in "accessory" circuit. B. Connector body loose or defective. C. Defective wiring. | A. Replace fuse. B. Tighten or replace. C. Repair or replace. |

Fig. 3B4-4--Automatic Transmission Column Diagnosis Chart B

**IGNITION SYSTEM – ELECTRICAL SYSTEM –
WILL NOT FUNCTION (CONT'D.)**

| Cause | Solution |
|---|------------------------------|
| D. Defective ignition switch. | D. Replace ignition switch. |
| E. Ignition switch not adjusted properly. | E. Readjust ignition switch. |

SWITCH WILL NOT ACTUATE MECHANICALLY

| Cause | Solution |
|-------------------------------|-----------------------------|
| A. Defective ignition switch. | A. Replace ignition switch. |

SWITCH CAN NOT BE SET CORRECTLY

| Cause | Solution |
|--|---|
| A. Switch actuator rod deformed. | A. Repair or replace switch actuator rod. |
| B. Sector to rack engaged in wrong tooth (tilt). | B. Engage sector to rack correctly. |

NOISE IN COLUMN

| Cause | Solution |
|---|--|
| A. Coupling bolts loose. | A. Tighten pinch bolts to specified torque. |
| B. Column not correctly aligned. | B. Realign column. |
| C. Coupling pulled apart. | C. Replace coupling and realign column. |
| D. Sheared intermediate shaft plastic joint. | D. Replace or repair steering shaft and realign column. |
| E. Horn contact ring not lubricated. | E. Lubricate with lubriplate. |
| F. Lack of grease on bearings or bearing surfaces. | F. Lubricate bearings. |
| G. Lower shaft bearing tight or frozen. | G. Replace bearing. Check shaft and replace if scored. |
| H. Upper shaft tight or frozen. | H. Replace housing assembly. |
| I. Shaft lock plate cover loose. | I. Tighten three screws or, if missing, replace. CAUTION: Use specified screws. (15 in. lbs.) |
| J. Lock plate snap ring not seated. | J. Replace snap ring. Check for proper seating in groove. |
| K. Defective buzzer dog cam on lock cylinder. | K. Replace lock cylinder. |
| L. One click when in "off-lock" position and the steering wheel is moved. | L. Normal condition - lock bolt is seating. |

Fig. 3B4-5—Automatic Transmission Column Diagnosis Chart C

HIGH STEERING SHAFT EFFORT

| Cause | Solution |
|---|---|
| <ul style="list-style-type: none"> A. Column assembly misaligned in vehicle. B. Improperly installed or deformed dust seal. C. Tight or frozen upper or lower bearing. D. Flash on I.D. of shift tube from plastic joint. | <ul style="list-style-type: none"> A. Realign. B. Remove and replace. C. Replace affected bearing or bearings. D. Replace shift tube. |

HIGH SHIFT EFFORT

| Cause | Solution |
|--|--|
| <ul style="list-style-type: none"> A. Column not aligned correctly in car. B. Improperly installed dust seal. C. Lack of grease on seal or bearing areas. D. Burr on upper or lower end of shift tube. E. Lower bowl bearing not assembled properly (tilt). F. Wave washer with burrs (tilt only). | <ul style="list-style-type: none"> A. Realign. B. Remove and replace. C. Lubricate bearings and seals. D. Remove burr. E. Reassemble properly. F. Replace wave washer. |

IMPROPER TRANSMISSION SHIFTING

| Cause | Solution |
|--|--|
| <ul style="list-style-type: none"> A. Sheared shift tube joint. B. Improper transmission linkage adjustment. C. Loose lower shift lever. D. Improper gate plate. E. Sheared lower shift lever weld. | <ul style="list-style-type: none"> A. Replace shift tube assembly. B. Readjust linkage. C. Replace shift tube assembly. D. Replace with correct part. E. Replace tube assembly. |

LASH IN MOUNTED COLUMN ASSEMBLY

| Cause | Solution |
|--|--|
| <ul style="list-style-type: none"> A. Instrument panel mounting bolts loose. B. Broken weld nuts on jacket. C. Instrument panel bracket capsule sheared. D. Instrument panel to jacket mounting bolts loose. E. Loose shoes in housing (tilt only). F. Loose tilt head pivot pins (tilt only). G. Loose shoe lock pin in support (tilt only). | <ul style="list-style-type: none"> A. Tighten to specifications. (20 ft. lbs.) B. Replace jacket assembly. C. Replace bracket assembly. D. Tighten to specifications. (15 ft. lbs.) E. Replace. F. Replace. G. Replace. |

MISCELLANEOUS

| Cause | Solution |
|--|--|
| <ul style="list-style-type: none"> A. Housing loose on jacket - will be noticed with ignition in "Off-Lock" and a torque applied to the steering wheel. B. Shroud loose on shift bowl. | <ul style="list-style-type: none"> A. Tighten four mounting screws - (60 in. lbs.) B. Bend tabs on shroud over lugs on bowl. |

Fig. 3B4-6--Automatic Transmission Column Diagnosis Chart D

MANUAL TRANSMISSION COLUMNS

GENERAL INFORMATION

All of the preceding diagnosis information for automatic transmission will apply to the manual transmission. The following information is supplied in addition to and specifically for manual transmission columns.

DRIVER CAN LOCK STEERING IN SECOND GEAR

| Cause | Solution |
|---|---------------------------------|
| A. Defective upper shift lever. | A. Replace shift lever. |
| B. Defective shift lever gate. | B. Replace shift lever gate. |
| C. Loose relay lever on shift tube. | C. Replace shift tube assembly. |
| D. Use of upper shift lever prior to 1969 model year. | D. Replace with current lever. |

HIGH SHIFT EFFORT

| Cause | Solution |
|---|---|
| A. Column not aligned correctly in car. | A. Realign column. |
| B. Lower bowl bearing not assembled correctly. | B. Reassemble correctly. |
| C. Improperly installed seal. | C. Remove and replace. |
| D. Wave washer in lower bowl bearing defective. | D. Replace wave washer. |
| E. Improper adjustment of lower shift levers. | E. Readjust (see Sec. 7). |
| F. Lack of grease on seal, bearing areas or levers. | F. Lubricate seal, levers and bearings. |
| G. Damaged shift tube in bearing areas. | G. Replace shift tube assembly. |

IMPROPER TRANSMISSION SHIFTING

| Cause | Solution |
|-------------------------------------|---------------------------------|
| A. Loose relay lever on shift tube. | A. Replace shift tube assembly. |

Fig. 3B4-7—Manual Transmission Column Diagnosis

TILT COLUMNS**GENERAL INFORMATION**

All of the preceding diagnosis will generally apply to tilt columns. The following is supplied in addition to and specifically for tilt columns.

HOUSING SCRAPING ON BOWL

| Cause | Solution |
|--|------------------|
| A. Bowl bent or not concentric with hub. | A. Replace bowl. |

STEERING WHEEL LOOSE

| Cause | Solution |
|---|--------------------------------|
| A. Excessive clearance between holes in support or housing and pivot pin diameters. | A. Replace either or both. |
| B. Defective or missing anti-lash spring in spheres. | B. Add spring or replace both. |
| C. Upper bearing seat not seating in bearing. | C. Replace both. |
| D. Upper bearing inner race seat missing. | D. Install seat. |
| F. Loose support screws. | F. Tighten to 60 in. lbs. |
| G. Bearing preload spring missing or broken. | G. Replace preload spring. |

STEERING WHEEL LOOSE EVERY OTHER TILT POSITION

| Cause | Solution |
|---|------------------|
| A. Loose fit between shoe and shoe pivot pin. | A. Replace both. |

NOISE WHEN TILTING COLUMN

| Cause | Solution |
|------------------------------------|-------------------------|
| A. Upper tilt bumper worn. | A. Replace tilt bumper. |
| B. Tilt spring rubbing in housing. | B. Lubricate. |

STEERING COLUMN NOT LOCKING IN ANY TILT POSITION

| Cause | Solution |
|---|--------------------------------|
| A. Shoe seized on its pivot pin. | A. Replace shoe and pivot pin. |
| B. Shoe grooves may have burrs or dirt. | B. Replace shoe. |
| C. Shoe lock spring weak or broken. | C. Replace lock spring. |

STEERING WHEEL FAILS TO RETURN TO TOP TILT POSITION

| Cause | Solution |
|--|-------------------------|
| A. Pivot pins are bound up. | A. Replace pivot pins. |
| B. Wheel tilt spring is defective. | B. Replace tilt spring. |
| C. Turn signal switch wires too tight. | C. Reposition wires. |

Fig. 3B4-8--Tilt Column Diagnosis

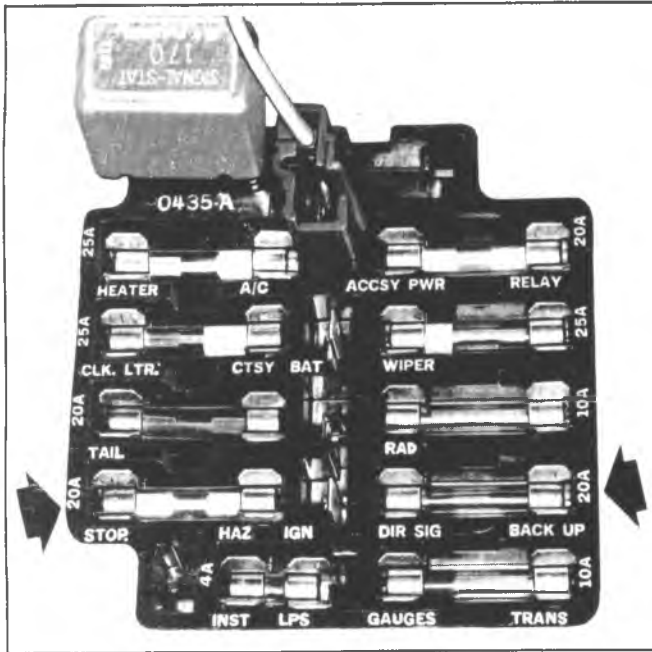


Fig. 3B4-9--Checking Fuses on Fuse Block

TURN SIGNAL DIAGNOSIS C AND K SERIES

Figs. 3B4-9 Through 3B4-16

When a complaint is made involving the turn signal system, it must first be determined whether the problem is mechanical or electrical. If mechanical, the switch itself is at fault and must be repaired or replaced. If electrical, J-23980 should be used to determine whether the switch, or the chassis wiring is in need of repair or replacement.

This diagnostic procedure has been designed to guide the mechanic through the proper diagnosis and repair of the turn signal system. The service section is to be used where assembly and/or disassembly procedures are required. The wiring diagram, found in Section 12, should be used to trouble shoot the chassis and body wiring after the problem has been isolated.

The nature of the customer complaint will generally point to the problem area.

Electrical

Chassis Electrical

The most common turn signal system problems are generally electrical and may easily, be fixed by the replacement of **fuses, bulbs, or flashers**.

First make these checks and replace any non-operative components.

1. **Check fuses** (Figure 3B4-9). Replace if blown. If new fuse blows, replace flasher in system. (There are 2 flashers in the signal switch system. The hazard warning flasher and turn signal flasher are located on the fuse block.

2. Check for secure connection at the chassis to switch connector. This is the harmonica connector on the column (Figure 3B4-10). Secure if loose. Check all individual wire terminals for proper seating in the connector bodies. Terminals should be locked in place.

3. Depress hazard warning button and check all lights in signal switch system. Replace any which do not work.

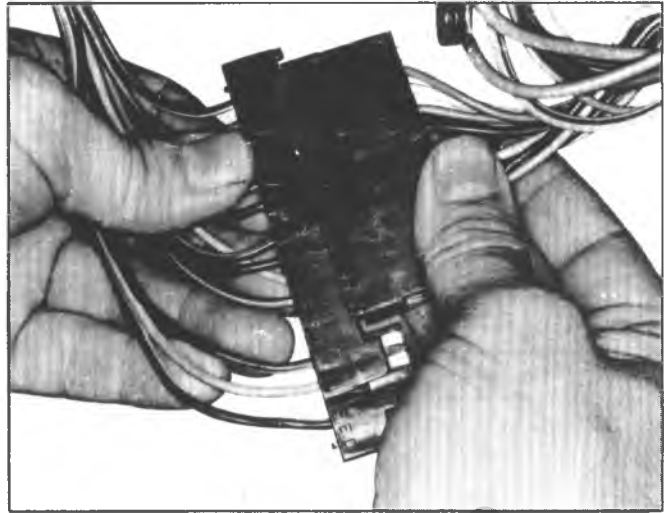


Fig. 3B4-10--Checking Harmonica Connector on Column

If **all** lamps light when hazard warning is depressed, but flashing does not occur, replace hazard warning flasher. (On fuse block) (Figure 3B4-11).

4. If **all** directional lamps light when lane change or turn indicator is actuated, but no flashing occurs, replace the turn signal flasher.

The above four steps will, in most cases, cure the common signal switch system troubles. If the system is still not operating correctly, use J-23980 to determine whether the chassis wiring or the signal switch itself is at fault.

Mechanical

1. If the customer's complaint indicates the problem is in the switch, function check as to return from full left and full right turns.

Actuate the turn lever into a full turn position in either direction, then turn the steering wheel (motor on - power steering) at least 1/4 turn in the direction indicated and then

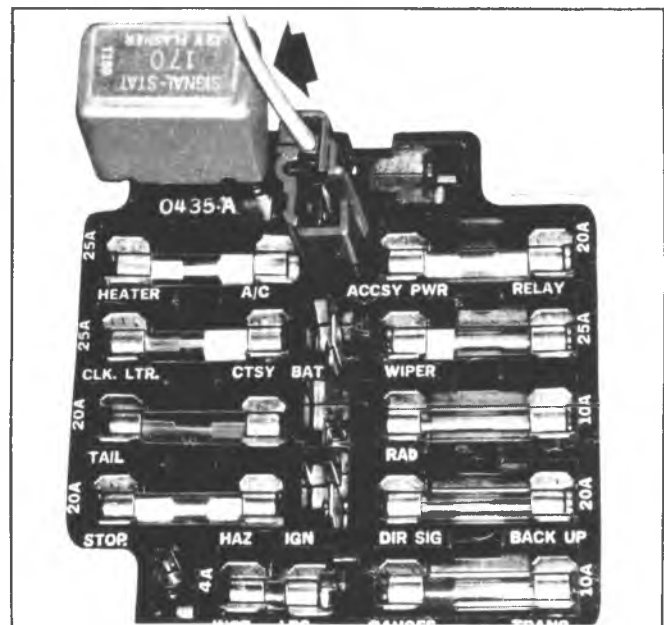


Fig. 3B4-11--Checking Hazard Warning Flasher

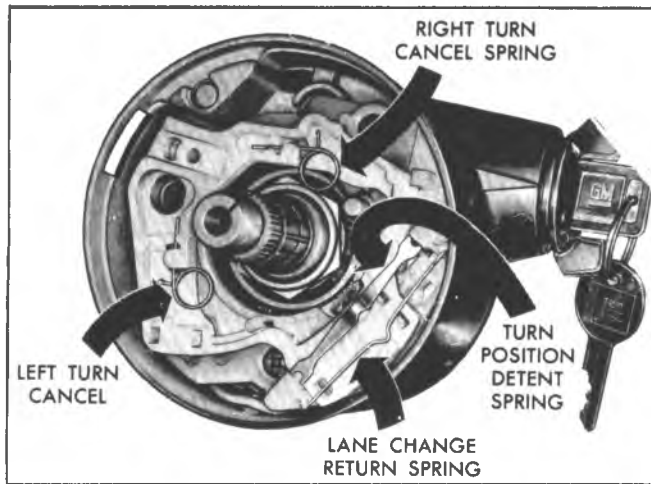


Fig. 3B4-12--Checking Turn Signal Switch Visually

back to center. Do this in both directions. If the lever does not return to the neutral position, disassemble the upper part of the column until the switch is visible.

2. Check the return from lane change by holding the lever in lane change and releasing (both left and right). If the lever does not return to neutral, disassemble the upper part of the column.

3. If the hazard warning button cannot be depressed or released, the switch must be replaced.

Switch Visual Inspection

1. With the upper part of the column disassembled so that the signal switch is visible (Figure 3B4-12) check for missing springs. Replace any spring that is missing, inspecting the molded pins which secure them. If these pins are broken, the switch must be replaced.

2. Check the position of the switch in the bowl. If it appears cocked or crooked, loosen the securing screws (3) and visually inspect the switch. If any of the plastic is broken or badly deformed, the switch must be replaced.

3. If the switch appears undamaged, replace it being careful to seat the pilot into the housing, tighten the screws to 25 lbs. in. of torque.

SIGNAL SWITCH DIAGNOSIS

| CONDITION | POSSIBLE CAUSE | CORRECTION |
|--|---|---|
| Turn signal will not cancel | <ul style="list-style-type: none"> A. Loose switch mounting screws B. Switch or anchor bosses broken C. Broken, missing or out of position detent, return or cancelling spring D. Uneven or incorrect cancelling cam to cancelling spring interference. (.120)/side | <ul style="list-style-type: none"> A. Tighten to specified torque (25 in-lbs) B. Replace switch C. Reposition or replace springs as required D. Adjust switch position <ol style="list-style-type: none"> 1. If interference is correct and switch will still not cancel, replace switch. 2. If interference cannot be corrected by switch adjustment, replace cancelling cam. |
| Turn signal difficult to operate | <ul style="list-style-type: none"> A. Actuator rod loose B. Yoke broken or distorted C. Loose or misplaced springs D. Foreign parts and/or materials E. Switch mounted loosely | <ul style="list-style-type: none"> A. Tighten mounting screw (12 in-lb) B. Replace switch C. Reposition or replace springs D. Remove foreign parts and/or material E. Tighten mounting screws (25 in-lbs) |
| Turn signal will not indicate lane change | <ul style="list-style-type: none"> A. Broken lane change pressure pad or spring hanger B. Broken, missing or misplaced lane change spring C. Jammed base or wires | <ul style="list-style-type: none"> A. Replace switch B. Replace or reposition as required C. Loosen mounting screws, reposition base or wires and retighten screws (25 in-lbs) |
| Turn signal will not stay in turn position | <ul style="list-style-type: none"> A. Foreign material or loose parts impeding movement of yoke B. Broken or missing detent or cancelling springs C. None of the above | <ul style="list-style-type: none"> A. Remove material and/or parts B. Replace spring C. Replace switch |
| Hazard switch cannot be turned off | <ul style="list-style-type: none"> A. Foreign material between hazard support cancelling leg and yoke | <ul style="list-style-type: none"> A. Remove foreign material <ol style="list-style-type: none"> 1. No foreign material impeding function of hazard switch – replace turn signal switch |

Fig. 3B4-13—Turn Signal Switch Diagnosis Chart A

SIGNAL SWITCH DIAGNOSIS

| CONDITION | POSSIBLE CAUSE | CORRECTION |
|---|--|---|
| Hazard switch will not stay on or difficult to turn off | A. Loose switch mounting screws B. Interference with other components C. Foreign material D. None of the above | A. Tighten mounting screws (25 in-lbs) B. Remove interference C. Remove foreign material D. Replace switch |
| No turn signal lights | A. Defective or blown fuse B. Inoperative turn signal flasher C. Loose chassis to column connector D. Disconnect column to chassis connector. Connect new switch to chassis and operate switch by hand. If vehicle lights now operate normally, signal switch is inoperative E. If vehicle lights do not operate check chassis wiring for opens, grounds, etc. | A. Replace fuse and check operation B. Replace turn signal flasher C. Connect securely, check operation D. Replace signal switch E. Repair chassis wiring as required using manual as guide |
| Turn indicator lights on, but not flashing | A. Inoperative turn flasher B. Loose chassis to column connection C. Inoperative turn signal switch D. To determine if turn signal switch is defective, substitute new switch into circuit and operate switch by hand. If the vehicle's lights operate normally, signal switch is inoperative E. If the vehicle's lights do not operate, check light sockets for high resistance connections, the chassis wiring for opens, grounds, etc. | A. Replace turn flasher Note: There are two flashers in the system. Consult manual for location. B. Connect securely and check operation C. Replace turn signal switch D. Replace signal switch E. Repair chassis wiring as required using manual as guide |

Fig. 3B4-14--Turn Signal Switch Diagnosis Chart B

SIGNAL SWITCH DIAGNOSIS

| CONDITION | POSSIBLE CAUSE | CORRECTION |
|---|---|--|
| Front or rear turn signal lights not flashing | <p>A. Burned out fuse</p> <p>B. Burned out or damaged turn signal bulb</p> <p>C. High resistance connection to ground at bulb socket</p> <p>D. Loose chassis to column connector</p> <p>E. Disconnect column to chassis connector. Connect new switch into system and operate switch by hand. If turn signal lights are now on and flash, turn signal switch is inoperative.</p> <p>F. If vehicle lights do not operate, check chassis wiring harness to light sockets for opens, grounds, etc.</p> | <p>A. Replace fuse and check operation</p> <p>B. Replace bulb</p> <p>C. Remove or repair defective connection and check operation</p> <p>D. Connect securely and check operation</p> <p>E. Replace turn signal switch.</p> <p>F. Repair chassis wiring as required using manual as guide</p> |
| Stop light not on when turn indicated | <p>A. Burned out fuse</p> <p>B. Loose column to chassis connection</p> <p>C. Disconnect column to chassis connector. Connect new switch into system without removing old. Operate switch by hand. If brake lights work with switch in the turn position, signal switch is defective</p> <p>D. If brake lights do not work check connector to stop light sockets for grounds, opens, etc.</p> | <p>A. Replace fuse and check operation</p> <p>B. Connect securely and check operation</p> <p>C. Replace signal switch</p> <p>D. Repair connector to stop light circuits using manual as guide.</p> |
| Turn indicator panel lights not flashing | <p>A. Burned out bulbs</p> <p>B. High resistance to ground at bulb socket</p> <p>C. Opens, grounds in wiring harness from front turn signal bulb socket to indicator lights</p> | <p>A. Replace bulbs</p> <p>B. Replace socket</p> <p>C. Locate and repair as required. Use shop manual as guide.</p> |

Fig. 3B4-15--Turn Signal Switch Diagnosis Chart C

SIGNAL SWITCH DIAGNOSIS

| CONDITION | POSSIBLE CAUSE | CORRECTION |
|--|---|--|
| Turn signal lights flash very slowly | <p>A. Inoperative turn signal flasher</p> <p>B. System charging voltage low</p> <p>C. High resistance ground at light sockets</p> <p>D. Loose chassis to column connection</p> <p>E. Disconnect column to chassis connector. Connect new switch into system without removing old. Operate switch by hand. If flashing occurs at normal rate, the signal switch is defective.</p> <p>F. If the flashing rate is still extremely slow, check chassis wiring harness from the connector to light sockets for grounds, high resistance points, etc.</p> | <p>A. Replace turn signal flasher</p> <p>B. Increase voltage to specified. See Sec. 6Y</p> <p>C. Repair high resistance grounds at light sockets</p> <p>D. Connect securely and check operation</p> <p>E. Replace signal switch</p> <p>F. Locate and repair as required. Use manual as guide. See Section 12</p> |
| Hazard signal lights will not flash — turn signal functions normally | <p>A. Blown fuse</p> <p>B. Inoperative hazard warning flasher</p> <p>C. Loose chassis to column connection</p> <p>D. Disconnect column to chassis connector. Connect new switch into system without removing old. Depress the hazard warning button and observe the hazard warning lights. If they now work normally, the turn signal switch is defective.</p> <p>E. If the lights do not flash, check wiring harness "K" lead (brown) for open between hazard flasher and harmonica connector. If open, fuse block is defective.</p> | <p>A. Replace fuse and check operation</p> <p>B. Replace hazard warning flasher</p> <p>C. Connect securely and check operation</p> <p>D. Replace the turn signal switch</p> <p>E. Replace fuse block (See Sec. 12)</p> |

Fig. 3B4-16—Turn Signal Switch Diagnosis Chart D

MAINTENANCE AND ADJUSTMENTS

STEERING WHEEL ALIGNMENT

On all series vehicles, check steering gear for high point centering as shown in Sections 3B2 and 3B3 before checking steering wheel alignment.

1. Set wheels in straight ahead position by driving vehicle a short distance.

2. Note steering wheel position. If off more than 1 inch from center (Fig. 3B4-17), remove steering wheel as outlined under "Steering Wheel - Removal", center high point on gear, reposition and reinstall the wheel.

STEERING COLUMN LOWER BEARING ADJUSTMENT

G and P Series Only

1. Loosen clamp on steering shaft.
2. Applying 50 lb. force to the steering wheel end of the steering shaft, adjust clamp to obtain clearances indicated in Figure 3B4-18.
3. Tighten clamp bolt to specified torque.

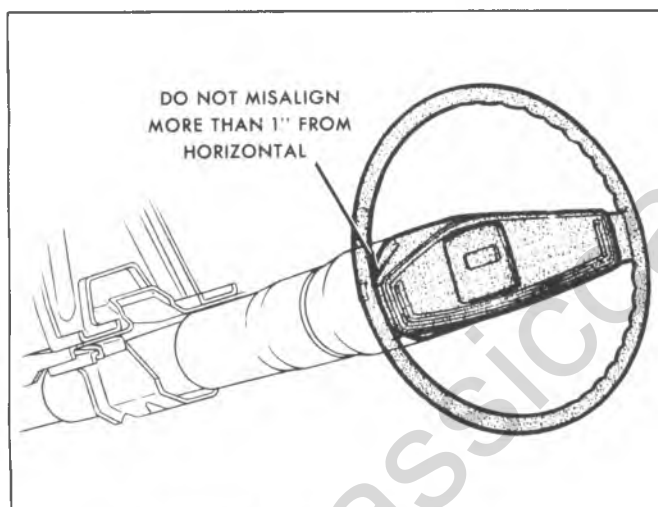


Fig. 3B4-17—Steering Wheel Alignment

SHIFTER TUBE ADJUSTMENT

G and P Series Only

3-Speed Transmission

1. Loosen adjusting ring attaching screws and clamp bolt.
2. Rotate adjusting ring to give .005" end play between adjusting ring and first and reverse shifter lever (Fig. 3B4-19).
3. Tighten attaching screws and clamp bolt.

Automatic Transmission

1. Place the shift tube lever in "Neutral" or "Drive".
2. Loosen adjusting ring clamp screws and rotate the shift tube adjusting ring to obtain .33" to .36" clearance between the shift tube lever and adjusting ring (Fig. 3B4-20).
3. Tighten the adjusting ring clamp screws to 70 in. lbs.

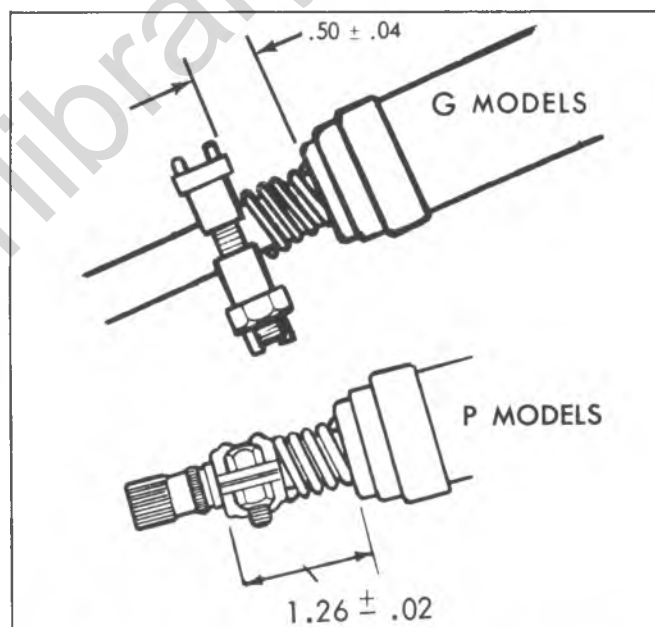


Fig. 3B4-18—Steering Column Lower Bearing Adjustment

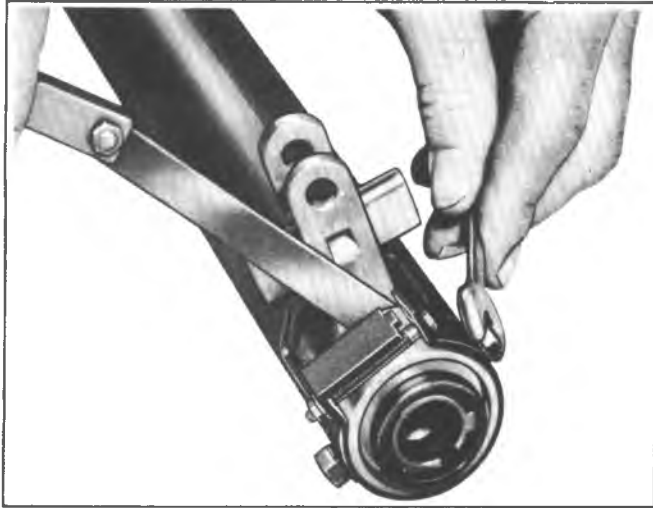


Fig. 3B4-19--Shift Tube Adjustment-3 Speed Manual Transmission

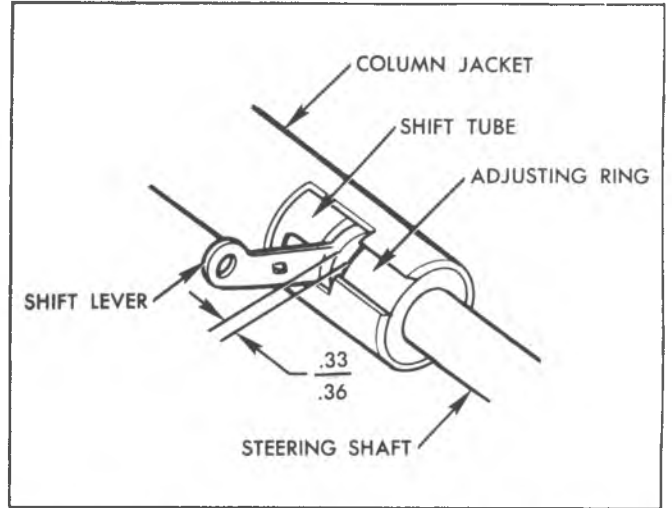


Fig. 3B4-20--Shift Tube Adjustment-Automat Transmission

classiccarylbrary.com

ON-VEHICLE SERVICE

INDEX

| | |
|--|--------|
| C-Series and K-Series | 3B4-18 |
| Steering Wheel | 3B4-18 |
| Flexible Coupling | 3B4-18 |
| Intermediate Shaft | 3B4-19 |
| Directional Signal Switch | 3B4-20 |
| Lock Cylinder | 3B4-21 |
| Ignition Switch | 3B4-22 |
| Steering Column | 3B4-23 |
| Removal | 3B4-24 |
| Disassembly, Standard Column | 3B4-24 |
| Disassembly, Tilt Column | 3B4-29 |
| Installation, Mandatory Sequence | 3B4-34 |

| | |
|--|--------|
| G-Series and P-Series | 3B4-35 |
| Steering Wheel | 3B4-35 |
| Flexible Coupling | 3B4-35 |
| Intermediate Shaft | 3B4-36 |
| Column Upper Bearing | 3B4-38 |
| Column Lower Bearing | 3B4-38 |
| Tilt Column Bearing Housing | 3B4-39 |
| Directional Signal Switch | 3B4-40 |
| Steering Column | 3B4-41 |
| Removal | 3B4-41 |
| Disassembly, Standard Column | 3B4-41 |
| Disassembly, Tilt Column | 3B4-44 |
| Installation, Mandatory Sequence | 3B4-48 |

STEERING WHEEL

Removal

1. Disconnect battery ground cable.
2. Remove horn button cap.
3. Remove snap ring and steering wheel nut.
4. Using tool J-2927, thread puller anchor screws into holes provided on steering wheel. See Fig. 3B4-21. Turn center bolt of tool clockwise to remove wheel.

NOTICE: Do not hammer on puller, or damage could occur to the components. The tool centering adapters need not be used.

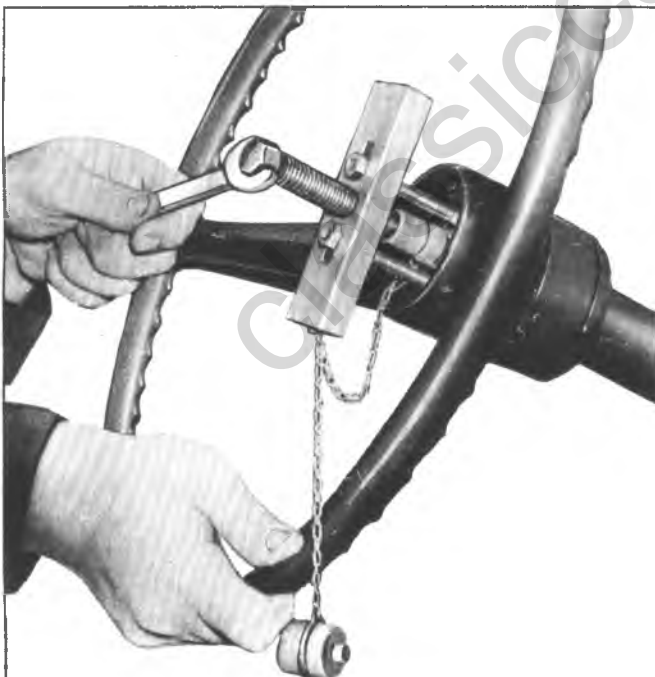


Fig. 3B4-21--Steering Wheel Removal

Installation

NOTICE: See NOTICE on page 1 of this section regarding the fasteners referred to in step 1.

1. With turn signal in neutral position, align marks and set wheel onto steering shaft. Torque steering shaft nut to specifications and install snap ring.

NOTICE: Do not over torque shaft nut or steering wheel rub may result.

2. Place steering wheel horn button on wheel and snap into proper position.
3. Connect battery ground cable.

STEERING COUPLING (FLEXIBLE TYPE)

Removal (Fig. 3B4-22)

1. Remove the coupling to steering shaft flange bolt nuts.

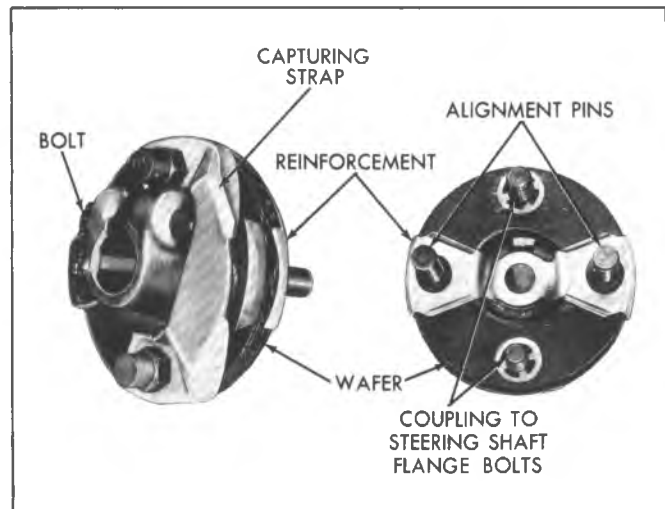


Fig. 3B4-22--Flexible Type Steering Coupling

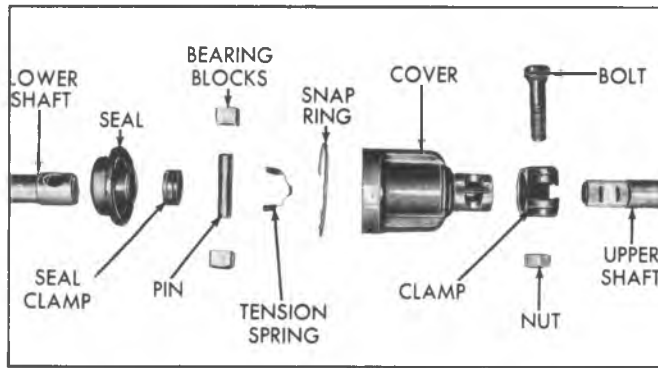


Fig. 3B4-23--Steering Shaft Intermediate Coupling

2. Remove the coupling clamp bolt. This is a special bolt and will require a 12 pt. socket or box wrench.

3. Remove the steering gear to frame bolts and lower the steering gear far enough to remove the flexible coupling. It is not necessary to disconnect the pitman arm from the pitman shaft.

4. Tap lightly on the flexible coupling with a soft mallet to remove the coupling from the steering gear wormshaft.

Installation

NOTICE: See NOTICE on page 1 of this section regarding the fasteners referred to in steps 2, 4 and 5.

1. Install the flexible coupling onto the steering gear wormshaft, aligning the flat on the shaft with the flat in the coupling. Push the coupling onto the wormshaft until the coupling reinforcement bottoms against the end of the worm.

2. Install the special bolt into the split clamp and torque to specifications.

NOTICE: The bolt must pass through the shaft undercut, or damage could occur to the components.

3. Place the steering gear into position, guiding the flexible coupling bolts into the proper holes in the steering shaft flange.

4. Install and tighten the steering gear to frame bolts.

5. Install the coupling to flange bolt nuts and washers and torque to specifications. Be sure to maintain a coupling to flange dimension of .250" to .375". The coupling alignment pins should be centered in the flange slots.

INTERMEDIATE STEERING SHAFTS WITH POT JOINT COUPLINGS

Removal (Fig. 3B4-23)

1. Remove the lower shaft flange to flexible coupling bolts.

2. Remove upper shaft to intermediate coupling bolt.

3. If necessary, remove the steering gear to frame bolts and lower the steering gear far enough to remove the intermediate shaft assembly. It is not necessary to remove

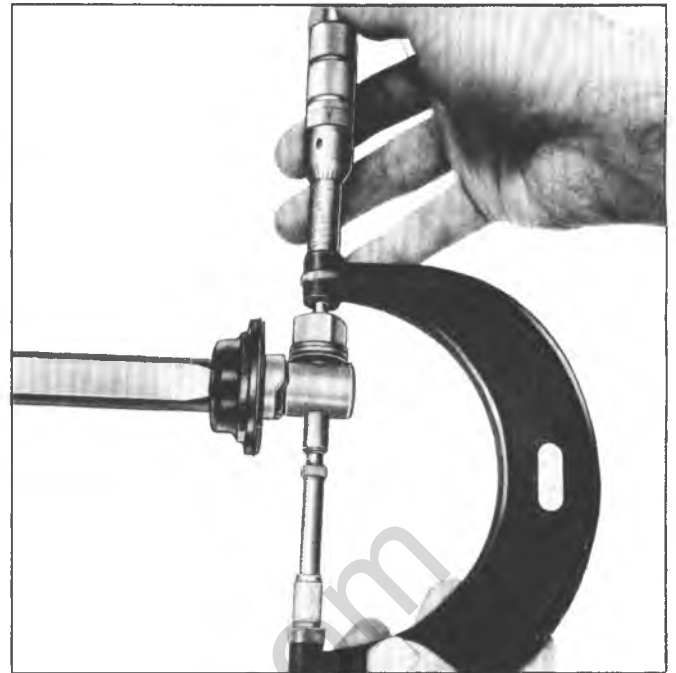


Fig. 3B4-24--Checking Coupling Pin Centering

the pitman arm from the pitman shaft.

Disassembly

1. Mark cover to shaft relationship. Pry off snap ring and slide cover from shaft.

2. Remove bearing blocks and tension spring from pivot pin.

3. Clean grease off pin and end of shaft. Scribe location mark on pin on same side as chamfer in shaft.

4. Supporting shaft assembly securely, with chamfer up, press pin out of shaft with arbor press.

NOTICE: Do not drive pin out with hammer. This could cause sticky or binding bearings when reassembled.

5. Remove seal clamp and slide seal off end of shaft.

Assembly

1. Be sure all parts are free of dirt. Slide seal onto steering shaft. With lip of seal against step in shaft clamp seal.

2. Press pin back into shaft from chamfered side. Locate pin in shaft using scribe mark as reference.

NOTICE: Pin must be centered within .012 in. or binding in the coupling could result.

3. Check centering of pin (Fig. 3B4-24).

a. Place just enough 3/8" flat washers on pin to prevent bearing block from bottoming when installed.

b. Measure distance from end of pin to top of bearing with micrometer.

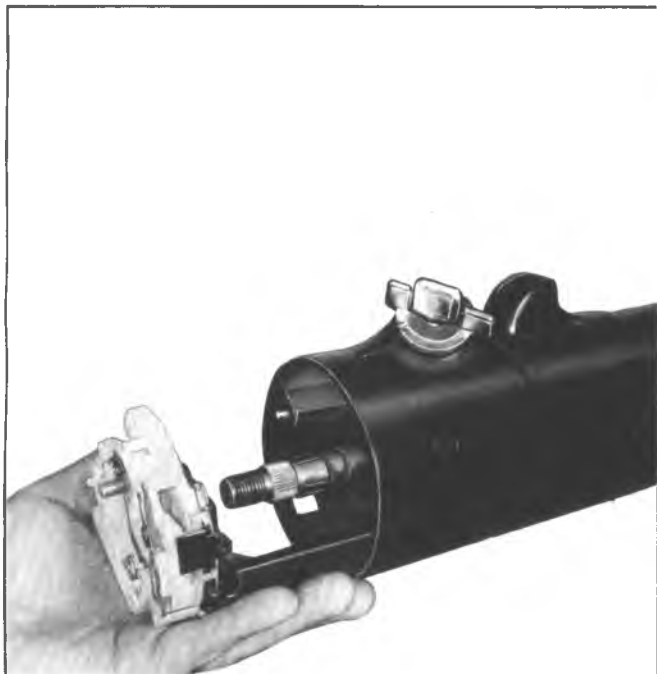


Fig. 3B4-25--Directional Signal Switch

c. Remove bearing and washers and place same bearing and washers on other end of pin. Measure distance from end of pin to top of bearing. If micrometer readings in Steps b and c differ more than .012, repeat last part of Step 2 and recheck.

4. Apply a liberal amount of wheel bearing grease to inside and outside of bearing blocks and inside of cover.

5. Position tension spring and bearing blocks on pin.

6. Slide cover over bearing blocks aligning reference mark on cover with mark on shaft. Install seal into end of cover and secure with snap ring retainer.

Installation

NOTICE: See NOTICE on page 1 of this section regarding the fasteners referred to in steps 1, 3 and 4.

1. Install the intermediate shaft assembly onto the steering shaft, aligning the flat on the shaft with the flat in the coupling. Install the pot joint clamp bolt and torque to specifications.

2. Lift the steering gear into position, guiding the flexible coupling bolts into the shaft flange holes.

3. Install the steering gear to frame bolts and torque to specifications.

4. Install the flexible coupling to steering shaft flange bolt lockwashers and nuts. Check that the coupling alignment pins are centered in the flange slots and then torque the coupling bolts to specifications.

DIRECTIONAL SIGNAL SWITCH

The directional signal switch can be removed with the steering column in the vehicle and without disturbing any of the column mountings.

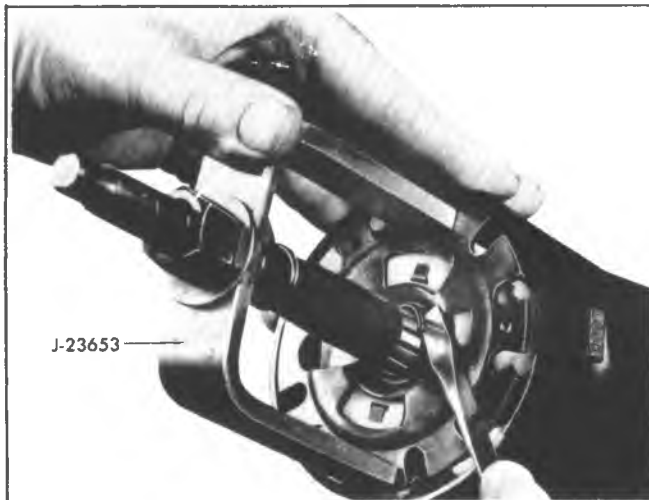


Fig. 3B4-26--Removing Lock Plate Retaining Ring

Removal (Fig. 3B4-25)

1. Remove the steering wheel as outlined under "Steering Wheel - Removal".

2. Remove the column to instrument panel trim cover.

3. Position screwdriver blade into cover slot. Pry up and out to free cover from lock plate.

4. Screw the center post of Lock Plate Compressing Tool J-23653 onto the steering shaft as far as it will go. Compress the lock plate by turning the center post nut clockwise (Fig. 3B4-26). Pry the round wire snap ring out of the shaft groove and discard the ring. Remove Tool J-23653 and lift the lock plate off the end of the shaft.

NOTICE: If the column is being disassembled on the bench, with the snap ring removed the shaft could slide out of the lower end of the mast jacket, damaging the shaft assembly.

5. Slide the directional signal cancelling cam, upper bearing preload spring and thrust washer off the end of the shaft.

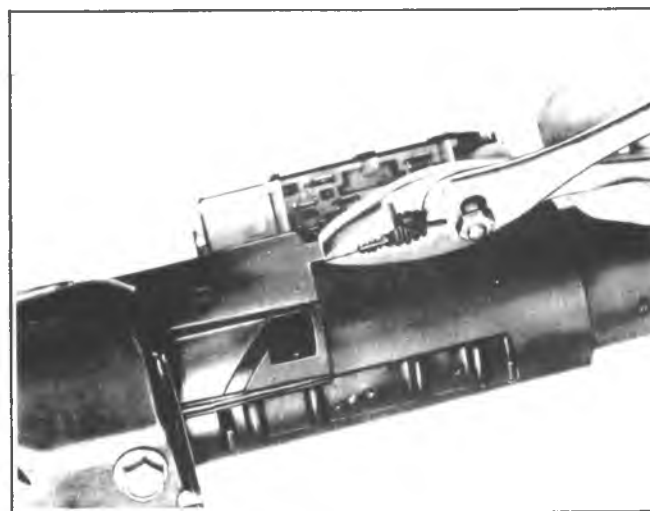


Fig. 3B4-27--Removing Directional Signal Wire Protector

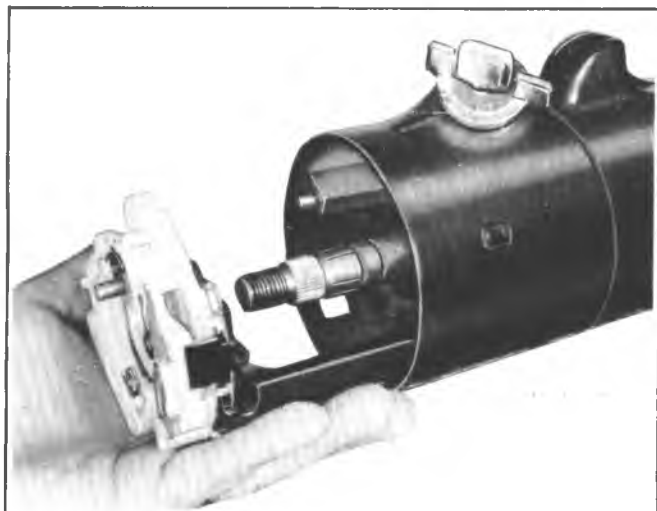


Fig. 3B4-28--Removing Directional Signal Switch Assembly

6. Remove the directional signal lever screw and remove the lever.

7. Push the hazard warning knob in and unscrew the knob.

8. Remove the three switch mounting screws.

9. **All Columns** - Pull the switch connector out of the bracket on the jacket and feed switch connector through column support bracket and pull switch straight up, guiding the wiring harness through the column housing and protector.

10. Remove wire protector by pulling downward out of column with pliers using tab provided (Fig. 3B4-27).

Tilt Column - Position the direction signal and shifter housing in the "low" position. Remove the harness cover by pulling toward the lower end of the column, be careful not to damage the wires.

11. Remove the three switch mounting screws and pull the switch straight up, guiding the wiring harness and cover through the column housing (Fig. 3B4-28).



Fig. 3B4-29--Installing Switch Connector Onto Jacket Clips



Fig. 3B4-30--Installing Snap Ring

Installation

CAUTION: It is extremely important that only the specified screws, bolts and nuts be used at assembly, or personal injury could result. Use of overlength screws could prevent a portion of the assembly from compressing under impact.

1. **All except Tilt** - Be sure that the wiring harness is in the protector. Feed the connector and cover down through the housing and under the mounting bracket (column in vehicle).

Tilt - Feed the connector down through the housing and under the mounting bracket. Then install the cover on the harness.

2. Install the three mounting screws and clip the connector to the bracket on the jacket (Fig. 3B4-29).

3. Install the column to instrument panel trim plate.

4. Install the hazard warning knob and directional signal lever.

5. Make certain that the switch is in "Neutral" and the hazard warning knob is out. Slide the thrust washer, upper bearing preload spring and cancelling cam onto the upper end of the shaft.

6. Place the lock plate onto the end of the shaft. Screw the center post of Lock Plate Compressing Tool J-23653 onto the steering shaft as far as it will go. Place a NEW snap ring over the center post. Place the "C" bar over the center post and then compress the lock plate by turning the nut clockwise. Slide the new snap ring down the tapered center post and into the shaft groove (Fig.3B4-30). Remove Tool J-23653.

Always use a new snap ring when reassembling.

7. Place cover on the lock plate and snap into position.

8. Install the steering wheel as outlined under "Steering Wheel-Installation".

LOCK CYLINDER

The lock cylinder is located on the upper right hand side of the column. The lock cylinder should be removed in the "RUN" position only.

LOCK CYLINDER INSTALLATION

DISASSEMBLE

1. Place lock in "run".
2. Remove lock plate, turn signal switch and buzzer switch (see service manual.)
3. Remove screw & lock cylinder. **CAUTION:** If screw is dropped on removal, it could fall into the column, requiring complete disassembly to retrieve the screw.

ASSEMBLE

1. Rotate as shown, align cylinder key with keyway in housing.
2. Push lock all the way in.
3. Install screw. Tighten to 4.5 N·m for regular columns—2.5 N·m for adjustable columns.

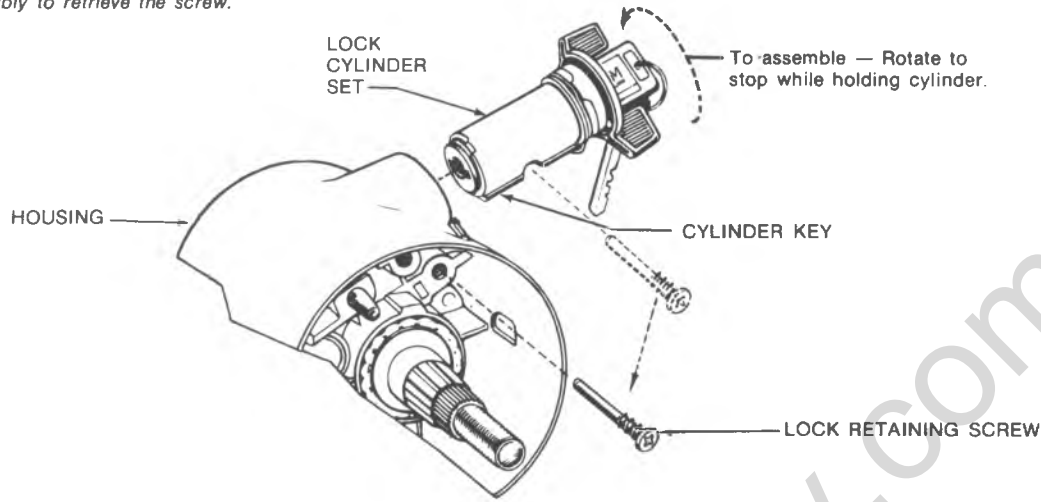


Fig. 3B4-31—Lock Cylinder Removal

Replacement

1. Remove the steering wheel as outlined under "Steering Wheel - Removal".
2. Remove the directional signal switch as outlined under "Directional Signal Switch - Removal".

It is not necessary to completely remove the directional signal switch from the column. Pull the switch rearward far enough to slip it over the end of the shaft - do not pull the harness out of the column.

3. Refer to Fig. 3B4-31 for details on replacement of lock cylinder.

IGNITION SWITCH

The ignition switch is mounted on top of the column jacket near the front of the dash. For anti-theft reasons, the switch is located inside the channel section of the brake pedal support and is completely inaccessible without first lowering the steering column (see steering column removal).

The switch is actuated by a rod and rack assembly. A portion of the rack is toothed and engages a gear on the end of the lock cylinder, thus enabling the rod and rack to be moved axially (with respect to the column) to actuate the switch when the lock cylinder is rotated.

Removal

1. Lower the steering column as outlined under "Steering Column Removal" later in this section. It is not necessary to remove the steering wheel.

If the steering column is not removed from the vehicle, be sure that it is properly supported, before proceeding.

2. The switch should be positioned in "Lock" position before removing. If the lock cylinder has already been removed, the actuating rod to the switch should be pulled up until there is a definite stop, then moved down one

detent, which is the "Lock" position.

3. Remove the two switch screws and remove the switch assembly.

Installation

1. Before replacing the switch, be sure that the lock is in the "Lock" position (Fig. 3B4-32); if it is not, a screwdriver (placed in the locking rod slot) can be used to move the switch to "Lock".

2. Install the activating rod into the switch and assemble the switch on the column; tighten the mounting screws.

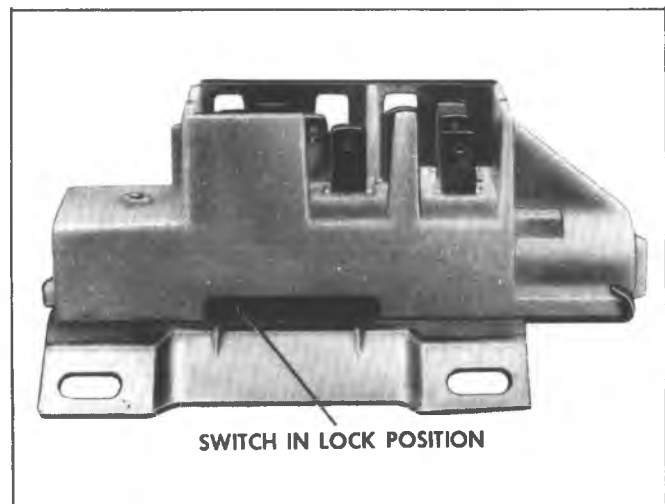


Fig. 3B4-32—Ignition Switch Assembly

CAUTION: Use only the specified screws since over-length screws could prevent a portion of the assembly from compressing under impact, which could result in personal injury.

3. Reinstall the steering column assembly following the "Mandatory Installation Sequence" outlined later in this section.

STEERING COLUMN

To perform service procedures on the steering column upper end components, it is not necessary to remove the column from the vehicle.

The steering wheel, horn components, directional signal switch, and ignition lock cylinder may be removed with the column remaining in the vehicle as described earlier in this section.

CAUTION: The outer mast jacket shift tube, steering shaft and instrument panel mounting bracket are designed as energy absorbing units. Because of the design of these components, it is absolutely necessary to handle the column with care when performing any service operation. Avoid hammering, jarring, dropping or leaning on any portion of the column. When reassembling the column components, use only the specified screws, nuts and bolts and tighten to specified torque. Care should be exercised in using over-length screws or bolts as they may prevent a portion of the column from compressing under impact.

Inspection

To determine if the energy absorbing steering column components are functioning as designed, or if repairs are required, a close inspection should be made. Inspection is called for in all cases where damage is evident or whenever the vehicle is being repaired due to a front end collision. Whenever a force has been exerted on the steering wheel or steering column, or its components, inspection should also be made. If damage is evident, the affected parts must be replaced.

The inspection procedure for the various steering column components on all C and K Series Trucks is as follows:

Column Support Bracket

Damage in this area will be indicated by separation of the mounting capsules from the bracket. The bracket will have moved forward toward the engine compartment and will usually result in collapsing of the jacket section of the steering column.

Column Jacket

Inspect jacket section of column for looseness, and/or bends.

Shifter Shaft

Separation of the shifter shaft sections will be internal and cannot be visually identified. Hold lower end of the "shifter shaft" and move "shift lever" on column through its ranges and up and down. If there is little or no movement

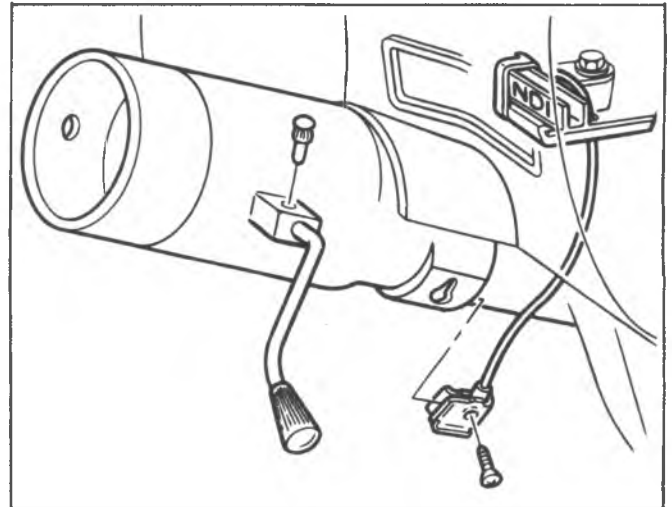


Fig. 3B4-33—Automatic Transmission Indicator Connection-CK-Typical

of the "shifter shaft", the plastic joints are sheared.

Steering Shaft

If the steering shaft plastic pins have been sheared, the shaft will rattle when struck lightly from the side and some lash may be felt when rotating the steering wheel while holding the rag joint. It should be noted that if the steering shaft pins are sheared due to minor collision the vehicle can be safely steered; however, steering shaft replacement is recommended.

Because of the differences in the steering column types, be sure to refer to the set of instructions below which apply to the column being serviced.

Removal

Front of dash mounting plates must be loosened whenever the steering column is to be lowered from the instrument panel.

1. Disconnect the battery ground cable.
2. Remove the steering wheel as outlined under "Steering Wheel Removal".
3. Remove the nuts and washers securing the flanged end of the steering shaft to the flexible coupling.

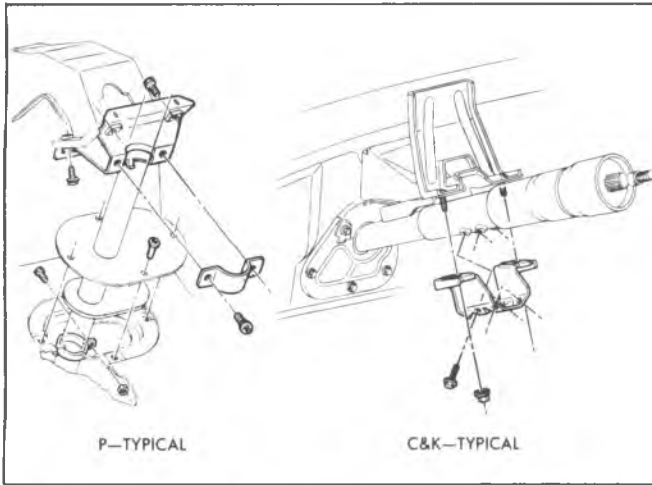


Fig. 3B4-34—Steering Column to Dash Panel-C, K Typical

4. Disconnect the transmission control linkage from the column shift tube levers.
5. Disconnect the steering column harness at the connector. Disconnect the neutral-start switch and back-up lamp switch connectors if so equipped.
6. Remove the floor pan trim cover screws and remove the cover.
7. Remove the transmission indicator cable, if so equipped (Fig. 3B4-33).
8. Remove the screws securing the two halves of the floor pan cover; then remove the screws securing the halves and seal to the floor pan and remove the covers (Fig. 3B4-34).
9. Move the front seat as far back as possible to provide maximum clearance.

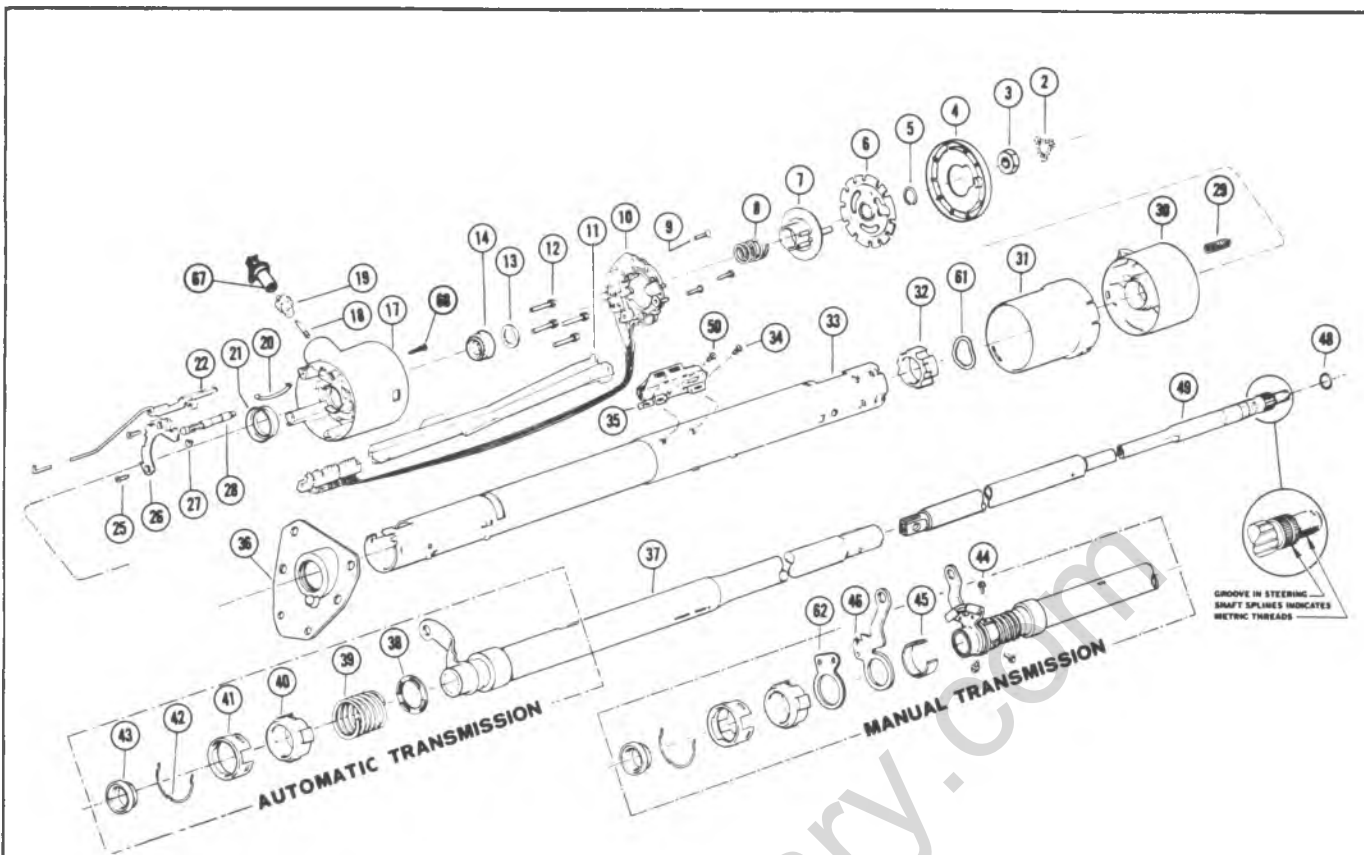
10. Remove the two column bracket-to-instrument panel nuts and carefully remove from vehicle. Additional help should be obtained to guide the lower shift levers through the firewall opening.

C and K Series, Standard Column - (Fig. 3B4-40)**Disassembly**

1. Remove the four dash panel bracket-to-column screws and lay the bracket in a safe place to prevent damage to the mounting capsules.
2. Place the column in a vise using both weld nuts of either Set A or B as shown in Figure 3B4-41. The vise jaws must clamp onto the sides of the weld nuts indicated by arrows shown on Set B.

NOTICE: Do not place the column in a vise by clamping onto one weld nut of both sets A and B or by clamping onto the sides not indicated by arrows, since damage to the column could result.

3. Remove the Directional Signal Switch, Lock Cylinder, and Ignition Switch as outlined previously in this section.
4. **Column Shift Models** - Drive out the upper shift lever pivot pin and remove the shift lever.
5. Remove the upper bearing thrust washer. Remove the four screws attaching the turn signal and ignition lock housing to the jacket and remove the housing assembly (Fig. 3B4-42).
6. Remove the thrust cap from the lower side of the housing.
7. Lift the ignition switch actuating rod and rack assembly, the rack preload spring and the shaft lock bolt and spring assembly out of the housing (Fig. 3B4-43).
8. Remove the shift lever detent plate (shift gate).
9. Remove the ignition switch actuator sector through the lock cylinder hole by pushing firmly on the block tooth of the sector with a blunt punch or screwdriver (Fig. 3B4-44).
10. Remove the gearshift lever housing and shroud from the jacket assembly (transmission control lock tube housing and shroud on floor shift models).
11. Remove the shift lever spring from the gearshift lever housing (lock tube spring on floor shift models).
12. Pull the steering shaft from lower end of the jacket assembly.



- | | |
|------------------------------------|------------------------------------|
| 1. STEERING COLUMN | 30. BOWL, Gearshift Lever |
| 2. RETAINER | 31. SHROUD, Shift Bowl |
| 3. NUT, Hexagon Jam | 32. BEARING, Bowl Lower |
| 4. COVER, Shaft Lock | 33. JACKET ASM, Steering Column |
| 5. RING, Retaining | 34. SCREW, Washer Head |
| 6. LOCK, Steering Shaft | 35. SWITCH ASM, Ignition |
| 7. CAM ASM, Turn Signal Cancelling | 36. SEAL, Dash |
| 8. SPRING, Upper Bearing | 37. TUBE ASM, Shift |
| 9. SCREW, Pan Head Cross Recess | 38. WASHER, Spring Thrust |
| 10. SWITCH ASM, Turn Signal | 39. SPRING, Shift Tube Return |
| 11. PROTECTOR, Wiring | 40. ADAPTER, Lower Bearing |
| 12. SCREW, Hex Washer Head Tapping | 41. RETAINER, Bearing Adapter |
| 13. WASHER, Thrust | 42. CLIP, Lower Bearing Adapter |
| 14. BEARING ASM | 43. BEARING ASM |
| 17. HOUSING, Steering Column | 44. SCREW ASM, Lockwasher & |
| 18. SHAFT, Sector | 45. SPACER, Lower Shift Lever |
| 19. SECTOR, Switch Actuator | 46. LEVER, Lower Shift |
| 20. SPRING, Rack Preload | 47. BUSHING ASM, Steering Shaft |
| 21. CUP, Thrust | 48. RING, Retaining |
| 22. RACK ASM, Rod & | 49. SHAFT ASM, Steering |
| 23. SCREW, Dimmer Switch Mounting | 50. SCREW, Flat Head |
| 24. SWITCH ASM, Dimmer | 51. ROD, Dimmer Switch Actuator |
| 25. SCREW, Flat Head Cross Recess | 61. WASHER, Wave |
| 26. GATE, Shift Lever | 62. PLATE, Support & Alignment |
| 27. WASHER, Spring Thrust | 67. LOCK CYLINDER SET, Strg Column |
| 28. BOLT ASM, Spring & | 68. SCREW, Lock Retaining |
| 29. SPRING, Upper Shift Lever | |

Fig. 3B4-40a--Std. Column; Auto. Trans. or 3-Speed

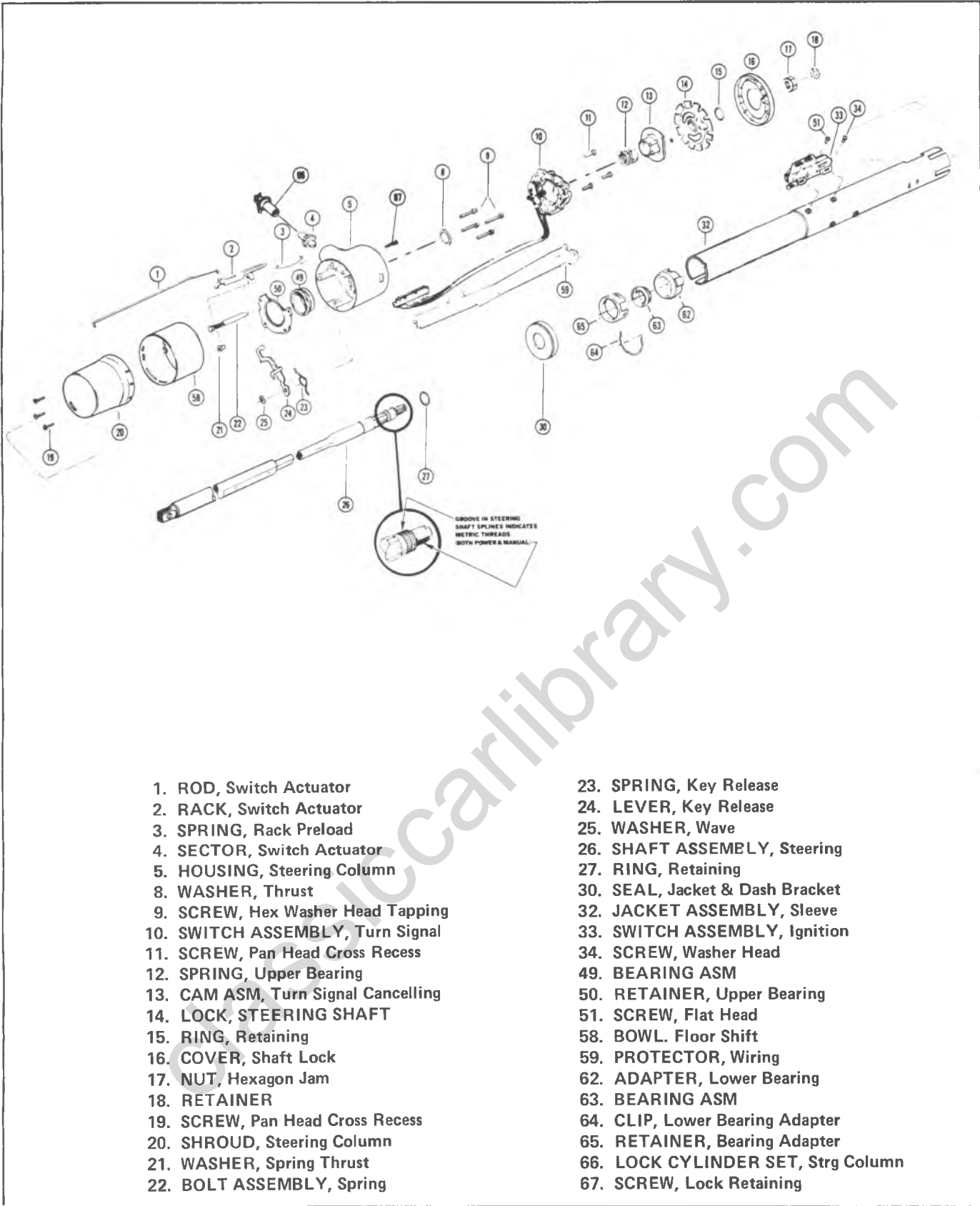


Fig. 3B4-40b--Std. Column, 4-Speed Trans.

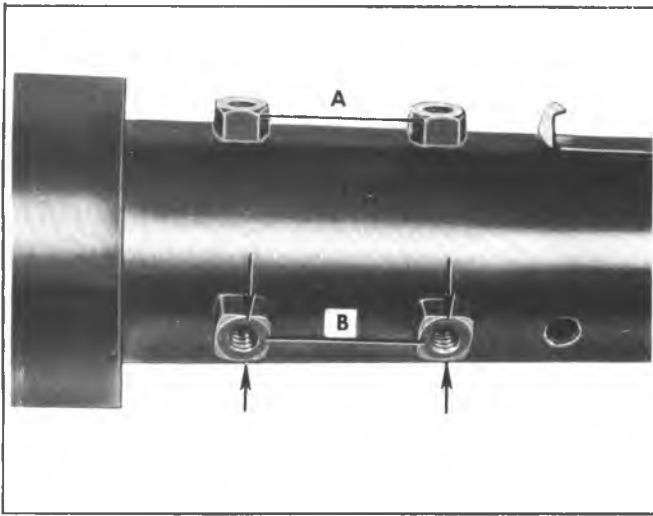


Fig. 3B4-41--Installing Steering Column in Vise

13. Remove the two screws holding the back-up switch or neutral-safety switch to the column and remove the switch.

14. Remove the lower bearing retainer clip (Fig. 3B4-45).

15. **Automatic and Floorshift Columns** - Remove the lower bearing retainer, bearing adapter assembly, shift tube thrust spring and washer. The lower bearing may be removed from the adapter by light pressure on the bearing outer race. Slide out the shift tube assembly.

Manual Transmission - Column Shift - Remove the lower bearing adapter, bearing and the first reverse shift lever. The lower bearing may be removed from the adapter by light pressure on the bearing outer race. Remove the three screws from bearing at the lower end and slide out the shift tube assembly. Remove the gearshift housing lower bearing from the upper end of the mast jacket.

Assembly of Standard Columns

Apply a thin coat of lithium soap grease to all friction surfaces.

1. Install the sector into the turn signal and lock cylinder housing. Install the sector in the lock cylinder hole over the sector shaft with the tang end to the outside of the hole. Press the sector over the shaft with a blunt tool.

2. Install the shift lever detent plate onto the housing.

3. Insert the rack preload spring into the housing from the bottom side. The long section should be toward the handwheel and hook onto the edge of the housing (Fig. 3B4-46).

4. Assemble the locking bolt onto the crossover arm on the rack and insert the rack and lock bolt assembly into the housing from the bottom with the teeth up (toward hand-wheel) and toward the centerline of the column (Fig. 3B4-43). Align the 1st tooth on the sector with the 1st tooth on the rack; if aligned properly, the block teeth will line up when the rack assembly is pushed all the way in.

5. Install the thrust cup on the bottom hub of the housing.

6. Install the gearshift housing lower bearing. Insert the bearing from the very end of the jacket. Aligning the indentations in the bearing with the projections on the jacket (Fig. 3B4-47). If the bearing is not installed correctly, it will not rest on all of the stops provided.

7. Install the shift lever spring into the gearshift lever (or lock tube) housing. Install the housing and shroud assemblies onto the upper end of the mast jacket. Rotate the housing to be sure it is seated in the bearing.

8. With the shift lever housing in place, install the turn signal and lock cylinder housing onto the jacket. The gearshift housing should be in "Park" position and the rack pulled downward. Be sure the turn signal housing is seated on the jacket and drive the four screws.

9. Press the lower bearing into the adapter assembly.

10. Insert the shift tube assembly into the lower end of the jacket and rotate until the upper shift tube key slides into the housing keyway.

11. **Automatic and Floor shift Columns** - Assemble the spring and lower bearing and adapter assembly into the bottom of the jacket. Holding the adapter in place, install the lower bearing reinforcement and retainer clip. Be sure the clip snaps into the jacket and reinforcement slots.

12. **Manual Transmission - Column Shift** - Loosely attach the three screws in the jacket and shift tube bearing.

Assemble the 1st-Reverse lever and lower bearing and adapter assembly into the bottom of the jacket. Holding the adapter in place, install the bearing reinforcement and retaining clip. Be sure the retaining clip snaps into the jacket and reinforcement slots.

Refer to Fig. 3B4--48 for adjustment procedure.

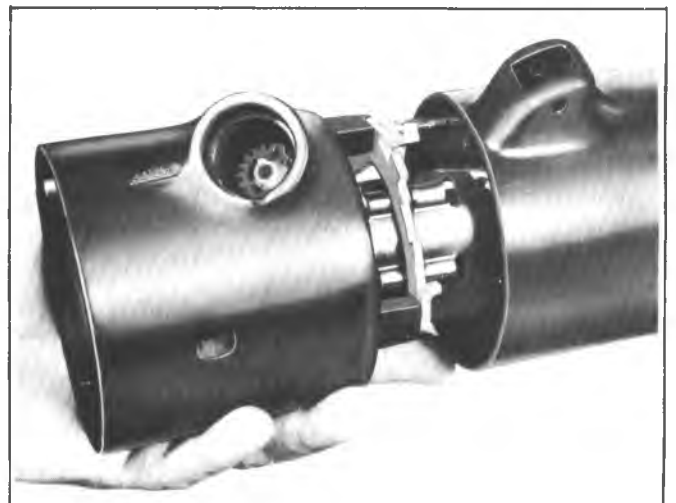


Fig. 3B4-42--Removing Turn Signal Housing

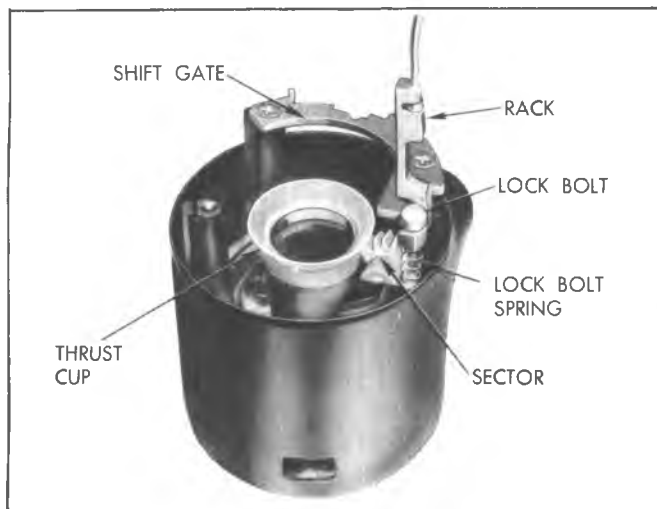


Fig. 3B4-43--Turn Signal Housing Assembly

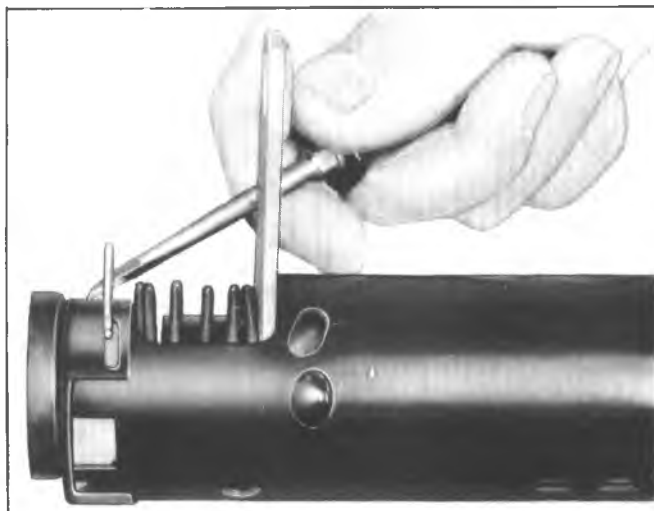


Fig. 3B4-45--Removing Lower Bearing Retainer



Fig. 3B4-44--Removing Ignition Switch Actuator Sector

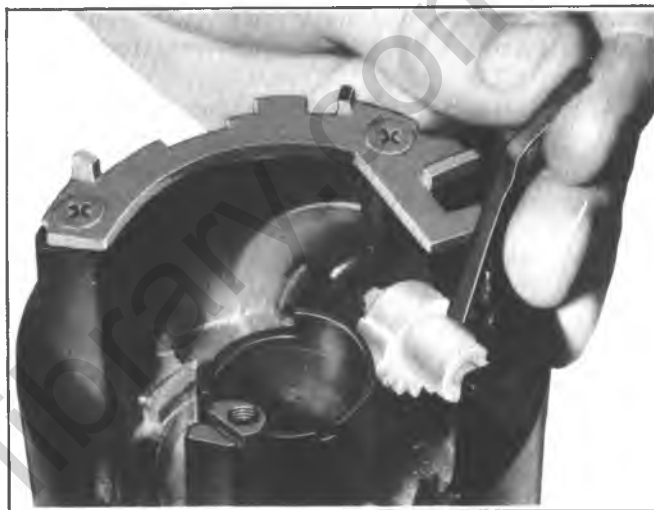


Fig. 3B4-46--Installing Rack Preload Spring

13. Install the neutral-safety or back-up switch as outlined in Section 8 of this manual.

14. Slide the steering shaft into the column and install the upper bearing thrust washer.

15. Install the turn signal switch, lock cylinder assembly and ignition switch as previously outlined in this section.

16. Install the shift lever and shift lever pivot pin.

17. Remove the column from the vise.

18. Install the dash bracket to the column; torque the screws to specifications.

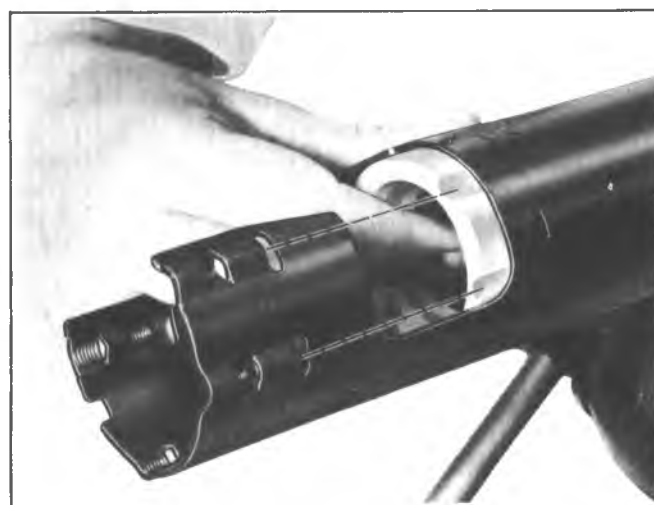


Fig. 3B4-47--Installing Gearshift Housing Lower Bearing

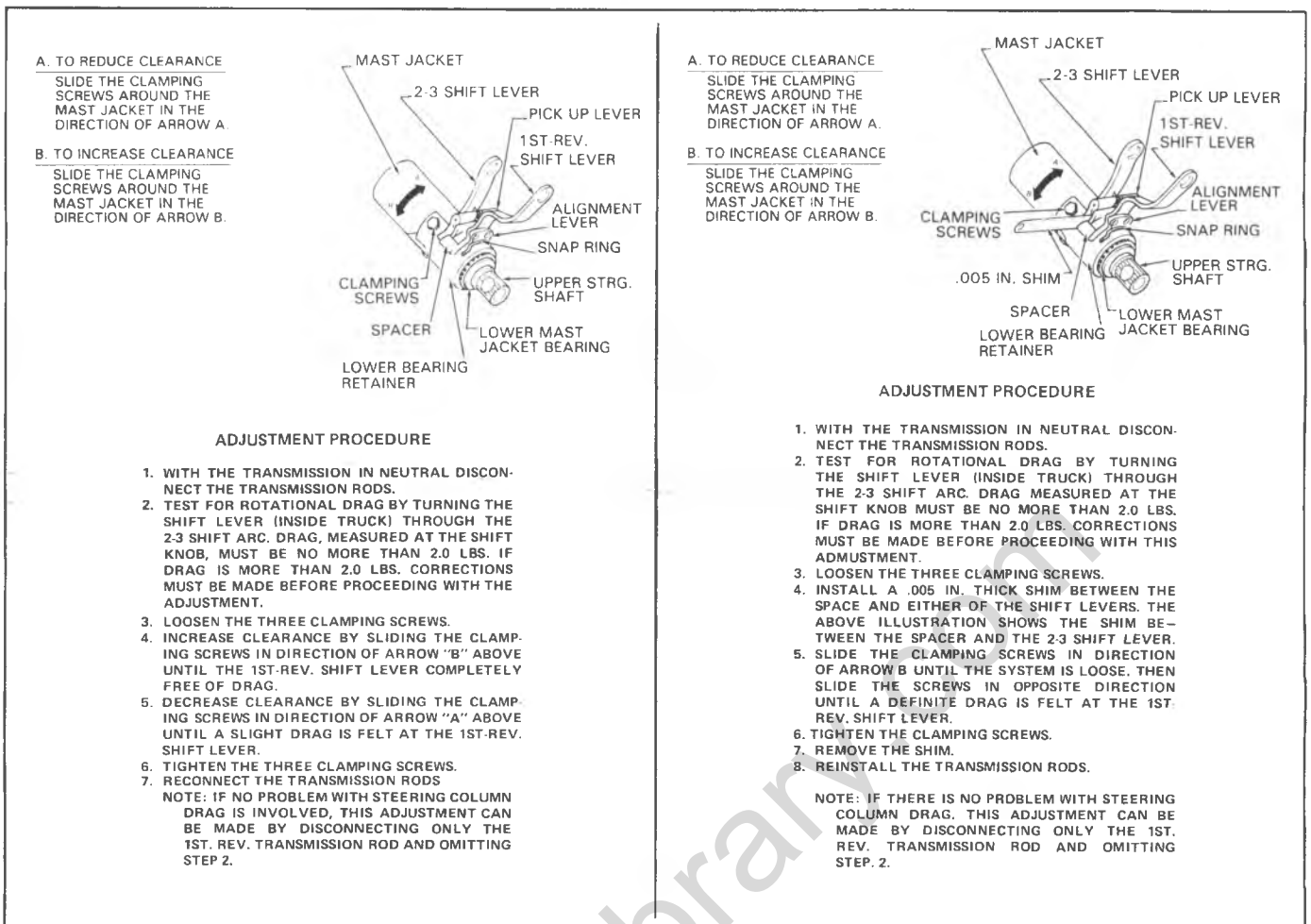


Fig. 3B4-48--Adjusting Lower Bearing-Typical

Disassembly-Tilt Columns (Fig. 3B4-49)

Steps 3-14 may be performed with the steering column in the vehicle.

1. Remove the four screws retaining the dash mounting bracket to the column and set the bracket aside to protect the breakaway capsules.

2. Mount the column in a vise using both weld nuts of either Set A or B as shown in Figure 3B4-41. The vise jaws must clamp onto the sides of the weld nuts indicated by arrows shown on Set B.

NOTICE: Do not place the column in a vise by clamping onto only one weld nut, by clamping onto one weld nut of both Sets A and B or by clamping onto the sides not indicated by arrows, since damage to the column could result.

3. Remove the directional signal switch, lock cylinder and ignition switch as outlined previously in this section.

4. Remove the tilt release lever. Drive out the shift lever pivot pin and remove the shift lever from the housing.

5. Remove the three turn signal housing screws and remove the housing.

6. Install the tilt release lever and place the column in the full "up" position. Remove the tilt lever spring retainer using a #3 phillips screwdriver that just fits into the slot opening. Insert the phillips screwdriver in the slot, press in approximately 3/16", turn approximately 1/8 turn counterclockwise until the ears align with the grooves in the housing and remove the retainer, spring and guide (Fig. 3B4-50).

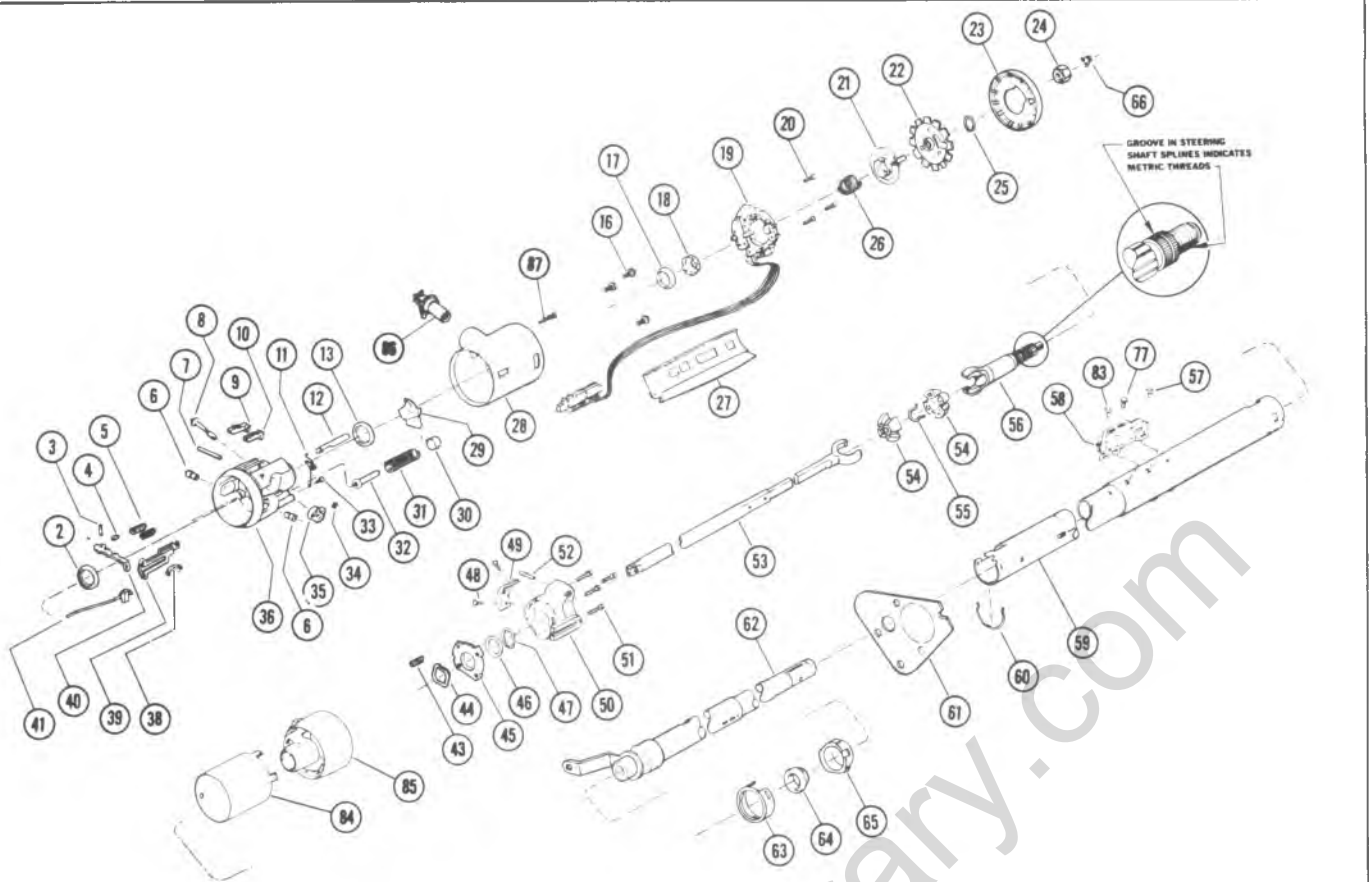
7. Remove the pot joint to steering shaft clamp bolt and remove the intermediate shaft and pot joint assembly.

Push the upper steering shaft in sufficiently to remove the steering shaft upper bearing inner race and seat. Pry off the lower bearing retainer clip and remove the bearing reinforcement, bearing and bearing adapter assembly from the lower end of the mast jacket.

8. Remove the upper bearing housing pivot pins using Tool J-21854-1 (Fig. 3B4-51).

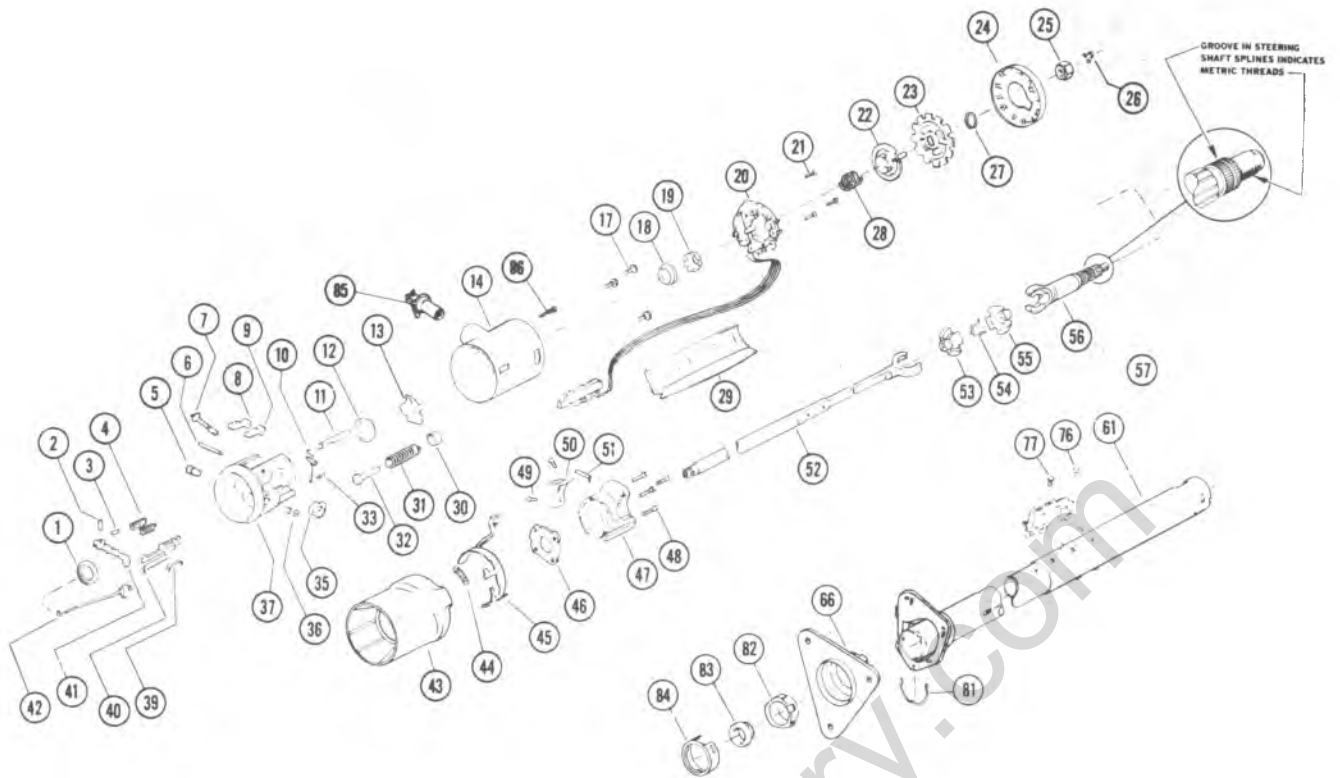
9. Install the tilt release lever and disengage the lock shoes. Remove the bearing housing by pulling upward to extend the rack full down, and then moving the housing to the left to disengage the ignition switch rack from the actuator rod.

10. Remove the steering shaft assembly from the upper end of the column.



- | | | |
|--|---|---|
| <ul style="list-style-type: none"> 1. STEERING COLUMN 2. BEARING ASM 3. PIN, Release Lever 4. SPRING, Release Lever 5. SPRING, Shoe 6. PIN, Pivot 7. PIN, Dowel 8. SHAFT, Drive 9. SHOE, Steering Wheel Lock 10. SHOE, Steering Wheel Lock 11. SPRING, Lock Bolt 12. BOLT, Lock 13. BEARING ASM 16. SCREW, Oval Head Cross Recess 17. RACE, Inner 18. SEAT, Upper Bearing Inner Race 19. SWITCH ASM, Turn Signal 20. SCREW, Binding HD. Cross Recess 21. CAM ASM, Turn Sig. Cancelling 22. LOCK, Shaft 23. COVER, Shaft Lock 24. NUT, Hexagon Jam 25. RING, Retaining | <ul style="list-style-type: none"> 26. SPRING, Upper Bearing 27. PROTECTOR, Wiring 28. COVER, Lock Housing (Painted) 29. SHIELD, Tilt Lever Opening 30. RETAINER, Spring 31. SPRING, Wheel Tilt 32. GUIDE, Spring 33. SCREW, Hex. Washer Head 34. RING, Retaining 35. SECTOR, Switch Actuator 36. HOUSING, Steering Column 38. SPRING, Rack Preload 39. RACK, Switch Actuator 40. LEVER, Shoe Release 41. ACTUATOR ASM, Ignition Switch 43. SPRING, Shift Lever 44. WASHER, Wave 45. PLATE, Lock 46. WASHER, Thrust 47. RING, Shift Tube Retaining 48. SCREW, Oval Head Cross Recess 49. GATE, Shift Lever 50. SUPPORT, Strg. Column Housing | <ul style="list-style-type: none"> 51. SCREW, Support 52. PIN, Dowel 53. SHAFT ASM, Lower Steering 54. SPHERE, Centering 55. SPRING, Joint Preload 56. SHAFT ASM, Race & Upper 57. SCREW, Wash. Hd. 58. SWITCH ASM, Ignition 59. JACKET ASM, Steering Column 60. CLIP, Lower Bearing Adapter 61. SEAL, Dash 62. TUBE ASM, Shift 63. RETAINER, Bearing Adapter 64. BEARING ASM 65. ADAPTER, Lower Bearing 66. RETAINER 77. SCREW, Flat Head 84. SHROUD, Gearshift Bowl 85. BOWL, Gearshift Lever 86. LOCK CYLINDER SET, Strg Column 87. SCREW, Lock Retaining |
|--|---|---|

Fig. 3B4-49a--Tilt Column With Auto. Trans.



- | | | |
|-------------------------------------|--------------------------------------|---------------------------------------|
| 1. BEARING ASM | 26. RETAINER | 51. PIN, Dowel |
| 2. PIN, Release Lever | 27. RING, Retainer | 52. SHAFT ASM, Lower Steering |
| 3. SPRING, Release Lever | 28. SPRING, Upper Bearing | 53. SPHERE, Centering |
| 4. SPRING, Shoe | 29. PROTECTOR, Wiring | 54. SPRING, Joint Preload |
| 5. PIN, Pivot | 30. RETAINER, Spring | 55. SPHERE, Centering |
| 6. PIN, Dowel | 31. SPRING, Wheel Tilt | 56. SHAFT ASM, Race & Upper |
| 7. SHAFT, Drive | 32. GUIDE, Spring | 57. SWITCH ASM, Ignition |
| 8. SHOE, Steering Wheel Lock | 33. SCREW, Hex. Washer Head | 61. JACKET ASM, Sleeve & |
| 9. SHOE, Steering Wheel Lock | 35. SECTOR, Switch Actuator | 62. BEARING ASM, Adapter & |
| 10. SPRING, Lock Bolt | 36. PIN, Pivot | 63. BEARING ASM |
| 11. BOLT, Lock | 37. HOUSING, Steering Column | 64. SPACER, Steering Shaft |
| 12. BEARING ASM | 39. SPRING, Rack Preload | 65. SEAL, Jacket & Dash Bracket |
| 13. SHIELD, Tilt Lever Opening | 40. RACK, Switch Actuator | 66. BRACKET ASM, Column Dash |
| 14. COVER, Lock Housing | 41. LEVER, Shoe Release | 76. SCREW, Washer Head (#10-24 x .25) |
| 17. SCREW, Oval Head Cross Recess | 42. ACTUATOR ASM, Switch | 77. SCREW, Flat Head (#10-24 x .31) |
| 18. RACE, Inner | 43. SHROUD, Column Housing | 81. CLIP, Lower Bearing Adapter |
| 19. SEAT, Upper Bearing Inner Race | 44. SPRING, Key Release | 82. ADAPTER, Lower Bearing |
| 20. SWITCH ASM, Turn Signal | 45. LEVER, Key Release | 83. BEARING ASM |
| 21. SCREW, Binding HD Cross Recess | 46. PLATE, Lock | 84. RETAINER, Bearing Adapter |
| 22. CAM ASM, Turn Signal Cancelling | 47. SUPPORT, Steering Column Housing | 85. LOCK CYLINDER SET, Strg Column |
| 23. LOCK, Shaft | 48. SCREW, Support | 86. SCREW, Lock Retaining |
| 24. COVER, Shaft Lock | 49. SCREW, Oval Head Cross Recess | |
| 25. NUT, Hexagon Jam (9/16-18) | 50. PLATE, Shroud Retaining | |

Fig. 3B4-49b--Tilt Column With 4-Speed

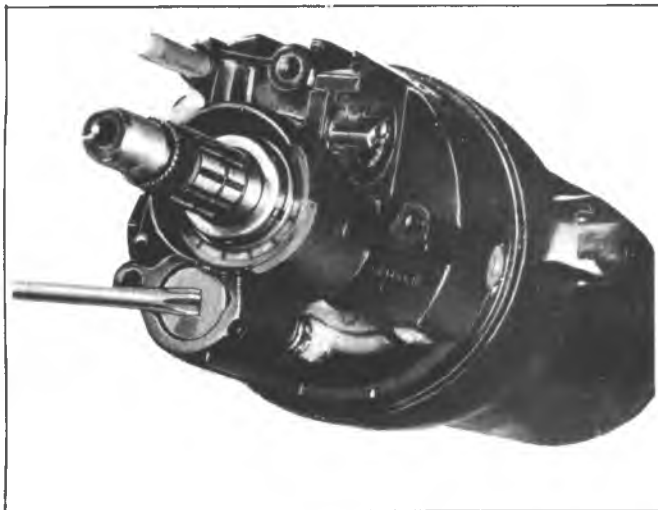


Fig. 3B4-50—Removing Tilt Lever Spring Retainer

11. Disassemble the steering shaft by removing the centering spheres and the anti-lash spring.

12. Remove the transmission indicator wire, if so equipped.

13. Remove the four steering shaft bearing housing support to gearshift housing screws and remove the bearing housing support. Remove the ignition switch actuator rod.

14. Remove the shift tube retaining ring with a screwdriver and then remove the thrust washer.

15. Install Tool J-23072 into the lock plate, making sure that the tool screws have good thread engagement in the lock plate. Then, turning the center screw clockwise, force the shift tube from the housing (Fig. 3B4-52). Remove the shift tube (transmission control lock tube on floor shift models) from the lower end of the mast jacket. Remove Tool J-23072.

NOTICE: When removing the shift tube, be sure to guide the lower end through the slotted opening in the mast jacket. If the tube is allowed to interfere with the jacket in any way, damage to the tube and jacket could result.



Fig. 3B4-51—Removing Bearing Housing Pivot Pins

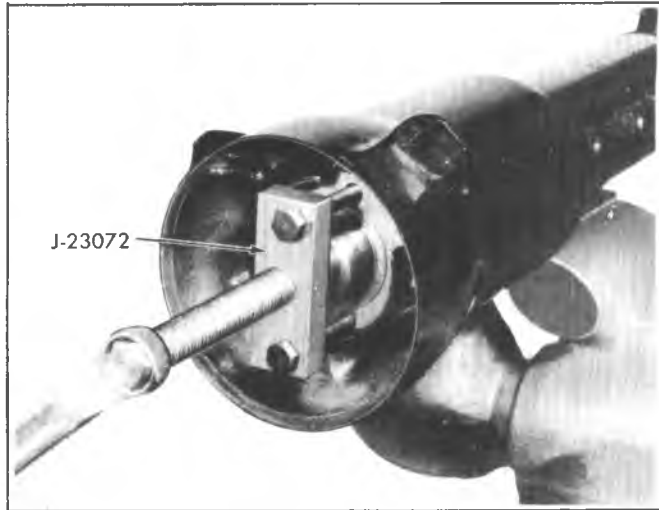


Fig. 3B4-52—Removing Shift Tube

16. Remove the bearing housing support lock plate by sliding it out of the jacket notches, tipping it down toward the housing hub at the 12 o'clock position and sliding it under the jacket opening. Remove the wave washer.

17. **All Columns** - Remove the shift lever housing from the mast jacket (transmission control lock tube housing on floor shift models). Remove the shift lever spring by winding the spring up with pliers and pulling it out. On floor shift models, remove the spring plunger.

18. Disassemble the bearing housing as follows:

a. Remove the tilt lever opening shield.

b. Remove the lock bolt spring by removing the retaining screw and moving the spring clockwise to remove it from the bolt (Fig. 3B4-53).

c. Remove the snap ring from the sector drive shaft. With a small punch, lightly tap the drive shaft from the sector (Fig. 3B4-54). Remove the drive shaft, sector and lock bolt. Remove the rack and rack spring.

d. Remove the tilt release lever pin with a punch and hammer. Remove the lever and release lever spring. To relieve the load on the release lever, hold the shoes inward and wedge a block between the top of the shoes (over slots)

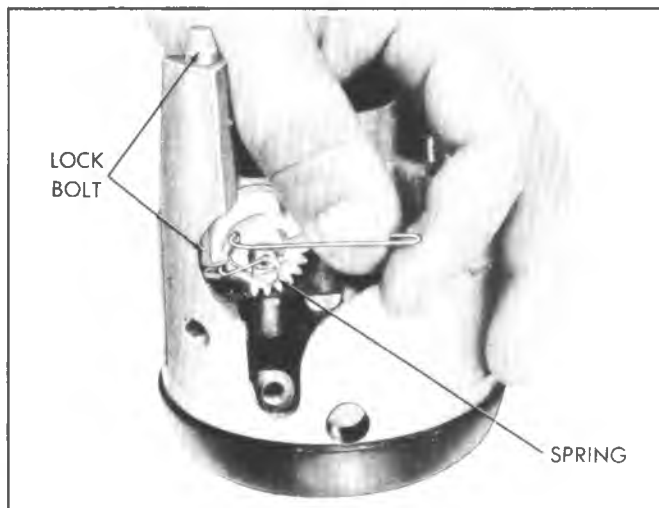


Fig. 3B4-53—Replacing Lock Bolt Spring

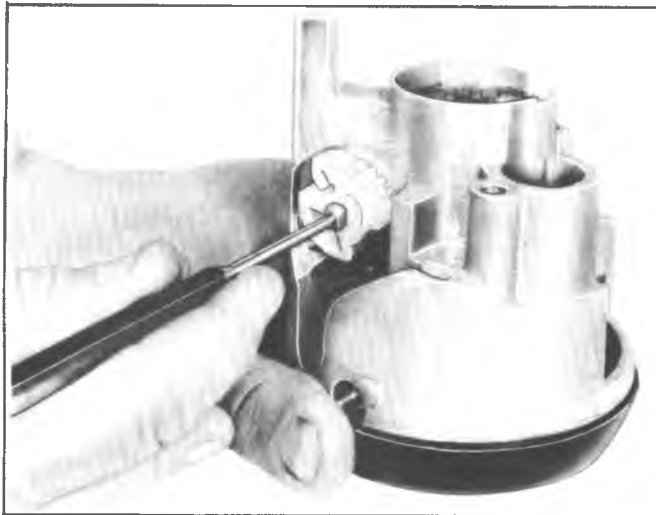


Fig. 3B4-54--Removing Sector Drive Shaft

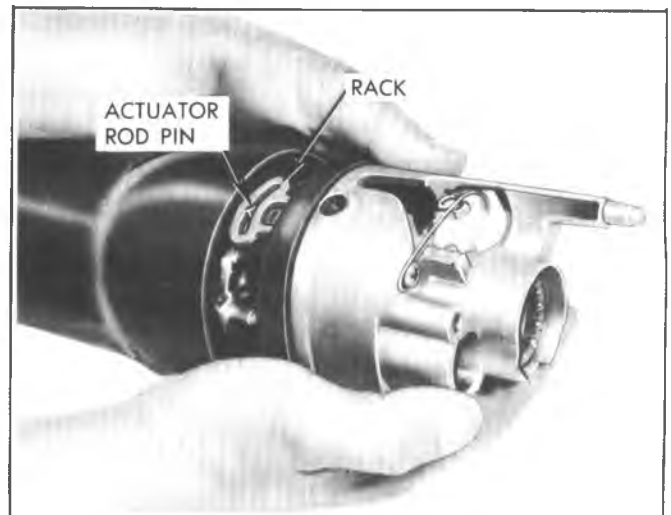


Fig. 3B4-56--Installing Bearing Housing

and bearing housing.

e. Remove the lock shoe retaining pin with a punch and hammer. Remove the lock shoes and lock shoe springs. With the tilt lever opening on the left side and shoes facing up, the four slot shoe is on the left.

f. Remove the bearings from the bearing housing only if they are to be replaced. Remove the separator and balls from the bearings. Place the housing on work bench and with a pointed punch against the back surface of the race, carefully hammer the race out of the housing until a bearing puller can be used. Repeat for the other race.

Assembly-Tilt Columns

Apply a thin coat of lithium grease to all friction surfaces.

1. If the bearing housing was disassembled, repeat the following steps:

a. Press the bearings into the housing, if removed, using a suitable size socket. Be careful not to damage the housing or bearing during installation.

b. Install the lock shoe springs, lock shoes and shoe pin in the housing. Use an approximate .180" rod to line up the

shoes for pin installation.

c. Install the shoe release lever, spring and pin. To relieve the load on the release lever, hold the shoes inward and wedge a block between the top of the shoes (over slots) and bearing housing.

d. Install the sector drive shaft into the housing. Lightly tap the sector onto the shaft far enough to install the snap ring. Install the snap ring.

e. Install the lock bolt and engage it with the sector cam surface. Then install the rack and spring. The block tooth on the rack should engage the block tooth on the sector (Fig. 3B4-55). Install the external tilt release lever.

f. Install the lock bolt spring and retaining screw (Fig. 3B4-50). Tighten the screw to 35 in. lbs.

2. Install the shift lever spring into the housing by winding it up with pliers and pushing it into the housing. On floor shift models, install the plunger, slide the gearshift lever housing onto the mast jacket.

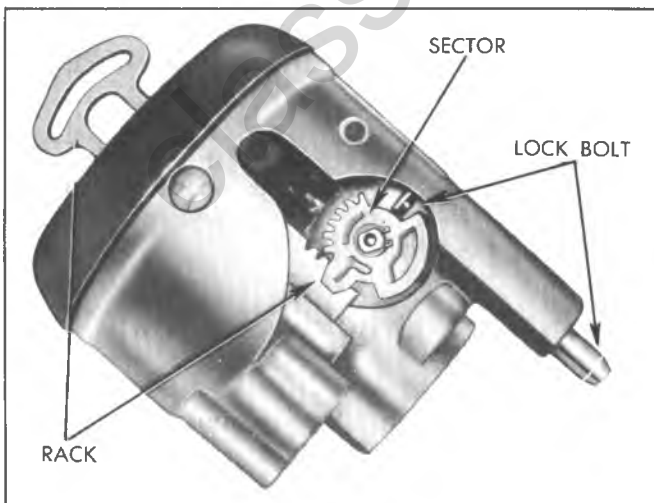


Fig. 3B4-55--Installing Lock Bolt and Rack Assemblies

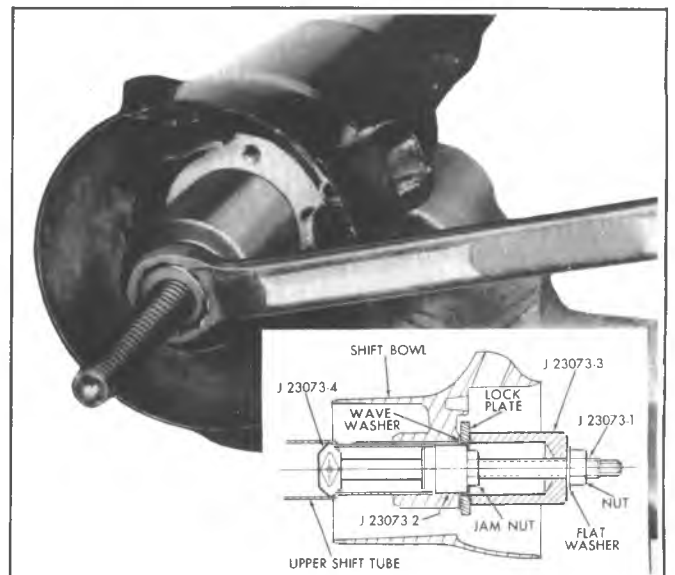


Fig. 3B4-57--Installing Shift Tube

3. Install the bearing support lock plate wave washer.
4. Install the bearing support lock plate. Work it into the notches in the jacket by tipping it toward the housing hub at the 12 o'clock position and sliding it under the jacket opening. Slide the lock plate into the notches in the jacket.
5. Carefully install the shift tube into the lower end of the mast jacket. Align keyway in the tube with the key in the shift lever housing. Install the wobble plate end of Tool J-23073 into the upper end of the shift tube far enough to reach the enlarged portion of the tube. Then install the adapter over the end of the tool, seating it against the lock plate. Place the nut on the threaded end of the tool and pull the shift tube into the housing (Fig. 3B4-57). Remove Tool J-23073.

NOTICE: Do not push or tap on the end of the shift tube. Be sure that the shift tube lever is aligned with the slotted opening at the lower end of the mast jacket or damage to the shift tube and mast jacket could result.

6. Install the bearing support thrust washer and retaining ring by pulling the shift lever housing up far enough to compress the wave washer.
7. Install the bearing support by aligning the "V" in the support with the "V" in the jacket. Insert the screws through the support and into the lock plate and torque to 60 lbs. in.

8. Align the lower bearing adapter with the notches in the jacket and push the adapter into the lower end of the mast jacket. Install lower bearing, bearing reinforcement and retaining clip, being sure that the clip is aligned with the slots in the reinforcement, jacket and adapter.

9. Install the centering spheres and anti-lash spring in the upper shaft. Install the lower shaft from the same side of the spheres that the spring ends protrude.

10. Install the steering shaft assembly into the shift tube from the upper end. Carefully guide the shaft through the shift tube and bearing.

11. Install the ignition switch actuator rod through the shift lever housing and insert in the slot in the bearing support. Extend the rack downward from the bearing housing.

12. Assemble the bearing housing over the steering shaft and engage the rack over the end of the actuator rod (Fig. 3B4-56).

13. With the external release lever installed, hold the lock shoes in the disengaged position and assemble the bearing housing over the steering shaft until the pivot pin holes line up.

14. Install the pivot pins.
15. Place the bearing housing in the full "up" position and install the tilt lever spring guide, spring and spring retainer. With a suitable screwdriver, push the retainer in and turn clockwise to engage in the housing.
16. Install the upper bearing inner race and race seat.
17. Install the tilt lever opening shield.
18. Remove the tilt release lever, install the turn signal housing and torque the three retaining screws to 45 lbs. in.
19. Install the tilt release lever and shift lever. Drive the shift lever pin in.

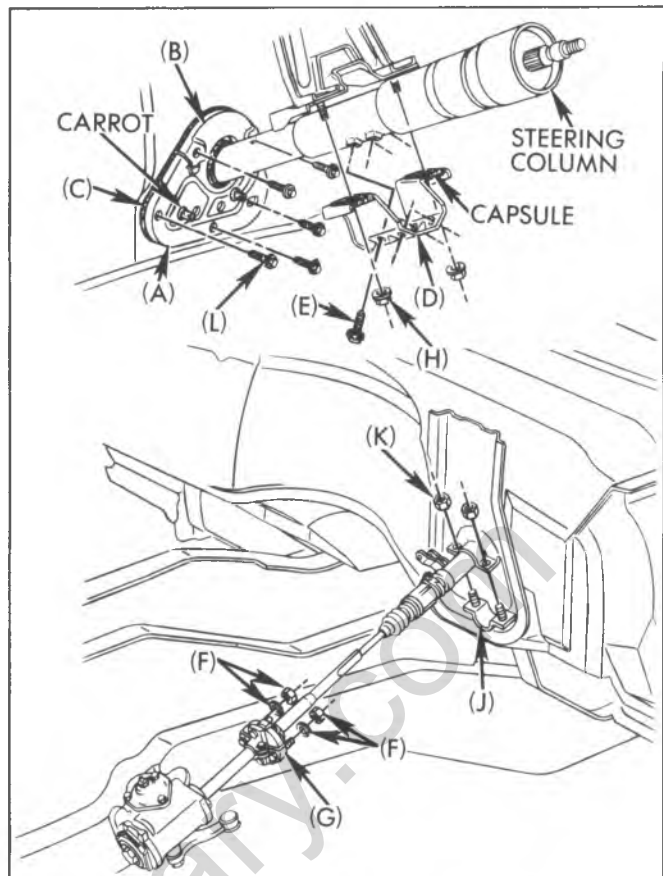


Fig. 3B4-58—Steering Column Installation-CK

20. Install the lock cylinder, turn signal switch and ignition switch as outlined previously in this section.
21. Align the groove across the upper end of the pot joint with the flat on the steering shaft. Assemble the intermediate shaft assembly to the upper shaft. Install the clamp and bolt and torque the nut to specifications.

NOTICE: The clamp bolt must pass through the shaft undercut, or damage may occur to the components.

22. Install the neutral-safety switch or back-up switch as outlined in Section 12 of this manual.
23. Install the four dash panel bracket to column screws and torque to specifications.

CAUTION: Be sure that the slotted openings in the bracket (for the mounting capsules) face the upper end of the steering column.

COLUMN INSTALLATION-MANDATORY SEQUENCE

Mandatory Preliminary Instructions

1. Assemble lower dash cover (A) and upper dash cover (B) to seal (C) with "Carrots" (part of seal).
2. Attach bracket (D) to jacket and tighten four bolts (E) to specified torque.

Mandatory Installation Sequence

1. Position column in body and position flange to rag joint and install lock washers and nuts (F) (May be tightened to specified torque at this time). Coupling (G) on manual steering must be installed prior to column installation.
2. Loosely assemble (2) capsules nuts (H) at the instrument panel bracket (D).
3. Position lower clamp (J) and tighten attaching nuts (K) to specified torque.
4. Tighten two nuts (H) at capsules to specified torque.
5. Install seal (C) and covers (A and B) to dash.
6. Install attaching screws (L) and tighten to specified torque.
7. Tighten two nuts (F) at capsules to specified torque if not already done.
8. Remove plastic spacers from flexible coupling pins.
9. Install transmission indicator cable on column automatics.
10. Install the instrument panel trim cover.
11. Connect the transmission control linkage at the shift tube levers.
12. Install the steering wheel as outlined previously in this section.
13. Connect the battery ground cable.

Mandatory System Requirements

1. Pot joint operating angle must be $1\ 1/2^\circ \pm 4^\circ$.
2. Flexible coupling must not be distorted greater than $\pm .06$ due to pot joint bottoming, in either direction.

STEERING COLUMN SERVICE FOR G AND P SERIES

STEERING WHEEL

Removal

1. Disconnect battery ground cable.
2. Remove horn button or shroud, receiving cup, Belleville spring and bushing and mark steering wheel to steering shaft relationship.
3. Remove snap ring, and steering shaft nut.
4. Use Tool J-2927 to remove wheel (Fig. 3B4-59).

Installation

NOTICE: See NOTICE on page 1 of this section regarding the fastener referred to in step 2.

Directional signal control assembly must be in neutral position when assembling steering wheel to prevent damage to cancelling cam and control assembly.

1. Place the steering wheel onto the steering shaft, aligning the marks made at removal.
2. Position into place and secure to proper torque with nut. Install snap ring.
3. Install horn button assembly.
4. Connect battery ground cable.

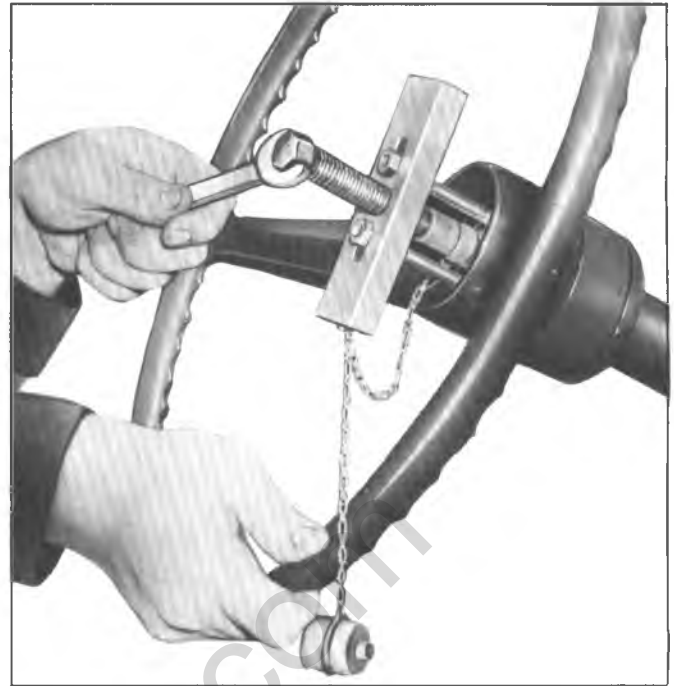


Fig. 3B4-59--Steering Wheel Removal-Typical

STEERING COUPLING (FLEXIBLE TYPE)

Removal (Fig. 3B4-60)

1. Remove the coupling to steering shaft flange bolt nuts.
2. Remove the coupling clamp bolt. This is a special bolt and will require a 12 pt. socket or box wrench.
3. Remove the steering gear to frame bolts and lower the steering gear far enough to remove the flexible coupling. It is not necessary to disconnect the pitman arm from the pitman shaft.
4. Tap lightly on the flexible coupling with a soft mallet to remove the coupling from the steering gear wormshaft.

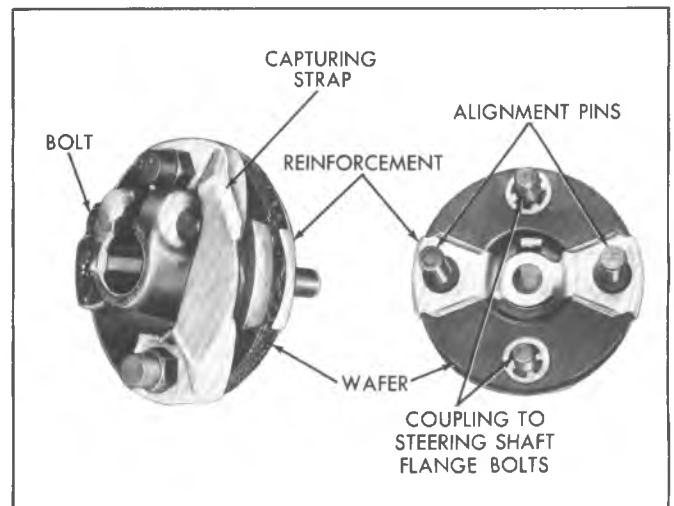


Fig. 3B4-60--Flexible Type Steering Coupling

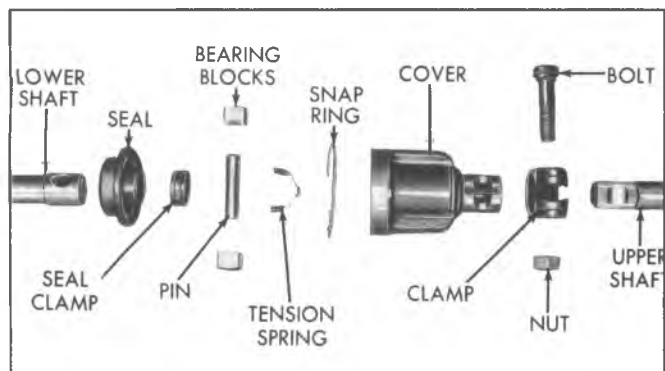


Fig. 3B4-61--Steering Shaft Intermediate Coupling

Installation

NOTICE: See NOTICE on page 1 of this section regarding the fasteners referred to in steps 2, 4 and 5.

1. Install the flexible coupling onto the steering gear wormshaft, aligning the flat on the shaft with the flat in the coupling. Push the coupling onto the wormshaft until the coupling reinforcement bottoms against the end of the worm.

2. Install the special bolt into the split clamp and torque to specifications.

NOTICE: The bolt must pass through the shaft undercut, or damage may occur to the components.

3. Place the steering gear into position, guiding the flexible coupling bolts into the proper holes in the steering shaft flange.

4. Install and tighten the steering gear to frame bolts.

5. Install the coupling to flange bolt nuts and washers and torque to specifications. Be sure to maintain a coupling to flange dimension of .250" to .375". The coupling alignment pins should be centered in the flange slots.

INTERMEDIATE STEERING SHAFTS WITH POT JOINT COUPLINGS

Removal (Fig. 3B4-61)

1. Remove the lower shaft flange to flexible coupling bolts.

2. Remove upper shaft to intermediate coupling bolt

3. If necessary, remove the steering gear to frame bolts and lower the steering gear far enough to remove the intermediate shaft assembly. It is not necessary to remove the pitman arm from the pitman shaft.

Disassembly

1. Mark cover to shaft relationship. Pry off snap ring and slide cover from shaft.

2. Remove bearing blocks and tension spring from pivot pin.

3. Clean grease off pin and end of shaft. Scribe location mark on pin on same side as chamfer in shaft.

4. Supporting shaft assembly securely, with chamfer up, press pin out of shaft with arbor press.

NOTICE: Do not drive pin out with hammer. This

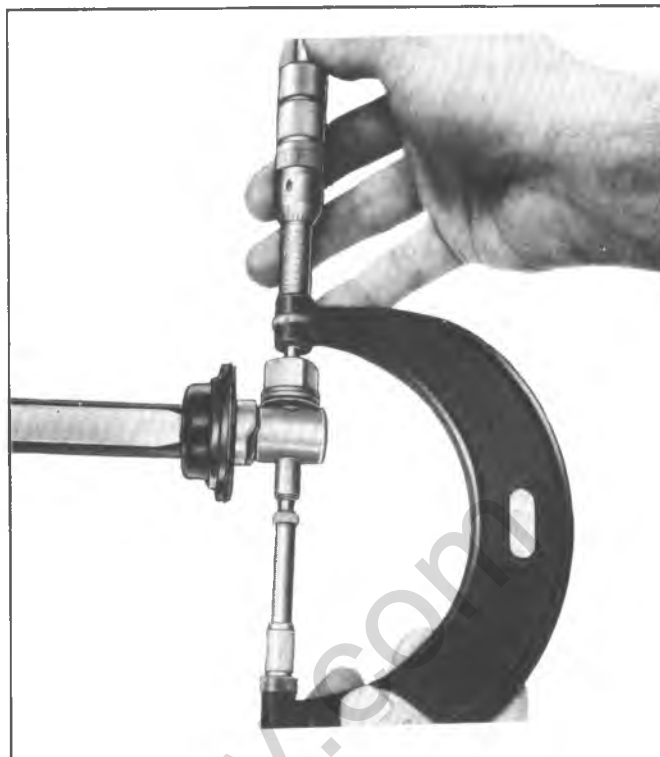


Fig. 3B4-62--Checking Coupling Pin Centering

may cause sticky or binding bearings when reassembled.

5. Remove seal clamp and slide seal off end of shaft.

Assembly

1. Be sure all parts are free of dirt. Slide seal onto steering shaft. With lip of seal against step in shaft clamp seal.

2. Press pin back into shaft from chamfered side. Locate pin in shaft using scribe mark as reference.

NOTICE: Pin must be centered within .012 in. or binding in the coupling could result.

3. Check centering of pin (Fig. 3B4-62).

a. Place just enough 3/8" flat washers on pin to prevent bearing block from bottoming when installed.

b. Measure distance from end of pin to top of bearing with micrometer.

c. Remove bearing and washers and place same bearing and washers on other end of pin. Measure distance from end of pin to top of bearing. If micrometer readings in Steps b and c differ more than .012, repeat last part of Step 2 and recheck.

4. Apply a liberal amount of wheel bearing grease to inside and outside of bearing blocks and inside of cover.

5. Position tension spring and bearing blocks on pin.

6. Slide cover over bearing blocks aligning reference mark on cover with mark on shaft. Install seal into end of cover and secure with snap ring retainer.

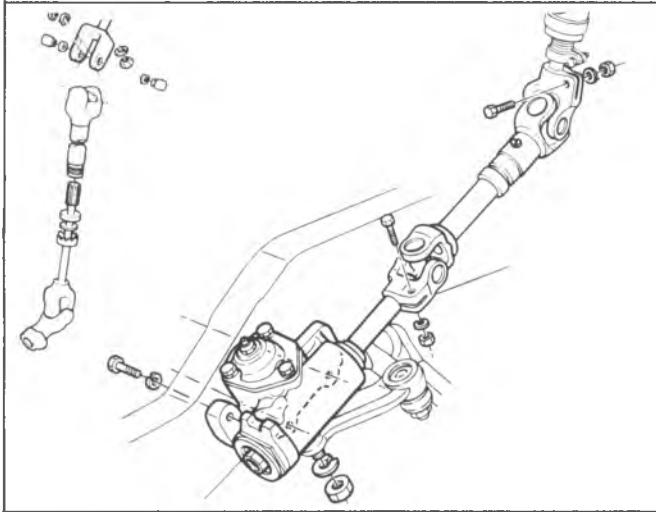


Fig. 3B4-63--Intermediate Steering Shaft-P Series

Installation

NOTICE: See NOTICE on page 1 of this section regarding the fasteners referred to in steps 1, 3 and 4.

1. Install the intermediate shaft assembly onto the steering shaft, aligning the flat on the shaft with the flat in the coupling. Install the pot joint clamp bolt and torque to specifications.
2. Lift the steering gear into position, guiding the flexible coupling bolts into the shaft flange holes.
3. Install the steering gear to frame bolts and torque to specifications.
4. Install the flexible coupling to steering shaft flange bolt lockwashers and nuts. Check that the coupling alignment pins are centered in the flange slots and then torque the coupling bolts to specifications.

INTERMEDIATE STEERING SHAFT WITH UNIVERSAL JOINT COUPLINGS

Removal (Fig. 3B4-63)

1. Set front wheels in straight ahead position. This can be done by driving the vehicle a short distance on a flat surface.
2. Mark upper universal joint yoke to steering shaft relationship and lower yoke to steering gear wormshaft relationship.
3. Remove both upper and lower universal yoke pinch bolts.
4. Remove steering gear to frame bolts and lower the gear. It is not necessary to disconnect the pitman arm from the steering gear pitman shaft.
5. Remove the intermediate steering shaft and universal joint assembly.

Disassembly

1. If the upper or lower half of the intermediate steering shaft is to be replaced, proceed as follows:
 - a. With the shaft assembly on a bench, straighten the tangs on the dust cap. Separate the upper and lower portions of the shaft assembly.

- b. Remove the felt washer, plastic washer and dust cap. Discard the felt washer.

2. If the trunion assemblies are to be replaced, proceed as follows:

- a. Remove the snap rings retaining the trunion bushings in one of the yokes.

- b. Support the yoke on a bench vise and drive out one bushing by tapping on the opposite bushing using a soft drift and hammer.

- c. Support the other side of the yoke and drive out the remaining bushing as in Step b above.

- d. Move the yoke on the trunion as necessary to separate the upper and lower yokes.

- e. Remove the trunion from the lower yoke as outlined in Steps a through d above. Remove and discard the seals.

Assembly

1. If the yoke trunnions were removed, reassemble as follows:

- a. Place the new trunion into the lower yoke.

- b. Place new seals onto the trunion and then press the new bushings into the yoke and over the trunion hubs far enough to install the snap rings.

- c. Install the snap rings.

- d. Repeat Steps a through c to attach the upper yoke to the trunion.

2. Reassemble the intermediate shaft assembly as follows:

- a. Place the dust cap, plastic washer and a new felt seal over the shaft on the lower yoke assembly.

- b. Align the arrow on the lower yoke assembly shaft with the arrow on the upper yoke assembly tube and push the two assemblies together.

- c. Push the dust cap, plastic washer and felt washer into position on the lower end of the upper yoke assembly and bend the tangs of the dust cap down against the yoke tube.

Installation

NOTICE: See NOTICE on page 1 of this section regarding the fasteners referred to in steps 1, 3 and 4.

1. Align the marks made at removal and assemble the intermediate shaft lower yoke onto the steering gear wormshaft. Install the pinch bolt and torque to specifications. The pinch bolt must pass through the shaft undercut. If a new yoke was installed, the slit in the yoke should be in the 12 o'clock position.

2. Raise the steering gear into position while guiding the upper yoke assembly onto the steering shaft.

The marks on the coupling and steering shaft must align. If a new yoke was installed, assemble the upper yoke to the steering shaft with the steering wheel in straight ahead position (gear must be on high point).

3. Install the steering gear to frame bolts and torque to specifications.

4. Install the upper yoke to steering shaft pinch bolt and torque to specifications.

NOTICE: The pinch bolt must pass through the shaft undercut, or damage may occur to the components.

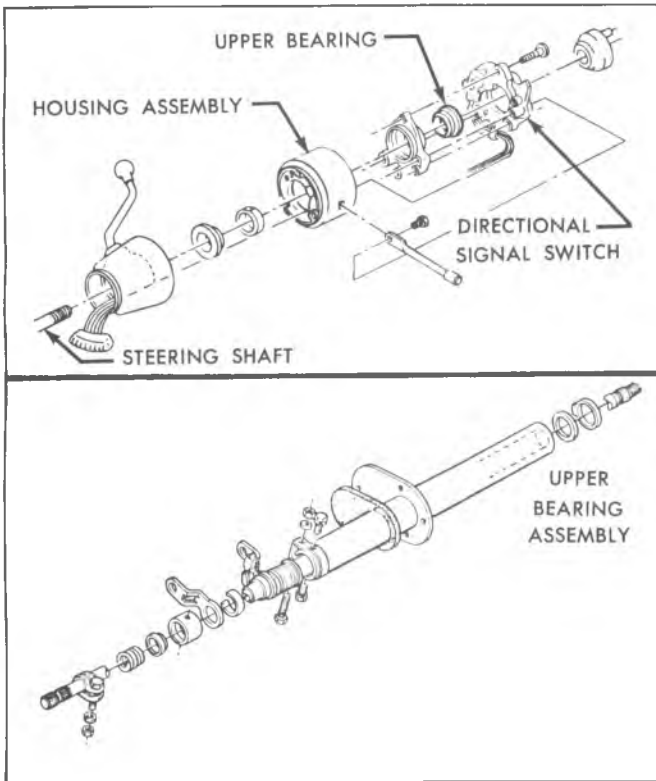


Fig. 3B4-64--Steering Column Upper Bearing

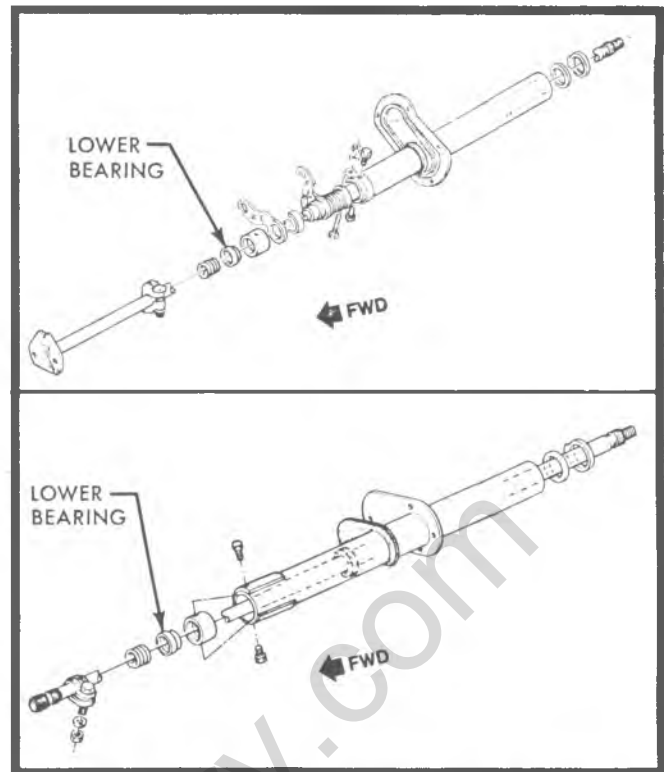


Fig. 3B4-65--Steering Column Lower Bearing

STEERING COLUMN UPPER BEARING-G AND P SERIES

Standard Column

Removal

1. Remove steering wheel as outlined in this section.
2. Remove directional signal cancelling cam.
3. Pry out upper bearing.

Installation

NOTICE: See NOTICE on page 1 of this section regarding the fasteners referred to in step 1.

1. Replace all component parts in reverse order of removal making sure that directional switch is in neutral position before installing steering wheel. Torque steering wheel nut to specifications.

Tilt Column

The upper bearings on the tilt column are spun into the bearing housing assembly. If the bearings indicate need of replacement, the entire bearing housing must be replaced. See "Tilt Steering Column - Disassembly and Assembly" for the correct replacement procedure.

STEERING COLUMN LOWER BEARING P SERIES

Removal

1. Remove the intermediate steering shaft and universal joint assembly as outlined earlier in this section. Remove the preload spring clamp and spring from the end of the steering shaft.

2. Pry out the lower bearing assembly.

Installation

NOTICE: See NOTICE not on page 1 of this section regarding fasteners referred to in step 2.

1. Place the new bearing over the end of the steering shaft and press into position in the column.
2. Install the preload spring and clamp and torque the clamp bolt nut to specifications. Refer to "Bearing Adjustment" in "Maintenance and Adjustment Section. Reinstall the intermediate shaft and universal joint assembly as outlined under "Intermediate Steering Shaft with Universal Joint Couplings - Installation".

TILT COLUMN BEARING HOUSING ASSEMBLY - G AND P SERIES

Removal (Column in Vehicle)

1. Disconnect the battery ground cable.
2. Remove the steering wheel as outlined under "Steering Wheel - Removal".
3. Remove the directional signal switch as outlined under "Directional Signal Switch - Removal".
4. **Column Shift Models** - Using a suitable size punch, drive out the shift lever pivot pin and remove the shift lever.
5. Install the tilt release lever and place the column in the full "up" position. Remove the tilt lever spring and retainer using a screwdriver that just fits into the slot opening. Insert the screwdriver into the slot, push in approximately 3/16", rotate clockwise approximately 1/8 turn until the retainer ears align with the grooves in the housing and remove the retainer and spring.

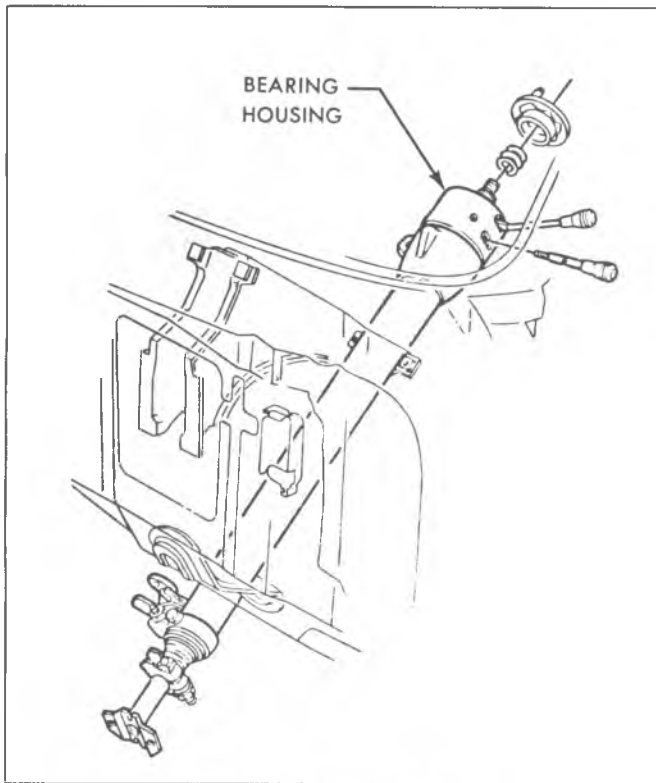


Fig. 3B4-66--Tilt Column Bearing Housing

6. Remove the steering shaft bearing locknut using Socket J-22599. Remove the upper bearing race seat and race.

7. Remove the two bearing housing pivot pins using Tool J-21854.

8. Pull up on the tilt release lever (to disengage the lock shoes) and remove the bearing housing.

If the bearing housing is being replaced or it is necessary to disassemble the bearing housing, proceed as follows:

a. Press the upper and lower bearings out of the housing.

b. Using Puller J-5822 and Slide Hammer J-2619, pull the bearing races from the housing.

c. Remove the tilt release lever.

d. Drive out the shoe release pivot pin using Tool J-22635 or a suitable punch. Remove the lever spring and remove the wedge.

e. Using a suitable size punch, drive out the lock shoe retaining pin. Remove the shoes and shoe springs.

If the upper steering shaft, lower steering shaft, or centering spheres are being removed, proceed as follows:

9. To remove the steering shaft assembly through the upper end of the column. If it is necessary to disassemble the shaft, proceed as follows:

a. To remove the lower steering shaft first disconnect the shaft at the pot joint coupling clamp.

b. Turn the upper shaft 90° to the lower shaft and slide the upper shaft and centering spheres from the lower shaft.

c. Rotate the centering spheres 90° and remove the centering spheres and preload spring from the upper shaft.

If the bearing housing support is being replaced, proceed as follows:

10. Remove the four bearing housing support screws and remove the support.

Assembly

NOTICE: See NOTICE on page 1 of this section regarding the fasteners referred to in steps 3, 9 and 11.

1. Assemble the steering shaft as follows:

a. Lubricate and assemble the centering spheres and preload spring.

b. Install the spheres into the upper (short) shaft and rotate 90°.

c. Install the lower shaft 90° to the upper shaft and over the centering spheres. Slowly straighten the shafts while compressing the preload spring.

2. Install the shaft assembly into the housing from the upper end.

3. Install the lower shaft to the pot joint coupling clamp. Install the coupling clamp bolt and torque to specifications.

NOTICE: The coupling bolt must pass through the shaft undercut, or damage may occur to the components.

4. Assemble the bearing housing as follows:

a. Press the new upper and lower bearing races into the bearing housing.

b. Lubricate and install the bearings into the bearing races.

c. Place the lock shoe springs in position in the housing. Install each shoe in place and compress the spring until a suitable size straight punch can be used to hold the shoe in position (it may be necessary to acquire assistance to install the shoes). Once the shoes are in place, drive in the shoe retaining pin.

d. Install the shoe release lever and drive in the pivot pin.

e. Install the tilt release lever.

f. Lubricate the shoes and release lever.

5. Install the bearing housing assembly to the support. Hold the tilt release lever in the "up" position until the shoes have fully engaged the support. Lubricate and install the bearing housing pivot pins. Press the pins in flush with the housing.

6. Place the housing in the full "up" position and then install tilt spring and retainer (tapered end of spring first). Push into the housing approximately 3/16" and rotate counterclockwise 1/8 turn.

7. Lubricate and install the upper bearing race, race seat and locknut. Tighten the locknut (using Socket J-22599) to remove the lash and then carefully further tighten 1/16 to 1/8 of a turn (column must be in straight ahead position).

8. Remove the tilt release lever.

9. Install the directional signal switch as outlined under "Directional Signal Switch - Installation".

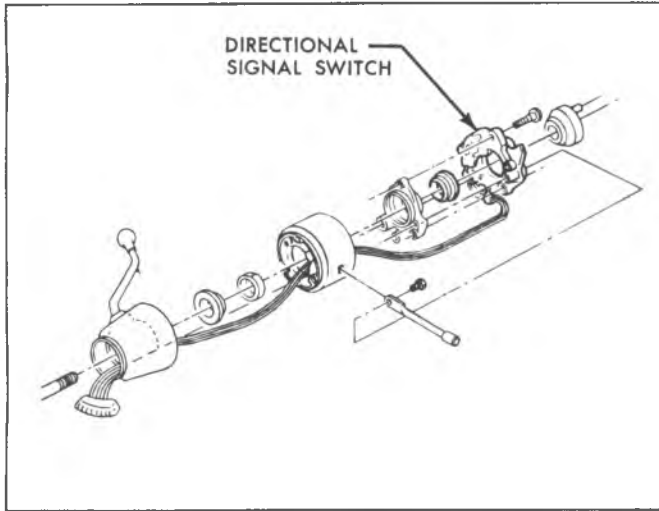


Fig. 3B4-67--Directional Signal Switch

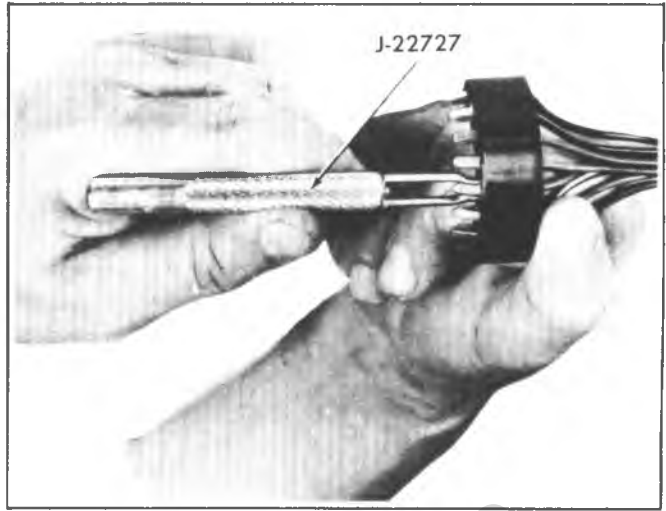


Fig. 3B4-69--Removing Wires from Connector

10. Column Shift Models - Install the shift lever and pivot pin.
11. Install the steering wheel as outlined under "Steering Wheel - Installation".
12. Check electrical and mechanical functioning of column.

DIRECTIONAL SIGNAL SWITCH

If the directional signal switch must be replaced, the steering column does not have to be removed from the vehicle.

Removal

1. Remove the steering wheel as outlined under "Steering Wheel - Removal".
2. Remove the directional signal switch cancelling cam and spring.
3. Remove the column to instrument panel trim plate (if so equipped).
4. Disconnect the directional signal switch wiring harness at the half-moon connector.

5. Pry the wiring harness protector out of the column retaining slots as shown in Figure 3B4-68.
6. Mark the location of each wire in the half-moon connector and then remove each individual wire from the connector using Tool J-22727 (Fig. 3B4-69). Insert the tool into the lower end of the connector and push in until the tool bottoms on the connector. Remove the tool and then pull the wire from the connector.
7. Remove the directional signal lever screw and remove the lever.
8. Push in on the hazard warning light knob and then unscrew and remove the knob.
9. **Tilt Columns Only**
 - a. Automatic Transmission Models - Remove the PRNDL dial screws and remove the dial and indicator needle. Remove the cap and dial illumination bulb from the housing cover.
 - b. Unscrew and remove the tilt release lever.
 - c. Assemble Tool J-22708 inside the directional signal housing cover; push in until the tangs lock inside the cover flange (Fig. 3B4-70). Turn the tool center screw clockwise to pull the cover from the housing.

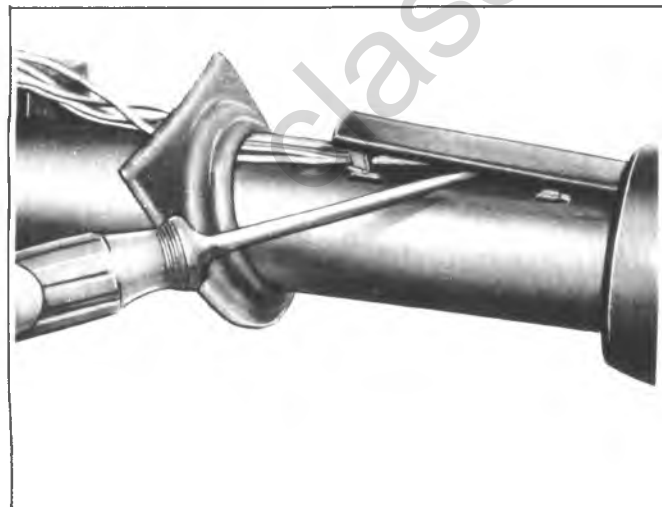


Fig. 3B4-68--Removing Wiring Harness Protector

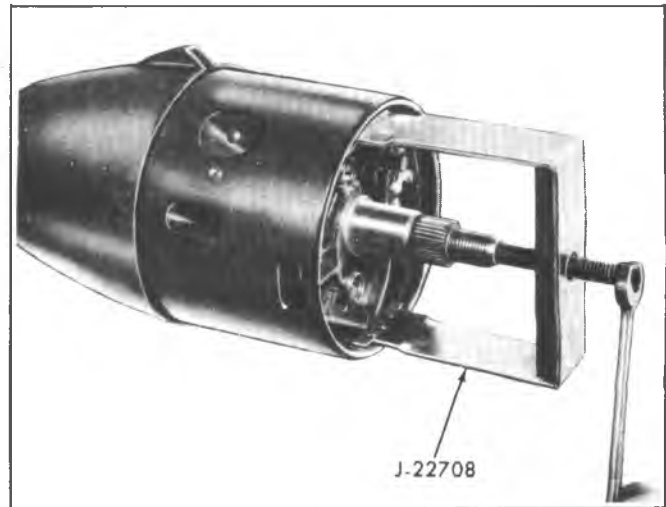


Fig. 3B4-70--Removing Directional Signal Housing Cover

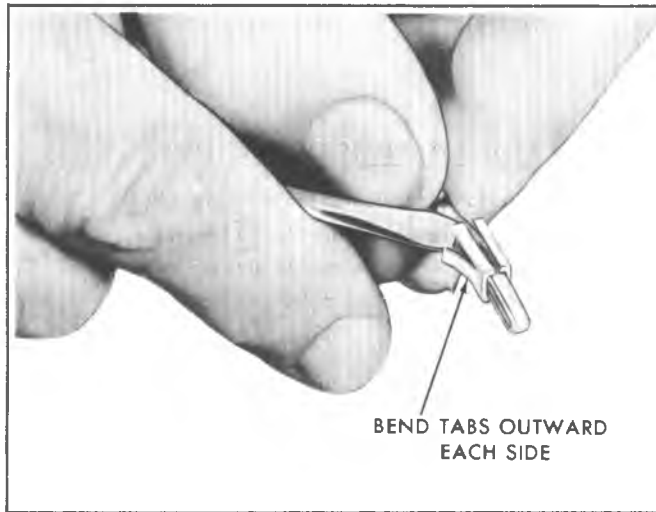


Fig. 3B4-71--Preparing Wire Retaining Tabs for Installation

10. Remove the three directional signal switch mounting screws and then carefully remove the switch assembly from the column while guiding the wiring harness through the opening in the shift lever housing.

Installation

NOTICE: See **NOTICE** on page 1 of this section regarding the fasteners referred to in step 9.

1. Wrap the ends of the directional signal switch wires with tape and then guide them through the opening at the lower left hand side of the bearing housing (tilt columns)

STEERING COLUMN G AND P SERIES

Removal

1. Disconnect the battery ground cable.
2. Column Shift Models - Disconnect transmission shifter rods at the lower end of the column.
3. **G Models** - Remove the intermediate steering shaft flange to flexible coupling bolts.
4. **P Models** - Remove the intermediate steering shaft upper universal yoke to steering shaft pinch bolt. Mark the coupling to shaft relationship.
4. Remove column clamp screw(s) on engine side of firewall, if equipped, and remove or slide the clamp down the column.
5. From inside the vehicle, remove the screws from the toe pan cover and slide the cover and seal up the column.
6. Remove the steering wheel as outlined under "Steering Wheel-Removal", and reinstall the shaft nut and washer.
7. All Columns - Disconnect the directional signal wiring harness. Standard Column with Automatic Transmission - Disconnect the conductor tube (for transmission indicator) at the instrument panel.

Tilt Column with Automatic Transmission - Disconnect the single wire at the fuse block and unclip it from the parking brake bracket.

out the lower end of the shift lever housing and under the dash seal.

2. Place the directional signal switch in position and install the three mounting screws; torque to 25 lbs. in. after screw head has been firmly seated.

3. Tilt Columns Only-

a. Align the openings in the directional signal switch cover with the proper lever positions and tap the cover into place using a plastic hammer.

b. Install the tilt release lever.

c. Automatic Transmission Model - Install the PRNDL dial, pointer, dial illumination bulb and cap.

4. Install the directional signal switch lever and hazard warning knob.

5. Bend the wire retaining tabs slightly outward on each wire in the wiring harness as shown in Figure 3B4-71; this will provide proper retention of the wire in the half-moon connector.

6. Install each wire in its marked location in the half-moon connector. Push in until square part of clip is flush with the bottom side of the connector. Connect the directional signal switch wiring harness.

7. Snap the wiring harness protector into the column retaining slots.

8. Install the directional signal cancelling cam and spring.

9. Install the steering wheel as outlined under "Steering Wheel - Installation".

10. Install the column to instrument panel trim plate (if so equipped).

8. Remove the cap screws from the column support bracket at the dash panel.

9. Carefully lower and then withdraw the column assembly, rotating so that the shift levers clear the toe pan opening.

Disassembly of Standard Column (Fig. 3B4-74)

For floor shift transmission models, omit Steps 4, 14, 15 and 16.

1. Remove the steering wheel nut and lock washer and then slide the steering shaft assembly from the lower end of the column.

2. **G Models** - Remove the lower bearing preload spring and clamp from the steering shaft.

P Models - Remove the lower bearing preload spring and clamp.

3. Remove the back-up lamp switch.

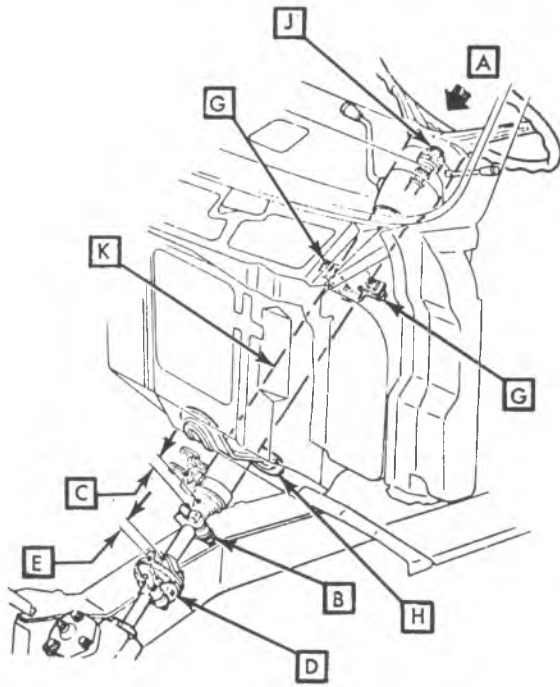
4. Drive out the shift lever pivot pin and remove the shift lever.

5. Remove the directional signal cancelling cam. Remove the directional signal switch lever.

6. Remove the column wiring harness cover.

7. Remove the directional signal switch screws.

8. Rotate the directional signal switch housing counterclockwise and remove the housing from the column. The housing and switch cannot be fully removed from the column until the shift lever housing is removed.

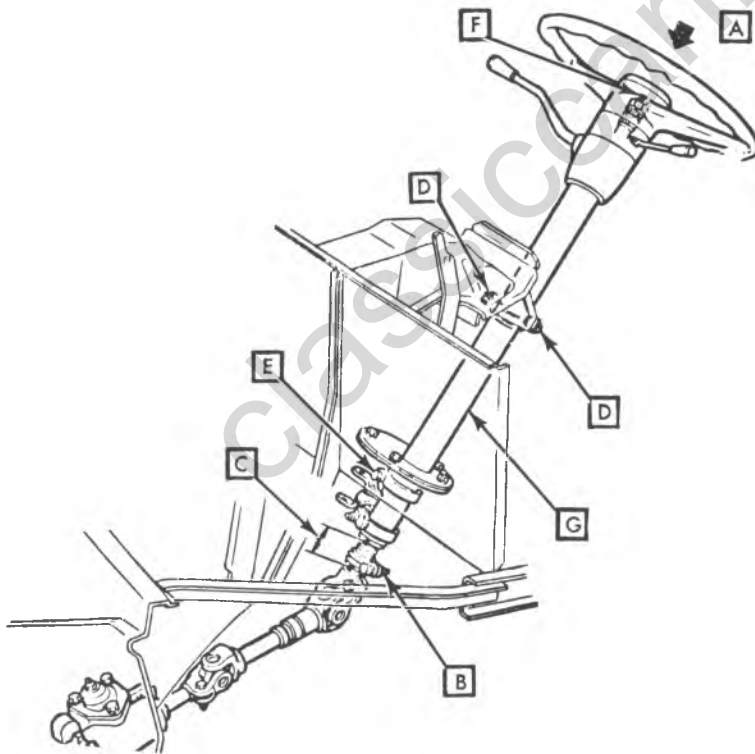


STEERING SYSTEM MANDATORY REQUIREMENTS

1. Using a 50 lb. force applied to the steering wheel end of Shaft **A**, Lower Clamp Nut **B** must be tightened to the specified torque to give a compressed spring dimension **C** of $.50 \pm .04$ after assembly.
2. Flexible Coupling **D** setup dimension **E** must be $.250/.375$. **NOTICE** This dimension must be held to prevent distortion of Flexible Coupling with resultant bind and harshness.
3. All Mast Jacket attachments **G** & **H** must be tightened to recommended torque.
4. Threaded portion of Steering Shaft **J** must be completely free of lubricant after Mast Jacket **K** assembly to maintain steering wheel clamping load and hub clearance.

Fig. 3B4-72--Steering Column Attachment-G Series

9. Remove the plastic thrust washer assembly and then remove the shift lever housing (or extension housing) from



STEERING SYSTEM MANDATORY REQUIREMENTS

1. Using a 50 lb. force applied to the steering wheel end of Shaft **A**, Lower Clamp Nut **B** must be tightened to the specified torque to give a compressed spring dimension **C** of $1.26 \pm .02$ after assembly.
2. All Mast Jacket attachments **D** & **E** must be tightened to recommended torque.
3. Threaded portion of Steering Shaft **F** must be completely free of lubricant after Mast Jacket **G** assembly to maintain steering wheel clamping load and hub clearance.

Fig. 3B4-73--Steering Column Attachment - P Series

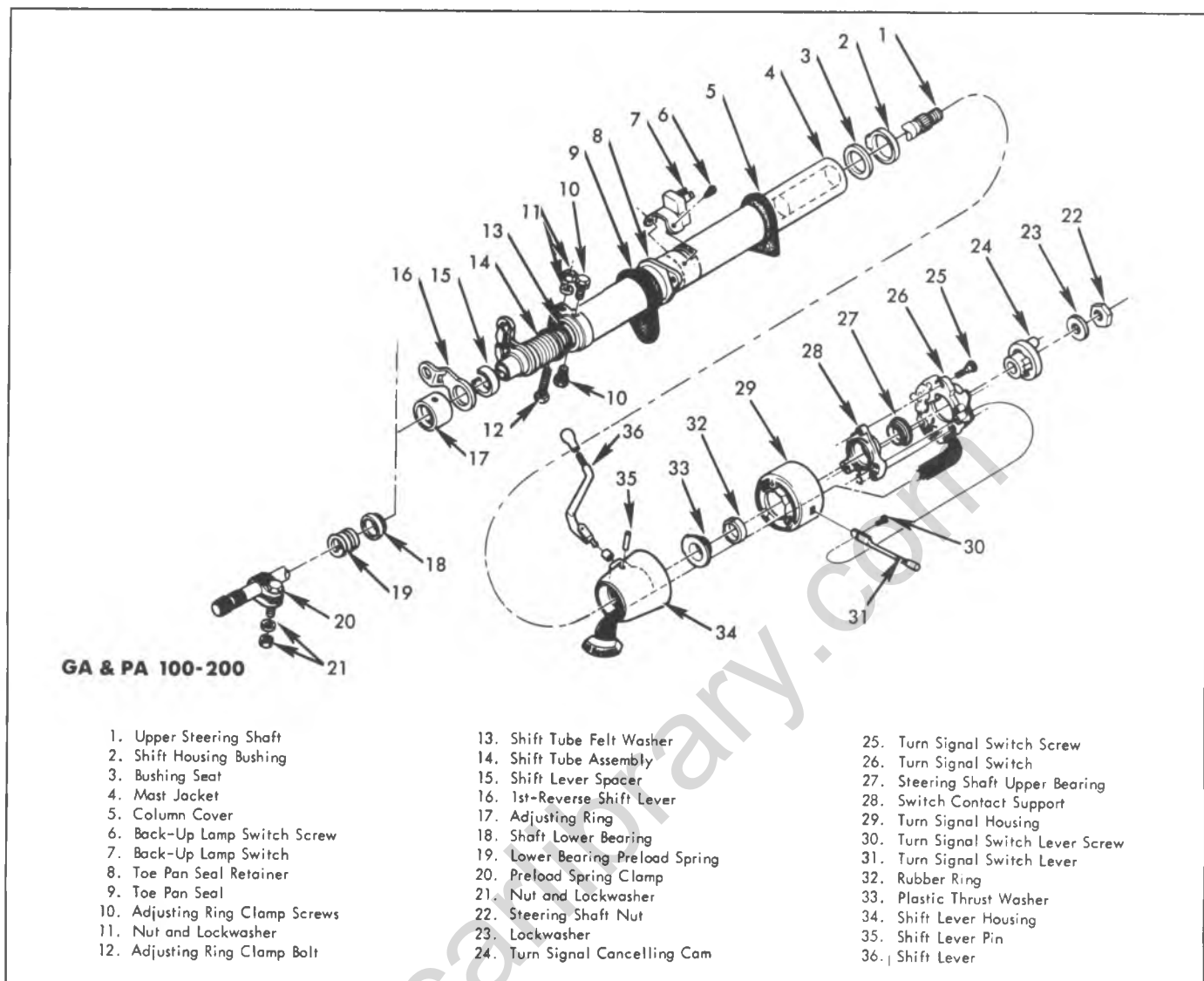


Fig. 3B4-74—Standard Column—Typical G & P

the column.

10. Separate the directional signal switch, switch control support assembly, directional signal housing and shift lever housing (or housing extension) assemblies.

11. Press the steering shaft upper bearing out of the switch contact support.

12. Remove the shift lever housing (or extension housing) seat and bushing from the upper end of the column.

13. Remove the bolt and screws from the adjusting ring clamp and remove the clamp, adjusting ring and lower bearing. Press the lower bearing out of the adjusting ring.

14. 3-Speed Columns - Remove 1st-reverse shift lever and lever spacer.

Automatic Columns - Remove the selector plate clamping ring screws (3).

15. Place the column upright on the floor, supporting it with two pieces of wood. Place a block of wood on the upper end of the shift tube. Press down on the shift lever with foot while tapping on the wood block to withdraw the tube from the column jacket.

NOTICE: In some tolerance stack-up cases it may be necessary to use a press. Be careful not to damage the tube or jacket.

16. Remove the felt seal from the shift tube.
 17. Remove firewall clamp, toe pan seal and dash panel seals from the jacket.

Assembly

In the following assembly sequence use any general purpose lithium soap grease for lubricating those components so indicated.

1. Install the dash panel seal, toe panel and firewall clamps over the end of the jacket.

2. Lubricate all bearing surfaces on the shift tube.

3. Place the felt seal onto the shift tube (next to spring) and then place the shift tube in the jacket.

4. 3-Speed Columns - Temporarily install spacer, 1st-reverse shift lever and lower adjusting ring. Place a block of wood on top of the adjusting ring and tap until the shift tube bottoms. Remove adjusting ring, shift lever and spacer.

Automatic Columns - Align the three holes in the selector plate with the three holes in the jacket, position the clamping ring and install the three screws. The shift tube spring retainer must be bottomed against the jacket stops.

5. 3-Speed Columns-Lubricate and install the spacer and 1st-reverse shift lever (tang of lever towards top of column).

6. Install lower bearing in the adjusting ring and then install the adjusting ring, clamp and screws.

7. Install the shift lever housing (or extension housing) seat and bushing to upper end of housing.

8. Thread directional signal switch wiring harness through the switch and lever (or extension) housings, lubricate the inner diameter of the shift housing, and then place the shift lever (or extension) housing onto the upper end of the column.

9. Install the switch housing plastic washer assembly. Press the upper bearing into the switch contact support.

10. Install the directional signal switch housing, contact support, bearing and switch and torque the switch screws to 25 lbs. in.

11. Install the column wiring harness cover and back-up lamp switch.

12. Install the directional signal and gearshift levers.

13. Adjust the shift tube as outlined under "Shifter Tube Adjustment."

14. Loosely install the lower bearing preload spring and clamp.

15. Slide the steering shaft assembly up through the column assembly. Install the directional signal cancelling cam, steering shaft nut and lock washer.

Disassembly Of Tilt Column (Fig. 3B4-75)

1. If the column is removed from the vehicle, place the column in a bench vise using Holding Fixtures J-22573 (Fig. 3B4-76).

NOTICE: Clamping the column directly in a vise, could result in a damaged column.

2. Remove the directional signal switch as outlined under "Directional Signal Switch-Removal".

3. Remove the lower steering shaft and pot joint assembly and lower bearing and adapter assembly as outlined under "Lower Bearing and Adapter-Removal".

4. Column Shift Models - Using a suitable size punch, drive out the shift lever pivot pin and remove the shift lever.

5. Install the tilt release lever and place the column in the full "up" position. Remove the tilt lever spring and retainer using a screwdriver that just fits into the slot opening (Fig. 3B4-77). Insert the screwdriver clockwise approximately 1/8 turn until the retainer ears align with the grooves in the housing and remove the retainer and spring.

6. Remove the steering shaft bearing locknut using socket J-22599. Remove the upper bearing race seat and race.

7. Remove the two bearing housing pivot pins using Tool J-21854 (Fig. 3B4-78).

8. Pull up on the tilt release lever (to disengage the lock shoes) and remove the bearing housing. If it is necessary to disassemble the bearing housing, proceed as follows:

a. Press the upper and lower bearings out of the housing.

b. Using Puller J-5822 and Slide Hammer J-2619 pull the bearing races from the housing (Fig. 3B4-79).

c. Remove the tilt release lever.

d. Drive out the shoe release lever pivot pin using Tool J-22635 or a suitable punch (Fig. 3B4-80). Remove the lever spring and remove the wedge.

e. Using a suitable size punch, drive out the lock shoe retaining pin. Remove the shoes and shoe springs.

9. Remove the steering shaft assembly through the upper end of the column. If it is necessary to disassemble the shaft proceed as follows:

a. Turn the upper shaft 90° to the lower shaft and slide the upper shaft and centering spheres from the lower shaft.

b. Rotate the centering spheres 90° and remove the center spheres and preload spring from the upper shaft.

10. Remove the four bearing housing support screws and remove the support.

Column Shift Models - If the shift tube index plate must be removed, remove the two retaining screws and remove the plate.

11. Remove the shift tube retaining ring with a screwdriver (Fig. 3B4-81). Remove the thrust washer.

12. Remove the neutral-safety or back-up lamp switch screws and remove the switch.

13. Rework Shift Tube Removing Tool J-22551 by removing 1/2" from the pilot end of the tool (Fig. 3B4-82). This allows the shift tube to be pushed further out of the housing and will not affect the use of the tool on other columns.

14. Remove the shift tube assembly using Tool J-22551 (Fig. 3B4-83). Insert the hooked end of the tool into the notch in the shift tube just below the shift lever housing key. Pilot the sleeve over the threaded end of the tool and into the upper end of the shift tube. Force the shift tube out of the housing by turning the nut onto the tool. If the shift tube is not completely free when the nut is bottomed on the threads, complete the removal by hand.

NOTICE: Do not hammer or pull on the shift tube during removal. On column shift models, guide the lower shift lever through the slotted opening in the column to prevent damage to the tube or column.

15. Remove the lock plate by sliding out of the column notches, tipping the plate downward toward the housing (to compress the wave washer) and then removing as shown in Figure 3B4-84. Remove the wave washer.

16. Remove the shift lever housing.

17. Column Shift Models - Remove the shift lever spring by winding the spring up with pliers.

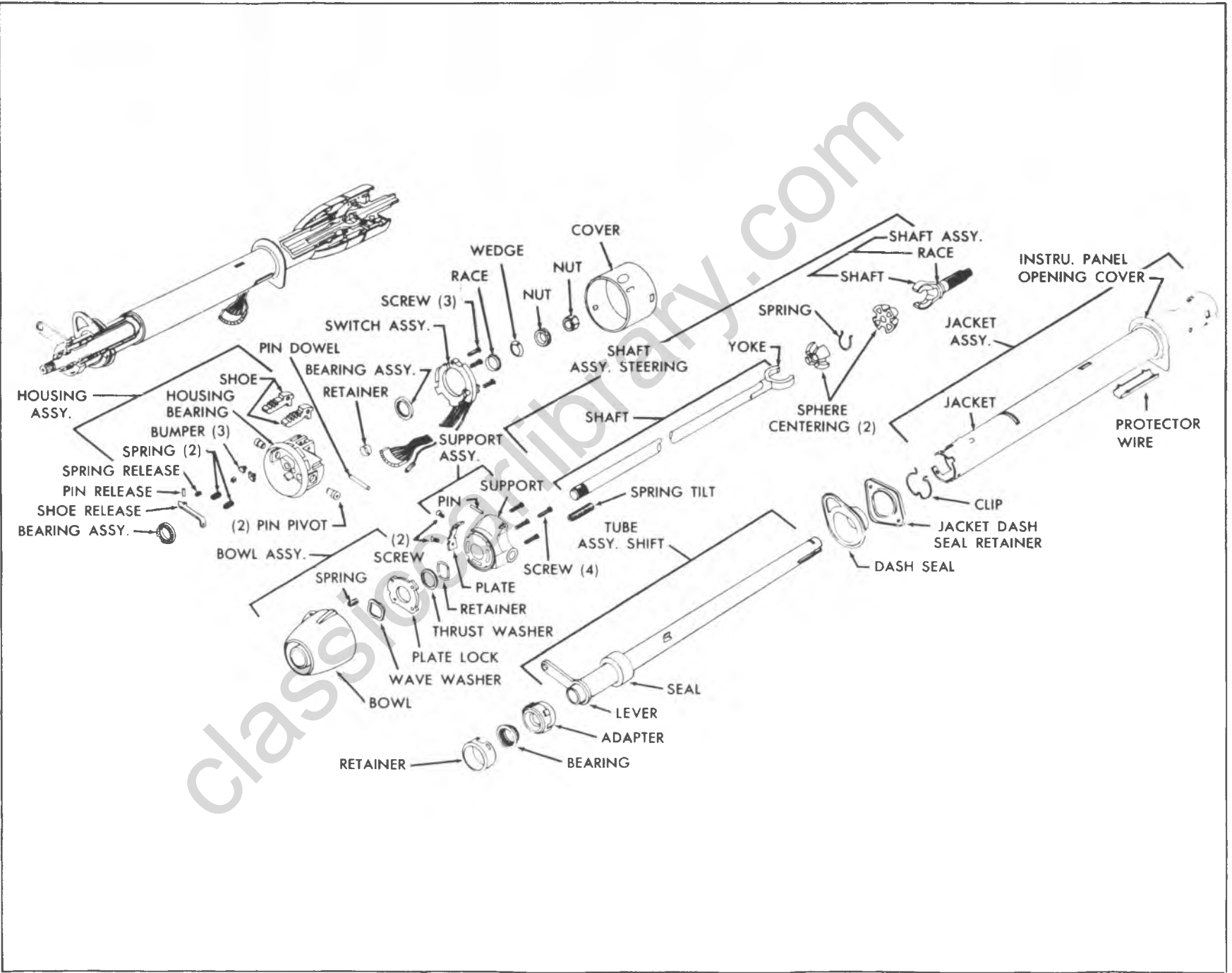
18. If necessary, remove the dash panel seal, mounting plate and the instrument panel seal from the column jacket.

Assembly of Tilt Column

When lubricating components during the following installation sequence, use any general purpose lithium soap grease.

1. Install the dash panel seal, mounting plate and the instrument panel seal on the column.

Fig. 3B4-75-Tilt Steering Column-G & P



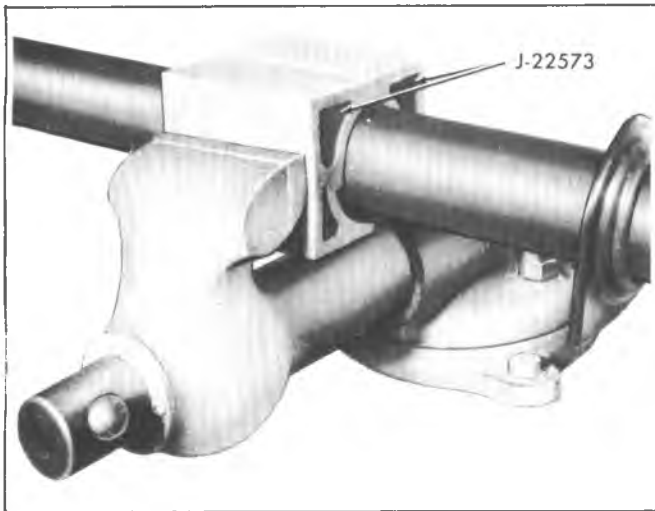


Fig. 3B4-76--Securing Column with J-22573

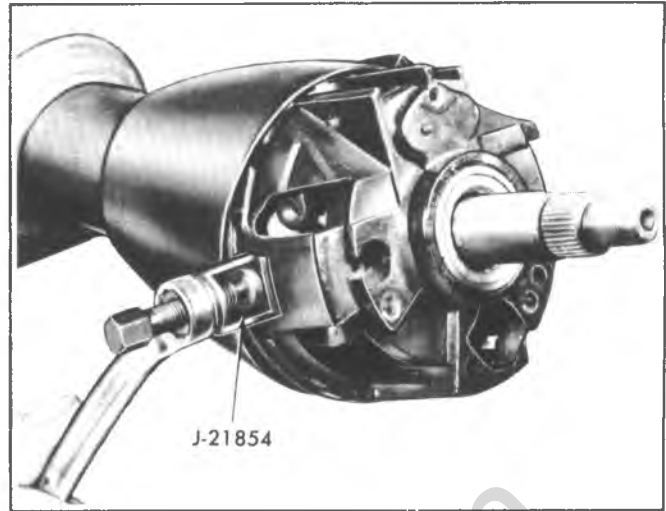


Fig. 3B4-78--Removing Bearing Housing Pivot Pin

2. Column Shift Models - Press a new shift lever spring into the shift lever housing.

3. Slide the shift lever housing over the upper end of the column.

4. Place the wave washer and lock plate in position. Work the lock plate into the notches by tipping the plate toward the housing (compressing the wave washer) at the open side of the column. Lubricate the lock plate and upper end of the shift tube.

5. Carefully install the shift tube into the lower end of the column (make sure the foam seal is at lower end of the shift tube). Align the keyway in the tube with the key in the shift lever housing and complete installation of the shift tube using Tool J-22549 (Fig. 3B4-85). The shift lever housing key must bottom in the shift tube slot to be fully installed. Remove Tool J-22549 from the column. Lubricate and push foam seal in flush with column housing.

NOTICE: Do Not hammer or force the tube when installing in the column, or damage could occur to the components.

6. Pull up on the shift lever housing (to compress the wave washer) and install the thrust washer and retaining ring. Be sure the ring is seated in both slots of the shift tube.

7. Lubricate the I.D. of the bearing housing support and install the support, aligning the bolt holes in the support with the bolt holes in the lock plate. Install the four support screws and torque to 45 in. lbs.

8. Assemble the steering shaft as follows:

a. Lubricate and assemble the centering spheres and preload spring.

b. Install the spheres into the upper (short) shaft and rotate 90°.

c. Install the lower shaft 90° to the upper shaft and over the centering spheres. Slowly straighten the shafts while compressing the preload spring.

9. Install the shaft assembly into the housing from the upper end.

10. Install the lower bearing and adapter, bearing reinforcement, wire clip, pot joint coupling and lower shaft as described under "Lower Bearing Installation".

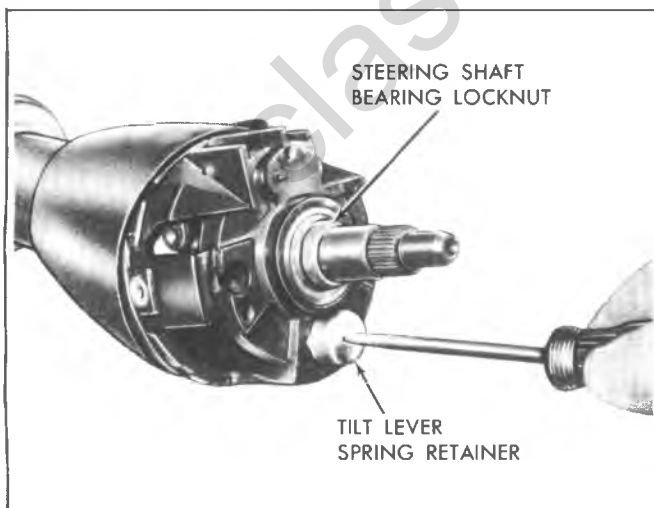


Fig. 3B4-77--Removing Tilt Spring and Retainer

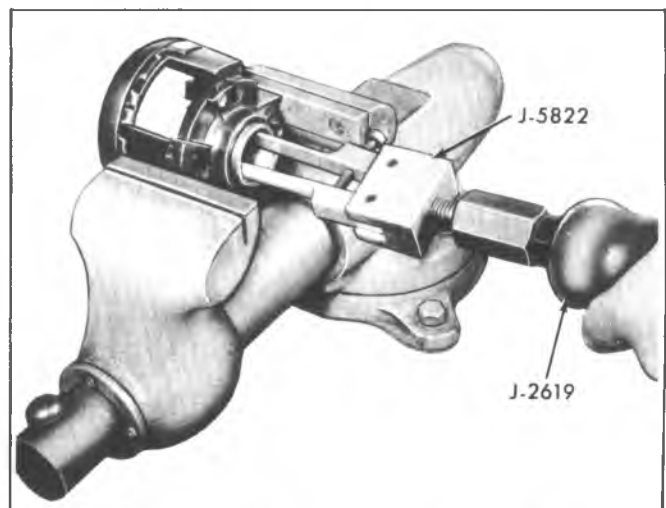


Fig. 3B4-79--Removing Bearing Race



Fig. 3B4-80--Removing Release Lever Pivot Pin

11. Assemble the bearing housing as follows:
 - a. Press the new upper and lower bearing races into the bearing housing.
 - b. Lubricate and install the bearings into the bearing races.
 - c. Place the lock shoe springs in position in the housing. Install each shoe in place and compress the spring until a suitable size straight punch can be used to hold the shoes in position (it may be necessary to acquire assistance to install the shoes). Once the shoes are in place, drive in the shoe retaining pin.
 - d. Install the shoe release lever and drive in the pivot pin.
 - e. Install the tilt release lever.
 - f. Lubricate the shoes and release lever.

12. Install the bearing housing assembly to the support. Hold the tilt release lever in the "up" position until the shoes have fully engaged the support. Lubricate and install the bearing housing pivot pins. Press the pins in flush with the housing.

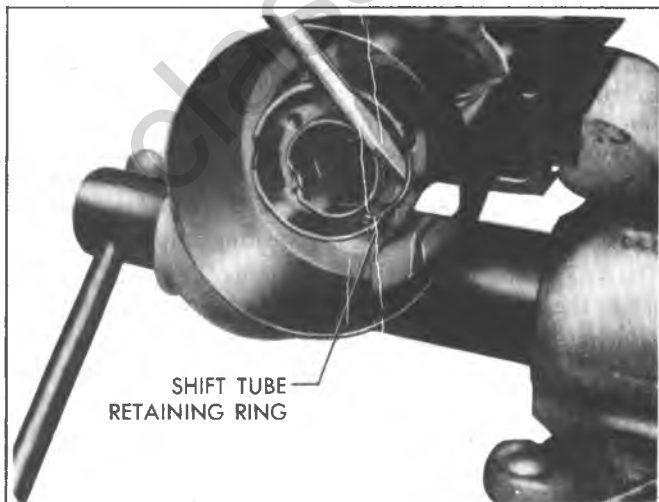


Fig. 3B4-81--Removing Shift Tube Retaining Ring

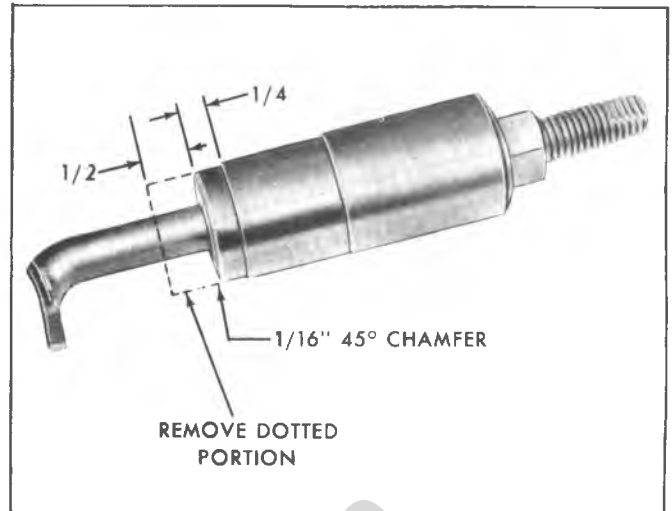


Fig. 3B4-82--Revised Shift Tube Removing Tool J-22551

13. Place the housing in the full "up" position and then install tilt spring and retainer (tapered end of spring first). Push into the housing approximately $3/16$ " and rotate counter clockwise $1/8$ turn.

14. Lubricate and install the upper bearing upper race, race seat and locknut. Tighten the locknut (using Socket J-22549) to remove the lash and then further tighten $1/16$ to $1/8$ of a turn (column must be in straight ahead position).

15. Remove the tilt release lever.

16. Install the directional signal switch as outlined under "Directional Signal Switch-Installation".

17. Column Shift Models - Install the shift lever and pivot pin.

18. Install the neutral-safety or back-up lamp switch.

19. Remove the column from the bench vise.

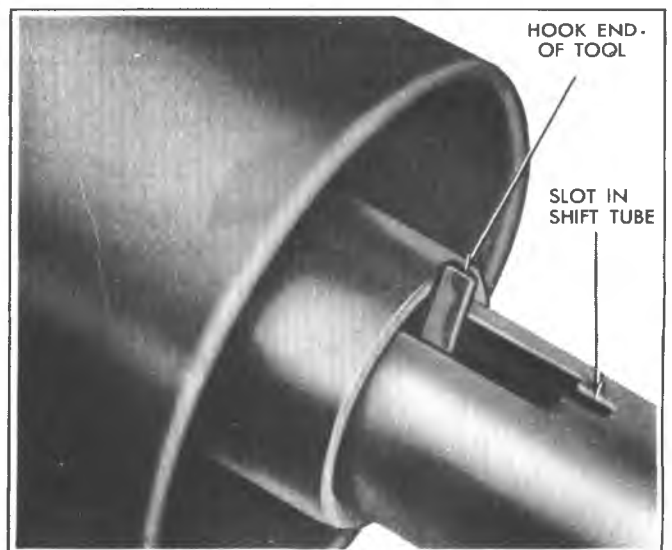


Fig. 3B4-83--Removing Shift Tube Assembly

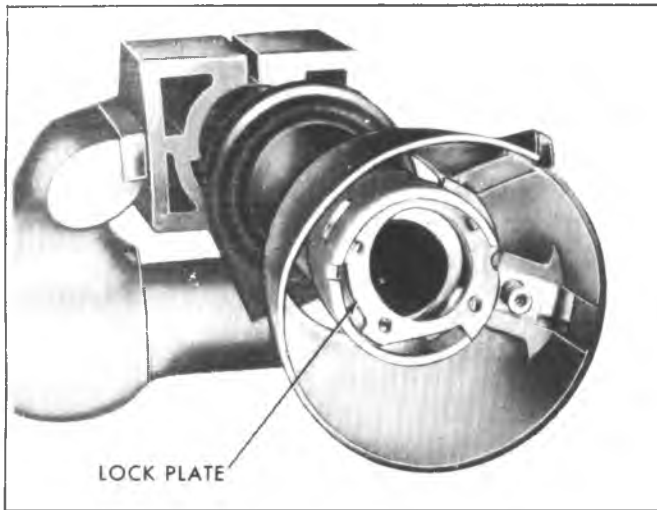


Fig. 3B4-84--Removing Lock Plate Assembly

COLUMN INSTALLATION

Mandatory Installation Sequence G Series

NOTICE: See NOTICE on page 1 of this section regarding the fasteners referred to in steps 3 and 10.

1. Adjust the column lower bearing preload by applying a force on the steering wheel end of the steering shaft (A). Position the spring and clamp to maintain the dimension as detailed under "Maintenance and Adjustments".

2. Install the plastic spacers onto the flexible coupling alignment pins.

3. From inside the vehicle, carefully insert the lower end of the column through the toe pan opening guiding the steering shaft flange onto the flexible coupling. Install and torque the glange to coupling bolts.

4. Locate the index slot in the column jacket with the protrusion on the clutch and brake pedal support.

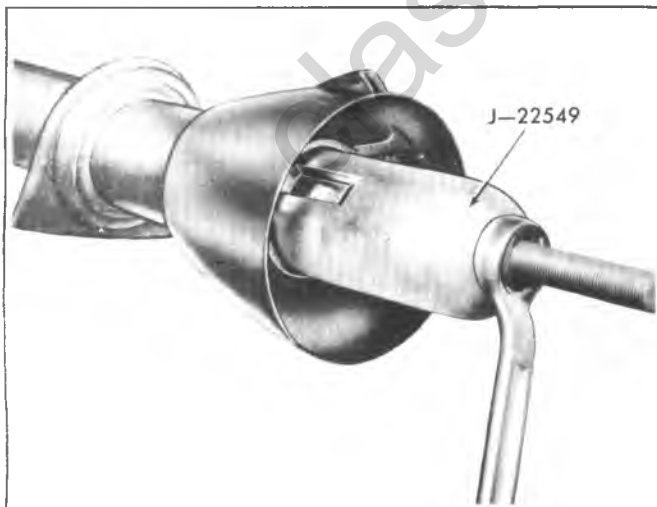


Fig. 3B4-85--Installing Shift Pin Tube

5. Loosely install the column dash bracket and screws.
6. Push the column down until the steering shaft flange bottoms on the plastic spacers on the flexible coupling and then torque the dash bracket screws.

7. Remove the plastic spacer from the alignment pins using a wire hook. Check the flexible coupling to steering shaft flange clearance (.25" to .325"), if not within specifications, the dash bracket screws must be loosened and the column raised or lowered as required. Retorque the bracket screws.

The alignment pin plastic spacers must be removed before the vehicle can be driven.

8. Push the toe pan seal to the toe pan, install and torque the mounting screws.

9. All Columns—Connect the directional signal switch wiring harness.

Automatic Columns—Connect the conductor tube (for transmission indicator) to the instrument panel. See Fig. 3B4-87.

10. Install the steering wheel as outlined under "Steering Wheel Installation".

11. Connect the transmission linkage.

12. Connect the battery ground cable.

Mandatory Sequence P Series

NOTICE: See NOTICE note on page 1 of this section regarding the fasteners referred to in steps 1, 2, 3 and 10.

1. Applying 50 lbs. force on the steering wheel end of the steering shaft, adjust the lower bearing preload to allow steering shaft end play as indicated in "Maintenance and Adjustments". Tighten the shaft clamp on pot joint bolt to specifications.

2. From the passenger side of the dash panel, carefully insert the lower end of the steering column through the toe panel opening.

Guide the steering shaft into the universal yoke, lining up the marks made at removal. Install the yoke pinch bolt and torque to specifications. The pinch bolt must pass through the shaft undercut.

3. Position and attach the lower clamp mounting bracket to the firewall. Locate the steering column protrusions against the toe pan bracket while at the same time, aligning protrusion in brake and clutch pedal support with index slot in the steering column, as shown in Figure 3B4-87. Install the column to bracket clamp and torque the clamp bolt to specifications. The toe pan bracket must not override the protrusions on the steering column.

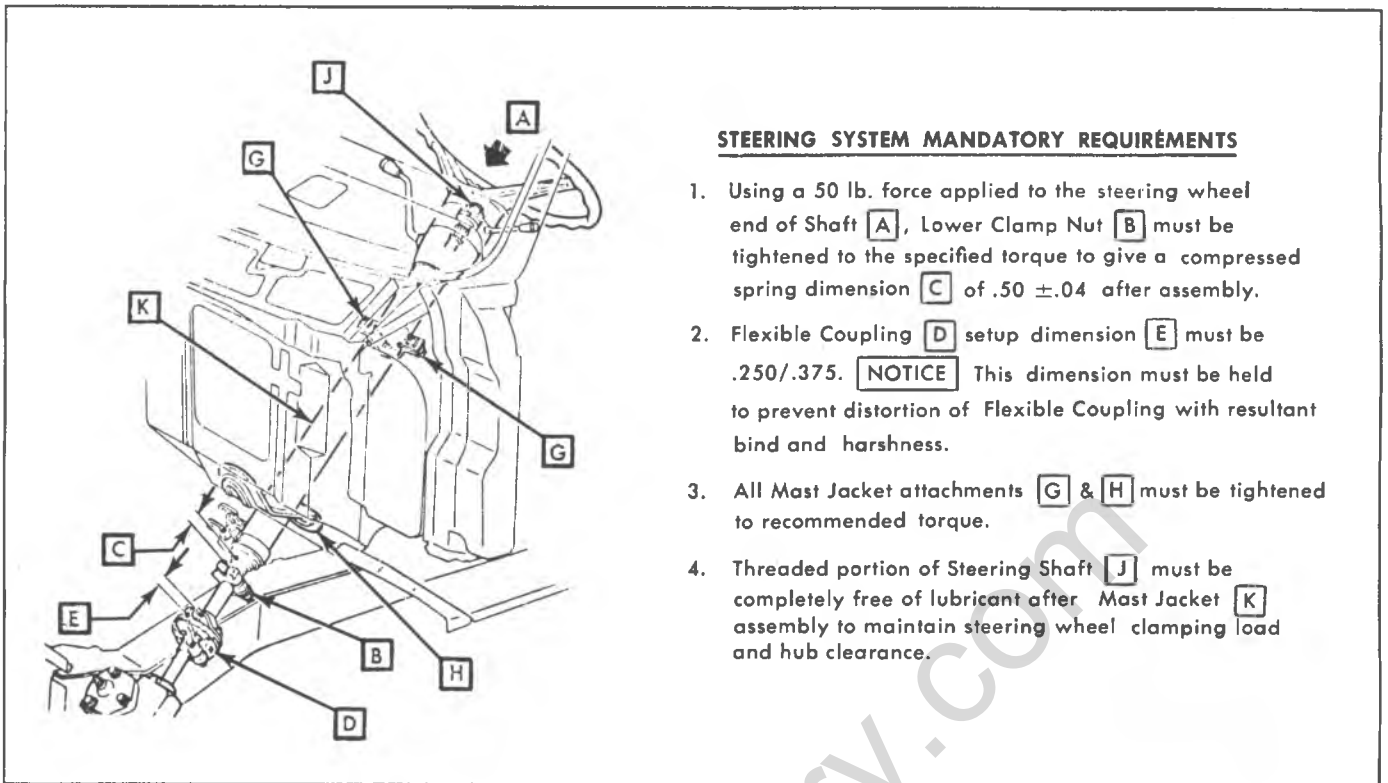
4. Position the steering column to dash panel bracket, install the attaching bolts and torque to specifications.

5. If plastic spacers were used on the flexible coupling alignment pins, remove the spacers after all bolts have been properly torqued.

6. Install the seal at the toe pan and then install the toe pan bracket screws; torque to specifications.

7. Install the dash panel trim plate (if so equipped).

8. Connect the transmission shift linkage on column shift models.



STEERING SYSTEM MANDATORY REQUIREMENTS

1. Using a 50 lb. force applied to the steering wheel end of Shaft **A**, Lower Clamp Nut **B** must be tightened to the specified torque to give a compressed spring dimension **C** of $.50 \pm .04$ after assembly.
2. Flexible Coupling **D** setup dimension **E** must be $.250/.375$. **NOTICE** This dimension must be held to prevent distortion of Flexible Coupling with resultant bind and harshness.
3. All Mast Jacket attachments **G** & **H** must be tightened to recommended torque.
4. Threaded portion of Steering Shaft **J** must be completely free of lubricant after Mast Jacket **K** assembly to maintain steering wheel clamping load and hub clearance.

Fig. 3B4-86-Mandatory Sequence For Installation Of G Series Column

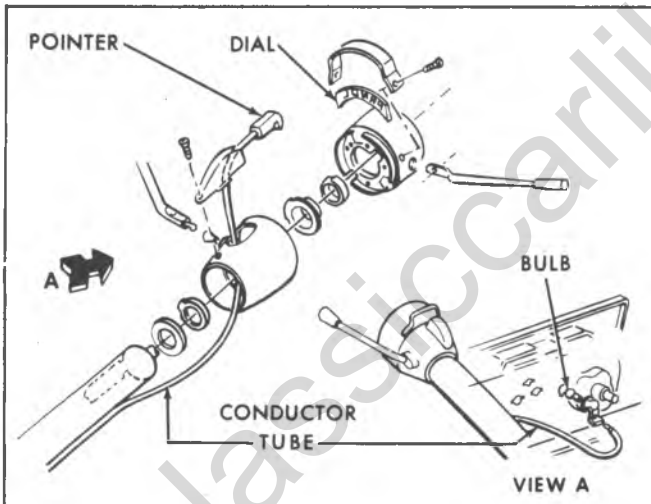


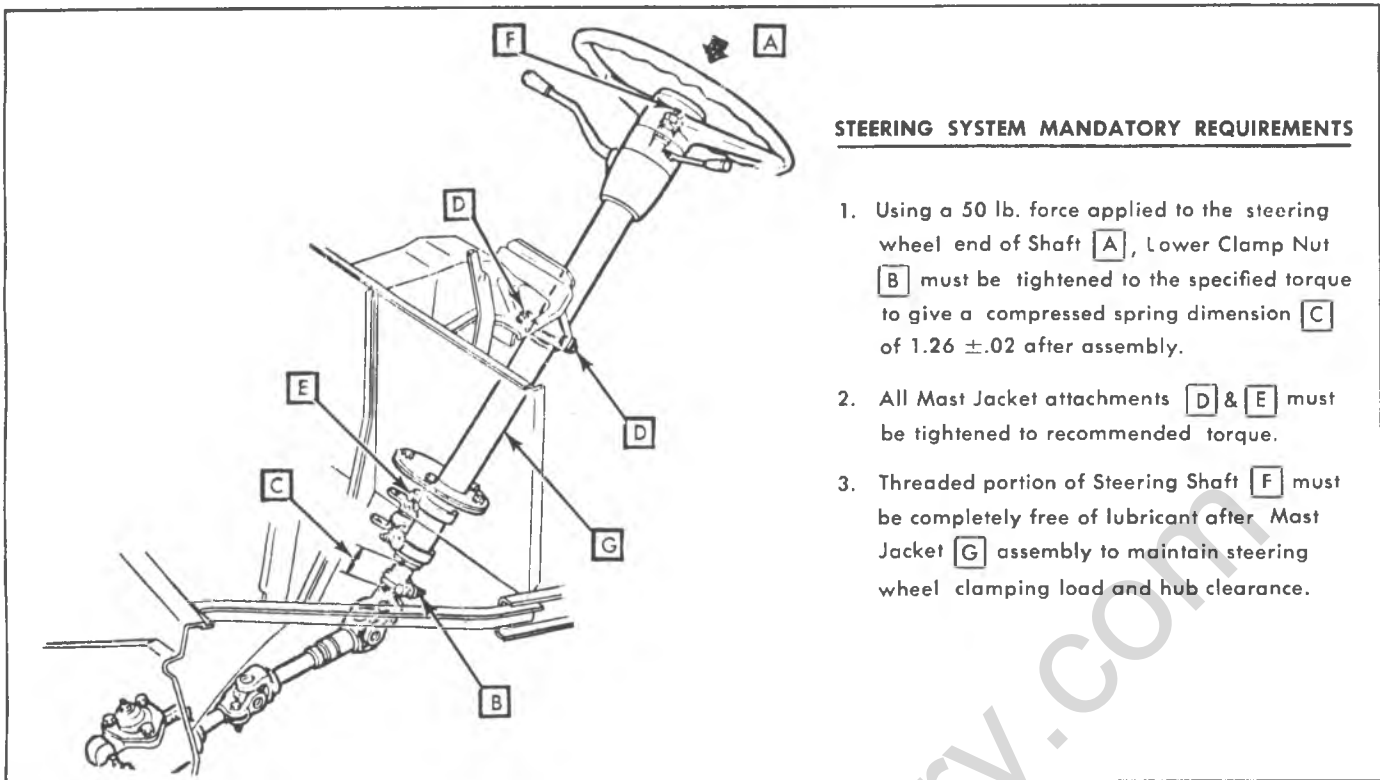
Fig. 3B4-87-Conductor Tube For Automatic Transmission Indicator

9. All Columns - Connect the directional signal wiring harness.

Standard Column with Automatic Transmission - Connect the conductor tube (for transmission indicator) at the instrument panel (Fig. 3B4-88).

10. Install steering wheel as outlined under "Steering Wheel-Installation".

11. Connect battery ground cable.



STEERING SYSTEM MANDATORY REQUIREMENTS

1. Using a 50 lb. force applied to the steering wheel end of Shaft [A], Lower Clamp Nut [B] must be tightened to the specified torque to give a compressed spring dimension [C] of $1.26 \pm .02$ after assembly.
2. All Mast Jacket attachments [D] & [E] must be tightened to recommended torque.
3. Threaded portion of Steering Shaft [F] must be completely free of lubricant after Mast Jacket [G] assembly to maintain steering wheel clamping load and hub clearance.

Fig. 3B4-88--Mandatory Sequence For Installation of P Series Column

classiccarslibrary.com

SPECIFICATIONS

STEERING GEAR RATIOS

| Vehicle | Manual | | Power | |
|------------|------------|------------------|--------------|------------------|
| | Gear Ratio | Overall Ratio | Gear Ratio | Overall Ratio |
| G10-20 | 24:1 | 29.4:1 to 36.7:1 | 14:1 | 21.4:1 to 26.7:1 |
| G30 | 24:1 | 29.4:1 to 36.4:1 | 14:1 | 21.4:1 to 26.5:1 |
| P10 | 24:1 | 29.1:1 to 35.5:1 | 17.5:1 | 21.2:1 to 25.7:1 |
| P20-30 | 24:1 | 29.1:1 to 35.3:1 | 17.5:1 | 21.2:1 to 25.7:1 |
| Motor Home | — | — | 14:1 | 16.0:1 to 21.9:1 |
| C 10 | 24:1 | 29.1:1 to 37.0:1 | 16:1 to 13:1 | 16.9:1 to 20.2:1 |
| C20-30 | 24:1 | 29.4:1 to 36.3:1 | 16:1 to 13:1 | 17.2:1 to 20.6:1 |
| K10-20 | 24:1 | 24.6:1 to 28.0:1 | 16:1 to 13:1 | 13.2:1 to 17.2:1 |

MANUAL STEERING GEAR

| Components | G10 - 30 | C10 - 30 P10 | K10 - 20 | P20 - 30 |
|-----------------------------|-------------------|-------------------|------------------|-------------------|
| Thrust Bearing Preload | 6 to 11 lbs. in. | 4 to 6 lbs. in. | | 9 to 12 lbs. in. |
| Adjuster Plug Lock Nut | 85 lbs. ft. | | | |
| Over Center Preload | 5 to 11 lbs. in.* | 4 to 10 lbs. in.* | | 9 to 13 lbs. in.* |
| Over Center Lock Nut | 25 lbs. ft. | | | |
| Total Steering Gear Preload | 18 lbs. in. Max. | 14 lbs. in. Max. | 25 lbs. in. Max. | |

*In excess of thrust bearing preload.

POWER STEERING GEAR

| Components | All C, P, K and G |
|-------------------------------------|--------------------|
| Steering Gear Ball Drag | 3 lbs. in. Max. |
| Thrust Bearing Preload | 1/2 to 2 lbs. in.* |
| Adjuster Plug Locknut | 80 lbs. ft. |
| Over-Center Preload | 5 lbs. in. |
| Over-Center Adjusting Screw Locknut | 35 lbs. ft. |
| Total Steering Gear Preload | 14 lbs. in. Max. |

*In excess of ball drag.

**In excess of ball drag and thrust bearing preload.

POWER STEERING PUMP PRESSURES

| Vehicle | Pressure |
|----------------|-----------------|
| C10-30 | 1200 - 1300 psi |
| G10-20 | 900 - 1000 psi |
| G30 | 1200 - 1300 psi |
| P10-30 | 1200 - 1300 psi |
| Motor Home & K | 1350 - 1450 psi |

Fig. 3B4--Specs

SPECIAL TOOLS



Fig. 3B-1ST--Special Tools C and K Models

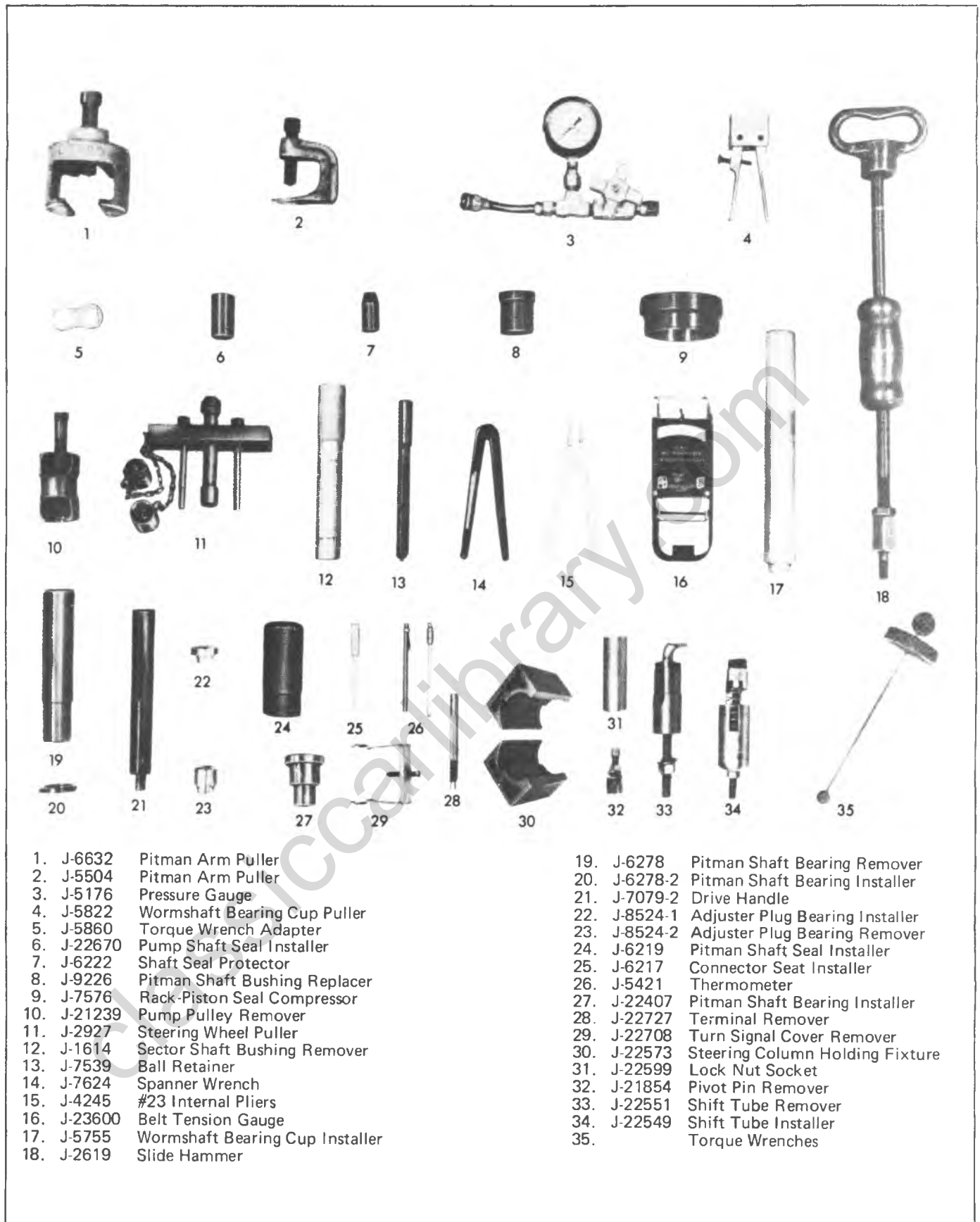


Fig. 3B-2ST--Special Tools G and P Models

classiccarylbrary.com

SECTION 3C

FRONT SUSPENSION

The following notice applies to one or more steps in the assembly procedure of components in this portion of the manual as indicated at appropriate locations by the terminology "See Notice on page 1 of this section".

NOTICE: This fastener is an important attaching part in that it could affect the performance of vital components and systems, and/or could result in major repair expense. It must be replaced with one of the same part number or with an equivalent part if replacement becomes necessary. Do not use a replacement part of lesser quality or substitute design. Torque values must be used as specified during reassembly to assure proper retention of this part.

CONTENTS OF THIS SECTION

| | |
|--------------------------------------|-------|
| Front Suspension (C-G-P Series)..... | 3C-1 |
| Front Suspension (K-Series)..... | 3C-23 |

FRONT SUSPENSION, TWO-WHEEL DRIVE

INDEX

| | | | |
|----------------------------------|-------|------------------------------|-------|
| General Description..... | 3C-1 | Lower Control Arm Shaft..... | 3C-16 |
| Maintenance and Adjustments..... | 3C-3 | Upper Control Arm..... | 3C-17 |
| Diagnosis..... | 3C-4 | Lower Control Arm..... | 3C-17 |
| Component Parts Replacement..... | 3C-14 | Ball Joint..... | 3C-20 |
| Wheel Hubs, Bearings..... | 3C-14 | Steering Knuckle..... | 3C-21 |
| Shock Absorber..... | 3C-14 | Suspension Unit..... | 3C-22 |
| Stabilizer..... | 3C-15 | Specifications..... | 3C-37 |
| Coil Spring..... | 3C-15 | Special Tools..... | 3C-38 |
| Upper Control Arm Shaft..... | 3C-16 | | |

GENERAL DESCRIPTION

C-G-P Series

The C-G-P Series trucks incorporate an independent coil spring front suspension system, as shown in Figures 3C-1 and 3C-2. The control arms are of unequal length (S.L.A. Type).

This suspension system consists of upper and lower control arms pivoting on steel threaded or rubber bushings on upper and lower control arm shafts. The lower control arms are attached to the crossmember. The upper control arms are attached to a frame bracket. These control arms are connected to the steering knuckle through pivoting ball

joints.

A coil spring is located between the lower control arm and a formed seat in the suspension crossmember, thus the lower control arm is the load carrying member. Double acting shock absorbers are also attached to the lower control arms and connect with the frame to the rear on the upper end. The front wheel bearings are tapered roller type and are used on all models.

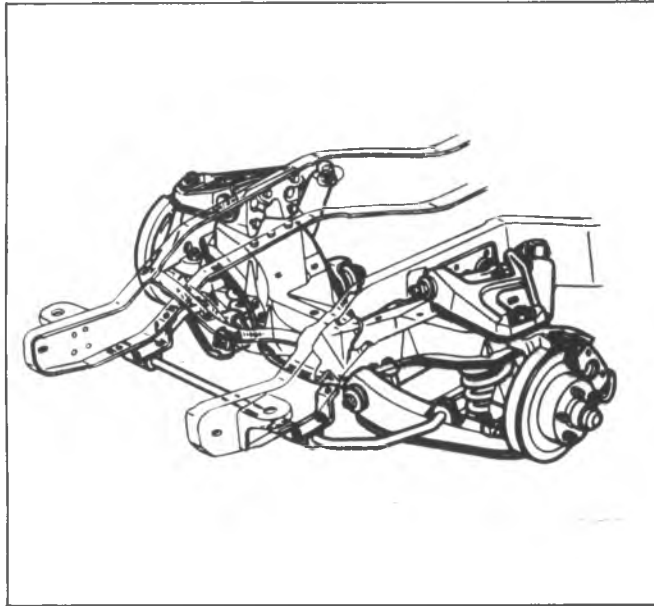


Fig. 3C-1--Front Suspension, C-P Series

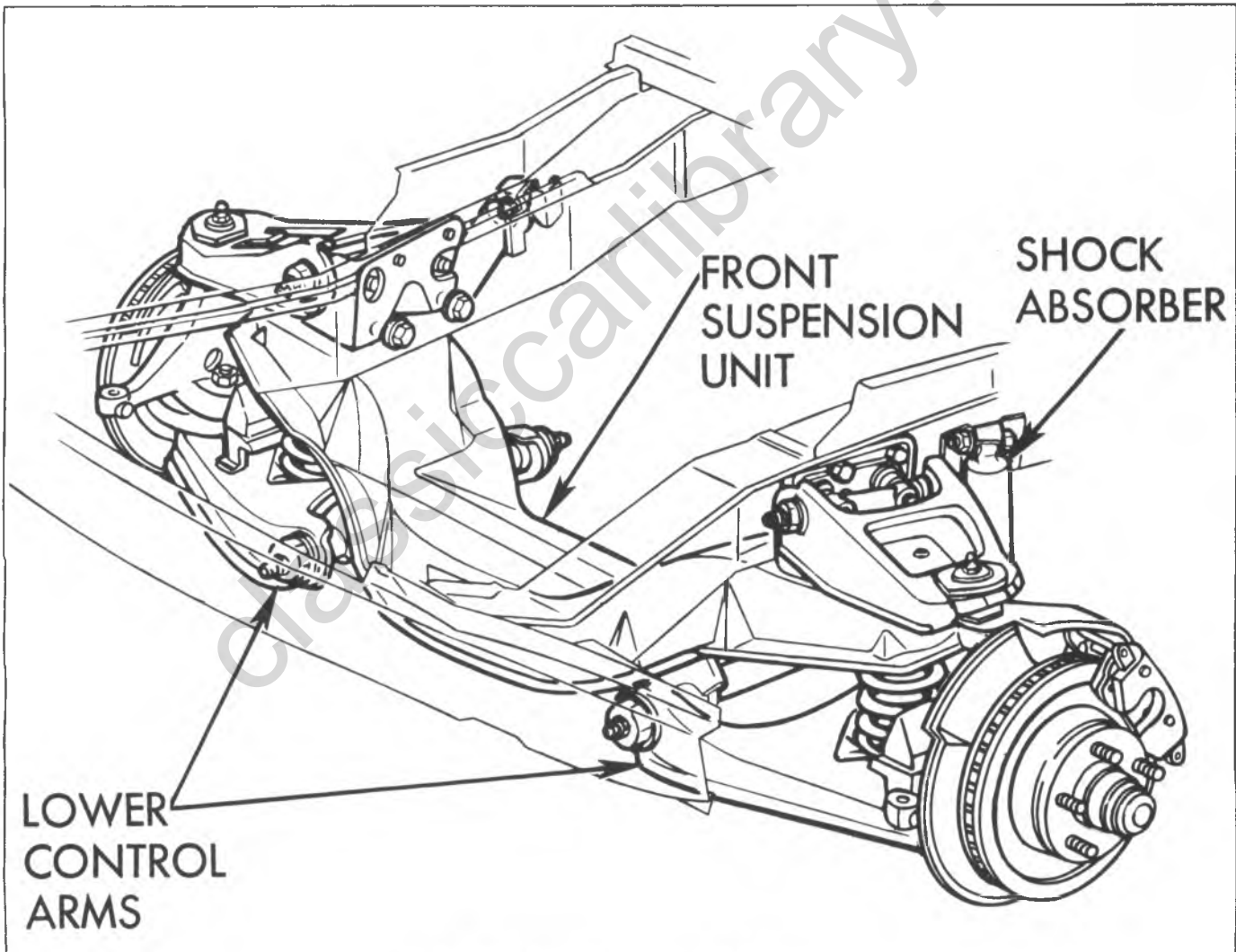


Fig. 3C-2--Front Suspension - G-Typical

MAINTENANCE AND ADJUSTMENTS

NOTICE: See NOTICE on page 1 of this section regarding the fasteners referred to in the maintenance and adjustment procedures below.

WHEEL BEARINGS-CHECK ADJUSTMENT

NOTICE: Tapered roller bearings are used on all series vehicles and they have a slightly loose feel when properly adjusted. A design feature of front wheel taper roller bearings is that they must NEVER be pre-loaded. Damage can result by the steady thrust on roller ends which comes from preloading.

1. Raise vehicle and support at front lower control arm.

2. Spin wheel to check for unusual noise or roughness.

3. If bearings are noisy, tight, or excessively loose, they should be cleaned, inspected and relubricated prior to adjustment. If it is necessary to inspect bearings, see "Wheel Hubs, Bearings" under "Component Parts Replacement."

To check for tight or loose bearings, grip the tire at the top and bottom and move the wheel assembly in and out on the spindle. Measure movement of hub assembly. If movement is less than .025 mm (.001") or greater than .127 mm (.005"), adjust bearings per adjustment procedure.

ADJUSTMENT OF WHEEL BEARINGS (FIG. 3C-3)

1. Remove hub cap or wheel disc from wheel.

2. Remove dust cap from hub.

3. Remove cotter pin from spindle and spindle nut.

4. Tighten the spindle nut to 16.26 N·m (12 ft. lbs.) while turning the wheel assembly forward by hand to fully seat the bearings. This will remove any grease or burrs which could cause excessive wheel bearing play later. See Fig. 3C-3.

5. Back off the nut to the "just loose" position.

6. Hand tighten the spindle nut. Loosen spindle nut until either hole in the spindle lines up with a slot in the nut. (Not more than 1/2 flat).

7. Install new cotter pin. Bend the ends of the cotter pin against nut, cut off extra length to ensure ends will not interfere with the dust cap.

8. Measure the looseness in the hub assembly. There will be from .025 mm (.001) to .127 mm (.005 inches) end play when properly adjusted.

9. Install dust cap on hub.

10. Replace the wheel cover or hub cap.

11. Lower vehicle to floor.

12. Perform the same operation for each front wheel.

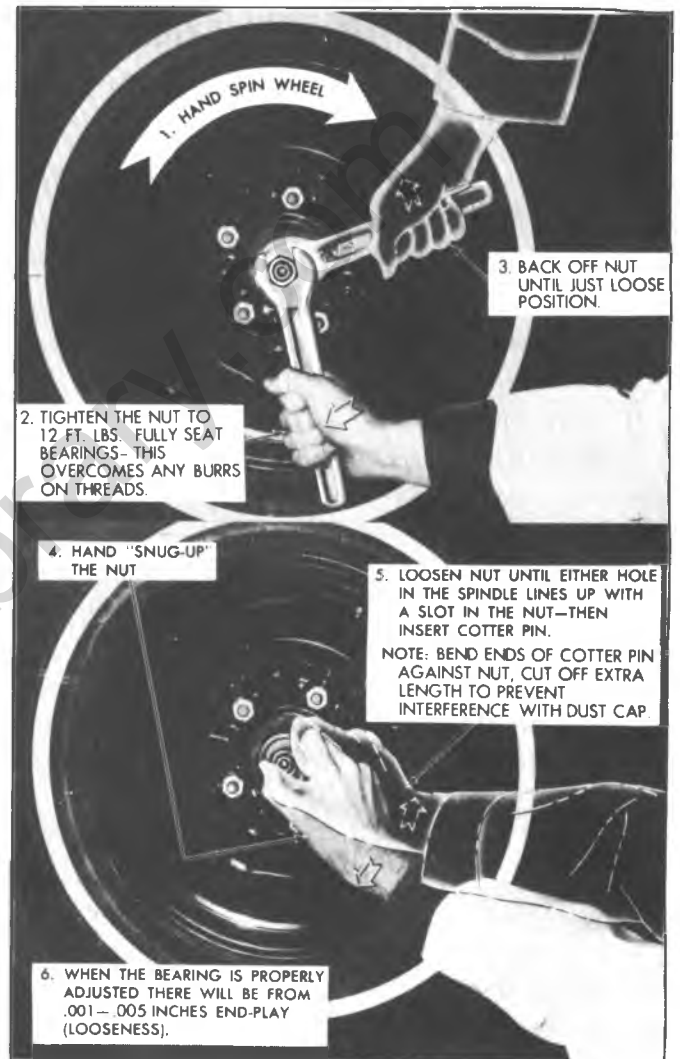


Fig. 3C-3--Wheel Bearing Adjustment

DIAGNOSIS

HARD STEERING

Probable Cause

- a. Ball joints and steering linkage need lubrication
- b. Low or uneven front tire pressure
- c. Power steering partially or not operative
- d. Steering gear not properly adjusted
- e. Incorrect front wheel alignment (manual steering)

Probable Remedy

- a. Lubricate ball joints and linkage
- b. Inflate tires to the proper recommended pressure
- c. Check power steering components for proper operation
- d. Adjust steering gear
- e. Check and align front suspension

POOR DIRECTIONAL STABILITY

- a. Ball joints and steering linkage need lubrication
- b. Low or uneven front or rear tire pressure
- c. Loose wheel bearings
- d. Steering Gear not on high point
- e. Incorrect front wheel alignment (caster)
- f. Broken springs
- g. Malfunctioning shock absorber.
- h. Broken stabilizer bar, or missing link

- a. Lubricate at proper intervals
- b. Inflate tires to the proper recommended pressure
- c. Adjust wheel bearings
- d. Adjust steering gear
- e. Check and align front suspension
- f. Replace springs
- g. Diagnose shock absorbers.
- h. Replace stabilizer or link

FRONT WHEEL SHIMMY (SMOOTH ROAD SHAKE)

- a. Tire and wheel out of balance, or out of round
- b. Worn or loose wheel bearings
- c. Worn tie rod ends
- d. Worn ball joints
- e. Malfunctioning shock absorber

- a. Balance tires, check run-out
- b. Adjust wheel bearings
- c. Replace tie rod end
- d. Replace ball joints
- e. Diagnose shock absorbers

VEHICLE PULLS TO ONE SIDE (NO BRAKING ACTION)

- a. Low or uneven tire pressure
- b. Front or rear brake dragging
- c. Broken or sagging front spring
- d. Incorrect front wheel alignment (Camber)

- a. Inflate tires to the proper recommended pressure
- b. Adjust brakes
- c. Replace spring
- d. Check and align front suspension

EXCESSIVE PLAY IN STEERING

- a. Incorrect steering gear adjustment
- b. Worn steering gear parts

- a. Adjust steering gear
- b. Overhaul Gear

Fig. 3C-4--Front Suspension Diagnosis Chart A

| NOISE IN FRONT END | |
|---|--|
| <u>Probable Cause</u> | <u>Probable Remedy</u> |
| <ul style="list-style-type: none"> a. Ball joints and steering linkage need lubrication b. Shock absorber loose or bushings worn c. Worn control arm bushings d. Worn tie rod ends e. Worn or loose wheel bearings f. Loose stabilizer bar g. Loose wheel nuts h. Spring improperly positioned i. Loose suspension bolts | <ul style="list-style-type: none"> a. Lubricate at recommended intervals b. Tighten bolts and/or replace bushings c. Replace bushings d. Replace tie rod ends e. Adjust or replace wheel bearings f. Tighten all stabilizer bar attachments g. Tighten the wheel nuts to proper torque h. Reposition i. Torque to specifications or replace |
| WHEEL TRAMP | |
| <ul style="list-style-type: none"> a. Tire and wheel out of balance b. Tire and wheel out of round c. Blister or bump on tire d. Improper shock absorber action | <ul style="list-style-type: none"> a. Balance wheels b. Replace tire c. Replace tire d. Replace shock absorber |
| EXCESSIVE OR UNEVEN TIRE WEAR | |
| <ul style="list-style-type: none"> a. Underinflated or overinflated tires b. Improper toe-in c. Wheels out of balance d. Hard Driving e. Over loaded vehicle | <ul style="list-style-type: none"> a. Inflate tire to proper recommended pressure b. Adjust toe-in c. Balance wheels d. Instruct driver e. Instruct driver |
| SCUFFED TIRES | |
| <ul style="list-style-type: none"> a. Toe-in incorrect b. Excessive speed on turns c. Tires improperly inflated d. Suspension arm bent or twisted | <ul style="list-style-type: none"> a. Adjust toe-in to specifications b. Advise driver c. Inflate tires to proper recommended pressure d. Replace arm |
| CUPPED TIRES | |
| <ul style="list-style-type: none"> a. Front shock absorbers defective b. Worn ball joints c. Wheel bearings incorrectly adjusted or worn d. Wheel and tire out of balance e. Excessive tire or wheel runout | <ul style="list-style-type: none"> a. Replace shock absorbers b. Replace ball joints c. Adjust or replace wheel bearings d. Balance wheel and tire e. Compensate for runout |

Fig. 3C-5--Front Suspension Diagnosis Chart B

SHOCK ABSORBER DIAGNOSIS

ON VEHICLE CHECKS

(Follow the Procedures Outlined Below in the Order Indicated).

Preliminary Inspection and Ride Test:

Tire Pressure

Check tire pressure compare to vehicle specifications and adjust as required. Poor vehicle control and ride complaints are caused in many cases by improper tire inflation.

"DOG" TRACKING

Probable Cause

Probable Remedy

LEAF TYPE REAR SPRING

- | | |
|--|--------------------|
| a. Rear leaf spring broken | a. Replace spring |
| b. Bent rear axle housing | b. Replace housing |
| c. Frame or underbody out of alignment | c. Align frame |

COIL TYPE REAR SPRING

- | | |
|---|---|
| a. Damaged rear suspension arm and/or worn bushings | a. Replace suspension arm and/or bushings |
| b. Frame out of alignment | b. Align frame |
| c. Bent rear axle housing | c. Replace housing |

RETURNABILITY POOR

- | | |
|--|---|
| a. Steering column alignment | a. See Section 3b in shop manual for proper alignment |
| b. Steering linkage needs lubrication | b. Lubricate chassis |
| c. Idler arm bushing worn | c. Replace idler arm |
| d. Steering gear adjustment | d. Adjust gear as outlined in Section 3b of shop manual |
| e. Power steering gear valve spool binding | e. See Section 3b in shop manual |
| f. Obstruction within power steering gear | f. See Section 3b in shop manual |
| g. Improper caster setting (negative) | g. Check and reset if necessary |

ERRATIC STEERING ON BRAKE APPLICATION

- | | |
|---|--|
| a. Low or uneven tire pressure | a. Inflate tires to proper recommended pressure |
| b. Front wheel bearing incorrectly adjusted | b. Adjust bearing as necessary |
| c. Brakes incorrectly or unevenly adjusted | c. Adjust brakes as necessary |
| d. Front spring sagged | d. Check shop manual for proper riding heights and replace spring if necessary |
| e. Steering gear off high point | e. Check and correct steering if necessary |
| f. Incorrect or uneven caster | f. Check and adjust caster as necessary |
| g. Leaking wheel cylinders | g. Replace (See sec. 5) |

Fig. 3C-6—Front Suspension Diagnosis Chart C

Special Suspension Equipment

Check Service Parts Identification Sticker for any special suspension equipment; such as, a heavy duty suspension. Vehicles equipped with this type of option have a somewhat stiffer or harsh ride, and this should be kept in mind during the following tests. If complaint about stiffness should occur while vehicle is still new (under 5,000 miles) (8 000 km), owner should be advised to have ride

rechecked after 7,000 to 8,000 miles (11 200 to 12 800 km).

Vehicle Load Conditions

Note any exceptional load conditions under which the owner normally operates the vehicle; such as, large tool boxes full of tools, pick up bed full etc. If exceptional loading is apparent, check the distribution of this weight. Note if it is all toward one side of the vehicle or at the extreme rear of the vehicle. Reposition load as required to obtain a more uniform weight distribution.

BALL JOINT DIAGNOSTIC PROCEDURE

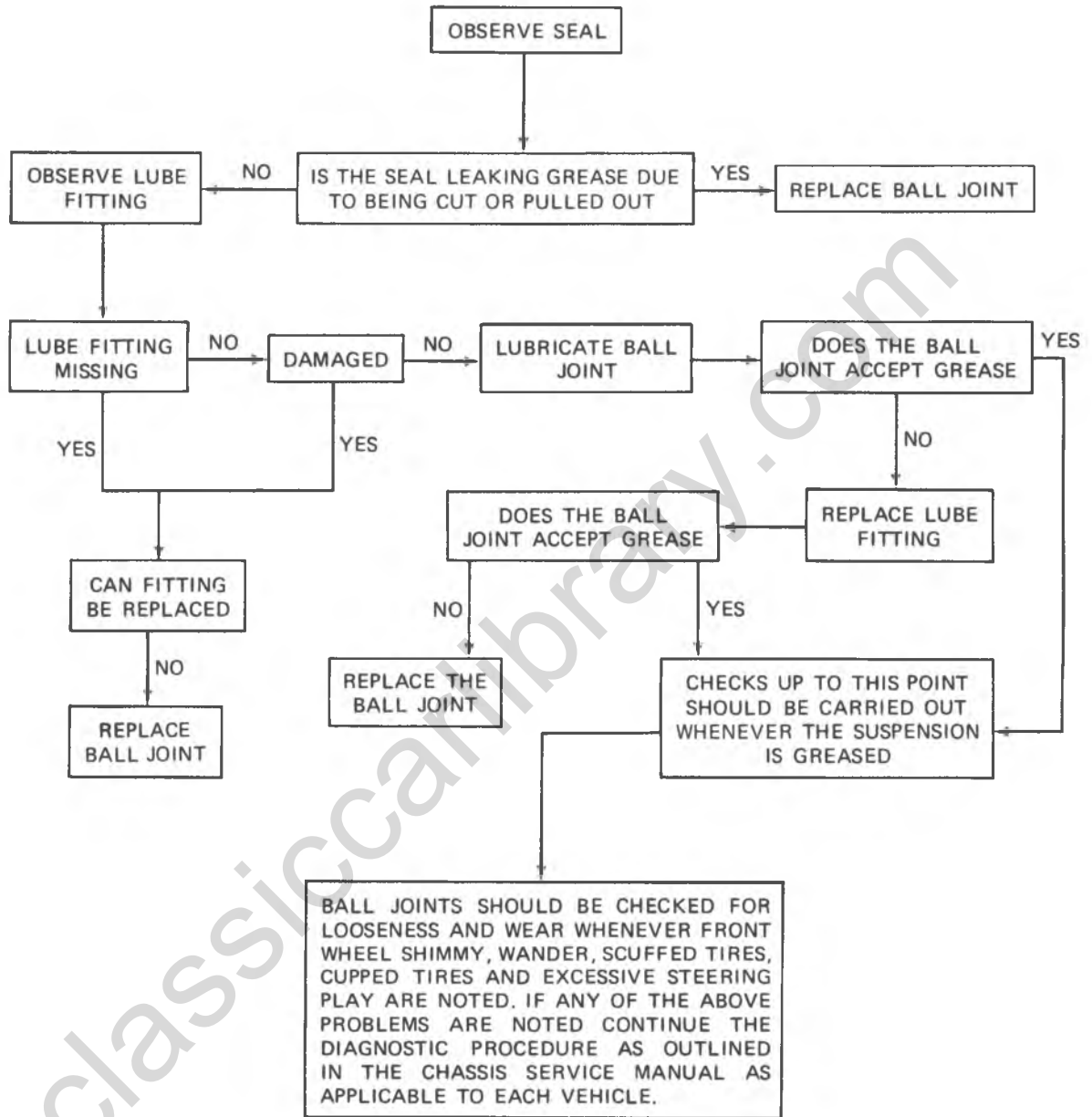


Fig. 3C-7--Ball Joint Diagnostic Procedure

Check Vehicle Ride and Handling

After completing previous checks, ride vehicle with owner to determine if problem has been corrected or to definitely establish type of problem that still exists. If problem still exists (poor handling, bottoming, noise, ride sway, etc.), proceed.

Inspecting and Testing the Shocks

Three procedures are included in this step. They are (a) Bounce Test, (b) Inspecting Shock Mountings for Noise (Looseness) and (c) Manually Operating Shocks to Determine if Shocks are Weak, Leaking Hydraulic Fluid, and/or if Shocks have an Internal Noise Condition.

SIMP Test procedures (b) and (c) require vehicle to be on a hoist that supports wheels or rear axle housing and front lower control arms.

Bounce Test

This is only a comparison type test to help locate the suspected shock or noise condition before proceeding.

Test each front and rear shock by bouncing each corner of the vehicle. This can usually be done by lifting up and pushing down on the end of the bumper near each corner of the vehicle until maximum movement up and down is reached. Then let go of bumper and observe if the up and down motion stops very quickly. If up and down motion continues longer at one corner when compared to opposite corner (example, both front shocks), the one having the longer up and down motion may be suspect. **Do Not** compare front to rear. If complaint is noise, this test should help to locate the suspected area.

Inspecting Shock Mountings

If noisy and/or loose shock mountings are suspected, place vehicle on hoist that supports wheels and check all mountings for the following conditions:

- (1) Worn or defective grommets
- (2) Loose mounting nuts
- (3) Possible interference condition
- (4) Bump stops missing

If no apparent defects are noted in this step but noise condition still exists when vehicle is bounced up and down, proceed.

Inspecting Shocks for Leaks and

Manually Operating Shocks

This procedure is sub-divided into two general areas, (1) Inspecting Shocks for Loss of Hydraulic Fluid and (2) Manually Operating Shock. It should aid the technician to localize defective shocks caused by internal noise in the shock, weak, leaking, etc.

1. Inspecting Shocks for Possible Loss of Hydraulic Fluid

(a) Disconnect each shock lower mounting as required and pull down on the shock until it is fully extended.

(b) Inspect shocks for leaks in seal cover area. Shock fluid is a very thin hydraulic fluid and has a characteristic odor and dark brown tint (Figure 3C-8).

Certain precautions should be observed when inspecting shocks for leaks:

- shocks may have glossy paint on them. Do not confuse this paint with a leak condition.
- a slight trace of shock fluid around the seal cover area is **not** cause for replacement. The shock seal is engineered

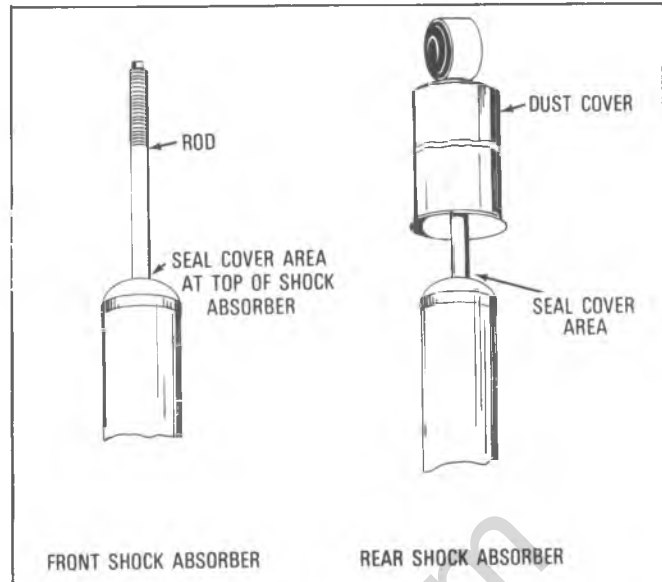


Fig. 3C-8--Seal Cover Area of Shock

to permit a slight seepage to lubricate the rod. The shock absorber has reserve fluid to compensate for the slight seepage.

- shocks are sometimes incorrectly diagnosed as leakers due to oil spray originating from some other source. If in doubt, wipe the wet area from and manually operate shock as described in Step (2). Fluid will reappear if shock is leaking.

2. Manually Operating Shocks .

It may be necessary with certain types of shock mountings to fabricate a bracket that can be installed on a shock to enable a technician to securely grip the shock when manually operating the shock. See Figure 3C-9 for suggested methods of providing temporary grip.

This test should help the mechanic to isolate the following shock defects:

- binding condition internally
- verify leaking shock
- improper or defective valving

(a) If suspected problem is in front shocks, disconnect both front shock lower mountings and stroke each shock as follows: Grip the lower end of the shock securely and pull down (rebound stroke) then push up (compression stroke). The control arms will limit the movement of the front shocks during the compression stroke. Compare the rebound resistance between both front shocks, then compare the compression resistance. If a noticeable difference can be felt during either stroke, usually the shock having the least resistance is at fault.

(b) If shock has an internal noise condition, extend shock fully, then exert an extra pull. If noisy shock should be replaced.

Other noise conditions that require shock replacement are:

- a grunt or squeal after one full stroke in both directions
- a clicking noise on fast reverse

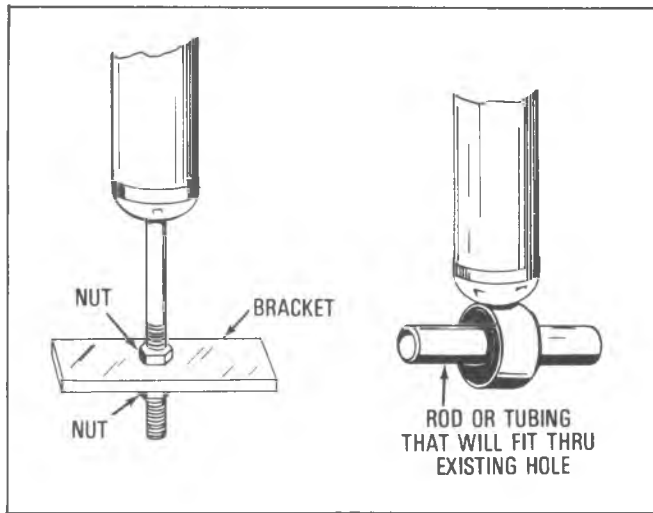


Fig. 3C-9--Gripping Methods

- a skip or lag at reversal near mid-stroke

When air adjustable shocks are being manually operated, the air line must be disconnected at the shock absorber.

BENCH CHECKS

The bench checks are recommended if the proper type hoist is not available to perform the "on vehicle" tests, or if there is still some doubt as to whether the shocks are defective. In addition, the bench test allows a more thorough visual inspection.

Bench check procedures are discussed for three general types of shocks.

SPIRAL GROOVE RESERVOIR

If this type of shock has been stored or allowed to lay in a horizontal position for any length of time, an air void will develop in the pressure chamber of the shock absorber. This air void if not purged, can cause a technician to diagnose the shock as defective. To purge the air from the pressure chamber, proceed as follows: (Refer to Figure 3C-10)

- Holding the shock in its normal vertical position (top end up), fully extend shock.
- Hold the top end of the shock **down** and fully collapse the shock.
- Repeat Steps (a) and (b) at least five (5) times to assure air is purged.

Bench Test Procedure

- This is a comparison type test. If possible, obtain a new or known good shock with same part number as shock under test.
- With shocks in vertical position (top end up), clamp bottom mounts in vise. Do not clamp on reservoir tube or mounting threads.
- Manually pump each shock by hand at various rates of speed and compare resistance of suspected shock with the new one.

Rebound resistance (extending the shock) is normally stronger than the compression resistance (approximately 2:1). However, resistance should be smooth and constant for each stroking rate.

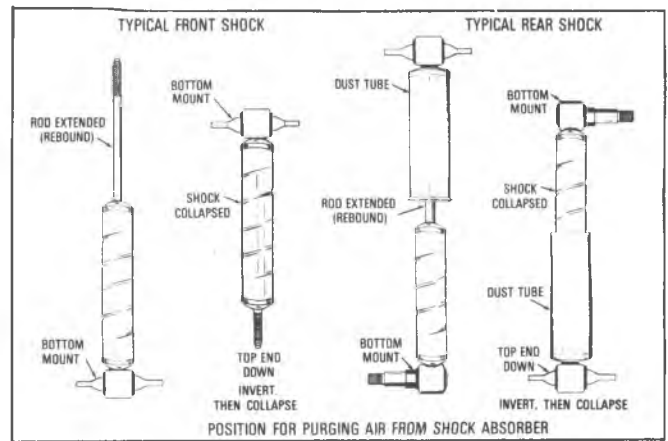


Fig. 3C-10--Position for Purging Air From Shocks

4. Observe or listen for the following conditions that will indicate a defective shock:

- a skip or lag when reversing stroke at mid travel.
- seizing or binding condition except at extreme end of either stroke.
- a noise, such as a grunt or squeal, after completing one full stroke in both directions.
- a clicking type noise at fast reversal.
- fluid leakage.

5. To check for a loose piston, completely extend shock to full rebound; then exert an extra hard pull. If a give is felt, a loose piston is indicated and shock should be replaced.

PLIACELL OR GENETRON

Pliacell and Genetron are some of the trade names used to indicate a gas-filled cell in the shock reservoir. The reservoirs of Pliacell and Genetron shocks are smooth, compared to the spiral groove type. The cell takes the place of air in the reservoir. Thus, aeration or foaming of the fluid is eliminated, as air and fluid cannot mix.

Due to this feature, these shocks should be bench checked in an **inverted position** (top end down). If, when stroked, a lag is noticed, it means the gas-filled cell has been ruptured, and the shock should be replaced. If no lag is noticed, the remainder of the bench check is the same as given in the Spiral Groove Reservoir, Section 1, Bench Check Procedure.

AIR ADJUSTABLE SHOCKS

This type of shock contains an air chamber like the spiral groove reservoir type, and must have the air purged from the working chamber. See Section 1, Spiral Groove Reservoir. After air has been purged from shock, proceed as follows:

- Clamp lower shock mounting ring in vise in vertical position with larger diameter tube at the top.
- Pump unit by hand at different rates of speed. Smooth resistance should be felt through the length of the stroke. Since the units are normally pressurized, the sound of air bubbles or a gurgling noise is **normal**.

(c) The remainder of the bench check is the same as given in the Spiral Groove Reservoir, Section 1, Bench Check Procedure.

BEARINGS AND RACES**BENCH DIAGNOSTIC PROCEDURE**

This section describes common types of bearing distress and their causes. Illustrations are included to help diagnose the cause of distress and comments are provided to help make effective repairs.

Consider The Following Factors When**Diagnosing Bearing Distress:**

1. Note General Condition of all parts during teardown and examinations.
2. Classify the failure with the aid of these illustrations where possible.
3. Determine the cause. Recognizing the cause will permit correction of the problem and prevent a repeat failure of the same type.
4. Make all repairs following recommended procedures.

Common Causes For Bearing Distress**Include The Following:**

1. Improper adjustment or preloading.
2. Mounting or teardown abuse.
3. Improper mounting methods.
4. Inadequate or wrong lubricants.
5. Entrance of dirt or water.
6. Wear from dirt or metal chips.
7. Corrosion or rusting.
8. Overload.
9. Overheating causing tempering.
10. Fretting of bearing seats.
11. Brinelling from impact loads and shipping.
12. Manufacturing defects.

classiccarlibrary.com

BEARINGS AND RACES

FRONT WHEEL, PINION, DIFFERENTIAL SIDE AND REAR WHEEL ROLLER BEARINGS

DIAGNOSIS

| | EXCESS NOISE COMPLAINT DIAGNOSTIC PROCEDURE |
|-------------------------------------|--|
| Road Test | <ol style="list-style-type: none"> 1. Check tires for irregular wear 2. Check tire pressure 3. Check lubricant level 4. Drive to warm-up rear axle 5. Test at various speeds in drive, float, coast and cornering |
| Tire Noises | <ol style="list-style-type: none"> 1. Change tire pressure to minimize noises 2. Drive over different road surfaces 3. Smooth black-top minimizes tire noise 4. Cross switch tires, if necessary 5. Snow tire treads and studs caused added noises |
| Engine or Exhaust Noises | <ol style="list-style-type: none"> 1. Drive slightly above speed where noise occurs, place transmission in neutral 2. Let engine speed drop to idle 3. Stop car 4. Run engine at various speeds |
| Test for Wheel Bearing Noise | <ol style="list-style-type: none"> 1. Drive car at low speed on a smooth road 2. Turn car to develop left and right motions, traffic permitting 3. Noise should change due to cornering loads 4. Jack-up wheels to verify roughness at wheels |
| Test for Differential Bearing Noise | <ol style="list-style-type: none"> 1. Drive car at low speed on a smooth road 2. Constant low pitch bearing noise may be heard 3. Noise should not change in reversing turns 4. Noise pattern should vary with wheel speed |
| Test for Pinion Bearing Noise | <ol style="list-style-type: none"> 1. Roughness or whine noise should increase with speed 2. Noise pitch should be higher than differentials 3. Test on smooth road to minimize tire noises 4. Test at various speeds in drive, float, and coast 5. Rear pinion bearing noise may be louder on acceleration 6. Front pinion bearing noise may be louder on deceleration 7. Gear noises tend to peak in a narrow speed range |

Fig. 3C-11--Bearing Diagnosis Chart

FRONT WHEEL BEARING DIAGNOSIS

CONSIDER THE FOLLOWING FACTORS WHEN DIAGNOSING BEARING CONDITION:

1. GENERAL CONDITION OF ALL PARTS DURING DISASSEMBLY AND INSPECTION.
2. CLASSIFY THE FAILURE WITH THE AID OF THE ILLUSTRATIONS.
3. DETERMINE THE CAUSE.
4. MAKE ALL REPAIRS FOLLOWING RECOMMENDED PROCEDURES.



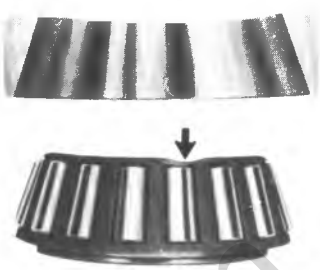


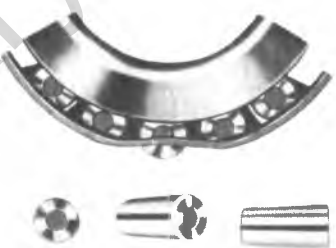



| | | |
|--|--|---|
|  <p>ABRASIVE ROLLER WEAR</p> <p>PATTERN ON RACES AND ROLLERS CAUSED BY FINE ABRASIVES.</p> <p>CLEAN ALL PARTS AND HOUSINGS. CHECK SEALS AND BEARINGS AND REPLACE IF LEAKING, ROUGH OR NOISY.</p> |  <p>GALLING</p> <p>METAL SMEARS ON ROLLER ENDS DUE TO OVERHEAT, LUBRICANT FAILURE OR OVERLOAD (WAGON'S)</p> <p>REPLACE BEARING -- CHECK SEALS AND CHECK FOR PROPER LUBRICATION.</p> |  <p>BENT CAGE</p> <p>CAGE DAMAGE DUE TO IMPROPER HANDLING OR TOOL USAGE.</p> <p>REPLACE BEARING</p> |
|  <p>ABRASIVE STEP WEAR</p> <p>PATTERN ON ROLLER ENDS CAUSED BY FINE ABRASIVES</p> <p>CLEAN ALL PARTS AND HOUSINGS. CHECK SEALS AND BEARINGS AND REPLACE IF LEAKING, ROUGH OR NOISY.</p> |  <p>ETCHING</p> <p>BEARING SURFACES APPEAR GRAY OR GRAYISH BLACK IN COLOR WITH RELATED ETCHING AWAY OF MATERIAL USUALLY AT ROLLER SPACING.</p> <p>REPLACE BEARINGS -- CHECK SEALS AND CHECK FOR PROPER LUBRICATION.</p> |  <p>BENT CAGE</p> <p>CAGE DAMAGE DUE TO IMPROPER HANDLING OR TOOL USAGE.</p> <p>REPLACE BEARING.</p> |
|  <p>INDENTATIONS</p> <p>SURFACE DEPRESSIONS ON RACE AND ROLLERS CAUSED BY HARD PARTICLES OF FOREIGN MATERIAL.</p> <p>CLEAN ALL PARTS AND HOUSINGS. CHECK SEALS AND BEARINGS IF ROUGH OR NOISY.</p> |  <p>CAGE WEAR</p> <p>WEAR AROUND OUTSIDE DIAMETER OF CAGE AND ROLLER POCKETS CAUSED BY ABRASIVE MATERIAL AND INEFFICIENT LUBRICATION.</p> <p>CLEAN RELATED PARTS AND HOUSINGS. CHECK SEALS AND REPLACE BEARINGS.</p> |  <p>MISALIGNMENT</p> <p>OUTER RACE MISALIGNMENT DUE TO FOREIGN OBJECT.</p> <p>CLEAN RELATED PARTS AND REPLACE BEARING. MAKE SURE RACES ARE PROPERLY SEATED.</p> |

Fig. 3C-12--Bearing Diagnosis Illustration A

FRONT WHEEL BEARING DIAGNOSIS (CONT'D)








| | | |
|---|--|--|
|  <p style="text-align: center;">CRACKED INNER RACE</p> <p>RACE CRACKED DUE TO IMPROPER FIT, COCKING, OR POOR BEARING SEATS.</p> <p>REPLACE BEARING AND CORRECT BEARING SEATS.</p> |  <p style="text-align: center;">FATIGUE SPALLING</p> <p>FLAKING OF SURFACE METAL RESULTING FROM FATIGUE.</p> <p>REPLACE BEARING - CLEAN ALL RELATED PARTS.</p> |  <p style="text-align: center;">BRINELLING</p> <p>SURFACE INDENTATIONS IN RACEWAY CAUSED BY ROLLERS EITHER UNDER IMPACT LOADING OR VIBRATION WHILE THE BEARING IS NOT ROTATING.</p> <p>REPLACE BEARING IF ROUGH OR NOISY.</p> |
|  <p style="text-align: center;">FRETTAGE</p> <p>CORROSION SET UP BY SMALL RELATIVE MOVEMENT OF PARTS WITH NO LUBRICATION.</p> <p>REPLACE BEARING. CLEAN RELATED PARTS. CHECK SEALS AND CHECK FOR PROPER LUBRICATION</p> |  <p style="text-align: center;">STAIN DISCOLORATION</p> <p>DISCOLORATION CAN RANGE FROM LIGHT BROWN TO BLACK CAUSED BY INCORRECT LUBRICANT OR MOISTURE.</p> <p>RE-USE BEARINGS IF STAINS CAN BE REMOVED BY LIGHT POLISHING OR IF NO EVIDENCE OF OVER HEATING IS OBSERVED.</p> <p>CHECK SEALS AND RELATED PARTS FOR DAMAGE.</p> |  <p style="text-align: center;">HEAT DISCOLORATION</p> <p>HEAT DISCOLORATION CAN RANGE FROM FAINT YELLOW TO DARK BLUE RESULTING FROM OVER LOAD (WAGON'S) OR INCORRECT LUBRICANT.</p> <p>EXCESSIVE HEAT CAN CAUSE SOFTENING OF RACES OR ROLLERS.</p> <p>TO CHECK FOR LOSS OF TEMPER ON RACES OR ROLLERS A SIMPLE FILE TEST MAY BE MADE. A FILE DRAWN OVER A TEMPERED PART WILL GRAB AND CUT METAL, WHEREAS, A FILE DRAWN OVER A HARD PART WILL GLIDE READILY WITH NO METAL CUTTING</p> <p>REPLACE BEARINGS IF OVER HEATING DAMAGE IS INDICATED. CHECK SEALS AND OTHER PARTS.</p> |
|  <p style="text-align: center;">SMEARS</p> <p>SMEARING OF METAL DUE TO SLIPPAGE. SLIPPAGE CAN BE CAUSED BY POOR FITS, LUBRICATION, OVERHEATING, OVERLOADS OR HANDLING DAMAGE.</p> <p>REPLACE BEARINGS, CLEAN RELATED PARTS AND CHECK FOR PROPER FITS AND LUBRICATION.</p> | | |

Fig. 3C-13--Bearing Diagnosis, Illustration B

COMPONENT PARTS REPLACEMENT

WHEEL HUBS, BEARINGS (Fig. 3C-14)

Removal C, G and P Series

1. Raise vehicle on hoist and remove wheel and tire assembly. Remove dust cap from end of hub and withdraw cotter pin.
2. Remove the brake caliper and hang by wire to the suspension. Do not allow the caliper assembly to hang by the brake flex line.
3. Remove hub and disc assembly.
4. Remove outer bearing from hub. The inner bearing will remain in the hub and may be removed by prying out the inner grease seal.
5. Wash all parts in cleaning solvent.

Inspection

1. Check all bearings for cracked bearing cages, worn or pitted rollers.
2. Check bearing races for cracks or scoring, check brake discs for out-of-round or scored conditions and check bearing outer races for looseness in hubs.

Repairs

Replacement of Bearing Cups

If necessary to replace an outer race, drive out old race from the hub with a brass drift inserted behind race in notches in hub. Install new race by driving it into hub with the proper race installer J-8457, J-8458, J-8849 or J-9276-2. Remove and install the inner race in the same manner.

NOTICE: Use care when installing new race to start it squarely into hub, to avoid distortion and possible cracking.

Wheel Stud Replacement (Fig. 3C-14)

Use a piece of water pipe or other similar tool to support the hub while pressing a wheel stud either in or out.

Installation

NOTICE: See NOTICE on page 1 of this section regarding the fasteners referred to in steps 8 and 9.

1. Clean off any grease in the hub and spindle and thoroughly clean out any grease in the bearings. Use cleaning solvent. Use a small brush with no loose bristles to clean out all old grease. Do not spin the bearing with compressed air while drying it or the bearing may be damaged.
2. Use a GM approved high temperature front wheel bearing grease or equivalent. Do not mix greases as mixing may change the grease properties and result in poor performance.
3. Apply a thin film of grease to the spindle at the outer bearing seat and at the inner bearing seat, shoulder, and seal seat.
4. Put a small quantity of grease inboard of each bearing cup in the hub. This can be applied with your finger forming a dam to provide extra grease availability to the bearing and to keep thinned grease from flowing out of the

bearing.

5. Fill the bearing cone and roller assemblies 100% fill of grease. A method for doing this is with a cone type grease machine that forces grease into the bearing. If a cone greaser is not available, the bearings can be packed by hand. If hand packing is used, it is extremely important to work the grease thoroughly into the bearings between the rollers, cone, and the cage. Failure to do this could result in premature bearing failure.

6. Place the inner bearing cone and roller assembly in the hub. Then using your finger, put an additional quantity of grease outboard of the bearing.

7. Install a new grease seal using a flat plate until the seal is flush with the hub. Lubricate the seal lip with a thin layer of grease.

8. Carefully install the hub and rotor assembly. Place the outer bearing cone and roller assembly in the outer bearing cup. Install the washer and nut and initially tighten the nut to 12 ft. lbs. while turning the wheel assembly forward by hand. Put an additional quantity of grease outboard the bearing. This provides extra grease availability to the bearing.

9. Final wheel bearing adjustment should be performed as previously outlined.

SHOCK ABSORBER

Removal (Fig. 3C-15)

1. Raise vehicle on hoist.
2. Remove nuts and eye bolts securing upper and lower shock absorber eyes.
3. Withdraw shock absorber and inspect rubber eye bushings. If defective, replace shock absorber assembly.

Installation

Place shock absorber into position over mounting bolts or into mounting brackets. Install eye bolts and nuts and torque as shown in Specifications Section. Lower vehicle to floor.

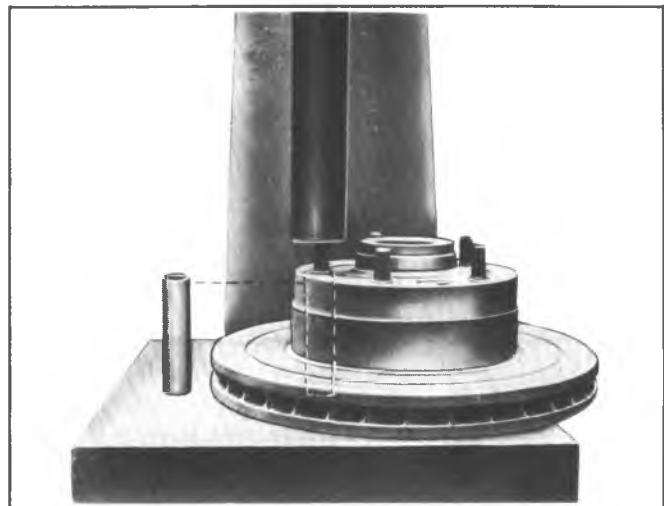


Fig. 3C-14—Pressing Hub Bolt

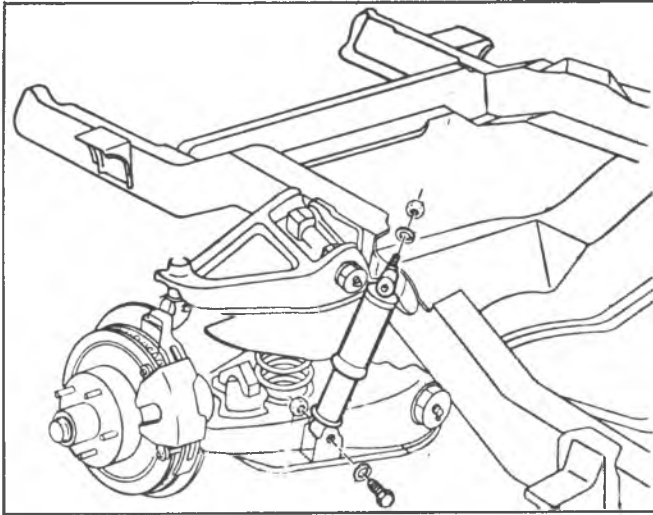


Fig. 3C-15—Shock Absorber Attachments

STABILIZER BAR

Removal (Fig. 3C-16)

1. Raise vehicle on hoist and remove nuts and bolts attaching stabilizer brackets and bushings at frame location.
2. Remove brackets and bushings at lower control arms and remove stabilizer from vehicle.

Inspection

Inspect rubber bushings for excessive wear or aging—replace where necessary. Use rubber lubricant when installing bushings over stabilizer bar.

Installation

NOTICE: See NOTICE on page 1 of this section regarding the fasteners referred to in step 2.

Slit in bar to frame bushings should be facing forward.

1. Place stabilizer in position on frame and install frame brackets over bushings. Install nuts and bolts loosely.
2. Install brackets over bushings at lower control arm location. Be sure brackets are positioned properly over bushings. Torque all nuts and bolts to specifications.

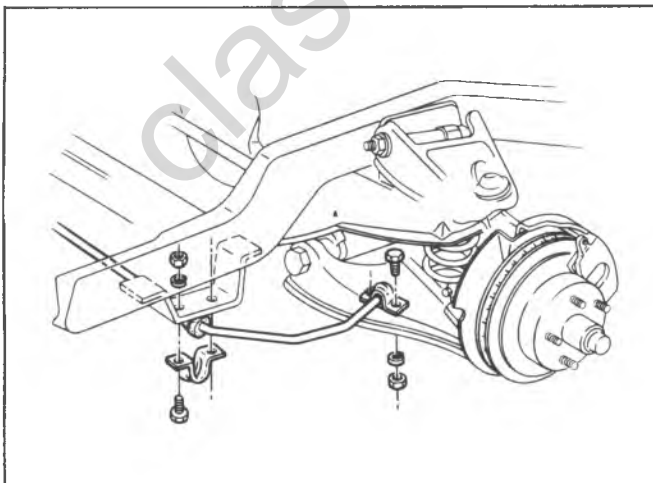


Fig. 3C-16—Stabilizer Bar - C, P and G Typical

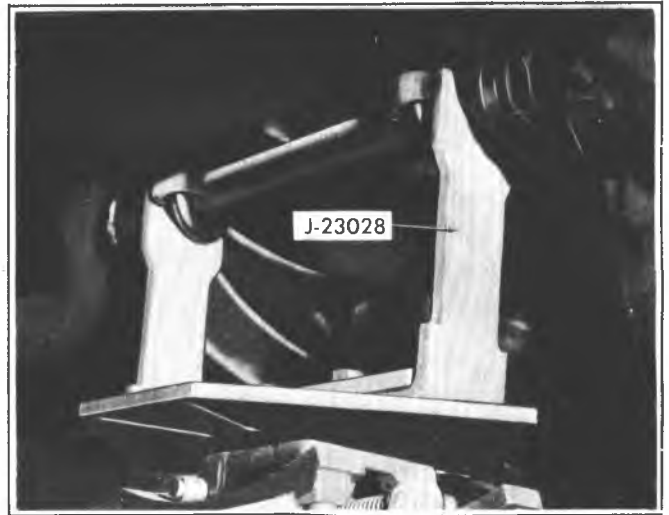


Fig. 3C-17—Removing Coil Spring with Tool J-23028

3. Lower vehicle to floor.

COIL SPRING

Removal (Fig. 3C-17)

1. Place vehicle on hoist and place jack stands under frame, allowing control arms to hang free.
2. Disconnect shock absorber at lower end and move aside. Disconnect the stabilizer bar attachments to the lower control arm.
3. Bolt Tool J-23028 to a suitable jack.
4. Place tool under cross-shaft so that the cross-shaft seats in the grooves of the tool. As a safety precaution install and secure a chain through the spring and lower control arm.
5. Raise the jack to remove tension on the lower control arm cross-shaft and remove the two "U" bolts securing the cross-shaft to crossmember. The crossshaft and lower control arm keeps the coil spring compressed. Use care when lowering.
6. Lower control arm by slowly releasing the jack until spring can be removed. Be sure all compression is relieved from spring.
7. Remove spring.

Installation

NOTICE: See NOTICE on page 1 of this section regarding the fasteners referred to steps 3 and 4.

1. Properly position spring on the control arm, and lift control arm using jack and tool J-23028.

Some models are equipped with air cylinders in the coil springs. These cylinders should be checked for leaks and damage at this time. Air pressure in these cylinders should be 40 PSI \pm 10.

2. Position control arm cross-shaft to crossmember and install "U" bolts and attaching nuts. Make certain front indexing hole in cross-shaft is lined up with crossmember attaching saddle stud.
3. Torque nut to specifications.
4. Install shock absorber to lower control arm and install stabilizer bar.

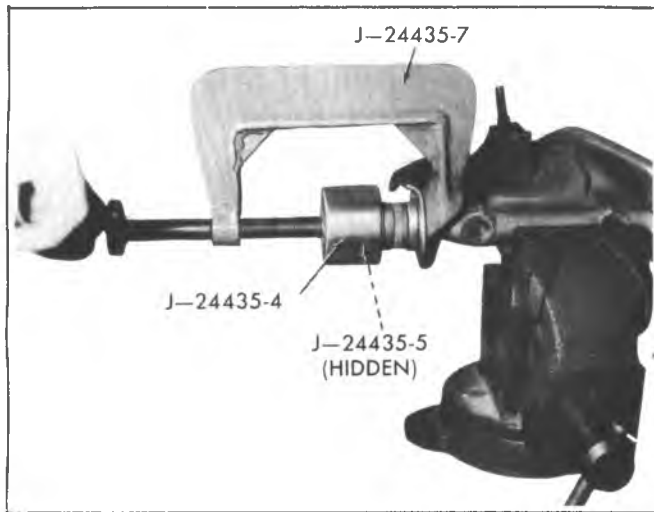


Fig. 3C-23--U.C.A. Rubber Bushing Installation

4. The pivot shaft may now be removed from the control arm assembly.

5. Reposition the control arm in the vise and repeat the removal procedure on the remaining bushing.

Bushing Installation

1. Again using "C" clamp J-24435-7 and installers J-24435-4 (outer) and J-24435-5 (inner) tighten clamp to install bushing onto control arm.

2. Install pivot shaft into inside diameter of first installed bushing.

3. Install remaining bushing as shown in Figure 3C-23 and described in step 1.

4. Remove tools and install control arm on vehicle following procedure described below. Torque all fasteners to proper specifications.

Upper Control Arm Installation

NOTICE: See NOTICE on page 1 of this section regarding the fasteners referred to in steps 1, 2 and 3.

When installing the upper control arm be sure to position the special aligning washers to the pivot shaft with concave and convex sides together.

1. Place control arm in position on bracket and install nuts. Before tightening nuts, insert caster and camber shims in the same order as when removed. Torque the nuts to specifications.

A normal shim pack will leave at least two (2) threads of the bolt exposed beyond the nut. If two (2) threads cannot be obtained: Check for damaged control arms and related parts. Difference between front and rear shim packs must not exceed 7.62 mm (.30 inches). Front shim pack must be at least 6.09 mm (.24 inches).

Always tighten the thinner shim packs' nut first for improved shaft to frame clamping force and torque retention.

2. Insert ball joint stud into steering knuckle and install nut. Torque stud nut to specifications and install cotter pin.

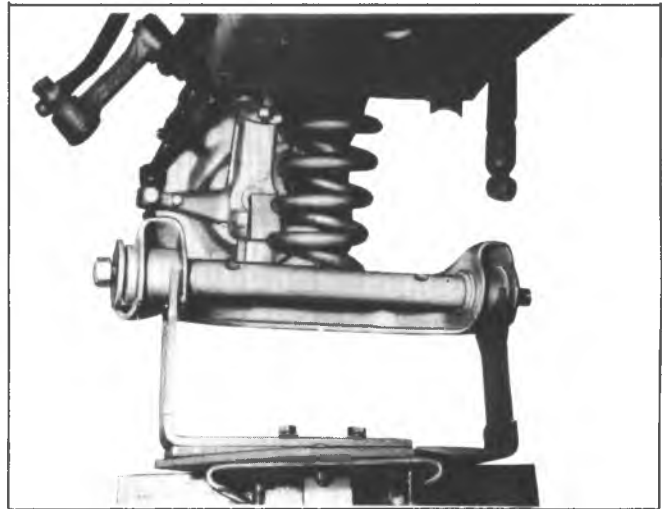


Fig. 3C-24--Lowering Control Arm for Bushing Replacement

3. Install brake caliper assembly if removed (see section 5).

4. Remove adjustable support from under lower control arm. Install wheel and tire assembly.

5. Lower the vehicle to the floor.

LOWER CONTROL ARM ASSEMBLY

Removal

1. Raise vehicle on hoist and remove spring as outlined under spring removal. Support the inboard end of the control arm after spring removal.

2. Remove cotter pin from lower ball stud and loosen stud nut one turn.

3. Install Ball Stud Remover J-23742, position large cup end of the tool over the upper ball stud nut and piloting the threaded end of tool on end of the lower ball stud. Extend bolt from Tool J-23742 to loosen lower ball stud in steering knuckle. When stud is loosened, remove tool and nut from lower stud.

It is necessary to remove the brake caliper assembly and wire it to the frame to gain clearance for tool J-23742. See section 5 for proper procedure.

4. Remove the lower control arm.

Lower Control Arm Inner Pivot Shaft and/or Bushing Replacement-On Vehicle

C10 (Rubber Bushings)

Removal (Figs. 3C-24, 3C-25)

If just bushings or pivot shaft are to be replaced the lower control arm does not have to be removed from the vehicle.

1. Raise vehicle on hoist and support the frame so that the control arms hang free.

2. Position an adjustable floor jack under the lower control arm inboard of spring and into depression of control arm.

3. Install a chain over the upper arm inboard of the stabilizer and outboard of shock absorber as a safety measure.

4. Disconnect shock and stabilizer bar attachments at lower control arm.

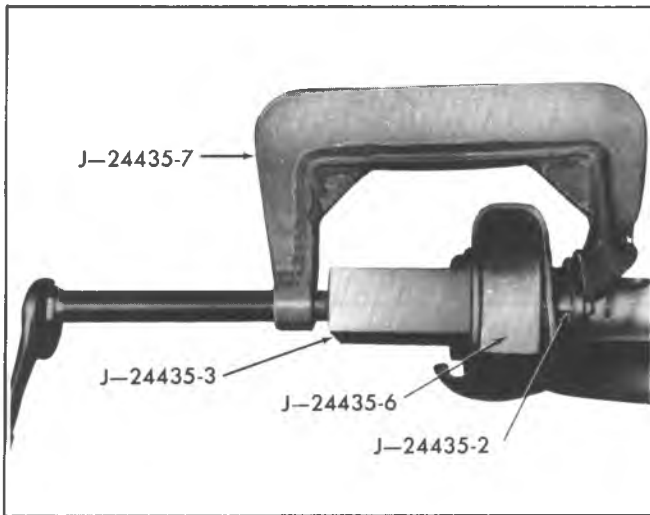


Fig. 3C-25--L.C.A. Rubber Bushing Removal

5. Loosen shaft end nuts.
6. Remove "U" bolts that retain the inboard end of the lower control arm.
7. Lower jack SLOWLY to release spring compression (Fig. 3C-24) and gain clearance to remove bushings. Be sure all compression is released from coil springs.
8. Remove the stakes on the front bushing using tool J-22717 or equivalent tool.
9. Bushings may now be replaced. Install "C" clamps J-24435-7 and receiver J-24435-3 with remover J-24435-2 and spacer J-24435-6 as shown in Figure 3C-25.
10. Tighten the "C" clamp to remove the bushing.
11. Remove tools and discard old bushing.
12. Pivot shaft may now be removed if necessary.
13. Remove second bushing (leave pivot shaft in to pilot tool) by the same method as in steps 8-12.

Bushing Installation (Fig. 3C-26)

NOTICE: See NOTICE on page 1 of this section regarding the fasteners referred to in step 5.

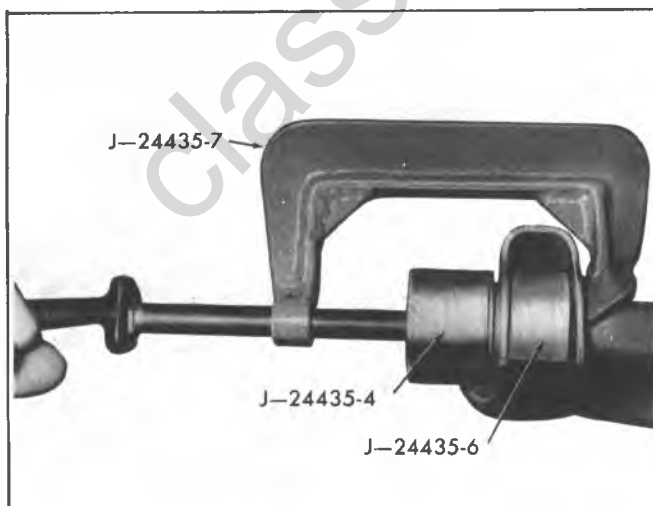


Fig. 3C-26--L.C.A. Rubber Bushing Installation

1. Install new bushings as shown in Figure 3C-26 using spacer J-24435-6, installer J-24435-4 and "C" clamp J-24435-7.

2. Turn clamp in until bushing seats firmly.

NOTICE: Be sure spacer J-24435-6 is in position as shown in Figure 3C-26 to avoid collapsing control arm during assembly.

3. Install one bushing then insert the pivot shaft and install second bushing.

4. Stake front bushing at least in two places when installed.

5. Install the lower control arm to the vehicle as described under "Lower Control Arm - Installation", being sure to torque all fasteners to the proper specification.

Lower Control Arm Inner Pivot Shaft And Bushing Replacement-G10-G20 Models

Removal

1. Remove lower control arm as previously outlined.
2. Remove pivot shaft nuts.
3. Place control arm in an arbor press, press front end of pivot shaft to remove rear bushing, and pivot shaft assembly.
4. Remove the stakes on the front bushing using Tool J-22717 or equivalent tool.
5. Install "C" clamp J-24435-7 and receiver J-24435-3 with remover J-24435-2 and spacer J-24435-6 as shown in Figure 3C-25.
6. Tighten "C" clamp to remove the bushing.

Installation

NOTICE: See NOTICE on page 1 of this section regarding the fasteners referred to in step 5.

1. Install new bushings as shown in Figure 3C-26 using spacer J-24435-6, installer J-24435-4 and "C" clamp J-24435-7.

2. Turn clamp in until bushing seats firmly.

Be sure outer tube hole is to the front or forwards to the staked bushing.

NOTICE: Be sure spacer J-24435-6 is in position as shown in Figure 3C-26 to avoid collapsing control arm during assembly.

3. Stake front bushing at least in two places when installed.

4. Insert the pivot shaft and install second bushing.

5. Install the lower control arm to the vehicle as described under "Lower Control Arm - Installation", being sure to torque all fasteners to the proper specification.

Lower Control Arm Installation

NOTICE: See NOTICE on page 1 of this section regarding the fasteners referred to in steps 2 and 3.

1. Install lower ball stud through steering knuckle and tighten nut.

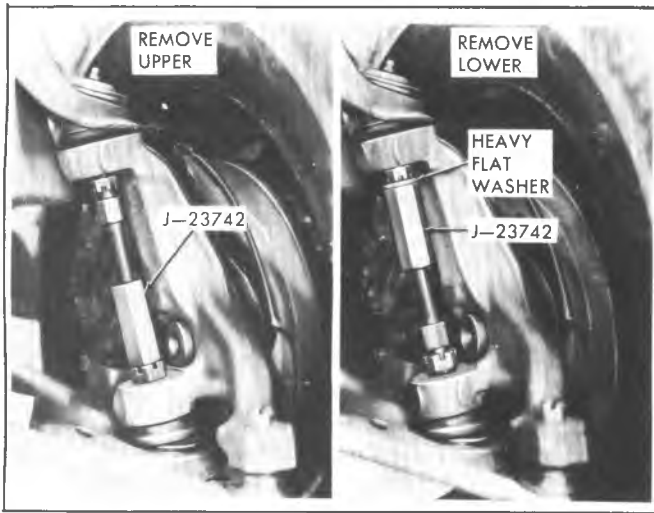


Fig. 3C-27—Disconnecting Ball Joints—Typical

2. Install spring and control arm as outlined under spring installation.
3. Torque lower control arm ball stud to specifications and install cotter pin.
4. Install brake caliper assembly if removed (see section 5).
5. Lower the vehicle to the floor.

BALL JOINT SERVICE—ON VEHICLE

Ball Joint—Inspection

The upper ball stud is spring loaded in its socket. This minimizes looseness at this point and compensates for normal wear, if the upper stud has any perceptible lateral shake, or if it can be twisted in its socket with the fingers, the upper ball joint should be replaced.

Upper—Removal

1. Raise vehicle on hoist. If a frame hoist is used, it will be necessary to support the lower control arm with a floor jack.
2. Remove cotter pin from upper ball stud and loosen stud nut (two turns) but do not remove nut.
3. Install J-23742 between the ball studs as shown in Figure 3C-27.

It is necessary to remove the brake caliper assembly and wire it to the frame to gain clearance for tool J-23742. See section 5 for the proper procedure.

4. Be sure lower control arm is supported as pointed out in step 1. Extend bolt from Tool J-23742 to loosen ball stud in steering knuckle. When stud is loose, remove tool and stud nut.
5. Center punch rivet heads and drill out rivets.
6. Remove the ball joint assembly.

Installation

NOTICE: See NOTICE on page 1 of this section regarding the fasteners referred to in steps 1, 3 and 6.

1. Install new service ball joint, using bolts and nuts supplied with joint, to upper arm. Torque nuts to 60 N·m (45 ft. lbs.).

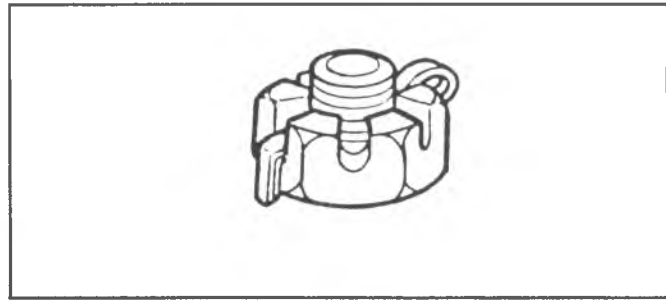


Fig. 3C-28—Cotter Pin Installation

2. Mate ball stud to steering knuckle and install stud nut.
3. Torque the ball stud nut as follows:
 - A. 10 Series 54–80 N·m (40–60 ft. lbs.) plus additional torque to align cotter pin not to exceed 120 N·m (90 ft. lbs.). Never back off to align cotter pin.
 - B. 20–30 Series 110–140 N·m (80–100 ft. lbs.) plus additional torque to align cotter pin not to exceed 175 N·m (130 ft. lbs.) Never back off to align cotter pin.
4. Install new cotter pin as shown in Figure 3C-28.
5. Install lube fitting and lube new joint.
6. Install brake caliper assembly if removed (see section 5).
7. Install tire and wheel assembly.
8. Lower the vehicle to the floor.

Ball Joint—Inspection

Lower

Lower ball joints are a loose fit when not connected to the steering knuckle. Wear may be checked without disassembling the ball stud, as follows:

1. Support weight of control arms at wheel hub and drum.
2. Accurately measure distance between tip of ball stud and tip of grease fitting below ball joint.
3. Move support to control arm to allow wheel hub and drum to hang free. Measure distance as in Step 2. If the difference in measurements exceeds 2.38 mm (.094" (3/



Fig. 3C-29—Checking Lower Ball Joint

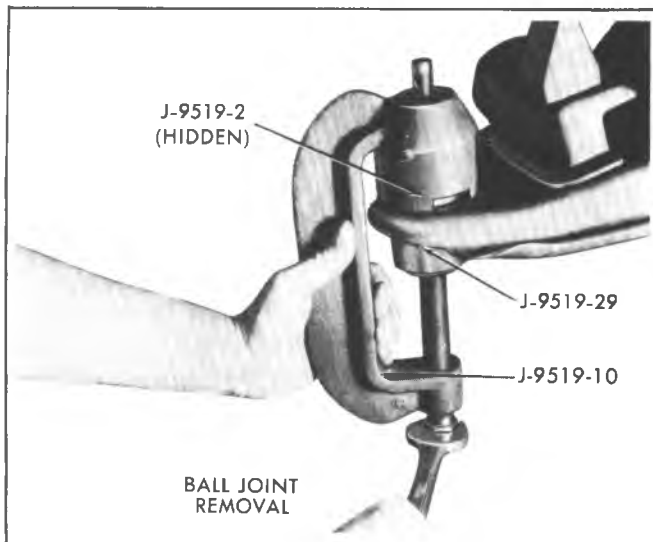


Fig. 3C-30--Ball Joint Removal

32") for all models, ball joint is worn and should be replaced (Fig. 3C-29).

Lower-Removal

1. Raise vehicle on a hoist. If a frame hoist is used it will be necessary to support the lower control arm with a floor stand.
2. Remove the tire and wheel assembly.
3. Remove the lower stud cotter pin and loosen (two turns) but do not remove the stud nut.
4. Install J-23742 between the ball studs as shown in Figure 3C-27.

It may be necessary to remove the brake caliper assembly and wire it to the frame to gain clearance for tool J-23742. See section 5 for proper procedure.

5. Be sure lower control arm is supported as pointed out in Step 1. Extend bolt from Tool J-23742 to loosen ball stud in steering knuckle. When stud is loosened, remove tool and ball stud nut.
6. Pull the brake disc and knuckle assembly up off the ball stud and support the upper arm with a block of wood so that assembly is out of working area.

NOTICE: Do not put stress on the brake line flex hose or damage to the brake line may result.

7. Install Tools J-9519-10 and J-9519-2 and J-9519-29 as shown in Fig. 3C-30.
8. Turn hex head screw until ball joint is free of control arm.
9. Remove tools and the ball joint.

Installation (Fig. 3C-31)

NOTICE: See NOTICE on page 1 of this section regarding the fasteners referred to in steps 4, 5 and 7.

1. Start the new ball joint into the control arm and install J-9519-10 and J-10519-16 as shown. Position bleed vent in rubber boot facing inward.

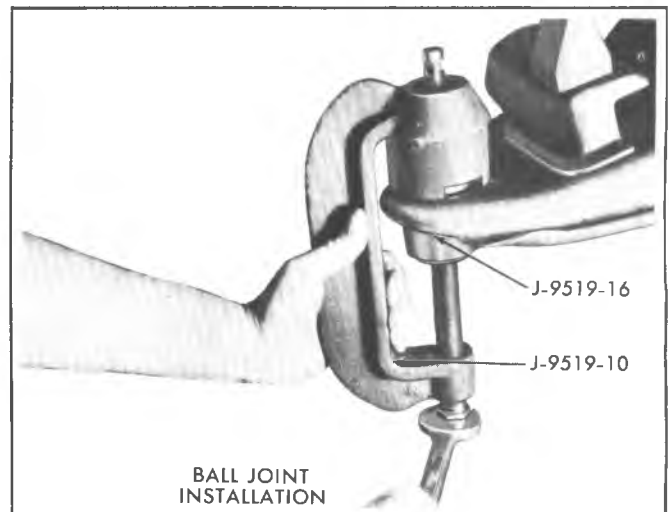


Fig. 3C-31--Installing Ball Joint

2. Turn hex head screw until ball joint is seated in control arm.
3. Lower the upper arm and mate the steering knuckle to the lower ball stud.
4. Install brake caliper assembly if removed (see Section 5).
5. Install ball stud nut and torque as follows. All Series, 110 - 140 N·m (80-100 ft. lbs.) plus additional torque to align cotter pin hole not to exceed 175 N·m (130 ft. lbs.) maximum. Never back off to align cotter pin.
6. Install a lube fitting and lube the joint.
7. Install tire and wheel assembly and lower vehicle to floor.

STEERING KNUCKLE

It is recommended that vehicle be raised and supported as on a twin-post hoist so that the front coil spring remains compressed, yet the wheel and steering knuckle assembly remain accessible. If a frame hoist is used, support lower control arm with an adjustable jackstand to safely retain spring in its curb height position.

Removal

1. Raise vehicle on hoist and support lower control arm as noted above.
2. Remove wheel and tire assembly.
3. Remove caliper as outlined under "Front Wheel Hub - Removal".
4. Remove disc splash shield bolts securing the shield to the steering knuckle. Remove Shield.
5. Refer to Section 3B-Steering for service removal operations.
6. Remove upper and lower ball stud cotter pins and loosen ball stud nuts. Free steering knuckle from ball studs by installing Special Tool J-23742. Remove ball stud nuts and withdraw steering knuckle.

Installation

NOTICE: See NOTICE on page 1 of this section regarding the fasteners referred to in steps 2, 3, 4 and 5.

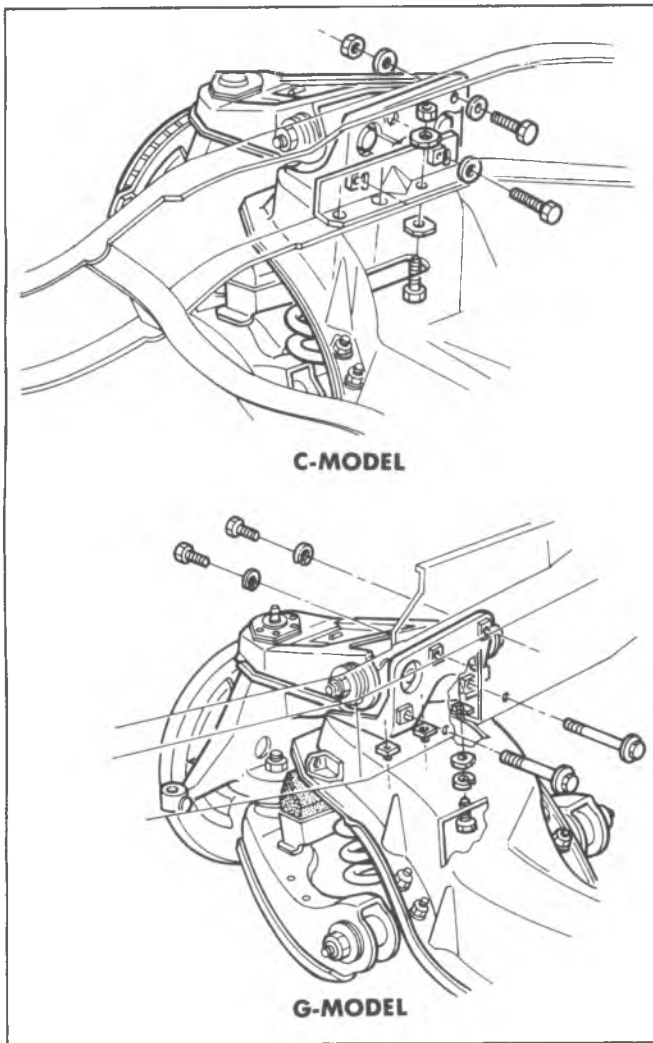


Fig. 3C-32--Suspension Unit to Frame

1. Place steering knuckle in position and insert upper and lower ball studs into knuckle bosses.

Steering knuckle hole, ball stud and nut should be free of dirt and grease before tightening nut.

2. Install ball stud nuts and tighten nut to specifications. (See Specification Section.)

If necessary, tighten one more notch to insert cotter pins. Do not loosen nut to insert cotter pin. Refer to Ball Joint text for proper nut installation sequence.

3. Reverse remaining removal procedure, and tighten splash shield mounting bolt. Tighten two caliper assembly mounting bolts to 48 N·m (35 ft. lbs.) torque.

4. Adjust wheel bearings as outlined under Front Wheel Bearing Adjustment.

5. Tighten wheel nuts to 100 N·m (75 ft. lbs.).

CROSSMEMBER AND SUSPENSION UNIT

Component parts of the front suspension may be serviced separately as outlined in the preceding service operations. However, if extensive service is to be performed to crossmember, frame, etc., the unit can be removed and installed as follows:

Removal (Fig. 3C-32)

1. Raise hood and disconnect negative battery cable from battery.
2. Raise vehicle on hoist.
3. Remove front wheels.
4. Disconnect front brake hose clip from each upper control arm.
5. Support front of vehicle with jack stands at frame side rails. Lower front hoist.
6. Clean area adjacent to brake hose fittings. Disconnect front brake hoses from calipers. Discard special washers (2 each hose). Cover disconnected end of each hose with suitable material.
7. Disconnect tie rod ends from steering knuckles. Discard cotter pins. Refer to Section 3B.
8. If equipped, disconnect front stabilizer from lower control arms.
9. Disconnect front shock absorbers from lower control arms.
10. Remove brake line clip bolts from front suspension crossmember. On C-Models the clip is located under right hand engine mount support bracket.

NOTICE: Failure to disconnect these clips from the front suspension unit will result in severe damage to the brake line when unit is lowered from vehicle.

11. Remove engine mount support bracket to front suspension crossmember bolts.
12. Remove crossmember to lower frame rail bolts.
13. Raise hoist to support front suspension unit.
14. Support engine. Engine must be supported adequately before front suspension unit is lowered from vehicle.
15. Remove upper control arm bracket to frame side rail bolts. Suspension unit is now disconnected from vehicle.
16. Lower hoist to lower front suspension unit from vehicle.

Installation

1. Raise hoist to align new suspension unit with frame rail holes.

NOTICE: See NOTICE, on page 1 of this section regarding fasteners referred to in steps 2-14.

2. Assemble (finger-tight) upper control arm bracket bolts and crossmember bolts to frame rails.
3. Torque upper control arm bracket bolts to frame side rails to 90 N·m (65 ft. lbs.). Control arm bracket bolts must be torqued before crossmember bolts are torqued. Crossmember must be in contact with siderails.
4. Torque crossmember bolts to frame lower rails 100 ft. lbs. Engine support can be removed at this time.
5. Lower hoist.
6. Assemble (finger-tight) engine mount support bracket to front suspension crossmember bolts.
7. Torque engine mount support bracket bolts to 48 N·m (35 ft. lbs.).
8. Install brake line clip bolt to front suspension crossmember. Torque to 17 N·m (150 in. lbs.) (C-models), 12 N·m (100 in. lbs.) (G-models).

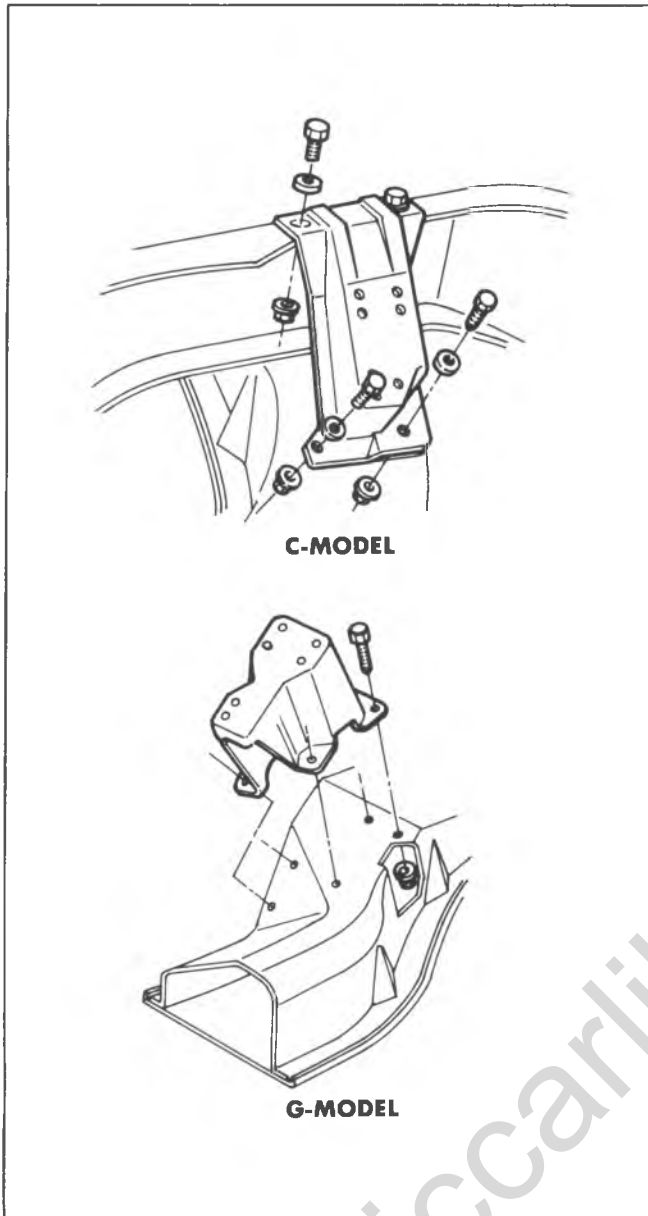


Fig. 3C-33—Engine Front Mounting Bracket

9. Connect front shock absorbers to L.C.A.'s. Torque to 80 N·m (60 ft. lbs.) (C-models), 95 N·m (70 ft. lbs.) (G-models).

10. If equipped, connect front stabilizer to L.C.A.'s. Torque to 34 N·m (25 ft. lbs.).

11. Connect tie rod ends to steering knuckles. Refer to Section 3B.

12. Connect front brake hose to caliper, using new special washers. Refer to Section 5.

13. Connect front brake hose clips to upper control arms. Torque nuts to 17 N·m (150 in. lbs.).

14. Lubricate upper and lower ball joints.

15. Install front wheels.

16. Bleed brake system. Refer to Section 5 for correct bleeding procedures.

17. Lower vehicle.

18. Connect battery cable.

FRONT SUSPENSION, FOUR-WHEEL DRIVE SERIES K10, K20, K30

INDEX

| | | | |
|---|-------|-----------------------------------|-------|
| General Description..... | 3C-24 | Steering Knuckle (K10, K20) | 3C-29 |
| Maintenance and Adjustments..... | 3C-25 | Steering Knuckle (K30)..... | 3C-31 |
| Ball Joint Adjustment..... | 3C-25 | Shock Absorber..... | 3C-32 |
| Bearing Lubrication | 3C-26 | Stabilizer Bar..... | 3C-32 |
| Wheel Bearing Adjustment | 3C-26 | Leaf Spring..... | 3C-33 |
| Component Replacement..... | 3C-27 | Specifications..... | 3C-37 |
| Hubs, Free-Wheeling (K10, K20, K30) | 3C-27 | Special Tools..... | 3C-38 |
| Spindle..... | 3C-27 | | |

GENERAL DESCRIPTION

Front drive axles used on K10, K20, and K30 trucks have several styles of wheel-end construction.

At the wheel ends of the axle tubes, two types of steering knuckle attachment are used. Figures 3C-1K show the K10 and K20 knuckle attached with ball joints. Figure 3C-2K shows the king-pin attachment used in K30. The tapered upper king pin fits in a tapered nylon bushing. The

lower king pin is part of the bearing cap, and this king pin rides in a tapered roller bearing.

A free-wheeling hub is used on all four wheel drive trucks. The free-wheeling hub (for K10, K20 and K30) is shown in Figure 3C-4K. This hub allows the driver to manually engage or disengage the hub from the axle shafts.

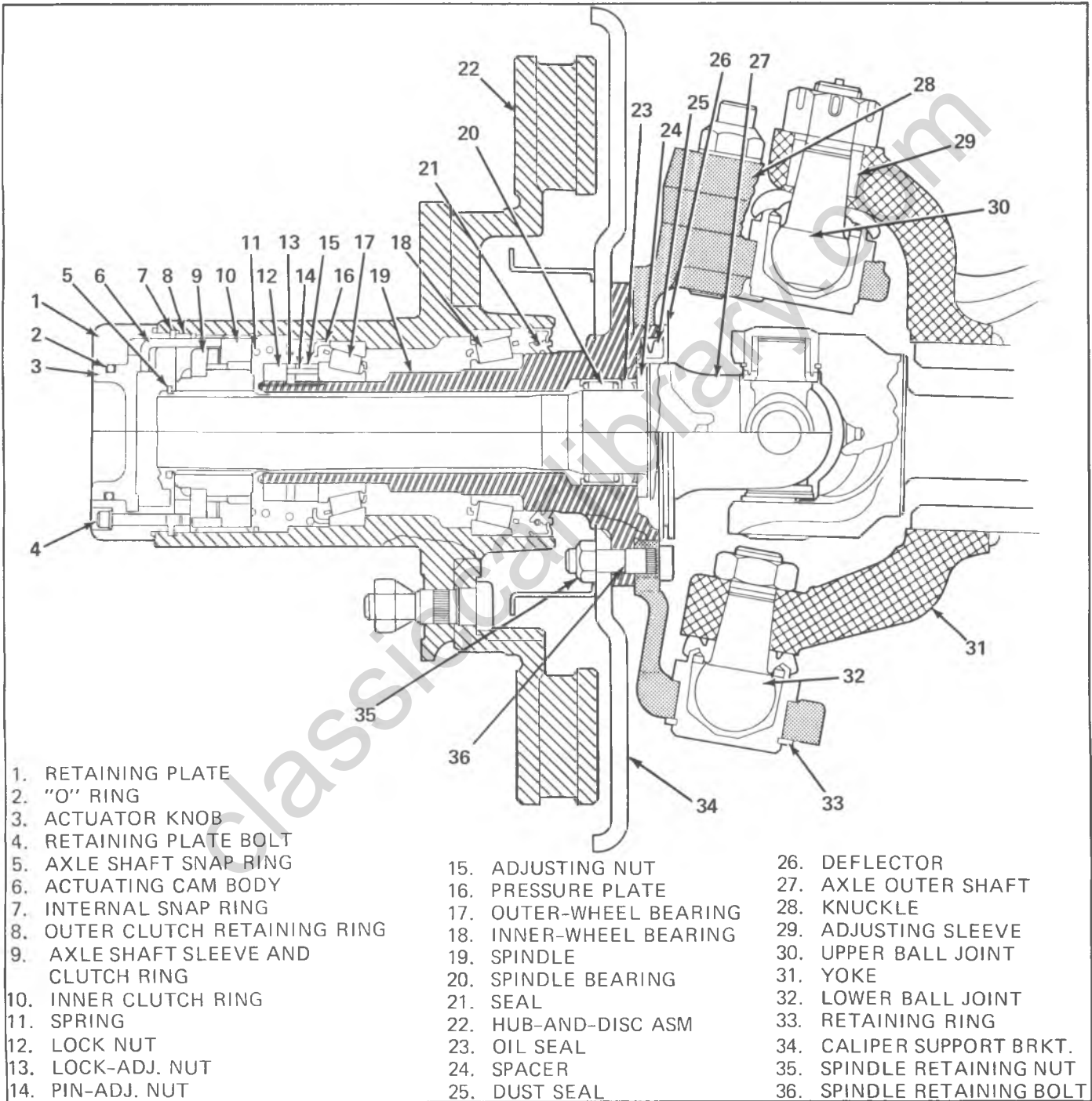


Fig. 3C-1K-K10, K20 with Free-Wheeling Hub and Ball Joints

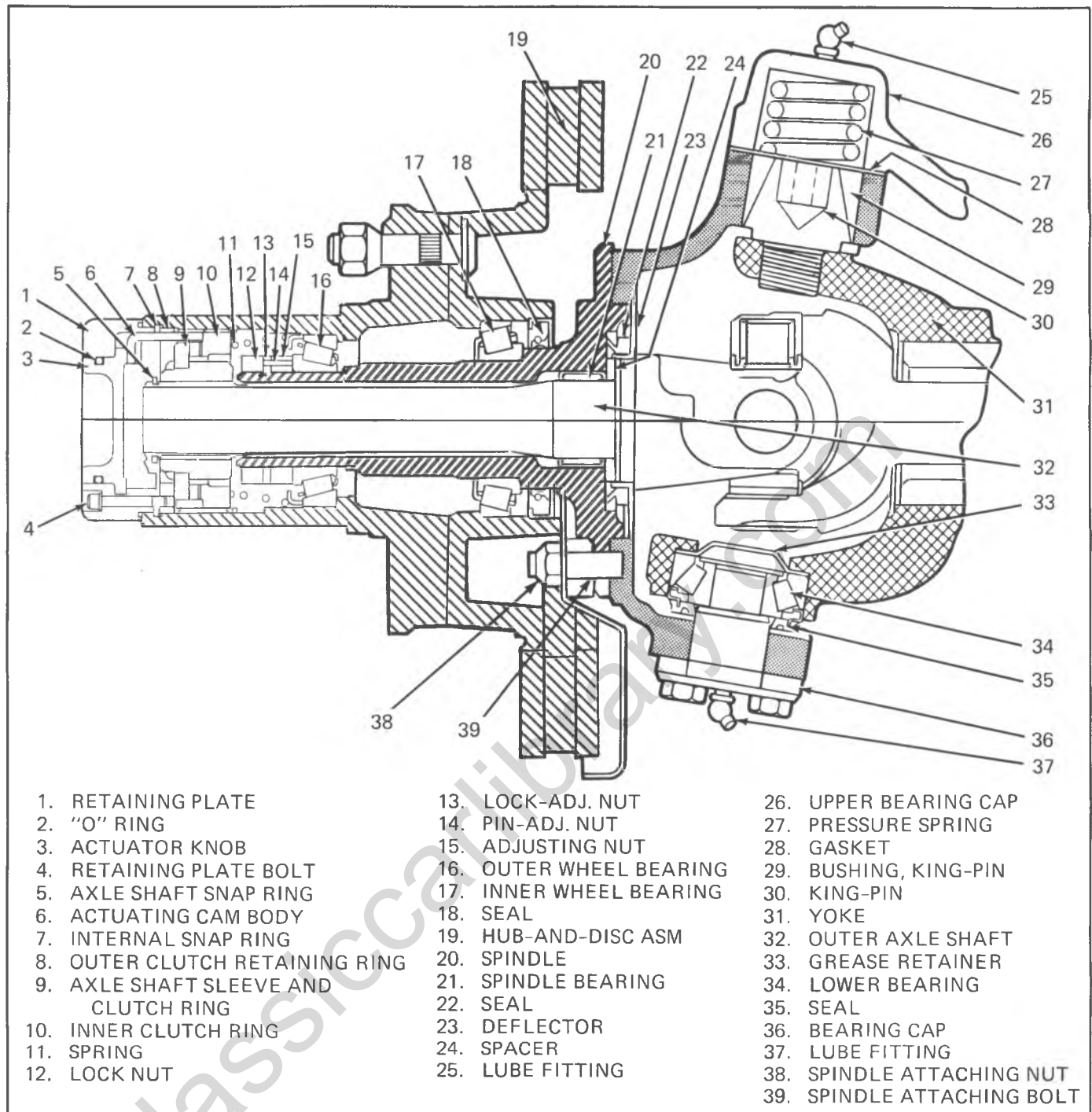


Fig. 3C-2K-K30 with Free-Wheeling Hub and King-Pins

MAINTENANCE AND ADJUSTMENTS

BALL JOINT ADJUSTMENT (K10, K20)

Front axle ball joint adjustment is generally necessary only when there is excessive play in steering, irregular wear on tires or persistent loosening of the tie rod is observed.

1. Raise vehicle on hoist then place jack stands just inside of front springs.

2. Disconnect connecting rod and tie rod to allow independent movement of each steering knuckle.

3. Apply a fish-scale to the tie rod mounting hole of the steering knuckle arm. With the knuckle assembly in the straight-ahead position, determine the right angle pull required to keep the knuckle assembly turning after initial

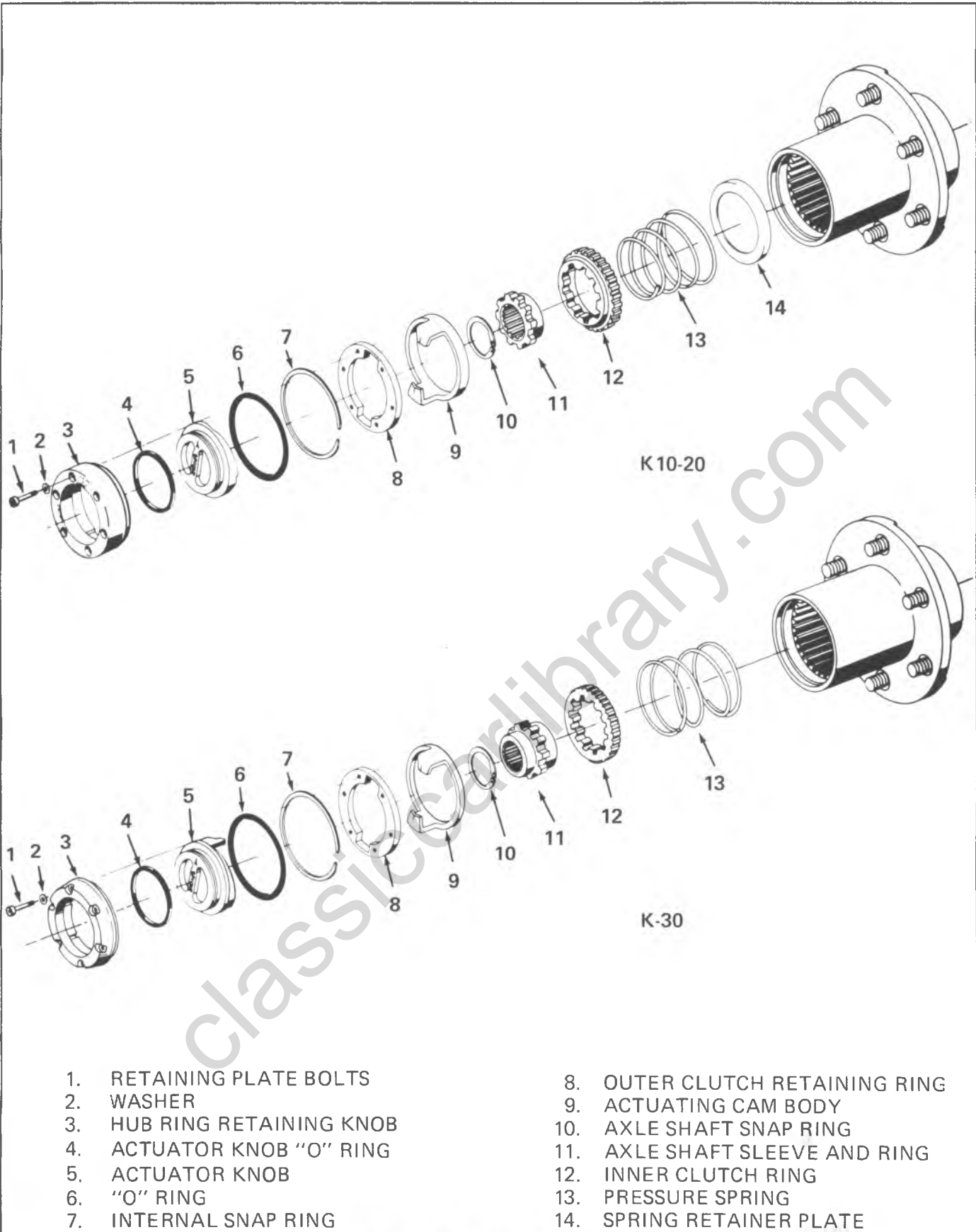


Fig. 3C-4K--Free-Wheeling Hub--Explode

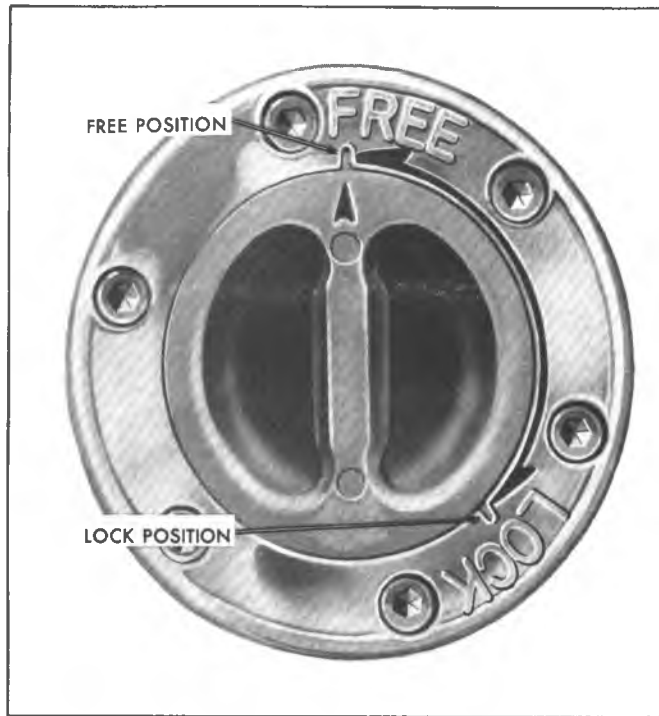


Fig. 3C-5K--Hub Key Position - Typical

NOTICE: See NOTICE on page 1 of this section.

KNUCKLE

K10, K20, (WITH BALL JOINTS)

Removal

1. Remove hub and spindle components as outlined earlier.
2. If the steering arm is to be removed, disconnect the tie rod.
 - a. Remove cotter pin.
 - b. Loosen tie rod nuts and tap on nut with a soft hammer to break the studs loose from the knuckle arm.

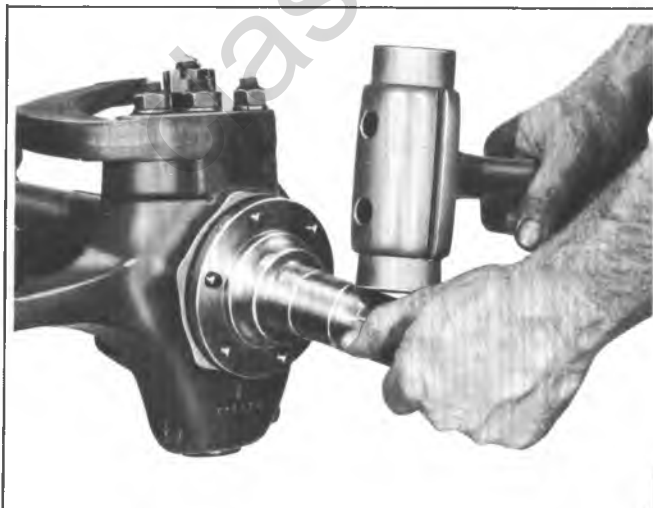


Fig. 3C-6K--Removing Spindle and Thrust Washer

c. Remove nuts and disconnect the tie rod. If it is necessary to remove the steering arm, discard the self-locking nuts (Fig. 3C-9K) and replace with new nuts at assembly.

3. Remove the cotter pin from the upper ball socket nut.

4. Remove the retaining nuts from the upper and lower ball sockets as shown in Figure 3C-10K.

5. Remove the knuckle assembly from the yoke by inserting a suitable wedge-shaped tool between the lower ball stud and the yoke and tapping on the tool to release the knuckle assembly. Repeat as required at the upper ball stud location.

Ball Joint Service

NOTICE: Do not remove the yoke upper ball stud adjusting sleeve unless new ball studs are being installed. If it is necessary to loosen the sleeve to remove the knuckle, do not loosen it more than two threads using Spanner J-23447 as shown in Figure 3C-15K. The nonhardened threads in the yoke can be easily damaged by the hardened threads in the adjusting sleeve if caution is not used during knuckle removal.

Remove the lower ball joint snap ring before beginning. Lower ball joint must be removed before any service can be performed on the upper ball joint.

1. Remove the lower ball joint using tools J-9519-10, J-23454-1, and sleeve J-6382-3 or equivalent as shown in Figure 3C-11K.

If Tool J-6382-3 is not available, a suitable tool may be fabricated from 63.50 mm (2-1/2") O.D. steel tubing with 4.75 mm (3/16") wall thickness, cut 63.50 mm (2-1/2") long.

2. Remove the upper ball joint using tools J-9519-10, J-23454-1, and sleeve J-6382-3 or equivalent as shown in Figure 3C-12K.

3. Install the lower ball joint into the knuckle. Make sure that the lower ball joint (the joint without cotter pin hole in the stud end) is straight. Press the stud into the knuckle until properly seated using tools J-9519-10, J-23454-2, and J-6382-3 or equivalent as shown in Figure 3C-13K and install snap ring.

4. Install the upper ball joint into the knuckle. Press the stud into the knuckle until properly seated using Tools J-9519-10, J-23454-2, and J-6382-3 or equivalent as shown in Figure 3C-14K.

Installation

NOTICE: See NOTICE on page 1 of this section regarding the fasteners in the following steps.

1. Position the knuckle and sockets to the yoke. Install new nuts finger tight to the upper (the nut with the cotter pin slot) and lower ball socket studs.

2. Push up on the knuckle (to keep the ball socket from turning in the knuckle) while tightening the lower socket retaining nut. Torque lower nut to 95 N·m (70 ft. lbs.).

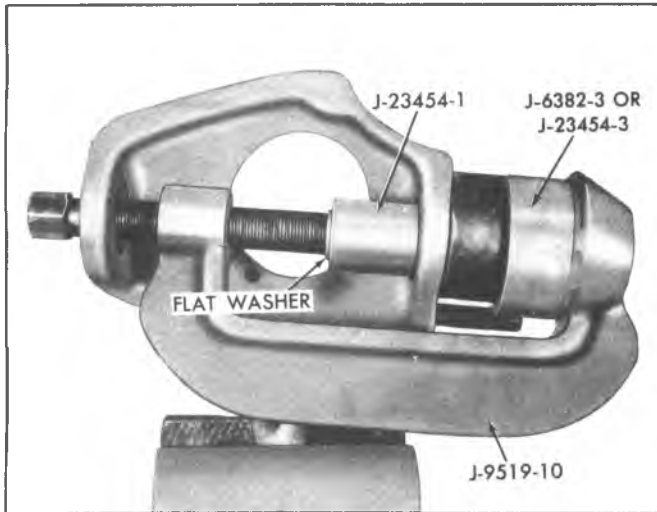


Fig. 3C-12K--Removing Upper Ball Joint

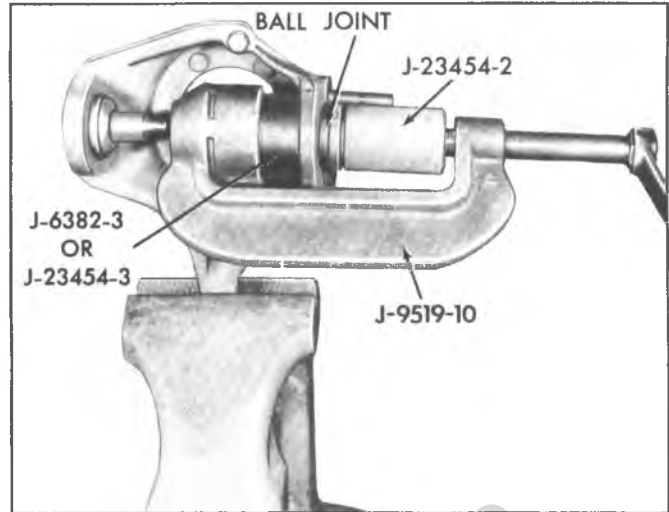


Fig. 3C-14K--Installing Upper Ball Joint

Do not distort oil seal. It will protrude slightly from the surface of yoke flange when fully installed.

3. Install upper king-pin, using J-28871 as shown in Figure 3C-26K. Torque to 677.50-813.00 N·m (500-600 ft. lbs.).

4. Assemble felt seal to king pin, assemble knuckle, assemble tapered bushing over king pin, as shown in Figure 3C-27K.

5. Assemble lower bearing cap-and-king pin with four cap screws. Tighten cap screws alternately and evenly; see Figure 3C-28K. Torque cap screws to 95-120 N·m (70-90 ft. lbs.).

6. Assemble compression spring on upper king pin bushing. Assemble bearing cap, with new gasket, over four studs. Tighten nuts alternately and evenly. Torque nuts to 95-120 N·m (70-90 lb. ft.) See Figure 3C-29K.

SHOCK ABSORBER

Removal (Fig. 3C-30K)

1. Raise vehicle on hoist.
2. Remove nuts and eye bolts securing upper and lower shock absorber eyes.
3. Withdraw shock absorber and inspect rubber eye bushings. If defective, replace shock absorber assembly.

Installation

Place shock absorber into position over mounting bolts or into mounting brackets. Install eye bolts and nuts and torque as shown in Specifications Section. Lower vehicle to floor.

STABILIZER BAR-TYPICAL

Removal (Fig. 3C-31K)

1. Raise vehicle on hoist and remove nuts and bolts attaching stabilizer brackets and bushings at frame location.
2. Remove brackets and bushings at lower spring anchor plates and remove stabilizer from vehicle.

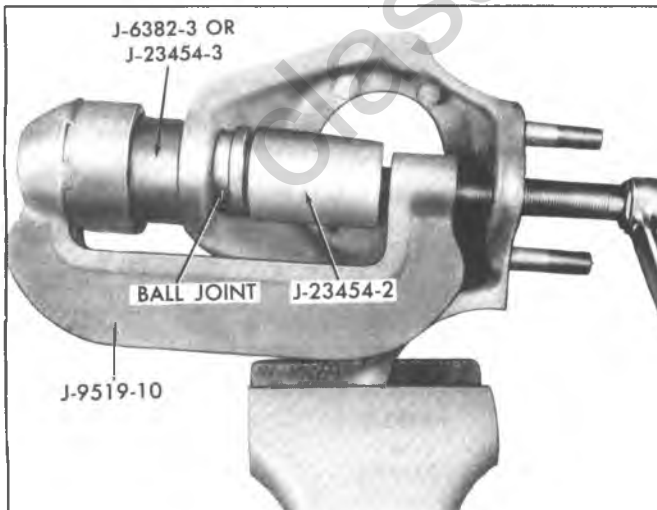


Fig. 3C-13K--Installing Lower Ball Joint

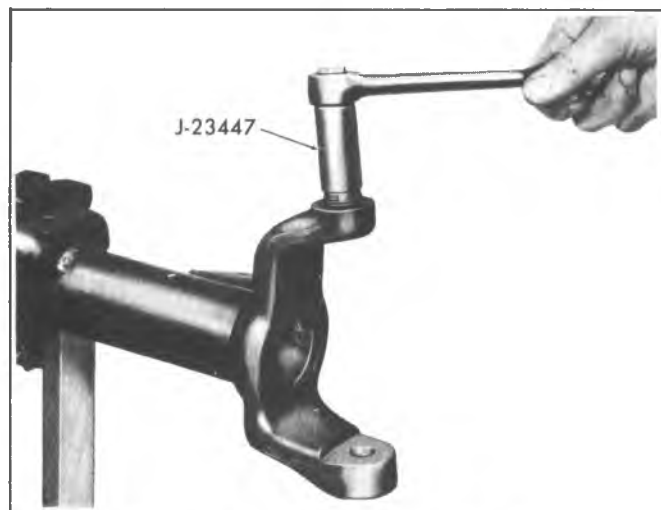


Fig. 3C-15K--Ball Stud Adjusting Sleeve

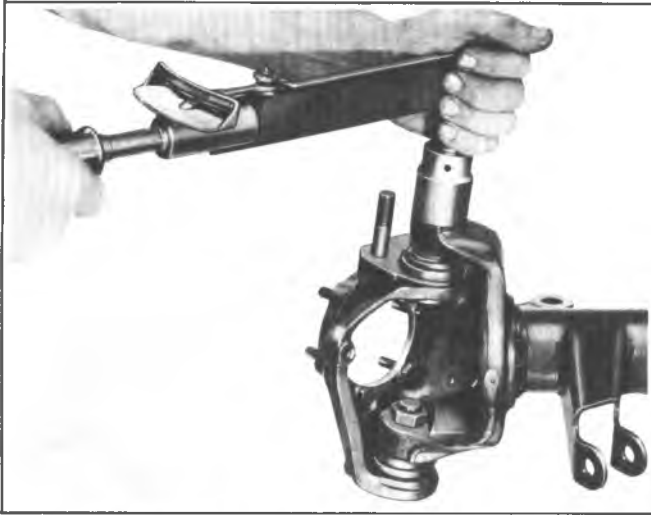


Fig. 3C-16K--Torquing Upper Ball Socket Nut

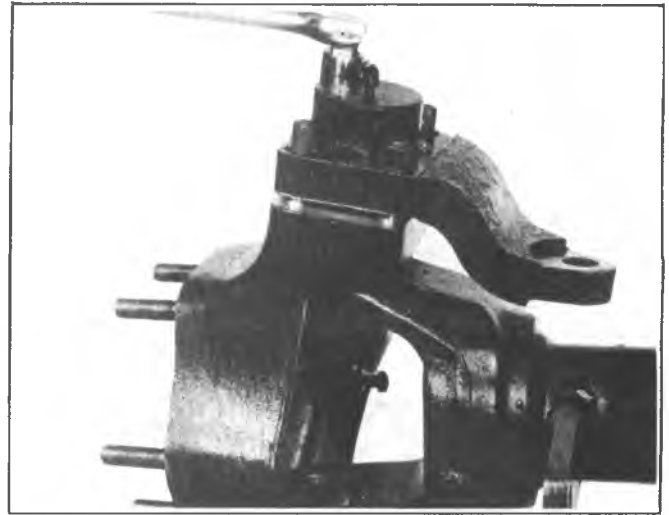


Fig. 3C-18K--Removing Nuts Alternately

Inspection

Inspect rubber bushings for excessive wear or aging—replace where necessary. Use rubber lubricant when installing bushings over stabilizer bar.

Installation

NOTICE: See NOTICE on page 1 of this section regarding the fasteners referred to in step 2.

Slit in bar to frame bushings should be facing forward.

1. Place stabilizer in position on frame and install frame brackets over bushings. Install nuts and bolts loosely.
2. Install brackets over bushings at lower control arm location. Be sure brackets are positioned properly over bushings. Torque all nuts and bolts to specifications.
3. Lower vehicle to floor.

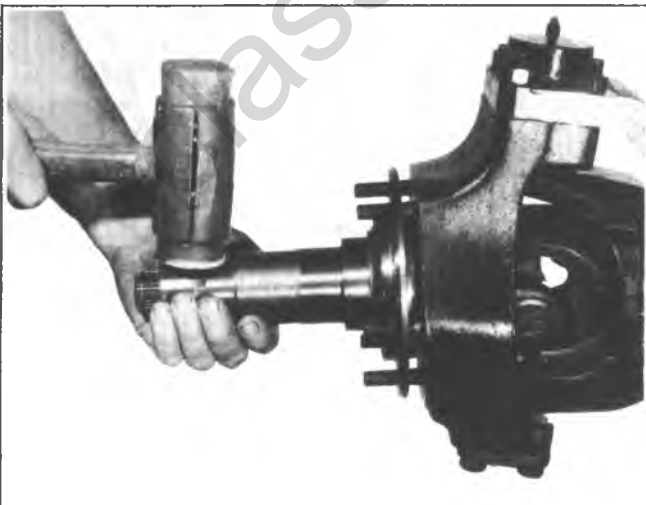


Fig. 3C-17K--Removing Spindle

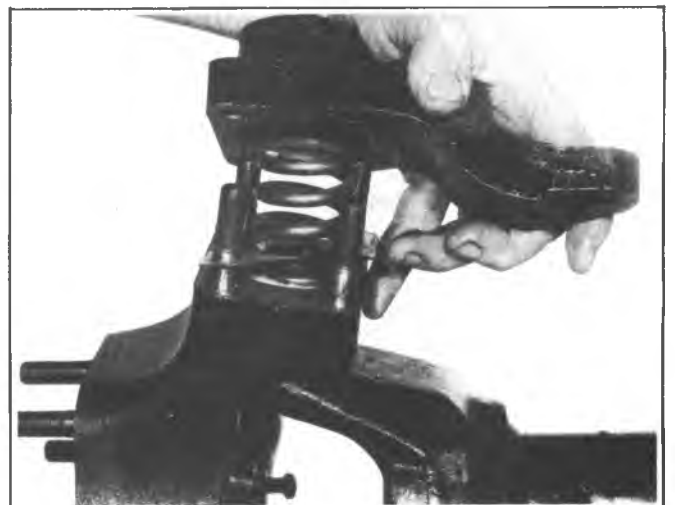


Fig. 3C-19K--Removing Cap, Spring and Gasket

LEAF SPRING AND BUSHINGS (Figs. 3C-32K and 3C-33K)

Removal

1. Raise vehicle on hoist.
2. Place adjustable lifting device under axle.
3. Position axle so that all tension is relieved from spring.
4. Remove shackle upper retaining bolt.
5. Remove front spring eye bolt.
6. Remove spring-to-axle u-bolt nuts and remove spring, lower plate and spring pads.
7. Remove shackle to spring bolt and remove bushings and shackle.

Bushing Replacement

1. Place spring on press and press out bushing using a suitable rod, pipe, or tool.
2. Press in new bushing; assure that tool presses on steel outer shell of bushing. Install until bushing protrudes an equal amount on each side of spring.

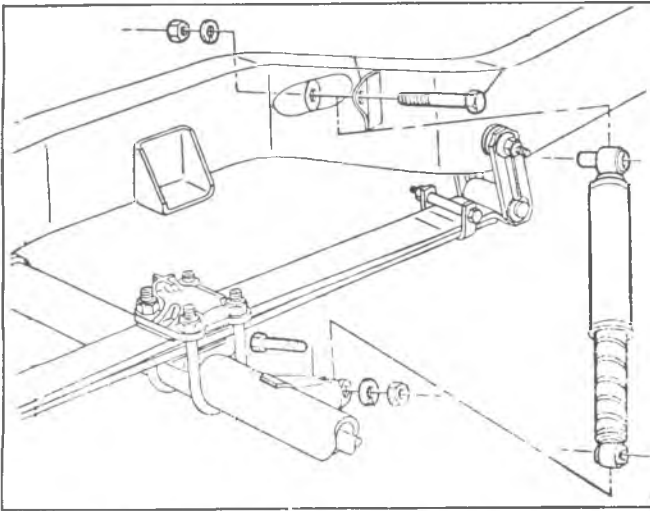


Fig. 3C-30K--Shock Absorber Attachment

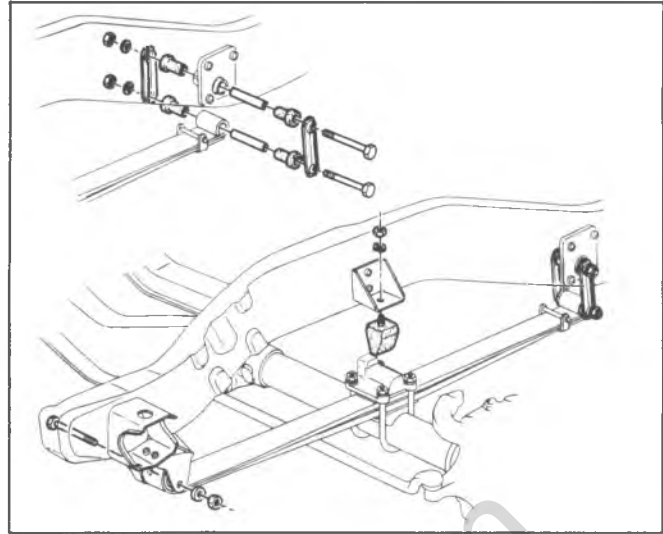


Fig. 3C-32K--Leaf Spring Assembly

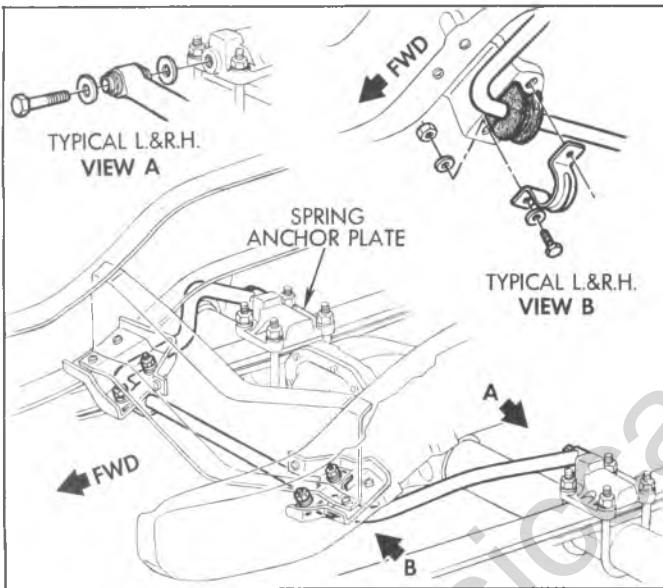


Fig. 3C-31K--Stabilizer Bar Attachment

TIGHTENING SEQUENCE

1. Install all four nuts to uniform engagement on 'U' Bolts to retain and position anchor plate in design position (perpendicular to axis of 'U' Bolts).
2. Torque nuts in positions 1 and 3 to 10-25 ft. lbs. (14-34 N·m).
3. Torque all nuts to full torque in following sequence: 2-4-1-3.

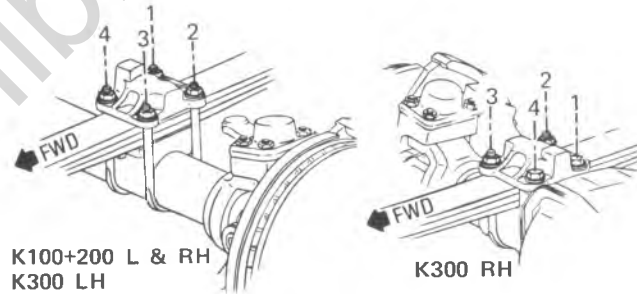


Fig. 3C-33K--U-Bolt Tightening Sequence

SPECIFICATIONS

FRONT SUSPENSION BOLT TORQUE (ft. lbs.) * †

| | CP-10 | CP-20-30 | K-All | G-10-20 | G-30 |
|------------------------------------|--------------|---------------------|-------------------------|--------------|---------------------|
| Lower Control Arm Shaft U-Bolt | 85 | 85 | — | 65 | 85 |
| Upper Control Arm Shaft Nuts | 70 | 105 | — | 70 | 105 |
| Control Arm Rubber Bushings | 115 | — | — | 115 | — |
| Upper Control Arm Bushing Steel †† | | New 190 Used 115 | — | — | New 190 Used 115 |
| Lower Control Arm Bushing Steel †† | | New 280 Used 130 | — | — | New 280 Used 130 |
| Upper Ball Joint Nut | * 50 | **90 | **100 | * 50 | **90 |
| Lower Ball Joint Nut | **90 | **90 | ***80 | **90 | **90 |
| Crossmember to Side Rail ● | 65 | 65 | — | 65 | 65 |
| Crossmember to Bottom Rail ●● | 90 | 90 | — | 90 | 90 |
| Crossmember Brake Support Struts | 60 | 60 | | 60 | 60 |
| Stabilizer Bar to Control Arm | 25 | 25 | Anchor Plate —130 | 25 | |
| Stabilizer Bar to Frame | 25 | 25 | .55 | 25 | |
| Shock Absorber Upper End | 140 | 140 | 65 | 75 | |
| Shock Absorber Lower End | 60 | 60 | 65 | 75 | |
| Brake Splash Shield to Knuckle | 120 in. lbs. | 120 in. lbs. | 120 in. lbs. | 120 in. lbs. | |
| Wheel Bearing Adjustment | — | — | Inner #-35 Outer ●●● | — | |
| Wheel Bearing Preload | Zero | Zero | Zero | Zero | |
| Wheel Bearing End Movement | .001-.005" | .001-.005" | .001-.010" | .001-.005" | |
| Caliper Mounting Bolt | 35 | 35 | — | 35 | |
| Spring — Front Eye Bolt | — | — | 90 | — | |
| Spring — Rear Eye Bolt | — | — | 50 | — | |
| Spring — To Rear Shackle Bolt | — | — | 50 | — | |
| Spring — To Axle U-Bolt | — | — | 150 | — | |
| Spring — Front Support to Frame | — | — | 25 | — | |
| Suspension Bumper | 15 | 15 | 25 | 15 | |
| Stabilizer to Spring Plate | — | — | 130 | — | |

* Plus additional torque to align cotter pin. Not to exceed 90 ft. lbs. maximum.

** Plus additional torque to align cotter pin. Not to exceed 130 ft. lbs. maximum.

*** Plus additional torque to align cotter pin.

Back nut off to align cotter pin at nearest slot.

† All specifications are given in foot pounds of Torque unless indicated otherwise.

†† C10, G10-20 Rubber Bushings; C20-30, P10-30 Steel Bushings.

● P300 (32), P300 (42) and JF9 — 100 ft. lbs.

●● P300 (32) — 215 ft. lbs., P300 (42) and JF9 — 130 ft. lbs.

●●● (K10-20) 80 ft. lbs., (K30) 65 ft. lbs.

3D-2 REAR SUSPENSION

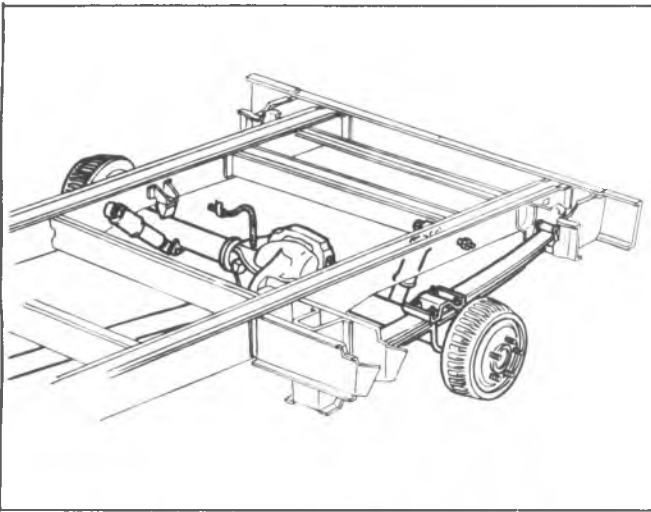


Fig. 3D-2--Typical G-Truck Rear Suspension

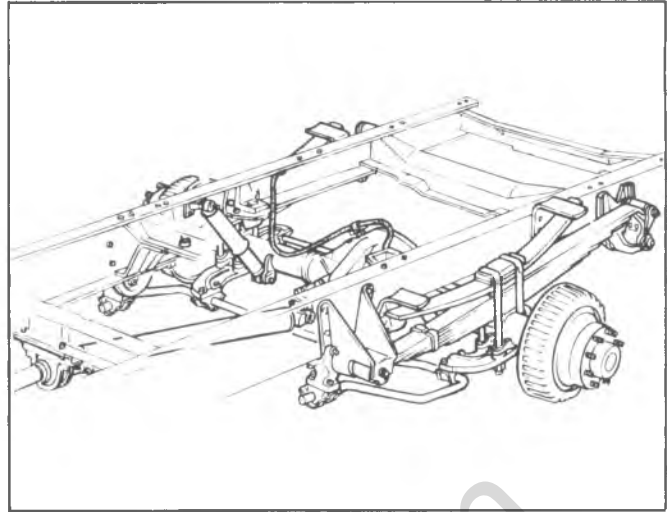


Fig. 3D-3--Typical P-30 H.D. Truck Rear Suspension

COMPONENT PARTS REPLACEMENT

SHOCK ABSORBERS

Replacement

Refer to Figs. 3D-4 through 3D-8 for specific vehicle mounting provisions.

1. Raise vehicle on hoist, and support rear axle.
2. At the upper mounting location, disconnect shock absorber by removing nut and washers shown, and bolt on G-models.
3. At the lower mounting location, remove nut, washers and bolt as shown.
4. Remove shock absorbers from vehicle.

5. To install shock absorber, place into position and reattach at upper mounting location. Be sure to install nuts and washers as shown.

6. Align lower end of shock absorber with axle bracket, and install bolt, washers and nut, as shown.

7. Tighten nuts to specifications.

NOTICE: See NOTICE on page 1 of this section regarding shock absorber fasteners.

8. Lower vehicle and remove from hoist.

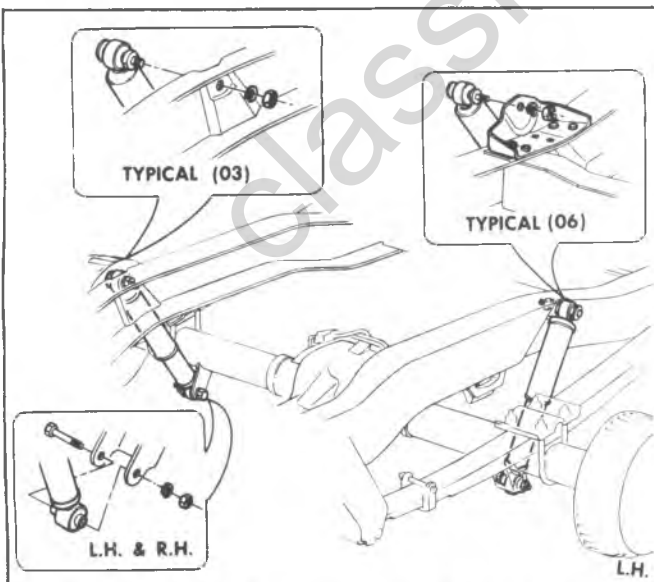


Fig. 3D-4--Shock Absorber-CK-10, CK-20 (03, 06)

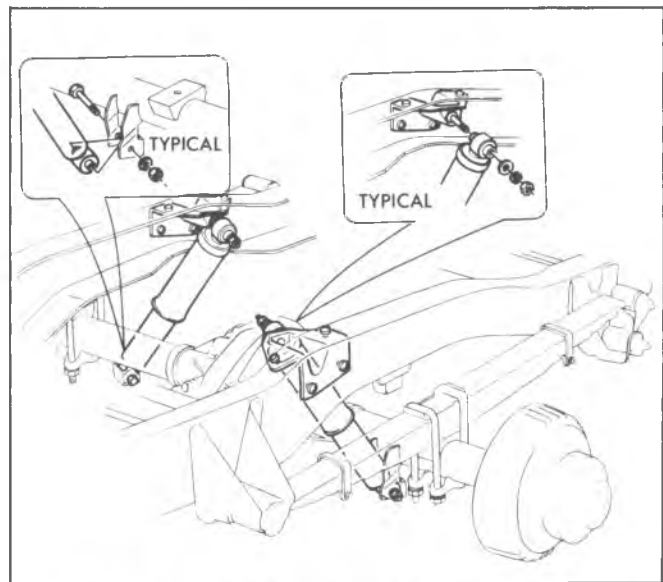


Fig. 3D-5--Shock Absorber-CK-20 (43), CK-30

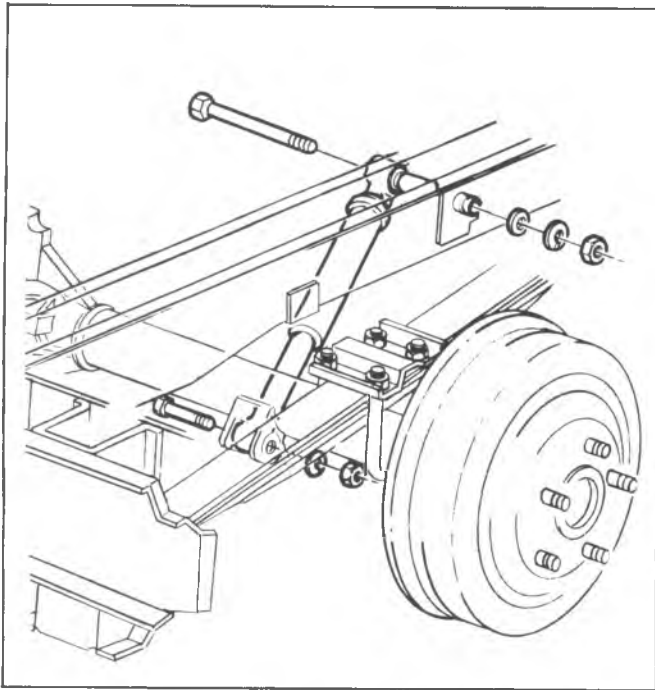


Fig. 3D-6--Shock Absorber-G-10, 20, 30

STABILIZER SHAFTS

Refer to Fig. 3D-9, 3D-10 and 3D-11 for specific rear stabilizer shaft mounting on C and P models.

Replacement

1. Raise vehicle on hoist and support rear axle.
2. Remove nut, washer and grommet from link bolt at the frame side member on each side.
3. Withdraw link bolt, washers, grommets and spacer.

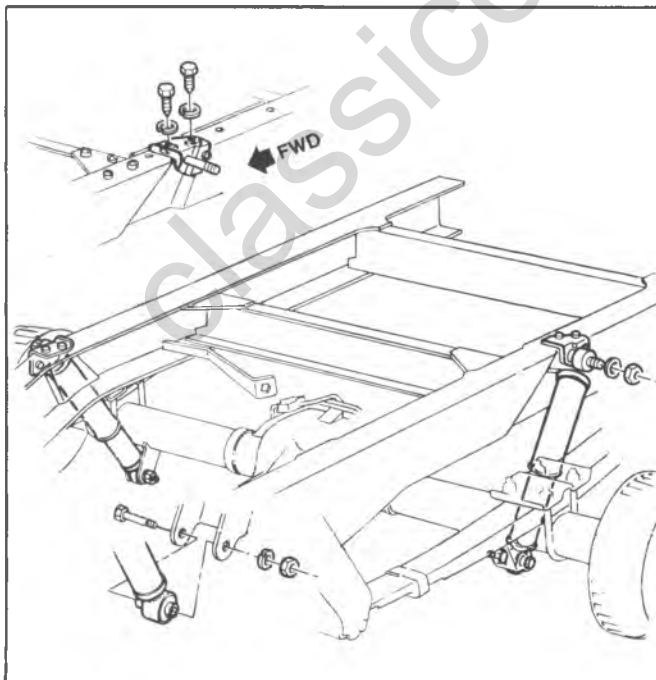


Fig. 3D-7--Shock Absorber-P-10, 20

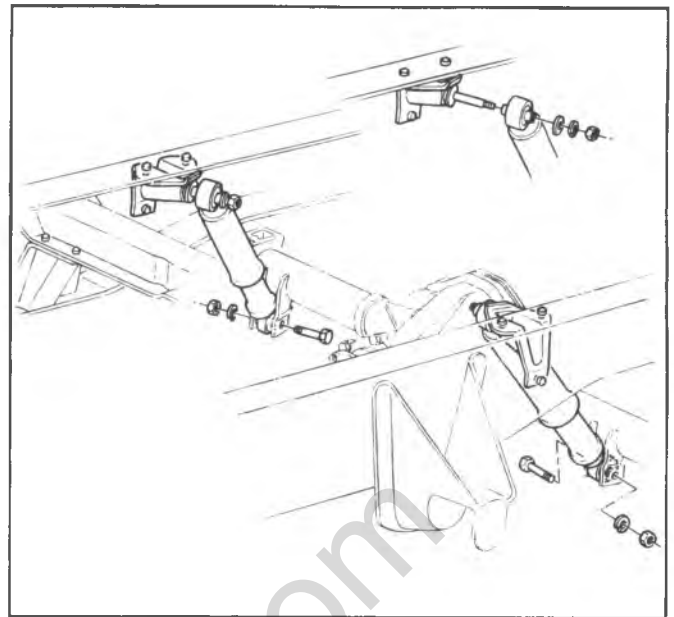


Fig. 3D-8--Shock Absorber-P30

4. Remove brackets from anchor plates by removing attaching screws.

5. Remove stabilizer shafts.

6. Reverse above steps to install stabilizer shaft. On installation, position shaft so parking brake cable is routed over stabilizer.

7. Torque all bolts to specifications.

NOTICE: See NOTICE on page 1 of this section, regarding stabilizer fasteners.

8. Lower hoist and remove vehicle.

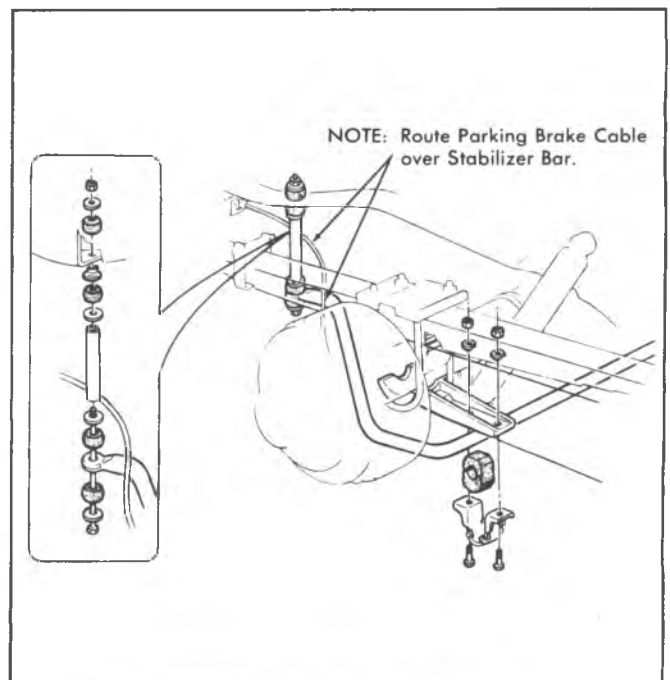


Fig. 3D-9--Rear Stabilizer Shaft-C-20(03)

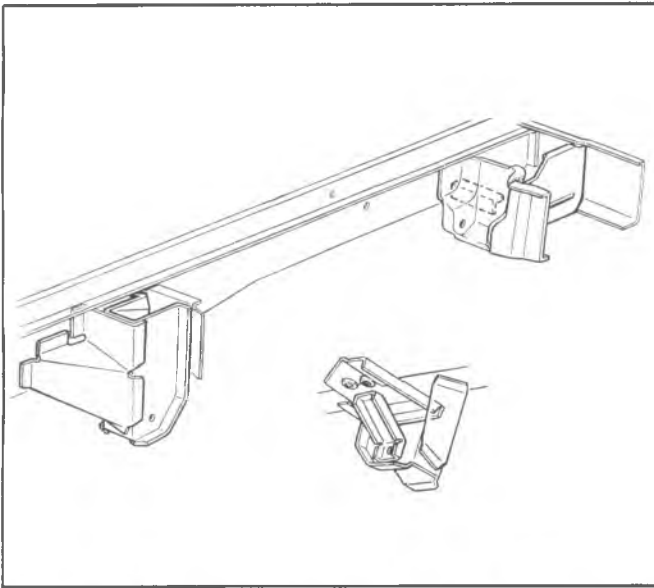


Fig. 3D-15--Rear Spring Hangers-G Models (Cutaway Vans)

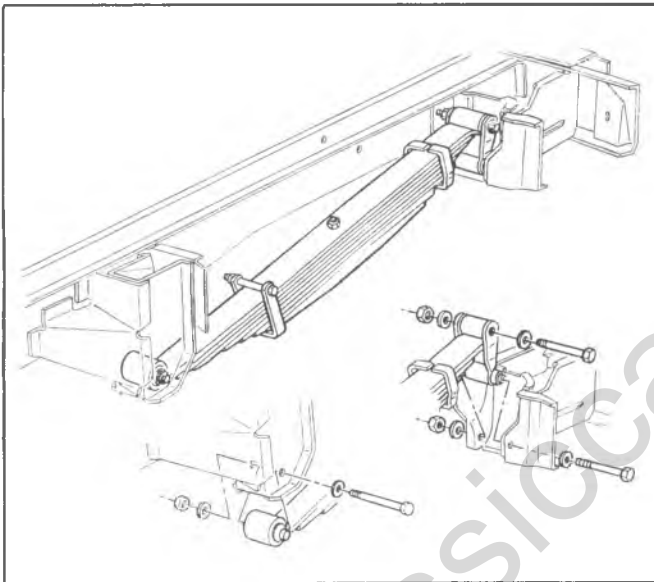


Fig. 3D-16--Rear Spring Installation - G Models (Cutaway Vans)

3. Jack frame as required to align spring and shackle with spring hangers.

4. Install shackle bolt and nut and again reposition spring, if necessary to align front eye. Install front eye bolt and nut. Torque hanger and shackle nuts to specifications.

Make certain that the bolts are free-turning in their bushings prior to torquing.

5. Lower vehicle so that weight of vehicle is on suspension components and torque U-bolt nuts to specifications.

6. Lower vehicle and remove from hoist.

U-Bolt and Anchor Plate Installation

Fig. 3D-23 illustrates the mandatory sequence of tightening U-bolt nuts. Tighten diagonally opposite nuts to 40-50 foot pounds, then tighten all nuts as shown to specifications.

NOTICE: See NOTICE on page 1 of this section, regarding "U"-Bolt fasteners.

SHACKLE REPLACEMENT

1. Raise vehicle on hoist. Place adjustable lifting device under axle.

2. Remove load from spring by jacking frame.

3. Loosen spring-to-shackle retaining bolt, but do not remove.

4. Remove shackle-to-frame bracket retaining bolt then remove shackle bolt from spring eye.

5. Position shackle to spring eye and loosely install retaining bolt. Do not torque retaining bolt at this time.

6. Position shackle to frame bracket and install retaining bolt. Arrow stamped on shackle must point forward.

7. Rest vehicle weight on suspension components and torque both shackle bolt retaining nuts to specifications.

NOTICE: See NOTICE on page 1 of this section, regarding these fasteners.

8. Lower vehicle and remove from hoist.

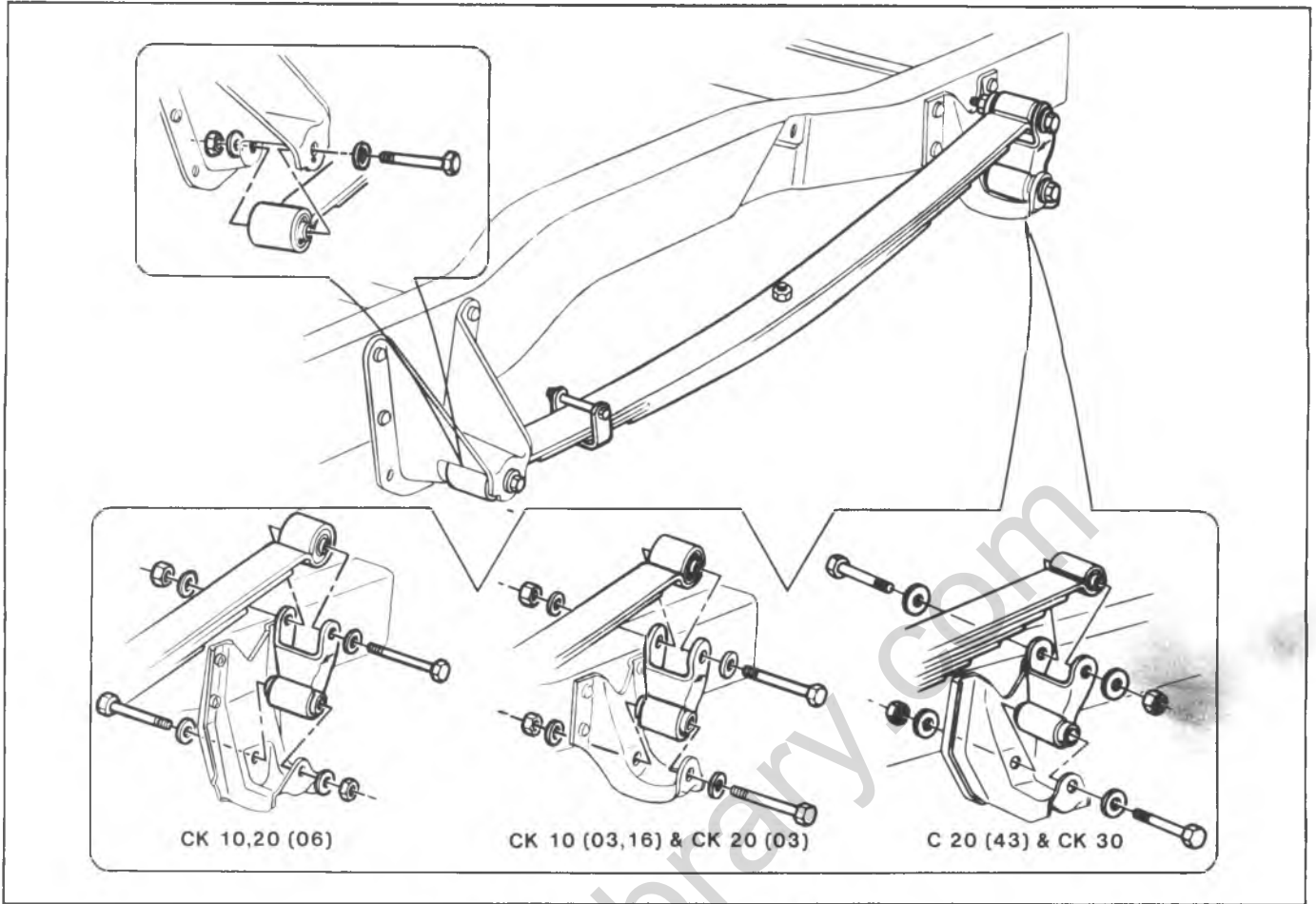


Fig. 3D-17-Rear Spring Installation-C-K Models

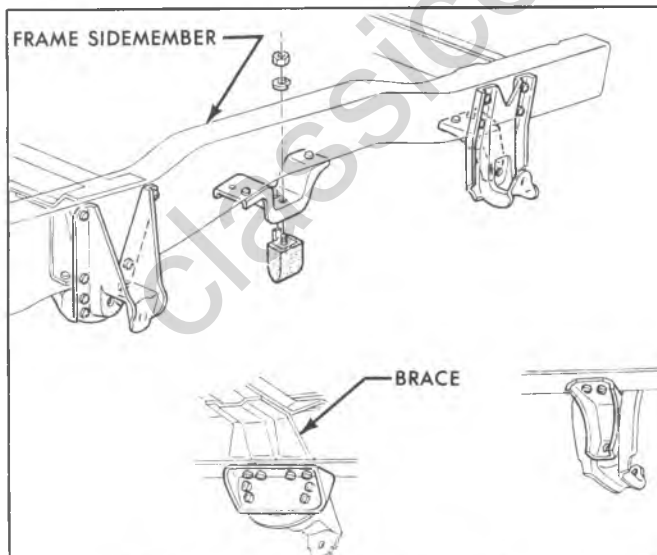


Fig. 3D-18-Rear Spring Hangers (K30)

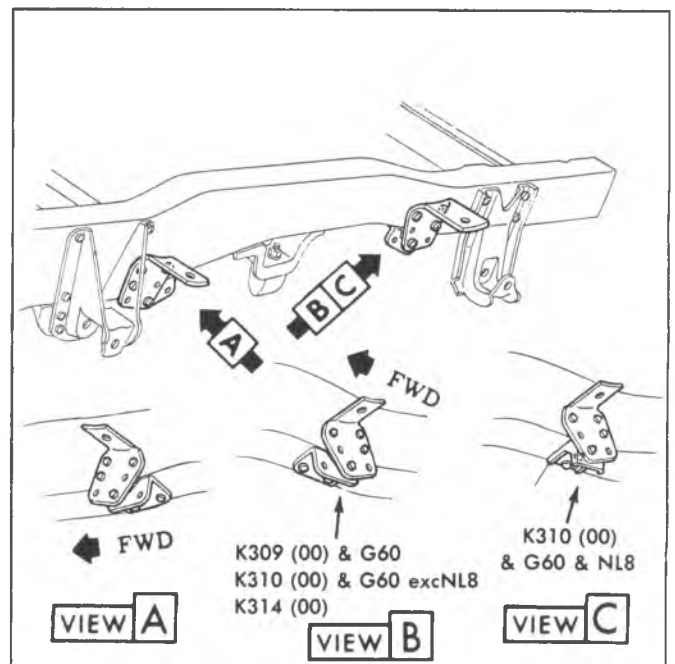


Fig. 3D-19-Auxiliary Spring Bracket (K30)

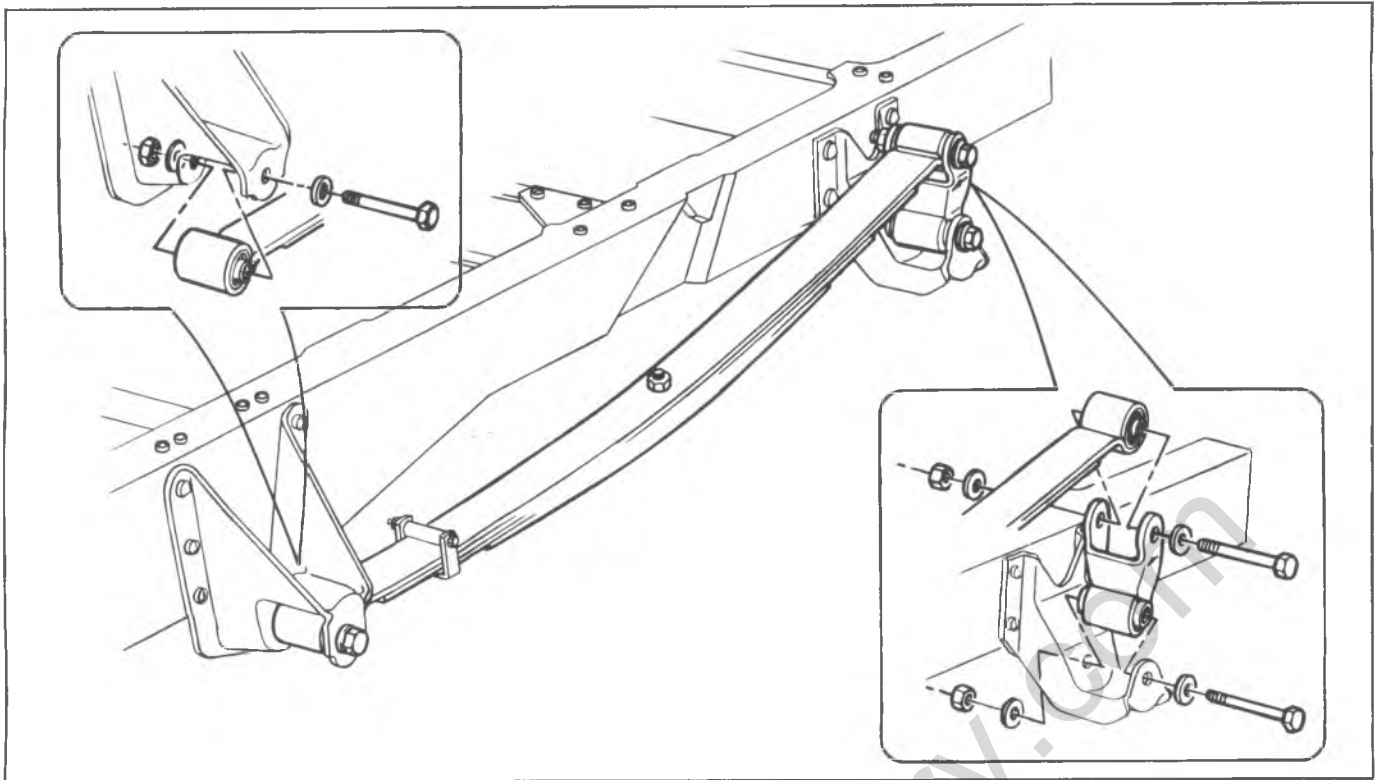


Fig. 3D-20--Rear Spring Installation-P10,20

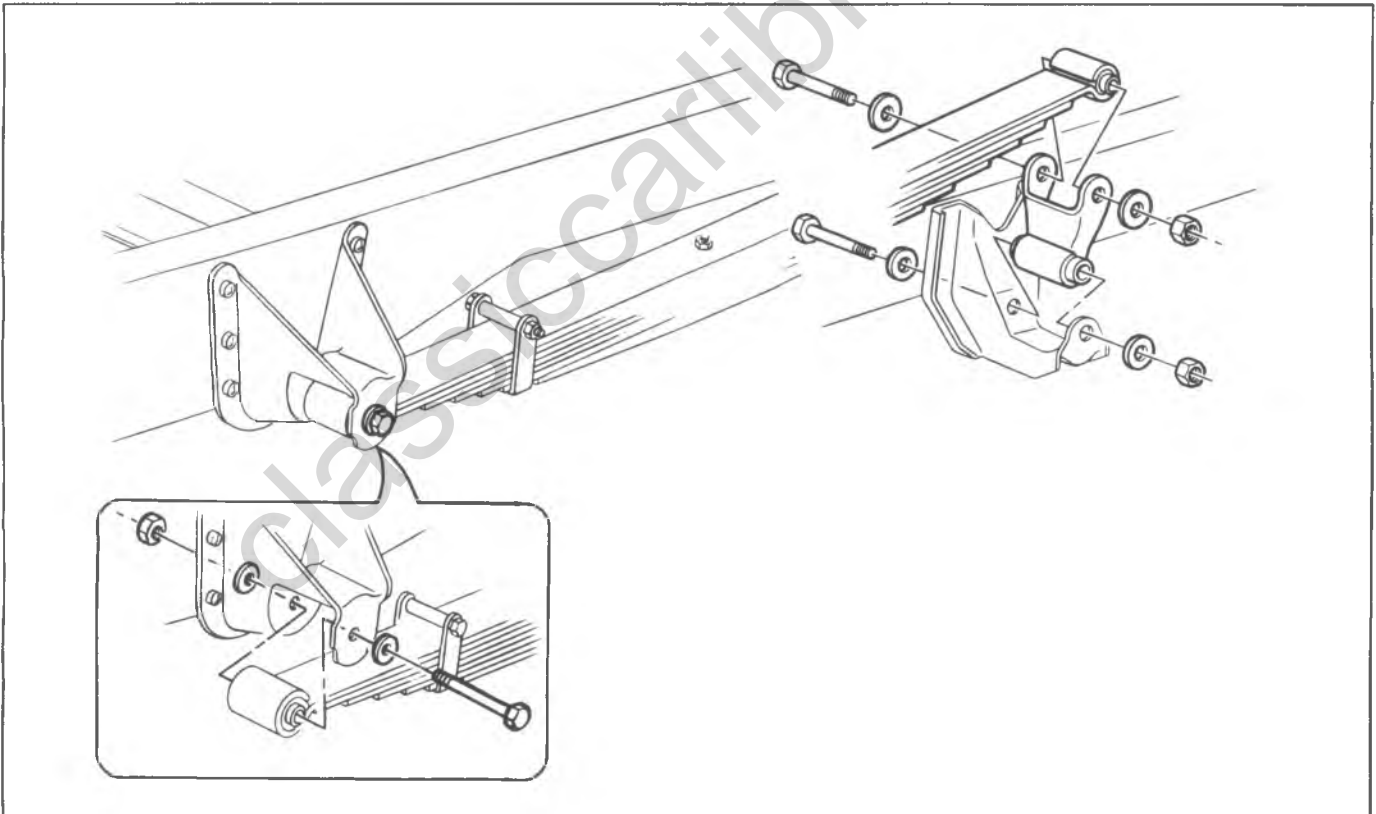


Fig. 3D-21--Rear Spring Installation-P30

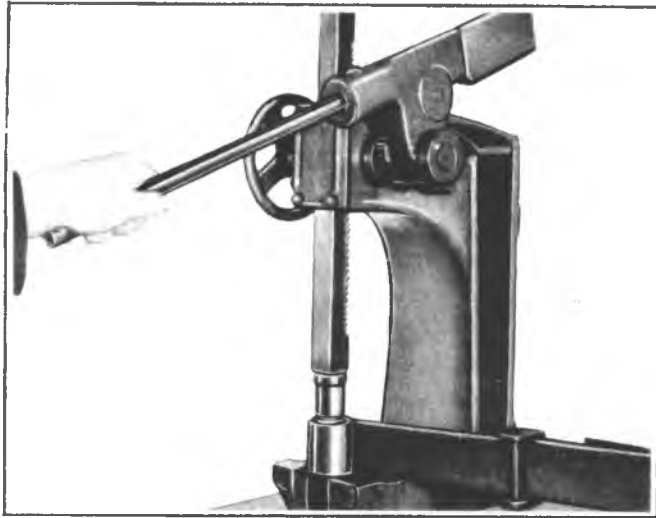


Fig. 3D-22--Pressing Out Bushing

1. Install all four nuts to uniform engagement on 'U' Bolts to retain and position anchor plate in design position (perpendicular to axis of 'U' Bolts).
2. Torque all nuts in a diagonal sequence (e.g. 1-3-2-4) to 14-35 N•m.
3. Torque all nuts to full torque using a diagonal sequence.

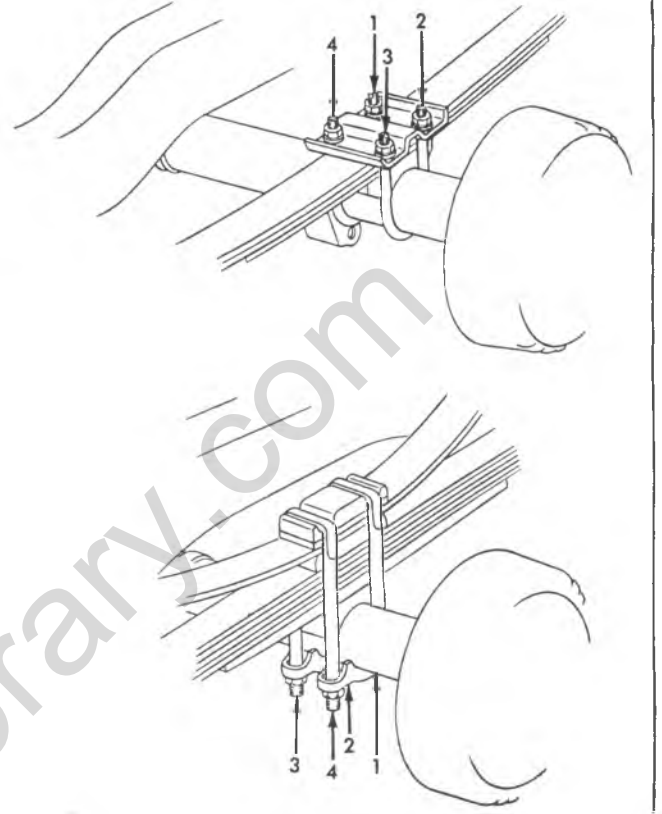


Fig. 3D-23—U-Bolt Installation

classiccarslibrary.com

SPECIFICATIONS

TORQUE SPECIFICATION

| | C-K | G | P |
|---------------------------------|-------|-------------------------------|---|
| Spring-to-Axle "U" Bolt Nuts | 140 | G10 120 G20 120 G30 150 | P10 140 P20 140 P30 170 (Exc. W/3/4" Bolt) 200 (W/3/4" Bolt) |
| Leaf Spring | | | |
| —Front Bushing Bolt | 110 | 90/135* (G316 . . .90) | 110 |
| —Rear Shackle Bolt | 110 | 90/135* (G316 . . .90) | 110 |
| Shock Absorber | | | |
| —Upper Attachment | 150 | 75 | P10 25 P20 140 P30 50 |
| —Lower Attachment | 115 | 75 | 115 |
| Propeller Shaft | | | |
| To Rear Axle (Strap) | 12-17 | 12-17 | 12-17 |
| To Rear Axle ("U" Bolt) | 18-22 | 18-22 | 18-22 |
| Bearing Support-to-Hanger | 20-30 | 20-30 | 20-30 |
| Hanger-to-Frame | 40-50 | — | — |
| Rear Stabilizer-to-Anchor Plate | 20-30 | — | 20-30 |

*90 Ft. Lbs. when tightening the nut.
135 Ft. Lbs. when tightening the bolt.

SECTION 3E

WHEELS AND TIRES

NOTICE: The Wheel bolt and nut fasteners are an important attaching part in that they could affect the performance of vital components and systems, and/or could result in major repair expense. They must be replaced with one of the same part number or with an equivalent part if replacement becomes necessary. Do not use a replacement part of lesser quality or substitute design. Torque values must be used as specified during reassembly to assure proper retention of this part.

INDEX

| | | | |
|-----------------------------------|------|-------------------------------------|------|
| General Description..... | 3E-1 | Tire Inflation Pressure..... | 3E-3 |
| Replacement Tires | 3E-1 | Correcting Irregular Tire Wear..... | 3E-4 |
| Metric Tires..... | 3E-1 | Wheel Installation..... | 3E-7 |
| Replacement Wheels..... | 3E-2 | Tire Mounting and Demounting..... | 3E-8 |
| Certification Label | 3E-2 | Tire Repair..... | 3E-9 |
| Service Operations | 3E-3 | Wheel Nut Torques | 3E-9 |
| Tire Inspection and Rotation..... | 3E-3 | | |

GENERAL DESCRIPTION

The factory installed tires and wheels are designed to operate satisfactorily with loads up to and including the full rated load capacity when inflated to the recommended inflation pressures.

Correct tire pressures and driving techniques have an important influence on tire life. Heavy cornering, excessively rapid acceleration, and unnecessary sharp braking increase tire wear.

REPLACEMENT TIRES

CAUTION: Do not mix different types of tires on the same vehicle such as radial, bias, and bias-belted tires except in emergencies, because vehicle handling may be seriously affected and may result in loss of control.

Some truck-type tires and most passenger-car-type radial tires have a TPC Spec. No. (Tire Performance Criteria Specification Number) molded into the tire sidewall near the tire size marking. This shows that the tire meets rigid size and performance standards which were developed for the vehicle. The TPC Spec. No. assures a proper combination of endurance, load capacity, handling, and traction on wet, dry and snow covered surfaces. When replacing tires with tires having the same TPC Spec. No., tires will be compatible with the vehicle. When replacing tires with those not having a TPC spec. use the same size, load range, and construction type (bias, bias-belted, or radial) as the original tires on the vehicle (see the

Certification Label Fig. 3E-3). Use of any other size or type tire may affect load carrying capacity, ride, handling, speedometer/odometer calibration, vehicle ground clearance, and tire clearance to the body and chassis. If replacing only a single tire, it should be paired on the same axle with the least worn tire of the others.

All tires on four-wheel drive vehicles must be of equal size (but not necessarily ply rating) and of same tread configuration.

Replace tires when:

1. Tires are worn to a point where 2/32 inch (1.6 millimetres) or less tread remains, or the cord or fabric is exposed. To help detect this, tires have built-in tread wear indicators (Fig. 3E-2) that appear between the tread grooves when the tread depth is 2/32 inch (1.6mm) or less. When the indicators appear in two or more adjacent grooves at three spots around the tire, the tire should be replaced.
2. Tire thread or sidewall is cracked, but, or snagged deep enough to expose the cord or fabric.
3. Tire has a bump, bulge, or split.
4. Tire sustains a puncture, cut, or other injury that can't be correctly repaired because of the size or location of the injury.

METRIC TIRES

Metric tires are available in two load ranges, Standard load and Extra load. Figure 3E-1 shows the meaning of the metric tire format. Most metric tire sizes do not have exact corresponding alpha tire sizes. For example, a P205/75R15 is not exactly equal in size and load carrying capacity to an FR78-15. For this reason, replacement tires should be of the same size, load range, and construction as those originally on the car. If metric tires must be replaced with other sizes,

**WHEEL USAGE AND TIRE LOAD LIMITS (LBS) AT VARIOUS INFLATION PRESSURES
BIAS LIGHT TRUCK (LT) TIRES**

| Wheel Code | Tire Size | Load Range | Inflation Pressures (PSI) | | | | | | | | | |
|------------------------------|-----------|------------|---------------------------|------|------|------|------|------|------|------|------|------|
| | | | 30 | 35 | 40 | 45 | 50 | 55 | 60 | 65 | 70 | 75 |
| TIRES USED AS SINGLES | | | | | | | | | | | | |
| ZJ | 9.50-16.5 | D | 1860 | 2030 | 2190 | 2350 | 2500 | 2650 | 2780 | | | |
| ZJ | 9.50-16.5 | E | 1860 | 2030 | 2190 | 2350 | 2500 | 2650 | 2780 | 2920 | 3050 | 3170 |
| TIRES USED AS DUALS | | | | | | | | | | | | |
| ZX | 7.00-16 | C | 1260 | 1365 | 1475 | 1580 | | | | | | |
| ZX | 7.50-16 | C | 1430 | 1565 | 1690 | 1815 | | | | | | |
| ZX | 7.50-16 | D | 1430 | 1565 | 1690 | 1815 | 1930 | 2040 | 2140 | | | |
| ZW | 8.75-16.5 | C | 1380 | 1515 | 1630 | 1750 | | | | | | |
| ZW | 8.75-16.5 | D | 1380 | 1515 | 1630 | 1750 | 1855 | 1970 | 2070 | | | |

WHEEL CODE AND LIMITS

| Code | Size of Wheel | Wheel Limits | | Code | Size of Wheel | Wheel Limits | |
|--------|---------------|------------------|-------------------|------|---------------|------------------|-------------------|
| | | Max. Load (Lbs.) | Max. Press. (PSI) | | | Max. Load (Lbs.) | Max. Press. (PSI) |
| CF, BU | 15 x 7 JJ | 1670 | 40 | ZK | 16.5 x 6.00 | 2350 | 70 |
| BT, CK | 15 x 8 JJ | 1910 | 40 | ZJ | 16.5 x 6.75 | 3170 | 85 |
| CH | 15 x 8 JJ | 1780 | 40 | ZF | 16 x 6½ L | 2780 | 85 |
| CB | 15 x 6 JJ | 1670 | 55 | ZH | 16.5 x 8.25 | 2750 | 70 |
| ZW | 16.5 x 6.00 | 2680 | 85 | XW | 15 x 6 JJ | 1910 | 70 |
| CB | 15 x 6 JJ | 1670 | 55 | XX | 15 x 6 JJ | 2040 | 70 |
| ZR | 16 x 5 K | 1800 | 55 | ZT | 19.5 x 6.00 | 2780 | 95 |
| CC | 15 x 6 JJ | 1670 | 55 | ZX | 16 x 6 KS | 2440 | 75 |
| ZD | 16 x 5 K | 1800 | 55 | ZW | 16.5 x 6.00 | | 85 |
| ZY | 19.5 x 6.00 | 2540 | 80 | | | | |
| BW, ZC | 15 x 8 JJ | 2030 | 40 | | | | |

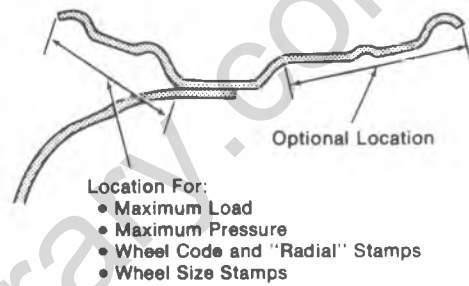


Fig. 3E-6--Tire/Wheel Load and Inflation Pressure-C Models

CORRECTING IRREGULAR TIRE WEAR

Heel and Toe Wear

This is a saw-toothed effect where one end of each tread block is worn more than the other. The end that wears is the one that first grips the road when the brakes are applied.

Heel and toe wear is less noticeable on rear tires than on front tires, because the propelling action of the rear wheels creates a force which tends to wear the opposite end of the tread blocks. The two forces, propelling and braking, make for more even wear of the rear tires, whereas only the braking forces act on the front wheels, and the saw-tooth effect is more noticeable.

A certain amount of heel and toe wear is normal. Excessive wear is usually due to high speed driving and excessive use of brakes. The best remedy, in addition to cautioning the owner on his driving habits, is to interchange tires regularly.

Side Wear

This may be caused by incorrect wheel camber, underinflation, high cambered roads or by taking corners at too high a rate of speed. The first two causes are the most common. Camber wear can be readily identified because it occurs only on one side of the treads, whereas underinflation causes wear on both sides. Camber wear requires correction of the camber first and then interchanging tires. There is, of course, no correction for high cambered roads. Cornering

wear is discussed further on.

Misalignment Wear

This is wear due to excessive toe-in or toe-out. In either case, tires will revolve with a side motion and scrape the tread rubber off. If misalignment is severe, the rubber will be scraped off of both tires; if slight, only one will be affected. The scraping action against the face of the tire causes a small feather edge of rubber to appear on one side of the tread and this feather edge is certain indication of misalignment. The remedy is readjusting toe-in, or rechecking the entire front end alignment if necessary.

Uneven Wear

Uneven or spotty wear is due to such irregularities as unequal caster or camber, bent front suspension parts, out-of-balance wheels, brake drums out of round, brakes out of adjustment or other mechanical conditions. The remedy in each case consists of locating the mechanical defect and correcting it.

Cornering Wear

When a truck makes an extremely fast turn, the weight is shifted from an even loading on all wheels to an abnormal load on the tires on the outside of the curve and a very light load on the inside tires, due to centrifugal force. This unequal loading may have two unfavorable results.

WHEEL USAGE AND TIRE LOAD LIMITS (LBS) AT VARIOUS INFLATION PRESSURES
BIAS LIGHT TRUCK (LT) TIRES

| Wheel Code | Tire Size | Load Range | Inflation Pressures (PSI) | | | | | | | | | | |
|------------|-----------|------------|---------------------------|------|------|------|------|------|------|------|------|------|--|
| | | | 30 | 35 | 40 | 45 | 50 | 55 | 60 | 65 | 70 | 75 | |
| ZJ | 9.50-16.5 | D | 1860 | 2030 | 2190 | 2350 | 2500 | 2650 | 2780 | | | | |
| ZJ | 9.50-16.5 | E | 1860 | 2030 | 2190 | 2350 | 2500 | 2650 | 2780 | 2920 | 3050 | 3170 | |

WHEEL CODE AND LIMITS

| Code | Size of Wheel | Wheel Limits | |
|--------|---------------|------------------|-------------------|
| | | Max. Load (Lbs.) | Max. Press. (PSI) |
| CF BU | 15 x 7 JJ | 1670 | 40 |
| BT, CK | 15 x 8 JJ | 1910 | 40 |
| CH | 15 x 8 JJ | 1760 | 40 |
| CB | 15 x 6 JJ | 1670 | 55 |
| ZW | 16.5 x 6.00 | 2680 | 85 |
| CB | 15 x 6 JJ | 1670 | 55 |
| CC | 15 x 6 JJ | 1670 | 55 |
| ZY | 19.5 x 6.00 | 2540 | 80 |
| BW, ZC | 15 x 8 JJ | 2030 | 40 |

| Code | Size of Wheel | Wheel Limits | |
|------|---------------|------------------|-------------------|
| | | Max. Load (Lbs.) | Max. Press. (PSI) |
| ZK | 16.5 x 6.00 | 2350 | 70 |
| ZJ | 16.5 x 6.75 | 3170 | 85 |
| BF | 16 x 6½ L | 2780 | 85 |
| XW | 15 x 6 JJ | 1910 | 70 |
| XX | 15 x 6 JJ | 2040 | 70 |
| ZT | 19.5 x 6.00 | 2780 | 95 |
| ZX | 16 x 6 KS | 2440 | 75 |

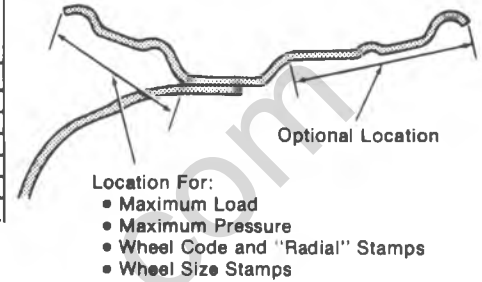


Fig. 3E-7--Tire/Wheel Load and Inflation Pressure-K Models

First, the rear tire on the inside of the curve may be relieved of so much load that it is no longer geared to the road and it slips, grinding off the tread on the inside half of the tire at an excessive rate. This type of tire shows much

the same appearance of tread wear as tire wear caused by negative camber.

WHEEL USAGE AND TIRE LOAD LIMITS AT VARIOUS INFLATION PRESSURES*
BIAS TIRES FOR LIGHT TRUCKS
USED AS SINGLES

| Wheel Code | | Tire Size | Load Range | Ply Rating | Tire Load Limits at Various Inflation Pressures (PSI) | | | | | | | | | |
|--|----------|-----------|------------|------------|---|------|------|------|------|------|------|------|------|------|
| Regular | Optional | | | | 30 | 35 | 40 | 45 | 50 | 55 | 60 | 65 | 70 | 75 |
| ZM | — | 8.75-16.5 | D | 8 | 1570 | 1720 | 1850 | 1990 | 2110 | 2240 | 2350 | 2470 | 2570 | 2680 |
| ZM | — | 8.75-16.5 | E | 10 | 1570 | 1720 | 1850 | 1990 | 2110 | 2240 | 2350 | 2470 | 2570 | 2680 |
| WIDE BASE TUBELESS TIRES USED AS DUALS | | | | | | | | | | | | | | |
| ZW | ZZ | 8.00-16.5 | C | 6 | 1195 | 1310 | 1415 | 1520 | 1620 | 1710 | 1800 | | | |
| ZW | ZZ | 8.00-16.5 | D | 8 | 1195 | 1310 | 1415 | 1520 | 1620 | 1710 | 1800 | | | |

* Wheel load limits are shown below. Vehicle loading must be limited such that neither the wheel or tire load limits are exceeded.

WHEEL CODE AND LIMITS

| Code | Size of Wheel | Wheel Limits | |
|--------|---------------|------------------|-------------------|
| | | Max. Load (Lbs.) | Max. Press. (PSI) |
| CB | 15 x 6 JJ | 1670 | 55 |
| ZW, ZZ | 16.5 x 6.00 | 2680 | 85 |
| CB | 15 x 6 JJ | 1670 | 55 |
| ZM | 16.5 x 6.75 | 2680 | 85 |
| CD | 15 x 6½ JJ | 1690 | 40 |
| XW | 15 x 6 JJ | 1910 | 70 |
| BX | 15 x 7 JJ | 1690 | 40 |
| - | 15 x 6½ JJ | 1690 | 40 |

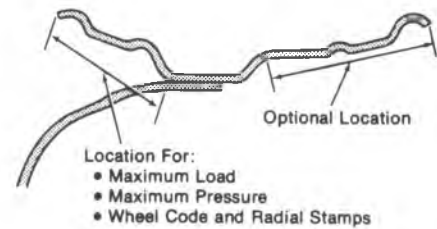
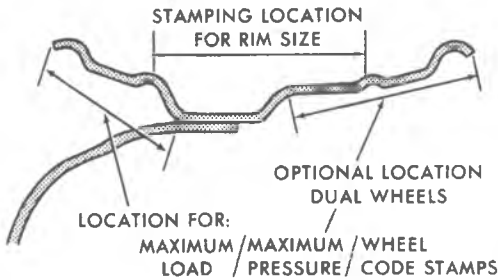


Fig. 3E-8--Tire/Wheel Load and Inflation Pressure-G Models

MINIMUM TIRE INFLATION PRESSURE AT GROSS VEHICLE WEIGHT RATING GVWR LBS.



| WHEEL CODE AND LIMITS | | | |
|-----------------------|---------------|------------------|-------------------|
| CODE | SIZE OF WHEEL | WHEEL LIMITS | |
| | | MAX. LOAD (LBS.) | MAX. PRESS. (PSI) |
| ZW, FJ | 16.5 x 6.0 | 2680 | 85 |
| ZK | 16.5 x 6.0 | 2350 | 70 |
| ZJ | 16.5 x 6.75 | 3170 | 85 |
| BF | 16 x 6.50 L | 2780 | 85 |
| ZX | 16 x 6.00 KS | 2440 | 75 |

**WHEEL USAGE AND TIRE LOAD LIMITS (LBS) AT VARIOUS INFLATION PRESSURES
PASSENGER TYPE TIRES FOR LIGHT TRUCKS**

| Wheel Code | Tire Size | Load Range | Inflation Pressure (PSI) | | | | | | | | |
|------------|-----------|------------|--------------------------|------|------|------|------|------|------|------|------|
| | | | 24 | 26 | 28 | 30 | 32 | 34 | 36 | 38 | 40 |
| XW | L78-15 | B | 1527 | 1590 | 1663 | 1727 | 1790 | 1854 | 1905 | 1972 | 2025 |
| XW | L78-15 | D | 1527 | 1590 | 1663 | 1727 | 1790 | 1854 | 1905 | 1972 | 2025 |

**TIRES USED AS SINGLES
BIAS LIGHT TRUCK (LT) TYPE TIRES**

| Wheel Code | Tire Size | Load Range | Inflation Pressures (PSI) | | | | | | | | | |
|------------|-----------|------------|---------------------------|------|------|------|------|------|------|------|------|------|
| | | | 30 | 35 | 40 | 45 | 50 | 55 | 60 | 65 | 70 | 75 |
| BF | 7.50-16LT | C | 1620 | 1770 | 1930 | 2060 | 2190 | 2310 | 2440 | 2560 | 2670 | 2780 |
| BF | 7.50-16LT | D | 1620 | 1770 | 1930 | 2060 | 2190 | 2310 | 2440 | 2560 | 2670 | 2780 |
| BF | 7.50-16LT | E | 1620 | 1770 | 1930 | 2060 | 2190 | 2310 | 2440 | 2560 | 2670 | 2780 |

| | | | | | | | | | | | | |
|----|-----------|---|------|------|------|------|------|------|------|------|------|------|
| ZK | 8.75-16.5 | C | 1570 | 1720 | 1850 | 1990 | 2110 | 2240 | 2350 | 2470 | 2570 | 2680 |
| ZK | 8.75-16.5 | D | 1570 | 1720 | 1850 | 1990 | 2110 | 2240 | 2350 | 2470 | 2570 | 2680 |
| ZJ | 8.75-16.5 | E | 1570 | 1720 | 1850 | 1990 | 2110 | 2240 | 2350 | 2470 | 2570 | 2680 |
| ZJ | 9.50-16.5 | D | 1860 | 2030 | 2190 | 2350 | 2500 | 2650 | 2780 | 2920 | 3050 | 3170 |
| ZJ | 9.50-16.5 | E | 1860 | 2030 | 2190 | 2350 | 2500 | 2650 | 2780 | 2920 | 3050 | 3170 |

BIAS TRUCK TYPE TIRES

| Wheel Code | Tire Size | Load Range | Inflation Pressures (PSI) | | | | | | | | | |
|------------|-----------|------------|---------------------------|----|----|----|------|------|------|------|------|------|
| | | | 30 | 35 | 40 | 45 | 50 | 55 | 60 | 65 | 70 | 75 |
| ZY & ZT | 8-19.5 | D-E | — | — | — | — | 2110 | 2270 | 2410 | 2540 | 2680 | 2800 |

**TIRES USED AS DUALS
BIAS LIGHT TRUCK (LT) TYPE TIRES**

| Wheel Code | Tire Size | Load Range | Inflation Pressures (PSI) | | | | | | | | | |
|------------|-----------|------------|---------------------------|------|------|------|------|------|------|----|----|----|
| | | | 30 | 35 | 40 | 45 | 50 | 55 | 60 | 65 | 70 | 75 |
| ZX | 7.50-16LT | C | 1430 | 1565 | 1690 | 1815 | 1930 | 2040 | 2140 | | | |
| ZX | 7.50-16LT | D | 1430 | 1565 | 1690 | 1815 | 1930 | 2040 | 2140 | | | |
| | 8.75-16.5 | C | 1380 | 1515 | 1630 | 1750 | 1855 | 1970 | 2070 | | | |
| | 8.75-16.5 | D | 1380 | 1515 | 1630 | 1750 | 1855 | 1970 | 2070 | | | |

BIAS TRUCK TYPE TIRES

| | | | | | | | | | | | | |
|--------|--------|---|---|---|------|------|------|------|------|------|------|----------|
| ZY, ZT | 8-19.5 | D | — | — | 1850 | 1990 | 2110 | 2230 | 2350 | 2460 | 2570 | 2680 (g) |
| ZY | 8-19.5 | E | — | — | 1850 | 1990 | 2110 | 2230 | 2350 | 2460 | 2570 | 2680 (g) |

(g) 2780 lbs. at 80 lbs. pressure.

Fig. 3E-9--Tire/Wheel Load and Inflation Pressure-P Models

Second, the transfer of weight may also overload the outside tires so much that they are laterally distorted resulting in excessive wear on the outside half of the tire, producing a type of wear like that caused by excessive positive camber.

Cornering wear can be most easily distinguished from abnormal camber wear by the rounding of the outside shoulder or edge of the tire and by the roughening of the tread surface which denotes abrasion.

Cornering wear often produces a fin or raised portion along the inside edge of each row in the tread pattern. In some cases this fin is almost as pronounced as a toe-in fin, and in others, it tapers into a row of tread blocks to such an extent that the tire has a definite "step wear" appearance.

The only remedy for cornering wear is proper instruction of operators. Driving more slowly on curves and turns will avoid grinding rubber off tires. To offset normal cornering wear as much as possible tires should be interchanged at regular intervals.

Wheel and Tire Balancing

It is desirable from the standpoints of tire wear and vehicle ride and handling ease to maintain proper balance of wheel and tire assemblies on all models. This may be accomplished by either of the two types of balancing systems in correct use which balance wheels either on the vehicle or off. The "on the vehicle" type, however, is the more desirable in that all rolling components (brake drums, bearings, seals, etc.) are included in the balancing procedure and thereby have any existing unbalance corrected.

Truck Wheel Balance Weights

All truck wheels equipped with a tubular side ring (rolled flange rim) on the outboard side of the wheel rims require special design weights to fit. Dynamic balancing can be accomplished through use of these special balance weights which are designed only for installations on the outboard side of these wheels. Conventional weights fit only the inboard side of these wheels.

Static Balance

Static balance (sometimes called still balance) is the equal distribution of weight of the wheel and tire assembly about the axis of rotation in such a manner that the assembly has no tendency to rotate by itself, regardless of its position. For example: A wheel with chunk of dirt on the rim will always rotate by itself until the heavy side is at the bottom. Any wheel with a heavy side like this is statically out of balance. Static unbalance of a wheel causes a hopping or pounding action (up and down) which frequently leads to wheel "flutter" and quite often to wheel "tramp".

Dynamic Balance

Dynamic balance (sometimes called running balance) means that the wheel must be in static balance, and also run smoothly at all speeds.

To insure successful, accurate balancing, the following precautions must be observed:

- Wheel and tire must be clean and free from all foreign matter.
- The tires should be in good condition and properly mounted with the balance mark on the tire, if any, lined up with the valve.

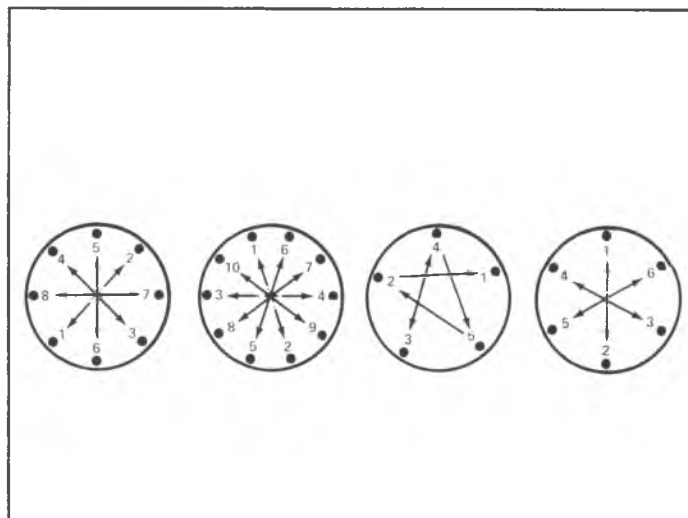


Fig. 3E-10—Wheel Nut Tightening Sequence

- Bent wheels that have runout over 1/16" should be replaced.

- Inspect tire and wheel assembly to determine if an eccentric or out-of-round condition exists. Note that this condition, if severe, cannot be "balanced out". An assembly which has an out-of-round condition exceeding 3/16" on tire sizes through 19.5" is not suitable for use on the front of the vehicle. Its use on the rear should be governed by its general condition and whether the roundness defect seriously detracts from overall ride quality.

- When balancing wheels and tires, it is recommended that the instructions covering the operation of the wheel balancer being used be closely followed.

- When balancing truck type nylon tires, tires must be hot (run for several miles) before raising vehicle to balance so that flat spot is eliminated. A tire which is flat spotted will be incorrectly balanced.

WHEEL INSTALLATION

Single Wheels

When installing the tire and wheel on the vehicle, the following procedure should be followed:

After wheel nuts are put on loosely, turn the wheel until one nut is at the top of the bolt circle; tighten the nut just snug. Snug up the remaining nuts criss-cross to minimize runout, then tighten the nuts to the recommended torque alternately and evenly to avoid excessive runout.

CAUTION: Before re-installing aluminum wheels, any build up of corrosion of the wheel mounting surface and brake drum or disc mounting surface should be removed by scraping and wire brushing. Installation of aluminum wheels without good metal-to-metal contact at the mounting surfaces can result in loosening of the wheel nuts which can eventually allow the wheel to come off while the vehicle is in motion, causing loss of control.

Dual Wheels

When installing wheels on vehicles with dual rear wheels:

1. Install inner and outer wheel and clamp ring on rear, or wheel and clamp ring on front (be sure pins on clamp ring face outboard).
2. Install and snug nuts finger tight.
3. Torque nuts to specified torque in sequence shown in Fig. 3E-12.

Lateral runout should not exceed 1/8" on front wheel or 3/16" on rear wheel.

Attachment of Dual Wheels On P300 Models

To assure secure attachment of the dual disc wheels, it is important that all dirt or rust scale be removed from the mating surface of the wheels, hub, and clamp ring as well as the stud and nut. **POWER DRIVE NUTS THEN MANUALLY INSPECT TORQUE AT 130-180 FT. LBS. MANUAL TORQUE ONLY: 150-200 FT. LB.**

Side and Lock Rings

Side and lock rings of different rim types are not interchangeable. Some may appear to be, but they do not fit properly on the rim base. Serious accidents have resulted from the use of mismatched rings. Rim base and rings must be matched according to manufacturer, size and type. This information is stamped on each part.

Inspection for Leaks

1. With wheel assembly removed from vehicle, inflate the tire to recommended operating pressure.
2. Check for leaks at rim bead by placing wheel and tire horizontal and allowing water to stand in groove between rim and tire. Check for other leaks by lowering assembly into water tank or running water over tire.

Installing Synthetic Tubes

NOTICE: When tube and flap are not properly lubricated and mounted, they will stretch thin in the tire bead and rim region. This will cause premature failure.

1. Before installing tube in tire, clean inside of casing thoroughly.
2. Insert tube in tire and inflate until it is nearly rounded out.
3. Inspect rim for rust scale and bent flanges--clean rust scale and straighten flanges where necessary.
4. Using a brush or cloth swab, apply a solution of neutral vegetable oil soap to the inside and outside of tire beads and also the the rim side of the tube. Do not allow soap solution to run down into tire.
5. When mounting tire and tube on a drop center rim, follow the standard procedure. Be sure tire is centered on rim so that beads are out of rim well before inflating. Do not allow tire to hang loosely on wheel while inflating.
6. Center valve and pull it firmly against the rim. Hold in this position and inflate until tire beads are firmly seated on rim against flanges.
7. Completely deflate tire by removing valve core.
8. Reinflate tire to recommended pressure.

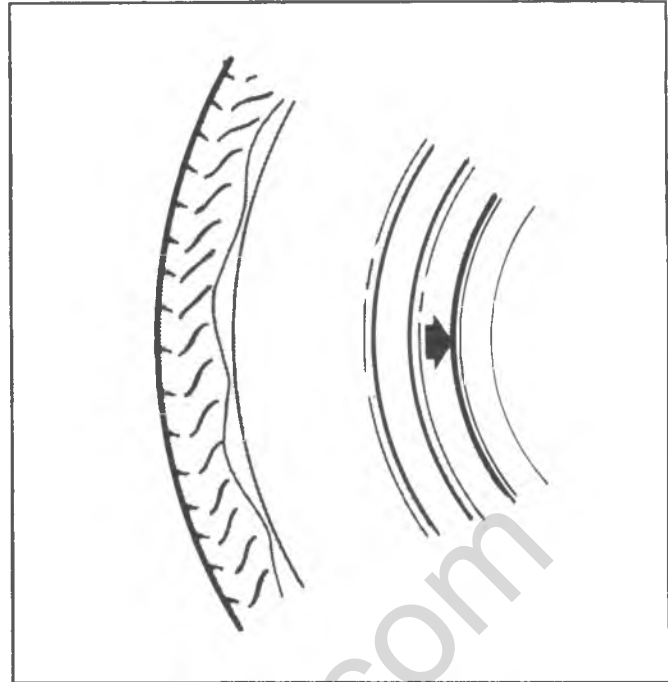


Fig. 3E-11-Tire Locating Rings

TUBELESS TIRES

Tubeless tires mounted on one piece full drop center rims are standard on some trucks. These tires have a safety inner liner which if punctured, tends to cling to the penetrating object forming a partial seal until the object is removed from the tire.

Mounting and Demounting

Use a tire changing machine to mount or demount tires. Follow the equipment manufacturer's instructions. Do not use hand tools or tire irons alone to change tire as they may damage the tire beads or wheel rim.

Rim bead seats should be cleaned with a wire brush or coarse steel wool to remove lubricants, old rubber, and light rust. Before mounting or demounting a tire, the bead area should be well lubricated with an approved tire lubricant.

After mounting, inflate to 40 psi so that beads are completely seated.

CAUTION: Do not stand over tire when inflating. Bead may break when beads snaps over safety hump and cause serious personal injury.

Do not exceed 275 kPa (40 psi) pressure when inflating. If 275 kPa (40 psi) pressure will not seat beads, deflate, re-lubricate and reinflate. Overinflation may cause the bead to break and cause serious personal injury.

Install valve core and inflate to proper pressure. Check the locating rings of the tire to be sure they show around the rim flanges on both sides (Fig. 3E-14).

RADIAL TIRES

Recommended truck tire mounting and inflation procedures are especially important with radial truck tires. Failure to follow these recommendations can cause bead deformation in both tube type and tubeless tires due to incorrect bead seating. Bead deformation may lead to chafing, lower sidewall and bead area cracking, demounting difficulties, eccentric wear, ride vibration and non-retreadable casing.

Mounting

To insure correct mounting and bead seating and to prevent bead deformation, the following steps must be taken:

A. Tube Type Tires

1. Only use rims approved for radial tire usage by rim manufacturer. Thoroughly clean rim parts, removing all rust and other foreign material. Make sure rim parts match and are not sprung or broken.

2. Thoroughly lubricate tire beads, portion of tube between beads, and flaps with an approved rubber lubricant. Radial tubes are identifiable by the letter "R" in the size designation. Example 100R20. Also, to further identify the radial tube, a red band on the valve stem has been required since March, 1975. Radial flaps are also identified by the letter "R". Example - 20R8.

NOTICE: Do not use silicone base lubricants - this could cause the tire to slip on the wheel.

3. Double inflate. Inflate to operating pressure, deflate completely and reinflate to operating pressure. This allows tube, flap and tire to fit together properly.

4. Check bead seating. Visually check slot and side ring gap (on two piece rim) to make sure bead is seated. The flange and one of the three lower sidewall rim line rings while the tire is laying flat (measurements should be taken each 90° around the circumference of the rim flange). If spacing is uneven around bead from side to side, repeat Step 1 through 3, and recheck.

B. Tubeless Tires.

1. Only use rims approved for radial tire usage by rim manufacturer. Thoroughly clean rim, removing all rust and other foreign material.

2. Thoroughly lubricate tire beads and rim bead seats with an approved rubber lubricant.

NOTICE: Do not use silicone base lubricants - this could cause the tire to slip on the wheel.

| Series | Description | Torque |
|---|---|------------------|
| K | 7/16" Bolts (6) | 70-90 Ft. Lbs. |
| C10, P10, G10, G20 | 1/2" Bolts (5) | 75-100 Ft. Lbs. |
| C20, P20 C30, P30 and K20, G30 Single Wheels | 9/16" Bolts (8) | 90-120 Ft. Lbs. |
| CKPG30 Dual Wheels | 9/16" Bolts (8) | 110-140 Ft. Lbs. |
| | Heavy Duty Wheels 5/8" Bolts (10) | 130-180 Ft. Lbs. |

Fig. 3E-12-Wheel Nut Torque

3. Inflation. Inflate tire to operating pressure. Due to the construction of radial truck tires, particularly in the lower sidewall and bead area, it may be difficult to get the tire to take air. An inflation aid may be necessary to help seat the bead of tubeless radial tires. Two types of inflation aids are commercially available, (1) metal rings which use compressed air to seat beads, and (2) rubber rings which seal between the tirebead and rim bead seat allowing the bead to move out and seat. Lubrication is mandatory with both items.

4. Check bead seating. This check is made by measuring the space between the rim flange and one of the three lower sidewall rim line rings while the tire is laying flat (measurements should be taken each 90° around the circumference of the rim flange). If spacing is uneven around the bead from side to side, repeat Steps 1 through 3, and recheck.

It's important that this procedure be followed to insure proper bead seating in order to prevent bead deformation.

Radial tires, as well as the bias tires, must be mounted and inflated in accordance with safety precautions noted in RMA Radial and Bias Truck Tire Service Manuals.

TIRE REPAIR

There are many different materials and techniques on the market to repair tires. As not all of these work on all types of tires, tire manufacturers have published detailed instructions on how and when to repair tires. These instructions can be obtained from the tire manufacturer.

classiccarylbrary.com

SECTION 4A

PROPELLER SHAFT

The following notice applies to one or more steps in the assembly procedure of components in this portion of the manual as indicated at appropriate locations by the terminology "See Notice on page 1 of this Section".

NOTICE: This fastener is an important attaching part in that it could affect the performance of vital components and systems, and/or could result in major repair expense. It must be replaced with one of the same part number or with an equivalent part if replacement becomes necessary. Do not use a replacement part of lesser quality or substitute design. Torque values must be used as specified during reassembly to assure proper retention of this part.

CONTENTS

| | |
|--------------------------|------|
| General Description..... | 4A-1 |
| Universal Joints..... | 4A-1 |
| Propeller Shaft..... | 4A-2 |
| Diagnosis..... | 4A-3 |
| On Car Service..... | 4A-5 |

GENERAL DESCRIPTION

Universal Joints

The simple universal joint is basically two Y-shaped yokes connected by a crossmember called a spider. The spider is shaped like an X and arms that extend from it are called trunnions. See figure 4A-1.

The spider allows the two yoke shafts to operate at an angle to each other. When torque is transmitted at an angle, through this type of joint, the driving yoke rotates at a

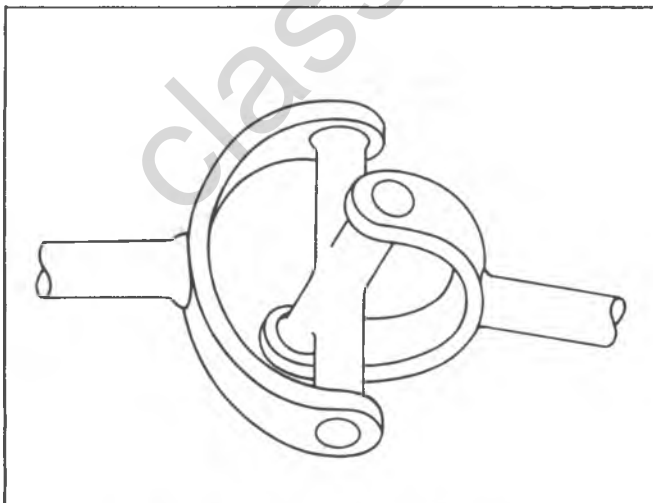


Fig. 4A-1-Simple Universal Joint

constant speed while the driven yoke speeds up and slows down twice per revolution. This changing of velocity (acceleration) of the driven yoke increases as the angle between the two yoke shafts increases. This is the prime reason why single universal joints are not used for angles greater than three to four degrees. At four degrees, for example the change of velocity is .5%. At ten degrees it is 3%. If the universal joint were set at 30 degrees and the driving yoke were turning at 1000 RPM the velocity of the driven yoke would change from 856 RPM to 1155 RPM in one quarter of a revolution. In the remaining quarter revolution the velocity would change from 1155 RPM to 866 RPM.

On a one-piece drive shaft this problem can be eliminated by arranging two simple universal joints so that the two driving yokes are rotated 90 degrees to each other. However the angle between the drive and driven yokes must be very nearly the same on both joints for this to work. Refer to figure 4A-2. This allows the alternate acceleration and deceleration of one joint to be offset by the alternate deceleration and acceleration of the second joint. When the two joints do not run at approximately the same angle, operation can be rough and an objectionable vibration can be produced.

Universal joints are designed to consider the effects of various loadings and rear axle windup, during acceleration. Within the design angle variations the universal joints will operate safely and efficiently. However, when the design angles are exceeded the operational life of the joints may

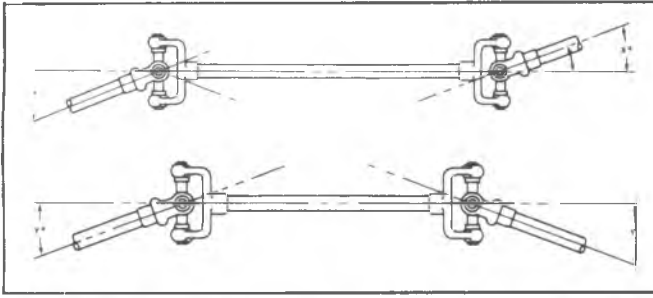


Fig. 4A-2--Universal Joints Arranged for Constant Velocity

decrease.

The bearings used in universal joints are the needle roller type. The needle rollers are held in place on the trunnion by round bearing cups. The bearing cups are held in the yoke by either (depending on the manufacturer) snap rings or plastic injection. These joints usually are lubricated for life and cannot be lubricated while on the vehicle.

Constant Velocity Joint--Double Cardan Joint

As mentioned previously, the simple universal joint will operate efficiently through small angles only. Also, two simple universal joints phased properly and operating through the same angle will transmit constant velocity. When a large angle is encountered in a driveline, a simple universal joint will introduce two vibrations in each revolution. It is in this situation that a constant velocity joint is used.

Essentially, the constant velocity joint is two simple universal joints closely coupled by a coupling yoke, phased properly for constant velocity.

A centering ball socket between the joints maintains the relative position of the two units. This centering device causes each of the two units to operate through one-half of the complete angle between the drive shaft and differential carrier. See figure 4A-3.

The ball/socket on this Constant Velocity joint requires periodic lubrication. A lubrication fitting is provided for this purpose, and is illustrated later in this section.

Propeller Shafts

The propeller shaft is a steel tube which is used to transmit power from the transmission output shaft to the differential. To accommodate various model, wheelbase and transmission combinations, drive shafts differ in length,

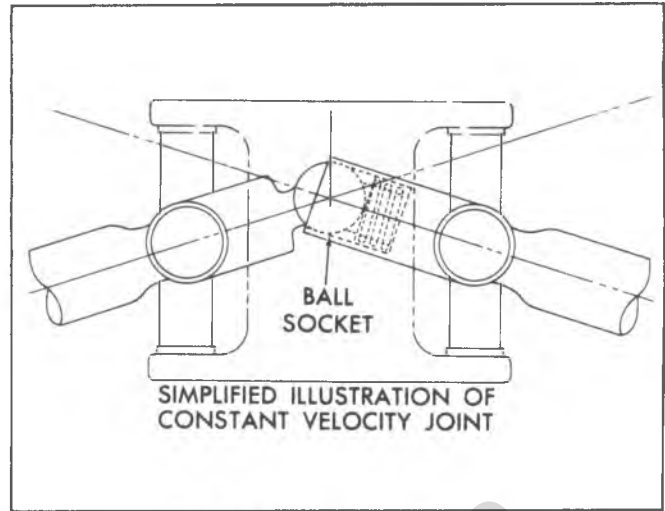


Fig. 4A-3--Ball-Socket Location

diameter and the type of splined yoke. Each shaft is installed in the same manner. A universal joint and splined slip yoke are located at the transmission end of the shaft, where they are held in alignment by a bushing in the transmission rear extension. The slip yoke permits fore and aft movement of the drive shaft as the differential assembly moves up and down. The spline is lubricated internally by transmission lubricant or grease. An oil seal at the transmission prevents leakage and protects the slip yoke from dust, dirt and other harmful material.

Since the drive shaft is a balanced unit, it should be kept completely free of undercoating and other foreign material which would upset shaft balance.

Both one piece and two piece propeller shafts are used depending on the model. All are tubular and use needle bearing type universal joints.

On models that use a two piece shaft, the shaft is supported near its splined end in a rubber cushioned ball bearing which is mounted in a bracket attached to a frame crossmember. The ball bearing is permanently lubricated and sealed.

Four wheel drive models use a front propeller shaft incorporating a constant velocity joint.

PROPELLER SHAFT AND UNIVERSAL JOINT DIAGNOSIS

Checking and Correcting

Propeller Shaft Unbalance

1. Place vehicle on a twin post hoist so that the rear wheels are free to rotate.

2. Remove both rear tire and wheel assemblies and brake drums.

Use care not to apply brakes with drums removed.

3. Visually inspect propshaft, U-Joints and attachments for mud undercoating or other discrepancies. Make necessary corrections prior to running.

4. With vehicle running in gear at the indicated speed where disturbance is at its peak, observe the intensity of the disturbance.

5. Stop engine and disconnect drive shaft from companion flange. Reinstall shaft by rotating it 180° from its original position. Determine which position of the companion flange gives the best balance.

6. Install rear drums and wheels, and road test vehicle for final check of balance. If balance is still unacceptable, replace drive shaft.

DIAGNOSTIC CHART

| COMPLAINT | POSSIBLE CAUSE | CORRECTION |
|--|---|--|
| Leak at front slip yoke. NOTE: An occasional drop of lubricant leaking from splined yoke is normal and requires no attention. | a. Rough outside surface on splined yoke. b. Defective transmission rear oil seal. | a. Replace seal if cut by burrs on yoke. Minor burrs can be smoothed by careful use of crocus cloth or honing with a fine stone. Replace yoke if outside surface is rough or burred badly. b. Replace transmission rear oil seal. c. Bring transmission oil up to proper level after correction. |
| Knock in drive line, clunking noise when car is operated under floating condition at 10 mph in high gear or neutral. | a. Worn or damaged universal joints. b. Side gear hub counterbore in differential worn oversize. | a. Disassemble universal joints, inspect and replace worn or damaged parts. b. Replace differential case and/or side gears as required. |
| Ping, Snap or Click in drive line. NOTE: Usually occurs on initial load application after transmission has been put into gear, either forward or reverse. | a. Loose upper or lower control arm bushing bolts. b. Loose companion flange. | a. Tighten bolts to specified torque. b. Remove companion flange, turn 180° from its original position, apply white lead to splines and reinstall. Tighten pinion nut to specified torque. |

Fig. 4A-4-Diagnosis Chart A

4A-4 PROPELLER SHAFT

| COMPLAINT | POSSIBLE CAUSE | CORRECTION |
|---|--|---|
| <p>Roughness, Vibration or Body Boom at any speed.</p> <div style="border: 1px solid black; padding: 5px; margin-top: 10px;"> <p>NOTE: With tachometer installed in car, determine whether propeller shaft is cause of complaint by driving through speed range and note the engine speed (rpm) at which vibration (roughness) is most pronounced. Then, shift transmission to a different gear range and drive car at same engine speed (rpm) at which vibration was noted before. Note the effect on the vibration.</p> <p>If vibration occurs at the same engine speed (rpm), regardless of transmission gear range selected, drive shaft assembly is <u>not</u> at fault, since the shaft speed (rpm) varies.</p> <p>If vibration decreased, or is eliminated, in a different gear range but at the same engine speed (rpm), check the possible causes:</p> </div> | <ul style="list-style-type: none"> a. Bent or dented drive shaft. b. Undercoating on drive shaft. c. Tire unbalance. (30-80 mph, not throttle conscious) d. Excessive U-bolt torque. e. Tight universal joints. f. Worn universal joints. g. Burrs or gouges on companion flange. Check snap ring locating surfaces on flange yoke. h. Drive shaft or companion flange unbalance. i. Excessive looseness at slip yoke spline. j. Drive shaft runout (50-80 mph throttle conscious) | <ul style="list-style-type: none"> a. Replace. b. Clean drive shaft. c. Balance or replace as required. d. Check and correct to specified torque. e. Impact yokes with a hammer to free up. Overhaul joint if unable to free up or if joint feels rough when rotated by hand. f. Overhaul, replacing necessary parts. g. Rework or replace companion flange. h. Check for missing balance weights on drive shaft. Remove and reassemble drive shaft to companion flange, 180° from original position. i. Replace necessary parts. j. Check drive shaft runout at front and rear. Should be less than specified. If above, rotate shaft 180° and recheck. If still above specified, replace shaft. |
| <p>Roughness usually at low speeds, light load, 15-35 mph.</p> | <ul style="list-style-type: none"> a. U-bolt clamp nuts excessively tight. | <ul style="list-style-type: none"> a. Check and correct torque to that specified. If torque was excessive or if brenelled pattern on trunnions is evident, replace joints. |
| <p>Scraping noise.</p> | <ul style="list-style-type: none"> a. Slinger, companion flange, or end yoke rubbing on rear axle carrier. | <ul style="list-style-type: none"> a. Straighten slinger to remove interference. |
| <p>Roughness on heavy acceleration (short duration.)</p> | <ul style="list-style-type: none"> a. Double cardan joint ball seats worn. Ball seat spring may be broken. | <ul style="list-style-type: none"> a. Replace joint and shaft assembly. |
| <p>Roughness -- above 35 mph felt and/or heard.</p> | <ul style="list-style-type: none"> a. Tires unbalanced or worn. | <ul style="list-style-type: none"> a. Balance or replace as required. |

Fig. 4A-5—Diagnosis Chart B

UNIT REPAIR

PROPELLER SHAFT

The rear universal joint to propshaft bolt on some CK 1 ton dual wheel models requires a #10 "Six Lobed Socket" (J-25085), for proper removal and installation. 34 N·m, (Torque to 25 lbs. ft.).

Removal

1. Raise vehicle on hoist. Mark relationship of shaft to companion flange and disconnect the rear universal joint by removing trunnion bearing "U" bolts or straps. Tape bearing cups to trunnion to prevent dropping and loss of bearing rollers.

2. For models with two-piece shafts remove bolts retaining bearing support to hanger.

3. Slide propeller shaft forward disengaging trunnion from axle flange, then slide assembly rearward disengaging from transmission.

For models using strap or U-bolt attachments to transmission or transfer case use same removal procedure as above.

Universal Joints

On models with between center slip propshaft it is important that components are marked prior to disassembly for proper phasing. Arrows are stamped on assemblies as shown in Fig. 4A-7.

The universal joints are of the extended-life design and do not require periodic inspection or lubrication; however, when these joints are disassembled, repack bearings and lubricate reservoir at end of trunnions with high-melting point wheel bearing lubricant. Use care not to damage or dislodge seals from trunnion.

Snap Ring Type

Disassembly

1. Remove bearing lock rings from trunnion yoke.
2. Support trunnion yoke on a piece of 31.75 mm (1-1/4") I.D. pipe on an arbor bed.

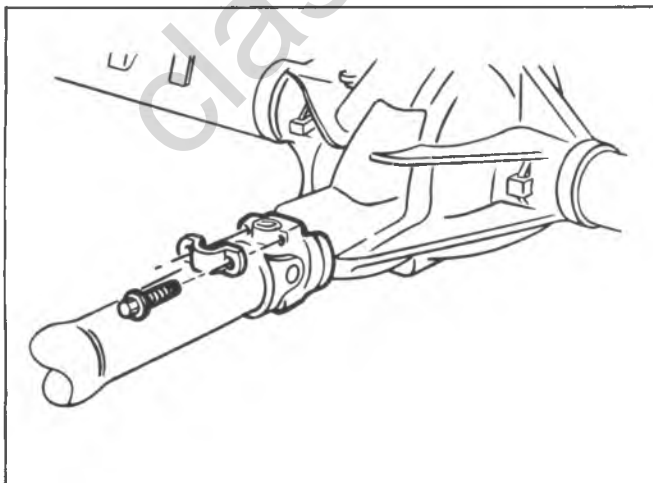


Fig. 4A-6--Strap Attachment

Due to length of the propeller shaft it may be more convenient to use a bench vise, for removal and installation, instead of an arbor press. In this case, proceed with disassembly and assembly procedure as with an arbor press Fig. 4A-8 and 4A-9.

3. Using a suitable socket or rod, press on trunnion until bearing cup is almost out. Grasp cup in vise and work cup out of yoke. See figures 4A-8 and 4A-9. The bearing cup cannot be fully pressed out.

4. Press trunnion in opposite direction and remove other cup as in Step 3.

5. Clean and inspect dust seals, bearing rollers, and trunnion. Relubricate bearings as indicated in Section 0.

In addition to packing the bearings, make sure that the lubricant reservoir at the end of each trunnion is completely filled with lubricant. In filling these reservoirs, pack lubricant into the hole so as to fill from the bottom (use of squeeze bottle is recommended). This will prevent air pockets and ensure an adequate supply of lubricant.

Reassembly Fig. 4A-10

1. Position trunnion into yoke. Partially install one bearing cup into yoke. Start trunnion into bearing cup. Partially install other cup. Align trunnion into cup, and press cups into yoke.

2. Install lock rings.

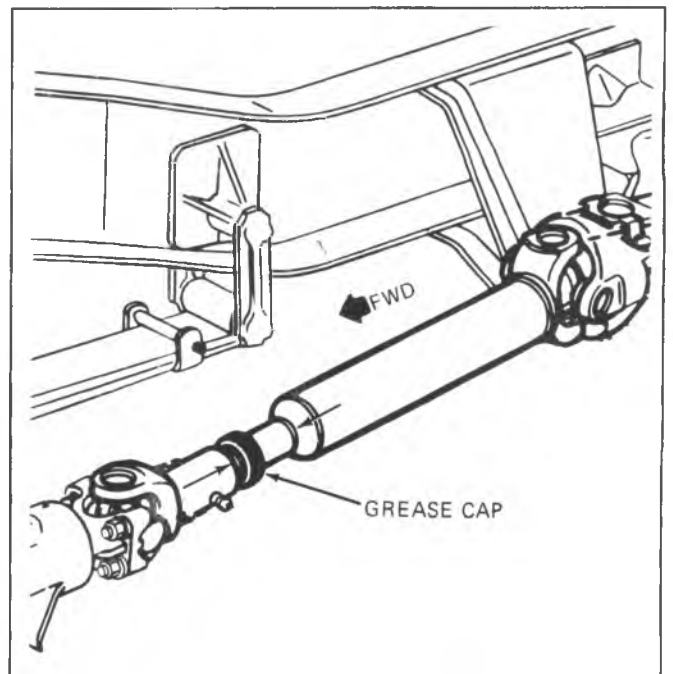


Fig. 4A-7--Proper Alignment

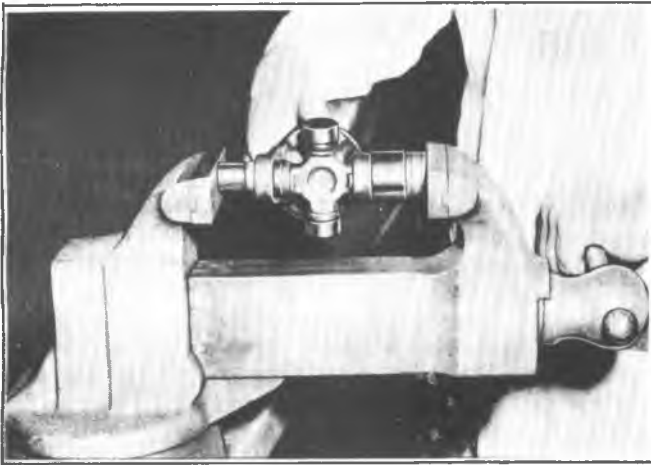


Fig. 4A-8--Bearing Cup Removal with Vise

Injected Plastic Type

Disassembly

NOTICE: Never clamp drive shaft tubing in a vise as the tube may be dented. Always clamp on one of the yokes, and support the shaft horizontally. Avoid damaging the slip yoke sealing surface. Nicks may damage the bushing or cut the seal lip.

1. Support the drive shaft in a horizontal position in line with the base plate of a press. Place the universal joint so that the lower ear of the shaft yoke is supported on a 28.57 mm (1-1/8") socket. Place the cross press, J-9522-3, on the open horizontal bearing cups, and press the lower bearing cup out of the yoke ear as shown in figure 4A-11. This will shear the plastic retaining the lower bearing cup.

2. If the bearing cup is not completely removed, lift the cross and insert Spacer J-9522-5 between the seal and bearing cup being removed, as shown in figure 4A-12.

Complete the removal of the bearing cup, by pressing it out of the yoke.

3. Rotate the drive shaft, shear the opposite plastic retainer, and press the opposite bearing cup out of the yoke as before, using Spacer J-9522.

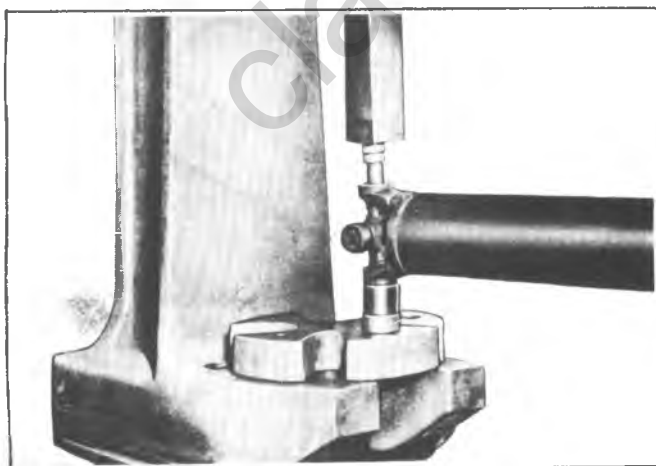


Fig. 4A-9--Bearing Cup Removal with Press

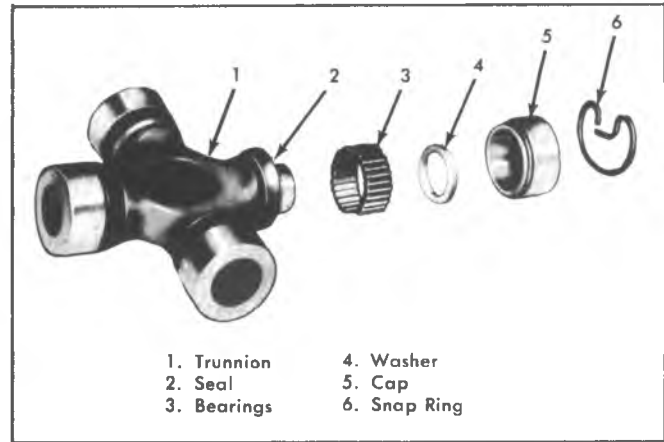


Fig. 4A-10--Universal Joint Repair Kit

4. Disengage cross from yoke and remove. Production universal joints cannot be reassembled. There are no bearing retainer grooves in production bearing cups. Discard all universal joint parts removed.

5. Remove the remains of the sheared plastic bearing retainer from the ears of the yoke. This will aid in reassembly of the service joint bearing cups. It usually is easier to remove plastic if a small pin or punch is first driven through the injection holes.

6. If the front universal joint is being serviced, remove the pair of bearing cups from the slip yoke in the same manner.

Reassembly

A universal joint service kit is used when reassembling this joint. See figure 4A-13. This kit includes one pregreased cross assembly, four service bearing cup assemblies with seals, needle rollers, washers, grease and four bearing retainers.

Make sure that the seals are in place on the service bearing cups to hold the needle rollers in place for handling.

1. Remove all of the remains of the sheared plastic bearing retainers from the grooves in the yokes. The sheared plastic may prevent the bearing cups from being pressed into place, and this prevent the bearing retainers from being

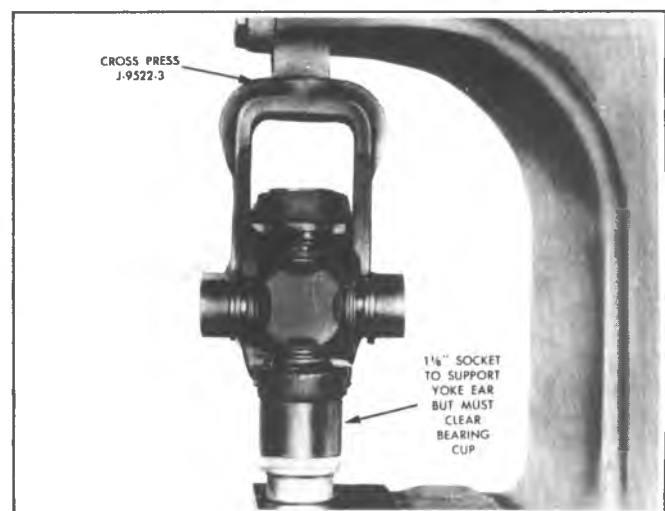


Fig. 4A-11--Pressing Out Bearing Cup



Fig. 4A-12--Using Spacer to Remove Bearing Cup



Fig. 4A-14--Installing Trunnion into Yoke

properly seated.

2. Install one bearing cup part way into one side of the yoke, and turn this yoke ear to the bottom.

3. Insert cross into yoke so that the trunnion seats freely into bearing cup as shown in figure 4A-14.

4. Install opposite bearing cup part way. Make sure that both trunnions are started straight and true into both bearing cups.

5. Press against opposite bearing cups, working the cross all of the time to check for free movement of the trunnions in the bearings. If there seems to be a hang-up, stop pressing and recheck needle rollers, to determine if one or more of them has been tipped under the end of the trunnion.

6. As soon as one bearing retainer groove clears the inside of the yoke, stop pressing and snap the bearing retainer into place as shown in figure 4A-15.

7. Continue to press until the opposite bearing retainer can be snapped into place. If difficulty is encountered, strike the yoke firmly with a hammer to aid in seating bearing retainers. This springs the yoke ears slightly. See figure 4A-16.

8. Assemble the other half of the universal joint in the same manner.

9. Check the freedom of rotation of both sets of trunnions of the cross. If too tight, again rap the yoke ears as described above. This will loosen the bearings and help seat the bearing retainers.

CENTER SUPPORT BEARING-FIG. 4A-17

NOTICE: See NOTICE on page 1 of this section regarding Center Support Bearing fasteners.

1. Remove strap retaining rubber cushion from bearing support.

2. Pull support bracket from rubber cushion and pull cushion from bearing.

3. Pull bearing assembly from shaft.

4. Assemble bearing support as follows:

a. Install inner deflector on propeller shaft, if removed, and prick punch deflector at two opposite points to make sure it is tight on shaft (Dana Style).

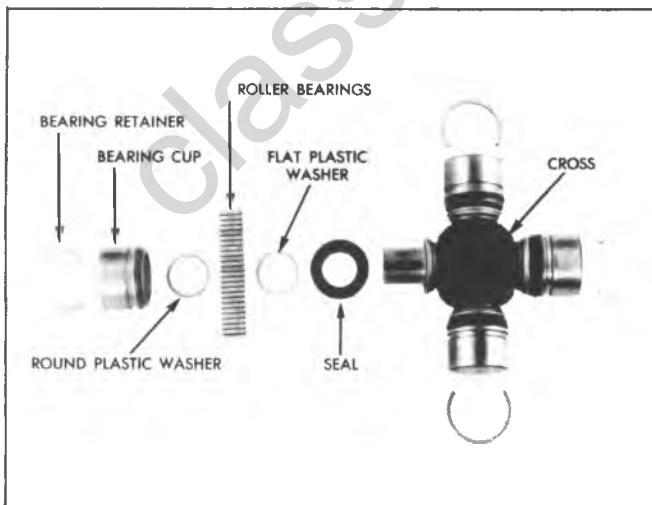


Fig. 4A-13--Repair Kit

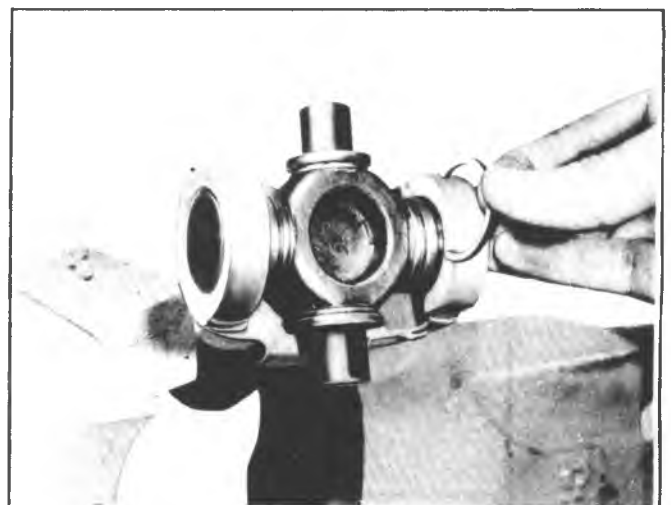


Fig. 4A-15--Installing Snap Ring to Retain Trunnion

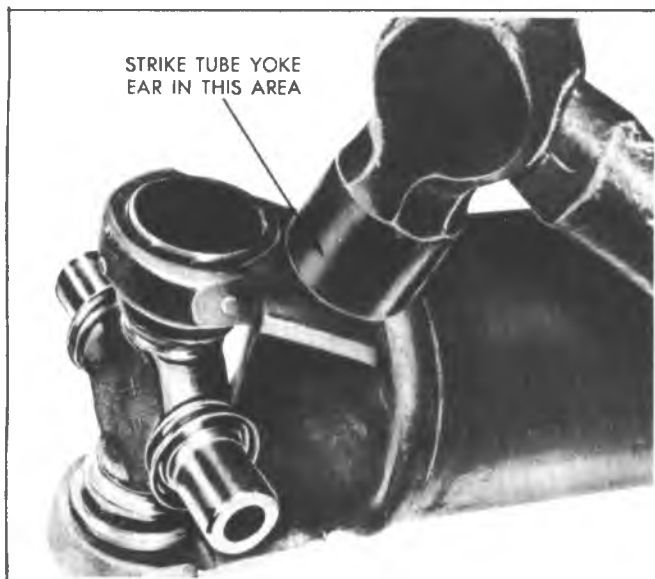


Fig. 4A-16--Seating Snap Rings

- b. Fill space between inner dust shield and bearing with lithium soap grease (Dana Style).
- c. Start bearing and slinger assembly straight on shaft journal. Support propeller shaft and, using suitable length of pipe over splined end of shaft, press bearing and inner slinger against shoulder on shaft.
- d. Install dust shield over shaft, small diameter (Dana Style). Install bearing retainer (GM Style).
- e. Install rubber cushion onto bearing.
- f. Install bracket onto cushion.
- g. Install retaining strap.

Installation of Propshafts

NOTICE: When reinstalling propshafts, it is necessary to place the shafts into particular positions to assure proper operation. This is called phasing.

All models with 32 splines use an alignment key, as shown in figure 4A-18, to obtain proper phasing. The shafts can mate only in the correct position.

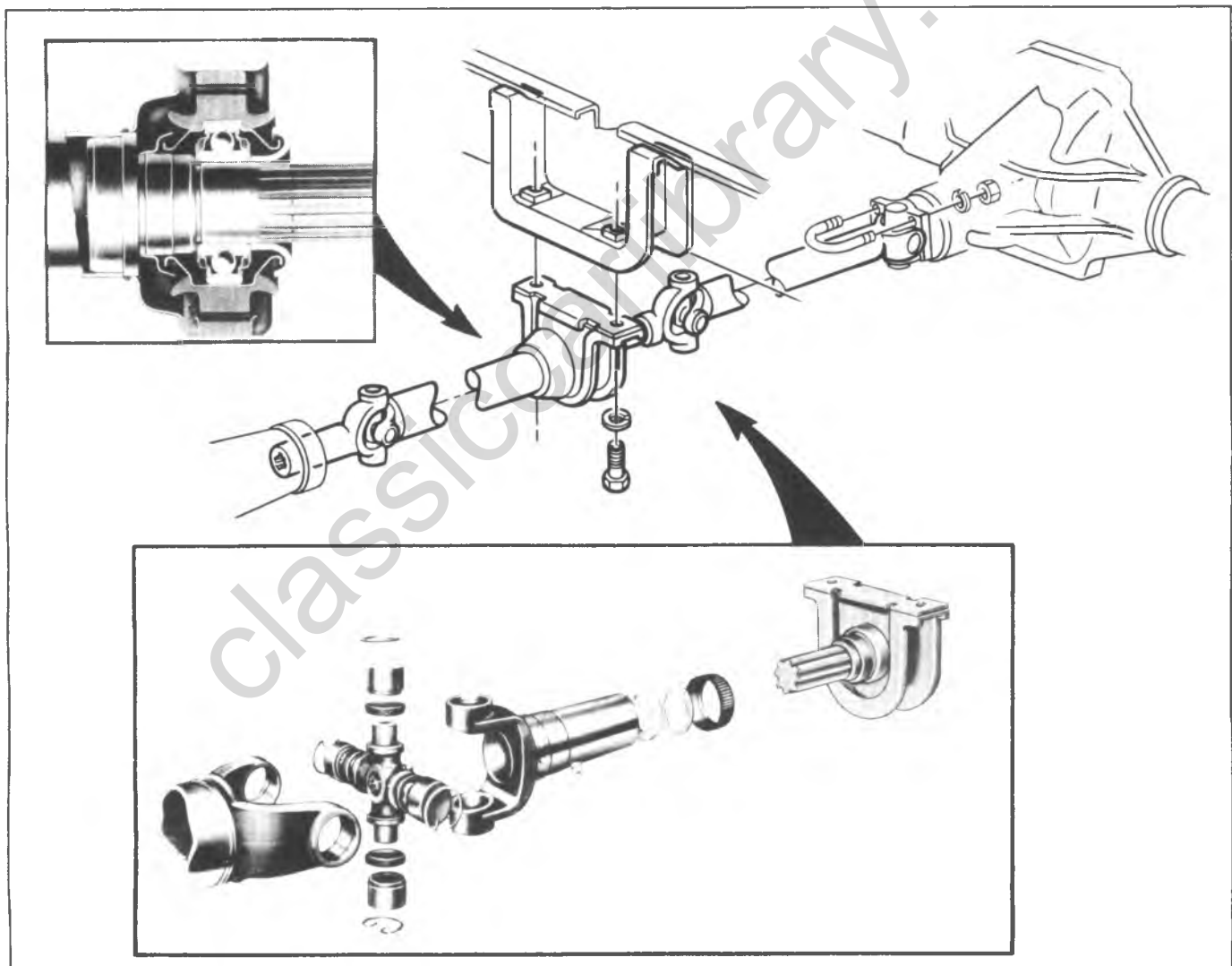


Fig. 4A-17--Propeller Shaft, Universal Joint and Bearing Support

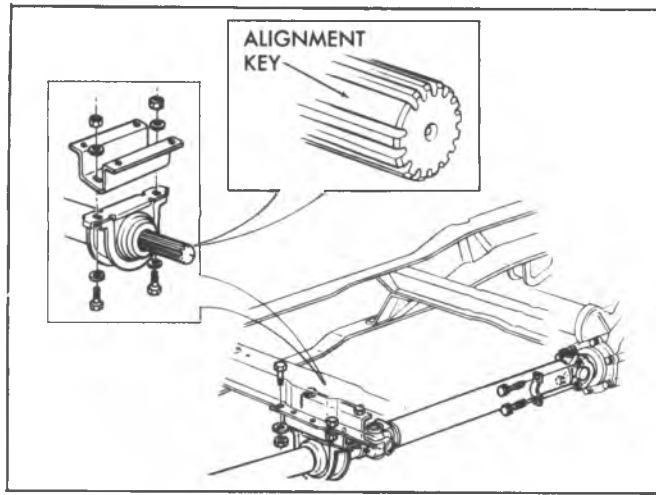


Fig. 4A-18--Alignment Key

G and K models with 16 splines must be phased as shown in figure 4A-19.

1. For models with one piece propeller shafts, slide shaft into transmission and attach rear U-joint to axle.

On vehicles with two piece propshafts, the front propshaft yoke must be bottomed out in the transmission fully forward before installation to the hanger .

2. For C-P models with two-piece propeller shafts, proper phasing is accomplished with the alignment key, shown in figure 4A-18.

3. For G-K models with two piece shafts, install front half into transmission and bolt support to crossmember.

a. Slide grease cap and gasket onto rear splines.

b. Rotate shaft so front U-joint trunnion is in correct position. See figure 4A-19.

c. Take rear propeller shaft and before installing, align U-joint trunnions as shown in figure 4A-19. Attach rear U-joint to axle. Tighten grease cap.

d. Torque bearing support to crossmember and U-joint to axle attachments.

CONSTANT VELOCITY UNIVERSAL JOINT (Snap Ring Type) RETENTION

Disassembly

1. Remove auxiliary front propeller shaft from vehicle.

2. Remove rear trunnion snap rings from center yoke. Remove grease fitting.

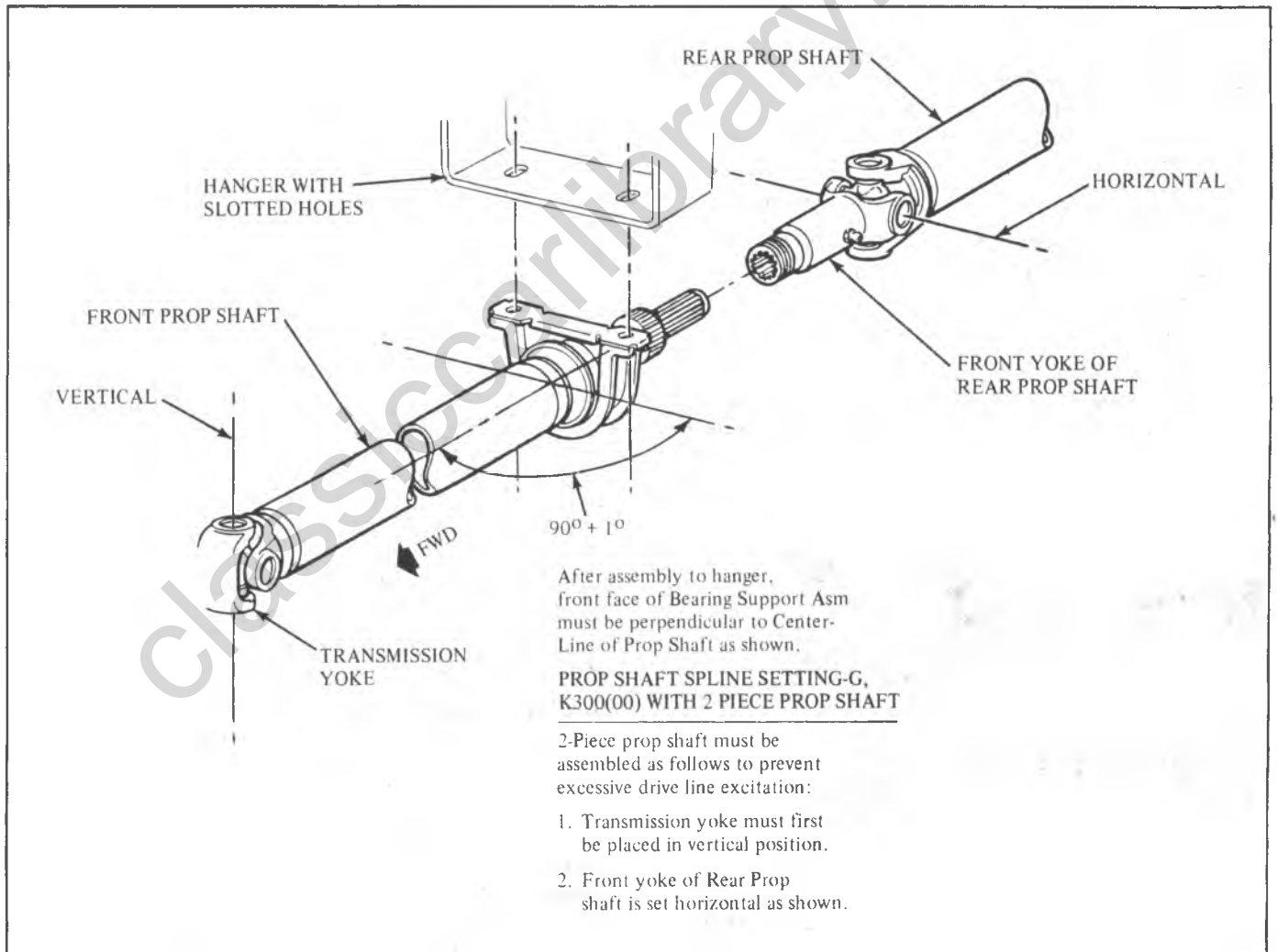


Fig. 4A-19--Alignment for Phasing

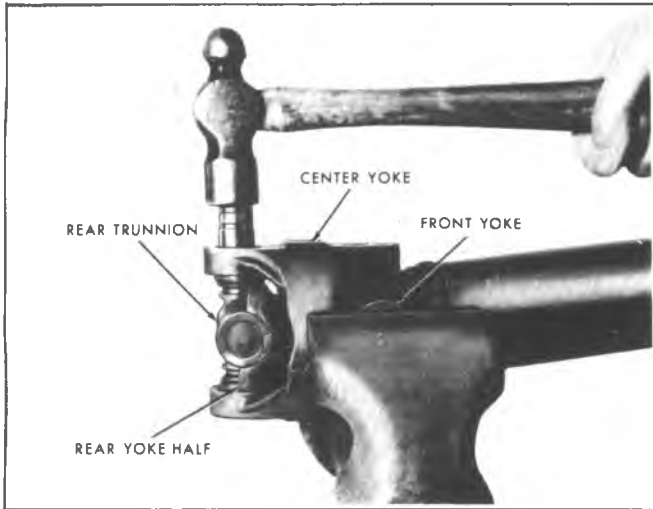


Fig. 4A-20--Driving Out Bearing Cups

3. Place propeller shaft in vice as shown in figure 4A-20. Drive one rear trunnion bearing cap from center yoke as shown in figure 4A-20 until it protrudes approximately 9.52 mm (3/8").

Keep rear portion of propeller shaft up to avoid interference of rear yoke half with center yoke.

4. Once the bearing cup protrudes 9.52 mm (3/8"), release vice. Grasp protruding portion of cup in vice and strike center yoke as shown in Figure 4A-21 until cup is removed. Remove cup seal by prying off with a thin screwdriver.

5. Repeat steps 3 and 4 for remaining bearing cup.

6. Once the center yoke cups have been removed, remove rear yoke half bearing cups. Remove rear trunnion.

7. Gently pull rear yoke half from prop shaft. Remove all loose needle bearings. Remove spring seal.

8. Remove front trunnion from center and front yoke in same manner as described in Steps 2, 3 and 4. Before front trunnion can be removed all four (4) bearing caps must be removed.

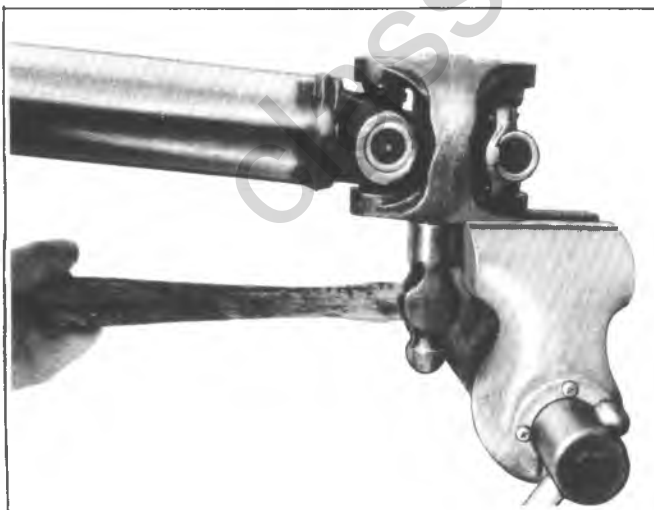


Fig. 4A-21--Bearing Cup Removal

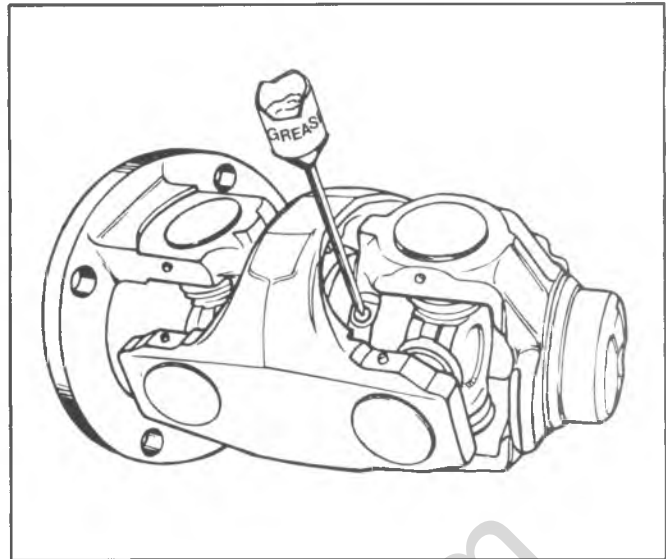


Fig. 4A-22--Lubrication Fitting

Assembly

1. Clean and inspect all needle bearings, cups, seals, fittings, trunnions and yokes. Assemble all needle bearings in caps (27 per cap); assemble needle bearings in front yoke (28 total). Retain bearings with a heavy grease. Assemble seals to bearing cups. If seals are damaged U-joint should be replaced.

2. Place front trunnion in drive shaft. Place center yoke on front trunnion. Install one bearing cup assembly in front yoke. Drive in to a depth that the snap ring can be installed. Install snap ring. Install remaining cup in front yoke. Install snap ring.

3. Install front trunnion bearing cups in center yoke in same manner.

4. With front trunnion completely installed, install seal on prop shaft (large face first). Gently slip rear yoke half on prop shaft using care not to upset rollers. Insert rear trunnion in center yoke.

Install rear yoke half bearing caps on rear trunnion. Install one rear trunnion bearing cap in center yoke and press into yoke until snap ring can be installed. Install remaining cap and snap ring.

5. Grease centering ball. The lubrication fitting location is shown in Figure 4A-22. A needle nose grease gun adapter J-25512 should be used. The access hole in the crossmember should be used to help locate the lube fitting.

6. Install propeller shaft with constant velocity joint next to transfer case. Torque to specifications.

DOUBLE CARDAN TYPE-CV JOINT

Inspection

An inspection kit including two bearing caps and two snap rings is available to allow the removal of the two trunnion caps shown at location 1, in figure 4A-23. Mark the flange yoke and coupling yoke for reassembly in the same position, as shown in figure 4A-24.

To service the trunnion caps, use the appropriate procedures given in the beginning of this Section.

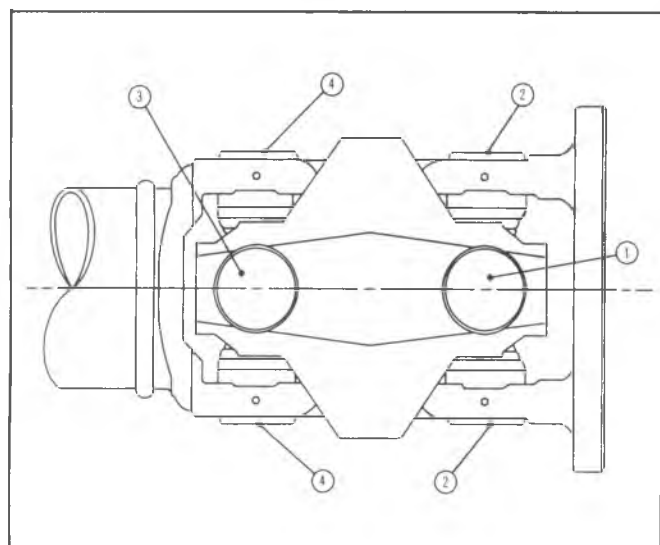


Fig. 4A-23--Bearing Cap Removal Sequence

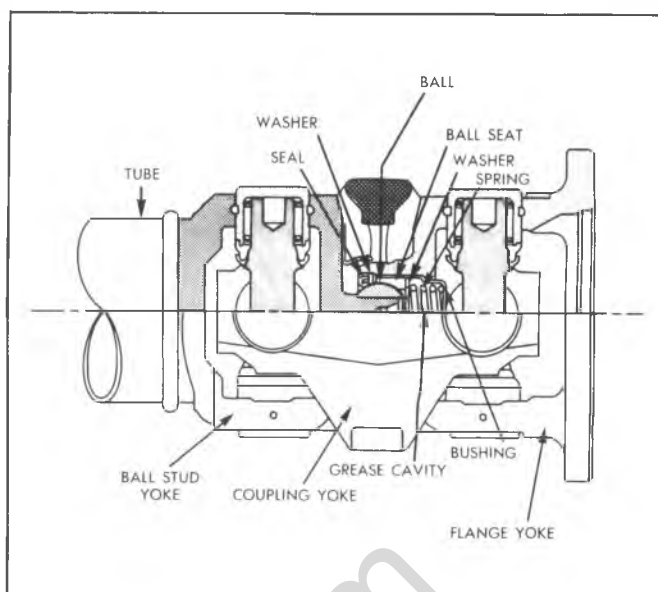


Fig. 4A-25--Cross Sectional View of CV Joint

When both bearing cups are free, disengage the flange yoke and trunnion from the centering ball. Note that the ball socket is part of the flange yoke assembly, while the centering ball is pressed onto a stud and is part of the ball stud yoke. See figure 4A-25. Pry the seal from the ball socket and remove washers, spring and the three ball seats as illustrated in figure 4A-26.

1. Clean and inspect ball seat insert bushing for wear. If bushing is worn, replace flange yoke and cross assembly.

2. Clean and inspect seal and ball seats along with spring and washers. If any parts show indication of excessive wear or are broken, replace the entire set with a service kit.

Whenever the seal is removed to inspect ball seat parts, it should be discarded and replaced with a new seal.

3. Remove all plastic from groove of coupling yoke.

4. Inspect the centering ball surface. If it shows signs of wear beyond smooth polish, replace it.

Centering Ball Replacement

1. Place fingers of inner part of Tool J-23996 under ball as shown in figure 4A-27.

2. Place outer cylinder of Tool J-23996 over outside of ball as shown in figure 4A-28.

3. Thread nut on Tool J-23996 and draw ball off stud, using wrench as shown in figure 4A-29.

4. Place the replacement ball on stud.

5. Using Tool J-23996, drive ball onto stud as in figure 4A-30, until the ball can be seen to seat firmly against the shoulder at the base of the stud. This is important as the center of the double Cardan joint is determined by the ball seating tightly in the proper location.

6. Using grease provided in the ball seat kit, lubricate all parts and insert them into the clean ball seat cavity in the following order: spring, washer (smallest OD), three ball seats (with largest opening outward to receive ball), washer (largest OD) and seal.

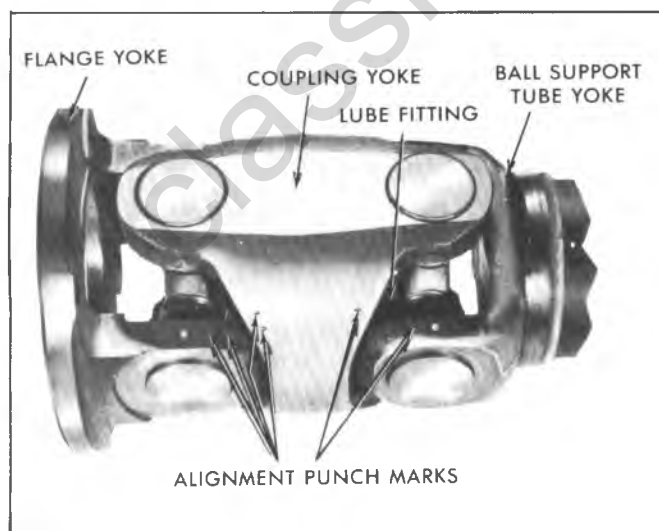


Fig. 4A-24--Reassembling Coupling Yoke

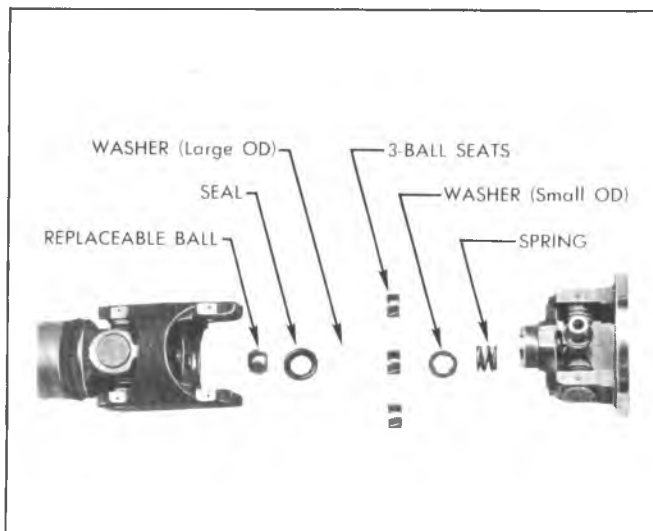


Fig. 4A-26--Exploded View of Centering Ball Mechanism

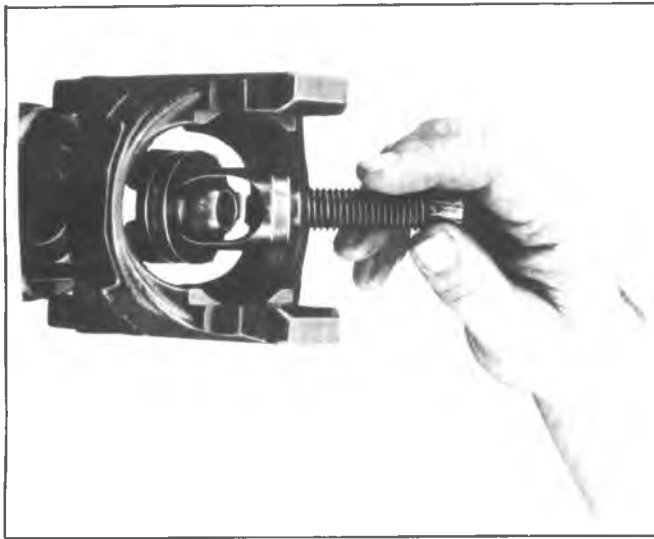


Fig. 4A-27--Installing Tool J-23996 Over Ball

7. Lubricate seal lip and press seal flush with Tool J-23694, as shown in figure 4A-31. Sealing lip should tip inward.

8. Fill cavity with grease provided in kit.

9. Install flange yoke to centering ball as shown in figure 4A-32, making sure alignment marks are correctly positioned. Install trunnion and bearing caps as previously outlined.

LUBRICATION

The front axle propshaft found on all four-wheel drive trucks requires special lubrication procedures at two locations: The C/V joint, and the slip yoke.

Constant Velocity Joints (C/V)

The constant velocity (C/V) joint, located at the transfer case end of the front propshaft, must be lubricated



Fig. 4A-29--Removing Centering Ball

periodically (see Section 0) with special lubricant, # 1050679, or equivalent. If the fitting cannot be seen from beneath the vehicle Figure 4A-22 shows how the fitting may be lubricated from above the C/V joint, with a special adapter J-25512-2 on the end of a flex hose.

Slip Spline

Apply chassis lubricant at the fitting until grease begins to leave through the vent hole.

If the slip spline is dry or corroded, it may be necessary to disconnect the propshaft from the truck, remove the slip yoke, and wire brush the affected areas. Wipe clean before reinstallation. When installing the propshaft to transfer case front output flange attaching bolts, torque to specification 95-110 N·m (70-80 ft. lbs.).

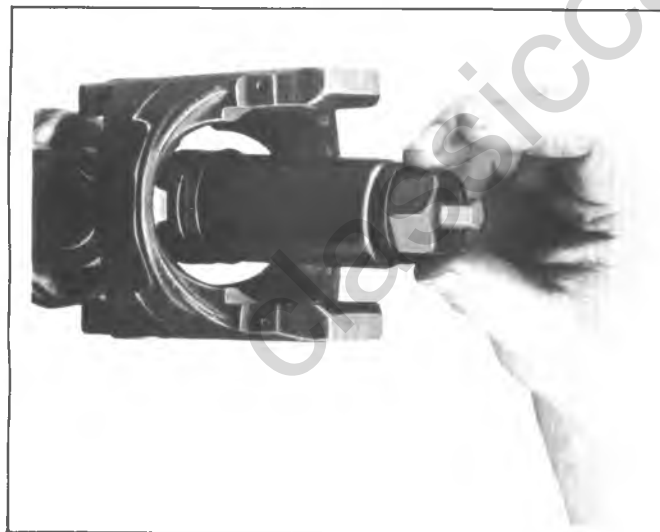


Fig. 4A-28--Installing Outer Cylinder of Tool J-23996 Over Ball

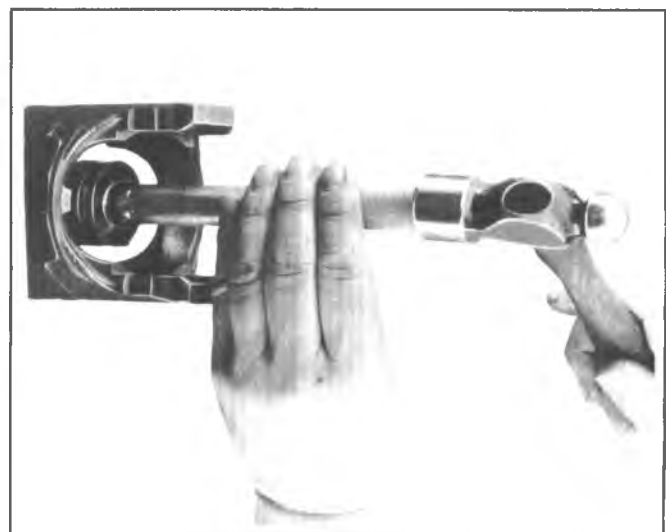


Fig. 4A-30--Installing Centering Ball



Fig. 4A-31—Installing Centering Ball Seal



Fig. 4A-32—Reassembling Flange Yoke

SPECIFICATIONS

| PROPELLER SHAFT | | | |
|---------------------------|-------|-------|-------|
| | CK | G | P |
| Propeller Shaft | | | |
| To Rear Axle (Strap) | 12-17 | 12-17 | 12-17 |
| Bearing Support-to-Hanger | 20-30 | 20-30 | 20-30 |
| Hanger-to-Frame | 40-50 | — | — |
| To Transfer Case | | | |
| Dana Style | 20-30 | | |
| GM Style | 70-80 | | |

Torque Specifications (Ft.-Lbs.)

classicalcarlibrary.com

SECTION 4B

REAR AXLE

The following notice applies to one or more steps in the assembly procedure of components in this portion of the manual as indicated at appropriate locations by the terminology "See Notice on Page 1 of this Section".

NOTICE: This fastener is an important attaching part in that it could affect the performance of vital components and systems, and/or could result in major repair expense. It must be replaced with one of the same part number or with an equivalent part if replacement becomes necessary. Do not use a replacement part of lesser quality or substitute design. Torque values must be used as specified during reassembly to assure proper retention of this part.

CONTENTS

| | |
|---|-------|
| General Description..... | 4B-1 |
| Differential Diagnosis | 4B-7 |
| General Diagnostic Procedure..... | 4B-7 |
| Differential and Rear Axle Bearing Diagnosis..... | 4B-11 |
| On Vehicle Service..... | 4B-13 |
| 8-1/2" and 8-7/8" Ring Gear..... | 4B-13 |
| Chevrolet 10-1/2" Ring Gear | 4B-17 |
| Dana 10-1/2" Ring Gear | 4B-20 |
| Dana 9-3/4" Ring Gear..... | 4B-20 |
| Chevrolet 12-1/4" Ring Gear..... | 4B-21 |
| Specifications..... | 4B-25 |
| Special Tools | 4B-26 |

GENERAL DESCRIPTION

A differential is an arrangement of gears that divides the torque between the axle shafts and allows them to rotate at different speeds. A basic differential consists of a set of four gears. Two of these gears are called differential side gears, and the other two are differential pinion gears. Some differentials have more than two pinion gears. Each side gear is splined to an axle shaft. Consequently, each axle shaft must turn when its side gear rotates.

The differential pinion gears are mounted on a differential pinion shaft, and the gears are free to rotate on this shaft. The pinion shaft is fitted into a bore in the differential case and is at right angles to the axle shafts.

Power flow through the differential is as follows: The drive pinion rotates the ring gear. The ring gear, being bolted to the differential case, rotates the case. The differential pinion, as it rotates with the case, forces the pinion gears against the side gears. When both wheels have equal traction, the pinion gears do not rotate on the pinion shaft because the input force on the pinion gear is equally divided between the two side gears. See figure 4B-1. Consequently, the pinion gears revolve with the pinion shaft, but do not rotate around the shaft itself. The side gears, being splined

to the axle shafts and in mesh with the pinion gears, rotate the axle shafts.

If a vehicle were always driven in a straight line, the ring and pinion gears would be sufficient. The axle shaft could then be solidly attached to the ring gear and both driving wheels would turn at equal speeds.

However, if it became necessary to turn a corner, the tires would scuff and slide because the outer wheel would travel further than the inner wheel, as in figure 4B-2. To prevent tire scuffing and sliding, the differential becomes effective and allows the axle shafts to rotate at different speeds.

As the inner wheel slows down, the side gear splined to that axle shaft also slows down. At this point, the pinion gears act as balancing levers by maintaining equal speeds of rotation of the axle shafts. See figure 4B-3. If the vehicle speed remains constant and the inner wheel slows to 90% of vehicle speed, the outer wheel speeds up to 110%. If the inner wheel slows to 75%, the outer wheel would turn 125%. If one wheel stopped, the other wheel would turn 200%.

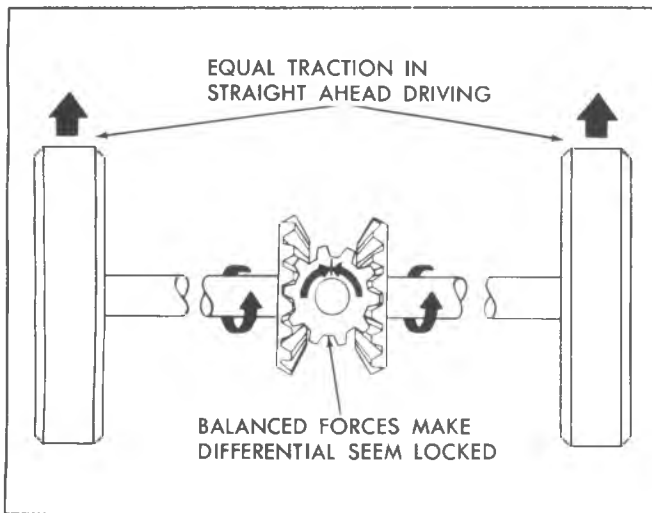


Fig. 4B-1--Differential Inactive

Six distinct axles compromise the truck line-up. These six, categorized by ring gear diameter, are a) 8-1/2" and b) 8-7/8" Ring Gear, c) Chevrolet 10-1/2" Ring Gear, d) Dana 10-1/2" Ring Gear, e) Dana 9-3/4" Ring Gear and f) Chevrolet 12-1/4" Ring Gear.

8-1/2" and 8-7/8" Ring Gear Axle

The axle shown in figure 4B-4 is a semifloating, fabricated constructed type consisting of a cast carrier with large bosses on each end into which two welded steel tubes are fitted. The carrier contains an overhung hypoid pinion and ring gear. The differential is a two pinion arrangement.

The axle housing is made up of two steel welded tubes pressed into the crossbore of the cast carrier. Each tube is puddle welded to the carrier. Welded-on brackets provide attachment points for suspension components such as shock absorbers and leaf springs. A welded flange is provided for brake flange plate attachment.

An overhung hypoid drive pinion is supported by two preloaded tapered roller bearings. The pinion shaft is sealed by means of a molded, spring loaded, rubber seal. The seal is mounted on the pinion flange which is splined and bolted

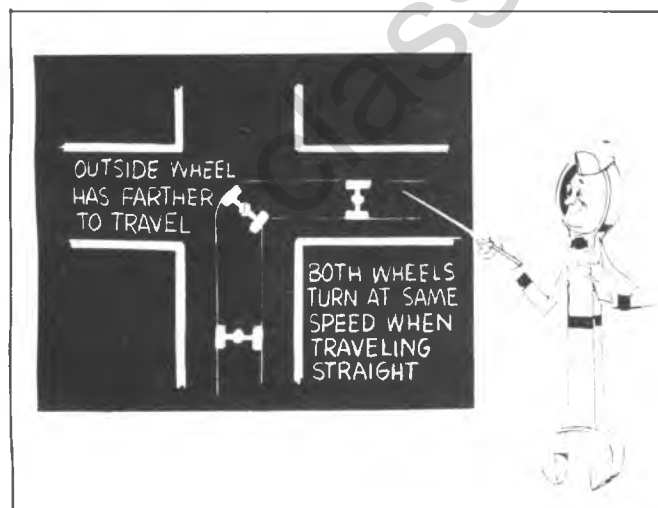


Fig. 4B-2--Need for Differential Action

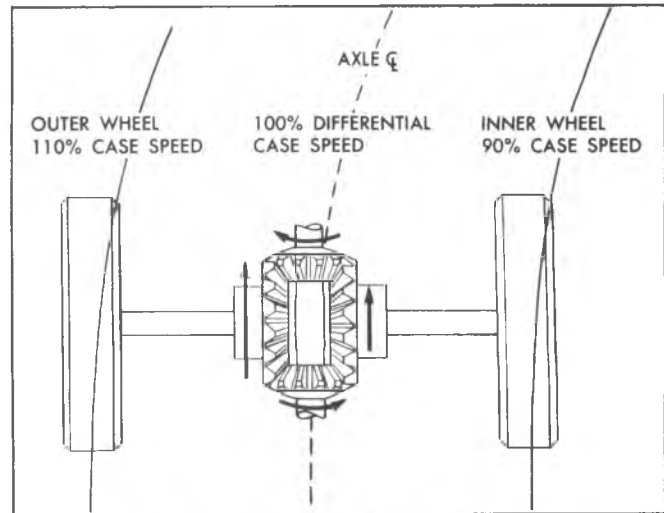


Fig. 4B-3--Differential Action on Turns

to the hypoid pinion shaft.

The hypoid ring gear is bolted to a one-piece differential case which is supported by two preloaded tapered roller bearings.

Chevrolet 10-1/2" Ring Gear Axle

The axle shown in figure 4B-5 is of the full floating type with hypoid ring gear and drive pinion. The full floating construction enables easy removal of axle shafts without removing truck load and without jacking up the axle. The differential carrier is heavily ribbed to provide rigid support for the differential assembly.

The straddle-mounted drive pinion is supported at the front by two opposed tapered roller bearings. The pinion straddle bearing is a roller bearing assembly consisting of an outer race and roller assembly. A precision ground diameter on the pinion pilot functions as an inner race.

Side bearing preload and ring gear-to-pinion backlash are controlled by side bearing adjusting nuts threaded into the carrier near the axle tubes. Pinion depth is controlled by a shim located between the pinion bearing retainer assembly and the differential carrier.

Dana 10-1/2" Ring Gear Axle

The Dana axle shown in figure 4B-6 is a Salisbury-type similar in design to the 8-7/8" ring gear axle in figure 4B-4. It does differ in several points, however. The axle shafts are full floating; the carrier must be spread to remove the differential; and the drive pinion incorporates two shim packs. The inner pack controls pinion depth, while the outer pack controls pinion bearing preload.

Dana 9-3/4" Ring Gear Axle

The Dana axle shown in figure 4B-7 is similar to the unit shown in 4B-6; however, the differential side bearing shims are located between the case and the side bearings.

Chevrolet 12-1/4" Ring Gear Axle

(11,000 Pound Capacity)

The 11,000 lb. capacity, single-speed hypoid axle, illustrated in figure 4B-8, has a straddle mounted drive pinion which is supported at the rear by a straight roller bearing. The pinion front bearing consists of a double row

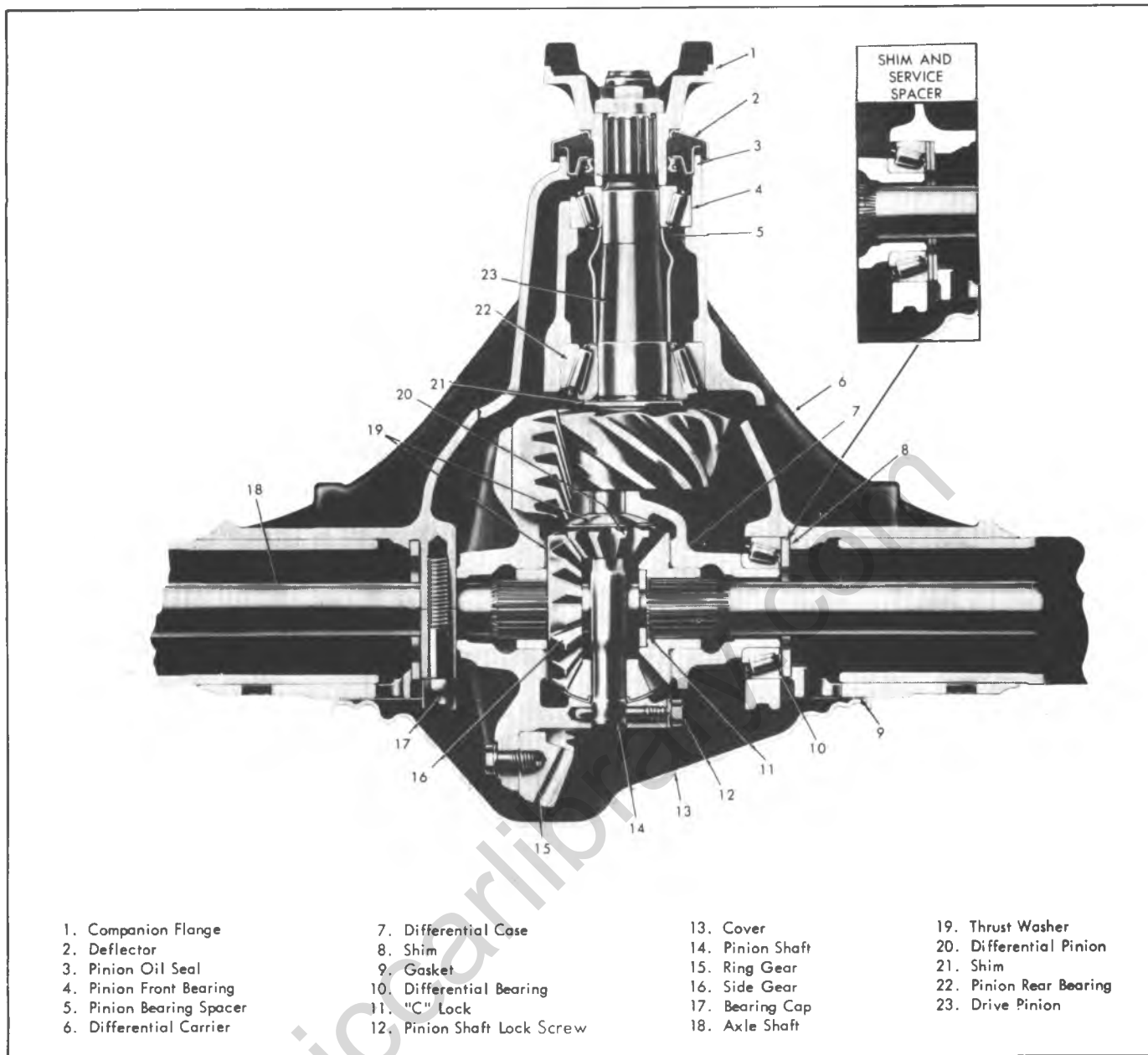


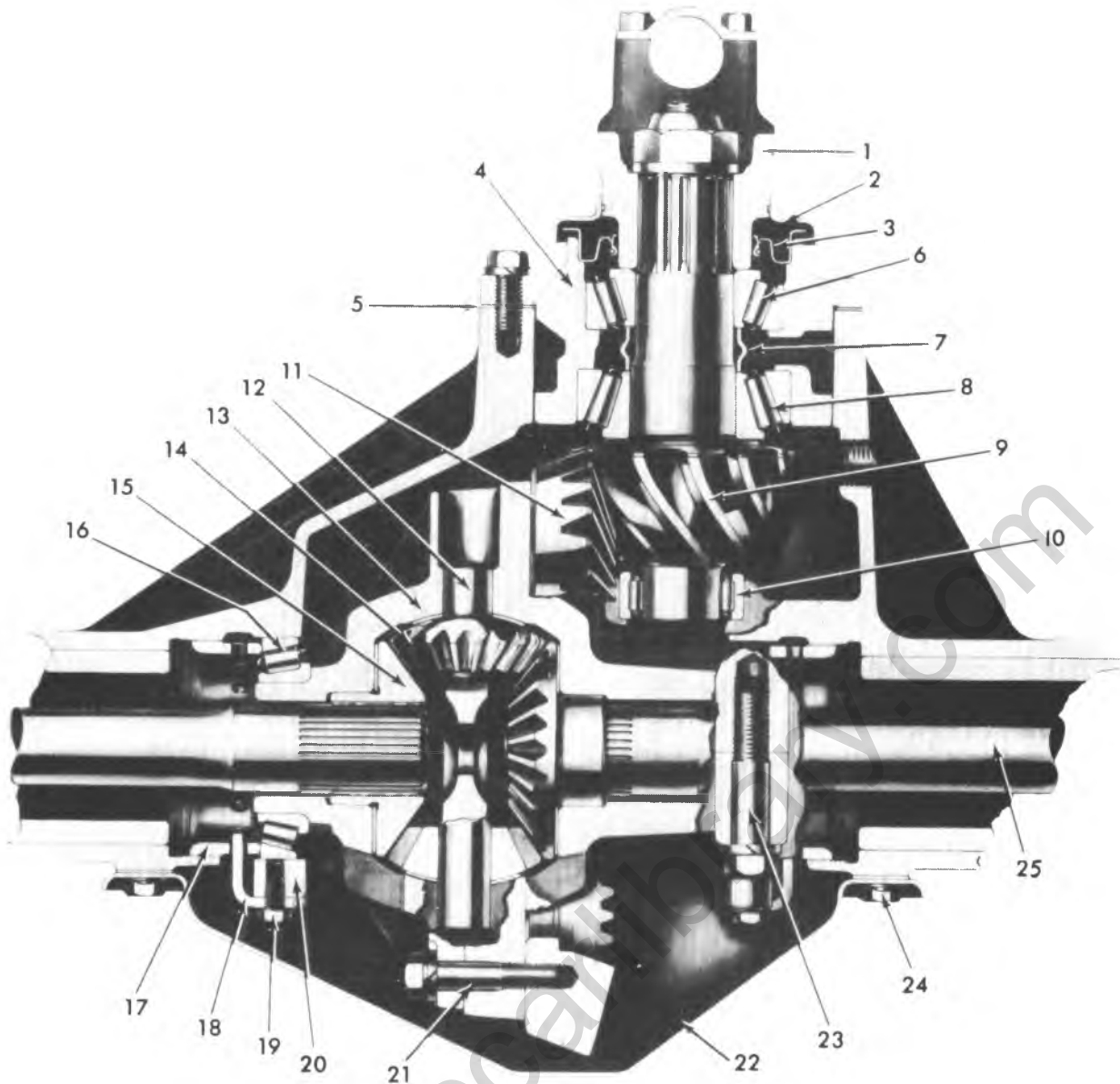
Fig. 4B-4--8-1/2" and 8-7/8" Ring Gear Axle Cross-Section Typical

ball bearing.

The differential is a conventional four-pinion type. Thrust washers are used between the side gears and case and also between differential pinions and the differential case.

A thrust pad mounted on the end of an adjusting screw threaded into the carrier housing limits deflection of the ring gear under high torque conditions.

Involute splines are incorporated in the axle shaft flange and in the wheel hubs. This design provides for the driving torque to be transmitted from the axle shaft to the hub through the mating splines.



- | | | |
|-------------------------|--------------------------------|----------------------------|
| 1. Companion Flange | 10. Straddle Bearing | 19. Retainer Screw |
| 2. Oil Deflector | 11. Ring Gear | 20. Bearing Cap |
| 3. Oil Seal | 12. Differential Spider | 21. Case-to-Ring Gear Bolt |
| 4. Bearing Retainer | 13. Differential Case | 22. Differential Cover |
| 5. Shim | 14. Differential Pinion | 23. Bearing Cap Bolt |
| 6. Pinion Front Bearing | 15. Differential Side Gear | 24. Cover Screw |
| 7. Collapsible Spacer | 16. Side Bearing | 25. Axle Shaft |
| 8. Pinion Rear Bearing | 17. Side Bearing Adjusting Nut | |
| 9. Drive Pinion | 18. Adjusting Nut Retainer | |

Fig. 4B-5--Chevrolet 10-1/2" Ring Gear Axle Cross-Section

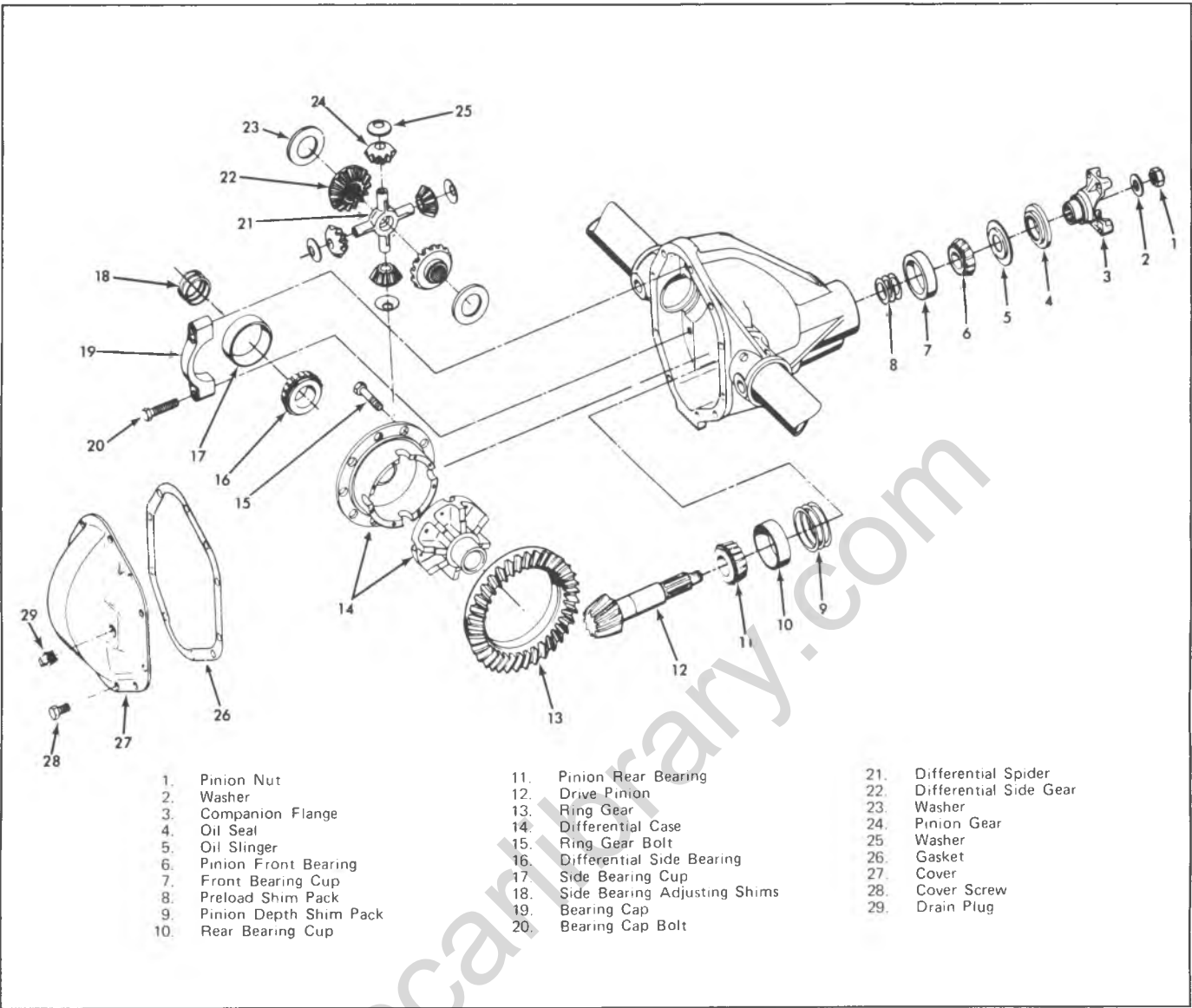


Fig. 4B-6--Dana 10-1/2" Ring Gear Axle Exploded View

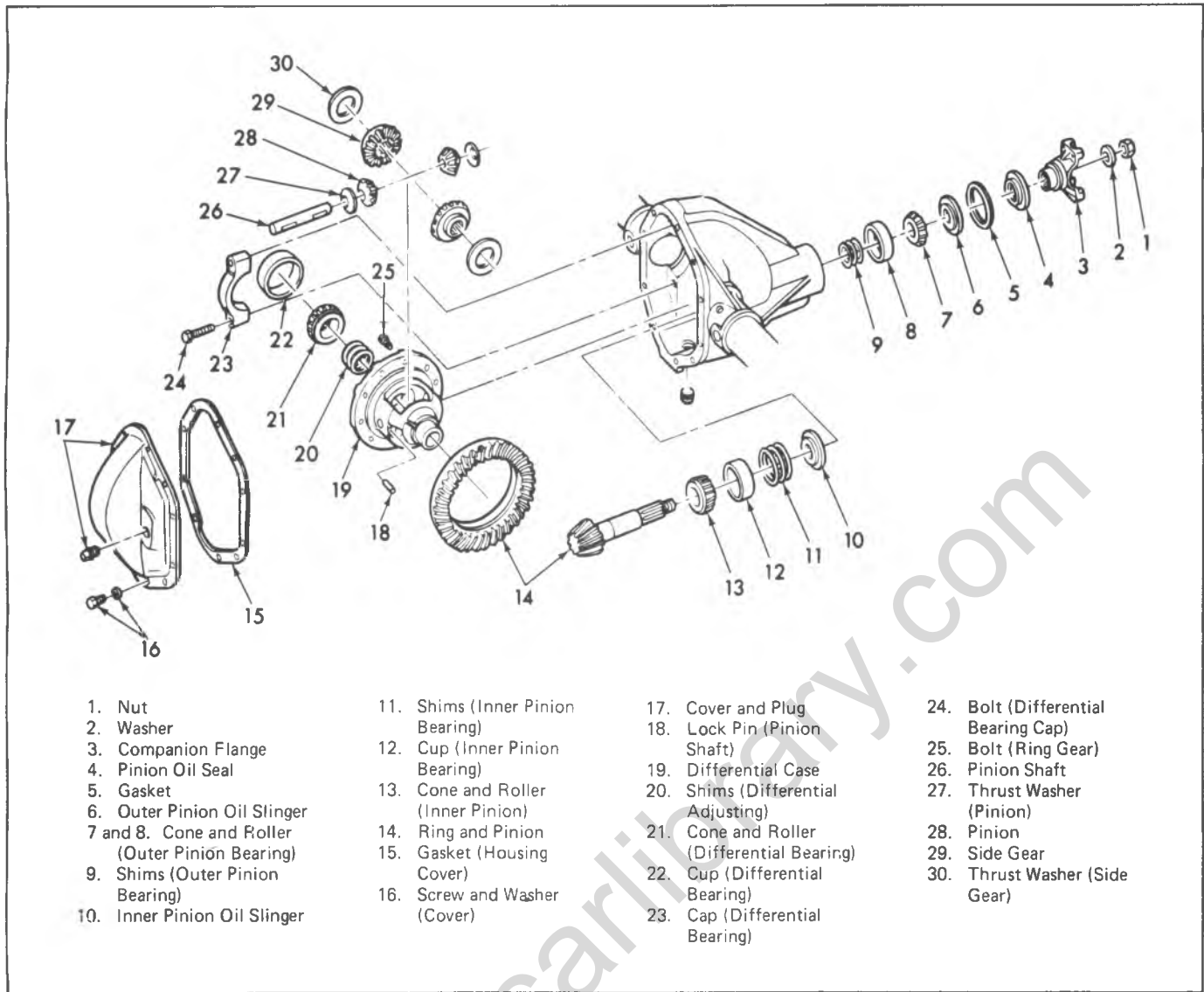


Fig. 4B-7--Dana 9-3/4" Ring Gear Axle Exploded View

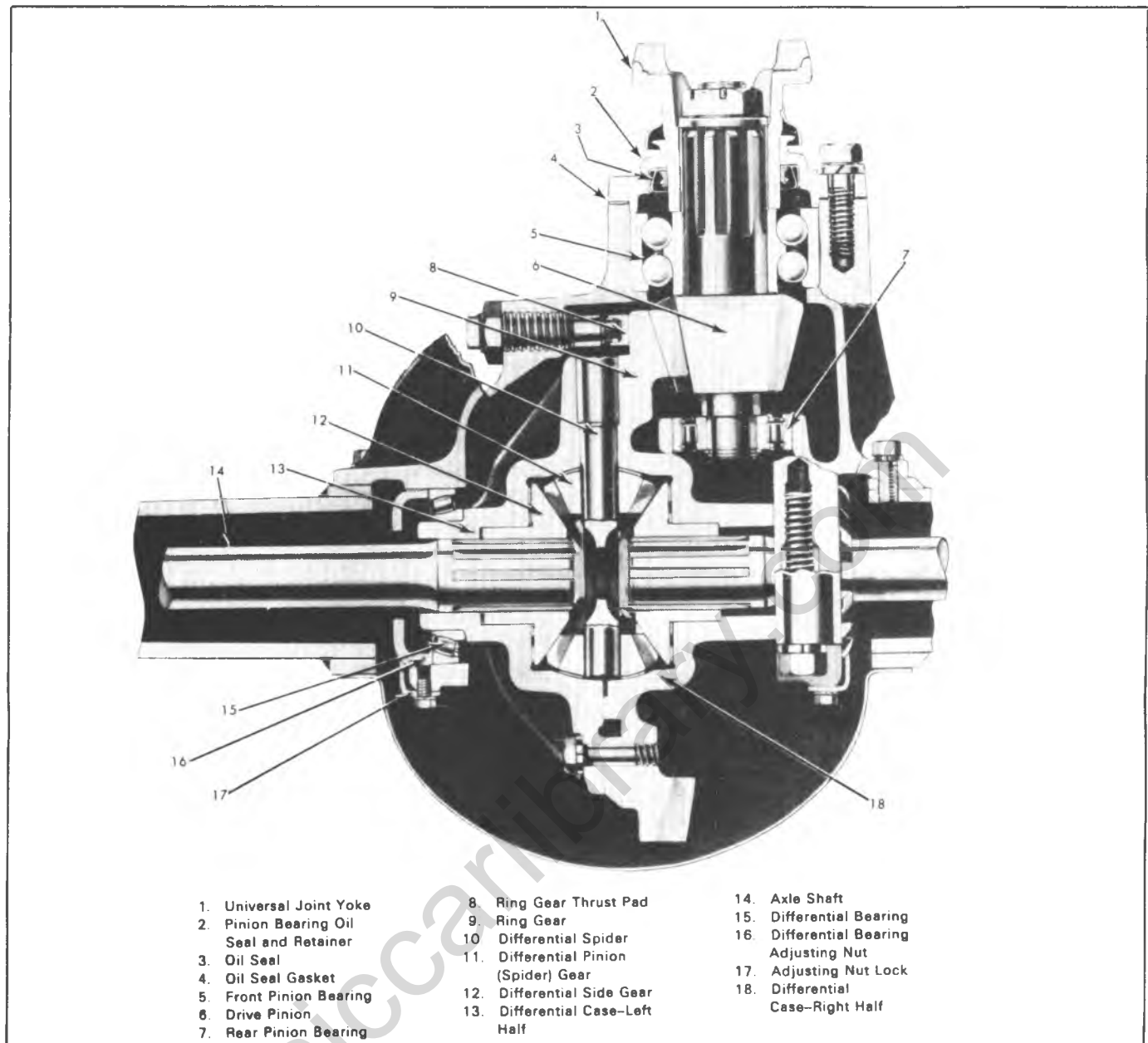


Fig. 4B-8--Chevrolet 12-1/4" Ring Gear Axle--11,000# Capacity

DIFFERENTIAL DIAGNOSIS

STANDARD DIFFERENTIAL

Noise

The most essential part of rear axle service, as with any mechanical repair, is proper diagnosis of the problem, and, in axle work one of the most difficult areas to diagnosis is noise. Locating a broken axle shaft, or broken differential gear, presents little or no problem, but, locating and isolating axle noise can be an entirely different matter.

Degree of Noise

Any gear driven unit, and especially an automotive drive axle where engine torque multiplication occurs at a 90° turn in the drive line, produces a certain amount of noise. Therefore, an interpretation must be made for each vehicle to determine whether the noise is normal or if a problem actually exists. A normal amount of noise must be expected and cannot be eliminated by conventional repairs or adjustment. See figure 4B-9.

Acceptable noise can be defined as a slight noise heard only at a certain speed or under unusual or remote



Fig. 4B-9--Noise Level

conditions. For example, this noise tends to reach a "peak" at speeds from 40 to 60 miles per hour (60 to 100 km/h) depending on road and load conditions, or on gear ratio and tire size. This slight noise is in no way indicative of trouble in the axle assembly.

Drive line noises may baffle even the best diagnostician. Vehicle noises coming from tires, transmission, propeller shaft, universal joints, and front or rear wheel bearings, are often mistaken for axle noise. Such practices as: raising tire pressure to eliminate tire noise (although this will not silence tread noise of mud and snow tires), listening for the noise at varying speeds and road surfaces, on drive, float, and coast conditions will aid in locating the source of alleged axle noises. Thus, every effort should be made to isolate the noise to a specific drive line component instead of making a random guess that could be a costly waste of time.

Elimination of External Noises

When a rear axle is suspected of being noisy, it is advisable to make a thorough test to determine whether the noise originates in the tires, road surface, front wheel bearings, engine, transmission, or rear axle assembly. Noise which originates in other places cannot be corrected by adjustment or replacement of parts in the rear axle assembly.

Road Noise –Some road surfaces, such as brick or rough-surfaced concrete, cause noise which may be mistaken for tire or rear axle noise. Driving on a different type of road, such as smooth asphalt or dirt, will quickly show whether the road surface is the cause of noise. Road noise usually is the same on drive or coast.

Tire Noise –Tire noise may easily be mistaken for rear axle noise, even though the noisy tires may be located on the front wheels. Tires worn unevenly, or having surfaces on non-skid divisions worn in saw-tooth fashion, are usually noisy and may produce vibrations which seem to originate elsewhere in the vehicle. This is particularly true with low tire pressure.

Test for Tire Noise –Tire noise changes with different road surfaces, but rear axle noise does not. Temporarily inflating all tires to approximately 50 pounds pressure, for test purposes only will materially alter noise caused by tires but will not affect noise caused by the

rear axle. Rear axle noise usually ceases when coasting at speeds under 30 miles per hour; however, tire noise continues but with lower tone as vehicle speed is reduced. Rear axle noise usually changes when comparing "pull" and "coast" but tire noise remains about the same.

Engine and Transmission Noises –Sometimes a noise which seems to originate in the rear axle is actually caused by the engine or transmission. To determine which unit is actually causing the noise, observe approximate car speeds and conditions under which the noise is most pronounced; then stop vehicle in a quiet place to avoid interfering noises. With transmission in neutral, run engine slowly up and down through engine speeds corresponding to vehicle speed at which the noise was most pronounced. If a similar noise is produced with vehicle standing, it is caused by the engine or transmission and not the rear axle.

Front Wheel Bearing Noise –Loose or rough front wheel bearings will cause noise which may be confused with rear axle noises; however, front wheel bearing noise does not change when comparing "pull" and "coast". Light application of brake, while holding vehicle speed steady, will often cause wheel bearing noise to diminish, as this takes some weight off the bearing. Front wheel bearings may be easily checked for noise by jacking up the wheels and spinning them, and also by shaking wheels to determine if bearings are excessively loose.

Body Boom Noise or Vibration

Objectional "body boom" noise or vibration at 55-65 mph (90-100 km/h) can be caused by an unbalanced propeller shaft. Excessive looseness at the spline can contribute to this unbalance.

Other items that may also contribute to the noise problem are as follows:

1. Undercoating or mud on the shaft, causing unbalance.
2. Shaft or companion flange balance weights missing.
3. Shaft damage, such as bending, dents, or nicks.
4. Tire-type roughness. Switch tires from a known good car to determine tire fault.

If, after making a comprehensive check of the vehicle, all indications point to the rear axle, further diagnostic steps are necessary to determine the axle components at fault. True axle noises generally fall into two categories: gear noise and bearing noise.

Rear Axle Noises

If a careful test of vehicle shows that noise is not caused by external items it is then reasonable to assume that noise is caused by rear axle assembly. The rear axle should be tested on a smooth level road to avoid road noise. It is not advisable to test rear axle for noise by running with rear wheels jacked up.

Noises in rear axle assembly may be caused by a faulty propeller shaft, faulty rear wheel bearings, faulty differential or pinion shaft bearings, misalignment between two U-joints, or worn differential side gears and pinions; noises may also be caused by mismatched, improperly adjusted, or scored ring and pinion gear set.

Rear Wheel Bearing Noise –A rough rear wheel bearing produces a vibration or growl which continues with vehicle coasting and transmission in neutral. A brinelled rear wheel bearing causes a knock or click approximately

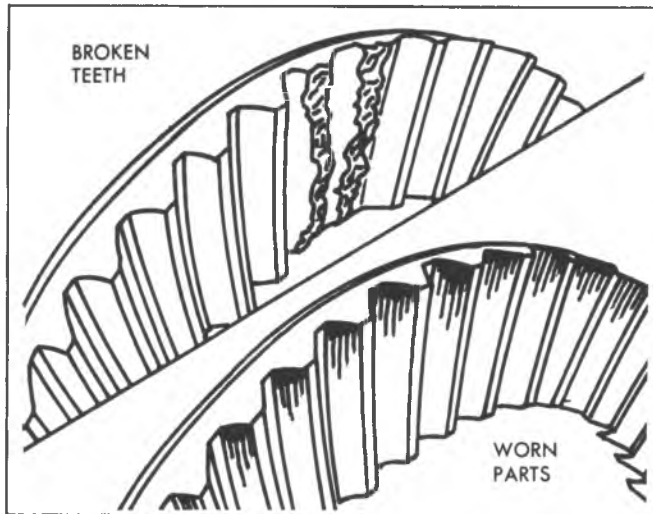


Fig. 4B-10--Two Causes of Gear Noise

every two revolutions of rear wheel, since the bearing rollers do not travel at the same speed as the rear axle and wheel. With rear wheels jacked up, spin rear wheels by hand while listening at hubs for evidence of rough or brinelled wheel bearing.

Differential Side Gear and Pinion Noise –

Differential side gears and pinions seldom cause noise since their movement is relatively slight on straight ahead driving. Noise produced by these gears will be most pronounced on turns.

Pinion Bearing failures can be distinguished because they rotate at higher speeds than differential side bearings and axle shaft bearings. Rough or brinelled pinion bearings produce a continuous low pitched whirring or scraping noise starting at relatively low speed.

Side Bearings produce a constant rough noise of a lower pitch than pinion bearings. Side bearing noise may also fluctuate in the above wheel bearing test. Bearing

Diagnosis Charts appear later in this section.

Gear Noise

There are two basic types of gear noise. The first type is produced by broken, bent, or forcibly damaged gear teeth and is usually quite audible over the entire speed range and presents no particular problem in diagnosis.

For example, hypoid gear tooth scoring as seen in figure 4B-10 generally results from the following: insufficient lubricant improper breakin, improper lubricant, insufficient gear backlash, improper ring and pinion gear alignment, or loss of drive pinion nut torque. The scoring will progressively lead to complete erosion of the gear tooth, or gear tooth pitting and eventual fracture if the initial scoring condition is not corrected. Another cause of hypoid tooth fracture is extended overloading of the gear set which will produce fatigue fracture, or shock loading which will result in sudden failure.

Differential pinion and side gears rarely give trouble. Common causes of differential failure are shock loading, extended overloading, and seizure of the differential pinions to the cross shaft resulting from excessive wheel spin and consequent lubrication breakdown.

The second type of gear noise pertains to the mesh pattern of the gear teeth. This form of abnormal gear noise can be recognized as it produces a cycling pitch (whine) and will be very pronounced in the speed range at which it occurs, appearing under either "drive", "float" or "coast" conditions. "Drive" is acceleration or heavy pull. "Coast" is with a closed throttle and vehicle in gear and "float" is using just enough throttle to keep the car from driving the engine—the vehicle slows down gradually but engine still pulls slightly. Gear noise tends to peak in a narrow speed range or ranges, and will tend to remain constant in pitch. Bearing noise will vary in pitch with vehicle speeds. See figure 4B-11.

**A GENERAL DIAGNOSTIC PROCEDURE FOR
ISOLATING REAR AXLE NOISE PROBLEMS**

| Problem | Cause |
|---|---|
| 1. Noise is the same in drive or coast | 1. a) Road noise b) Tire noise c) Front wheel bearing noise |
| 2. Noise changes on a different type of road | 2. a) Road noise b) Tire noise |
| 3. Noise tone lowers as car speed is lowered | 3. Tire noise |
| 4. Similar noise is produced with car standing and driving | 4. a) Engine noise b) Transmission noise |
| 5. Vibration | 5. a) Rough rear wheel bearing b) Unbalanced or damaged propeller shaft c) Tire unbalance d) Worn universal joint in propeller shaft e) Mis-indexed propeller shaft at companion flange f) Companion flange runout too great |
| 6. A knock or click approximately every two revolutions of rear wheel | 6. A brinelled rear wheel bearing |
| 7. Noise most pronounced on turns | 7. Differential side gear and pinion |
| 8. A continuous low pitch whirring or scraping noise starting at relatively low speed | 8. Pinion bearing |
| 9. Drive noise, coast noise or float noise | 9. Ring and pinion gear |
| 10. Clunk on acceleration or deceleration | 10. Worn differential cross shaft in case |
| 11. Grunt on stops | 11. No grease in propeller shaft slip yoke |
| 12. Groan in Forward or Reverse | 12. Wrong lube in differential |
| 13. Chatter on turns | 13. a) Wrong lube in differential b) Clutch plates worn |
| 14. Clunk or knock on rough road operation | 14. Excessive end play of axle shafts to differential cross shaft |

Fig. 4B-11—Diagnosis of Noise Problems

DIFFERENTIAL AND REAR AXLE BEARING DIAGNOSIS

CONSIDER THE FOLLOWING FACTORS WHEN DIAGNOSING BEARING CONDITION:

1. GENERAL CONDITION OF ALL PARTS DURING DISASSEMBLY AND INSPECTION.
2. CLASSIFY THE FAILURE WITH THE AID OF THE ILLUSTRATIONS.
3. DETERMINE THE CAUSE.
4. MAKE ALL REPAIRS FOLLOWING RECOMMENDED PROCEDURES.





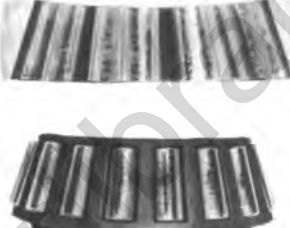

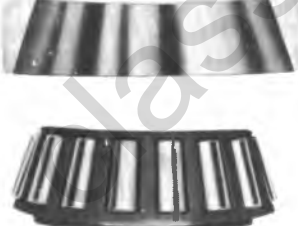


| | | |
|--|--|---|
|  <p style="text-align: center;">ABRASIVE ROLLER WEAR</p> <p>PATTERN ON RACES AND ROLLERS CAUSED BY FINE ABRASIVES.</p> <p>CLEAN ALL PARTS AND HOUSINGS. CHECK SEALS AND BEARINGS AND REPLACE IF LEAKING, ROUGH OR NOISY.</p> |  <p style="text-align: center;">GALLING</p> <p>METAL SMEARS ON ROLLER ENDS DUE TO OVERHEAT, LUBRICANT FAILURE OR OVERLOAD (WAGON'S)</p> <p>REPLACE BEARING -- CHECK SEALS AND CHECK FOR PROPER LUBRICATION.</p> |  <p style="text-align: center;">BENT CAGE</p> <p>CAGE DAMAGE DUE TO IMPROPER HANDLING OR TOOL USAGE.</p> <p>REPLACE BEARING</p> |
|  <p style="text-align: center;">ABRASIVE STEP WEAR</p> <p>PATTERN ON ROLLER ENDS CAUSED BY FINE ABRASIVES.</p> <p>CLEAN ALL PARTS AND HOUSINGS. CHECK SEALS AND BEARINGS AND REPLACE IF LEAKING, ROUGH OR NOISY.</p> |  <p style="text-align: center;">ETCHING</p> <p>BEARING SURFACES APPEAR GRAY OR GRAYISH BLACK IN COLOR WITH RELATED ETCHING AWAY OF MATERIAL USUALLY AT ROLLER SPACING.</p> <p>REPLACE BEARINGS -- CHECK SEALS AND CHECK FOR PROPER LUBRICATION.</p> |  <p style="text-align: center;">BENT CAGE</p> <p>CAGE DAMAGE DUE TO IMPROPER HANDLING OR TOOL USAGE.</p> <p>REPLACE BEARING.</p> |
|  <p style="text-align: center;">INDENTATIONS</p> <p>SURFACE DEPRESSIONS ON RACE AND ROLLERS CAUSED BY HARD PARTICLES OF FOREIGN MATERIAL.</p> <p>CLEAN ALL PARTS AND HOUSINGS. CHECK SEALS AND REPLACE BEARINGS IF ROUGH OR NOISY.</p> |  <p style="text-align: center;">CAGE WEAR</p> <p>WEAR AROUND OUTSIDE DIAMETER OF CAGE AND ROLLER POCKETS CAUSED BY ABRASIVE MATERIAL AND INEFFICIENT LUBRICATION.</p> <p>CLEAN RELATED PARTS AND HOUSINGS. CHECK SEALS AND REPLACE BEARINGS.</p> |  <p style="text-align: center;">MISALIGNMENT</p> <p>OUTER RACE MISALIGNMENT DUE TO FOREIGN OBJECT.</p> <p>CLEAN RELATED PARTS AND REPLACE BEARING. MAKE SURE RACES ARE PROPERLY SEATED.</p> |

Fig. 4B-12--Differential and Axle Bearing Diagnosis Chart A

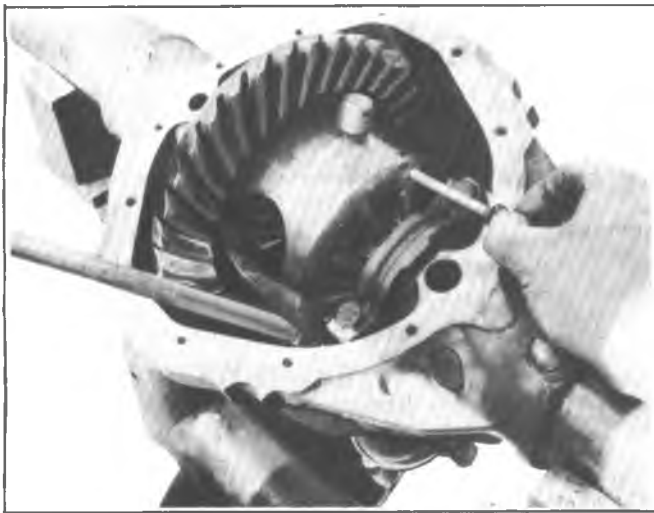


Fig. 4B-15--Removing Lock Screw

7. When installing C-locks keep the pinion shaft partially withdrawn. Place the C-lock in the same position shown in figure 4B-17. Carefully withdraw the axle shaft until the C-lock is clear of the thrust block. When both locks are installed, install the pinion shaft and lock screw.

Oil Seal/Bearing--Replacement Fig. 4B-19

1. Remove oil seal by using button end of axle shaft. Insert button end behind the steel case of the oil seal, then pry seal out of bore being careful not to damage seal. If both seal and bearing are being replaced proceed to step 2.

2. Using J-23689, insert into bore so that tool grasps behind the bearing. See figure 4B-20. Slide washer against outside of seal (or bearing) and turn nut finger tight against washer. Attach Slide Hammer J-2619 and remove bearing and seal.

3. Back off nut and remove bearing and seal from tool.

4. Lubricate cavity between seal lips with wheel bearing lubricant and also lubricate new bearing with wheel bearing lubricant.

5. To reinstall bearing, use J-23690 Installer. Install bearing until tool bottoms against tube as illustrated in figure 4B-21.

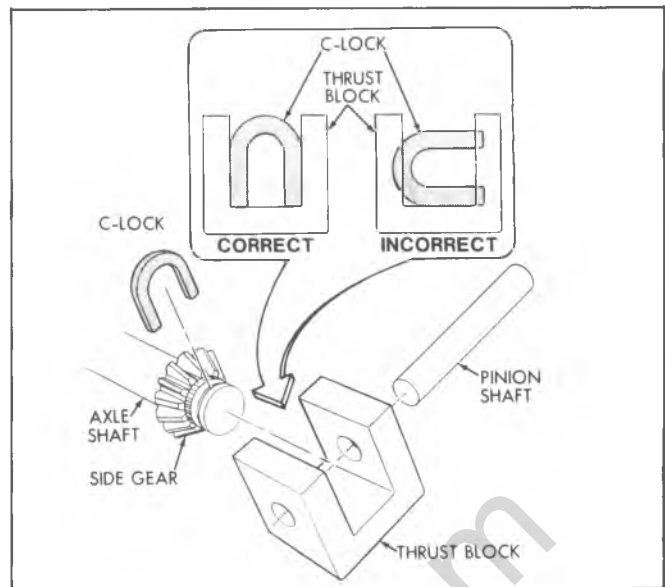


Fig. 4B-17--Correct C-Lock Position

6. To install oil seal, place seal on J-21128 and drive into bore until tool bottoms against end of tube. See figure 4B-22. This tool installs the seal flush with the end of the tube.

Brake Backing Plate--Replacement

1. Remove brake line at wheel cylinder inlet and disassemble brake components from flange plate. Refer to Section 5 for brake disassembly procedure.

2. Remove bolts retaining flange plate to axle, and remove flange plate.

3. Install new flange plate to axle housing and torque nuts to specifications.

4. Install brake components on flange and connect hydraulic line to wheel cylinder inlet. See Section 5 for brake assembly, bleeding and adjustment procedures.

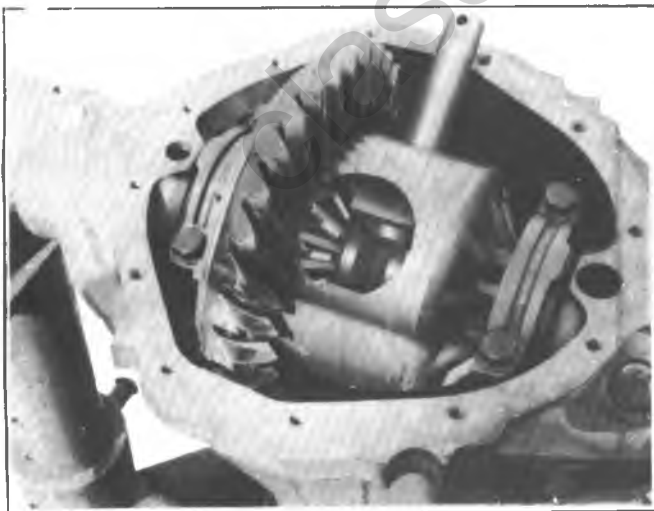


Fig. 4B-16--Positioning Case For Best Clearance

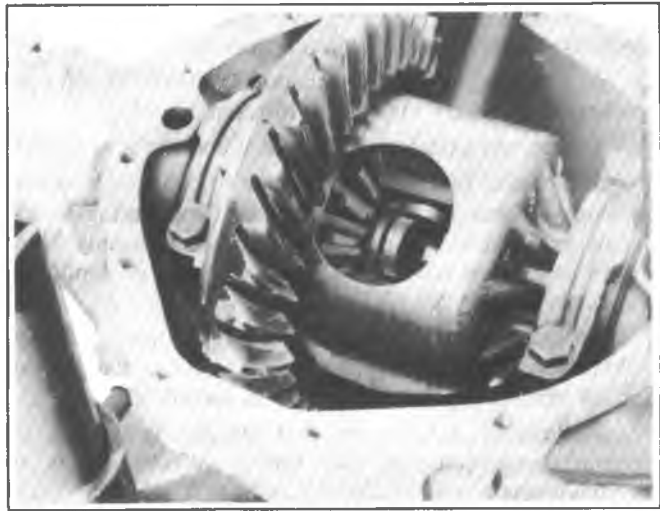


Fig. 4B-18--Push Axle Shaft Inward

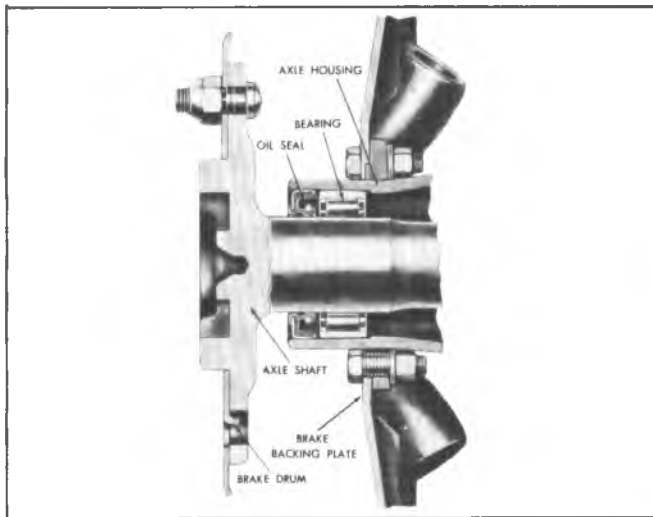


Fig. 4B-19--Oil Seal and Wheel Bearing

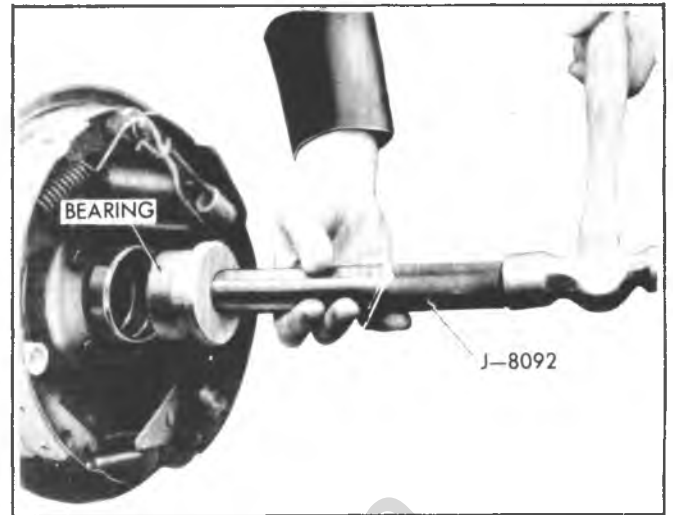


Fig. 4B-21--Wheel Bearing Installation

Axle Shaft--Installation

1. Slide axle shaft into place. Exercise care that splines on end of shaft do not damage oil seal and that they engage with splines of differential side gear.
2. Install axle shaft "C" lock on button end of axle shaft and push shaft outward so that shaft lock seats in counterbore of differential side gear.
3. Position differential pinion shaft through case and pinions, aligning hole in shaft with lock screw hole. Install lock screw.
4. Using a new gasket, install carrier cover. Make sure both gasket surfaces on carrier and cover are clean before installing new gasket. Torque carrier cover bolts in a crosswise pattern to ensure uniform draw on cover gasket.
5. Fill axle with lubricant as specified in Section 0 of this manual to a level even with the bottom of filler hole.
6. Install brake drum and wheel and tire assembly.
7. Lower vehicle and remove from hoist.

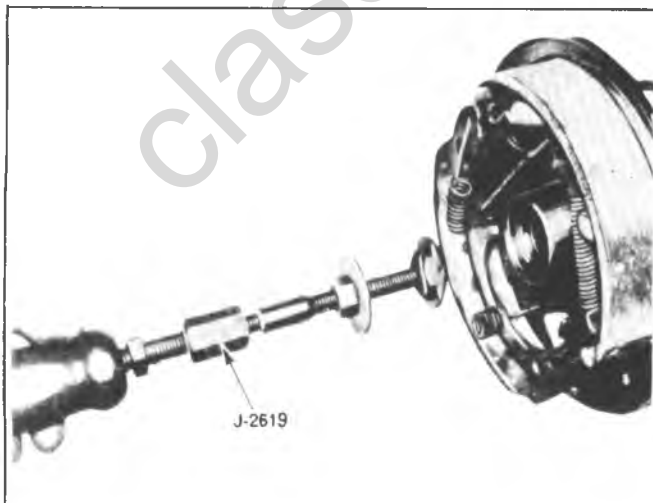


Fig. 4B-20--Wheel Bearing Removal

Wheel Bolt--Replacement

1. Raise vehicle on hoist allowing axle to hang freely.
2. Remove wheel and tire and brake drum.
3. Using Tool J-5504 or J-6627 press out stud as shown in figure 4B-23.
4. Place new stud in axle flange hole. Slightly start stud serrations in hole by firmly pressing back of stud with your hand.
5. Install a lug nut with flat side first (tapered face outboard). Tighten on lug nut drawing stud into flange until stud head is bottomed on back side of flange.
6. Remove lug nut.
7. Reinstall brake drum and wheel and tire.
8. Lower vehicle and remove from hoist.

PINION FLANGE, DUST DEFLECTOR AND/OR OIL SEAL

Removal

1. Raise vehicle on hoist.
2. Disconnect propeller shaft from axle.

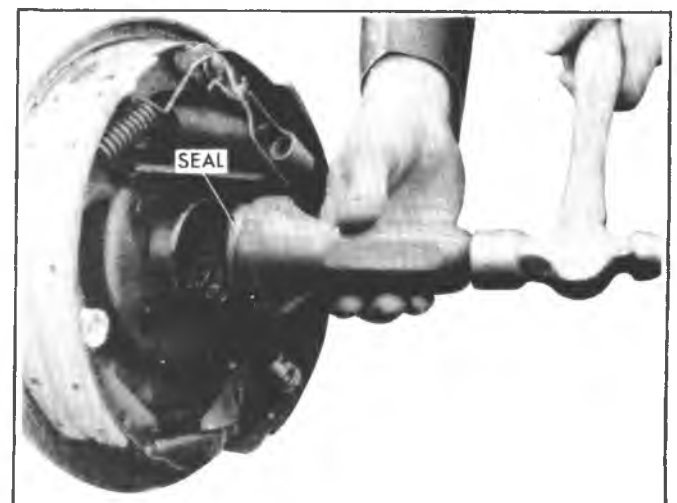


Fig. 4B-22--Seal Installation

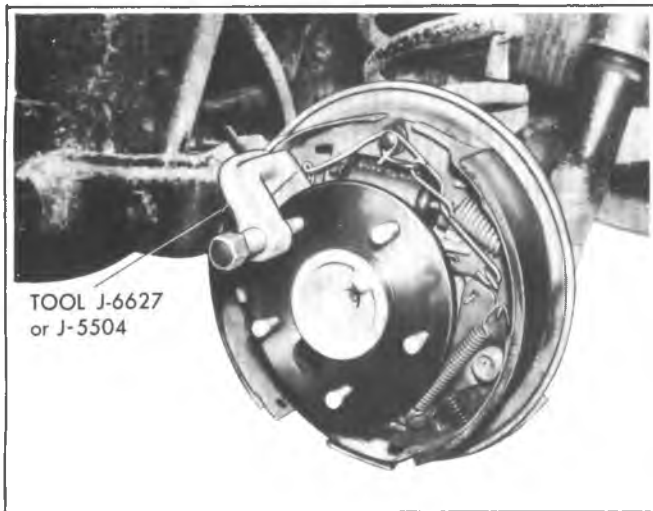


Fig. 4B-23--Pressing Out Wheel Stud

3. Position propeller shaft to one side and tie it to frame side rail.

4. Measure the torque required to rotate the pinion, as shown in figure 4B-24. Record the torque for later reference.

5. Scribe a line down pinion stem, pinion nut, and flange to aid on reinstallation. Make sure lines show the relationship of components accurately. Count the number of exposed threads on pinion stem, and record for later reference. See figure 4B-25.

6. Install Tool J-8614-11 on pinion flange and remove pinion flange self-locking washer faced nut as shown in figure 4B-26. (Position J-8614-11 on flange so that the four notches are toward flange.) Save scribed nut for reinstallation.

7. Thread pilot end of Tool J-8614-3 into small O.D. end of J-8614-2. Then with J-8614-11 installed as in Step 6, insert J-8614-2 into J-8614-11 and turn it 45 degrees to locked position. Remove flange by turning J-8614-3 while holding J-8614-11 as shown in figure 4B-27.

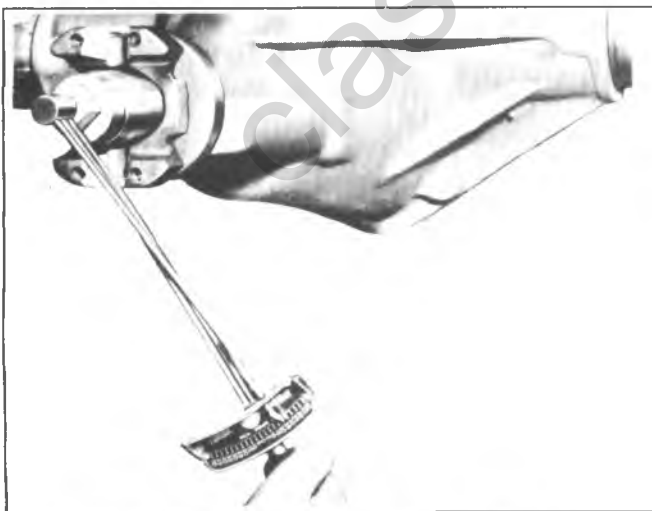


Fig. 4B-24--Measuring Pinion Rotating Torque

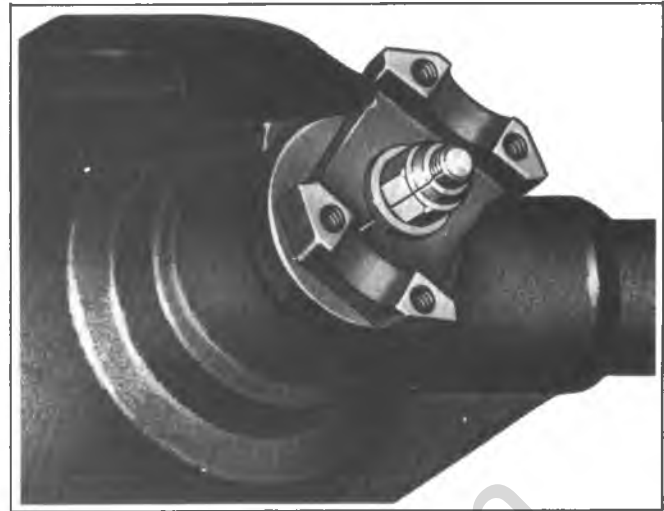


Fig. 4B-25--Scribe Marks

8. Pry old seal out of bore, using a screw driver or a hammer and chisel.

Inspection

1. Inspect pinion flange for smooth oil seal surface, worn drive splines, damaged ears, and for smoothness of bearing contact surface. Replace if necessary.

2. If deflector requires replacement, remove by tapping from flange, clean up stake points; install new deflector, and stake deflector at three new equally spaced positions. Staking operation must be performed in such a manner that the seal operating surface is not damaged.

Installation

1. Lubricate cavity between the seal lips of the pinion flange oil seal with a lithium-base extreme pressure lubricant.

2. Position seal in bore and place gauge plate J-22 over seal and against seal flange. The gauge plate assures proper seating of seal in carrier bore.

3. Use J-21057, as shown in figure 4B-28, to press seal into carrier bore until gauge plate is flush with the carrier shoulder and seal flange. Turn gauge plate 180° from

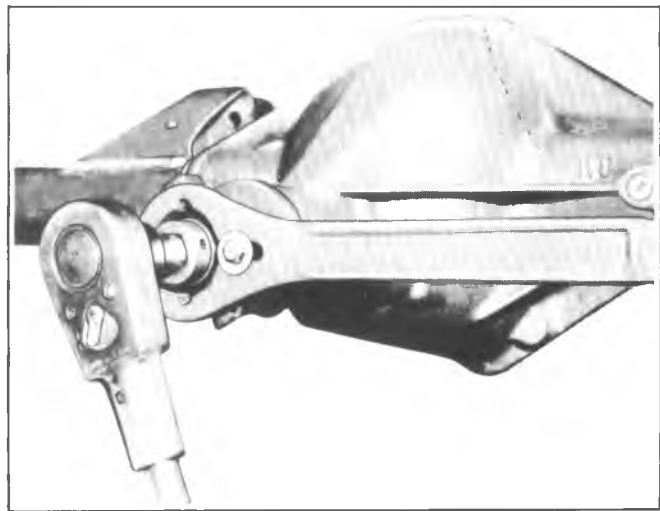


Fig. 4B-26--Removing Nut from Drive Pinion

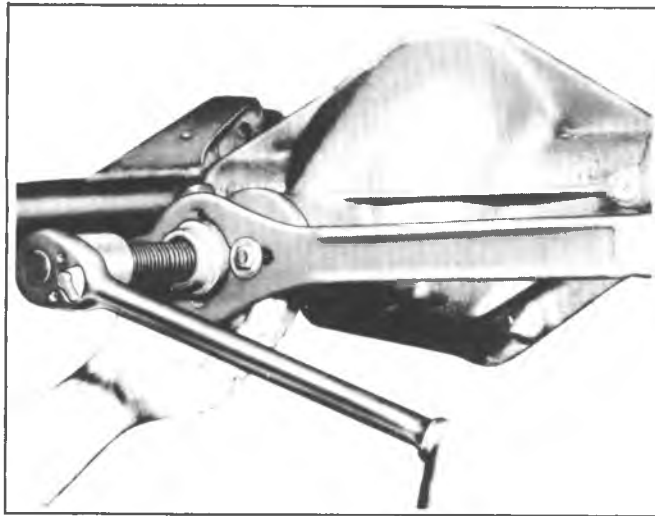


Fig. 4B-27--Drive Pinion Flange Removal

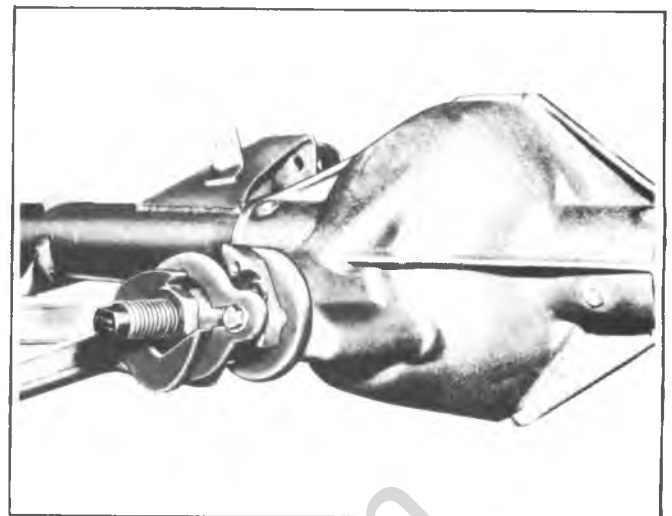


Fig. 4B-29--Installing Pinion Flange

installed position; seal must be square in carrier bore to seal properly against pinion flange.

4. Pack the cavity between end of pinion splines and pinion flange with a non-hardening sealer (such as Permatex Type A or equivalent) prior to installing washer and nut on pinion.

5. Using J-8614-11 as shown in figure 4B-29, install flange onto pinion. Install washer and nut, and tighten nut to original position. Refer to scribe marks and number of exposed threads, recorded earlier.

NOTICE: Do not attempt to hammer the flange onto pinion shaft. To do so may damage the ring gear and pinion.

6. Measure rotating torque of pinion and compare with torque recorded before removal. Tighten pinion nut in additional **small** increments until the torque necessary to rotate the pinion exceeds the original figure by 1 to 5 inch pounds. **Do not** exceed the original torque by more than 5 inch pounds.

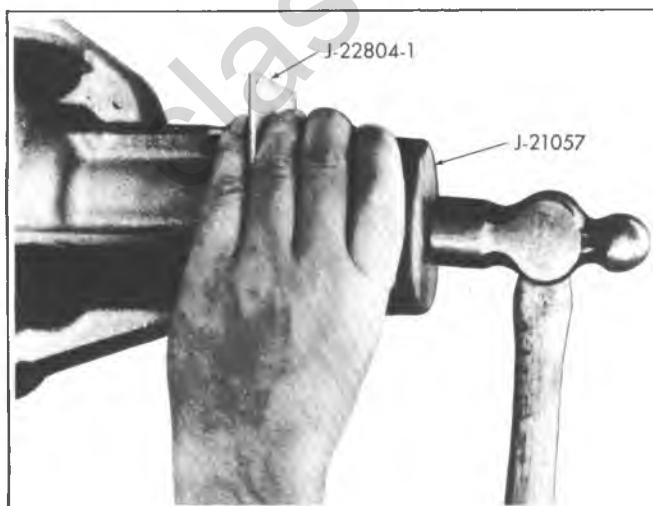


Fig. 4B-28--Pinion Oil Seal Installation

7. Reattach propeller shaft and torque to specifications. Reinstall brake drums and wheels.

NOTICE: See **NOTICE** on page 1 of this section regarding the fasteners referred to in step 7.

8. Lower vehicle and remove from hoist.

CHEVROLET 10-1/2" RING GEAR AXLES

AXLE ASSEMBLY

Service operations on these axle assemblies may be performed with the housing installed in the vehicle or with the housing installed in a holding fixture. There may be occasions, however, when it will be necessary to remove the complete housing assembly. The following axle assembly removal and installation procedure, therefore, is necessary only when housing replacement is required.

NOTICE: All axle attachments are important attaching parts. See **NOTICE** on page 1 of this section.

Removal

1. Raise vehicle, place stand jacks under frame side rails, and remove rear wheels.

2. Remove two trunnion bearing "U" bolts from the rear yoke, split rear universal joint, position propeller shaft to one side, and tie it to the frame side rail.

The bearings can be left on the trunnion and held in place with tape.

3. Remove hub and drum assembly and disconnect parking brake cable at lever and at flange plate. See Section 5 for cable removal.

4. Disconnect hydraulic brake hose at connector on rear axle housing. Refer to Section 5.

5. Disconnect shock absorbers at axle brackets.

6. Support axle assembly with hydraulic jack, remove spring "U" bolts, and lower axle assembly to the floor.

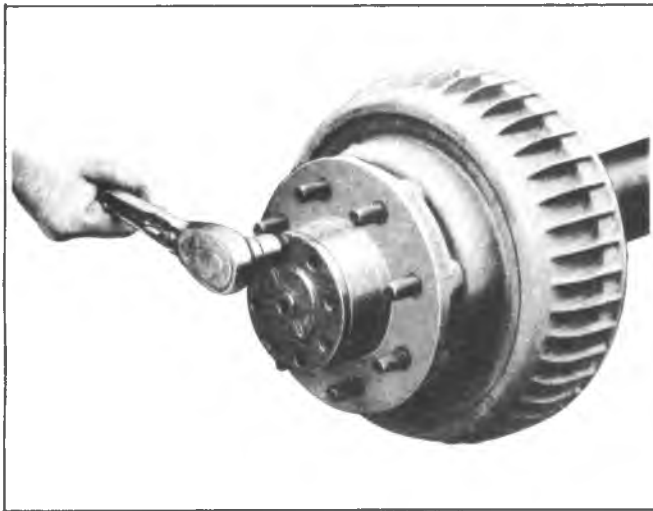


Fig. 4B-30—Removing Flange-to-Hub Bolts

Installation

1. Place axle assembly under vehicle, raise into position, install spring "U" bolts, anchor plates and nuts, and tighten securely.
 2. Connect and secure shock absorbers to axle brackets.
 3. Connect brake hose at connector on rear axle housing.
 4. Connect parking brake cable at lever and flange plate. Install hub and drum assembly. Bleed brake hydraulic system and adjust parking brake.
- Before reinstalling wheel hub and drum assembly replace hub oil seal.
5. Reassemble the rear universal joint, making sure that "U" bolts are drawn up tight and locked properly. Caution should be taken not to overtighten "U" bolt nuts and cause bearing cups to become distorted.
 6. Install rear wheels, remove stand jacks, and lower vehicle.
 7. Test operation of brakes and rear axle.

AXLE SHAFT

Replacement

1. Remove bolts that attach the axle shaft flange to the wheel hub. See figure 4B-30.
2. Rap on flange with a soft-faced hammer to loosen shaft. Grip the rib on end of flange with a pair of locking pliers and twist to start shaft removal. Remove shaft from axle tube.
3. Thoroughly clean both the axle shaft flange and the end of the wheel hub. Any lubricant on these surfaces tends to loosen axle shaft flange bolts.
4. Place a new gasket over the axle shaft and position the axle shaft in the housing so that the shaft splines enter the differential side gear. Position gasket so that holes are in alignment and install flange-to-hub attaching bolts. Torque bolts to specifications.

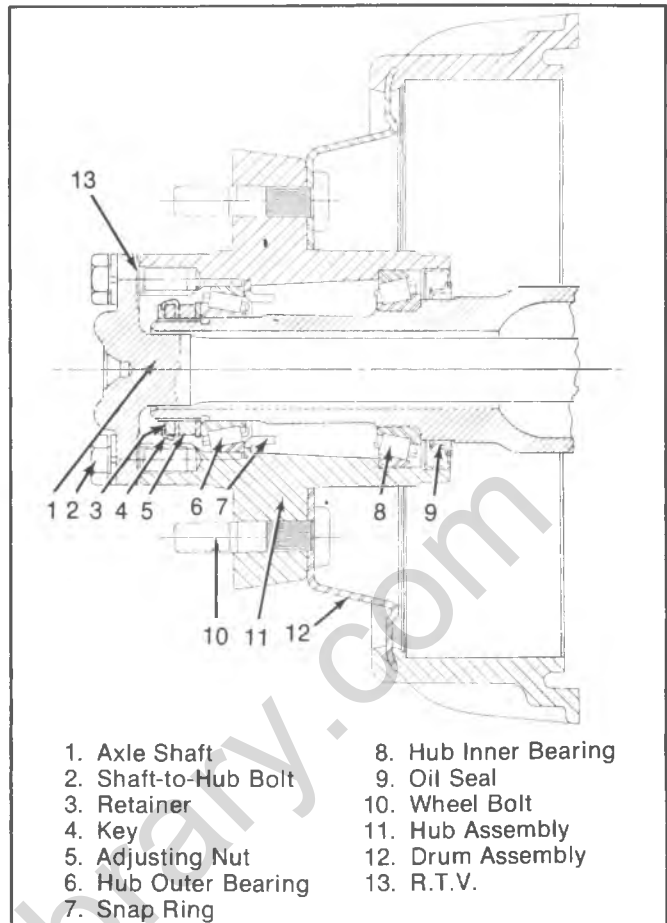


Fig. 4B-31—Hub and Drum Assembly—10-1/2" Axles

HUB AND DRUM ASSEMBLY—FIG. 4B-31

Removal

1. Remove axle shaft as outlined earlier.
2. Disengage tang of retainer from slot or flat of locknut, then remove locknut from housing tube, using J-2222, as shown in figure 4B-32.
3. Disengage tang of retainer from slot or flat of adjusting nut and remove retainer from housing tube.

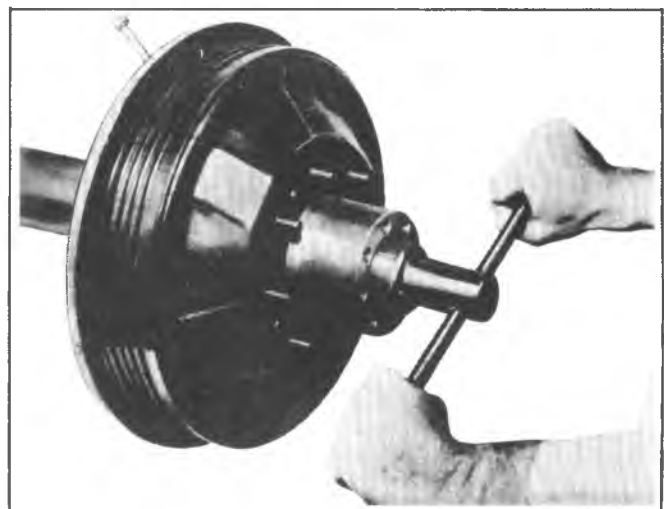


Fig. 4B-32—Removing Lock Nut—Typical

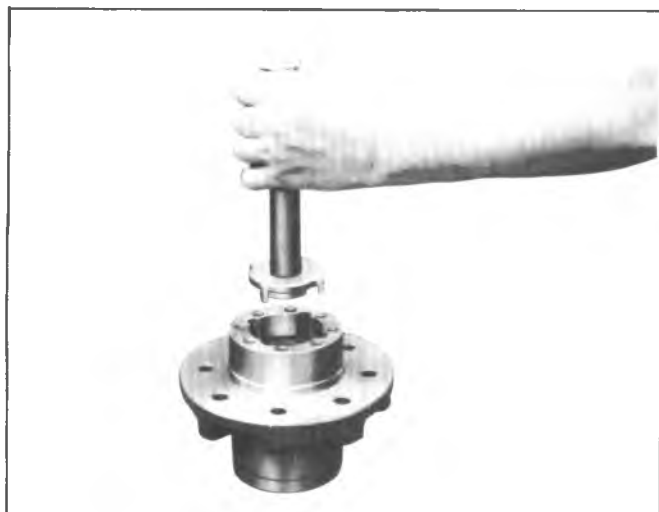


Fig. 4B-33--Removing Outer Bearing and Cup

4. Use appropriate tool as specified in Step 2 to remove adjusting nut from housing tube. Remove thrust washer from housing tube.

5. Pull hub and drum assembly straight off axle housing.

6. Remove oil seal, and discard.

Bearing/Cup-Removal

1. Use a hammer and long drift to knock the **inner** bearing, cup and oil seal from the hub assembly.

2. Remove **outer** bearing snap ring with a pair of pliers.

3. With J-24426 on Handle J-8092, as shown in figure 4B-33, drive **outer** bearing and cup from the hub assembly.

Inspection and Cleaning of Bearings

1. Inspect bearing rollers for excessive wear, chipped edges, and other damage. Slowly move rollers around cone to detect any flat or rough spots on rollers or cone.

2. Examine bearing cups in hub for pits, cracks, and other damage.

3. Examine axle shaft flange studs, wheel studs, hub splines, hub bore, and tapped holes for evidence of damage. Clean up threads or replace parts where required.

4. Examine oil seal sleeve for evidence of wear or roughness, check axle housing oil deflector and brake drum oil deflector for evidence of damage. Replace parts where required.

5. Examine brake drum for excessive scoring and other damage. To replace brake drum refer to "Brake Drum Replacement."

6. Immerse bearing cone and roller assemblies in cleaning solvent. Clean with stiff brush to remove old lubricant. Blow bearings dry with compressed air, directing air stream across bearing. Do not spin bearings while blowing them dry.

7. Thoroughly remove all lubricant from axle housing tube and from inside the hub, wipe dry. Make sure all particles of gasket are removed from outer end of hub, axle shaft, and hub cap.

8. Scrape old sealing compound out of oil seal bore in the hub.

Bearing/Cup-Installation

1. Place **outer** bearing into hub.

2. Install cup of outer bearing into hub by using Handle J-8092 and J-8608, **installed upside-down**. Be sure J-8608 is upside down on driver handle, so that chamfer does **not** contact bearing cup.

3. Drive cup **beyond** the snap ring groove.

4. Using a pair of pliers, install snap ring into its groove.

5. Drive cup back **against** snap ring by using J-24426, as shown in figure 4B-33.

6. To install **inner** bearing cup, use J-24427 on Handle J-8092. Drive cup into place until it seats against shoulder of hub bore.

7. Install new oil seal with J-24428.

Drum-Non-Demountable-Type-Fig. 4B-31

Replacement

Construction of the nondemountable-type hub and drum assembly is such that replacement cannot be accomplished with the hub assembly installed on the vehicle.

1. Separate the drum and hub by removing the drum-to-hub retaining bolts, hub stud nuts, or by pressing out the wheel studs, as applicable.

2. Position brake drum to hub assembly, making certain that all drain holes are in alignment.

3. Apply a light, even coating of sealing compound to the hub oil deflector contact surface, and position deflector to drum.

4. Install drum-to-hub retaining bolts, hub stud nuts, or press wheel studs into drum, as applicable.

Wheel Bolt

Replacement

Wheel bolts are serrated and may also be swaged in place; however, replacement procedure remains the same for both types of installation.

Press bolts out of hub flange and press new bolts into place, making sure they are a tight fit. If all bolts are removed, be sure that hub oil deflector is in position under bolt heads. See figure 4B-34.

Installation of Hub and Drum Assembly

1. Using a high melting point EP bearing lubricant, liberally pack bearings and apply a light coat on I.D. of hub bearing contact surface and O.D. of axle housing tube.

2. Make sure inner bearing, oil seal, axle housing oil deflector, and inner bearing race and oil seal are properly positioned.

3. Install hub and drum assembly on axle housing, exercising care so as not to damage oil seal or dislocate other internal components.

4. Install thrust washer so that tang on I.D. of washer is in keyway on axle housing.

5. Install adjusting nut and complete the installation as directed under "Bearing Adjustment."

BEARING ADJUSTMENT

Before checking bearing adjustment, make sure brakes are fully released and do not drag.

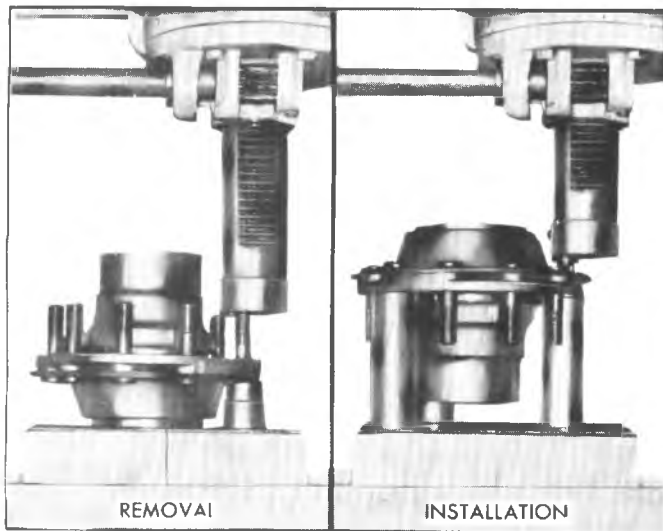


Fig. 4B-34--Wheel Bolt Replacement

Check bearing play by grasping tire at top and pulling back and forth, or by using a pry bar under tire. If bearings are properly adjusted, movement of brake drum in relation to brake flange plate will be barely noticeable and wheel will turn freely. If movement is excessive, adjust bearing as follows:

1. Remove axle shaft and raise vehicle until wheel is free to rotate.
2. Keyways and threads on tube and nut must be clean and free from chips, burrs and shavings.
3. Disengage tang of retainer and remove retainer from axle housing tube.
4. Torque adjusting nut to 50 ft. lbs., at the same time rotating the hub assembly and making sure bearing cones are seated and in contact with the spindle shoulder.

Proper wheel bearing adjustment can be made using tool J-2222-02 with some modification or tool J-2222-L (Fig. 4B-36).

5. Back off nut until loose.
6. If adjusting nut slot is in alignment with keyway in axle spindle, insert square key into slot. If adjusting nut slot is not aligned, back off nut a slight amount and insert square key into slot. Do not back off nut more than one slot to align key.
7. Assemble snap ring at end of spindle to retain key in position.

DRIVE PINION OIL SEAL

Replacement

The pinion oil seal may be replaced with the carrier assembly installed in the vehicle.

1. Disconnect propeller shaft.
2. Scribe a line down the pinion stem, pinion nut and companion flange.
3. Use J-8614-11 to remove the pinion nut and the companion flange.
4. Pry the oil seal from the bore, using care not to damage the machined surfaces. Thoroughly clean all foreign material from contact area.
5. Lubricate the cavity between the seal lips with a high melting point bearing lubricant.

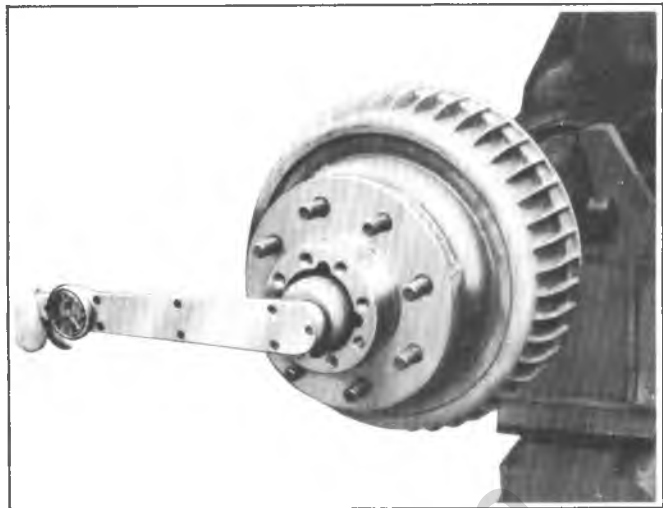


Fig. 4B-35--Tightening Adjusting Nut-Typical

6. Install a new pinion oil seal into the bore, using J-24434.
7. Reinstall the companion flange, pinion nut and propeller shaft.

NOTICE: See NOTICE on page 1 of this section, regarding the above fasteners.

DANA 10-1/2" RING GEAR AXLE DANA 9-3/4" RING GEAR AXLE

Procedures for service to axle assembly, axle shafts, hub and drum components and bearing adjustments are identical to those listed for "Chevrolet 10-1/2 Ring Gear Axle".

Drive pinion oil seal replacement requires different special tools for the Dana axles. Follow the same procedure listed for "Chevrolet 10-1/2" Ring Gear Axle"; use J-24384 for seal replacement on Dana 10-1/2" Ring Gear Axles, and use J-22281 for pinion oil seal replacement on Dana 9-3/4" Ring Gear Axles.

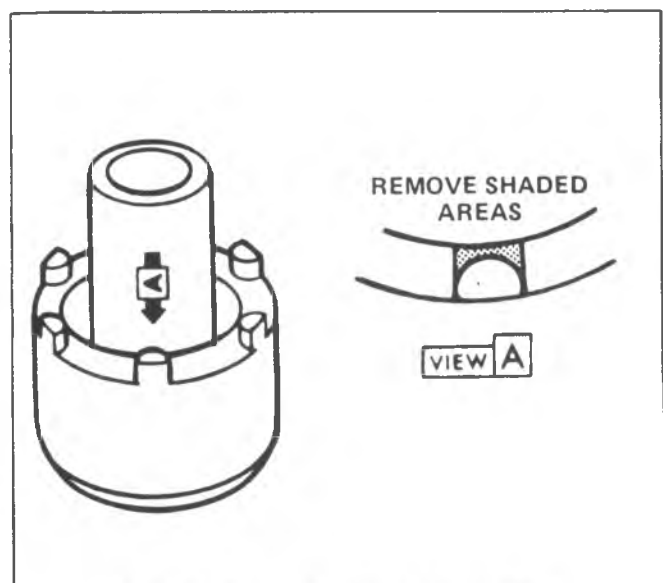


Fig. 4B-36--Wheel Bearing Adjusting Tool

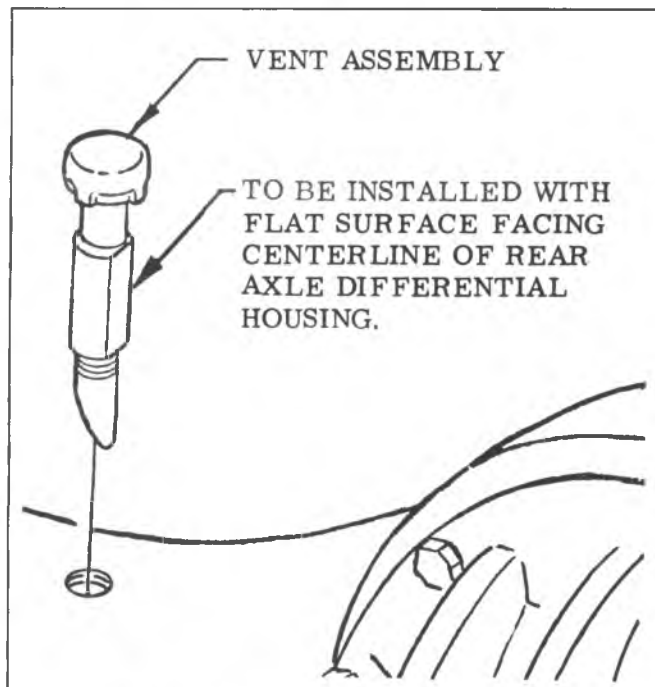


Fig. 4B-37--Typical Axle Vent Installation

12-1/4" RING GEAR AXLE

AXLE ASSEMBLY

The axle assembly removal and installation is identical to the procedure given earlier for "Chevrolet 10-1/2" Ring Gear Axle".

AXLE VENT

Replacement

Service replacement axle housing assemblies are not equipped with an axle vent; therefore, always make sure that a new vent assembly is installed when replacing the housing. If axle vent requires replacement, pry old vent from housing being sure that entire vent is removed. Prick punch around carrier hole to insure fit of replacement vent. Tap new vent into housing using a soft-faced hammer. Vent should be positioned in housing so that flat surface is toward centerline of differential carrier. See figure 4B-37.

AXLE SHAFT

Replacement

1. Remove hub cap, and install Tool J-8117 in tapped hole on shaft flange.
2. Install slide hammer, Tool J-2619, and remove axle shaft.
3. Thoroughly remove old gasket material from hub and hub cap. Clean shaft flange and mating surfaces in the wheel hub.
4. Install axle shaft so that the flange splines index into hub splines. Tap shaft into position, using J-8117 and J-2619.
5. Install new gasket, position flange to hub and install attaching bolts. Torque bolts to specifications.

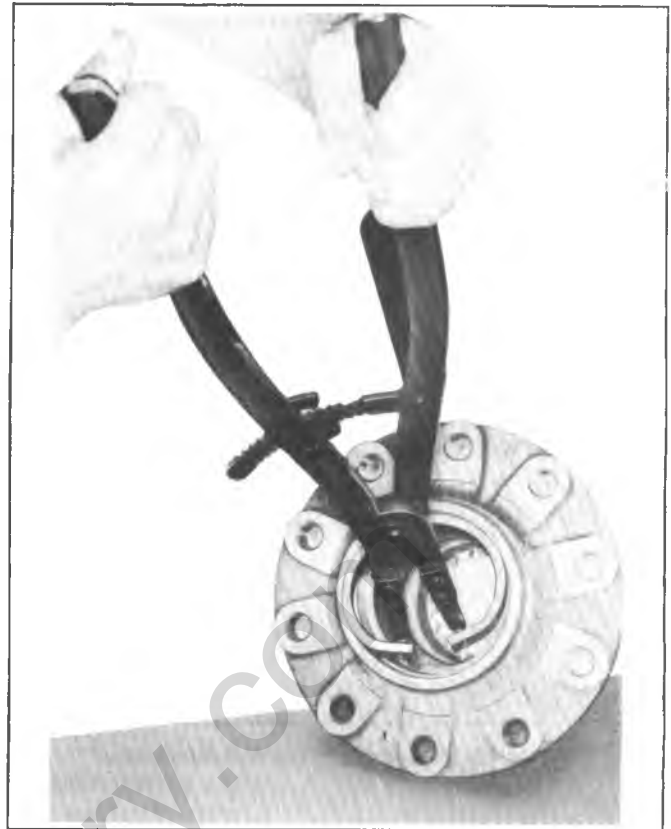


Fig. 4B-38--Removing Hub Outer Bearing Retainer Ring

HUB AND DRUM ASSEMBLY

Removal

Use the procedure given for "Chevrolet 10-1/2" Ring Gear Axle", and use J-0870 to remove the adjusting nut. Refer to figure 65.

Bearing Cup-Removal

1. Cut a suitable length of 1/2 inch steel bar stock for press-out tool.
2. Place bar stock tool behind inner bearing cup, index tool in provided notches, and press out cup with an arbor press.
3. Use J-22380, as shown in figure 4B-38, to remove outer bearing retainer ring.
4. Remove the outer bearing by driving on the axle shaft spacer, using the splined flange cut from an old axle shaft, as shown in figure 4B-39.

Inspection and Cleaning of Bearings

Refer to procedures listed for "Chevrolet 10-1/2" Ring Gear Axle.

Bearing Cup-Installation

1. To install **outer** bearing, place axle shaft spacer in hub, followed by the outer bearing. The larger O.D. of the bearing goes toward the outer end of the hub.
2. Position outer bearing cup in hub with the thin edge of the cup toward the outer end of the hub.
3. Press the cup into the hub, using J-8114 and Handle J-8092.
4. Withdraw cup installer, then install retainer ring, using J-22380 as shown in figure 4B-37. Press the cup into contact with the retainer ring as shown in figure 4B-39.

SPECIFICATIONS

DIFFERENTIAL SPECIFICATIONS

| | 8 1/2" | 8 7/8" | Dana 10 1/2" 9 3/4" | Chevrolet 10 1/2" | 12 1/4" |
|-----------------------------------|-------------|-------------|---------------------------|----------------------|-------------|
| Gear Backlash Preferred | .005"-.008" | .005"-.008" | .004"-.009" | .005"-.008" | .005"-.008" |
| Min. and Max. | .003"-.010" | .003"-.010" | .004"-.009" | .003"-.012" | .003"-.012" |
| Pinion Bearing Preload (In.-Lbs.) | | | | | |
| — New | 15-30 | 15-30 | 20-40 | 25-35 | |
| — Used | 5-10 | 5-10 | 10-20 | 5-15 | |

BOLT TORQUES (FT.-LBS.)▲

| | 8 1/2" | 8 7/8" | Dana 10 1/2" 9 3/4" | Chevrolet 10 1/2" | 12 1/4" |
|---------------------------|--------|--------|---------------------------|----------------------|---------|
| Carrier Cover | 20 | 20 | 35 | 30 | — |
| Ring Gear | 80 | 60 | 110 | 120 | 105 |
| Differential Bearing Caps | 55 | 55 | 85 | 135 | 205 |

▲Except where noted otherwise.

BOLT TORQUES (FT.-LBS.)▲

| | 8 1/2" | 8 7/8" | Dana 10 1/2" 9 3/4" | Chevrolet 10 1/2" | 12 1/4" |
|--------------------------------------|--------|--------|---------------------------|----------------------|---------|
| Filler Plugs | 25 | 18 | 10 | 18 | 10 |
| Differential Pinion Lock | 20" # | 20" # | — | — | — |
| Drive Pinion Nut | | — | * | * | 220 |
| Differential Carrier to Axle Housing | | — | — | — | 85 |
| Differential Bearing Adjusting Lock | | — | — | 20 | 15 |
| Pinion Bearing Cage To Carrier | | — | — | 65 | 165 |
| Thrust Pad Lock Nut | | — | — | — | 135 |
| Brake Backing Plate | 35 | 35 | 105 | 105 | 155 |
| Axle Shaft To Hub Bolts | | — | 115 | 115 | 15 |

*Torque as necessary to obtain correct preload.

| Ring Gear Size | Lubricant Capacity |
|-------------------|--------------------|
| 8 1/2" | 4.2 Pints |
| 8 7/8" | 3.5 Pints |
| Chevrolet 10 1/2" | 5.4 Pints |
| Dana 10 1/2" | 7.2 Pints |
| Dana 9 3/4" | 6.0 Pints |
| 12 1/4" | 14.0 Pints |

| MODEL | SOURCE | TYPE/CAPACITY | RING GEAR SIZE |
|-------|-----------|------------------|----------------|
| C10 | Chevrolet | Salisbury/3750# | 8-7/8" |
| C10 | Chevrolet | Salisbury/3750# | 8-1/2" |
| K10 | Chevrolet | Salisbury/3750# | 8-7/8" |
| K10 | Chevrolet | Salisbury/4000# | 8-7/8" |
| P10 | Chevrolet | Salisbury/3500# | 8-7/8" |
| G10 | Chevrolet | Salisbury/3500 # | 8-7/8" |
| G10 | Chevrolet | Salisbury/3100# | 8-1/2" |

| | | | |
|--------------------------|-----------|-----------------|---------|
| C20 (Except Crew Cab) | Chevrolet | Salisbury/5700# | 10-1/2" |
| C20 (Crew Cab) | Chevrolet | Salisbury/7500# | 10-1/2" |
| K20 | Chevrolet | Salisbury/5700# | 10-1/2" |
| P20 | Chevrolet | Salisbury/5700# | 10-1/2" |
| G20 | Chevrolet | Salisbury/3500# | 8-7/8" |
| G20 | Chevrolet | Salisbury/3500# | 8-1/2" |

| | | | |
|--|-----------|-----------------|---------|
| C30 K30 (Except Dual Wheel Camper) | Chevrolet | Salisbury/7500# | 10-1/2" |
| C30 K30 (Dual Wheel Camper) | Dana | Salisbury/7500# | 10-1/2" |
| P30 | Chevrolet | Salisbury/7900# | 10-1/2" |
| P30 (With H22/H23) | Chevrolet | Banjo/11,000# | 12-1/4" |
| G30 | Chevrolet | Salisbury/5700# | 10-1/2" |
| G30 (Dual Wheel) | Dana | Salisbury/6200# | 9-3/4" |
| G30 (Dual Wheel) | Dana | Salisbury/7500# | 10 1/2" |

REAR WHEEL BEARING ADJUSTMENT SPECIFICATION

| RING GEAR SIZE | BEARING ADJUSTING NUT TORQUE* | ADJUSTING NUT BACK-OFF* | OUTER LOCKNUT TORQUE | RESULTING BEARING ADJUSTMENT | TYPE OF BEARING |
|----------------|-------------------------------|-------------------------|----------------------|------------------------------|-------------------|
| 10-1/2" | 50 FT. LBS. | | | .001 TO .010 END PLAY | TAPERED ROLLER |
| 9-3/4" | 50 FT. LBS. | ** | 65 FT. LBS. | | |
| 12-1/4" | 90 FT. LBS. | 1/8 * | 250 FT. LBS. | SLIGHT PRELOADED | BARREL ROLLER |

**Back-off nut and retighten to 35 Ft. Lbs. then, back-off nut 1/4 turn.

*With wheel rotating.

Specifications Chart 4B-A2

SPECIAL TOOLS

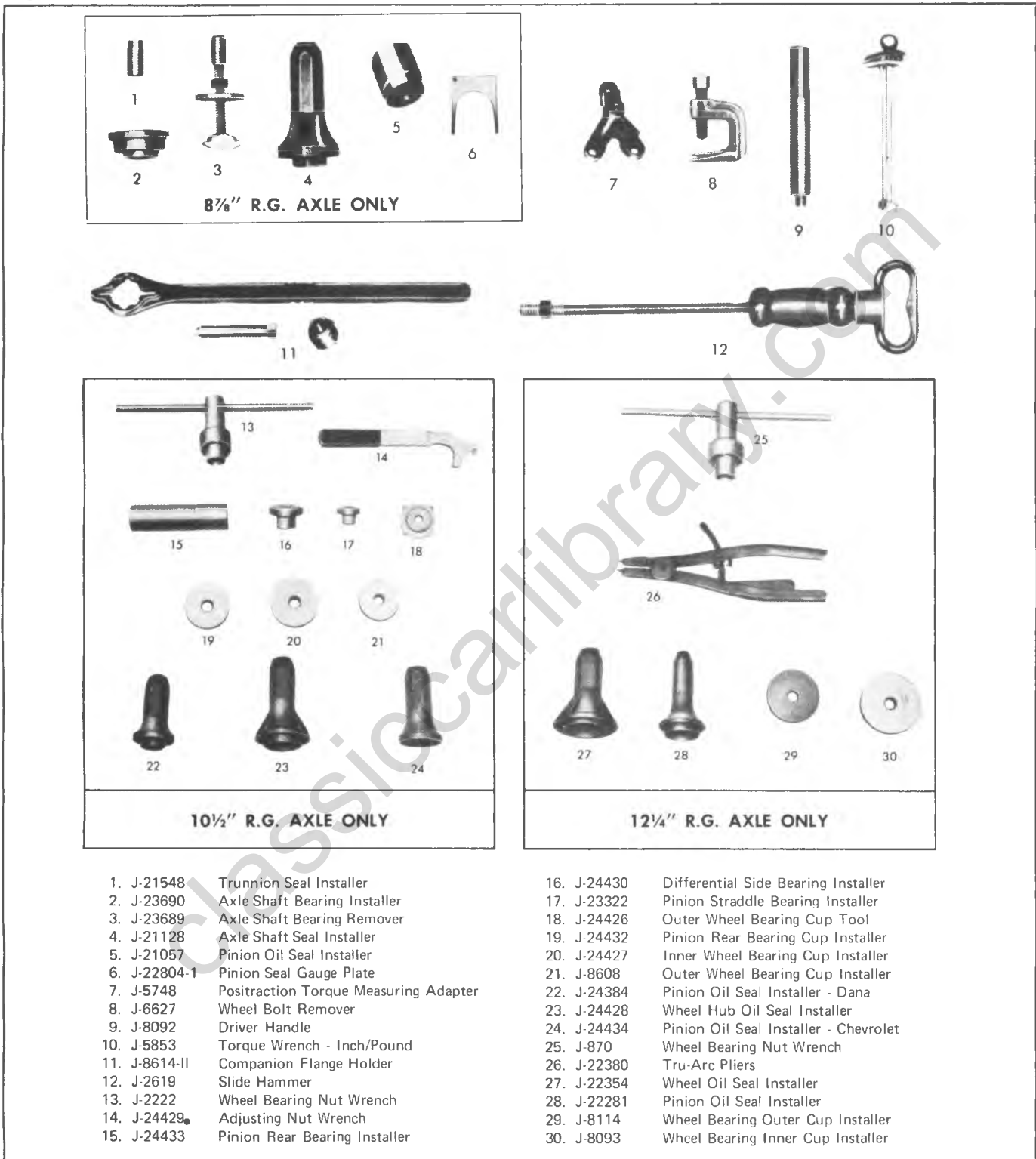


Fig. 4B-42--Special Tools

SECTION 4C

FRONT WHEEL DRIVE

The following notice applies to one or more steps in the assembly procedure of components in this portion of the manual as indicated at appropriate locations by the terminology "See Notice on page 1 of this Section"

NOTICE: This fastener is an important attaching part in that it could affect the performance of vital components and systems, and/or could result in major repair expense, it must be replaced with one of the same part number or with an equivalent part if replacement becomes necessary. Do not use a replacement part of lesser quality or substitute design. Torque values must be used as specified during reassembly to assure proper retention of this part.

CONTENTS

| | |
|-----------------------------------|------|
| General Description..... | 4C-1 |
| Diagnosis..... | 4C-1 |
| Front Axle Assembly..... | 4C-1 |
| Removal..... | 4C-1 |
| Installation..... | 4C-1 |
| Repair Axle Joint Components..... | 4C-3 |
| Specifications..... | 4C-4 |

GENERAL DESCRIPTION

The front axle is a hypoid gear axle unit equipped with steering knuckles. Axle assembly number and production date are stamped on left tube of assembly.

K 10-20 Models use a Chevrolet or the Dana (44 Series) front axle, both incorporate a 8-1/2" ring gear. A 4500 lb. capacity unit is used on the K-30 Model. The K-30 axle assembly is a Dana (60 Series) which incorporates a 9-3/4" ring gear.

FRONT AXLE ASSEMBLY (Refer to Fig. 4C-2)

Removal

1. Raise front of vehicle on hoist until weight is removed from front springs. Support truck with jack stands behind front springs.
2. Disconnect propeller shaft from front axle differential.
3. Disconnect connecting rod from steering arm.
4. Remove and support caliper.
5. Disconnect shock absorbers from axle brackets.
6. Disconnect axle vent tube clip at the differential housing (see fig. 4C-3).
7. Dismount "U" bolts from axle to separate axle from truck springs.
8. Raise truck to clear axle assembly and roll front axle out from under the truck.

Installation

NOTICE: See NOTICE on page 1 of this section regarding the fasteners referred to in steps 3, 5, 6 and 8.

1. Truck should be on jack stands as in Step 1 of removal instructions.
2. Place axle in position under truck.
3. Install "U" bolts attaching axle to front springs.
4. Attach shock absorbers to axle brackets.
5. Install caliper (see Section 5).
6. Attach connecting rod to steering arm.
7. Remove jack stands and lower front of truck.
8. Assemble propeller shaft to front axle differential.
9. Lower vehicle to floor.

BEARINGS AND RACES

FRONT WHEEL, PINION, DIFFERENTIAL SIDE AND REAR WHEEL ROLLER BEARINGS

DIAGNOSIS

| | EXCESS NOISE COMPLAINT DIAGNOSTIC PROCEDURE |
|-------------------------------------|--|
| Road Test | <ol style="list-style-type: none"> 1. Check tires for irregular wear 2. Check tire pressure 3. Check lubricant level 4. Drive to warm-up rear axle 5. Test at various speeds in drive, float, coast and cornering |
| Tire Noises | <ol style="list-style-type: none"> 1. Change tire pressure to minimize noises 2. Drive over different road surfaces 3. Smooth black-top minimizes tire noise 4. Cross switch tires, if necessary 5. Snow tire treads and studs caused added noises |
| Engine or Exhaust Noises | <ol style="list-style-type: none"> 1. Drive slightly above speed where noise occurs, place transmission in neutral 2. Let engine speed drop to idle 3. Stop car 4. Run engine at various speeds |
| Test for Wheel Bearing Noise | <ol style="list-style-type: none"> 1. Drive car at low speed on a smooth road 2. Turn car to develop left and right motions, traffic permitting 3. Noise should change due to cornering loads 4. Jack-up wheels to verify roughness at wheels |
| Test for Differential Bearing Noise | <ol style="list-style-type: none"> 1. Drive car at low speed on a smooth road 2. Constant low pitch bearing noise may be heard 3. Noise should not change in reversing turns 4. Noise pattern should vary with wheel speed |
| Test for Pinion Bearing Noise | <ol style="list-style-type: none"> 1. Roughness or whine noise should increase with speed 2. Noise pitch should be higher than differentials 3. Test on smooth road to minimize tire noises 4. Test at various speeds in drive, float, and coast 5. Rear pinion bearing noise may be louder on acceleration 6. Front pinion bearing noise may be louder on deceleration 7. Gear noises tend to peak in a narrow speed range |

Fig. 4C-1--Bearing Diagnosis

Disassembly

Refer to Section 3C for hub, spindle and knuckle removal and installation procedures.

1. Securely mount the axle assembly in a suitable holding fixture.

2. If the vehicle is not equipped with RPO F76 freewheeling hubs, remove the hub cap and snap ring.

3. Remove the drive gear and pressure spring. Place a hand over the drive gear and use a screwdriver to pry the gear out.

4. Remove the wheel bearing outer lock nut, lock ring, and wheel bearing inner adjusting as outlined in Section 3C.

5. Remove the disc assembly outer wheel bearing and the spring retainer plate.

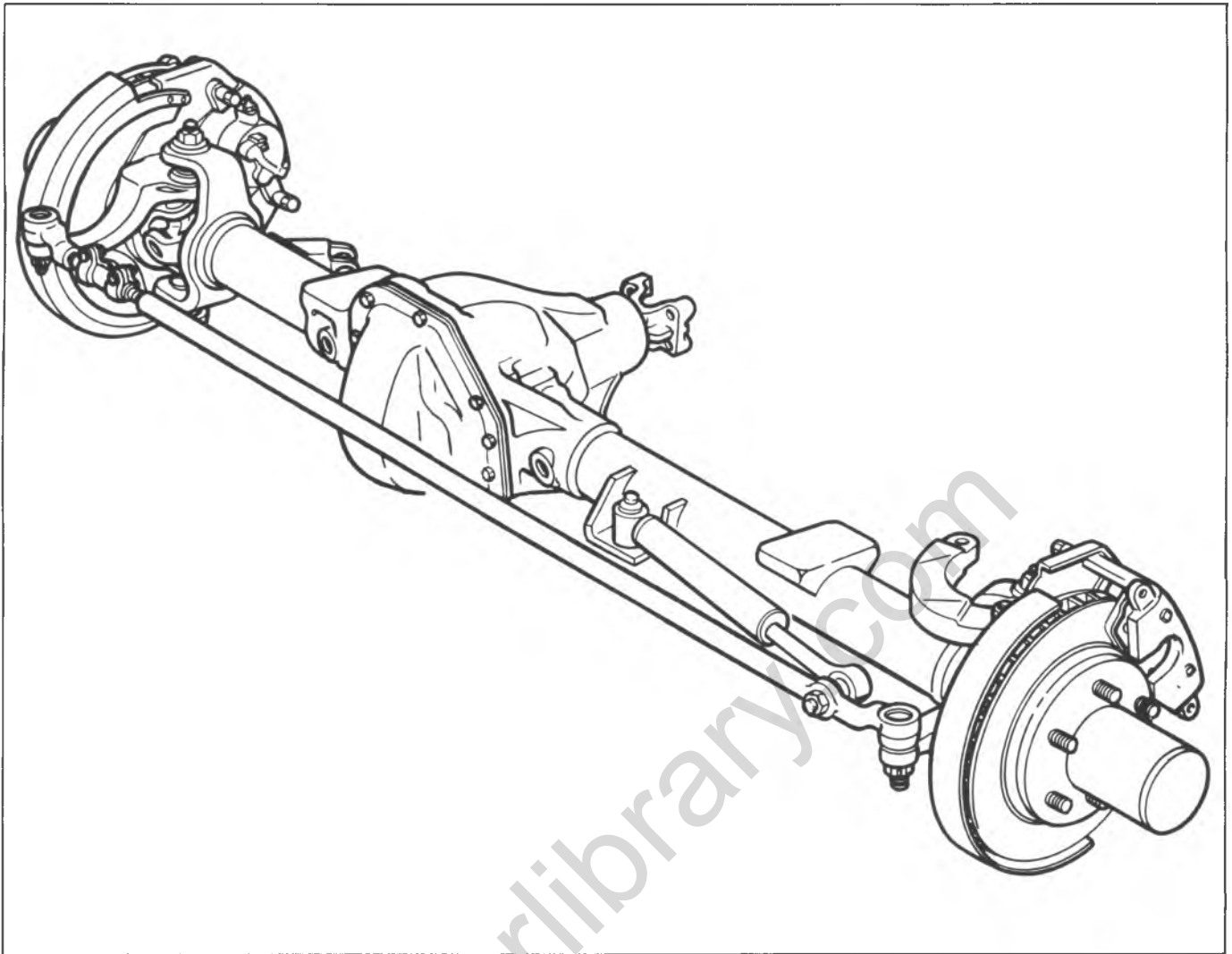


Fig. 4C-2--Front Drive Axle Typical

If the disc or other brake components require repairs or replacement, refer to Section 5.

Repair The Axle Joint Components:

1. Remove the lock rings after removing pressure from the trunnion bearings by squeezing the ends of the bearing in a vise.

2. Support the shaft yoke in a bench vise or on a short length of pipe.

3. Using a brass drift and a soft hammer, drive on end of one trunnion bearing just far enough to drive opposite bearing from yoke.

4. Support the other side of the yoke in the vise and drive the other bearing out by tapping on the end of the trunnion using a brass drift.

5. Remove trunnion.

6. Clean and inspect bearings. Lubricate with a high melting point type wheel bearing grease.

7. Replace trunnion and press new or relubricated bearings into yoke and over trunnion hubs far enough to install lock rings.

8. Hold trunnion in one hand and tap yoke lightly to seat bearings against lock rings.

Assembly

Reverse disassembly procedure.

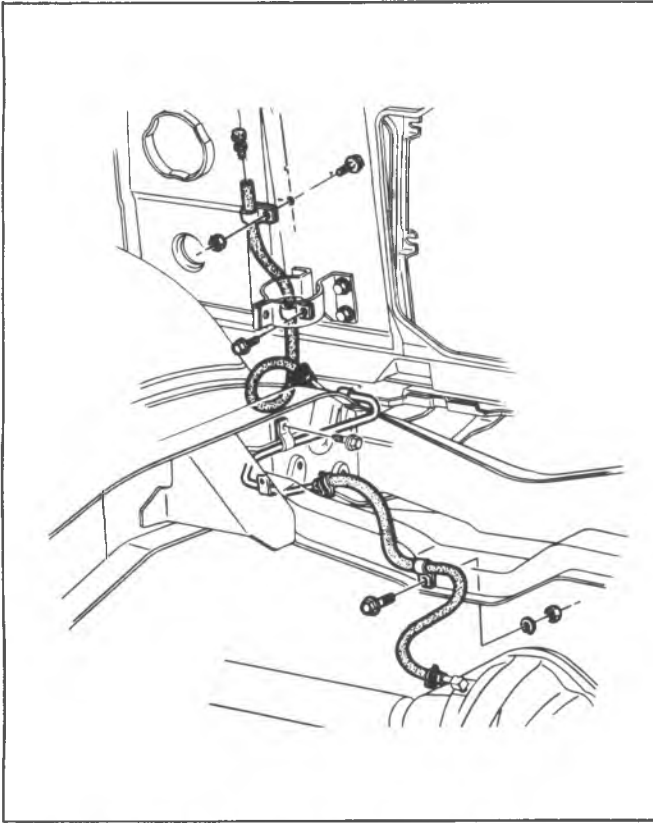


Fig. 4C-3-Axle Vent Hose Routing Typical

classiccarlibrary.com

SPECIFICATIONS

CHEVROLET

| Axle | Bolt Torques (Ft.-Lbs.) | Axle | Bolt Torques (Ft.-Lbs.) |
|-----------------------------|----------------------------|---------------------------|----------------------------|
| Gear and Backlash Preferred | .005-.008 | Carrier Cover | 20 |
| Min. and Max. | .003-.010 | Ring Gear | 80 |
| New Pinion Bearing Preload | 15-30 in.-lbs. | Differential Bearing Caps | 55 |
| Used Pinion Bearing Preload | 5-10 in.-lbs. | Filler Plugs | 25 |
| | | | |
| | | | |

DANA

| Axle | Bolt Torques (Ft.-Lbs.) | Axle | Bolt Torques (Ft.-Lbs.) |
|-----------------------------|----------------------------|---------------------------|----------------------------|
| Gear Backlash Preferred | .004"-.009" | Carrier Cover | 35 |
| Min. and Max. | .004"-.009" | Ring Gear* — K-30 | 110 |
| New Pinion Bearing Preload | 20-40 in.-lbs. | Differential Bearing Caps | 85 |
| Used Pinion Bearing Preload | 10-20 in.-lbs. | Filler Plugs | 10 |
| | | Drive Pinion Nut** — K-30 | 270 |
| | | *K-10-20 | 53 |
| | | **K-10-20 | 210 |
| | | | |
| | | | |

classiccarylbrary.com

SECTION 5

BRAKES

The following notice applies to one or more steps in the assembly procedure of components in this portion of the manual as indicated at appropriate locations by the terminology "See Notice on page 1 of this section".

NOTICE: This fastener is an important attaching part in that it could affect the performance of vital components and systems, and/or could result in major repair expense. It must be replaced with one of the same part number or with an equivalent part if replacement becomes necessary. Do not use a replacement part of lesser quality or substitute design. Torque values must be used as specified during reassembly to assure proper retention of this part.

CAUTION: When servicing wheel brake parts, do not create dust by grinding or sanding brake linings or by cleaning wheel brake parts with a dry brush or with compressed air. (A water dampened cloth should be used.) Many wheel brake parts contain asbestos fibers which can become airborne if dust is created during servicing. Breathing dust containing asbestos fibers may cause serious bodily harm."

CONTENTS

| | | | |
|--|------|--|------|
| General Description..... | 5-1 | Delco Disc Brake Shoe and Lining | 5-25 |
| Diagnosis | 5-2 | Bendix Disc Brake Shoe and Lining..... | 5-29 |
| On-Vehicle Service..... | 5-10 | Caliper Overhaul..... | 5-31 |
| Pedal Travel | 5-10 | Rotor Servicing | 5-33 |
| Stop Light Switch | 5-10 | Brake Drum Shoe and Lining..... | 5-34 |
| Bleeding and Flushing Brakes..... | 5-10 | Standard Drum Brake | 5-34 |
| Hydro-Boost Bleeding Procedure..... | 5-11 | Propeller Shaft Brake..... | 5-36 |
| Brake Pipes..... | 5-11 | Brake Drums..... | 5-38 |
| Brake Hoses | 5-16 | Wheel Cylinder | 5-38 |
| Parking Brake Pedal or Handle..... | 5-16 | Power Brake Unit | 5-39 |
| Parking Brake Adjustment..... | 5-17 | Vacuum Booster..... | 5-39 |
| Parking Brake (Propshaft) Internal Expanding | 5-20 | Hydro-Boost Unit | 5-39 |
| Parking Brake Cable..... | 5-20 | Specifications..... | 5-48 |
| Combination Valve | 5-20 | Brake System Description | 5-48 |
| Brake Pedal | 5-21 | Torque Specifications..... | 5-49 |
| Brake Pedal Rod..... | 5-21 | Special Tools | 5-50 |
| Master Cylinder | 5-22 | | |

GENERAL DESCRIPTION

All vehicles are equipped with a dual hydraulic brake system.

The split system consists basically of two separate brake systems. When a failure is encountered on either, the other is adequate to stop the vehicle. If one system is not functioning, it is normal for the brake pedal lash and pedal effort to substantially increase. This occurs because of the design of the master cylinder which incorporates an actuating piston for each system. When the rear system loses fluid, its piston will bottom against the front piston. When the front system loses fluid, its piston will bottom on the

end of the master cylinder body. The pressure differential in one of the systems causes an uneven hydraulic pressure balance between the front and rear systems. The combination valve (near the master cylinder) detects the loss of pressure and illuminates the brake alarm indicator light on the instrument panel. The pressure loss is felt at the brake pedal by an apparent lack of brakes for most of the brake travel and then, when failed chamber is bottomed, the pedal will harden.

If a vehicle displays these symptoms, it is a good indication that one of the systems contains air or has failed, and it is necessary to bleed or repair the brakes.

MASTER CYLINDER

The system is designed with a separate hydraulic system for the front and rear brakes using a dual master cylinder. The cylinder has two separate reservoirs and outlets in a common body casting.

COMBINATION VALVE

All models, except JF9 equipped vehicles, have a combination valve. The front and rear hydraulic lines are routed through this combination "metering" and "brake failure warning switch" to their appropriate wheel cylinders or caliper.

The metering portion of the combination valve tends to "hold off" front hydraulic pressure until the rear brake system overcomes the pull back springs; then pressure is allowed to flow with the result being a good distribution of braking effort.

The brake failure warning switch portion of the combination valve "senses" a loss of hydraulic pressure, if a failure should occur, and turns "on" a red light in the dash to warn the operator of the failure.

DIAGNOSIS

INSPECTION AND TESTING BRAKES

Testing Brakes

New linings must be protected from severe use for several hundred miles.

Brakes should be tested on dry, clean, reasonably smooth and level roadway. A true test of brake performance cannot be made if roadway is wet, greasy or covered with loose dirt so that all tires do not grip the road equally. Testing will also be adversely affected if roadway is crowned so as to throw weight of vehicle toward wheels on one side or if roadway is so rough that wheels tend to bounce.

Test brakes at different vehicle speeds with both light and heavy pedal pressure; however, avoid locking the wheels and sliding the tires on roadway. Locked wheels and sliding tires do not indicate brake efficiency since heavily braked but turning wheels will stop vehicle in less distance than locked wheels. More tire-to-road friction is present with a heavily braked turning tire than with a sliding tire.

External Conditions that Affect Brake Performance

1. **Tires**-- Tires having unequal contact and grip on road will cause unequal braking. Tires must be equally inflated and tread pattern of right and left tires must be approximately equal.

2. **Vehicle Loading**-- When vehicle has unequal loading, the most heavily loaded wheels require more braking power than others. A heavily loaded vehicle requires more braking effort.

3. **Front Wheel Bearings**-- A loose front wheel bearing permits the drum to tilt and have spotty contact with the brake shoe linings causing erratic action.

DISC BRAKES FRONT

All models have disc brakes on the front. The one piece caliper mounts on the steering knuckle/steering arm, which is also a one piece casting, and astride the brake disc. The caliper is the single piston design which is said to be a sliding caliper sliding piston. No front brake adjustment is necessary once the system is in operation and the pedal has been stroked to "seat" the shoes to the caliper.

DISC BRAKES REAR (JF9)

Rear disc brakes operate in the same manner as front disc brakes except the caliper is mounted to a support attached to the axle flange.

DRUM BRAKES REAR

The rear brakes are duo servo and self adjusting. Brake adjustment takes place when the brakes are applied with a firm pedal effort while the vehicle is backing up. Applying the brakes moves the actuator which turns the star wheel and lengthens the adjuster screw assembly. This action moves the shoes outward until clearance between the lining and drum is within proper limits.

4. **Front End Alignment**-- Misalignment of the front end, particularly in regard to limits on camber and theoretical king pin inclination, will cause the brakes to pull to one side.

HYDRO-BOOST

Prior to performing the Booster Function Tests, or the Accumulator Leakdown Test, the following preliminary checks must be made:

NOTICE: Power steering fluid and brake fluid cannot be mixed. If brake seals contact steering fluid or steering seals contact brake fluid, seal damage will result.

1. Check all power steering and brake lines and connections for leaks and/or restrictions.
2. Check and fill brake master cylinder with BRAKE FLUID.
3. Check and fill power steering pump reservoir with POWER STEERING FLUID. Be sure fluid is not aerated (air mixed with fluid).
4. Check power steering pump belt for tension and/or damage. Adjust if necessary.
5. Check engine idle speed and adjust if necessary.
6. Check steering pump pressure; Refer to Section 3B.

SEAL LEAK DIAGNOSIS (FIG. 5-1)

1. **INPUT ROD SEAL:** A damaged seal will show up as a fluid leak from the mounting bracket vent hole. The booster must be removed from the vehicle and disassembled. The input rod bore should be checked for any scratches that

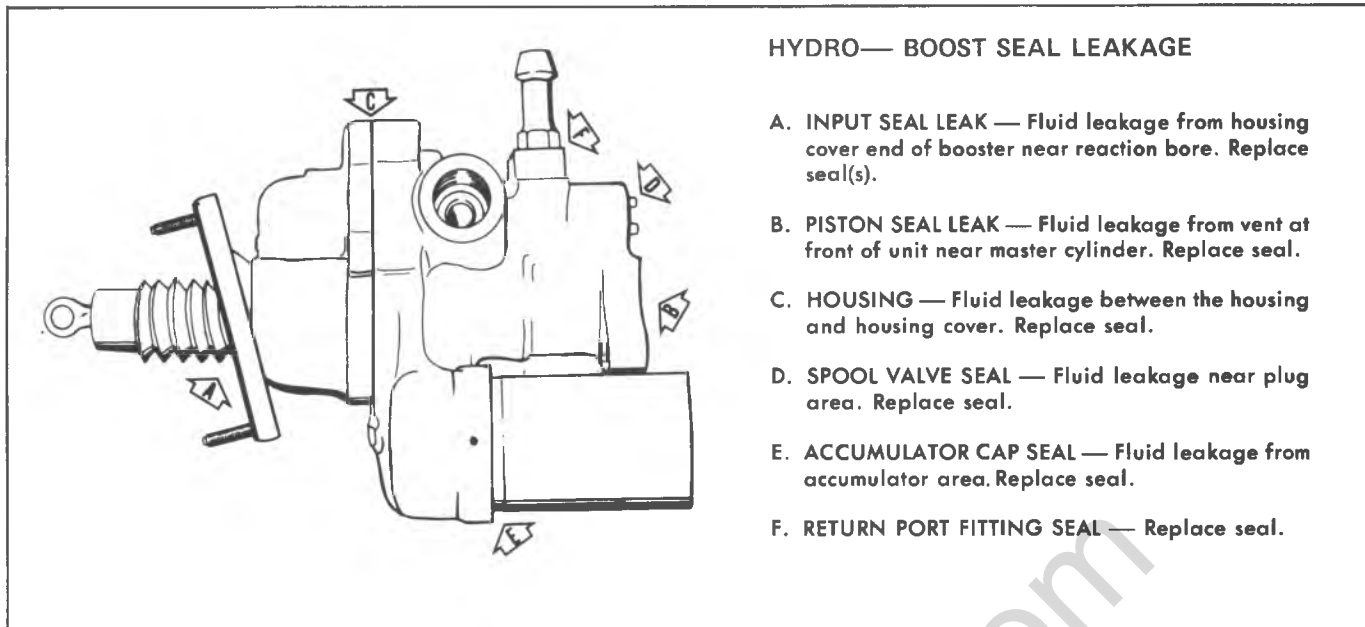


Fig. 5-1--Seal Leakage Diagnosis

may cause the leak. If scratches are present, housing cover must be replaced. If no excessive scratches are present, then the booster seal kit can be used to replace the appropriate seals.

2. **POWER PISTON SEAL:** Power piston seal damage will be noticed by fluid leaking out at the common master cylinder-brake booster vent and possible reduction in power assist. The booster must be removed from the vehicle and disassembled. The piston should be checked for any scratches that may be the cause of the leak. If scratches are present, then the input rod and power piston assembly must be replaced. If no excessive scratches are present, then the booster seal kit can be used to replace the appropriate seals.

3. **HOUSING SEAL:** If the housing seal is damaged, fluid will leak out from between the two housings. The booster must be removed from the vehicle and disassembled. The booster seal kit should be used to replace the housing and input rod and power piston seals.

4. **SPOOL VALVE PLUG "O" RING SEAL:** Damage to this seal will be noticed by fluid leaking out past the plug. The booster need not be removed from the vehicle. The master cylinder should be disconnected from the booster.

Press in on spool plug, insert a small screwdriver between snap ring and housing bore. This unseats one side of the spool plug snap ring from its groove in the bore. Then remove the snap ring from the bore.

5. **ACCUMULATOR "O" RING SEAL:** Damage to this seal will result in fluid leakage past the accumulator cap. The seal can be replaced while the booster is installed on the vehicle. A catch basin should be placed under the booster to catch the fluid when the accumulator or spring cap is removed.

CAUTION: Before removing the cap, the brake pedal must be pumped 4-5 times to deplete accumulator pressure. Refer to

HYDRO— BOOST SEAL LEAKAGE

- A. **INPUT SEAL LEAK** — Fluid leakage from housing cover end of booster near reaction bore. Replace seal(s).
- B. **PISTON SEAL LEAK** — Fluid leakage from vent at front of unit near master cylinder. Replace seal.
- C. **HOUSING** — Fluid leakage between the housing and housing cover. Replace seal.
- D. **SPOOL VALVE SEAL** — Fluid leakage near plug area. Replace seal.
- E. **ACCUMULATOR CAP SEAL** — Fluid leakage from accumulator area. Replace seal.
- F. **RETURN PORT FITTING SEAL** — Replace seal.

"Pneumatic Accumulator On-Vehicle Service Procedure".

6. **EXTERNAL LEAKAGE AT THE RETURN PORT FITTING:** Tighten fitting to 7 lb. ft. (10 N·m). If it continues to leak, replace "O" ring under fitting.

7. **EXTERNAL LEAKAGE AT THE HIGH PRESSURE GEAR OR PUMP:** Torque tube nut to 30 lb. ft. (40 N·m). If it continues to leak, check for damaged tube flares; if OK, replace tube seats.

TROUBLE SHOOTING AND TESTING (Fig. 5-2)

The Hydro-Boost differs from vacuum brake boosters not only in the source of power (hydraulic versus vacuum) but in the fact that it is also a part of another major subsystem of the vehicle--the power steering system. Therefore, problems or malfunctions in the steering system may affect the operation of the booster, just as a problem in the booster may affect the steering system. The following noises are associated with the Hydro-boost system and may or may not be cause for customer complaint. Some are normal and for the most part temporary in nature. Others may be a sign of excessive wear or the presence of air in either the booster or the steering system.

1. Moan or low frequency hum usually accompanied by a vibration in the pedal and/or steering column may be observed during parking maneuvers or other very low speed maneuvers. This may be caused by a low fluid level in the power steering pump or by air in the power steering fluid due to holding the pump at relief pressure (steering wheel held all the way in one direction) for an excessive amount of time (more than 5 seconds). Check the fluid level and fill to mark. System must sit for 1 hour to remove the air. If the condition persists, this may be a sign of excessive pump wear and the pump should be checked; Refer to Section 3B.

2. At or near power runout, (brake pedal near fully depressed position) a high speed fluid noise (faucet type) may be heard. This is a normal condition and will not be heard except in emergency braking conditions, or with

vehicle stopped and pedal pushed near fully depressed position.

3. Whenever the accumulator pressure is used, a slight hiss may be noticed. It is the sound of the hydraulic fluid escaping through the accumulator valve, and is completely normal.

4. After the accumulator has been emptied, and the engine is started again, another hissing sound may be heard during the first brake application or the first steering maneuver. This is caused by the fluid rushing through the accumulator charging orifice. It is normal and will only be heard once after the accumulator is emptied. However, if this sound continues, even though no apparent accumulator pressure assist was made, it could be an indication that the accumulator is not holding pressure and should be checked using the procedure for "ACCUMULATOR LEAKDOWN TEST".

5. After bleeding, a "gulping" sound may be present during brake applications as noted in the bleeding instructions.

CHECKING THE RESERVE SYSTEM

1. Start engine and charge accumulator by applying the brake pedal or by turning the steering wheel from stop to stop. Turn off engine and let vehicle sit for one hour. After one hour there should be at least two power assisted applications with the engine off.

2. If the reserve system will not retain a charge for one hour, but functions normally immediately following charging, the accumulator valves are at fault and the booster must be disassembled and the accumulator valves replaced.

3. If the accumulator can be heard charging and discharging, but it does not hold a charge, disassemble the booster and replace the accumulator valves.

4. Deplete the accumulator by pressing the brake pedal 4 or 5 times. If the accumulator can no longer hold its gas charge, it is possible to rotate or wobble the accumulator can with respect to the housing. Replace the accumulator assembly.

BOOSTER FUNCTIONAL TEST

With the engine off, apply the brake pedal several times until the accumulator is completely depleted. Depress the brake pedal (approximately 40 pounds/180 N pedal force) and start the engine. The pedal should fall and then push back against driver's foot.

ACCUMULATOR LEAKDOWN TEST

Start engine and charge accumulator by either applying the brake pedal (approximately 100 pounds/450 N force) or by turning the steering wheel from stop to stop. Turn off engine and let vehicle sit for one hour. After one hour there should be two power assisted applies with engine stopped.

HYDRO — BOOST DIAGNOSIS

| CONDITION | CAUSE | CORRECTION |
|---|--|---|
| Excessive Brake Pedal Effort | Loose or broken power steering pump belt. | Tighten or replace the belt. |
| | No fluid in power steering reservoir. | Fill reservoir and check for external leaks. |
| | Leaks in Hydro-Boost | Replace faulty parts. |
| | Leaks at Hydro-Boost tube fittings. | Tighten fittings or replace tube seats, if faulty. |
| | External leakage at accumulator | Replace "O" ring and retainer. |
| | Faulty booster piston seal causing leakage at booster flange vent. | Overhaul with new seal or input rod and piston assembly. |
| | Faulty booster input rod seal with leakage at input rod end. | Overhaul with new seal kit. |
| | Faulty booster cover seal with leakage between housing and cover. | Overhaul with new seal kit. |
| Slow Brake Pedal Return | Faulty booster spool plug seal. | Overhaul with spool plug seal kit. |
| | Excessive seal friction in booster. | Overhaul with new seal kit. |
| | Faulty spool action. | Flush steering system while pumping brake pedal. |
| | Restriction in return line from booster to pump reservoir. | Replace line. |
| Grabby Brakes | Damaged input rod end. | Replace input rod and piston assembly. |
| | Faulty spool action caused by contamination in system. | Flush steering system while pumping brake pedal. |
| Booster Chatters - Pedal Vibrates | Power steering pump belt slips. | Tighten belt. |
| | Low fluid level in power steering pump reservoir. | Fill reservoir and check for external leaks. |
| | Faulty spool operation caused by contamination in system. | Flush steering system while pumping brake pedal. |
| Accumulator Leak Down-System does not hold charge | Contamination in steering hydro-boost system | Flush steering system while pumping brake pedal |
| | Internal leakage in accumulator system | Overhaul unit using accumulator rebuild kit and seal kit. |

Fig. 5-2--Hydro-Boost Diagnosis

| CONDITION | POSSIBLE CAUSE | CORRECTION |
|--|---|--|
| Pulls | 1. Incorrect tire pressures. | 1. Inflate evenly on both sides to the recommended pressures. |
| | 2. Front end out of line. | 2. Check and align to manufacturer's specifications. |
| | 3. Unmatched tires on same axle. For radial tire lead refer to Section 3E. | 3. Tires with approximately the same amount of tread should be used on the same axle. |
| | 4. Restricted brake pipes or hoses. | 4. Check for soft hoses and damaged lines. Replace with new hoses and new double-walled steel brake tubing. |
| | 5. Malfunctioning caliper assembly. | 5. Check for stuck or sluggish pistons, proper lubrication. Remove and rebuild caliper. |
| | 6. Defective or damaged shoe and lining (grease or brake fluid on lining or bent shoe). | 6. Install new shoe and lining in complete axle sets. |
| | 7. Malfunctioning rear brakes. | 7. Check for inoperative auto adjusting mechanism, defective lining (grease or brake fluid on lining) or defective wheel cylinders. Repair as necessary. |
| | 8. Loose suspension parts. | 8. Check and torque all suspension mountings to specifications. |
| | 9. Loose calipers. | 9. Check and torque bolts to specifications. |
| Noise (high pitched squeak without brake applied). | 1. Front linings worn out. | 1. Replace linings. |
| Brake roughness or chatter (Pedal Pulsates) | 1. Excessive lateral runout. | 1. Check per instructions and replace or machine rotor, if not within specifications. |
| | 2. Parallelism not within specifications. | 2. Check per instructions and replace or machine the rotor, if not within specifications. |
| | 3. Wheel Bearings not adjusted. | 3. Adjust wheel bearings to correct specifications. |
| | 4. Rear drums out of round. | 4. Check runout and, if not within specifications, turn the drums (not over maximum of 0.060 on the diameter). |

| CONDITION | POSSIBLE CAUSE | CORRECTION |
|---|---|---|
| Brake roughness or chatter (Pedal Pulsates) — Continued | 5. Shoe reversed (steel against iron). | 5. Replace shoe and lining and machine rotor within specifications. |
| Excessive Pedal Effort | 1. Malfunctioning power brake. | 1. Check power brake and repair if necessary. |
| | 2. Partial system failure. | 2. Check front and rear brake system and repair, if necessary. Also, check and repair brake warning light circuit if a failed system is found and light did not function. |
| | 3. Excessively worn shoe and lining. | 3. Check and replace in axle sets. |
| | 4. Piston in caliper stuck or sluggish. | 4. Remove caliper and rebuild. |
| | 5. Fading brakes due to incorrect lining. | 5. Remove and replace with original equipment lining (or equivalent). |
| Excessive Pedal Travel | 1. Partial brake system failure. | 1. Check both front and rear system for a failure and repair. Also check and repair warning light circuit. It should have indicated a failure. |
| | 2. Insufficient fluid in master cylinder. | 2. Fill reservoirs with approved brake fluid. Check for leaks. Check warning light. |
| | 3. Air trapped in system. | 3. Bleed system. |
| | 4. Rear brake not adjusting. | 4. Adjust rear brakes and repair auto adjusters. |
| | 5. Bent shoe and lining. | 5. Replace axle set of shoe and lining. |
| Dragging Brakes (A very light drag is present in all disc brakes immediately after pedal is released.) | 1. Master cylinder pistons not returning correctly. | 1. With reservoir cover off, check for fluid spurt at bypass holes as pedal is depressed. Adjust push rod, if necessary, or rebuild master cylinder. |
| | 2. Restricted brake pipes or hoses. | 2. Check for soft hoses or damaged pipes and replace with new hoses and new double-walled steel brake tubing. |

| CONDITION | POSSIBLE CAUSE | CORRECTION |
|---|--|---|
| Dragging Brakes (A very light drag is present in all disc brakes immediately after pedal is released.) — Continued | 3. Incorrect parking brake adjustment on rear brakes. | 3. Check and readjust to correct specifications. |
| | 4. Check valve installed in outlet to front disc brakes. | 4. Check master cylinder outlet and remove check valve if present. |
| | 5. Incorrect installation of inboard shoe and lining. | 5. Refer to caliper installation in this section. |
| Grabbing or Uneven Braking Action | 1. All conditions listed under "PULLS". | 1. All corrections listed under "PULLS". |
| | 2. Malfunction of combination valve. | 2. Replace and bleed system. |
| | 3. Malfunction of power brake unit. | 3. Check operation and repair, if necessary. |
| | 4. Binding brake pedal mechanism. | 4. Check and lubricate, if necessary. Possibly replace pedal bushing and/or spacer. |
| Pulsation (roughness) Felt during normal brake application. | 1. Uneven pad wear caused by caliper not sliding due to improper clearance or dirt. | 1. Remove caliper and correct as necessary. |
| | 2. Uneven rotor wear causing a thickness variation between the two braking surfaces. | 2. Machine rotors as follows: a. Machine rotors to obtain a circumferential thickness variation no greater than .0005" in 360° and a lateral runout no greater than .004" (max. rate of change not exceed .001" in 30°). b. Check caliper freeness. With rotor removed, install caliper and mounting bolts (pins). Check for .005"-.012" clearance at both top and bottom of caliper. If less than .005" is found, file with a flat file until at least .005" is obtained. DO NOT EXCEED A MAXIMUM of .012" per end or .024" total clearance. Caliper clearance to inboard and outboard reaction pads must be equal within .004" both at the top and bottom of the caliper. This is to ensure correct alignment of caliper to knuckle during a brake application. c. Remove caliper after freeness check. Clean pins and sleeves, replace "O" rings, and apply a light coating of silicone grease or equivalent to all contact points and "O" rings. |

| CAUSE | SYMPTOM | | | | | | | | | | | | | |
|--|------------------------------|---------------------------------|-----------------------|------------------------------|------------------------|-------------|------------------------|--------------------------------------|---------------------------------------|----------------------------|----------------------------------|----------------------|--|-----------------------------------|
| | Excessive Brake Pedal Travel | Brake Pedal Gradually Increases | Excessive Brake Pedal | Excessive Brake Pedal Effort | Brakes Slow to Respond | Brakes Drag | Brakes Slow to Release | Uneven Braking Action (Side to Side) | Uneven Braking Action (Front to Rear) | Scraping Noise from Brakes | Brakes Squeak During Application | Brakes Squeak During | Brakes Chatter (Roughness) During Stop | Brake Tell-Tale Glows During Stop |
| Leaking Brake Line or Connection | X | XX | | | | | | | | | X | | | XX |
| Leaking Wheel Cylinder or Piston Seal | X | XX | | | X | | | | | X | | | | X |
| Leaking Master Cylinder | X | XX | | | | | | | | | | | | X |
| Air In Brake System | XX | | | | | | | | | X | | | | XX |
| Contaminated or Improper Brake Fluid | | | | | | X | X | X | | | | | | X |
| Leaking Vacuum System | | | | XX | X | | | | | | | | | |
| Restricted Air Passage in Power Head | | | | X | XX | X | | | | | | | | |
| Damaged Power Head | | | | X | X | X | X | X | | | | | | |
| Improperly Assembled Power Head Valving | | | | X | X | X | X | XX | | | | | | |
| Worn Out Brake Lining - Replace | | | | X | X | | | | X | X | X | X | X | X |
| Uneven Brake Lining Wear - Replace and Correct | X | | | X | | | | | X | X | X | X | XX | X X |
| Glazed Brake Lining | | | | XX | X | | | | X | X | | X | X | |
| Incorrect Lining Material - Replace | | | | X | X | | | | X | X | | | X | X |
| Contaminated Brake Lining - Replace | | | | | XX | | | | XX | XX | X | X | X | X |
| Linings Damaged by Abusive Use - Replace | | | | X | XX | | | | X | X | X | X | X | X |
| Excessive Brake Lining Dust | | | | X | XX | | | | XX | XX | | X | XX | X |
| Heat Spotted or Scored Brake Drums or Rotors | | | | | X | | | | X | X | | X | X | XX X |
| Out-of-Round or Vibrating Brake Drums | | | | | | | | | | | | | X | XX |
| Out-of-Parallel Brake Rotors | | | | | | | | | | | | | | XX |
| Excessive Rotor Run-Out | | | | | | | | | | | | | | X |
| Faulty Automatic Adjusters | X | | | | | | | | X | X | X | | | |
| Incorrect Wheel Cylinder Sizes | | | | X | X | | | | X | X | | | | |
| Weak or Incorrect Brake Shoe Retention Springs | | | | | X | | | X | XX | X | X | XX | X | XX |
| Brake Assembly Attachments - Missing or Loose | X | | | | | | | | X | X | X | X | | X X X |
| Insufficient Brake Shoe Guide Lubricant | | | | | | | | X | X | X | X | XX | XX | |
| Restricted Brake Fluid Passage or Sticking Wheel Cylinder Piston | | X | X | | | X | X | X | X | X | | | | |
| Faulty Metering Valve | X | | | X | X | X | X | X | | X | | | | X |
| Brake Pedal Linkage Interference or Binding | | | | X | | X | XX | XX | | | | | | |
| Improperly Adjusted Parking Brake | | | | | | | | | X | | | | | |
| Drums Tapered or Threaded | | | | | | | | | | | | XX | | |
| Incorrect Front End Alignment | | | | | | | | | | XX | | | | |
| Incorrect Tire Pressure | | | | | | | | | | X | X | | | |
| Incorrect Wheel Bearing Adjustment | X | | | | | | | | | | X | | | X |
| Loose Front Suspension Attachments | | | | | | | | | | X | | XX | | X X |
| Out-of-Balance Wheel Assemblies | | | | | | | | | | | | | | XX |
| Operator Riding Brake Pedal | X | X | X | | | | | X | | X | | | | X |
| Improperly Adjusted Master Cylinder Push Rod | X | | | | | | X | XX | | | | | | X |
| Sticking Wheel Cylinder or Caliper Pistons | | | | X | | | X | X | X | X | | | | |
| Faulty Proportioning Valve | | | | X | | X | X | X | | | | | | |

XX - Indicates more probable causes) X - Indicates causes

ON-VEHICLE SERVICE

PEDAL TRAVEL

At reasonably frequent intervals, the brakes should be inspected for pedal travel, which is the distance the pedal moves toward the floor from a fully-released position. Inspection should be made with the brake pedal firmly depressed (approximately 90 lbs.) while the brakes are cold.

| | |
|---------------------------|---------------|
| _____C-K-G Manual | 4.5" (115 mm) |
| _____C-K-G Power | 3.5" (90 mm) |
| _____P (Except JF9) | 3.5" (90 mm) |
| _____P (JF9) | 6.0" (150 mm) |

On power brake-equipped vehicles, pump the pedal a minimum of 3 times with the engine off before making pedal travel checks. This exhausts all vacuum from the power booster.

STOP LIGHT SWITCH

Adjustment (Fig. 5-3)

The design of the switch and valve mounting provides for automatic adjustment when the brake pedal is manually returned to its mechanical stop as follows:

1. With brake pedal depressed, insert switch and/or valve assembly into tubular clip until switch body and/or valve assembly seats on tube clip. Note that audible "clicks" can be heard as threaded portion of switch and valve are pushed through the clip toward the brake pedal.

2. Pull brake pedal fully rearward against pedal stop, until audible "click" sounds can no longer be heard. Switch and/or valve assembly will be moved in tubular clip providing proper adjustment.

3. Release brake pedal, and then repeat Step 2 to assure that no audible "click" sounds remain.

Electrical contact should be made when the brake pedal is depressed 1.0-1.24" (25-31 mm) (C-K models), .45-.95" (11-24 mm) (G-P models) from its fully released

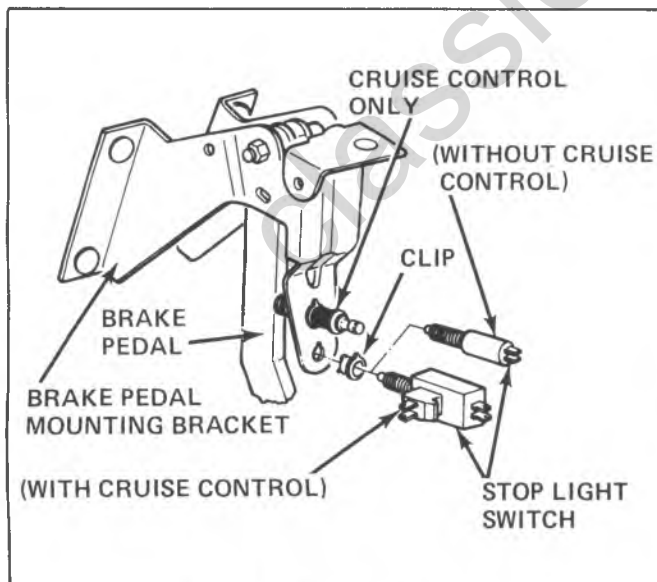


Fig. 5-3--Stop Light Switch

position.

BLEEDING AND FLUSHING BRAKE SYSTEM

Bleeding Brake Hydraulic System

A bleeding operation is necessary to remove air whenever it is introduced into the hydraulic brake system.

It may be necessary to bleed the hydraulic system at all four wheel cylinders if air has been introduced through low fluid level or by disconnecting brake pipes at master cylinder. If brake pipe is disconnected at any wheel cylinder, then that wheel cylinder only need be bled. If pipes are disconnected at any fitting located between master cylinder and wheel cylinders, then all wheel cylinders served by the disconnected pipe must be bled.

Manual Bleed

If the vehicle is equipped with power brakes, deplete the vacuum reserve by applying the brakes several times.

1. Fill master cylinder with brake fluid and keep at least one-half full of fluid during bleeding operation.

Bleed right rear brake, left rear brake, right front brake and left front brake.

2. With the proper size box end wrench or Tool J-21472 over bleeder valve, attach bleeder tube to valve and allow tube to hang submerged in brake fluid in a clean glass jar (fig. 5-4).

3. Open the bleeder valve and fully depress the brake pedal.

4. Close bleeder valve and release brake pedal.

5. Repeat steps 3 and 4 until all air is evacuated.

Check and refill master cylinder reservoir as required to prevent air from being drawn through master cylinder.

6. Repeat the bleeding procedure at all wheels if the entire system is to be bled.

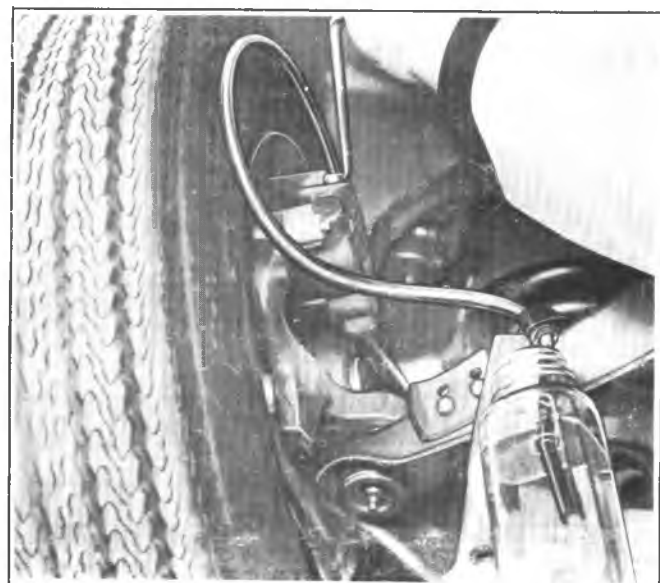


Fig. 5-4--Bleeding Wheel Cylinder

7. Check the brake pedal, feel for "sponginess" and repeat entire bleeding procedure if necessary.

Pressure Bleeding

Pressure bleeding equipment must be of the diaphragm type. That is, it must have a rubber diaphragm between the air supply and the brake fluid to prevent air, moisture, oil and other contaminants from entering the hydraulic system.

1. Install pressure bleeding adapter J-23518 to the master cylinder.
2. Make sure the pressure tank is at least 1/3 full of Supreme #11 brake fluid or its equivalent.

The bleeder ball must be re-bled each time fluid is added.

3. Charge the bleeder ball to between 20 and 25 psi (140-170 kPa).
4. When ready to begin bleeding, connect hose to master cylinder bleeder adapter and open the tank valve.
5. Disc brakes require a manual override of the front brake metering or combination valve to permit flow to the front wheels. Therefore, it will be necessary to hold the valve stem open manually pressure bleeding.

To hold the metering valve open to bleed the front brakes, the valve stem must be either pushed in or pulled out. Install metering valve actuator J-23709.

6. Bleed the brakes in the following sequence: right rear, left rear, right front and left front.
7. With the proper size wrench over the bleeder valve attach bleeder tube. The discharge end must hang submerged in a clean container partially filled with brake fluid.
8. Open the bleeder valve at least 3/4 turn and allow flow to continue until no air is seen in the fluid.
9. Close the bleed valve; Be sure it seals.
10. Repeat Steps 7-9 for the remaining bleeder valves (see Step 6 for sequence).
11. Check the pedal feel for "sponginess" and repeat the entire procedure if necessary.
12. Dispose of all removed brake fluid.
13. Remove Tool J-23709 from the combination valve and tighten the mounting bolt.
14. Disconnect bleeder equipment from the brake bleeder adapter.
15. Remove bleeder adapter. Wipe all areas dry if fluid was spilled during adapter removal.
16. Fill master cylinder reservoir(s) to proper level and install master cylinder diaphragm and cover.

Flushing Brake Hydraulic System

It is recommended that the entire hydraulic system be thoroughly flushed with clean brake fluid whenever new parts are installed in the hydraulic system.

Flushing is also recommended if there is any doubt as to the grade of fluid in the system. If fluid has been used which contains the slightest trace of mineral oil, all rubber parts that have been subjected to the contaminated fluid should be replaced.

HYDRO-BOOST BLEEDING PROCEDURE

Whenever the booster is removed and reinstalled, the steering system should be bled as outlined below.

NOTICE: Power steering fluid and brake fluid cannot be mixed. If brake seals contact steering fluid or steering seals contact brake fluid, seal damage will result.

1. Fill oil reservoir to proper level and let oil remain undisturbed for at least two minutes.
2. Start engine and run momentarily.
3. Add oil, if necessary.
4. Repeat above procedure until oil level remains constant after running engine.
5. Raise front end of vehicle so that wheels are off the ground.
6. Turn the wheels (off ground) right and left, lightly contacting the wheel stops.
7. Add oil if necessary.
8. Lower the vehicle.
9. Start engine and depress the brake pedal several times while rotating the steering wheel from stop to stop.
10. Turn engine off and then pump brake pedal 4-5 times to deplete accumulator pressure.
11. Check oil level and refill as required.
12. If oil is extremely foamy, allow vehicle to stand a few minutes with engine off and repeat above procedure.
 - a. Check belt tightness and check for a bent pulley. (Pulley should not wobble with engine running.)
 - b. Check to make sure hoses are not touching any other parts of the vehicle, particularly sheet metal.
 - c. Check oil level, filling to proper level if necessary, following operations 1 through 10. This step and Step "d" are extremely important as low oil level and/or air in the oil are the most frequent causes of objectionable pump noises.
 - d. Check the presence of air in the oil. Air will show up as milky appearing oil. If air is present, attempt to bleed system as described in operations 1 through 10. If it becomes obvious that the pump will not bleed after a few trials, proceed as outlined under Power Steering System Test Procedure in the "Steering" section of this manual.
13. The presence of trapped air in the system will cause the fluid level in the pump to rise when the engine is turned off. Continue to bleed system until this condition no longer occurs.

BRAKE PIPES

Replacement (Figs. 5-5 thru 5-7)

CAUTION: Never use copper tubing because copper is subject to fatigue cracking and corrosion which could result in brake failure.

1. Procure the recommended tubing and steel fitting nuts of the correct size. (Outside diameter of tubing is used to specify size.)
2. Cut tubing to length. Correct length may be determined by measuring old pipe using a cord and adding

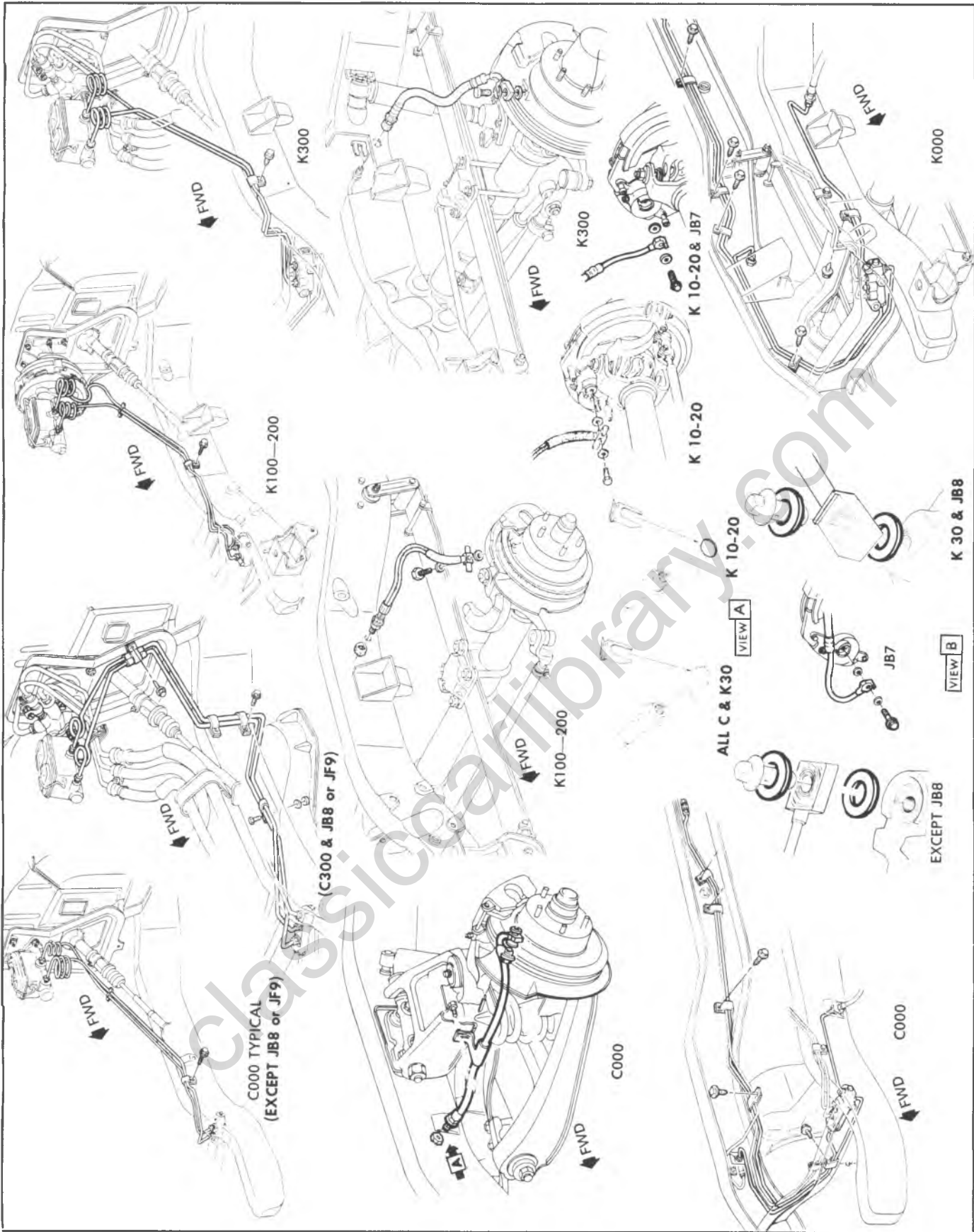
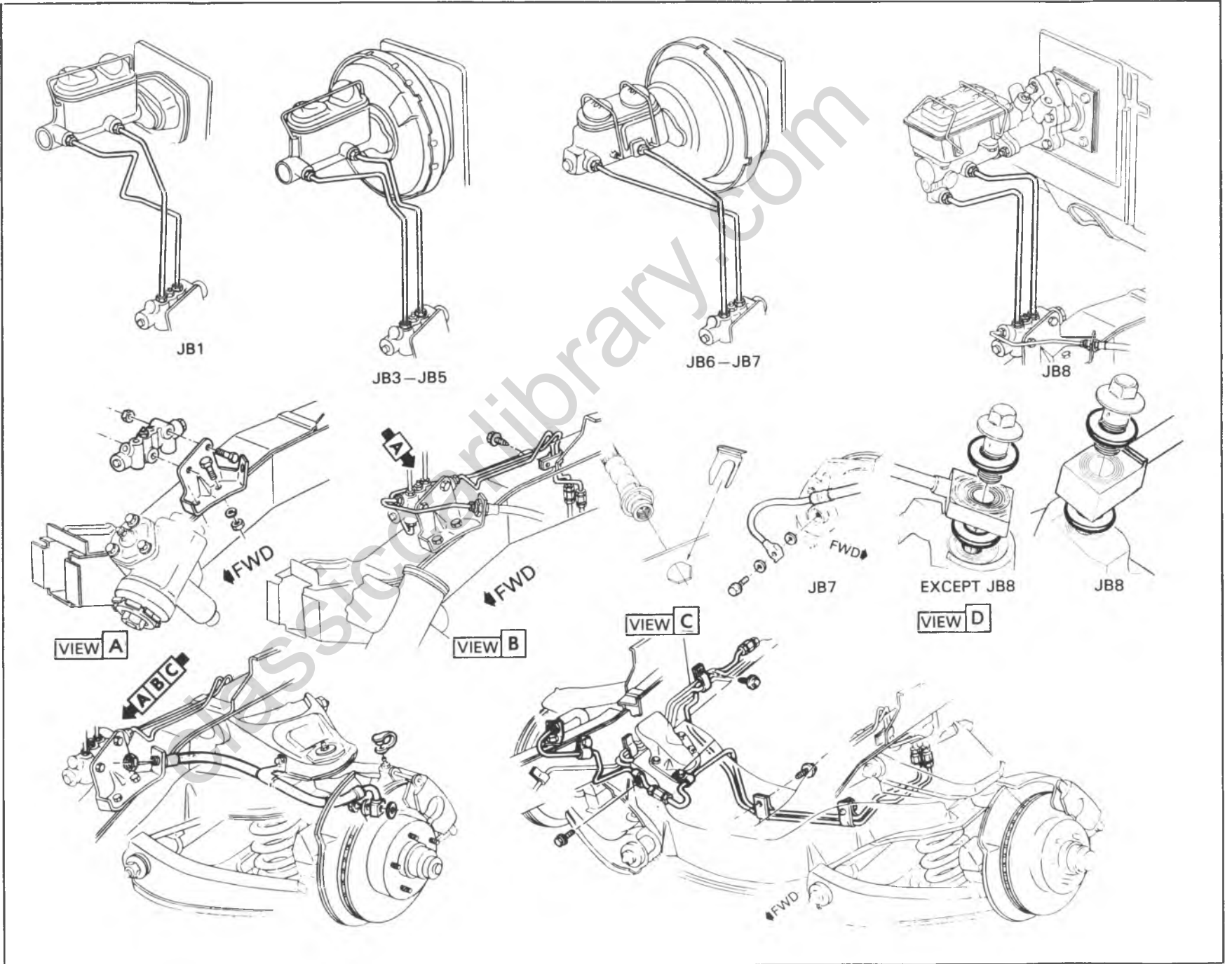


Fig. 5-5--Front Brake Pipes and Hoses--C-K Models

Fig. 5-6-Front Brake Pipes and Hoses--G Models



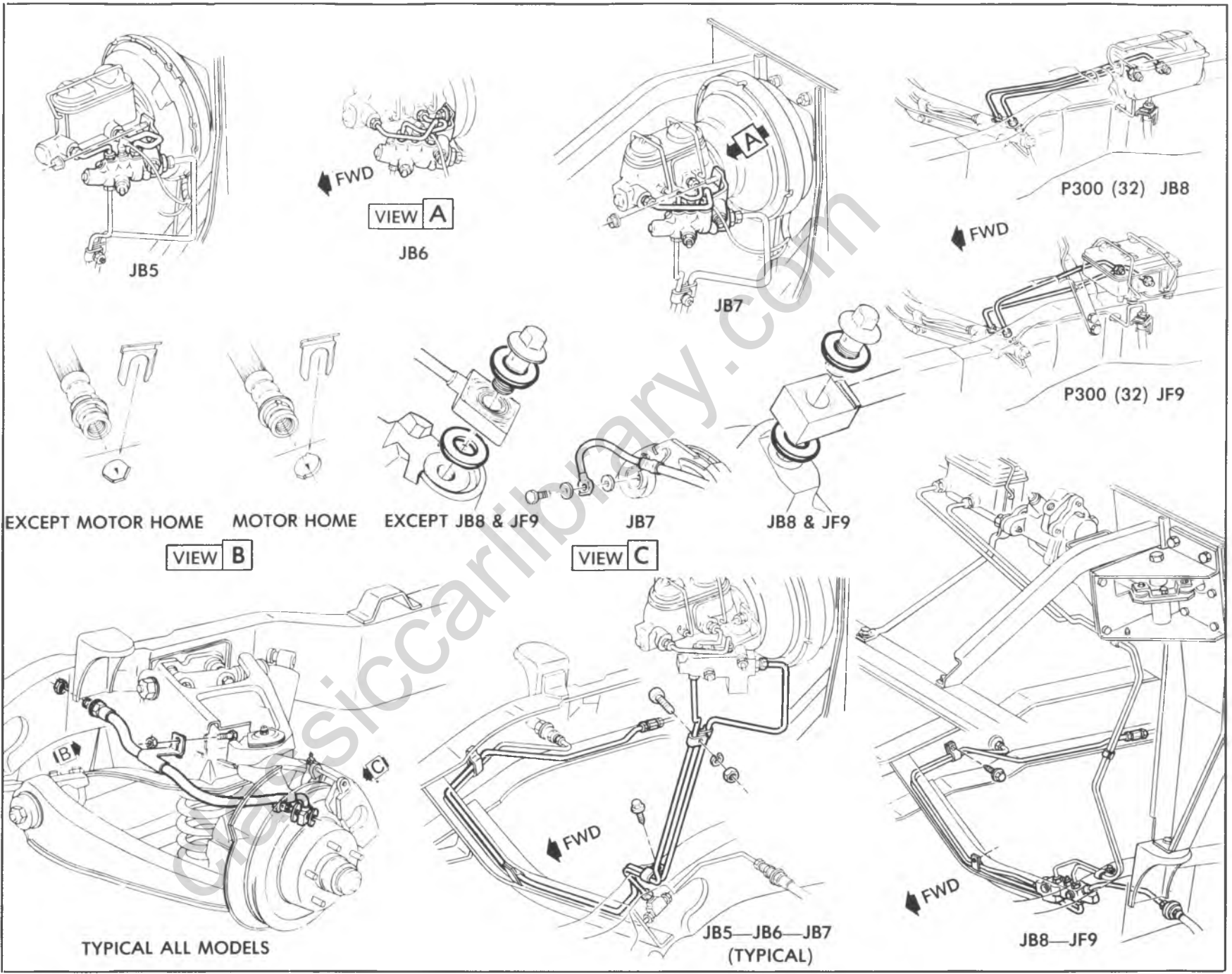


Fig. 5-7--Front Brake Pipes and Hoses--P Models

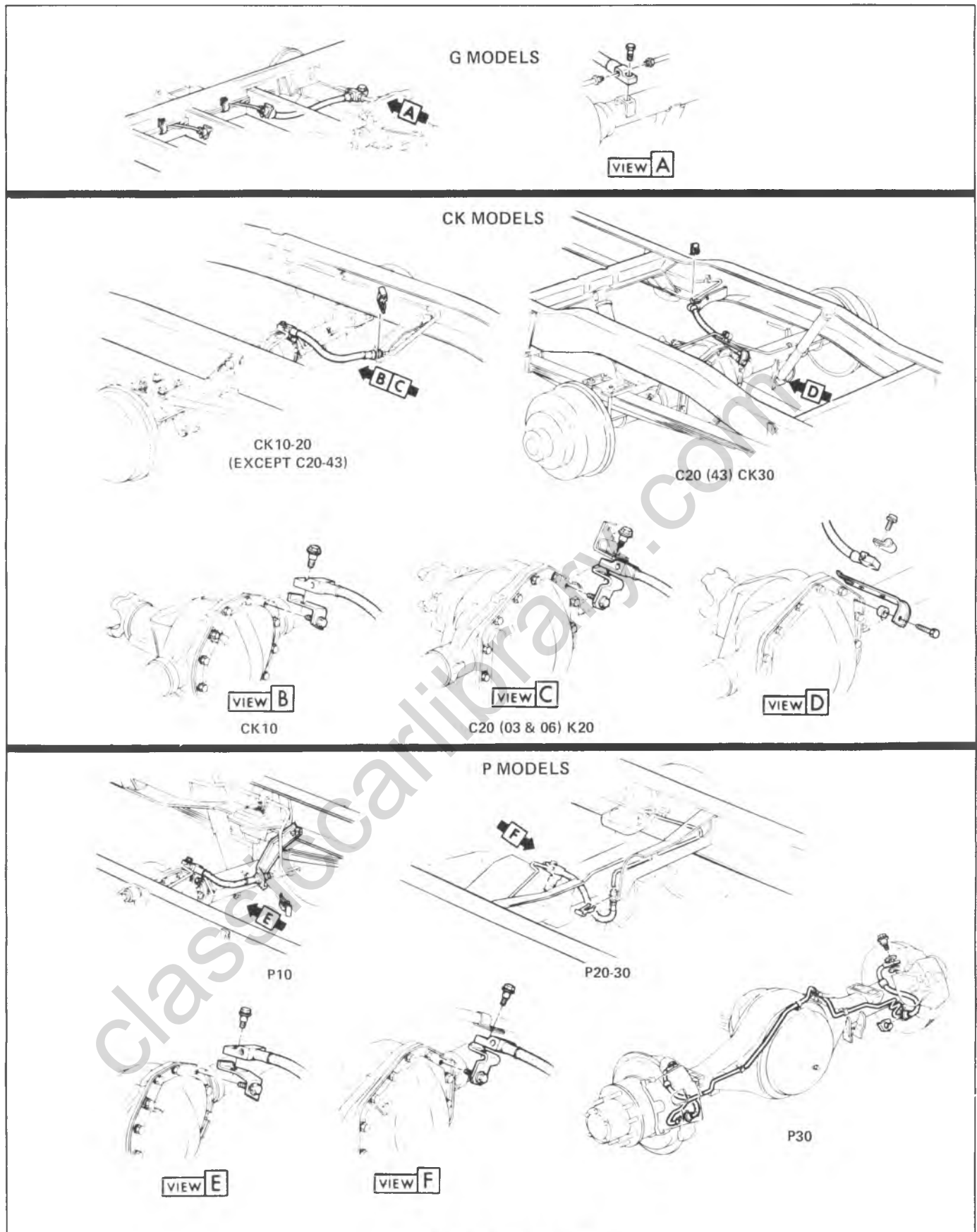


Fig. 5-8—Rear Brake Hoses

1/8" (3 mm) for each double flare.

3. Double flare tubing ends using a suitable flaring tool such as J-23530. Follow instructions included in tool set.

Make sure fittings are installed before starting second flare.

CAUTION: Double flaring tool must be used as single flaring tools cannot produce a flare strong enough to hold the necessary pressure.

4. Bend pipe assembly to match old pipe using a tubing bender. Clearance of .75" (19 mm) must be maintained to all moving or vibrating parts.

BRAKE HOSES

Inspection

The flexible hydraulic brake hose which transmits hydraulic pressure from the steel brake pipe on the frame to the rear axle and to the calipers should be inspected every 4 months or 6,000 miles (9 600 km) (heavy duty emission vehicles), every 12 months or 7,500 miles (12 000 km) (light duty emission vehicles). The brake hose assembly should be checked for road hazard damage, for cracks and chafing of the outer cover, and for leaks and blisters. A light and mirror may be needed for an adequate inspection. If any of the above conditions are observed on the brake hose, it will be necessary to replace it.

Front Brake Hose

Removal (figs. 5-5 thru 5-7)

1. Raise vehicle on hoist.
2. Clean dirt and foreign material from both hose end fittings.
3. Disconnect brake pipe from hose fitting using a back-up wrench on fitting. Be careful not to bend frame bracket or brake pipe. It may be necessary to soak the connections with penetrating oil.
4. Remove "U" clip from female fitting at bracket and remove hose from bracket.
5. Remove bolt from caliper end of hose. Remove hose from caliper, and discard the two copper gaskets on either side of fitting block.

Installation

1. Use new copper gaskets on both sides of fitting block, wet bolt threads with brake fluid, then with fitting orientation flange engaged with the caliper orientation ledge on JB8 and JF9 (hose located in caliper gate on all except JB8 and JF9), fasten hose to caliper; torque to specifications.
2. With weight of vehicle on suspension, pass female fitting through frame or frame bracket. Fitting fits the bracket in only one position. With least amount of twist in hose, install fitting in this position. There should be no kinks in hose.
3. Install "U" clip to female fitting at frame bracket.
4. Attach brake pipe to hose fitting using a backup wrench on fitting; torque to specifications.
5. Inspect to see that hose doesn't make contact with any part of suspension. Check in extreme right hand and extreme left hand turn conditions. If hose makes any contact, remove and correct.

6. Bleed brake system.
7. Lower vehicle from hoist.

Rear Brake Hose

Removal (Fig. 5-8)

1. Raise vehicle on hoist.
2. Remove all three brake pipes from hose, two at junction block and, with the use of a back-up wrench, one on the female fitting at bracket. Be careful not to bend bracket or pipes; use penetrating oil if necessary.
3. Remove "U" clip and take female fitting out of bracket.
4. Observe position at which junction block is mounted to the axle. When installing new hose be sure this junction block is in the same position.
5. Remove bolt attaching junction block to axle.

Installation

1. Thread both rear axle pipes into junction block.
2. Bolt junction block to axle and then torque rear pipes into block.
3. Pass female end of hose through bracket; female fitting will fit bracket in only 1 position (except G models), 2 positions (G models). Without twisting hose, position female end in bracket.
4. Install "U" clip.
5. Attach pipe to female fitting using a back-up wrench on fitting; torque to specification, again be careful not to bend bracket or pipe. Check to see that hose installation did not loosen frame bracket. re-torque bracket if necessary.
6. Bleed system.
7. Lower vehicle from hoist.

PARKING BRAKE PEDAL OR HANDLE

Removal (Fig. 5-9)

1. Place parking brake pedal or handle in the released position.
 2. Remove nuts from the engine compartment on C, K and G models or bolts from mounting bracket on P models.
- Take notice of the spacers on P models for reinstallation.
3. Disconnect the release handle rod at the parking brake assembly end (C-K models).
 4. Remove the bolts from the underside of the dash and lower the brake assembly (C-K-G Models).
 5. **C-K-G Models-** Disconnect the cable ball from the parking brake clevis and remove the assembly.

P Models- Remove the clevis pin and disconnect the cable from the brake assembly; remove the assembly.

Installation

Reverse the removal procedure. Torque all bolts and nuts. After installing the clevis-pin, use a new cotter pin to secure the clevis pin. Adjust the cable if necessary as outlined below.

NOTICE: See "Notice" on Page 1 of this section.

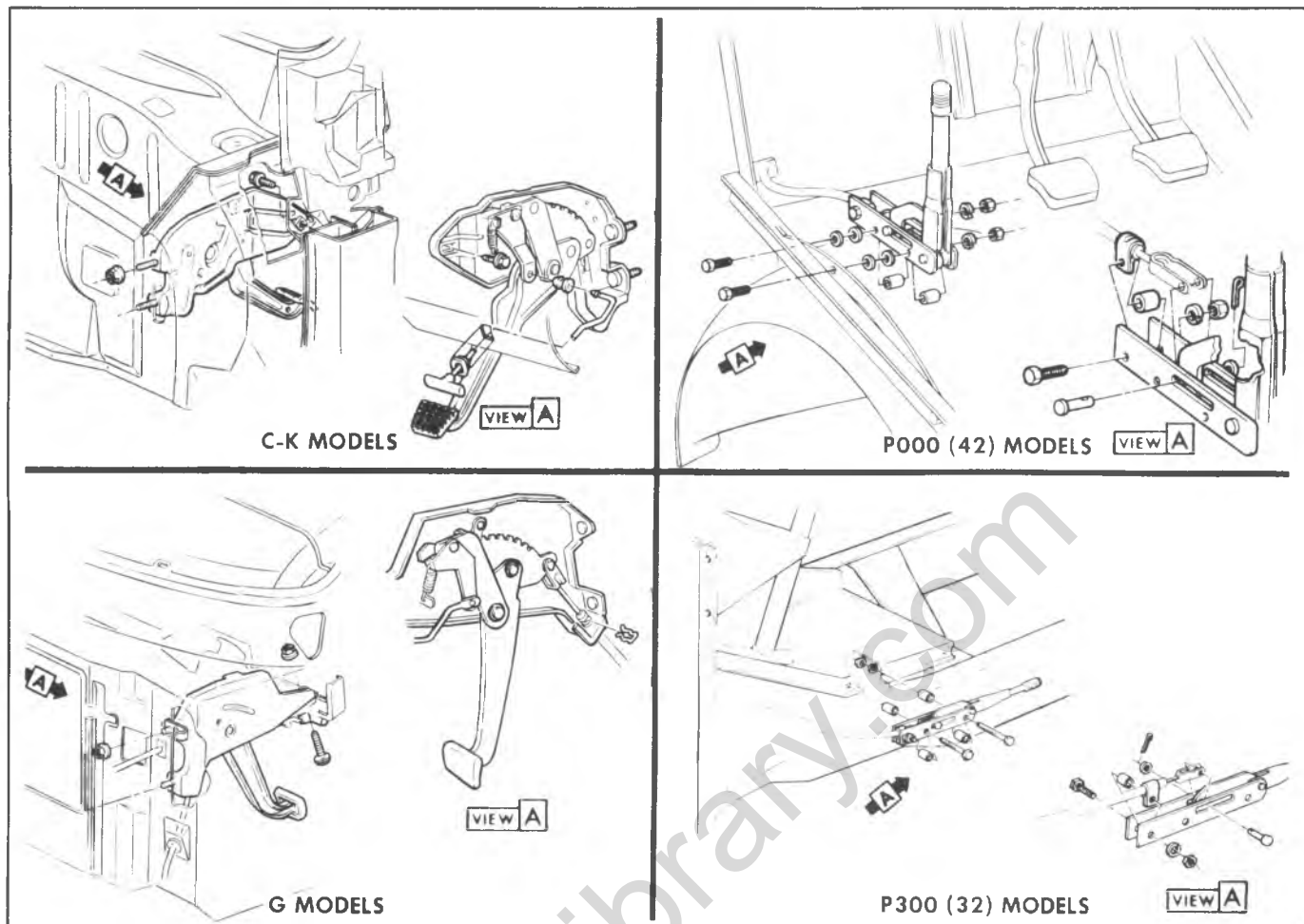


Fig. 5-9--Parking Brake Assembly--Typical

PARKING BRAKE ADJUSTMENT

Adjustment of parking brake cable is necessary whenever holding ability is not adequate or whenever the center brake cables have been disconnected.

The service brake must be properly adjusted as a base for parking brake adjustment; conversely the parking brake must be properly adjusted for the service brake to function as intended.

Inspection

If complete release of the parking brake is not obtained, unless it is forcibly returned to its released position, or if application effort is high, check parking brake assembly for free operation. If operation is sticky or a bind is experienced, correct as follows:

1. Clean and lubricate brake cables and equalizer with Delco Brake Lube (or equivalent).
2. Inspect brake assembly for straightness and alignment (replace if necessary).
3. Clean and lubricate parking brake assembly with Delco Brake Lube (or equivalent).
4. Checking routing of cables for kinks or binding.

Adjustment--Foot Pedal Type

Before adjusting parking brake, check service brake condition and adjustment.

1. Raise vehicle on hoist.
2. Loosen the equalizer adjusting nut.
3. Apply parking brake 4 notches from fully released position.
4. Tighten the equalizer nut until a moderate drag is felt when the rear wheels are rotated forward.

NOTICE: See "Notice" on Page 1 of this section.

5. Fully release parking brake and rotate the rear wheels. No drag should be present.
6. Remove vehicle from hoist.

Adjustment--Orscheln Lever Type

1. Turn adjusting knob on parking brake lever counterclockwise to stop.
2. Apply parking brake.
3. Raise vehicle on a hoist.
4. Loosen nut at intermediate cable equalizer and then adjust nut to give light drag at rear wheels.

NOTICE: See "Notice" on Page 1 of this section.

5. Readjust parking brake lever knob to give a definite snap-over-center feel.

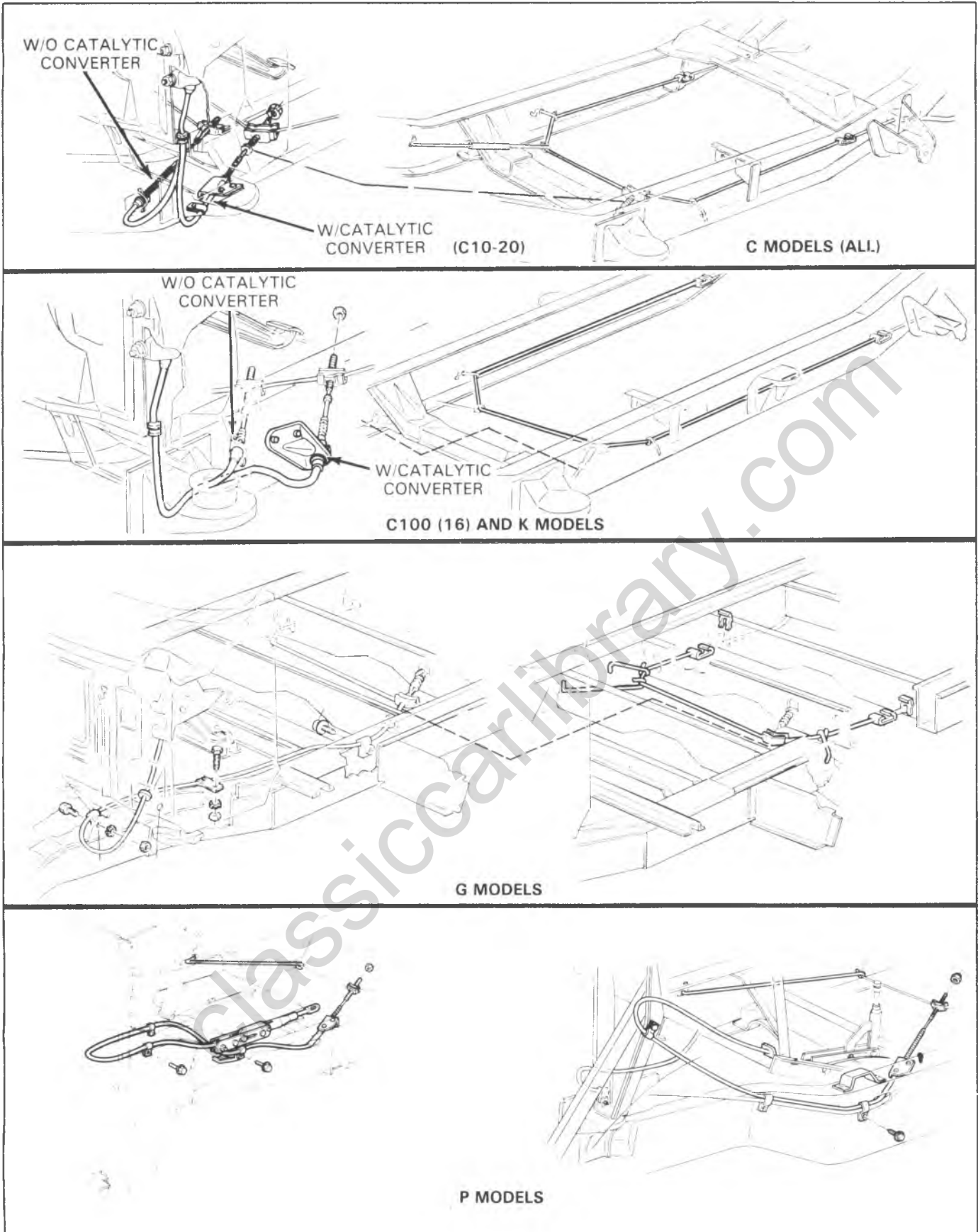


Fig. 5-10--Parking Brake System--Typical

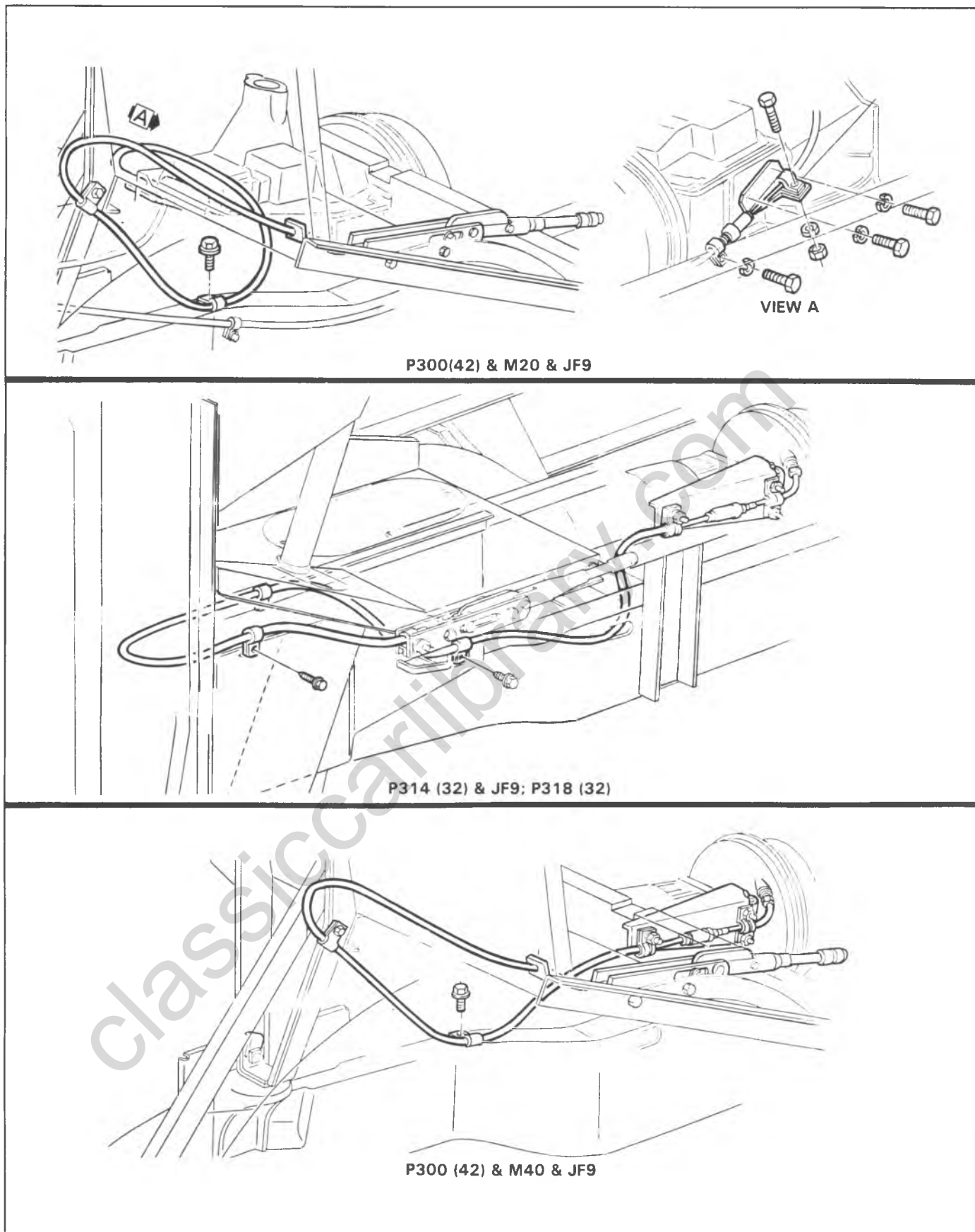


Fig. 5-11--Parking Brake System (Propshaft)

PARKING BRAKE (PROPELLER SHAFT)-**INTERNAL EXPANDING****Adjustment-Drum On**

1. Jack up at least one rear wheel. Block wheels and release hand brake.
2. Remove cotter pin and clevis pin connecting pull rod and relay lever. This will assure freedom for full shoe release.

NOTICE: It may be necessary to knock out lanced area in brake drum with punch and hammer to gain entry into adjusting screw through brake drum. Be sure all metal has been removed from parking brake compartment.

3. Rotate brake drum to bring one of access holes into line with adjusting screw at bottom of shoes (manual transmission), top of shoes (automatic transmission).
4. Expand shoes by rotating adjusting screws with screwdriver inserted through hole in drum. Move outer end of screwdriver away from drive shaft. Continue adjustment until shoes are tight against drum and drum cannot be rotated by hand. Back off adjustment ten notches and check drum for free rotation.
5. Place parking brake lever in fully released position. Take up slack in brake linkage by pulling back on cable just enough to overcome spring tension. Adjust clevis of pull rod or front cable to line up with hole in relay levers.
 - a. Insert clevis pin and cotter pin, then tighten clevis locknut.
 - b. Install a new **metal** hole cover in drum to prevent contamination of brake.
 - c. Lower rear wheels. Remove jack and wheel blocks.

NOTICE: See "Notice" on Page 1 of this section.

Adjustment-Drum Off

1. With parking brake drum off, use special Tool J-21177 or J-22364, Drum to Brake Shoe Clearance Gauge, to check diameter of drum clearance surface.
2. Turn the tool to the opposite side and fit over brake shoes by turning the star wheel until the gauge just slides over the linings.
3. Rotate the gauge around the brake shoe lining surface to insure proper clearance.
4. Install propeller shaft flange at mainshaft as outlined in transmission section.
5. Lower rear wheels. Remove jack and wheel blocks.

PARKING BRAKE CABLES (Fig. 5-10)**Front Parking Brake Cable Replacement**

1. Raise vehicle on hoist.
2. Remove adjusting nut from equalizer.
3. Remove retainer clip from rear portion of front cable at frame and from lever arm.
4. Disconnect front brake cable from parking brake pedal or lever assemblies. Remove front brake cable. On some models it may assist installation of new cable if a heavy cord is tied to other end of cable in order to guide new cable through proper routing.

5. Install cable by reversing removal procedure.
6. Adjust parking brake.

Center Parking Brake Cable Replacement

1. Raise vehicle on hoist.
2. Remove adjusting nut from equalizer.
3. Unhook connector at each end and disengage hooks and guides.
4. Install new cable by reversing removal procedure.
5. Adjust parking brake.
6. Apply parking brake 3 times with heavy pressure and repeat adjustment.

Rear Parking Brake Cable Replacement

1. Raise vehicle on hoist.
2. Remove rear wheel and brake drum.
3. Loosen adjusting nut at equalizer.
4. Disengage rear cable at connector.
5. Bend retainer fingers.
6. Disengage cable at brake shoe operating lever.
7. Install new cable by reversing removal procedure.
8. Adjust parking brake.

COMBINATION VALVE**Testing Electrical Circuit of Combination Valve**

1. Disconnect wire from switch terminal and use a jumper to connect wire to a good ground.
2. Turn ignition key on "On" - warning lamp should light. If lamp does not light, bulb is burned out or electrical circuit is defective. Replace bulb or repair electrical circuit as necessary.
3. When warning lamp lights, turn ignition switch off. Disconnect jumper and reconnect wire to switch terminal.

Testing Warning Light Switch Portion of Combination Valve

1. Raise vehicle on hoist. Attach a bleeder hose to a rear brake bleed screw and immerse the other end of the hose in a container partially filled with clean brake fluid. Be sure master cylinder reservoir is full.
2. Turn ignition switch to "On"; open bleeder screw while a helper applies moderate pressure to the brake pedal; warning lamp should light. Close bleeder screw before helper releases brake pedal. Reapply brake pedal with moderate-to-heavy pressure; light should go out.
3. Attach the bleeder hose to a front brake bleeder screw and repeat above test. Warning lamp action should be the same as in Step No. 2. Turn ignition switch off.
4. If warning lamp does not light during Steps 2 and 3 but does light when a jumper is connected to ground, the warning light switch portion of the combination valve is defective. Do not attempt to disassemble the combination valve. If any portion of the combination valve is defective, it must be replaced with a new combination valve.
5. Lower vehicle to floor. Check and refill master cylinder to proper level.

Replacement

The combination valve is not repairable and must be serviced as a complete assembly.

1. Disconnect hydraulic lines at combination valve. Plug lines to prevent loss of fluid and entrance of dirt. Disconnect warning switch wiring harness from valve switch terminal.

2. Remove combination valve.
3. Install combination valve by reversing removal steps.
4. Bleed entire brake system. Do not move vehicle until a firm brake pedal is obtained.

BRAKE PEDAL

The brake pedal mounting is an integral design with the clutch pedal (except automatic transmission), necessitating the removal of the clutch pedal before removing the brake pedal.

Removal (Fig. 5-12)

1. Remove the pull back spring from the body or brake pedal support bracket.

2. **Manual Transmission Vehicles--** Remove the clutch pedal as outlined under "Clutch Pedal" in Section 7C.

Automatic Transmission Vehicles-- Remove pedal pivot bolt nut or pivot pin retainer and remove bolts or pin and bushings.

3. **P Models--** Remove the sleeve assembly screw attachment and remove sleeve.

4. Disengage the push rod from the master cylinder and remove the pedal.

Inspection

Clean all parts and inspect for wear, cracks or any other damage that might impair operation; replace if required.

Installation

Reverse the above procedure and make certain the brake pedal is secure and adjusted properly before operating the vehicle. Lubricate pedal pivot bushings and pivot pin, bolt or sleeve with Delco Brake Lube (or equivalent). Adjust stoplamp switch.

NOTICE: See "Notice" on Page 1 of this section.

BRAKE PEDAL ROD

P30(32) Models

Replacement (Fig. 5-13)

1. Remove the cotter pin, nut, special washers and bolt at the brake pedal lever end of rod; discard the cotter pin.
2. Remove the boot to floorpan screws.
3. Raise the vehicle on a hoist.
4. Remove the cotter pin, nut, special washers and bolt at the lower end of the rod and remove the pedal rod assembly. Discard the cotter pin.
5. To install a new rod, adjust the rod length to 31.00" (790 mm) (center of upper attachment to center of lower attachment).
6. Lubricate the pedal rod bolts and special washers with Delco Brake Lube (or equivalent).
7. Install the rod up through the floorpan opening and install the lower pivot bolt, special washers and nut. Tighten the nut to 22-30 lb. ft. (30-40 N·m) and install a NEW cotter pin.
8. Push the boot up to the floorpan.
9. Lower the vehicle from the hoist.
10. Install the rod upper pivot bolt, special washers and nut. Tighten the nut to 22-30 lb. ft. (30-40 N·m) and install a NEW cotter pin.

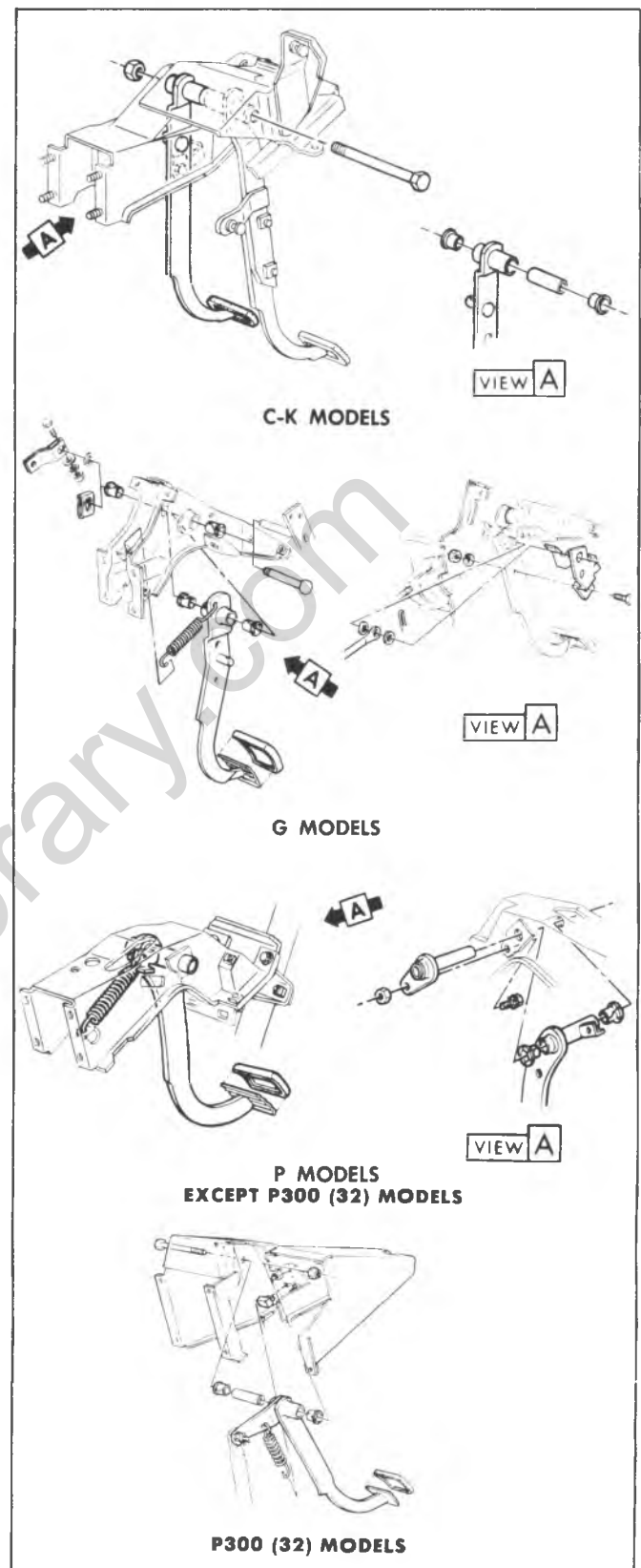


Fig. 5-12--Brake Pedal Installation

11. Fasten the boot to the floorpan and compress the boot to 2.54" (65 mm) installed height; tighten the boot to 2.54" (65 mm) installed height; tighten the boot screws to 13-18 lb. in. (1.5 - 2.0 N·m). (Refer to Figure 5-13).

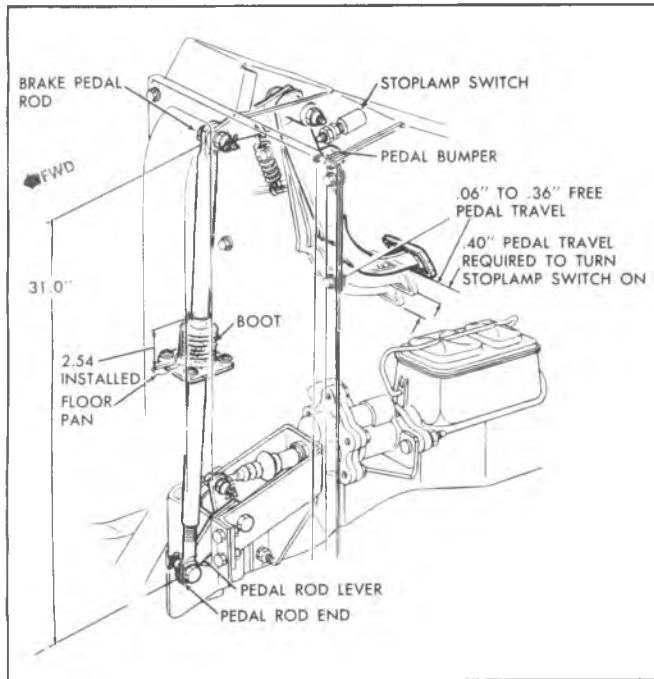


Fig. 5-13--Brake Pedal and Stop Lamp Adjustment P30(32) Model

12. Adjust brake pedal and stoplamp switch as outlined previously.

P30(42) and G Models

Replacement

1. **G Models-** Remove the brake pedal striker screw and remove the striker. Remove the cotter pin and washer and disconnect the pedal rod from the brake pedal.
2. **P30(42) Models-** Remove the cotter pin nut and bolt to disconnect the pedal rod from the brake pedal.
3. Remove the pedal rod retainer bolt (at the rod pivot) and remove the retainer.
4. Remove the cotter pin and washer and remove the pedal rod.
5. To install a new rod, reverse Steps 1-4 above. Lubricate pivot points with Delco Brake Lube (or equivalent).

NOTICE: See "Notice" on Page 1 of this section.

6. Check brake pedal and stoplamp switch adjustments as outlined previously.

MASTER CYLINDER

Filling Brake Master Cylinder

The master cylinder must be kept properly filled to insure adequate reserve and to prevent air from entering the hydraulic system. However, because of expansion due to heat absorbed from brakes and from engine, master cylinder must not be overfilled.

The brake fluid reservoir is on the master cylinder which is located under the hood on the left side of the dash.

Thoroughly clean reservoir cover before removal to avoid getting dirt into reservoir. Remove cover and diaphragm. Add fluid as required to bring level to 1/4" (6 mm) (plus or minus 1/8"--3 mm) from the lowest portion

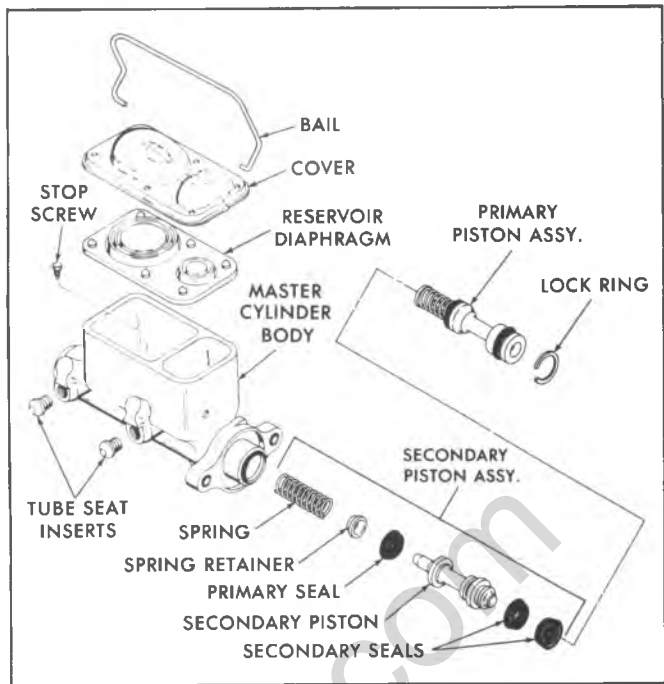


Fig. 5-14--Delco Master Cylinder--Exploded View

of the top of each reservoir. Use Delco Supreme No. 11 Hydraulic Brake Fluid or equivalent.

Do not use shock absorber fluid or any other fluid which contains mineral oil. Do not use a container which has been used for mineral oil or a container which is wet from water. Mineral oil will cause swelling and distortion of rubber parts in the hydraulic brake system and water will mix with brake fluid, lowering the fluid boiling point. Keep all fluid containers capped to prevent water contamination.

Except Bendix Mini-Master Cylinder

Removal

1. Disconnect brake pipes from master cylinder and tape end of pipes to prevent entrance of dirt.
2. **Manual brake only--** Disconnect brake pedal from master cylinder push rod.

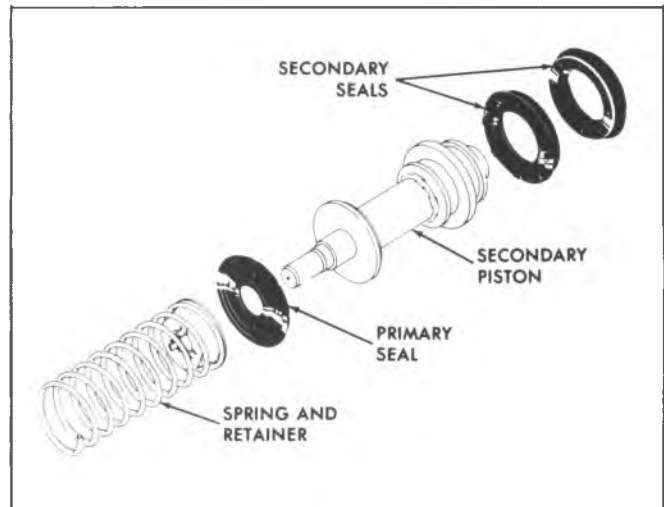


Fig. 5-15--Delco Secondary Piston - Exploded View

3. Remove two nuts holding master cylinder to dash or power cylinder and remove master cylinder from vehicle. Be careful not to drip brake fluid on exterior paint.

Disassembly (Figs. 5-14 and 5-15)

1. Clean outside of master cylinder thoroughly. Remove reservoir cover and diaphragm. Turn cylinder over and pump push rod by hand to drain all brake fluid. Always discard used fluid.

2. **Manual brake only**-- Pull boot away from master cylinder to uncover push rod retainer. The retainer has a small, depressed tab in the side. This tab must be pried up to release retainer.

3. Depress piston and remove secondary piston stop bolt from bottom of front fluid reservoir (if so equipped).

4. Place master cylinder in a vise so that lock ring can be removed from groove in the inside diameter of bore. Remove lock ring and primary piston assembly. Remove secondary piston, secondary piston spring and retainer by blowing air through the outlet port.

5. Place master cylinder in vise, so that outlet holes are up. Enlarge hole in tube fitting insert using a 13/64" drill. Place a heavy washer over outlet on master cylinder and thread a 1/4-20 x 3/4" screw into the insert. Tighten screw until insert is unseated. Remove insert, screw, and washer.

6. Remove primary seal, and secondary seal from secondary piston.

7. Use clean brake fluid to clean all metal brake parts thoroughly. Air dry and place cleaned parts on clean paper or lint free clean cloth.

Do not use anti-freeze alcohol, gasoline, kerosene, or any other cleaning fluid that might contain even a trace of mineral oil.

Inspection

Inspect cylinder bore for scoring or corrosion. It is best to replace a corroded cylinder. Corrosion can be identified as pits or excessive roughness.

Polish any discolored or stained area with crocus cloth by revolving cylinder on cloth supported by finger.

Rinse cylinder in clean brake fluid. Shake excess rinsing fluid from cylinder. Do not use a rag to dry cylinder, as lint from rag cannot be kept from cylinder bore surfaces.

Make certain that compensating port in cylinder is clear.

If scratches or corroded spots are too deep to be polished satisfactorily, the cylinder should be replaced.

Assembly

1. Place brass tube fitting insert (new parts) in outlet holes so that it is in a position to be pressed into outlet hole. The recommended method of inserting tube fitting insert is to thread a spare brake line tube nut into outlet hole and turn nut down until tube fitting insert bottoms. Remove tube nut and check outlet hole for loose burrs, which might have been turned up when tube fitting insert was pressed down.

2. Put new secondary seal in groove in end of secondary piston (fig. 5-15).

3. Assemble a new primary seal over end of secondary piston, so that flat side of the seal seats against flange of piston (fig. 5-15).

4. Assemble new secondary seal into groove on end of the secondary piston.

5. In order to insure correct assembly of the primary assembly, a complete primary piston assembly is included in the repair kits.

6. Coat bore of master cylinder with clean brake fluid. Coat primary and secondary seals on secondary piston with clean brake fluid. Insert the secondary piston spring retainer into secondary piston spring. Place retainer and spring over end of secondary piston, so that retainer locates inside lip of primary cup.

7. Hold master cylinder with open end of bore down, push secondary piston into bore, so that spring will seat against closed end of bore.

8. Place master cylinder in a vise with open end of bore up. Coat primary and secondary seal on primary piston with clean brake fluid. Push primary piston assembly, spring end first, into bore of master cylinder. Hold the piston down and snap lock ring into position in groove in inside diameter of bore.

9. Install a new reservoir diaphragm in reservoir cover where needed, and install cover on master cylinder. Beaded side faces master cylinder casting to insure positive sealing. The bail wire is now pushed into position to hold reservoir cover.

10. **Manual brake only**-- Assemble push rod through push rod retainer, if it has been disassembled. Push retainer over end of master cylinder. Assemble new boot over push rod and press it down over the push rod retainer.

Installation

NOTICE: Refer to "Notice" on Page 1 of this section regarding fasteners referred to in Steps 1 and 2 below.

1. **Manual brake only**-- Connect push rod to brake pedal pin and install retainer while holding master cylinder in place.

2. Install master cylinder on dash or power cylinder; torque nuts to specifications.

3. Connect brake pipes to master cylinder.

4. Bleed hydraulic system.

5. Road test vehicle for proper brake performance.

All Models

Bench Bleeding

The time required to bleed the hydraulic system later on can be reduced if the master cylinder is filled with fluid and as much air as possible expelled before the cylinder is installed on the car.

1. Insert threaded plugs into outlets and fill reservoirs with brake fluid.

2. Loosen one plug at a time and push piston into bore to force air from the master cylinder. To prevent air from being sucked back into the master cylinder, you must tighten outlet plugs before allowing piston to return to its original position.

3. Stroke the master cylinder 3-4 times for each outlet to assure expelling all air out of the master cylinder.

4. Fill the master cylinder reservoir and install cover.

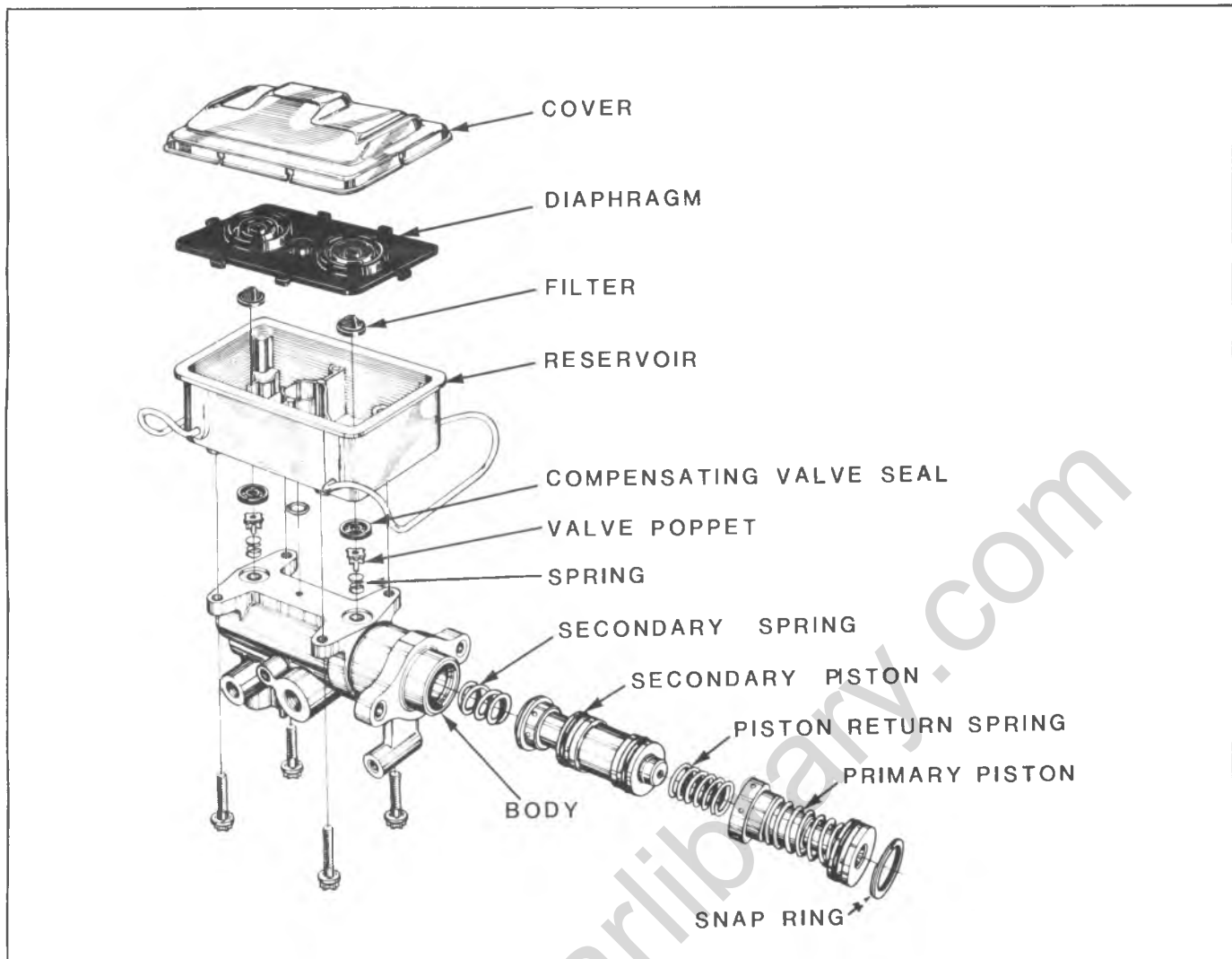


Fig. 5-16--Bendix Mini-Master Cylinder--Exploded View

Bendix Mini-Master Cylinder

Removal, Inspection and Installation procedures are the same as described for "Except Bendix Mini-Master Cylinder".

Disassembly

1. Remove the reservoir cover and diaphragm, and drain the fluid from the reservoir.
2. Remove the four bolts that secure the body to the reservoir using Socket J-25085.
3. Remove the small "O" ring and the two compensating valve seals from the recessed areas on the bottom side of the reservoir.

Do not remove the two small filters from the inside of the reservoir unless they are damaged and are to be replaced.

4. Depress the primary piston using a tool with a smooth rounded end. Then remove the compensating valve poppets and the compensating valve springs from the compensating valve ports in the master cylinder body.

5. Using a small screwdriver, remove the snap ring at the end of the master cylinder bore. Then release the piston and remove the primary and secondary piston assemblies from the cylinder bore. It may be necessary to plug the front outlet port and to apply low air pressure to the front

compensating valve port to remove the secondary piston assembly.

Assembly

1. Lubricate the secondary piston assembly and the master cylinder bore with clean brake fluid.
2. Assemble the secondary spring (shorter of the two springs) in the open end of the secondary piston actuator, and assemble the piston return spring (longer spring) on the projection at the rear of the secondary piston.
3. Insert the secondary piston assembly, actuator end first, into the master cylinder bore, and press assembly to the bottom of the bore.
4. Lubricate the primary piston assembly with clean brake fluid. Insert the primary piston assembly, actuator end first, into the bore.
5. Place the snap ring over a smooth round ended tool and depress the pistons in the bore.
6. Assemble the retaining ring in the groove in the cylinder bore.
7. Assemble the compensating valve seals and the small "O" ring seal in the recesses on the bottom of the reservoir. Be sure that all seals are fully seated.

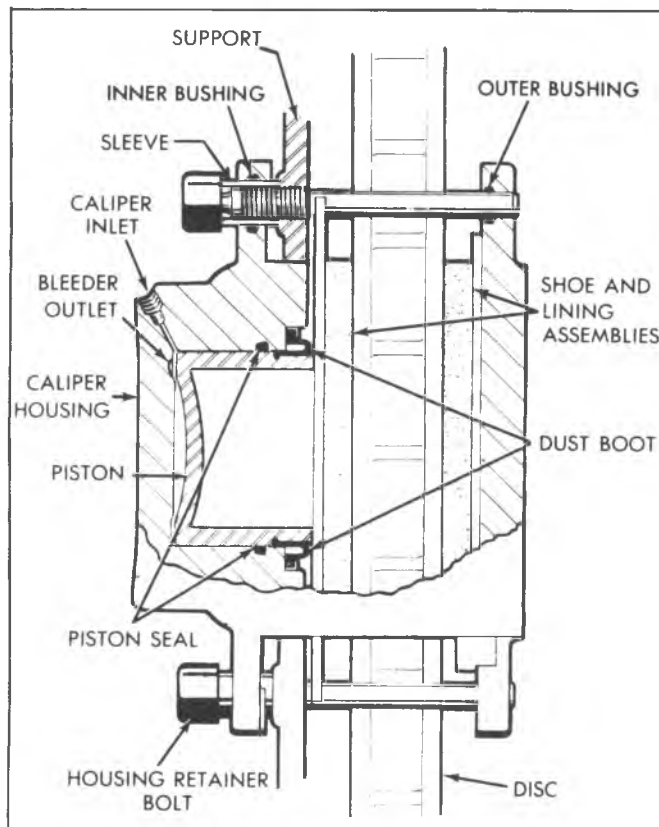


Fig. 5-17--Delco Single Piston Disc Brake

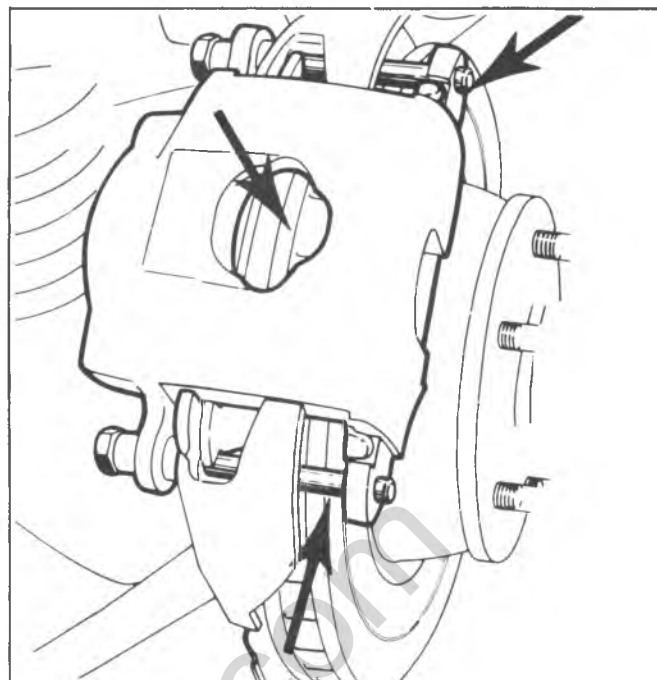


Fig. 5-18--Lining Inspection

8. While holding the pistons depressed, assemble the compensating valve springs and the compensating valve poppets in the compensating valve ports.

9. Holding the pistons compressed, position the reservoir on the master cylinder body and secure with the four mounting bolts. Tighten the bolts to 12-15 lb. ft. (16-20 N·m).

DELCO DISC BRAKE SHOE AND LINING

Lining Inspection

Inspect the brake linings per maintenance schedule and anytime that the wheels are removed (tire rotation, etc.) Check both ends of the outer shoe by looking in at each end of the caliper (see figure 5-18). Check the lining thickness on the inner shoe by looking down through the inspection hole in the top of the caliper housing. Whenever the lining is worn to the approximate thickness of the shoe, the shoe and lining should be removed. After removal, measure the lining thickness. The shoe and lining should be replaced at any time when the lining is worn to within $1/32$ " (0.80 mm) of a rivet or $1/32$ " (0.80 mm) of the shoe at any point.

All front disc brakes have a wear indicator that makes a noise when the linings wear to a degree where replacement is required, (fig. 5-19). The spring clip is an integral part of the inboard shoe and lining. When the lining is worn, the clip contacts the rotor and produces a warning noise.

Caliper Removal

NOTICE: See "Notice" on Page 5-1 of this section.

1. Remove two thirds of the total fluid capacity from the front master cylinder reservoir. Removal of the fluid is

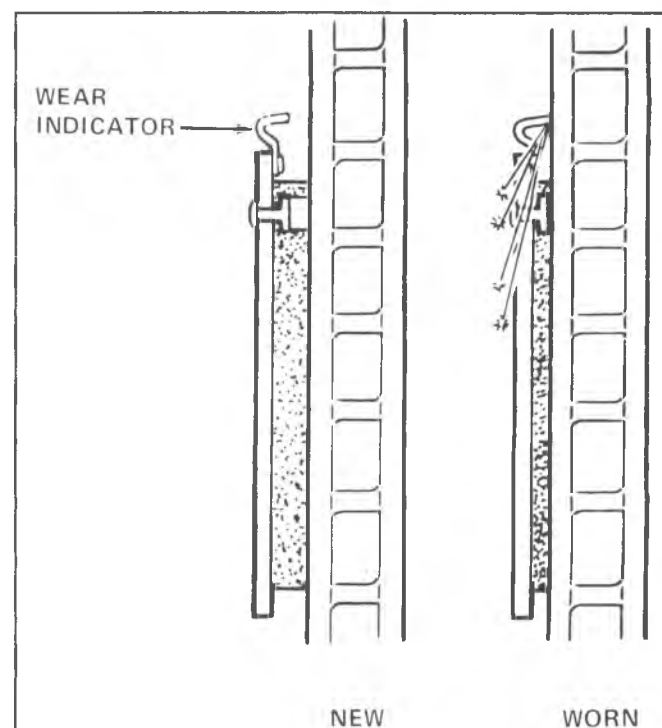


Fig. 5-19--Disk Brake Wear Indicators

necessary to prevent reservoir overflow when the caliper piston is pushed back in its bore to remove the caliper. This may be done by breaking the front line connection at the master cylinder and bleeding down the fluid level. Do not remove the brake line or completely empty the reservoir or it will be necessary to bleed the hydraulic system. Discard -- do not attempt to reuse -- the brake fluid removed.

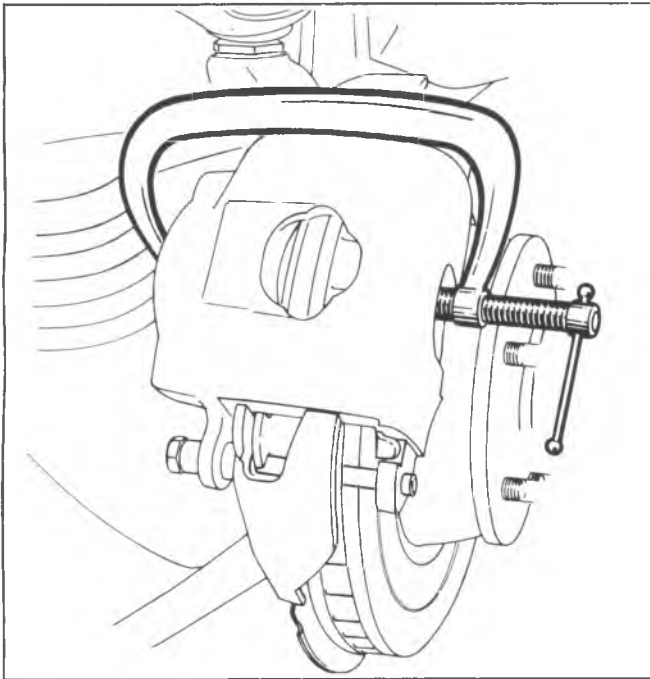


Fig. 5-20--Use of "C" Clamp

2. Raise the vehicle on a hoist and remove the wheel covers and wheel assemblies. Position a 7 inch "C" clamp on the caliper so that solid side of the clamp rests against the metal part of the outboard shoe (fig. 5-20). Tighten the "C" clamp until the caliper moves away from the vehicle far enough to push the piston to the bottom of the piston bore. This will allow the shoes to back off from the rotor surfaces. Remove the "C" clamp.

3. It is not necessary to disconnect the brake hose for shoe and lining replacement. Remove the two mounting bolts which attach the caliper to the support bracket (fig.

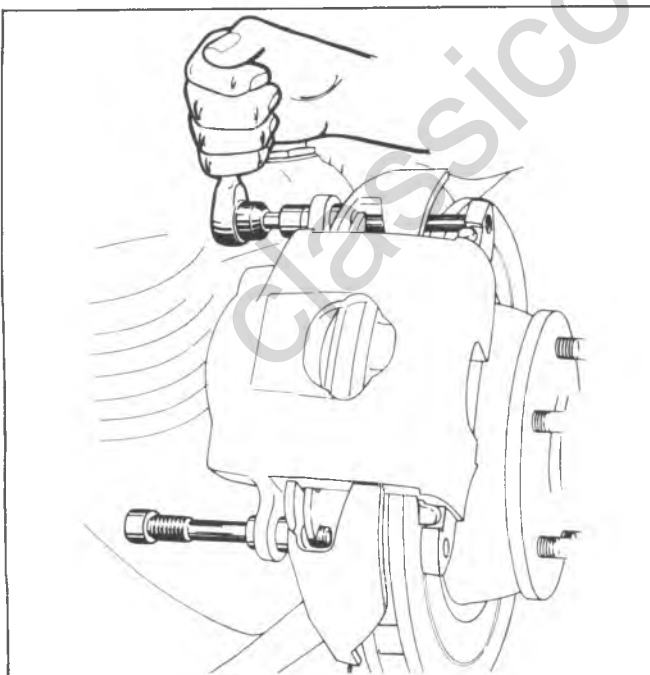


Fig. 5-21--Removing Mounting Bolts

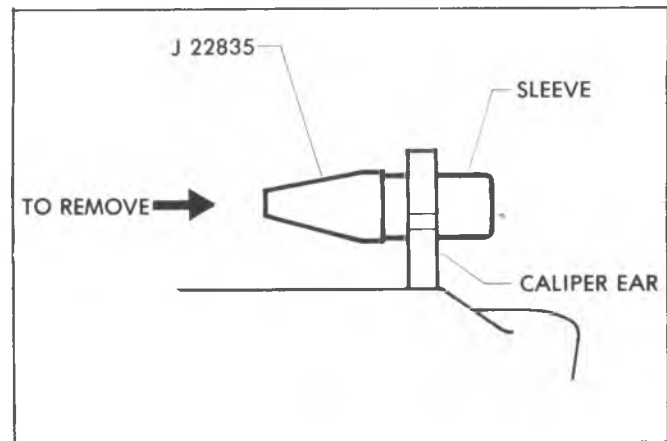


Fig. 5-22--Removing Sleeves

5-21). Lift the caliper off the rotor and remove the inboard shoe. Dislodge the outboard shoe and position the caliper on the front suspension arm so that the brake hose will not support the weight of the caliper. Remove the shoe support spring from the cavity in the piston.

4. Using Tool J-22835, remove the sleeves from the inboard ears of the caliper (fig. 5-22). Next, remove the rubber bushings from the grooves in each of the four caliper ears.

Cleaning and Inspection

1. Thoroughly clean the holes and the bushing grooves in the caliper ears. Wipe all dirt from the mounting bolts. Do not use abrasives on the bolts since this will damage the plating. If the bolts are corroded, or damaged, they should be replaced.

2. Examine the inside of the caliper for evidence of fluid leakage. If leakage is noted, the caliper should be overhauled. Wipe the inside of the caliper clean, including the exterior of the dust boot. Check the boot for cuts, cracks or other damage. Make sure that the boot is properly engaged in the groove in the piston and also in the caliper counter-bore (fig. 5-24).

NOTICE: Do not use compressed air to clean the inside of the caliper since this may cause the dust boot to become unseated.

3. If the vehicle has a brake problem and diagnosis points to the rotor, it should be inspected and checked for runout at this time.

Caliper Installation

1. Install rubber bushings in all four caliper ears.

NOTICE: It is essential that the new sleeves and rubber bushings be used in order to insure the proper functioning of the sliding caliper design.

2. Use Tool, J-22835, to install the sleeves (fig. 5-25). Position the sleeves so that the end toward the shoe and lining assemblies is flush with the machined surface of the ear.

3. Install the shoe support spring by replacing the single tang end of the spring over the notch in the center of the edge of the shoe. Then press the two tangs at the

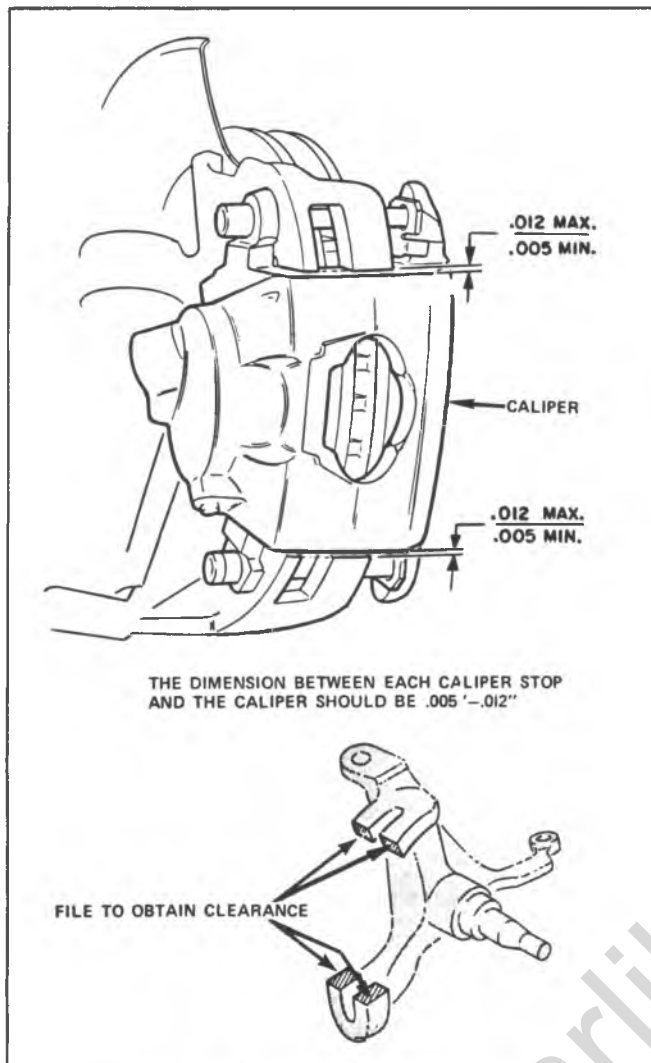


Fig. 5-23-Caliper to Stop Clearance

spring end of the inboard shoe spring over the bottom edge of the shoe so that they engage the shoe securely, as shown in Figure 5-26.

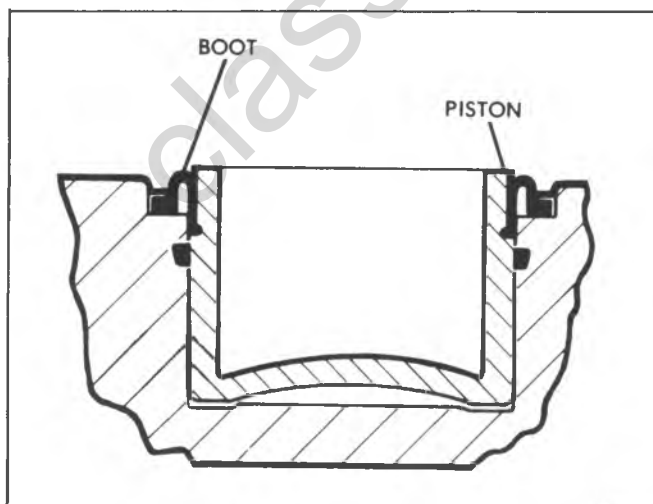


Fig. 5-24-Boot Installation

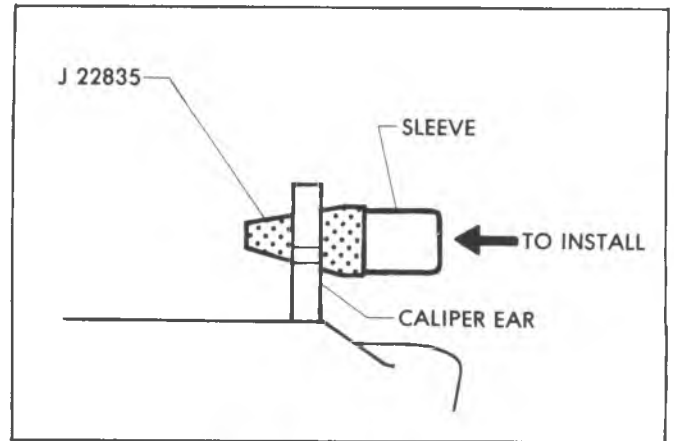


Fig. 5-25-Sleeve Installation

4. Position the inboard shoe and lining assembly (with spring attached) in the caliper so that the ear end of the shoe and lining is down and the bottom end up at an angle with the spring resting on the piston I.D. (fig. 5-27). Press down on both ends of the shoe until the shoe is in a flat position, resting on the piston. The spring end of the inboard shoe support spring should be resting on the I.D. of the piston.

NOTICE: On inboard shoes there is a specific left hand and right hand shoe. When properly installed the wear sensor will be toward rear of caliper.

5. Position the outboard shoe in the caliper, with the ears at the top of the shoe over the caliper ears and the tab at the bottom of the shoe engaged in the caliper cut-out (see fig. 5-28). Be sure to note right and left brake shoes.

6. Position the caliper over the rotor, lining up the holes in the caliper ears with the holes in the mounting bracket.

NOTICE: When reinstalling caliper be sure you haven't turned it over, end over end. This would cause a severe twist in the brake hose. After positioning caliper on disc, observe brake hose being sure it is not

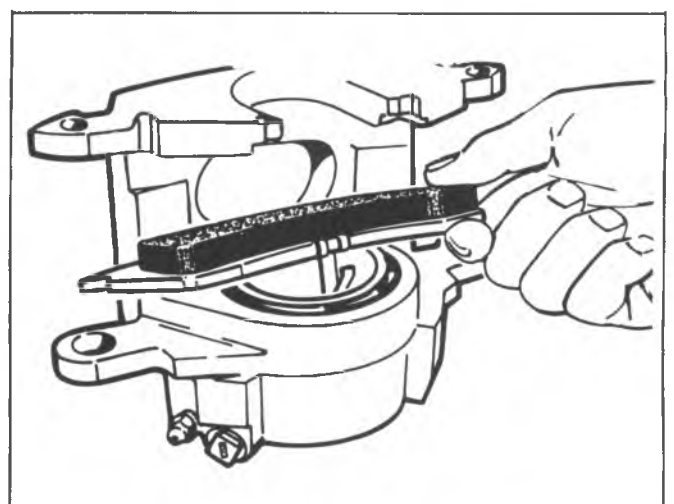


Fig. 5-26-Inserting Shoe Support Spring

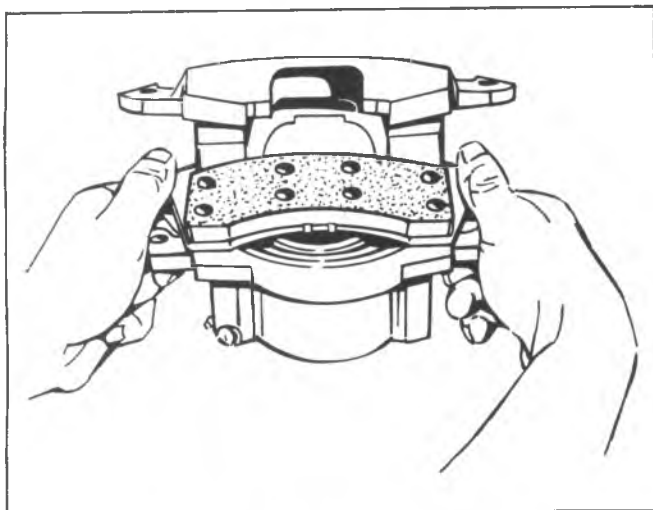


Fig. 5-27-Installing Inboard Shoe

twisted.

Start the bolts through the sleeves in the inboard caliper ears and through the mounting bracket, making sure that the ends of the bolts pass under the retaining ears on the inboard shoe (fig. 5-29). Push bolts on through to engage the holes in the outboard shoes and the outboard caliper ears at the same time, threading the bolts into the mounting bracket. Torque the bolts to 35 lb. ft. (50 N·m).

NOTICE: See "Notice" on Page 1 of this section.

7. Add fresh approved brake fluid to the master cylinder reservoirs to bring the level up to within 1/8" (3 mm) of the top.

8. Pump brake pedal to seat linings against rotor.

9. Clinch upper ears of outboard shoe by positioning channel lock pliers with one jaw on top of upper ear and one jaw in notch on bottom of shoe opposite upper ear (fig. 5-30).

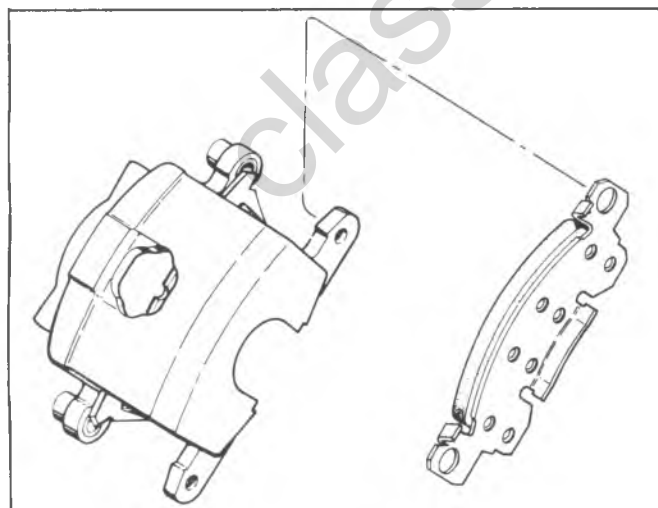


Fig. 5-28-Installing Outboard Shoe

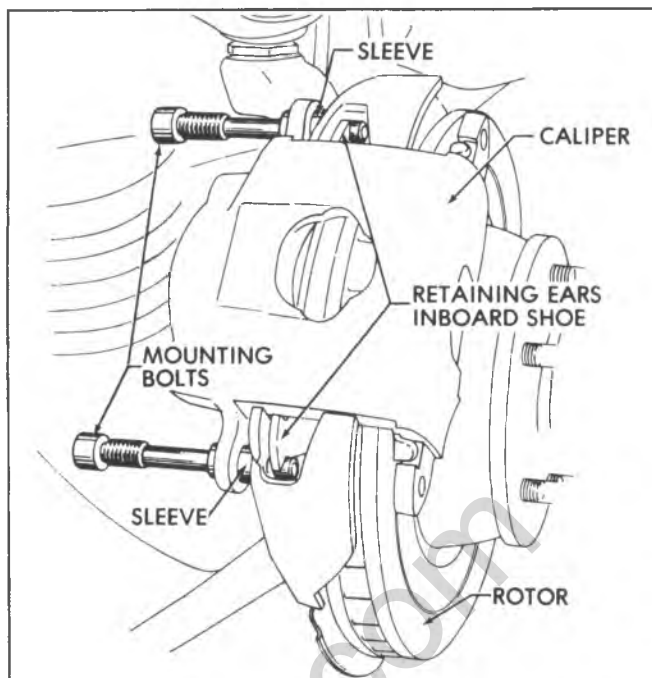


Fig. 5-29-Installing Mounting Bolts

10. After clinching, ears are to be flat against caliper housing with no radial clearance.

11. If radial clearance exists, repeat clinching procedure.

Completion

1. Replace the shoe and linings on the other front wheel disc brake in exactly the same manner as just described. Relining is to be done in full axle sets only. When completed, reinstall the wheel and tire assemblies. Torque wheel nuts to specifications. Install wheel covers and lower the vehicle to the floor.

NOTICE: See "Notice" on Page 1 of this section.

2. Whenever the front wheel disc brakes are relined, the rear drum brakes should be checked also.

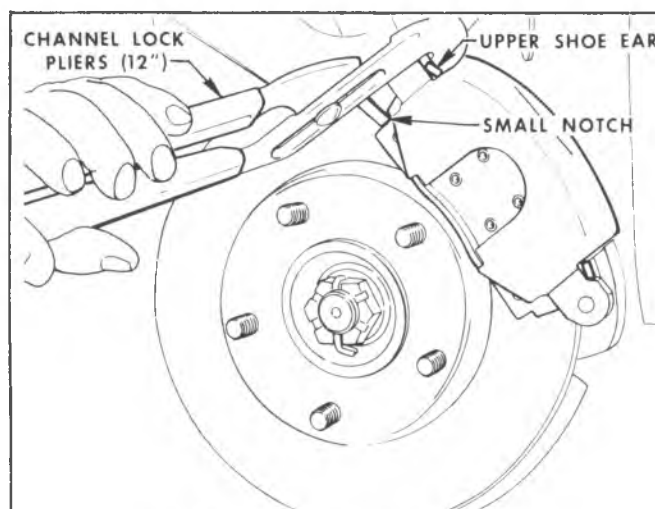


Fig. 5-30-Clinching Outboard Shoe

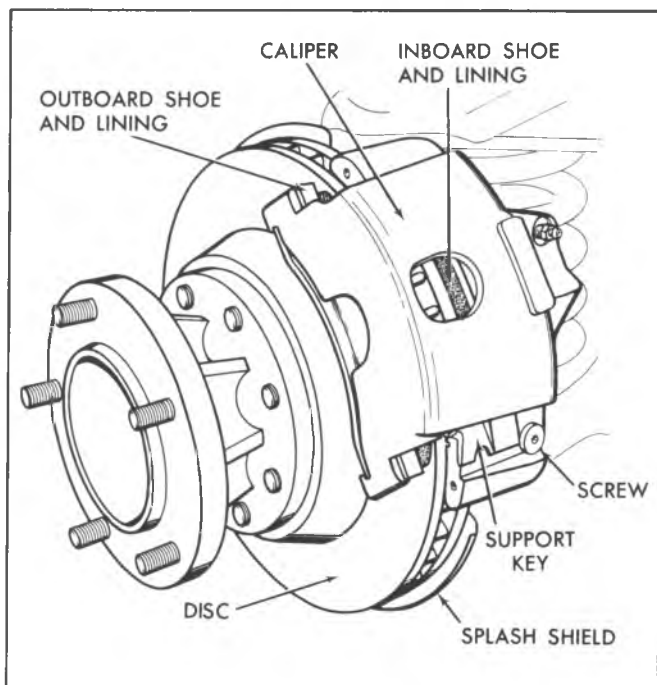


Fig. 5-31--Bendix Front Disc Brake Assembly

BENDIX DISC BRAKE SHOE AND LINING

The brake linings should be inspected any time the wheels are removed. Check both ends of the outboard shoe by looking in at each end of the caliper (fig. 5-31). This is the point at which the highest rate of wear normally occurs. At the same time, check the lining thickness on the inboard shoe by looking down through the inspection hole in the top of the caliper; see "Brake Inspection" portion of this section. The inboard shoe is installed with the ends of the shoe resting in the steering knuckle. The large tab at the bottom of the outboard shoe is bent over at the right angle and fits in the cutout in the outboard section of the caliper.

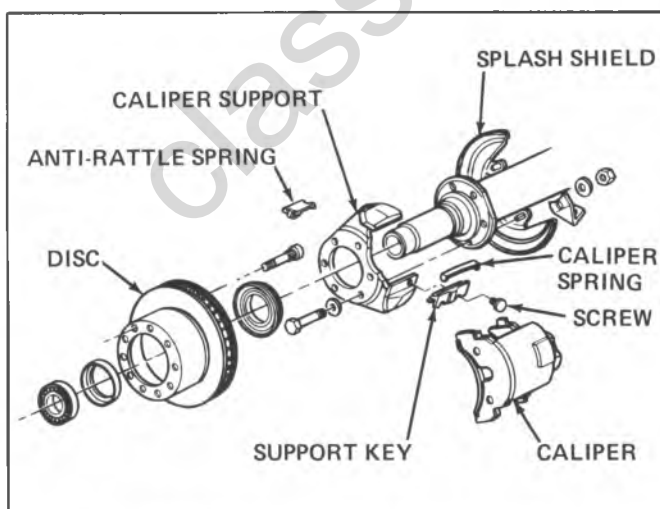


Fig. 5-32--Bendix Rear Disc Brake Assembly

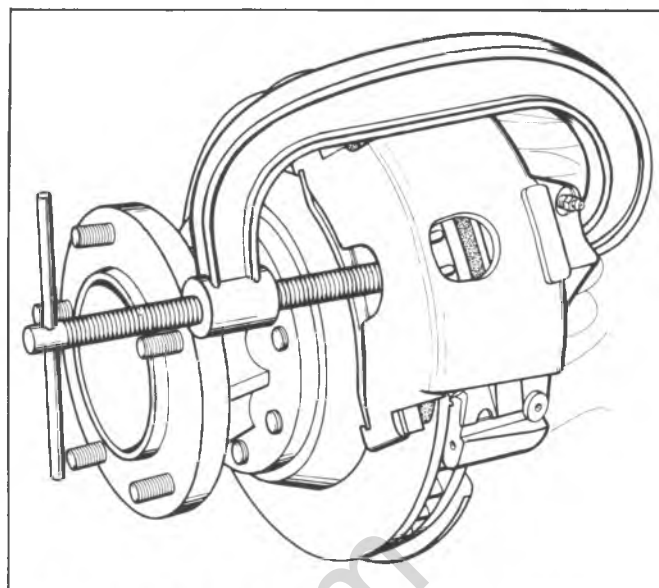


Fig. 5-33--Pushing Piston into Bore Using a "C" Clamp

Removal (Front or Rear)

NOTICE: See "Notice" on page 1 of this section.

1. Remove master cylinder cover and observe brake fluid level in front reservoir is more than 1/3 full, siphon the necessary amount out to bring the level to 1/3 full. This step is taken to avoid reservoir overflow when the caliper piston is pushed back into its bore. Discard the brake fluid removed. Never reuse brake fluid.
2. Raise the vehicle on a hoist and remove wheels.
3. Push the piston back into its bore. This can be accomplished by using a "C" clamp as shown in Figure 5-33.
4. Remove the bolt at the caliper support key. Using a brass punch, remove the key and spring (fig. 5-34).
5. Lift the caliper off the disc and support in a raised position with a heavy wire (fig. 5-35).

NOTICE: Do not support the weight of the caliper on the brake hose as damage to the brake hose could result.

6. Remove the inboard shoe from the steering knuckle or rear caliper support (fig. 5-32). Remove and discard the inboard shoe clip. Remove the outboard shoe from the caliper. It may be necessary to tap the shoe to loosen it in the caliper housing.

Mark disc pad positions if pads are to be reinstalled.

Cleaning and Inspection

The shoes should be replaced when the lining is worn to approximately 1/32" (0.80 mm) thickness over the rivet heads. Replace shoes in axle sets.

1. Examine the inside of the caliper for evidence of fluid leakage. If leakage is noted, the caliper should be overhauled.
2. Wipe the inside of the caliper clean, including the exterior of the dust boot. Check the boot for cuts, cracks or other damage.

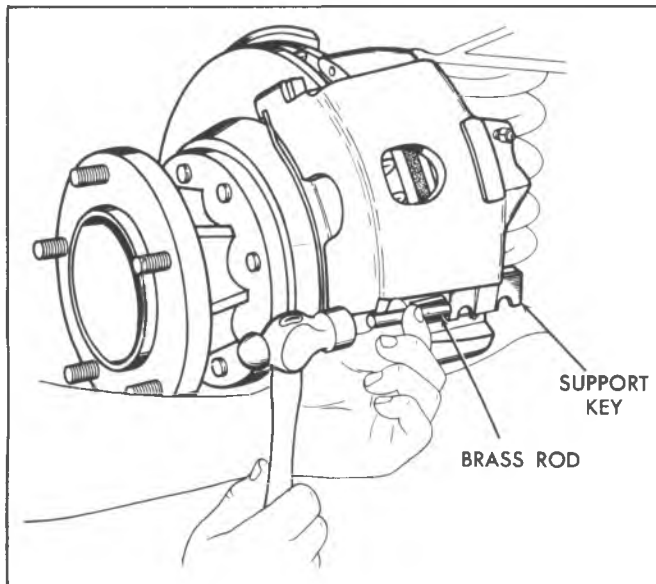


Fig. 5-34--Removing the Caliper Support Key

NOTICE: Do not use compressed air to clean the inside of the caliper since this may cause the dust boot to become unseated.

3. Use a wire brush to remove any rust or corrosion from the machined surfaces of the steering knuckle (or support) and caliper. It is important to clean those areas of the caliper and support that are in contact during the sliding action of the caliper.

Installation

If original disc pads are being reinstalled, they must be installed in original positions (as marked at removal).

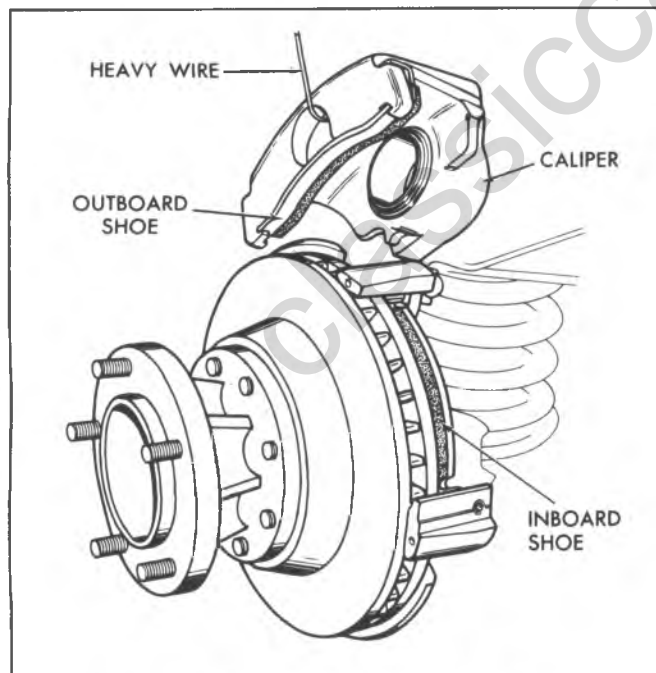


Fig. 5-35--Removing Caliper from the Disc

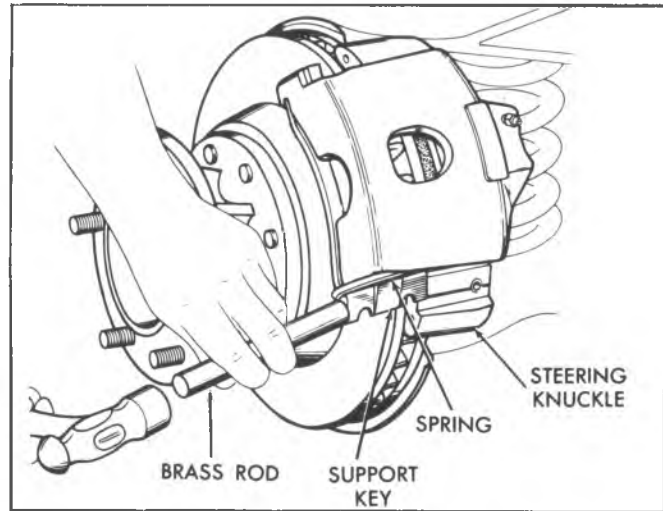


Fig. 5-36--Installing the Caliper Support Key

1. Lubricate the caliper and steering knuckle (or support) sliding surfaces and the support spring with Delco Silicone Lube (or equivalent).

2. Install a NEW inboard shoe clip in the steering knuckle or rear support. Be sure the tabs are positioned correctly and the loop-type spring positioned away from the rotor. Install the lower end of the inboard shoe into the groove provided in the steering knuckle or support (against the spring clip). Slide the upper end of the shoe into position. Be sure the clip remains in position.

3. Position the outboard shoe in the caliper with the ears at the top of the shoe over the caliper ears and the tab at the bottom of the shoe engaged in the caliper cutout. If assembly is difficult, a "C" clamp may be used. Be careful not to mar the lining.

4. With both shoes installed, lift up the caliper and rest the bottom edge of the outboard lining on the outer edge of the brake disc to make sure there is no clearance between the tab at the bottom of the outboard shoe and the caliper abutment. The outboard shoe should fit tightly in the caliper and should not rattle.

5. Position the caliper over the brake disc, guiding the upper caliper groove onto the mating surface of the steering knuckle or caliper support. Position the caliper to the lower steering knuckle (or support) sliding surface.

NOTICE: Make sure that the brake hose is not twisted or kinked since damage to the brake hose could result.

6. Place the spring over the caliper support key, install the assembly between the steering knuckle (or rear support) and lower caliper groove. Tap into place (until the key retaining screw can be installed) using a brass punch and a light hammer (fig. 5-36).

7. Install the screw and torque to 12 to 18 lb. ft. (18-24 N·m). The bolt boss must fit fully into the circular cutout in the key.

NOTICE: See "Notice" on Page 1 of this section.

8. Reinstall the front wheel and tire assembly.

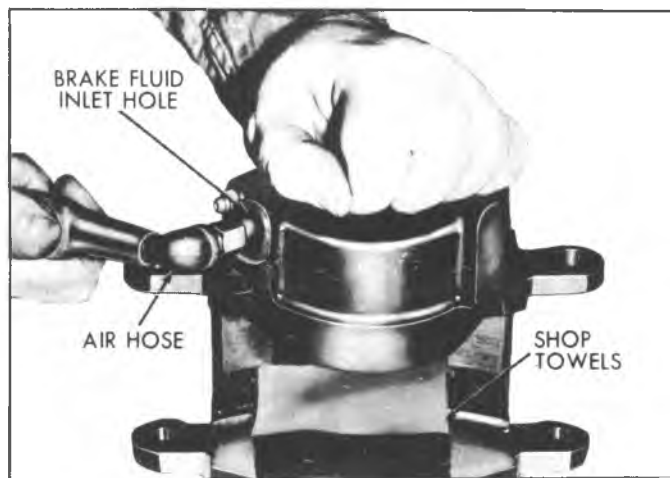


Fig. 5-37--Removing Piston

9. Add brake fluid to the master cylinder reservoir to bring the fluid level up to within 1/4" (6 mm) of the top.

NOTICE: Before moving the vehicle, pump the brake pedal several times to make sure that it is firm. Do not move vehicle until a firm pedal is obtained. Check master cylinder fluid level again after pumping the brake pedal.

CALIPER OVERHAUL

Delco

Removal

1. Removal of the caliper for overhaul is the same as for shoe and lining replacement except that it will be necessary to disconnect the brake hose; (Refer to front brake hose replacement).

2. First, disconnect the hose from the steel brake pipe and cap the fittings to prevent dirt from entering the pipe or the hose. Then, remove the U-shaped retainer from the hose fitting. Withdraw the hose from the frame support bracket and remove the caliper -- with hose attached -- to a work bench for overhaul.

Disassembly

1. Before beginning disassembly, thoroughly clean the exterior of the caliper using brake cleaner. Place the caliper on a clean work surface.

2. Remove the brake hose from the caliper, discarding the copper gasket. Check the hose for worn spots, cracks or other signs of deterioration, discard the hose, if damaged, to be replaced with a new hose at reassembly. Drain brake fluid from the caliper.

3. Use clean shop towels to pad the interior of the caliper.

Remove the piston by directing compressed air into the caliper inlet hole (fig. 5-37).

CAUTION: Do not place the fingers in front of the piston in an attempt to catch or protect it when applying compressed air. This could result in serious injury.

NOTICE: Use just enough air pressure to ease the piston out of the bore. If the piston is blown out, even with padding provided, it may become damaged.

4. Use a screwdriver to pry the boot out of the caliper. Extend the screwdriver across the caliper bore, under the boot, and pry up. Be careful not to scratch the caliper bore.

5. Use a piece of wood or plastic -- a plastic toothpick is ideal -- to remove the piston seal from its groove in the caliper bore. **DO NOT USE A METAL TOOL OF ANY TYPE FOR THIS OPERATION.**

6. Remove the bleeder valve from the caliper.

Cleaning and Inspection

1. The boot, piston seal, rubber bushings and sleeves are to be replaced each time the caliper is overhauled. Discard, do not bother to clean and inspect, these parts.

2. Clean all other parts in clean denatured alcohol or brake cleaner. Use dry, filtered compressed air to dry parts and blow out all passages in the caliper and bleeder valves.

The use of lubricated shop air will leave a film of mineral oil on the metal parts. This may damage rubber parts when they come in contact after reassembly.

3. Check the mounting for corrosion, breaks in the plating or other damage. Do not use abrasives in an attempt to clean the pins -- replace them.

4. Carefully examine the piston outside diameter for scoring, nicks, corrosion and worn or damaged chrome plating. If any surface defects are detected, replace the piston.

5. Check the bore in the caliper for the same defects as the piston with the exception of plating damage. The piston bore is not plated and stains or minor corrosion can be polished with crocus cloth. Do not use emery cloth. Thoroughly clean the caliper after the use of crocus cloth. If the bore cannot be cleaned up in this manner, replace the caliper.

Reassembly

1. Lubricate the bore in the caliper and the new piston seal with clean brake fluid. Position the seal in the caliper bore groove. Lubricate the piston with clean brake fluid and assemble a new boot into the groove in the piston so that the fold faces the open end of the piston. Insert the piston into the caliper bore, using care not to unseat the seal and force down to the bottom in the bore. This will require a force of 50 to 100 pounds (220 to 440 N). Position the outside diameter of the boot in the caliper counterbore and seat with Tool J-22904 (fig. 5-38).

2. Check the boot installation to make sure that the retaining ring molded into the boot is not bent and that the boot is installed fully, below the caliper face, and evenly all around. Otherwise dirt or moisture may enter the bore and cause damage or corrosion.

3. Install the brake hose in the caliper inlet using a new copper gasket.

Installation

1. Installation of the caliper and mounting parts (rubber bushing, sleeves, shoe and lining assemblies and pins) is the same as for lining replacement except for the following:

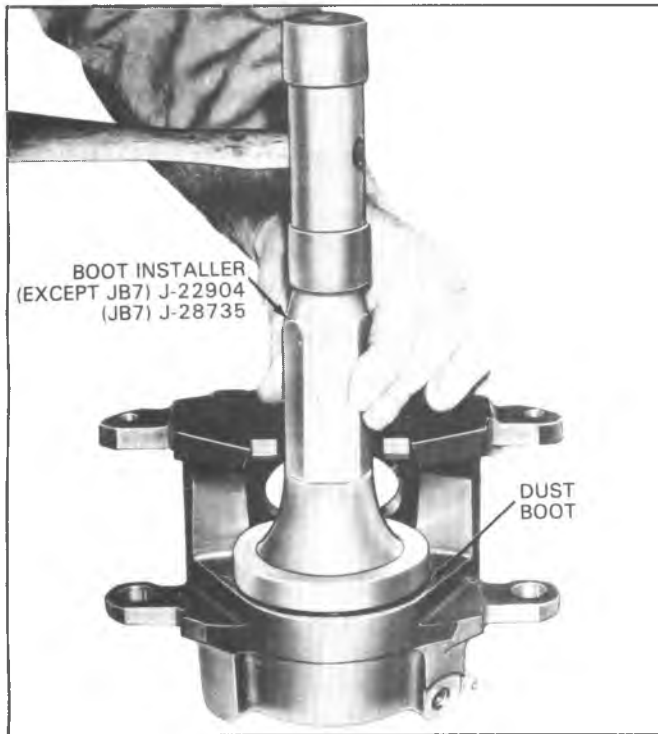


Fig. 5-38-Seating Boot

a. The brake hose must be connected to the brake pipe at the frame or frame bracket.

Use extreme care to orient the hose so that the keyed hose end fitting aligns with the slot in the bracket without twisting or kinking the hose.

b. After overhaul -- or any time that the brake hose or line is disconnected -- the calipers must be bled.

Bendix

Removal

Clean dirt from hose to caliper connection before proceeding with removal.

1. Remove the hose to caliper bolt and cap or tape the open connections to prevent dirt from entering the hose or caliper. Discard the copper gaskets.

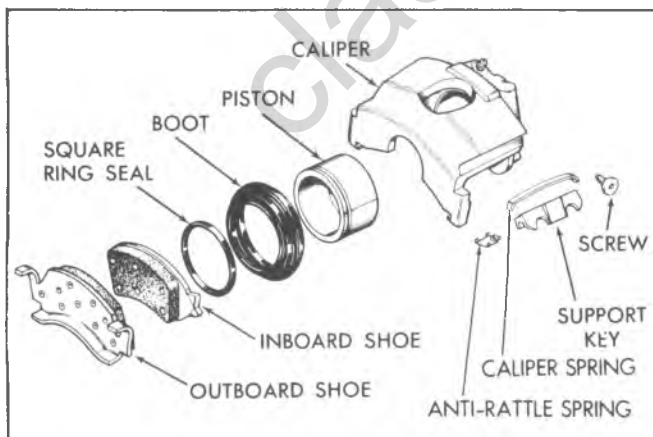


Fig. 5-39-Bendix Brake Caliper Assembly

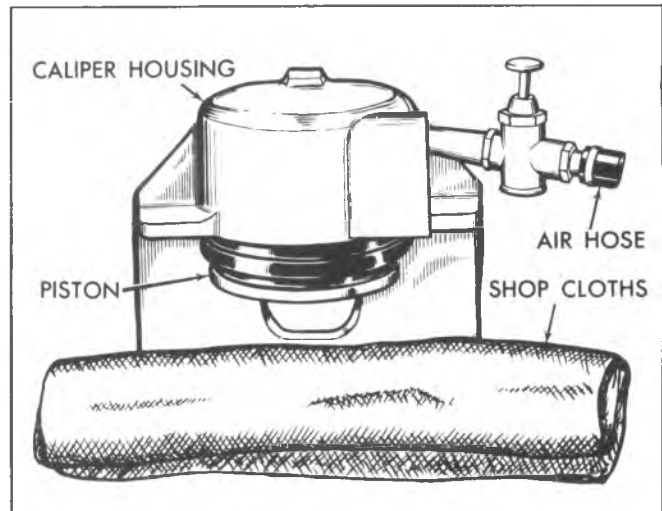


Fig. 5-40-Removing the Caliper Piston

2. Remove the caliper assembly as described under "Shoe and Linings-Removal".

Disassembly (Fig. 5-39)

1. Clean the exterior of the caliper using clean brake fluid and place on a clean work surface.

2. Drain the brake fluid from the caliper.

CAUTION: Do not place the fingers in front of the piston in an attempt to catch or protect it when applying compressed air.

3. Using clean shop cloths, pad the interior of the caliper and remove the piston by directing compressed air into the caliper inlet hole (fig. 5-40).

NOTICE: Use just enough air pressure to ease the piston out of the bore. If the piston is seized or cocked or does not come out readily, release the air pressure and use a soft (brass) hammer to rap sharply on and around the end of the piston. Reapply air pressure to remove the piston.

An alternate method of removing the piston is to stroke the brake pedal (gently) while the hydraulic lines are still connected. This will push the piston out of the caliper bore.

Do not blow piston out of the bore as damage to the piston could occur.

4. Remove the boot from the piston bore.

5. Using a small piece of wood or plastic, remove the square ring seal from the piston bore.

NOTICE: Do not use a metal tool of any kind for this operation as it may damage the bore.

6. Remove the bleeder valve from the caliper.

Cleaning and Inspection

The dust boot and piston seal are to be replaced whenever the caliper is overhauled. Discard these parts.

1. Clean all parts (other than those mentioned above) in clean brake fluid. Use dry, filtered, compressor air to blow out all passages in the caliper and bleeder valve.

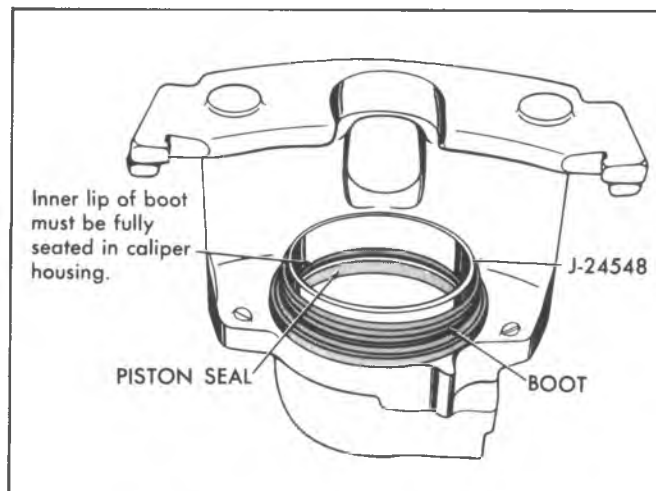


Fig. 5-41—Installing Caliper Piston Boot

NOTICE: The use of lubricated shop air will leave a film of mineral oil on the metal parts. This may damage rubber parts when they come in contact after reassembly.

2. Check the sliding surfaces of the caliper, steering knuckle (or rear support) and support spring for rust or corrosion. Clean up any surface defects with crocus cloth.

3. Carefully examine the outside surface of the piston for scoring, nicks, corrosion and worn or damaged plating. If any surface defects are detected, replace the piston.

NOTICE: The piston outside diameter is the primary sealing surface in the caliper assembly. It is manufactured and plated to close tolerances. Refinishing by any means or the use of any abrasive is not acceptable practice.

4. Check the bore in the caliper for the same defects as the piston. The piston bore, however, is not plated and stains or minor corrosion can be polished with crocus cloth.

Do not use emery cloth or any other form of abrasive. Thoroughly clean the caliper after the use of crocus cloth. If the bore cannot be cleaned up in this manner, replace the caliper.

Assembly

1. Lubricate the caliper piston bore and the NEW piston seal with the clean brake fluid. Position the square ring seal in the caliper bore groove.

2. Lubricate both sealing lips of the dust boot and the piston with a light film of clean brake fluid. Place the new boot over Piston Installer Tool J-24548. This is most easily accomplished by placing the boot large diameter over the tool first, then riding the smaller diameter onto the tool. The large diameter lip must then be slid off the tool to make ready for installation into the bore groove. Install the boot (large bead) into the piston bore groove by reaching inside of Tool J-24548 and pressing the boot bead into the groove (fig. 5-41).

Be sure boot is fully seated in the groove before proceeding.

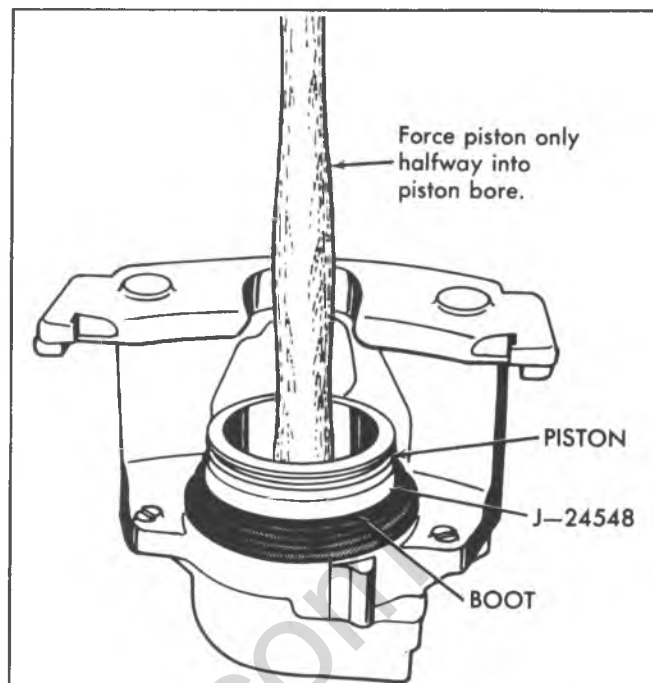


Fig. 5-42—Installing Piston in Caliper

3. Place the piston inside of Tool J-24548, force the piston halfway into the piston bore using a wood hammer handle or "C" clamp (fig. 5-42); remove Tool J-24548. Check to be sure the boot was not unseated at piston installation. Make sure the outer bead of the boot is seated in the piston outer groove.

Installation

Installation of the caliper and mounting parts is the same for: "Shoe and Lining-Disc Brake" except for steps given below:

1. Connect the brake hose to the caliper using NEW copper gaskets.

NOTICE: Hose must be properly positioned to prevent hose twist or misalignment or hose damage may result.

2. Bleed the caliper assemblies as outlined earlier in this section.

ROTOR SERVICING

Checking Lateral Runout

1. Lateral runout is the movement of the rotor from side to side as it rotates on the steering knuckle spindle. This could be described as "rotor wobble".

2. The movement of the rotor from side to side in the lateral plane causes the brake shoe and lining and pistons to be knocked back into their bores. This results in additional pedal travel required and a vibration during the braking action.

3. To check lateral runout, first tighten the wheel bearings until all of the play is out of the bearings. Fasten a dial indicator to some portion of the suspension so that the point of the stylus contacts the rotor face approximately 1" (25 mm) from the rotor edge (fig. 5-43). Set the dial at zero. Move the rotor one complete rotation, checking the indicator as the rotor moves.

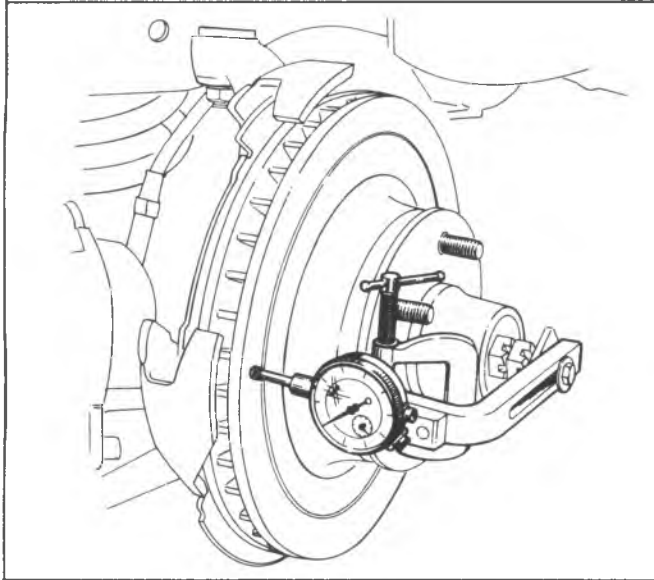


Fig. 5-43--Checking Rotor for Lateral Runout

4. Lateral runout should not be over .004" (0.10 mm) total indicator reading.

Parallelism Check

1. Parallelism is the measurement of the thickness of the rotor at four or more points around the circumference of the rotor. All measurements must be made at the same distance in from the edge of the rotor.

2. A rotor that varies over .0005" (0.013 mm) causes pedal vibration, as well as front end vibration during brake applications. A rotor that does not meet these specifications may be refinished to specifications if precision equipment is available.

Rotor Tolerance and Surface Finish

In manufacturing the brake rotor, tolerances of the rubbing surfaces for flatness, for parallelism and for lateral runout are held very closely. The maintenance of these close controls on the shape of the rubbing surfaces is necessary to prevent brake roughness.

In addition to these tolerances, the surface finish must be held to a specified range. The control of the rubbing surface finish is necessary to avoid pulls and erratic performance and to extend lining life.

Light scoring of the rotor surfaces not exceeding .015" (0.38 mm) in depth, which may result from normal use, is not detrimental to brake operation.

Machining

Since accurate control of the rotor tolerances is necessary for proper performance of the disc brakes, machining of the rotor should be done only with precision equipment.

CAUTION: All brake rotors have a minimum thickness dimension cast into them. This dimension is the minimum wear dimension and not a refinish dimension. Do not use a brake rotor that will not meet the specifications, as shown below, after refinishing. Replace with new brake rotor.

| ROTOR THICKNESS | |
|------------------------------|--------------------------|
| MINIMUM AFTER REFINISHING | REPLACEMENT (DISCARD) |
| 1.480 | 1.465 |
| 1.230 | 1.215 |
| .980 | .965 |

Wheel Bolt Replacement (Disc Brakes)

NOTICE: See "Notice" on page 1 of this section.

1. Remove hub and rotor assembly from vehicle.
2. Mark rotor to hub location and remove bolts attaching hub to rotor.
3. The wheel bolts on disc brakes can be pressed out from the outside of the hub and installed from inside the rotor by pressing into place. No drilling or cutting is required.
4. Reinstall assembly and adjust wheel bearings.

DRUM BRAKE SHOE AND LINING

Service Brake

Adjustment

1. Using a punch, knock out lanced area in brake drum. If this is done with the drum installed on the vehicle, the drum must be removed and all metal cleaned out of the brake compartment. Be sure to procure a new metal hole cover and install it in the drum after adjustment to prevent dirt and water from getting into the brakes. Use J-6166 to turn brake adjusting screw; expand brake shoes at each wheel until the wheel can just be turned by hand. The drag should be equal at all wheels.

2. Back off brake adjusting screw at each wheel 30 notches. If shoes still drag lightly on drum, back off adjusting screw one or two additional notches. Brakes should be free of drag when screw has been backed off approximately 12 notches. Heavy drag at this point indicates tight parking brake cables.

3. Install metal adjusting hole cover in brake drum.
4. Check parking brake adjustment.

Removal and Inspecting

NOTICE: See "Notice" on Page 1 of this section.

1. Raise vehicle on hoist. Remove wheel and brake drum. It may be necessary to back off the brake shoe adjustment before the brake drums can be removed. To back off shoe adjustment, rotate shoe adjusting screw downward.

On JB6, JB7 and JB8 equipped vehicles, it is necessary to remove the axle shafts to remove the hub and drum assembly; refer to Section 4B of this manual.

2. Unhook the primary and secondary shoe return springs using large pliers.
3. Remove shoe hold down springs.
4. Lift up on actuator, unhook actuating link from anchor pin, then remove.

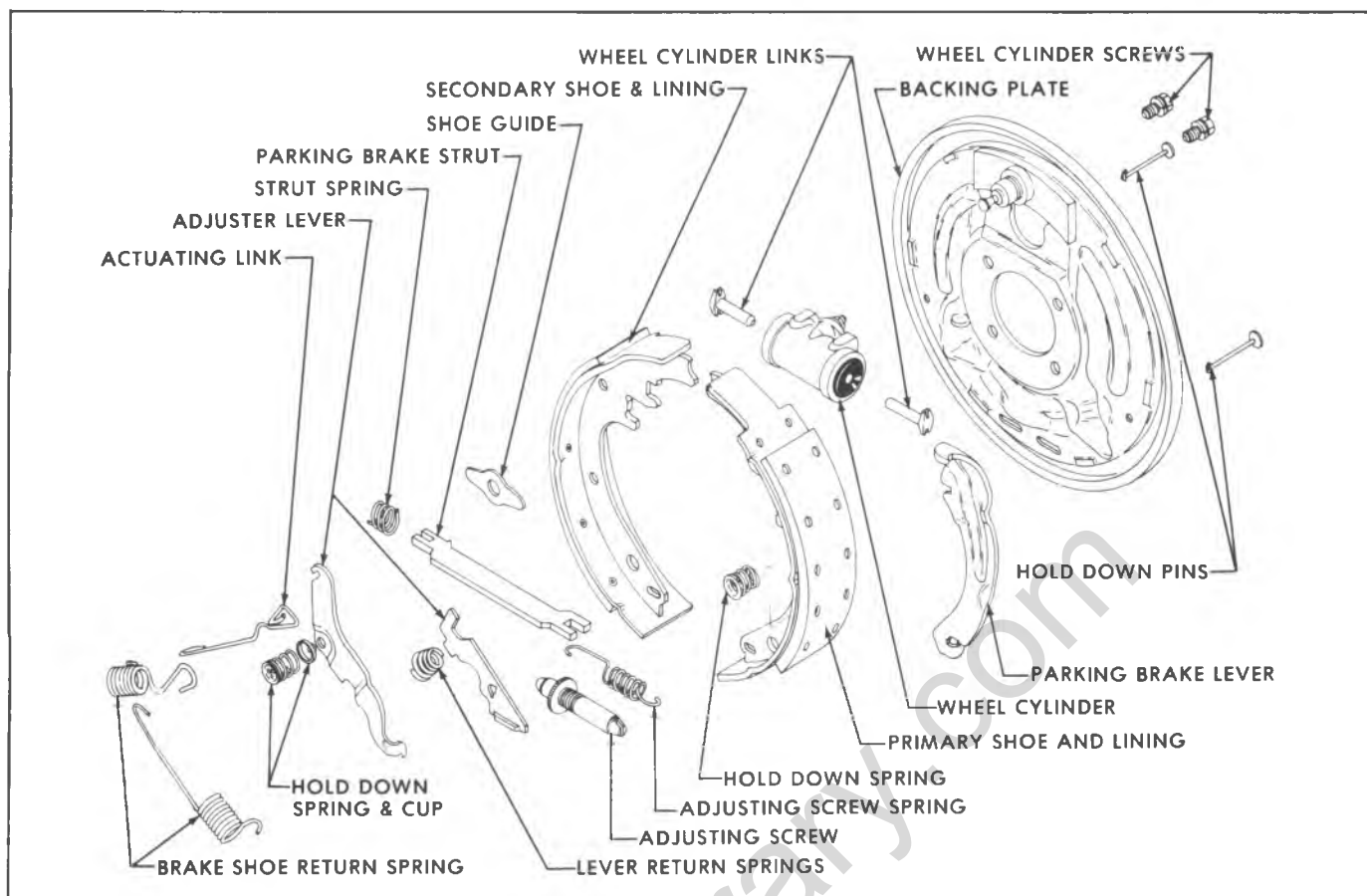


Fig. 5-44--Typical Drum Brake Assembly

5. Spread shoes to clear wheel cylinder connecting links, remove parking brake strut and spring, disconnect cable from parking brake lever, remove shoes from the backing plate.

6. Separate the brake shoes by removing adjusting-screw and lock spring. Remove parking brake lever and secondary brake shoe.

7. Clean all dirt out of brake drum. Inspect drums and replace or recondition if required.

8. Clean all dirt from brake assemblies and inspect for any unusual condition.

9. Wheel cylinders having torn, cut, or heat-cracked boots should be completely overhauled.

Inspection for leakage may be accomplished at the boot center hole after removal of link pin. Fluid coatings on piston within cylinder and on end of link pin removed from boot are normal, as cylinder contains a porous PISTON WHICH IS IMPREGNATED WITH A CORROSION INHIBITING FLUID. Fluid spilling from boot center hole, after link pin is removed, indicates cup leakage and necessity for completely over-hauling cylinder.

10. Inspect backing plate for oil leakage past wheel bearing oil seals. Correct any leak by installation of new seals (See Section 4B).

11. Check all backing plate attaching bolts to make sure they are tight. Using fine emery cloth, clean all rust and dirt from shoe contact surfaces on plate.

Installation and Adjustment

1. Lubricate fulcrum end of parking brake lever with Delco Brake Lubricant or equivalent, then attach lever to secondary shoe. Make sure that lever is free moving.

2. Connect brake shoes together with adjusting screw spring, then place adjusting screw in position. When installing the adjusting screw spring and adjusting screw,

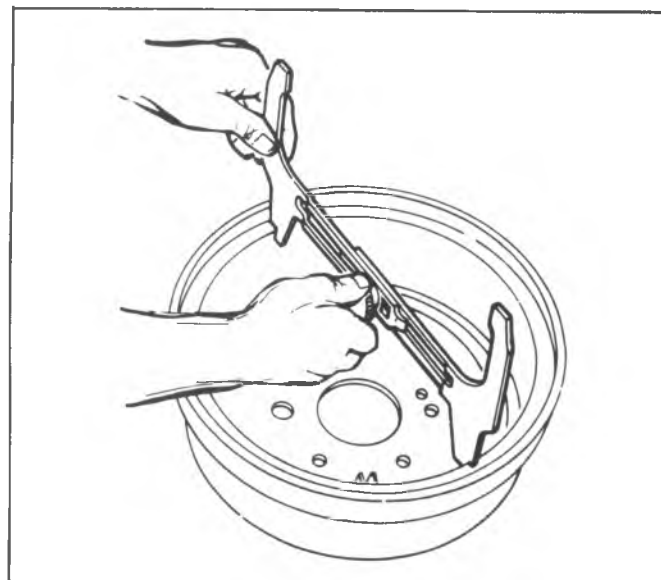


Fig. 5-45--Measuring Brake Drum I.D.

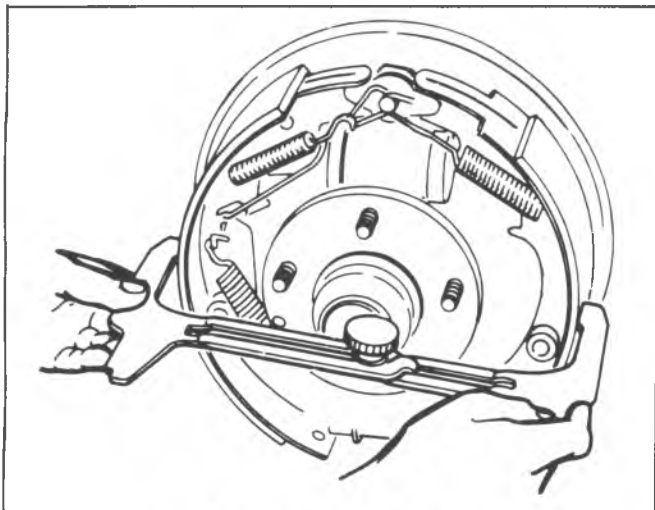


Fig. 5-46—Adjusting Brake Shoes

make sure the spring does not touch the starwheel portion of the adjusting screw; and, also, when installing adjusting screw, make sure right hand thread adjusting screw is on left side of vehicle and left hand thread adjusting screw is on right side of vehicle. Make certain starwheel lines up with adjusting hole in backing plate.

3. Lubricate shoe contact surfaces on backing plate with a thin coating of Delco Brake Lubricant or equivalent. Sparingly apply same lubricant where brake cable backing contacts backing plate.

4. Place brake shoes on backing plate, at the same time engaging shoes with wheel cylinder links. The primary shoe (short lining) goes toward front of vehicle. Connect cable to parking brake lever and install strut and spring between lever and primary shoe.

5. Install actuator, actuator return spring and actuating link. If old brake shoe return springs are nicked, distorted or of doubtful strength (discolored from heat), it is advisable to install new parts.

6. Install shoe hold down springs.

7. Install the primary and secondary shoe return springs using large pliers. Be careful not to distort springs.

8. Measure brake drum I.D. using inside caliper portion of Tool J-21177 (fig. 5-45). Adjust brake shoes to dimension obtained on outside caliper portion of Tool J-21177 (fig. 5-46).

9. Install brake drums and wheels.

10. If any hydraulic connections were disturbed, bleed hydraulic system.

11. Adjust parking brake.

12. Inspect all brake pipes, hoses and connections for evidence of fluid leakage. Tighten any leaking connection. Then apply heavy pedal pressure to brake pedal and recheck connections.

13. Check fluid level in master cylinder and add fluid if necessary.

14. Check brake pedal for proper feel and for proper return.

15. Remove vehicle from hoist and road test for proper brake action. Brakes must not be severely applied immediately after installation of new brake shoes or linings. Severe application may permanently damage new linings

and may score brake drums. When linings are new, they must be given moderate use for several hundred miles of burnishing.

Repair Brake Lining

This procedure is to be used when brake action is unequal, severe, hard, noisy or otherwise unsatisfactory and when brake linings have had little wear.

1. Check fluid in master cylinder and add fluid if necessary.

2. Check brake pedal for proper feel and for proper return.

3. Raise vehicle on hoist and remove all wheels.

4. Remove all brake drums. Brake pedal must not be operated while drums are removed.

NOTICE: See "Notice" on page 1 of this section.

5. Clean all dirt out of brake drums. Inspect drums and replace or recondition if required.

6. Clean all dirt from brake assemblies, then inspect brake linings for uneven wear, oil soaking, loose rivets or imbedded foreign particles. If linings are oil soaked, replacement is required.

7. If linings are otherwise serviceable, tighten or replace loose rivets and thoroughly clean all steel or other imbedded particles from surfaces and rivet counterbores of linings.

8. Check all backing plate bolts to make sure they are tight. (Refer to Section 4B for wheel stud replacement procedure.)

9. Measure brake drum I.D. using inside caliper portion of Tool J-21177. Adjust brake shoes to dimension obtained on outside caliper portion of Tool J-21177 (figs. 5-45 and 5-46).

10. Install drum and wheel and tire assemblies.

11. Remove vehicle from hoist and road test for proper brake action. Brakes must not be severely applied immediately after installation. Severe application may permanently damage new linings and may score brake drums. When linings are new, they must be given moderate use for several hundred miles of burnishing.

Propeller Shaft Brake

Removal (Fig. 5-47)

1. Remove the propeller shaft; see Section 4A.

2. Remove the brake drum. It may be necessary to back off the shoe adjustment before removing the drum.

On automatic transmission models, the exhaust crossover pipe may be in the way. If so, loosen the transmission rear mounting bolts and jack the transmission sufficiently for brake drum to clear the pipe.

3. Remove the two pull back springs.

4. Remove the guide plate from anchor pin.

5. Remove shoe hold down cups, springs, and washers from hold down pins--remove pins.

6. Pull brake shoe and lining assemblies away from anchor pin and remove the strut and spring.

7. Lift the brake shoes and linings with the adjusting nut and bolt and connecting spring off the flange plate.

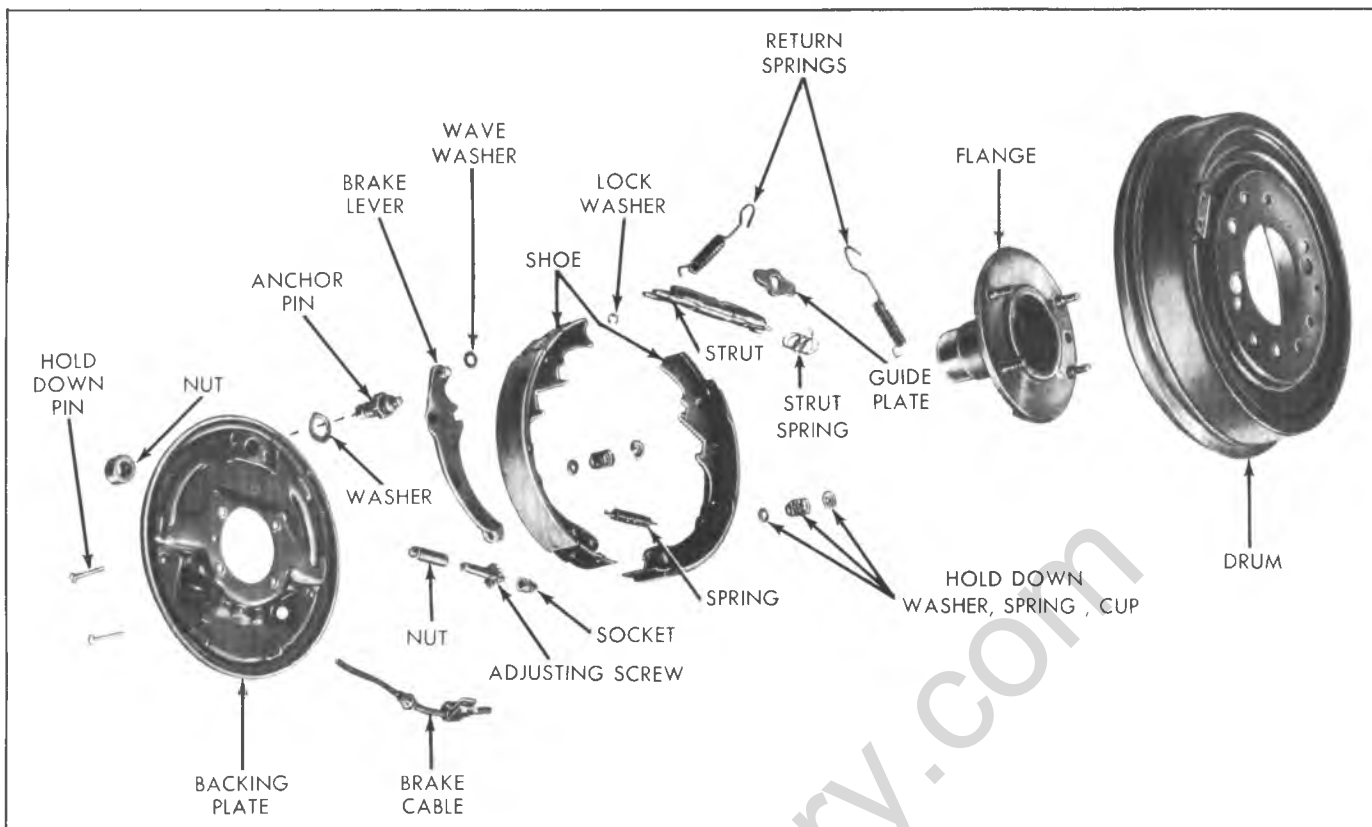


Fig. 5-47--Propshaft Parking Brake Components

8. Move the shoes toward each other until the adjusting bolt and connecting spring drop off.

9. Remove the clip holding the brake lever to the primary shoe (shoe with short lining).

10. Compress the spring on the brake cable and remove the cable from the lever.

11. If necessary to remove the anchor pin, straighten the washer from pin hex and reinforcement. Remove reinforcement and washer with anchor pin.

12. If necessary to remove the cable, compress tangs on cable and pull assembly out of the hole in the flange plate.

13. If necessary to remove the flange plate, remove the transmission flange nut and transmission output flange. Remove bolts holding the flange plate to bearing retainer and remove the flange plate.

Inspection

Replace any worn or broken parts.

Installation

NOTICE: Refer to "Notice" on Page 1 of this section when installing fasteners in steps 1, 2 and 4 below.

1. Place the flange plate in position on the rear bearing retainer and fasten with four bolts. Torque bolts to 24 lb. ft. (33 N·m).

2. Install transmission output flange on spline of mainshaft and fasten with flange nut. Torque nut to 100 lb. ft. (136 N·m).

3. Install cable assembly from back of flange plate. Push retainer through hole in flange plate until tangs securely grip the inner side of the plate.

4. Place washer and reinforcement over the threaded end of anchor pin. Hold anchor pin nut (flat side against flange on flange plate) in position behind flange plate and insert threaded end of anchor pin from front side. Thread the anchor pin into nut and tighten securely (140 lb. ft.--190 N·m). Bend tang of washer over reinforcement and side of washer over hex of anchor pin.

5. Install lever on cable by compressing spring and inserting cable in channel of lever. Release spring.

6. Install primary shoe (short lining) to lever as follows: Place pin in lever, place washer on pin and push pin through hole in primary shoe. Fasten parts together by installing the clip in groove of pin.

7. Fasten two brake shoes and linings together by installing connecting spring. Move the shoes toward each other and install adjusting screw.

8. Lubricate the flange plate contact surfaces with a very light coat of Delco Brake Lube (or equivalent).

9. Place shoe and linings in position on flange plate.

When facing the brake assembly, the shoe with the short lining should be to the left with the lever assembled to it (automatic transmission), to the right (manual transmission).

10. Pull brake shoes apart and install strut lever and spring between them. The loop on the strut spring should be in the "up" position.

11. Install hold down pins, washers, springs and cups from flange plate to shoes.

12. Place guide plate on anchor pin.

13. Install pull back springs.

14. Remove the "knock out" plug (if necessary) and install a new metal plug in the brake drum adjusting hole.

15. Install the brake drum.

16. Install the propeller shaft.

BRAKE DRUMS

Inspection and Reconditioning

NOTICE: See "Notice" on Page 1 of this section.

Whenever brake drums are removed, they should be thoroughly cleaned and inspected for cracks, scores, deep grooves and out-of-round.

Cracked, Scored, or Grooved Drum

A cracked drum is unsafe for further service and must be replaced. Do not attempt to weld a cracked drum.

Smooth up any slight scores. Heavy or extensive scoring will cause excessive brake lining wear, and it will probably be necessary to rebore in order to true up the braking surface.

If the brake linings are slightly worn and the drum is grooved, the drum should be polished with fine emery cloth but should not be turned. At this stage, eliminating the grooves in drum would necessitate removal of too much metal, while if left alone, the grooves and lining ridges match and satisfactory service can be obtained.

If brake linings are to be replaced, a grooved drum should be turned for use with new linings. A grooved drum, if used with new lining, will not only wear the lining, but will make it difficult, if not impossible to obtain efficient brake performance.

Out-Of-Round or Tapered Drum

An out-of-round drum makes accurate brake shoe adjustment impossible and is likely to cause excessive wear of other parts of brake mechanism due to its eccentric action. An out-of-round drum can also cause severe and irregular tire tread wear as well as pulsating brake pedal. When the braking surface of a brake drum exceeds the factory specification limits in taper (and/or) being out-of-round, the drum should be turned to true up the braking surface. Out-of-round as well as taper and wear can be accurately measured with an inside micrometer fitted with proper extension rods.

When measuring a drum for out-of-round, taper and wear, take measurements at the open and closed edges of machined surface and at right angles to each other.

Turning Brake Drums

If a drum is to be turned, only enough metal should be removed to obtain a true, smooth braking surface. If a drum does not clean-up when turned to a maximum diameter as shown in the general specification, it must be replaced. Removal of more metal will affect dissipation of heat and may cause distortion of the drum.

CAUTION: All brake drums have a maximum diameter cast into them. This diameter is the maximum wear diameter and not a refinish diameter. Do not refinish a brake drum that will not meet the specifications, as shown below, after

| DRUM DIAMETERS | | |
|----------------|------------------|-----------------------|
| ORIGINAL | MAXIMUM REFINISH | REPLACEMENT (DISCARD) |
| 11.000 | 11.060 | 11.090 |
| 11.150 | 11.210 | 11.240 |
| 12.000 | 12.060 | 12.090 |
| 13.000 | 13.060 | 13.090 |

refinishing.

Brake Drum Balance

During manufacture, brake drums are balanced. Any balance weights must not be removed.

WHEEL CYLINDER

Removal

1. Remove wheel, drum and brake shoes. Be careful not to get grease or dirt on brake lining.
2. Remove wheel cylinder from backing plate.

Disassembly

1. Inspect cylinder bore for scoring or corrosion. It is best to replace a corroded cylinder.
2. Polish any discolored or stained area with crocus cloth by revolving cylinder on cloth supported by a finger.
3. Rinse cylinder in clean brake fluid.
4. Shake excessive rinsing fluid from cylinder. Do not use a rag to dry cylinder, as lint from the rag cannot be kept from cylinder bore surfaces.

Assembly

1. Lubricate cylinder bore and counterbore with clean brake fluid and insert spring-expander assembly.
2. Install new cups. (Be sure cups are lint and dirt free.) Do not lubricate cups prior to assembly.
3. Install new pistons.
4. Press new boots into cylinder counterbores by hand. Do not lubricate boots prior to assembly.

Installation

NOTICE: See "Notice" on page 1 of this section.

1. Install wheel cylinder on brake backing plate and connect brake pipe to hose. Torque rear wheel brake pipe to wheel cylinder to specifications.
2. Install brake shoes, drum and wheel; then flush and bleed hydraulic system.

POWER BRAKE VACUUM HOSE FILTER

Removal

1. Use a pair of pliers to move the hose clamp approximately 2" (50 mm).
2. Twist the filter in the hose to break the seal and remove the filter.

Installation

1. Install the filter. Be sure the vacuum check valve on the power brake unit is positioned from vertical as shown in figure(s) 5-48 and 5-49.

2. Position hose clamp to retain filter.

POWER BRAKE UNIT

Vacuum Booster

Replacement (Fig. 5-50)

NOTICE: See "Notice" on page 1 of this section when installing fasteners referred to in steps 6, 7 and 9 below.

1. Remove two nuts holding master cylinder to power cylinder and position it away from power cylinder.

Do not disconnect hydraulic brake lines; be careful not to bend or kink pipes.

2. Disconnect the vacuum hose from the vacuum check valve on the front housing of the power head. Plug vacuum hose to prevent dust and dirt from entering hose.

3. Disconnect the power brake push rod from the brake pedal.

4. Remove the four nuts from the mounting studs which hold the power brake to the cowl.

5. Carry the power brake to a clean work area and clean the exterior of the power brake prior to disassembly.

6. Mount power brake assembly to cowl and torque nuts to specified torque.

7. Connect power brake push rod to brake pedal.

8. Connect vacuum hose to vacuum check valve.

9. Connect master cylinder to power cylinder and torque nuts to specifications.

HYDRO-BOOST BRAKE SYSTEM

NOTICE: Power steering fluid and brake fluid cannot be mixed. If brake seals contact steering fluid or steering seals contact brake fluid, seal damage will result.

The following operations can be performed with the booster installed in the vehicle; exceptions to this statement may exist where Body Manufacturers sheet metal ("P" Models) would require removal of the booster from the vehicle.

Pneumatic Accumulator

CAUTION: The accumulator contains compressed gas. Always use proper tools and follow recommended procedures or personal injury may result. Do not apply heat to accumulator. Do not attempt to repair an inoperative accumulator, always replace with a new accumulator. Dispose of an inoperative accumulator by drilling a 1/16" (1.6 mm) diameter hole through the end of the accumulator can opposite the "O" ring.

Removal

1. Turn engine off and pump brake pedal 4 or 5 times to deplete accumulator.
2. Disconnect the high pressure hose.

3. Remove two nuts from master cylinder, then move master cylinder away from booster with brake lines attached.

4. Place the accumulator retaining cap Tool J-26889 over the master cylinder stud and install the nut as shown in Figure 5-51.

5. Using Tool J-22269-01 or a large "C" clamp (6" (150 mm) minimum), depress the accumulator. Insert a punch into the hole in the housing and remove retaining ring with a small screwdriver, (fig. 5-51).

If the accumulator is not easily compressed approximately 1/8" (3 mm) it is still charged. This indicates an internal problem with the accumulator valves and the booster must be disassembled.

6. Slowly back off the clamp until tension on the accumulator is released; remove accumulator and "O" ring.

Installation

1. Using clean power steering fluid, lubricate accumulator seal. Install seal and accumulator in housing and then place the retaining ring over the accumulator (fig. 5-52). Place Tool J-26889 over accumulator.

2. Using Tool J-22269-01 or a large "C" clamp (6" (150 mm) minimum) depress the accumulator making certain that the accumulator is compressed straight (fig. 5-51).

3. Snap the retaining ring into the housing groove by pushing it down all the way around with a small screwdriver.

4. Remove Tool J-22269-01 or "C" clamp and retaining cap Tool J-26889.

NOTICE: Carefully check to make sure the retaining ring was completely installed properly.

5. Connect high pressure hose and check power steering fluid.

6. Install the master cylinder two nuts and accumulator retaining cap Tool J-26889 and close the vehicle hood. Test the unit by starting the engine and turning the steering wheel from stop to stop a few times. Turn off engine and apply brake pedal 4 or 5 times.

7. Remove accumulator retaining cap Tool J-26889 and install master cylinder nut.

NOTICE: See "Notice" on Page 1 of this section.

Spool Valve Plug

Removal

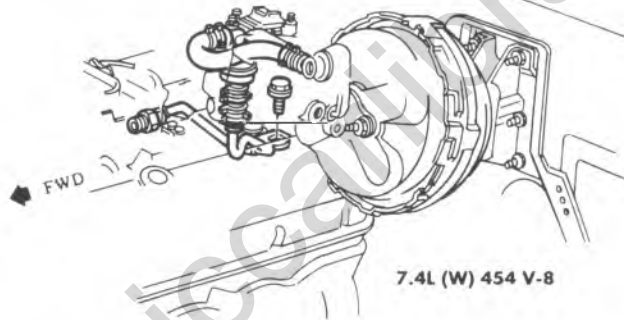
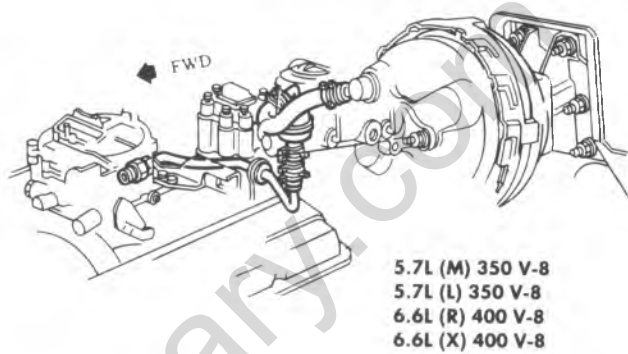
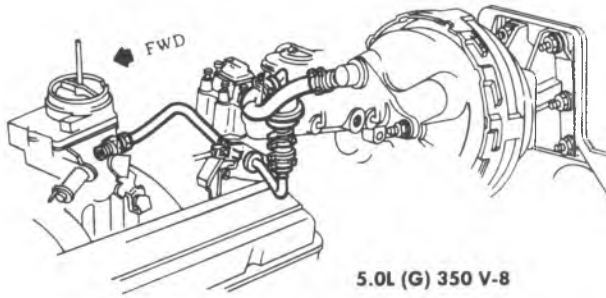
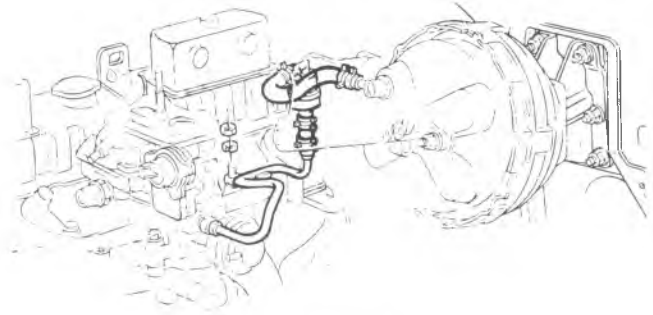
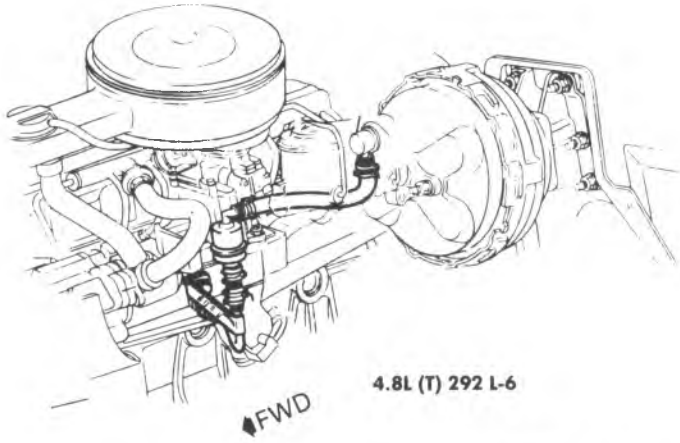
1. Turn engine off and pump brake pedal 4 or 5 times to deplete accumulator.

2. Remove two nuts from master cylinder, then move master cylinder away from booster with brake lines attached.

3. Push spool valve plug in and use a small screwdriver to remove retaining ring (fig. 5-53).

4. Remove spool valve plug and "O" ring.

C-K MODELS



P MODELS

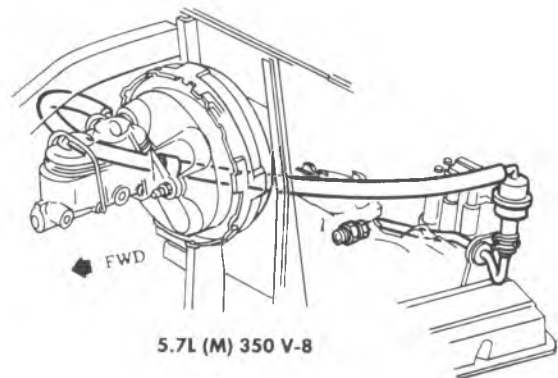
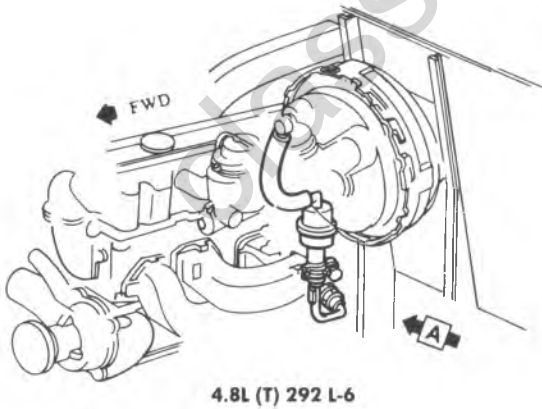


Fig. 5-48--Power Brake Vacuum Hose Filter Installation--C-K-P Trucks

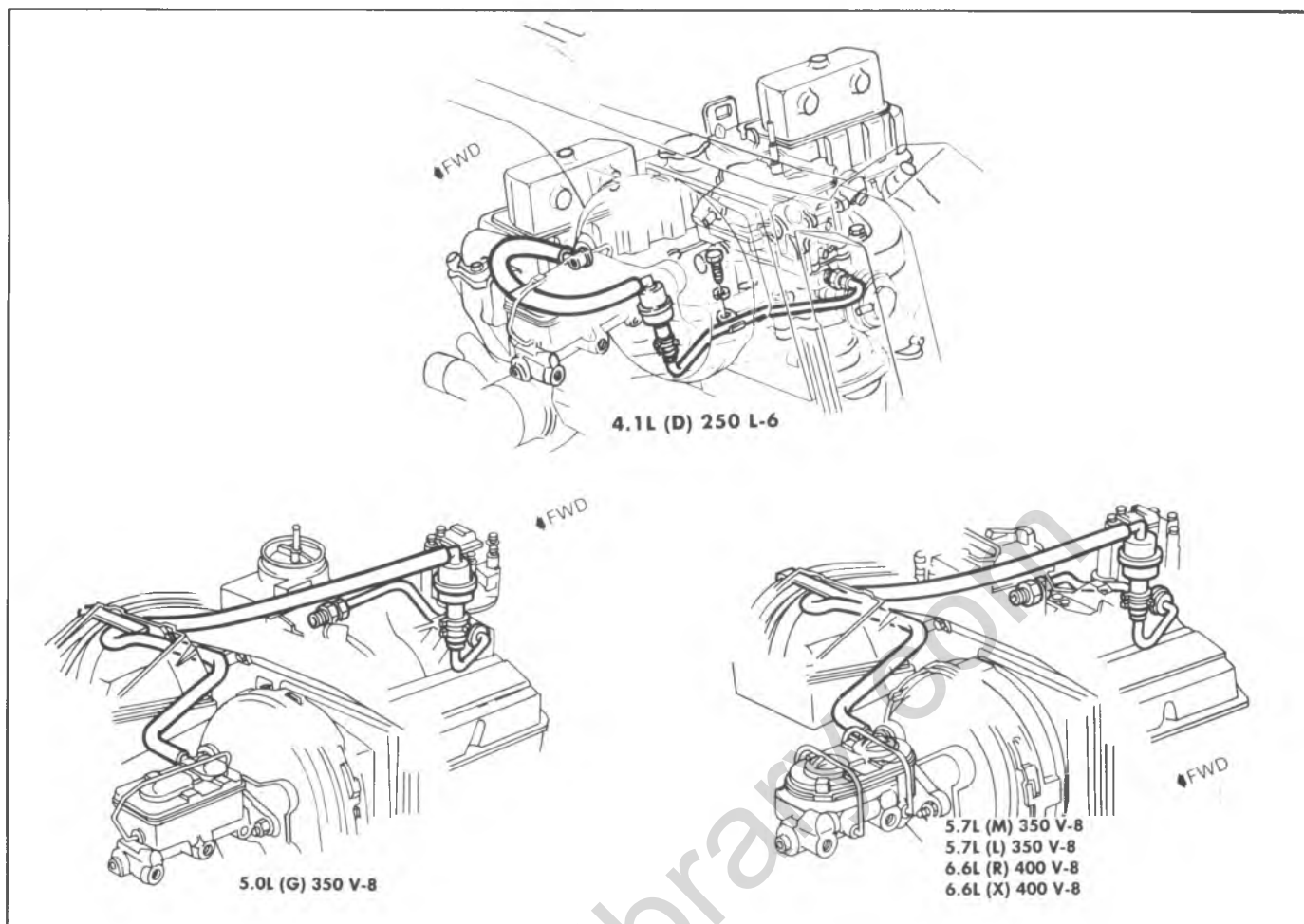


Fig. 5-49--Power Brake Vacuum Hose Filter Installation--G Models

Installation

1. Install "O" ring and spool valve plug (fig. 5-53).
2. Push spool valve plug in and install retaining ring.
3. Install master cylinder and two nuts to booster.

NOTICE: See "Notice" on Page 1 of this section.

4. Bleed system. Refer to "HYDRO-BOOST BLEEDING PROCEDURE".

Tube Seat

Replacement

1. Turn engine off and pump brake pedal 4 or 5 times to deplete accumulator.
2. Clean dirt around fitting before removing fitting, then disconnect pressure hose at Hydro-Boost and secure hose in a raised position to prevent loss of fluid.
3. To prevent metal chips from entering booster, pack inside of tube seat with petrolatum.
4. Remove tube seat using No. 4 easy-out as shown in Figure 5-54.
5. Wipe petrolatum from housing and clean housing thoroughly to remove any metal chips or dirt.
6. Install tube seat with Tool J-6217 as shown in Figure 5-55.

7. Fill and bleed system. Refer to "HYDRO-BOOST BLEEDING PROCEDURE".

Hydro-Boost Unit

Replacement (fig. 5-56 thru 5-59)

1. Depress and release the brake pedal several times (engine not running) to be sure that all pressure is discharged from the accumulator prior to disconnecting the hoses from the booster.

2. **P30(32) Models-** Raise the vehicle on a hoist.

3. Clean all dirt from the booster at the hydraulic line connections and master cylinder.

4. Remove the nuts and lockwashers that secure the master cylinder to the booster and the support bracket. Support the master cylinder, being careful to avoid kinking or bending the hydraulic lines attached to the master cylinder. Cover the end of the master cylinder with a clean cloth.

It should not be necessary to disconnect the hydraulic lines from the master cylinder.

5. Disconnect the hydraulic lines from the booster ports. Plug all lines and the booster ports to prevent loss of fluid and to keep out foreign material.

6. **P30(42) and C-K-G Models-**

- a. Remove booster pedal push rod cotter pin and washer and disconnect the push rod from the brake pedal

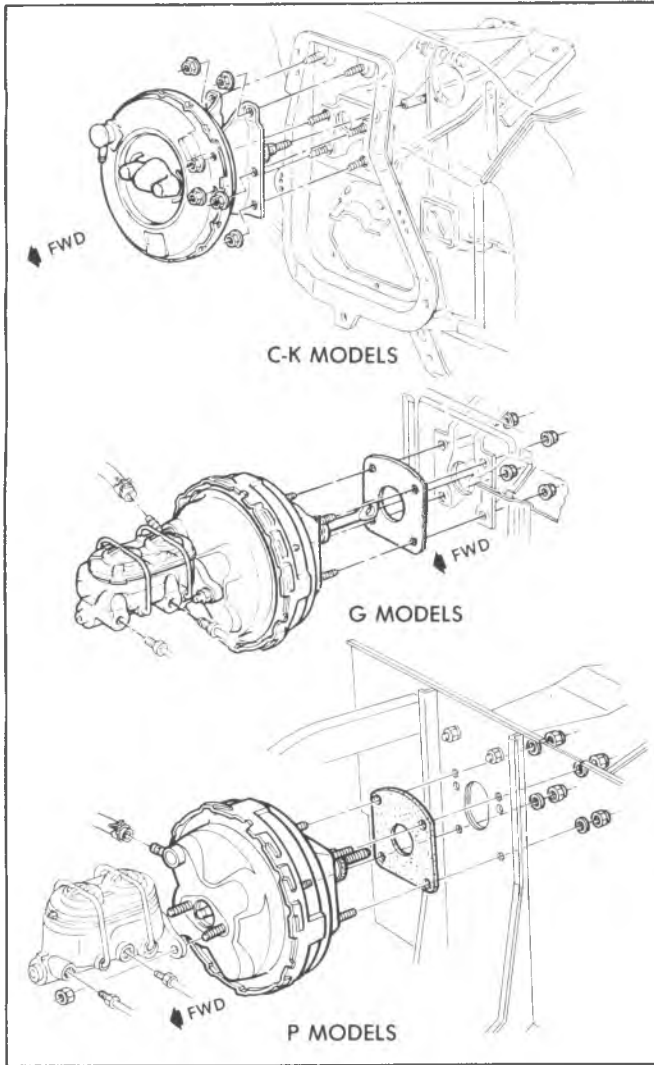


Fig. 5-50--Vacuum Booster Installation

(C and K models) or booster bracket pivot lever (G and P

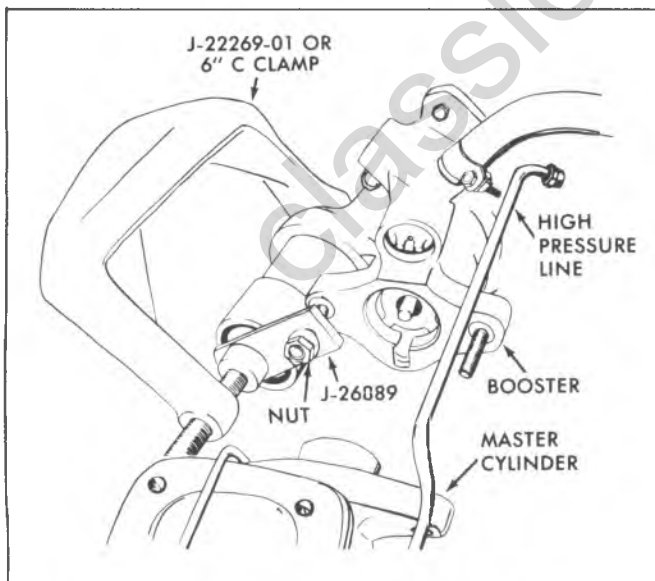


Fig. 5-51--Compressing Accumulator With J-26889

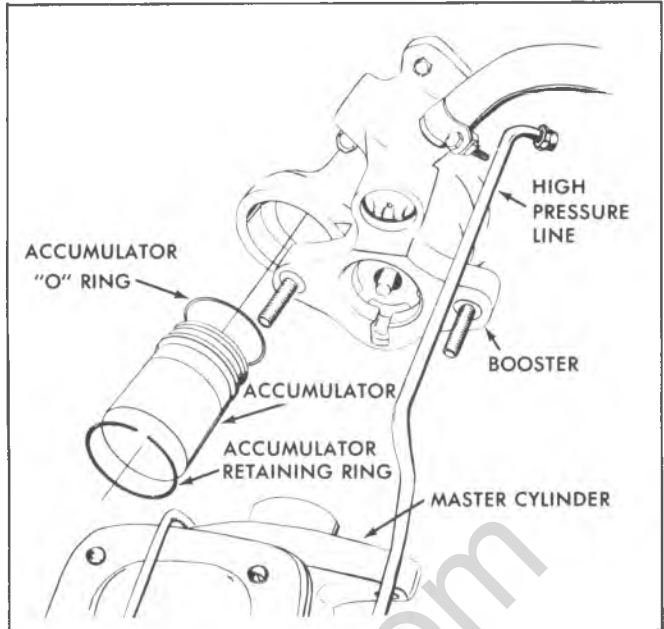


Fig. 5-52--Accumulator Installation

models).

b. Remove the booster support bracket on C and K models, support braces on G and P30(42) models.

c. Remove the booster bracket to dash panel or support bracket nuts and remove the booster assembly.

7. P30(32) Models-

a. Remove the cotter pin, nut, bolt and washers that secure the operating lever to the vertical brake rod.

b. Remove the six nuts, lock washer and bolts that secure the booster linkage bracket to the front and rear support brackets, and remove the booster from the vehicle by sliding the booster off the rear support studs.

c. Remove the cotter pin, nut, washer and bolt that secures the operating lever to the pedal rod.

d. Remove the brake pedal rod lever nut and bolt and then remove the lever, sleeve and bushings.

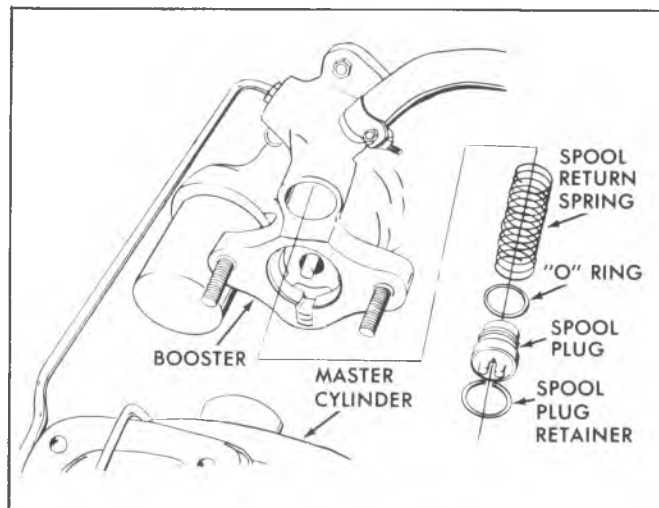


Fig. 5-53--Spool Valve Plug Removal

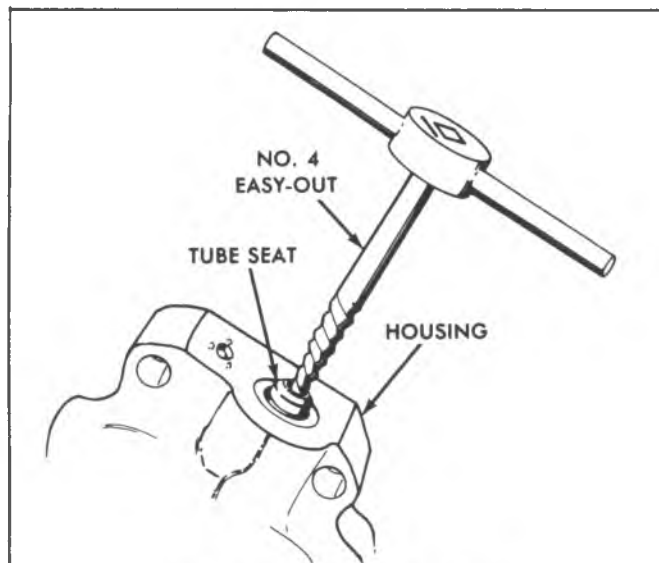


Fig. 5-54--Removing Tube Seat

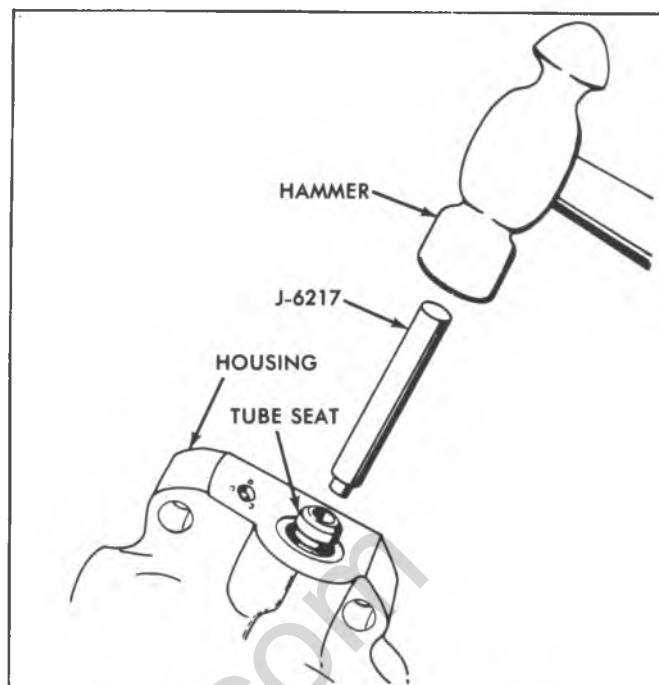


Fig. 5-55--Installing Tube Seat Using J-6217

8. To install, reverse Steps 1-7 above. Torque all hydraulic lines and attaching bolts to specifications.

Lubricate pedal rod and linkage pivot bolts, pins, sleeves and bushings with Delco Brake Lube (or equivalent).

NOTICE: See "Notice" on Page 1 of this section.

9. Fill and bleed system. Refer to "Hydro-Boost bleeding procedure."

10. Check brake pedal and stoplamp switch adjustment.

classiccarlibrary.com

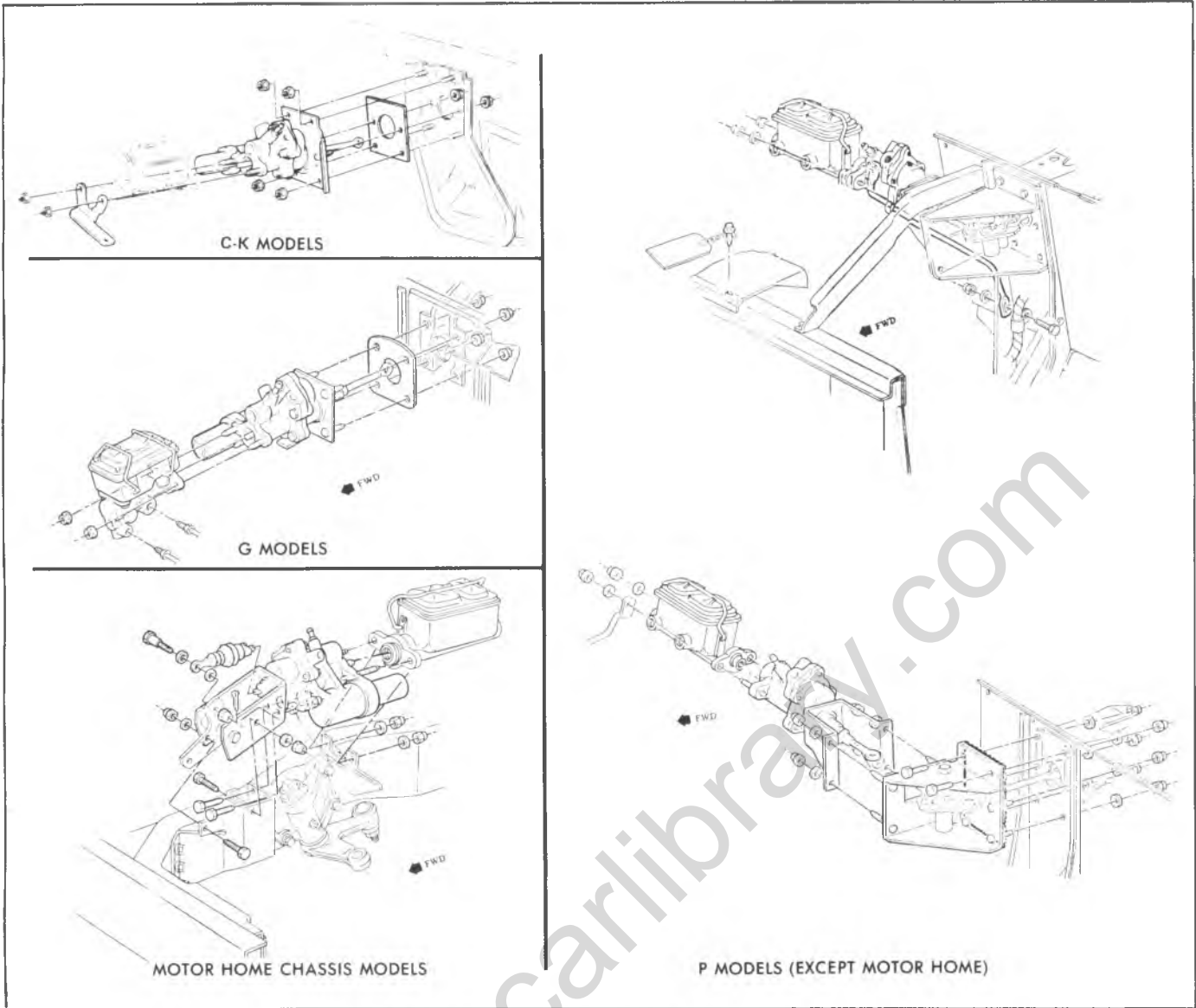


Fig. 5-56--Booster Installation (Hydro-Boost)

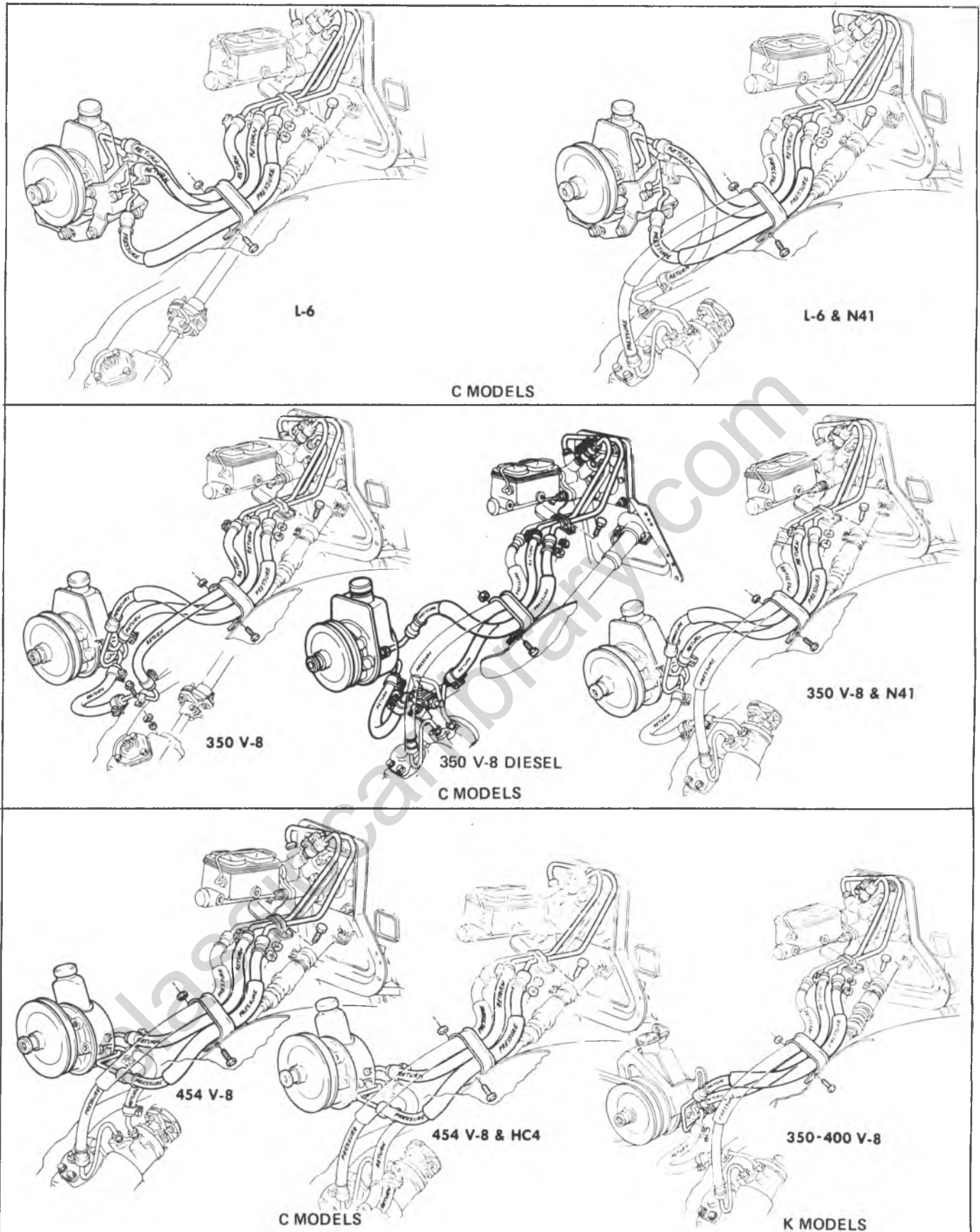


Fig. 5-57--Power Steering Hose Routing--C-K Models

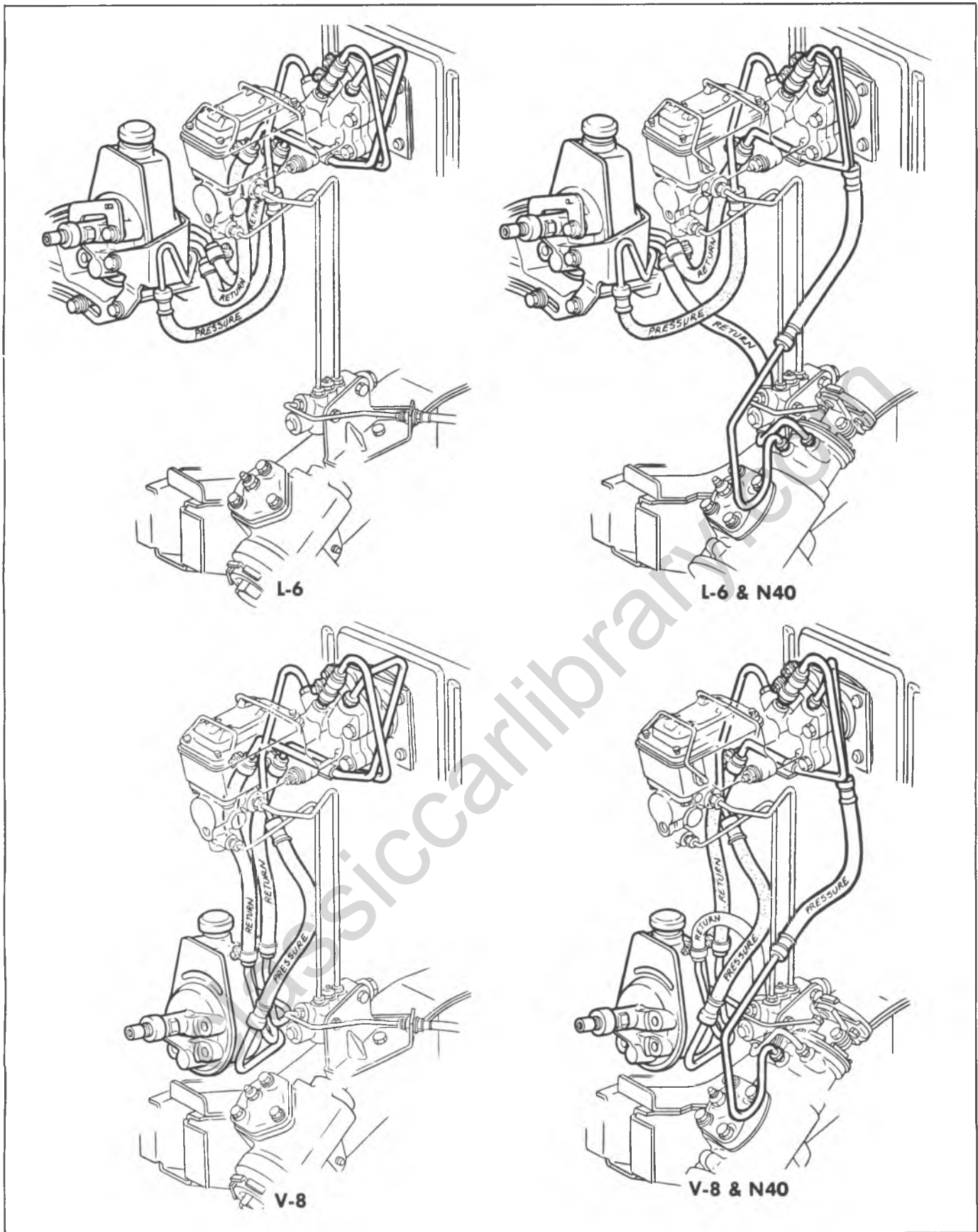


Fig. 5-58--Power Steering Hose Routing--G Models

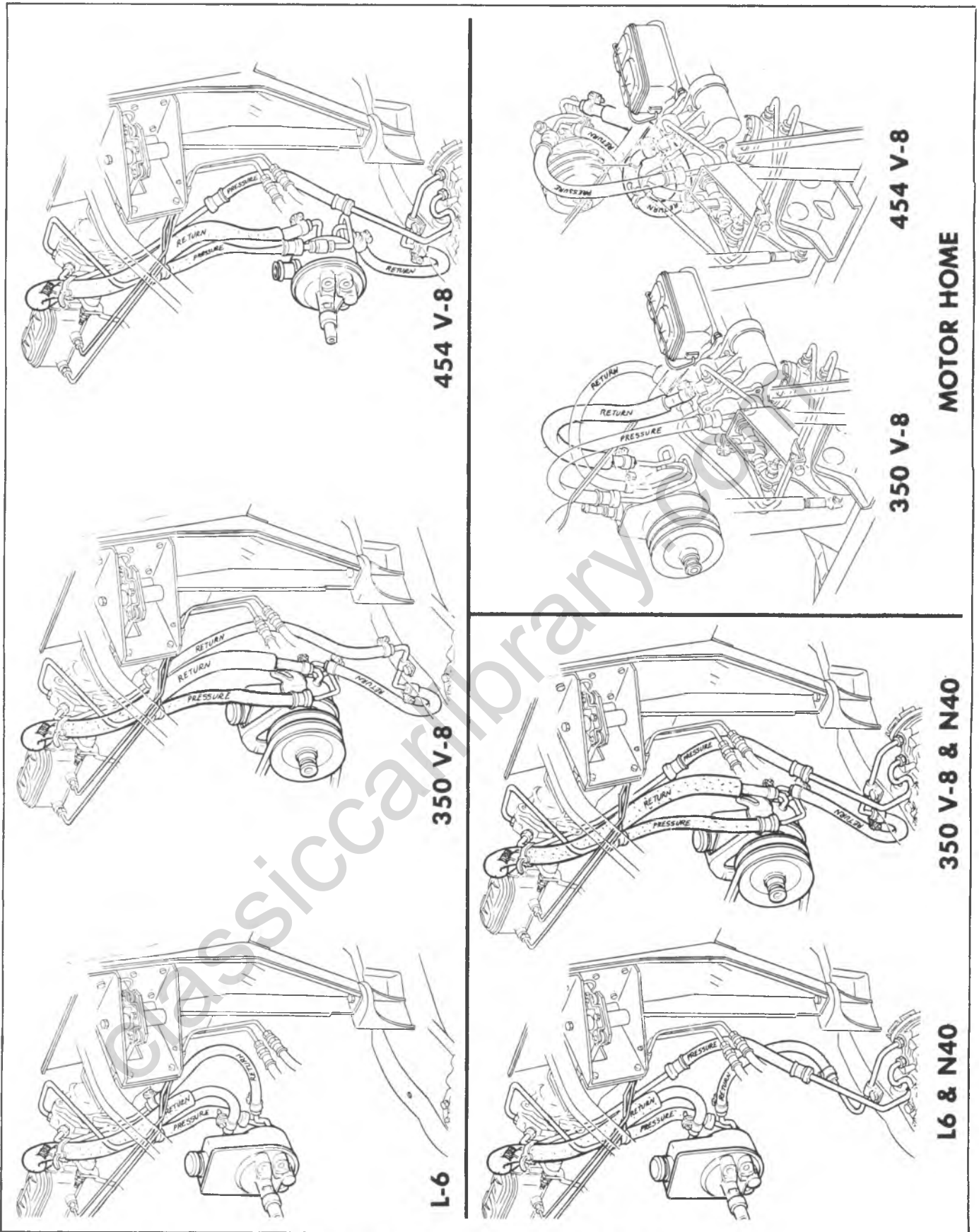


Fig. 5-59—Power Steering Hose Routing—P Models

SPECIFICATIONS

SPECIFICATIONS

BRAKE SYSTEM DESCRIPTION

| <u>SYSTEM</u> | <u>FRONT BRAKES</u> | <u>REAR BRAKES</u> | <u>BRAKE ASSIST</u> |
|---------------------------------|---------------------|--------------------|---------------------------|
| <u>GASOLINE ENGINE VEHICLES</u> | | | |
| JB1 | Disc 11.86 x 1.28 | Drum 11.00 x 2.00 | None (Manual Brakes) |
| JB3 | Disc 11.86 x 1.28 | Drum 11.00 x 2.00 | Vacuum — Single Diaphragm |
| JB5 | Disc 11.86 x 1.28 | Drum 11.15 x 2.75 | Vacuum — Dual Diaphragm |
| JB6 | Disc 12.50 x 1.28 | Drum 11.15 x 2.75 | Vacuum — Dual Diaphragm |
| JB7 | Disc 12.50 x 1.28 | Drum 13.00 x 2.50 | Vacuum — Dual Diaphragm |
| JB8 | Disc 12.50 x 1.53 | Drum 13.00 x 3.50 | Hydraulic — Hydroboost |
| JF9 | Disc 14.25 x 1.53 | Disc 13.75 x 1.53 | Hydraulic — Hydroboost |
| <u>DIESEL ENGINE VEHICLES</u> | | | |
| JD3 | Disc 11.86 x 1.28 | Drum 11.00 x 2.00 | Hydraulic — Hydroboost |
| JD5 | Disc 11.86 x 1.28 | Drum 11.15 x 2.75 | Hydraulic — Hydroboost |

SPECIFICATIONS

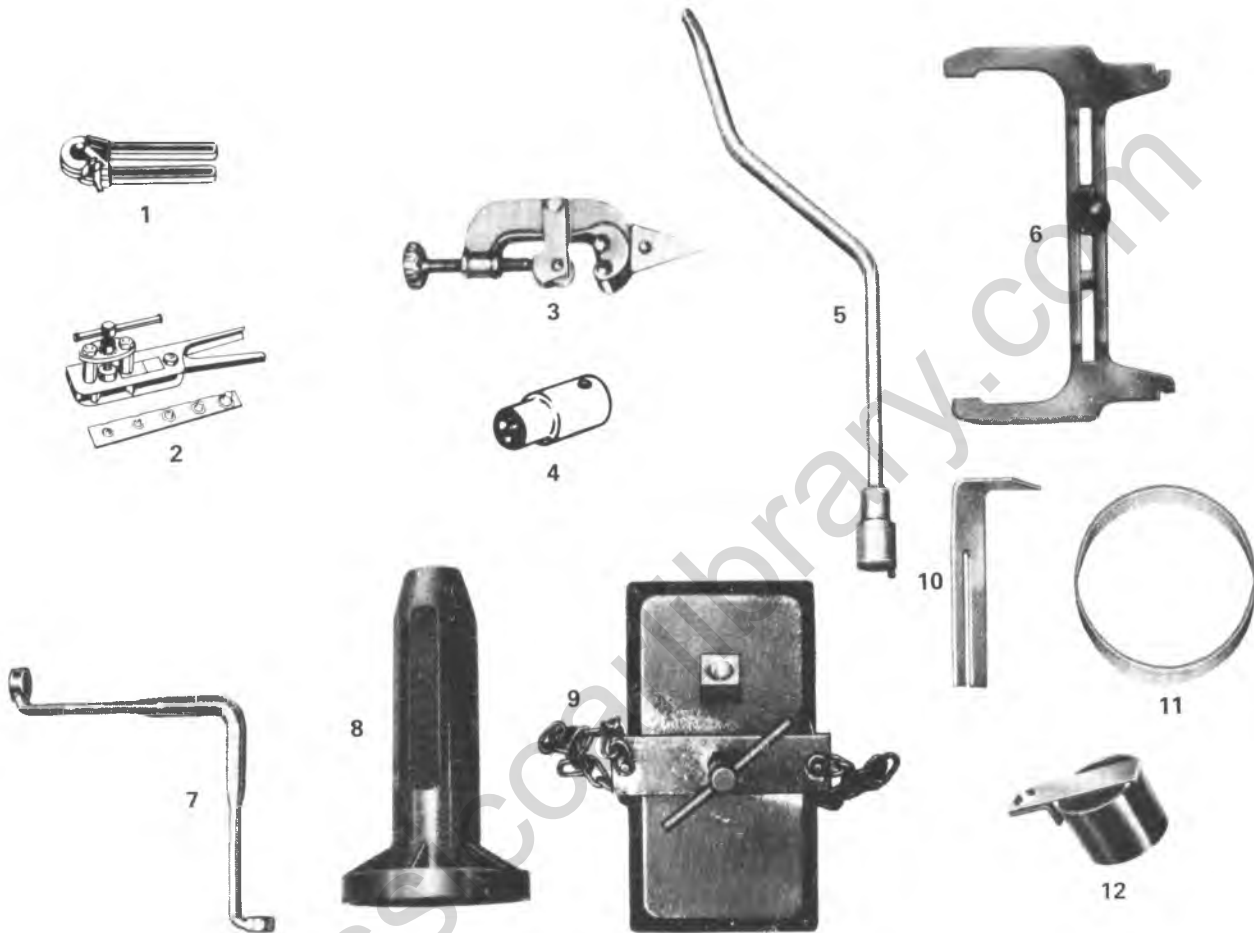
| | C | K | G | P |
|--|---|-------------------|--------------------|--------------------|
| Master Cylinder - to Dash or Booster | **25 ft. lbs. | **25 ft. lbs. | 25 ft. lbs. | 25 ft. lbs. |
| Booster to Dash or Frame | **25 ft. lbs. | **25 ft. lbs. | 25 ft. lbs. | 25 ft. lbs. |
| Combination Valve - Mounting Bolts | 150 in. lbs. | 150 in. lbs. | 17 ft. lbs. | 17 ft. lbs. |
| - Bracket | - | - | 25 ft. lbs. | 25 ft. lbs. |
| Caliper - Mounting Bolt | 35 ft. lbs. | | | |
| - Support Plate to Knuckle | 140 in. lbs. | | | |
| Brake Pedal - Bracket to Dash | 25 ft. lbs. | 25 ft. lbs. | 150 in. lbs. | 25 ft. lbs. |
| - Bracket to I.P. | 25 in. lbs. | 25 in. lbs. | - | - |
| - Pivot Bolt Nut | 25 ft. lbs. | 25 ft. lbs. | - | 45 ft. lbs. |
| - Sleeve to Bracket | - | - | - | 85 in. lbs. |
| - Stoplamp Switch Bracket | 25 ft. lbs. | 25 ft. lbs. | 25 ft. lbs. | - |
| - Push Rod to Pedal | - | - | - | 25 ft. lbs. |
| - Push Rod Adjusting Nut | - | - | - | 22 ft. lbs. |
| Parking Brake - to Dash | 100 in. lbs. | 100 in. lbs. | 100 in. lbs. | - |
| - to I.P., Kick Panel or Floorpan | 150 in. lbs. | 150 in. lbs. | 100 in. lbs. | 18 ft. lbs. |
| - Cable Clips - Screws | 17 N·m(150in.lbs.) | - | 12 N·m(100in.lbs.) | 17 N·m(150in.lbs.) |
| - Bolts | 150 in. lbs. | - | 18 ft. lbs. | 55 in. lbs. |
| Propshaft Parking Brake - Adjusting Nut | - | - | - | 30 ft. lbs. |
| - Bracket to Trans. | - | - | - | 20 ft. lbs. |
| - Cable Clip to Frame | - | - | - | 150 in. lbs. |
| - Cable Clip to Dash | - | - | - | 55 in. lbs. |
| - Cable Clip to Trans. Brkt. | - | - | - | 20 ft. lbs. |
| - Flange Plate | - | - | - | 30 ft. lbs. |
| - Drum | - | - | - | 80 ft. lbs. |
| Wheel Cylinder to Flange Plate Bolt | 50 in. lbs. (180 in. lbs. on JB5, JB6, JB7 and JB8) | | | |
| Rear Brake Anchor Pin | 140 ft. lbs. (230 ft. lbs. JB7 and JB8) | | | |
| Front Brake Hose - to Caliper | 44 N·m(32ft.lbs.) | | | |
| - to Frame Nut | 58 in. lbs. | | | |
| - Bracket Bolt | 150 in. lbs. | - | 150 in. lbs. | 150 in. lbs. |
| Rear Brake Hose - to Axle Bracket | 150 in. lbs. | 150 in. lbs. | 90 in. lbs. | 150 in. lbs. |
| - Bracket to Axle | 150 in. lbs.* | 150 in. lbs.* | - | 150 in. lbs.* |
| Brake Line - Attaching Nuts | 150 in. lbs. | | | |
| - Retaining Clips - Screws | 17 N·m(150in.lbs.) | 17N·m(150in.lbs.) | 12 N·m(100in.lbs.) | 17 N·m(150in.lbs.) |
| - Bolts | - | - | 150 in. lbs. | 18 ft. lbs. |
| Brake Bleeder Valves | 60 in. lbs. | | | |
| Hydro-Boost - Pedal Rod - P30(32) Models | - | - | - | 25 ft. lbs. |
| - Pedal Rod Boot - P30(32)Models | - | - | - | 15 in. lbs. |
| - Pivot Lever Rod Retainer | - | - | - | 25 ft. lbs. |
| - Pivot Lever Bolt | - | - | - | 45 ft. lbs. |
| - Booster Brackets | - | - | - | 25 ft. lbs. |
| - Booster Brace at Dash or Rad. Supt. | - | - | - | 150 in. lbs. |
| - Power Steering Pump to Booster Line | 25 ft. lbs. | | | |
| - Booster to Gear Line | 25 ft. lbs. | | | |
| - Return Line at Booster & Gear | 25 ft. lbs. | | | |
| - Return Line Clamp Screw | 15 in. lbs. | | | |
| - Line Clamp to Bracket Screw | 150 in. lbs. | | | |
| - Hose Clamp to Skirt Screw | 40 in. lbs. | - | - | - |
| - Line Clamp to Frame Bolt | 150 in. lbs. | - | - | 150 in. lbs. |

*20 ft. lbs. (CKP20-30)

**32 ft. lbs. — Master Cylinder to Booster

-- Master Cylinder or Booster to Dash Reinforcement

SPECIAL TOOLS



- | | |
|---------------------------------------|--|
| 1. J-25310 Tubing Bender | 7. J-21472 or J-22364 Bleeder Wrench |
| 2. J-23530 Flaring Tool | 8. J-22904 Dust Boot Installer |
| 3. J-23533 Tubing Cutter | J-28735 Dust Boot Installer (JB7) |
| 4. J-25085 Socket | 9. J-23518 Bleeder Adapter |
| 5. J-8049 or J-22348 Spring Remover | 10. J-23709 Combination Valve Pin Retainer |
| 6. J-21177 or J-22364 Drum/Shoe Gauge | 11. J-24548 Dust Boot Installer |
| | 12. J-26889 Accumulation Piston Compressor |

SECTION 6A

ENGINE MECHANICAL

NOTICE: The following information is important in preventing engine damage and in providing reliable engine performance.

When raising or supporting the engine for any reason, do not use a jack under the oil pan, any sheet metal or crankshaft pulley. Due to the small clearance between the oil pan and the oil pump screen, jacking against the oil pan may cause it to be bent against the pump screen, resulting in a damaged oil pickup unit.

It should be kept in mind, while working on the engine, that the 12-volt electrical system is capable of violent and damaging short circuits. When performing

any work where electrical terminals could possibly be grounded, the ground cable of the battery should be disconnected at the battery.

Any time the carburetor or air cleaner is removed, the intake opening should be covered. This will protect against accidental entrance of foreign material which could follow the intake passage into the cylinder and cause extensive damage when the engine is started.

CONTENTS

| | |
|------------------------------|-------|
| Engine Identification..... | 6A-1 |
| Diagnosis | 6A-2 |
| 4.1 L (D) L-6 - RPO LE3..... | 6A1-1 |
| 4.8 L (T) L-6 - RPO L25..... | 6A1-1 |
| 5.0 L (G) V-8 - RPO LG9..... | 6A4-1 |
| 5.7 L (L) V-8 - RPO LS9..... | 6A4-1 |
| 5.7 L (M) V-8 - RPO LT9..... | 6A4-1 |
| 6.6 L (R) V-8 - RPO LF4..... | 6A4-1 |
| 6.6 L (X) V-8 - RPO LE4..... | 6A4-1 |
| 7.4 L (W) V-8 - RPO LE8..... | 6A5-1 |
| 5.7 L (Z) V-8 - RPO LF9..... | 6A6-1 |

ENGINE IDENTIFICATION

All engines used in 1980 are referred to by their liter displacement followed by the VIN code letter in parenthesis. This VIN code can be found on the vehicle by observing the VIN plate located on the left door striker pillar. The third character in the VIN code identifies the engine (fig. 6A-1).

| THIRD CHARACTER IS ENGINE CODE | | | | | |
|-----------------------------------|-----|------|-----------------|-------------------------------|---------|
| ↓ | | | | | |
| C C D 1 4 A 1 1 0 0 0 0 1 | | | | | |
| CODE | RPO | TYPE | CARB BARRELS | DISPLACEMENT LITRE/CU. IN. | SECTION |
| D | LE3 | L6 | 2 | 4.1/250 | 6A1 |
| T | L25 | L6 | 1 | 4.8/292 | 6A1 |
| G | LG9 | V8 | 2 | 5.0/305 | 6A4 |
| L | LS9 | V8 | 4 | 5.7/350 | 6A4 |
| M | LT9 | V8 | 4 | 5.7/350 | 6A4 |
| P | LF5 | V8 | 2 | 5.7/350 | 6A4 |
| R | LF4 | V8 | 4 | 6.6/400 | 6A4 |
| X | LE4 | V8 | 4 | 6.6/400 | 6A4 |
| W | LE8 | V8 | 4 | 7.4/454 | 6A5 |
| Z | LF9 | V8 | F.I.* Diesel | 5.7/350 | 6A6 |

* Fuel Injected

Fig. 6A-1—Engine Codes

DIAGNOSIS

ENGINE FAILS TO START

- a. Check for sufficient fuel to operate engine.
- b. Carburetor flooded and/or fuel level in carburetor bowl not correct.
- c. Dirt and water in gas line or carburetor.
- d. Sticking choke.
- e. Faulty fuel pump.
- f. Corroded or loose battery terminal connections and/or weak battery.
- g. Broken or loose ignition wires and/or faulty ignition switch.
- h. Excessive moisture on plugs, caps or ignition system.
- i. Damaged distributor rotor or cracked distributor cap.
- j. Fouled spark plugs and/or improper spark plug gap.
- k. Weak or faulty coil.
- l. Faulty solenoid or starting motor.
- m. Park or neutral switch inoperative.

ENGINE LOPES WHILE IDLING

- a. Check for air leaks between intake manifold and head.
- b. Check for blown head gasket.
- c. Check for worn timing gears, chain or sprockets.
- d. Check for worn camshaft lobes.
- e. Check for overheated engine.
- f. Check for plugged crankcase vent valve.
- g. Check for faulty fuel pump.
- h. Check for leaky EGR valve.

ENGINE MISSES WHILE IDLING

- a. Check, inspect and regap spark plugs. Replace as necessary.
- b. Remove moisture from spark plug wires and/or distributor cap.
- c. Check for broken or loose ignition wires. Repair or replace as necessary.
- d. Check condition of cylinders for uneven compression. Repair as necessary.
- e. Check for weak or faulty HEI system coil as outlined in Section 6D of this manual.
- f. Inspect condition of distributor cap and rotor. Replace if damaged or cracked.
- g. Check carburetor for internal obstructions, incorrect idle speed, faulty altitude compensator, sticking choke or enrichment system and adjust, repair or replace as necessary.
- h. Inspect carburetor fuel filter for presence of water and/or impurities and correct as necessary.
- i. Check carburetor mounting gasket for air leaks. Repair as necessary.
- j. Check distributor spark advance mechanism for proper operation. Repair or replace as necessary.
- k. Inspect valve train components. Adjust, repair and/or replace as necessary.
- l. Check engine for low compression. Repair as necessary.
- m. Check operation of exhaust gas recirculation valve. Repair or replace as necessary.
- n. Check ignition timing, and condition of ignition system as outlined in Section 6D of this manual. Correct as necessary.
- o. Check for vacuum leaks. Correct as necessary.
- p. Check operation of EFE valve as outlined in Section 6E of this manual. Repair or replace as necessary.

ENGINE MISSES AT VARIOUS SPEEDS

- a. Inspect carburetor fuel filter for presence of water and/or impurities. Correct as necessary.
- b. Check fuel system for leaks, plugged fuel lines, incorrect fuel pump pressure and/or plugged carburetor jets. Correct as necessary.
- c. Check ignition timing. Correct as necessary.
- d. Check for excessive play in distributor shaft. Repair or replace as necessary.
- e. Check for weak or faulty H.E.I. system coil as outlined in Section 6D of this manual.
- f. Check, inspect and regap spark plugs. Replace as necessary.
- g. Detonation and pre-ignition may be caused by using sub-standard fuel. Correct as necessary.
- h. Check for weak valve springs and condition of camshaft lobes. Repair or replace as necessary.
- i. Check engine operating temperature. Correct as necessary.
- j. Check operation of exhaust gas recirculation valve. Repair or replace as necessary.
- k. Inspect distributor cap for evidence of carbon tracking. Replace if necessary.
- l. Check for faulty altitude compensator and incorrect carburetor adjustments. Correct as necessary.
- m. Check for vacuum leaks. Correct as necessary.
- n. Check operation EFE valve as outlined in Section 6E of this manual. Repair or replace as necessary.

ENGINE STALLS

- a. Check carburetor for incorrect and/or misadjusted idle speed, float level, leaking needle and seat, air valve, sticking choke or enrichment system and secondary vacuum break operation. Adjust, repair or replace as necessary.
- b. Inspect carburetor fuel filter for presence of water and/or impurities. Correct as necessary.
- c. Check H.E.I. system as outlined in Section 6D of this manual.
- d. Check, inspect and regap spark plugs. Replace as necessary.
- e. Check distributor spark advance mechanism for proper operation. Repair or replace as necessary.
- f. Inspect exhaust system for restrictions. Correct as necessary.
- g. Check carburetor mounting gasket for air leaks. Repair as necessary.
- h. Check and adjust valve lash.
- i. Check for burned, warped or sticking valves. Repair or replace as necessary.
- j. Check engine for low compression. Repair as necessary.
- k. Check engine operating temperature. Correct as necessary.
- l. Check for loose, corroded or leaking wiring connections (bulk-head connectors, etc.). Repair as necessary.
- m. Check operation of exhaust gas recirculation system. Repair or replace as necessary.
- n. Check fuel system for leaks and/or obstructions. Repair as necessary.
- o. Check for vacuum leaks. Correct as necessary.
- p. Check operation of EFE valve as outlined in Section 6E of this manual. Repair or replace as necessary.

ENGINE HAS LOW POWER

- a. Check for weak or faulty H.E.I. system coil as outlined in Section 6D of this manual.
- b. Check ignition timing. Correct as necessary.
- c. Check for excessive play in distributor shaft. Repair or replace as necessary.
- d. Check, inspect and regap spark plugs. Replace as necessary.
- e. Check carburetor for incorrect and/or misadjusted idle speed, float level, leaking needle and seat, air valve and sticking choke or enrichment system. Adjust, repair or replace as necessary.
- f. Inspect carburetor fuel filter for presence of water and/or impurities. Correct as necessary.
- g. Check fuel pump for leaks and proper operation. Correct as necessary.
- h. Check for sticking valves, weak valve springs, incorrect valve timing, lifter noise and worn camshaft lobes. Adjust, repair or replace as necessary.
- i. Check for excessive piston to bore clearance. Correct as necessary.
- j. Check condition of cylinders for uneven compression and/or blown head gasket. Repair as necessary.

k. Check power steering flow control valve operation. Repair or replace as necessary.

l. Check for clutch slippage (vehicles with manual transmissions) and adjust or replace as necessary.

m. Check hydraulic brake system for proper operation. Correct as necessary.

n. Check engine operating temperature. Correct as necessary.

o. Check pressure regulator valve (automatic transmission) for proper operation. Repair as necessary.

p. Check transmission fluid level. Correct as necessary.

q. Loss of power may be caused by using sub-standard fuel. Correct as necessary.

r. Check operation of EFE valve as outlined in Section 6E of this manual. Repair or replace as necessary.

s. Check operation of diverter valve (A.I.R. system). Repair or replace as necessary.

t. Check for engine vacuum leaks. Correct as necessary.

ENGINE DIESELING ON SHUT OFF

a. Check base idle speed for improper adjustment and correct as necessary.

b. Check ignition timing and reset to specifications if required.

c. Check idle mixture setting and correct as necessary.

d. Check accelerator and choke linkage operation and correct as necessary.

e. Check engine operating temperature and correct as necessary.

f. Check thermac valve for sticking and correct as necessary.

NOISY CONNECTING RODS

a. Check connecting rods for improper alignment and correct as necessary.

b. Check for excessive bearing clearance and correct as necessary.

c. Check for eccentric or out-of-round crankshaft journals and correct as necessary.

d. Check for insufficient oil supply and correct as

necessary.

e. Check for low oil pressure and correct as necessary.

f. Check for connecting rod bolts not tightened correctly and correct as necessary.

EXTERNAL OIL LEAKAGE

a. Check for improperly seated or fuel pump gasket. Replace as necessary.

b. Check for improperly seated or broken push rod cover gasket. Replace as necessary.

c. Check for improperly seated or broken oil filter gasket. Replace as necessary.

d. Check for broken or improperly seated oil pan gasket. Replace as necessary.

e. Inspect gasket surface of oil pan to be bent or distorted. Repair or replace as necessary.

f. Check for improperly seated or broken timing chain cover gasket. Replace as necessary.

g. Inspect timing cover oil seal. Replace if necessary.

h. Check for worn or improperly seated rear main bearing oil seal. Replace if necessary.

i. Inspect for loose oil line plugs. Repair or replace if necessary.

j. Check for engine oil pan drain plug improperly seated. Correct as necessary.

k. Inspect camshaft rear bearing drain hole for obstructions. Correct as necessary.

l. Check for loose rocker arm cover. Broken or distorted cover correct as necessary.

m. Check EFE valve switch for leakage. Replace if necessary.

n. Check oil pressure switch for leakage. Replace if necessary.

EXCESSIVE OIL CONSUMPTION DUE TO OIL ENTERING COMBUSTION CHAMBER THROUGH HEAD AREA

- a. Check for intake and exhaust valve "O" ring seals to be damaged, missing or loose. Repair or replace as necessary.
- c. Inspect for plugged oil drain back holes in head. Correct as necessary.
- b. Check for worn valve stems or guides. Repair as necessary.
- d. Inspect PCV system operation. Correct as necessary.

EXCESSIVE OIL CONSUMPTION DUE TO OIL ENTERING COMBUSTION CHAMBER BY PASSING PISTON RINGS

- a. Check engine oil level too high. Correct as necessary.
- g. Inspect rings sticking in ring grooves of piston and correct as necessary.
- b. Check for piston ring gaps not staggered and correct as necessary.
- h. Inspect ring grooves worn excessively in piston and correct as necessary.
- c. Check for incorrect size rings installed and correct as necessary.
- i. Inspect compression rings installed upside down and correct as necessary.
- d. Check for piston rings out of round, broken or scored and replace as necessary.
- j. Check for excessively worn or scored cylinder walls and correct as necessary.
- e. Inspect insufficient piston ring tension due to engine overheating and replace as necessary.
- k. Inspect oil too thin and replace if necessary.
- f. Check for ring grooves or oil return slots clogged and corrected as necessary.
- l. Inspect mis-match of oil ring expander and rail and correct as necessary.

NO OIL PRESSURE WHILE IDLING

- a. Check faulty oil gauge sending unit, and correct as necessary.
- d. Inspect for loose camshaft bearings and correct as necessary.
- b. Check for oil pump not functioning properly. (Regulator ball stuck in position by foreign material) and correct as necessary.
- e. Inspect leakage at internal oil passages and correct as necessary.
- c. Inspect for excessive clearance at main and connecting rod bearings and correct as necessary.

NO OIL PRESSURE WHILE ACCELERATING

- a. Check low oil level in oil pan and correct as necessary.
- correct as necessary.
- b. Inspect leakage at internal oil passages and correct as necessary.
- c. Check oil pump suction screen loose or fallen off and

BURNED, STICKING OR BROKEN VALVES

- a. Check for weak springs and replace as necessary.
- b. Check for improper valve lifter clearance and adjust as necessary.
- c. Check for improper valve guide clearance and/or worn valve guides and correct as necessary.
- d. Check for out-of-round valve seats or incorrect valve seat width and correct as necessary.
- e. Check for deposits on valve seats and/or gum formation on stems or guides and correct as necessary.
- f. Check for warped valves or faulty valve forgings and

correct as necessary.

g. Check for exhaust back pressure and correct as necessary.

h. Check improper spark timing and correct as necessary.

i. Check excessive idling and correct as necessary.

NOISY VALVES

- a. Check and adjust valve lash if necessary.
- b. Check for excessively worn, dirty or faulty valve lifters. Replace if necessary.
- c. Check for worn valve guides. Repair as necessary.
- d. Check for excessive run-out of valve seat or valve face. Repair as necessary.

e. Check for worn camshaft lobes. Replace camshaft if necessary.

f. Inspect for pulled or loose rocker arm studs. Repair or replace as necessary.

g. Check for bent push rods. Replace if necessary.

h. Inspect for broken valve spring. Replace if necessary.

NOISY PISTONS AND RINGS

- a. Check for excessive piston to bore clearance. Correct as necessary.
- b. Inspect for improper fit of piston pin. Correct as necessary.
- c. Inspect for excessive accumulation of carbon in combustion chamber or on piston tops. Clean and/or repair as necessary.
- d. Check for connecting rods alignment. Correct as

necessary.

e. Inspect for excessive clearance between rings and grooves. Repair or replace as necessary.

f. Check for broken piston rings. Replace as necessary.

BROKEN PISTONS AND/OR RINGS

- a. Check for undersize pistons. Replace if necessary.
- b. Check for wrong type and/or size rings installed. Replace if necessary.
- c. Check for tapered or eccentric cylinder bores. Correct as necessary.
- d. Check connecting rod alignment. Replace if necessary.
- e. Check for excessively worn ring grooves. Replace if necessary.
- f. Check for improperly assembled piston pins. Replace

as necessary.

g. Check for insufficient ring gap clearance. Correct as necessary.

h. Inspect for engine overheating. Correct as necessary.

i. Check for sub-standard fuel. Correct as necessary.

j. Check ignition timing. Correct as necessary.

NOISY MAIN BEARINGS

- a. Check low oil pressure and/or insufficient oil supply and correct as necessary.
- b. Check for excessive bearing clearance and correct as necessary.
- c. Check for excessive crankshaft end play and correct as necessary.
- d. Check for eccentric or out-of-round crankshaft journals and correct as necessary.
- e. Check for excessive belt tension and adjust as necessary.
- f. Check for loose torsional damper and replace as necessary.

NOISY VALVE LIFTERS

- a. Check for broken valve springs and replace as necessary.
- b. Check for worn or sticking rocker arms and repair or replace as necessary.
- c. Check for worn or bent push rods and replace as necessary.
- d. Check for valve lifters incorrectly fitted to bore size and correct as necessary.
- e. Check faulty valve lifter plunger or push rod seat and replace lifters as necessary.
- f. Check for plungers excessively worn causing fast leakdown under pressure and replace as necessary.
- g. Check for excessively worn camshaft lobes and replace if necessary.
- h. Check valve lifter oil feed holes plugged causing internal breakdown and correct as necessary.
- i. Check faulty valve lifter check ball. (nicked, flat spot, or out of round) and replace as necessary.
- j. Check rocker arm retaining nut to be installed upside down and correct as necessary.
- k. Check for end of push rod excessively worn or flaked and replace as necessary.

ENGINE DETONATION

- a. Check for overadvanced ignition timing and/or faulty ignition system and correct as necessary.
- b. Check for loose or improper application of spark plugs, or spark plugs with cracked or broken ceramic cores and replace as necessary.
- c. Check for the use of sub-standard fuel and correct as necessary.
- d. Check for foreign material in fuel lines and/or carburetor and correct as necessary.
- e. Check for restricted fuel delivery to carburetor (pinched lines, faulty fuel tank cap or pick-up) and correct as necessary.
- f. Check fuel pump operation and replace if necessary.
- g. Check EFE system operation and repair or replace as necessary.
- h. Check EGR system operation and correct as necessary.
- i. Check thermostatically controlled air cleaner operation and correct as necessary.
- j. Check P.C.V. system operation and correct as necessary.
- k. Check for vacuum leaks and repair or replace as necessary.
- l. Check engine operating temperature and correct as necessary.
- m. Check for excessive combustion chamber deposits and correct as necessary.
- n. Check for leaking, sticking, or broken valves and repair or replace as necessary.

| Condition | Possible Cause | Correction |
|---|---|--|
| Engine Will Not Crank | Loose or Corroded Battery Cables | Check connections at battery, engine block and starter solenoid. |
| | Discharged Batteries | Check generator output as described in Section 6D. |
| | Starter Inoperative | Refer to Starter Diagnosis as described in Section 6D. |
| Engine Cranks Slowly - Will Not Start (Minimum Engine Cranking Speed - 100 RPM) | Battery Cable Connections Loose or Corroded | Check connections at battery, engine block and starter. |
| | Batteries Undercharged | Check charging system as described in Section 6D. |
| | Wrong Engine Oil | Drain and refill with recommended oil. |
| Engine Cranks Normally - Will Not Start | Incorrect Starting Procedure | Use recommended starting procedure. |
| | Incorrect or Contaminated Fuel | Flush fuel system and install correct fuel. |
| | No Fuel to Nozzles | Loosen injection line at a nozzle. Do not disconnect. Use care to direct fuel away from sources of ignition. Wipe connection to be sure it is dry. Crank 5 seconds. Fuel should flow from injection line. Tighten connection. If fuel does not flow, check fuel solenoid operation as follows: Connect a 12 volt test lamp from wire at injection pump solenoid to ground. Turn ignition to "ON". Lamp should light. If lamp does not light, check wiring to solenoid. |
| | No Fuel to Injection Pump | Remove line at inlet to injection pump fuel filter. Connect hose from line to metal container. Crank engine. If no fuel is discharged, test the fuel supply pump. If the pump is OK, check the injection pump fuel filter and, if plugged, replace it. |
| | Plugged Fuel Return System | Disconnect fuel return line at injection pump. Connect a hose from the return line to a metal container. Connect a second hose to the injection pump connection; route it to the metal container. Crank the engine; if engine starts and runs, correct restriction in fuel return system. |

Fig. 6A-2--Diesel Diagnosis

| Condition | Possible Cause | Correction |
|--|--|---|
| Engine Cranks Normally - Will Not Start (Cont'd) | Pump Timing Incorrect | Make certain that pump timing mark is aligned with mark on adapter. |
| | Glow Plug Control System Inoperative | <p>Disconnect wires from one glow plug on each bank. Use care that disconnected wires do not ground to chassis. Connect a 12 volt test lamp in turn from each glow plug wire to ground. Turn ignition to "ON". Test lamp should light while instrument panel lamp signals "DON'T START".</p> <p>NOTE: Cycle ignition switch to "OFF" between tests to recycle glow plug circuitry. If instrument panel lamp does not signal "DON'T START", engine is warm; glow plug circuitry is not called for; disconnect wire from glow plug circuit thermistor on intake manifold; "DON'T START" lamp and glow plug circuitry will remain "ON" for approximately 2 minutes each time ignition is switched "ON" allowing sufficient time to conduct test.</p> <p>If test lamp does not light as outlined above, refer to Electronics Diagnosis Section.</p> |
| | Glow Plugs Inoperative | <p>Disconnect wire from each glow plug. With 12 volt test lamp connected to 12 volt source, touch each glow plug terminal.</p> <p>a. If test lamp lights, glow plug is operational.</p> <p>b. If test lamp does not light, replace glow plug or plugs.</p> |
| Engine Starts But Will Not Continue To Run At Idle | Internal Engine Problems | Refer to Engine Section 6A. |
| | No Fuel in Tank | Install correct fuel in tank. |
| | Incorrect or Contaminated Fuel | Flush fuel system and install correct fuel. |
| | Limited Fuel to Injection Pump Fuel Solenoid Disengaged with Ignition Switch in the "ON" Position | <p>Test the fuel supply pump. Replace as necessary.</p> <p>Connect a 12 volt test lamp from wire at injection pump solenoid to ground. Turn ignition to "ON". Lamp should light. Turn ignition to "START". Lamp should light. If lamp does not light in both positions, check wiring to solenoid.</p> |

Fig. 6A-3-Diesel Diagnosis

| Condition | Possible Cause | Correction |
|--|---|--|
| <p>Engine Starts But Will Not Continue To Run At Idle (Cont'd)</p> | <p>Restricted Fuel Return System</p> | <p>Disconnect fuel return line at injection pump. Connect a hose from the return line to a metal container. Connect a second hose to the injection pump connection; route it to the metal container. Start the engine and allow it to idle. If engine idles normally, correct restriction in fuel return system.</p> |
| | <p>Fast Idle Solenoid Inoperative</p> | <p>With engine cold, start car; solenoid should move to support injection pump lever in "fast idle position" for about 5 seconds. If solenoid does not move, refer to Diesel Electrical Diagnosis Section 6D.</p> |
| | <p>Low Idle Incorrectly Adjusted</p> | <p>Adjust idle screw to specification.</p> |
| | <p>Pump Timing Incorrect</p> | <p>Make certain that timing mark, on injection pump, is aligned with mark on adapter.</p> |
| | <p>Glow Plug Control System Malfunction</p> | <p>Refer to Electrical Diagnosis Section 6D.</p> |
| | <p>Injection Pump Malfunction</p> | <p>Install replacement pump.</p> |
| | <p>Internal Engine Problems</p> | <p>Refer to Engine Diagnosis.</p> |
| <p>Engine Starts, Idles Rough, Without Abnormal Noise or Smoke</p> | <p>Low Idle Incorrectly Adjusted</p> | <p>Adjust idle screw to specification.</p> |
| | <p>Injection Line Leaks</p> | <p>Wipe off injection lines and connections. Run engine and check for leaks. Correct leaks.</p> |
| | <p>Restricted Fuel Return System</p> | <p>Disconnect fuel return line at injection pump. Connect a hose from the return line to a metal container. Connect a second hose to the injection pump connection; route it to the metal container. Start the engine and allow it to idle; if engine idles normally, correct restriction in fuel return system.</p> |
| | <p>Incorrect or Contaminated Fuel</p> | <p>Flush fuel system and install correct fuel.</p> |
| | <p>Nozzle(s) Inoperative</p> | <p>With engine running, loosen injection line fitting at each nozzle in turn. Use care to direct fuel away from sources of ignition. Each nozzle should contribute to rough running. If nozzle is found that does not change idle quality, it should be replaced.</p> |

Fig. 6A-4--Diesel Diagnosis

| Condition | Possible Cause | Correction |
|--|---|--|
| Engine Starts, Idles Rough, Without Abnormal Noise or Smoke (Cont'd) | Internal Fuel Leak at Nozzle(s) | Disconnect fuel return system from nozzles on one bank at a time. With the engine running, observe the normal fuel seepage at the nozzles. Replace any nozzle with excessive fuel leakage. |
| | Fuel Supply Pump Malfunctions | Test the fuel supply pump. Replace if necessary. |
| | Uneven Fuel Distribution to Cylinders | Install new or reconditioned nozzles, one at a time, until condition is corrected as indicated by normal idle. |
| Engine Starts And Idles Rough With Excessive Noise and/or Smoke | Injection Pump Timing Incorrect | Be sure timing mark on injection pump is aligned with mark on adapter. |
| | Nozzle(s) Inoperative | With engine running, crack injection line at each nozzle, one at a time. Use care to direct fuel away from sources of ignition. Each nozzle should contribute to rough running. If a nozzle is found that does not affect idle quality or changes noise and/or smoke, it should be replaced. |
| | High Pressure Lines Incorrectly Installed | Check routing of each line. Correct as required. |
| Engine Misfires But Idles Correctly | Plugged Fuel Filter | Replace filter. |
| | Incorrect Injection Pump Timing | Be sure that timing mark on injection pump and adapter are aligned. |
| | Incorrect or Contaminated Fuel | Flush fuel system and install correct fuel. |
| | Internal Engine Damage | Refer to Engine Diagnosis. |
| Engine Will Not Return To Idle | External Linkage Mis-adjustment or Failure | Reset linkage or replace as required. |
| | Internal Injection Pump Malfunction | Install replacement injection pump. |
| Fuel Leaks On Ground - No Engine Malfunction | Loose or Broken Fuel Line or Connection | Examine complete fuel system, including tank, supply, injection and return system. Determine source and cause of leak and repair. |
| | Internal Injection Pump Failure | Install replacement injection pump. |
| Significant Loss of Power | Incorrect or Contaminated Fuel | Flush fuel system and install correct fuel. |
| | Pinched or Otherwise Restricted Return System | Examine system for restriction and correct as required. |

Fig. 6A-5--Diesel Diagnosis

| Condition | Possible Cause | Correction |
|--|--|---|
| Significant Loss of Power (Cont'd) | Plugged Fuel Tank Vent | Remove fuel cap. If "hissing" noise is heard, vent is plugged and should be cleaned. |
| | Restricted Supply | Examine fuel supply system to determine cause of restriction. Repair as required. |
| | Plugged Fuel Filter | Remove and replace filter. |
| | External Compression Leaks | Check for compression leaks at all nozzles and glow plugs, using "Leak-Tec" or equivalent. If leak is found, tighten nozzle clamp or glow plug. If leak persists at a nozzle, remove it and reinstall with a new carbon stop seal and compression seal. |
| | Plugged Nozzle(s) | Remove nozzles, check for plugging and have repaired or replaced. |
| | Internal Engine Problem | See Engine Section 6A. |
| Noise - "Rap" From One or More Cylinders | Air in Fuel System | Check for leaks and correct. |
| | Air in High Pressure Line(s) | Crack line at nozzle(s) and bleed air at each cylinder determined to be causing noise. Use care to direct fuel away from sources of ignition and be sure to carefully retighten lines. |
| | Nozzle(s) Sticking Open or with Very Low Blowoff Pressure | Replace the nozzle(s) causing the problem. |
| | Internal Engine Problem | See Engine Section 6A. |
| Noise - Significant Overall Combustion Noise Increase With Excessive Black Smoke | Timing Not Set To Specification | Align timing marks on adapter and injection pump. |
| | Internal Engine Problem | Check for presence of oil in the air crossover. If present, determine cause and correct. See Engine Section 6A for disassembly and inspection procedures. |
| | Injection Pump Housing Pressure Out of Specifications. | Check housing pressure as described in Section 6A5. If incorrect, replace fuel return line connector assembly. |
| | Internal Injection Pump Problem | Replace pump. |
| Noise - Internal or External | Fuel Supply Pump, Alternator, Water Pump, Valve Train, Short Block, Etc. | See appropriate section of Service Manual for inspection, disassembly and repair procedures. |

Fig. 6A-6--Diesel Diagnosis

| Condition | Possible Cause | Correction |
|---|--|--|
| Engine Overheats | Coolant System Leak Oil Cooler System Leak | Check for leaks and correct as required. |
| | Belt Failure | Replace. |
| | Thermostat Malfunction Head Gasket Failure Internal Engine Problem | See Engine Diagnosis and repair procedures. |
| Instrument Panel Oil Warning Lamp "ON" at Idle | Oil Cooler or Oil Cooler Line Restricted | Remove restriction in cooler or cooler line. |
| | Internal Engine Problem | See Engine Section for diagnosis and repair procedures. |
| Odor or Smoke – Excessive and Not Previously Covered | Same as Gasoline Engines | See Engine Diagnosis. |
| Engine Will Not Shut Off With Key | Injection Pump Solenoid Does Not Drop Out | See Electronics Diagnosis Section 6D. If problem is determined to be internal with the injection pump, replace the injection pump. |
| NOTE: With engine at idle, pinch the fuel return line at the injection pump to shut off engine. | Injection Pump Solenoid Return Spring Failed | Replace injection pump. |

Fig. 6A-7--Diesel Diagnosis

classicalcarlibrary.com

Section 6A1

Contents

4.1 L (D) L-6 - RPO LE3

4.8 L (T) L-6 - RPO L25

| | | | |
|--|--------|---|--------|
| General Description..... | 6A1-1 | Valves | 6A1-16 |
| Engine Lubrication | 6A1-2 | Torsional Damper..... | 6A1-16 |
| On Vehicle Service..... | 6A1-9 | Crankcase Front Cover | 6A1-16 |
| Engine Mounts..... | 6A1-9 | Oil Seal (Front Cover)..... | 6A1-17 |
| Manifold Assembly-Non-Integrated Head..... | 6A1-10 | Camshaft | 6A1-17 |
| Exhaust Manifold-Integrated Head..... | 6A1-10 | Camshaft Bearings | 6A1-18 |
| Rocker Arm Cover..... | 6A1-11 | Oil Pan | 6A1-19 |
| Push Rod Side Cover | 6A1-11 | Oil Pump..... | 6A1-19 |
| Valve Mechanism..... | 6A1-11 | Engine Bearings | 6A1-20 |
| Valve Stem Oil Seal and/or Valve Spring..... | 6A1-11 | Oil Seal (Rear Main)..... | 6A1-23 |
| Valve Lifters..... | 6A1-13 | Piston and Connecting Rod Assemblies..... | 6A1-24 |
| Cylinder Head..... | 6A1-14 | Flywheel | 6A1-28 |
| Rocker Arm Studs..... | 6A1-15 | Engine Assembly..... | 6A1-29 |
| Valve Guides | 6A1-15 | Crankshaft..... | 6A1-30 |
| Valve Seats | 6A1-16 | Specifications..... | 6A1-31 |

GENERAL DESCRIPTION

CYLINDER BLOCK

The cylinder block is made of cast iron and has 6 cylinders arranged "In-Line". Seven main bearings support the crankshaft which is retained by recessed bearing caps that are machined with the block for proper alignment and clearances. Cylinders are completely encircled by coolant jackets.

CYLINDER HEAD

The cast iron cylinder head has individual intake and exhaust ports for each cylinder. Valve guides are integral and rocker arms are retained on individual threaded studs pressed into head. The 4.1 L(D) heads have integrated inlet manifolds. The 4.8 L(T) uses separate inlet manifolds.

CRANKSHAFT AND BEARINGS

The crankshaft is cast nodular iron and is supported by seven main bearings. Number seven bearing is the end thrust bearing. Main bearings are lubricated from oil holes which intersect the main oil gallery located on the right side of the block. The cam bearings are also fed oil by intersecting holes with main oil gallery. The lifters are located in the main oil gallery.

A damper assembly, on the forward end of the crankshaft, dampens any engine torsional vibrations. The outer ring of the damper is grooved for the accessory drive belts.

CAMSHAFT AND DRIVE

The cast iron camshaft is supported by four bearings and is gear driven. A cast iron crankshaft gear drives the aluminum camshaft gear. Cam lobes are ground, hardened and tapered with the high side toward the rear. This, coupled with a spherical face on the lifters, causes the valve lifters to rotate.

PISTONS AND CONNECTING RODS

The pistons are made of a cast aluminum alloy using two compression rings and one oil control ring.

Piston pins in the 4.1 L (D) engine are offset .060" (1.5mm) toward the thrust side (right hand side) to provide a gradual change in thrust pressure against the cylinder wall as the piston travels its path. This also provides for quieter operation. 4.8 L (T) engine piston pins are on piston centerline for best durability and reduced friction. Pins are chromium steel and have a floating fit in the pistons. They are retained in the connecting rods by a press fit.

Connecting rods are made of forged steel. Full pressure lubrication is directed to the connecting rods by drilled oil passages from the adjacent main bearing journal. Oil holes at the connecting rod journals are located so that oil is supplied to give maximum lubrication just prior to full bearing load.

VALVE TRAIN

A very simple ball pivot-type train is used. Motion is transmitted from the camshaft through the hydraulic lifters and push rods to the rocker arms. The rocker arm pivots on its ball and transmits the camshaft motion to the valve. The rocker arm ball is retained by a self locking nut.

HYDRAULIC VALVE LIFTERS

Hydraulic Valve Lifters are used to keep all parts of the valve train in constant contact for quiet operation.

The hydraulic lifter assembly consists of: the lifter body, which rides in the cylinder block boss, a plunger, a push rod seat, a metering valve, a plunger spring, a check ball and spring, a check ball retainer and a push rod seat retainer.

When the lifter is riding on the low point (base circle) of the cam, the plunger spring keeps the plunger and push rod seat in contact with the push rod.

When the lifter body begins to ride up the cam lobe, the check ball traps the oil in the reservoir below the plunger. The plunger and lifter body then rise as a unit, pushing up the push rod and opening the valve. A very small amount of oil will leak out between the plunger and the body.

As the lifter body rides down the other side of the cam, the plunger follows with it until the valve closes. The lifter body continues to follow the cam to its low point, but the plunger spring keeps the plunger in contact with the push

rod. The ball check valve will then move off its seat and the lifter reservoir will be refilled with oil.

INTAKE MANIFOLD

The intake manifold is of cast iron, single level design for efficient fuel distribution. The 4.1 L (D) manifold is an integral unit with the head on all vehicles. 4.8 L (T) engines use separate components. The carburetor pad is centrally located with an early fuel evaporation (EFE) passage running underneath the pad, through which exhaust gases are forced, to promote faster fuel vaporization when the engine is cold. An exhaust gas recirculation port is also cast into the manifold on 4.1 L (D) engines, for the induction of a metered amount of exhaust gases into the air and fuel mixture which has entered through the carburetor.

EXHAUST MANIFOLD

On 4.8 L (T) engines a single four port, underslung, center take down manifold of cast iron is used to direct exhaust gases from the combustion chambers. On 4.1 L (D) engines a single four port, underslung, dual center take down manifold of cast iron is used. A heat shield is mounted to the manifold that is used to route heated air to the air cleaner for better fuel vaporization.

Engine Lubrication

Full pressure lubrication, through a full flow oil filter is furnished by a gear-type oil pump. The distributor, driven by a helical gear on the camshaft, drives the oil pump.

Oil drawn by the pick-up screen and pipe is pressurized in the pump and routed to the oil filter. If excessive backpressure is encountered at the filter, a bypass valve allows oil flow to the main oil gallery, located along the right side of the block. This rifle drilled gallery supplies oil to the camshaft bearings, the hydraulic lifters and the crankshaft main bearings.

The connecting rod bearings are supplied oil from the crankshaft main bearings by means of cross drilled passages.

The valve train is supplied its lubrication from the valve lifters. Oil within the lifters is pumped up through the top of the lifters through the hollow push rods to the rocker arms. From the head, oil is drained back to the crankcase through oil drain back holes and the push rod holes. (Fig. 6A1-1).

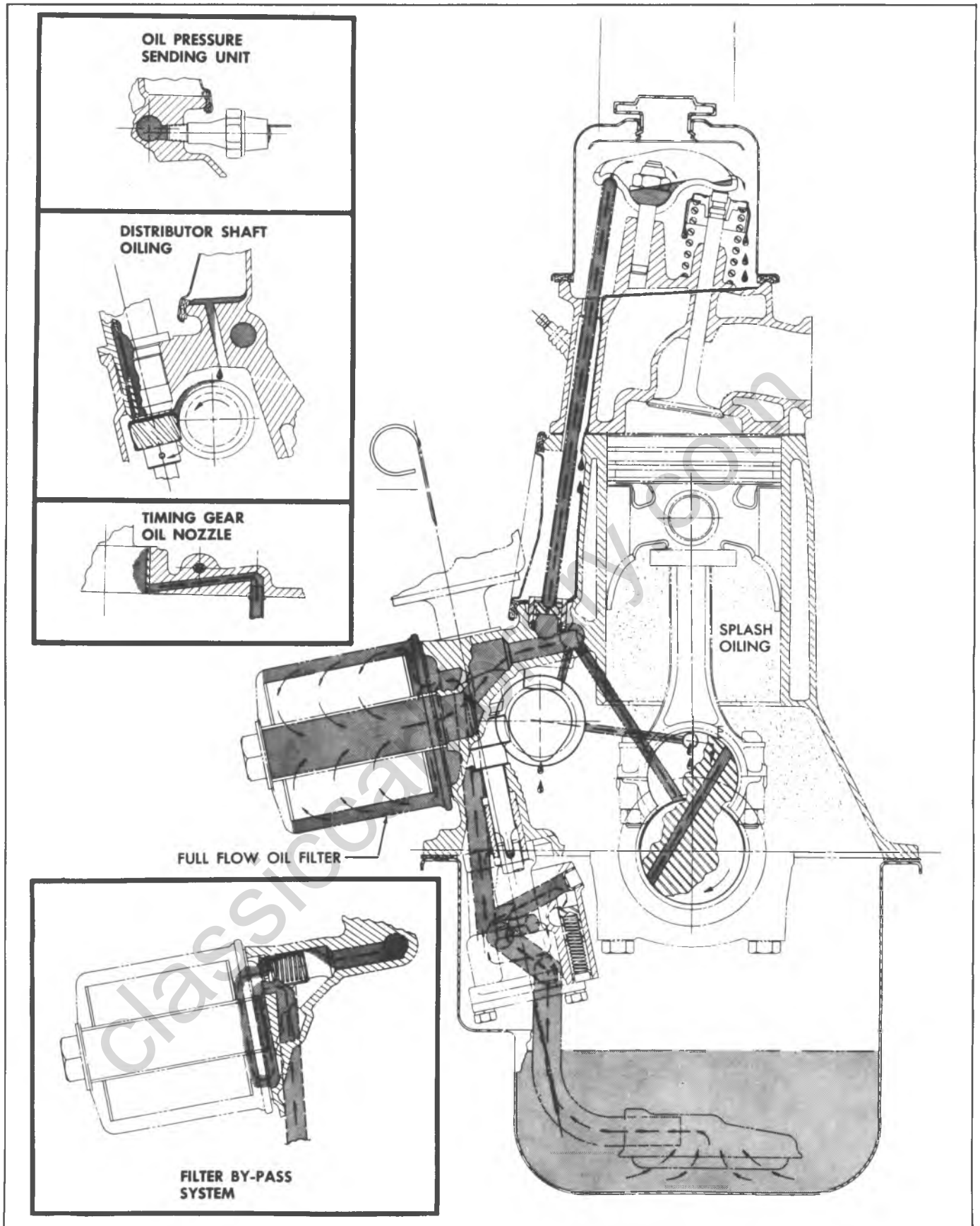


Fig. 6A1-1--In-Line Engine Lubrication

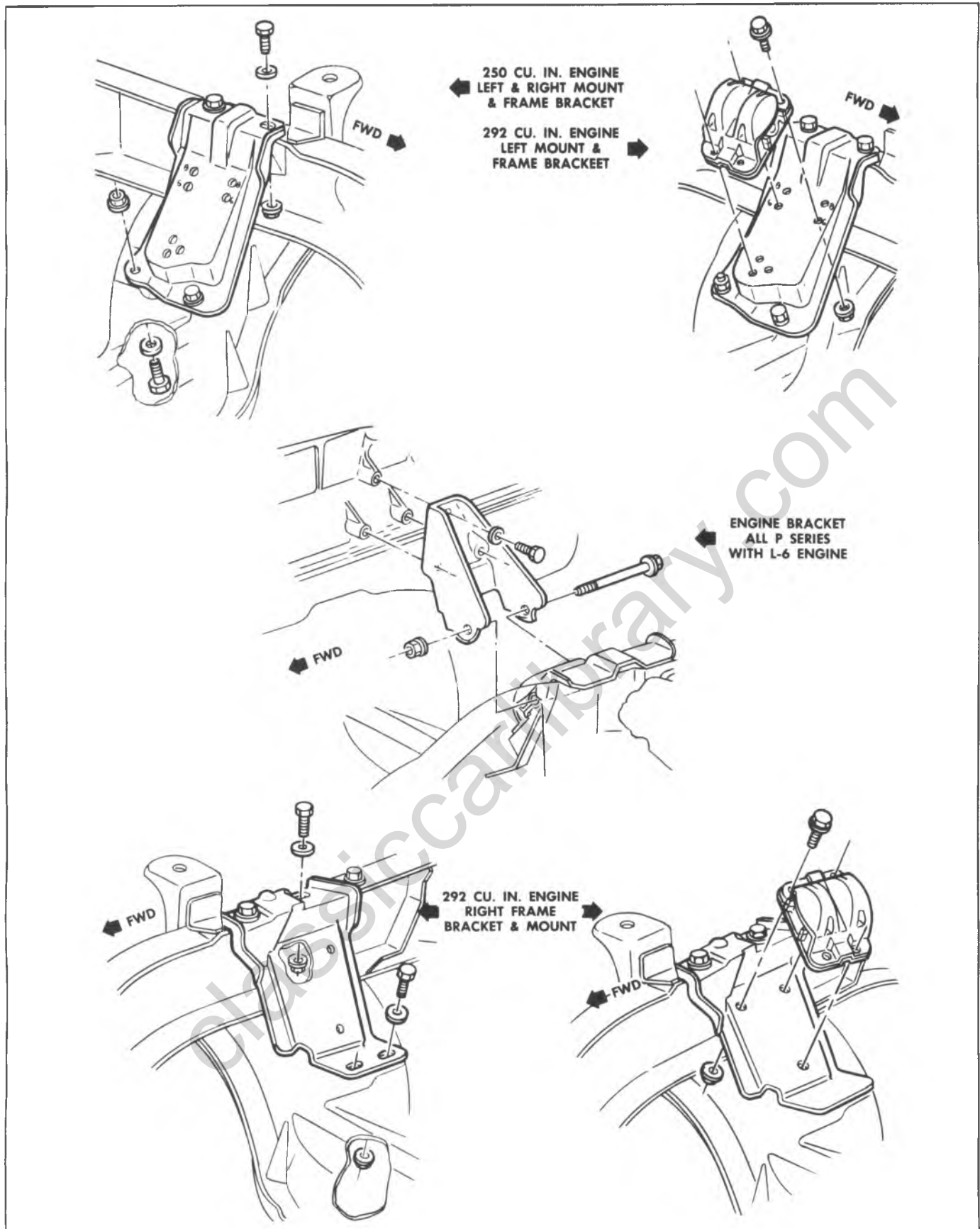


Fig. 6A1-2-"P" Series - Engine Front Mount

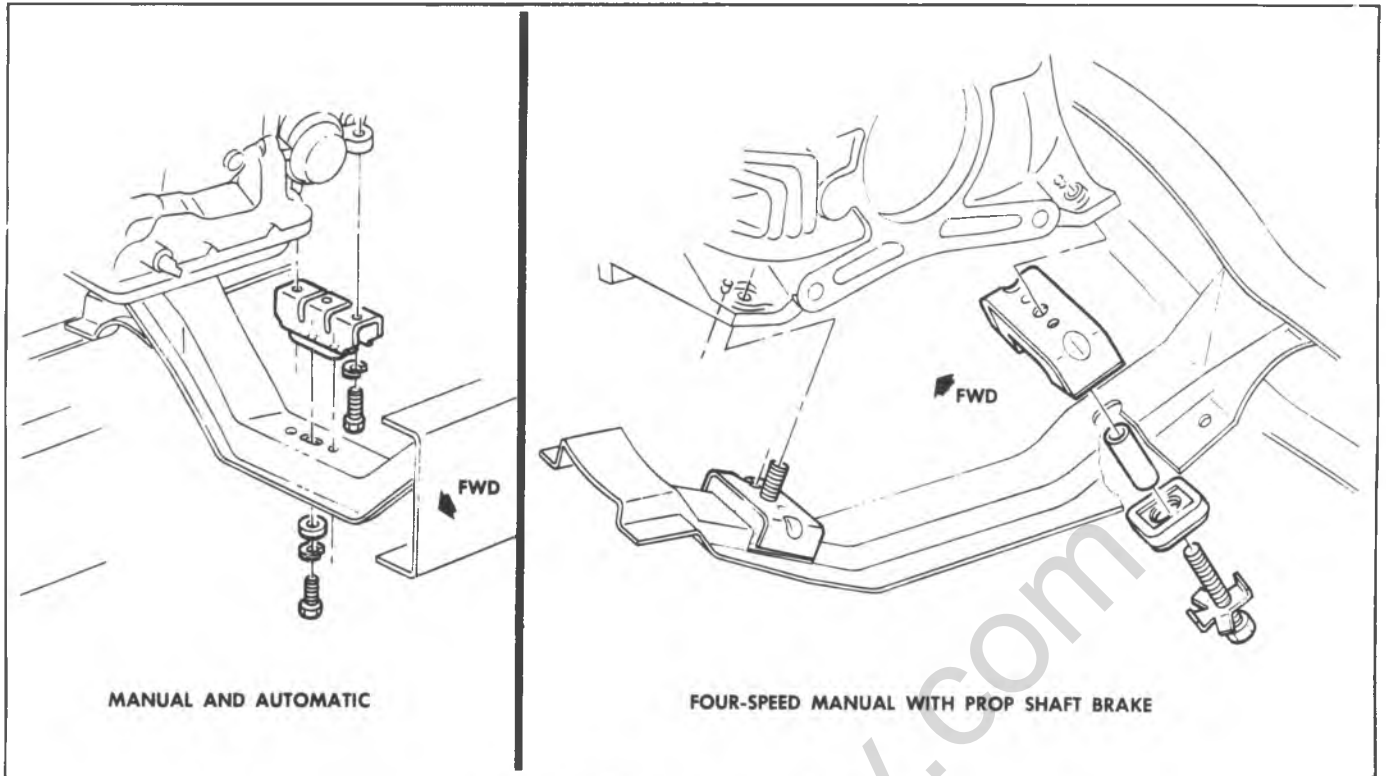


Fig. 6A1-3--"P" Series - Engine Rear Mount

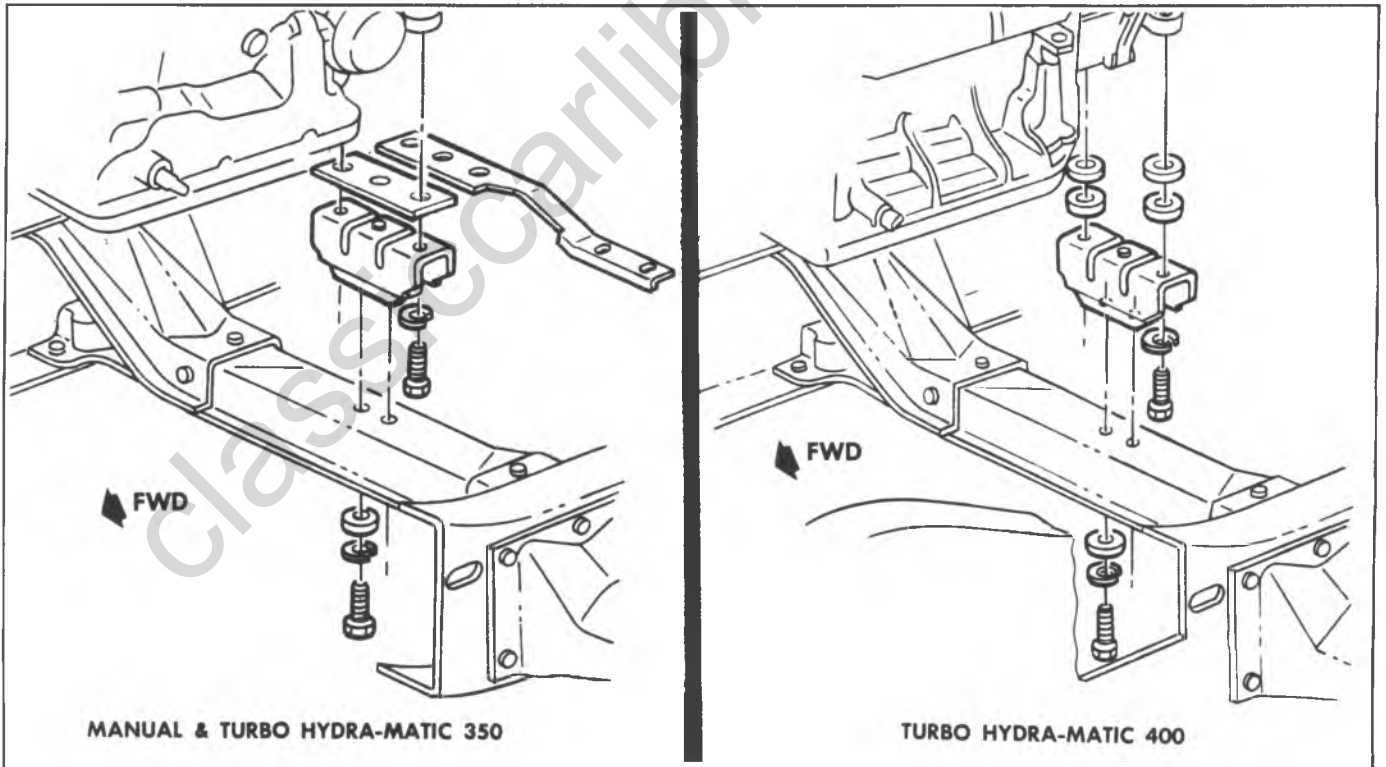


Fig. 6A1-4--"C" Series - Engine Rear Mounts

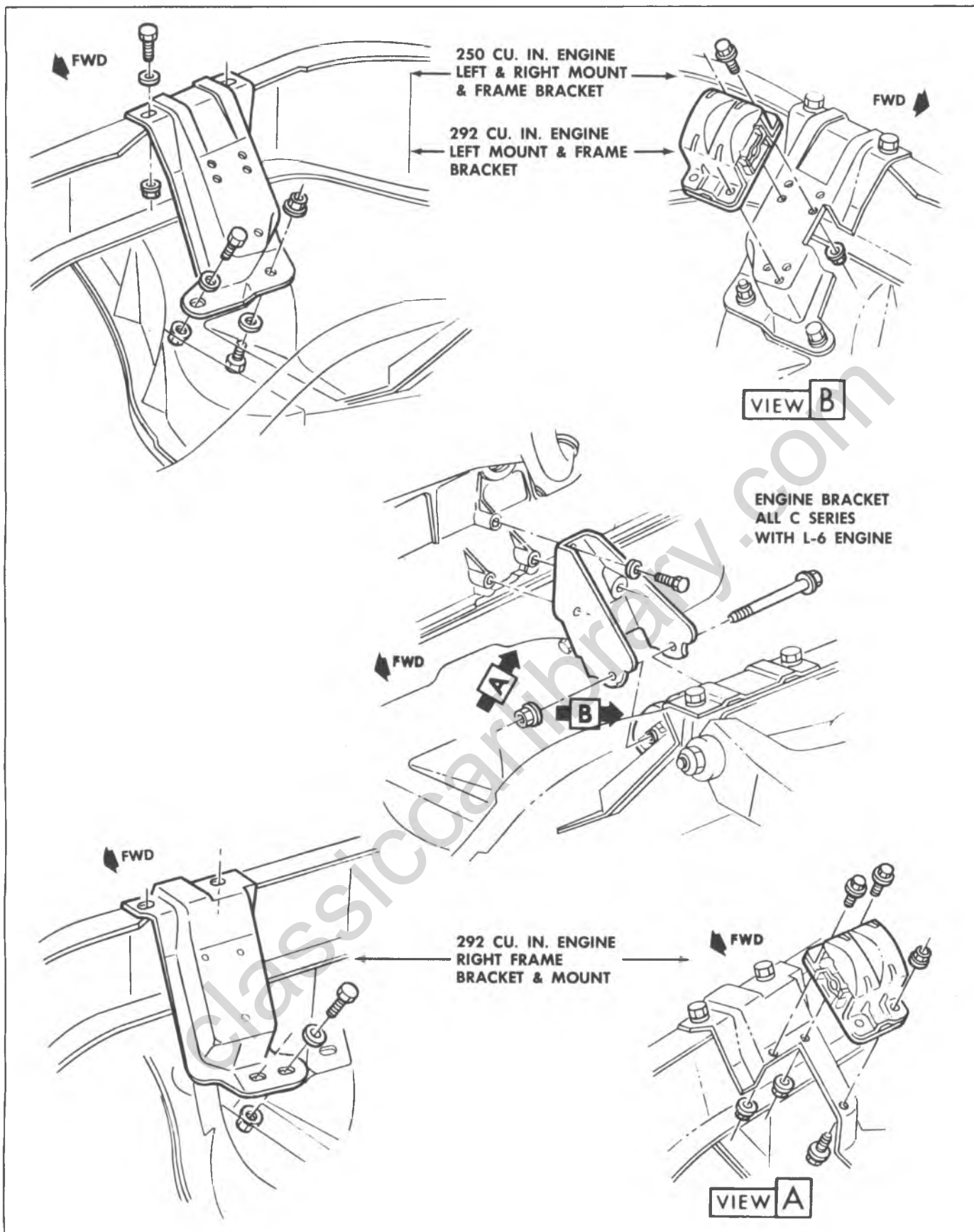
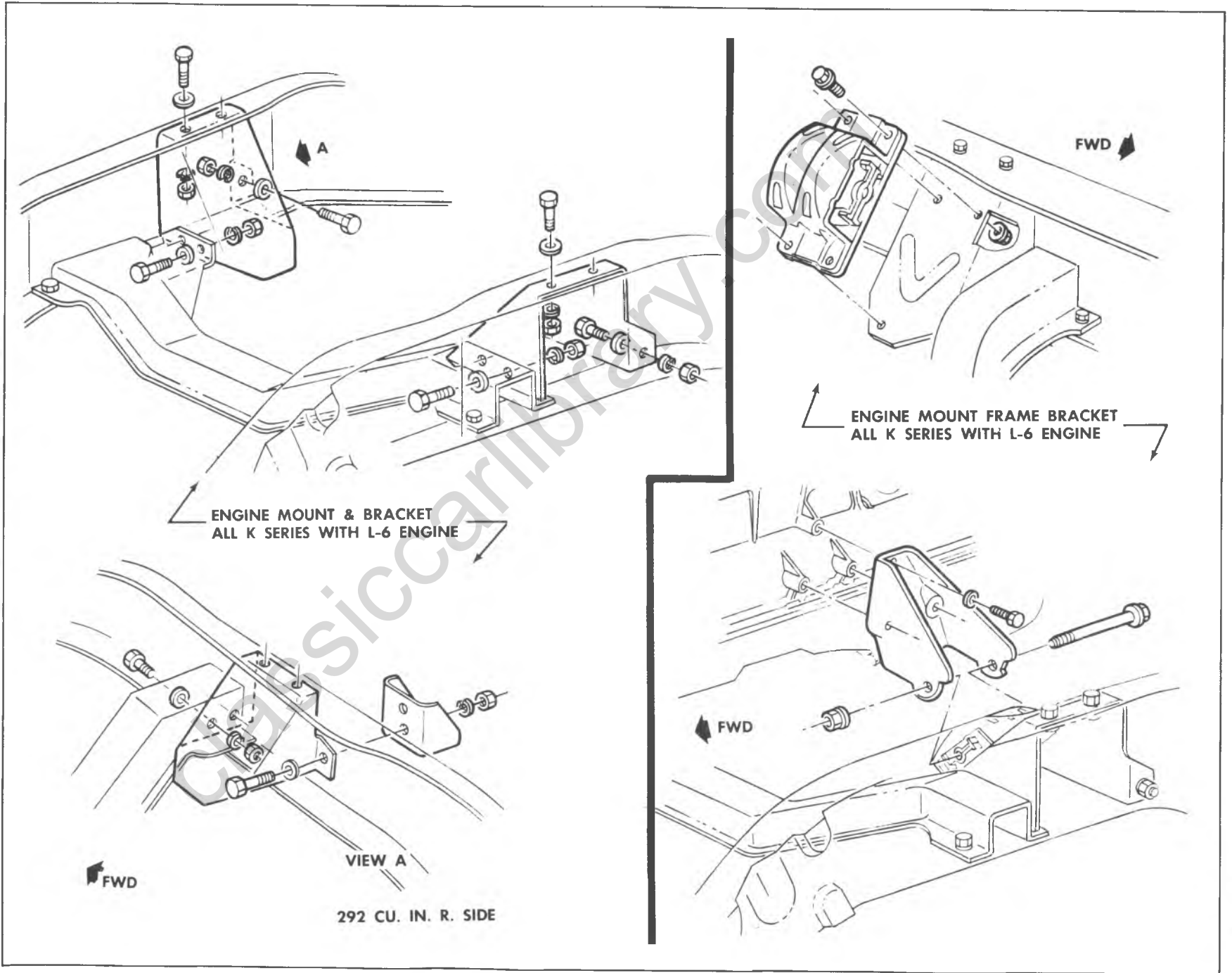


Fig. 6A1-5--"C" Series - Engine Front Mount

Fig. 6A1-6--"K" Series - Engine Front Mount



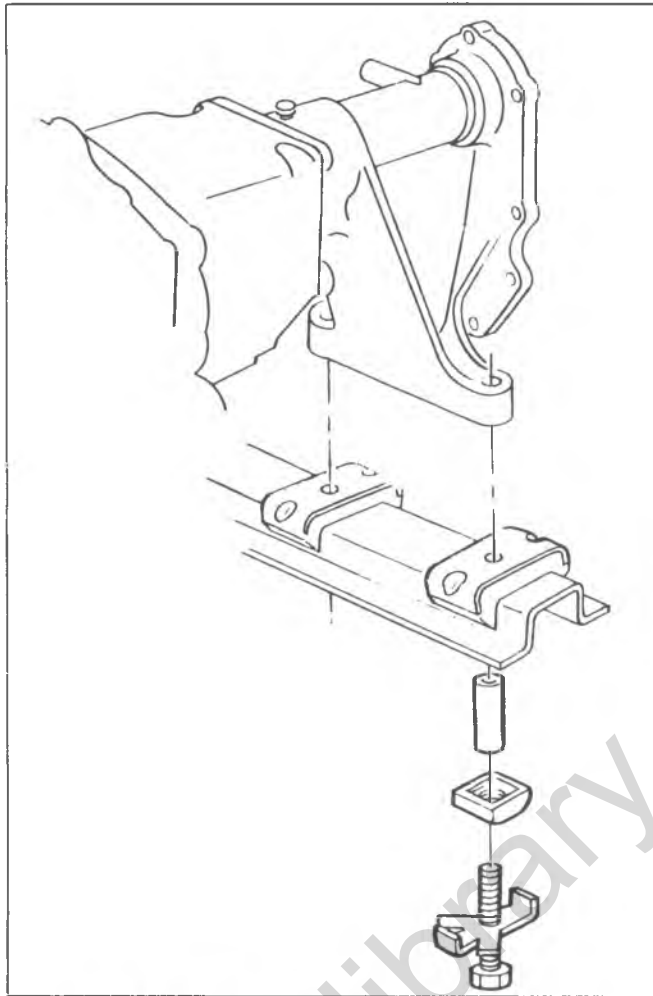


Fig. 6A1-7-"K" Series - Engine Rear Mount

classiccarslibrary.com

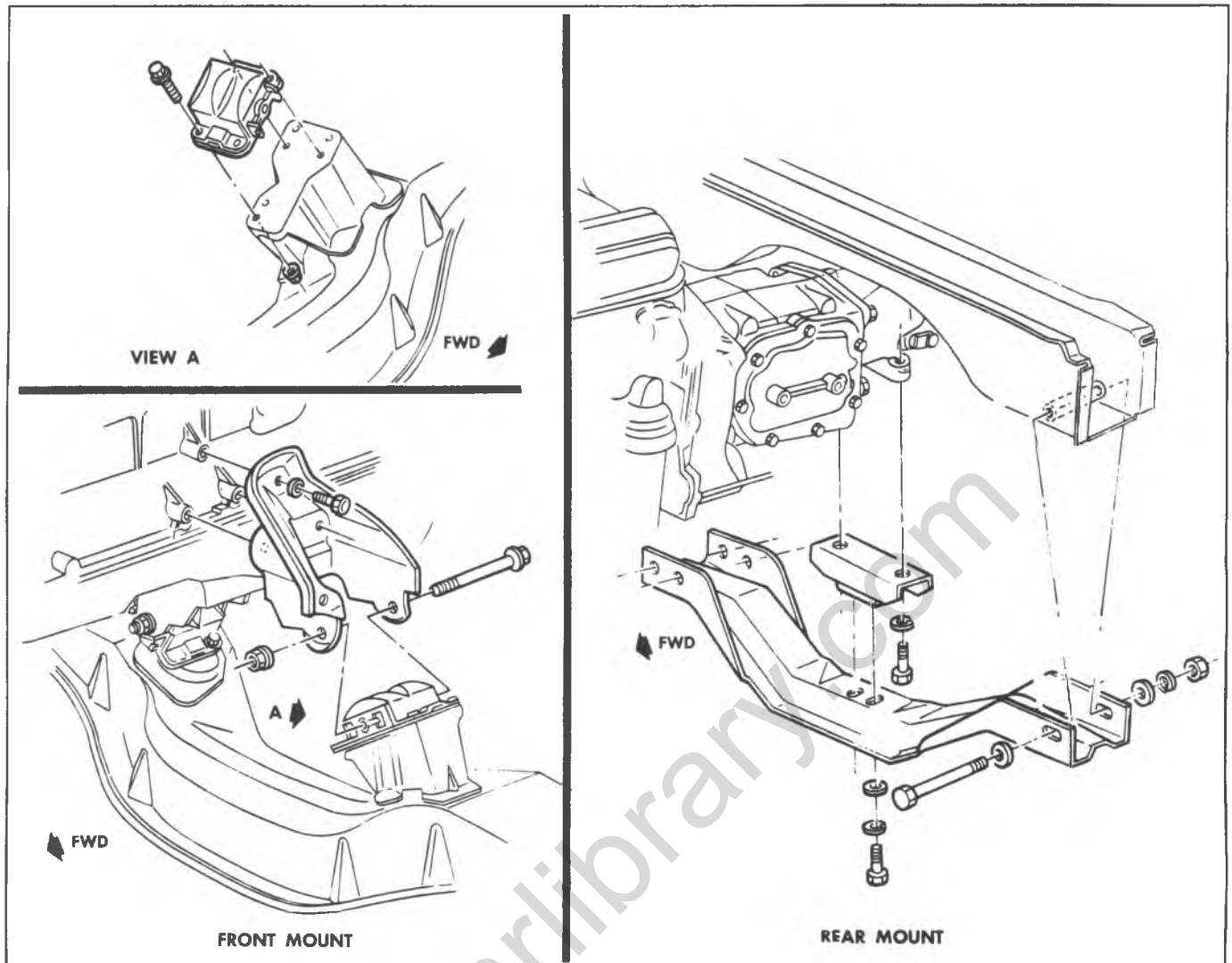


Fig. 6A1-8--"G" Series - Engine Mounts

ON VEHICLE SERVICE

ENGINE MOUNTS

Engine mounts (Fig. 6A1-2 - 6A1-8) are the non-adjustable type and seldom require service. Broken or deteriorated mounts should be replaced immediately, because of the added strain placed on other mounts and drive line components.

Checking Engine Mounts

Front Mount

Raise the engine to remove weight from the mounts and to place a slight tension in the rubber. Observe both mounts while raising engine. If an engine mount exhibits:

- Hard rubber surface covered with heat check cracks;
- Rubber separated from a metal plate of the mount;
- Rubber split through center,

replace the mount. If there is relative movement between a metal plate of the mount and its attaching points, lower the engine on the mounts and tighten the screws or nuts attaching the mount to the engine, frame, or bracket.

Rear Mount

Raise the vehicle on a hoist. Push up and pull down on the transmission tailshaft while observing the transmission mount. If the rubber separates from the metal plate of the mount or if the tailshaft moves up but not down (mount bottomed out) replace the mount. If there is relative movement between a metal plate of the mount and its attaching point, tighten the screws or nuts attaching the mount to the transmission or crossmember.

Front Mount Replacement

1. Remove engine mount through bolt.
2. Raise engine and remove mount to frame bracket attaching bolts. Remove mount. Raise engine only enough for sufficient clearance. Check for interference between rear of engine and cowl panel.
3. Install new engine mount to frame bracket and torque attaching bolts to specifications.
4. Install engine mount through bolt and torque to 30 lb. ft. (40 N·m) specifications.

Rear Mount Replacement

1. Support engine weight to relieve rear mounts.
2. Remove crossmember-to-mount bolts.
3. On "P" Series with manual transmission and propeller shaft parking brake, remove mount attaching bolts from frame outrigger and clutch housing and remove rear mounting cushions.
4. Remove mount-to-transmission bolts, then remove mount.
5. On "P" Series with manual transmission and propeller shaft parking brake, install new mounting cushions and bolts.
6. Install new mount on transmission.
7. While lowering transmission, align and start crossmember-to-mount bolts.
8. Torque bolts to 45 lb. ft. (60 N·m) then bend lock tabs to bolt head as applicable.

MANIFOLD ASSEMBLY - NON-INTEGRATED HEAD**Removal**

1. Disconnect battery negative cable at battery.
2. Remove air cleaner.
3. Disconnect both throttle controls at bellcrank and remove throttle return spring.
4. Disconnect fuel and vacuum lines at carburetor.
5. Disconnect crankcase ventilation hose at rocker arm cover.
6. Disconnect vapor hose at canister.
7. Disconnect exhaust pipe at manifold flange.
8. Remove manifold attaching bolts and clamps then remove manifold assembly.
9. Check for cracks in manifold castings.
10. Separate manifolds by removing one bolt and two nuts at center of assembly.
11. Observe gaskets and packing if necessary to diagnose a leakage problem.

Installation

1. Clean gasket surfaces on cylinder head and manifolds.
2. Lay a straight edge along the full length of the exhaust port faces and measure any gaps between the straight edge and the port faces. If at any point a gap of .030" (.80mm) or more exists, it is likely that the manifold has distorted to a point where it will not seat properly. If a good exhaust seal is to be expected, the exhaust manifold must be replaced.
3. Assemble intake and exhaust manifolds using a new gasket by reinstalling the one bolt and two nuts at the center of the manifold to finger tight.

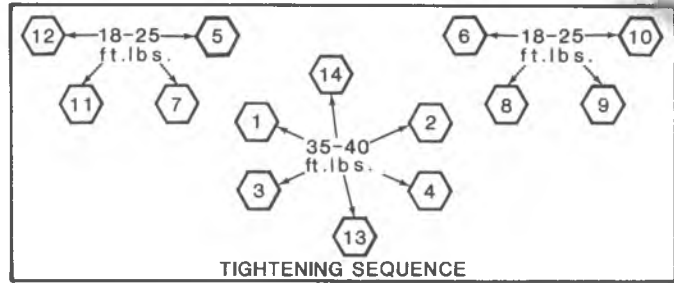


Fig. 6A1-9--Cylinder Head To Exhaust Manifold Tightening Sequence

4. Position a new gasket over manifold end studs on the cylinder head.
5. Install manifold assembly bolts, clamps and washers while holding manifold assembly in place by hand.
6. Clean, oil and torque all manifold assembly to cylinder head bolts and nuts to 40 lbs. ft. (55 N·m).
7. Complete torquing the inlet to exhaust manifold bolt and two nuts at the center of the manifold to 45 lb. ft. (61 N·m).
8. Connect exhaust pipe to manifold using a new packing.
9. Connect crankcase ventilation hose at rocker arm cover.
10. Connect vapor hoses at canister.
11. Connect fuel and vacuum lines a carburetor.
12. Connect throttle controls at bellcrank and install throttle return spring.
13. Install air cleaner, start engine, check for leaks and adjust carburetor idle speed.

EXHAUST MANIFOLD ASSEMBLY - INTEGRATED HEAD**Removal**

1. Disconnect negative battery cable.
2. Remove air cleaner.
3. Remove power steering pump and/or A.I.R. pump brackets, if so equipped.
4. Remove PAIR pipes as outlined in Section 6E.
5. Raise vehicle on hoist and disconnect exhaust pipe at manifold and converter bracket at transmission mount.
6. Lower vehicle.
7. Remove exhaust manifold bolts.
8. Remove exhaust manifold, check EFE Valve to see if free and check manifold for cracks.

Installation

- If a new exhaust manifold is being installed, the E.F.E. valve and actuator and rod assembly must be transferred from the old component.
1. Clean gasket surface and position new gasket on exhaust manifold.
 2. Install manifold bolts, while holding manifold assembly in place.
 3. Torque all manifold to cylinder head bolts in sequence to torques shown in figure 6A1-9.
 4. Raise vehicle on hoist.
 5. Connect exhaust pipe at manifold flange and converter bracket at transmission mount. Attach exhaust pipe and align exhaust system. Torque attaching bolts to

specification.

6. Lower vehicle.
7. Install PAIR pipes as outlined in Section 6E.
8. Install power steering pump and/or A.I.R. pump and brackets, if so equipped. Tighten drive belt using strand tension gage.
9. Install air cleaner.
10. Connect negative battery cable.
11. Start engine and check for leaks.

ROCKER ARM COVER

Removal

1. Disconnect crankcase ventilation hose(s) at rocker arm cover.
2. Remove air cleaner.
3. Disconnect all wires, fuel and vacuum pipes from rocker arm cover clips.
4. On LE3 engines, remove pulse air pipes (as outlined in Section 6E) and disconnect accelerator linkage and springs from bracket.
5. Remove rocker arm cover bolts and remove cover.

NOTICE: If cover adheres to cylinder head, try bumping end of rocker arm cover with a rubber mallet. If cover still will not come loose, CAREFULLY pry until loose. DO NOT DISTORT SEALING FLANGE.

Installation

1. Clean sealing surfaces on cylinder head and rocker arm cover with degreaser. Remove all loose pieces of RTV or pieces that will cause installation interference.
2. Place a 3/16" (5mm) bead of RTV sealant, #1052366 or equivalent, all around the rocker arm cover sealing surface of the cylinder head. When going around the attaching bolt holes, always flow the RTV on the inboard side of the holes.
3. Place cover on head while RTV is still wet, install retaining bolts and torque to 45 lb. in. (5N·m).
4. Connect wires, fuel and vacuum pipes at rocker arm cover clips.
5. Install pulse air pipes (as outlined in Section 6E), and accelerator linkage and springs where removed.
6. Install air cleaner.
7. Connect crankcase ventilation hoses (where so equipped).

PUSH ROD SIDE COVER

Removal

1. Disconnect battery negative cable.
2. "CK" Models-Remove dipstick tube (rear cover).
3. Remove cover bolts.
4. Remove cover. If cover sticks to block, a heated knife blade, or similar device, used to pry at the sealing surfaces will aid in removal.

Installation (Front Cover)

1. Clean sealing surfaces of both the cover and block with degreaser. Remove loose RTV, or pieces causing installation interference.
2. Place a continuous 1/8" (3mm) bead of RTV sealant, #1052366 or equivalent, all around the cover sealing surface. Place cover on block while sealant is still

wet (within 10 minutes). Install retaining bolts and torque to 50 lb. in. (5.6 N·m).

3. "CK" Models - Clean dipstick tube and apply sealant #1052080 or equivalent around tube 1/2" below bead. Install dipstick tube.
4. Connect battery negative cable.

VALVE MECHANISM

Removal

1. Remove rocker arm cover as previously outlined.
2. Remove rocker arm nuts, rocker arm balls, rocker arms and push rods. Place rocker arms, rocker arm balls and push rods in a rack so that they may be reinstalled in the same location.

Installation and Adjustment

Whenever new rocker arms and/or rocker arm balls are being installed, coat bearing surfaces of rocker arms and rocker arm balls with "Molykote" or its equivalent.

1. Install push rods. Be sure push rods seat in lifter socket.
2. Install rocker arms, rocker arm balls and rocker arm nuts. Tighten rocker arm nuts until all lash is eliminated.
3. Adjust valves when lifter is on base circle of camshaft lobe as follows:
 - a. Mark distributor housing, with chalk, at #1 and #6 positions (plug wire). Remove distributor cap and lay aside.
 - b. Crank engine until distributor rotor points to #1 cylinder position. The following valves can be adjusted with engine in #1 firing position:
 - #1 cylinder-Exhaust and Intake.
 - #2 cylinder-Intake
 - #3 cylinder-Exhaust
 - #4 cylinder-Intake
 - #5 cylinder-Exhaust
 - c. Back out adjusting nut until lash is felt at the push rod then turn in adjusting nut until all lash is removed. This can be determined by rotating the push rod while turning adjusting nut (Fig. 6A1-10). When play has been removed, turn adjusting nut in one full additional turn (to center lifter plunger).
 - d. Crank engine until distributor rotor points to #6 position. The following valves can be adjusted with engine in #6 firing position:
 - #2 cylinder-Exhaust
 - #3 cylinder-Intake
 - #4 cylinder-Exhaust
 - #5 cylinder -Intake
 - #6 cylinder-Intake and Exhaust
4. Install distributor cap.
5. Install rocker arm cover as outlined.
6. Adjust carburetor idle speed (if necessary).

VALVE STEM OIL SEAL AND/OR VALVE SPRING

Replacement

1. Remove rocker arm cover as previously outlined.
2. Remove spark plug, rocker arm and push rod on the cylinder(s) to be serviced.



Fig. 6A1-10--Valve Adjustment

3. Install air line adapter Tool J-23590 to spark plug port and apply compressed air to hold the valves in place.

4. Using Tool J-5892 to compress the valve spring, remove the valve locks, valve cap, valve shield and valve spring and damper (fig. 6A1-11).

5. Remove the valve stem oil seal.

6. To replace, set the valve spring, oil shedder and valve cap in place. Compress the spring with Tool J-5892 and install new oil seal in the lower groove of the stem, making sure the seal is flat and not twisted. A light coat of oil on the seal will help prevent twisting.

7. Install the valve locks and release the compressor tool, making sure the locks seat properly in the upper groove of the valve stem. Grease may be used to hold the locks in

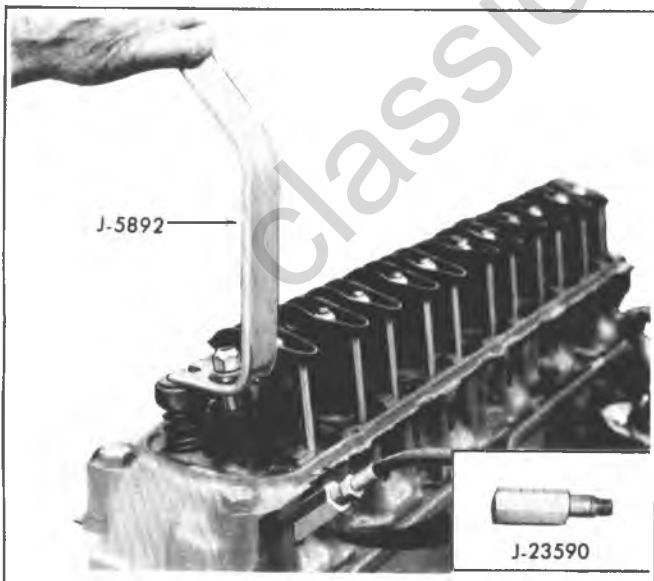


Fig. 6A1-11--Compressing Valve Spring

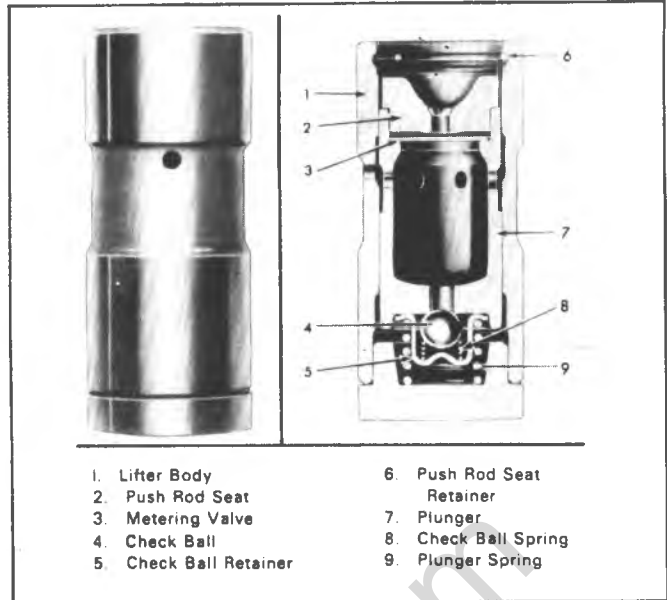


Fig. 6A1-12--Hydraulic Valve Lifter

place while releasing the compressor tool.

8. Using Tool J-23994, apply vacuum to the valve assembly to make sure no air leaks past the seal.

9. Install spark plug, and torque to 15 lb. ft. (20 N·m).

10. Install and adjust valve mechanism as previously outlined.

VALVE LIFTERS

Hydraulic valve lifters very seldom require attention. The lifters are extremely simple in design. Readjustments are not necessary, and servicing of the lifters requires only that care and cleanliness be exercised in the handling of parts.

Removal

1. Remove rocker arm cover and loosen rocker arms sufficiently to remove the push rods. Place push rods in a rack so that they may be returned to their original location.

2. Mark distributor housing, with chalk, at #1 and #6 positions. Remove distributor cap and lay aside.

3. Remove push rod covers as outlined.

4. Remove valve lifters. Place valve lifters in a rack so that they may be installed in the same location.

Disassembly

1. Hold the plunger down with a push rod, and using the blade of a small screw driver, remove the push rod seat retainer.

2. Remove the push rod seat and metering valve (fig. 6A1-12).

3. Remove the plunger, ball check valve assembly and the plunger spring.

4. Remove the ball check valve and spring by prying the ball retainer loose from the plunger with the blade of a small screw driver (fig. 6A1-13).

Cleaning and Inspection

Thoroughly clean all parts in cleaning solvent, and inspect them carefully. If any parts are damaged or worn, the entire lifter assembly should be replaced. If the lifter body wall is scuffed or worn, inspect the cylinder block lifter



Fig. 6A1-13--Removing Ball Check Valve

bore, if the bottom of the lifter is scuffed or worn inspect the camshaft lobe, if the push rod seat is scuffed or worn inspect the push rod.

An additive containing EP lube, such as EOS, should always be added to crankcase oil for run-in when any new camshaft or lifters are installed. All damaged or worn lifters should be replaced.

For proper lifter rotation during engine operation, lifter foot must be convex.

Assembly

1. Place the check ball on small hole in bottom of the plunger.



Fig. 6A1-14--Installing Ball Check Valve

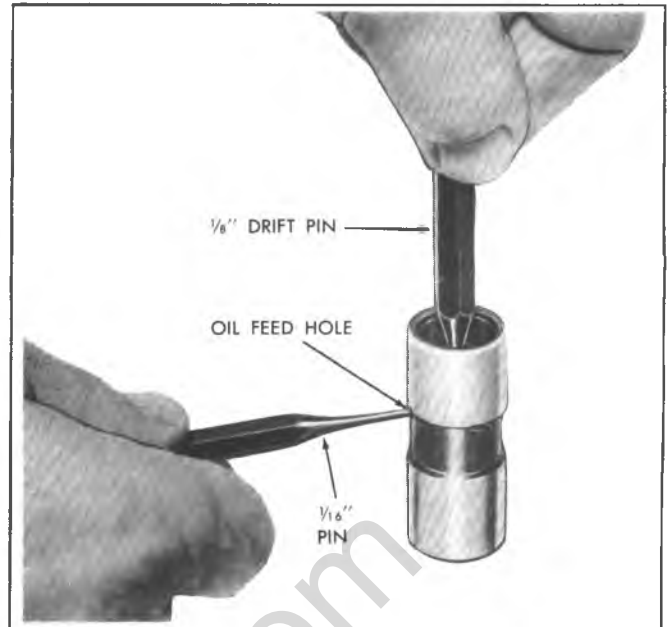


Fig. 6A1-15--Assembling Hydraulic Lifter

2. Insert check ball spring on seat in ball retainer and place retainer over ball so that spring rests on the ball. Carefully press the retainer into position in plunger with the blade of a small screw driver (fig. 6A1-14).

3. Place the plunger spring over the ball retainer and slide the lifter body over the spring and plunger, being careful to line up the oil feed holes in the lifter body and plunger.

4. Fill the assembly with SAE 10 oil, then insert the end of a 1/8" (3mm) drift pin into the plunger and press down solid. (Do not attempt to force or pump the plunger). At this point oil holes in the lifter body and plunger assembly will be aligned (fig. 6A1-15).

5. Insert a 1/16" (1.6mm) drift pin through both oil holes to hold the plunger down against the lifter spring tension (fig. 6A1-15).

6. Remove the 1/8" (3mm) drift pin, refill assembly with SAE 10 oil.

7. Install the metering valve and push rod seat (refer to fig. 6A1-12).

8. Install the push rod seat retainer, press down on the push rod seat and remove the 1/16" (1.6mm) drift pin from the oil holes. The lifter is now completely assembled, filled with oil and ready for installation.

Installation

1. Coat foot of valve lifters with "Molykote" or its equivalent. Install valve lifters.

2. Using a 1/8" (3mm) bead of RTV, #1052366 or equivalent, on the covers, install push rod side covers and torque bolts to specifications.

3. Install distributor cap.

4. Install push rods and adjust valve mechanism as outlined.

5. Adjust ignition timing and carburetor idle speed.

CYLINDER HEAD ASSEMBLY

Removal

1. Remove manifold assembly as previously outlined.
2. Remove rocker arm cover and valve mechanism as previously outlined.
3. Drain cooling system.
4. Remove fuel and vacuum line from retaining clips then disconnect wires from temperature sending units.
5. Disconnect air injection hose at check valve (if so equipped).
6. Disconnect radiator upper hose at coolant outlet housing and battery ground strap.
7. Remove cylinder head bolts, cylinder head and gasket. Place cylinder head on two blocks of wood to prevent damage.

Disassembly

1. With the cylinder head removed, use tool J-8062 to compress the valve springs and remove the valve keys. Release the compressor tool and remove rotators or spring caps, oil shedders springs and spring damper assemblies, then remove oil seals and valve spring shims.
2. Remove valves from cylinder head and place them in a rack in their proper sequence so that they can be assembled in their original positions.

Cleaning

1. Clean all deposits from combustion chambers and valve ports using Tool J-8089.
2. Thoroughly clean the valve guides using Tool J-8101.
3. Clean all carbon and sludge from push rods, rocker arms and push rod guides.
4. Clean valve stems and heads on a buffing wheel.
5. Clean carbon deposits from head gasket mating surface.

Inspection

1. Inspect the cylinder head for cracks in the exhaust ports, combustion chambers, or external cracks to the water chamber.
2. Inspect the valves for burned heads, cracked faces or damaged stems.

NOTICE: Excessive valve stem to bore clearance will cause excessive oil consumption and may cause valve breakage. Insufficient clearance will result in noisy and sticky functioning of the valve and disturb engine smoothness.

3. Measure valve stem clearance as follows:
 - a. Clamp a dial indicator on one side of the cylinder head rocker arm cover sealant rail. Locate the indicator so that movement of the valve stem from side to side (crosswise to the head) will cause a direct movement of the indicator stem.
 - b. Drop the valve head about 1/16" (1.6mm) off the valve seat.

of the valve from side to side using light pressure to obtain a clearance reading. If clearance exceeds specifications it will be necessary to ream valve guides for oversize valves as outlined.



Fig. 6A1-16—Checking Valve Spring Tension

4. Check valve spring tension with Tool J-8056 spring tester (fig. 6A1-16). Springs should be replaced if not within 10 lbs. (44 N) of the specified load (without dampers).
5. Inspect rocker arm studs for wear or damage.

Assembly

1. Insert valves in the proper ports.
2. Set the valve spring shim, valve spring (with damper), oil shedder and valve cap or rotator in place (fig. 6A1-17).
3. Compress the spring with Tool J-8062.
4. Install new oil seal in the lower groove of the stem, making sure that the seal is flat and not twisted.

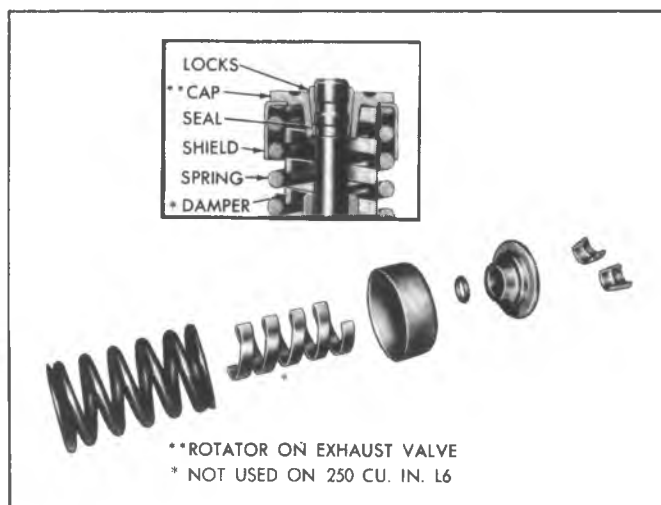


Fig. 6A1-17—Valve Spring Installation

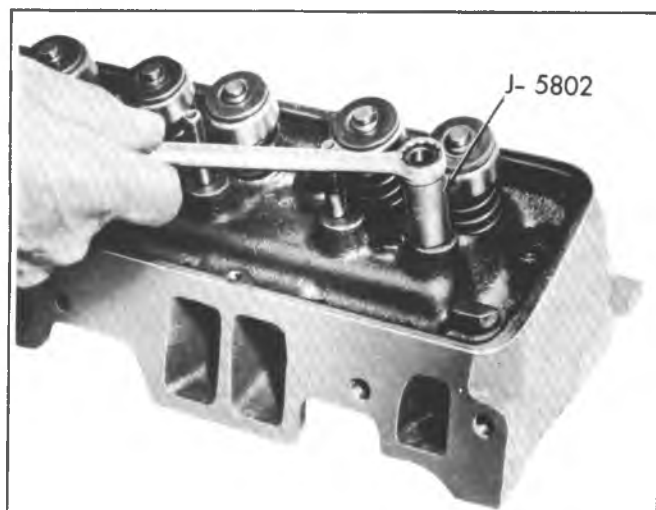


Fig. 6A1-18--Removing Rocker Arm Stud - Typical

5. Install the valve locks and release the compressor tool, making sure that the locks seat properly in the upper groove of the valve stem.

6. Using Tool J-23994, apply vacuum to the valve assembly to make sure no air leaks past the seal.

Installation

The gasket surfaces on both the head and the block must be clean of any foreign matter and lay aside.

Cylinder bolt threads in the block and threads on the cylinder head bolt must be cleaned. (Dirt will affect bolt torque.) Do not use gasket sealer on composition steel asbestos gasket.

1. Place the gasket in position over the dowel pins.
2. Carefully guide cylinder head into place over dowel pins and gasket.
3. Coat threads of cylinder head bolts with sealing compound, #1052080 or equivalent, and install finger tight.
4. Tighten cylinder head bolts a little at a time until 95 lb. ft. (125N·m) torque is reached. The left-hand front head bolt torque is 85 lb. ft. (115N(m)).
5. Connect radiator upper hose and engine ground strap.
6. Connect temperature sending unit wires and install fuel and vacuum lines in clips.
7. Fill cooling system.
8. Install manifold assembly as previously outlined.
9. Install and adjust valve mechanism as previously outlined.
10. Install and torque rocker arm cover.
11. Connect AIR pipe (if so equipped).

ROCKER ARM STUDS

Replacement

Rocker arm studs that have damaged threads or are loose in cylinder heads should be replaced with new studs available in .003" and .013" oversize. Studs may be installed after reaming the holes as follows:

1. Remove old stud by placing Tool J-5802-A over the stud, installing nut and flat washer and removing stud by turning nut (fig. 6A1-18).

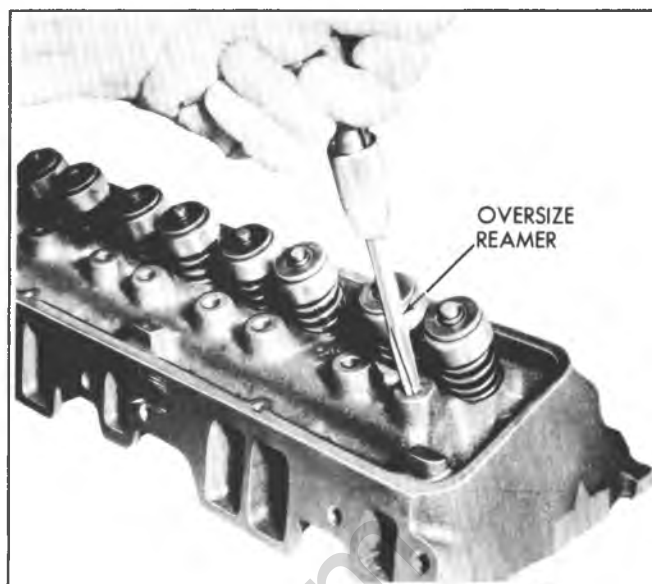


Fig. 6A1-19--Reaming Rocker Arm Stud Bore - Typical

2. Ream hole for oversize stud using Tool J-5715 for .003" oversize or Tool J-6036 for .013" oversize (fig. 6A1-19).

NOTICE: Do not attempt to install an oversize stud without reaming stud hole as this could damage the casting.

3. Coat press-fit area of stud with hypoid axle lubricant. Install new stud, using Tool J-6880 as a guide. Gage should bottom on head (fig. 6A1-20).

VALVE GUIDE BORES

Valves with oversize stems are available (see specifications). To ream the valve guide bores for oversize valves, use Tool Set J-5830.

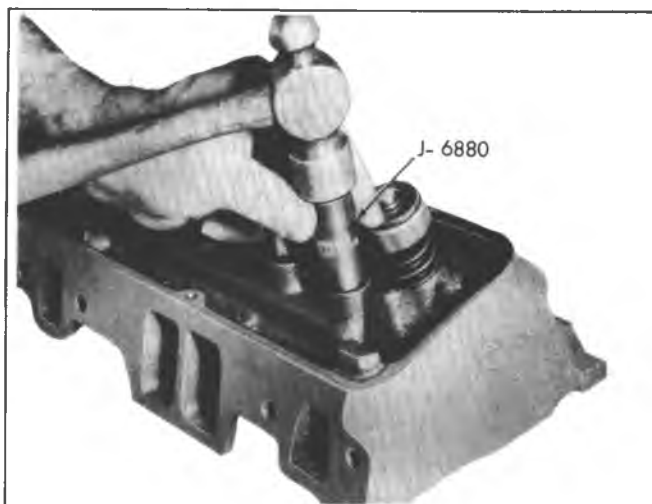


Fig. 6A1-20--Installing Rocker Arm Stud - Typical

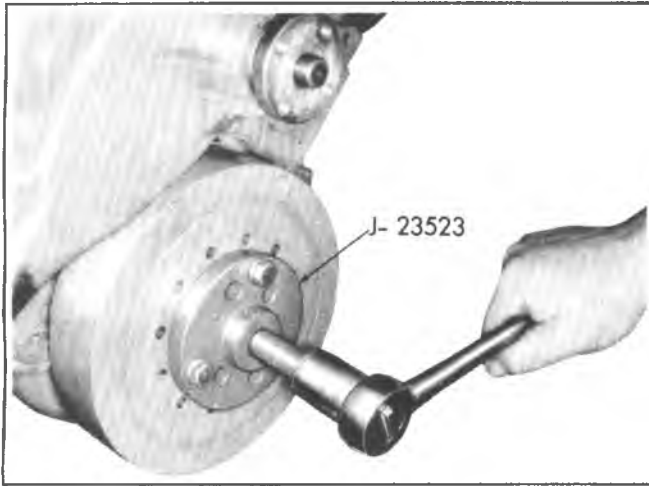


Fig. 6A1-21—Removing Torsional Damper

VALVE SEATS

Reconditioning the valve seats is very important, because the seating of the valves must be perfect for the engine to deliver the power and performance built into it.

Another important factor is the cooling of the valve heads. Good contact between each valve and its seat in the head is imperative to insure that the heat in the valve head will be properly carried away.

Several different types of equipment are available for reseating valves seats. The recommendations of the manufacturer of the equipment being used should be carefully followed to attain proper results.

Regardless of what type of equipment is used, however, it is essential that valve guide bores be free from carbon or dirt to ensure proper centering of pilot in the guide.

VALVES

Valves that are pitted can be refaced to the proper angle, insuring correct relation between the head and stem on a valve refacing mechanism. Valve stems which show excessive wear, or valves that are warped excessively should be replaced. When a valve head which is warped excessively is refaced, a knife edge will be ground on part or all of the valve head due to the amount of metal that must be removed to completely reface. Knife edges lead to breakage, burning or pre-ignition due to heat localizing on this knife edge. If the edge of the valve head is less than 1/32" (.80mm) thick after grinding, replace the valve.

Several different types of equipment are available for refacing valves. The recommendations of the manufacturer of the equipment being used should be carefully followed to attain proper results.

TORSIONAL DAMPER

Removal

1. Drain radiator and remove.
2. Remove accessory drive belt(s) and pulley (if so equipped).
3. Remove drive pulley from torsional damper.
4. Install Tool J-23523 to damper and turn puller screw to remove damper (fig. 6A1-21).

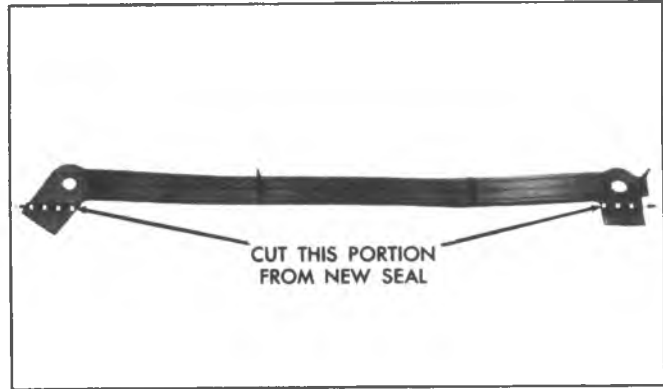


Fig. 6A1-22—Oil Pan Front Seal Modification - L25

Installation

1. Coat front cover oil seal contact area of damper with engine oil.

NOTICE: It is necessary to use installer Tool J-22197 to prevent the inertia weight section from walking off the hub during installation of damper.

The damper on the L25 engine should be pulled on by using special tool J-23523 or equivalent.

2. Attach damper installer Tool J-22197 to damper. Tighten fingers of tool to prevent weight from moving.
3. Position damper on crankshaft and drive into position, using J-5590 until it bottoms against crankshaft gear. Remove installer tool.
4. Install drive pulley on torsional damper (if so equipped).
5. Install accessory drive belt(s) and adjust using strand tension gage.
6. Install radiator.
7. Fill cooling system and check for leaks.

CRANKCASE FRONT COVER (TIMING GEAR COVER)

Removal (without removing oil pan)

1. Remove torsional damper as previously outlined.
2. Remove the oil pan-to-front cover attaching screws.
3. Remove the front cover-to-block attaching screws.
4. On L25 engine only proceed as follows:
 - a. Pull the cover slightly forward only enough to permit cutting of oil pan front seal.
 - b. Using a sharp knife or other suitable cutting tool, cut oil pan front seal flush with cylinder block at both sides of cover.
 - c. Remove front cover and attached portion of oil pan front seal. Remove front cover gasket.

LE3 engine uses RTV for oil pan sealing. There is no front rubber seal.

Installation

1. Clean gasket surfaces on block and crankcase front cover.
2. Cut tabs from the new oil pan front seal (fig. 6A1-22) use a sharp instrument to ensure a clean cut (L25 engine only).

3. Install seal to front cover, pressing tips into holes provided in cover.

On LE3 engine, place a 3/16" (5mm) diameter bead of RTV on cover sealing surface.

4. Coat the gasket with gasket sealer and place in position on cover.

5. Apply a 1/8" (3mm) bead of RTV sealant, #1052366 or equivalent, to the joint formed at the oil pan and cylinder block.

6. Install centering Tool J-23042 in crankcase front cover seal.

NOTICE: It is important that centering tool be used to align crankcase front cover so that torsional damper installation will not damage seal and so that seal is positioned evenly around balancer.

7. Install crankcase front cover to block. Install and partially tighten the two, oil pan-to-front cover screws.

8. Install the front cover-to-block attaching screws.

9. Remove centering Tool J-23042 and torque all cover attaching screws to 80 lb. in. (9N·m).

10. Install torsional damper as outlined.

OIL SEAL (FRONT COVER)

Replacement

With Cover Installed

1. With torsional damper removed, pry old seal out of cover from the front with a large screw driver, being careful not to damage the seal surface on the cover.

2. Install new seal so that open end of seal is toward the inside of cover and drive it into position with Tool J-23042.

With Cover Removed

1. With cover removed, pry old seal out of cover from the front with screw driver, being careful not to distort cover.

2. Install new seal so that open end of the seal is toward the inside of cover and drive it into position with Tool J-23042.

CAMSHAFT

Measuring Lobe Lift

1. Remove valve mechanism as previously outlined.

2. Position indicator with ball socket adapter (Tool J-8520) on push rod (fig. 6A1-23).

3. Rotate the cranksahft slowly in the direction of rotation until the lifter is on the heel of the cam lobe. At this point, the push rod will be in its lowest position.

4. Set dial indicator on zero, then rotate the crankshaft slowly, or attach an auxiliary starter switch and "bump" the engine over, until the push rod is in the fully raised position. Disconnect the coil primary lead before cranking.

5. Compare the total lift recorded from the dial indicator with specifications.

6. Continue to rotate the crankshaft until the indicator reads zero. This will be a check on the accuracy of the original indicator reading.

7. If camshaft readings for all lobes are within specifications, remove dial indicator assembly.

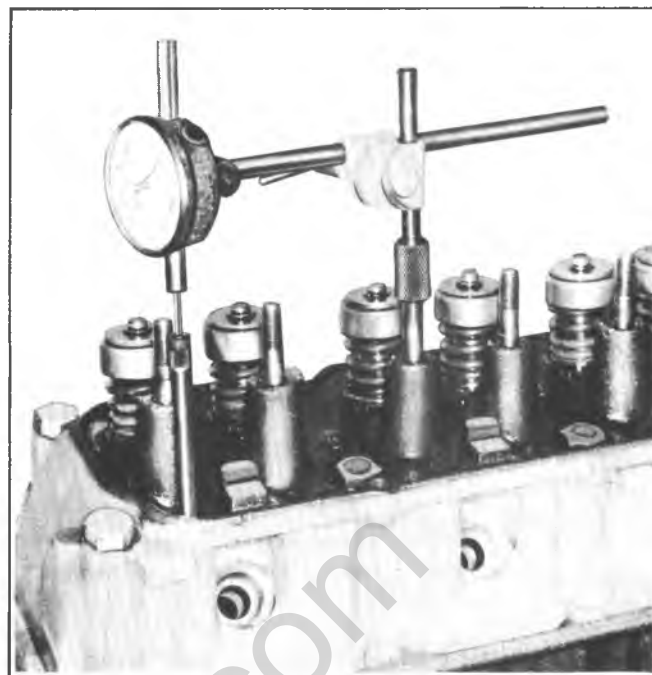


Fig. 6A1-23--Measuring Camshaft Lobe Lift

8. Install and adjust valve mechanism as outlined.

Removal

1. Remove engine following procedure in this section.

2. Remove lifters as previously outlined.

3. Remove crankcase front cover as previously outlined.

4. Remove fuel pump.

5. Align timing gear marks then remove the two camshaft thrust plate bolts by working through holes in camshaft gear.

6. Remove the camshaft and gear assembly by pulling it out through the front of the block. Support camshaft carefully when removing so as not to damage the camshaft bearings.

Inspection

The camshaft bearing journals should be measured with a micrometer for an out-of-round condition. If the journals exceed .001" out-of-round, the camshaft should be replaced.

Inspect the camshaft gear and thrust plate for wear or damage. Measure the camshaft end play. This should be .001" to .005".

Gear Replacement

1. If the inspection indicated that the camshaft, gear or thrust plate should be replaced, the gear must be removed from the camshaft. This operation requires the use of camshaft gear remover J-971.

2. Place the camshaft through the gear remover, place end of remover on table of a press and press shaft out of gear.

NOTICE: Thrust plate must be positioned so that woodruff key in shaft does not damage it when the shaft is pressed out of gear. Also support the hub of the gear or the gear will be seriously damaged.

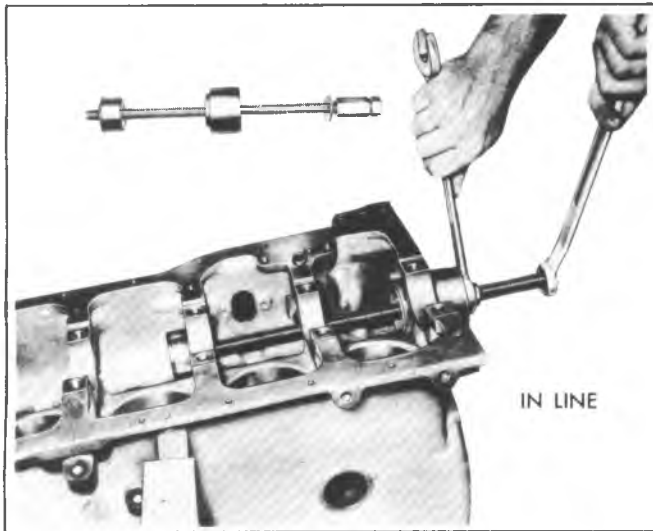


Fig. 6A1-24--Replacing Camshaft Intermediate Bearings

3. To assemble camshaft gear thrust plate and gear spacer ring to camshaft firmly support camshaft at back of front journal in an arbor press.

4. Place gear spacer ring and thrust plate over end of shaft, and install woodruff key in shaft keyway. Install camshaft gear and press it onto the shaft until it bottoms against the gear spacer ring. The end clearance of the thrust plate should be .001" to .005".

Installation

1. Install the camshaft and gear assembly in the engine block, being careful not to damage camshaft bearings or camshaft.

2. Turn crankshaft and camshaft so that the valve timing marks on the gear teeth will line up. Push camshaft into position. Install camshaft thrust plate-to-block bolts and torque to 80 lb. in. (9N·m).

3. Check camshaft and crankshaft gear run out with a dial indicator. The camshaft gear run out should not exceed .004" and the crankshaft gear run out should not exceed .003".

4. If gear run out is excessive, the gear will have to be removed and any burrs cleaned from the shaft or the gear will have to be replaced.

5. Check the backlash between the timing gear teeth with a dial indicator. The backlash should be not less than .004" nor more than .006" for new parts and not more than .008" for worn parts.

6. Install fuel pump.
7. Install crankcase front cover.
8. Install lifters.
9. Install engine in vehicle.

CAMSHAFT BEARINGS

Removal

1. Remove camshaft as previously outlined.
2. Remove oil pan and oil pump as described in this section.
3. Drive camshaft rear plug from cylinder block.
4. Using Tool Set J-6098, with nut and thrust washer installed to end of threads, index pilot in camshaft front bearing and install puller screw through pilot.

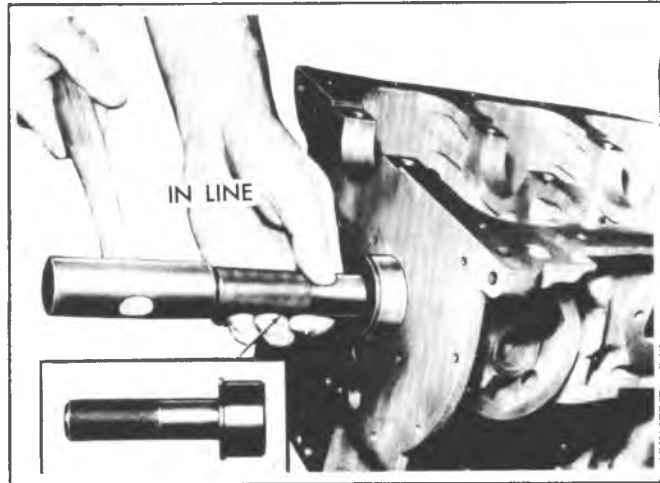


Fig. 6A1-25--Replacing Camshaft Front Bearing

5. Install remover and installer tool with shoulder toward bearing, making sure a sufficient amount of threads are engaged.

6. Using two wrenches, hold puller screw while turning nut. When bearing has been pulled from bore, remove remover and installer tool and bearing from puller screw (fig. 6A1-24).

7. Remove remaining bearings (except front and rear) in the same manner. It will be necessary to index pilot in camshaft rear bearing to remove the rear intermediate bearing.

8. Assemble remover and installer tool on driver handle and remove camshaft front and rear bearings by driving towards center of cylinder block (fig. 6A1-25).

Installation

The camshaft front and rear bearings should be installed first. These bearings will act as guides for the pilot and center the remaining bearings being pulled into place.

1. Assemble remover and installer tool on driver handle and install camshaft front and rear bearings by driving towards center of cylinder block (fig. 6A1-25).

2. Using Tool Set J-6098, with nut and thrust washer installed to end of threads, index pilot in camshaft front bearings and install puller screw through pilot.

3. Index camshaft bearing in bore, then install remover and installer tool on puller screw with shoulder toward bearing.

NOTICE: All cam bearing oil holes must be aligned with oil holes in cam bore to prevent oil starvation and subsequent failure.

4. Using two wrenches, hold puller screw while turning nut. After bearing has been pulled into bore, remove the remover and installer tool from puller screw and check alignment of oil hole in camshaft bearing.

5. Install remaining bearings in the same manner. It will be necessary to index pilot in the camshaft rear bearing to install the rear intermediate bearing.

6. Install a new camshaft rear plug flush to 1/32" (.80mm) deep and parallel with rear surface of cylinder block.

OIL PAN**All except 'G' Van****Removal**

1. Disconnect battery negative cable.
2. Raise vehicle and drain engine oil.
3. Remove starter.
4. Remove flywheel splash shield or converter housing underpan, as applicable.
5. Remove "through" bolts from engine front mounts.
6. Raise front of engine, reinstall mount "through" bolts and lower engine.
7. Remove oil pan bolts.
8. Remove oil pan.

Installation

1. Thoroughly clean all gasket sealing surfaces.
2. Using a new gasket, install rear seal in rear main bearing cap.
3. Install front seal on crankcase front cover, pressing tips into holes provided in cover.
4. Install side gaskets to engine block, using a gasket sealant with sufficient body to act as a retainer.
5. Install oil pan, torquing the retaining bolts to 80 lb. in. (9N·m).
6. Raise engine sufficiently to allow removal of "through" bolts - lower engine and install mount "through" bolts. Torque bolts to 75 lb. ft. (100 N·m).
7. Install flywheel splash shield or converter housing underpan, as applicable.
8. Install starter.
9. Lower vehicle and fill crankcase with oil. (See Owner's Manual)
10. Connect battery negative cable, start engine and check for leaks.

"G" Van**Removal**

1. Disconnect battery negative cable.
2. Remove engine cover.
3. Remove air cleaner and studs.
4. Remove fan finger guard.
5. Remove radiator upper support brackets.
6. Raise vehicle. ● If vehicle is equipped with a standard transmission, perform the following steps before continuing.
 - a. Disconnect clutch cross shaft from left front mount bracket.
 - b. Remove transmission to bell housing upper bolt.
 - c. Remove transmission rear mount bolts and install two 7/16" x 3" bolts.
 - d. Raise transmission using jack and install 2" (51mm) block between mount and crossmember.
7. Remove starter and lay aside.
8. Drain crankcase.
9. Remove mount "through" bolts.
10. Raise engine sufficiently to insert wooden blocks between engine mounts and cross member brackets.
11. Remove flywheel splash shield or converter cover, as applicable.

12. Remove oil pan bolts.
13. Remove oil pan and clean gasket surfaces.

Installation

1. Install new gasket on cleaned gasket surface.
2. Install oil pan and retaining bolts and torque to specifications.
3. Install flywheel splash shield or converter cover, as applicable.
4. Raise engine sufficiently to remove wooden blocks, lower engine and install mount 'through' bolts. Torque bolts to specification.
5. Install starter.
 - If vehicle is equipped with a standard transmission, perform the following steps.
 - a. Raise transmission using jack and remove 2" (51mm) block from between mount and cross member.
 - b. Lower transmission on cross member, remove two 7/16" x 3" bolts, install rear mount bolts and torque to specifications.
 - c. Install transmission to bell housing upper bolt.
 - d. Connect clutch cross shaft to left front mount bracket.
6. Lower vehicle on hoist.
7. Install radiator upper support brackets.
8. Install fan finger guard.
9. Install air cleaner studs and air cleaner.
10. Install engine cover.
11. Fill crankcase with oil. (See Owner's Manual).
12. Connect battery negative cable, start engine and check for leaks.

OIL PUMP**Removal**

1. Remove oil pan as previously outlined.
2. Remove two flange mounting bolts, pickup pipe bolt, then remove pump and screen as an assembly.

Disassembly

1. Remove the pump cover attaching screws, the pump cover and the pump cover gasket (fig. 6A1-26).
2. Mark gear teeth so they may be reassembled with the same teeth indexing. Remove the idler gear and the drive gear and shaft from the pump body.
3. Remove the pressure regulator valve retaining pin, pressure regulator valve and related parts.
4. If the pickup screen and pipe assembly need replacing, mount the pump in a soft-jawed vise and extract pipe from pump.

Do not disturb the pickup screen on the pipe. This is serviced as an assembly.

Cleaning and Inspection

1. Wash all parts in cleaning solvent and dry with compressed air.
2. Inspect the pump body and cover for cracks or excessive wear.
3. Inspect pump gears for damage or excessive wear.
4. Check the drive gear shaft for looseness in the pump body.
5. Inspect inside of pump cover for wear that would permit oil to leak past the ends of the gears.

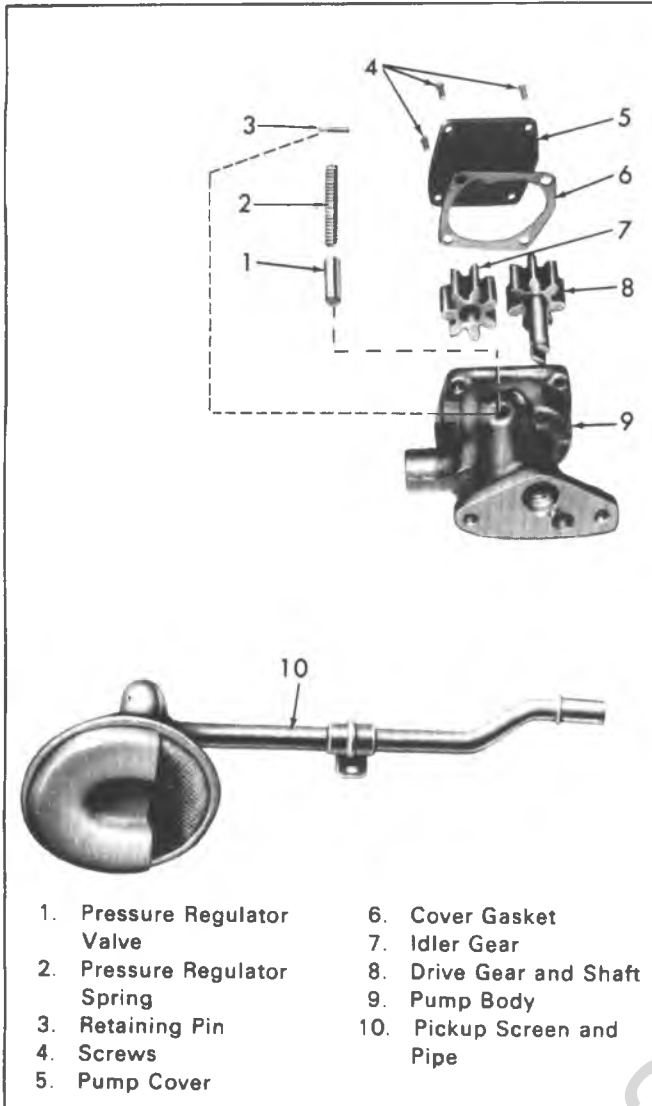


Fig. 6A1-26--Oil Pump

6. Inspect the pickup screen and pipe assembly for damage to screen, pipe or relief grommet.

7. Check the pressure regulator valve for fit.

The pump gears and body are not serviced separately. If the pump gears or body are damaged or worn, replacement of the entire oil pump assembly is necessary.

Assembly

1. If the pickup screen and pipe assembly was removed, it should be replaced with a new part. Loss of press fit condition could result in an air leak and loss of oil pressure. Mount the pump in a soft-jawed vice, apply sealer to the end of pipe and tap the pipe in place with a plastic hammer using Tool J-8369.

NOTICE: Be careful of twisting, shearing or collapsing pipe while installing in pump. Pickup screen must be parallel to bottom of oil pan when oil pump is installed.

2. Install the pressure regulator valve and related parts.

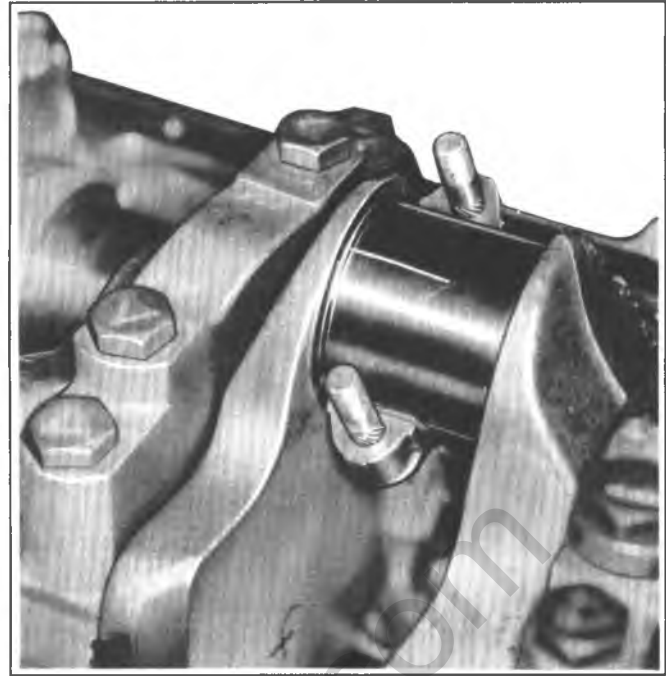


Fig. 6A1-27--Gaging Plastic on Crankpin

3. Install the drive gear and shaft in the pump body.

4. Install the idler gear in the pump body with the smooth side of gear towards pump cover opening.

5. Install the pump cover, with new gasket, and torque attaching screws to 70 lb. in. (8N·m).

6. Turn drive shaft by hand to check for smooth operation.

CONNECTING ROD BEARINGS

Connecting rod bearings are of the precision insert type and do not utilize shims for adjustment. **DO NOT FILE RODS OR ROD CAPS.** If clearances are found to be excessive a new bearing will be required. Service bearings are available in standard size and .001" and .002" undersize for use with new and used standard size crankshafts, and in .010" and .020" undersize for use with reconditioned crankshafts.

On removing a connecting rod cap, it is possible to find a .009" undersize bearing. These are used in manufacturing for selective fitting.

Inspection and Replacement

1. With oil pan and oil pump removed, remove the connecting rod cap and bearing.

Before removal of connecting rod cap, mark the side of the rod and cap with the cylinder number to assure matched reassembly of rod and cap.

2. Inspect the bearings for evidence of wear or damage. (Bearings showing the above should not be installed.)

3. Wipe both upper and lower bearing shells and crankpin clean of oil.

4. Measure the crankpin for out-of-round or taper with a micrometer. If not within specifications replace or recondition the crankshaft. If within specifications and a new bearing is to be installed, measure the maximum diameter of the crankpin to determine new bearing size required.



Fig. 6A1-28—Measuring Gaging Plastic

5. If within specifications measure new or used bearing clearances with Plastigage or its equivalent.

If a bearing is being fitted to an out-of-round crankpin, be sure to fit to the maximum diameter of the crankpin. If the bearing is fitted to the minimum diameter and the crankpin is out-of-round .001" interference between the bearing and crankpin will result in rapid bearing failure.

a. Place a piece of gaging plastic, the length of the bearing (parallel to the crankshaft), on the crankpin or bearing surface (fig. 6A1-27). Plastic gage should be positioned in the middle of upper or lower bearing shell. (Bearings are eccentric and false readings could occur if placed elsewhere).

b. Install the bearing in the connecting rod and cap.

c. Install the bearing cap and evenly torque nuts to 35 lb. ft. (47N·m).

Do not turn the crankshaft with the gaging plastic installed.



Fig. 6A1-29—Measuring Connecting Rod Side Clearance

d. Remove the bearing cap and using the scale on the gaging plastic envelope, measure the gaging plastic width at the widest point (fig. 6A1-28).

6. If the clearance exceeds specifications, select a new, correct size, bearing and remeasure the clearance.

Be sure to check what size bearing is being removed in order to determine proper replacement size bearing. Undersize is marked on the back of the bearing. If clearance cannot be brought within specification, the crankpin will have to be ground undersize. If the crankpin is already at maximum undersize, replace crankshaft.

7. Coat the bearing surface with oil, install the rod cap and torque nuts to 35 lb. ft. (47N·m).

8. When all connecting rod bearings have been installed, tap each rod lightly (parallel to the crankpin) to make sure they have clearance.

9. Measure all connecting rod side clearances between the connecting rod cap and side of crankpin (fig. 6A1-29).

CRANKSHAFT MAIN BEARINGS

Main bearings are of the precision insert type and do not utilize shim for adjustment. If clearances are found to be excessive, a new bearing, both upper and lower halves, will be required. Service bearings are available in standard size and .001", .002", .009", .010" and .020" undersize.

Selective fitting of both rod and main bearing inserts is necessary in production in order to obtain close tolerances. For this reason you may find one half of a standard insert with one half of a .001" undersize insert which will decrease the clearance .0005" from using a full standard bearing.

When a production crankshaft cannot be precision fitted by this method, it is then ground .009" undersize **on only those main journals that cannot be properly fitted. All journals will not necessarily be ground.** A .009" undersize bearing or .010" undersize bearing will then be used for precision fitting in the same manner as previously described.

A reground crankshaft will be identified by the following:

- The crankshaft throw will be stamped on one side of the undersize journal with "9", along with a large spot of light green paint.

- The main bearing cap will be painted light green on each side of the affected.

If, for any reason, main bearings caps are replaced, shimming may be necessary. Laminated shims for each cap are available for service. Shim requirement will be determined by bearing clearance.

Inspection

In general, the lower half of the bearing (except #1 bearing) shows a greater wear and the most distress from fatigue. If upon inspection the lower half is suitable for use, it can be assumed that the upper half is also satisfactory. If the lower half shows evidence of wear or damage, both upper and lower halves should be replaced. **Never replace one half without replacing the other half.**

Checking Clearance

To obtain the most accurate results with "Plastigage", or its equivalent, a wax-like plastic material which will compress evenly between the bearing and journal surfaces without damaging either surface, certain precautions should

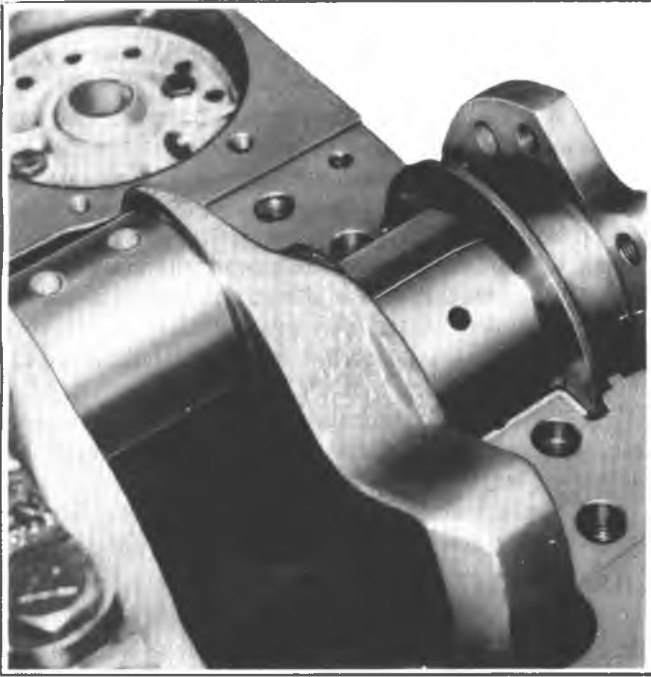


Fig. 6A1-30—Gaging Plastic on Journal – Typical

be observed. If the engine is out of the vehicle and upside down, the crankshaft will rest on the upper bearings and the total clearance can be measured between the lower bearing and journal. If the engine is to remain in the vehicle, the crankshaft must be supported upward to remove any clearance from the upper bearing. The total clearance can then be measured between the lower bearing and journal.

To assure the proper seating of the crankshaft all bearing cap bolts must be at their specified torque. In addition, preparatory to checking fit of bearings, the surface of the crankshaft journal and bearing must be wiped clean

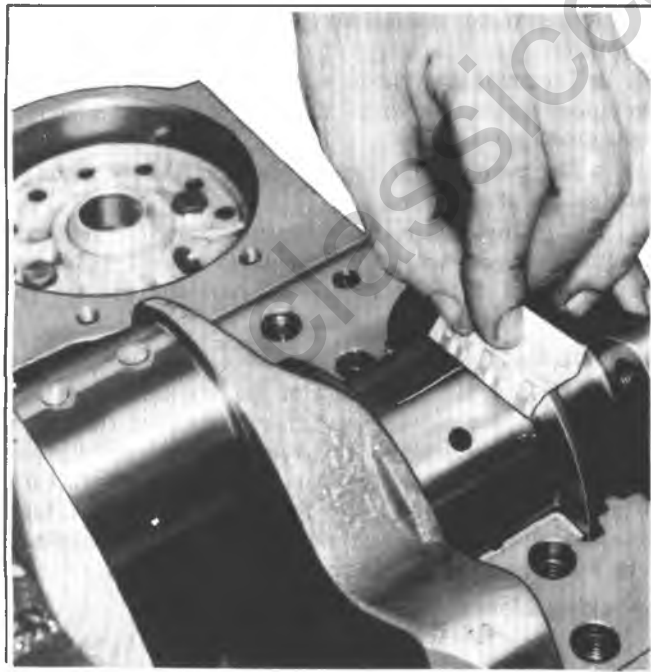


Fig. 6A1-31—Measuring Gaging Plastic – Typical

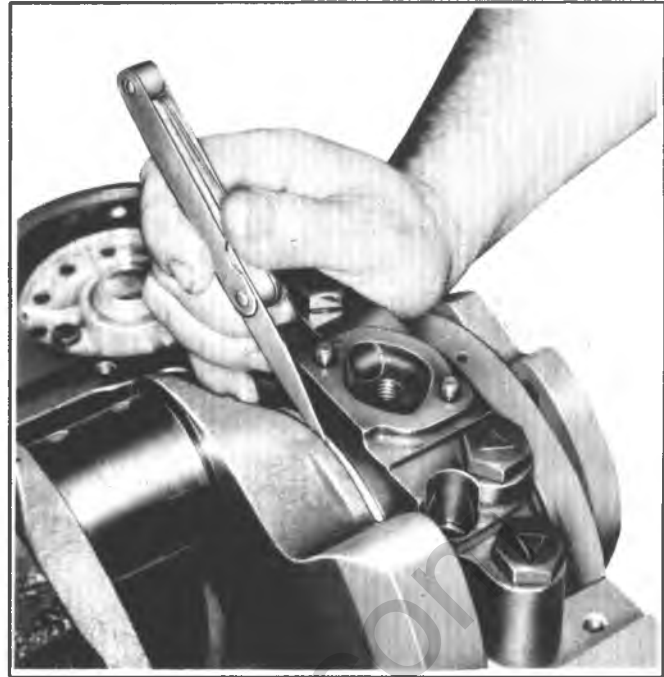


Fig. 6A1-32—Measuring Crankshaft End Play – Typical

of oil.

1. With the oil pan and oil pump removed, and starting with the rear main bearing, remove bearing cap and wipe oil from journal, both bearing shells and bearing cap.

2. Place a piece of gaging plastic the full width of the bearing (parallel to the crankshaft) on the journal (fig. 6A1-30).

Do not rotate the crankshaft while the gaging plastic is between the bearing and journal.

3. Install the bearing cap and evenly torque the retaining bolts to 65 lb. ft. (88N·m). Bearing cap **MUST** be torqued to specification in order to assure proper reading. Variations in torque affect the compression of the plastic gage.

4. Remove bearing cap. The flattened gaging plastic will be found adhering to either the bearing shell or journal.

5. On the edge of gaging plastic envelope there is a graduated scale which is correlated in thousandths of an inch. Without removing the gaging plastic, measure its compressed width, **at the widest point**, with the graduations on the gaging plastic envelope (fig. 6A1-31).

Normally, main bearing journals wear evenly and are not out-of-round. However, if a bearing is being fitted to an out-of-round journal (.001" max.), be sure to fit to the maximum diameter of the journal. If the bearing is fitted to the minimum diameter and the journal is out-of-round .001", interference between the bearing and journal will result in rapid bearing failure. If the flattened gaging plastic tapers toward the middle or ends, there is a difference in clearance indicating taper, low spot or other irregularity of the bearing or journal. Be sure to measure the journal with a micrometer if the flattened gaging plastic indicates more than .001" difference.

6. If the bearing clearance is within specifications, the bearing insert is satisfactory. If the clearance is not within specifications, replace the insert. Always replace both upper

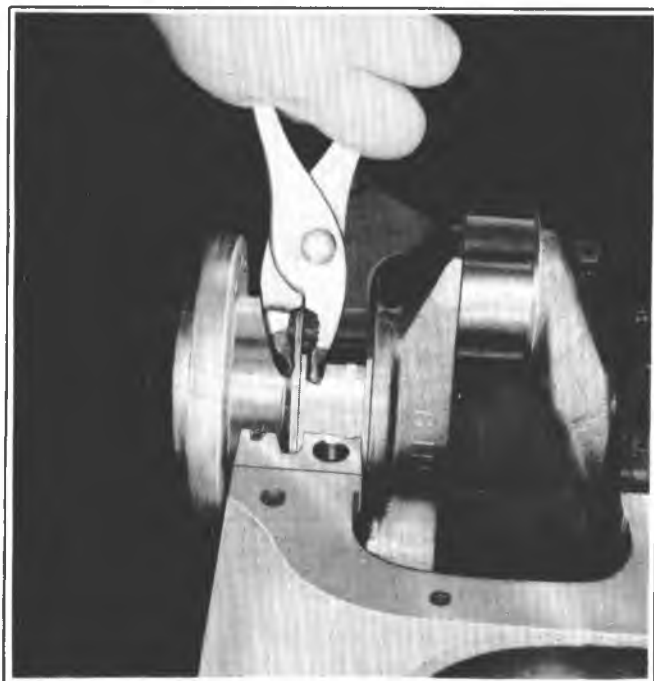


Fig. 6A1-33--Replacing Upper Main Bearing

and lower insert as a unit.

If a new bearing cap is being installed and clearance is less than .001", inspect for burrs or nicks; if none are found then install shims as required.

7. A standard, .001" or .002" undersize bearing may produce the proper clearance. If not, it will be necessary to regrind the crankshaft journal for use with the next undersize bearing.

After selecting new bearing, recheck clearance.

8. Proceed to the next bearing. After all bearings have been checked, rotate the crankshaft to see that there is no excessive drag.

When checking #1 main bearing, loosen accessory drive belts so as to prevent tapered reading with plastic gage.

9. Measure crankshaft end play (see specifications) by forcing the crankshaft to the extreme front position. Measure at the front end of the rear main bearing with a feeler gage (fig. 6A1-32).

10. Install a new rear main bearing oil seal in the cylinder block and main bearing cap.

Replacement

Main bearings may be replaced with or without removing the crankshaft.

With Crankshaft Removed

1. Remove and inspect the crankshaft.
2. Remove the main bearings from the cylinder block and main bearing caps.
3. Coat bearing surfaces of new, correct size, main bearings with oil and install in the cylinder block and main bearing caps.
4. Install the crankshaft.

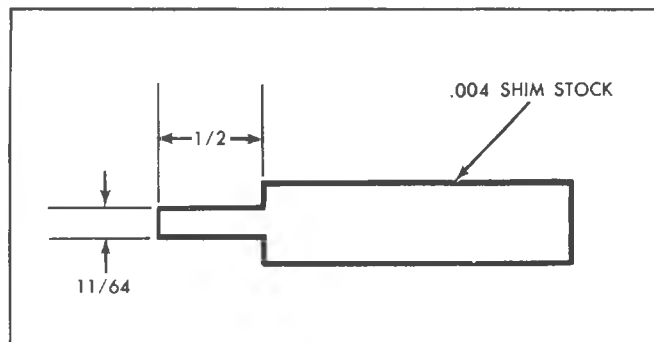


Fig. 6A1-34--Oil Seal Installation Tool

Without Crankshaft Removal

1. With oil pan, oil pump and spark plugs removed, remove cap on main bearing requiring replacement and remove bearing from cap.

2. The rear main journal has no oil hole. Replace the rear main bearing upper half as follows:

a. Use a small drift punch and hammer to start the upper bearing half rotating out of block.

b. Use a pair of pliers (with taped jaws) to hold the bearing thrust surface to the oil slinger and rotate the crankshaft to remove bearing (fig. 6A1-33).

c. Oil new selected size upper bearing and insert plain (unnotched) end between crankshaft and indented or notched side of block.

d. Use pliers as in removing to rotate bearing into place. The last 1/4" (6.5mm) movement may be done by holding just the slinger with the pliers or tap in place with a drift punch.

3. All other crankshaft journals have oil holes. Replace the main bearing upper half as follows:

a. Install a main bearing removing and installing tool, such as Tool J-8080, in oil hole in crankshaft journal. If such a tool is not available, a cotter pin may be bent as required to do the job.

b. Rotate the crankshaft clockwise as viewed from the front of engine. This will roll upper bearing out of block.

c. Oil new selected size upper bearing and insert plain (unnotched) end between crankshaft and indented or notched side of block. Rotate the bearing into place and remove tool from oil hole in crankshaft journal.

4. Oil new lower bearing and install in bearing cap.

5. Install main bearing caps with arrows pointing toward front of engine.

6. Torque all main bearing caps **except the rear main cap** to 65 lb. ft. (88N·m). Torque rear main bearing cap to 10-12 lb. ft. (14-16N·m) then tap end of crankshaft, first rearward then forward with a lead hammer. This will line up rear main bearing and crankshaft thrust surfaces. Retorque **all** main bearing cap bolts to 65 lb. ft. (88N·m).

OIL SEAL (REAR MAIN)

Replacement

The rear main bearing oil seal can be replaced (both halves) without removal of the crankshaft. Always replace the upper and lower seal as a unit. Install seal with lip facing front of engine. Extreme care should be exercised when installing this seal to protect the sealing bead located in the



Fig. 6A1-35--Removing Oil Seal Lower Half - Typical

channel on the outside diameter of the seal. An installation tool (fig. 6A1-34) can be used to protect the seal bead when positioning seal as follows:

1. With the oil pan and oil pump removed, remove the rear main bearing cap.
2. Remove oil seal from the bearing cap by prying from the bottom with a small screw driver (fig. 6A1-35).
3. Use a small hammer to tap a brass pin punch on one end of the upper seal until it protrudes far enough to be removed with pliers (fig. 6A1-36).
4. Clean all sealant and foreign material from cylinder case bearing cap and crankshaft, using a nonabrasive cleaner.
5. Inspect components for nicks, scratches, burrs and machining defects at all sealing surfaces, case assembly and crankshaft.
6. Coat seal lips and seal bead with light engine oil - keep oil off seal mating ends.
7. Position tip of tool between crankshaft and seal seat in cylinder case.
8. Position seal between crankshaft and tip of tool so that seal bead contacts tip of tool. Make sure that oil-seal lip is positioned toward front of engine (fig. 6A1-37).

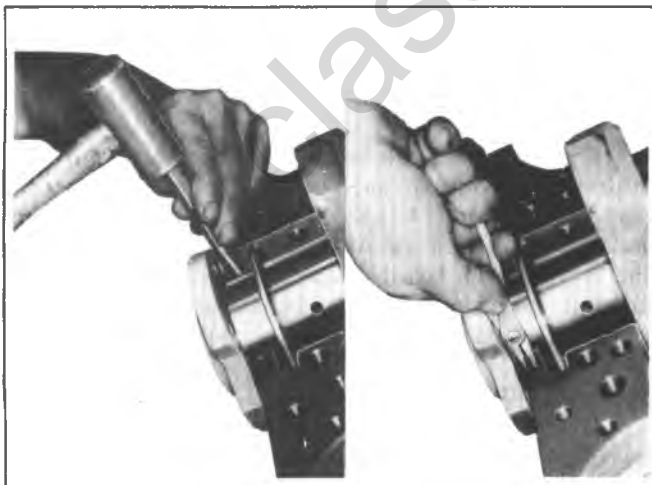


Fig. 6A1-36--Removing Oil Seal Upper Half - Typical

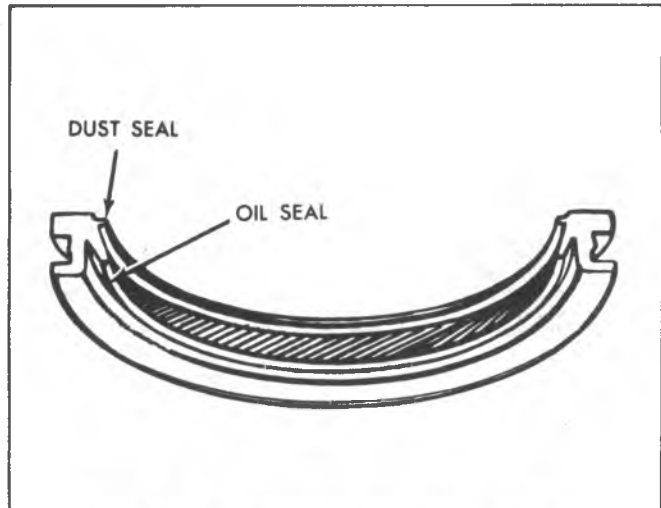


Fig. 6A1-37--Crankshaft Oil Seal - Rear Main

9. Roll seal around crankshaft using tool as a "shoe-horn" to protect seal bead from sharp corner of seal seat surface in cylinder case. Installation tool must remain in position until seal is properly positioned with both ends flush with block.

10. Remove tool, being careful not to withdraw seal.

11. Install seal half in bearing cap, again using tool as a "shoe-horn", feeding seal into cap using light pressure with thumb and finger.

12. Install bearing cap to case with sealant applied to the cap-to-case interface being careful to keep sealant off the seal split line (fig. 6A1-38).

13. Install the rear main bearing cap (with new seal) and torque to 10-12 lb. ft. (14-16 N·m). Tap end of crankshaft first rearward then forward with a lead hammer. This will line up rear main bearing and crankshaft thrust surfaces. Retorque bearing cap to 65 lb. ft. (88N·m).

PISTON AND CONNECTING ROD ASSEMBLIES

Removal

1. Remove oil pan, oil pump and cylinder head as previously outlined.
2. For the cylinder being serviced, turn crankshaft until piston is at the bottom of the stroke. Place a cloth on

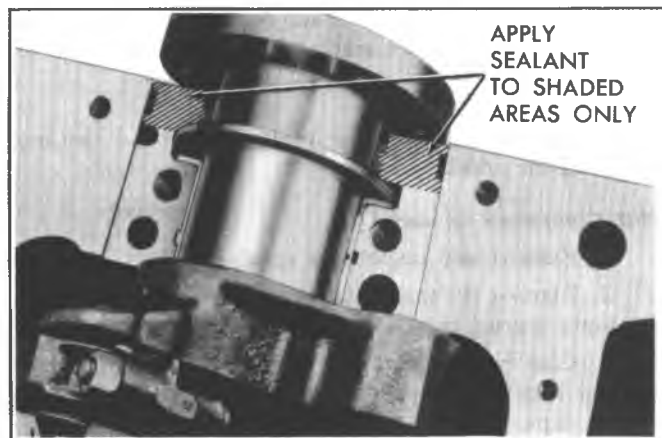


Fig. 6A1-38--Sealing Bearing Cap - Typical

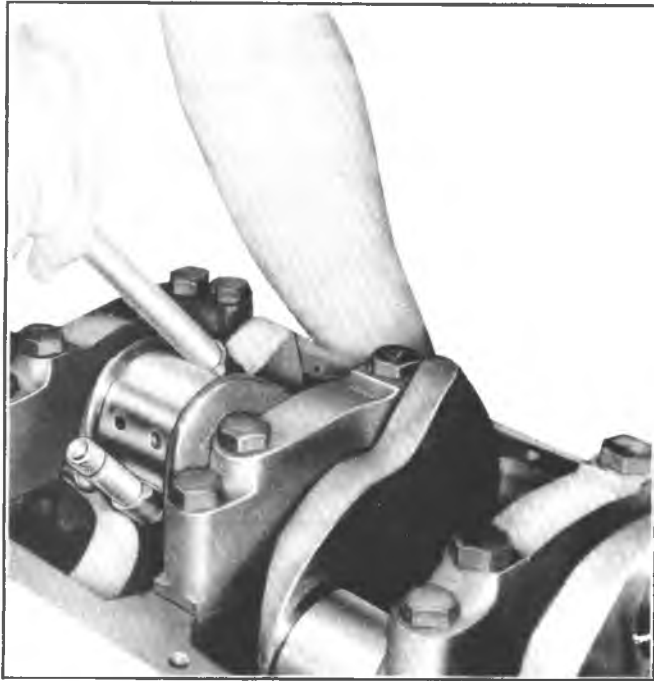


Fig. 6A1-39—Removing Connecting Rod & Piston Assembly

top of the piston.

3. Use a ridge reamer to remove any ridge and/or deposits from the upper end of the cylinder bore.

4. Turn crankshaft until piston is at top of stroke and remove cloth and cuttings.

5. Remove connecting rod cap and install Tool J-6305 (11/32") on studs. Push connecting rod and piston assembly out of top of cylinder block (fig. 6A1-39). It will be necessary to turn the crankshaft slightly to disconnect some of the connecting rod and piston assemblies and push them out of the cylinder.

Disassembly

1. Remove connecting rod bearings from connecting rods and caps. If bearings are being reused, place them in a rack so they may be reinstalled in their original positions.

2. Remove piston rings by expanding and sliding them off the pistons. Tools J-8021 (3-7/8") and J-22249 (3-15/16") are available for this purpose.

3. Place connecting rod and piston assembly on tool J-24086-20. Using an arbor press and piston pin remover, J-24086-8, press the piston pin out of connecting rod and piston (fig. 6A1-40).

Cleaning and Inspection

Connecting Rods

Wash connecting rods in cleaning solvent and dry with compressed air.

Check for twisted or bent rods and inspect for nicks or cracks. Replace connecting rods that are damaged.

Pistons

Clean varnish from piston skirts and pins with a cleaning solvent. **DO NOT WIRE BRUSH ANY PART OF THE PISTON.** Clean the ring grooves with a groove cleaner and make sure oil ring holes and slots are clean.

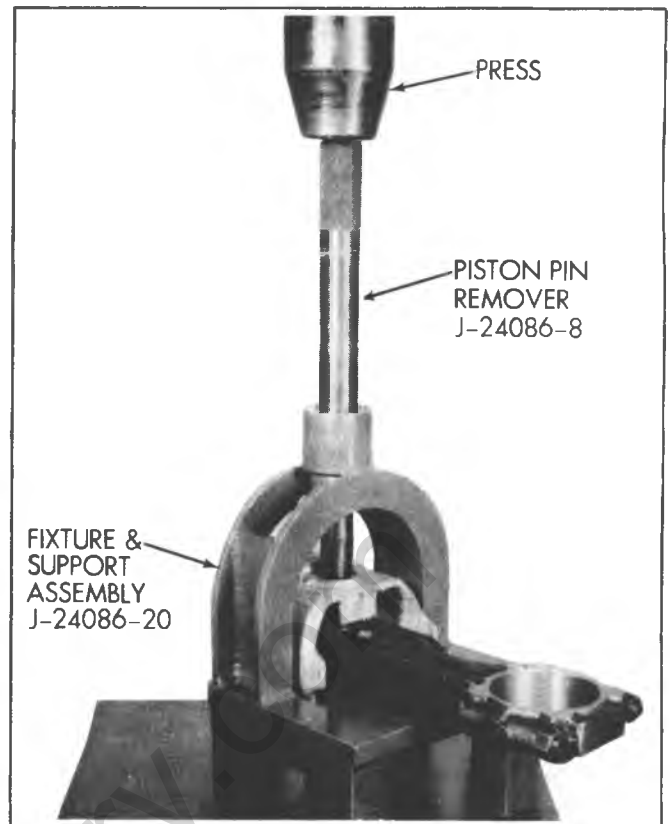


Fig. 6A1-40—Removing Piston Pin

Inspect the piston for cracked ring lands, skirts or pin bosses, wavy or worn ring lands, scuffed or damaged skirts, eroded areas at top of the piston. Replace pistons that are damaged or show signs of excessive wear.

Inspect the grooves for nicks or burrs that might cause the rings to hang up.

Measure piston skirt (across center line of piston pin) and check clearance.

Piston Pins

The piston pin clearance is designed to maintain adequate clearance under all engine operating conditions. Because of this, the piston and piston pin are a matched set and not serviced separately.

Inspect piston pin bores and piston pins for wear. Piston pin bores and piston pins must be free of varnish or scuffing when being measured. The piston pin should be measured with a micrometer and the piston pin bore should be measured with a dial bore gage or an inside micrometer. If clearance is in excess of the .001" wear limit, the piston and piston pin assembly should be replaced.

ASSEMBLY

1. Lubricate piston pin holes in piston and connecting rod to facilitate installation of pin.

2. Place connecting rod in piston and hold in place with piston pin guide and piston pin. Place connecting rod and piston assembly on fixture and support assembly.

3. Using piston pin installer, J-24086-9, press the piston pin into the piston and connecting rod (Fig. 6A1-41). Make sure installer is set properly (see tool instructions).

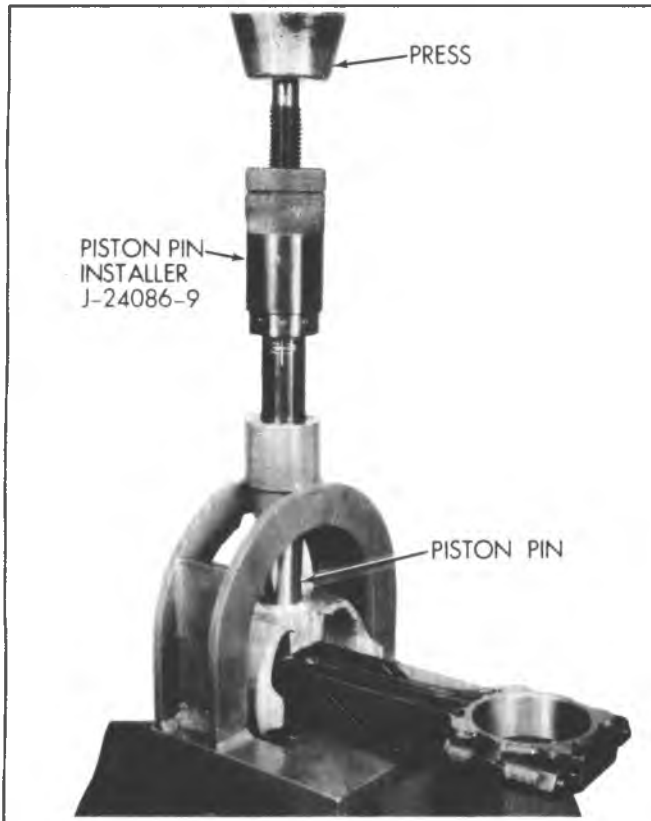


Fig. 6A1-41--Installing Piston Pin

NOTICE: After installer hub bottoms on support assembly, do not exceed 5000 psi pressure, as this could cause structural damage to the tool.

4. Remove piston and connecting rod assembly from tool and check piston for freedom of movement on piston pin.

Piston Rings

All compression rings are marked on the upper side of the ring. When installing compression rings, make sure the marked side is toward the top of the piston. The top ring is chrome faced, or treated with molybdenum for maximum life.

The oil control rings are of three piece type, consisting of two segments (rails) and a spacer.

1. Select rings comparable in size to the piston being used.

2. Slip the compression ring in the cylinder bore; then press the ring down into the cylinder bore about 1/4" (6.5mm) (above ring travel). Be sure ring is square with cylinder wall.

3. Measure the space or gap between the ends of the ring with a feeler gage.

4. If the gap between the ends of the ring is below specifications, remove the ring and try another for fit.

5. Fit each compression ring to the cylinder in which it is going to be used.

6. If the pistons have not been cleaned and inspected as previously outlined, do so.

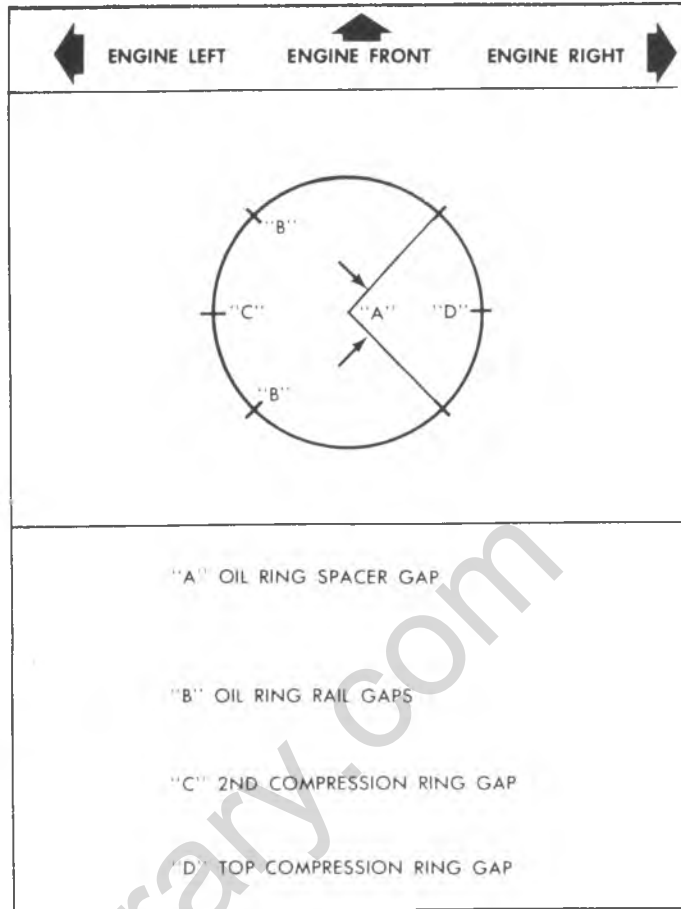


Fig. 6A1-42--Ring Gap Location

7. Slip the outer surface of the top and second compression ring into the respective piston ring groove and roll the ring entirely around the groove to make sure that the ring is free. If binding occurs at any point the cause should be determined, and if caused by ring groove, remove by dressing with a fine cut file. If the binding is caused by a distorted ring, check a new ring.

8. Install piston rings as follows (fig. 6A1-42):

a. Install oil ring spacer in groove and insert anti-rotation tang in oil hole.

b. Hold spacer ends butted and install lower steel oil ring rail with gap properly located.

c. Install upper steel oil ring rail with gap properly located.

d. Flex the oil ring assembly to make sure ring is free. If binding occurs at any point, the cause should be determined, and if caused by ring groove, remove by dressing groove with a fine cut file. If binding is caused by a distorted ring, check a new ring.

e. Install second compression ring expander then ring with gaps properly located.

f. Install top compression ring with gap properly located.

9. Proper clearance of the piston ring in its piston ring groove is very important to provide proper ring action and reduce wear. Therefore, when fitting new rings, the clearances between the surfaces of the ring groove should be measured (fig. 6A1-43). (See Specifications.)



Fig. 6A1-43—Measuring Ring Groove Clearance

Installation

Cylinder bores must be clean before piston installation. This may be accomplished with a hot water and detergent wash or with a light honing as necessary. After cleaning, the bores should be swabbed several times with light engine oil and a clean dry cloth.

1. Lubricate connecting rod bearings and install in rods and rod caps.
2. Lightly coat pistons, rings and cylinder walls with light engine oil.
3. With bearing caps removed, install Tool J-6305 (11/32") on connecting rod bolts.
4. Install each connecting rod and piston in its respective bore. Pistons must have notches facing front of

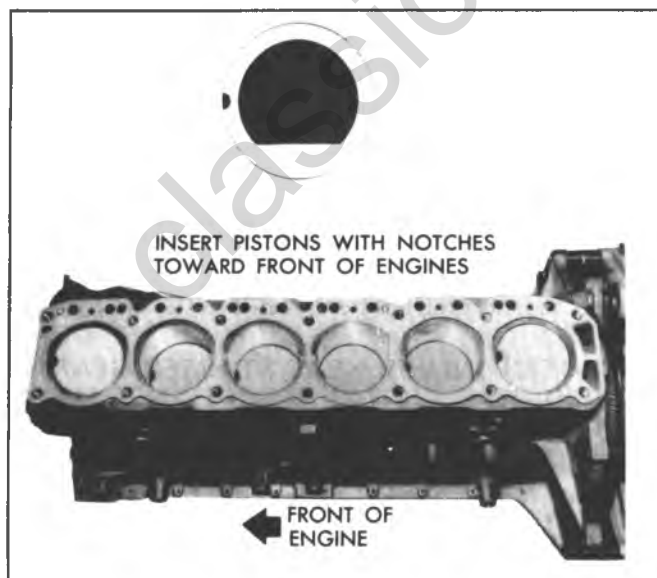


Fig. 6A1-44—Pistons—Installed Position



Fig. 6A1-45—Installing Connecting Rod and Piston Assembly

engine (fig. 6A1-44).

Use Tool J-8037 to compress the rings (fig. 6A1-45). Guide the connecting rod into place on the crankshaft journal with Tool J-6305 (11/32"). Use a hammer handle and light blows to install the piston into the bore. Hold the ring compressor firmly against the cylinder block until all piston rings have entered the cylinder bore.

5. Remove J-6305.
6. Install the bearing caps and torque nuts to 35 lb. ft. (47N·m).

CYLINDER BLOCK

Cleaning and Inspection

1. Wash cylinder block thoroughly in cleaning solvent and clean all sealing surfaces.
2. Remove oil gallery plugs and clean all oil passages.
3. Clean and inspect water passages in the cylinder block.
4. Inspect the cylinder block for cracks in the cylinder walls, water jacket, valve lifter bores and main bearing webs.
5. Measure the cylinder walls for taper, out-of-round or excessive ridge at top of ring travel. This should be done with a dial indicator. Set the gage so that the thrust pin must be forced in about 1/4" (6.5mm) to enter gage in cylinder bore. Center gage in cylinder and turn dial to "O". Carefully work gage up and down cylinder to determine taper and turn it to different points around cylinder wall to determine the out-of-round condition. If cylinders were found to exceed specifications, honing or boring will be necessary.

Conditioning

The performance of the following operation is contingent upon engine condition at time of repair.

If the cylinder block inspection indicated that the block was suitable for continued use except for out-of-round or tapered cylinders, they can be conditioned by honing or boring.

If the cylinders were found to have less than .005" taper or wear they can be conditioned with a hone and fitted with the high limit standard size piston. A cylinder bore of less

then .005" wear or taper may not entirely clean up when fitted to a high limit piston. If it is desired to entirely clean up the bore in these cases, it will be necessary to rebore for an oversize piston. If more than .005" taper or wear, they should be bored and honed to the smallest oversize that will permit complete resurfacing of all cylinders.

When pistons are being fitted and honing is not necessary, cylinder bores may be cleaned with a hot water and detergent wash. After cleaning, the cylinder bores should be swabbed several times with light engine oil and a clean cloth and then wiped with a clean dry cloth.

Boring

1. Before using any type boring bar, the top of the cylinder block should be filed to remove any dirt or burrs. This is very important. If not checked, the boring bar may be tilted which would result in the rebored cylinder wall not being at right angles to the crankshaft.

2. The piston to be fitted should be measured with a micrometer, measuring at the center of the piston skirt and at right angles to the piston pin. The cylinder should be bored to the same diameter as the piston and honed to give the specified clearance.

3. The instructions furnished by the manufacturer of the equipment being used should be carefully followed.

Honing

1. When cylinders are to be honed follow the hone manufacturer's recommendations for the use of the hone and cleaning and lubrication during honing.

2. Occasionally during the honing operation, the cylinder bore should be thoroughly cleaned and the piston selected for the individual cylinder checked for correct fit.

3. When finish honing a cylinder bore to fit a piston, the hone should be moved up and down at a sufficient speed to obtain very fine uniform surface finish marks in a cross-hatch pattern of approximately 45 to 65° included angle. The finish marks should be clean but not sharp, free from imbedded particles and torn or folded metal.

4. Permanently mark the piston for the cylinder to which it has been fitted and proceed to hone cylinders and fit the remaining pistons.

NOTICE: Handle the pistons with care and do not attempt to force them through the cylinder until the cylinder has been honed to correct size as this type piston can be distorted through careless handling.

5. Thoroughly clean the bores with hot water and detergent. Scrub well with a stiff bristle brush and rinse thoroughly with hot water. It is extremely essential that a good cleaning operation be performed. If any of the abrasive material is allowed to remain in the cylinder bores, it will rapidly wear the new rings and cylinder bores in addition to the bearings lubricated by the contaminated oil. The bores should be swabbed several times with light engine oil and a clean cloth and then wiped with a clean dry cloth. Cylinders should not be cleaned with kerosene or gasoline. Clean the remainder of the cylinder block to remove the excess material spread during the honing operation.

PISTON SELECTION

1. Check USED piston to cylinder bore clearance as follows:

a. Measure the "Cylinder Bore Diameter" with a telescope gage (2-1/2" (64mm) from top of cylinder bore).

b. Measure the "Piston Diameter" (at skirt across center line of piston pin).

c. Subtract piston diameter from cylinder bore diameter to determine "Piston to Bore Clearance".

d. Determine if piston to bore clearance is in the acceptable range.

2. If used piston is not acceptable, determine if a new piston can be fitted to the cylinder bore.

3. If cylinder bore must be reconditioned, measure new piston diameter (across center line of piston pin) then hone cylinder bore to correct clearance.

4. Mark the piston to identify the cylinder for which it was fitted.

FLYWHEEL

Removal

All Except L25 Engines

1. Remove transmission and/or clutch housing and clutch from engine.

2. Remove flywheel retaining bolts and remove flywheel.

L25 Engines

1. Remove transmission and/or clutch housing and clutch from engine.

2. Mark relationship of flywheel and crankshaft so that dowel holes can be aligned in their original positions on assembly.

3. Remove engine oil pan and rear main bearing cap.

4. Remove flywheel retaining bolts and drive crankshaft dowels out of flywheel and crankshaft. Rotate crankshaft as necessary so dowels clear cylinder block.

5. Remove flywheel and discard used dowel pins.

Repair

Only repair recommended at flywheel used with conventional clutch is replacement of starter gear in event gear is worn or otherwise damaged.

Use torch to heat the gear around entire circumference, then drive the gear off flywheel, using care not to damage the flywheel.

Uniformly heat the flywheel gear to temperature which will expand gear to permit installation. [Temperature must not exceed 400°F (204° C)].

As soon as gear has been heated, install on flywheel.

NOTICE: NEVER HEAT STARTER GEAR TO RED HEAT AS THIS WILL CHANGE METAL STRUCTURE .

Installation

All Except L25 Engines

1. Clean the mating surfaces of flywheel and crankshaft to make certain there are no burrs.

2. Install flywheel on crankshaft and position to align dowel hole of crankshaft flange and flywheel.

3. Install flywheel retaining bolts and torque to specifications.

L25 Engine

1. Clean the mating surfaces of flywheel and crankshaft to make certain there are no burrs.

2. Install flywheel on crankshaft and position to align dowel holes of crankshaft flange and flywheel.

3. Install flywheel retaining bolts and torque to specifications.

● The interference fit dowel pins used on 4.8 L (T) engines must be replaced with an oversize dowel pin when installing the flywheel.

4. When installing the original flywheel, ream the dowel pin holes with Tool J-22808-2. When installing a new flywheel, first ream the dowel pin holes with Tool J-22808-2 and then finish reaming them with Tool J-22808-1.

5. Install oversize dowel pins flush with flywheel retaining bolt surface.

6. Install rear main bearing cap and torque bolts to specifications. Install oil pan with new gaskets and seals. Torque oil pan retaining screws to specifications.

ENGINE ASSEMBLY

Removal ("G" Van/Code D Engine)

1. Disconnect battery negative cable at battery.

2. Drain cooling system.

3. Remove engine cover.

4. Remove air cleaner.

5. If equipped, evacuate A/C system and remove A/C compressor.

6. Disconnect accelerator linkage at carburetor and remove carburetor from manifold.

7. Remove grille and grille cross brace.

8. Remove windshield washer jar and, if equipped, A/C vacuum reservoir.

9. Disconnect radiator hoses from radiator.

10. Remove radiator to radiator support attaching brackets and remove radiator.

● If equipped with automatic transmission, remove cooler lines from radiator before attempting removal.

● If equipped with A/C, remove condenser to radiator support attaching bolts and swing condenser to the side, out of the way.

11. Remove heater hoses from engine.

12. Disconnect all necessary wiring from engine:

● Generator

● Distributor

● All sending switches

● Starter

13. Raise vehicle.

14. Remove fuel line hose from suction side of fuel pump.

15. Drain crankcase.

16. Remove propshaft and plug end of transmission.

17. Remove exhaust pipe from manifold flange.

18. Remove linkage from transmission and disconnect speedometer cable.

19. Remove transmission mount bolts.

● If equipped with manual transmission, disconnect clutch linkage and remove clutch cross shaft.

20. Remove engine mount "through" bolts.

21. Lower vehicle.

22. Attach lifting device to engine.

23. Raise engine slightly and remove right hand mount assembly from engine.

24. Remove engine/transmission assembly.

Installation ("G" Van/Code D Engine)

1. Place engine/transmission assembly into vehicle.

2. Install right hand engine mount assembly and lower engine onto mounts.

3. Remove lifting tool.

4. Raise vehicle and install engine mount "through" bolts. Torque to specifications.

5. Install transmission mount bolts. Torque to specifications.

6. Connect transmission shift linkage and speedometer cable.

● If equipped with manual transmission, connect clutch linkage and install clutch cross shaft.

7. Attach exhaust pipe to manifold flange.

8. Install propshaft.

9. Connect fuel tank line to fuel pump.

10. Lower vehicle.

11. Connect all wiring to engine components:

● Generator

● Distributor

● All sending units

● Starter

12. Connect heater hoses to engine.

13. Install radiator and hold in place with radiator to support attaching brackets.

● If equipped with Automatic Transmission, connect cooler lines to radiator.

● If equipped with A/C, install condenser in front of radiator. Bolt to radiator support.

14. Connect radiator hoses to radiator.

15. Install windshield washer jar and, if equipped, A/C vacuum reservoir.

16. Install grille cross brace and grille.

17. Using a new pad gasket, install carburetor. Connect accelerator linkage.

18. If equipped, mount A/C compressor.

19. Fill crankcase with oil.

20. Fill cooling system.

21. Connect battery negative cable and start engine. Check ignition timing and adjust carburetor if necessary.

22. Install air cleaner and engine cover.

Removal (CK Series/Code D & T Engines)

1. Disconnect battery cables at battery.

2. Remove air cleaner.

3. Drain cooling system.

4. Disconnect accelerator cable from carburetor throttle lever.

● If equipped with automatic transmission, remove detent cable from carburetor throttle lever.

5. Disconnect all wiring from engine.

6. Remove radiator hoses from radiator.

7. Remove heater hoses from engine.
8. Remove radiator.
9. Remove fan and water pump pulley.
10. Disconnect fuel line from fuel pump.
11. Remove vehicle hood.
12. Raise vehicle.
13. Remove starter.
14. Remove flywheel or torque converter splash shield, as applicable.
15. Disconnect exhaust pipe from exhaust manifold flange. Wire up and out of way.
16. Remove engine mount 'through' bolts.
 - If equipped with automatic transmission, remove converter to flex plate bolts.
 - If 'K' model, remove strut rods at motor mounts.
17. Remove bell housing to engine retaining bolts. Support transmission with chain.
18. Lower vehicle.
19. Attach engine lifting device.
20. Remove engine.

Installation (CK Series/Code D & T Engines)

1. Place engine in vehicle.
2. Raise vehicle.
3. Install bell housing to engine retaining bolts. Torque to specifications.
 - If equipped with automatic transmission, install torque converter to flex plate attaching bolts. Torque to specifications.
4. Install engine mount to frame retaining bolts. Torque to specifications.
5. Connect exhaust pipe to exhaust manifold flange.
6. Install flywheel or torque converter splash shield, as applicable.
7. Install starter. Torque bolts to specifications.
8. Lower vehicle.
9. Attach fuel line to fuel pump.
10. Install water pump pulley and fan. Torque bolts to specifications.
11. Install radiator.
12. Connect heater hoses to engine.
13. Connect radiator hoses to radiator.
14. Connect all wiring to engine.
15. Connect accelerator cable to carburetor throttle lever.
 - If equipped with automatic transmission, connect detent cable to throttle lever.
16. Fill cooling system.
17. Fill crankcase with oil.
18. Install vehicle hood.
19. Connect battery cables, start engine. Check timing and carburetor adjustment. Adjust if necessary.
20. Install air cleaner.

CRANKSHAFT

Removal

1. Remove engine as previously outlined. Remove clutch, if applicable, and flywheel and mount engine on stand.

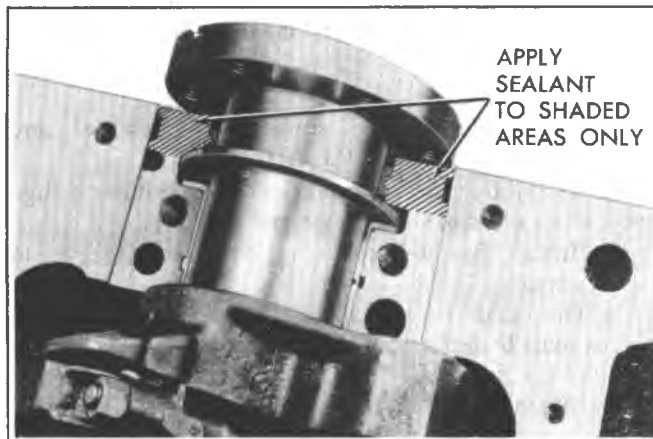


Fig. 6A1-46—Sealing Bearing Cap

2. Remove the oil dipstick and oil dipstick tube.
3. Remove the spark plugs.
4. Remove crankshaft pulley and torsional damper.
5. Remove oil pan and oil pump.
6. Remove crankcase front cover.
7. Remove the connecting rod caps and push the pistons to the top of bores.
8. Remove main bearing caps and lift crankshaft out of cylinder block.
9. Remove rear main bearing oil seal and main bearings from cylinder block and main bearing caps.

Cleaning and Inspection

1. Wash crankshaft in solvent and dry with compressed air.
2. Measure dimensions of main bearing journals and crankpins with a micrometer for out-of-round, taper or undersize. (See Specifications.)
3. Check crankshaft for run-out by supporting the front and rear main bearing journals in "V" blocks and check at the front and rear intermediate journals with a dial indicator. (See Specifications.)
4. Replace or recondition the crankshaft if out of specifications.

Installation

1. Install rear main bearing oil seal in cylinder block and rear main bearing cap grooves. Install with lip of seal toward front of engine. Install lip and helix towards front of engine.
2. Lubricate lips of seal with engine oil. Keep oil off parting line surface.
3. Install main bearings in cylinder block and main bearing caps then lubricate bearing surface with engine oil.
4. Install crankshaft, being careful not to damage bearing surfaces.
5. Apply a thin coat of brush-on type oil sealing compound to block mating surface and corresponding surface of cap only (fig. 6A1-46). Do not allow sealer on crankshaft or seal.
6. Install main bearing caps with arrows pointing toward front of engine.
7. Torque all except rear main bearing cap bolts to specifications. Torque rear main bearing cap bolts to 10-12 lbs. ft. (14-16 N·m) then tap end of crankshaft, first

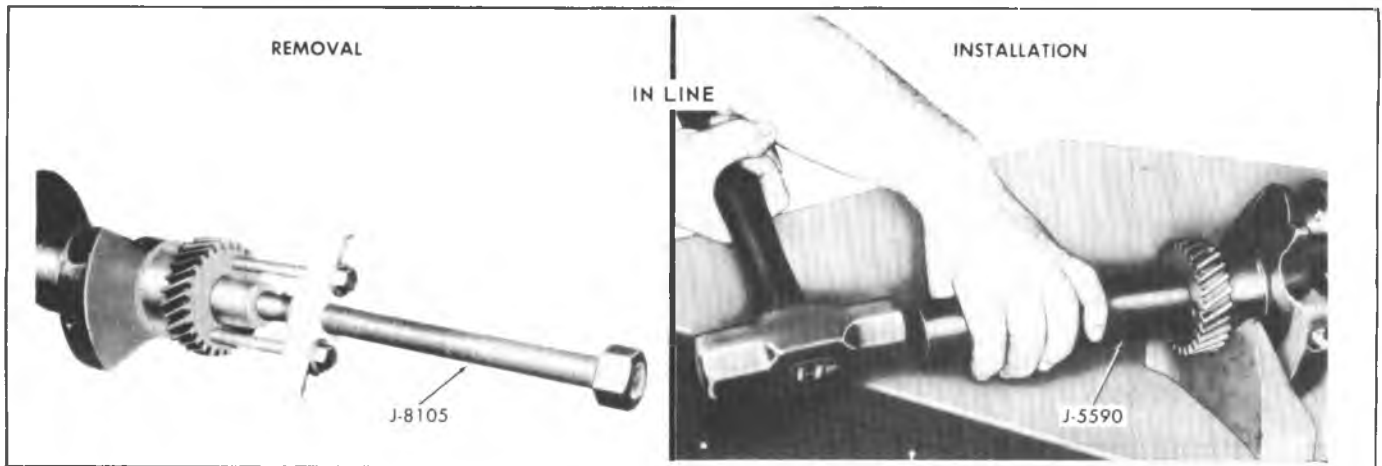


Fig. 6A1-47--Gear Replacement

rearward then forward with a lead hammer. This will line up rear main bearing and crankshaft thrust surfaces. Retorque all main bearing cap bolts to specifications.

8. Measure crankshaft end play with a feeler gage. Force crankshaft forward and measure clearance between the front of the rear main bearing and the crankshaft thrust surface.

9. Install flywheel and torque to specifications. Align dowel hole in flywheel with dowel hole in crankshaft.

● On vehicles equipped with automatic transmissions, install flywheel with the converter attaching pads towards transmission.

Gear Replacement

Remove crankshaft gear using Tool J-8105 and install using Tool J-5590 (fig. 6A1-47).

classiccarslibrary.com

GENERAL DATA:

| | | | |
|--------------------------|------------------|-------------|---------|
| TYPE | | IN LINE L-6 | |
| DISPLACEMENT | LITRE (*) | 4.1 (D) | 4.8 (T) |
| RPO | | LE3 | L25 |
| BORE | | 3.876 | |
| STROKE | | 3.530 | 4.120 |
| COMPRESSION RATIO | | 8.25:1 | 8.0:1 |
| FIRING ORDER | | 1-5-3-6-2-4 | |

CYLINDER BORE:

| | | | |
|---------------------|-------------------|--------------------|------------|
| DIAMETER | | 3.8745-3.8775 | |
| OUT OF ROUND | PRODUCTION | .0005 MAX. | |
| | SERVICE | .002 MAX. | |
| TAPER | PRODUCTION | THRUST SIDE | .0005 MAX. |
| | | RELIEF SIDE | .0005 MAX. |
| | SERVICE | | .001 MAX. |

SPECIFICATIONS

PISTON:

| | | | |
|------------------|-------------------|-------------|-------------|
| CLEARANCE | PRODUCTION | .0010-.0020 | .0026-.0036 |
| | SERVICE | .0030 MAX. | .0045 MAX. |

PISTON RING:

| | | | | | | |
|--------------------|-------------------------|-------------------|-----------------|-----------------|-------------|--|
| COMPRESSION | GROOVE CLEARANCE | PRODUCTION | TOP | .0012-.0027 | .0020-.0040 | |
| | | | 2ND | .0012-.0032 | .0020-.0040 | |
| | | SERVICE | | HI LIMIT + .001 | | |
| | GAP | PRODUCTION | TOP | .010-.020 | | |
| | | | 2ND | .010-.020 | | |
| | | SERVICE | | HI LIMIT + .010 | | |
| OIL | GROOVE CLEARANCE | PRODUCTION | .005 MAX. | .005-.0055 | | |
| | | SERVICE | HI LIMIT + .001 | | | |
| | GAP | PRODUCTION | .015-.055 | | | |
| | | SERVICE | HI LIMIT + .010 | | | |

* VIN Designation

PISTON PIN

LE3

L25

| | | | |
|-------------------|-------------------|--------------------------|--|
| DIAMETER | | .9270-.9273 | |
| CLEARANCE | PRODUCTION | .00015-.00025 | |
| | SERVICE | .001 MAX. | |
| FIT IN ROD | | .0008-.0016 INTERFERENCE | |

CRANKSHAFT

| | | | | |
|-------------------------------|---------------------|-------------------|------------------------------------|-------------|
| MAIN JOURNAL | DIAMETER | | ALL 2.2979-2.2994 | |
| | TAPER | PRODUCTION | .0002 MAX. | |
| | | SERVICE | .001 MAX. | |
| | OUT OF ROUND | PRODUCTION | .0002 MAX. | |
| SERVICE | | .001 MAX. | | |
| MAIN BEARING CLEARANCE | PRODUCTION | | #1-6 .0010-.0024 #7 .0016-.0035 | |
| | SERVICE | | #1-6 | .0010-.0025 |
| CRANKSHAFT END PLAY | | | .002-.006 | |
| CRANKPIN | DIAMETER | | 1.999-2.000 | 2.099-2.100 |
| | TAPER | PRODUCTION | .0005 | |
| | | SERVICE | .001 MAX. | |
| | OUT OF ROUND | PRODUCTION | .0005 | |
| SERVICE | | .001 MAX. | | |
| ROD BEARING CLEARANCE | PRODUCTION | | .0010-.0026 | |
| | SERVICE | | .0030 | |
| ROD SIDE CLEARANCE | | | .006-.017 | |

CAMSHAFT

| | | | |
|--------------------------|----------------|---------------|-------|
| LOBE LIFT ± .002 | INTAKE | .2217 | .2315 |
| | EXHAUST | .2315 | |
| JOURNAL DIAMETER | | 1.8677-1.8697 | |
| CAMSHAFT END PLAY | | .003-.008 | |

| VALVE SYSTEM | | | LE3 | L25 |
|--------------------------|--------------------------|--------|------------------------------|---------------------------------|
| LIFTER | | | HYDRAULIC | |
| ROCKER ARM RATIO | | | 1.75:1 | |
| VALVE LASH | INTAKE | | ONE TURN DOWN FROM ZERO LASH | |
| | EXHAUST | | | |
| FACE ANGLE (INT. & EXH.) | | | 45° | 46° |
| SEAT ANGLE (INT. & EXH.) | | | 46° | |
| SEAT RUNOUT | | | .002 MAX. | |
| SEAT WIDTH | INTAKE | | 1/32-1/16 | |
| | EXHAUST | | 1/16-3/32 | |
| STEM CLEARANCE | PRODUCTION | INT. | .0010-.0027 | |
| | | EXH. | .0015-.0032 | |
| | SERVICE | | HI LIMIT | + .001 INTAKE + .002 EXHAUST |
| VALVE SPRING (OUTER) | FREE LENGTH | | 1.88 | 1.90 |
| | PRESSURE LBS. @ IN. | CLOSED | 56-64 @ 1.66 | 78-86 @ 1.66 |
| | | OPEN | 166-178 @ 1.26 | 170-180 @ 1.26 |
| | INSTALLED HEIGHT ± 1/32" | | 1-21/32 | 1-21/32 |
| DAMPER | FREE LENGTH | | NONE | 1.94 |
| | APPROX. # OF COILS | | NONE | 4 |

TORQUE SPECIFICATIONS

| | |
|---------------------------------|----------------|
| Camshaft Thrust Plate | .80 lb. in. |
| Crankshaft Front Cover | .80 lb. in. |
| Flywheel Housing Cover | .80 lb. in. |
| Oil Pan (To Crankcase) (1/4-20) | .80 lb. in. |
| Oil Pan (To Front Cover) | .50 lb. in. |
| Oil Pump Cover | .70 lb. in. |
| Rocker Arm Cover | .45 lb. in. |
| Connecting Rod Cap | .35 lb. ft.* |
| Clutch Pressure Plate | .20 lb. ft.* |
| Oil Pan (To Crankcase) 5/16-18) | .75 lb. in. |
| Oil Pump | .115 lb. in. |
| Push Rod Cover | .50 lb. in. |
| Water Pump | .15 lb. in. |
| Clutch Pressure Plate | .30 lb. ft.@ |
| Distributor Clamp | .25 lb. ft. |
| Flywheel Housing | .30 lb. ft. |
| Manifold (Exhaust) | .30 lb. ft. 2 |
| Manifold (Exhaust To Inlet) | .45 lb. ft. |
| Manifold To Head | .40 lb. ft. |
| Thermostat Housing | .30 lb. ft. |
| Water Outlet | .30 lb. ft. |
| Connecting Rod Cap | .40 lb. ft.@ |
| Main Bearing Cap | .65 lb. ft. |
| Flywheel | .60 lb. ft.* |
| Torsional Damper | .60 lb. ft.@1 |
| Cylinder Head | .95 lb. ft. 1 |
| Temperature Sending Unit | .20 lb. ft. |
| Oil Filter | Hand Tight |
| Oil Pan Drain Plug | .20 lb. ft. |
| Flywheel | .110 lb. ft.@ |
| Spark Plug | .17-27 lb. ft. |

* 4.1 (D) only
@ 4.8 (T) only

- 1 Except LH Front Bolt 85 lb. ft.
- 2 Non-Integral Head

classicalcarlibrary.com

SECTION 6A4

5.0 L (G) V-8 - RPO LG9

5.7 L (L) V-8 - RPO LS9

5.7 L (M) V-8 - RPO LT9

6.6 L (R) V-8 - RPO LF4

6.6 L (X) V-8 - RPO LE4

Contents

| | | | |
|-----------------------------|--------|---------------------------------------|--------|
| General Description..... | 6A4-1 | Crankcase Front Cover | 6A4-19 |
| Engine Lubrication | 6A4-2 | Oil Seal (Front Cover) | 6A4-19 |
| On Vehicle Service..... | 6A4-5 | Camshaft | 6A4-19 |
| Engine Mounts | 6A4-5 | Camshaft Bearings | 6A4-20 |
| Intake Manifold | 6A4-5 | Oil Pan | 6A4-21 |
| Exhaust Manifold..... | 6A4-11 | Oil Pump | 6A4-22 |
| Rocker Arm Cover..... | 6A4-12 | Connecting Rod Bearings..... | 6A4-22 |
| Valve Mechanism..... | 6A4-12 | Main Bearings | 6A4-23 |
| Valve Stem Oil Seal and/or | | Oil Seal (Rear Main)..... | 6A4-25 |
| Valve Spring..... | 6A4-13 | Connecting Rod Piston Assemblies..... | 6A4-27 |
| Valve Lifters..... | 6A4-13 | Cylinder Block | 6A4-30 |
| Cylinder Head Assembly..... | 6A4-14 | Oil Filter Bypass Valve | 6A4-30 |
| Rocker Arm Studs..... | 6A4-17 | Engine Assembly..... | 6A4-30 |
| Valve Guide Bores..... | 6A4-18 | Crankshaft | 6A4-32 |
| Valve Seats | 6A4-18 | Sprocket or Gear Replacement | 6A4-32 |
| Valves | 6A4-18 | Specifications..... | 6A4-34 |
| Torsional Damper..... | 6A4-18 | | |

GENERAL DESCRIPTION

CYLINDER BLOCK

The cylinder block is made of cast iron and has 8 cylinders arranged in a "V" shape with 4 cylinders in each bank. Five main bearings support the crankshaft which is retained by bearing caps that are machined with the block for proper alignment and clearances. Cylinders are completely encircled by coolant jackets.

CYLINDER HEAD

The cylinder heads are cast with individual intake and exhaust ports for each cylinder. Valve guides are integral, and rocker arms are retained on individual studs.

CRANKSHAFT AND BEARINGS

The crankshaft is cast nodular iron, and is supported by five main bearings. Number five bearing is the end thrust bearing.

Main bearings are lubricated from oil holes which intersect the camshaft bearings. The camshaft bearings are fed oil by the main oil gallery which is rifle drilled down

the center of the block, above the camshaft. Two additional oil galleries are on either side of the main oil gallery to provide an oil supply for the hydraulic lifters.

A torsional damper on the forward end of the crankshaft dampens any engine torsional vibrations.

CAMSHAFT AND DRIVE

The cast iron camshaft is supported by five bearings and is chain driven. A steel or sintered iron crankshaft gear drives the timing chain which in turn drives the camshaft through either a nylon/aluminum or cast iron gear depending on application.

Cam lobes are ground, hardened and tapered with the high side toward the rear. This, coupled with a spherical face on the lifter, causes the valve lifters to rotate.

Camshaft bearings are lubricated through oil holes which intersect the main oil gallery. The main oil gallery is rifle drilled down the center of the block, above the camshaft.

PISTONS AND CONNECTING RODS

The pistons are made of cast aluminum alloy using two compression rings and one oil control ring. Piston pins are offset 1/16" (1.6mm) toward the thrust side (right hand side) to provide a gradual change in thrust pressure against the cylinder wall as the piston travels its path. Pins are Chromium steel and have a floating fit in the pistons. They are retained in the connecting rods by a press fit.

Connecting rods are made of forged steel. Full pressure lubrication is directed to the connecting rods by drilled oil passages from the adjacent main bearing journal. Oil holes at the connecting rod journals are located so that oil is supplied to give maximum lubrication just prior to full bearing load.

VALVE TRAIN

A very simple ball pivot-type train is used. Motion is transmitted from the camshaft through the hydraulic lifter and push rod to the rocker arm. The rocker arm pivots on its ball and transmits the camshaft motion to the valve. The rocker-arm ball is retained by a nut.

HYDRAULIC VALVE LIFTERS

Hydraulic Valve Lifters are used to keep all parts of the valve train in constant contact.

The hydraulic lifter assembly consists of: the lifter body, which rides in the cylinder block boss, a plunger, a push rod seat, a metering valve, a plunger spring, a check ball and spring, a check ball retainer and a push rod seat retainer.

When the lifter is riding on the low point of the cam, the plunger spring keeps the plunger and push rod seat in contact with the push rod.

When the lifter body begins to ride up the cam lobe, the check ball cuts off the transfer of oil from the reservoir

below the plunger. The plunger and lifter body then rise as a unit, pushing up the push rod and opening the valve.

As the lifter body rides down the other side of the cam, the plunger follows with it until the valve closes. The lifter body continues to follow the cam to its low point, but the plunger spring keeps the plunger in contact with the push rod. The ball check valve will then move off its seat and the lifter reservoir will remain full.

INTAKE MANIFOLD

The intake manifold is of cast iron double level design for efficient fuel distribution. The carburetor pad is centrally located with a passage running underneath the pad (E.F.E.) through which exhaust gases are forced to promote faster fuel vaporization when the engine is cold. An EGR port is also cast into the manifold for the mixture of exhaust gases with the fuel air mixture.

EXHAUST MANIFOLDS

Two cast iron exhaust manifolds are used to direct exhaust gases from the combustion chambers to the exhaust system. The right hand side manifold receives a heat shield that is used to route heated air to the air cleaner for better fuel vaporization.

COMBUSTION CHAMBERS

Combustion Chambers are cast to insure uniform shape for all cylinders. Spark plugs are located between the intake and exhaust valves.

The contoured wedge shape of the combustion chamber minimizes the possibility of detonation, facilitates breathing, and provides swirling turbulence for smooth, complete combustion.

ENGINE LUBRICATION

Full pressure lubrication through a full flow oil filter, is furnished by a gear-type oil pump. The distributor, driven by a helical gear on the camshaft, drives the oil pump. The main oil gallery feeds oil, through drilled passages, to the camshaft and crankshaft to lubricate the bearings. The valve

lifter oil gallery feeds the valve lifters which, through hollow push rods, feed the individually mounted rocker arms (fig. 6A4-1 and 6A4-2).

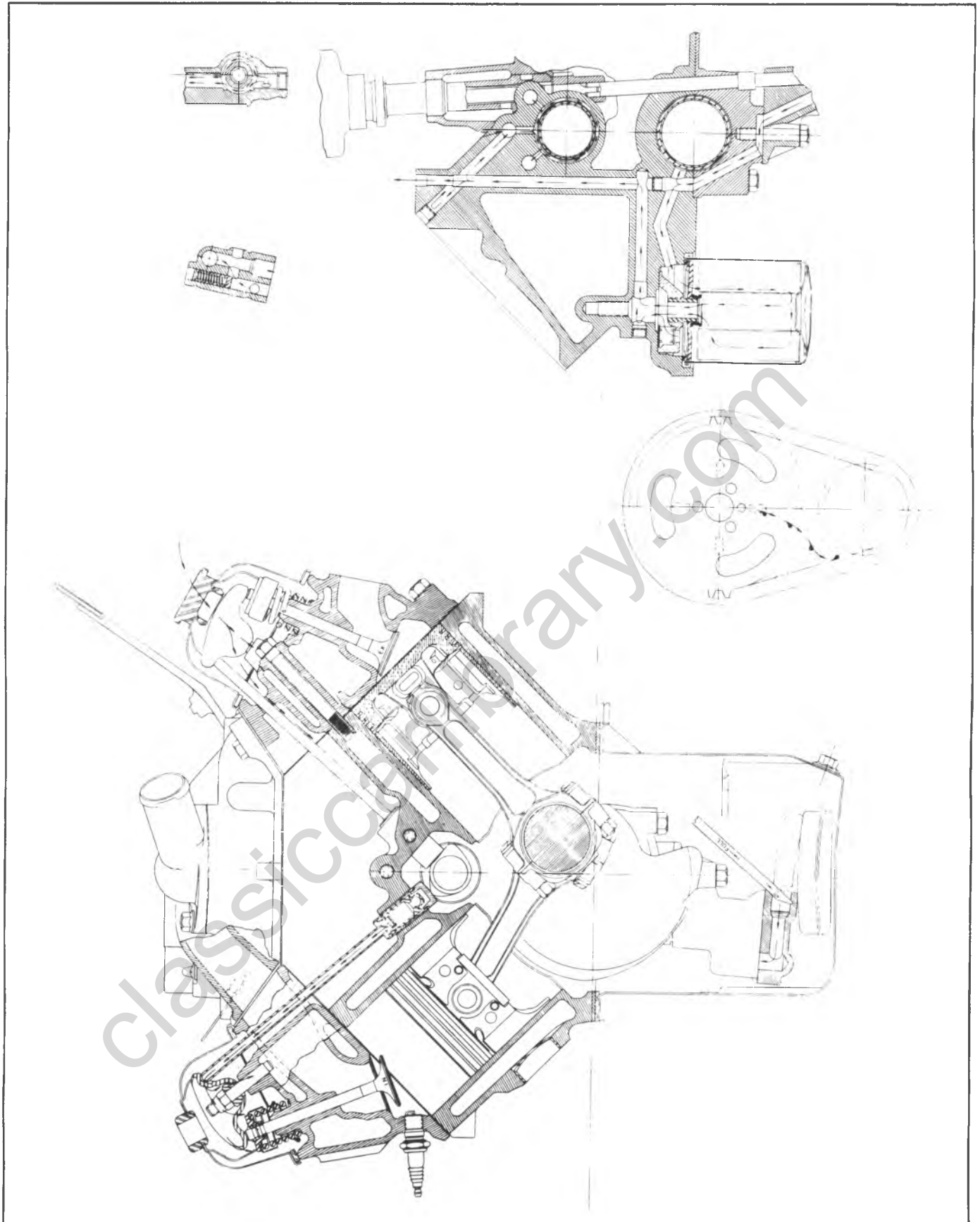


Fig. 6A4-1-Engine Lubrication

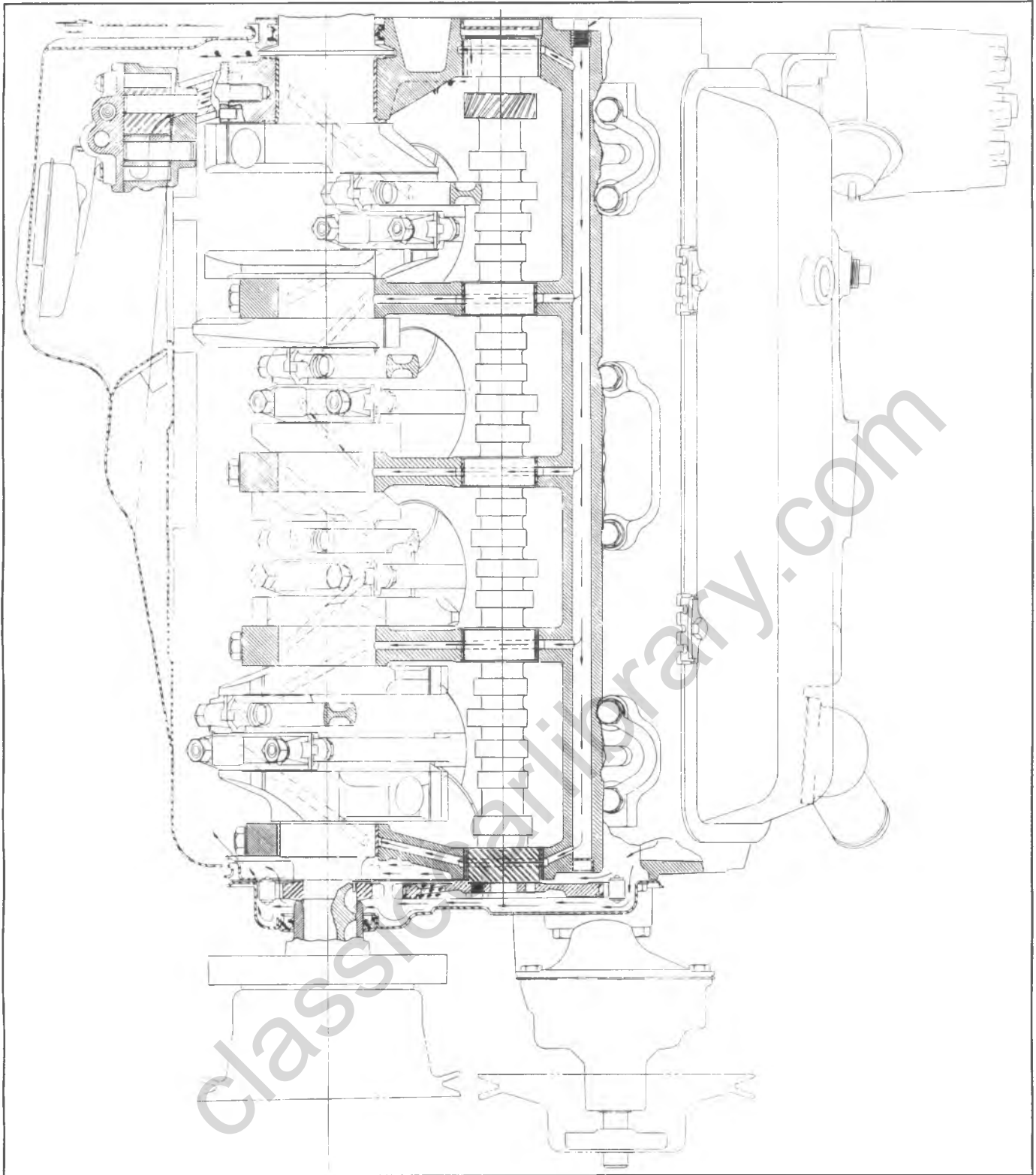


Fig. 6A4-2--Engine Lubrication

ON VEHICLE SERVICE

ENGINE MOUNTS

Engine mounts (fig. 6A4-3 – 6A4-8) are the non-adjustable type and seldom require service. Broken or deteriorated mounts should be replaced immediately, because of the added strain placed on other mounts and drive line components.

Checking Engine Mounts

Front Mount

Raise the engine to remove weight from the mounts and to place a slight tension in the rubber. Observe both mounts while raising engine. If an engine mount exhibits:

- Hard rubber surface covered with heat check cracks;
- Rubber separated from a metal plate of the mount;
- Rubber split through center

replace the mount. If there is relative movement between a metal plate of the mount and its attaching points, lower the engine on the mounts and tighten the screws or nuts attaching the mount to the engine, frame, or bracket.

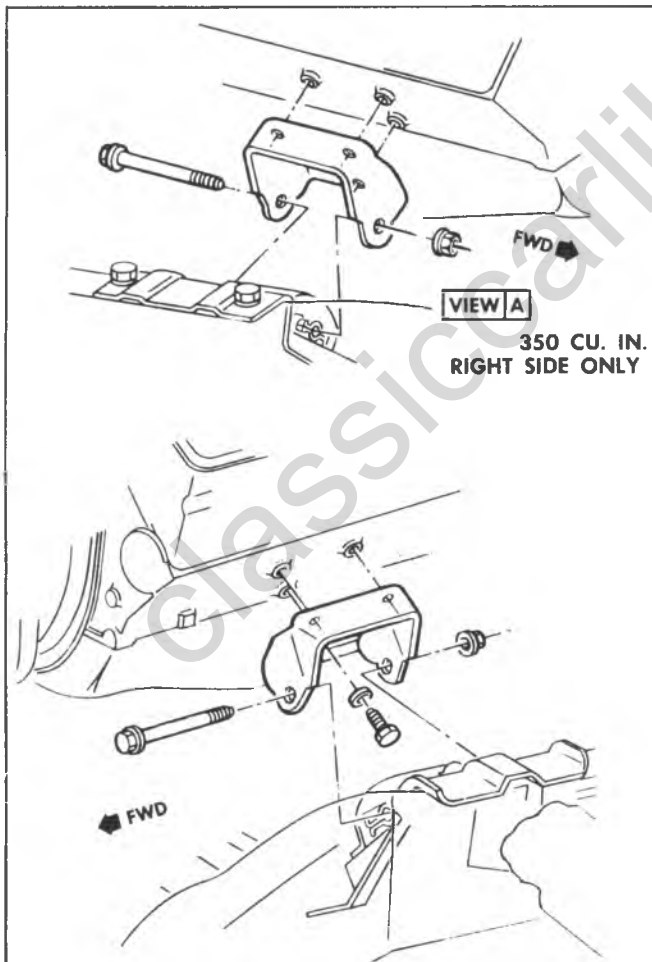


Fig. 6A4-3--"P" Series Engine Mount Bracket

Rear Mount

Raise the vehicle on a hoist. Push up and pull down on the transmission tailshaft while observing the transmission mount. If the rubber separates from the metal plate of the mount or if the tailshaft moves up but not down (mount bottomed out) replace the mount. If there is relative movement between a metal plate of the mount and its attaching point, tighten the screws or nuts attaching the mount to the transmission or crossmember.

Front Mount Replacement

- Remove mount retaining bolt from below frame mounting bracket.
- Raise front of engine and remove mount-to-engine bolts and remove mount.

NOTICE: Raise engine only enough for sufficient clearance. Check for interference between rear of engine and cowl panel which could cause distributor damage.

- Replace mount to engine and lower engine into place.
- Install retaining bolt and torque all bolts to specifications.

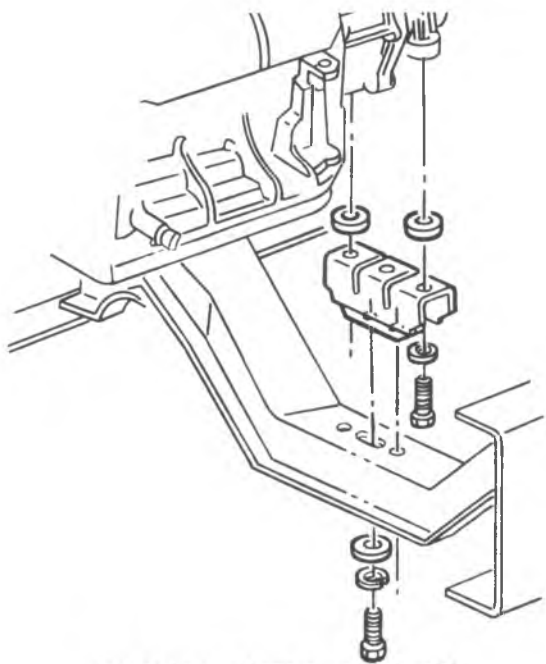
Rear Mount Replacement

- Support engine weight to relieve rear mounts.
- Remove crossmember-to-mount bolts.
- On "P" Series with manual transmission and propeller shaft parking brake, remove mount attaching bolts from frame outrigger and clutch housing and remove rear mounting cushions.
- Remove mount-to-transmission bolts, then remove mount.
- On "P" Series with manual transmission and propeller shaft parking brake, install new mounting cushions and bolts.
- Install new mount on transmission.
- While lowering transmission, align and start crossmember-to-mount bolts.
- Torque bolts to specifications then bend lock tabs to bolt head as applicable.

INTAKE MANIFOLD

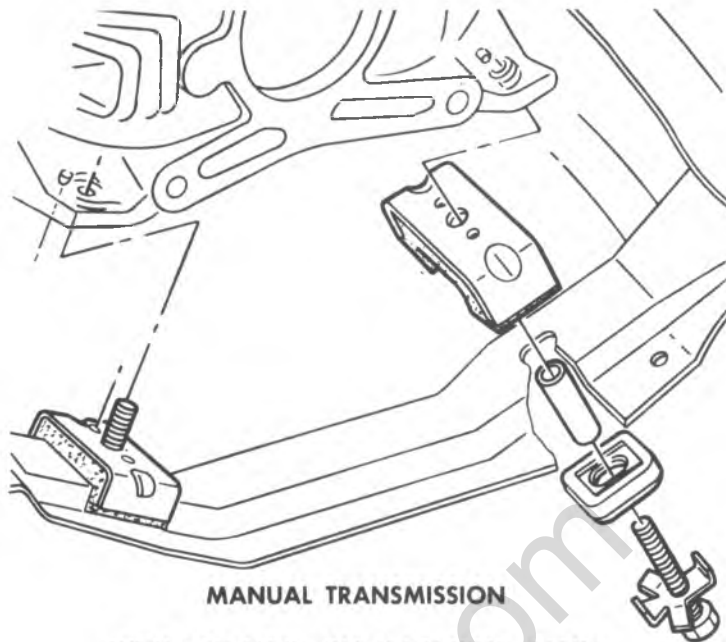
Removal

- Drain radiator and remove air cleaner.
- Disconnect:
 - Battery negative cable at battery.
 - Radiator upper hose and heater hose at manifold.
 - Accelerator linkage at carburetor.
 - Fuel line at carburetor.
 - Crankcase ventilation lines.
 - Spark advance hose at distributor.
- Remove distributor cap and mark rotor position with chalk, then remove distributor.



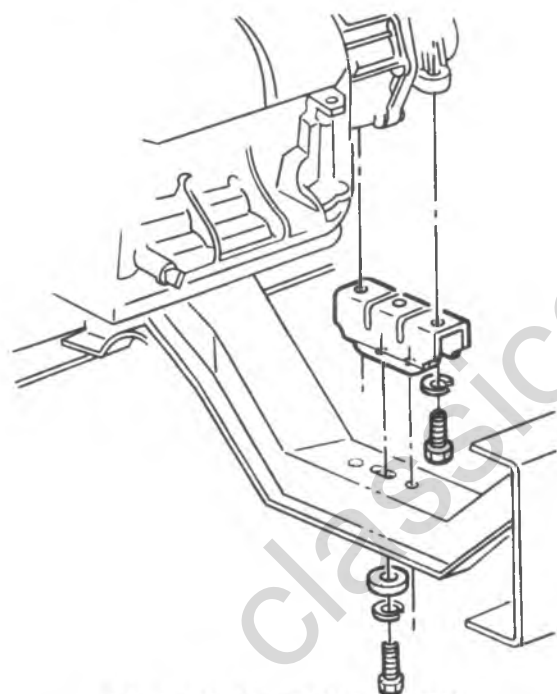
ALL TURBO HYDRA-MATIC 400
(EXCEPT MOBILE HOME CHASSIS)

WITHOUT PROPELLER SHAFT PARKING BRAKE



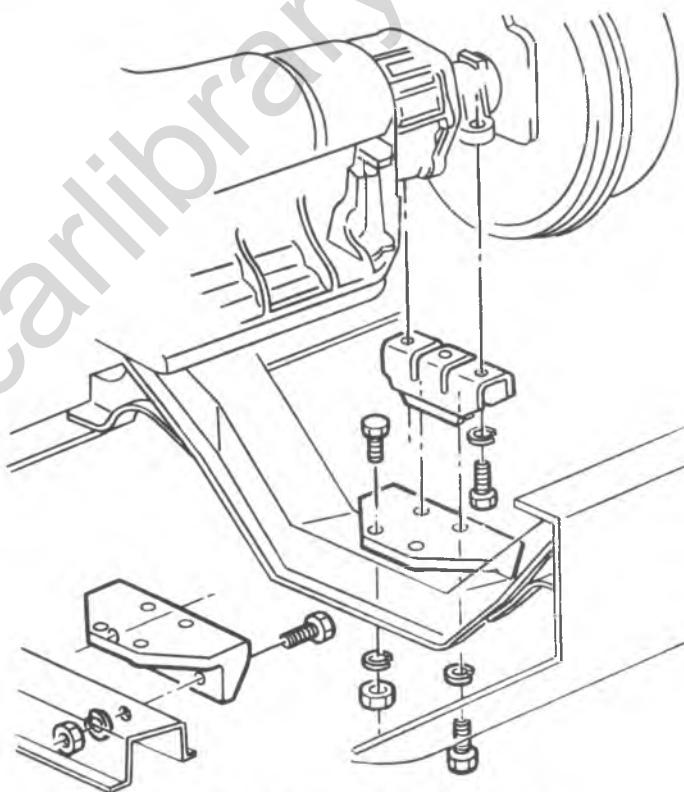
MANUAL TRANSMISSION

WITH PROPELLER SHAFT PARKING BRAKE



ALL MANUAL TRANSMISSION
ALL TURBO HYDRA-MATIC 350
ALL MOBILE HOME CHASSIS

WITHOUT PROPELLER SHAFT PARKING BRAKE



AUTOMATIC TRANSMISSION

WITH PROPELLER SHAFT PARKING BRAKE

Fig. 6A4-4--"P" Series Engine Rear Mount

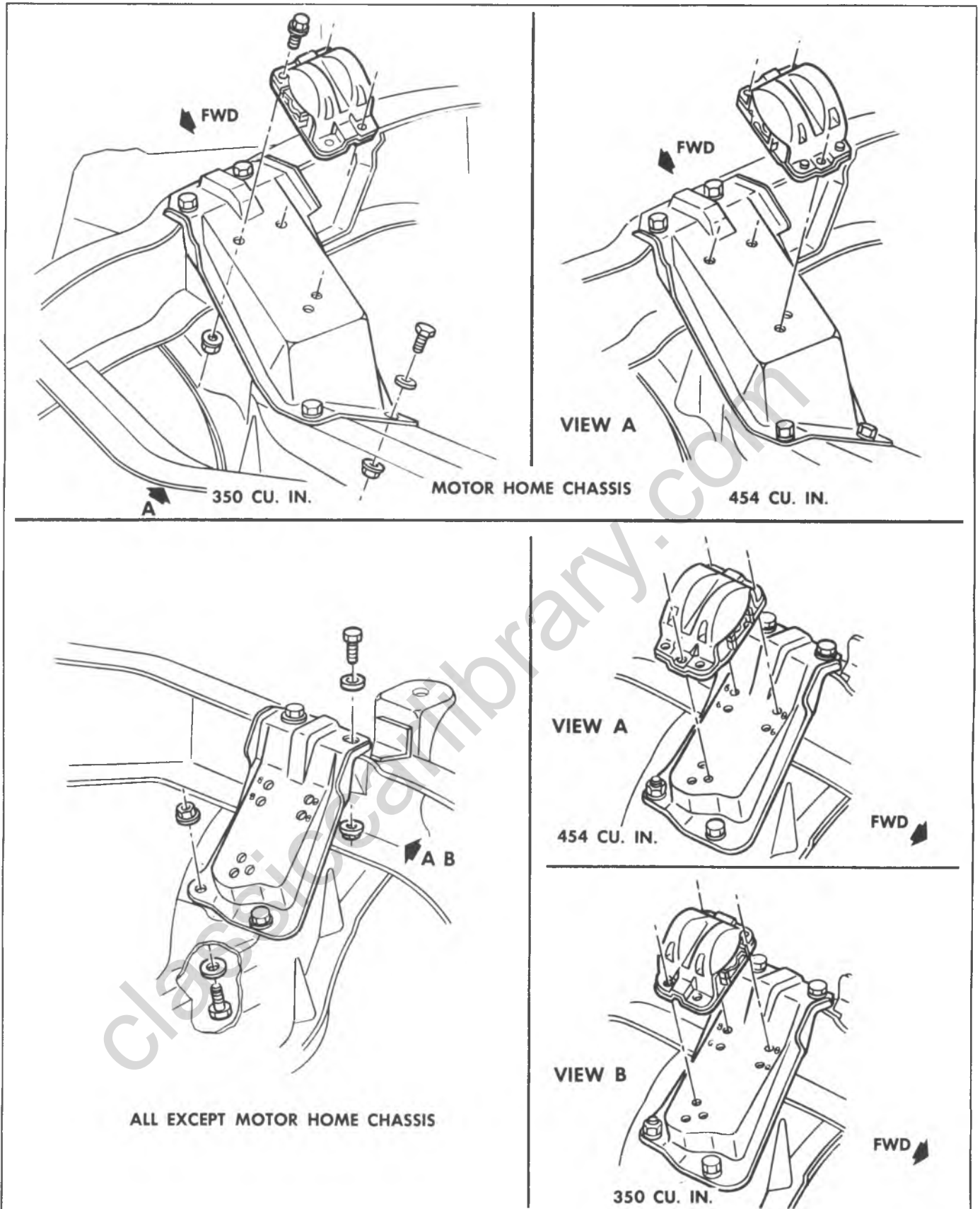


Fig. 6A4-5--"P" Series Engine Front Mount

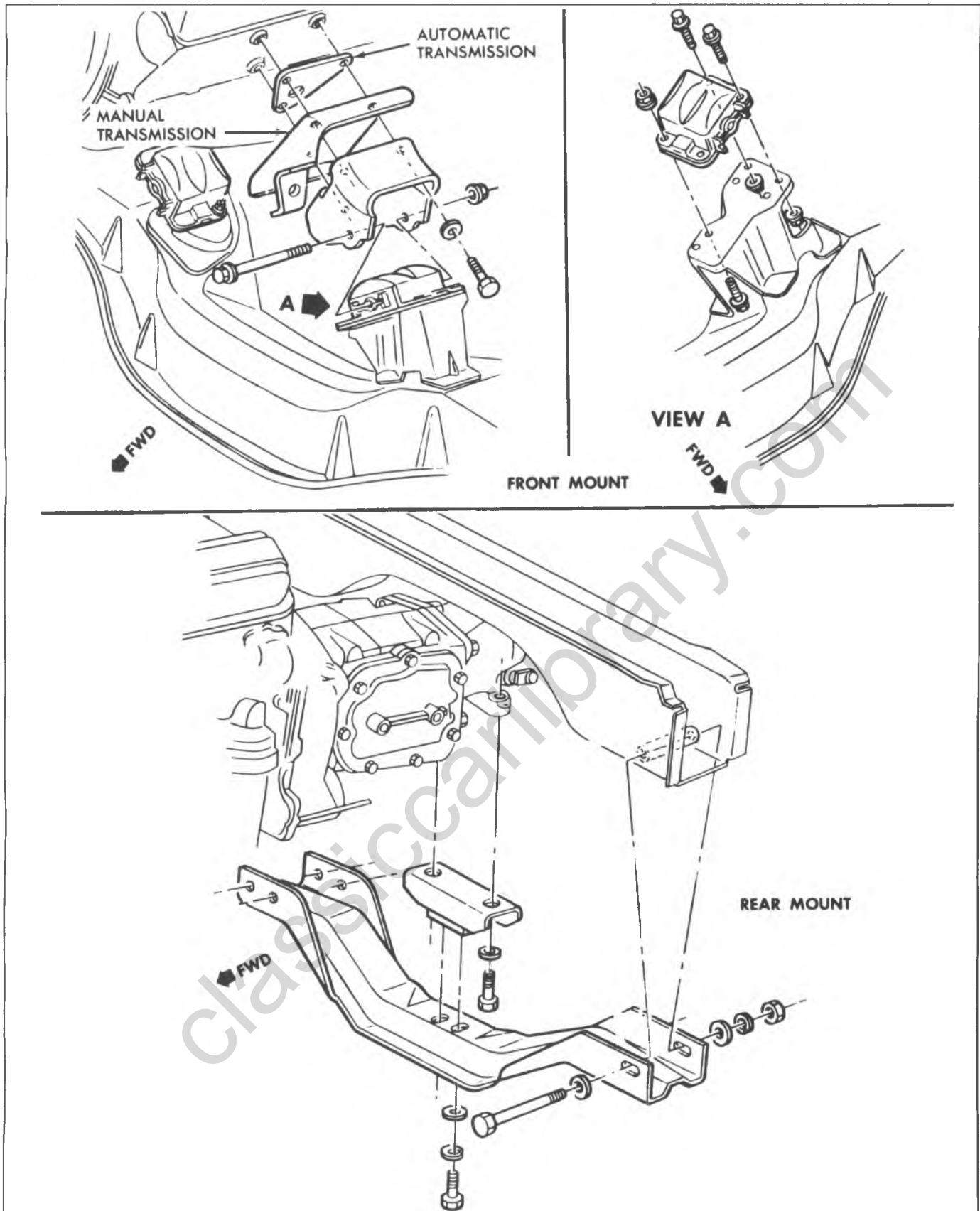


Fig. 6A4-6--"G" Series Engine Mounts

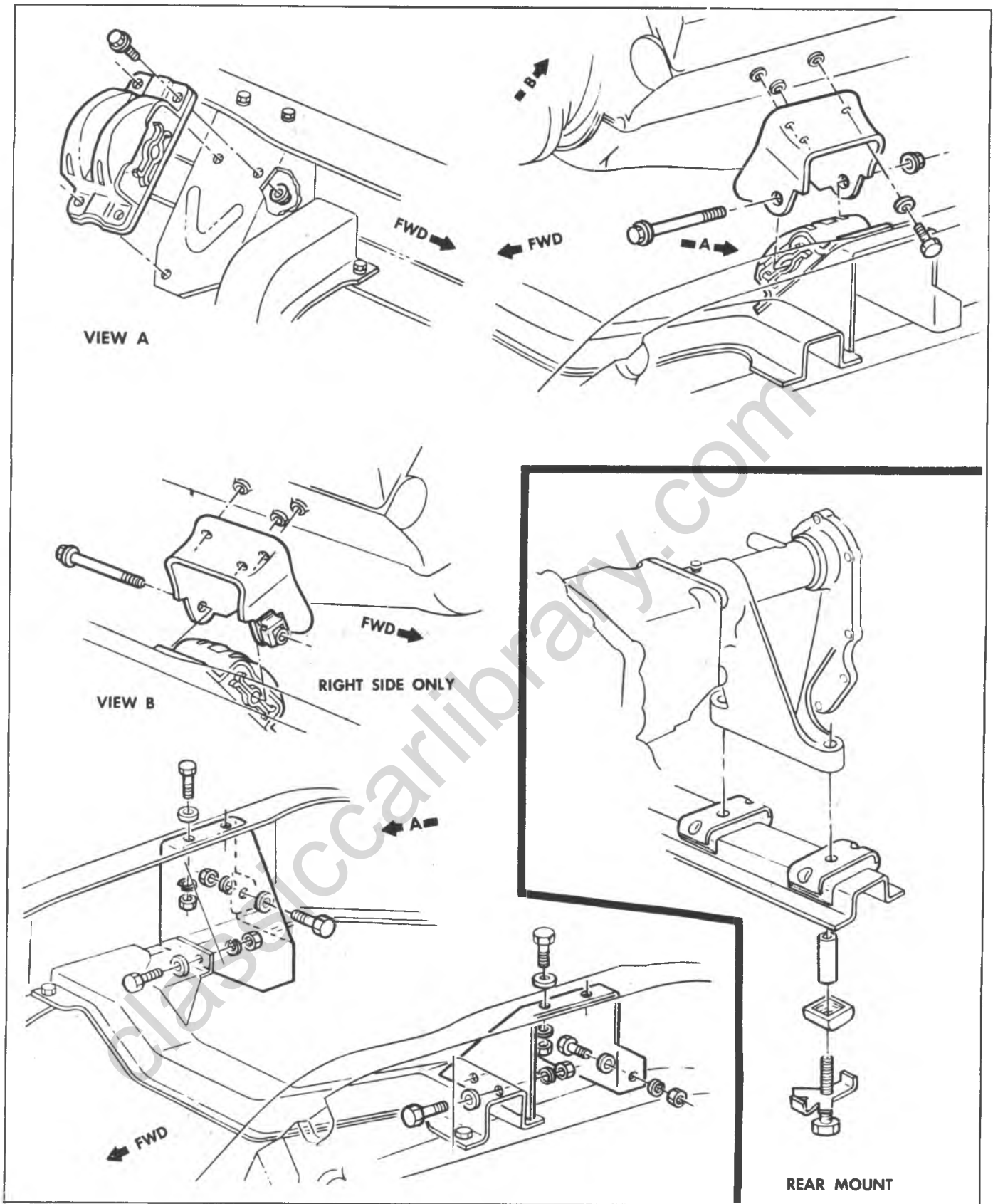


Fig. 6A4-7-"K" Series Engine Mounts

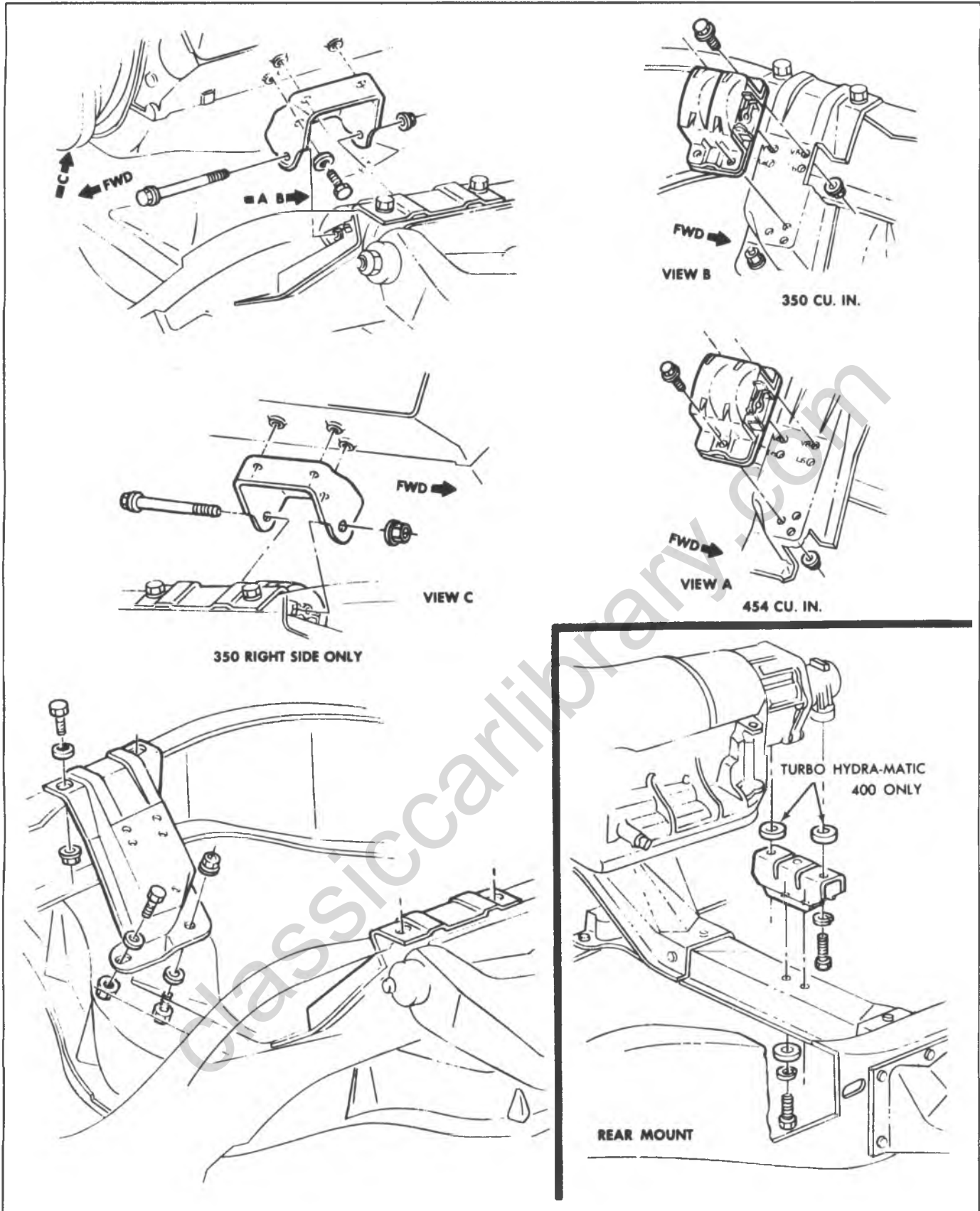


Fig. 6A4-8--"C" Series Engine Mounts

4. Remove air compressor and bracket (if equipped), accelerator return spring and bracket, and accelerator bellcrank.

5. Remove generator upper mounting bracket.

6. Remove manifold attaching bolts, then remove manifold and carburetor as an assembly. Discard gaskets.

7. If manifold is being replaced, transfer:

- Carburetor and carburetor attaching bolts.
- Temperature sending unit.
- Thermostat with housing (use new gasket).
- Heater hose adapter.
- EGR Valve (use new gasket).
- TVS switch.
- Vacuum fitting(s).
- Choke spring assembly (where applicable).

Installation

1. Clean gasket and seal surfaces on manifold, block, and cylinder heads with degreaser. Remove all RTV that is loose or will cause installation interference.

2. Install gaskets on cylinder heads and place a 3/16" (5mm) bead of RTV, #1052366 or equivalent, on the front and rear ridges of the cylinder case. Extend the bead 1/2" (13mm) up each cylinder head to seal and retain the manifold side gaskets.

3. Install manifold and torque bolts to specifications in the sequence outlined in fig. 6A4-9.

4. Install (if removed) air compressor and bracket, accelerator bellcrank.

5. Install distributor, positioning rotor at chalk mark, then install distributor cap.

6. Connect:

- Spark advance hose at distributor.
- Crankcase ventilation lines.
- Fuel line at carburetor.
- Accelerator linkage at carburetor.
- Battery negative cable at battery.

7. Install air cleaner.

8. Fill with coolant (refer to section 6B for proper procedure), start engine, adjust ignition timing and carburetor idle speed (if necessary) and check for leaks.

EXHAUST MANIFOLD

Removal

1. Remove carburetor heat stove pipe.
2. Remove the spark plug wiring heatshields.
3. Disconnect exhaust pipe from manifold and hang exhaust pipe from frame with wire.
4. Remove end bolts then remove center bolts and remove manifold.

Installation

● If installing a new right side manifold, the carburetor heat stove must be transferred from the old unit (fig. 6A4-10).

1. Clean mating surfaces on manifold and head, then install manifold in position and install bolts (fingertight).
2. Torque manifold bolts to specifications.
3. Connect exhaust pipe to manifold.
4. Install carburetor heat stove pipe.

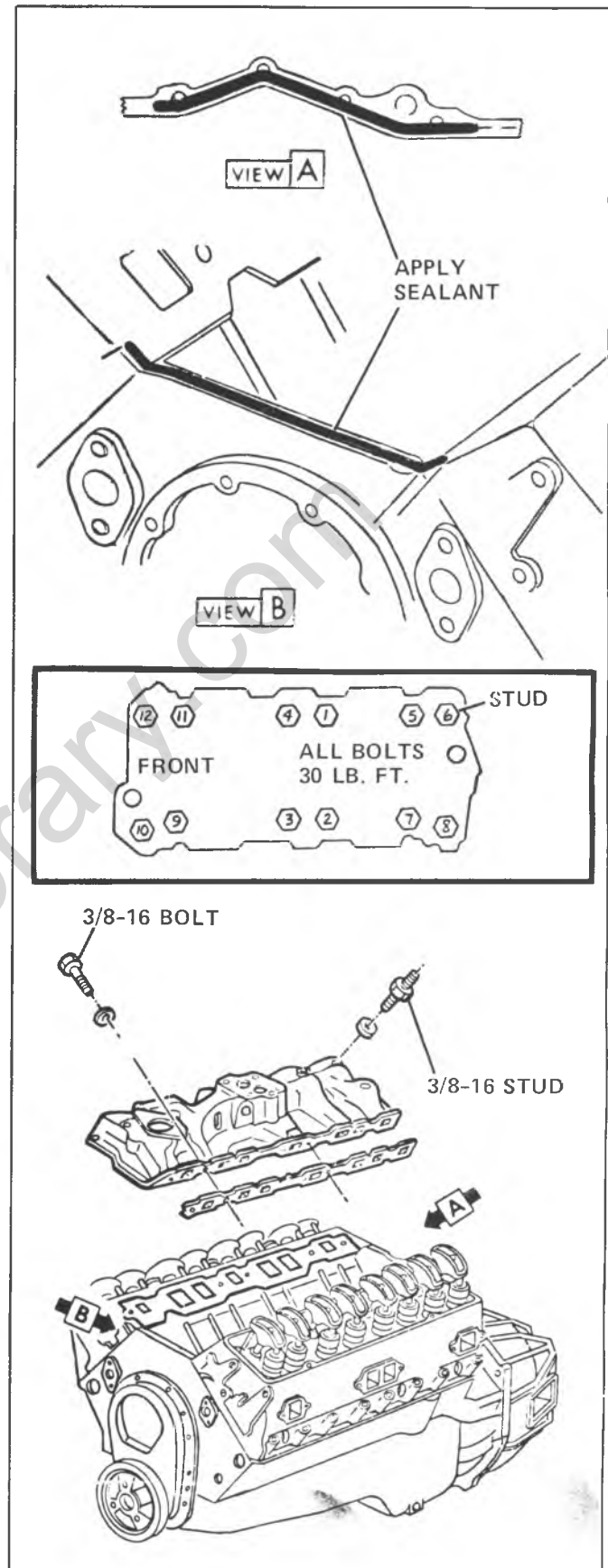


Fig. 6A4-9-Intake Manifold Torque Sequence

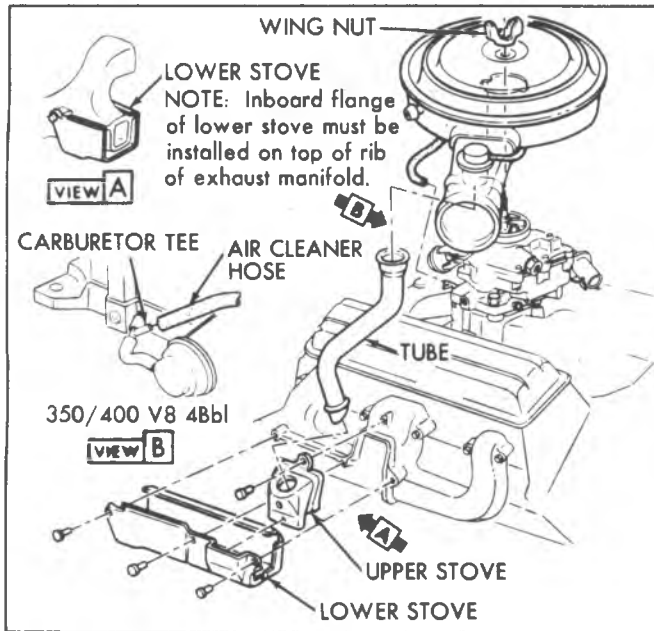


Fig. 6A4-10-Carburetor Heat Stove Assembly

5. Install spark plug wiring heatshields.
6. Start engine and check for leaks.

ROCKER ARM COVER

Removal

1. Disconnect battery negative cable.
2. Remove air cleaner.
3. Disconnect crankcase ventilation hoses at rocker arm covers.
4. Disconnect electrical wiring harness from rocker arm clips.

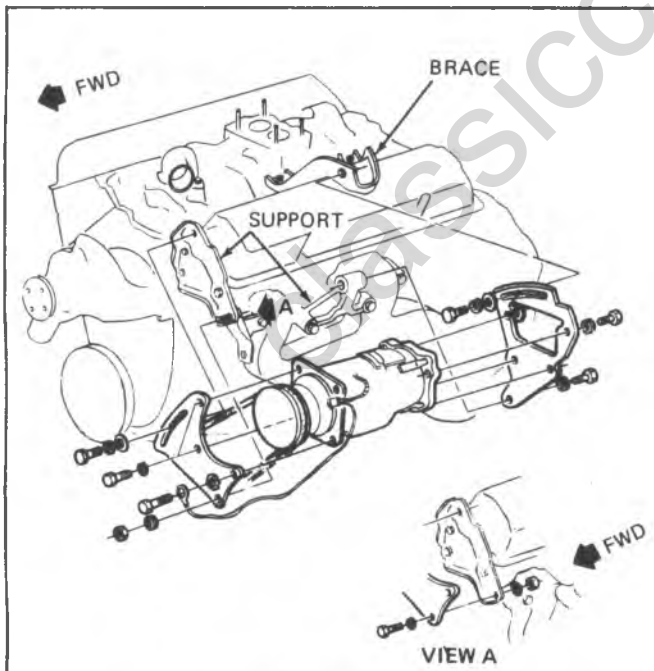


Fig. 6A4-11-A/C Compressor Mounting

5. Remove carburetor heat stove pipe from right exhaust manifold.

6. If the vehicle is equipped with air conditioning, remove the A/C compressor rear brace (fig. 6A4-11).

7. Remove rocker arm cover to head attaching bolts and remove rocker arm cover.

NOTICE: If cover adheres to cylinder head, shear off by bumping end of rocker arm cover with a block of wood and a rubber mallet. If cover still will not come loose, **CAREFULLY** pry until loose. **DO NOT DISTORT SEALING FLANGE.**

Installation

1. Clean sealing surface on cylinder head and rocker arm cover with degreaser. Using a 3/16" (5mm) bead of RTV, #1052366 or equivalent, place rocker arm cover on the head, install retaining bolts and torque to 40 lb. in. (4.6 N·m). Loose RTV sealant, or pieces causing installation interference, must be removed from both cylinder head and cover seal surfaces prior to applying new sealant.

- When going around the attaching bolt holes, always flow the RTV on the inboard side of the holes. Install cover and torque bolts while RTV is still wet (within 10 minutes).
2. On A/C equipped vehicles, install the A/C compressor upper brace. Adjust pulley belt to specification.
 3. Install carburetor heat stove pipe.
 4. Connect electrical wiring harness at clips on rocker arm cover.
 5. Connect crankcase ventilation hoses.
 6. Install air cleaner. Connect battery negative cable, start engine and check for leaks.

VALVE MECHANISM

Removal

1. Remove rocker arm covers as previously outlined.
2. Remove rocker arm nuts, rocker arm balls, rocker arms and push rods. Place rocker arms, rocker arm balls and push rods in a rack so they may be reinstalled in the same locations.

Installation and Adjustment

• Whenever new rocker arms and/or rocker arm balls are being installed, coat bearing surfaces of rocker arms and rocker arm balls with "Molykote" or its equivalent.

1. Install push rods. Be sure push rods seat in lifter socket.
2. Install rocker arms, rocker arm balls and rocker arm nuts. Tighten rocker arm nuts until all lash is eliminated.
3. Adjust valves when lifter is on base circle of camshaft lobe as follows:
 - a. Crank engine until mark on torsional damper lines up with center or "O" mark, on the timing tab, fastened to the crankcase front cover, and the engine is in the #1 firing position. This may be determined by placing fingers on the #1 valve as the mark on the damper comes near the "O" mark on the crankcase front cover. If the valves are not moving, the engine is in the #1 firing position. If the valves move as the mark comes up to the timing tab, the engine is in #6 firing position and should be rotated one more time to reach the #1 position.



Fig. 6A4-12--Valve Adjustment

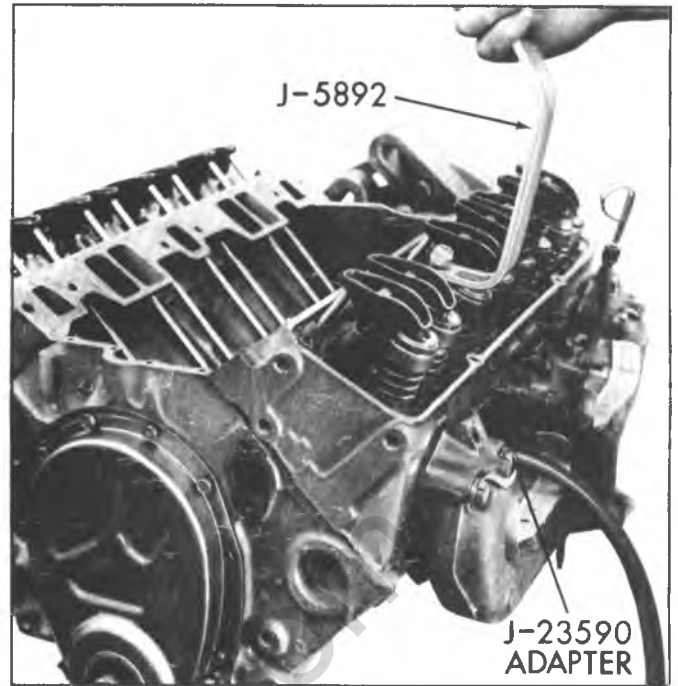


Fig. 6A4-13--Compressing Valve Spring

b. With the engine in the #1 firing position as just determined, the following valves may be adjusted:

- Exhaust--1, 3, 4, 8
- Intake--1, 2, 5, 7

c. Back out adjusting nut until lash is felt at the push rod then turn in adjusting nut until all lash is removed. This can be determined by rotating push rod while turning adjusting nut (fig. 6A4-12). When play has been removed, turn adjusting nut in one full additional turn (to center lifter plunger).

d. Rotate the engine one revolution until the pointer "O" mark and torsional damper mark are again in alignment. This is the #6 firing position. With the engine in this position the following valves may be adjusted.

- Exhaust--2, 5, 6, 7
- Intake--3, 4, 6, 8

4. Install rocker arm covers as previously outlined.

5. Start engine and adjust carburetor idle speed, if needed.

VALVE STEM OIL SEAL and/or VALVE SPRING

Removal

1. Remove rocker arm cover as previously outlined.
2. Remove spark plug, rocker arm and push rod on the cylinder(s) to be serviced.
3. Install air line adapter Tool J-23590 to spark plug port and apply compressed air to hold the valves in place.
4. Using Tool J-5892 to compress the valve spring, remove the valve locks, valve cap, oil shedder and valve spring and damper (fig. 6A4-13).

5. Remove the valve stem oil seal.

Installation

1. Set the valve spring and damper, oil shedder and valve cap in place. Compress the spring with Tool J-5892 and install oil seal in the lower groove of the stem, making sure the seal is flat and not twisted. A light coat of oil on

the seal will help prevent twisting.

2. Install the valve locks and release the compressor tool making sure the locks seat properly in the upper groove of the valve stem. Grease may be used to hold the locks in place while releasing the compressor tool.

3. Using tool J-23994, apply vacuum to the valve cap to make sure no air leaks past the seal.

4. Install spark plug, and torque to 22 lb. ft. (30 N·m).

5. Install and adjust valve mechanism as previously outlined.

VALVE LIFTERS

Hydraulic valve lifters very seldom require attention. The lifters are extremely simple in design, readjustments are not necessary, and servicing of the lifters requires only that care and cleanliness be exercised in the handling of parts.

Removal

1. Remove intake manifold as previously outlined.
2. Remove valve mechanism as previously outlined.
3. Remove valve lifters. Place valve lifters in a rack so that they may be reinstalled in the same location.

Installation

1. Coat foot of valve lifters with "Molykote" or its equivalent and install valve lifters. Make sure lifter foot is convex.
2. Install intake manifold as previously outlined.
3. Install and adjust valve mechanism as outlined.

Disassembly

1. Hold the plunger down with a push rod, and using the blade of a small screw driver, remove the push rod seat retainer.
2. Remove the push rod seat and metering valve (fig. 6A4-14).
3. Remove the plunger, ball check valve assembly and the plunger spring.

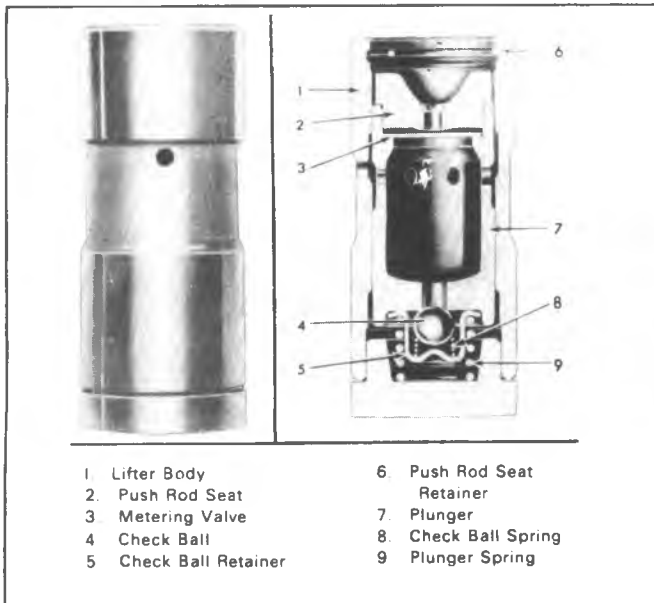


Fig. 6A4-14-Hydraulic Valve Lifter

4. Remove the ball check valve and spring by prying the ball retainer loose from the plunger with the blade of a small screw driver (fig. 6A4-15).

Cleaning and Inspection

Thoroughly clean all parts in cleaning solvent, and inspect them carefully. If any parts are damaged or worn, the entire lifter assembly should be replaced. If the lifter body wall is scuffed or worn, inspect the cylinder block lifter bore. If the bottom of the lifter is scuffed or worn, inspect the camshaft lobe. If the push rod seat is scuffed or worn, inspect the push rod. An additive containing EP lube, such as EOS, should always be added to crankcase oil for run-in when any new camshaft or lifters are installed. All damaged or worn lifters should be replaced.



Fig. 6A4-15-Removing Ball Check Valve



Fig. 6A4-16-Installing Ball Check Valve

● For proper lifter rotation during engine operation, lifter foot must be convex.

Assembly

1. Place the check ball on small hole in bottom of the plunger.
2. Insert check ball spring on seat in ball retainer and place retainer over ball so that spring rests on the ball. Carefully press the retainer into position in plunger with the blade of a small screw driver (fig. 6A4-16).
3. Place the plunger spring over the ball retainer and slide the lifter body over the spring and plunger, being careful to line up the oil feed holes in the lifter body and plunger.
4. Fill the assembly with SAE 10 oil, then insert the end of a 1/8" drift pin into the plunger and press down solid. Do not attempt to force or pump the plunger. At this point, oil holes in the lifter body and plunger assembly will be aligned (fig. 6A4-17).
5. Insert a 1/16" drift pin through both oil holes to hold the plunger down against the lifter spring tension (fig. 6A4-17).
6. Remove the 1/8" drift pin, refill assembly with SAE 10 oil.
7. Install the metering valve and push rod seat (fig. 6A4-14).
8. Install the push rod seat retainer, press down on the push rod seat and remove the 1/16" drift pin from the oil holes. The lifter is now completely assembled, filled with oil and ready for installation. Before installing lifters, coat the bottom of the lifter with "Molykote" or its equivalent.

CYLINDER HEAD ASSEMBLY

Removal

1. Remove intake manifold as previously outlined.
2. Remove generator lower mounting bolt and lay unit aside.

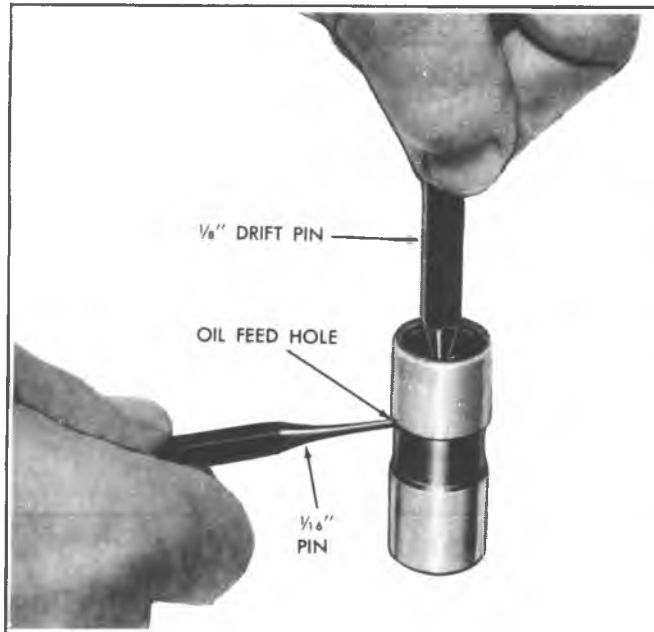


Fig. 6A4-17--Assembling Hydraulic Lifter

3. Remove exhaust manifolds as previously outlined.
4. Drain cylinder block of coolant.
5. If vehicle is equipped with A/C, remove A/C compressor and forward mounting bracket. Lay unit aside.
6. Remove valve push rods as previously outlined.
7. Remove cylinder head bolts, cylinder head and gasket. Place cylinder head on two blocks of wood to prevent damage.

Disassembly

1. With cylinder head removed, remove valve rocker arm nuts, balls and rocker arms (if not previously done).
2. Using Tool J-8062, compress the valve springs (fig. 6A4-18) and remove valve keys. Release the compressor tool and remove rotators or spring caps, oil shedders, springs and spring damper, then remove oil seals and valve

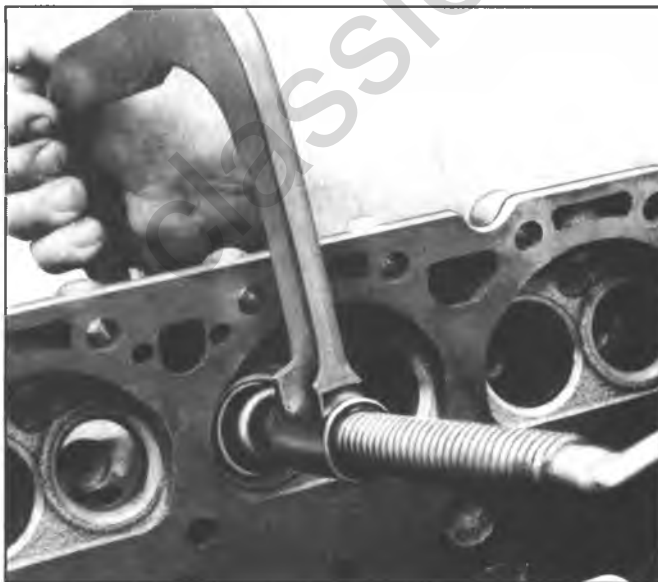


Fig. 6A4-18--Compressing Valve Spring

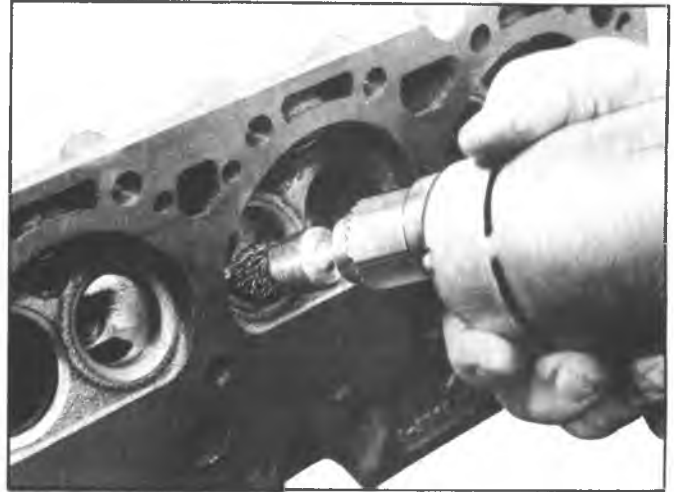


Fig. 6A4-19--Cleaning Combustion Chambers

spring shims.

3. Remove valves from cylinder head and place them in a rack in their proper sequence so that they can be assembled in their original positions.

Cleaning

1. Clean all carbon from combustion chambers and valve ports using Tool J-8089 (fig. 6A4-19).
2. Thoroughly clean the valve guides using Tool J-8101.
3. Clean all carbon and sludge from push rods, rocker arms and push rod guides.
4. Clean valve stems and heads on a buffing wheel.
5. Clean carbon deposits from head gasket mating surface.

Inspection

1. Inspect the cylinder head for cracks in the exhaust ports, combustion chambers, or external cracks to the coolant chamber.
2. Inspect the valves for burned heads, cracked faces or damaged stems.

NOTICE: Excessive valve stem to bore clearance will cause excessive oil consumption and may cause valve breakage. Insufficient clearance will result in noisy and sticky functioning of the valve and disturb engine smoothness.

3. Measure valve stem clearance (fig. 6A4-20) as follows:

- a. Clamp a dial indicator on one side of the cylinder head rocker arm cover gasket rail.

- b. Locate the indicator so that movement of the valve stem from side to side (crosswise to the head) will cause a direct movement of the indicator stem. The indicator stem must contact the side of the valve stem just above the valve guide.

- c. Drop the valve head about 1/16" (1.6mm) off the valve seat.

from side to side using light pressure to obtain a clearance reading. If clearance exceeds specifications, it will be necessary to ream valve guides for oversize valves as outlined.



Fig. 6A4-20--Measuring Valve Stem Clearances

4. Check valve spring tension with Tool J-8056 spring tester (fig. 6A4-21). Springs should be compressed to the specified height and checked against the specifications chart. Springs should be replaced if not within 10 lbs. (44 N) of the specified load (without dampers).

5. Inspect rocker arm studs for wear or damage.



Fig. 6A4-21--Checking Valve Spring Tension

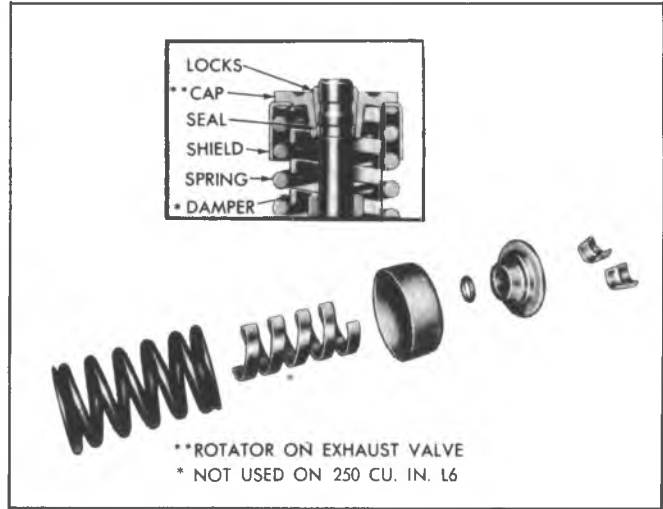


Fig. 6A4-22--Valve Spring Installation

Assembly

1. Insert a valve in the proper port.
2. Assemble the valve spring and related parts as follows:
 - a. Set the valve spring shim, valve spring, oil shedder and valve cap or rotator in place (fig. 6A4-22).
 - b. Compress the spring with Tool J-8062.
 - c. Install oil seal in the lower groove of the stem, making sure that the seal is flat and not twisted.
 - d. Install the valve locks and release the compressor tool, making sure that the locks seat properly in the upper groove of the valve stem. Grease may be used to hold the locks in place while releasing the compressor tool.
3. Install the remaining valves.
4. Check each valve stem oil seal by placing Valve Seal Leak Detector (Tool J-23994) over the end of the valve stem and against the cap. Operate the vacuum pump and make sure no air leaks past the seal (fig. 6A4-23).

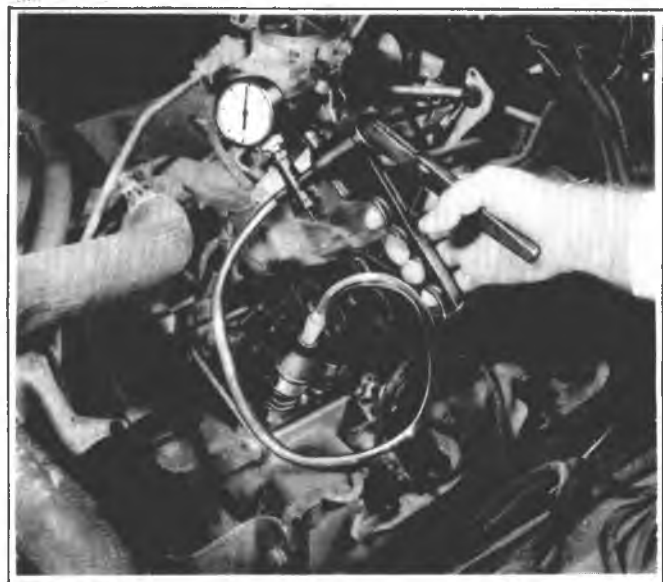


Fig. 6A4-23--Checking Valve Stem Oil Seals

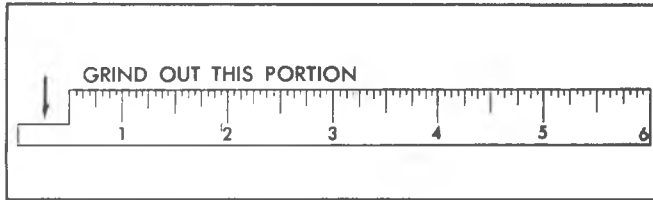


Fig. 6A4-24--Cutaway Scale

5. Check the installed height of the valve springs, using a narrow thin scale. A cutaway scale will help (fig. 6A4-24). Measure from the top of the shim or the spring seat to the top of the oil shedder (fig. 6A4-25). If this is found to exceed the specified height, install a valve spring seat shim approximately 1/16" (1.6mm) thick. At no time should the spring be shimmed to give an installed height under the minimum specified.

Installation

- The gasket surfaces on both the head and the block must be clean of any foreign matter and free of nicks or heavy scratches. Cylinder bolt threads in the block and threads on the cylinder head bolts must be clean as dirt will affect bolt torque.

1. If using a STEEL gasket, coat both sides of a new gasket with a good sealer. Spread the sealer thin and even. One method of applying the sealer that will assure the proper coat is with the use of a paint roller. Too much sealer may hold the gasket away from the head or block.

- Use no sealer if using a composition STEEL ASBESTOS gasket.

2. Place the gasket in position over the dowel pins with the bead up.

3. Carefully guide the cylinder head into place over the dowel pins and gasket.

4. Coat threads of cylinder head bolts with sealing compound, #1052080 or equivalent, and install bolts finger tight.

5. Tighten each cylinder head bolt a little at a time in the sequence shown in the torque sequence chart until the specified torque is reached.

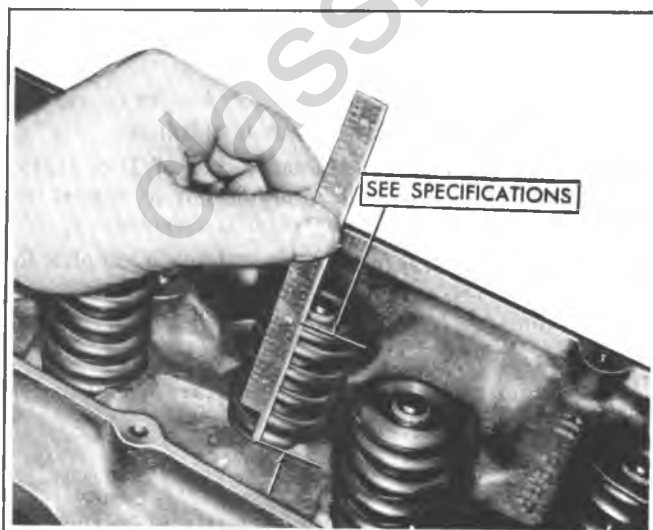


Fig. 6A4-25--Measuring Valve Spring Installed Height

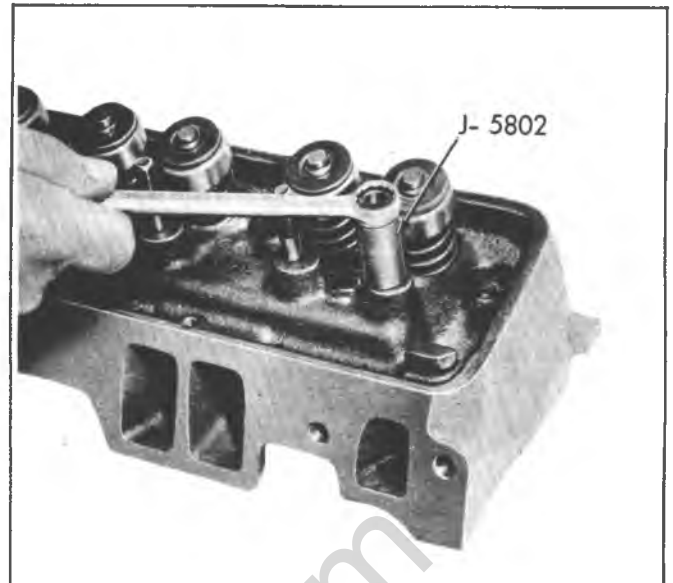


Fig. 6A4-26--Removing Rocker Arm Stud

6. Install exhaust manifolds as previously outlined.
7. Install intake manifold as previously outlined.
8. Install and adjust valve mechanism as previously outlined.

ROCKER ARM STUDS

Replacement

Rocker arm studs that have damaged threads or are loose in cylinder heads should be replaced with new studs available in .003" and .013" oversize. Studs may be installed after reaming the holes as follows:

1. Remove old stud by placing Tool J-5802-1 over the stud, installing nut and flat washer and removing stud by turning nut (fig. 6A4-26).

2. Ream hole for oversize stud using Tool J-5715 for .003" oversize or Tool J-6036 for .013" oversize (fig. 6A4-27).

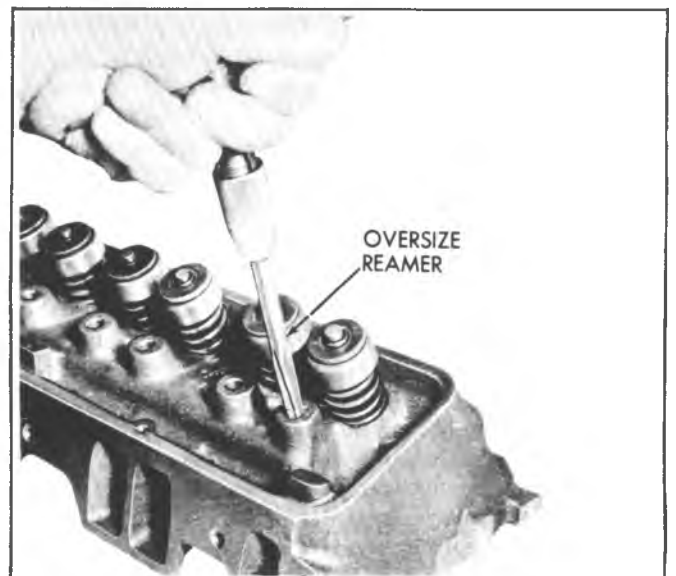


Fig. 6A4-27--Reaming Rocker Arm Stud Bore

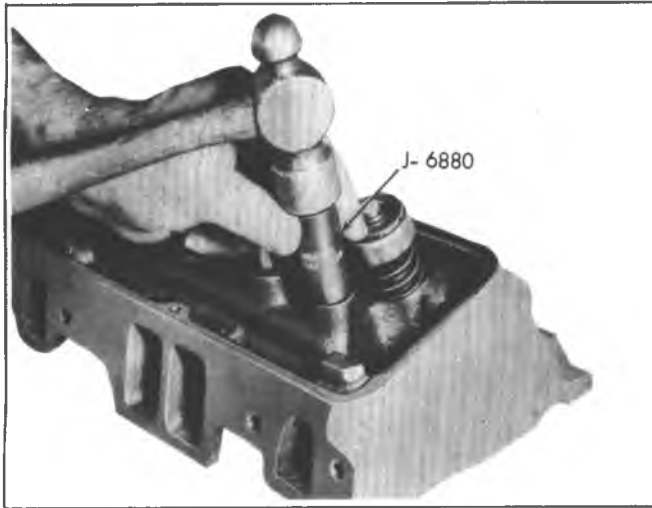


Fig. 6A4-28--Installing Rocker Arm Stud

NOTICE: Do not attempt to install an oversize stud without reaming stud hole as this could damage the head casting.

3. Coat press-fit area of stud with hypoid axle lubricant. Install new stud, using Tool J-6880 as a guide. Gage should bottom on head (fig. 6A4-28).

VALVE GUIDE BORES

Valves with oversize stems are available (see specifications). To ream the valve guide bores for oversize valves use Tool Set J-5830.

VALVE SEATS

Reconditioning the valve seats is very important, because the seating of the valves must be perfect for the engine to deliver the power and performance built into it.

Another important factor is the cooling of the valve heads. Good contact between each valve and its seat in the head is imperative to insure that the heat in the valve head will be properly carried away.

Several different types of equipment are available for reseating valves seats. The recommendations of the manufacturer of the equipment being used should be carefully followed to attain proper results.

Regardless of what type of equipment is used, however, it is essential that valve guide bores be free from carbon or dirt to ensure proper centering of pilot in the guide.

VALVES

Valves that are pitted can be refaced to the proper angle, insuring correct relation between the head and stem on a valve refacing mechanism. Valve stems which show excessive wear, or valves that are warped excessively should be replaced. When a valve head which is warped excessively is refaced, a knife edge will be ground on part or all of the valve head due to the amount of metal that must be removed to completely reface. Knife edges lead to breakage, burning or pre-ignition due to heat localizing on this knife edge. If the edge of the valve head is less than 1/32" (.80mm) thick after grinding, replace the valve.

Several different types of equipment are available for refacing valves. The recommendation of the manufacturer of the equipment being used should be carefully followed

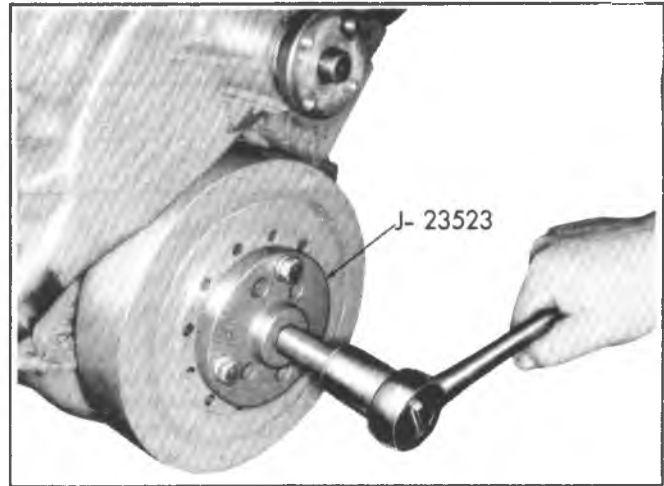


Fig. 6A4-30--Removing Torsional Damper - Typical

to attain proper results.

TORSIONAL DAMPER

Removal

1. Remove fan belt, fan and pulley.
2. Remove the fan shroud assembly.
 - If additional operations (such as camshaft removal) are not being performed, radiator removal will not be necessary.
3. Remove accessory drive pulley then remove damper retaining bolt.
4. Install Tool J-23523 on damper then, turning puller screw, remove damper (fig. 6A4-30).

Installation

NOTICE: The inertial weight section of the torsional damper is assembled to the hub with a rubber type material. The installation procedures (with proper tool) must be followed or movement of the inertia weight section on the hub will destroy the tuning of the torsional damper.

1. Coat front cover seal contact area (on damper) with engine oil.
2. Place damper in position over key on crankshaft.
3. Pull damper onto crankshaft as follows:
 - a. Install appropriate threaded end of Tool J-23523 into crankshaft. Install tool in crankshaft so that at least 1/2" (13mm) of thread engagement is obtained.
 - b. Install plate, thrust bearing and nut to complete tool installation.
 - c. Pull damper into position as shown in Figure 6A4-31.
 - d. Remove tool from crankshaft then install damper retaining bolt and torque to specifications.
4. Install accessory drive pulley.
5. Install fan shroud.
6. Install fan and pulley to water pump hub and tighten securely.
7. Install fan belt and adjust (see section 6B).

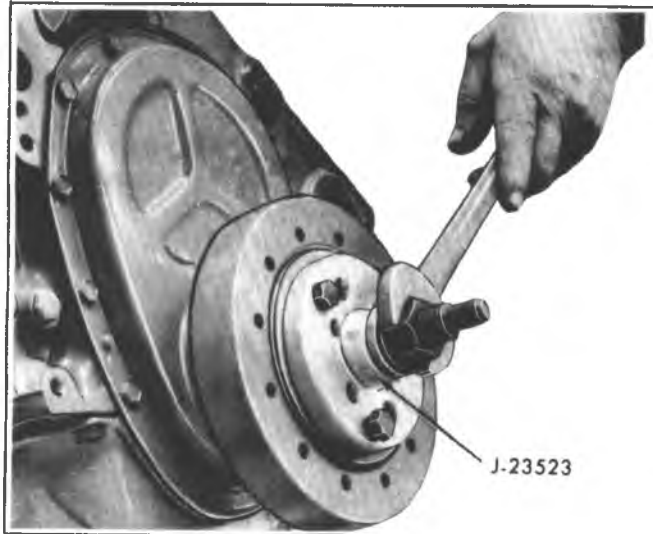


Fig. 6A4-31--Installing Torsional Damper

8. Fill cooling system (see section 6B) and check for leaks.

CRANKCASE FRONT COVER

Removal

1. Remove torsional damper as previously outlined.
2. Remove water pump (see section 6B).
3. Remove crankcase front cover attaching screws and remove front cover and gasket, then discard gasket.

Installation

1. Clean gasket surface on block and crankcase front cover.
2. Use a sharp knife or other suitable cutting tool to remove any excess oil pan gasket material that may be protruding at the oil to engine block junction.
3. Apply a 1/8" (3mm) bead of RTV, #1052366 or equivalent, to the joint formed at the oil pan and cylinder block.
4. Coat the cover gasket with gasket sealant and place in position on cover.
5. Install cover-to-oil pan seal, lightly coat bottom of seal with engine oil, and position cover over crankshaft end.
6. Loosely install the cover-to-block upper attaching screws.
7. Tighten screws alternately and evenly while pressing downward on cover so that dowels in block are aligned with corresponding holes in cover. Position cover so that dowels enter holes in cover without binding. Do not force cover over dowels so that cover flange or holes are distorted.
8. Install remaining cover screws and torque to specifications.
9. Install torsional damper and water pump as previously outlined.

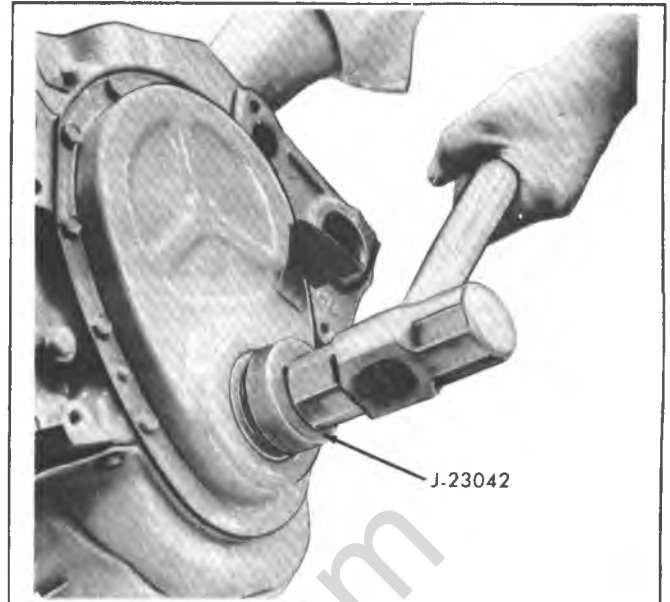


Fig. 6A4-32--Installing Oil Seal

OIL SEAL (FRONT COVER)

Replacement

With Cover Removed

1. With cover removed, pry oil seal out of cover from the front with a large screw driver.
2. Install new seal so that open end of the seal is toward the inside of cover and drive it into position with Tool J-23042. Support rear of cover at seal area.

With Cover Installed

1. With torsional damper removed, pry seal out of cover from the front with a large screw driver. Be careful not to damage the surface on the crankshaft.
2. Install new seal so that open end of seal is toward the inside of cover and drive it into position with Tool J-23042 (fig. 6A4-32).

CAMSHAFT

Measuring Lobe Lift

1. Remove the valve mechanism as previously outlined.
2. Position indicator with ball socket adapter (Tool J-8520) on push rod (fig. 6A4-33). Make sure push rod is in the lifter socket.
3. Rotate the crankshaft slowly in the direction of rotation until the lifter is on the heel of the cam lobe. At this point, the push rod will be in its lowest position.
4. Set dial indicator on zero, then rotate the crankshaft slowly, or attach an auxiliary starter switch and "bump" the engine over, until the push rod is fully raised position.
 - Whenever the engine is cranked remotely at the starter, with a special jumper cable or other means, the distributor primary lead should be disconnected from the distributor (coil).
5. Compare the total lift recorded from the dial indicator with specifications.
6. If camshaft readings for all lobes are within specifications, remove dial indicator assembly.



Fig. 6A4-33--Measuring Camshaft Lobe Lift

7. Install and adjust valve mechanism as outlined.

Removal

1. Remove valve lifters as previously outlined.
2. Remove crankcase front cover as previously outlined.
3. Remove grille.
4. Remove fuel pump and push rod (see section 6C).
5. Complete camshaft removal as follows:
 - Sprocket is a light fit on camshaft. If sprocket does not come off easily a light blow on the lower edge of the sprocket (with a plastic mallet) should dislodge the sprocket.
6. Install two 5/16" - 18 x 4" bolts in camshaft bolt holes then remove camshaft (fig. 6A4-34).

NOTICE: All camshaft journals are the same diameter

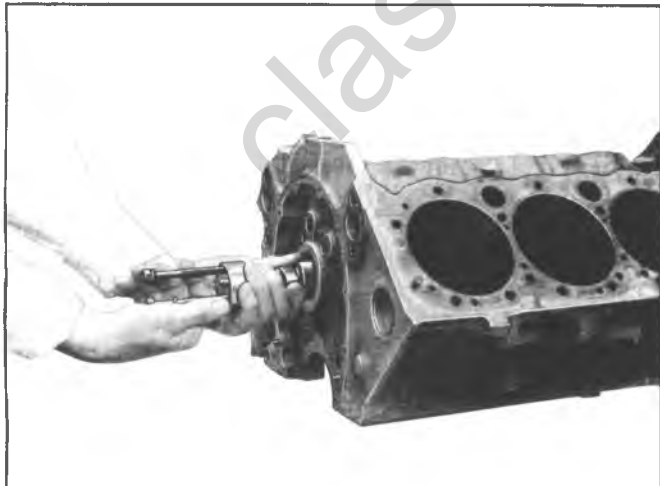


Fig. 6A4-34--Removing Camshaft

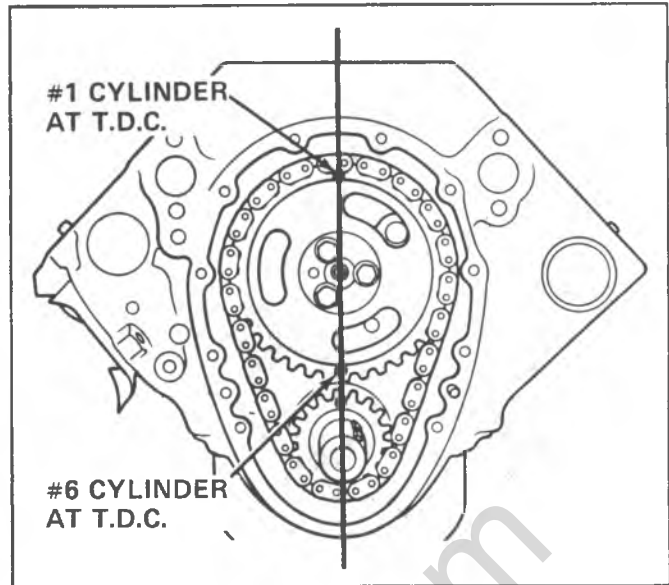


Fig. 6A4-35--Camshaft Sprocket Alignment Marks

and care must be used in removing camshaft to avoid damage to bearings.

Inspection

The camshaft bearing journals should be measured with a micrometer for an out-of-round condition. If the journals exceed .001" (.025mm) out-of-round, the camshaft should be replaced.

Installation

Whenever a new camshaft is installed coat camshaft lobes with "Molykote" or its equivalent.

Whenever a new camshaft is installed, replacement of all valve lifters is recommended to insure durability of the camshaft lobes and lifter feet.

1. Lubricate camshaft journals with engine oil and install camshaft.
2. Install timing chain on camshaft sprocket (fig. 6A4-35). Hold the sprocket vertically with the chain hanging down and align marks on camshaft and crankshaft sprockets.
3. Align dowel in camshaft with dowel hole in camshaft sprocket then install sprocket on camshaft.
4. Draw the camshaft sprocket onto camshaft using the mounting bolts. Torque to specifications.
5. Lubricate timing chain with engine oil.
6. Install fuel pump push rod and fuel pump (see section 6C).
7. Install grille.
8. Install crankcase front cover as previously outlined.
9. Install valve lifters as previously outlined.

CAMSHAFT BEARINGS

Removal

Camshaft bearings can be replaced with engine completely or partially disassembled. To replace bearings without complete disassembly, remove the camshaft and crankshaft leaving cylinder heads attached and pistons in place. Before removing crankshaft, tape threads of connecting rod bolts to prevent damage to crankshaft. Fasten connecting rods against sides of engine so they will

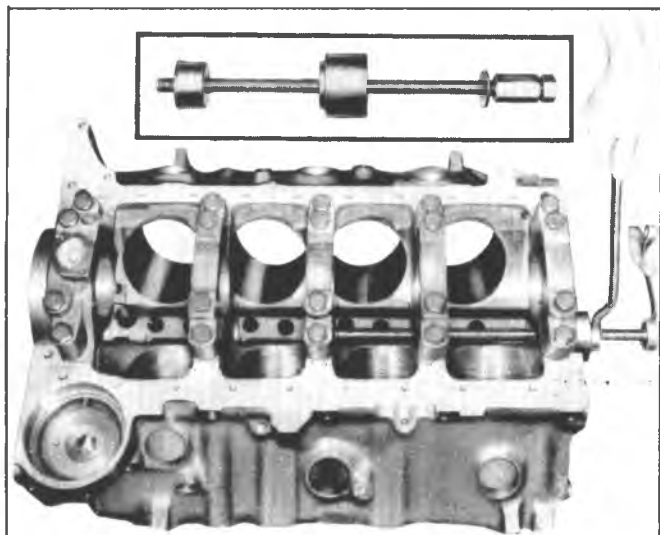


Fig. 6A4-36--Removing Camshaft Bearings

not be in the way while replacing camshaft bearings.

1. With camshaft and crankshaft removed, drive camshaft rear plug from cylinder block.

2. Using Tool J-6098, with nut and thrust washer installed to end of threads, index pilot in camshaft front bearing and install puller screw through pilot.

3. Install remover and installer tool with shoulder toward bearing, making sure a sufficient amount of threads are engaged.

4. Using two wrenches, hold puller screw while turning nut. When bearing has been pulled from bore, remove remover and installer tool and bearing from puller screw (fig. 6A4-36).

5. Remove remaining bearings (except front and rear) in the same manner. It will be necessary to index pilot in camshaft rear bearing to remove the rear intermediate bearing.

6. Assemble remover and installer tool on driver handle and remove camshaft front and rear bearings by driving towards center of cylinder block (fig. 6A4-37).

Installation

The camshaft front and rear bearings should be installed first. These bearings will act as guides for the pilot and center the remaining bearings being pulled into place.

1. Assemble remover and installer tool on driver handle and install camshaft front and rear bearings by driving towards center of cylinder block (fig. 6A4-37).

2. Using Tool Set J-6098, with nut then thrust washer installed to end of threads, index pilot in camshaft front bearing and install puller screw through pilot.

3. Index camshaft bearing in bore (with oil hole aligned as outlined below), then install remover and installer tool on puller screw with shoulder toward bearing.

- Number one cam bearing oil hole must be positioned so that oil holes are equidistant from 6 o'clock position.

- Number two through number four bearing oil holes must be positioned at 5 o'clock position (toward left side of engine, and at a position even with bottom of cylinder bore).

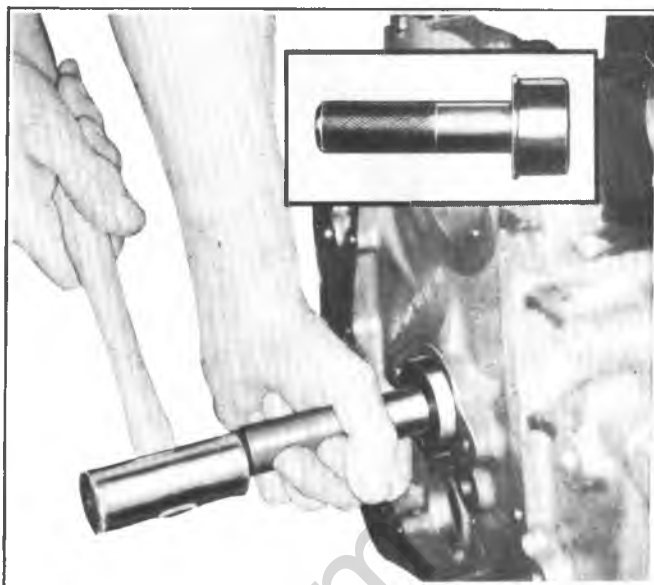


Fig. 6A4-37--Replacing Camshaft Front Bearing

- Number five bearing oil hole must be in 12 o'clock position.

4. Using two wrenches, hold puller screw while turning nut. After bearing has been pulled into bore, remove the remover and installer tool from puller screw, and check alignment of oil hole in camshaft bearing.

5. Install remaining bearings in the same manner. It will be necessary to index pilot in the camshaft rear bearing to install the rear intermediate bearing.

6. Coat new camshaft rear plug O.D. with #1052080 sealant, or equivalent, and install flush to 1/32" (.80mm) deep.

OIL PAN

Removal

1. Drain engine oil.
2. Remove exhaust crossover pipe.
3. On vehicles equipped with automatic transmission, remove converter housing under pan.
4. On 'K' models with automatic transmission, remove strut rods at motor mounts.
5. Remove oil pan and discard gaskets and seals.

Installation

1. Thoroughly clean all gasket and seal surfaces on oil pan, cylinder block, crankcase front cover and rear main bearing cap.

2. Install new oil pan side gaskets on cylinder block using gasket sealant as a retainer. Install new oil pan rear seal in rear main bearing cap groove, with ends butting side gaskets. Install new oil pan front seal in groove in crankcase front cover with ends butting side gaskets.

3. Install oil pan and torque bolts to specifications.

4. If 'K' model, replace strut rods.

5. Install converter housing under pan.

6. Install exhaust crossover pipe.

7. Fill with oil, start engine and check for leaks.

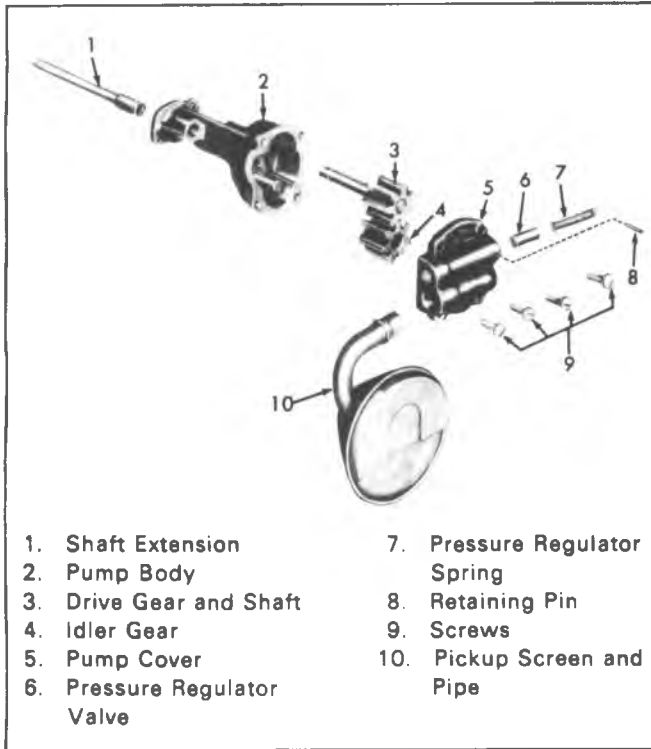


Fig. 6A4-38--Oil Pump

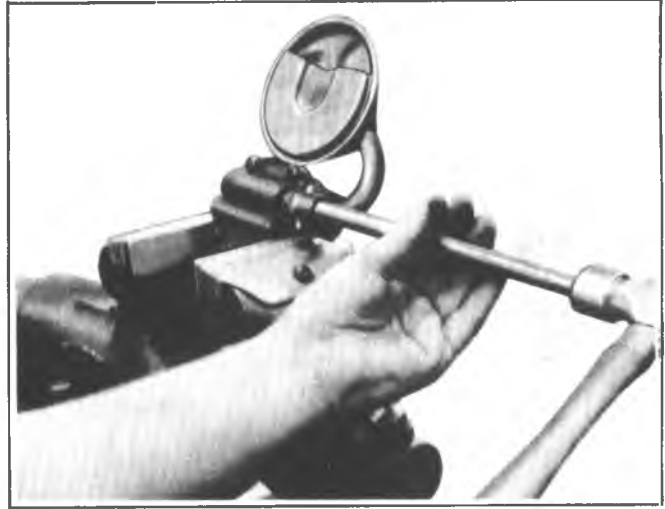


Fig. 6A4-39--Installing Screen

OIL PUMP

Removal

1. Remove oil pan as previously outlined.
2. Remove pump to rear main bearing cap bolt and remove pump and extension shaft.

Disassembly (Figure 6A4-38)

1. Remove the pump cover attaching screws and the pump cover.
2. Mark gear teeth so they may be reassembled with the same teeth indexing. Remove the idler gear and the drive gear and shaft from the pump body.
3. Remove the pressure regulator valve retaining pin, pressure regulator valve and related parts.
4. If the pickup screen and pipe assembly need replacing, mount the pump in a soft-jawed vise and extract pipe from pump. Do not disturb the pickup screen on the pipe. This is serviced as an assembly.

Cleaning and Inspection

1. Wash all parts in cleaning solvent and dry with compressed air.
2. Inspect the pump body and cover for cracks or excessive wear.
3. Inspect pump gears for damage or excessive wear.
 - The pump gears and body are not serviced separately. If the pump gears or body are damaged or worn, replacement of the entire oil pump assembly is necessary.
4. Check the drive gear shaft for looseness in the pump body.
5. Inspect inside of pump cover for wear that would permit oil to leak past the ends of the gears.
6. Inspect the pickup screen and pipe assembly for damage to screen, pipe or relief grommet.

7. Check the pressure regulator valve for fit.

Assembly (Figure 6A4-38)

1. If the pickup screen and pipe assembly was removed, it should be replaced with a new part. Loss of press fit condition could result in an air leak and loss of oil pressure. Mount the pump in a soft-jawed vise, apply sealer to end of pipe, and using Tool J-8369 (fig. 6A4-39) tap the pipe in place with a plastic hammer.

NOTICE: Be careful of twisting, shearing or collapsing pipe while installing in pump.

2. Install the pressure regulator valve and related parts.
3. Install the drive gear and shaft in the pump body.
4. Install the idler gear in the pump body with the smooth side of gear towards pump cover opening.
5. Install the pump cover and torque attaching screws to specifications.
6. Turn drive shaft by hand to check for smooth operation.

Installation

1. Assemble pump and extension shaft to rear main bearing cap, aligning slot on top end of extension shaft with drive tang on lower end of distributor drive shaft.
2. Install pump to rear bearing cap bolt and torque to specifications.
3. Install oil pan previously outlined.

CONNECTING ROD BEARINGS

Connecting rod bearings are of the precision insert type and do not utilize shims for adjustment. **DO NOT FILE RODS OR ROD CAPS.** If clearances are found to be excessive a new bearing will be required. Service bearings are available in standard size and .001" and .002" undersize for use with new and used standard size crankshafts, and in .010" and .020" undersize for use with reconditioned crankshafts.

On removing a connecting rod cap, it is possible to find a .009" undersize bearing. These are used in manufacturing for selective fitting.

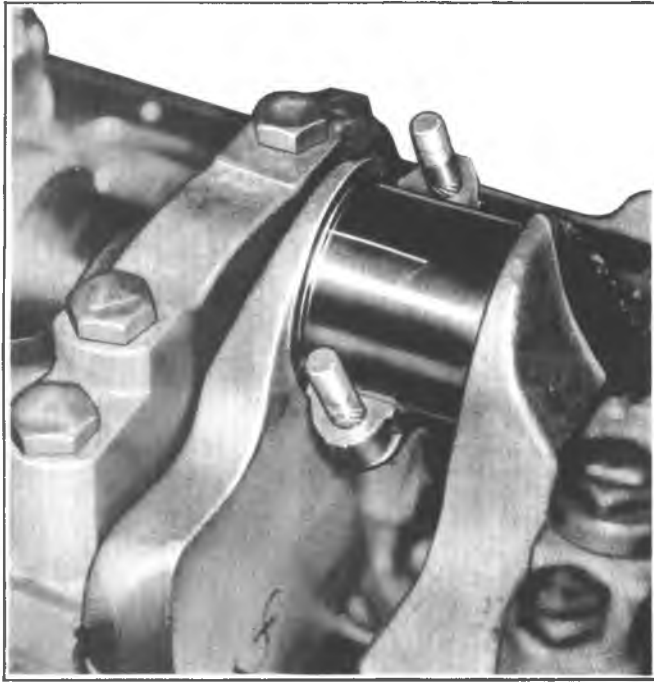


Fig. 6A4-40--Gaging Plastic On Crankpin

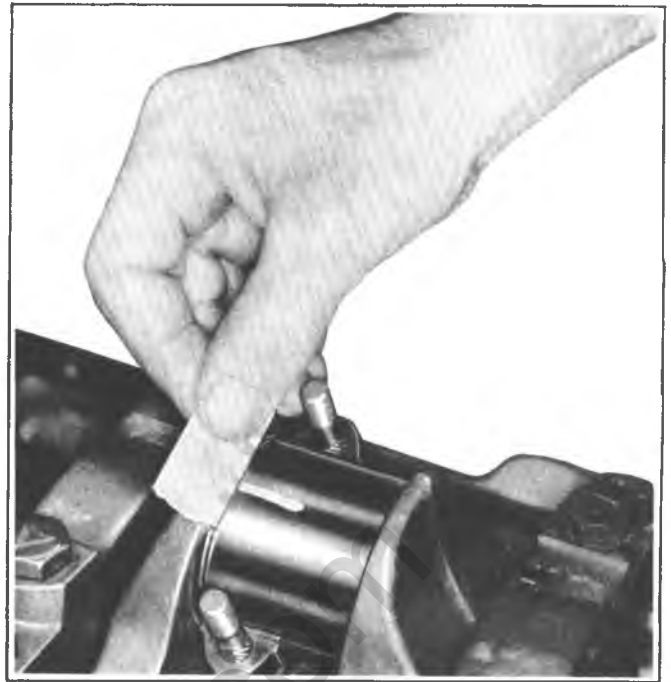


Fig. 6A4-41--Measuring Gaging Plastic

Inspection and Replacement

1. With oil pan and oil pump removed, remove the connecting rod cap and bearing.

Before removal of connecting rod cap, mark the side of the rod and cap with the cylinder number to assure matched reassembly of rod and cap.

2. Inspect the bearing for evidence of wear or damage. (Bearings showing the above should not be installed.)

3. Wipe both upper and lower bearing shells and crankpin clean of oil.

4. Measure the crankpin for out-of-round or taper with a micrometer. If not within specifications replace or recondition the crankshaft. If within specifications and a new bearing is to be installed, measure the maximum diameter of the crankpin to determine new bearing size required.

5. If within specifications measure new or used bearing clearances with Plastigage or its equivalent.

If a bearing is being fitted to an out-of-round crankpin, be sure to fit to the maximum diameter of the crankpin. If the bearing is fitted to the minimum diameter and the crankpin is out-of-round .001" interference between the bearing and crankpin will result in rapid bearing failure.

a. Place a piece of gaging plastic, the length of the bearing (parallel to the crankshaft), on the crankpin or bearing surface (fig. 6A4-40). Plastic gage should be positioned in the middle of upper or lower bearing shell. (Bearings are eccentric and false readings could occur if placed elsewhere).

b. Install the bearing in the connecting rod and cap.

c. Install the bearing cap and evenly torque nuts to specifications.

Do not turn the crankshaft with the gaging plastic installed.

d. Remove the bearing cap and using the scale on the gaging plastic envelope, measure the gaging plastic width at the widest point (fig.6A4-41).

6. If the clearance exceeds specifications, select a new, correct size, bearing and remeasure the clearance.

Be sure to check what size bearing is being removed in order to determine proper replacement size bearing. If clearance cannot be brought to within specifications, the crankpin will have to be ground undersize. If the crankpin is already at maximum undersize, replace crankshaft.

7. Coat the bearing surface with oil, install the rod cap and torque nuts to specifications.

8. When all connecting rod bearings have been installed tap each rod lightly (parallel to the crankpin) to make sure they have clearance.

9. Measure all connecting rod side clearances (see specifications) between connecting rod caps (fig. 6A4-42).

MAIN BEARINGS

Main bearings are of the precision insert type and do not utilize shims for adjustment. If clearances are found to be excessive, a new bearing, both upper and lower halves, will be required. Service bearings are available in standard size and .001", .002", .009", .010" and .020" undersize.

Selective fitting of both rod and main bearing inserts is necessary in production in order to obtain close tolerances. For this reason you may find one half of a standard insert with one half of a .001" undersize insert which will decrease the clearance .0005" from using a full standard bearing.

When a production crankshaft cannot be precision fitted by this method, it is then ground .009" undersize **ON ONLY THOSE MAIN JOURNALS THAT CANNOT BE PROPERLY FITTED. ALL JOURNALS WILL NOT NECESSARILY BE GROUND.** A .009" undersize bearing or .010" undersize bearing will then be used for precision fitting in the same manner as previously described.



Fig. 6A4-42--Measuring Connecting Rod Side Clearance

Identification of a reground crankshaft is by the following:

- The crankshaft throw will be stamped on one side of the undersize journal with "9", along with a large spot of green paint.

- The main bearing cap will be painted light green on each side of the affected journal.

If, for any reason, main bearing caps are replaced, shimming may be necessary. Laminated shims for each cap are available for service. Shim requirement will be determined by bearing clearance.

Inspection

In general, the lower half of the bearing (except #1 bearing) shows a greater wear and the most distress from fatigue. If upon inspection the lower half is suitable for use, it can be assumed that the upper half is also satisfactory. If the lower half shows evidence of wear or damage, both upper and lower halves should be replaced. **NEVER REPLACE ONE HALF WITHOUT REPLACING THE OTHER HALF.**

Checking Clearance

To obtain the most accurate results with "Plastigage" (or its equivalent) a wax-like plastic material which will compress evenly between the bearing and journal surfaces without damaging either surface, certain precautions should be observed.

If the engine is out of the vehicle and upside down, the crankshaft will rest on the upper bearings and the total clearance can be measured between the lower bearing and journal. If the engine is to remain in the vehicle, the crankshaft must be supported upward to remove any clearance from the upper bearing. The total clearance can then be measured between the lower bearing and journal.

To assure the proper seating of the crankshaft, all bearing cap bolts should be at their specified torque. In addition, preparatory to checking fit of bearings, the surface

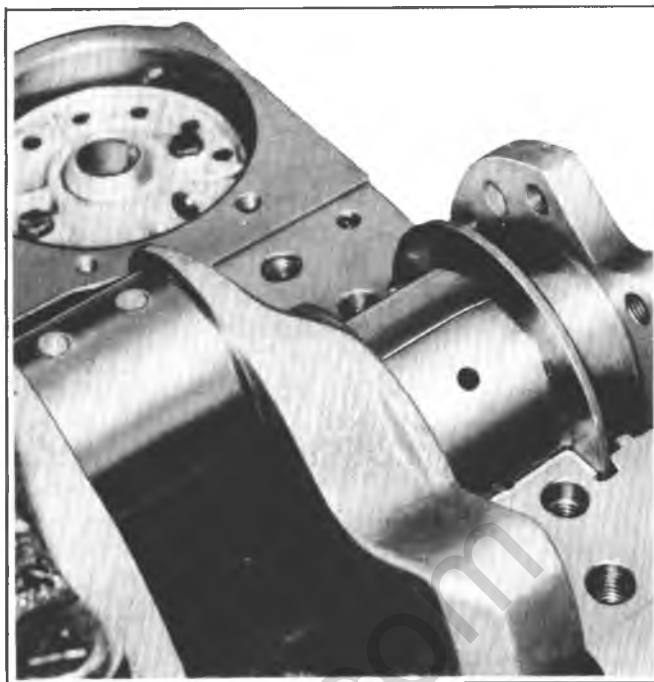


Fig. 6A4-43--Gaging Plastic on Journal

of the crankshaft journal and bearing should be wiped clean of oil.

1. With the oil pan and oil pump removed, and starting with the rear main bearing, remove bearing cap and wipe oil from journal and bearing cap.

2. Place a piece of gaging plastic the full width of the bearing (parallel to the crankshaft) on the journal (fig. 6A4-43).

Do not rotate the crankshaft while the gaging plastic is between the bearing and journal.

3. Install the bearing cap and evenly torque the retaining bolts to specifications. Bearing cap **MUST** be torqued to specifications in order to assure proper reading. Variations in torque affect the compression of the plastic gage.

4. Remove bearing cap. The flattened gaging plastic will be found adhering to either the bearing shell or journal.

5. On the edge of gaging plastic envelope there is a graduated scale which is correlated in thousandths of an inch. Without removing the gaging plastic, measure its compressed width (at the widest point) with the graduations on the gaging plastic envelope (fig. 6A4-44).

Normally main bearing journals wear evenly and are not out-of-round. However, if a bearing is being fitted to an out-of-round (.001" max.), be sure to fit to the maximum diameter of the journal: If the bearing is fitted to the minimum diameter and the journal is out-of-round .001", interference between the bearing and journal will result in rapid bearing failure. If the flattened gaging plastic tapers toward the middle or ends, there is a difference in clearance indicating taper, low spot or other irregularity of the bearing or journal. Be sure to measure the journal with a micrometer if the flattened gaging plastic indicates more than .001" difference.

6. If the bearing clearance is within specifications, the bearing insert is satisfactory. If the clearance is not within

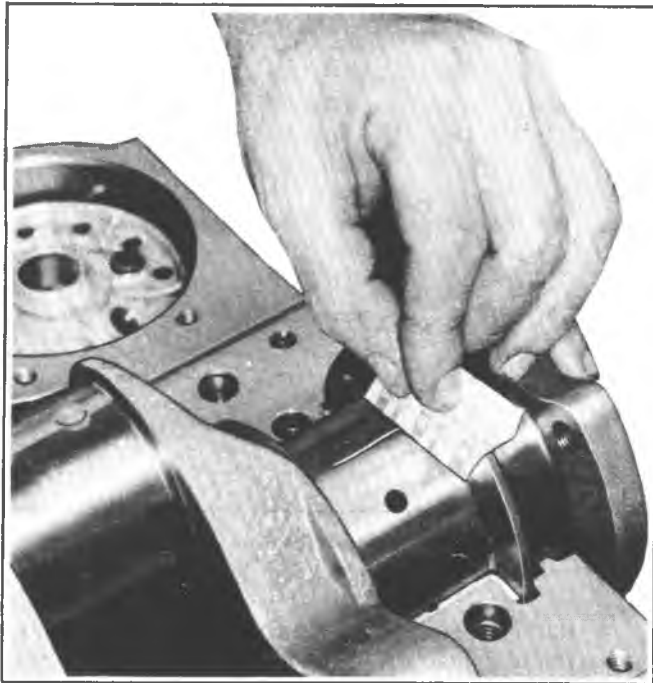


Fig. 6A4-44--Measuring Gaging Plastic

specifications, replace the insert. Always replace both upper and lower inserts as a unit.

If a new bearing cap is being installed and clearance is less than .001", inspect for burrs or nicks; if none are found then install shims as required.

7. A standard, .001" or .002" undersize bearing may produce the proper clearance. If not, it will be necessary to regrind the crankshaft journal for use with the next undersize bearing.

After selecting new bearing, recheck clearance.

8. Proceed to the next bearing. After all bearings have been checked rotate the crankshaft to see that there is no excessive drag.

When checking #1 main bearing, loosen accessory drive belts so as to prevent tapered reading with plastic gage.



Fig. 6A4-45--Measuring Crankshaft End Play

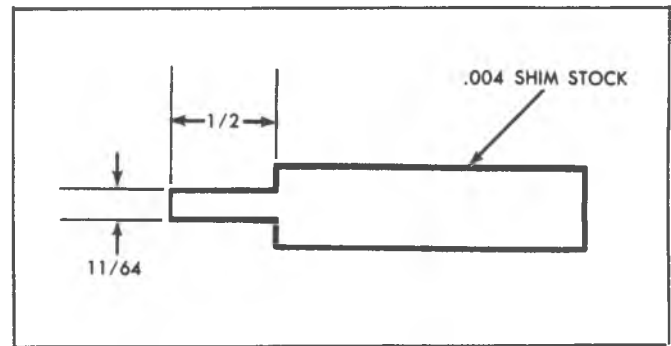


Fig. 6A4-46--Oil Seal Installation Tool

9. Measure crankshaft end play (see specifications) by forcing the crankshaft to the extreme front position. Measure at the front end of the rear main bearing with a feeler gage (fig. 6A4-45).

10. Install a new rear main bearing oil seal in the cylinder block and main bearing cap.

Replacement

Main bearings may be replaced with or without removing the crankshaft.

With Crankshaft Removal

1. Remove and inspect the crankshaft.
2. Remove the main bearings from the cylinder block and main bearing caps.
3. Coat bearing surfaces of new, correct size, main bearings with oil and install in the cylinder block and main bearing caps.
4. Install the crankshaft.

Without Crankshaft Removal

1. With oil pan, oil pump and spark plugs removed, remove cap on main bearing requiring replacement and remove bearing from cap.
2. Install a main bearing removing and installing tool in oil hole in crankshaft journal. If such a tool is not available, a cotter pin may be bent as required to do the job.
3. Rotate the crankshaft clockwise as viewed from the front of engine. This will roll upper bearing out of block.
4. Oil new selected size upper bearing and insert plain (unnotched) end between crankshaft and indented or notched side of block. Rotate the bearing into place and remove tool from oil hole in crankshaft journal.
5. Oil new lower bearing and install in bearing cap.
6. Install main bearing cap with arrows pointing toward front of engine.
7. Torque all main bearing caps EXCEPT THE REAR MAIN CAP to specifications. Torque rear main bearing cap to 10-12 lb. ft. (14-16N·m) then tap end of crankshaft, first rearward then forward with a lead hammer. This will line up rear main bearing and crankshaft thrust surfaces. Retorque all main bearing caps to specifications.

OIL SEAL (REAR MAIN)

Replacement

● ALWAYS REPLACE THE UPPER AND LOWER SEAL AS A UNIT.

The rear main bearing oil seal can be replaced (both halves) without removal of the crankshaft. Extreme care



Fig. 6A4-47--Removing Oil Seal - Lower Half

should be exercised when installing this seal to protect the sealing bead located in the channel on the outside diameter of the seal. An installation tool (fig. 6A4-46) must be used to protect the seal bead when positioning seal as follows:

1. With the oil pan and oil pump removed, remove the rear main bearing cap.

2. Remove oil seal from the bearing cap by prying from the bottom with a small screw driver (fig. 6A4-47).

3. To remove the upper half of the seal, use a small hammer to tap a brass pin punch on one end of seal until it protrudes far enough to be removed with pliers (fig. 6A4-48).

4. Clean all sealant and foreign material from cylinder case bearing cap and crankshaft, using a non-abrasive cleaner.

5. Inspect components for nicks, scratches, burrs and machining defects at all sealing surfaces, case assembly and crankshaft.

6. Coat seal lips and seal bead with light engine oil - keep oil off seal mating ends.

7. Position tip of tool between crankshaft and seal seat in cylinder case.

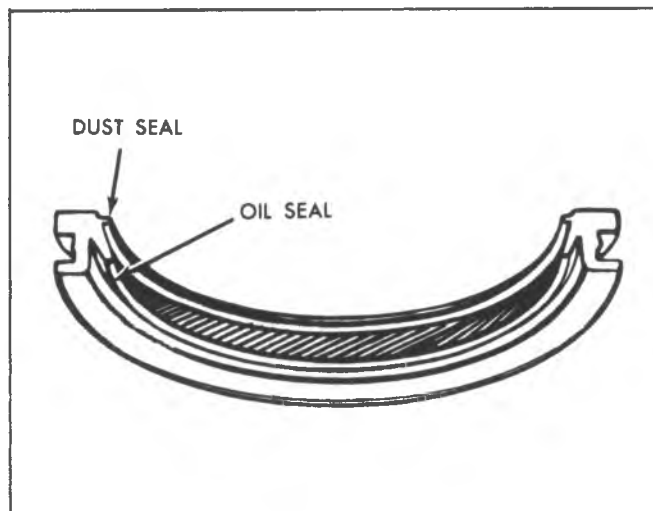


Fig. 6A4-49--Crankshaft Oil Seal - Rear Main

8. Position seal between crankshaft and tip of tool so that seal bead contacts tip of tool. Make sure that oil-seal lip is positioned toward front of engine (fig. 6A4-49).

9. Roll seal around crankshaft using tool as a "shoe-horn" to protect seal bead from sharp corner of seal seat surface in cylinder case. Installation tool must remain in position until seal is properly positioned with both ends flush with block.

10. Remove tool, being careful not to withdraw seal.

11. Install seal half in bearing cap, again using tool as a "shoe-horn", feeding seal into cap using light pressure with thumb and finger.

12. Install bearing cap to case with sealant applied to the cap-to-case interface being careful to keep sealant off the seal split line (fig. 6A4-50).

13. Install the rear main bearing cap (with new seal) and torque to 10-12 lb. ft. (14-16N·m). Tap end of crankshaft rearward then forward with lead hammer. This will line up thrust surfaces. Retorque bearing cap to specifications.

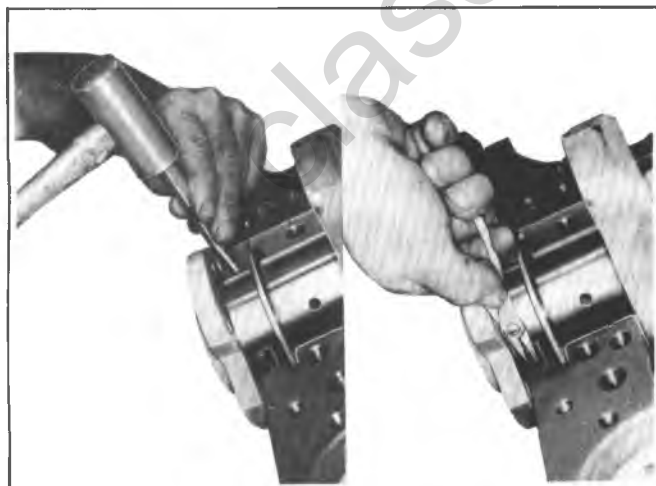


Fig. 6A4-48--Removing Oil Seal - Upper Half

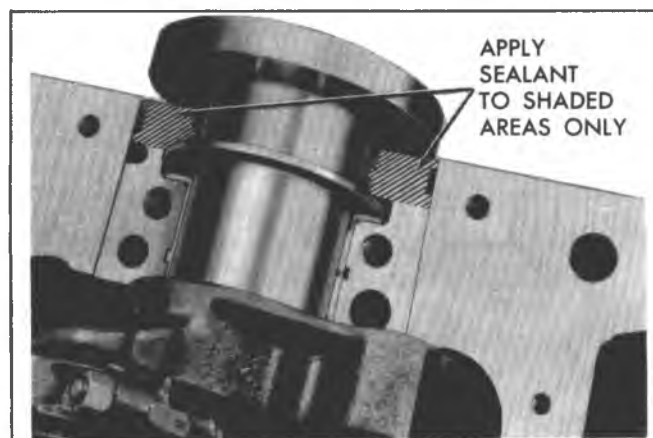


Fig. 6A4-50--Sealing Bearing Cap

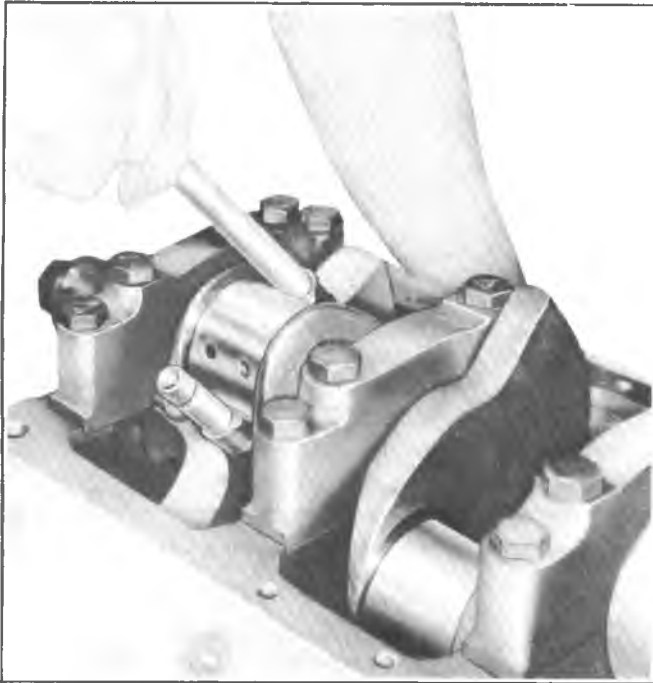


Fig. 6A4-51--Removing Connecting Rod & Piston Assembly

CONNECTING ROD AND PISTON ASSEMBLIES

Removal

1. Remove oil pan, oil pump and cylinder head as previously outlined.
2. For the cylinder being serviced turn crankshaft until piston is at the bottom of the stroke. Place a cloth on top of the piston.
3. Use a ridge reamer to remove any ridge and/or deposits from the upper end of the cylinder bore.
4. Turn crankshaft until piston is at top of stroke and remove cloth and cuttings.
5. Remove connecting rod cap and install Tool J-5239 (3/8") on studs. Push connecting rod and piston assembly out of top of cylinder block (fig. 6A4-51). It will be necessary to turn the crankshaft slightly to disconnect some of the connecting rod and piston assemblies and push them out of the cylinder.

Disassembly

1. Remove connecting rod bearings from connecting rods and caps. If bearings are being reused, place them in a rack so they may be reinstalled in their original rod and cap.
2. Remove piston rings by expanding and sliding them off the pistons.
3. Place connecting rod and piston assembly on Tool J-24086-20. Using an arbor press and piston pin remover, J-24086-8, press the piston pin out of connecting rod and piston (fig. 6A4-52).

Cleaning and Inspection

Connecting Rods

Wash connecting rods in cleaning solvent and dry with compressed air. Check for twisted or bent rods and inspect for nicks or cracks. Replace connecting rods that are damaged.

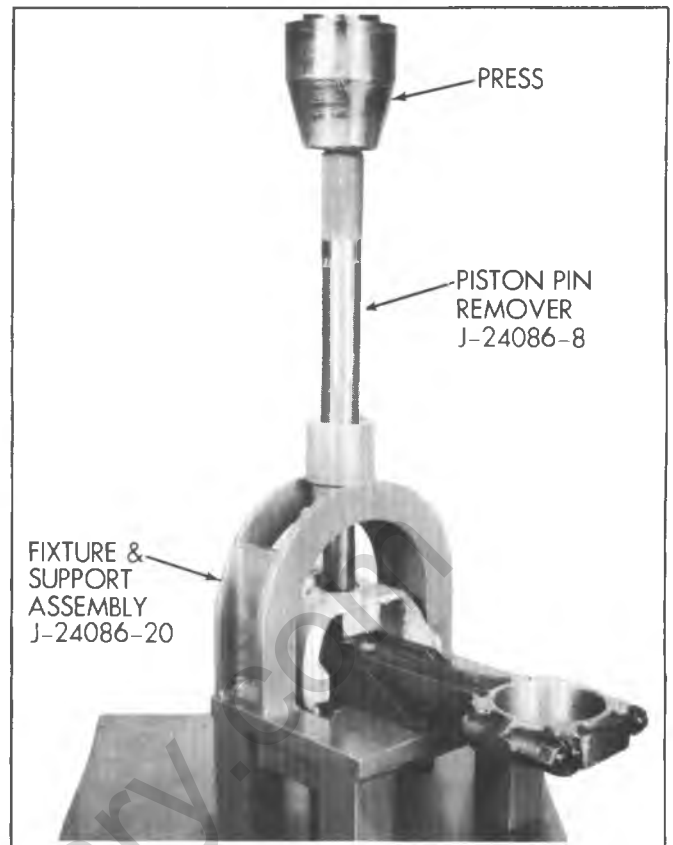


Fig. 6A4-52--Removing Piston Pin

Pistons

Clean varnish from piston skirts and pins with a cleaning solvent. **DO NOT WIRE BRUSH ANY PART OF THE PISTON.** Clean the ring grooves with a groove cleaner and make sure oil ring holes and slots are clean.

Inspect the piston for cracked ring lands, skirts or pin bosses, wavy or worn ring lands, scuffed or damaged skirts, eroded areas at top of the piston. Replace pistons that are damaged or show signs of excessive wear.

Inspect the grooves for nicks or burrs that might cause the rings to hang up.

Measure piston skirt (across center line of piston pin) and check clearance.

Piston Pins

The piston pin clearance is designed to maintain adequate clearance under all engine operating conditions. Because of this, the piston and piston pin are a matched set and not serviced separately.

Inspect piston pin bores and piston pins for wear. Piston pin bores and piston pins must be free of varnish or scuffing when being measured. The piston pin should be measured with a micrometer and the piston pin bore should be measured with a dial bore gage or an inside micrometer. If clearance is in excess of the .001" wear limit, the piston and piston pin assembly should be replaced.

Assembly

1. Lubricate piston pin holes in piston and connecting rod to facilitate installation of pin.
2. Place connecting rod in piston and hold in place with piston pin guide and piston pin. Place assembly on

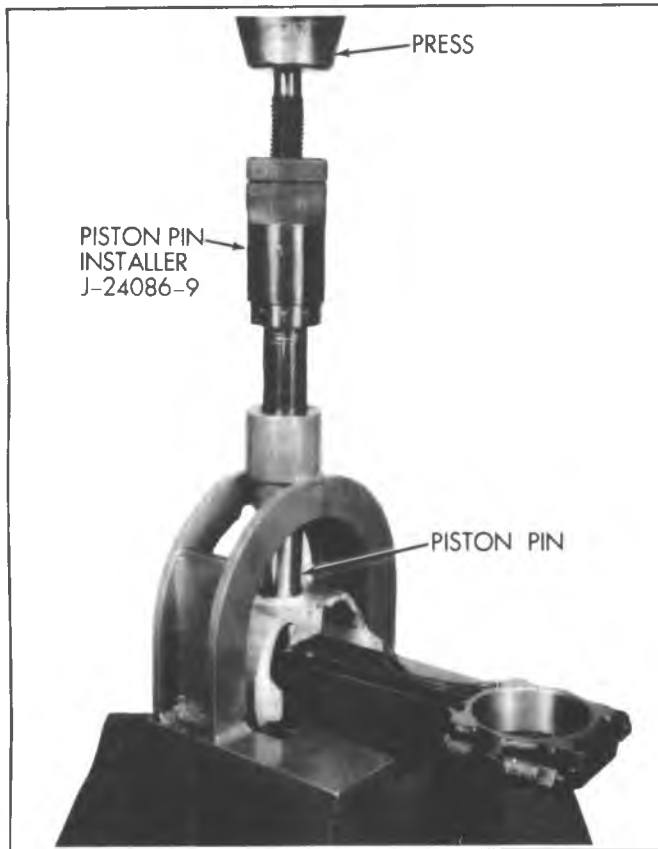


Fig. 6A4-53--Installing Piston Pin

fixture and support assembly.

3. Using piston pin installer, J-24086-9, press the piston pin into the piston and connecting rod (fig. 6A4-53).

NOTICE: After installer hub bottoms on support assembly, do not exceed 5000 psi pressure, as this could cause structural damage to the tool.

4. Remove piston and connecting rod assembly from tool and check piston for freedom of movement on piston pin.

Piston Rings

All compression rings are marked on the upper side of the ring. When installing compression rings, make sure the **MARKED SIDE IS TOWARD THE TOP OF THE PISTON**. The top ring is chrome faced, or treated with molybdenum for maximum life. The second compression ring is a tapered face acting as both a compression and oil control ring.

The oil control rings are of three piece type, consisting of two segments (rails) and a spacer.

1. Select rings comparable in size to the piston being used.

2. Slip the compression ring in the cylinder bore; then press the ring down into the cylinder bore about 1/4" (6.5mm) (above ring travel). Be sure ring is square with cylinder wall.

3. Measure the space or gap between the ends of the ring with a feeler gage (fig. 6A4-54).



Fig. 6A4-54--Measuring Ring Gap

4. If the gap between the ends of the ring is below specifications, remove the ring and try another for fit.

5. Fit each compression ring to the cylinder in which it is going to be used.

6. If the pistons have not been cleaned and inspected as previously outlined, do so.

7. Slip the outer surface of the top and second compression ring into the respective piston ring groove and roll the ring entirely around the groove (fig. 6A4-55) to make sure that the ring is free. If binding occurs at any point, the cause should be determined. If binding is caused by ring groove, correct by dressing with a fine cut file. If the binding is caused by a distorted ring, check a new ring.

8. Install piston rings as follows (fig. 6A4-56):

- a. Install oil ring spacer in groove and insert anti-rotation tang (where applicable) in drilled hole.
- b. Hold spacer ends butted and install lower steel oil ring rail with gap properly located.
- c. Install upper steel oil ring rail with gap properly located.

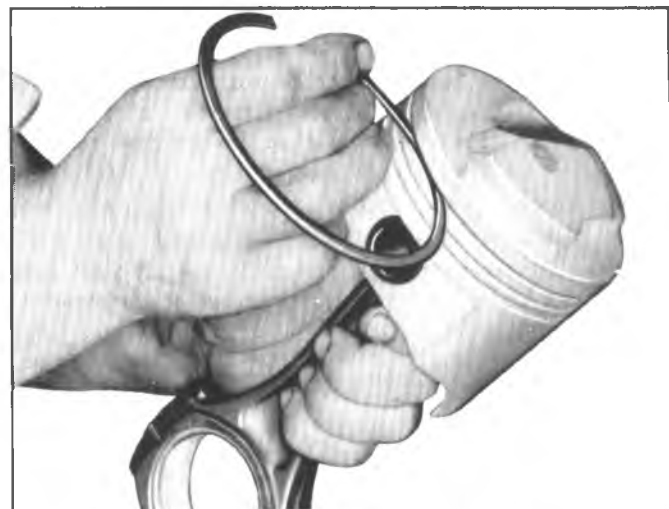


Fig. 6A4-55--Checking Ring in Groove

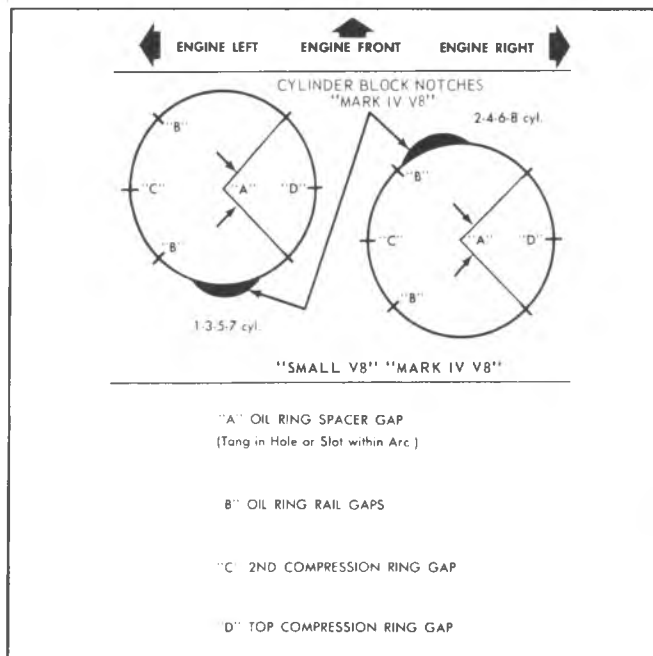


Fig. 6A4-56--Ring Gap Location

d. Flex the oil ring assembly to make sure ring is free. If binding occurs at any point the cause should be determined. If binding is caused by ring groove, correct by dressing groove with a fine cut file. If binding is caused by a distorted ring, check a new ring.

e. Install second compression ring (manufacturer mark up) with gaps properly located.

f. Install top compression ring (manufacturer mark up) with gap properly located.

9. Proper clearance of the piston ring in its piston ring



Fig. 6A4-57--Measuring Ring Groove Clearance



Fig. 6A4-58--Installing Connecting Rod & Piston Assembly

groove is very important to provide proper ring action and reduce wear. Therefore, when fitting new rings, the clearances between the surfaces of the ring and groove should be measured (fig. 6A4-57). (See Specifications).

Installation

Cylinder bores must be clean before piston installation. This may be accomplished with a hot water and detergent wash or with a light honing as necessary. After cleaning, the bores should be swabbed several times with light engine oil and a clean dry cloth.

1. Lubricate connecting rod bearings and install in rods and rod caps.
2. Lightly coat pistons, rings and cylinder walls with light engine oil.
3. With bearing caps removed, install Tool J-5239 (3/8") on connecting rod bolts.
4. Install each connecting rod and piston assembly in its respective bore. Install with connecting rod bearing tang slots on side opposite camshaft. Use Tool J-8037 to compress the rings (fig. 6A4-58). Guide the connecting rod into place on the crankshaft journal with Tool J-5239 (3/8") Use a hammer handle and light blows to install the piston into the bore. Hold the ring compressor firmly against the cylinder block until all piston rings have entered the cylinder bore.
5. Remove Tool J-5239.
6. Install the bearing caps and torque nuts to specifications.

Be sure to install new pistons in the cylinders for which they were fitted, and used pistons in the cylinder from which they were removed. Each connecting rod and bearing cap should be marked, beginning at the front of the engine. Cylinders 1,3,5 and 7 are the left bank and, 2,4,6 and 8 are the right bank. The numbers on the connecting rod and bearing cap must be on the same side when installed in the cylinder bore. If a connecting rod is ever transposed from one block or cylinder to another, new bearings should be fitted and the connecting rod should be numbered to correspond with the new cylinder number.

CYLINDER BLOCK

Cleaning and Inspection

1. Wash cylinder block thoroughly in cleaning solvent and clean all gasket surfaces.
2. Remove oil gallery plugs and clean all oil passages.
3. Clean and inspect coolant passages in the cylinder block.
4. Inspect the cylinder block for cracks in the cylinder walls, coolant jacket, valve lifter bores and main bearing webs.
5. Measure the cylinder walls for taper, out-of-round or excessive ridge at top of ring travel. This should be done with a dial indicator. Set the gage so that the thrust pin must be forced in about 1/4" (6.5mm) to enter gage in cylinder bore. Center gage in cylinder and turn dial to "0". Carefully work gage up and down cylinder to determine taper and turn it to different points around cylinder wall to determine the out-of-round condition. If cylinders were found to exceed specifications, honing or boring will be necessary.

Conditioning

The performance of the following operation is contingent upon engine condition at time of repair.

If the cylinder block inspection indicated that the block was suitable for continued use except for out-of-round or tapered cylinders, they can be conditioned by honing or boring.

If the cylinders were found to have less than .005" (.13mm) taper or wear, they can be conditioned with a hone and fitted with the high limit standard size piston. A cylinder bore of less than .005" (.13mm) wear or taper may not entirely clean up when fitted to a high limit piston. If it is desired to entirely clean up the bore in these cases, it will be necessary to rebore for an oversize piston. If more than .005" (.13mm) taper or wear, they should be bored and honed to the smallest oversize that will permit complete resurfacing of all cylinders.

When pistons are being fitted and honing is not necessary, cylinder bores may be cleaned with a hot water and detergent wash. After cleaning, the cylinder bores should be swabbed several times with light engine oil and a clean cloth and then wiped with a clean dry cloth.

Boring

1. Before using any type boring bar, the top of the cylinder block should be filed to remove any dirt or burrs. This is very important. If not checked, the boring bar may be tilted which would result in the rebored cylinder wall not being at right angles to the crankshaft.

2. The piston to be fitted should be measured with a micrometer, measuring at the center of the piston skirt and at right angles to the piston pin. The cylinder should be bored to the same diameter as the piston and honed to give the specified clearance.

3. The instructions furnished by the manufacturer of the equipment being used should be carefully followed.

Honing

1. When cylinders are to be honed, follow the hone manufacturer's recommendations for the use of the hone and cleaning and lubrication during honing.

2. Occasionally during the honing operation, the cylinder bore should be thoroughly cleaned and the piston selected for the individual cylinder checked for correct fit.

3. When finish honing a cylinder bore to fit a piston, the hone should be moved up and down at a sufficient speed to obtain very fine uniform surface finish marks in a cross-hatch pattern of approximately 45° to 65° included angle. The finish marks should be clean but not sharp, free from imbedded particles and torn or folded metal.

4. Permanently mark the piston for the cylinder to which it has been fitted and proceed to hone cylinders and fit the remaining pistons.

NOTICE: Handle the pistons with care and do not attempt to force them through the cylinder until the cylinder has been honed to correct size as this type piston can be distorted through careless handling.

5. Thoroughly clean the bores with hot water and detergent. Scrub well with a stiff bristle brush and rinse thoroughly with hot water. It is extremely essential that a good cleaning operation be performed. If any of the abrasive material is allowed to remain in the cylinder bores, it will rapidly wear the new rings and cylinder bores in addition to the bearings lubricated by the contaminated oil, the bores should be swabbed and then wiped with a clean dry cloth. Cylinder should not be cleaned with kerosene or gasoline. Clean the remainder of the cylinder block to remove the excess material spread during the honing operation.

Piston Selection

1. Check USED piston to cylinder bore clearance as follows:

- a. Measure the "Cylinder Bore Diameter" with a telescope gage [2-1/2" (64mm) from top of cylinder bore].
- b. Measure the "Piston Diameter" (at skirt across center line of piston pin).
- c. Subtract piston diameter from cylinder bore diameter to determine "Piston to Bore Clearance".

d. Locate piston to bore clearance on Piston Selection Chart and determine if piston to bore clearance is in the acceptable range.

2. If used piston is not acceptable, determine if a new piston can fit cylinder bore.

3. If cylinder bore must be reconditioned, measure new piston diameter (across center line of piston pin) then hone cylinder bore to correct clearance.

4. Mark the piston to identify the cylinder for which it was fitted.

OIL FILTER BYPASS VALVE

Inspection and Replacement

With the oil filter removed, check the spring and fibre valve for operation. Inspect for a cracked or broken valve. If replacement is necessary, the oil filter adapter and bypass valve assembly must be replaced as an assembly. Clean valve chamber in cylinder block thoroughly. Torque retaining screws to specifications.

ENGINE ASSEMBLY

Removal ("G" Van/Code U, L & R Engines)

1. Disconnect battery cables at battery.
2. Drain cooling system.
3. Remove coolant reservoir bottle.

4. Remove grille, upper radiator support and lower grille valance.

5. Disconnect radiator hoses at radiator.

● If equipped with automatic transmission, remove cooler lines from radiator.

● If equipped with A/C, evacuate system and remove condenser. Remove A/C vacuum reservoir.

6. Remove washer jar and bracket.

7. Remove radiator to radiator support attaching brackets and remove radiator and shroud.

8. If equipped with P/S, remove pump and lay aside.

9. Remove engine cover.

10. Remove air cleaner air stove pipe.

11. Remove accelerator cable from carburetor and remove carburetor.

12. Disconnect engine wiring harness from connection on firewall.

13. Disconnect heater hoses at engine.

14. Remove thermostat housing.

15. Remove oil fill pipe.

16. If equipped with cruise control, remove servo and bracket and transducer.

17. Raise vehicle.

18. Disconnect exhaust pipe from exhaust manifold flanges.

19. Remove propshaft; plug transmission end.

20. Disconnect transmission shift linkage and speedometer cable.

21. Disconnect fuel hose from fuel pump.

22. Remove transmission mount bolts.

23. Remove engine mount bracket to frame bolts.

24. Drain crankcase.

25. Remove engine mount "through" bolts.

26. Raise engine slightly and remove engine mounts. Block up engine with wood between oil pan and crossmember.

27. Lower vehicle and install lifting tool.

28. Remove engine/transmission assembly.

Installation ("G" Van/Code U, L & R Engines)

1. Place engine/transmission assembly into vehicle. Support engine with blocks of wood between the oil pan and crossmembers.

2. Raise vehicle and install engine mounts. Retain by inserting engine mount "through" bolts.

3. Raise engine slightly, remove wooden blocks and lower engine onto mounts.

4. Install engine mount bracket to frame bolts. Torque to specifications.

5. Install transmission mount bolts. Torque to specifications.

6. Connect fuel tank line and return line to fuel pump.

7. Connect transmission shift linkage and speedometer cable.

8. Install propshaft.

9. Connect exhaust pipe to exhaust manifold flanges.

10. Lower vehicle.

11. Connect heater hoses.

12. Connect engine wiring harness.

13. Using a new gasket, install carburetor. Connect accelerator cable.

14. Install radiator. Install radiator to radiator support attaching brackets.

● If equipped with automatic transmission, connect cooler lines to radiator.

● If equipped with A/C, install condenser to radiator support.

15. Connect radiator hoses to radiator.

16. Install grille cross brace and grille.

17. Fill cooling system.

18. Fill crankcase with oil.

● If equipped with A/C, mount compressor, connect hosing and charge system.

19. Connect battery cables and start engine. Check ignition timing and adjust carburetor if necessary.

20. Install air cleaner and engine cover.

Removal (CK Series/Code U, L & R Engines)

1. Disconnect battery cables at battery.

2. Drain cooling system.

3. Remove air cleaner.

4. Remove all accessory drive belts.

5. Remove fan and water pump pulley.

6. Disconnect upper and lower radiator hoses at engine.

7. Disconnect heater hoses at engine.

● If equipped with automatic transmission, disconnect cooler lines at radiator.

8. Remove radiator and shroud.

9. Disconnect accelerator linkage and detent linkage, if so equipped, from carburetor.

10. If A/C equipped, remove compressor from engine and lay aside.

11. If power steering equipped, remove pump from engine and lay aside.

12. Remove engine wiring harness from engine.

13. Disconnect fuel line at fuel pump.

14. Disconnect all vacuum lines from intake manifold.

15. Raise vehicle.

16. Drain crankcase.

17. Disconnect exhaust pipe from exhaust manifold flanges.

● 'K' models with automatic transmission, remove strut rods at motor mounts.

18. Remove flywheel or convertor splash shield, as applicable.

19. Disconnect wiring along right pan rail.

20. Disconnect wiring at starter and remove starter.

21. Disconnect wiring for gas gage.

22. If equipped with automatic transmission, remove convertor to flex plate attaching bolts.

23. Support transmission.

24. Remove bell housing to engine retaining bolts.

25. Remove lower engine mount bracket to frame bolts.

26. Lower vehicle.

27. Remove vehicle hood.

28. Attach engine lifting device.

29. Remove engine.

Installation (CK Series/Code U, L & R Engines)

1. Place engine in vehicle.
2. Raise vehicle.
3. Install engine mount bracket to frame bolts.
4. Install bell housing to engine retaining bolts.

Remove transmission support.

5. If equipped with automatic transmission, install convertor to flex plate attaching bolts.
6. Install flywheel or convertor splash shield, as applicable.
7. Connect wiring for gas gage.
8. Install starter. Connect wiring.
9. Install engine wiring harness along right pan rail.
10. Connect exhaust pipe to exhaust manifold flanges.
11. Lower vehicle.
12. Connect all vacuum lines to intake manifold.
13. Connect fuel line at fuel pump.
14. Install engine wiring harness to engine.
15. If power steering equipped, install pump on engine.
16. If A/C equipped, install compressor on engine.
17. Connect accelerator linkage and detent linkage, if so equipped, to carburetor.
18. Install radiator.
 - If equipped with automatic transmission, connect cooler lines to radiator.
19. Connect heater hoses to engine.
20. Connect radiator hoses to engine.
21. Install water pump pulley and fan to water pump.
22. Install accessory drive belts. Adjust to specifications.
23. Fill cooling system.
24. Fill crankcase.
25. Connect battery cables and start engine. Check timing and carburetor adjustment and adjust if necessary.
26. Install air cleaner and vehicle hood.

CRANKSHAFT

The crankshaft can be removed while the engine is disassembled for overhaul, as previously outlined, or without complete disassembly as outlined below.

Removal

1. With the engine removed from the vehicle and the transmission and/or clutch housing removed from the engine, mount engine in stand and clamp securely.
2. Remove the oil dip stick and oil dip stick tube, (if applicable).
3. Remove the starting motor, clutch assembly (if equipped) and flywheel.
4. Remove the spark plugs.
5. Remove crankshaft pulley and torsional damper.
6. Remove oil pan and oil pump.
7. Remove crankcase front cover, and if so equipped, remove timing chain and camshaft sprocket.
8. Check the connecting rod caps for cylinder number identification. If necessary, mark them.
9. Remove the connecting rod caps and push the pistons to top of bores.
10. Remove main bearing caps and lift crankshaft out of cylinder block.

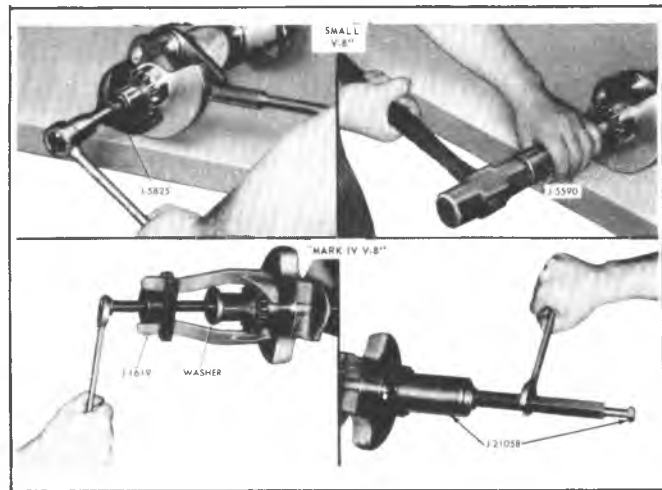


Fig. 6A4-59--Sprocket or Gear Replacement

11. Remove rear main bearing oil seal and main bearings from cylinder block and main bearing caps.

Cleaning and Inspection

1. Wash crankshaft in solvent and dry with compressed air.
2. Measure dimensions of main bearing journals and crankpins with a micrometer for out-of-round, taper or undersize. (See Specifications.)
3. Check crankshaft for run-out by supporting at the front and rear main bearings journals in "V" blocks and check at the front and rear intermediate journals with a dial indicator. (See Specifications.)
4. Replace or recondition the crankshaft if out of specifications.

SPROCKET OR GEAR REPLACEMENT (REFER TO FIG. 6A4-59)

- Remove crankshaft sprocket using Tool J-5825, install using Tool J-5590.

Installation

1. Install rear main bearing oil seal in cylinder block and rear main bearing cap grooves. Install with lip of seal toward front of engine. Where seal has two lips install lip with helix towards front of engine.

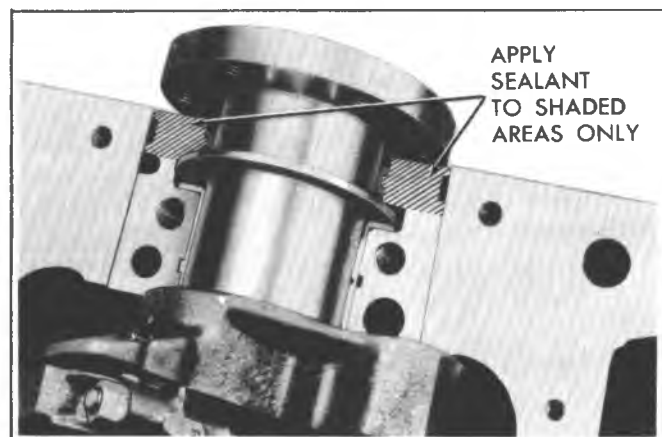


Fig. 6A4-60--Sealing Bearing Cap

2. Lubricate lips of seal with engine oil. Keep oil off parting line surface.

3. Install main bearings in cylinder block and main bearing caps then lubricate bearing surface with engine oil.

4. Install crankshaft, being careful not to damage bearing surfaces.

5. Apply a thin coat of brush-on type oil sealing compound to block mating surface and corresponding surface of cap only (fig. 6A4-60). Do not allow sealant on crankshaft or seal.

6. Install main bearing caps with arrows pointing toward front of engine.

7. Torque all except rear main bearing cap bolts to specifications. Torque rear main bearing cap bolts to 10-12 lbs. ft. (14-16 N·m) then tap end of crankshaft, first rearward then forward with a lead hammer. This will line

up rear main bearing and crankshaft thrust surfaces. Retorque all main bearing cap bolts to specifications.

8. Measure crankshaft end play with a feeler gage. Force crankshaft forward and measure clearance between the front of the rear main bearing and the crankshaft thrust surface.

9. Install flywheel and torque to specifications. A wood block placed between the crankshaft and cylinder block will prevent crankshaft from rotating.

● Align dowel hole in flywheel with dowel hole in crankshaft. On vehicles equipped with automatic transmissions, install flywheel with the converter attaching pads towards transmission.

classiccarslibrary.com

GENERAL DATA:

| | | | | |
|-------------------|-----------|------------------|--------------------|--------------------|
| TYPE | | 90° V-8 GASOLINE | | |
| DISPLACEMENT | LITRE (*) | 5.0 (G) | 5.7 (L) 5.7 (M) | 6.6 (R) 6.6 (X) |
| RPO | | LG9 | LS9/LT9 | LF4/LE4 |
| BORE | | 3.736 | 4.000 | 4.125 |
| STROKE | | 3.480 | | 3.750 |
| COMPRESSION RATIO | | 8.5:1 | | |
| FIRING ORDER | | 1-8-4-3-6-5-7-2 | | |

CYLINDER BORE:

| | | | | |
|--------------|------------|---------------|---------------|---------------|
| DIAMETER | | 3.7350-3.7385 | 3.9995-4.0025 | 4.1246-4.1274 |
| OUT OF ROUND | PRODUCTION | .001 MAX. | | |
| | SERVICE | .002 MAX. | | |
| TAPER | PRODUCTION | THRUST SIDE | .0005 MAX. | |
| | | RELIEF SIDE | .001 MAX. | |
| SERVICE | | .001 MAX. | | |

PISTON:

| | | | |
|-----------|------------|-------------|-------------|
| CLEARANCE | PRODUCTION | .0007-.0017 | .0014-.0024 |
| | SERVICE | .0027 MAX. | .0035 MAX. |

PISTON RING:

| | | | | |
|---|------------------|------------|----------------------------|-------------|
| C O M P R E S S I O N | GROOVE CLEARANCE | PRODUCTION | TOP | .0012-.0032 |
| | | | 2ND | .0012-.0032 |
| | | SERVICE | HI LIMIT PRODUCTION + .001 | |
| | GAP | PRODUCTION | TOP | .010-.020 |
| | | | 2ND | .010-.025 |
| | | SERVICE | HI LIMIT PRODUCTION + .010 | |
| O I L | GROOVE CLEARANCE | PRODUCTION | .002-.007 | |
| | | SERVICE | HI LIMIT PRODUCTION + .001 | |
| | GAP | PRODUCTION | .015-.055 | |
| | | SERVICE | HI LIMIT PRODUCTION + .010 | |

* VIN Designation

PISTON PIN

LG9

LS9/LT9

LF4/LE4

| | | | |
|------------|------------|--------------------------|--|
| DIAMETER | | .9270-.9273 | |
| CLEARANCE | PRODUCTION | .00025-.00035 | |
| | SERVICE | .001 MAX. | |
| FIT IN ROD | | .0008-.0016 INTERFERENCE | |

CRANKSHAFT

| | | | | |
|------------------------|---------------|----------------------|---------------------------|-------|
| MAIN JOURNAL | DIAMETER | #1 2.4484-2.4493 | #1-2-3-4 2.6484-2.6493 | |
| | | #2-3-4 2.4481-2.4490 | #5 2.6479-2.6488 | |
| | TAPER | PRODUCTION | .0002 MAX. | |
| | | SERVICE | .001 MAX. | |
| OUT OF ROUND | PRODUCTION | .0002 MAX. | | |
| | SERVICE | .001 MAX. | | |
| MAIN BEARING CLEARANCE | PRODUCTION | #1 .008-.0020 | | |
| | | #2-3-4 .0011-.0023 | | |
| | | #5 .0017-.0032 | | |
| SERVICE | #1 .001-.0015 | #2-4 .001-.0025 | #5 .0025-.0035 | |
| CRANKSHAFT END PLAY | | .002-.006 | | |
| CRANKPIN | DIAMETER | 2.0988-2.0998 | | |
| | | TAPER | PRODUCTION | .0005 |
| | SERVICE | | .001 MAX. | |
| | OUT OF ROUND | PRODUCTION | .0005 | |
| SERVICE | | .001 MAX. | | |
| ROD BEARING CLEARANCE | PRODUCTION | .0013-.0035 | | |
| | SERVICE | .0030 | | |
| ROD SIDE CLEARANCE | | .008-.014 | | |

CAMSHAFT

| | | | |
|---------------------|---------|---------------|---------------|
| LOBE LIFT ± .002 | INTAKE | .2484 | .2600 |
| | EXHAUST | .2667 | .2733 |
| JOURNAL DIAMETER | | 1.8682-1.8692 | 1.9482-1.9492 |
| CAMSHAFT END PLAY | | .004-.012 | |

SPECIFICATIONS

SPECIFICATIONS

| VALVE SYSTEM | | LG9 | LS9/LT9 | LF4/LE4 |
|--------------------------|---------------------|---------------------------------------|---------------------------------|-------------|
| LIFTER | | HYDRAULIC | | |
| ROCKER ARM RATIO | | 1.50:1 | | 1.70:1 |
| VALVE LASH | INTAKE | ONE TURN DOWN FROM ZERO LASH | | |
| | EXHAUST | | | |
| FACE ANGLE (INT. & EXH.) | | 45° | | |
| SEAT ANGLE (INT. & EXH.) | | 46° | | |
| SEAT RUNOUT | | .002 MAX. | | |
| SEAT WIDTH | INTAKE | 1/32-1/16 | | |
| | EXHAUST | 1/16-3/32 | | |
| STEM CLEARANCE | PRODUCTION | INT. | .0010-.0027 | |
| | | EXH. | .0010-.0027 | .0012-.0029 |
| | SERVICE | HI LIMIT + .001 INTAKE + .002 EXHAUST | | |
| VALVE SPRING (OUTER) | FREE LENGTH | | 2.03 | |
| | PRESSURE LBS. @ IN. | CLOSED | 76-84 @ 1.70 INT. @ 1.61 EXH. | |
| | | OPEN | 194-206 @ 1.25 INT. @ 1.16 EXH. | |
| INSTALLED HEIGHT ± 1/32" | | 1-23/32 INT. 1-19/32 EXH. | | |
| DAMPER | FREE LENGTH | | 1.86 | |
| | APPROX. # OF COILS | | 4 | |

TORQUE SPECIFICATIONS

| | |
|---|-------------------------|
| CRANKCASE FRONT COVER | 80 LB. IN. |
| FLYWHEEL HOUSING COVER | 80 LB. IN. |
| OIL FILTER BYPASS VALVE | 80 LB. IN. |
| OIL PAN (TO CRANKCASE) (1/4-20) | 80 LB. IN. |
| OIL PUMP COVER | 80 LB. IN. |
| ROCKER ARM COVER | 45 LB. IN. |
| CAMSHAFT SPROCKET | 20 LB. FT. |
| OIL PAN TO CRANKCASE (5/16-18) | 165 LB. IN. |
| CLUTCH PRESSURE PLATE | 30 LB. FT. |
| DISTRIBUTOR CLAMP | 25 LB. FT. |
| FLYWHEEL HOUSING | 30 LB. FT. |
| MANIFOLD (EXHAUST) | 20 LB. FT. ¹ |
| MANIFOLD (INLET) | 30 LB. FT. |
| WATER OUTLET | 30 LB. FT. |
| WATER PUMP | 30 LB. FT. |
| CONNECTING ROD CAP | 45 LB. FT. |
| CYLINDER HEAD | 65 LB. FT. |
| MAIN BEARING CAP | 80 LB. FT. ² |
| OIL PUMP | 65 LB. FT. |
| FLYWHEEL | 60 LB. FT. |
| TORSIONAL DAMPER | 60 LB. FT. |
| TEMPERATURE SENDING UNIT | 20 LB. FT. |
| OIL FILTER | 25 LB. FT. |
| OIL PAN DRAIN PLUG | 20 LB. FT. |
| SPARK PLUG | 17-27 LB. FT. |

¹ Inside bolts on 5.7 (L) 30 LB. FT.

² Intermediate outer bolts are 70 LB. FT.

classiccarylbrary.com

SECTION 6A5

7.4 L (W) V-8 - RPO LE8

Contents

| | | | |
|-----------------------------|--------|--------------------------------------|--------|
| General Description..... | 6A5-1 | Crankcase Front Cover | 6A5-17 |
| Engine Lubrication | 6A5-4 | Oil Seal (Front Cover)..... | 6A5-18 |
| On Vehicle Service..... | 6A5-6 | Camshaft | 6A5-18 |
| Engine Mounts..... | 6A5-6 | Camshaft Bearings | 6A5-19 |
| Intake Manifold | 6A5-6 | Oil Pan | 6A5-20 |
| Exhaust Manifold..... | 6A5-10 | Oil Pump..... | 6A5-21 |
| Rocker Arm Cover | 6A5-10 | Connecting Rod Bearings..... | 6A5-21 |
| Valve Mechanism..... | 6A5-11 | Main Bearings | 6A5-22 |
| Valve Stem Oil Seal and/or | | Oil Seal (Rear Main)..... | 6A5-24 |
| Valve Spring..... | 6A5-11 | Connecting Rod Piston Asemblies..... | 6A5-25 |
| Valve Lifters..... | 6A5-12 | Cylinder Block | 6A5-28 |
| Cylinder Head Assembly..... | 6A5-13 | Oil Filter ByPass Valve..... | 6A5-29 |
| Rocker Arm Studs..... | 6A5-16 | Engine Assembly..... | 6A5-29 |
| Valve Guide Bores..... | 6A5-16 | Crankshaft..... | 6A5-30 |
| Valve Seats | 6A5-16 | Sprocket or Gear Replacement..... | 6A5-30 |
| Valves | 6A5-16 | Specifications..... | 6A5-31 |
| Torsional Damper..... | 6A5-17 | | |

GENERAL DESCRIPTION (FIG. 6A5-1 & 6A5-2)

CYLINDER BLOCK

The cylinder block is made of cast iron and has 8 cylinders arranged in a "V" shape with 4 cylinders in each bank. Five main bearings support the crankshaft which is retained by bearing caps that are machined with the block for proper alignment and clearances. Cylinders are completely encircled by coolant jackets.

CYLINDER HEAD

The cast iron cylinder heads have individual intake and exhaust ports for each cylinder. Valve guides are integral, and rocker arms are retained on individual threaded studs.

CRANKSHAFT AND BEARINGS

The crankshaft is cast nodular iron, and is supported by five main bearings. Number five bearing is the end thrust bearing.

All main bearings are lubricated from oil holes that connect to the main oil gallery. This runs along the left side of the cylinder case, just above the oil pan rail. Two additional galleries supply oil to the valve lifters.

A torsional damper on the forward end of the crankshaft dampens any engine torsional vibrations.

CAMSHAFT AND DRIVE

The cast iron camshaft is supported by five bearings and is chain driven. A steel crankshaft gear drives the timing chain which in turn drives the camshaft through an aluminum and nylon sprocket.

Cam lobes are ground, hardened and tapered with the high side toward the rear. This, coupled with a spherical face on the lifter, causes the valve lifters to rotate.

Camshaft bearings are lubricated through oil holes which intersect the main oil gallery. The main oil gallery is rifle drilled down the left side of the cylinder case.

PISTONS AND CONNECTING RODS

The pistons are made of cast aluminum alloy using two compression rings and one oil control ring. Pins are Chromium steel and have a floating fit in the pistons. They are retained in the connecting rods by a press fit.

Connecting rods are made of forged steel. Full pressure lubrication is directed to the connecting rods by drilled oil passages from the adjacent main bearing journal. Oil holes at the connecting rod journals are located so that oil is supplied to give maximum lubrication just prior to full bearing load.

VALVE TRAIN

A very simple ball pivot-type train is used. Motion is transmitted from the camshaft through the hydraulic lifter and push rod to the rocker arm. The rocker arm pivots on its ball and transmits the camshaft motion to the valve. The rocker-arm ball is retained by a nut.

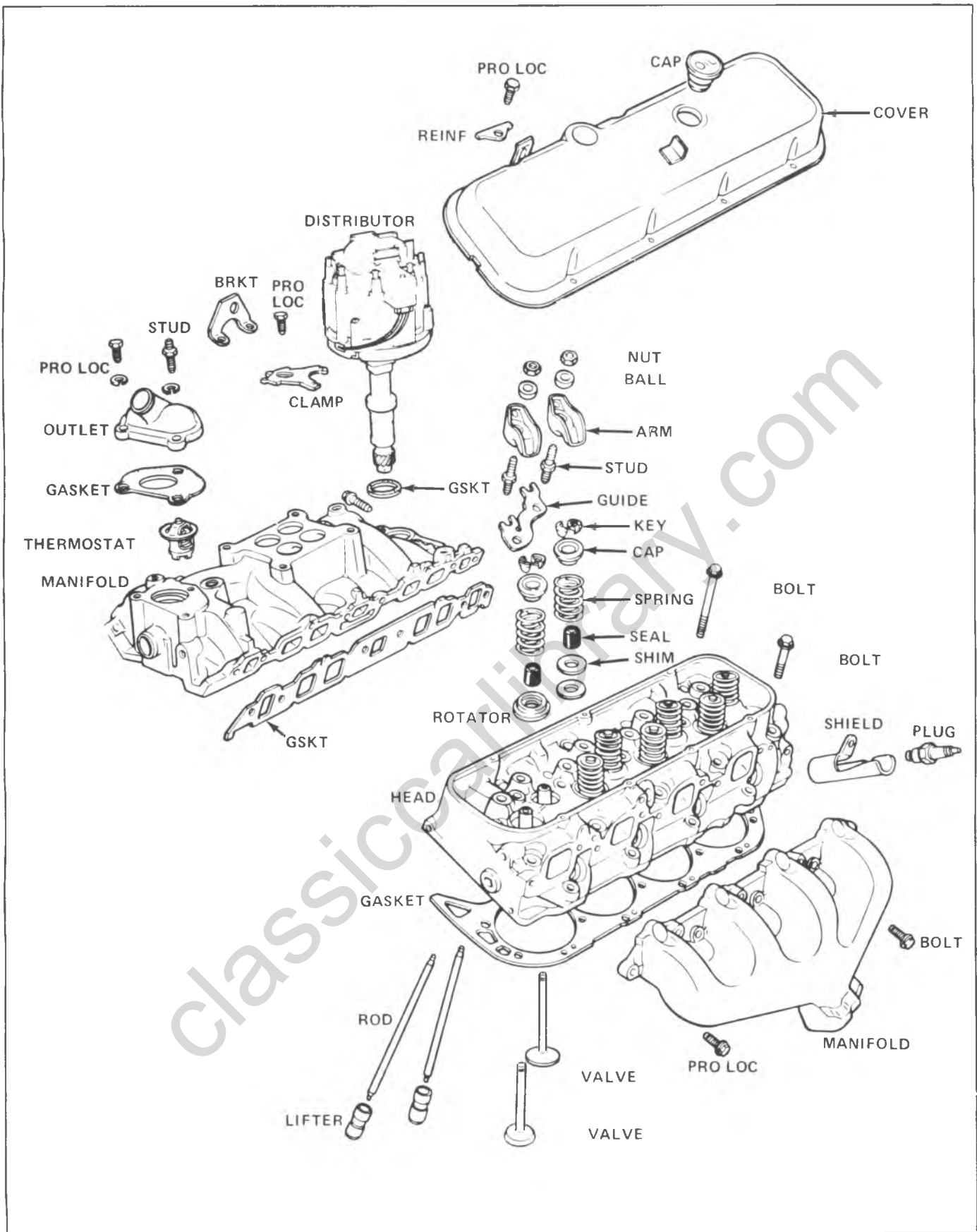


Fig. 6A5-1-Engine Upper End

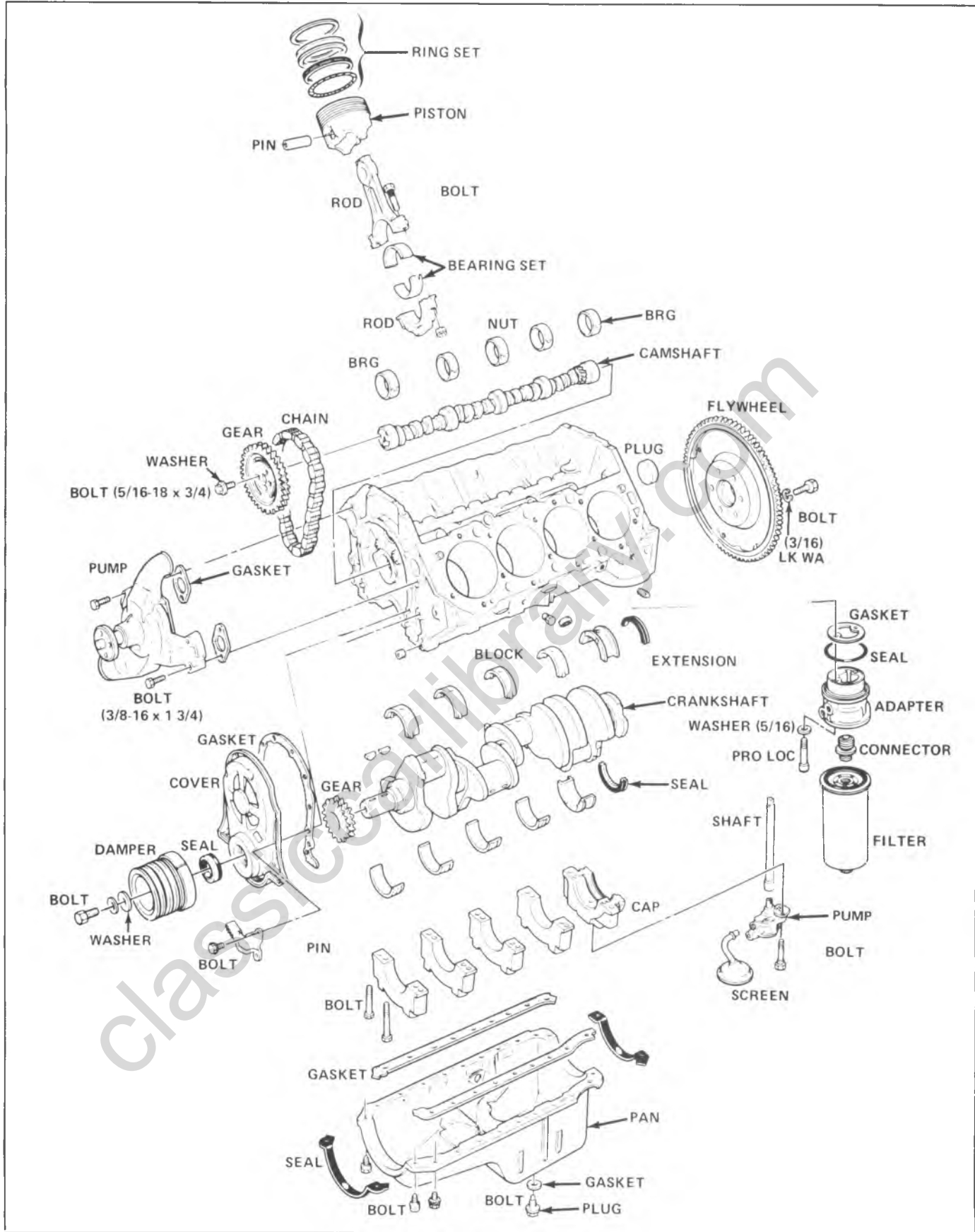


Fig. 6A5-2-Engine Lower End

HYDRAULIC VALVE LIFTERS

Hydraulic Valve Lifters are used to keep all parts of the valve train in constant contact.

The hydraulic lifter assembly consists of: the lifter body, which rides in the cylinder block boss, a plunger, a push rod seat, a metering valve, a plunger spring, a check ball and spring, a check ball retainer and a push rod seat retainer.

When the lifter is riding on the low point of the cam, the plunger spring keeps the plunger and push rod seat in contact with the push rod.

When the lifter body begins to ride up the cam lobe, the check ball cuts off the transfer of oil from the reservoir below the plunger. The plunger and lifter body then rise as a unit, pushing up the push rod and opening the valve.

As the lifter body rides down the other side of the cam, the plunger follows with it until the valve closes. The lifter body continues to follow the cam to its low point, but the plunger spring keeps the plunger in contact with the push rod. The ball check valve will then move off its seat and the lifter reservoir will remain full.

INTAKE MANIFOLD

The intake manifold is of cast iron double level design for efficient fuel distribution. The carburetor pad is centrally located with a passage running underneath the pad (E.F.E.) through which exhaust gases are forced to promote faster fuel vaporization when the engine is cold.

EXHAUST MANIFOLDS

Two cast iron exhaust manifolds are used to direct exhaust gases from the combustion chambers to the exhaust system. The right hand side manifold receives a heat shield that is used to route heated air to the air cleaner for better fuel vaporization.

COMBUSTION CHAMBERS

Combustion Chambers are cast to insure uniform shape for all cylinders. Spark plugs are located between the intake and exhaust valves.

The contoured wedge shape of the combustion chamber minimizes the possibility of detonation, facilitates breathing, and provides swirling turbulence for smooth, complete combustion.

ENGINE LUBRICATION

Full pressure lubrication through a full flow oil filter, is furnished by a gear-type oil pump. The distributor, driven by a helical gear on the camshaft, drives the oil pump. The main oil gallery feeds oil, through drilled passages, to the

camshaft and crankshaft to lubricate the bearings. The valve lifter oil gallery feeds the valve lifters which, through hollow push rods, feed the individually mounted rocker arms (fig. 6A5-3).

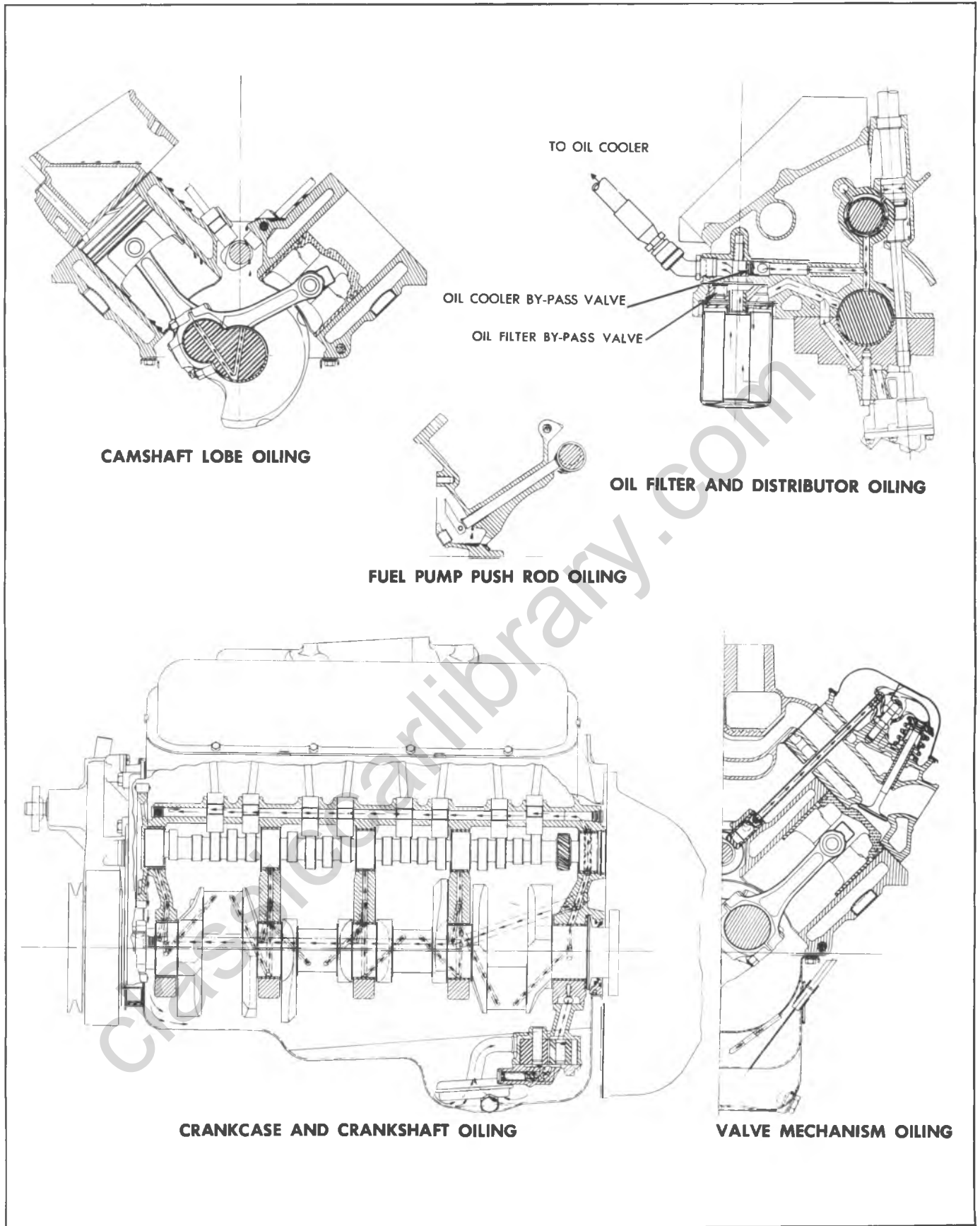


Fig. 6A5-3--"Mark IV" Engine Lubrication

ON VEHICLE SERVICE

ENGINE MOUNTS

Engine mounts (fig. 6A5-4 – 6A5-7) are the non-adjustable type and seldom require service. Broken or deteriorated mounts should be replaced immediately, because of the added strain placed on other mounts and drive line components.

Checking Engine Mounts

Front Mount

Raise the engine to remove weight from the mounts and to place a slight tension in the rubber. Observe both mounts while raising engine. If an engine mount exhibits:

- Hard rubber surface covered with heat check cracks;
 - Rubber separated from a metal plate of the mount;
- or
- Rubber split through center

Replace the mount. If there is relative movement between a metal plate of the mount and its attaching points, lower the engine on the mounts and tighten the screws or nuts attaching the mount to the engine, frame, or bracket.

Rear Mount

Raise the vehicle on a hoist. Push up and pull down on the transmission tailshaft while observing the transmission mount. If the rubber separates from the metal plate of the mount or if the tailshaft moves up but not down (mount bottomed out) replace the mount. If there is relative movement between a metal plate of the mount and its attaching point, tighten the screws or nuts attaching the mount to the transmission or crossmember.

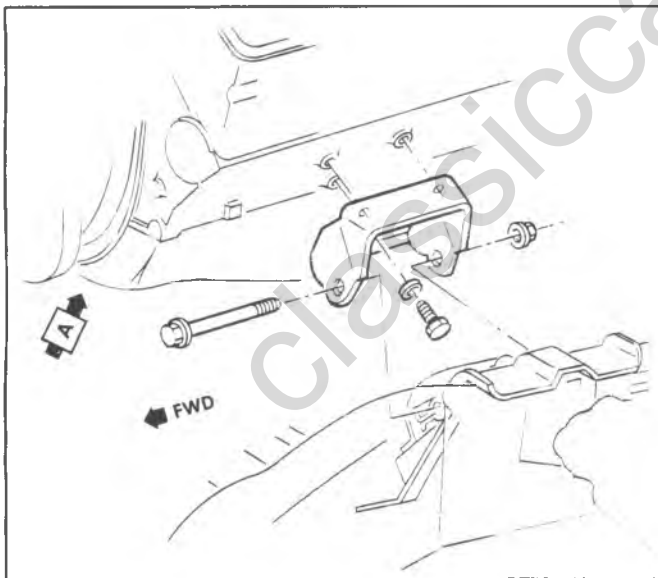


Fig. 6A5-4--"P" Series Engine Mount Bracket

Front Mount Replacement

- Remove mount retaining bolt from below frame mounting bracket.
- Raise front of engine and remove mount-to-engine bolts and remove mount. Raise engine only enough for sufficient clearance. Check for interference between rear of engine and cowl panel which could cause distributor damage.
- Replace mount to engine and lower engine into place.
- Install retaining bolt and torque all bolts to specifications.

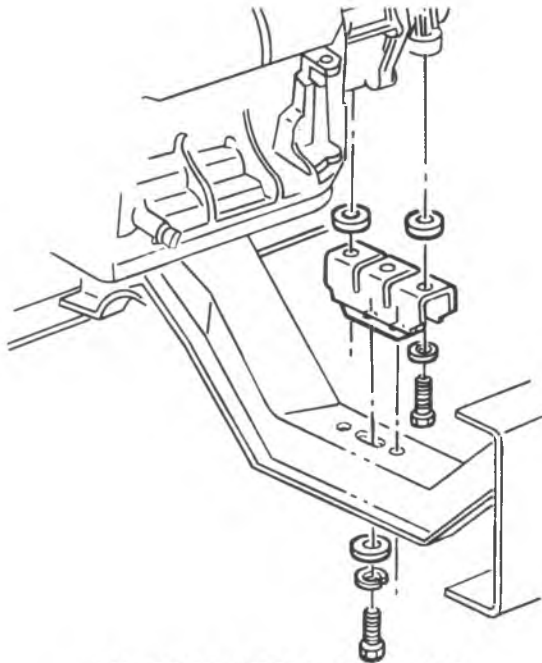
Rear Mount Replacement

- Support engine weight to relieve rear mounts.
- Remove crossmember-to-mount bolts.
- On "P" Series with manual transmission and propeller shaft parking brake, remove mount attaching bolts from frame outrigger and clutch housing and remove rear mounting cushions.
- Remove mount-to-transmission bolts, then remove mount.
- On "P" Series with manual transmission and propeller shaft parking brake, install new mounting cushions and bolts.
- Install new mount on transmission.
- While lowering transmission, align and start crossmember-to-mount bolts.
- Torque bolts to specifications then bend lock tabs to bolt head as applicable.

INTAKE MANIFOLD

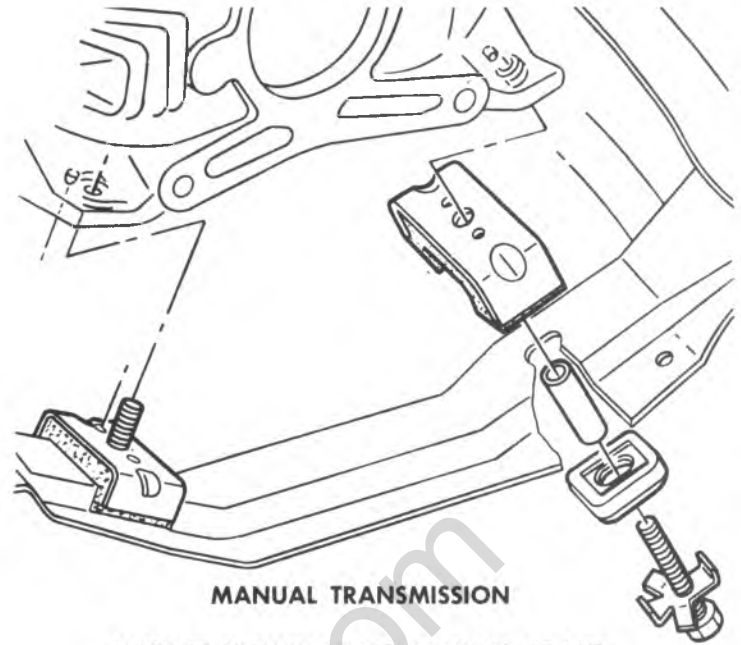
Removal

- Drain radiator and remove air cleaner.
- Disconnect:
 - Battery negative cable at battery.
 - Radiator upper hose and heater hose at manifold.
 - Water pump by-pass at water pump.
 - Accelerator linkage at carburetor.
 - Fuel line at carburetor.
 - Crankcase ventilation lines.
 - Spark advance hose at distributor.
- Remove distributor cap and mark rotor position with chalk, then remove distributor.
- Remove (as required) air compressor and bracket, accelerator return spring and bracket, and accelerator bellcrank.
- Remove generator upper mounting bracket.
 - With A/C, remove rear compressor bracket.
- Remove manifold attaching bolts, then remove manifold and carburetor as an assembly. Discard gaskets and seals.



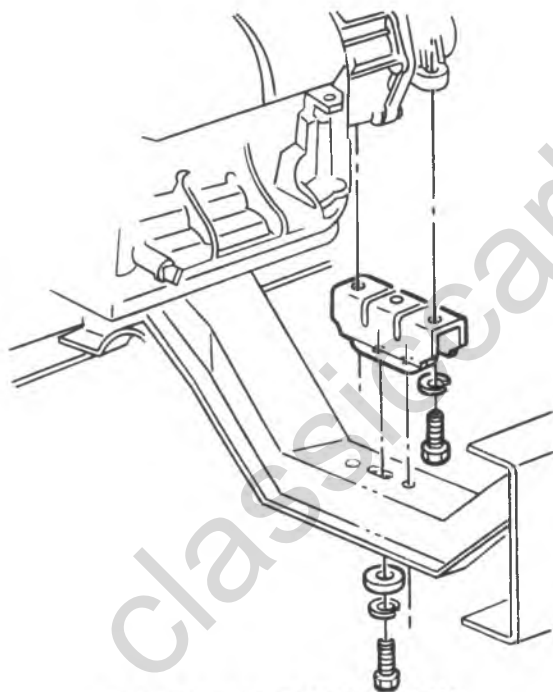
ALL TURBO HYDRA-MATIC 400
(EXCEPT MOBILE HOME CHASSIS)

WITHOUT PROPELLER SHAFT PARKING BRAKE



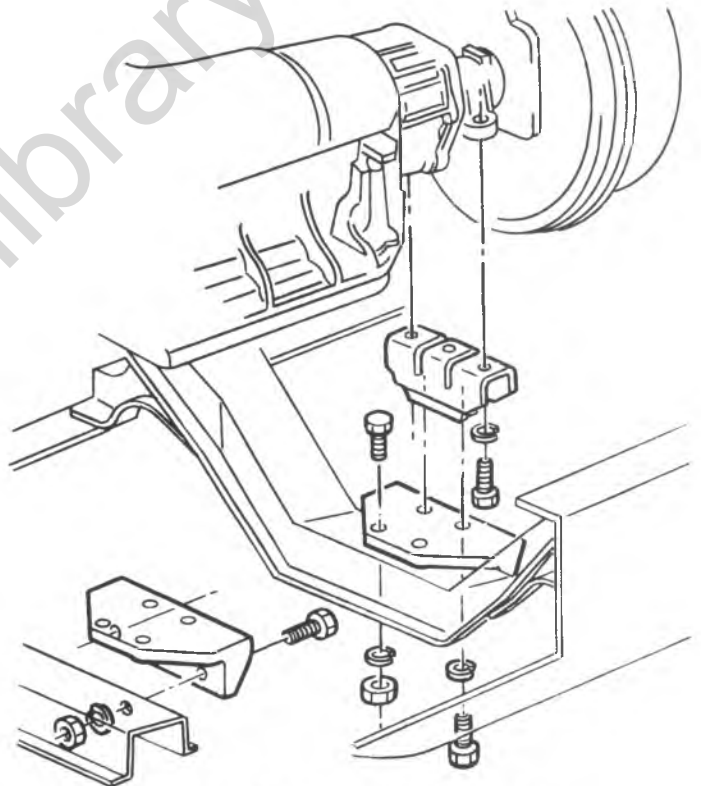
MANUAL TRANSMISSION

WITH PROPELLER SHAFT PARKING BRAKE



ALL MANUAL TRANSMISSION
ALL TURBO HYDRA-MATIC 350
ALL MOBILE HOME CHASSIS

WITHOUT PROPELLER SHAFT PARKING BRAKE



AUTOMATIC TRANSMISSION

WITH PROPELLER SHAFT PARKING BRAKE

Fig. 6A5-5--"P" Series Engine Rear Mount

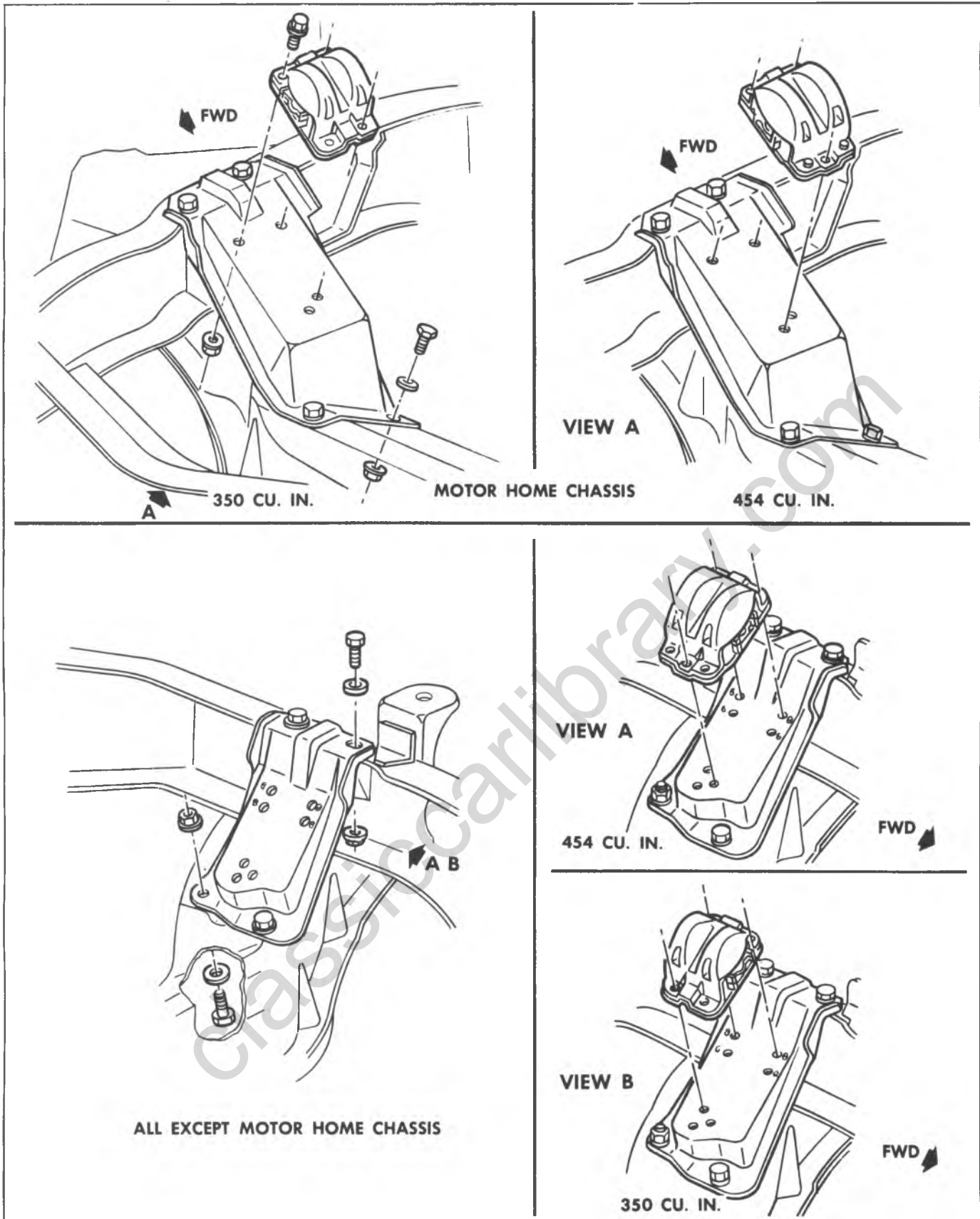


Fig. 6A5-6-"P" Series Engine Front Mount

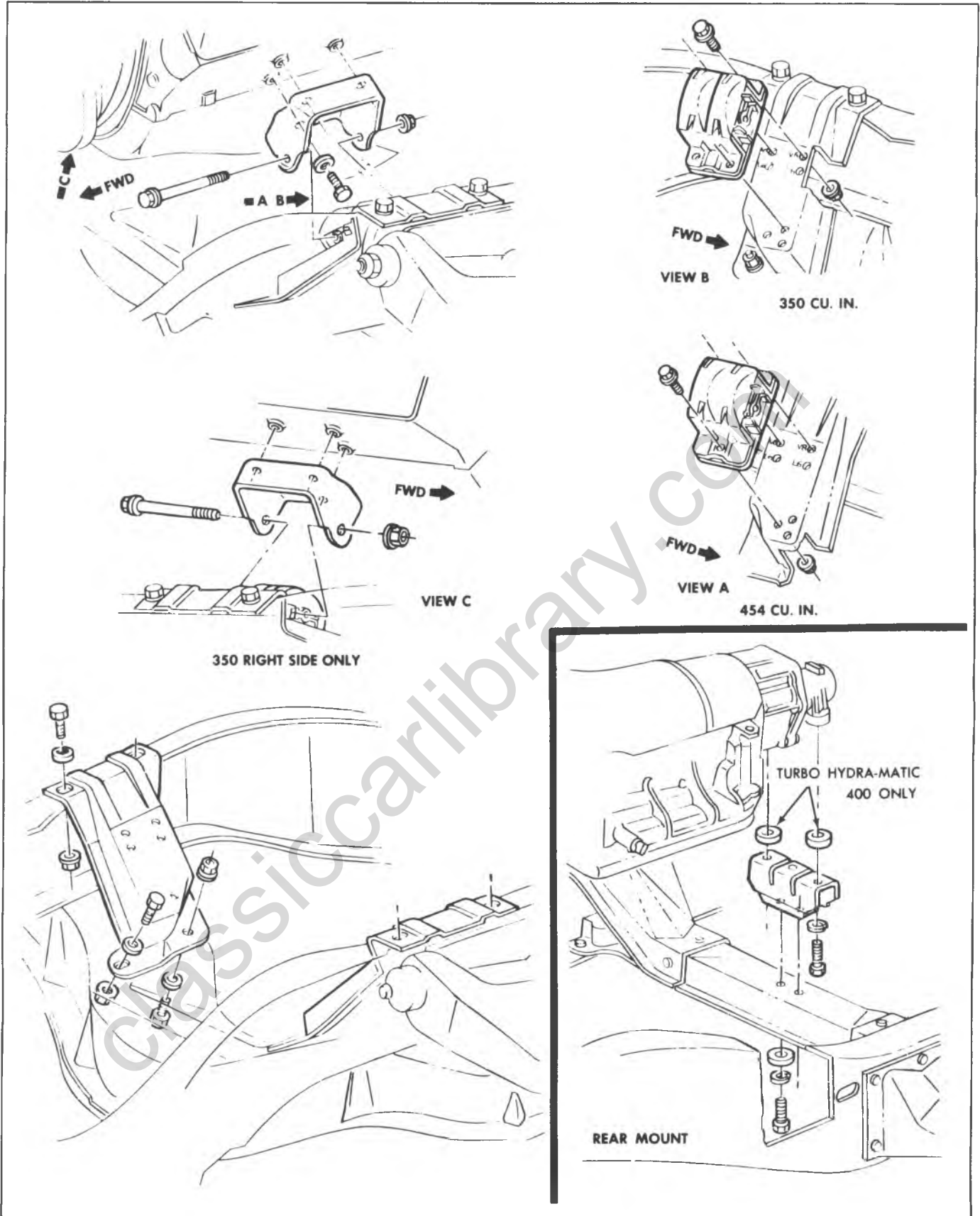


Fig. 6A5-7--"C" Series Engine Mounts

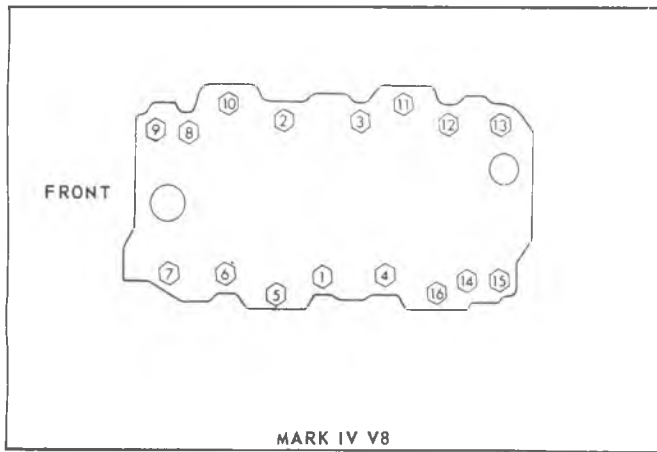


Fig. 6A5-8--Intake Manifold Torque Sequence

7. If manifold is to be replaced, transfer:
- Carburetor and carburetor attaching bolts.
 - Temperature sending unit.
 - Thermostat with housing (use new gasket).
 - Heater hose and water pump by-pass adapters.
 - TVS switch (if applicable).
 - Vacuum fitting(s).

Installation

1. Clean gasket and seal surfaces on manifold, block, and cylinder heads with degreaser.
2. Install gaskets on cylinder heads and new end seals on block.
3. Install manifold and torque bolts to specifications in the sequence outlined in fig. 6A5-8.
4. Install (if removed) air compressor and bracket, accelerator bellcrank.
5. Install distributor, positioning rotor at chalk mark, then install distributor cap.
6. Connect:
 - Spark advance hose at distributor.
 - Crankcase ventilation lines.
 - Fuel line at carburetor.
 - Accelerator linkage at carburetor.
 - Water pump by-pass at water pump.
 - Battery negative cable at battery.
7. Install air cleaner.
8. Fill with coolant, start engine, adjust ignition timing and carburetor idle speed and check for leaks.

EXHAUST MANIFOLD

Removal

1. Remove carburetor air cleaner and heat stove pipe.
2. Remove spark plugs.
3. Disconnect exhaust pipe from manifold and hang exhaust pipe from frame with wire.
4. Remove end bolts then remove center bolts and remove manifold.

Installation

If installing a new right side manifold, the carburetor heat stove must be transferred from the old unit (fig. 6A5-9).

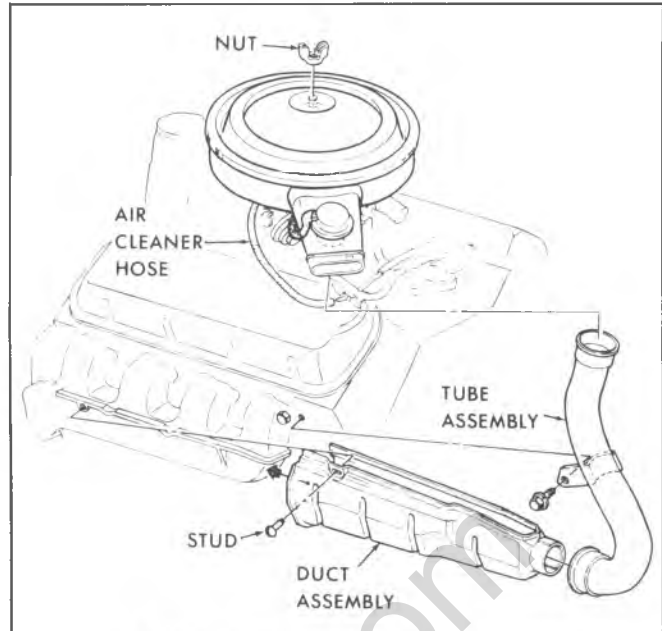


Fig. 6A5-9--Carburetor Heat Stove Assembly

1. Clean mating surfaces on manifold and head, then install manifold in position and install bolts.
2. Torque manifold bolts to specifications.
3. Connect exhaust pipe to manifold.
4. Install spark plugs and torque to 22 lb. ft. (30 N·m).
5. Install carburetor heat stove pipe.
6. Start engine and check for leaks.

ROCKER ARM COVER

Removal

1. Remove air cleaner.
2. Disconnect crankcase ventilation hoses at rocker arm covers.

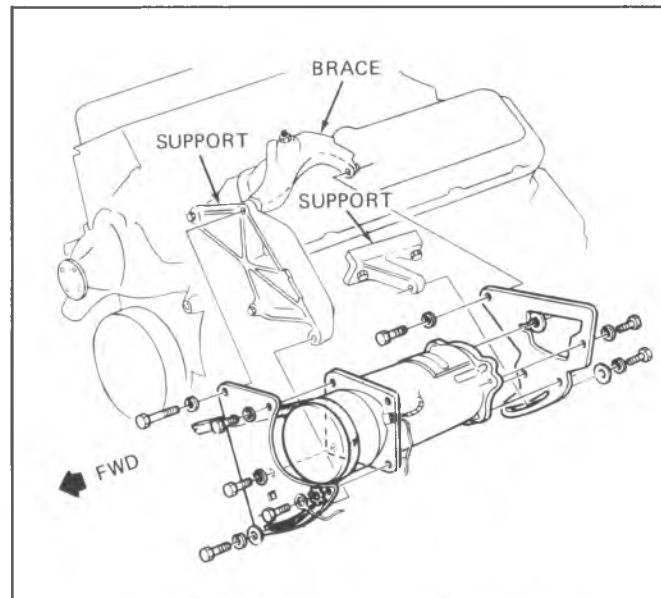


Fig. 6A5-10--A/C Compressor Mounting

3. Disconnect electrical wiring harness from rocker arm clips.
4. Remove carburetor heat stove pipe from right exhaust manifold.
5. If the vehicle is equipped with air conditioning, remove the A/C compressor upper brace (fig. 6A5-10).
6. Remove rocker arm cover to head attaching bolts and remove rocker arm cover.

NOTICE: If cover adheres to cylinder head, shear off by bumping end of rocker arm cover with a rubber mallet. If cover will not come loose, **CAREFULLY** pry until loose. **DO NOT DISTORT SEALING FLANGE.**

Installation

1. Clean sealing surface on cylinder head and rocker arm cover with degreaser. Using a 3/16" (5mm) bead of RTV, #1052366 or equivalent, place rocker arm cover on the head, install retaining bolts and torque to specification. Loose RTV sealant, or pieces causing installation interference, must be removed from both cylinder head and cover seal surfaces prior to applying new sealant.

- When going around the attaching bolt holes, always flow the RTV on the inboard side of the holes.

2. On A/C equipped vehicles, install the A/C compressor upper brace. Adjust pulley belt to specification.
3. Install carburetor heat stove pipe.
4. Connect electrical wiring harness at clips on rocker arm cover.
5. Connect crankcase ventilation hoses.
6. Install air cleaner, start engine and check for leaks.

VALVE MECHANISM

Removal

1. Remove rocker arm covers as previously outlined.
2. Remove rocker arm nuts, rocker arm balls, rocker arms and push rods. Place rocker arms, rocker arm balls and push rods in a rack so they may be reinstalled in the same locations.

Installation and Adjustment

Whenever new rocker arms and/or rocker arm balls are being installed, coat bearing surfaces of rocker arms and rocker arm balls with "Molykote" or its equivalent.

1. Install push rods. Be sure push rods seat in lifter socket.
2. Install rocker arms, rocker arm balls and rocker arm nuts. Tighten rocker arm nuts until all lash is eliminated.

3. Adjust valves when lifter is on base circle of camshaft lobe as follows:

- a. Crank engine until mark on torsional damper lines up with center or "O" mark on the timing tab fastened to the crankcase front cover and the engine is in the #1 firing position. This may be determined by placing fingers on the #1 valve as the mark on the damper comes near the "O" mark on the crankcase front cover. If the valves are not moving, the engine is in the #1 firing position. If the valves move as the mark comes up to the timing tab, the engine is in #6 firing position and should be turned over one more time to reach the #1 position.

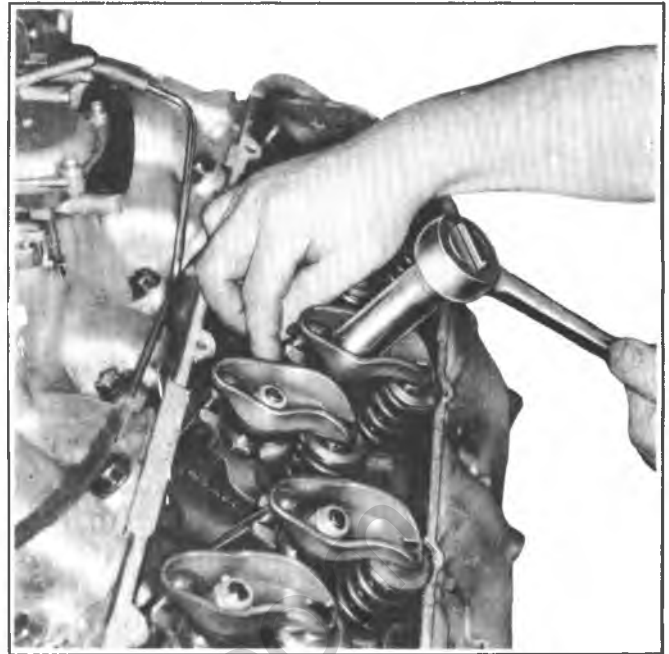


Fig. 6A5-11--Valve Adjustment

- b. With the engine in the #1 firing position as determined above, the following valves may be adjusted.

- Exhaust--1, 3, 4, 8
- Intake--1, 2, 5, 7

- c. Back out adjusting nut until lash is felt at the push rod then turn in adjusting nut until all lash is removed. This can be determined by rotating push rod while turning adjusting nut (fig. 6A5-11). When play has been removed, turn adjusting nut in one full additional turn (to center lifter plunger).

- d. Crank the engine one revolution until the pointer "o" mark and torsional damper mark are again in alignment. This is #6 firing position. With the engine in this position the following valves may be adjusted.

- Exhaust--2, 5, 6, 7
- Intake--3, 4, 6, 8

4. Install rocker arm covers as previously outlined.
5. Start engine and adjust carburetor idle speed.

VALVE STEM OIL SEAL and/or VALVE SPRING

Removal

1. Remove rocker arm cover as previously outlined.
2. Remove spark plug, rocker arm and push rod on the cylinder(s) to be serviced.
3. Install air line adapter Tool J-23590 to spark plug port and apply compressed air to hold the valves in place.
4. Using Tool J-5892 to compress the valve spring, remove the valve locks, valve cap and valve spring and damper (fig. 6A5-12).
5. Remove the valve stem oil seal.

Installation

1. Install new valve stem oil seal (coated with oil) in position over valve guide (fig. 6A5-13). Seal installation instructions are supplied with each service kit. Install seal following procedures outlined on the supplied instruction sheet.

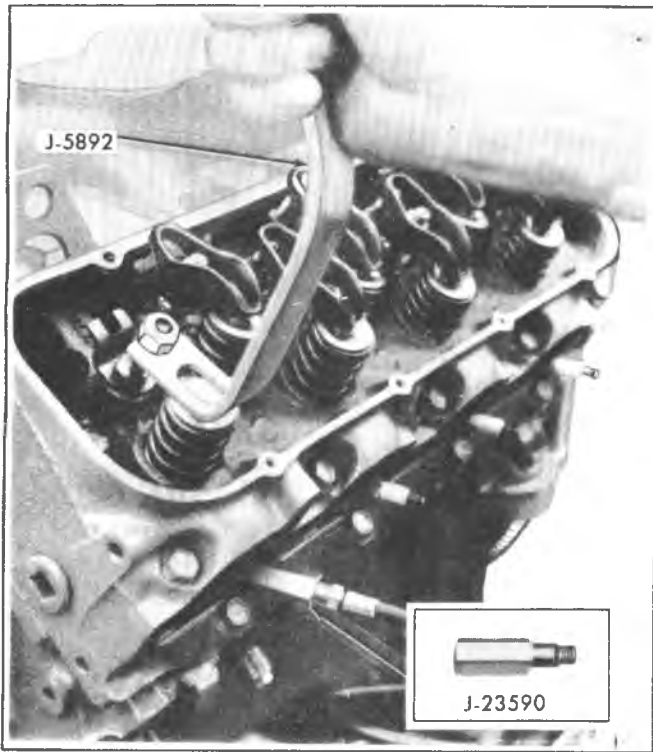


Fig. 6A5-12--Compressing Valve Spring

2. Set the valve spring and damper and valve cap in place.

3. Compress the spring with Tool J-5892 and install the valve locks then release the compressor tool, making sure the locks seat properly in the groove of the valve stem. Grease may be used to hold the locks in place while releasing the compressor tool.

4. Install spark plug, and torque to 22 lb. ft. (30 N·m).

5. Install and adjust valve mechanism as previously outlined.



Fig. 6A5-13--Installing Valve Stem Oil Seal

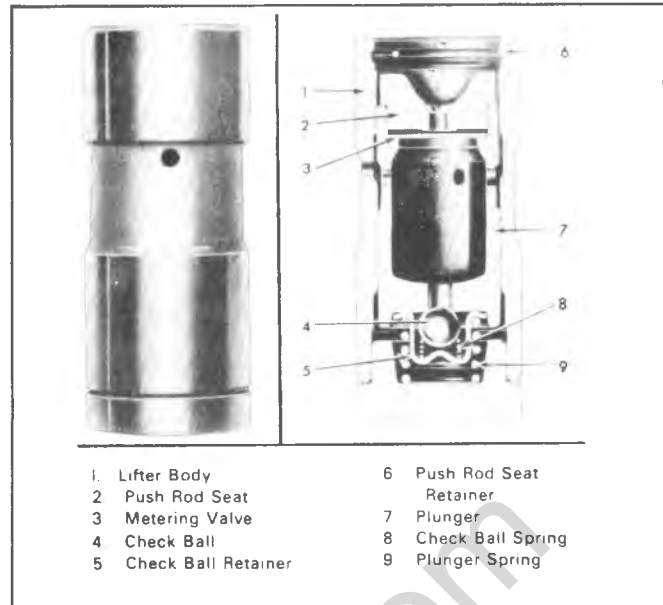


Fig. 6A5-14--Hydraulic Valve Lifter

VALVE LIFTERS

Hydraulic valve lifters very seldom require attention. The lifters are extremely simple in design, readjustments are not necessary, and servicing of the lifters requires only that care and cleanliness be exercised in the handling of parts.

Removal

1. Remove intake manifold as previously outlined.
2. Remove valve mechanism as previously outlined.
3. Remove valve lifters. Place valve lifters in a rack so that they may be reinstalled in the same location.

Installation

1. Coat foot of valve lifters with "Molykote" or its equivalent and install valve lifters. Make sure lifter foot is convex.
2. Install intake manifold as previously outlined.
3. Install and adjust valve mechanism as outlined.

Disassembly

1. Hold the plunger down with a push rod, and using the blade of a small screw driver, remove the push rod seat retainer.
2. Remove the push rod seat and metering valve (fig. 6A5-14).
3. Remove the plunger, ball check valve assembly and the plunger spring.
4. Remove the ball check valve and spring by prying the ball retainer loose from the plunger with the blade of a small screw driver (fig. 6A5-15).

Cleaning and Inspection

Thoroughly clean all parts in cleaning solvent, and inspect them carefully. If any parts are damaged or worn, the entire lifter assembly should be replaced. If the lifter body wall is scuffed or worn, inspect the cylinder block lifter bore. If the bottom of the lifter is scuffed or worn, inspect the camshaft lobe. If the push rod seat is scuffed or worn, inspect the push rod. An additive containing EP lube, such as EOS, should always be added to crankcase oil for run-in when any new camshaft or lifters are installed. All damaged



Fig. 6A5-15--Removing Ball Check Valve

or worn lifters should be replaced.

● For proper lifter rotation during engine operation, lifter foot must be convex.

Assembly

1. Place the check ball on small hole in bottom of the plunger.
2. Insert check ball spring on seat in ball retainer and place retainer over ball so that spring rests on the ball. Carefully press the retainer into position in plunger with the blade of a small screw driver (fig. 6A5-16).
3. Place the plunger spring over the ball retainer and slide the lifter body over the spring and plunger, being careful to line up the oil feed holes in the lifter body and



Fig. 6A5-16--Installing Ball Check Valve

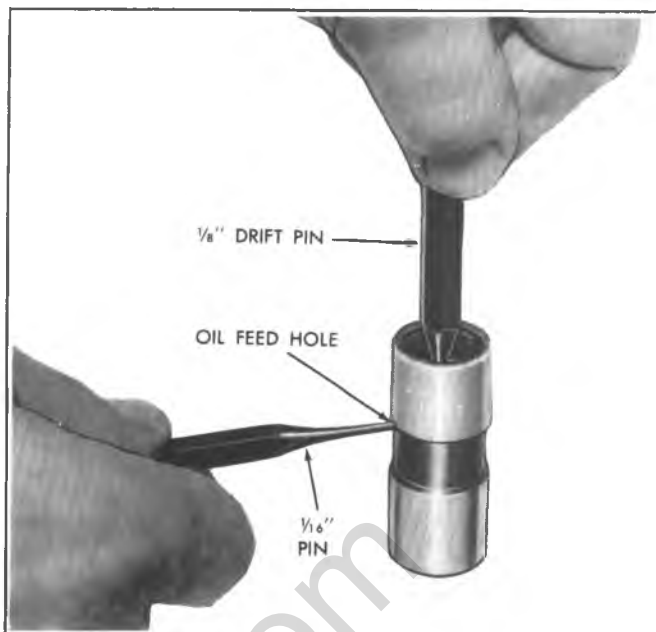


Fig. 6A5-17--Assembling Hydraulic Lifter

plunger.

4. Fill the assembly with SAE 10 oil, then insert the end of a 1/8" drift pin into the plunger and press down solid. Do not attempt to force or pump the plunger. At this point, oil holes in the lifter body and plunger assembly will be aligned (fig. 6A5-17).

5. Insert a 1/16" drift pin through both oil holes to hold the plunger down against the lifter spring tension (fig. 6A5-17).
6. Remove the 1/8" drift pin, refill assembly with SAE 10 oil.
7. Install the metering valve and push rod seat (fig. 6A5-14).
8. Install the push rod seat retainer, press down on the push rod seat and remove the 1/16" drift pin from the oil holes. The lifter is now completely assembled, filled with oil and ready for installation. Before installing lifters, coat the bottom of the lifter with "Molykote" or its equivalent.

CYLINDER HEAD ASSEMBLY

Removal

1. Remove intake manifold as previously outlined.
2. Remove generator lower mounting bolt and lay unit aside.
3. Remove exhaust manifolds as previously outlined.
4. If vehicle is equipped with A/C, remove A/C compressor and forward mounting bracket. Lay unit aside.
5. Remove valve mechanism as previously outlined.
6. Drain cylinder block of coolant.
7. Remove cylinder head bolts, cylinder head and gasket. Place cylinder head on two blocks of wood to prevent damage.

Disassembly

1. With cylinder head removed, remove valve rocker arm nuts, balls and rocker arms (if not previously done).
2. Using Tool J-8062, compress the valve springs (fig. 6A5-18) and remove valve keys. Release the compressor

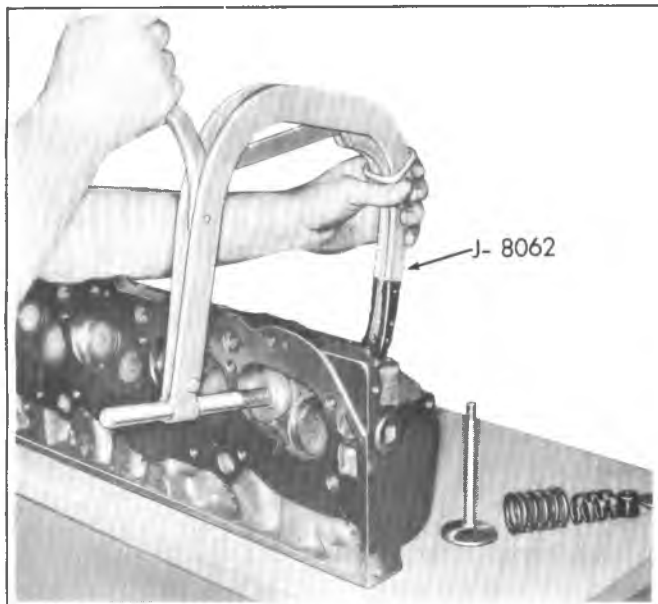


Fig. 6A5-18--Compressing Valve Spring

tool and remove rotators or spring caps, springs and spring damper, then remove oil seals and valve spring shims.

3. Remove valves from cylinder head and place them in a rack in their proper sequence so that they can be assembled in their original positions.

Cleaning

1. Clean all carbon from combustion chambers and valve ports using Tool J-8089 (fig. 6A5-19).

2. Thoroughly clean the valve guides using Tool J-8101 (fig. 6A5-20).

3. Clean all carbon and sludge from push rods, rocker arms and push rod guides.

4. Clean valve stems and heads on a buffing wheel.

5. Clean carbon deposits from head gasket mating surface.

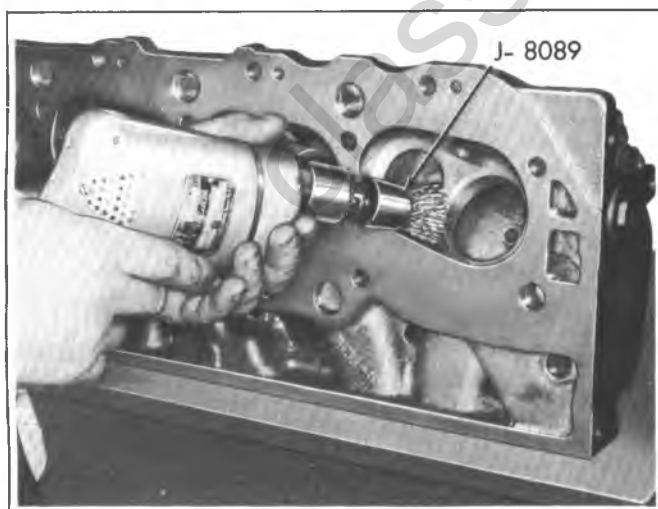


Fig. 6A5-19--Cleaning Combustion Chambers

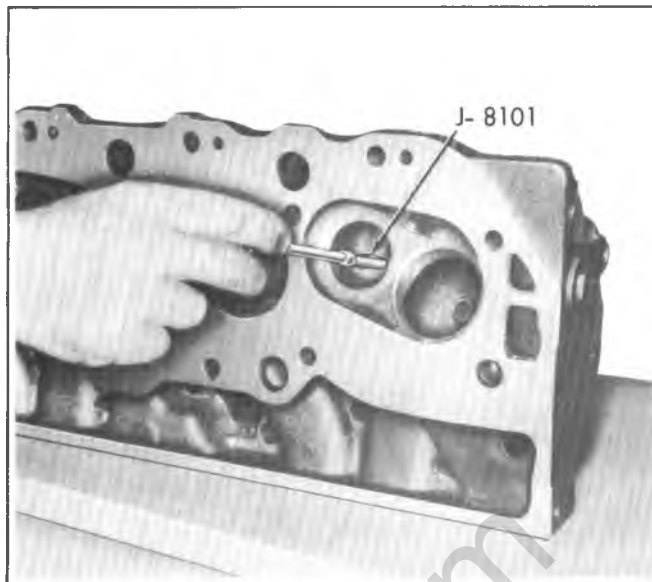


Fig. 6A5-20--Cleaning Valve Guides

Inspection

1. Inspect the cylinder head for cracks in the exhaust ports, combustion chambers, or external cracks to the coolant chamber.

2. Inspect the valves for burned heads, cracked faces or damaged stems.

NOTICE: Excessive valve stem to bore clearance will cause excessive oil consumption and may cause valve breakage. Insufficient clearance will result in noisy and sticky functioning of the valve and disturb engine smoothness.

3. Measure valve stem clearance (fig. 6A5-21) as

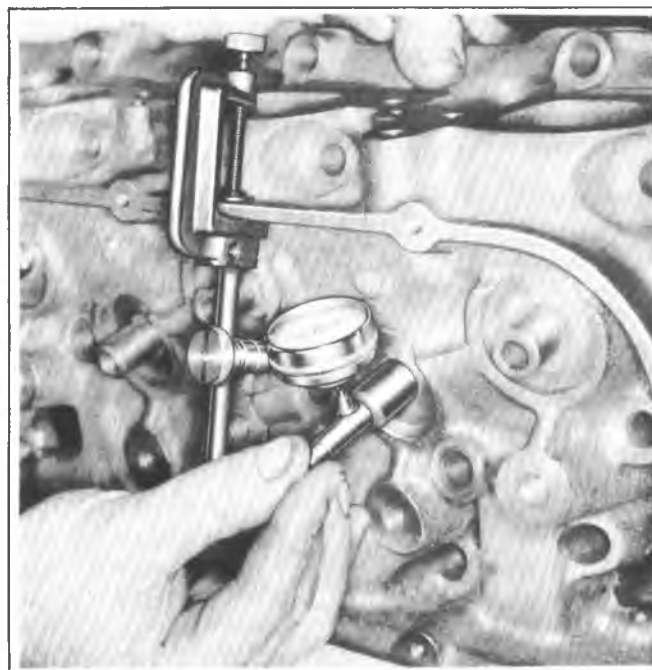


Fig. 6A5-21--Measuring Valve Stem Clearances



Fig. 6A5-22--Checking Valve Spring Tension

follows:

a. Clamp a dial indicator on one side of the cylinder head rocker arm cover gasket rail.

b. Locate the indicator so that movement of the valve stem from side to side (crosswise to the head) will cause a direct movement of the indicator stem. The indicator stem must contact the side of the valve stem just above the valve guide.

c. Drop the valve head about 1/16" (1.6mm) off the valve seat.

d. Move the stem of the valve from side to side using light pressure to obtain a clearance reading. If clearance exceeds specifications, it will be necessary to ream valve guides for oversize valves as outlined.

4. Check valve spring tension with Tool J-8056 spring tester (fig. 6A5-22). Springs should be compressed to the specified height and checked against the specifications chart. Springs should be replaced if not within 10 lbs. (44 N) of the specified load (without dampers).

5. Inspect rocker arm studs for wear or damage. Inspect push rod guides for wear or damage.

Assembly

1. Insert a valve in the proper port.

2. Assemble the valve spring and related parts as follows:

a. Install valve spring shim on valve spring seat then install a new valve stem oil seal over valve and valve guide.

b. Set the valve spring (with damper); and valve cap in place (fig. 6A5-23).

c. Compress the spring with Tool J-8062.

d. Install the valve locks and release the compressor tool, making sure the locks seat properly in the groove of the valve stem. Grease may be used to hold the locks in place while releasing the compressor tool.

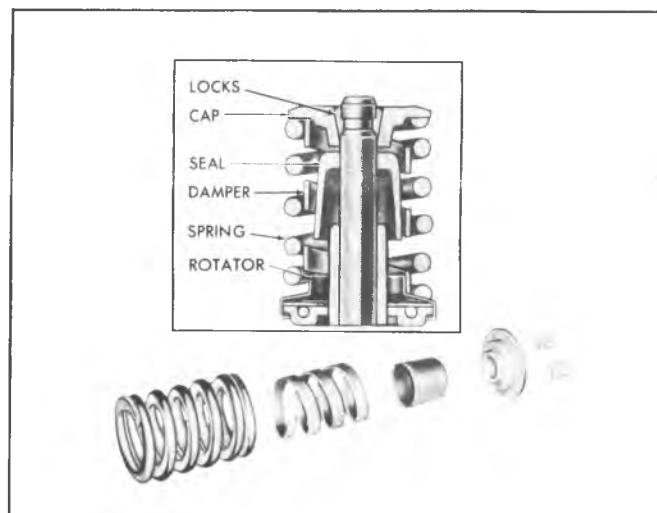


Fig. 6A5-23--Valve Spring Installation

3. Install the remaining valves.

4. Check the installed height of the valve springs, using a narrow thin scale. A cutaway scale will help (fig. 6A5-24). Measure from the top of the shim or the spring seat to the top of the valve spring or valve spring shield (fig. 6A5-25). If this is found to exceed the specified height, install a valve spring seat shim approximately 1/16" (1.6mm) thick. At no time should the spring be shimmed to give an installed height under the minimum specified.

Installation

• The gasket surfaces on both the head and the block must be clean of any foreign matter and free of nicks or heavy scratches. Cylinder bolt threads in the block and threads on the cylinder head bolts must be clean as dirt will affect bolt torque.

1. On engines using a STEEL gasket, coat both sides of a new gasket with a good sealer. Spread the sealer thin and even. One method of applying the sealer that will assure the proper coat is with the use of a paint roller. Too much sealer may hold the gasket away from the head or block.

• Use no sealer on engines using a composition STEEL ASBESTOS gasket.

2. Place the gasket in position over the dowel pins with the bead up.

3. Carefully guide the cylinder head into place over the dowel pins and gasket.

4. Coat threads of cylinder head bolts with sealing compound, #1052080 or equivalent, and install bolts finger tight.

5. Tighten each cylinder head bolt a little at a time in the sequence shown in figure 6A5-26 until the specified torque is reached.

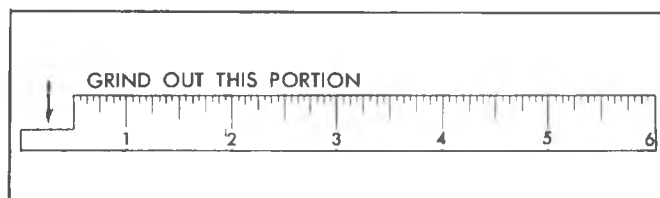


Fig. 6A5-24--Cutaway Scale

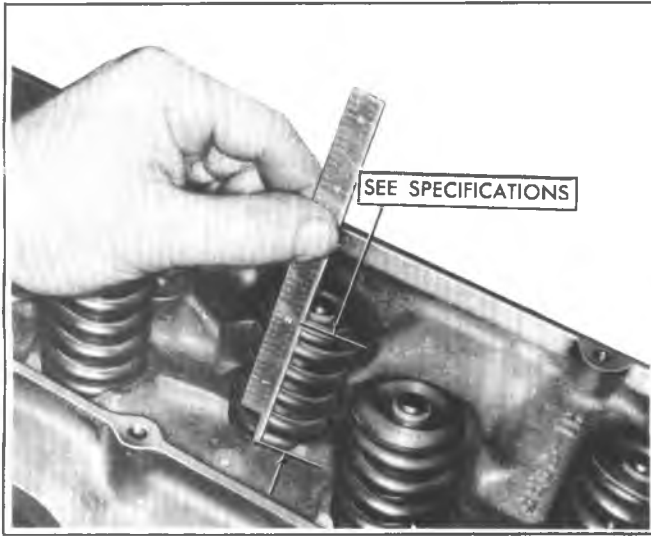


Fig. 6A5-25--Measuring Valve Spring Installed Height

6. Install exhaust manifolds as previously outlined.
7. Install intake manifold as previously outlined.
8. Install and adjust valve mechanism as previously outlined.

ROCKER ARM STUDS

Replacement

The push rod guides are attached to the cylinder head by the rocker arm studs (fig. 6A5-27). Replace where necessary and torque rocker arm studs to specifications.

VALVE GUIDE BORES

Valves with oversize stems are available (see specifications). To ream the valve guide bores for oversize valves use Tool Set J-7049.

VALVE SEATS

Reconditioning the valve seats is very important, because the seating of the valves must be perfect for the engine to deliver the power and performance built into it.

Another important factor is the cooling of the valve heads. Good contact between each valve and its seat in the

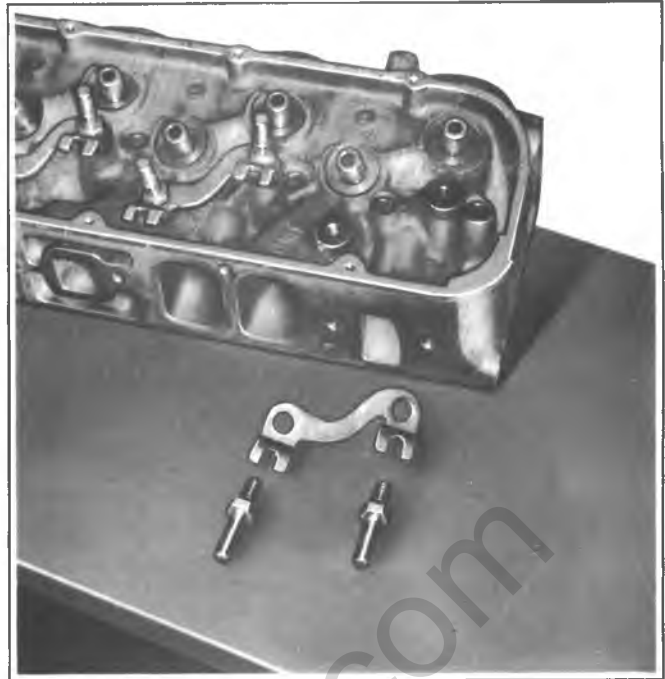


Fig. 6A5-27--Rocker Arm Stud & Push Rod Guide

head is imperative to insure that the heat in the valve head will be properly carried away.

Several different types of equipment are available for reseating valves seats. The recommendations of the manufacturer of the equipment being used should be carefully followed to attain proper results.

Regardless of what type of equipment is used, however, it is essential that valve guide bores be free from carbon or dirt to ensure proper centering of pilot in the guide.

VALVES

Valves that are pitted can be refaced to the proper angle, insuring correct relation between the head and stem on a valve refacing mechanism. Valve stems which show excessive wear, or valves that are warped excessively should be replaced. When a valve head which is warped excessively is refaced, a knife edge will be ground on part or all of the

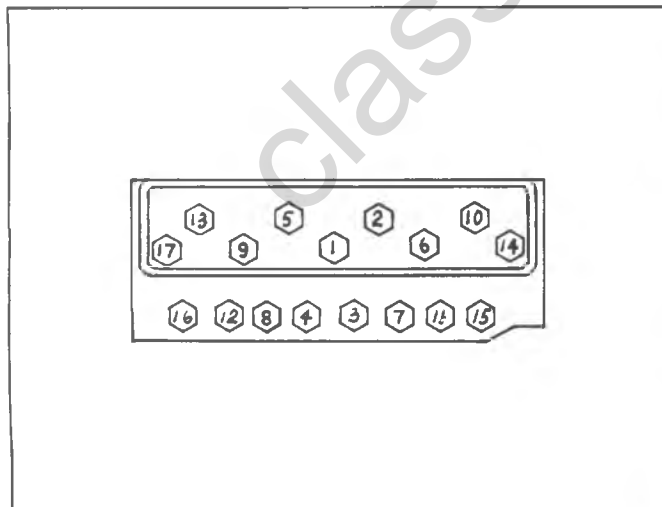


Fig. 6A5-26--Cylinder Head Torque Sequence



Fig. 6A5-29--Measuring Valve Head

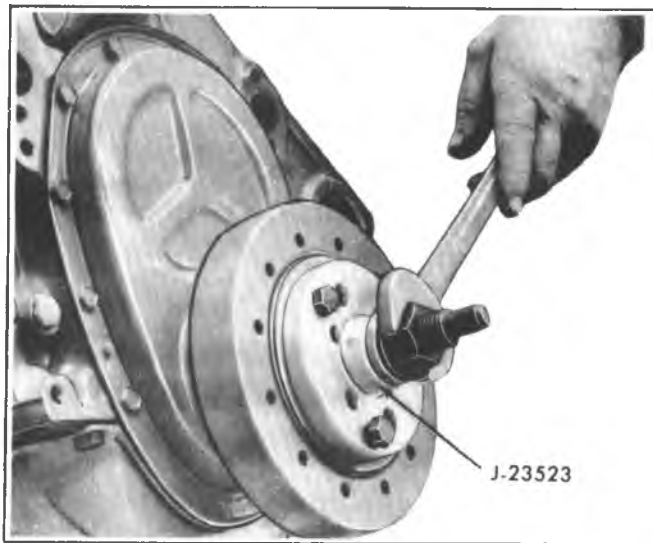


Fig. 6A5-30--Installing Torsional Damper

valve head due to the amount of metal that must be removed to completely reface. Knife edges lead to breakage, burning or pre-ignition due to heat localizing on this knife edge. If the edge of the valve head is less than $1/32$ " (.80mm) thick after grinding, replace the valve (fig. 6A5-29).

Several different types of equipment are available for re-facing valves. The recommendation of the manufacturer of the equipment being used should be carefully followed to attain proper results.

TORSIONAL DAMPER

Removal

1. Remove fan belt, fan and pulley.
2. Remove the fan shroud assembly as outlined in Section 6B.
 - If additional operations (such as camshaft removal) are not being performed, the radiator removal will not be necessary.
3. Remove accessory drive pulley then remove damper retaining bolt.
4. Install Tool J-23523 on damper then, turning puller screw, remove damper.

Installation

NOTICE: The inertial weight section of the torsional damper is assembled to the hub with a rubber type material. The installation procedures (with proper tool) must be followed or movement of the inertia weight section on the hub will destroy the tuning of the torsional damper.

1. Coat front cover seal contact area (on damper) with engine oil.
2. Place damper in position over key on crankshaft.
3. Pull damper onto crankshaft as follows:
 - a. Install appropriate threaded end of Tool J-23523 into crankshaft. Install tool in crankshaft so that at least $1/2$ " (6.5mm) of thread engagement is obtained.
 - b. Install plate, thrust bearing and nut to complete tool installation.

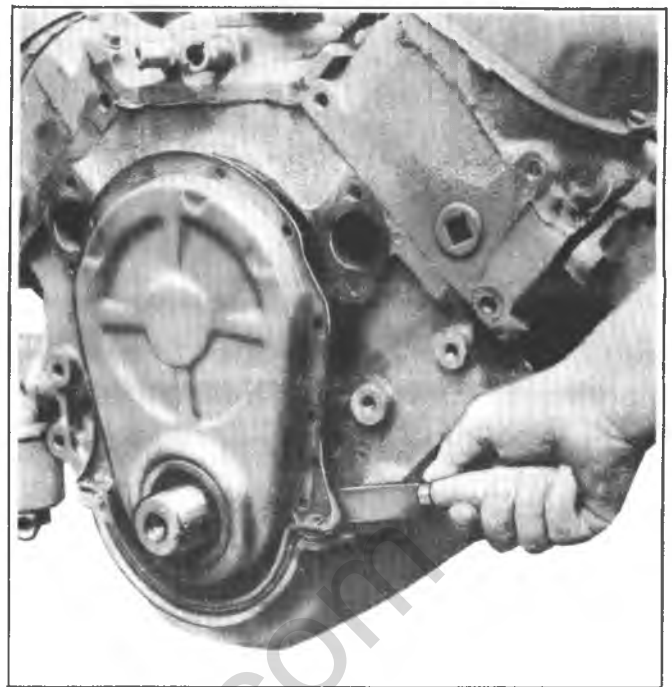


Fig. 6A5-31--Cutting Tabs on Oil Pan Front Seal

- c. Pull damper into position as shown in Figure 6A5-30.
- d. Remove tool from crankshaft then install damper retaining bolt and torque to specifications.
4. Install accessory drive pulley.
5. Install fan shroud as outlined in Section 6B.
6. Install fan and pulley to water pump hub and tighten securely.
7. Install fan belt and adjust to specifications using strand tension gage.
8. Fill cooling system, start engine and check for leaks.

CRANKCASE FRONT COVER

Removal

1. Remove torsional damper and water pump as outlined.
2. Remove the two, oil pan-to-front cover attaching screws.
3. Remove the front cover-to-block attaching screws.
4. Pull the cover slightly forward only enough to permit cutting of oil pan front seal.
5. Using a sharp knife or other suitable cutting tool, cut oil pan front seal flush with cylinder block at both sides of cover (fig. 6A5-31).
6. Remove front cover and attaching portion of oil pan front seal. Remove front cover gasket.

Installation

1. Clean gasket surface on block and crankcase front cover.
2. Cut tabs from the new oil pan front seal (fig. 6A5-32). Use a sharp instrument to ensure a clean cut.
3. Install seal to front cover, pressing tips into holes provided in cover.
4. Coat the gasket with gasket sealer and place in position on cover.

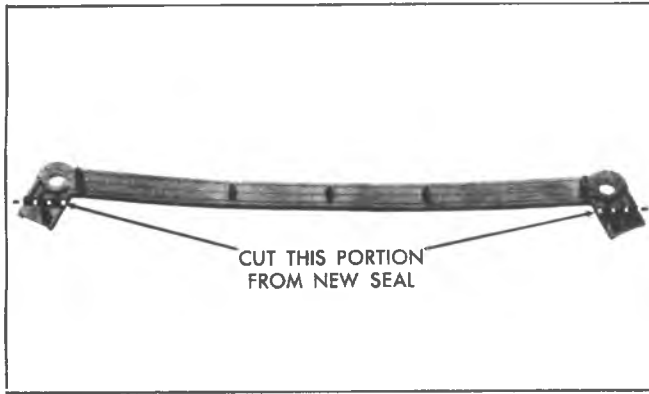


Fig. 6A5-32--Oil Pan Front Seal Modification

5. Apply a 1/8" (3mm) bead of RTV sealer, #1052366 or equivalent, to the joint formed at the oil pan and cylinder block (fig. 6A5-33).

6. Position crankcase front cover over crankshaft.

7. Press cover downward against oil pan until cover is aligned and installed over dowel pins on block.

8. Install and partially tighten the two, oil pan-to-front cover attaching screws.

9. Install the front cover-to-block attaching screws.

10. Torque all screws to specifications.

11. Install torsional damper and water pump as previously outlined.

OIL SEAL (FRONT COVER)

Replacement

With Cover Removed

1. With cover removed, pry oil seal out of cover from the front with a large screw driver.

2. Install new seal so that open end of the seal is toward the inside of cover and drive it into position with Tool J-22102. Support rear of cover at seal area.

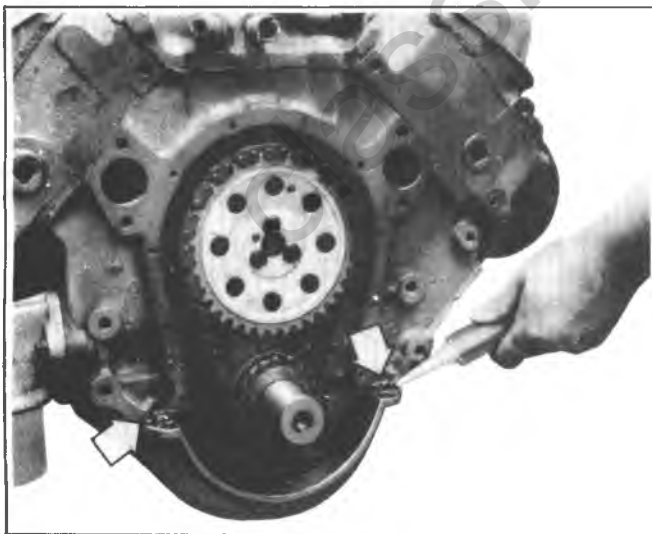


Fig. 6A5-33--Applying Front Cover Sealer

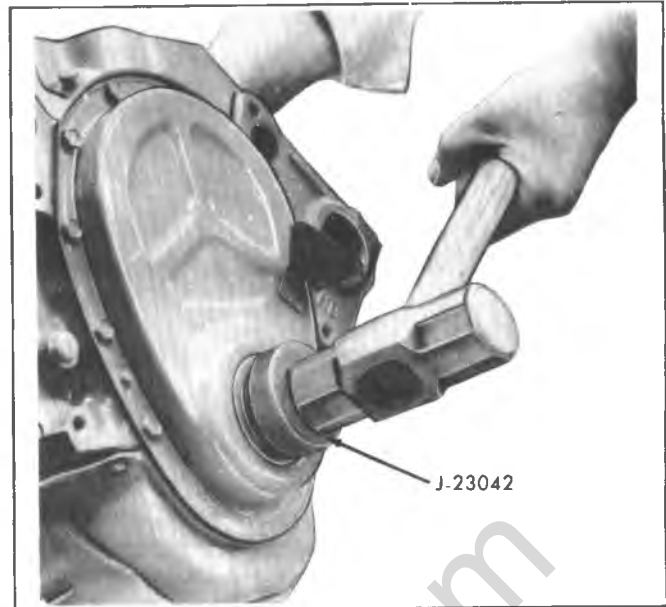


Fig. 6A5-34--Installing Oil Seal

With Cover Installed

1. With torsional damper removed, pry seal out of cover from the front with a large screw driver. Be careful not to damage the surface on the crankshaft.

2. Install new seal so that open end of seal is toward the inside of cover and drive it into position with Tool J-22102. (fig. 6A5-34).

CAMSHAFT

Measuring Lobe Lift

1. Remove the valve mechanism as previously outlined.

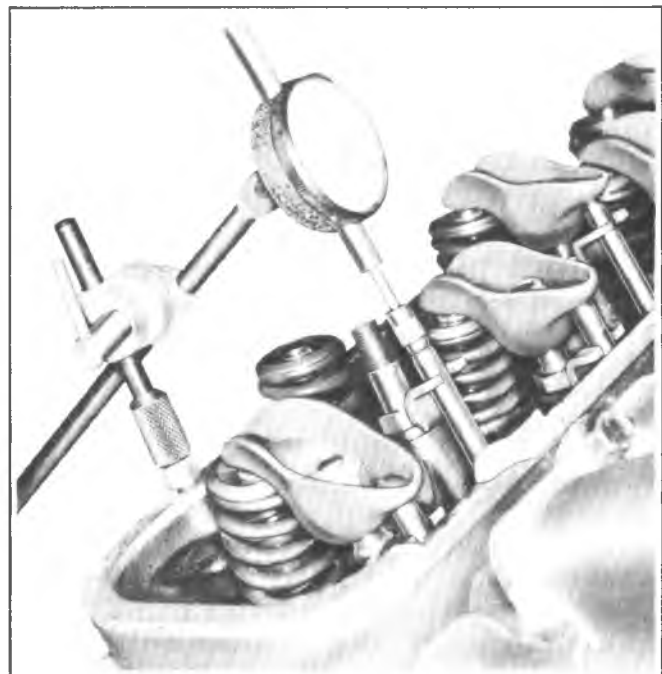


Fig. 6A5-35--Measuring Camshaft Lobe Lift

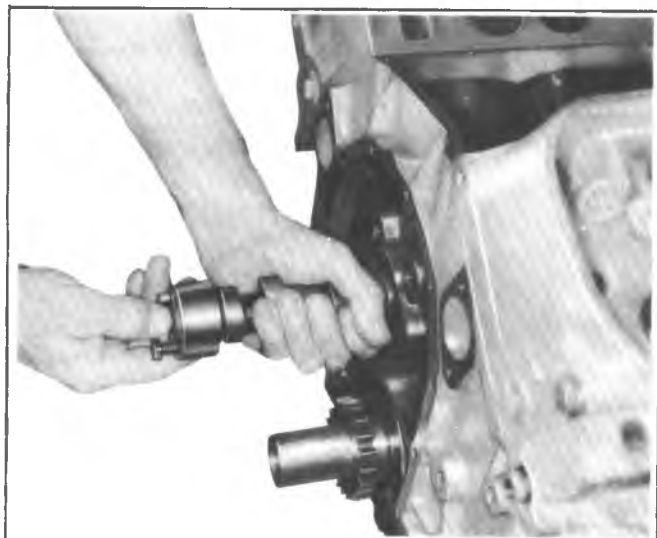


Fig. 6A5-36--Removing Camshaft

2. Position indicator with ball socket adapter (Tool J-8520) on push rod (fig. 6A5-35). Make sure push rod is in the lifter socket.

3. Rotate the crankshaft slowly in the direction of rotation until the lifter is on the heel of the cam lobe. At this point, the push rod will be in its lowest position.

4. Set dial indicator on zero, then rotate the crankshaft slowly, or attach an auxiliary starter switch and "bump" the engine over, until the push rod is fully raised position.

● Whenever the engine is cranked remotely at the starter, with a special jumper cable or other means, the distributor primary lead should be disconnected from the distributor (coil).

5. Compare the total lift recorded from the dial indicator with specifications.

6. If camshaft readings for all lobes are within specifications, remove dial indicator assembly.

7. Install and adjust valve mechanism as outlined.

Removal

1. Remove valve lifters as previously outlined.

2. Remove crankcase front cover as previously outlined.

3. Remove grille.

4. Remove fuel pump push rod as outlined in Section 6C.

5. Complete camshaft removal as follows:

● Sprocket is a light fit on camshaft. If sprocket does not come off easily a light blow on the lower edge of the sprocket (with a plastic mallet) should dislodge the sprocket.

6. Install two 5/16" - 18 x 4" bolts in camshaft bolt holes then remove camshaft (fig. 6A5-36).

NOTICE: All camshaft journals are the same diameter and care must be used in removing camshaft to avoid damage to bearings.

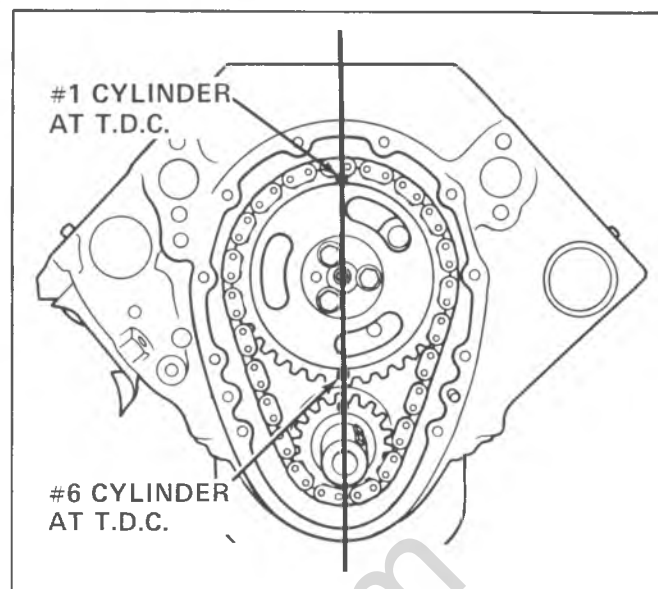


Fig. 6A5-37--Timing Sprocket Alignment Marks

Inspection

The camshaft bearing journals should be measured with a micrometer for an out-of-round condition. If the journals exceed .001" out-of-round, the camshaft should be replaced.

Installation

Whenever a new camshaft is installed coat camshaft lobes with "Molykote" or its equivalent.

Whenever a new camshaft is installed, replacement of all valve lifters is recommended to insure durability of the camshaft lobes and lifter feet.

1. Lubricate camshaft journals with engine oil and install camshaft.

2. Install timing chain on camshaft sprocket. Hold the sprocket vertically with the chain hanging down and align marks on camshaft and crankshaft sprockets. (Refer to fig. 6A5-37).

3. Align dowel in camshaft with dowel hole in camshaft sprocket then install sprocket on camshaft.

4. Draw the camshaft sprocket onto camshaft using the mounting bolts. Torque to specifications.

5. Lubricate timing chain with engine oil.

6. Install fuel pump push rod as outlined in Section 6C.

7. Install grille.

8. Install crankcase front cover as previously outlined.

9. Install valve lifters as previously outlined.

CAMSHAFT BEARINGS

Removal

Camshaft bearings can be replaced while engine is disassembled for overhaul or without complete disassembly of the engine. To replace bearings without complete disassembly remove the camshaft and crankshaft leaving cylinder heads attached and pistons in place. Before removing crankshaft, tape threads of connecting rod bolts to prevent damage to crankshaft. Fasten connecting rods against sides of engine so they will not be in the way while replacing camshaft bearings.

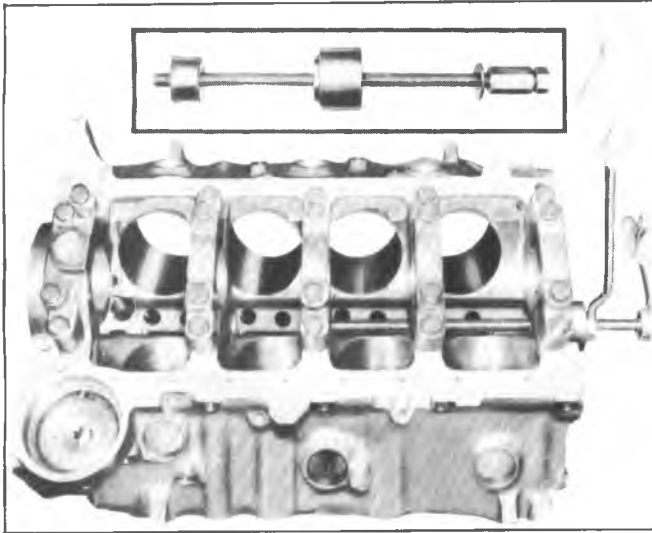


Fig. 6A5-38--Removing Camshaft Bearings

1. With camshaft and crankshaft removed, drive camshaft rear plug from cylinder block.

2. Using Tool J-6098 with nut and thrust washer installed to end of threads, index pilot in camshaft front bearing and install puller screw through pilot.

3. Install remover and installer tool with shoulder toward bearing, making sure a sufficient amount of threads are engaged.

4. Using two wrenches, hold puller screw while turning nut. When bearing has been pulled from bore, remove remover and installer tool and bearing from puller screw (fig. 6A5-38).

5. Remove remaining bearings (except front and rear) in the same manner. It will be necessary to index pilot in camshaft rear bearing to remove the rear intermediate bearing.

6. Assemble remover and installer tool on driver handle and remove camshaft front and rear bearings by driving towards center of cylinder block (fig. 6A5-39).

Installation

The camshaft front and rear bearings should be installed first. These bearings will act as guides for the pilot and center the remaining bearings being pulled into place.

1. Assemble remover and installer tool on driver handle and install camshaft front and rear bearings by driving towards center of cylinder block (fig. 6A5-39).

2. Using Tool Set J-6098 with nut then thrust washer installed to end of threads, index pilot in camshaft front bearing and install puller screw through pilot.

3. Index camshaft bearing in bore (with oil hole aligned as outlined below), then install remover and installer tool on puller screw with shoulder toward bearing.

● Number one through number four cam bearing oil hole must be aligned with oil holes in cam bearing bore.

● The number five bearing bore is annulus, and cam bearing must be positioned at or near the 6 o'clock position.

4. Using two wrenches, hold puller screw while turning nut. After bearing has been pulled into bore, remove the remover and installer tool from puller screw, and check alignment of oil hole in camshaft bearing.

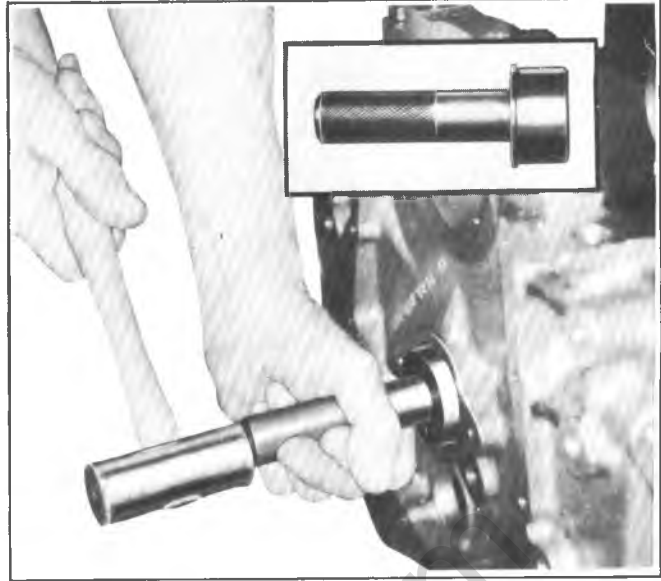


Fig. 6A5-39--Replacing Camshaft Front Bearing

5. Install remaining bearings in the same manner. It will be necessary to index pilot in the camshaft rear bearing to install the rear intermediate bearing.

6. Coat new rear plug O.D. with # 1052080 sealant, or equivalent, and install flush to 1/32" (.80mm) deep.

OIL PAN

Removal

1. Disconnect battery negative cable.
2. Loosen fan shroud.
3. Remove air cleaner.
4. Remove distributor cap.
5. Raise vehicle and drain oil pan.
 - If equipped with manual transmission, remove starter.
6. Remove torque converter cover or clutch cover as applicable.
7. Remove oil filter.
8. On gage equipped vehicles, remove oil pressure line from side of block.

NOTICE: Removal of pressure line is important to prevent crushing of line when raising engine.

9. Remove mount "through" bolts and raise engine.
10. Remove oil pan bolts and drop pan.

Installation

If installing new oil pan, transfer dipstick tube from old unit.

1. With clean sealing surfaces on pan and block, place oil pan on block and install oil pan bolts. Torque to 135 lb. in. (15N·m).
2. Lower engine on mounts and install mount through bolts. Torque to 75 lb. ft. (100 N·m).
3. Install oil pressure line, if applicable, and install oil filter.
4. Install torque converter cover or clutch cover, as applicable.

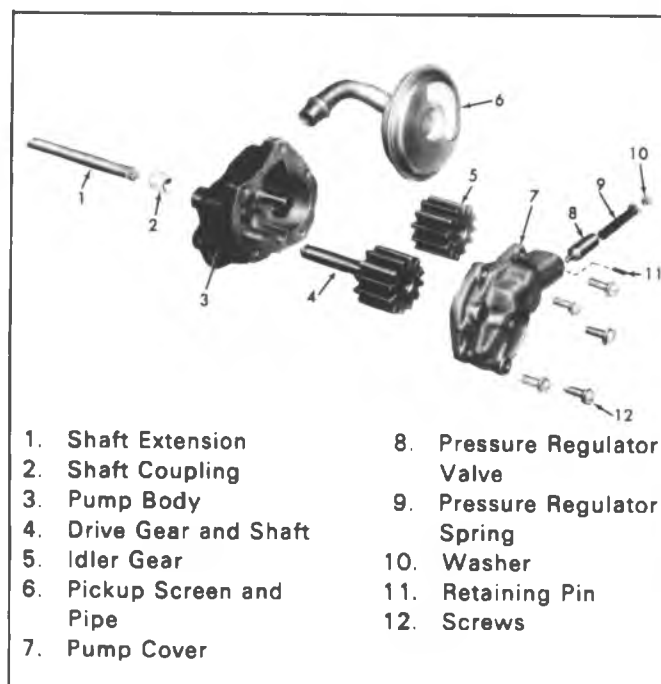


Fig. 6A5-40—Oil Pump

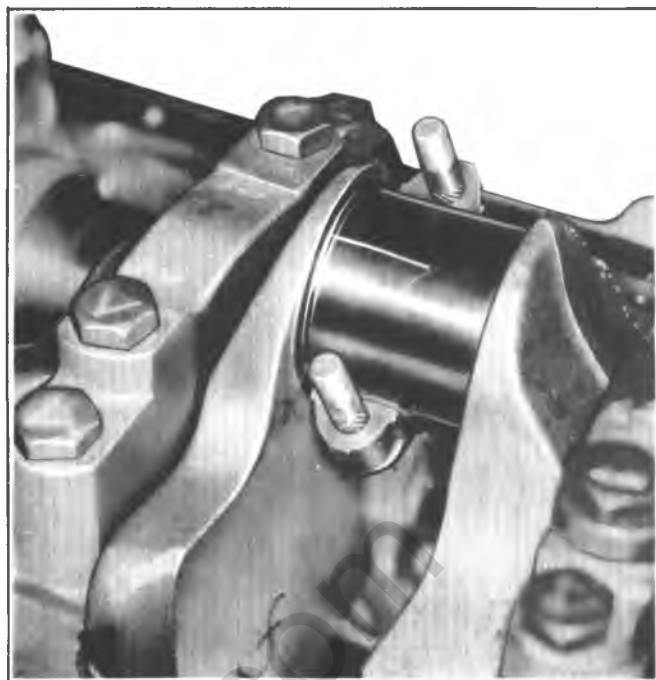


Fig. 6A5-41—Gaging Plastic On Crankpin

- If equipped with manual transmission, install starter.
- 5. Lower vehicle.
- 6. Install distributor cap and tighten fan shroud.
- 7. Fill crankcase with oil; see owners manual.
- 8. Install air cleaner and connect battery negative cable.
- 9. Start engine and check for leaks.

OIL PUMP

Removal

1. Remove oil pan as previously outlined.
2. Remove pump to rear main bearing cap bolt and remove pump and extension shaft.

Disassembly (Figure 6A5-40)

1. Remove the pump cover attaching screws and the pump cover.
2. Mark gear teeth so they may be reassembled with the same teeth indexing. Remove the idler gear and the drive gear and shaft from the pump body.
3. Remove the pressure regulator valve retaining pin, pressure regulator valve and related parts.
4. If the pickup screen and pipe assembly need replacing, the entire pump must be replaced. The screen and pipe assembly is welded to the pump body.

Cleaning and Inspection

1. Wash all parts in cleaning solvent and dry with compressed air.
2. Inspect the pump body and cover for cracks or excessive wear.
3. Inspect pump gears for damage or excessive wear.

● The pump gears and body are not serviced separately. If the pump gears or body are damaged or worn, replacement of the entire oil pump assembly is necessary.

4. Check the drive gear shaft for looseness in the pump body.

5. Inspect inside of pump cover for wear that would permit oil to leak past the ends of the gears.
6. Inspect the pickup screen and pipe assembly for damage to screen, pipe or relief grommet.
7. Check the pressure regulator valve for fit.

Assembly (Figures 6A5-40)

1. Install the pressure regulator valve and related parts.
2. Install the drive gear and shaft in the pump body.
3. Install the idler gear in the pump body with the smooth side of gear towards pump cover opening.
4. Install gasket and the pump cover and torque attaching screws to specifications.
5. Turn drive shaft by hand to check for smooth operation.

Installation

1. Assemble pump and extension shaft to rear main bearing cap, aligning slot on top end of extension shaft with drive tang on lower end of distributor drive shaft.
2. Install pump to rear bearing cap bolt and torque to specifications.
3. Install oil pan previously outlined.

CONNECTING ROD BEARINGS

Connecting rod bearings are of the precision insert type and do not utilize shims for adjustment. **DO NOT FILE RODS OR ROD CAPS.** If clearances are found to be excessive a new bearing will be required. Service bearings are available in standard size and .001" and .002" undersize for use with new and used standard size crankshafts, and in .010" and .020" undersize for use with reconditioned crankshafts.

Inspection and Replacement

1. With oil pan and oil pump removed, remove the connecting rod cap and bearing. Before removal of connecting rod cap, mark the side of the rod and cap with



Fig. 6A5-42--Measuring Gaging Plastic



Fig. 6A5-43--Measuring Connecting Rod Side Clearance

the cylinder number to assure matched reassembly of rod and cap.

2. Inspect the bearing for evidence of wear or damage. (Bearings showing the above should not be installed.)

3. Wipe both upper and lower bearing shells and crankpin clean of oil.

4. Measure the crankpin for out-of-round or taper with a micrometer. If not within specifications replace or recondition the crankshaft. If within specifications and a new bearing is to be installed, measure the maximum diameter of the crankpin to determine new bearing size required.

5. If within specifications measure new or used bearing clearances with Plastigage or its equivalent.

If a bearing is being fitted to an out-of-round crankpin, be sure to fit to the maximum diameter of the crankpin. If the bearing is fitted to the minimum diameter and the crankpin is out-of-round .001" interference between the bearing and crankpin will result in rapid bearing failure.

a. Place a piece of gaging plastic, the length of the bearing (parallel to the crankshaft), on the crankpin or bearing surface (fig. 6A5-41). Plastic gage should be positioned in the middle of upper or lower bearing shell. (Bearings are eccentric and false readings could occur if placed elsewhere).

b. Install the bearing in the connecting rod and cap.

c. Install the bearing cap and evenly torque nuts to specifications. Do not turn the crankshaft with the gaging plastic installed.

d. Remove the bearing cap and using the scale on the gaging plastic envelope, measure the gaging plastic width at the widest point (fig. 6A5-42).

6. If the clearance exceeds specifications, select a new, correct size, bearing and remeasure the clearance. Be sure to check what size bearing is being removed in order to determine proper replacement size bearing.

If clearance cannot be brought to within specifications, the crankpin will have to be ground undersize. If the crankpin is already at maximum undersize, replace crankshaft.

7. Coat the bearing surface with oil, install the rod cap and torque nuts to specifications.

8. When all connecting rod bearings have been installed tap each rod lightly (parallel to the crankpin) to make sure they have clearance.

9. Measure all connecting rod side clearances (see specifications) between connecting rod caps (fig. 6A5-43).

MAIN BEARINGS

Main bearings are of the precision insert type and do not utilize shims for adjustment. If clearances are found to be excessive, a new bearing, both upper and lower halves, will be required. Service bearings are available in standard size and .001", .002", .009", .010" and .020" undersize.

Selective fitting of both rod and main bearing inserts is necessary in production in order to obtain close tolerances. For this reason you may find one half of a standard insert with one half of a .001" undersize insert which will decrease the clearance .0005" from using a full standard bearing.

Inspection

In general, the lower half of the bearing (except #1 bearing) shows a greater wear and the most distress from fatigue. If upon inspection the lower half is suitable for use, it can be assumed that the upper half is also satisfactory. If the lower half shows evidence of wear or damage, both upper and lower halves should be replaced. Never replace one half without replacing the other half.

Checking Clearance

To obtain the most accurate results with "Plastigage", (or its equivalent) a wax-like plastic material which will compress evenly between the bearing and journal surfaces

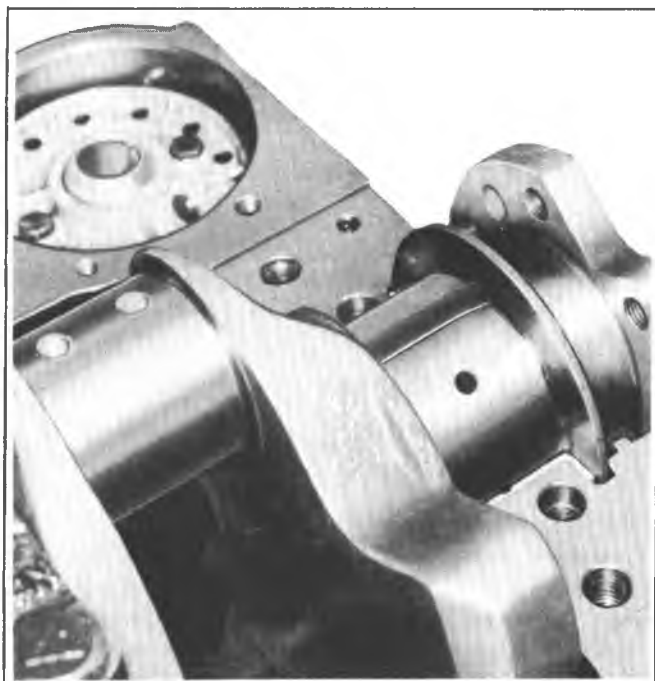


Fig. 6A5-44--Gaging Plastic on Journal

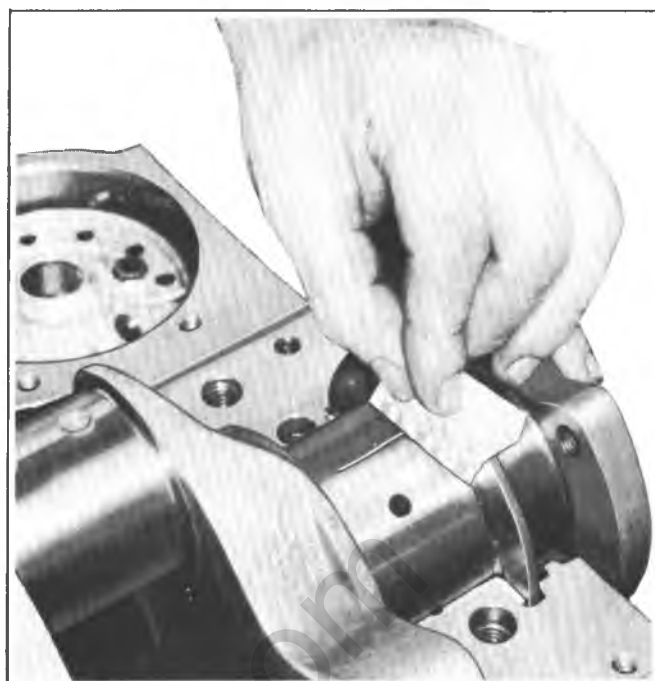


Fig. 6A5-45--Measuring Gaging Plastic

without damaging either surface, certain precautions should be observed.

If the engine is out of the vehicle and upside down, the crankshaft will rest on the upper bearings and the total clearance can be measured between the lower bearing and journal. If the engine is to remain in the vehicle, the crankshaft must be supported upward to remove the clearance from the upper bearing. The total clearance can then be measured between the lower bearing and journal.

To assure the proper seating of the crankshaft, all bearing cap bolts should be at their specified torque. In addition, preparatory to checking fit of bearings, the surface of the crankshaft journal and bearing should be wiped clean of oil.

1. With the oil pan and oil pump removed, and starting with the rear main bearing, remove bearing cap and wipe oil from journal and bearing cap.

2. Place a piece of gaging plastic the full width of the bearing (parallel to the crankshaft) on the journal (fig. 6A5-44). Do not rotate the crankshaft while the gaging plastic is between the bearing and journal.

3. Install the bearing cap and evenly torque the retaining bolts to specifications. Bearing cap **MUST** be torqued to specifications in order to assure proper reading. Variations in torque affect the compression of the plastic gage.

4. Remove bearing cap. The flattened gaging plastic will be found adhering to either the bearing shell or journal.

5. On the edge of gaging plastic envelope there is a graduated scale which is correlated in thousandths of an inch. Without removing the gaging plastic, measure its compressed width (at the widest point) with the graduations on the gaging plastic envelope (fig. 6A5-45).

Normally main bearing journals wear evenly and are not out-of-round. However, if a bearing is being fitted to an out-of-round (.001" max.), be sure to fit to the maximum

diameter of the journal: If the bearing is fitted to the minimum diameter and the journal is out-of-round .001", interference between the bearing and journal will result in rapid bearing failure. If the flattened gaging plastic tapers toward the middle or ends, there is a difference in clearance indicating taper, low spot or other irregularity of the bearing or journal. Be sure to measure the journal with a micrometer if the flattened gaging plastic indicates more than .001" difference.

6. If the bearing clearance is within specifications, the bearing insert is satisfactory. If the clearance is not within specifications, replace the insert. Always replace both upper and lower inserts as a unit. If a new bearing cap is being installed and clearance is less than .001", inspect for burrs or nicks; if none are found then install shims as required.

7. A standard, .001" or .002" undersize bearing may produce the proper clearance. If not, it will be necessary to regrind the crankshaft journal for use with the next undersize bearing. After selecting new bearing, recheck clearance.

8. Proceed to the next bearing. After all bearings have been checked rotate the crankshaft to see that there is no excessive drag. When checking #1 main bearing, loosen accessory drive belts so as to prevent tapered reading with plastic gage.

9. Measure crankshaft end play (see specifications) by forcing the crankshaft to the extreme front position. Measure at the front end of the rear main bearing with a feeler gage (fig. 6A5-46).

10. Install a new rear main bearing oil seal in the cylinder block and main bearing cap.

Replacement

Main bearings may be replaced with or without removing the crankshaft.

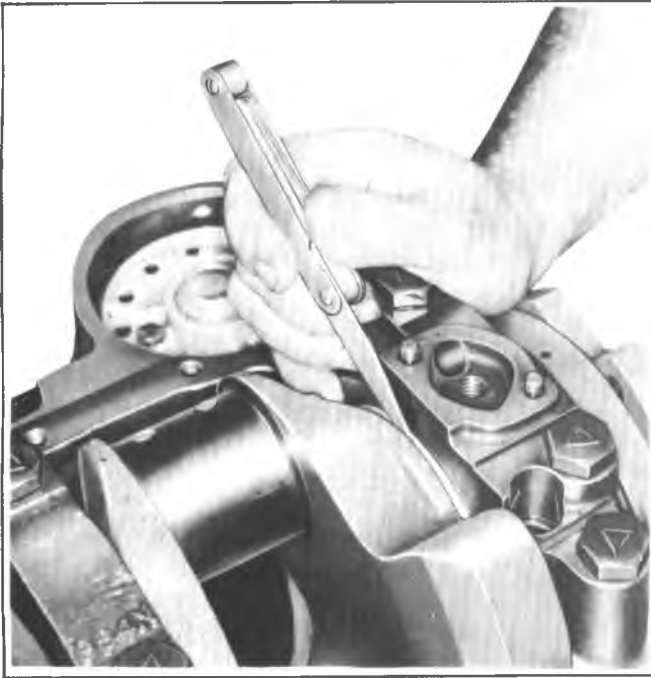


Fig. 6A5-46--Measuring Crankshaft End Play

With Crankshaft Removal

1. Remove and inspect the crankshaft.
2. Remove the main bearings from the cylinder block and main bearing caps.
3. Coat bearing surfaces of new, correct size, main bearings with oil and install in the cylinder block and main bearing caps.
4. Install the crankshaft.

Without Crankshaft Removal

1. With oil pan, oil pump and spark plugs removed, remove cap on main bearing requiring replacement and remove bearing from cap.
2. Install a main bearing removing and installing tool in oil hole in crankshaft journal. If such a tool is not available, a cotter pin may be bent as required to do the job.
3. Rotate the crankshaft clockwise as viewed from the front of engine. This will roll upper bearing out of block.
4. Oil new selected size upper bearing and insert plain (unnotched) end between crankshaft and indented or notched side of block. Rotate the bearing into place and remove tool from oil hole in crankshaft journal.
5. Oil new lower bearing and install in bearing cap.
6. Install main bearing cap with arrows pointing toward front of engine.
7. Torque all main bearing caps EXCEPT THE REAR MAIN CAP to specifications. Torque rear main bearing cap to 10-12 lb. ft. (14-16N·m) then tap end of crankshaft, first rearward then forward with a lead hammer. This will line up rear main bearing and crankshaft thrust surfaces. Retorque all main bearing caps to specifications.

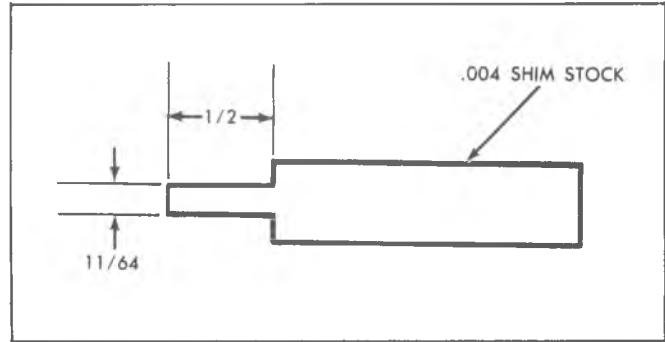


Fig. 6A5-47--Oil Seal Installation Tool

OIL SEAL (REAR MAIN)**Replacement**

- Always replace the upper and lower seal as a unit.

The rear main bearing oil seal can be replaced (both halves) without removal of the crankshaft. Extreme care should be exercised when installing this seal to protect the sealing bead located in the channel on the outside diameter of the seal. An installation tool (fig. 6A5-47) can be used to protect the seal bead when positioning seal as follows:

1. With the oil pan and oil pump removed, remove the rear main bearing cap.
2. Remove oil seal from the bearing cap by prying from the bottom with a small screw driver (fig. 6A5-48).
3. To remove the upper half of the seal, use a small hammer to tap a brass pin punch on one end of seal until it protrudes far enough to be removed with pliers (fig. 6A5-49).
4. Clean all sealant and foreign material from cylinder case bearing cap and crankshaft, using a non-abrasive cleaner.
5. Inspect components for nicks, scratches, burrs and machining defects at all sealing surfaces, case assembly and crankshaft.
6. Coat seal lips and seal bead with light engine oil - keep oil off seal mating ends.
7. Position tip of tool between crankshaft and seal seat in cylinder case.



Fig. 6A5-48--Removing Oil Seal - Lower Half

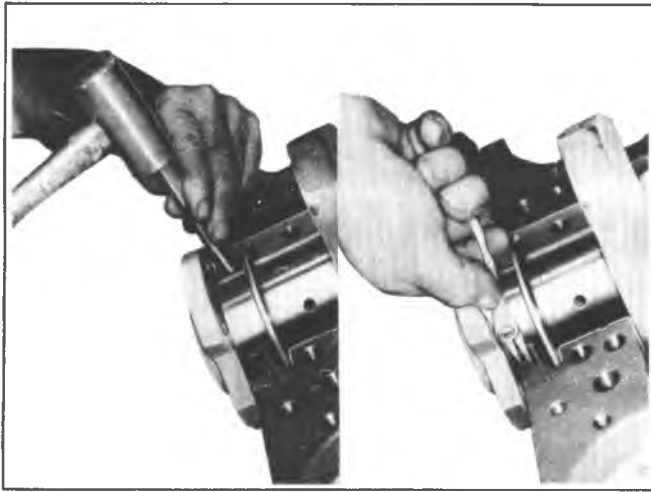


Fig. 6A5-49--Removing Oil Seal - Upper Half

8. Position seal between crankshaft and tip of tool so that seal bead contacts tip of tool. Make sure that oil-seal lip is positioned toward front of engine (fig. 6A5-50).

9. Roll seal around crankshaft using tool as a "shoe-horn" to protect seal bead from sharp corner of seal seat surface in cylinder case. Installation tool must remain in position until seal is properly positioned with both ends flush with block.

10. Remove tool, being careful not to withdraw seal.

11. Install seal half in bearing cap, again using tool as a "shoe-horn", feeding seal into cap using light pressure with thumb and finger.

12. Install bearing cap to case with sealant applied to the cap-to-case interface being careful to keep sealant off the seal split line (fig. 6A5-51).

13. Install the rear main bearing cap (with new seal) and torque to 10-12 lb. ft. (14-16N·m). Tap end of crankshaft first rearward then forward with lead hammer. This will line up thrust surfaces. Retorque bearing cap to specifications.

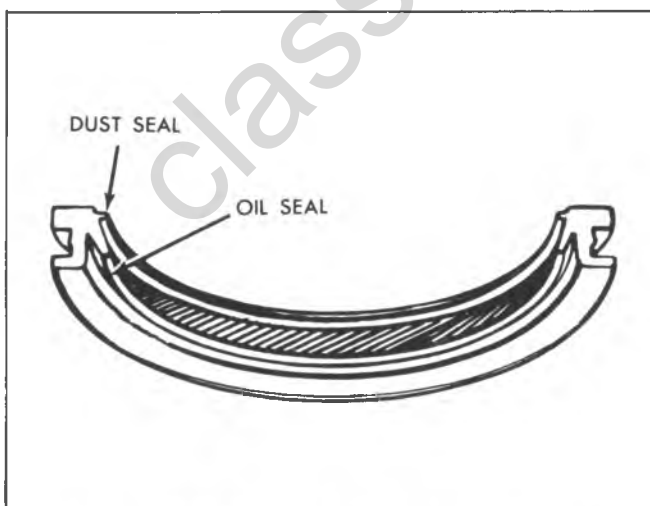


Fig. 6A5-50--Crankshaft Oil Seal - Rear Main

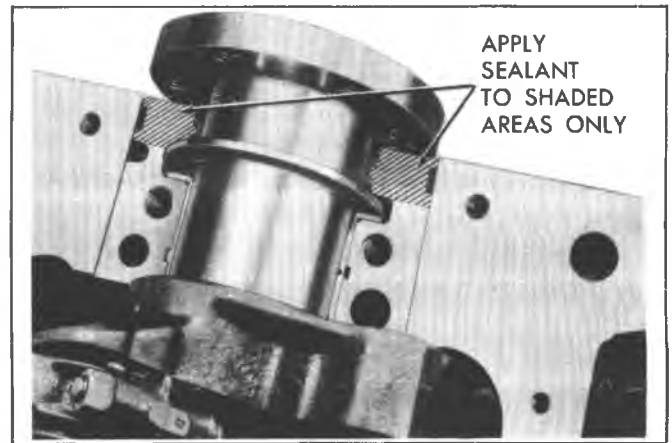


Fig. 6A5-51--Sealing Bearing Cap

CONNECTING ROD AND PISTON ASSEMBLIES

Removal

1. Remove oil pan, oil pump and cylinder head as previously outlined.

2. For the cylinder being serviced, turn crankshaft until piston is at the bottom of the stroke. Place a cloth on top of the piston.

3. Use a ridge reamer to remove any ridge and/or deposits from the upper end of the cylinder bore.

4. Turn crankshaft until piston is at top of stroke and remove cloth and cuttings.

5. Remove connecting rod cap and install Tool J-5329 (3/8") on studs. Push connecting rod and piston assembly out of top of cylinder block. It will be necessary to turn the crankshaft slightly to disconnect some of the connecting rod and piston assemblies and push them out of the cylinder.

Disassembly

1. Remove connecting rod bearings from connecting rods and caps. If bearings are being reused, place them in a rack so they may be reinstalled in their original rod and cap.

2. Remove piston rings by expanding and sliding them off the pistons.

3. Place connecting rod and piston assembly on Tool J-24086-20. Using an arbor press and piston pin remover, J-24086-8, press the piston pin out of connecting rod and piston (fig. 6A5-52).

Cleaning and Inspection

Connecting Rods

Wash connecting rods in cleaning solvent and dry with compressed air. Check for twisted or bent rods and inspect for nicks or cracks. Replace connecting rods that are damaged.

Pistons

Clean varnish from piston skirts and pins with a cleaning solvent. **DO NOT WIRE BRUSH ANY PART OF THE PISTON.** Clean the ring grooves with a groove cleaner and make sure oil ring holes and slots are clean.

Inspect the piston for cracked ring lands, skirts or pin bosses, wavy or worn ring lands, scuffed or damaged skirts, eroded areas at top of the piston. Replace pistons that are damaged or show signs of excessive wear.

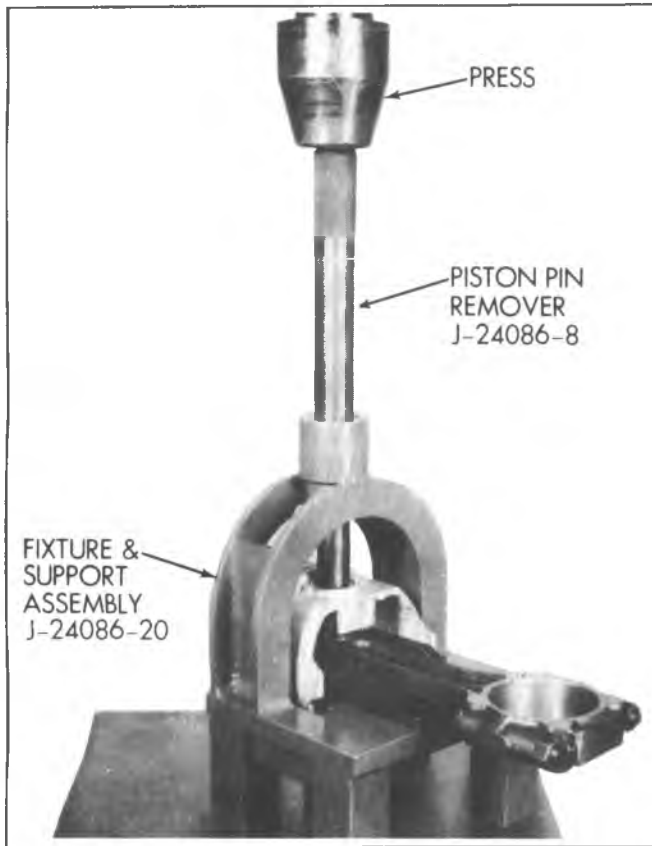


Fig. 6A5-52--Removing Piston Pin

Inspect the grooves for nicks or burrs that might cause the rings to hang up.

Measure piston skirt (across center line of piston pin) and check clearance.

Piston Pins

The piston pin clearance is designed to maintain adequate clearance under all engine operating conditions. Because of this, the piston and piston pin are a matched set and not serviced separately.

Inspect piston pin bores and piston pins for wear. Piston pin bores and piston pins must be free of varnish or scuffing when being measured. The piston pin should be measured with a micrometer and the piston pin bore should be measured with a dial bore gage or an inside micrometer. If clearance is in excess of the .001" wear limit, the piston and piston pin assembly should be replaced.

Assembly

1. Lubricate piston pin holes in piston and connecting rod to facilitate installation of pin.
2. Place connecting rod in piston and hold in place with piston pin guide and piston pin. Place assembly on fixture and support assembly.
3. Using piston pin installer, J-24086-9, press the piston pin into the piston and connecting rod (fig. 6A5-53).

NOTICE: After installer hub bottoms on support assembly, do not exceed 5000 psi pressure, as this could cause structural damage to the tool.



Fig. 6A5-53--Installing Piston Pin

4. Remove piston and connecting rod assembly from tool and check piston for freedom of movement on piston pin.

Piston Rings

All compression rings are marked on the upper side of the ring. When installing compression rings, make sure the marked side is toward the top of the piston. The top ring is chrome faced, or treated with molybdenum for maximum life.

The oil control rings are of three piece type, consisting of two segments (rails) and a spacer.

1. Select rings comparable in size to the piston being used.
2. Slip the compression ring in the cylinder bore; then press the ring down into the cylinder bore about 1/4" (6.5mm) (above ring travel). Be sure ring is square with cylinder wall.
3. Measure the space or gap between the ends of the ring with a feeler gage (fig. 6A5-54).
4. If the gap between the ends of the ring is below specifications, remove the ring and try another for fit.
5. Fit each compression ring to the cylinder in which it is going to be used.
6. If the pistons have not been cleaned and inspected as previously outlined, do so.
7. Slip the outer surface of the top and second compression ring into the respective piston ring groove and roll the ring entirely around the groove (fig. 6A5-55) to make sure that the ring is free. If binding occurs at any point, the cause should be determined. If binding is caused

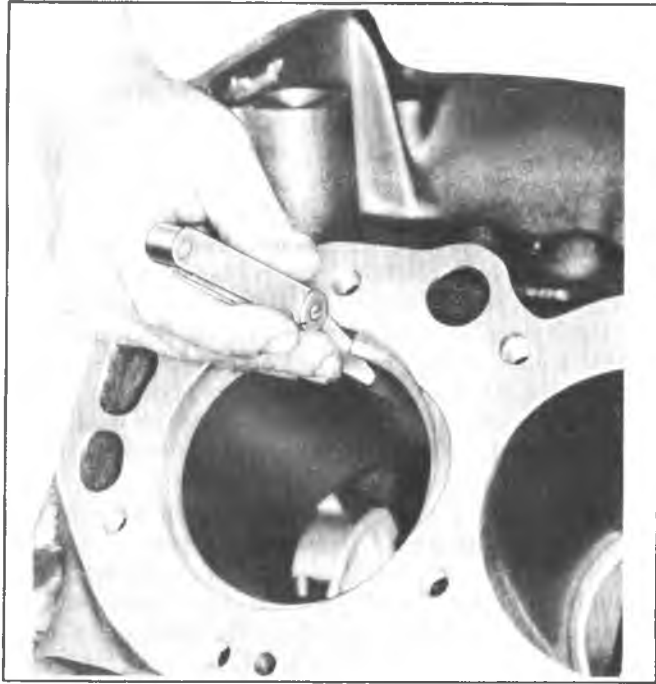


Fig. 6A5-54--Measuring Ring Gap

by ring groove, correct by dressing with a fine cut file. If the binding is caused by a distorted ring, check a new ring.

8. Install piston rings as follows (fig. 6A5-56):

- a. Install oil ring spacer in groove.
- b. Hold spacer ends butted and install lower steel oil ring rail with gap properly located.
- c. Install upper steel oil ring rail with gap properly located.
- d. Flex the oil ring assembly to make sure ring is free. If binding occurs at any point the cause should be determined. If binding is caused by ring groove, correct by dressing groove with a fine cut file. If binding is caused by

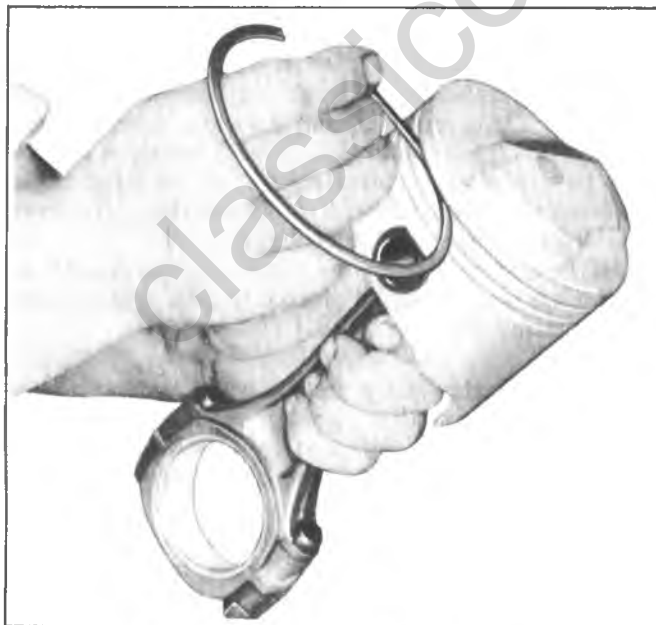


Fig. 6A5-55--Checking Ring in Groove

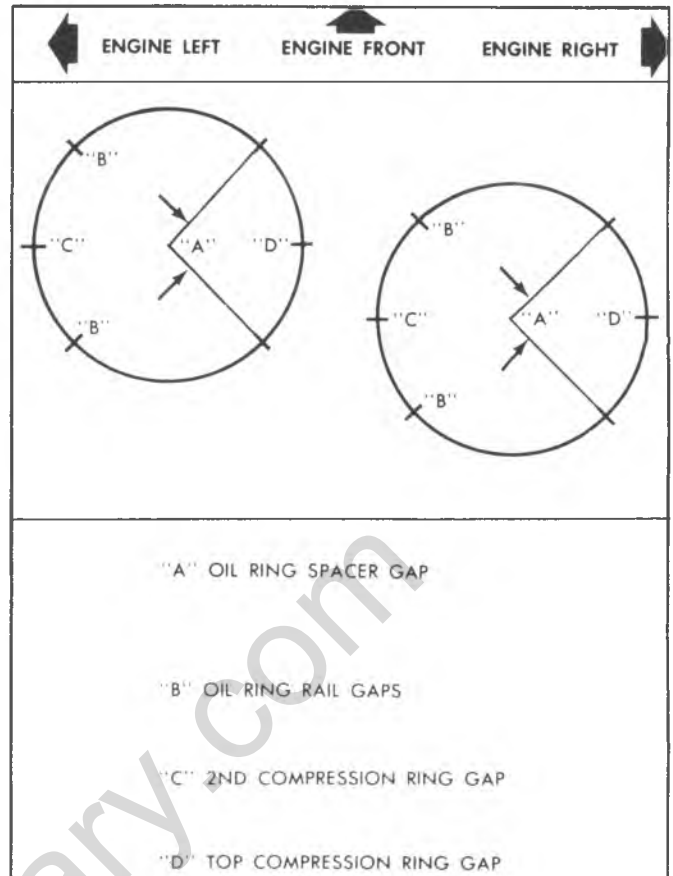


Fig. 6A5-56--Ring Gap Location

a distorted ring, check a new ring.

e. Install second compression ring expander then ring with gaps properly located.

f. Install top compression ring with gap properly located.

9. Proper clearance of the piston ring in its piston ring groove is very important to provide proper ring action and reduce wear. Therefore, when fitting new rings, the clearances between the surfaces of the ring and groove should be measured (fig. 6A5-57). (See Specifications).

Installation

Cylinder bores must be clean before piston installation. This may be accomplished with a hot water and detergent wash or with a light honing as necessary. After cleaning, the bores should be swabbed several times with light engine oil and a clean dry cloth.

- 1. Lubricate connecting rod bearings and install in rods and rod caps.
- 2. Lightly coat pistons, rings and cylinder walls with light engine oil.
- 3. With bearing caps removed, install Tool J-5329 (3/8") on connecting rod bolts.
- 4. Install each connecting rod and piston assembly in its respective bore. Install with connecting rod bearing tang slots on side opposite camshaft. Use Tool J-8037 to compress the rings. Guide the connecting rod into place on the crankshaft journal with Tool J-6305 (11/32"). Use a hammer handle and light blows to install the piston into the bore. Hold the ring compressor firmly against the cylinder



Fig. 6A5-57—Measuring Ring Groove Clearance

block until all piston rings have entered the cylinder bore.

5. Remove Tool J-5329.

6. Install the bearing caps and torque nuts to specifications.

Be sure to install new pistons in the cylinders for which they were fitted, and used pistons in the cylinder from which they were removed. Each connecting rod and bearing cap should be marked, beginning at the front of the engine. Cylinders 1,3,5 and 7 in the left bank and, 2,4, 6 and 8 in the right bank. The numbers on the connecting rod and bearing cap must be on the same side when installed in the cylinder bore. If a connecting rod is ever transposed from one block or cylinder to another, new bearings should be fitted and the connecting rod should be numbered to correspond with the new cylinder number.

CYLINDER BLOCK

Cleaning and Inspection

1. Wash cylinder block thoroughly in cleaning solvent and clean all gasket surfaces.
2. Remove oil gallery plugs and clean all oil passages.
3. Clean and inspect water passages in the cylinder block.
4. Inspect the cylinder block for cracks in the cylinder walls, water jacket, valve lifter bores and main bearing webs.
5. Measure the cylinder walls for taper, out-of-round or excessive ridge at top of ring travel. This should be done with a dial indicator. Set the gage so that the thrust pin must be forced in about 1/4" (6.5mm) to enter gage in cylinder bore. Center gage in cylinder and turn dial to "0". Carefully work gage up and down cylinder to determine taper and turn it to different points around cylinder wall to determine the out-of-round condition. If cylinders were found to exceed specifications, honing or boring will be necessary.

Conditioning

The performance of the following operation is contingent upon engine condition at time of repair.

If the cylinder block inspection indicated that the block was suitable for continued use except for out-of-round or tapered cylinders, they can be conditioned by honing or boring.

If the cylinders were found to have less than .005" taper or wear, they can be conditioned with a hone and fitted with the high limit standard size piston. A cylinder bore of less than .005" wear or taper may not entirely clean up when fitted to a high limit piston. If it is desired to entirely clean up the bore in these cases, it will be necessary to rebore for an oversize piston. If more than .005" taper or wear, they should be bored and honed to the smallest oversize that will permit complete resurfacing of all cylinders.

When pistons are being fitted and honing is not necessary, cylinder bores may be cleaned with a hot water and detergent wash. After cleaning, the cylinder bores should be swabbed several times with light engine oil and a clean cloth and then wiped with a clean dry cloth.

Boring

1. Before using any type boring bar, the top of the cylinder block should be filed off to remove any dirt or burrs. This is very important. If not checked, the boring bar may be tilted which would result in the rebored cylinder wall not being at right angles to the crankshaft.

2. The piston to be fitted should be measured with a micrometer, measuring at the center of the piston skirt and at right angles to the piston pin. The cylinder should be bored to the same diameter as the piston and honed to give the specified clearance.

3. The instructions furnished by the manufacturer of the equipment being used should be carefully followed.

Honing

1. When cylinders are to be honed, follow the hone manufacturer's recommendations for the use of the hone and cleaning and lubrication during honing.

2. Occasionally during the honing operation, the cylinder bore should be thoroughly cleaned and the piston selected for the individual cylinder checked for correct fit.

3. When finish honing a cylinder bore to fit a piston, the hone should be moved up and down at a sufficient speed to obtain very fine uniform surface finish marks, in a cross-hatch pattern of approximately 45° to 65° included angle. The finish marks should be clean but not sharp, free from imbedded particles and torn or folded metal.

4. Permanently mark the piston for the cylinder to which it has been fitted and proceed to hone cylinders and fit the remaining pistons.

NOTICE: Handle the pistons with care and do not attempt to force them through the cylinder until the cylinder has been honed to correct size as this type piston can be distorted through careless handling.

5. Thoroughly clean the bores with hot water and detergent. Scrub well with a stiff bristle brush and rinse thoroughly with hot water. It is extremely essential that a good cleaning operation be performed. If any of the abrasive material is allowed to remain in the cylinder bores, it will rapidly wear the new rings and cylinder bores in addition

to the bearings lubricated by the contaminated oil, the bores should be swabbed and then wiped with a clean dry cloth. Cylinder should not be cleaned with kerosene or gasoline. Clean the remainder of the cylinder block to remove the excess material spread during the honing operation.

Piston Selection

1. Check USED piston to cylinder bore clearance as follows:

- a. Measure the "Cylinder Bore Diameter" with a telescope gage [2-1/2" (64mm) from top of cylinder bore].
- b. Measure the "Piston Diameter" (at skirt across center line of piston pin).
- c. Subtract piston diameter from cylinder bore diameter to determine "Piston to Bore Clearance".
- d. Locate piston to bore clearance on Piston Selection Chart and determine if piston to bore clearance is in the acceptable range.

2. If used piston is not acceptable, determine if a new piston can fit cylinder bore.

3. If cylinder bore must be reconditioned, measure new piston diameter (across center line of piston pin) then hone cylinder bore to correct clearance.

4. Mark the piston to identify the cylinder for which it was fitted.

OIL FILTER BYPASS VALVE

Inspection and Replacement

With the oil filter removed, check the spring and fibre valve for operation. Inspect for a cracked or broken valve. If replacement is necessary, the oil filter adapter and bypass valve assembly must be replaced as an assembly. Clean valve chamber in cylinder block thoroughly. Torque retaining screws to specifications.

ENGINE ASSEMBLY

Removal

1. Remove hood.
2. Disconnect battery cables at battery.
3. Remove air cleaner.
4. Drain radiator and block.
5. Disconnect radiator and heater hoses and remove radiator and fan shroud.
6. Disconnect wires at:
 - Starter Solenoid
 - Generator
 - TRC Speed Switch
 - TRC Solenoid
 - Temperature switch
 - Oil Pressure Switch
 - Distributor
7. Disconnect:
 - Accelerator linkage at inlet manifold.
 - Fuel line, from tank, at fuel pump.
 - Hoses at fuel vapor storage canister (if applicable).
 - Vacuum line to power brake unit at manifold, if so equipped.
8. Remove power steering pump and A/C compressor and lay aside, if so equipped.
9. Raise vehicle on hoist.

10. Drain crankcase.
11. Disconnect exhaust pipe at manifold and, if so equipped, converter bracket at transmission rear mount.
12. Remove starter.
13. Remove flywheel splash shield or converter housing cover as applicable.
14. On vehicles with automatic transmission, remove converter to flywheel attaching bolt.
15. Remove mount "through" bolts.
16. Remove bell housing bolts.
17. Lower vehicle on hoist.
18. Raise transmission using floor jack.
19. Attach engine lifting devices, raise engine.
20. Remove motor mount to engine brackets.
21. Remove engine assembly.

Installation

1. Position engine assembly in vehicle.
2. Attach motor mount to engine brackets and lower engine in place.
3. Remove engine lifting device.
4. Remove transmission floor jack.
5. Raise vehicle on hoist.
6. Install mount "through" bolts. Torque to specifications.
7. Install bell housing bolts. Torque to specifications.
8. On vehicles with automatic transmissions, install converter to flywheel attaching bolts. Torque to specifications.
9. Install flywheel splash shield of converter housing cover as applicable. Torque attaching bolts to specifications.
10. Install starter.
11. Connect exhaust pipe at manifold and converter bracket at transmission rear mount.
12. Lower vehicle on hoist.
13. Reinstall power steering pump and A/C compressor, if so equipped.
14. Connect:
 - Accelerator linkage at inlet manifold.
 - Fuel line, from tank, at fuel pump.
 - Hoses at fuel vapor storage canister.
 - Vacuum line to power brake unit at manifold, if equipped.
15. Connect wires at:
 - Starter Solenoid
 - Generator
 - TRC Speed Switch
 - TRC Solenoid
 - Temperature Switch
 - Oil Pressure Switch
 - Distributor
16. Install radiator and fanshroud and reconnect radiator and heater hoses.
17. Fill cooling system.
18. Fill crankcase with oil. See Section 0B for specifications.
19. Install air cleaner.
20. Install hood.

21. Connect battery cables.

NOTICE: To avoid possible arcing of battery, connect positive battery cable first.

22. Start engine, check for leaks and check timing.

CRANKSHAFT

The crankshaft can be removed while the engine is disassembled for overhaul, as previously outlined or without complete disassembly as outlined below.

Removal

1. With the engine removed from the vehicle and the transmission and/or clutch housing removed from the engine, mount engine in stand and clamp securely.
2. Remove the oil dip stick and oil dip stick tube, (if applicable).
3. Remove the starting motor, clutch assembly (if equipped) and flywheel.
4. Remove the spark plugs.
5. Remove crankshaft pulley and torsional damper.
6. Remove oil pan and oil pump.
7. Remove crankcase front cover, and if so equipped, remove timing chain and camshaft sprocket.
8. Check the connecting rod caps for cylinder number identification. If necessary, mark them.
9. Remove the connecting rod caps and push the pistons to top of bores.
10. Remove main bearing caps and lift crankshaft out of cylinder block.
11. Remove rear main bearing oil seal and main bearings from cylinder block and main bearing caps.

Cleaning and Inspection

1. Wash crankshaft in solvent and dry with compressed air.
2. Measure dimensions of main bearing journals and crankpins with a micrometer for out-of-round, taper or undersize. (See Specifications.)
3. Check crankshaft for run-out by supporting at the front and rear main bearings journals in "V" blocks and check at the front and rear intermediate journals with a dial indicator. (See Specifications.)
4. Replace or recondition the crankshaft if out of specifications.

SPROCKET OR GEAR REPLACEMENT

Remove crankshaft sprocket using Tool J1619, install using Tool J-21058.

Installation

1. Install rear main bearing oil seal in cylinder block and rear main bearing cap grooves. Install with lip of seal

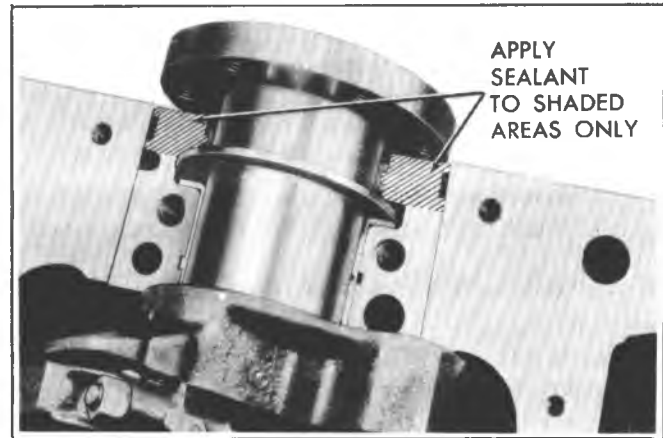


Fig. 6A5-58--Sealing Bearing Cap

toward front of engine. Where seal has two lips install lip with helix towards front of engine.

2. Lubricate lips of seal with engine oil. Keep oil off parting line surface.
3. Install main bearings in cylinder block and main bearing caps then lubricate bearing surface with engine oil.
4. Install crankshaft, being careful not to damage bearing surfaces.
5. Apply a thin coat of brush-on type oil sealing compound to block mating surface and corresponding surface of cap only (fig. 6A5-58). Do not allow sealant on crankshaft or seal.
6. Install main bearing caps with arrows pointing toward front of engine.
7. Torque all except rear main bearing cap bolts to specifications. Torque rear main bearing cap bolts to 10-12 lbs. ft. (14-16 N·m) then tap end of crankshaft, first rearward then forward with a lead hammer. This will line up rear main bearing and crankshaft thrust surfaces. Retorque all main bearing cap bolts to specifications.
8. Measure crankshaft end play with a feeler gage. Force crankshaft forward and measure clearance between the front of the rear main bearing and the crankshaft thrust surface.
9. Install flywheel and torque to specifications. A wood block placed between the crankshaft and cylinder block will prevent crankshaft from rotating.
 - Align dowel hole in flywheel with dowel hole in crankshaft. On vehicles equipped with automatic transmissions, install flywheel with the converter attaching pads towards transmission.

GENERAL DATA:

| | | |
|-------------------|-----------|------------------|
| TYPE | | 90° V-8 GASOLINE |
| DISPLACEMENT | LITRE (*) | 7.4 (W) |
| RPO | | LE8 |
| BORE | | 4.250 |
| STROKE | | 4.000 |
| COMPRESSION RATIO | | 8.5:1 |
| FIRING ORDER | | 1-8-4-3-6-5-7-2 |

CYLINDER BORE:

| | | | |
|--------------|------------|---------------|------------|
| DIAMETER | | 4.2495-4.2525 | |
| OUT OF ROUND | PRODUCTION | .001 MAX. | |
| | SERVICE | .002 MAX. | |
| TAPER | PRODUCTION | THRUST SIDE | .0005 MAX. |
| | | RELIEF SIDE | .001 MAX. |
| | SERVICE | | .001 MAX. |

PISTON:

| | | |
|-----------|------------|-------------|
| CLEARANCE | PRODUCTION | .0030-.0040 |
| | SERVICE | .0050 MAX. |

PISTON RING:

| | | | | |
|---|------------------|------------|-----|---------------------------|
| C O M P R E S S I O N | GROOVE CLEARANCE | PRODUCTION | TOP | .0017-.0032 |
| | | | 2ND | .0017-.0032 |
| | | SERVICE | | HI LIMIT PRODUCTION +.001 |
| | GAP | PRODUCTION | TOP | .010-.020 |
| | | | 2ND | .010-.020 |
| | | SERVICE | | HI LIMIT PRODUCTION +.010 |
| O I L | GROOVE CLEARANCE | PRODUCTION | | .005-.0065 |
| | | SERVICE | | HI LIMIT PRODUCTION +.001 |
| | GAP | PRODUCTION | | .015-.055 |
| | | SERVICE | | HI LIMIT PRODUCTION +.010 |

* VIN Designation

PISTON PIN

LF8

| | | |
|------------|------------|--------------------------|
| DIAMETER | | .9895-.9898 |
| CLEARANCE | PRODUCTION | .00025-.00035 |
| | SERVICE | .001 MAX. |
| FIT IN ROD | | .0013-.0021 INTERFERENCE |

CRANKSHAFT

| | | | |
|------------------------|--------------|-------------|--------------------------------|
| MAIN JOURNAL | DIAMETER | | #1-2-3-4 2.7481-2.7490 |
| | | | #5 2.7476-2.7486 |
| | TAPER | PRODUCTION | .0002 MAX. |
| | | SERVICE | .001 MAX. |
| OUT OF ROUND | PRODUCTION | .0002 MAX. | |
| | SERVICE | .001 MAX. | |
| MAIN BEARING CLEARANCE | PRODUCTION | | #1-2-3-4 .0013-.0025 |
| | | | #5 .0024-.0040 |
| | SERVICE | | #1-4 .001-.0025 #5 .0025-.0035 |
| CRANKSHAFT END PLAY | | | .006-.010 |
| CRANKPIN | DIAMETER | | 2.2000-2.1990 |
| | TAPER | PRODUCTION | .0005 |
| | | SERVICE | .001 MAX. |
| | OUT OF ROUND | PRODUCTION | .0005 |
| SERVICE | | .001 MAX. | |
| ROD BEARING CLEARANCE | PRODUCTION | .0009-.0025 | |
| | SERVICE | .0030 MAX. | |
| ROD SIDE CLEARANCE | | | .013-.023 |

CAMSHAFT

| | | |
|---------------------|---------|---------------|
| LOBE LIFT ± .002 | INTAKE | .2343 |
| | EXHAUST | .2530 |
| JOURNAL DIAMETER | | 1.9482-1.9492 |

SPECIFICATIONS

VALVE SYSTEM

LE8

| | | | |
|-------------------------------------|---------------------------------|-------------------------------|----------------|
| LIFTER | | HYDRAULIC | |
| ROCKER ARM RATIO | | 1.70:1 | |
| VALVE LASH | INTAKE | ONE TURN DOWN FROM ZERO LASH | |
| | EXHAUST | | |
| FACE ANGLE (INT. & EXH.) | | 45° | |
| SEAT ANGLE (INT. & EXH.) | | 46° | |
| SEAT RUNOUT | | .002 MAX. | |
| SEAT WIDTH | INTAKE | 1/32-1/16 | |
| | EXHAUST | 1/16-3/32 | |
| STEM CLEARANCE | PRODUCTION | INT. | .0010-.0027 |
| | | EXH. | .0012-.0029 |
| | SERVICE | HI LIMIT + .001 IN. +.002 EX. | |
| VALVE SPRING (OUTER) | FREE LENGTH | | 2.12 |
| | PRESSURE LBS. @ IN. | CLOSED | 84-96 @ 1.80 |
| | | OPEN | 210-230 @ 1.40 |
| | INSTALLED HEIGHT ± 1/32" | | 1-51/64 |
| DAMPER | FREE LENGTH | | 1.86 |
| | APPROX. # OF COILS | | 4 |

TORQUE SPECIFICATIONS

| | |
|--|---------------|
| CRANKCASE FRONT COVER | 80 LB. IN. |
| FLYWHEEL HOUSING COVER | 80 LB. IN. |
| OIL FILTER BYPASS VALVE | 80 LB. IN. |
| OIL PAN (TO FRONT COVER) | 55 LB. IN. |
| OIL PUMP COVER | 80 LB. IN. |
| ROCKER ARM COVER | 50 LB. IN. |
| CAMSHAFT SPROCKET | 20 LB. FT. |
| OIL PAN TO CRANKCASE (5/16-18) | 135 LB. IN. |
| CLUTCH PRESSURE PLATE | 30 LB. FT. |
| DISTRIBUTOR CLAMP | 25 LB. FT. |
| FLYWHEEL HOUSING | 30 LB. FT. |
| MANIFOLD (EXHAUST) | 20 LB. FT. |
| MANIFOLD (INLET) | 30 LB. FT. |
| WATER OUTLET | 30 LB. FT. |
| WATER PUMP | 30 LB. FT. |
| CONNECTING ROD CAP | 50 LB. FT. |
| CYLINDER HEAD | 80 LB. FT. |
| OIL PUMP | 65 LB. FT. |
| ROCKER ARM STUD | 50 LB. FT. |
| FLYWHEEL | 65 LB. FT. |
| MAIN BEARING CAP | 110 LB. FT. |
| TEMPERATURE SENDING UNIT | 20 LB. FT. |
| TORSIONAL DAMPER | 85 LB. FT. |
| OIL FILTER | 25 LB. FT. |
| OIL PAN DRAIN PLUG | 20 LB. FT. |
| SPARK PLUG | 17-27 LB. FT. |

SECTION 6A6-

5.7 L (Z) 350 Diesel

Contents

| | | | |
|---|--------|--------------------------------------|--------|
| General Description..... | 6A6-1 | Connecting Rod and Piston | 6A6-21 |
| On Vehicle Service..... | 6A6-4 | Rod Bearings..... | 6A6-21 |
| Oil Filter Base..... | 6A6-4 | Rod Assembly..... | 6A6-22 |
| Engine Mounting | 6A6-4 | Piston..... | 6A6-23 |
| Exhaust Manifolds..... | 6A6-4 | Rod and Piston | 6A6-24 |
| Checking or Adjusting Timing..... | 6A6-4 | Piston Pins | 6A6-25 |
| Compression Test..... | 6A6-5 | Crankshaft Pulley | 6A6-26 |
| Linkage Adjustments..... | 6A6-5 | Balancer..... | 6A6-26 |
| Transmission Vacuum Regulator Valve | 6A6-5 | Front Cover..... | 6A6-26 |
| Checking Injection Pump Housing Fuel Pressure | 6A6-6 | Oil Seal..... | 6A6-28 |
| Injection Pump Fuel Lines..... | 6A6-7 | Timing Chain and Gears..... | 6A6-28 |
| Injection Pump and Lines..... | 6A6-8 | Camshaft, Injection Pump Drive and | |
| Injection Pump Adapter and Seal..... | 6A6-9 | Driven Gear | 6A6-28 |
| Valve Cover..... | 6A6-10 | Camshaft and Injection Pump Driven | |
| Intake Manifold | 6A6-10 | Gear Bearing | 6A6-29 |
| Rocker Arm Assemblies..... | 6A6-12 | UNIT REPAIR..... | 6A6-30 |
| Valve Lifters..... | 6A6-12 | Engine..... | 6A6-30 |
| Injection Nozzle..... | 6A6-15 | Crankshaft | 6A6-31 |
| Cylinder Head and Gasket..... | 6A6-16 | Main Bearings..... | 6A6-32 |
| Valves and Springs with Head Removed | 6A6-17 | Main Bearing Upper Oil Seal..... | 6A6-33 |
| Valve Guide Bore | 6A6-18 | Rear Main Bering Lower Oil Seal..... | 6A6-34 |
| Replacing Valve Spring (Head on Engine)..... | 6A6-19 | Flex Plate | 6A6-34 |
| Oil Pan | 6A6-20 | Engine Oil Dipstick and Guides..... | 6A6-34 |
| Oil Pump..... | 6A6-20 | Specifications..... | 6A6-35 |

GENERAL DESCRIPTION

ENGINE CONSTRUCTION

The engine is a 5.7 Liter V-8 four cycle diesel fuel engine. Cylinder numbers 1, 3, 5 and 7 are on the left bank. Cylinder numbers 2, 4, 6 and 8 are on the right bank. The firing order is 1-8-4-6-5-7-2. The major difference between a gasoline engine and the diesel is in the cylinder heads, combustion chamber, fuel distribution system, air intake manifold and method of ignition. The cylinder block, crankshaft, main bearings, rods, pistons and pins are of a heavier construction because of the high compression ratio required to ignite diesel fuel. Diesel ignition occurs because of heat developed in the combustion chamber during compression. This eliminates the need for spark plugs and high voltage ignition.

Intake and exhaust valves in the cylinder heads operate the same as in a gasoline engine, but are of a special design and material for diesel operation. The stainless steel pre-chamber inserts in the cylinder head combustion chambers are serviced separately from the head. With the cylinder head removed they can be pushed out after removing the glow plugs and injection nozzles. Glow plugs are threaded, injection nozzles are retained by a bolt and clamp. The

injection nozzles are spring loaded and calibrated to open at a specified fuel pressure.

FUEL SYSTEM (Figs. 6A6-1, 2, 3&4)

The diesel fuel injection pump is mounted on top of the engine. It is gear driven off the camshaft and turns at camshaft speed. It is a high pressure rotary pump that injects a metered amount of fuel to each cylinder at the proper time. The eight high pressure delivery pipes from the pump to the injection nozzle in each cylinder are the same length to prevent any difference in timing, cylinder-to-cylinder. The fuel injection pump provides the required timing advance under all operating conditions. Engine RPM is controlled by a rotary fuel metering valve. Pushing down on the accelerator pedal moves the throttle cable to open the metering valve and allow more fuel to be delivered. The injection pump also has a low pressure transfer pump to deliver fuel from the fuel line to the high pressure pump.

The fuel filter is located between the mechanical fuel pump and the injection pump. The diaphragm type mechanical fuel pump is mounted on the right side of the engine and driven by a cam on the crankshaft. The fuel tank is connected by fuel pipes and hoses to the mechanical fuel

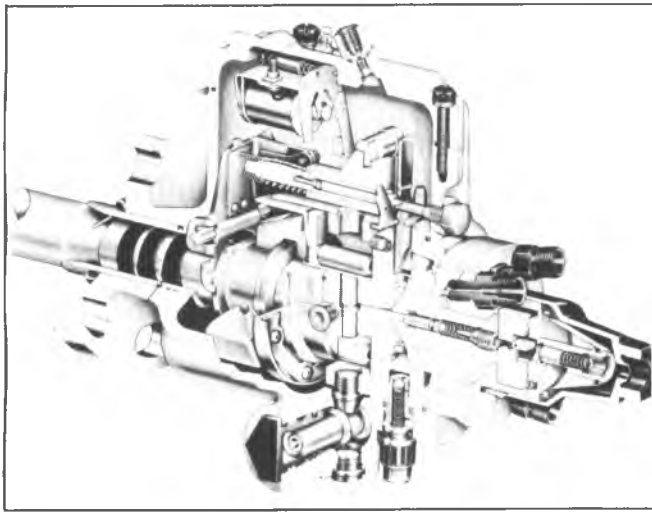


Fig. 6A6-1--Injection Pump-Cutaway

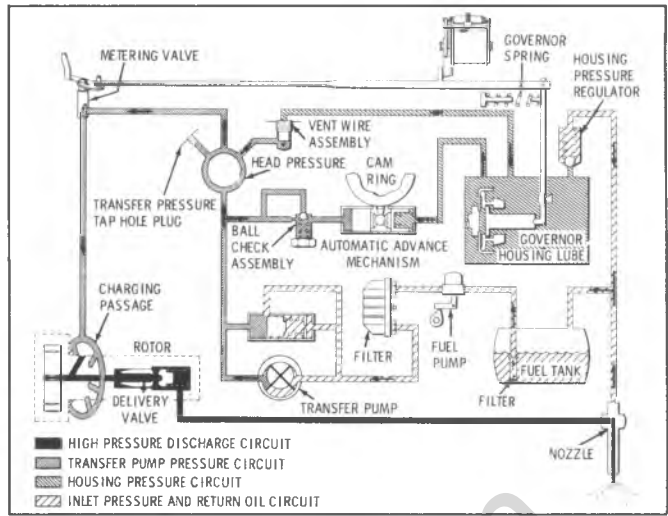


Fig. 6A6-3--Pump Fuel Circuit

pump. Excess fuel returns from the fuel injection pump and injection nozzles to the fuel tank through pipes and hoses.

ENGINE LUBRICATION SYSTEM (Fig. 6A6-5)

The engine oil pan forms a reservoir for engine oil to provide lubrication and also hydraulic fluid to operate the valve lifters. Oil pressure for lubrication is furnished by a gear type oil pump that is bolted to the rear main bearing cap and driven by the camshaft gear through a hexagonal drive shaft.

Oil enters the pump through a screened inlet located near the bottom rear of the oil pan. The pressurized oil from the pump passes through the oil filter located on the right rear side of the engine block. The oil filter base has a by-pass valve which, in the event of filter restriction, will open at 5.5 to 6.5 psi (38 to 45 kPa). Engine oil is directed to the oil cooler, located in the radiator, then from the cooler to the filter base. The oil then is directed back to the engine oil galleries. A by-pass valve in the filter base allows continuous oil flow to the engine in case of cooler line or cooler restriction. This by-pass valve opens at about 12 psi (83 kPa). Oil then enters the right oil gallery where it is distributed to the five main bearings. The right bank valve

lifters receive oil from this gallery from eight feed holes that intersect the gallery.

The five camshaft bearings are lubricated from vertical passages intersecting the main bearing oil passages. At the front main bearing a third passage connects the right main oil gallery to the left gallery which then feeds the left bank of valve lifters.

The injection pump driven gear is lubricated by oil directed through a passage from the top of the front camshaft bearing. An angled passage in the shaft portion of the driven gear then directs the oil to the rear driven gear bearing.

The engine oil pressure warning light switch is connected to the front of the left oil gallery. The switch is calibrated to turn on the instrument panel warning light when engine oil pressure is too low. The switch, normally closed, is set to open at 2-6 psi (14 to 41 kPa). The rear oil gallery plug has a .040" (1mm) orifice to help purge contaminants from the gallery and to lubricate the vacuum pump driven gear.

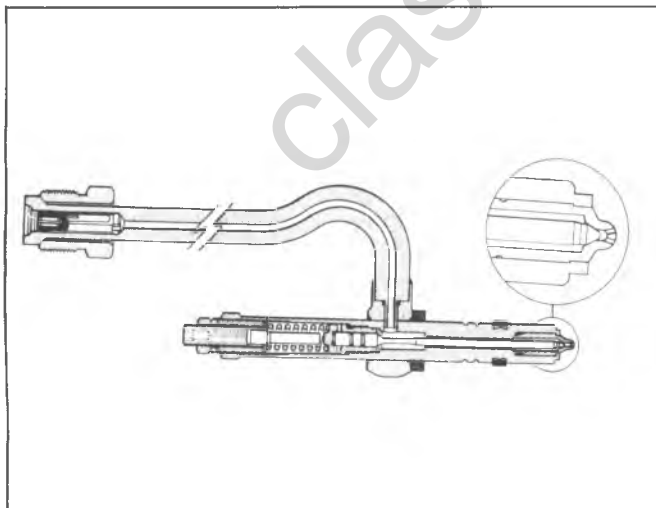


Fig. 6A6-2--Nozzle Cutaway

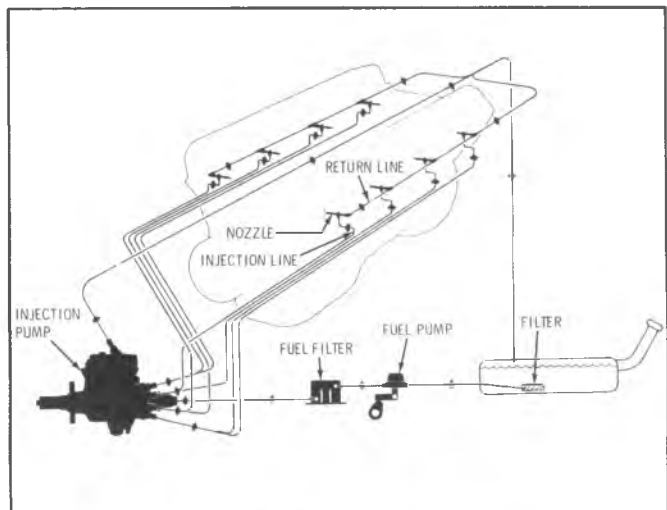


Fig. 6A6-4--System Fuel Circuit

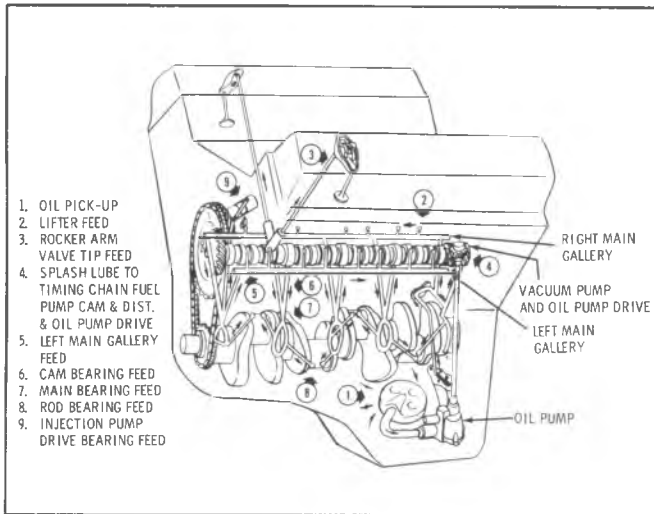


Fig. 6A6-5--Engine Lubrication

At the front end of the right gallery, a small orifice sprays oil to lubricate the fuel pump eccentric cam on the crankshaft and the timing chain.

The vacuum pump drive gear is lubricated by oil from the left rear oil gallery.

The rocker arms and valve tips are lubricated by oil furnished through the hydraulic lifters and hollow push-rods. A disc valve in the lifter meters oil to the push rods.

The connecting rod bearings are oiled by constant oil flow from passages drilled through the crankshaft, connecting the main journals to the rod journals. A groove around each main bearing furnishes oil to the drilled

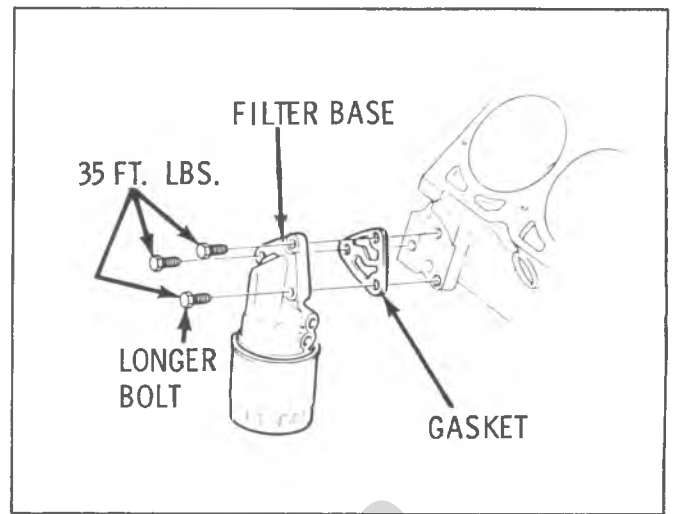


Fig. 6A6-7--Oil Filter Base

crankshaft passages.

Oil returns to the oil pan reservoir from the rocker arms through passages at each end of the cylinder heads. Oil from the valve lifter compartment returns through clearance holes in the lower portion of the compartment near the camshaft. The timing chain compartment drains directly into the oil pan.

To check engine oil pressure, See Fig. 6A6-6.

COOLING

Engine cooling is the same as used in gasoline engines except the radiator tank has two oil coolers. One is connected to the transmission, the other one connects into the oil filter base.

ELECTRICAL

Eight glow plugs are used to heat the pre-chamber to aid in starting. They are 12 volt heaters that turn on when the ignition key is turned to the "RUN" position prior to starting the engine. They remain on a short time after starting, then automatically turn off. (The circuit and operation is covered in detail under the subject-Diesel Electrical.) Two 12-volt batteries connected in parallel are required for the higher electrical load due to the glow plugs and starter. The starter is larger and designed to crank the engine at least the 100 RPM required for starting. The two batteries, one on each side in the engine compartment, provide the required capacity and eliminates the need for a single double size special battery. A standard generator supplies charging current to both batteries at the same time. There are no switches or relays in the charging circuit.

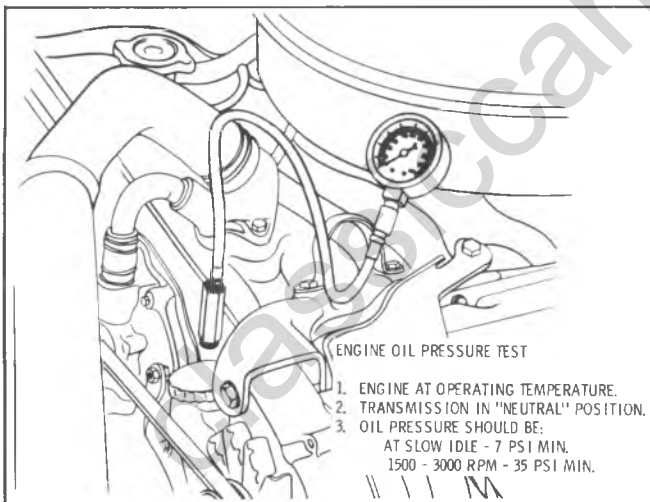


Fig. 6A6-6--Checking Engine Oil Pressure

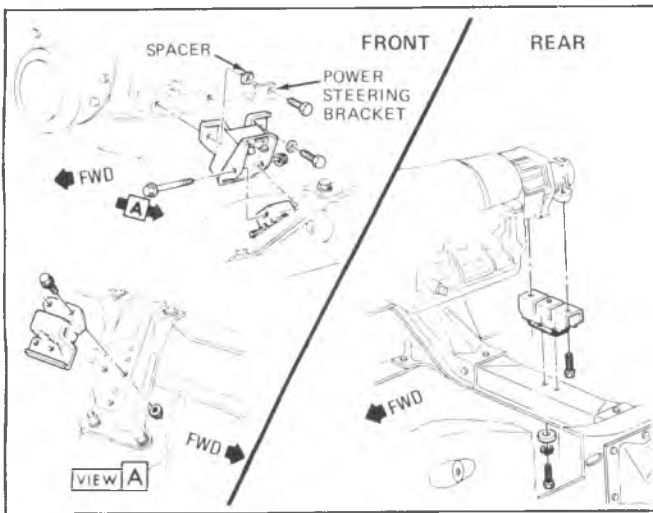


Fig. 6A6-8--Engine Mounts

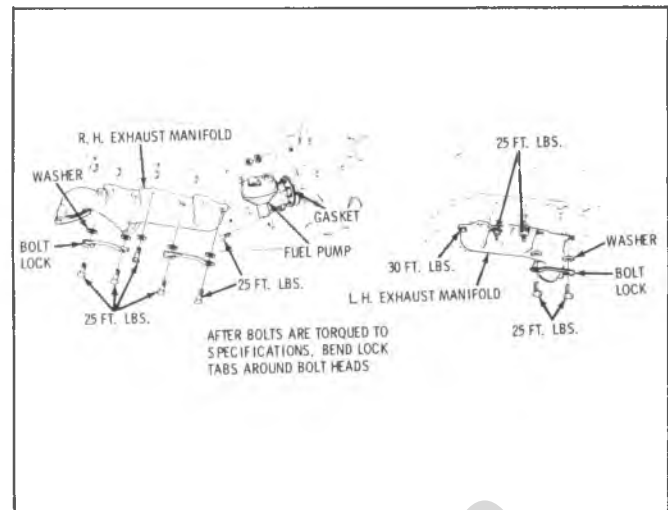


Fig. 6A6-9--Exhaust Manifold Bolts

ON VEHICLE SERVICE

OIL FILTER BASE (Fig. 6A6-7)

Removal

1. Remove oil cooler lines.
2. Bend exhaust manifold lock tabs away from bolts.
3. Hoist vehicle.
4. Disconnect exhaust system from exhaust manifold.
5. Remove exhaust manifold.
6. Remove oil filter base retaining bolts and remove base.

Installation

If a new oil filter element is installed, add one quart of oil. Clean sealing surfaces and re-bend manifold bolt lock tabs. Start engine, check for leaks and proper oil level. Torque oil filter base attaching bolts to 35 lbs. ft. (47N·m) and exhaust manifold bolts to 25 lbs. ft. (34N·m).

ENGINE MOUNTING

Refer to Fig. 6A6-8.

EXHAUST MANIFOLD

Removal and Installation (Left Side)

1. Remove air cleaner and install air crossover screened cover J-26996-1.
2. Remove lower generator bracket.
3. Hoist vehicle.
4. Remove exhaust pipe at manifold flange.
5. Lower vehicle.
6. Remove exhaust manifold from above.

To install, reverse removal procedure. Refer to Fig. 6A6-9 for proper bolt torque.

Removal and Installation (Right Side)

1. Hoist vehicle.
2. Disconnect exhaust pipe at manifold flange.
3. Remove exhaust manifold.

To install, reverse removal procedure. See figure 6A6-9 for proper bolt torque.

CHECKING OR ADJUSTING TIMING

Checking (Fig. 6A6-10)

For the engine to be properly timed, the marks on the top of the injection pump adapter and the flange of the injection pump must be aligned. The engine must be off when the timing is reset.

Adjusting

If the marks are not aligned, adjustment is necessary.

1. Loosen the three pump retaining nuts with tool J-26987.

2. Align the mark on the injection pump with the marks on the adapter and tighten nuts. Torque to 35 lbs. ft. (47N·m).

● Use a 3/4" open end wrench on the boss at the front of the injection pump to aid in rotating the pump to align the marks.

3. Adjust throttle rod (See "LINKAGE ADJUSTMENT").

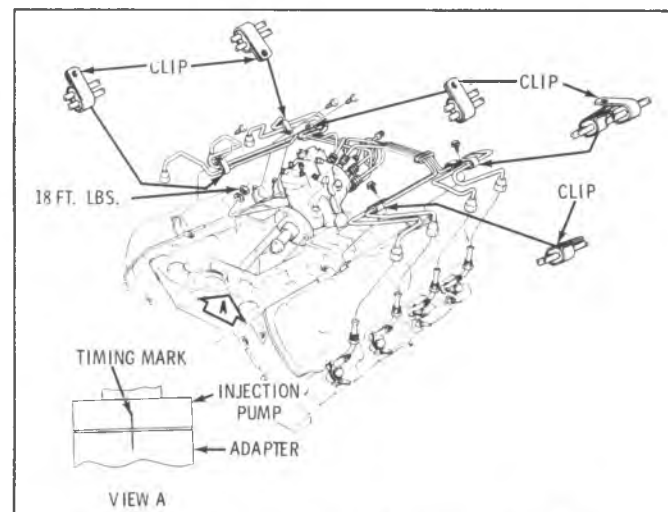


Fig. 6A6-10--Timing Mark & Injection Pump Lines

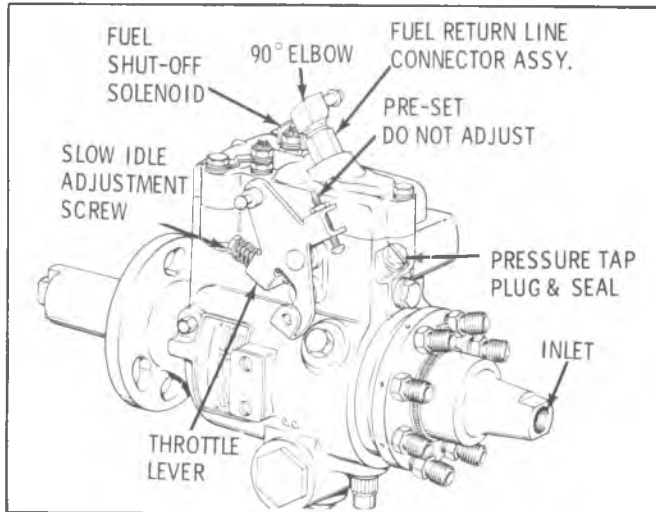


Fig. 6A6-11--Injection Pump Slow Idle Screw

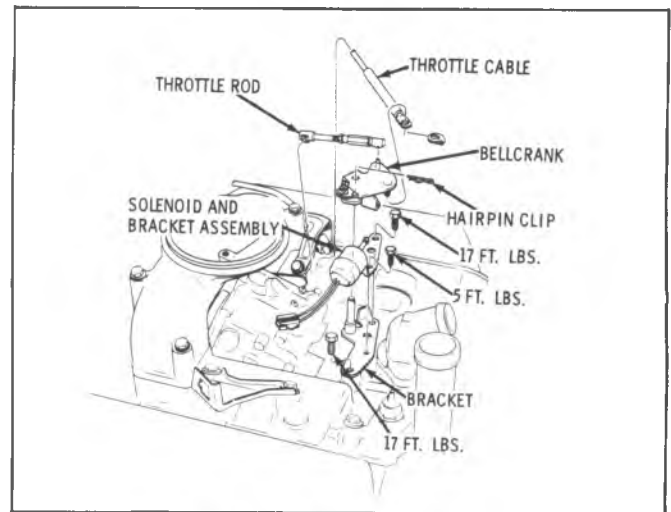


Fig. 6A6-12--Throttle Linkage

COMPRESSION TEST

To determine if the valves or rings are the cause of low compression, a test should be made to determine the cylinder compression pressure.

When checking compression, the batteries should be at or near full charge. The lowest reading cylinder should not be less than 70% of the highest and no cylinder reading should be less than 275 p.s.i. (1900 kPa).

1. Remove air cleaner then install air crossover cover J-26996-1.
2. Disconnect the wire from the fuel solenoid terminal of the injection pump.
3. Disconnect wires from glow plugs then remove all glow plugs.
4. Screw the compression gage J-26999 into the glow plug hole of the cylinder that is being checked.
5. Crank engine.

This should be done with six "puffs" per cylinder.

- Normal-Compression builds up quickly and evenly to specified compression on each cylinder.
- Piston Rings Leaking-Compression low on first stroke tends to build up on following strokes but does not reach normal.

LINKAGE ADJUSTMENTS (Figs 6A6-11 and 12)

1. **TIMING:** Check timing, adjust if necessary (engine off).
2. **THROTTLE ROD ADJUSTMENT:** (Engine off)
 - a. With the transmission vacuum regulator valve already installed, loosen the locknut on the throttle rod, then shorten the rod several turns.
 - b. Rotate the bellcrank to the full throttle stop, then lengthen the throttle rod until the injection pump lever contacts the injection pump full throttle stop. Release the bellcrank.
 - c. Tighten the throttle rod locknut.

3. IDLE ADJUSTMENT:

To check idle speeds, it will be necessary to insert the probe of the magnetic pickup tachometer. J-26925 in the timing indicator hole.

- With the driving wheels blocked and the parking brake on, adjust the slow idle screw on the injection pump to 575 RPM (Drive range, A/C Off).

4. HIGH IDLE SPEED ADJUSTMENT:

- a. Insure that the fast idle solenoid is energized by attaching a jumper wire across the fast idle temperature switch connector terminals. This temperature switch is located in the left rear corner of the intake manifold. It should not be necessary to remove the connector from the temperature switch.
- b. Advance throttle momentarily to ensure that the fast idle solenoid is fully extended (also, check to make sure it is energized).
- c. Adjust the extended solenoid to 650 RPM in drive gear.
- d. Remove jumper wire.

TRANSMISSION VACUUM REGULATOR VALVE

Removal

1. Remove air cleaner and install screened cover J-26996-1.
2. Remove the two hoses from the valve, noting the locations.
3. Remove the two attaching bolts and remove valve.

Installation

1. Disconnect throttle rod and return spring from pump throttle lever.
2. Rotate cam of regulator valve until cam is in W.O.T. position. Using a .090" diameter rod, such as from carburetor gage kit, pin the cam so as to maintain the W.O.T. position.
3. Loosely install the vacuum regulator valve to the pump using the two attaching bolts.
4. Rotate pump throttle lever to the W.O.T. position and hold there.
5. Rotate vacuum regulator valve clockwise until throttle shaft pin contacts cam drive surface (fig. 6A6-13).
6. Tighten two attaching bolts to 75 lb. in. (8 N·m).
7. Remove locking rod from valve and release injection pump from W.O.T. position.

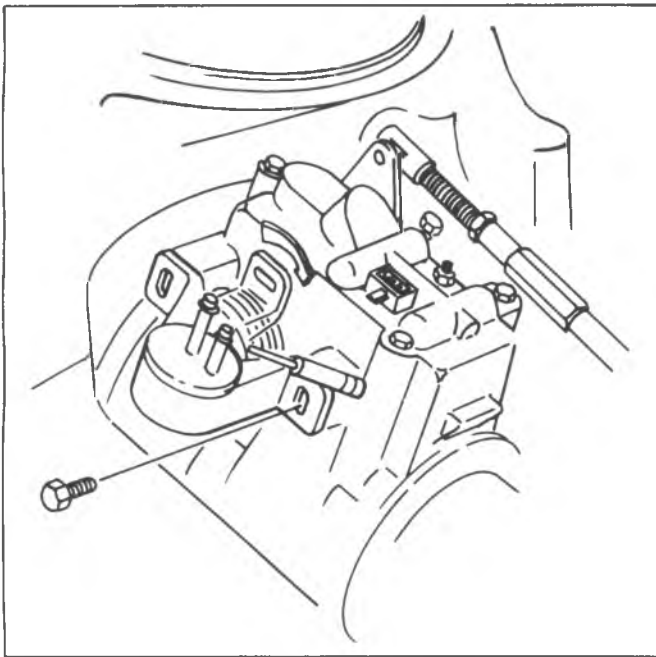


Fig. 6A6-13--Transmission Vacuum Regulator Valve Adjustment

8. Connect two vacuum hoses to valve.
9. Connect throttle rod and return spring to throttle lever and check adjustment.
10. Remove screened cover J-26996-1 and install air cleaner.

TRANSMISSION VACUUM VALVE ADJUSTMENT

After transmission vacuum regulator valve installation or adjustment, if shifting complaints are noted, perform the following checks on the engine:

1. Check vacuum pump for an output of 22" Hg. Repair or replace as necessary.
2. Perform a functional check of regulator valve by doing the following:
 - a. Remove throttle rod from throttle lever.
 - b. Loosen the transmission vacuum valve to injection pump bolts.
 - c. Install carburetor angle gage adapter, J-26701-15, to the injection pump throttle lever. Place angle gage, J-26701, on adapter.
 - d. Rotate throttle lever to the wide open throttle position and set angle gage to 0° (Fig. 6A6-14).
 - e. Center bubble in level.
 - f. Set angle gage to 50°.
 - g. Rotate throttle lever so leveling bubble is centered (Fig. 6A6-15).
 - h. Attach outside vacuum source to inboard port of vacuum valve and install vacuum gage to outboard port. Apply 18-22" hg. (Fig. 6A6-16).
 - i. Rotate vacuum valve clockwise to obtain 7 to 8" hg.
 - j. Tighten vacuum valve bolts. Remove vacuum source and gage.
 - k. Install throttle rod to bellcrank.
1. If shift complaint still exists, refer to Section 7A for transmission diagnosis.

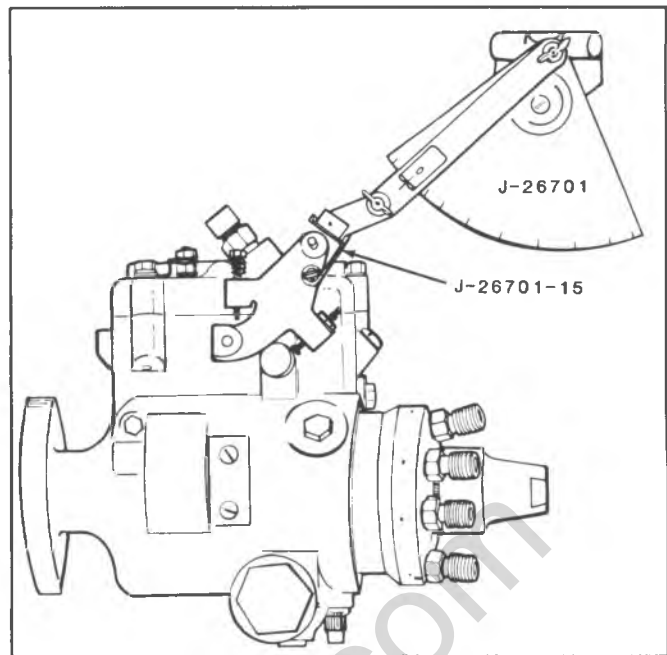


Fig. 6A6-14--Mounting Gage

CHECKING INJECTION PUMP HOUSING FUEL PRESSURE

1. Remove air crossover and install screened covers J-26996-2.

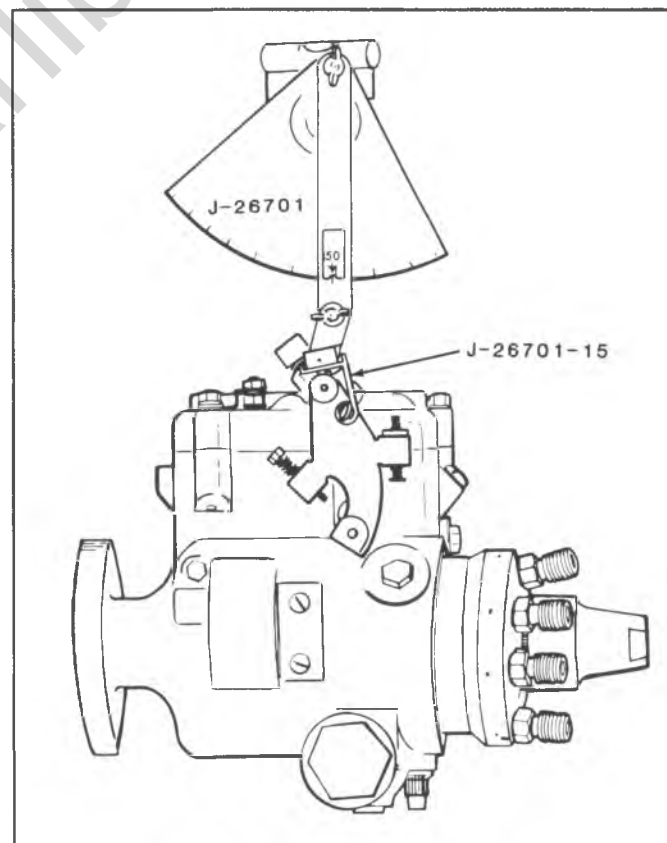


Fig. 6A6-15--Zero Leveling Bubble

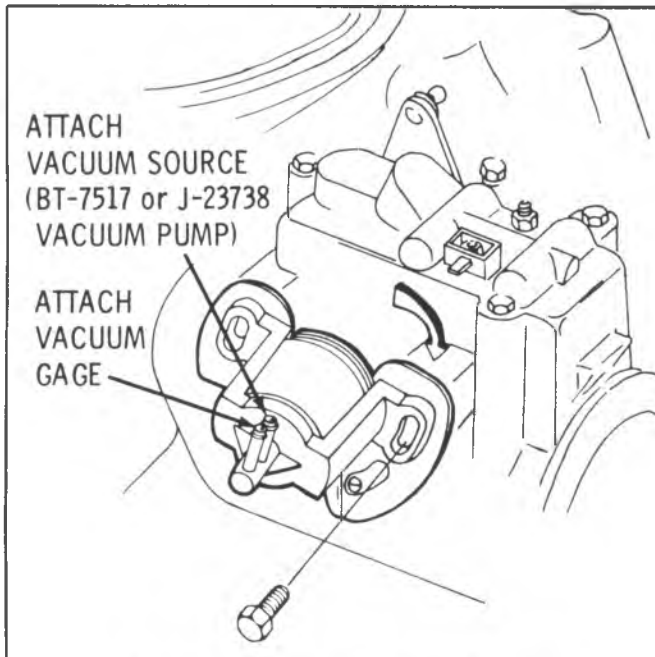


Fig. 6A6-16--Instrument Hook Up Points

2. Remove the pressure tap plug.
3. Put the seal from the pressure tap plug on the pressure tap adapter J-29382, then screw the adapter into the pump housing.
4. Screw pressure tap adapter J-28526 into pressure tap adapter J-29382 then attach a low pressure gage to the adapter.
5. Install magnetic pick-up tachometer J-26925.
6. Check the pressure with the engine running at 1000 RPM (PARK). The pressure should be 8-12 PSI (55-83 kPa) with not more than 2 PSI (14 kPa) fluctuation.
7. If the pressure is too low, proceed to step 10. If the pressure is too high, the fuel return system may be restricted.
8. Remove the return line at the injection pump. Install a fitting and short piece of hose that can empty the fuel return fuel into a small container.
9. Recheck the pressure. If the pressure is lower than before, correct the restriction in the fuel line. (Normal fuel return pressure is about 1/2 PSI).
10. If the return line pressure is OK, replace the fuel return line connector assembly.
11. Recheck the pressure. If the pressure is still incorrect, remove the injection pump for repair.
12. Remove the tachometer, pressure gage and adapter J-28526.
13. Put a new pressure tap plug seal on the plug and screw in the plug.
14. Remove screened covers J-26996-2, then install air crossover.

INJECTION PUMP FUEL LINES (Fig. 6A6-10)

When lines are to be removed, clean all line fittings thoroughly before loosening. Immediately cap all lines, nozzles and pump fittings to maintain cleanliness.

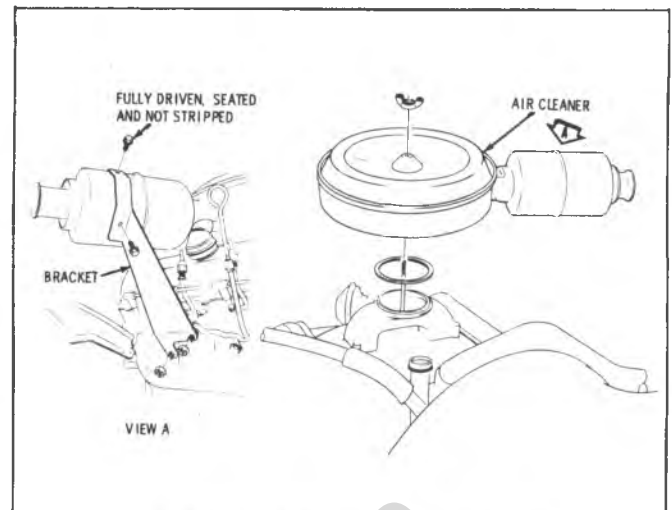


Fig. 6A6-17--Air Cleaner Attachment

Removal

All lines may be removed without removing injection pump. It is not necessary to use a back-up wrench when removing the lines from pump.

1. Remove air cleaner. (Fig. 6A6-17).
2. Remove filters and pipes from valve covers and air crossover.
3. Remove air crossover and cap intake manifold with J-26996-2 screened covers.
4. Remove injection pump line clamps, then remove the injection pump lines and cap open lines, nozzles, and pump fittings.

Installation

1. Install new injection pump line, install loose then torque both ends. Torque pump end to 35 lbs. ft. (47N·m) and nozzle end to 25 lbs. ft. (34 N·m) then install clamps.
 - If several lines are to be replaced, start with the bottom lines.
2. Start engine and check for fuel leaks.
3. Remove screened covers J-26996-2 from intake manifold and install air crossover. (Fig. 6A6-18).

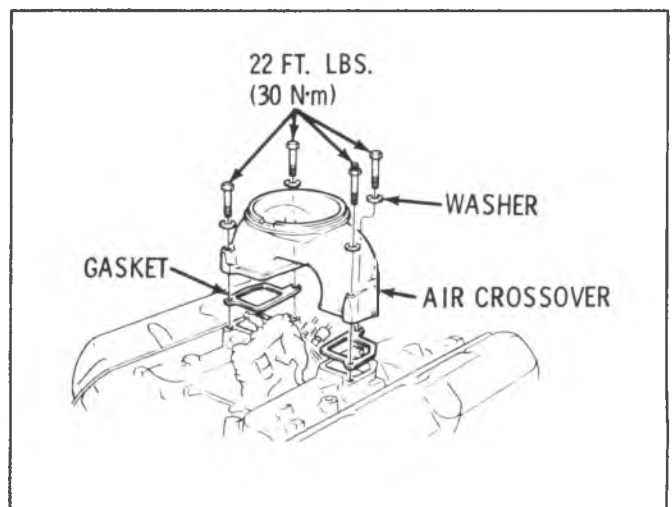


Fig. 6A6-18--Air Crossover

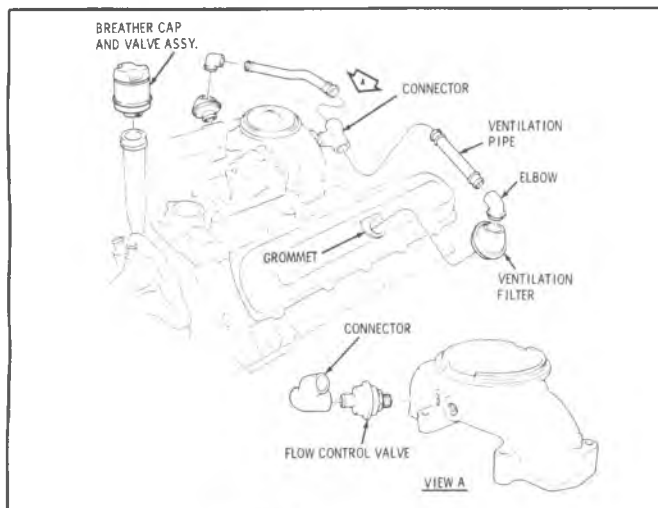


Fig. 6A6-19--Ventilation System

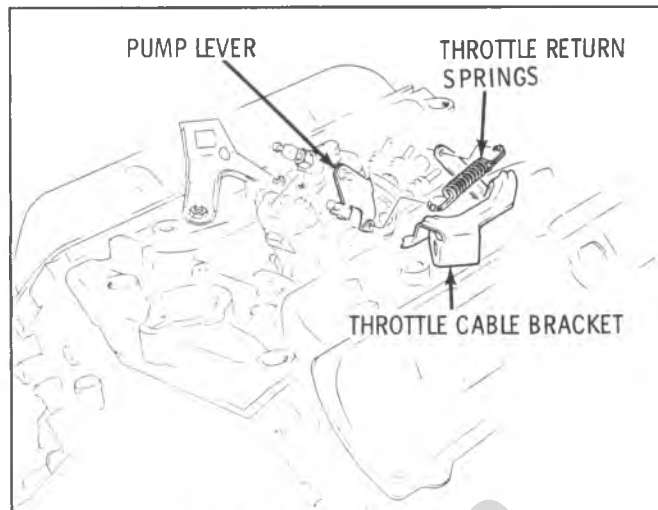


Fig. 6A6-21--Throttle Return Springs

4. Connect pipes to flow control valve in air crossover and ventilation filters in the valve covers. (Fig. 6A6-19).
5. Install air cleaner.

INJECTION PUMP AND LINES

Removal

1. Remove air cleaner.
2. Remove filters and pipes from valve covers and air crossover.
3. Remove air crossover and cap intake manifold with J-26996-2 screened covers.
4. Disconnect throttle rod and return spring. (Figs. 6A6-20 and 6A6-21).
5. Remove bellcrank.
6. Remove throttle cable from intake manifold brackets. Position cable away from engine.
7. Remove lines to fuel filter, then remove fuel filter and bracket. (Fig. 6A6-22).
8. Disconnect fuel line at fuel pump.
9. Disconnect the fuel return line from the injection pump.

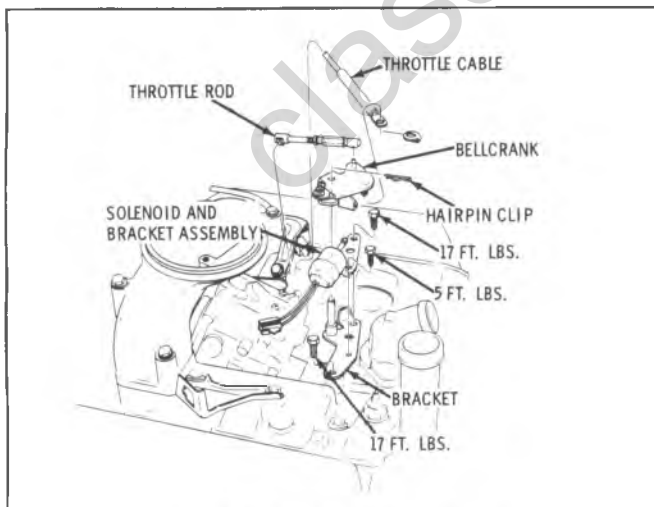


Fig. 6A6-20--Throttle Linkage

10. Using two wrenches, disconnect injection pump lines at the nozzles.
11. Remove 3 nuts retaining injection pump, using tool J-26987.
12. Remove pump and cap all open lines and nozzles.

Installation

1. Remove protective caps then line up offset tang on pump driveshaft with the pump driven gear and install pump, fully seating pump by hand.
2. Install 3 nuts and lock washers retaining injection pump, do not tighten. Connect injection pump lines at nozzles, then tighten, using two wrenches. Torque to 25 lbs. ft. (34 N·m).
3. Connect fuel return lines to the injection pump (fig. 6A6-23).
4. Align mark on injection pump with line on adapter and tighten nuts. Torque to 18 lbs. ft. (24N·m).
 - Use a 3/4" open end wrench on the boss at the front of the injection pump to aid in rotating the pump to align the marks.

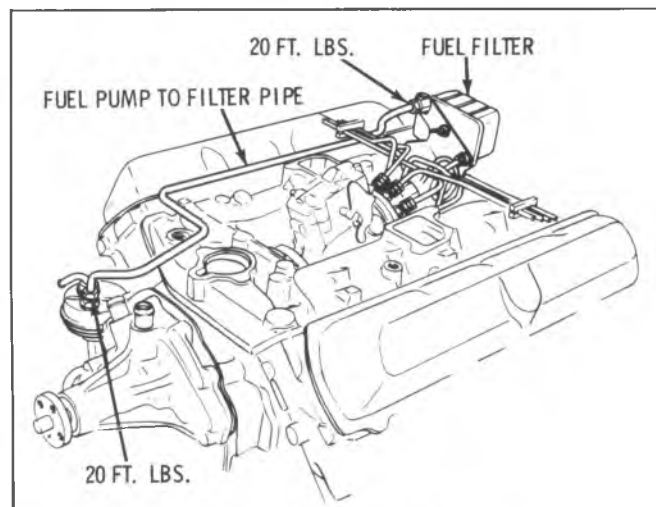


Fig. 6A6-22--Fuel Filter & Lines

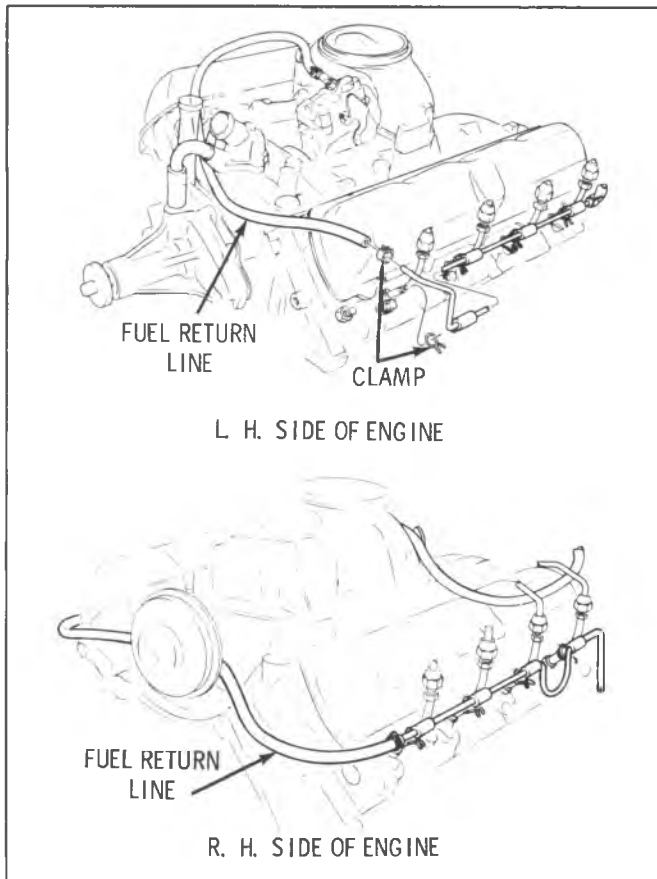


Fig. 6A6-23--Fuel Return Lines

5. Adjust the throttle rod (as previously outlined).
6. Install fuel line from fuel pump to fuel filter.
7. Install bellcrank and hairpin clip.
8. Install throttle cable to intake manifold and attach to bellcrank.
9. Connect throttle rod and return spring.
10. Start engine and check for fuel leaks.
11. Remove screened covers J-26996-2 from intake manifold then install air crossover.
12. Install tubes in flow control valve in air crossover and ventilation filters in the valve covers.
13. Install air cleaner.

INJECTION PUMP ADAPTER AND SEAL

Removal

1. Refer to "INJECTION PUMP AND LINES" removal.
2. Remove injection pump adapter.
3. Remove seal from injection pump adapter.

Installation

Follow steps 3, 4 5 when only the injection pump seal is being replaced.

1. File mark off from injection pump adapter.
 - DO NOT FILE MARK FROM PUMP.
2. Position engine on #1 cylinder T.D.C. Align mark on balancer with zero mark on indicator. Refer to Fig. 6A6-24 for position of injection pump driven gear. (The index is offset to the right when number one is a T.D.C.).

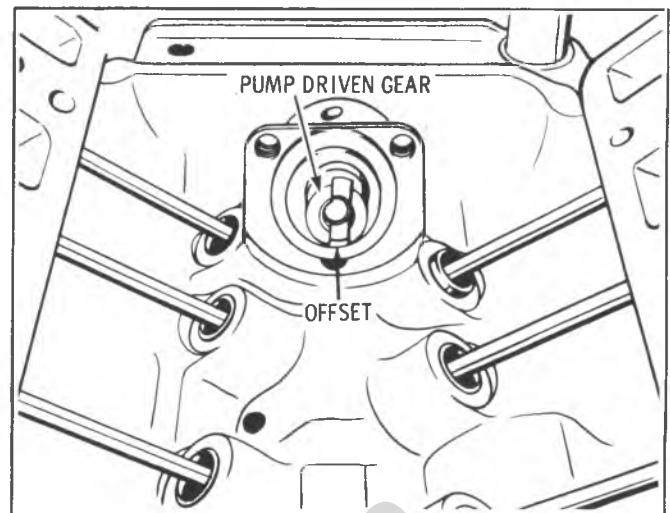


Fig. 6A6-24--Offset on Pump Driven Gear

3. Apply chassis lube to seal area on adapter, tapered edge and seal area in intake manifold then install adapter. Leave loose.

4. Apply chassis lube to I.D. and O.D. of adapter seal and to seal installing tool J-28425. Install seal on tool.

5. Push seal on injection pump adapter with tool J-28425 (fig. 6A6-25).

6. Remove tool and inspect to see if seal is properly positioned.

7. Torque adapter bolts to 25 lbs. ft. (34 N·m) (Fig. 6A6-26).

8. Install Timing Tool, J-26896, into injection pump adapter. Torque Tool toward cylinder #1 to 50 lb. ft. (68 N·m). While holding torque, mark injection pump adapter. Remove tool. (See Fig. 6A6-27).

9. Refer to "INJECTION PUMP AND LINES" installation.

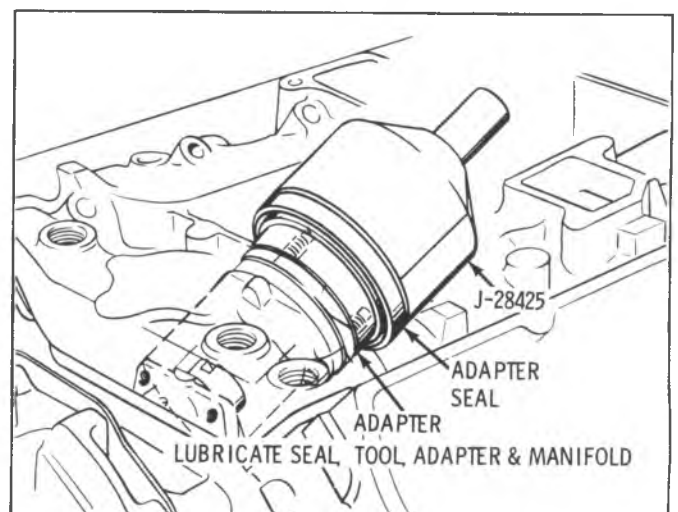


Fig. 6A6-25--Installing Adapter Seal

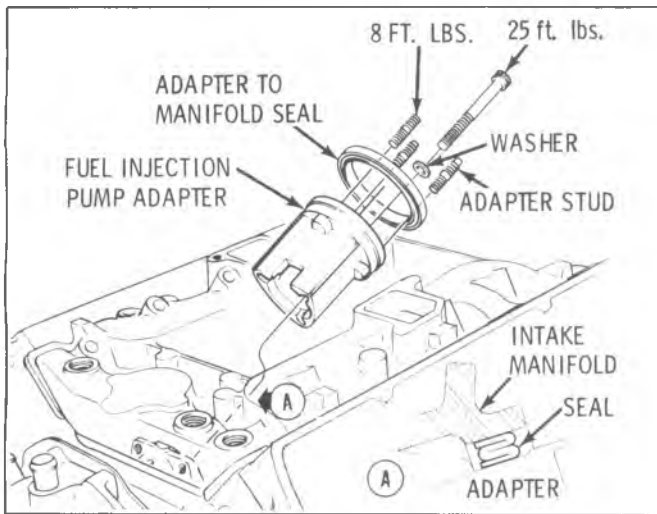


Fig. 6A6-26—Injection Pump Adapter Bolts

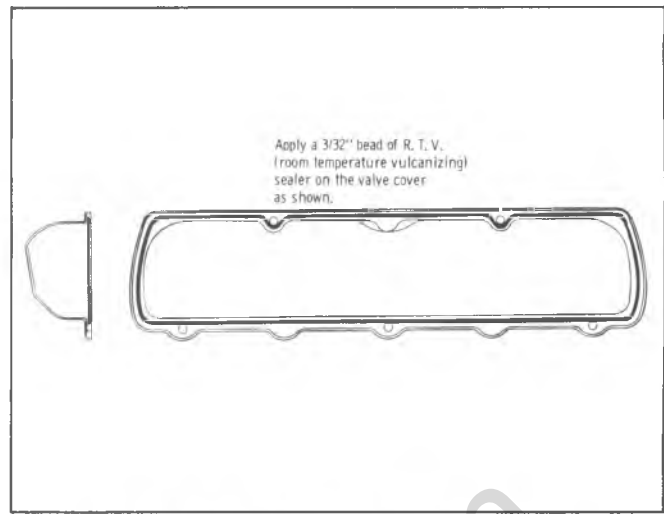


Fig. 6A6-28—Applying Sealer on Valve Cover

VALVE COVER

Removal

1. Refer to "INJECTION PUMP AND LINES" for removal of lines.
2. Remove valve cover to cylinder head attaching screws. Remove accessory mounting brackets as necessary and remove valve cover.

Installation

1. Thoroughly clean the head and valve cover sealing surfaces. Apply #1052289 RTV sealer (or equivalent) to the valve cover. (Fig. 6A6-28).
2. Install valve cover and screws so they are fully seated and not stripped. Install any mounting brackets which were removed. (Fig. 6A6-29).
3. Refer to "INJECTION PUMP AND LINES" for installation of lines.

INTAKE MANIFOLD

Removal

1. Remove air cleaner assembly.
2. Drain radiator, loosen upper bypass hose clamp, remove thermostat housing bolts and remove thermostat housing.
3. Remove breather pipes from valve covers and air crossover.
4. Remove air crossover and cap intake manifold with J-26996-2 screened covers.
5. Disconnect throttle rod and return spring. If equipped with cruise control, remove servo.
6. Remove hairpin clip at bellcrank and disconnect cables, then remove throttle cable from bracket on the intake manifold and position cable away from engine.
7. Disconnect wiring as necessary.
8. Remove generator and/or air conditioning compressor brackets as necessary.
9. Disconnect fuel line from fuel pump and fuel filter and remove fuel filter and bracket.

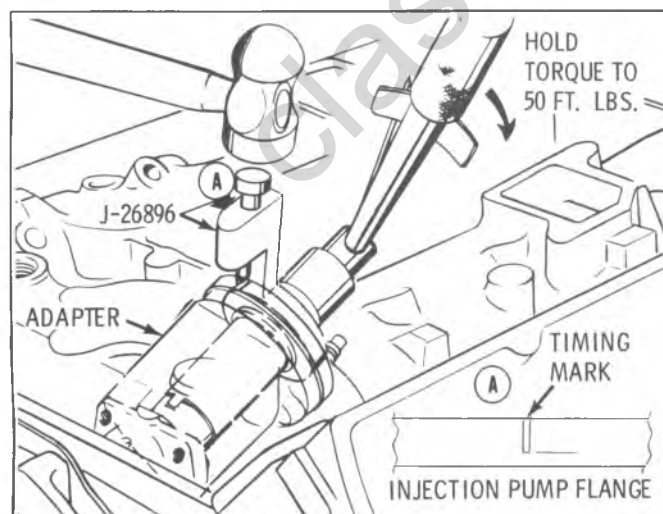


Fig. 6A6-27—Marking Injection Pump Adapter

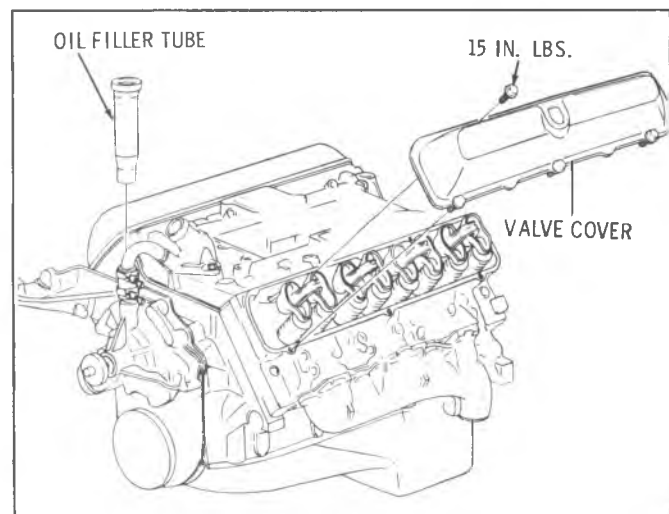


Fig. 6A6-29—Valve Cover

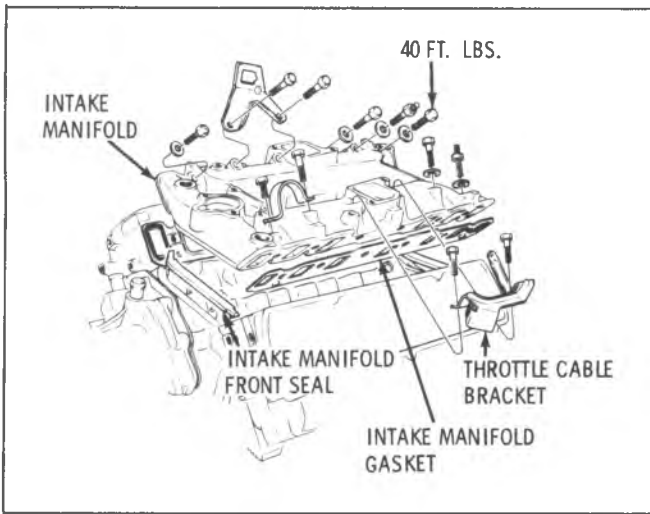


Fig. 6A6-30--Intake Manifold & Gasket

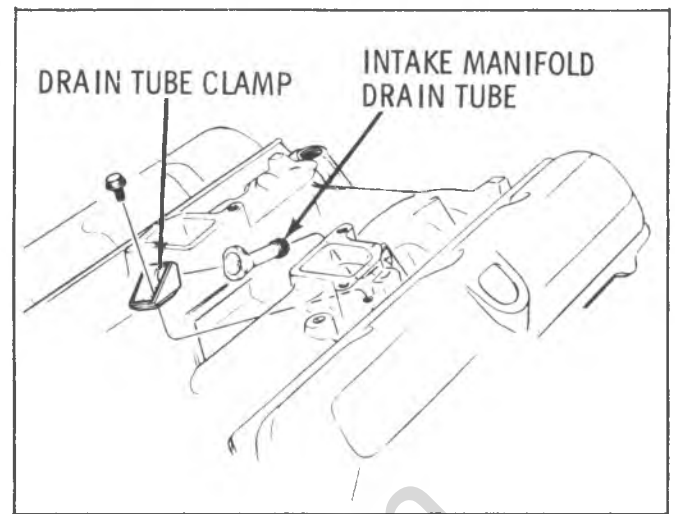


Fig. 6A6-32--Intake Manifold Drain Tube

10. Disconnect high pressure lines at nozzles and remove injection pump and cap all open lines and fittings on injection pump, filter and nozzles. **DO NOT BEND INJECTION PUMP LINES.**

11. Disconnect fuel return line from injection pump.
12. Disconnect vacuum lines at vacuum pump and remove vacuum pump.
13. Remove drain tube.
14. Remove intake manifold bolts, then remove intake manifold. Remove adapter seal.
15. Remove injection pump adapter.
16. Clean machined surfaces of cylinder head and intake manifold with a putty knife. Use care not to gouge or scratch machines surfaces.

Installation

1. Coat both sides of gasket sealing surface that seal the intake manifold to the head with #1050805 sealer, or equivalent, and position intake manifold gasket. (Fig. 6A6-30).
2. Install end seals, making sure that ends are positioned under cylinder heads.

3. Position intake manifold on engine.
4. Dip intake manifold bolt in engine oil and torque in sequence shown to 15 lbs. ft. (20 N·m). Then re-torque to 40 lbs. ft. (54 N·m) (Fig. 6A6-31).
5. Install drain tube (Fig. 6A6-32).
6. Apply chassis lube to seal area on adapter, taper edge and seal area in intake manifold then install injection pump adapter - leave loose.
7. Apply chassis lube to I.D. and O.D. of adapter seal and to seal installing tool J-28425. Install seal on tool.
8. Push seal on injection pump adapter with tool J-28425 (fig. 6A6-33).
9. Remove tool and inspect to see if properly positioned.
10. Torque adapter bolts to 25 lbs. ft. (34 N·m).
11. Remove caps from injection pump lines. Align offset tang on pump drive shaft with offset in pump driven gear then install injection pump. Connect injection pump lines to nozzles. Align mark on injection pump with mark on adapter. Use a 3/4" open end wrench on the boss at the front of the injection pump to aid in rotating the pump to align the marks.

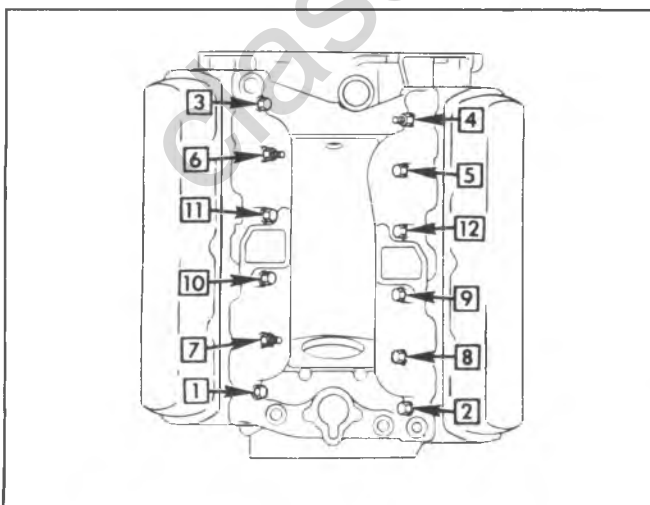


Fig. 6A6-31--Intake Manifold Torque Sequence

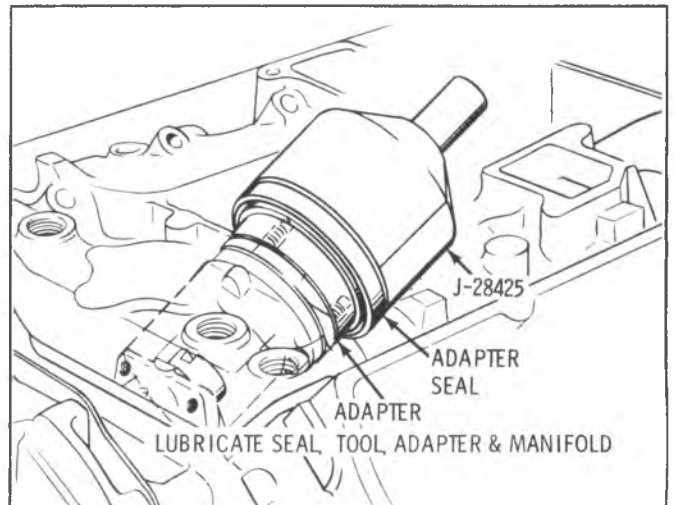


Fig. 6A6-33--Installing Adapter Seal

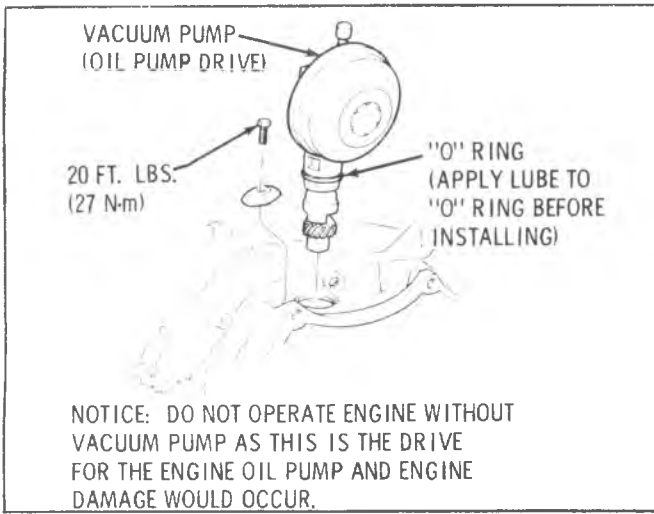


Fig. 6A6-34--Drive & Vacuum Pump

12. Install fuel filter bracket and filter, then connect fuel lines.
13. Connect the fuel return line to the injection pump.
14. Install vacuum pump and vacuum lines. (Fig. 6A6-34).

NOTICE: Do not operate engine without vacuum pump assembly, as this is the drive for the engine oil pump.

15. Connect wiring.
16. Install and/or connect generator and air conditioning compressor brackets as necessary.
17. Install cable in cable bracket and bellcrank, then install bellcrank to intake manifold.
18. Connect throttle rod and return spring.
19. Start engine and check for fuel leaks.
20. Remove screened covers J-26996-2 from intake manifold.
21. Install air crossover.
22. Install breather tubes from valve cover filters and flow control valve at the air crossover.
23. Connect upper radiator hose and heater hose.
24. Fill cooling system.

ROCKER ARM ASSEMBLIES (Figs. 6A6-35 & 6A6-36)

Removal

1. Remove air cleaner and install screened cover J-26996-1.
2. Remove high pressure fuel lines to nozzles.
3. Remove valve cover.
4. Remove rocker arm flanged bolts, pivots and rocker arms. Remove each set (one set per cylinder) as a unit.

Installation

1. Position a set of rocker arms (for one cylinder) in the proper location. Refer to "Valve Lifter Bleed Down" as lifters must be bled down as possible valve to piston interference, due to close tolerances, could exist.

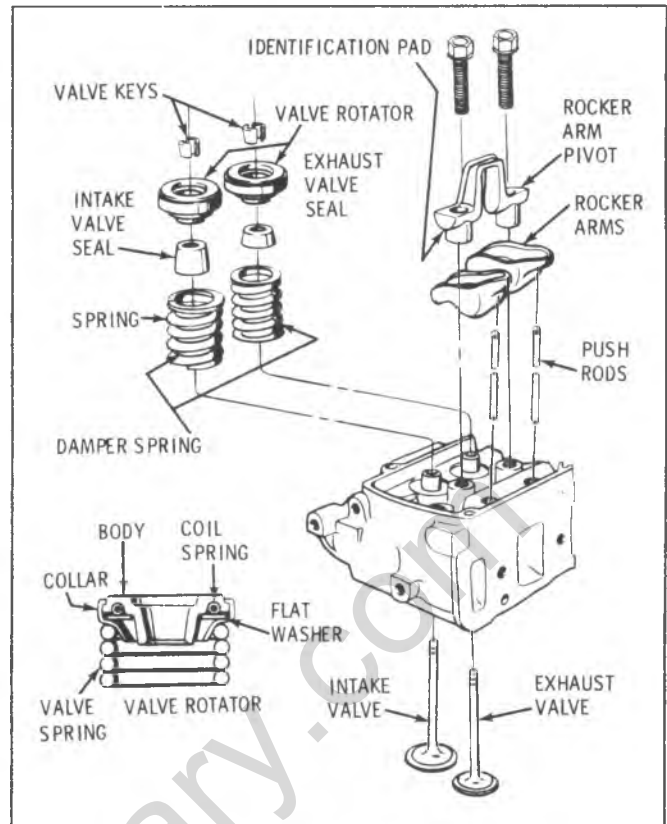


Fig. 6A6-35--Cylinder Head-Exploded View

2. Lubricate wear points with #1050169 lubricant or equivalent and install the pivots.
3. Install the hardened flanged bolts and tighten alternately. Torque bolts to 25 lbs. ft. (34 N·m).

VALVE LIFTERS

Operation

Oil is supplied to the lifter through a hole in the side of the lifter body which indexes with a groove and hole in the lifter plunger. Oil is then metered past the oil metering valve in the lifter, through the push-rods to the rocker arms. (Fig. 6A6-37).

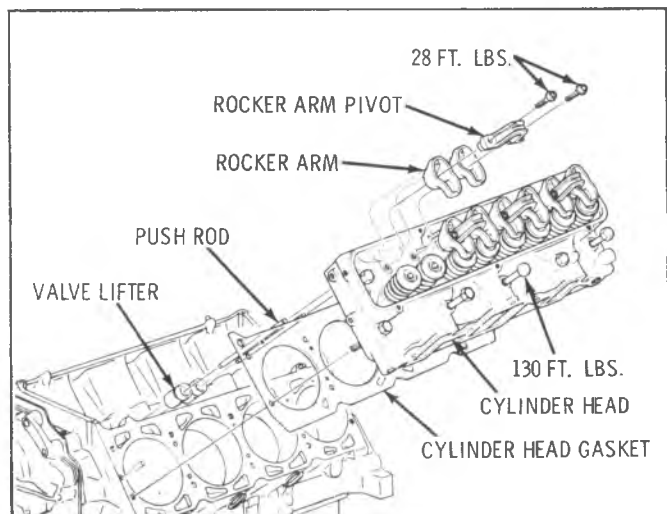


Fig. 6A6-36--Removing Rocker Arms

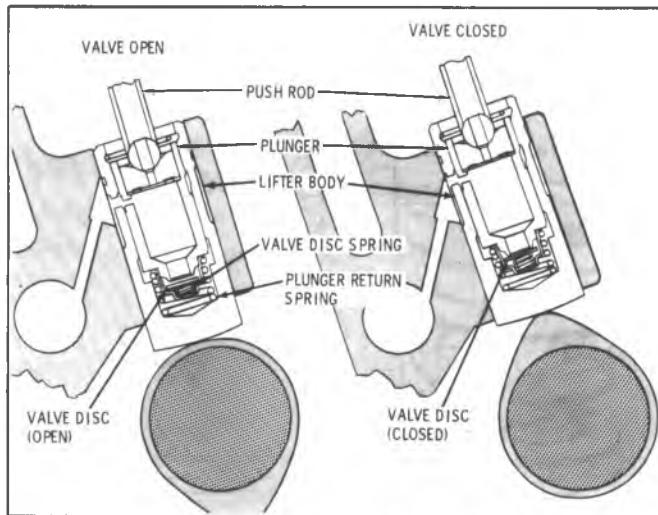


Fig. 6A6-37--Valve Lifter-Cutaway View

When the lifter begins to ride up the cam lobe, the check valve disc is held against its seat in the plunger by the check valve disc spring which traps the oil in the base of the lifter body below the plunger. The plunger and lifter body then raise as a unit, pushing up the push-rod to open the valve. The force of the valve spring which is exerted on the plunger through the rocker arm and push-rod causes a slight amount of leakage between the plunger and lifter body. This "leak-down" allows a slow escape of trapped oil in the base of the lifter body. As the lifter rides down the other side of the cam lobe and reaches the base circle or "valve closed" position, the plunger spring quickly moves the plunger back (up) to its original position. This movement causes the check valve disc to open against the check valve disc spring and oil from within the plunger is drawn into the base of the lifter. This restores the lifter to zero lash.

- Hydraulic valve lifters are not the same as used in gasoline engines.

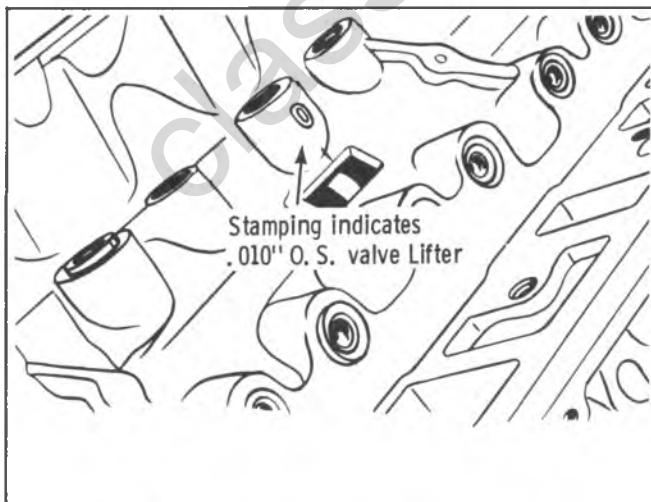


Fig. 6A6-38--O.S. Valve Lifter Identification

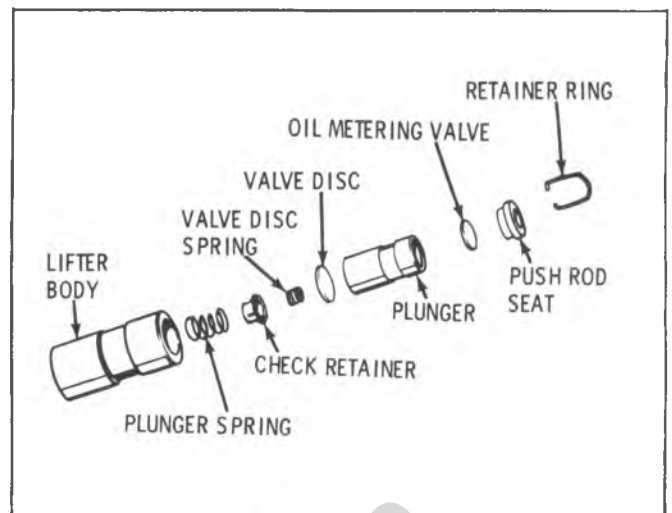


Fig. 6A6-39--Valve Lifter-Exploded View

Removal

Valve lifters and push-rods should be kept in order so they can be reinstalled in their original position. Some engines will have both standard and .010" oversize valve lifters. The .010" oversize lifter is etched "O" on the side of the lifter. The cylinder block will also be marked if the oversize lifter is used. (Fig. 6A6-38).

1. Refer to "INTAKE MANIFOLD" for removal.
2. Remove valve covers, rocker arm assemblies and push-rods.
3. Remove valve lifters.

Disassembly

1. Remove the retainer ring with a small screwdriver.
2. Remove push-rod seat and oil metering valve.
3. Remove plunger and plunger spring.
4. Remove check valve retainer from plunger, then remove valve and spring.

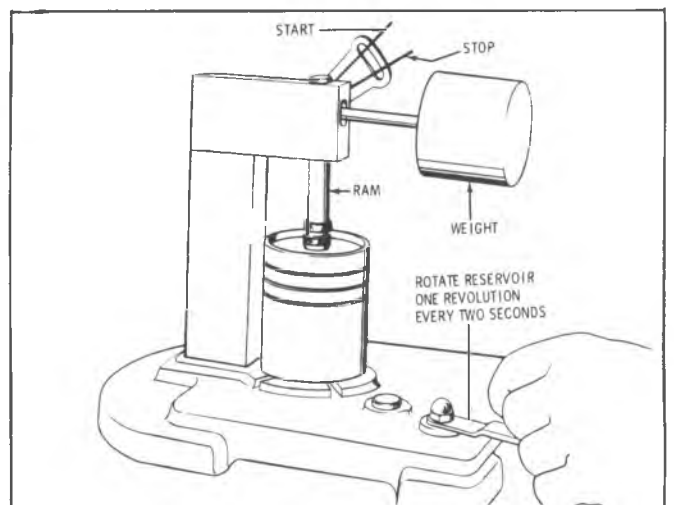


Fig. 6A6-40--Valve Lifter Testing

Cleaning and Inspection

After lifters are disassembled, all parts should be cleaned in clean solvent. A small particle of foreign material under the check valve will cause malfunctioning of the lifter. Close inspection should be made for nicks, burrs or scoring of parts. If either the body or plunger is defective, replace with a new lifter assembly.

Whenever lifters are removed, check the lifter foot for abnormal wear as follows:

1. Place a straight edge across the lifter foot. Lifter foot must be clean and dry.
2. While holding the lifter at eye level, check for light between the straight edge and lifter foot.
3. If light indicates a concave surface of the lifter foot, the lifter should be replaced and the camshaft inspected for wear. Wear at the CENTER of the cam base circle is NORMAL. The camshaft should be replaced ONLY when wear is present across FULL WIDTH of cam base circle. Full wear across the nose of the cam is normal.

4. Assemble valve disc spring and retainer into plunger. (Fig. 6A6-39). Make sure retainer flange is pressed tight against bottom of recess in plunger.

5. Install plunger spring over check retainer.
 6. Hold plunger with spring up and insert into lifter body. Hold plunger vertically to prevent cocking spring.
 7. Assemble oil metering valve and push rod seat and seat retaining ring in groove.
- Lifters must be assembled while submerged in kerosene or diesel fuel and leak-down tested before placing into service.

8. Fill tester J-5790 with kerosene to 1/2" (12.7mm) below top of reservoir.

9. Place assembly into the tester cup, then position oil control valve and push-rod seat onto plunger.

10. Position the 1/4" (6.5mm) steel ball on the push-rod seat. Lower tester ram until it contacts the steel ball.

11. Allow ram to move downward by its own weight until air bubbles disappear.

12. Raise ram, then allow to lower. Repeat this procedure several times or until all air is expelled from lifter. Do not attempt to expel air from lifter by pumping on ram.

13. After all air is expelled, allow ram to bleed down lifter until retaining groove is exposed.

14. Install retaining ring.

15. Adjust ram screw so that it contacts the steel ball in the push-rod seat when the pointer is at the start line.

16. Raise arm, then start test by resting ram on steel ball. Rotate reservoir one revolution every two seconds and time the indicator from the start to the stop line. (Fig. 6A6-40). Allowable leak-down rate is 6 seconds minimum for used lifters and 9 to 60 seconds for new lifter.

17. If leak-down tolerance is within specifications, remove test fluid before placing lifter in service.

Bleed Down

If the intake manifold has been removed and if any rocker arms have been loosened or removed; it will be necessary to remove those valve lifters, disassemble, drain the engine oil then reassemble the lifters. See "VALVE LIFTER DISASSEMBLY".

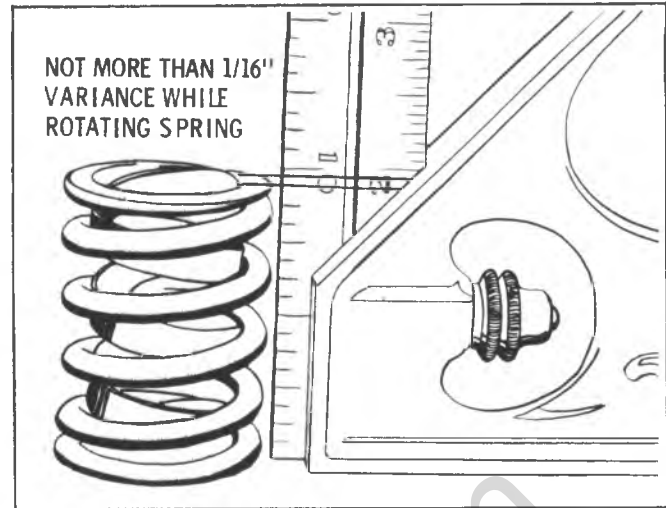


Fig. 6A6-41--Checking Valve Spring

If the intake manifold has not been removed but rocker arms have been loosened or removed, valve lifters can be bled down by the following procedure:

1. For cylinders #3, 5, 7, 2, 4 & 8 turn the crankshaft so the saw slot on the harmonic balancer is a 0° on the timing indicator. For cylinders #1, 3, 7, 2, 4 & 6 turn the crankshaft so the saw slot on the harmonic balancer is at 4 O'Clock.
2. Tighten the rocker arm pivot bolts to 25 lbs. ft. (34 N·m).

NOTICE: It will take up to 45 minutes at each position for the valve lifters to be completely bled down. Do not rotate the engine until the valve lifters have been bled down, or damage to the valve train could occur.

3. Finish reassembling the engine as the lifters are being bled.

Diagnosis

1. Momentarily Noisy When Vehicle Is Started:

This condition is normal. Oil drains from the lifters which are holding the valves open when the engine is not running. It will take a few seconds for the lifters to fill after the engine is started.

2. Intermittently Noisy On Idle Only, Disappearing When Engine Speed Is Increased:

Intermittent clicking may be an indication of a pitted check valve disc, or it may be caused by dirt.

Correction: Clean the lifter and inspect. If check valve disc is defective, replace lifter.

3. Noisy At Slow Idle Or With Hot Oil, Quiet With Cold Oil Or As Engine Speed Is Increased:

Leak check the suspected lifters and replace any lifters that do not meet specifications.

4. Noisy At High Car Speeds And Quiet At Low Speeds:

a. High oil level-Oil level above the "Full" mark allows crankshaft counterweights to churn the oil into foam. When foam is pumped into the lifters, they will become noisy since a solid column of oil is required for proper operation.

Correction: Drain oil until proper level is obtained. See PERIODIC MAINTENANCE Section.

b. Low oil level - Oil level below the "Add" mark allows air to the pump at high speeds which results in noisy lifters.

Correction: Fill until proper oil level is obtained. See PERIODIC MAINTENANCE Section.

c. Oil pan bent on bottom or pump screen cocked, replace or repair as necessary.

5. Noisy At Idle Becoming Louder As Engine Speed Is Increased To 1500 rpm:

This noise is not connected with lifter malfunction. It becomes most noticeable in the vehicle at 10 to 15 mph (16 to 24 km/h) "L" range, or 30 to 35 mph (48 to 56 km/h) "D" range and is best described as a hashy sound. At slow idle, it may be entirely gone or appear as a light ticking noise in one or more valves. It is caused by one or more of the following:

- Badly worn or scuffed valve tip and rocker arm pad.
- Excessive valve stem to guide clearance.
- Excessive valve seat runout.
- Off square valve spring.
- Excessive valve face runout.
- Valve spring damper clicking on rotator.

To check valve spring and valve guide clearance, remove the valve covers:

a. Occasionally this noise can be eliminated by rotating the valve spring and valve. Crank engine until noisy valve is off its seat. Rotate spring. This will also rotate valve. Repeat until valve becomes quiet. If correction is obtained, check for an off square valve spring. If spring is off square more than 1/16" (1.6mm) in free position, replace spring. (Fig. 6A6-41).

b. Check for excessive valve stem to guide clearance. If necessary, correct as required.

6. Valves Noisy Regardless Of Engine Speed: This condition can be caused by foreign particles or excessive valve lash.

Check for valve lash by turning engine so the piston in that cylinder is on top dead center of firing stroke. If valve lash is present, the push-rod can be freely moved up and down a certain amount with rocker arm held against valve. If OK, clean suspected valve lifters.

Valve lash indicates one of the following:

- Worn push-rod.
- Worn rocker arm.
- Lifter plunger stuck in down position due to dirt or carbon.
- Defective lifter.

Checking of the above four items:

1. Look at the upper end of push-rod. Excessive wear of the spherical surface indicates one of the following conditions.

a. Improper hardness of the push-rod ball. The push-rod and rocker arm must be replaced.

b. Improper lubrication of the push-rod. The push-rod and rocker arm must be replaced. The oiling system to the push-rod should be checked.

2. If push-rod appears in good condition and has been properly lubricated, replace rocker arm and recheck valve lash.

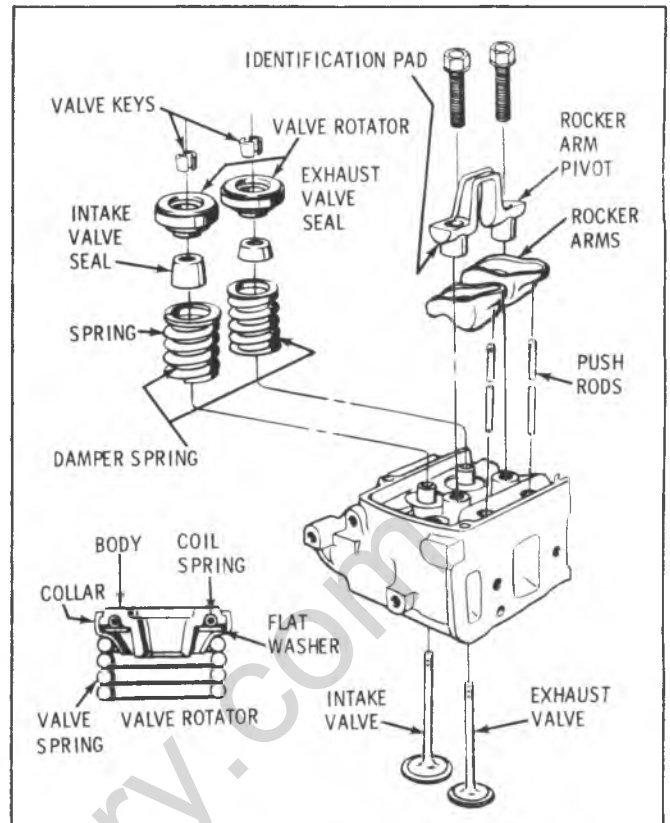


Fig. 6A6-42--Cylinder Head-Exploded View

3. If valve lash exists and push-rod and rocker arm are okay, trouble is in the lifter. Lifter should be replaced.

Installation

Coat foot of lifter with #562458 lubricant or equivalent.

Prime new lifters by working lifter plunger while submerged in new kerosene or diesel fuel. Lifter could be damaged if dry when starting engine

1. When a rocker arm is loosened or removed, valve lifter bleed down is required. Refer to "VALVE LIFTER BLEED DOWN". Lifters must be bled down as possible valve to piston interference, due to close tolerances, could exist.

2. Install lifters and push-rods into original position in cylinder block. See note under Removal.

3. Install manifold gaskets and manifold.

4. Position rocker arms, pivots and bolts on cylinder head as shown in Fig. 6A6-42.

5. Install valve covers.

6. Install intake manifold assembly.

INJECTION NOZZLE (WITH LINES REMOVED)

Removal

1. Remove the fuel return line clamps from all nozzles on the bank where a nozzle is to be removed then remove that fuel return line.

2. Remove nozzle spring clamp and spacer then remove nozzle using Tool J-29082.

3. Cap the nozzle inlet line and the tip of the nozzle.

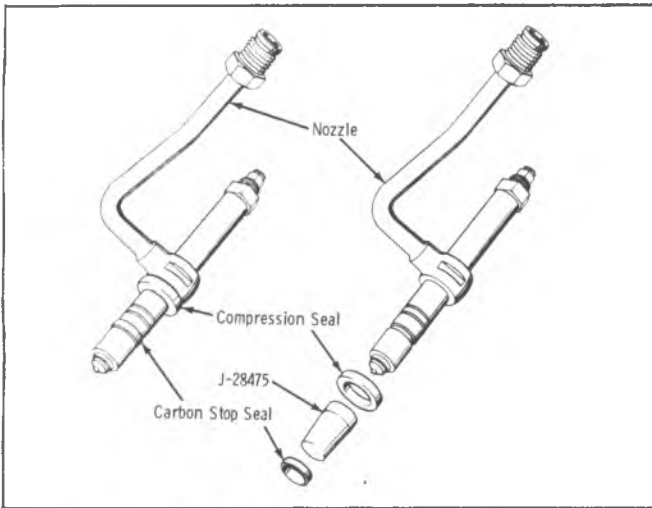


Fig. 6A6-43--Installation of Nozzle Seals

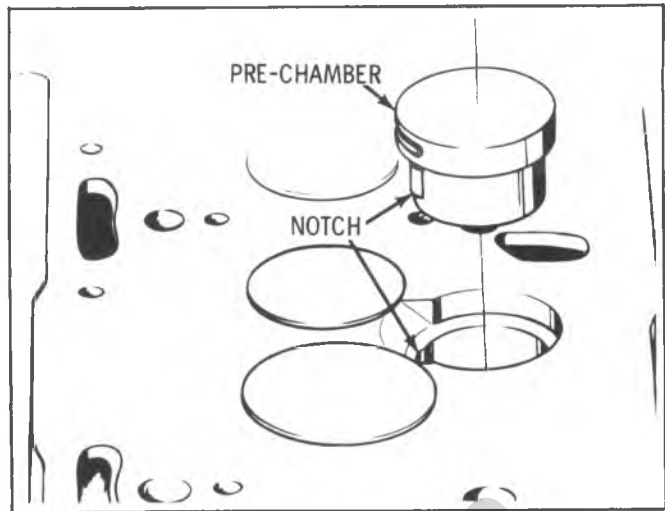


Fig. 6A6-45--Installing Pre-Chamber in Head

Installation

1. If a nozzle is to be reinstalled after removal, a new compression seal and carbon stop seal must be installed after removal of the used seals. See figure 6A6-43 for seal installation.
2. Remove protective caps then install injection nozzle and spring clamp and spacer. Torque bolt to 25 lb. ft. (34 N·m) (Fig. 6A6-44).
3. Install fuel return line.
4. Start engine and check for leaks.

CYLINDER HEAD AND GASKET

Removal

1. Remove intake manifold. See "INTAKE MANIFOLD" for removal.
2. Remove valve cover.
3. Disconnect glow plug wiring.
4. Remove ground strap from right cylinder head.
5. Remove rocker arm bolts, pivots, rocker arms and push rods. Scribe pivots and keep rocker arms separated so they can be installed in their original locations.

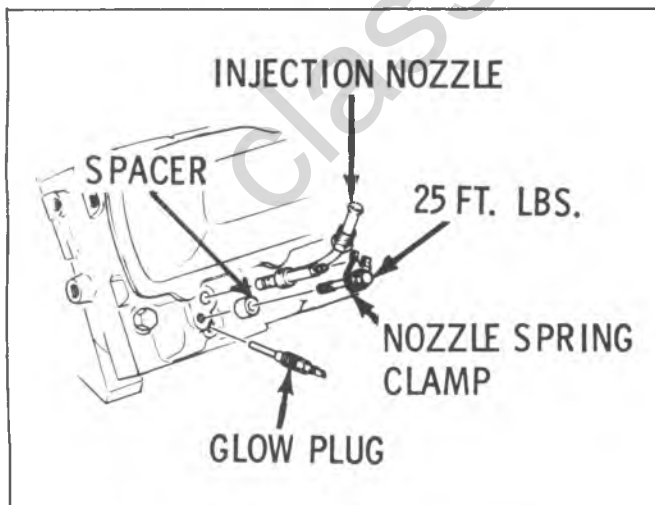


Fig. 6A6-44--Injection Nozzle Installation

6. Remove fuel return lines from nozzles.
7. Remove exhaust manifold.
8. Remove engine block drain plug on the side of the engine where the cylinder head is being removed.
9. Remove cylinder head bolts and remove cylinder head.
10. If necessary to remove pre-chamber, remove the glow plug or injection nozzle, then tap out with a small blunt drift.

Installation

Head gaskets are a special composition gasket that must be used **WITHOUT** a sealer.

No additional sealer can be used when installing the head gaskets as the passage surfaces are sealed when the gaskets are made, using a newly developed method and material. This sealer is accurately printed on the surface of the gasket in the exact quantity required and provides the desired bond between the head and the block. Applying additional sealer would only result in the possibility of leakage.

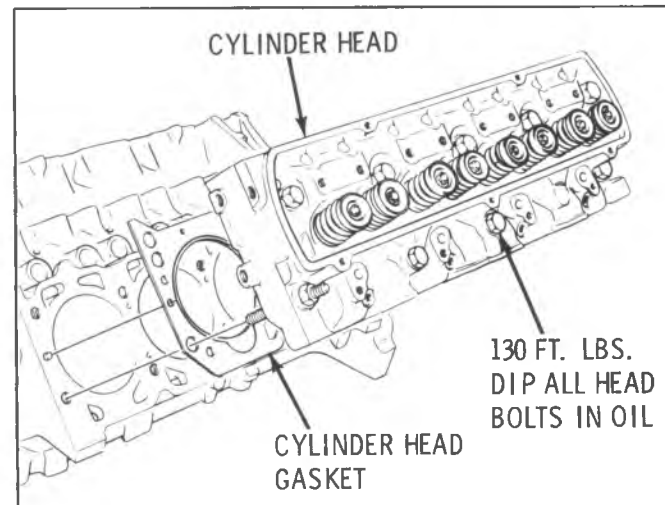


Fig. 6A6-46--Cylinder Head & Gasket

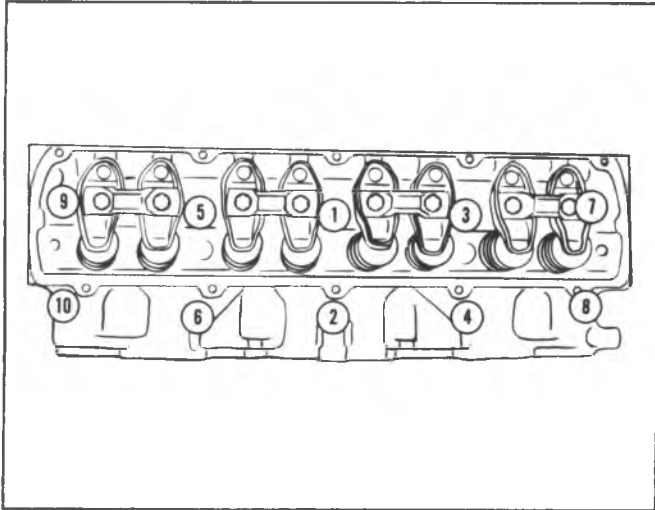


Fig. 6A6-47--Cylinder Head Torque Sequence

1. Install pre-chamber, if removed. The pre-chamber can only be installed in one position. (Fig. 6A6-45).
2. Use a small mallet and install in cylinder head.
3. Install glow plug.
4. Clean cylinder head bolts and dip in engine oil, torque bolts to 100 lbs. ft. (136 N·m) in sequence shown, then re-torque in sequence to 130 lbs. ft. (176 N·m). (Figs. 6A6-46 & 6A6-47). Torque head bolts before installing rocker arms and pivots.

VALVES AND SPRINGS WITH HEAD REMOVED (Fig. 6A6-48)

Removal

1. Remove valve keys by compressing valve spring with a tool such as J-5892-1.
2. Remove valve spring rotators or retainers and springs.
3. Remove oil seals from valve stems.
4. Remove valves. Keep valves separated so they can be installed in their original locations. (Fig. 6A6-49).

Installation

1. Install valves in their respective guides.
2. Install new oil seals over valve stem. Position seals down as far as possible on valve stem. The seals will correctly position themselves when the engine is started.
3. Position valve springs over valve stems.
4. Install valve rotators then compress springs with a tool such as J-5892-1 and install valve stem keys.

| VALVE TRAIN INFORMATION | | | | | |
|-------------------------|---------------|------------------|---------------------|-------------------|-------------------------------|
| TYPE | HEAD DIAMETER | VALVE FACE ANGLE | VALVE SPRING DAMPER | VALVE SEAT INSERT | INDUCTION HARDENED VALVE SEAT |
| Intake | 1.875" | 44° | Yes | No | Yes |
| Exhaust | 1.625" | 30° | Yes | No | No |

Fig. 6A6-48--Valve Train Information Chart

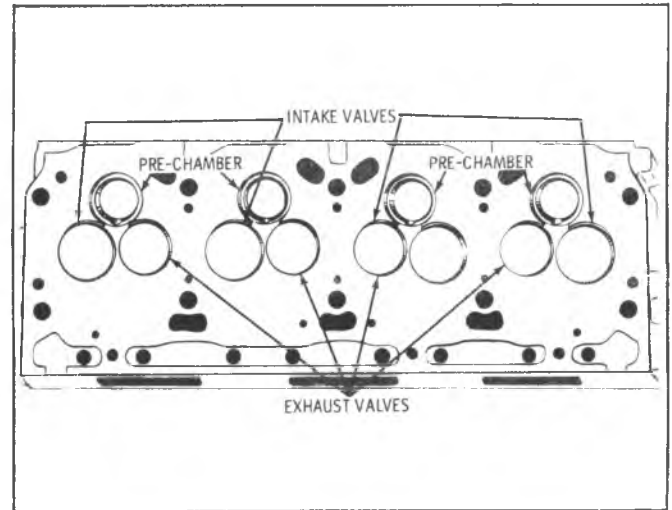


Fig. 6A6-49--Valve Location

5. Check valve springs and keys to be sure they are properly seated.

6. Install exhaust manifold. Torque bolts and nuts to 25 ft. lbs. (34 N·m). Bend exhaust manifold bolt lock tabs.

Reconditioning

When reconditioning valves and valve seats, clean carbon from cylinder heads and valves using care not to gouge or scratch machined surfaces. A soft wire brush is suitable for this purpose. Whenever valves are replaced or new valves installed, the valve seats must be reconditioned. (Fig. 6A6-50).

Narrow the valve seats to the specified width.

This operation is done by grinding the portside with a 30° stone to lower the seat and a 60° stone to raise the seat.

Intake valve seats are induction hardened and must be ground, not cut.

If valve guide bores are worn excessively, they can be reamed oversize. This will require replacement of the valves with oversize valves (stems). The guide bores should be reamed before grinding the valve seats. Valve clearance in guide bore should be .0015" to .0032" (exhaust) or .001"

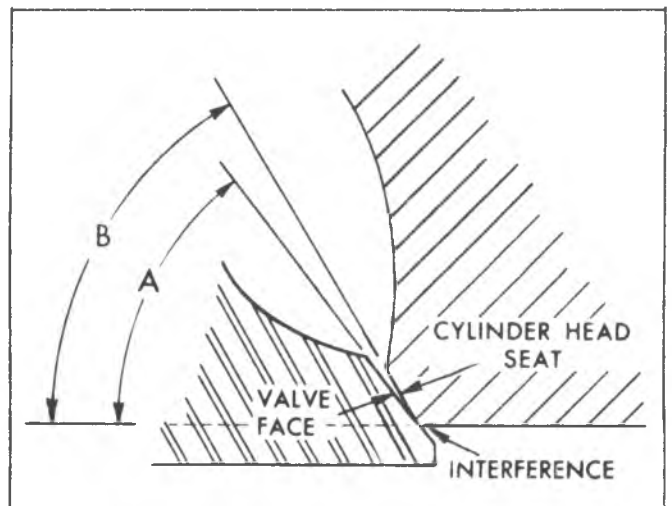


Fig. 6A6-50--Relation of Valve & Seat Angles

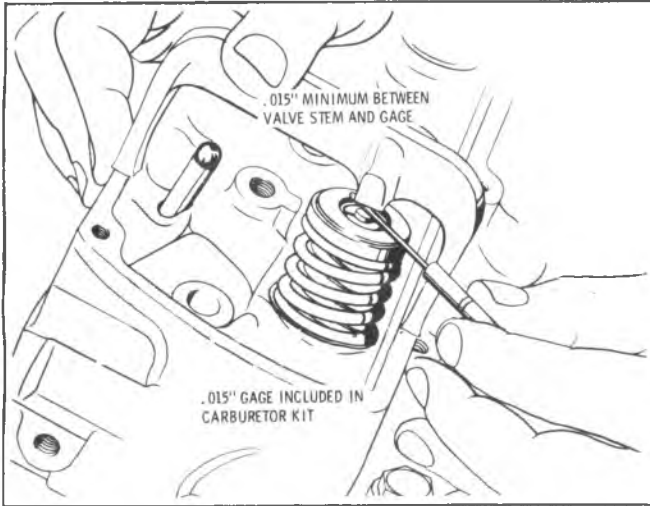


Fig. 6A6-51--Measuring Valve Stem Height

to .0027" for the intake valve.

Measuring Valve Stem Height

Whenever a new valve is installed, or after grinding valves, it will be necessary to measure valve stem height as follows:

Install gage J-25289 as shown in Fig. 6A6-51.

There should be at least .015" (.38mm) clearance on all valves between gage surface and end of valve stem. (Valve stem can be gaged with or without the valve rotator on the valve.) If clearance is less than .015" (.38mm), remove valve and grind tip of valve stems as required on a valve refacing machine, using the "Vee" block attachment to insure a smooth 90° end. Also be certain to break sharp edge on ground valve tip. Observe an original valve to determine chamfer.

After all valve keys have been installed on valves, tap each valve stem end with a mallet to seat valve rotators and keys. Using gage J-25289 as shown in Figs. 6A6-51 and 6A6-52, regage all valves between valve stem and gage [.015" (.38mm) minimum] and valve rotator and gage [.030" (.76mm) minimum]. If any valve stem end is less than .005" (.12mm) above rotator, the valve is too short and a

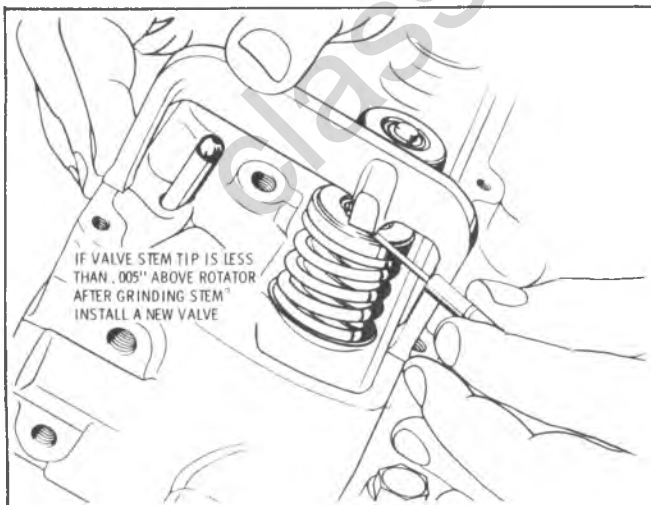


Fig. 6A6-52--Measuring Rotator Height

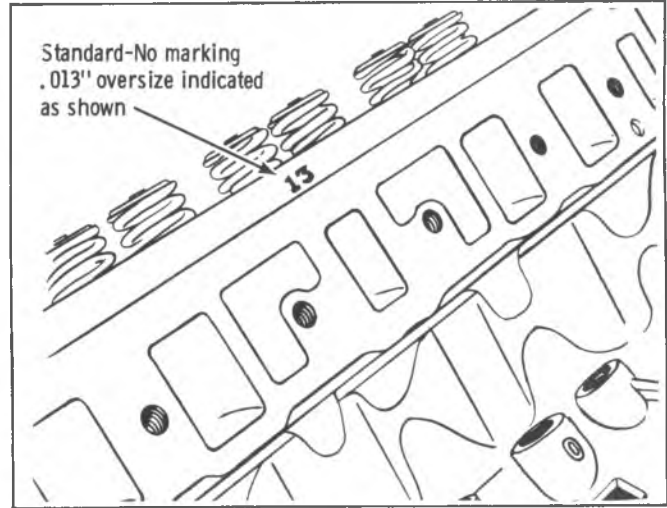


Fig. 6A6-53--Valve Guide Bore Marking

new valve must be installed.

EXAMPLE:

Valve Rotator to Gage Clearance-.038" (.97mm)

Minus Valve Stem to Gage Clearance-.035" (.89mm)

-.003" (.08mm).

This is less than .005" (.12mm) and new valve should be installed.

There must be a minimum of .030" (.76mm) clearance between valve rotator and gage. Failure to maintain this clearance will cause rocker arm and valve rotator interference.

VALVE GUIDE BORE

If the valve guide bores are worn excessively, they can be reamed oversize. The following reamers are available:

J-5830-1003" (.08mm) Oversize Valve Guide Reamer

J-6621005" (.12mm) Oversize Valve Guide Reamer

J5830-7013" (.33mm) Oversize Valve Guide Reamer

If a standard or .003" O.S. valve guide bore is being reamed, use the .003" oversize reamer. For the .005" oversize valve guide bore, use the .005" oversize reamer; use the .013" reamer for the .010" or .013" O.S. valve guide bore. If too large a reamer is used and the spiraling is removed, the valve may not receive the proper lubrication.

Occasionally a valve guide bore will be oversize as manufactured. These are marked on the inboard side of the cylinder heads on the machined surface just above the intake manifold surface. (Fig. 6A6-53). These markings are visible without removing any parts other than the air cleaner assembly. Before removing the cylinder heads to perform service to either the valves or valve guide bores, the cylinder heads should be inspected to determine if these markings are present. If no markings are present, the guide bores are standard. If oversize markings are present, any valve replacement will require an oversize valve. If the oversize marking is present, only that particular bore would be oversize, not all bores in that cylinder head. Service valves are available in five different stem diameters: Standard, .003" oversize, .005" oversize, .010" oversize, and .013"

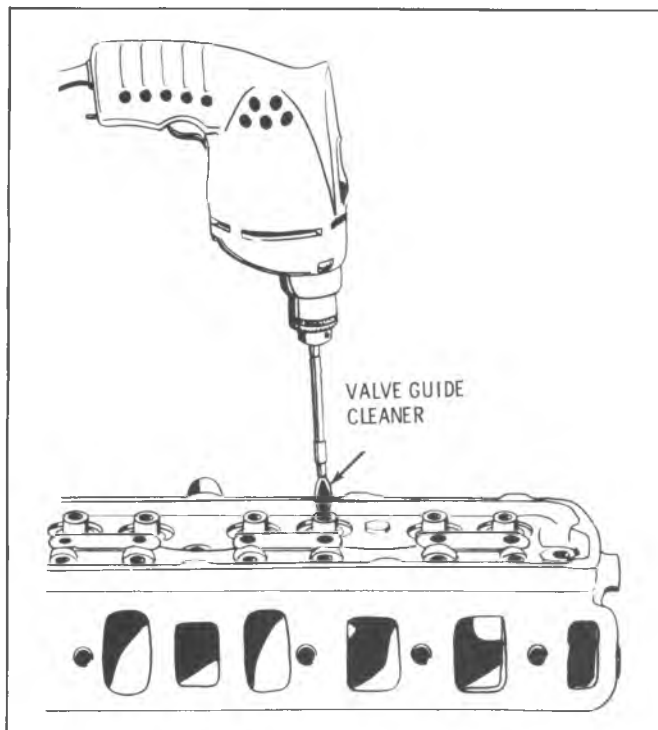


Fig. 6A6-54--Cleaning Valve Guide Bores

oversize.

Reaming

Before attempting to ream the valve guide bores they should be cleaned using Tool J-8101 as shown in Fig. 6A6-54.

This procedure to ream valve guide bores is shown in Fig. 6A6-55. Use care to hold reamer straight in valve guide bore.

VALVE SPRING (HEAD ON ENGINE)

To replace a worn or broken valve spring without removing the cylinder head proceed as follows:

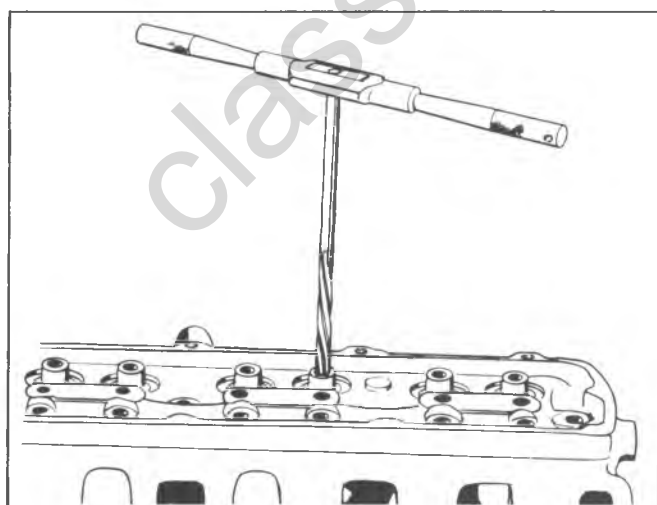


Fig. 6A6-55--Reaming Valve Guide Bores

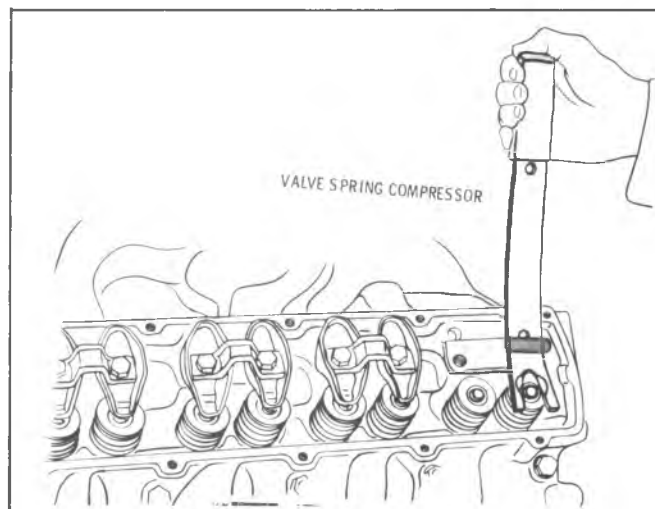


Fig. 6A6-56--Removing Valve Spring

Removal

1. Remove rocker arm assemblies.
2. Rotate engine so piston is at top dead center for each cylinder.
3. Install Tool J-5892-1 (Fig. 6A6-56) and compress the valve spring until valve keys are accessible; then remove keys, valve rotators and springs. If valve spring does not compress, tap tool with a mallet to break bind at rotator and keys.

Checking Rotators

The rotators cannot be disassembled and require replacement only when they fail to rotate the valve.

Rotator action can be checked by applying a daub of paint across the top of the body and down the collar. Run engine approximately 1500 rpm. There should appear to be motion between the body and collar; the body will appear to "walk" around the collar. Rotator action can be either clockwise or counterclockwise. Sometimes on removal and reinstallation, the direction of rotation will change but this does not matter so long as it rotates.

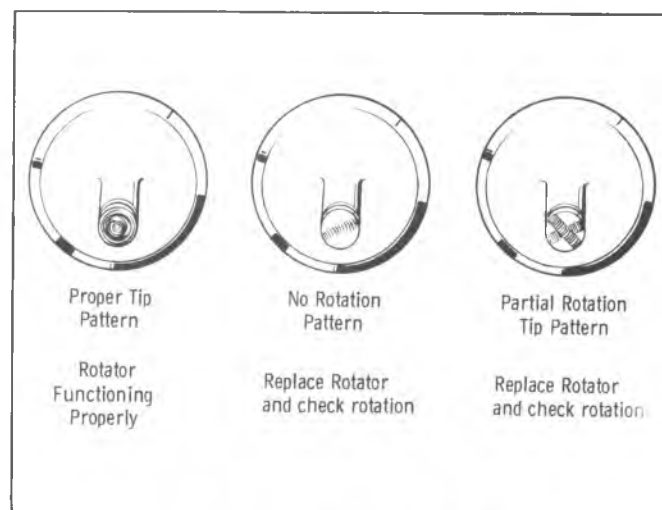


Fig. 6A6-57--Valve Stem Wear

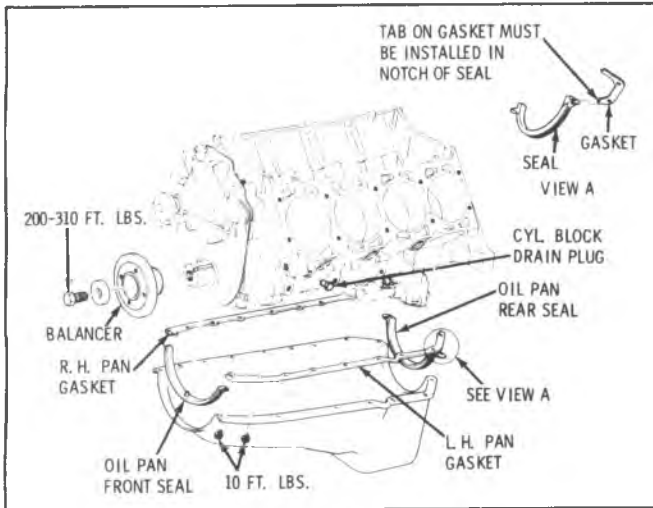


Fig. 6A6-58--Oil Pan Assembly

Any time the valves are removed for service the tips should be inspected for improper pattern which could indicate valve rotator malfunction. (Fig. 6A6-57).

Installation

1. Install valve spring and rotator. Using Tool J-5892-1, compress the valve spring until the valve keys can be installed.
2. Install rocker arm assemblies.
3. Bleed valve lifters where rocker arm pivots were loosened. Refer to "VALVE LIFTER BLEED DOWN".

OIL PAN

Removal

1. Disconnect battery cables.
2. Remove air cleaner.
3. Remove drive and vacuum pump.
4. Remove fan shroud attaching screws and pull up from clips.
5. Hoist the vehicle and drain oil.
6. Remove flywheel cover.
7. Remove starter assembly.
8. Remove both mount through bolts then raise engine. LOOSEN left-hand mount and REMOVE right-hand mount.
9. Remove oil pan.

● If extended work is to be done, the mounts should be reinstalled and the engine lowered to the frame brackets.

Installation (Fig. 6A6-58)

1. Apply #1050805 sealer or equivalent to both sides of pan gaskets and install on block.
2. Install front and rear seals (rubber).
3. Wipe lube, #1050169 or equivalent, on seal area and install pan. Torque bolts to 10 lbs. ft. (14N·m). Reverse the removal procedure. Fill crankcase as explained in the PERIODIC MAINTENANCE Section.

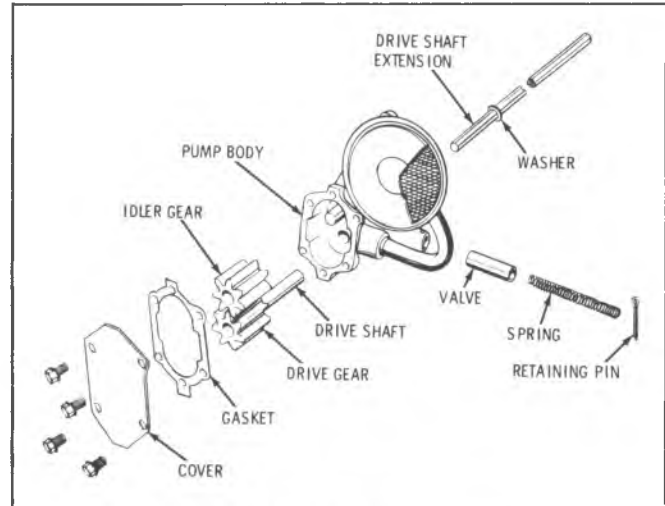


Fig. 6A6-59--Oil Pump-Exploded View

OIL PUMP

Removal

1. Remove oil pan.
2. Remove the oil pump to rear main bearing cap attaching bolts, then remove pump and drive shaft extension.

Disassembly (Fig. 6A6-59)

1. Remove the oil pump drive shaft extension. Do not attempt to remove the washers from the drive shaft extension. The drive shaft extension and washers must be serviced as an assembly. (Fig. 6A6-60).
2. Remove the cotter pin, spring and the pressure regulator valve. Position thumb over pressure regulator bore before removing cotter pin, as the spring is under pressure.
3. Remove the oil pump cover attaching screws and remove the oil pump cover and gasket.
4. Remove the drive gear and idler gear from the pump body.

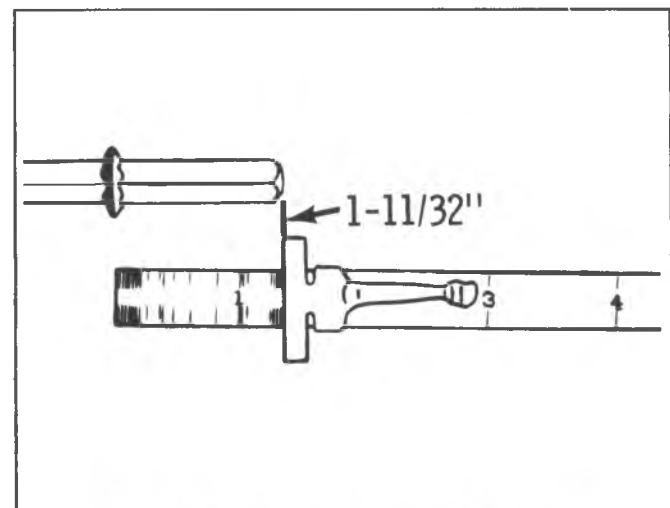


Fig. 6A6-60--Oil Pump Driveshaft Extension

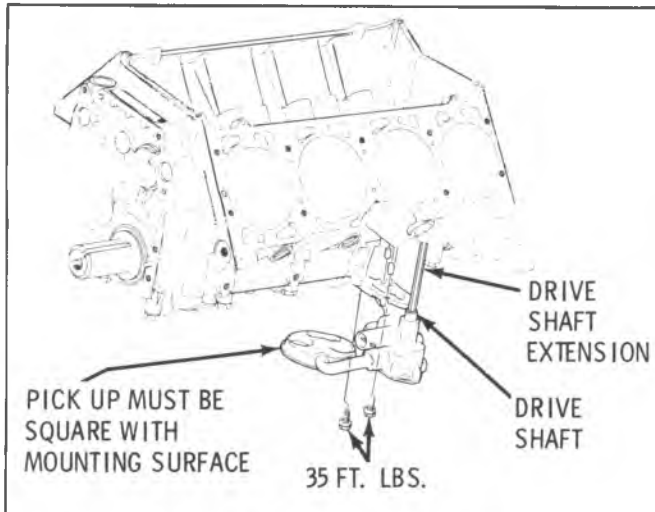


Fig. 6A6-61--Oil Pump Installation

Inspection

Check the gears for scoring or other damage. If they are damaged, new gears should be installed. During assembly, the gear end clearance should be gaged. Proper end clearance is .0005" to .0075". Also check the pressure regulator valve, valve spring and bore for damage. Proper valve to bore clearance is .0025" to .0050". The checking of gear end clearance will be covered in "Assembly". Check the extension shaft at each end for abnormal wear. The shaft is hardened at both ends and identified by a red dye marking.

Assembly

1. Install the gears and shaft in the oil pump body and check the gear end clearance by placing a straight edge over the gears and measure the clearance between the straight edge and the gasket surface. The clearance should be between .0005" to .0075". If the end clearance is to the high limit, check for scores in the cover that would bring the total clearance over the specified amount.
2. Install the cover screws and tighten alternately and evenly. The torque is 8 lbs. ft. (11N·m).
3. Position the pressure regulator valve into the pump cover, closed end first, then install the spring and retaining pin.
4. When assembling the drive shaft extension to the drive shaft, **THE END OF THE EXTENSION NEAREST THE WASHERS MUST BE INSERTED INTO THE DRIVE SHAFT.**

Installation

1. Insert the drive shaft extension through the opening in the main bearing cap and block until the shaft mates into the vacuum pump driven gear.
2. Position pump onto the rear main bearing cap and install attaching bolts. Torque bolts to 35 lb. ft. (47 N·m) (Fig. 6A6-61).
3. Install the oil pan. Refer to OIL PAN Installation.

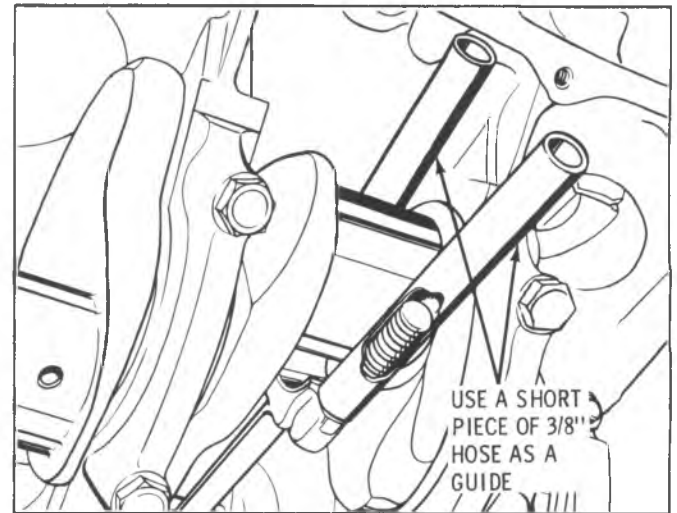


Fig. 6A6-62--Connecting Rod Bolt Guide

CONNECTING ROD AND PISTON

Removal

1. Remove intake manifold, head or heads.
2. Remove oil pan.
3. Remove oil pump assembly.
4. Stamp cylinder number on the machined surfaces of the bolt bosses of the connecting rod and cap for identification when reinstalling. If the pistons are to be removed from the connecting rod, mark cylinder number on piston with a silver pencil or quick drying paint for proper cylinder identification and cap to rod location. The right bank is numbered 2-4-6-8, left bank 1-6-5-7.
5. Examine the cylinder bore above ring travel. If ridge exists, remove ridge with ridge reamer before attempting to remove the piston and rod assembly.
6. Remove rod bearing cap and bearing.
7. Install guide hose over threads of rod bolts. This to prevent damage to bearing journal and rod bolt threads. (Fig. 6A6-62).
8. Remove rod and piston assembly through the top of the cylinder bore.
9. Remove other rod and piston assemblies in the same manner.

ROD BEARINGS

The connecting rod bearings are designed to have a slight projection above the rod and cap faces to insure a positive contact.

Connecting rod bearings can be replaced without removing the rod and piston assembly from the engine.

1. Remove oil pan.
 - It may be necessary to remove oil pump to provide access to rear connecting rod bearings.
2. With crankpin at the bottom, stamp cylinder number on machined surfaces of connecting rod and cap for identification when reinstalling, then remove caps.
3. Inspect crankpins for roughness and wear. Slight roughness may be removed with a fine grit polishing cloth saturated with engine oil. Burrs may be removed with a fine oil stone by moving the stone on the crankpin circumference. Do not move the stone back and forth across the crankpin. If the crankpins are scored or ridged, the

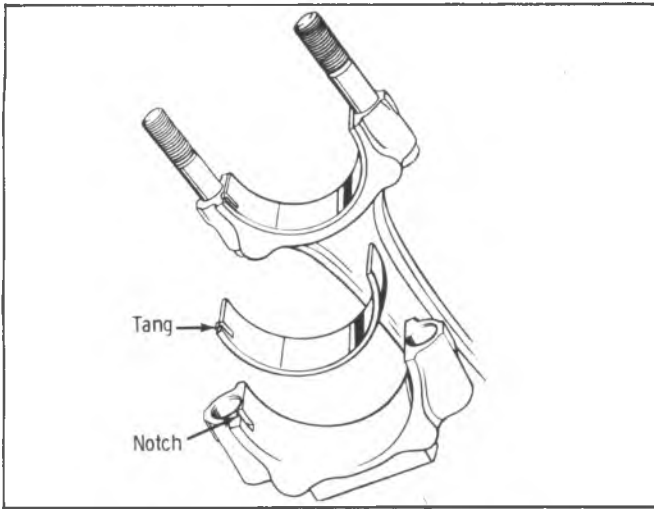


Fig. 6A6-63--Bearing Tang & Notch

crankshaft must be replaced.

4. The crankpins should be checked for out-of-round and correct size with a micrometer. Maximum out-of-round must not exceed .0015".

• Crankpins will normally be standard size. If any undersized crankshafts are used, all will be .010" U.S. and an "X" will be stamped on the pad at the L.F. upper corner of the block.

5. Clean oil from crankpin bearing cap, connecting rod and outer and inner surface of bearing inserts. Position insert so that tang is properly aligned with notch in rod and cap. (Fig. 6A6-63).

6. Place a piece of plastic gaging material in the center of lower bearing shell.

7. Remove bearing cap and determine bearing clearances by comparing the width of the flattened plastic gaging material at its widest point with the graduation on the container. The number within the graduation on the envelope indicates the clearance in thousandths of an inch. If this clearance is greater than .0035", replace the bearing and recheck clearance with plastic gaging material. Lubricate bearing with engine oil before installation. Repeat

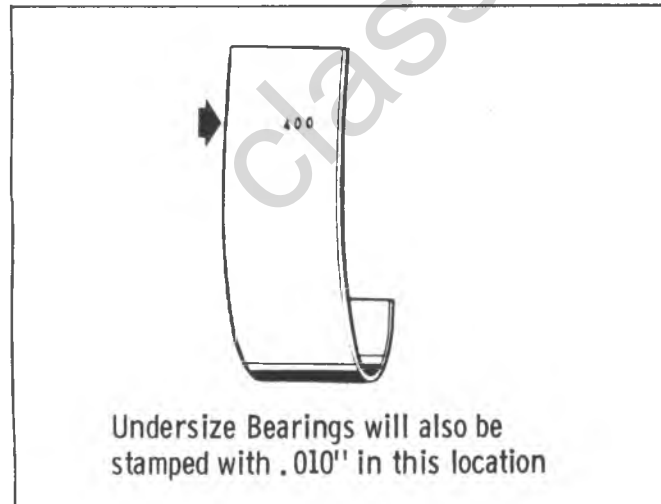


Fig. 6A6-64--Bearing Identification

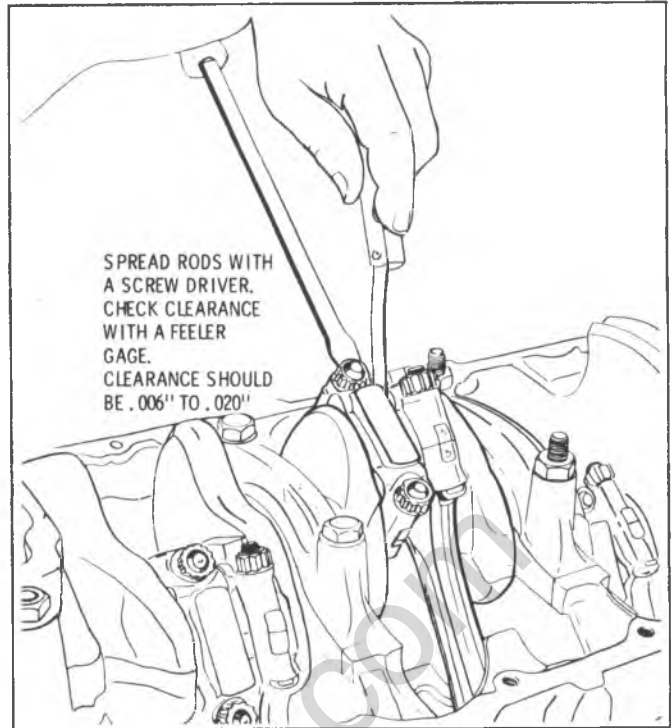


Fig. 6A6-65--Connecting Rod Side Clearance

Steps 2 through 8 on remaining connecting rod bearings. All rods must be connected to their crankpins when rotating the crankshaft to prevent engine damage. Bearings are identified as shown in Fig. 6A6-64.

8. Measure the rod side clearance as shown in Fig. 6A6-65. Clearance should be .006" to .020".

ROD ASSEMBLY

If a rod is twisted or bent, a new rod must be installed. **NO ATTEMPT SHOULD BE MADE TO STRAIGHTEN CONNECTING RODS.**

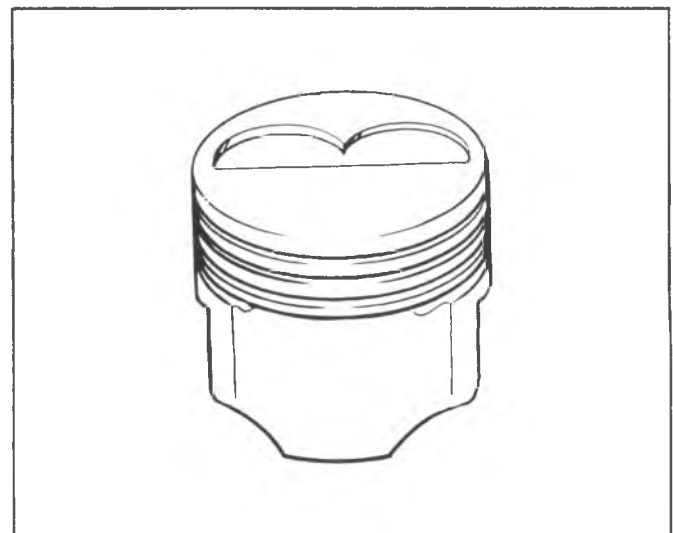


Fig. 6A6-66--Piston Identification

| BORE DIA. | CYL. BORE SELECTION | BORE SIZES | PISTON SELECTION | PISTON SIZE | PISTON DIA. | PISTON TO CYL. BORE CLEARANCE |
|--------------------------|---------------------|---------------|------------------|-----------------|------------------------------|-------------------------------|
| 4.056-4.058 STD. | A | 4.0560-4.0565 | A | 4.0505 - 4.0510 | 4.0505 - 4.0525 STD. | .0050 to .0060 |
| | B | 4.0565-4.0570 | B | 4.0510 - 4.0515 | | |
| | C | 4.0570-4.0575 | C | 4.0515 - 4.0520 | | |
| | D | 4.0575-4.0580 | D | 4.0520 - 4.0525 | | |
| 4.066-4.068 .010 O.S. | J | 4.0660-4.0665 | J | 4.0605 - 4.0610 | 4.0605 - 4.0625 .010 O.S. | |
| | K | 4.0665-4.0670 | K | 4.0610 - 4.0615 | | |
| | L | 4.0670-4.0675 | L | 4.0615 - 4.0620 | | |
| | M | 4.0675-4.0680 | M | 4.0620 - 4.0625 | | |

Fig. 6A6-67--Piston Information Chart

PISTON (Fig. 6A6-66)

Measuring

Refer to PISTON INFORMATION CHART FIGURE 6A6-67.

When replacing pistons, the original cylinder size is stamped with a code letter on the block near each cylinder on the oil pan rail. (Fig. 6A6-68).

When measuring piston for size or taper, measurement must be made on skirt 90° from piston pin hole (with the piston pin removed). (Fig. 6A6-69).

When measuring taper, measure at the centerline of the piston pin hole and at the bottom of the skirt. The largest reading must be at the bottom of the skirt. Allowable taper is .000" to .002".

The piston and cylinder bore must be free of oil and at the same temperature.

On some vehicles oversize pistons may be found. These pistons will be .010" oversize.

Each piston should be fitted to its individual cylinder and marked for that cylinder. Piston to bore clearance is .005" to .006".

Checking Cylinder Bore

Refer to PISTON INFORMATION Chart Figure 6A6-64.

Cylinder bore size can be measured with inside micrometers or a cylinder gage. Maximum allowable taper of the cylinder bore is .001". The most wear will occur at the top of the ring travel.

Reconditioned cylinder bores should be held to not more than .001" out-of-round and .001" taper.

If the cylinder bores are smooth, the cylinder walls should not be deglazed. If the cylinder walls are scored, the walls may have to be honed before installing new rings. It is important that reconditioned cylinder bores be thoroughly washed with a soap and water solution to remove all traces of abrasive material to eliminate premature wear.

Cleaning Piston

Clean the pistons by scraping carbon off the top of the piston. Deposits in the ring grooves should be removed with a suitable ring groove cleaning tool. It is important that the ring grooves be completely free of deposits.

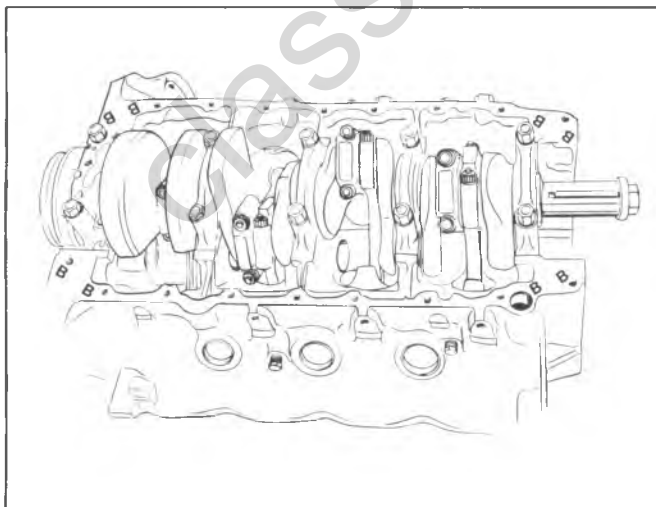


Fig. 6A6-68--Cylinder Bore Marking

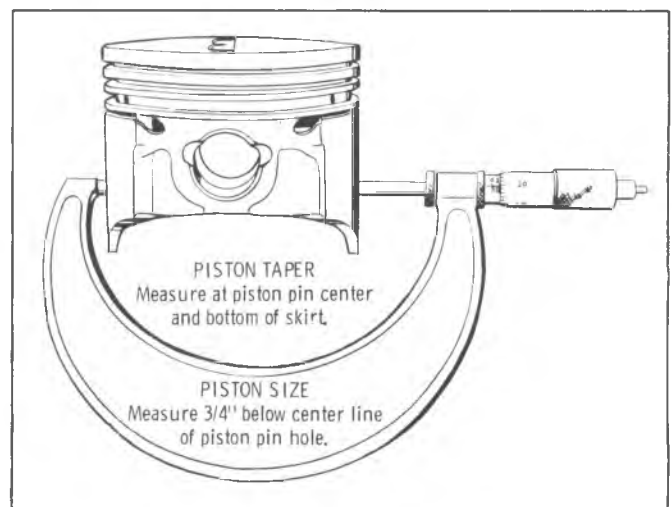


Fig. 6A6-69--Measuring Piston

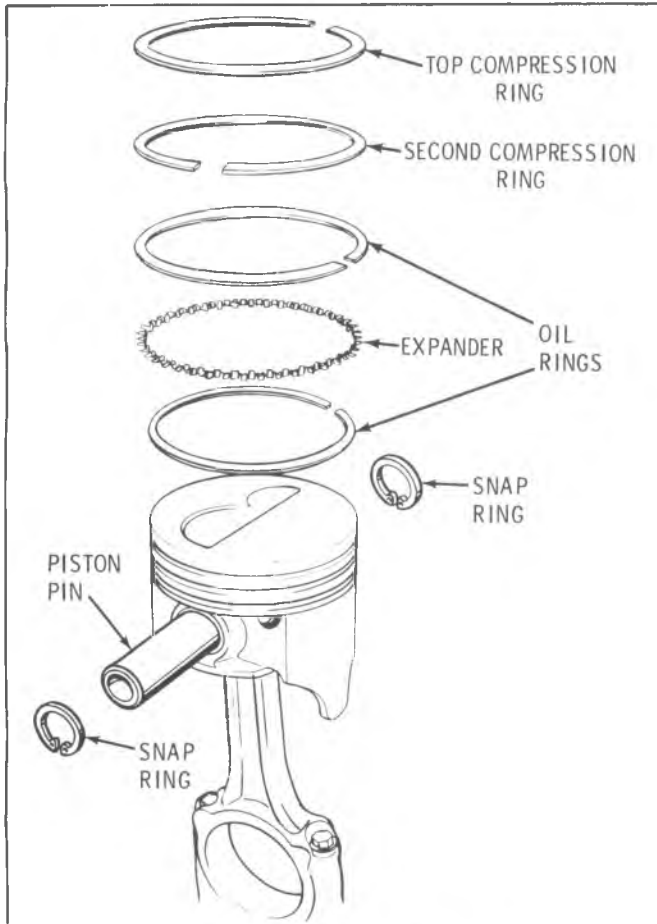


Fig. 6A6-70--Piston Rings

Rings (Fig. 6A6-70)

The pistons have three rings (two compression rings and one oil ring). The oil ring consists of two rails and an expander.

Pistons do not have oil drain holes behind rings.

Ring Tolerances

When installing new rings, ring gap and side clearance should be checked as follows:

Piston Ring and Rail Gap

Each ring and rail gap must be measured with the ring or rail positioned squarely and at the bottom of the ring-travel area of the bore. (Fig. 6A6-71).

The end gap measurement should be .015" to .025" for compression rings and .015" to .055" for oil rings.

Side Clearance

Each ring must be checked for side clearance in its respective piston groove by inserting a feeler gage between the ring and its upper land. (Fig. 6A6-72). The piston grooves must be cleaned before checking ring for side clearance. Compression ring clearance is .005" to .007" for top ring, .0018" to .0038" for second ring and .001" to .005" for oil ring. To check oil ring side clearance, the oil rings must be installed on the piston.

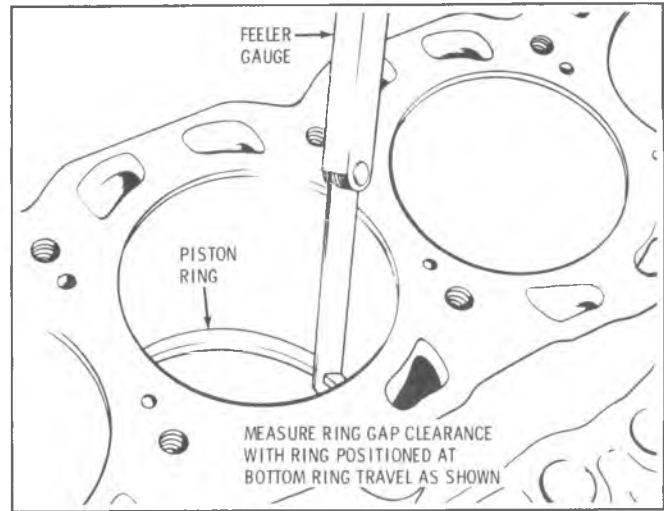


Fig. 6A6-71--Measuring Piston Ring Gap

Ring Installation

For service ring specifications and detailed installation instructions, refer to the instructions furnished with the parts package.

ROD AND PISTON

Installation

1. Install connecting rod bolt guide hose over rod bolt threads. (Fig. 6A6-73).
2. Apply engine oil to rings and piston, then install piston ring compressing tool on piston. (Fig. 6A6-74).
3. Install each piston and rod in its respective cylinder bore so valve depression in top of piston is towards the inner side of engine. (Fig. 6A6-75).
 - On the forward half of the engine, cylinders 1, 2, 3 and 4, the large valve depression goes to the front.
 - On the rear half of the engine, cylinders 5, 6, 7 and 8, the large valve depression goes to the rear of engine.
4. Lubricate the crankpin with engine oil and install connecting rod bearing and cap, with bearing index tang in rod and cap on same side.

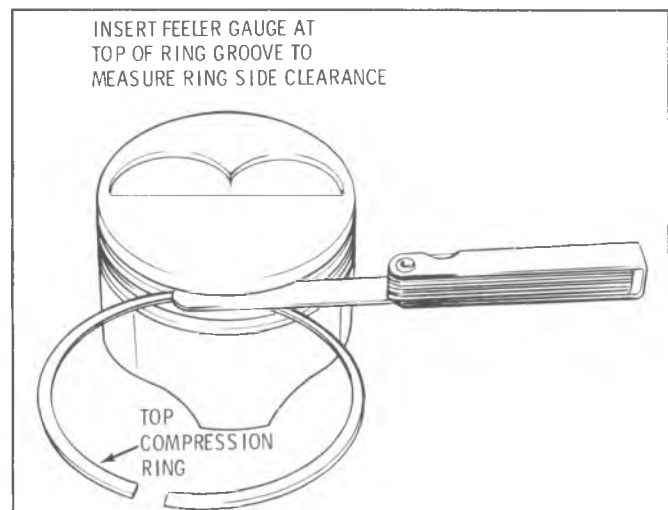


Fig. 6A6-72--Piston Ring Side Clearance

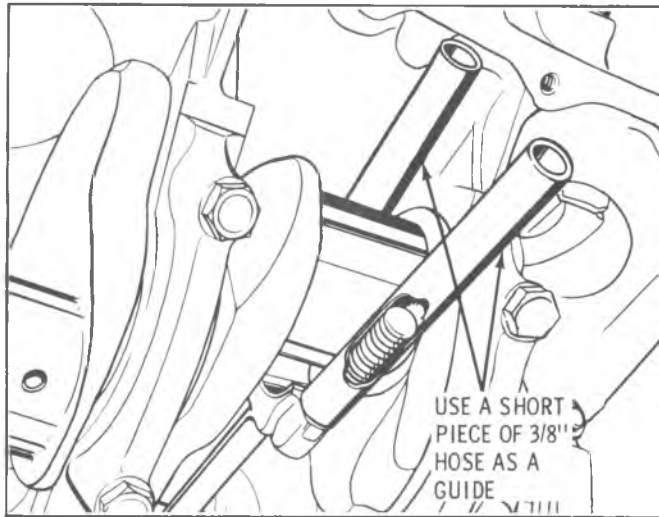


Fig. 6A6-73--Connecting Rod Bolt Guide

When more than one rod and piston is being installed, the connecting rod cap attaching nuts should only be tightened enough to keep each rod in position until all have been installed. This will facilitate installation of remaining piston assemblies.

The clearance between the adjacent rods, when checked with a feeler gage on each crankpin, should be from .006" to .020". (Fig. 6A6-76).

5. Torque rod bolt nuts to 42 lbs. ft. (57 N·m).

PISTON PINS

The piston pin is free floating and the correct fit in the piston is .0003" to .0005" and rod is .0003" to .0013" loose. If the pin to piston clearance is to the high limit (.0005" piston or .0013" rod), the pin can be inserted in the piston or rod with very little hand pressure and will fall through the piston or rod by its own weight. If the clearance is .0003", the pin will not fall through. It is important that the piston and rod pin hole be clean and free of oil when checking pin fit.

The rod may be installed in the piston with either side facing up.

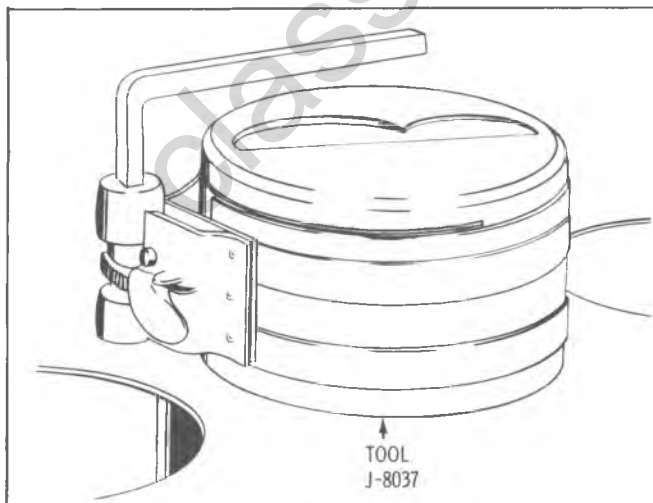


Fig. 6A6-74--Piston Ring Compressor

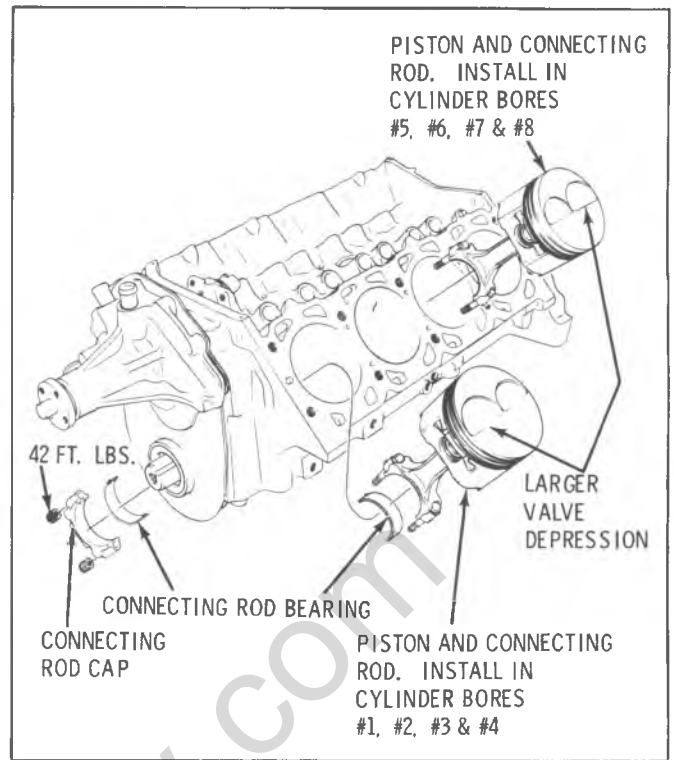


Fig. 6A6-75--Piston Locations in Block

Whenever the replacement of a piston pin is necessary, remove the snap ring retaining the pin. Then remove the pin.

It is very important that after installing the piston pin retaining snap rings that the rings be rotated to make sure they are fully seated in their grooves.

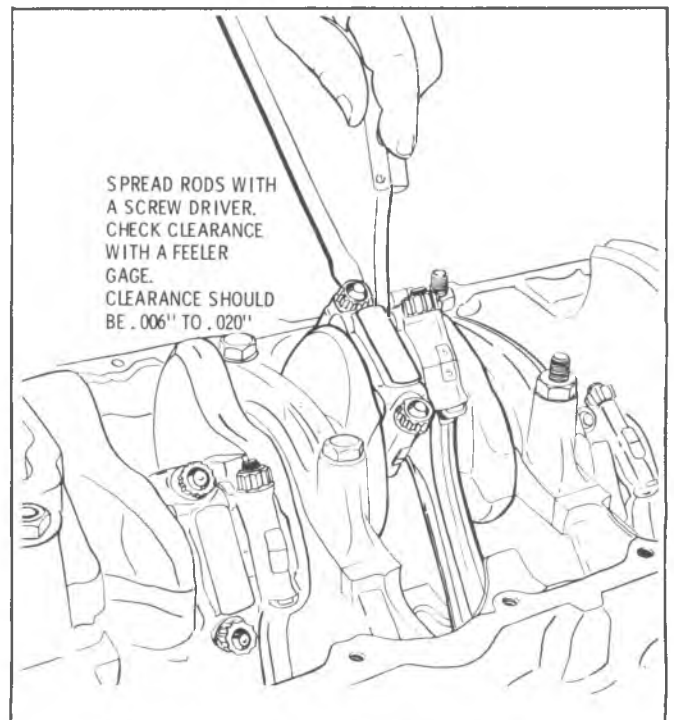


Fig. 6A6-76--Connecting Rod Side Clearance

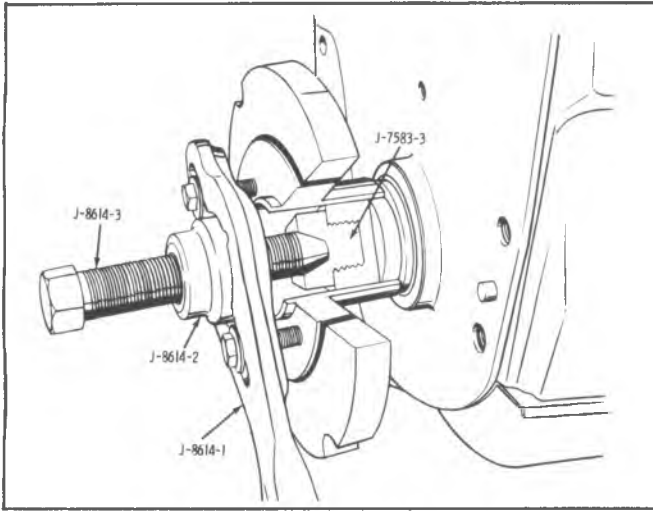


Fig. 6A6-77—Removing Balancer

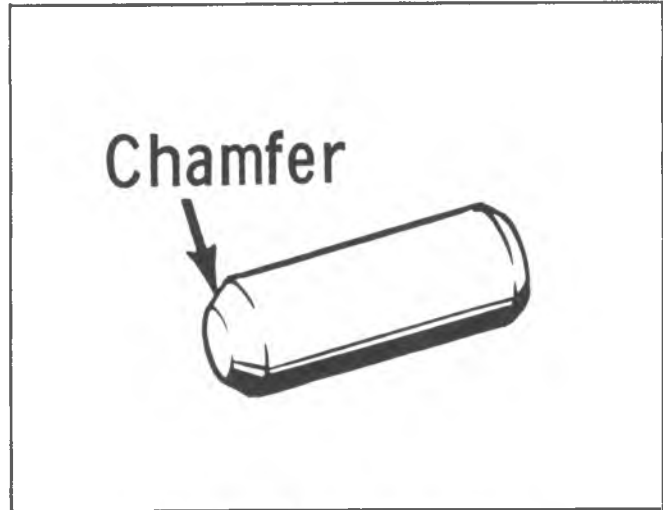


Fig. 6A6-79—Dowel Pin Chamfer

CRANKSHAFT PULLEY

Removal

1. Remove belt(s).
2. Hoist vehicle.
3. Remove pulley bolts and pulley.

Installation

1. Install pulley, and bolts. Torque to 20 lbs. ft. (27 N·m).
2. Install belt(s). Adjust belts using Tool J-23600.

BALANCER

Removal

1. Remove belts and crankshaft pulley.
2. Remove balancer hub bolt and washer.
3. Using balancer puller, remove balancer as shown in Fig. 6A6-77.

NOTICE: Use of any other type puller such as a universal claw type which pulls on the outside of the hub can destroy the harmonic balancer. The outside ring of the balancer is bonded in rubber to the hub; by

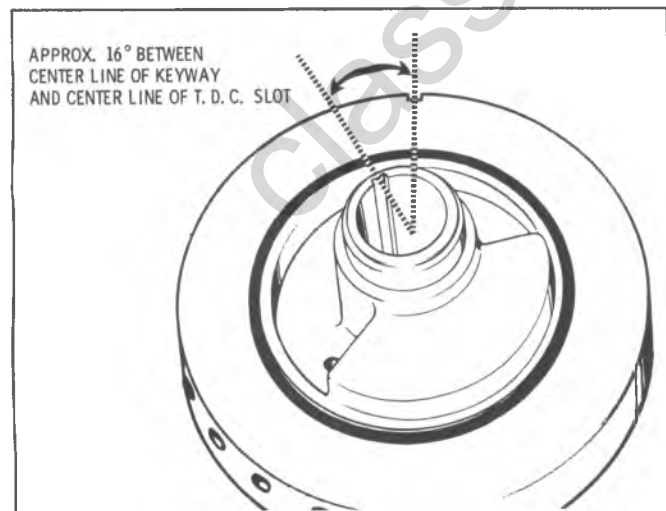


Fig. 6A6-78—Harmonic Balancer

pulling on the outside, rather than the hub, it is possible to break the bond. The T.D.C. slot is on the outside ring of the balancer; if the bond between the hub and the outside ring is broken, the outside ring could slip which would change the location of the slot mark.

If it is suspected that the bond between the sections of the harmonic balancer has been broken and the slot changed, it can be visually checked as shown in Fig. 6A6-78. The center of the keyway should be approximately 16° from the center of the timing slot. In addition, there are chisel aligning marks between the weight and hub, marks should be together.

Installation

1. Apply sealer #1050805, or equivalent, to inside diameter of pulley hub and to crankshaft key to prevent possible oil leakage. Coat outside area of crankshaft pulley hub which enters seal with seal lubricant #1050169, or equivalent.
2. Install balancer on crankshaft. Balancer to crankshaft fit is .001" tight to .007" loose.
3. Install washer and bolt. Torque 200-310 lb. ft. (271-420 N·m).
4. Install pulley and belts. Adjust belts using belt adjusting gage J-23600. Torque pulley bolts to 10 lb. ft. (14N·m).

FRONT COVER

Removal

1. Drain cooling system. Disconnect radiator hoses and bypass hose.
2. Remove all belts, fan and fan pulley, crankshaft pulley and harmonic balancer, and accessory brackets.
3. Remove cover to block attaching bolts and remove cover, timing indicator and water pump assembly.
4. Remove front cover and both dowel pins. It may be necessary to grind a flat on the pins to get a rough surface for gripping.

Installation

1. Grind a chamfer on one end of each dowel pin as shown in Fig. 6A6-79.

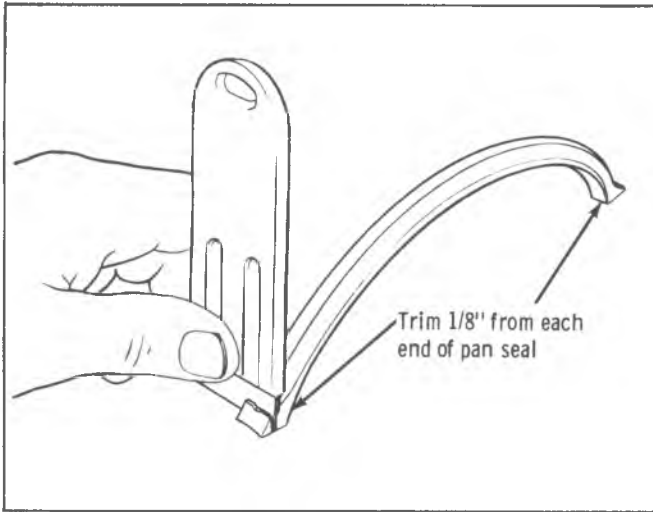


Fig. 6A6-80--Trimming Pan Seal

2. Cut excess material from front end of oil pan gasket on each side of engine block.
3. Clean block, oil pan and front cover mating surfaces with solvent.
4. Trim about 1/8" (3mm) from each end of new front pan seal, using a sharp tool as shown in Fig. 6A6-80.
5. Install new front cover gasket on engine block and new front seal on front cover. Apply 1050805 or equivalent sealer to gasket around coolant holes and place on block.
6. Apply R.T.V. sealer (#1052289) at junction of block, pan and front cover as shown in Fig. 6A6-81.
7. Place cover on front of block and press downward to compress seal. Rotate cover left and right and guide pan seal into cavity using a small screwdriver as shown in Fig. 6A6-82.
8. Apply engine oil to bolts (threads and heads).
9. Install two bolts finger tight to hold cover in place.
10. Install two dowel pins (chamfered end first).
11. Install timing indicator and water pump assembly. Then torque bolts evenly as shown in Fig. 6A6-83.

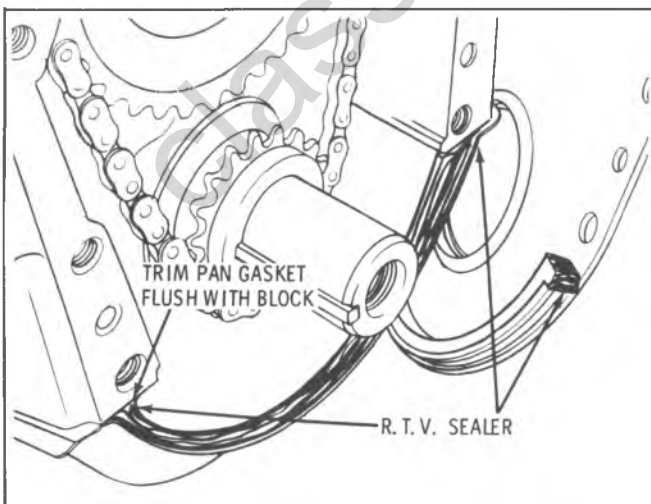


Fig. 6A6-81--Applying RTV & Trimmed Pan Gasket

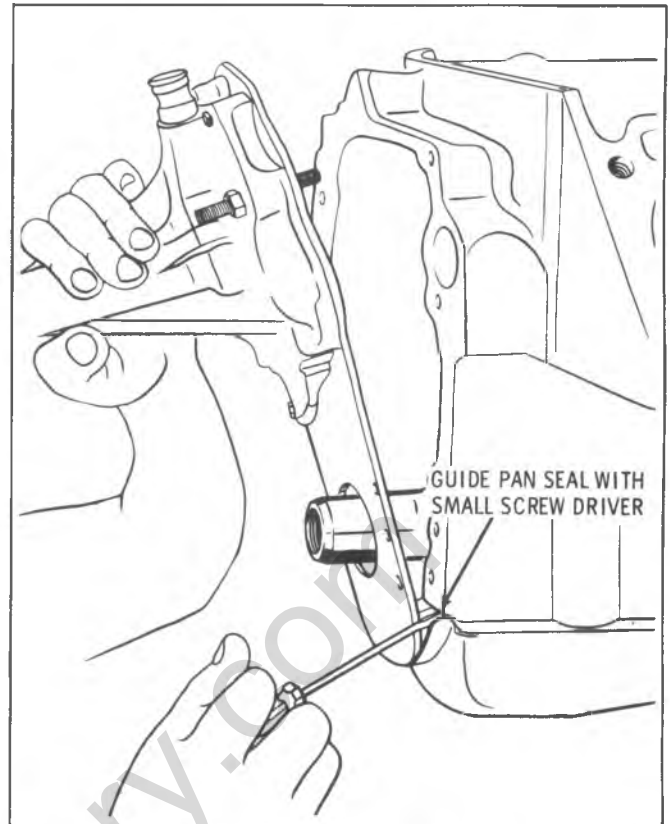


Fig. 6A6-82-- Guide Seal in Pan While Pushing Downward

12. Apply lubricant #1050169 or equivalent on balancer seal surface.
13. Install balancer and balancer bolt. Torque from 200-310 lb. ft. (271-420N·m).
14. Install necessary brackets.
15. Connect bypass hose and radiator hoses.
16. Install crankshaft pulley and four attaching bolts. Torque to 20 lbs. ft. (27 N·m).
17. Install fan pulley, fan and four attaching bolts. Torque bolts to 20 lbs. ft. (27 N·m).

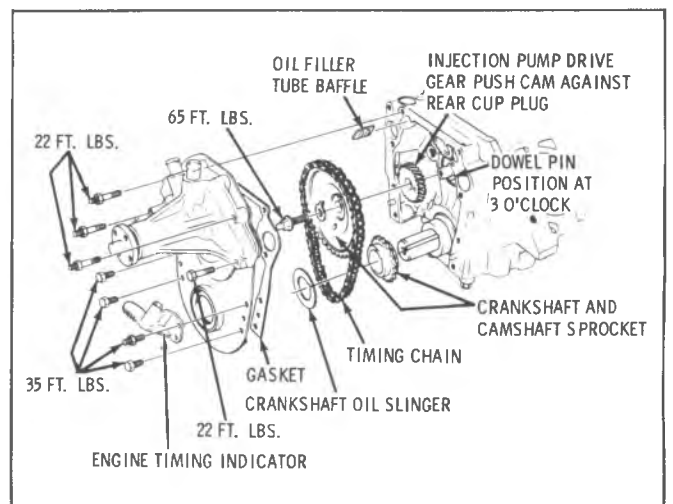


Fig. 6A6-83--Engine Front Cover Bolts

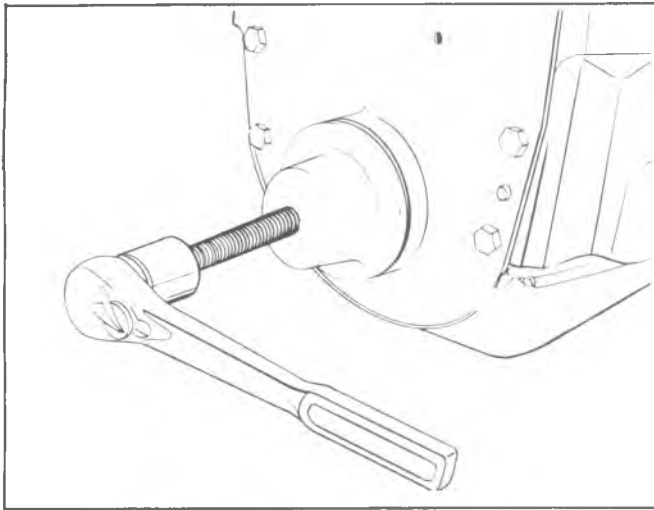


Fig. 6A6-84--Front Oil Seal Installation

18. Install belts and adjust, using Tool J-23600.
19. Fill radiator.
20. Road test vehicle and check for leaks. Use of spray foot powder or equivalent may aid in detecting leaks.

OIL SEAL

Removal (Front Cover Installed)

1. Remove the belts.
2. Remove the crankshaft pulley and pulley hub.
3. Remove oil seal.

Installation

1. Apply #1050805 Sealer or equivalent, to outside diameter of seal.
2. Using Tool J-25264 and Screw J-23952, install oil seal as shown in Fig. 6A6-84.
3. Install the pulley hub and crankshaft pulley.
4. Install and adjust belts using Tool J-23600.

TIMING CHAIN AND GEARS

Removal

1. Remove oil slinger, cam gear, crank gear and timing chain.
2. Remove fuel pump eccentric from crankshaft if replacement is necessary.

Installation

1. Install key in crankshaft if removed.
2. If removed, install fuel pump eccentric.
3. Install camshaft gear, crankshaft gear and timing chain together, and align timing marks. (Fig. 6A6-85)
4. Torque camshaft sprocket bolt to 65 lbs. ft. (88 N·m).

● When the two marks are in alignment, number six is at T.D.C. To obtain T.D.C. for number one cylinder, slowly rotate crankshaft one revolution. This will bring the cam mark to the top, number one then will be in firing position.

5. Install oil slinger.

● Any time the timing chain and gears are replaced, it will be necessary to retime the engine. Refer to "INJECTION PUMP ADAPTER".

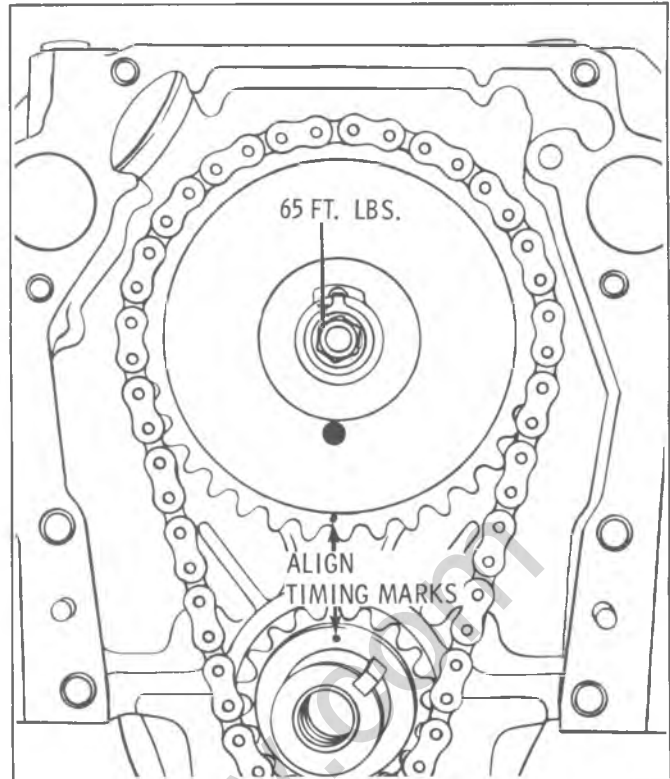


Fig. 6A6-85--Aligning Timing Marks

CAMSHAFT, INJECTION PUMP DRIVE AND DRIVEN GEARS

Removal

1. Disconnect battery.
2. Drain coolant from engine.
3. Remove upper radiator baffle.
4. Disconnect upper radiator hose at water outlet.
5. Disconnect upper radiator hose support clamp.
6. Disconnect cooler lines at radiator.
7. Remove radiator fan shroud.
8. Remove radiator.
9. Remove intake manifold and gasket, front and rear seal.
10. Remove balancer pulley.
11. Remove balancer attaching bolt.
12. Remove balancer.
13. Remove engine front cover.
14. Remove both valve covers.
15. Remove rocker arms, push rods and valve lifters. Parts position should be noted so they will be installed in their original position.
16. If equipped with air conditioning, discharge A/C system, remove condenser attaching bolts and remove condenser.
17. Remove bolt securing camshaft gear and timing chain, then remove timing gears and chain.
18. Position camshaft dowel pin at the 3 o'clock position.
19. With the camshaft held rearward, remove pump drive gear by sliding off the camshaft while rocking the pump driven gear.

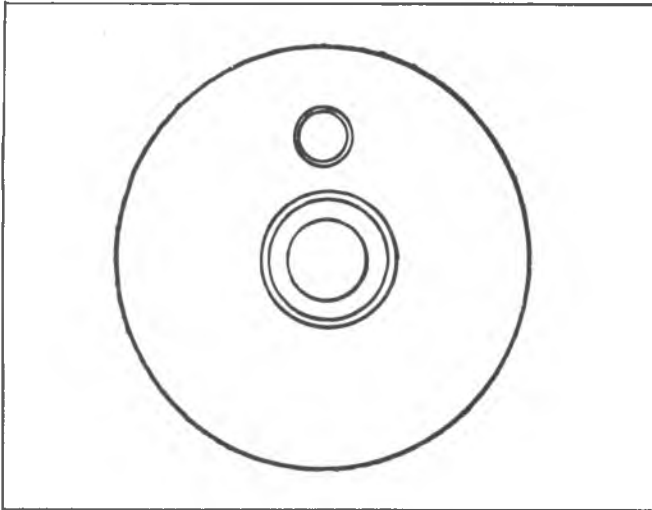


Fig. 6A6-86--Camshaft Identification

20. If necessary to remove pump driven gear, remove injection pump adapter, then remove snap ring and selective washer. Remove the driven gear and spring.

21. Remove camshaft by carefully sliding it out the front of the engine. Do not force shaft as damage can occur to camshaft bearings. Refer to Fig. 6A6-86 for camshaft identification.

22. If cam bearings are being replaced, it is necessary to remove oil pan. Refer to "OIL PAN REMOVAL".

- If either the pump drive or driven gears are to be replaced, replace BOTH gears.

Installation

Any time the injection pump adapter is replaced or if pump drive or driven gears or chain and gears are replaced, it is necessary to retune engine.

Coat camshaft and bearings liberally with #562458 or equivalent before installing. Camshaft gear and crankshaft gear must be aligned as shown in Fig. 6A6-85.

Check the injection pump driven gear bushing, etc.

Install the injection pump driven gear, spring, shim and snap ring. Check the gear end play. If not within .002" to

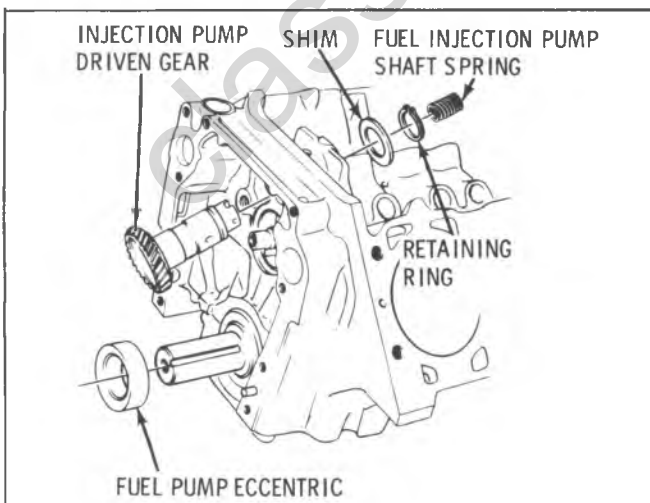


Fig. 6A6-87--Injection Pump Driven Gear Shim

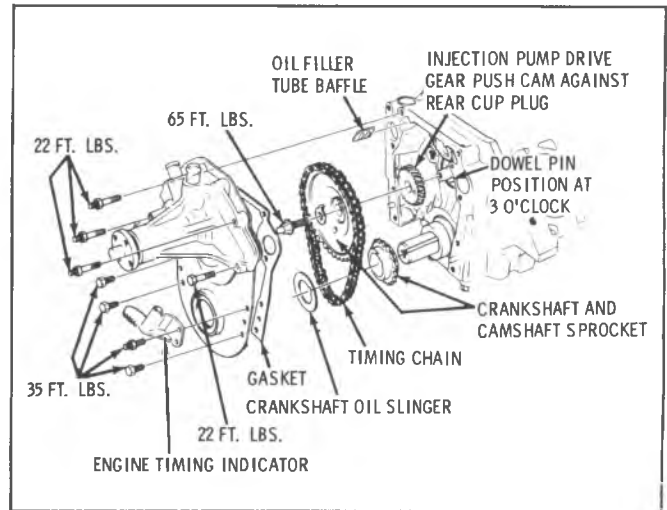


Fig. 6A6-88--Engine Front Cover Bolts

.005", replace the shim to obtain the clearance. (Fig. 6A6-87).

Shims are available from .080" to .115" in .003" increments.

Position the camshaft dowel pin at 3 o'clock, align the "O" marks on the pump drive and driven gears. Then with the camshaft held in the rearward position, slide the pump drive gear on the camshaft. (Fig. 6A6-88).

Timing indicator attaching stud must be installed and properly torqued before installing power steering pump bracket. Start engine, recharge A/C system, check for possible leaks.

CAMSHAFT AND INJECTION PUMP DRIVEN GEAR BEARINGS

The camshaft bearings must be replaced in complete sets. All bearings must be removed before any can be installed. #1 bearing must be removed first, then #2, then 3, 4 and 5. When installing the bearings, #5 must be installed first, then 4, 3, 2 and 1.

Camshaft Bearing Remover and Installer J-6098-01 is available for this procedure.

This set can be used to remove cam bearings with the engine either in or out of the vehicle.

To replace bearings with engine in vehicle proceed as follows:

Removal

1. Remove engine oil pan and camshaft.
2. Install #1 Cam Bearing Remover and Installer on Handle J-8092 and drive out front cam bearing.
3. Place Pilot on Driver and install #2 Cam bearing Tool on driver and drive out #2 bearing.
4. Remove #3, 4 and 5 bearings in the same manner.

- Each cam bearing is a different diameter and the correct sequence must be used both for removal and installation.

5. To remove the injection pump driven gear bushings, drive both bushings at the same time from the rear to the front of the block using tool J-28439-2 and driver handle J-8092.

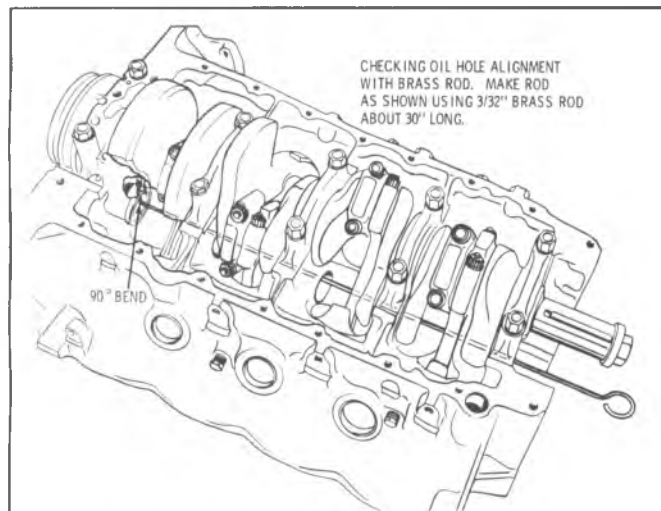


Fig. 6A6-89--Checking #5 Oil Hole

Installation

To aid aligning bearings with oil passages, place each bearing in the front bore with tapered edge toward block and align the oil hole in the bearing with the center of the oil slot in the bore. Mark bottom of bearing. When installing the bearings, the mark will act as a guide.

Slide bearing pilot spacer on bearing pilot. For bearings 5, 4, 3 and 2 put the driver through the pilot, then screw the installer on the driver. Install the bearings as follows:

1. Place new #5 bearing on driver and drive bearing in until the last white line on the driver is flush with the front face of the pilot.
2. Use a piece of 3/32" (2.4mm) brass rod with a 90° bend at the end to check the oil hole opening as shown in Fig. 6A6-89.
3. Place #4 bearing on installer and drive in until the next to last white line on driver is flush with pilot.
4. Follow the same procedure to install #3 and #2.
5. Place #1 bearing on installer. Drive bearing in until it is flush with front face of block.
6. To install the injection pump bushings, align the holes in the bushings with the holes in the block. Install both bushings from the front; driving the rear bushing first, using the long end of tool J-28439-1 and driver handle J-8092.

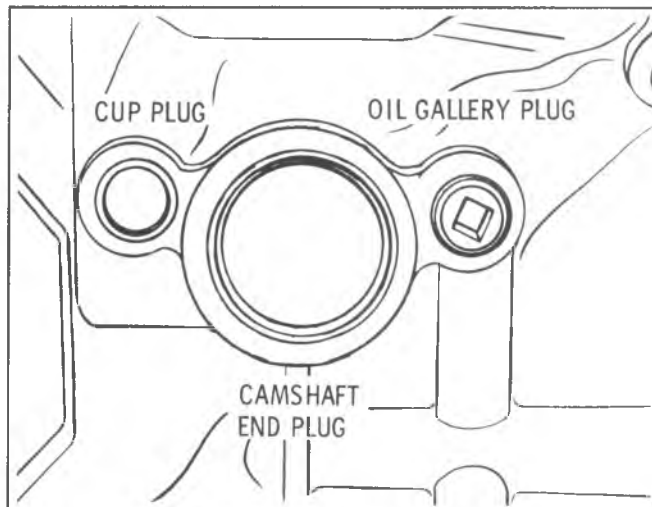


Fig. 6A6-90--Camshaft & Oil Gallery Plugs

Drive the front bushing with the short end of J-28439-1.

7. Use a piece of 3/32" (2.4mm) brass rod with a 90° bend at the end to check all oil hole openings. Wire must enter hole or the bearing will not receive sufficient lubrication. (See Fig. 6A6-89).

8. Install camshaft and engine oil pan.

Camshaft and Oil Gallery Plugs (Fig. 6A6-90)

The left-hand rear oil gallery plug is not shown. It is a threaded plug in the end of the left gallery just rearward of the vacuum pump. A small hole is provided in the plug for vacuum pump lubrication. The cup plug shown provides access to the threaded plug.

The front oil gallery plugs (not shown) are threaded. The plug on the right side has a small hole which provides lubrication for the timing chain and gears.

To find out if the camshaft plug at the rear of the engine is properly installed, place a straight edge across the machined surface of the rear of the block and measure from the straight edge to the lip of the plug. Dimension should be .250" (6mm) maximum to .160" (4mm) minimum.

UNIT REPAIR

ENGINE

Removal

1. Drain cooling system.
2. Remove air cleaner and install screened cover J-26996-1.
3. Remove hood from hinges, mark hood for reassembly.
4. Disconnect battery negative cables at batteries and ground wires at inner fender panel. Disconnect engine ground strap.

5. Disconnect radiator hoses, cooler lines, heater hoses, vacuum hoses, power steering pump hoses at power steering gear, air conditioning compressor with brackets and hoses attached, fuel hose from fuel pump and wiring.

6. Remove hairpin clip at bellcrank.
7. Remove throttle cable from intake manifold bracket, then position cable away from engine.
8. Remove upper radiator support and radiator.
9. Raise vehicle.
10. Disconnect exhaust pipes at manifolds.
11. Remove torque converter cover and three bolts holding converter to flywheel.

12. Remove engine mount through bolts.
13. Remove three bolts, transmission to engine on the right side. Disconnect wires from starter and remove starter.
14. Lower vehicle.
15. Place board on top of jack and slightly raise transmission. Remove three left transmission to engine bolts. Remove engine.
16. If vehicle is to be moved, install converter holding tool J-21654 and support transmission with chain support.

Installation

1. Install engine in place. Locate engine dowels into transmission and position through bolts into mounts and tighten. Install three left transmission to engine bolts. Remove support chains and jack.
2. Raise vehicle. Replace three transmission to engine bolts on the right side. Replace starter and attaching bolts and attach wires.
3. Install three converter to flywheel bolts and torque converter cover bolts to 40 lbs. ft. (54 N·m).
4. Connect exhaust pipes and lower vehicle.
5. Install radiator and upper radiator support.
6. Connect radiator hoses, cooler lines, heater hoses, vacuum hoses, power steering pump hoses at pump, power steering hose bracket to engine, air conditioning compressor, fuel hose to fuel pump and wiring.
7. Position bellcrank and cables to intake manifold. Install bellcrank. Install throttle rod to bellcrank. Connect breather pipes and connect fuel return line to pump.
8. Install air cleaner.
9. Install and align hood with scribe marks.
10. Connect battery cables and ground wires.
11. Add engine oil and coolant.

CRANKSHAFT

Removal (Cylinder Heads On)

1. With engine on stand and oil pan, oil pump and front cover removed, rotate crankshaft to the position where the connecting rod nuts are most accessible. Fig. 6A6-91 shows the engine with the #3 and #4 rods in the fully extended position.
2. Remove connecting rod caps and install thread protectors. Remove fuel pump eccentric from crankshaft.
3. Remove main bearing caps.
4. Note position of keyway in crankshaft so it can be installed in the same position.
5. Lift crankshaft out of block. Rods will pivot to the center of the engine when the crankshaft is removed. Do not allow pistons to move in their bore during or after crankshaft removal.

Installation

1. Install sufficient oil pan bolts in pan rails to align rods with rubber bands. Align rods so that the inner thread protectors of adjacent rods overlap approximately one inch as shown. Alignment can be adjusted by increasing tension on rubber bands with additional turns around the pan bolts or thread protectors.
2. Measure the crankshaft journals and crankpins with a micrometer to determine the correct size rod and main bearings to be used.

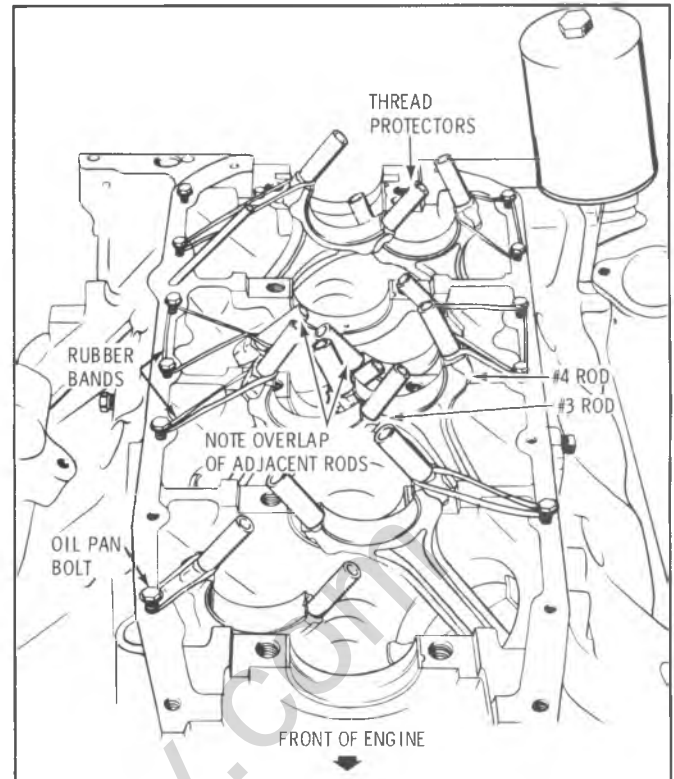


Fig. 6A6-91--Crankshaft Removal

- Whenever a new or reconditioned crankshaft is installed, new connecting rod bearings and main bearings should be installed.

3. Position crankshaft keyway in the same position as removed and lower into block. The connecting rods will follow the crankpins into the correct position as the crankshaft is lowered.

4. Remove rubber bands, thread protectors and pan bolts and assemble engine.

Removal (Cylinder Heads Removed)

1. With engine on stand, remove oil pan, front cover, connecting rods, oil pump and fuel pump eccentric from crankshaft.
2. Remove main bearing caps and lift crankshaft out of block.

Installation

1. Measure the crankshaft journals and crankpins with a micrometer to determine the correct size rod and main bearings to be used.

- Whenever a new or reconditioned crankshaft is installed, new connecting rod bearings and main bearings should be installed.

2. Position upper half of main bearings in block and lubricate with engine oil.

3. Install a new rear main bearing seal. (Fig. 6A6-92). Rear bearing must be removed to replace seal.

4. After oil passages in crankshaft have been checked for being open and shaft is clean, place shaft in block. Lubricate thrust flanges of the center bearing with #1050169 Lubricant or equivalent. Install caps with lower half of bearing lubricated with engine oil. Lubricate cap bolts with engine oil and install, but do not tighten.

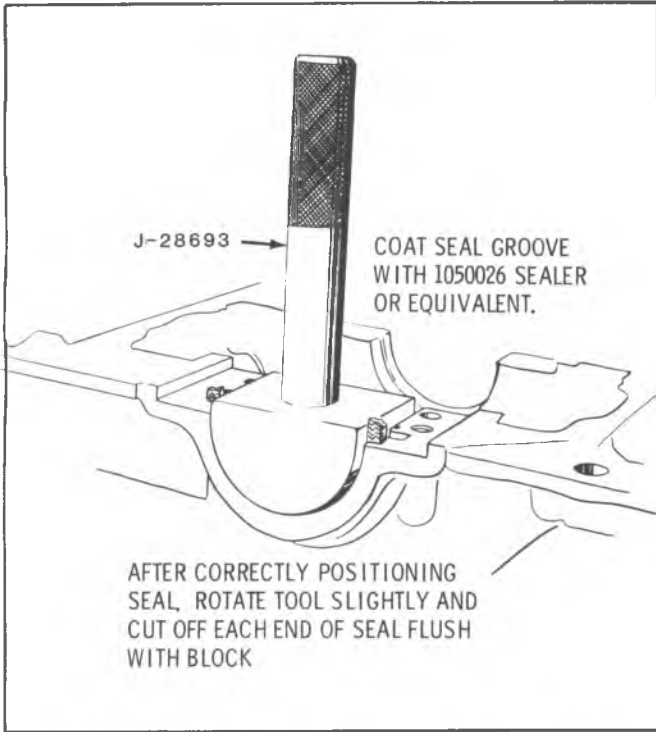


Fig. 6A6-92—Installing Rear Main Oil Seal—Upper Half

5. With a block of wood (Fig. 6A6-93) bump shaft in each direction to align thrust flanges of center main bearing. After bumping shaft in each direction, wedge the shaft to the front and hold it while torquing #3 cap bolts.

6. Torque all main bearing bolts to 120 lbs. ft. (163 N·m). (Fig. 6A6-94).

7. Reassemble engine and install in chassis.

MAIN BEARINGS

Main bearing clearance must not exceed .0035" on all bearings. The .0035" clearance is permissible only if the engine is disassembled for other than a bearing noise condition. If bearings are noisy or if a visual inspection indicates defective bearings, new bearings must be installed within the specifications outlined under MAIN

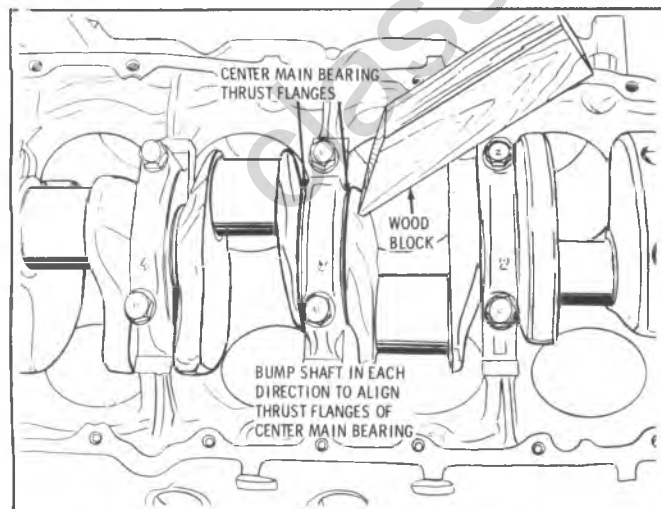


Fig. 6A6-93—Aligning Center Main Bearing Flanges

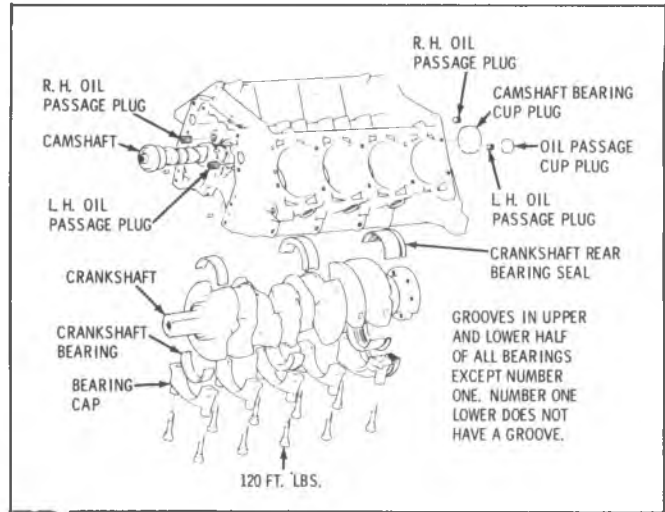


Fig. 6A6-94—Crankshaft—Exploded View

BEARINGS-REPLACE.

Bearings which fall within the .0035" specifications should not be replaced if the bearings show normal wear pattern or slight radial grooves.

Checking Bearing Clearances

1. Remove bearing cap and wipe oil from crankshaft journal and outer and inner surfaces of bearing shell.

2. Place a piece of plastic gaging material in the center of bearing.

3. Use a floor jack or other means to hold crankshaft against upper bearing shell. This is necessary to obtain accurate clearance readings when using plastic gaging material.

4. Reinstall bearing cap and bearing. Place engine oil on cap bolts and install. Torque bolts to 120 lbs. ft. (163 N·m).

5. Remove bearing cap and determine bearing clearance by comparing the width of the flattened plastic gaging material at its widest point with graduations on the gaging material container. The number within the graduation on the envelope indicates the clearance in

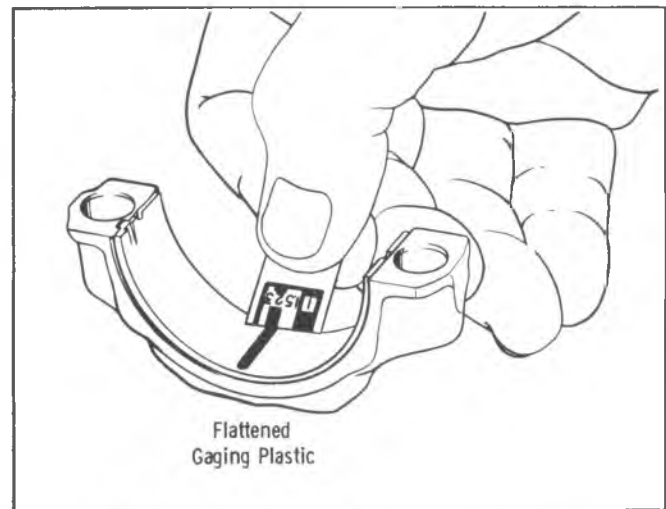


Fig. 6A6-95—Checking Bearing Clearances

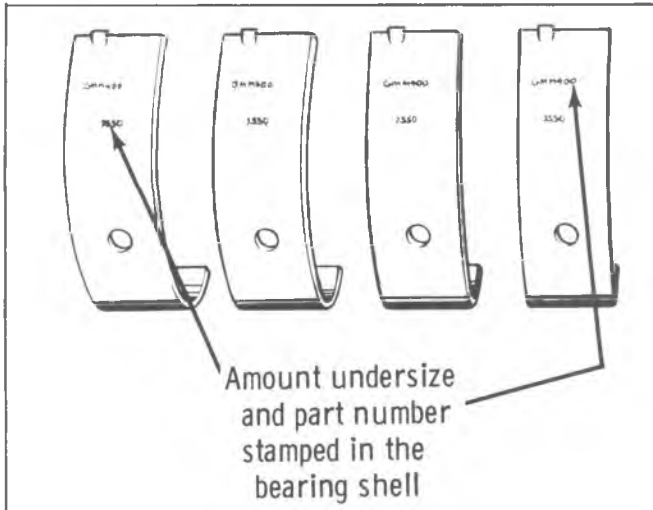


Fig. 6A6-96--Main Bearing Identification

thousandths of an inch. (Fig. 6A6-95). If the clearance is greater than .0035", **REPLACE BOTH BEARING SHELLS AS A SET**. Recheck clearance after replacing shells. (Refer to **MAIN BEARINGS-REPLACE**) Main bearing end thrust clearance should be .0035" to .0135" as checked with a dial indicator.

Main Bearings Replacement

Main bearing clearances must be corrected by the use of selective upper and lower shells. **UNDER NO CIRCUMSTANCES** should the use of shims behind the shells, to compensate for wear, be attempted.

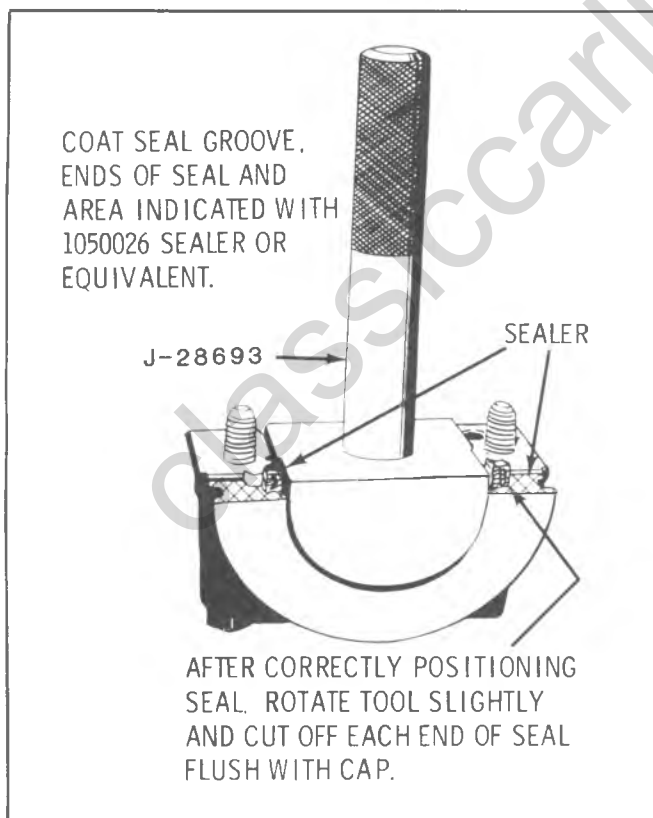


Fig. 6A6-97--Installing Rear Main Oil Seal

The upper and lower shells must be installed in pairs. Sizes of the bearings are located on the tang. (Fig. 6A6-96). It is possible to have more than one bearing size in the same engine.

To install main bearing shells, proceed as follows:

1. Loosen all main bearing caps.
2. Remove bearing cap and remove lower shell.
3. Insert a flattened cotter pin or roll out pin in the oil passage hole in the crankshaft, then rotate the crankshaft in the direction opposite to cranking rotation. The pin will contact the upper shell and roll it out.
4. The main bearing journals should be checked for roughness and wear. Slight roughness may be removed with a fine grit polishing cloth saturated with engine oil. Burrs may be removed with a fine oil stone. If the journals are scored or ridged, the crankshaft must be replaced.

● The journals can be measured for out-of-round with the crankshaft installed by using a crankshaft caliper and inside micrometer or a main bearing micrometer. The upper bearing shell must be removed when measuring the crankshaft journals. Maximum out-of-round of the crankshaft journals must not exceed .0015".

5. Clean crankshaft journals and bearing caps thoroughly before installing new main bearings.

6. Apply Special Lubricant, #1050169 or equivalent, to the thrust flanges of bearing shells on #3 bearing.

7. Place new upper shell on crankshaft journal with locating tang in correct position and rotate shaft to turn it into place using cotter pin or roll out pin as during removal.

8. Place new bearing shell in bearing cap.

9. #5 bearing - Install new asbestos oil seal in the rear main bearing cap. (**REAR MAIN BEARING OIL SEAL**) (Fig. 6A6-97) Install #1050026 or equivalent sealer on cap as shown.

10. Install bearing caps, lubricate bolt threads with engine oil, then install. Torque bolts to 120 lbs. ft. (163 N·m).

REAR MAIN BEARING UPPER OIL SEAL

Repair

Tools have been released to provide a means of correcting engine rear main bearing upper seal leaks without the necessity of removing the crankshaft. The procedure for seal leak correction is listed below.

1. Drain oil and remove oil pan and rear main bearing cap.
2. Insert Packing Tool J-25286 against one end of seal in cylinder block and drive the old seal gently into the groove until it is packed tight. This varies from 1/4" (6mm) to 3/4" (19mm), depending on the amount of pack required. (Fig. 6A6-98).
3. Repeat this on the other end of the seal in the cylinder block.
4. Measure the amount the seal was driven up on one side; add 1/16" (1.6mm), then cut this length from the old seal removed from the main bearing cap with a single edge razor blade. Measure the amount the seal was driven up on the other side. Add 1/16" (1.6mm) and cut another length from old seal. Use main bearing cap as a holding fixture when cutting seal as shown in Fig. 6A6-99.

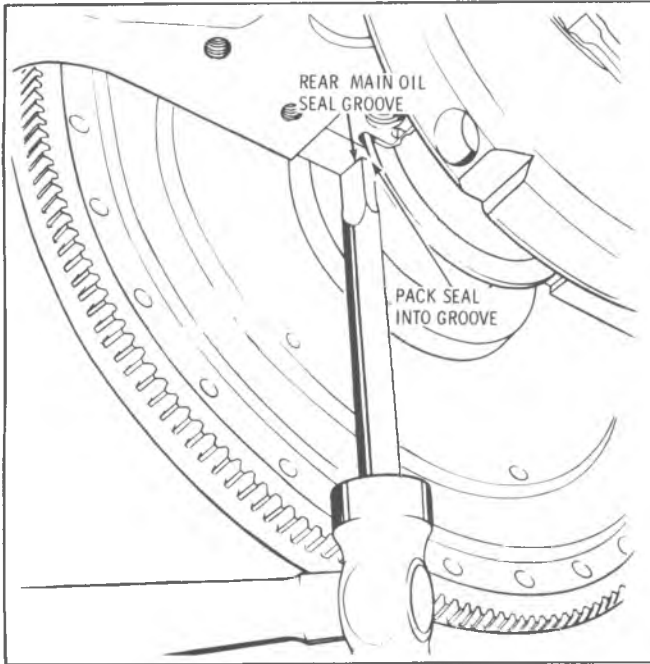


Fig. 6A6-98--Packing Oil Seal

5. Place a drop of #1050026 Sealer or equivalent, on each end of seal and cap as indicated.

6. Work these two pieces of seal into the cylinder block (one piece on each side) with two small screwdrivers. Using Packing Tool, pack these short pieces up into the block.

7. Form a new rope seal in the rear main bearing cap as outlined.

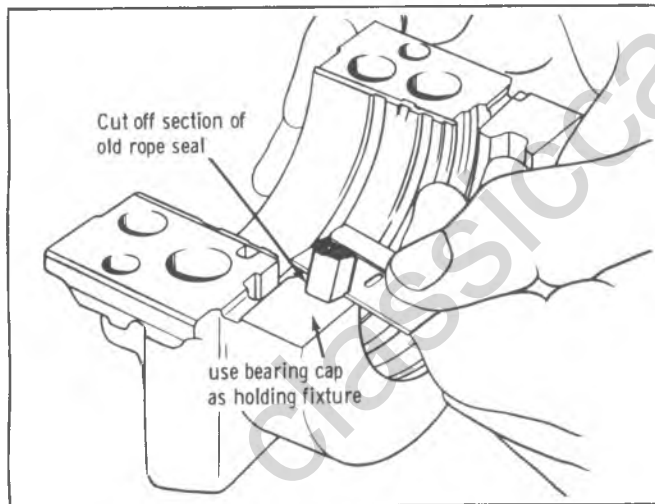


Fig. 6A6-99--Cutting Off Lower Seal Ends

8. Assemble the cap to the block and torque to specifications.

REAR MAIN BEARING LOWER OIL SEAL

Removal

1. Remove oil pan.
2. Remove the rear main bearing cap.
3. Remove rear main bearing insert and old seal.
4. Clean bearing cap and seal grooves and inspect for cracks.

Installation

1. Install seal into bearing cap, packing by hand.
2. Using seal installer, hammer seal into groove.

To check if seal is fully seated in the bearing cap, slide the tool away from seal. With tool fully seated in the bearing cap, slide tool against the seal. If undercut area of tool slides over the seal, the seal is fully seated. If tool butts against the seal, the seal must be driven further into the seal groove. Rotate tool before cutting off excess seal packing.

3. With tool slightly rotated, cut seal flush with mating surface. With screwdriver, pack seal end fibers towards center, away from edges. Rotate seal installer when cutting seal to avoid damage to tool.

4. Clean bearing insert and install in bearing cap.
5. Clean crankshaft bearing journal and seal contact. Install sealer on cap as shown.

6. Install bearing caps, lubricate bolt threads with engine oil and install. Torque bolts to 120 lbs. ft. (163 N·m).

7. Install pan with new gaskets.
8. Install lower flex plate cover.

FLEX PLATE

One bolt hole in the flex plate is offset and the flywheel will attach to the crankshaft in only one position. The flex plate ring gear is not replaceable.

ENGINE OIL DIPSTICK AND DIPSTICK GUIDES

Removal

Removal of the dipstick guide will assist in easier removal and installation of the left cylinder head. Before removing the left cylinder head, the guide can be removed using the following procedure:

1. Position the slide hammer from Tool J-2619 on a 1/4" (6mm) diameter 6" (152mm) long bolt.
2. Insert the threaded end of the bolt into the oil dipstick guide and clamp with a vise grip type pliers.
3. Use slide hammer to tap out tube.

To install, insert a 1/4" (6mm) diameter x 1/2" (13mm) long bolt into the tube and tap on the bolt head to drive tube into the block.

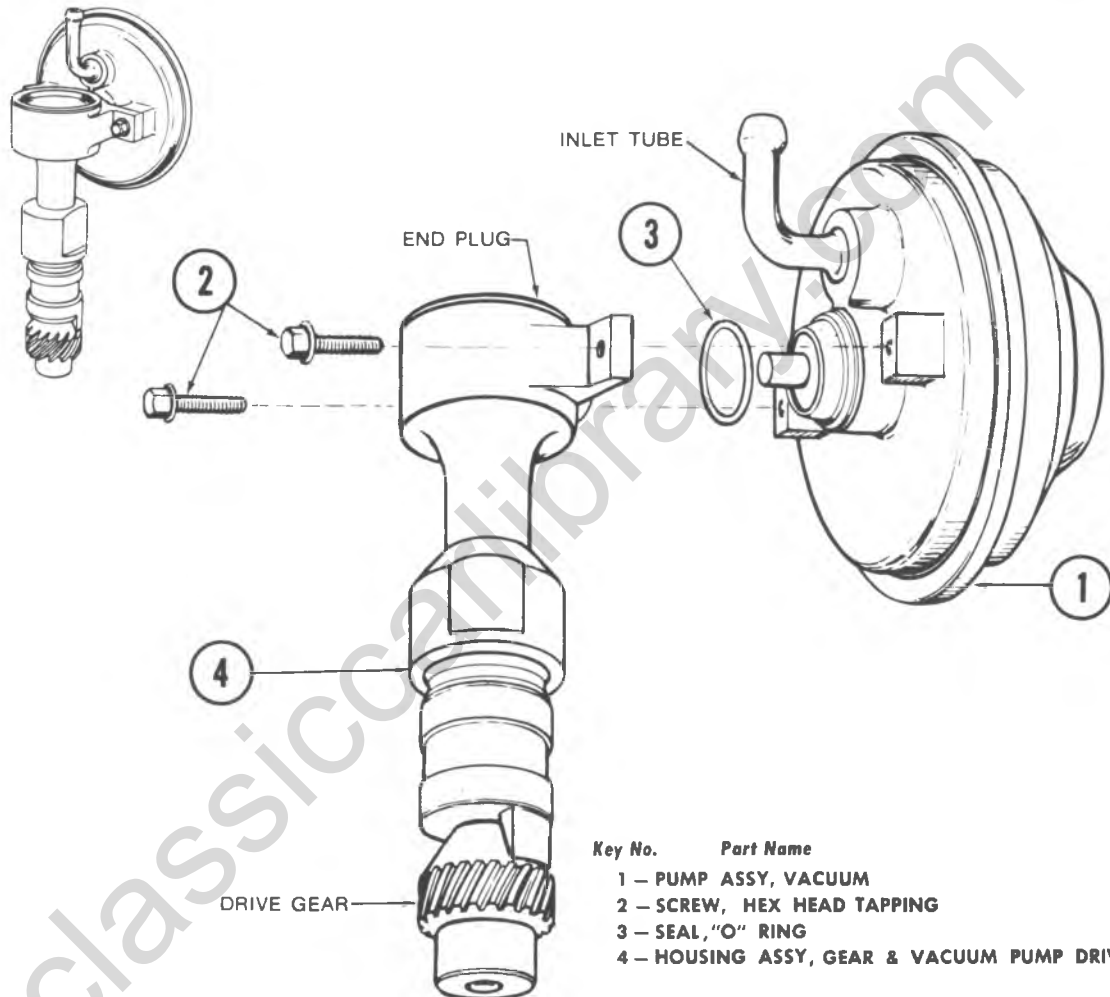
DRIVE AND VACUUM PUMPS

GENERAL DESCRIPTION

The vacuum pump is used on diesel engines to provide the vacuum required for some accessories. It is a diaphragm pump which needs no periodic maintenance. It is driven by a cam inside the drive assembly to which it mounts. The pump's diaphragm moves back and forth causing air to flow into the inlet tube, through the pump, and exhaust out the rear port.

The drive housing assembly has a drive gear on the lower end which meshes with the cam shaft gear in the engine. This drive gear causes the cam in the drive housing to rotate. The drive gear also powers the engine oil lubricating pump.

CAUTION: Do not operate engine without drive and vacuum pump assembly as this is also the drive for the engine oil pump.



Drive & Vacuum Pump Assembly—Serviceable Components

Fig. 6A6-100—Vacuum Pump

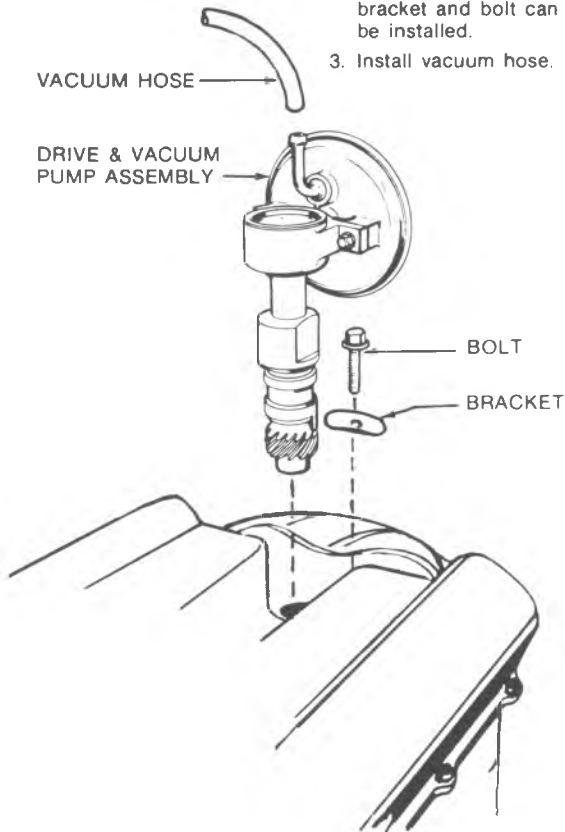
1. REMOVE AND INSTALL

REMOVE

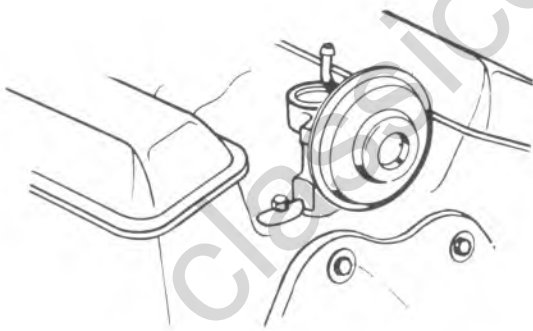
1. Remove hose from pump inlet.
2. Remove bolt and bracket holding pump to engine block.
3. Remove pump.

INSTALL

1. Insert pump in engine, making sure the gears on the pump mesh with the gears on the engine cam shaft.
2. Rotate the pump into position so the bracket and bolt can be installed.
3. Install vacuum hose.



Removing assembly from engine.



View showing assembly from rear of engine.

2. DISASSEMBLE AND ASSEMBLE

CAUTION: Take extreme care when clamping the vacuum pump in vise.

DISASSEMBLE

1. Remove hex head tapping screws.
2. Remove "O" Ring Seal.

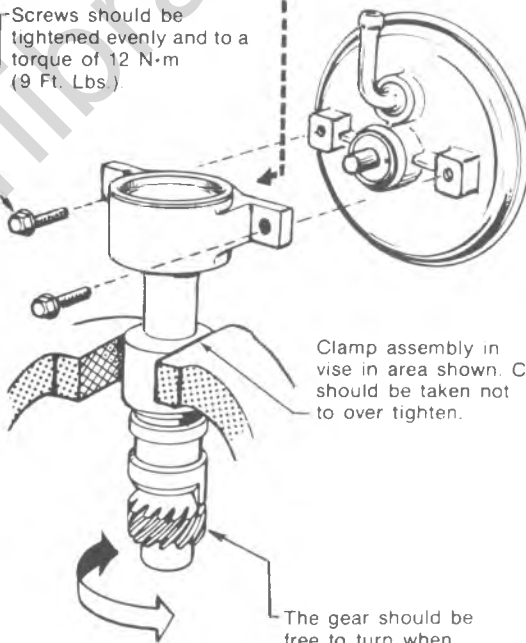
ASSEMBLE

1. Install "O" Ring Seal in cavity of drive assembly.
2. Connect drive assembly to vacuum pump with hex head tapping screws.



Install "O" Ring Seal in cavity of drive assembly.

Screws should be tightened evenly and to a torque of 12 N-m (9 Ft. Lbs.).



Clamp assembly in vise in area shown. Care should be taken not to over tighten.

The gear should be free to turn when installing the screws to the pump assembly.

Fig. 6A6-101-Vacuum Pump Service

GENERAL DATA:

| | | |
|-------------------|-----------|-----------------|
| TYPE | | V-8 DIESEL |
| DISPLACEMENT | LITRE (*) | 5.7 (Z) |
| RPO | | LF9 |
| BORE | | 4.057 |
| STROKE | | 3.385 |
| COMPRESSION RATIO | | 22.5:1 |
| FIRING ORDER | | 1-8-4-3-6-5-7-2 |

CYLINDER BORE:

| | | | |
|--------------|------------|-------------|------|
| DIAMETER | | 4.056-4.058 | |
| OUT OF ROUND | PRODUCTION | | |
| | SERVICE | N.A. | |
| TAPER | PRODUCTION | THRUST SIDE | N.A. |
| | | RELIEF SIDE | N.A. |
| | SERVICE | | N.A. |

PISTON:

| | | |
|-----------|------------|------|
| CLEARANCE | PRODUCTION | N.A. |
| | SERVICE | N.A. |

PISTON RING:

| | | | | |
|---|------------------|------------|-----------|-------------|
| C O M P R E S S I O N | GROOVE CLEARANCE | PRODUCTION | TOP | .005-.007 |
| | | | 2ND | .0018-.0038 |
| | | SERVICE | | N.A. |
| | GAP | PRODUCTION | TOP | .015-.025 |
| | | | 2ND | .015-.025 |
| | | SERVICE | | N.A. |
| O I L | GROOVE CLEARANCE | PRODUCTION | .001-.005 | |
| | | SERVICE | N.A. | |
| | GAP | PRODUCTION | .015-.055 | |
| | | SERVICE | N.A. | |

* VIN Designation

PISTON PIN

LF9

| | | |
|------------|------------|---------------|
| DIAMETER | | 1.0949-1.0953 |
| CLEARANCE | PRODUCTION | .0003-.0005 |
| | SERVICE | N.A. |
| FIT IN ROD | | .0003-.0013 |

CRANKSHAFT

| | | | |
|------------------------|--------------|-------------|-------------------------|
| MAIN JOURNAL | DIAMETER | | ALL 2.9993-3.0003 |
| | TAPER | PRODUCTION | N.A. |
| | | SERVICE | N.A. |
| | OUT OF ROUND | PRODUCTION | N.A. |
| SERVICE | | N.A. | |
| MAIN BEARING CLEARANCE | PRODUCTION | | #1-2-3-4 .0005-.0021 |
| | | | #5 .0015-.0031 |
| | SERVICE | | N.A. |
| CRANKSHAFT END PLAY | | | .0035-.0135 |
| CRANKPIN | DIAMETER | | 2.1238-2.1248 |
| | TAPER | PRODUCTION | N.A. |
| | | SERVICE | N.A. |
| | OUT OF ROUND | PRODUCTION | N.A. |
| SERVICE | | N.A. | |
| ROD BEARING CLEARANCE | PRODUCTION | .0005-.0026 | |
| | SERVICE | N.A. | |
| ROD SIDE CLEARANCE | | | .006-.020 |

CAMSHAFT

| | | | |
|---------------------|---------|------------------|------------------|
| LOBE LIFT ± .002 | INTAKE | N.A. | |
| | EXHAUST | N.A. | |
| JOURNAL DIAMETER | | #1 2.0357-2.0365 | #4 1.9757-1.9765 |
| | | #2 2.0157-2.0165 | #5 1.9657-1.9665 |
| | | #3 1.9957-1.9965 | |
| CAMSHAFT END PLAY | | .011-.077 | |

TORQUE SPECIFICATIONS

| | lb. ft. | N-m |
|--|---------|---------|
| Injection Pump Attaching Nuts | 19 | 26 |
| Injection Line Nut To Pump | 25 | 34 |
| Injection Pump Adapter Bolts | 25 | 34 |
| Injection Line Nut To Nozzle | 25 | 34 |
| Injection Pump Fuel Filter Inlet Line | 20 | 27 |
| Injection Pump Fuel Filter Outlet Line | 18 | 24 |
| Injection Pump Fuel Inlet Line | 20 | 27 |
| Injection Nozzle Hold-Down Clamp | 25 | 34 |
| Glow Plug | 12 | 16 |
| Crankshaft Bearing Cap Bolts | 120 | 163 |
| Flywheel To Converter | 40 | 54 |
| Flywheel To Crankshaft | 60 | 81 |
| Oil Pump To Bearing Cap Bolts | 35 | 47 |
| Oil Pump Cover To Pump Bolts | 8 | 11 |
| Rocker Arm Pivot Bolt To Head | 28 | 38 |
| Valve Cover Bolts Fully Driven, Seated, Not Stripped | | |
| Oil Pan Bolts | 10 | 14 |
| Oil Pan Drain Plug | 30 | 41 |
| Crankshaft Balancer To Crankshaft Bolt | 200-310 | 271-420 |
| Oil Filter Element To Base | 20 | 27 |
| Oil Filter Assembly To Cylinder Block Bolts | 35 | 47 |
| Oil Cooler Lines To Oil Filter Base | 12 | 16 |
| Oil Cooler Lines To Radiator | 25 | 34 |
| Support/Front Cover To Cylinder Block Bolts 3/8" | 35 | 34 |
| Fan Driven Pulley To Hub Bolts | 20 | 27 |
| Fan Driving Pulley To Balancer Bolts | 20 | 27 |
| Water Pump To Front Cover Bolts | 13 | 18 |
| Water Outlet To Manifold Bolts | 20 | 27 |
| *Intake Manifold To Cylinder Head Bolts | 40 | 54 |
| Exhaust Manifold To Cylinder Head Bolts | 25 | 34 |
| Engine Mount To Cylinder Block Bolts | 75 | 102 |
| Engine Mount To Frame Mount | 50 | 68 |
| Starter To Cylinder Block Bolts | 35 | 47 |
| Starter Brace To Cylinder Block Bolts | 25 | 34 |
| Starter Brace To Starter Bolt | 15 | 20 |
| Vaccum Pump Clamp To Cylinder Block Bolt | 17 | 23 |
| *Cylinder Head Bolts | 130 | 176 |
| Connecting Rod Nuts | 42 | 57 |
| Camshaft Sprocket Bolt | 65 | 88 |

* Clean and dip entire bolt in engine oil before tightening to obtain a correct torque reading.

Specifications

| VALVE SYSTEM | | LF9 | |
|--------------------------|--------------------------|----------------|-----------------|
| LIFTER | | HYDRAULIC | |
| ROCKER ARM RATIO | | N.A. | |
| VALVE LASH | INTAKE | NON-ADJUSTABLE | |
| | EXHAUST | | |
| FACE ANGLE (INT. & EXH.) | | @ | |
| SEAT ANGLE (INT. & EXH.) | | * | |
| SEAT RUNOUT | | .003 | |
| SEAT WIDTH | INTAKE | .075-.098 | |
| | EXHAUST | .037-.075 | |
| STEM CLEARANCE | PRODUCTION | INT. | .0010-.0027 |
| | | EXH. | .0015-.0032 |
| | SERVICE | N.A. | |
| VALVE SPRING (OUTER) | FREE LENGTH | | 2.09 |
| | PRESSURE LBS. @ IN. | CLOSED | 77-83 @ 1.670 |
| | | OPEN | 144-158 @ 1.300 |
| | INSTALLED HEIGHT ± 1/32" | | N.A. |
| DAMPER | FREE LENGTH | | N.A. |
| | APPROX. # OF COILS | | N.A. |

@ — 44° INTAKE — 30° EXHAUST

* — 45° INTAKE — 31° EXHAUST

SECTION 6B

ENGINE COOLING

CONTENTS

| | | | |
|--------------------------|------|------------------------------|-------|
| General Description..... | 6B-1 | On Vehicle Service..... | 6B-10 |
| Coolant Level..... | 6B-1 | Water Pump..... | 6B-10 |
| Thermostat..... | 6B-2 | Thermostat..... | 6B-10 |
| Drive Belts..... | 6B-2 | Radiator..... | 6B-11 |
| Diagnosis..... | 6B-6 | Fan Shroud..... | 6B-11 |
| System Checks..... | 6B-6 | Fan/Fan Clutch..... | 6B-11 |
| Overheat/Noise..... | 6B-6 | Coolant Recovery Bottle..... | 6B-12 |
| Fan Clutch..... | 6B-7 | Engine Oil Cooler..... | 6B-13 |

GENERAL DESCRIPTION

All Chevrolet Light Duty Trucks have pressure type engine cooling systems with thermostatic control of coolant circulation. The cooling system is sealed by a pressure type radiator filler cap which causes the system to operate at higher than atmospheric pressure. The higher pressure raises the boiling point of the coolant which increases the cooling efficiency of the radiator. The 15 pound (103 kPa) pressure cap used raises the boiling point of coolant to approximately 262° F (128°C) at sea level.

The radiator cap should be washed with clean water and pressure checked every 12 months.

All models have a closed cooling system using a round pressure cap (Fig. 6B-1) and a coolant reservoir. Coolant can be added without removing the radiator cap.

A pressure-vacuum valve radiator cap is used which allows the coolant to expand through the pressure valve in the center of the cap without building unnecessary pressure. The expanding coolant flows into the coolant reservoir. The vent valve closes due to expansion and coolant flow. The nominal 15 pound (103 kPa) pressure will not be reached until the system is working at maximum capacity.

Any air or vapor in the cooling system will be forced to the coolant reservoir under the liquid level and leave through the vent tube at the top of the reservoir. As the system cools, the extra coolant in the reservoir will be drawn back to the radiator through the vent valve. In this manner,

the radiator will keep itself full at all times.

COOLANT LEVEL

The need for additional coolant can be detected by observing the level of coolant in the reservoir while the engine is at normal operating temperature. The radiator cap need not normally be removed.

The coolant level should be at the "Full Cold" mark when the system is cool and at ambient temperature. After the vehicle has been driven sufficiently to obtain normal operating temperatures, the level should be at the "Full Hot" mark.

Periodically, the radiator cap should be removed to observe coolant level in the radiator.

CAUTION: The radiator coolant level should only be checked when the engine is cool. If the radiator cap is removed from a hot cooling system, serious personal injury may result.

Coolant levels in crossflow radiators with coolant recovery bottles should be maintained to the top of the filler neck.

The recovery bottle should be at its appropriate mark when checked.

Regardless of whether freezing temperatures are expected or not, cooling system protection should be maintained at least to -34°F (-37°C), to provide adequate corrosion protection and loss of coolant from boiling. With glycol content less than requirement for -34°F (-37°C) protection, coolant boiling point is less than the temperature indicating light setting. When adding solution due to loss of coolant for any reason or in areas where temperatures lower than -34°F (-37°C) may occur, a sufficient amount of an ethylene glycol base anti-freeze that meets GM Specification 1899-M should be used.

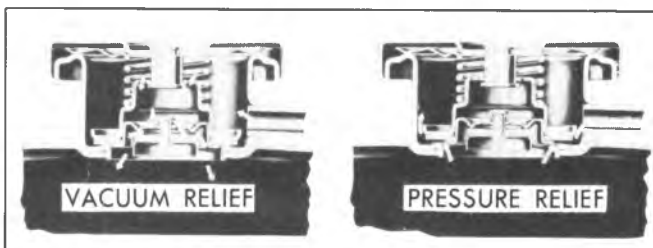


Fig. 6B-1--Radiator Pressure Cap

| ALL L6 ENGINES AND ALL V8 ENGINES EXCEPT DIESEL | | |
|---|---------------------------|--|
| GENERATOR A.I.R. PUMP P/S PUMP | 50 LB. (222 N) MIN. | ADJUST TO 75 ± 5 LBS. USED (334 ± 22 N) ADJUST TO 125 ± 5 LBS. NEW (556 ± 22 N) |
| A/C COMPRESSOR | 65 LB. (289 N) MIN. | ADJUST TO 95 ± 5 LBS. USED (423 ± 22 N) ADJUST TO 140 ± 5 LBS. NEW (623 ± 22 N) |
| 5.7L — V8 DIESEL | | |
| GENERATOR P/S PUMP A.I.R. PUMP (NON A/C) | 70 LB. (311 N) MIN. | ADJUST TO 75 ± 5 LBS. USED (334 ± 22 N) ADJUST TO 110-140 LBS. NEW (480-623 N) |
| A/C COMPRESSOR A.I.R. PUMP | 80 LB. (356 N) MIN. | ADJUST TO 90 ± 5 LBS. USED (400 ± 22 N) ADJUST TO 135-165 LBS. USED (600-734 N) |

Fig. 6B-2--Drive Belt Tension Specifications

NOTICE: Alcohol or methanol base anti-freeze, or plain water, are not recommended for your engine at anytime. They will not provide proper protection against corrosion.

Flushing Cooling System

Various methods and equipment may be used to perform this service. If special equipment such as a back flusher is used, equipment manufacturer's instructions

should be followed. However, it is advisable to remove the thermostat before flushing the system.

THERMOSTAT

The thermostat consists of a restriction valve actuated by a thermostatic element. This is mounted in the housing at the cylinder head coolant outlet above the water pump on L-6, and in the forward part of the intake manifold, under the coolant outlet on "small block" and "Mark". Thermostats are designed to open and close at predetermined temperatures and if not operating properly should be removed and tested.

DRIVE BELTS

Frayed or cracked belts should be replaced and tensioned to specifications using a strand tension gage, such as tool J-23600-B or equivalent.

Loose belts may place an extremely high impact load on driven component bearings due to the whipping action of the belt.

An over tightened belt places unnecessary loads on the component bearings.

In figure 6B-2, the minimum reading is the lowest allowable setting before the belt must be reset. When readjusting, the adjustment specification should be met. When adjusting a drive belt, it is important that the proper adjustment specification be used. Refer to figures 6B-3 thru 6B-5 for adjustment.

- A 'Used' belt is one that has been rotated at least one complete revolution on engine pulleys. This begins the 'seating' of the belt and it should never be reset to 'New' belt specifications.

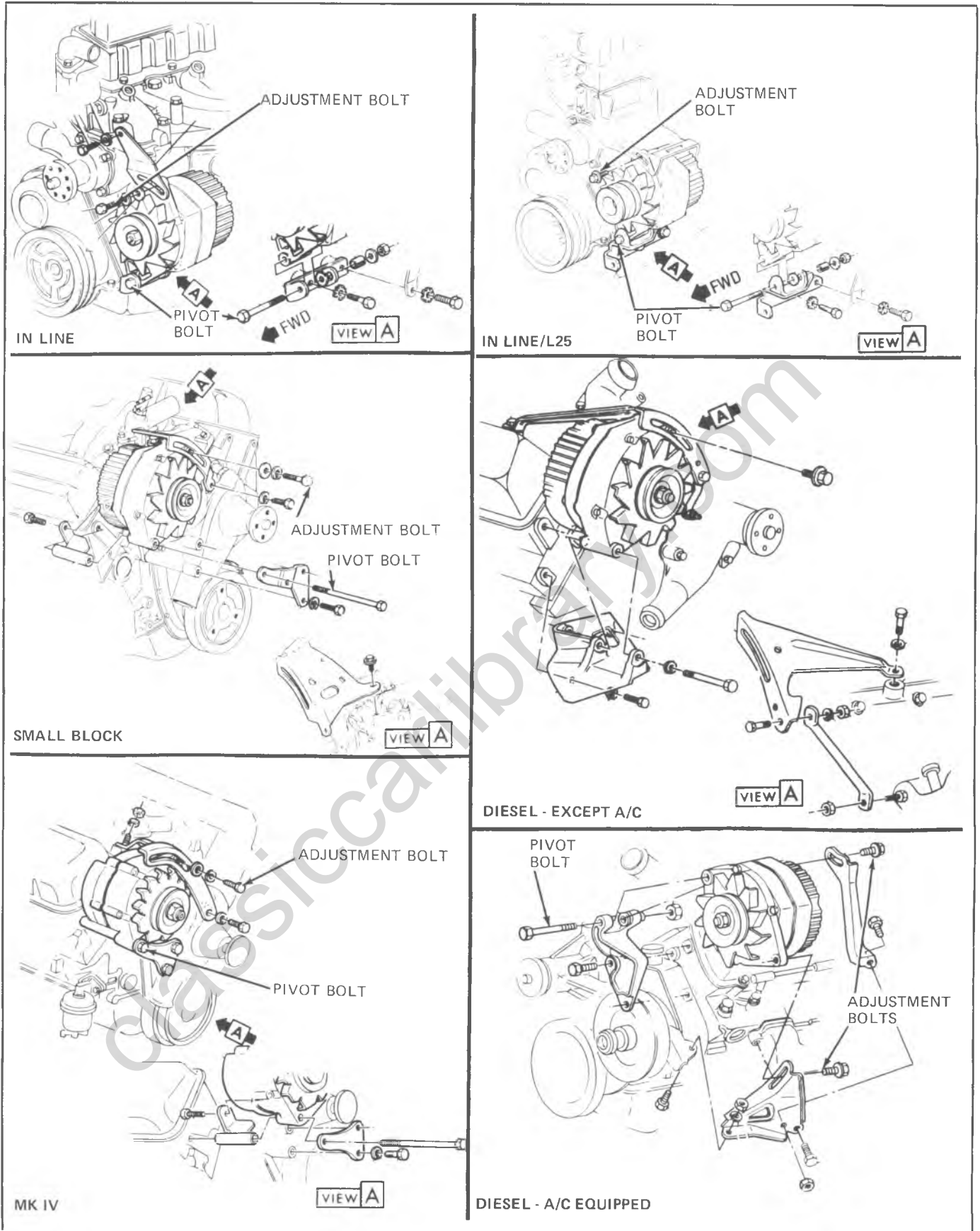


Fig. 6B-3--Generator Adjustment

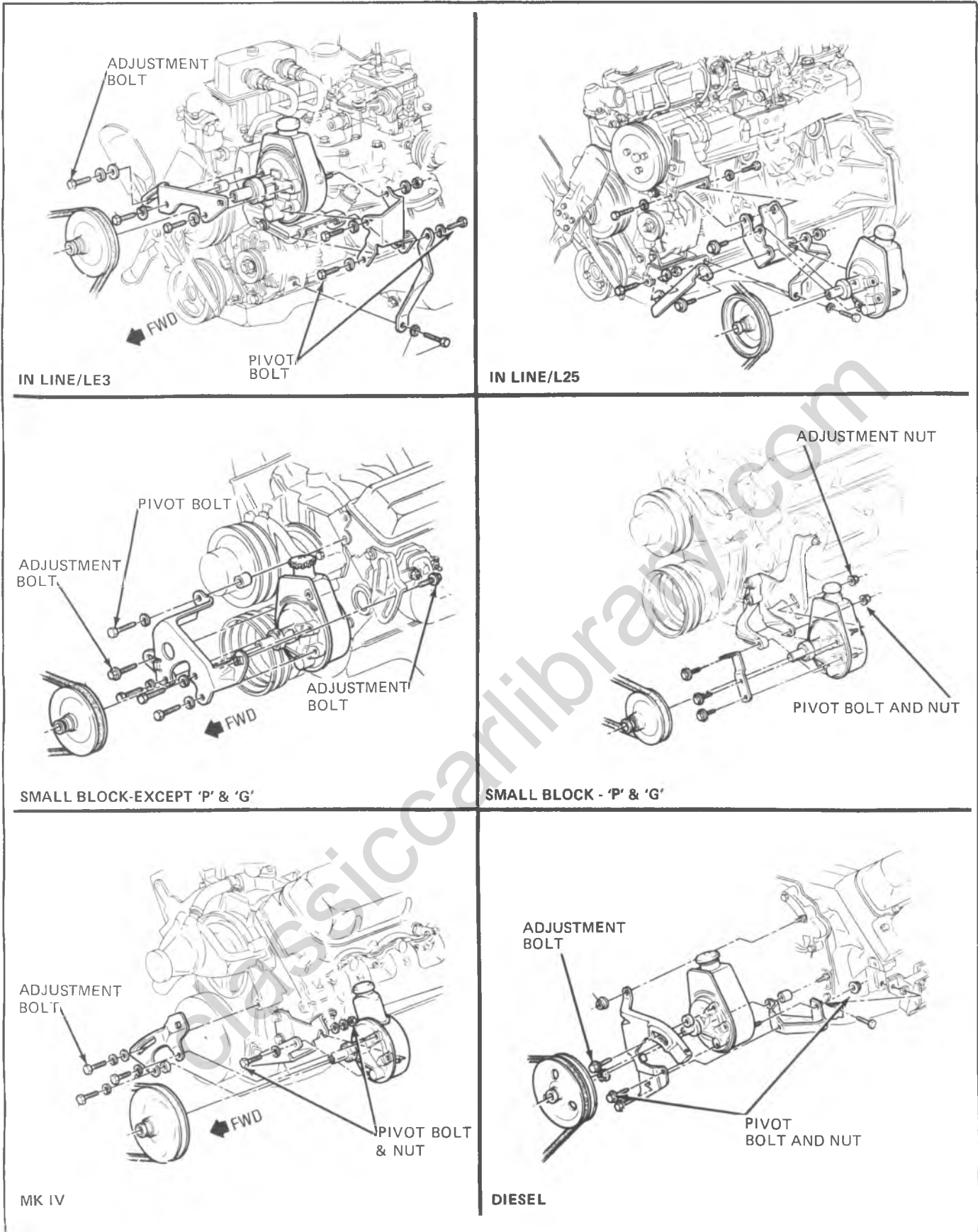


Fig. 6B-4--P/S Pump Adjustment

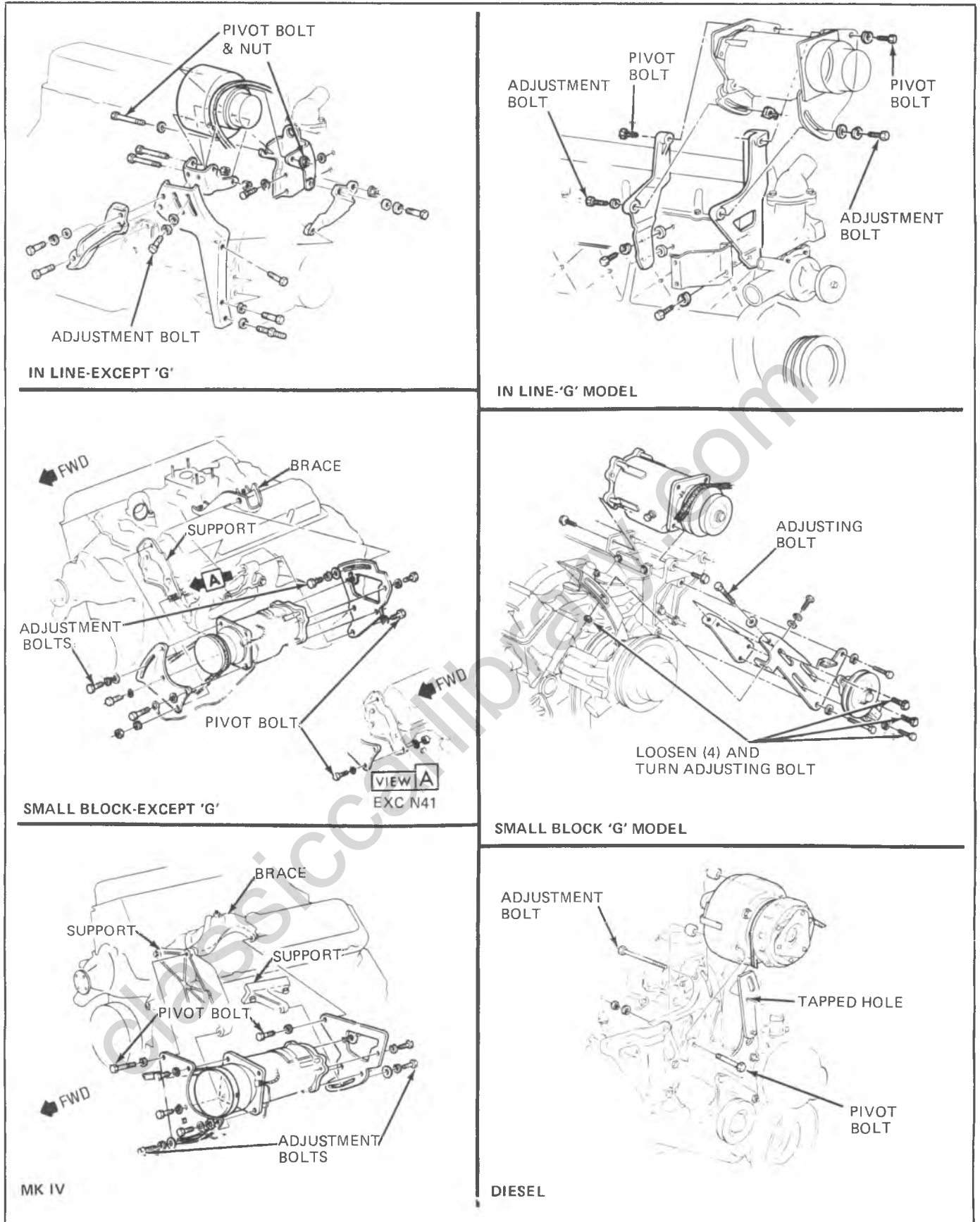


Fig. 6B-5--A/C Compressor Adjustment

DIAGNOSIS

If the cooling system requires frequent addition of coolant in order to maintain the proper level, check all units and connections in the cooling system for evidence of leakage. Inspection should be made with cooling system cold. Small leaks which may show dampness or dripping can easily escape detection when the engine is hot, due to the rapid evaporation of coolant. Tell-tale stains of grayish white or rusty color, or dye stains from anti-freeze, at joints in cooling system are almost always sure signs of small leaks even though there appears to be no damage.

Air may be drawn into the cooling system through leakage at the water pump seal or through leaks in the coolant recovery system. Gas may be forced into the cooling system through leakage at the cylinder head gasket(s) even though the leakage is not sufficient to allow coolant to enter the combustion chamber.

SYSTEM CHECKS

Exhaust Leaks

To check for exhaust leaks into the cooling system, drain the system until the coolant level stands just above the top of the cylinder head(s), then disconnect the radiator upper hose and remove the thermostat and fan belt(s). Start the engine and quickly accelerate several times. At the same time note any appreciable coolant rise or the appearance of bubbles which are indicative of exhaust gases leaking into the cooling system.

NOTICE: A defective head gasket may allow exhaust gases to leak into the cooling system. This is particularly damaging to the cooling system as the gases combine with the water to form acids which are harmful to the radiator and engine.

Water Pump

Water pump operation may be checked by running the engine while squeezing the radiator upper hose (engine warm). A pressure surge should be felt. Check for a plugged venthole in pump.

Radiator

Test for restriction in the radiator, by warming the engine up and then turning the engine off and feeling the radiator. The radiator should be hot along the left side and warm along the right side, with an even temperature rise from right to left. Cold spots in the radiator indicate clogged sections.

Thermostat

An operational check of the thermostat can be made by hanging the thermostat on a hook in a 33% glycol solution 25°F (4°C) above the temperature stamped on the thermostat valve. Submerge the valve completely and agitate the solution thoroughly. Under this condition the valve should open. Remove the thermostat and place in a 33% glycol solution 10°F (-12°C) below temperature indicated on the valve. With valve completely submerged and coolant agitated thoroughly, the valve should close completely.

Overheat and/or Noise

Engine overheat and/or cooling system noise may be caused by restrictions in the cooling system.

Components which may be prone to this condition are cylinder head, water pump, block, thermostat housing and inlet manifold. Symptoms of this condition are as follows:

- Engine may make snapping/cracking noises.
- Heater core may gurgle or surge.
- Radiator hoses may collapse and expand.
- Heater hoses may vibrate and thump.
- Overheat light may or may not come on.

Symptoms are the result of coolant boiling at some localized area and may be noticed after extending idling and/or while being driven. Determine which side of the engine is involved and whether it is more at the front or rear of engine.

Diagnosis & Inspection

1. Isolate area of engine the localized boiling is originating from. This can be done by probing engine with a sounding bar (large screw driver).

2. With radiator cap removed, observe water being circulated in radiator. Feel the front area of radiator for cold spots which indicate blockage. Blocked radiators generally occur on units that have accrued miles and not on new vehicles.

CAUTION: The radiator cap should be removed from a cool engine only. If the radiator cap is removed from a hot cooling system, serious personal injury may result.

3. Inspect thermostat to see if it opens completely.
4. Inspect thermostat housing to make sure it is completely free of obstructions.
5. Remove water pump from vehicle and remove the back cover on the pump. All internal passages can be inspected using a flash light.
6. Inspect cross over at the front of the inlet manifold. This entire passage can be seen with only the thermostat removed.
7. Remove heads, but lay them aside for now and check the block first because the heads are the most complex pieces as far as coolant passages are concerned.
8. With water pump and heads removed, ALL coolant passages CAN be inspected by using a pen light flash light. All water jacket areas can be seen directly and a block should never be replaced as being suspect unless the restricted area can be **DIRECTLY SEEN**.
9. If none of the above inspections reveal the problem area, the heads must be considered prime suspect. Heads with blocked coolant passages generally have more than one area that is blocked. Inspect the heads for signs of overheat discoloration (a dark blue or black area). If none are found look in the coolant passages for blockage and probe all passages that are accessible.

The head is very intricate and all passages cannot be reached. Use a probe that is fairly substantial as a tag wire may go through or around a partially blocked area. If nothing is found by visual inspection and probing, inspect the passages for a rough ragged appearance. The roughest internal passages are probably the ones that are blocked.

Replace a blocked or suspect head and inspect the replacement head in the same manner before installing it.

FAN CLUTCH

1.- Noise

Fan noise is sometimes evident under the following normal conditions:

- When clutch is engaged for maximum cooling.
- During first few minutes after start-up until the clutch can re-distribute the silicone fluid back to its normal disengaged operating condition after overnight settling.

Fan noise or an excessive roar will generally occur continuously, however, under all high engine speed conditions (2500 r.p.m. and up) if the clutch assembly is locked up due to an internal failure. If the fan cannot be rotated by hand or there is a rough grating feel as the fan

is turned, the clutch should be replaced.

2. - Looseness

Under various temperature conditions, there is a visible lateral movement that can be observed at the tip of the fan blade. This is a normal condition due to the type of bearing used. Approximately 1/4" (6.5mm) maximum lateral movement measured at the fan tip is allowable. This is not cause for replacement.

3. - Silicone Fluid Leak

The operation of the unit is generally not affected by small fluid leaks which may occur in the area around the bearing assembly. If the degree of leakage appears excessive, however, proceed to item 4.

4. - Engine Overheating

If the fan and clutch assembly free-wheels with no drag (revolves over 5 times when spun by hand), the clutch should be replaced.

Classiccarlibrary.com

ENGINE COOLING SYSTEM COMPLAINT

TO AVOID NEEDLESS TIME AND COST IN DIAGNOSING COOLING SYSTEM COMPLAINTS, THE CUSTOMER SHOULD BE QUESTIONED ABOUT DRIVING CONDITIONS THAT PLACE ABNORMAL LOADS ON THE COOLING SYSTEM.

1. DOES OVERHEATING OCCUR WHILE PULLING A TRAILER?

IF ANSWER IS "YES" – HOW HEAVY IS TRAILER? IF TRAILER WEIGHT IS GREATER THAN 2,000 LBS. & CAR IS EQUIPPED WITH NORMAL DUTY COOLING SYSTEM, A HEAVY DUTY COOLING PACKAGE IS REQUIRED [PER MFR'S TRAILER HAULING SPECS.]. FURTHER DIAGNOSTIC CHECKS SHOULD NOT BE REQUIRED.

2. IS CAR EQUIPPED WITH ADD-ON OR AFTER MARKET AIR CONDITIONING SYSTEM?

IF ANSWER IS "YES" – WAS HEAVY DUTY RADIATOR INSTALLED WITH THE SYSTEM? IF NOT, INSTALL HEAVY DUTY AIR CONDITIONING RADIATOR FOR THE CAR MODEL INVOLVED [PER MANUFACTURER'S SPECS.]. FURTHER DIAGNOSTIC CHECKS SHOULD NOT BE REQUIRED.

3. IS OVERHEATING OCCURRING AFTER PROLONGED IDLE, IN GEAR, A/C SYSTEM OPERATING?

IF ANSWER IS "YES" – INSTRUCT OWNER ON DRIVING TECHNIQUES THAT WOULD AVOID OVERHEATING SUCH AS:

- a. IDLE IN NEUTRAL AS MUCH AS POSSIBLE – INCREASE ENGINE R.P.M. TO GET HIGHER AIR FLOW & WATER FLOW THROUGH RADIATOR.
 - b. TURN A/C SYSTEM OFF DURING EXTENDED IDLES IF OVERHEATING IS INDICATED BY HOT LIGHT OR TEMP. GAGE.
- FURTHER DIAGNOSTIC CHECKS SHOULD NOT BE REQUIRED.

4. IS OVERHEATING OCCURRING AFTER PROLONGED DRIVING IN SLOW CITY TRAFFIC, TRAFFIC JAMS, PARADES, ETC.?

IF ANSWER IS "YES" – INSTRUCT OWNER ON DRIVING TECHNIQUES THAT WOULD AVOID OVERHEATING – SAME AS FOR PROLONGED IDLES – NO. 3. FURTHER DIAGNOSTIC CHECKS SHOULD NOT BE REQUIRED.

IF NONE OF THE ABOVE APPLY, GO TO DIAGNOSTIC CHART

TO EFFECTIVELY USE THIS CHART, QUESTION THE OWNER TO DETERMINE WHICH OF THE FOLLOWING [3] CATEGORIES APPLIES TO THE COMPLAINT:

1. HOT LIGHT OR HOT INDICATION ON TEMPERATURE GAGE
2. BOILING
3. COOLANT LOSS

1. IF COMPLAINT IS HOT LIGHT OR HOT INDICATION ON TEMPERATURE GAGE –

WAS HOT LIGHT ACCOMPANIED BY BOILING? IF ANSWER IS "YES", GO TO BOILING ON CHART
IF ANSWER IS "NO", GO TO HOT LIGHT ON CHART

2. IF COMPLAINT IS BOILING – GO TO BOILING ON CHART3. IF COMPLAINT IS COOLANT LOSS –

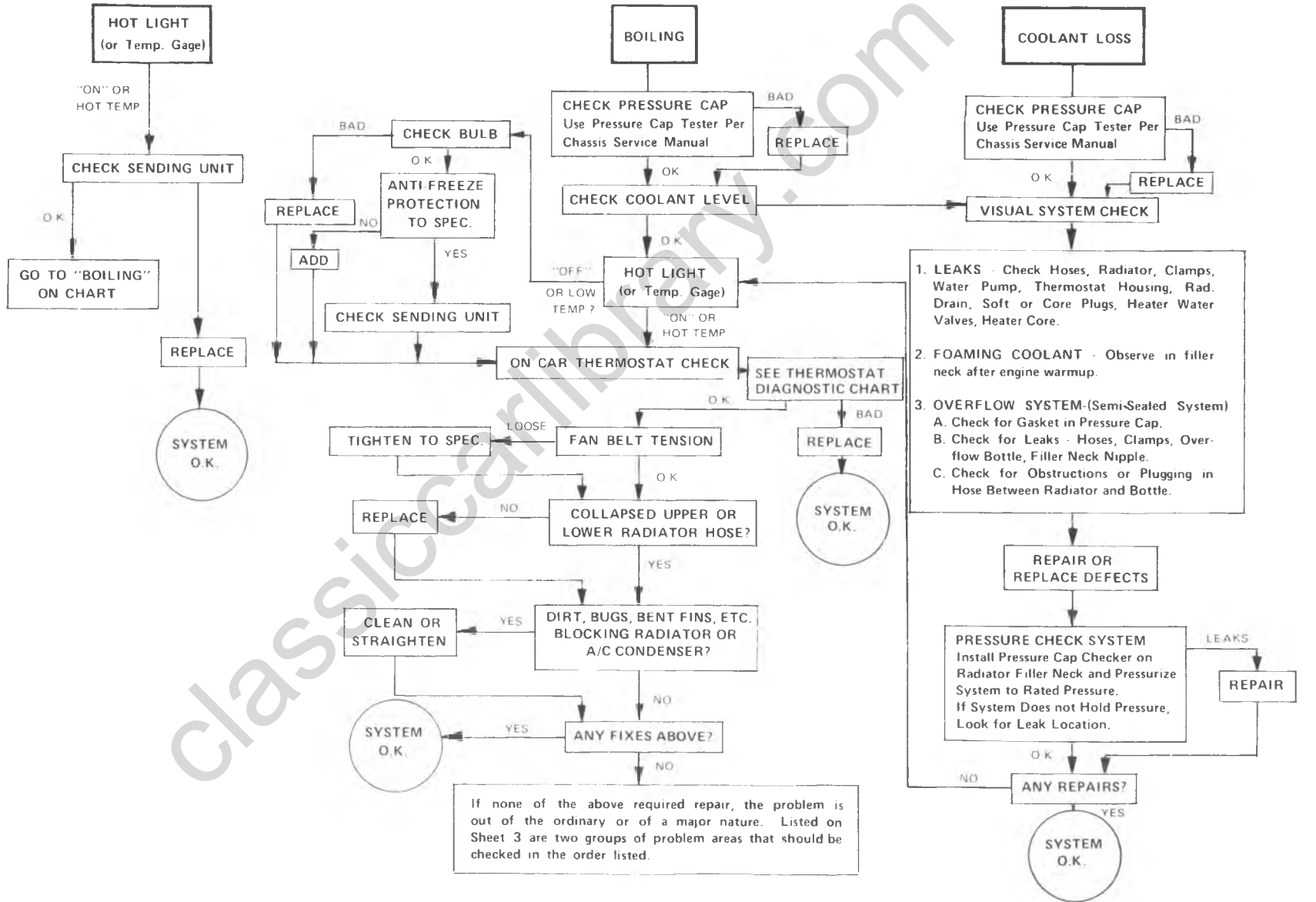
DETERMINE IF CUSTOMER IS OVERFILLING THE SYSTEM, THIS WOULD NORMALLY RESULT IN SMALL AMOUNTS OF COOLANT LOSS THROUGH THE OVERFLOW TUBE. IF THIS IS THE CASE, INSTRUCT THE CUSTOMER ON PROPER FILL LEVEL & NO FURTHER DIAGNOSTIC CHECKS SHOULD BE REQUIRED.

IF OVERFILLING IS NOT THE PROBLEM, GO TO COOLANT LOSS ON CHART.

NOTICE: ANYTIME COOLING SYSTEM IS OBVIOUSLY CONTAMINATED, THE SYSTEM SHOULD BE DRAINED AND FLUSHED.

CAUTION – THE COOLING SYSTEM IS DESIGNED TO OPERATE AT 15 P.S.I. PRESSURE & TEMPERATURES EXCEEDING 200° F. CAUTION SHOULD BE EXERCISED WHEN REMOVING PRESSURE CAP OR SERVICING THE SYSTEM.

DIAGNOSIS CHART



ON VEHICLE SERVICE

WATER PUMP

Removal - L6

1. Disconnect battery negative cable at battery.
2. Drain cooling system.
3. Remove accessory drive belts.
4. Remove fan to water pump hub (or fan clutch to water pump hub) attaching bolts (or nuts) and remove fan and pulley.
5. Remove lower radiator hose and heater hose from water pump.
6. Remove water pump to block attaching bolts and remove water pump.

● On some vehicles, the generator adjusting brace is retained by one of the water pump to block bolts. If necessary, loosen generator adjusting bolt to allow this brace to be moved away from pump to prevent removal interference.

Installation - L6

1. With clean sealing surfaces on both water pump and block, place new gasket on water pump, mount on block and retain with attaching bolts. Torque bolts to 15 lb. ft. (20 N·m).

● If generator adjusting brace was moved, move to original position before torquing water pump bolts.

2. Install lower radiator hose and heater hose to pump.
3. Install water pump pulley and fan (or fan clutch assembly) on water pump hub. Torque retaining fasteners to 30 N·m (25 N·m if engine has fan clutch assembly).
4. Install accessory drive belts and adjust to specifications.
5. Connect battery negative cable.
6. Fill cooling system with an ethylene glycol anti-freeze and water mixture of 50/50%.
7. Start engine and run, with radiator cap removed, until radiator upper hose becomes hot (thermostat open).
8. With engine idling, add coolant to radiator until level reaches bottom of filler neck.
9. Install cap, making sure arrows line up with overflow tube.

Removal - V8

1. Disconnect battery negative cable at battery.
2. Drain cooling system.
3. Remove accessory drive belts.
4. Remove fan to water pump hub (or fan clutch to water pump hub) attaching bolts (or nuts) and remove fan and pulley.
5. Remove generator lower brace to water pump attaching bolts and swing brace down and out of way.
6. Remove generator upper brace to water pump attaching bolts.
7. Remove lower radiator hose and heater hose from water pump. On 7.4 liter engine, remove by-pass hose.
8. Remove water pump to block attaching bolts and remove pump.

Installation - V8

If installing new water pump, transfer heater hose fitting from old unit. On 7.4 liter engine, also transfer by-pass fitting.

1. With clean sealing surfaces on both water pump and block, place a 1/8" (3mm) bead of RTV, #1052366 or equivalent, along the sealing edge of each water pump leg. Place pump against block and retain with attaching bolts. Torque bolts to 20 N·m.
2. Attach lower radiator hose and heater hose to water pump. On 7.4 liter engine, install by-pass hose.
3. Attach generator upper and lower braces to water pump. Torque bolts to 35 N·m.
4. Install water pump pulley and fan (or fan clutch) to water pump hub. Torque fasteners to 30 N·m.
5. Install accessory drive belts. Adjust to specifications.
6. Connect battery negative cable.
7. Fill cooling system with an ethylene glycol anti-freeze and water mixture of 50/50%.
8. Start engine and run, with radiator cap removed, until radiator upper hose becomes hot (thermostat open).
9. With engine idling, add coolant to radiator until level reaches bottom of filler neck.
10. Install cap, making sure arrows line up with overflow tube.

Removal - Diesel

1. Drain radiator.
2. Disconnect lower radiator hose at water pump.
3. Disconnect heater hose and by-pass hose at water pump.
4. Remove fan assembly.
5. Remove all pulley belts.
6. Remove water pump pulley.
7. Disconnect generator, P/S pump bracket and, if equipped, A/C compressor bracket.
8. Remove water pump attaching bolts and water pump.

Installation - Diesel

1. Transfer studs to new water pump, if applicable.
2. Clean gasket material from engine block.
3. Apply a thin coat of #1050026 sealer, or equivalent, to the water pump housing to retain gasket, then position new gasket on housing.
4. Reverse removal procedure.
5. Adjust belts to specifications.
6. Refill cooling system.

THERMOSTAT

Removal (All Engines)

1. Disconnect battery negative cable at battery.
2. Drain cooling system until radiator coolant level is below thermostat.
3. Remove water outlet attaching bolts and remove outlet. Remove thermostat.

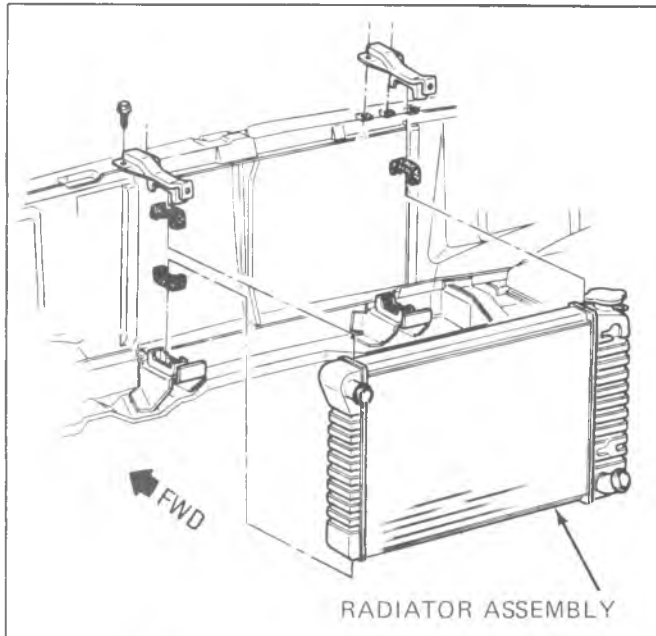


Fig. 6B-6--'G' Van Radiator Mounting

Installation (All Engines)

Prior to installing thermostat, make sure thermostat housing and coolant outlet sealing surfaces are clean.

1. Place a 1/8" (3mm) bead of RTV sealer, #1052366 or equivalent, all around the coolant outlet sealing surface on the thermostat housing.
2. Place thermostat in housing.
3. Install coolant outlet while RTV is still wet. Torque retaining bolts to 20 lb. ft. (27 N·m).
4. Connect battery negative cable.
5. Fill cooling system with an ethylene glycol anti-freeze and water mixture of 50/50%.
6. Start engine and run, with radiator cap removed, until radiator upper hose becomes hot (thermostat open).
7. With engine idling, add coolant to radiator until level reaches bottom of filler neck.
8. Install cap, making sure arrows line up with overflow tube.

RADIATOR (FIG. 6B-6 THRU 6B-9)**Removal (G & CK Series)**

1. Disconnect battery negative cable at battery.
2. Drain cooling system.
3. Remove radiator hoses from radiator.
4. Remove overflow hose from radiator.
5. Remove fan shroud.
6. Remove radiator to radiator support retainers (upper mounting panel on "CK") and remove radiator.

Installation

1. Place radiator in vehicle and install radiator to radiator support retainers.
2. Install fan shroud.
3. Connect overflow hose to radiator.
4. Connect radiator hoses to radiator.
5. Connect battery negative cable.

6. Fill cooling system with an ethylene glycol anti-freeze and water mixture of 50/50%.

7. Start engine and run, with radiator cap removed, until radiator upper hose becomes hot (thermostat open).

8. With engine idling, add coolant to radiator until level reaches bottom of filler neck.

9. Install cap, making sure arrows line up with overflow tube.

FAN SHROUD (FIG. 6B-10 THRU 6B-12)**Removal (CK Series)**

1. Disconnect battery negative cable.
2. Remove fan shroud to radiator retainer attaching screws.
3. Remove fan clutch to water pump hub attachments.
4. Remove shroud by pulling up and out of lower retaining clips. Fan shroud and fan clutch assembly must be removed together.

Installation (CK Series)

1. Lower fan shroud and fan clutch along back of radiator. Make sure lower edge fits into lower retaining clips.
2. Install fan clutch to water pump attachments and torque to 27 N·m.
3. Install shroud to radiator retainer attaching screws. Torque to 6 N·m.
4. Connect battery negative cable.

Removal ("G" Series-V8 Engines)

1. Disconnect battery negative cable.
2. If A/C equipped, remove vacuum reservoir.
3. Remove windshield washer jar and bracket.
4. Remove shroud retaining screws.
5. Remove radiator support bracket.
6. Remove dip stick from engine (transmission also if equipped with automatic).
7. Remove radiator hose strap from shroud.
8. Remove fan shroud from water pump (leave pulley), then remove fan and shroud together.

Installation ("G" Series-V8 Engines)

1. Install fan and shroud together then, attach fan to water pump.
2. Attach radiator hose strap to shroud.
3. Install dipstick in engine and, where applicable, in transmission.
4. Install radiator support bracket.
5. Install shroud retaining screws.
6. Install windshield washer jar and bracket.
7. If equipped with A/C, install vacuum reservoir.
8. Connect battery cable.

FAN/FAN CLUTCH**Removal (All)**

1. Remove battery negative cable at battery.
2. Remove radiator fan shroud as required.
3. Remove fan clutch hub-to-water pump hub attaching bolts or nuts, as applicable, and remove fan clutch assembly.
4. Remove fan from fan clutch hub.

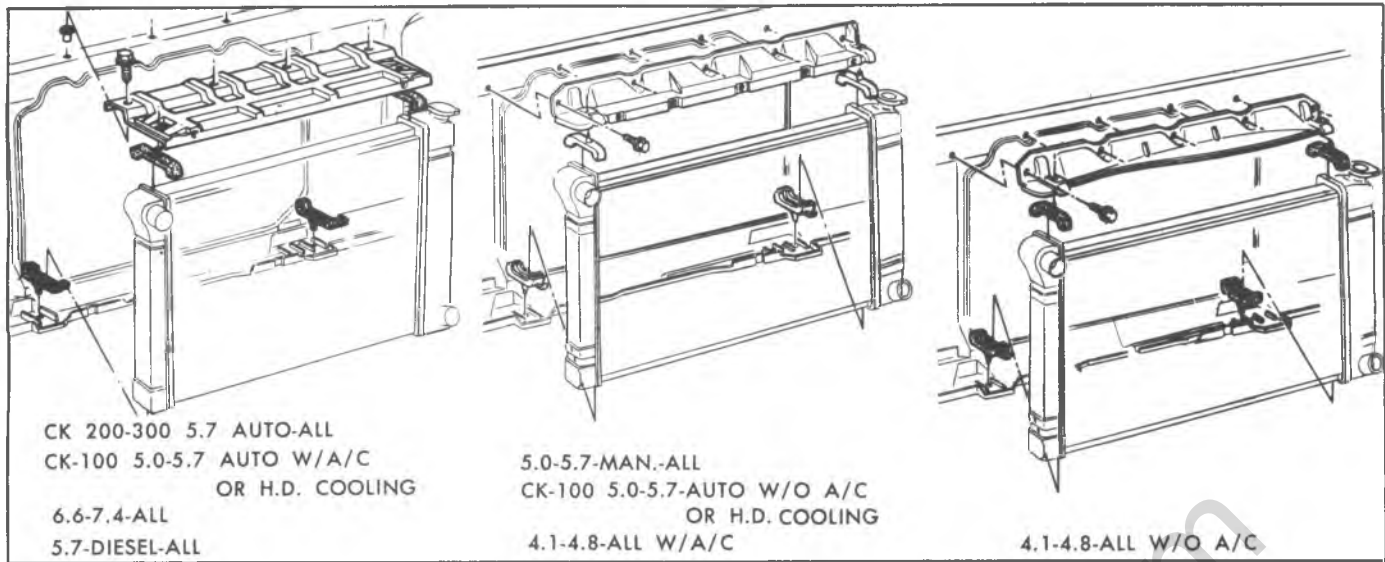


Fig. 6B-7--'CK' Radiator Mounting

Installation (All)

CAUTION: If a fan blade is bent or damaged in any way, no attempt should be made to repair and/or reuse the damaged part. A bent or damaged fan assembly should always be replaced with a new fan assembly.

It is essential that the fan assembly remain in proper balance. Balance cannot be assured once a fan assembly has been bent or damaged. A fan assembly that is not in proper balance could fail and fly apart during subsequent use, creating an extremely dangerous condition.

All mating surfaces (water pump hub and fan clutch hub) should be inspected for smoothness and reworked as necessary to eliminate burrs or other imperfections.

1. With fan on fan clutch hub, install fan clutch assembly to water pump hub. Torque attaching bolts, or nuts, to 20 lb. ft. (27 N·m). Be sure to align reference marks on both hubs.
2. Install radiator shroud as required.
3. Connect battery negative cable.

COOLANT RECOVERY BOTTLE (FIG. 6B-13 & 6B-14)

Removal

1. Disconnect battery negative cable.
2. Remove coolant overflow hose from recovery bottle.
3. Remove recovery bottle retaining fasteners and remove bottle from vehicle.

Installation

When installing coolant recovery bottle, make sure unit is clean and free from contamination. If needed, wash bottle with soap and water. Rinse thoroughly.

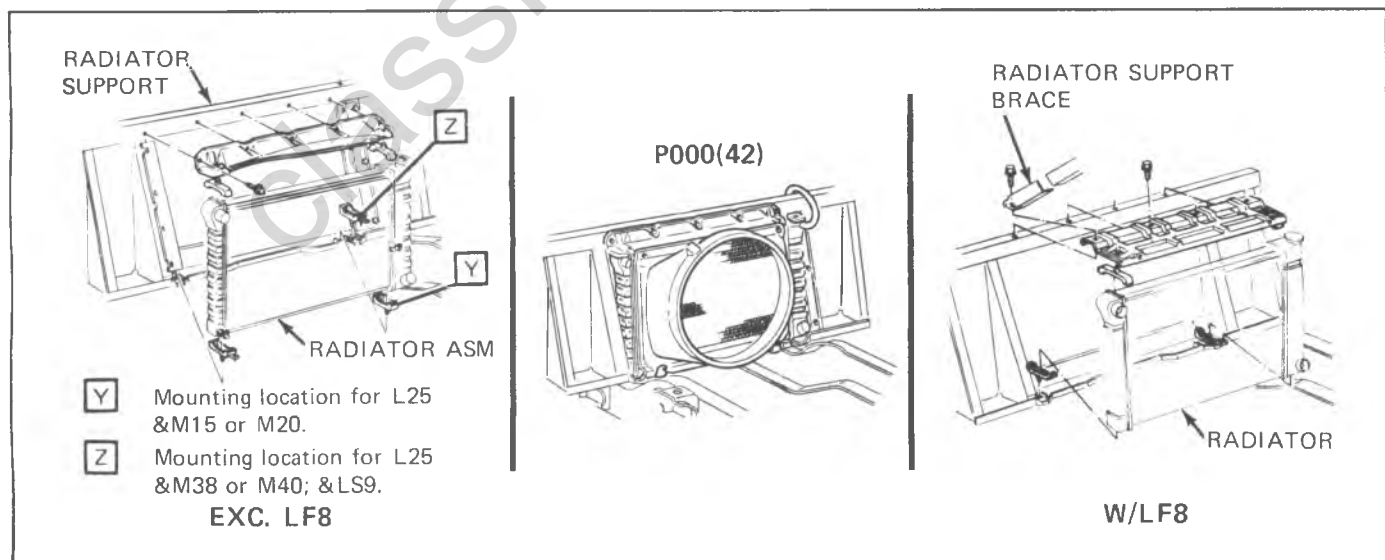


Fig. 6B-8--'P' (42) Radiator Mounting

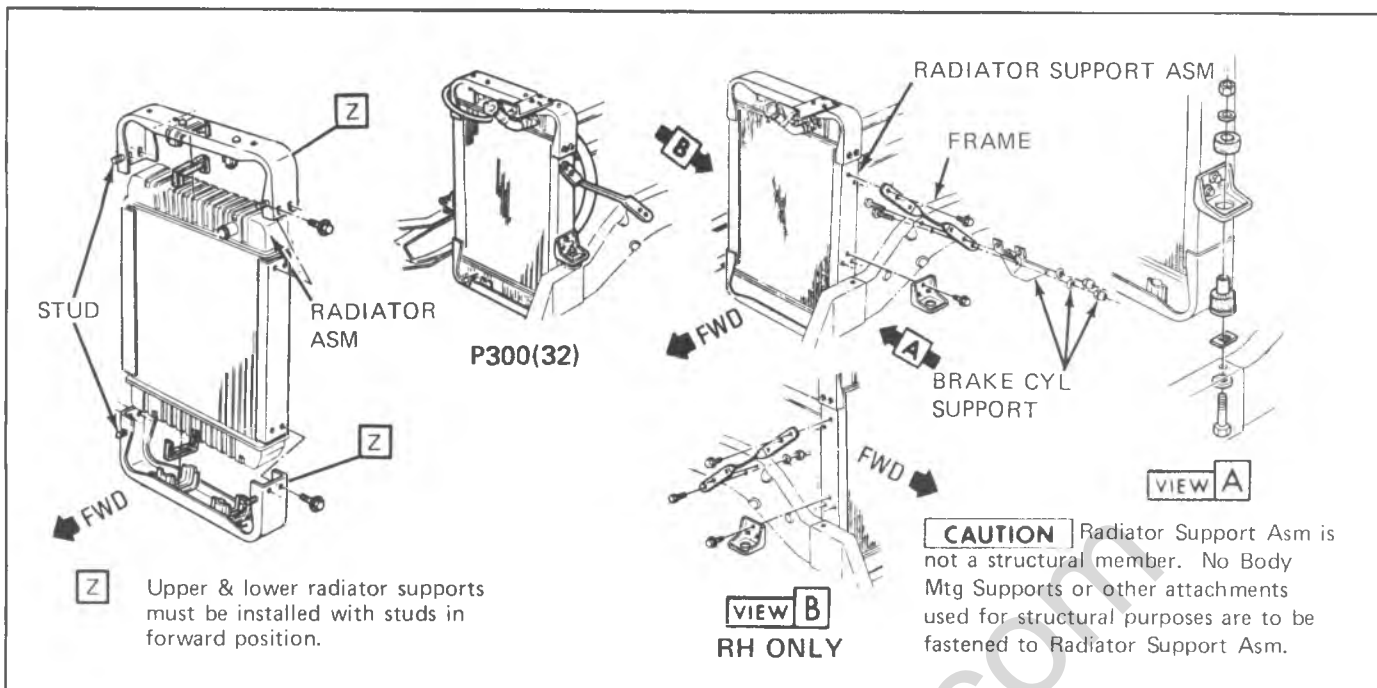


Fig. 6B-9--'P' (32) Radiator Mounting

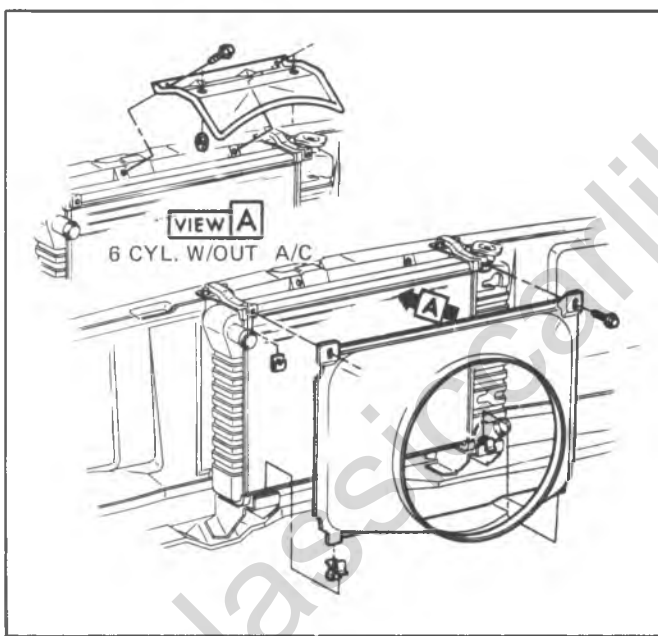


Fig. 6B-10--'G' Van Fan Shroud

1. Install bottle in vehicle and retain with appropriate fasteners.
2. Connect coolant overflow hose to recovery bottle.
3. Fill recovery bottle to appropriate mark with a 50/50 solution of water and ethylene glycol base anti-freeze.
4. Connect battery cable.

ENGINE OIL COOLER

All truck vehicle lines have available, as either standard or optional equipment, oil coolers for the engine oil. For the location of these units, refer to figures 6B-15 & 6B-16.

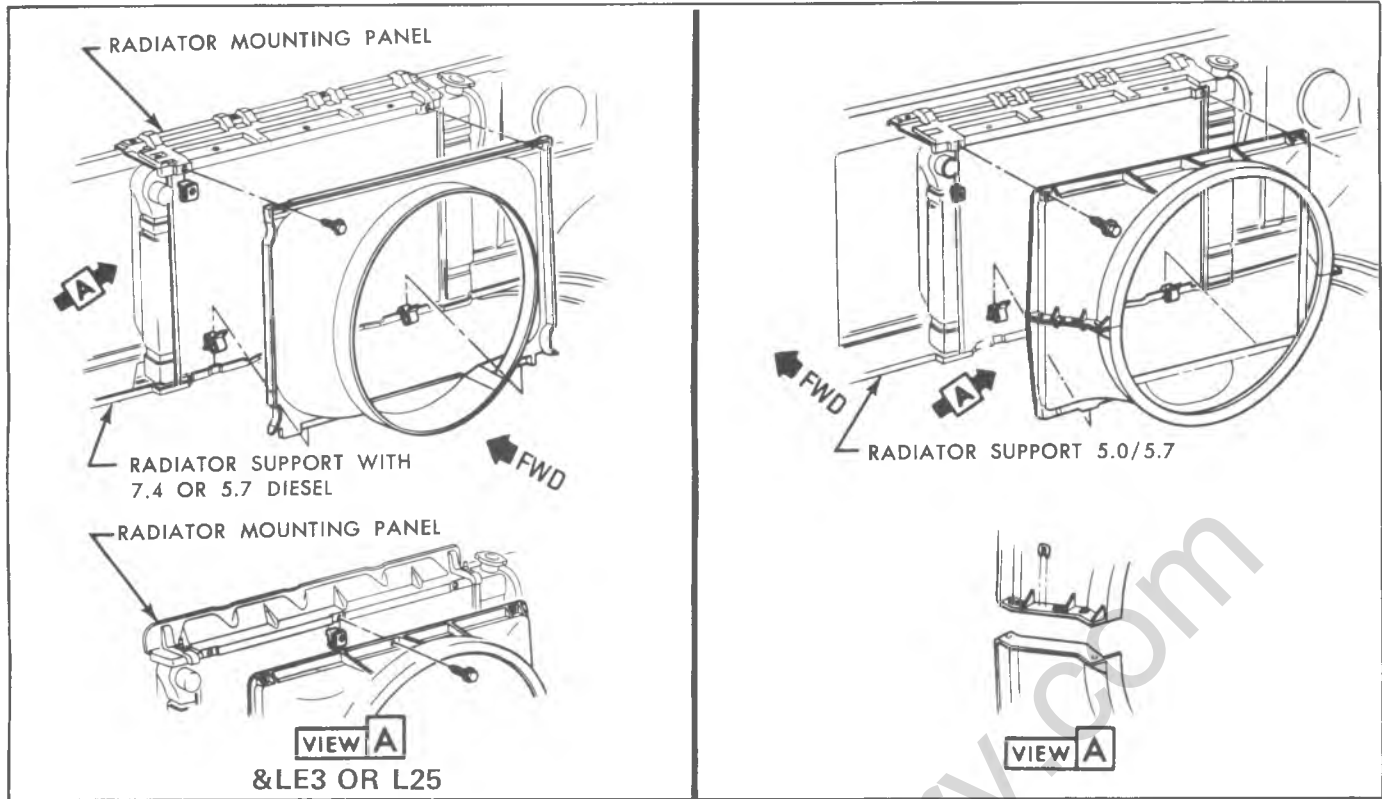


Fig. 6B-11--"CK" Series Fan Shroud

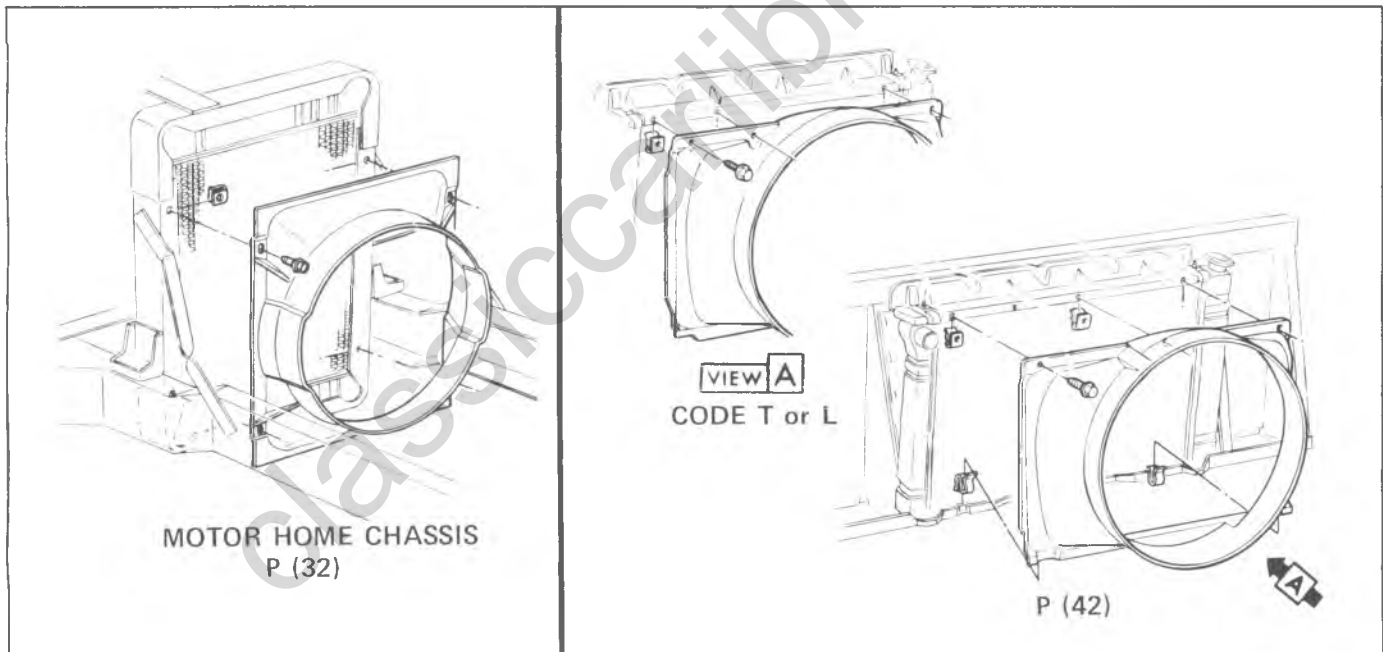


Fig. 6B-12--"P" Series Fan Shroud

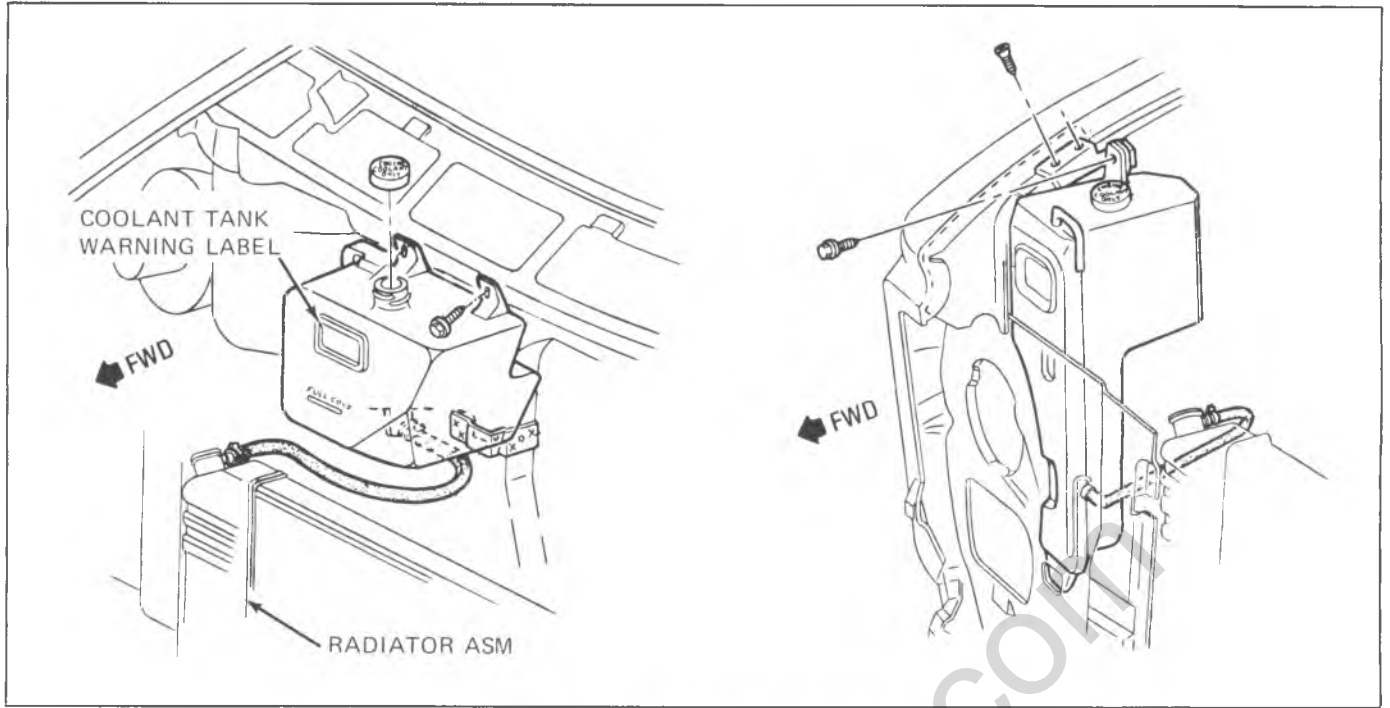


Fig. 6B-13--'G' Van Coolant Recovery Bottle

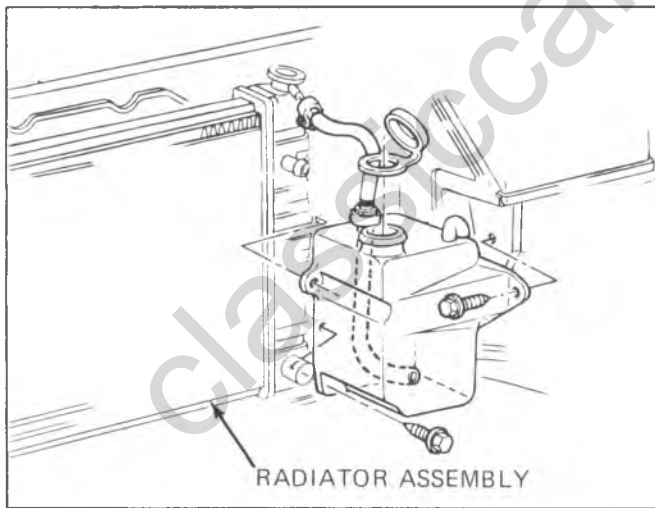


Fig. 6B-14--'CK' Series Coolant Recovery Bottle

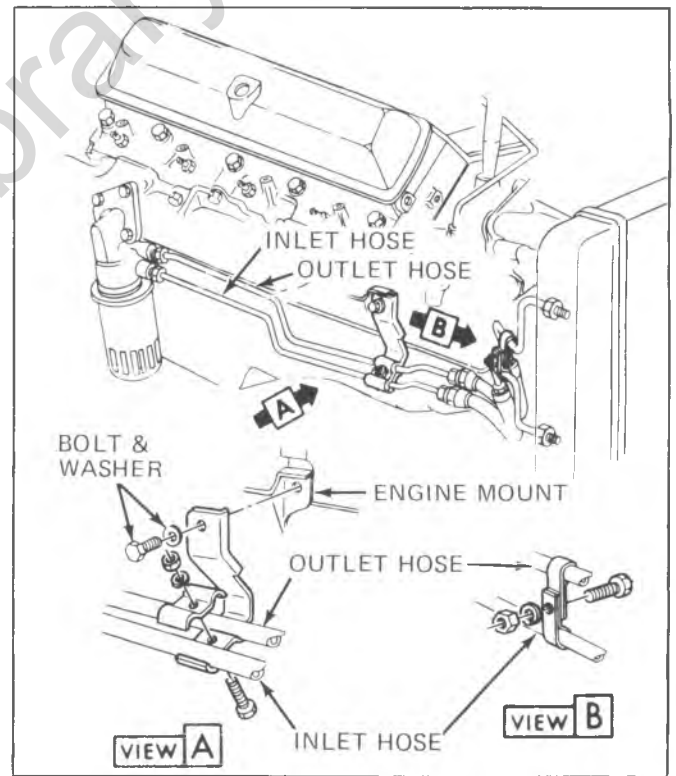
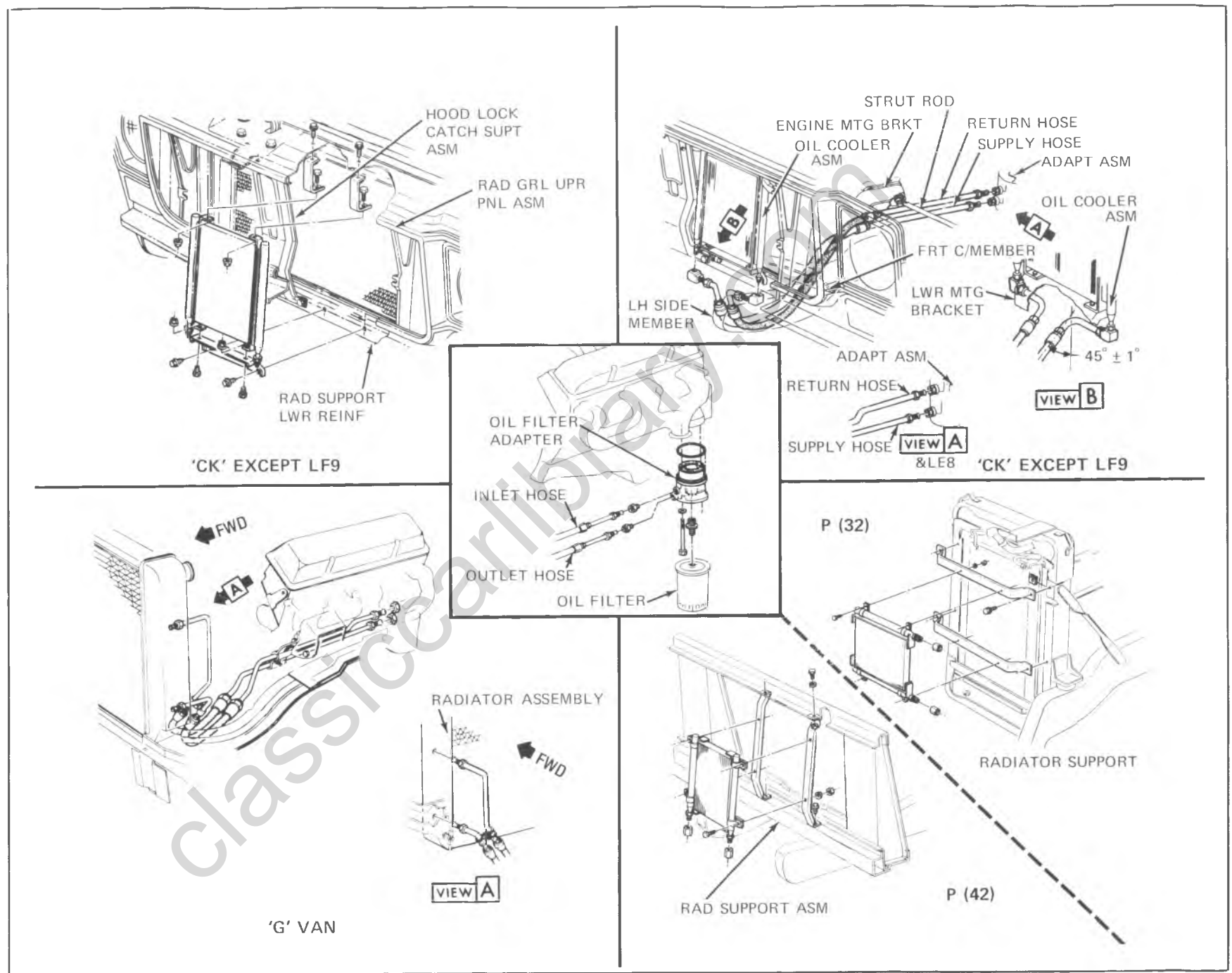


Fig. 6B-15--Engine Oil Cooler - LF9

Fig. 6B-16--Engine Oil Coolers Except LF9



SECTION 6C

FUEL SYSTEM

CONTENTS

| | | | |
|----------------------------|-------|----------------------------------|--------|
| General..... | 6C-1 | Model M4MC Carburetor..... | 6C4-1 |
| Diagnosis..... | 6C-2 | Sealed Idle Mixture Needles..... | 6C4-29 |
| Model 1ME Carburetor..... | 6C1-1 | External Float Checking..... | 6C4-31 |
| Model 2SE Carburetor..... | 6C2-1 | Fuel Supply..... | 6C5-1 |
| Model M2MC Carburetor..... | 6C3-1 | | |

ALL NEW 1980 CHEVROLETS ARE CERTIFIED BY THE ENVIRONMENTAL PROTECTION AGENCY AS CONFORMING TO THE REQUIREMENTS OF THE REGULATIONS FOR THE CONTROL OF AIR POLLUTION FROM NEW MOTOR VEHICLES. THIS CERTIFICATION IS CONTINGENT ON CERTAIN ADJUSTMENTS BEING SET TO FACTORY STANDARDS. FOR THIS REASON, THE FACTORY PROCEDURE FOR SETTING IGNITION TIMING, AND SLOW IDLE MUST BE FOLLOWED EXACTLY WHEN ADJUSTMENTS ARE MADE.

GENERAL

This section, divided into sub-sections by carburetor model, covers the repair and adjustment procedure for various carburetors used. Although illustrations showing bench operations are used, most single operations when not part of an overhaul, should be performed with the

carburetor on the engine.

Typical illustrations and procedures are used except where specific illustrations or procedures are necessary to clarify the operation.

CARBURETOR DIAGNOSIS

The following diagnostic procedures are for carburetor related problems and their effects on car performance. Other systems of the car can also cause similar problems and should be checked when listed on the chart. The problem areas described are:

1. Engine cranks normally. Will not start.
2. Engine starts and stalls.
3. Engine starts hard.
4. Engine idles abnormally and/or stalls.
5. Inconsistent engine idle speeds.
6. Engine diesels (after-run) upon shut off.
7. Engine hesitates on acceleration.
8. Engine has less than normal power at low speeds.
9. Engine has less than normal power on heavy acceleration or at high speed.
10. Engine surges.
11. Poor gas mileage.

| CONDITION | POSSIBLE CAUSE | CORRECTION |
|---|--|--|
| <p>Engine Cranks Normally – Will Not Start.</p> | <p>Improper starting procedure used.</p> <p>Choke valve not operating properly.</p> <p>No fuel in carburetor.</p> <p>Engine flooded. To check for flooding, remove the air cleaner with the engine immediately shut off and look into the carburetor bores. Fuel will be dripping off nozzles.</p> | <p>Check with the customer to determine if proper starting procedure is used, as outlined in the Owner's Manual.</p> <p>Adjust the choke thermostatic coil to specification. Check the choke valve and/or linkage as necessary. Replace parts if defective. If caused by foreign material and gum, clean with suitable non-oil base solvent.</p> <p>NOTE: After any choke system work, check choke vacuum break settings and correct as necessary.</p> <p>Remove fuel line at carburetor. Connect hose to fuel line and run into metal container. Remove the wire from the "bat" terminal of the distributor. Crank over engine – if there is no fuel discharge from the fuel line, test fuel pump as outlined in Section 6. If fuel supply is okay, check the following:</p> <ol style="list-style-type: none"> a. Inspect fuel inlet filter. If plugged, replace. b. If fuel filter is okay, remove air horn and check for a bind in the float mechanism or a sticking inlet needle. If okay, adjust float as specified. <p>Remove the air horn.</p> <p>Check fuel inlet needle and seat for proper seal. If a needle and seat tester is not available, apply vacuum to the needle seat with needle installed. If the needle is leaking, replace.</p> <p>Check float for free movement, bent float hanger or binds in the float arm.</p> <p>If foreign material is in fuel system, clean the system and replace fuel filters as necessary. If excessive foreign material is found, completely disassemble and clean.</p> |

Fig. 6C-1—Diagnosis 1 of 9

CARBURETOR DIAGNOSIS CONT'D.

| CONDITION | POSSIBLE CAUSE | CORRECTION |
|--|--|--|
| <p>Engine Starts — Will Not Keep Running</p> | <p>Fuel pump.</p> <p>Idle speed.</p> <p>Choke heater system malfunctioning (may cause loading).</p> <p>Loose, broken or incorrect vacuum hose routing.</p> <p>Engine does not have enough fast idle speed when cold.</p> <p>Choke vacuum break units are not adjusted to specification or are defective.</p> <p>Choke valve sticking and/or binding.</p> <p>Insufficient fuel in carburetor.</p> | <p>Check fuel pump pressure and volume, replace if necessary. See FUEL SYSTEM DIAGNOSIS, Section 6.</p> <p>Adjust idle to specifications.</p> <p>Check vacuum supply at hot air inlet to choke housing. Should be not less than manifold vacuum minus 3" Hg. with engine running at idle. (Exc. IMV) Check wiring.</p> <p>Check for plugged, restricted, or broken heat tubes.</p> <p>Check routing of all hot air parts.</p> <p>Check condition and routing of all vacuum hoses — correct as necessary.</p> <p>Check for free movement of fast idle cam. Clean and/or realign as necessary.</p> <p>Adjust both vacuum break assemblies to specification. If adjusted okay, check the vacuum break units for proper operation as follows:</p> <p>To check the vacuum break units, apply a constant vacuum source of at least 10" Hg., plungers should slowly move inward and hold vacuum. If not, replace the unit.</p> <p>Always check the fast idle cam adjustment when adjusting vacuum break units.</p> <p>Clean and align linkage or replace if necessary. Readjust all choke settings, see Section 6M, if part replacement or realignment is necessary.</p> <p>Check fuel pump pressure and volume.</p> <p>Check for partially plugged fuel inlet filter. Replace if contaminated.</p> <p>Check the float level adjustment for binding condition. Adjust as specified.</p> |
| <p>Engine Starts Hard (Crankes Normally)</p> | <p>Loose, broken or incorrect vacuum hose routing.</p> <p>Incorrect starting procedure.</p> | <p>Check condition and routing of all vacuum hoses — correct as necessary. See Section 6E.</p> <p>Check to be sure customer is using the starting procedure outlined in Owner's Manual.</p> |

Fig. 6C-2--Diagnosis 2 of 9

CARBURETOR DIAGNOSIS CONT'D.

| CONDITION | POSSIBLE CAUSE | CORRECTION |
|--|--|---|
| <p>Engine Starts Hard (Crankes Normally) (Continued)</p> | <p>Malfunction in accelerator pump system.</p> <p>Choke valve not closing.</p> <p>Vacuum breaks misadjusted or malfunctioning.</p> <p>Insufficient fuel in bowl.</p> <p>Flooding.</p> <p>Slow engine cranking speed.</p> | <p>Check accelerator pump adjustment and operation.</p> <p>Check pump discharge ball for sticking or leakage.</p> <p>Adjust choke thermostatic coil. Check choke valve and linkage for binds and alignment. Clean and repair or replace as necessary.</p> <p>Check for adjustment and function of vacuum breaks. Correct as necessary.</p> <p>Check fuel pump pressure and volume. Check for partially plugged fuel inlet filter. Replace if dirty. Check float mechanism. Adjust as specified.</p> <p>Check float and needle and seat for proper operation.</p> <p>Refer to starting circuit diagnosis. Section 6D.</p> |
| <p>Engine Idles Abnormally (Too fast or too slow)</p> | <p>Incorrect idle speed.</p> <p>Air leaks into carburetor bores beneath throttle valves, manifold leaks, or vacuum hoses disconnected or installed improperly.</p> <p>Clogged or malfunctioning PCV system.</p> <p>Carburetor flooding.</p> <p>Check by using procedure outlined under "Engine Flooded".</p> | <p>Reset idle speed per instructions on underhood label.</p> <p>Check all vacuum hoses and restrictors leading into the manifold or carburetor base for leaks or being disconnected. Install or replace as necessary.</p> <p>Torque carburetor to manifold bolts to 10 ft. lbs. Using a pressure oil can, spray light oil or kerosene around manifold to head surfaces and carburetor throttle body. NOTE: Do not spray at throttle shaft ends. If engine RPM changes, tighten or replace the carburetor or manifold gaskets as necessary.</p> <p>Check PCV system. Clean and/or replace as necessary.</p> <p>Remove air horn and check float adjustments.</p> <p>Check float needle and seat for proper seal. If a needle and seat tester is not available, apply vacuum to the needle seat with needle installed. If the needle is leaking or damaged, replace.</p> |

Fig. 6C-3--Diagnosis 3 of 9

CARBURETOR DIAGNOSIS CONT'D.

| CONDITION | POSSIBLE CAUSE | CORRECTION |
|---|---|---|
| <p>Engine Idles Abnormally (Too fast or too slow) (Continued)</p> | <p>Restricted air cleaner element.</p> <p>Idle system plugged or restricted.</p> <p>Incorrect idle mixture adjustment.</p> <p>Defective idle stop solenoid, idle speed-up solenoid or wiring.</p> <p>Throttle blades or linkage sticking and/or binding.</p> | <p>Check float for free movement. Check for bent float hanger or binds in the float arm.</p> <p>If foreign material is found in the carburetor, clean the fuel system and carburetor. Replace fuel filter as necessary.</p> <p>Replace as necessary.</p> <p>Clean carburetor, see Section 6C1.</p> <p>Readjust per specified procedure. See Section 6C1.</p> <p>Check solenoid and wiring.</p> <p>Check throttle linkage and throttle blades (primary and secondary) for smooth and free operation. Correct problem areas.</p> |
| <p>Engine Diesels (After Run) upon Shut Off</p> | <p>Loose, broken or improperly routed vacuum hoses.</p> <p>Incorrect idle speed.</p> <p>Malfunction of idle stop solenoid, idle speed-up solenoid or dashpot.</p> <p>Fast idle cam not fully off.</p> <p>Excessively lean condition caused by maladjusted carburetor idle mixture.</p> <p>Ignition timing retarded.</p> | <p>Check condition and routing of all vacuum hoses. Correct as necessary.</p> <p>Reset idle speed per instructions on label in engine compartment.</p> <p>Check for correct operation of idle solenoid. Check for sticky or binding solenoid.</p> <p>Check fast idle cam for freedom of operation. Clean, repair, or adjust as required. Check choke heated air tubes for routing, fittings being tight or tubes plugged. Check choke linkage for binding. Clean and correct as necessary.</p> <p>Adjust carburetor idle mixture as described in Section 6C1.</p> <p>Set to specifications.</p> |
| <p>Engine Hesitates On Acceleration</p> | <p>Loose, broken or incorrect vacuum hose routing</p> <p>Accelerator pump not adjusted to specification or inoperative.</p> <p>Inoperative accelerator pump system.</p> | <p>Check condition and routing of all vacuum hoses — correct or replace.</p> <p>Adjust accelerator pump, replace.</p> <p>Remove air horn and check pump cup. If cracked, scored or distorted, replace the pump plunger.</p> |

Fig. 6C-4--Diagnosis 4 of 9

CARBURETOR DIAGNOSIS CONT'D.

| CONDITION | POSSIBLE CAUSE | CORRECTION |
|---|---|--|
| <p>Engine Hesitates On Acceleration (Continued)</p> | <p>NOTE: A quick check of the pump system can be made as follows: With the engine off, look into the carburetor bores and observe pump nozzles while quickly opening throttle lever. A full stream of fuel should emit from each pump nozzle.</p> <p>Foreign matter in pump passages.</p> <p>Float level too low.</p> <p>Front vacuum break diaphragm not functioning properly.</p> <p>Air valve malfunction.</p> <p>Power enrichment system not operating correctly.</p> <p>Inoperative air cleaner heated air control.</p> <p>Fuel filter dirty or plugged.</p> <p>Distributor vacuum or mechanical advance malfunctioning.</p> <p>Timing not to specifications.</p> <p>Choke coil misadjusted (cold operation.)</p> <p>EGR valve stuck open.</p> | <p>Check the pump discharge ball for proper seating and location.</p> <p>Clean and blow out with compressed air.</p> <p>Check and reset float level to specification.</p> <p>Check adjustment and operation of vacuum break diaphragm.</p> <p>Check operation of secondary air valve. Check spring tension adjustment.</p> <p>Check for binding or stuck power piston(s) — correct as necessary.</p> <p>Check operation of thermostatic air cleaner system.</p> <p>Replace filter and clean fuel system as necessary.</p> <p>Check for proper operation.</p> <p>Adjust to specifications.</p> <p>Adjust to specifications.</p> <p>Inspect and clean EGR valve.</p> |
| <p>Engine Has Less Than Normal Power At Normal Accelerations.</p> | <p>Loose, broken or incorrect vacuum hose routing.</p> <p>Clogged or defective PCV system.</p> <p>Choke sticking.</p> <p>Clogged or inoperative power system.</p> | <p>Check condition and routing of all vacuum hoses.</p> <p>Clean or replace as necessary.</p> <p>Check complete choke system for sticking or binding. Clean and realign as necessary. Check adjustment of choke thermostatic coil.</p> <p>Check connections and operation of choke hot air system.</p> <p>Check jets and channels for plugging; clean and blow out passages.</p> <p>Remove air horn and check for free operation of power pistons.</p> |

Fig. 6C-5--Diagnosis 5 of 9

CARBURETOR DIAGNOSIS CONT'D.

| CONDITION | POSSIBLE CAUSE | CORRECTION |
|---|---|--|
| <p>Engine Has Less Than Normal Power At Normal Accelerations. (Continued)</p> <p>Less Than Normal Power On Heavy Acceleration Or At High Speed</p> | <p>Air cleaner temperature regulation improper.</p> <p>Transmission malfunction.</p> <p>Ignition system malfunction.</p> <p>Exhaust system.</p> <p>Carburetor throttle valves not going wide open. Turn off engine and check by pushing accelerator pedal to floor.</p> <p>Secondary throttle lockout not allowing secondaries to open.</p> <p>Spark plugs fouled, incorrect gap.</p> <p>Plugged air cleaner element.</p> <p>Air valve malfunction. (Where applicable)</p> <p>Plugged fuel inlet filter.</p> <p>Insufficient fuel to carburetor.</p> <p>Power enrichment system not operating correctly.</p> <p>Choke closed or partially closed.</p> <p>Float level too low.</p> | <p>Check regulation and operation of air cleaner system.</p> <p>Refer to transmission diagnosis.</p> <p>Check ignition system. See Section 6D. Refer to H.E.I. diagnosis.</p> <p>Check for restrictions. Correct as required.</p> <p>Correct throttle linkage to obtain wide open throttle in carburetor.</p> <p>Check for binding or sticking lockout lever.</p> <p>Check for free movement of fast idle cam.</p> <p>Check choke heated air system for proper and tight connections plus flow through system.</p> <p>Check adjustment of choke thermostatic coil.</p> <p>Make necessary corrections and adjustments.</p> <p>Clean, regap, or replace plugs.</p> <p>Replace element.</p> <p>Check for free operation of air valve.</p> <p>Check spring tension adjustment. Make necessary adjustments and corrections.</p> <p>Replace with a new filter element.</p> <p>Check fuel pump and system, run pressure and volume test. See FUEL SYSTEM DIAGNOSIS, Section 6.</p> <p>Remove the air horn and check for free operation of both power piston(s), clean and correct as necessary.</p> <p>Free choke valve or linkage.</p> <p>Check for loose jets.</p> <p>Check and reset float level to specification.</p> |

Fig. 6C-6--Diagnosis 6 of 9

CARBURETOR DIAGNOSIS CONT'D.

| CONDITION | POSSIBLE CAUSE | CORRECTION |
|---|--|---|
| Less Than Normal Power On Heavy Acceleration Or At High Speed (Continued) Engine Surges | Transmission malfunction. | Refer to transmission diagnosis. |
| | Ignition system malfunction. | Check ignition system. See Section 6D. |
| | Fuel metering jets restricted. | If the fuel metering jets are restricted and an excessive amount of foreign material is found in the fuel bowl, the carburetor should be completely disassembled and cleaned. |
| | Fuel pump. | Check fuel pump pressure and volume, inspect lines for leaks and restrictions. See FUEL SYSTEM DIAGNOSIS, Section 6. |
| | Exhaust system. | Check for restrictions. Correct as required. |
| | Loose, broken or incorrect vacuum hose routing. | Check condition and routing of all vacuum hoses. Correct as necessary. |
| | PCV system clogged or malfunctioning. | Check PCV system. Clean or replace as necessary. |
| | Loose carburetor, EGR or intake manifold bolts and/or leaking gaskets. | Torque carburetor to manifold bolts to 10 ft. lbs. Using a pressure oil can, spray light oil or kerosene around manifold to head mounting surface and carburetor base. If engine RPM changes, tighten or replace the carburetor or manifold gaskets as necessary. Check EGR mounting bolt torque. |
| | Low or erratic fuel pump pressure. | Check fuel delivery and pressure. |
| | Contaminated fuel. | Check for contaminants in fuel. Clean system if necessary. |
| | Fuel filter plugged. | Check and replace as necessary. |
| | Float level too low. | Check and reset float level to specification. |
| | Malfunctioning float and/or needle and seat. | Check operation of system. Repair or replace as necessary. |
| | Power piston stuck or binding. | Check for free movement of power piston(s). Clean and correct as necessary. |
| | Poor Gas Mileage | Fuel jets or passages plugged or restricted. |
| Ignition system malfunction. | | Check ignition system. See Section 6D. |
| Exhaust system. | | Check for restrictions. Correct as necessary. |
| Customer driving habits. | | Run mileage test with customer driving if possible. Make sure car has 2000-3000 miles for the "break-in" period. |

Fig. 6C-7--Diagnosis 7 of 9

CARBURETOR DIAGNOSIS CONT'D.

| CONDITION | POSSIBLE CAUSE | CORRECTION |
|--|---|---|
| <p>Poor Gas Mileage (Continued)</p> | <p>Loose, broken or improperly routed vacuum hoses.</p> <p>Engine in need of service.</p> | <p>Check condition of all vacuum hose routings. Correct as necessary.</p> <p>Check engine compression, examine spark plugs; if fouled or improperly gapped, clean and regap or replace. Check ignition wire condition and check and reset ignition timing. Replace air cleaner element if dirty. Check for restricted exhaust system and intake manifold for leakage. Check carburetor mounting bolt torque. Check vacuum and mechanical advance.</p> |
| <p>Poor Gas Mileage and/or Black Smoke from Tail Pipe</p> | <p>Fuel leaks.</p> <p>High fuel level in carburetor.</p> | <p>Check fuel tank, fuel lines and fuel pump for any fuel leakage.</p> <p>Check fuel inlet needle and seat for proper seal. Test, using suction from a vacuum source. If needle is leaking, replace.</p> <p>Check for loaded float. Reset float level to specification.</p> <p>If excessive foreign material is present in the carburetor bowl, the carburetor should be cleaned.</p> |
| <p>Car feels like it is running out of gas — surging occurs in mid-speed range</p> | <p>Power system in carburetor not functioning properly. Power piston(s) sticking or metering rods out of jets.</p> <p>Choke system.</p> <p>Plugged air cleaner element.</p> <p>Exhaust system.</p> <p>Low tire pressure or incorrect tire size. Evaporative emission canistor Transmission malfunction or in wrong gear. Plugged fuel filters.</p> <p>Faulty fuel pump.</p> <p>Foreign material in fuel system or kinked fuel pipes or hoses.</p> | <p>Remove air horn and check for free movement of power piston(s). Clean and correct as necessary.</p> <p>Check choke heated air tubes for routing and/or plugging which would restrict hot air flow to choke housing. Check choke linkage for binding. Clean or repair as required. Check adjustment of thermostatic coil. Readjust to specification as required. Check electric choke wiring. Replace element.</p> <p>Check for restrictions. Correct as required.</p> <p>Inflate tires to specifications and use correct size tires. See evaporative section (Daignosis) Refer to transmission diagnosis.</p> <p>Remove and replace filters.</p> <p>Perform fuel pump test. Remove and replace fuel pump as required.</p> <p>Inspect pipes, and hoses for kinks and bends, blow out to check for plugging. Remove and replace as required.</p> |

Fig. 6C-8--Diagnosis 8 of 9

CARBURETOR DIAGNOSIS CONT'D.

| CONDITION | POSSIBLE CAUSE | CORRECTION |
|--|---|---|
| Engine starts but will not continue to run or will run but surges and backfires. | Faulty fuel pump. | Perform fuel pump test. Remove and replace fuel pump as required. |
| Engine will not start | Faulty fuel pump. | Perform diagnostic tests on the fuel pump as described in Section 6B. Remove and replace fuel pump as required. |
| GASOLINE ODOR | Tank overfilled. | Do not "pack" tank. Fill to automatic shut-off. |
| | Fuel feed or vapor return line leaking. | Correct as required. |
| | Leak in fuel tank. | Purge tank and repair or replace tank as required. |
| | Disconnected fuel tank vent lines or hoses. | Connect lines or hoses as required. |
| | Purge lines not connected, improperly routed, plugged or pinched. | Check, connect and open lines as required. |
| | Faulty fill cap. | Install new cap. |
| COLLAPSED FUEL TANK | Plugged or pinched vent lines or hoses, and defective cap. | Check all lines from tank to canister and replace cap. |
| | Canister filter plugged and defective cap. | Replace filter in canister and cap. |
| FUEL TANK RATTLES | Mounting straps loose. | Tighten straps to specifications. |
| | Baffle loose. | Replace fuel tank. |
| | Foreign material in tank. | Remove tank and clean. |
| | Felt strips improperly located (Station Wagon). | Install strips. |
| FUEL STARVATION | Tank gauge unit filter plugged. | Replace filter. |
| | Fuel line pinched, plugged or mis-routed. | Check open or re-route as required. |
| | Fuel pump not operating. | See FUEL PUMP TEST. |
| Fuel odor | Vapor leak from evaporative system. | Inspect and correct as necessary fuel and evap. hoses and pipes, fuel sender sealing gasket, fuel cap. |

Fig. 6C-9--Diagnosis 9 of 9

DIAGNOSIS

EVAPORATIVE CONTROL SYSTEM

| CONDITION | POSSIBLE CAUSE | CORRECTION |
|--|--|---|
| <p>Evidence of fuel loss or fuel vapor odor</p> <p>A) From area of fuel tank or fuel cap - Perform pressure check to determine possible causes</p> | <ol style="list-style-type: none"> 1. Leaking or plugged fuel or EVAP hoses 2. Leaking fuel cap 3. Leaking fuel filler neck 4. Fuel filler neck gasket surface nicked, burred, or dented 5. Leaking sending unit or gasket 6. Leaking tank switch unit (Dual tank system) 7. Inoperative tank switch unit (Dual tank system) 8. Plugged or inoperative tank pressure control valve | <ol style="list-style-type: none"> 1. Repair or replace hoses as necessary 2. Repair or replace cap as necessary 3. Repair or replace as necessary 4. Repair or replace as necessary 5. Repair or replace as necessary 6. Replace unit 7. Replace unit 8. Repair or replace as necessary |
| <p>B) From under hood - Perform pressure check to determine possible causes</p> | <ol style="list-style-type: none"> 1. Liquid fuel leaking from fuel lines, fuel pump or carburetor 2. Cracked or damaged canisters 3. Inoperative bowl vent valve (see Bowl Vent Check Procedures) 4. Inoperative purge valve (see Purge Valve Check Procedures) 5. Disconnected, misrouted, kinked, deteriorated or damaged vapor hoses or control hoses 6. Bowl vent hose misrouted 7. Air cleaner or air cleaner gasket improperly seated 8. Leaking or inoperative tank pressure control valve | <ol style="list-style-type: none"> 1. Tighten fuel lines, repair or replace fuel pump or carburetor as necessary 2. Repair or replace canisters as necessary 3. Repair or replace hoses Replace canister 4. Repair or replace hoses Replace canister 5. Check for proper connections, and check routing as well as condition. Correct as necessary 6. Reroute hose without low spots 7. Reinstall air cleaner and/or replace gasket 8. Repair or replace as necessary |
| <p>Poor idle or driveability or driveability slugging</p> | <ol style="list-style-type: none"> 1. Inoperative purge valve (see Purge Valve Check Procedures) 2. Inoperative bowl vent valve (see Bowl Vent Check Procedures) 3. Vacuum leak at tank pressure control valve | <ol style="list-style-type: none"> 1. Replace or repair hoses Replace canister 2. Repair or replace hoses Replace canister 3. Repair or replace hoses and/or valve |
| <p>Collapsed fuel tank (Loss of tank capacity)</p> | <ol style="list-style-type: none"> 1. Plugged or pinched vapor pipe or hoses and defective cap 2. Canister filter plugged and defective cap 3. Plugged or ruptured diaphragm in tank pressure control valve and defective cap | <ol style="list-style-type: none"> 1. Check all lines from tank to canister and replace cap 2. Replace filter in canister and cap 3. Replace tank pressure control valve and cap |

Fig. 6C-10-Evaporative Control System Diagnosis

classicalcarlibrary.com

SECTION 6C1

MODEL 1ME CARBURETOR

CONTENTS

| | | | |
|---------------------------------|-------|------------------------------|-------|
| General Description..... | 6C1-1 | Carburetor Replacement..... | 6C1-7 |
| On-Vehicle Service..... | 6C1-3 | Solenoid Replacement..... | 6C1-7 |
| Adjustments | 6C1-3 | Choke Coil Replacement..... | 6C1-7 |
| Choke Checking Procedure..... | 6C1-3 | Throttle Lever Actuator..... | 6C1-8 |
| Idle Mixture Adjustment..... | 6C1-3 | Unit Repair | 6C1-9 |
| Carburetor Mounting Torque..... | 6C1-7 | | |

GENERAL DESCRIPTION

The Monojet, carburetor (Fig. 6C1-1) is a single bore downdraft carburetor using a triple venture in conjunction with a plain tube nozzle.

Fuel flow through the main metering system is controlled by a main well air bleed and a variable orifice jet. A power enrichment system is used to provide good performance during moderate to heavy acceleration and at higher engine speeds.

The model 1ME incorporates an integral automatic choke system which uses an electrically heated choke coil. The vacuum diaphragm unit is mounted externally on the air horn and connects to the thermostatic coil lever through a connecting line.

The electric choke coil is contained in a choke housing mounted on a bracket attached to the float bowl. Special rivets are installed to retain the factory setting of the choke coil and provide a non-adjustable design.

An integral, pleated-paper fuel inlet filter is mounted in the fuel bowl behind the fuel inlet nut to give maximum filtration of incoming fuel. A check valve on light duty emissions is used in the filter inlet to prevent fuel draining from the fuel system after roll-over.

To improve hot engine starting and meet evaporative emission requirements, fuel vapors from the carburetor bowl are vented to the vapor canister on some models. A tube (location F) is added to the air horn to connect air horn and canister.

Other features of the Monojet carburetor include an aluminum throttle body for decreased weight and improved heat distribution and a thick throttle body to bowl insulator gasket to keep excessive engine heat from the float bowl.

On California models seals have been added in the float bowl to seal the power piston drive rod and the pump lever to prevent escape of fuel vapors to atmosphere. During unit repair, the seals and retainer, where used, must be removed prior to immersion of the float bowl in carburetor cleaner.

The carburetor model identification is stamped on a vertical portion of the float bowl, adjacent to the fuel inlet nut (Fig. 6C1-2).

If replacing the float bowl, follow the manufacturer's instructions contained in the service package so that the identification number can be transferred to the new float

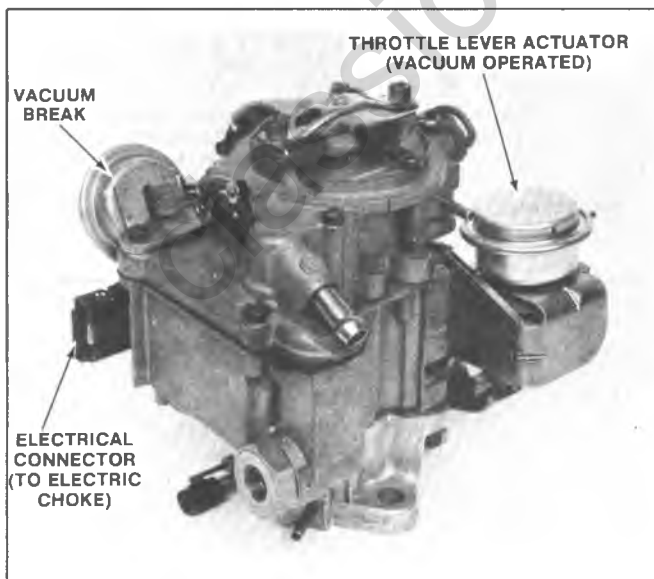


Fig. 6C1-1--Model 1ME Carburetor

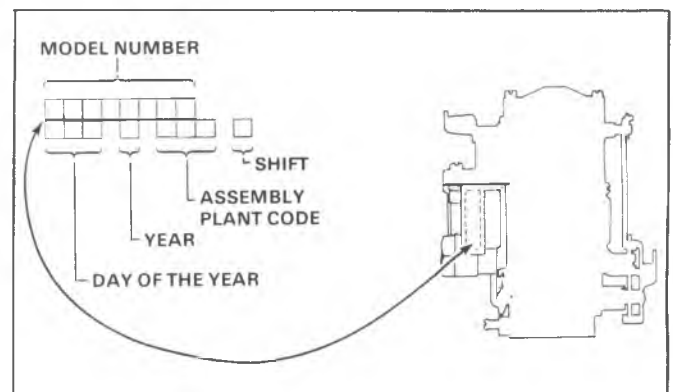


Fig. 6C1-2--Model 1ME Carburetor Identification

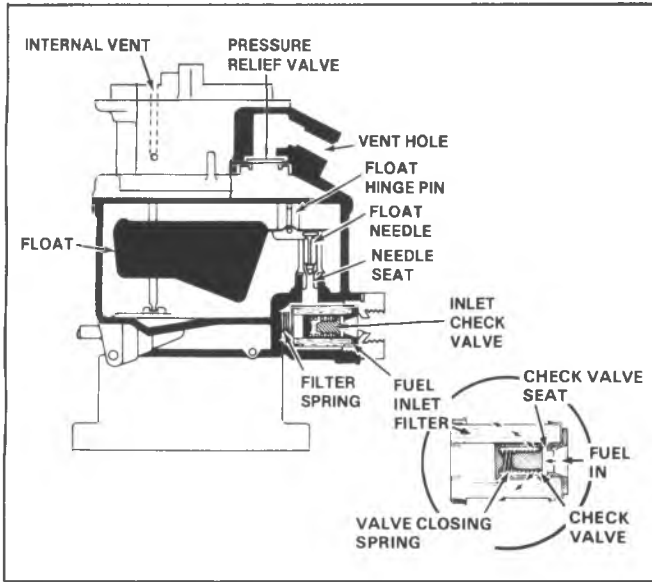


Fig. 6C1-3--Float System

bowl.

An electrically operated idle stop solenoid is used on all models.

Dual throttle return springs are used on all carburetors.

The throttle lever has a spun-in plastic bushing, this is used as the bearing surface for the dual throttle return springs.

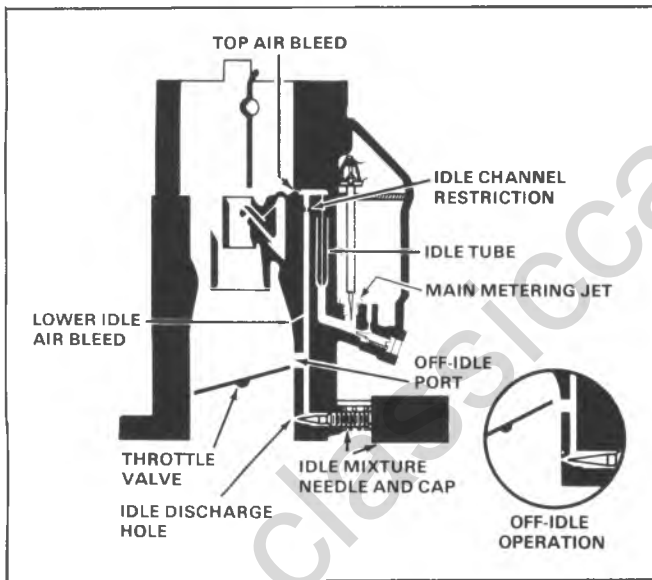


Fig. 6C1-4--Idle System

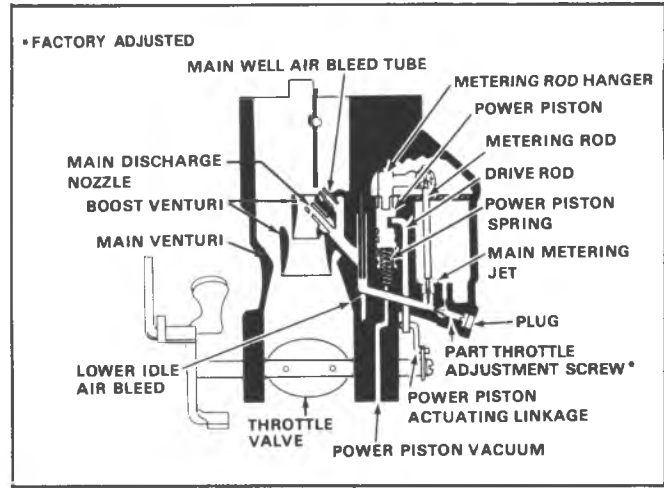


Fig. 6C1-5--Main Metering System Typical

The spun-in plastic return spring bushing will withstand normal cleaning time in an approved cold immersion type carburetor cleaner. The bushing is not serviced separately and should not be removed from the carburetor throttle lever.

Six basic systems of operation are used: float, idle, main metering, power enrichment, pump and choke. 6C1-3 through 8).

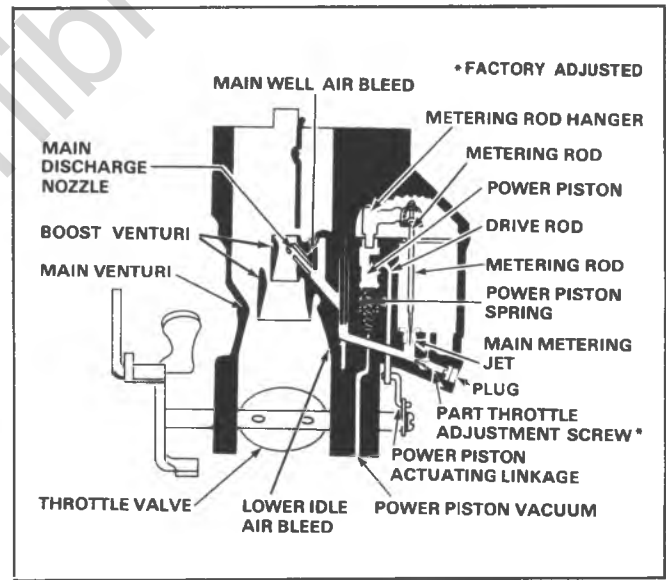


Fig. 6C1-6--Power Enrichment System

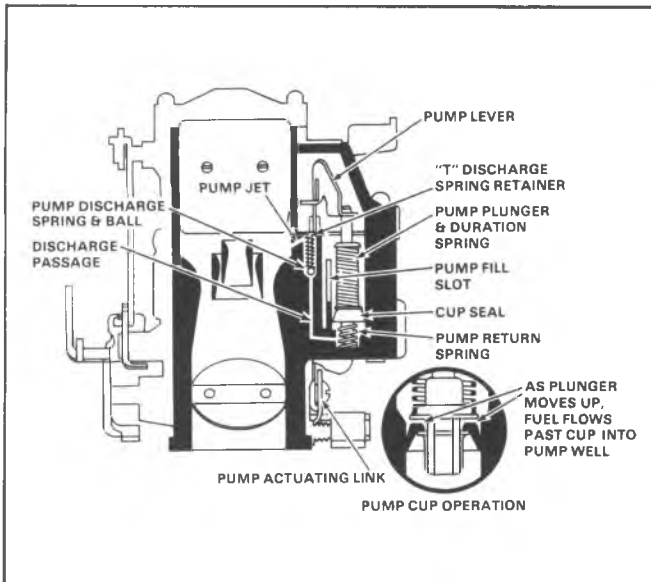


Fig. 6C1-7--Pump System

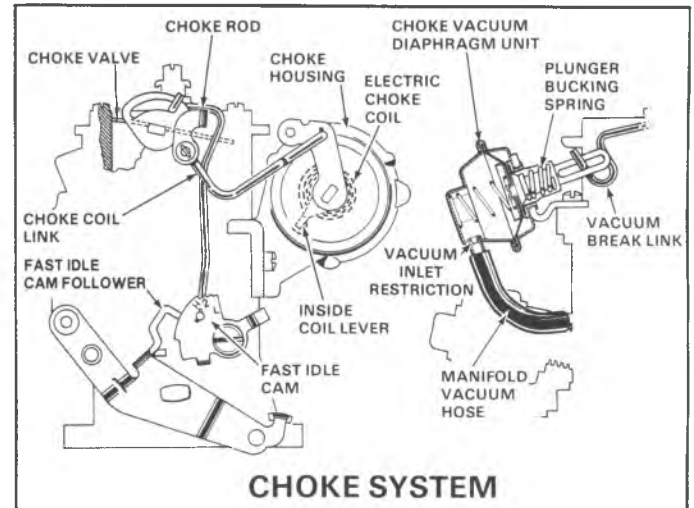


Fig. 6C1-8--Choke System

ON-VEHICLE SERVICE

1ME CARBURETOR ADJUSTMENTS

Refer to figure 6C1-9 through 6C1-11 for adjustment specifications and procedures.

Choke Checking Procedure

1. Remove air cleaner. With engine off, hold throttle half open. Open and close choke several times. Watch linkage to be certain all links are connected and there are no signs of damage.

2. If choke or linkage binds, sticks, or works sluggishly, clean with Choke Cleaner X-20-A or equivalent. Use cleaner as directed on can. Refer to disassembly instructions for additional direction if cleaning does not correct.

3. Visually inspect carburetor to be certain all vacuum hoses are connected. Inspects hoses for cracks, abrasions, hardness or other signs of deterioration. Replace or correct as necessary.

4. Make sure vacuum break diaphragm shaft is fully extended when engine is off. If shaft is not fully extended, replace vacuum break assembly. Start engine - vacuum break diaphragm shaft should fully retract within 10 seconds. If unit fails to retract, replace vacuum break assembly.

5. Allow choke to cool so that when throttle is opened slightly choke blade fully closes. This check must be performed at an ambient temperature of 60°F to 80°F.

6. Start engine and determine time for choke blade to reach full open position. (Start timer when engine starts).

7. If the choke blade fails to open fully within 3-1/2 minutes proceed with steps 8-9-10 below.

8. Check voltage at the choke heater connection. (Engine must be running). If the voltage is approximately 12-15 volts, replace the electric choke unit.

9. If the voltage is low or zero, check all wires and connections. If the connections at the oil pressure switch are faulty, the oil warning light will be off with the key "on"

and engine off. If the fuse is blown, the radio or turn signal indicator will be inoperative. Repair wires or replace fuses as required.

10. If step 9 is good, replace oil pressure switch.

No gasket is used between the choke cover and the choke housing due to grounding requirements.

Checking Solenoid

1. Turn on ignition, but do not start engine.

2. Open throttle to allow solenoid plunger to extend.

3. Hold throttle lever wide open, feel end of plunger and disconnect wire at solenoid.

4. Plunger should move. Some spring tension should be felt.

5. If plunger did not move, back out 1/8 hex screw (counterclockwise) one full turn and repeat steps 3 and 4.

6. If plunger moves in step 5, connect wire to solenoid and adjust idle speed.

7. If plunger did not move in step 5 insert test lamp (1893 bulb or smaller) between solenoid feed wire and ground.

8. If lamp lights, replace solenoid.

9. If lamp does not light, locate cause of open circuit in solenoid feed wire.

IDLE MIXTURE ADJUSTMENT (LEAN DROP)

For Heavy Duty Emission Vehicles Without 4 Barrel

1. Set parking brake and block drive wheels.

2. Remove air cleaner for access to carburetor, but keep vacuum hoses connected.

3. Disconnect and plug other hoses, as directed on Emission Control information Label under the hood.

4. Start engine and bring to normal operating temperature, choke open, air conditioning off.

5. Connect an ACCURATE tachometer to engine.

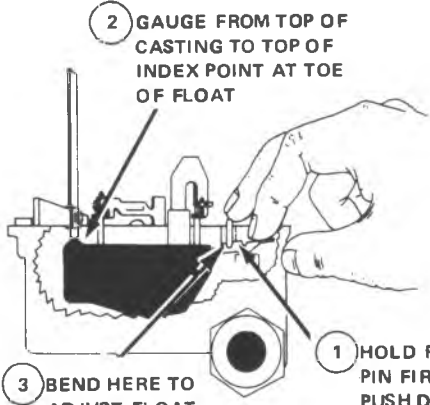
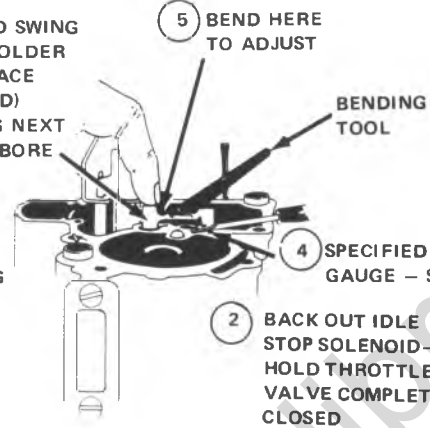
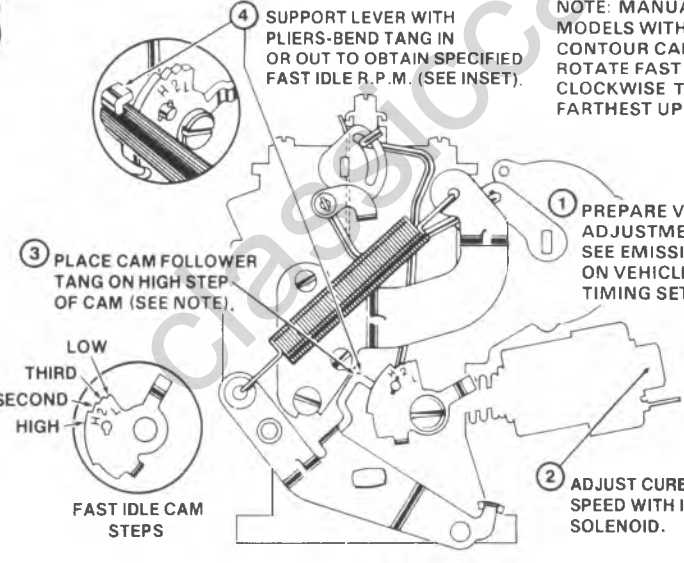
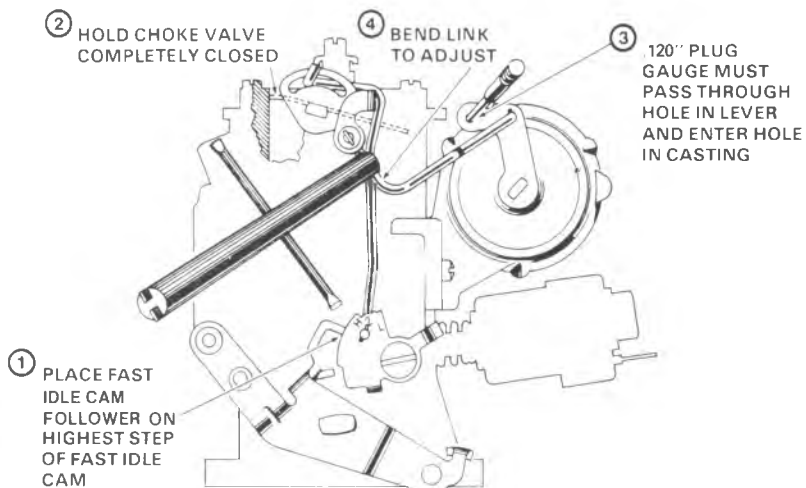
| | | |
|---|---|--------------------------------|
| <p>1</p>  <p>2 GAUGE FROM TOP OF CASTING TO TOP OF INDEX POINT AT TOE OF FLOAT</p> <p>3 BEND HERE TO ADJUST FLOAT UP OR DOWN</p> <p>1 HOLD FLOAT RETAINING PIN FIRMLY IN PLACE - PUSH DOWN ON END OF FLOAT ARM, AGAINST TOP OF FLOAT NEEDLE</p> <p>FLOAT LEVEL ADJUSTMENT</p> | <p>CARB. NO.</p> <p>17080009 17080309 17080359</p> | <p>GAUGE</p> <p>11/32"</p> |
| <p>2</p>  <p>3 HOLD POWER PISTON DOWN AND SWING METERING ROD HOLDER OVER FLAT SURFACE (GASKET REMOVED) OF BOWL CASTING NEXT TO CARBURETOR BORE</p> <p>5 BEND HERE TO ADJUST</p> <p>BENDING TOOL</p> <p>4 SPECIFIED PLUG GAUGE - SLIDE FIT</p> <p>2 BACK OUT IDLE STOP SOLENOID - HOLD THROTTLE VALVE COMPLETELY CLOSED</p> <p>1 REMOVE METERING ROD BY HOLDING THROTTLE VALVE WIDE OPEN. PUSH DOWNWARD ON METERING ROD AGAINST SPRING TENSION, THEN SLIDE METERING ROD OUT OF SLOT IN HOLDER AND REMOVE FROM MAIN METERING JET.</p> <p>METERING ROD ADJUSTMENT</p> | <p>CARB. NO.</p> <p>17080009 17080309 17080359</p> | <p>PLUG GAUGE</p> <p>.090"</p> |
| <p>3</p>  <p>4 SUPPORT LEVER WITH PLIERS-BEND TANG IN OR OUT TO OBTAIN SPECIFIED FAST IDLE R.P.M. (SEE INSET).</p> <p>NOTE: MANUAL CHOKE MODELS WITH SMOOTH CONTOUR CAM SURFACE - ROTATE FAST IDLE CAM CLOCKWISE TO ITS FARTHEST UP POSITION.</p> <p>3 PLACE CAM FOLLOWER TANG ON HIGH STEP OF CAM (SEE NOTE).</p> <p>LOW THIRD SECOND HIGH</p> <p>FAST IDLE CAM STEPS</p> <p>1 PREPARE VEHICLE FOR ADJUSTMENTS - SEE EMISSION LABEL ON VEHICLE. IGNITION TIMING SET PER LABEL.</p> <p>2 ADJUST CURB IDLE SPEED WITH IDLE STOP SOLENOID.</p> <p>FAST IDLE ADJUSTMENT</p> | <p>HEAVY DUTY EMISSIONS 2400 RPM (IN PARK OR NEUTRAL)</p> | |

Fig. 6C1-9--1ME Adjustments - 1 of 3

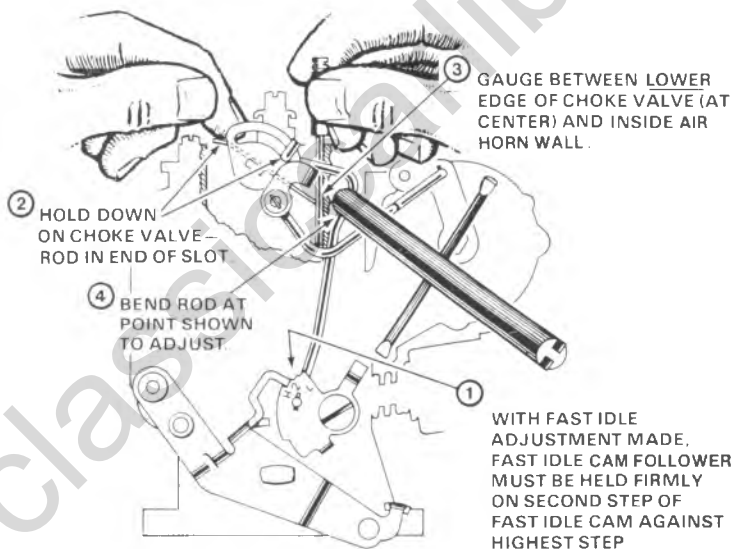
4



CHOKE COIL LEVER ADJUSTMENT - 1ME

| CARB. NO. | PLUG GAUGE |
|----------------------------------|------------|
| 17080009 17080309 17080359 | .120" |

5



CHOKE ROD (FAST IDLE CAM) ADJUSTMENT (2ND STEP)

| CARB. NO. | INDEX MARK |
|----------------------------------|------------|
| 17080009 17080309 17080359 | .275" |

Fig. 6C1-10--1ME Adjustments - 2 of 3

| | | |
|--|---|--------------------------------|
| <p>6</p> <p>NOTE: HOLD GAUGE VERTICAL.</p> <p>④ PLACE GAUGE BETWEEN LOWER EDGE OF CHOKE VALVE AND INSIDE AIR HORN WALL.</p> <p>② USE OUTSIDE VACUUM SOURCE TO SEAT DIAPHRAGM.</p> <p>⑤ BEND LINK TO ADJUST.</p> <p>NOTE: ON DELAY FEATURE MODELS, COVER PLUG AND PURGE BLEED HOLE WITH 1" SQUARE PIECE OF MASKING TAPE. REMOVE AFTER ADJUSTMENT.</p> <p>③ PUSH DOWN ON CHOKE VALVE (COMPRESS PLUNGER BUCKING SPRING AND SEAT PLUNGER STEM ON MODELS SO EQUIPPED).</p> <p>① PLACE FAST IDLE CAM FOLLOWER ON HIGHEST STEP OF CAM.</p> <p>VACUUM BREAK ADJUSTMENT - 1ME (BOWL SIDE)</p> | <p>CARB. NO.</p> <p>17080009 17080309 17080359</p> | <p>PLUG GAUGE</p> <p>.400"</p> |
| <p>7</p> <p>① INSTALL CHOKE COIL IN CHOKE HOUSING AND INDEX PROPERLY (SEE NOTE).</p> <p>NOTE: IF CHOKE COIL IS WARM, COOL DOWN TO POINT WHERE CHOKE VALVE WILL CLOSE FULLY.</p> <p>② HOLD THROTTLE VALVE WIDE OPEN.</p> <p>③ GAUGE BETWEEN LOWER EDGE OF CHOKE VALVE AND INSIDE AIR HORN WALL (SEE NOTE).</p> <p>④ BEND TANG TO ADJUST (SEE INSET).</p> <p>UNLOADER ADJUSTMENT - 1ME (WIDE OPEN KICK)</p> | <p>CARB. NO.</p> <p>17080009 17080309 17080359</p> | <p>PLUG GAUGE</p> <p>.520"</p> |
| <p>8</p> <p>① NOTE: ENGINE MUST BE WARM - CHOKE WIDE OPEN - FAST IDLE CAM FOLLOWER OFF STEPS OF CAM (SEE EMISSION LABEL)</p> <p>② SET CURB IDLE TO SPECIFICATIONS - TURN ASSEMBLY IN OR OUT TO ADJUST R.P.M. (SOLENOID ENERGIZED)</p> <p>③ TO ADJUST BASE IDLE TURN 1/8" HEX SCREW (SOLENOID NOT ENERGIZED)</p> <p>HEX WRENCH</p> <p>IDLE SPEED ADJUSTMENT</p> | <p>SPECIFICATION</p> <p>SEE VEHICLE (ENGINE) EMISSION CONTROL INFORMATION LABEL</p> | |

Fig. 6C1-11-1ME Adjustments - 3 of 3

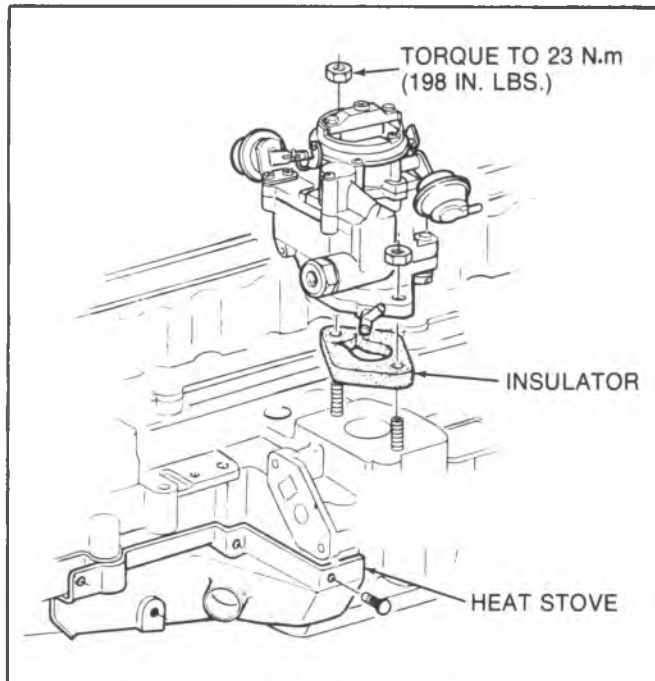


Fig. 6C1-12--1ME Carburetor Replacement

6. Disconnect vacuum advance and plug hose. Check ignition timing. If necessary, adjust to specification shown on Emission Control Information Label. Reconnect vacuum advance.

7. Carefully remove cap from idle mixture screw. Be careful not to bend screw. Lightly seat screw, then back out just enough so engine will run.

8. Place transmission in Neutral.

9. Back screw out (richen) 1/8 turn at a time until maximum idle speed is obtained. Then set idle speed to value shown on Engine Emission Control Information Label. Repeat step 9 to be certain you have maximum idle speed.

10. Turn screw in (lean) with 1/8 turn increments until idle speed reaches value shown on Engine Emission Control Information Label.

11. Reset idle speed to specification shown on Engine Emission Control Information Label.

12. Check and adjust fast idle as described on the Engine Emission Control Information Label.

13. Reconnect vacuum hoses. Install air cleaner.

14. Recheck idle speed. If necessary, reset to specification.

CARBURETOR MOUNTING TORQUE

When torquing carburetor after removed, overhaul, replacement or when installing a new heat insulator, torque mounting bolts, in a clockwise direction to 23 N·m (198 in. lbs.).

When retorquing carburetor at recommended maintenance intervals, retorque to 16 N·m (144 in. lbs.) maximum.

CARBURETOR REPLACEMENT (FIG. 6C1-12)

Removal

Flooding, stumble on acceleration and other performance complaints are, in many instances, caused by presence of dirt, water, or other foreign matter in carburetor. To aid in diagnosing cause, carburetor should be carefully removed from engine without draining fuel from bowl. Contents of fuel bowl may then be examined for contamination as carburetor is disassembled. Check filter.

1. Remove air cleaner.
2. Disconnect fuel and vacuum lines from carburetor.
3. Disconnect electrical connector at choke.
4. Disconnect accelerator linkage.
5. Disconnect solenoid electrical connector.
6. Remove carburetor attaching nuts and remove carburetor and solenoid assembly attachment.
7. Remove insulator gasket.

Installation

It is good shop practice to fill carburetor bowl before installing carburetor. This reduces strain on starting motor and battery and reduces the possibility of backfiring while attempting to start engine. A small supply of fuel will enable carburetor to be filled and the operation of float and intake needle and seat to be checked. Operate throttle lever several times and check discharge from pump jets before installing carburetor.

1. Be certain throttle body and intake manifold sealing surface are clean.
2. Install carburetor insulator.
3. Install carburetor over manifold studs.
4. Install vacuum and fuel lines at carburetor
5. Install attaching nuts and tighten alternately to 21 N·m (16 ft. lbs.).
6. Tighten fuel line.
7. Connect accelerator linkage.
8. Connect choke and solenoid electrical connectors.
9. Install air cleaner.
10. Check and adjust idle speed.

SOLENOID REPLACEMENT

An inoperative solenoid should be replaced.

Removal

1. Remove carburetor air cleaner.
2. Disconnect electrical connector at solenoid.
3. Unscrew and remove solenoid from float bowl assembly.

Installation

1. Hold choke valve wide open so that fast idle cam follower clears fast idle cam.
2. Install solenoid and turn in until it contacts lever tang.
3. Connect electrical connector.
4. Install air cleaner.
5. Check and adjust idle speed.

CHOKE COIL REPLACEMENT (Fig. 6C1-12a)

Choke mechanism should be checked for free operation. A binding condition may have developed from petroleum gum formation on the choke shaft or from damage. Choke shafts can usually be cleaned without disassembly by using Carbon X(X55) or equivalent.

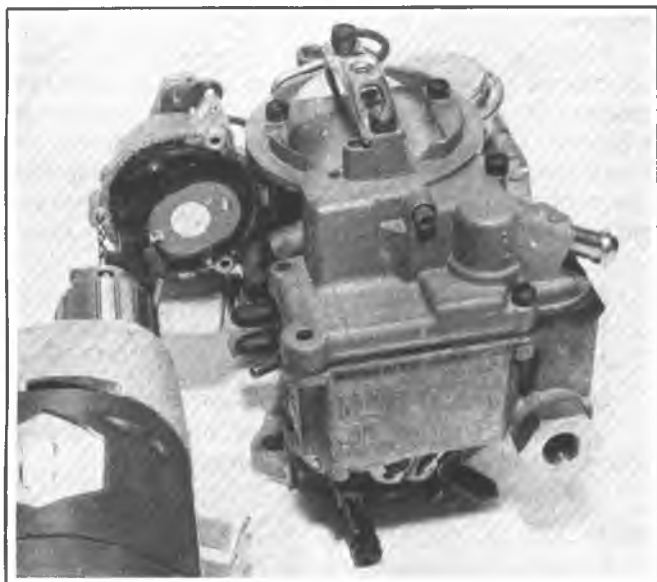


Fig. 6C1-12a--Choke Coil

1. Remove air cleaner and disconnect choke electrical connector.

2. Align a #21 drill (.159") on rivet head and drill enough to remove rivet head. Drill the two remaining rivet heads and then use a drift and small hammer to drive the remainder of the rivets out of the choke housing. Use care in drilling to prevent damage to choke cover or housing. Remove the three retainers and choke cover assembly from choke housing.

3. Install the choke cover and coil assembly in choke housing as follows:

a. Start the three (3) self tapping screws (supplied with service kits) in the choke housing, checking to be sure screws start easily and are aligned properly. Then, remove screws.

b. Place fast idle screw on highest step of fast idle cam.

c. Install the thermostatic cover and coil assembly in the choke housing, aligning notch in cover with raised casting projection on housing cover flange. Make sure coil pick-up tang engages the inside choke coil lever.

4. Connect choke electrical connector.

5. Start engine, check operation of choke and then install air cleaner.

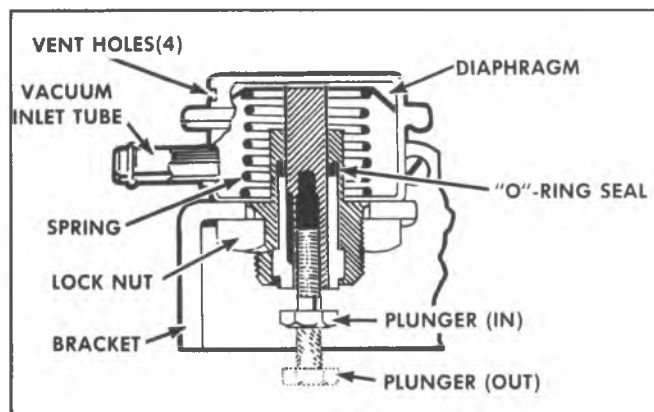


Fig. 6C1-12b--TRC

THROTTLE LEVER ACTUATOR ADJUSTMENT

(Fig. 6C1-12b)

Adjust the Throttle Return Control (TRC) idle speed to specification, shown on Vehicle Emission Label, as follows:

1. Disconnect hose from solenoid valve to actuator at the solenoid valve, and connect hose to an external vacuum source equipped with a vacuum gage.

2. Check the throttle lever, shaft, and linkage to be sure that they operate freely without binding or sticking.

3. Apply 20 in. Hg. vacuum to the actuator. Manually open the throttle slightly and allow to close against the extended actuator plunger. Note the engine rpm.

4. If the rpm is not within the specified TRC speed range, then turn the screw on the actuator plunger in the appropriate direction and repeat step 3 until the specified TRC speed range is obtained.

UNIT REPAIR

DISASSEMBLY

Place carburetor on a holding fixture to prevent damage to throttle valve.

Air Horn

Removal

1. Remove choke vacuum break diaphragm hose.
2. Remove vacuum break diaphragm assembly from air horn by removing two attaching screws. These screws have a tapered head and do not use lockwashers. Remove diaphragm plunger stem from diaphragm to choke lever link. (Fig. 6C1-13).

NOTICE: Screw that retains vacuum break lever to choke shaft is installed with thread torque retaining compound. It is not necessary to remove this screw and lever unless choke shaft replacement is required.

3. Remove fast idle cam attaching screw; then remove fast idle cam (Fig. 6C1-14).

Remove choke rod from choke coil lever on end of choke shaft.

4. Remove choke coil assembly as follows: Align a #21 drill (.159") on rivet head and drill only enough to remove rivet head. Drill the two remaining rivet heads and then use a drift and small hammer to drive the remainder of the rivets out of the choke housing. Remove the three retainers and choke cover assembly from choke housing.

5. Choke coil housing need not be removed from float bowl unless replacement is necessary. To remove choke housing, remove three attaching screws from float bowl. Two screws have lockwashers and the one facing the choke housing has a tapered head for locating choke housing.

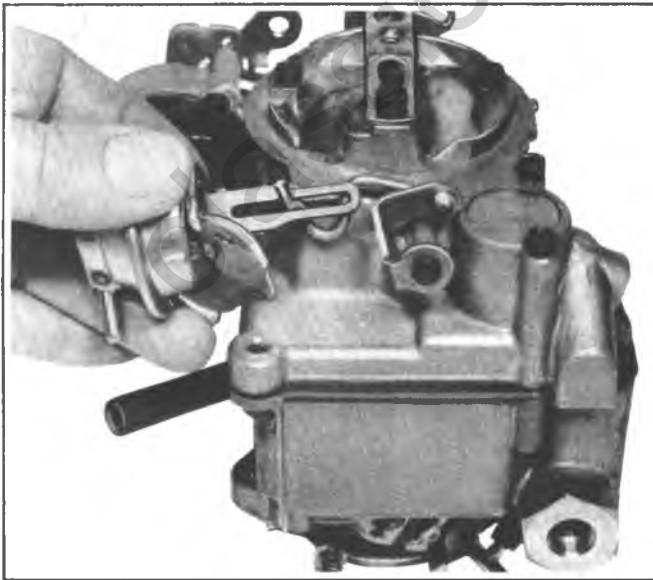


Fig. 6C1-13--Vacuum Break Diaphragm

6. Remove four remaining air horn to bowl attaching screws and lockwashers (three long and one short screw).

7. Remove air horn by lifting and twisting back towards choke housing so that the choke coil lever link will disengage from the choke coil lever at the choke housing, invert and place on clean bench. Air horn to float bowl gasket can remain on bowl for removal later (Fig. 6C1-15).

Disassembly

1. If required, the choke valve and choke shaft can be removed from air horn by removing the screw that retains the vacuum break lever to the choke shaft. Care should be exercised when removing this screw because it is retained in place by thread torque retaining compound. Remove the two attaching screws from the choke valve, then, remove the choke valve and choke shaft from air horn.

The choke valve screws are staked in place so it will be necessary to file off staking and re-stake during assembly. Do not bend choke shaft when restaking.

2. No further disassembly of the air horn is necessary.

Float Bowl Disassembly

1. Remove air horn to float bowl gasket. Gasket is slit next to metering rod lever so that it can be slid over lever for ease in removal. (Fig. 6C1-16).

2. Remove float assembly from float bowl by lifting upward on float hinge pin. Remove hinge pin from float arm.

3. Remove float needle from seat.

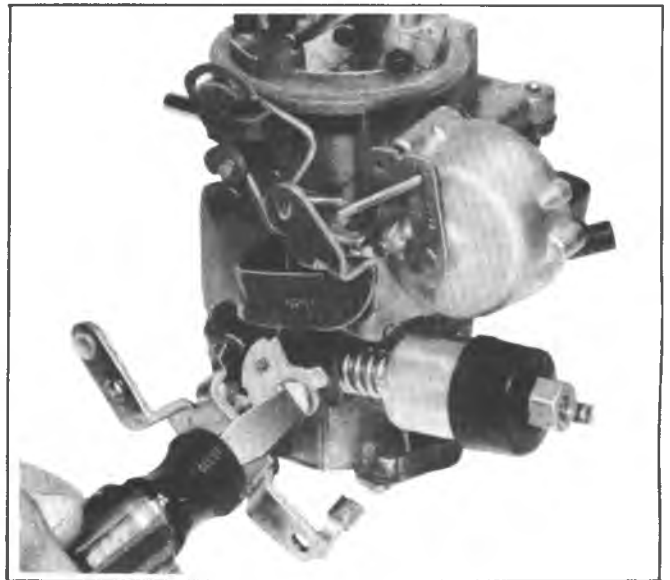


Fig. 6C1-14--Fast Idle Cam



Fig. 6C1-15--Air Horn Removal

4. Disconnect accelerator pump and power piston actuator lever from end of throttle shaft by removing lever attaching screw (Fig. 6C1-17).

5. Hold down on power piston while removing lever. Power piston spring and metering rod assembly may now be removed from float bowl (Fig. 6C1-18).

6. Remove lower end of power piston link from actuator lever by rotating until tang on rod slides out of notch in lever.

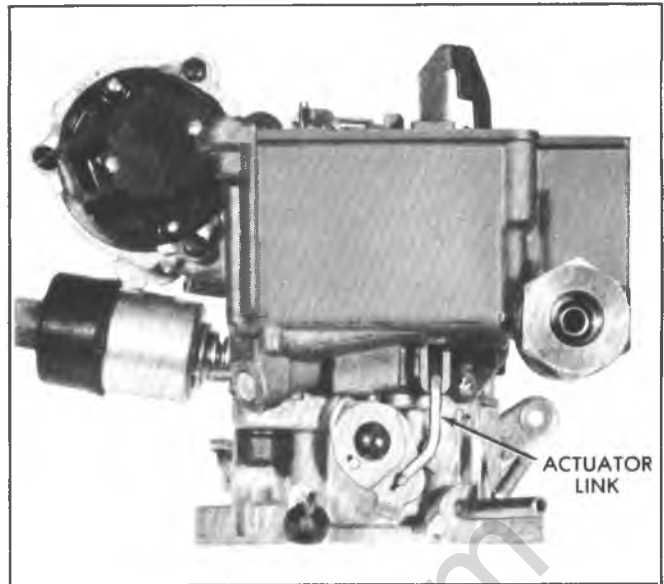


Fig. 6C1-17--Pump and Power Piston Actuator Lever

7. Remove actuator lever from lower end of accelerator pump link in same manner.

8. Push down on accelerator pump and remove actuator link by rotating until tang on rod aligned with slot on pump plunger lever. Remove the link.

9. Remove pump assembly from float bowl (Fig. 6C1-19).

10. Remove pump return spring and power piston spring from float bowl (Fig. 6C1-19).

11. Remove "T" guide and pump discharge spring using needle nose pliers (Fig. 6C1-20).

12. Pump discharge ball and idle tube can be removed at the same time by inverting the bowl.

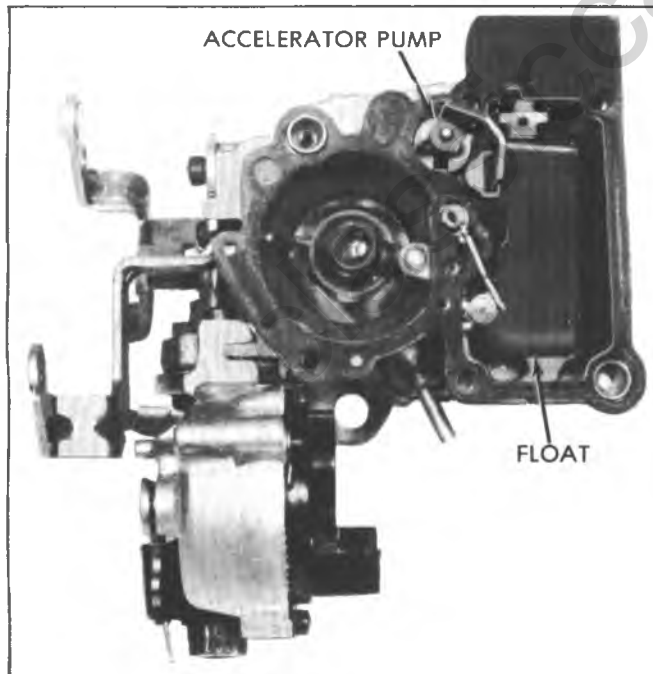


Fig. 6C1-16--Float Bowl Disassembly

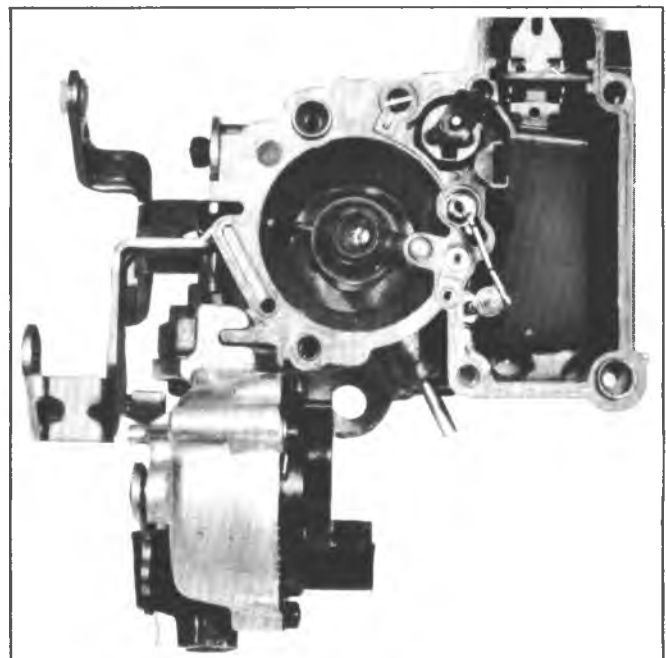


Fig. 6C1-18--Float Bowl Assembly

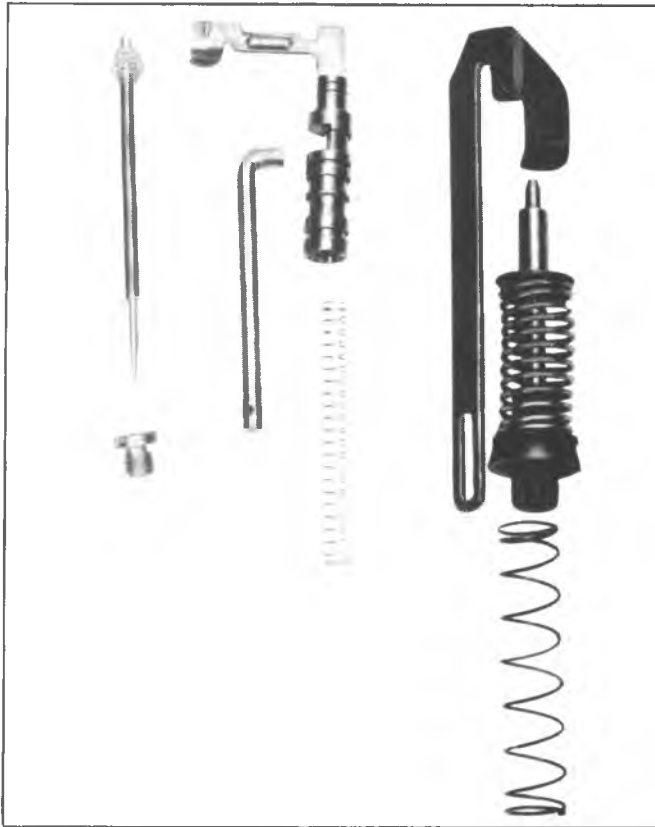


Fig. 6C1-19--Metering Rod and Accelerator Pump

13. Remove main metering jets from bottom of fuel bowl.

14. Remove float needle seat and gasket using Tool J-22769.

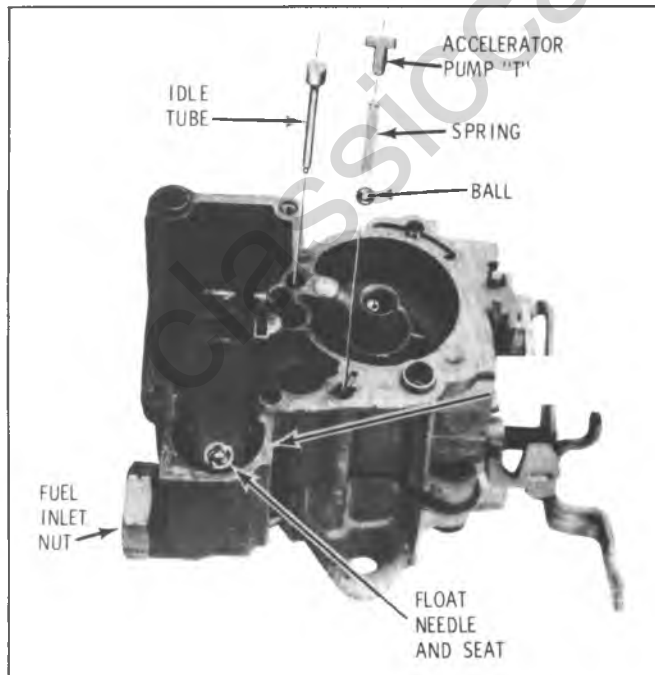


Fig. 6C1-20--Pump Discharge "T" Retainer

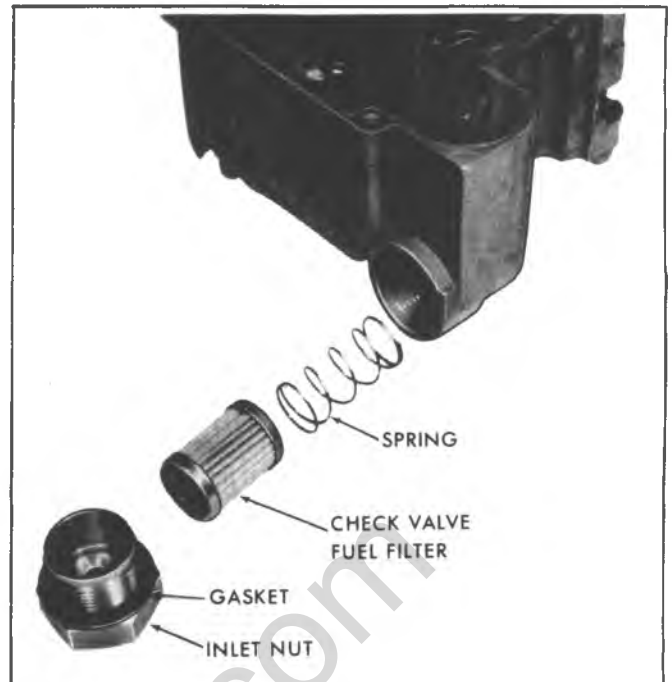


Fig. 6C1-21--Fuel Filter and Check Valve

15. The idle stop solenoid can be removed at this time if desired.

16. Remove the fuel inlet nut, filter and spring (Fig. 6C1-21).

No further disassembly of the float bowl is required.

Throttle Body (Fig. 6C1-22)

1. Invert carburetor bowl on bench and remove two throttle body to bowl attaching screws. Throttle body and insulator gasket may now be removed.

2. No further disassembly of the throttle body is necessary unless the idle mixture needle is damaged or the idle channels need cleaning. If necessary to remove the idle mixture needle, cut the tang from the plastic limiter cap. Do not install a replacement cap as a bare mixture screw is sufficient to indicate that the mixture has been readjusted.

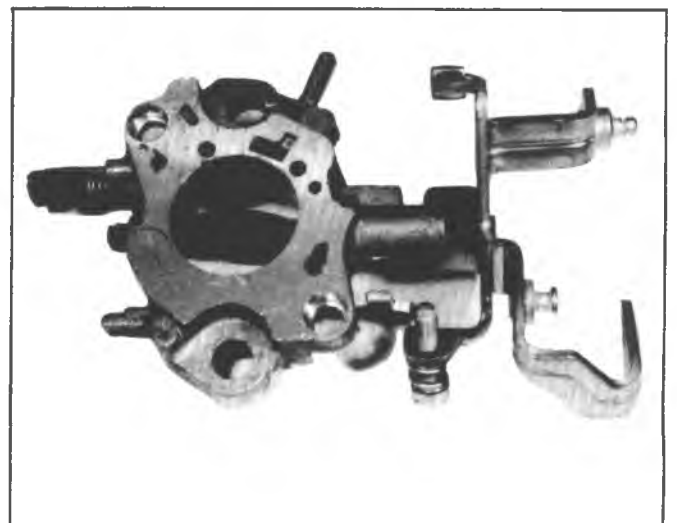


Fig. 6C1-22--Throttle Body

Due to the close tolerance fit of the throttle valve in the bore of the throttle body, do not remove the throttle valve or shaft.

CLEANING AND INSPECTION

The carburetor should be cleaned in a cold immersion type cleaner.

Rubber and plastic parts should not be immersed in carburetor cleaner. However, the air horn which has the plastic relief valve will withstand normal cleaning in carburetor cleaner.

1. Thoroughly clean carburetor castings and metal parts in an approved carburetor cleaner such as Carbon X (X-55) or equivalent.
2. Blow out all passages in castings with compressed air. Do not pass drills through jets or passages.
3. Examine float needle and seat assembly for wear. Install a new factory matched set if worn.
4. Inspect upper and lower casting sealing surfaces for damage.
5. Inspect holes in levers for excessive wear or out of round condition. If levers are worn they should be replaced.
6. Examine fast idle cam for excessive wear or damage.
7. Check throttle and choke levers and valve for binds and other damage.
8. Check all springs for distortion or loss in tension; replace as necessary.

CARBURETOR ASSEMBLY

After carburetor has been disassembled, new gaskets and filter must be used.

Throttle Body (Fig. 6C1-22)

1. If removed, install idle mixture needle and spring into throttle body until lightly seated. Back out two turns as a preliminary adjustment. Final idle mixture adjustment will be made on vehicle.
2. Invert float bowl and install new throttle body to bowl insulator gasket.
3. Install throttle body on bowl gasket so all holes in throttle body are aligned with holes in gasket.
4. Install two throttle body to bowl attaching screws and lockwashers. Tighten even and securely to 20 N·m (15 ft. lbs.).

Float Bowl

1. Install fuel filter spring, filter, and check valve assembly, (if used), inlet nut and gasket rubber seal on check valve faces fuel inlet nut.
- The fuel inlet check valve must be installed (where required) in the filter to meet Motor Vehicle Safety Standards (M.V.S.S.) for roll-over. New service replacement filter include the check valve, where required.
2. Install idle stop solenoid and spring, if removed. Adjust later for correct idle speed.
3. Install main metering jet into bottom of fuel bowl. Tighten securely.
4. Using wide blade screwdriver install needle seat and gasket.
5. Install idle tube flush with bowl casting.
6. Install pump ball, spring and "T" into pump discharge hole (Fig. 6C1-20).

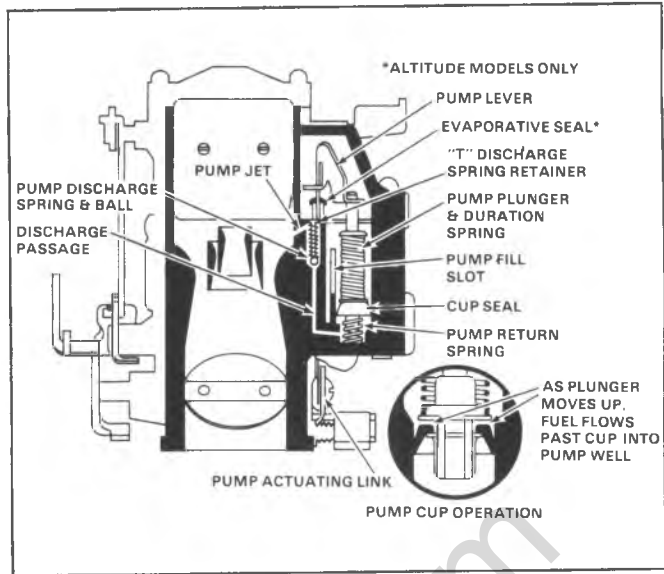


Fig. 6C1-23--Pump Drive Link

7. Drive pump discharge "T" in until flush with bowl casting.
8. Install accelerator pump return spring.
9. Install power piston return spring into piston cavity in the bowl.
10. Install lower end of pump link into actuator lever which fits on throttle shaft. Ends of link point toward carburetor. Bend in link faces fuel inlet nut.
11. Install curved power piston actuator link into throttle actuator lever. End protrudes outward away from throttle bore and has tang which retains link to lever.
12. Install pump plunger assembly into pump well with actuating lever protruding through bottom of bowl casting. Push downward on pump lever and install pump assembly drive link into slot in lower end of shaft. Tang on upper end of link retains link to pump shaft (Fig. 6C1-23).
13. Assemble metering rod to holder on power piston. Spring must be on top of arm when assembled correctly. Then install power piston actuating rod (right angle end) into slot in the power piston.
14. Install power piston, metering rod and drive rod assembly into the float bowl. End of drive rod must enter hole in bowl and end of metering rod into jet.
15. Before fastening power piston and pump actuator lever to end of throttle shaft, hold power piston assembly down and slide upper end of curved power piston actuator link into lower end of power piston actuating rod.
16. Install actuating lever on end of throttle shaft by aligning flats or lever with flats on shaft. Install lever retaining screw and tighten securely.
17. Install float needle valve on to float arm hooking pull clip over edge of float arm.
18. Install float hinge pin into float arm. Install float needle into seat and float with hinge pin into float bowl. Hinge pin should be in locating channels in float bowl.

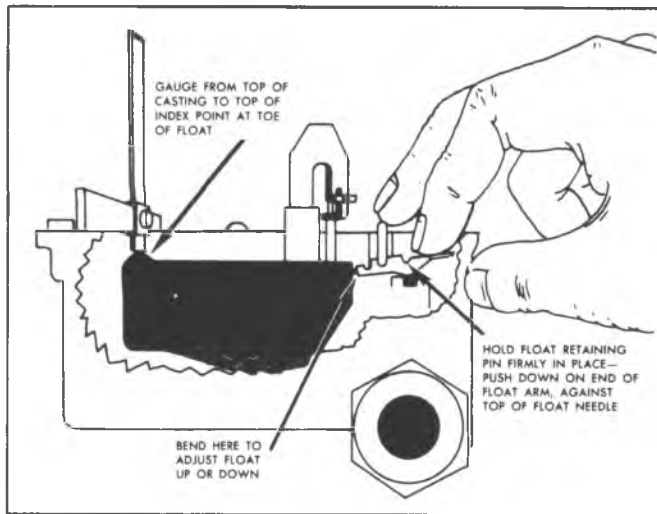


Fig. 6C1-24--Float Level Adjustment

Float Level Adjustment (Fig. 6C1-24)

1. Hold float retaining pin firmly in place push down on float arm at outer end against top of float needle, as shown.
2. Use adjustable "T" scale and measure distance from top of float at index point on toe to float bowl gasket surface (gasket removed).
3. To adjust, bend float pontoon up or down at float arm junction.

Metering Rod Adjustment (Fig. 6C1-25)

1. Open throttle valve, slide metering rod out of holder and remove from main metering jet.
2. To check adjustment, back out 1/8" hex screw on idle stop solenoid and rotate fast idle cam so that cam follower is not contacting steps on cam.
3. With throttle valve completely closed, apply pressure to top of power piston and hold piston down against stop.

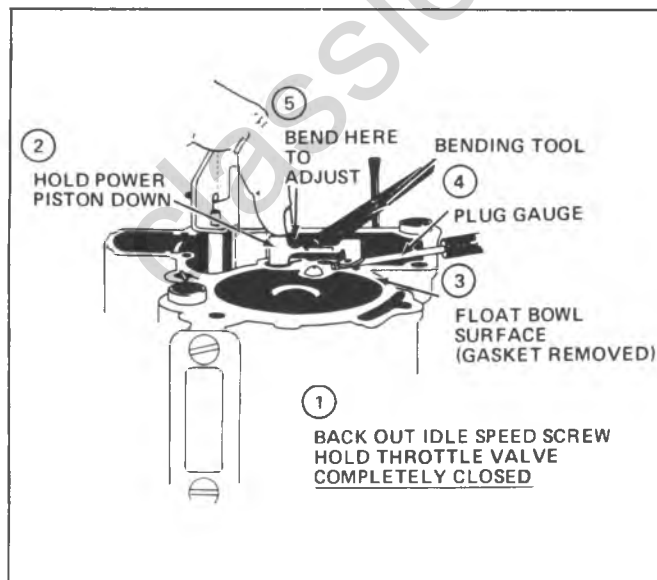


Fig. 6C1-25--Metering Rod Adjustment

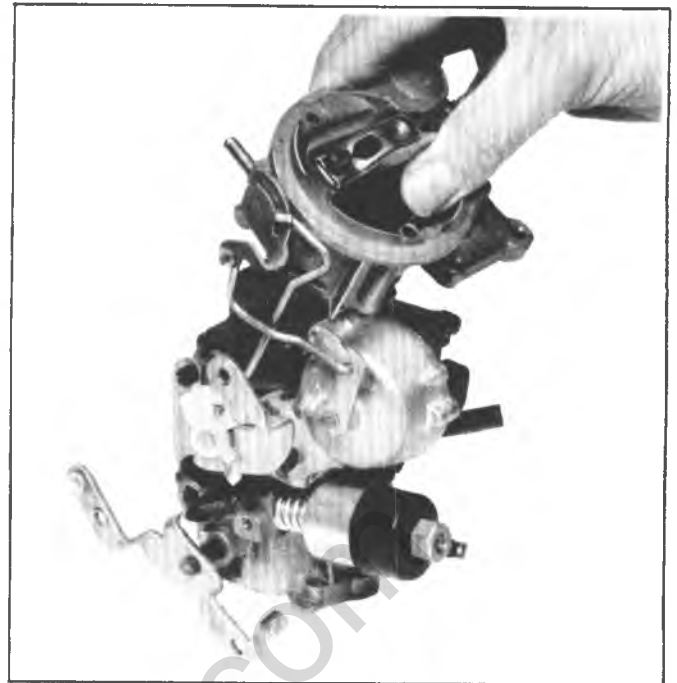


Fig. 6C1-26--Installing Air Horn

4. Holding downward pressure on power piston, swing metering rod holder over flat surface of bowl casting next to carburetor bore.
5. Insert gage between bowl casting and lower surface of metering rod holder. Gage should have a slide fit between both surfaces, as shown.
6. To adjust, carefully bend metering rod holder up or down.
7. Install air horn gasket on float bowl by carefully sliding slit portion of gasket over metering rod holder. Then align gasket with dowels provided on top of bowl casting and press gasket firmly in place.

Air Horn

1. Install choke shaft assembly and choke valve into air horn, if removed. Align choke valve, tighten two retaining screws and stake securely in place.

NOTICE: Apply a torque retaining compound to the vacuum break lever retaining screw and install lever to choke shaft.

2. Install air horn to float bowl by engaging choke coil lever link into notched hole in choke coil lever on choke housing. Then carefully twist and lower air horn onto float bowl. Install three long and one short air horn to float bowl attaching screws and lockwashers (Fig. 6C1-26).

3. Install the choke vacuum break diaphragm assembly using two short air horn screws opposite the choke housing, connecting the choke vacuum break diaphragm link to slotted diaphragm plunger stem. The two attaching screws for the choke vacuum break assembly have tapered heads for locating choke diaphragm bracket. Make sure to use these in this location. Tighten all air horn screws evenly and securely using proper tightening sequence (Fig. 6C1-27).

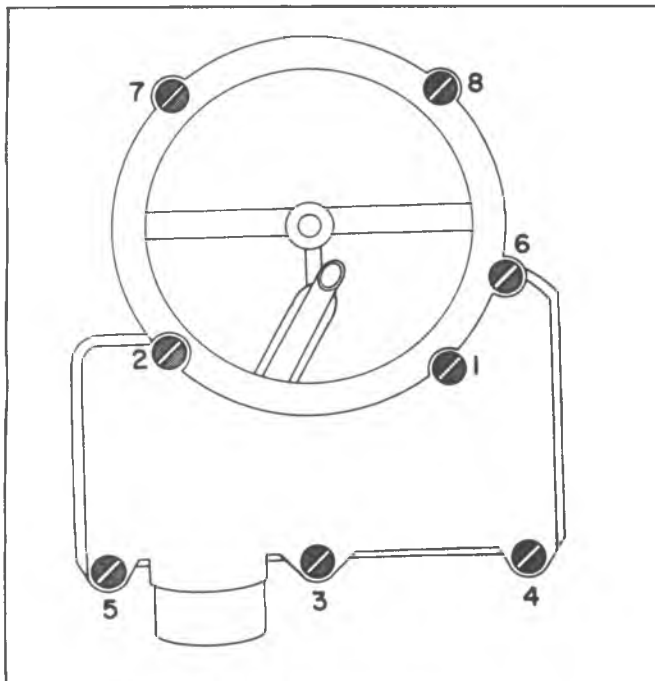


Fig. 6C1-27--Tightening Sequence

4. If removed, install choke housing to float bowl using three attaching screws. Two screws have lockwashers and the other one which face the choke housing has a tapered head for locating choke housing.

5. Install fast idle cam, and fast idle cam link to upper choke lever assembly. Numbers on fast idle cam face outward.

6. Install the choke cover and coil assembly in choke housing as follows:

a. Start the three (3) self-tapping screws in the choke housing; checking to be sure screws start easily and are aligned properly. Then, remove screws.

Self-tapping cover retaining screws are supplied with service kits.

b. Place fast idle screw on highest step of fast idle cam.

c. Install the thermostatic cover and coil assembly in the choke housing, aligning notch in cover with raised casting projection on choke housing. Make sure coil pick-up tang engages the inside choke coil lever. Do not use a gasket between electric coil and housing, as the coil is electrically grounded through housing.

7. Install choke vacuum diaphragm hose to tube on diaphragm and connect to vacuum tube on bowl.

SECTION 6C2

MODEL 2SE CARBURETOR

CONTENTS

| | | | |
|---------------------------|-------|---------------------------------|--------|
| General Description..... | 6C2-1 | Choke Coil Replacement..... | 6C2-12 |
| On-Vehicle Service..... | 6C2-4 | Idle Mixture Adjustment..... | 6C2-12 |
| Adjustments | 6C2-4 | Carburetor Mounting Torque..... | 6C2-12 |
| Checking Solenoid..... | 6C2-4 | Carburetor Replacement..... | 6C2-12 |
| Solenoid Replacement..... | 6C2-4 | Unit Repair | 6C2-13 |

GENERAL DESCRIPTION

The Model 2SE is a two barrel, two stage carburetor of down-draft design for use on the 4.1 litre engine. To reduce carburetor weight, aluminum die castings are used for the air horn, float bowl, throttle body and choke housing. A heat insulator gasket is used between the throttle body and float bowl to reduce heat transfer to the float bowl.

The primary stage has a triple venturi, with a small 35mm bore that results in good fuel control during idle and part throttle operation.

The secondary stage has a large 46mm bore that provides sufficient air capacity for engine power requirements. An air valve is used in the secondary stage with a single tapered metering rod.

On the 2SE models, an integral 2" pleated paper fuel filter with check valve is mounted in the front of the float bowl behind the fuel inlet nut to give maximum filtration of incoming fuel. The check valve is used to shut off fuel flow to the carburetor and prevent fuel leaks if a vehicle

roll-over should occur.

The float chamber is located adjacent to the primary and secondary bores (Fig. 6C2-3). This feature assures adequate fuel supply to both carburetor bores during all vehicle normal maneuvers. A single pontoon float, brass needle seat, and a rubber tipped float valve with pull clip are used to control fuel level in the float chamber. The float chamber is internally vented through a vertical vent cavity in the air horn. Above this vent cavity is a removable vent stack assembly that has a small meshed screen as its top portion. This vent stack provides the correct height for the internal vent and the screen offers necessary backfire protection to the float chamber.

The Model 2SE float chamber also is externally vented through a tube in the air horn. A hose connects this tube directly to a vacuum operated vapor vent valve located in the vapor canister. When the engine is not running, the canister vapor vent valve is open allowing fuel vapors from

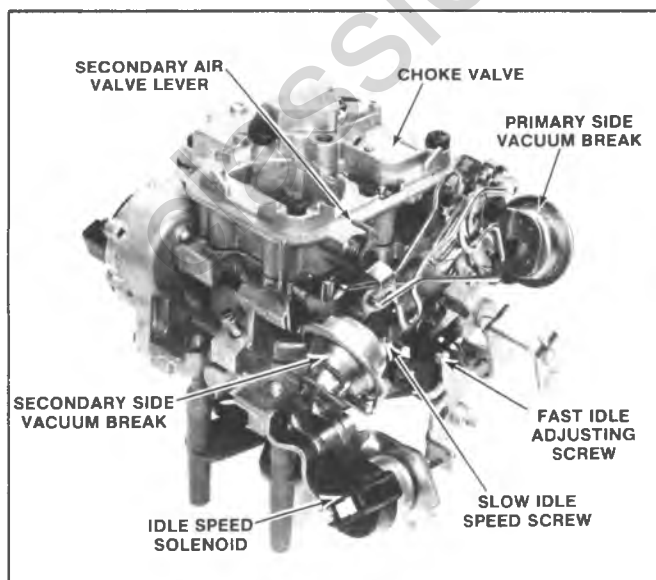


Fig. 6C2-1-Model 2SE Carburetor

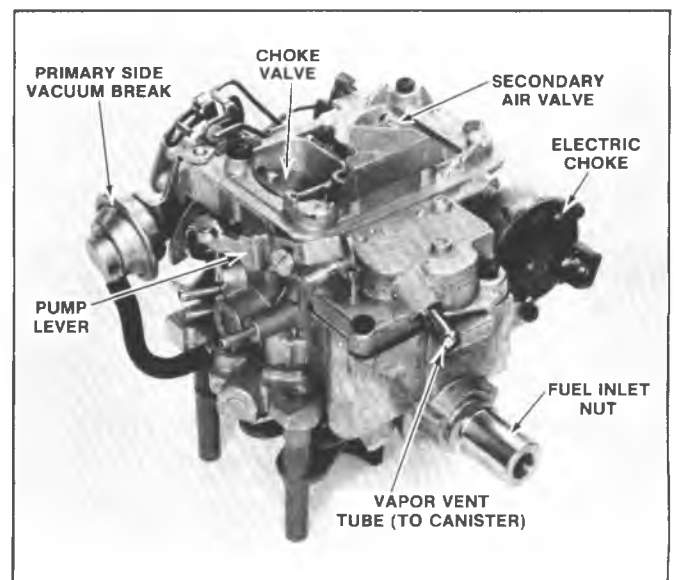


Fig. 6C2-2-Model 2SE Carburetor

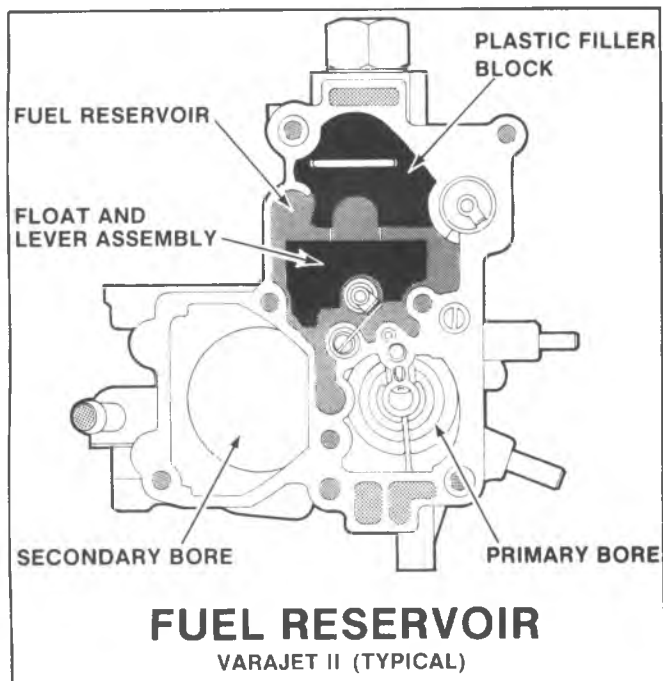


Fig. 6C2-3--Fuel Reservoir

the float chamber to pass into the canister where they are stored until normally purged. The venting of fuel vapors from the carburetor float bowl to the canister meets evaporative emission requirements and improves hot engine starting.

An adjustable part throttle screw is used in the float bowl to aid in refinement of fuel mixtures for good emission control. This screw is pre-set at the factory and a plug is installed to prevent tampering and to seal against any fuel leaks. The plug should not be removed and the screw adjusted in service. If it becomes necessary to replace the float bowl, the new service float bowl will include an adjustable part throttle (A.P.T.) screw which has been pre-

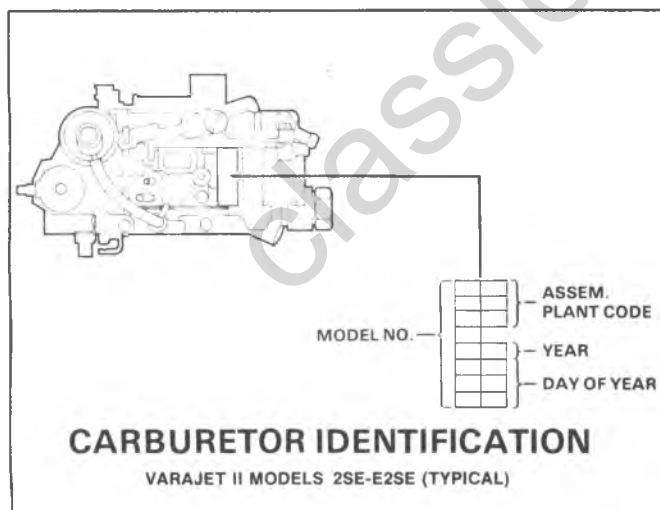


Fig. 6C2-4--Model 2SE Identification

set at the factory and plugged as required.

A hot idle compensator assembly (when used) is located in the air horn casting. The opening and closing of the hot idle compensator valve is controlled by a bi-metal strip that is calibrated to a specific temperature. When the valve opens, additional air is allowed to by-pass the throttle valves and enters the intake manifold to prevent rough idle during periods of hot engine operation.

The idle mixture needle is recessed in the throttle body casting and sealed with a hardened steel plug to discourage tampering with the factory adjusted mixture setting in the field which could upset exhaust emissions. The plug must not be removed and idle mixture screw re-adjusted unless required due to major carburetor overhaul or throttle body replacement in which case special service procedures must be carefully followed.

The choke system of the 2SE carburetor uses a dual vacuum break system. The front (primary side) vacuum break unit with bracket is mounted on the air horn and the rear unit is mounted on the idle speed solenoid bracket located on the secondary side of the carburetor. An electrically heated thermostatic choke coil is mounted in the choke housing located on the secondary side of the carburetor. Special rivets are installed to retain the factory setting of the choke coil and provide a non-adjustable design.

The 2SE carburetor has a separate screw located in the primary throttle lever for fast idle speed adjustment. A separate screw, located in the throttle body, is used to make the base speed setting (solenoid de-energized).

For ease of service, alphabetical code letters are included on the air horn, float bowl, and throttle body castings at external tube locations to identify air and vacuum hose connections.

The carburetor model identification is stamped vertically on the float bowl in a flat area adjacent to the vacuum tube (location B, Figure 6C2-4). If replacing the float bowl, follow the manufacturer's instructions contained in the service package so that the identification number can be transferred to the new float bowl. Refer to the part number on the bowl when servicing the carburetor.

An exhaust gas recirculation system (E.G.R.) is used on all applications to help control oxides of nitrogen. The vacuum supply ports necessary to operate the recirculation valve are located in the throttle body and connect through a channel to a tube (location C) in the float bowl. This tube is connected by a rubber hose to the E.G.R. valve. See Idle System (Fig. 6C2-6) for port location and operation. California models use a fixed idle air by-pass system to reduce the amount of air flowing through the carburetor primary venturi to prevent the main nozzle from feeding fuel at idle.

A throttle body mounted idle speed solenoid is used to position the primary throttle valve to obtain idle speed requirements of the engine.

The model 2SE carburetor has six basic systems. They are float, idle, main metering, secondary stage, pump and choke.

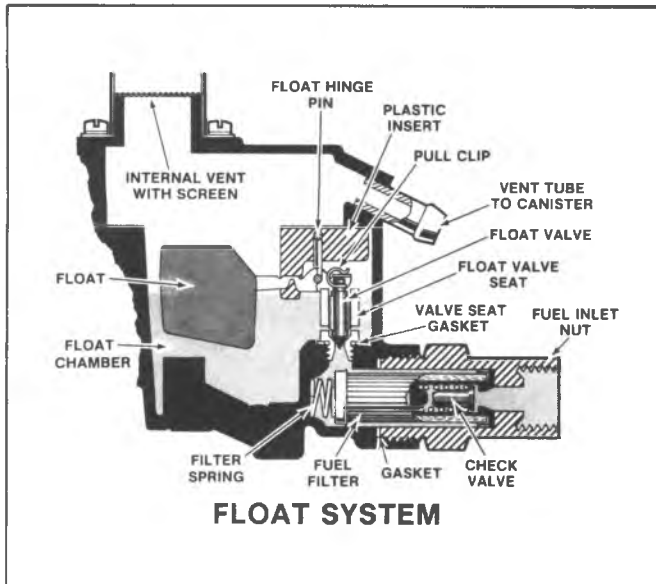


Fig. 6C2-5--Float System

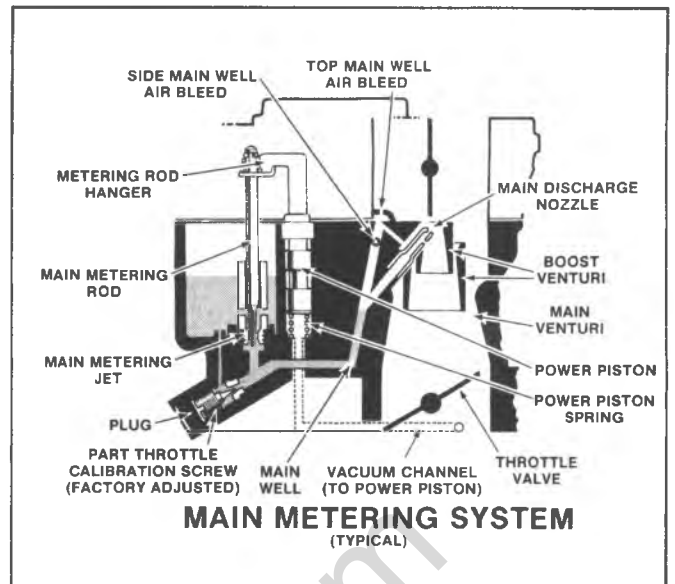


Fig. 6C2-7--Main Metering System

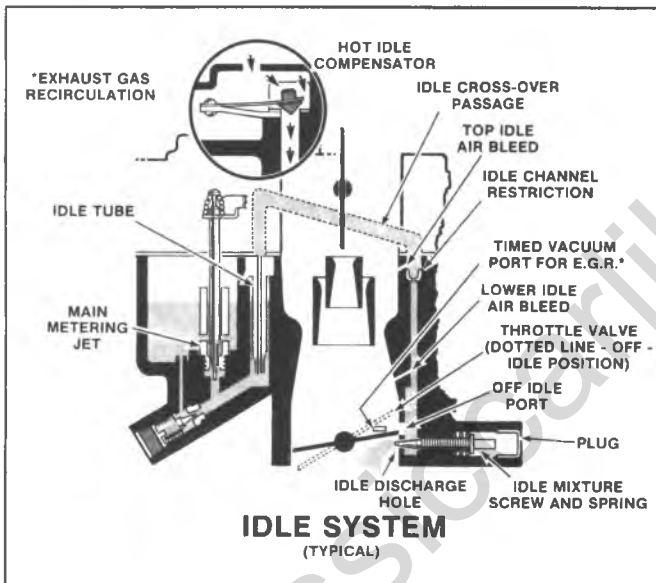


Fig. 6C2-6--Idle System

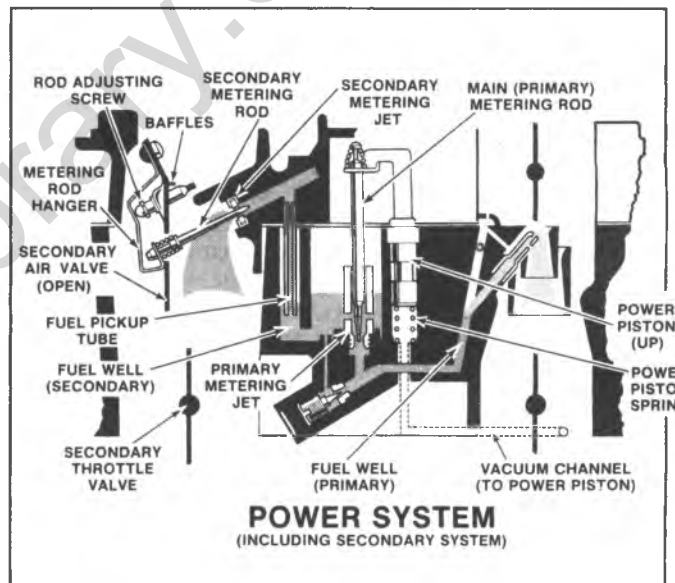


Fig. 6C2-8--Secondary Stage System

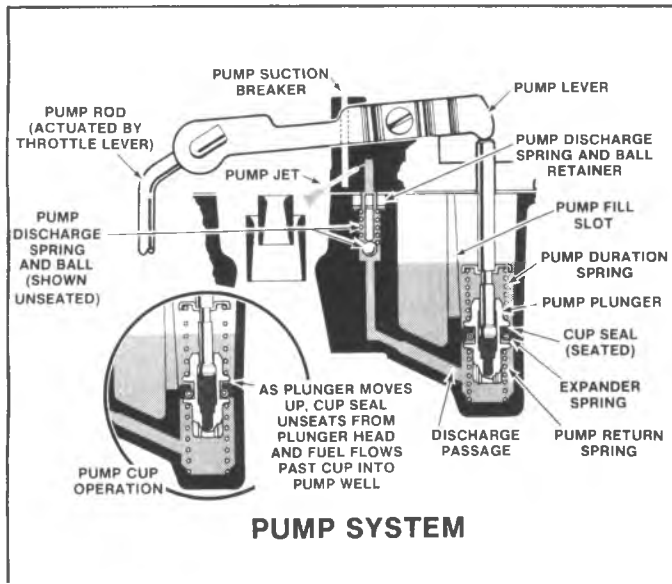


Fig. 6C2-9--Pump System

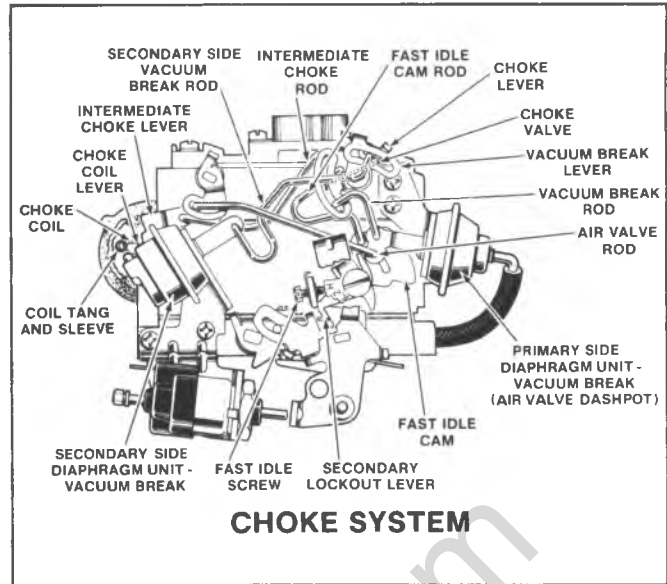


Fig. 6C2-10--Choke System

ON-VEHICLE SERVICE

MODEL 2SE ADJUSTMENTS

Before checking or resetting the carburetor as the cause of poor engine performance or rough idle, check ignition system including distributor, timing, spark plugs and wires. Check air cleaner, evaporative emission system, EFE system, PCV system, EGR valve and engine compression. Also inspect intake manifold vacuum hose gaskets and connections for leaks and check torques of carburetor mounting bolts/nuts.

Refer to Figures 6C2-11 through 6C2-17 for carburetor adjustment procedures and specifications.

Checking Solenoid

1. Turn on ignition, but do not start engine.
2. Open throttle to allow solenoid plunger to extend, close throttle.
3. Disconnect lead at solenoid. Solenoid plunger should drop away from throttle lever.
4. Connect solenoid lead. Plunger should move out and contact the throttle lever. Solenoid may not be strong enough to open the throttle, but the plunger should move.
5. If plunger does not move in and out as lead is disconnected and connected, insert test lamp (1893 bulb or smaller) between the solenoid feed wire and ground.
6. If light lights, replace solenoid.
7. If light does not light, locate cause of open circuit in solenoid feed wire.

SOLENOID REPLACEMENT

An inoperative solenoid should be replaced.

Removal

1. Remove carburetor air cleaner.
2. Disconnect electrical connector at solenoid.
3. Unscrew and remove solenoid from float bowl assembly.

Installation

1. Hold choke valve wide open so that fast idle cam follower clears fast idle cam.
2. Install solenoid and turn in until it contacts lever tang.
3. Connect electrical connector.
4. Install air cleaner.
5. Check and adjust idle speed.

CHECKING ELECTRIC CHOKE

1. Remove air cleaner. With engine off, hold throttle half open. Open and close choke several times. Watch linkage to be certain all links are connected and there are no signs of damage or binding.
2. If choke or linkage binds, sticks or works sluggishly due to petroleum gum formation, clean with AC-Delco choke cleaner X-20-A or equivalent. Use cleaner as directed on can.
3. Allow choke to cool so that when throttle is opened slightly, choke blade fully closes. This check should be made at an ambient temperature of 15° to 27°C (59° to 80°F).
4. Start engine and determine time for choke blade to reach full open position. (Start timer when engine starts.)
5. If choke blade fails to open fully within 3-1/2 minutes, open throttle about 1/3. If choke still fails to open fully, proceed with steps 6 and 7.
6. Check voltage at the choke heater connection: (Engine must be running).

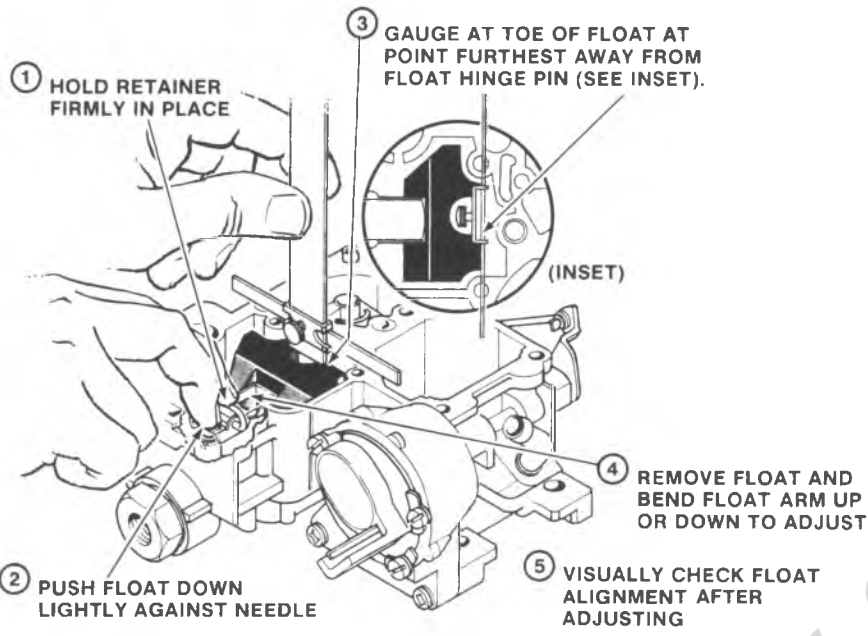
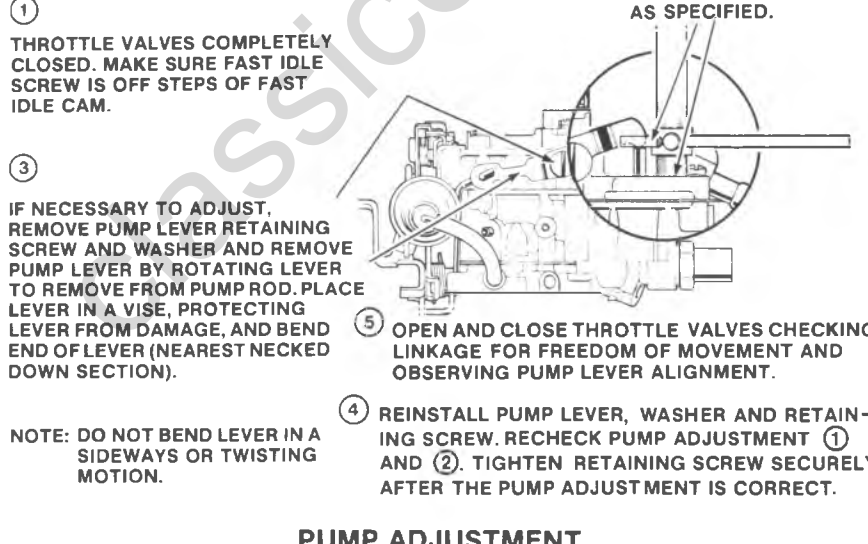
| 1 | CARB. NO. | USE GAUGE |
|--|--|----------------------------|
| <p>1 HOLD RETAINER FIRMLY IN PLACE</p> <p>2 PUSH FLOAT DOWN LIGHTLY AGAINST NEEDLE</p> <p>3 GAUGE AT TOE OF FLOAT AT POINT FURTHEST AWAY FROM FLOAT HINGE PIN (SEE INSET).</p> <p>4 REMOVE FLOAT AND BEND FLOAT ARM UP OR DOWN TO ADJUST</p> <p>5 VISUALLY CHECK FLOAT ALIGNMENT AFTER ADJUSTING</p> <p style="text-align: center;">FLOAT ADJUSTMENT</p>  | <p>17080621 17080622 17080623 17080626 17080720 17080721 17080722 17080723</p> | <p>1/8 (3.40 mm)</p> |
| <p>2</p> <div style="border: 1px solid black; padding: 5px; margin: 10px 0;"> <p>NOTE: THE PUMP ADJUSTMENT SHOULD NOT BE CHANGED FROM ORIGINAL FACTORY SETTING UNLESS GAUGING SHOWS OUT OF SPECIFICATION. THE PUMP LEVER IS MADE FROM HEAVY DUTY, HARDENED STEEL MAKING BENDING DIFFICULT. DO NOT REMOVE PUMP LEVER FOR BENDING UNLESS ABSOLUTELY NECESSARY.</p> </div> <p>1 THROTTLE VALVES COMPLETELY CLOSED. MAKE SURE FAST IDLE SCREW IS OFF STEPS OF FAST IDLE CAM.</p> <p>2 GAUGE FROM AIR HORN CASTING SURFACE TO TOP OF PUMP STEM. DIMENSION SHOULD BE AS SPECIFIED.</p> <p>3 IF NECESSARY TO ADJUST, REMOVE PUMP LEVER RETAINING SCREW AND WASHER AND REMOVE PUMP LEVER BY ROTATING LEVER TO REMOVE FROM PUMP ROD. PLACE LEVER IN A VISE, PROTECTING LEVER FROM DAMAGE, AND BEND END OF LEVER (NEAREST NECKED DOWN SECTION).</p> <p>4 REINSTALL PUMP LEVER, WASHER AND RETAINING SCREW. RECHECK PUMP ADJUSTMENT 1 AND 2. TIGHTEN RETAINING SCREW SECURELY AFTER THE PUMP ADJUSTMENT IS CORRECT.</p> <p>5 OPEN AND CLOSE THROTTLE VALVES CHECKING LINKAGE FOR FREEDOM OF MOVEMENT AND OBSERVING PUMP LEVER ALIGNMENT.</p> <p>NOTE: DO NOT BEND LEVER IN A SIDEWAYS OR TWISTING MOTION.</p> <p style="text-align: center;">PUMP ADJUSTMENT (TYPICAL)</p>  | <p>ALL</p> | <p>9/16 (13.95 mm)</p> |

Fig. 6C2-11-2SE Carburetor Adjustments

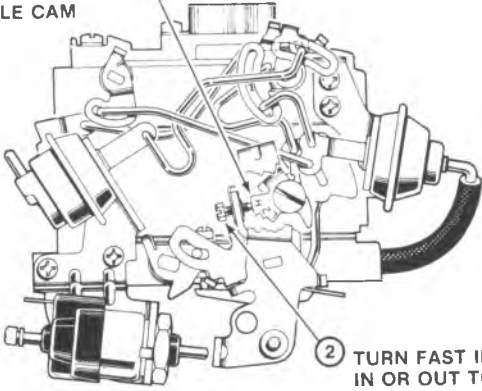
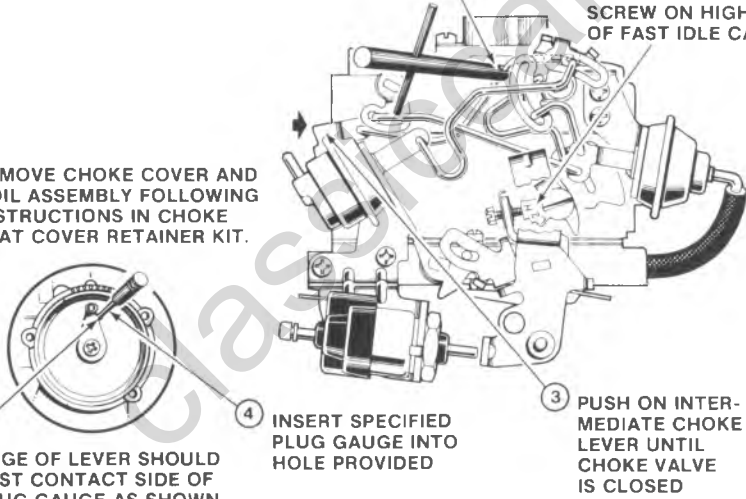
| | | |
|--|-----------|------------------|
| <p style="font-size: 2em; font-weight: bold; margin-bottom: 10px;">3</p> <p>① PLACE FAST IDLE SCREW ON HIGHEST STEP OF FAST IDLE CAM</p>  <p>② TURN FAST IDLE SCREW IN OR OUT TO SPECIFIED NUMBER OF TURNS</p> <p style="text-align: center; font-weight: bold; margin-top: 20px;">FAST IDLE ADJUSTMENT (BENCH SETTING)</p> | CARB. NO. | R.P.M. |
| | | |
| <p style="font-size: 2em; font-weight: bold; margin-bottom: 10px;">4</p> <p>① REMOVE CHOKE COVER AND COIL ASSEMBLY FOLLOWING INSTRUCTIONS IN CHOKE STAT COVER RETAINER KIT.</p>  <p>② PLACE FAST IDLE SCREW ON HIGH STEP OF FAST IDLE CAM</p> <p>③ PUSH ON INTERMEDIATE CHOKE LEVER UNTIL CHOKE VALVE IS CLOSED</p> <p>④ INSERT SPECIFIED PLUG GAUGE INTO HOLE PROVIDED</p> <p>⑤ EDGE OF LEVER SHOULD JUST CONTACT SIDE OF PLUG GAUGE AS SHOWN</p> <p>⑥ BEND INTERMEDIATE CHOKE ROD AT THIS POINT TO ADJUST</p> <p style="text-align: center; font-weight: bold; margin-top: 20px;">CHOKE COIL LEVER ADJUSTMENT (TYPICAL)</p> | CARB. NO. | PLUG GAUGE |
| | ALL | .085 (2.2 mm) |

Fig. 6C2-12-2SE Carburetor Adjustments

| | | |
|---|--|-------------------------------|
| <p>5</p> <p>FIGURE 1</p> <ol style="list-style-type: none"> 1. CHOKE COIL LEVER ADJUSTMENT MUST BE CORRECT AND FAST IDLE ADJUSTMENT MUST BE MADE BEFORE PROCEEDING. 2. USE CHOKE VALVE MEASURING GAUGE J-26701 OR TOOL MAY BE USED WITH CARBURETOR ON OR OFF ENGINE. IF OFF ENGINE, PLACE CARBURETOR ON HOLDING FIXTURE SO THAT IT WILL REMAIN IN SAME POSITION WHEN GAUGE IS IN PLACE. 3. ROTATE DEGREE SCALE UNTIL ZERO (0) IS OPPOSITE POINTER. 4. WITH CHOKE VALVE COMPLETELY CLOSED, PLACE MAGNET SQUARELY ON TOP OF CHOKE VALVE. 5. ROTATE BUBBLE UNTIL IT IS CENTERED. <p>FIGURE 2</p> <ol style="list-style-type: none"> 6. ROTATE SCALE SO THAT DEGREE SPECIFIED FOR ADJUSTMENT IS OPPOSITE POINTER. 7. PLACE FAST IDLE SCREW ON SECOND STEP OF CAM AGAINST RISE OF HIGH STEP. 8. CLOSE CHOKE BY PUSHING ON INTERMEDIATE CHOKE LEVER. 9. PUSH ON VACUUM BREAK LEVER TOWARD OPEN CHOKE UNTIL LEVER IS AGAINST REAR TANG ON CHOKE LEVER. 10. TO ADJUST, BEND FAST IDLE CAM ROD UNTIL BUBBLE IS CENTERED. 11. REMOVE GAUGE. <p>FAST IDLE CAM (CHOKE ROD) RELATION ADJUSTMENT</p> | <p>CARB. NO.</p> <p>ALL</p> | <p>ANGLE GAUGE</p> <p>17°</p> |
| | <p>6</p> <p>AIR VALVE ROD ADJUSTMENT (L-6 TRUCK)</p> | <p>CARB. NO.</p> <p>ALL</p> |

Fig. 6C2-13-2SE Carburetor Adjustments

7

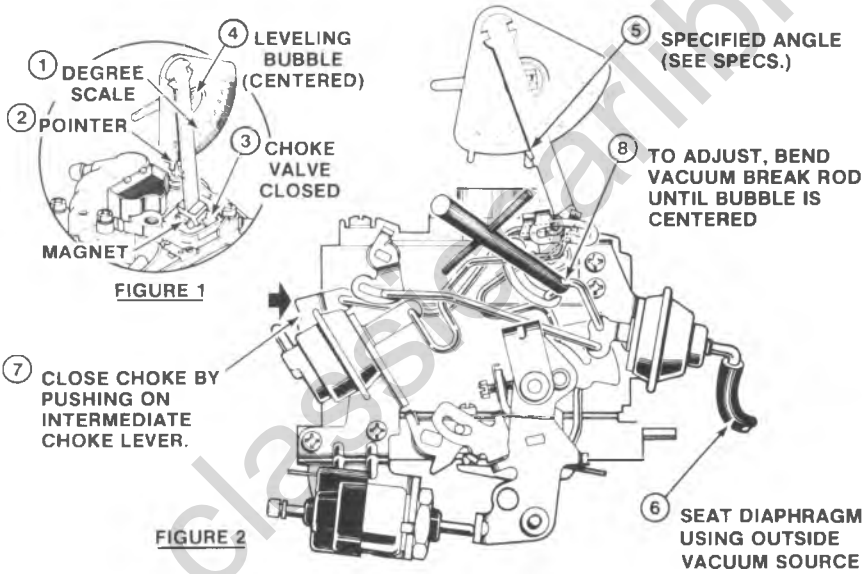
FIGURE 1

1. USE CHOKE VALVE MEASURING GAUGE J-26701 OR TOOL MAY BE USED WITH CARBURETOR ON OR OFF ENGINE. IF OFF ENGINE, PLACE CARBURETOR ON HOLDING FIXTURE SO THAT IT WILL REMAIN IN SAME POSITION WHEN GAUGE IS IN PLACE.
2. ROTATE DEGREE SCALE UNTIL ZERO (0) IS OPPOSITE POINTER.
3. WITH CHOKE VALVE COMPLETELY CLOSED, PLACE MAGNET SQUARELY ON TOP OF CHOKE VALVE.
4. ROTATE BUBBLE UNTIL IT IS CENTERED.

FIGURE 2

5. ROTATE SCALE SO THAT DEGREE SPECIFIED FOR ADJUSTMENT IS OPPOSITE POINTER.
6. SEAT CHOKE VACUUM DIAPHRAGM USING VACUUM SOURCE.
7. HOLD CHOKE VALVE TOWARD CLOSED POSITION BY PUSHING ON INTERMEDIATE CHOKE LEVER.
8. TO ADJUST, BEND VACUUM BREAK ROD UNTIL BUBBLE IS CENTERED.
9. REMOVE GAUGE.

| CARB. NO. | ANGLE GAUGE |
|--|-------------|
| 17080621 17080622 17080623 17080626 | 22° |
| 17080720 17080722 | 20° |
| 17080721 17080723 | 23.5° |



PRIMARY SIDE VACUUM BREAK ADJUSTMENT

(TRUCK L-6)

Fig. 6C2-14-2SE Carburetor Adjustments

8

| CARB. NO. | ANGLE GAUGE |
|-----------|-------------|
|-----------|-------------|

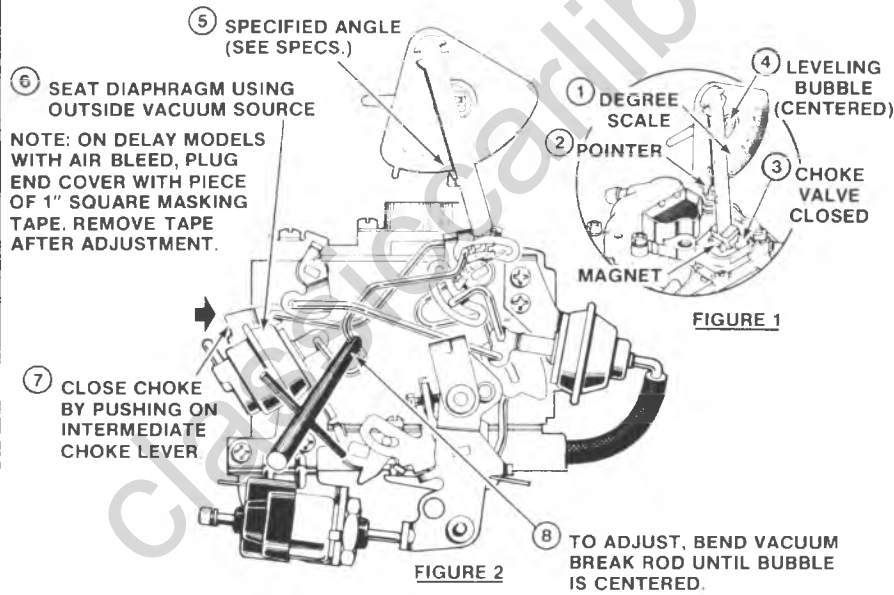
| | |
|-----|-----|
| ALL | 35° |
|-----|-----|

FIGURE 1

1. USE CHOKE VALVE MEASURING GAUGE J-26701 OR TOOL MAY BE USED WITH CARBURETOR ON OR OFF ENGINE. IF OFF ENGINE, PLACE CARBURETOR ON HOLDING FIXTURE SO THAT IT WILL REMAIN IN SAME POSITION WHEN GAUGE IS IN PLACE.
2. ROTATE DEGREE SCALE UNTIL ZERO (0) IS OPPOSITE POINTER.
3. WITH CHOKE VALVE COMPLETELY CLOSED, PLACE MAGNET SQUARELY ON TOP OF CHOKE VALVE.
4. ROTATE BUBBLE UNTIL IT IS CENTERED.

FIGURE 2

5. ROTATE SCALE SO THAT DEGREE SPECIFIED FOR ADJUSTMENT IS OPPOSITE POINTER.
6. SEAT CHOKE VACUUM DIAPHRAGM USING VACUUM SOURCE.
7. HOLD CHOKE VALVE TOWARDS CLOSED POSITION BY PUSHING ON INTERMEDIATE CHOKE LEVER. MAKE SURE PLUNGER BUCKING SPRING (IF USED) IS COMPRESSED AND SEATED.
8. TO ADJUST, BEND VACUUM BREAK ROD UNTIL BUBBLE IS CENTERED.
9. REMOVE GAUGE.



SECONDARY VACUUM BREAK ADJUSTMENT

(TRUCK L-6)

Fig. 6C2-15--2SE Carburetor Adjustments

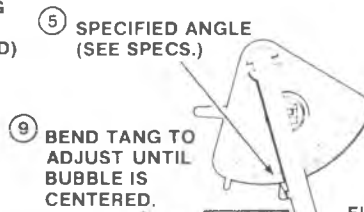
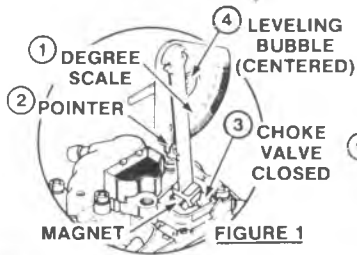
9

FIGURE 1

1. USE CHOKE VALVE MEASURING GAUGE J-26701 OR TOOL MAY BE USED WITH CARBURETOR ON OR OFF ENGINE. IF OFF ENGINE, PLACE CARBURETOR ON HOLDING FIXTURE SO THAT IT WILL REMAIN IN SAME POSITION WHEN GAUGE IS IN PLACE.
2. ROTATE DEGREE SCALE UNTIL ZERO (0) IS OPPOSITE POINTER.
3. WITH CHOKE VALVE COMPLETELY CLOSED, PLACE MAGNET SQUARELY ON TOP OF CHOKE VALVE.
4. ROTATE BUBBLE UNTIL IT IS CENTERED.

FIGURE 2

5. ROTATE SCALE SO THAT DEGREE SPECIFIED FOR ADJUSTMENT IS OPPOSITE POINTER.
6. INSTALL CHOKE THERMOSTATIC COVER AND COIL ASSEMBLY IN HOUSING. ALIGN INDEX MARK WITH SPECIFIED POINT ON HOUSING.
7. HOLD PRIMARY THROTTLE VALVE WIDE OPEN.
8. ON WARM ENGINE, CLOSE CHOKE VALVE BY PUSHING CLOCKWISE ON INTERMEDIATE CHOKE LEVER (HOLD IN POSITION WITH RUBBER BAND).
9. TO ADJUST, BEND TANG ON THROTTLE LEVER UNTIL BUBBLE IS CENTERED.
10. REMOVE GAUGE.



8 ON WARM ENGINE, CLOSE CHOKE VALVE BY PUSHING CLOCKWISE ON INTERMEDIATE CHOKE LEVER (HOLD IN POSITION WITH RUBBER BAND).

6 INSTALL CHOKE THERMOSTATIC COVER AND COIL ASSEMBLY IN HOUSING. ALIGN INDEX MARK WITH SPECIFIED POINT ON HOUSING.

7 HOLD PRIMARY THROTTLE VALVE WIDE OPEN

**UNLOADER ADJUSTMENT
(TYPICAL)**

CARB. NO.

ALL

41°

Fig. 6C2-16--2SE Carburetor Adjustments

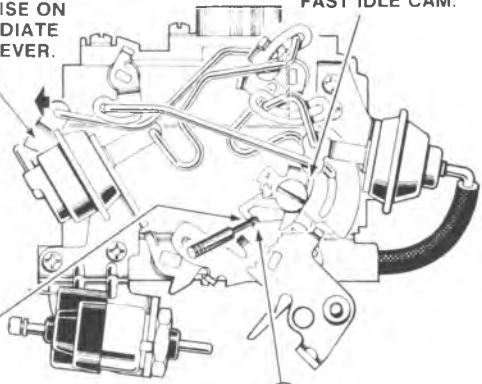
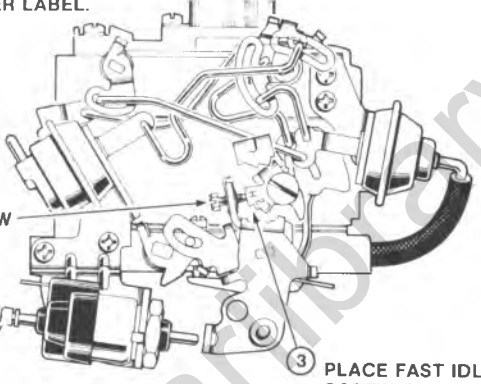
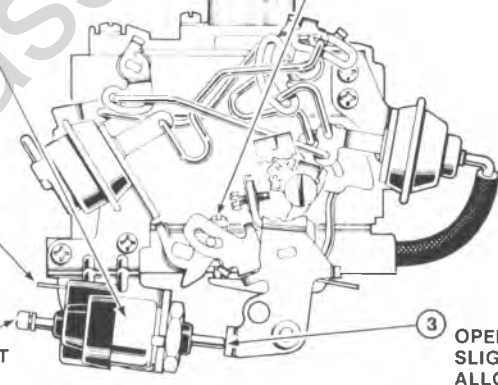
| | | |
|--|---|--|
| <p>10 ① HOLD CHOKE VALVE WIDE OPEN BY PUSHING COUNTER-CLOCKWISE ON INTERMEDIATE CHOKE LEVER.</p> <p>④ IF NECESSARY TO ADJUST, BEND LOCKOUT LEVER TANG CONTACTING FAST IDLE CAM.</p>  <p>③ GAUGE CLEARANCE - DIMENSION SHOULD BE AS SPECIFIED.</p> <p>② OPEN THROTTLE LEVER UNTIL END OF SECONDARY ACTUATING LEVER IS OPPOSITE TOE OF LOCKOUT LEVER.</p> <p style="text-align: center;">SECONDARY LOCKOUT ADJUSTMENT</p> | <p>CARB. NO.</p> <p>ALL</p> | <p>PLUG GAUGE</p> <p>.011-.040 (.3-.1mm)</p> |
| <p>11 ① PREPARE VEHICLE FOR ADJUSTMENTS - SEE EMISSION LABEL ON VEHICLE. NOTE: IGNITION TIMING SET PER LABEL.</p> <p>④ TURN FAST IDLE SCREW IN OR OUT TO OBTAIN SPECIFIED FAST IDLE R.P.M. - (SEE LABEL)</p>  <p>② ADJUST CURB IDLE SPEED IF REQUIRED</p> <p>③ PLACE FAST IDLE SCREW ON HIGHEST STEP OF FAST IDLE CAM</p> <p style="text-align: center;">FAST IDLE ADJUSTMENT (ON VEHICLE)</p> | <p>CARB. NO.</p> <p>17080621 17080622 17080623 17080626 17080720 17080721 17080722 17080723</p> | <p>R.P.M.</p> <p>SEE EMISSION LABEL</p> |
| <p>12 ① PREPARE VEHICLE FOR ADJUSTMENTS - SEE EMISSION LABEL ON VEHICLE. NOTE: IGNITION TIMING SET PER LABEL.</p> <p>② SOLENOID ENERGIZED - A/T IN DRIVE, M/T IN NEUTRAL</p> <p>⑤ TURN IDLE SPEED SCREW TO SET BASE IDLE SPEED TO SPECIFICATIONS (SOLENOID DE-ENERGIZED)</p>  <p>⑥ RECONNECT SOLENOID ELECTRICAL LEAD AFTER ADJUSTMENT</p> <p>④ TURN SOLENOID SCREW TO ADJUST CURB IDLE SPEED TO SPECIFIED RPM (SOLENOID ENERGIZED)</p> <p>③ OPEN THROTTLE SLIGHTLY TO ALLOW SOLENOID PLUNGER TO FULLY EXTEND</p> <p style="text-align: center;">IDLE SPEED ADJUSTMENT (ON VEHICLE)</p> | <p>CARB. NO.</p> <p>17080621 17080622 17080623 17080626 17080720 17080721 17080722 17080723</p> | <p>R.P.M.</p> <p>SEE EMISSION LABEL</p> |

Fig. 6C2-17-2SE Carburetor Adjustments

a. If the voltage is approximately 12-15 volts, replace the electric choke unit.

b. If the voltage is low or zero, check all wires and connections. If any connections in the oil pressure switch circuitry are faulty or if the oil pressure switch is failed open, the oil pressure warning light will be on with engine running. Repair wires or connections as required.

7. If steps 4a and 4b do not correct problem, replace oil pressure switch.

No gasket is used between the choke cover and the choke housing due to grounding requirements.

8. Reinstall air cleaner.

CHOKE COIL REPLACEMENT

Choke mechanism should be checked for free operation. A binding condition may have developed from petroleum gum formation on the choke shaft or from damage. Choke shafts can usually be cleaned without disassembly by using Carbon X(X55) or equivalent.

1. Remove air cleaner and disconnect choke electrical connector.

2. Align a #21 drill (.159") on rivet head and drill only enough to remove rivet head. Drill the two remaining rivet heads out of the choke housing. Use care in drilling to prevent damage to choke cover or housing. Remove the three retainers and choke cover assembly from choke housing.

3. Install the choke cover and coil assembly in choke housing as follows:

a. Start the three (3) self-tapping screws in the choke housing, checking to be sure screws start easily and are aligned properly. Then, remove screws.

Self-tapping cover retaining screws are supplied with service kits.

b. Place fast idle screw on highest step of fast idle cam.

c. Install the thermostatic cover and coil assembly in the choke housing, aligning notch in cover with raised casting projection on housing cover flange. Make sure coil pick-up tang engages the inside choke coil lever.

4. Connect choke electrical connector.

5. Start engine, check operation of choke and then install air cleaner.

Idle Mixture Check and Adjustment (Propane Enrichment)

Idle mixture screws have been present at the factory and sealed. Idle mixture should be adjusted only in the case of major carburetor overhaul, throttle body replacement or high emissions as determined by official inspections. Adjusting mixture by other than the following method may violate Federal and/or California or other state or provincial laws.

Because of the sealed idle mixture screws, the idle mixture checking procedure requires artificial enrichment by adding propane.

1. Set parking brake and block drive wheels. On cars equipped with vacuum parking brake release, disconnect and plug hose at brake. Engine must be at normal operating temperature and air conditioning off.

2. Disconnect and plug hoses as directed on the Emission Control Information Label under the hood.

3. Connect an accurate tachometer to engine.

4. Disconnect vacuum advance and set timing to specification shown on the Emission Control Information Label. Re-connect vacuum advance.

5. Set carburetor idle speed to specification as shown on Emission Control Information Label.

6. Disconnect crankcase ventilation tube from air cleaner.

7. Using tool J-26911, insert hose with rubber stopper, from propane valve into crankcase ventilation tube opening in air cleaner. Propane cartridge must be vertical.

8. With engine idling in drive (neutral for manual shifts) slowly open propane control valve while pressing button. Continue to add propane until speed drops due to over richness. Note maximum engine speed (enriched speed). If rich speed drop cannot be obtained check for empty cartridge or propane system leaks.

9. If the enriched idle speed is within the enriched idle specification the mixture is correct. Go to step 17.

10. If the enriched idle speed is not within specifications, remove mixture screw plugs following procedures.

11. Lightly seat screws, then back out equally, just enough so engine will run.

12. Place transmission in Drive (automatics) or Neutral (manuals).

13. Back each screw out (richen 1/8 turn at a time until maximum idle speed is obtained). Then set idle speed to the enriched idle specification.

14. Turn each mixture screw in (clockwise) 1/8 turn at a time until idle speed reaches value given on Emission Control Information Label.

15. Recheck enriched speed with propane. If not within specification, repeat adjustment beginning with Step 12.

16. Check and adjust fast idle as described on Emission Control Information Label.

17. Turn off engine. Remove propane tool, connect crankcase ventilation tube. Re-connect vacuum hoses.

Carburetor Mounting Torque

When torquing carburetor after removed, overhaul, replacement or when installing a new heat insulator, torque mounting bolts in a clockwise direction to 23 N·m (198 in. lbs.).

When retorquing carburetor at recommended maintenance intervals, retorque to 16 N·m (144 in. lbs.) maximum.

CARBURETOR REPLACEMENT (FIG. 6C2-18)

Removal

Flooding, stumble on acceleration and other performance complaints are, in many instances, caused by presence of dirt, water, or other foreign matter in carburetor. To aid in diagnosing cause, carburetor should be carefully removed from engine without draining fuel from bowl. Contents of fuel bowl may then be examined for contamination as carburetor is disassembled. Check filter.

1. Remove air cleaner.

2. Disconnect fuel and vacuum lines from carburetor.

3. Disconnect electrical connector at choke.

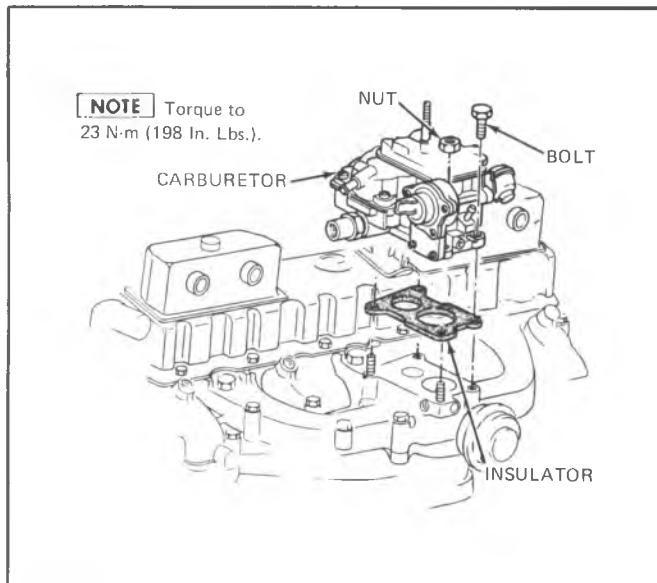


Fig. 6C2-18--2SE Carburetor Replacement

4. Disconnect accelerator linkage and transmission cable.
5. Disconnect solenoid electrical connector.

6. Remove carburetor attaching nuts and remove carburetor and solenoid assembly attachment.

7. Remove insulator gasket.

Installation

It is good shop practice to fill carburetor bowl before installing carburetor. This reduces strain on starting motor and battery and reduces the possibility of backfiring while attempting to start engine. A small supply of fuel will enable carburetor to be filled and the operation of float and intake needle and seat to be checked. Operate throttle lever several times and check discharge from pump jets before installing carburetor.

1. Be certain throttle body and intake manifold sealing surface are clean.
2. Install carburetor insulator.
3. Install carburetor over manifold studs.
4. Install vacuum and fuel lines at carburetor.
5. Install attaching nuts and tighten alternately to 16 pounds-feet (21 N·m).
6. Tighten fuel line.
7. Connect accelerator linkage and transmission cable.
8. Connect choke and solenoid electrical connectors.
9. Install air cleaner.
10. Check and adjust idle speed.

UNIT REPAIR

The procedures below apply to the complete overhaul with the carburetor removed from the engine. However, in many cases service adjustments of individual systems may be completed without removing the carburetor from the engine (refer to On-Car Service). A complete carburetor overhaul includes disassembly, thorough cleaning, inspection, and replacement of all gaskets - diaphragms - seals - worn or damaged parts, and service adjustment of individual systems.

CARBURETOR DISASSEMBLY

Before performing any service on the carburetor, it is essential that the carburetor be placed on a holding fixture such as tool J-9789-118 or equivalent. Without the use of the holding fixture, it is possible to damage throttle valves.

Idle Speed Solenoid

Removal

1. Bend back retaining tabs on lockwasher; then remove large solenoid retaining nut using suitable wrench. Use care in removing nut with wrench to avoid bending or damaging choke linkage, solenoid bracket, vacuum break unit or throttle lever.

2. Remove lockwasher and solenoid unit from bracket.

NOTICE: The solenoid should not be immersed in any type of carburetor cleaner and should always be removed before complete carburetor overhaul.

Air Horn

1. Remove pump lever retaining screw from air horn (Fig. 6C2-19). Then rotate pump lever to remove from pump rod.

2. Remove hose from primary side vacuum break assembly.

3. Remove (2) screws securing primary side vacuum break bracket to air horn (Fig. 6C2-20); then, rotate vacuum

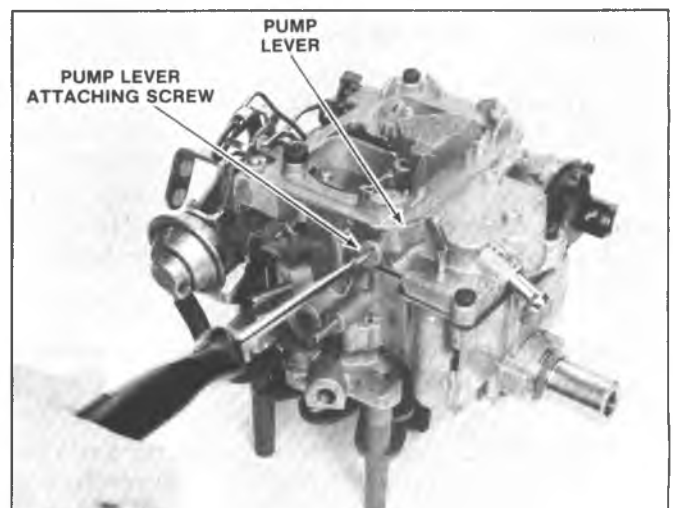


Fig. 6C2-19--Removing Pump Lever

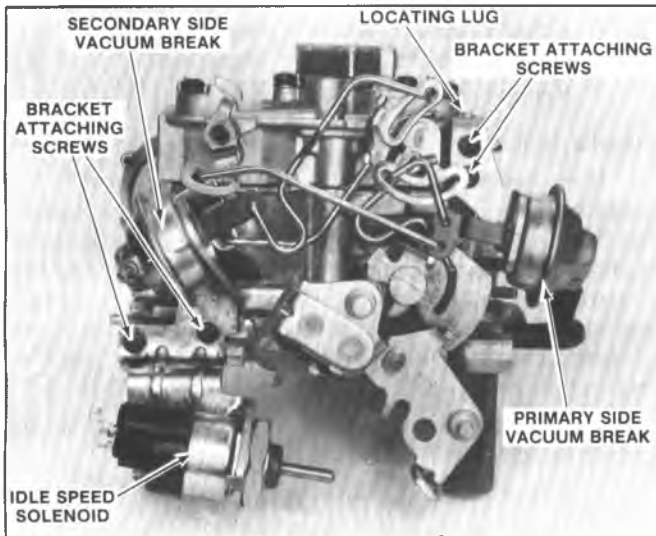


Fig. 6C2-20--Vacuum Break and Idle Speed Solenoid

break and bracket assembly to disengage rods from vacuum break and air valve levers. It is not necessary to remove the vacuum break or air valve rods from the vacuum break plunger unless replacement of the rods is necessary.

NOTICE: Do not place vacuum break assembly in carburetor cleaner.

4. If necessary to replace the vacuum break rod or air valve rod, remove retaining clips from end of rods. Remove plastic bushing used on rods and retain for later re-use.

5. Remove secondary side idle speed solenoid-vacuum break bracket attaching screws from throttle body (Fig. 6C2-20). Then, rotate bracket to remove secondary side vacuum break rod from vacuum break lever. If not removed previously, solenoid may be removed from bracket following procedure described above. It is not necessary to remove the secondary side vacuum break rod from the vacuum break plunger unless replacement of the rod is necessary.

NOTICE: Do not place vacuum break assembly and solenoid in carburetor cleaner.

6. If necessary to replace the secondary side vacuum break rod, remove retaining clip from end of rod. Remove plastic bushing used on rod and retain for later re-use.

7. Remove and discard retaining clip from intermediate choke rod at choke lever (Fig. 6C2-21). A new retaining clip is required for reassembly. Remove choke rod and plastic bushing from choke lever.

NOTICE: The plastic bushing will be loose and should be saved for later reassembly.

8. If equipped, remove (2) small screws that retain the hot idle compensator valve (Fig. 6C2-22). Remove valve and seal from air horn. Discard seal. Hot idle compensator valve must be removed to gain access to short air horn to bowl attaching screw.

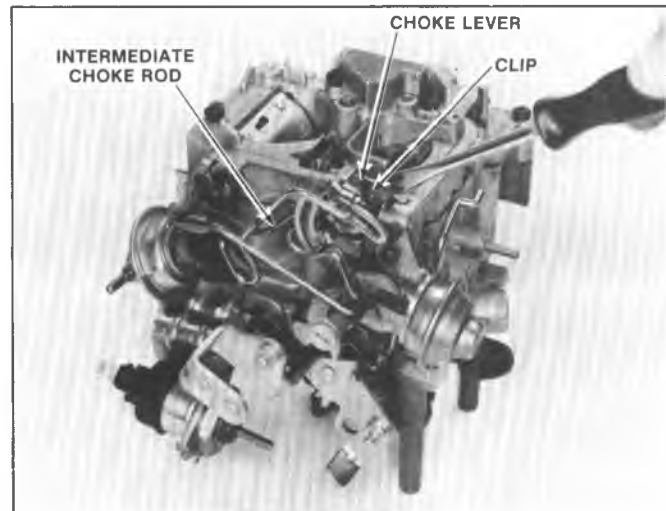


Fig. 6C2-21--Choke Rod and Choke Lever

9. Remove the (7) air horn to bowl attaching screws and lockwashers (Fig. 6C2-23). Remove vent and screen assembly.

10. Rotate fast idle cam to the full UP position and remove air horn assembly by tilting to disengage fast idle cam rod from slot in fast idle cam (Fig. 6C2-24). The air horn gasket should remain on the float bowl for removal later.

NOTICE: Do not remove fast idle cam screw and cam unless replacement is necessary from float bowl. These parts are not serviced separately and are to remain in place as installed by the factory. The new service replacement float bowl will include the secondary lock-out lever, fast idle cam and screw installed as required.

11. Remove fast idle cam rod from choke lever by rotating rod to align squirt on rod with small slot in lever.

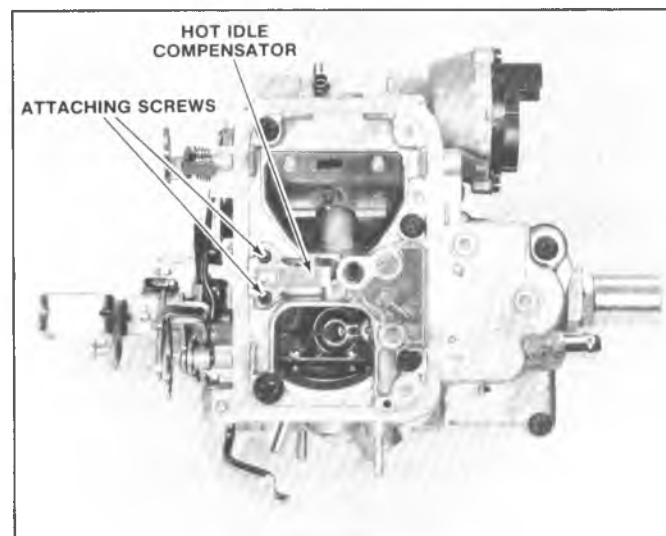


Fig. 6C2-22--Hot Idle Compensator

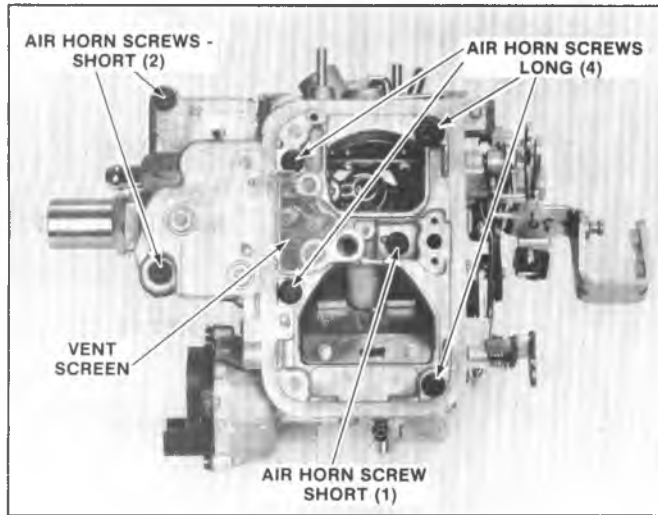


Fig. 6C2-23--Air Horn Screws

Air Horn Disassembly

1. If used, remove pump plunger stem seal by inverting air horn and use a small screwdriver to remove staking holding the seal retainer in place. Remove and discard retainer and seal.

2. Further disassembly of the air horn is not required for cleaning purposes. If part replacement is required, remove staking on (2) choke valve attaching screws. Remove screws, choke valve, and shaft from air horn.

The air valve screws are permanently staked in place and should not be removed. Do not attempt to remove the secondary metering rod from the air valve assembly. The secondary metering rod adjustment screw is pre-set at the factory and no attempt should be made to change this adjustment in the field. If air horn replacement is required during carburetor service, the new service air horn assembly will include the secondary metering rod-air valve assembly pre-set as required.

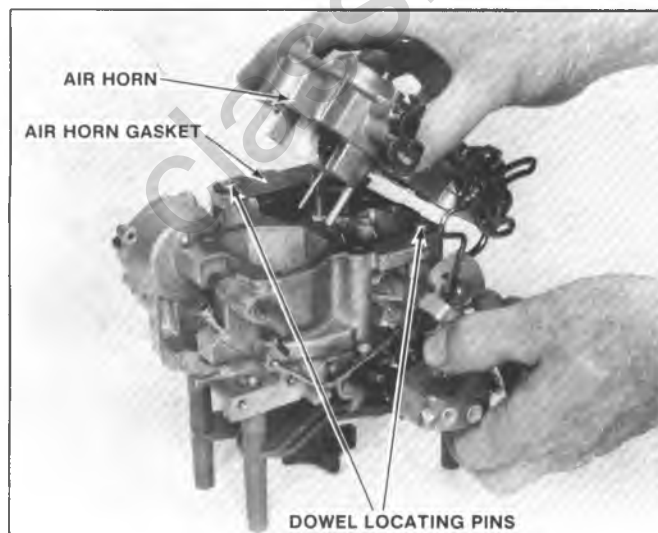


Fig. 6C2-24--Air Horn Assembly

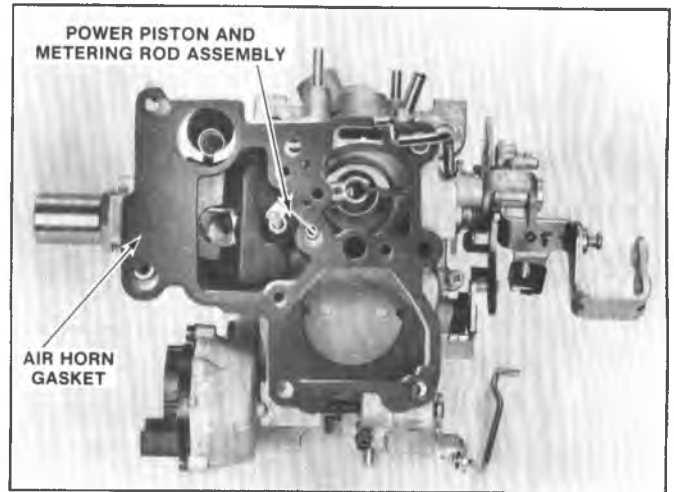


Fig. 6C2-25--Float Bowl

Float Bowl Disassembly (Fig. 6C2-25)

1. Remove air horn gasket. Gasket is pre-cut for easy removal around metering rod and hanger assembly.
2. Remove pump plunger from pump well.
3. Remove pump return spring from pump well.
4. Remove plastic filler block over float valve.
5. Remove float assembly and float valve by pulling up on retaining pin. Remove float valve seat and gasket, using seat remover J-22769 (Fig. 6C2-26).
6. Remove power piston and metering rod assembly by depressing piston stem and allowing it to snap free (Fig. 6C2-27). The power piston can be easily removed by

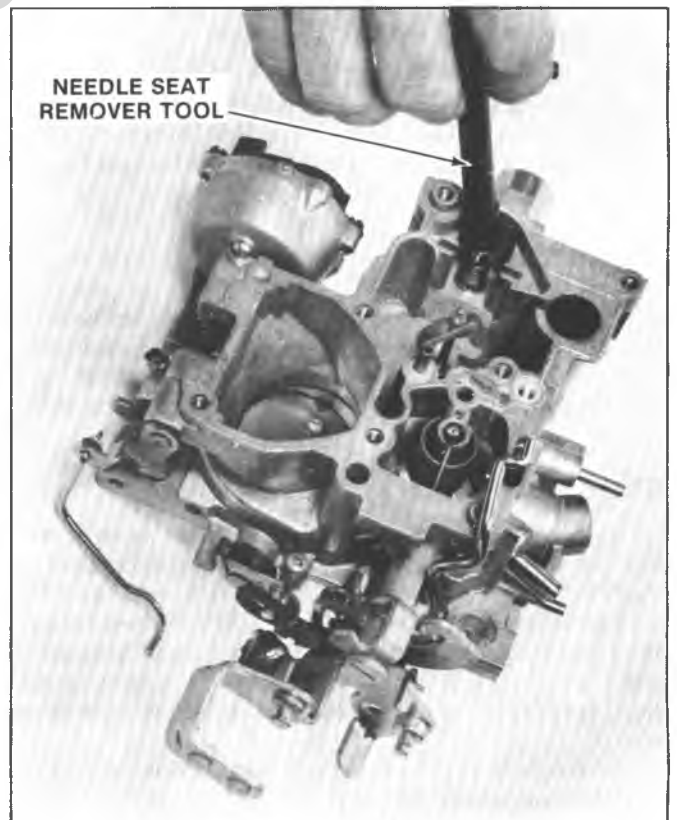


Fig. 6C2-26--Float Valve Seat

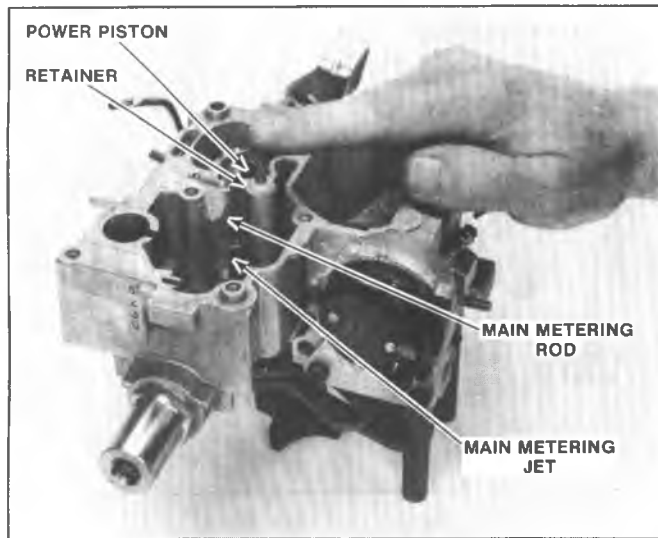


Fig. 6C2-27--Power Piston and Metering Rod Assembly

pressing the piston down and releasing it with a snap. This will cause the power piston spring to snap the piston up against the plastic retainer. This procedure may have to be repeated several times. Do not remove power piston by using pliers on metering rod holder.

7. Remove the power piston spring from the piston bore. If necessary, metering rod may be removed from power piston hanger by compressing spring on top of metering rod and aligning groove on rod with slot in holder (Fig. 6C2-26). Use extreme care in handling the metering rod to prevent damage to metering rod tip.

8. Remove the main metering jet using Tool J-22769 or suitable screwdriver that fully fits the slot in top of the jet to prevent damage to the jet (Fig. 6C2-27).

9. Using a small slide hammer or equivalent, remove plastic retainer holding pump discharge spring and check ball in place (Fig. 6C2-30). Discard plastic retainer (a new retainer is required for reassembly).

NOTICE: Do not attempt to remove plastic retainer by prying out with a tool such as a punch or screwdriver - this will damage the sealing beads on the bowl casting surface requiring complete float bowl replacement. Turn bowl upside down catching pump discharge spring and check ball in palm of hand.

Choke Disassembly

1. Support float bowl and throttle body as an assembly on a suitable holding fixture such as Tool J-9789-118. Align a #21 drill (.159") on rivet head and drill only enough to remove rivet head. Drill the two remaining rivet heads and then use a drift and small hammer to drive the remainder of the rivets out of the choke housing. Use care to prevent damage to choke cover or housing.

3. Remove the three retainers and choke cover assembly from choke housing.

4. Remove screw from end of intermediate choke shaft inside choke housing. Remove choke coil lever from shaft.

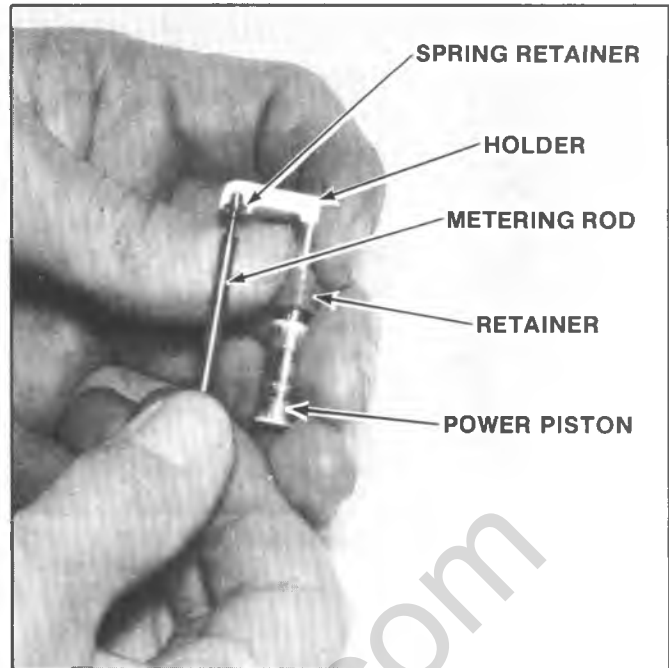


Fig. 6C2-28--Power Piston Assembly

5. Remove intermediate choke shaft and lever assembly from float bowl by sliding rearward out throttle lever side (Fig. 6C2-31).

6. Remove choke housing by removing two (2) attaching screws in throttle body (Fig. 6C2-32).

Disassembly of Remaining Float Bowl Parts

1. Remove fuel inlet nut, gasket, check valve filter assembly, and spring.

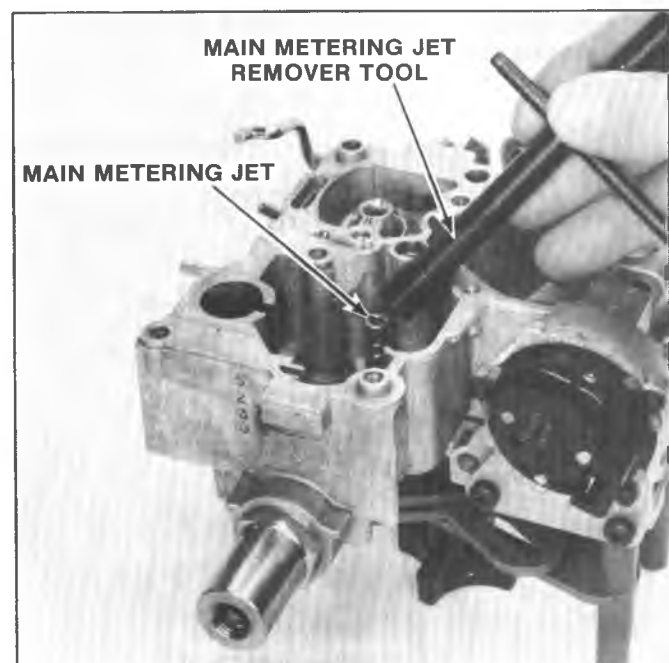


Fig. 6C2-29--Main Metering Jet

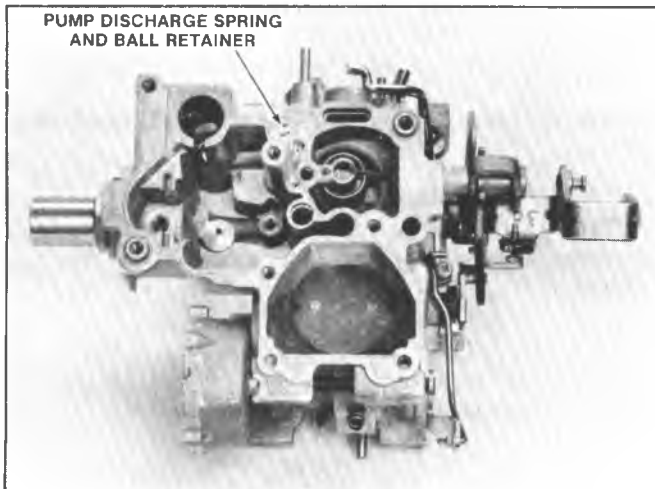


Fig. 6C2-30—Pump Discharge Spring and Ball

2. Remove (4) throttle body to bowl attaching screws and lockwashers and remove throttle body assembly (Fig. 6C2-33).

3. Remove throttle body to bowl insulator gasket.

Throttle Body

Disassembly (Fig. 6C2-34)

NOTICE: Place throttle body assembly on carburetor holding fixture to avoid damaging throttle valves.

1. Hold primary throttle lever wide-open and disengage pump rod from throttle lever by rotating rod until squirt on rod aligns with slot in lever.

2. If replacement is necessary, remove fast idle screw and clip in primary throttle lever.

3. If required, remove slow idle speed screw and spring in throttle body. Further disassembly of the throttle body is not required for cleaning purposes.

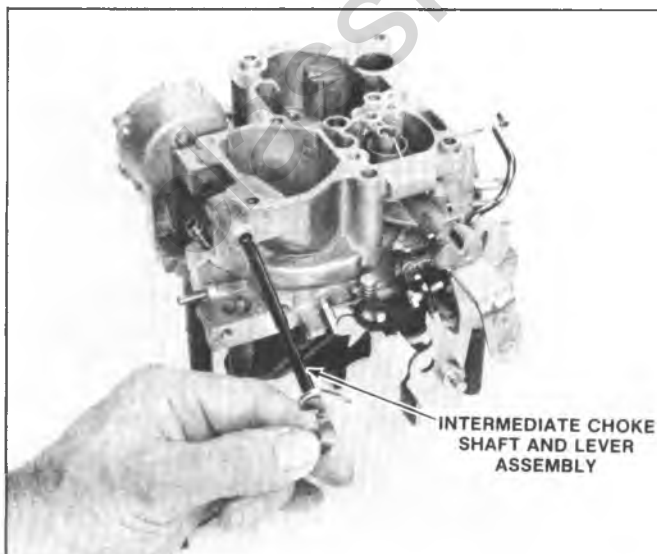


Fig. 6C2-31—Choke Shaft and Lever Assembly

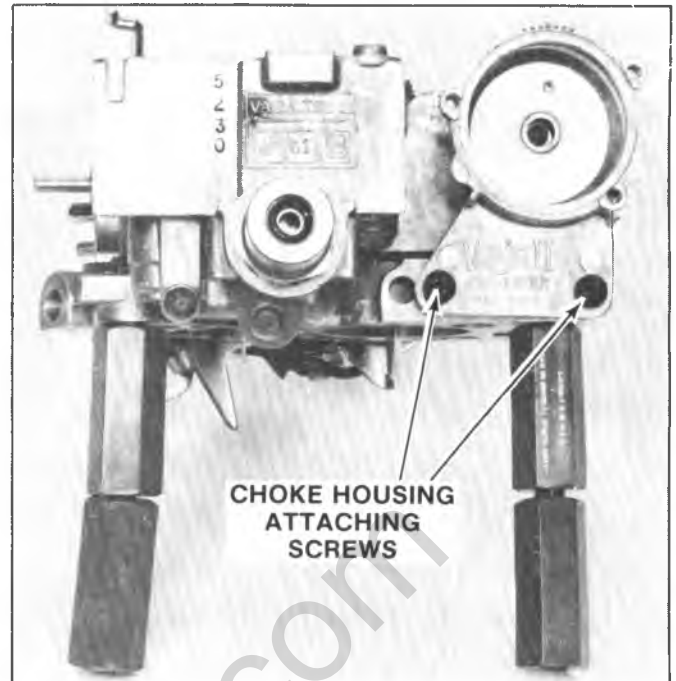


Fig. 6C2-32—Choke Housing Screws

NOTICE: The primary and secondary throttle valve screws are permanently staked in place and should not be removed. The throttle body is serviced as a complete assembly.

4. DO NOT REMOVE plug covering idle mixture needle unless it is necessary to replace the mixture needle or normal soaking and air pressure fails to clean the idle mixture passages.

NOTICE: Idle mixture should be adjusted only if required at time of major carburetor overhaul, throttle body replacement, or high emissions as determined by official inspections.

Remove idle mixture needle and plug as follows:

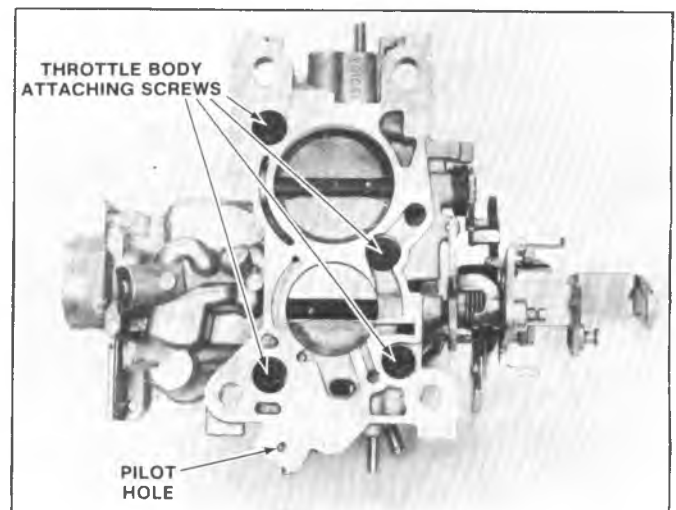


Fig. 6C2-33—Throttle Body Screws

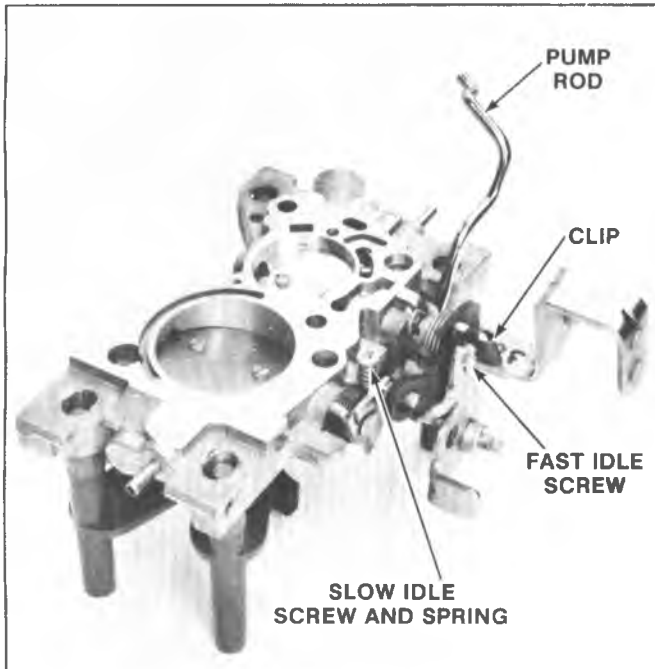


Fig. 6C2-34--Throttle Body

a. Invert throttle body and place on carburetor holding fixture-manifold side up.

b. Place a punch in the locator point in the pilot hole in the throttle body beneath the idle mixture needle plug (manifold side) (see Fig. 6C2-33 for locator point). Then, holding the punch vertical, drive punch through the locator until hardened steel plug shatters. Then, holding punch at a 45 degree angle, break out throttle body casting to gain access to the mixture needle plug; drive out hardened steel plug.

NOTICE: Hardened plug will shatter rather than remaining intact. It is not necessary to remove the plug completely; instead, remove loose pieces to allow use of Idle Mixture Adjusting Tool J-29030.

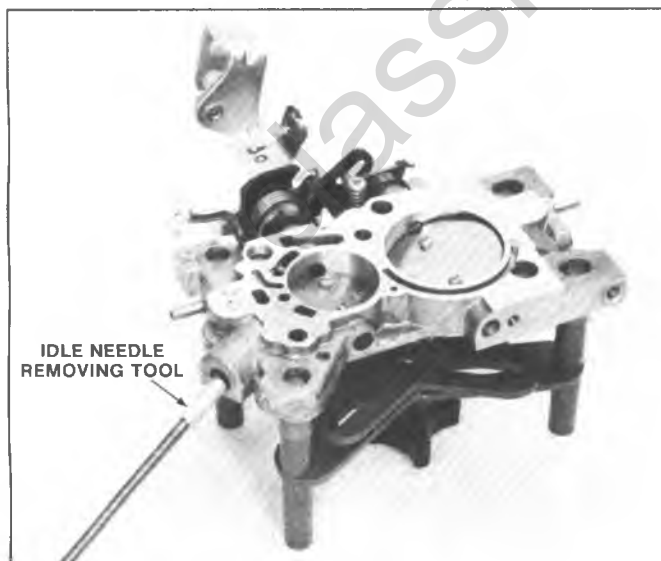


Fig. 6C2-35--Removing Idle Needle

c. Using Tool J-29030 remove idle mixture needle, washer (if used), and spring from throttle body (Fig. 6C2-35).

CLEANING AND INSPECTION

The carburetor parts should be cleaned in a cold immersion-type cleaner such as Carbon X (X-55) or its equivalent.

NOTICE: The solenoid, electric choke, rubber parts, plastic parts, diaphragms, pump plunger, plastic filler block should NOT be immersed in carburetor cleaner as they will swell, harden or distort.

1. Thoroughly clean all metal parts and blow dry with compressed air. Make sure all fuel passages and metering parts are free of burrs and dirt. Do not pass drills or wires through jets and passages.

2. Inspect upper and lower surface of carburetor castings for damage.

3. Inspect holes in levers for excessive wear or out of round conditions. If worn, levers should be replaced. Inspect plastic bushings for damage and excessive wear. Replace as required.

4. Check, repair, or replace parts if the following problems are encountered:

A. Flooding

1. Inspect float valve and seat for dirt, deep wear grooves, scores, and proper seating.

2. Inspect float valve pull clip for proper installation (Fig. 6C2-36). Be careful not to bend pull clip.

3. Inspect float, float arms and hinge pin for distortion, binds, and burrs. Check density of material in the float; if heavier than normal, replace float.

4. Clean or replace fuel inlet filter and check valve assembly.

B. Hesitation

1. Inspect pump plunger and cup for cracks, scores, or cup excessive wear. A used pump cup will shrink when dry. If dried out, soak in fuel for 8 hours before testing.

2. Inspect pump duration and return springs for being weak or distorted.

3. Check all pump passages and jet for dirt, improper seating of discharge check ball and scores in pump well. Check condition of pump discharge check ball spring.

4. Check pump linkage for excessive wear; repair or replace as necessary.

C. Hard Starting - Poor Cold Operation

1. Check choke valve and linkage for excessive wear, binds or distortion.

2. Inspect choke vacuum diaphragms for leaks.

3. Clean or replace carburetor fuel filter.

4. Inspect float valve for sticking, dirt, etc.

5. Also check items under "Flooding".

D. Poor Performance - Poor Gas Mileage

1. Clean all fuel and vacuum passages in castings.

2. Check choke valve for freedom of movement.

3. Check power piston, metering rod, and jet for dirt, sticking, binding, damaged parts or excessive wear.

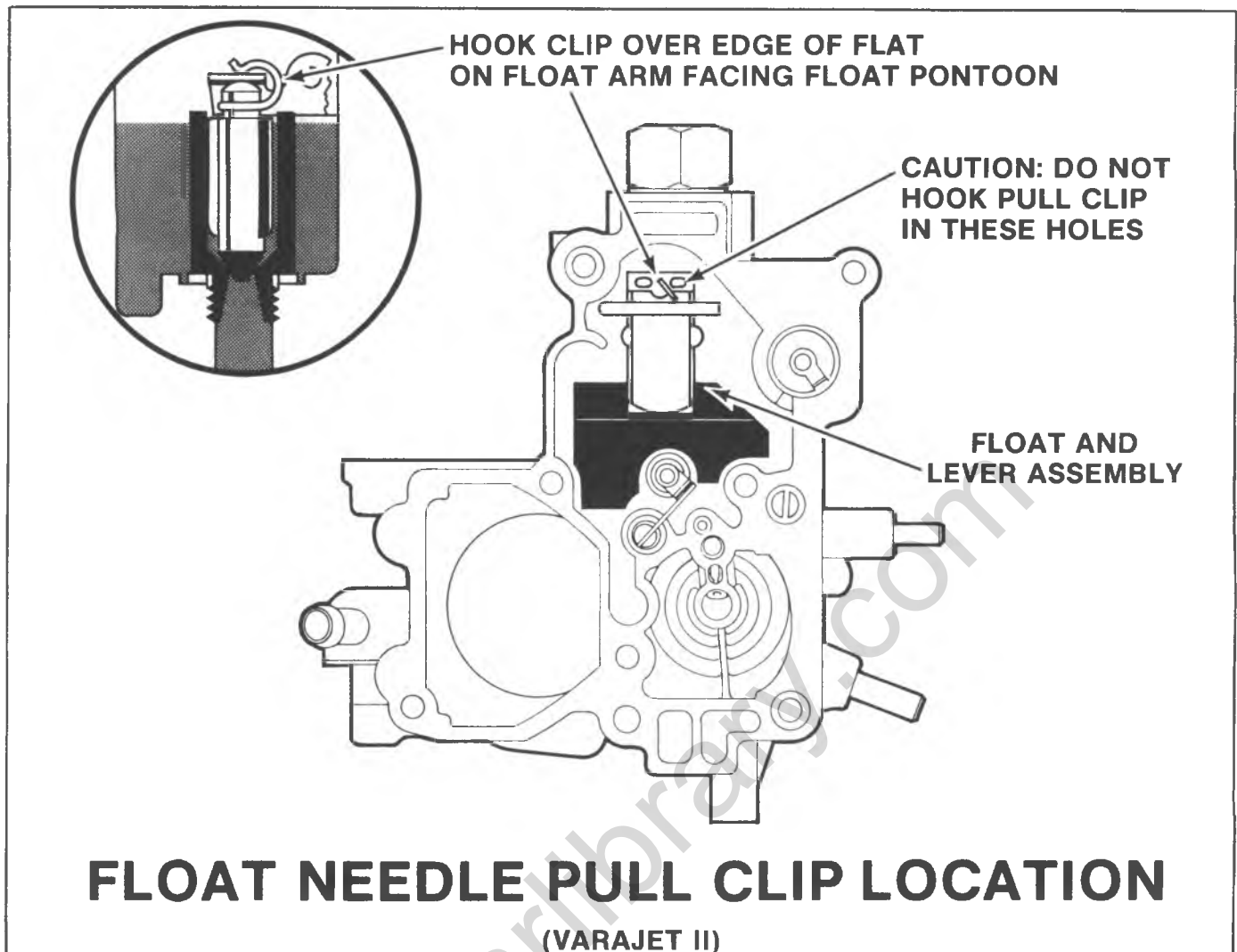


Fig. 6C2-36--Pull Clip Location

4. Check air valve and secondary metering rod for binding conditions.

If air valve or metering rod is damaged, the air horn assembly must be replaced.

E. Rough Idle

1. Inspect gasket and gasket mating surfaces on castings for damage to sealing beads, nicks, burrs and other damage.

2. Clean all idle fuel passages.

3. If removed, inspect idle mixture needle for ridges, burrs, or being bent.

4. Check throttle lever and valves for bind, nicks and other damage.

5. Check all diaphragms for possible ruptures or leaks.

6. Clean plastic parts only in Stoddard solvent - never in gasoline.

CARBURETOR ASSEMBLY

Throttle Body

1. Install slow idle speed screw and spring, if removed, in throttle body (Fig. 6C2-32).

2. If removed, install fast idle adjustment screw and clip in primary throttle lever (Fig. 6C2-32).

3. Holding primary throttle lever wide open, install lower end of pump rod in throttle lever by aligning squirt on rod with slot in lever. End of rod should point outward toward throttle lever.

4. If removed, install idle mixture needle, washer (if used), and spring using tool J-29030 (Fig. 6C2-35). Lightly seat needle and then back out 2 turns as a preliminary idle mixture adjustment. Final idle mixture adjustment must be made on-car using the procedure described under Idle Mixture Adjustment.

Float Bowl

Assembly

NOTICE: If a new float bowl assembly is used, stamp or engrave the model number on the new float bowl (see Fig. 6C2-4).

1. Install new throttle body to bowl insulator gasket over two locating dowels on bowl (Fig. 6C2-37).

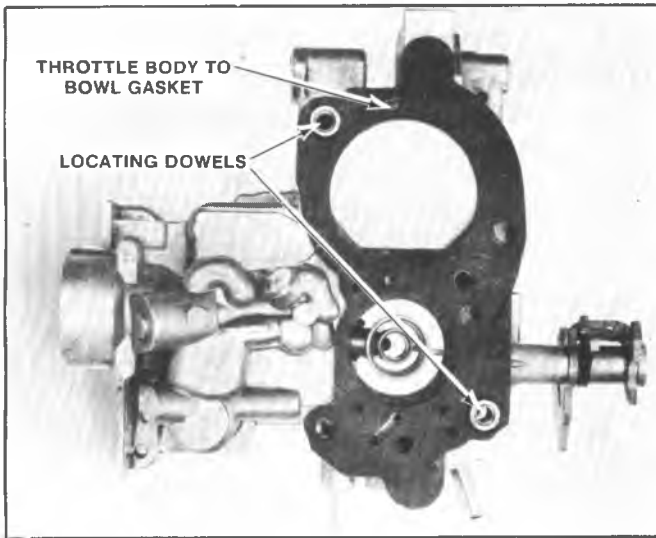


Fig. 6C2-37--Throttle Body to Bowl Gasket

2. Holding fast idle cam so that cam steps face fast idle screw on throttle lever when properly installed, install throttle body making certain throttle body is properly located over dowels on float bowl; then install (4) throttle body to bowl screws and lockwashers and tighten securely (Fig. 6C2-33).

NOTICE: Inspect linkage to insure lockout tang is located properly to engage slot in secondary lockout lever and that linkage moves freely and does not bind.

3. Place carburetor on proper holding fixture such as J-9789-118 or equivalent.

4. Install fuel inlet filter spring, check valve filter assembly, new gasket and inlet nut and tighten nut to 24 N·m (18 ft. lbs.). Tightening beyond specified torque can damage nylon gasket and cause fuel leak.

NOTICE: When installing a service replacement filter, make sure the filter is the type that includes the check valve to meet U.S. Motor Vehicle Safety Standards (M.V.S.S.). General Motors service replacement filters with check valve meet this requirement. When properly installed, hole in filter faces toward inlet nut. Ribs on closed end of filter element prevent filter from being installed incorrectly unless forced.

5. Install choke housing on throttle body, making sure raised boss and locating lug on rear of housing fit into recesses in float bowl casting (Fig. 6C2-32). Install (2) choke housing attaching screws and lockwashers in throttle body and tighten screws evenly and securely.

6. Install intermediate choke shaft and lever assembly in float bowl by pushing through from throttle lever side (Fig. 6C2-31).

7. With intermediate choke lever in the UP (12 o'clock) position, install thermostatic coil lever inside choke housing onto flats on intermediate choke shaft. Coil is properly aligned when the coil pick-up tang is at the top (12 o'clock) position. Install inside lever retaining screw into end of intermediate choke shaft and tighten securely.

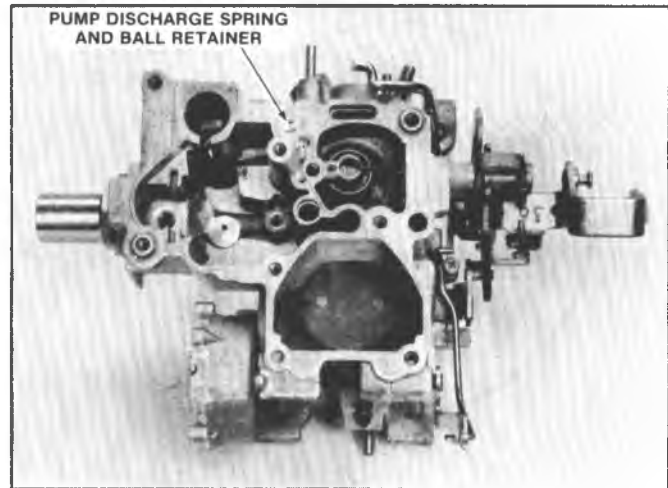


Fig. 6C2-38--Pump Discharge Spring and Ball

NOTICE: Do not install thermostatic choke cover and coil assembly in housing until inside coil lever is adjusted (see Adjustments).

8. Install pump discharge steel check ball and spring in passage next to float chamber (Fig. 6C2-38). Insert end of new plastic retainer into end of spring and install retainer in float bowl, tapping lightly in place until top of retainer is flush with bowl casting surface.

9. Using screwdriver that fully fits the slot in the top, install main metering jet into bottom of float chamber. Tighten jet securely.

10. Install float valve seat assembly, with gasket, using seat installer J-22769 or equivalent (Fig. 6C2-26).

11. To make adjustment easier, carefully bend float arm upward at notch in arm before assembly.

12. Install float valve onto float arm by sliding float lever under pull clip. Correct installation of the pull clip is to hook the clip over the edge of the float on the float arm facing the float pontoon (Fig. 6C2-36).

13. Install float retaining pin into float arm with end of loop of pin facing pump well. Then, install float assembly by aligning valve in the seat and float retaining pin into locating channels in float bowl.

14. Float Level Adjustment (Fig. 6C2-11).

a. Hold float retaining pin firmly in place and push down lightly on float arm at outer end against top of float needle.

b. Using adjustable "T" scale, measure from top of float bowl casting surface (air horn gasket removed) to top of float at toe, gaging point 3/16" back from end of float at toe. (See inset, Float Adjustment Fig. 6C2-11).

c. Bend float arm as necessary for proper adjustment by pushing on pontoon (see Adjustment Chart for specifications).

d. Visually check float alignment after adjustment.

15. Install power piston spring into piston bore.

16. If removed, assemble metering rod to holder on power piston. Spring must be on top of arm when assembled correctly (Fig. 6C2-28).

17. Install power piston and metering rod assembly into the float bowl and main metering jet. Use care installing the

metering rod into the jet to prevent damaging the metering rod tip. Press down firmly on plastic power piston retainer to make sure the retainer is seated in recess in bowl and the top is flush with the top of the bowl casting. If necessary, tap retainer lightly in place using a drift and small hammer.

18. Install plastic filler block over float valve, pressing downward until properly seated (flush with bowl casting surface).

19. Install air horn gasket on float bowl by carefully sliding slit portion of gasket over the two dowel locating pins on the float bowl.

20. Install pump return spring in pump well.

21. Install pump plunger assembly in pump well.

Air Horn

Assembly

1. If removed, install choke shaft, choke valve, and two attaching screws. Tighten screws securely and stake lightly in place. Check choke valve for freedom of movement and proper alignment before staking screws in place.

2. If used, install new pump plunger stem seal and retainer in air horn casting. Lightly stake seal retainer in three places, choosing locations different from the original stakings.

Air Horn To Bowl

Installation

1. Rotate fast idle cam to the full UP position and tilt the air horn assembly to engage lower end of fast idle cam rod in slot in fast idle cam (Fig. 6C2-24); then, holding down on the pump plunger assembly, carefully lower air horn assembly onto float bowl, guiding pump plunger stem through hole in air horn casting. Do not force air horn assembly onto bowl, but rather lightly lower in place.

2. Install vent and screen assembly on air horn assembly located in area between the primary and secondary bores (Fig. 6C2-23). Then, install (7) air horn to bowl attaching screws and lockwashers. (4) long air horn screws are located in the primary and secondary venturi area of which (2) longer screws hold the vent and screen assembly in place and one (1) larger head screw goes next to the choke valve on the primary side. In addition (2) short screws are located on the fuel inlet side; and (1) short screw is located in the area beneath the hot idle compensator valve. All air horn screws must be tightened evenly and securely. See Fig. 6C2-39 for proper tightening sequence.

3. If equipped, install new seal in recess of float bowl; then install hot idle compensator valve and retain with (2) small attaching screws. Tighten screws securely.

4. Install plastic bushing in hole in choke lever, making sure small end of bushing faces retaining clip when installed. With inner choke coil lever at (12 o'clock) position, install intermediate choke rod in bushing. Retain rod with new clip, pressing clip securely in place using tool J-28697 or needlenose pliers. Make sure clip has full contact on rod but is not seated tightly against the bushing. Rod to bushing clearance should be .030".

Retaining clip is "dished". Install clip on rod with outward bend of self-locking lugs facing end of rod. Check that clip fully engages rod and that clip is not distorted.

5. If removed, install solenoid in hole on bracket, large lockwasher and retaining nut. Tighten nut securely. Then,

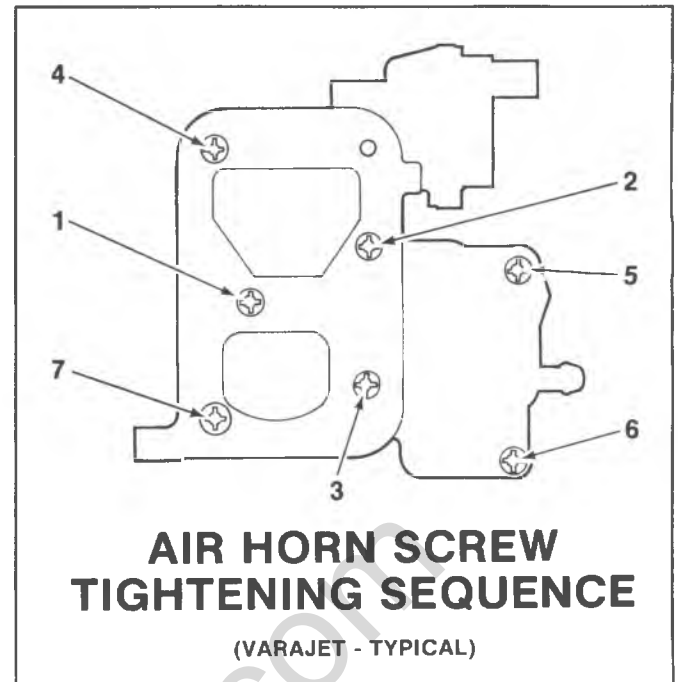


Fig. 6C2-39--Air Horn Tightening Sequence

bend back (2) retaining tabs on lockwasher to fit in slots in bracket.

6. If removed, install plastic bushing in hole in secondary side vacuum break plunger, making sure small end of bushing faces retaining clip when installed. Then, install secondary side vacuum break rod and secure new clip to rod using tool J-28697 or needlenosed pliers.

Retaining clip is "dished". Install clip on rod with outward bend of self-locking lugs facing end of rod. Check that clip fully engages rod and that clip is not distorted.

7. Rotate solenoid bracket and insert end of secondary side vacuum break rod into upper slot of vacuum break lever. Install bracket on throttle body and install countersunk screws. Tighten screws securely (Fig. 6C2-20).

8. If removed, install plastic bushings in holes in primary side vacuum break plunger, making sure small end of bushings face retaining clips when installed. Then install vacuum break rod in upper hole of plunger and air valve rod in lower hole of plunger and secure new clips to rods using tool J-28697 or needlenosed pliers.

Retaining clip is "dished". Install clip on rod with outward bend of self-locking lugs facing end of rod. Check that clips fully engage rods and that clip is not distorted.

9. Rotate primary side vacuum break bracket to engage vacuum break and air valve rods in vacuum break and in air valve lever, positioning bracket over locating lug on air horn. Install (2) countersunk screws and tighten securely (Fig. 6C2-20).

10. Install pump rod in hole in pump lever by rotating lever (Fig. 6C2-19). Install retaining screw in pump lever, then install washer and pump lever to air horn. Then, holding down on pump plunger stem, install pump lever to air horn with retaining screw. Make sure shoulder on screw seats in hole in lever and goes between lever and air horn casting. Holding down pump plunger stem, install pump lever on air horn. Tighten screw securely.

The vacuum break and choke rod (fast idle cam) adjustments must be performed, and the thermostatic coil lever inside the choke housing has to be indexed properly before installing the choke thermostatic coil and cover assembly. Refer to the Adjustment Procedures.

11. After the vacuum break, choke rod (fast idle cam) and inside choke coil lever are adjusted, the thermostatic coil and cover assembly should be installed, making sure coil pick-up tang engages the inside choke coil lever.

12. Install the choke cover and coil assembly in choke housing as follows: Self-tapping cover retaining screws are supplied with service kits.

a. Start the three (3) self-tapping screws in the choke housing, checking to be sure screws start easily and are aligned properly. Then, remove screws.

b. Place fast idle screw on highest step of fast idle cam.

c. Install the thermostatic cover and coil assembly in the choke housing, aligning notch in cover with raised casting projection on housing cover flange. Make sure coil pick-up tang engages the inside choke coil lever.

Classiccarlibrary.com

SECTION 6C3

MODEL M2MC CARBURETOR

CONTENTS

| | | | |
|--------------------------|-------|---------------------------------|--------|
| General Description..... | 6C3-1 | Idle Mixture Adjustment..... | 6C3-3 |
| On-Vehicle Service..... | 6C3-2 | Carburetor Mounting Torque..... | 6C3-7 |
| Adjustments | 6C3-2 | Carburetor Replacement..... | 6C3-7 |
| Checking Choke..... | 6C3-2 | Unit Repair | 6C3-10 |
| Checking Solenoid..... | 6C3-2 | | |

GENERAL DESCRIPTION

The Model 210 (Fig. 6C3-1) is a 2-barrel, single stage carburetor of downdraft design. It has the proven design features of the primary side of the M4MC carburetor.

An adjustable part throttle screw is used in the float bowl to aid in refinement of fuel mixtures for good emission control. This screw is preset at the factory and should not be adjusted in service. If it becomes necessary to replace the float bowl, the new service float bowl will include an adjustable part throttle (A.P.T.) screw which has been preset at the factory.

An integral, 2-inch pleated paper fuel filter with check valve is mounted in the front of the float bowl behind the fuel inlet nut to give maximum filtration of incoming fuel. The check valve is used to shut off fuel flow to the carburetor and prevent fuel leaks if a car roll-over should occur.

The Model M2MC uses a plastic float with a windowless type needle seat for better fuel handling. The float needle is Viton tipped and uses a pull clip for maximum fuel delivery to the float bowl. A plastic filler block is used above the float chamber to reduce fuel slosh in the float

bowl.

A tube is used in the air horn which through a hose connects directly to a vacuum operated vapor vent valve located in the vapor canister. When the engine is not running, the canister vapor vent valve is open allowing fuel vapors from the carburetor float bowl to pass on into the canister where they are stored until purged. Purging of the canister is accomplished through the Positive Crankcase Ventilation (P.C.V.) System.

The choke system includes a non-adjustable exhaust heated air thermostatic choke coil for control of choke mixtures during the warm-up period. A single front vacuum break unit controls choke valve opening after initial engine starting.

For ease of service, alphabetical code letters are cast in the air horn and float bowl at external tube locations to identify air and vacuum hose connections.

The carburetor model identification is stamped vertically on the left rear corner of the float bowl (Fig. 6C3-2). If replacing the float bowl, follow the manufacturer's instructions contained in the service package so that the identification number can be transferred to the new float bowl.

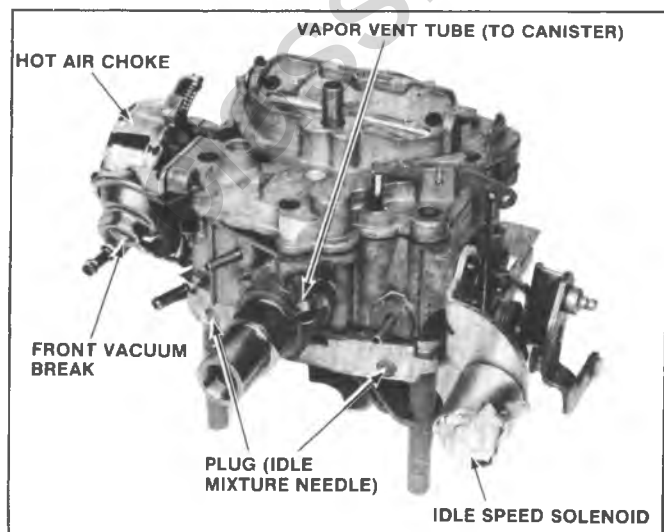


Fig. 6C3-1-Model M2MC

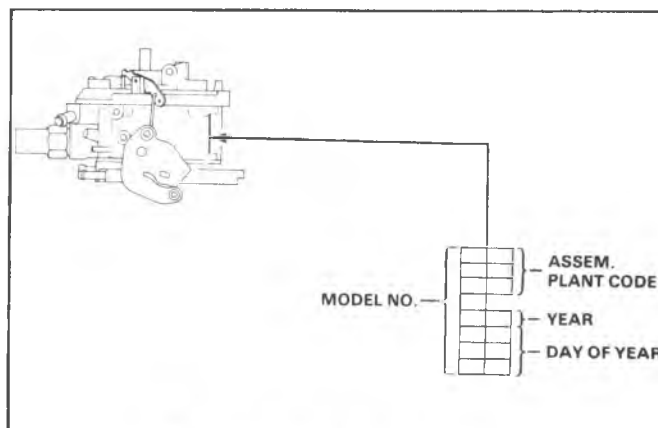


Fig. 6C3-2-Model Identification

An Exhaust Gas Recirculation (E.G.R.) system is used on all applications to control oxides of nitrogen.

The vacuum supply ports necessary to operate the recirculation valve are located in the throttle body and connect through a channel to a tube in the throttle body. This tube is connected by a rubber hose to the E.G.R. valve. See Idle System (Fig. 6C3-4) for port location and operation.

On M2ME models used with air conditioning applications, an electrically operated A/C idle speed solenoid is used to maintain proper idle speed when the air conditioning is in operation.

Incorporated in the Model M2MC carburetors are six basic systems. They are float, idle, main metering, power, pump, and choke (Figs. 6C3-3 through 6C3-8).

ON-VEHICLE SERVICE

CARBURETOR ADJUSTMENTS

Before checking or resetting the carburetor as the cause of poor engine performance or rough idle, check ignition system including distributor, timing, spark plugs and wires. Check air cleaner, evaporative emission system, EFE system, PCV system, EGR valve and engine compression. Also inspect intake manifold vacuum hose gaskets and connections for leaks and check torques of carburetor mounting bolts/nuts.

Refer to Figures 6C3-9 through 6C3-13 for carburetor adjustment procedures and specifications.

CHECKING CARBURETOR CHOKE

1. Remove air cleaner. With engine off, hold throttle half open. Open and close choke several times. Watch linkage to be certain all links are connected and there are no signs of damage.

2. If choke or linkage binds, sticks or works sluggish, clean with choke cleaner X-20-A or equivalent. Use cleaner as directed on can. Refer to Unit Repair for additional direction if cleaning does not correct.

3. Visually inspect carburetor to be certain all vacuum hoses are connected. Inspect hoses for cracks, abrasions, hardness or other signs of deterioration. Replace or correct as necessary.

4. Make sure vacuum break diaphragm shaft is fully extended when engine is off. If shaft is not fully extended, replace vacuum break. Diaphragm shaft should fully retract within 10 seconds after engine starts. If unit fails to retract, replace vacuum break assembly.

Checking Solenoid

1. Turn on ignition, but do not start engine.
2. Turn A/C to "on" position.
3. Open throttle to allow solenoid plunger to extend, close throttle.
4. Disconnect lead at solenoid. Solenoid plunger should drop away from throttle lever.
5. Connect solenoid lead. Plunger should move out and contact the throttle lever. Solenoid may not be strong enough to open the throttle, but the plunger should move.
6. If plunger does not move in and out as lead is disconnected and connected, insert test lamp (1893 built or smaller) between the solenoid feed wire and ground.
7. If light lights, replace solenoid.
8. If light does not light, locate cause of open circuit in solenoid feed wire.

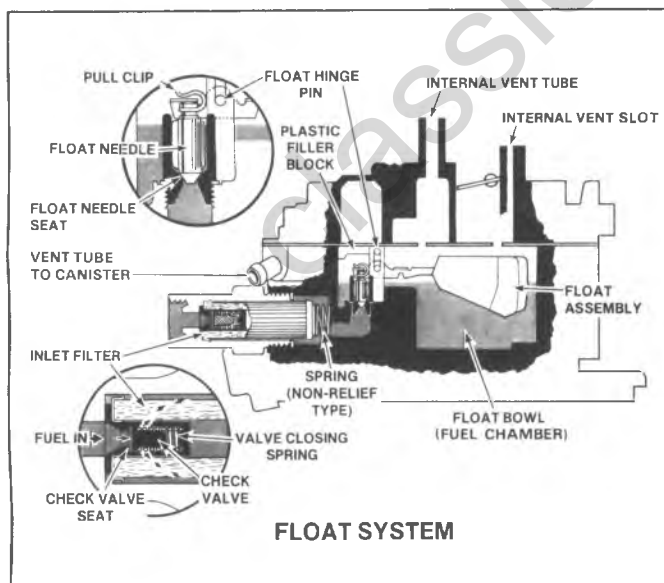


Fig. 6C3-3--M2MC Float System

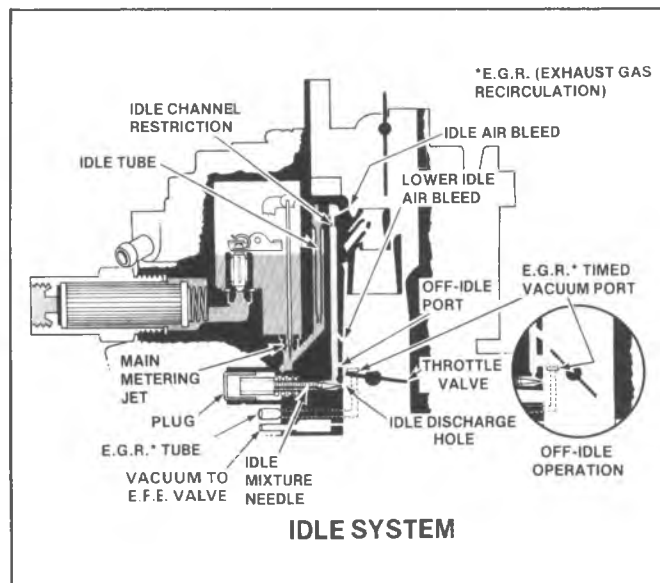


Fig. 6C3-4--M2MC Idle System

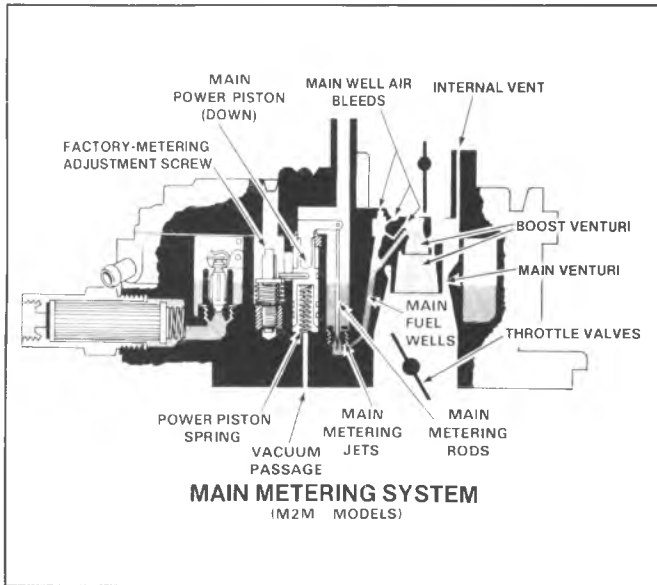


Fig. 6C3-5--M2MC Main Metering System

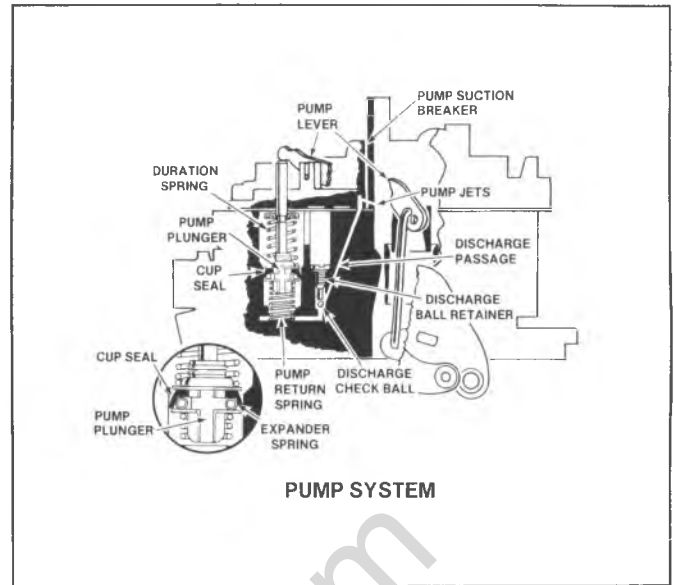


Fig. 6C3-7--M2MC Pump System

Idle Mixture Check and Adjustment (Propane Enrichment)

Idle mixture screws have been preset at the factory and sealed. Idle mixture should be adjusted only in the case of major carburetor overhaul, throttle body replacement or high emissions as determined by official inspections. Adjusting mixture by other than the following method may violate Federal and/or California or other state or Provincial laws.

Because of the sealed idle mixture screws, the idle mixture checking procedure requires artificial enrichment by adding propane.

1. Set parking brake and block drive wheels. On cars equipped with vacuum parking brake release, disconnect and plug hose at brake. Engine must be at normal operating temperature and air conditioning off.

2. Disconnect and plug hoses as directed on the Emission Control Information Label under the hood.

3. Connect an accurate tachometer to engine.

4. Disconnect vacuum advance and set timing to specification shown on the Emission Control Information Label. Re-connect vacuum advance.

5. Set carburetor idle speed to specification as shown on Emission Control Information Label.

6. Disconnect crankcase ventilation tube from air cleaner.

7. Using tool J-26911, insert hose with rubber stopper, from propane valve into crankcase ventilation tube opening in air cleaner. Propane cartridge must be vertical.

8. With engine idling in drive (neutral for manual shifts) slowly open propane control valve while pressing button. Continue to add propane until speed drops due to

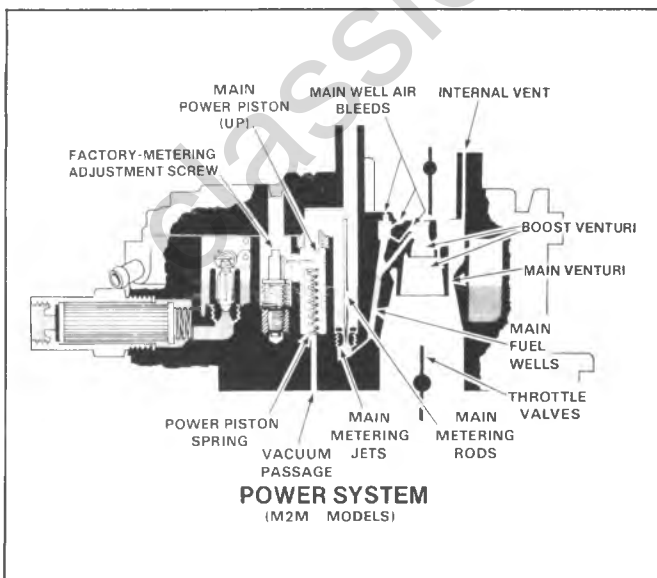


Fig. 6C3-6--M2MC Power System

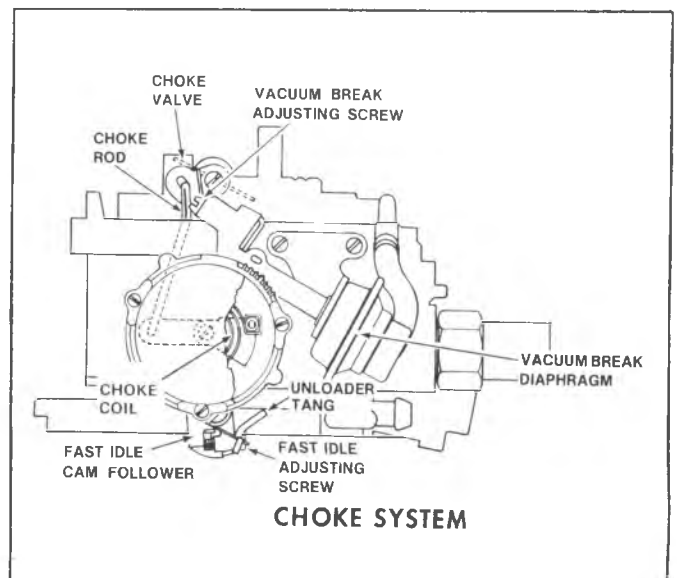
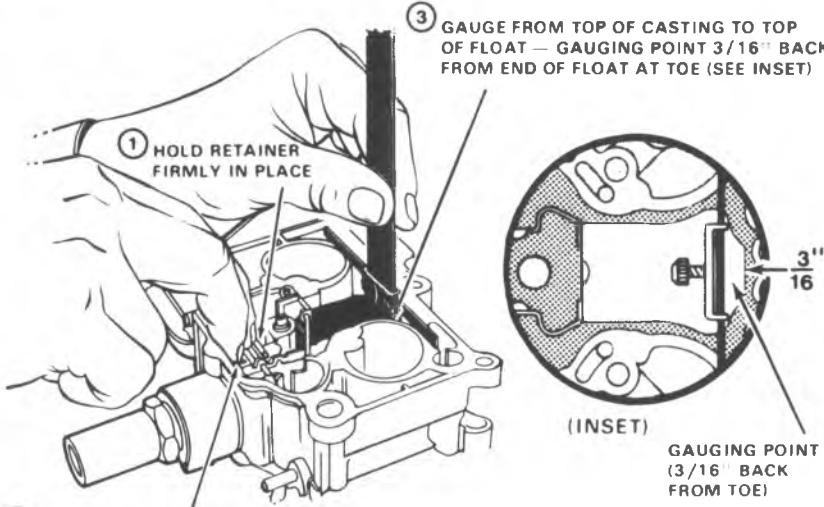
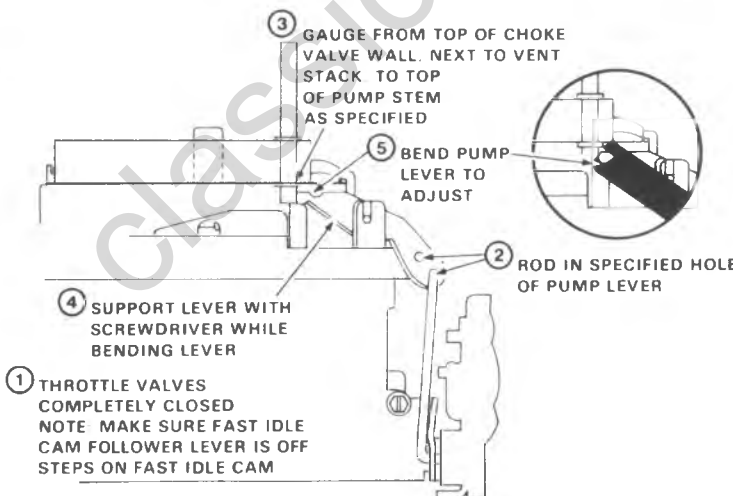


Fig. 6C3-8--M2MC Choke System

| 1 | CARB. NO. | GAUGE | |
|---|--|--------------|----------------------------|
| <p>1 HOLD RETAINER FIRMLY IN PLACE</p> <p>2 PUSH FLOAT DOWN LIGHTLY AGAINST NEEDLE</p> <p>3 GAUGE FROM TOP OF CASTING TO TOP OF FLOAT — GAUGING POINT 3/16" BACK FROM END OF FLOAT AT TOE (SEE INSET)</p>  <p>4 REMOVE FLOAT AND BEND FLOAT ARM UP OR DOWN AT NOTCH TO ADJUST.</p> <p>5 ON C-4 CARBURETORS, IF FLOAT LEVEL VARIES OVER ±1/16" FROM SPECIFICATIONS, ADJUST FLOAT AS FOLLOWS:</p> <p><u>LEVEL TOO HIGH</u> - HOLD RETAINER FIRMLY IN PLACE (1 AND 2) AND PUSH DOWN ON CENTER OF FLOAT PONTOON TO OBTAIN CORRECT SETTING.</p> <p><u>LEVEL TOO LOW</u> - LIFT OUT METERING RODS. REMOVE SOLENOID CONNECTOR SCREW. TURN LEAN MIXTURE SOLENOID SCREW CLOCKWISE <u>COUNTING NUMBER OF TURNS UNTIL SCREW IS BOTTOMED LIGHTLY IN FLOAT BOWL. RECORD NUMBER OF TURNS COUNTED.</u> TURN SCREW COUNTERCLOCKWISE AND REMOVE SCREW. LIFT SOLENOID AND CONNECTOR FROM FLOAT BOWL. REMOVE FLOAT AND BEND FLOAT ARM UP TO ADJUST. VISUALLY CHECK FLOAT ALIGNMENT AFTER ADJUSTING. REVERSE PROCEDURE TO RE-INSTALL PARTS REMOVED, MAKING SURE SOLENOID LEAN MIXTURE SCREW IS BACKED OUT OF FLOAT BOWL <u>EXACTLY THE SAME NUMBER OF TURNS COUNTED AT DISASSEMBLY.</u></p> <p>FLOAT ADJUSTMENT (MECHANICAL SETTING)</p> | <p>17080100 17080102 17080142 17080143 17080144 17080145</p> | <p>7/16"</p> | |
| <p>2</p> <p>1 THROTTLE VALVES COMPLETELY CLOSED NOTE MAKE SURE FAST IDLE CAM FOLLOWER LEVER IS OFF STEPS ON FAST IDLE CAM</p> <p>2 ROD IN SPECIFIED HOLE OF PUMP LEVER</p> <p>3 GAUGE FROM TOP OF CHOKE VALVE WALL, NEXT TO VENT STACK TO TOP OF PUMP STEM AS SPECIFIED</p> <p>4 SUPPORT LEVER WITH SCREWDRIVER WHILE BENDING LEVER</p> <p>5 BEND PUMP LEVER TO ADJUST</p>  <p>PUMP ADJUSTMENT</p> | <p>ALL</p> | <p>9/32"</p> | <p>HOLE LOC. INNER</p> |

DUALJET CARB. 210 OVERHAUL ADJUSTMENTS

Fig. 6C3-9--Model M2MC Adjustments 1 of 5

| 3 | CARB. NO. | PLUG GAUGE |
|--|-----------|------------|
| <p>CHOKE COIL LEVER ADJUSTMENT *</p> | ALL | .120" |
| 4 | CARB. NO. | NO. TURNS |
| <p>FAST IDLE ADJUSTMENT (BENCH SETTING)</p> | ALL | 2 |

DUALJET CARB. 210 OVERHAUL ADJUSTMENTS

Fig. 6C3-10-Model M2MC Adjustments 2 of 5

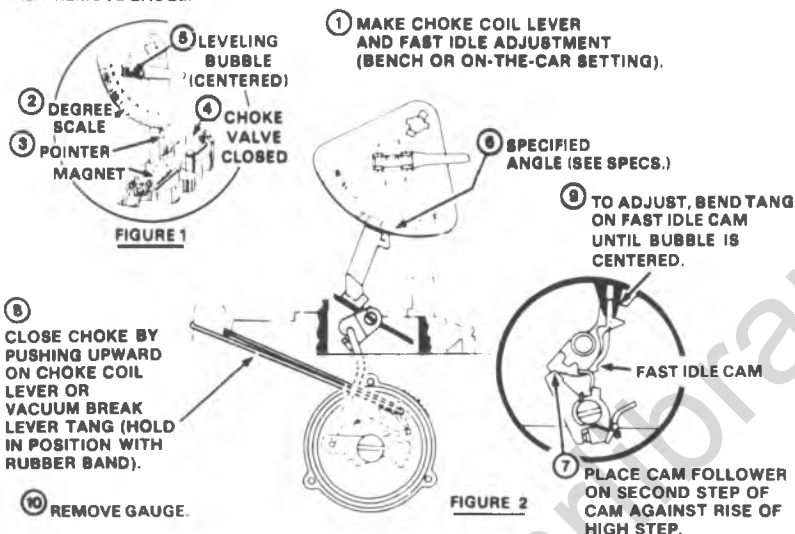
5

FIGURE 1

1. CHOKE COIL LEVER ADJUSTMENT MUST BE CORRECT AND FAST IDLE ADJUSTMENT MUST BE MADE BEFORE PROCEEDING.
2. USE CHOKE VALVE MEASURING GAUGE J-26701 TOOL MAY BE USED WITH CARBURETOR ON OR OFF ENGINE. IF OFF ENGINE, PLACE CARBURETOR ON HOLDING FIXTURE SO THAT IT WILL REMAIN IN SAME POSITION WHEN GAUGE IS IN PLACE.
3. ROTATE DEGREE SCALE UNTIL ZERO (0) IS OPPOSITE POINTER.
4. WITH CHOKE VALVE COMPLETELY CLOSED, PLACE MAGNET SQUARELY ON TOP OF CHOKE VALVE.
5. ROTATE BUBBLE UNTIL IT IS CENTERED.

FIGURE 2

6. ROTATE SCALE SO THAT DEGREE SPECIFIED FOR ADJUSTMENT IS OPPOSITE POINTER.
7. PLACE CAM FOLLOWER ON SECOND STEP OF CAM AGAINST RISE OF HIGH STEP.
8. CLOSE CHOKE BY PUSHING UPWARD ON CHOKE COIL LEVER OR VACUUM BREAK LEVER TANG (HOLD IN POSITION WITH RUBBER BAND).
9. TO ADJUST, BEND TANG ON FAST IDLE CAM UNTIL BUBBLE IS CENTERED.
10. REMOVE GAUGE.



FAST IDLE CAM (CHOKE ROD) RELATION ADJUSTMENT

DUALJET CARB. 210 OVERHAUL ADJUSTMENTS

Fig. 6C3-11--Model M2MC Adjustments 3 of 5

over richness. Note maximum engine speed (enriched speed).

NOTICE: If rich speed drop cannot be obtained check for empty cartridge or propane system leaks.

9. If the enriched idle speed is within the enriched idle specification the mixture is correct. Go to step 17.

10. If the enriched idle speed is not within specifications, remove mixture screw plugs following procedures.

11. Lightly seat screws, then back out equally, just enough so engine will run.

12. Place transmission in Drive (automatics) or Neutral (manuals).

13. Back each screw out (richen 1/8 turn at a time until

maximum idle speed is obtained). Then set idle speed to the enriched idle specification.

14. Turn each mixture screw in (clockwise) 1/8 turn at a time until idle speed reaches value given on Emission Control Information Label.

15. Re-check enriched speed with propane. If not within specification, repeat adjustment beginning with Step 12.

16. Check and adjust fast idle as described on Emission Control Information Label.

17. Turn off engine. Remove propane tool, connect crankcase ventilation tube. Re-connect vacuum hoses.

CARBURETOR MOUNTING TORQUE

When torquing carburetor after removal, overhaul,

CARB. NO.

ANGLE
GAUGE

ALL

38°

6

FIGURE 1

- USE CHOKE VALVE MEASURING GAUGE J-26701 OR TOOL MAY BE USED WITH CARBURETOR ON OR OFF ENGINE. IF OFF ENGINE, PLACE CARBURETOR ON HOLDING FIXTURE SO THAT IT WILL REMAIN IN SAME POSITION WHEN GAUGE IS IN PLACE.
- ROTATE DEGREE SCALE UNTIL ZERO (0) IS OPPOSITE POINTER.
- WITH CHOKE VALVE COMPLETELY CLOSED, PLACE MAGNET SQUARELY ON TOP OF CHOKE VALVE.
- ROTATE BUBBLE UNTIL IT IS CENTERED.

FIGURE 2

- ROTATE SCALE SO THAT DEGREE SPECIFIED FOR ADJUSTMENT IS OPPOSITE POINTER.
- SEAT CHOKE VACUUM DIAPHRAGM USING VACUUM SOURCE.
- HOLD CHOKE VALVE TOWARDS CLOSED POSITION, PUSHING UPWARD ON CHOKE COIL LEVER OR VACUUM BREAK LEVER TANG (HOLD IN POSITION WITH RUBBER BAND).
- TO ADJUST, TURN SCREW IN OR OUT UNTIL BUBBLE IS CENTERED.
- REMOVE GAUGE.

FRONT VACUUM BREAK ADJUSTMENT- ANGLE GAUGE METHOD

| CARB. NO. | ANGLE GAUGE |
|-----------|-------------|
| ALL | 29° |

DUALJET CARB. 210 OVERHAUL ADJUSTMENTS

Fig. 6C3-12-Model M2MC Adjustments 4 of 5

replacement, removal or when installing a new heat insulator, torque mounting bolts, in a clockwise direction, to 16 N·m, (144 in. lbs.).

When retorquing carburetor at recommended maintenance intervals, check in a clockwise direction. If less than 7 N·m (60 in. lbs.), retorque to 11 N·m (96 in. lbs.); if greater than 7 N·m (60 in. lbs.), do not retorque.

CARBURETOR REPLACEMENT (FIG. 6C3-16)

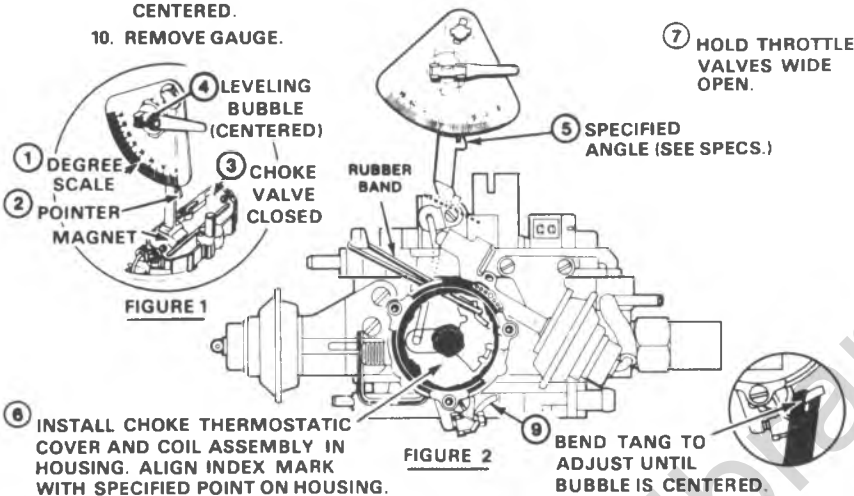
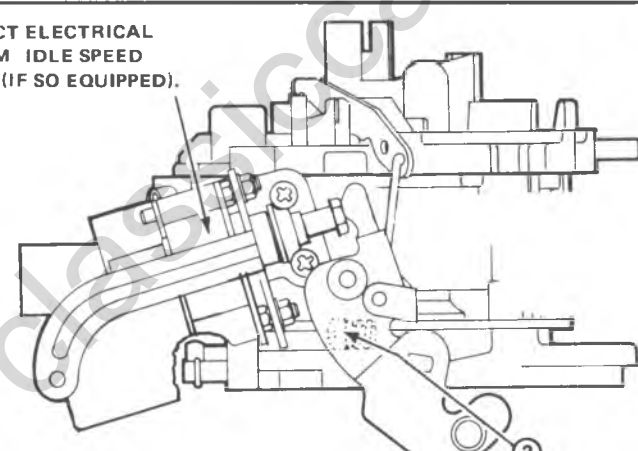
Removal

Flooding, stumble on acceleration and other performance complaints are, in many instances, caused by presence of dirt, water, or other foreign matter in carburetor. To aid in diagnosis, carburetor should be carefully removed from engine without draining fuel from bowl. Contents of fuel bowl may then be examined for contamination as carburetor is disassembled, check filter.

1. Remove air cleaner and gasket.
2. Disconnect solenoid wire if equipped.
3. Disconnect fuel and vacuum lines from carburetor.
4. Disconnect electrical connections.
5. Disconnect accelerator linkage.
6. If equipped with automatic transmission, disconnect downshift cable.
7. If equipped with cruise control, disconnect linkage.
8. Remove carburetor attaching bolts and remove carburetor and insulator.

Installation

1. Fill carburetor bowl before installing carburetor.
2. With clean sealing surfaces on carburetor and intake manifold, install new insulator.

| | CARB. NO. | ANGLE GAUGE |
|---|---|-------------|
| <p>7</p> <p>FIGURE 1</p> <ol style="list-style-type: none"> USE CHOKE VALVE MEASURING GAUGE J-26701. TOOL MAY BE USED WITH CARBURETOR ON OR OFF ENGINE. IF OFF ENGINE, PLACE CARBURETOR ON HOLDING FIXTURE SO THAT IT WILL REMAIN IN SAME POSITION WHEN GAUGE IS IN PLACE. ROTATE DEGREE SCALE UNTIL ZERO (0) IS OPPOSITE POINTER. WITH CHOKE VALVE COMPLETELY CLOSED, PLACE MAGNET SQUARELY ON TOP OF CHOKE VALVE. ROTATE BUBBLE UNTIL IT IS CENTERED. <p>FIGURE 2</p> <ol style="list-style-type: none"> ROTATE SCALE SO THAT DEGREE SPECIFIED FOR ADJUSTMENT IS OPPOSITE POINTER. INSTALL CHOKE THERMOSTATIC COVER AND COIL ASSEMBLY IN HOUSING. ALIGN INDEX MARK WITH SPECIFIED POINT ON HOUSING. HOLD THROTTLE VALVES WIDE OPEN. ON WARM ENGINE, CLOSE CHOKE VALVE BY PUSHING UP ON TANG ON VACUUM BREAK LEVER (HOLD IN POSITION WITH RUBBER BAND). TO ADJUST, BEND TANG ON FAST IDLE LEVER UNTIL BUBBLE IS CENTERED. REMOVE GAUGE.  <p>UNLOADER ADJUSTMENT - ANGLE GAUGE METHOD (TYPICAL)</p> | <p>ALL</p> | <p>38°</p> |
| <p>8</p> <ol style="list-style-type: none"> DISCONNECT ELECTRICAL LEAD FROM IDLE SPEED SOLENOID (IF SO EQUIPPED).  <p>IDLE SPEED</p> <ol style="list-style-type: none"> ADJUST BASE IDLE SPEED SCREW TO R.P.M. SPECIFIED ON EMISSION LABEL (AUTOMATIC TRANSMISSION IN DRIVE OR MANUAL TRANSMISSION IN NEUTRAL). | <ol style="list-style-type: none"> RECONNECT ELECTRICAL LEAD TO IDLE SPEED SOLENOID. | |

DUALJET CARB. 210 OVERHAUL ADJUSTMENTS

Fig. 6C3-13--Model M2MC Adjustments 5 of 5

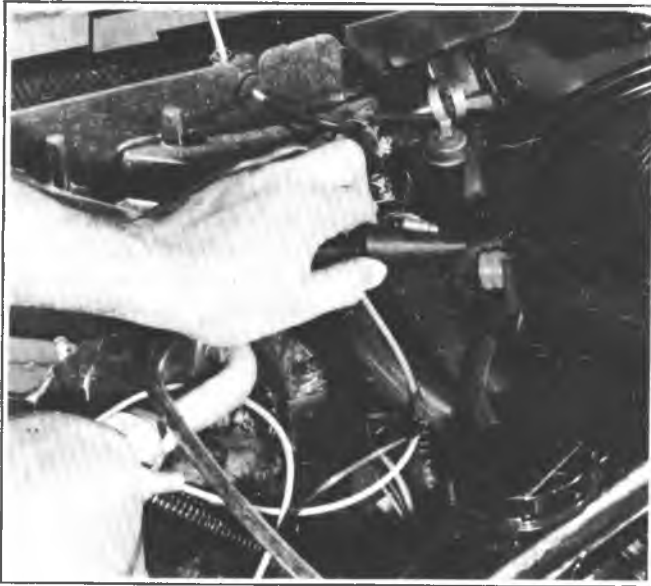


Fig. 6C3-14--Propane Air Cleaner Connection

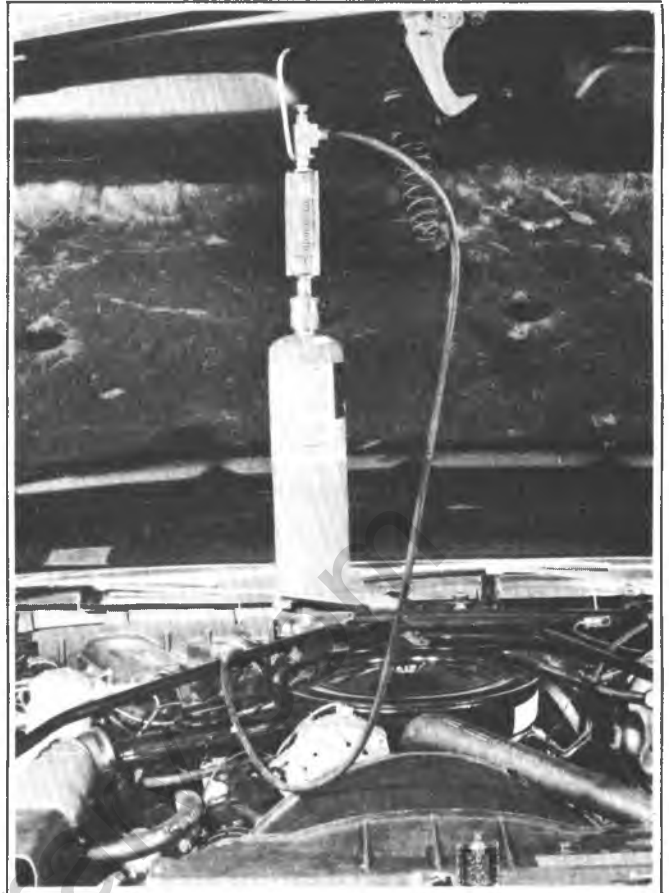


Fig. 6C3-15--Propane Tool Position

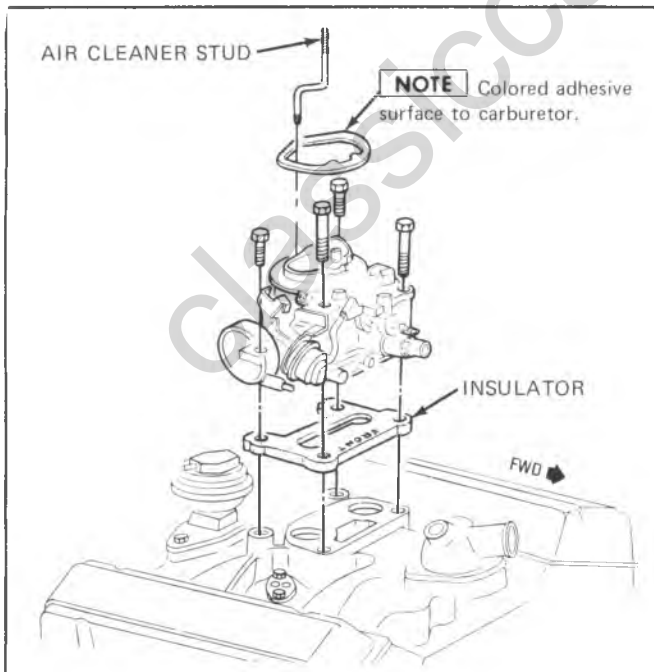


Fig. 6C3-16--Carburetor Replacement

3. Position carburetor over insulator and install bolts. Torque bolts to correct torque (See Carburetor Mounting Torque).

4. Connect downshift cable as required.
5. Connect cruise control cable as required.
6. Connect accelerator linkage.
7. Connect electrical connections.
8. Connect fuel pipe and vacuum hoses.
9. Connect solenoid wire as required.
10. Install air cleaner.
11. Check and adjust idle speed.

UNIT REPAIR

DISASSEMBLY

Before doing any service on the carburetor place it on a holding fixture. Without the use of the holding fixture, it is possible damage throttle valves.

Solenoid (If Equipped)

Removal

Remove screws holding the solenoid and bracket to float bowl and remove solenoid and bracket assembly. The solenoid should not be immersed in any type of carburetor cleaner and should always be removed before complete carburetor overhaul.

Air Horn

Removal

1. Remove upper choke lever from the end of choke shaft by removing retaining screw (Fig. 6C3-17). Then rotate upper choke lever to remove choke rod from slot in lever.
2. Remove choke rod from lower lever inside the float bowl casting. Remove rod by holding lower lever outward with small screwdriver and twisting rod counterclockwise.
3. With Tool J-25322 drive roll pin (pump lever pivot pin) inward just until pump lever can be removed from air horn. Then remove pump lever from pump rod (Fig. 6C3-18). Note location of accelerator pump rod for reassembly.
4. Remove seven air horn to bowl attaching screws; two countersunk attaching screws are located next to the venturi (Fig. 6C3-19).
5. Remove air horn from float bowl by lifting straight up. The air horn gasket should remain on the float bowl for removal later (Fig. 6C3-20).

Air Horn - Disassembly

Remove front vacuum break hose. Then remove two attaching screws and remove vacuum break control and bracket assembly. (Fig. 6C3-21). Do not place vacuum break assembly in carburetor cleaner.

Further disassembly of the air horn is not required for cleaning purposes. If part replacement is required, remove staking on two choke valve attaching screws. Remove screws, choke valve and shaft from air horn.

Float Bowl

Disassembly (Fig. 6C3-22)

1. Remove air horn gasket by lifting out of dowel locating pins and lifting tab of gasket from beneath the power piston hanger, being careful not to distort springs holding the main metering rods.
 2. Remove pump plunger from pump well.
 3. Remove pump return spring from pump well.
 4. Remove power piston and metering rods by depressing piston stem and allowing it to snap free. The power piston can be easily removed by pressing the piston down and releasing it with a snap. This will cause the power piston spring to snap the piston up against the retainer. This procedure may have to be repeated several times. Remove power piston spring from the well. Do not remove power piston by using pliers on metering rod hanger.
- The A.P.T. metering rod adjustment screw is pre-set at the factory and no attempt should be made to change this adjustment in the field. If float bowl replacement is required during service, the new bowl assembly will be supplied with an A.P.T. metering rod screw which will be pre-set as required.
5. Remove metering rods from power piston by disconnecting tension spring from top of each rod. Note position of tension spring for later reassembly. Then rotate rod to remove from hanger (Fig. 6C3-23).

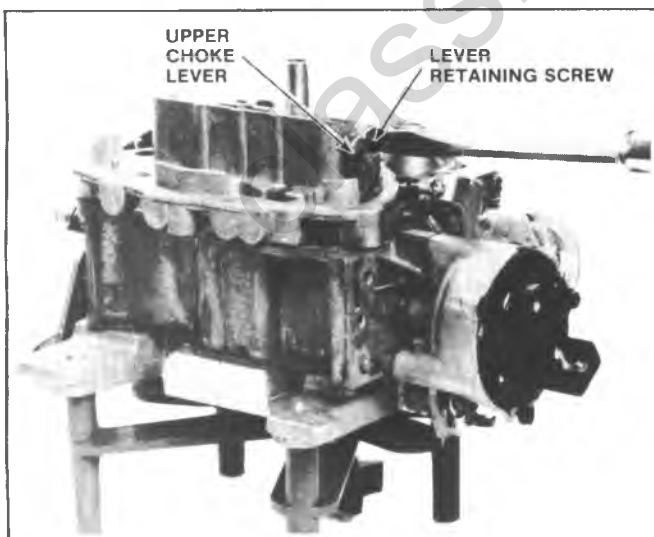


Fig. 6C3-17—Removing Upper Choke Lever

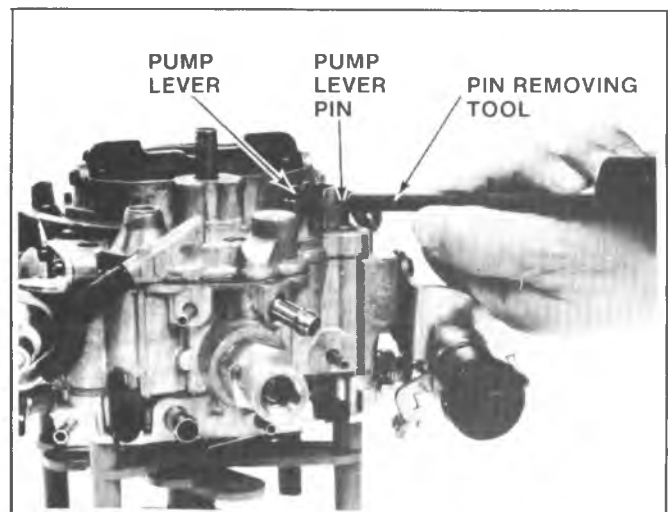


Fig. 6C3-18—Removing Pump Lever

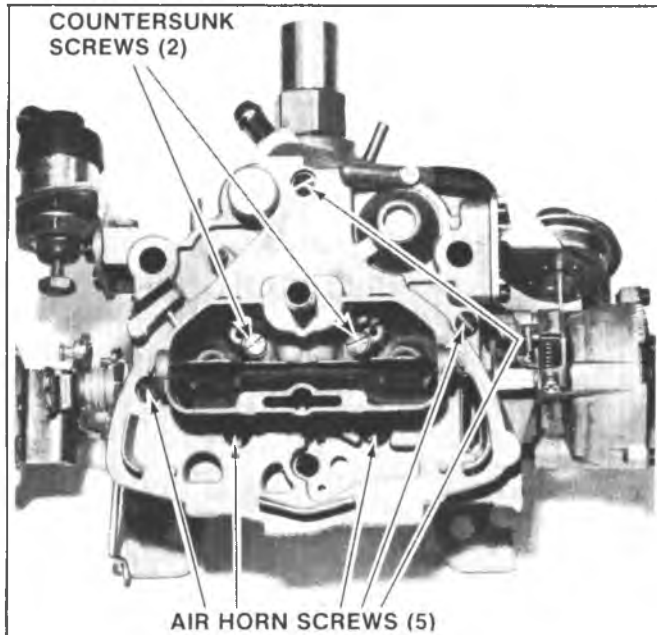


Fig. 6C3-19--Removing Air Horn Screws

6. Remove plastic filler block over float valve.
7. Remove float assembly and float needle by pulling up on retaining pin. Remove float needle seat and gasket, using Seat Remover (Fig. 6C3-24).
8. Remove aneroid cavity insert from float bowl (Fig. 6C3-25).
9. Remove main metering jets, only if necessary (Fig. 6C3-26).
10. Remove pump discharge check ball retainer and check ball (Fig. 6C3-27).
11. Remove pump well fill slot baffle.

Choke Disassembly

Removal of Choke Cover

1. Support float bowl and throttle body as an assembly on a suitable holding fixture such as Tool J-9789-118.
2. Align a 21 drill (.159") on rivet head and drill only enough to remove rivet head. Drill the two (2) remaining rivet heads and then use a drift and small hammer to drive the remainder of the rivets out of the choke housing.

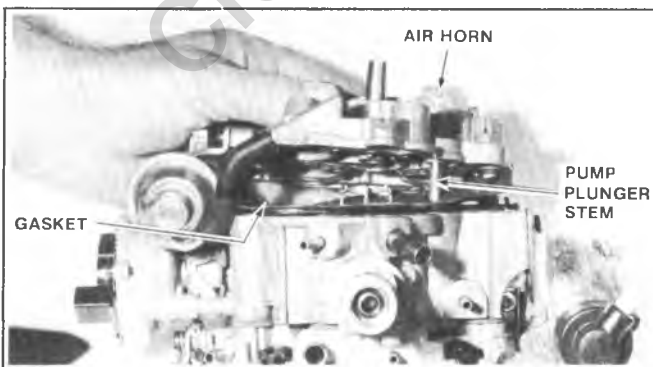


Fig. 6C3-20--Removing Air Horn

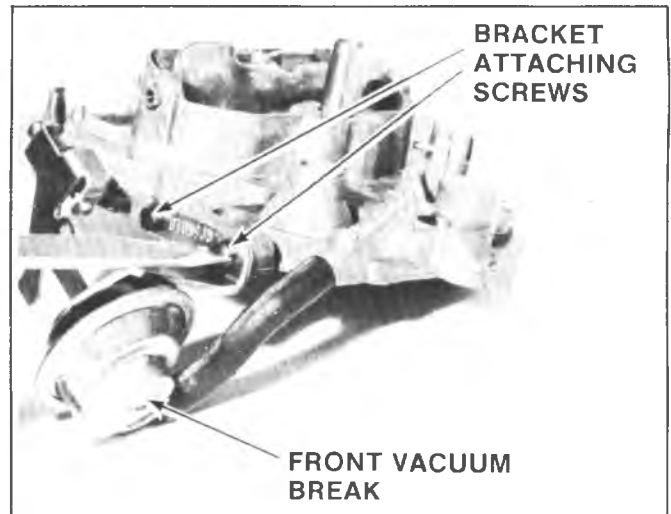


Fig. 6C3-21--Removing Front Vacuum Break

3. Remove the two conventional retainers, retainer with tab, choke cover gasket and choke cover assembly from choke housing. Do not remove baffle plate from beneath the thermostatic coil on the choke cover.
4. Remove choke housing assembly from float bowl by removing retaining screw and washer inside the choke housing (Fig. 6C3-28).
5. Remove lower choke lever from inside float bowl cavity by inverting bowl.
6. To disassemble intermediate choke shaft from choke housing, remove coil lever retaining screw at end of shaft inside the choke housing (Fig. 6C3-29). Then remove thermostatic coil lever from flats on intermediate choke shaft. Remove intermediate choke shaft from the choke housing by sliding outward. The fast idle cam can now be removed from the intermediate choke shaft (Fig. 6C3-29).

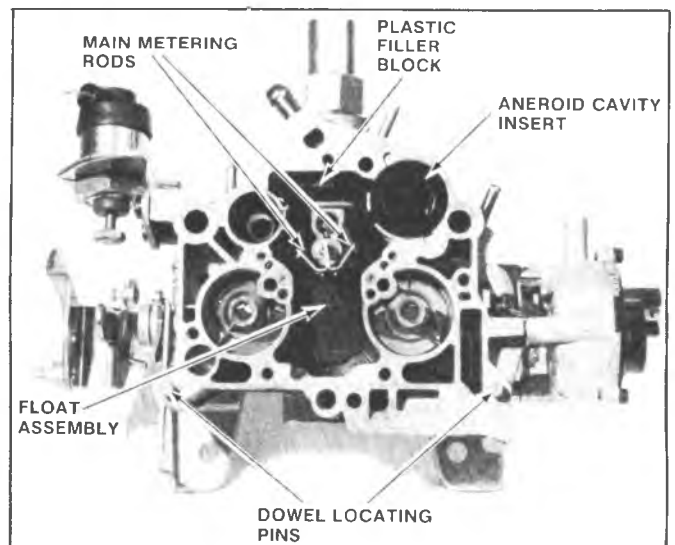


Fig. 6C3-22--Float Bowl

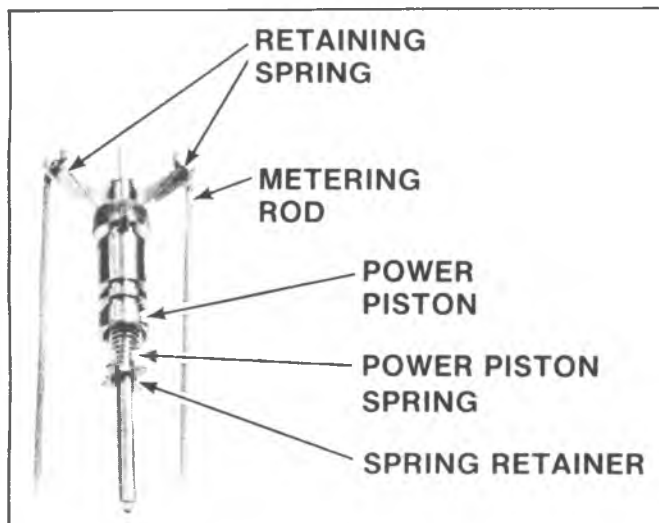


Fig. 6C3-23--Power Piston and Metering Rods

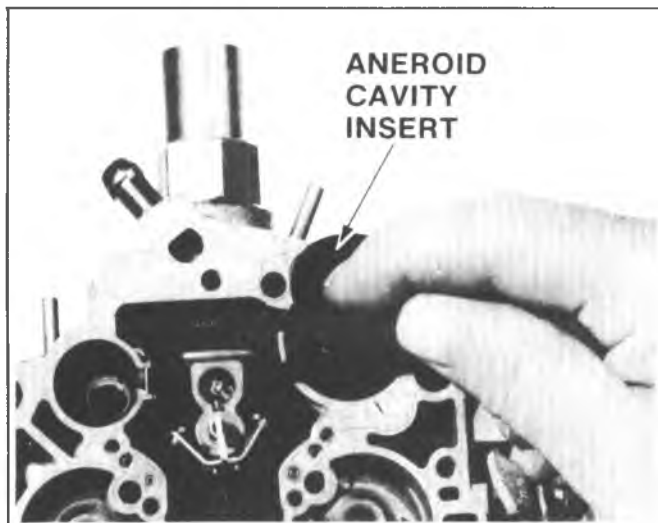


Fig. 6C3-25--Aneroid Cavity Insert

Remaining Float Bowl Parts

Disassembly

1. Remove fuel inlet nut, gasket, check valve filter assembly and spring.
2. Remove throttle body by removing throttle body to bowl attaching screws.
3. Remove throttle body to bowl insulator gasket.

Throttle Body

Disassembly

1. Remove pump rod from throttle lever.
2. Do not remove the plugs covering idle mixture needles unless it is necessary to replace the mixture screws or normal soaking and air pressure fails to clean the mixture passages.

Remove idle mixture needle and plug as follows:

- a. Invert throttle body and place on carburetor holding fixture (manifold side up).
- b. Using a punch between the two locator points in throttle body beneath idle mixture needle plug (manifold side) (Fig. 6C3-30), break-out throttle body to gain access

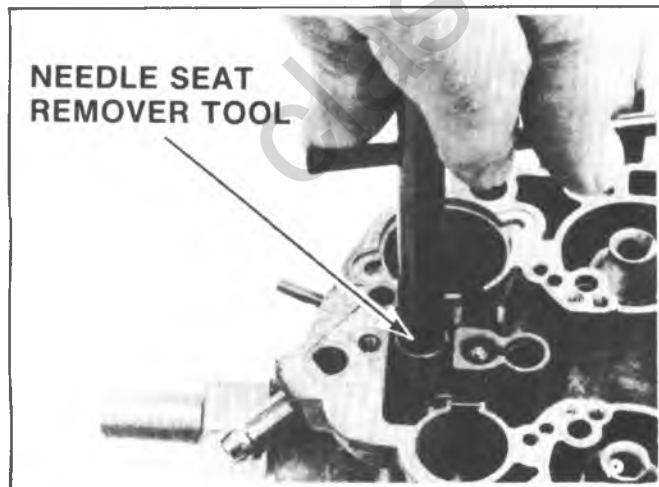


Fig. 6C3-24--Removing Needle and Seat

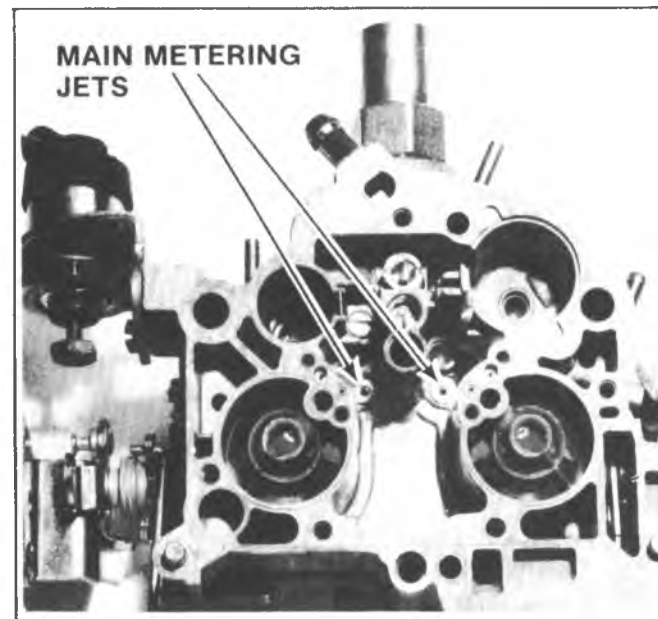


Fig. 6C3-26--Metering Jets

to the idle mixture needle plug. Then, drive out hardened steel plug covering mixture needle.

Hardened plug will shatter rather than remaining intact. It is not necessary to remove the plug completely; instead, remove loose pieces to allow use of Idle Mixture Adjusting Tool J-29030.

- c. Using Tool J-29030 remove idle mixture needle, washer, and spring from throttle body. Repeat procedure a. and b. for remaining idle mixture needle.

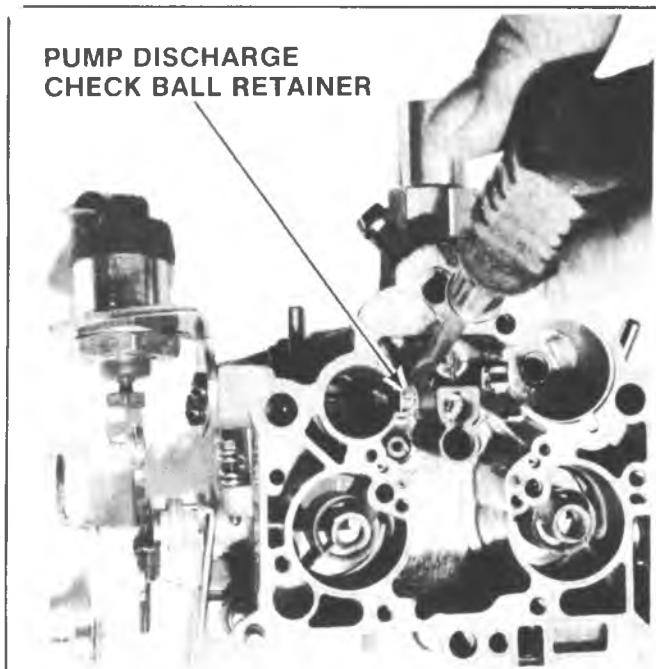


Fig. 6C3-27--Pump Discharge Retainer and Check Ball

CLEANING AND INSPECTION

The carburetor parts should be cleaned in cold immersion type cleaner.

NOTICE: Any rubber parts, electric choke, solenoid, plastic parts, diaphragms, pump plunger, should not be put in immersion type cleaner as they will swell, harden or distort.

The plastic bushing in bowl will withstand normal cleaning. Rinse thoroughly after cleaning.

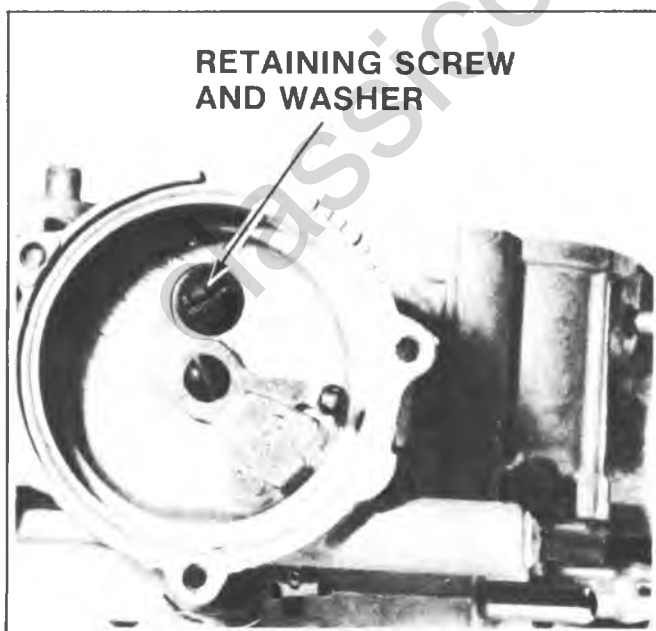


Fig. 6C3-28--Choke Housing

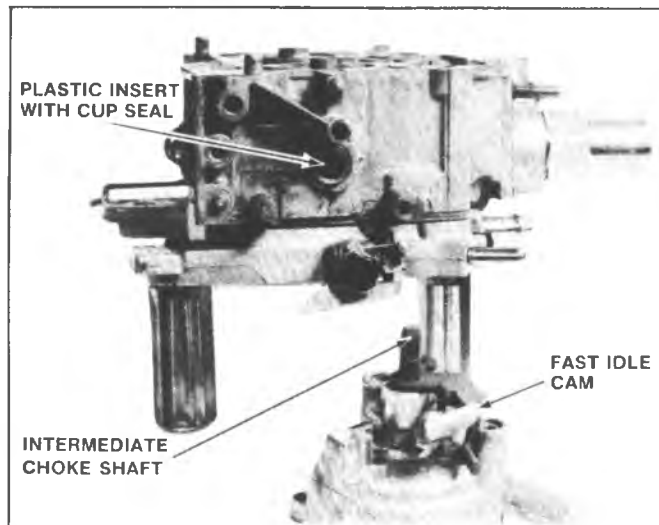


Fig. 6C3-29--Choke Assembly

1. Thoroughly clean all metal parts and blow dry with compressed air. Make sure all fuel passages and metering parts are free of burrs and dirt.

2. Check, repair or replace parts if the following problems are encountered.

A. FLOODING

1. Inspect float needle seat for dirt, deep wear grooves, scores and proper seating.

2. Inspect float, float arms and hinge pin for distortion, binds and burrs. Check float for leaks and/or being loaded (heavier than normal).

B. HESITATION

1. Inspect pump plunger and cup for cracks, scores on cup, excessive wear. A used pump cup will shrink when dry. Soak in fuel for 8 hrs. before testing if dried out.

2. Inspect pump duration and return spring for being weak or distorted.

3. Check all pump passages and jets for dirt, improper seating inlet or discharge balls, scores in pump well.

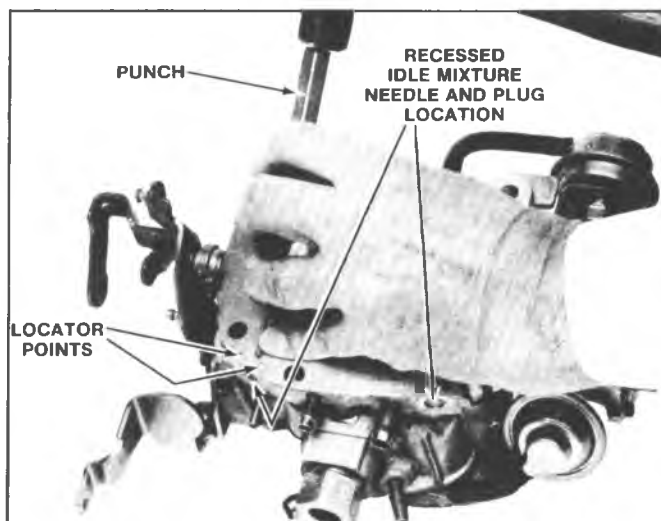


Fig. 6C3-30--Removing Idle Mixture Plug

4. Check pump linkage for excessive wear, repair or replace as necessary.

C. HARD-STARTING - POOR COLD OPERATION

1. Inspect needle for sticking, dirt, etc.
2. Examine fast idle cam for wear or damage.
3. Also check items under "FLOODING".

D. POOR PERFORMANCE - POOR GAS MILEAGE

1. Inspect power piston, metering rods for dirt, sticking, binding, damaged parts or excessive wear.
2. Clean all fuel and vacuum passages in castings.

E. ROUGH IDLE

1. Inspect idle needle for ridges, burrs or being bent.
2. Inspect gasket mating surfaces on castings for damage to sealing beads, nicks and burrs.
3. Clean all idle fuel passages.
4. Check throttle lever and valves for binds, nicks and other damage.

ASSEMBLY

Throttle Body

Assembly

1. If removed, install idle mixture needle, washer, and spring using Idle Mixture Adjusting Tool J-29030. Lightly seat needle and then back out 2 turns as a preliminary idle mixture adjustment. Final idle mixture adjustment must be made on car using the procedures described under Idle Mixture Adjustment.

2. Install lower end of pump rod in throttle lever by aligning tang on rod with slot in lever. End of rod should point outward toward throttle lever.

Float Bowl

Assembly

1. Install new throttle body to bowl gasket over two locating dowels on bowl.

2. Install throttle body making certain throttle body is properly located over dowels on float bowl, then install throttle body to bowl screws and tighten evenly and securely.

3. Place carburetor on proper holding fixture.

4. Install fuel inlet filter spring, check valve filter assembly (if used), new gasket and inlet nut and tighten nut 24 N·m (18 ft. lbs.). Ribs on closed end of filter element prevent filter from being installed incorrectly unless forced.

When installing a Service replacement filter, make sure the filter is the type that includes the check valve to meet U.S. Motor Vehicle Safety Standards (M.V.S.S.).

Choke Housing To Float Bowl

Assembly

1. Install new cup seal into insert on side of float bowl for intermediate choke shaft. Lip on cup seal faces outward.

2. Install fast idle cam onto the intermediate choke shaft (steps on fast idle cam face downward).

3. Carefully install fast idle cam and intermediate choke shaft assembly through seal in choke housing, then install thermostatic coil lever onto flats on intermediate choke shaft assembly through seal in choke housing, then install thermostatic coil lever onto flats on intermediate

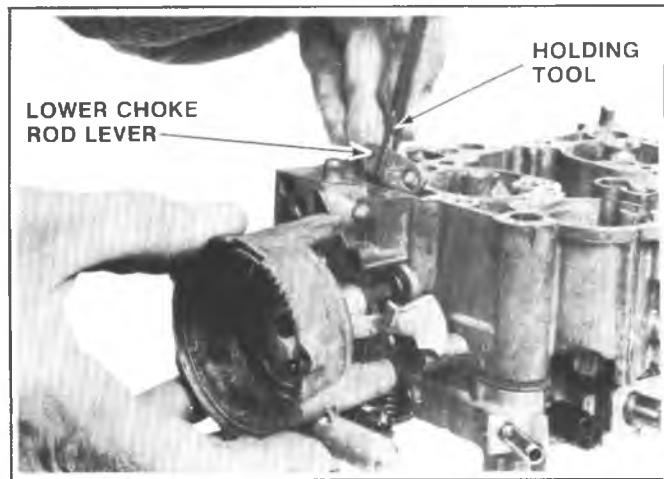


Fig. 6C3-31--Choke Lever And Housing

choke shaft. Inside thermostatic choke coil lever is properly aligned when both inside and outside levers face toward fuel inlet. Install inside lever retaining screw into end of intermediate choke shaft. Tighten securely.

4. Install lower choke rod inner lever into cavity in float bowl. Install choke housing to bowl sliding intermediate choke shaft into lower choke inner lever (Fig. 6C3-31).

Tool J-23417 can be used to hold the lower choke lever in correct position while installing the choke housing. The intermediate choke shaft lever and fast idle cam are in correct position when the tang on lever is beneath the fast idle cam. Do not install choke cover and coil assembly until inside coil lever is adjusted. See Adjustments.

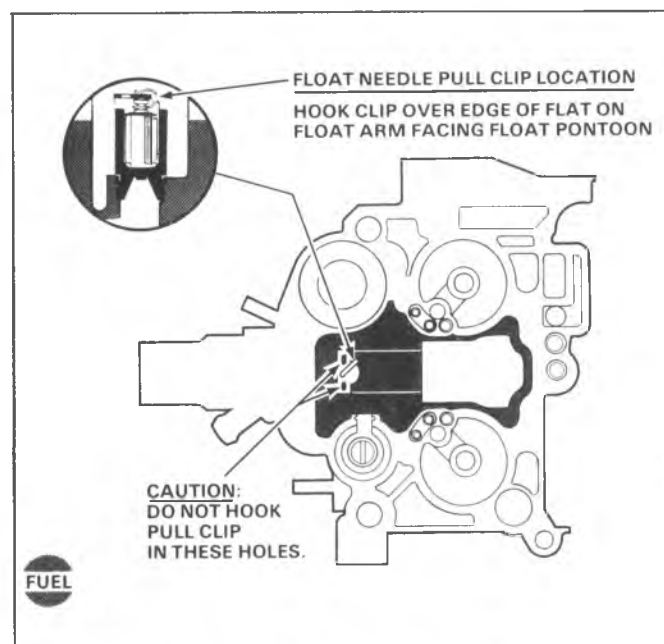


Fig. 6C3-32--Pull Clip Location

Completion Of Float Bowl Assembly

1. Install baffle inside of pump well with slot toward bottom.
2. Install pump discharge check ball and retainer in passage next to pump well. Tighten retainer securely.
3. Install main metering jets, if removed (Fig. 6C3-26).
4. Install aneroid cavity insert into float bowl.
5. Install new needle seat assembly, with gasket, using Seat Installer.
6. To make float adjustment easier, carefully bend float arm upward at notch in arm before assembly.
7. Install needle by sliding float lever under needle pull clip - correct installation of the needle pull clip is to hook the clip over the edge of the float on the float arm facing the float pontoon (Fig. 6C3-32). With float lever in pull clip, hold float assembly at toe and install retaining pin from aneroid cavity side (ends of retaining pin face the accelerating pump well). Do not install float needle pull clip into holes in float arm.

Float Level Adjustment (See Adjustments)

1. Hold float retainer firmly in place.
2. Push float down tightly against needle.
3. With adjustable T-scale, gage from top of float bowl casting (air horn gasket removed) to top of float at toe - gaging point $3/16$ " back from toe.
4. Bend float arm as necessary for proper adjustment by pushing on pontoon.
5. Visually check float alignment after adjustment.
6. Install plastic filler block over float needle, pressing downward until properly seated.
7. If metering rods were removed from hanger, reinstall making sure tension spring is connected to top of each rod (Fig. 6C3-23). Install power piston assembly in well (aligning pin on piston with slot in well) with metering rods properly positioned in metering jets. Press down firmly on plastic power piston retainer to make sure the retainer is seated in recess in bowl and the top is flush with the top of the bowl casting. If necessary, using a drift punch and small hammer, tap retainer lightly in place.
8. Install pump return spring in pump well.
9. Install air horn gasket by carefully sliding tab of gasket around metering rods and beneath the power piston hanger. Position gasket over the two dowel pins on the float bowl.

10. Carefully lift corner of the air horn gasket and install pump plunger in the pump well by pushing the plunger to the bottom of the well against return spring tension. While holding in this position, align pump plunger stem with hole in gasket.

Air Horn

Assembly

If removed, install choke shaft, choke valve and two attaching screws. Tighten screws securely and stake lightly in place.

Check choke valve for freedom of movement and proper alignment before staking screws in place.

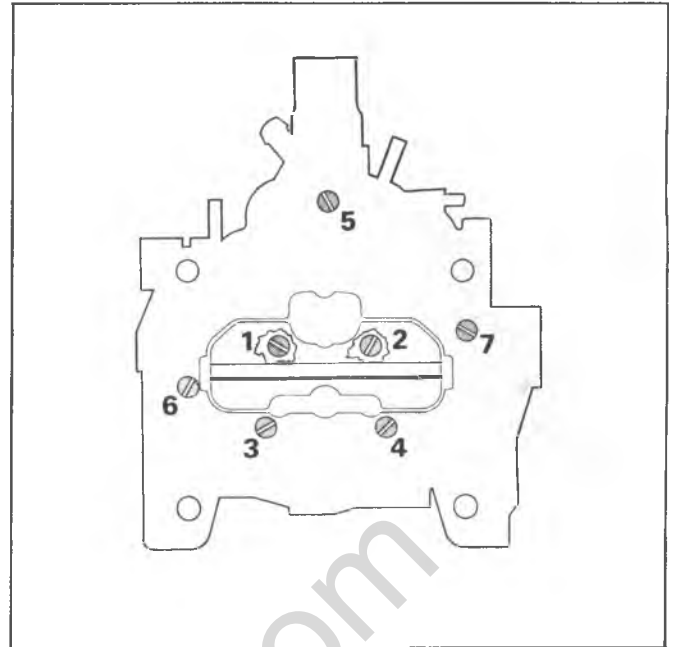


Fig. 6C3-33--Air Horn Screw Tightening Sequence

Air Horn To Bowl

Installation

1. Holding down on air horn gasket at pump plunger location, carefully lower air horn assembly onto float bowl making sure that the pump plunger stem is positioned properly through the holes in the air horn gasket. Do not force the air horn assembly onto the bowl but rather lightly lower in place.

2. Install seven air horn screws. All air horn screws must be tightened evenly and securely (See Fig. 6C3-33) for proper tightening sequence.

3. Install front vacuum break diaphragm and bracket assembly to float bowl using two retaining screws through the bracket. Tighten screws securely (Fig. 6C3-21).

Do not attach vacuum break hose until vacuum break adjustment is completed. See adjustments.

4. Connect upper end of pump rod to pump lever by placing rod in specified hole in lever, noted at disassembly. Align hole in pump lever with hole in air horn casting. Using screwdriver, push pump lever roll pin back through casting until end of pin is flush with casting bosses in air horn (Fig. 6C3-34). Use care installing the small roll pin to prevent damage to pump lever casting bosses.

5. Connect choke rod into lower choke lever inside bowl cavity; then install choke rod into slot in upper choke lever and retain the choke lever to the end of the choke shaft with attaching screw. Make sure that the flats on the end of the choke shaft align with flats in the choke lever. Tighten securely (Fig. 6C3-17).

The front vacuum break, fast idle cam adjustments must be performed, and the thermostatic coil lever inside the choke housing has to be indexed properly before installing the choke thermostatic coil and cover assembly. Refer to the Adjustment Procedures.

6. After the vacuum break, fast idle cam, and inside thermostatic coil lever are adjusted, install the cover and coil assembly in choke housing so that the choke pick-up

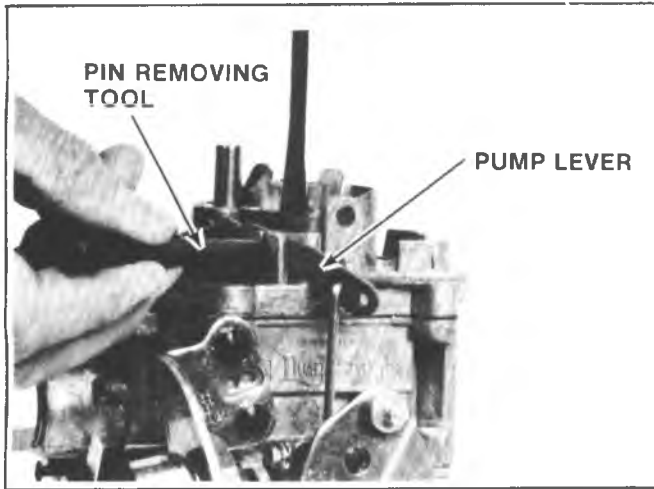


Fig. 6C3-34--Pump Lever

lever fits into loop on end of choke coil (Fig. 6C3-35) as follows:

- a. Start the three self-tapping screws (supplied with service kit) in the choke housing, checking to be sure screws start easily and are aligned properly. Then, remove screws.
- b. Place cam follower on highest step of fast idle cam.
- c. Install the thermostatic cover and coil assembly, and gasket in the choke housing, making sure coil tang engages inside coil pick-up lever.

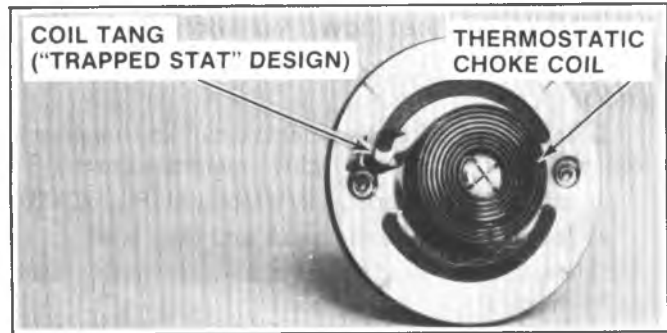


Fig. 6C3-35--Choke Coil Assembly

d. Install retainer with tab and align notch in cover with tab on retainer. Install one self-tapping screw.

e. Install the remaining (2) retainers and screws. Then, tighten all (3) retainer screws evenly and securely.

7. Install vacuum break hose.

8. Position idle speed solenoid - bracket assembly on float bowl, retaining with two large countersunk screws. Tighten screws securely.

9. Refer to "On-Vehicle" Service and perform carburetor adjustments listed.

SECTION 6C4

MODEL M4MC CARBURETOR

CONTENTS

| | | | |
|--------------------------|-------|----------------------------------|--------|
| General Description..... | 6C4-1 | Mixture Control Adjustments..... | 6C4-4 |
| On-Vehicle Service | 6C4-4 | Carburetor Mounting Torque | 6C4-15 |
| Checking Choke | 6C4-4 | Carburetor Replacement..... | 6C4-15 |
| Checking Solenoid | 6C4-4 | Unit Repair..... | 6C4-15 |
| Adjustments..... | 6C4-4 | | |

GENERAL DESCRIPTION

The Model M4MC carburetor (Fig. 6C4-1 and 6C4-2) is a two stage carburetor of downdraft design. The triple venturi system is used on the primary side of the carburetor with 1-3/8 inch throttle valve bores.

The secondary side has two 2-1/4 inch bores. Using the air valve principle in the secondary side, fuel is metered in direct proportion to the air passing through the secondary bores. A baffle is attached to the secondary side of the air horn above the main well bleed tubes to deflect incoming air to improve secondary nozzle operation on heavy acceleration.

A solenoid is used on air conditioned equipped vehicles with automatic transmission and light duty emissions to increase throttle opening slightly when the air conditioning is in operation. This allows the engine to idle at the same speed when the air conditioning is in operation, as when it is off.

The float assembly is used along with a windowless type needle seat for better fuel handling in the float bowl. Also, a plastic filler block is used above the float chamber to reduce fuel slosh in this area. A fuel inlet filter check valve is used on light duty emission models to shut off fuel flow to the carburetor float bowl to prevent fuel leaks if a vehicle roll over should occur.

The main metering system on all models uses separate main wells to feed each fuel nozzle for improved fuel flow in the venturi system.

A hose connects the air horn to a vacuum operated vent valve located in the vapor canister. When the engine is not running, the canister vapor vent is open allowing fuel vapors from the carburetor float bowl to pass into the canister where they are stored until purged.

Adjustable Part Throttle-M4MC

In order to provide a close tolerance adjustment in the main metering system, an adjustment is provided to very accurately set the depth of the metering rods in the main metering jets.

The adjustment feature consists of a pin pressed in the side of the power piston which extends through a slot in the side of the piston well. When the power piston is down (economy position), the side of the pin stops on top of a flat surface on the adjustment screw located in the cavity next to the power piston. The adjustment screw is held from turning by a tension spring beneath the head of the adjustment screw. During production flow test this adjustment screw is turned up or down which, in turn, raises

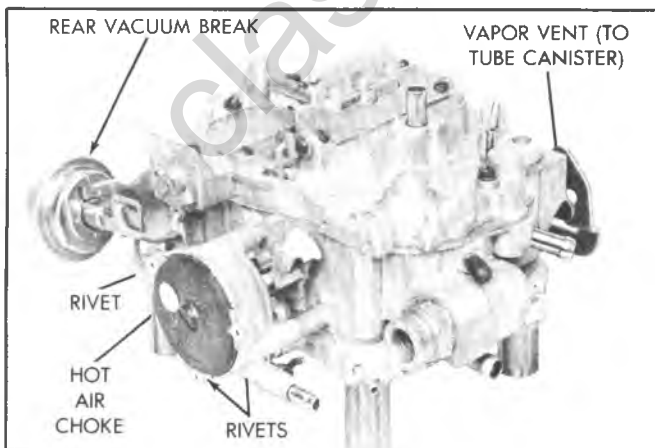


Fig. 6C4-1--Model M4MC with L.D. Emissions

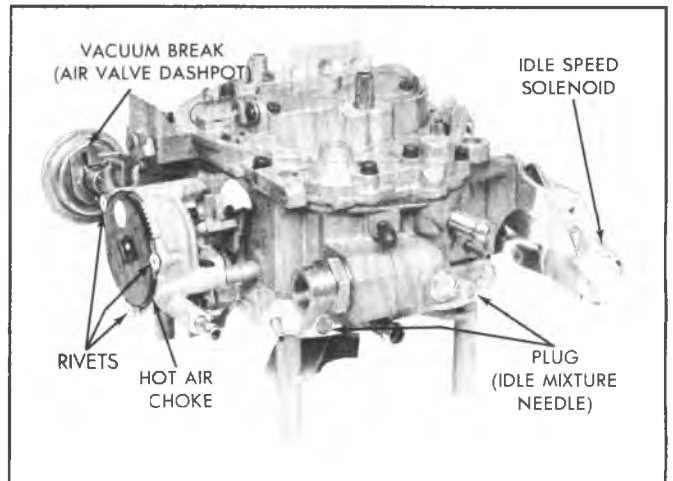


Fig. 6C4-1a--M4MC W/Calif. Emissions

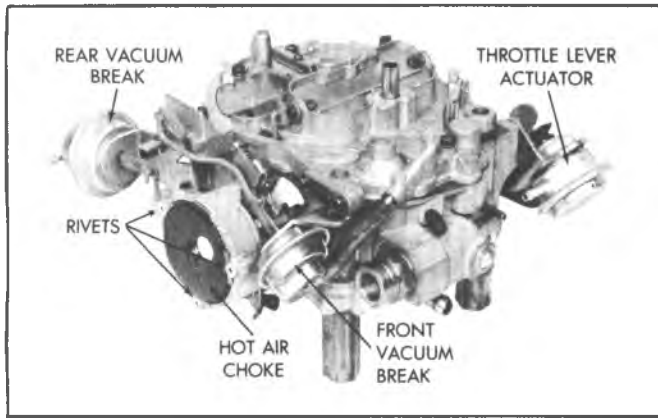


Fig. 6C4-2-Model M4MC With H.D. Emissions

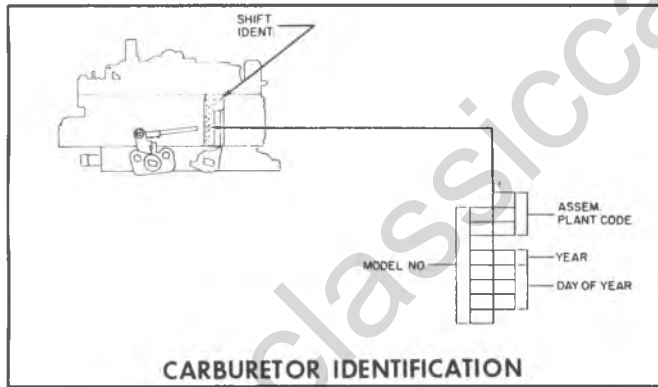
or lowers the power piston and metering rod assembly. This very accurately controls the fuel flow between the rods and jets to meet emission requirements.

NOTICE: No attempt should be made to change the APT adjustment. If float bowl replacement is required, the new bowl assembly will include an adjustment screw pre-set by the factory.

An expander (garter) spring beneath the plunger cup on the accelerator pump assembly improves pump fuel delivery.

All M4MC models use a bowl mounted choke housing with a non-adjustable thermostatic control assembly.

The carburetor part number (Fig. 6C4-3) is stamped on a vertical section of the bowl, near the secondary throttle lever. Refer to the part number on the bowl when servicing this carburetor. When replacing the float bowl assembly,



CARBURETOR IDENTIFICATION
"4M" TYPE
Fig. 6C4-3-Carburetor Identification

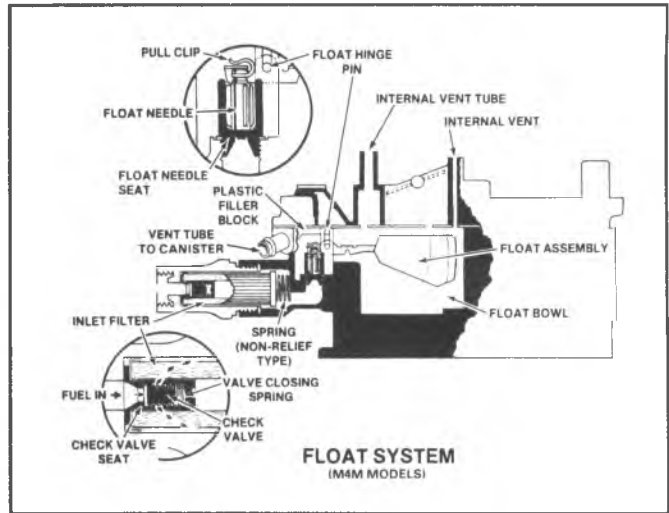


Fig. 6C4-4-Float System

follow the instructions contained in the service package. Stamp or engrave the model number on the new float bowl.

The primary side of the carburetor has six systems of operation. They are float, idle, main metering, power, pump, and choke (Figs. 6C4-4 through 6C4-12). The secondary side has one metering system which supplements the primary main metering system and receives fuel from a common float chamber.

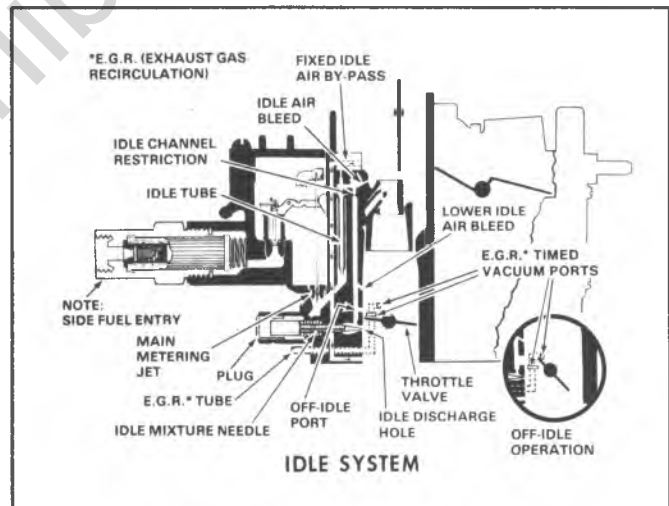


Fig. 6C4-5-M4MC With L.D. Emissions

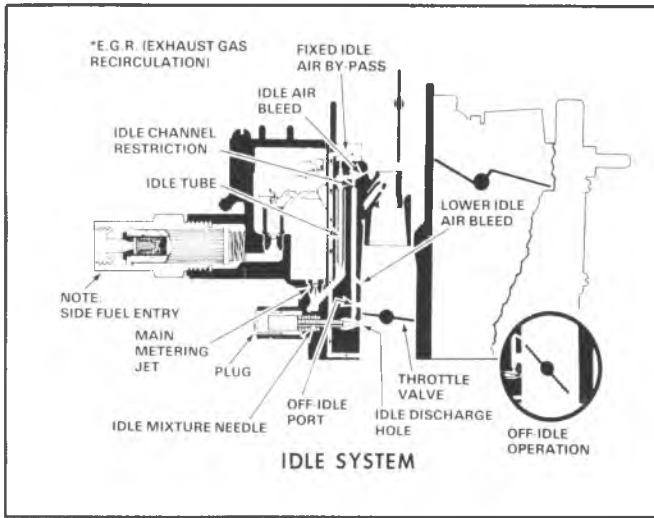


Fig. 6C4-6--M4MC With H.D. Emissions

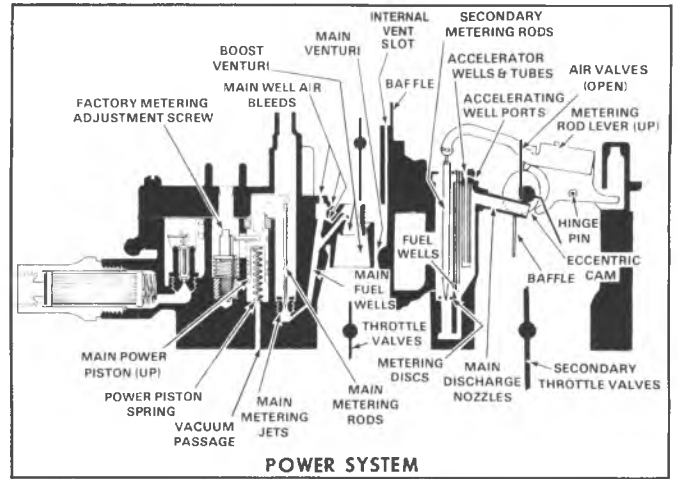


Fig. 6C4-8--Power System-M4MC

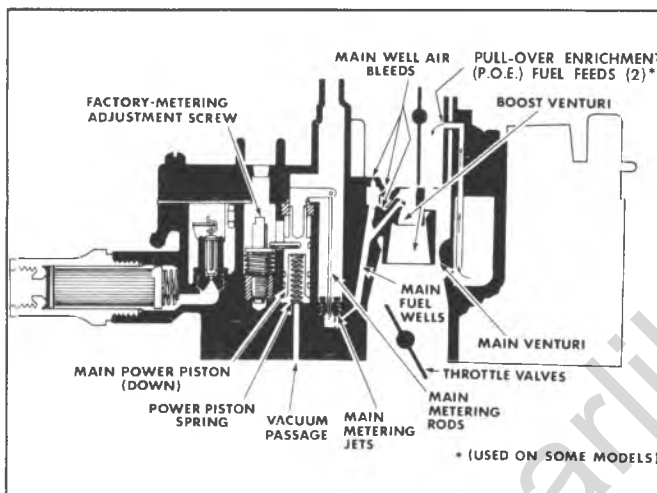


Fig. 6C4-7--Main Metering System-M4MC

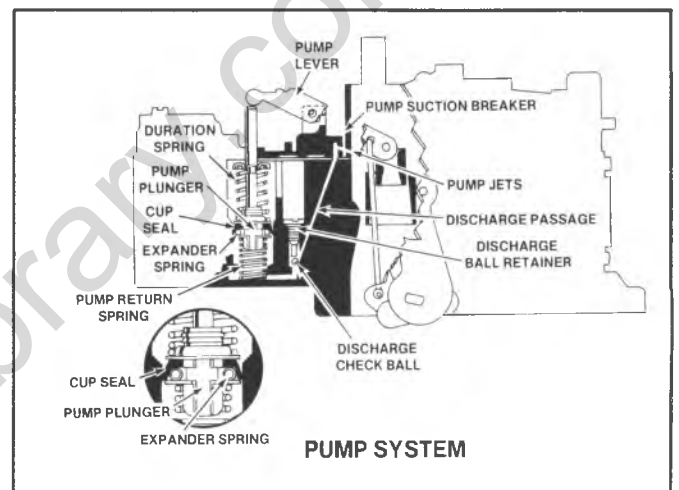


Fig. 6C4-9--Pump System-M4MC

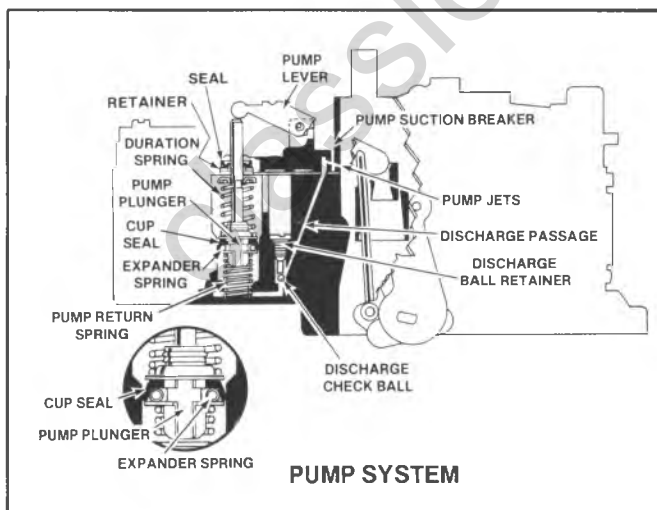


Fig. 6c4-10--Pump System - M4MC

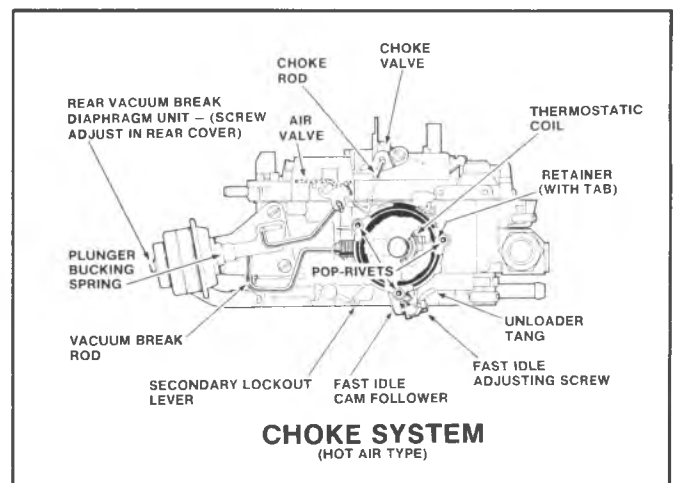


Fig. 6C4-11--M4MC With L.D. Emissions

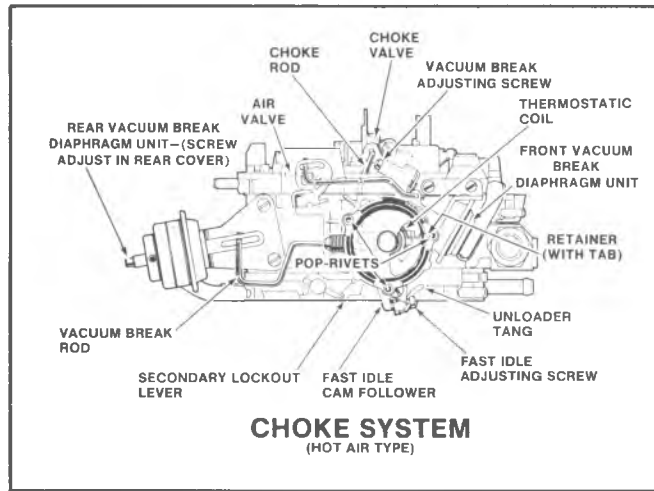


Fig. 6C4-12—M4MC With H.D. Emissions

ON-VEHICLE SERVICE

Adjustments

Before checking or resetting the carburetor as the cause of poor engine performance or rough idle; check ignition system including distributor, timing, spark plugs and wires. Check air cleaner, evaporative emission system, EFE System, PCV system, EGR valve and engine compression. Also inspect intake manifold, vacuum hoses and connections for leaks and check torque of carburetor mounting bolts/nuts.

Make all adjustments with engine at normal operating temperature, choke full open, air cleaner installed. Except as noted air conditioning should be "off" and all vacuum lines and all electrical leads connected. Set parking brake and block drive wheels. Air cleaner can be removed for set-up accessibility but must be completely installed during actual setting.

Refer to Figure 6C4-13 through 6C4-21 for carburetor adjustment procedures and specifications.

Checking Carburetor Choke

1. Remove air cleaner. With engine off, hold throttle half open. Open and close choke several times. Watch linkage to be certain all links are connected and there are no signs of damage.
2. If choke or linkage binds, sticks or works sluggish, clean with choke cleaner X-20-A or equivalent. Use cleaner as directed on can. Refer to Unit Repair instructions for additional direction if cleaning does not correct.
3. Visually inspect carburetor to be certain all vacuum hoses are connected. Inspect hoses for cracks, abrasions, hardness or other signs of deterioration. Replace or correct as necessary.
4. Make sure vacuum break diaphragm shaft is fully extended when engine is off. If shaft is not fully extended, replace vacuum break assembly. Shaft should fully retract within 10 seconds after starting engine. If unit fails to retract, replace vacuum break assembly.

Checking Solenoid

1. Turn on ignition, but do not start engine.
2. Turn A/C to "on" position.
3. Open throttle to allow solenoid to extend, close throttle.
4. Disconnect lead at solenoid. Solenoid plunger should drop away from throttle lever.
5. Connect solenoid lead. Plunger should move out and contact the throttle lever. Solenoid may not be strong enough to open the throttle, but the plunger should move.
6. If plunger does not move in and out as lead is disconnected and connected, insert test light (1893 bulb or smaller) between the solenoid feed wire and ground.
7. If light lights, replace solenoid.
8. If light does not light, locate cause of open circuit in solenoid feed wire.

IDLE MIXTURE CHECK AND ADJUSTMENT (PROPANE ENRICHMENT)

Light Duty Emission Vehicles Only

Idle mixture screws have been preset at the factory and sealed. Idle mixture should be adjusted only in the case of major carburetor overhaul, throttle body replacement or high emissions as determined by official inspections. Adjusting mixture by other than the following method may violate Federal and/or California or other state or Provincial laws.

Because of the sealed idle mixture screws, the idle mixture checking procedure requires artificial enrichment by adding propane.

1. Set parking brake and block drive wheels. On cars equipped with vacuum parking brake release, disconnect and plug hose at brake. Engine must be at normal operating temperature and air conditioning off.
2. Disconnect and plug hoses as directed on the Emission Control Information Label under the hood.

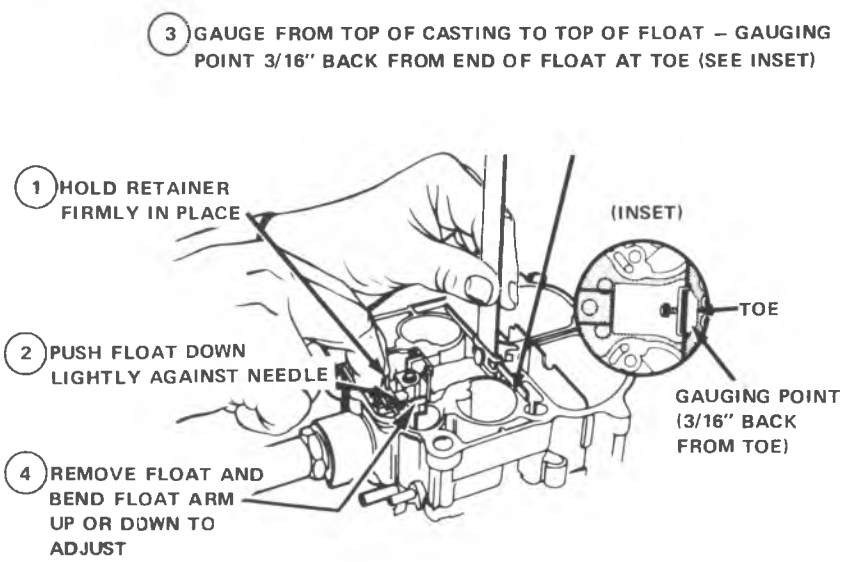
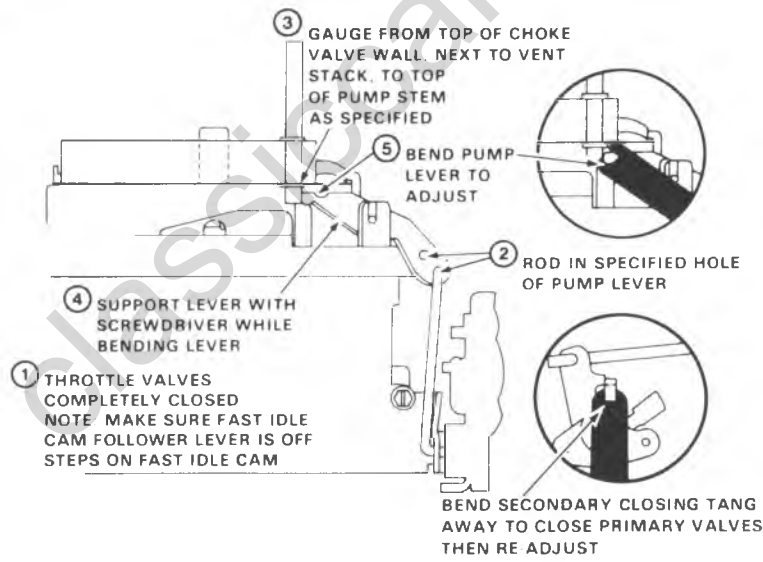
| 1 | CARB. NO. | GAUGE | |
|--|--|---|----------------------------|
| <p>1 HOLD RETAINER FIRMLY IN PLACE</p> <p>2 PUSH FLOAT DOWN LIGHTLY AGAINST NEEDLE</p> <p>4 REMOVE FLOAT AND BEND FLOAT ARM UP OR DOWN TO ADJUST</p>  <p>3 GAUGE FROM TOP OF CASTING TO TOP OF FLOAT – GAUGING POINT 3/16" BACK FROM END OF FLOAT AT TOE (SEE INSET)</p> <p>5 VISUALLY CHECK FLOAT ALIGNMENT AFTER ADJUSTING</p> <p style="text-align: center;">FLOAT LEVEL ADJUSTMENT</p> | <p>17080201 17080205 17080206 17080224 17080225 17080290 17080291 17080292 17080295 17080297 17080503 17080506 17080508 17080523 17080524 17080525 17080526 17080226 17080227 17080527 17080528</p> <hr style="border-top: 1px dashed black;"/> <p>17080213 17080215 17080513 17080515 17080229 17080529</p> | <p>15/32"</p> <hr style="border-top: 1px dashed black;"/> <p>3/8"</p> | |
| <p>2</p>  <p>1 THROTTLE VALVES COMPLETELY CLOSED NOTE MAKE SURE FAST IDLE CAM FOLLOWER LEVER IS OFF STEPS ON FAST IDLE CAM</p> <p>3 GAUGE FROM TOP OF CHOKE VALVE WALL, NEXT TO VENT STACK, TO TOP OF PUMP STEM AS SPECIFIED</p> <p>4 SUPPORT LEVER WITH SCREWDRIVER WHILE BENDING LEVER</p> <p>5 BEND PUMP LEVER TO ADJUST</p> <p>2 ROD IN SPECIFIED HOLE OF PUMP LEVER</p> <p>BEND SECONDARY CLOSING TANG AWAY TO CLOSE PRIMARY VALVES, THEN RE ADJUST</p> <p style="text-align: center;">PUMP ADJUSTMENT</p> | <p>ALL</p> | <p>9/32"</p> | <p>HOLE LOC. INNER</p> |

Fig. 6C4-13-M4MC Adjustments-1 of 9

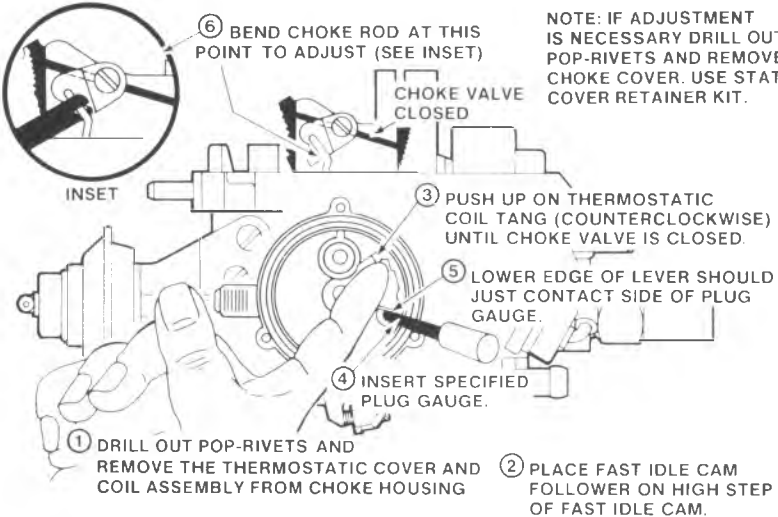
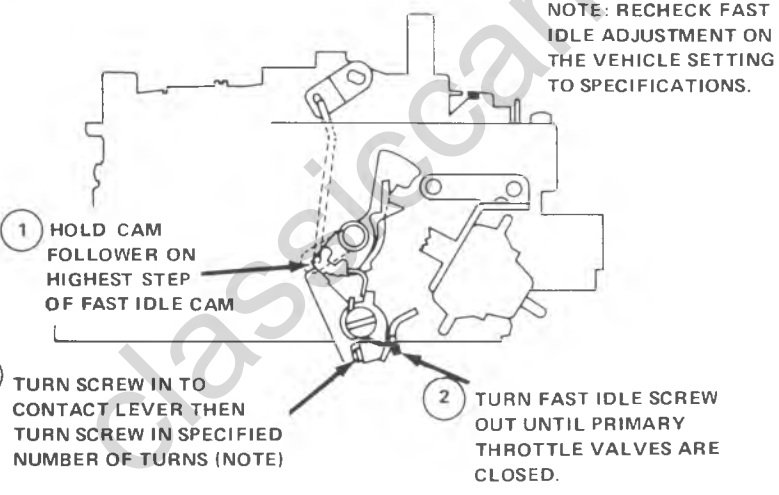
| <div style="text-align: center; font-size: 2em; font-weight: bold;">3</div>  <div style="text-align: center; font-weight: bold;">CHOKE COIL LEVER ADJUSTMENT (SEE NOTE)</div> | <div style="text-align: center; font-weight: bold;">CARB. NO.</div> <div style="text-align: center; font-weight: bold;">ALL</div> | <div style="text-align: center; font-weight: bold;">PLUG GAUGE</div> <div style="text-align: center; font-weight: bold;">.120"</div> | |
|--|---|--|--|
| <div style="text-align: center; font-size: 2em; font-weight: bold;">4</div>  <div style="text-align: center; font-weight: bold;">FAST IDLE ADJUSTMENT (BENCH SETTING)</div> | <div style="text-align: center; font-weight: bold;">CARB. NO.</div> <div style="text-align: center; font-weight: bold;">ALL</div> | <div style="text-align: center; font-weight: bold;">NO. TURNS</div> <div style="text-align: center; font-weight: bold;">2</div> | |

Fig. 6C4-14--M4MC Adjustments - 2 of 9

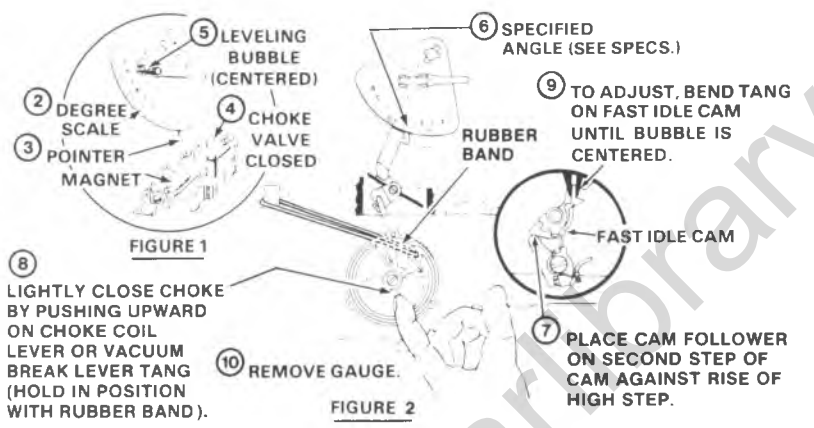
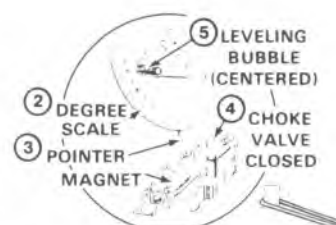
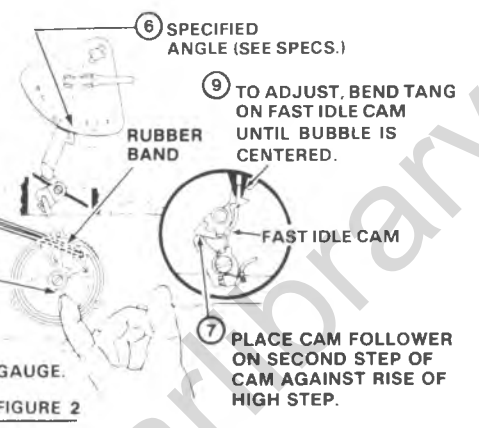
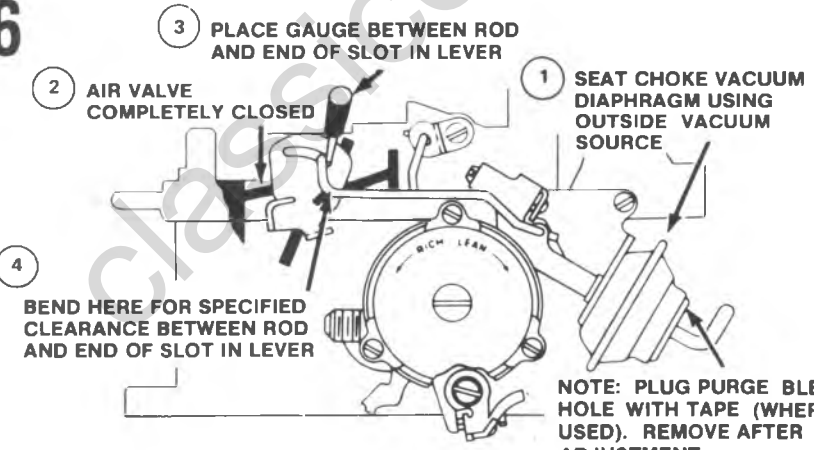
| 5 | CARB. NO. | ANGLE GAUGE |
|---|--|-------------|
| <p>FIGURE 1</p> <ol style="list-style-type: none"> CHOKE COIL LEVER ADJUSTMENT MUST BE CORRECT AND FAST IDLE ADJUSTMENT MUST BE MADE BEFORE PROCEEDING. USE CHOKE VALVE MEASURING GAUGE J-26701 TOOL MAY BE USED WITH CARBURETOR ON OR OFF ENGINE. IF OFF ENGINE, PLACE CARBURETOR ON HOLDING FIXTURE SO THAT IT WILL REMAIN IN SAME POSITION WHEN GAUGE IS IN PLACE. ROTATE DEGREE SCALE UNTIL ZERO (0) IS OPPOSITE POINTER. WITH CHOKE VALVE COMPLETELY CLOSED, PLACE MAGNET SQUARELY ON TOP OF CHOKE VALVE. ROTATE BUBBLE UNTIL IT IS CENTERED. <p>FIGURE 2</p> <ol style="list-style-type: none"> ROTATE SCALE SO THAT DEGREE SPECIFIED FOR ADJUSTMENT IS OPPOSITE POINTER PLACE CAM FOLLOWER ON SECOND STEP OF CAM AGAINST RISE OF HIGH STEP. CLOSE CHOKE BY PUSHING UPWARD ON CHOKE COIL LEVER OR VACUUM BREAK LEVER TANG (HOLD IN POSITION WITH RUBBER BAND). TO ADJUST, BEND TANG ON FAST IDLE CAM UNTIL BUBBLE IS CENTERED. REMOVE GAUGE. <p>① MAKE CHOKE COIL LEVER AND FAST IDLE ADJUSTMENT (BENCH OR ON-THE-CAR SETTING). NOTE: DO NOT REMOVE RIVETS AND CHOKE COVER TO PERFORM THIS ADJUSTMENT. USE RUBBER BAND ON VACUUM BREAK LEVER TANG TO HOLD CHOKE VALVE CLOSED, (STEP 8).</p>  <p>FAST IDLE CAM (CHOKE ROD) RELATION ADJUSTMENT</p> | 17080201 17080205 17080206 17080224 17080225 17080290 17080291 17080292 17080295 17080297 17080503 17080506 17080508 17080523 17080524 17080525 17080526 17080226 17080227 17080527 17080528 17080212 17080512 | 46° |
|   <p>② DEGREE SCALE ③ POINTER MAGNET ④ CHOKE VALVE CLOSED ⑤ LEVELING BUBBLE (CENTERED) ⑥ SPECIFIED ANGLE (SEE SPECS.) ⑦ PLACE CAM FOLLOWER ON SECOND STEP OF CAM AGAINST RISE OF HIGH STEP. ⑧ LIGHTLY CLOSE CHOKE BY PUSHING UPWARD ON CHOKE COIL LEVER OR VACUUM BREAK LEVER TANG (HOLD IN POSITION WITH RUBBER BAND). ⑨ TO ADJUST, BEND TANG ON FAST IDLE CAM UNTIL BUBBLE IS CENTERED. ⑩ REMOVE GAUGE.</p> | 17080213 17080215 17080513 17080515 17080229 17080529 | 37° |
| 6 | CARB. NO. | PLUG GAUGE |
|  <p>① SEAT CHOKE VACUUM DIAPHRAGM USING OUTSIDE VACUUM SOURCE ② AIR VALVE COMPLETELY CLOSED ③ PLACE GAUGE BETWEEN ROD AND END OF SLOT IN LEVER ④ BEND HERE FOR SPECIFIED CLEARANCE BETWEEN ROD AND END OF SLOT IN LEVER</p> <p>NOTE: PLUG PURGE BLEED HOLE WITH TAPE (WHERE USED). REMOVE AFTER ADJUSTMENT</p> <p>AIR VALVE ROD ADJUSTMENT - FRONT</p> | ALL | .015" |

Fig. 6C4-15--M4MC Adjustments-3 of 9

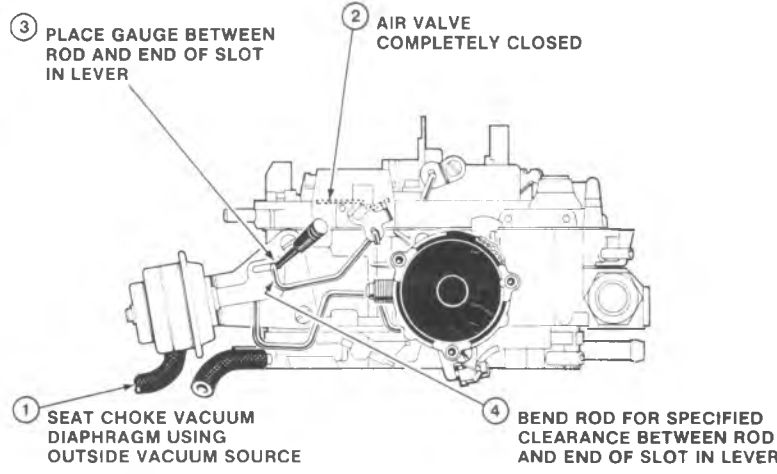
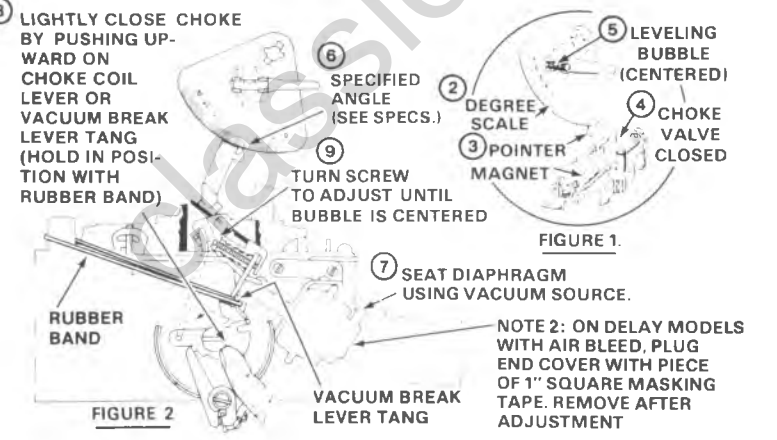
| | | |
|--|--|--|
| <p>7</p>  <p>③ PLACE GAUGE BETWEEN ROD AND END OF SLOT IN LEVER</p> <p>② AIR VALVE COMPLETELY CLOSED</p> <p>① SEAT CHOKE VACUUM DIAPHRAGM USING OUTSIDE VACUUM SOURCE</p> <p>④ BEND ROD FOR SPECIFIED CLEARANCE BETWEEN ROD AND END OF SLOT IN LEVER</p> <p>AIR VALVE ROD ADJUSTMENT - REAR (LIGHT DUTY TRUCK ONLY)</p> | <p>ALL</p> | <p>.025"</p> |
| <p>8</p> <p>1. USE CHOKE VALVE MEASURING GAUGE J-26701 TOOL MAY BE USED WITH CARBURETOR ON OR OFF ENGINE. IF OFF ENGINE, PLACE CARBURETOR ON HOLDING FIXTURE SO THAT IT WILL REMAIN IN SAME POSITION WHEN GAUGE IS IN PLACE.</p> <p>FIGURE 1</p> <p>2. CHOKE COIL LEVER ADJUSTMENT MUST BE CORRECT AND FAST IDLE ADJUSTMENT MUST BE MADE BEFORE PROCEEDING.</p> <p>3. ROTATE DEGREE SCALE UNTIL ZERO (0) IS OPPOSITE POINTER.</p> <p>4. WITH CHOKE VALVE COMPLETELY CLOSED, PLACE MAGNET SQUARELY ON TOP OF CHOKE VALVE.</p> <p>5. ROTATE BUBBLE UNTIL IT IS CENTERED.</p> <p>FIGURE 2</p> <p>6. ROTATE SCALE SO THAT DEGREE SPECIFIED FOR ADJUSTMENT IS OPPOSITE POINTER.</p> <p>7. SEAT CHOKE VACUUM DIAPHRAGM USING VACUUM SOURCE.</p> <p>8. HOLD CHOKE VALVE TOWARD CLOSED POSITION, PUSHING UPWARD ON CHOKE COIL LEVER OR VACUUM BREAK LEVER TANG (HOLD IN POSITION WITH RUBBER BAND).</p> <p>9. TO ADJUST, TURN SCREW IN OR OUT UNTIL BUBBLE IS CENTERED.</p> <p>10. REMOVE GAUGE.</p> <p>① MAKE CHOKE COIL LEVER AND FAST IDLE ADJUSTMENT (BENCH OR ON-THE-CAR SETTING). NOTE1: DO NOT REMOVE RIVETS AND CHOKE COVER TO PERFORM THIS ADJUSTMENT. USE RUBBER BAND ON VACUUM BREAK LEVER TANG TO HOLD CHOKE VALVE CLOSED (STEP 8).</p> <p>⑧ LIGHTLY CLOSE CHOKE BY PUSHING UPWARD ON CHOKE COIL LEVER OR VACUUM BREAK LEVER TANG (HOLD IN POSITION WITH RUBBER BAND)</p>  <p>⑥ SPECIFIED ANGLE (SEE SPECS.)</p> <p>② DEGREE SCALE</p> <p>③ POINTER MAGNET</p> <p>⑤ LEVELING BUBBLE (CENTERED)</p> <p>④ CHOKE VALVE CLOSED</p> <p>⑦ SEAT DIAPHRAGM USING VACUUM SOURCE.</p> <p>NOTE 2: ON DELAY MODELS WITH AIR BLEED, PLUG END COVER WITH PIECE OF 1" SQUARE MASKING TAPE. REMOVE AFTER ADJUSTMENT</p> <p>RUBBER BAND</p> <p>VACUUM BREAK LEVER TANG</p> <p>FIGURE 2</p> <p>TURN SCREW TO ADJUST UNTIL BUBBLE IS CENTERED</p> <p>FRONT VACUUM BREAK ADJUSTMENT - ANGLE GAUGE METHOD (SEE NOTE 1)</p> | <p>CARB. NO.</p> <p>17080212 17080512</p> <p>17080213 17080215 17080513 17080515 17080229 17080529</p> | <p>ANGLE GAUGE</p> <p>24°</p> <p>23°</p> |

Fig. 6C4-16--M4MC Adjustments - 4 of 9

9

1. USE CHOKE VALVE MEASURING GAUGE J-26701 OR . . . TOOL MAY BE USED WITH CARBURETOR ON OR OFF ENGINE. IF OFF ENGINE, PLACE CARBURETOR ON HOLDING FIXTURE SO THAT IT WILL REMAIN IN SAME POSITION WHEN GAUGE IS IN PLACE.

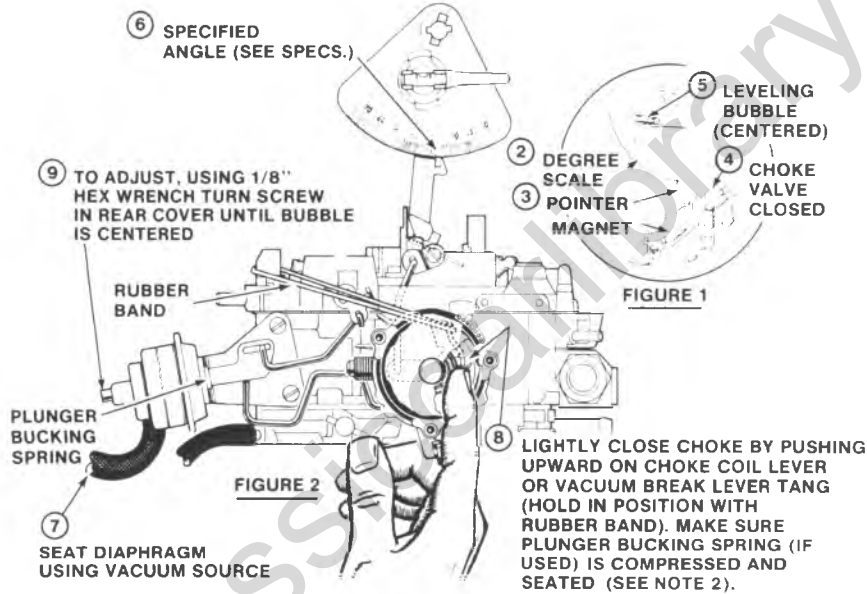
FIGURE 1

2. CHOKE COIL LEVER ADJUSTMENT MUST BE CORRECT AND FAST IDLE ADJUSTMENT MUST BE MADE BEFORE PROCEEDING.
3. ROTATE DEGREE SCALE UNTIL ZERO (0) IS OPPOSITE POINTER.
4. WITH CHOKE VALVE COMPLETELY CLOSED, PLACE MAGNET SQUARELY ON TOP OF CHOKE VALVE.
5. ROTATE BUBBLE UNTIL IT IS CENTERED.

FIGURE 2

6. ROTATE SCALE SO THAT DEGREE SPECIFIED FOR ADJUSTMENT IS OPPOSITE POINTER.
7. SEAT CHOKE VACUUM DIAPHRAGM USING VACUUM SOURCE.
8. HOLD CHOKE VALVE TOWARD CLOSED POSITION, PUSHING UPWARD ON CHOKE COIL LEVER OR VACUUM BREAK LEVER TANG (HOLD IN POSITION WITH RUBBER BAND).
9. TO ADJUST, USING 1/8" HEX WRENCH TURN SCREW IN REAR COVER UNTIL BUBBLE IS CENTERED.
10. REMOVE GAUGE.

- ① MAKE CHOKE COIL LEVER AND FAST IDLE ADJUSTMENT (BENCH OR ON-THE-CAR SETTING).
NOTE 1: DO NOT REMOVE RIVETS AND CHOKE COVER TO PERFORM THIS ADJUSTMENT. USE RUBBER BAND ON VACUUM BREAK LEVER TANG TO HOLD CHOKE VALVE CLOSED (STEP 8).



NOTE 2: ON DELAY MODELS, PLUG END COVER WITH TOOL J- . . . OR EQUIVALENT (SUCH AS A PUMP PLUNGER CUP). REMOVE PLUG AFTER ADJUSTMENT.

REAR VACUUM BREAK ADJUSTMENT - TYPICAL
(SCREW ADJUSTMENT TYPE)

| CARB. NO. | ANGLE GAUGE | |
|-----------|-------------|--|
| 17080201 | 23° | |
| 17080205 | | |
| 17080206 | | |
| 17080224 | | |
| 17080225 | | |
| 17080295 | | |
| 17080297 | | |
| 17080523 | | |
| 17080524 | | |
| 17080525 | | |
| 17080526 | 26° | |
| 17080226 | | |
| 17080227 | | |
| 17080527 | | |
| 17080528 | | |
| 17080290 | | |
| 17080291 | 30° | |
| 17080292 | | |
| 17080503 | | |
| 17080506 | | |
| 17080508 | | |
| 17080212 | | |
| 17080512 | | |
| 17080213 | | |
| 17080215 | | |
| 17080513 | | |
| 17080515 | | |
| 17080229 | | |
| 17080529 | | |

Fig. 6C4-17--M4MC Adjustments-5 of 9

10

1. USE CHOKE VALVE MEASURING GAUGE J-26701 . TOOL MAY BE USED WITH CARBURETOR ON OR OFF ENGINE. IF OFF ENGINE, PLACE CARBURETOR ON HOLDING FIXTURE SO THAT IT WILL REMAIN IN SAME POSITION WHEN GAUGE IS IN PLACE.

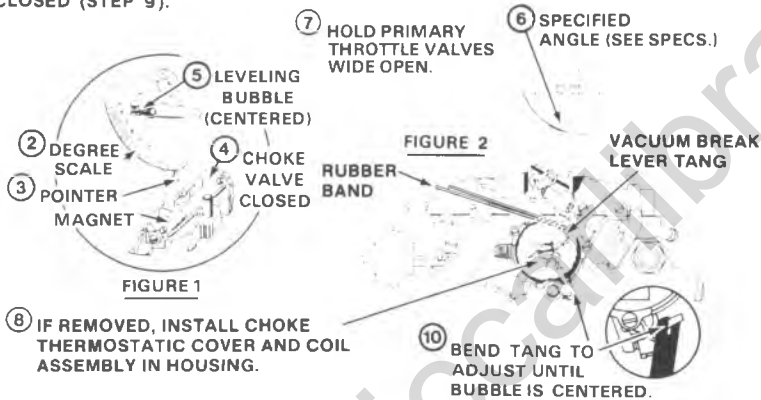
FIGURE 1

2. CHOKE COIL LEVER ADJUSTMENT MUST BE CORRECT AND FAST IDLE ADJUSTMENT MUST BE MADE BEFORE PROCEEDING.
3. ROTATE DEGREE SCALE UNTIL ZERO (0) IS OPPOSITE POINTER.
4. WITH CHOKE VALVE COMPLETELY CLOSED, PLACE MAGNET SQUARELY ON TOP OF CHOKE VALVE.
5. ROTATE BUBBLE UNTIL IT IS CENTERED.

FIGURE 2

6. ROTATE SCALE SO THAT DEGREE SPECIFIED FOR ADJUSTMENT IS OPPOSITE POINTER.
7. HOLD PRIMARY THROTTLE VALVES WIDE OPEN.
8. IF REMOVED, INSTALL CHOKE THERMOSTATIC COVER AND COIL ASSEMBLY IN HOUSING.
9. CLOSE CHOKE VALVE BY PUSHING UP ON TANG ON VACUUM BREAK LEVER (HOLD IN POSITION WITH RUBBER BAND).
10. TO ADJUST, BEND TANG ON FAST IDLE LEVER UNTIL BUBBLE IS CENTERED.
11. REMOVE GAUGE.

- 1 MAKE CHOKE COIL LEVER AND FAST IDLE ADJUSTMENT (BENCH OR ON-THE-CAR SETTING).
NOTE: DO NOT REMOVE RIVETS AND CHOKE COVER TO PERFORM THIS ADJUSTMENT. USE RUBBER BAND ON VACUUM BREAK LEVER TANG TO HOLD CHOKE VALVE CLOSED (STEP 9).



- 8 IF REMOVED, INSTALL CHOKE THERMOSTATIC COVER AND COIL ASSEMBLY IN HOUSING.
- 9 CLOSE CHOKE VALVE BY PUSHING UP ON TANG ON VACUUM BREAK LEVER (HOLD IN POSITION WITH RUBBER BAND).
- 10 BEND TANG TO ADJUST UNTIL BUBBLE IS CENTERED.

UNLOADER ADJUSTMENT - TYPICAL

| CARB. NO. | ANGLE GAUGE |
|--|-------------|
| 17080201 17080205 17080206 17080224 17080225 17080290 17080291 17080292 17080295 17080297 17080503 17080506 17080508 17080523 17080524 17080525 17080526 17080226 17080227 17080527 17080528 | 42° |
| 17080212 17080512 17080213 17080215 17080513 17080515 17080229 17080529 | 40° |

Fig. 6C4-18-M4MC Adjustments - 6 of 9

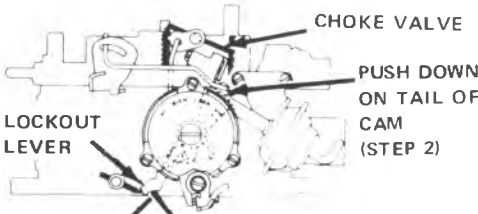
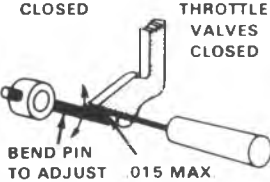
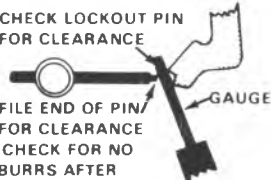
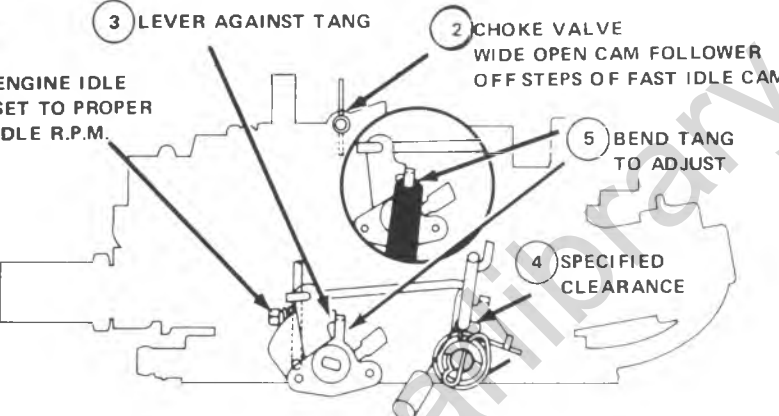
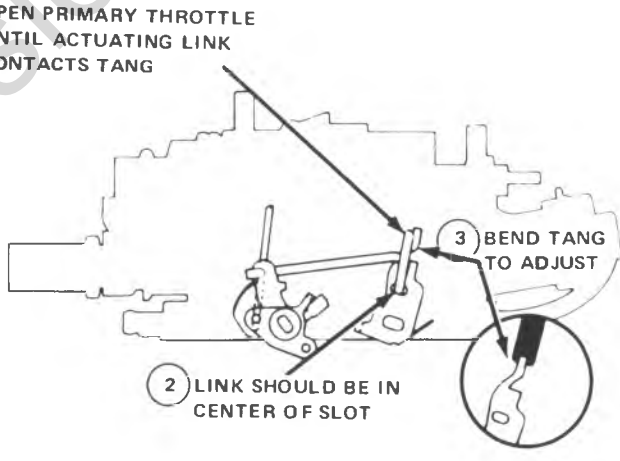
| | | |
|---|---|--|
| <p>11</p>  <p>CHOKE VALVE PUSH DOWN ON TAIL OF CAM (STEP 2) LOCKOUT LEVER</p> <div style="display: flex; justify-content: space-around;"> <div style="border: 1px solid black; padding: 5px;"> <p>CHOKE VALVE CLOSED THROTTLE VALVES CLOSED</p>  <p>BEND PIN TO ADJUST .015 MAX CLEARANCE</p> <p>① SECONDARY LOCKOUT LEVER SIDE CLEARANCE</p> </div> <div style="border: 1px solid black; padding: 5px;"> <p>HOLD CHOKE VALVE WIDE OPEN BY PUSHING DOWN ON TAIL OF FAST IDLE CAM</p>  <p>CHECK LOCKOUT PIN FOR CLEARANCE</p> <p>FILE END OF PIN FOR CLEARANCE (CHECK FOR NO BURRS AFTER FILING)</p> <p>② SECONDARY LOCKOUT OPENING CLEARANCE</p> </div> </div> <p style="text-align: center;">SECONDARY LOCKOUT ADJUSTMENT</p> | <p>CARB. NO.</p> <p style="text-align: center;">ALL</p> | <p>PLUG GAUGE</p> <p style="text-align: center;">.015"</p> |
| <p>12</p>  <p>① ENGINE IDLE SET TO PROPER IDLE R.P.M. ③ LEVER AGAINST TANG ② CHOKE VALVE WIDE OPEN CAM FOLLOWER OFF STEPS OF FAST IDLE CAM ⑤ BEND TANG TO ADJUST ④ SPECIFIED CLEARANCE</p> <p style="text-align: center;">SECONDARY CLOSING ADJUSTMENT</p> | <p>CARB. NO.</p> <p style="text-align: center;">ALL</p> | <p>PLUG GAUGE</p> <p style="text-align: center;">.020"</p> |
| <p>13</p>  <p>① OPEN PRIMARY THROTTLE UNTIL ACTUATING LINK CONTACTS TANG ② LINK SHOULD BE IN CENTER OF SLOT ③ BEND TANG TO ADJUST</p> <p style="text-align: center;">SECONDARY OPENING ADJUSTMENT</p> | | |

Fig. 6C4-19--M4MC Adjustments - 7 of 9

14 ③ TURN TENSION ADJUSTING SCREW CLOCKWISE UNTIL AIR VALVE JUST CLOSES. THEN TURN ADJUSTING SCREW CLOCKWISE SPECIFIED NUMBER OF TURNS

④ TIGHTEN LOCK SCREW

① LOOSEN LOCK SCREW USING SPECIAL HEX WRENCH

② TURN TENSION ADJUSTING SCREW COUNTERCLOCKWISE UNTIL AIR VALVE OPENS PART WAY

AIR VALVE SPRING ADJUSTMENT

| CARB. NO. | NO. TURNS |
|--|-----------|
| 17080201 170802-5 17080206 17080224 17080225 17080290 17080291 17080292 17080295 17080297 17080503 17080506 17080508 17080523 17080524 17080525 17080526 17080226 17080227 17080527 17080528 | 7/8" |
| 17080212 17080512 | 3/4" |
| 17080213 17080215 17080513 17080515 17080229 17080529 | 1" |

15 ① PREPARE VEHICLE FOR ADJUSTMENTS - SEE EMISSION LABEL ON VEHICLE. NOTE: IGNITION TIMING SET PER LABEL.

② TURN IDLE SPEED SCREW TO SET CURB IDLE SPEED TO SPECIFICATIONS - A / C OFF (SEE EMISSION LABEL)

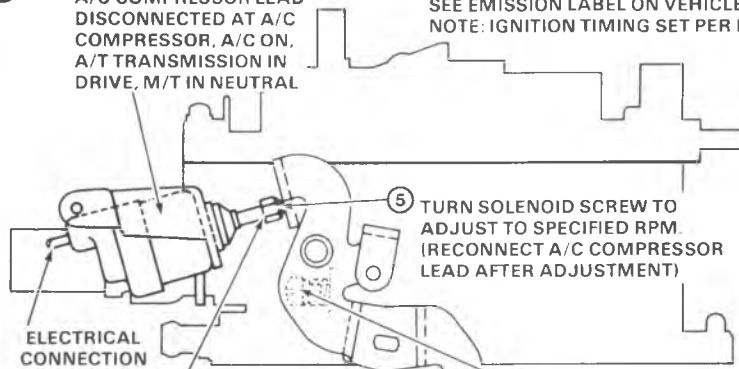
IDLE SPEED ADJUSTMENT - WITHOUT SOLENOID

Fig. 6C4-20-M4MC Adjustments 8 of 9

16

③ SOLENOID ENERGIZED — A/C COMPRESSOR LEAD DISCONNECTED AT A/C COMPRESSOR, A/C ON, A/T TRANSMISSION IN DRIVE, M/T IN NEUTRAL

① PREPARE VEHICLE FOR ADJUSTMENTS — SEE EMISSION LABEL ON VEHICLE. NOTE: IGNITION TIMING SET PER LABEL.



⑤ TURN SOLENOID SCREW TO ADJUST TO SPECIFIED RPM. (RECONNECT A/C COMPRESSOR LEAD AFTER ADJUSTMENT)

④ OPEN THROTTLE SLIGHTLY TO ALLOW SOLENOID PLUNGER TO FULLY EXTEND

② TURN IDLE SPEED SCREW TO SET CURB IDLE SPEED TO SPECIFICATIONS — A/C OFF (SEE EMISSION LABEL)

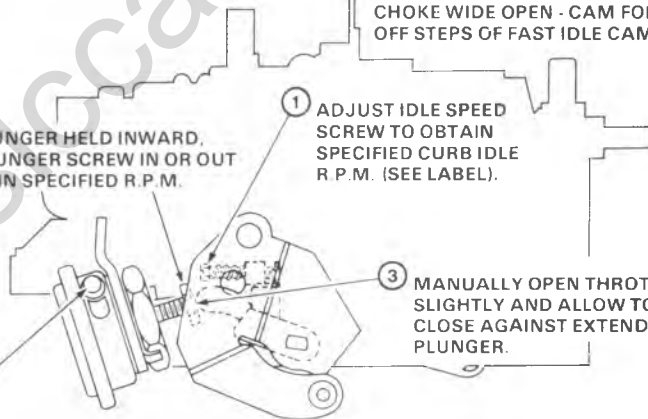
A/C IDLE SPEED ADJUSTMENT - WITH SOLENOID

17

NOTE: ENGINE MUST BE WARM - CHOKE WIDE OPEN - CAM FOLLOWER OFF STEPS OF FAST IDLE CAM.

④ WITH PLUNGER HELD INWARD, TURN PLUNGER SCREW IN OR OUT TO OBTAIN SPECIFIED R.P.M.

① ADJUST IDLE SPEED SCREW TO OBTAIN SPECIFIED CURB IDLE R.P.M. (SEE LABEL).



③ MANUALLY OPEN THROTTLE SLIGHTLY AND ALLOW TO CLOSE AGAINST EXTENDED PLUNGER.

② WITH ENGINE SET AT SPECIFIED IDLE SPEED, USING OUTSIDE VACUUM SOURCE APPLY SUFFICIENT VACUUM TO THE ACTUATOR TO EXTEND THE PLUNGER FULLY.

THROTTLE LEVER ACTUATOR ADJUSTMENT

(ON CAR)

Fig. 6C4-21-M4MC Adjustments 9 of 9

3. Connect an accurate tachometer to engine.
4. Disconnect vacuum advance and set timing to specification shown on the Emission Control Information Label. Re-connect vacuum advance.
5. Set carburetor idle speed to specification as shown on Emission Control Information Label.
6. Disconnect crankcase ventilation tube from air cleaner.
7. Using tool J-26911, insert hose with rubber stopper, from propane valve into crankcase ventilation tube opening in air cleaner (Fig. 6C4-22). Propane cartridge must be vertical (Fig. 6C4-23).
8. With engine idling in drive (neutral for manual shifts) slowly open propane control valve while pressing button. Continue to add propane until speed drops due to over richness. Note maximum engine speed (enriched speed).

If rich speed drop cannot be obtained check for empty cartridge or propane system leaks.

9. If the enriched idle speed is within the enriched idle specification the mixture is correct. Go to step 17.

10. If the enriched idle speed is not within specifications, remove mixture screw plugs following procedures.

11. Lightly seat screws, then back out equally, just enough so engine will run.

12. Place transmission in Drive (automatics) or Neutral (manuals).

13. Back each screw out (richen 1/8 turn at a time until maximum idle speed is obtained). Then set idle speed to the enriched idle specification.

14. Turn each mixture screw in (clockwise) 1/8 turn at a time until idle speed reaches value given on Emission Control Information Label.

15. Re-check enriched speed with propane. If not within specification, repeat adjustment beginning with Step 12.

16. Check and adjust fast idle as described on Emission Control Information Label.

17. Turn off engine. Remove propane tool, connect crankcase ventilation tube. Re-connect vacuum hoses.

IDLE MIXTURE ADJUSTMENT - BEST IDLE METHOD

(For Heavy Duty Emission Vehicles With 4-Barrel)

Perform this adjustment with engine at operating temperature, parking brake applied and transmission in park or neutral.

1. Remove air cleaner.
2. Connect tachometer and vacuum gage to engine.
3. As a preliminary adjustment, turn idle mixture screws in lightly to seat and back out 2 turns.

NOTICE: Do not turn idle mixture screw tightly against seat or damage may result.

4. With engine running (choke wide open and transmission in neutral) adjust idle speed screw to idle speed specified on Engine Emission Control Information Label.

5. Adjust idle mixture screw to obtain highest RPM.



Fig. 6C4-22--Propane Air Cleaner Connection

6. Repeat steps 4 and 5 until "best" idle is obtained.

7. Shut down the engine, remove gages and install air cleaner.

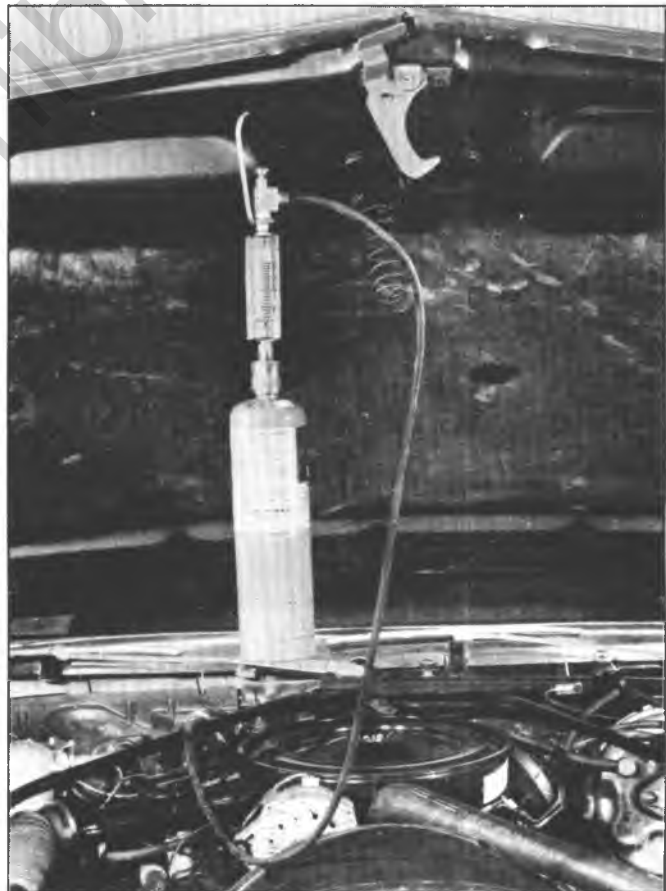


Fig. 6C4-23--Propane Tool Position

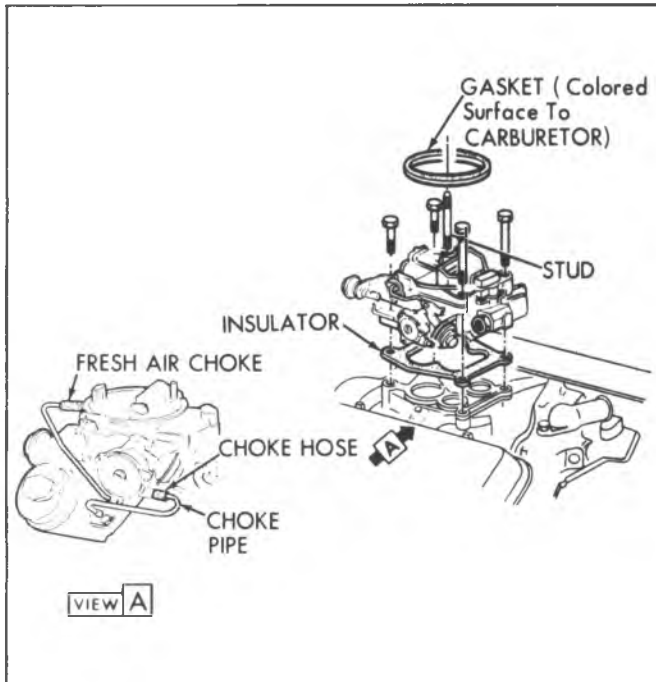


Fig. 6C4-24--Carburetor and Choke Pipes-M4MC

CARBURETOR MOUNTING TORQUE

When torquing carburetor after removal overhaul, replacement or when installing a new heat insulator, torque mounting bolts, in a clockwise direction, to 16 N·m (144 in. lbs.).

When retorquing carburetor at recommended maintenance intervals, check in clockwise direction. If less than 7 N·m (60 in. lbs.), retorque to 11 N·m (96 in. lbs.); if greater than 7 N·m (60 in. lbs.), do not retorque.

CARBURETOR REPLACEMENT

Model M4MC (Fig. 6C4-24)

DISASSEMBLY

Place carburetor on a holding fixture to prevent damage to throttle plates.

Solenoid (If Equipped)

Remove screws securing the solenoid and bracket to float bowl and remove solenoid and bracket assembly.

The solenoid should not be immersed in any type of carburetor cleaner and should always be removed before complete carburetor overhaul.

Air Horn

1. Remove upper choke lever from the end of choke shaft by removing retaining screw (Fig. 6C4-25). Then rotate upper choke lever to remove choke rod from slot in lever.

2. Remove choke rod from lower lever inside the float bowl casting by holding lower lever outward with small screwdriver and twisting rod counterclockwise.

Removal

Flooding, stumble on acceleration and other performance complaints are in many instances, caused by presence of dirt, water, or other foreign matter in carburetor. To aid in diagnosis, carburetor should be carefully removed from engine without draining fuel from bowl. Contents of fuel bowl may then be examined for contamination as carburetor is disassembled. Check filter.

1. Remove air cleaner and gasket.
2. Disconnect wire at solenoid, if equipped.
3. Disconnect fuel pipe and vacuum lines.
4. Disconnect choke system.
5. Disconnect accelerator linkage.
6. If equipped with automatic transmission, disconnect downshift cable.
7. If equipped with cruise control, disconnect linkage.
8. Remove carburetor attaching bolt, carburetor and insulator.

Installation

1. Clean sealing surfaces on intake manifold and carburetor.
2. Fill carburetor bowl before installing carburetor.
3. Install carburetor with new insulator and tighten bolts to correct torque (See Carburetor Mounting Torque).
4. Connect downshift cable as required.
5. Connect cruise control cable as required.
6. Connect accelerator linkage.
7. Connect choke system.
8. Connect fuel pipe and vacuum hoses.
9. Connect solenoid as required.
10. Install air cleaner.
11. Check and adjust idle speed.

UNIT REPAIR

3. Remove secondary metering rods by removing the small screw in the top of the metering rod hanger. Lift upward on metering rod hanger until the secondary metering rods are completely out of the air horn. Metering rods may be disassembled from the hanger by rotating ends out of the holes in the end of the hanger. (Fig. 6C4-26).

4. Using special tool J-25322, drive small roll pin (pump lever pivot pin) inward just enough until pump lever can be removed from air horn. Then remove pump lever from pump rod (Fig. 6C4-27).

5. Remove nine (eleven on California models) air horn to bowl attaching screws; then remove the two countersunk screws located next to the venturi (Fig. 6C4-28). Remove secondary air baffle deflector from under the two center air horn screws.

6. Remove air horn from float bowl by lifting straight up. The air horn gasket should remain on the float bowl for removal later (Fig. 6C4-29).

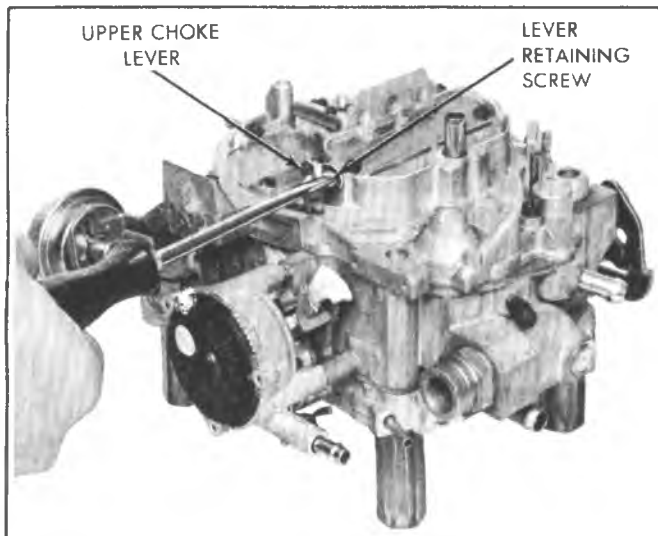


Fig. 6C4-25--Removing Upper Choke Lever

When removing air horn from float bowl, use care to prevent bending the small tubes protruding from the air horn. These tubes are permanently pressed into the air horn casting. DO NOT REMOVE.

Air Horn Disassembly

Remove front vacuum break bracket attaching screws. The diaphragm assembly may now be removed from the air valve dashpot rod and the dashpot rod from the air valve lever (Fig. 6C4-30). Do not place vacuum break assembly in carburetor cleaner.

Further disassembly of the air horn is not required for cleaning purposes. If part replacement is required, proceed as follows:

1. Remove staking on two choke valve attaching screws, then remove choke valve and shaft from air horn.
2. Air valves and air valve shaft should not be removed.
3. If it is necessary to replace the air valve closing spring or center plastic eccentric cam, a repair kit is available. Instructions for assembly are included in the

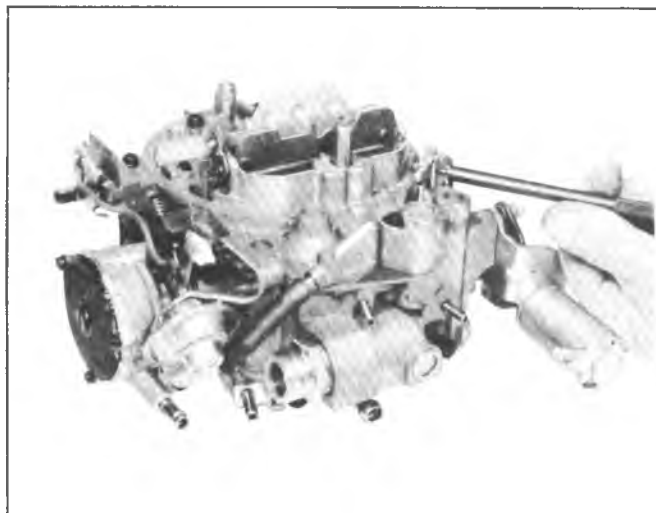


Fig. 6C4-27--Removing Pump Lever

repair kit.

Float Bowl

1. Remove air horn gasket by lifting out of dowel locating pins and lifting tab of gasket from beneath the power piston hanger, being careful not to distort springs holding the main metering rods (Fig. 6C4-31).
2. Remove pump plunger, and pump plunger stem seal (Fig. 6C4-30a) if used, from pump well.
3. Remove pump return spring from pump well.
4. Remove power piston and metering rods by depressing piston stem and allowing it to snap free (Fig. 6C4-32).

The power piston can be easily removed by pressing the piston down and releasing it with a snap. This will cause the power piston spring to snap the piston up against the retainer. This procedure may have to be repeated several

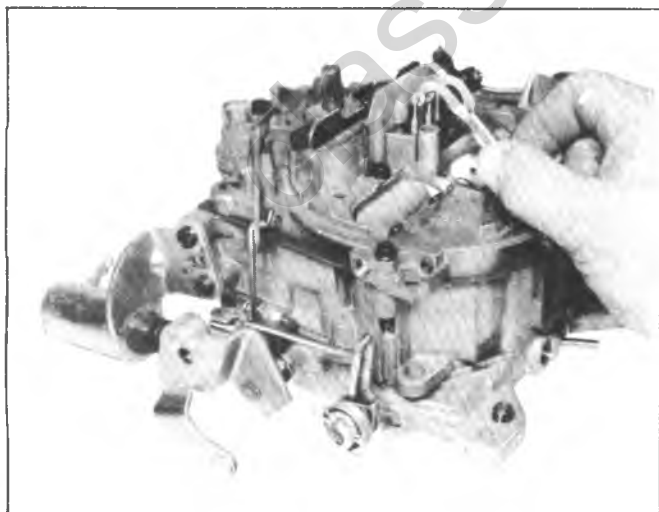


Fig. 6C4-26--Removing Secondary Metering Rods

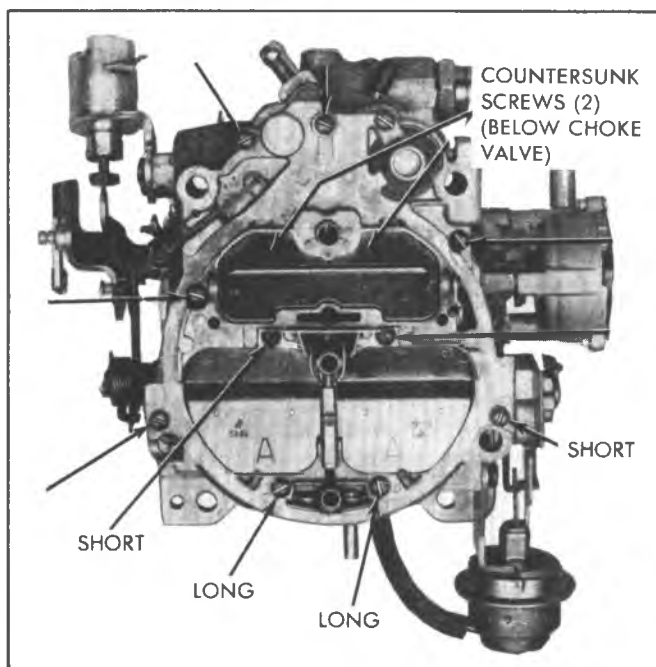


Fig. 6C4-28--Air Horn Screws

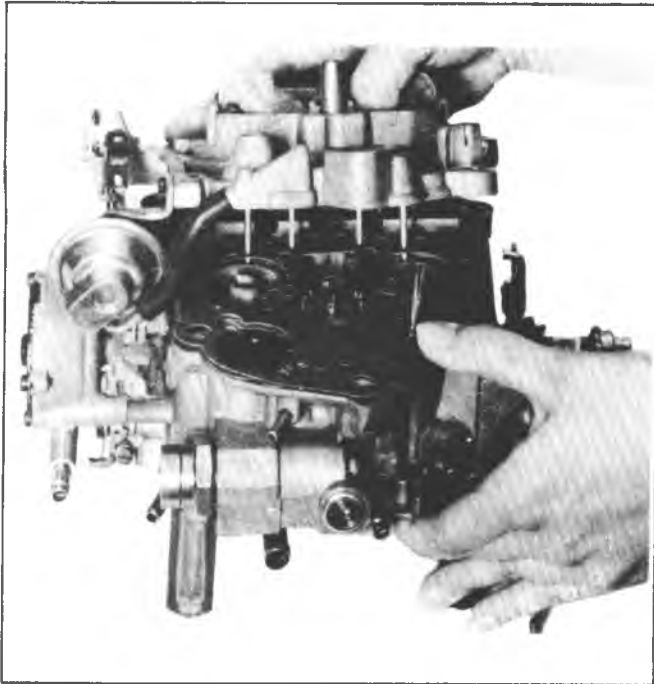


Fig. 6C4-29--Removing Air Horn

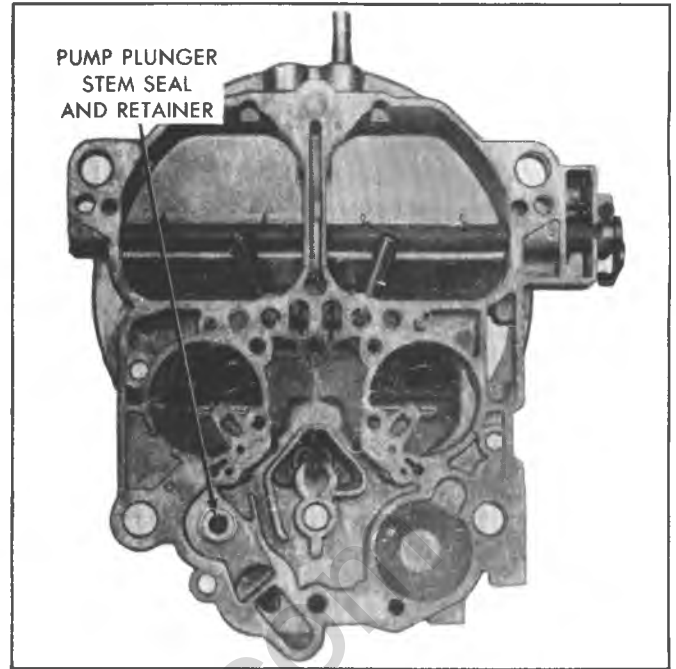


Fig. 6C4-30a--Pump Plunger Stem Seal

times.

Do not remove power piston by using pliers on metering rod hanger.

Remove the power piston spring from the well.

The A.P.T. metering rod adjustment screw is pre-set at the factory and no attempt should be made to change this adjustment in the field. If float bowl replacement is required during service, the new bowl assembly will be supplied with an A.P.T. metering rod screw which will be pre-set as required.

5. Remove metering rods from power piston by disconnecting tension spring from top of each rod, then rotate rod to remove from hanger (Fig. 6C4-33).

Use care when disassembling rods to prevent distortion of tension spring and/or metering rods. Note carefully position of tension spring for later reassembly.

6. Remove plastic filler block over float valve.
7. Remove float assembly and float needle by pulling up on retaining pin. Remove float needle seat and gasket. (Fig. 6C4-34 and 35).
8. Remove aneroid cavity insert from float bowl (Fig. 6C4-36).
9. Remove primary main metering jets (only if necessary) (Fig. 6C4-37).

NOTICE: No attempt should be made to remove the secondary metering jet (metering orifice plates). These

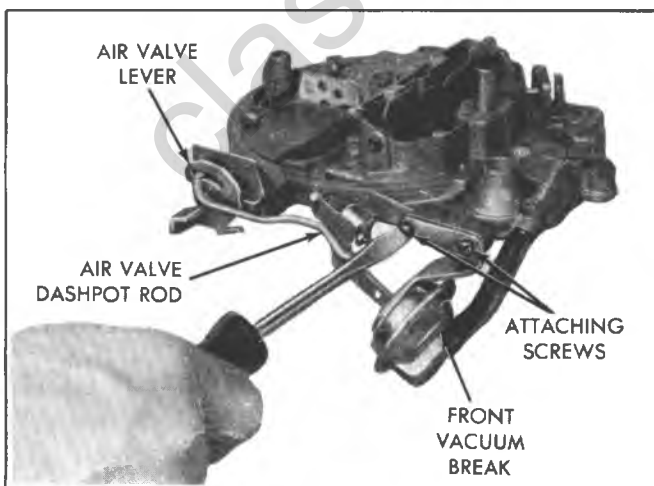


Fig. 6C4-30--Removing Front Vacuum Break-Typical

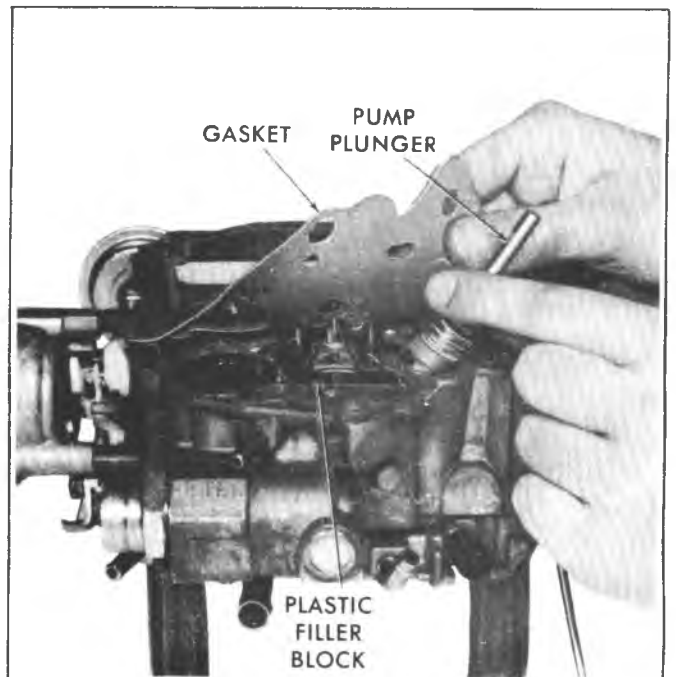


Fig. 6C4-31--Removing Air Horn Gasket and Pump Plunger

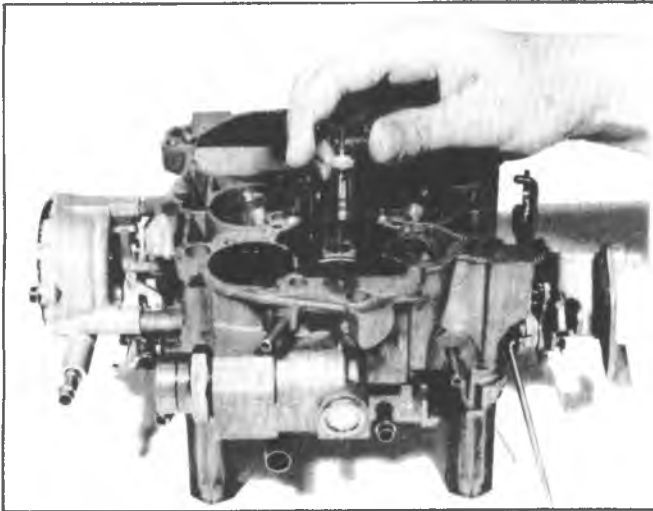


Fig. 6C4-32--Power Piston and Metering Rods

jets are fixed and, if damaged, bowl replacement is required.

10. Remove pump discharge check ball retainer and check ball.
11. Remove secondary air baffle, if replacement is required.
12. Remove pump well fill slot baffle.
13. Remove rear vacuum break (Fig. 6C4-38).

Choke

Disassembly

The non-adjustable choke cover design is used to discourage readjustment of the choke thermostatic cover and coil assembly in the field. However, it is necessary to remove the cover and coil assembly during normal

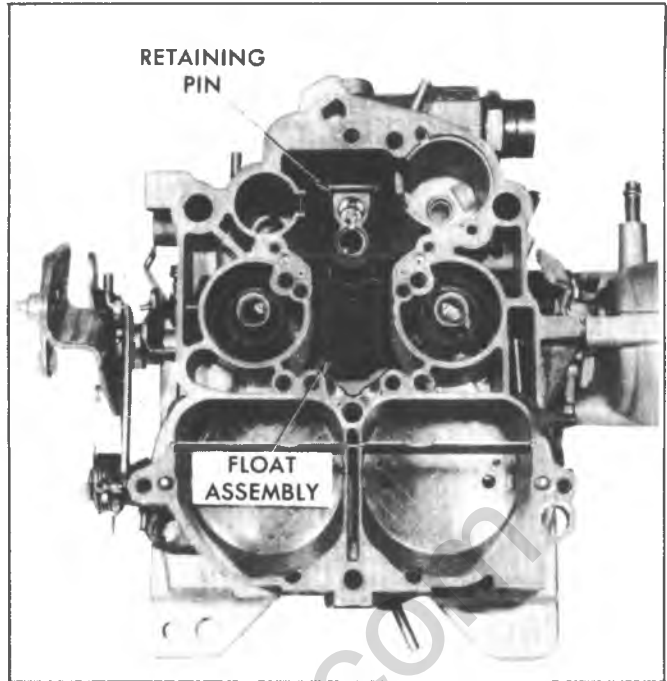


Fig. 6C4-34--Float Assembly

carburetor disassembly for cleaning and overhaul using procedures described below.

Removal of Choke Cover

1. Support float bowl and throttle body as an assembly on a suitable holding fixture such as Tool J-9789-118.
2. Carefully align a #21 drill (.159") on rivet head and drill only enough to remove rivet head (Fig. 6C4-39). Drill the two (2) remaining rivet heads and then use a drift and small hammer to drive the remainder of the rivets out of the choke housing. Use care in drilling to prevent damage to choke cover or housing.

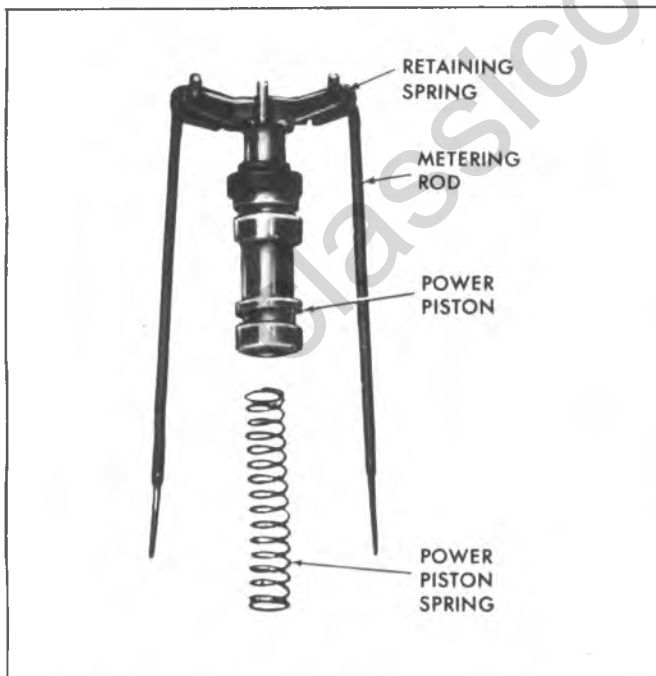


Fig. 6C4-33--Power Piston and Metering Rods

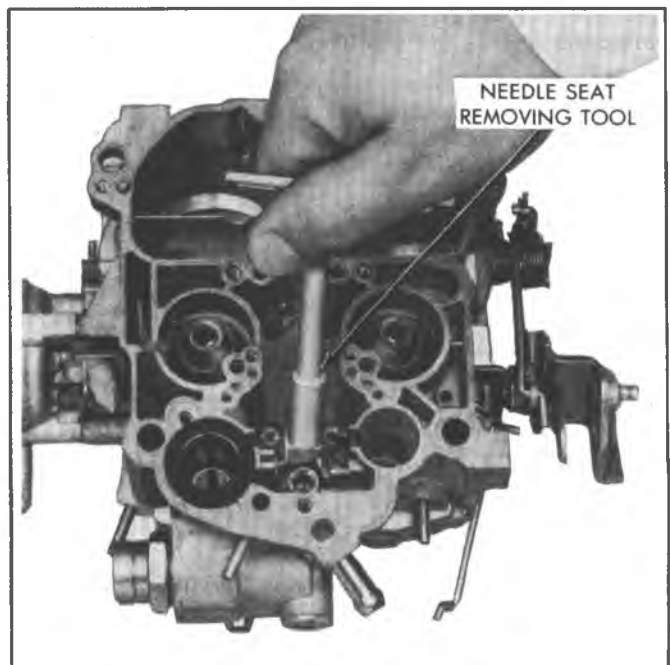


Fig. 6C4-35--Removing Needle Seat-Typical

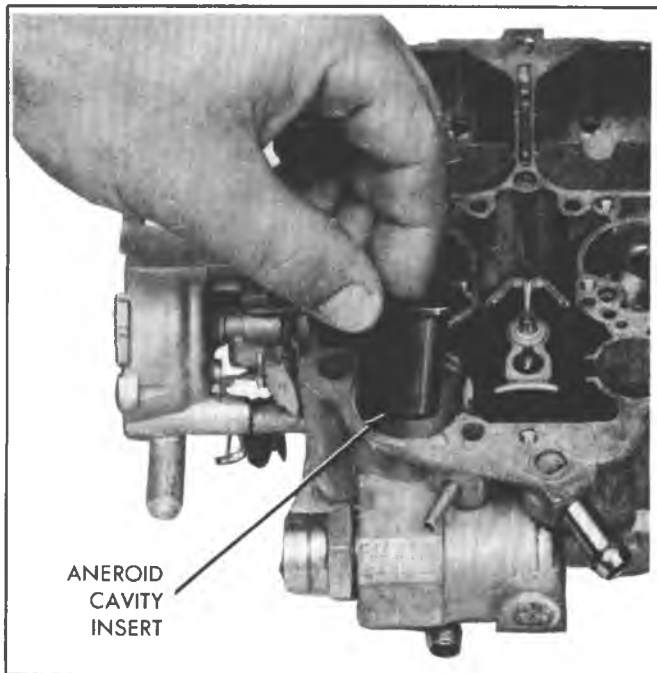


Fig. 6C4-36--Removing Aneroid Cavity Insert

3. Remove the two conventional retainers, retainer with tab, (Location A, Fig. 6C4-39), choke cover gasket, and choke cover assembly from choke housing.

Do not remove baffle plate from beneath the thermostatic coil on the choke cover.

2. Remove choke housing assembly from float bowl by removing retaining screw and washer inside the choke housing (Fig. 6C4-40). The complete choke assembly can be removed from the float bowl by sliding outward.

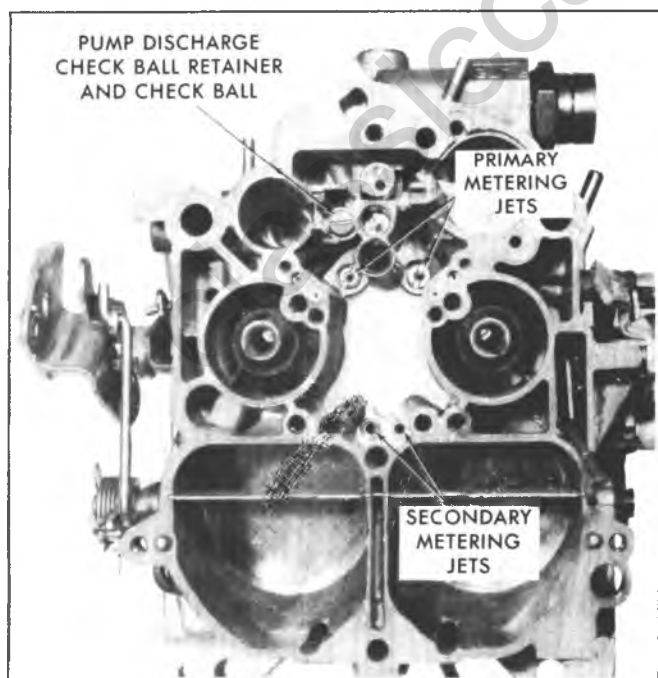


Fig. 6C4-37--Float Bowl Jets

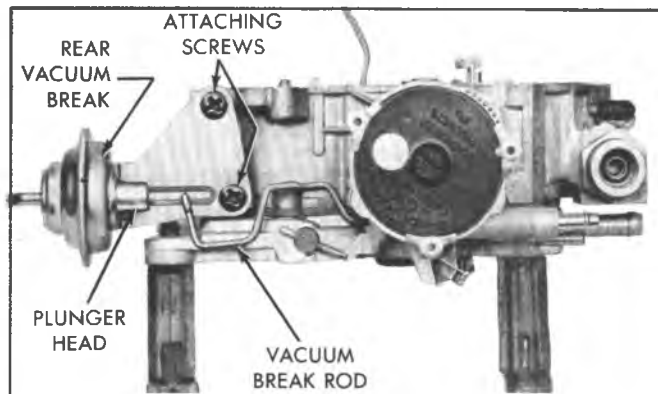


Fig. 6C4-38--Rear Vacuum Break-Typical

3. Remove secondary throttle valve lock-out lever from float bowl. (Fig. 6C4-41).

4. Remove lower choke lever from inside float bowl cavity by inverting bowl.

5. Remove plastic tube seal from choke housing (Fig. 6C4-41).

Plastic tube seal should not be immersed in carburetor cleaner.

6. To disassemble intermediate choke shaft from choke housing, remove coil lever retaining screw at end of shaft inside the choke housing (Fig. 6C4-40). Then remove thermostatic coil lever from flats on intermediate choke shaft. Remove intermediate choke shaft from the choke housing by sliding outward. The fast idle cam can now be removed from the intermediate choke shaft (Fig. 6C4-41).

Remove the cup seal from inside choke housing shaft hole if the housing is to be immersed in carburetor cleaner. Also, remove the cup seal from the float bowl plastic insert for bowl cleaning purposes. **DO NOT ATTEMPT TO REMOVE PLASTIC INSERT.**

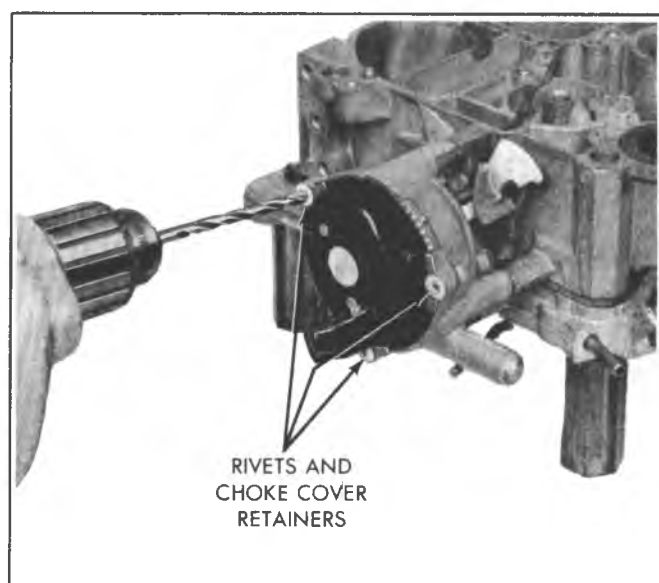


Fig. 6C4-39--Choke Rivets

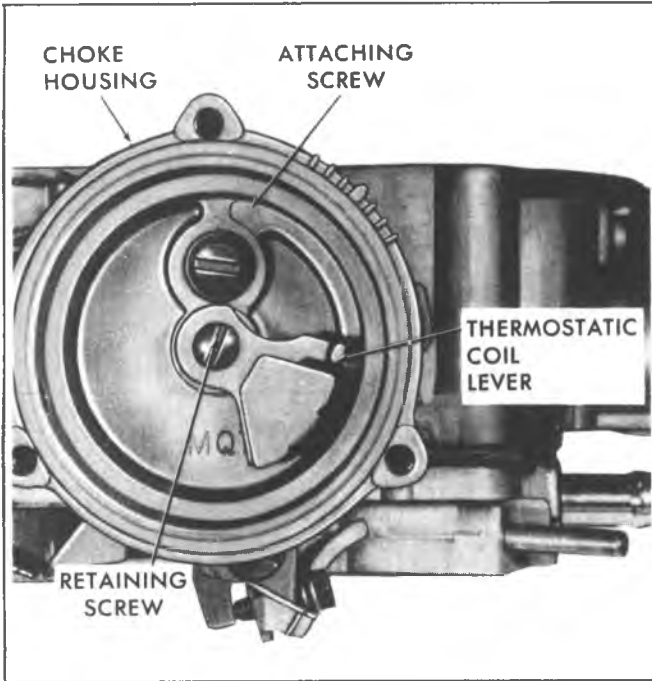


Fig. 6C4-40-Removing Choke Housing

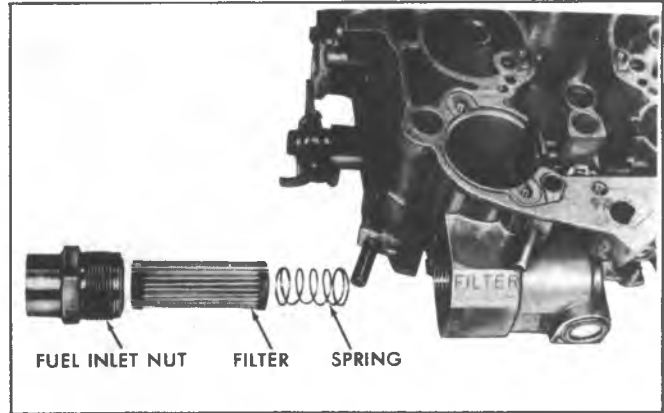


Fig. 6C4-42-Fuel Filter

Float Bowl Disassembly

1. Remove fuel inlet nut, gasket and filter (Fig. 6C4-42).
2. Remove throttle body by removing throttle body to bowl attaching screws (Fig. 6C4-43).
3. Remove throttle body to bowl insulator gasket (Fig. 6C4-44).

Throttle Body Disassembly

1. Remove pump rod from throttle lever.
2. Do not remove the plugs covering idle mixture needles unless it is necessary to replace the mixture screws or normal soaking and air pressure fails to clean the mixture passages.

Idle mixture should be adjusted only if required at time of major carburetor overhaul, throttle body replacement or high idle CO as determined by state or local inspections.

Remove idle mixture needle and plug as follows:

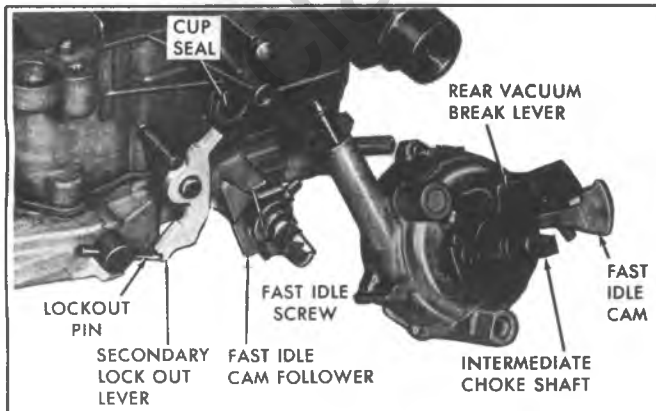


Fig. 6C4-41-Choke Housing Assembly

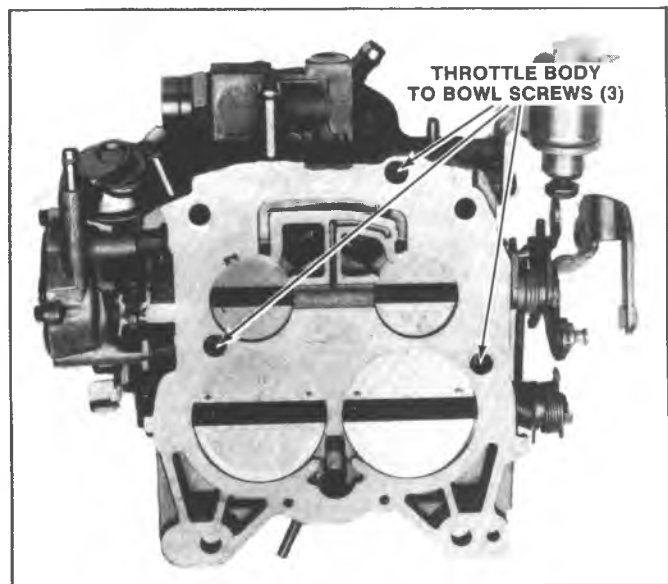


Fig. 6C4-43-Removing Throttle Body Screws

a. Invert throttle body and place on carburetor holding fixture (manifold side up).

b. Using a punch between the two locator points in throttle body beneath idle mixture needle plug (manifold side) (Fig. 6C4-45), break-out throttle body to gain access to the idle mixture needle plug. Then, drive out hardened steel plug covering mixture needle.

Hardened plug will shatter rather than remaining intact. It is not necessary to remove the plug completely; instead, remove loose pieces to allow use of Idle Mixture Adjusting Tool J-29030.

c. Using Tool J-29030 remove idle mixture needle, washer, and spring from throttle body. Repeat procedure a. and b. for remaining idle mixture needle.

CLEANING AND INSPECTION

The carburetor parts should be cleaned in cold immersion type cleaner.

NOTICE: The electric solenoid, rubber parts, plastic parts, diaphragms, pump plungers, should not be put in immersion type cleaner as they will swell, harden or distort.

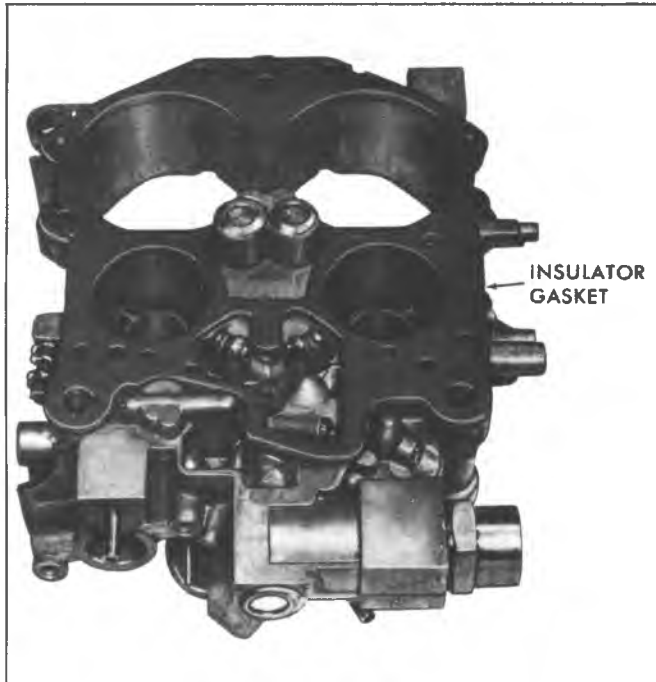


Fig. 6C4-44--Removing Insulator Gasket

1. Thoroughly clean all metal parts and blow dry with compressed air. Make sure all fuel passages and metering parts are free of burrs and dirt.

2. Check, repair or replace the following parts if the following problems were encountered.

a. Flooding

1. Inspect float needle seat for dirt, deep wear grooves, scores and proper seating.

2. Inspect float, float arm and hinge pin for distortion, binds and burrs. Check float for leaks and/or being loaded (heavier than normal).

b. Hesitation

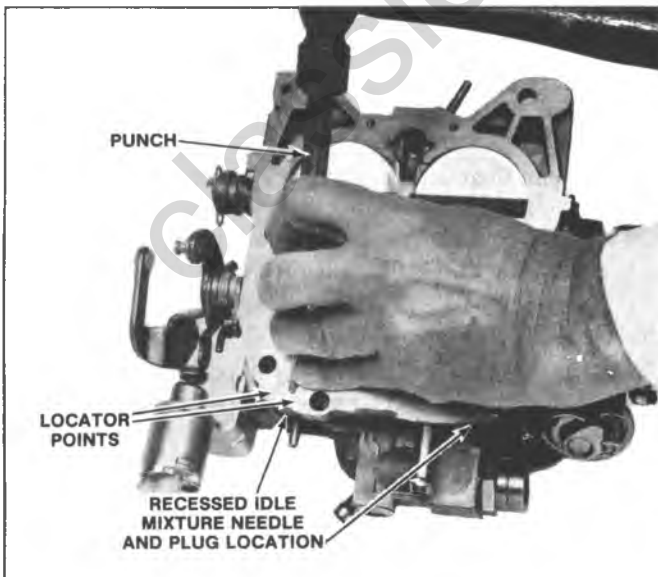


Fig. 6C4-45--Removing Idle Mixture Plug

1. Inspect pump plunger for cracks, scores or cup, excessive wear. A used pump cup will shrink when dry. Soak in fuel for 8 hours before testing if dried out.

2. Inspect pump duration and return spring for being weak or distorted.

3. Check all pump passages and jets for dirt, improper seating inlet or discharge balls, scores in pump well.

4. Check pump linkage for excessive wear, repair or replace as necessary.

c. Hard Starting - Poor Cold Operation

1. Check choke valve and linkage for excessive wear, binds or distortion.

2. Inspect choke vacuum diaphragm for leaks.

3. Clean or replace carburetor filter.

4. Inspect needle for sticking, dirt etc.

5. Examine fast idle cam for wear or damage.

6. Also check items under "flooding".

d. Poor Performance - Poor Gas Mileage

1. Power Piston, power valve, metering rods for dirt, sticking, binding, damaged parts or excessive wear.

2. Clean all fuel and vacuum passages in castings.

e. Rough Idle

1. Inspect idle needle for ridges, burrs or being bent.

2. Inspect gasket mating surfaces on castings for damage to sealing bends, nicks and burrs.

3. Clean all idle fuel passages.

4. Check throttle lever and valves for binds, nicks and other damage.

ASSEMBLY

1. If removed, install idle mixture needle, washer, and spring using Idle Mixture Adjusting Tool J-29030. Lightly seat needle and then back out 2 turns as a preliminary idle mixture adjustment. Final idle mixture adjustment must be made on car using the procedures described under Idle Mixture Adjustment.

2. Install lower end of pump rod in throttle lever by aligning tang on rod with slot in lever. End of rod should point outward toward throttle lever.

Float Bowl Assembly

1. Install new throttle body to bowl gasket over two locating dowels on bowl.

2. Install throttle body making certain throttle body is properly located over dowels on float bowl, then install throttle body to bowl screws and tighten evenly and securely (Fig. 6C4-43).

3. Place carburetor on proper holding fixture J-8328.

4. Install fuel inlet filter spring, filter, new gasket and inlet nut and tighten nut to 24 N·m (18 ft. lbs.) (Fig. 6C4-42).

The fuel inlet check valve on a vehicle with light duty emissions must be installed in the filter to meet Motor Vehicle Safety Standards (M.V.S.S.) for roll-over. New service replacement filter includes the check valve.

Ribs on closed end of filter element prevent filter from being installed incorrectly unless forced.

Tightening beyond specified torque can damage nylon gasket.

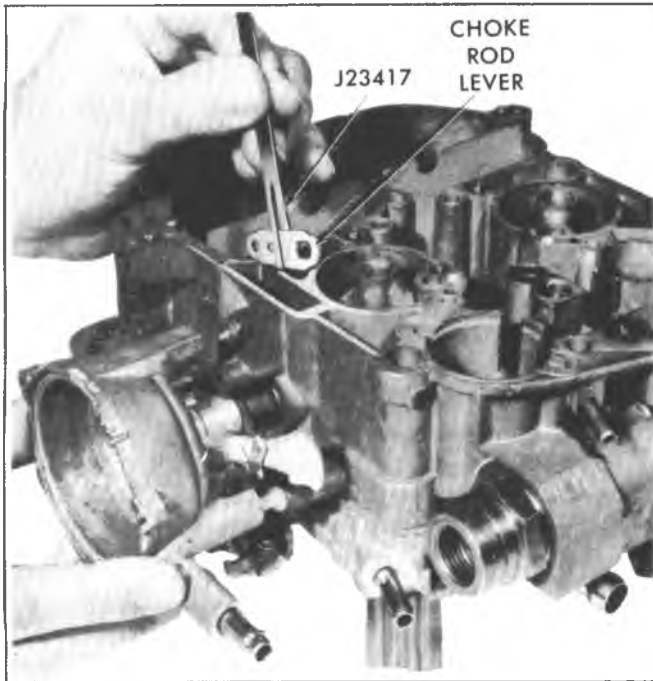


Fig. 6C4-46--Installing Choke Rod Lever

Choke

1. Install new cup seal into plastic insert on side of float bowl for intermediate choke shaft. Lip on cup seal faces outward.

2. Install secondary throttle valve lock-out lever on boss on float bowl with recess in hole in lever facing inward.

3. Install new cup seal into inside choke housing shaft hole. Lips on seal face inward, towards inside of housing.

4. Install fast idle cam onto the intermediate choke shaft (steps on fast idle cam face downward) (Fig. 6C4-41).

5. Carefully install fast idle cam and intermediate choke shaft assembly through seal in choke housing; then install thermostatic coil lever onto flats on intermediate choke shaft. Inside thermostatic choke coil lever is properly aligned when both inside and outside levers face towards fuel inlet. Install inside lever retaining screw into end of intermediate choke shaft. Tighten securely.

6. Using Tool J-23417, install lower choke rod lever into cavity in float bowl. Install plastic tube seal into cavity on choke housing before assembling choke housing to bowl. Install choke housing to bowl sliding intermediate choke shaft into lower choke lever (Fig. 6C4-46).

The intermediate choke shaft lever and fast idle cam are in correct relation when the tang on lever is beneath the fast idle cam. Do not install choke cover and coil assembly until inside coil lever is adjusted. Refer to Service Section for adjustment procedures.

Float Bowl

1. If removed, install air baffle in secondary side of float bowl with notches toward the top. Top edge of baffle must be flush with bowl casting.

2. If removed, install baffle in pump well fill slot.

3. Install pump discharge check ball and retainer in passage next to pump well. Tighten retainer securely.

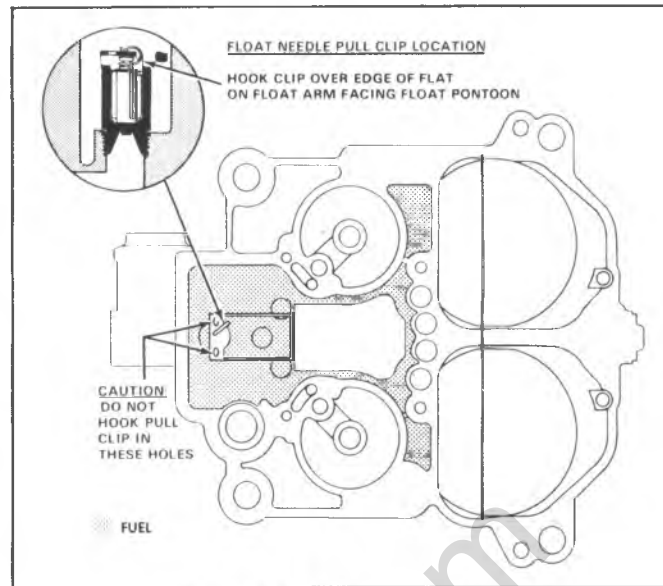


Fig. 6C4-47--Pull Clip Location

4. Install primary main metering jets (if removed).
5. Install aneroid cavity insert into float bowl.
6. Install new needle seat assembly, with gasket.
7. To make adjustment easier, bend float arm upward at notch in arm before assembly.

Install needle by sliding float lever under needle pull clip--correct installation of the needle pull clip is to hook the clip over the edge of the flat on the float arm facing the float pontoon (Fig. 6C4-47). With float lever in pull clip, hold float assembly at toe and install retaining pin from aneroid cavity side (ends of retaining pin face the accelerating pump well).

Do not install float needle pull clip into holes in float arm.

8. Adjust float level.

Float Level Adjustment (Fig. 6C4-48)

- a. Hold float retainer firmly in place.
- b. Push float down lightly against needle.
- c. With adjustable T-scale, gage from top of float bowl casting (air horn gasket removed) to top of float gauging point $3/16$ " back from end of float at toe.
- d. Bend float arm as necessary for proper adjustment by pushing on pontoon. Refer to adjustment for specification.

- e. Visually check float alignment after adjustment.

9. Install plastic filler block over float needle, pressing downward until properly seated.

10. Install power piston spring in power piston well. If main metering rods were removed from hanger, reinstall making sure tension spring is connected to top of each rod (Fig. 6C4-32). Install power piston assembly in well (aligning pin on piston with slot in well) with metering rod properly positioned in metering jets. Press down firmly on plastic power piston retainer to make sure the retainer seated in recess in bowl and the top is flush with the top of the bowl casting. If necessary, using a drift punch or small hammer, tap retainer lightly in place.

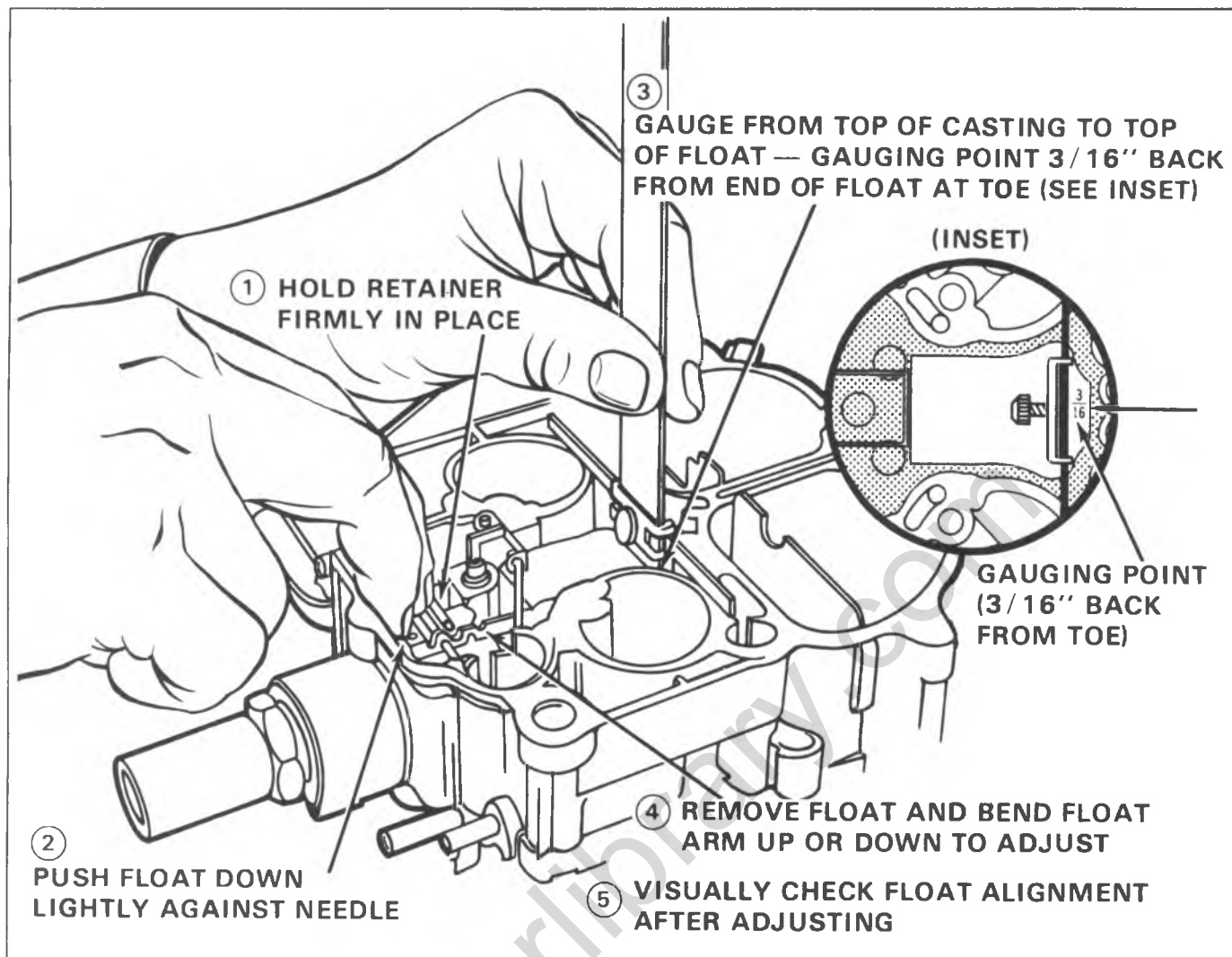


Fig. 6C4-48--Float Level Adjustment

11. Install pump return spring in pump well.
12. Install pump plunger stem seal if removed.
13. Install air horn gasket by carefully sliding tab of gasket around main metering rods and beneath the power piston hanger. Position gasket over the two dowel pins on the float bowl.
14. Carefully lift one corner of the air horn gasket and install pump plunger in the pump well by pushing the plunger to the bottom of the well against return spring tension. While holding in this position, align pump plunger stem with hole in gasket and press gasket in place.

Air Horn

1. If removed, install choke shaft, choke valve, and two attaching screws. Tighten screws securely and stake lightly in place.
2. Check choke valve for freedom of movement and proper alignment before staking screws in place.

Air Horn to Bowl Installation

1. Holding down on air horn gasket at pump plunger location, carefully lower air horn assembly onto float bowl making sure that the bleed tubes, accelerating well tubes, pull-over enrichment tubes (if used), and pump plunger

stem are positioned properly through the holes in the air horn gasket.

Do not force the air horn assembly onto the bowl but rather lightly lower in place.

2. Install two long air horn screws with lockwashers, and two countersunk screws located next to the venturi area.

Install secondary air baffle beneath screw number 3 and 4.

All air horn screws must be tightened evenly and securely. See Figure 6C4-49 for proper tightening sequence.

3. Install vacuum break diaphragm rod into the slot in lever on the end of the air valve shaft. Then install the other end of rod into hole in the front vacuum break diaphragm plunger. Install front vacuum break control and bracket assembly to air horn using two retaining screws through the bracket. Tighten screws securely.

Do not attach vacuum break hose until vacuum break adjustment is completed. Refer to On Vehicle Service for adjustment procedure.

4. Connect upper end of pump rod to pump lever by placing rod in specified hole in lever. Align hole in pump lever with hole in air horn casting using J-25322. Using

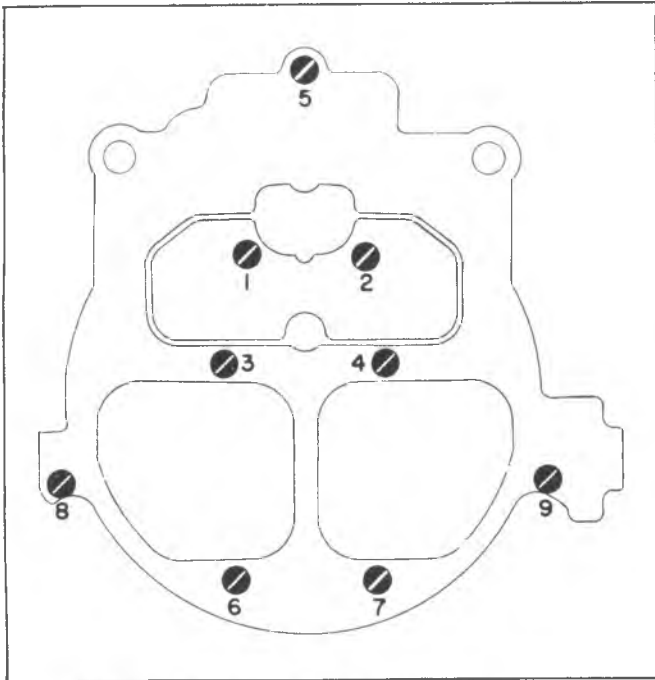


Fig. 6C4-49-Air Horn Screw Tightening Sequence

small screwdriver, push pump lever roll pin back through casting until end of pin is flush with casting bosses in air horn (Fig. 6C4-50).

Use care installing the small roll pin to prevent damage to pump lever casting bosses.

5. Install two secondary metering rods into the secondary metering rod hanger (upper end of rods point

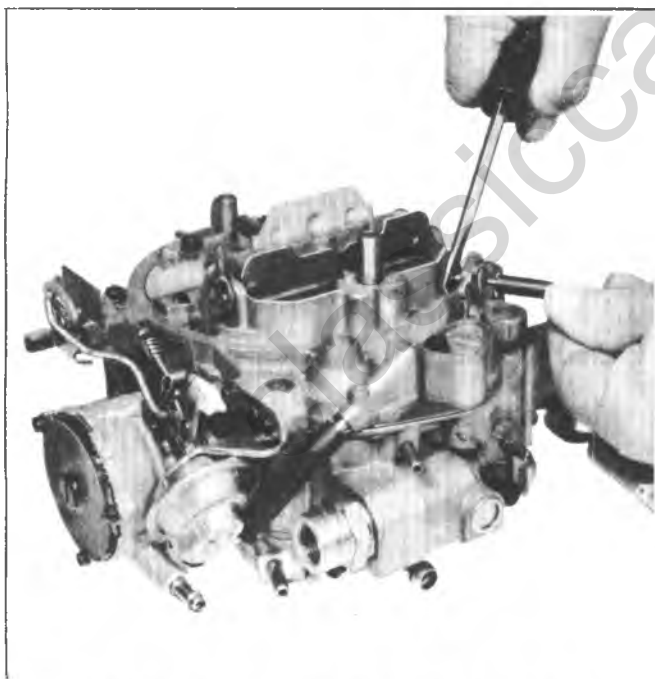


Fig. 6C4-50-Installing Pump Lever Pivot Pin

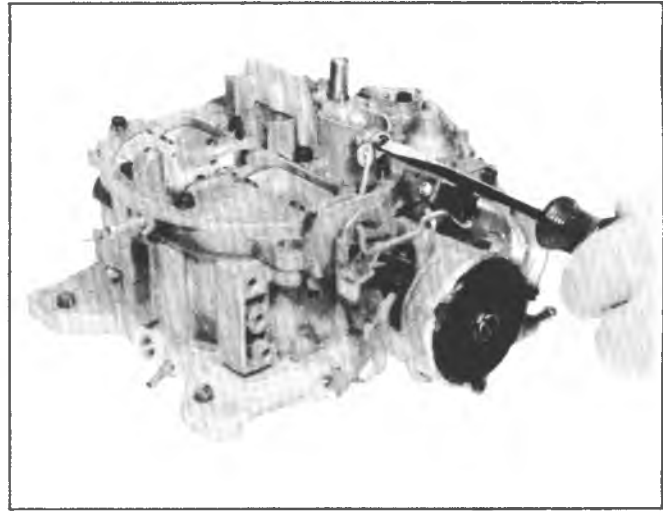


Fig. 6C4-51-Choke Lever and Housing

toward each other). Install secondary metering rod holder, with rods, onto air valve cam follower. Install retaining screw end tighten securely. Work air valves up and down several times to make sure they are free in all positions.

6. Connect check rod into lower choke lever inside bowl cavity; they install choke rod into slot in upper choke lever and retain the choke lever to the end of the choke shaft with attaching screw. Tighten securely. When properly installed, the lever will point to the rear of the carburetor and the number on the lever will face outward (Fig. 6C4-51).

Make sure that the flats on the end of the choke shaft align with flats in the choke lever.

The front and rear vacuum break, and fast idle cam adjustments must be performed, and the thermostatic coil pick-up lever inside the choke housing has to be indexed properly before installing the choke thermostatic coil and cover assembly. Refer to the Adjustment Procedures.

7. After the vacuum break, fast idle cam, and inside thermostatic coil lever are adjusted, install the cover and coil assembly in choke housing as follows:

a. Start the three self-tapping screws (supplied with service kit) in the choke housing, checking to be sure screws start easily and are aligned properly (Fig. 6C4-51). Then, remove screws.

b. Place cam follower on highest step of fast idle cam.

c. Install the thermostatic cover and coil assembly, and gasket in the choke housing, making sure coil tang engaged inside coil pick-up lever (Fig. 6C4-51).

d. Install retainer with tab at Location A (Fig. 6C4-51) and align notch in cover with tab on retainer. Install one self-tapping screw.

e. Install the remaining (2) retainers and screws. Then, tighten all (3) retainer screws evenly and securely.

8. Install vacuum break hose on rear vacuum control unit.

9. Position idle speed solenoid - bracket assembly on float bowl, retaining with two large countersunk screws. Tighten screws securely.

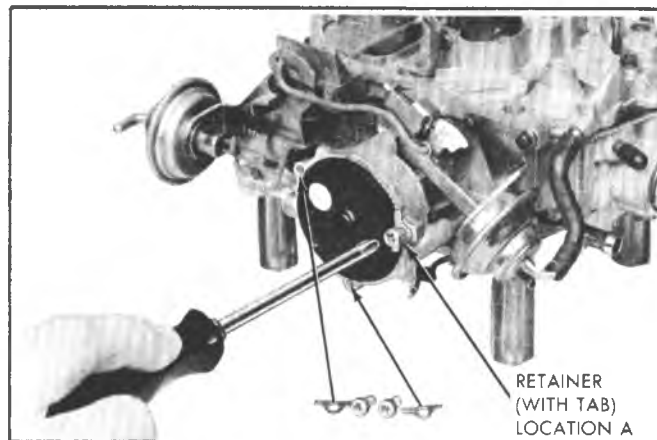


Fig. 6C4-52 -Choke Cover - Typical

classiccarylbrary.com

classicalcarlibrary.com

SECTION 6C5

FUEL SUPPLY

CONTENTS

| | | | |
|---------------------------------|--------|----------------------------------|--------|
| Fuel Filter | 6C5-1 | Accelerator Controls..... | 6C5-11 |
| Fuel Pump..... | 6C5-1 | Specifications..... | 6C5-15 |
| Fuel Tank..... | 6C5-3 | Idle Speeds | 6C5-16 |
| Cleaning Fuel System | 6C5-4 | Angle to Decimal Conversion..... | 6C5-17 |
| Fuel Feed and Vapor Pipes..... | 6C5-10 | Special Tools..... | 6C5-18 |
| Evaporative Control System..... | 6C5-10 | | |

FUEL FILTER

GENERAL DESCRIPTION

All engine fuel filters are located in the carburetor fuel inlet. These fuel filter elements are of pleated paper. Elements are placed in the inlet hole with the gasket surface outward. A spring holds the element outward, sealing it by compressing a gasket surface against the inlet fitting.

ON-VEHICLE SERVICE

The carburetor inlet fuel filter should be replaced at intervals shown in Section 0B. A plugged filter and/or check valve will restrict fuel flow.

After assembling any filter element in the carburetor, always start the engine and check for leaks in the fuel line and fittings before installing the air cleaner.

Other Filters or Strainers

A woven plastic filter is located on the lower end of the fuel pickup pipe in the gas tank. This filter prevents dirt from entering the fuel line and also stops water unless the filter becomes completely submerged in water. This filter is self cleaning and normally required no maintenance. Fuel stoppage at this point indicates that the gas tank contains an abnormal amount of sediment or water; the tank should therefore be removed and thoroughly cleaned.

Fuel Filter Replacement

1. Disconnect fuel line connection at fuel inlet filter nut.
2. Remove fuel inlet filter nut from carburetor.
3. Remove filter and spring.
4. If removed, install check valve in fuel inlet filter.

The fuel inlet check valve must be installed in the filter to meet Motor Vehicle Safety Standards (M.V.S.S.) for roll-over. New service replacement filter must include the check valve.

5. Install fuel inlet filter spring, filter, and check valve assembly in carburetor. Check valve end of filter faces toward fuel line. Ribs on closed end of filter element prevent filter from being installed incorrectly unless forced.
6. Install new gasket on fuel inlet filter nut and install nut in carburetor. Tighten nut to 24 N·m (18 ft. lbs.). Tightening beyond specified torque can damage gasket.
7. Install fuel line and tighten connection.
8. Start engine and check for leaks.

FUEL PUMP

GENERAL DESCRIPTION

The fuel pump (Figs. 6C5-1 through 6C5-5) is a diaphragm type pump and is actuated by the rocker arm through a link and a push rod.

Some vehicles have a fuel pump with an outlet for a vapor return system. Any vapor which forms is returned to the fuel tank along with hot fuel through a separate line. This greatly reduces any possibility of vapor lock by keeping cool fuel from the tank constantly circulating through the fuel pump.

DIAGNOSIS

Complete diagnosis of all possible causes of the trouble prior to replacement of the fuel pump will save time, expense and possible causes of the trouble prior to replacement of the fuel pump will save time, expense and possibly prevent a repeat complaint.

Low Pressure Complaint

The only way to check fuel pump pressure is by connecting an accurate pressure gage to the fuel line at carburetor level. Never replace a fuel pump without first making that simple check.

Not Enough Fuel Flow Complaint

When an engine has a "starving-out" condition, many mechanics jump to the conclusion that the fuel pump is not pumping enough fuel. Many times the "starving-out" condition is actually due to a weakness in the ignition system, since these two troubles are very hard to separate. Even when an engine is starving for fuel, the cause is more likely to be a plugged fuel filter or a restricted fuel line than a malfunctioning fuel pump.

ON-VEHICLE SERVICE

Inspection and Test

If the fuel system is suspected of delivering an improper amount of fuel to the carburetor, it should be inspected and tested in the vehicle, as follows:

Inspection of Fuel System

1. Make certain that there is fuel in the tank.
2. With the engine running, inspect for leaks at all fuel feed hose connections from fuel tank to carburetor. Tighten any loose connections. Inspect all hoses for flattening or kinks which would restrict the flow of fuel. Air leaks or restrictions on suction side of mechanical fuel pump will seriously affect pump output.
3. Inspect for leaks at fuel pump diaphragm flange.
4. Disconnect feed pipe near carburetor.
5. Disconnect distributor connectors so that engine can be cranked without firing. Place suitable container at end of pipe and crank engine a few revolutions. If no fuel, or only a little flows from pipe, the feed line is clogged or fuel pump is inoperative. Before condemning the fuel pump, disconnect feed line at both ends and blow through it with air hose to make certain that fuel pump is operating within specifications.

Fuel Pump Pressure Test

1. Disconnect fuel line at pump and connect a suitable pressure gage (such as Pressure-Leakdown Tester J-22109).
2. Start engine and check pressure with engine running at slow idle speed. Fuel pump pressure should be as specified at the end of this section. On vehicles equipped with a vapor return system, squeeze off the return hose so that an accurate reading can be obtained.
3. If fuel pump pressure is below minimum, pump must be replaced.

Fuel Pump Flow Test

1. Disconnect fuel line from carburetor. Run fuel line into a suitable measuring container.
2. While observing the sweep second hand of a clock or watch, run the engine at idle until there is one pint of fuel in the container. One pint should be pumped in 30 seconds or less.
3. If flow is below minimum, check for restriction in the line.

Removal

1. Disconnect fuel inlet hose from pump. Disconnect vapor return hose, if so equipped.
2. Disconnect fuel outlet pipe.
3. Remove two bolts holding fuel pump.
4. Remove fuel pump, push rod, gasket and mounting plate (if used).

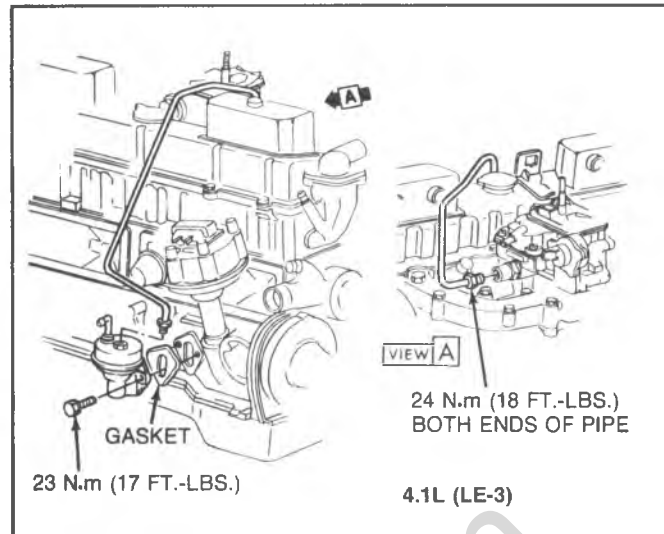


Fig. 6C5-1—Fuel Pump—4.1 L

Installation

1. Install push rod, gasket, mounting plate (if used) and fuel pump.
2. Install two hex head bolts, turning them alternately and evenly.
3. Install fuel outlet pipe. If it is difficult to start fitting, time can be saved by disconnecting upper end of pipe from carburetor. Tighten fitting securely, meanwhile holding fuel pump nut with a wrench. Install and tighten fitting at carburetor, if removed.
4. Install fuel inlet hose and clamp. Install vapor return hose and clamp, if so equipped.
5. Start engine and check for leaks.

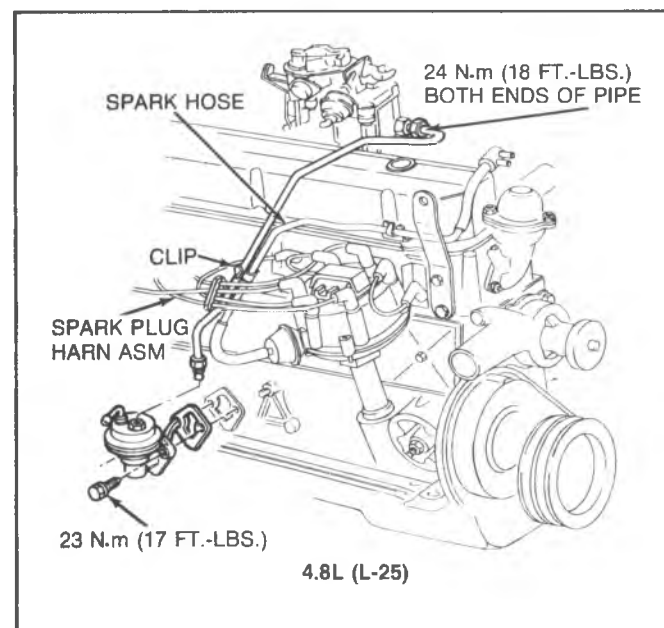


Fig. 6C5-2—Fuel Pump—4.8 L

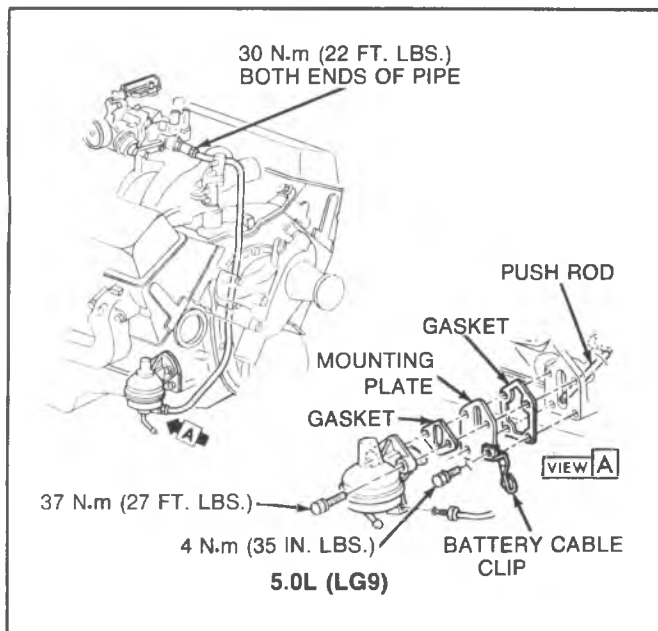


Fig. 6C5-3-Fuel Pump-5.0 L

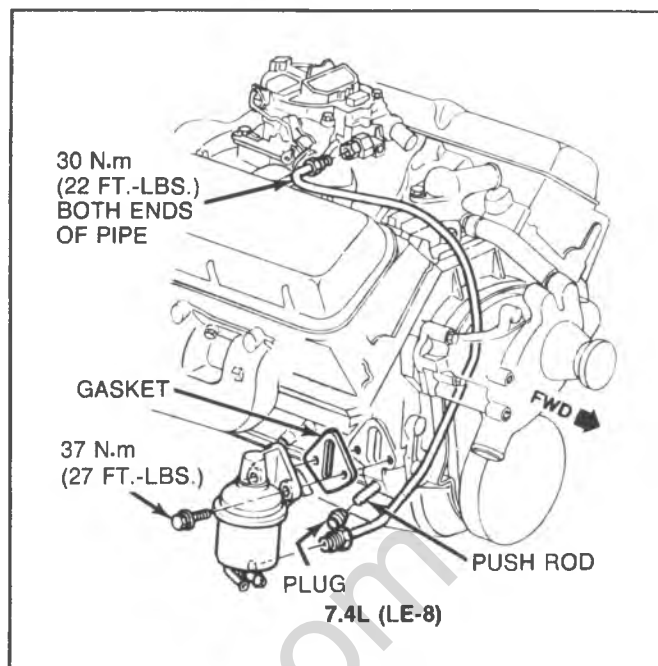


Fig. 6C5-5-Fuel Pump-7.4 L

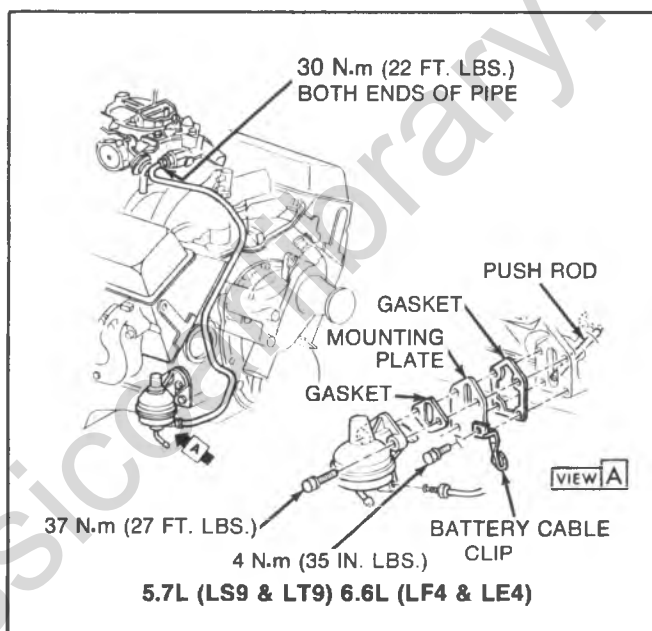


Fig. 6C5-4-Fuel Pump-5.7 L & 6.6L

FUEL TANK

ON-VEHICLE SERVICE

Outside Frame Rail Fuel Tank-

Cab and Crewcab (Figs. 6C5-6 and 8)

1. Drain tank.
2. Disconnect fuel lines, meter wire and ground lead.
3. Remove strap supports (lines, vent) and clip.

4. Loosen clamps from filler neck and vent line.

5. Remove strap bolts and lock washers from tank front and rear locations on inside frame rail.

6. Remove tank from frame simultaneously disengaging filler neck hose from filler neck (Fig. 6C5-8 and 6C5-9).

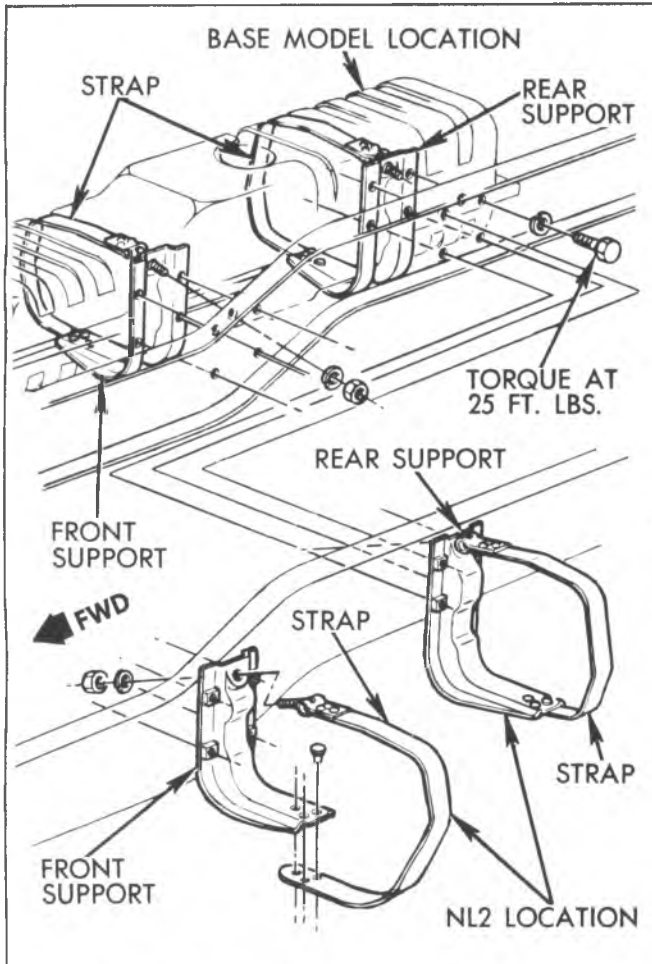


Fig. 6C5-6--Fuel Tank Mounting-Cab and Crewcab

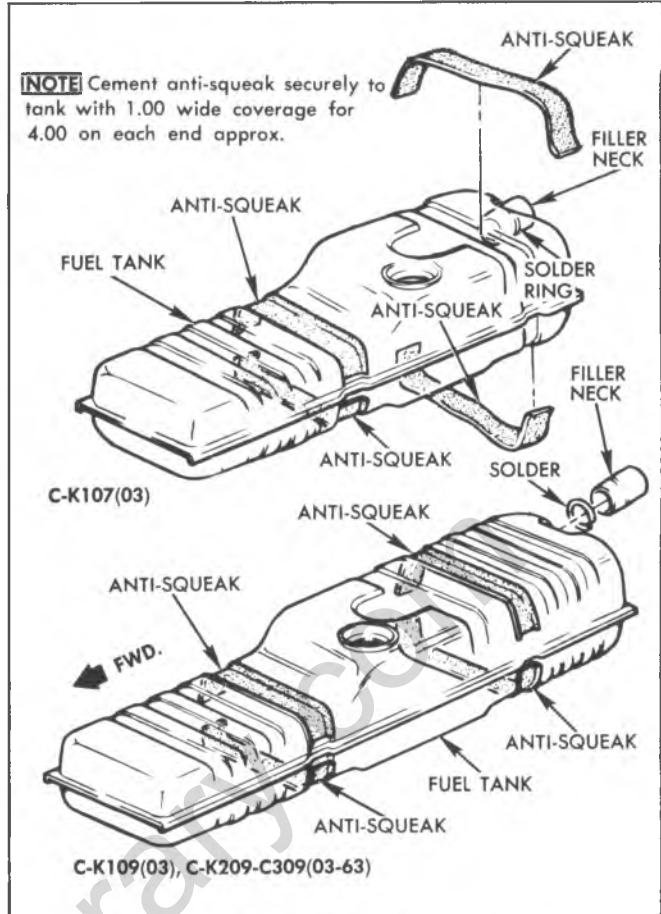


Fig. 6C5-7--Fuel Tank-Cab and Crewcab

7. Remove meter assembly from fuel tank using Tool J-24187 (Fig. 6C5-10).

8. Reverse removal procedure to install fuel tank.

Center and Auxiliary Fuel Tank

CK 10 and 20 (06, 16) (Figs. 6C5-11, 12) G Van (Fig. 6C5-13).

1. Drain tank.
2. Raise vehicle on hoist.
3. Unclamp upper filler neck and vent tube hose (Fig. 6C5-8 and 9).
4. Unclamp gage unit hoses at frame end.
5. Support tank and remove support straps.
6. Lower tank and disconnect meter wire.
7. Remove tank.
8. Install in the reverse order, using new antisqueak material.
9. Lower vehicle and remove from hoist.

Frame Mounted Fuel Tank - P Model (Figs. 6C5-15, 16, 17)

1. Drain tank.
2. Remove filler neck.
3. Disconnect meter unit fuel line and wiring.
4. Remove bolts attaching tank supports to frame.

5. Remove tank complete with mounting bracket and support straps.

6. Remove tank from brackets and support straps, if necessary.

7. Install in reverse order and replace antisqueak material.

CLEANING FUEL SYSTEM

Cleaning

If trouble is due to contaminated fuel or foreign material that has been put into the tank, it can usually be cleaned. If tank is rusted internally, it should be replaced.

1. Disconnect battery negative cable and distributor feed wire.
2. Drain fuel tank.
3. Remove fuel tank.
4. Remove fuel inlet filter at carburetor and inspect for contamination. If filter is plugged replace (leave fuel line disconnected).
5. Locate tank away from heat, flame, or other source of ignition. Remove fuel gage tank unit and inspect condition of filter. If filter is contaminated a new filter should be installed upon reassembly.
6. Complete draining of tank by rocking it and allowing fuel to run out of tank unit hole.
7. Purge fuel tank with steam or running hot water for at least five minutes. Pour water out of tank unit hole (rock tank to assure complete removal of water).

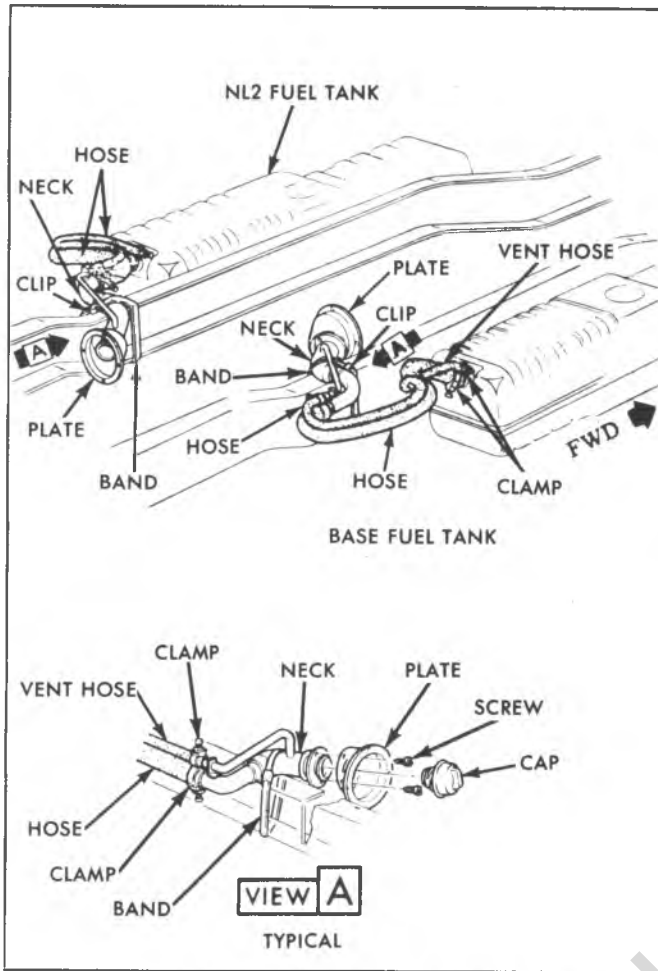


Fig. 6C5-8--Fuel Tank Filler neck (03 & 43)

This procedure will not remove fuel vapor. Do not

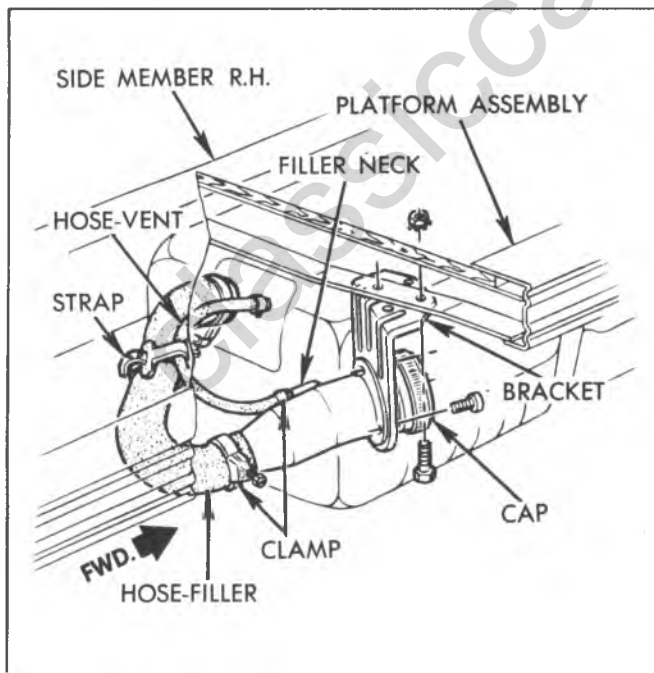


Fig. 6C5-9--Filler Neck-Cab Stake Body

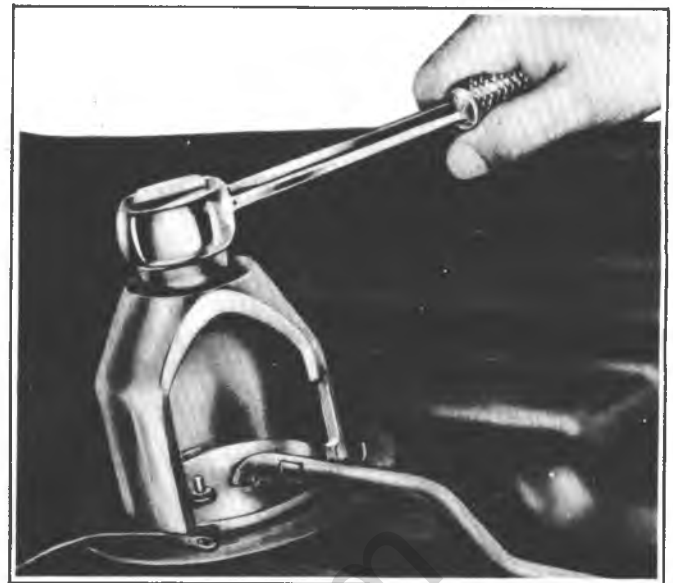


Fig. 6C5-10--Removing Meter Assembly

attempt any repair on tank or filler neck where heat or flame is required.

8. Disconnect inlet fuel line at pump and use air pressure to clean fuel line and fuel return line (if equipped). Apply air pressure in the direction fuel normally flows through line.

9. Use low air pressure to clean pipes on tank unit.

10. Clean filter on fuel tank unit, if required. Install fuel tank gage unit, (with new gasket) into tank and install tank. Connect tank unit wires and all fuel lines, except pump to

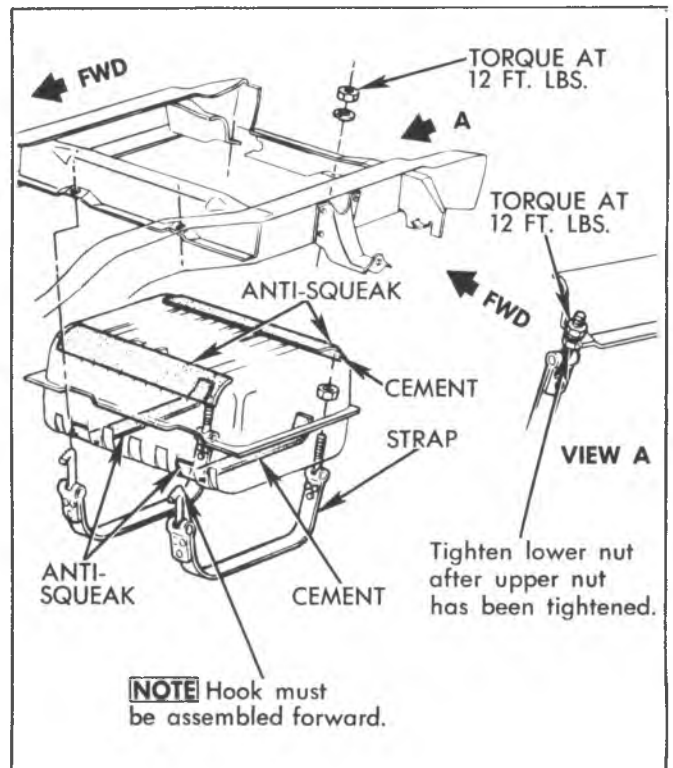


Fig. 6C5-11--Fuel Tank, CK 10-20 (06, 16)

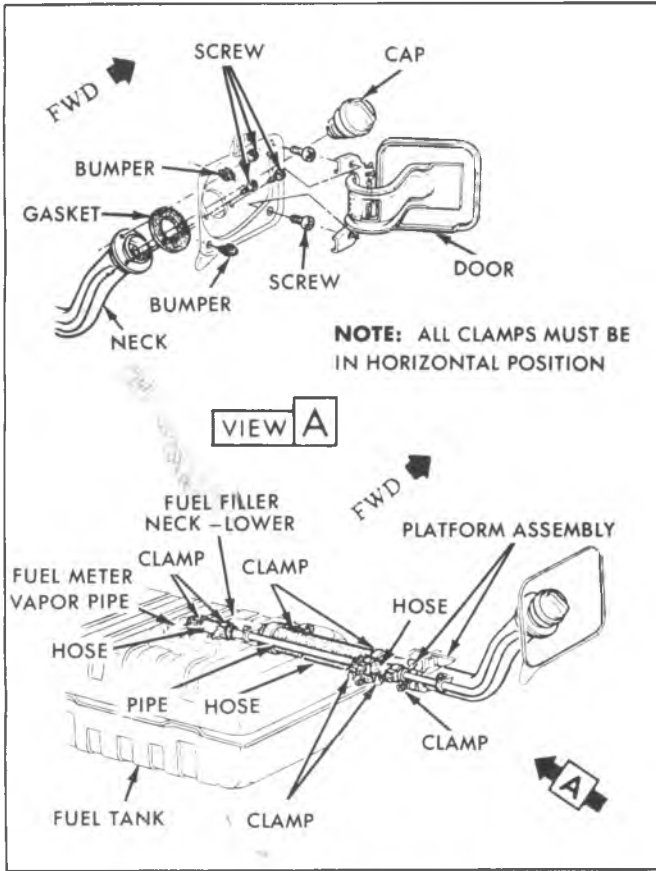


Fig. 6C5-12--Fuel Tank, CK 10-20 (06, 16)

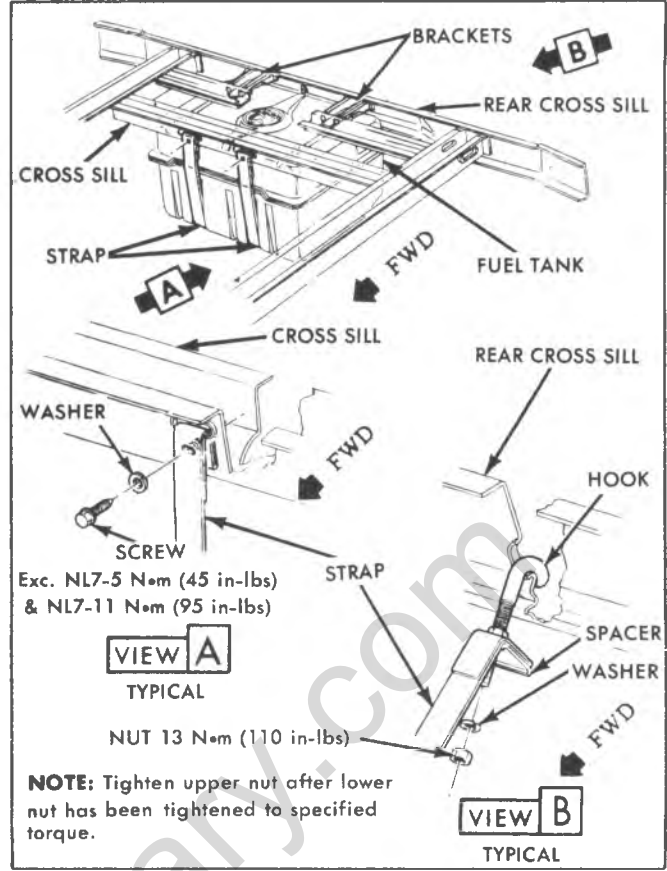


Fig. 6C5-13--Fuel Tank Installation G Van

carburetor line (see "Removal of Tank" for proper procedure).

11. Connect a hose to fuel line at carburetor; insert other end of hose into a one gallon fuel can.

12. Connect battery cable. Make sure distributor feed wire is disconnected.

13. Put six gallons of clean fuel in tank and operate starter to pump two quarts of fuel into fuel can. This will purge fuel pump.

14. Remove hose and connect fuel line to carburetor.

15. Connect distributor feed wire.

16. Check all connections for leaks.

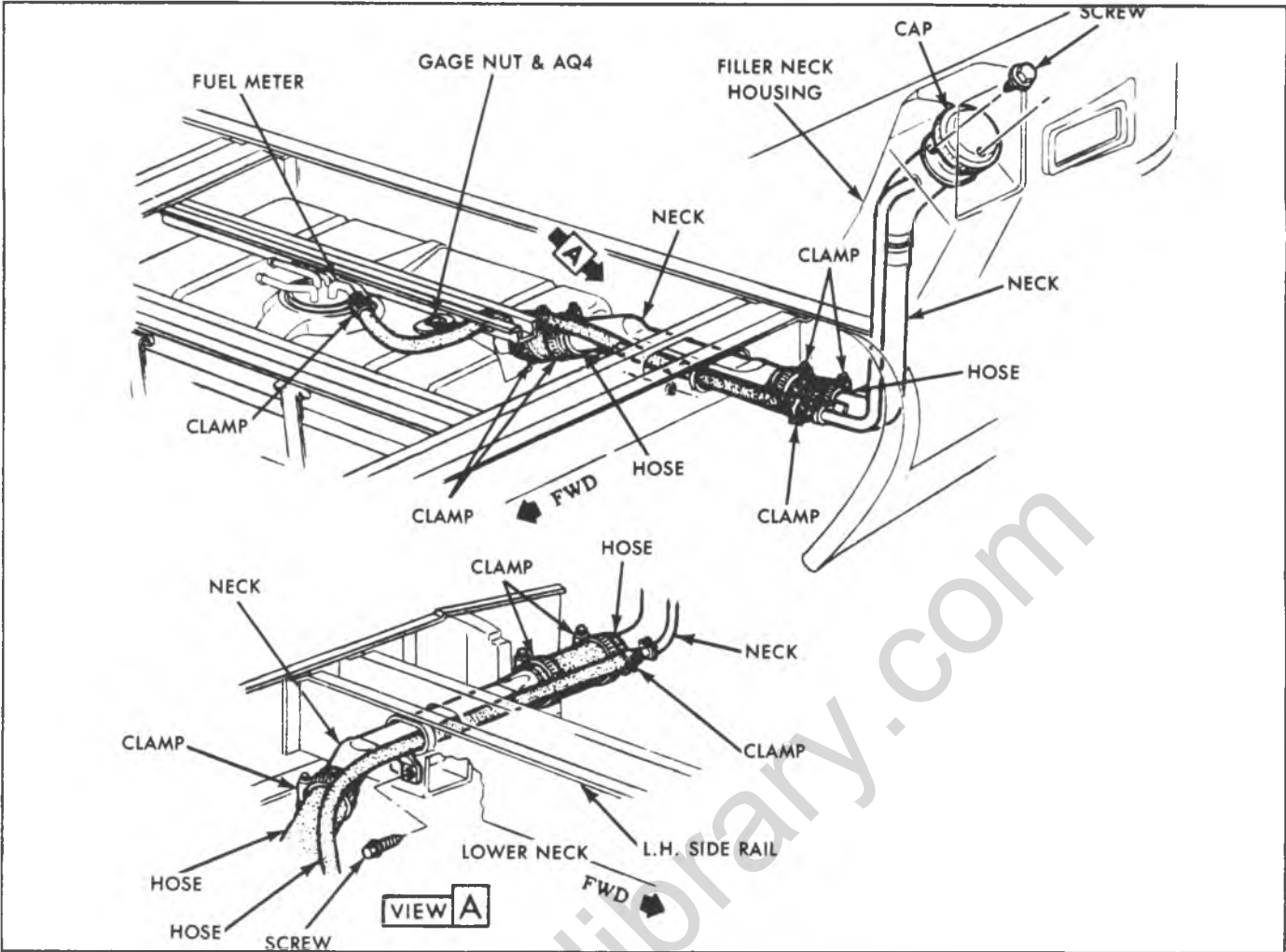


Fig. 6C5-14-Fuel Tank and Filler Neck G Van

classiccarlibrary.com

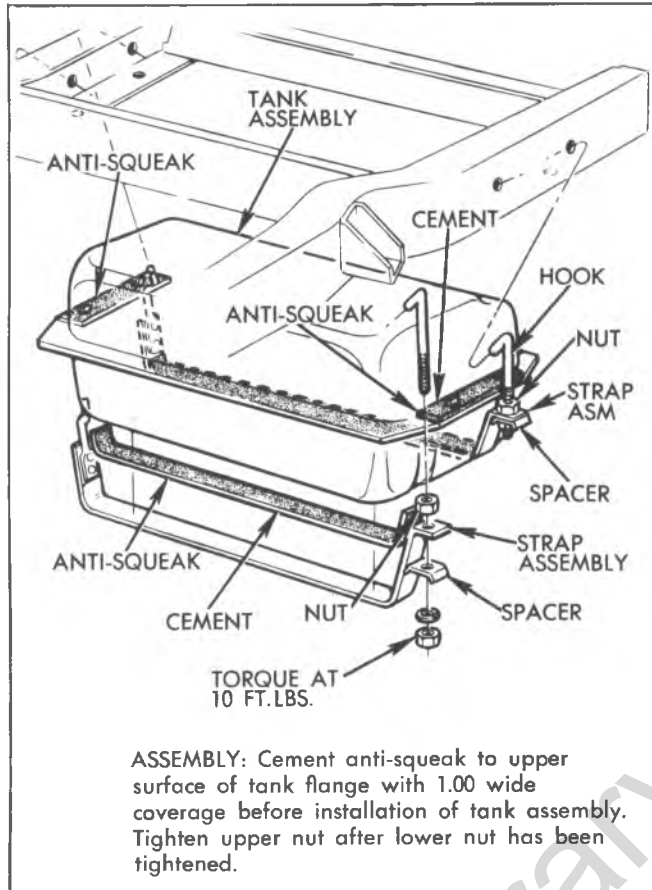


Fig. 6C5-15--Fuel Tank and Mounting - P10

classiccarslibrary.com

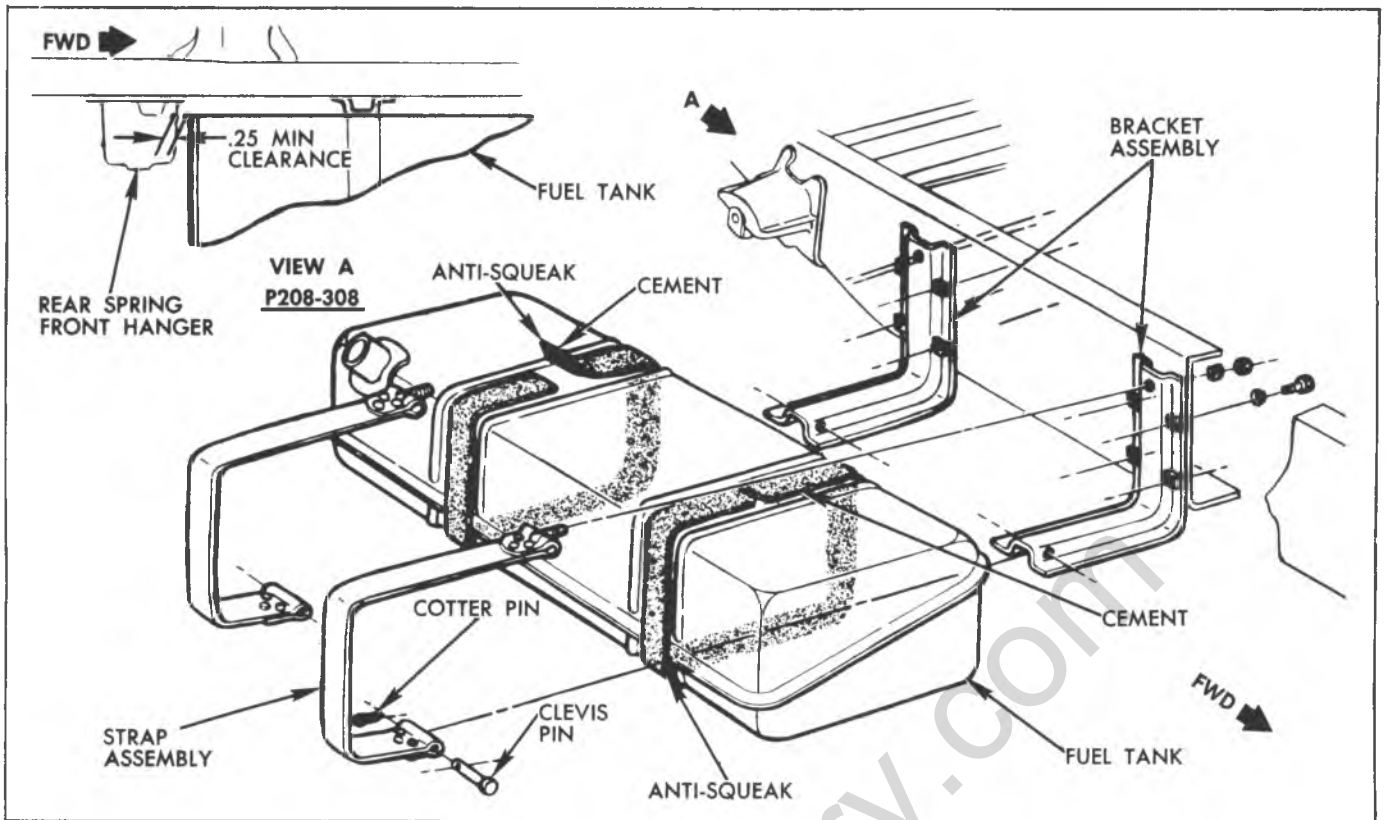


Fig. 6C5-16--Fuel Tank and Mounting - P20, 30

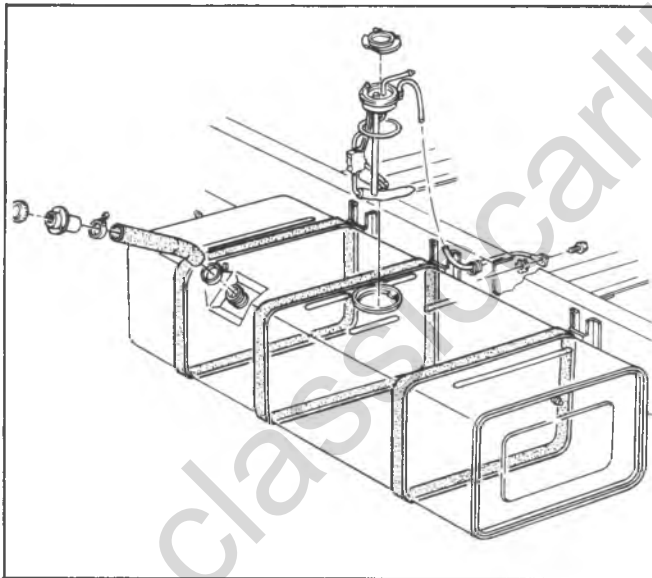


Fig. 6C5-17--Fuel Tank (50 Gal.) Meter and Filler Neck - P30

FUEL FEED AND VAPOR PIPES

GENERAL DESCRIPTION

Fuel feed pipes are secured to the underbody with clamp and screw assemblies. Flexible hoses are located at fuel tank fuel, vapor and return lines and fuel pump. The pipes should be inspected occasionally for leaks, kinks or dents. If evidence of dirt or foreign material is found in carburetor, fuel pump or pipes, pipe should be disconnected and blown out. Dirt or foreign material may be caused by a damaged or omitted fuel strainer in fuel tank.

ON-CAR SERVICE

Fuel Line Repair

Replacement

1. If replacement of a fuel feed, fuel return or emission pipe is required use welded steel tubing meeting GM Specification 124-M or its equivalent.

2. Do not use copper or aluminum tubing to replace steel tubing. Those materials do not have satisfactory durability to withstand normal vehicle vibrations.

3. When rubber hose is used to replace pipe, use only reinforced fuel resistant hose which meets GM Specification 6165-M. Hose inside diameter must match pipe outside diameter.

4. Do not use rubber hose within 4" (100 mm) of any part of the exhaust system or within 10" (254 mm) of the catalytic converter.

5. In repairable areas, cut a piece of fuel hose 4" (100 mm) longer than portion of the line removed.

If more than a 6 inch (152 mm) length of pipe is removed, use a combination of steel pipe and hose so that hose lengths will not be more than 10 inches (254 mm).

Follow the same routing as the original pipe.

6. Cut ends of pipe remaining on car square with a tube cutter. Using the first step of a double flaring tool, form a bead on the end of both pipe sections. If pipe is too corroded to withstand bead operation without damage, the pipe should be replaced. If a new section of pipe is used, form a bead on both ends of it also.

7. Use screw type hose clamp, Part Number 2494772, or equivalent. Slide clamps onto pipe and push hose 2" (51 mm) onto each portion of fuel pipe. Tighten clamps on each side of repair.

8. Pipes must be properly secured to the frame to prevent chafing.

EVAPORATIVE CONTROL SYSTEM (ECS)

GENERAL DESCRIPTION

All light duty emissions and some heavy duty emission vehicles are equipped with a system designed to prevent escape of fuel vapor to the atmosphere. Vapor generated by evaporation of fuel in the tank, previously exhausted to atmosphere, is transferred by an emission line to the engine compartment. During periods of operation, vapors are fed directly to the engine for consumption. During periods of inoperation, an activated charcoal canister located in the emission line stores any vapor generated for consumption during the next period of operation.

The amount of vapor drawn into the engine at any time is too small to have any effect on fuel economy or engine operation.

With this closed system it is extremely important that only vapors be transferred to the engine. To avoid the possibility of liquid fuel being drawn into the system, these following features are included as part of the total system:

1. A fuel tank overflow protector is provided on all series to assure adequate room for expansion of liquid fuel volume with temperature changes.

2. A one point fuel tank venting system is provided on all series to assure that the tank will be vented under any conceivable vehicle attitude.

3. To protect the tank from mechanical damage in the event of excessive internal or external pressures resulting from the operation of this closed system, a pressure-vacuum relief valve, located in the gas cap, will control the tank internal pressure.

ON-VEHICLE SERVICE

Maintenance requirement is that the oiled fiberglass filter assembled in the bottom of the canister, be replaced at intervals shown in Section 0B. Under extremely dusty conditions, more frequent attention may be required.

Check operation of bowl vent and purge valve.

Canister and Filter

Removal

1. Note installed position of hoses on canister.
2. Disconnect hoses from top of canister.
3. Loosen clamps and remove canister.
4. If replacing filter, pull out filter from bottom of canister with your fingers.

Inspection

1. Check hose connection openings. Assure that they are open.
2. Check operation of purge valve by applying vacuum to the valve. A good valve will hold vacuum.

Installation

1. Install new filter.
2. Install canister and tighten clamp.
3. Connect hoses in same order.

Canister Purge Valve

Disassembly

1. Disconnect lines at valve.
2. Snap off valve cap (slowly remove cap as diaphragm is under spring tension). Remove diaphragm, spring retainer and spring.

3. Replace parts as necessary. Check orifice openings.

Assembly

1. Install spring, spring retainer, diaphragm and cap.
2. Connect lines to valve.

Checking Purge Valve

1. Remove purge valve control vacuum line. Check for a vacuum signal with engine operating above idle (1500 RPM). If no vacuum signal, perform EGR System Function Check.
2. Apply an external vacuum source to the purge valve control diaphragm. A good valve will hold vacuum.
3. If the valve will not hold vacuum, replace canister.
4. If valve holds vacuum, remove purge line and check for vacuum. If no vacuum, check PCV hoses and system. Repair or replace as necessary.

Checking Bowl Vent Valve

1. Remove the bowl vent vapor hose from the carburetor.
2. Check the open condition of the valve by connecting to a manual vacuum pump. It should not be possible to obtain .5 inch Hg if the valve is open.
3. If a high resistance or plugged system is found, check for a plugged or restricted hose. Hose may be cleared with compressed air. If the hose is clear, remove the canister filler. If the restriction persists, replace the canister.

4. A simple check of the valve closed condition can be obtained with the same procedure as in Step 2, but with the engine operating at operating temperature. Manifold vacuum will be applied to the valve through the control line. The bowl vent line should exhibit a plugged condition.

5. If the valve is not closed, remove the control vacuum line and check for vacuum. If no vacuum is present, check hose for restriction or vacuum leak. Repair or replace as required. If vacuum is present, replace canister.

Pressure Checking Evaporative Control System

1. Stabilize vehicle by operating until warmed up.
2. Remove tank line at canister and observe for liquid in the line. Hook-up pressure device.
3. Apply 15" H₂O pressure to the fuel vapor line.
 - A. Observe for excessive loss of pressure.
 - B. If negligible pressure loss occurs observe for fuel vapor smell or fuel loss at points listed in Diagnostics under Possible Cause.
 - C. Remove fuel filler cap(s) and observe for pressure in tank(s).
4. Remove fuel cap (LH on dual tank units) and blow on vent line to check for obstructions. (Install LH cap on dual tank units and remove RH cap. Repeat above.)

ACCELERATOR CONTROLS

GENERAL

The accelerator control system is cable type. There are no linkage adjustments. A reference between the bottom of accelerator pedal and floor pan should be used only as a check for bent bracket assembly. Check torque references.

Check for correct opening and closing positions by operating accelerator pedal and if any binding is present, check routing of cable.

ACCELERATOR CONTROL CABLE

Refer to figures 6C5-18 through 6C5-21 for removal and installation of accelerator control cable.

ACCELERATOR PEDAL

Refer to figures 6C5-22 through 25 for removal and installation of accelerator pedal.

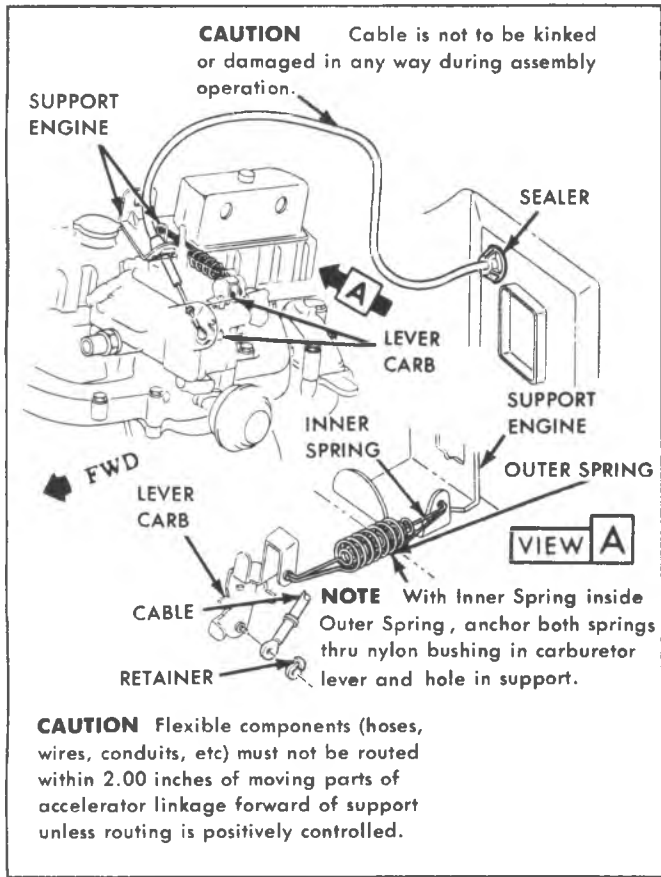


Fig. 6C5-18--Accelerator Controls L6-Light Duty Emissions

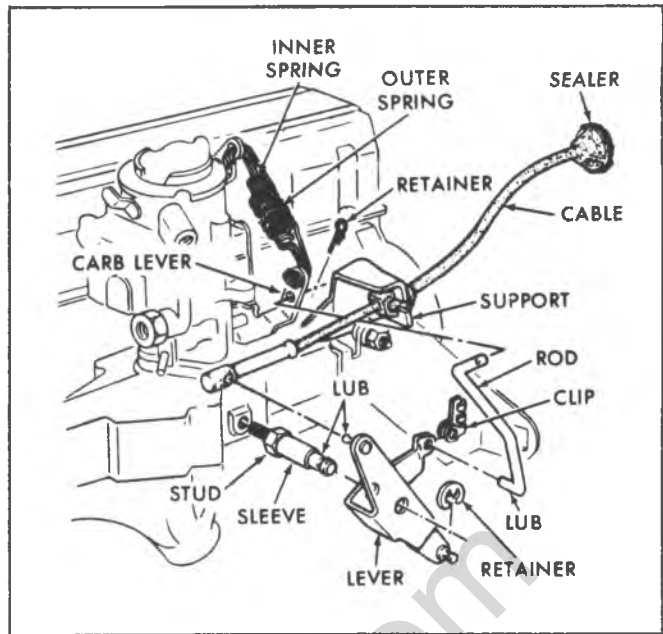


Fig. 6C5-19--Accelerator Controls L6-Heavy Duty Emissions.

classiccarlibrary.com

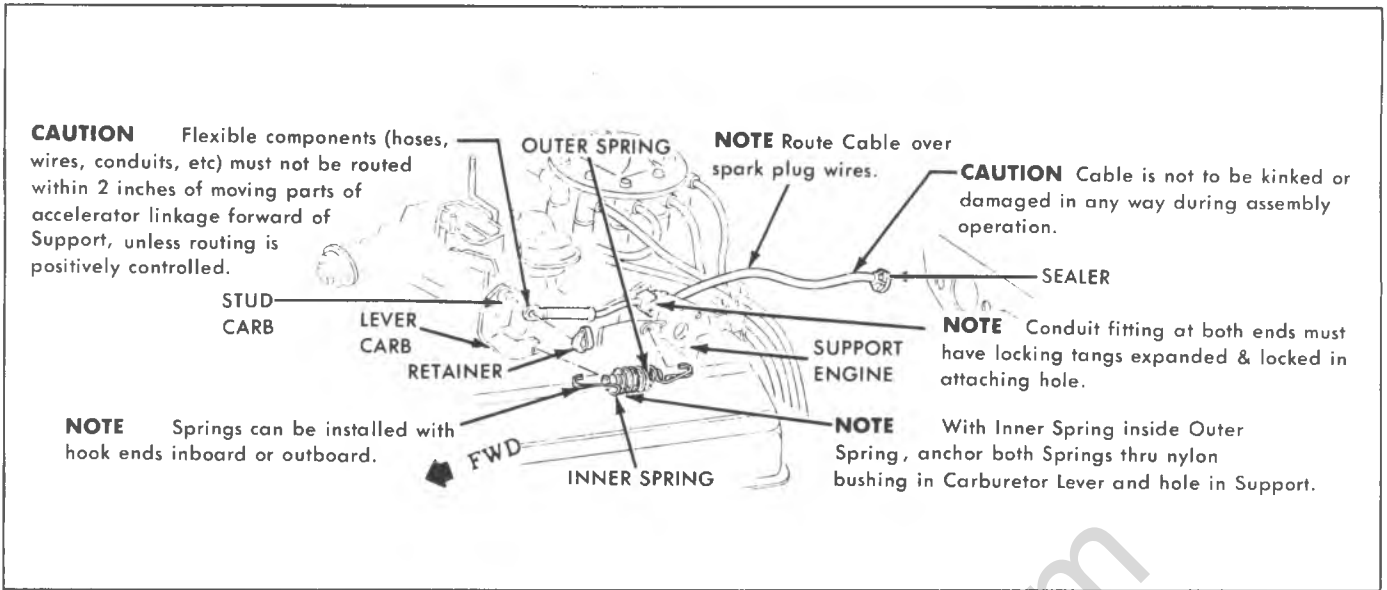


Fig. 6C5-20--Accelerator Controls V8-2Bbl.

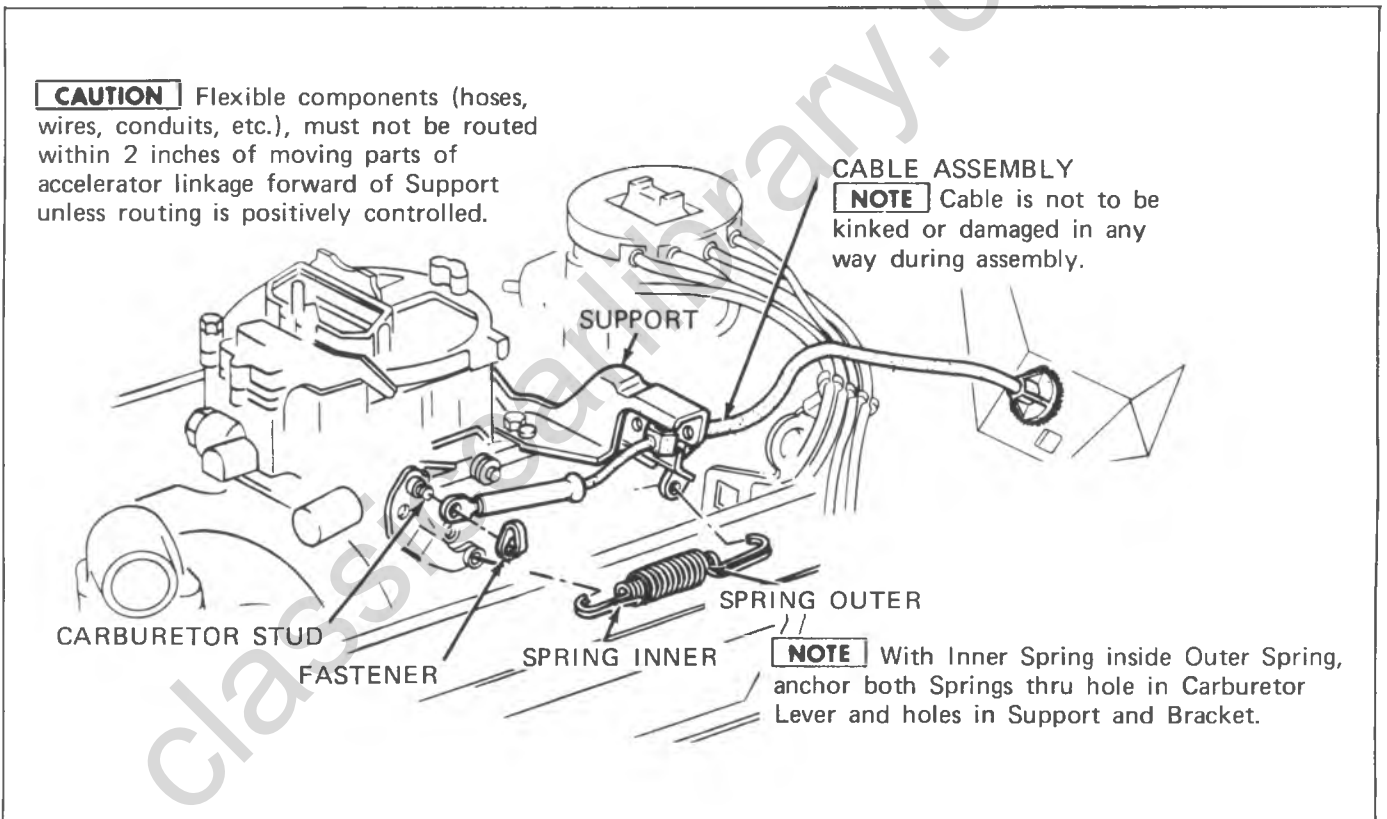


Fig. 6C5-21--Accelerator Controls V8-4Bbl.

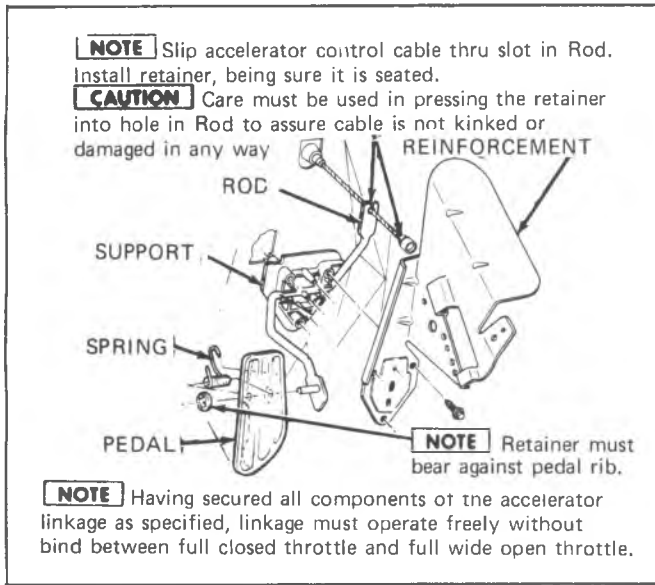


Fig. 6C5-22--Accelerator Pedal-CK

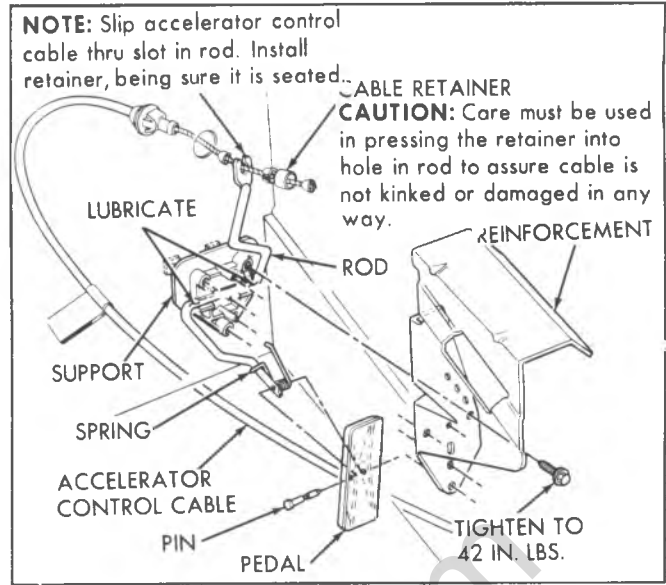


Fig. 6C5-24--Accelerator Pedal-P42

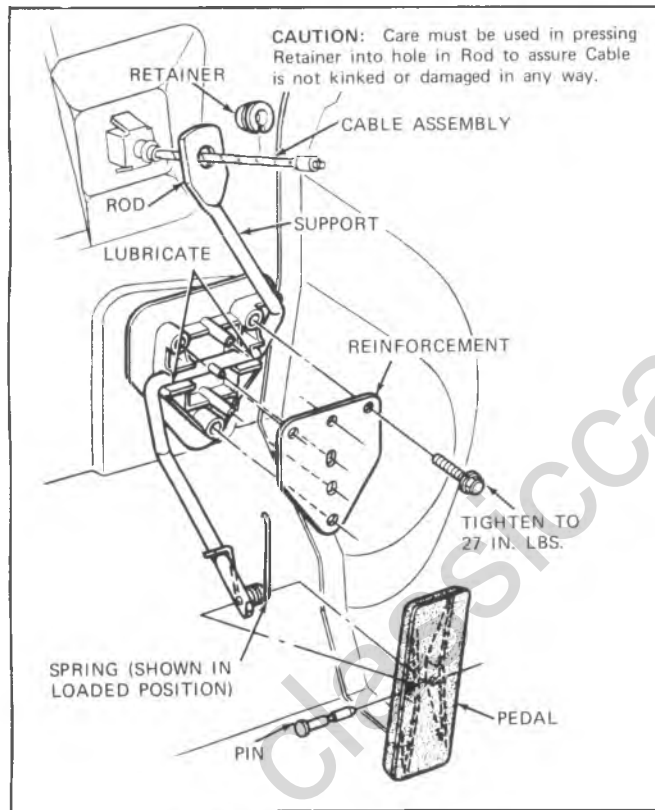


Fig. 6C5-23--Accelerator Pedal-G

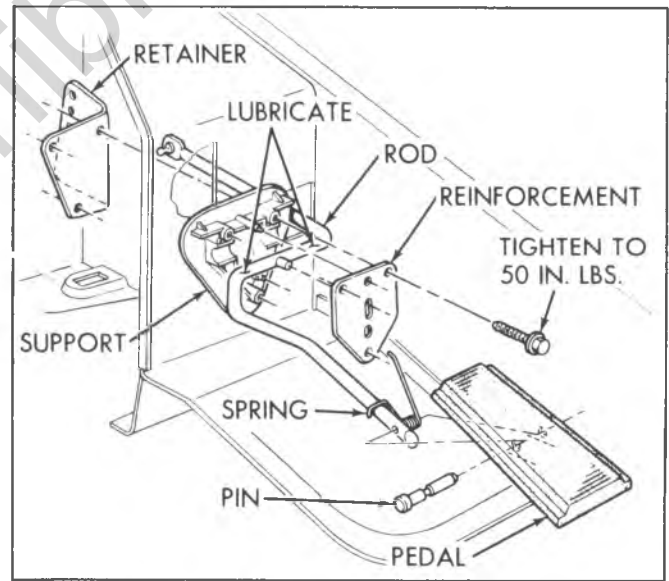


Fig. 6C5-25--Accelerator Pedal-P32

SPECIFICATIONS

FUEL PUMP PRESSURE

| ENGINE | P.S.I. |
|--|--------|
| L6 (ALL) | 4½-6 |
| V8 (ALL) WITHOUT VAPOR RETURN LINE | 7½-9 |
| V8 (EXC LF8) WITH VAPOR RETURN LINE | 5½-7 |
| V8 (LF8) WITH VAPOR RETURN LINE | 7½-9 |

TORQUE SPECIFICATIONS IME CARBURETOR

| SCREW | TORQUE (IN. LBS.) | SCREW | TORQUE (IN. LBS.) |
|-----------------------|----------------------|----------------|----------------------|
| AIR HORN TO BOWL | 45 | FUEL INLET NUT | 400 |
| AIR CLEANER BRIDGE | 70 | FAST IDLE CAM | 50 |
| THROTTLE BODY TO BOWL | 180 | CHOKE LEVER | 25 |
| NEEDLE SEAT | 45 | PUMP LEVER | 30* |
| METERING JET | 40 | | |

* Loctite AVV or equivalent

M2M- M4M CARBURETOR

| SCREW | TORQUE (IN. LBS.) |
|---|---|
| THROTTLE BODY THROTTLE BODY TO BOWL | 46 |
| CHOKE HOUSING CHOKE LEVER CHOKE HOUSING ATTACHING CHOKE HOUSING COVER | 14 46 26 |
| AIR HORN AIR HORN TO BOWL 10-32 AIR HORN TO BOWL 8-32 AIR HORN TO THROTTLE BODY CHOKE LEVER VACUUM BREAK UNIT FUEL INLET NUT NEEDLE SEAT METERING JET SOLENOID BRACKET | 46 26 46 14 26 400 45 40 71 |

Fig. 6C5-26--Specifications

| 1980 LIGHT DUTY TRUCK IDLE SPEEDS | | | | | | |
|---|--------------------------|------------|--------------|-----------------|-----------------------|--|
| ENGINE | TRANSMISSION | CURB IDLE* | ENRICHED RPM | SOLENOID SPEED* | FAST IDLE IN NEUTRAL* | |
| 4.1L (250 CID) CALIFORNIA | LE3 AUTO | 600 | 0-50 | 425 | 2200 | |
| 4.1L (250 CID) C, G-10 CALIFORNIA | LE3 MANUAL | 750 | 0-250 | 425 | 2000 | |
| 4.1L (250 CID) C, G20 & G30 CALIFORNIA | LE3 MANUAL | 750 | 0-200 | 425 | 2000 | |
| 4.1L (250 CID) FEDERAL | LE3 AUTO | 650 | 0-50 | 450 | 2200 | |
| 4.1L (250 CID) FEDERAL | LE3 MANUAL | 750 | 0-150 | 450 | 2000 | |
| 5.0L (305 CID) FEDERAL | LG9 CK SERIES AUTO | 500 | 25-50 | 600 | 1600 | |
| 5.0L (305 CID) FEDERAL | LG9 G SERIES AUTO | 500 | 50-75 | 600 | 1600 | |
| 5.0L (305 CID) FEDERAL | LG9 MANUAL | 600 | 100-170 | 700 | 1300 | |
| 5.7L (350 CID) FEDERAL EXC./ CHASSIS CAB | LS9 AUTO | 500 | 40-60 | 600 | 1600 | |
| 5.7L (350 CID) FEDERAL | LS9 MANUAL | 700 | 170-200 | N/A | 1300 | |
| 5.7L (350 CID) FEDERAL WITH CHASSIS CAB | LS9 AUTO | 500 | 60-80 | 600 | 1600 | |
| 5.7L (350 CID) CALIFORNIA | LS9 AUTO | 500 | 0-20 | 600 | 1600 | |
| 5.7L (350 CID) CALIFORNIA | LS9 MANUAL | 700 | 0-20 | N/A | 1600 | |
| 5.7L (350 CID) HIGH ALTITUDE | LS9 AUTO | 500 | 30-50 | 600 | 1600 | |
| 6.6L (400 CID) FEDERAL | LF4 AUTO | 500 | 80-100 | 600 | 1600 | |
| 6.6L (400 CID) CALIFORNIA | LF4 AUTO | 500 | 40-60 | 600 | 1600 | |
| 4.8L (292 CID) NATIONWIDE W/H.D. EMISSION | L25 ALL | 700(N) | 75-0 | N/A | 2400 | |
| 5.7L (350 CID) NATIONWIDE W/H.D. EMISSION | LT9 ALL | 700(N) | N/A | N/A | 1900 | |
| 6.6L (400 CID) NATIONWIDE W/H.D. EMISSION | LE4 ALL | 700(N) | N/A | N/A | 1900 | |
| 7.4L (454 CID) NATIONWIDE W/H.D. EMISSION | LE8 ALL | 700(N) | N/A | N/A | 1900 | |

Refer to Vehicle Emission Label for latest specifications.

N/A Not Applicable

Fig. 6C5-27—Idle Speeds

**ANGLE DEGREE TO DECIMAL CONVERSION
MODEL M2MC, M2ME AND M4MC CARBURETOR**

THE RELATION BETWEEN DECIMAL AND ANGLE READINGS IS NOT EXACT DUE TO MANUFACTURING TOLERANCES OF THE COMPONENT PARTS. THIS CHART IS SUPPLIED FOR USE BY THE MECHANIC WHO HAS ACCESS TO PLUG GAUGES ONLY. THE RECOMMENDED TOOL IS AN ANGLE GAUGE FOR ACCURACY AND BEST OVERALL PERFORMANCE AND EMISSIONS.

| ANGLE DEGREES | DECIMAL EQUIV. TOP OF VALVE | ANGLE DEGREES | DECIMAL EQUIV. TOP OF VALVE |
|---------------|--------------------------------|---------------|--------------------------------|
| 5 | .023 | 33 | .203 |
| 6 | .028 | 34 | .211 |
| 7 | .033 | 35 | .220 |
| 8 | .038 | 36 | .227 |
| 9 | .043 | 37 | .234 |
| 10 | .049 | 38 | .243 |
| 11 | .054 | 39 | .251 |
| 12 | .060 | 40 | .260 |
| 13 | .066 | 41 | .269 |
| 14 | .071 | 42 | .277 |
| 15 | .077 | 43 | .287 |
| 16 | .083 | 44 | .295 |
| 17 | .090 | 45 | .304 |
| 18 | .096 | 46 | .314 |
| 19 | .103 | 47 | .322 |
| 20 | .110 | 48 | .332 |
| 21 | .117 | 49 | .341 |
| 22 | .123 | 50 | .350 |
| 23 | .129 | 51 | .360 |
| 24 | .136 | 52 | .370 |
| 25 | .142 | 53 | .379 |
| 26 | .149 | 54 | .388 |
| 27 | .157 | 55 | .400 |
| 28 | .164 | 56 | .408 |
| 29 | .171 | 57 | .418 |
| 30 | .179 | 58 | .428 |
| 31 | .187 | 59 | .439 |
| 32 | .195 | 60 | .449 |

Fig. 6C5-28—Angle to Decimal Conversion

SPECIAL TOOLS



J9789-02 UNIVERSAL CARBURETOR GAUGE SET



J9789-118 CARBURETOR HOLDING STAND



J9789-111 BENDING TOOL



J25322 PUMP LEVER PIN DRIVE PUNCH



J23417 CHOKE LEVER INSTALLING TOOL



J26701 CHOKE VALVE ANGLE GAUGE

Fig. 6C5-29-Special Tools

SECTION 6D

ENGINE ELECTRICAL

CONTENTS

| | | | |
|---|-------|--------------------------|-------|
| Electric Choke Heater | 6D-1 | Diesel Engine | 6D-18 |
| General Electrical System Diagnosis | 6D-1 | Conventional Engine..... | 6D-33 |
| Battery | 6D-5 | Cranking System..... | 6D-43 |
| Charging System | 6D-8 | Specifications..... | 6D-58 |
| Ignition System | 6D-18 | | |

ELECTRIC CHOKE HEATER-OIL PRESSURE SWITCH

6 CYL ENGINES

All 6 cylinder engines have a two-terminal oil pressure switch (sending unit) for controlling current to the electric choke heater. This switch and its associated circuitry provide for the illumination of the "Oil" tell tale lamp in the event of loss of oil pressure or loss of voltage at the choke heater.

The diagram in Figure 6D-1A shows how the dual function is accomplished. The "Bulb Check" feature is same as present system. That is, with ignition switch in "Run" position with engine off. This circuit will also indicate continuity in the choke heater and its connector.

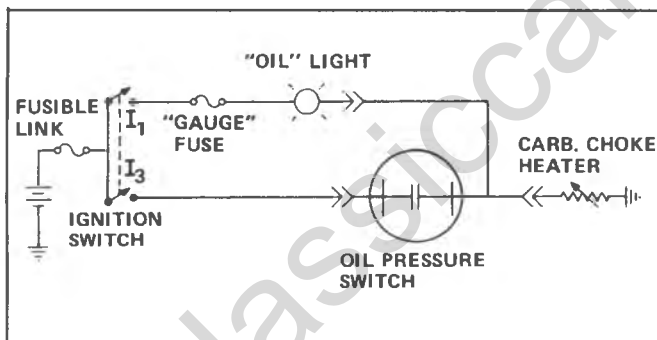


Fig. 6D-1A—Electric Choke Heater Diagram

If "Oil" tell tale lamp illuminates with engine running, it could indicate one or more of the following:

1. Loss of oil pressure.
2. Loss of choke heater voltage.
3. Blown GAUGE fuse.

ELECTRIC CHOKE HEATER CHECKING PROCEDURE

1. Allow choke to cool so that when throttle is opened slightly, choke blade fully closes. This check must be performed with engine not running and at an ambient temperature of (60°C to 27°C).
2. Start engine and determine time for choke blade to reach full open position. (Start timer when engine starts).
3. If the choke blade fails to open fully within 3.5 minutes, proceed with steps 4-5-6 below.
4. Check voltage at the choke heater connection. (Engine must be running). If the voltage is approximately 12-15 volts, replace the electrical choke unit.
5. If the voltage is low or zero, check all wires and connections. If any connections in the oil pressure switch circuitry are faulty or if the oil pressure switch is failed open, the oil warning light will be on with the engine running. Repair wires or connections as required.
6. If all wiring and connections are good, replace oil pressure switch. No gasket is used between the choke cover and the choke housing because of grounding requirements.

GENERAL ELECTRICAL SYSTEM DIAGNOSIS

The diagnosis in figures 6D-2A and 6D-3A can be used to find electrical system - faults. Once a fault has been traced

to a particular component, refer to that components section of the service manual.

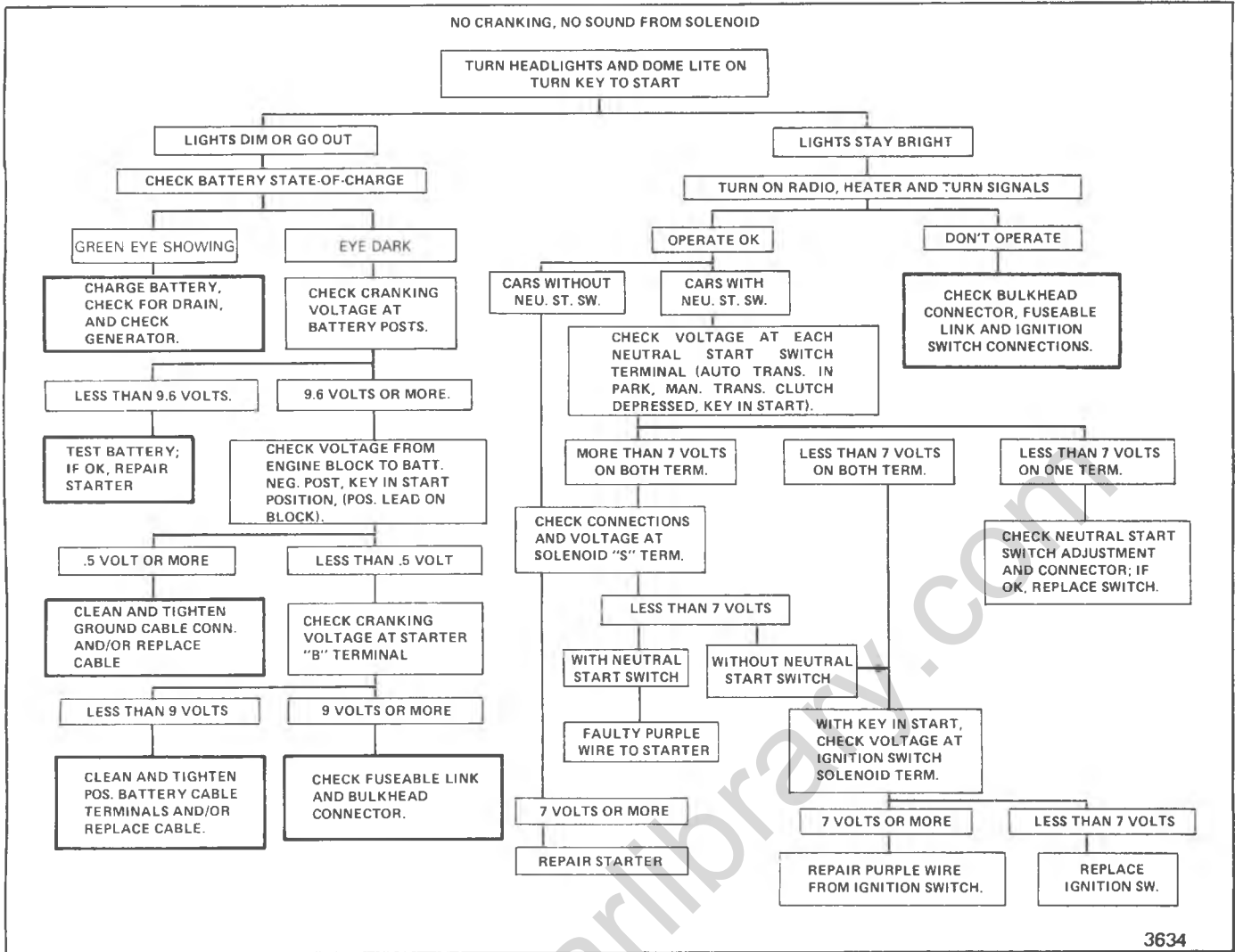


Fig. 6D-2A—Electrical System Diagnosis

SLOW CRANKING, SOLENOID CLICKS OR CHATTERS

CHECK: BATTERY FOR GREEN INDICATOR.

VISUAL CONDITION OF BATTERY CABLES AND CONNECTIONS.

IF BATTERY NEEDS CHARGING, MAKE GENERATOR AND BATTERY DRAIN CHECK, CHARGE BATTERY AND RECHECK CRANKING. IF TROUBLE HAS NOT BEEN FOUND, PROCEED.

REMOVE BATTERY LEAD FROM DISTRIBUTOR ON HEI. MAKE ALL VOLTMETER READINGS WITH KEY IN START POSITION.

MEASURE CRANKING VOLTAGE AT BATTERY TERMINAL POSTS.

9.6 VOLTS OR MORE

LESS THAN 9.6 VOLTS

MEASURE VOLTAGE FROM BATTERY NEGATIVE TERMINAL TO ENGINE BLOCK. (POS. LEAD ON BLOCK.)

CHECK BATTERY CONDITION AND CAPACITY

.5 VOLT OR MORE

LESS THAN .5 VOLT

OK

DEFECTIVE

REPAIR GROUND CABLE AND CONNECTIONS

MEASURE VOLTAGE AT SOLENOID "B" TERMINAL, CLEAN AND TIGHTEN CONNECTIONS AT STARTER.

REPAIR STARTER

REPLACE BATTERY

9 VOLTS OR MORE

LESS THAN 9 VOLTS

REPAIR STARTER

CLEAN AND TIGHTEN POSITIVE CABLE CONNECTIONS. IF OK, REPLACE CABLE.

NOTE: THIS PROCEDURE IS DESIGNED FOR USE ON ENGINES AND BATTERIES AT ROOM OR NORMAL OPERATING TEMPERATURES. IT ALSO ASSUMES THERE ARE NO ENGINE DEFECTS WHICH WOULD CAUSE CRANKING PROBLEMS. TO USE IT UNDER OTHER CONDITIONS MIGHT RESULT IN MISDIAGNOSIS.

Fig. 6D-3A—Electrical System Diagnosis

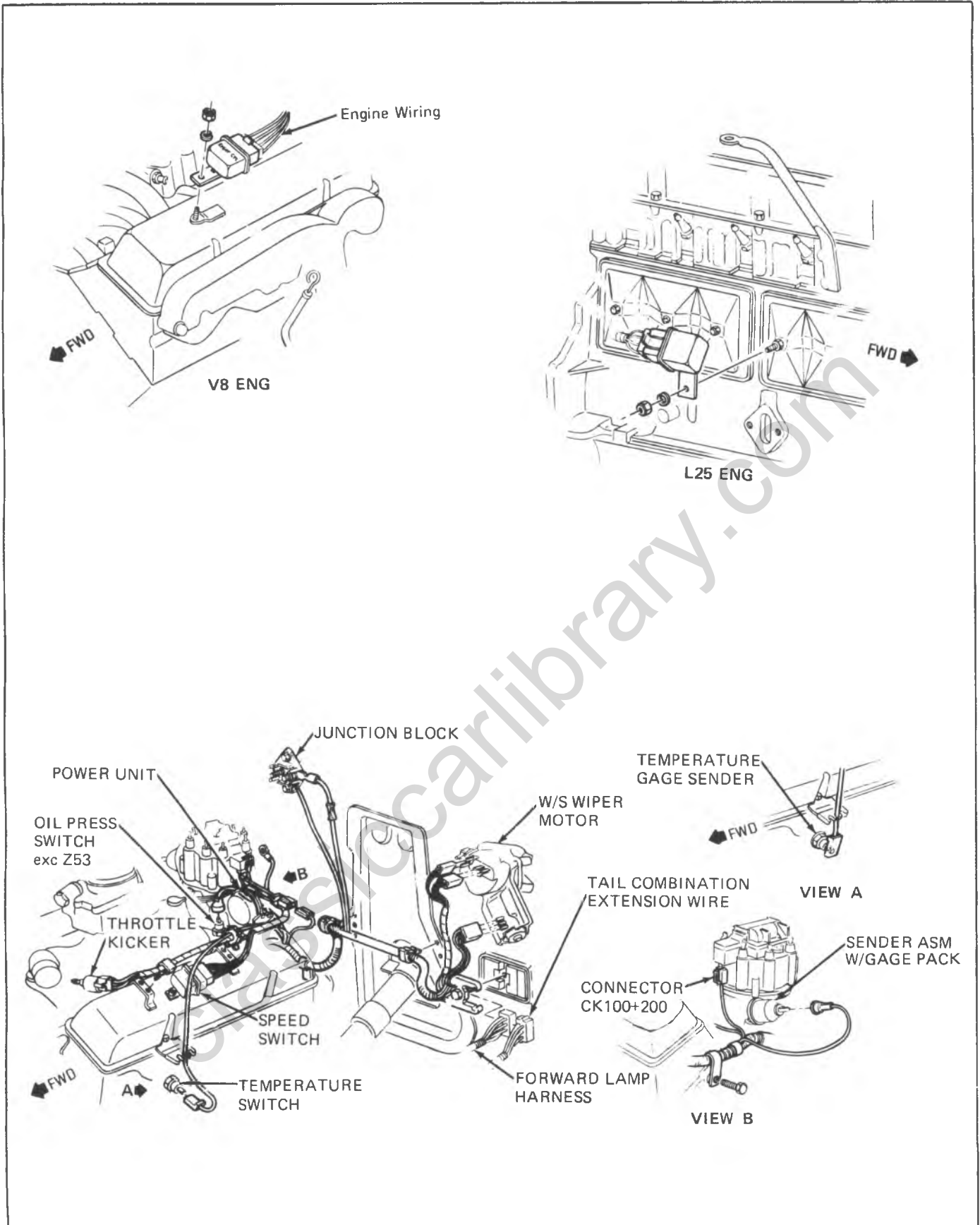


Fig. 6D-4A-Engine Speed Switch

BATTERY

| | | | |
|-------------------------------|------|--------------------------|------|
| General Description..... | 6D-5 | Built In Hydrometer..... | 6D-6 |
| General Information..... | 6D-5 | Diagnosis..... | 6D-6 |
| Common Causes of Failure..... | 6D-5 | On-Vehicle Service..... | 6D-7 |
| Electrolyte Freezing..... | 6D-5 | Charging Procedure..... | 6D-7 |
| Carrier and Hold Down..... | 6D-6 | Jump Starting..... | 6D-8 |
| Cleaning..... | 6D-6 | Remove and Replace..... | 6D-8 |
| Ratings..... | 6D-6 | | |

GENERAL DESCRIPTION

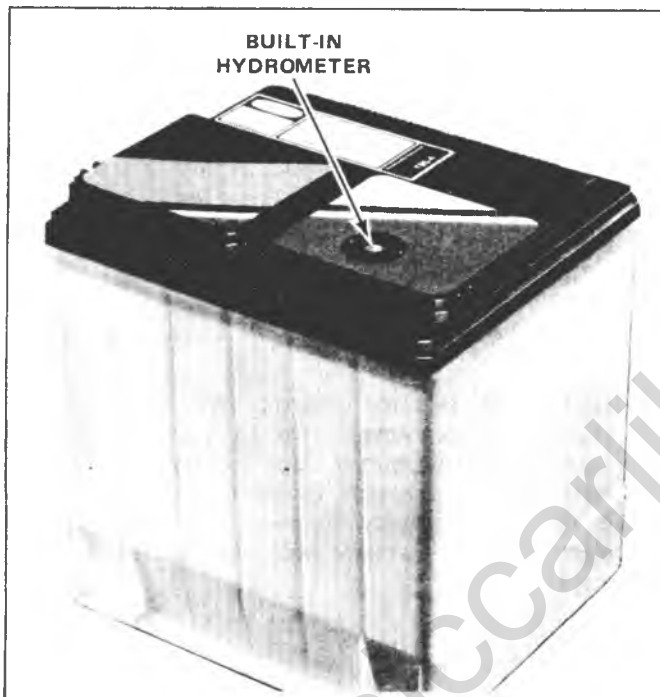


Fig. 6D-1B--Sealed Top Battery

The sealed battery (see Fig. 6D-1B) is standard on all vehicle lines (see Specifications for specific applications). There are no vent plugs in the cover. The battery is completely sealed, except for a small vent hole in the side. This vent hole allows what small amount of gases are produced in the battery to escape. The battery has the following advantages over conventional batteries:

1. No water addition for the life of the battery. This improvement makes the sealed battery possible.
2. Overcharge protection. If too high a level voltage is applied to the battery, it will not accept as much current as a conventional battery, the excess voltage will cause gassing, which leads to liquid loss.
3. Reduced self-discharge compared to a conventional battery. This is important when a battery is left standing for long periods of time.
4. Comparable power available in a lighter and smaller case.

The battery has three major functions in the electrical system.

First, it is a source of electrical energy for cranking the engine. Second it acts as a voltage stabilizer for the electrical system. And third, it can, for a limited time, provide energy when the electrical load exceeds the output of the generator.

GENERAL INFORMATION

COMMON CAUSES OF FAILURE

A battery is not designed to last indefinitely; however, with proper care, it will provide many years of service. If the battery tests good but fails to perform satisfactorily in service, the following are some of the more important factors that may point to the cause of the trouble.

1. Car accessories left on overnight .
2. Slow average driving speeds for short periods.
3. The cars electrical load is more than the generator output particularly with the addition of after market equipment such as radio equipment, air conditioning, window defoggers or light systems.

4. Defects in the charging system such as electrical shorts slipping fan belt, faulty generator or voltage regulator.

5. Battery abuse, including failure to keep the battery cable terminals clean and tight or loose battery hold down. See On Car Service for torque specifications.

Electrolyte Freezing

The freezing point of electrolyte depends on its specific gravity. Since freezing may ruin a battery, it should be protected against freezing by keeping it in a fully charged condition.

Carrier and Hold-Down

The battery carrier and hold-down should be clean and free from rust before installing the battery. The carrier should be in good condition so that it will support the battery securely and keep it level.

Make certain there are no parts in carrier before installing the battery.

To prevent the battery from shaking in its carrier, the hold-down bolts should be tight. See On Car Service for torque specifications.

Visual Inspection

The external condition of the battery should be checked periodically for damage such as cracked cover or case.

RATINGS

A battery two ratings: (1) a reserve capacity rating at 80°F (27°C) which is the time a fully charged battery will operate the car with no generator operation, (2) a cold crank rating at 0°F (18°C) which indicates the cranking load capacity. (See Specifications for specific battery ratings). The Ampere/Hour rating formerly found on batteries was based on the reserve capacity rating and is no longer used.

Built-In Hydrometer

The sealed battery has a built-in temperature compensated hydrometer in the top of the battery. This hydrometer is to be used with the following diagnostic procedure. When observing the hydrometer, make sure that the battery has a clean top. A light may be required in some poorly-lit areas to see the right indication.

Under normal operation, two indications can be observed (see Figure 6D-2B):

1. GREEN DOT VISIBLE

Any green appearance is interpreted as a green dot and the battery is ready for testing.

2. DARK; GREEN DOT NOT VISIBLE

If there is a cranking complaint, the battery should be tested as described in the Diagnosis section. The charging and electrical systems should also be checked at this time.

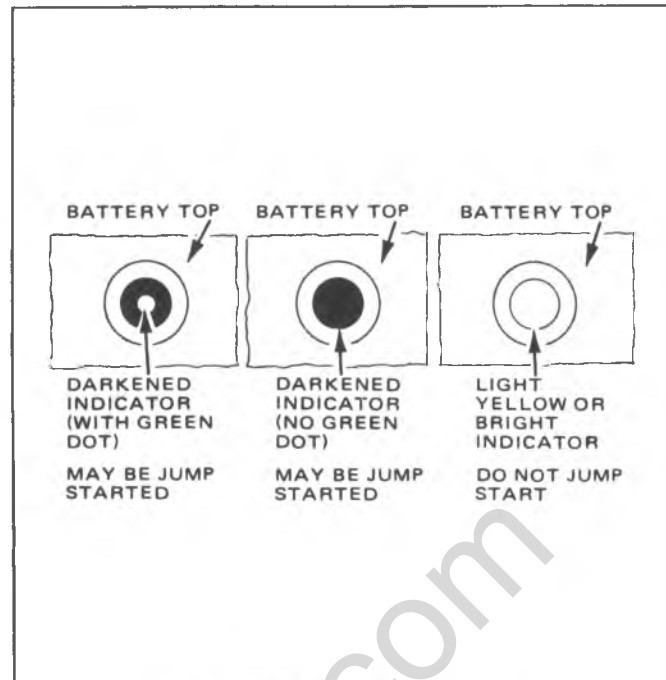


Fig. 6D-2B--Built-In Hydrometer

Occasionally, a third condition may appear:

3. CLEAR OR LIGHT YELLOW

Replace battery. Do not charge, test or jump-start.

CAUTION: Do not charge, test or jump start battery when the hydrometer is clear or light yellow. Not following this caution could result in serious personal injury (particularly to eyes) or property damage from battery explosion or battery acid.

DIAGNOSIS

The following procedure should be used for testing batteries:

1. VISUAL INSPECTION

Check for obvious damage, such as cracked or broken case or cover, that could permit loss of electrolyte. If obvious damage is noted, replace the battery. Determine cause of damage and correct as needed. If not, go to step 2.

2. HYDROMETER CHECK (Fig. 6D-2B)

a. GREEN DOT VISIBLE

b. DARK; GREEN DOT NOT VISIBLE.

Charge the battery as outlined under Charging Procedure section and proceed to Step 3.

3. LOAD TEST

Load testing may require use of battery side terminal adapters to insure good connections (see Fig. 6D-3B).

a. Connect a voltmeter and a battery load tester across the battery terminals.

b. Apply 300 ampere load for 15 seconds to remove surface charge. Remove load.

c. Wait 15 seconds to let battery recover and apply specified load from load test chart. Read voltage after 15 seconds, then remove load.

d. If voltage does not drop below the minimum listed in Fig. 6D-5B, the battery is good. Temperature of the battery will change the minimum voltage to pass the load test. See Temperature vs. voltage drop Chart, and estimate the temperature the battery has been exposed to for the last several hours.

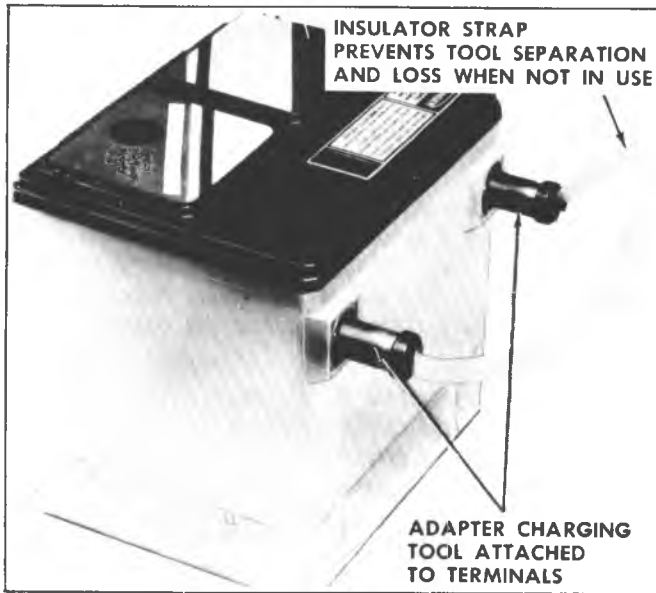


Fig. 6D-3B--Side Terminal Battery Adapters

| MINIMUM VOLTAGE | TEMPERATURE | |
|-----------------|-------------|-----|
| | °F | °C |
| 9.6 | 70 | 21 |
| 9.5 | 60 | 16 |
| 9.4 | 50 | 10 |
| 9.3 | 40 | 4 |
| 9.1 | 30 | - 1 |
| 8.9 | 20 | - 7 |
| 8.7 | 10 | -12 |
| 8.5 | 0 | -18 |

Fig. 6D-5B--Minimum Voltage Drop

| BATTERY | TEST LOAD |
|---------|-----------|
| Y85-4 | 130 AMPS |
| R85-5 | 170 AMPS |
| R87-5 | 210 AMPS |
| R89-5 | 230 AMPS |

2996

Fig. 6D-4B--Load Test Values

ON-VEHICLE SERVICE

CHARGING PROCEDURES

When it is necessary to charge the battery, the following safety precautions must be followed:

1. DO NOT CHARGE battery if hydrometer is clear or light yellow. Replace battery.
2. If the battery feels hot 125°F (52°C), or if violent gassing or spewing of electrolyte through the vent hole occurs, discontinue charging or reduce charging rate. Charge the battery until the green ball appears. Tipping or shaking the battery may be necessary to make the green ball appear.

Temperature of the battery will effect the charging rate, and most charging equipment will not charge at a constant rate. For example, if the charger starts at 30 amperes and drops off to 10 amperes after 1 hour, the average current for that hour was 20 amperes. The actual boost charge was 20 ampere-hours. The sealed battery can be fast charged or slow charged with ordinary chargers in the same manner as conventional batteries. Either method will restore the battery to full charge.

Many chargers have special settings for sealed batteries. These settings reduce the charge voltage and limit

the current. It is not necessary to use these settings with this sealed battery.

JUMP STARTING IN CASE OF EMERGENCY WITH AUXILIARY (BOOSTER) BATTERY

NOTICE: Do not push or tow this vehicle to start. Damage to the emission system and/or to other parts of the vehicle may result.

Both booster and discharged battery should be treated carefully when using jumper cables. Follow the procedure outlined below, being careful not to cause sparks:

CAUTION: Departures from these conditions or the procedure below could result in:

1. Serious personal injury (particularly to eyes) or property damage from such causes as battery explosion, battery acid, or electrical burns; and/or

2. Damage to electronic components of either vehicle.

Never expose battery to open flame or electric spark - batteries generate a gas which is flammable and explosive. Remove rings, watches, and other jewelry. Wear approved eye protection. Do not allow battery fluid to contact eyes, skin, fabrics, or painted surfaces - it is a corrosive acid. Flush any contacted area with water immediately and thoroughly. Be careful that metal tools or jumper cables do not contact the positive battery terminal (or metal in contact with it) and any other metal on the car, because a short circuit could occur. Batteries should always be kept out of the reach of children.

1. Set parking brake and place automatic transmission in PARK (NEUTRAL for manual transmission.) Turn off lights, heater, and other electrical loads.

2. Check the built-in hydrometer. If it is clear or light yellow, replace the battery, **do not attempt to jump start**.

3. Only 12 volt batteries can be used to start this engine.

4. Hook up one end of the positive jumper cable to the positive terminal of the booster battery and the other end to the positive terminal of the discharged battery. **DO NOT PERMIT** vehicles to touch each other as this could cause a ground connection and counteract the benefits of this procedure.

5. Hook up one end of the negative jumper cable to the negative terminal of the booster battery, and the other end to a solid engine ground (such as A/C compressor or generator mounting bracket) at least 450 mm (18 inches) from the battery of the vehicle being started (**DO NOT CONNECT DIRECTLY TO THE NEGATIVE TERMINAL OF THE DEAD BATTERY**).

6. Start the engine of the vehicle that is providing the jump start and turn off electrical accessories. Then start the engine in the car with the discharged battery.

7. Reverse these directions **exactly** when removing the jumper cables. The negative cable must be removed from the engine that was jump started **first**.

REMOVE AND REPLACE

When handling a battery, the following safety precautions should be observed:

1. Hydrogen gas is produced by the battery. A flame or spark near the battery may cause the gas to ignite.

2. Battery fluid is highly acidic. Avoid spilling on clothing or other fabric. Any spilled electrolyte should be flushed with large quantities of water and cleaned immediately. To remove or replace a battery, always disconnect the negative cable first, then the positive cable. Torque battery cables at battery to 12 N·m (9 lb. ft.). Two types of battery hold-downs are used. The hold-down rod going across the battery top should be torqued to 3.0 N·m (25 lb. in.), and the clamp which holds the bottom of the battery should be torqued to 16.0 N·m (12 lb. ft.).

CHARGING SYSTEM

| | | | |
|---------------------------------------|-------|--|-------|
| General Description..... | 6D-9 | Rotor Field Winding Checks | 6D-14 |
| Diagnosis | 6D-11 | Diode Trio Check | 6D-14 |
| Faulty Indicator Lamp Operation | 6D-11 | Rectifier Bridge Check | 6D-15 |
| Undercharged Battery..... | 6D-11 | Stator Checks | 6D-15 |
| Overcharged Battery..... | 6D-13 | Brush Holder and Regulator Replacement | 6D-15 |
| On-Vehicle Service..... | 6D-13 | Slip Ring Servicing | 6D-16 |
| Overhaul..... | 6D-14 | Bearing Replacement and Lubrication | 6D-16 |
| Disassembly | 6D-14 | Reassembly | 6D-17 |

GENERAL DESCRIPTION

The basic charging system is the SI integral regulator charging system (Fig. 6D-1C). The internal components are connected electrically as shown in Fig. 6D-2C. The generator is connected to the car electrically as shown in Fig. 6D-3C.

The 15-SI generator is similar to the 10-SI except that:

1. It is slightly larger physically.
2. It produces 70 amps output at full speed.
3. It uses different drive end and slip ring and bearings.
4. The stator uses delta windings, which cannot be checked for opens.

The brown field wire to the generator is used to initially activate the generator. The 10 ohm resistance, provided by either the generator warning lamp or the resistance wire with optional gages, is needed to protect the diode trio.

Although several models of generators are available with different outputs at idle and different maximum outputs, their basic operating principles are the same.

The generator features a solid state regulator that is mounted inside the generator slip ring end frame. All regulator components are enclosed into a solid mold, and this unit along with the brush holder assembly is attached to the slip ring end frame. The regulator voltage setting never needs adjusting, and no means for adjustment is provided.

The generator rotor bearings contain a supply of lubricant sufficiently adequate to eliminate the need for periodic lubrication. Two brushes carry current through the two slip rings to the field coil mounted on the rotor, and under normal conditions will provide long periods of attention-free service.

The stator windings are assembled on the inside of a laminated core that forms part of the generator frame. A rectifier bridge connected to the stator windings contains six diodes, and electrically changes the stator a.c. voltages to a d.c. voltage which appears at the generator output terminal. Generator field current is supplied through a diode trio which also is connected to the stator windings. A capacitor or condenser, mounted in the end frame protects the rectifier bridge and diode trio from high voltages, and suppresses radio noise.

No periodic adjustments or maintenance of any kind are required on the entire generator assembly.

NOISY GENERATOR

Noise from a generator may be caused by a loose drive pulley, loose mounting bolts, worn or dirty bearings, defective diode, or defective stator.

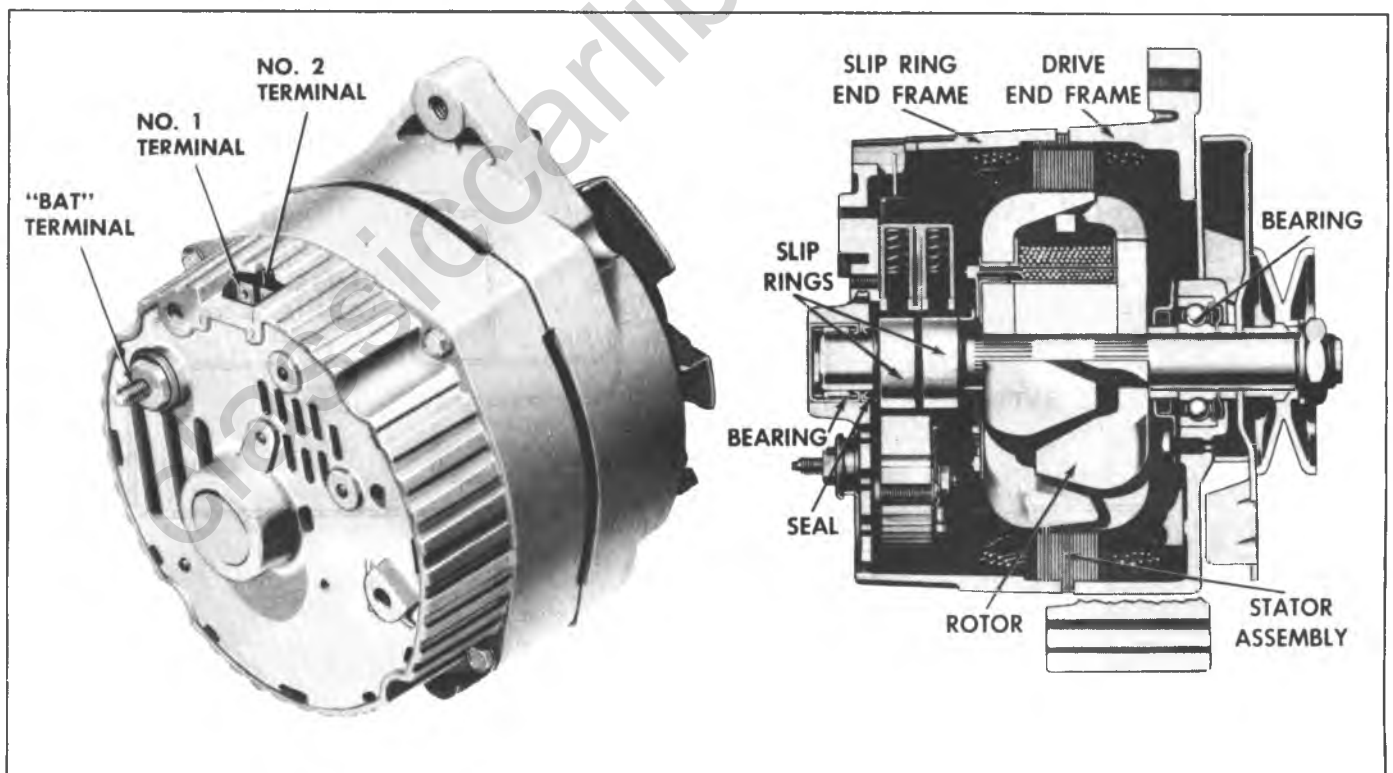


Fig. 6D-1C-10SI Generator

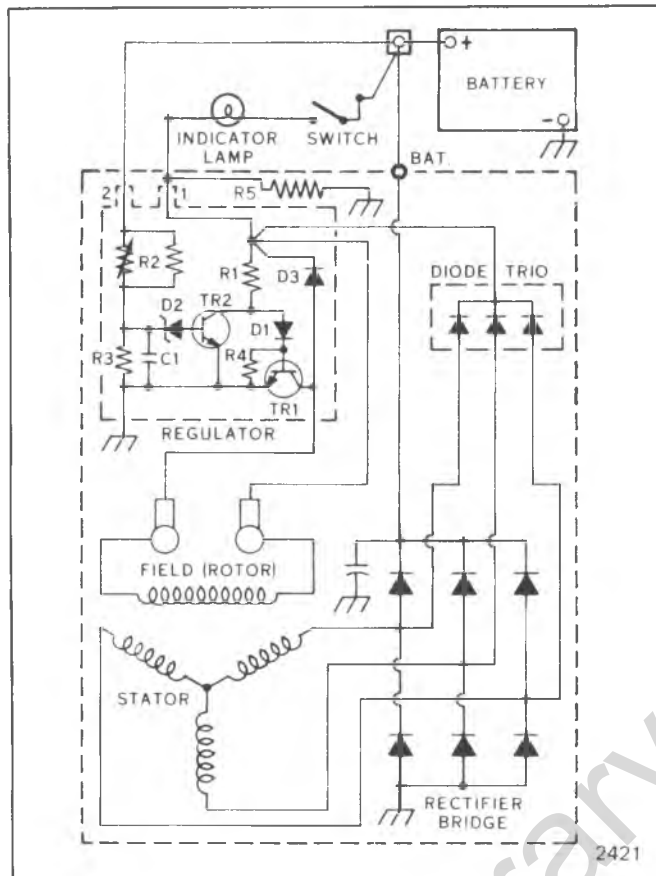


Fig. 6D-2C—Regulator in Charging Circuit

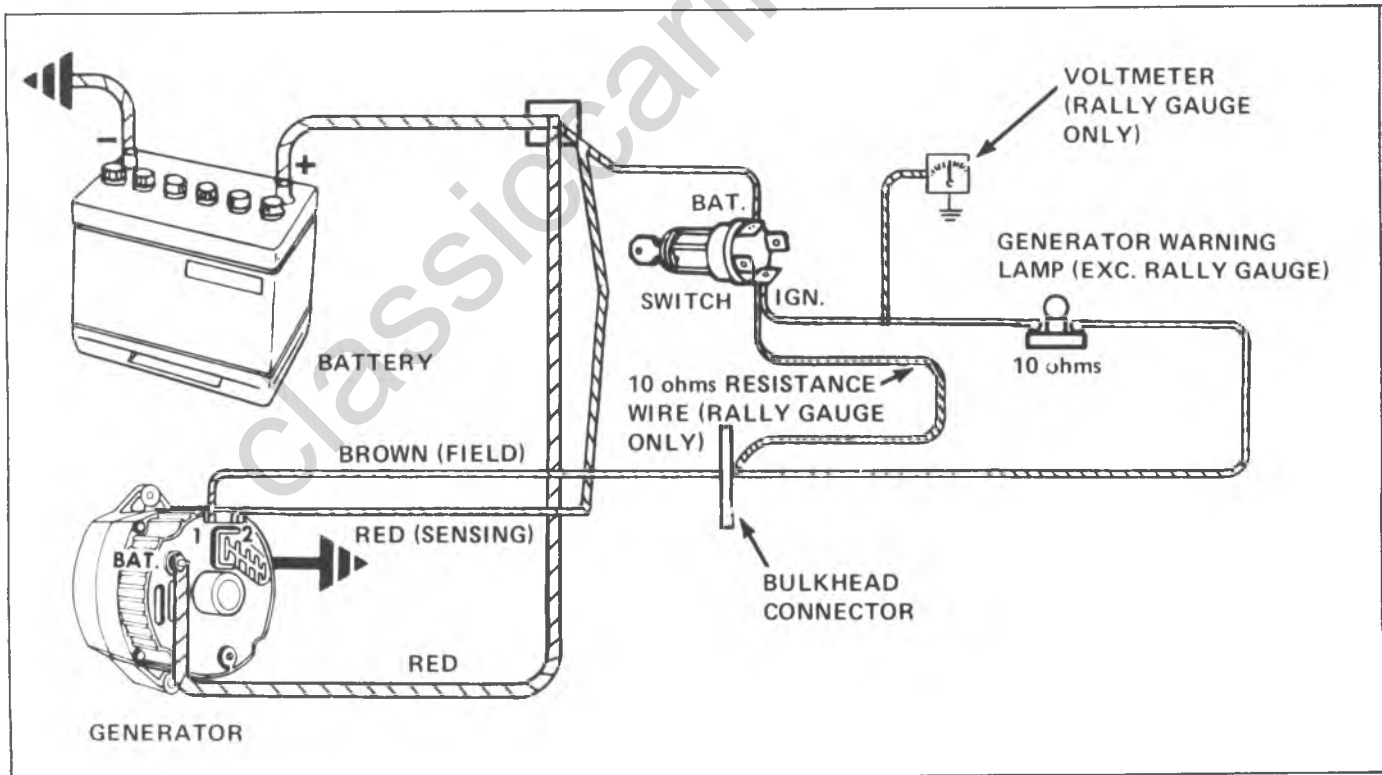


Fig. 6D-3C—Charging Circuit - SI System

DIAGNOSIS

Most charging system troubles show up as a faulty indicator lamp, an undercharged or an overcharged battery. Since the battery itself may be defective, it should be checked first to determine its condition. Also, in the case of an undercharged battery, check for battery drain caused by grounds or by accessories being left on.

A basic wiring diagram showing lead connections is shown in Figure 6D-3C. To avoid damage to the electrical equipment, always observe the following precautions:

- Do not polarize the generator.
- Do not short across or ground any of the terminals in the charging circuit except as specifically instructed.
- Never operate the generator with the output terminal open circuited.
- Make sure the generator and battery are of the same ground polarity.
- When connecting a charger or a booster battery to the vehicle battery, see Battery Charging Section.
- In some circuits (Gage option), a voltmeter may be used instead of an indicator lamp. In this case, Section "A" pertaining to faulty indicator lamp operation should be omitted from the troubleshooting procedure.

Trouble in the charging system will show up as one or more of the following conditions:

- A. Faulty indicator lamp operation.
- B. An undercharged battery as evidenced by slow cranking or test indicator dark.
- C. An overcharged battery as evidenced by excessive spewing of electrolyte from the vent holes.

FAULTY INDICATOR LAMP OPERATION

Check the indicator lamp for normal operation as shown in Fig. 6D-5C.

If the indicator lamp operates normally, proceed to "Undercharged Battery" section. Otherwise, proceed to either one of the following three abnormal conditions.

1. **Switch Off, Lamp On**—In this case, disconnect the two leads from the generator No. 1 and No. 2 terminals. If the lamp stays on, there is a short between these two leads. If the lamp goes out, replace the rectifier bridge as covered in the Generator Repair Section. This condition will cause an undercharged battery.

2. **Switch On, Lamp Off, Engine Stopped**—This condition can be caused by the defects listed in part 1 above, or by an open in the circuit. To determine where an open exists, proceed as follows:

- a. Check for a blown fuse, or fusible link, a burned out bulb, defective bulb socket, or an open in No. 1 lead circuit between generator and ignition switch.
- b. If no defects have been found, proceed to Undercharged Battery section.

3. **Switch On, Lamp On, Engine Running**—The possible causes of this condition are covered in the "UNDERCHARGED BATTERY" section. If a defect has been found and corrected at this point, no further checks need be made.

UNDERCHARGED BATTERY

This condition, as evidenced by slow cranking and battery test indicator dark can be caused by one or more of the following conditions even though the indicator lamp may be operating normally. The following procedures also applies to circuits with a voltmeter.

1. Insure that the undercharged condition has not been caused by accessories having been left on for extended periods.
2. Check the drive belt for proper tension (see Section 6B).
3. If a battery defect is suspected, refer to Battery Section.
4. Inspect the wiring for defects. Check all connections for tightness and cleanliness, including the slip connectors at the generator and firewall, and the cable clamps and battery posts.
5. With ignition switch "on" and all wiring harness leads connected, connect a voltmeter from generator "BAT" terminal to ground, generator No. 1 terminal to ground and generator No. 2 terminal to ground. A zero reading indicates an open between voltmeter connection and battery.

Generators have a built-in feature which avoids overcharge and accessory damage by preventing the generator from turning on if there is an open in the wiring harness connected to the No. 2 generator terminal. Opens in the wiring harness connected between the No. 2 generator terminal and battery may be between the terminals, at the crimp between the harness wire and terminal, or in the wire.

6. If previous Steps 1 through 5 check satisfactorily, check generator as follows:

- a. Disconnect battery ground cable.
- b. Connect an ammeter in the circuit at the "BAT" terminal of the generator.
- c. Reconnect battery ground cable.
- d. Turn on radio, windshield wipers, lights high beam and blower motor high speed. Connect a carbon pile across the battery.
- e. Operate engine at moderate speed as required, and adjust carbon pile as required, to obtain maximum current output.
- f. If ampere output is within 10 amperes of rated output as stamped on generator frame, generator is not defective; recheck Steps 1 through 5.
- g. If ampere output is not within 10 percent of rated output, determine if test hole is accessible (Fig. 6D-6C). If accessible go to step h. If not accessible go to step l.
- h. Ground the field winding by inserting a screwdriver into the test hole (Fig. 6D-6C).

NOTICE: Tab is within 3/4 inch (19mm) of casting surface. Do not force screwdriver deeper than one inch (25mm) into end frame to avoid damaging the tab.

- i. Operate engine at moderate speed as required, and

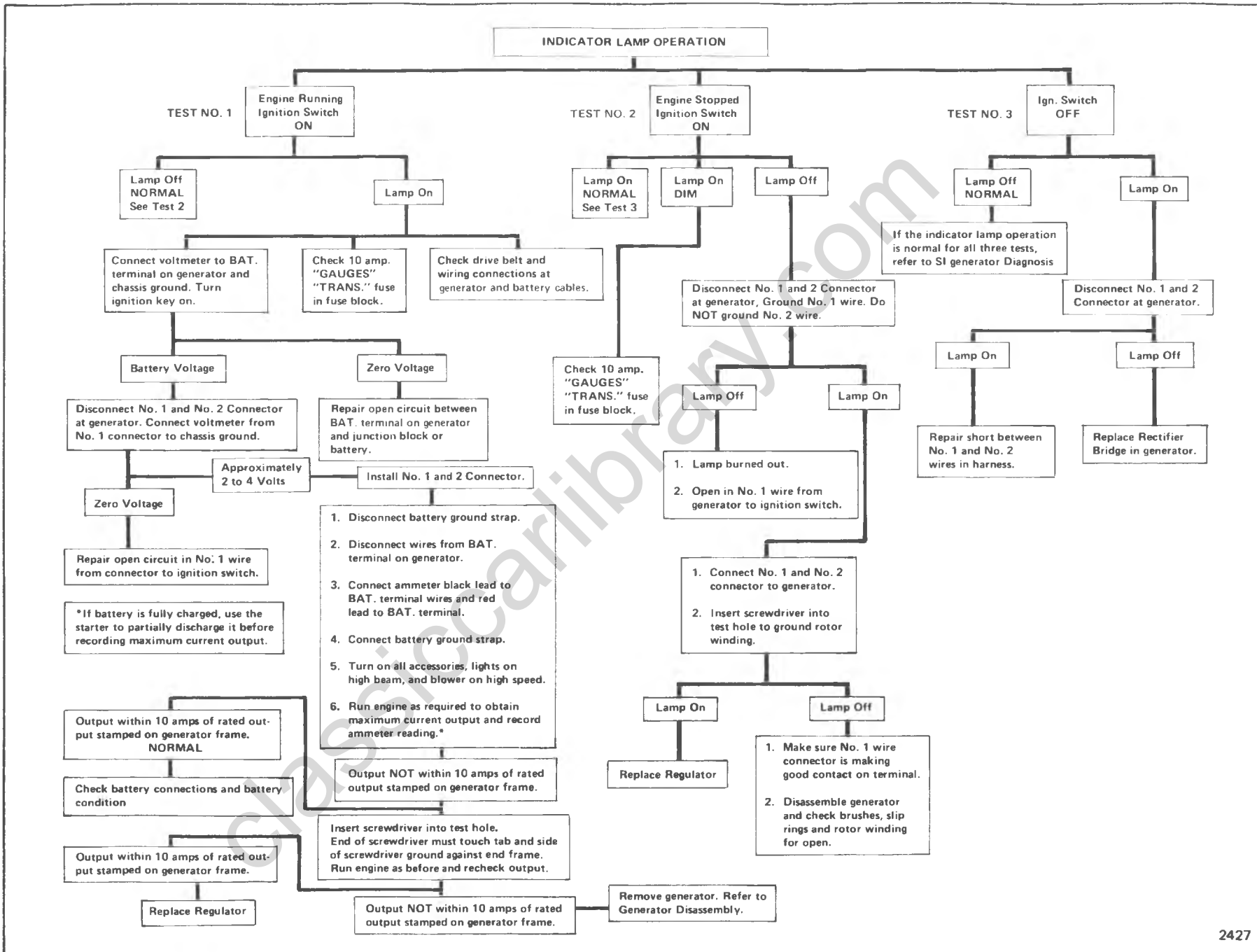


Fig. 6D-4C-Charging System Diagnosis

| Switch | Lamp | Engine |
|--------|------|---------|
| OFF | OFF | STOPPED |
| ON | ON | STOPPED |
| ON | OFF | RUNNING |

Fig. 6D-5C--Indicator Lamp Operation

adjust carbon pile as required to obtain maximum current output.

j. If output is within 10 amperes of rated output, check field winding as covered in Generator Repair section, and test regulator with an approved regulator tester.

k. If output is not within 10 amperes of rated output, check the field winding, diode trio, rectifier bridge, and stator as covered in the Generator Repair Section.

7. If test hole is not accessible, disassemble generator and make tests listed in Overhaul section.

OVERCHARGED BATTERY

1. To determine battery condition refer to Battery section.

2. Connect a voltmeter from generator No. 2 terminal to ground. If reading is zero, No. 2 lead circuit is open.

ON-VEHICLE SERVICE

The generator does not require periodic lubrication. The rotor shaft is mounted on ball bearings at the drive end and roller bearings at the slip ring end, and each contains a permanent grease supply. At periodic intervals, check mounting bolts for tightness and adjust belt tension (see Sec. 6B).

When adjusting belt tension, apply pressure at center of generator, never against either end frame.

Remove From Vehicle

1. Disconnect negative battery terminal at battery.

CAUTION: Failure to observe this step may result in an injury from hot battery lead at generator.

2. Remove two terminal plug and battery leads on back of generator.

3. Loosen adjusting bolts (see Fig. 6D-6 through 6D-8 for generator mounting).

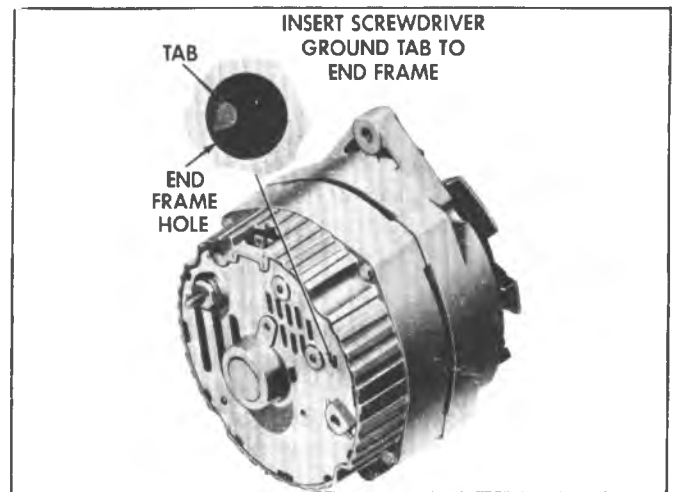


Fig. 6D-6C--Generator Test Hole

3. If battery and No. 2 lead circuit check good, but an obvious overcharge condition exists as evidenced by excessive spewing of electrolyte, proceed to disassembly section of Generator Overhaul and check field windings for grounds and shorts. If defective, replace rotor, and test regulator with an approved regulator tester.

Generator Tester - many testers are available to check the generator. They provide a quick on-vehicle test, and can save time over conventional diagnostic methods. Consult manufacturer's instructions for usage.

4. Remove generator drive belt.
5. Remove thru bolt which retains generator.
6. Remove generator from vehicle.

Install In Vehicle

1. If removed from vehicle, install generator to mounting bracket with bolts, washers and nuts. Do not tighten.

2. Install generator drive belt.

3. Tighten belt to the specified belt tension. See Engine Cooling Section for proper belt tensioning procedures.

4. Tighten bolts to 41 N·m (30 lb. ft.), except bolt at sliding slots on brackets which is 27 N·m (20 lb. ft.).

5. Install generator terminal plug and battery leads to generator.

6. Connect negative battery terminal.

UNIT REPAIR

To repair the generator, observe the following procedure:

DISASSEMBLY

To disassemble the generator, take out the four thru bolts, and separate the drive end frame and rotor assembly from the stator assembly by prying apart with a screwdriver at the stator slot. A scribe mark will help locate the parts in the same position during assembly (see Fig. 6D-7C). After disassembly, place a piece of tape over the slip ring end frame bearing to prevent entry of dirt and other foreign material, and also place a piece of tape over the shaft on the slip ring end. If brushes are to be reused, clean with a soft dry cloth.

NOTICE: Use pressure sensitive tape and not friction tape which would leave a gummy deposit on the shaft.

To remove the drive end frame from the rotor, place the rotor in a vise and tighten only enough to permit removal of the shaft nut.

NOTICE: Avoid excessive tightening as this may cause distortion of the rotor. Remove the shaft nut, washer, pulley, fan, and the collar, and then separate the drive end frame from the rotor shaft.

ROTOR FIELD WINDING CHECKS

To check for opens, connect the test lamp or ohmmeter to each slip ring. If the lamp fails to light, or if the ohmmeter reading is high (infinite), the winding is open (Fig. 6D-8C).

Connect test lamp or ohmmeter from one slip ring to shaft. If lamp lights, or if reading is low, the rotor winding is grounded.

The winding is checked for short circuits or excessive resistance by connecting a battery and ammeter in series with the edges of the two slip rings. The field current at 12 volts and 80°F (27°C) should be between 4.0 - 5.0 amperes.

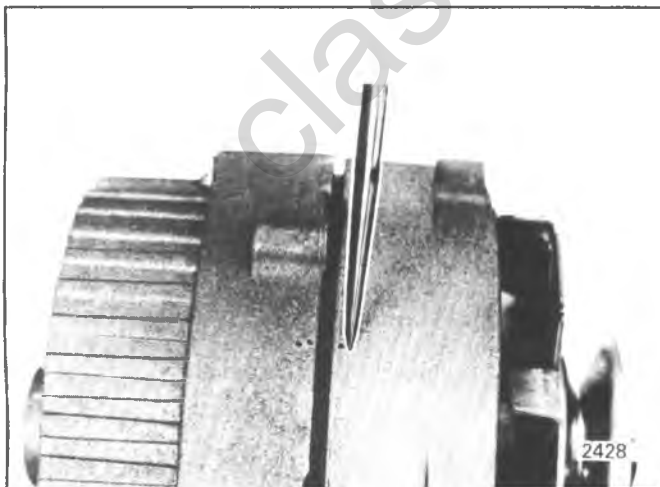


Fig. 6D-7C—Marking End Frames

As an alternate method, an ohmmeter can be used, and readings should be approximately 2.4 to 3.0 ohms. An ammeter reading above the specified value indicates shorted windings; a reading below the specified value indicates excessive resistance. If the resistance reading is below the specified value, the winding is shorted; if above the specified value the winding has excessive resistance.

Remember that the winding resistance and ammeter readings will vary slightly with winding temperature changes. If the rotor is not defective, but the generator fails to supply rated output, the defect is in the diode trio, rectifier bridge, stator, or regulator.

DIODE TRIO CHECK

The diode trio is identified in Figure 6D-10C.

To check the diode trio, remove it from the end frame assembly by detaching the three nuts, the attaching screw, and removing the stator assembly. Note that the insulating washer on the screw is assembled over the top of the diode trio connector. Connect an ohmmeter having a 1 1/2 volt cell, and using the lowest range scale, to the single connector and to one of the three connectors (Fig. 6D-10C). Observe the reading. Then reverse the ohmmeter leads to the same two connectors. If both readings are the same, replace the diode trio. A good diode trio will give one high and one low reading. Repeat this same test between the single connector and each of the other two connectors. Also, connect the ohmmeter to each pair of the three connectors (not illustrated). If any reading is zero, replace the diode trio.

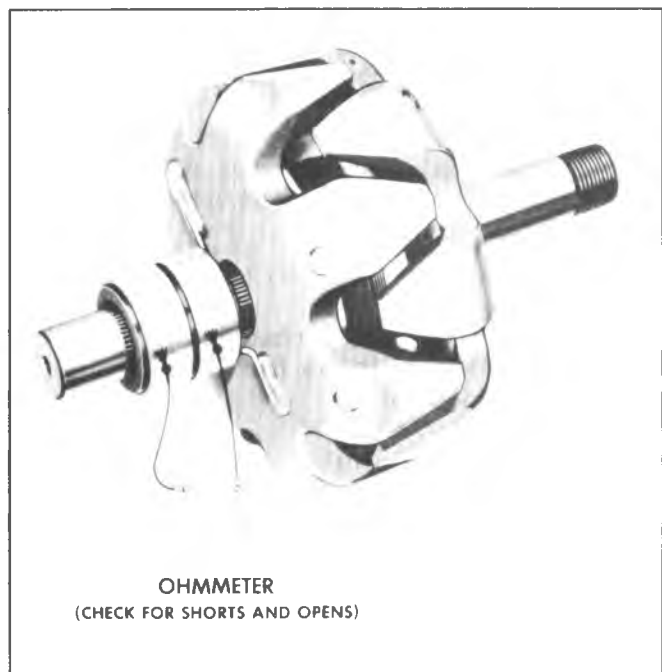


Fig. 6D-8C—Checking Rotor

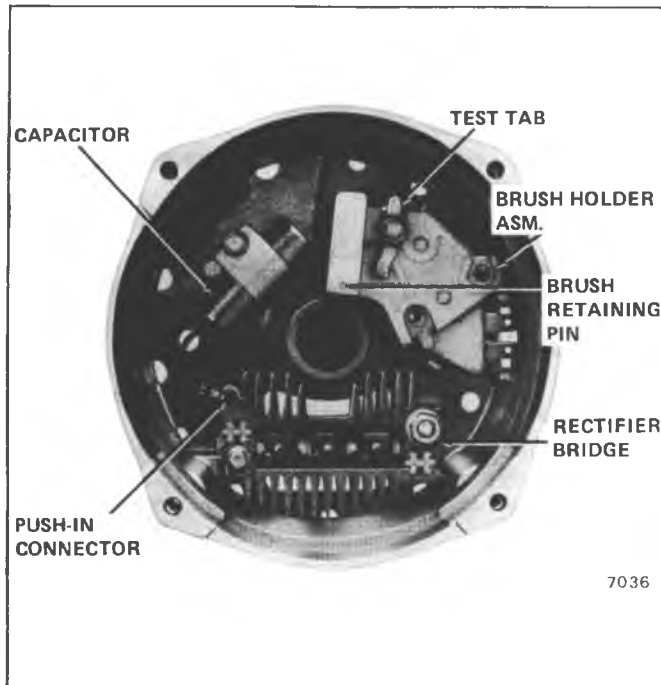


Fig. 6D-9C--Slip Ring End Frame Assembly

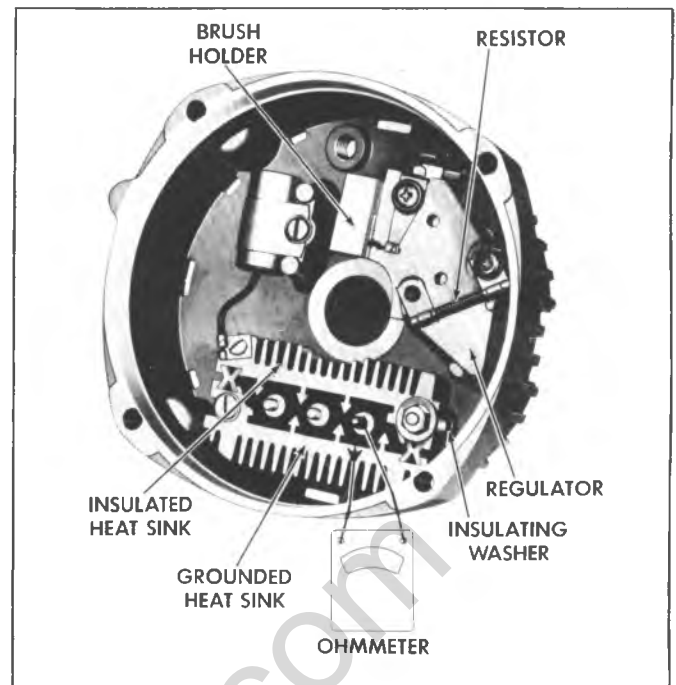


Fig. 6D-11C--Checking Rectifier Bridge

RECTIFIER BRIDGE CHECK

Note that the rectifier bridge has a grounded heat sink and an insulated heat sink connected to the output terminal. Also, note the insulating washer located between the insulated heat sink and end frame on 10-SI generators.

To check the rectifier bridge, connect the ohmmeter to the grounded heat sink and one of the three terminals (Fig. 6D-11C). Then reverse the lead connections to the grounded heat sink and same terminal. If both readings are the same, replace the rectifier bridge. A good rectifier bridge will give one high and one low reading. Repeat this same test between the grounded heat sink and the other two terminals, and between the insulated heat sink and each of the three terminals. This makes a total of six checks, with two

readings taken for each check.

The ohmmeter check of the rectifier bridge, and of the diode trio as previously covered, is a valid and accurate check. Do not replace either unit unless at least one pair of readings is the same.

NOTICE: Do not use high voltage to check these units such as a 110 volt test lamp.

To replace the rectifier bridge, remove the attaching screws, and disconnect the capacitor lead. Note the insulator between the insulated heat sink and end frame. Rectifier bridges may vary in appearance but are completely interchangeable in these generators.

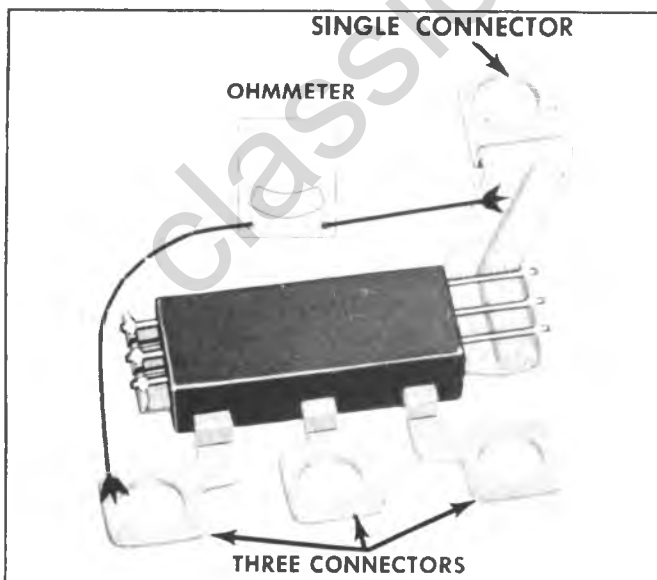


Fig. 6D-10C--Checking Diode Trio

STATOR CHECKS

The stator windings may be checked with a 110-volt test lamp or an ohmmeter. If the lamp lights, or if the meter reading is low when connected from any stator lead to the frame, the windings are grounded. If the lamp fails to light, or if the meter reading is high when successively connected between each pair of stator leads on 10-SI Series, the windings are open (Fig. 6D-12C).

A short circuit in the stator windings is difficult to locate without laboratory test equipment due to the low resistance of the windings. However, if all other electrical checks are normal and the generator fails to supply rated output, shorted stator windings are indicated. Also, a shorted stator can cause the indicator lamp to be on with the engine at low speed. Check the regulator in next section before replacing stator.

BRUSH HOLDER AND REGULATOR REPLACEMENT

To determine if the regulator is defective, an approved regulator tester must be used. After removing the three attaching nuts, the stator, and diode trio screw (Fig. 6D-

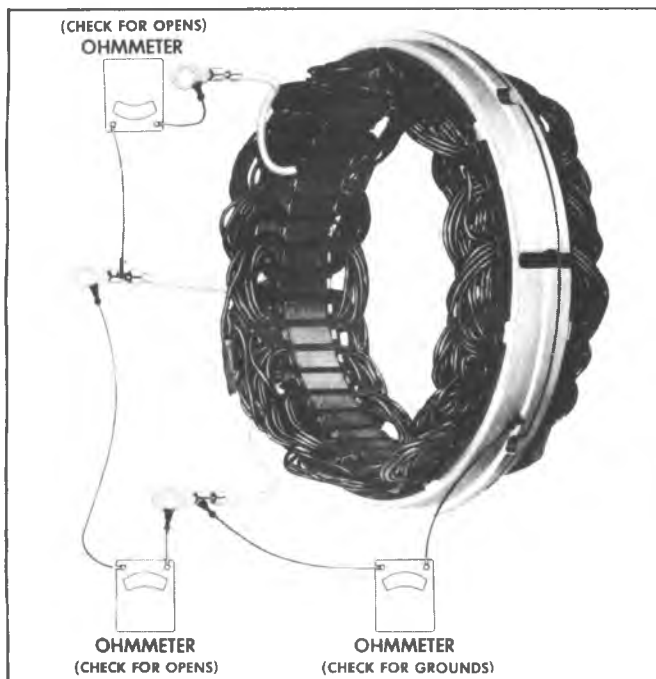


Fig. 6D-12C—Checking Stator

9C), the brush holder and regulator may be replaced by removing the two remaining screws. Note the two insulators located over the top of the brush clips in Figure 6D-9C, and that these two screws have special insulating sleeves over the screw body above the threads. The third mounting screw may or may not have an insulating sleeve. If not, this screw must not be interchanged with either one of the other two screws, as a ground may result, causing no output or uncontrolled generator output. Regulators may vary in appearance but are completely interchangeable in these generators.

Using voltage regulator tester CTW-1170 or equivalent (Fig. 6D-13C), it is possible to check the voltage regulator both on the vehicle and on the bench. Use the instructions on the tester cover for testing the regulator on the bench and use the following instructions for the on vehicle test and the continuity test.

On-Vehicle Test

This on-vehicle test procedure helps to quickly determine if a problem exists in the generator/regulator circuit. If you do not obtain the proper results in this test, the generator must be dismantled and the regulator removed for further testing.

1. Turn the tester OFF.
2. Make sure a regulator is not installed in the Tester regulator holder.
3. Plug the on-vehicle testing accessory cable into the accessory socket on the Tester front panel.
4. Disconnect the regulator connector from the generator. Then plug the on-vehicle testing accessory cable in its place. Connect the ground lead (alligator clip) to the generator case.
5. Test the generator/regulator circuit using steps 2, 3, 4 and 15 of the instruction label located on the inside of the case cover. If you do not obtain the proper lamp and/or voltmeter indication, or if either or both lamps flicker on

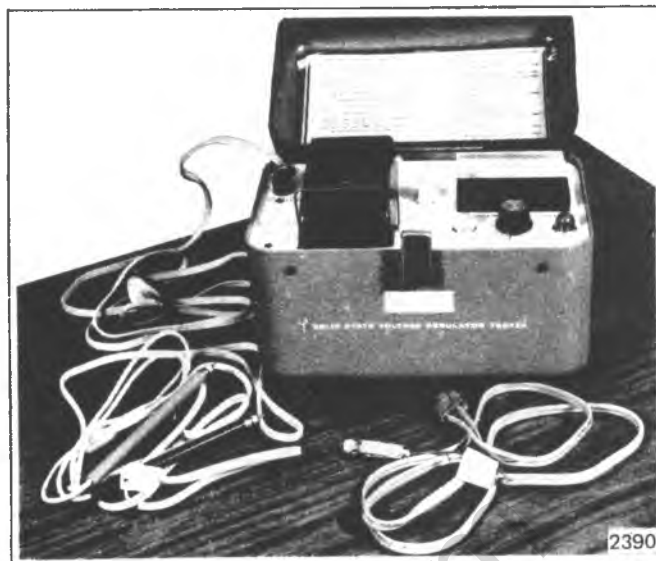


Fig. 6D-13C—Voltage Regulator Tester

and off when you perform these steps, the regulator must be removed from the generator for further testing to determine whether the problem is in the generator or in the regulator.

Continuity Test

The continuity test accessory cable is used in conjunction with the meter on the Tester. A high meter reading indicates an open circuit (no continuity) while a zero meter reading indicates continuity.

When you make a continuity test, keep the following points in mind:

1. Make sure a regulator is not installed in the holder.
2. The knob is turned clockwise only until it clicks.
3. All components must be isolated for testing.
4. Make sure voltage is not applied to the component being tested.

SLIP RING SERVICING

If the slip rings are dirty, they may be cleaned and finished with 400 grain or finer polishing cloth. Spin the rotor, and hold the polishing cloth against the slip rings until they are clean.

NOTICE: The rotor must be rotated in order to clean the slip rings evenly. Cleaning the slip rings by hand without spinning the rotor may result in flat spots on the slip rings, causing brush noise.

Slip rings which are rough or out of round should be trued in a lathe to .002 inch maximum indicator reading. Remove only enough material to make the rings smooth and round. Finish with 400 grain or finer polishing cloth and blow away all dust.

BEARING REPLACEMENT AND LUBRICATION

The bearing in the drive end frame can be removed by detaching the retainer plate screws, and then pressing the bearing from the end frame. If the bearing is in satisfactory condition, it may be reused, and it should be filled one-quarter full with lubricant part no. 1948791 or equivalent,

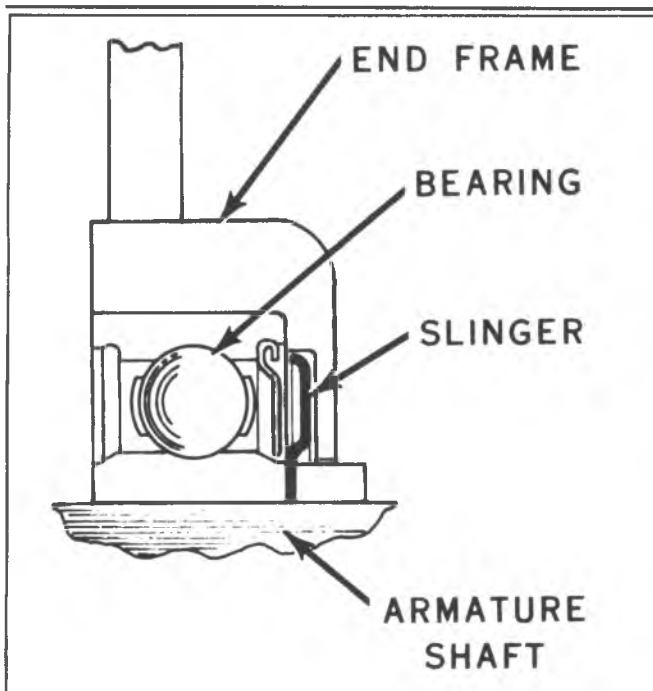


Fig. 6D-14C--Drive End Frame Bearing Assembly

before reassembly.

NOTICE: Do not overfill, as this may cause the bearing to overheat, and use only 1948791 lubricant or equivalent.

To install a new bearing, press in with a tube or collar that just fits over the outer race, with the bearing and slinger assembled into the end frame as shown in Figure 6D-14C. It is recommended that a new retainer plate be installed if the felt seal in the retainer plate is hardened or excessively worn. Fill the cavity between the retainer plate and bearing with 1948791 lubricant or equivalent.

The bearing in the slip ring end frame should be replaced if its grease supply is exhausted. No attempt should be made to re-lubricate and reuse the bearing. To remove the bearing from the slip ring end frame, press out with a tube or collar that just fits inside the end frame housing. Press from the outside of the housing towards the inside.

To install a new bearing, place a flat plate over the bearing and press in from the outside towards the inside of the frame until the bearing is flush with the outside of the end frame. Support the inside of the frame with a hollow cylinder to prevent breakage of the end frame. Use extreme care to avoid misalignment or otherwise placing undue stress on the bearing.

If the seal is separate from the bearing, it is recommended that a new seal be installed whenever the bearing is replaced. Press the seal in with the lip of the seal toward the rotor when assembled, that is, away from the bearing. If the new bearing has a built-in seal, discard the old seal. Lightly coat the seal lip with oil to facilitate assembly of the shaft into the bearing.

REASSEMBLY

Reassembly is the reverse of disassembly. Remember when assembling the pulley to secure the rotor in a vise only lightly enough to permit tightening the shaft nut to 68 N·m (50 lb. ft.). If excessive pressure is applied against the rotor, the assembly may become distorted. To install the slip ring end frame assembly to the rotor and drive end frame assembly, remove the tape over the bearing and shaft, and make sure the shaft is perfectly clean after removing the tape. Insert a pin through the holes to hold up the brushes. Carefully install the shaft into the slip ring end frame assembly to avoid damage to the seal. After tightening the thru-bolts remove the brush retaining pin to allow the brushes to fall down onto the slip rings.

SPECIAL TOOLS

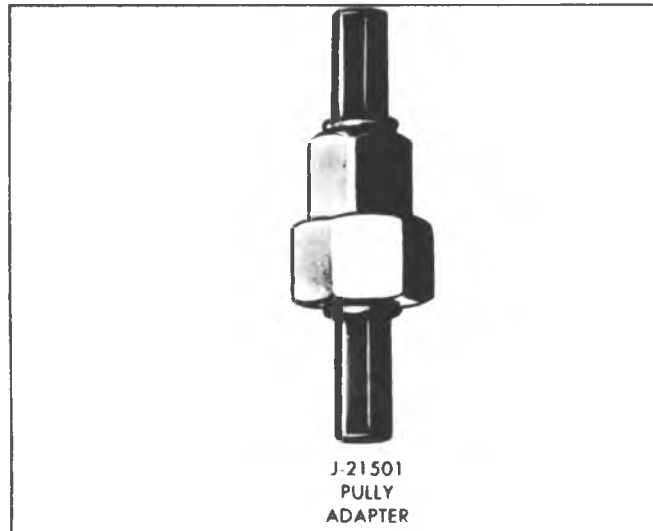


Fig. 6D-15C—Special Tool

C10 Series Diesel Engine Electrical

The diesel electrical system used on 1980 C-10 Series trucks is extensively modified from the 1979 system, as outlined below.

DIESEL ELECTRONIC CONTROL SYSTEM

General Description

The major components of the system are, an electronic control module, engine thermal probe, glow plugs, glow plug relay, fast idle control (with A/C only), fast idle temp switch, fast idle solenoid and auto disengagement lockout relay.

Diesel Electrical Circuitry

The diesel engine electrical circuitry differs from conventional gasoline engines as follows:

Battery

Two 12 volt sealed top batteries connected in parallel are required for the higher electrical load due to the glow plugs and starter.

Starter

The starter is larger and designed to crank the engine at least the 100 RPM required for starting.

Charging

A Standard generator supplies charging current to both batteries at the same time. There are no switches or relays in the charging circuit.

Ignition

In the diesel engine, air alone is compressed in the cylinder; then after the air has been compressed a charge of fuel is sprayed into the cylinder and ignition occurs due to the heat of compression. Eight glow plugs are used to preheat the chamber as an aid to starting.

They are 6 volt heaters (operated at 12 volts) that turn on when the ignition key is turned to the run position prior to starting the engine. They remain on a short time after starting, then automatically turn off.

Instrumentation

Vehicles with the optional diesel engine have special instrumentation indicators to permit the operator to properly apply the starting procedure. A dual indicator (Don't start/Glow Plugs) light on the I.P. provides this information on engine starting conditions.

Electronic Module

Operating on electrical signals from the probe, the module controls glow plug operation and determines glow plug power requirements.

The electronic module is designed to monitor the system, probe, and associated wiring for malfunctions. Should a malfunction occur, that might result in glow plug damage, the module provides for system shutdown and driver notification.

The electronic module provides automatic system shutdown due to a malfunction and disconnects glow plug relay from battery plus and ground.

Thermal Probe

The thermal probe, mounted on the engine in such a position as to sense engine temperature, transmits this information to the electronic module for controlling glow plug operation.

Glow Plugs

The glow plugs used in this system are 6 volt units operated at system voltage (12 volts), to provide rapid heating.

Glow Plug Relay

The glow plug relay is used to switch power to the glow

plugs, on or off, as determined by the electronic module.

Fast Idle System

The fast idle relay increases engine speed at cold start or low engine temperature or with A/C on, and after each ignition cycle.

Auto Disengagement Lockout Relay

This relay senses "engine running" condition and disengages starter circuitry at start up.

STARTER GENERATOR MOUNTING

Starter and Generator mounting is illustrated in Figures 6D-7D through 6D-9D.

Classiccarlibrary.com

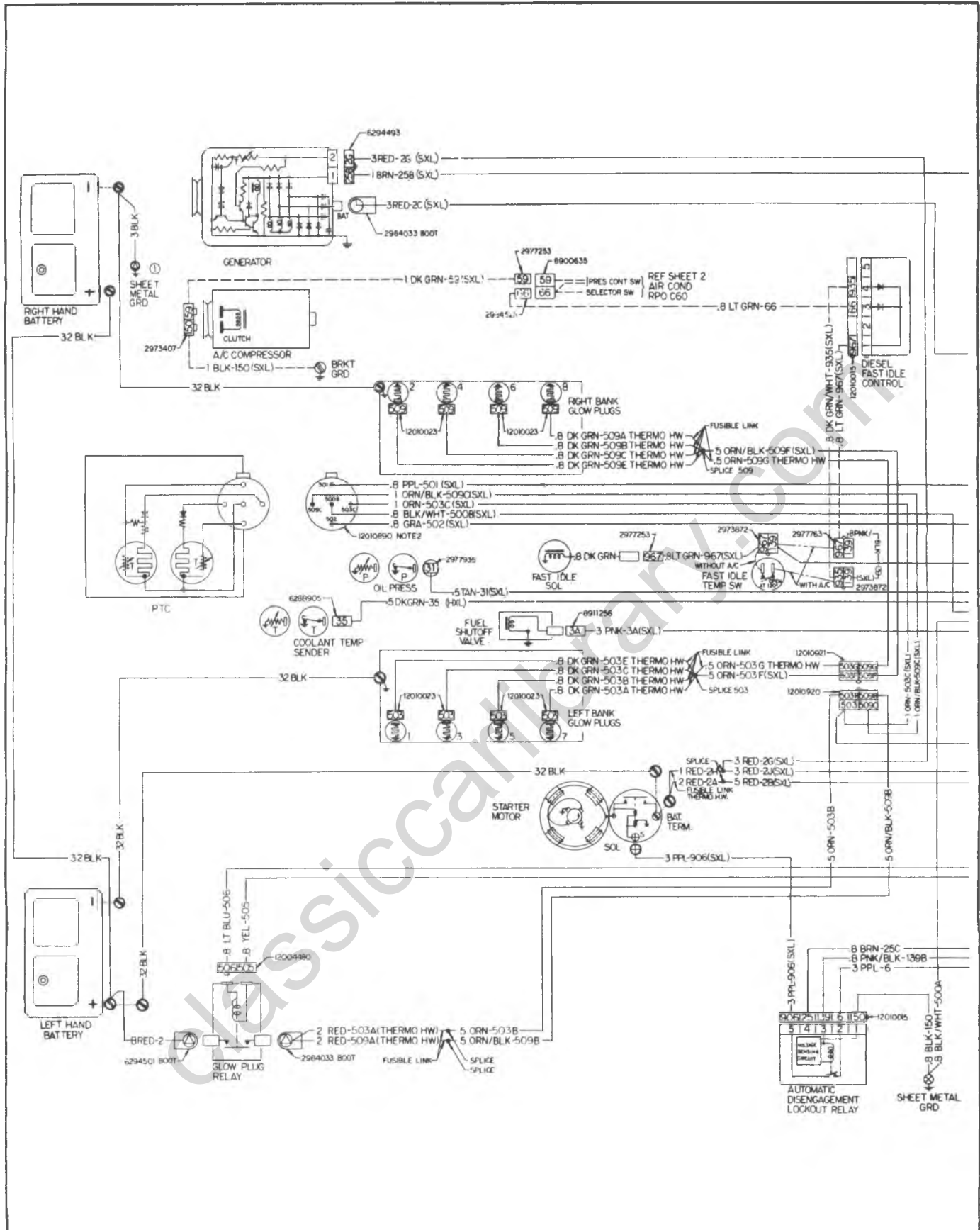


Fig. 6D-1D-C-10 Series Diesel Electrical Schematic

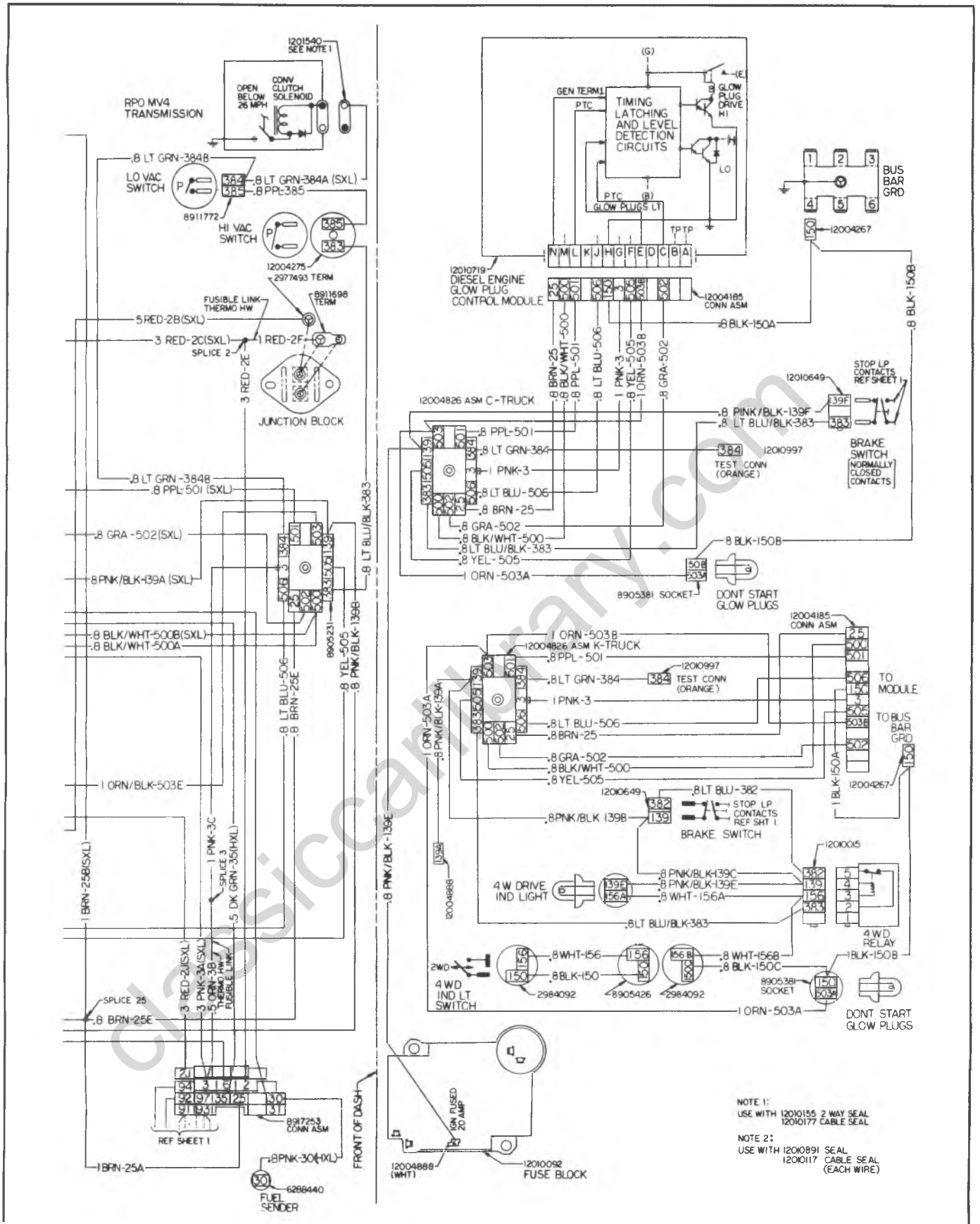


Fig. 6D-2D-C-10 Series Diesel Electrical Schematic

MODULE CIRCUITS

| Module Terminal | Circuit | Relay Circuits |
|-----------------|---------------------------------------|-----------------------------------|
| A | - Blank | |
| B | - Blank | |
| C | - 502 - Probe | 506 Glow Plug Relay Coil Feed (-) |
| D | - Blank | 505 Glow Plug Relay Coil Feed (+) |
| E | - 503 Right Bank Glow Plugs (Monitor) | Glow Plug Feed (Power) |
| F | - 505 Glow Plug Relay Coil Feed (+) | |
| G | - 3 - Ignition | |
| H | - 150 Ground (Power) | |
| J | - 506 - Glow Plug Relay Coil Feed (-) | |
| K | - Blank | |
| L | - 501 - Probe | |
| M | - 500 Module Logic Ground | |
| N | - Generator Output (Monitor) | |

System Operation (at Cold Start)

1
Ignition Switch-Off
Don't Start/Glow Plugs Lamp-Off

2
Ignition Switch - "Run"
Don't Start/Glow Plugs Lp - On

3
Ignition Switch "Start"
Don't Start/Glow Plugs Lp -
Pulsing on/off

4
Ign Sw Run
Don't Start/Glow Plugs Lp -
Pulsing on/off*

*Glow Plugs (Don't Start/Glow Plugs Lp) will cycle on/off for a maximum of 30 seconds after engine starts, then turn off, and remain off.

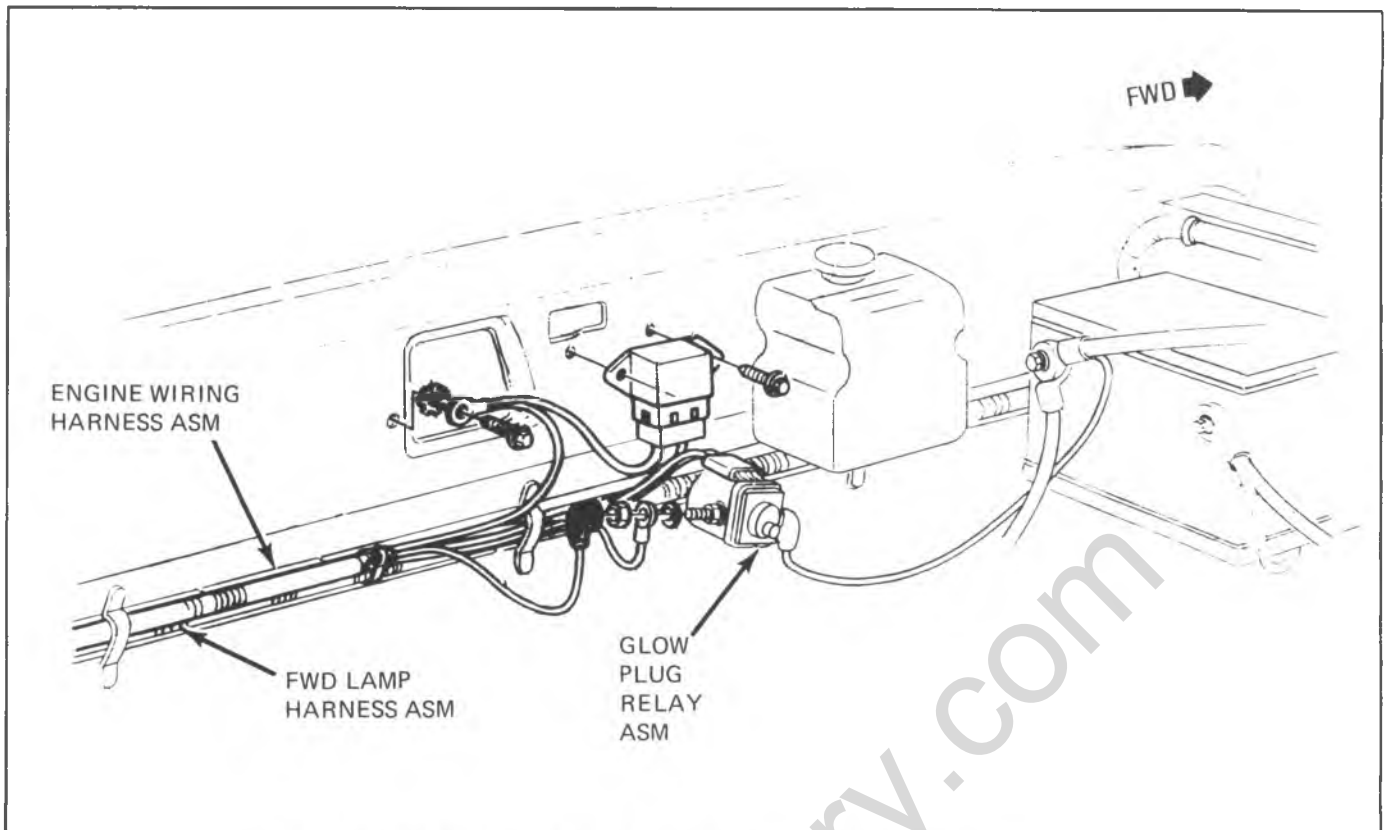


Fig. 6D-3D-C-10 Series Diesel Engine Compartment Component Location

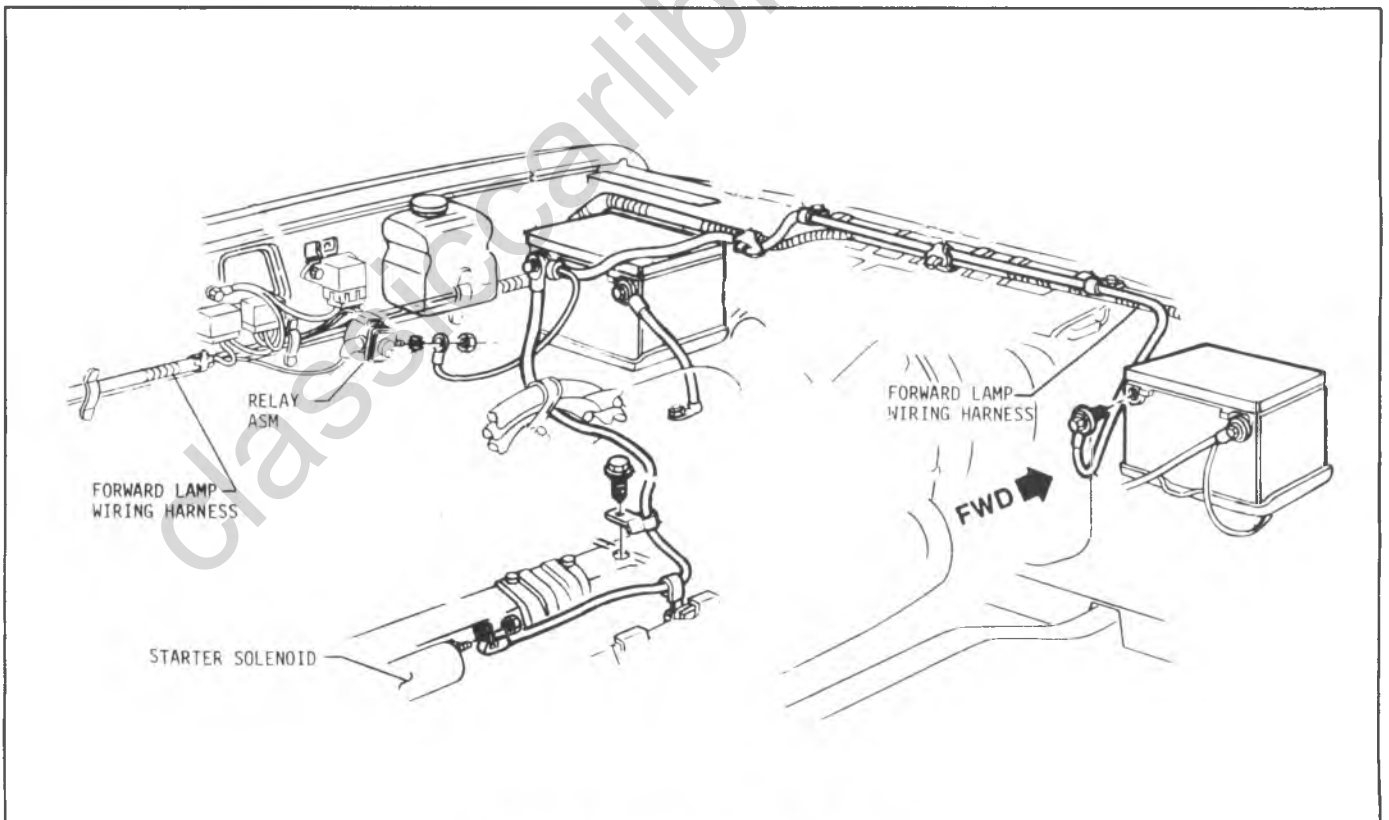


Fig. 6D-4D-Diesel Engine Wiring - Relays

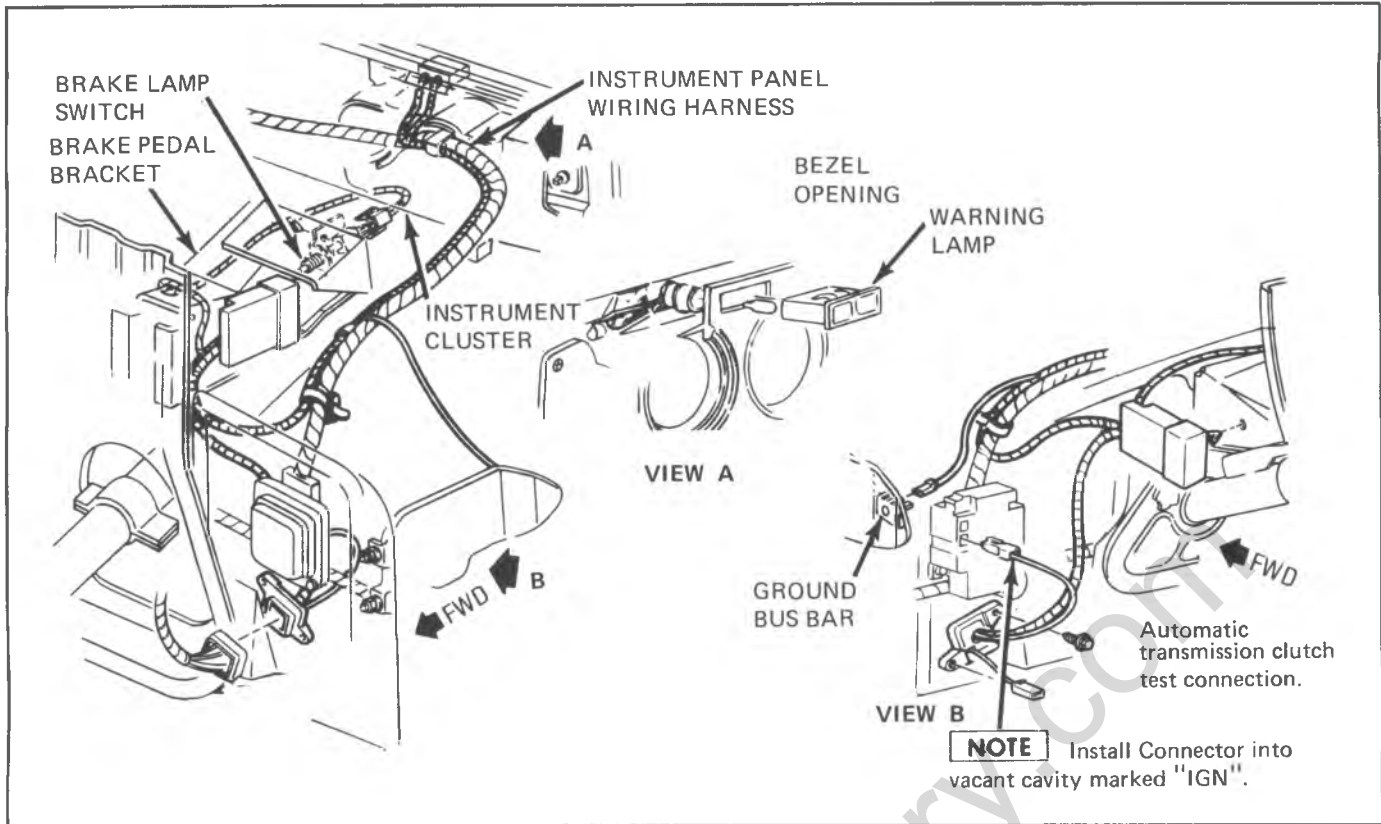


Fig. 6D-5D--Diesel Control Module Wiring

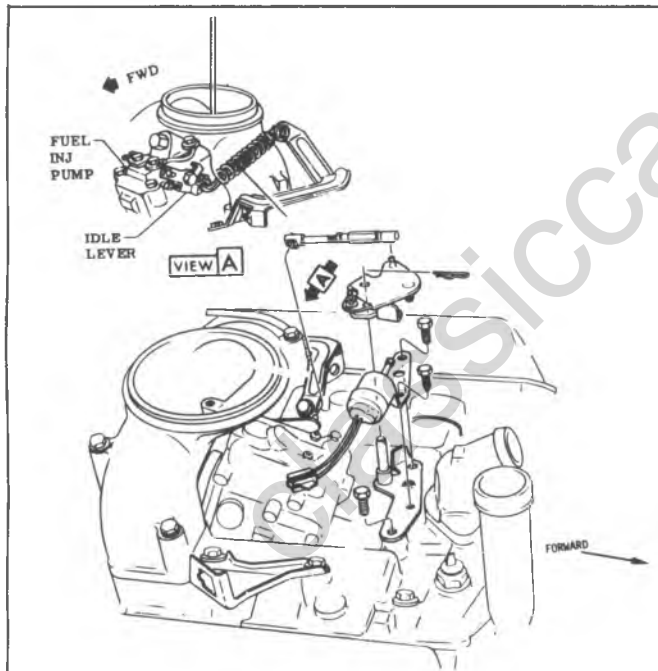


Fig. 6D-6D--Diesel Engine - Accelerator Control and Solenoid Assembly

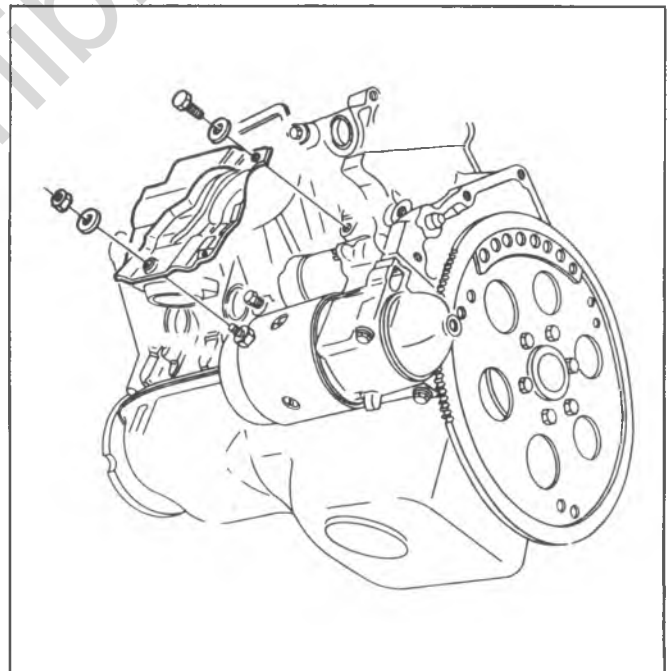


Fig. 6D-7D--Diesel Starter Mounting

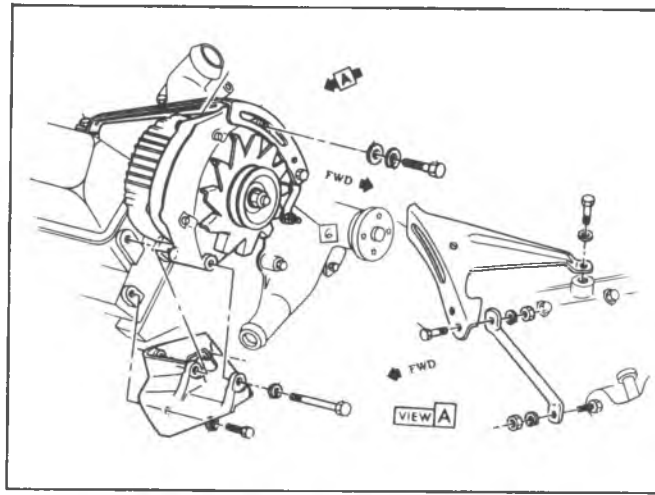


Fig. 6D-8D-Generator Mounting - LF9

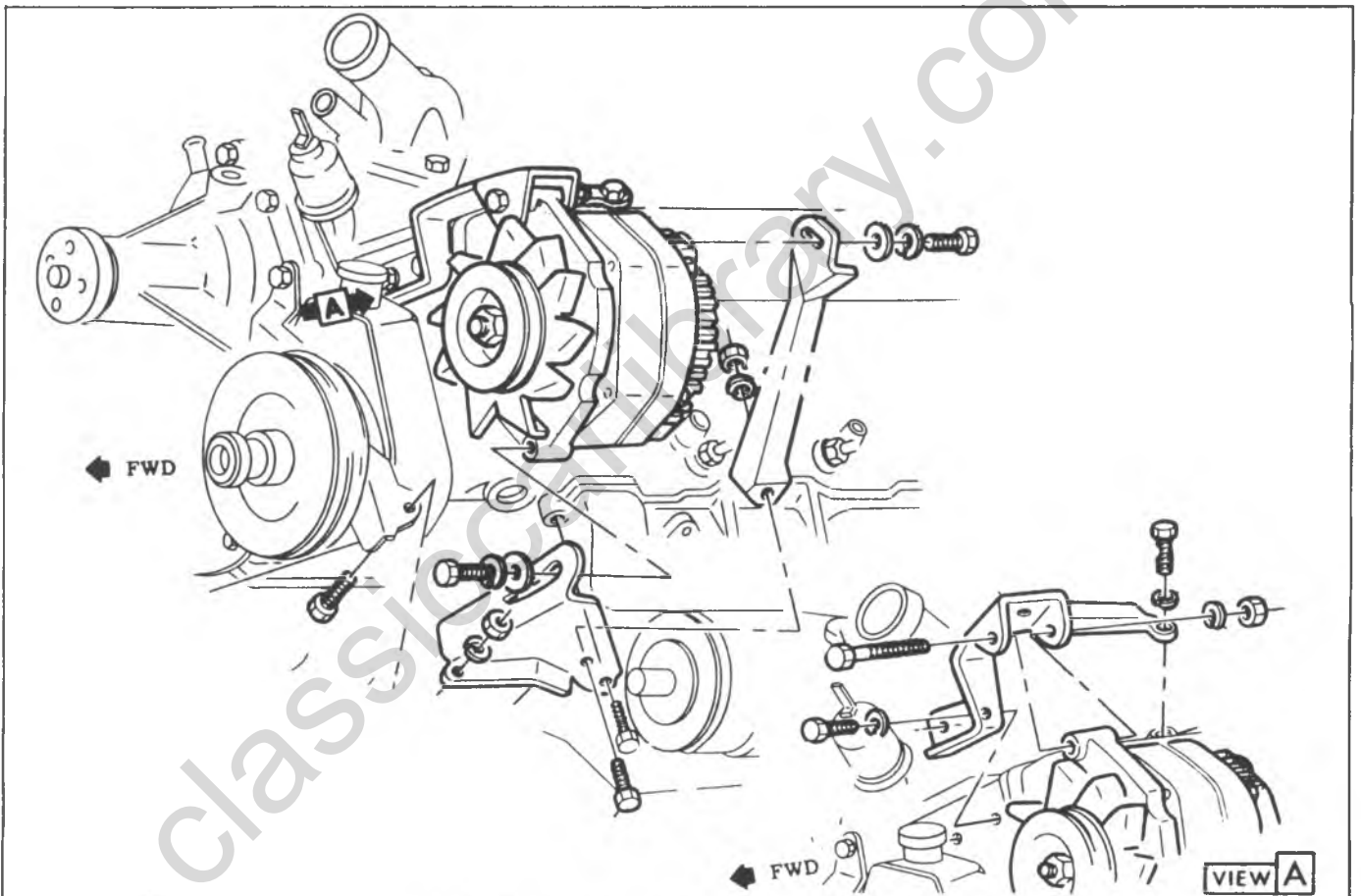
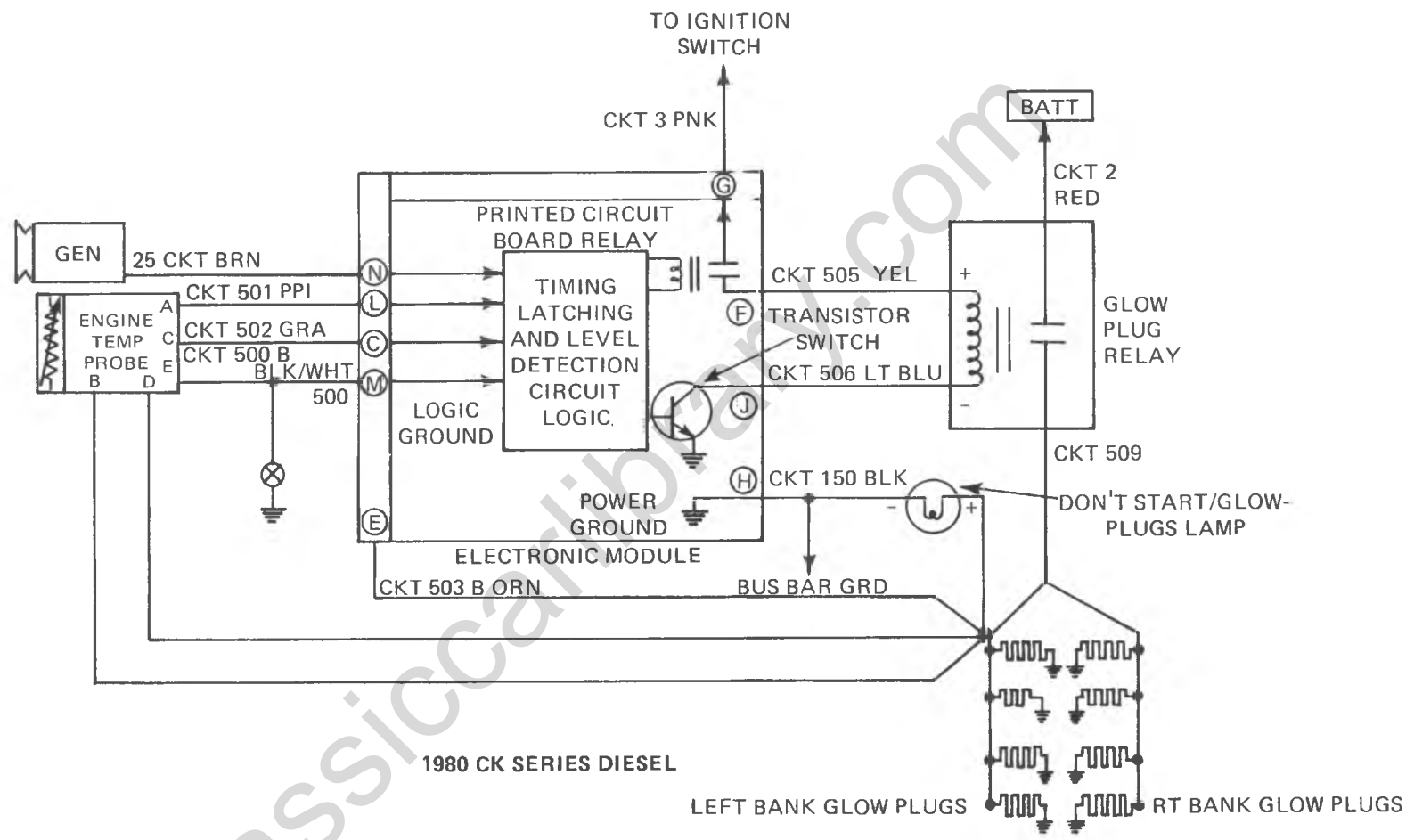


Fig. 6D-9D-Generator Mounting - LF9 with A/C



SIMPLIFIED WIR. DIAGRAM GLOW PLUG CONTROL

Fig. 6D-10D-C-10 Series Diesel Electrical System Diagnosis

ENGINE DOES NOT START-COLD

1. Fuel system checked and is OK.
2. Battery voltage 12.4 or more (Ignition OFF)
3. Engine cranking speed OK (100 RPM or more)

WITH IGNITION SW IN "RUN"

Listen for Glow Plug Relay clicking with cold engine. Relay should come on for approximately 6 seconds. (Varies with engine temperature) Then turn off and then pulse ON/OFF.

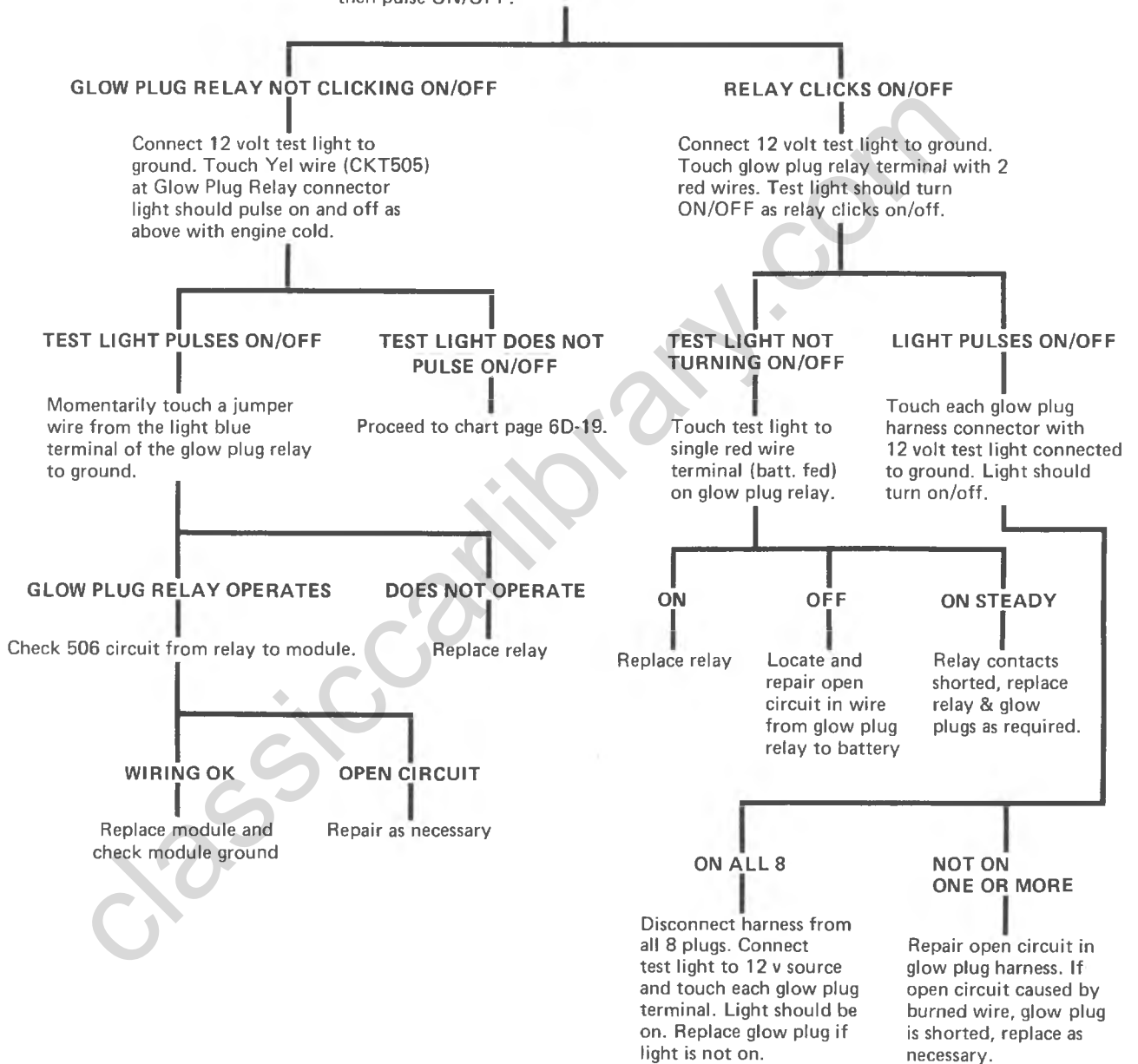


Fig. 6D-11D-C-10 Series Diesel Electrical System Diagnosis

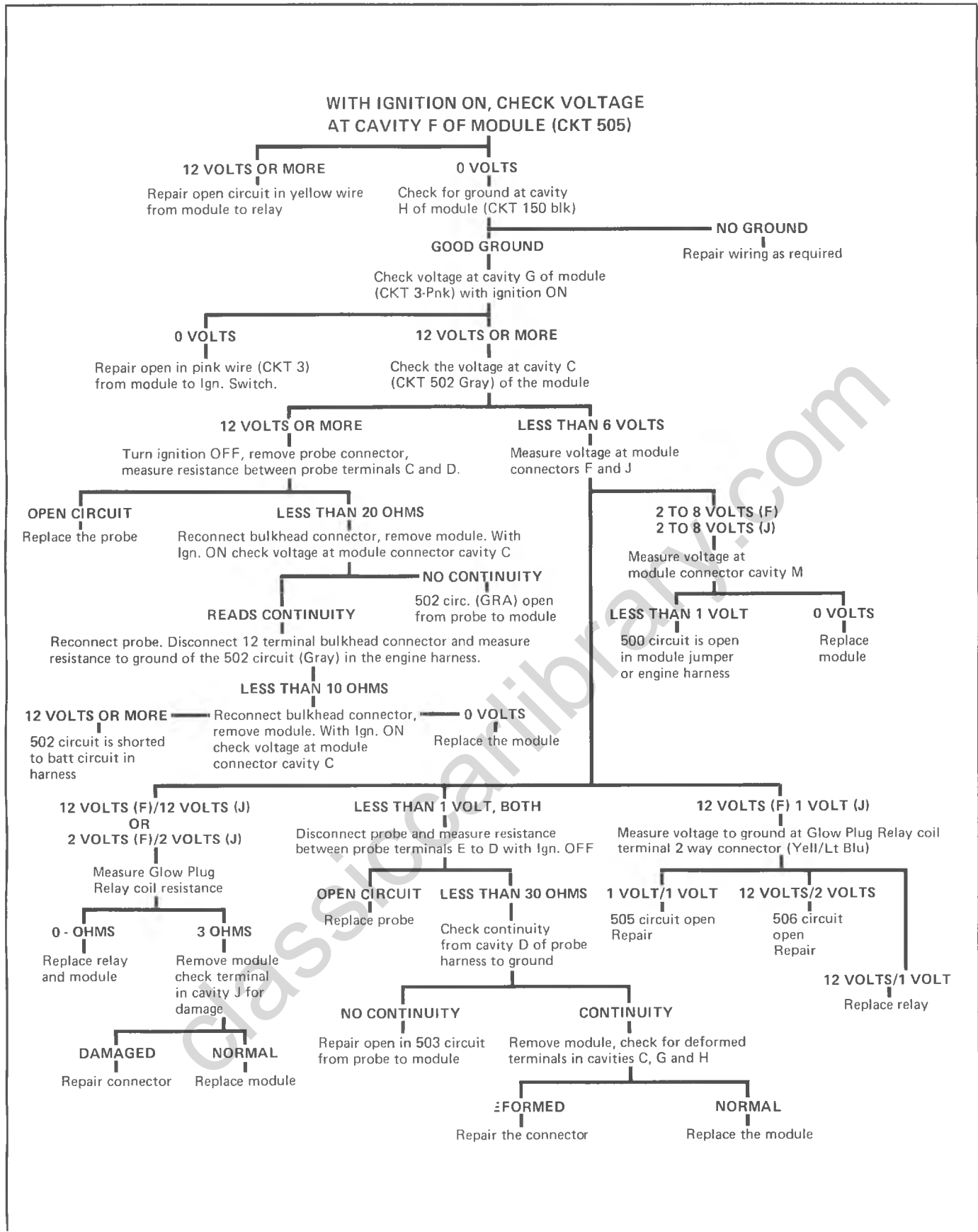
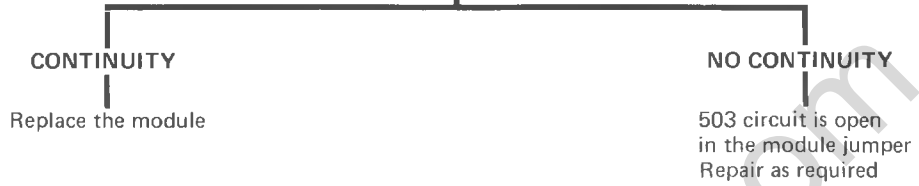


Fig. 6D-12D-C-10 Series Diesel Electrical System Diagnosis

GLOW PLUG RELAY BUZZING

Disconnect the 12 way bulkhead connector. Check the continuity of the 503 circuit in the module connector to the glow plug relay.



**GLOW PLUG RELAY NORMAL
DON'T START/GLOW PLUGS
LAMP DOES NOT LIGHT**

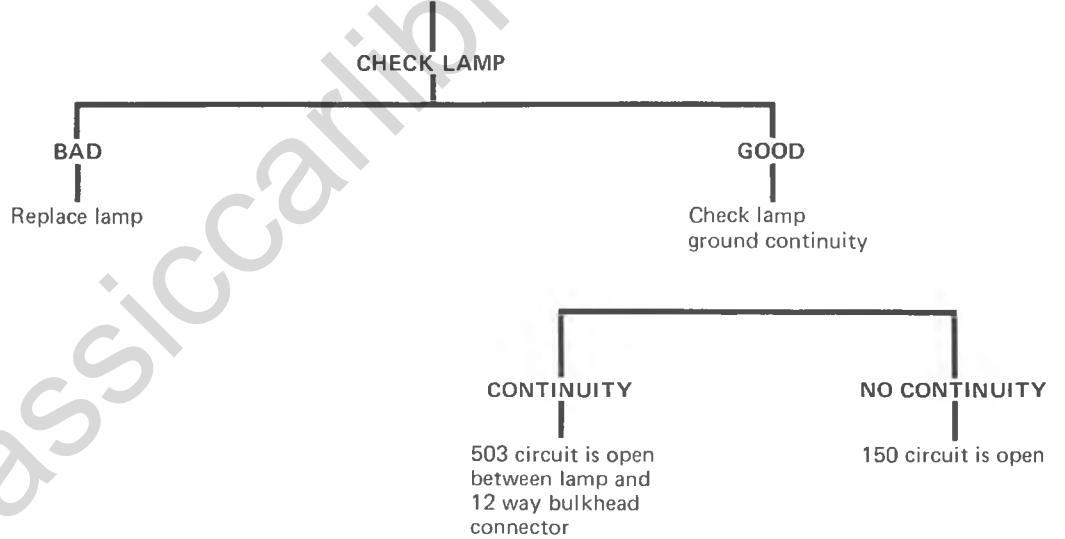


Fig. 6D-13D-C-10 Series Diesel Electrical System Diagnosis

**GLOW PLUG RELAY AND
DON'T START/GLOW PLUGS LAMP
ON AT COLD START, DOES NOT
CYCLE AFTER INITIAL ON PERIOD
(APPROX. 6 SECONDS AT 32°F)**

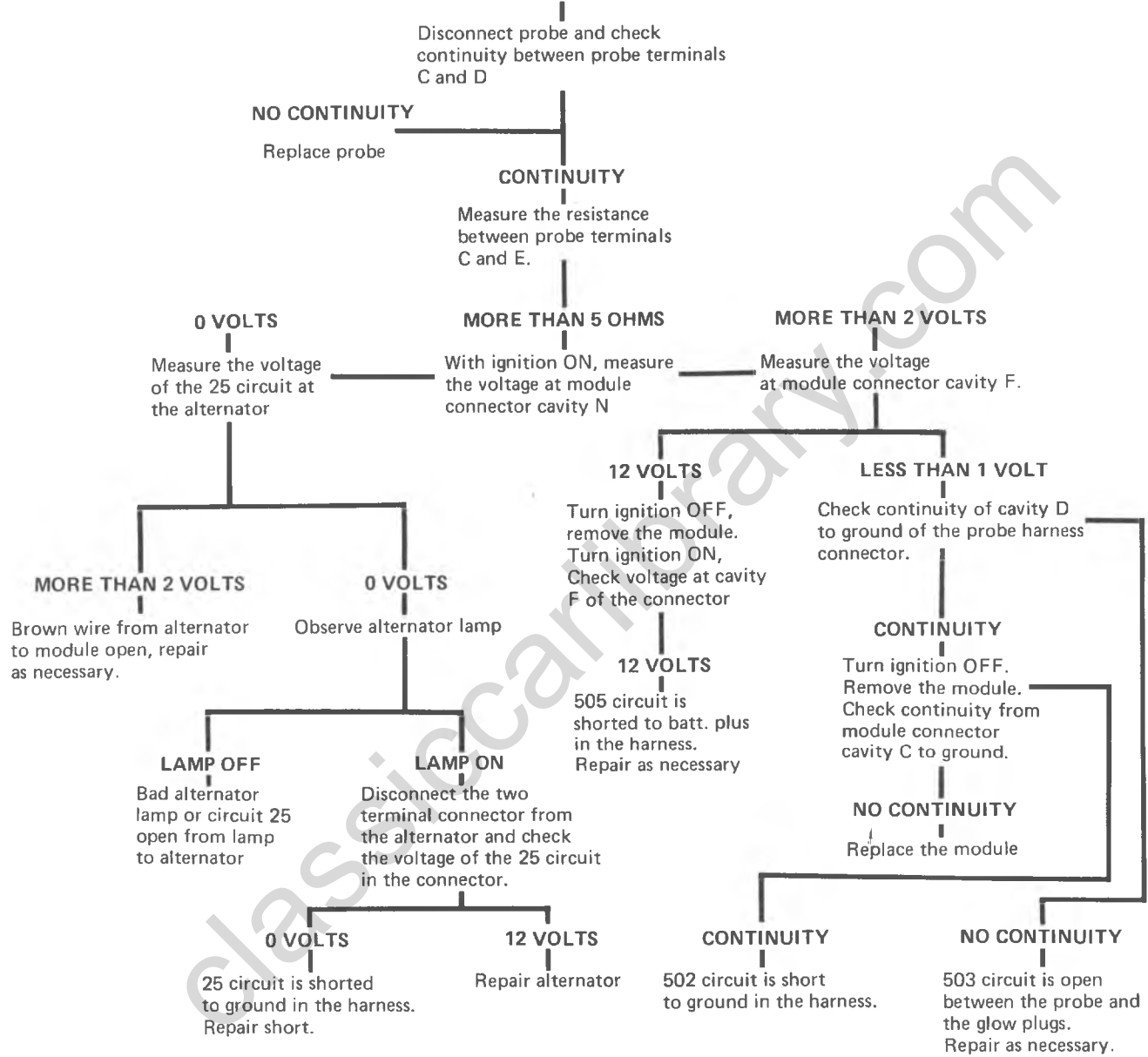


Fig. 6D-14D-C-10 Series Diesel Electrical System Diagnosis

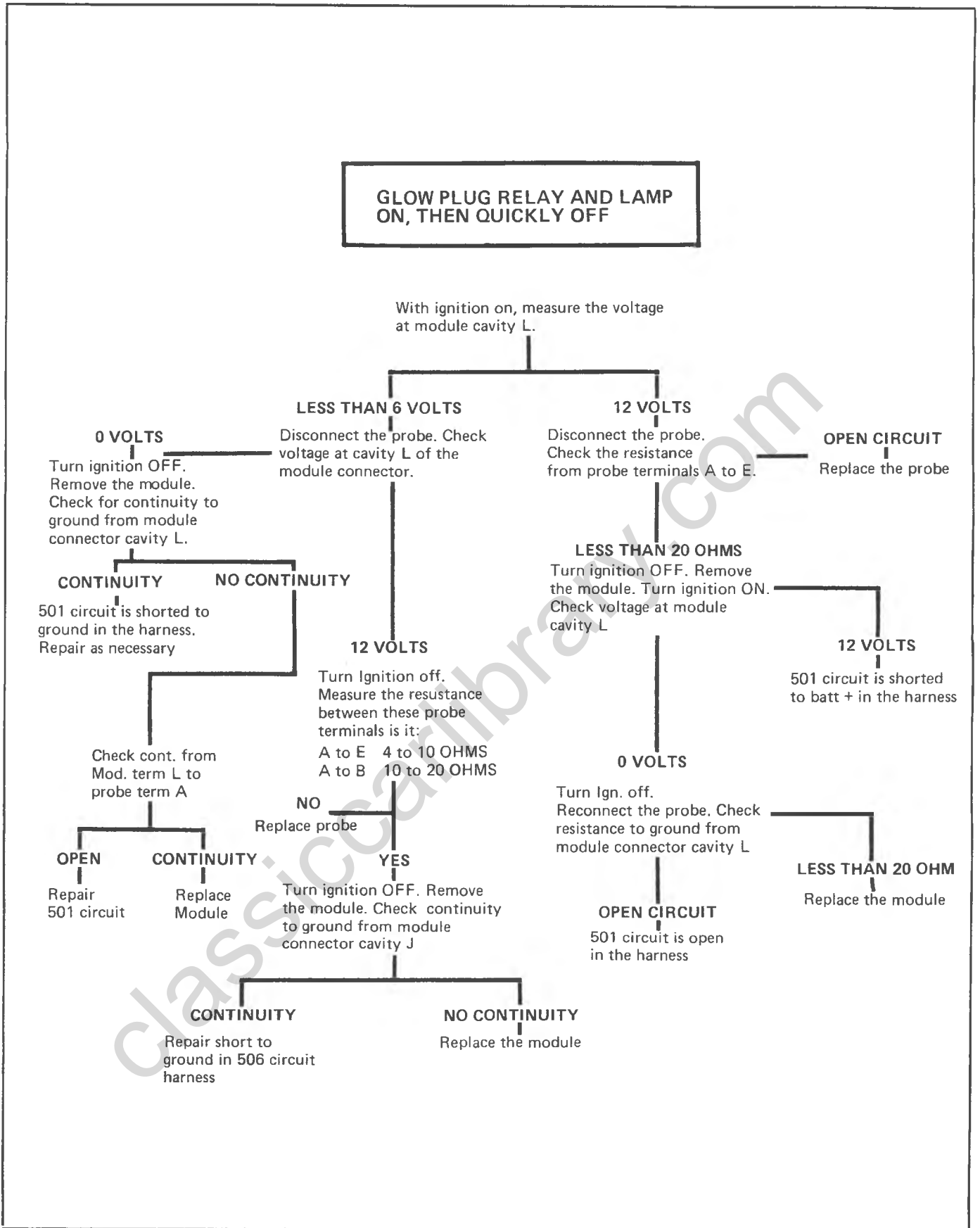


Fig. 6D-15D-C-10 Series Diesel Electrical System Diagnosis

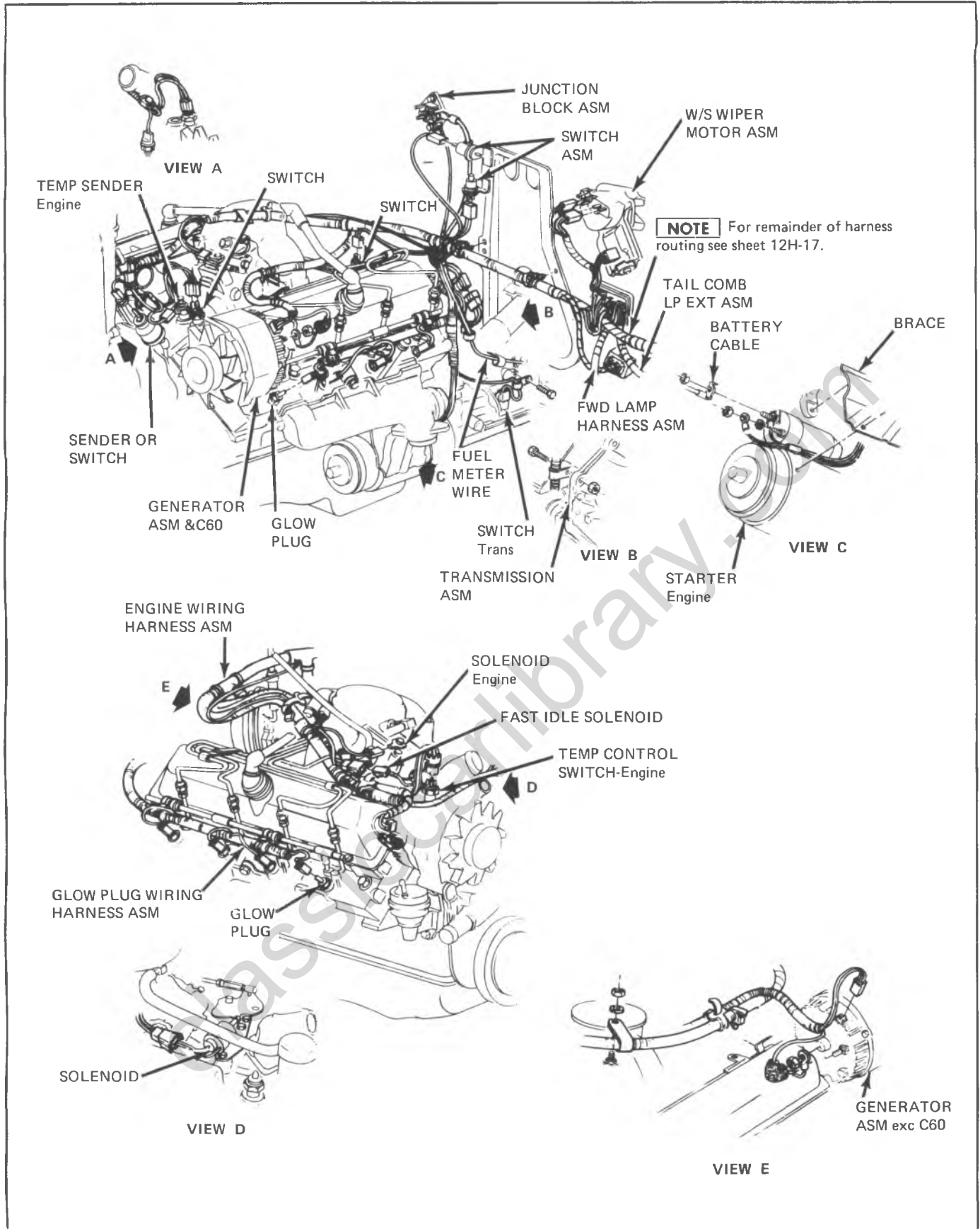


Fig. 6D-16D-Engine Compartment Wiring

IGNITION SYSTEM - CONVENTIONAL ENGINES

GENERAL DESCRIPTION

CONTENTS

| | | | |
|--------------------------|-------|-----------------------------|-------|
| General Description..... | 6D-33 | Remove and Replace | 6D-38 |
| H.E.I. Distributor | 6D-34 | Distributor | 6D-38 |
| Ignition Timing | 6D-34 | Module..... | 6D-38 |
| Secondary Wiring..... | 6D-34 | Pick-up Coil | 6D-39 |
| Spark Plugs | 6D-34 | Rotor..... | 6D-39 |
| Ignition Switch..... | 6D-35 | Vacuum Advance Unit..... | 6D-40 |
| Diagnosis | 6D-35 | Integral Ignition Coil..... | 6D-40 |
| H.E.I. Distributor | 6D-35 | Capacitor | 6D-40 |
| On-Vehicle Service..... | 6D-38 | Set Ignition Timing..... | 6D-40 |
| H.E.I. Distributor | 6D-38 | Spark Plug Wires..... | 6D-40 |

GENERAL DESCRIPTION

The ignition circuit consists of the battery, the distributor, the ignition switch, the spark plugs, and the primary and secondary wiring. Refer to the Battery portion of this section for battery information.

H.E.I. DISTRIBUTOR

The High Energy Ignition distributor used on all engines combines all ignition components in one unit (Fig. 6D-17D and 6D-18D). The external electrical connections are the ignition switch feed wire, the tachometer pickup, and the four, six or eight spark plug leads. The ignition switch feed connector to the distributor has full battery voltage when the ignition switch is in the "RUN" and "START" positions. There is **NO RESISTOR WIRE FROM THE IGNITION SWITCH TO THE DISTRIBUTOR**. The ignition coil is in the distributor cap and connects through a resistance brush to the rotor. The High Energy Ignition System is basically identical in operation to conventional ignition except the module and pick-up coil replace the contact points.

The High Energy Ignition is a magnetic pulse triggered, transistor controlled, inductive discharge ignition system. The magnetic pick-up assembly located inside the distributor contains a permanent magnet, a pole piece with internal teeth, and a pick-up coil. When the teeth of the timer core rotating inside the pole piece line up with the teeth of the pole piece, an induced voltage in the pick-up coil signals the electronic module to trigger the coil primary circuit. The primary current decreases and a high voltage is induced in the ignition coil secondary winding which is directed through the rotor and secondary leads to fire the spark plugs. The capacitor in the distributor is for radio noise suppression.

The magnetic pick-up assembly is mounted over the main bearing on the distributor housing, and is made to rotate by the vacuum control unit, thus providing vacuum advance. The timer core is made to rotate about the shaft by conventional advance weights, thus providing centrifugal

advance.

The module automatically controls the dwell period, stretching it with increasing engine speed. The HEI system also features a longer spark duration, made possible by the higher amount of energy stored in the coil primary. This is desirable for firing lean mixtures.

When making compression checks, disconnect ignition switch connector (pink wire) from HEI system.

No periodic lubrication is required. Engine oil lubricates the lower bushing and an oil-filled reservoir provides lubrication for the upper bushing.

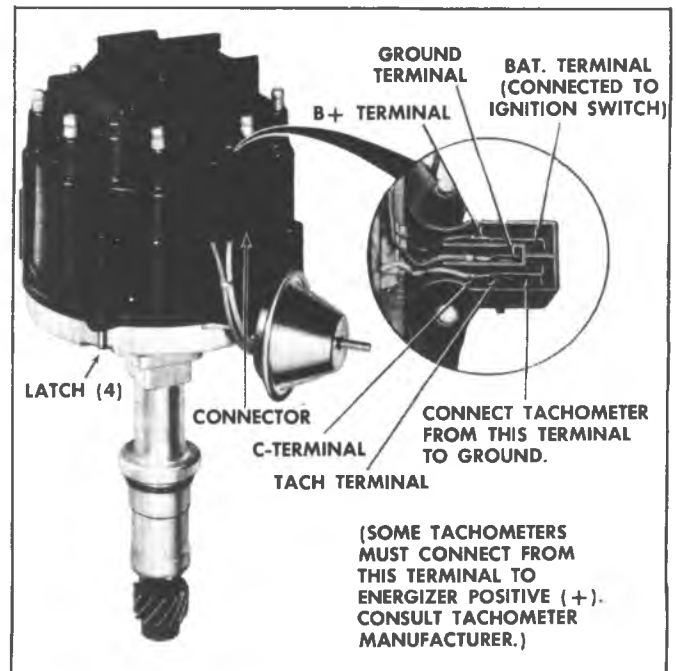


Fig. 6D-17D-HEI Distributor Assembly

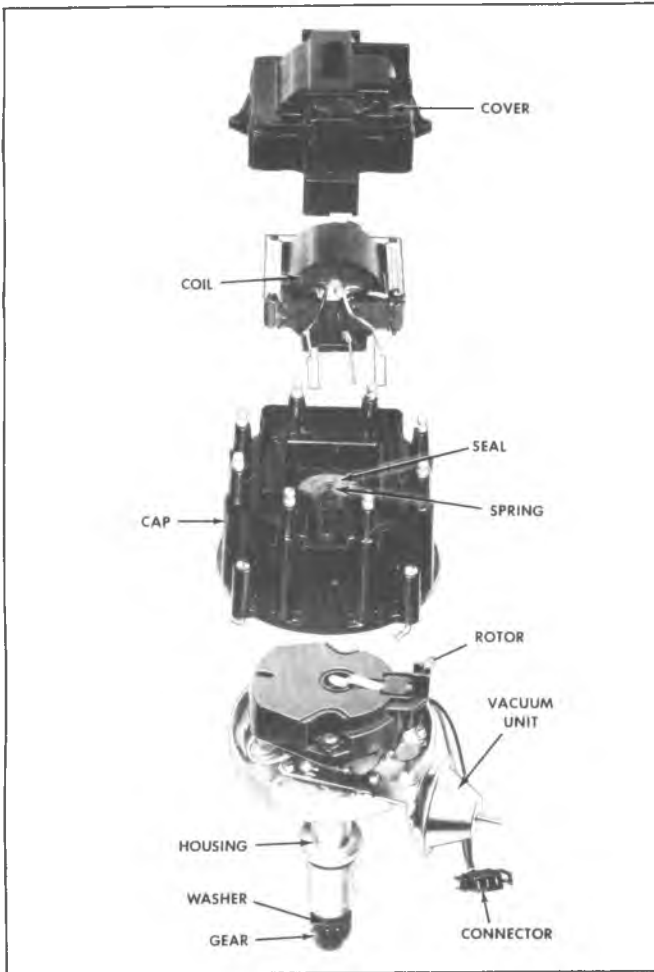


Fig. 6D-18D--HEI Distributor - Exploded View

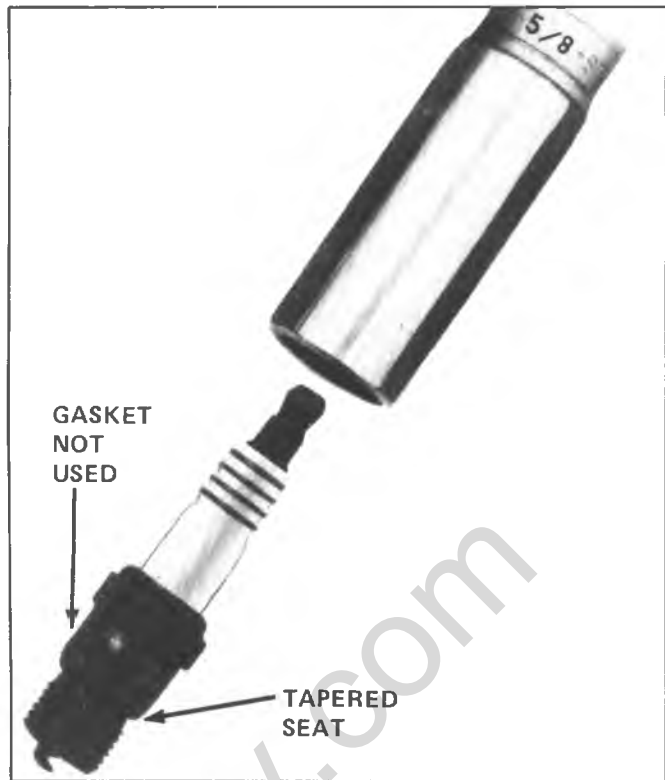


Fig. 6D-19D--Spark Plug - Tapered Seat

light or other pick-up equipment. Do not force contacts between the boot and wiring or through the silicone jacket. Connections should be made in parallel using an adapter. **DO NOT** pull on the wire to remove. Pull on the boot, or use a tool designed for this purpose.

SPARK PLUGS (FIG. 6D-19D)

Resistor type, tapered seat spark plugs are used on all gasoline engines. No gasket is used on these tapered seat plugs. See Fig. 6D-20D for an explanation of letter coding on spark plugs.

See Engine Exhaust Emissions Section (6E) for spark plug application and gap sizes. Always replace plugs with the correct plug listed on the tune-up label.

Normal or average service is assumed to be a mixture of idling, slow speed, and high speed operation with some of each making up the daily total driving. Occasional or intermittent high-speed driving is essential to good spark plug performance as it provides increased and sustained combustion heat that burns away any excess deposits of carbon or oxide that may have accumulated from frequent idling or continual stop-and-go or slow-speed driving. Spark plugs are protected by an insulating nipple made of special heat-resistant material which covers the spark plug terminal and extends downward over a portion of the plug insulator. These nipples prevent flash-over with resultant missing of engine, even though a film is allowed to accumulate on exposed portion of plug porcelains.

NOTICE: Do not mistake corona discharge for flash-over or a shorted insulator. Corona is a steady blue light appearing around insulator, just above the shell crimp. It is the visible evidence of high-tension field, and has no effect on ignition performance. Usually it

IGNITION TIMING

Timing specifications for each engine are listed in Section 6E and on the Vehicle Emissions Control Information label on the radiator support. When using a timing light, connect an adapter between the No. 1 spark plug and the No. 1 spark plug wire, or use an inductive type pick-up. Do not pierce the plug lead. Once the insulation of the spark plug cable has been broken, voltage will jump to the nearest ground, and the spark plug will not fire properly. The timing procedure remains the same as the conventional ignition system. Always follow Vehicle Emissions Control Information label procedures when adjusting timing.

Some engines will incorporate a magnetic timing probe hole for use with special electronic timing equipment. Consult manufacturer's instructions for use of this equipment.

SECONDARY WIRING

The spark plug wiring used with the HEI system is a carbon impregnated cord conductor encased in an 8mm diameter silicone rubber jacket. The silicone wiring will withstand very high temperatures and also provides an excellent insulator for the higher voltage of the HEI system. The silicone spark plug boots form a tight seal on the plug and the boot should be twisted 1/2 turn before removing. Care should also be exercised when connecting a timing

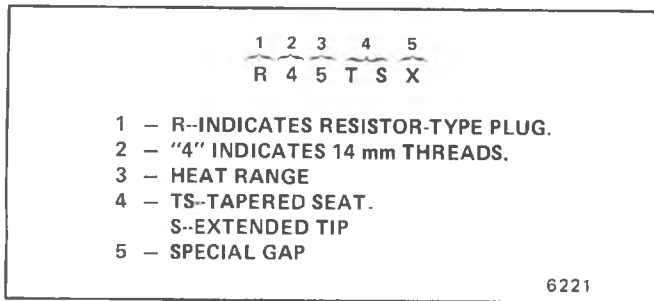


Fig. 6D-20D--Spark Plug Coding

can be detected only in darkness. This discharge may repel dust particles, leaving a clear ring on the insulator just above the shell. This ring is sometimes mistakenly regarded as evidence that combustion gases have blown out between shell and insulator.

DIAGNOSIS

H.E.I. DISTRIBUTOR

Use Figure 6D-21D & 22D for H.E.I. Diagnosis.

SPARK PLUGS

Worn or dirty plugs may give satisfactory operation at idling speed, but under operating conditions they frequently fail. Faulty plugs are indicated in a number of ways: poor fuel economy, power loss, loss of speed, hard starting and general poor engine performance.

Spark plug failure, in addition to normal wear, may be due to carbon fouled plugs, excessive gap or broken insulator.

Fouled plugs may be indicated by checking for black carbon deposits. The black deposits are usually the result of slow-speed driving and short runs where sufficient engine operating temperature is seldom reached. Worn pistons, rings, faulty ignition, over-rich carburetion and spark plugs which are too cold will also result in carbon deposits.

Excessive gap wear, on plugs of low mileage, usually indicates the engine is operating at high speeds or loads that are consistently greater than normal or that a plug which is too hot is being used. In addition, electrode wear may be

IGNITION SWITCH

The mechanical switch is located in the steering column on the right hand side just below the steering wheel. The electrical switching portion of the assembly is separate from the key and lock cylinder. However, both are synchronized and work in conjunction with each other through the action of the actuator rod assembly.

For a complete explanation of the key and lock cylinder, and the actuator rod assembly, see STEERING, Section 3B. See Section 8 for the detailed explanation of the electrical switching.

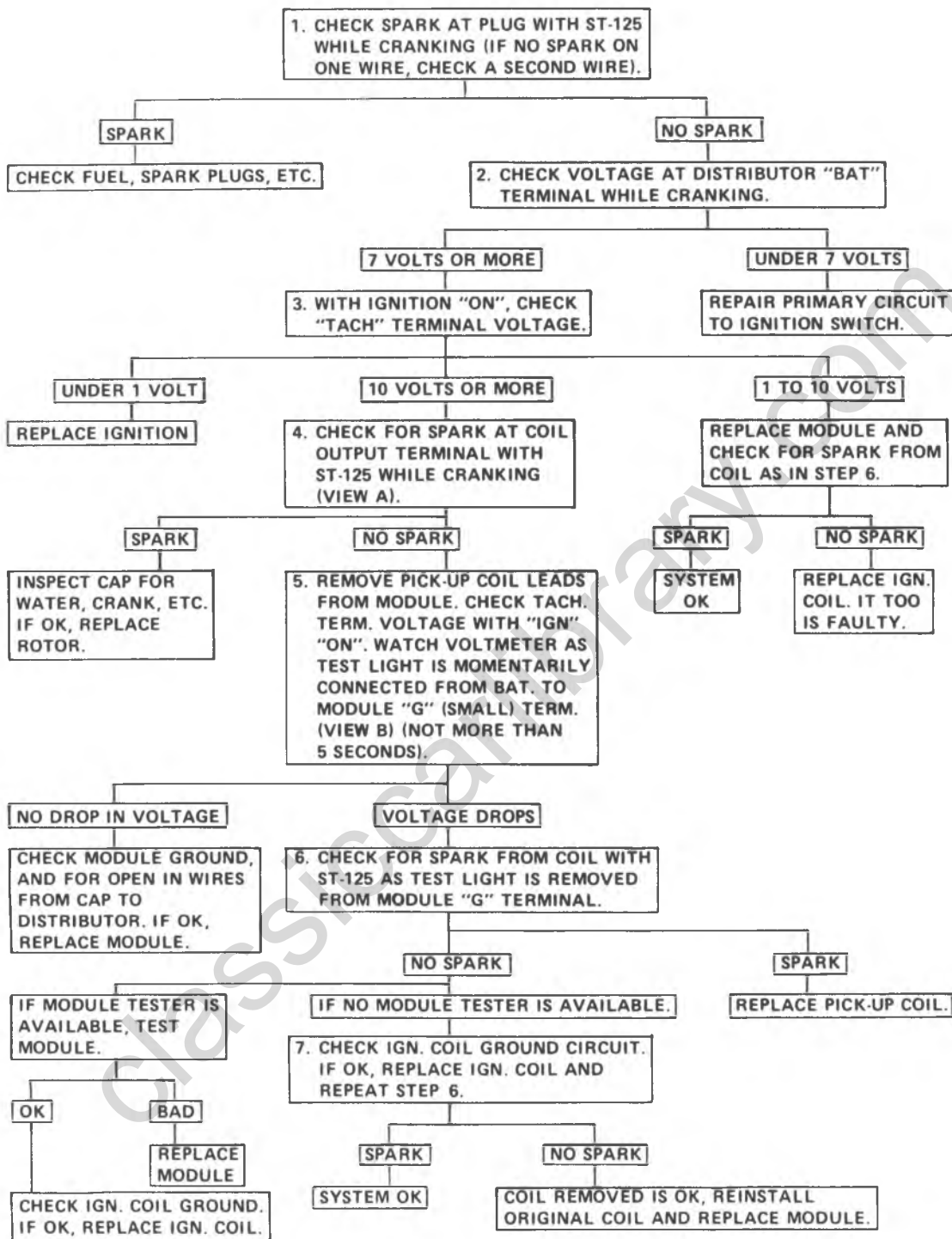
the result of plug overheating, caused by combustion gases leaking past the threads, due to insufficient torquing of the spark plug. Excessively lean carburetion will also result in excessive electrode wear.

Broken insulators are usually the result of improper installation or carelessness when regapping the plug. Broken upper insulators usually result from a poor fitting wrench or an outside blow. The cracked insulator may not make itself evident immediately, but will as soon as oil or moisture penetrates the fracture. The fracture is usually just below the crimped part of shell and may not be visible.

Broken lower insulators usually result from carelessness when regapping and generally are visible. In fairly rare instances, this type of break may result from the plug operating too "hot", encountered in sustained periods of high-speed operation or under extremely heavy loads. When regapping a spark plug, to avoid lower insulator breakage, always make the gap adjustment by bending the ground (side) electrode. Spark plugs with broken insulators should always be replaced.

ENGINE CRANKS, BUT WILL NOT START

NOTE: IF A TACHOMETER IS CONNECTED TO THE TACHOMETER TERMINAL, DISCONNECT IT BEFORE PROCEEDING WITH THE TEST.



NOTE: VIEWS ARE IN PART 2.

6741

Fig. 6D-21D-HEI Diagnosis

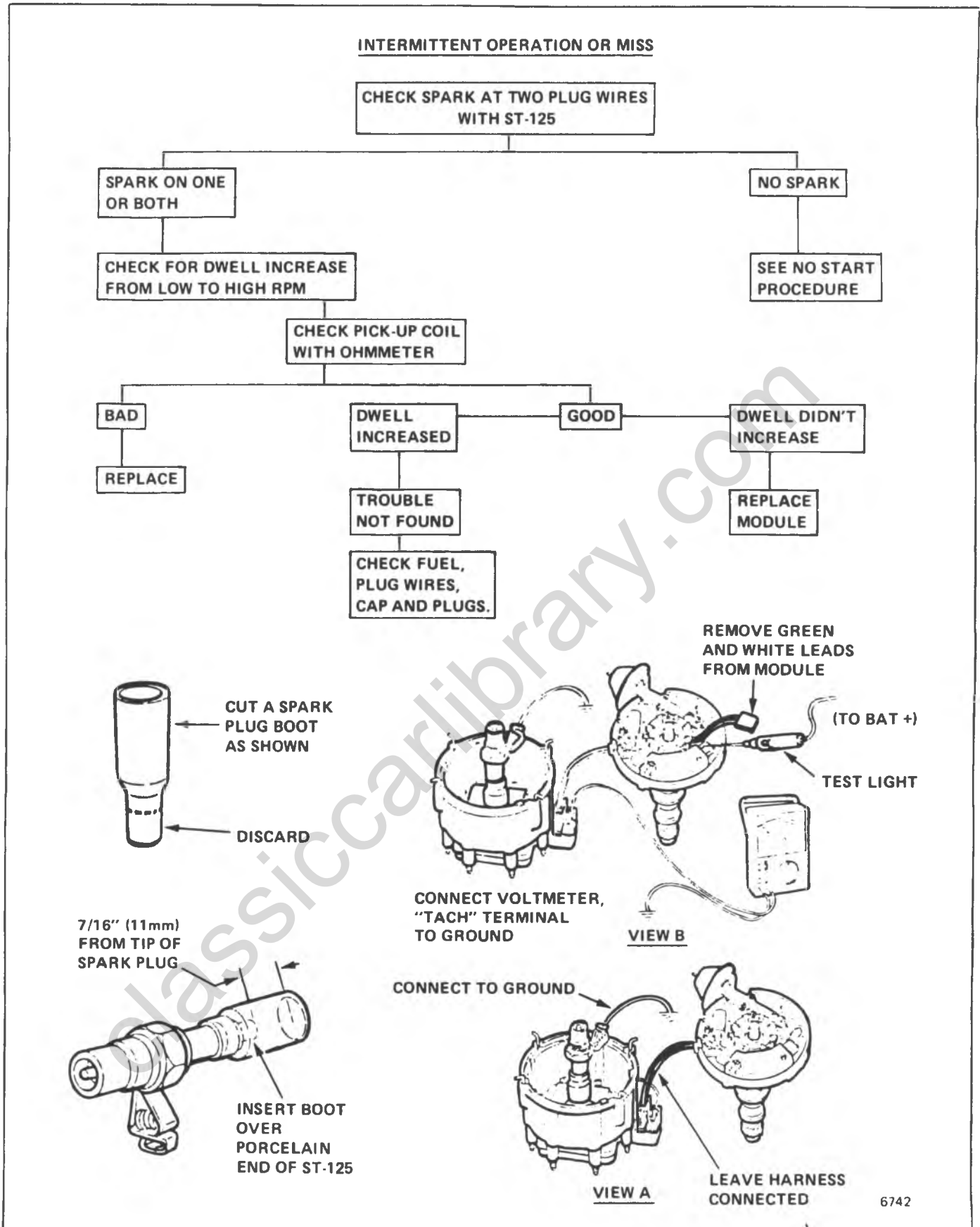


Fig. 6D-22D-HEI Diagnosis

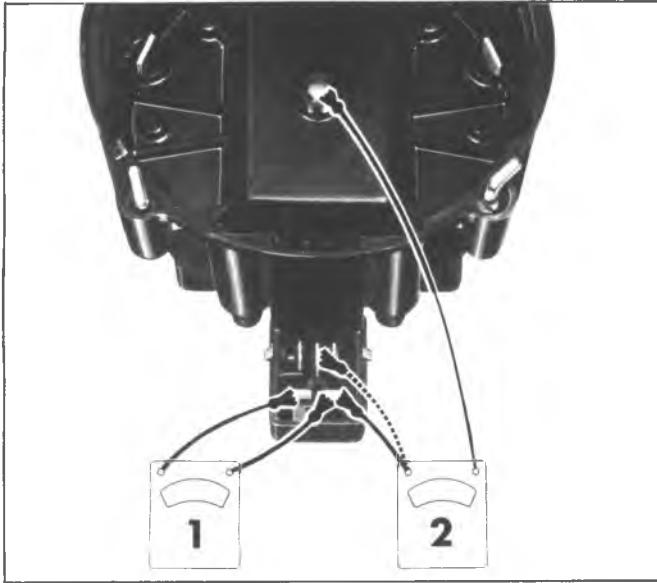


Fig. 6D-23D--Checking Internal Coil

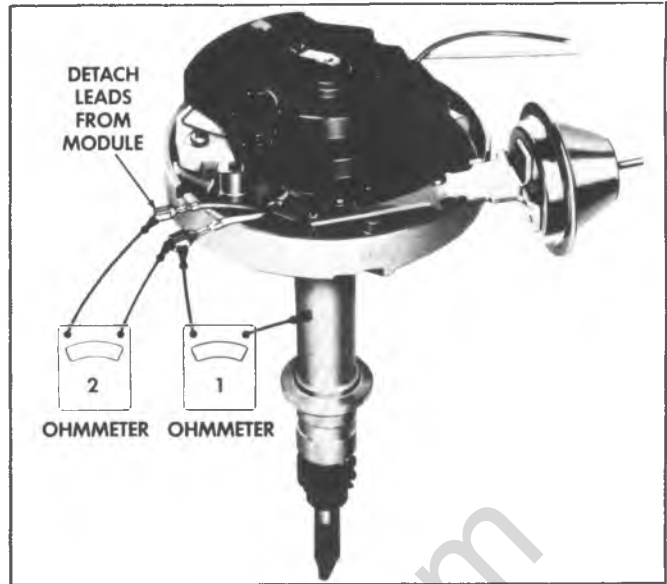


Fig. 6D-24D--Checking Pickup Coil

ON-VEHICLE SERVICE

H.E.I. DISTRIBUTOR

Service Precautions

1. When making compression checks, disconnect the ignition switch feed wire at the distributor. When disconnecting this connector do not use a screwdriver or tool to release the locking tab as it may break.

2. No periodic lubrication is required. Engine oil lubricates the lower bushing and an oil-filled reservoir provides lubrication for the upper bushing.

3. The tachometer (TACH) terminal is next to the ignition switch (BAT) connector on the distributor cap.

NOTICE: The tachometer terminal must NEVER be allowed to touch ground, as damage to the module and/or ignition coil can result.

Some service tachometers and electronic diagnostic equipment currently in use may NOT be compatible with the High Energy Ignition System. It is recommended that you consult your representative of such equipment as to the necessary updating of your equipment for compatibility with the HEI System.

4. There is no dwell adjustment as this is controlled by the module.

5. The centrifugal advance and vacuum advance are similar to the conventional ignition.

6. The material used to construct the spark plug cables is very pliable and soft. This cable will withstand more heat and carry a higher voltage. Due to the more pliable cable, scuffing and cutting become easier. It is therefore extremely important that the spark plug cables be routed correctly to prevent chaffing or cutting. See Spark Plug Section of On-Vehicle Service. Also when removing a spark plug wire from

a spark plug, twist the boot on the spark plug and pull on the boot to remove the wire.

Remove and Replace

Fig. 6D-25D shows a new type connector for the module and capacitor. There are no changes to either diagnosis or circuitry.

Distributor

1. Disconnect ignition switch battery feed wire and tachometer lead (if equipped) from distributor cap. Also release the coil connectors from the cap. (DO NOT use a screwdriver or tool to release the locking tabs.)

2. Remove distributor cap by turning four latches counterclockwise. Move cap out of the way.

If necessary to remove secondary wires from cap, release wiring harness latches and remove wiring harness retainer. The spark plug wire numbers are indicated on the retainer.

3. Remove vacuum hose from vacuum advance unit.

4. Remove distributor clamp screw and hold-down clamp.

5. Note position of rotor, then pull distributor up until rotor just stops turning counterclockwise and again note position of rotor.

NOTICE: To insure correct timing of the distributor, the distributor must be INSTALLED with the rotor correctly positioned as noted in Step 5.

If the engine was accidentally cranked after the distributor was removed, the following procedure can be used for installing:

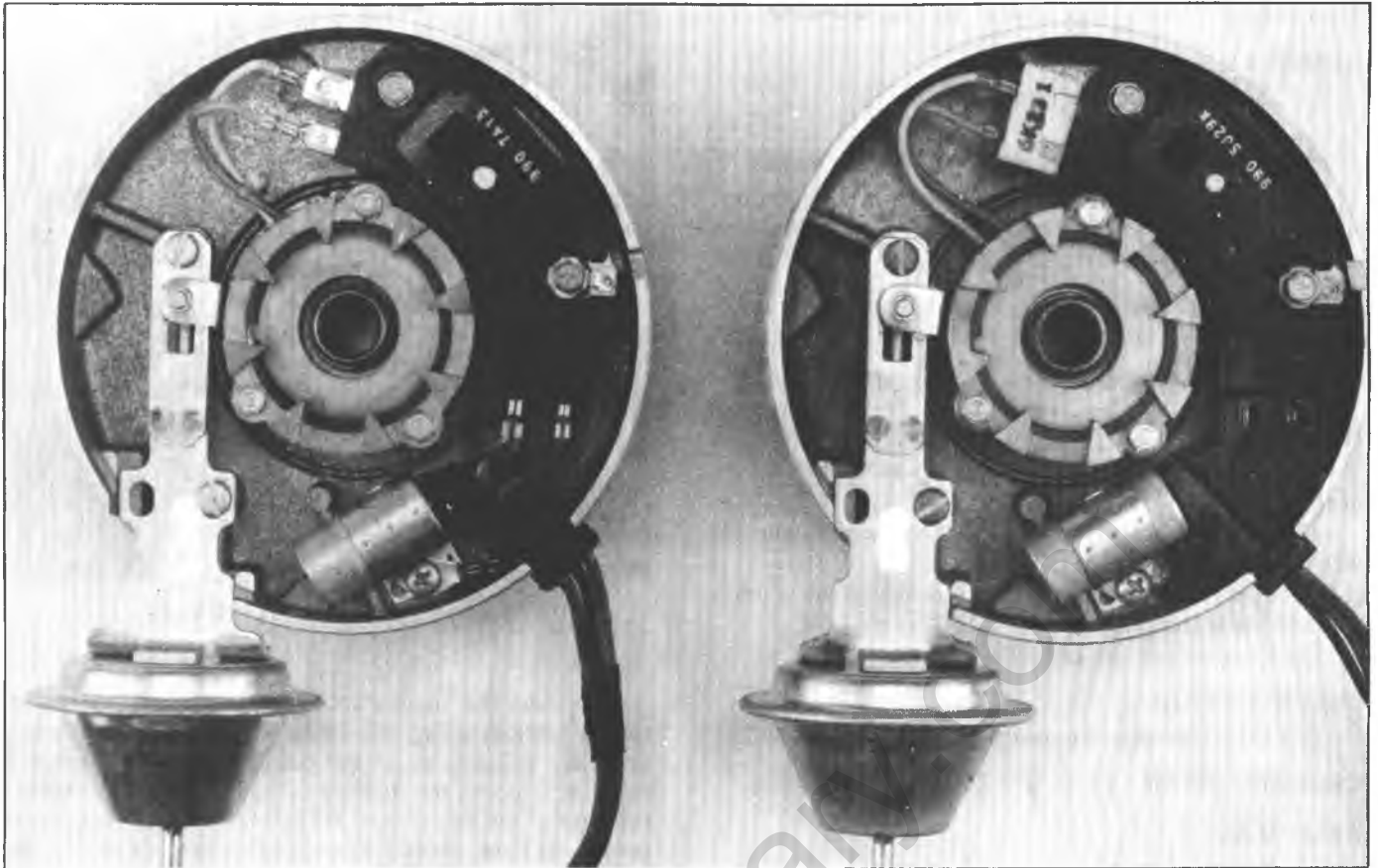


Fig. 6D-25D—Distributor Base and Components

- a. Remove No. 1 spark plug.
- b. Place finger over No. 1 spark plug hole and crank engine slowly until compression is felt.
- c. Align timing mark on pulley to "O" on engine timing indicator.
- d. Turn rotor to point between No. 1 and No. 8 spark plug towers on distributor cap.
- e. Install distributor and connect ignition feed wire.
- f. Install distributor cap and spark plug wires.
- g. Check engine timing (see Set Ignition Timing below).

Module (Refer to Fig. 6D-25D)

It is not necessary to remove the distributor from vehicle.

REMOVAL

1. Remove distributor cap and rotor.
2. Disconnect two pick-up leads from module. (Observe color code on leads as these cannot be interchanged.)
3. Remove two module attaching screws.
4. Remove module from distributor base and remove two wire connectors.

NOTICE: Do not wipe grease from module or distributor base if same module is to be replaced. If a new module is to be installed, a package of silicone lubricant will be included with it. Spread the lubricant on the metal face of the module and on the distributor base where the module seats. This lubricant is

important as it aids heat transfer for module cooling.

INSTALLATION

To install, reverse removal procedure.

Pick-Up Coil (Refer to Fig. 6D-25D)**REMOVAL**

1. Remove distributor from vehicle. Mark distributor shaft and gear so that they may be reassembled in the same position (see Distributor Removal above).
2. Drive out the roll pin and remove gear.
3. Remove distributor cap.
4. Remove distributor shaft with rotor and advance weights.

5. Remove the thin "C" washer on top of pick-up coil assembly, remove pick-up coil leads from module, and remove the pick-up coil assembly. (Do not remove the three screws.)

INSTALLATION

To install reverse removal procedure noting alignment marks when installing gear.

Rotor (Refer to Fig. 6D-25D)

The rotor is retained by two screws and is provided with a slot which fits over a square lug on the advance weight base, so that the rotor can be installed in only one position.

Vacuum Advance Unit (Refer to Fig. 6D-25D)**REMOVAL**

1. Remove distributor cap and rotor.
2. Remove module.
3. Remove two vacuum advance attaching screws.
4. Turn the pick-up coil clockwise and push the rod end of the vacuum advance down so that it will disengage and clear the pick-up coil plate.

INSTALLATION

To install, reverse removal procedure.

Integral Ignition Coil (Refer to Fig. 6D-17D)**REMOVAL**

1. Remove wiring connector from distributor cap by lifting two retaining tabs.
2. Remove three coil cover attaching screws, and lift off cover.
3. Remove four coil attaching screws and lift ignition coil and leads from cap.
4. Remove coil arc seal.

INSTALLATION

To install, reverse removal procedure.

Capacitor (Refer to Fig. 6D-25D)**REMOVAL**

1. Remove distributor cap and rotor.
2. Remove capacitor attaching screw, and unplug capacitor.

INSTALLATION

1. Plug in capacitor.
2. Install hold down screw making sure ground lead is under screw.

SET IGNITION TIMING

1. Refer to the tune-up label located on the radiator support panel. Follow all instructions on the label.
2. With ignition off, connect the pick-up lead of timing light to the number one spark plug. Use a jumper lead between the wire and plug or an inductive type pick-up. **DO NOT** pierce the wire or attempt to insert a wire between the boot and the wire. Connect the timing light power leads according to manufacturer's instructions.



Fig. 6D-26D—Timing Mark - Typical

3. Start the engine, and aim the timing light at the timing mark (see Fig. 6D-26D). The line on the balancer or pulley will line up at the timing mark. If a change is necessary, loosen the distributor hold-down clamp bolt at the base of the distributor. While observing the mark with the timing light, slightly rotate the distributor until the line indicates the correct timing. Tighten the hold-down bolt, and re-check the timing.

4. Turn off the engine and remove the timing light. Reconnect the number one spark plug wire, if removed.

SPARK PLUG WIRES

Use care when removing spark plug wire boots from spark plugs. Twist the boot 1/2 turn before removing, and pull on the boot only to remove the wire.

It is extremely important when replacing plug wires to route the wires correctly and through the proper retainers. Failure to route the wires properly can lead to radio ignition noise and crossfiring of the plugs, or shorting of the leads to ground.

Refer to Figure 6D-27D for proper spark plug wire routing.

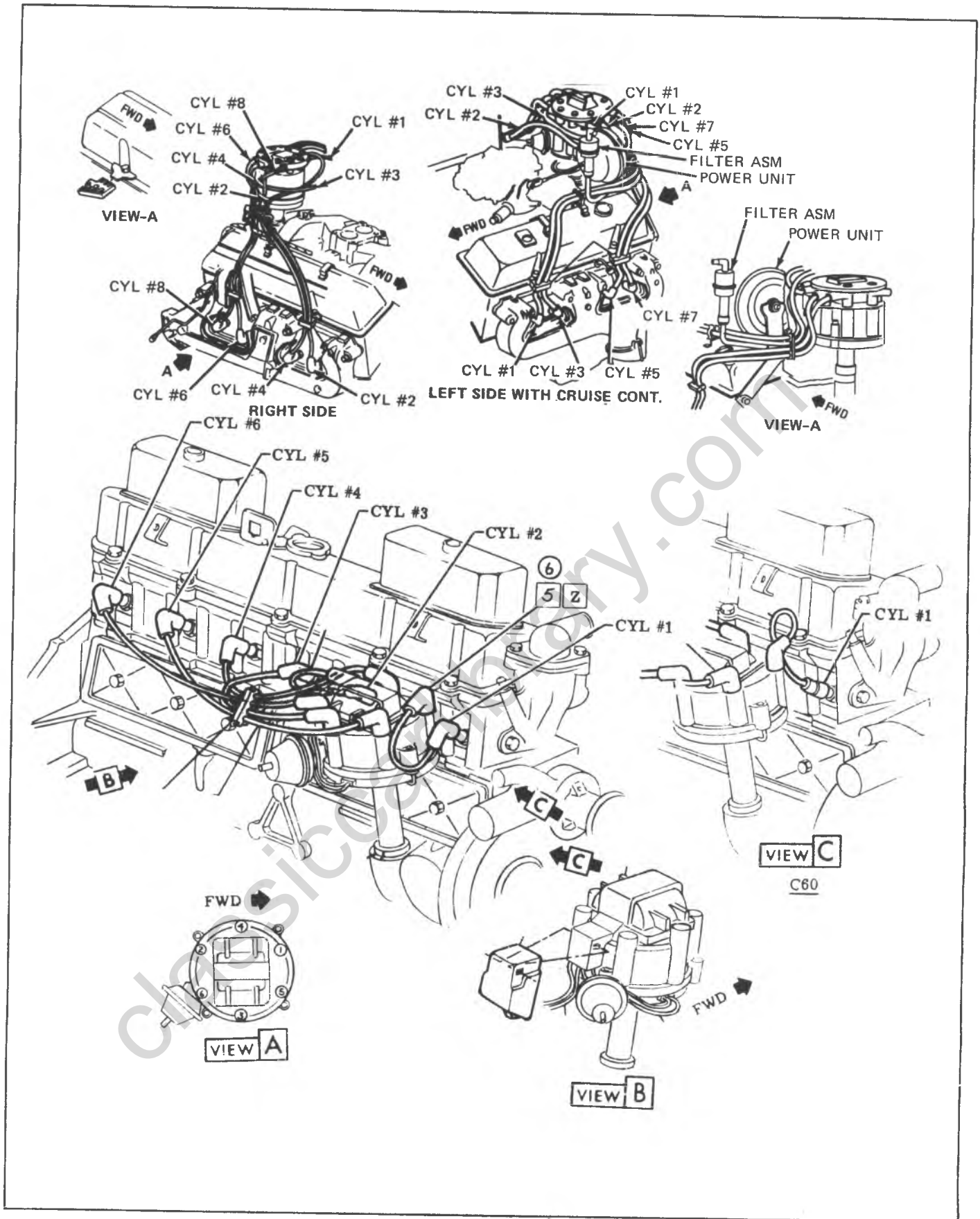


Fig. 6D-27D-Spark Plug Wire Routing

IGNITION SWITCH

GENERAL DESCRIPTION

The electrical switching portion of the assembly is separate from the key and lock cylinder. However, both are synchronized and work in conjunction with each other through the action of the actuator rod assembly. For a complete explanation of the key and lock cylinder, and the actuator rod assembly, refer to the Steering section of this manual.

The ignition switch is key operated through the actuator rod assembly to close the ignition primary circuit and to energize the starting motor solenoid for cranking. The ignition switch used on all cars have five positions: OFF, LOCK, ACCESSORY, RUN and START. OFF is the center position of the key-lock cylinder, and LOCK is the next position to the left. ACCESSORY is located one more detent to the left of LOCK. Turning the key to the right of the OFF position until spring pressure is felt will put the ignition switch in the RUN position, and when turned fully to the right against spring pressure, the switch will be in the START position.

All Chevrolet ignition switches have five terminals which are connected in different combinations for each of the three operating positions. A brass plate, inside the switch, has three contacts which connect these terminals. Figure 6D-28D shows the positions of the contacts in all positions as viewed from the key side of the switch. There is also a ground pin in the switch which contacts the "ground" terminal when the ignition switch is in the START position. This pin contacts the IGN. terminal when in the OFF position.

Ignition Start and Run Circuit

The ignition switch is fed from the battery to the BAT.

terminal of the switch. When the ignition switch is in the OFF position, no current flows through the switch. When the ignition switch is turned to the ACC. position, the BAT. terminal is connected to the ACC. terminal. This permits operation of accessories when the engine is not running.

When the ignition switch is turned to the START position, the BAT. terminal is connected to the SOL. and IGN. terminals. When the clutch or automatic transmission neutral start switches are closed, current flows to the starter solenoid. This energizes the solenoid windings. The solenoid has two sets of windings: a "pull-in" winding and a "hold-in" winding. Both windings are used to create the magnetic field to actuate the the solenoid plunger and move the starter pinion into engagement with the flywheel. As the solenoid plunger reaches the end of its travel, it closes a switch which connects battery voltage to the starter motor. With battery voltage applied to both terminals of the "pull-in" windings, the "pull-in" winding is no longer energized, so that only the "hold-in" winding keeps the starter solenoid engaged.

The instrument panel warning lights are fed from the ignition terminal of the ignition switch and have battery voltage applied to them when the ignition switch is in the START and RUN position. These circuits are explained in the Chassis Electrical Section.

When the ignition switch is released from the START to the RUN position, the IGN. terminal is still connected to the BAT. terminal. With the ignition switch in the RUN position, the BAT. terminal is connected to the IGN. terminal and the ACC. terminal. This permits operation of all accessories and the ignition system.

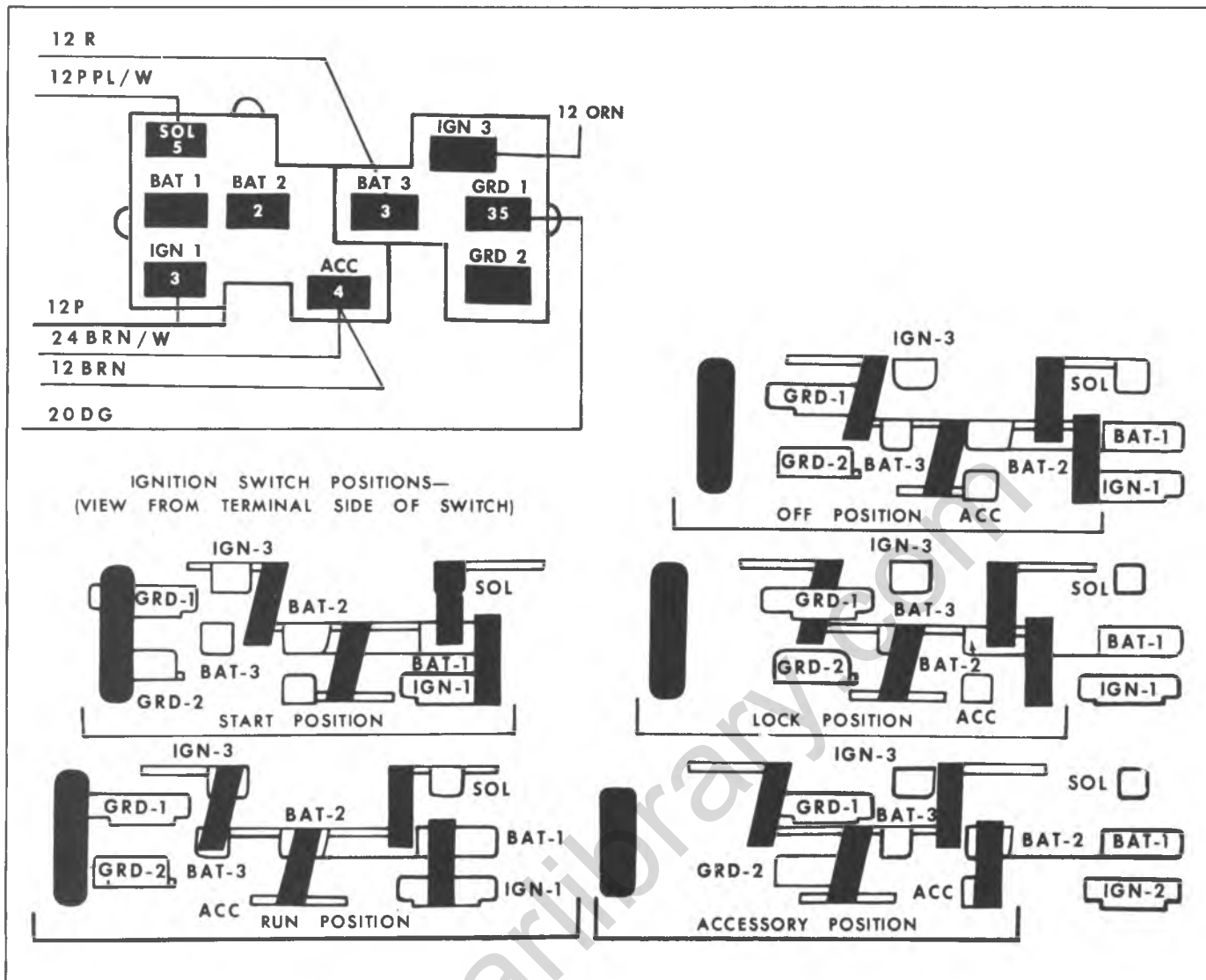


Fig. 6D-28D—Ignition Switch Circuit

CRANKING SYSTEM

| | | | |
|--------------------------|-------|---------------------------|-------|
| General Description..... | 6D-43 | Solenoid | 6D-50 |
| Cranking Circuit..... | 6D-43 | Overhaul..... | 6D-50 |
| Starter Motor..... | 6D-44 | Disassembly..... | 6D-50 |
| Diagnosis..... | 6D-46 | Component Inspection..... | 6D-51 |
| On-Vehicle Service..... | 6D-50 | Reassembly..... | 6D-52 |
| Remove and Replace..... | 6D-50 | Specifications..... | 6D-58 |
| Starter..... | 6D-50 | | |

GENERAL DESCRIPTION

CRANKING CIRCUIT

The cranking circuit consists of the battery, starting motor, ignition switch, and related electrical wiring. These components are connected electrically as shown in Figure

6D-1E. Only the starting motor will be covered in this portion.

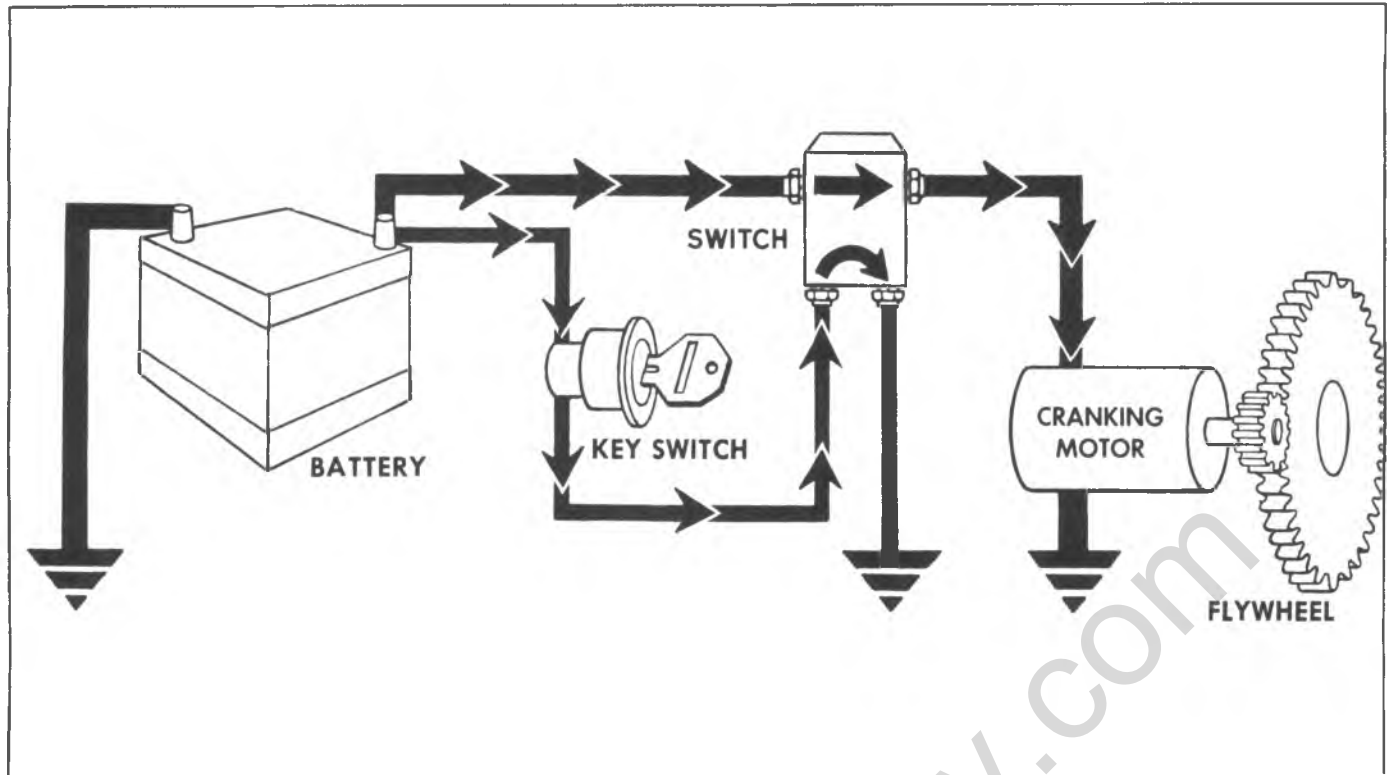


Fig. 6D-1E--Cranking Circuit - All

STARTING MOTOR

Two types of starter motors are used. The first, referred to as the 10MT series, is shown in Fig. 6D-2E. The second type, referred to as the 20MT series used on diesel equipped engines, is shown in Fig. 6D-3E. The main difference is that the 20MT has a center bearing. Fig. 6D-4E shows an exploded view of the 20MT series. Differences in service procedures will be pointed out as they occur.

Enclosed shift lever cranking motors have the shift lever mechanism and the solenoid plunger enclosed in the drive housing protecting them from exposure to dirt, icing conditions and splash.

In the basic circuit shown in Figure 6D-1E, the solenoid windings are energized when the switch is closed. The resulting plunger and shift lever movement causes the pinion to engage the engine flywheel ring gear and the solenoid main contacts to close, and cranking takes place. When the engine starts, pinion overrun protects the armature from excessive speed until the switch is opened, at which time the return spring causes the pinion to disengage. To prevent excessive overrun, the switch should be opened immediately when the engine starts.

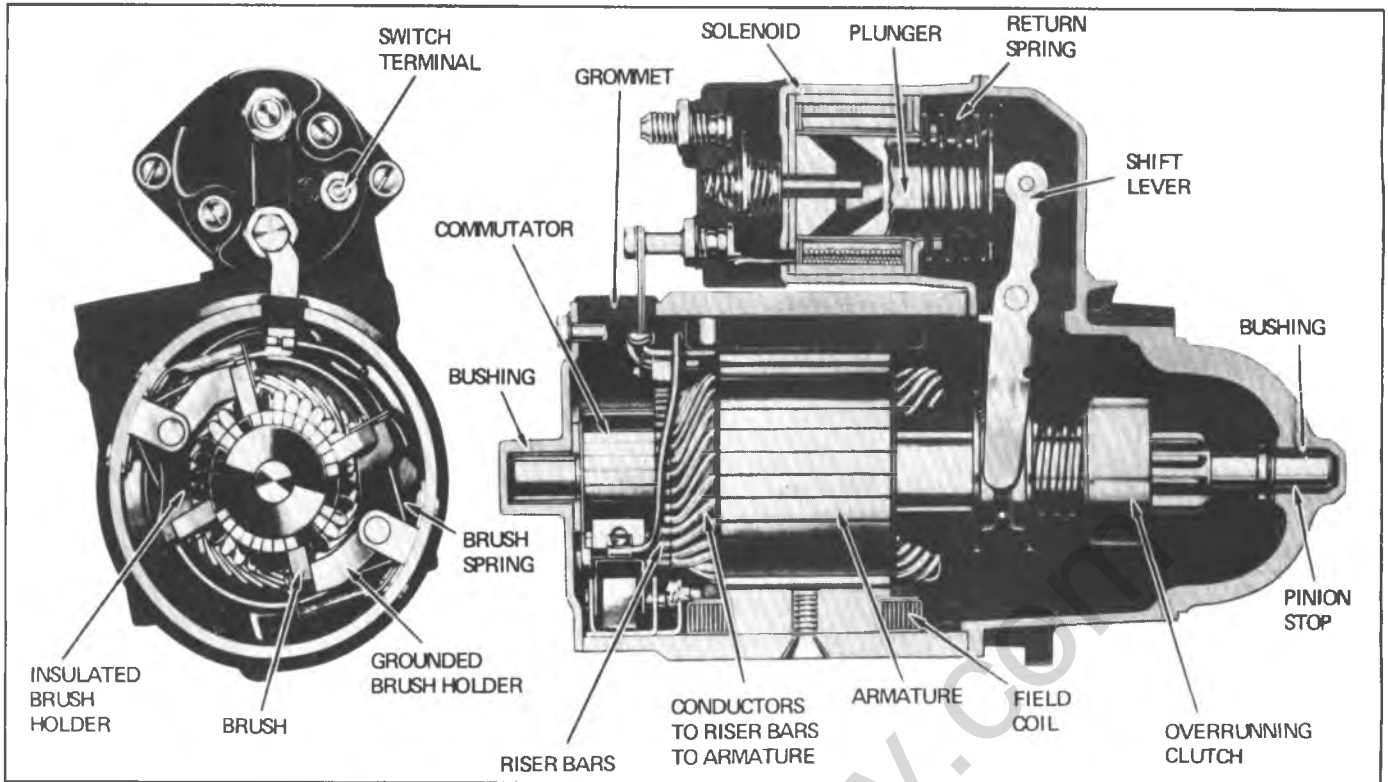


Fig. 6D-2E--Cross Section of 10MT Starting Motor

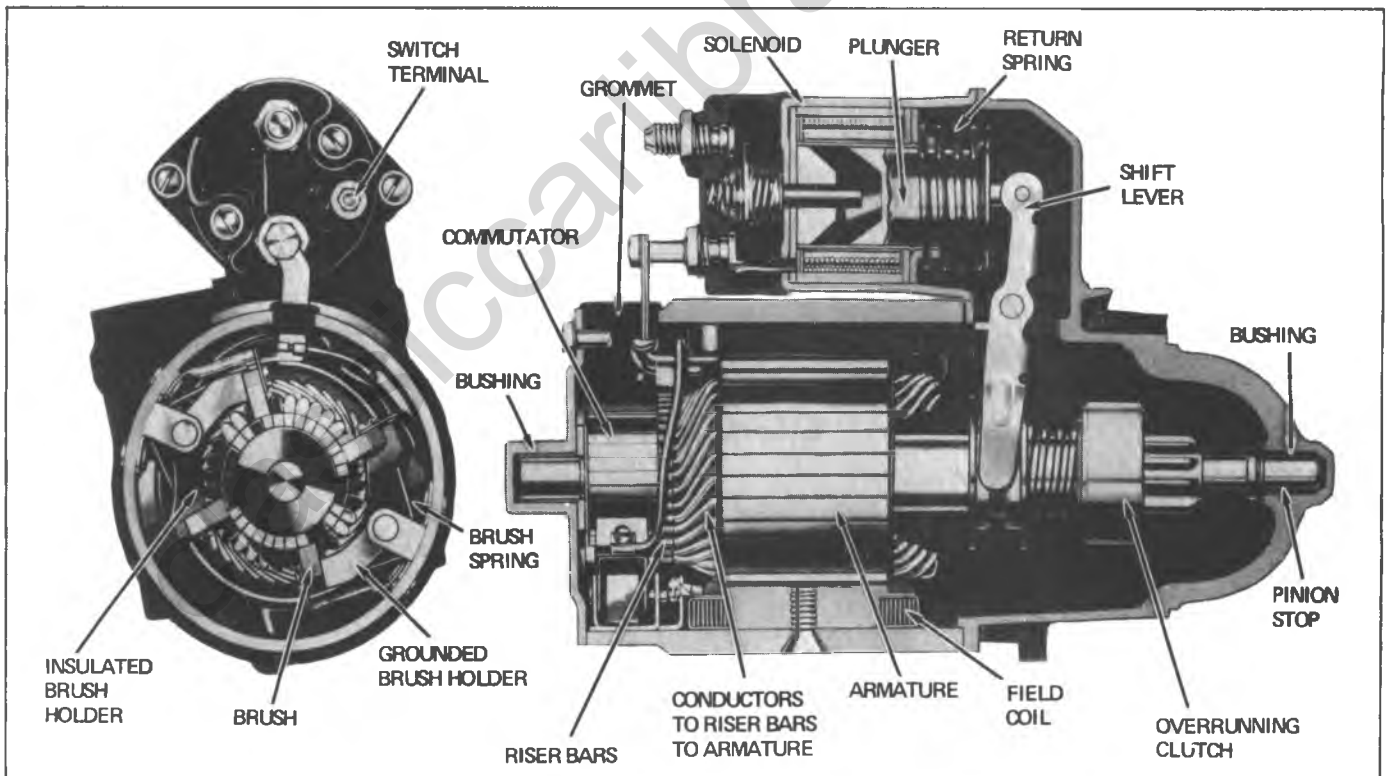


Fig. 6D-3E--Cross Section of 20MT Starting Motor

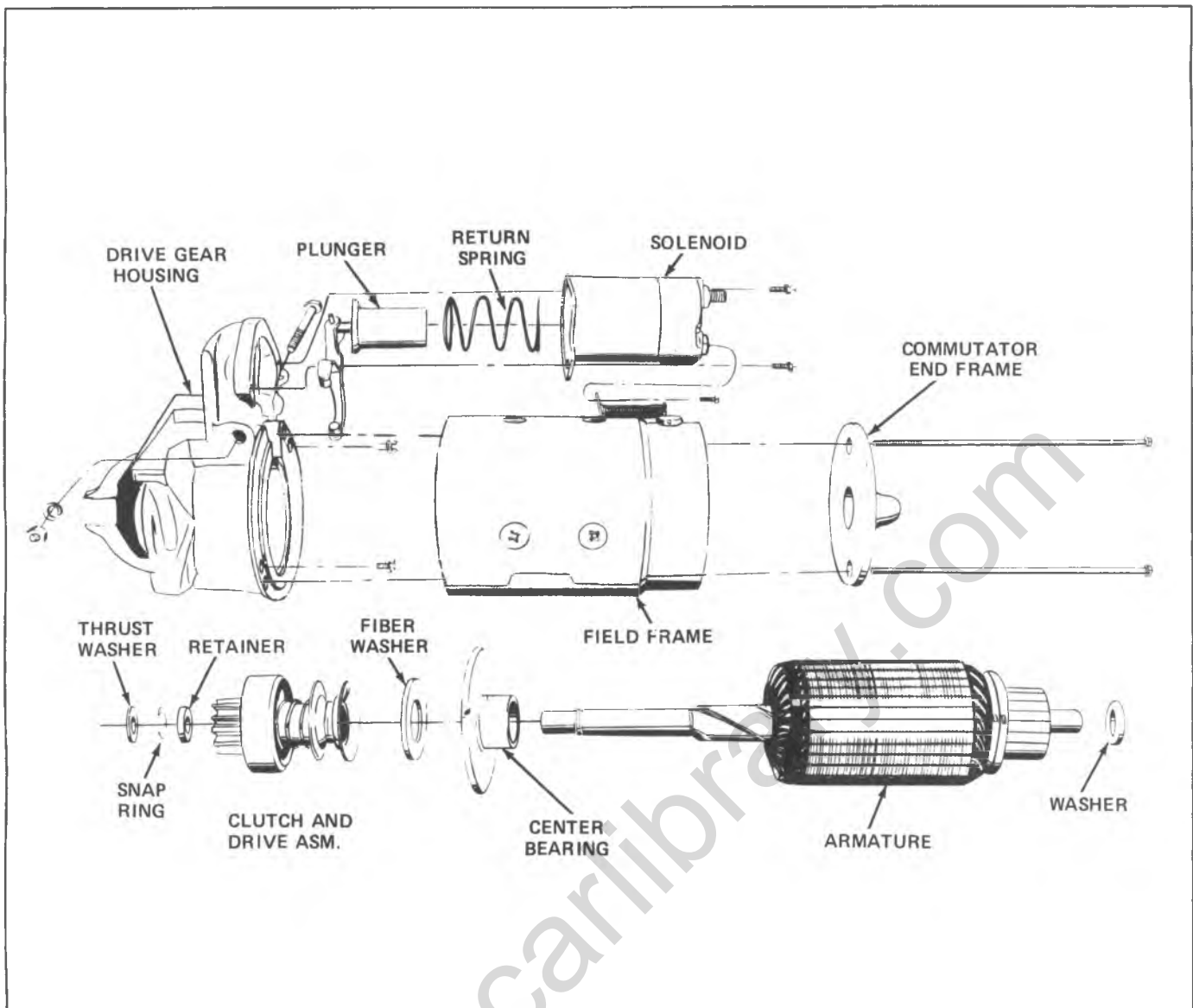


Fig. 6D-4E—Exploded View of 20MT Starting Motor

DIAGNOSIS

Before removing any unit in a cranking circuit for repair, the following checks should be made:

Battery:

To determine the condition of the battery, follow the testing procedure outlined in the Battery Section.

Wiring:

Inspect the wiring for damage. Inspect all connections to the cranking motor, solenoid, ignition switch, and battery, including all ground connections. Clean and tighten all connections as required.

Solenoid and Ignition Switch:

Inspect all switches to determine their condition.

Starter Motor Noise:

To correct starter motor noise during starting, use the following procedure:

1. Refer to Fig. 6D-5E to determine the problem.
2. If the complaint is similar to problem categories 1 or 2 above, correction can be achieved by proper "shimming" as follows:
 - a. Remove lower flywheel housing cover and examine for visual problems - bent flywheel, unusual wear, etc.
 - b. Start engine and carefully touch outside diameter of rotating flywheel ring gear with chalk or crayon to show high point of tooth runout after engine is turned off. Turn

| PROBLEM | CAUSE |
|---|---|
| 1. HIGH PITCHED WHINE DURING CRANKING (BEFORE ENGINE FIRES) BUT ENGINE CRANKS AND FIRES OKAY. | DISTANCE TOO GREAT BETWEEN STARTER PINION AND FLYWHEEL. |
| 2. HIGH PITCHED "WHINE" AFTER ENGINE FIRES, AS KEY IS BEING RELEASED. ENGINE CRANKS AND FIRES OKAY. THIS INTERMITTENT COMPLAINT IS OFTEN DIAGNOSED AS "STARTER HANG-IN" OR "SOLENOID WEAK." | DISTANCE TOO SMALL BETWEEN STARTER PINION AND FLYWHEEL. FLYWHEEL RUNOUT CONTRIBUTES TO THE INTERMITTENT NATURE. |
| 3. A LOUD "WHOOOP" AFTER THE ENGINE FIRES BUT WHILE THE STARTER IS STILL HELD ENGAGED. SOUNDS LIKE A SIREN IF THE ENGINE IS REVVED WHILE STARTER IS ENGAGED. | MOST PROBABLE CAUSE IS A DEFECTIVE CLUTCH. A NEW CLUTCH WILL OFTEN CORRECT THIS PROBLEM. |
| 4. A "RUMBLE", "GROWL" OR (IN SEVERE CASES) A "KNOCK" AS THE STARTER IS COASTING DOWN TO A STOP AFTER STARTING THE ENGINE. | MOST PROBABLE CAUSE IS A BENT OR UNBALANCED STARTER ARMATURE. A NEW ARMATURE WILL OFTEN CORRECT THIS PROBLEM. |

5488

Fig. 6D-5E--Starter Motor Noise Diagnosis

engine off and rotate flywheel so that the marked teeth are in the area of the starter pinion gear.

c. Disconnect negative battery cable to prevent inadvertent cranking of engine.

Insert screwdriver in small hole in bottom of starter shown by arrow in Fig. 6D-6E and move starter pinion and clutch assembly so that pinion teeth and flywheel teeth are meshed. If necessary, rotate the flywheel so that a pinion tooth is directly in the center of two flywheel teeth and on the centerline of the two gears, as shown in Fig. 6D-7E.

d. Check pinion to flywheel clearance, as shown in Fig. 6D-50, by using a wire gage of .20" minimum thickness (or diameter). If the clearance is under this minimum, shimming the starter away from the flywheel is required. Shim (Part #9785608 or equivalent, .015" thick), installed as shown in Fig. 6D-8E, will increase the clearance by approximately .005". More than one shim may be required.

NOTICE: It is very important to center the pinion tooth between the flywheel teeth and gage, as shown in Fig. 6D-50, and not in the corners, where a misleading larger dimension may be observed.

e. If the clearance is grossly over .020" (in the vicinity of .060" or more), shimming the starter towards the flywheel is required. (This is generally the problem causing broken flywheel teeth or starter housings.) Shimming the starter towards the flywheel can be accomplished by shimming only the outboard starter mounting pad. A shim of .015" thickness, Part #1246249 or equivalent, at this location will decrease the clearance by approximately .010".

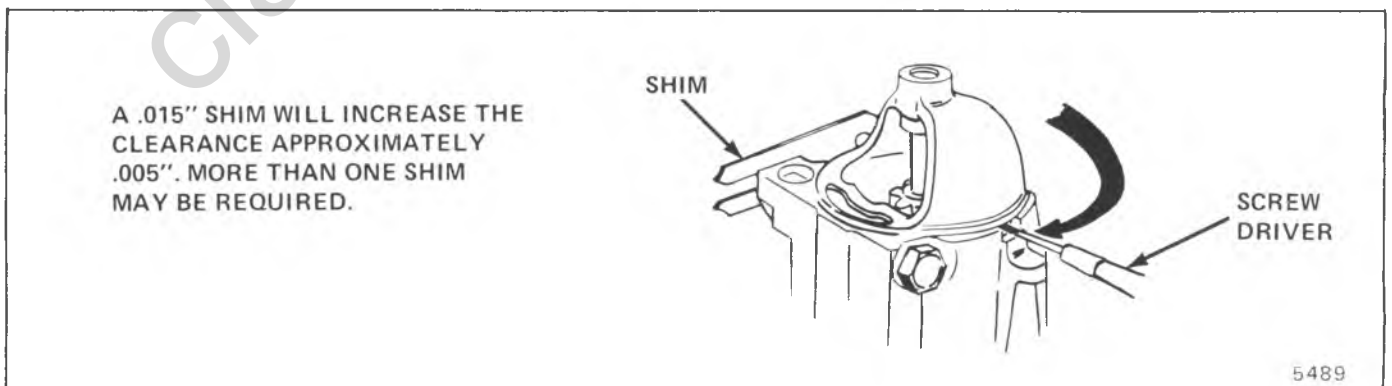
Substitute shims can be improvised from plain washers or other suitable material.

3. Problem categories 3 and 4 above may require starter motor replacement or repair in some cases.

Motor:

If the battery, wiring and switches are in satisfactory condition, and the engine is known to be functioning properly, remove the motor and follow the test procedures outlined below.

Regardless of the construction, never operate the cranking motor more than 30 seconds at a time without pausing to allow it to cool for at least two minutes. Overheating, caused by excessive cranking, will seriously damage the cranking motor.



5489

Fig. 6D-6E--Meshing Starter and Flywheel Teeth

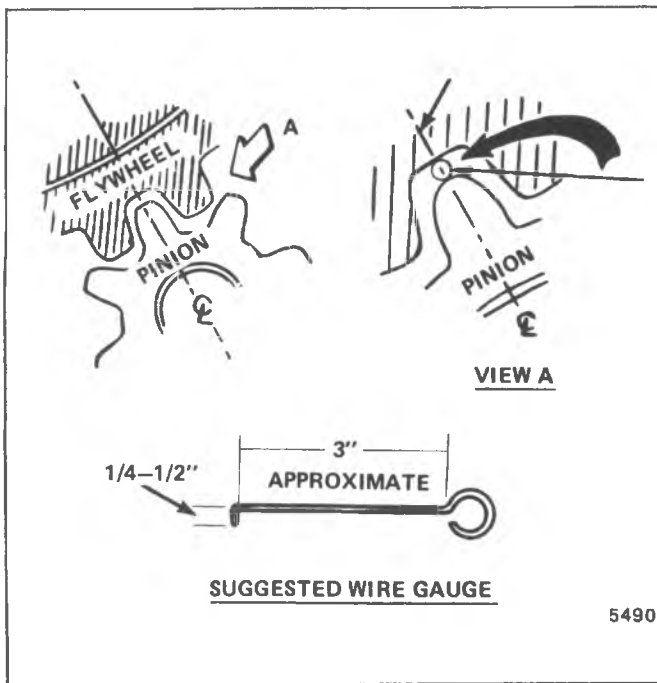


Fig. 6D-7E--Flywheel to Pinion Clearance

A general diagnosis is covered in Figure 6D-2A and 6D-3A. Once a problem has been traced to the starter, proceed to the test procedure below.

Test Procedure

With the cranking motor removed from the engine, the pinion should be checked for freedom of operation by turning it on the screw shaft. The armature should be checked for freedom of rotation by prying the pinion with a screwdriver. Tight bearings, a bent armature shaft, or a loose pole shoe screw will cause the armature to not turn freely. If the armature does not turn freely the motor should be disassembled immediately. However, if the armature does rotate freely, the motor should be given a no-load test before disassembly.

No-Load Test (Fig. 6D-9E)

Connect a voltmeter from the motor terminal to the motor frame, and use an RPM indicator to measure armature speed. Connect the motor and an ammeter in series with a fully charged battery of the specified voltage, and a switch in the open position from the solenoid battery terminal to the solenoid switch terminal. Close the switch and compare the RPM, current, and voltage readings with

the specifications at the end of this section. It is not necessary to obtain the exact voltage specified in the figure, as an accurate interpretation can be made by recognizing that if the voltage is slightly higher the RPM will be proportionately higher, with the current remaining essentially unchanged. However, if the exact voltage is desired, a carbon pile connected across the battery can be used to reduce the voltage to the specified value. If the specified current draw does not include the solenoid, deduct from the ammeter reading the specified current draw of the solenoid hold-in winding. Make disconnections only with the switch open. Interpret the test results as follows:

1. Rated current draw and no-load speed indicates normal condition of the cranking motor.
2. Low free speed and high current draw indicates:
 - a. Too much friction - tight, dirty, or worn bearings, bent armature shaft or loose pole shoes allowing armature to drag.
 - b. Shorted armature. This can be further checked on a growler after disassembly.
 - c. Grounded armature or fields. Check further after disassembly.
3. Failure to operate with high current draw indicates:
 - a. A direct ground in the terminal or fields.
 - b. "Frozen" bearings (this should have been determined by turning the armature by hand).
4. Failure to operate with no current draw indicates:
 - a. Open field circuit. This can be checked after disassembly by inspecting internal connections and tracing circuit with a test lamp.
 - b. Open armature coils. Inspect the commutator for badly burned bars after disassembly.
 - c. Broken brush springs, worn brushes, high insulation between the commutator bars or other causes which would prevent good contact between the brushes and commutator.
5. Low no-load speed and low current draw indicates:
 - a. High internal resistance due to poor connections, defective leads, dirty commutator and causes listed under Number 4.
6. High free speed and high current draw usually indicate shorted fields. If shorted fields are suspected, replace the field coil assembly and check for improved performance. In some instances, the armature could also be shorted. Check on a growler.

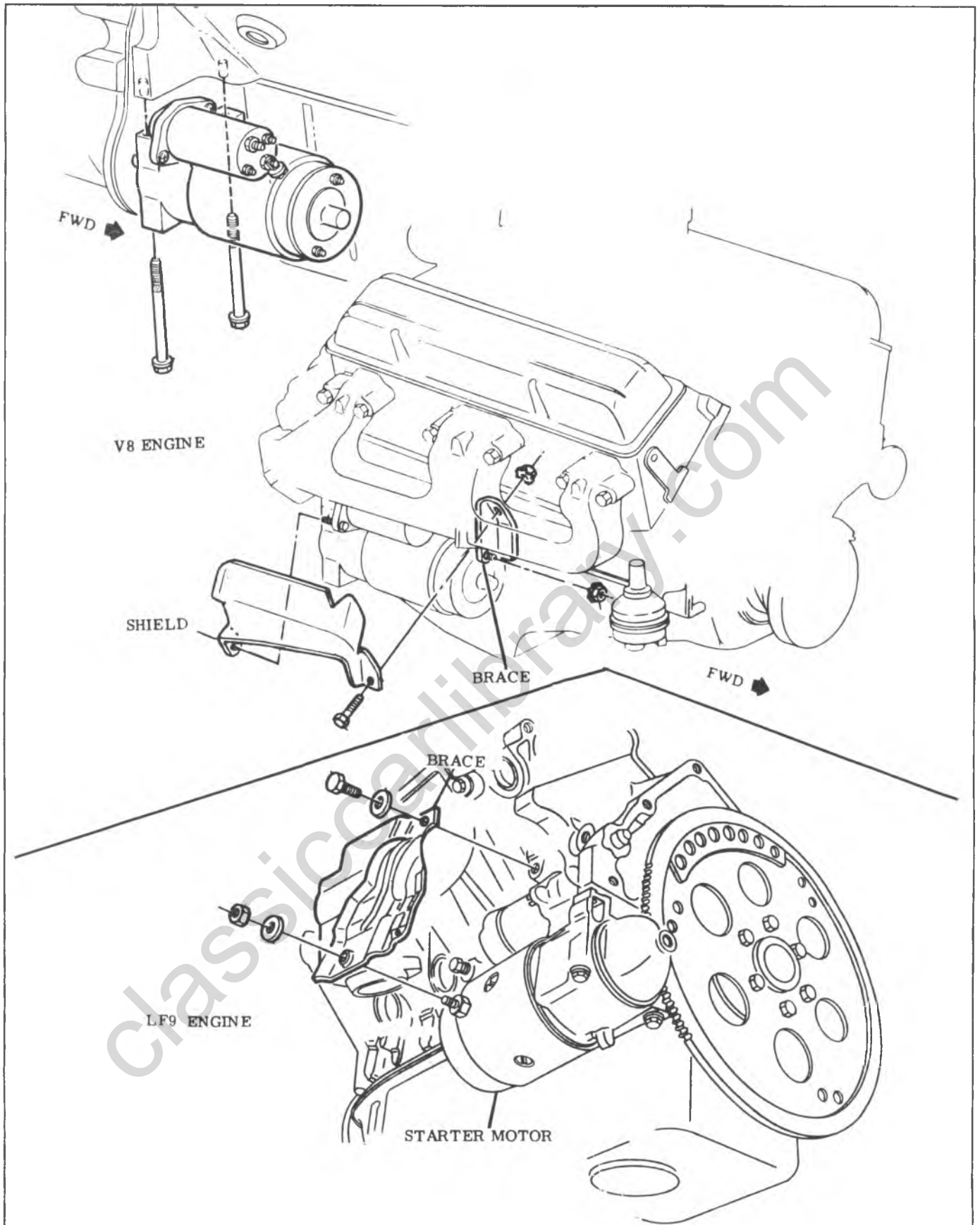


Fig. 6D-8E--Starter Motor Mounting

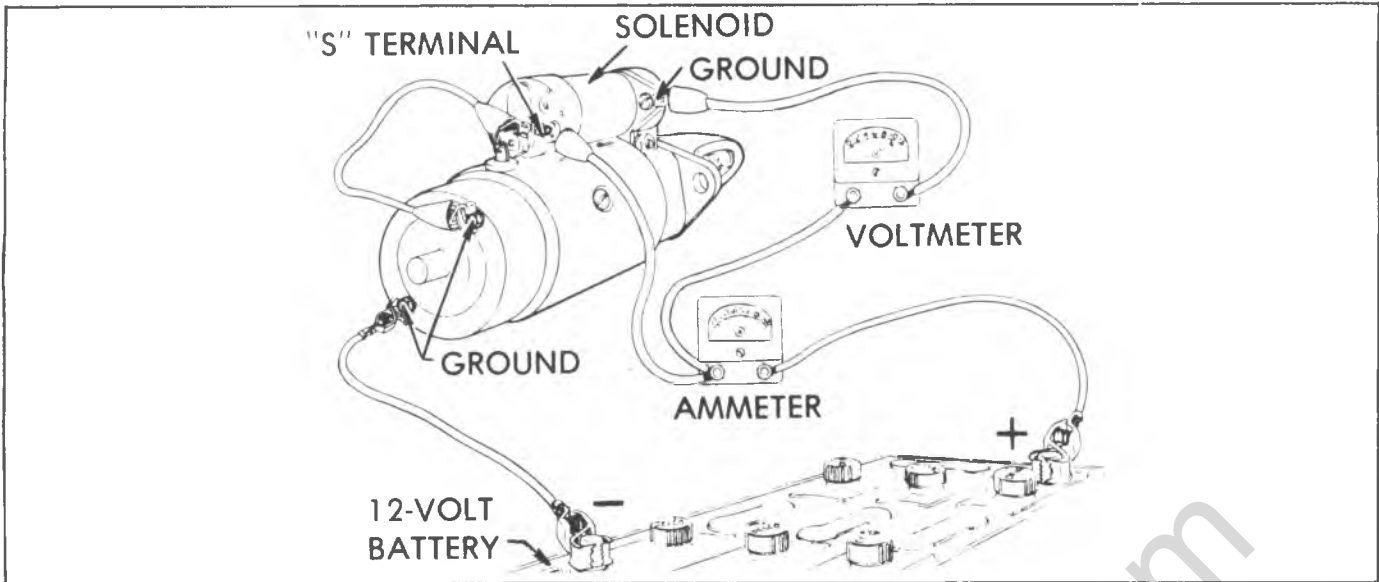


Fig. 6D-9E--No Load Test Hook Up

ON-VEHICLE SERVICE

Starting motors do not require lubrication except during overhaul.

When the motor is disassembled for any reason, lubricate as follows:

1. The armature shaft and drive end and commutator end bushings should be coated with no. 1960954 lubricant or equivalent.

2. The roll type overrunning clutch requires no lubrication. However, the drive assembly should be wiped clean. Do not clean in any degreasing tank or with grease dissolving solvents; this will dissolve the lubricant in the clutch mechanism. Use silicon grease General Electric CG321, Dow Corning 33 Medium or equivalent, on the shaft underneath the overrunning clutch assembly.

REMOVE AND REPLACE

Starter (Fig. 6D-8E)

Use the following procedure to remove the starter:

1. Disconnect negative battery lead at battery.
2. Raise vehicle.
3. Remove starter braces, shields, etc., that may be in the way.
4. Remove two starter motor to engine bolts, and allow starter to drop down.
5. Remove solenoid wires and battery cable and remove starter.
6. To replace, reverse the above procedure. Insure that any shims removed are replaced.

Solenoid

Use the following procedure to remove the solenoid from the starter:

1. Disconnect field strap.
2. Remove solenoid to drive housing attaching screws, motor terminal bolt, and remove solenoid by twisting.
3. Replace by reversing above procedures.

UNIT REPAIR

The following procedure will be used to disassemble and reassemble the starter motor. Component checks are also included in this section.

DISASSEMBLY - 10 MT MOTOR

1. Disconnect the field coil connector(s) from the motor solenoid terminal.

2. Remove through bolts.
3. Remove commutator end frame, field frame assembly and armature assembly from drive housing.
4. Remove the armature assembly from the drive housing. On some models it will be necessary to remove the solenoid and shift lever assembly from the drive housing before removing the armature assembly.

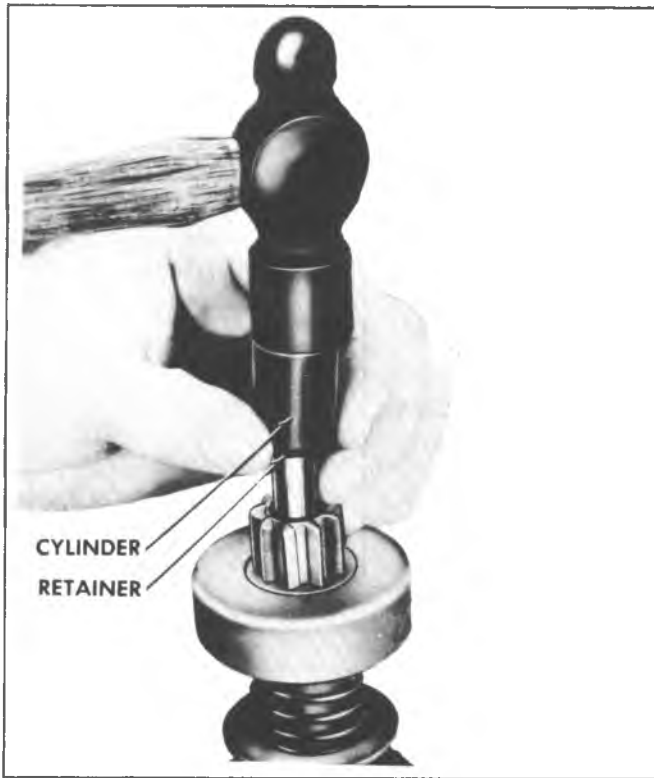


Fig. 6D-10E—Removing Retainer From Snap Ring

5. Remove the thrust collar from the armature shaft.
6. Remove the pinion from the armature by sliding a metal cylinder onto the shaft; with a hammer striking the metal cylinder against the retainer, drive the retainer toward the armature core and off the snap ring (Fig. 6D-10E).
7. Remove the snap ring from the groove in the armature shaft.
8. Roller type clutches are designed to be serviced as a complete unit, therefore do not disassemble. Replace if necessary.

Component Inspection

Brushes and Brush Holders Inspect the brushes for wear. If they are worn excessively when compared with a new brush, they should be replaced. Make sure the brush holders are clean and the brushes are not binding in the holders. The full brush surface should ride on the commutator to give proper performance. Check by hand to insure that the brush springs are giving firm contact between the brushes and commutator. If the springs are distorted or discolored, they should be replaced.

Armature - Commutators should not have insulation undercut, and out-of-round commutators should not be turned in a lathe.

The armature should be checked for short circuits, opens, and grounds:

1. Short circuits are located by rotating the armature in a growler with a steel strip such as a hacksaw blade held on the armature. The steel strip will vibrate on the area of the short circuit. Shorts between bars are sometimes produced by brush dust or copper between the bars. Cleaning the dust out of the bars may eliminate these shorts.

2. Opens may be located by inspecting the points where the conductors are joined to the commutator for loose connections. Poor connections cause arcing and burning of the commutator. If the bars are not badly burned, leads originally soldered to the riser bars can be resoldered.

3. Grounds in the armature can be detected by the use of a test lamp. If the lamp lights when one test prod is placed on the commutator and the other test prod on the armature core or shaft, the armature is grounded.

Field Coils The field coils should be checked for grounds and opens using a test lamp. Typical circuits are shown in Figure 6D-11E.

1. Grounds - Disconnect field coil ground connections. Connect one test prod to the field frame and the other to the field connector.

If the lamp lights, the field coils are grounded and must be repaired or replaced. This check cannot be made if the ground connection cannot be disconnected (See Fig. 6D-12E).

2. Opens - Connect test lamp prods to ends of field coils. If lamp does not light, the field coils are open (see Fig. 6D-13E).

3. 10MT Motor - If the field coils need to be removed for repair or replacement, a pole shoe spreader and pole shoe screwdriver should be used. Care should be exercised in replacing the field coils to prevent grinding or shorting them as they are tightened into place. Where the pole shoe has a long lip on the side, it should be assembled in the direction of armature rotation.

Solenoid - A basic solenoid circuit is shown in Figure 6D-1E. Solenoids may differ in appearance, but can be checked electrically by connecting a battery of the specified voltage, a switch, and an ammeter to the two solenoid windings. With all leads disconnected from the solenoid, make test connections to the solenoid switch terminal and to ground, or to the second switch terminal, if present, to check the hold-in winding (Fig. 6D-14E). Use the carbon pile across the battery to decrease the battery voltage to the value listed in Fig. 6D-14, and compare the ammeter reading with the specifications. A high reading indicates a shorted or grounded hold-in winding, and a low reading excessive resistance. To check the pull-in winding, connect from the solenoid switch terminal and to the solenoid motor terminal.

If needed to reduce the voltage to the specified value, connect the carbon pile between the battery and "M" terminal as shown in dashed lines instead of across the battery as shown in solid lines. If not needed, connect a jumper directly from the battery to the "M" terminal as shown in dashed lines.

To prevent overheating, do not leave the pull-in winding energized more than 15 seconds. The current draw will decrease as the winding temperature increases.

Overrunning Clutch

1. Test overrunning clutch action. The pinion should turn freely in the overrunning direction. Check pinion teeth to see that they have not been chipped, cracked, or excessively worn. Replace assembly if necessary. Badly chipped pinion teeth may indicate chipped teeth on the ring gear. This should be checked under such conditions and replaced if necessary.

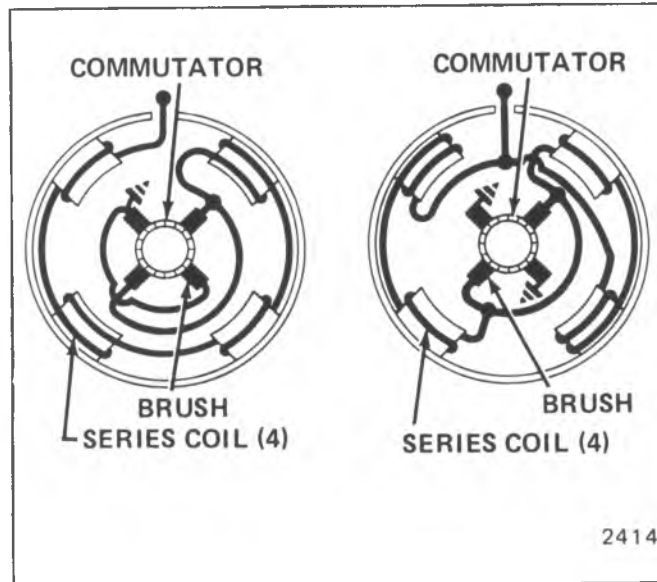


Fig. 6D-11E--Starter Motor Circuits

2. Check the overrunning clutch for slipping by leaving the clutch attached to the armature, wrap the armature with a shop towel and clamp the armature in a vice. Using a 15/16 12 point deep socket and torque wrench, put the socket on the clutch and turn counterclockwise. The clutch should not slip up to 50 ft. lb. (600 in. lb.) of torque. If it does, replace the clutch.

REASSEMBLY

1. Place the clutch assembly on the armature shaft. To facilitate replacing the snap ring and retainer onto the armature:

a. Place the retainer on the armature shaft with the cupped surface facing the snap ring groove.

b. Place the snap ring on the end of the shaft. With a piece of wood on top, force the ring over the shaft with a light hammer blow (Fig. 6D-15E), then slide the ring down into the groove.

c. To force the retainer over the snap ring, place a suitable washer over the shaft and squeeze retainer and washer together with pliers (Fig. 6D-16E).



Fig. 6D-12E--Testing Field Coils for Ground



Fig. 6D-13E--Testing Field Coils for Open

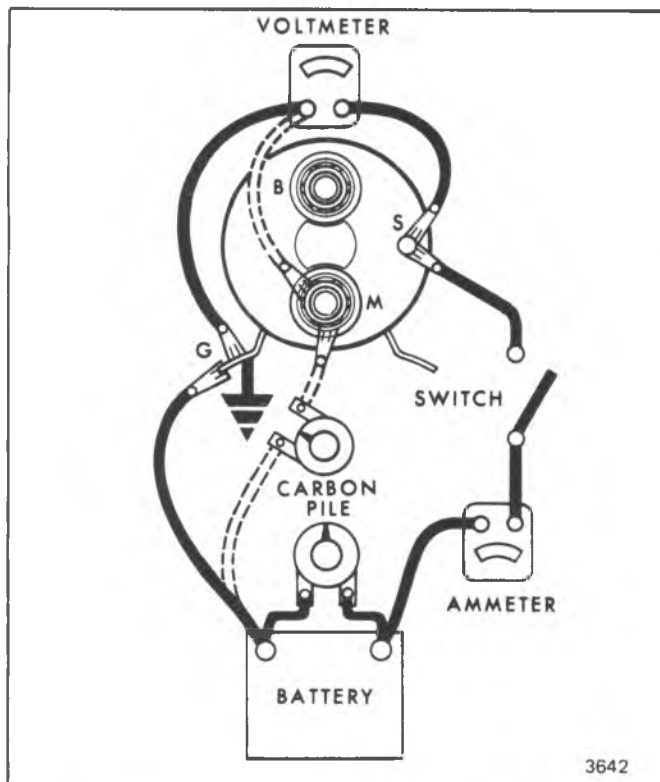


Fig. 6D-14E--Connections for Checking Solenoid

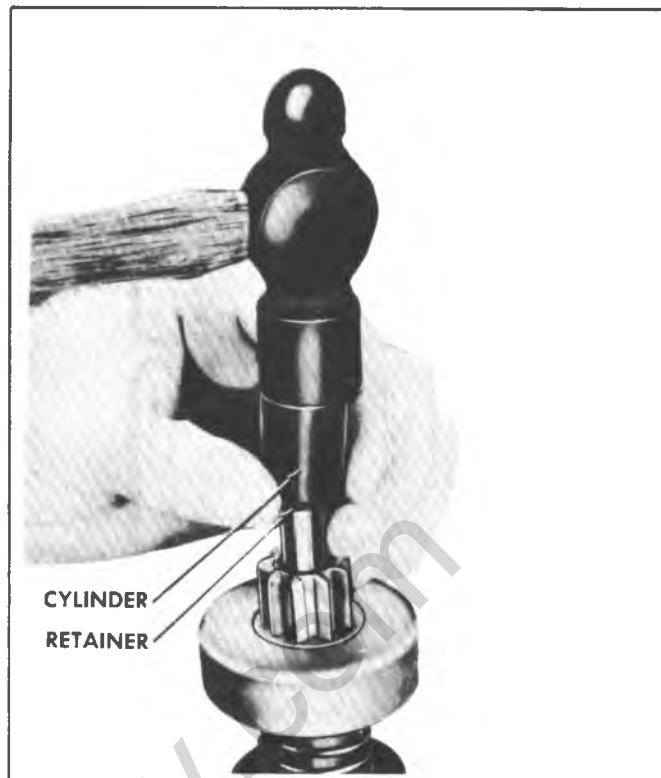


Fig. 6D-15E--Forcing Snap Ring Over Shaft

- d. Remove the washer.
- e. Assemble collar over shaft.
2. Refer to the disassembly procedure and follow in reverse to complete the reassembly.
3. When the solenoid is reinstalled, apply sealing compound between field frame, flange, and solenoid junction.

Pinion Clearance

The pinion clearance cannot be adjusted but should be checked after reassembly of the motor to insure proper clearance. Improper clearance is an indication of worn parts.

To check pinion clearance, follow the steps listed below:

1. Disconnect the motor field coil connector from the solenoid motor terminal and **INSULATE IT CAREFULLY**.
2. Connect a battery from the solenoid switch terminal to the solenoid frame (Fig. 6D-17E).
3. **MOMENTARILY** flash a jumper lead from the solenoid motor terminal to the solenoid frame. This will shift the pinion into cranking position and it will remain so until the battery is disconnected.
4. Push the pinion back towards the commutator end to eliminate slack movement.
5. Measure the distance between pinion and pinion stop (Fig. 6D-17E).

STARTER-DIESEL ENGINE-20 MT MOTOR (FIG. 6D-19E)

Starter Disassembly 20MT Motor (Fig. 6D-19E)

1. Remove screw from field coil connector and solenoid mounting screws. Rotate solenoid 90° and remove along with plunger return spring.

Solenoid may be removed and serviced without further starter disassembly at this time.

2. Remove 2 through bolts, then remove commutator end frame and washer.

3. Remove field frame assembly from drive gear housing. (On diesel starter armature remains in drive end frame.)

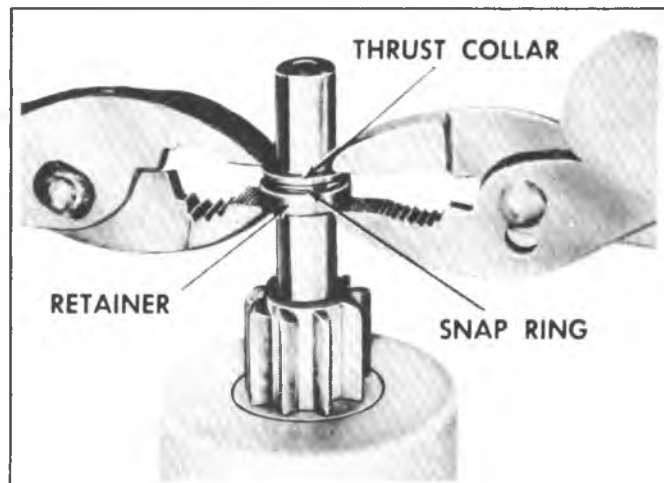


Fig. 6D-16E--Forcing Retainer Over Snap Ring

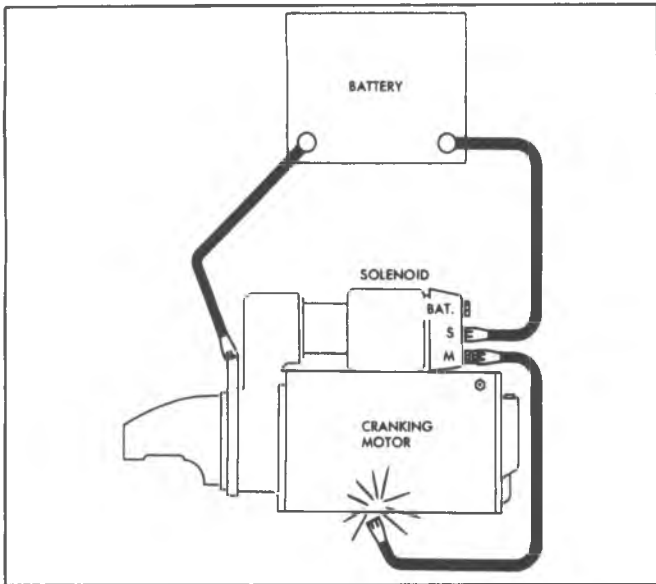


Fig. 6D-17E--Circuit For Checking Pinion Clearance

4. Remove shift lever pivot bolt.

5. Remove center bearing screws and remove drive gear housing from armature shaft. Shift lever and plunger assembly will now fall away from starter clutch. (Fig. 6D-24s).

6. If necessary to remove overrunning clutch from armature shaft, proceed as follows: (Fig. 6D-21E)

a. Remove thrust washer or collar from armature shaft.

b. Slide a 5/8" deep socket or piece of pipe of suitable size over shaft against retainer as a driving tool. Tap tool to move retainer off snap ring.

c. Remove snap ring from groove in shaft. If snap ring is distorted, it will be necessary to use a new one on reassembly. (Fig. 6D-22E).

d. Remove retainer, clutch assembly, (also fiber washer and center bearing on diesel) from armature shaft.

7. The shift lever and plunger may be disassembled at this time by removing the roll pin.

8. If necessary to replace brush holder parts, proceed as follows:

a. Remove brush holder pivot pin which positions one insulated and one grounded brush. (Fig. 6D-23E).

b. Remove brush spring.

c. Replace brushes as necessary.

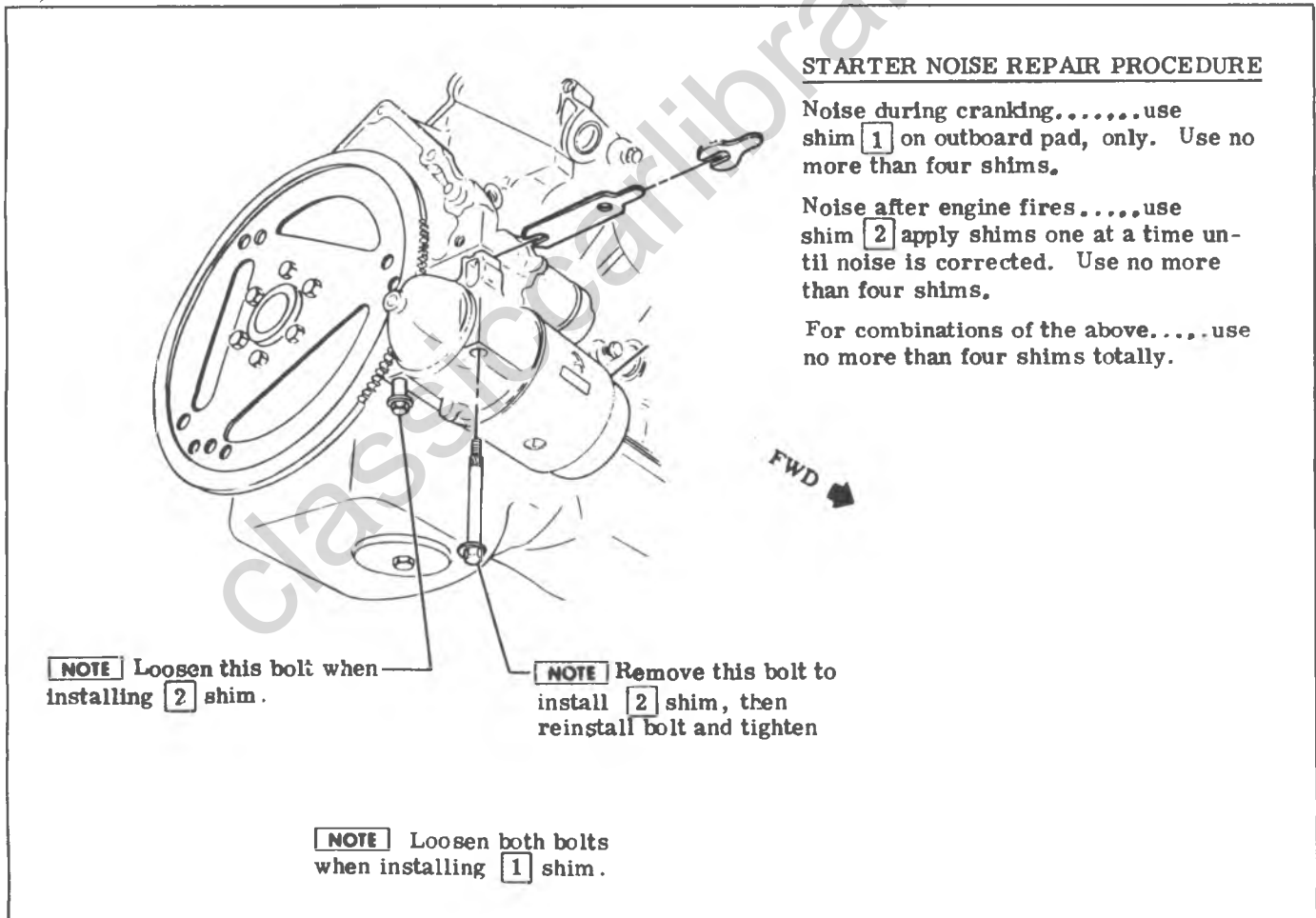
NOTICE: If necessary to remove field coils or pole shoes, care must be taken during reassembly not to break through insulation material on the field coils. Be sure long lip on pole shoes is in direction of armature rotation.

STARTER NOISE REPAIR PROCEDURE

Noise during cranking.....use shim [1] on outboard pad, only. Use no more than four shims.

Noise after engine fires.....use shim [2] apply shims one at a time until noise is corrected. Use no more than four shims.

For combinations of the above.....use no more than four shims totally.



NOTE Loosen this bolt when installing [2] shim.

NOTE Remove this bolt to install [2] shim, then reinstall bolt and tighten

NOTE Loosen both bolts when installing [1] shim.

Fig. 6D-18E--Starter Motor Shimming (Exc LF9)

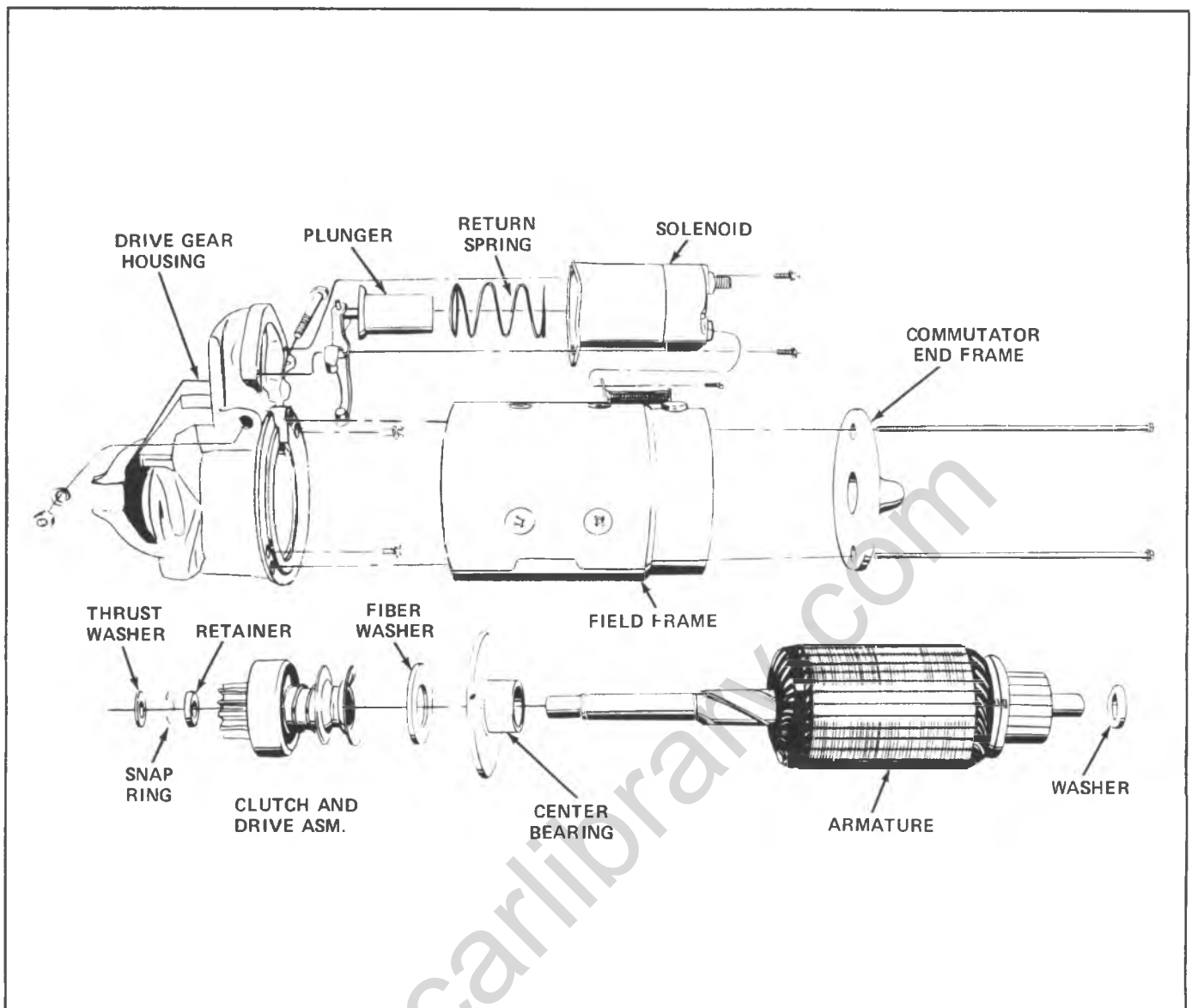


Fig. 6D-19E--Diesel Starter-Exploded View

Solenoid Switch

The starter solenoid switch is serviced as an assembly only. The cover can be removed to inspect the contacts and contact disc if necessary. (Fig. 6D-24E).

Starter Assembly

1. Assemble the armature and clutch as follows:

- a. Lubricate drive end of armature shaft with lubricant 1960954 or equivalent.
- b. Install center bearing with bearing toward the armature winding. Then install the fiber washer on the armature shaft. Refer to Fig. 6D-22E.
- c. Slide clutch assembly onto armature shaft with pinion away from armature.
- d. Slide retainer onto shaft with cupped side facing the end of shaft.
- e. Install snap ring into groove on armature shaft.

f. Install thrust washer on shaft.

g. Position retainer and thrust washer with snap ring in between. Using two pliers, grip retainer and thrust washer or collar and squeeze until snap ring is forced into retainer and is held securely in groove in armature shaft. (Fig. 6D-25E).

2. Lubricate drive gear housing bushing with lubricant 1960954 or equivalent.

3. Engage shift lever yoke with clutch and slide complete assembly into drive gear housing.

NOTICE: Shift lever may be installed in drive gear housing first.

4. Install the center bearing screws (diesel only) and the shift lever pivot bolt. Tighten securely.

5. Install solenoid assembly on drive gear housing.

6. Apply sealer, No. 1050026 or equivalent to solenoid flange where field frame against drive gear housing on alignment pin using care to prevent damage to brushes.

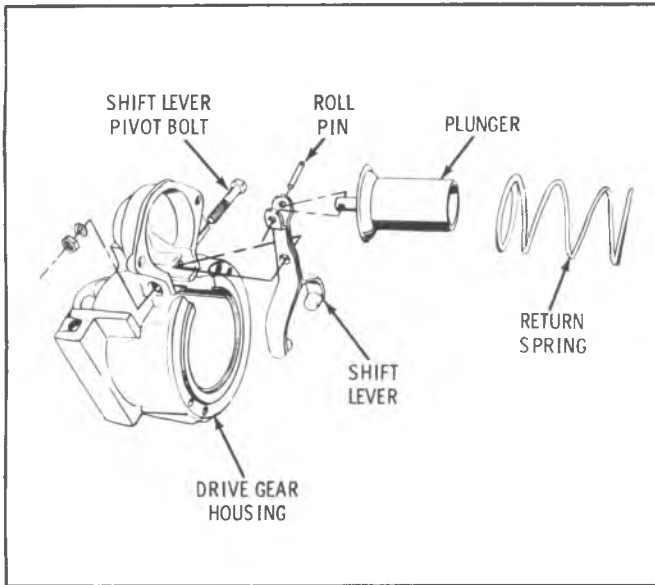


Fig. 6D-20E--Remove Shift Lever

7. Position field frame against drive gear housing on alignment pin using care to prevent damage to brushes.

8. Lubricate commutator end-frame bushing with lubricant 1960954 or equivalent.

9. Install washer on armature shaft and slide end frame onto shaft, then install and tighten through-bolts.

10. Connect the field coil connector to the solenoid terminal.

11. Check pinion clearance as outlined under PINION CLEARANCE.

Pinion Clearance

When the starter motor has been disassembled or the solenoid has been replaced, it is necessary to check the pinion clearance. Pinion clearance must be correct to prevent the buttons on the shift lever yoke from rubbing on

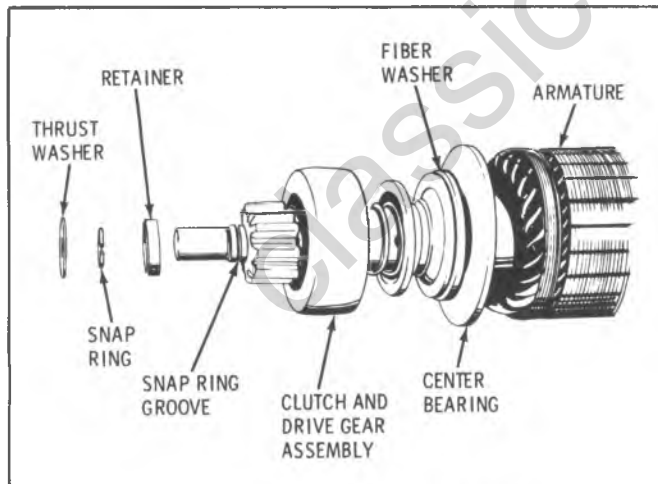


Fig. 6D-21E--Remove Thrust Collar

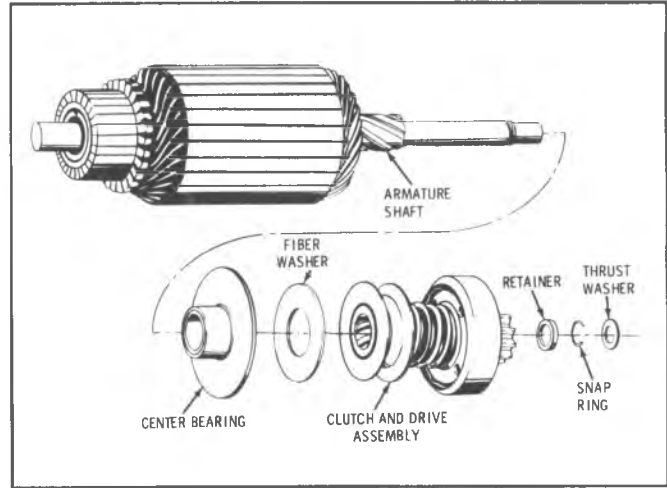


Fig. 6D-22E--Remove Starter Drive

the clutch collar during cranking.

1. Disconnect the motor field coil connector from the solenoid motor terminal and insulate it carefully.

2. Connect one 12 volt battery lead to the solenoid switch terminal and the other to the starter frame.

3. Flash a jumper lead momentarily from the solenoid motor terminal to the starter frame. This will shift the pinion into cranking position and will remain so until the battery is disconnected.

4. Push the pinion back as far as possible to take up any movement, and check the clearance with a feeler gage. (Fig. 6D-26E). The clearance should be .010" to .140".

Means for adjusting pinion clearance is not provided on the starter motor. If the clearance does not fall within limits, check for improper installation and replace all worn parts.

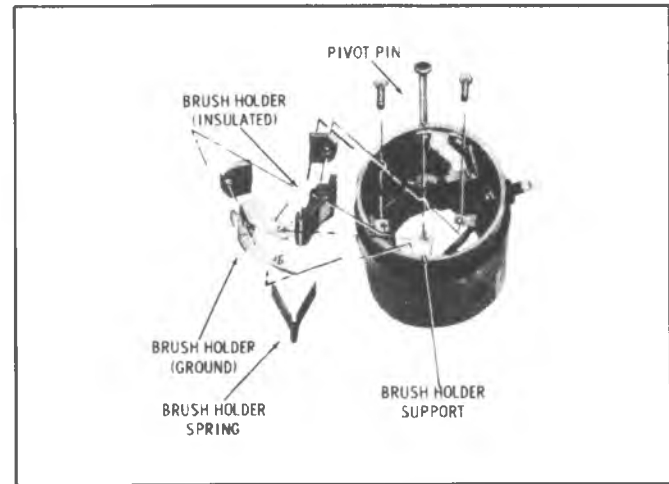


Fig. 6D-23E--Brush Replacement

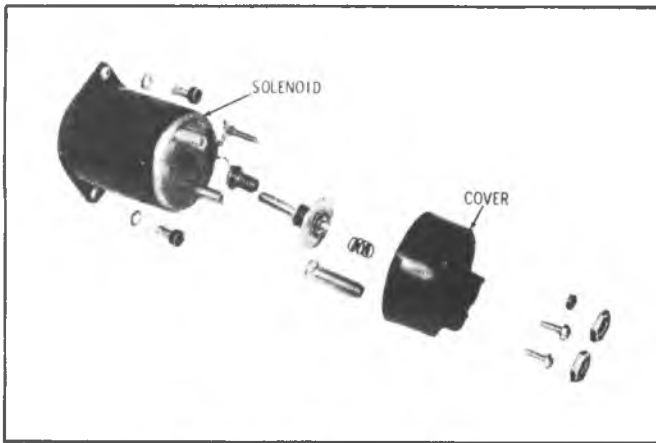


Fig. 6D-24E--Solenoid Switch

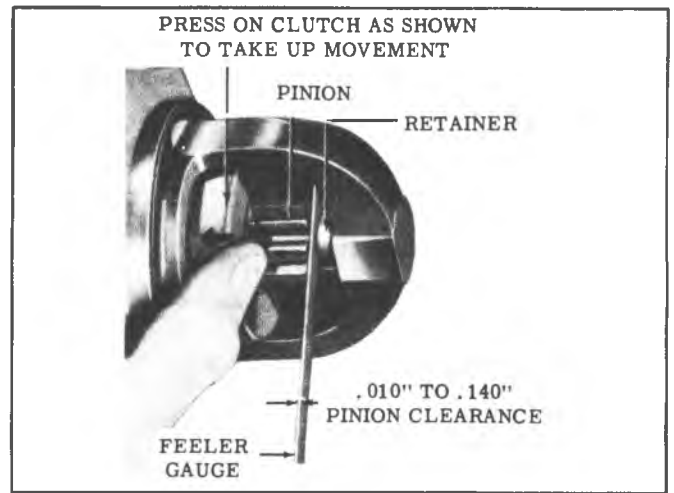


Fig. 6D-26E--Check Pinion Clearance

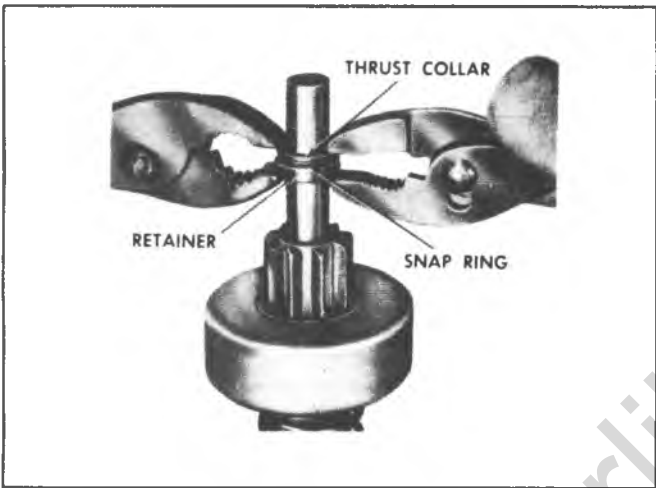


Fig. 6D-25E--Install Snap Ring and Retainer

classiccarlibrary.com

SPECIFICATIONS

GENERATOR

| MODEL NO. | APPLICATION | DELCO REMY SPEC. NO. | FIELD CURRENT AMPS 27°C (80°F) @ 12 VOLTS | COLD OUTPUT* AMPS @ 5000 RMP | RATED HOT OUTPUT** AMPS |
|--|---|-------------------------|---|------------------------------------|----------------------------|
| 1102394 1102491 1102889 | All L-6 (Base) (Except G-20, 30 & P-Truck) All C-K-G Truck Base V-8 (Except K31303 & G30003) | 4519 | 4-4.5 | 33 | 37 |
| 1102485 1102841 1102887 | 292 L-6 (L25) (Base) (G-20, 30 & P-Truck) All P-Truck Base V-8 (Except P31832) | 4521 | 4-4.5 | 38 | 42 |
| 1102480 1102486 1102886 1102888 | P31832 Truck (Base) All L-6 or V-8 with RPO K76 454 V-8 (FL8) (Base) K31303 & G30003 Truck Base V-8 | 4522 | 4-4.5 | 57 | 61 |
| 1101016 1101028 | Optional (COPO) | 4525 | 4-4.5 | 76 | 80 |

*Generator temperature approximately 27°C. (80°F.).

**Ambient temperature 27°C. (80°F.).

Note: The only difference between generators within each group above is the position end frame is rotated.

Insert Chart 6D-S1

SPECIFICATIONS

DISTRIBUTOR & SPARK PLUGS

Distributor and spark plug specifications are shown in the Emission Control Chart in Section 6E Specifications.

BATTERY

| MODEL NO. | APPLICATION | COLD CRANK RATE @ 0°F (-18°C) | AMPS FOR LOAD TEST | 25 AMP. RESERVE CAPACITY (MINUTES) |
|-----------|--|----------------------------------|-----------------------|---------------------------------------|
| 85-4 | 250 L-6 (LD4) | 275 Amps | 130 | 60 |
| 85-5 | 292 L-6 (L25) 305 V-8 (LG9) 350 V-8 (LS9) 400 V-8 (LF4) | 350 Amps | 170 | 80 |
| 89-5 | 454 V-8 (LF8) RPO UA1 | 465 Amps | 230 | 125 |
| 87-5 | RPO TP2 | 430 Amps | 210 | 100 |

STARTING MOTOR

| MODEL NO. | APPLICATION | SPEC. NO. | VOLTS | FREE SPEED AMPERES | RPM |
|-----------|--------------------------------|----------------------------|-------|-----------------------|------------|
| 1108778 | 250 L-6 (LD4) (C & K-10) | 3573 | 9 | 50-80* | 5500-10500 |
| 1108779 | 250 L-6 (LD4) (G-Van) | 3573 | 9 | 50-80* | 5500-10500 |
| 1108780 | 292 L-6 (L25) | 2438 | 9 | 50-80* | 3500-6000 |
| 1109056 | 305 V-8 (LG9) (C & K) | 3573 | 9 | 50-80* | 5500-10500 |
| 1109798 | 305 V-8 (LG9) (G-Van) | 3573 | 9 | 50-80* | 5500-10500 |
| 1109052 | 350 V-8 (LS9) | 3563 | 9 | 65-95* | 7500-10500 |
| 1108776 | 400 V-8 (LF4) 454 V-8 (LF8) | 3563 Insert Chart 6D-52 | 9 | 65-95* | 7500-10500 |

*Includes Solenoid

classicalcarlibrary.com

SECTION 6E

ENGINE EMISSION CONTROLS

CONTENTS

| | |
|---|-------|
| General Description..... | 6E-1 |
| General Description of Emission Control Components..... | 6E-1 |
| Early Fuel Evaporation-EFE..... | 6E-3 |
| Exhaust Gas Recirculation-EGR..... | 6E-5 |
| Positive Crankcase Ventilation-PCV..... | 6E-11 |
| Thermostatic Air Cleaner-TAC..... | 6E-11 |
| Air Injection Reactor-AIR..... | 6E-16 |
| Pulse Air Injection Reactor - PAIR..... | 6E-21 |
| Throttle Return Control-TRC..... | 6E-24 |
| Vacuum Advance Control..... | 6E-26 |
| Emission Hose Routing..... | 6E-26 |
| Engine Performance Specifications..... | 6E-27 |

GENERAL DESCRIPTION

The normal operation of the engine results in the release of several compounds to the atmosphere. Federal Government and State of California legislation has placed limitations on the quantities of three compounds which can be emitted. The three controlled compounds are:

- Hydrocarbons - HC
- Carbon Monoxide - CO
- Oxides of Nitrogen - NO_x

The emission control systems for engines include:

- Carburetor Calibration

- Distributor Calibration
- Catalytic Converter (Light Duty Emissions)
- Early Fuel Evaporation (EFE)
- Exhaust Gas Recirculation (EGR)
- Positive Crankcase Ventilation (PCV)
- Choke Calibration
- Thermostatic Air Cleaner (THERMAC)
- Evaporation Control System (ECS)
- Air Injection Reactor (AIR)
- Pulse Air Injection Reactor (PAIR)

GENERAL DESCRIPTION OF EMISSION CONTROL COMPONENTS

CARBURETOR CALIBRATION

While the carburetor's main function is to provide the engine with a combustible air/fuel mixture, the carburetor calibration is critical to maintaining proper emission levels.

The carburetor's idle, off-idle, main metering, power enrichment, and accelerating pump systems are calibrated to provide the best possible combination of engine performance, fuel economy and exhaust emission control. Carburetor adjustments and service must be performed using the recommended procedures to insure engine exhaust emission levels remain within official limits.

See Section 6C, Fuel System, for carburetor adjustment specifications and recommended service procedures.

DISTRIBUTOR CALIBRATION

The distributor is an integral part of the engine ignition system and the distributor calibration is an important part of exhaust emission control.

The initial timing centrifugal advance and vacuum advance are calibrated to provide the best engine performance and fuel economy at varying speeds and loads while remaining within exhaust emission limits. Distributor diagnostics and service procedures are in Section 6D, Engine Electrical.

CATALYTIC CONVERTER

The catalytic converter is an emission control device added to the exhaust system of light duty emission vehicles to reduce hydrocarbon and carbon monoxide from the exhaust gas stream. The converter contains material which

is coated with a catalytic material containing platinum and palladium.

THE CATALYTIC CONVERTER REQUIRES THE USE OF UNLEADED FUEL ONLY.

Periodic maintenance of the exhaust system is not required; however, if the vehicle is raised for other service, it is advisable to check the general condition of the underfloor catalytic converter, pipes and mufflers.

Refer to Section 6F, Engine Exhaust System, for catalytic converter service procedures and diagnostics.

EARLY FUEL EVAPORATION SYSTEM (EFE)

The EFE system is used to provide a source of rapid heat to the engine induction system during cold driveway. Rapid heating is desirable because it provides for quick fuel evaporation and more uniform fuel distribution to aid cold driveability. It also reduces the length of time carburetor choking is required making reductions in exhaust emission levels possible.

EFE systems may use a valve which increases the exhaust gas flow under the intake manifold during cold engine operation. The valve is vacuum operated and is controlled by a thermal vacuum switch (TVS) which applies vacuum when the coolant temperature is below the calibration valve.

Diagnosis and service procedures of the EFE system can be found in this section.

EXHAUST GAS RECIRCULATION SYSTEM (EGR)

The Exhaust Gas Recirculation System meters exhaust gas into induction system for recirculation through the combustion cycle to reduce oxides of nitrogen emissions.

The EGR valve remains closed during periods of engine idle and deceleration to prevent rough idle from excessive exhaust gas dilution in the idle air/fuel mixtures.

All exhaust gas recirculation systems perform the same function, however, differences in operation of system will be covered in the Service Procedure Section.

Diagnosis and service procedure of EGR system can be found in this section.

CLOSED POSITIVE CRANKCASE VENTILATION SYSTEM (PCV)

All engines have closed Positive Crankcase Ventilation System to provide more complete scavenging of crankcase vapors.

An engine which is operated without any crankcase ventilation can be damaged seriously. Therefore, it is important to replace the ventilator valve periodically.

NOTICE: If an engine is idling too slow or rough, this may be caused by a clogged ventilator valve or plugged hose; therefore, never adjust the carburetor idle without first checking the PCV valve and hose.

After installing a new PCV valve, readjust engine idle if necessary.

With this system, any blow-by in excess of the system capacity (from a badly-worn engine, sustained heavy load, etc.) is exhausted into the air cleaner and is drawn into the engine.

Diagnosis and service procedures for the PCV system can be found in this section.

CHOKE SYSTEM

An automatic choke system maintains proper engine performance during engine warm-up. Modifications to the choke system have been necessary in recent years to meet the lower legislated exhaust emission levels.

THERMOSTATIC AIR CLEANER (THERMAC)

The Thermostatic Air Cleaner (THERMAC) is on all engines. The TAC uses a damper assembly in the air cleaner inlet, controlled by a vacuum motor to mix pre-heated and non pre-heated air entering the air cleaner to maintain a controlled air temperature into the carburetor. The vacuum motor is modulated by a temperature sensor in the air cleaner. The pre-heating of the air cleaner inlet air allows leaner carburetor and choke calibrations resulting in lower emission levels, while maintaining good driveability. Diagnostics and service procedures for the thermostatic air cleaner can be found in this section.

AIR INJECTION REACTOR SYSTEM (AIR)

An air injection reactor (AIR) is used on some engines to provide additional oxygen to continue the combustion process after the exhaust gases leave the combustion chamber. An engine driven pump provides pressurized air which is injected into the exhaust port of the cylinder head or exhaust pipe and then into the exhaust system. The AIR system operates at all times and will bypass air only for a short duration of time during deceleration and at high speeds. The diverter valve performs the bypass function, and the check valve protects the air pump from damage by preventing a back flow of exhaust gas.

Diagnosis and service procedures for air injection reactor system is in this section.

PULSE AIR INJECTION REACTOR SYSTEM (PAIR)

The PAIR system consists of four pulse air valves. The firing of the engine creates a pulsating flow of exhaust gases which are positive or negative pressure. A negative pressure at the pulse air valves results in the flow of fresh air into the exhaust system. If pressure is positive the check valve is forced closed and no exhaust gas will flow past the valve into the fresh air supply line.

VACUUM CONTROLS

Various types of vacuum controls are used in the emission control system to modify or control the operation of the various emission control components to optimize emission control effectiveness, while minimizing any negative effect on driveability.

Refer to the emission hose routings at the end of this section for usage of these systems.

ON-VEHICLE SERVICE

EARLY FUEL EVAPORATION (EFE)

INSPECTION (EXCEPT 4.8L - 292 CID)

- Visually inspect exhaust heat valve for damage or binding linkage.
- Check that linkage is connected and vacuum hoses are properly routed and connected.
- Move exhaust heat valve by hand. If binding or stuck, free with manifold heat valve lubricant, GM Part No. 1050422 or equivalent. If valve cannot be freed, replace valve.

HEAT VALVE INSPECTION (WITH 4.8L - 292 CID)

- Visually inspect manifold heat valve for damage or binding.
- Move valve by hand. If binding or stuck, free with manifold heat valve lubricant, GM Part No. 1050422 or equivalent. If valve cannot be freed, replace valve.

CHECKING EFE SYSTEM

1. With engine cold, position transmission in neutral or park and apply parking brake.
2. Start engine and observe movement of actuator rod and exhaust heat valve. Valve should move to its closed position.
3. If valve does not close, disconnect hose at actuator and check for vacuum.
 - If there is vacuum, replace actuator.
 - If there is no vacuum, disconnect hose at TVS-to-vacuum source.
 - If there is vacuum at hose, replace TVS.
 - If there is no vacuum, check for deteriorated hose and vacuum source to determine lack of vacuum.
4. When coolant reaches 180°F (82°C) (V8), or oil reaches 150°F (66°C) (six cylinder), the exhaust heat valve should move to its open position.

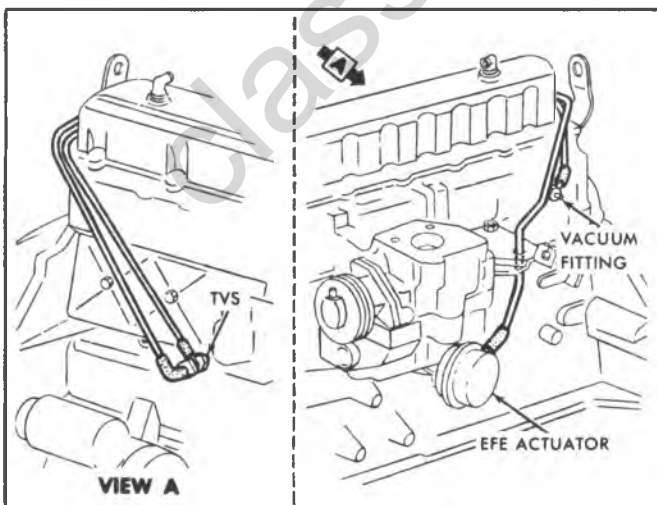


Fig. 6E-1—EFE System-4.1L

5. If valve does not move, disconnect hose at actuator and check for vacuum.

- If there is vacuum, replace TVS.
- If there is no vacuum, replace actuator.

COOLANT TEMPERATURE THERMAL VACUUM SWITCH (TVS) - V8

Replacement

1. Drain coolant below level of engine coolant outlet housing.
2. Disconnect hoses at TVS ports.
3. Remove TVS.
4. Apply a soft setting sealant uniformly on replacement TVS male threads. No sealant should be applied to sensor end of TVS.
5. Install TVS, tighten to 120 pound inches (14. N·m) and then hand torque clockwise as required to align TVS to accommodate hoses.
6. Connect hoses to TVS ports.
7. Add coolant as required.

OIL TEMPERATURE THERMAL VACUUM SWITCH (TVS) - L6

Replacement

1. Disconnect hoses at TVS ports.
2. Remove TVS switch.
3. Install TVS switch.
4. Connect hoses to TVS ports.

ACTUATOR AND ROD ASSEMBLY

The actuator and rod assembly is located on a bracket attached to right exhaust manifold on V8 engines (figs. 6E-2 and 6E-3) and on left side attached to exhaust manifold on L6 engine (figs. 6E-4 and 5).

Replacement

1. Disconnect hose from actuator.
2. Remove 2 nuts attaching actuator-to-bracket.
3. Disconnect rod from valve and remove actuator and rod.
4. Install actuator and rod reversing steps 1 and 3. Tighten nuts to 25 pound inches (3 N·m).

EXHAUST HEAT VALVE - V8

Replacement

1. Remove crossover exhaust pipe.
2. Disconnect rod from valve.
3. Remove valve.
4. Install valve and connect rod.
5. Install crossover exhaust pipe.

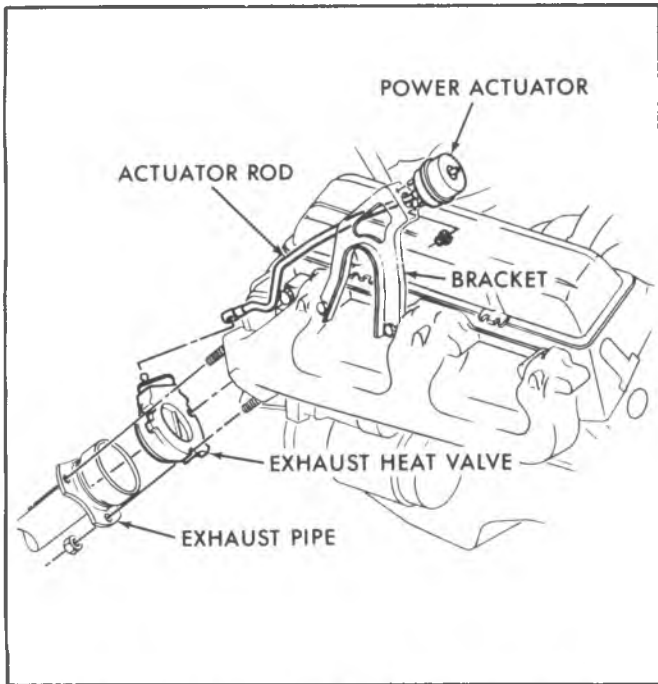


Fig. 6E-2-Actuator and Rod-305/350/400 V8

EXHAUST HEAT VALVE - 4.1L

Replacement

1. Remove 2 nuts attaching actuator bracket-to-valve and exhaust manifold.

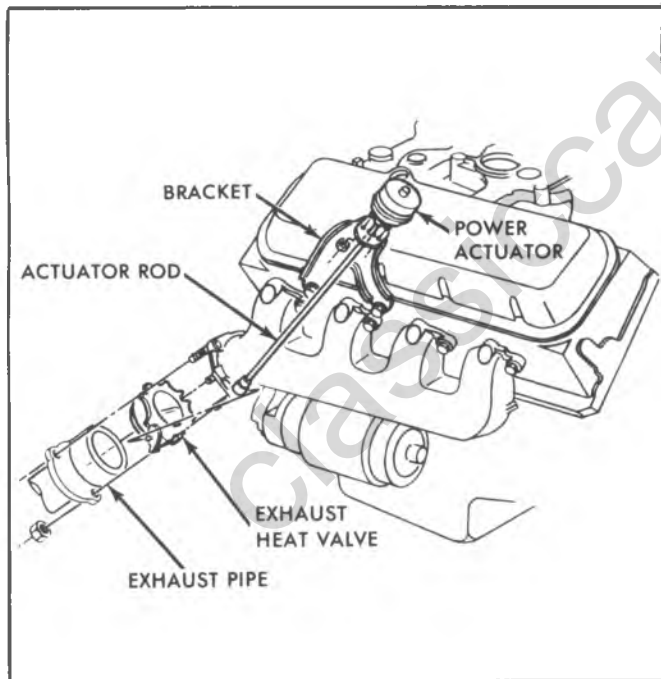


Fig. 6E-3-Actuator and Rod 454 V8

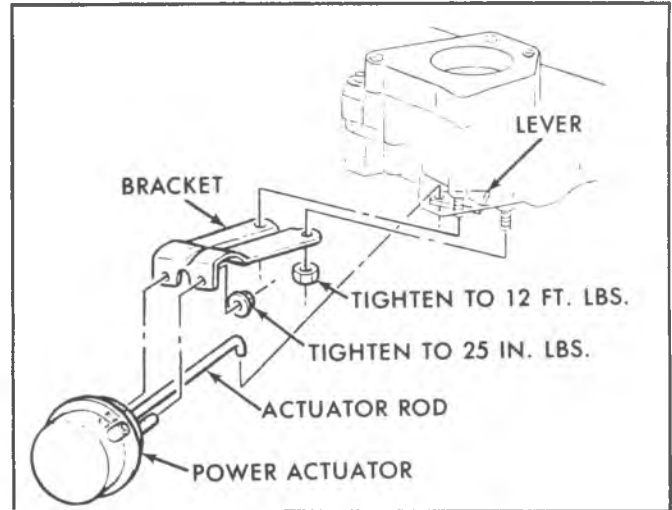


Fig. 6E-4-Actuator and Rod-L6

2. Remove bracket and disconnect rod from valve.
3. Remove 2 additional nuts from valve and remove valve.
4. Install valve reversing Steps 1 through 3.

MANIFOLD HEAT VALVE - 4.8 L

Replacement

1. Remove exhaust pipe to manifold nuts and lower exhaust pipe.
2. Remove heat valve and packings.
3. Reverse above steps to install.

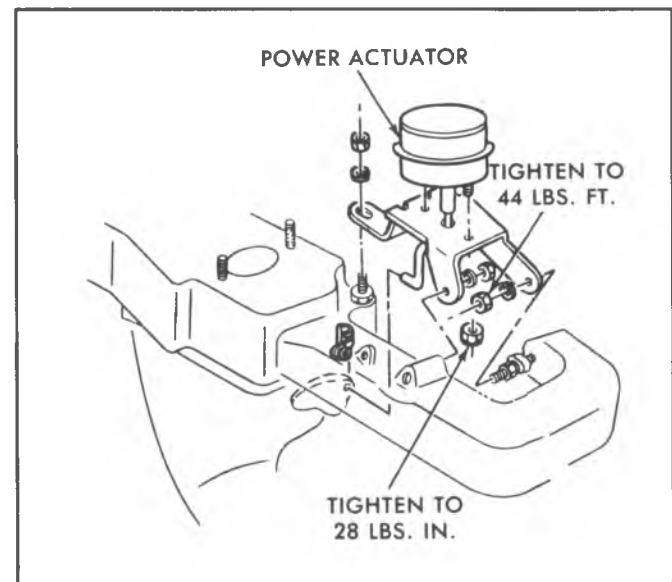


Fig. 6E-5-Power Actuator

EXHAUST GAS RECIRCULATION (EGR)

GENERAL DESCRIPTION

The E.G.R. system introduce exhaust gases into the engine induction system through passages cast into the intake manifold.

Introduction of these gases into the air/fuel mixture lowers the combustion temperatures to reduce the formation of oxides of nitrogen. The E.G.R. control valves are at a normally closed position during curb idle (no recirculation) and will open to "mix" gases at throttle plate angles just slightly "off-idle".

There are three kinds of EGR valves used and they are similar in appearance. The major difference is in the method used to control how far each valve opens.

A ported signal vacuum EGR (Fig. 6E-6) valve is used on some engines. The valve opening is determined by the amount of vacuum received from a ported source on the carburetor.

A backpressure EGR valve is used on most Federal, California and high altitude engines. The valve opening is determined by the amount of vacuum received from a ported source on the carburetor and the amount of backpressure in the exhaust system.

Two different types of backpressure EGR valves are used. A positive transducer valve (Fig. 6E-7) and a negative transducer valve (Fig. 6E-8). The negative transduced backpressure valve is used on engines with a relatively low backpressure to provide the desired opening point and flow rate.

EGR VALVE IDENTIFICATION

Refer to figures 6E-9 through 6E-11 for identification of the three different EGR valves.

EGR OPERATIONAL SYSTEM CHECK

1. Place finger under EGR valve and push on diaphragm plate. Diaphragm should move freely from open to closed position. If it does not move freely replace valve.

CAUTION: If valve is hot it may be necessary to wear gloves to avoid burning fingers.

2. Hook up vacuum gage between EGR signal tube and vacuum hose.

3. With vehicle in "Park" or "Neutral" and engine running open throttle to obtain at least 5" of vacuum at EGR. Engine must be at coolant operating temperature (approx. 195°F).

4. Remove vacuum hose from EGR signal tube and check for diaphragm plate to move downward (valve closed). This should be accompanied by an increase in engine speed.

5. Replace vacuum hose and check for diaphragm plate to move upward (valve open). Engine speed should decrease.

NOTICE: A vibration of the diaphragm plate may be

noticed on back pressure EGR valves. This does not indicate a bad valve or require correction.

Operational System Diagnosis

Diaphragm doesn't move:

1. Check engine vacuum, it should be at least 5" at EGR valve with engine running and throttle open.
2. Make sure engine is at operating temperature.
3. Check for vacuum at EGR hose. If no vacuum is present find the cause (hose routing not correct, plugged or leaking hose or carburetor port).
4. On back pressure EGR valves, check transducer control valve operation (refer to functional check).

Diaphragm moves with no change in engine speed:

1. Check EGR manifold passages for blockage (clean if blocked).

If cause is not found perform functional checks.

FUNCTIONAL CHECKS

Ported Signal and Negative Backpressure EGR Valves

1. Check hose routing (Refer to Vehicle Engine Emission Control Information Label).
2. Check EGR valve signal tube orifice for obstructions.
3. Hook up vacuum gage between EGR valve and carburetor and check vacuum (engine must be at operating temperature approx. 195°F). With engine running at approximately 3000 RPM their should be at least 5" of vacuum.
4. Check EGR TVS for correct operation (see EGR TVS checking procedure).
5. Valve check (valve can be left on or removed from engine).
 - a. Depress the valve diaphragm.
 - b. With diaphragm still depressed hold a finger over source tube and release diaphragm.
 - c. Check diaphragm and seat for movement. Valve is good if it takes over 20 seconds for the diaphragm to move to the seated position (valve closed).
 - d. Replace EGR valve if it takes less than 20 seconds to move to the seated position.

Positive Backpressure EGR Valve

1. Check hose routing (Refer to Vehicle Emission Control Information Label).
2. Check EGR valve signal tube orifice for obstructions.
3. Check EGR-TVTS for correct operation. (See EGR-TVTS functional check).
4. Valve check.
 - a. Remove EGR valve from vehicle.
 - b. Apply a constant external vacuum (10" or more) supply to EGR vacuum signal tube.

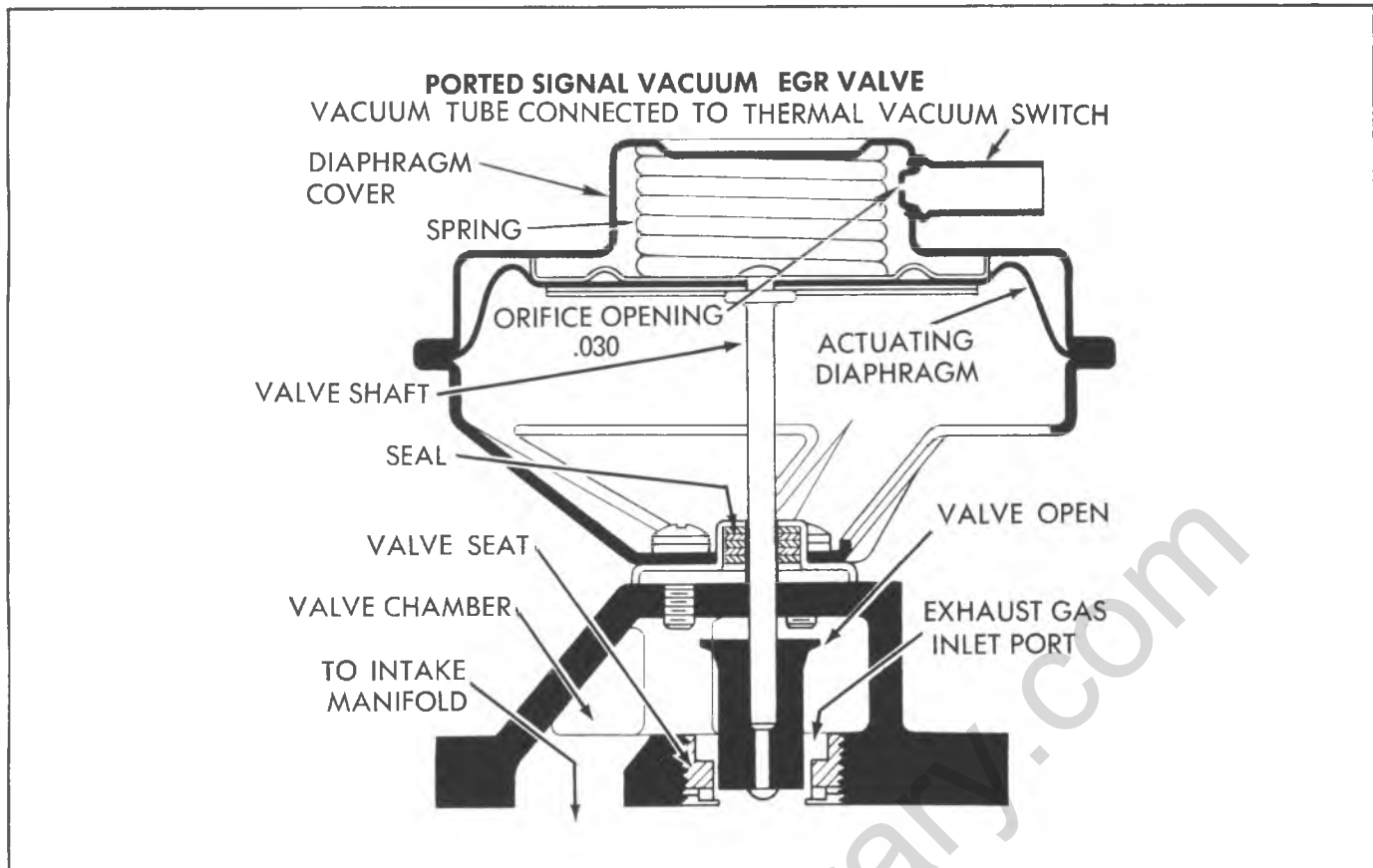


Fig. 6E-6--Ported Signal Vacuum EGR Valve

c. Valve should not open. If it does transducer control valve is stuck closed and EGR valve must be replaced.

d. With the vacuum supply still applied, direct a stream of air from a low pressure source (15 psi max) into the valve exhaust gas intake.

e. Valve should open completely. If it does not open at all transducer control valve is stuck open and EGR valve must be replaced.

f. If EGR valve and transducer control valve are both operating clean the EGR mounting surfaces and install valve.

EGR VALVE REPLACEMENT

1. Disconnect EGR valve vacuum hose at valve.
2. Remove bolts or nuts holding EGR valve on manifold.
3. Remove EGR valve from manifold.
4. Clean EGR mounting surfaces.
5. Reassemble replacement EGR valve on intake manifold using new gasket(s). Install spacer (if used). Torque attachments to correct torque.
6. Connect vacuum hose to valve.

EGR PASSAGE

If inspection of EGR passages in the inlet manifold indicates excessive build-up of deposits, the passages should be cleaned. Care should be taken to ensure that all loose particles are completely removed to prevent them from clogging the EGR valve or from being ingested into the engine.

EGR THERMAL VACUUM SWITCH

Replacement

1. Drain engine coolant.
2. Disconnect vacuum lines from the thermal vacuum switch.
3. Remove switch.
4. Apply an approved sealer to threaded portion of switch.
5. Install switch and torque to 20 N·m (15 lbs. ft.).
6. Rotate switch head as required to align for proper hose routing.
7. Install vacuum hoses to switch.
8. Replace engine coolant and check level.

Functional Check - Hot

The EGR Thermal Vacuum Delay Switch opens as coolant temperature increases, permitting the ported vacuum signal to reach the EGR valve. Check as follows:

1. Remove EGR valve vacuum hose at EGR valve and connect hose to a vacuum gage.
2. Start engine. With transmission selector lever in Neutral or Park open throttle partially. (Do not overspeed engine.) as throttle is opened, the vacuum gage should respond with an increase in vacuum reading.
3. If operation is satisfactory, remove gage and reconnect hose to EGR valve.

If gage does not respond to throttle opening, proceed to Step 4.

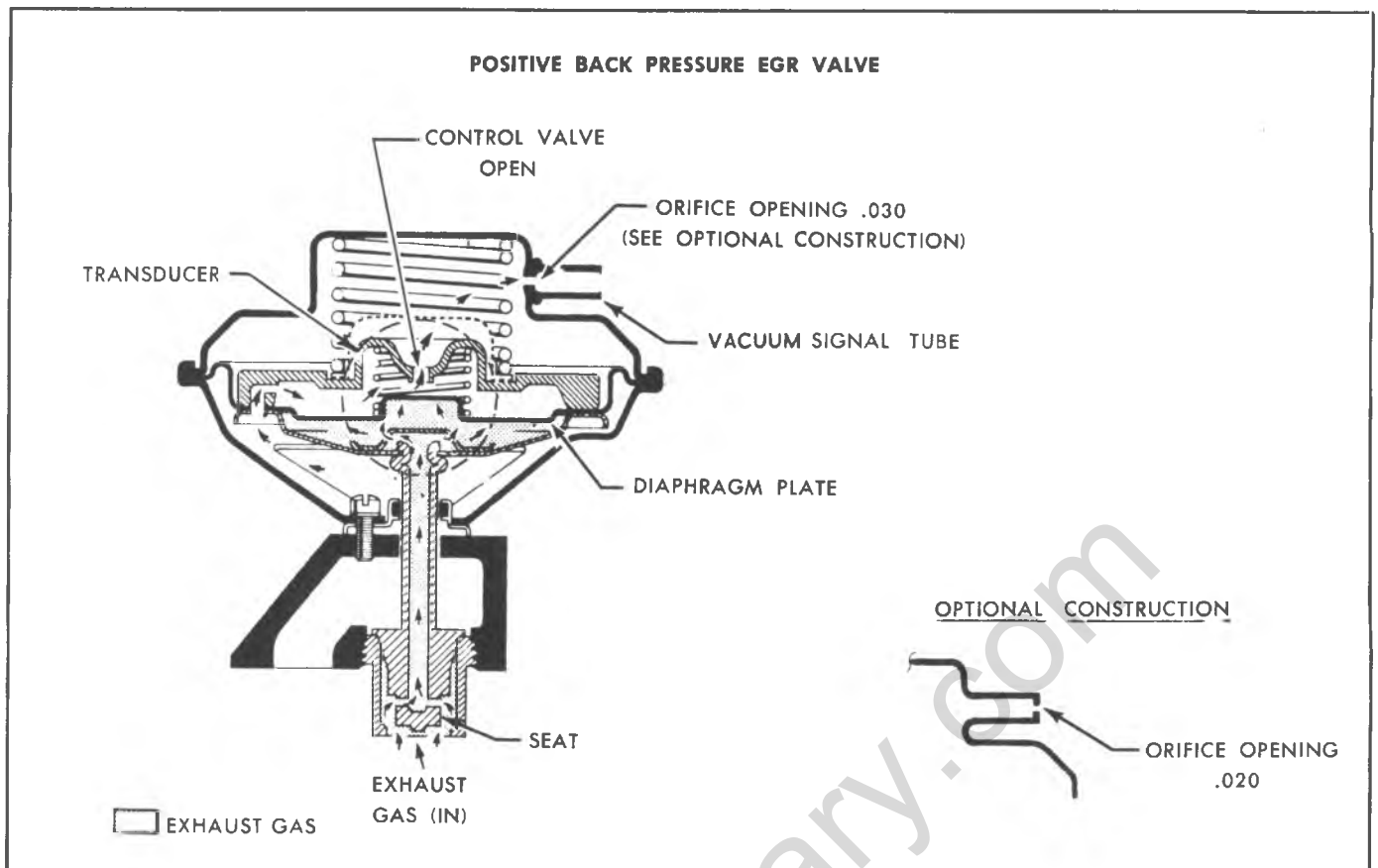


Fig. 6E-7--Positive Backpressure EGR Valve

4. Remove Carb-to-switch hose from switch and connect hose to vacuum gage. Repeat Step 2.

5. If vacuum gage responds to throttle opening, then switch is defective. Remove switch and replace with new part.

If gage does not respond to throttle opening, then check for plugged hose or defective carburetor.

Functional Check - Cold

This check can be used to diagnosis a stall after cold start or poor driveability immediately after cold start.

The EGR thermal vacuum delay switch should be closed below a coolant temperature of 85°F (29°C) thereby blocking the ported vacuum signal from reaching the EGR valve below that temperature. Check as follows:

1. Drain coolant to below level of switch.

2. Disconnect vacuum lines and remove switch.

3. Inspect switch to make sure it is in good condition.

4. Connect a vacuum hose to lower nipple of switch, marked "C" or "CARB". Connect a vacuum gage to upper nipple, marked "E" or "EGR".

5. Place switch in water at 75°F (24°C) and submerge completely for 2 minutes while agitating water thoroughly.

6. Apply 12 in. hg. (-41 kPa) vacuum to hose on lower nipple of switch. Under this condition, the switch should be closed.

NOTICE: Leakage of up to 2 in. hg. (-7 kPa) of vacuum in 2 minutes is allowable and does not mean a defective switch.

7. If operation is satisfactory, reinstall switch. If switch is defective, replace with a new part.

8. Replace coolant and check level.

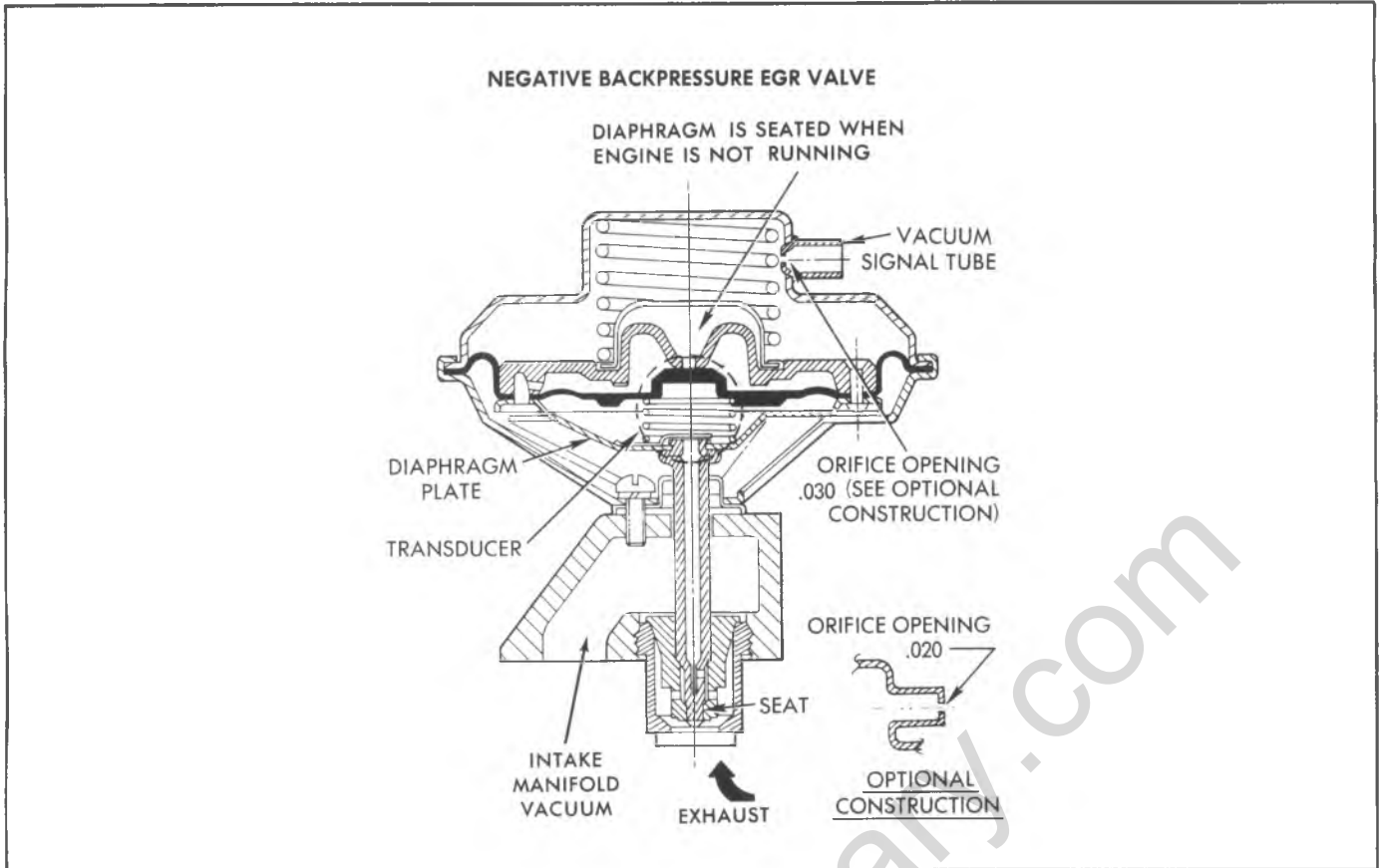


Fig. 6E-8--Negative Backpressure EGR Valve

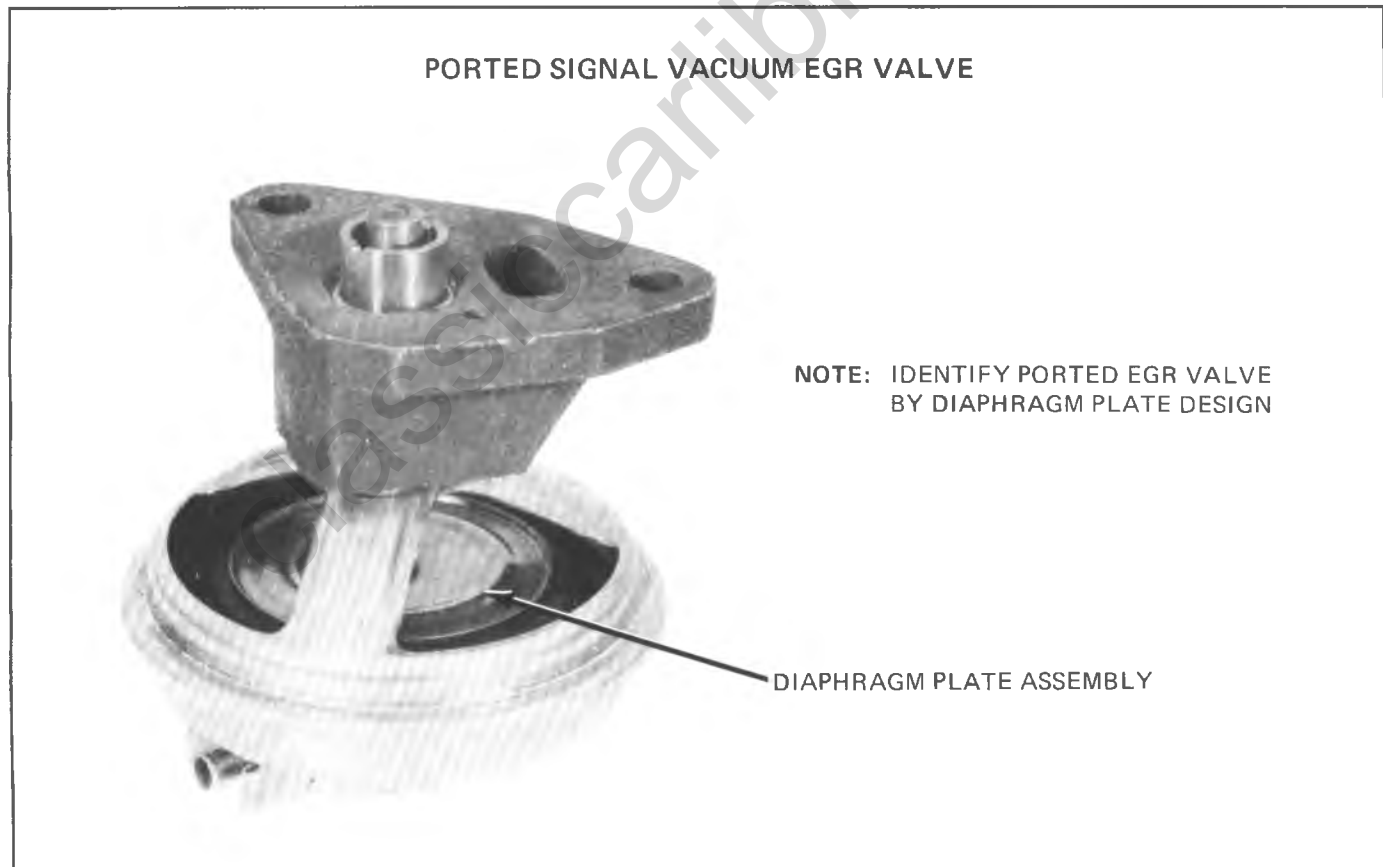


Fig. 6E-9--Ported EGR Identification

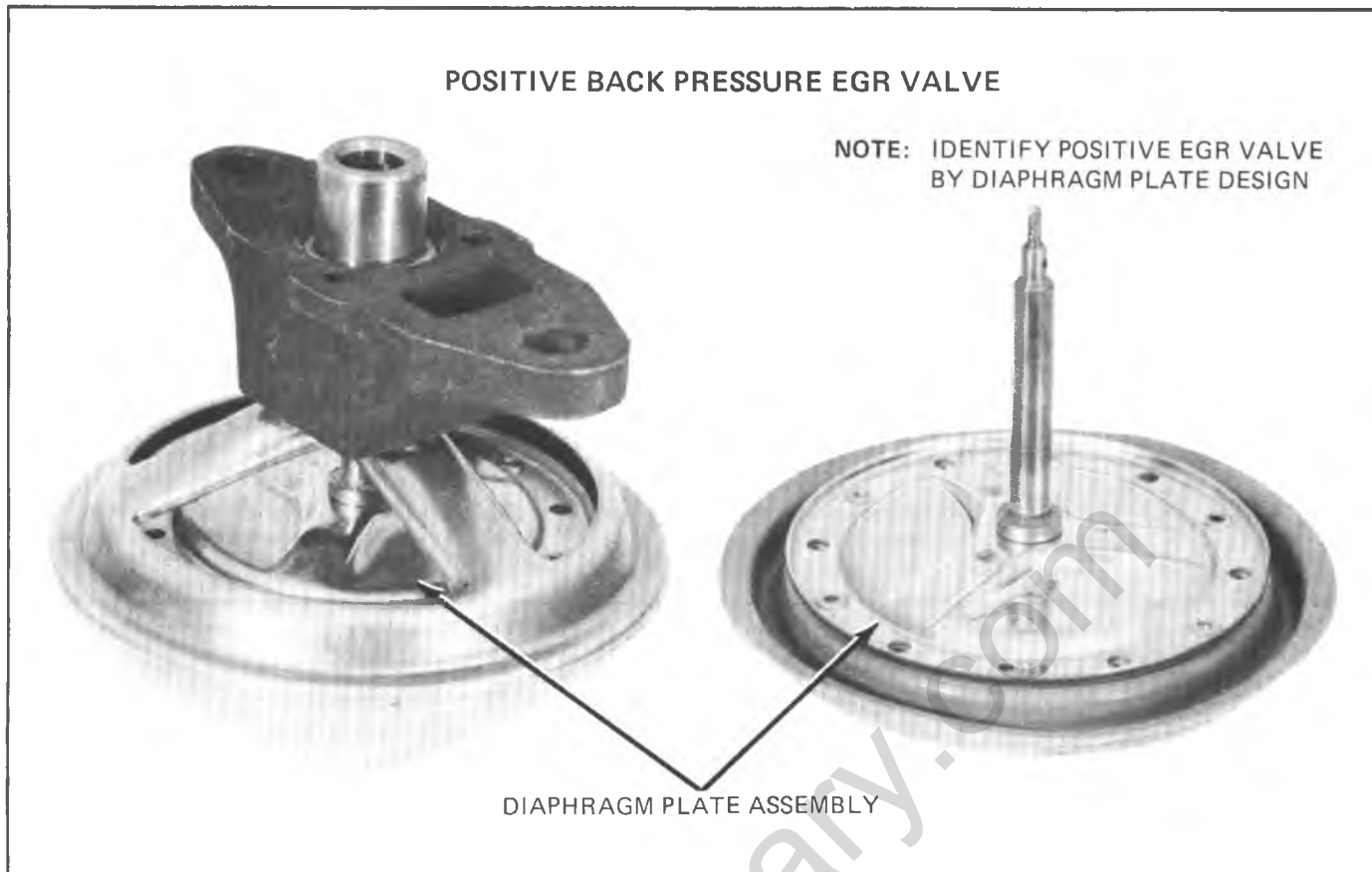


Fig. 6E-10-Positive EGR Identification

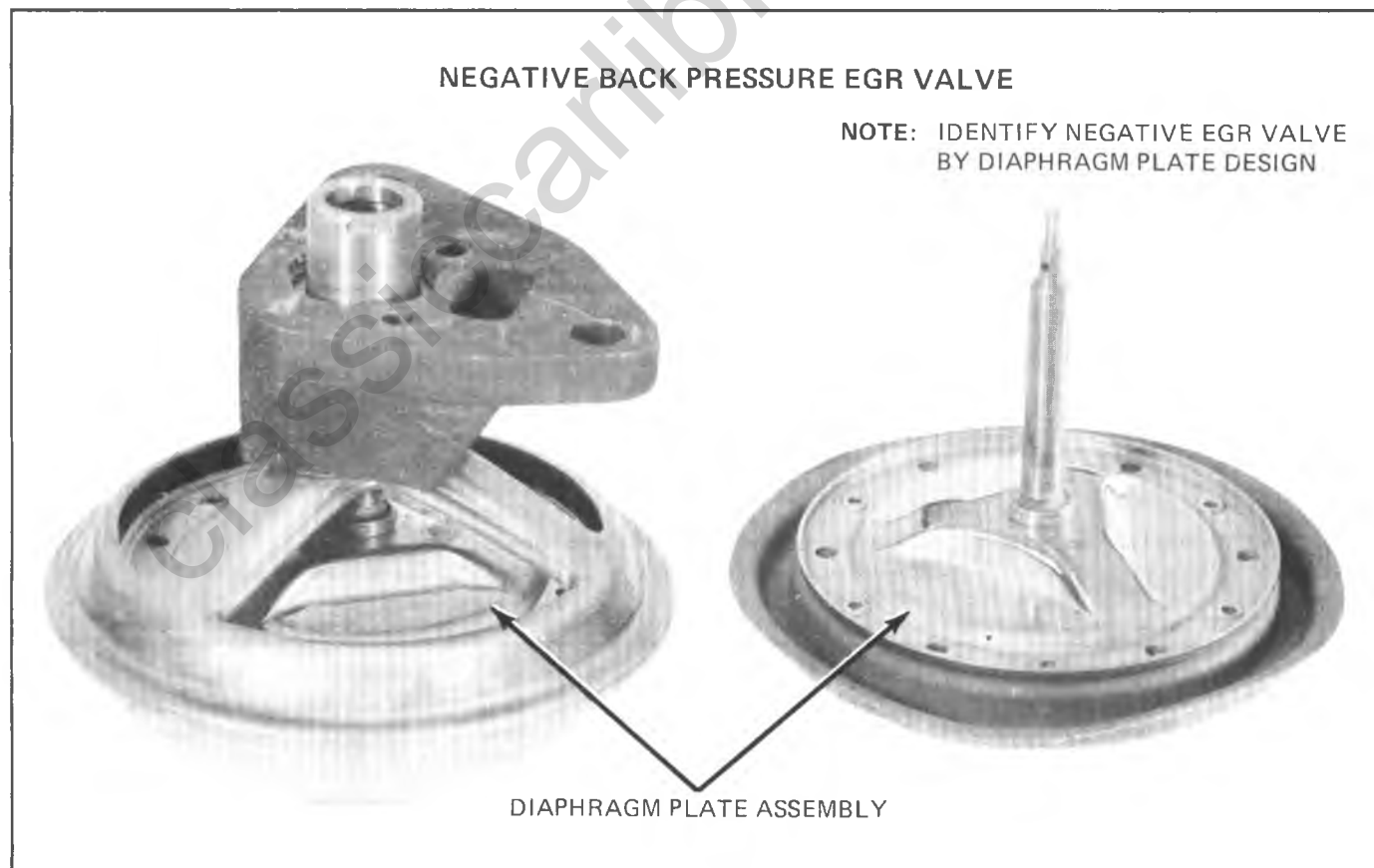


Fig. 6E-11-Negative EGR Identification

EXHAUST GAS RECIRCULATION SYSTEM DIAGNOSIS CHART

| Condition | Possible Cause | Correction |
|--|---|---|
| Engine idles abnormally rough and/or stalls. | EGR valve vacuum hoses misrouted. Leaking EGR valve. EGR valve gasket failed or loose EGR attaching bolts. EGR thermal control valve and/or EGR-TVS. Improper vacuum to EGR valve at idle. | Check EGR valve vacuum hose routing. Correct as required. Check EGR valve for correct operation. Check EGR attaching bolts for tightness. Tighten as required. If not loose, remove EGR valve and inspect gasket. Replace as required. Check vacuum into valve from carburetor EGR port with engine at normal operating temperature and at curb idle speed. Then check the vacuum out of the EGR thermal control valve to EGR valve. If the two vacuum readings are not equal within $\pm 1/2$ in. Hg. (1.7 kPa), then proceed to EGR vacuum control diagnosis. Check vacuum from carburetor EGR port with engine at stabilized operating temperature and at curb idle speed. If vacuum is more than 1.0 in. Hg., refer to carburetor idle diagnosis. |
| Engine runs rough on light throttle acceleration and has poor part load performance. | EGR valve vacuum hose misrouted. Check for loose valve. Failed EGR vacuum control valve. (TVS open below 130°F.) Sticky or binding EGR valve. Wrong or no EGR gasket(s) and/or Spacer. | Check EGR valve vacuum hose routing. Correct as required. Torque valve. Same as listing in "Engine Idles Rough" condition. Clean EGR passage of all deposits. Remove EGR valve and inspect. Replace as required. Check and correct as required. Install new gasket(s), install spacer (if used), torque attaching parts. |
| Engine stalls on decelerations. | Control valve blocked or air flow restricted. Restriction in EGR vacuum line or valve vacuum signal tube. Sticking or binding EGR valve. | Check internal control valve function per service procedure. Check EGR vacuum lines for kinks, bends, etc. Remove or replace hoses as required. Check EGR vacuum control valve function. Check EGR valve for excessive deposits causing sticky or binding operation. Replace valve. Remove EGR valve and replace valve. |
| Part throttle engine detonation. | Control valve blocked or air flow restricted. Insufficient exhaust gas recirculation flow during part throttle accelerations. | Check internal control valve function per service procedure. Check EGR valve hose routing. Check EGR valve operation. Repair or replace as required. Check EGR thermal control valve and/or EGR-TVS as listed in "Engine Idles Rough" section. Replace valve as required. Check EGR passages and valve for excessive deposit. Clean as required. |
| (NOTICE: Non-Functioning EGR valve could contribute to part throttle detonation.) | Control valve blocked or flow restricted. | Check EGR per service procedure. |
| (NOTICE: Detonation can be caused by several other engine variables. Perform ignition and carburetor related diagnosis.) | | |
| Engine starts but immediately stalls when cold. | EGR valve hoses misrouted. EGR TVS system malfunctioning when engine is cold. | Check EGR valve hose routings. Perform check to determine if the EGR thermal control valve and/or EGR-TVS are operational. Replace as required. |
| (NOTICE: Stalls after start can also be caused by carburetor problems.) | | |

Fig. 6E-12-EGR Diagnosis

POSITIVE CRANKCASE VENTILATION SYSTEM (PCV)

GENERAL DESCRIPTION

Ventilation air is drawn through a filter assembly located in the air cleaner, through a hose, down into the crankcase, up through the ventilator valve, through a hose and into the intake manifold. Intake manifold vacuum draws any fumes from the crankcase to be burned in the engine.

When air flow through the carburetor is high, added air from the Positive Crankcase Ventilation System has no noticeable effect on engine operation; however, at idle speed, air flow through the carburetor is so low that any large amount added by the ventilating system would upset the air-fuel mixture, causing rough idle.

For this reason, a flow control valve is used which restricts the ventilating system flow whenever intake manifold vacuum is high.

ON-VEHICLE SERVICE

1. Remove PCV valve from intake manifold or rocker arm shaft cover.
2. Run the engine at idle.
3. Place your thumb over end of valve to check for vacuum. If there is no vacuum at valve, check for plugged hoses or valve. Replace deteriorated hoses.
4. Shut off the engine and remove PCV valve. Shake valve and listen for the rattle of check needle in valve. If valve does not rattle, replace valve.

THERMOSTATIC AIR CLEANER (THERMAC)

INSPECTION

Vacuum Motor Check

1. Check all hoses for proper hook-up. Check for kinked, plugged or damaged hoses.
2. With the engine "OFF", observe damper door position through snorkel opening. If position of snorkel makes observation difficult, use the aid of a mirror. At this point damper door should be in such a position that the heat stove passage is covered (snorkel passage open) If not, check for binds in linkage.
3. Apply at least 7 in Hg. of vacuum to the diaphragm assembly through hose disconnected at sensor unit. Damper door should completely close snorkel passage when vacuum is applied. If not, check to see if linkage is hooked up correctly and for a vacuum leak.
4. With vacuum applied, bend or clamp hose to trap vacuum in diaphragm assembly. Damper door should remain in position (closed snorkel passage). If it does not, there is a vacuum leak in diaphragm assembly. Replace diaphragm assembly.

Sensor Check (Quick Check of System)

1. Start test with engine cold, air cleaner at a temperature below 80°F (27°C). If the engine has been in recent use, allow it to cool. Placing a cool wet rag on sensor will aid in cooling.
2. Observe the damper door before starting the engine: it should be in the open snorkel position.
3. Start the engine and allow it to idle. Immediately after starting the engine, the damper door should be in the closed snorkel passage position.
4. As the engine warms up, the damper door should start to allow outside air and heated air to enter the carburetor inlet.

5. The system is operating normally as described above. If the air cleaner fails to operate as above, or if correct operation of the air cleaner is still in doubt, proceed to the thermometer check of sensor.

Thermometer Check of Sensor

1. Start test with air cleaner temperature below 80°F. (27°C). If engine has been run recently, remove air cleaner and place a cool wet rag on sensor (this will help quickly cool the air cleaner). Remove air cleaner cover and place thermometer as close as possible to the sensor. Let air cleaner cool until thermometer reads below 80°F. (27°C.) about 5 to 10 minutes. Reinstall air cleaner on engine and continue to step 2 below.
2. Start and idle engine. Damper door should move to close the snorkel passage immediately if engine is cool enough. When damper door starts to open the snorkel passage (in a few minutes), remove air cleaner cover and read temperature gage. It must read 100°F. \pm 20°F. (38°C. \pm 7°C).
3. If the damper door does not start to open up the snorkel passage at temperature indicated, temperature sensor is malfunctioning and must be replaced.

ON VEHICLE SERVICE

Checking Air Cleaner

1. Inspect system to be sure all hoses and ducts are connected.
2. If engine is warm above 80°F (27°C) remove air cleaner. Permit it to cool to room temperature.
3. Install cooled air cleaner. with cold air intake hose disconnected (if equipped).
4. Start engine. Watch damper valve in air cleaner snorkel.

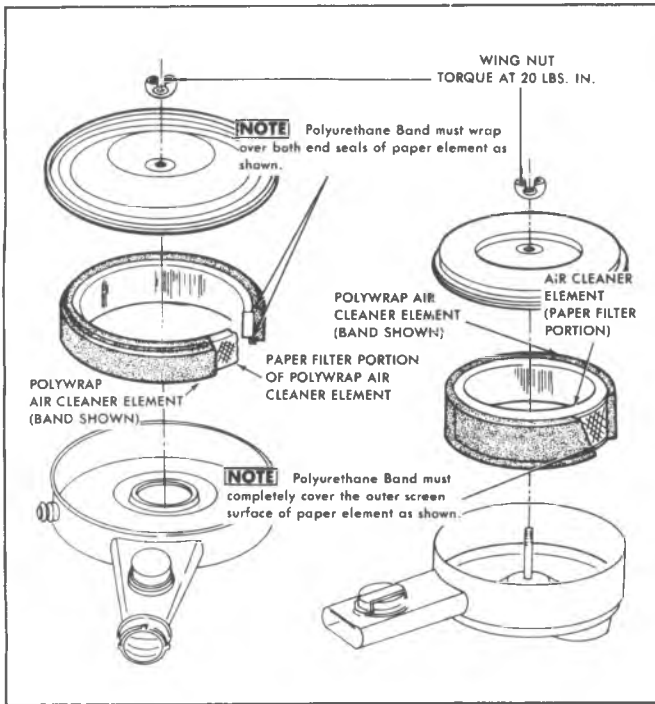


Fig. 6E-13-Polywrap Air Cleaner Element

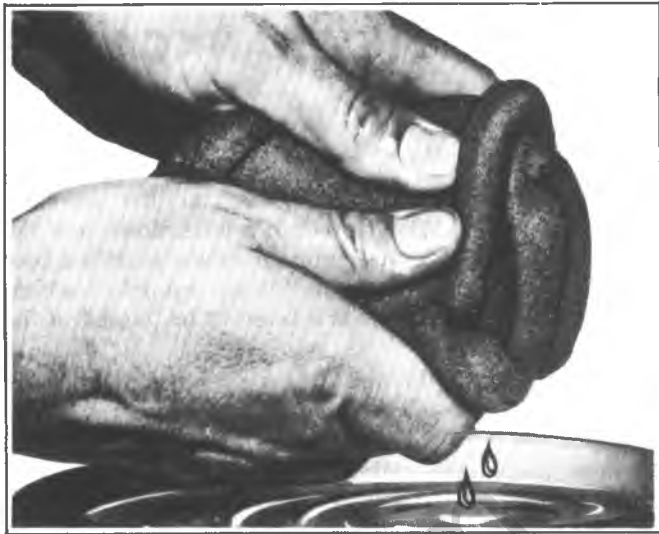


Fig. 6E-14-Cleaning Polywrap Band

5. When engine is first started, valve should be closed. As air cleaner warms up, valve should slowly open.

NOTICE: In hot weather the room temperature may be too hot for the snorkel valve to close when the engine is started. In this case, cool the temperature sensor in the air cleaner with a cool wet rag.

6. If valve doesn't close when the engine is started, check for vacuum at the diaphragm.

7. If vacuum is present, check for binding in the damper valve and operating link. If damper moves freely, replace diaphragm. (Failure of the diaphragm to close is more likely to result from mechanical bind due to a damaged or corroded snorkel assembly than from a failed diaphragm. This should be checked first, before replacing the diaphragm).

8. If no vacuum is present, check hoses for disconnects, cracks or pinches. Repair or replace as necessary.

9. If hoses are OK, replace temperature sensor in the air cleaner.

Air Cleaner Element Replacement

Paper Element

1. Remove air cleaner cover.
2. Remove element.
3. Install new element in air cleaner with either end up.
4. Install air cleaner cover. Do not over-torque wing nut.

Polywrap Element (P Models)

1. Remove air cleaner cover.
2. Remove element.
3. Remove polywrap band from paper element and discard element (Fig. 6E-13).
4. Clean bottom section of air cleaner and inspect cover seal for tears or cracks. Replace seal if damaged.
5. Inspect band for tears and replace if damaged.
6. If band is serviceable, wash in kerosene or mineral spirits and squeeze out excess solvent (Fig. 6E-14).

NOTICE: Never use a hot degreaser or any solvent containing acetone or similar solvent; also, never shake, swing or wring the element to remove excess solvent as this may tear the polyurethane material. Instead, "squeeze" the excess solvent from the element.

7. Dip band into light engine oil and squeeze out excess oil.
8. Install band around outer surface of new paper element.
9. Install element in bottom section of air cleaner with either end up.
10. Install air cleaner cover. Do not over-torque wing nuts(s).

Air Cleaner Replacement

Refer to figures 6E-15 and 6E-16 for air cleaner used with in line L6 engine.

Refer to figure 6E-17 for air cleaner used on CK truck with 305/350/400 V8 engine.

Refer to figure 6E-18 for air cleaner used on G truck with V8 engine.

Refer to figure 6E-19 for air cleaner used with 454 V8 engine.

Refer to figure 6E-20 for air cleaner used on P20(42), P30(42) and P30(32) truck with 350 V8 engine and 4MV carburetor.

Refer to figure 6E-21 for air cleaner used on 350 V8 diesel engine.

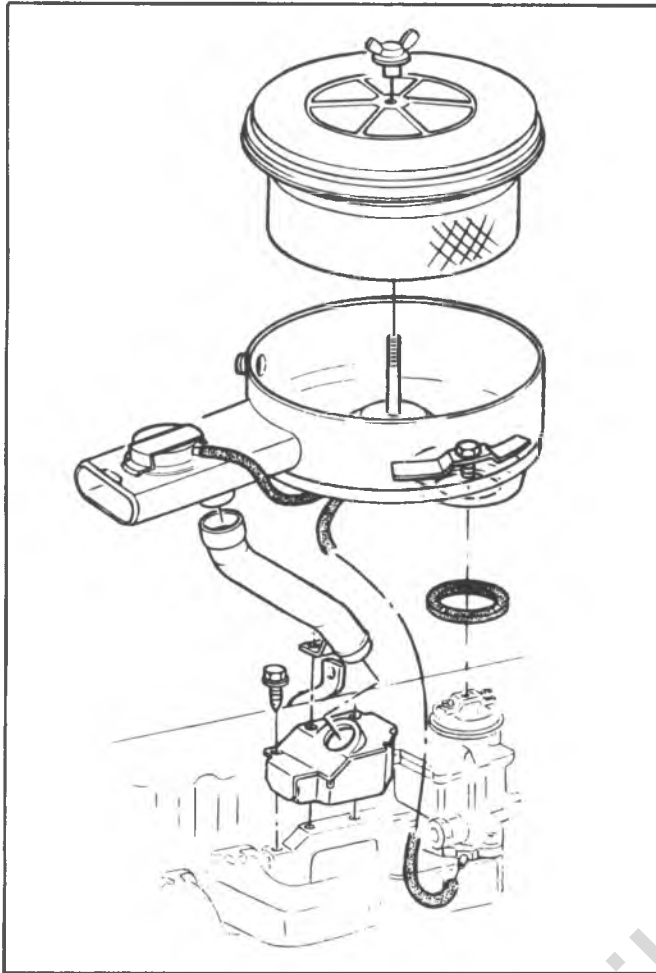


Fig. 6E-15—Air Cleaner-L6

Vacuum Motor

Removal

1. Remove air cleaner.
2. Disconnect vacuum hose from motor.
3. Drill out the two spot welds initially with a 1/6" hole, then enlarge as required to remove the retaining strap. Do not damage the snorkel tube.
4. Remove motor retaining strap.
5. Lift up motor, cocking it to one side to unhook the motor linkage at the control damper assembly.

Installation

1. Drill a 7/64" hole in snorkel tube at center of vacuum motor retaining strap (Fig. 6E-22).
2. Insert vacuum motor linkage into control damper assembly.
3. Use the motor retaining strap and sheet metal screw provided in the motor service package to secure the retaining strap and motor to the snorkel tube.

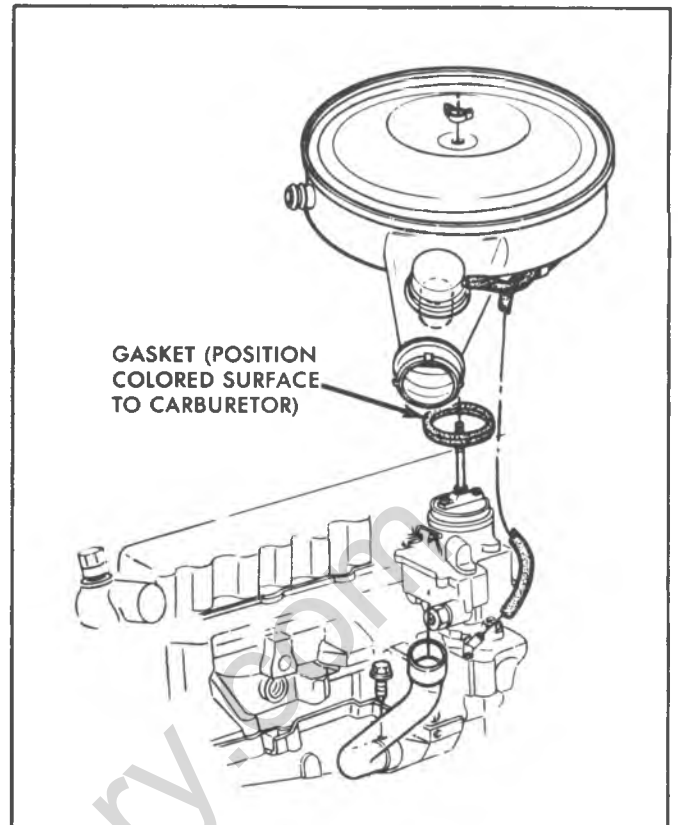


Fig. 6E-16—Air Cleaner-L6

4. Make sure the screw does not interfere with the operation of the damper assembly. Shorten screw if required.

5. Connect vacuum hose to motor and install air cleaner.

Sensor

Removal

1. Remove air cleaner.
2. Detach hoses at sensor.
3. Pry up tabs on sensor retaining clip (Fig. 6E-23); remove clip and sensor from air cleaner. Note position of sensor for installation.

Installation

1. Install sensor and gasket assembly in original position.
2. Press retainer clip on hose connectors.
3. Connect vacuum hoses and install air cleaner on engine.

Carburetor Air Intake

Refer to figure 6E-24 and 6E-25 for repair or replacement of air intake.

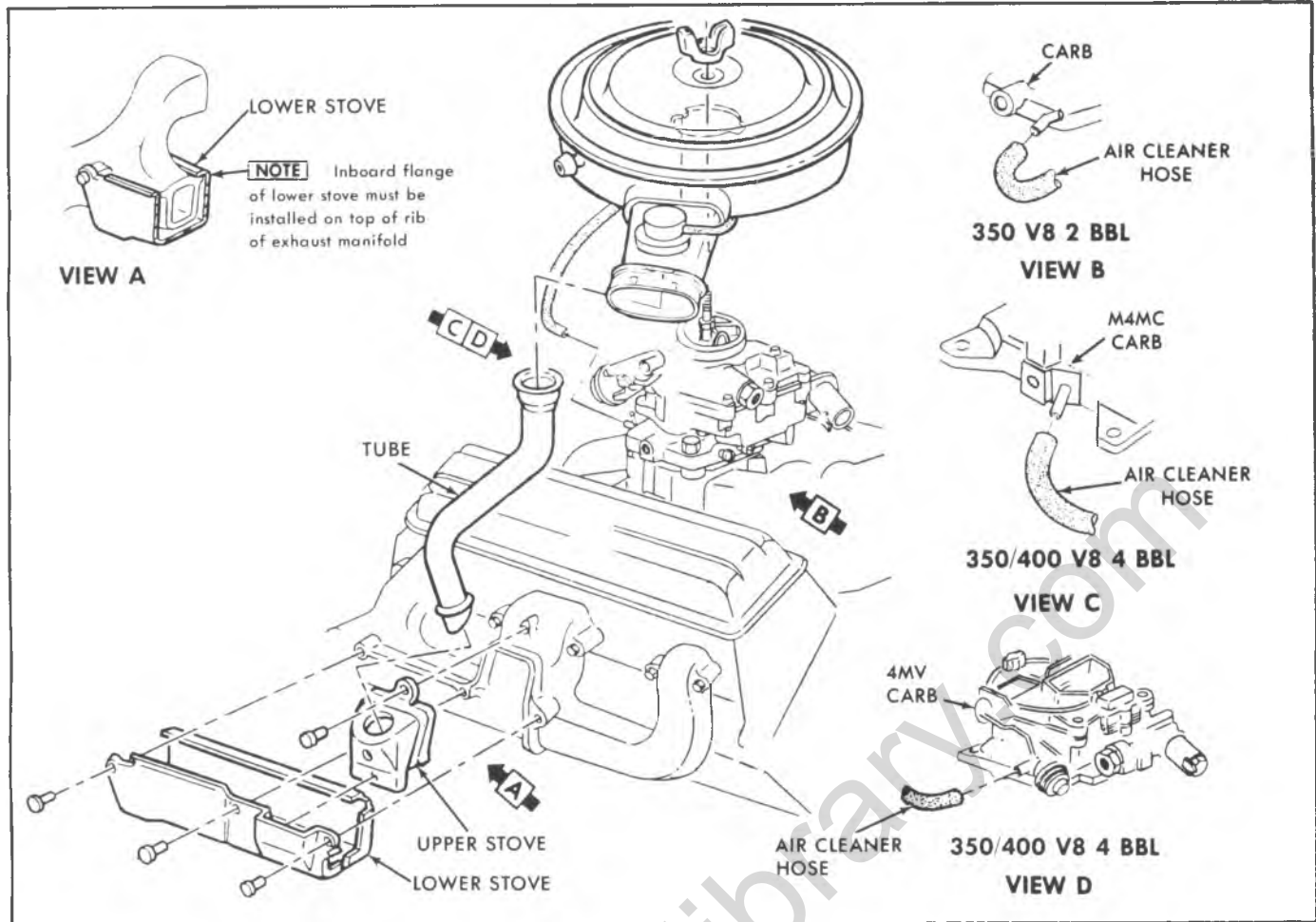


Fig. 6E-17-Air Cleaner-305/350/400 V8 CK

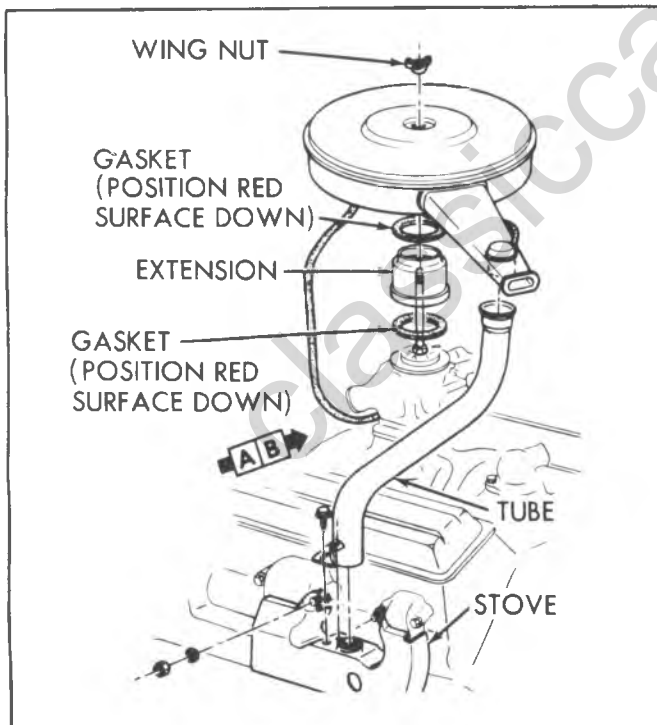


Fig. 6E-18-Air Cleaner-V8 G

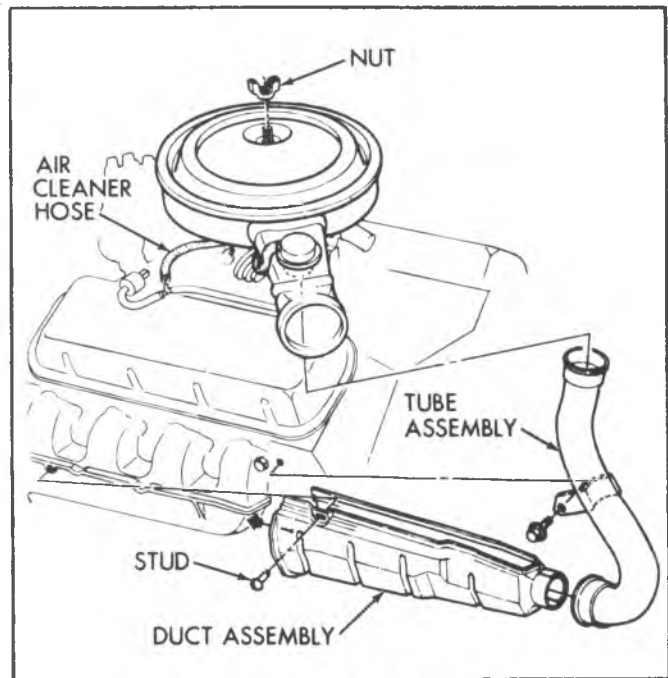


Fig. 6E-19-Air Cleaner-454 V8

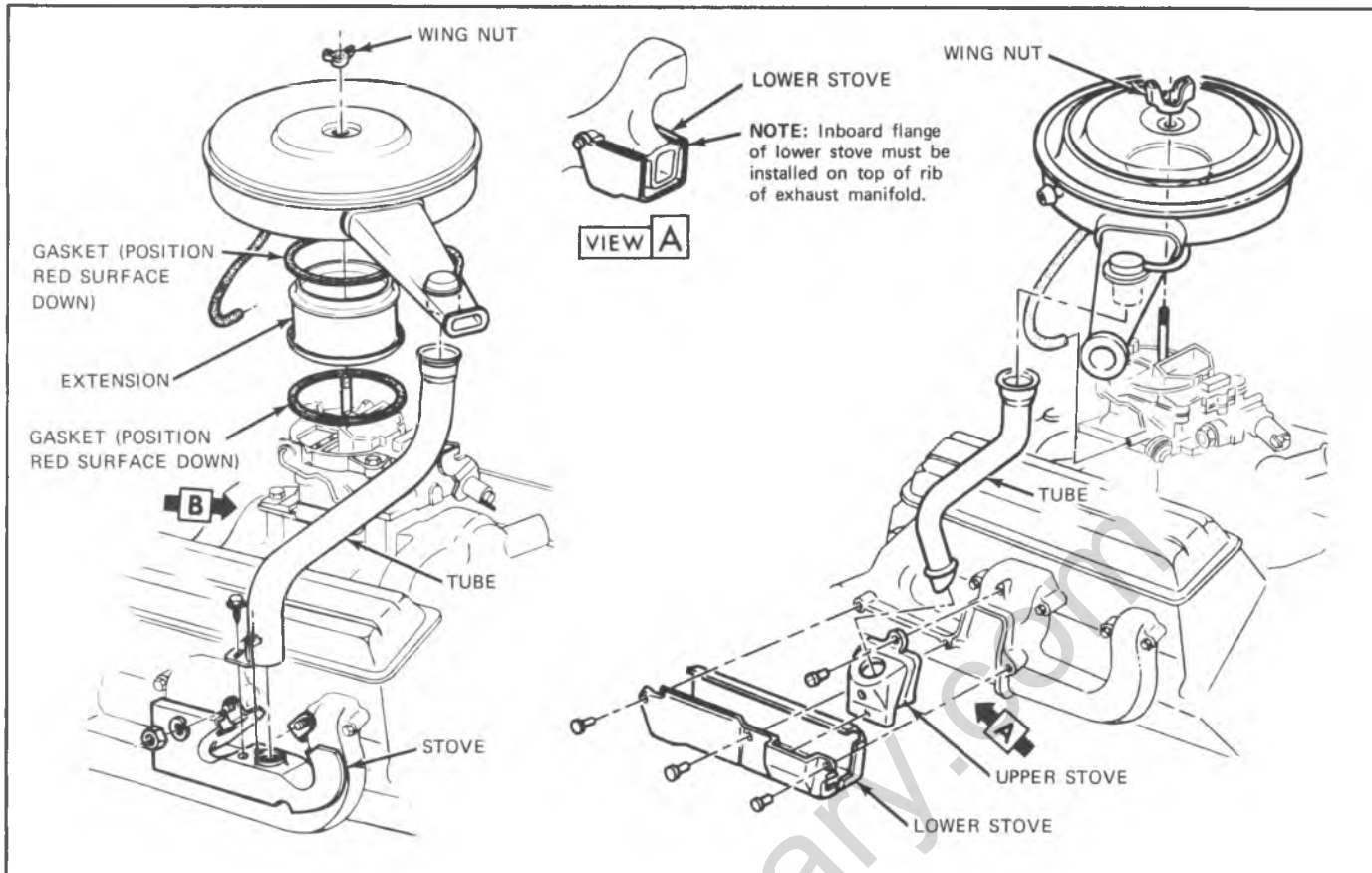


Fig. 6E-20—Air Cleaner-P20(42), P30(42), P30(32)-V8

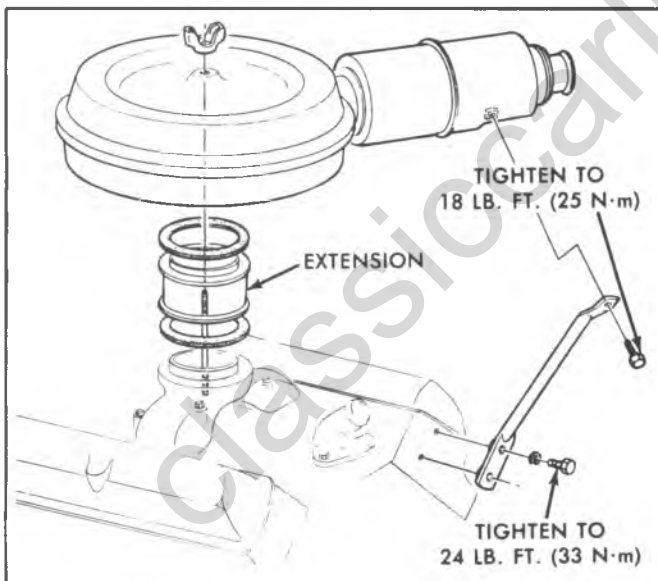


Fig. 6E-21—Air Cleaner-350 V8 Diesel

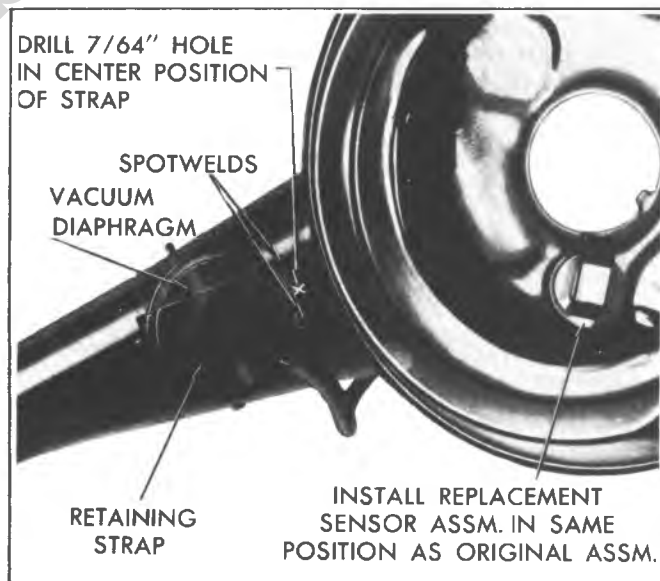


Fig. 6E-22—Vacuum Diaphragm Replacement



Fig. 6E-23-Removing Sensor Unit

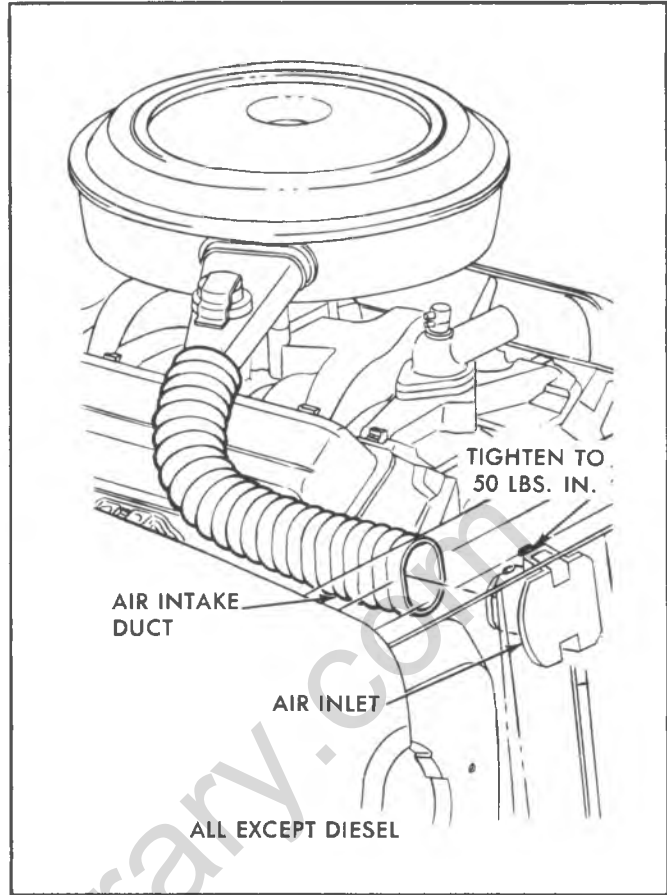


Fig. 6E-25-Carburetor Air Intake - V8

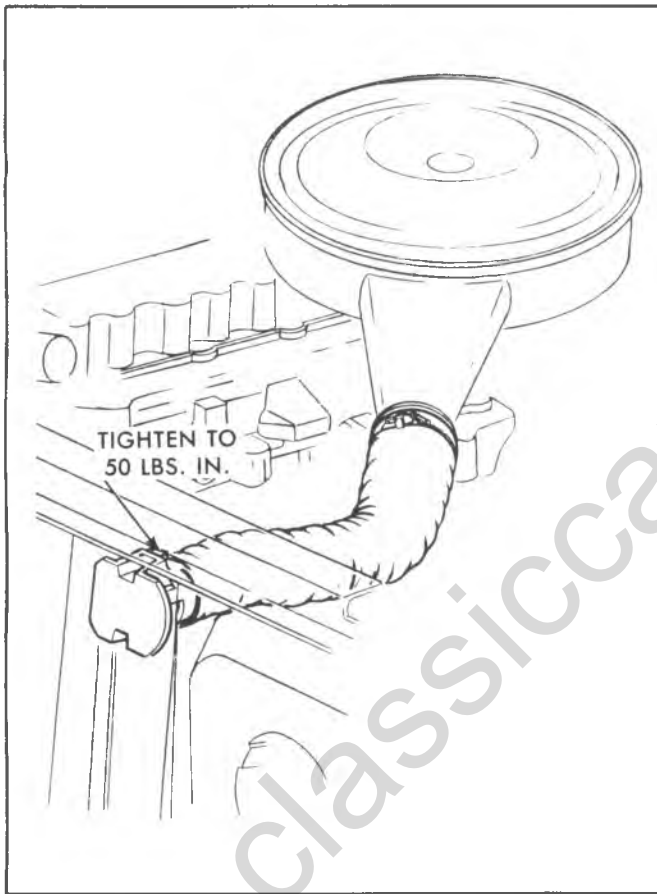


Fig. 6E-24-Carburetor Air Intake-L6

AIR INJECTION REACTOR (AIR) SYSTEM

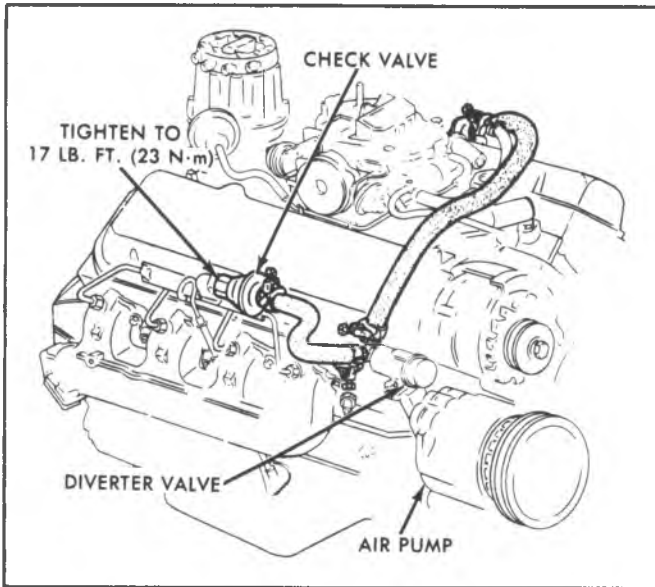


Fig. 6E-26-A.I.R. Pipe Installation-C Series (454)

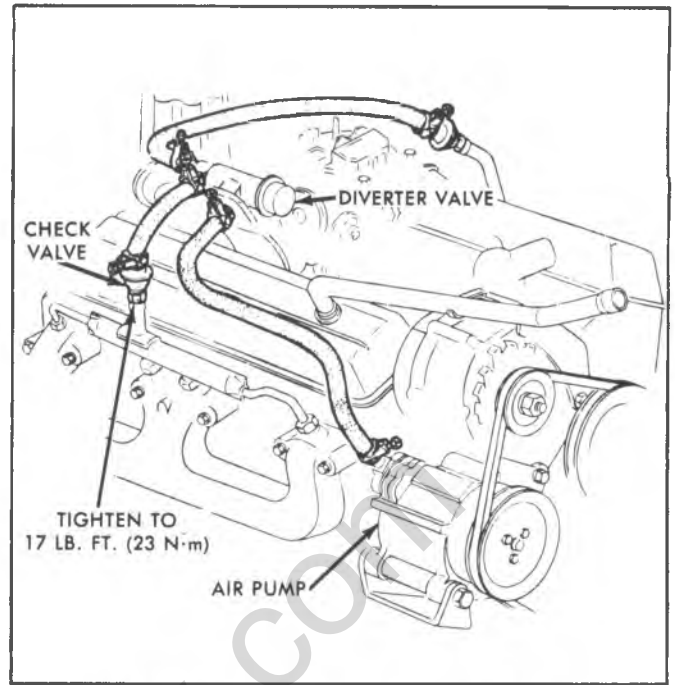


Fig. 6E-28-A.I.R. Pipe Installation-G Series

GENERAL DESCRIPTION

The Air Injection Reactor (A.I.R.) System consists of: an air injection pump (with necessary brackets and drive attachments), air diverter valve, a check valve and air pipe hose necessary to connect diverter valve (Figs. 6E-26 through 28).

The Air Injection Pump (Fig. 6E-29) with an integral filter, compresses the air and injects it through the air manifolds, into the exhaust system in the area of the exhaust valves. The fresh air helps burn the unburned portion of the exhaust gases in the exhaust system, thus minimizing exhaust contamination.

The diverter valve Fig. 6E-30) when triggered by a sharp increase in manifold vacuum, shuts off the injected air to the exhaust port areas and prevents backfiring during this richer period.

On engine overrun the total air supply is dumped through the muffler on the diverter valve. At high engine speeds the excess air is dumped through the pressure relief valve which is incorporated in the diverter valve.

The check valve (Fig. 6E-26 through 28) prevents exhaust gases from entering and damaging the air injection pump, as back flow can occur even under normal operating conditions.

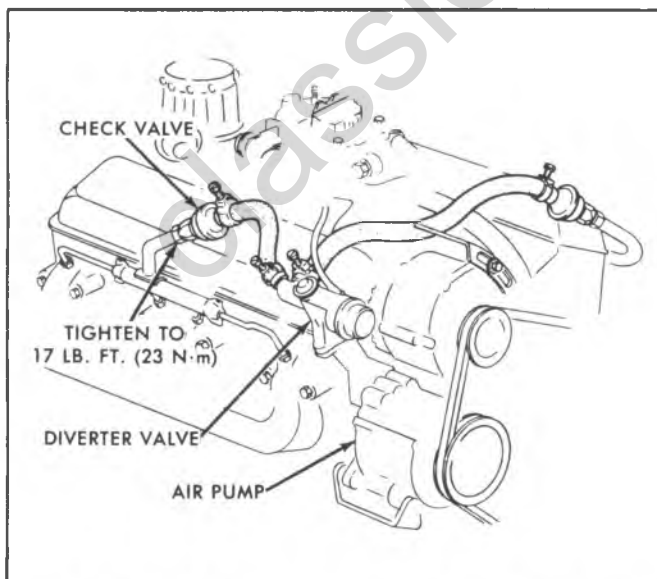


Fig. 6E-27-A.I.R. Pipe Installation - CK Series (350/400)

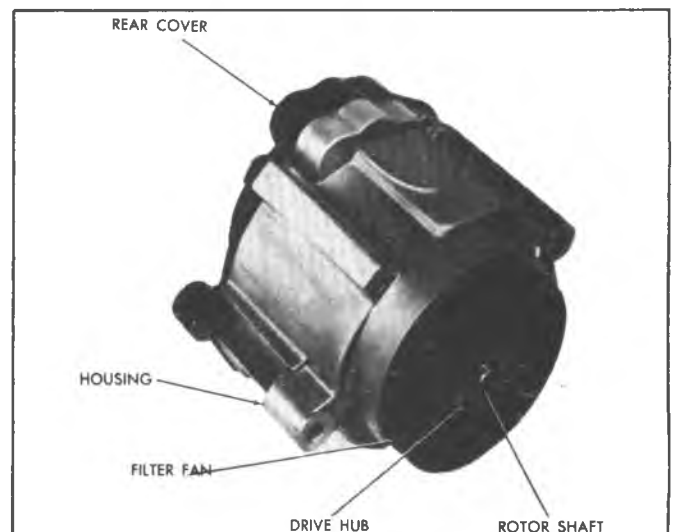


Fig. 6E-29-Air Injection Pump

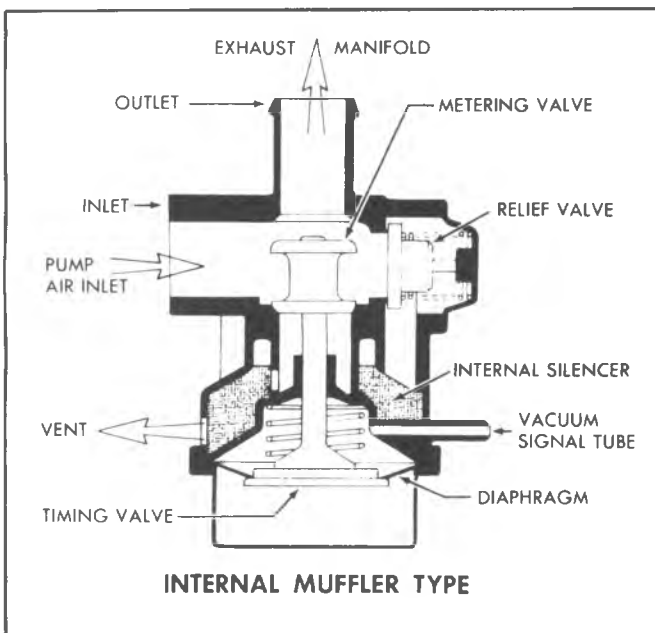


Fig. 6E-30--Diverter Valve

ON-VEHICLE SERVICE

Drive Belt

Inspection

1. Inspect drive belt for wear, cracks or deterioration and replace if required.
2. Inspect belt tension and adjust if below 70 lbs. using a tension gauge.

Adjustment

Loosen pump mounting bolt and pump adjustment bracket bolt. Move pump until belt is properly tensioned then tighten adjustment bracket bolt and mounting bolt. Use a belt tension gauge to check adjustment.

NOTICE: Do not pry on the pump housing. Distortion of the housing will result in extensive damage to the Air Injection Pump.

Replace

1. Loosen pump mounting bolt and pump adjustment bracket bolt, then swing pump until drive belt may be removed.
2. Install a new drive belt and adjust as outlined above.

Pump Pulley

Replace

1. Hold pump pulley from turning by compressing drive belt then loosen pump pulley bolts.
2. Remove drive belt as outlined above then remove pump pulley.

Install

1. Install pump pulley with retaining bolts hand tight. Install and adjust drive belt as outlined above.
2. Hold pump pulley from turning by compressing drive belt then torque pump pulley bolts to 24 lb. ft. (32N·m).

3. Recheck drive belt tension and adjust if required.

Pump Filter

Replace

1. Remove drive belt and pump pulley as previously outlined.
2. Insert needle nose pliers and pull fan from hub (Fig. 6E-32).

NOTICE: Care should be taken to prevent fragments from entering the air intake hole. Do not insert a screwdriver between pump and filter. It is seldom possible to remove the filter without destroying it. Do not attempt to remove the metal hub.

Install

1. Install the new filter by drawing it on with the pulley and pulley bolts (Fig. 6E-33). Do not attempt to install a filter by hammering it on or pressing it on.
2. Draw the filter down evenly by alternately torquing the bolts. Make certain that the outer edge of the filter slips into the housing. The slight amount of interference with the housing bore is normal.

NOTICE: The new filter may squeal upon initial operation until it's O.D. sealing lip has worn in.

Air Hoses and Tubes

Inspection

1. Inspect all hoses for deterioration or holes.
2. Inspect all tubes for cracks or holes.
3. Check all hose and tube connections.
4. Make repairs or replace parts as needed.
5. Check all tube and hose routing. Interference may cause wear.
6. If leak is suspected on the pressure side of the system or any tubes and/or hoses have been disconnected on the pressure side, the connections should be checked for leaks with soapy water solution.
7. With the pump running, bubbles will form if a leak exists.

Replace

To replace any hose and/or tube, note routing then remove hose(s) and/or tube(s) as required.

Install

1. Install new hose(s) and/or tube(s), routing them as when removed.
2. Tighten all connections.

Check Valve

Inspection

1. The check valve should be inspected whenever the hose is disconnected from the check valve or whenever check valve failure is suspected. (A pump that had become inoperative and had shown indications of having exhaust gases in the pump would indicate check valve failure.)
2. Blow through the check valve (toward the cylinder head) then attempt to suck back through check valve. Flow should only be in one direction (toward the exhaust manifold). Replace valve which does not function this way.

DIAGNOSIS – AIR INJECTION REACTOR SYSTEM

| CONDITION | POSSIBLE CAUSE | CORRECTION |
|---|--|---|
| No air supply – accelerate engine to 1500 rpm and observe air flow from hoses. If the flow increases as the rpm's increase, the pump is functioning normally. If not, check possible cause. | <ol style="list-style-type: none"> 1. Loose drive belt. 2. Leaks in supply hose. 3. Leak at fittings. 4. Air expelled through by-pass valve. 4a. Connect a vacuum line directly from engine manifold vacuum to by-pass valve. 4b. Connect vacuum line from engine manifold vacuum source to by-pass valve through vacuum differential valve directly, by passing the differential vacuum delay and separator valve. 5. Check valve inoperative. 6. Pump failure. | <ol style="list-style-type: none"> 1. Tighten to specifications. 2. Locate leak and repair 3. Tighten or replace clamps. 4a. If this corrects the problem go to step b. If not, replace air by-pass valve. 4b. If this corrects the problem, check differential vacuum, delay and separator valve and vacuum source line for plugging. Replace as required. If it doesn't, replace vacuum differential valve. 5. Disconnect hose and blow through hose toward check valve. If air passes, function is normal. If air can be sucked from check valve, replace check valve. 6. Replace pump. |
| Excessive pump noise, chirping, rumbling, knocking, loss of engine performance. | <ol style="list-style-type: none"> 1. Leak in hose. 2. Loose hose. 3. Hose touching other engine parts. 4. Vacuum differential valve inoperative. 5. By-pass valve inoperative 6. Pump mounting fasteners loose. 7. Pump failure. 8. Check valve inoperative. | <ol style="list-style-type: none"> 1. Locate source of leak using soap solution and correct. 2. Reassemble and replace or tighten hose clamp. 3. Adjust hose position. 4. Replace vacuum differential valve. 5. Replace by-pass valve. 6. Tighten mounting screws as specified. 7. Replace pump. 8. Replace check valve. |
| Excessive belt noise. | <ol style="list-style-type: none"> 1. Loose belt 2. Seized pump | <ol style="list-style-type: none"> 1. Tighten to spec. 2. Replace pump. |
| Excessive pump noise. Chirping | <ol style="list-style-type: none"> 1. Insufficient break-in | <ol style="list-style-type: none"> 1. Run vehicle 10-15 miles at interstate speeds--recheck. |
| Centrifugal filter fan damaged or broken. | <ol style="list-style-type: none"> 1. Mechanical damage | <ol style="list-style-type: none"> 1. Replace centrifugal filter fan. |
| Exhaust tube bent or damaged. | <ol style="list-style-type: none"> 1. Mechanical damage | <ol style="list-style-type: none"> 1. Replace exhaust tube. |
| Poor idle or driveability. | <ol style="list-style-type: none"> 1. A defective A.I.R. system cannot cause poor idle or driveability. | <ol style="list-style-type: none"> 1. Do not replace A.I.R. system. |

Fig. 6E-31–Diagnosis–Air Injection Reactor System

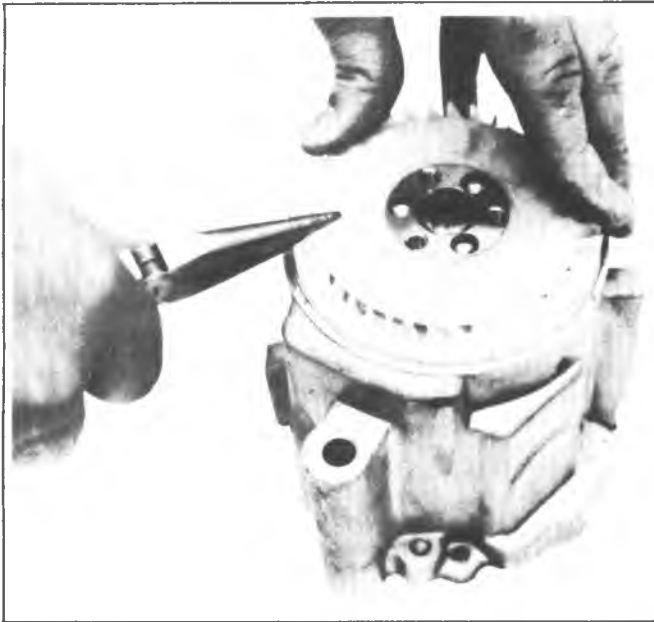


Fig. 6E-32—Removing Centrifugal Filter



Fig. 6E-33—Installing Centrifugal Filter

Replace

Disconnect pump outlet hose at check valve. Remove check valve from pipe assembly, being careful not to bend or twist the assembly.

Diverter Valve and Silencer Assembly

Inspection

1. Check condition and routing of all lines especially the signal line. All lines must be secure without crimps and not leaking. Replace deteriorated lines.

2. Disconnect signal line at valve. A vacuum signal must be available with engine running.

Install

1. Install diverter valve to pump or elbow with new gasket. Torque valve attaching screws to 85 lb. in. (9.5N·m).

2. Install outlet and vacuum signal hoses and check system for leaks.

Air Injection Pump

Inspection

Accelerate engine to approximately 1500 RPM and observe air flow from hose(s). If air flow increases as engine is accelerated, pump is operating satisfactorily. If air flow does not increase or is not present, proceed as follows:

1. Check for proper drive belt tension.
2. Check for a leaky pressure relief valve. Air may be heard leaking with the pump running.

NOTICE: The AIR System is not completely noiseless. Under normal conditions, noise rises in pitch as engine speed increases. To determine if excessive noise is the fault of the Air Injection Reactor System, operate the engine with the pump drive belt removed. If excessive noise does not exist with the belt removed proceed as follows:

3. Check diverter valve attaching screws for tightness. Screws should be torqued to 85 lb. in. (10N·m).

4. Defective valves should be replaced (see Functional Test).

Replace

1. Disconnect vacuum signal line. Disconnect valve outlet hose.

2. Remove diverter valve from pump or elbow.

3. Check for a seized Air Injection Pump.

4. Check hoses, tubes and all connections for leaks and proper routing.

CAUTION: Do not oil AIR pump.

5. Check diverter valve.

6. Check AIR injection pump for proper mounting and bolt torque.

7. Repair irregularities in these components as necessary.

8. If no irregularities exist and the AIR injection pump noise is still excessive, remove and replace pump.

Replace

1. Disconnect the hoses at the pump.

2. Remove pump pulley as outlined.

3. Remove pump mounting bolts and remove pump.

Install

1. Install pump with mounting bolts loose.

2. Install pump pulley as outlined.

3. Install and adjust belt as outlined.

4. Connect the hoses at the pump.

5. Tighten mounting bolts to 20-35 lb. ft. (27 N·m - 48N·m).

PULSE AIR INJECTION REACTOR SYSTEM - PAIR

FAILURE DIAGNOSIS

1. A hissing noise may indicate a defective pulse air valve or improper torque at manifold. Inspect pulse air valve.

2. If one or more check valves have failed, exhaust gas will enter the carburetor through the air cleaner and cause poor driveability indicated by a surge or poor performance. Check pulse air valves. Be sure pulse air pipe extension tubes (fig. 6E-34) are installed in exhaust manifold.

a. If exhaust gases pass through the pulse air valve, excessive heat is transmitted to the rocker cover plenum, indicated by burned off paint. Also, rubber grommets and hose will deteriorate. Failure could also be indicated by a hissing noise. Repair rocker cover plenum seals and replace grommets and hose as required.

b. If rubber hose to air cleaner deteriorates, particles may enter carburetor causing poor driveability. It will be necessary to clean carburetor, and remove particles from pulse air plenums and connecting pipe.

INSPECTION AND CHECKING PULSE AIR VALVE

Inspect pulse air valves, pipes, grommets and hose for leaks and cracks and replace as required.

Check operation of pulse air valves by creating a vacuum at grommet end of valve by adapting tool J-23738, with a tight fitting length of 3/4" hose. With vacuum of 5 kPa (17" Hg.) there will be an allowable drop to 1.7 kPa (6" Hg.) in 2 seconds. Replace valve and/or hose if vacuum

drops in less than two seconds.

NOTICE: Vacuum drop must be a result of a leaking valve not a leaking hose or connection.

Replacement of Pulse Air Valve (Fig. 6E-34)

1. Remove air cleaner and disconnect rubber hose from plenum connecting pipe.

2. Disconnect four pipe check valve fittings at cylinder head and remove check valve pipes from plenum grommets.

3. Disconnect check valve from check valve pipe.

4. Bench assemble check valves to check valve pipe.

5. Install pipe check valve assemblies to cylinder head as shown in fig. 6E-34 and finger tighten the fittings.

6. Using a 1" open end wrench or similar tool as a lever, align check valve on pipe "A" (fig. 6E-35) to the plenum grommet. Then using palm of your left hand install check valve into the grommet. Use rubber lubricant on grommets to ease assembly.

7. Repeat procedure in step 6 on pipe "B" (fig. 6E-36) but use your left hand on the tool for alignment of check valve and install valve with the palm of your right hand.

8. Tighten fittings to specified torque and reinstall air cleaner and hose.

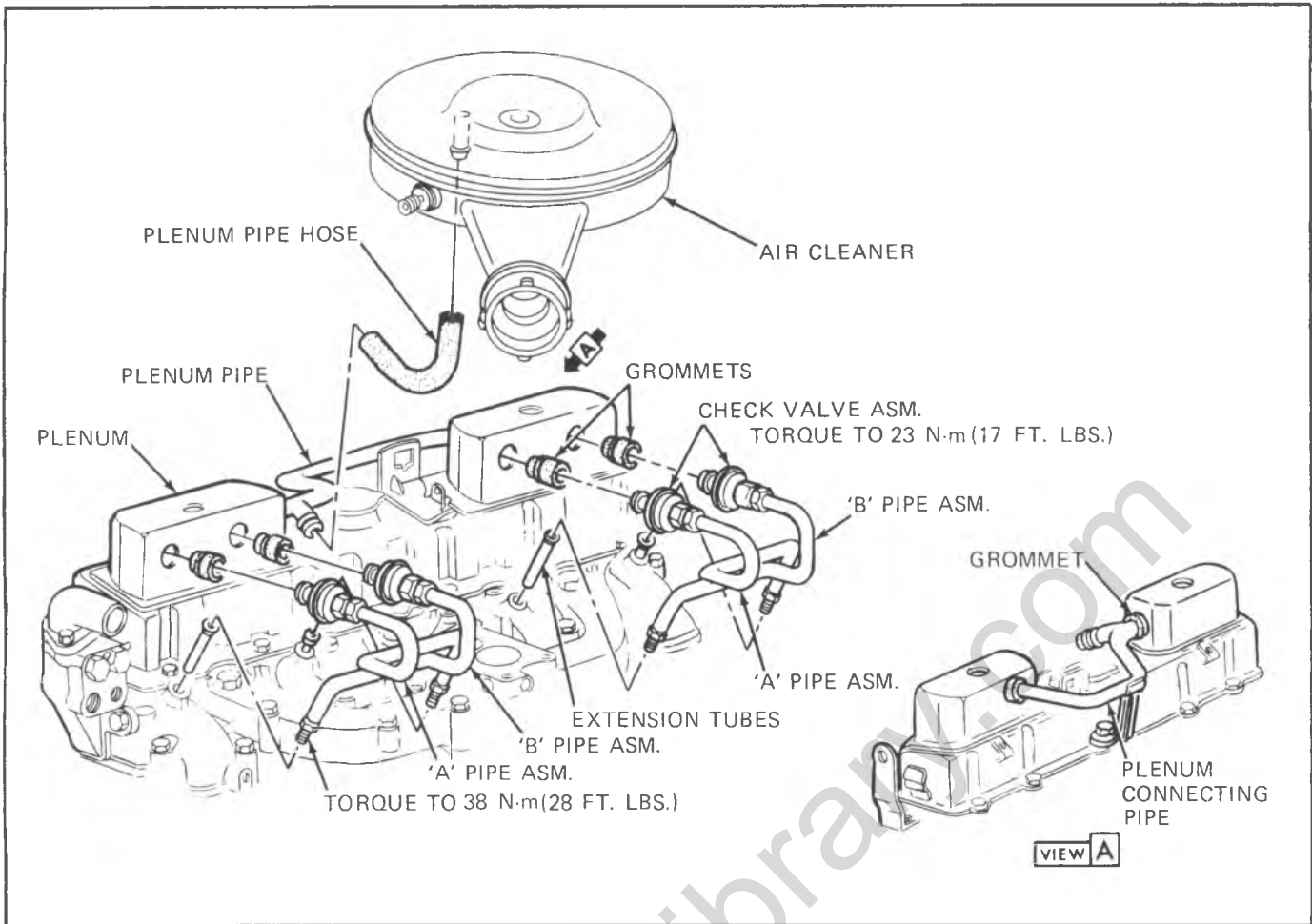


Fig. 6E-34-PAIR System

ClassicCarLibrary.com

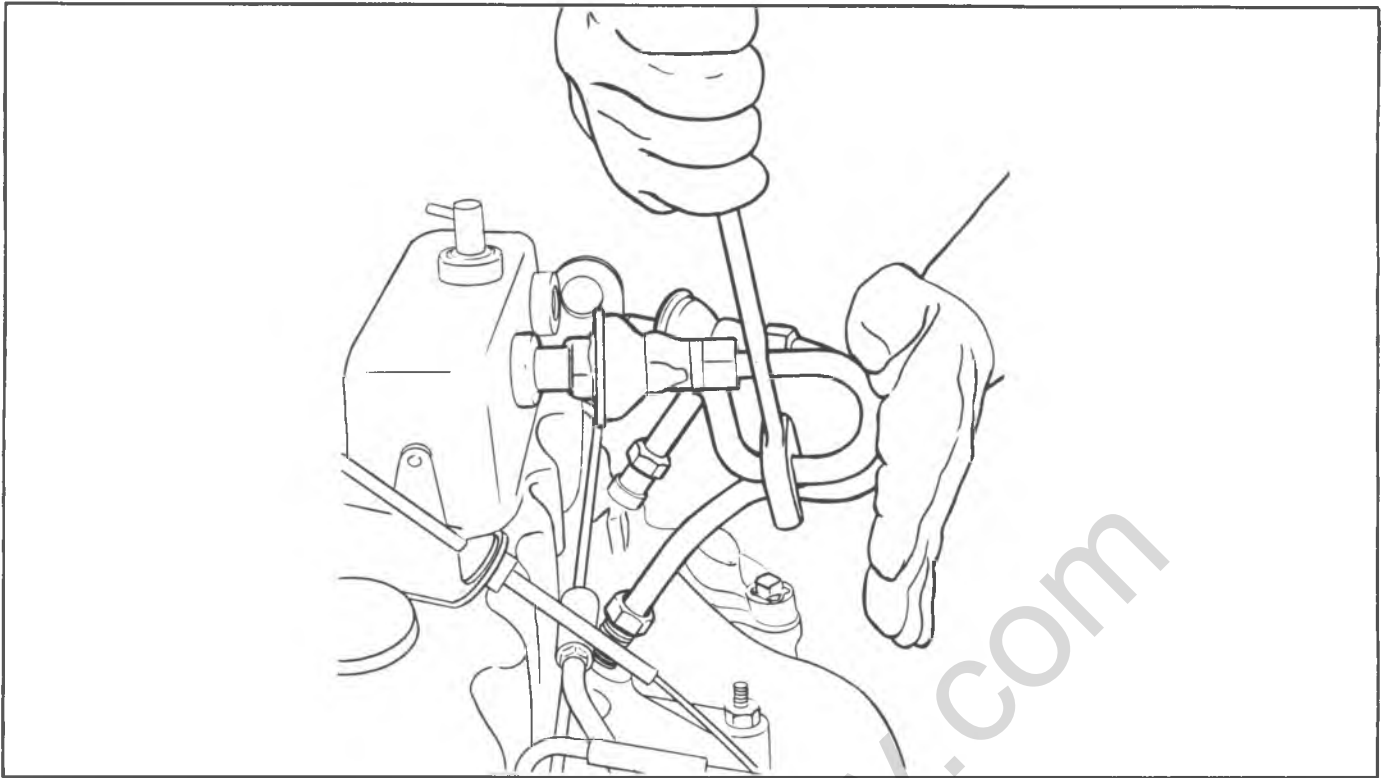


Fig. 6E-35-PAIR (Pipe A)

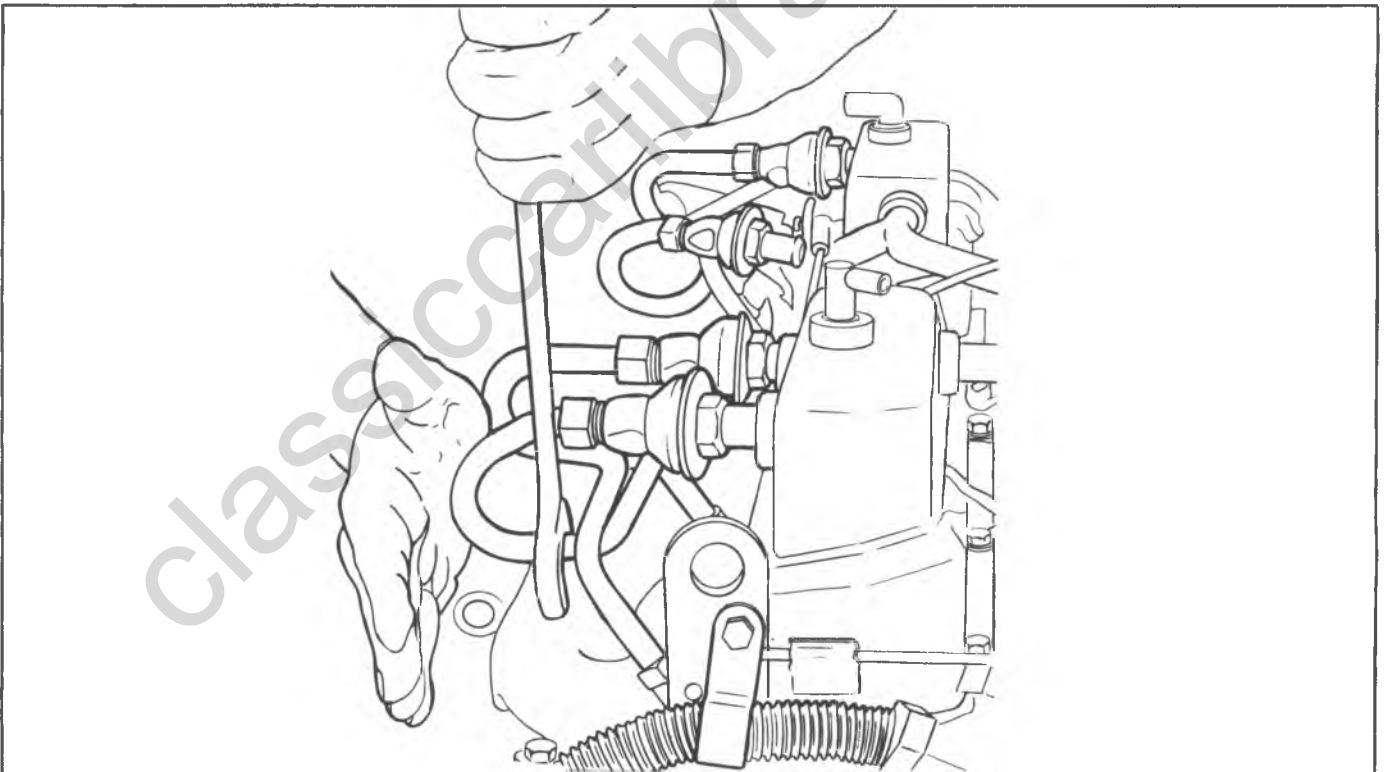


Fig. 6E-36-PAIR (Pipe B)

THROTTLE RETURN CONTROL SYSTEM (TRC)

The TRC system used on heavy duty emission vehicles consists of three major components (Fig. 6E-37 through 39):

1. **Throttle Lever Actuator** - Mounted as part of the carburetor assembly, this device opens the primary throttle blades a preset amount in excess of curb idle when engine vacuum is applied to it. This actuating vacuum is controlled by a separate solenoid control valve.

2. **Solenoid Vacuum Control Valve** - Mounted separately from the carburetor, this off-on valve is held open above a present nominal engine speed by a signal from an electronic speed sensor. The valve when open allows a vacuum signal to be applied to the throttle lever actuator as long as the present engine speed is exceeded.

3. **Electronic Speed Sensor** - Mounted separately from the solenoid vacuum control valve, this switching device monitors engine speed at the distributor and supplies a continuous electrical signal to the solenoid vacuum control valve as long as the preset engine speed is exceeded.

CHECKING AND ADJUSTING TRC SYSTEM

Check hoses for cracking, abrasion, or deterioration and replace as necessary. Check for shorted or broken wires and ensure that electrical connectors are fully engaged at the distributor, speed switch and vacuum solenoid. Check system function for proper operation and adjust as necessary.

How To Check The TRC System

1. Connect precision tachometer (capable of resolving 10 RPM) to the distributor "TACH" terminal.

2. Start engine and advance throttle to indicated 1890 RPM. Throttle lever actuator should be extended at this speed.

3. Reduce throttle opening to indicated 1700 RPM. Throttle lever actuator should be retracted at this speed.

4. If the throttle lever actuator operates outside of the 1700 to 1890 RPM limits, the speed switch is out of calibration and should be replaced.

5. If the actuator does not operate at any speed, proceed with the following steps.

a. With a voltmeter, check for voltage at the vacuum solenoid and speed switch. This is accomplished by connecting the negative probe of the voltmeter to the engine "ground" and inserting the positive probe in the connector cavity of the voltage source wire.

A voltage of 12-14 volts should be measured at this terminal on both the solenoid and speed switch. When making this measurement, it is not necessary to unplug the connector from its component. The voltmeter probe can be inserted in the connector body on the wire side of the connector to contact the metal terminal.

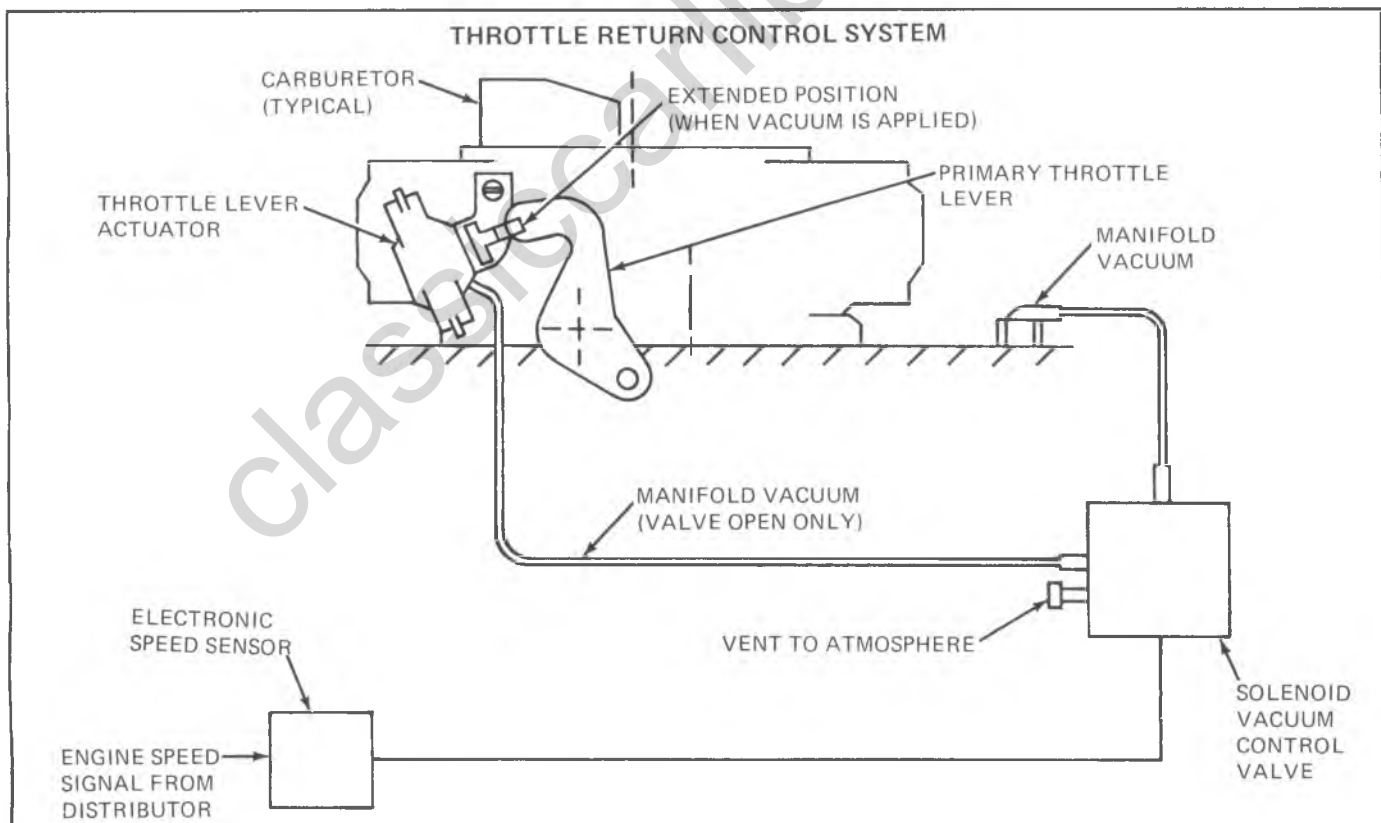


Fig. 6E-37--Throttle Return Control System

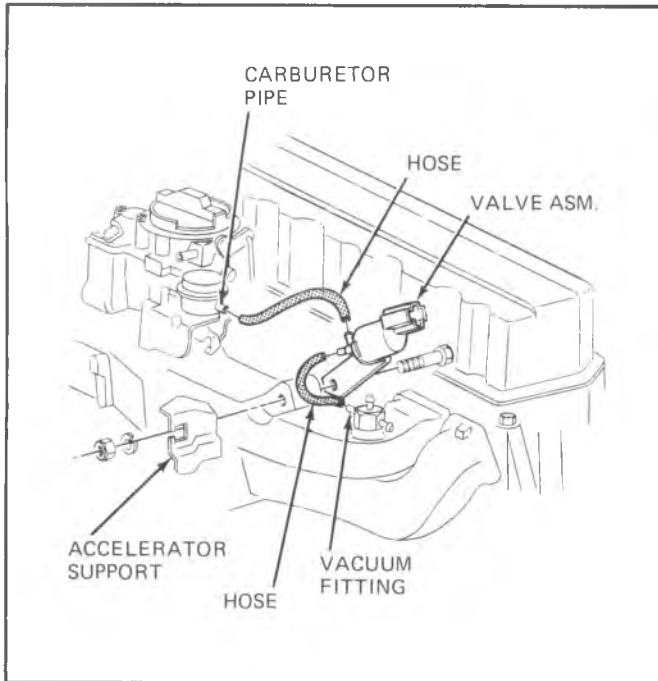


Fig. 6E-38--Throttle Valve (L6)

b. If voltage is present at one device and not the other, repair the engine wiring harness as required.

c. If voltage is not present at either device, check the engine harness connections at the distributor and/or bulkhead connector. Repair as required.

d. If the proper voltage exists at each device, to check for proper solenoid valve operation "ground" the solenoid-to-switch connecting wire terminal at the solenoid connector using a jumper wire. The throttle lever actuator should extend (engine running).

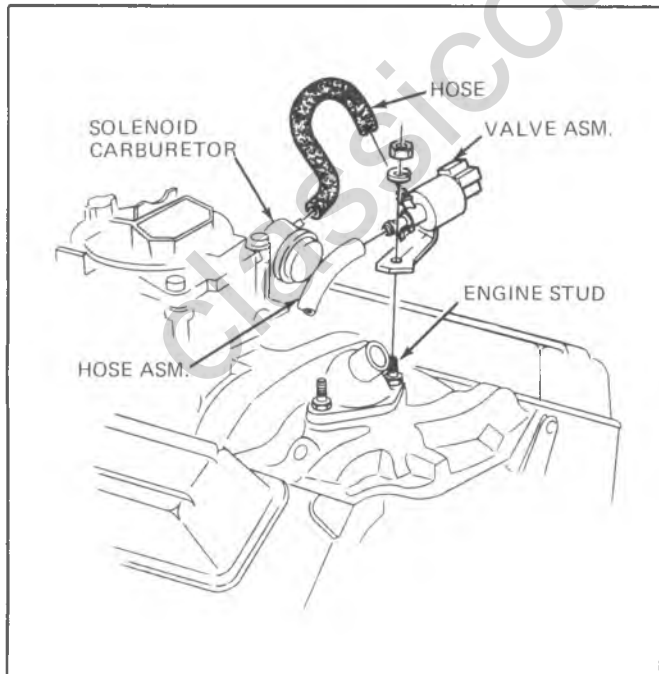


Fig. 6E-39--Throttle Valve (V8)

e. If it does not extend, remove the hose from the solenoid side port that connects to the actuator hose. Visually check the orifice in this port for plugging. Clear the orifice as required. If not plugged, replace the solenoid.

f. If the actuator extends in Step D, ground the solenoid-to-switch wire terminal at the speed switch. If it does not extend, repair the wire connecting the speed switch and solenoid. If it does extend, check the speed switch ground wire for "ground" - it should read 0 volts when checked with a voltmeter with the engine running; check the speed switch-to-distributor wire for proper connection. With both the ground and distributor wires properly connected and if the actuator does not extend when operating above 1890 RPM, replace the speed switch.

6. If the actuator remains extended at all speeds, proceed as with following steps.

a. Remove connector from vacuum solenoid.

b. If actuator remains extended, check the orifice in the solenoid side port for plugging. If plugged, clear and reconnect system and recheck. If the actuator again remains extended, remove the solenoid connector. If the actuator does not retract, replace the vacuum solenoid.

c. If the actuator retracts with the solenoid connector off, reconnect and then remove the speed switch connector. If the actuator retracts, replace the speed switch. If the actuator does not retract, the solenoid-to-switch wire is shorted to ground in the wiring harness. Repair as required.

Throttle Lever Actuator - Checking Procedure

1. Disconnect valve to actuator hose at valve and connect to an external vacuum source equipped with a vacuum gage.

2. Apply 20 in. Hg vacuum to the actuator and seal off the vacuum source. If the vacuum gage reading drops, then the actuator is leaking and must be replaced.

3. To check the actuator for proper operation:

a. Check the throttle lever, shaft, and linkage to be sure that they operate freely without binding or sticking.

b. Start engine and run until warmed up and idle is stable. Note idle rpm.

c. Apply 20 in. Hg vacuum to the actuator. Manually open the throttle slightly and allow to close against the extended actuator plunger. Note the engine rpm.

d. Release and reapply 20 in. Hg vacuum to the actuator and note the rpm to which the engine speed increases (do not assist the actuator).

e. If the rpm obtained in step D is not within 150 rpm of that obtained in step C, then the actuator plunger may be binding due to dirt, corrosion, varnish, etc., or the actuator diaphragm may be too weak. If binding is not indicated or cannot be corrected then the actuator must be replaced.

f. Release the vacuum from the actuator and the engine speed should return to within 50 rpm of the idle speed noted in step 2. If it does not, the plunger may be binding due to dirt, corrosion, varnish, etc. If the problem cannot be corrected, the actuator must be replaced.

g. If the engine rpm noted in step 3 is not within the specified TRC speed range, the TRC actuator must be adjusted. See Throttle Lever Actuator Adjusting Procedure in section 6C.

VACUUM ADVANCE CONTROL

TRAPPED VACUUM SPARK

Trapped vacuum spark is on all engines. A thermal vacuum switch (TVS) is used to sense engine coolant temperature. A check valve is between manifold vacuum, distributor and thermal vacuum switch.

When engine temperature is below specified value, the manifold vacuum signal is routed through the check valve to the distributor. Ports on TVS are blocked. The check valve will keep the vacuum to the distributor at vacuum levels higher than manifold depression during vehicle acceleration. A small sintered iron bleed orifice is provided in the check valve to allow for a leak-down to enable restarts in case of engine stalls (except on light duty emission Calif. and high altitude; heavy duty emission 5.7L and 6.6L; all 7.4L engines).

When engine temperature is above specified value, the ports on TVS will be open to allow manifold vacuum to the distributor. The check valve in this mode of operation acts as a connector.

SPARK VACUUM DELAY

General Description

On 5.7L and 6.6L heavy duty emission engines a check valve with an internal bleed is installed between the Trapped Vacuum Spark check valve and the distributor. When manifold vacuum increases it opens the check valve which allows the distributor vacuum to increase to the same level. Decreasing manifold vacuum, as during vehicle acceleration; closes the check valve and the distributor vacuum will decrease at a rate controlled by the internal bleed.

Classiccarlibrary.com

LIGHT DUTY TRUCK ENGINE PERFORMANCE SPECIFICATION CHART

| ENGINE & CODE (See Section "0" for Location of Engine and VIN Codes) | IGNITION TIMING B.T.D.C. DEGREES | SPARK PLUG TYPE & GAP | SOLENOID SCREW (RPM) | CURB IDLE (RPM) | FAST IDLE (RPM) | CARBURETOR IDENTIFICATION | DISTRIBUTOR | | VACUUM & MECHANICAL ADVANCE | |
|--|---|--------------------------------|----------------------------|-----------------------|-----------------------|------------------------------|--------------------|-----------------|---|--|
| | | | | | | | DIST. MODEL | VACUUM MODEL | VACUUM ADVANCE (In Crank Degrees @ Inches of Vacuum) | MECHANICAL ADVANCE (Crank Degrees @ Engine RPM) |
| 4.1 L (250 C.I.D.) (VIN D) (LE3) FED./MANUAL C-10, C-20 G-10, 20, K-10 | 10° | R46TS (.035) | 450 (N) | 750 (N) | 2000 (N) | 17080621 17080623 | 1110755 | 690 | 0°@ 5" 16°@ 11.5" | 0°@ 1100 14°@ 2300 24°@ 4100 |
| 4.1 L (250 C.I.D.) (VIN D) (LE3) CALIF./MANUAL C-10, G10, C20, G20 | 10° | R46TS (.035) | 425 (N) | 750 (N) | 2000 (N) | 17080721 17080723 | 1110747 | 620 | 0°@ 4" 15°@ 12" | 0°@ 1100 14°@ 2300 24°@ 4100 |
| 4.1 L (250 C.I.D.) (VIN D) (LE3) FED./AUTO. C-10, 20 G-10, 20, K10 | 10° | R46TS (.035) | 450 (D) | 650 (D) | 2200 (P) or (N) | 17080622 17080626 | 1110717 1110755 | 690 | 0°@ 5" 16°@ 11.5" | 0°@ 1100 14°@ 2300 24°@ 4100 |
| 4.1 L (250 C.I.D.) (VIN D) (LE3) CALIF./AUTO. C-10; G10 | 10° | R46TS (.035) | 425 (D) | 600 (D) | 2200 (P) or (N) | 17080720 | 1110749 | 626 | 0°@ 4" 10°@ 8" | 0°@ 1100 7°@ 2300 16°@ 4200 |
| 4.1 L (250 C.I.D.) VIN (D) (LE3) CALIF./AUTO. C-20, G20 | 8° | R46TS (.035) | 425 | 600 | 2200 (P) or (N) | 17080722 | 1110717 | 621 | 0°@ 4" 18°@ 12" | 0°@ 1100 14°@ 2300 24°@ 4100 |
| 4.8 L (292 C.I.D.) (VIN T) (L25) NATION./MANUAL CK-30, P10, 20, 30 CK20 | 8° | R44T (.035) | | 700 (N) | 2400 (N) | 17080009 | 1110753 | 626 | 0°@ 4" 10°@ 8" | 0°@ 1100 14°@ 2300 24°@ 4100 |
| 4.8 L (292 C.I.D.) (VIN T) (L25) NATION./AUTO. CK-30, P-10, 20, 30 CK20 | 8° | R44T (.035) | | 700 (N) | 2400 (P) or (N) | 17080009 17080359 | 1110753 | 626 | 0°@ 4" 10°@ 8" | 0°@ 1100 14°@ 2300 24°@ 4100 |
| 5.0 L (305 C.I.D.) (VIN U) (LG9) FED./MANUAL CKG-10 | 8° 6° | R45TS (.045) | 700 (N) | 600 (N) | 1300 (N) | 17080143 17080144 | 1103381 1103369 | 691 644 | 0°@ 3" 10°@ 7.5" 0°@ 3" 16°@ 6.5" | 0°@ 1200 8°@ 2000 20°@ 4200 |
| 5.0 L (305 C.I.D.) (VIN U) (LG9) FED./AUTO. C-10 | 8° | R45TS (.045) | 600 (D) | 500 (D) | 1600 (P) or (N) | 17080142 17080144 | 1103369 1103381 | 644 691 | 0°@ 3" 16°@ 6.5" 0°@ 3" 20°@ 7.5" | 0°@ 1200 8°@ 2000 20°@ 4200 |
| 5.0 L (305 C.I.D.) (VIN U) (LG9) FED./AUTO. G-10 | 8° | R45TS (.045) | 600 (D) | 500 (D) | 1600 (P) or (N) | 17080100 17080102 | 1103369 | 644 | 0°@ 3" 16°@ 6.5" | 0°@ 1200 8°@ 2000 20°@ 4200 |

Fig. 6E-40-Engine Performance Specifications

LIGHT DUTY TRUCK ENGINE PERFORMANCE SPECIFICATION CHART (Continued)

| ENGINE & CODE (See Section "0" for Location of Engine and VIN Codes) | IGNITION TIMING B.T.D.C. DEGREES | SPARK PLUG TYPE & GAP | SOLENOID SCREW (RPM) | CURB IDLE (RPM) | FAST IDLE (RPM) | CARBURETOR IDENTIFICATION | DISTRIBUTOR | | VACUUM & MECHANICAL ADVANCE | |
|---|---|--------------------------------|----------------------------|-----------------------|-----------------------|--|----------------|-----------------|---|--|
| | | | | | | | DIST. MODEL | VACUUM MODEL | VACUUM ADVANCE (In Crank Degrees @ Inches of Vacuum) | MECHANICAL ADVANCE (Crank Degrees @ Engine RPM) |
| 5.7 L (350 C.I.D.) (VIN L) (LS9) CALIF./AUTO. C10, 20 | 8° | R45TS (.045) | 600 (D) | 500 (D) | 1600 (P) or (N) | 17080506 17080508 | 1103436 | 691 | 0° @ 3" 10° @ 7.5" | 0° @ 1100 12° @ 1600 |
| | | | | | | | 1103435 | 644 | 0° @ 3" 16° @ 6.5" | 16° @ 2400 22° @ 4600 |
| 5.7 L (350 C.I.D.) (VIN L) (LS9) NATION./AUTO. CK10, 20 | 8° | R45TS (.045) | 600 (D) | 500 (D) | 1600 (P) or (N) | 17080290 17080292 17080506 17080508 | 1103436 | 691 | 0° @ 3" 20° @ 7.5" | 0° @ 1100 12° @ 1600 16° @ 2400 22° @ 4600 |
| | | | | | | | 1103372 | 604 | 0° @ 4" 14° @ 8" | |
| | | | | | | | 1103435 | 644 | 0° @ 3" 16° @ 6.5" | |
| 5.7 L (350 C.I.D.) (VIN L) (LS9) NATION./AUTO C10, 20 | 6° | R45TS (.045) | 600 (D) | 500 (D) | 1600 (P) or (N) | 17080295 17080224 17080525 17080523 | 1103339 | 626 | 0° @ 4" 10° @ 8" | 0° @ 1100 12° @ 1600 16° @ 2400 22° @ 4600 |
| 5.7 L (350 C.I.D.) (VIN L) (LS9) CALIF./AUTO G10, 20 | 8° | R45TS | 600 (D) | 500 (D) | 1600 (P) or (N) | 17080506 17080508 | 1103339 | 626 | 0° @ 4" 10° @ 8" | 0° @ 1100 12° @ 1600 16° @ 2400 22° @ 4600 |
| | | | | | | | 1103436 | 691 | 0° @ 3" 20° @ 7.5" | |
| 6.6 L (400 C.I.D.) (VIN R) (LF4) FED./AUTO G20 | 4° | R45TS | 600 (D) | 500 (D) | 1600 | 17080227 17080226 | 1103439 | 604 | 0° @ 4" 14° @ 8" | 0° @ 1000 8° @ 1600 19° @ 3450 |
| 6.6 L (400 C.I.D.) (VIN R) (LF4) CALIF./AUTO. G20 | 4° | R45TS | 600 (D) | 500 (D) | 1600 (P) or (N) | 17080527 17080528 | 1103423 | 665 | 0° @ 4" 15° @ 10" | 0° @ 1000 8° @ 1600 19° @ 3450 |
| 5.7 L (350 C.I.D.) (VIN M) (LT9) FED./MAN. CKG 20, 30 | 4° | R44T (.045) | *1500 | 700 (N) | 1900 (N) | 17080213 | 1103375 | 626 | 0° @ 4" 10° @ 8" | 0° @ 1150 17° @ 2900 22° @ 4200 |
| 5.7 L (350 C.I.D.) (VIN M) (LT9) CALIF./MAN. CKG 20, 30 P30 | 6° | R44T | *1500 | 700 (N) | 1900 (N) | 17080513 | 1103420 | 681 | 0° @ 10" 10° @ 13" | 0° @ 1800 24° @ 4000 |
| 5.7 L (350 C.I.D.) (VIN M) (LT9) FED./MAN. P20, 30 | 4° | R44T | *1600 | 700 (N) | 1900 (N) | 17080213 | 1103375 | 626 | 0° @ 4" 10° @ 8" | 0° @ 1150 17° @ 2900 22° @ 4200 |

*TRC ACTUATOR SPEED

Fig. 6E-4-1-Engine Performance Specifications

LIGHT DUTY TRUCK ENGINE PERFORMANCE SPECIFICATION CHART (Continued)

| ENGINE & CODE (See Section "0" for Location of Engine and VIN Codes) | IGNITION TIMING B.T.D.C. DEGREES | SPARK PLUG TYPE & GAP | SOLENOID SCREW (RPM) | CURB IDLE (RPM) | FAST IDLE (RPM) | CARBURETOR IDENTIFICATION | DISTRIBUTOR | | VACUUM & MECHANICAL ADVANCE | |
|---|---|--------------------------------|----------------------------|-----------------------|-----------------------|------------------------------|----------------|-----------------|---|--|
| | | | | | | | DIST. MODEL | VACUUM MODEL | VACUUM ADVANCE (In Crank Degrees @ Inches of Vacuum) | MECHANICAL ADVANCE (Crank Degrees @ Engine RPM) |
| 5.7 L (350 C.I.D.) (VIN L) (LS9) FED./MANUAL K10, 20 | 8° | R45TS | — | 700 (N) | 1300 (N) | 17080205 | 1103436 | 691 | 0° @ 3" 2° @ 7.5" | 0° @ 1100 12° @ 1600 16° @ 2400 22° @ 4600 |
| 5.7 L (350 C.I.D.) (VIN L) (LS9) FED./MANUAL C10, 20 G10, 20 | 8° | R45TS (.045) | — | 700 (N) | 1300 (N) | 17080201 | 1103372 | 604 | 0° @ 4" 14° @ 8" | 0° @ 1100 12° @ 1600 16° @ 2400 22° @ 4600 |
| 5.7 L (350 C.I.D.) (VIN L) (LS9) CALIF./MANUAL K10, C20 | 8° | R45TS (.045) | — | 700 (N) | 1300 (N) | 17080524 | 1103339 | 626 | 0° @ 4" 10° @ 8" | 0° @ 1100 12° @ 1600 16° @ 2400 22° @ 4600 |
| 5.7 L (350 C.I.D.) (VIN L) (LS9) NATION./MANUAL C10, | 8° | R45TS (.045) | — | 700 (N) | 1600 (N) | 17080291 17080503 | 1103435 | 644 | 0° @ 3" 16° @ 6.5" | 0° @ 1100 12° @ 1600 16° @ 2400 22° @ 4600 |
| 5.7 L (350 C.I.D.) (VIN L) (LS9) NATION./MANUAL C10, 20 | 6° | R45TS (.045) | — | 700 (N) | 1600 (N) | 17080201 17080526 | 1103339 | 626 | 0° @ 4" 10° @ 8" | 0° @ 1100 12° @ 1600 16° @ 2400 22° @ 4600 |
| 5.7 L (350 C.I.D.) (VIN L) (LS9) FED./MANUAL K10 | 8° | R45TS (.045) | — | 700 (N) | 1600 (N) | 17080291 | 1103436 | 691 | 0° @ 3" 2° @ 7.5" | 0° @ 1100 12° @ 1600 16° @ 2400 22° @ 4600 |
| 5.7 L (350 C.I.D.) (VIN L) (LS9) FED./AUTO. C10, 20 G10, 20 | 8° | R45TS (.045) | 600 (D) | 500 (D) | 1600 (P) or (N) | 17080205 17080206 | 1103372 | 604 | 0° @ 4" 14° @ 8" | 0° @ 1100 12° @ 1600 16° @ 2400 22° @ 4600 |

LIGHT DUTY TRUCK ENGINE PERFORMANCE SPECIFICATION CHART (Continued)

| ENGINE & CODE (See Section "0" for Location of Engine and VIN Codes) | IGNITION TIMING B.T.D.C. DEGREES | SPARK PLUG TYPE & GAP | SOLENOID SCREW (RPM) | CURB IDLE (RPM) | FAST IDLE (RPM) | CARBURETOR IDENTIFICATION | DISTRIBUTOR | | VACUUM & MECHANICAL ADVANCE | |
|---|---|--------------------------------|----------------------------|-----------------------|-----------------------|------------------------------|----------------|-----------------|---|--|
| | | | | | | | DIST. MODEL | VACUUM MODEL | VACUUM ADVANCE (In Crank Degrees @ Inches of Vacuum) | MECHANICAL ADVANCE (Crank Degrees @ Engine RPM) |
| 5.7 L (350 C.I.D.) (VIN M) (LT9) FED./AUTO. CK20, 30 G30 P20, 30 | 4° | R44T (.045) | *1600 | 700 (N) | 1900 (N) | 17080213 | 1103375 | 626 | 0° @ 4" 10° @ 8" | 0° @ 1150 17° @ 2900 22° @ 4200 |
| | | | | | | 17080215 | 1103439 | 604 | 0° @ 4" 14° @ 8" | 0° @ 1000 8° @ 1600 19° @ 3450 |
| 5.7 L (350 C.I.D.) (VIN M) (LT9) CALIF./AUTO. CK10, 30 G30 | 6° | R44T (.045) | *1500 | 700 (N) | 1900 (N) | 17080513 17080515 | 1103420 | 681 | 0° @ 10" 10° @ 13" | 0° @ 1800 24° @ 4000 |
| 6.6 L (400 C.I.D.) (VIN X) (LE4) FED./AUTO. K20, 30 G30 | 4° | R44T (.045) | *1600 | 700 (N) | 1900 (N) | 17080229 | 1103375 | 626 | 0° @ 4" 10° @ 8" | 0° @ 1150 17° @ 2900 22° @ 4200 |
| 6.6 L (400 C.I.D.) (VIN X) (LE4) CALIF./AUTO K20, 30 G30 | 6° | R44T (.045) | *1500 | 700 (N) | 1900 (N) | 17080529 | 1103420 | 681 | 0° @ 10" 10° @ 13" | 0° @ 1800 24° @ 4000 |
| 7.4 L (454 C.I.D.) (VIN W) (LEB) NATION./AUTO./MAN. C20, 30 P30 | 4° | R44T (.045) | *1500 | 700 (N) | 1900 (N) | 17080212 17080213 | 1103376 | 682 | 0° @ 8" 10° @ 13" | 0° @ 1100 14° @ 2800 20° @ 4200 |

*TRC ACTUATOR SPEED

Fig. 6E-42--Engine Performance Specifications

EMISSION HOSE ROUTING

Emission hose routings Figs. 6E-43 through 54 are shown for reference information only. Use the Vehicle (Engine) Emission Control Information Label for the most up to date information concerning hose routings and tune up data.

classiccarlibrary.com

EMISSION HOSE ROUTING

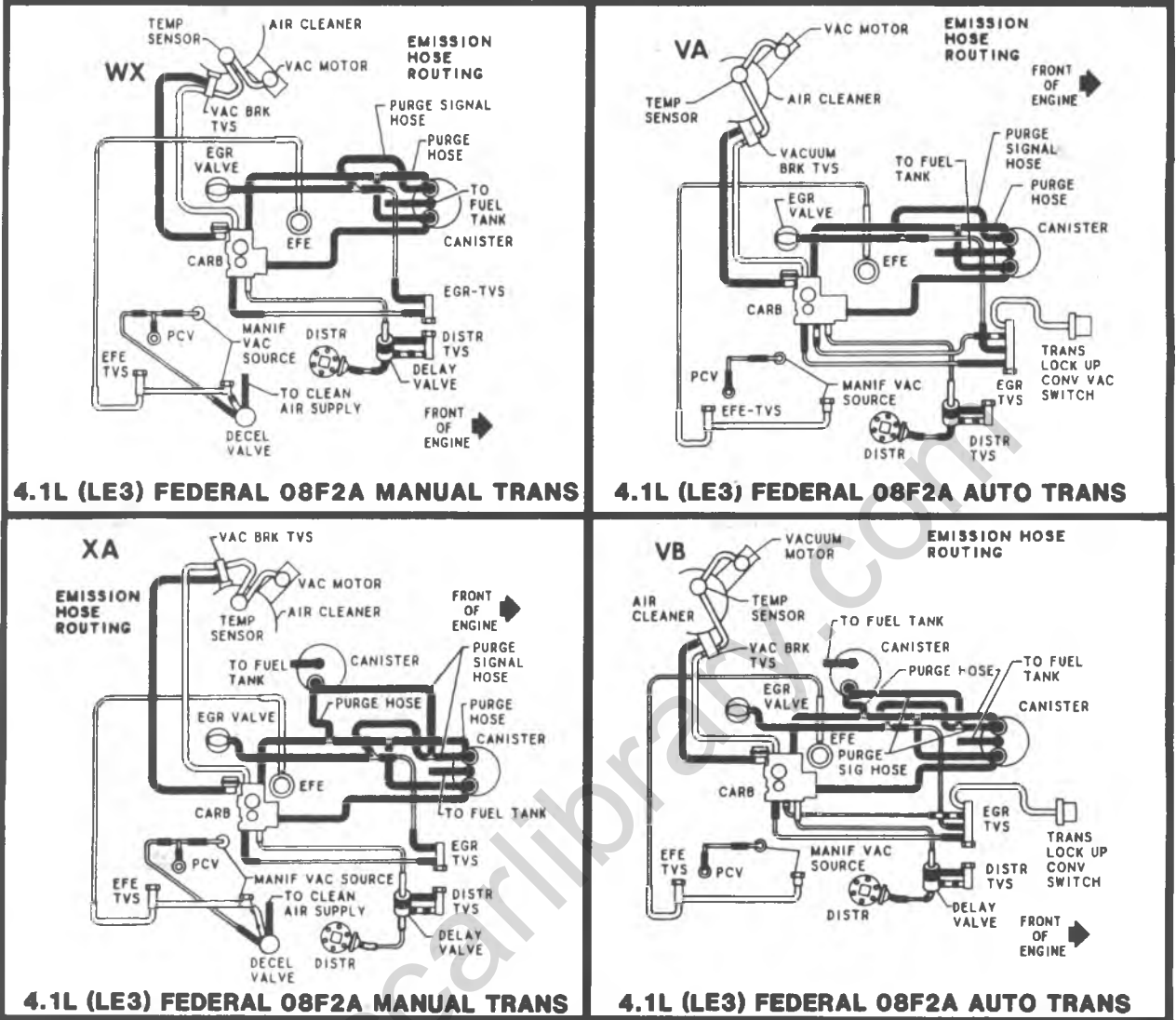
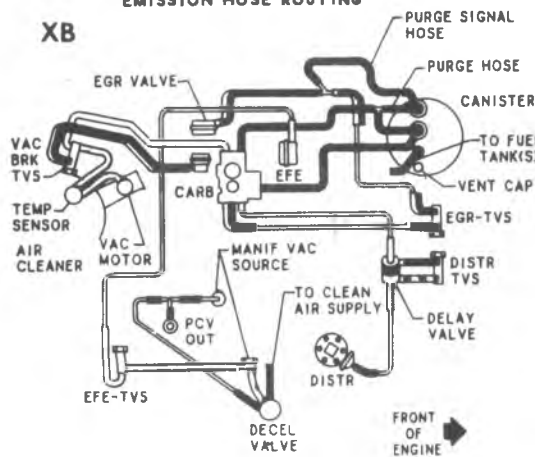


Fig. 6E-43—Emission Hoise Routing

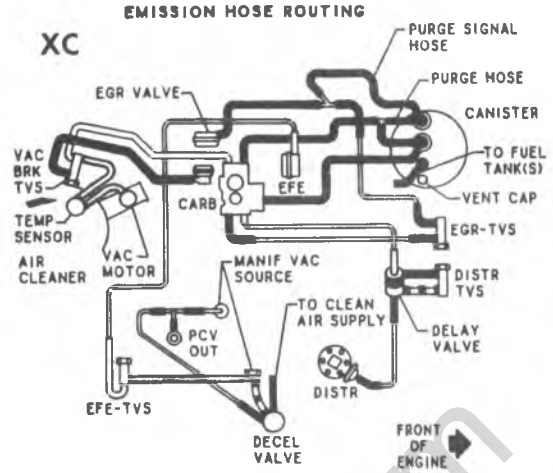
EMISSION HOSE ROUTING

XB



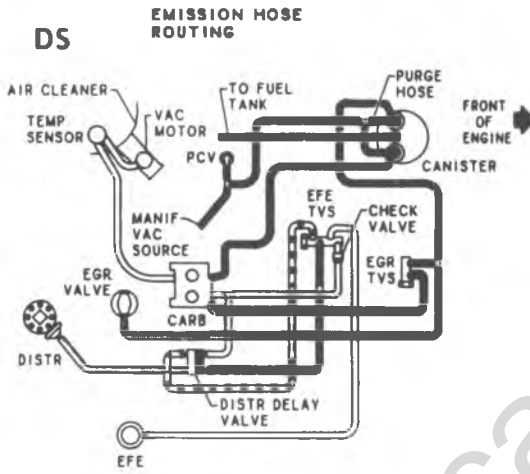
4.1L (LE3) CALIFORNIA 08F2A MAN/AUTO

XC



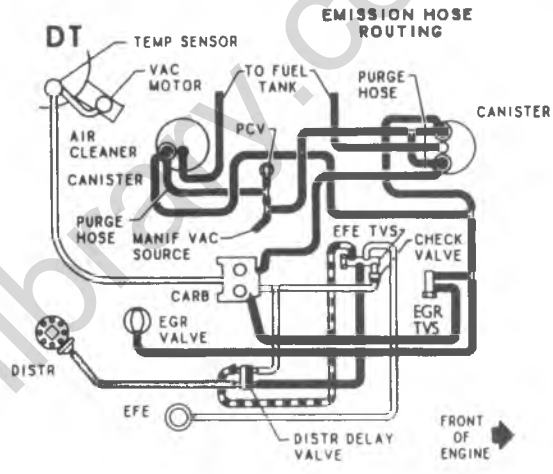
4.1L (LE3) CALIFORNIA 08F2A MAN/AUTO

DS



5.0L (LG9) FEDERAL 08Y2A MANUAL TRANS

DT



5.0L (LG9) FEDERAL 08Y2A MANUAL TRANS

Fig. 6E-44—Emission Hose Routing

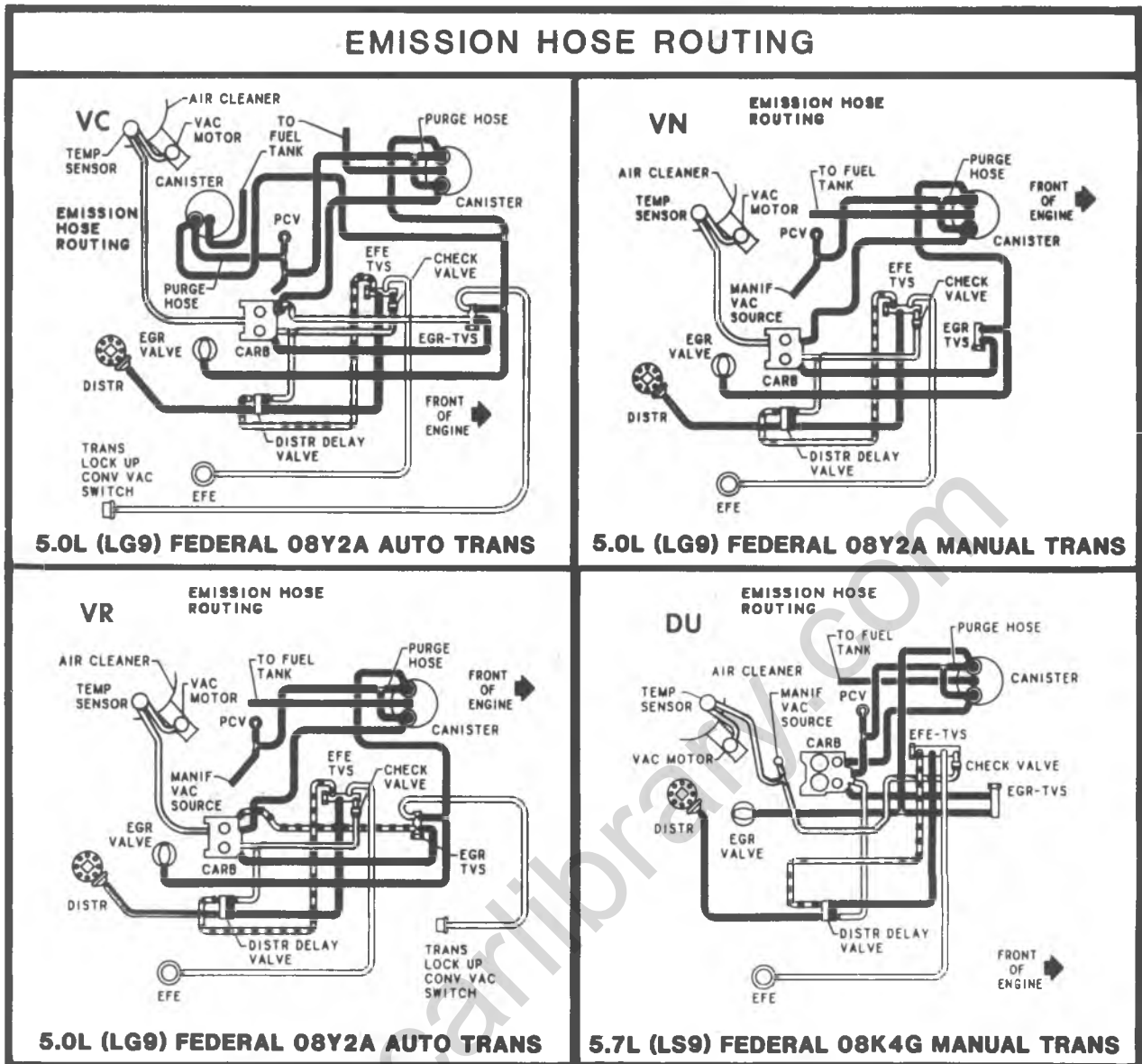
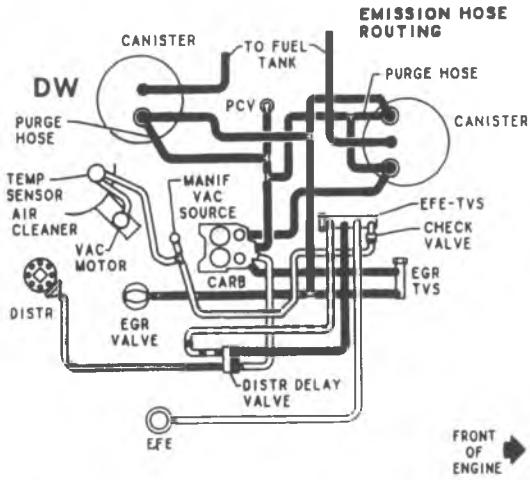
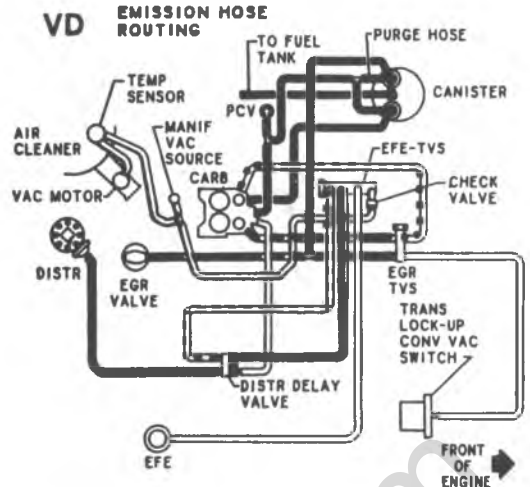


Fig. 45--Emission Hose Routing

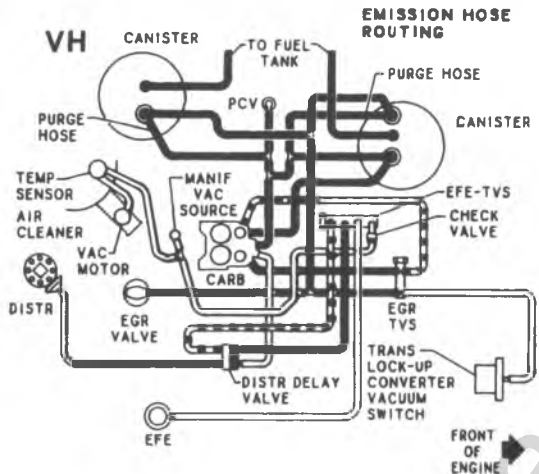
EMISSION HOSE ROUTING



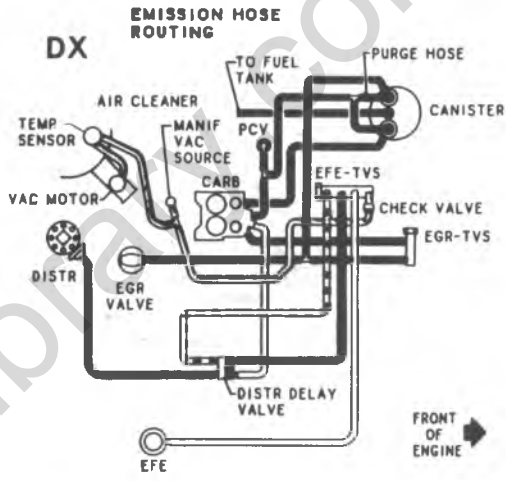
5.7 (LS9) FEDERAL 08K4G MANUAL TRANS



5.7L (LS9) FEDERAL 08K4G AUTO TRANS



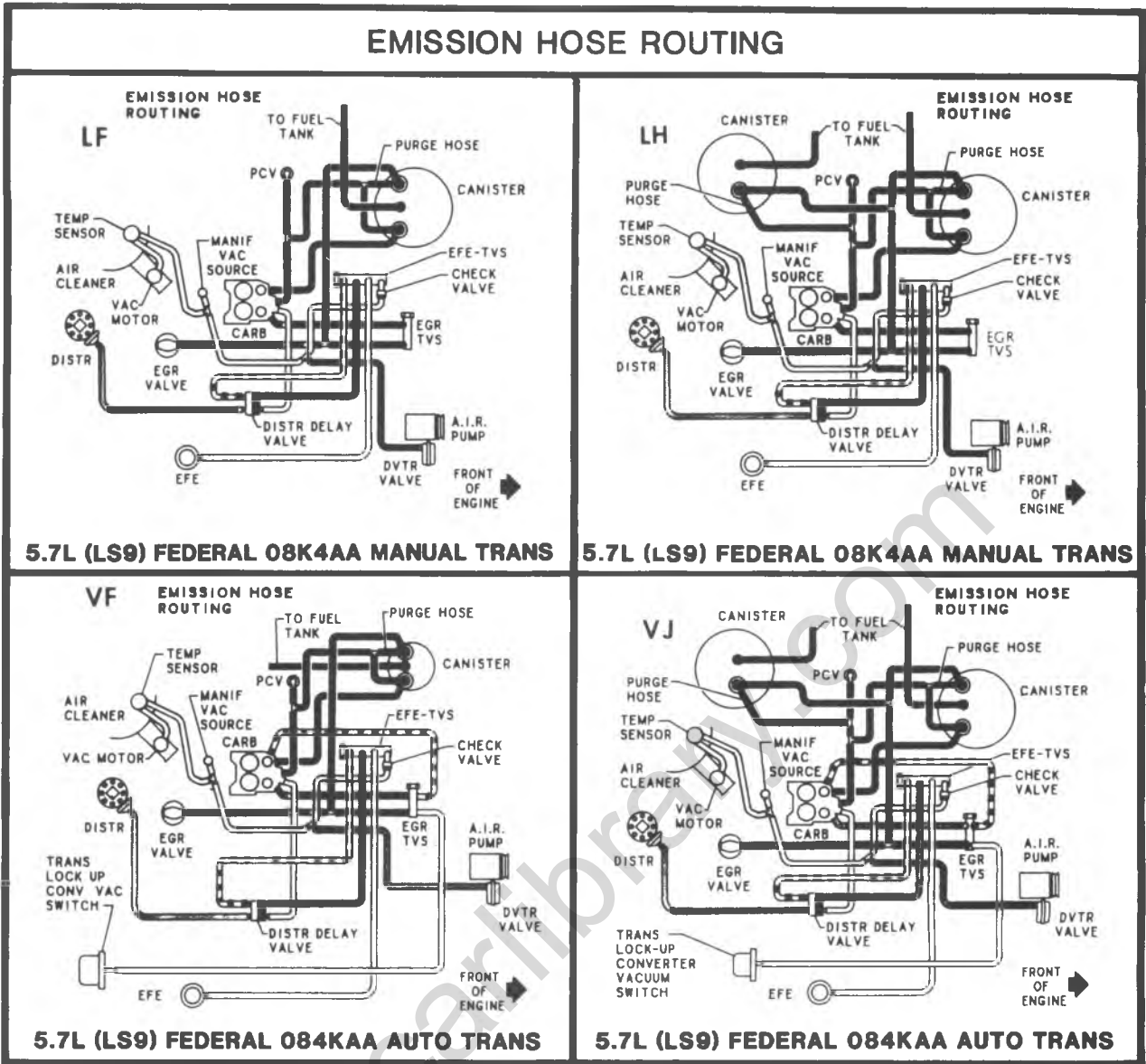
5.7L (LS9) FEDERAL 08K4G AUTO TRANS



6.6L (LF4) FEDERAL 08K4G AUTO TRANS

Fig. 6E-46-Emission Hose Routing

EMISSION HOSE ROUTING



5.7L (LS9) FEDERAL 08K4AA MANUAL TRANS

5.7L (LS9) FEDERAL 08K4AA MANUAL TRANS

5.7L (LS9) FEDERAL 084KAA AUTO TRANS

5.7L (LS9) FEDERAL 084KAA AUTO TRANS

Fig. 6E-47—Emission Hose Routing

EMISSION HOSE ROUTING

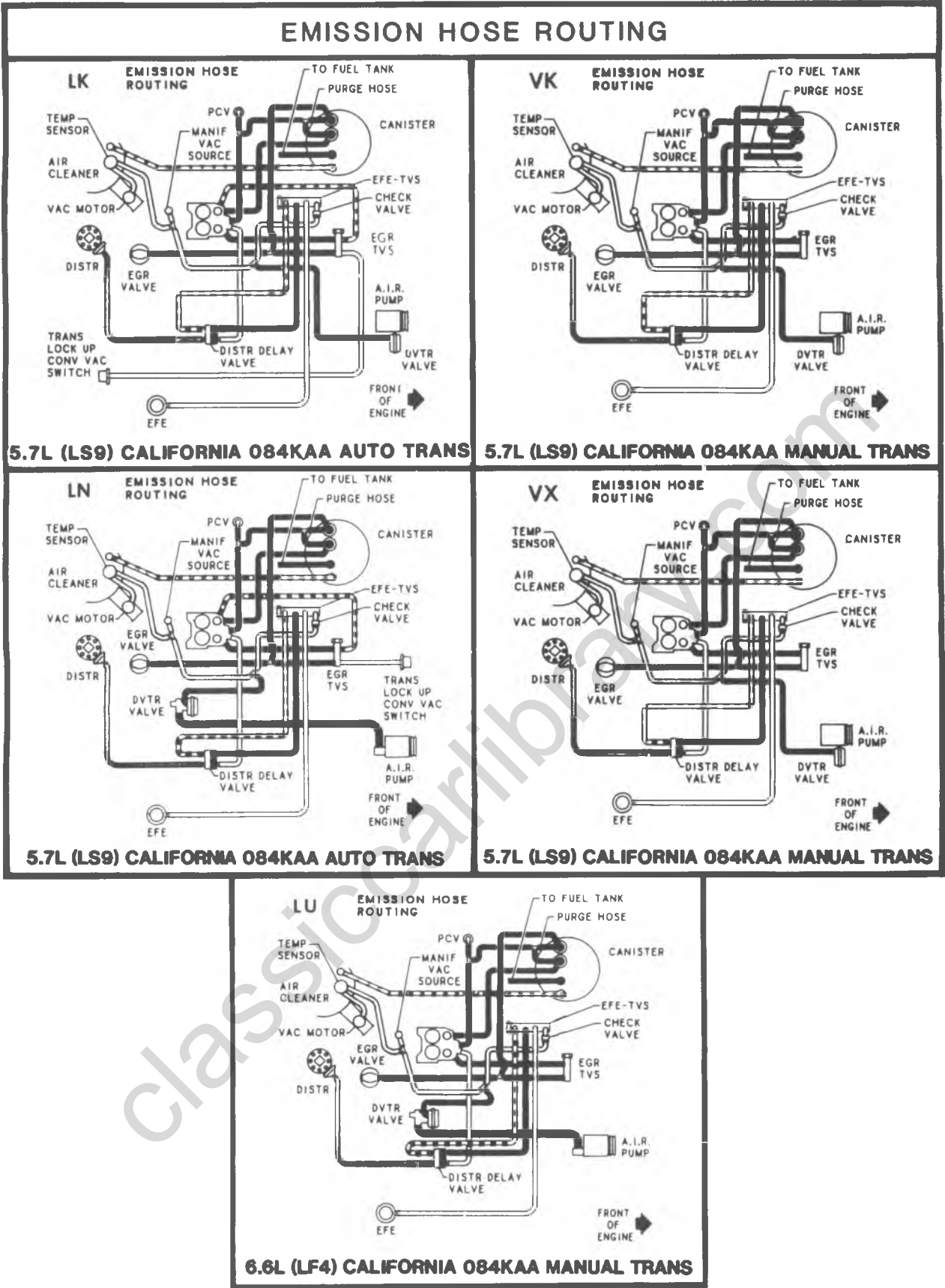
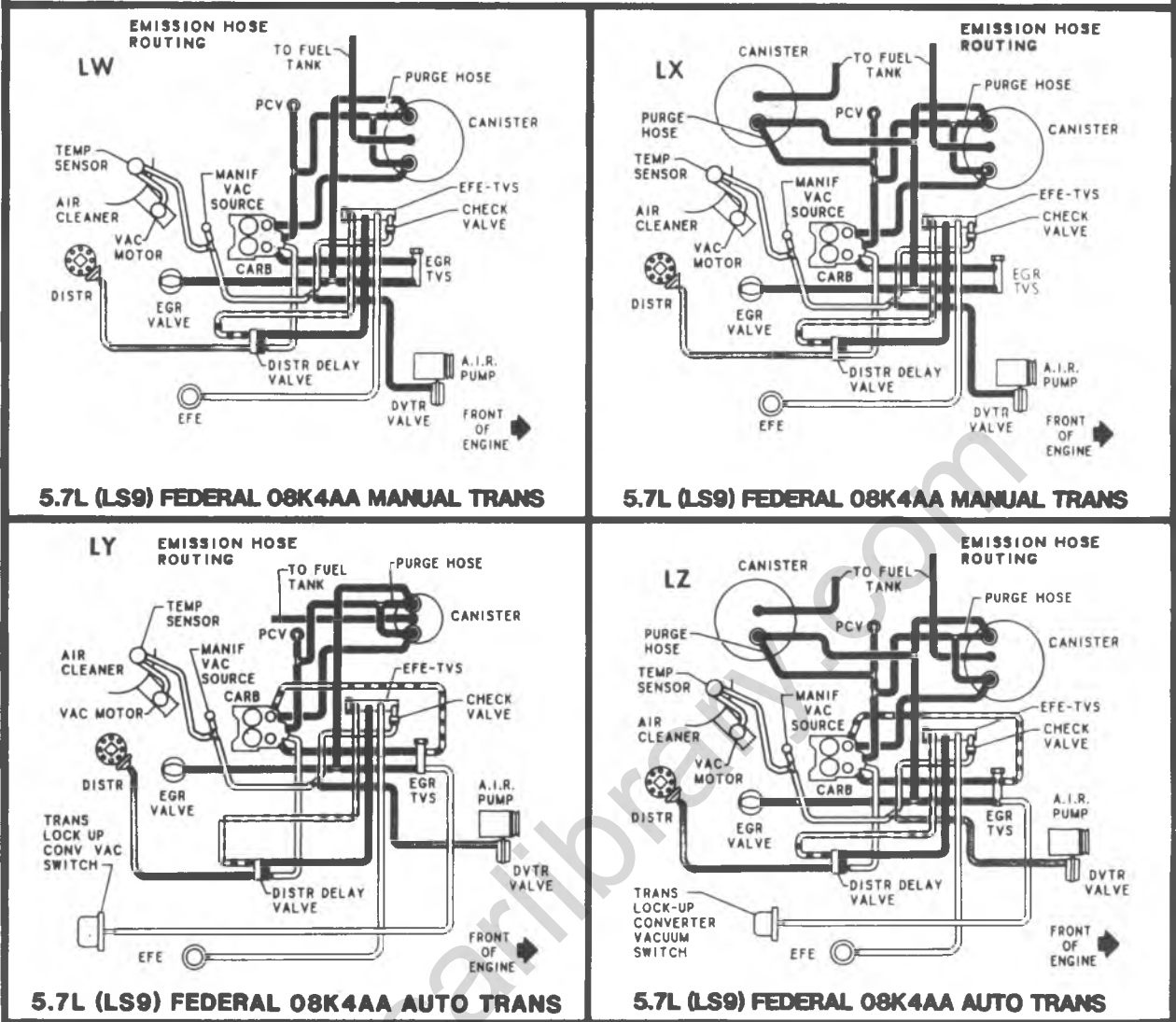


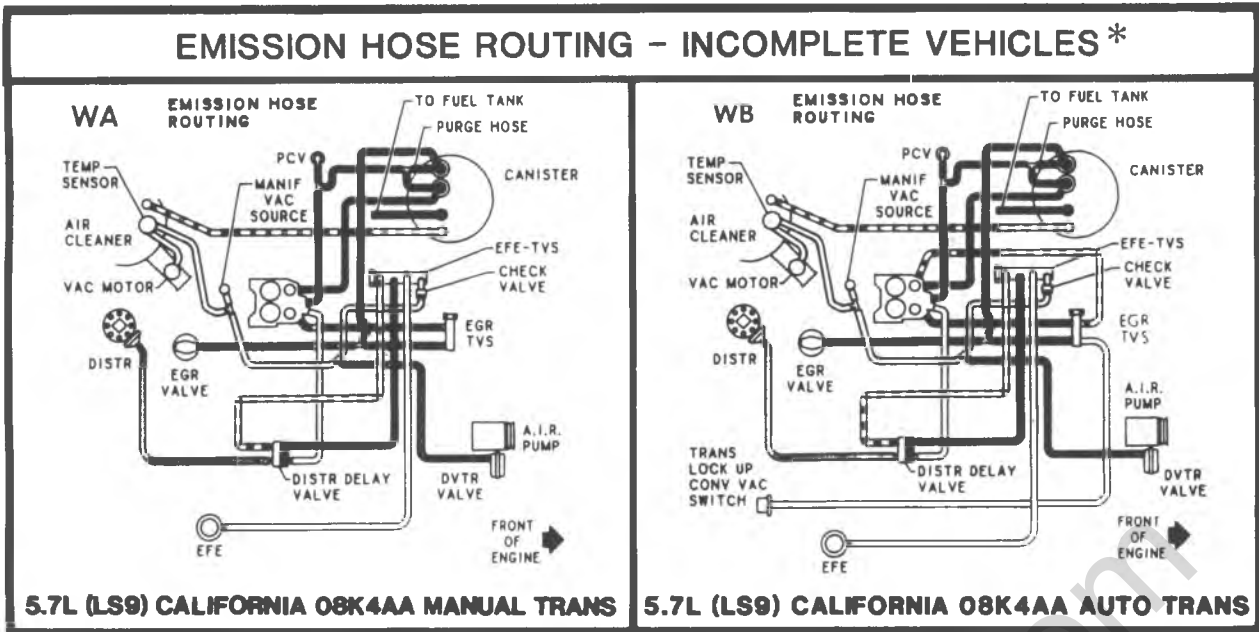
Fig. 6E-48-Emission Hose Routing

EMISSION HOSE ROUTING - INCOMPLETE VEHICLES*



* LABELS RELATE TO CAB & CHASSIS ONLY

Fig. 6E-49-Emission Hose Routing



* LABELS RELATE TO CAB & CHASSIS ONLY

classiccarslibrary.com

Fig. 6E-50--Emission Hose Routing

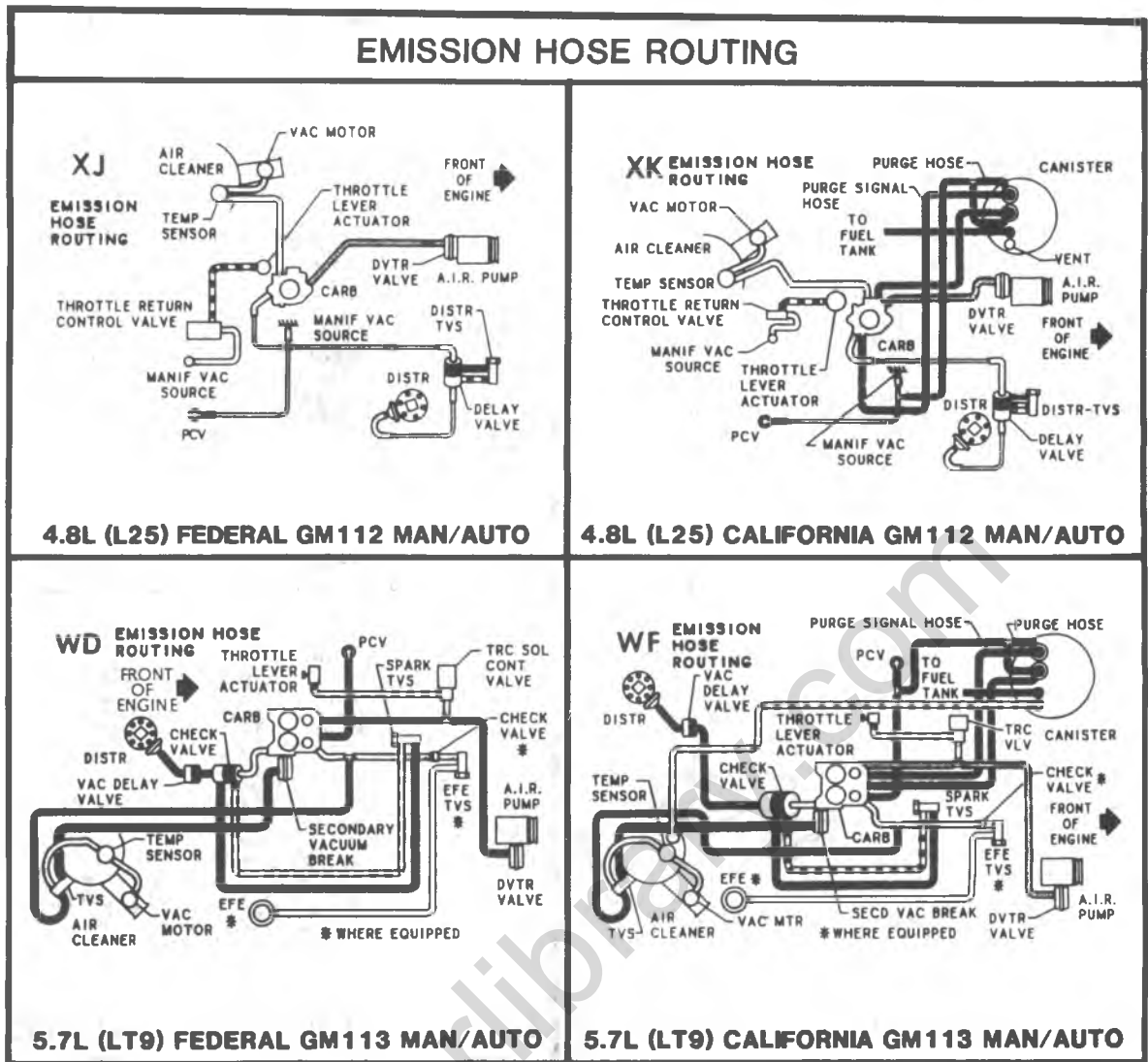


Fig. 6E-51--Emission Hose Routing

EMISSION HOSE ROUTING

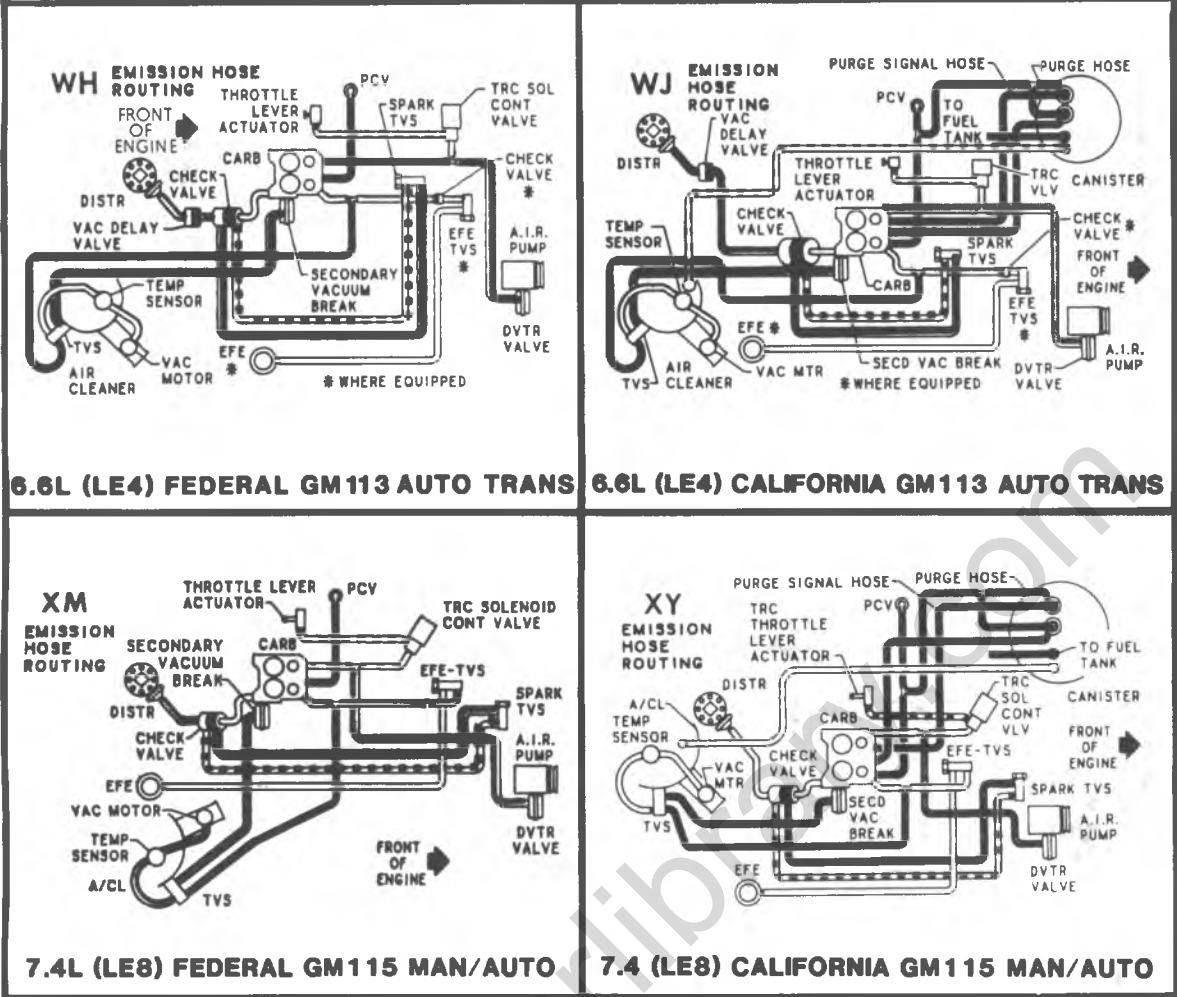
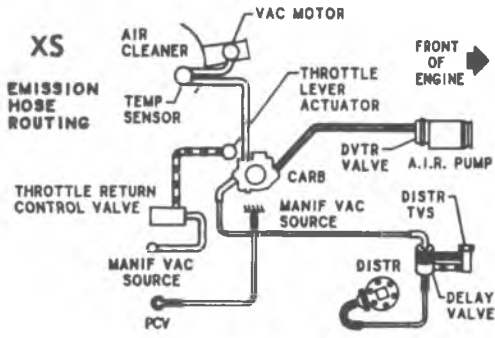
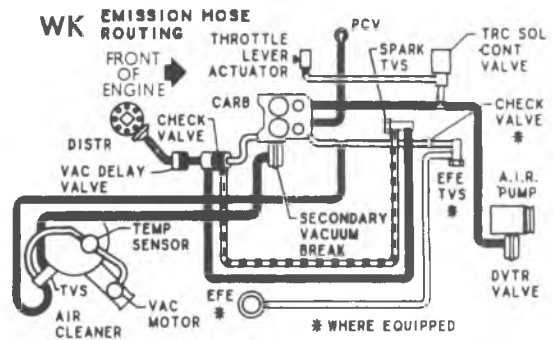


Fig. 6E-52--Emission Hose Routing

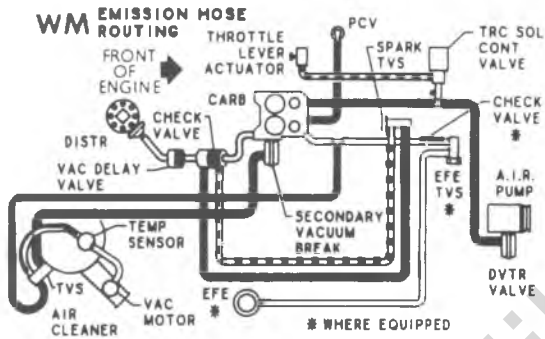
EMISSION HOSE ROUTING



4.8L (L25) FEDERAL GM112 MAN/AUTO

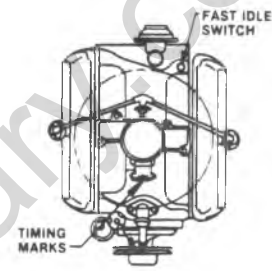


5.7L (LT9) FEDERAL GM113 MAN/AUTO



6.6L (LT9) FEDERAL GM113 AUTO TRANS

SF



5.7L (LF9) CALIFORNIA 09J92 AUTO TRANS

Fig. 53--Emission Hose Routing

classicalibrary.com

SECTION 6F

ENGINE EXHAUST SYSTEM

GENERAL DESCRIPTION

The Exhaust System is suspended by hangers attached to the frame members (Figs. 6F-3 & 6F-4).

Annoying rattles and noise vibrations in the Exhaust System are usually caused by misalignment of parts. When aligning the system, leave all bolts or nuts loose until all parts are properly aligned, then tighten, working from front to rear.

When replacing a muffler, the tailpipe(s) should also be replaced.

Sealer such as #1051249, or equivalent, should be used at all clamped joint connections.

CATALYTIC CONVERTER

The catalytic converter is an emission control device added to the exhaust system to reduce hydrocarbon and carbon monoxide pollutants from the exhaust gas stream (Figs. 6F-1 & 6F-2).

THE CATALYTIC CONVERTER REQUIRES THE USE OF UNLEADED FUEL ONLY.

Periodic maintenance of the exhaust system is not required; however, if the vehicle is raised for other service, it is advisable to check the general condition of the catalytic converter, pipes and muffler(s).

The catalyst in monolith converters is not serviceable.

The catalyst in bead type converters can be replaced, on vehicle, using tool #J-29132 or off vehicle by removing the converter or the exhaust system.

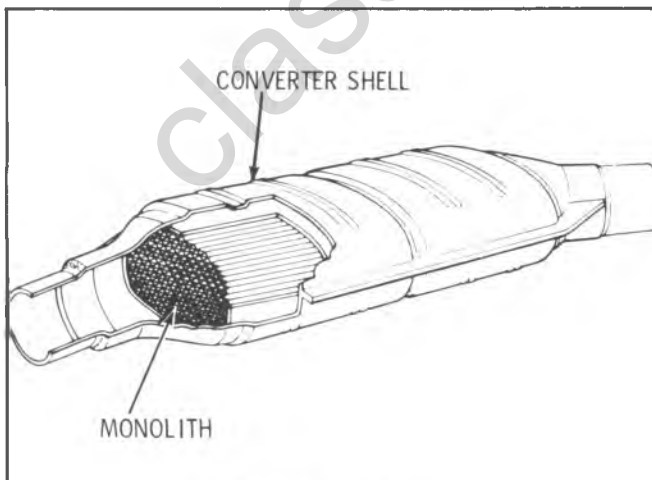


Fig. 6F-1 — Monolith Converter

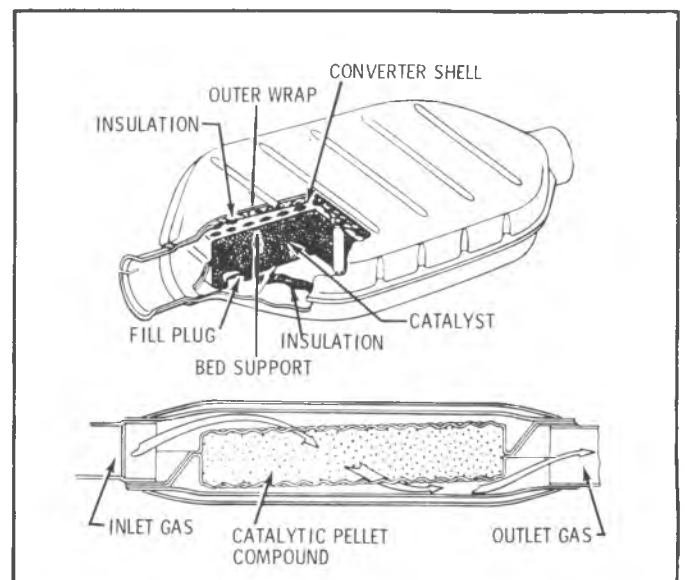


Fig. 6F-2 — Underfloor Converter

6F-2 ENGINE EXHAUST SYSTEM

| CONDITION | POSSIBLE CAUSE | CORRECTION |
|--|--|---|
| Leaking Exhaust Gases | Leaks at pipe joints. | Tighten U-bolt nuts at leaking joints to 30 lb. ft. (40 N·m). |
| | Damaged or improperly installed seals or packing. | Replace seals or packing as necessary. |
| | Loose exhaust pipe heat tube extension connections. | Replace seals or packing as required. Tighten stud nuts or bolts to specifications. |
| | Burned or rusted out exhaust pipe heat tube extensions. | Replace heat tube extensions as required. |
| Exhaust Noises | Leaks at manifold or pipe connections. | Tighten clamps at leaking connections to specified torque. Replace gasket or packing as required. |
| | Burned or blown out muffler. | Replace muffler assembly. |
| | Burned or rusted out exhaust pipe. | Replace exhaust pipe. |
| | Exhaust pipe leaking at manifold flange. | Tighten attaching bolts nuts to 17 lb. ft. (23 N·m) |
| | Exhaust manifold cracked or broken. | Replace manifold. |
| | Leak between manifold and cylinder head. | Tighten manifold to cylinder head stud nuts or bolts to specifications. |
| Loss of engine power and/or internal rattles in muffler. | Dislodged turning tubes and or baffles in muffler. | Replace muffler. |
| Loss of engine power. | Imploding (inner wall collapse) of exhaust pipe (except "P" Truck) | Replace exhaust pipe. |

ON-VEHICLE SERVICE

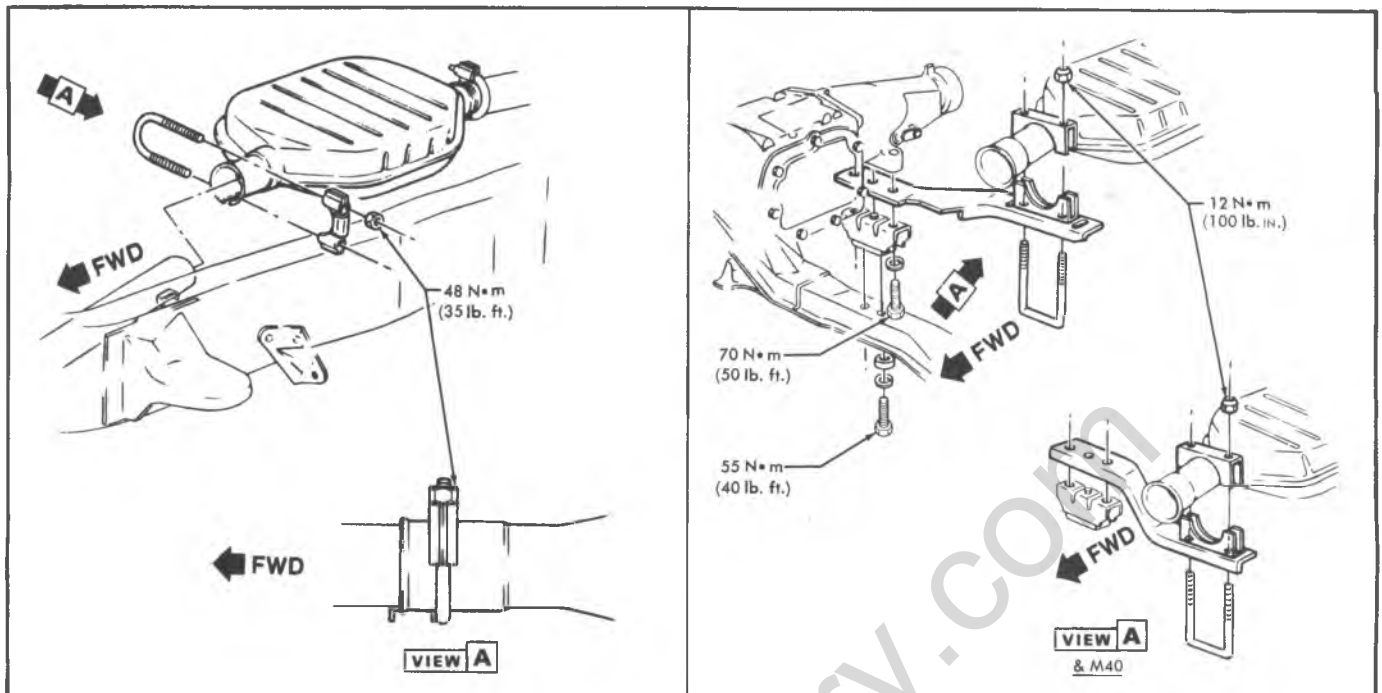


Fig. 6F-3 — Catalytic Converter - CK Series

CATALYST (Figs. 6F-3 & 6F-4)

Removal (Off Vehicle)

1. Raise vehicle.
2. Remove converter.
3. Remove converter pressed fill plug by driving a small chisel between the converter shell and the fill plug (Fig. 6F-5). Continue to deform fill plug until it can be removed with pliers (Fig. 6F-6).

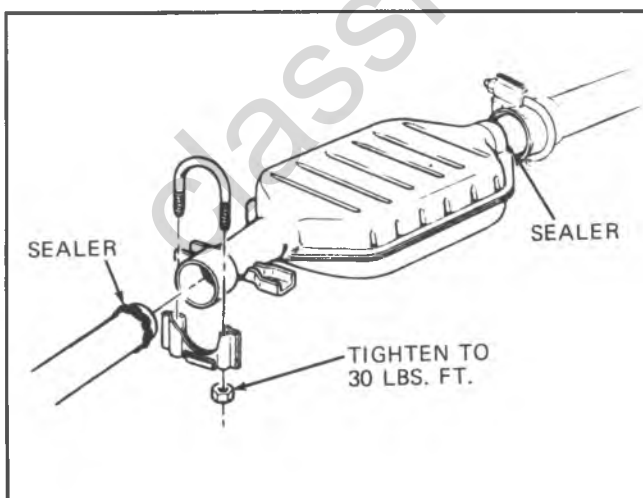


Fig. 6F-4 — Catalytic Converter - G Series

NOTICE: Do not pry fill plug from converter as damage to fill plug sealing surface could result.

4. Holding converter over a container, empty catalyst from converter by shaking until all beads are removed.

Installation (Off Vehicle)

1. Raise front of converter to approximately 45° and fill with approved new catalyst. Filling can be accomplished by tapping on converter belt (Fig. 6F-7) with a hammer, 90° to the converter, while pouring beads into the converter thru the fill plug hole. Continue tapping and pouring until converter is full. Not all beads will be able to be installed.

2. Install service fill plug (Fig. 6F-8) as follows: Install the bolt into the bridge and put the bridge into the converter opening. Move bolt back and forth to loosen catalyst beads until bridge is positioned as shown in Fig. 6F-9.

3. Remove bolt from bridge then put the washer and fill plug, dished side out, over the bolt.

4. While holding the fill plug and washer against the bolt head (Fig. 6F-10), thread the bolt 4 or 5 turns into the bridge.



Fig. 6F-5 — Removing Pressed Plug

5. After the fill plug is seated, tighten the bolt to 38 N·m (28 lb. ft.).
6. Install converter.
7. Start engine and check for leaks.

BOTTOM COVER

If, for any reason, the bottom cover of the converter is torn or damaged, it can be replaced with a repair kit.



Fig. 6F-6 — Removing Pressed Plug With Pliers

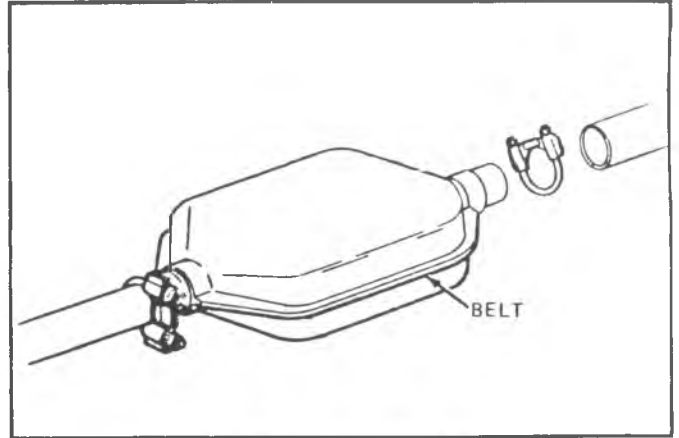


Fig. 6F-7 — Converter Belt

BOTTOM COVER REPLACEMENT

1. Remove bottom cover by cutting close to the bottom outside edge, Fig. 6F-11. Do not remove the fill plug. The depth of the cut must be very shallow to prevent damage to the inner shell of the converter.
2. Remove insulation.
3. Inspect inner shell of the converter for damage. If there is damage in the inner shell, the converter assembly must be replaced.
4. Place new insulation in the replacement cover (Fig. 6F-12). Apply sealing compound, #8998245 or equivalent, all around the cover after the insulation is in position. Apply extra sealer at the front and rear opening for the pipes (Fig. 6F-13).

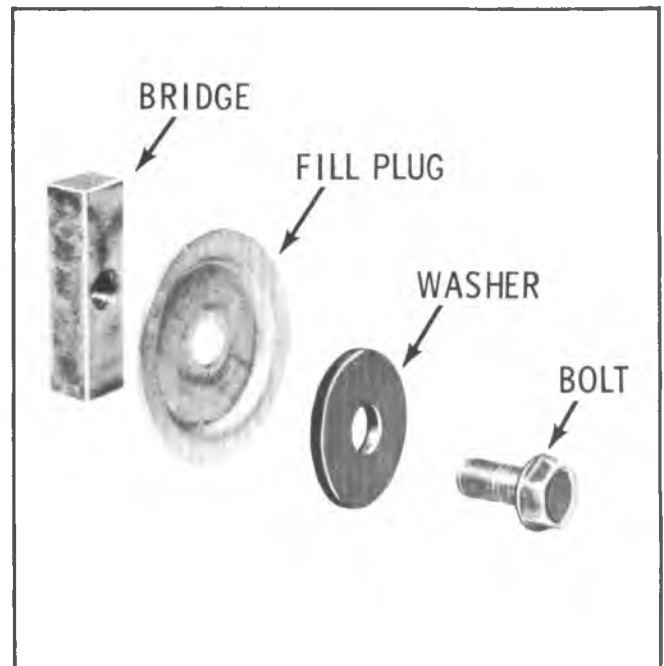


Fig. 6F-8 — Service Fill Plug

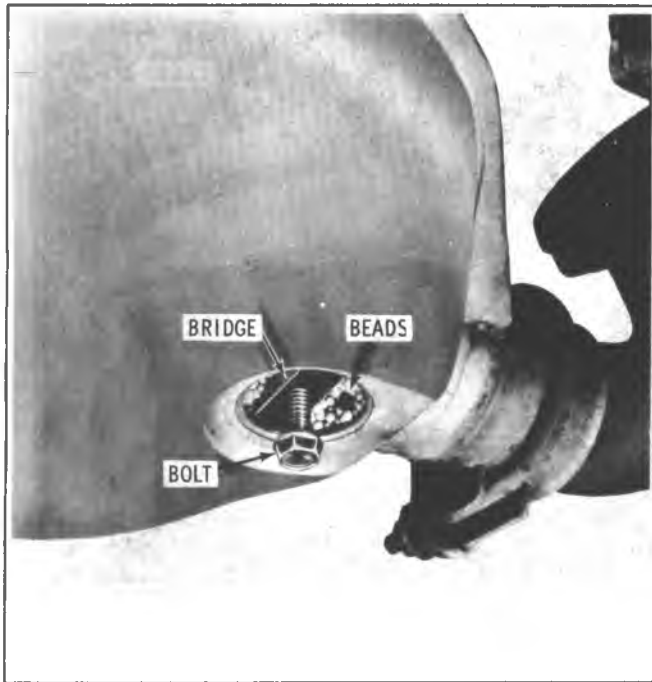


Fig. 6F-9 — Positioning Fill Plug Bridge

5. Install replacement cover on converter (Fig. 6F-14).
6. Install cover retaining channels on both sides of the converter (Fig. 6F-15).
7. Attach 2 clamps over retaining channels at each end of the converter (Fig. 6F-16).

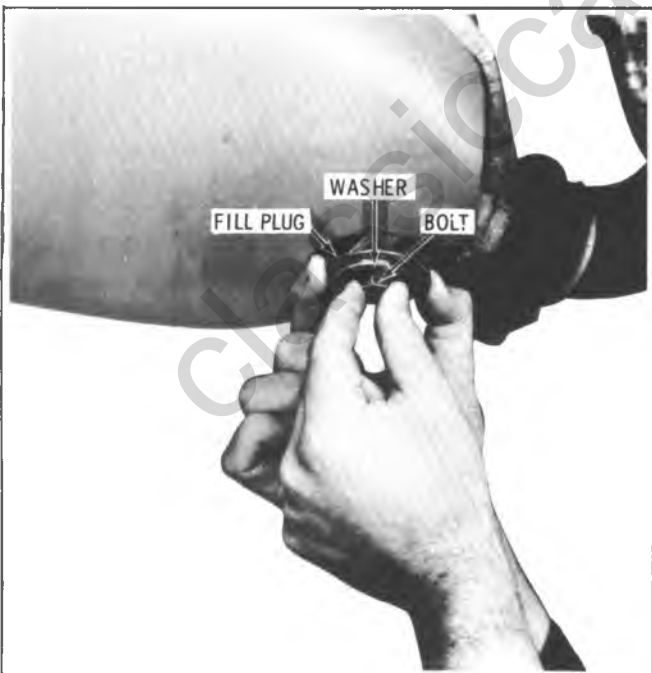


Fig. 6F-10 — Installing Fill Plug



Fig. 6F-11 — Removing Bottom Cover

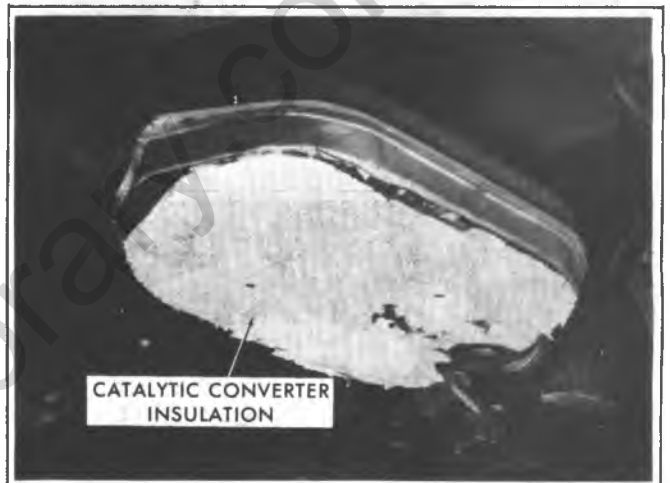


Fig. 6F-12 — Catalytic Converter Insulation

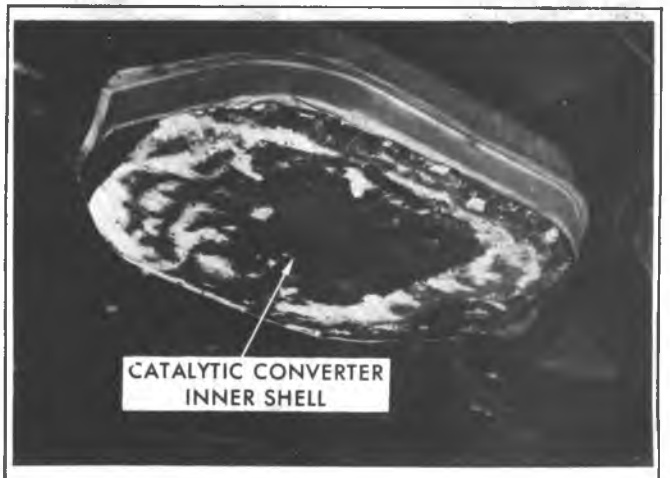


Fig. 6F-13 — Catalytic Converter Inner Shell

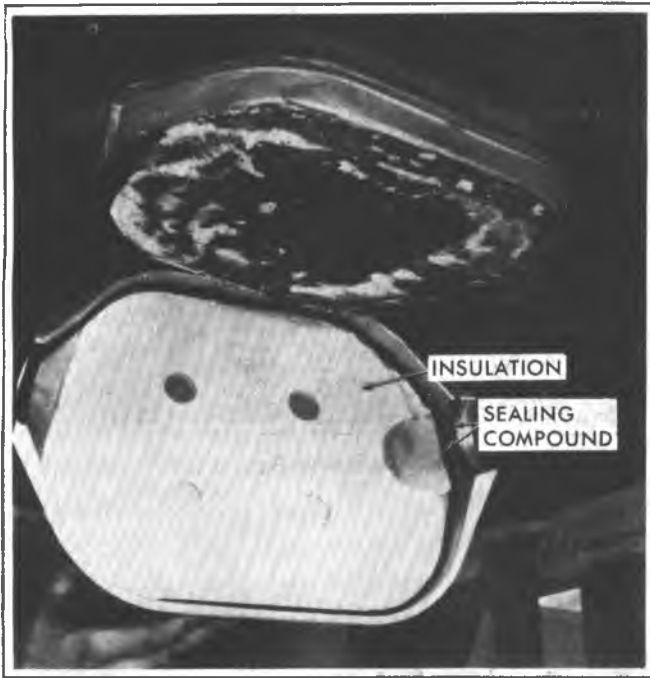


Fig. 6F-14 — Installing Bottom Cover Replacement



Fig. 6F-16 — Installing Bottom Cover Clamps

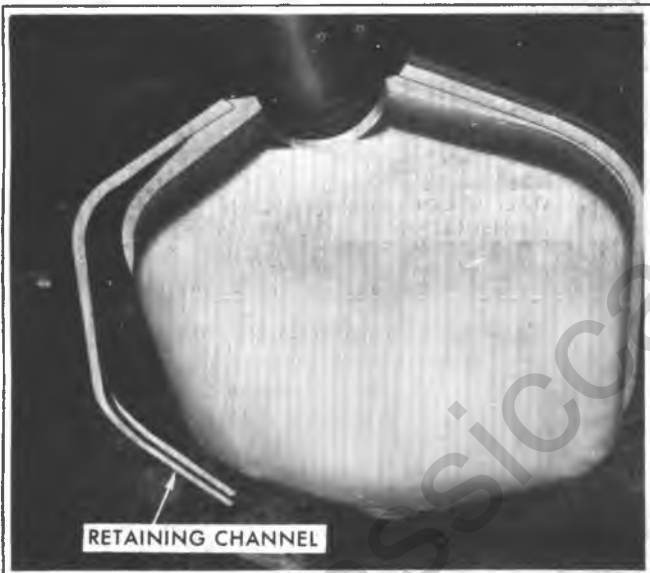


Fig. 6F-15 — Installing Bottom Cover Retaining Channels

SECTION 7A

AUTOMATIC TRANSMISSION

CONTENTS

| | |
|------------------------------------|-------|
| Torque Converter Clutch (TCC)..... | 7A-1 |
| 350 Automatic Transmission..... | 7A-8 |
| 400 Automatic Transmission | 7A-29 |
| Specifications..... | 7A-47 |

TORQUE CONVERTER CLUTCH (TCC)

INDEX

| | | | |
|---|------|--|------|
| General Description..... | 7A-1 | External Controls Check..... | 7A-6 |
| Converter Clutch Diagnosis | 7A-4 | Vacuum Switch Check..... | 7A-6 |
| Complaints and Possible Causes | 7A-4 | Low And High Vacuum Switch Check (Diesel)... | 7A-6 |
| Converter Clutch Applied In All Ranges..... | 7A-4 | High Vacuum Switch Adjustment | 7A-6 |
| Converter Clutch Applies Erratically | 7A-5 | Thermal Vacuum Valve Check | 7A-7 |
| Converter Clutch Applies At All Times | 7A-5 | Brake Release Switch Check..... | 7A-7 |
| Internal Controls Check..... | 7A-5 | Solenoid Diode Check | 7A-7 |
| Internal Hydraulic/Mechanical Controls Check... | 7A-5 | | |

GENERAL DESCRIPTION

The torque converter clutch (as shown in Fig. 7A-1a) is an internal mechanism (with a friction material attached to the front plate) splined to the turbine assembly, and when operated applies against the converter cover. This provides a mechanical direct drive coupling of the engine to the planetary gears. By applying the converter clutch, slippage is eliminated, resulting in improved fuel economy and reduced fluid operating temperatures.

The operation of the converter clutch is determined by a series of controls, and by drive range selection (as shown in Fig. 7A-2a and 2b). The converter clutch is applied in direct drive and above a minimum preset vehicle speed. At wider throttle openings, where the 2-3 upshift occurs above converter clutch apply, the apply of the converter clutch will occur immediately after the 2-3 shift. When vehicle speed decreases or the transmission shifts out of direct drive, the fluid pressure is released, the converter clutch is released, and the converter operates in a conventional manner.

The apply or release of the converter clutch is also determined by the direction that converter feed oil is fed to the converter. Converter feed oil from the pressure regulator valve flows to the converter clutch apply valve. The position

of the converter clutch apply valve controls which direction converter feed oil flows to the converter.

A spring loaded damper assembly is splined to the converter turbine assembly. The converter clutch pressure plate is attached to the pivoting mechanism of the damper assembly. This pivoting action allows the pressure plate to rotate independent of the damper assembly, up to approximately 45 degrees. The rate of independent rotation is controlled by the pivoting mechanism acting on the springs in the damper assembly. The spring cushioning effect of the damper assembly aids in reducing converter clutch apply "feel."

To further aid the apply and release of the converter clutch during various driving situations, controls have been incorporated in the electrical system. The converter clutch is applied when all of the following conditions exist:

- Transmission in 3rd gear
- Vehicle exceeds 24 to 30 mph (38 to 48 km/h)
- Engine coolant is above 130° F (54°C)
- Engine vacuum is above 2.5 in. hg.(8 kPa)
- Brake pedal is released

- Direct clutch oil passages in pump blocked, restricted or interconnected.

- Converter Malfunction.

13. After test, remove test governor and replace with original governor. If the original governor was used for the test, ensure that the weight springs are in the correct position, before reinstalling in the vehicle.

EXTERNAL CONTROLS CHECK

1. Turn car ignition "ON".
2. Check vacuum switch connector for 12 volts and check vacuum switch for proper operation. (Refer to Vacuum Switch Check).
 - a. If no voltage is present at switch:
 1. Check fuse.
 2. Check brake switch (Refer to Brake Switch Check).
 3. Check wiring to vacuum switch.
 - b. If 12 volts are present at switch, and switch check OK, continue to Step 3.
3. Reconnect electrical connector to vacuum switch and using a hand held vacuum pump with a gage (J-23738 or equivalent) apply 2.5 to 7 in. (18 to 23 kPa) of vacuum to vacuum switch.
 4. With the ignition switch in the "ON" position, check for 12 volts at female end of transmission connector.
 - a. If "NO" or low voltage is present, check and repair the wire between vacuum switch and transmission.
 - b. If 12 volts are present at transmission, check Thermal Vacuum Valve for proper operation (Refer to Thermal Vacuum Valve Check) if operation checks OK return vehicle to owner.

VACUUM SWITCH CHECK

1. Disconnect vacuum hose and electrical connector from vacuum switch.
2. Attach one lead of a test light to either terminal of the vacuum switch.
3. Ground remaining terminal of vacuum switch.
4. Apply 12 volts to remaining test light lead.
5. Attach a hand vacuum pump with a gage (J-23738 or equivalent) to vacuum port of switch.
6. Turn ignition "ON".
7. Actuate hand vacuum pump. Test light should be "OFF" and remain OFF until hand vacuum pump gage reads between 2.5 and 7 in. (8 to 23 kPa) of vacuum. Test light should come "ON".
8. Decrease vacuum slowly--light should remain "ON" until vacuum drops to between 1.5 and 2.5 in. (5 to 8 kPa) of vacuum.
9. If the vacuum switch does not turn the test light "ON" and "OFF" between the values specified, the switch is defective.
10. The high vacuum limit, (the point at which the test light goes "OUT") and the low vacuum limit, (the point at which the test light comes back "ON") must have at least 4 in. (13 kPa) of vacuum difference.

LOW AND HIGH VACUUM SWITCH CHECK (DIESEL)

1. Disconnect vacuum hose and electrical connector from vacuum switch (low or high).

2. Attach one lead of a test light to either terminal of the vacuum switch (low or high).

3. Ground the remaining terminal of the vacuum switch (low or high).

4. Attach the remaining lead of the test light to the hot

5. Attach a hand vacuum pump with a gage (J-23738 or equivalent) to the vacuum port of the vacuum switch (low or high).

6. Turn car ignition ON.

7. If using a self-powered test light, connect one lead of the test light to either terminal of the vacuum switch (low or high) and connect the remaining lead of the test light to the other terminal of the low or high vacuum switch. Car ignition does not have to be turned ON when using this type of test light.

8. Actuate hand vacuum pump.

- a. For LOW vacuum test light should be OFF, and remain OFF, until vacuum gage reads approximately 5.5 in. (18 kPa) of vacuum.

- b. For HIGH vacuum test light should be ON, and remain ON, until vacuum gage reads approximately 12.5 in. (41 kPa) of vacuum. Test light should be OFF with vacuum above 12.5 in. (41 kPa).

9. Decrease vacuum slowly.

- a. For LOW vacuum test, light should remain ON until vacuum drops to approximately 4 in. (13 kPa).

- b. For HIGH vacuum test, light should come back ON at 12.5 in. (41 kPa) high vacuum.

10. If the LOW vacuum switch does not turn the test light "ON" at approximately 5.5 in. (18 kPa) of vacuum and "OFF" at approximately 4 in. (13 kPa) of vacuum, the low vacuum switch is malfunctioning.

11. If the HIGH vacuum does not turn OFF and ON at approximately 12.5 in. (41 kPa) of vacuum, the high vacuum switch is malfunctioning.

HIGH VACUUM SWITCH ADJUSTMENT (DIESEL)

The high vacuum switch must be adjusted anytime the throttle rod, transmission vacuum valve and high idle speed adjustments are changed.

1. Disconnect high vacuum switch electrical connector.

2. Using self-powered test light, connect one lead to either terminal of the high vacuum switch and connect the probe of the test light to the other vacuum switch terminal.

3. Start engine and run at high idle speed. Energize fast idle solenoid by disconnecting pink and green wire connector from coolant switch located on the left rear of the engine on the intake manifold.

4. Remove seal cap on back of high vacuum switch.

5. High vacuum switch contacts must be closed (test light ON) before making adjustment. If contacts are open (test light OFF), turn switch adjustment screw clockwise until contacts close (test light ON).

6. Adjust vacuum switch by slowly turning the adjustment screw counterclockwise until switch contacts just open (test light OFF). Turn adjustment screw slowly to prevent adjusting past this position.

7. Reinstall seal cap on back of switch, reconnect high vacuum switch electrical connector, and reconnect coolant switch connector.

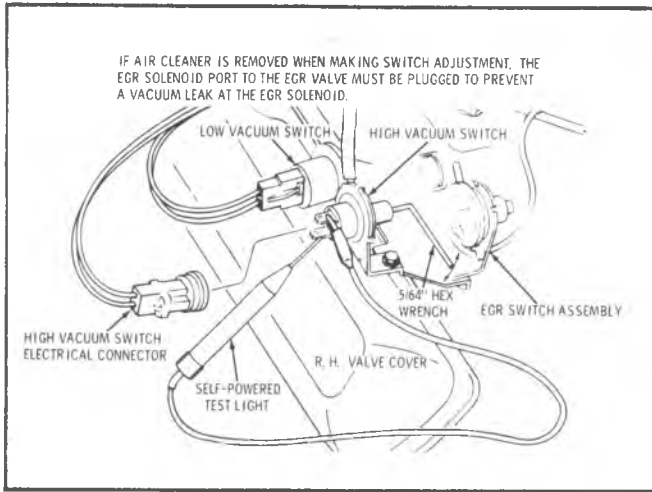


Fig. 4a—High Vacuum Switch Adjustment

THERMAL VACUUM VALVE CHECK

1. Disconnect vacuum hose at vacuum switch.
2. Attach vacuum gage to hose.
3. Start car and check vacuum in Park(P).
 - a. With engine cold, engine coolant temperature below 130° F (54°C), vacuum at idle and at 2000 rpm should read zero(0).
 - b. With engine warm (approximately five minutes running time at fast idle), engine coolant temperature above 130° F (54°C), vacuum at idle should be zero(0), while vacuum at 2000 rpm should be 10 in. (33 kPa) minimum.

BRAKE SWITCH CHECK

1. Disconnect electrical connector from rear of brake switch. These are the cruise control/converter clutch release terminals.
2. Turn ignition switch on the "ON" position.
3. Now ground one of the terminals of the brake release switch.

4. Connect one lead of the test light to the remaining brake release switch terminal.

5. Attach remaining lead of test light to brake connector wire. The test light should now be "ON".

6. Apply brakes. Test light should now go "OUT". If test light is "OFF" before applying brakes or "ON" during brake apply, switch is malfunctioning, replace switch.

SOLENOID DIODE CHECK

Solenoids should not be bench tested by touching the leads to an automotive battery. The internal diode will be destroyed by touching the negative terminal (BLACK, marked with -) to the positive battery terminal and the positive terminal (RED, +) to negative battery terminal.

Diode used in solenoids may be checked using ONLY a METER READING or SCALE-TYPE ohm meter, set on the X1 SCALE. Electronic or digital-type meters, CANNOT be used because a false defective indication can be obtained.

Proper procedure is as follows:

1. Set the SCALE-TYPE or METER-READING ohm meter on the X1 SCALE and zero the needle.
2. Attach the POSITIVE SOLENOID LEAD (RED, marked with +) to the POSITIVE METER LEAD and the NEGATIVE SOLENOID LEAD (black, marked -) to the NEGATIVE METER LEAD.
 - a. A meter reading of 20 to 40 ohms (depending on solenoid temperature), diode or coil is not shorted.
 - b. A meter reading of 0 ohms, diode or coil is shorted.
 - c. Open circuit reading, coil is open.
3. Reverse the solenoid lead attachment.
 - a. Lower reading than in Step 2 (usually 2 to 15 ohms), solenoid is OK.
 - b. Same reading as in Step 2, diode is open.

350 AUTOMATIC TRANSMISSION

INDEX

| | | | |
|-------------------------------------|-------|--|-----------|
| General Description..... | 7A-8 | Road Test..... | 7A-17 |
| Maintenance and Adjustment..... | 7A-9 | Trouble Diagnosis..... | 7A-17 |
| Transmission Fluid..... | 7A-9 | Clutch Apply Chart..... | 7A-21 |
| Checking Transmission Mount..... | 7A-11 | Diagnosis Chart..... | 7A-22 |
| Shift Controls..... | 7A-11 | Hydraulic Circuit..... | 7A-23, 24 |
| Detent Downshift Cable..... | 7A-12 | On Vehicle Service..... | 7A-25 |
| Neutral Start Switch..... | 7A-12 | Transmission Replacement (Except K Models)..... | 7A-25 |
| Diagnosis..... | 7A-14 | Transmission Replacement (K Models)..... | 7A-25 |
| Diagnosis Sequence..... | 7A-14 | Extension Housing Oil Seal..... | 7A-26 |
| Fluid Checking Procedures..... | 7A-14 | Speedometer Driven Gear..... | 7A-26 |
| Fluid Leak Diagnosis..... | 7A-14 | Speedometer Drive Gear..... | 7A-26 |
| Fluid Pressure Check..... | 7A-15 | Manual Shaft, Range Selector Inner Lever and Parking Linkage..... | 7A-27 |
| Case Porosity Repair..... | 7A-15 | Governor..... | 7A-27 |
| Vacuum Modulator Diagnosis..... | 7A-15 | Vacuum Modulator and Modulator Valve..... | 7A-28 |
| Clutch Plate Diagnosis..... | 7A-16 | Valve Body Assembly..... | 7A-28 |
| Causes of Burned Clutch Plates..... | 7A-16 | 1-2 Accumulator..... | 7A-28 |
| Governor Pressure Check..... | 7A-17 | Oil Cooler Pipes..... | 7A-29 |
| Manual Linkage..... | 7A-17 | | |

GENERAL DESCRIPTION

The 350 transmission is a fully automatic unit consisting primarily of a 3-element hydraulic torque converter and two planetary gear sets. Four multiple-disc clutches, two roller clutches, and an intermediate overrun band provide the friction elements required to obtain the desired function of the two planetary gear sets.

The 3-element torque converter consists of a pump, turbine and a stator assembly, with the addition of a converter clutch. The stator is mounted on a one way roller clutch which will allow the stator to turn clockwise, but not counterclockwise. References to clockwise and counterclockwise are determined by looking toward rear of vehicle.

The torque converter is of welded construction and is serviced as a complete assembly. The unit is filled with oil and is attached to the engine crankshaft by a flywheel, thus always rotates at engine speed. The converter pump is an integral part of the converter housing, therefore, the pump blades, rotating at engine speed, set the oil within the converter into motion and direct it to the turbine, causing the turbine to rotate.

As the oil passes throughout the turbine it is traveling in such a direction that if it were not redirected by the stator it would hit the rear of the converter pump blades and impede its pumping action. So at low turbine speeds, oil is redirected by the stator to the converter pump in such a manner that it actually assists the converter pump to deliver power, or multiply engine torque.

As turbine speed increases, the direction of oil leaving the turbine changes and flows against the rear side of the stator vanes in a clockwise direction. Since the stator is now

impeding the smooth flow of oil, its roller clutch releases and it revolves freely on its shaft. Once the stator becomes inactive, there is no further multiplication of engine torque within the converter.

At this point, the converter is merely acting as a fluid coupling as both the converter pump and turbine are being driven at approximately the same speed.

A hydraulic system pressurized by a gear type pump provides the working pressure required to operate the friction elements and automatic controls.

External control connections to the transmission are:

- Manual Linkage - To select the desired operating range.
- Engine Vacuum - To operate the vacuum modulator.
- Cable Control - To operate the detent valve.

A vacuum modulator is used to automatically sense any change in the torque input to the transmission. The vacuum modulator transmits this signal to the pressure regulator, which controls line pressure, so that all torque requirements of the transmission are met and smooth shifts are obtained at all throttle openings.

The detent valve is activated by a cable that is connected to the accelerator lever assembly. When the throttle is half open, the valve is actuated causing throttle downshift at speeds below 50 mph (80 km/h). When the throttle is fully open the detent valve is actuated causing the transmission to downshift from 3-1 at speeds below 40 mph (65 km/h) and 3-2 below 75 mph (120 km/h).

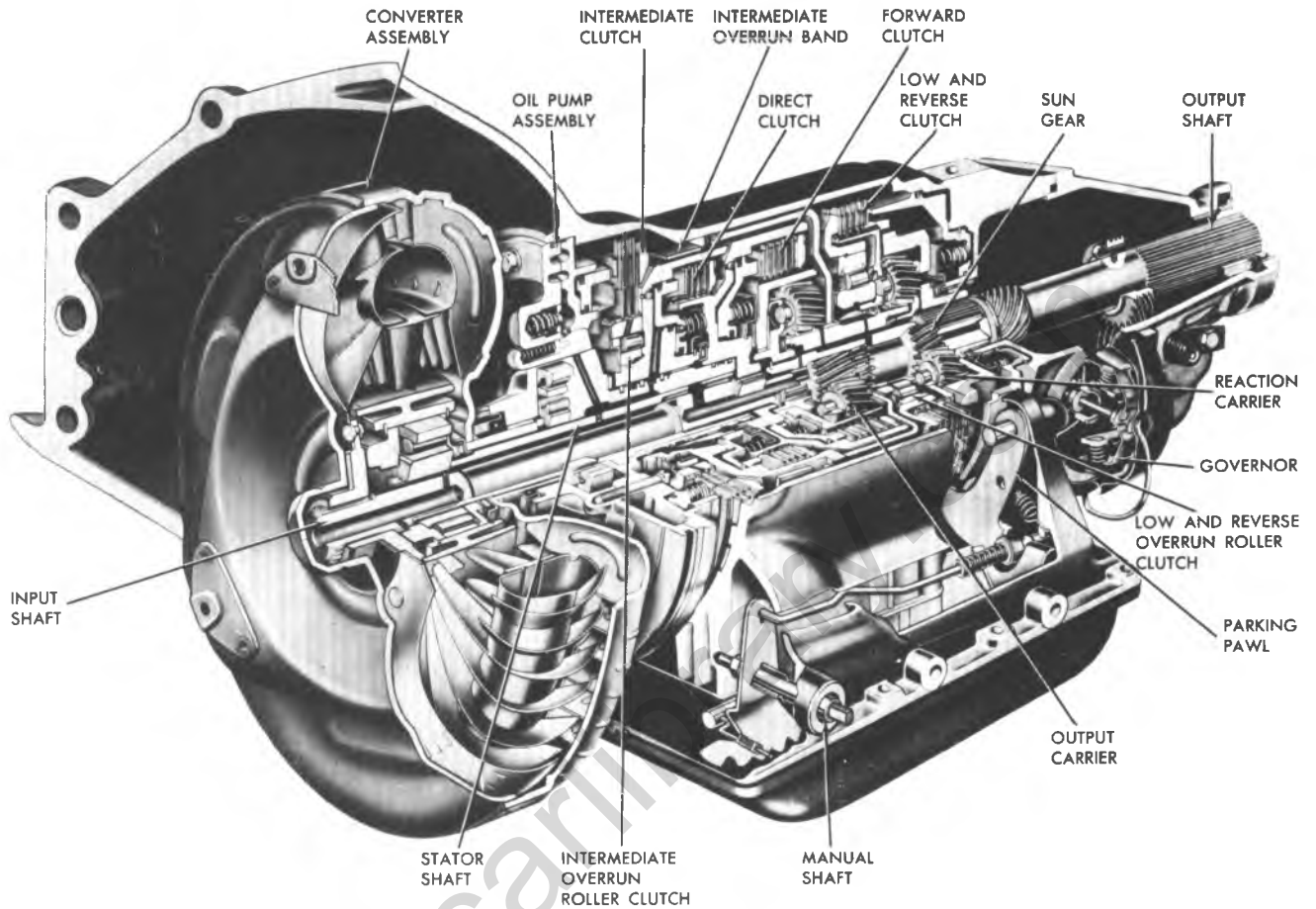


Fig. 7A-1--350 Automatic Transmission, Cross-Section View

MAINTENANCE AND ADJUSTMENTS

TRANSMISSION FLUID

Fluid Level and Capacity

The fluid level indicator is located in filler tube at right rear of engine. To bring the fluid level from the "ADD" mark to the "FULL" mark requires one pint of fluid. Fluid level should be checked at every engine oil change.

Fluid level should be to the FULL mark with the transmission fluid at normal operating temperature of 200°F (93°C). With warm fluid at room temperature of 70°F (21°C), the level will be 1/4 in. (6 mm) below the ADD mark on the dipstick. The normal operating temperature is obtained only after at least 15 miles (24 km/h) of highway type driving or the equivalent of city driving.

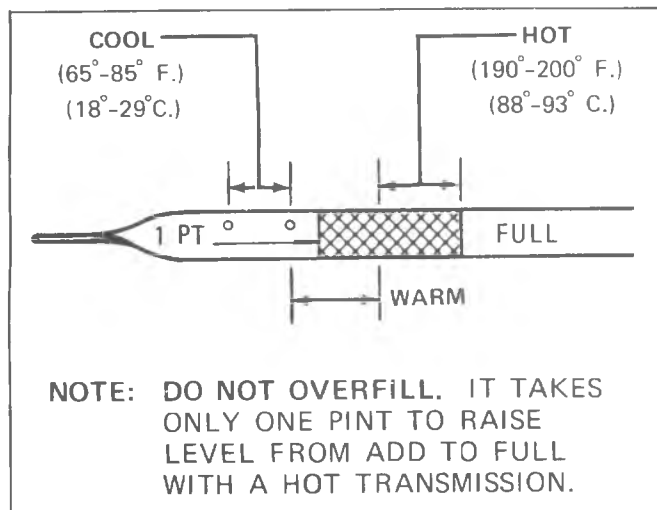


Fig. 7A-2--Dipstick

Approximately 3 liters (6 pints) of fluid are required to refill the transmission after the oil pan has been drained. The fluid capacity of the 350 transmission and converter assembly is approximately 10 liters (20 pints) but **correct level is determined by the mark on the dipstick rather than by amount added.** Use only DEXRON® II automatic transmission fluid or its equivalent.

An early change to a darker color from the usual red color and/or a strong odor that is usually associated with overheated transmission fluid is normal, and is not a positive sign of required maintenance or transmission failure.

Checking Procedure and Adding Fluid

To determine proper fluid level at normal operating temperature, proceed as follows:

1. Position vehicle on a level surface, place selector lever in PARK (P), apply parking brake and have engine running at normal idle.
2. Remove fluid level indicator, wipe it clean and reinstall fully until cap seats.
3. Remove indicator and reading of fluid level should be at full "F" mark.
4. If additional fluid is required, add DEXRON® II automatic transmission fluid or its equivalent to "F" mark on indicator.

If the vehicle cannot be driven sufficiently to bring the transmission to operating temperature and it becomes necessary to check the fluid level, the transmission may be checked at room temperature of 70°F (21°C) as follows:

1. Position selector lever in PARK (P), apply parking brake and start engine. **DO NOT RACE ENGINE.** Move selector lever through each range.
2. Immediately check fluid level with selector lever in Park, engine running and vehicle on LEVEL surface.

Fluid level on indicator should be 1/4 in. (6 mm) below the "ADD" mark.

3. If additional fluid is required, add enough fluid to bring level to 1/4 in. (6 mm) below the ADD mark on the dipstick. If transmission fluid level is correctly established at 70°F, (21°C), it will appear at the FULL mark on the dipstick when the transmission reaches its normal operating temperature of 200°F, (93°C).

NOTICE: DO NOT OVERFILL (or this may cause damage to the transmission) as foaming and loss of fluid through the vent pipe might occur as fluid heats up.

If fluid is too low, especially when cold, complete loss of drive may result, which can cause transmission failure.

Draining and Refilling Transmission Oil Pan

The oil pan should be drained and the strainer cleaned at the intervals detailed in Section O-B of this manual, and fresh fluid added to obtain the proper level on indicator. Section O-B also details intervals for vehicles subjected to heavy city traffic during hot weather, or in commercial use, or when the engine is regularly idled for prolonged periods or when vehicle is used for towing.

Drain fluid immediately after operation before it has had an opportunity to cool. Transmission fluid temperature can exceed 350°F, (177°C).

1. Raise vehicle.
2. Support transmission with suitable jack at the transmission.
3. With fluid receptacle placed under transmission oil pan, remove oil pan attaching bolts from front and side of pan.
4. Loosen rear pan attaching bolts approximately four (4) turns.
5. Carefully pry transmission oil pan loose with screwdriver, allowing fluid to drain.
6. Remove remaining screws and remove oil pan and gasket. Discard gasket.
7. Drain fluid from oil pan. Clean pan with solvent and dry thoroughly with clean compressed air.
8. Remove two (2) strainer-to-valve body screws, strainer and gasket. Discard gasket.
9. Thoroughly clean strainer assembly in solvent and dry thoroughly with clean compressed air.
10. Install new strainer-to-valve body gasket, strainer and two (2) screws.
11. Install new gasket on oil pan and install oil pan. Tighten its 13 attaching bolt and washer assemblies to 12 ft. lb. (16 N·m) torque.
12. Lower vehicle. Add approximately 3 liters (6 pints) of DEXRON® II automatic transmission fluid or its equivalent through filler tube.
13. With selector lever in PARK (P) position, apply hand brake, start engine and let idle (carburetor off fast idle step). **DO NOT RACE ENGINE.**
14. Move selector lever through each range and, with selector lever in PARK(P) range, check the fluid level.
15. Add additional fluid to bring level to 1/4 in. (6.35 mm) below the ADD mark on the dipstick.

NOTICE: Do not overfill. Foaming can result if overfilled.

Adding Fluid to Fill Dry Transmission and Converter Assembly

In cases of transmission overhaul, when a complete fill of approximately 10 liters (20 pints) is required, proceed as follows:

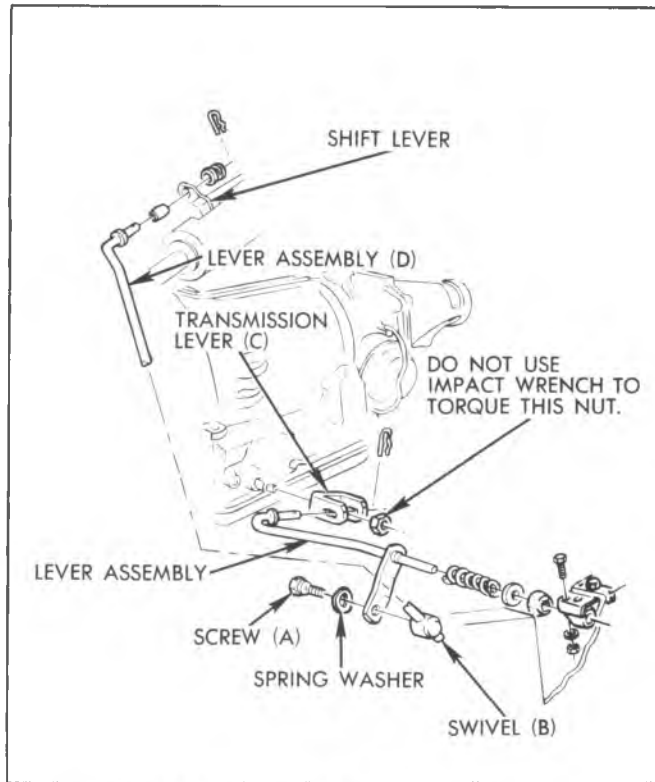


Fig. 7A-3--Column Shift Linkage - CK Series

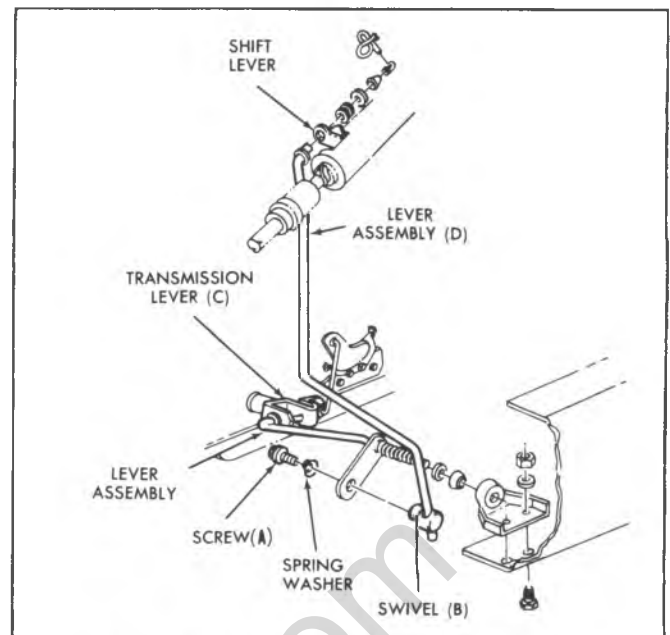


Fig. 7A-4--Column Shift Linkage-P Series

1. Add a sufficient quantity of transmission fluid through filler tube to raise the level to the lower portion of the dipstick.

2. With manual control lever in PARK (P) position, start engine and place on cold idle cam. **DO NOT RACE ENGINE.** Move manual control lever through each range.

3. Immediately check fluid level with selector lever in PARK (P), engine running and vehicle on LEVEL surface and add additional fluid to bring level to 1/4 in. (6.35 mm) below the "ADD" mark on the dipstick. Do not overfill.

CHECKING TRANSMISSION MOUNT

Raise vehicle on a hoist. Push up and pull down on transmission tailshaft while observing transmission mount. If rubber separates from metal plate of mount or if tailshaft moves up but not down (mount bottomed out) replace mount. If there is relative movement between a metal plate of mount and its attaching point, tighten screws or nuts attaching mount to transmission or crossmember.

SHIFT CONTROLS

Column Shift Linkage - CK and P Series

(Fig. 7A-3 and 4)

1. The shift tube and lever assembly must be free in the mast jacket. See Section 3B for alignment of steering column assembly if necessary.

2. To check for proper shift linkage adjustment, lift the transmission selector lever towards the steering wheel. Allow the selector lever to be positioned in DRIVE (D) by the transmission detent.

Do not use the indicator pointer as a reference to position the selector lever. When performing linkage adjustment, pointer is adjusted last.

3. Release the selector lever. The lever should be inhibited from engaging low range unless the lever is lifted.

4. Lift the selector lever towards the steering wheel, and allow the lever to be positioned in NEUTRAL (N) by the transmission detent.

5. Release the selector lever. The lever should now be inhibited from engaging reverse range unless the lever is lifted.

6. A properly adjusted linkage will prevent the selector lever from moving beyond both the neutral detent, and the drive detent unless the lever is lifted to pass over the mechanical stop in the steering column.

7. If adjustment is required, remove screw (A) and spring washer from swivel (B).

8. Set transmission lever (C) in Neutral (N) position by moving lever counterclockwise to L1 detent and then clockwise three (3) detent positions to NEUTRAL(N).

9. Position transmission selector lever in NEUTRAL(N) position as determined by the mechanical stop in steering column assembly.

Do not use the indicator pointer as a reference to position the selector lever. When performing linkage adjustment, pointer is adjusted last.

10. Assemble swivel, spring washer and screw to lever assembly (D) and tighten screw to 20 ft. lb. (27 N·m)

11. Readjust indicator needle if necessary to agree with the transmission detent positions. Refer to Section 9.

12. Readjust neutral start switch if necessary to provide the correct relationship to the transmission detent positions. Refer to Section 8.

13. Check operation (CK Series):

a. With key in "Run" position and transmission in REVERSE(R) be sure that key cannot be removed and that steering wheel is not locked.

b. With key in "Lock" position and shift lever in PARK (P), be sure that key can be removed, that steering wheel is locked, and that transmission remains in PARK(P)

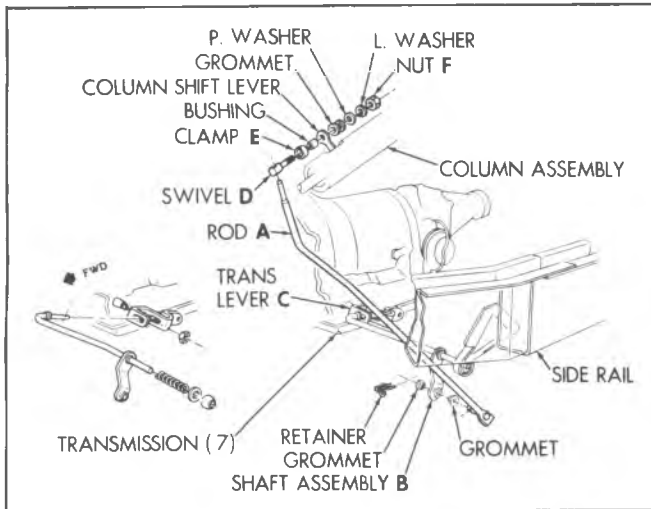


Fig. 7A-5--Column Shift Linkage-G Series

when steering column is locked.

NOTICE: Any inaccuracies in the above adjustments may result in premature failure of the transmission due to operation without controls in full detent. Such operation results in reduced oil pressure and in turn partial engagement of the affected clutches. Partial engagement of the clutches with sufficient pressure to cause apparent normal operation of the vehicle will result in failure of the clutches or other internal parts after only a few miles of operation.

Column Shift Linkage - G Series (Fig. 7A-5)

1. The shift tube and lever assembly must be free in the mast jacket.

2. Set transmission lever (C) in "neutral" position by one of the following optional methods.

Obtain NEUTRAL(N) position by moving transmission lever (C) counter-clockwise to "L1" detent, then clockwise three detent positions to "neutral" or obtain "neutral" position by moving transmission lever (C) clockwise to the PARK(P) detent then counter-clockwise two detents to NEUTRAL(N).

3. Set the column shift lever in NEUTRAL (N) position. This is obtained by rotating shift lever until it locks into mechanical stop in the column assembly.

Do not use indicator pointer as a reference to position the shift lever.

4. Attach rod (A) to shaft assembly (B) as shown (Fig. 7A-5).

5. Slide swivel (D) and clamp (E) onto rod (A) align the column shift lever and loosely attach as shown.

6. Hold column lever against "neutral" stop "park" position side.

7. Tighten nut (F) to 18 ft. lb. (24 N·m)

8. Readjust indicator needle if necessary to agree with the transmission detent positions.

9. Readjust neutral start switch if necessary to provide the correct relationship to the transmission detent positions.

NOTICE: Any inaccuracies in the above adjustments may result in premature failure of the transmission due to operation without controls in full detent. Such operation results in reduced oil pressure and in turn partial engagement of the affected clutches. Partial engagement of the clutches with sufficient pressure to cause apparent normal operation of the vehicle will result in failure of the clutches or other internal parts after only a few miles of operation.

DETENT DOWNSHIFT CABLE (Fig. 7A-6 and 7)

Removal

1. Push up on bottom of snap-lock and release lock and detent downshift cable.

2. Disconnect cable from carburetor lever.

3. Compress locking tabs and disconnect snap-lock assembly from bracket.

4. Remove clamp around filler tube, remove screw and washer securing cable to transmission and disconnect detent downshift cable.

Installation

1. Install new seal into transmission case. Lubricate seal with transmission fluid.

2. Connect transmission end of detent downshift cable and secure to transmission case with bolt and washer tightened to 75 in. lb. (95 N·m)

3. Route cable in front of filler tube and install clamp around filler tube, modulator pipe and detent downshift cable. Locate clamp approximately 2 in. (50 mm) above filler tube bracket.

4. Pass cable through bracket and engage locking tabs of snap-lock on bracket.

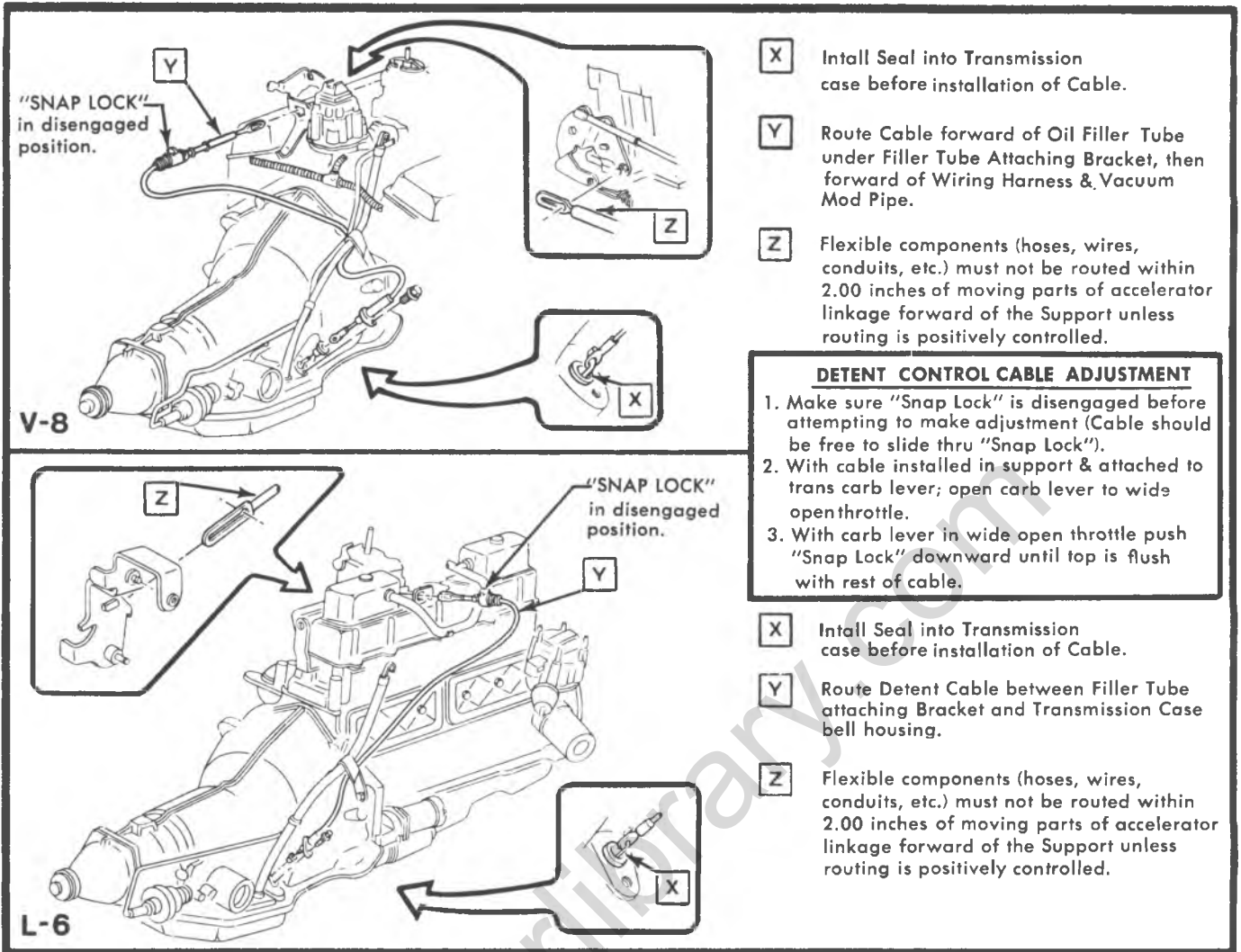
5. Connect cable to carburetor lever.

Adjustment

With snap-lock disengaged, position carburetor to wide open throttle (W.O.T.) position and push snap-lock downward until top is flush with rest of cable.

NEUTRAL START SWITCH

The adjustment of the neutral start switch is described in Section 8, Electrical.



- X** Intall Seal into Transmission case before installation of Cable.
- Y** Route Cable forward of Oil Filler Tube under Filler Tube Attaching Bracket, then forward of Wiring Harness & Vacuum Mod Pipe.
- Z** Flexible components (hoses, wires, conduits, etc.) must not be routed within 2.00 inches of moving parts of accelerator linkage forward of the Support unless routing is positively controlled.

- X** Intall Seal into Transmission case before installation of Cable.
- Y** Route Detent Cable between Filler Tube attaching Bracket and Transmission Case bell housing.
- Z** Flexible components (hoses, wires, conduits, etc.) must not be routed within 2.00 inches of moving parts of accelerator linkage forward of the Support unless routing is positively controlled.

Fig. 7A-6-Detent Downshift Cable - C, K, and P Series

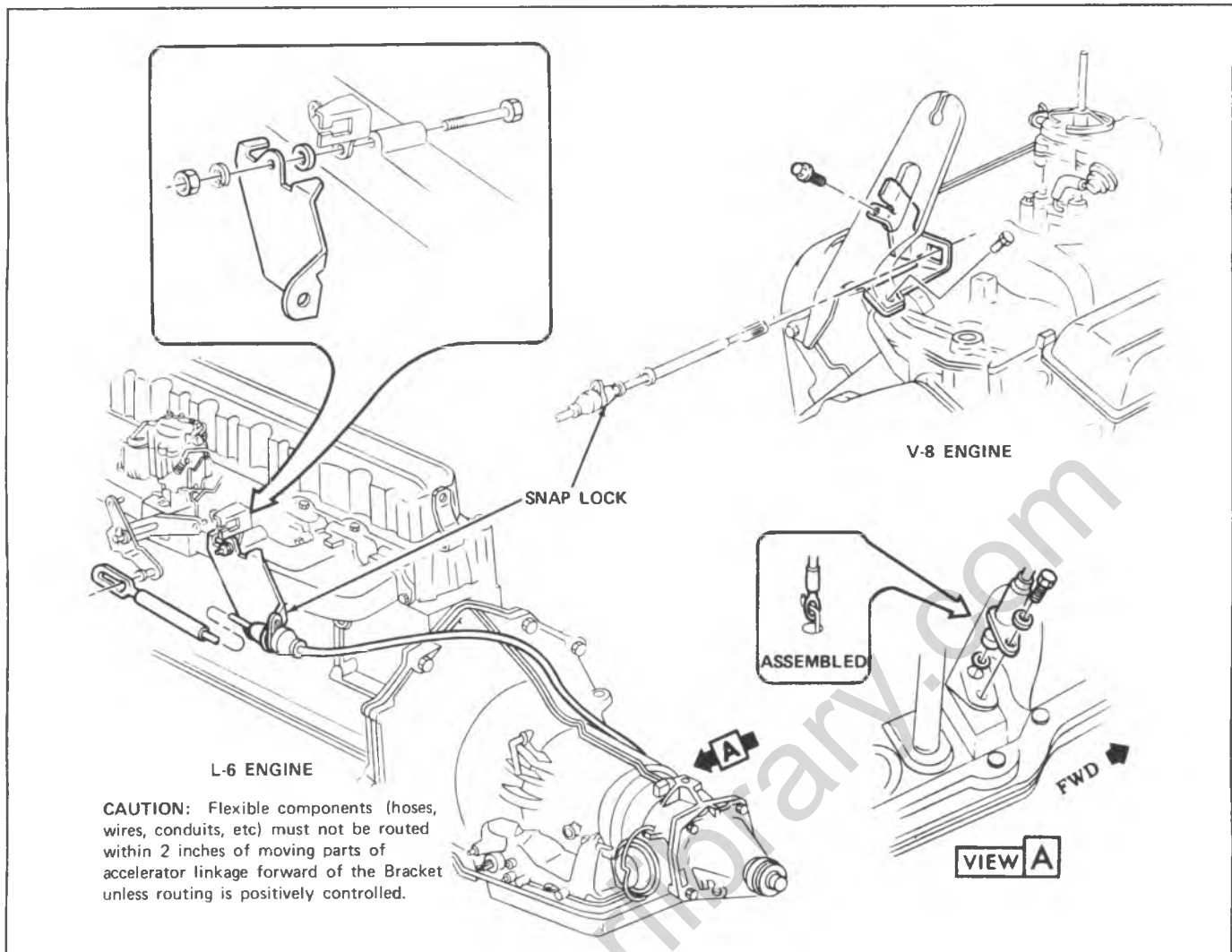


Fig. 7A-7--Detent Downshift Cable - G Series

DIAGNOSIS

DIAGNOSIS SEQUENCE

1. Check and correct fluid level.
2. Check detent cable adjustment.
3. Check and correct vacuum line and fittings.
4. Check and correct manual linkage.
5. Road test vehicle.
 - a. Install oil pressure gage.
 - b. Road test using all selective ranges, noting when discrepancies in operation or oil pressure occur.
 - c. Attempt to isolate the unit or circuit involved in the malfunction.
 - d. If engine performances indicates an engine tune-up is required, this should be performed before road testing is completed or transmission correction attempted. Poor engine performance can result in rough shifting or other malfunctions.

FLUID CHECKING PROCEDURES

Refer to Maintenance and Adjustment Section for fluid checking procedures.

FLUID LEAK DIAGNOSIS

Determining Source of Leak

Before attempting to correct an oil leak, the actual source of the leak must be determined. In many cases, the source of the leak can be deceiving due to "wind flow" around the engine and transmission.

The suspected area should be wiped clean of all oil before inspecting for the source of the leak.

The use of a "Black Light" to locate the point at which the oil is leaking is helpful. Comparing the oil from the leak to that on the engine or transmission dipstick, when viewed by black light, will determine the source of the leak - engine or transmission.

Oil leaks around the engine and transmission are generally carried toward the rear of the vehicle by air stream. For example, a transmission oil filler tube to case leak will sometimes appear as a leak at the rear of the transmission. In determining the source of a leak, proceed as follows:

1. Degrease underside of transmission.
2. Road test to get unit at operating temperature.
3. Inspect for leak with engine running.
4. With engine OFF, check for oil leaks due to the raised oil level caused by drain back.

Possible Points of Oil Leak

1. Transmission Oil Pan Leak.
 - a. Attaching bolts not correctly torqued.
 - b. Improperly installed or damaged pan gasket.
 - c. Oil pan gasket mounting face not flat.
2. Extension Housing.
 - a. Attaching bolts not correctly torqued.
 - b. Rear seal assembly damaged or improperly installed.
 - c. Square seal, extension to case, damaged or improperly installed.
 - d. Porous casting. Refer to Subparagraph C.
3. Case Leak.
 - a. Filler pipe seal damaged or missing; misposition of filler pipe bracket to engine.
 - b. Modulator assembly "O" ring seal damaged or improperly installed.
 - c. Detent cable connector seal damaged or improperly installed.
 - d. Governor cover not tight.
 - e. Speedometer gear "O" ring damaged.
 - f. Manual shaft seal damaged or improperly installed.
 - g. Line pressure tap plug loose.
 - h. Vent pipe (refer to item 5).
 - i. Porous casting. Refer to Subparagraph C.
4. Leak at Front of Transmission.
 - a. Front pump seal leaks.
 1. Seal lip cut. Check converter hub, etc.
 2. Bushing moved and damaged, Oil return hole plugged.
 3. No oil return hole.
 - b. Front pump attaching bolts loose or bolt washer type seals damaged or missing.
 - c. Front pump housing "O" ring damaged or cut.
 - d. Converter leak in weld area.
 - e. Porous casting (pump).
5. Oil Comes Out Vent Pipe.
 - a. Transmission overfilled.
 - b. Water in oil.
 - c. Foreign material between pump and case or between pump cover and body.
 - d. Case - porous near converter bosses. Front pump cover or housing oil channels shy or stock near breather. See Subparagraph C.
 - e. Pump to case gasket mispositioned.

FLUID PRESSURE CHECK

While vehicle is stationary (service brake ON), engine speed set to 1200 rpm, transmission oil pressure gage attached as shown in Fig. 7A-10B, and vacuum modulator tube **disconnected**, the transmission line pressure tap should read 167 psi (1152 kPa) in Drive(D), 166 psi (1145 kPa) in L1 or L2, and 254 psi (1752 kPa) in reverse.

While vehicle is stationary (service brake ON), engine speed set to maintain 12 in. hg. (39 kPa) absolute manifold pressure, transmission oil pressure gage attached, and vacuum modulator tube **connected**, the transmission line pressure tap should read 85 psi (586 kPa) in DRIVE (D), 105 psi (724 kPa) in L1 or L2, and 129 psi (890 kPa) in reverse.

CASE POROSITY REPAIR

External oil leaks caused by case porosity can be successfully repaired with the transmission in the vehicle by using the following recommended procedures:

1. Road test and bring the transmission to operating temperature, approximately 180°F (82°C).
2. Raise vehicle on a hoist or jack stand, engine running, and locate source of oil leak. Check for oil leaks in Low(L), Drive(D), and Reverse(R).
3. Shut engine off and thoroughly clean area to be repaired with a suitable cleaning solvent and a brush and air dry.

A clean, dry soldering acid brush can be used to clean the area and also to apply the epoxy cement.

4. Using instructions of the manufacturer, mix a sufficient amount of epoxy to make the repair. Make certain the area to be repaired is fully covered.
5. Allow cement to cure for 3 hours before starting engine.
6. Road test and check for leaks.

VACUUM MODULATOR DIAGNOSIS

A defective vacuum modulator can cause one or more of the following complaints.

1. Harsh upshifts and downshifts.
2. Delayed upshifts.
3. Soft upshifts and downshifts.
4. Slips in Low(L), Drive(D) and Reverse(R).
5. Transmission overheating.
6. Engine burning transmission oil.

If any one of the above complaints are encountered, the modulator must be checked.

Vacuum Diaphragm Leak Check

Insert a pipe cleaner into the vacuum connector pipe as far as possible and check for the presence of transmission oil. If oil is found, replace the modulator.

Gasoline or water vapor may settle in the vacuum side of the modulator. If this is found without the presence of oil, the modulator is serviceable and should not be changed.

Atmospheric Leak Check

Apply a liberal coating of soap bubble solution to the vacuum connector pipe seam, the crimped upper to lower housing seam (Fig. 7A-8). Using a short piece of rubber tubing, apply air pressure to the vacuum pipe by blowing into the tube and observe for leak bubbles. If bubbles appear, replace the modulator.

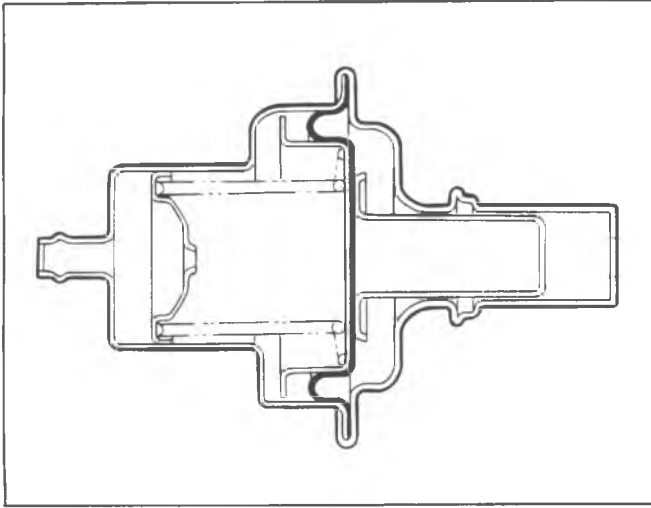


Fig. 7A-8--Vacuum Modulator Assembly

NOTICE: Do not use any method other than human lung power for applying air pressure, as pressures over 6 psi (41 kPa) may damage the modulator.

Spring Tension Comparison Check

Using tool J-24466, as shown in Fig. 7A-9, compare the load of a known good modulator with the assembly in question.

- a. Install the modulator that is known to be acceptable on either end of the tool.
- b. Install the modulator in question on the opposite end of the tool.

c. Holding the modulators in a horizontal position, bring them together under pressure until either modulator sleeve just touches the tool. The indicator in the gage will show white if the modulator is acceptable. A nonconforming modulator will cause the indicator to shift, thus showing blue. If white does not appear, the modulator in question should be replaced.

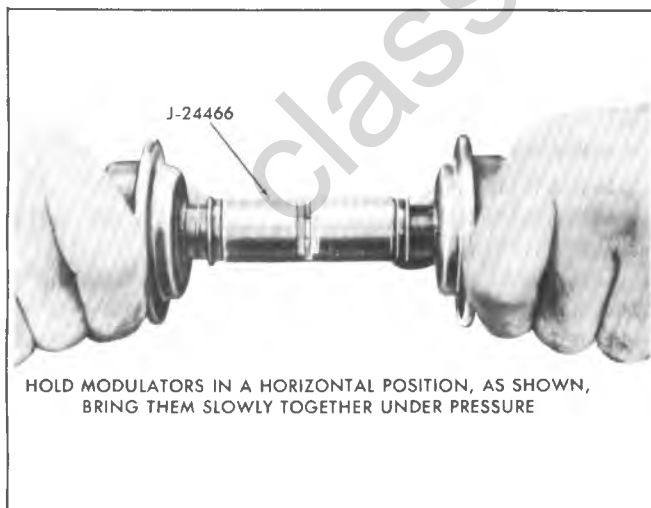


Fig. 7A-9--Spring Tension Comparison

Sleeve Alignment Check

Roll the main body of the modulator on a flat surface and observe the sleeve for concentricity to the cam. If the sleeve is concentric and the plunger is free, the modulator is acceptable.

Once the modulator assembly passes all of the above tests, it is an acceptable part and may be reused.

TRANSMISSION CLUTCH PLATES DIAGNOSIS

1. Lined Drive Plates.
 - a. Dry plates with compressed air and inspect the lined surface for:

1. pitting and flaking
2. wear
3. glazing
4. cracking
5. charring
6. chips or metal particles imbedded in lining.

If a lined drive plate exhibits any of the above conditions, replacement is required. Do not diagnose drive plates by color.

2. Steel Driven Plates

Wipe plates dry and check for heat discoloration. If the surface is smooth and an even color smear is indicated, the plate should be reused. If severe heat spot discoloration or surface scuffing is indicated, the plate must be replaced.

3. Clutch Release Springs

Evidence of extreme heat or burning in the area of the clutch may have caused the springs to take a heat set and would justify replacement of the springs.

CAUSES OF BURNED CLUTCH PLATES

1. FORWARD CLUTCH
 - a. Check ball in clutch housing damaged, stuck or missing.
 - b. Clutch piston cracked, seals damaged or missing.
 - c. Low line pressure.
 - d. Pump cover oil seal rings missing, broken or undersize; ring groove oversize.
 - e. Case valve body face not flat or porosity between channels.
2. INTERMEDIATE CLUTCH
 - a. Intermediate clutch piston seals damaged or missing.
 - b. Low line pressure.
 - c. Case valve body face not flat or porosity between channels.
3. DIRECT CLUTCH
 - a. Restricted orifice in vacuum line to modulator (poor vacuum response).
 - b. Check ball in direct clutch piston damaged, stuck or missing.
 - c. Defective modulator bellows.
 - d. Clutch piston seals damaged or missing.
 - e. Case valve body face not flat or porosity between channels.
 - f. Clutch installed backwards.

NOTICE: Burned clutch plates can be caused by incorrect usage of clutch plates. Also, anti-freeze in transmission fluid can cause severe damage, such as

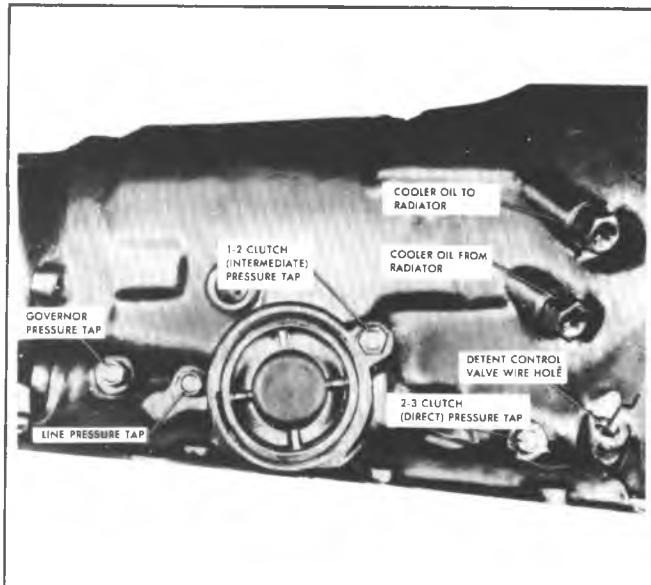


Fig. 7A-10--Pressure Tap Locations

large pieces of composition clutch plate material peeling off.

GOVERNOR PRESSURE CHECK

1. Install line Pressure Gage, to tap location shown in Fig. 7A-10.
2. Disconnect vacuum line to moldulator.
3. With car on hoist (rear wheels, off ground), foot-off brake, in **DRIVE (D)**, check line pressure at 1000 rpm.
4. Slowly increase engine rpm to 3000 rpm and determine if a line pressure drop occurs (7 psi - 48 kPa or more).
5. If no pressure drop occurs:
 - a. Inspect Governor
 1. Stuck valve.
 2. Free Weights.
 3. Restricted orifice in governor valve.
 - b. Governor Feed System
 1. Check screen in control valve assembly.
 2. Check for restrictions in feed line.
 3. Scored governor bore.

MANUAL LINKAGE

Manual linkage adjustment and the associated neutral safety switch are important from a safety standpoint. The neutral safety switch should be adjusted so that the engine will start in the Park (P) and Neutral (N) positions only.

With the selector lever in the **PARK(P)** position, the parking pawl should freely engage and prevent the vehicle from rolling. The pointer on the indicator quadrant should line up properly with the range indicators in all ranges.

ROAD TEST

Drive Range

Position selector lever in **DRIVE (D)** range and accelerate the vehicle from 0 mph (0 km/h). A 1-2 and 2-3 shift should occur at all throttle openings. (The shift points will vary with the throttle opening). As the vehicle decreases in speed to 0 mph (0 km/h), the 3-2 and 2-1 shifts should occur.

Low L2 Range

Position the selector lever in **L2** range and accelerate the vehicle from 0 mph (0 km/h). A 1-2 shift should occur at all throttle openings. (No. 2-3 shift can be obtained in this range). The 1-2 shift point will vary with throttle opening. As the vehicle decreases in speed to 0 mph (0 km/h), a 2-1 shift should occur.

The 1-2 shift in **INTERMEDIATE (D)** range is somewhat firmer than in **DRIVE RANGE**. This is normal.

Low L1 Range

Position the selector lever in **L1** range and accelerate the vehicle from 0 mph (0 km/h). No upshift should occur in this range.

2ND Gear - Overrun Braking: (L2)

Position the selector lever in **DRIVE RANGE**, and with the vehicle speed at approximately 35 mph (56 km/h), move the selector lever to **L2 RANGE**. The transmission should downshift to 2nd. An increase in engine RPM and an engine braking effect should be noticed. Line pressure should change from approximately 100 psi (690 kPa) to approximately 125 psi (875 kPa) in 2nd.

1ST Gear - Overrun Braking: (L1)

Position the selector lever in **L2 RANGE** at approximately 30 to 50 MPH (48 to 80 km/h), with throttle closed, move the selector lever to **L1**. A 2-1 downshift should occur in the speed range of approximately 45 to 30 mph (70 to 48 km/h), depending on axle ratio and valve body calibration. The 2-1 downshift at closed throttle will be accompanied by increased engine rpm and an engine braking effect should be noticed. Line pressure should be approximately 150 psi (1035 kPa). Stop vehicle.

Reverse Range: (R)

Position the selector lever in **REVERSE(R)** Position and check for reverse operation.

TROUBLE DIAGNOSIS, BY CONDITION

Refer to Fig. 7A-12, (Diagnosis Chart), to determine a possible cause of a transmission problem.

Additional diagnosis of a malfunction is as follows:

No Drive in Drive (D) Range

(Install pressure gage)

- Low Oil Level - correct level and check for external leaks or defective vacuum modulator (leaking diaphragm will evacuate oil from unit).
- Manual Linkage - misadjusted, correct alignment to manual lever shift quadrant is essential.
- Low Oil Pressure - refer to **LOW LINE PRESSURE**.
- Forward Clutch:
 - a. Forward clutch does not apply - piston cracked; seals missing or damaged; clutch plates burned (Refer to **BURNED CLUTCH PLATES**).
 - b. Pump feed circuit-to-forward clutch oil seal rings missing or broken on pump cover; leak in feed circuits; pump-to-case gasket mispositioned or damaged; clutch drum ball check stuck or missing.
- Low and Reverse Roller Clutch Assembly - broken spring, damaged cage or installed backwards.

High or Low Oil Pressure

(Refer to OIL PRESSURE CHECKS)

High Line Pressure

- Vacuum Leak:
 - a. Vacuum line disconnected.
 - b. Leak in line from engine to modulator.
 - c. Improper engine vacuum.
 - d. Leak in vacuum-operated accessory (hoses, vacuum advance, etc.).
- Modulator:
 - a. Stuck modulator valve.
 - b. Water in modulator.
 - c. Damaged, not operating properly.
- Detent System - detent valve or cable stuck in detent position.
- Valve Body:
 - a. Pressure regulator and/or boost valve stuck.
 - b. Boost valve sleeve broken or defective.
 - c. Incorrect pressure regulator valve spring.
 - d. 2-3 shift control valve and sleeve installed in pressure regulator bore.
 - e. Pressure regulator exhaust hole not drilled or blocked.

Low Line Pressure

- Low transmission oil level.
- Defective vacuum modulator assembly.
- Strainer Assembly:
 - a. Blocked or restricted.
 - b. Gasket omitted or damaged.
- Oil Pump:
 - a. Gear clearance, damaged, worn, gear installed backwards:
 - b. Pump-to-case gasket mispositioned.
 - c. Defective pump body and/or cover.
 - d. Bottom seal ring on pump cover hub omitted or damaged.
 - e. Priming valve in pump omitted.
- Valve Body:
 - a. Pressure regulator or boost valve stuck.
 - b. Pressure regulator valve spring, too weak.
 - c. #1 rubber ball omitted.
 - d. Loose valve body bolts.
 - e. Valve body spacer plate support omitted.
 - f. Reverse and modulator booster valve stuck.
- Internal Circuit Leaks:
 - a. Forward clutch leak (pressure low in Drive range, pressure normal in Neutral (N) and Reverse (R)).
 1. Check pump oil seal rings.
 2. Check forward clutch seals.
 - b. Direct clutch leak (pressure low in Reverse (R), pressure normal in other ranges).
 1. Check direct clutch outer seal.
 2. Check 1-2 accumulator and 2-3 accumulator pistons and rings for damage or missing.
 - c. Intermediate servo piston seal ring broken or omitted.
 - Case Assembly - check ball missing from cored passage in case face.

No Pressure

- Flashing blocking suction cavity in case.
- Priming valve in pump omitted.
- Front pump drive gear lugs sheared off.
- Vacuum modulator valve omitted.
- Pump to case gasket incorrectly installed.

No Upshift

- Governor valve stuck (chips).
- 1-2 shift control or shift valve stuck.
- Nylon gear of governor assembly mutilated or broken.
- Governor locating pin in case loose.
- 1-2 accumulator piston ring omitted or broken.
- Incorrect intermediate clutch pack.
- Intermediate piston seals omitted or damaged.
- Governor inner weights jammed.

Low Downshifts 3-2 and 2-1 (Full Detent)

- Detent regulator valve stuck.
- Detent regulator valve spring seat omitted.
- Shift control or shift valves sticking.
- Detent linkage not hooked up.
- Incorrect vacuum setting.
- Defective governor.
- Modulator valve sticking.

High Downshifts 3-2 and 2-1 (Full Detent)

- Detent regulator valve sticking or stuck.
- Defective governor assembly.
- Shift control and shift valves sticking.

No Drive in Drive Range

- Forward clutch apply holes in pump hub not drilled.
- Clutch apply hole in forward clutch drum not drilled.
- Lip seals of forward clutch piston omitted or damaged.
- Steel relief ball in forward clutch drum omitted or not sealing.
- Incorrect pressure plate (excessive clearance).
- Rear roller clutch slipping or installed backwards.
- Damaged shifter shaft (transmission not in drive range).
- Input ring gear omitted.
- Manual valve incorrectly installed.

No Drive in Reverse (R) Range

- Reverse clutch pack snap ring omitted.
- Direct clutch apply holes in pump hub not drilled.
- Direct clutch apply oil seal rings omitted or broken.
- Reverse apply holes in case not drilled or blocked.
- Incorrect clutch pack.
- Manual valve incorrectly installed.

Low Lube Pressures

- Bushings omitted in front of stator shaft I.D.

1-2 Shift - Full Throttle Only

- Detent Valve - sticking or linkage misadjusted.
- Vacuum Leak - vacuum line or fittings leaking.

- Control Valve Assembly:
 - a. Valve body gaskets - leaking, damaged or incorrectly installed.
 - b. Detent valve train stuck.
 - c. 1-2 valve stuck closed (in downshifted position).
- Case Assembly - refer to case porosity repair.

First Speed Only - No 1-2 Shift

- Detent (downshift) cable - binding.
- Governor Assembly:
 - a. Governor valve sticking.
 - b. Driven gear loose, damaged or worn (check for pin in case and length of pin showing; also, check output shaft drive gear for nicks or rough finish if driven gear shows damage).
- Control Valve Assembly:
 - a. Valve body gaskets - leaking, damaged or incorrectly installed.
 - b. Governor feed channels blocked.
 - c. 1-2 shift valve train stuck closed (in downshifted position).
- Intermediate Clutch:
 - a. Clutch piston seals - missing, improperly installed or cut.
 - b. Intermediate roller clutch - broken spring or damaged cage.
- Case:
 - a. Porosity between channels.
 - b. Governor feed channel blocked; governor bore scored or worn, allowing cross pressure leak.

First and Second Speeds Only - No 2-3 Shift

- Control Valve Assembly:
 - a. Valve body gaskets - leaking, damaged or incorrectly installed.
 - b. 2-3 shift valve train stuck closed (in downshifted position).
- Direct Clutch:
 - a. Pump hub - direct clutch oil seal rings - broken or missing.
 - b. Clutch piston seals - missing, improperly assembled or cut.
 - c. Clutch plates burned (Refer to BURNED CLUTCH PLATES).

No First Speed - Starts in Second Speed

(Locks up in L1 Range)

Intermediate Clutch:

1. Too many plates in intermediate clutch pack.
2. Incorrect intermediate clutch piston.

Drive in Neutral

- Manual Linkage - misadjusted, (correct alignment in manual lever shift quadrant is essential).
- Internal Linkage - manual valve disconnected or end broken.
- Oil Pump - line pressure leaking into forward clutch apply passage.
- Forward Clutch - incorrect clutch plate usage or burned clutches (Refer to BURNED CLUTCH PLATES).

No Motion in Reverse or Slips in Reverse

(Install pressure gage)

- Low Oil Level - add oil.
- Manual Linkage - misadjusted (correct alignment in manual lever shift quadrant is essential).
- Low Oil Pressure - Refer to LOW LINE PRESSURE.
- Control Valve Assembly:
 - a. Valve body gaskets - leaking, damaged or incorrectly installed.
 - b. 2-3 shift valve train stuck open (in upshifted position).
- Intermediate Servo - piston or pin stuck so intermediate overrun band is applied.
- Low and Reverse Clutch - piston outer seal damaged or missing.
- Direct Clutch:
 - a. Outer seal damaged or missing.
 - b. Clutch plates burned (Refer to BURNED CLUTCH PLATES).
- Forward Clutch - clutch does not release (will cause DRIVE in NEUTRAL).

Slips In All Ranges Or Slips On Start

(Install pressure gage)

- Low Oil Level - add oil.
- Low Oil Pressure - Refer to LOW LINE PRESSURE.
- Forward clutch:
 - a. Clutch plates burned (Refer to BURNED CLUTCH PLATES).
 - b. Pump cover oil seal rings broken or worn.
- Case - cross leaks or porosity.

Slipping 1-2 Shift

(Install pressure gage)

- Low Oil Level - add oil.
- Low Oil Pressure - Refer to LOW LINE PRESSURE.
- 2-3 Accumulator - oil ring damaged or missing.
- 1-2 Accumulator - oil ring damaged, missing or case bore damaged.
- Pump-to-Case Gasket - mispositioned or damaged.
- Intermediate Clutch:
 - a. Piston seals damaged or missing.
 - b. Clutch plates burned (Refer to BURNED CLUTCH PLATES).
- Case - porosity between channels.

Slipping 2-3 Shift

(Install pressure gage)

- Low Oil Level - add oil.
- Low Oil Pressure - Refer to LOW LINE PRESSURE.
- Direct Clutch:
 - a. Piston seals leaks, damaged or missing.
 - b. Clutch plates burned (Refer to BURNED CLUTCH PLATES).
- c. Inspect for proper number and type of clutch plates.

- Case - refer to case porosity repair.

Rough 1-2 Shift

(Install pressure gage)

- High Oil Pressure - Refer to HIGH LINE PRESSURE.
- 1-2 Accumulator:
 - a. Oil rings damaged.
 - b. Piston stuck.
 - c. Broken or missing spring.
 - d. Bore damaged.
- Intermediate Clutch - check for burned and number (type) of plates.
- Case:
 - a. Check for correct number and location of check balls.
 - b. Porosity between channels.

Rough 2-3 Shift

(Install pressure gage)

- High Oil Pressure - Refer to HIGH LINE PRESSURE.
- 2-3 Accumulator:
 - a. Oil ring damaged.
 - b. Piston stuck.
 - c. Broken or missing spring.
 - d. Piston bore damaged.

No Engine Braking in L2

(Install pressure gage)

- Low Oil Pressure - pressure regulator and/or boost valve stuck.
- Intermediate Servo and 2-3 Accumulator:
 - a. Servo or accumulator oil rings or bores leaking or damaged.
 - b. Servo piston stuck or cocked.
- Intermediate Overrun Band - intermediate overrun band broken or burned (look for cause), not engaged or servo pin.

No Engine Braking in L1

(Install pressure gage)

- Low Oil Pressure - pressure regulator and/or boost valves stuck.
- Manual Low Control Valve Assembly - stuck.
- Low and Reverse Clutch - piston inner seal damaged or missing.

No Part Throttle Downshift

(Install pressure gage)

- Oil Pressure - vacuum modulator assembly, modulator valve or pressure regulator valve train (other malfunctions may also be noticed).
- Detent Valve and Linkage - sticks, disconnected or broken.
- 2-3 shift valve - stuck.

No Detent (Wide Open Throttle)

Downshift

- Detent cable or retainer not adjusted properly.
- Detent cable disconnected at transmission or throttle linkage.
- Valve Body:
 - a. Detent valve sticks.
 - b. Detent regulator valve sticks.
 - c. Incorrect spacer plate or gasket.

High or Low Shift Points

(Install pressure gage)

- Oil Pressure:
 - a. Engine Vacuum - check at transmission end of modulator pipe.
 - b. Check vacuum line connections at engine and transmission.
 - c. Vacuum modulator assembly and valve and pressure regulator valve train.
- Governor:
 - a. Valve sticking.
 - b. Feed holes restricted or leaking.
- Detent Valve and Linkage - stuck open (will cause high shift points).
- Control Valve Assembly:
 - a. 1-2 shift valve train sticking.
 - b. 2-3 shift valve train sticking.
- Case - refer to case porosity repair.

Won't Hold in PARK(P)

- Manual Linkage - misadjusted (correct alignment in manual lever shift quadrant is essential).
- Internal Linkage:
 - a. Inner lever and actuating rod assembly - defective or improperly installed.
 - b. Parking pawl - broken or inoperative.
 - c. Parking lock bracket loose, burred or rough edges or incorrectly installed.
 - d. Parking pawl disengaging spring missing, broken or incorrectly hooked.

Transmission Noisy

Before checking transmission for noise, make certain that the noise is not coming from the water pump, alternator, power steering, etc. These components can be isolated by removing the proper belt and running the engine not more than two minutes at one time.

Park, Neutral and all Driving Ranges

- Pump Cavitation:
 - a. Low oil level.
 - b. Plugged or restricted strainer.
 - c. Strainer-to-valve body gasket damaged.
 - d. Porosity in valve body intake area.
 - e. Water in oil.
 - f. Porosity or voids at transmission case (pump face) intake port.
 - g. Pump-to-case gasket off location.
- Pump Assembly:

| | INTERMEDIATE CLUTCH | INTER. OVERRUN ROLLER CLUTCH | INTERMEDIATE BAND | DIRECT CLUTCH | FORWARD CLUTCH | LOW/REV. CLUTCH | LOW AND ROLLER CLUTCH |
|--------------------|---------------------|------------------------------|-------------------|---------------|----------------|-----------------|-----------------------|
| NEUTRAL | OFF | Ineffective | OFF | OFF | OFF | OFF | Ineffective |
| DRIVE, First Gear | OFF | Ineffective | OFF | OFF | ON | OFF | Locked |
| DRIVE, Second Gear | ON | Locked | OFF | OFF | ON | OFF | Free-Wheeling |
| DRIVE, Third Gear | ON | Free-Wheeling | OFF | ON | ON | OFF | Free-Wheeling |
| L ₁ | OFF | Ineffective | OFF | OFF | ON | ON | Locked |
| L ₂ | ON | Locked | ON | OFF | ON | OFF | Free-Wheeling |
| REVERSE | OFF | Ineffective | OFF | ON | OFF | ON | Ineffective |

Fig. 7A-11-350 Clutch Apply Chart

- a. Gears damaged.
- b. Driving gear assembled backwards.
- c. Crescent interference.
- d. Oil seal rings damaged or worn.
- Converter:
 - a. Loose flexplate-to-converter bolts.
 - b. Converter damage.
 - c. Water in oil (causes whine).

First, Second and/or Reverse Gear
Planetary Gear Set:

- 1. Gears or thrust bearings damaged.
- 2. Input or output ring gear damaged.

During Acceleration - Any Gear

- Transmission or cooler lines grounded to underbody.
- Motor mounts loose or broken.

Squeal at Low Vehicle Speed

Speedometer driven gear shaft seal - requires lubrication or replacement.

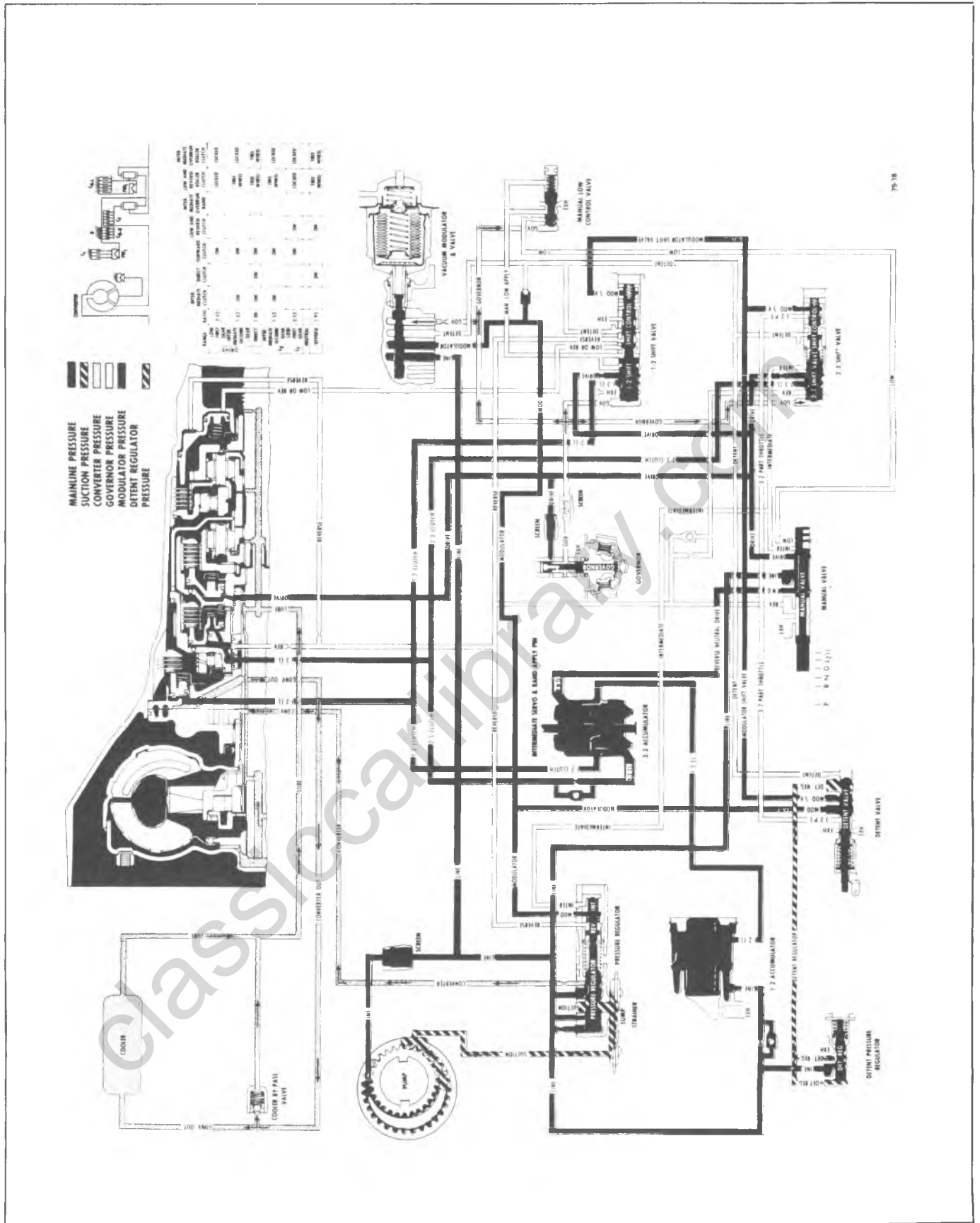


Fig. 7A-13-350 Hydraulic Circuit

ON VEHICLE SERVICE

TRANSMISSION REPLACEMENT

(All Except K Model)

If necessary, the catalytic converter may have to be disconnected to provide adequate clearance for transmission removal. This procedure will include removal of the converter support bracket.

1. Before raising the vehicle, disconnect the negative battery cable detent downshift cable at carburetor and release the parking brake.

2. Raise vehicle on hoist.

3. Remove propeller shaft.

4. Disconnect speedometer cable, detent downshift cable, modulator vacuum line and oil cooler pipes at transmission.

5. Disconnect shift control linkage.

6. Support transmission with suitable transmission jack.

7. Disconnect rear mount from frame crossmember.

8. Remove two bolts at each end of frame crossmember. Remove crossmember.

9. Remove converter under pan.

10. Remove converter-to-flexplate bolts, as shown in Fig. 7A-14.

11. Lower transmission until jack is barely supporting it.

12. Remove transmission to engine mounting bolts and remove oil filler tube at transmission.

13. Raise transmission to its normal position, support engine with jack and slide transmission rearward from engine and lower it away from vehicle.

Use suitable converter holding tool when lowering transmission or keep rear of transmission lower than front so as not to lose converter.

The installation of the transmission is the reverse of the removal with the following added step. Before installing the flexplate-to-converter bolts, make certain that the attaching lugs on the converter are flush with the flex plate and the converter rotates freely by hand in this position. Refer to Fig. 7A-14 for instructions on attaching the converter-to-flexplate. This will insure proper converter alignment.

After installation of transmission, lower vehicle and remove vehicle from hoist. Check linkage for proper adjustment.

Check transmission fluid level.

TRANSMISSION REPLACEMENT (K MODEL)

1. Disconnect battery cable.

2. Remove transmission dipstick.

3. Disconnect detent downshift cable at carburetor.

4. Remove transfer case shift lever knob and boot.

5. Raise vehicle on hoist.

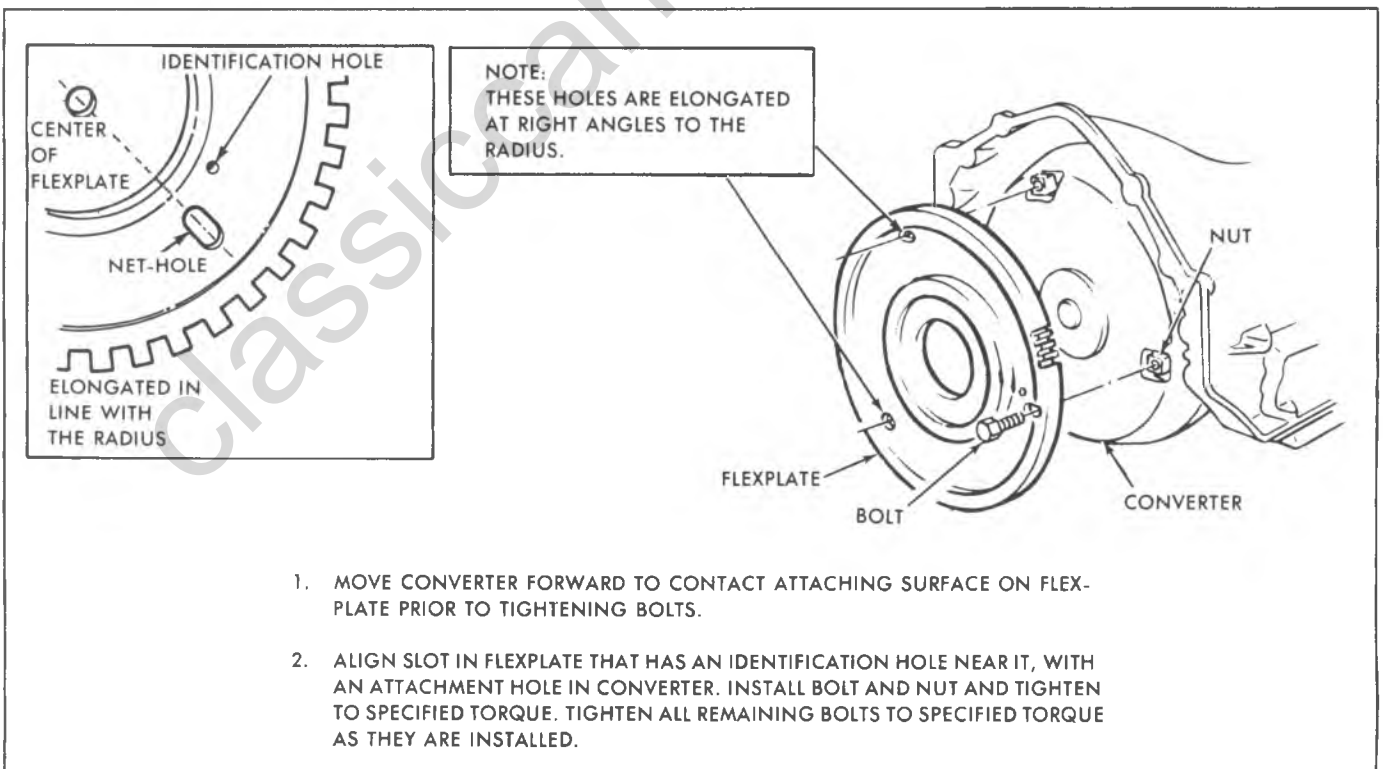


Fig. 7A-14--Typical Transmission Mounting, Net-Hole Design

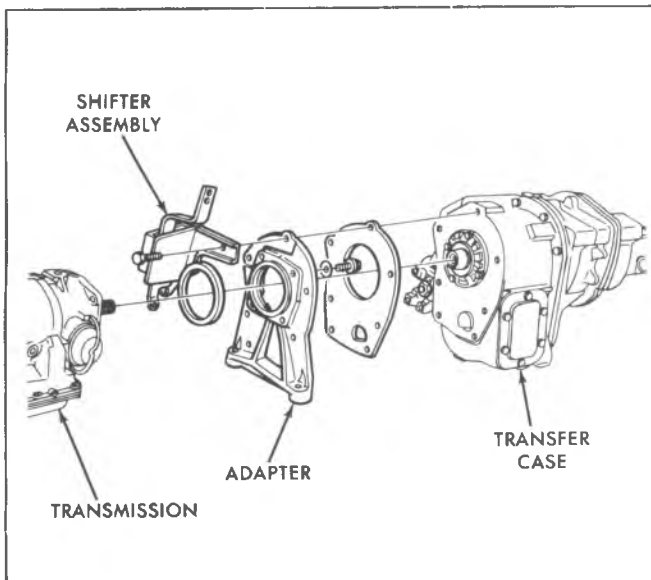


Fig. 7A-15--Typical Transfer Case-To-Transmission Mounting

6. Remove flexplate cover.
7. Remove torque converter to flexplate attaching bolts. Refer to Fig. 7A-14. Secure the converter.
8. Disconnect transmission shift linkage and speedometer cable.
9. Remove engine crossunder pipe to manifold bolts.
10. Disconnect vacuum modulator line, line to filler tube clip and detent downshift cable to filler tube strap.
11. Disconnect detent downshift cable at the transmission.
12. Disconnect transmission oil cooler lines at the transmission.
13. Remove transfer case adapter to crossmember bolts. When applicable, disconnect engine-to-transmission support strut rod from transmission. Refer to Fig. 7A-22.
14. Raise engine as necessary.
15. Remove crossmember bolts and remove crossmember.
16. Remove exhaust system hanger bolts.
17. Disconnect rear propeller shaft at transfer case.
18. Disconnect parking brake cable.
19. Disconnect exhaust system. (Tie aside.)
20. Disconnect front propeller shaft at front axle. (Tie aside.)
21. Support transmission and transfer case with jack (use safety chains).
22. Remove transfer case to frame bracket bolts.
23. Remove transmission to engine bolts, remove transmission and transfer case.
24. Disconnect transfer case-to-transmission strut rod. Remove transfer case from transmission (includes: new "O" ring seal). Refer to Fig. 7A-15.
25. Move transmission to bench fixture.
26. Drain transmission.
27. Remove torque converter.
28. Remove and discard front pump seal.

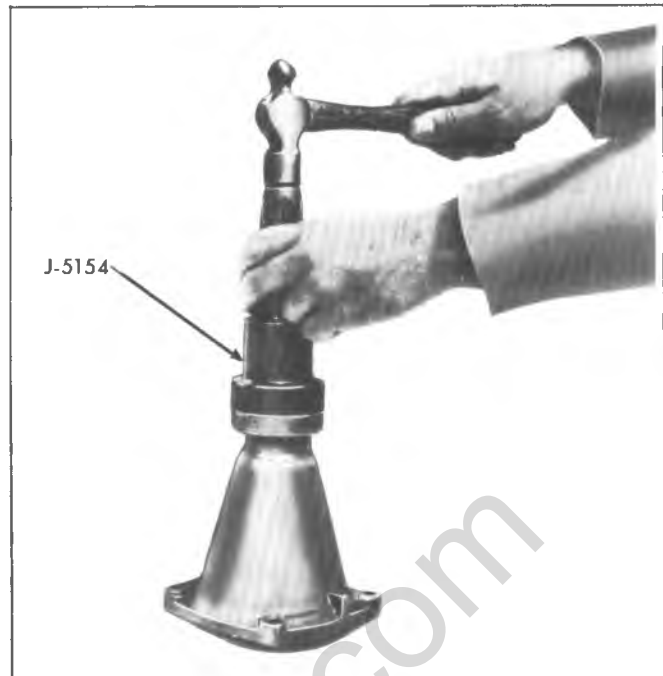


Fig. 7A-16--Installing Oil Seal into Extension Housing

29. Refill transfer case. Reverse removal procedure to install.

EXTENSION HOUSING OIL SEAL

Removal

1. Remove propeller shaft.
2. Pry out lip oil seal with screwdriver or small chisel.

Installation

1. Drive a new oil seal into place with Installer J-21426, as shown in Fig. 7A-16.
2. Install propeller shaft and adjust fluid level.

SPEEDOMETER DRIVEN GEAR

Removal

1. Disconnect speedometer cable.
2. Remove retainer bolt, retainer, speedometer driven gear and O-ring seal.

Installation

Installation of speedometer driven gear is the reverse of REMOVAL. Install new O-ring seal (if required) and adjust the fluid level.

SPEEDOMETER DRIVE GEAR

Removal

1. Raise vehicle and support transmission with suitable transmission jack.
2. Remove propeller shaft.
3. Disconnect speedometer cable.
4. Disconnect transmission rear mount from frame crossmember.
5. Remove two bolts at each end of frame cross member and remove crossmember.
6. Remove extension housing.
7. Install Special Tools J-21427-01 and J-8105 on output shaft and remove speedometer drive gear. Remove retaining clip.

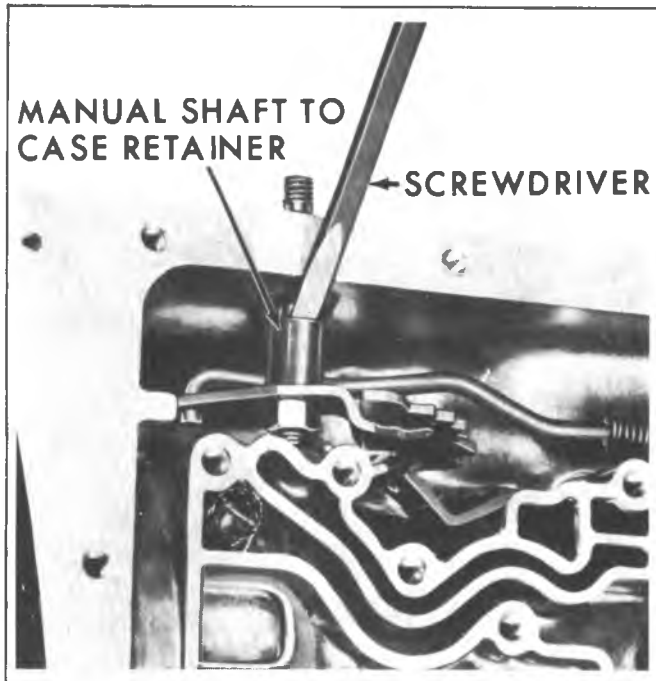


Fig. 7A-17--Removing Manual Shaft-to-Case Retainer

Installation

1. Place speedometer drive gear retaining clip into hole in output shaft.
2. Align slot in speedometer drive gear with retaining clip and install.
3. Install extension housing and tighten attaching bolts to 25 ft. lb. (33 N·m)
4. Connect speedometer cable.
5. Install crossmember to frame and transmission.
6. Install propeller shaft.
7. Remove transmission jack and lower vehicle.

MANUAL SHAFT, RANGE SELECTOR INNER LEVER AND PARKING LINKAGE ASSEMBLIES

Removal

1. Referring to draining procedures, drain transmission fluid from oil pan.
2. After oil pan and strainer have been removed, remove valve body assembly. Discard gaskets.
3. Remove manual shaft-to-case retainer and unthread jam nut holding range selector inner lever to manual shaft. Refer to Fig. 7A-17.
4. Remove jam nut and remove manual shaft from range selector inner lever and case.
Do not remove manual shaft lip oil seal unless replacement is required.
5. Remove parking pawl actuating rod and range selector inner lever from case.
6. Remove bolts and parking lock bracket.
7. Remove parking pawl disengaging spring and, if necessary to replace parking pawl or shaft, clean up bore in case and remove parking pawl shaft retaining plug, park pawl shaft and pawl.



Fig. 7A-18--Governor Cover

Installation

Installation of parking linkage, selector lever and manual shaft is the reverse of REMOVAL. Install new plug (if required), new lip oil seal (if required) and new gaskets. Adjust the fluid level.

Before installing the propeller shaft, liberally lubricate splines of the transmission yoke with a Lithium soap base lubricant. The lubricant should seep from the vent hole (rear cap of yoke) when installing yoke on transmission output shaft. It is essential that the vent hole is not obstructed.

GOVERNOR

Removal

1. Raise vehicle and disconnect speedometer cable at transmission.
2. Remove governor cover, as shown in Fig. 7A-18.

NOTICE: Be careful not to damage cover.

3. Remove governor. Inspect weights and valve for freeness.

Installation

1. Install governor.
2. Apply anaerobic sealant to cover, then install governor cover using a brass drift around the outside flange of the cover.

NOTICE: Do not distort cover on installation.

3. Install a retainer wire.

NOTICE: Be sure to install a bail wire retainer, to prevent loss of cover, which could result in damage to the transmission.

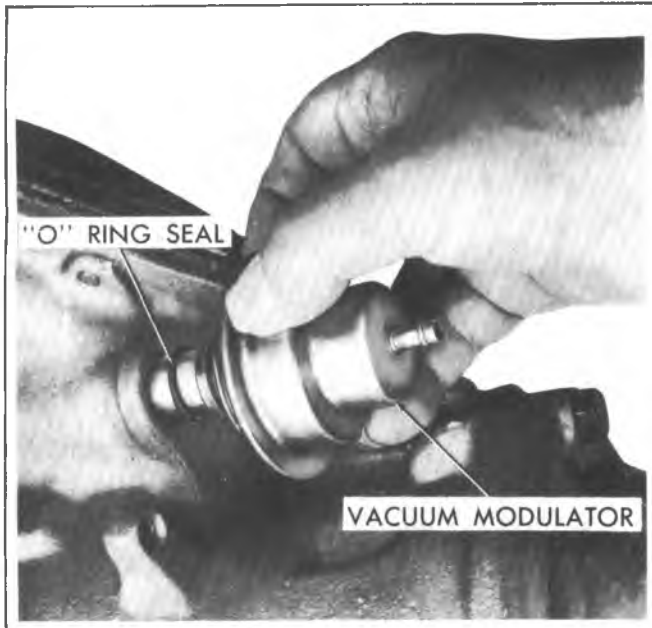


Fig. 7A-19—Removing Vacuum Modulator

4. Connect speedometer cable, lower vehicle and check transmission fluid level.

VACUUM MODULATOR AND MODULATOR VALVE ASSEMBLY

Removal

1. Disconnect vacuum hose from vacuum modulator stem and remove vacuum modulator attaching screw and retainer.
2. Remove modulator assembly and its O-ring seal from case. Refer to Fig. 7A-19.
3. Remove modulator valve from case.

Installation

Installation of the modulator and modulator valve is the reverse of REMOVAL. Install a new O-ring seal and adjust the fluid level.

4. Remove tool and install oil pan bolts.

VALVE BODY ASSEMBLY

Removal

1. Referring to draining procedures, drain transmission fluid from oil pan.
2. After oil pan and strainer, have been removed, discard gaskets.
3. Remove detent spring and roller assembly from valve body and remove valve body-to-case bolts. Refer to Fig. 7A-20.
4. Remove valve body assembly while disconnecting manual control valve link from range selector inner lever and removing detent control valve link from the detent actuating lever.
5. Remove manual valve and link assembly from valve body assembly.

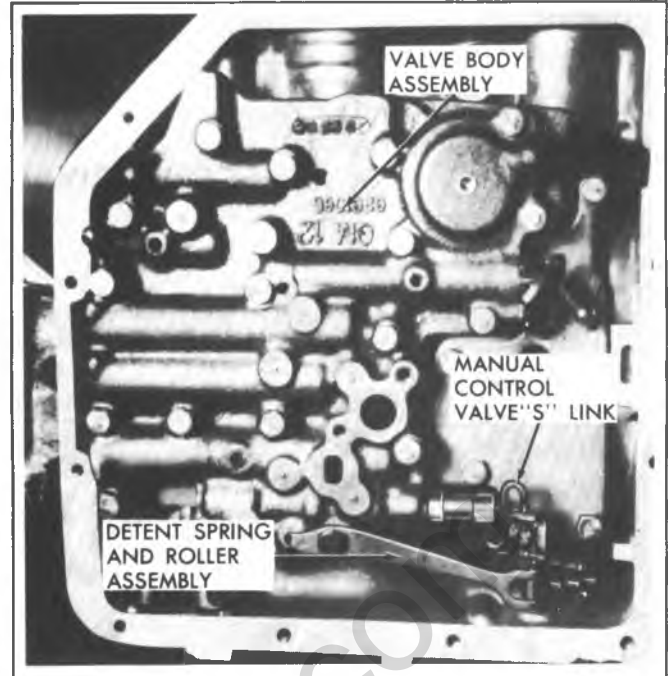


Fig. 7A-20—Detent Spring/Valve Body

Installation

Installation of the valve body assembly is the reverse of REMOVAL. Install new gaskets to strainer and oil pan and adjust the fluid level.

1-2 ACCUMULATOR

Removal

1. Remove two transmission oil pan bolts below the 1-2 accumulator cover. Install J-23069 in place of bolts removed.
2. Press in on cover and remove retaining ring.
3. Remove cover "O" ring seal, spring and 1-2 accumulator, as shown in Fig. 7A-21.

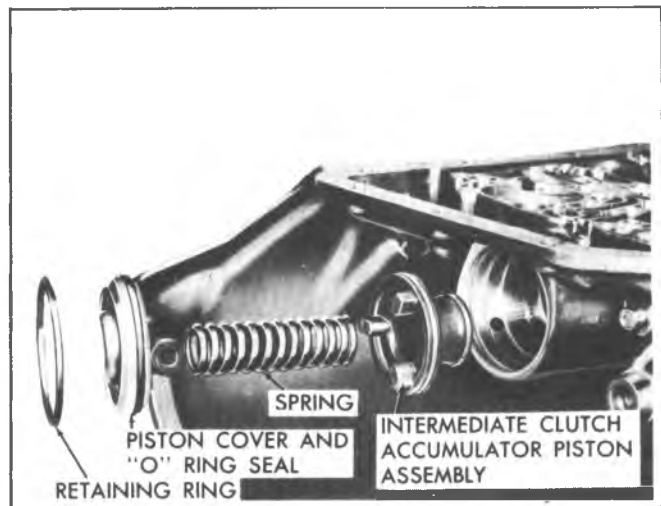


Fig. 7A-21—Intermediate Clutch Accumulator Components

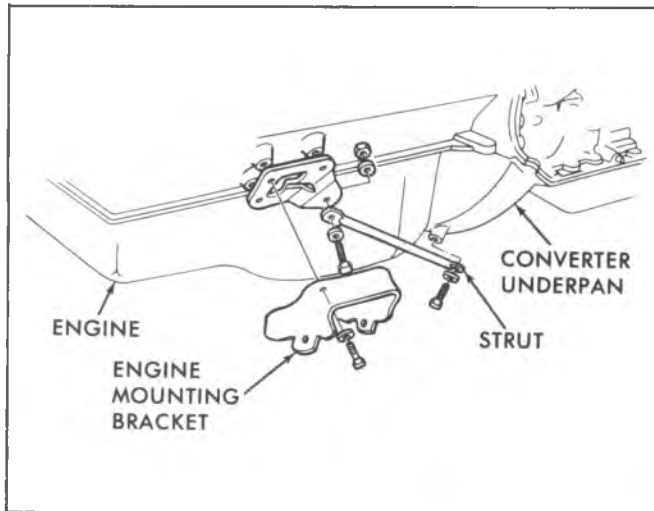


Fig. 7A-22--Transmission Support Strut Rod

Install

1. Install 1-2 accumulator piston.

Rotating piston slightly when installing will help to get rings started in bore.

2. Position spring, "O" ring seal and cover in place.
3. Press in on cover with J-23069 and install retaining ring.
4. Remove tool and install oil pan bolts.

SUPPORT STRUT ROD

Replacement

The transmission support strut rod attachment is shown in Fig. 7A-22. Remove the two bolts when replacing the strut rod. When removing the transmission, it is only necessary to remove the bolt at the transmission end of the strut rod.

OIL COOLER PIPES

If replacement of transmission steel tubing cooler pipes is required, use only double wrapped and brazed steel tubing meeting GM specification 123M or its equivalent. Under no condition use copper or aluminum tubing to replace steel tubing. Those materials do not have satisfactory fatigue durability to withstand normal vehicle vibrations.

Steel tubing should be flared using the upset (double lap) flare method which is detailed in Section 5.

400 AUTOMATIC TRANSMISSION

INDEX

| | | | |
|---|-------|------------------------------------|-------|
| General Description..... | 7A-29 | Trouble Diagnosis..... | 7A-36 |
| Maintenance and Adjustment | 7A-31 | Clutch Apply Chart..... | 7A-41 |
| Checking Transmission Mount | 7A-31 | Hydraulic Circuit..... | 7A-42 |
| Transmission Fluid | 7A-31 | On Vehicle Service..... | 7A-43 |
| Column Shift Linkage Adjustment | 7A-32 | Transmission Replacement..... | 7A-43 |
| Detent Switch Adjustment | 7A-33 | Rear Seal..... | 7A-44 |
| Neutral Start Backup Lamp Switch Adjustment ... | 7A-33 | Governor | 7A-44 |
| Vacuum Regulator Valve | 7A-33 | Modulator and Modulator Valve..... | 7A-44 |
| Diagnosis | 7A-34 | Parking Linkage..... | 7A-44 |
| Diagnosis Sequence..... | 7A-34 | Control Valve Body..... | 7A-45 |
| Oil Checking Procedure | 7A-34 | Pressure Regulator Valve | 7A-45 |
| Oil Leak Diagnosis..... | 7A-34 | Oil Cooler Pipes..... | 7A-46 |
| Oil Pressure Check..... | 7A-34 | Other Service Operations..... | 7A-46 |
| Case Porosity Repair..... | 7A-35 | Specifications..... | 7A-47 |
| Vacuum Modulator Diagnosis | 7A-35 | Special Tools..... | 7A-48 |
| Manual Linkage..... | 7A-36 | | |

GENERAL DESCRIPTION

The 400 automatic transmission is a fully automatic unit consisting primarily of a 3-element hydraulic torque converter and a compound planetary gear set. Three multiple-disc clutches, one gear unit, one roller clutch, and two bands provide the friction elements required to obtain the desired function of the compound planetary gear set.

The torque converter couples the engine to the planetary gears through oil and provides hydraulic torque multiplication when required. The compound planetary

gear set produces three forward speeds and reverse.

The 3-element torque converter consists of a pump or driving member, a turbine or driven member, and a stator assembly. The stator is mounted on a one-way roller clutch which will allow the stator to turn clockwise but not counter-clockwise.

The torque converter housing is filled with oil and is attached to the engine crankshaft by a flexplate and always rotates at engine speed. The converter pump is an integral

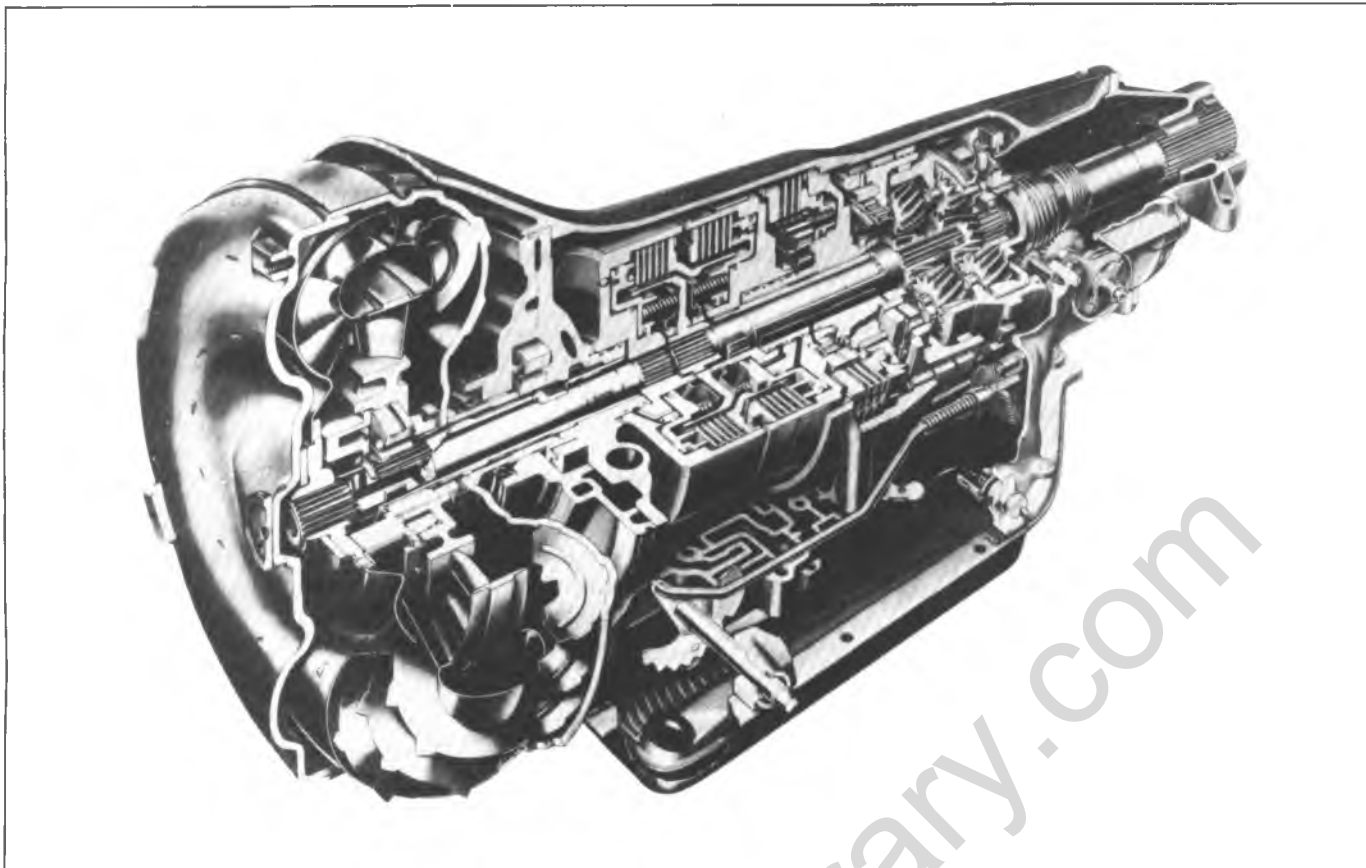


Fig. 7A-30-400 Automatic Transmission Cross-Section View

part of the converter housing, therefore the pump blades, rotating at engine speed, set the oil within the converter into motion and direct it to the turbine, causing the turbine to rotate.

As the oil passes through the turbine it is traveling in such a direction that if it were not redirected by the stator it would hit the rear of the converter pump blades and impede its pumping action. So at low turbine speeds, the oil is redirected by the stator to the converter pump in such a manner that it actually assists the converter pump to deliver power or multiply engine torque.

As turbine speed increases, the direction of the oil leaving the turbine changes and flows against the rear side of the stator vanes in a clockwise direction. Since the stator is now impeding the smooth flow of oil, its roller clutch releases and it revolves freely on its shaft. Once the stator becomes inactive, there is no further multiplication of engine torque within the converter. At this point, the converter is merely acting as a fluid coupling as both the converter pump and turbine are being driven at approximately the same speed or at one-to-one ratio.

A hydraulic system pressurized by a gear type pump provides the working pressure required to operate the friction elements and automatic controls.

External control connections to transmission are:

Manual Linkage - To select the desired operating range.

Engine Vacuum - To operate a vacuum modulator unit.

12 Volt Electrical - To operate an electrical detent solenoid.

A vacuum modulator is used to automatically sense any change in the torque input to the transmission. The vacuum modulator transmits this signal to the pressure regulator for line pressure control, to the 1-2 accumulator valve, and to the shift valves so that all torque requirements of the transmission are met and smooth shifts are obtained at all throttle openings.

The detent solenoid is activated by an electric switch on the carburetor. When the throttle is fully opened, the switch on the carburetor is closed, activating the detent solenoid and causing the transmission to downshift for passing speeds.

The selector quadrant has six selector positions: P, R, N, D, L2, L1.

P. PARK position positively locks the output shaft to the transmission case by means of a locking pawl to prevent the vehicle from rolling in either direction (not on CL model). The engine may be started in Park position.

R. REVERSE enables the vehicle to be operated in a reverse direction.

N. Neutral position enables the engine to be started and run without driving the vehicle.

D. DRIVE Range is used for all normal driving conditions and maximum economy. Drive Range has three gear ratios, from the starting ratio to direct drive. Detent downshifts are available by depressing the accelerator to the floor.

L2. L2 Range has the same starting ration as Drive Range, but prevents the transmission from shifting ration when extra performance is desired. L2 Range can also be used for engine braking. L2 Range can be selected at any vehicle speed, and the transmission will shift to second gear and remain in second until the vehicle speed or the throttle are changed to obtain first gear operation in the same manner as in D Range.

L1. L1 Range can be selected at any vehicle speed, and the transmission will shift to second gear and remain in second until vehicle is reduced to approximately 40 MPH (60 km/h), depending on axle ratio. L1 Range position prevents the transmission from shifting out of first gear.

NOTICE: It is very important that any communication concerning the transmission always contain the transmission code and vehicle identification number.

MAINTENANCE AND ADJUSTMENTS

CHECKING TRANSMISSION MOUNT

Raise the vehicle on a hoist. Push up and pull down on the transmission extension while observing the transmission mount. If the rubber separates from the metal plate of the mount or if the extension moves up but not down (mount bottomed out), replace the mount. If there is relative movement between a metal plate of the mount and its attaching point, tighten the screws or nuts attaching the mount to the transmission or crossmember.

TRANSMISSION FLUID

Fluid Level and Capacity

The fluid level indicator is located in the filler tube at the right rear of the engine. To bring the fluid level from the ADD mark to the FULL mark requires one pint of fluid. Fluid level should be checked at every engine oil change.

Fluid level should be to the FULL mark with the transmission fluid at normal operating temperature of 180°F, (82°C). With warm fluid at room temperature of 70°F (21°C), the level will be 3/8 in. (9 mm) below the ADD mark on the dipstick. The normal operating temperature is obtained only after at least 15 miles of highway type driving or the equivalent of city driving.

Approximately 9 pints (4 L) of fluid are required to refill transmission after oil pan has been drained. The fluid capacity of the 400 transmission and converter assembly is approximately 22 pints (10 L) but **correct level is**

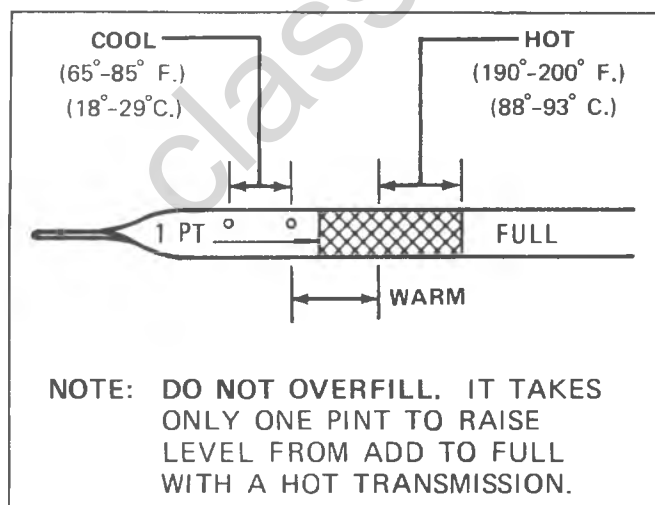


Fig. 7A-31—Dipstick Markings

determined by mark on the dipstick rather than by amount added. Use only DEXRON® II automatic transmission fluid or its equivalent.

An early change to a darker color from the usual red color and/or a strong odor that is usually associated with overheated transmission fluid is normal, and is not a positive sign of required maintenance or transmission failure.

Checking Procedure and Adding Fluid

To determine proper fluid level at normal operating temperature of 180°F (82°C), proceed as follows:

1. Position vehicle on a level surface, place selector lever in PARK (P), apply parking brake and have engine running at normal idle.
2. Remove fluid level indicator, wipe it clean and reinstall fully until cap seats.
3. Remove indicator and reading of fluid level should be at full "F" mark.
4. If additional fluid is required, add DEXRON® II automatic transmission fluid or its equivalent to "F" mark on indicator.

If the vehicle cannot be driven sufficiently to bring the transmission to operating temperature and it becomes necessary to check the fluid level, the transmission may be checked at room temperature of 70°F (21°C) as follows:

1. Position selector lever in PARK (P), apply parking brake and start engine. **DO NOT RACE ENGINE.** Move selector lever through each range.
2. Immediately check fluid level with selector lever in Park, engine running and vehicle on LEVEL surface. Fluid level on indicator should be 3/8 in. (9 mm) below the "ADD" mark.
3. If additional fluid is required, add enough fluid to bring level to 3/8 in. (9 mm) below the ADD mark on the dipstick. If transmission fluid level is correctly established at 70°F (21°C), it will appear at the FULL mark on the dipstick when the transmission reaches its normal operating temperature of 180°F (82°C).

NOTICE: DO NOT OVERFILL, as foaming and loss of fluid through the vent pipe might occur as fluid heats up.

If fluid is too low, especially when cold, complete loss of drive may result which can cause transmission failure.

Draining and Refilling Transmission Oil Pan

The oil pan should be drained and filter replaced and fresh fluid added to obtain the proper level on indicator, at the intervals detailed in section O-B of this manual. For vehicles subjected to heavy city traffic during hot weather, or in commercial use, when the engine is regularly idled for prolonged periods or when vehicle is used for towing, oil pan should be drained and filter replaced more frequently. Refer to Section O-B.

Drain fluid immediately after operation before it has had an opportunity to cool.

CAUTION: Transmission fluid temperature can exceed 350°F (177°C).

1. Raise vehicle and support transmission with suitable jack at transmission.
2. With fluid receptacle placed under transmission oil pan, remove oil pan attaching bolts from front and side of pan.
3. Loosen rear pan attaching bolts approximately four (4) turns.
4. Carefully pry transmission oil pan loose with screwdriver, allowing fluid to drain.
5. Remove remaining screws and remove oil pan and gasket. Discard gasket.
6. Drain fluid from oil pan. Clean pan with solvent and dry thoroughly with clean compressed air.
7. Remove oil filter retainer bolt, oil filter assembly, O-ring seal from intake pipe and discard the filter and O-ring seal.
8. Install new O-ring seal on intake pipe and install new filter on pipe assembly.
9. With O-ring seal on intake pipe, install pipe and filter assembly, attaching filter to the control valve assembly with its retainer bolt, torquing to 10 ft. lb. (13 N·m).
10. Install new strainer-to-valve body gasket, strainer and two (2) screws.
11. Install new gasket on oil pan and install oil pan. Tighten its 13 attaching bolt and washer assemblies to 12 ft. lb. (16 N·m).
12. Lower vehicle add approximately 5 pints U.S. measure (4 pints Imperial measure) of DEXRON®II automatic transmission fluid or its equivalent through filler tube.
13. With selector lever in PARK (P) position, apply hand brake, start engine and let idle (carburetor off fast idle step). DO NOT RACE ENGINE.
14. Move selector lever through each range and, with selector lever in PARK (P) range, check the fluid level.
15. Add additional fluid to bring level to 1/4 in. (6.35 mm) below the ADD mark on the dipstick.

CAUTION: Do not overfill. Foaming can result if overfilled.

Adding Fluid to Fill Dry Transmission and Converter Assembly

In cases of transmission overhaul, when a complete fill is required, including converter (approximately 22 pints (10 L), proceed as follows:

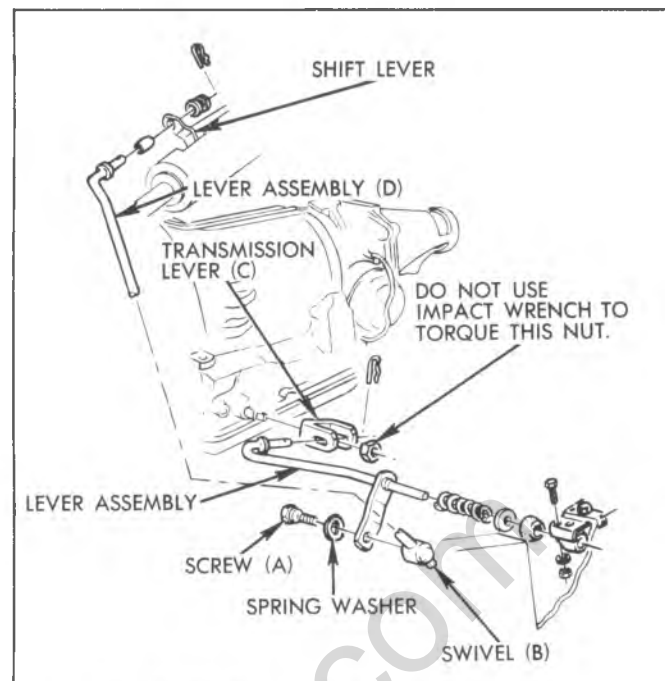


Fig. 7A-32--Column Shift Linkage - CK Series

1. Add 9 pints (4 L) of transmission fluid through filler tube.
2. With manual control lever in PARK (P) position, start engine and place on cold idle cam. DO NOT RACE ENGINE. Move manual control lever through each range.
3. Immediately check fluid level with selector lever in PARK (P), engine running and vehicle on LEVEL surface and add additional fluid to bring level to 3/8-in. (9 mm) below the "ADD" mark on the dipstick. Do not overfill.

SHIFT CONTROLS**Column Shift Linkage - CK and P Series**

(Figs. 7A-32 and 7A-33)

1. The shift tube and lever assembly must be free in the mast jacket. See Section 3B for alignment of steering column assembly if necessary.
2. To check for proper shift linkage adjustment, lift the transmission selector lever towards the steering wheel. Allow the selector lever to be positioned in Drive (D) by the transmission detent.

Do not use indicator pointer as a reference to position the selector lever. When performing linkage adjustment, pointer is adjusted last.
3. Release the selector lever. The lever should be inhibited from engaging low range unless the lever is lifted.
4. Lift the selector lever towards the steering wheel and allow the lever to be positioned in Neutral (N) by the transmission detent.
5. Release the selector lever. The lever should now be inhibited from engaging reverse range unless the lever is lifted.
6. A properly adjusted linkage will prevent the selector from moving beyond both the neutral detent, and the drive detent unless the lever is lifted to pass over the mechanical stop in the steering column.

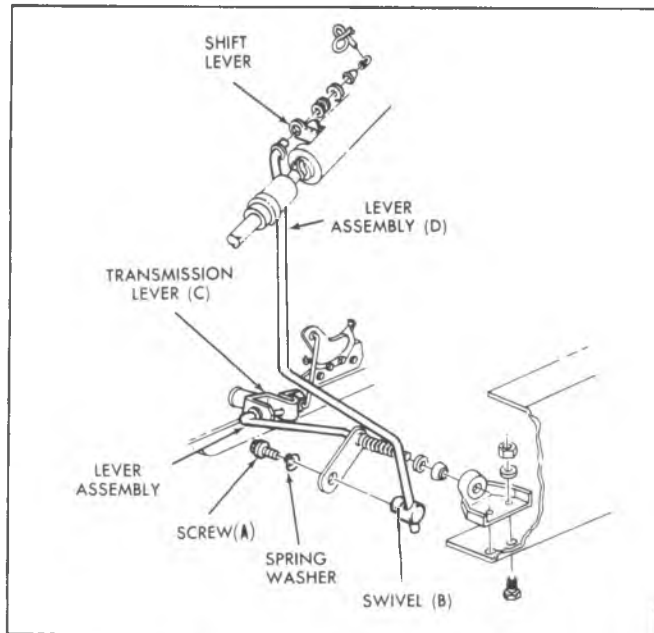


Fig. 7A-33-Column Shift Linkage - P Series

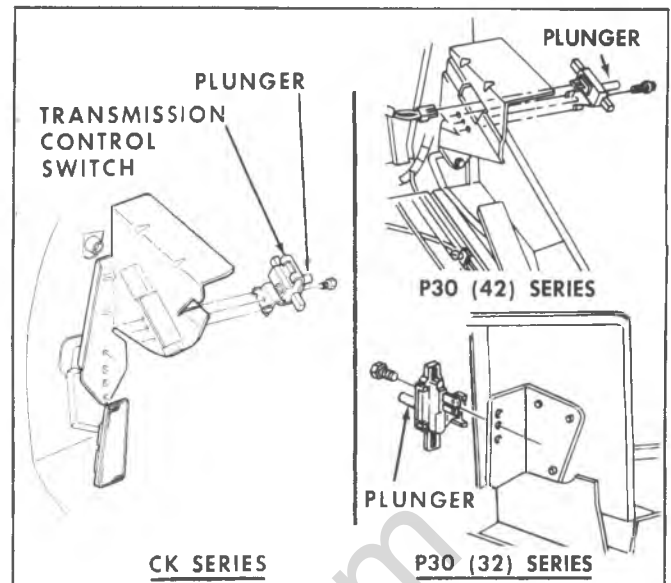


Fig. 7A-34-Detent Downshift Switch

7. If adjustment is required, remove screw (A) and spring washer from swivel (B).

8. Set transmission lever (C) in Neutral position by moving lever counter-clockwise to L1 detent and then clockwise three (3) detent positions to Neutral (N).

9. Position transmission selector lever in Neutral position as determined by the mechanical stop in steering column assembly.

Do not use the indicator pointer as a reference to position the selector lever. When performing linkage adjustment, pointer is adjusted last.

10. Assemble swivel, spring washer and screw to lever assembly (D) and tighten screw to 20 ft. lb. (27 N·m).

11. Readjust indicator needle if necessary to agree with the transmission detent positions. Refer to Section 3B.

12. Readjust neutral start switch if necessary to provide the correct relationship to the transmission detent positions. Refer to Section 8.

13. Check operation (CK Series):

a. With key in "Run" position and transmission in "Reverse (R)" be sure that key cannot be removed and that steering wheel is not locked.

b. With key in "Lock" position and shift lever in "Park (P)", be sure that key can be removed, that steering wheel is locked, and that transmission remains in "Park (P)" when steering column is locked.

NOTICE: Any inaccuracies in the above adjustments may result in premature failure of the transmission due to operation without controls in full detent. Such operation results in reduced oil pressure and in turn partial engagement of the affected clutches. Partial engagement of the clutches with sufficient pressure to cause apparent normal operation of the vehicle will result in failure of the clutches or other internal parts after only a few miles of operation.

DETENT DOWNSHIFT SWITCH

1. Install switch as shown in Fig. 7A-34.

2. After installing the switch, press the switch plunger as far forward as possible. This presets the switch for adjustment. The switch will then adjust itself with the first wide open throttle application of the accelerator pedal.

NEUTRAL START BACKUP LAMP SWITCH ADJUSTMENT

The neutral start backup lamp switch must be adjusted so that the car will start in the park or neutral position, but will not start in the other positions. For replacement and adjustment refer to Section 8 of this manual.

VACUUM REGULATOR VALVE-ADJUSTMENT

When the 400 automatic transmission is used with a diesel engine, the vacuum source for operation of the vacuum modulator is through a vacuum regulator valve. This valve is mounted on the high pressure fuel pump, and should be adjusted as detailed in Section 6A6 of this manual.

DIAGNOSIS

DIAGNOSIS SEQUENCE

1. Check and correct oil level.
2. Check detent switch.
3. Check and correct vacuum line and fittings.
4. Check and correct manual linkage.
5. Install oil pressure gage.
6. Road test car.
 - a. Road test using all selective ranges, noting when discrepancies in operation or oil pressure occur.
 - b. Attempt to isolate the unit or circuit involved in the malfunction.
 - c. If engine performance indicates an engine tune up is required, this should be performed before road testing is completed or transmission correction attempted. Poor engine performance can result in rough shifting or other malfunctions.

FLUID CHECKING PROCEDURES

Refer to Maintenance and Adjustment section for fluid checking procedure.

FLUID LEAK DIAGNOSIS

Determining Source of Oil Leak

Before attempting to correct an oil leak, the actual source of the leak must be determined. In many cases, the source of the leak can be deceiving due to "wind flow" around the engine and transmission.

The suspected area should be wiped clean of all oil before inspecting for the source of the leak. Red dye is used in the transmission oil at the assembly plant and will indicate if the oil leak is from the transmission.

The use of a "Black Light" to locate the point at which the oil is leaking is helpful. Comparing the oil from the leak to that on the engine or transmission dipstick, when viewed by black light, will determine the source of the leak - engine or transmission.

Oil leaks around the engine and transmission are generally carried toward the rear of the car by the air stream. For example, a transmission oil fill pipe to case leak will sometimes appear as a leak at the rear of the transmission. In determining the source of a leak, proceed as follows:

1. Degrease underside of transmission.
2. Road test to get unit at operating temperature. (180 degrees F - 68 degrees C).
3. Inspect for leak with engine running.
4. With engine off, check for oil leaks due to the raised oil level caused by drain back.

Possible Points of Oil Leak

1. Transmission Oil Pan Leak
 - a. Attaching bolts not correctly torqued.
 - b. Improperly installed or damaged pan gasket.
 - c. Oil pan gasket mounting face not flat.
2. Case Extension
 - a. Attaching bolts not correctly torqued.

- b. Rear seal assembly damaged or improperly installed.
 - c. Extension to case, gasket damage or improperly installed.
 - d. Porous casting. See paragraph C.
 - e. Output shaft "O" ring damaged.
3. Case Leak
 - a. Filler pipe seal damaged or missing; misposition of filler pipe bracket to engine "loading" one side of seal.
 - b. Modulator assembly "O" ring seal damaged or improperly installed.
 - c. Electrical connector "O" ring seal damaged or improperly installed.
 - d. Governor cover bolts not torqued, gasket damaged or leak between case face and gasket.
 - e. Speedometer gear "O" ring damaged.
 - f. Manual shaft lip seal damaged or improperly installed.
 - g. Parking pawl shaft cup plug damaged, improperly installed.
 - h. Line pressure band release tap plug loose.
 - i. Vent pipe (Refer to item 5).
 - j. Porous casting. See subparagraph C.
4. Leak at Front of Transmission
 - a. Front pump seal leaks.
 1. Seal lip cut. Check converter hub for nicks, etc.
 2. Bushing moved forward and damaged.
 3. Garter spring missing from seal.
 - b. Front pump attaching bolts loose or bolt seals damaged or missing.
 - c. Front pump housing "O" ring damaged or cut.
 - d. Converter leak in weld area.
 - e. Porous casting (pump).
 5. Oil Comes Out Vent Pipe
 - a. Transmission over-filled.
 - b. Water in oil.
 - c. Foreign matter between pump and case or between pump cover and body.
 - d. Case - porous, front pump cover mounting face shy of stock near breather. Refer to subparagraph C.
 - e. Pump to case gasket mispositioned.
 - f. Incorrect dipstick.
 - g. Cut "O" ring or grommet on filter.
 - h. Pump - shy of stock on mounting faces, porous casting, breather hole plugged in pump cover.

FLUID PRESSURE CHECK

Road or Normal Operating Conditions

While road testing with the transmission oil pressure gage attached and the vacuum modulator tube **connected**, the transmission pressure should check approximately as shown on Figure 7A-35.

| | | <u>Minimum</u> | <u>Maximum</u> |
|--|--|----------------|----------------|
| L2-2nd Gear - Steady road load at approximately 25 mph | | 145 psi | 155 psi |
| <u>Gear</u> | <u>Selector Lever Position</u> | <u>Minimum</u> | <u>Maximum</u> |
| 1st | Drive | | |
| 2nd | ("Zero" throttle to full throttle.) | 60 | 150 |
| 3rd | | | |
| 3rd | Drive Range, Zero Throttle at 30 mph | 60 | |
| Reverse | Rev. (Zero to full throttle) | 95 | 260 |

Fig. 7A-35--Fluid Pressure Check - Road or Normal Operating Conditions

Vehicle Stationary - Engine at 1200 RPM

With the transmission oil pressure gage attached and the vacuum modulator tube **disconnected**, the transmission pressures should check approximately as shown in Fig. 7A-36.

Vehicle Stationary - Engine at 1000 RPM

With the transmission oil pressure gage attached and the vacuum modulator tube **connected** for normal modulator operation, the transmission pressure should check approximately as shown in Fig. 7A-37.

Pressures are not significantly affected by altitude or barometric pressure when the vacuum modulator tube is connected.

Case Porosity Repair

External leaks caused by case porosity have successfully been repaired with the transmission in the vehicle by using the following recommended procedures:

1. Road test and bring the transmission to operating temperature, approximately 180 degrees (82°C).
2. Raise vehicle on hoist or jack stand, engine running and locate source of oil leak. Check for leak in all operating positions. Use of a mirror is helpful in finding leaks.
3. Shut engine off and thoroughly clean area to be repaired with a cleaning solvent and a brush air dry.
4. Using instructions of the manufacturer, mix a sufficient amount of epoxy to make repair. Observe cautions of manufacturer in handling.
5. While the transmission case is still HOT apply the epoxy to the area to be repaired. A clean, dry soldering acid brush can be used to clean the area and also to apply the epoxy cement. Make certain the area to be repaired is fully covered.
6. Allow cement to cure for three hours before starting engine.
7. Road test and check for leaks.

| <u>Drive, Neutral, Park</u> | <u>L₁ or L₂</u> | <u>Reverse</u> |
|-----------------------------|---------------------------------------|----------------|
| 150 | 150 | 233 |

Fig. 7A-36--Fluid Pressure Check - Vehicle Stationary, Vacuum Tube Disconnected

VACUUM MODULATOR DIAGNOSIS

A defective vacuum modulator can be determined by performing the following procedures.

Vacuum Diaphragm Leak Check

Insert a pipe cleaner into the vacuum connector pipe as far as possible and check for the presence of transmission oil. If oil is found, replace the modulator.

Gasoline or water vapor may settle in the vacuum side of the modulator. If this is found without the presence of oil, the modulator should not be changed.

Atmospheric Leak Check

Apply a liberal coating of soap bubble solution to the vacuum connector pipe seam, the crimped upper to lower housing seam, and the threaded screw seal (Fig. 7A-38). Using a short piece of rubber tubing apply air pressure to the vacuum pipe by blowing into the tube and observe for leak bubbles. If bubbles appear, replace the modulator.

NOTICE: Do not use any method other than human lung power for applying air pressure, as pressures over 6 psi (41 kPa) may damage the modulator.

Bellows Comparison Check

Using a comparison gage, as shown in Figure 7A-39, compare the load of a known good modulator with the assembly in question.

- a. Install the modulator that is known to be acceptable on either end of the gage (Fig. 7A-40).
- b. Install the modulator in question on the opposite end of the gage. (Fig. 7A-41).
- c. Holding the modulators in a horizontal position, bring them together under pressure until either modulator sleeve end just touches the line in the center of the gage (Fig. 7A-42). The gap between the opposite modulator sleeve end and the gage line should then be 1/16 in. (1.5 mm) or less. If the distance is greater than this amount, the modulator in question should be replaced.

| <u>Drive, Neutral, Park</u> | <u>L₁ or L₂</u> | <u>Reverse</u> |
|-----------------------------|---------------------------------------|----------------|
| 60 | 150 | 107 |

Fig. 7A-37--Fluid Pressure Check - Vehicle Stationary, Vacuum Tube Connected

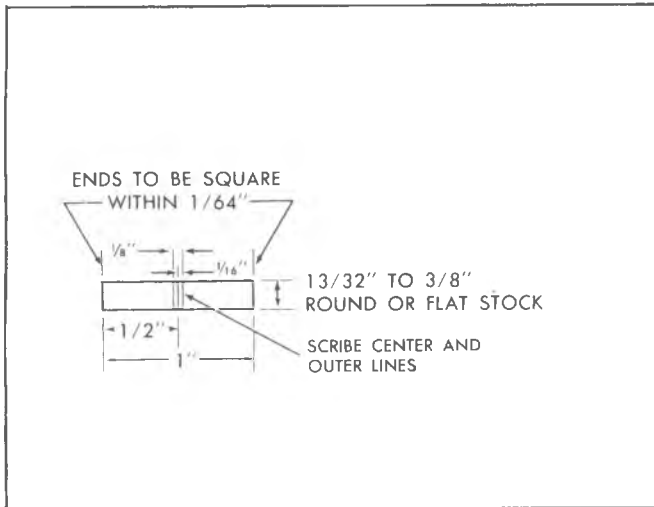


Fig. 7A-38-Vacuum Modulator

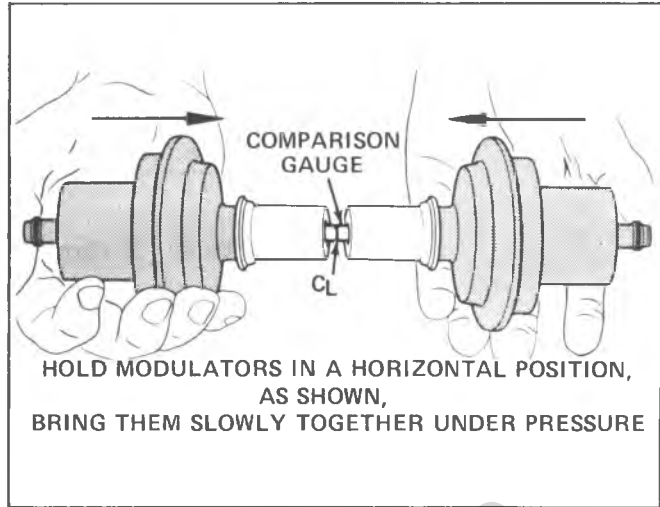


Fig. 7A-40-Holding Modulators in Horizontal Position

Sleeve Alignment Check

Roll the main body of the modulator on a flat surface and observe the sleeve for concentricity to the can. If the sleeve is concentric and the plunger is free, the modulator is acceptable.

Once the modulator assembly passes all of the above tests, it is an acceptable part and should be reused.

400 Trans. With Diesel Engine

If erratic or poor quality shifting occurs due to incorrect vacuum supply to the modulator, check the vacuum regulator valve and the vacuum pump as described in Section 6A-6 of this manual.

MANUAL LINKAGE

Manual linkage adjustment and the associated neutral safety switch are important from a safety standpoint. The neutral safety switch should be adjusted so that the engine will start in the Park (P) and Neutral (N) positions only.

With the selector lever in the Park position, the parking pawl should freely engage and prevent the vehicle from rolling. The pointer on the indicator quadrant should line up properly with the range indicators in all ranges.

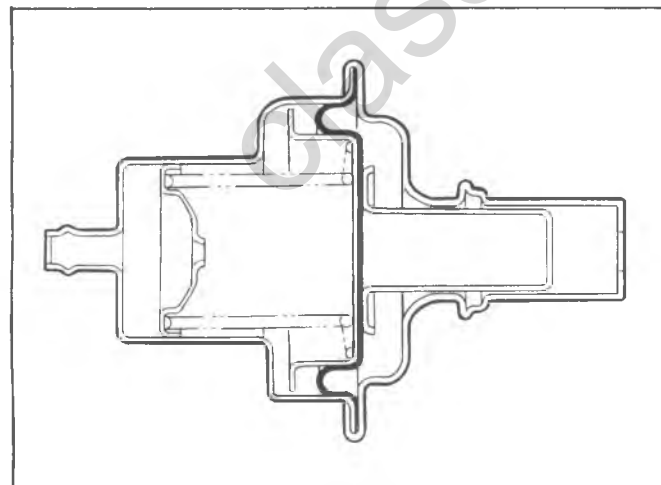


Fig. 7A-39-Bellows Comparison Gage

TROUBLE DIAGNOSIS, BY CONDITION

NOTICE: On vehicles with diesel engine, the vacuum source for the vacuum modulator is the Vacuum Regulator Valve. When diagnosing shift complaints on these vehicles, it is important to assure that the vacuum pump is providing 22 in. (28 kPa) of vacuum to this valve. Also check the throttle linkage adjustment as outlined in Section 6A-3 of this manual.

No Drive in Drive Range

(Install pressure gage)

- Low oil level - check for external leaks or defective vacuum modulator (leaking diaphragm will evacuate oil from unit).
- Manual linkage maladjusted (correct alignment in manual lever shift quadrant is essential); manual valve disconnected from manual lever pin.
- Low oil pressure - refer to **LOW LINE PRESSURE** below.

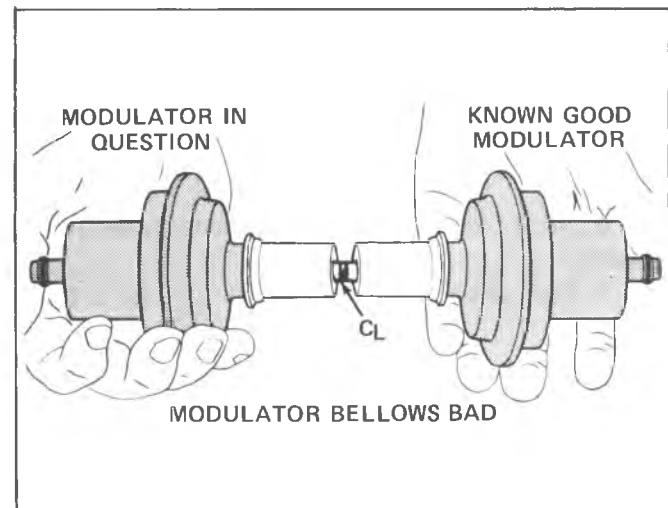


Fig. 7A-41-Modulator Bellows - Bad

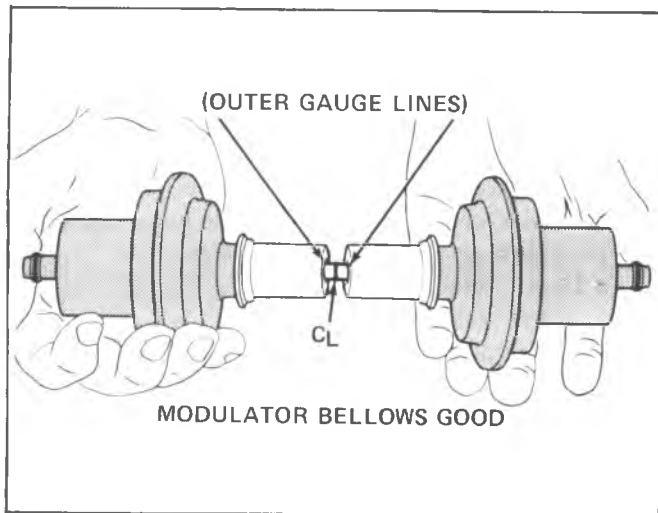


Fig. 7A-42-Modulator Bellows (Good)

● Forward clutch:

a. Clutch does not apply - piston cracked; seals missing, damaged; clutch plates burnt (Refer to BURNED CLUTCH PLATES).

b. Pump feed circuit-to-forward clutch oil seal rings missing or broken on pump cover; leak or restriction in feed circuits; pump-to-case gasket mispositioned or damaged. Clutch drum ball check stuck or missing.

● Roller Clutch - broken springs, damaged cage or installed backwards.

High or Low Oil Pressure

(Refer to FLUID PRESSURE CHECKS)

High Line Pressure

● Vacuum Leak:

- a. Vacuum line disconnected.
- b. Leak on line from engine to modulator.
- c. Improper engine vacuum.
- d. Leak in vacuum-operated accessory (hoses, vacuum advance, etc.).

● Modulator:

- a. Stuck modulator valve.
- b. Water in modulator.
- c. Damaged, not operating properly.

● Detent System:

- a. Detent switch actuated (plunger stuck) or shorted.
- b. Detent wiring shorted.
- c. Detent solenoid stuck open.
- d. Detent feed orifice in spacer plate blocked or restricted.

e. Detent solenoid loose.

f. Detent valve bore plug damaged.

g. Detent regulator valve pin short.

● Oil Pump:

- a. Pressure regulator and/or boost valve stuck.
- b. Incorrect pressure regulator valve spring.
- c. Too many pressure regulator valve spacers.
- d. Pressure boost valve installed backwards or defective.

e. Pressure boost bushing broken or defective.

f. Pump casting bad.

Low Line Pressure

● Low transmission oil level.

● Defective vacuum modulator assembly.

● Filter Assembly:

- a. Blocked or restricted.
- b. "O" Ring seal on intake pipe and/or grommet omitted or damaged.

c. Split or leaking intake pipe.

d. Wrong filter assembly.

● Oil Pump:

- a. Pressure regulator and/or boost valve stuck.
- b. Pressure regulator valve spring too weak.
- c. Not enough spacers in pressure regulator.
- d. Gear clearance, damaged, worn, drive gear installed backwards.

e. Pump-to-case gasket mispositioned.

f. Defective or mismatched pump body/pump cover.

● Internal Circuit Leaks:

a. Forward clutch leak (pressure low in Drive range - pressure normal in Neutral and Reverse).

1. Check pump oil seal rings.

2. Check forward clutch seals.

b. Direct clutch leak (pressure low in Reverse, pressure normal in all other ranges).

1. Check center support oil seal rings.

2. Check direct clutch outer seal.

3. Check rear servo and front accumulator pistons and rings for damage or missing.

6. Case Assembly:

a. Porosity in intake bore area.

b. Check case for intermediate clutch cup plug leak or blown out.

c. L1-reverse check ball mispositioned or missing (this will cause no reverse and no overrun braking in L1 range).

1-2 Shift-Full Throttle Only

● Detent switch sticking or defective (may stick in cold or wet weather). Can be detected by pulling connection at transmission and obtaining normal upshifts.

● Detent solenoid:

a. Loose.

b. Gasket leaking.

c. Sticks open.

● Control valve:

a. Valve body gaskets - leaking, damaged, incorrectly installed.

b. Detent valve train stuck.

c. 3-2 valve stuck.

● Case - porosity.

First Speed Only, No 1-2 Shift

● Governor:

a. Valve sticking.

b. Driven gear loose, damaged or worn (check for pin in case and length of pin showing); also check output shaft drive gear for nicks or rough finish if driven gear shows damage.

- Control valve:
 - a. 1-2 shift valve train stuck closed.
 - b. Governor feed channels blocked, leaking, pipes out of position, governor screen plugged.
 - c. Valve body gaskets leaking, damaged, incorrectly installed.
- Case:
 - a. Intermediate clutch cup plug leaking or blown out.
 - b. Porosity between channels.
 - c. Governor feed channel blocked; governor bore scored or worn, allowing cross pressure leak.
- Intermediate clutch:
 - a. Case center support - oil rings missing, broken, defective; orifice plug missing.
 - b. Clutch piston seals missing, improperly assembled, cut.

First and Second Speeds Only, No 2-3 Shift

- Detent solenoid - stuck open (detent shifts only - the 2-3 shift would occur at very high speeds, being interpreted as no 2-3 shift).
- Detent switch.
- Control valve:
 - a. 2-3 valve train stuck.
 - b. Valve body gaskets leaking, damaged, incorrectly installed.
- Direct clutch:
 - a. Center support oil rings missing, broken, defective.
 - b. Clutch piston seals missing, improperly assembled, cut; piston ball check stuck or missing.

Drive in Neutral

- Manual linkage maladjusted.
- Internal Linkage:
 - a. Manual valve disconnected or end broken.
 - b. Inside detent lever pin broken.
- Pump Assembly - transmission lube pressure leaking into forward clutch apply passage.
- Forward Clutch:
 - a. Burned plates - check cause.
 - b. Clutch doesn't release - will also cause no drive in Reverse.

No Drive in Reverse or Slips in Reverse

- (Install pressure gage)
- Low fluid level.
 - Manual linkage maladjusted.
 - Oil pressure - refer to LOW LINE PRESSURE above.
 - Control valve:
 - a. Valve body gaskets leaking, damaged, incorrectly installed (Other malfunctions may also be indicated).
 - b. Low reverse ball check missing from case (this will also cause no overrun braking in L1 Range).
 - c. 2-3 valve train stuck open (this will also cause 1-3 upshift in Drive range).
 - d. Reverse feed passage restricted; also check case passages.
 - Rear servo and accumulator:

- a. Servo piston seal ring damaged or missing.
- b. Short band apply pin (this may also cause no overrun braking or slips in overrun braking - L1 range). Refer to INSTALLATION OF REAR SERVO ASSEMBLY for pin selection procedure.
- c. Defective rear servo piston or bore.
 - Reverse or low band burnt, loose lining; apply pin or anchor pins not engaged; band broken.
 - Direct clutch:
 - a. Outer seal damaged or missing.
 - b. Clutch plates burnt (Refer to BURNED CLUTCH PLATES).
 - Forward clutch - clutch does not release (will also cause Drive in Neutral).
 - Center support - oil seal rings or grooves damaged or worn.

Slips in all Ranges, Slips on Start

- (Install pressure gage)
- Low fluid level.
 - Oil pressure - Refer to LOW LINE PRESSURE.
 - Case - cross leaks, porosity.
 - Forward and direct clutches slipping (if burnt, Refer to BURNED CLUTCH PLATE); oil seal rings on pump cover broken or worn.

Slips 1-2 Shift

- (Install pressure gage)
- Low fluid level.
 - Oil pressure - Refer to LOW LINE PRESSURE.
 - Front accumulator piston oil ring damaged or missing.
 - Control valve:
 - a. 1-2 accumulator valve train sticking.
 - b. Porosity in valve body or case.
 - c. Valve body attaching bolts not properly torqued.
 - Rear accumulator oil ring missing or damaged; case bore damaged.
 - Pump-to-case gasket mispositioned.
 - Case:
 - a. Intermediate clutch cup plug leaks excessively.
 - b. Porosity between channels.
 - c. Raised ridge around case center support bolt (does not allow control valve assembly to seat properly).
 - Intermediate clutch:
 - a. Piston seals missing or damaged; clutch plates burnt (Refer to BURNED CLUTCH PLATES).
 - b. Center support - leak in feed circuit (oil rings damaged or grooves defective), excessive leak between tower and bushing, orifice bleed plug hole (0.020 dia.) blocked, center support bolt not seated properly in case.

Rough 1-2 Shift

- (Install pressure gage)
- Oil pressure - Refer to HIGH LINE PRESSURE.
 - Control valve:
 - a. 1-2 accumulator valve train.
 - b. Valve body-to-case bolts loose.
 - c. Wrong gaskets or off location, damaged.

- Case:
 - a. Intermediate clutch ball missing or not sealing.
 - b. Porosity between channels.
- Rear servo accumulator:
 - a. Oil rings damaged.
 - b. Piston stuck.
 - c. Broken or missing spring.
 - d. Bore damaged.
- Intermediate clutch - clutch plates burnt (Refer to BURNED CLUTCH PLATES).

Slips 2-3 Shift

(Install pressure gage)

- Low fluid level.
- Oil pressure - Refer to LOW LINE PRESSURE.
- Control valve - accumulator piston pin (leak at swedge end).
 - Case porosity.
 - Direct clutch:
 - a. Piston seals leaking or ball check leaks.
 - b. Center support oil seal rings damaged; excessive leak between tower and bushing.

Rough 2-3 Shift

(Install pressure gage)

- Oil Pressure - Refer to HIGH LINE PRESSURE.
- Front servo accumulator:
 - a. Front accumulator spring missing, broken.
 - b. Accumulator piston stuck.
- Direct clutch - air check for leak to outer area of clutch piston or center piston seal.
- Damaged center support.

No Engine Braking in L2 Range - 2nd Gear

- Front servo accumulator:
 - a. Servo or accumulator oil rings or bores leaking.
 - b. Servo piston cocked or stuck.
- Front band broken, burnt (check for cause), not engaged on anchor pin and/or servo pin.

No Engine Braking in L1 Range - 1st Gear

- Case assembly - L1-reverse check ball mispositioned or missing from case; case damaged at L1-reverse check ball area.
 - Rear servo:
 - a. Oil seal ring, bore or piston damaged; leaking apply pressure.
 - b. Rear band apply pin short, improperly assembled.
 - Rear band broken, burnt (check for cause), not engaged on anchor pins or servo pin. Items above will also cause slips in Reverse or no Reverse.

No Part Throttle Downshift

(Install pressure gage)

- Oil pressure - Refer to HIGH OR LOW OIL PRESSURE.
- Control valve - 3-2 valve stuck spring missing or broken.

No Detent Downshifts

- Detent switch adjustments, connection (switch plunger activated approx. 7/8" at full throttle opening).
- Solenoid inoperative, connections.
- Control valve-detent valve train sticking.

Low or High Shift Points

(Install pressure gage)

- Oil Pressure - Refer to HIGH OR LOW OIL PRESSURE.
 - Governor:
 - a. Valve sticking.
 - b. Feed holes restricted or leaking; pipes damaged or mispositioned.
 - c. Feed line screen plugged.
 - Detent switch.
 - Detent solenoid stuck open, loose, etc. (will cause late shifts).
 - Control valve:
 - a. Detent valve train.
 - b. 3-2 valve train (detent upshifts possible).
 - c. 1-2 shift valve train - 1-2 regulator valve stuck (this would cause a constant 1-2 shift point, regardless of throttle opening).
 - d. Spacer plate gaskets mispositioned; spacer plate orifice holes missing or blocked.
 - Case porosity; intermediate clutch cup plug leaking, missing.

Won't Hold in Park

- Manual linkage maladjusted.
- Internal linkage:
 - a. Parking brake lever and actuator defective (check for chamfer on actuator rod sleeve).
 - b. Parking pawl broken.
 - c. Parking pawl bracket loose, burned, rough edges or incorrectly installed.
 - d. Parking pawl return spring missing, broken or incorrectly hooked.

Transmission Noisy

NOTICE: Before checking transmission for what is believed to be "transmission noise", make sure that the noise is not from the water pump, alternator, power steering, etc. These components can be isolated by removing the proper belt and running the engine no more than two minutes at one time.

Park, Neutral and all Driving Ranges

- Pump Cavitation:
 - a. Oil level low.
 - b. Plugged or restricted filter.
 - c. Intake pipe "O" ring damaged.
 - d. Intake pipe split, porosity in case intake pipe bore.
 - e. Water in oil.
 - f. Porosity or voids at transmission case (pump face) intake port.
 - g. Pump-to-case gasket off location.
- Pump Assembly:

- a. Gears damaged or defective; driving gear installed backwards.
- b. Crescent interference.
- c. Oil seal rings damaged or worn.
- Converter:
 - a. Loose flexplate-to-converter bolts.
 - b. Damaged converter.

First, Second and/or Reverse Gears**Planetary Gear Set:**

- a. Gears or thrust bearings damaged.
- b. Front internal gear ring damaged.

During Acceleration - Any Gear

- Transmission or cooler lines grounded to underbody.
- Motor mounts loose or broken.

Squeal at Low Vehicle Speed

Speedometer driven gear shaft seal - requires lubrication or replacement.

Burned Clutch Plates

● Forward clutch:

- a. Check ball in clutch drum damaged, stuck or missing.
- b. Clutch piston cracked, seals damaged or missing.
- c. Low line pressure (Refer to LOW LINE PRESSURE).
- d. Manual valve mispositioned (may also cause front band failure).
- e. Restricted oil feed to forward clutch (clutch housing to inner and outer areas not drilled, restricted, porosity in pump, etc.).
- f. Transmission case valve body face not flat or porosity between channels.
- g. Manual valve bent and center land not ground properly.
- h. Pump cover oil seal rings missing, broken or undersize, ring groove oversize.

● Intermediate Clutch:

- a. Constant bleed orifice in center support missing.
- b. Rear accumulator piston oil ring damaged or missing.
- c. 1-2 accumulator valve stuck in control valve assembly.
- d. Intermediate clutch piston seals damaged or missing.
- e. Center support bolt loose.
- f. Low line pressure (Refer to LOW LINE PRESSURE).
- g. Intermediate clutch cup plug in case missing.
- h. Transmission case valve body face not flat or porosity between channels.
- i. Manual valve bent and center land not ground properly.
- Direct Clutch:
 - a. Restricted orifice in vacuum line to modulator (poor vacuum response).
 - b. Check ball in clutch piston damaged, stuck or missing.
 - c. Defective modulator bellows.
 - d. Center support bolt loose (bolt may be tight in support but not holding support tight to the case).
 - e. Center support oil rings or grooves damaged or missing.
 - f. Clutch piston cracked, seals damaged or missing.
 - g. Front and rear servo pistons and/or seals damaged.
 - h. 3-2 valve, 3-2 valve spring or 3-2 spacer pin installed in wrong location in 3-2 valve train bore.
 - i. Manual valve bent and center land not ground properly.
 - j. Transmission case valve body not flat or porosity between channels.
 - k. Intermediate roller clutch installed backwards.
- In addition, burned clutch plates can be caused by incorrect usage of clutch plates. Also, anti-freeze in transmission fluid can cause severe damaged, such as large pieces of clutch plate material peeling off.

| | FORWARD CLUTCH | DIRECT CLUTCH | FRONT BAND | INTERMEDIATE CLUTCH | INTERMEDIATE ROLLER CLUTCH | LOW ROLLER CLUTCH | REAR BAND |
|--------------------|-----------------------|----------------------|-------------------|----------------------------|-----------------------------------|--------------------------|------------------|
| NEUTRAL | OFF | OFF | OFF | OFF | Ineffective | Ineffective | OFF |
| DRIVE, First Gear | ON | OFF | OFF | OFF | Ineffective | Effective | OFF |
| DRIVE, Second Gear | ON | OFF | OFF | ON | Effective | Ineffective | OFF |
| DRIVE, Third Gear | ON | ON | OFF | ON | Ineffective | Ineffective | OFF |
| L1 | ON | OFF | OFF | OFF | Ineffective | Effective | ON |
| L2 | ON | OFF | ON | ON | Effective | Ineffective | OFF |
| REVERSE | OFF | ON | OFF | OFF | Ineffective | Ineffective | ON |

Fig. 7A-43--400 Clutch Apply Chart

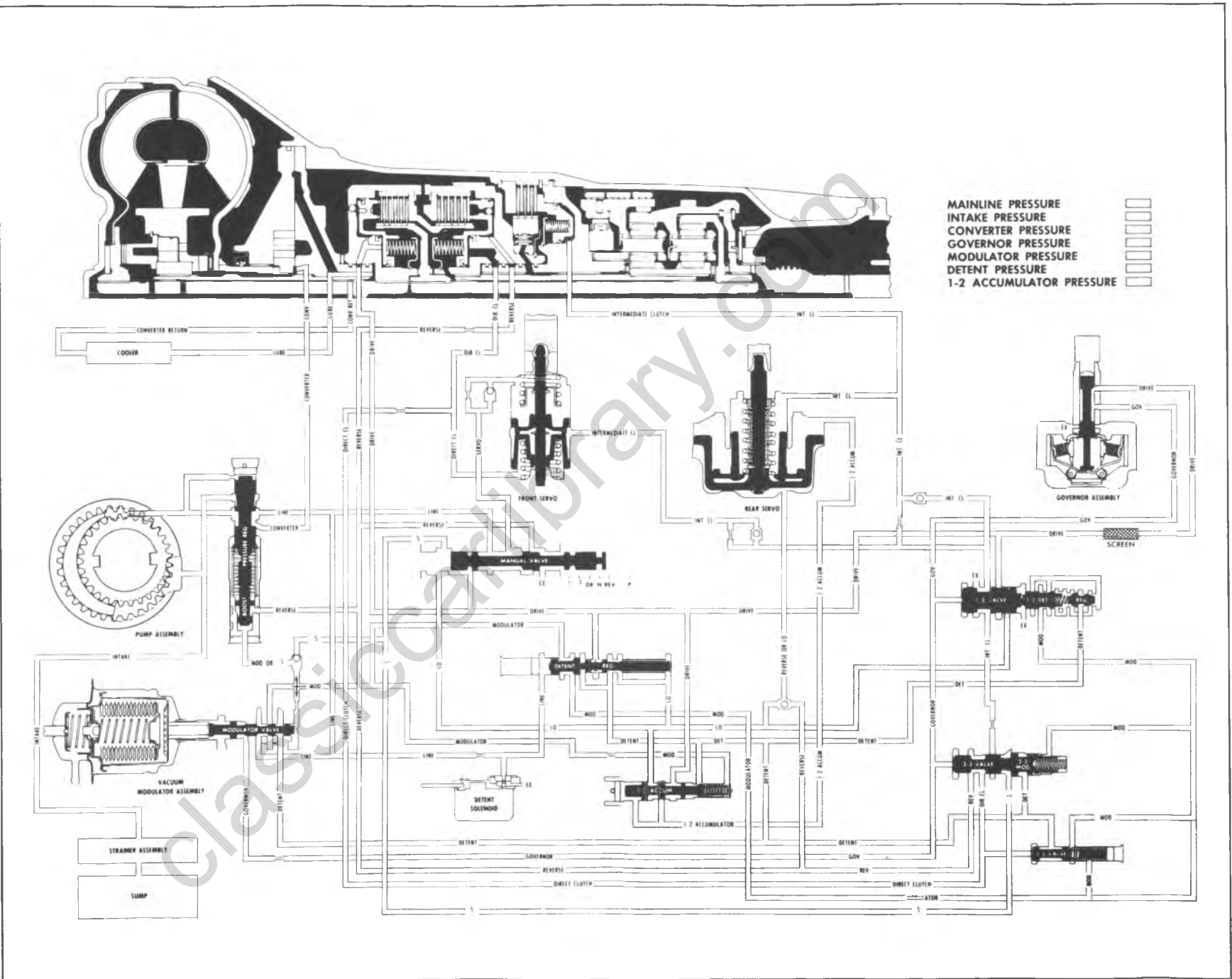


Fig. 7A-44--400 Hydraulic Circuit

ON VEHICLE SERVICE

TRANSMISSION REPLACEMENT

If necessary, the catalytic converter may have to be disconnected to provide adequate clearance for transmission removal. This procedure will include removal of the converter support bracket.

Removal

Before raising the truck, disconnect the battery and release the parking brake.

1. Raise truck on hoist.
2. Remove propeller shaft.
3. Disconnect speedometer cable, electrical lead to case connector, vacuum line at modulator, and oil cooler pipes.
4. Disconnect shift control linkage.
5. Support transmission with suitable transmission jack.
6. Disconnect rear mount from frame crossmember.
7. Remove two bolts at each end of the frame crossmember and remove crossmember.
8. Remove converter under pan.
9. Remove converter-to-flexplate bolts. Refer to Fig. 7A-45.
10. Loosen exhaust pipe to manifold bolts approximately 1/4 in. (6.35 mm), and lower transmission until jack is barely supporting it.

11. Remove transmission to engine mounting bolts and remove oil filler tube at transmission.

12. Raise transmission to its normal position, support engine with jack and slide transmission rearward from engine and lower it away from vehicle.

13. Use converter holding Tool J-5384 when lowering transmission or keep rear of transmission lower than front so as not to lose converter.

Installation

The installation of the transmission is the reverse of the removal with the following additional steps.

1. Before installing the flexplate to converter bolts, make certain that the weld nuts on the converter are flush with the flexplate and the converter rotates freely by hand in this position. Refer to Fig. 7A-45 for instructions on attaching the converter to flexplate. This will insure proper converter alignment.
2. Install transmission support crossmember to transmission and frame with taper on support sloping toward rear.
3. After installation of transmission, check linkage for proper adjustment.
4. Remove truck from hoist.

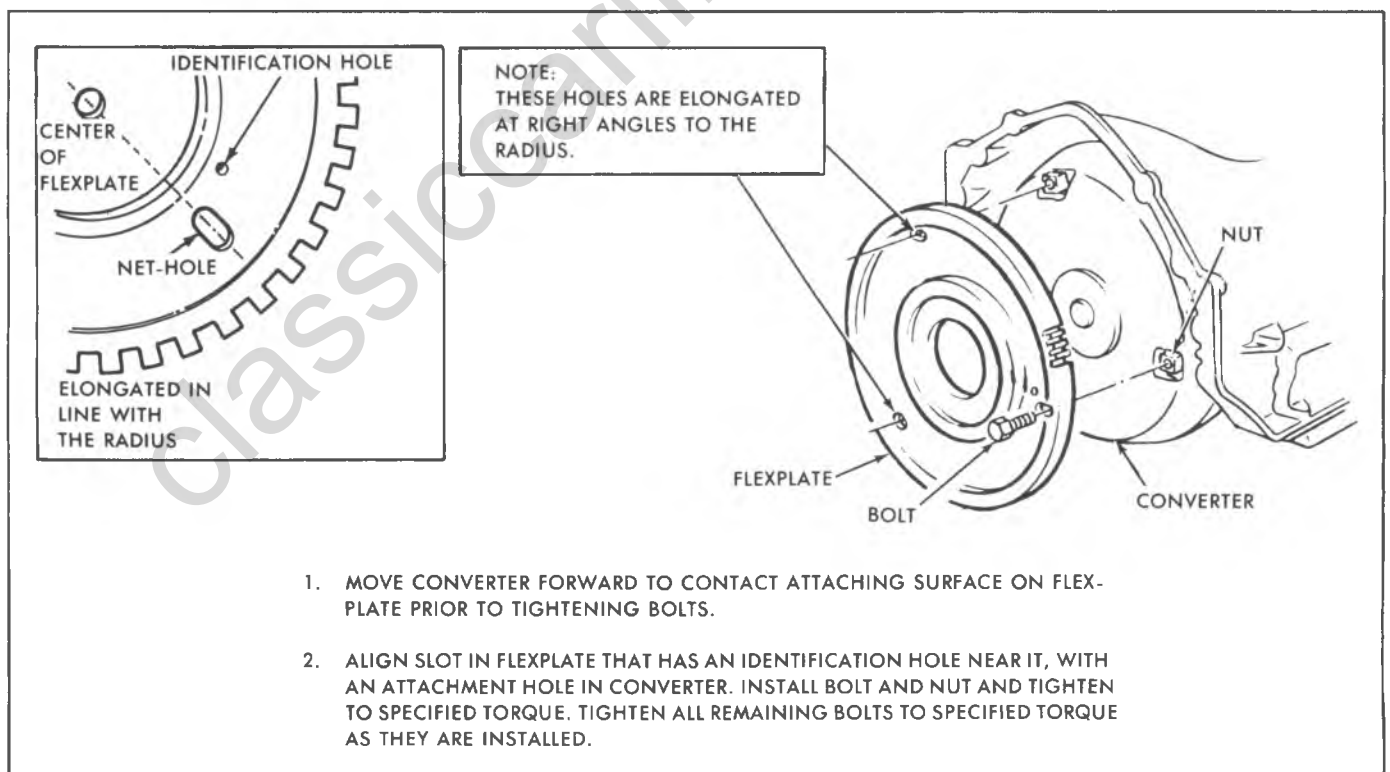


Fig. 7A-45--Typical Transmission Mounting, Net-Hole Design

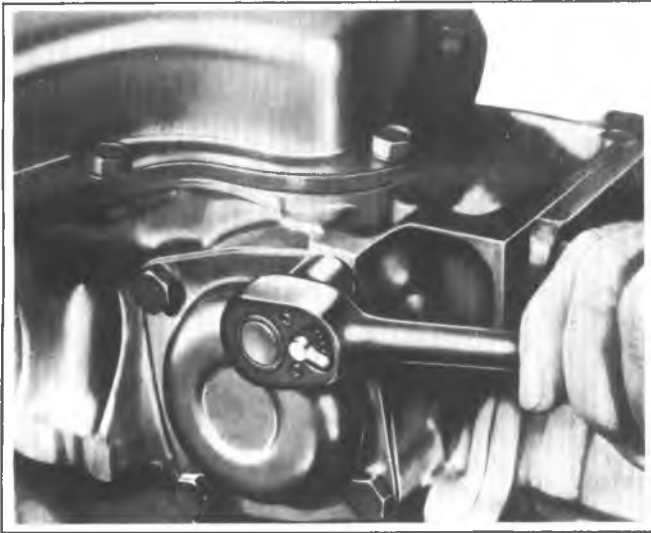


Fig. 7A-46--Removing Governor Attaching Screws

REAR EXTENSION OIL SEAL

Removal

1. Remove propeller shaft.
2. Pry seal out with screw driver.

Installation

1. For all models except CL, use Tool J-21359 to drive seal in place. For CL models, use J-24057.
2. Reinstall propeller shaft.

GOVERNOR

Removal

1. Remove governor cover attaching screws, cover, and gasket, as shown in Fig. 7A-46.
2. Discard gasket.
3. Withdraw governor assembly from case.

Installation

Installation of the governor assembly is the reverse of the removal. Use a new gasket under the governor cover. Adjust fluid level.

MODULATOR AND MODULATOR VALVE

Removal

1. Remove modulator assembly attaching screw and retainer.
2. Remove modulator assembly from case. Discard "O" ring seal.
3. Remove modulator valve from case. Refer to Fig. 7A-47.

Installation

Installation of the modulator assembly and modulator valve is the reverse of the removal. Use a new "O" ring seal on the modulator assembly.

Adjust fluid level.

PARKING LINKAGE-10, 20 SERIES

Removal

1. Remove bottom pan and oil filter.
2. Unthread jam nut holding detent lever to manual shaft.

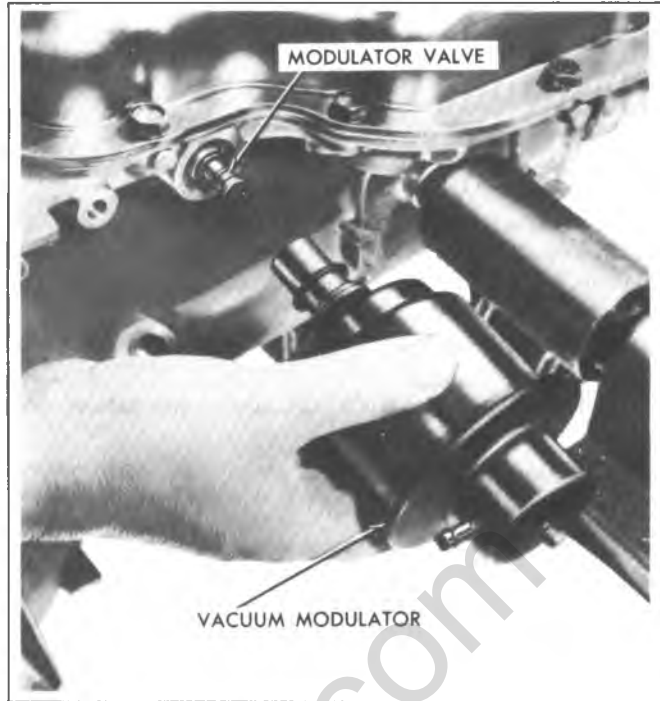


Fig. 7A-47--Removing Vacuum Modulator and Valve

3. Remove manual shaft retaining pin from case.
4. Remove manual shaft and jam nut from case, as shown in Fig. 7A-48.

Do not remove manual shaft seal unless replacement is required.

5. Remove parking actuator rod and detent lever assembly.
6. Remove parking pawl bracket attaching screws and bracket.
7. Remove parking pawl return spring.

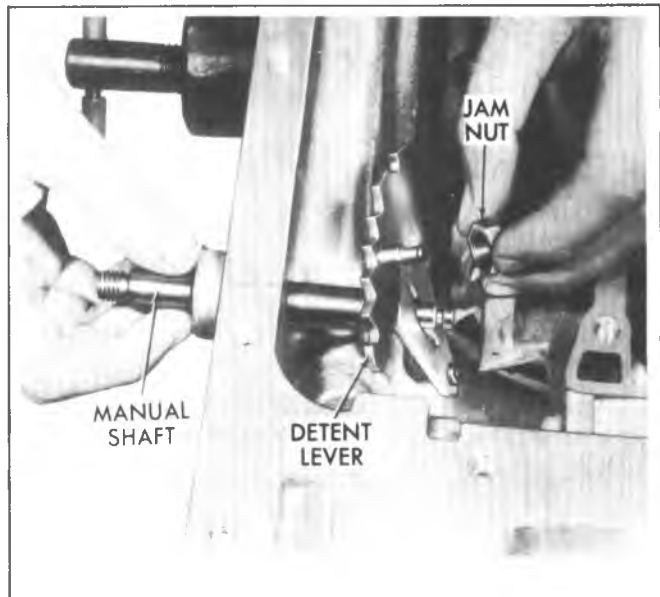


Fig. 7A-48--Removing Jam Nut from Manual Shaft

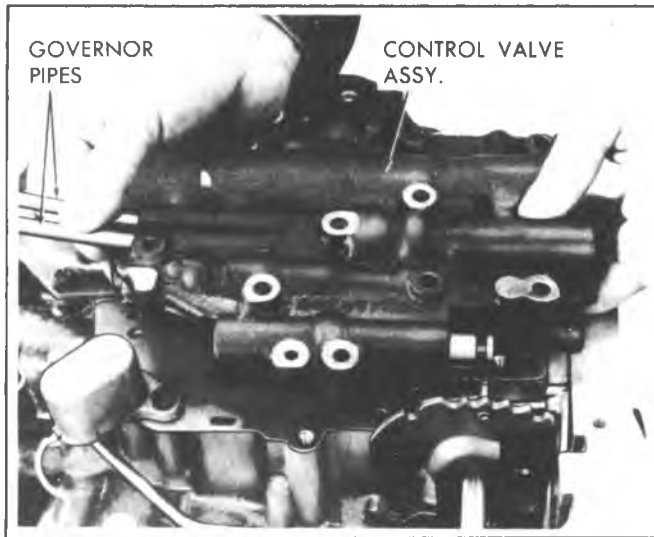


Fig. 7A-49--Removing Control Valve and Governor Pipes

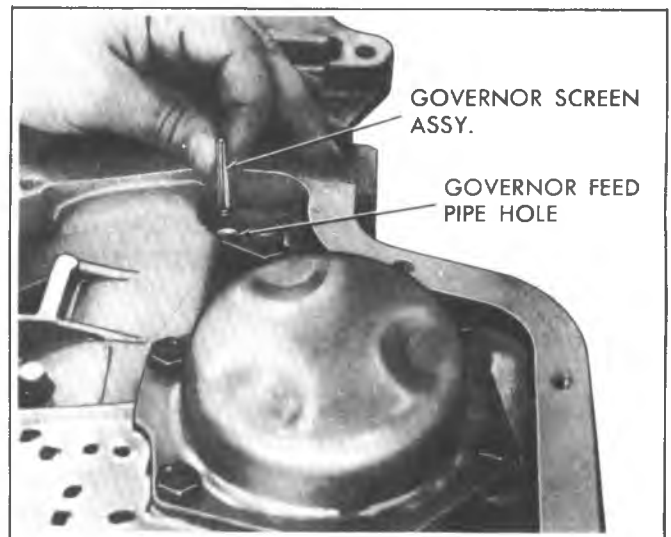


Fig. 7A-50--Governor Screen Position

The following steps should be completed unless part replacement is required.

8. Remove parking pawl shaft retainer.
9. Remove parking pawl shaft, cup plug parking pawl shaft, and parking pawl.

Installation

Installation of the parking linkage is the reverse of the removal. Use new seal and cup plug, if removed, and new bottom pan gasket.

CONTROL VALVE BODY

Removal

1. Remove bottom pan and filter.
2. Disconnect lead wire from pressure switch assembly.
3. Remove control valve body attaching screws and detent roller spring assembly.

Do not remove solenoid attaching screws.

NOTICE: If the transmission is in the vehicle, the front servo parts may drop out as the control valve assembly is removed.

4. Remove control valve body assembly and governor pipes. If care is taken in removing control valve body the six (6) check balls will stay in place above the spacer plate. Refer to Fig. 7A-49.

5. Remove the governor screen assembly from end of governor feed pipe or from the governor feed pipe hole in the case (Fig. 7A-50). Clean governor screen in clean solvent and air dry.

NOTICE: Do not drop manual valve.

6. Remove the governor pipes and manual valve from control valve body.

Installation

Installation of control valve body is in reverse of removal. See Overhaul Manual. Adjust fluid level.

PRESSURE REGULATOR VALVE

Removal

1. Remove bottom pan and filter.
2. Compress regulator boost valve bushing against pressure regulator spring and remove snap ring, using J-5403 pliers.
3. Remove regulator boost valve bushing and valve.
4. Remove pressure regulator spring.
5. Remove spring retainer, washer spacer(s) if present, and regulator valve.

Installation

A solid type pressure regulator valve must only be used in a pump cover with a squared-off pressure regulator boss (Refer to Figure 7A-51). A pressure regulator valve with oil holes and orifice cup plug may be used to service either type pump.

Installation of the pressure regulator valve is the reverse of the removal. Install new gasket on oil pan and adjust fluid level.

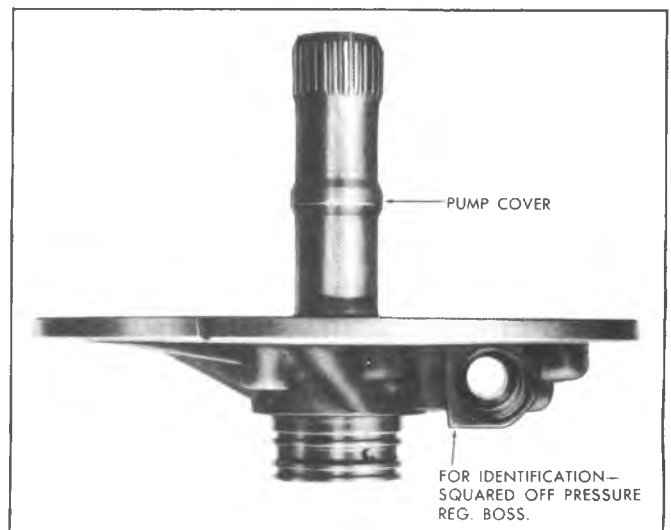


Fig. 7A-51--Pressure Regulator Valve

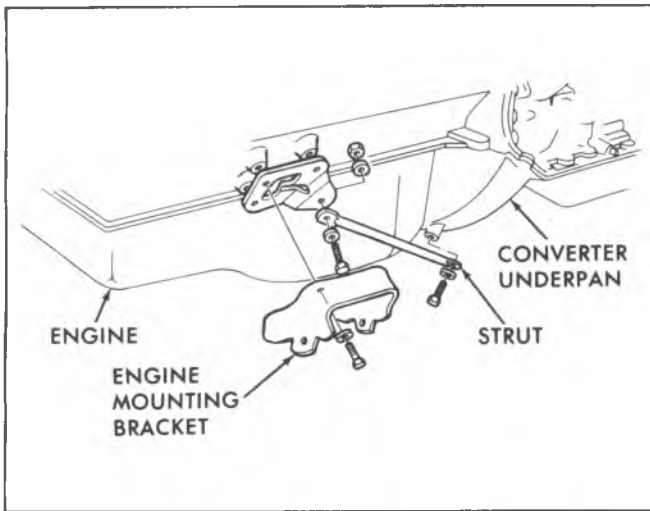


Fig. 7A-52--Transmission Support Strut Rod

SUPPORT STRUT ROD

Replacement

The transmission strut rod attachment is shown in Fig. 7A-52. Remove the two bolts when replacing the strut rod. When removing the transmission, it is only necessary to remove the bolt at the transmission end of the strut rod.

OIL COOLER PIPES

If replacement of transmission steel tubing cooler pipes is required, use only double wrapped and brazed steel tubing

meeting GM specification 123M or its equivalent. Under no condition use copper or aluminum tubing to replace steel tubing. Those materials do not have satisfactory fatigue durability to withstand normal vehicle vibrations.

Steel tubing should be flared using the upset (double lap) flare method which is detailed in Section 5.

OTHER SERVICE OPERATIONS

The following operations when done as single operations and not as part of a general overhaul should, as a practical matter, be performed with the transmission in the vehicle. Refer to the "Transmission Disassembly and Reassembly" section of the Overhaul Manual for service procedures.

1. Oil filler pipe.
2. Oil pan and gasket.
3. Down shift solenoid or connector.
4. Valve body spacer plate, gasket and check balls.
5. Front accumulator piston.
6. Rear servo and rear accumulator assembly.
7. Rear band apply checking with Tool J-21370.
8. Front servo assembly.
9. Speedo driven gear.
10. Case extension or gasket.
11. Filter and "O" ring.
12. Pressure switch assembly.

SPECIFICATIONS

350

| | |
|--|-----------------|
| Pump Cover to Pump Body | 17 ft. lbs. |
| Pump Assembly to Case | 18-1/2 ft. lbs. |
| Valve Body and Support Plate | 130 in. lbs. |
| Parking Lock Bracket | 29 ft. lbs. |
| Oil Suction Screen | 40 in. lbs. |
| Oil Pan to Case | 130 in. lbs. |
| Extension to Case | 25 ft. lbs. |
| Modulator Retainer to Case | 130 in. lbs. |
| Inner Selector Lever to Shaft | 25 ft. lbs. |
| Detent Valve Actuating Bracket | 52 in. lbs. |
| Converter to Flywheel Bolts | 35 ft. lbs. |
| Under Pan to Transmission Case | 110 in. lbs. |
| Transmission Case to Engine | 35 ft. lbs. |
| Oil Cooler Pipe Connectors to Transmission | |
| Case or Radiator | 125 in. lbs. |
| Oil Cooler Pipe to Connectors | 10 ft. lbs. |
| Detent Cable to Transmission | 75 in. lbs. |
| Detent Cable to Carb. | 112 in. lbs. |

400

| | |
|--|--------------|
| Pump Cover Bolts | 18 ft. lbs. |
| Parking Pawl Bracket Bolts | 18 ft. lbs. |
| Center Support Bolt | 23 ft. lbs. |
| Pump to Case Attaching Bolts | 18 ft. lbs. |
| Extension Housing to Case Attaching Bolts | 23 ft. lbs. |
| Rear Servo Cover Bolts | 18 ft. lbs. |
| Detent Solenoid Bolts | 7 ft. lbs. |
| Control Valve Body Bolts | 8 ft. lbs. |
| Bottom Pan Attaching Screws | 12 ft. lbs. |
| Modulator Retainer Bolt | 18 ft. lbs. |
| Governor Cover Bolts | 18 ft. lbs. |
| Manual Lever to Manual Shaft Nut | 8 ft. lbs. |
| Manual Shaft to Inside Detent Lever | 18 ft. lbs. |
| Linkage Swivel Clamp Nut | 43 ft. lbs. |
| Converter Dust Shield Screws | 93 ft. lbs. |
| Transmission to Engine Mounting Bolts | 35 ft. lbs. |
| Converter to Flywheel Bolts | 35 ft. lbs. |
| Rear Mount to Transmission Bolts | 40 ft. lbs. |
| Rear Mount to Crossmember Bolt | 40 ft. lbs. |
| Crossmember Mounting Bolts | 25 ft. lbs. |
| Oil Cooler Line | 10 ft. lbs. |
| Line Pressure Take-Off Plug | 13 ft. lbs. |
| Strainer Retainer Bolt | 10 ft. lbs. |
| Oil Cooler Pipe Connectors to Transmission | |
| Case or Radiator | 125 in. lbs. |
| Oil Cooler Pipe to Connector | 10 in. lbs. |
| Downshift Switch to Bracket | 22 in. lbs. |

Classiccarlibrary.com

SPECIAL TOOLS



- | | | | |
|---------------|--|------------------------|--|
| 1. J-8763-02 | Transmission Holding Fixture (Used with J-3289-20 Base) | 14. J-21424-7 | Stator Shaft Front Bushing Installer (Used with J-8092) |
| 2. J-3289-20 | Transmission Holding Fixture Base | 15. J-23062-5 | Input Ring Gear Bushing Remover and Installer |
| 3. J-8092 | Driver Handle (Threaded type) | 16. J-5154 or J-21426 | Extension Housing Oil Seal Installer |
| 4. J-21465-13 | Driver Handle Extension (Used with J-8092) | 17. J-21359 | Pump Oil Seal Installer |
| 5. J-23062-3 | Sun Gear and Reaction Carrier Bushing | 18. J-7004 | Slide Hammers (Pair) (Ear Pump Body removal) (3/8" x 16 tread) |
| 6. J-23062-7 | Output Shaft Bushing Installer | 19. J-21885 | 2-3 Accumulator Piston Compressor |
| 7. J-21465-15 | Stator Shaft Front Bushing Remover (Used with J-8092) | 20. J-23069 | Intermediate Accumulator Cover Remover and Installer |
| 8. J-23329 | Direct Clutch Bushing Installer | 21. J-2619-01 | Slide Hammer (5/8" x 18 with 1/2" x 13 Adapter) |
| 9. J-9534-01 | Output Shaft Bushing Remover | | |
| 10. J-23327 | Clutch Spring Compressor | <u>Not Illustrated</u> | |
| 11. J-23062-2 | Stator Shaft Rear Bushing Installer (Both Rear) | J-21369 | Converter Pressure Check Fixture |
| 12. J-23062-1 | Case Bushing Remover and Installer | J-8001 | Dial Indicator Set (.001" Increments, .001" Travel) |
| 13. J-21424-9 | Extension Housing Bushing Remover and Installer (Used with J-8092) | | |

Fig. 7A-1ST--350 Special Tools

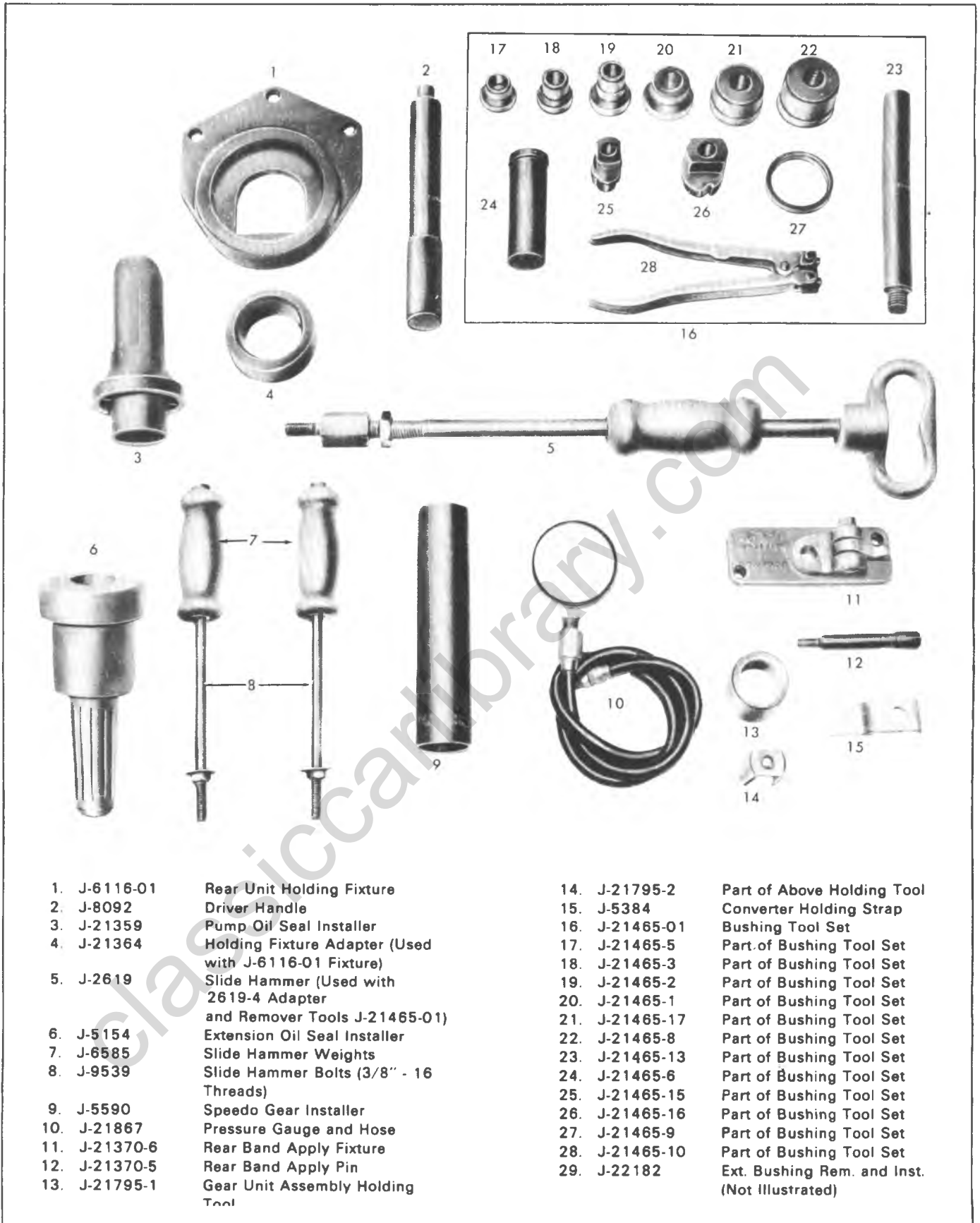
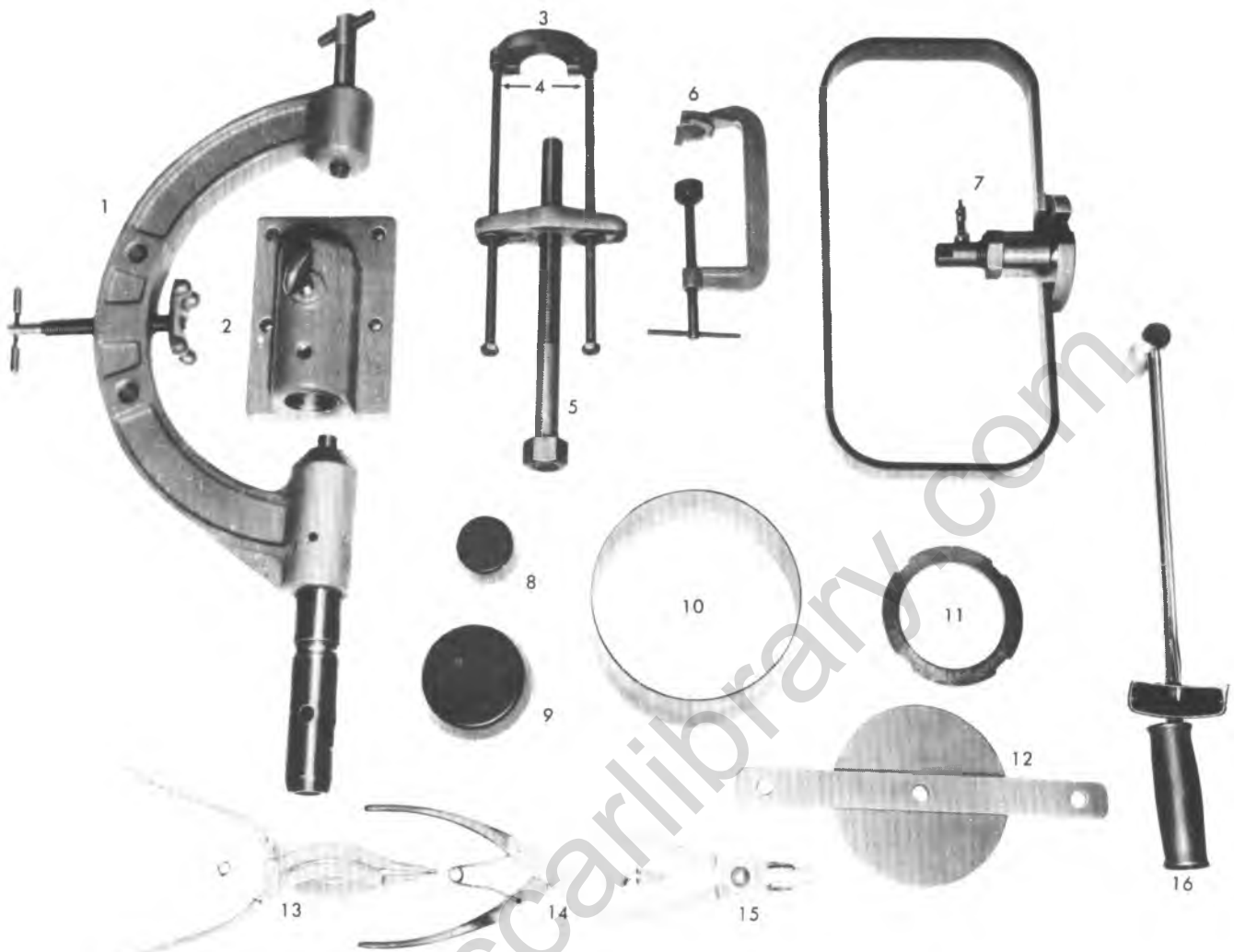


Fig. 7A-2ST-400 Special Tools



- | | | | |
|---------------|--|-----------------|---|
| 1. J-8763 | Transmission Holding Fixture | 11. J-21664 | Clutch Spring Compressor Adapter Ring |
| 2. J-3289-14 | Holding Fixture Base | 12. J-4670 | Clutch Spring Compressor |
| 3. J-21427-1 | Speedo Gear Remover | 13. J-8059 | Snap Ring Pliers |
| 4. J-9539 | Side Hammer Bolts (3/8" - 16 Threads) | 14. J-5586 | Snap Ring Pliers |
| 5. J-8105 | Speedo Gear Remover Puller | 15. J-5403 | Snap Ring Pliers |
| 6. J-22269-01 | Accumulator Piston Remover and Installer | 16. J-1313 | Torque Wrench 0-140 Ft. Lbs. |
| 7. J-21369 | Converter Pressure Check Fixture | Not Illustrated | |
| 8. J-21362 | Seal Protector - Forward and Direct Clutch - Inner | J-24684 | Pressure Regulator Valve Compressor |
| 9. J-21363 | Seal Protector - Intermediate Clutch - Inner | J-24675 | Accumulator Piston Adapter (Used with J-22269-01) |
| 10. J-21409 | Seal Protector - Forward Clutch - Outer | | |

Fig. 7A-3ST-400 Special Tools

SECTION 7B

MANUAL TRANSMISSION

INDEX

| | | | |
|----------------------------------|-------|-----------------------------|-------|
| General Description..... | 7B-1 | Component Parts Replacement | |
| 3-Speed 76mm..... | 7B-1 | Replacement..... | 7B-13 |
| 3-Speed 77mm..... | 7B-1 | Alignment..... | 7B-15 |
| 4-Speed 117mm..... | 7B-1 | Oil Seal..... | 7B-16 |
| Maintenance and Adjustments..... | 7B-7 | Speedo Gear..... | 7B-17 |
| Diagnosis..... | 7B-9 | Side Cover..... | 7B-17 |
| Free Pedal Travel..... | 7B-9 | Shift Control Lever..... | 7B-17 |
| Spin Down Time..... | 7B-9 | Specifications..... | 7B-18 |
| Shift Linkage..... | 7B-9 | Special Tools..... | 7B-19 |
| Shift Effort..... | 7B-10 | | |

GENERAL DESCRIPTION

THREE-SPEED TRANSMISSIONS

3-Speed 76mm

3-Speed 77mm

NOTICE: Manual transmissions are designated according to **A**) the number of forward gears, and **B**) the measured distance between centerlines of the mainshaft and the countergear.

The three speed synchromesh transmissions (Figs. 7B-1 through 7B-3) are representative of a constant-mesh transmission design. Fundamental components of these units are the case, which houses the gears and shaft; the shift control mechanism and the various shafts and gears. The input shaft has an integral main drive gear and rotates with the clutch driven plate; that is, the shaft rotates all the time the clutch is engaged and the engine is running. The input shaft is supported in the case by a ball bearing and at the front end by an oil impregnated bushing mounted in the engine crankshaft. The drive gear is in constant mesh with the countershaft drive gear. Since all gears in the countershaft cluster are integral to the shaft, they also rotate at the time the clutch is engaged. The countergear is carried on roller bearings at both ends and thrust is absorbed by thrust washers located between the countergear and thrust bosses in the case. The transmission mainshaft is held in line with the input shaft by a pilot bearing at its front end, which allows it to rotate or come to rest independently of the input shaft. In the 76 mm unit, the mainshaft is carried at the rear by a ball bearing mounted in the front face of the extension housing. In the 77 mm unit, the mainshaft is carried at the rear by a ball bearing mounted in the rear face of the case.

Helical gears are incorporated throughout, except for reverse gear in the 77 mm transmission. The mainshaft gears

are free to rotate independently on the mainshaft and are in constant mesh with the countershaft gears. The reverse idler gear is carried on a bushing, finish bored in place, and thrust is taken on the thrust bosses of the case.

The transmissions are fully synchronized in all forward speeds; however, reverse gear is not. The synchronizer assemblies consist of a hub, sleeve, two key springs and three synchronizer keys. The synchronizer hubs are splined to the mainshaft and retained by snap rings. These assemblies permit gears to be selected without clashing, by synchronizing the speeds of mating parts before they engage.

In the 76 mm unit, the driven gear, second speed gear, first speed gear and reverse gear are rigidly connected to the countergear. In the 77 mm transmission, only the driven gear, second speed gear and first speed gear are rigidly connected to the countergear. The engine driven clutch gear drives the countergear through a constant mesh countershaft driven gear. The countergear rotates in a direction opposite, or counter, to the rotation of the clutch gear. Forward speed gears on the countergear remain in constant mesh with two nonsliding mainshaft gears giving first and second speed. Third speed is a direct drive with the clutch gear engaged directly to the mainshaft. Forward gears are engaged through two sliding synchronizer sleeves mounted on the mainshaft. Engagement of the constant mesh mainshaft gears to the mainshaft is accomplished through blocker ring-type synchronizers.

FOUR-SPEED TRANSMISSION

4-Speed 117mm

The 117mm, Model CH 465 truck transmission (Figs. 7B-4 and 7B-5) uses a constant mesh first gear that engages with the second speed synchronizer sleeve. Second, third and fourth gears are synchronized. The clutch gear is

7B-2 MANUAL TRANSMISSIONS

supported by a heavy duty ball bearing. The forward end of the mainshaft is supported by a loose collar-type bearing inside the clutch gear, while the rear is carried on a ball bearing in the case. End play is taken up by the rear flange retaining nut. The countergear is supported at the rear by a single row ball bearing which takes the thrust load, and by a roller bearing at the front. Incorporated in the cover is a ball pin type interlock which prevents simultaneous engagement of two gears. As one rod is moved, it pushes a ball out that engages the other two rods to prevent their movement.

Gearshift levers on manual transmissions are located either on the steering column or on the floorboard. Regardless of location, the lever performs two operations: It selects the gear assembly to be moved, and moves it either forward or backward into the desired gear position. The transmission action is the same whether a floor-type shift lever or a steering column shift lever is used. When the shift lever is moved, the movement is carried by linkage to the transmission.

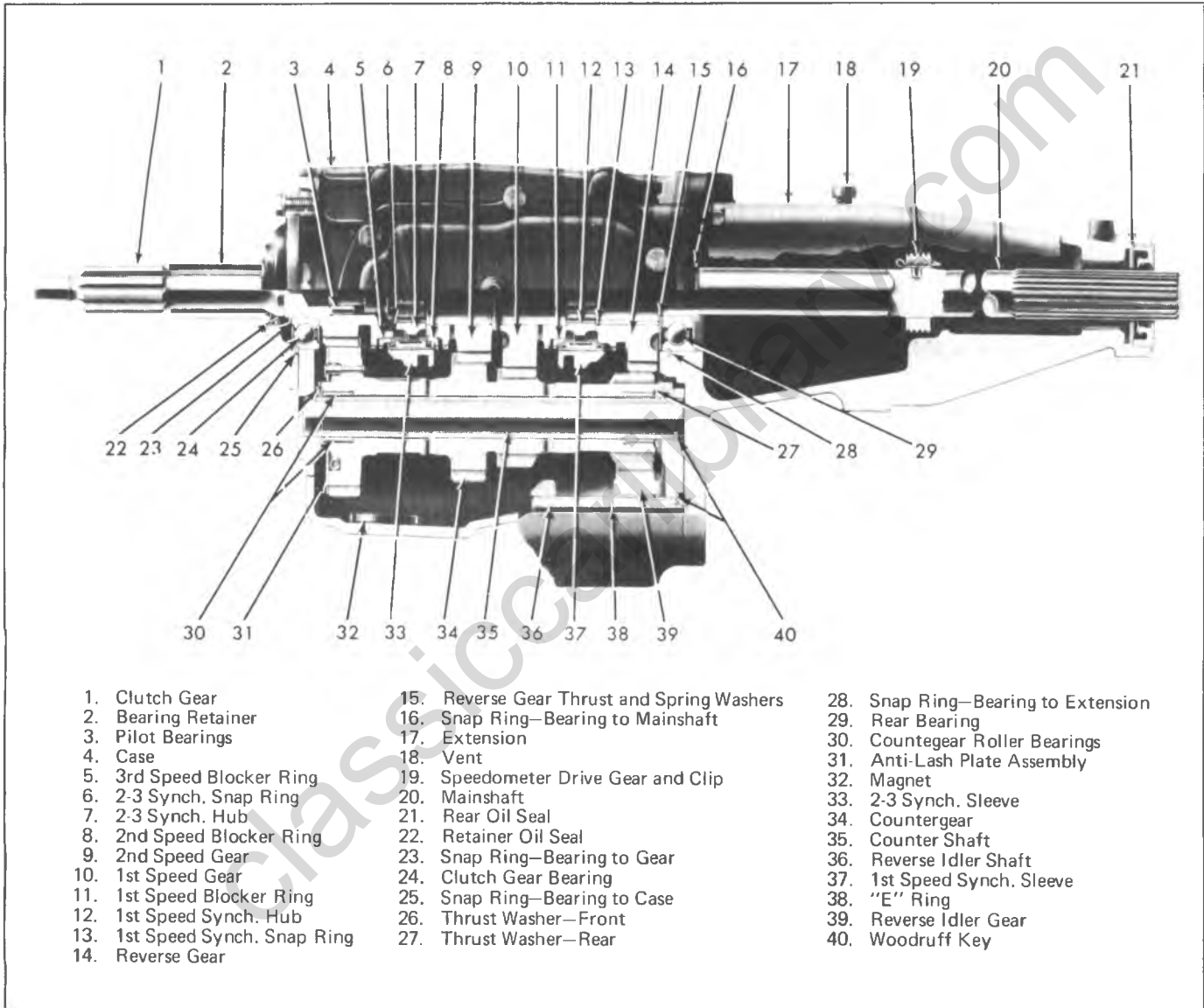
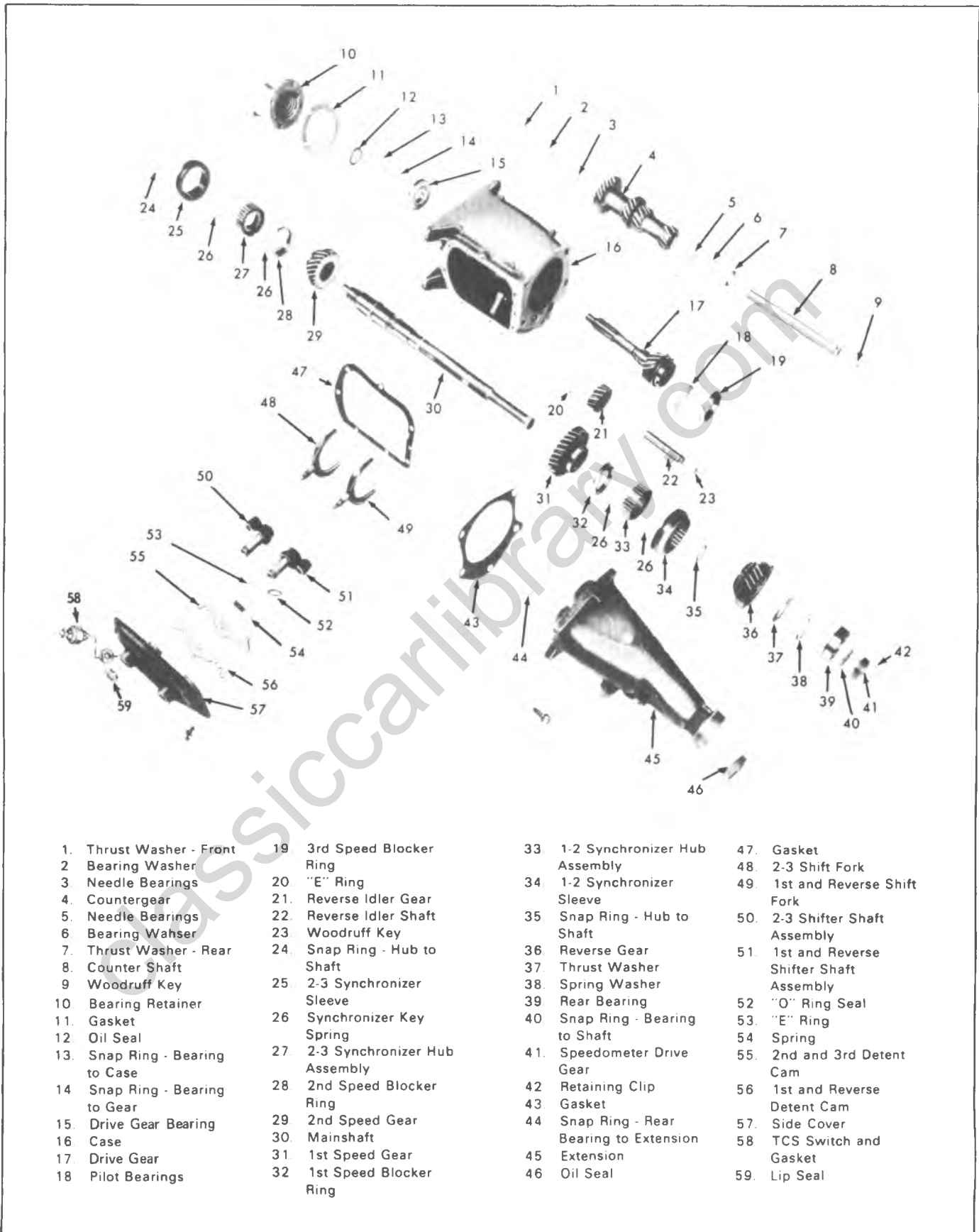
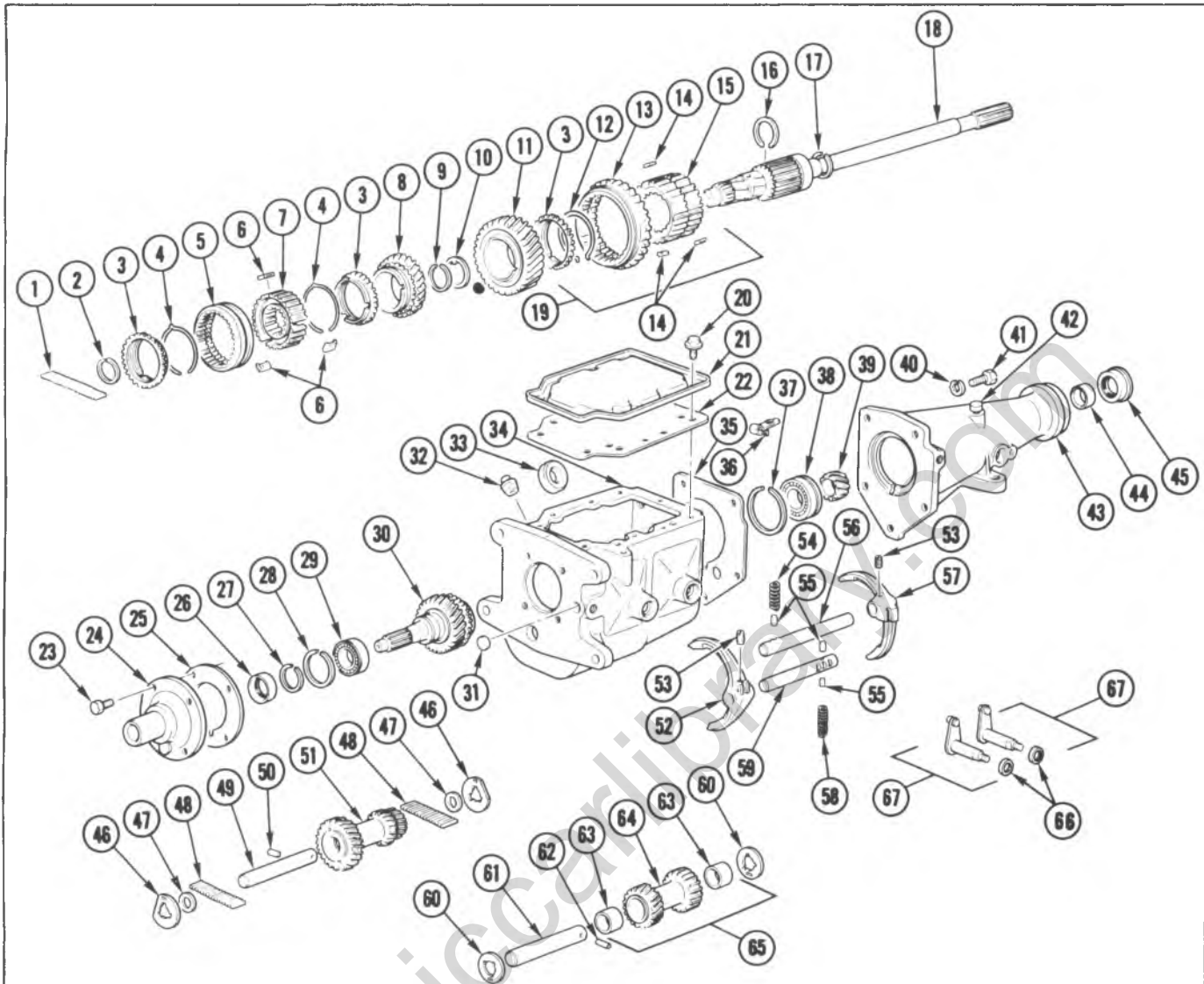


Fig. 7B-1--3-Speed 76mm, Cross-Section



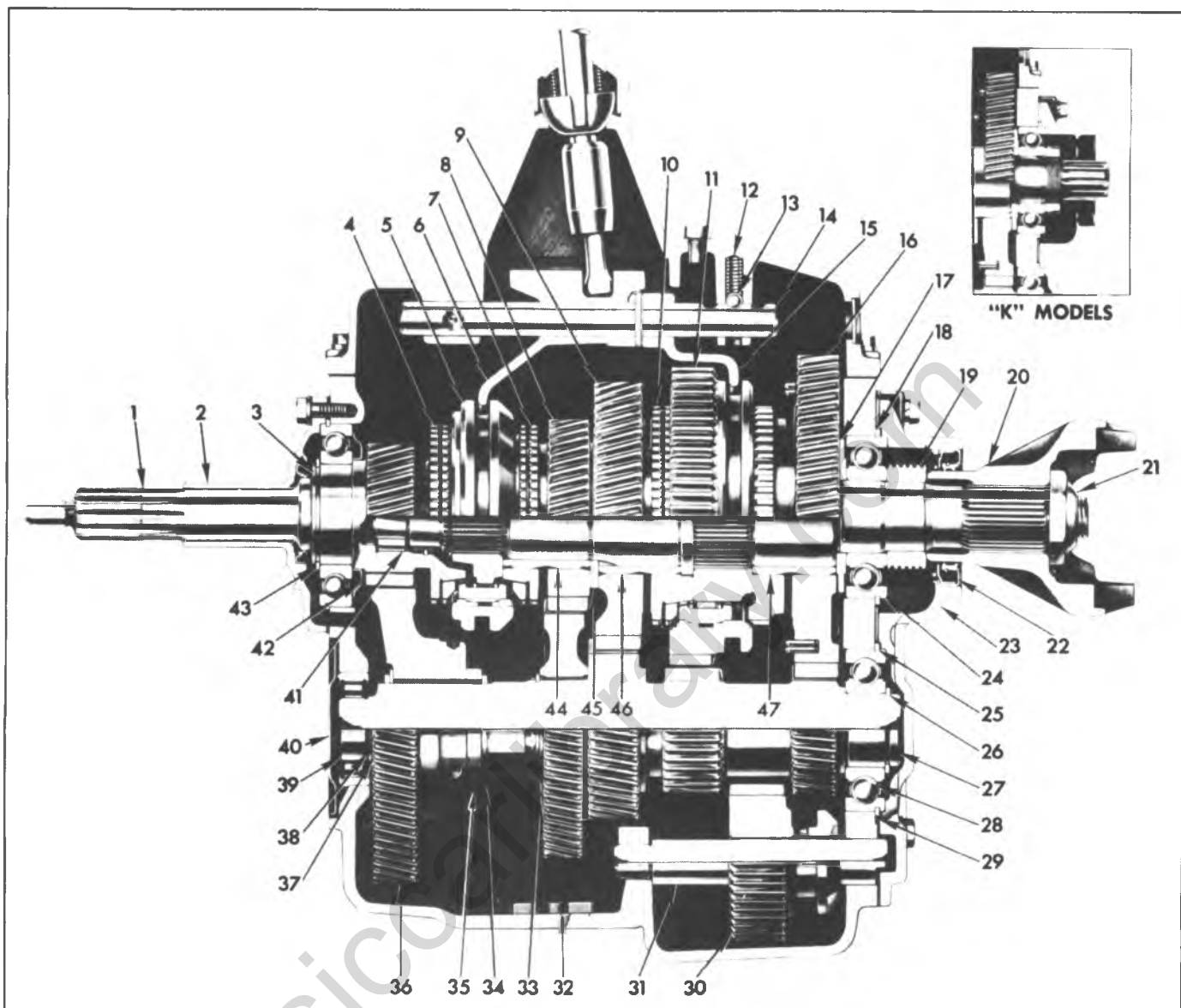
- | | | | |
|---------------------------------|-----------------------------------|---|--|
| 1. Thrust Washer - Front | 19. 3rd Speed Blocker Ring | 33. 1-2 Synchronizer Hub Assembly | 47. Gasket |
| 2. Bearing Washer | 20. "E" Ring | 34. 1-2 Synchronizer Sleeve | 48. 2-3 Shift Fork |
| 3. Needle Bearings | 21. Reverse Idler Gear | 35. Snap Ring - Hub to Shaft | 49. 1st and Reverse Shift Fork |
| 4. Countergear | 22. Reverse Idler Shaft | 36. Reverse Gear | 50. 2-3 Shifter Shaft Assembly |
| 5. Needle Bearings | 23. Woodruff Key | 37. Thrust Washer | 51. 1st and Reverse Shifter Shaft Assembly |
| 6. Bearing Washer | 24. Snap Ring - Hub to Shaft | 38. Spring Washer | 52. "O" Ring Seal |
| 7. Thrust Washer - Rear | 25. 2-3 Synchronizer Sleeve | 39. Rear Bearing | 53. "E" Ring |
| 8. Counter Shaft | 26. Synchronizer Key Spring | 40. Snap Ring - Bearing to Shaft | 54. Spring |
| 9. Woodruff Key | 27. 2-3 Synchronizer Hub Assembly | 41. Speedometer Drive Gear | 55. 2nd and 3rd Detent Cam |
| 10. Bearing Retainer | 28. 2nd Speed Blocker Ring | 42. Retaining Clip | 56. 1st and Reverse Detent Cam |
| 11. Gasket | 29. 2nd Speed Gear | 43. Gasket | 57. Side Cover |
| 12. Oil Seal | 30. Mainshaft | 44. Snap Ring - Rear Bearing to Extension | 58. TCS Switch and Gasket |
| 13. Snap Ring - Bearing to Case | 31. 1st Speed Gear | 45. Extension | 59. Lip Seal |
| 14. Snap Ring - Bearing to Gear | 32. 1st Speed Blocker Ring | 46. Oil Seal | |

Fig. 7B-2-3-Speed 76mm, Exploded View



- | | |
|--|---|
| <ol style="list-style-type: none"> 1. MAINSHAFT ROLLER BEARINGS 2. 2ND & 3RD SYNCHRONIZER RETAINING RING 3. SYNCHRONIZER BLOCKER RINGS 4. 2ND & 3RD SYNCHRONIZER SPRING 5. 2ND & 3RD SYNCHRONIZER SLEEVE 6. 2ND & 3RD SYNCHRONIZER KEYS 7. 2ND & 3RD SYNCHRONIZER HUB 8. SECOND SPEED GEAR 9. 1ST SPEED GEAR RETAINING RING 10. 1ST SPEED GEAR TABBED WASHER 11. 1ST SPEED GEAR 12. REVERSE SYNCHRONIZER SPRING 13. 1ST & REVERSE SYNCHRONIZER SLEEVE & GEAR 14. REVERSE SYNCHRONIZER KEYS 15. 1ST & REVERSE SYNCHRONIZER HUB 16. 1ST & REVERSE SYNCHRONIZER RETAINING RING 17. REAR BEARING RETAINING RING 18. TRANSMISSION MAINSHAFT 19. REVERSE SYNCHRONIZER ASSEMBLY 20. ACCESS COVER BOLTS 21. ACCESS COVER 22. ACCESS COVER GASKET 23. BEARING RETAINER - TO CASE BOLTS 24. BEARING RETAINER - CLUTCH GEAR 25. GASKET - CLUTCH GEAR BEARING RETAINER 26. SEAL ASSEMBLY - CLUTCH GEAR BEARING RETAINER 27. CLUTCH GEAR BEARING RETAINING RING 28. CLUTCH GEAR BEARING LOCK RING 29. CLUTCH GEAR BEARING ASSEMBLY 30. CLUTCH GEAR 31. EXPANSION PLUG 32. FILLER PLUG 33. TRANSMISSION CASE MAGNET 34. CASE | <ol style="list-style-type: none"> 35. EXTENSION HOUSING TO CASE GASKET 36. SPEEDOMETER DRIVER GEAR RETAINING CLIP 37. TRANSMISSION REAR BEARING LOCK RING 38. MAINSHAFT BEARING ASSEMBLY 39. SPEEDOMETER DRIVE GEAR 40. EXTENSION TO CASE WASHER 41. EXTENSION TO CASE BOLT 42. TRANSMISSION EXTENSION VENTILATOR ASSEMBLY 43. EXTENSION HOUSING ASSEMBLY 44. EXTENSION HOUSING BUSHING 45. EXTENSION HOUSING OIL SEAL ASSEMBLY 46. COUNTERGEAR THRUST WASHER 47. COUNTERGEAR SPACER 48. COUNTERGEAR ROLLET BEARINGS 49. COUNTERGEAR SHAFT 50. COUNTERGEAR SPRING PIN 51. COUNTERGEAR 52. 2ND & 3RD SHIFTER FORK 53. SHIFTER LOCKING SCREW 54. 1ST & 2ND SHIFTER INTERLOCK SPRING 55. SHIFTER INTERLOCK PIN 56. 1ST & REVERSE SHIFTER RAIL 57. 1ST & REVERSE SHIFTER FORK 58. 2ND & 3RD SHIFTER INTERLOCK SPRING 59. 2ND & 3RD SHIFTER RAIL 60. REVERSE IDLER GEAR THRUST WASHER 61. REVERSE IDLER GEAR SHAFT 62. SPRING PIN IDLER GEAR SHAFT 63. REVERSE IDLER GEAR BUSHING 64. REVERSE IDLER GEAR 65. REVERSE IDLER GEAR ASSEMBLY 66. SEAL TRANSMISSION SHIFTER 67. TRANSMISSION SHIFTER SHAFT & LEVER ASSEMBLY |
|--|---|

Fig. 7B-3--3-Speed 77mm, Exploded View



- | | | | |
|--|------------------------------------|-------------------------------|--------------------------------|
| 1. Main Drive Gear | 11. Reverse Driven Gear | 24. Mainshaft Rear Bearing | 37. Thrust Washer |
| 2. Drive Gear Bearing Retainer | 12. Poppet Spring | 25. Rear Bearing Snap Ring | 38. Snap Ring |
| 3. Snap Ring-Outer | 13. Poppet Ball | 26. Snap Ring | 39. Front Countershaft Bearing |
| 4. 3rd and 4th Synchronizer Ring | 14. Shift Rail | 27. Countershaft | 40. Countergear Front Cover |
| 5. 3rd and 4th Synchronizer Collar | 15. 1st and 2nd Shift Fork | 28. Countershaft Rear Bearing | 41. Pilot Bearing Rollers |
| 6. 3rd and 4th Shift Fork | 16. 1st Speed Gear | 29. Bearing Snap Ring | 42. Clutch Gear Oil Slinger |
| 7. 3rd and 4th Speed Synchronizer Ring | 17. Thrust Washer | 30. Reverse Idler Gear | 43. Snap Ring |
| 8. 3rd Speed Gear | 18. Bearing Snap Ring | 31. Reverse Idler Shaft | 44. 3rd Speed Gear Bushing |
| 9. 2nd Speed Gear | 19. Speedometer Drive Gear | 32. Case Magnet | 45. Thrust Washer |
| 10. 1st and 2nd Synchronizer Assembly | 20. Output Yoke | 33. Snap Ring | 46. 2nd Speed Gear Bushing |
| | 21. Flange Nut | 34. Snap Ring | 47. 1st Speed Gear Bushing |
| | 22. Rear Bearing Retainer Oil Seal | 35. Spacer | |
| | 23. Rear Bearing Retainer | 36. Countergear | |

Fig. 7B-4--4-Speed, 117mm, Cross-Section

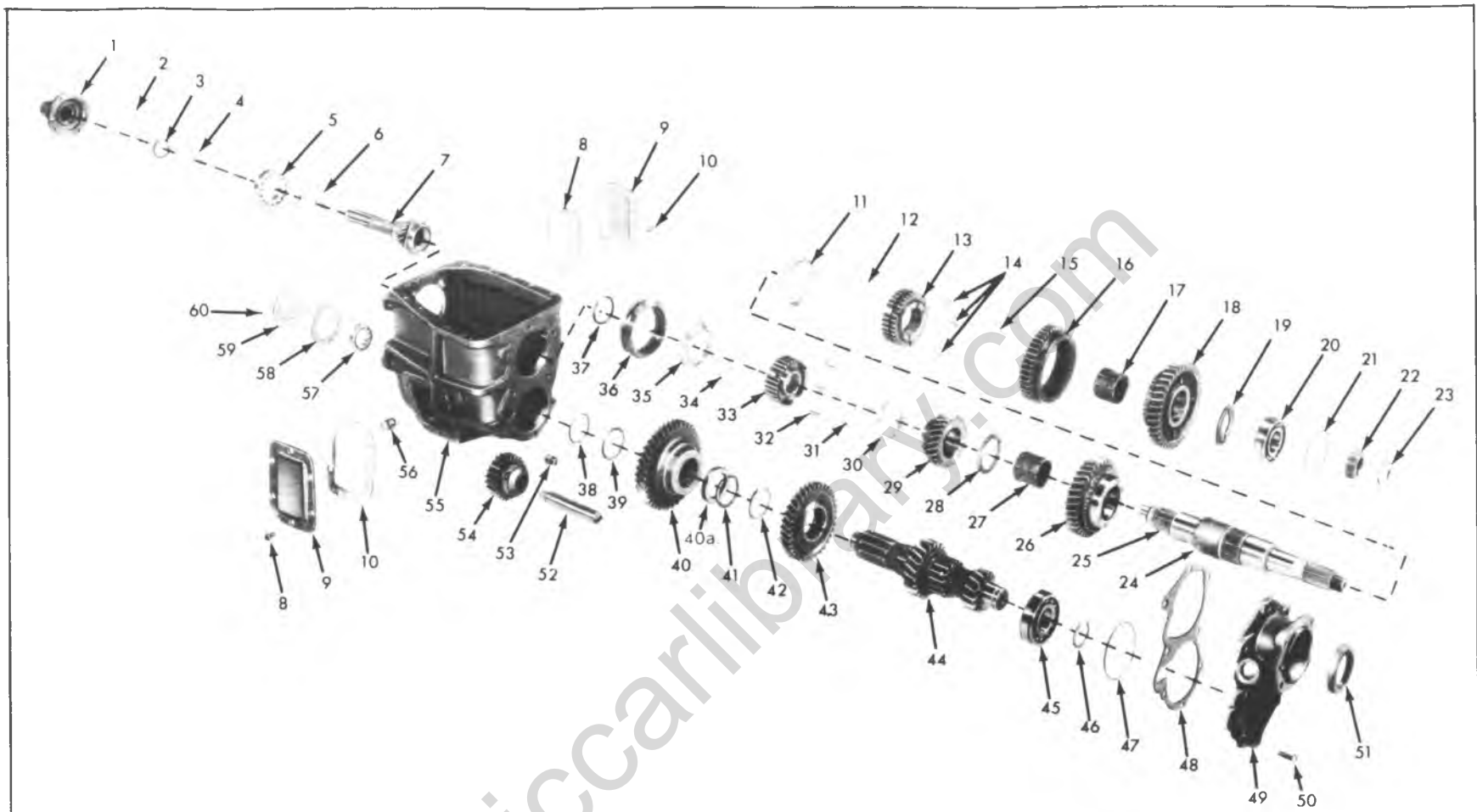


Fig. 7B-5-4-Speed 1.17mm, Exploded View

- | | | | | |
|----------------------------------|------------------------------------|---------------------------------------|------------------------------|-------------------------------|
| 1. Drive Gear Bearing Retainer | 13. 1st-2nd Speed Synchronizer Hub | 26. 2nd Speed Gear | 37. Snap Ring | 48. Rear Retainer Gasket |
| 2. Retainer Gasket | 14. Synchronizer Keys | 27. 3rd Gear Bushing | 38. Snap Ring | 49. Rear Retainer |
| 3. Lip Seal | 15. Synchronizer Spring | 28. Thrust Washer | 39. Thrust Washer | 50. Retainer Bolts |
| 4. Snap Ring | 16. Reverse Driven Gear | 29. 3rd Speed Gear | 40. Clutch Countergear | 51. Retainer Lip Seal |
| 5. Drive Gear Bearing | 17. 1st Gear Bushing | 30. 3rd Speed Blocker Ring | 40a. Spacer | 52. Reverse Idler Shaft |
| 6. Oil Slinger | 18. 1st Gear | 31. Synchronizer Spring | 41. Snap Ring | 53. Drain Plug |
| 7. Drive Gear and Pilot Bearings | 19. Thrust Washer | 32. Synchronizer Keys | 42. Snap Ring | 54. Reverse Idler Gear |
| 8. Power Take-Off Cover Gasket | 20. Rear Main Bearing | 33. 3rd-4th Synchronizer Hub | 43. 3rd Speed Countergear | 55. Case |
| 9. Power Take-Off Cover | 21. Bearing Snap Ring | 34. Synchronizer Spring | 44. Countergear Shaft | 56. Fill Plug |
| 10. Retaining Screws | 22. Speedometer Gear | 35. 3rd-4th Speed Blocker Ring | 45. Countergear Rear Bearing | 57. Countergear Front Bearing |
| 11. 1st 2nd Speed Blocker Ring | 23. Rear Mainshaft Lock Nut | 36. 3rd-4th Speed Synchronizer Sleeve | 46. Snap Ring | 58. Gasket |
| 12. Synchronizer Spring | 24. 2nd Speed Bushing (On Shaft) | | 47. Bearing Outer Snap Ring | 59. Front Cover |
| | 25. Mainshaft | | | 60. Cover Screws |

MAINTENANCE AND ADJUSTMENTS

TRANSMISSION LINKAGE ADJUSTMENT

3-Speed Column Shift

(Figs. 7B-6, 7B-7, and 7B-8)

In cases where gearshift linkage has been disconnected or removed, proper adjustment sequence is important.

1. Set both shifter levers in neutral position. Install control rods to both second and third shifter lever and first and reverse shifter lever.

2. Align both shifter tube levers on mast jacket in the neutral position. Install gauge (3/16 to 7/32 in.) in holes of levers so that gearshift control lever is in neutral position.

3. Connect control rods to tube levers making sure clamps are properly adjusted so that tube levers and

transmission shifter levers remain in their neutral positions while tightening.

4. Remove gauge and move selector lever through all positions to check adjustment and insure over-travel in all positions.

NOTICE: If mast jacket lower dash clamp has been disturbed at its mounting on dash, its adjustment to the steering mainshaft should be checked as outlined in Section 3B4 of this manual.

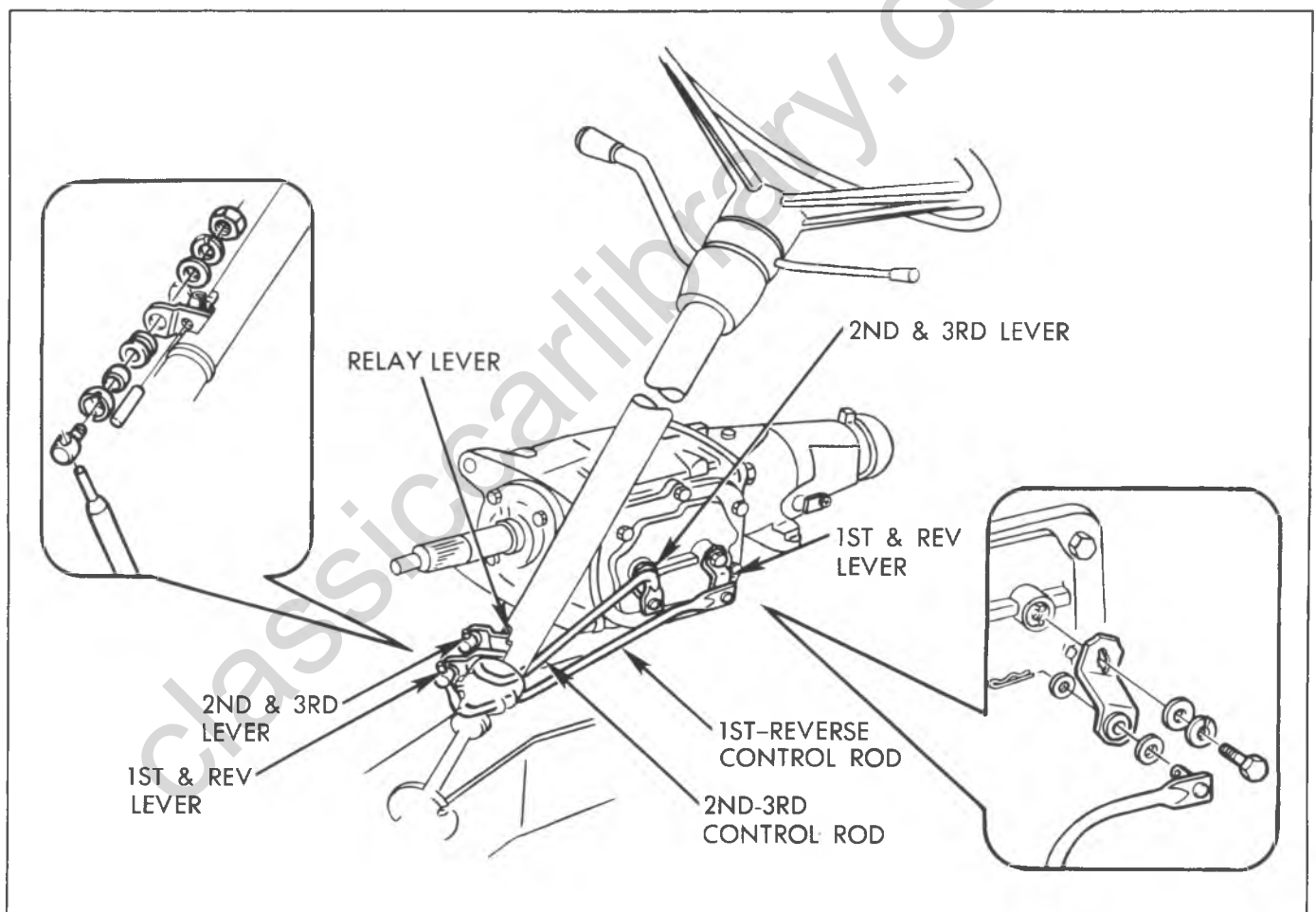
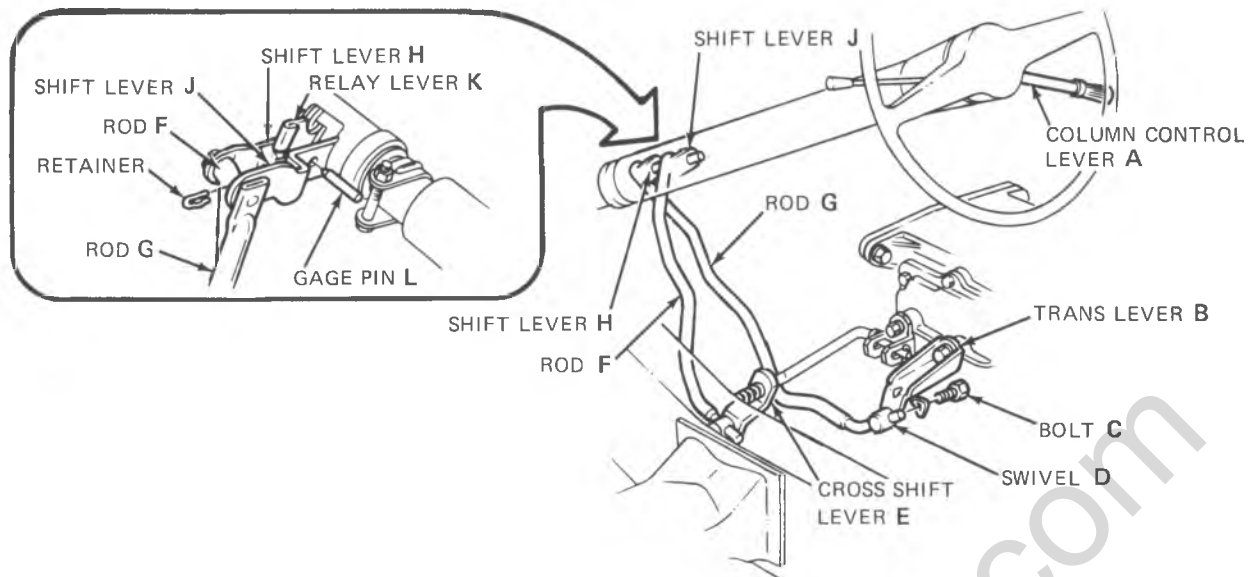


Fig. 7B-6--G-Truck Column Shift Linkage



TRANSMISSION CONTROL LINKAGE ADJUSTMENT

1. Set Levers (A) and (B) in "REVERSE" position and turn ignition switch to "LOCK" position. **NOTE** Obtain "REVERSE" position by moving Trans Lever (B) clockwise to forward detent.
2. Attach Rod (G) to Shift Lever (J) with retainer. See View A. Slide swivel (D) onto Rod (G). Insert Swivel (D) into Lever (B) and loosely assembly with bolt (C) and washer at this time.
3. Remove column "LASH" by rotating Lever (J) in a downward direction and complete attachment of Rod (G) to Lever (B) by tightening Bolt (C) using recommended torque.
4. Turn ignition key to "UNLOCK" position and position Levers (A), (B) and (E) in "NEUTRAL". **NOTE** Obtain "NEUTRAL" position by moving Levers (B) and (E) clockwise to forward detent then counter-clockwise one detent.
5. Align gage holes in Levers (H), (J) and (K) and insert Gage Pin (L).
6. Repeat steps 2 & 3 for Rod (F) & Levers (E) & (H).
7. Remove Gage Pin (L).

NOTE With shift lever in "REVERSE" the ignition key must move freely to "LOCK" position. It must not be possible to obtain ignition "LOCK" position in "NEUTRAL" or any gear other than "REVERSE".

Fig. 7B-7--C and K-Truck Column Shift Linkage

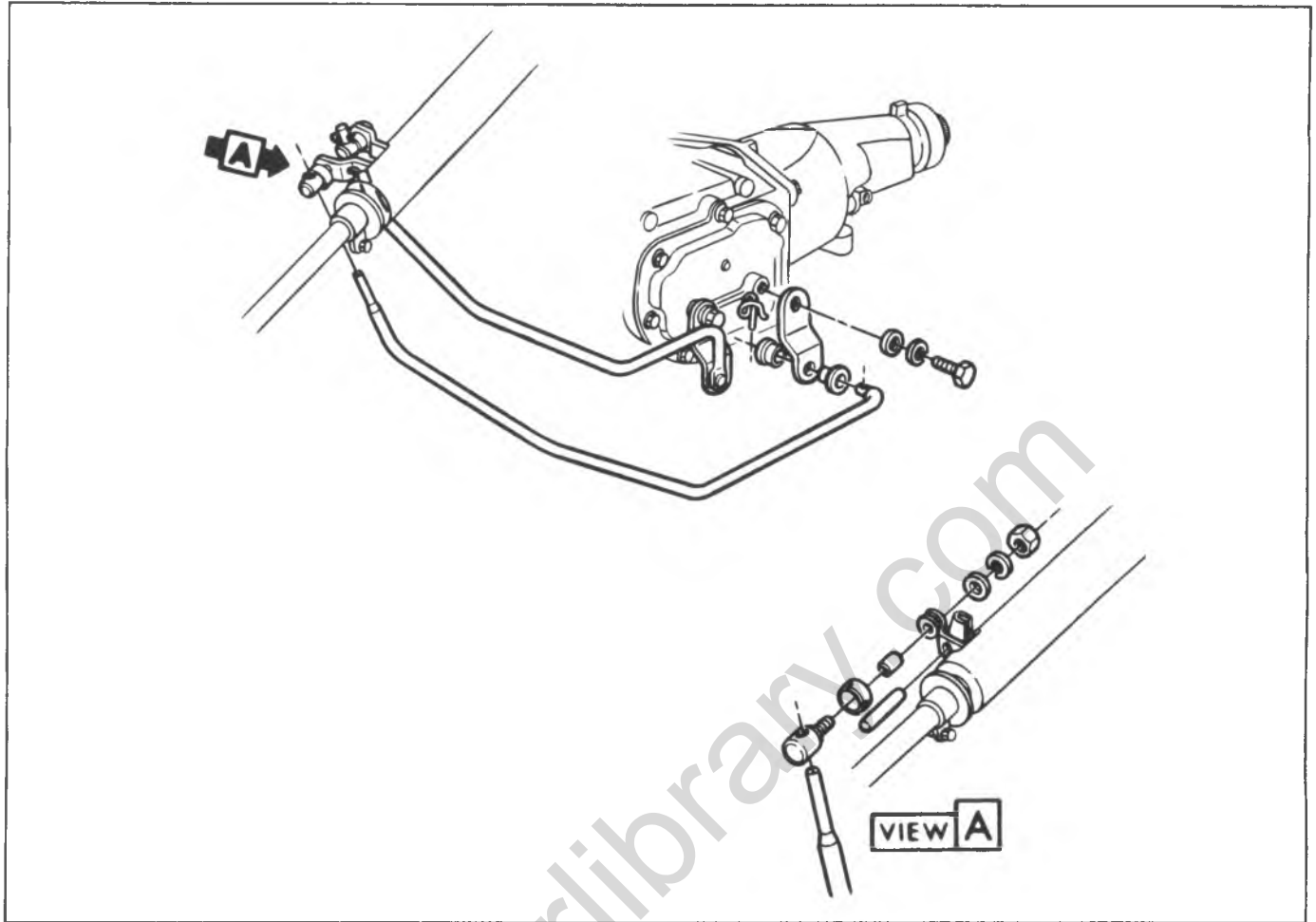


Fig. 7B-8--P-Truck Column Shift Linkage

DIAGNOSIS

Preliminary Inspection

Before attempting to repair the clutch, transmission or related linkages for any reason other than an obvious failure, the problem and probable cause should be identified. A large percentage of clutch and manual transmission problems are manifested by shifting difficulties such as high shift effort, gear clash and grinding or transmission blockout. When any of these problems occur a careful analysis of these difficulties should be accomplished, and the following checks and adjustments performed in the presented sequence before removing the clutch or transmission for repairs.

CLUTCH ADJUSTMENT

Clutch Free Pedal Travel

1. The clutch free pedal travel adjustment should be made as outlined in Section 7C.
2. Check clutch linkage for lost motion caused by loose or worn swivels, deflection of mounting brackets or damaged cordon shaft.

Clutch Spin Down Time

1. Run the engine at a normal idle with transmission in neutral and clutch engaged.
2. Disengage the clutch, wait nine seconds and shift the transmission to reverse. No grinding noise should be heard. A grinding noise indicates incorrect clutch adjustment, lost motion clutch misalignment, or internal problems such as failed dampers, facings, cushion springs, diaphragm spring fingers, pressure plate drive straps, etc.

SHIFT LINKAGE ADJUSTMENT

Steering Column Shift Control

1. Remove the shift control rods from the column levers.
2. Check shift effort at the shift control lever knob. (Effort should not exceed 2 lbs. with transmission linkage removed.)
3. If binding is felt, refer to the adjustment procedure for the steering column lower bearing in Section 3B.
4. Lubricate all rod and swivel connections and recheck

| | |
|-----------------------------|--------------|
| SHIFT TORQUE Inch-Pounds | 3-SPD — 76mm |
| | 50 |

Fig. 7B-9--Shift Torque Chart

shift effort after installation.

5. If shift linkage is free from binding, the column levers should be checked for end play. A .005" feeler gauge should fit between the levers and control lever.

6. Connect control rods and check steering column control levers for alignment. In neutral, the column control lever tangs should line up with the slot in the main control lever.

Floor Shift Control

All swivels, rods and mountings should be checked for lost motion and repaired or replaced as necessary. Transmission control levers should be checked for wear and repaired or replaced as necessary.

TRANSMISSION SHIFT EFFORT

Transmission Shift Effort Checking Procedures

1. Remove the shift rods at the transmission and align the sleeve, blocker ring and gear by shifting into the offending gear and then back into neutral.

2. Check the torque required to shift into gear with an inch pound torque wrench on the shift lever attaching bolt. If more than the specified torque (Fig. 7B-11) is required, the transmission shift lever should be checked for rust or dirt binding the lever.

3. Clean levers, lubricate and recheck the torque value.

NOTICE: If at this point in the procedure, it is found that high shift effort or blockout still exists, an anti-chatter lubricant (positraction additive) should be used. The lubricant is available in plastic bottle and can be squirted into the transmission through the filler plug.

Transmission Internal Problems Related to Shift Effort

When the above procedures have been checked and the problem still exists, the transmission will have to be removed and disassembled for further diagnosis. There are

three basic types of transmission internal problems reflected by shifting effort.

1. **Hard Shifting** - The effort to shift is excessive, but the gears engage. The lever moves with excessive effort throughout the entire travel range. If the static shift effort is high, (clutch depressed, engine not running) the synchronizer sleeve and hubs should be checked for a tight fit. With the three synchronizer keys removed, the sleeve should be loose on the hub. If the hub and sleeve are not a loose fit, replace the synchronizer assembly.

2. **Blockout** - The lever moves freely until the synchronizer is engaged. Synchronization should be heard to take place, but the gear will not engage. When it does engage, a double bump is generally felt in the lever. The synchronized blocker ring can be damaged by excessive force on gear cones that are finished improperly. The blocker ring material may stick to the synchronizer gear cone causing it to be a yellowish brass color, in streaks, which results in hard shifts when present. The gear cone should be a bright silver color. Polish the gear cone with 400 grit paper to a bright silver when this condition is present. The blocker rings should be replaced if the thread is damaged or worn.

3. **Clash** - Gear clash is a sound which sometimes occurs when the sleeve and gear chamfers contact each other in the unsynchronized state. The characteristics of clash are a grating or loud buzzing sound from the transmission. The shift lever load will be lower, but a vibration should be felt. The noise (clash) can be for a short instant or long enough to keep the gear from being engaged. This condition should not be confused with hard shifting or reported as such. Hard shifting and clash are directly opposite conditions. When the clash is slight, the load will build up on the shift lever and then fall off rapidly followed by the grating sound.

If the transmission has been clashing, the sleeve ends should be examined for chipping and burrs. If the sleeves are damaged, the synchronizer assemblies and blocker rings should be replaced. Synchronizer sleeve ends should have an angular surface. The surfaces should be even from side to side and the radii indicated should be very small. Any chipping will require synchronizer replacement.

Check the synchronizer load. When the keys are installed, the spring ends on one side of the hub should be hooked in one key and the spring on the opposite side of the synchronizer should not be hooked on the same key. A definite load should be felt when the sleeve is moved on the hubs with the keys and springs in proper position.

SHIFTING DIFFICULTY DIAGNOSIS

| CONDITION | PROBABLE CAUSE | CORRECTION |
|---|--|--|
| High Shift Effort-Column Shift (Effort exceeds 2 ft. lbs. at lever knob with transmission linkage disconnected.) | Binding of column levers | Adjust column mechanism per Section 3B Steering of the Chassis Service Manual |
| | | Clean and lubricate all rod and swivel connections. |
| | Lever end play exceeds .005 in. | Adjust levers |
| | Misalignment of column control levers. | Adjust levers |
| Gear Clash and binding | Improper linkage Adjustment | Adjust Shift linkage |
| Lost motion | Loose or worn swivels and grommets. Deflection of Mounting Brackets. Loose shift levers. Damaged Cordon Shaft | Replace defective parts |

Fig. 7B-10--Shifting Difficulty Diagnosis Chart

Classiccarlibrary.com

MANUAL TRANSMISSION DIAGNOSIS

| CONDITION | PROBABLE CAUSE | CORRECTION |
|--------------------------------------|--|--|
| Slips out of High Gear | <ul style="list-style-type: none"> a. Transmission loose on clutch housing b. Shift rods interfere with engine mounts or clutch throw-out lever c. Shift linkage does not work freely; binds d. Damaged mainshaft pilot bearing e. Main drive gear retainer broken or loose f. Dirt between transmission case and clutch housing g. Misalignment of transmission h. Stiff shift lever seal i. Pilot bearing loose in crankshaft j. Worn or improperly adjusted linkage | <ul style="list-style-type: none"> a. Tighten mounting bolts b. Replace or bend levers and rods to eliminate interference c. Adjust and free up shift linkage d. Replace pilot bearing e. Tighten or replace main drive gear f. Clean mating surfaces g. Refer to TRANSMISSION ALIGNMENT h. Replace seal i. See Section 6 for brg. fits j. Adjust or replace linkage as required |
| Noisy in All Gears | <ul style="list-style-type: none"> a. Insufficient lubricant b. Worn countergear bearings c. Worn or damaged main drive gear and countergear d. Damaged main drive gear or main shaft bearings e. Worn or damaged countergear anti-lash plate | <ul style="list-style-type: none"> a. Fill to correct level b. Replace countergear bearings and shaft c. Replace worn or damaged gears d. Replace damaged bearings or main drive gear e. Replace countergear |
| Noisy in High Gear | <ul style="list-style-type: none"> a. Damaged main drive gear bearing b. Damaged mainshaft bearing c. Damaged high speed gear synchronizer | <ul style="list-style-type: none"> a. Replace damaged bearing b. Replace damaged bearing c. Replace synchronizer |
| Noisy in Neutral with Engine Running | <ul style="list-style-type: none"> a. Damaged main drive gear bearing b. Damaged or loose mainshaft pilot bearing c. Worn or damaged countergear anti-lash plate d. Worn countergear bearings | <ul style="list-style-type: none"> a. Replace damaged bearing b. Replace pilot bearings. See Section 6 for bearing fits c. Replace countergear d. Replace countergear bearings and shaft |
| Noisy in all Reduction Gears | <ul style="list-style-type: none"> a. Insufficient lubricant b. Worn or damaged main drive gear or countergear | <ul style="list-style-type: none"> a. Fill to correct level b. Replace faulty or damaged gears |
| Noisy in Second Only | <ul style="list-style-type: none"> a. Damaged or worn second-speed constant mesh gears b. Worn or damaged countergear rear bearings c. Damaged or worn second-speed synchronizer | <ul style="list-style-type: none"> a. Replace damaged gears b. Replace countergear bearings and shaft c. Replace synchronizer |
| Noisy in Third Only (Four Speed) | <ul style="list-style-type: none"> a. Damaged or worn third-speed constant mesh gears b. Worn or damaged countergear bearings | <ul style="list-style-type: none"> a. Replace damaged gears b. Replace damaged countergear bearings and shaft |

Fig. 7B-11--Manual Transmission Diagnosis Chart A

MANUAL TRANSMISSION DIAGNOSIS (CONT'D.)

| CONDITION | PROBABLE CAUSE | CORRECTION |
|--|---|---|
| Noisy in Reverse Only | a. Worn or damaged reverse idler gear or idler bushing b. Worn or damaged reverse gear on mainshaft c. Damaged or worn reverse countergear d. Damaged Shift mechanism | a. Replace reverse idler gear assembly b. Replace reverse gear c. Replace countergear assembly d. Inspect linkage and adjust or replace damaged parts |
| Excessive Backlash in all Reduction Gears | a. Worn countergear bearings b. Excessive end play in countergear | a. Replace bearings b. Replace countergear thrust washers |
| Main Drive Gear Bearing Retainer Burned or Scored by Input Shaft | a. Loose or damaged mainshaft pilot bearing b. Misalignment of transmission | a. Replace bearing. See Section 6 for bearing fit b. Align transmission |
| Leaks Lubricant | a. Excessive amount of lubricant in transmission b. Loose or broken main drive gear bearing retainer c. Main drive gear bearing retainer gasket damaged d. Side cover loose or gasket damaged e. Rear bearing retainer oil seal leaks f. Countershaft loose in case g. Shift lever seals leak | a. Drain to correct level b. Tighten or replace retainer c. Replace gasket d. Tighten cover or replace gasket e. Replace seal f. Replace case g. Replace seal |

Fig. 7B-12--Manual Transmission Diagnosis Chart B

COMPONENT REPLACEMENT

TRANSMISSION REPLACEMENT

3-Speed and 4-Speed Transmission Removal

(Except K Series)

1. Raise vehicle on suitable hoist and drain lubricant

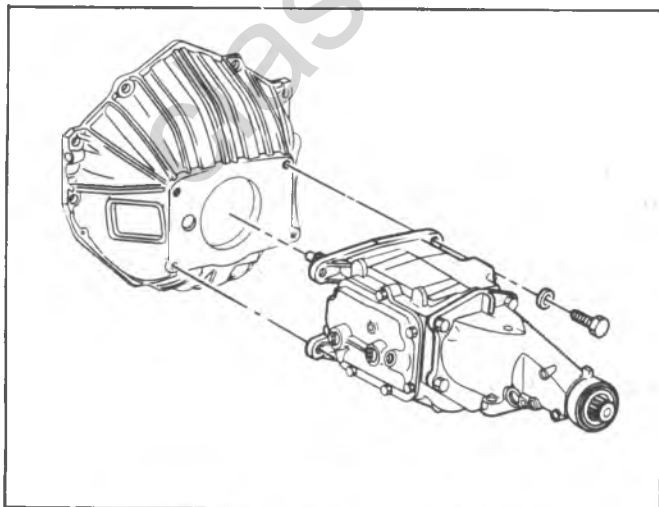


Fig. 7B-13--Typical Transmission Mounting

from transmission.

2. Disconnect speedometer cable.
3. Remove shift controls from transmission.

NOTICE: On vehicle equipped with 4-Speed transmission, remove the gearshift lever using Tool J-8109 as shown in Figure 7B-14. Press down firmly and rotate tool counterclockwise to release gearshift lever.

Place clean lint-free cloth or other suitable covering over opening on transmission to prevent entry of dirt or foreign material.

4. Disconnect parking brake lever and controls (when used) and back up lamp switch wire.
5. Disconnect propeller shaft from transmission as described in Section 4-A.
6. Position a suitable dolly or jack under the vehicle and adjust to carry the weight of the transmission.
7. Visually inspect to determine if other equipment, lines or brackets must be removed to permit removal of the transmission. Remove crossmember.

CAUTION: Be sure to support the clutch release bearing and support assembly during removal of the transmission main

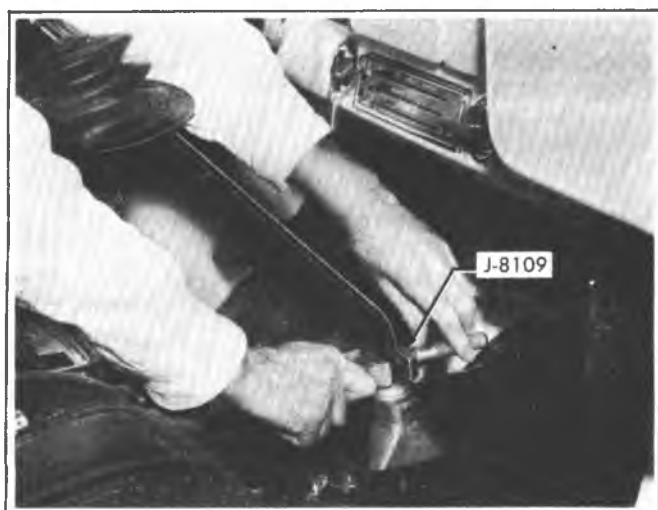


Fig. 7B-14--Removing Gearshift Lever

drive gear from the flywheel housing. This will prevent the release bearing from falling out of the flywheel housing when the transmission is removed.

8. Remove transmission-to-clutch housing mounting bolts.

CAUTION: When removing the transmission, do not allow the weight of the transmission to hang on the clutch disc hub, as the disc may become distorted, seriously affecting clutch operation.

9. Move the transmission assembly straight away from the engine, using care to keep the transmission main drive gear shaft in alignment with the clutch disc hub. See Fig. 7B-13.

10. When the transmission is free from the engine, lower the transmission and move from under the vehicle.

11. If desired, a careful check of clutch components should be made after the transmission has been removed. If the clutch requires repair, refer to Section 7C before transmission is reinstalled in the vehicle.

3-Speed and 4-Speed Transmission Installation

(Except K Series)

1. Apply a light coating of high temperature grease to the main drive gear bearing retainer and splined portion of transmission main drive gear shaft to assure free movement of clutch and transmission components during assembly.

CAUTION: Do not apply an excessive amount of grease in the above areas, as under normal operation this grease could be thrown onto clutch facings resulting in clutch problems.

2. Shift the transmission into high gear. Mount transmission on dolly or jack and move into position under

the vehicle.

CAUTION: Avoid springing the clutch when the transmission is being installed to the engine. Do not force the transmission into the clutch disc hub. Do not let the transmission hang unsupported in the splined portion of the clutch disc.

3. Align the transmission main drive gear shaft with the clutch disc hub by rotating the transmission companion flange or output yoke. Move the transmission forward, guiding the main drive gear shaft into the clutch disc splines.

4. Install transmission-to-clutch housing mounting bolts and washers. Tighten bolts to specifications.

5. Install crossmember.

6. Connect propeller shaft to transmission as described in Section 4A. Remove transmission jack.

7. Connect parking brake lever and control (if used). Adjust brakes as outlined in Section 5.

8. Reconnect speedometer cable to adapter at transmission.

9. Reinstall shift controls on transmission.

NOTICE: On vehicles equipped with a 3-speed transmission, reconnect shift levers to transmission side cover. On vehicles equipped with a 4-Speed, 117mm transmission, install gearshift lever using Tool J-8109 as shown in Figure 7B-14. Press down firmly and rotate clockwise to install gearshift lever. Install transmission floor pan cover and floor mat.

10. If other equipment (exhaust pipe, support brackets, etc.) was removed, reinstall these parts.

11. Refill transmission with lubricant recommended in Section 0-B of this manual.

12. If necessary, adjust clutch or transmission control linkage to achieve proper transmission operation.

3-Speed Transmission - "K" Series

Removal and Installation

1. Raise vehicle on hoist.

2. Drain transfer case and transmission. Disconnect the speedometer cable from speedometer driven gear fitting.

3. Disconnect propeller shaft front U-joint yoke at case, and tie up out of way.

4. Remove bolt holding the shift lever control assembly to the adapter assembly. Remove shift lever rod from transfer case shift rail connector link. Push assembly to one side and tie up out of way.

5. Remove the bolts attaching the strut to the right-hand side of the transfer case and also to the engine rear face. Remove the strut.

6. Support transfer case in a suitable cradle. Remove bolts attaching transfer case to adapter, and remove the transfer case.

7. Disconnect shift control rods from the shifter levers at the transmission.

8. Support rear portion of engine. Remove two (2) adapter mount bolts.

9. Remove the 2 top transmission to clutch housing cap screws and insert 2 transmission guide pins, Tool J-1126 in these holes.

10. Remove the 2 lower transmission-to-clutch housing cap screws.

11. Slide the transmission and adapter assembly straight back on guide pins until the clutch gear is free of splines in the clutch disc.

NOTICE: The use of the 2 guide pins during this operation will support the transmission and prevent damage to the clutch disc through springing.

12. Remove the transmission and adapter as an assembly from under the body.

13. Remove adapter from transmission.

14. To install, reverse removal procedure.

4-Speed Transmission Removal

K Series

1. Remove attaching screws from transfer case shift lever boot retainer and remove retainer.

2. Remove attaching screws from transmission shift lever boot retainer. Slide boot and retainer up lever and remove transmission shift lever using Tool J-8109 as shown in Figure 7B-14.

3. Remove floor mat or carpeting from compartment.

4. If necessary, remove center floor outlet from heater distributor duct. If equipped with a center console, remove console before proceeding to next step.

5. Remove transmission floor cover attaching screws and cover. Rotate cover approximately 90° to clear transfer case shift lever while lifting cover from vehicle.

6. Disconnect shift lever rod assembly from transfer case shift rail connecting link.

7. Remove shift lever attaching bolt and shift lever control from adapter.

8. Raise and support vehicle on hoist. Support engine with suitable floor stand. Drain transfer case and transmission assemblies.

9. Disconnect speedometer cable from transfer case.

10. Disconnect prop shaft at rear of transfer case and tie up away from work area.

11. Disconnect front prop shaft from transfer case and tie up away from work area.

12. Open lock tabs and remove transmission mount-to-frame crossmember bolts.

13. Support transmission and transfer case assembly with suitable floor stand.

14. Remove frame to crossmember bolts and remove crossmember from vehicle. Rotate crossmember to clear frame rails.

15. On V-8 engine models, remove exhaust crossover pipe.

16. Remove transmission to clutch housing attaching bolts.

NOTICE: Remove upper bolts first and install transmission guide pins J-1126. Use of the guide pins will prevent damage to the clutch assembly.

17. Slide transmission rearward until main drive gear clears the clutch assembly and lower assembly from vehicle.

4-Speed Transmission Installation

K Series

1. Position transmission, with transfer case attached, to the clutch housing. Install bolts attaching transmission to clutch housing.

2. On V-8 models, install exhaust crossover pipe.

3. Position frame crossmember and install retaining bolts. Install bolts retaining adapter assembly to crossmember and transfer case to frame rail bracket. Torque all bolts to specification.

4. Torque front and rear transfer case yoke lock nuts to specifications.

5. Install front and rear propshafts to transfer case output yokes.

6. Connect the speedometer cable.

7. Fill transmission and transfer case to proper level with lubricant specified in Section O-B.

8. Install transfer case shift lever assembly and attaching bolt. Connect shift lever rod to shift rail connector link.

9. Install transmission floor cover and attaching bolts.

10. Install heater distributor duct center outlet.

NOTICE: On models with center console, install console and retaining bolts.

11. Install floor mat, transfer case shift lever retainer and attaching screws.

12. Install transmission shift lever, boot and retainer.

TRANSMISSION ALIGNMENT

In some instances where excessive gear whine or high gear hop out, particularly at 50 MPH (80 km/h) and up, are encountered, and after all other probable causes have been checked, an alignment check of the transmission and clutch housing may be helpful.

A special tool, on which a dial indicator is mounted, is necessary to check the transmission case rear bore alignment. This tool may be made from a new or good used clutch gear which has a good bearing surface on the crankshaft pilot end and at the front main bearing location.

The splines on the clutch gear shaft and the teeth on the clutch gear should be ground off so the shaft may be rotated in a clutch disc hub without interference when assembled in the car. Weld a piece of 1/4" rod in the mainshaft pilot bore long enough to extend out the case rear bore. Assemble a good bearing on the clutch gear shaft and secure it with the clutch gear bearing snap ring. Attach a suitable dial indicator to the rod.

1. Remove the transmission from the vehicle and completely disassemble, except for the reverse idler gear.

NOTICE: In any case where the clutch gear pilot or pilot bearing is excessively loose or worn, the pilot bearing should be replaced before checking the transmission case rear bore alignment by the dial indicator method.

2. Carefully install the special tool with the dial indicator in the transmission case with the face of the indicator to the rear of the case and with the tracing finger contacting the I.D. of the case rear bore. Secure in place with a clutch gear bearing retainer.

3. Assemble the transmission case to the clutch housing and tighten the four transmission mounting bolts securely.

NOTICE: Be sure to clean off any paint or other foreign material on the mating faces of the clutch housing and transmission as any foreign material on these faces will change alignment; also, check carefully for dings or burrs on these mating surfaces and remove carefully as necessary.

4. Dial indicate the transmission case rear bore and record the indicator readings in the 12, 3, 6 and 9 o'clock positions.

NOTICE: It is best to start the reading at the 3, 6, 9 or 12 o'clock position closest to the point where the indicator plunger reaches its maximum outward travel. Set the dial indicator at "0" at this location and then record the 3, 6, 9 and 12 o'clock readings in rotation.

5. Install temporary slotted shims between the transmission case and the clutch housing in the quantities and at the bolt locations as necessary to bring misalignment at the transmission case rear bore to a maximum of .005" indicator reading in either the vertical or horizontal direction.

EXAMPLE: If the maximum indicator reading is at the 12 o'clock position, put shims on the two bottom bolts.

6. After the position and quantity of shims has been determined and recorded the transmission case may be removed.

NOTICE: The clutch housing should then be stamped, showing the position where shims are to be installed and the thickness of shims at each location.

7. Inspect the external clutching teeth of the clutch gear and second speed gear. Inspect the second and third speed clutch internal clutching teeth. If the teeth are worn or tapered, even slightly, the gears should be replaced. Reassemble the transmission.

8. Install the transmission assembly to the clutch housing, using the correct number of shims at the proper locations as previously determined. Shims are available by unit part number with each unit consisting of the following shims:

- 4--.002" shims Identification--two corners cut off.
- 2--.005" shims Identification--one corner cut off.
- 1--.010" shims Identification--all corners square.

NOTICE: These special shims have a tab on one end for ease of installation. Do not slot the shims for the permanent installation.

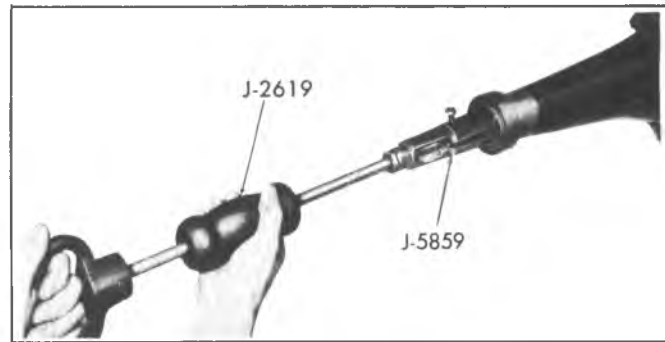


Fig. 7B-15--Removing Rear Oil Seal

REAR OIL SEAL REPLACEMENT

1. Drain lubricant from transmission.
2. Disconnect propeller shaft from transmission as described in Section 4A.
3. On 3-speed transmissions, perform the following replacement procedures:
 - a. Remove slip joint yoke from rear of transmission mainshaft.
 - b. Pry seal out of extension housing or remove oil seal using oil seal remover (J-5859) and slide hammer (J-2619) as shown in Figure 7B-15.
 - c. Coat outer diameter of new oil seal with sealing cement. Install new oil seal using extension housing oil seal installer (J-5154).
 - d. Install slip joint yoke on rear of transmission mainshaft.
4. On 4-speed transmissions, perform the following:
 - a. Remove parking brake from rear of transmission as described in Section 5, if so equipped.
 - b. Disconnect speedometer cable and remove speedometer driven gear from mainshaft rear bearing retainer.
 - c. Using flange or yoke holding tool, remove the output yoke or companion flange nut. Pull output yoke or companion flange nut off the mainshaft.
 - d. Support transmission while removing mounting bolts and bearing retainer. Remove mainshaft rear bearing retainer and gasket. Discard gasket.
 - e. Remove oil seal from rear bearing cap. Discard oil seal.
 - f. Coat outer diameter of new oil seal with sealing cement. Install oil seal in rear bearing cup using a suitable installer. Drive seal flush with outside of rear bearing cap, being careful not to damage seal. Use Installer J-22834 with Adapter J-22834-1 as required, as shown in Fig. 7B-16.
 - g. Clean all gasket surfaces, then install the rear bearing cap with a new gasket on the transmission. Tighten cap screws firmly.
 - h. Install output yoke or companion flange on mainshaft. Using a flange or yoke holding tool install retaining nut. Torque the retaining nut to specification.
 - i. Install speedometer driven gear, then connect speedometer cable.
5. Reconnect propeller shaft to transmission as described in Section 4A.
6. Refill transmission with lubricant recommended in Section 0-B.

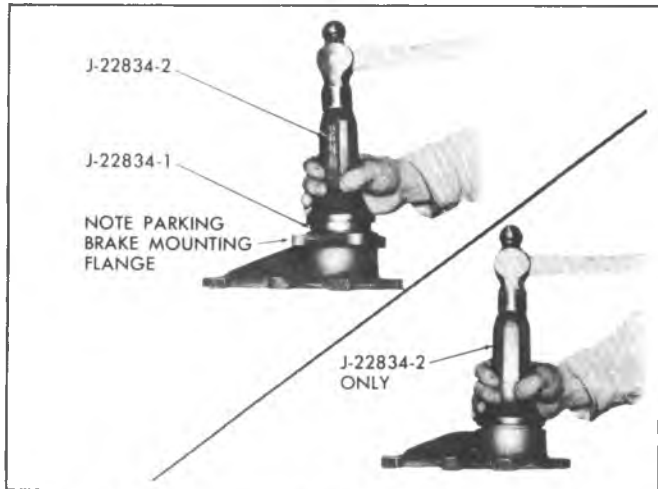


Fig. 7B-16--Replacing Rear Bearing Retainer Oil Seal

SPEEDOMETER DRIVEN GEAR REPLACEMENT

1. Disconnect speedometer cable on 3-speed units, then remove lock plate to housing bolt and lock washer and remove lock plate. Insert screw driver in lock plate slot in fitting and pry fitting, gear and shaft from housing. Pry "O" ring from groove in fitting.

2. Install new "O" ring in groove in fitting, coat "O" ring and driven gear shaft with transmission lubricant and insert shaft.

3. Hold the assembly so slot in fitting is toward lock plate boss on housing and install in housing. Push fitting into housing until lock plate can be inserted in groove and attached to housing.

TRANSMISSION SIDE COVER

Replacement/Repair (Fig. 7B-17)

1. Disconnect control rods from levers, back-up lamp wiring and TCS switch.

2. Shift transmission into neutral detent positions before removing cover. Remove cover assembly from transmission case carefully and allow oil to drain.

3. Remove the outer shifter levers.

4. Remove both shift forks from shifter shaft assemblies. Remove both shifter shaft assemblies from cover. Seals around shifter shaft may now be pried out if replacement is required because of damage.

5. Remove detent cam spring and pivot retainer "C" ring. Remove both detent cams.

6. With detent spring tang projecting up over the 2nd and 3rd shifter shaft cover opening, install the first and reverse detent cam onto the detent cam pivot pin. With the detent spring tang projecting up over the first and reverse shifter shaft cover hole install the 2nd and 3rd detent cam.

7. Install detent cam retaining "C" ring to pivot shaft, and hook spring into detent cam notches.

8. Install both shifter shaft assemblies in cover being careful not to damage seals. Install both shift forks to shifter shaft assemblies, lifting up on detent cam to allow forks to fully seat into position.

9. Install outer shifter levers, flat washers, lock washers and bolts.

10. Shift shifter levers into neutral detent (center) position and slide cover into place making sure the shift

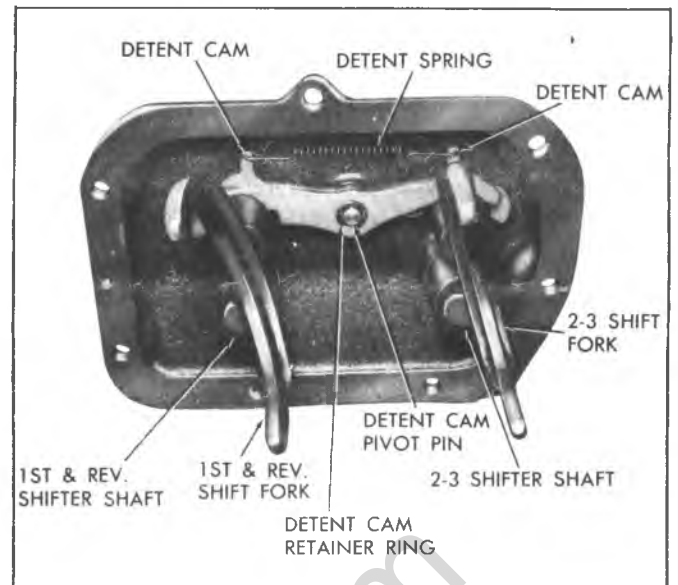


Fig. 7B-17--Transmission Side Cover Assembly

forks are aligned with their respective mainshaft clutch sliding sleeves.

11. Install cover attaching bolts and tighten evenly to specified torque. Install TCS switch and connect wiring.

12. Remove filler plug and add lubricant specified in Section 0-B to level of filler plug hole.

TRANSMISSION FLOOR SHIFT CONTROL

LEVER REPLACEMENT

1. On K-Series models, remove transfer case shift lever boot retainer attaching screws and retainer from compartment floor.

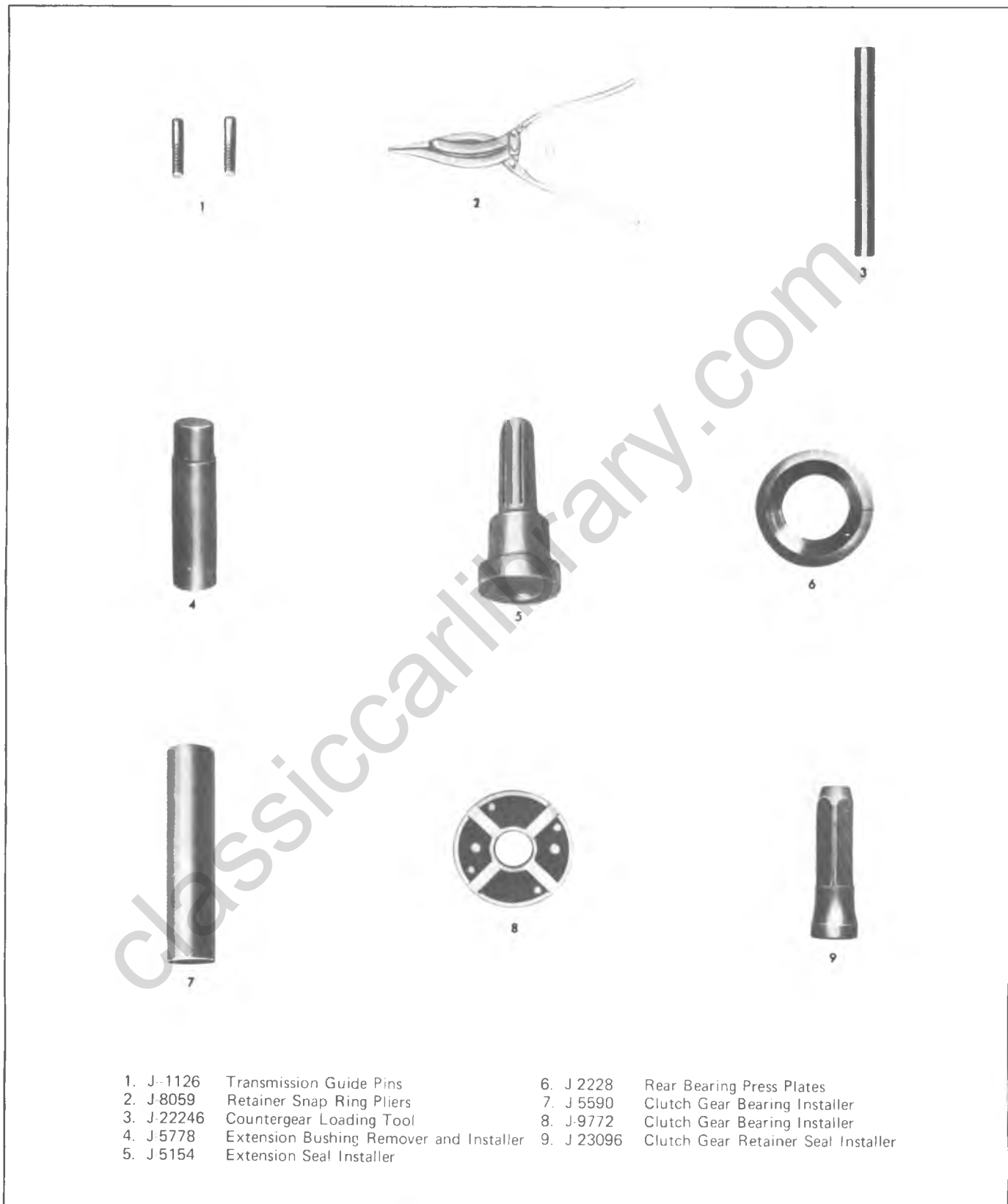
2. Remove floor covering from vehicle.

3. Remove transmission shift lever boot retainer attaching screws.

4. Slide boot and retainer up on shift lever and remove the transmission shift lever using Tool J-8109 as shown in Figure 7B-14.

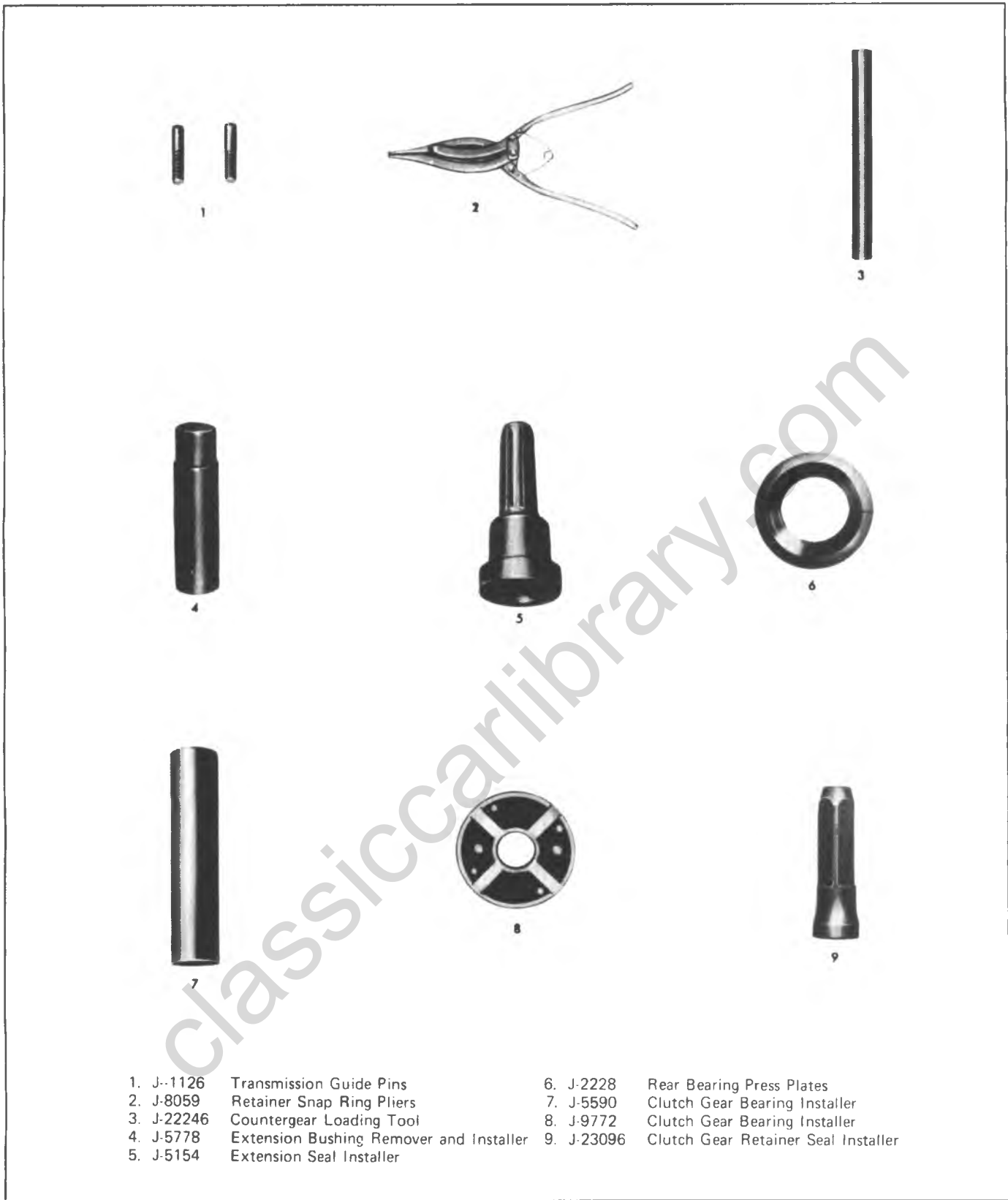
5. To install, reverse removal procedure Steps 1-4.

SPECIAL TOOLS



- | | | | |
|------------|---|------------|-------------------------------------|
| 1. J-1126 | Transmission Guide Pins | 6. J 2228 | Rear Bearing Press Plates |
| 2. J 8059 | Retainer Snap Ring Pliers | 7. J 5590 | Clutch Gear Bearing Installer |
| 3. J-22246 | Countergear Loading Tool | 8. J-9772 | Clutch Gear Bearing Installer |
| 4. J 5778 | Extension Bushing Remover and Installer | 9. J 23096 | Clutch Gear Retainer Seal Installer |
| 5. J 5154 | Extension Seal Installer | | |

Fig. 7B-1ST--3-Speed Special Tools



- | | | | |
|------------|---|------------|-------------------------------------|
| 1. J-1126 | Transmission Guide Pins | 6. J-2228 | Rear Bearing Press Plates |
| 2. J-8059 | Retainer Snap Ring Pliers | 7. J-5590 | Clutch Gear Bearing Installer |
| 3. J-22246 | Countergear Loading Tool | 8. J-9772 | Clutch Gear Bearing Installer |
| 4. J-5778 | Extension Bushing Remover and Installer | 9. J-23096 | Clutch Gear Retainer Seal Installer |
| 5. J-5154 | Extension Seal Installer | | |

Fig. 7B-2ST-4-Speed Special Tools

SECTION 7C

CLUTCH

INDEX

| | | | |
|----------------------------------|-------|-------------------------------------|-------|
| General Description..... | 7C-1 | Component Parts Replacement..... | 7C-11 |
| Clutch Systems..... | 7C-1 | Preliminary Inspection..... | 7C-11 |
| Diaphragm Type..... | 7C-1 | Clutch Disc and Pressure Plate..... | 7C-11 |
| Coil Spring Type..... | 7C-2 | Diaphragm Type..... | 7C-11 |
| Clutch Controls..... | 7C-3 | Coil Spring Type..... | 7C-12 |
| Maintenance and Adjustments..... | 7C-8 | Pedal..... | 7C-12 |
| Inspection..... | 7C-8 | Cross-Shaft..... | 7C-14 |
| Free Pedal Adjustment..... | 7C-8 | Special Tools..... | 7C-14 |
| Diagnosis..... | 7C-10 | | |

GENERAL DESCRIPTION

CLUTCH SYSTEMS

DIAPHRAGM SPRING CLUTCH

Principal Components

The principal parts of a diaphragm-type clutch system are: the driving members, attached to the engine and turning with it; the driven members attached to the transmission and turning with it; the operating members which include the spring or springs and the linkage required to apply and release the pressure which holds the driving and driven members in contact with each other. Figure 7C-1 shows a clutch cutaway so operating members can be seen.

Driving Members

The driving members of a clutch usually consist of two iron plates or flat surfaces machined to a smooth finish. Iron is desirable because it contains enough graphite to provide some lubrication when the driving member is slipping during engagement. One of these surfaces is usually the rear face of the engine flywheel, and the other is a comparatively heavy flat ring with one side machined. This part is known as the pressure plate. It is fitted into a steel cover, which also contains some of the operating members, and is bolted to the flywheel.

Driven Members

The driven member is the clutch disc with a splined hub which is free to slide lengthwise along the splines of the clutch shaft, but which drives the shaft through these same splines. Grooves on both sides of the clutch disc lining prevent sticking of the plate to the flywheel and pressure plate. Suitable frictional facings are attached to each side of the clutch disc by means of brass rivets. These facings must be heat resistant since friction produces heat. The most commonly used facings are made of cotton and asbestos fibers woven or molded together and impregnated with resin

or similar binding agents. Very often, copper wires are woven, or pressed into material to give it additional strength.

In order to make clutch engagement as smooth as possible and eliminate chatter, the steel segments attached to the splined hub are slightly waved, which causes the contact pressure on the facings to rise gradually as the waved springs flatten out.

The clutch disc is provided with a flexible center to absorb the torsional vibration of the crankshaft which would be transmitted to the power train unless it were eliminated. The flexible center takes the form of steel compression springs placed between the hub and the steel plate. The springs permit the disc to rotate slightly with relation to its hub until the springs are compressed and relative motion stops. Then the disc can rotate slightly backward as the springs decompress. This slight backward and forward rotation permitted by the springs allows the clutch shaft to rotate at a more uniform rate than the crankshaft, thereby eliminating some of the torsional vibration from the crankshaft and preventing the vibration from being carried back through the transmission.

Operating Members

The driving and driven members are held in contact by spring pressure. This pressure may be exerted by a one-piece conical or diaphragm spring. In the diaphragm design clutch, the clutch release bearing moves forward against the spring fingers forcing the diaphragm spring to pivot around the pivot ring, dishing the fingers toward the flywheel. The outer circumference of the spring now lifts the pressure plate away from the driven disc, through a series of retracting springs placed around the outer circumference of the pressure plate.

The clutch release bearing is a ball-thrust bearing contained in the clutch housing, mounted on a sleeve

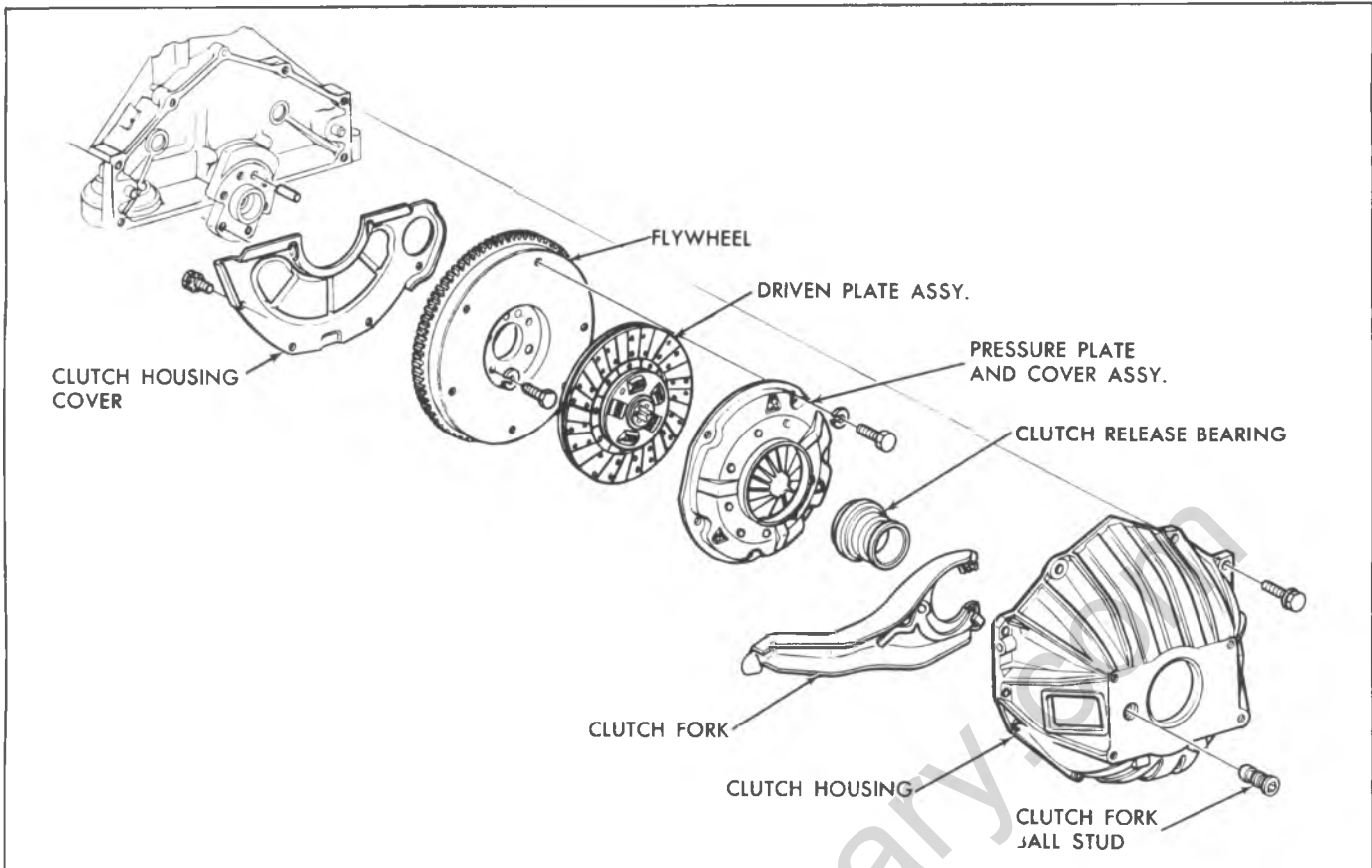


Fig. 7C-1—Clutch System Components

attached to the front of the transmission case. The release bearing is moved by the clutch fork to contact the release levers and move the pressure plate to the rear, thus separating the clutch driving members from the driven member when the clutch pedal is depressed by the driver. A return spring preloads clutch linkage, removing looseness due to wear, keeping the bearing clear of the spring fingers. The clutch free pedal travel, therefore, will increase with linkage wear and decrease with driven disc wear. The free travel felt at the clutch pedal is release bearing lash.

Clutch Spring Operation

In diaphragm spring type clutches, a diaphragm spring is used instead of coil springs. It is a conical piece of spring steel punched to give it greater flexibility. The diaphragm spring is positioned between the cover and the pressure plate so that the diaphragm spring is nearly flat when the clutch is in the engaged position. The action of this type of spring is similar to that of the bottom of an ordinary oil can. The pressure of the outer rim of the spring on the pressure plate decreases as the flat position is passed. The outer rim of the diaphragm is secured to the pressure plate and is pivoted on rings approximately 1 inch in from the outer edge so that the application of the pressure at the inner section will cause the outer rim to move away from the flywheel and draw the pressure plate away from the clutch disc, releasing or disengaging the clutch. When the pressure is released from the inner section, the oil-can action of the diaphragm causes the inner section to move out, and the movement of the outer rim forces the pressure plate against the clutch disc,

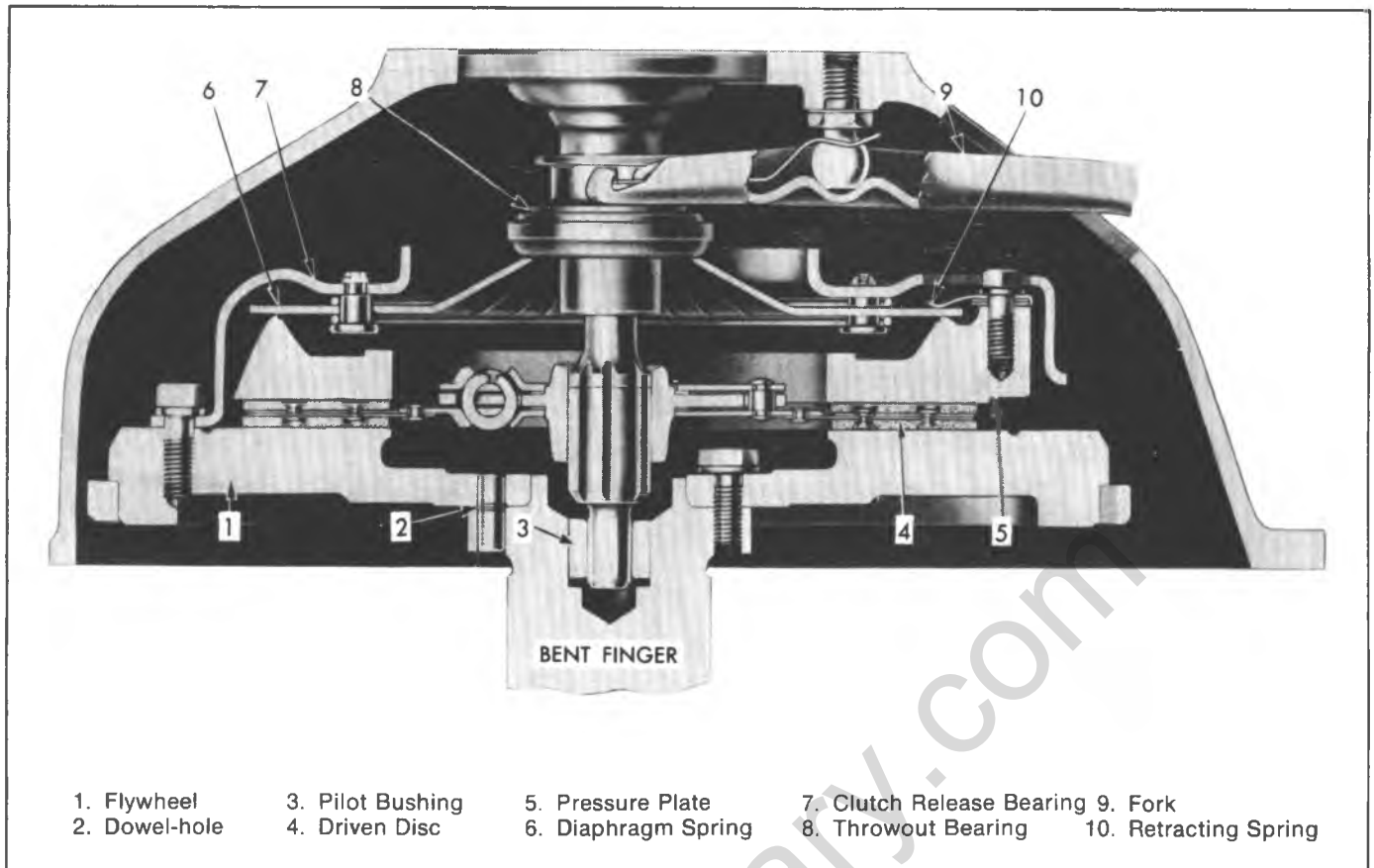
thus engaging the clutch.

COIL SPRING CLUTCH

The coil spring single plate clutch (Fig. 7C-4) is a dry disc type and no adjustment for wear is provided in the clutch itself. An individual adjustment is provided for locating each lever in manufacturing but the adjusting nut is locked in place and should never be disturbed, unless the clutch assembly is dismantled for replacement of parts.

When the clutch pedal is depressed the release bearing is moved toward the flywheel and contacts the inner ends of the release levers, (item 1 in Fig. 7C-5). Each release lever is pivoted on a floating pin which remains stationary in the lever and rolls across a short flat portion of the enlarged hole in the eyebolt (item 2). The outer end of each release lever engages the pressure plate lug by means of a strut (3), which provides knife-edge contact between the outer end of the lever and the lug. The outer ends of the eyebolts extend through holes in the stamped cover (4), and are fitted with adjusting nuts (5) to correctly position the levers.

When the clutch system is fully engaged, the clutch disc is firmly clamped between the flywheel and the pressure plate by the pressure of the springs. When the driver disengages the clutch by depressing the pedal, the release fork is moved on its pivot, and the pressure is applied to the release bearing. The rotating race of the release bearing presses against the clutch release levers and moves them on their pivot pins. The outer ends of the release levers, being fastened to the cover, move the pressure plate to the rear, compressing the clutch springs and allowing driving members to rotate independently of the driven member. The



- | | | | | |
|---------------|------------------|---------------------|---------------------------|-----------------------|
| 1. Flywheel | 3. Pilot Bushing | 5. Pressure Plate | 7. Clutch Release Bearing | 9. Fork |
| 2. Dowel-hole | 4. Driven Disc | 6. Diaphragm Spring | 8. Throwout Bearing | 10. Retracting Spring |

Fig. 7C-2--Cross-Section View of Diaphragm-Type

release fork moves only on its pivot, which contacts the clutch fork ball stud. All parts of the clutch system, except the clutch release bearing and collar, rotate with the flywheel when the clutch is engaged.

When the clutch is disengaged, the release bearing rotates with the flywheel, but the driven plate and the clutch shaft rotate as dictated by the transmission gear range and vehicle speed.

CLUTCH CONTROLS

The clutch operating controls for C-K trucks (Fig. 7C-6) are a mechanical type consisting of a pendant type pedal, return spring, pedal push rod, cross-shaft, fork push rod, routed vertically, inside the cab, from the pedal lever down through two boots on the toe pan, to the cross-shaft lever. When the clutch pedal is depressed, the pedal push rod moves rotating the cross-shaft, pushing the fork push rod rearward, and pivoting the clutch fork to move the release bearing against the clutch release fingers and releasing the clutch.

The clutch operating controls for "G" and "P" models are a mechanical type similar to the C-K models. On "G" models (Fig. 7C-7) a pedal pull rod is routed vertically from the clutch pedal lever down through the toe-panel to the cross shaft. When the pedal is depressed, the pedal pull rod moves, rotating the cross shaft, pushing the clutch fork rod rearward and pivoting the clutch fork. This action moves the release bearing against the clutch release fingers, releasing the clutch.

"P" model controls (Fig. 7C-8) have an upper pull rod connected from the clutch pedal shaft to a bell crank and a lower pull rod from the bell crank to the cross shaft. When the pedal is depressed, the pull rods are moved rotating the cross shaft and pushing the clutch fork rearward, thus subsequently activating the clutch release mechanism.

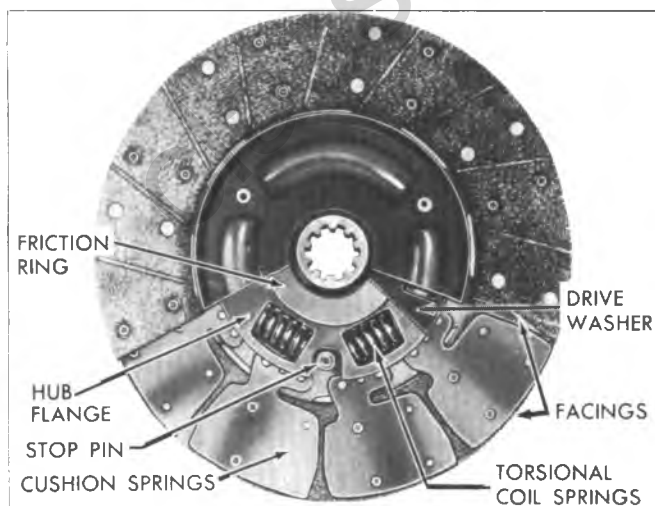


Fig. 7C-3--Clutch Disc

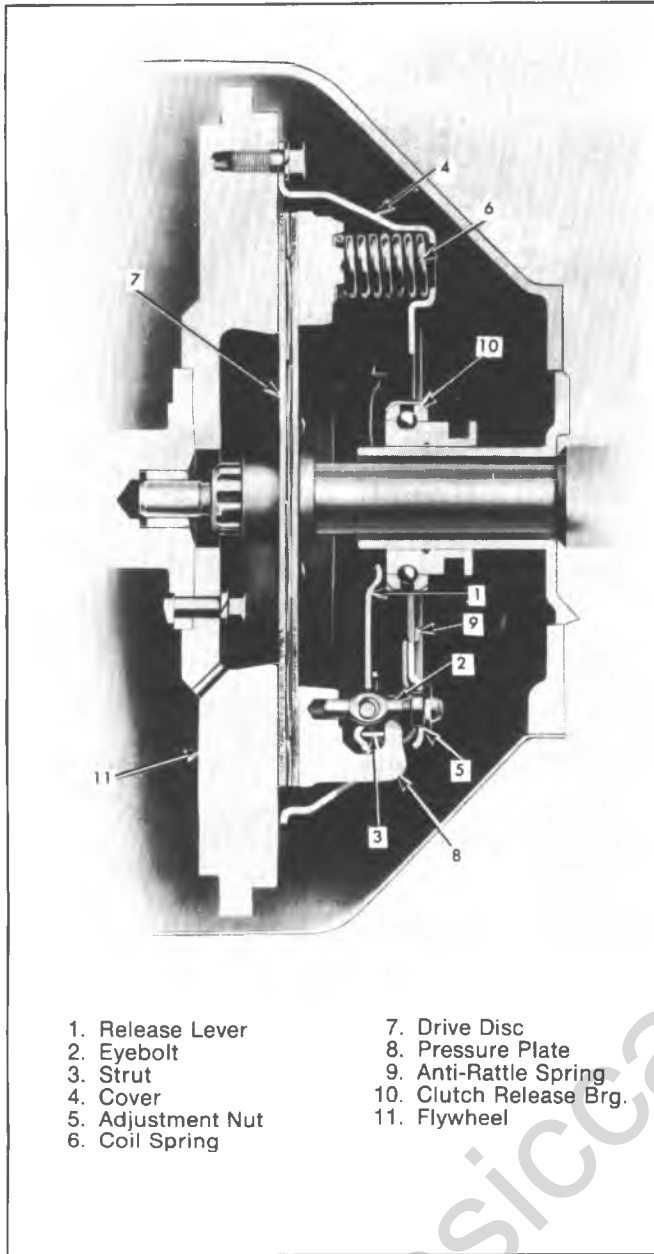


Fig. 7C-4--Cross-Section View of Coil Spring Type

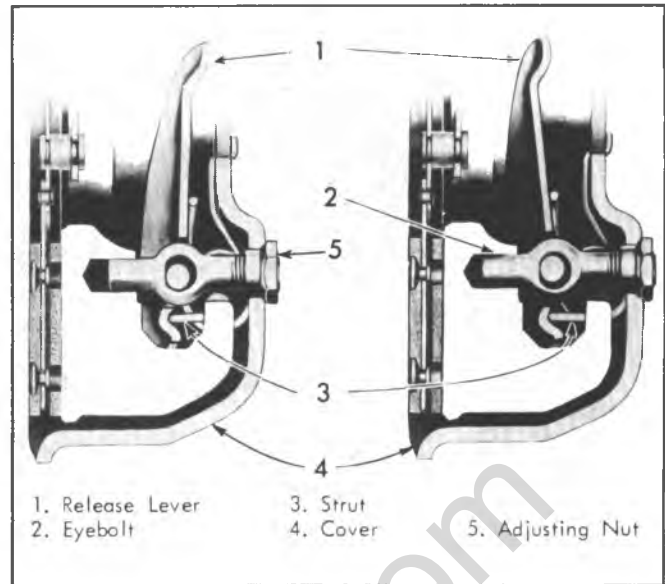


Fig. 7C-5--Release Lever, Coil Spring Type

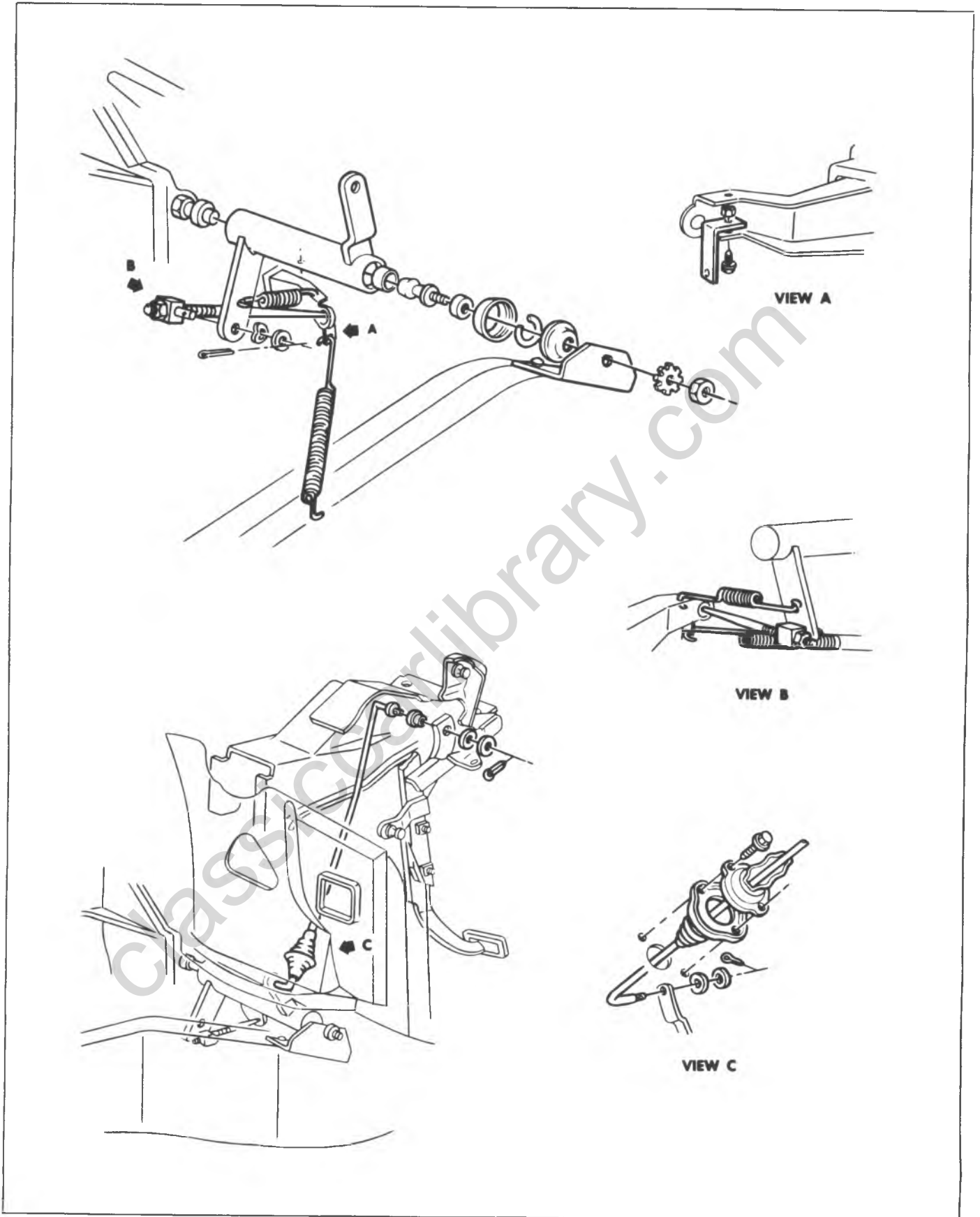


Fig. 7C-6--C-K Clutch Controls

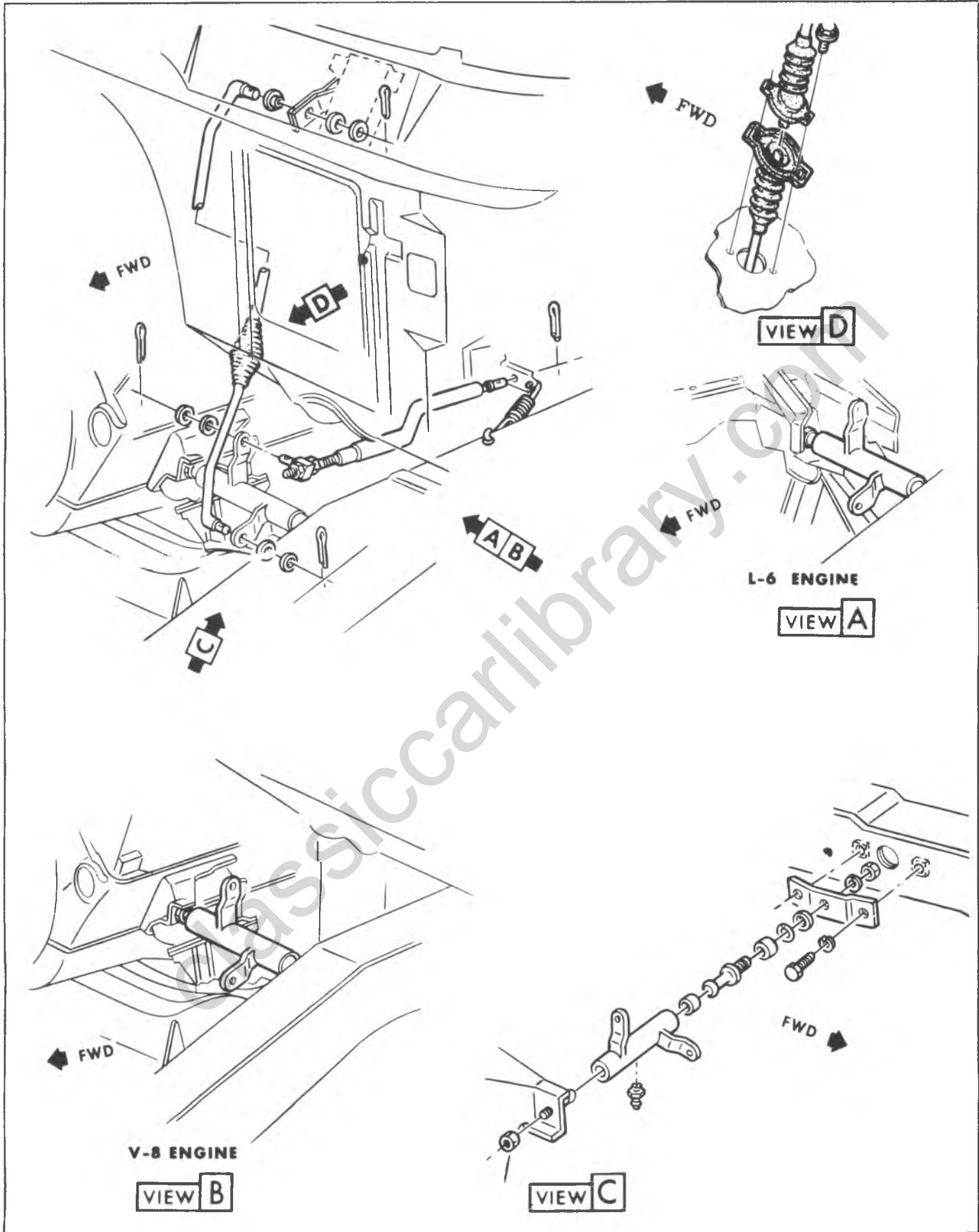


Fig. 7C-7--G-Truck Clutch Controls

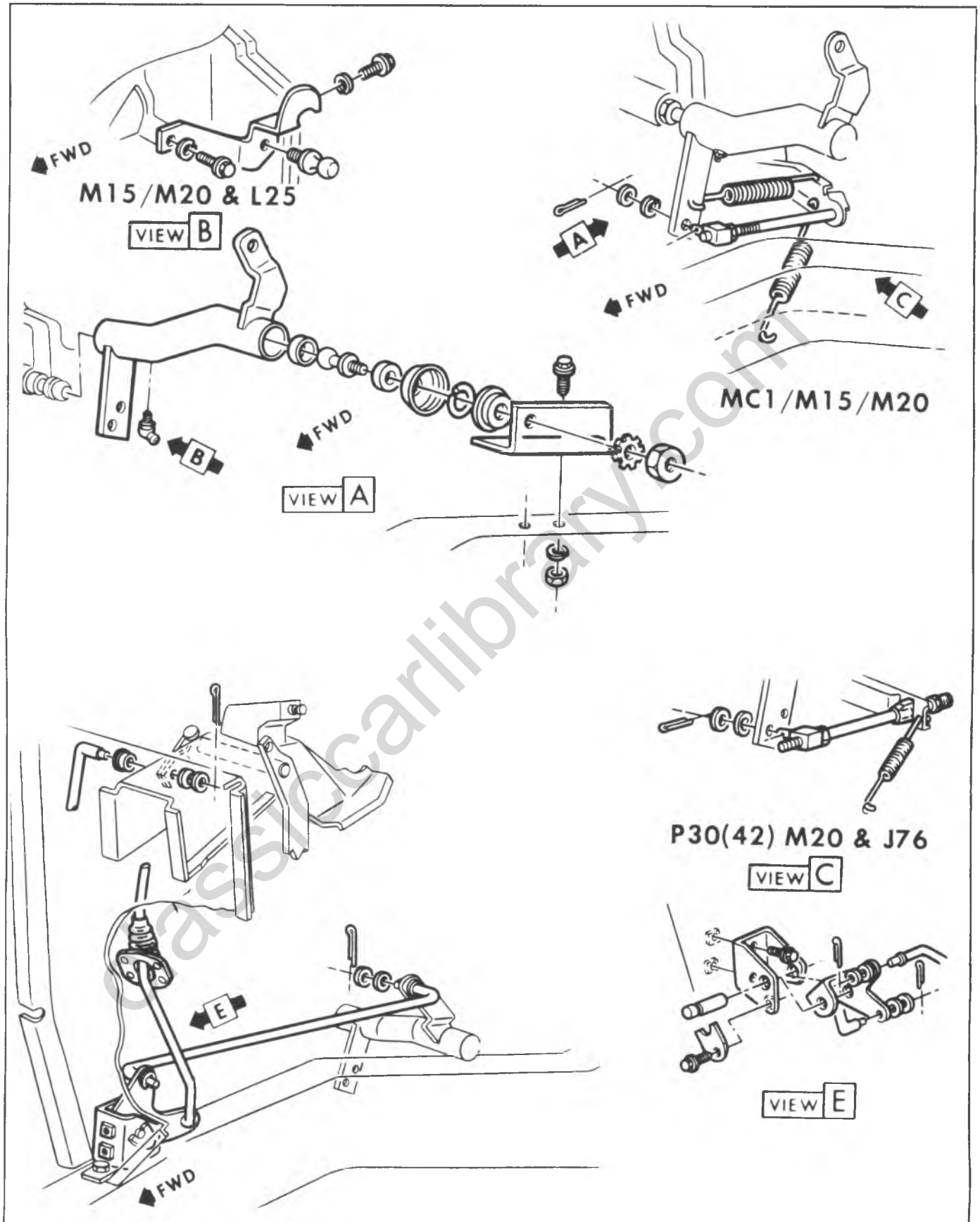


Fig. 7C-8-P-Truck Clutch Controls

MAINTENANCE AND ADJUSTMENTS

CLUTCH LINKAGE INSPECTION

There are several things which affect good clutch operations. Therefore, it is necessary, before performing any major clutch operations, to make preliminary inspections to determine whether trouble is actually in the clutch.

Check the clutch linkage to be sure the clutch releases fully as follows:

1. With engine running, hold the clutch pedal approximately 1/2" from floor mat and move shift lever between first and reverse several times. If this can be done smoothly, the clutch is fully releasing. If shift is not smooth, clutch is not fully releasing and adjustment is necessary.

2. Check clutch pedal bushings for sticking or excessive wear.

3. Check fork for proper installation on ball stud. Lack of lubrication on fork can cause fork to be pulled off the ball.

4. Check for bent, cracked or damaged cross shaft levers or support bracket.

5. Loose or damaged engine mounts may allow the engine to shift its position causing a bind on clutch linkage at the cross shaft. Check to be sure there is some clearance between cross shaft, both mount brackets, and ball studs.

6. Check clutch release bearing end clearance between spring fingers and front bearing retainer on the transmission. If no clearance exists, fork may be improperly installed on ball stud or clutch disc may be worn out.

CLUTCH FREE PEDAL TRAVEL ADJUSTMENT

Only one adjustment is necessary to compensate for all normal clutch wear. The clutch pedal should have free travel (measured at clutch pedal pad) before the release bearing engages the clutch diaphragm spring or levers. Lash is required to prevent clutch slippage which would occur if the bearing was held against the fingers or to prevent the bearing from running continually. A clutch that has been slipping prior to free play adjustment may still slip right after the new adjustment due to previous heat damage.

C, K and P Models (Except P30 W/J76)

1. Disconnect return spring at clutch fork.
2. Rotate clutch lever and shaft assembly until clutch pedal is firmly against rubber bumper on brake pedal bracket.

3. Push outer end of clutch fork rearward until release bearing lightly contacts pressure plate fingers or levers.

4. Loosen lock nut and adjust rod length so that swivel slips freely into gauge hole. Increase pushrod length until all lash is removed from system.

5. Remove swivel from gauge hole and insert into lower hole on lever. Install two washers and cotter pin. Tighten lock nut being careful not to change rod length.

6. Reinstall return spring and check pedal free travel. Pedal travel should be 1 3/8" to 1 5/8" on "C-K" models and 1 1/4" to 1 1/2" on "P" models.

P-30 Models W/J76 (Fig. 7C-10)

1. Disconnect clutch fork return spring.
2. Loosen nut "G" at swivel.
3. Move the clutch fork rod against fork to eliminate all clearance between release bearing and clutch fingers.
4. Rotate shaft lever until clutch pedal contacts the bumper mounted on the brake pedal bracket.
5. Rotate the fork rod until a clearance of approximately 1/4" to 5/16" (.29) is obtained between the shoulder on the fork rod and the adjustment nut.
6. Tighten nut "G" against swivel and install clutch return spring.
7. Check free pedal clearance at pedal. Pedal clearance should be 1 3/8" to 1 5/8". Readjust as required.

G-Models (Fig. 7C-11)

1. Disconnect clutch fork return spring at fork.
2. Loosen nut "A" and back off from swivel approximately 1/2 inch.
3. Hold clutch fork push rod against fork to move release bearing against clutch fingers (push rod will slide through swivel at cross-shaft).
4. Adjust nut "B" to obtain approximately 1/4" clearance between nut "B" and swivel.
5. Release push rod, connect return spring and tighten nut "A" to lock swivel against nut "B".
6. Check free pedal clearance at pedal (1 1/4" to 1 1/2" is proper clearance). Readjust if necessary.

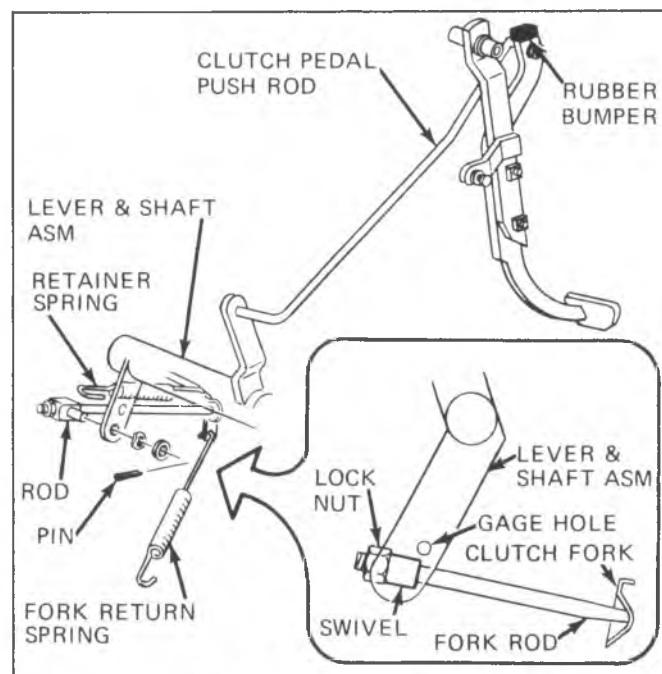


Fig. 7C-9--CK-Free Pedal Travel

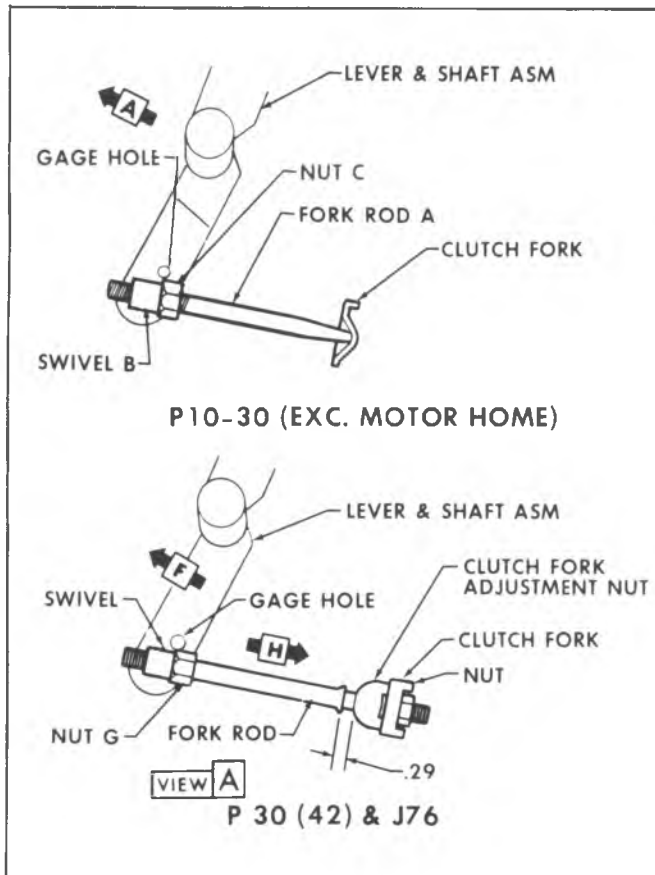


Fig. 7C-10--P-Truck Free Pedal Travel

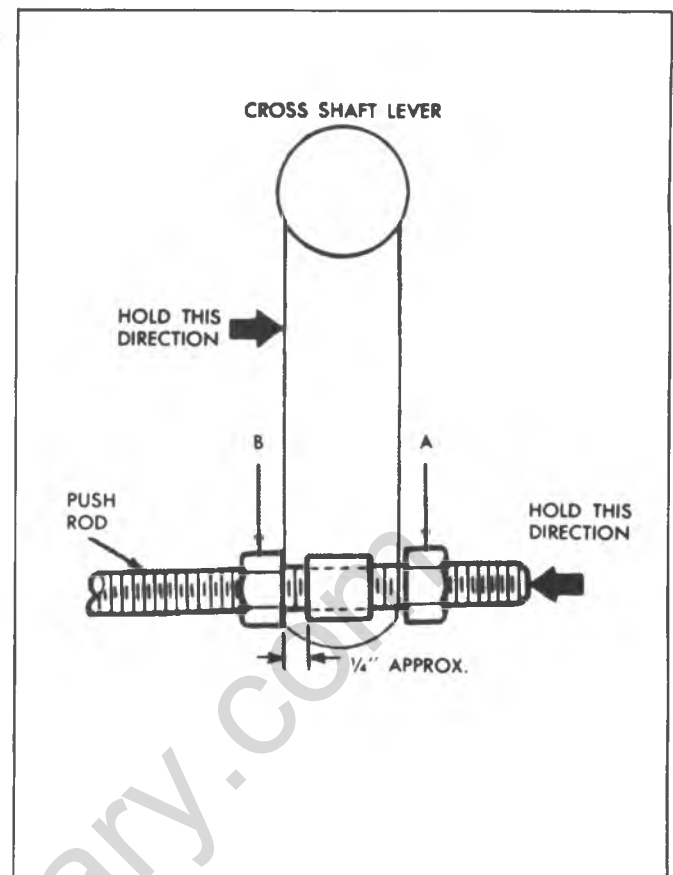


Fig. 7C-11--G-Truck Free Pedal Travel

INSUFFICIENT CLUTCH RELEASE

Where complaints of first or reverse gear clash due to insufficient clutch release are encountered, the following may be helpful. Cut off the existing clutch pedal stop bumper to a height of $\frac{3}{8}$ ". Since shortening the bumper increases the lash and not the usable stroke, the lash must

be reduced to specifications in order to gain the additional stroke benefit.

DIAGNOSIS

| CONDITION | PROBABLE CAUSE | CORRECTION |
|---|--|---|
| Fails to Release (Pedal pressed to floor-shift lever does not move freely in and out of reverse gear) | <ul style="list-style-type: none"> a. Improper linkage Adjustment b. Improper pedal travel c. Loose linkage d. Faulty pilot bearing e. Faulty driven disc f. Fork off ball stud g. Clutch disc hub binding on clutch gear spline h. Clutch disc warped or bent | <ul style="list-style-type: none"> a. Adjust Linkage b. Trim bumper stop and adjust linkage c. Replace as necessary d. Replace bearing e. Replace disc f. Install properly and* lubricate fingers at release bearing with wheel bearing grease. g. Repair or replace clutch gear and/or disc. h. Replace disc (run-out should not exceed .020"). <p>*Very lightly lubricate fingers</p> |
| Slipping | <ul style="list-style-type: none"> a. Improper Adjustment (no lash) b. Oil Soaked driven disc c. Worn facing or facing torn from disc. d. Warped pressure plate or flywheel e. Weak diaphragm spring f. Driven plate not seated in g. Driven plate overheated | <ul style="list-style-type: none"> a. Adjust linkage to spec. b. Install new disc and correct leak at its source c. Replace disc d. Replace pressure plate or flywheel e. Replace pressure plate (Be sure lash is checked before replacing plate.) f. Make 30 to 40 normal starts CAUTION: Do Not Overheat g. Allow to cool – check lash |
| Grabbing (Chattering) | <ul style="list-style-type: none"> a. Oil on facing. Burned or glazed facings. b. Worn splines on clutch gear. c. Loose engine mountings. d. Warped pressure plate or flywheel. e. Burned or smeared resin on flywheel or pressure plate. | <ul style="list-style-type: none"> a. Install new disc and correct leak. b. Replace transmission clutch gear. c. Tighten or replace mountings. d. Replace pressure plate or flywheel. e. Sand off if superficial, replace burned or heat checked parts. |
| Rattling-Transmission Click | <ul style="list-style-type: none"> a. Weak retracting springs. b. Clutch fork loose on ball stud or in bearing groove. c. Oil in driven plate damper. d. Driven plate damper spring failure. | <ul style="list-style-type: none"> a. Replace pressure plate. b. Check ball stud and retaining. c. Replace driven disc. d. Replace driven disc. |
| Release Bearing Noise with Clutch Fully Engaged | <ul style="list-style-type: none"> a. Improper adjustment. No Lash. b. Release bearing binding on transmission bearing retainer. c. Insufficient tension between clutch fork spring and ball stud. d. Fork improperly installed. e. Weak linkage return spring. | <ul style="list-style-type: none"> a. Adjust linkage. b. Clean, relubricate, check for burrs, nicks, etc. c. Replace fork. d. Install properly. e. Replace spring. |
| Noisy | <ul style="list-style-type: none"> a. Worn release bearing. b. Fork off ball stud (heavy clicking). c. Pilot Bearing loose in crankshaft. | <ul style="list-style-type: none"> a. Replace bearing. b. Install properly and lubricate fork fingers at bearing. c. See Section 6 for bearing fits. |
| Pedal Stays on Floor When Disengaged | <ul style="list-style-type: none"> a. Bind in linkage or release bearing. b. Springs weak in pressure plate. c. Springs being over traveled. | <ul style="list-style-type: none"> a. Lubricate and free up linkage and release bearing. b. Replace pressure plate. c. Adjust linkage to get proper lash, be sure proper pedal stop (bumper) is installed. |
| Hard Pedal Effort | <ul style="list-style-type: none"> a. Bind in linkage. b. Driven plate worn. | <ul style="list-style-type: none"> a. Lubricate and free up linkage. b. Replace driven plate. |

Fig. 7C-12-Clutch Diagnosis Chart

COMPONENT PARTS REPLACEMENT

PRELIMINARY INSPECTION

There are many things which affect good clutch operation. Therefore, it is necessary, before performing any major clutch operations, to make a preliminary inspection to determine whether or not the trouble is actually in the clutch.

1. Check the clutch pedal and make sure that the pedal has proper free travel, as described in "Maintenance and Adjustments".
2. Check the clutch pedal bushing for wear and for sticking on the shaft or loose mountings.
3. Lubricate the pedal linkage.
4. Tighten all front and rear engine mounting bolts.

CLUTCH DISC AND PRESSURE PLATE

(DIAPHRAGM TYPE)

Removal from Vehicle

1. Remove transmission as outlined in Section 7B.
2. Disconnect clutch fork push rod and pull back spring.
3. Remove clutch and flywheel housing.
4. Remove clutch fork by pressing it away from its ball mounting with a screwdriver, until the fork snaps loose from the ball or remove ball stud from rear of clutch housing. Remove release bearing from clutch fork.

NOTICE: The retainer may be removed from the fork by prying out with a small screwdriver.

5. Install Tool J-5824 or a used clutch drive gear to support the clutch assembly during removal.

NOTICE: Before removing clutch from flywheel, mark the flywheel, clutch cover and one pressure plate lug, so that these parts may be assembled in their same relative positions, as they were balanced as an assembly.

6. Loosen the clutch attaching bolts one turn at a time to prevent distortion of clutch cover until diaphragm spring is released.

7. Remove clutch pilot tool and remove clutch assembly from vehicle.

NOTICE: The flywheel should be inspected for cracks, heat checking, flatness and other defects.

Installation to Vehicle

1. Install the pressure plate in the cover assembly lining up the notch mark on pressure plate with notch mark on flange of cover.
2. Install pressure plate retracting springs, lockwashers and drive strap to pressure plate bolts. Tighten to 11 ft. lbs. torque. The clutch is now ready to be installed.
3. Hand crank the engine until "X" mark on flywheel is at the bottom.

4. Install clutch disc, pressure plate and cover assembly and support them with Tool J-5824 or a used clutch drive gear.

5. Turn clutch assembly until "X" mark or painted white letter on clutch cover flange lines up with "X" mark on flywheel.

6. Install attaching bolts and tighten each one a turn at a time to prevent distorting the cover as the spring pressure is taken up.

7. Remove clutch pilot tool.

8. Pack clutch fork ball seat with a small amount of high melting point grease. On "P" models with J76, install a new retainer in the groove of the clutch fork if the old retainer is worn or damaged.

NOTICE: Install retainer with high side up, away from bottom of the ball socket and with open end of retainer on the horizontal.

CAUTION: Be careful not to use too much lubricant. Excessive lubricant may get on clutch fingers and cause slippage.

9. Replace clutch fork ball if removed from the clutch housing and snap clutch fork onto the ball.

10. Pack lubricant in the recess on the inside of the release bearing collar and coat the clutch fork groove with

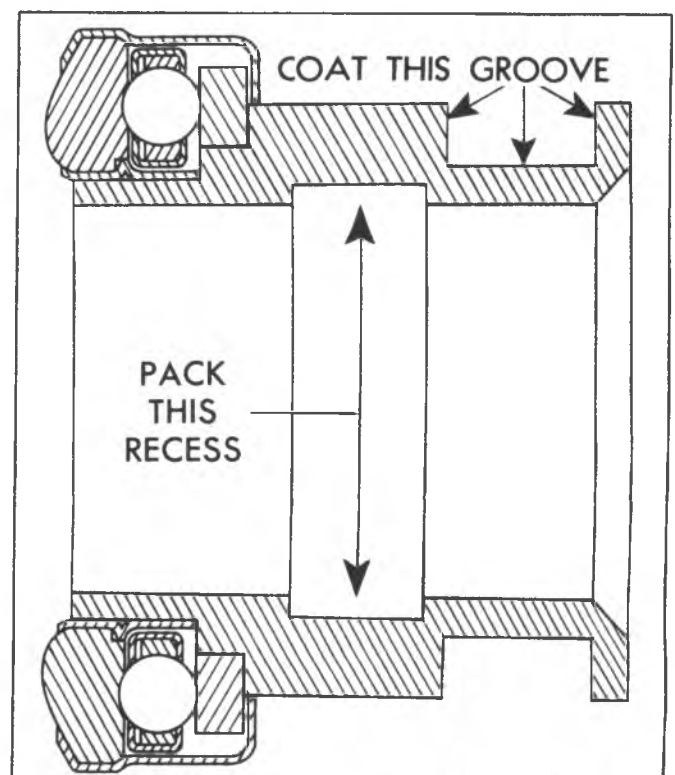


Fig. 7C-13--Lubrication Points on Clutch Release Bearing

a small amount of graphite grease, as shown in Figure 7C-13.

11. Install release bearing assembly to the clutch fork. Install clutch and flywheel housing to engine.
12. Assemble transmission as outlined in Section 7B.
13. Align push rod to clutch fork and attach return spring to clutch fork.
14. Adjust clutch linkage as described in "Maintenance and Adjustments."

CLUTCH DISC AND PRESSURE PLATE (COIL SPRING TYPE)

Removal From Vehicle

1. Remove transmission as outlined in Section 7B.
2. Disconnect clutch fork push rod and pull back spring.
3. Remove clutch and flywheel housing.
4. Remove clutch fork by pressing it away from its ball mounting with a screwdriver, until the fork snaps loose from the ball or remove ball stud from rear of clutch housing. Remove release bearing from clutch fork.

NOTICE: The retainer may be removed from the fork by prying out with a small screwdriver.

5. Install Tool J-5824 or a used clutch drive gear to support the clutch assembly during removal.

NOTICE: Before removing clutch from flywheel, mark the flywheel, clutch cover and one pressure plate lug, so that these parts may be assembled in their same relative positions, as they were balanced as an assembly.

6. Loosen the holding screws a turn or two at a time to avoid bending rim of cover. It is advantageous to place wood or metal spacers (approximately 3/8 thick) between the clutch levers and the cover to hold the levers down as the holding screws are removed or when clutch is removed from engine. When removing driven plate be sure to mark flywheel side.

7. Remove clutch pilot tool and remove clutch assembly from vehicle.

NOTICE: Inspect flywheel for heat defects, cracks, flatness, or other defects.

Installation To Vehicle

1. Assemble driven plate and clutch cover assembly to flywheel in accordance with marking on driven plate for flywheel side. Use Tool J-5824 or a dummy shaft to support assembly.
2. Line up the clutch assembly with "X" mark or painted white letter with "X" mark on flywheel, before tightening cover holding screws.
3. Tighten holding screws, a turn at a time, before removing dummy shaft.
4. Remove clutch pilot tool.
5. Pack clutch fork ball seat with a small amount of high melting point grease and install a new retainer in the groove of the clutch fork if the old retainer is worn or damaged.

NOTICE: Install retainer with high side up, away from bottom of the ball socket and with open end of retainer on the horizontal.

CAUTION: Be careful not to use too much lubricant. Excessive lubricant may get on clutch fingers and cause slippage.

6. Replace clutch fork ball if removed from the clutch housing and snap clutch fork onto the ball.

7. Pack lubricant in the recess on the inside of the release bearing collar and coat the clutch fork groove with a small amount of graphite grease, as shown in Figure 7C-13.

8. Install release bearing assembly to the clutch fork. Install clutch and flywheel housing to engine.

9. Assemble transmission as outlined in Section 7B.

10. Align push rod to clutch fork and attach return spring to clutch fork.

11. Adjust clutch linkage as described in "Maintenance and Adjustments."

CLUTCH PEDAL ARM, PUSH ROD OR BUSHING REPLACEMENT (Fig. 7C-14)

C-K Models

Removal

1. Disconnect battery negative ground cable at the battery terminal.
2. Disconnect clutch push rod at the cross shaft under the vehicle.
3. Remove steering column covers. Remove screws retaining push rod boots to bulkhead.
4. Remove air conditioning duct from lower left side of instrument cluster if so equipped. (Refer to Section 1A).

CAUTION: Maintain pressure on lower arm. When lower attaching bolt is removed upper section will snap upward.

5. Disconnect clutch neutral start switch from pedal arm.

6. Remove bolts attaching lower section of clutch pedal arm to the upper arm.

7. Remove lower arm and push rod from vehicle.

8. Remove pedal return spring.

9. Remove pedal pivot shaft retaining nut and pivot shaft. Insert a dummy shaft or rod through the support to hold the brake pedal components in place.

10. Remove the clutch pedal assembly from the support assembly.

11. Remove pedal bushings and spacer from pedal arm. Check pedal bumper for wear and replace as required.

Installation

1. Install new bushings and spacer in pedal arm. Components should be lubricated prior to assembly.

2. Position clutch pedal upper arm in support bracket and install pivot bolt through support and pedal arms.

NOTICE: Bolt must be installed in direction shown in

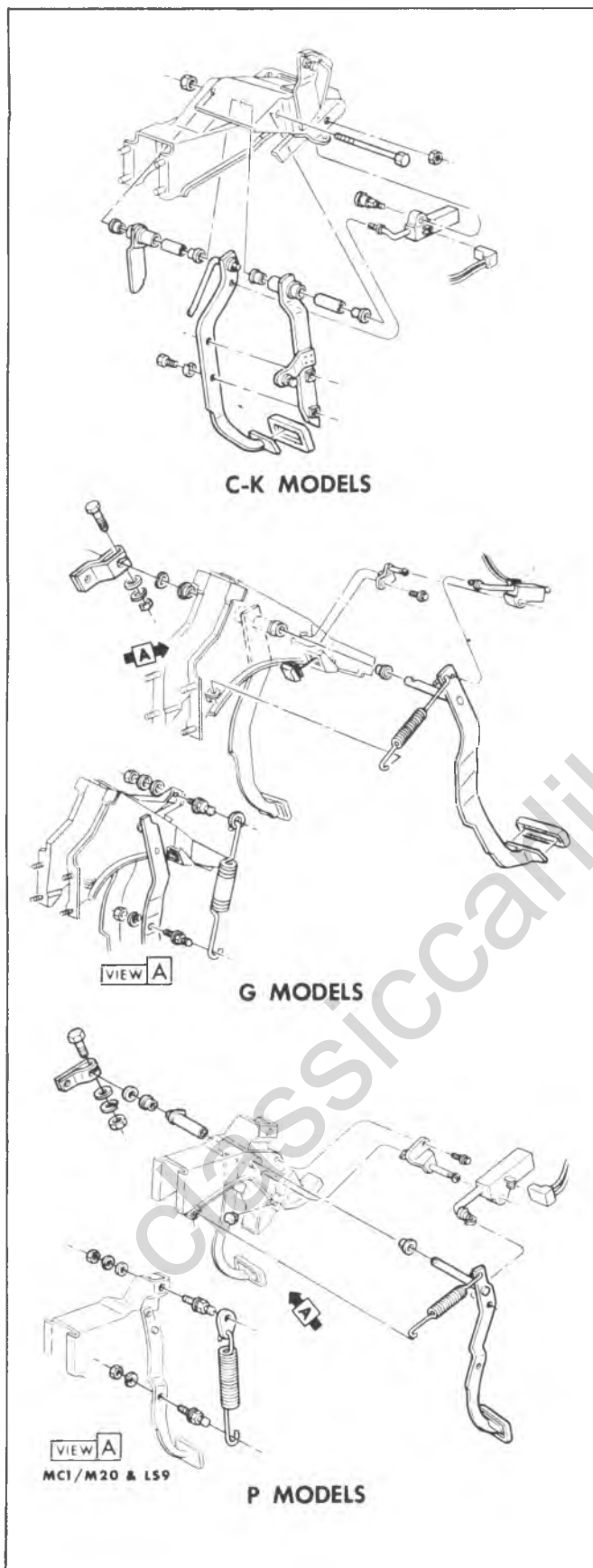


Fig. 7C-14—Clutch Pedal Mounting Attachment

Figure 7C-14 in order to clear return spring.

3. Install pivot bolt retaining nut and torque to specifications.

4. Install pull back spring to support and pedal arm.

NOTICE: If previously removed connect pedal push rod to clutch pedal arm.

5. Position lower pedal arm to upper arm and install upper attaching bolt. Push down on pedal and install lower bolt. Torque to specifications.

6. Install clutch neutral start switch.

7. Install air conditioning duct.

8. Install steering column covers. Install screws retaining push rod boots to bulk head.

9. Check operation of clutch assembly and adjust clutch as required.

G and P Models (Fig. 7C-14)

Removal

1. Apply parking brake firmly. Disconnect neutral start switch from pedal arm.

2. Remove bolt at clutch pedal push rod lever, then remove lever from pedal shaft.

3. Hold pedal pad with one hand and slide clutch pedal and shaft assembly outboard enough to clear pedal stop. Insert a dummy shaft or rod through support and brake pedal assembly to hold components in place while removing clutch pedal shaft. Allow return spring (or center spring) to pull pedal up high enough to unhook spring from pedal arm.

4. Remove pedal and shaft assembly from support bracket.

Inspection

1. Check clutch pedal bushings for excessive wear and replace as necessary.

2. Check clutch pedal shaft for wear and alignment. Straighten or replace as necessary.

Installation

NOTICE: Use new shaft bushing if needed. Lubricate with petrolatum.

1. Slide one pedal shaft bushing over shaft, install shaft in support enough to still clear pedal bumper stop, hook pedal return (or overcenter) spring to pedal, then rotate pedal forward of bumper stop; slide shaft into position in support and release pedal against bumper stop.

2. Install clutch pedal shaft bushing over pedal shaft end and into place in sleeve.

3. Assemble pedal push rod lever over pedal shaft and install bolts, washers, and nut.

4. Connect neutral start switch to pedal arm.

5. Adjust clutch pedal free travel as needed.

CLUTCH CROSS-SHAFT REPLACEMENT

(Figs. 7C-6, 7C-7, 7C-8)

1. Disconnect clutch fork return spring at fork.
2. Disconnect pedal push rod at cross-shaft lever and allow clutch fork push rod to hang free from lower lever.
3. On C-K models, remove ball stud retaining nut, at frame end and slide shaft toward engine. Then lift cross-shaft up to clear bracket and remove shaft from the engine

ball stud. On G models, remove frame bracket retaining bolts, then remove shaft from engine ball stud.

4. Remove clutch fork push rod from cross-shaft lever.
5. Reverse removal procedure to install.

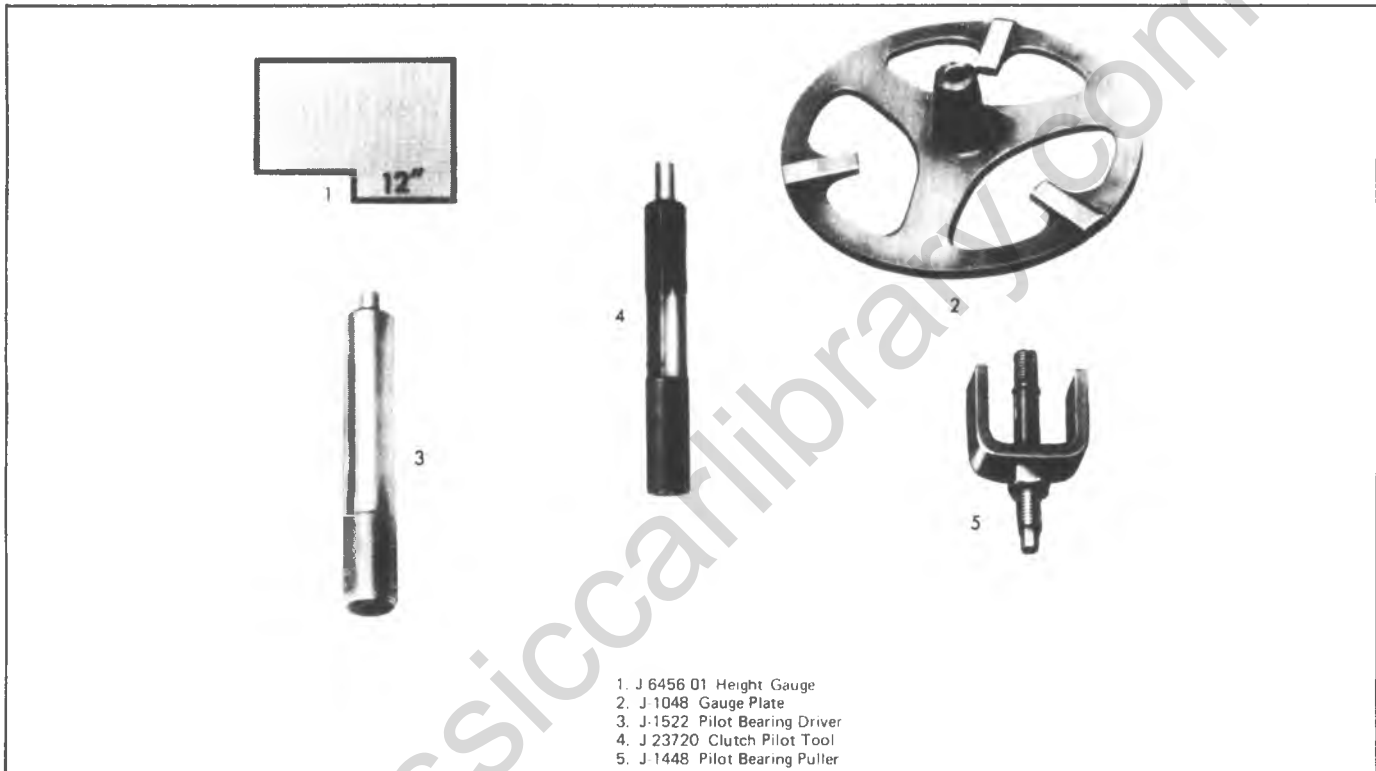
SPECIAL TOOLS

Fig. 7C-ST-Clutch Special Tools

SECTION 7E

TRANSFER CASE

INDEX

| | |
|----------------------------------|------|
| General Description..... | 7E-1 |
| Model 205 (Part-Time)..... | 7E-1 |
| Maintenance and Adjustments..... | 7E-4 |
| Diagnosis..... | 7E-4 |
| Component Parts Replacement..... | 7E-5 |
| Transfer Case..... | 7E-5 |
| Skid Plate..... | 7E-5 |
| Strut Rod..... | 7E-5 |
| Adapter Assemblies..... | 7E-5 |
| Specifications..... | 7E-8 |
| Special Tools..... | 7E-9 |

GENERAL DESCRIPTION

TRANSFER CASE

A transfer case mounts behind the transmission, as shown in Fig. 7E-1, and allows drive torque to be transmitted in a proportional split to both the front axle and the rear axle, resulting in four-wheel drive. The shift control lever for the transfer case is floor-mounted in the passenger compartment. Depending on the type of transfer case and the shift lever position, various combinations of rear wheel drive, four wheel drive, high traction (gear reduction) or direct drive may be selected.

Model 205, Part-Time

The model 205 transfer case shown in Fig. 7E-2 is a two-speed unit which can be used for either two-wheel or four-wheel drive. Direct drive (1:1 ratio) is available in two modes, 2H for two-wheel drive, or 4H for four-wheel drive. Gear reduction (1.96:1 ratio) is used in the 4L position. This

unit uses constant mesh helical gears to connect the input shaft, idler gear and two output gears, thus allowing gear selection to match driving conditions. The front input shaft gear (Item #27) is in constant mesh with the idler gear (#44) and, through the idler gear, with the front output gears (#59 and #67) and the rear output gear (#17). Sliding clutches (#26, #64) allow for selective gear engagement resulting in High or Lo range, and two-wheel or four-wheel drive. Ball bearings support the input shaft, rear output shaft and front output shaft. Tapered roller bearings are used on the idler shaft. When driving in a four-wheel mode (4L or 4H) the hubs on the front wheels must be turned to the "Locked" position.

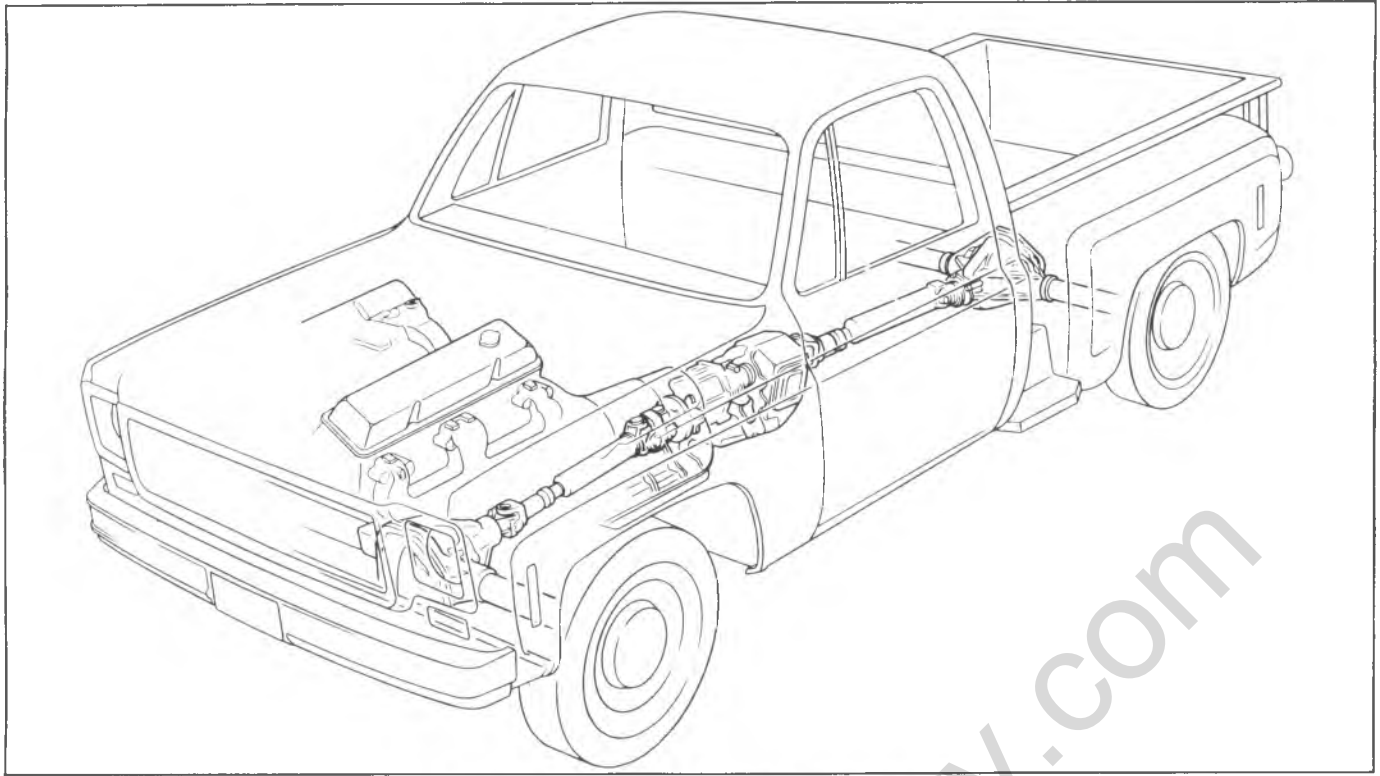


Fig. 7E-1--Transfer Case, Typical Functional View

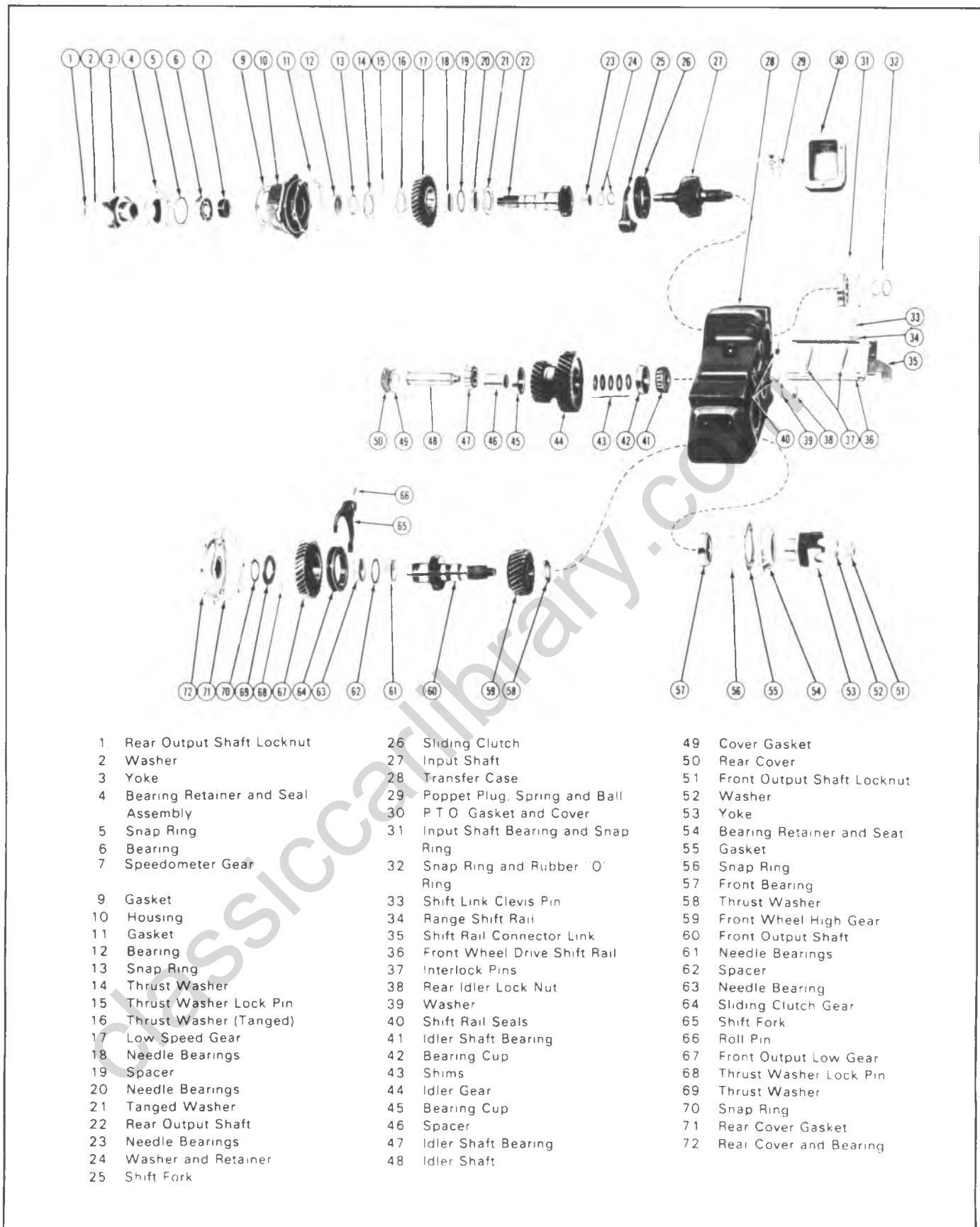


Fig. 7E-2--Model 205 Transfer Case, Exploded View

MAINTENANCE AND ADJUSTMENTS

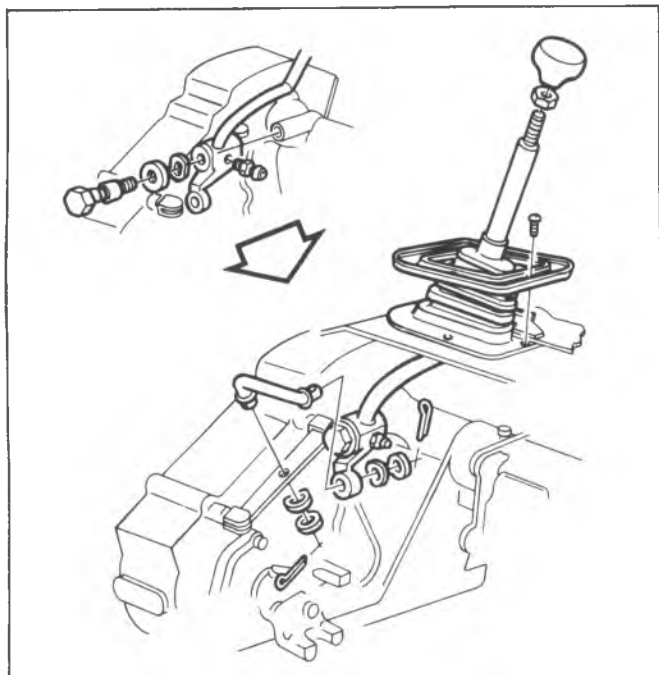


Fig. 7E-3-Model 205 Linkage

LUBRICATION INFORMATION

Refer to Section 0B of this manual for detailed information on recommended intervals and types of lubricant.

LINKAGE ADJUSTMENT AND INSPECTION

The control linkage for the transfer part-time case is shown in Fig. 7E-3. Periodically inspect the linkage system for freedom of operation, proper engagement, loose attaching bolts foreign material, etc. Adjust, clean and tighten as necessary.

DIAGNOSIS

| COMPLAINT | POSSIBLE CAUSES | REMEDIES |
|--|---|---|
| Excessive Noise | <ol style="list-style-type: none"> 1. Lubricant level-low 2. Worn or damaged bearings 3. Worn or damaged chain 4. Misalignment of drive shafts or universal joints 5. Yoke bolts loose 6. Loose adapter bolts | <ol style="list-style-type: none"> 1. Fill as required 2. Replace 3. Replace 4. Align 5. Torque to specs. 6. Torque to specs. |
| Shifter Lever Difficult to Move | <ol style="list-style-type: none"> 1. Dirt/contamination on linkage 2. Binding inside transfer case | <ol style="list-style-type: none"> 1. Clean and lubricate 2. Repair as required |
| Shifter Lever Disengages from Position | <ol style="list-style-type: none"> 1. Linkage misadjusted/loose 2. Gears worn or damaged 3. Shift rod bent 4. Missing detent ball or spring | <ol style="list-style-type: none"> 1. Readjust/tighten 2. Replace 3. Replace 4. Replace |
| Lubricant Leaking | <ol style="list-style-type: none"> 1. Excessive lubricant in case 2. Leaking seals or gaskets 3. Loose bolts 4. Scored yoke in seal contact area | <ol style="list-style-type: none"> 1. Adjust level 2. Replace 3. Tighten 4. Refinish or replace |

Fig. 7E-4--Transfer Case Diagnosis

COMPONENT REPLACEMENT

TRANSFER CASE REPLACEMENT

Removal (Fig. 7E-5)

1. Raise and support vehicle on hoist. Drain transfer case.
2. Disconnect speedometer cable.
3. Remove skid plate and crossmember supports as necessary.
4. Disconnect rear prop shaft from transfer case and tie up away from work area.
5. Disconnect front prop shaft from transfer case and tie up shaft away from work area.
6. Disconnect shift lever rod from shift rail link.
7. Support transfer case and remove bolts attaching transfer case to transmission adapter.
8. Move transfer case to rear until input shaft clears adapter and lower assembly from vehicle.

Installation

1. Support transfer case in suitable stand and position case to transmission adapter. Install bolts attaching case to adapter and torque to 45 ft. lb. (61 N·m).
2. Remove stand.

3. Install connecting rod to shift rail link or connect shift levers to transfer case, as applicable.

4. Connect front prop shaft to transfer case front output flange or yoke.

5. Connect rear prop shaft to transfer case rear output yoke.

6. Install crossmember support and skid plate, if removed.

7. Connect speedometer cable.

8. Fill transfer case to proper level with lubricant specified in Section 0-B.

9. Lower and remove vehicle from hoist.

Check and tighten all bolts to specified torques.

Before connecting prop shafts to companion flanges, be sure locknuts are torqued to specifications.

SKID PLATE, STRUT ROD

ADAPTER ASSEMBLIES

Attachment of the above items is shown in Fig. 7E-6, 7 and 8. Refer to these figures when removing or replacing these components.

Classiccarlibrary.com

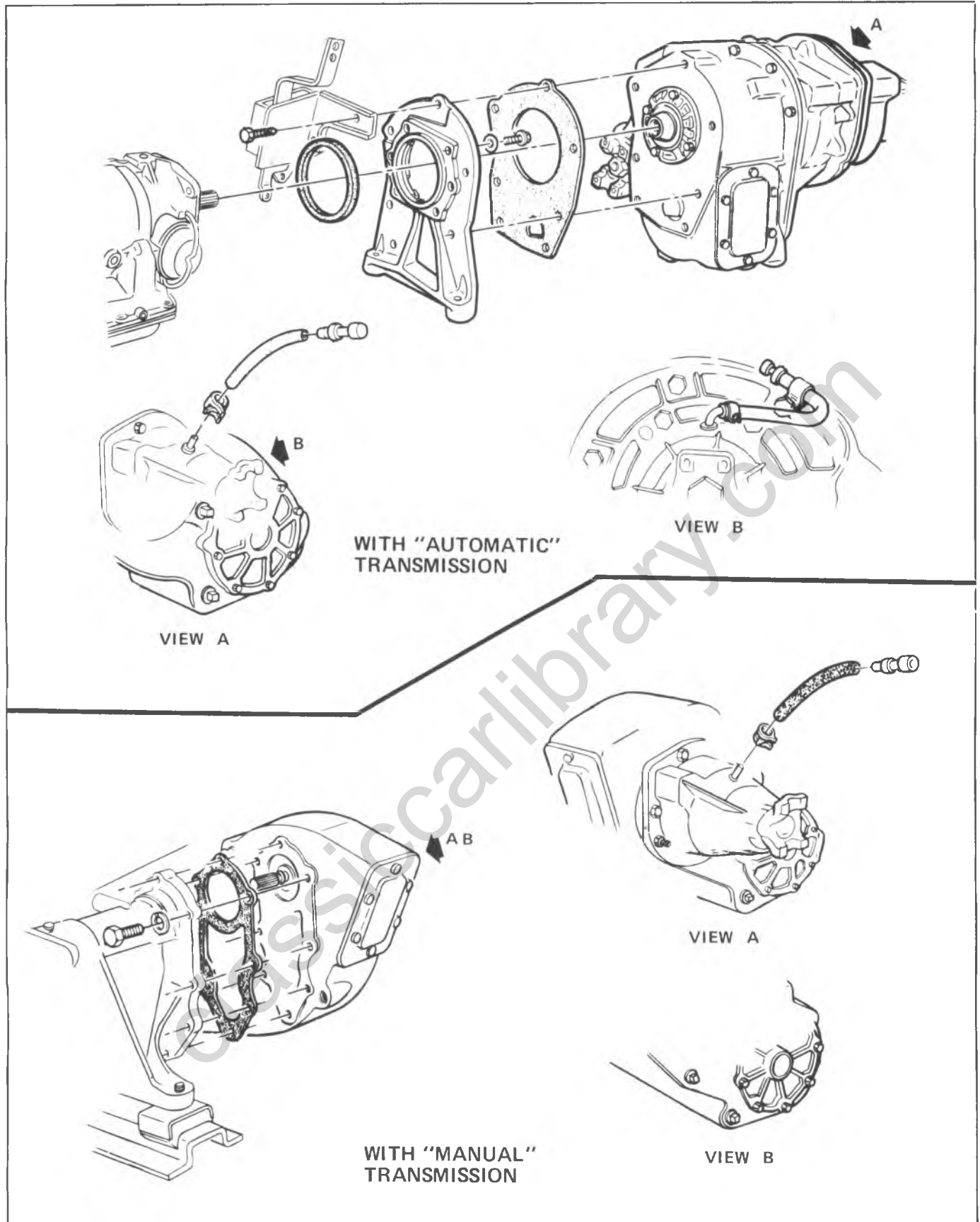


Fig. 7E-5--Transfer Case Attachment-Typical

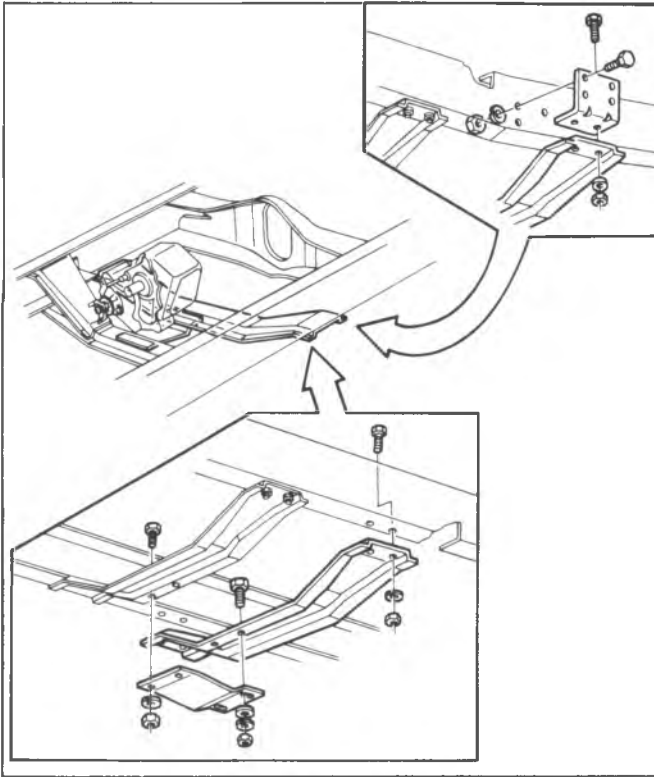


Fig. 7E-6--Skid Plates

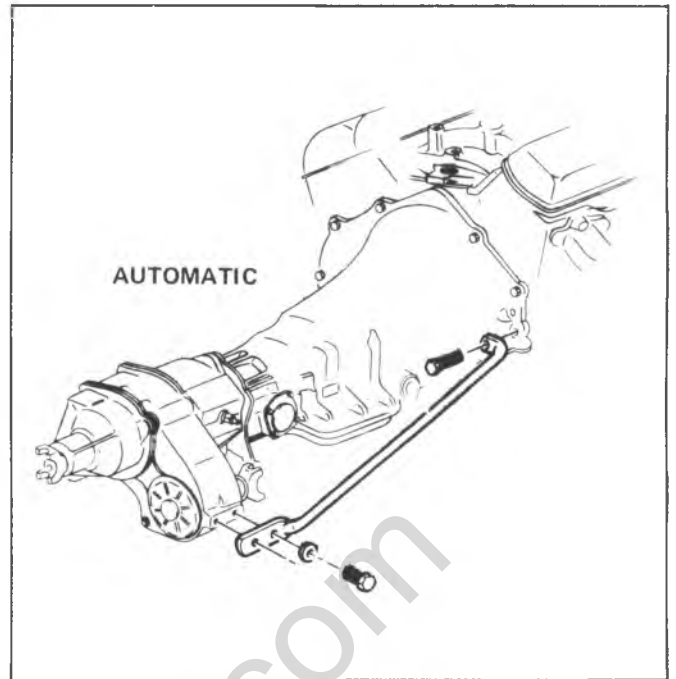


Fig. 7E-7--Strut Rods



Fig. 7E-8--Adapter Assemblies

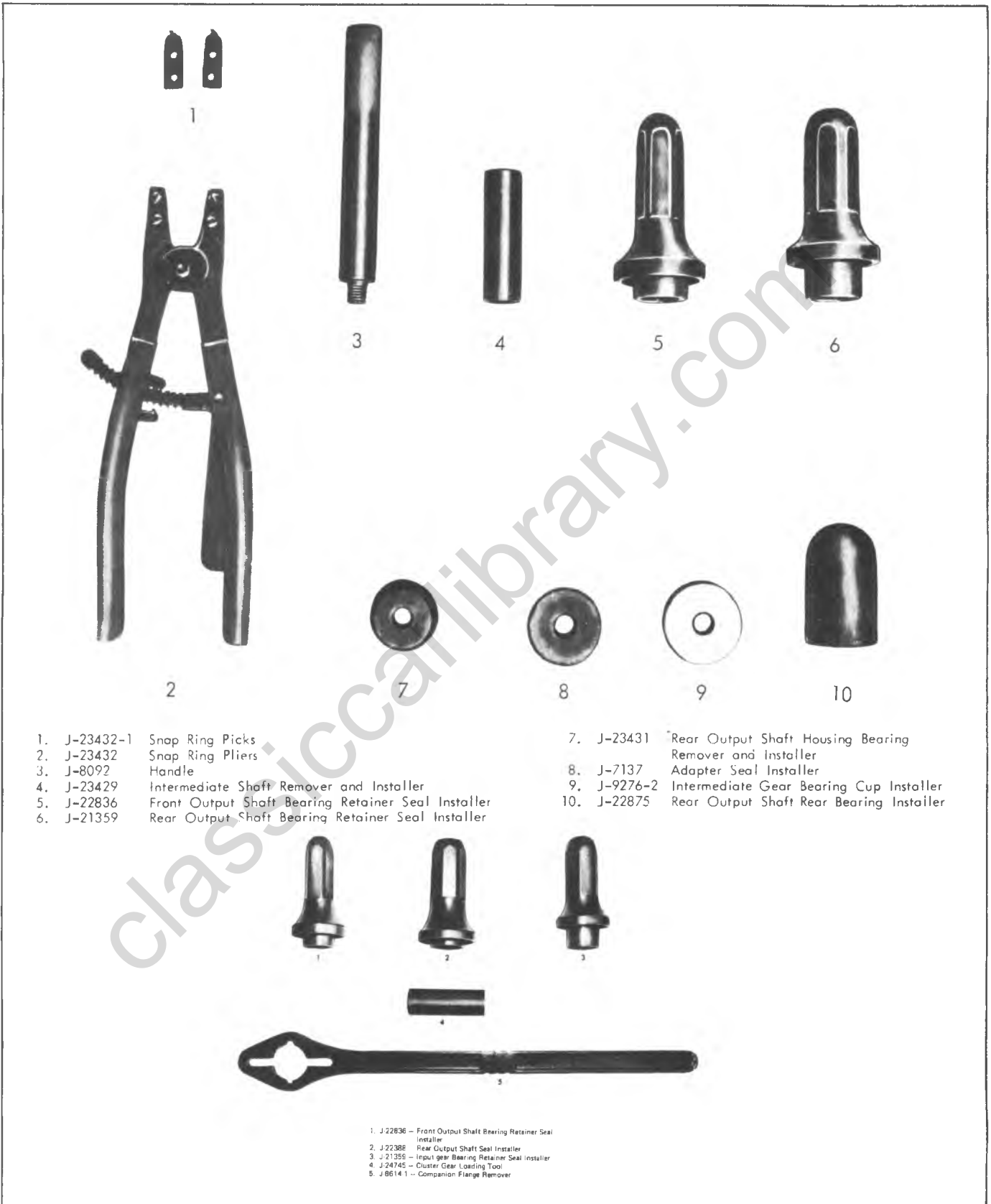
SPECIFICATIONS

| | N-m |
|------------------------------------|-----------|
| | Model 205 |
| Nut, Shift Lever-to-Shifter Asm | — |
| Nut, Knob Asm-to-Shift Lever | 26-40 |
| Bolt, Shifter Asm-to-Transfer Case | 120-140 |
| Nut, Shift Arms-to-Case | 14-20 |
| Screw, Shift Lever Boot Retainer | 2.2-3.2 |

| | |
|--------------------------------|-------|
| Bolt, Adapter-to-Transmission | 26-34 |
| Bolt, Adapter-to-Transfer Case | 27-41 |
| Filler Plug | 41-48 |
| Bolts P.T.O. Cover | 20-24 |
| Nut, Skid Plate-to-Crossmember | 55-70 |
| Bolt, Support Strut Rod | |
| - Transmission End | — |
| - Transfer Case End | — |

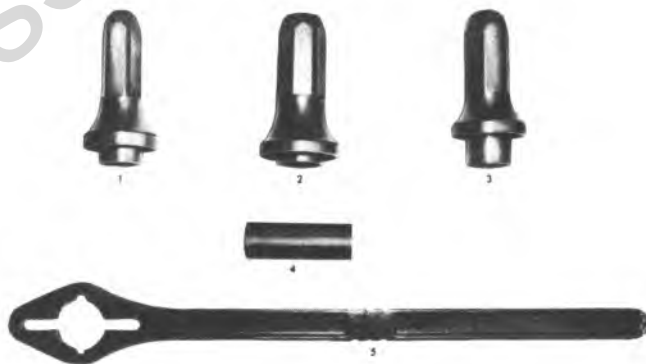
| | |
|---|--|
| Model No. | 205 (Part-Time) |
| Availability | K10-30 (Manual Trans) |
| Ratios: Hi Range | 1.00 to 1 |
| Lo Range | 1.96 to 1 |
| Lever Positions | 4-Lo (All wheel underdrive) N (Neutral) 2-Hi (Rear wheel drive) 4-Hi (All wheel direct drive) |
| Lever Location | Rear of trans. shift lever |
| Power Take-Off Data: Opening & Location | SAE 6-bolt; Left side |
| Lubricants: Oil capacity | 5.2 pints |
| Type, grade | See Owner's Manual |

SPECIAL TOOLS



- 1. J-23432-1 Snap Ring Picks
- 2. J-23432 Snap Ring Pliers
- 3. J-8092 Handle
- 4. J-23429 Intermediate Shaft Remover and Installer
- 5. J-22836 Front Output Shaft Bearing Retainer Seal Installer
- 6. J-21359 Rear Output Shaft Bearing Retainer Seal Installer

- 7. J-23431 Rear Output Shaft Housing Bearing Remover and Installer
- 8. J-7137 Adapter Seal Installer
- 9. J-9276-2 Intermediate Gear Bearing Cup Installer
- 10. J-22875 Rear Output Shaft Rear Bearing Installer



- 1. J-22836 - Front Output Shaft Bearing Retainer Seal Installer
- 2. J-22386 Rear Output Shaft Seal Installer
- 3. J-21355 - Input gear Bearing Retainer Seal Installer
- 4. J-24745 - Cluster Gear Loading Tool
- 5. J-8614-1 - Companion Flange Remover

Fig. 7E-ST-Special Tools

classiccarylbrary.com

SECTION 8A
ELECTRICAL - BODY AND CHASSIS
LIGHTING SYSTEM
CONTENTS

| | | | |
|-----------------------------------|-------|--|-------|
| Lighting System | 8A-1 | Front Side Marker | 8A-11 |
| General Description | 8A-1 | Rear Side Marker | 8A-11 |
| Diagnosis | 8A-3 | Tail, Stop and Backup Lamps | 8A-11 |
| On-Vehicle Service | 8A-9 | Directional Signal Lamps | 8A-11 |
| Maintenance and Adjustments | 8A-9 | Clearance, License Plate and Ident Lamps | 8A-11 |
| Headlamp Adjustment | 8A-9 | Light Switch | 8A-13 |
| Sealed Beam Unit | 8A-9 | Headlamp Beam Selector Switch | 8A-14 |
| Parking Lamp Bulb | 8A-11 | Stoplamp Switch | 8A-14 |
| Parking Lamp Housing | 8A-11 | Specifications | 8A-16 |

LIGHTING SYSTEM
GENERAL DESCRIPTION

The lighting system includes the main light switch; stop light, dimmer and backing lamp switches; head and parking lamps; stop, tail, side marker, clearance and identification lamps; instrument illumination, directional signal and indicator lamps and the necessary wiring to complete the various circuits.

A bulkhead fuse panel (fig. 8A-1) provides convenient power taps and fuse clips for the appropriate circuits. The engine wiring harness and forward lamp harness connectors are bolted to the fuse panel.

All wiring systems not protected by a fuse or circuit breaker incorporate a fusible link which provides increased overload protection. The starting motor circuit is the exception.

Composite wiring diagrams are available in a separate manual. The standardized color code is common to all wiring harnesses. The wire covering color designates a particular circuit usage. Wire size designations are metric, conversions to AWG sizes are provided.

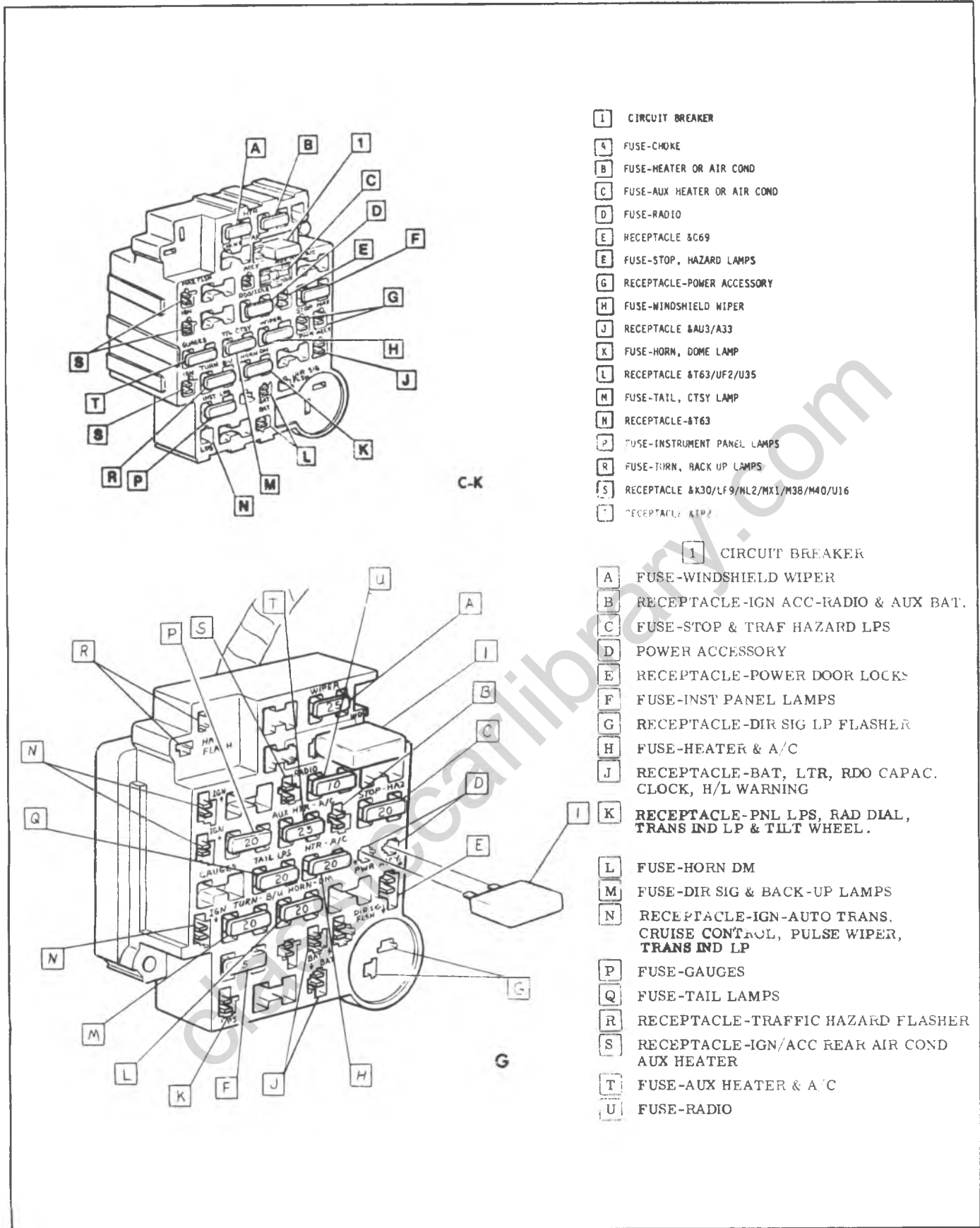


Fig. 8A-1-Fuse Panel

DIAGNOSIS

HEADLAMP DIAGNOSIS

| Condition | Possible Cause | Correction |
|--|---|--|
| One headlamp inoperative or intermittent | 1. Loose connection | 1. Secure connections to sealed beam including ground. (Black Wire) |
| | 2. Defective Sealed Beam | 2. Replace sealed beam |
| One or more headlights are dim. | 1. Open ground connection at headlight | 1. Repair black wire connection between sealed beam and body ground. |
| | 2. Black ground wire mislocated in headlight connector (type 2 sealed beam) | 2. Relocate black wire in connector |
| One or more headlights short life | 1. Voltage regulator misadjusted | 1. Readjust regulator to specifications. |
| All headlights inoperative or intermittent | 1. Loose connection | 1. Check and secure connections at dimmer switch and light switch. |
| | 2. Defective dimmer switch | 2. Check voltage at dimmer switch with test lamp. If test lamp bulb lights only at light blue wire terminal, replace dimmer switch. |
| | 3. Open wiring - light switch to dimmer switch | 3. Check light blue wire with test lamp. If bulb lights at light switch light blue wire terminal but not at dimmer switch, repair open wire. |
| | 4. Open wiring - light switch to battery | 4. Check red wire terminal at light switch with test lamp. If lamp does not light, repair open red wire circuit to battery. (possible open fusible link) |
| | 5. Shorted ground circuit | 5. If, after a few minutes operation, headlights flicker "ON" and "OFF" and or a thumping noise can be heard from the light switch (circuit breaker opening and closing), repair short to ground in circuit between light switch and headlights. After repairing short, check for headlight flickering after one minute operation. If flickering occurs, the circuit breaker has been damaged and light switch must be replaced. |
| | 6. Defective light switch | 6. Check red and white wire terminals at light switch with test lamp. If bulb lights at read wire terminal but not at light blue terminal, replace light switch. |

| | | |
|--|---|--|
| Upper or lower beam will not light or intermittent | 1. Open connection or defective dimmer switch | 1. Check dimmer switch terminals with test lamp. If bulb lights at light blue or tan wire terminals, repair open wiring between dimmer switch and headlights. If bulb will not light at one of these terminals, replace dimmer switch. |
| | 2. Short circuit to ground | 2. Follow diagnosis above (All headlights inoperative or intermittent) |

SIDE MARKER LAMP DIAGNOSIS

| Condition | Possible Cause | Correction |
|---------------------------------|---|--|
| One lamp inoperative | 1. Turn signal bulb burnt out (Front lamp) | 1. Switch turn signals on. If signal bulb does not light, replace bulb. (Bulb filament provides ground path for marker lamp bulb through the light blue or dark blue/white strip wires). |
| | 2. Side marker bulb burnt out | 2. Replace bulb. |
| | 3. Loose connection or open in wiring | 3. Using test lamp, check brown wire terminal at bulb socket. If test lamp lights, repair open ground circuit. If lamp does not light, repair open brown wire circuit. |
| Front or rear lamps inoperative | 1. Loose connection or open ground connection | 1. If associated tail or park lamps do not operate, secure all connectors in brown wire circuit. If park and turn lamps operate, repair open ground connections. |
| | 2. Multiple bulbs burnt out | 2. Replace burnt out bulbs. |
| All lamps inoperative | 1. Blown fuse | 1. If park and tail lamps do not operate, replace blown fuse. If new fuse blows, check for short to ground between fuse panel and lamps. |
| | 2. Loose connection | 2. Secure connector to light switch. |
| | 3. Open in wiring | 3. Check tail light fuse with test lamp. If test lamp lights, repair open wiring between fuse and light switch. If not, repair open wiring between fuse and battery. (Possible open fusible link). |

4. Defective light switch

4. Check light switch with test lamp. If test lamp lights at terminal No. 5 but not at terminal No. 4, replace light switch.

TAIL, PARK AND LICENSE LAMP DIAGNOSIS

| Condition | Possible Cause | Correction |
|------------------------|--|--|
| One side inoperative | 1. Bulb burnt out | 1. Replace bulb |
| | 2. Open ground connection at bulb socket or ground wire terminal | 2. Jumper bulb base socket connection to ground. If lamp lights, repair open ground circuit. |
| Both sides inoperative | 1. Tail lamp fuse blown | 1. Replace fuse. If new fuse blows, repair short to ground in brown wire circuit between fuse panel through light switch to lamps. |
| | 2. Loose connection | 2. Secure connector at light switch. |
| | 3. Open wiring | 3. Using test light, check circuit on both sides of fuse. If lamp does not light on either side, repair open circuit between fuse panel and battery. (possible open fusible link). If test lamp lights at light switch brown wire terminal, repair open wiring between light switch and lamps. |
| | 4. Multiple bulb burnout | 4. If test lamp lights at lamp socket brown wire terminal, replace bulbs. |
| | 5. Defective light switch | 5. If test lamp lights at light switch terminal No. 4 (Brown/white wire) but not at terminal No. 5 (Brown wire), replace defective light switch. |

TURN SIGNAL AND HAZARD WARNING LAMP

| Condition | Possible Cause | Correction |
|-----------------------------------|---|--|
| Turn signals inoperative one side | 1. Bulb(s) burnt out (Flasher cannot be heard) | 1. Turn hazard warning system on. If one or more bulbs are inoperative replace necessary bulbs. |
| | 2. Open wiring or ground connection | 2. Turn Hazard warning system on. If one or more bulbs are inoperative, use test lamp and check circuit at lamp socket. If test lamp lights, repair open ground connection. If not, repair open wiring between bulb socket and turn signal switch. |
| | 3. Improper bulb or defective turn signal switch. | 3. Turn hazard warning system on. If all front and rear lamps operate, check for improper bulb (1034 instead of 1157). If bulbs are OK, replace defective turn signal switch. |
| | 4. Short to ground. (Flasher can be heard, no bulbs operate) | 4. Locate and repair short to ground by disconnecting front and rear circuits separately. |
| Turn signals inoperative | 1. Blown turn signal fuse | 1. Turn hazard warning system on. If all lamps operate, replace blown fuse. If new fuse blows, repair short to ground between fuse and lamps. |
| | 2. Defective flasher (Located behind instrument panel near steering column) | 2. If turn signal fuse is OK and hazard warning system will operate lamps, replace defective turn signal flasher. |
| | 3. Loose connection | 3. Secure steering column connector. If necessary, check purple wire terminals in connector with test lamp. If test lamp lights only on one side of connector, clean or tighten connector contacts. |

| | | |
|----------------------------------|---|--|
| Hazard warning lamps inoperative | 1. Blown stop-hazard fuse | 1. Switch turn signals on. If lamps operate, replace stop-hazard fuse if blown. If new fuse blows, repair short to ground. (Could be in stop light circuit). |
| | 2. Defective hazard warning flasher. (Located on fuse panel). | 2. If stop-hazard fuse is OK, switch turn signals on. If lamps operate, replace defective hazard flasher. |
| | 3. Open in wiring or defective turn signal switch. | 3. Using test lamp, check brown wire in turn signal steering column connector. If lamp does not light on either side of connector, repair open circuit between flasher and connector. If lamp lights only on feed side of connector, clean connector contacts. If lamp lights on both sides of connector, replace defective turn signal switch assembly. |

BACK-UP LAMP

| Condition | Possible Cause | Correction |
|---|--|---|
| One lamp inoperative or intermittent | 1. Loose or burnt out bulb | 1. Secure or replace bulb. |
| | 2. Loose connection | 2. Tighten connectors. |
| | 3. Open ground connections | 3. Repair bulb ground circuit. |
| Both lamps inoperative or intermittent. | 1. Neutral start switch misadjusted (Open when shift lever is in reverse position) | 1. Readjust neutral start switch. |
| | 2. Loose connection or open circuit | 2. Secure all connectors. If OK, check continuity of circuit from fuse to lamps with test lamp. If lamp does not light on either side of fuse, correct open circuit from battery to fuse. |
| | 3. Blown fuse | 3. Replace fuse. If new fuse blows, repair short to ground in circuit from fuse through neutral start switch to back-up lamps. |
| | 4. Defective neutral start switch | 4. With ignition on, check switch terminals in back-up position with test lamp. If lamp lights at pink wire terminal but not at light green wire terminal, replace neutral start switch. |
| | 5. Defective ignition switch | 5. If test lamp lights at ignition switch battery terminal but not at output terminal, replace ignition switch. |

| | | |
|------------------------|---|---|
| Lamp will not turn off | 1. Neutral start switch misadjusted (closed when shift lever is not in reverse position) | 1. Readjust neutral start switch |
| STOP LIGHTS | | |
| Condition | Possible Cause | Correction |
| One bulb inoperative | 1. Bulb burnt out. | 1. Replace bulb. |
| One side inoperative | 1. Loose connection, open wiring or defective bulbs 2. Defective directional signal switch or cancelling cam | 1. Turn on directional signal. If lamp does not operate, check bulbs. If bulbs are OK, secure all connections. If lamp still does not operate, use test lamp and check for open wiring. 2. If lamp will operate by turning directional signal on, the switch is not centering properly during cancelling operation. Replace defective cancelling cam or directional signal switch. |
| All inoperative | 1. Stop-hazard fuse blown 2. Stop-switch misadjusted or defective | 1. Replace fuse. If new fuse blows, repair short to ground in circuit between fuse and lamps. 2. With brake pedal depressed, check white wire terminal in steering column connector with test lamp. If lamp does not light, check stop switch for proper adjustment. If adjustment is OK, replace stop switch. |
| Will not turn off | 1. Stop switch misadjusted or defective. | 1. Readjust switch. If switch still malfunctions, replace. |

ON-VEHICLE SERVICE

Maintenance of the lighting units and wiring system consists of an occasional check to see that all wiring connections are tight and clean, that the lighting units are securely mounted to provide good ground and that the headlamps are properly adjusted. Loose or corroded connections may cause a discharged battery, difficult starting, dim lights, and possible damage to the generator. Wire harnesses must be replaced if insulation becomes burned, cracked, or deteriorated. Whenever it is necessary to splice a wire or repair one that is broken, always use solder to bond the splice. Always use rosin flux solder on electrical connections. Use insulating tape to cover all splices or bare wires.

When replacing wires, it is important that the correct size be used. Never replace a wire with one of a smaller size. Fusible links in the wiring are four gage sizes smaller than the cable it is designed to protect. The links are marked on the insulation with wire gage size because of the heavy insulation which makes the link appear a heavier gage than it actually is.

Each harness and wire must be held securely in place by clips or other holding devices to prevent chafing or wearing away the insulation due to vibration.

By referring to the wiring diagram manual, circuits may be tested for continuous circuit or shorts with a conventional test lamp or low reading voltmeter. These wiring diagrams use metric wire size designations, a chart showing metric to AWG size conversions is provided in the manual.

HEADLAMP ADJUSTMENT (Fig. 8A-2)

The headlamps must be properly aimed to obtain

maximum road illumination. When using mechanical headlamp aimers, follow manufacturers instructions.

The headlamps must be checked for proper aim whenever a sealed beam unit is replaced and after repairs of the front end sheet metal assembly.

Regardless of the method used for checking headlamp aim, the truck must be at normal weight, that is with gas, oil, water and spare tire. Tires must be inflated to specified pressures.

Some states have special requirements for headlamp aiming adjustment and these requirements must be known and followed.

Horizontal and vertical aiming of each sealed beam is provided by two adjusting screws visible through the bezel which move the mounting ring against the tension of the coil spring (fig. 8A -2).

There is no adjustment for focus since the sealed beam unit is set for focus during manufacturing assembly.

ON-VEHICLE SERVICE

SEALED BEAM UNIT

Replacement (Figs. 8A-3 and 8A-4)

1. Remove bezel retaining screws and bezel.
2. Remove retaining ring.

Do not disturb adjusting screw setting.

3. Disconnect wiring harness connector located at rear of unit in engine compartment and remove sealed beam unit.
4. Attach wiring harness connector to unit.
5. Position new sealed beam unit in mounting ring and install retaining ring.

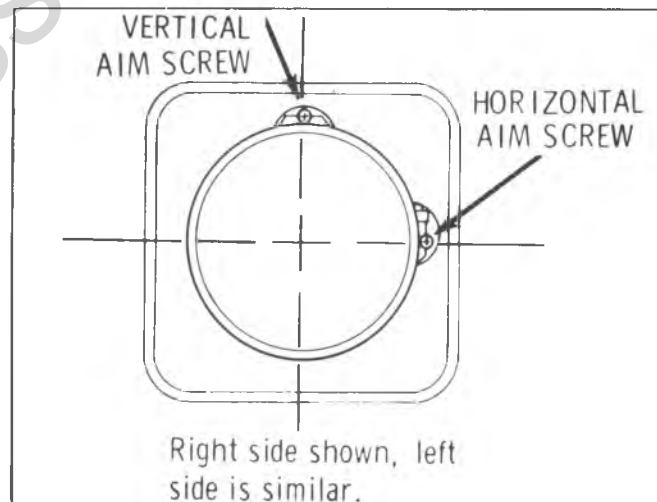


Fig. 8A-2—Headlamp Adjustments (Typical)

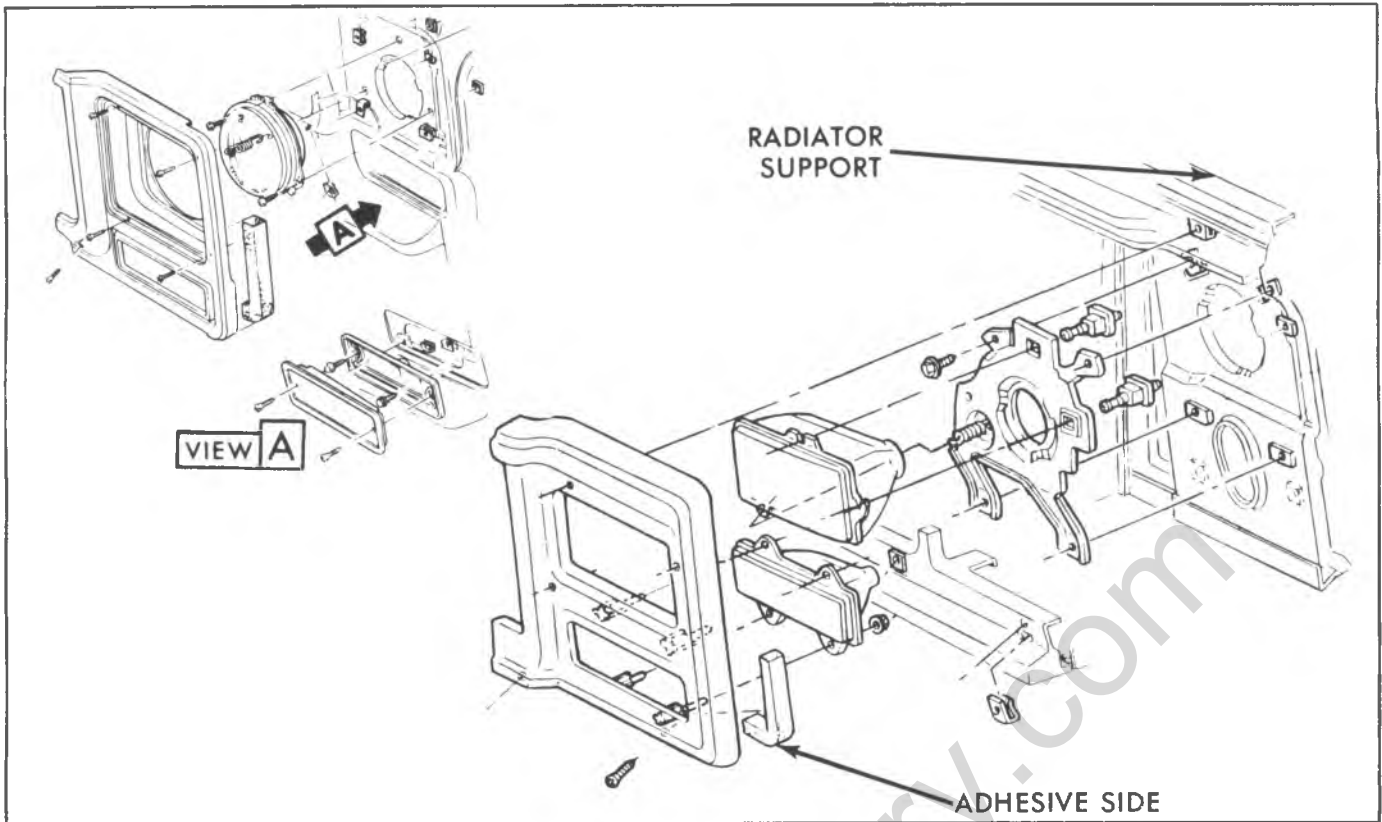


Fig. 8A-3—Front Lighting (C-K Models)

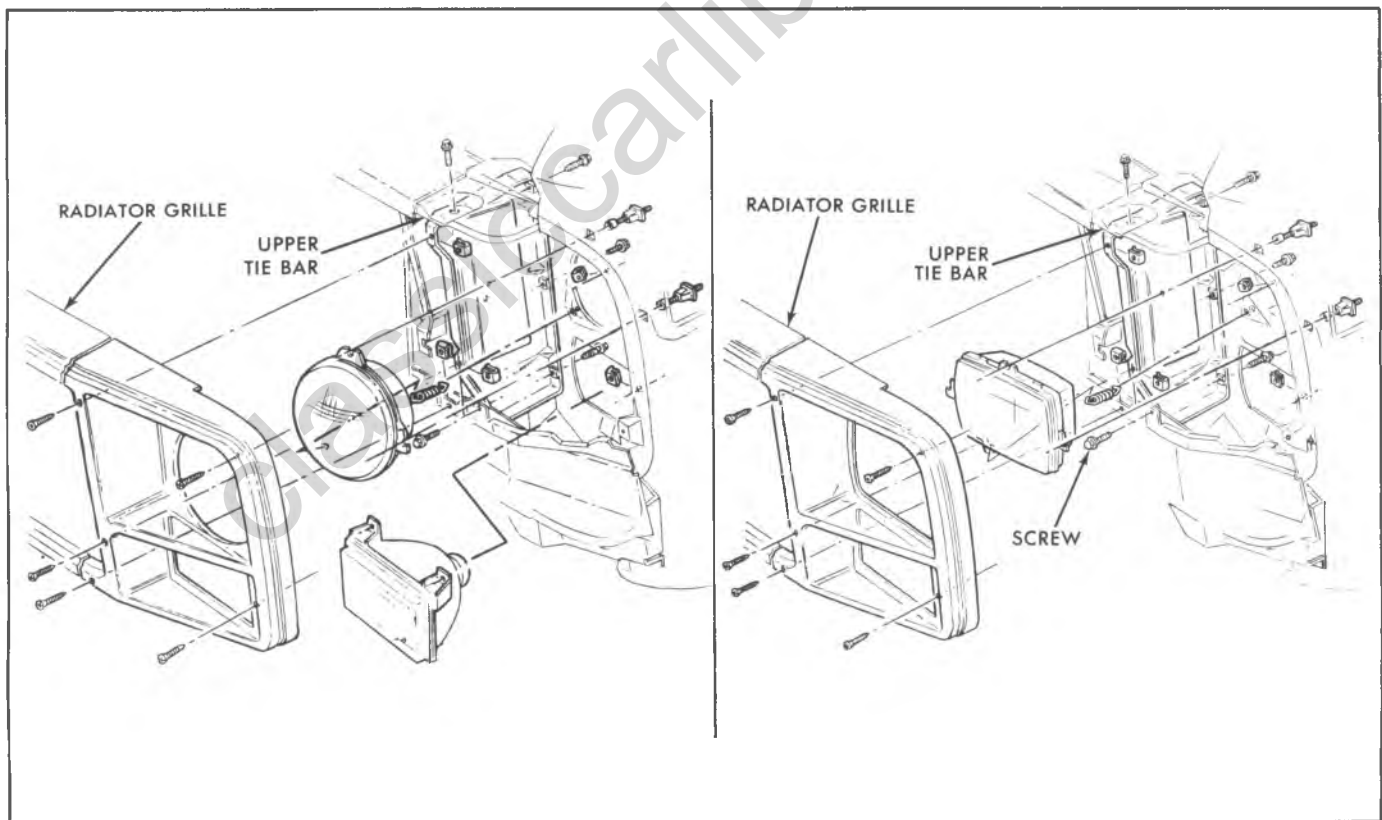


Fig. 8A-4—Front Lighting (G Models)

The number molded into lens face must be at top.

6. Install retaining ring then check operation of unit and install bezel.

PARKING LAMP BULB

Replacement (Figs. 8A-3 and 8A-4)

1. Remove lens retaining screws and remove lens from the housing.
2. Replace bulb and check lamp operation.
3. Install lens and retaining screws.

PARKING LAMP HOUSING

C-K Models

Replacement (Fig. 8A-3)

1. Remove parking lamp lens screws and remove the lens.
2. Remove lamp housing retaining screws and pull housing forward.
3. Disconnect parking lamp wiring harness from housing by rotating bulb socket counterclockwise.
4. Connect wiring harness to new housing by inserting bulb socket into housing and rotating clockwise.
5. Install bulb if removed during disassembly. Install lens and retaining screws.

G Models

Replacement (Fig. 8A-4)

Right Side

1. Remove both headlamp bezels.
2. Remove both parking lamp lens.
3. Remove grille.
4. Remove battery and battery box.
5. Disconnect wiring harness at connector.
6. Remove housing stud nuts and remove housing with pigtail.
7. To install, reverse removal steps.

Left Side

1. Remove two screws and parking lamp lens.
2. Disconnect wiring harness at connector.
3. Remove housing stud nuts and remove housing with pigtail.
4. To install, reverse removal steps.

FRONT SIDE MARKER LAMP BULB AND/OR HOUSING

All Models

Replacement

For housing replacement follow procedure for the right side bulb replacement below.

1. **Left Side** - Raise hood.
- Right Side** - Remove lamp assembly retaining screws and pull outward on assembly.
2. Twist wiring harness socket 90° counterclockwise and remove harness and bulb from housing.
3. Replace bulb and check lamp operation.
4. Insert bulb into housing, press in on harness socket and twist 90° clockwise. Check that socket is securely attached.

5. **Left Side** - Lower hood.

Right Side - Install housing in opening and install retaining screws.

REAR SIDE MARKER LAMP BULB AND/OR HOUSING

C-K 03 models with E62 and G Models

Replacement

Same as Right Front Side Marker Lamp Bulb and/or Housing Replacement - All Vehicles. Bulb on G Models without interior trim may be removed from inside the vehicle.

C-K 16, 03 and 63 with E63, and 06 Models

Replacement

1. Remove lens to housing four screws.
2. Replace bulb and check operation.
3. Position lens and install four attaching screws.

Platform and Stake Rack Models (E56)

Exploded view of the different rear lighting arrangements are shown in Figures 8A-7 and 8A-8. The bulbs may be replaced by removing the lamp lens attaching screws and lamp lens. The lamp housings may be replaced by removing housing attaching nuts or screws, or by removing nuts and bolts from bracket.

TAIL, STOP AND BACKUP LAMP BULBS

Replacement

1. Remove lens to housing attaching screws.
2. Replace bulb and check operation.
3. Position lens and install attaching screws.

TAIL, STOP AND BACKUP LAMP HOUSING

C-K 16, 03 and 63 w/E63 and 06 Models

All G Models

Replacement

1. Remove lens to housing attaching screws.
2. Remove bulbs from sockets.
3. Remove housing attaching screws (nuts on G Models).
4. Rotate wiring harness sockets counterclockwise and remove housing.
5. To install, reverse Steps 1-4 above.

DIRECTIONAL SIGNAL LAMPS

Directional signal lamps are an integral part of parking and tail lamp assemblies. Refer to the applicable lamp or bulb replacement procedures covered previously.

CLEARANCE, LICENSE PLATE AND IDENTIFICATION LAMPS

Refer to Figures 8A-7 through 8A-10 for clearance, license plate and identification lamp installations.

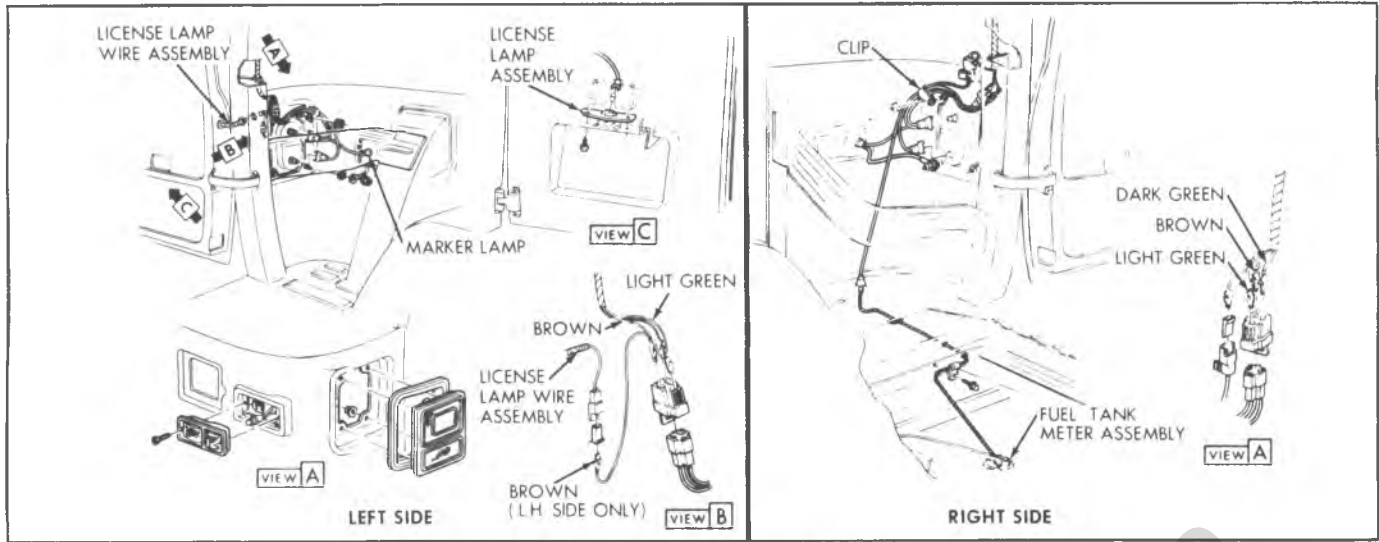


Fig. 8A-5 - Rear Lighting (G Models)

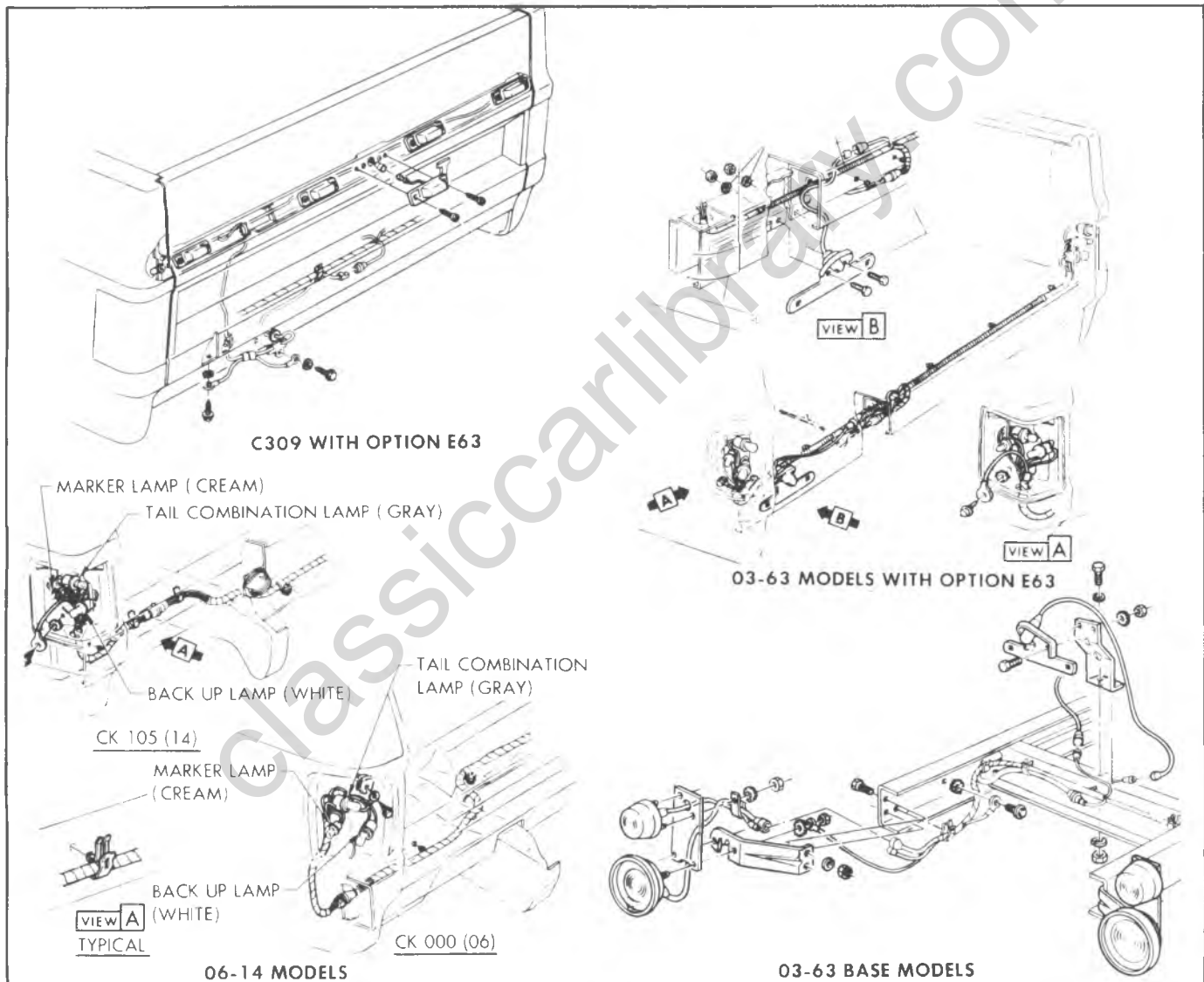


Fig. 8A-6 - Rear Lighting (C-K Models Except with E56 or E62)

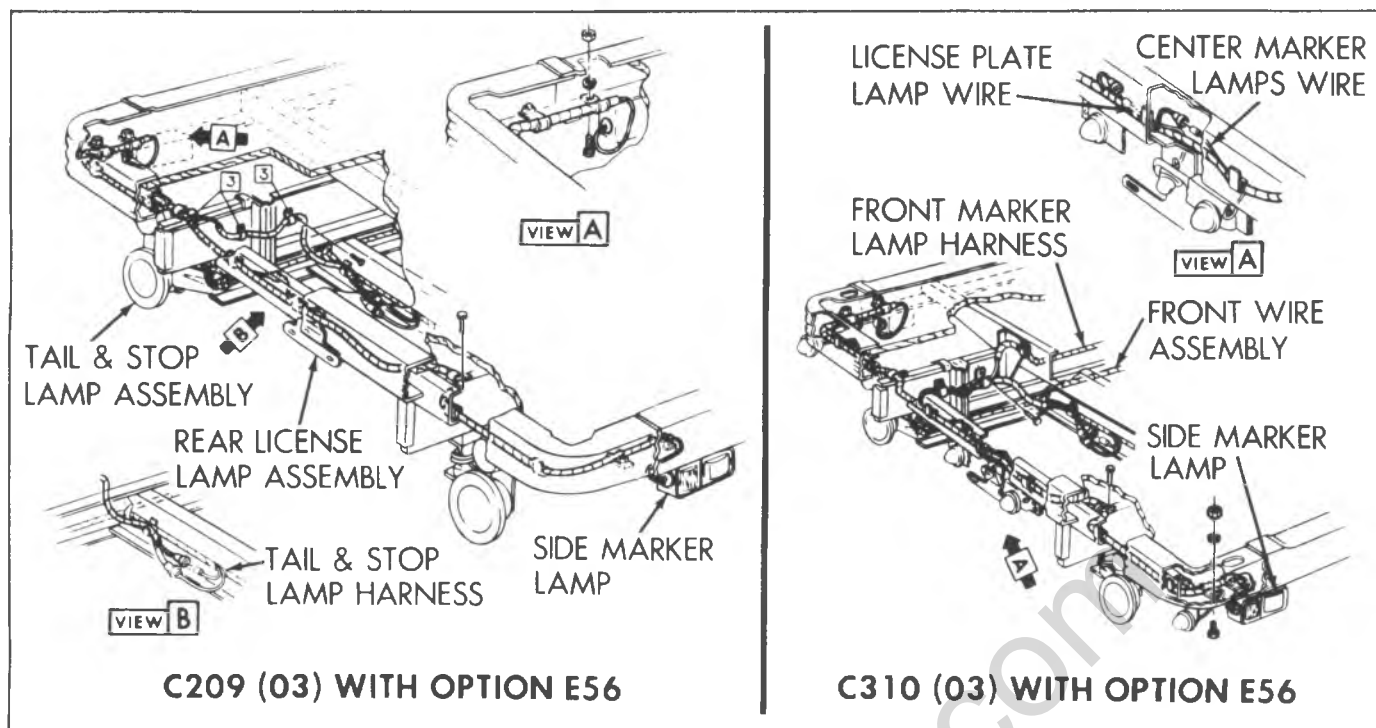


Fig. 8A-7—Rear Lighting (C-K Platform and Stake Rack Models)

LIGHT SWITCH

C-K Series (Fig. 8A-11)

Replacement

1. Disconnect battery ground cable.
2. Reaching up behind instrument cluster, depress shaft retaining button and remove switch knob and rod.
3. Remove instrument cluster bezel screws on left end. Pull out on bezel and hold switch nut with a wrench.

4. Disconnect multiple wiring connectors at switch terminals.
5. Remove switch by rotating while holding switch nut.
6. To install, reverse Steps 1-5 above.

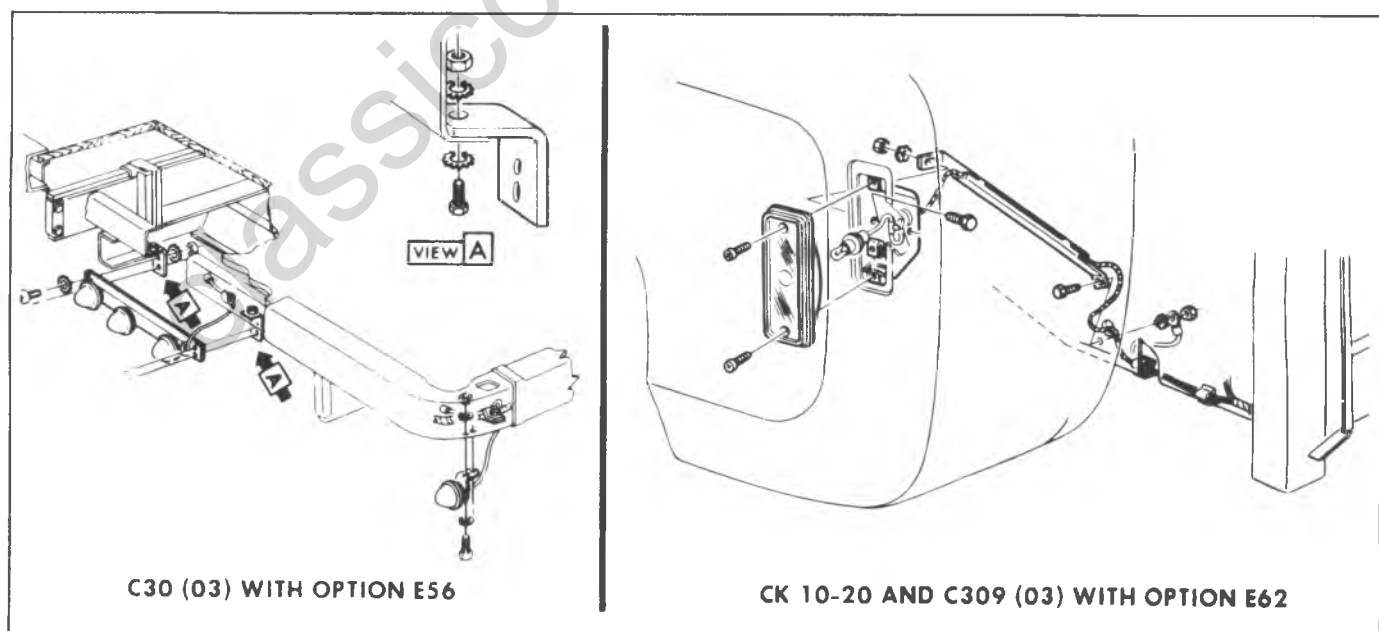


Fig. 8A-8—Rear Lighting (C30 03 Models with E56 and C-K Models with E62)

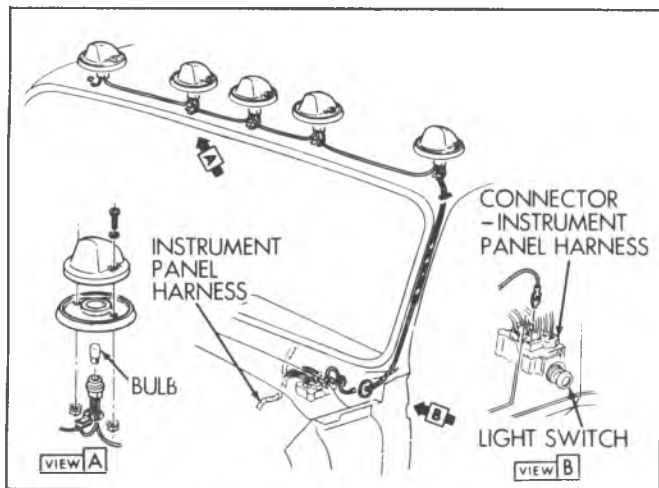


Fig. 8A-9—Clearance Lamps

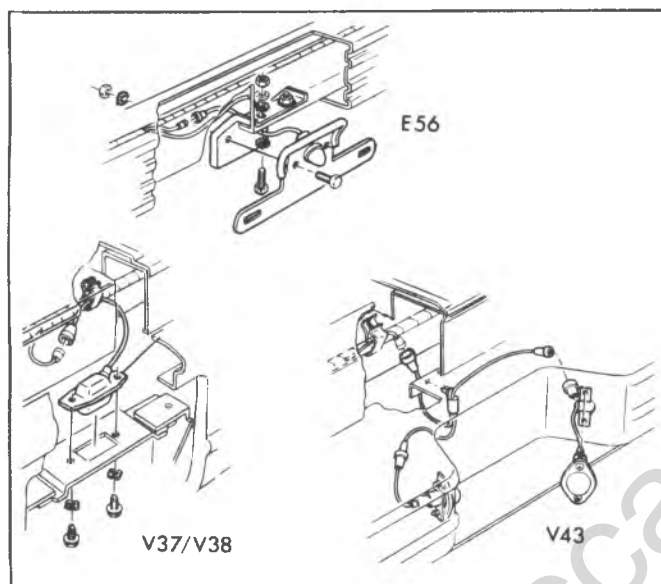


Fig. 8A-10—License Plate Lamps (C-K Series)

G Series (Fig. 8A-11)**Replacement**

1. Disconnect battery ground cable.
2. Reaching up behind instrument panel, depress shaft retaining button and remove switch knob-shaft.
3. From front of instrument panel remove switch retaining nut.
4. Push switch from panel opening and remove multiple electrical connector at switch terminals.
5. To install, reverse Steps 1-4, making sure grounding ring is installed on switch.

HEADLAMP BEAM SELECTOR SWITCH**Replacement**

1. Fold back upper left corner of the floor mat and remove two screws retaining switch to the floor pan.
2. Disconnect wiring connector from switch terminals.
3. Connect wiring to replacement switch and check operation.
4. Position switch to floor pan and install retaining screws.
5. Replace floor mat.

STOPLAMP SWITCH

See Section 5 (Brakes) of this manual for adjustment and replacement procedures.

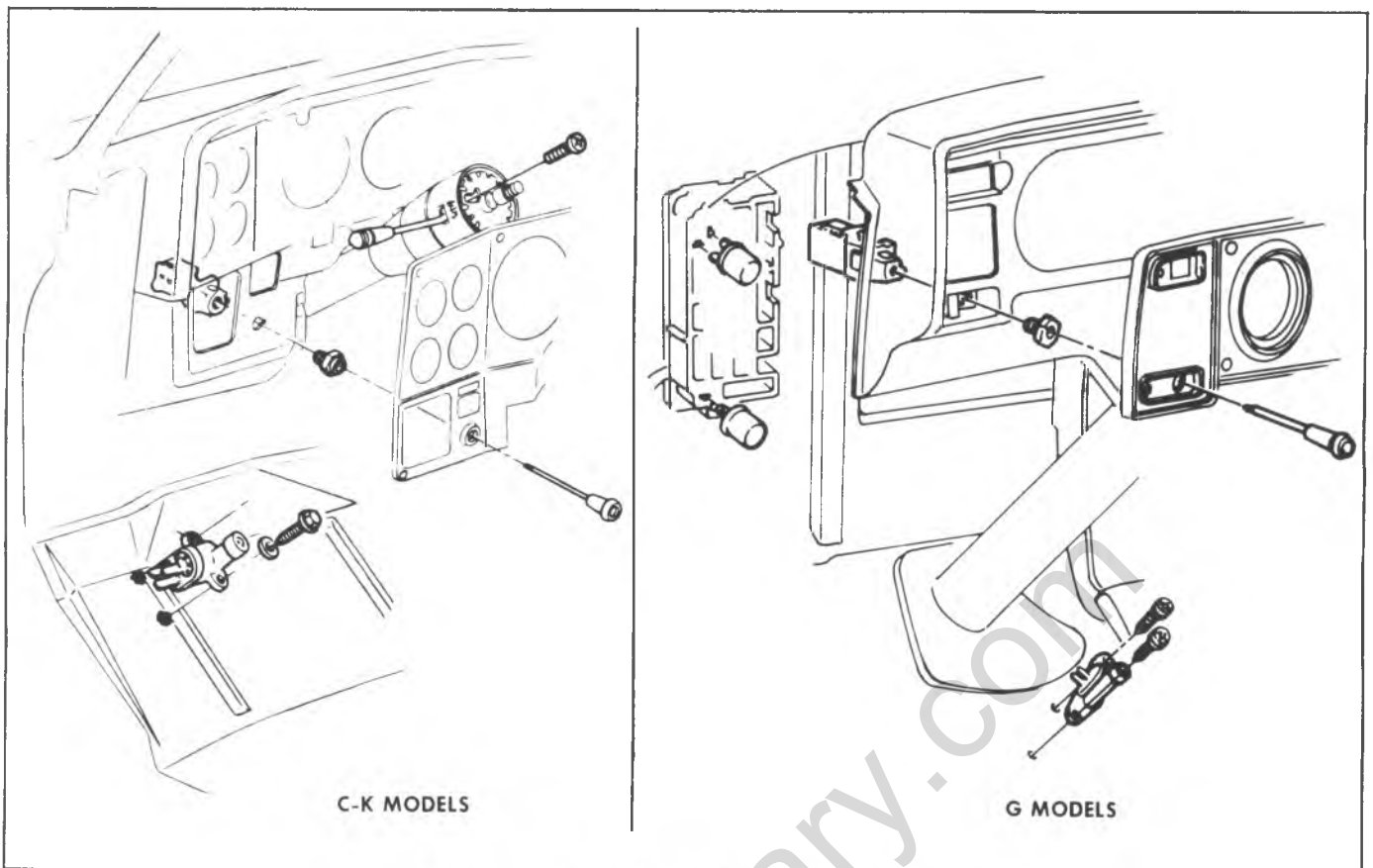


Fig. 8A-11—Light and Headlamp Beam Selector Switches

classiccarslibrary.com

SPECIFICATIONS

LAMP BULB DATA
C-K-P TRUCK

| USED IN | QUANTITY | TRADE # | POWER |
|--|----------|---------|---------|
| Dome Lamps: | | | |
| Cab | 1 | 1004 | 15 CP |
| Utility & Suburban | 1 | 211-2 | 12 CP |
| Oil Pressure indicator lamp ¹ | 1 | 168 | 3 CP |
| Generator indicator lamp ¹ | 1 | 168 | 3 CP |
| Instrument cluster lamps ² | 5 | 168 | 3 CP |
| Headlamp beam indicator lamp | 1 | 168 | 3 CP |
| Lamp assembly - tail & stop lamp | 2 | 1157 | 3-32 CP |
| License Lamp ⁴ | 1 | 67 | 4 CP |
| Directional signal (front park lamps) ⁶ | 2 | 1157 | 3-32 CP |
| Head Lamps | 2 | 6014 | 50-60 W |
| Temperature indicator lamp | 1 | 168 | 3 CP |
| Directional signal indicator lamp | 2 | 168 | 3 CP |
| Clearance and marker lamps | 4 | 168 | 3 CP |
| Roof marker lamps ⁵ | 5 | 194 | 2 CP |
| Brake warning indicator | 1 | 168 | 3 CP |
| Transmission control (auto) | 1 | 1445 | 0.7 CP |
| Backing lamp (exc. motor home) | 2 | 1156 | 32 CP |
| Backing lamp (motor home) | 2 | 1295 | 50 CP |
| Heater or A/C | 1 | 161 | 1 CP |
| Corner marker lamps (platform) | 7 | 67 | 4 CP |
| Cargo lamp (C-K cab) | 1 | 1142 | 21 CP |
| Radio dial lamp - AM | 1 | 1816 | 3 CP |
| - AM/FM | 1 | 216 | 1 CP |
| Courtesy lamp | 1 | 1003 | 15 CP |
| Windshield wiper switch | 1 | 161 | 1 CP |
| Clock | 1 | 168 | 3 CP |
| Rear identification ⁷ | 10 | 1895 | 2 CP |
| Underhood lamp | 1 | 93 | 15 CP |
| Seat belt warning | 1 | 168 | 3 CP |
| Cargo/dome lamp | 2 | 211-2 | 12 CP |
| Four wheel drive indicator | 1 | 161 | 1 CP |
| Choke heater Ind | 1 | 168 | 3 CP |

LAMP BULB DATA
G TRUCK

| USED IN | QUANTITY | TRADE# | POWER |
|--|----------|--------|---------|
| Dome lamps | 2 | 211-2 | 12 CP |
| Oil pressure indicator lamp | 1 | 161 | 1 CP |
| Generator indicator lamp | 1 | 194 | 2 CP |
| Instrument cluster lamps ¹¹ | 1 | 161 | 1 CP |
| Headlamp beam indicator lamp | 1 | 161 | 1 CP |
| Park, directional signal lamps | 2 | 1157 | 3-32 CP |
| Tail, stop lamps | 2 | 1157 | 3-32 CP |
| License lamp | 1 | 67 | 4 CP |
| Head lamps ¹² | 2 | 6014 | 50-60 W |
| Temperature indicator lamp | 1 | 194 | 2 CP |
| Directional signal indicator lamp | 2 | 194 | 2 CP |
| Marker lamps | 4 | 168 | 3 CP |
| Brake warning indicator lamp | 1 | 194 | 2 CP |
| Back-up lamp | 2 | 1156 | 32 CP |
| Radio dial lamp | 1 | 1893 | 2 CP |
| Heater or A/C control | 1 | 194 | 2 CP |
| Transmission control w/tilt wheel | 1 | 1445 | 0.7 CP |
| W/S wiper switch lamp | 1 | 161 | 1 CP |
| Transmission control | 1 | 73 | .3 CP |
| Choke heater ind | 1 | 1893 | 2 CP |
| Seat belt warning | 1 | 194 | 2 CP |
| Instrument cluster lamps ⁹ | 5 | 194 | 2 CP |
| Instrument cluster lamps ¹⁰ | 1 | 168 | 3 CP |

⁹ 'G' model w/o gauges; 1 lamp with gauges

¹⁰ 'G' model w/o gauges; 3 lamps with gauges

¹¹ 'G' model with gauges only

¹² Double filament sealed beam 60W high beam, 50W low beam.

- 1 On CA, KA 10-35 instrument clusters only.
- 2 3 lamps used on instrument cluster on P models or C-K w/o gauges.
- 3 Double filament sealed beam 60W high beam, 50W low beam.
- 4 2 lamps used with step bumper and P models.
- 5 4 required on P models.
- 6 1157 NA, 2.2-24 CP on C-K models.
- 7 Wideside Pickup.
- 8 'P' truck only.

SECTION 8B

ELECTRICAL AND WIRING

CONTENTS

| | | | |
|---------------------------|------|--------------------------------|-------|
| Radio Receiver | 8B-1 | Diagnosis | 8B-5 |
| Speakers | 8B-3 | On-Vehicle Service | 8B-6 |
| Circuit Protection | 8B-4 | Headlamp Warning Buzzer | 8B-6 |
| General Description | 8B-4 | Seat Belt Warning System | 8B-6 |
| Circuit Breaker | 8B-4 | Anti-Theft Alarm System | 8B-8 |
| Fuse | 8B-4 | Specifications | 8B-12 |
| Fusible Link | 8B-4 | | |

RADIO RECEIVER

REMOVAL AND INSTALLATION

C-K Series

Replacement (Fig. 8B-1)

1. Disconnect battery ground cable.

2. Pull off radio control knobs and remove knob bezels. Remove nuts and washers from control shafts using a deep well socket.

3. **AM Radio** -Remove the radio support bracket stud nut and lockwasher.

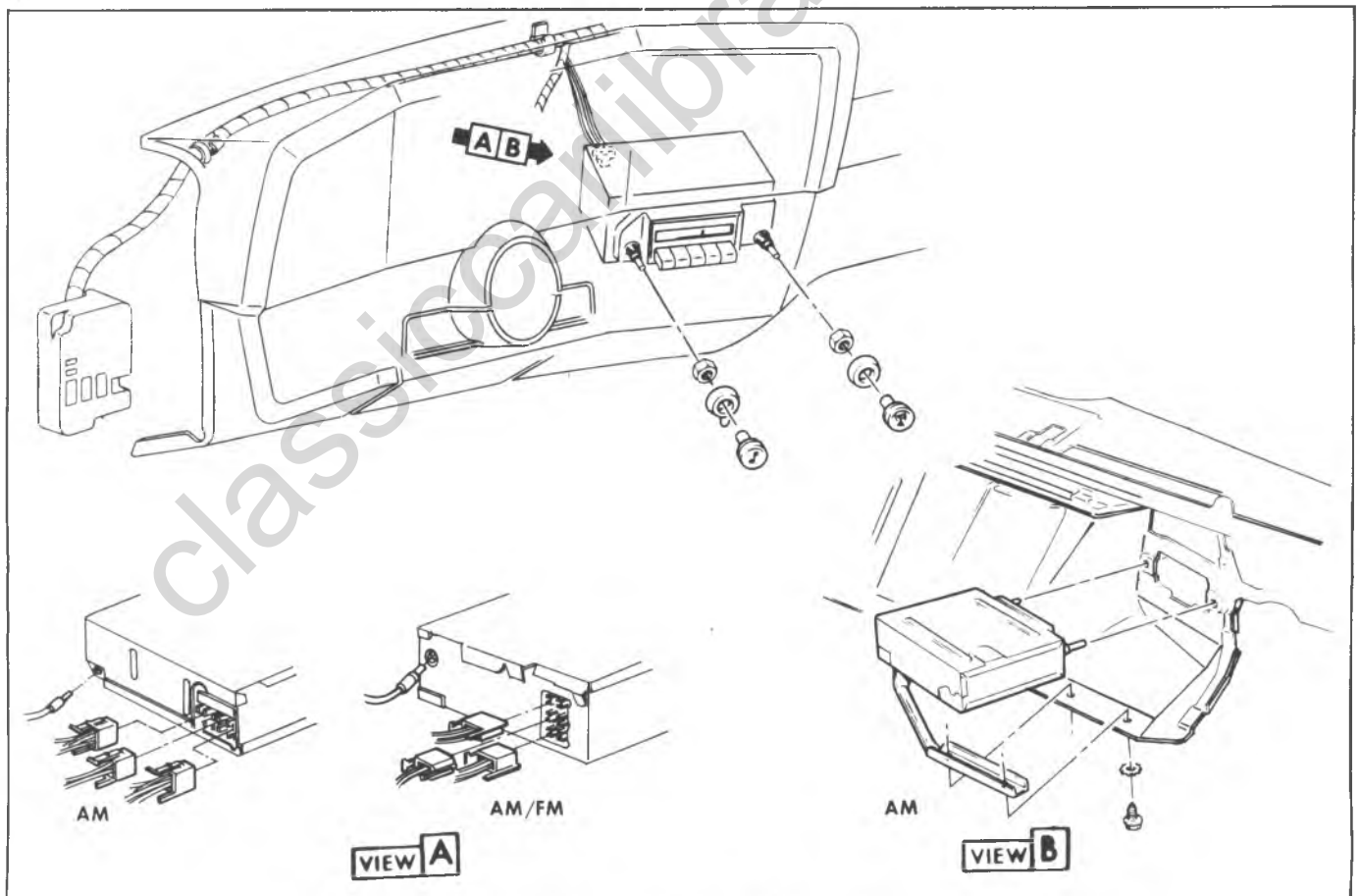


Fig. 8B-1—Radio Receiver (C-K Series)

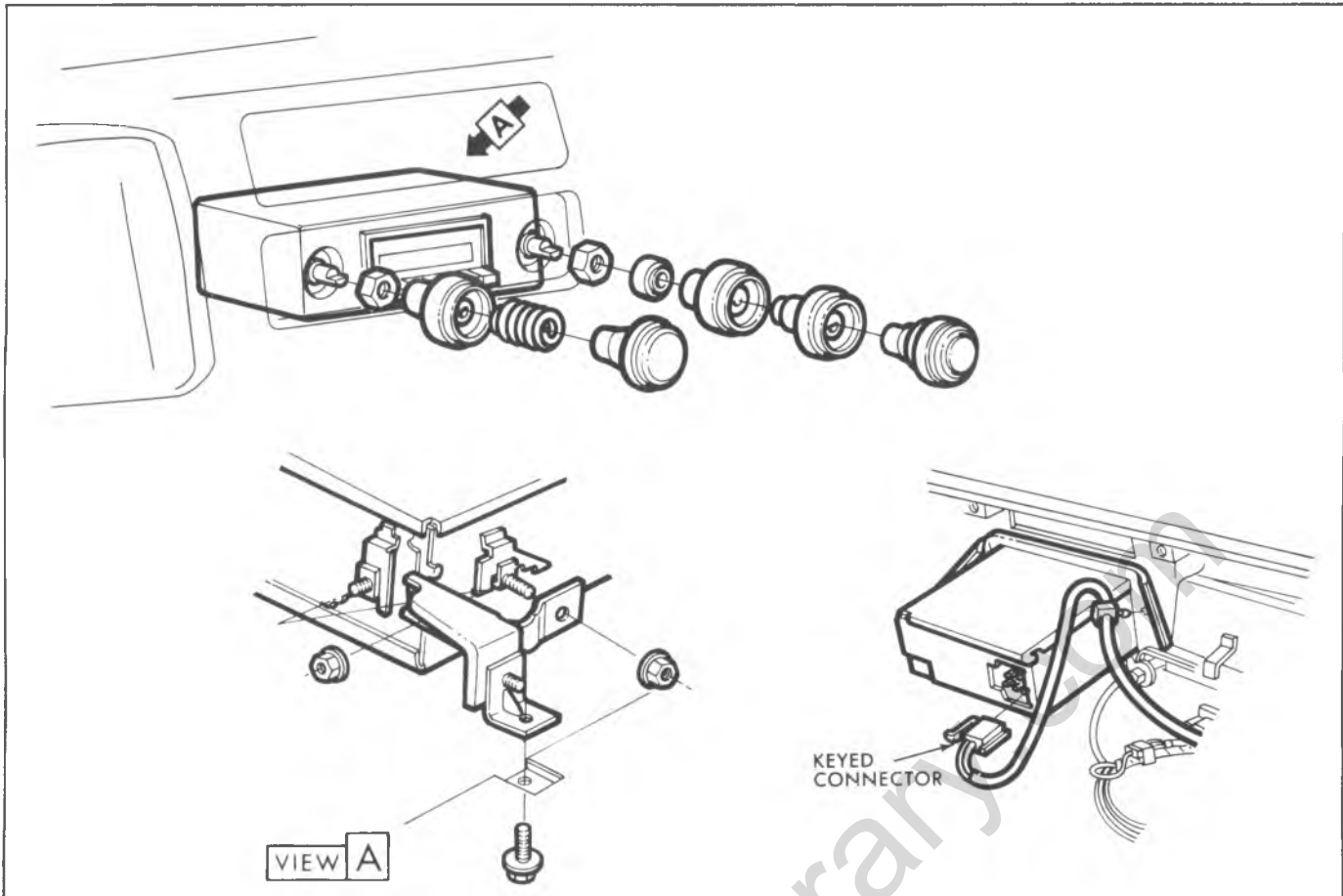


Fig. 8B-2--Radio Receiver Installation--G Models

AM/FM Radio -Remove radio support bracket to instrument panel screws.

4. Lift up on the rear edge of radio. Then push radio forward until control shafts clear instrument panel. Lower control far enough to disconnect electrical harness.

5. Disconnect power feed, speaker and antenna lead wires and remove radio.

6. To install, reverse Steps 1-5 above.

G Models

Replacement (Fig. 8B-2)

1. Disconnect battery ground cable.
2. Remove engine cover.
3. Remove air cleaner cover and element.
4. Remove radio control knobs and retaining nuts.
5. Remove rear mounting bracket.
6. Push radio forward in vehicle and then lower assembly and disconnect electrical harnesses and antenna lead.
7. Remove radio receiver from vehicle.
8. To install, reverse Steps 1-7 above.
9. Check operation.

NOTICE: Always attach speaker wiring harness before applying power to the radio to prevent receiver damage.

RADIO DIAL BULB

AM and AM/FM radio dial bulbs can be replaced with the radio in the truck. Tape player radios must be removed from the vehicle for dial bulb replacement.

It is not recommended that CB Radio dial bulb be replaced except by a qualified radio repair service.

Replacement (All Models)

AM Radio

1. Slide radio dial lens upward, approximately 1/8 inch.
2. Tip bottom edge of lens outward (toward technician) and remove lens.
3. Pull out bulb section and remove bulb.
4. Install new bulb into socket and then reinstall bulb section.
5. Reinstall dial lens.

AM-FM And Stereo Radio

1. Slide radio dial lens upward approximately 1/8 inch.
2. Tip bottom edge of lens outward (toward technician) and remove lens.
3. Remove rear dial plate screw. Place dial pointer at 16 and remove plate.
4. Remove bulb.
5. To install, reverse steps 1-4 above.

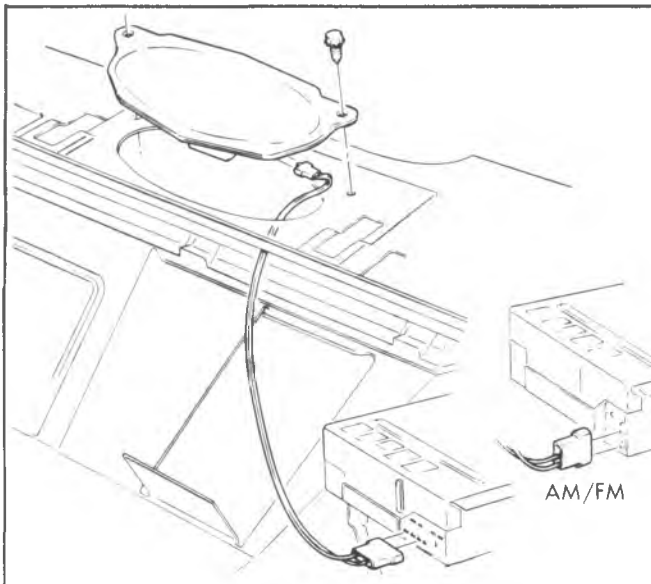


Fig. 8B-3--Radio Front Speaker (C-K Series)

Tape Player Radio

1. Remove radio from vehicle.
2. Remove radio top cover.
3. Remove bulb.
4. To install, reverse steps 1-3 above.

FRONT SPEAKER**C-K Models****Replacement (Fig. 8B-3)**

1. Disconnect battery ground cable.
2. Remove instrument cluster bezel upper four screws.
3. Remove instrument panel pad screws and remove pad.
4. Remove speaker to dash panel screws.
5. Lift up on speaker, disconnect speaker wiring harness and then remove speaker.
6. To install, reverse Steps 1-5 above.

G Models**Replacement (Fig. 8B-4)****G Models--Left Side**

1. Disconnect battery ground cable.
2. Remove instrument panel bezel.
3. Remove instrument cluster.
4. Remove speaker attaching screws, disconnect wiring harness and remove speaker.
5. To install, reverse Steps 1-4 above.
6. Check operation.

G Models--Right Side

1. Disconnect battery ground cable.
2. Remove engine cover.
3. Remove steering column brace bolts.
4. Remove radio support bracket bolt and instrument panel upper and lower attaching screws.
5. Pull instrument panel assembly rearward to gain access to speaker.

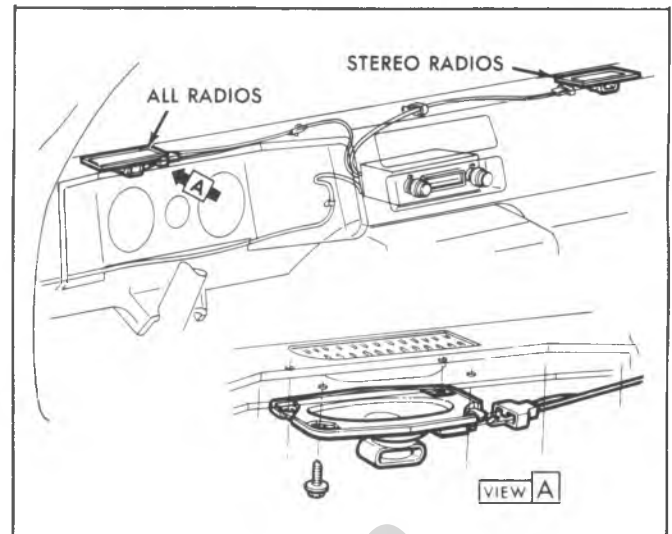


Fig. 8B-4--Speaker Installation--G Series

6. Remove speaker attaching screws, disconnect speaker wiring harness and remove speaker.

7. To install, reverse Steps 1-6 above.

8. Check operation.

REAR SPEAKER**C-K Series****Replacement (Fig. 8B-5)**

1. Remove four screws securing speaker grille to trim panel and remove grille.
2. Disconnect electrical connector from speaker.
3. Remove two screws securing speaker to trim panel and remove speaker. On 109 and 209 (06) models, there is a gasket between speaker and trim panel.
4. Install replacement speaker in reverse order of removal.

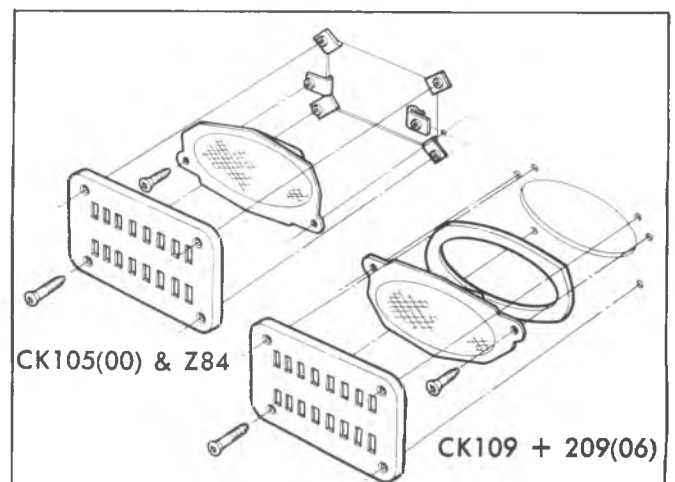


Fig. 8B-5--Rear Speaker (C-K Models)

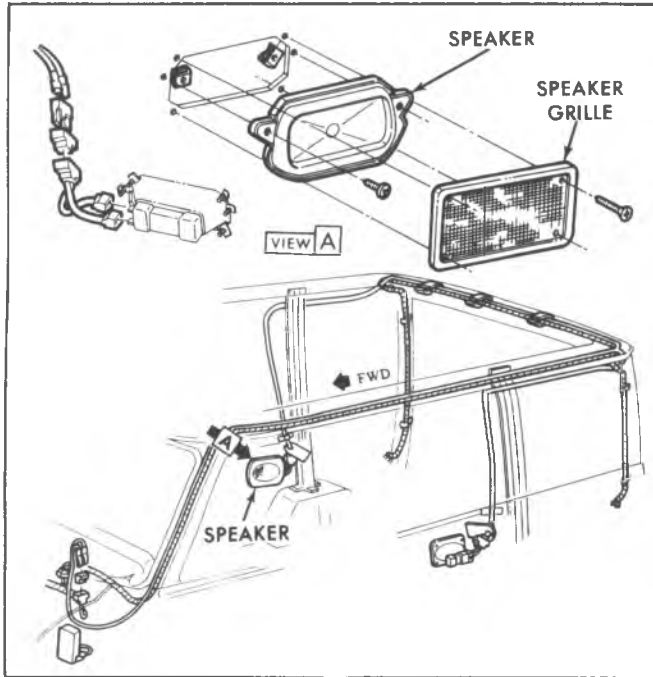


Fig. 8B-6--Rear Speaker (G (05) Truck)

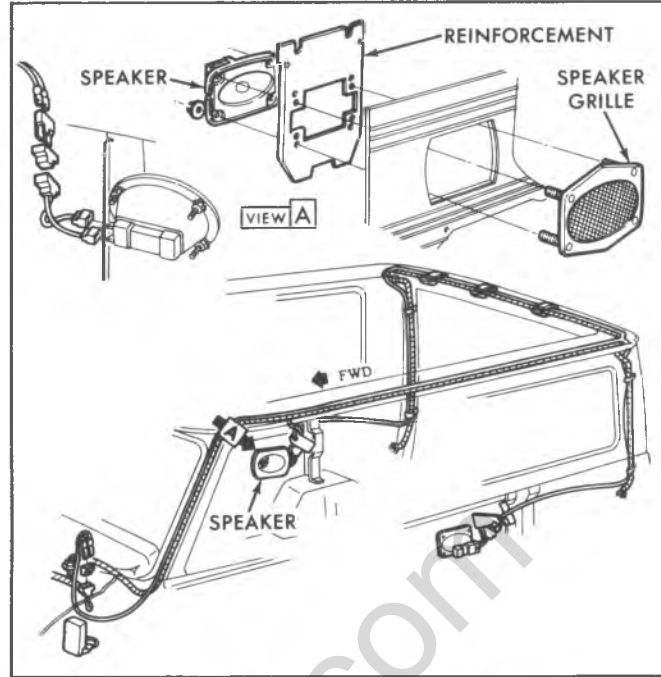


Fig. 8B-7--Rear Speaker (G (06) Truck)

G Models

Replacement (Figs. 8B-6 and 8B-7)

1. Remove the four most forward lower screws securing right rear trim panel. Pull trim panel outward slightly for access to speaker.

2. Disconnect electrical connector from speaker.

3. Remove four nuts securing speaker to grille studs and remove speaker.

4. Install replacement speaker in reverse order of removal.

CIRCUIT PROTECTION GENERAL DESCRIPTION

All electrical circuits are protected against excessive loads which might occur due to shorts or overloads in the wiring system. Such protection is provided by either a circuit breaker, fuse or fusible link. Each of these protective devices are explained below.

CIRCUIT BREAKER (Fig. 8B-8)

A circuit breaker is a protective device designed to open the circuit when a current load is in excess of rated breaker capacity. If there is a short or other type of overload condition in the circuit, the excess current will open the circuit breaker and cause it to cycle if it automatically resets, thus, indicating there is something wrong in the system. The circuit breaker will continue to cycle until the trouble is found and corrected. Excessive cycling of the breaker will eventually damage the breaker contacts to the point that replacement of the breaker is necessary.

FUSE (Fig. 8B-8)

A common method of protection is to use a fuse in the circuit. Whenever there is an excessive current through the circuit, the fusible element will melt and open the circuit. The disadvantage of using a fuse instead of a circuit breaker is the fuse in a one-time protection and replacement is required.

FUSIBLE LINK (FIG. 8B-9)

In addition to circuit breakers and fuses, the wiring harness incorporates fusible links to protect the wiring. Links are used rather than a fuse in wiring circuits that are not normally fused, such as the ignition circuit. Fusible links are color coded red in the charging and load circuits to match color coding of the circuit they protect. Each link is four gage sizes smaller than the cable it is designed to protect and are marked on the insulation with wire gage size because the heavy insulation makes the link appear a heavier gage than it actually is.

Engine compartment wiring harnesses incorporate several fusible links. The same size wire with special hypalon

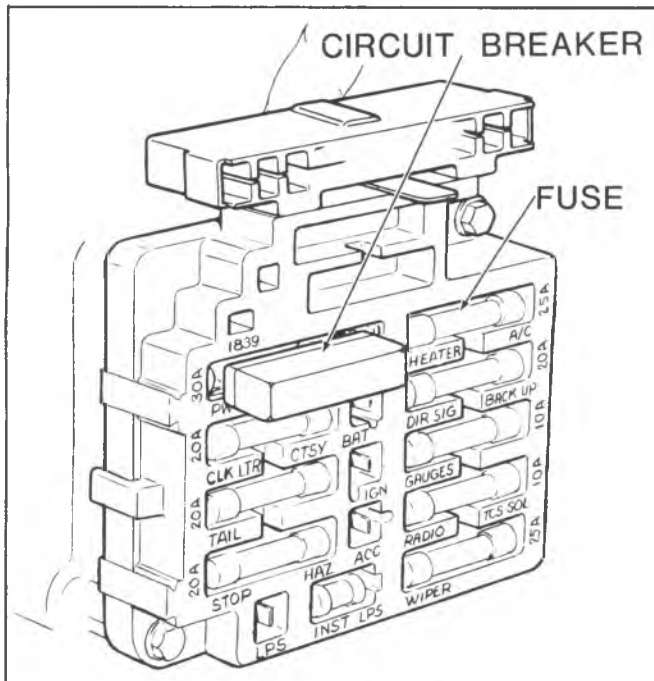


Fig. 8B-8--Fuse and Circuit Breaker

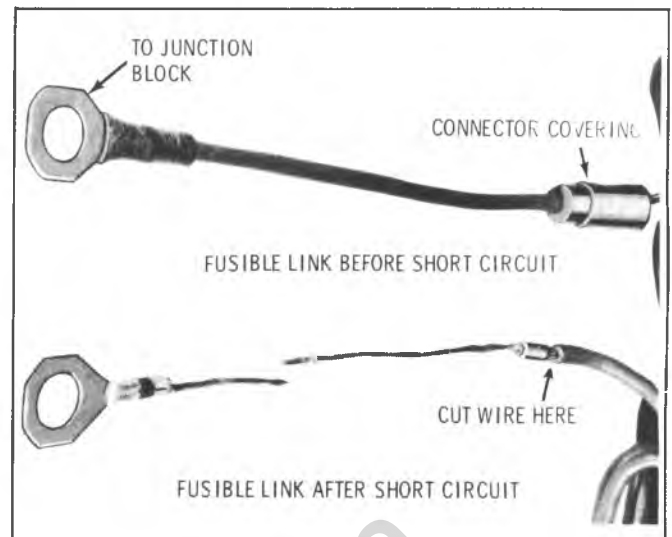


Fig. 8B-9--Fusible Link

insulation must be used when replacing a fusible link.

The links are:

1. A molded splice at the starter solenoid "Bat" terminal, 14 gage red wire. Servicing requires splicing in a new link.
2. A 16 gage red fusible link is located at junction block to protect all unfused wiring of 12 gage or larger. The link is molded into the bulkhead connector.
3. The generator warning light and field circuitry (16 gage wire) is protected by a fusible link (20 gage red wire) used in the "battery feed to voltage regulator #3 terminal". The link is installed as a molded splice in the circuit at the junction block. Service by splicing in a new 20 gage wire.

DIAGNOSIS

Failures in a circuit are usually caused by short or open circuits. Open circuits are usually caused by breaks in the wiring, faulty connections or mechanical failure in a component such as a switch or circuit breaker. Short circuits are usually caused by wires from different components of the circuit contacting one another or by a wire or component grounding to the metal of the body due to a screw driven through the wires, insulation cut through by a sharp metal edge, etc.

The following information may aid in locating and correcting a failure in the body wiring electrical system.

1. If a major portion of the electrical circuit becomes inoperative simultaneously, the failure may be due to improper connections between the front and rear harness, or between the front harness and the chassis wiring connector on top of fuse block.

2. If only one of the circuits is inoperative, the failure is due to an open circuit or short in the affected circuit. Short circuits usually result in blown fuses or in the case of power equipment circuits, in the circuit breaker opening the circuit. If the fuse is not blown and the circuit affected is a lamp circuit, check the bulb before proceeding with any checking procedures.

3. The dome lamp and courtesy lamp circuits are designed so that the switches are in the "ground" side of the circuit. If a condition is encountered where the lamps remain "on" even though the jamb or courtesy lamp switches are not actuated, the failure is probably due to defective switches, or to the wire leading to the switches being grounded to the metal body.

ON-VEHICLE SERVICE

Fusible Link Replacement (Fig. 8B-10)

A new fusible link can be installed, after the short circuit is located and repaired, as follows:

1. Disconnect battery ground cable.
2. Disconnect fusible link from junction block or starter solenoid.
3. Cut harness directly behind connector to remove damaged fusible link (fig. 8B-9).
4. Strip harness wire approximately 1/2".
5. Position clip around new fusible link and harness wire, crimp so that all wires are securely fastened.
6. Solder connection using rosin core solder. Use sufficient heat to obtain a good solder joint.
7. Tape all exposed wires with plastic electrical tape to prevent corrosion and shorting.
8. Connect fusible link to junction block or starter solenoid.
9. Connect battery ground cable.

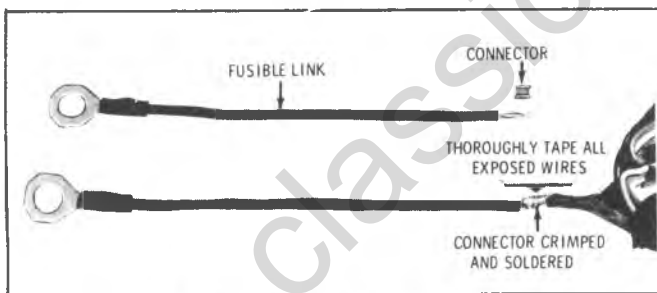


Fig. 8B-10—Fusible Link Replacement

HEADLAMPS WARNING BUZZER

Replacement (Fig. 8B-11)

1. Disconnect electrical connector from LPS (Lamps) socket of fuse panel.
2. Disconnect electrical connector from IGN (Ignition) socket of fuse panel.
3. Disconnect electrical connector to instrument panel harness.
4. Remove strap securing buzzer to instrument panel harness.
5. Install replacement headlamp warning buzzer in reverse wequence of removal.

SEAT BELT WARNING SYSTEM

All C-K type light duty trucks have a non-sequential timer controlled seat belt warning system. This system has an instrument panel warning light that will illuminate every time the ignition switch is turned on, whether or not the driver's seat belt is buckled, but will automatically go off after 4-8 seconds. The buzzer is also controlled by the 4-8 second timer, but will operate only if the driver has not buckled-up prior to turning on the ignition. If no attempt is made to buckle-up after turning on the ignition, the buzzer will also shut-off automatically after 4-8 seconds.

A trouble shooting diagnostic chart and wiring schematic are shown in Figures 8B-12 and 8B-13.

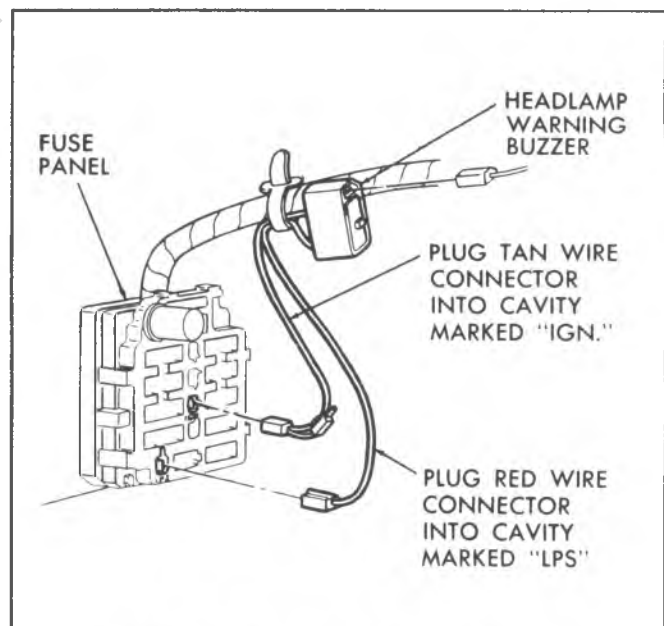


Fig. 8B-11—Healdamp Warning Buzzer

SEAT BELT REMINDER LIGHT/BUZZER DIAGNOSIS

NOTE: WHEN DIAGNOSING A WARNING SYSTEM FAILURE AND THE SYSTEM AUTOMATICALLY SHUTS OFF BECAUSE OF THE 4-8 SECOND TIMER, A MINIMUM OF 3 MINUTES MUST BE ALLOWED BETWEEN THE DIAGNOSTIC STEPS TO ALLOW THE TIMER TO RESET (KEY IN OFF POSITION DURING THIS PERIOD).

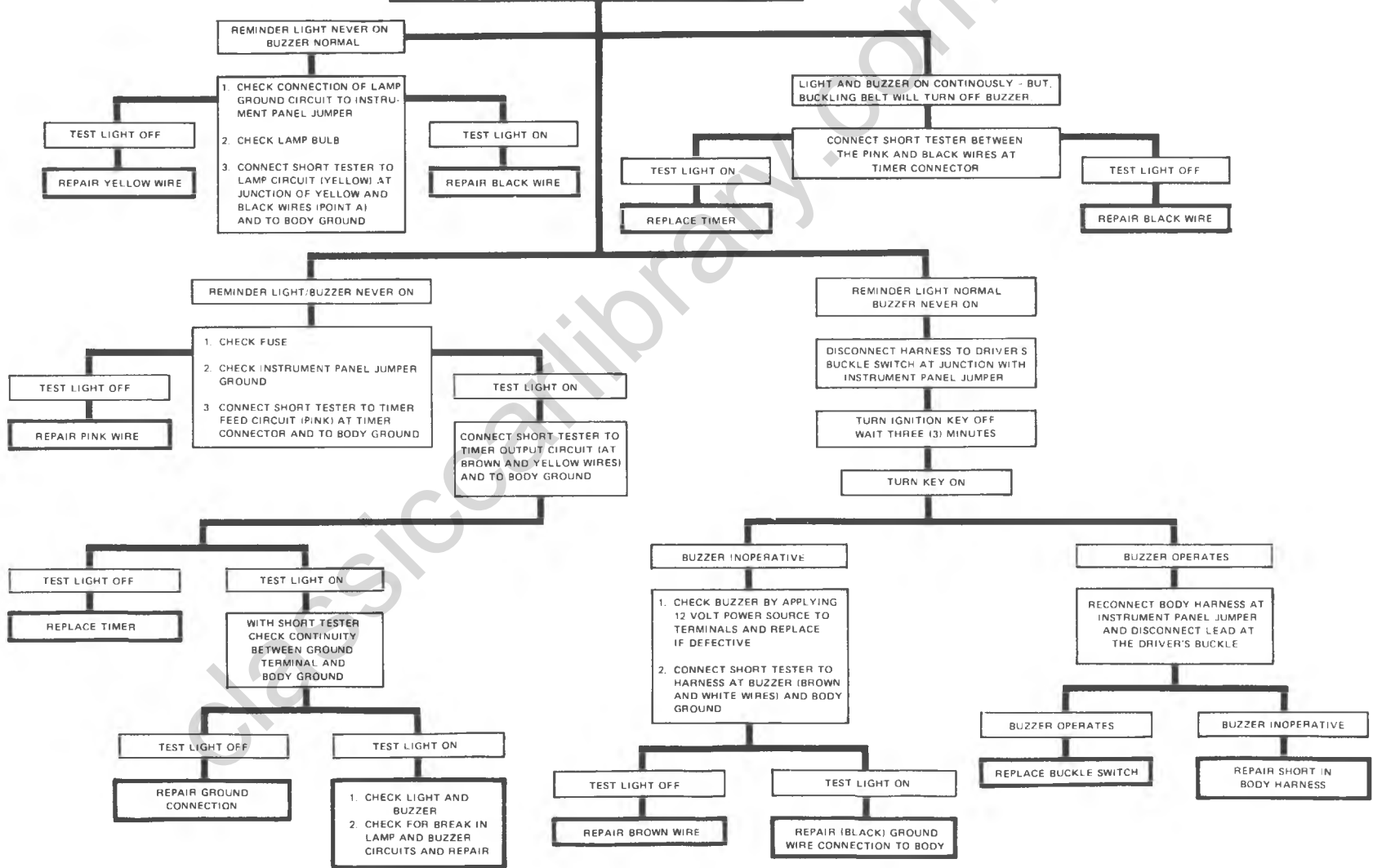


Fig. 8B-12--Seat Belt Reminder System Diagnosis

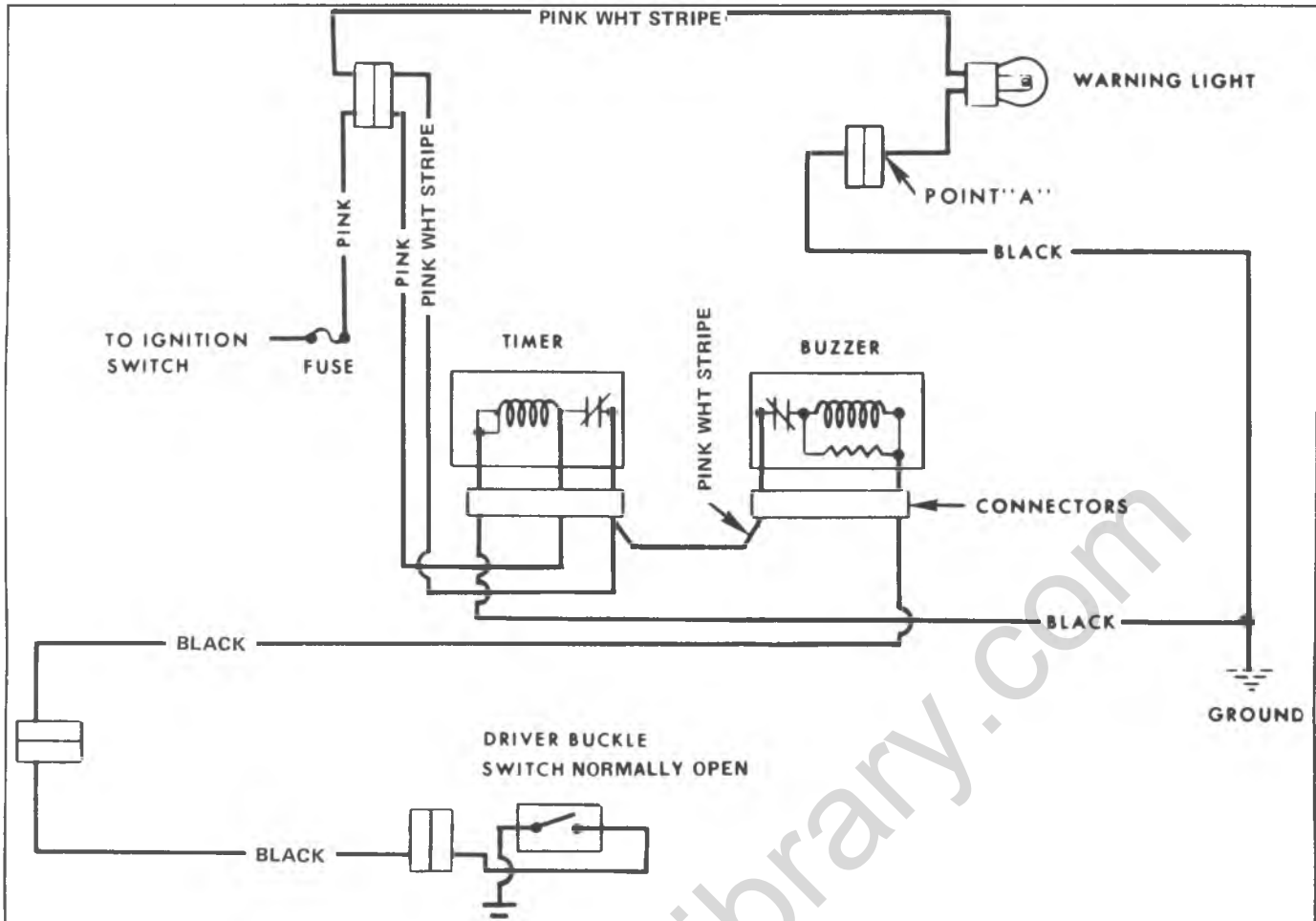


Fig. 8B-13--Seat Belt Reminder System Schematic

ANTI-THEFT ALARM SYSTEM - G SERIES

COMPONENTS AND LOCATIONS

Protective switches are located at each of the forward doors, at the side door lock pillar, at the right hand rear door hinge pillar, and at the hood. The anti-theft relays and flasher are located underneath the instrument panel at the left side of the vehicle near the parking brake mechanism.

The anti-theft warning horn is mounted to the fender inner support just forward of the battery tray at the right side of the vehicle. The fender mounted arming switch is protected by an anti-tamper switch which will sound the alarm if an attempt is made to forcibly remove the lock or cylinder. See Figures 8B-15 thru 8B-18.

OPERATION (SEE FIGURE 8B-14)

With the system (key) switch in the off position and all protective switches open no ground path exists for the coil of Relay A, or Relay B.

When the driver leaves the vehicle, closes the doors (opening the protective switches) and turns the arming switch clockwise to a closed position, the system is then armed. The closing of any of the protective switches will

then complete a path to ground for the Relay coil A. The plus terminal of this coil is hot (12V) at all times.

Thus energized, the relay coil closes the relay contacts, providing a path to ground for Relay B (plus terminal of coil is hot (12V) at all times).

At the same instant the closed contacts of Relay A provide a ground path through the key switch to terminal 3 of Relay A.

Terminal (#3) was initially grounded by the closing of a protective switch; however, if the door were closed, the alarm would stop. To ensure that the alarm continues to sound, a holding action is provided by the Diode, D1. As long as this path to ground is unbroken, the relay remains energized. Closing the door will not break this path to ground as illustrated in the diagram. As terminal 3 of Relay B is grounded, the relay pulls in closing the contacts and completing the flasher/horn circuit to +12 volts. The flasher then opens and closes pulsating the anti-theft horn, which process continues until the alarm is disarmed with the key switch, or the battery is exhausted.

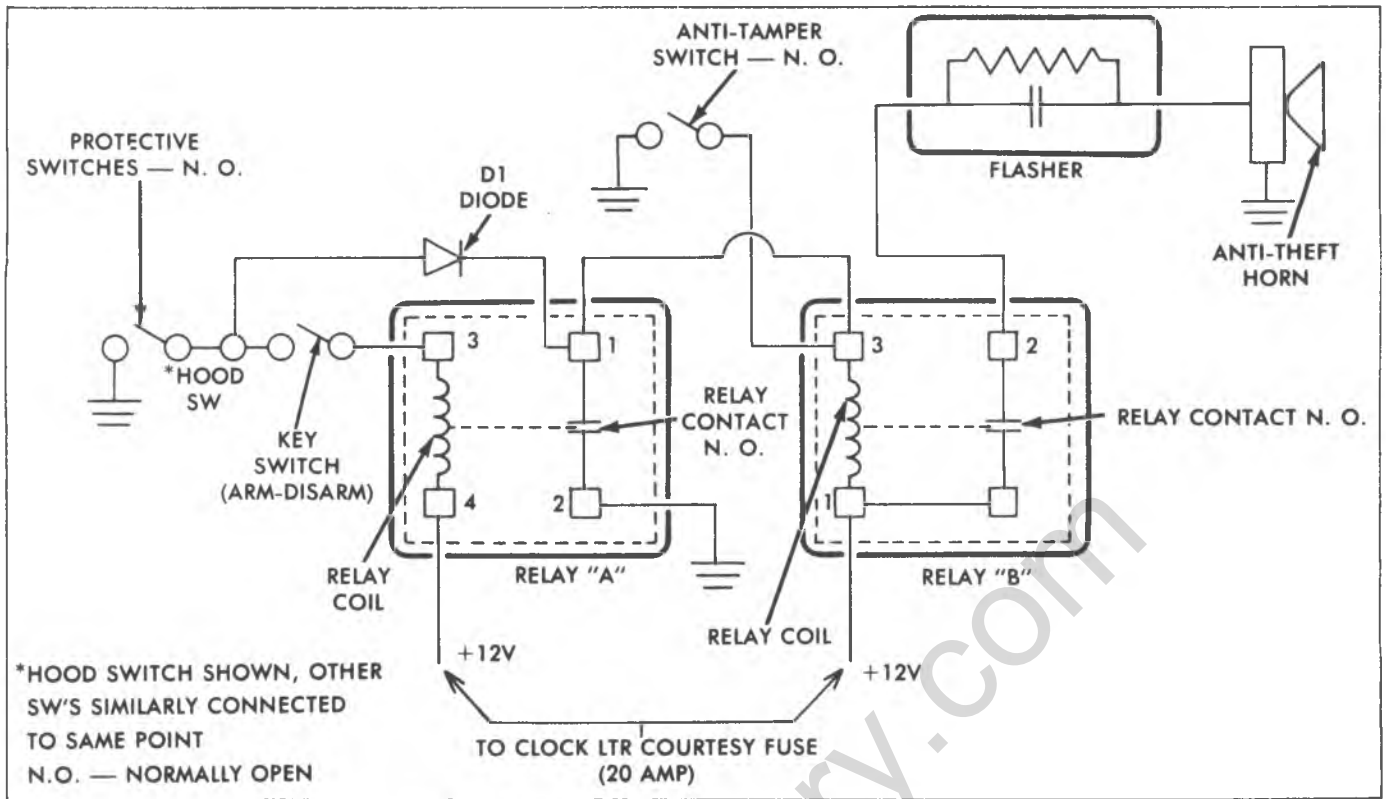


Fig. 8B-14-G Van Anti-Theft System - Wiring Diagram

The wiring diagram Figure 8 shows another switch at terminal 3 of Relay B. This is the anti-tamper switch, which closes if an attempt is made to remove or force the lock, regardless of whether the alarm has been set or not. When the switch closes, a ground path is provided for terminal #3 of Relay B and the alarm sounds. The other protective switches, the key switch, and Relay A not involved in this actuation of the alarm, and the key switch will not stop the

alarm. To stop the alarm, the plunger of the anti-tamper switch must be depressed, or power removed from the system (Relay B disconnected).

Component attachment and locations are illustrated in Figures 8B-15 thru 8B-18.

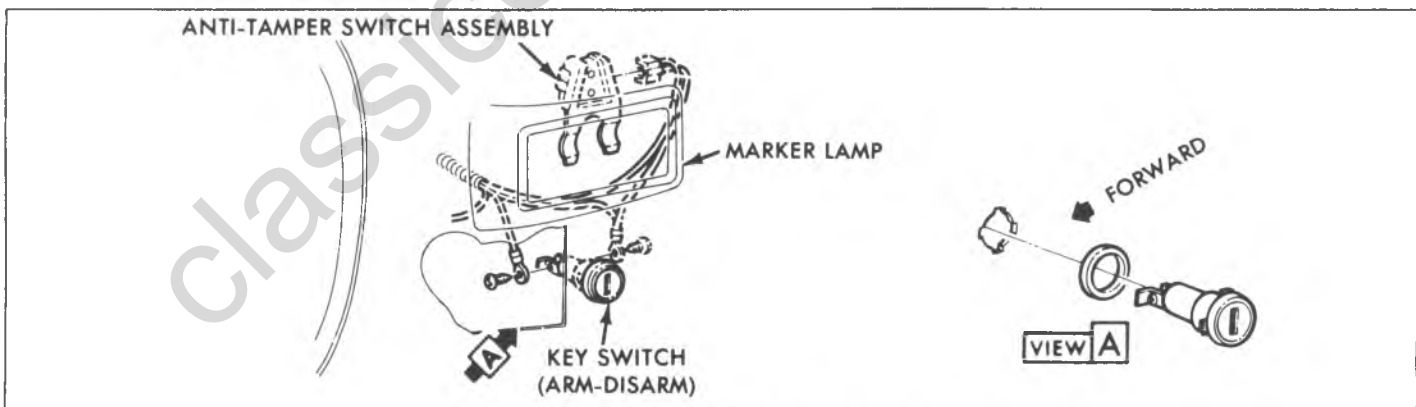


Fig. 8B-15-Anti-Theft System Anti-Tamper Switch Location

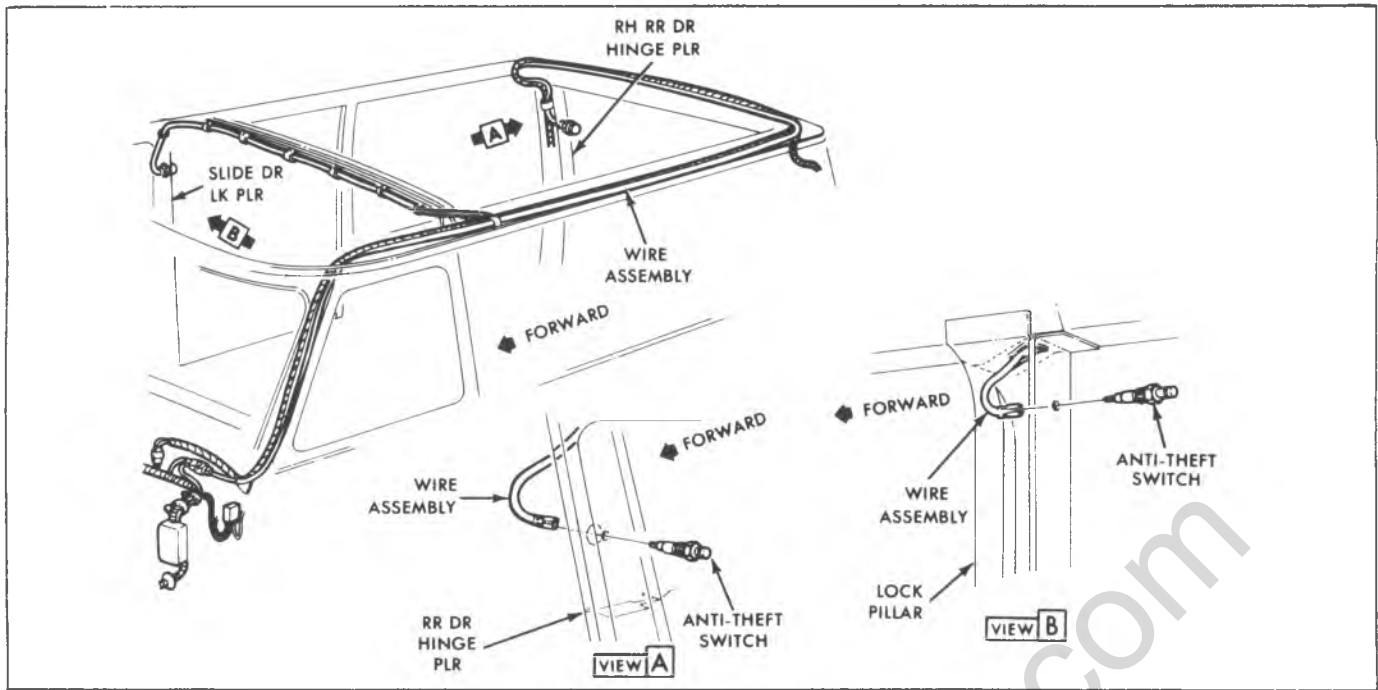


Fig. 8B-16--Door Anti-Theft Switch Location

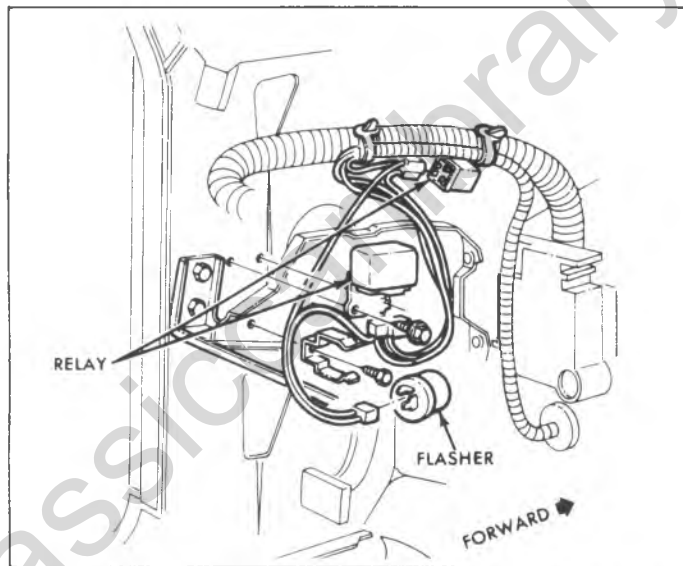


Fig. 8B-17--Anti-Theft System Flasher and Relay Location

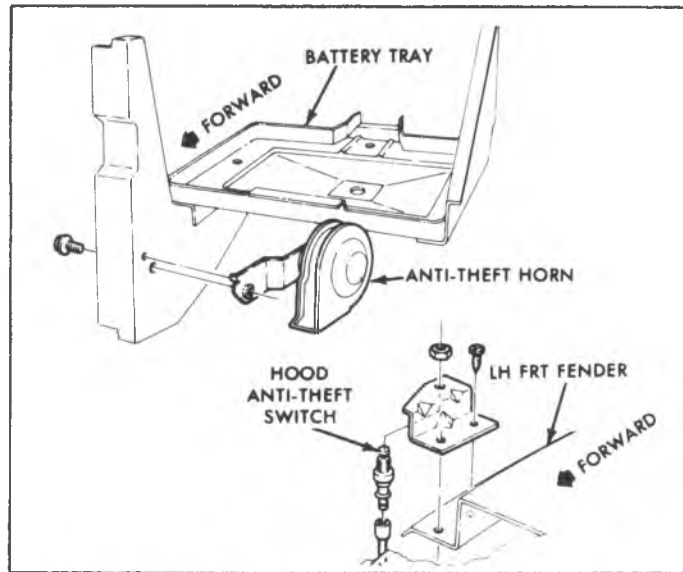


Fig. 8B-18—Anti-Theft Horn, and Hood Switch Location

classiccarslibrary.com

SPECIFICATIONS

FUSES — CIRCUIT BREAKERS

The wiring circuits are protected from short circuits by a combination of fuses, circuit breakers, and fusible thermal links in the wiring itself. This greatly reduces the hazard of electrically caused fires in the vehicles.

The headlamp circuits are protected by a circuit breaker in the light switch. An electrical overload on the breaker will cause the lamps to go on and off, or in some cases to remain off.

In addition to a fuse, the windshield wiper motor is also protected by a circuit breaker. If the motor overheats, due to overloading caused by heavy snow, etc., the wipers will remain stopped until the motor cools.

Fuses located in the Junction Block beneath the dash on the drivers side are:

C-K TRUCK

| | |
|--|--------|
| Heater, Front A/C, Generator Warning Lamp | 20 Amp |
| Idle Stop Solenoid, Aux. Battery, Radio, Time Delay Relay, Emission Control Solenoid, Transmission Downshift (M40) | 15 Amp |
| Cigarette Lighter, Clock, Dome Lamp, Cargo Lamp | 20 Amp |
| Fuel Gauge, Brake Warning Lamp, Temperature Warning Lamp, Oil Pressure Warning Lamp | 4 Amp |
| Courtesy Lamp, Roof Marker Lamp, License Plate Lamp, Parking Lamp, Side Marker Lamp, Tail Lamp, Clearance Lamp | 20 Amp |
| Directional Signal Indicator Lamp, Stop Lamp, Traffic Hazard | 15 Amp |
| Instrument Cluster Lamp, Heater Dial Lamp, Radio Dial Lamp, Cruise Control Lamp, Windshield Wiper Switch Lamp | 4 Amp |
| Windshield Wiper/Washer | 25 Amp |
| Cruise Control, Rear Window Aux., Fuel Tank, Tachometer, Back-up Lamp, Directional Signal Indicator Lamp, Directional Signal Lamp, Headlamp Buzzer | 15 Amp |

P TRUCK

| | |
|--|--------|
| Heater†, Air Conditioning† | 25 Amp |
| Instrument Cluster Lamp, Windshield Wiper Switch Lamp | 3 Amp |
| Directional Signal Indicator Lamp, Stop Lamp, Traffic Hazard | 15 Amp |
| Fuel Gauge, Brake Warning Lamp | 3 Amp |
| License Plate Lamp, Parking Lamp, Side Marker Lamp, Tail Lamp, Clearance Lamp, Identification Lamp | 15 Amp |
| Windshield Washer/Wiper | 25 Amp |
| Cigarette Lighter†, Clock†, Courtesy†, Dome Lamp† | 15 Amp |
| Auxiliary Battery†, Back-up Lamp, Radio | 15 Amp |

| | |
|---|--------|
| Idle Stop Solenoid, Cruise Control†, Directional Signal Lamp, Time Delay Relay, Emission Control Solenoid, Transmission Downshift (M40) | 10 Amp |
|---|--------|

In-line fuses are located in the auxiliary heater circuits (C-K-P models) and underhood lamp, front and rear A/C circuits (C-K models)

†When incorporated by body builder

Do not use fuses of higher amperage than those recommended above

The following wiring harnesses are protected by a "fusible link" which is a special wire incorporated in the circuit headlamp hi-beam indicator, horn, air conditioning high blower, ignition circuits (C-K-P models) starter solenoid (pull-in and hold) circuit (C-K models). Should an electrical overload occur, this wire will fail and prevent damage to the major harness.

G TRUCK

| | |
|---|--------|
| Heater, A/C | 25 Amp |
| Idle Stop Solenoid, Cruise Control, Directional Signal Lamp, Directional Signal Indicator Lamp, Transmission Downshift (M-40) | 10 Amp |
| Cigarette Lighter, Dome Lamp, Spot Lamp ... | 15 Amp |
| Fuel Gauge, Brake Warning Lamp, Temperature Warning Lamp, Generator Warning Lamp, Oil Pressure Warning Lamp | 3 Amp |
| Stop Lamp, Traffic Hazard | 15 Amp |
| Auxiliary Battery, Backing Lamp, Radio Dial Lamp, Radio | 15 Amp |
| Instrument Cluster Lamp, Heater Dial Lamp, Transmission Control Lamp with Tilt Wheel, Cruise Control Lamp, W/S Wiper Switch Lamp, Headlamp Buzzer | 3 Amp |
| License Lamp, Parking Lamp, Side Marker Lamp, Tail Lamp | 15 Amp |
| Windshield Wiper | 25 Amp |

An in-line fuse is located in the Ammeter and the auxiliary heater circuits.

Do not use fuses of higher amperage rating than those recommended above

The following wiring harnesses are protected by a "fusible link" which is a special wire incorporated in the circuit, ignition, horn and headlamp hi-beam indicator circuits, air conditioning high blower. Should an electrical overload occur, this wire will fail and prevent damage to the major harness.

CIRCUIT BREAKERS

| DEVICE OR CIRCUIT PROTECTED | MODELS | AMPERES | LOCATION |
|-----------------------------------|---------|---------|---------------------|
| Headlamp and parking lamp circuit | C-K-P-G | 15 | Light switch |
| Tailgate window motor | C-K | 30 | Dash (forward side) |
| Rear A/C (C69 overhead) | G | 35 | Dash (forward side) |

SECTION 8C

INSTRUMENT PANEL AND GAGES

CONTENTS

| | | | |
|---|-------|---|-------|
| Instrument Panel and Gages..... | 8C-1 | Windshield Wiper and Washer (C-K and G Models)..... | 8C-16 |
| General Description..... | 8C-1 | General Description..... | 8C-16 |
| Diagnosis..... | 8C-2 | Electrical Circuits..... | 8C-16 |
| On-Vehicle Service..... | 8C-6 | Diagnosis..... | 8C-20 |
| Component Part Replacement..... | 8C-6 | Wiper - On Vehicle..... | 8C-20 |
| Neutral Start Switch..... | 8C-6 | Wiper - Off Vehicle..... | 8C-20 |
| Backing Lamp Switch..... | 8C-6 | On Vehicle Service..... | 8C-30 |
| Windshield Wiper/Wiper/Washer Switch..... | 8C-6 | Component Part Replacement..... | 8C-30 |
| Ignition Switch..... | 8C-7 | Wiper Motor..... | 8C-30 |
| Instrument Cluster..... | 8C-8 | Unit Repair..... | 8C-30 |
| Indicator and Illuminating Bulbs..... | 8C-8 | Wiper/Washer Disassembly..... | 8C-30 |
| Laminated (Printed) Circuit..... | 8C-8 | Motor Disassembly..... | 8C-30 |
| Speedometer..... | 8C-10 | Motor Assembly..... | 8C-30 |
| Speedometer Cable Core..... | 8C-10 | Wiper Adjustments..... | 8C-31 |
| Fuel Gauge..... | 8C-10 | Washer Pump..... | 8C-31 |
| Temperature Gauge..... | 8C-10 | Windshield Wiper and Washer (P Models)..... | 8C-36 |
| Temperature Sending Unit..... | 8C-10 | General Description..... | 8C-36 |
| Oil Pressure Gauge..... | 8C-10 | Diagnosis..... | 8C-38 |
| Oil Pressure Sending Unit..... | 8C-10 | Wiper - On Vehicle..... | 8C-38 |
| Voltmeter..... | 8C-10 | Unit Repair..... | 8C-43 |
| Directional Signal Switch..... | 8C-14 | Wiper Motor..... | 8C-43 |
| Instrument Panel Wiring Harnesses..... | 8C-14 | Windshield Washer..... | 8C-44 |

GENERAL DESCRIPTION

All instruments and gages are installed in the instrument cluster. Instruments and gages can be serviced in the vehicle (C-K Series); however, the entire cluster must be removed from the vehicle for servicing of the instruments and gages (G Series). Illuminating and indicator lamps may be replaced without removing the cluster from the vehicle.

Bulbs are installed in plastic holders which lock into the cluster housing.

Regular maintenance is not required on the instrument cluster or its components other than maintaining clean, tight electrical connections, replacing defective parts and keeping the speedometer cable properly lubricated.

DIAGNOSIS

OIL PRESSURE INDICATOR

| Condition | Possible Cause | Correction |
|--|--|--|
| Light not lit, ignition on and engine not running. | 1. Bulb burned out. | 1. Replace bulb. |
| | 2. Open in light circuit. | 2. Locate and correct open. |
| | 3. Defective oil pressure switch. | 3. Replace oil pressure switch. |
| Light on, engine running above idle speed. | 1. Grounded wiring between light and switch. | 1. Locate and repair ground. |
| | 2. Defective oil pressure switch. | 2. Replace oil pressure switch. |
| | 3. Low oil pressure. | 3. Locate cause of low oil pressure and correct. |

COOLANT TEMPERATURE INDICATOR

| Condition | Possible Cause | Correction |
|--|--|--|
| "HOT" indicator; light not lit when cranking engine. | 1. Bulb burned out. | 1. Replace bulb. |
| | 2. Open in light circuit. | 2. Locate and correct open. |
| | 3. Defective ignition switch. | 3. Replace ignition switch. |
| Light on, engine running. | 1. Wiring grounded between light and switch. | 1. Locate and correct grounded wiring. |
| | 2. Defective temperature switch. | 2. Replace temperature switch. |
| | 3. Defective ignition switch. | 3. Replace ignition switch. |
| | 4. Coolant temperature above 258 degrees F. | 4. Locate and correct cause of high coolant temperature. |

HORNS WILL NOT OPERATE

| Cause | Correction |
|--|---|
| Loose connections in circuit. Defective horn switch. Defective horn relay. Defects within horn. | Check and tighten connections. Be sure to check ground straps. Replace defective parts. Replace relay. Replace horn. |

HORNS HAVE POOR TONE

| Cause | Correction |
|--|--|
| Low available voltage at horn. Defects within horn. | Check battery and charging circuit. Although horn should blow at any voltage above 7.0 volts, a weak or poor tone may occur at operating voltages below 11.0 volts. If horn has weak or poor tone at operating voltage of 11.0 volts or higher, remove horn and replace. |

HORNS OPERATE INTERMITTENTLY

| Cause | Correction |
|--|--|
| Loose or intermittent connections in horn relay or horn circuit. Defective horn switch. Defective relay. Defects within horn. | Check and tighten connections. Replace switch. Replace relay. Replace horn. |

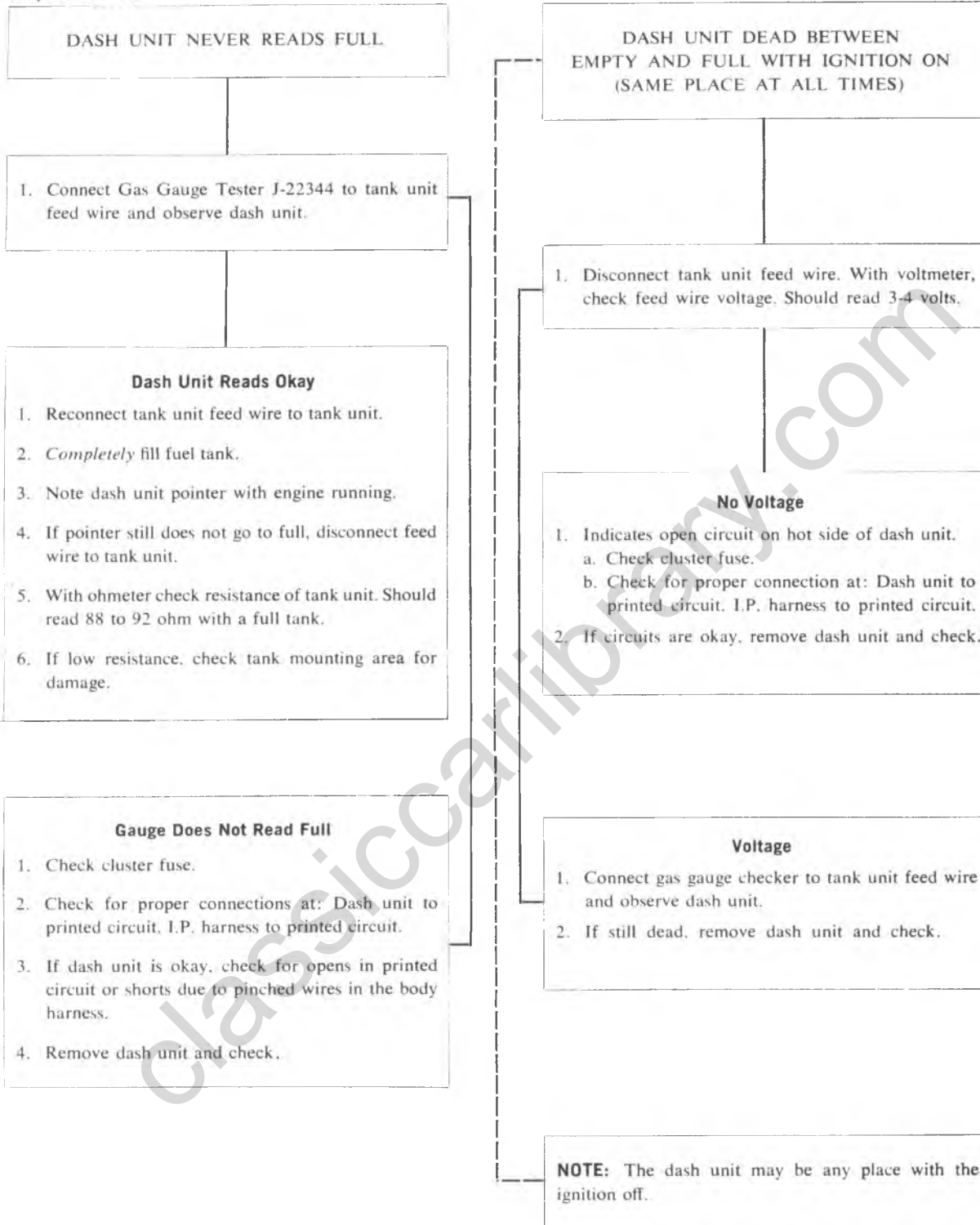
HORNS BLOW CONSTANTLY

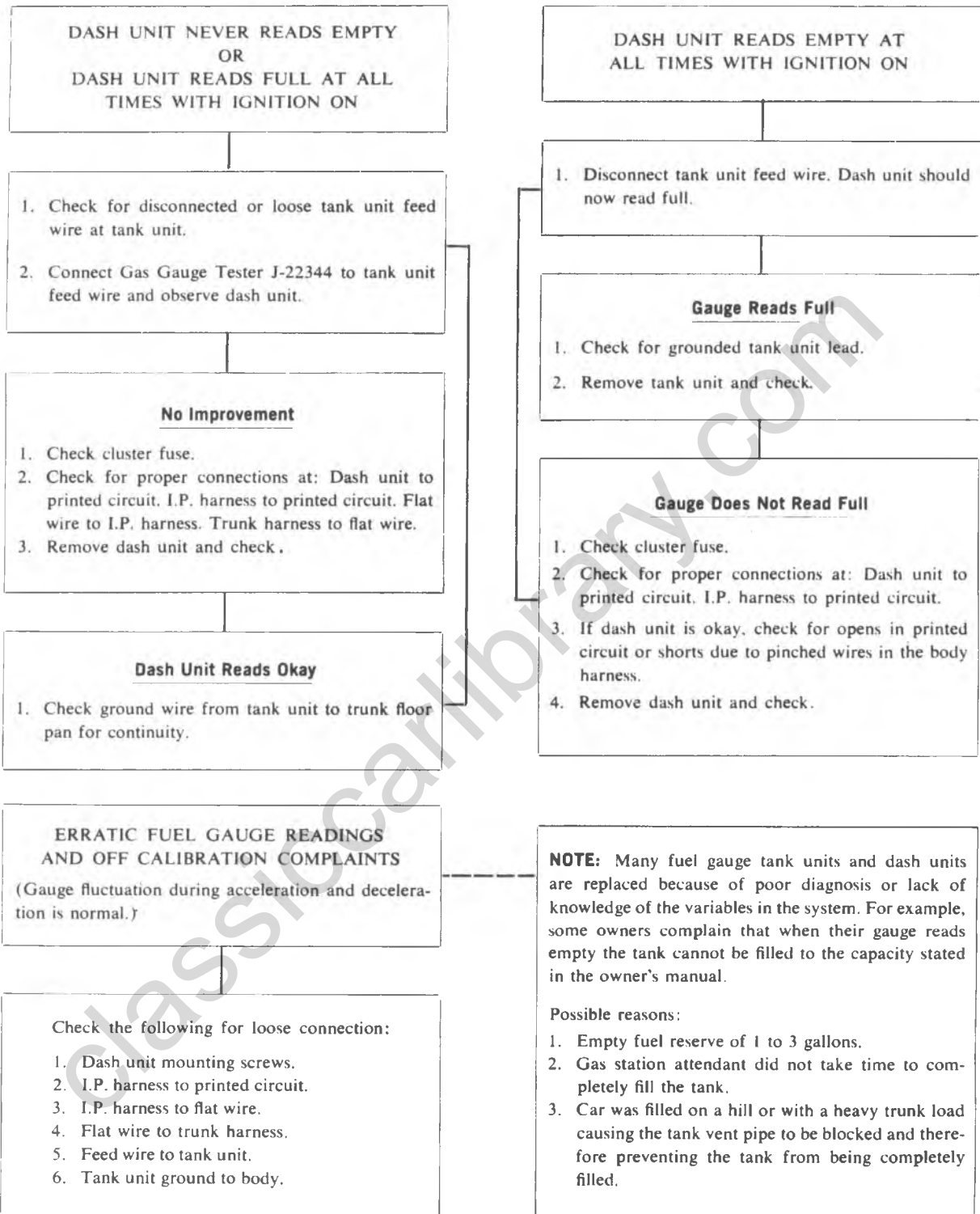
| Cause | Correction |
|--|--|
| Sticking horn relay. Horn relay energized by grounded or shorted wiring. Horn button can be grounded by sticking closed. | Replace relay. Check and adjust wiring. Adjust or replace damaged parts. |

SPEEDOMETER

| Cause | Correction |
|--|---|
| Noisy speedometer cable. Pointer and odometer inoperative. Inaccurate reading. Kinked cable. Defective speedometer head. | <ol style="list-style-type: none"> Loosen over-tightened casing nuts and snap-on at speedometer head. Replace housing and core. Replace broken cable. <ol style="list-style-type: none"> Check tire size. Check for correct speedometer driven gear. Replace cable. Reroute casing so that bends have no less than 6" radius. Replace or have repaired at authorized service station. |

GAS GAUGE





CHARGING SYSTEM INDICATOR

| Condition | Possible Cause | Correction |
|---|------------------------------------|---|
| Light on, ignition off. | 1. Shorted positive diode. | 1. Locate and replace shorted diode. |
| Light not on, ignition on and engine not running. | 1. Bulb burned out. | 1. Replace bulb. |
| | 2. Open in light circuit. | 2. Locate and correct open. |
| | 3. Open in field. | 3. Replace rotor. |
| Light on, engine running above idle speed. | 1. No generator output. | 1. Check and correct cause of no output. |
| | 2. Shorted negative diode. | 2. Locate and replace shorted diode. |
| | 3. Loose or broken generator belt. | 3. Tighten or replace and tighten generator belt. |

ON-VEHICLE SERVICE

NEUTRAL START SWITCH

C-K Models (Fig. 8C-1)

Replacement and Adjustment

1. Disconnect battery ground cable.
2. Disconnect electrical harness at switch.
3. Remove switch mounting screws and remove switch.
4. Position shift lever in neutral gate notch.
5. Insert .096" (2.4mm) gage pin to depth of 3/8 inch (9.5mm) into switch gage hole. switch assembly is fixed in neutral position with internal plastic shear pin.
6. Assemble the switch to column by inserting the switch carrier tang in the shift tube slot and fasten in position by assembling mounting screws to retainers. If retainer strips out it must be replaced.
7. Remove .096" gage pin.
8. Move shift lever out of neutral gate notch to park gate position to shear switch internal plastic pin.
9. Return shift lever to neutral gate notch.
10. Switch (2.0mm) gage hole will freely admit .080" gage pin to a depth of 3/8 inch (9.5mm).

11. If pin will not freely enter gage hole, switch must be reset as below.

12. Connect battery ground cable and electrical harness.

Reset Installation Procedure

1. Place shift lever in neutral gate notch.
2. Loosen attaching screws.
3. Rotate switch on column and insert .096" (2.4mm) gage pin to depth of 3/8 inch (9.5mm).
4. Tighten attaching screws.
5. Repeat installation procedure Steps 7 through 12 above.

G-P Series**Replacement (Fig. 8C-1)**

1. Raise vehicle on a hoist.
2. Disconnect the switch harness from the switch.
3. Remove switch mounting bolts and remove switch.
4. Assemble new switch loosely to mounting bracket.
5. Align .093/.097" (2.3/2.4mm) hole in Lever (B) with hole in Switch Assembly. Insert Pin (A) to hold in NEUTRAL position.

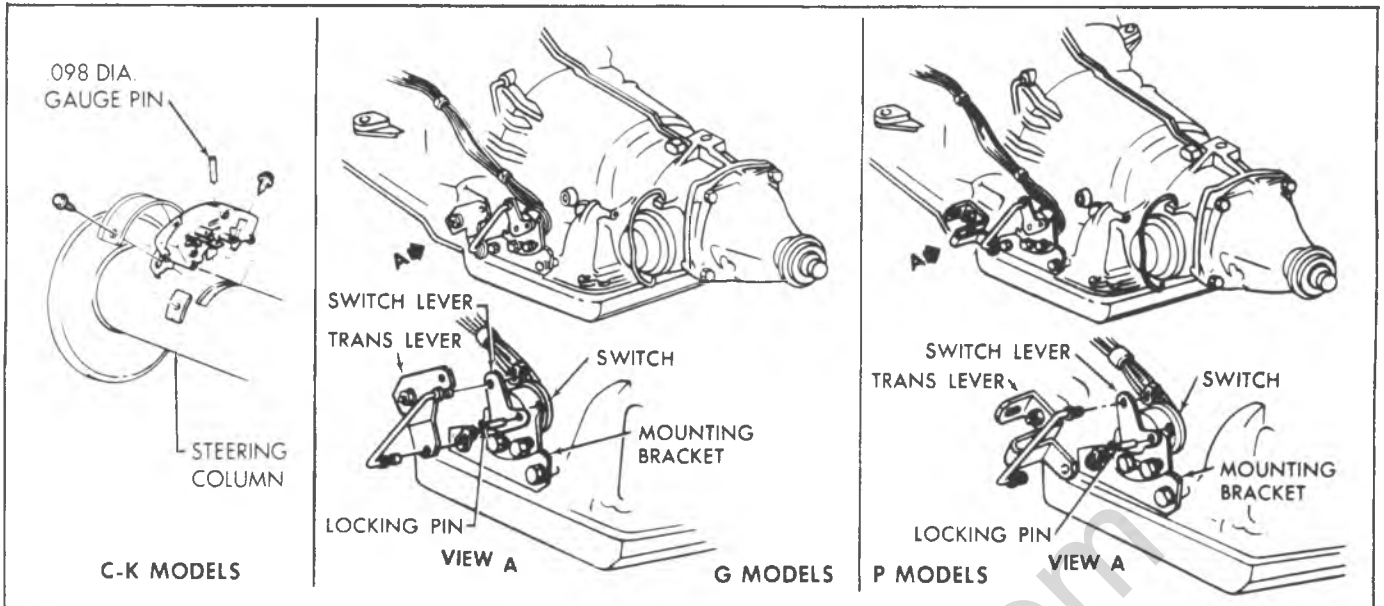


Fig. 8C-1--Neutral Start Switch Replacement - Typical

6. Set Transmission Lever (C) in NEUTRAL position by the following method.

Obtain NEUTRAL by moving Transmission Lever counterclockwise to L1 detent, then clockwise three detents to the NEUTRAL detent position.

7. Install Rod into Transmission Lever and Switch Lever. Secure with clips.

8. Tighten switch attaching screws.

9. Lower vehicle from hoist and carefully check switch operation.

BACKING LAMP SWITCH

See "Neutral Start Switch" for automatic transmission models.

Column Mounted Switch (Manual Transmission)

Replacement

1. Disconnect battery ground cable.
2. Disconnect switch wiring harness.
3. Remove column mounting screws and remove switch.
4. Assemble the switch to the column. Fasten in position by installing mounting screws.
5. Install battery ground cable.
6. Check operation to make sure back-up lights come on in reverse gear only.

Transmission Mounted Switch

Replacement

1. Raise vehicle on a hoist.
2. Disconnect switch wiring harness.
3. Remove switch from transmission.
4. To install a new switch, reverse Steps 1-3 above.

WINDSHIELD WASHER/WIPER SWITCH

C-K Models

Replacement

1. Disconnect battery ground cable.
2. Remove instrument panel bezel screws and bezel.
3. Remove switch attaching screws.
4. Pull out on switch assembly and disconnect electrical harness - remove switch.
5. To install, reverse Steps 1-4 above. Check switch operation before reinstalling instrument panel bezel.

G Models

Replacement

1. Disconnect battery ground cable.
2. Reach up behind left side of instrument panel, and:
 - a. Remove plug connector from rear of switch.
 - b. Remove (3) mounting screws securing bezel and ground wires to switch.
3. Replace switch, installing ground wire and connector. Check operation of switch, first observing washer solvent level.

IGNITION SWITCH

C-K Series

See Section 3B - Steering, for ignition switch replacement procedure.

G Series

Replacement (Fig. 8C-2)

1. Disconnect battery ground cable.
2. Remove lock cylinder by positioning switch in "ACC" position and inserting stiff wire in small hole in cylinder face. Push in on wire to depress plunger and continue to turn key counterclockwise until lock cylinder can be removed.
3. Remove metallic ignition switch nut.

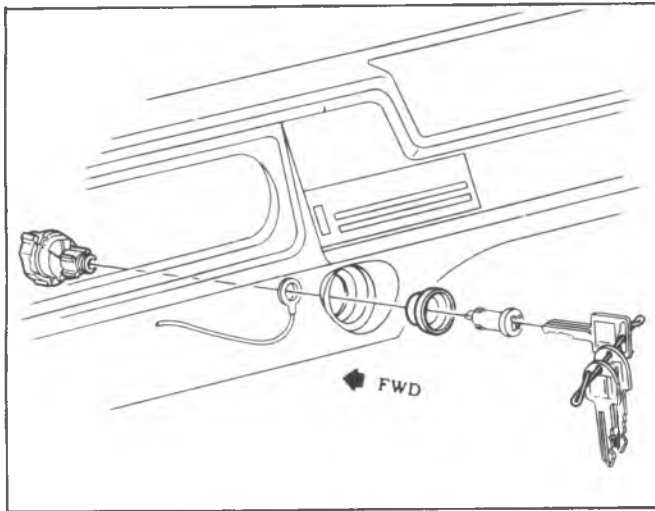


Fig. 8C-2-Ignition Switch (G Models)

4. Pull ignition switch out from behind instrument panel and remove "theft resistant" connector. Use a screwdriver to unsnap locking tangs on connector from their position on switch.

5. Snap connector into place on new ignition switch.
6. Place switch into position from behind instrument panel, first adding grounding ring then install ignition switch nut.
7. Install lock cylinder, key inserted.
8. Install battery ground cable.

INSTRUMENT CLUSTER

C-K Series

Replacement (Fig. 8C-3)

1. Disconnect battery ground cable.
2. Remove headlamp switch control knob.
3. Remove radio control knobs.
4. Remove four screws and remove steering column cover.
5. Remove eight screws and remove instrument bezel.
6. Reach up under instrument cluster and disconnect speedometer by first depressing tang on rear of speedometer head, then pulling cable free from head as tang is depressed.
7. Remove cluster to bench for further disassembly (laminated printed circuit, speedometer head, gages).
8. Install cluster in reverse order of removal.

G Series

Replacement (Fig. 8C-4)

1. Disconnect battery ground cable.
2. Reach up under instrument cluster and disconnect speedometer cable by first depressing tang on rear of speedometer head, then pulling cable free from head as tang is depressed.
3. Remove clock set stem knob.
4. Remove screws attaching instrument cluster bezel to instrument panel and remove bezel.
5. Remove two lower cluster attachment screws.
6. Pull top of cluster away from instrument panel and lift out bottom of cluster.

7. Unplug instrument panel harness connector from printed circuit.

8. Remove cluster to bench for further disassembly (laminated printed circuit, speedometer head, gages).

INDICATOR AND ILLUMINATING BULBS

All Models

Replacement (Figs. 8C-3 and 8C-4)

1. Reach up under instrument panel and turn bulb holder counterclockwise to remove from cluster housing.
2. Pull bulb straight out to remove from holder.
3. Install replacement bulb in holder, press inward to lock in place.
4. Insert holder into housing, with lugs on holder entering notches in case, and turn clockwise to lock holder against printed circuit.

LAMINATED (PRINTED) CIRCUIT

All Models

Replacement

1. Remove instrument cluster assembly as previously described in this section.
2. Remove all instrument cluster lamp bulb assemblies.
3. Remove laminated circuit retaining screws. These screws serve as a ground for the circuit and must be reinstalled to provide the proper connection of the gage terminals to the printed circuit.
4. **G Series** - Remove fuel, temperature and ammeter terminal nuts retaining laminated circuit to rear of cluster.
5. Lift laminated circuit from cluster cover.
6. To install, reverse Steps 1-5 and check electrical operation of all affected components.

SPEEDOMETER

NOTICE: Servicing of the speedometer assembly should only be performed by trained technicians having the proper test equipment.

C-K Models

Replacement

1. Disconnect battery ground cable.
2. Remove headlamp switch control knob.
3. Remove radio control knobs and clock adjuster stem.
4. Remove instrument cluster bezel and steering column cover.
5. Remove instrument cluster lens.
6. Remove transmission PRNDL indicator and case front cover.
7. Remove speedometer to cluster screws and speedometer assembly.
8. To install, reverse removal procedure. Check speedometer operation.

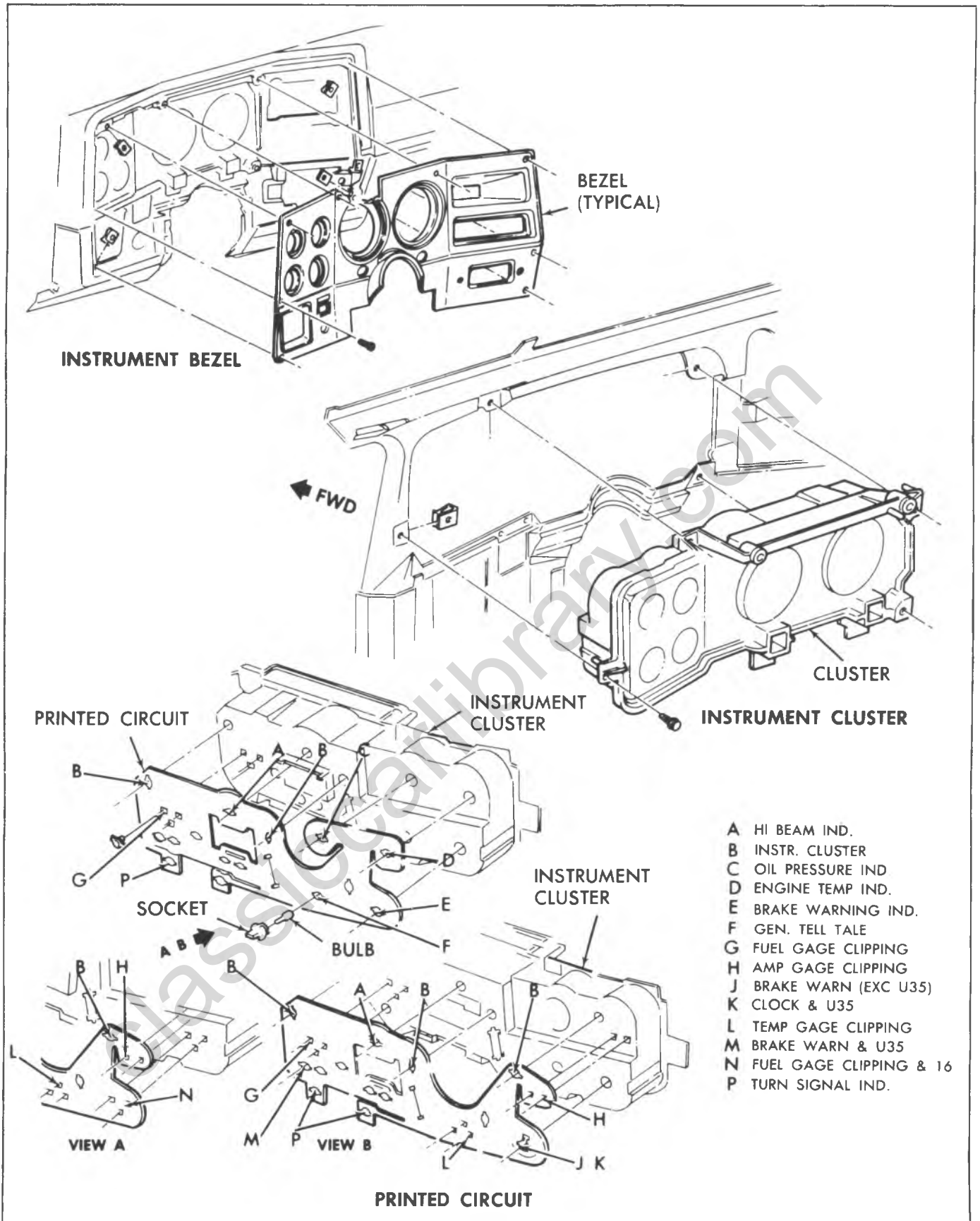


Fig. 8C-3-Instrument Cluster Assembly (C-K Series)

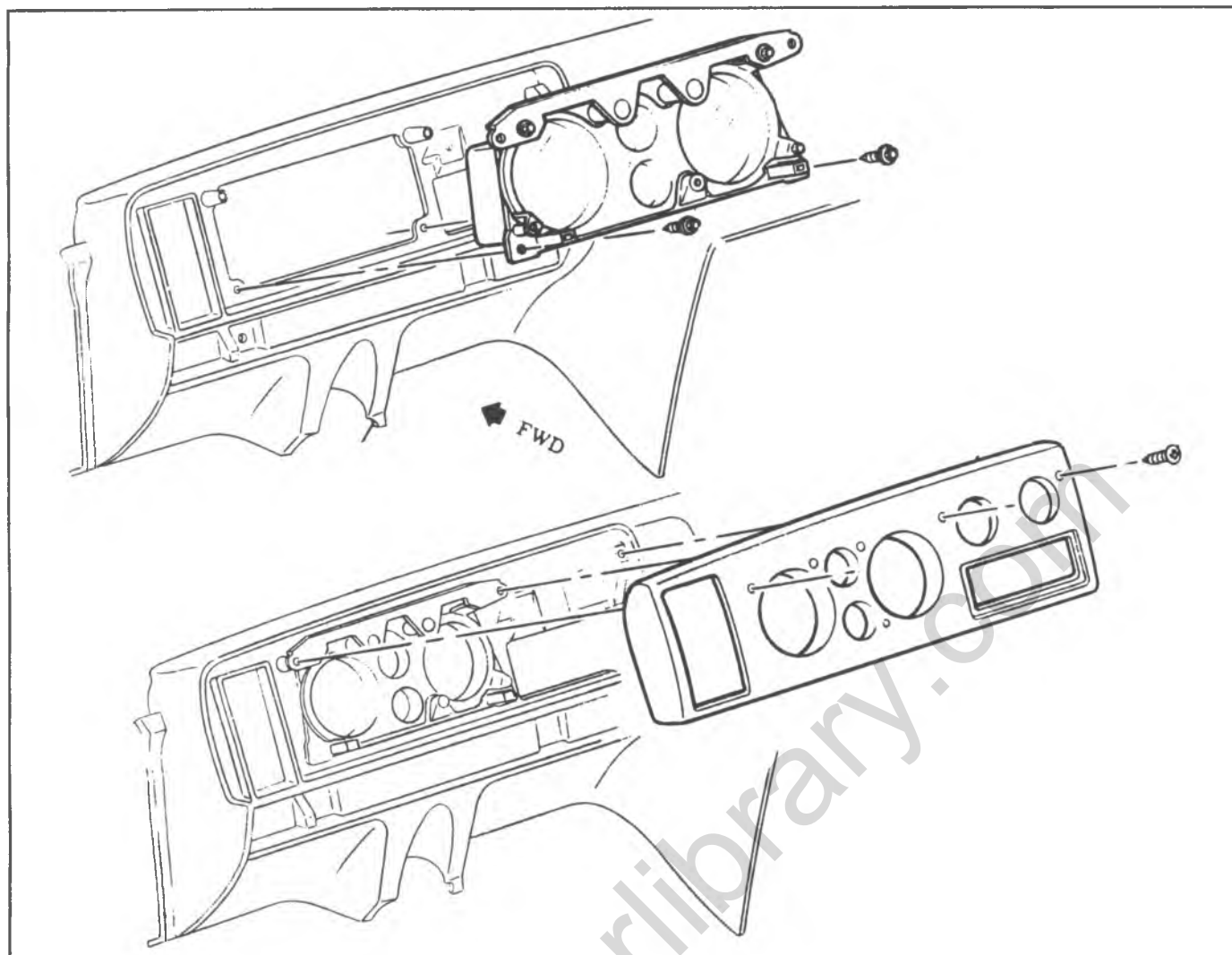


Fig. 8C-4—Instrument Cluster Assembly (G Series)

G Series**Replacement**

1. Remove instrument cluster as previously described in this section.
2. Remove screws retaining speedometer dial to cluster case.
3. Remove two hex head screws and rubber grommets securing speedometer assembly to cluster cover.
4. To install, reverse removal procedure and check operation of speedometer assembly.

NOTICE: Use care to prevent kinking the speedometer cable during removal and installation.

SPEEDOMETER CABLE CORE**All Vehicles****Replacement**

1. Disconnect battery ground cable.
2. Disconnect speedometer cable from speedometer head by reaching up under instrument panel, depressing spring clip and pulling cable from head.

3. Remove old core by pulling it out at end of speedometer cable casing.

NOTICE: If old cable core is broken it will be necessary to remove lower piece from transmission end of casing. It is also important to replace both casing and core.

4. Lubricate entire length of cable core with speedometer cable lubricant.
5. To install, reverse Steps 1-3 above.

NOTICE: Use care to prevent kinking speedometer cable core during installation.

FUEL GAGE**C-K Series****Replacement**

1. Perform Steps 1-6 of "Speedometer - Replacement".
2. Remove fuel gage attaching screws and remove the gage.

3. To install, reverse Steps 1-2 above. Check gage operation.

G Models

Replacement

1. Remove instrument cluster assembly as previously described.

2. Remove instrument cluster bulb holders, ground screws, nuts and washers retaining laminated circuit to cluster case.

3. Remove 6 screws to release front cover from cluster case.

4. Remove screws retaining fuel gage dial to case.

5. Lift gage away from laminated circuit and rear cluster cover.

6. To install, reverse Steps 1-4 and check operation of fuel gage.

Observe assembly sequence of nuts, insulator strip, and resistor bar to insure proper reinstallation of gages.

TEMPERATURE GAGE

C-K Series

Replacement

1. Perform Steps 1-6 of "Speedometer - Replacement".

2. Remove temperature gage attaching screws and remove the gage.

3. To install, reverse Steps 1 and 2 above and check gage operation.

Be sure gage studs engage clips holding laminated circuit to back of cluster housing.

G Models

Replacement

1. Remove instrument cluster assembly as previously described in this section.

2. Remove terminal nuts and bulb holders retaining laminated circuit to cluster case.

3. Remove attaching screws, cover and gage assembly from cluster housing.

4. Replace entire volt-temp-oil gage assembly.

5. To install, reverse removal procedure and check operation of gage.

TEMPERATURE SENDING UNIT

All Models

Replacement

CAUTION: Do not remove cap with engine hot, allow vehicle to cool off first.

1. Relieve cooling system pressure by loosening radiator cap to first stop. Tighten cap after pressure is relieved.

2. Disconnect sending unit wiring harness.

3. Remove sending unit from the engine.

4. Install new sending unit and connect electrical harness.

5. Check coolant level and unit operation.

Coolant must have at least 0°F (-18°C) freeze protection for sending unit to function properly.

OIL PRESSURE GAGE

C-K Series

Replacement

1. Perform Steps 1 of Speedometer - Replacement procedure.

2. Remove gage to cluster attaching screws and remove gage.

3. To install, reverse Steps 1-3 above and check gage operation.

G Models

Replacement

1. Remove instrument cluster as previously described in this section.

2. Remove and replace volt-temp-oil gage assembly as previously described.

OIL PRESSURE SENDING UNIT

All Models

Replacement

1. Disconnect wiring harness connector from sending unit terminal located in block above starter on L-6 engines, at left front of distributor on V-8 (except 454 V-8) or rear left side of block (454 V-8) engines.

2. Remove sending unit using Tool J21757. Replace with new unit and check operation.

VOLTMETER

C-K Series

Replacement

1. Perform Steps 1-6 of "Speedometer - Replacement" procedure.

2. Remove gage to instrument panel screws and remove meter.

3. To install, reverse Steps 1 and 2 above and check meter operation.

Be sure meter studs engage clips holding printed circuit to back of cluster housing.

G Models

Replacement

1. Remove instrument cluster assembly as previously described in this section.

2. Remove and replace volt-temp-oil gage assembly as previously described.

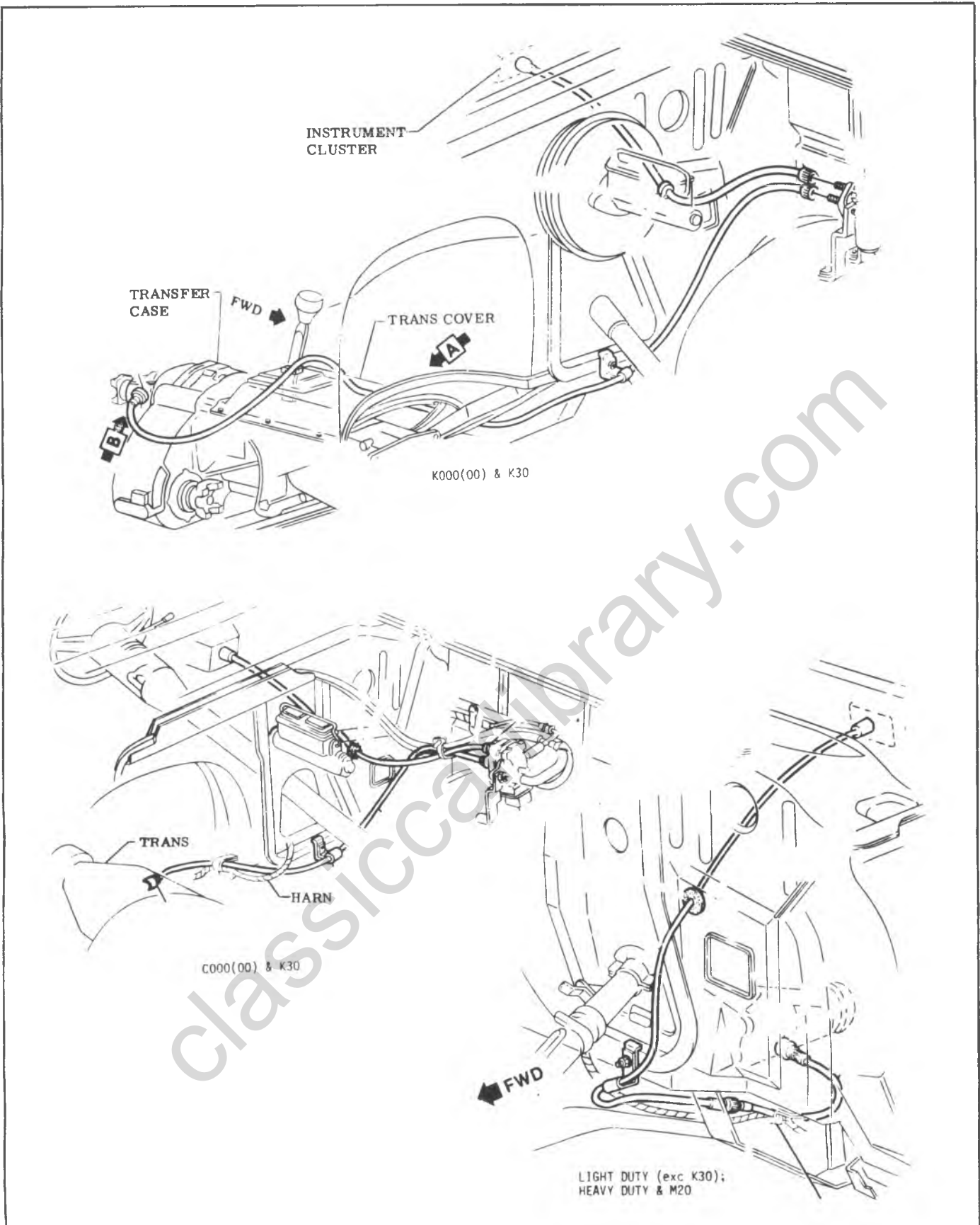


Chart 8C-F2-Speedometer Cable Routing

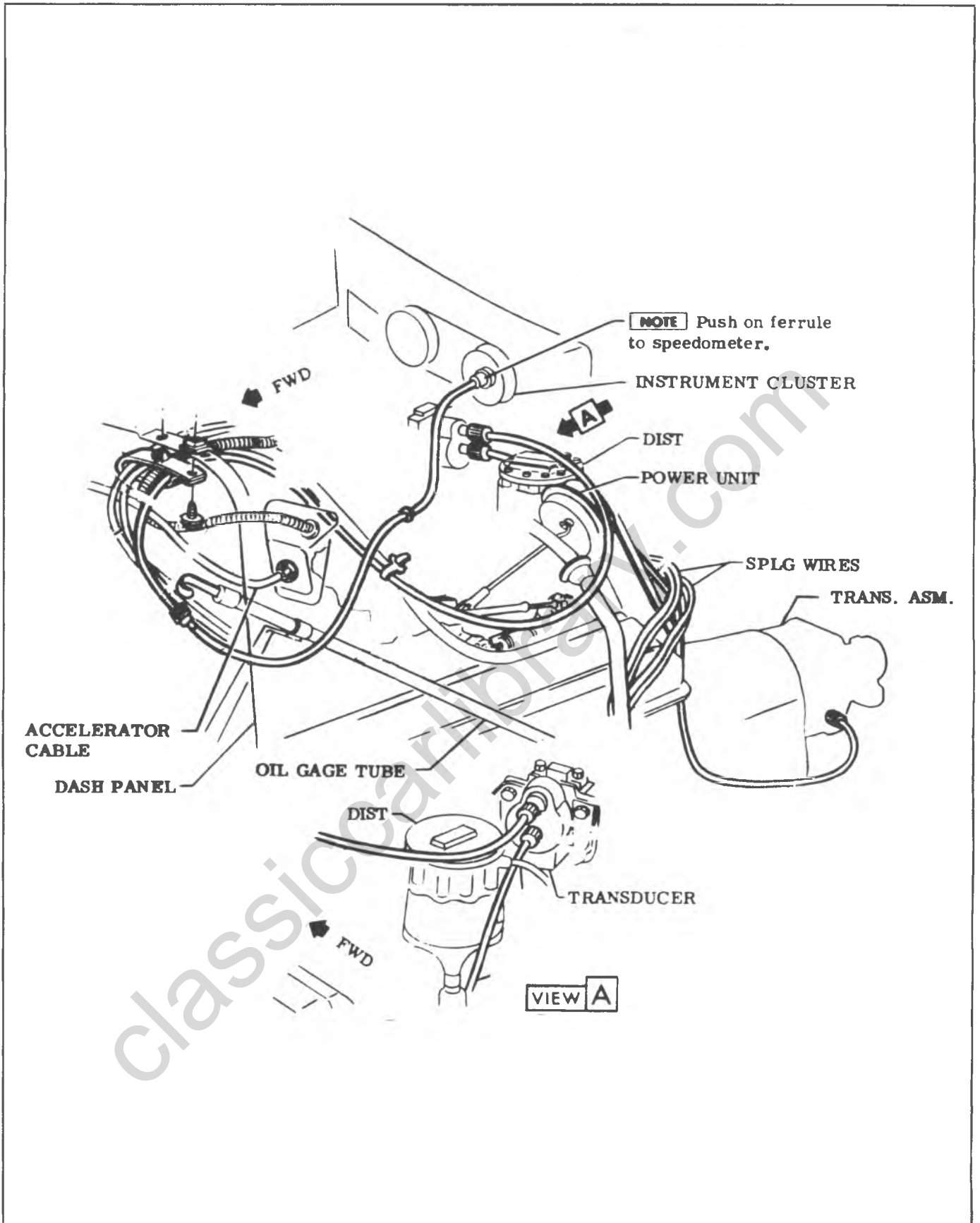


Chart 8C-G2-Speedometer Cable Routing

DIRECTIONAL SIGNAL SWITCH

The directional signal switch is a self-contained unit which incorporates the hazard warning switch and the lane changing signal.

The hazard warning circuit is activated by a push-pull switch which is located on the right side of the steering column, opposite the directional signal lever. The switch knob must be pulled to cancel circuit.

The lane changing circuit is activated by holding the directional signal lever in the first detent position; there is no lock in or cancelling device in this position.

See Section 3B "Steering" for all servicing procedures.

INSTRUMENT PANEL WIRING HARNESSES

Refer to Figs. 8C-5 thru 8C-8.

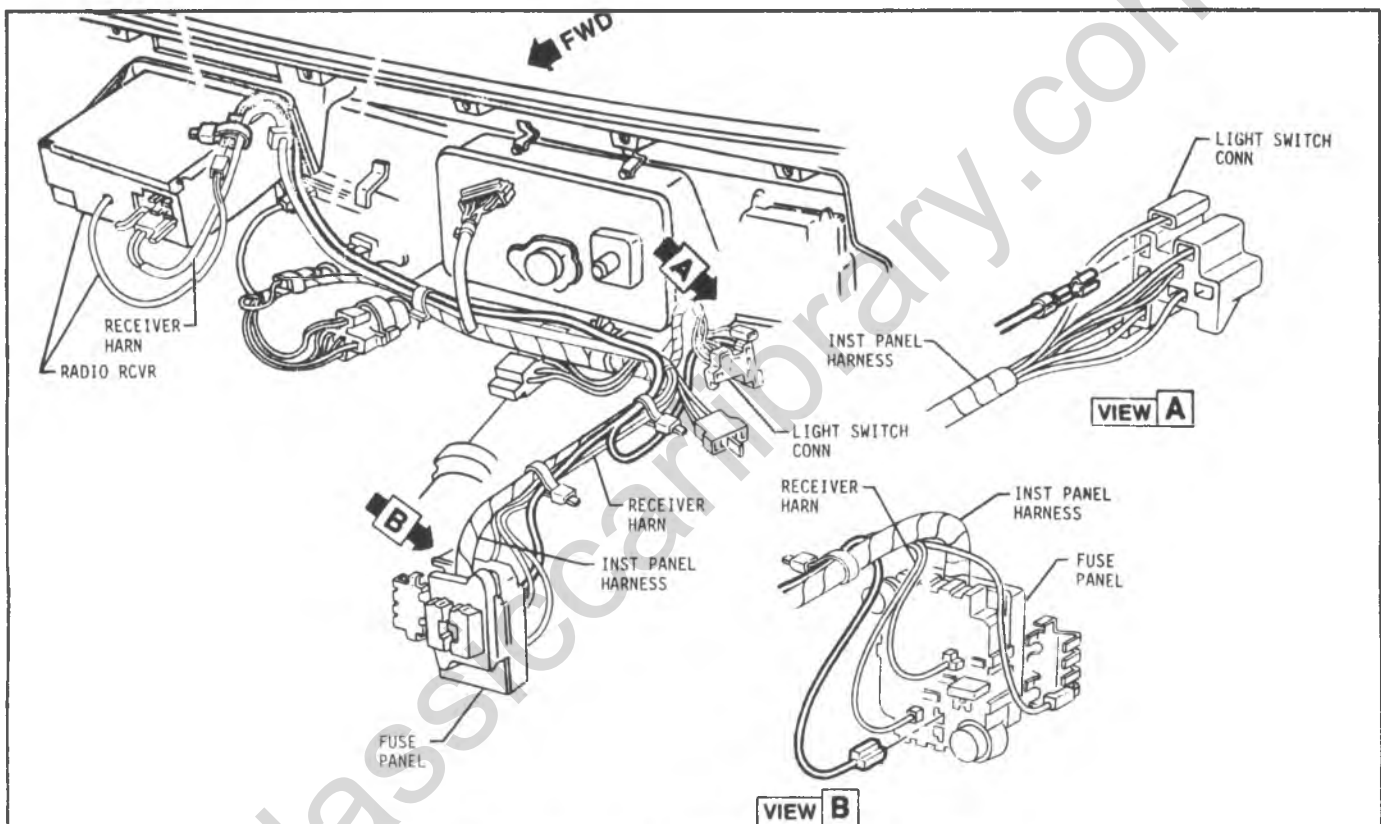


Fig. 8C-5—Instrument Panel Wiring - R.H. - G Models

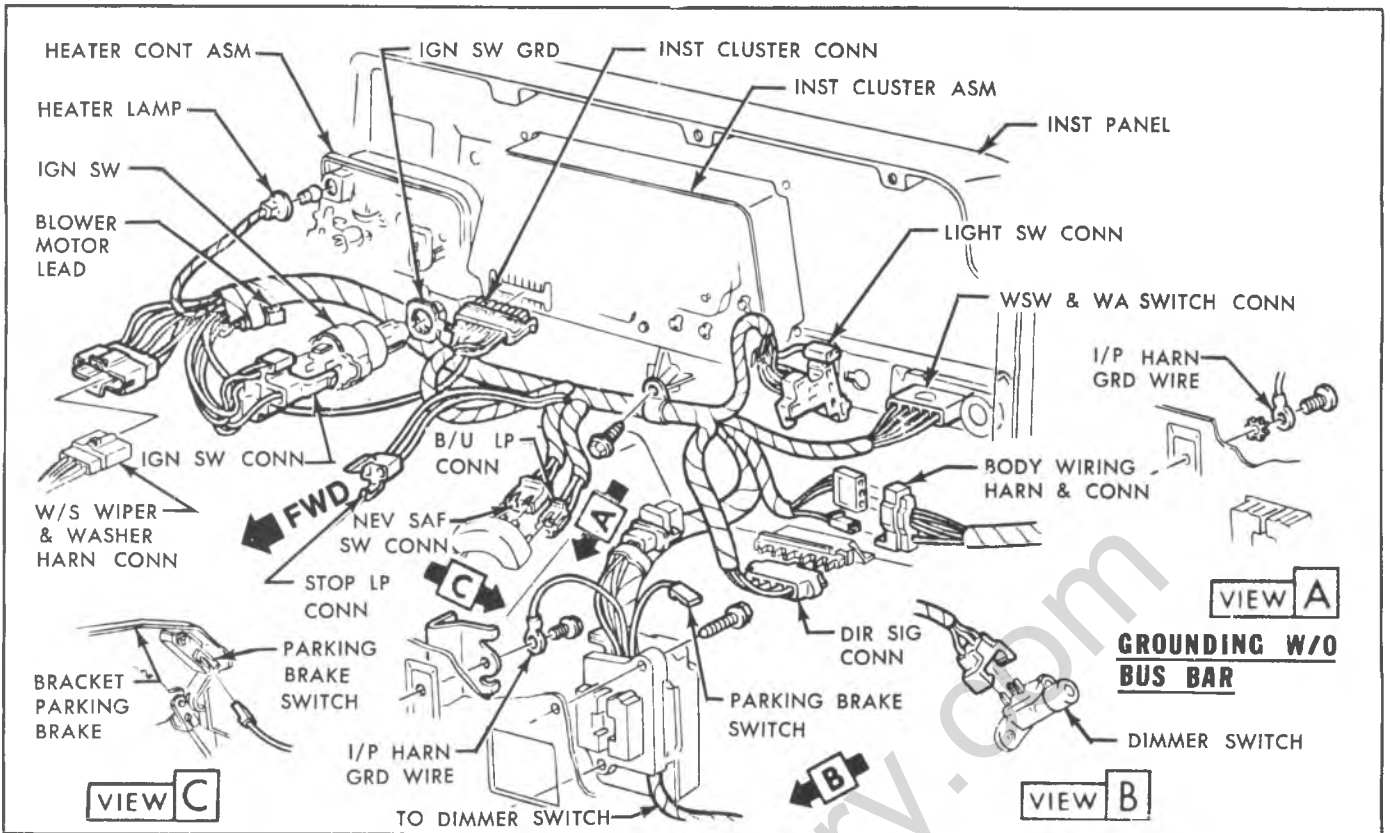


Fig. 8C-6--Instrument Panel Wiring - L.H. - G Models

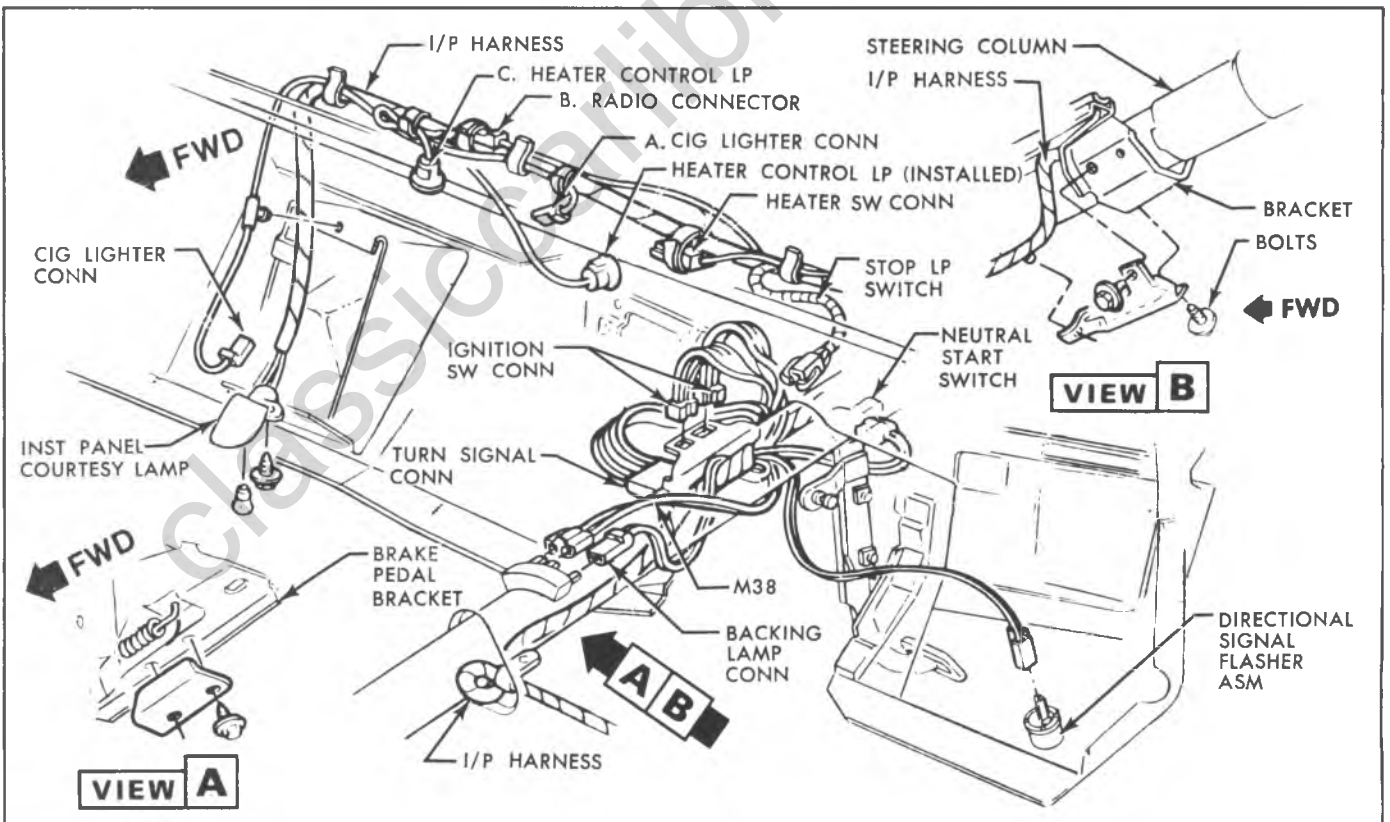


Fig. 8C-7--Instrument Panel Wiring R.H. - CK Models

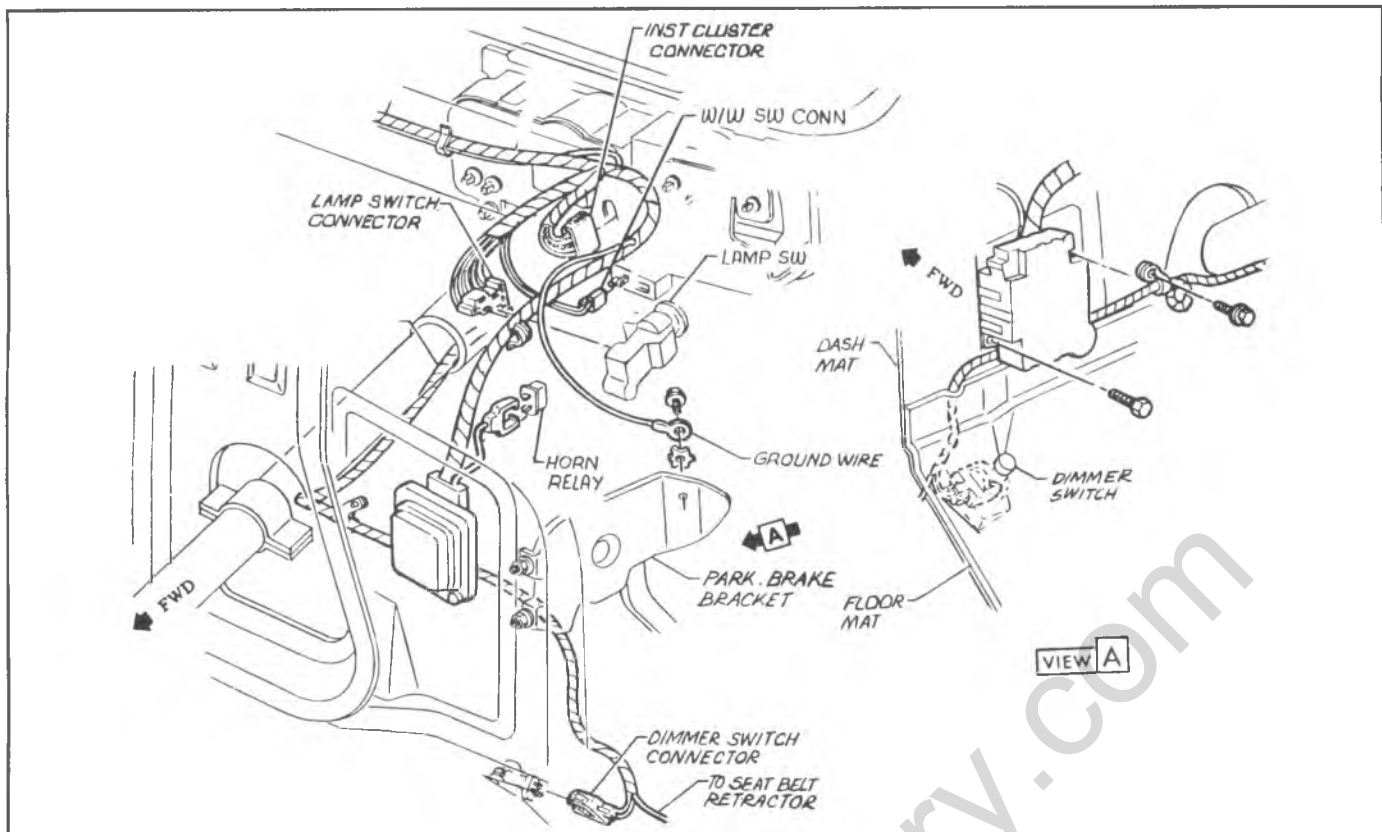


Fig. 8C-8—Instrument Panel Wiring - L.H. - CK Models

WINDSHIELD WIPER AND WASHER C-K-G Series

GENERAL DESCRIPTION

A permanent magnet type wiper is used on CK & G Series. The motor parts—field magnets, armature, drive gear etc. are enclosed in a two piece sheet metal housing. For purposes of explanation the housing halves are referred to as upper and lower housings. The two housings are attached to each other by ten extrusions which are staked over. Figure 8C-9.

As shown in Figure 8C-9, the washer pump parts are assembled on the outside surface of the upper half of the sheet metal housing. Thus, the washer pump becomes an integral part of the wiper motor assembly.

The wiper motor is protected by an automatic reset type circuit breaker located on the motor brush holder assembly. A fuse located in the fuse block protects the vehicle wiring.

The wiper motor can be operated only when the ignition switch is in the "run" or "accessory" position.

Referring to figure 8C-10 note that there are seven terminals which are numbered.

The function of each terminal is covered in the explanation that follows.

NOTICE: Wipers are equipped with locking type connectors for attaching vehicle wiring and care should be used when disconnecting wiring from wiper to avoid damaging the connector or terminals.

As shown in figure 8C-10, the wiper motor has three brushes which are referred to as "common", "Lo speed" and "Hi speed". When the ignition switch is "ON", 12 V(

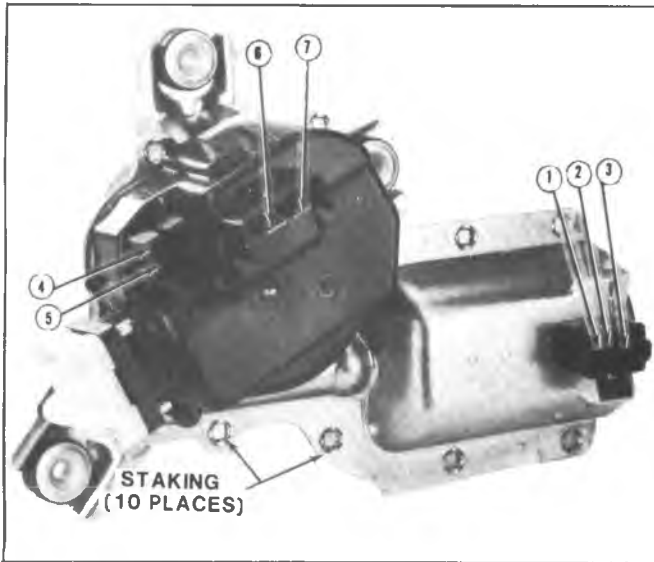


Fig. 8C-9--Wiper Motor Housing

via no. 1 terminal. The Lo and Hi speed brushes are connected to motor terminals two and three.

LO AND HI SPEED CIRCUITS

Moving the dash switch to the "Lo" or "Hi" speed position completes the respective brush circuit to ground at the dash switch and wiper motor runs at that speed.

WASHER PUMP OPERATION

The washer pump is an integral part of the wiper motor and cannot be replaced as a separate assembly as was possible with previous motors.

SHUTTING OFF THE WIPER

This explanation covers that portion of wiper operation when the owner first turns the wiper "off" at the dash switch and the wiper blades have not reached their normal park position, (approximately 1 1/2-2" above the lower windshield molding).

In order to have the blades stop in their normal park position and the wiper motor shut off properly, the motor operates in "Lo" speed. This is accomplished as follows: with the dash switch in the "OFF" position, the Lo speed brush circuit is completed to ground at the dash switch through a park switch located in the gear housing (Terminals 4 and 5). The park switch contacts are normally closed and this permits the wiper to continue to run.

When the blades reach their park position, a cam on the gear opens the normally closed part switch contacts shutting off the wiper.

WASHER PUMP CIRCUIT

Actuating the washer portion of the dash switch completes the washer pump magnet coil circuit to ground and mechanically moves the wiper motor switch to the Lo speed position. This dual function starts the wiper motor and washer operation simultaneously. When the wash cycle (10 squirts at full pressure) is completed, the wiper will continue to run until the owner returns the switch to the "off" position.

WASHER PUMP OPERATION

Pumping Mechanism

The basic pump consists of a spring loaded piston enclosed in a plastic cylinder housing. Attached to the piston and extending out of cylinder housing is an actuator plate. Attached to the end of the cylinder housing is a valve assembly consisting of two exhaust check valves and one

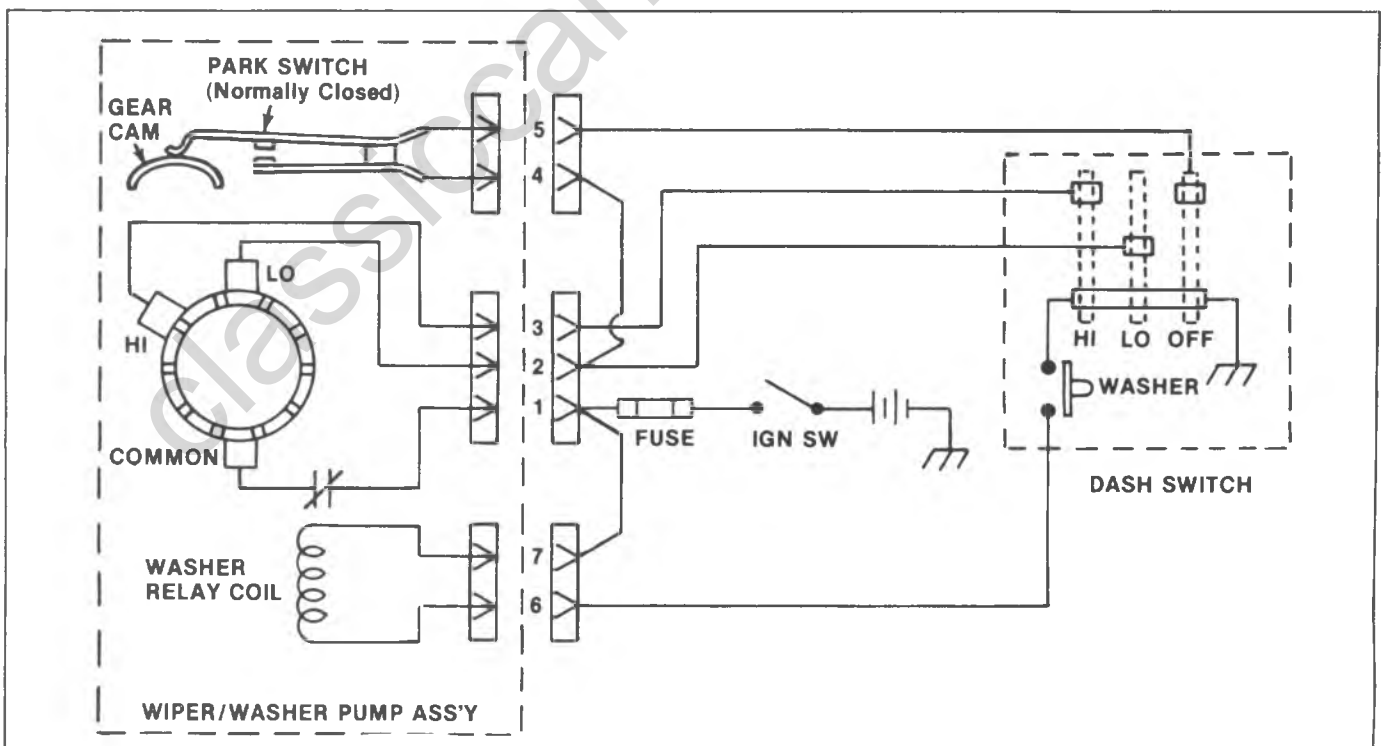


Fig. 8C-10--Wiper Motor Schematic

intake check valve. Figure 8C-11.

Note the cam follower pin that extends through an elongated opening in the piston actuator plate. When the wiper motor is running, a 4 lobe cam, which is part of the wiper gear, moves the cam follower back and forth.

Pump Idling (No Pumping Action)

Refer to Fig. 8C-12 and note that a tang on the piston actuator plate is resting against a ramp on the lower surface of the ratchet gear. This, in effect, holds the piston actuator plate in a lock-out position. With actuator plate in this position and the wiper running, the cam-follower pin merely moves back and forth in the elongated slot of the piston actuator plate and no pumping action can occur.

The ratchet gear, which, if rotated, would move the ramp away from the tang of the actuator plate releasing the pump action, is prevented from rotating as follows: The relay assembly, consisting of a coil and armature, is constructed in such a way that the ratchet gear pawl extends through an opening in the relay armature (Fig. 8C-12), preventing it from engaging the ratchet gear teeth.

Starting the Pump

Actuating the washer button to obtain windshield washer pump operation starts the wiper motor and energizes the relay. When relay is energized, the relay armature is pulled toward the coil, allowing the ratchet gear pawl to drop out of the relay armature opening and engage the teeth of the ratchet gear.

The ratchet pawl, which is actuated by the same cam-follower pin that moves the piston actuating plate, begins to rotate the ratchet gear. Rotating the ratchet gear one tooth moves the ratchet wheel ramp away from the tang of the piston actuating plate (Fig. 8C-13), permitting the piston spring to expand which in turn forces the piston toward the valve assembly resulting in the first exhaust stroke. This sequence then repeats through the remaining cycles.

Intake Stroke

When the cam-follower moves in the direction indicated by the arrow in Fig. 8C-14, the cam-follower pin, which extends through the piston actuating plate, pulls the actuator plate away from the valve assembly compressing the piston spring. As the piston moves away from the valve assembly, a vacuum is created in the cylinder which opens the intake valve, drawing washer solution into the cylinder (Fig. 8C-14).

Exhaust Stroke

As the 4-lobe cam continues to rotate, the cam follower moves in the opposite direction described in the intake stroke. This permits the piston spring to expand which in turn pushes the piston toward the valve assembly creating pressure between the piston and valve assembly. This pressure "build-up" forces the two exhaust valves open compelling the washer solution to flow to the nozzles. See Fig. 8C-14.

For purposes of explanation, only one exhaust valve opening is shown in Fig. 8C-14.

The intake and exhaust stroke cycle will occur four times for each revolution of the wiper drive gear while the washer pump is operating.

Stopping the Pump (Completion of the Wash Cycle)

The pumping operation is terminated automatically when the ratchet gear has rotated a full 360° and the 12th

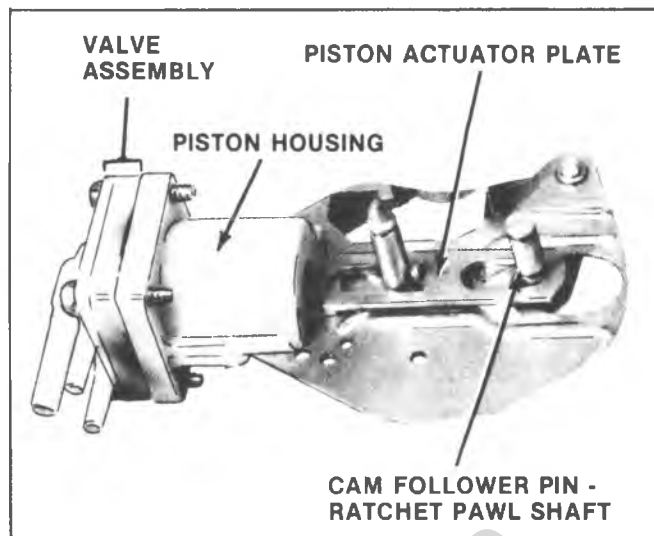


Fig. 8C-11--Washer Valve Assembly

cycle is completed. This is accomplished as follows.

As the ratchet gear approaches the completion of its 360° travel, two functions occur simultaneously:

1. A leg on the relay armature rides up a ramp located on the outer surface of the ratchet gear. When the leg reaches the top of the ramp, it moves over the top edge of the ratchet gear. This action allows the ratchet gear pawl to re-enter the armature opening preventing further rotation of the ratchet gear until the next time the relay coil is energized from the washer button. (Refer to Fig. 8C-14 for position of armature leg while pump is idling.)
2. The tang on the piston actuating plate is resting once more against the ramp on the lower side of the ratchet gear (Fig. 8C-11).

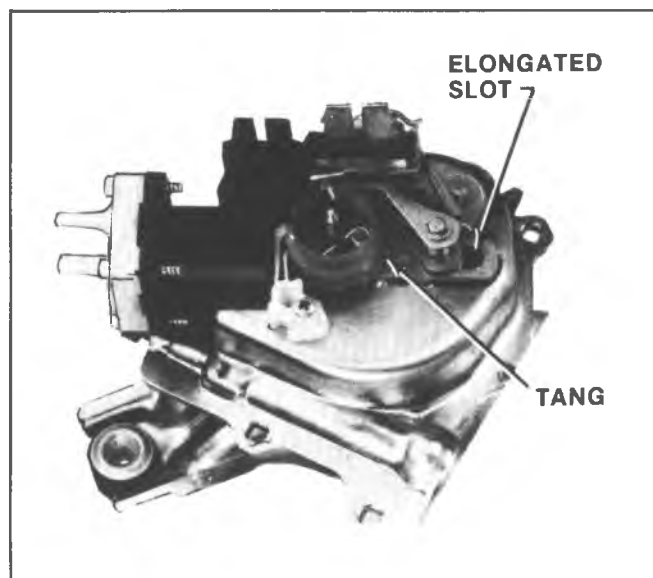


Fig. 8C-12--Ratchet Gear Pawl

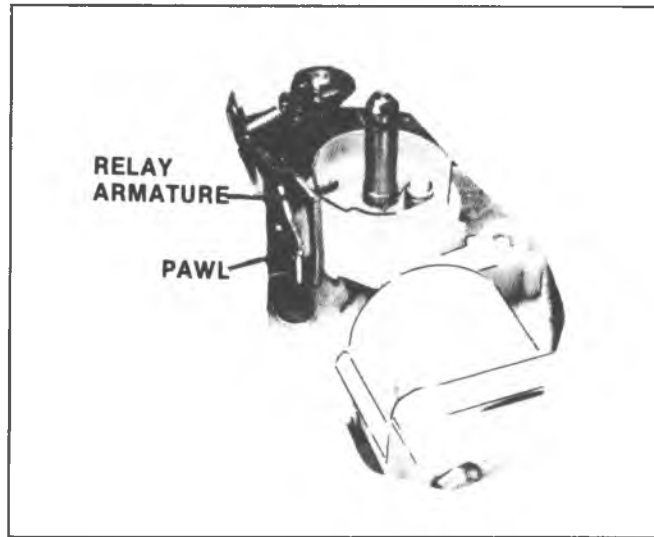


Fig. 8C-13--Relay Armature

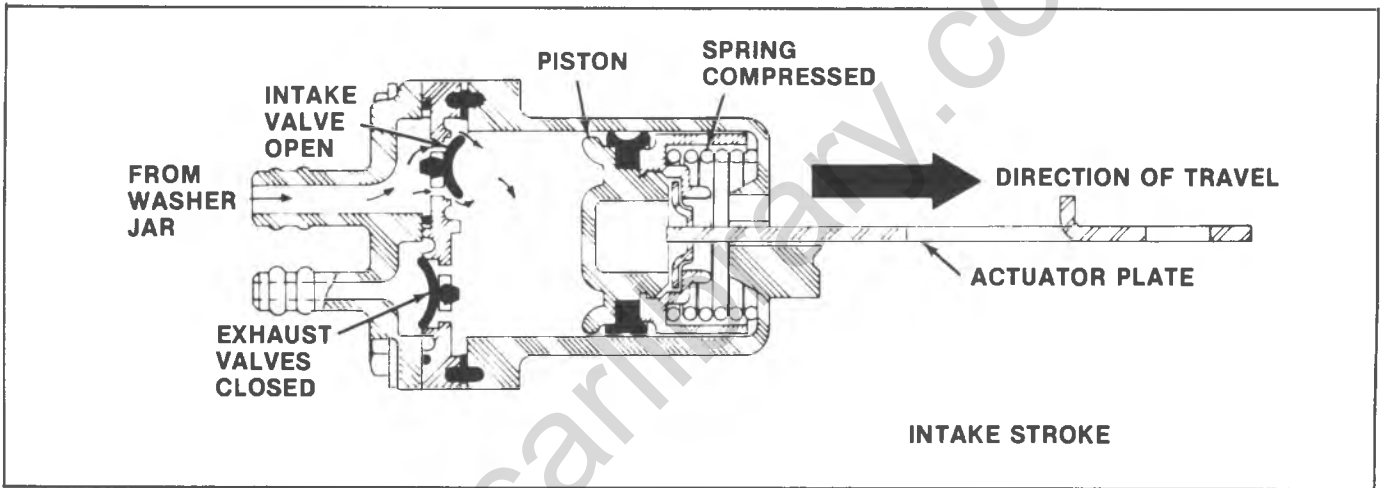


Fig. 8C-14--Pump Operation



Fig. 8C-15--Armature Leg Position

DIAGNOSIS

WIPER - ON VEHICLE

Troubleshooting with wiper installed on the vehicle consists of two basic steps: (A) Preliminary inspection and (B) Operating wiper independent of vehicle wiring and dash switch.

Preliminary Inspection Procedure

A. Preliminary Inspection - Check the following items:

1. Body wiring securely connected to wiper unit and dash switch.
2. Wiper ground connection to vehicle chassis.
3. Dash switch is mounted securely.
4. Fuse.

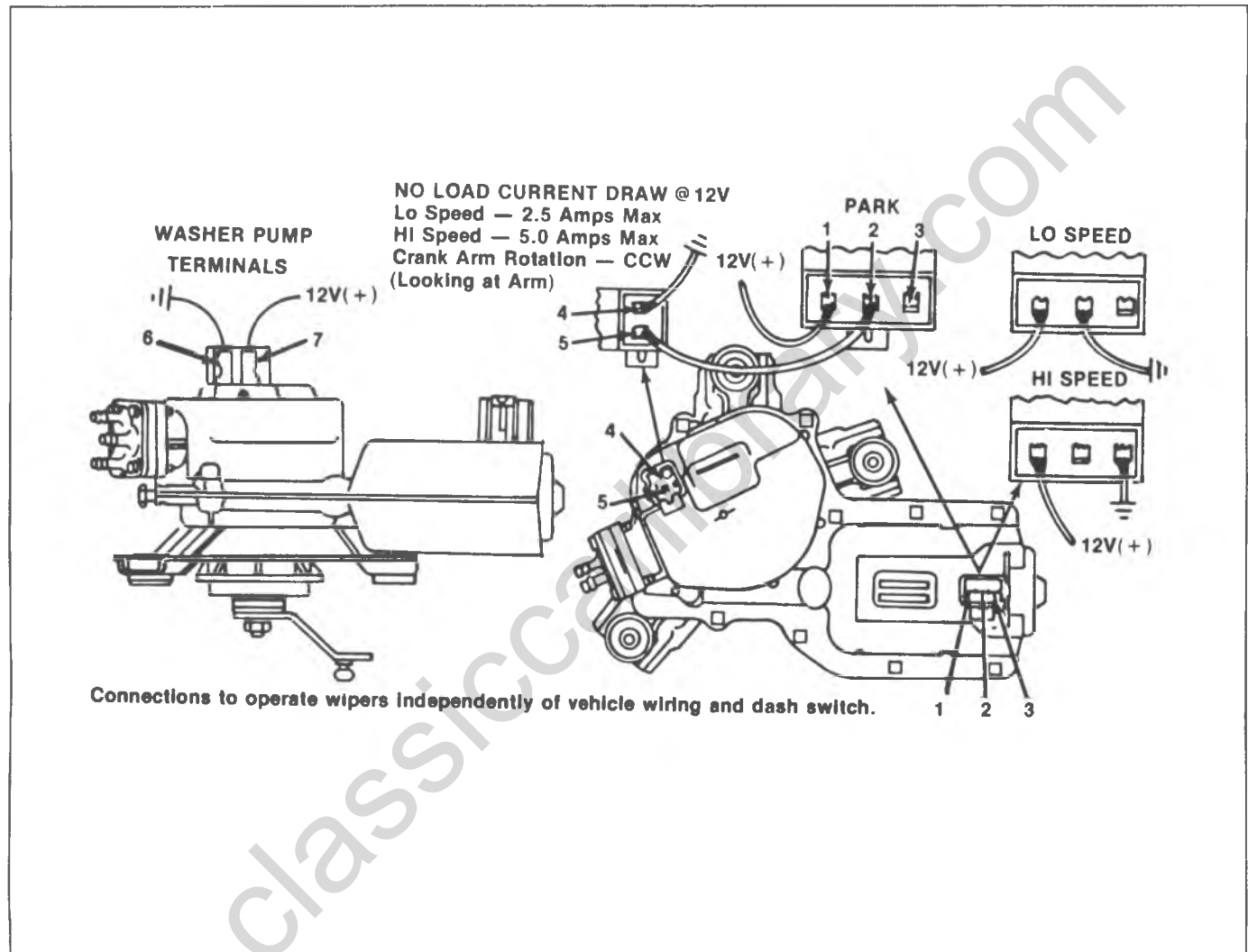


Fig. 8C-16—Wiper Motor Diagnosis Diagram

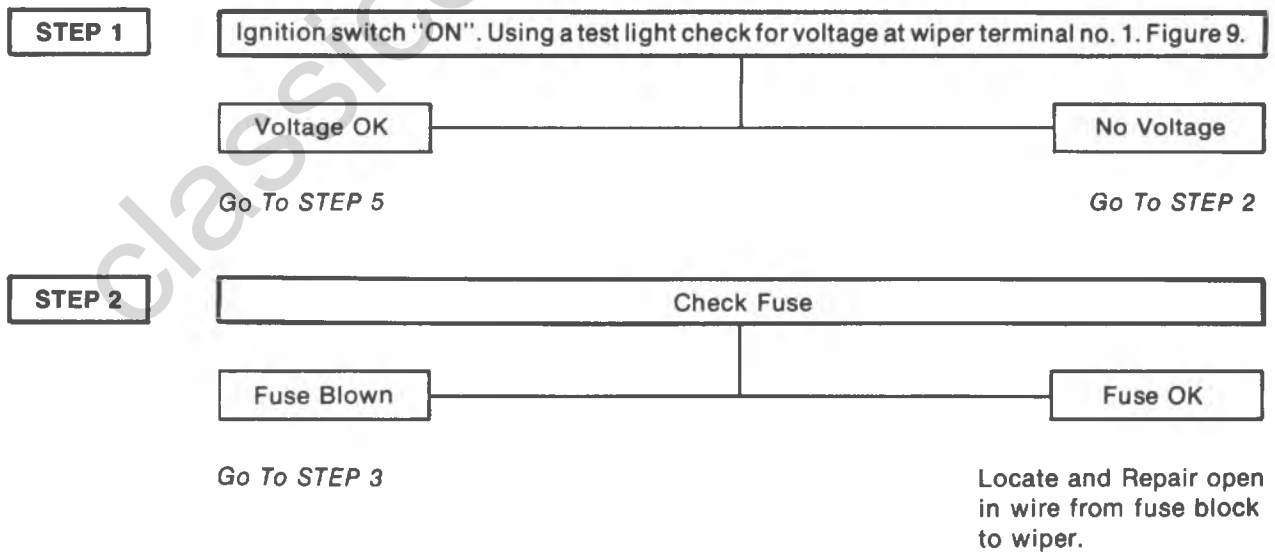
WIPER MOTOR/WASHER PUMP DIAGNOSIS

NOTE: Detached wiper/washer assemblies may be operated as shown in Figure 9 to determine possible problems.

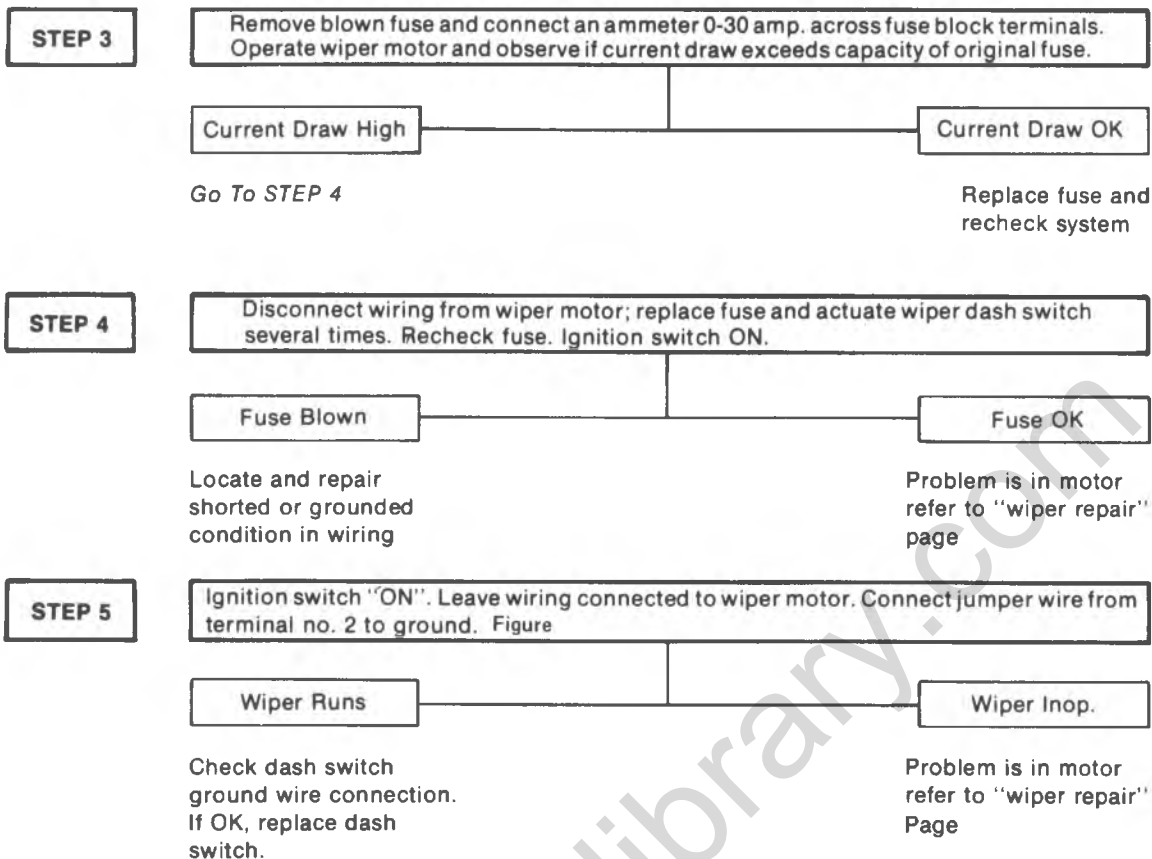
DIAGNOSIS CHART

| SYMPTOM | PROCEDURE NO. |
|---|---------------|
| 1) Wiper Inoperative - Both Lo and Hi | 1 |
| 2) Lo speed only - inoperative in Hi | 2 |
| 3) Hi speed only - inoperative in Lo | 3 |
| 4) One speed - same in both Lo and Hi | 4 |
| 5) Blades stop at random positions when wiper is turned off. (Do Not Return to Park Position) | 5 |
| 6) Wiper will not shut off | 6 |
| 7) Intermittent operation | 7 |
| 8) Wiper motor runs but blades don't move | 8 |
| 9) Washer pump inoperative | 9 |
| 10) Washer won't shut off | 10 |

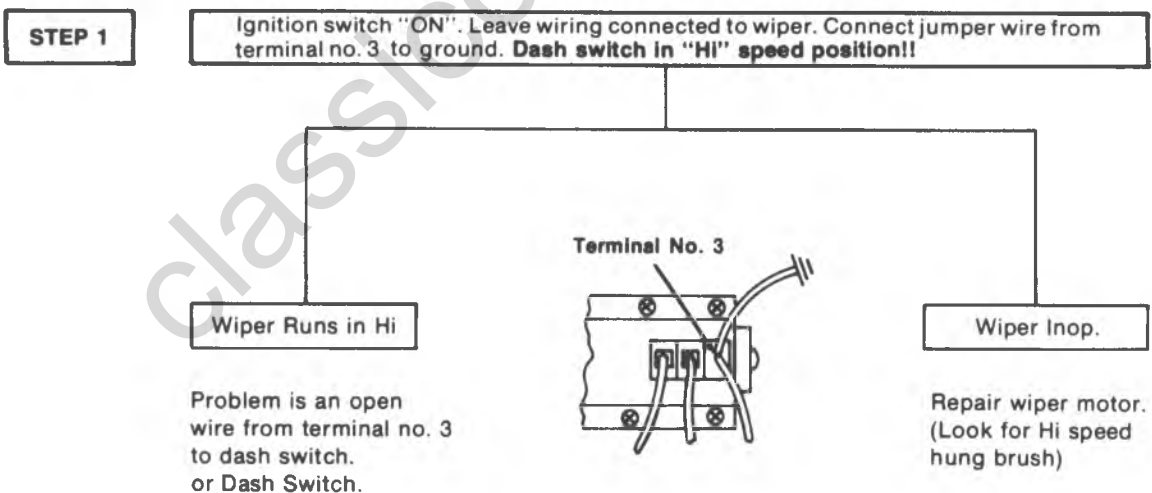
PROCEDURE I (Wiper Inoperative)



Procedure 1 (cont.)



PROCEDURE 2 (Lo Speed Only) (Inop in Hi)



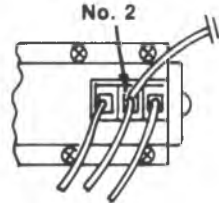
PROCEDURE 3 ("Hi" Speed Only) (Inop in Lo)

STEP 1

Ignition switch "ON". Dash switch in "Lo" speed position. Leave wiring connected to wiper and connect jumper wire from terminal no. 2 to grd.

Wiper Runs in Lo

Problem is on open wire from wiper terminal no. 2 to dash switch or The Dash Switch.



Wiper Inop.

Repair wiper motor (Look for Lo speed hung brush.)

PROCEDURE 4 (One speed - same in both Lo and Hi).

STEP 1

Remove wiring from wiper motor terminals 1, 2 and 3 and operate wiper in Lo and Hi as shown in Figure (NOTE: Current draw is usually above normal - approx. 6.0 amps.)

Wiper operates correctly

Problem is in wiring between dash switch and wiper or a defective dash switch.

Problem still present

Repair wiper motor. Check for Lo and Hi speed brush leads shorting together internally.

PROCEDURE 5 (Wiper shuts off but blades don't return to park position)

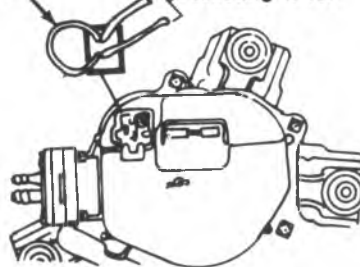
STEP 1

Ignition switch "ON". Dash switch in "OFF". Leave wiring connected to wiper and connect a jumper wire across terminals 4 and 5.

Wiper Runs

Replace wiper park switch assy.

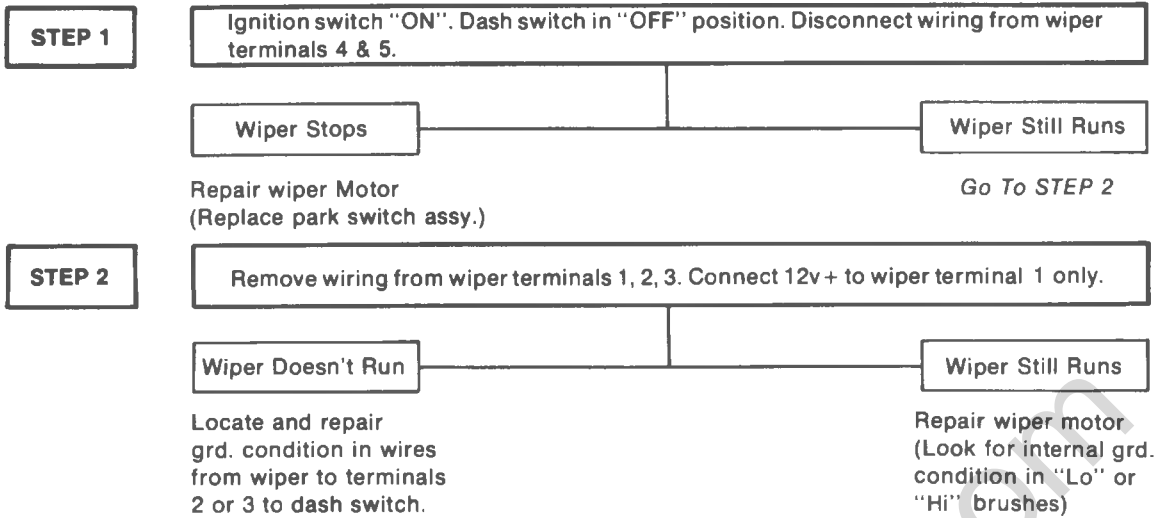
Jumper Wire Existing Wires



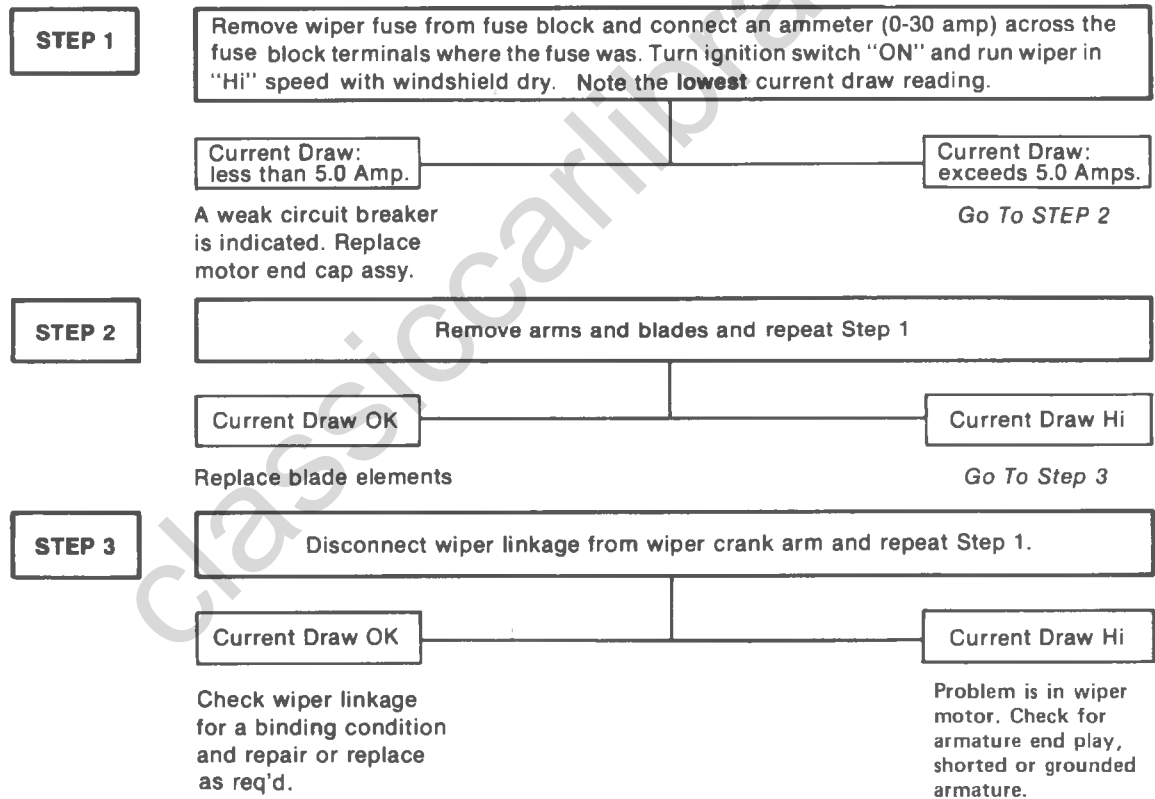
Wiper Inop.

Wire from wiper terminal no. 5 to dash switch open or dash switch is problem

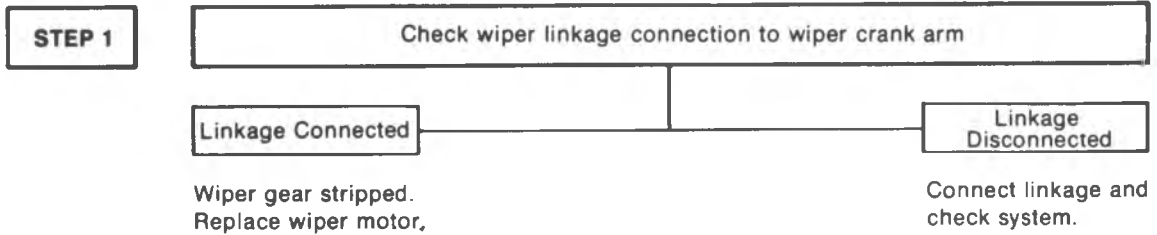
PROCEDURE 6 (Wiper will not shut off)



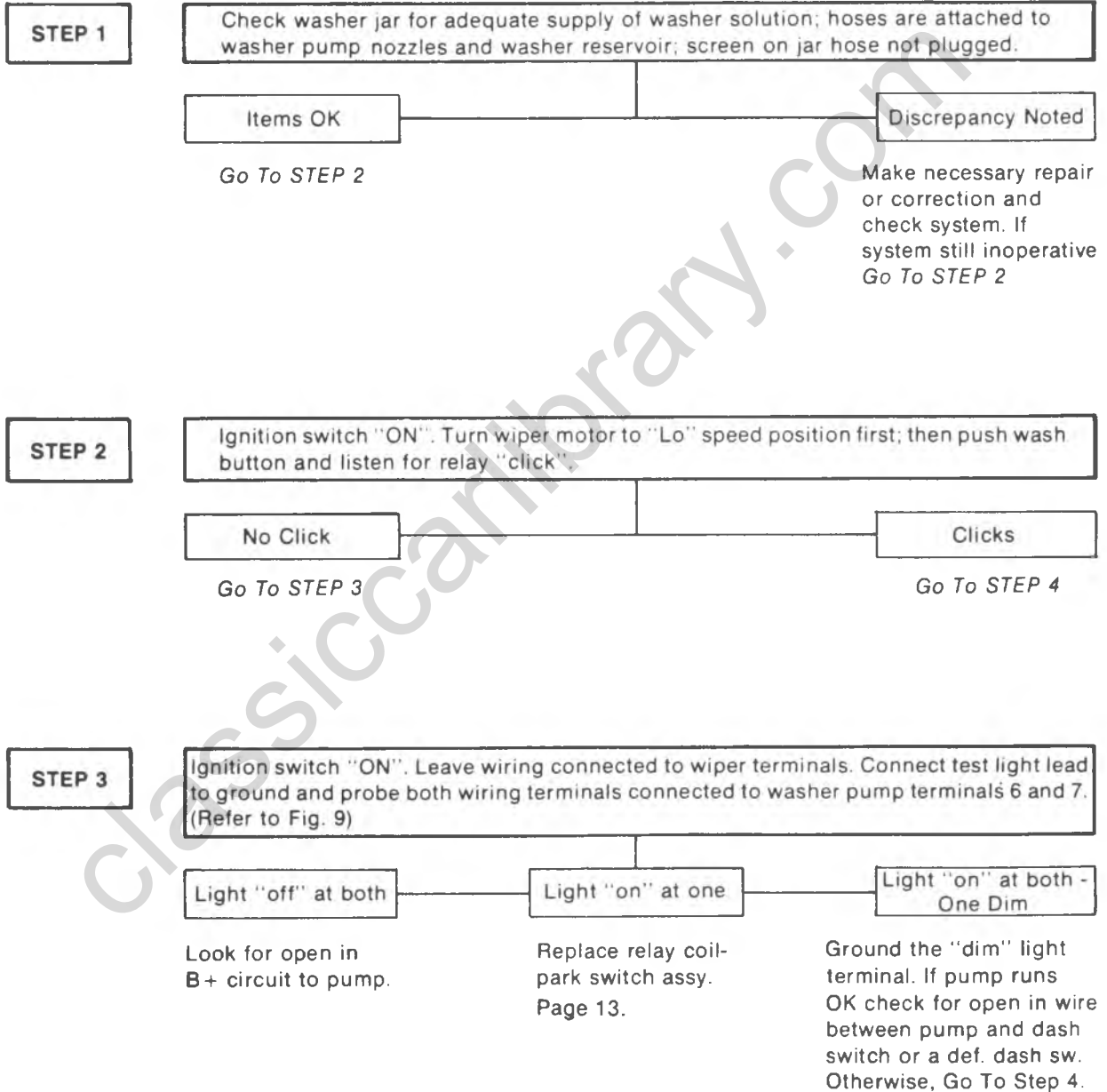
PROCEDURE 7 (Intermittent Operation) (Wiper has both speeds)



PROCEDURE 8 (Wiper Runs But Blades Don't Move)



PROCEDURE 9 (Washer Pump Inoperative)

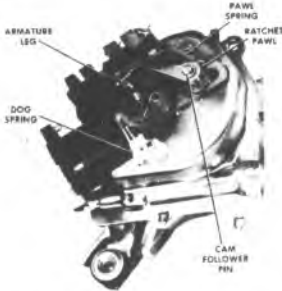


STEP 4

Remove washer pump cover and re-connect wiring to wiper motor terminals 1, 2 and 3. Turn on wiper motor and observe if ratchet pawl is moving back and forth.

Not moving

- Check the following:
- 1) Pawl spring properly connected.
 - 2) Cam-follower not binding.



Moves back and forth

Leave wiper running and Go To STEP 5

STEP 5

Connect 12(+) volts to one of washer pump terminals (6 or 7) and ground the other for approx. 2 seconds. Observe if relay armature is pulled toward the relay coil; armature leg drops down on gear ramp and ratchet pawl starts rotating ratchet gear. Refer to view in STEP 4.

Operates OK

Go To STEP 6

Relay armature operates correctly but ratchet gear doesn't rotate.

- Check ratchet gear teeth and/or ratchet gear dog spring engages gear teeth. Refer to above illustration.

Armature Leg doesn't clear rim on ratchet gear. Drops back in slot area on edge of rim.

- Check the following:
- a) Relay coil-sw. assy. correctly assembled to washer frame
 - b) Burr on end of armature leg. File off as required.
 - c) Loose coil on pole piece.

STEP 6

Observe if piston actuator plate move back and forth with the cam follower pin. Refer to view in STEP 4.

Piston Moves back and forth

Replace valve assembly and recheck pump. If washer pump still fails to pump solution, replace piston and housing assembly.

Piston Not Moving.

Replace piston and housing assembly.

PROCEDURE 10 (Washer Pumps Continuously)

STEP 1

Have wiper running and disconnect wiring from washer pump terminals 6 and 7. Observe if pump completes wash cycle and stops pumping.

Pump stops

Pump keeps running

Check for grounded wire between pump terminal and dash switch or a defective dash sw.

Go To STEP 2

STEP 2

Disconnect wiring from wiper unit; remove washer pump cover and re-connect wiring to wiper-washer. Turn on wiper and check the following items.

- a) Ratchet gear dog spring engaging ratchet gear teeth.
- b) Weak spring tooth on ratchet gear.
- c) Ratchet gear tooth damaged
- d) Cam-follower damaged.

Replace item(s) as required.

DELAY WIPER SYSTEM OPERATION AND DIAGNOSIS

Light duty trucks use a separate control assembly to operate the windshield wipers over a variable delay of 1 to 20 seconds. The control assembly plugs into the selector switch at two different connectors. One of these connectors has a piggy-back connector that connects to the regular wiper harness. There is also a lead from the control that plugs into the accessory cavity of the fuse panel. Moving the control knob of the selector switch to the extreme left position and holding it there, will result in a MIST mode. The mist mode feature provides momentary low speed wiper operation as long as the control knob is held in position. This position is spring loaded and will only remain activated as long as the knob is held in position. Upon releasing the control knob, it will automatically return to OFF position. By positioning the control knob in the first detent right of OFF, the selector switch is in the DELAY mode. Rotation of the control knob while in the delay mode regulates the delay period between the time it takes the wiper to make one sweep and momentarily stop.

Shifting the control knob right to next detent position will put the wipers in a LOW speed wiper mode. By moving the control again to the right (right most detent) will activate the HIGH speed wiper mode.

Depressing the control knob, in any mode, will result in washer fluid being squirted on the windshield.

Depressing the control knob on light duty trucks for one or two seconds will send a measured amount of fluid onto the windshield and then the washer will shut off. If the wiper control knob is any position other than HIGH, the wipers will continue to operate at low speed until they are manually turned OFF.

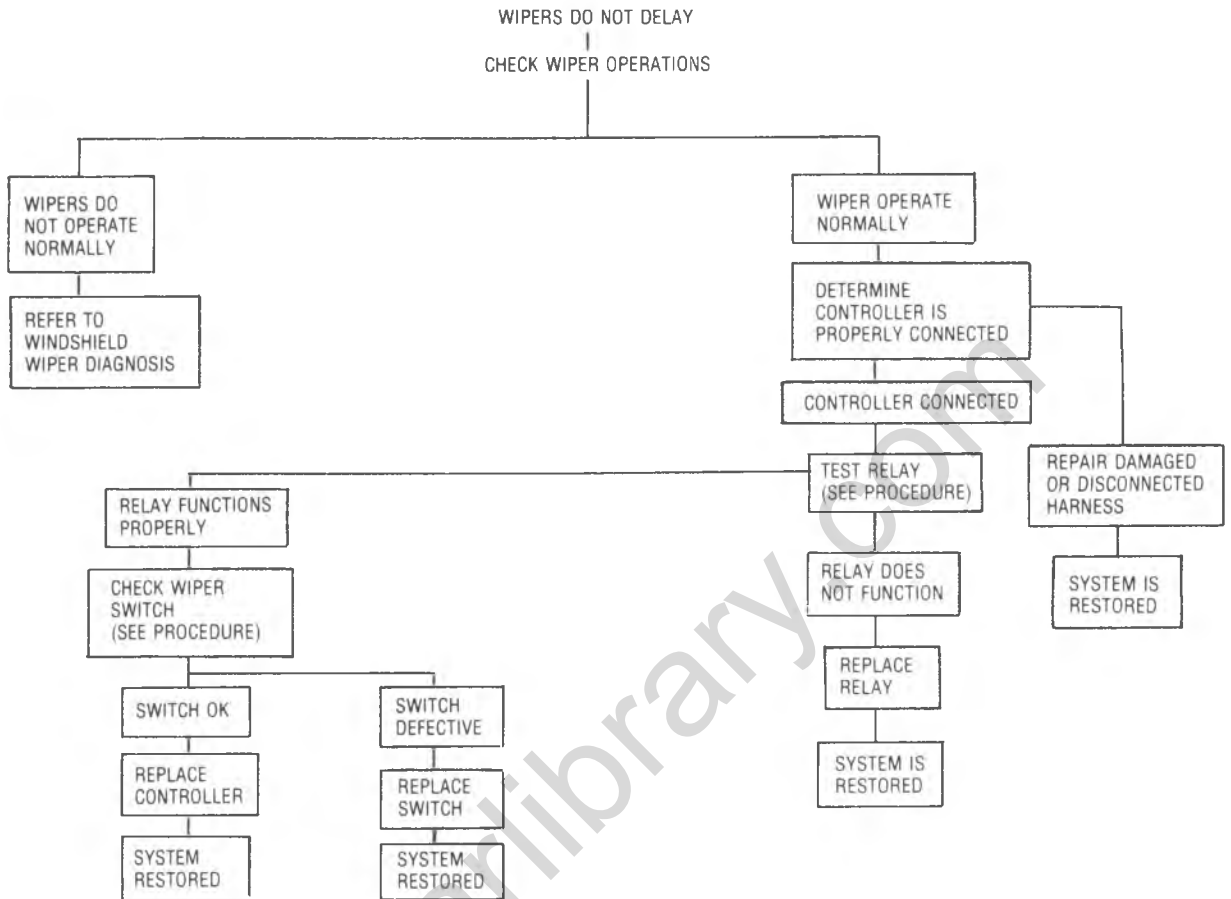
In the HIGH mode, depressing the knob results in washer fluid being dispensed with the wipers operating at the high speed mode.

Selector Switch Checking Procedure

If the wiper washer selector switch is suspected of being faulty, it can be checked with an ohmmeter as indicated in Chart 8-16. Before performing any continuity check disconnect both harness connectors from switch to controller.

Next, place selector switch in mode desired and perform a continuity check between the individual leads as indicated in the chart. If there is a meter reading at each check but no indication of shorts, the switch can be assumed to be good.

Diagnosis



Selector Switch Checking Procedure

If the wiper/washer selector switch is suspected of being faulty, it can be checked with an ohm meter as indicated in table below. Before performing any continuity check on selector switch, disconnect both harness connectors from switch to controller. Next, place selector switch in mode desired and perform a continuity check between the individual leads as indicated in table below, Figure 15. If there is a meter reading at each check but no indication of shorts, switch can be assumed to be good.

| | Mist | Off | Delay | Delay (Rotate Control full clockwise) | LO | HI | Wash (Off Mode — press in on control) |
|---------------|------|-----|-------|---|----|----|--|
| Dark Blue | | | | | | | X |
| Light Blue | X | | | | X | X | X |
| Green | X | X | | | X | X | X |
| Black | X | X | X | | X | X | X |
| Black Wht Str | X | X | X | | X | | X |
| Orange | | | | X | | | |
| White | | | | X | | | |

ON-VEHICLE SERVICE

COMPONENT PART REPLACEMENT

WIPER MOTOR

C-K Models

Replacement (Fig. 8C-17)

1. Make sure wiper motor is in Park position.
 2. Open hood and disconnect ground cable from battery.
 3. Disconnect electrical harness at wiper motor and hoses at washer pump.
 4. Reach down through access hole in plenum and loosen wiper drive rod attaching screws. Remove drive rod from wiper motor crank arm.
 5. Remove wiper motor to dash panel attaching screws and remove the motor assembly.
 6. To install, reverse Steps 1-5 above.
- Lubricate wiper motor crank arm pivot prior to reinstallation.

G Series

Replacement (Fig. 8C-18)

1. Make sure wiper motor is in Park position.
2. Open hood and disconnect battery ground cable.
3. Remove wiper arms from wiper transmission linkage.
4. Remove remaining screws securing cowl panel cover and lift off.
5. Loosen nuts holding transmission linkage to wiper motor crank arm and lift linkage off arm.
6. Disconnect power feed to wiper motor at multiple connector.
7. Remove left dash defroster outlet from flex hose and push hose aside for access to wiper motor screws.

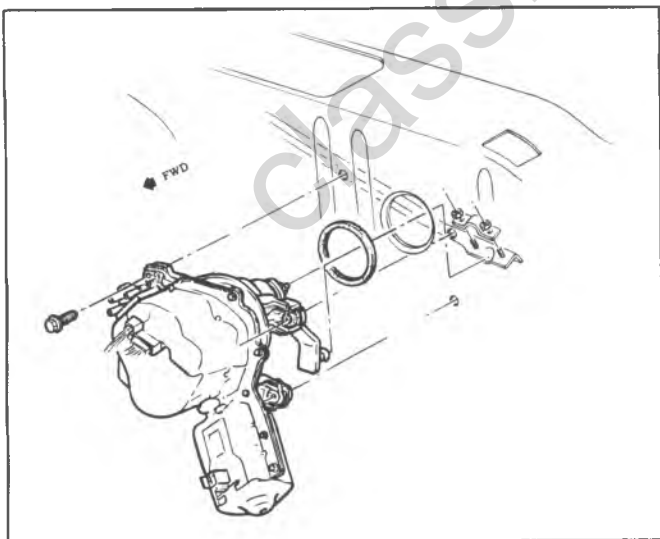


Fig. 8C-17--Wiper Motor (C-K Series)

8. Remove one screw securing left hand heater duct to engine cover shroud and slip heater duct down and out.

9. Protect carpet, then remove windshield washer hoses from washer pump.

10. Remove three screws securing wiper motor to cowl and lift wiper motor out from under dash for further disassembly on bench.

11. To install, reverse Steps 1-10 above.

NOTICE: Install wiper in the PARK position. Lube wiper motor crank arm pivot prior to installation.

UNIT REPAIR

WIPER MOTOR

Repairs to the motor/gear box section of the wiper are limited to the switch, armature, and cap and brush holder assy., plus the external parts such as the crank arm, spacer/seal (plastic) and output shaft seal.

PARK SWITCH

This is part of the washer pump relay coil assembly. Refer to figure 8C-19.

Removal

1. Disconnect wiring from wiper assembly and remove washer pump cover.
2. Remove pawl spring.
3. Push in retainer tab to release relay coil-park switch assembly from washer frame.
4. To re-assemble, reverse steps 1 thru 3 and check wiper operation, figure 8C-19.

ARMATURE ASSEMBLY END CAP-BRUSH HOLDER ASSEMBLY

Replacement

1. Bend retainer tabs as required to provide clearance for removing end cap assembly. Figure 8C-20.
2. To assist in pushing the end of the motor housing, rotate crank arm clock-wise (looking at crankarm).
3. Pull end cap assembly off the armature shaft and pull armature out of wiper housing.

Replace

1. Release brush spring tension figure 8C-21 and slide brushes back in their respective brush holders.
2. Assemble armature in end cap assembly and reposition brush spring legs behind their respective tabs, figure 8C-22.
3. To maintain the end cap in its assembled position on armature shaft during re-assembly of armature in the wiper housing proceed as follows: Using small wire such as tag wire, tie armature to end cap assembly as shown in figure 8C-23.
4. Guide armature worm shaft through the housing bearing.

The strong magnetic field will pull armature toward one of the magnets. It will be necessary to overcome the magnetic force to start shaft into the bearing.

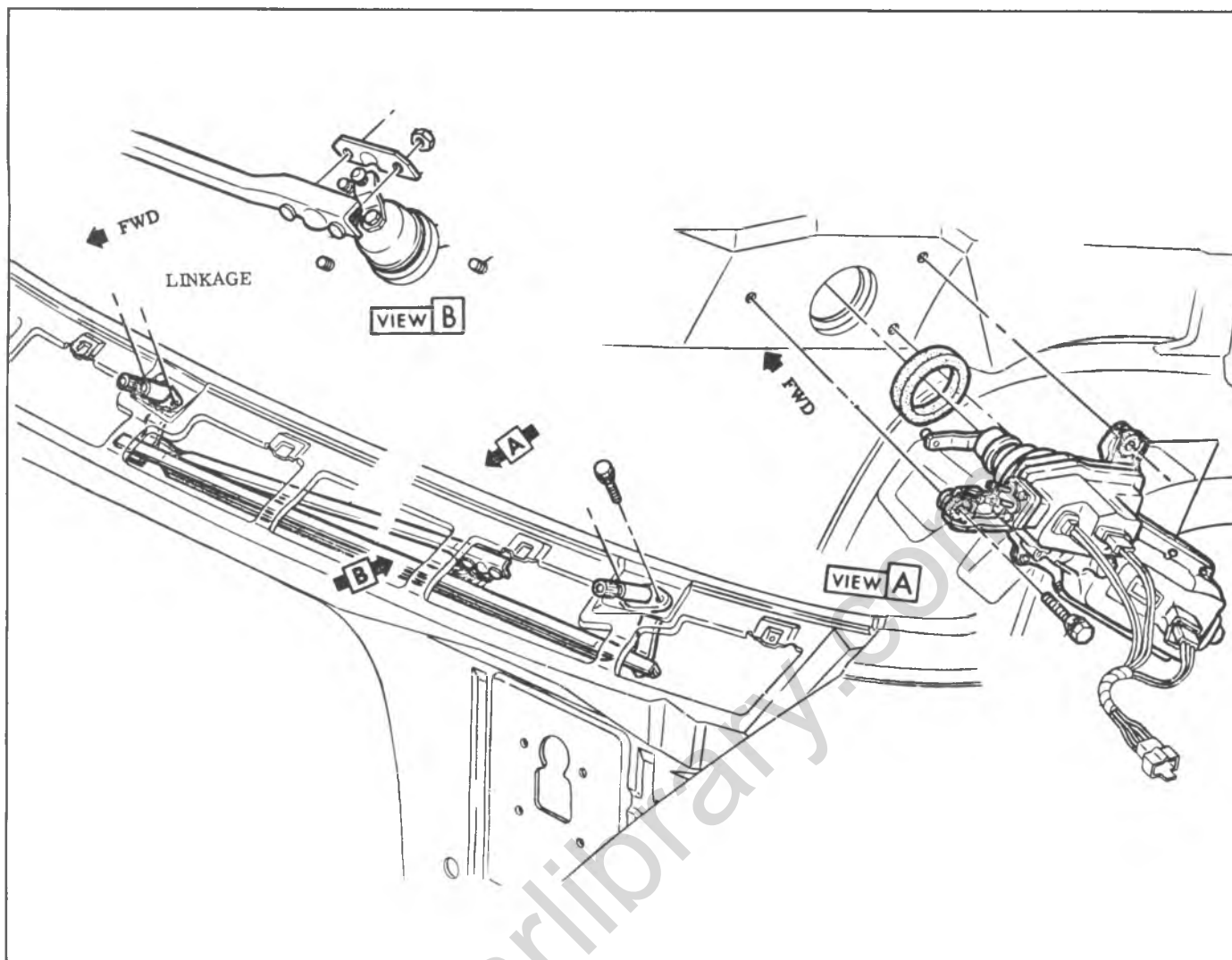


Fig. 8C-18--Wiper Motor (G Series)

5. Guide terminal housing of end cap into the slot area of the wiper housing.

6. Remove wire used to attach armature to end cap. This should be done before end cap enters the housing.

7. After wire is removed, rotate crank arm slightly to permit armature worm shaft to engage gear teeth. The end cap assembly can then be pushed into the housing until it bottoms against the end of the housing.

8. Bend the 4 tabs as required to secure the end cap in position figure 8-11.

9. Check wiper operation.

CRANK ARM, SPACER, SEAL Refer to Figure 8C-24

Replacement

1. Remove crank arm retaining nut, crank arm, shaft seal and spacer in the order indicated.

NOTICE: When re-assembling the shaft seal, be sure flat side is toward crank arm.

2. When re-assembling the crank arm, be sure wiper motor is in park (refer to figure 8C-25), and assemble crank

arm on shaft in position shown in Figure 8C-25.

WASHER PUMP

Relay Coil

This is part of park switch assembly. Refer to "Park switch" for disassembly-assembly procedure.

Ratchet Pawl

Refer to Figure 8C-26.

1. Disconnect pawl spring.
2. Remove "e" type retainer ring and slip pawl off of shaft.

Dog Spring: Refer to Figure 8C-26

1. Remove screw that attaches dog spring to washer frame.

Ratchet Gear: Refer to Figure 8C-26

1. Remove dog spring and ratchet pawl.
2. Move leg of retainer spring out of shaft groove and slide ratchet gear off shaft. Be careful not to lose retainer spring.
3. To re-assemble gear, reverse steps 1 and 2 but read note.

CONNECTIONS TO OPERATE WIPERS INDEPENDENTLY OF VEHICLE WIRING AND DASH SWITCH.

NO LOAD CURRENT DRAW @ 12V
 Lo Speed — 2.5 Amps Max
 HI Speed — 5.0 Amps Max
 Crank Arm Rotation — CCW
 (Looking at Arm)

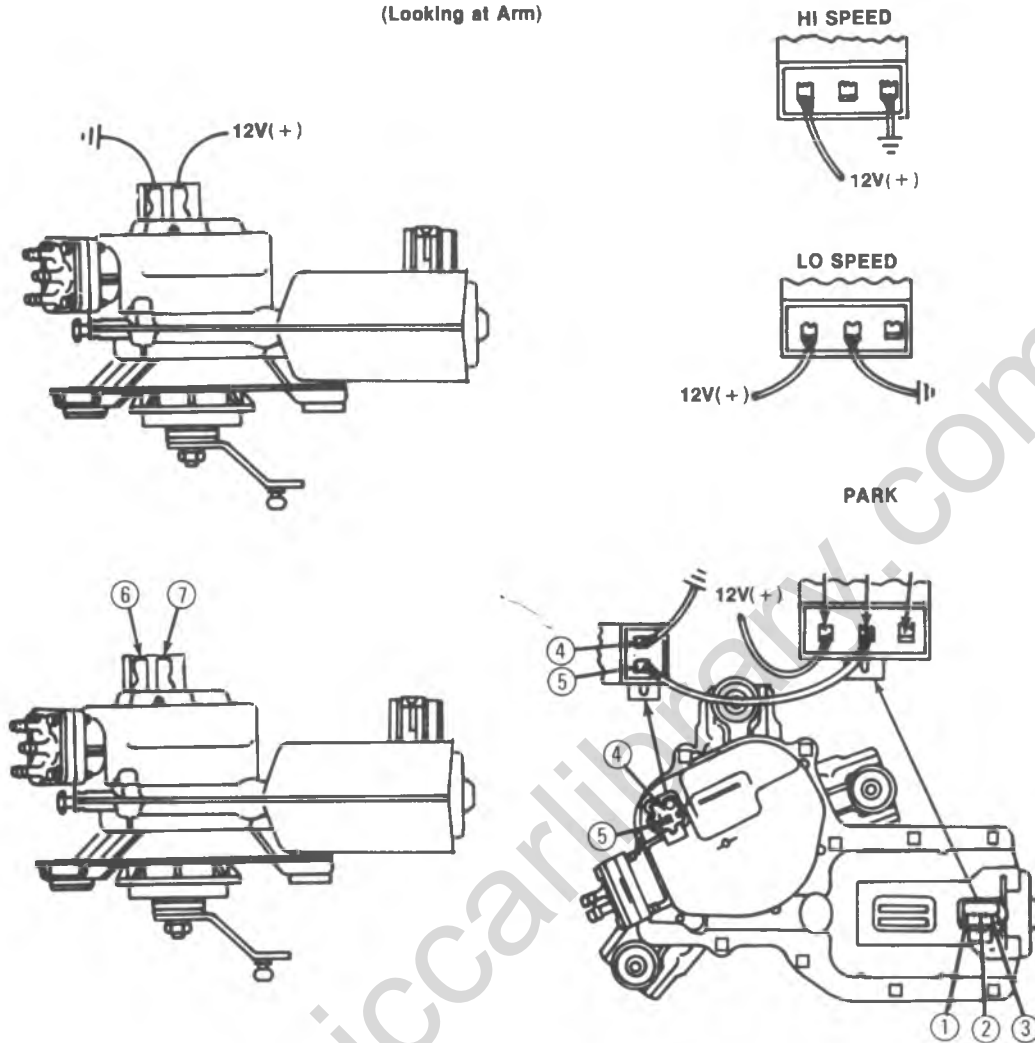


Fig. 8C-19--Checking Motor Operation

In order to push gear on shaft until it bottoms, move ratchet pawl shaft in a direction away from the gear. This will allow gear collar to slide past the tab on the piston actuator plate. (Refer to Figure 8C-12).

Piston and Housing Assy:

Refer to Figure 8C-27.

1. Remove ratchet pawl, dog spring and ratchet gear.
2. Pull piston housing away from frame until the mounting grooves clear the frame. During this step the piston spring is being compressed.

3. Remove valve assembly as required.

4. To re-assemble, reverse steps 1 thru 3.

Valve Assembly: Refer to Figure 8C-26.

1. Remove the four (4) attaching screws and remove valve assembly and gasket ring.
2. During re-assembly, be sure seal is properly installed in piston housing and valve assembly grooves.

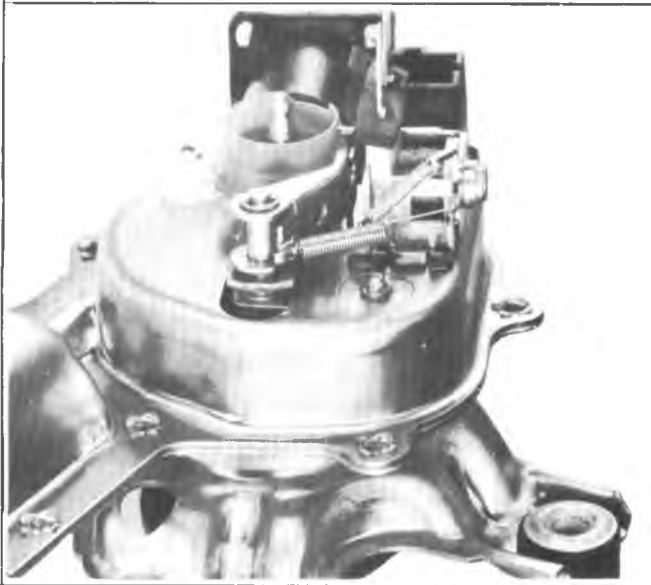


Fig. 8C-20--Relay Coil Assembly

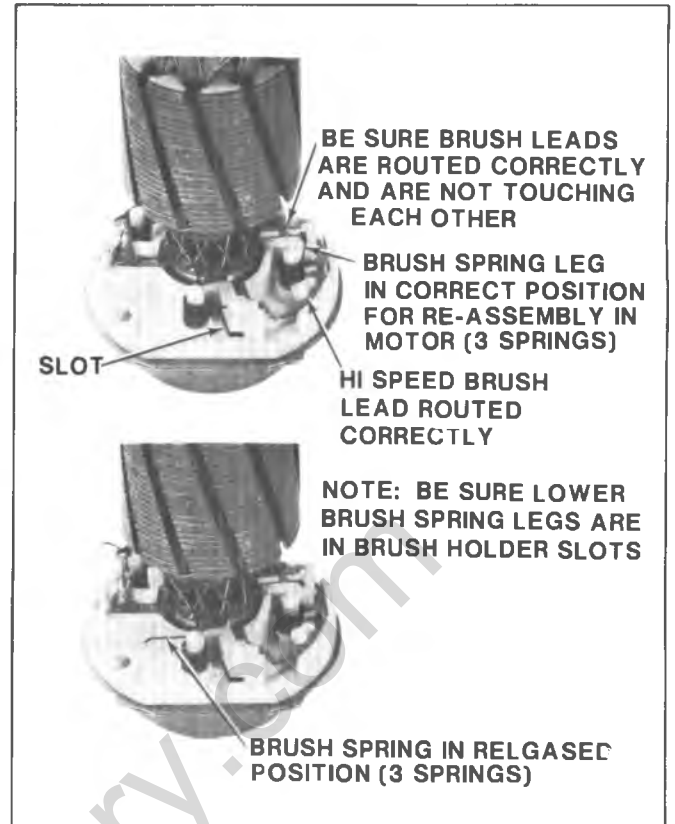


Fig. 8C-22--Brush Spring--Brush Spring-Released Position

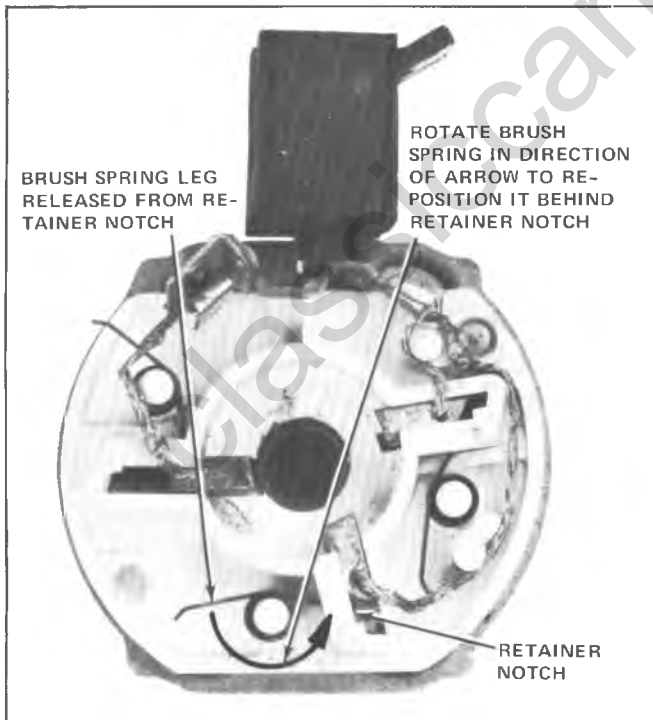


Fig. 8C-21--Releasing Brush Spring Tension

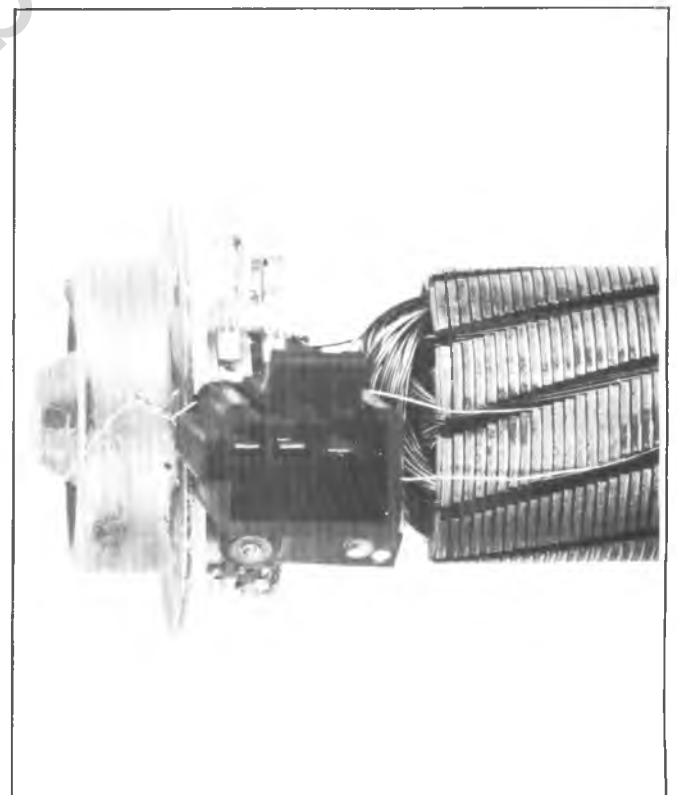


Fig. 8C-23--End Cap Assembly

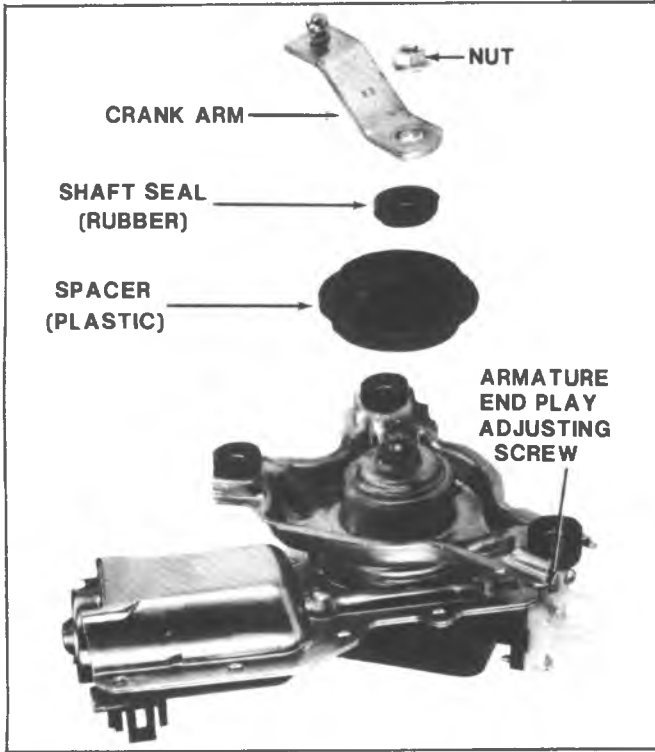


Fig. 8C-24-Crank Arm Spacer Seal

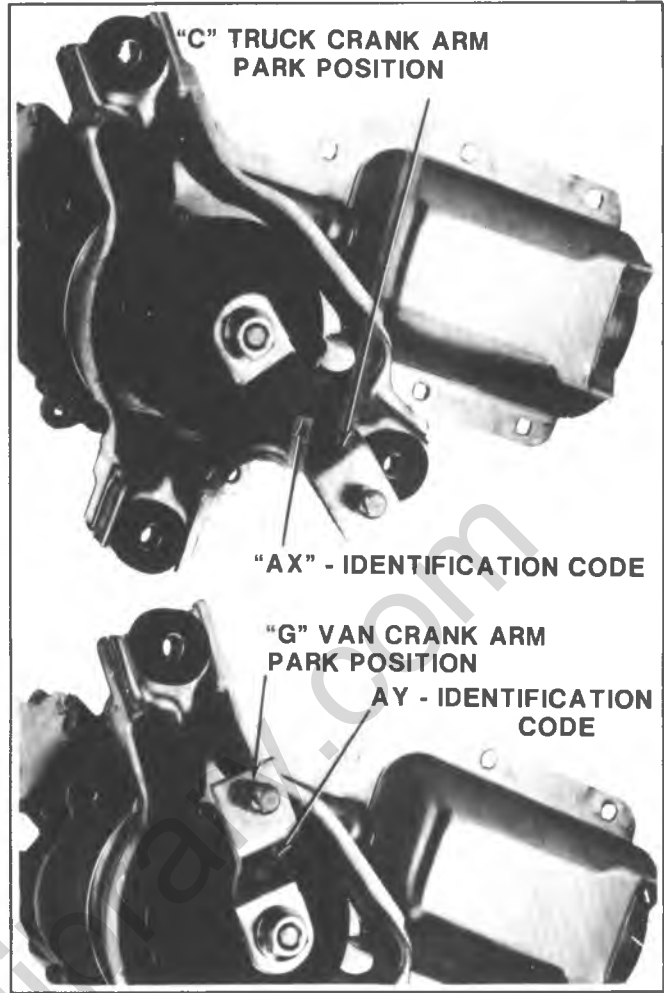


Fig. 8C-25-Crank Arm Park Position

classiccarlibrary.com

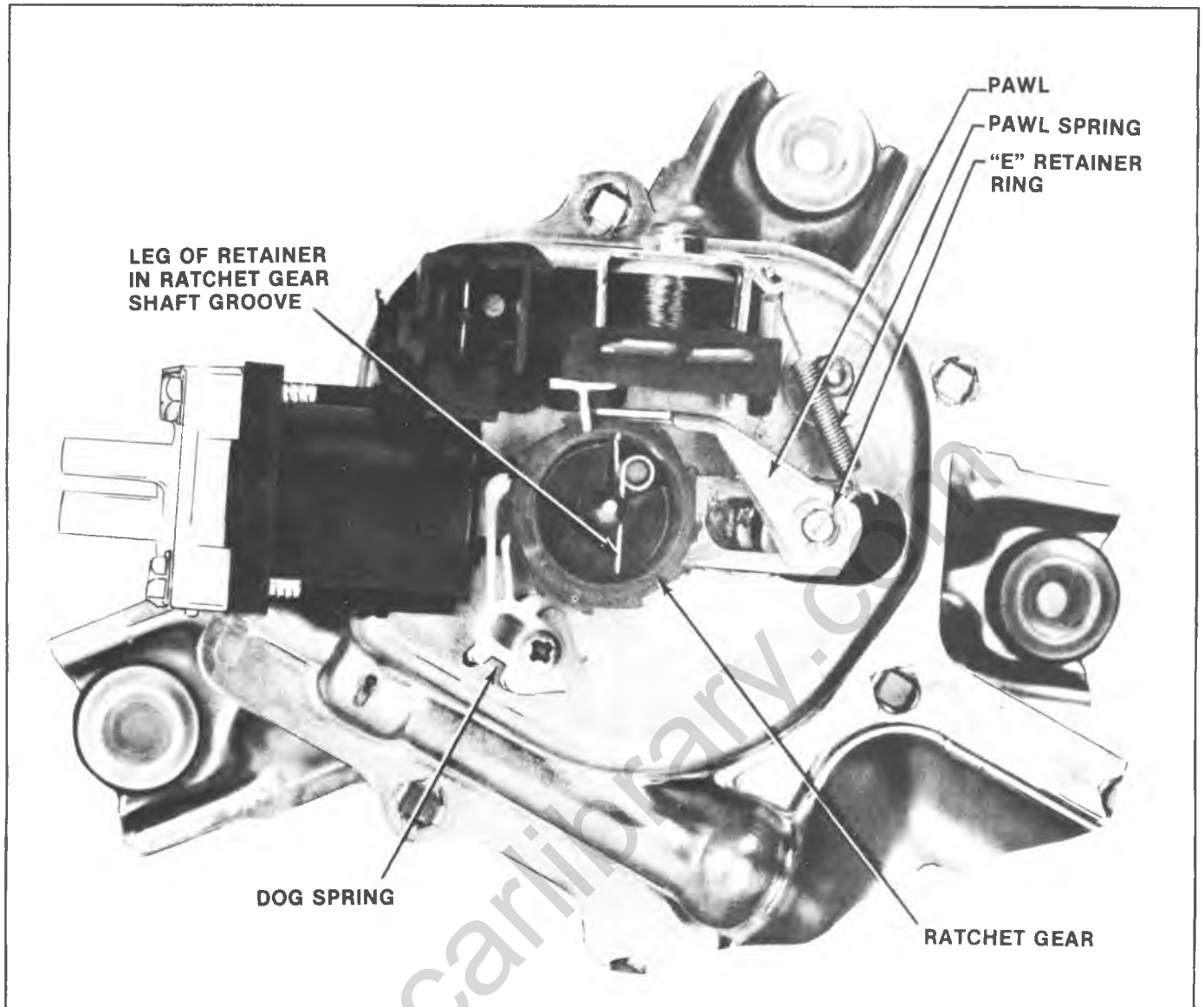


Fig. 8C-26-Washer Pump Assembly

ClassicCarLibrary.com

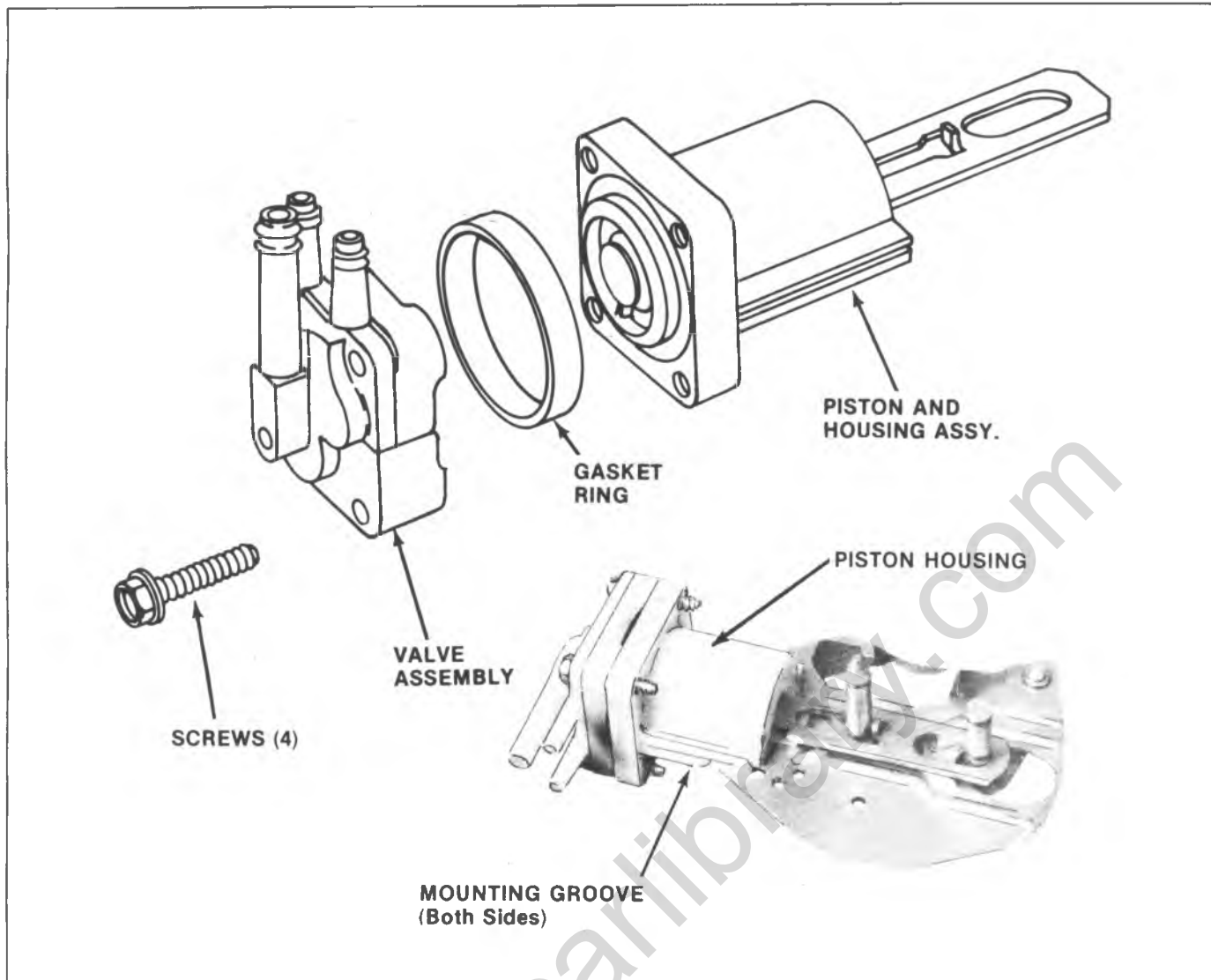


Fig. 8C-27-Washer Pump Exploded View

WINDSHIELD WIPER AND WASHER P MODELS GENERAL DESCRIPTION

The system consists of a compound wound rectangular-shaped motor attached to a gear box containing a parking switch in addition to the gear train. The gear train consists of a motor armature helical gearshaft which drives an intermediate gear and pinion assembly. The pinion gear of the intermediate gear and pinion drives an output gear and shaft assembly.

Turning the wiper switch to the LO speed position completes the circuits from the wiper terminals 1 and 3 to ground. Current then flows from the battery via wiper terminal No. 2 through the series field and divides; (1) part passes through the armature to ground via wiper terminal

No. 1 to the wiper switch and (2) the second part passes through the shunt field to ground through wiper terminal No. 3 to the wiper switch (fig. 8C-28).

NOTICE: The wiper switch must be securely grounded to body metal.

Moving the wiper switch to the HI speed position opens the shunt field circuit to ground at the switch. However, the shunt field is connected to a 20 ohm resistor which is connected across wiper terminals 1 and 3. The shunt field current then flows via terminal No. 3 through the resistor

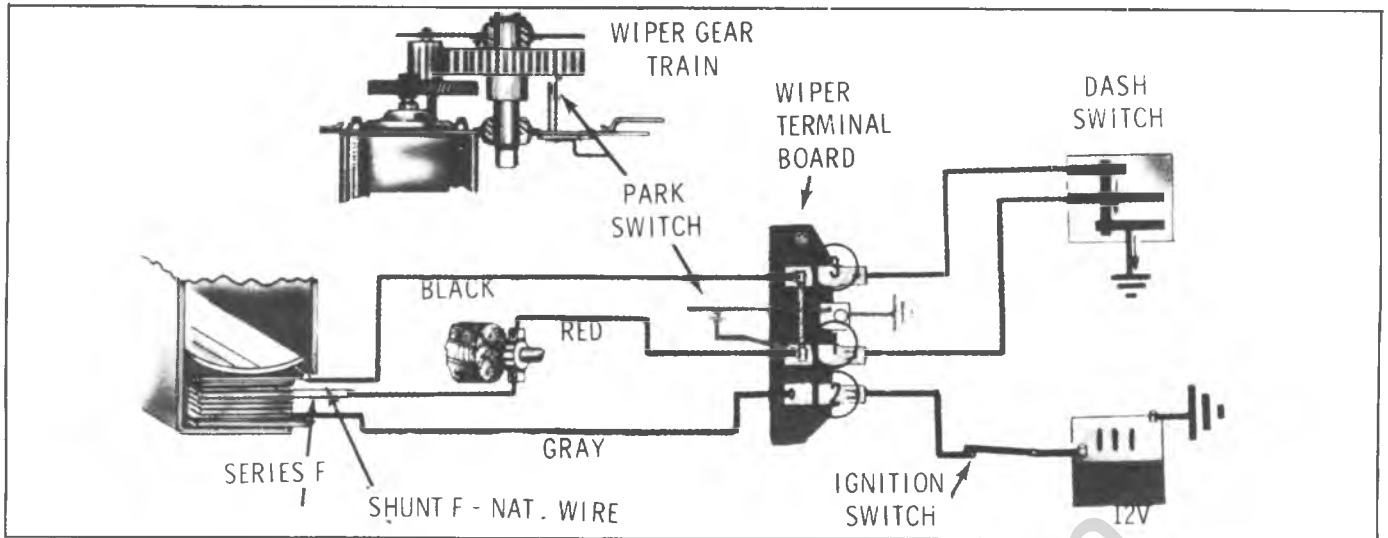


Fig. 8C-28--LO Speed Circuit

to terminal No. 1 to the switch, to ground (fig. 8C-29).

The parking circuit covers that portion of wiper operation when the wiper switch is turned "off" and the wiper blades have not reached the park position.

When the wiper blades are not in the normal park position, the parking switch contacts are still closed. The wiper will continue to operate until the wiper output gear is turned to a position where its cam opens the park switch. Referring to Figure 8C-30, it can be seen that the wiper motor circuits are completed to ground through the parking switch.

The wiper motor must be securely grounded to body metal.

The shunt field circuit is completed from terminal No. 3 via the switch to terminal No. 1 through the parking switch to ground. The series field and armature circuit is also completed from terminal No. 1 through the parking switch to ground.

The shunt field is connected direct to ground, bypassing the resistor. This results in LO speed operation during the parking operation.

When the output gear cam opens the park switch contacts, the wiper is OFF.

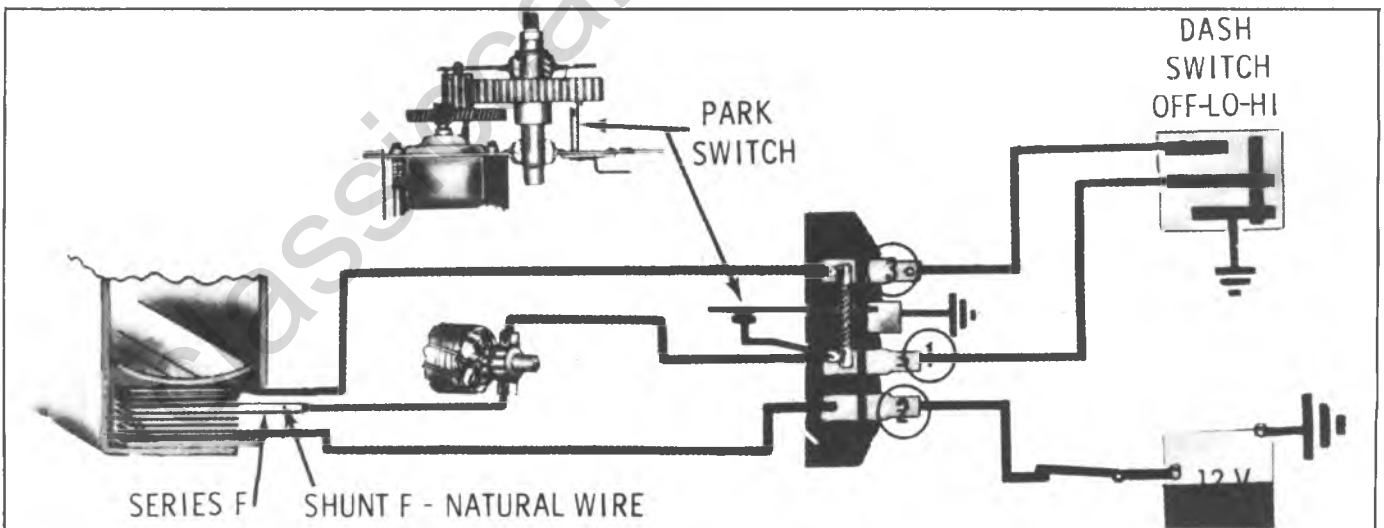


Fig. 8C-29--HI Speed Circuit

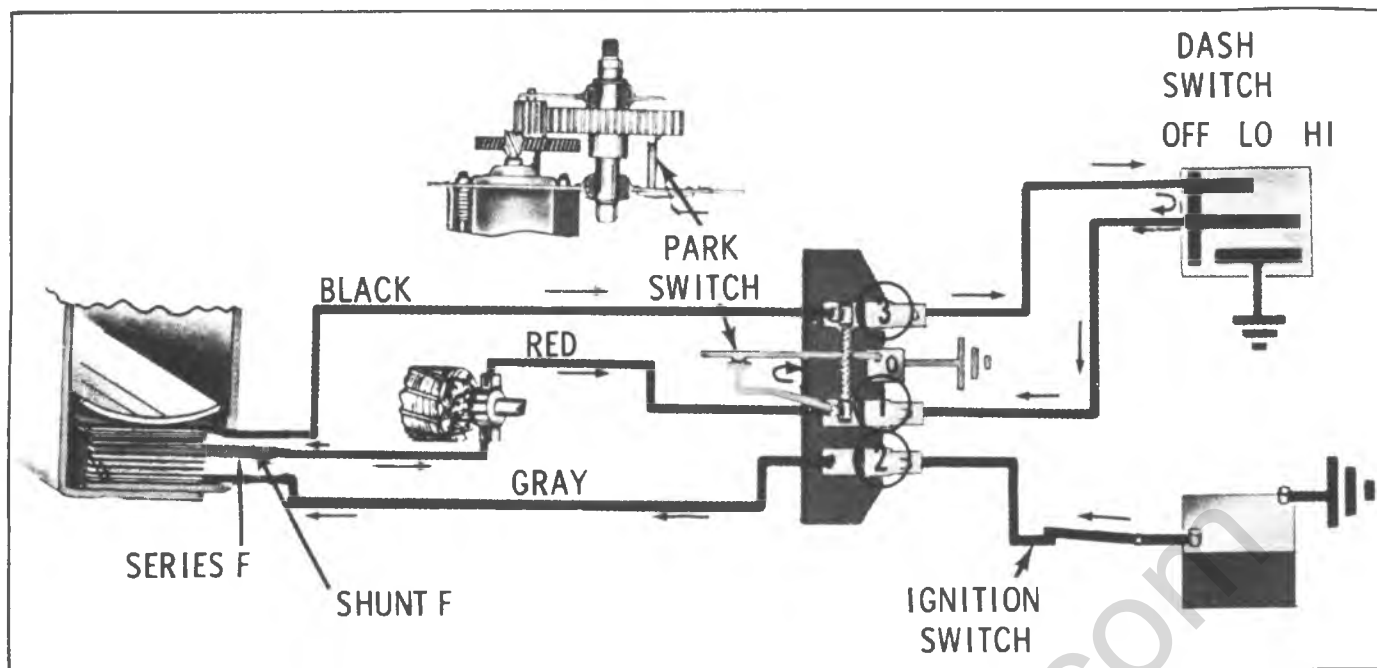


Fig. 8C-30--PARKING Circuit

DIAGNOSIS

WIPER - ON VEHICLE

1. Inspect for the following items:
 - a. Wiring harness is securely connected to wiper and switch.
 - b. Wiper motor is securely grounded to body.
 - c. Wiper switch is securely mounted and grounded.
 - d. Check fuse.
2. If items in Step 1 check out, try operating wiper in both "LO" and "HI" speeds, then turn wiper off (blades should return to park position). If wiper fails to operate correctly, proceed to Step 3.
3. Disconnect wiring harness from wiper and try operating wiper as shown in Figure 8C-31.
 - a. If wiper operates correctly independently of switch and vehicle wiring, refer to the DIAGNOSIS CHART - WIPER ON VEHICLE.
 - b. If wiper still fails to operate correctly in Step 3, disconnect wiper linkage from motor crankarm and try operating wiper again. If wiper operates correctly independently of linkage, check linkage for cause of wiper malfunction.
 - c. If wiper fails to operate correctly independently of linkage, remove wiper motor from vehicle and refer to DIAGNOSIS CHART-WIPER OFF VEHICLE.

DIAGNOSIS - WIPER ON VEHICLE

NOTE: Ignition switch must be "on" for all electrical tests.

| CONDITION | APPARENT CAUSE | CORRECTION |
|--|--|---|
| 1. Wiper Inoperative or intermittent | <p>A. Blown fuse</p> <p>B. Open circuit in feed wire (No. 2 terminal on wiper motor)</p> <p>C. Loose mounting of wiper switch</p> <p>D. Defective wiper switch</p> <p>E. Open circuit in wire to wiper switch (No. 1 terminal on wiper motor)</p> | <p>A. Locate short circuit and repair. Replace fuse.</p> <p>B. Locate broken wire and repair</p> <p>C. Tighten switch mounting</p> <p>D. Replace switch</p> <p>E. Locate broken wire and repair</p> |
| <p>2. Wiper will not shut off:</p> <p>A. Wiper has both "Lo" and "Hi" speeds</p> <p>B. Wiper has "Lo" speed only</p> <p>C. Wiper has "Hi" speed only</p> | <p>A. Grounded Wire (No. 1 terminal on wiper motor) to wiper switch</p> <p>A. Defective wiper switch</p> <p>B. Grounded wire (No. 3 terminal on wiper motor) to wiper switch</p> <p>A. Defective wiper switch</p> <p>B. Open circuit in wire (No. 3 terminal on wiper motor) to wiper switch</p> | <p>A. Locate short circuit and repair</p> <p>A. Replace wiper switch</p> <p>B. Locate and repair short circuit</p> <p>A. Replace wiper switch</p> <p>B. Locate and repair broken wire</p> |
| 3. Wiper has "Hi" speed only | A. Open circuit in wire (No. 3 terminal on wiper motor) to wiper switch | A. Locate broken wire and repair |
| 4. Wiper has "Lo" speed only | <p>A. Grounded wire (No. 3 terminal on wiper motor) to wiper switch</p> <p>B. Defective wiper switch</p> | <p>A. Locate short circuit and repair</p> <p>B. Replace wiper switch</p> |
| 5. Blades do not return to full park position | A. Loose wiper ground strap connection | A. Tighten strap connection |

DIAGNOSIS - WIPER OFF VEHICLE

| CONDITION | APPARENT CAUSE | CORRECTION |
|---|--|--|
| 1. Wiper Inoperative or Intermittent | <p>A. Broken or damaged gear train (only if inoperative)</p> <p>B. Poor solder connections at terminal board</p> <p>C. Loose splice joints at brush plate</p> <p>D. Brushes binding in brush holder</p> <p>E. Open circuit in armature</p> | <p>A. Replace gears as required</p> <p>B. Resolder wires at terminals</p> <p>C. Recrimp or solder splice joints</p> <p>D. Clean holder or replace brush, spring or brush plate assembly.</p> <p>E. Replace armature</p> |
| <p>2. Wiper will not shut-off:</p> <p>A. Wiper has normal "Hi" and "Lo" speed</p> <p>B. Wiper has "Lo" speed only</p> <p>C. Wiper has "Hi" speed only</p> | <p>A. Defective park switch</p> <p>B. Grounded red lead wire</p> <p>A. Grounded shunt field coil</p> <p>B. Grounded black wire</p> <p>A. Open circuit in shunt field coil</p> <p>B. Open circuit in black wire</p> | <p>A. Replace terminal board assembly</p> <p>B. Repair short circuit in red wire</p> <p>A. Replace frame and field assembly</p> <p>B. Repair short circuit in black wire</p> <p>A. Replace frame and field assembly</p> <p>B. Repair broken wire or poor solder connection</p> |
| 3. Wiper shuts off - but not in park position | A. Park switch defective or contacts dirty | A. Replace terminal board assembly or clean contacts |
| 4. "Hi" speed too fast | A. Resistor defective | A. Replace terminal board assembly |

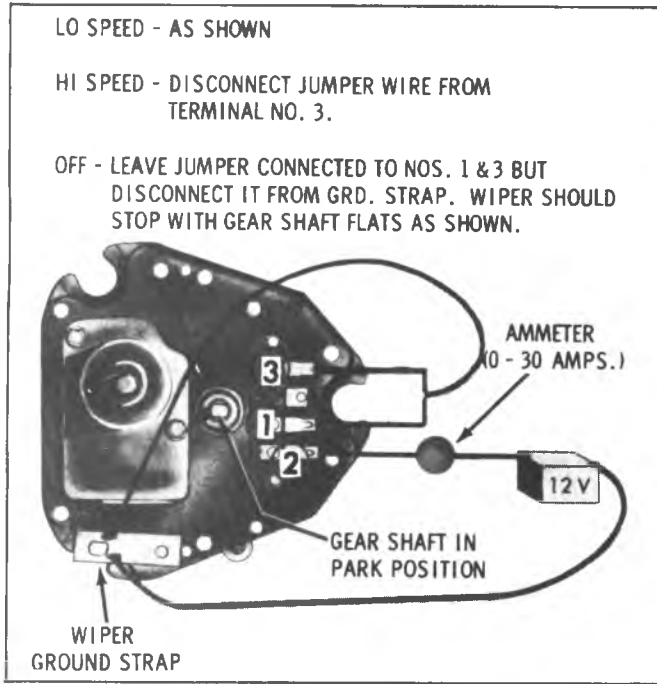


Fig. 8C-31--Jumper Wire Connections

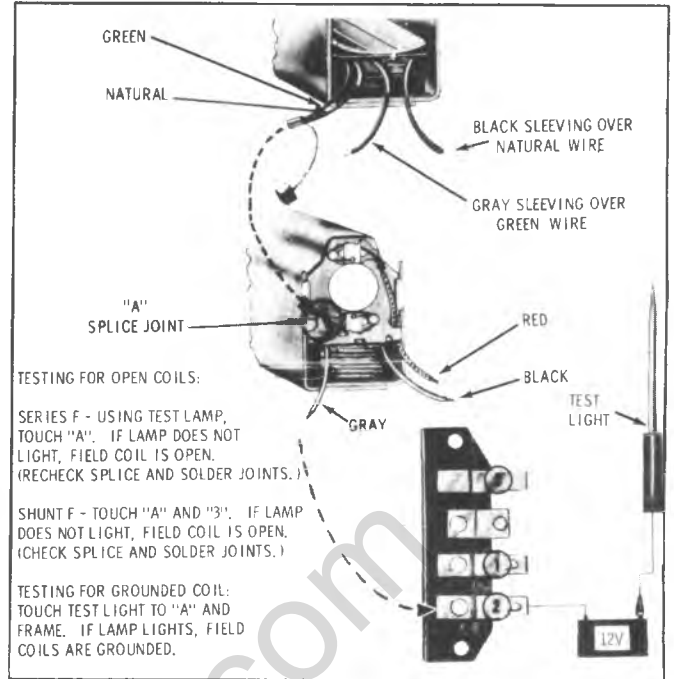


Fig. 8C-33--Testing Field Coils

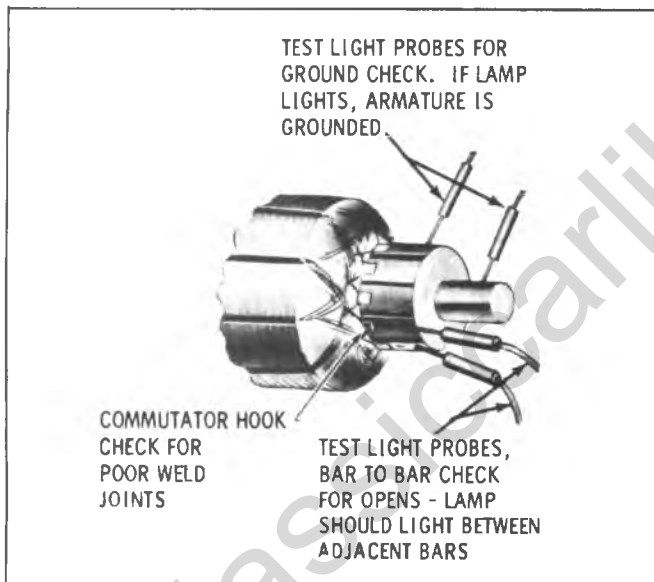


Fig. 8C-32--Checking Armature

DIAGNOSIS - WASHER SYSTEM

| CONDITION | APPARENT CAUSE | CORRECTION |
|--|---|--|
| 1. Washers inoperative | <p>A. Inadequate quantity of washer solution</p> <p>B. Hoses damaged or loose</p> <p>C. Plugged screen at end of jar cover hose</p> <p>D. Loose electrical connection to washer pump or wiper switch</p> <p>E. Open circuit in feed wire to ratchet relay coil</p> <p>F. Wiper switch defective</p> <p>G. Ratchet relay coil defective</p> <p>H. Washer nozzles plugged</p> <p>I. Ratchet wheel tooth missing</p> <p>J. Ratchet pawl spring missing</p> <p>K. Defective pump valve assembly</p> | <p>A. Add washer solution</p> <p>B. Cut short length off end of hose to insure air tight connection or replace hose</p> <p>C. Clean screen</p> <p>D. Check electrical connections and repair if necessary</p> <p>E. Locate open circuit and repair</p> <p>F. Replace wiper switch</p> <p>G. Replace ratchet relay</p> <p>H. Clean washer nozzles</p> <p>I. Replace ratchet wheel</p> <p>J. Replace ratchet pawl spring</p> <p>K. Replace pump valve assembly</p> |
| 2. Washer pumps continuously when wipers are operating | <p>A. Grounded wire from ratchet relay to switch</p> <p>B. Wiper switch defective</p> <p>C. Ratchet wheel tooth missing</p> <p>D. Ratchet wheel dog broken or not contacting ratchet wheel teeth</p> <p>E. Lock-out tang broken or bent on piston actuating plate</p> | <p>A. Locate grounded wire and repair</p> <p>B. Replace wiper switch</p> <p>C. Replace ratchet wheel</p> <p>D. Replace or repair ratchet wheel dog</p> <p>E. Replace piston actuating plate</p> |

ON-VEHICLE SERVICE

WIPER MOTOR

Wiper motor replacement procedures are not included here since installation is performed by the individual body manufacturers; however, disassembly of the unit will be covered.

UNIT REPAIR

WIPER MOTOR

Disassembly (Fig. 8C-34)

Gear Box

1. Remove the two washer pump mounting screws and lift pump off washer.
2. Remove washer pump drive cam as required (figs. 8C-33 and 8C-34). The cam is pressed on the shaft but can be wedged off by using two screwdrivers between cam and plate.
3. Clamp crank arm in a vise and remove crank arm retaining nut.

NOTICE: Failure to clamp crank arm may result in stripping of wiper gears.

4. Remove crank arm, seal cap, retaining ring, and end-play washers.

Seal cap should be cleaned and repacked with a waterproof grease before reassembly.

5. Drill out gear box cover retaining rivets, remove cover from gear train.

Screws, nuts and lockwashers for reassembling cover to wiper are contained in the service repair package.

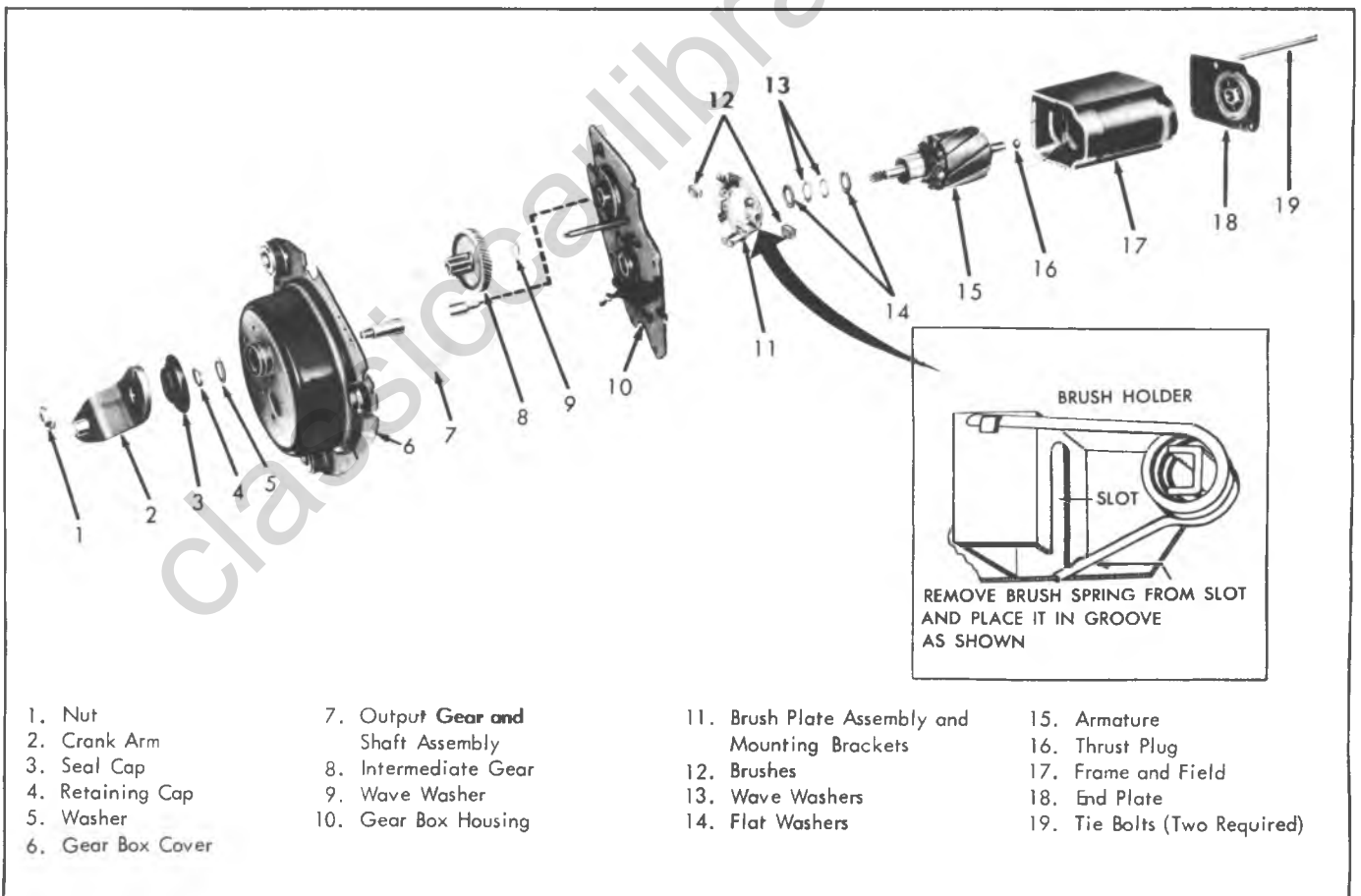


Fig. 8C-34--Wiper Motor and Gear Box Assembly

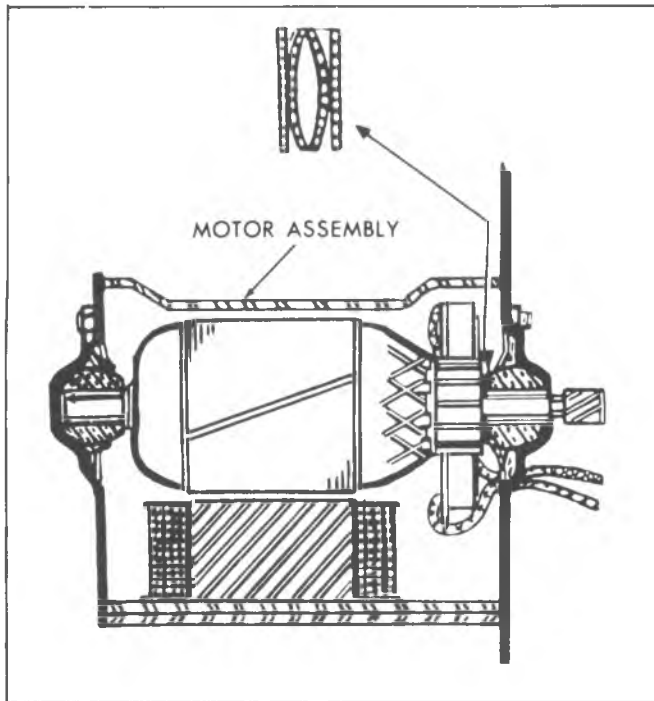


Fig. 8C-35--End Play Wave Washer Installation

6. Remove output gear and shaft assembly, then slide intermediate gear and pinion assembly off shaft.

7. If necessary, remove terminal board and park switch assembly as follows:

a. Unsolder motor leads from terminals. Code motor leads.

b. Drill out rivets securing terminal board and park switch ground strap to mounting plate. Screws, nuts and washers for attaching a replacement terminal board park switch assembly are included with the replacement assembly.

Motor

1. Follow Steps 1 through 7b under gear box disassembly.

2. Remove motor through bolts, tap motor frame lightly, and remove motor from mounting plate.

3. Remove brush spring tension (fig. 8C-34), slide armature and end plate from motor frame. Pull end plate from armature.

NOTICE: Thrust plug located between armature shaft and end plate.

4. Remove end play adjusting washers from armature, noting arrangement for proper reinstallation.

Inspection

Check and inspect all parts for wear; replace as necessary. All parts can be replaced individually except motor frame and field, which is serviced as an assembly. Service kits also provide screws, nuts and washers to replace gear cover and terminal board rivets.

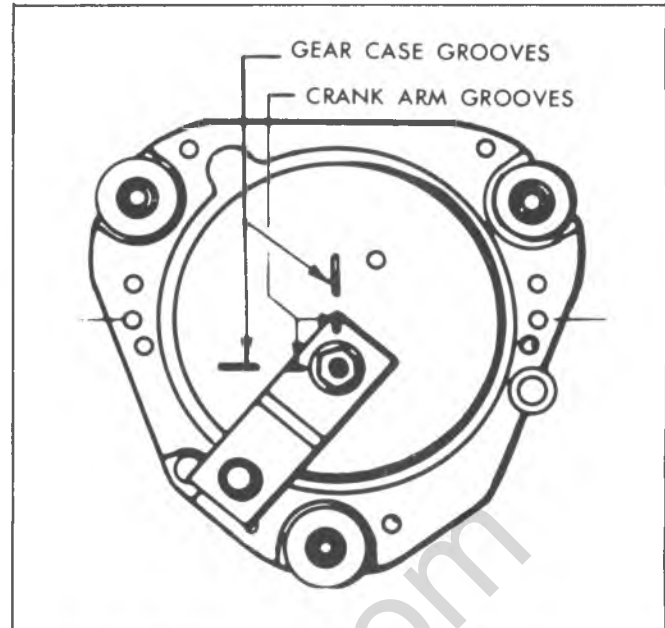


Fig. 8C-36--Wiper Motor Crank Arm in Park Position

Assembly

Refer to Figure 8C-34 for exploded view of motor and gear train.

Motor

Reassemble motor using reverse of disassembly procedure.

NOTICE: Armature end play is controlled by end play washers. See Figure 8C-35 for proper assembly of end play washers. Lubricate armature shaft bushings with light machine oil.

Gear Box

1. Assemble gear box using reverse of disassembly procedure.

Lubricate gear teeth with Delco Cam and Ball Bearing lubricant (or equivalent). Be sure cover is properly located over dowel pins and be sure to reinstall ground strap.

2. Place wiper in park position and install crank arm on output shaft, rotate crank so alignment marks line up with those on cover (fig. 8C-36).

3. Replace retaining nut, place crank arm in vise, tighten retaining nut.

WINDSHIELD WASHER

The positive displacement washer pump used on the two-speed non-depressed park wipers (fig. 8C-37) use a pump mechanism consisting of a piston, piston spring and valve arrangement driven by a (4) lobe cam, and follower assembly (fig. 8C-39). The cam is attached to one shaft of the wiper motor output gear (fig. 8-49). Programming is accomplished electrically and mechanically by a relay assembly and ratchet wheel arrangement.

Replacement

1. Disconnect battery ground cable.
2. Remove two pump mounting bolts.



Fig. 8C-37--Washer Pump Attaching Screws



Fig. 8C-39--Washer Pump Drive Cam and Actuator

3. Remove washer pump assembly.
4. To install reverse Steps 1-3 above.

NOTICE: Install washer multiplug harness connector with battery lead on terminal with no tang (fig. 8C-37). Incorrect installation of connector will result in direct ground and destroy wiper motor fuse.

Disassembly-Assembly (Figures 8C-40 thru 8C-43)

1. Remove washer pump cover by squeezing.
2. Solenoid assembly - ratchet dog.
 - a. Remove ratchet dog retaining screw. Hold spring loaded solenoid plunger in position and carefully lift solenoid assembly and ratchet dog off frame of pump.
 - b. Separate ratchet dog from solenoid mounting plate as required.
3. Ratchet pawl.
 - a. Disconnect ratchet pawl spring.
 - b. Remove ratchet pawl retaining ring and slide ratchet pawl off cam follower shaft.
4. Ratchet wheel.



Fig. 8C-38--Washer Pump Drive Cam

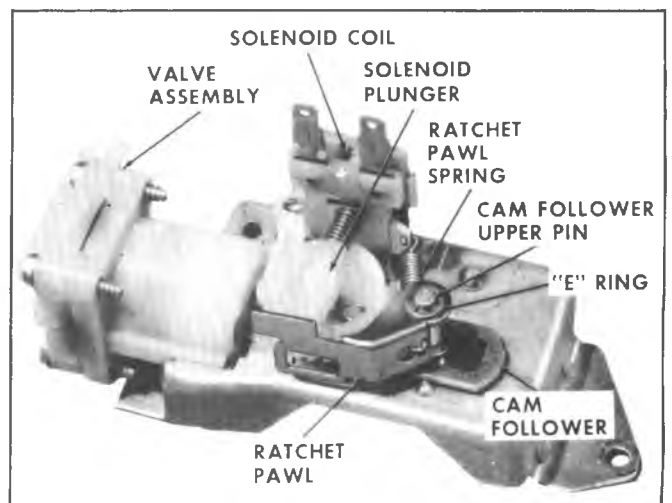


Fig. 8C-40--Washer Pump Mechanism

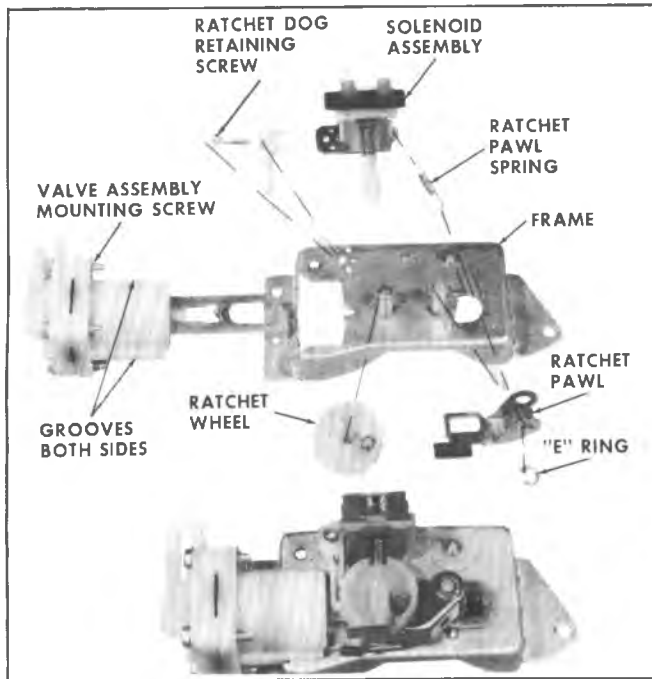


Fig. 8C-41--Washer Pump-Exploded View

a. Follow Step 1 under solenoid - ratchet dog disassembly.

b. Move ratchet wheel spring out of shaft groove and slide ratchet wheel off its shaft.

5. Pump and actuator plate assembly.

a. Remove solenoid assembly - ratchet pawl and ratchet wheel as outlined in their respective procedures.

b. To separate pump and pump actuator plate from frame, pull pump housing in direction of the arrow until grooves in housing clear the frame. Then remove actuator plate from ratchet wheel and cam follower shafts.

6. Valve assembly.

a. Remove four screws that attach the valve assembly to pump housing.

During assembly, be sure gasket between housing and valve plate is properly positioned in housing and valve plate grooves. Also be sure triple "O" ring is properly installed between valve body and pipe assembly.

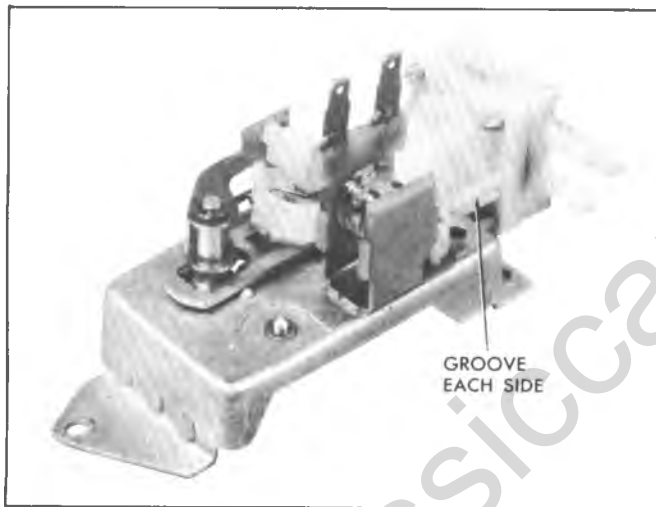


Fig. 8C-42--Releasing Pump From Lockout Position

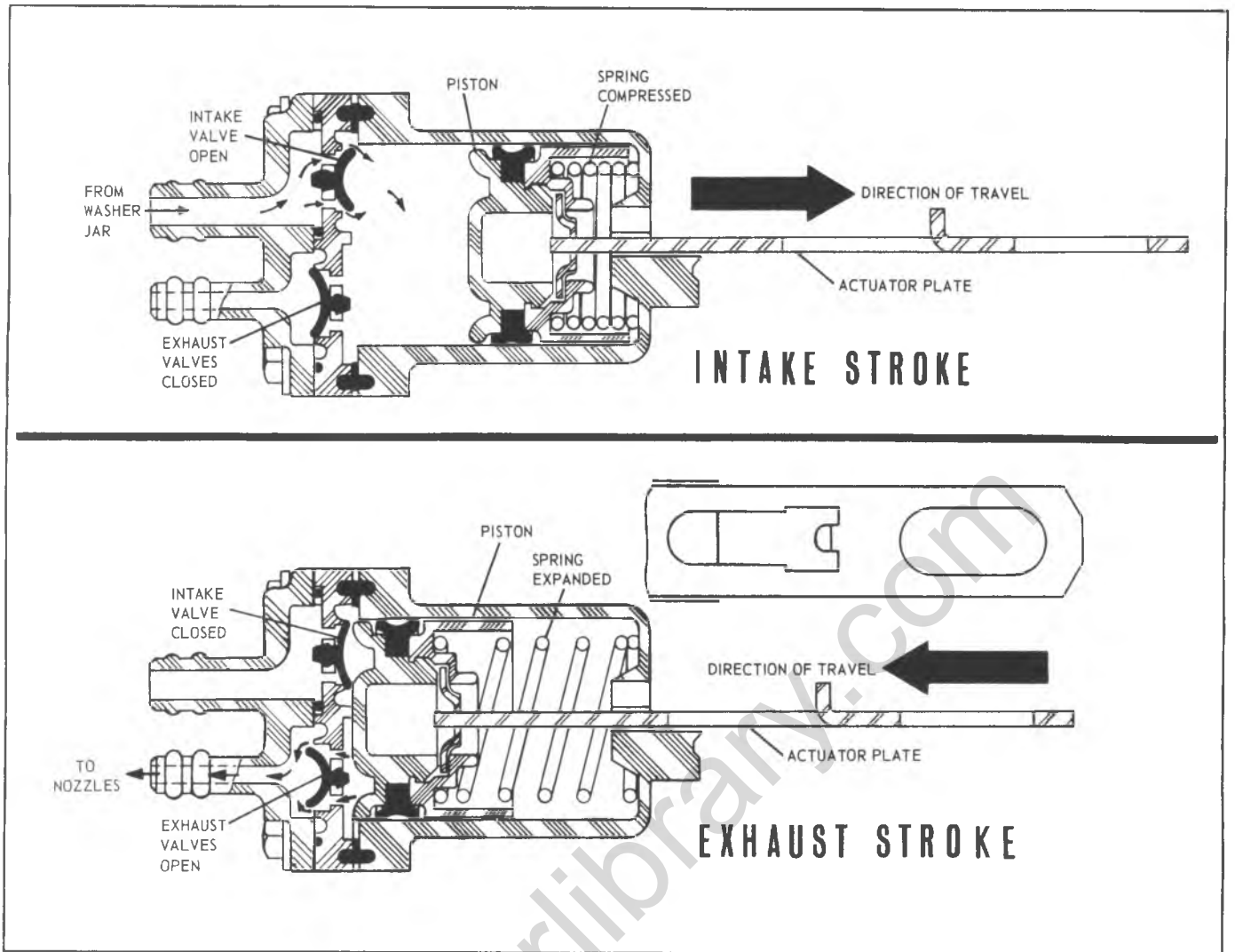


Fig. 8C-43--Cross Section of Windshield Washer Pump Valve

classiccarlibrary.com

classiccarylbrary.com

SECTION 9

ACCESSORIES

CONTENTS

| | | | |
|---------------------------------------|------|-------------------------------------|------|
| Cruise Master..... | 9-1 | Radio..... | 9-11 |
| General Description..... | 9-1 | General Description..... | 9-11 |
| Diagnosis..... | 9-3 | Diagnosis..... | 9-11 |
| Electrical System..... | 9-3 | Cassette Tape Player..... | 9-11 |
| Power Unit and Vacuum System..... | 9-3 | Eight-Track Stereo Tape Player..... | 9-11 |
| On-Vehicle Service..... | 9-7 | Static and Noise..... | 9-13 |
| Maintenance and Adjustments..... | 9-7 | Popping Noise..... | 9-13 |
| Transducer..... | 9-7 | Testing Windshield Antenna..... | 9-13 |
| Power Unit..... | 9-7 | On-Car Service..... | 9-24 |
| Brake Release Switches..... | 9-7 | Maintenance and Adjustments..... | 9-24 |
| Column Mounted Engagement Switch..... | 9-7 | Tape Player..... | 9-24 |
| Component Part Replacement..... | 9-7 | Trimming Radio..... | 9-24 |
| Transducer..... | 9-7 | Component Part Replacement..... | 9-24 |
| Power Unit..... | 9-7 | Radio..... | 9-24 |
| Column Mounted Engagement Switch..... | 9-7 | Speaker..... | 9-24 |
| Specifications..... | 9-10 | Antenna..... | 9-24 |

CRUISE MASTER

GENERAL DESCRIPTION

The Cruise Master is a speed control system which employs engine manifold vacuum to control the throttle power unit. The power unit moves the throttle, when speed adjustment is necessary, by receiving a varying amount of controlled vacuum from the transducer. The speedometer cable (from the transmission) drives the transducer, and a cable (from the transducer) drives the instrument panel speedometer. The engagement of the transducer is controlled by an engagement switch located at the end of the turn signal lever. Two brake release switches are provided: an electric switch disengages the transducer and a vacuum valve decreases the vacuum in the power unit to quickly return the throttle to idle position.

The purpose of the Cruise Master system is to allow the driver to maintain a constant highway speed without the necessity of continually applying foot pressure to the accelerator pedal. Speed changes are easily made and override features allow the vehicle to be stopped, slowed or accelerated as desired.

Engaging the Cruise System

The driver accelerates to the desired cruise speed and partially depresses and releases the cruise control engagement switch button located at the end of the directional signal lever. The cruise system takes over speed control, and within engine limitation, maintains this speed regardless of changes in terrain.

The Engagement Switch button performs these functions:

1. Above 30 mph (50 km/h), when partially depressed and released, it engages the cruise system.
2. When depressed fully and held there, it disengages the system.
3. When released slowly from the fully depressed position, it will engage the system at the existing speed and cruise at that speed (above 30 mph or 50 km/h). See Fig. 9-1C "Engage Switch Operation".

Speed Changes

Override -The accelerator pedal may be depressed at any time to override the cruise system. Release of the accelerator pedal will return the vehicle to the previous cruise speed.

To Cruise At A Higher Speed -Depress the accelerator pedal to reach the new desired speed. Then, fully depress and slowly release the cruise control engagement switch button. The system re-engages at the higher speed when the button is slowly released.

To Cruise At A Lower Speed -Disengage the system by depressing the engagement switch button fully and holding it there until the vehicle has decelerated to the new desired speed; then release the button slowly. The system re-engages at the lower speed when the button is slowly released.

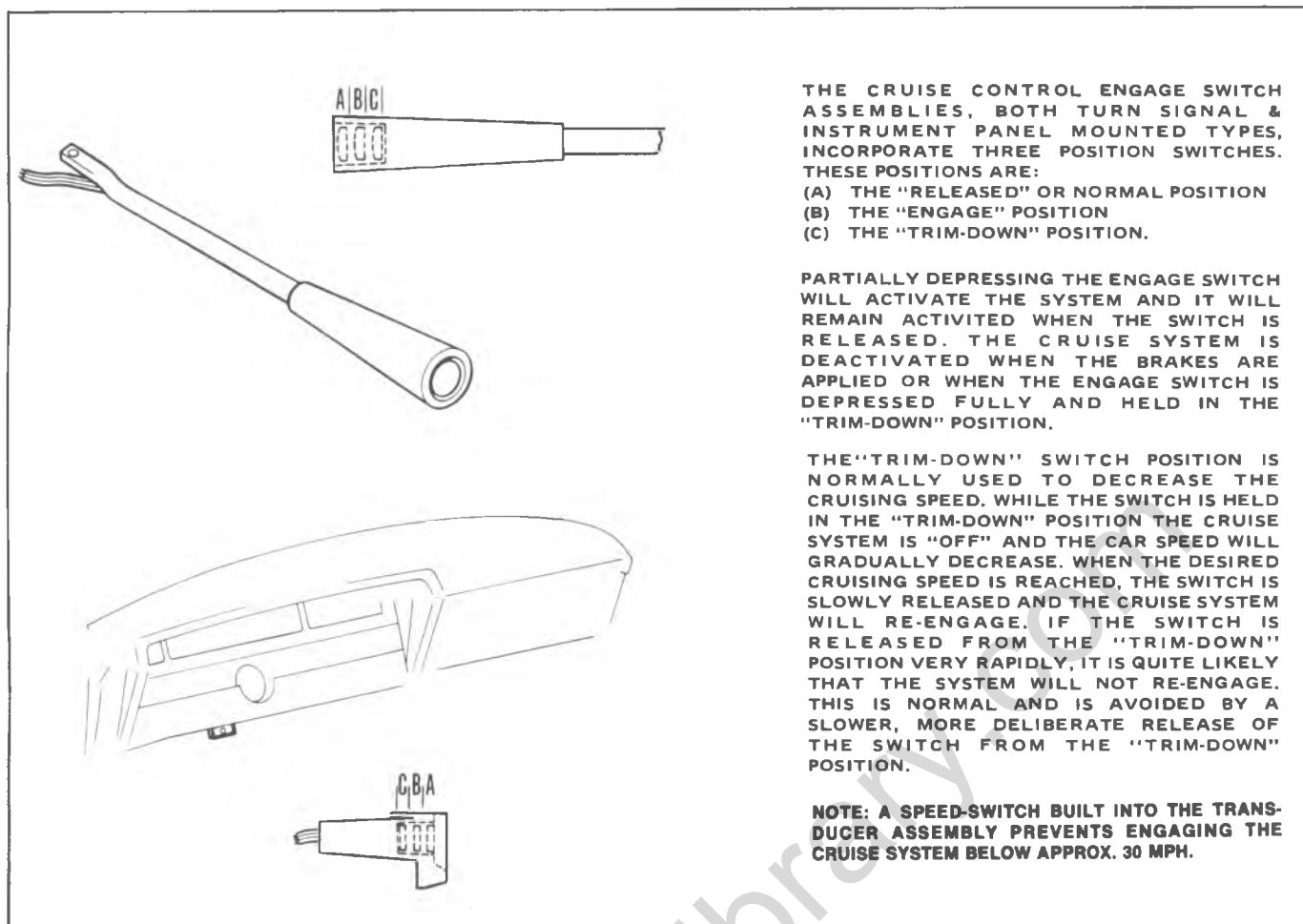


Fig. 9-1C--Cruise Master Engagement Switches

Cruise Master Units

1. The Engagement Switch, which is located at the end of the directional signal lever, is used to control the system and for upward and downward speed adjustments.

2. The Transducer (fig. 9-2C) is mounted in the speedometer cable line. It is a combination speed sensing device and control unit. When engaged, it senses vehicle speed and positions the Power Unit to maintain the selected speed.

3. The Power Unit is bracket mounted to the engine on all models. It opens or closes the throttle as dictated by the Transducer.

4. The Cruise Brake Release Switch, which is mounted on the brake pedal bracket, disengages the system electrically when the brake pedal is depressed.

5. The Cruise Brake Release Valve, which is mounted on the brake pedal bracket, disengages the system pneumatically when the brake pedal is depressed.

6. The Cable and Casing Assemblies drive the transducer and speedometer.

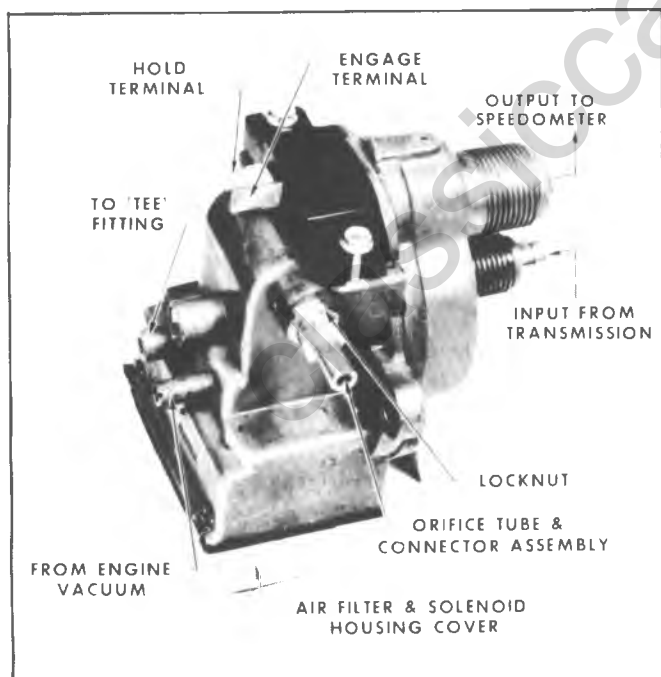


Fig. 9-2C--Typical Transducer

DIAGNOSIS

ELECTRICAL SYSTEM TROUBLESHOOTING

1. Check fuse and connector.
2. Check electric brake switch as follows:
 - a. Unplug connector at switch. (In some cases, the cruise control and automatic transmission clutch circuit share the same brake switch contacts).
 - b. Connect ohmmeter across cruise master contacts on brake switch. The ohmmeter must indicate no continuity when the pedal is depressed and continuity when pedal is released. The cruise release brake switch (electric) is adjusted as is the standard stop light brake switch.
 - c. Replace electric brake switch if needed.

Engagement Switch Test

Check engagement switch and connecting wiring as follows: Unplug engagement switch connector (brown, blue, black) at electrical wiring harness connector then perform the following tests (fig. 9-3C).

Test #1—Connect ohmmeter between terminal #1 (brown wire) and terminal #2 (blue wire). Continuity shall be maintained until switch is depressed all the way in.

Test #2—Connect ohmmeter between terminal #1 (brown wire) and terminal #3 (black wire). No continuity shall be shown; however, when the button is partially depressed, continuity shall be indicated. When the button is pressed all the way down, no continuity shall be shown.

Test #3—Connect ohmmeter between terminal #2 (blue wire) and terminal #3 (black wire). Button released, no continuity; however, when the button is depressed partially and fully, continuity shall be shown.

Harness Test (Fig. 9-3C)

1. Disconnect engage switch wire harness connector from the main harness connector (red, brown/white, and white wires).
2. Connect ohmmeter between point C (brown/white stripe wire in main wire harness) and ground. Make sure the Transducer is well grounded to the chassis. The ohmmeter should read between 42 and 49 ohms. If a resistance either above or below the value indicated is shown, then disconnect the connector from the Transducer and measure the resistance of the brown/white stripe wire

from point C to D. It should measure 40 ohms ± 2 ohms.

3. If a resistance either above or below the value indicated is shown, the main wiring harness should be replaced.

NOTICE: When disconnecting or reconnecting the main wiring harness connector from the Transducer, care should be exercised so as not to damage the blade connectors or the wiring harness. The disconnect may be facilitated by prying carefully on the plastic connector with a small screwdriver.

4. Measuring the solenoid coil circuit resistance between point E (Hold Terminal) and ground, the ideal resistance should be between 5 and 6 ohms. A reading of less than 4 ohms indicates shorting in the coil circuit. A reading of more than 7 ohms indicates excessive resistance in the coil circuit. Either extremity indicates replacement of the Transducer assembly. The main harness wiring from point F to G (white wire) should also be checked for continuity.

POWER UNIT AND VACUUM SYSTEM TEST

To determine the condition of the diaphragm, remove hose from the Power Unit and apply 14 inches of vacuum to the tube opening and hold in for one minute. The vacuum shall not leak down more than 5 inches of vacuum in one minute. If leakage is detected, replace the Power Unit. To utilize engine as a vacuum source, proceed as follows:

1. Disconnect Power Unit linkage at carburetor and vacuum hose from the Power Unit, then connect engine vacuum directly to the Power Unit fitting.
2. Note position of Power Unit diaphragm.
3. Start engine—the diaphragm should pull in.
4. Clamp off engine vacuum supply line and check for leakage.

The cruise release brake valve (vacuum) and connecting hoses can likewise be checked using a vacuum pump.

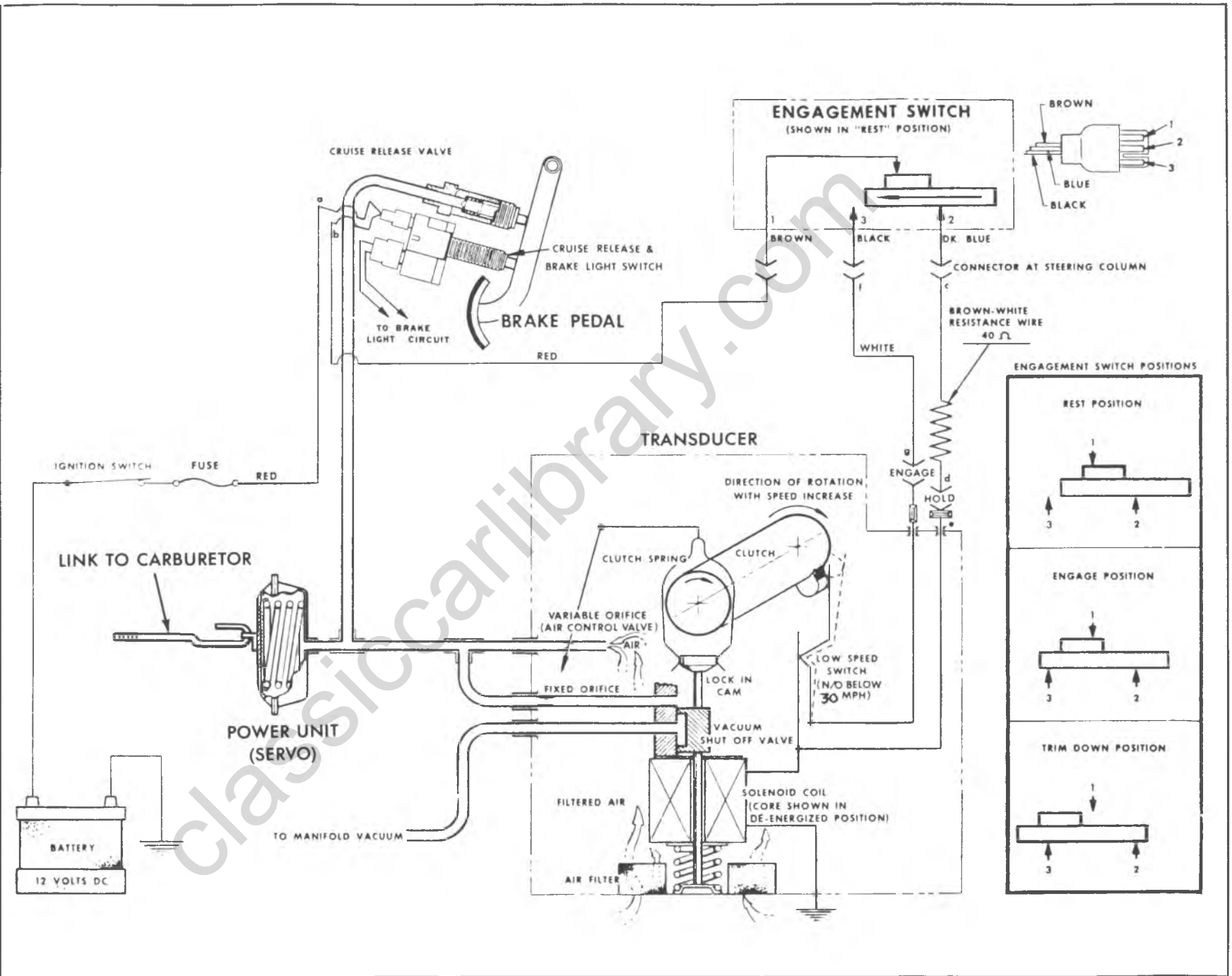
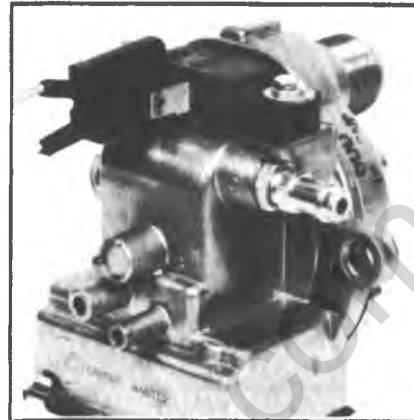
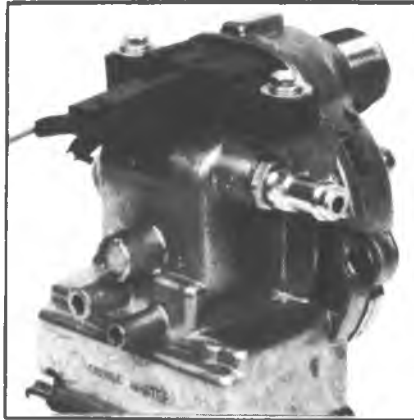


Fig. 9-3C-Electro-Pneumatic Schematic

CHEVROLET CRUISE MASTER TROUBLESHOOTING

CHECK I FOR SYSTEMS WITH ERRATIC CRUISE PERFORMANCE

CHECK II FOR INOPERATIVE SYSTEMS MAKE ALL TESTS WITH TRANSMISSION SELECTOR IN "PARK" & PARKING BRAKE ON EXCEPT WHERE INDICATED OTHERWISE. RECONNECT ANY DISCONNECTED HOSES AND/OR ELECTRICAL CONNECTORS IN PROPER MANNER AT THE COMPLETION OF TEST.



CHECK I

1. CHECK POWER UNIT ADJUSTMENT - SEE SERVICE ADJUSTMENT PROCEDURE
2. CHECK FOR PINCHED, KINKED, PLUGGED, OR DAMAGED VACUUM HOSES. ALSO CHECK VACUUM FITTINGS.
3. CHECK SPEEDOMETER CABLE ROUTING. IT MUST NOT BE KINKED OR HAVE TOO SHARP A TURNING RADIUS (NOT LESS THAN 6" RADIUS). CHECK DRIVE CABLE FOR DISTORTED OR BENT TIPS. FERRULES MUST BE SNUG.
4. CHECK FOR A BINDING THROTTLE LINKAGE CONDITION.
5. CHECK ADJUSTMENT OF BRAKE RELEASE SWITCH & VACUUM RELEASE VALVE. (SEE SERVICE & ADJUSTMENTS)
6. CHECK FOR PROPER OPERATING PROCEDURE OF THE ENGAGE SWITCH.
7. IF STEPS 1 THROUGH 6 DO NOT SOLVE THE PROBLEM PROCEED WITH CHECK II.

SPECIAL NOTE PERTAINING TO ENGAGEMENT-CRUISE SPEED ZEROING.

IF THE CAR CRUISES BELOW ENGAGEMENT SPEED, SCREW THE ORIFICE TUBE OUTWARD. IF THE CAR CRUISES ABOVE THE ENGAGEMENT SPEED, SCREW THE ORIFICE TUBE INWARD. EACH 1/4 TURN WILL CHANGE THE CAR SPEED APPROXIMATELY ONE MPH. ENGAGEMENT ACCURACY TESTING TO BE DONE AT 60 MPH. SNUG UP LOCK NUT AFTER EACH ADJUSTMENT.

CAUTION: DO NOT REMOVE ORIFICE TUBE FROM CASTING.

Fig. 9-4C--Cruise Master System Diagnosis Chart A

CHECK II

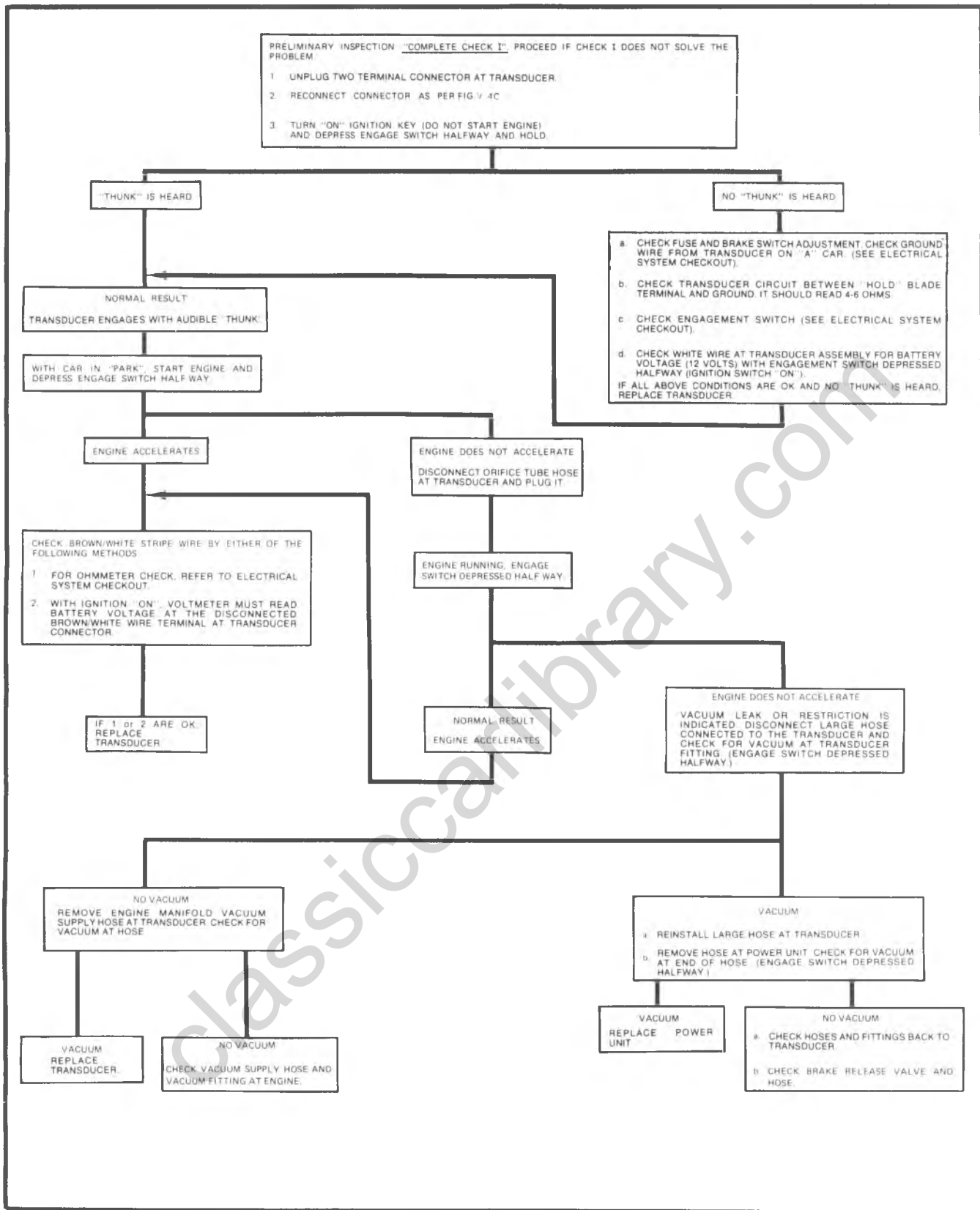


Fig. 9-5C--Cruise Master System Diagnosis Chart B

ON-VEHICLE SERVICE

MAINTENANCE AND ADJUSTMENTS

The components of the Cruise-Master System are designed to be replaced should they become inoperative. The Transducer is calibrated in such a manner during manufacturing that overhaul operations are impractical. However, one adjustment may be made to the Transducer to correct speed drop or increase at the time of engagement.

TRANSDUCER (Figs. 9-6C and 9-7C)

One transducer adjustment is possible - Engagement Cruising Speed Zeroing (to remove any difference between engagement and cruising speed). No transducer adjustment should be made, however, until the Power Unit linkage adjustment has been checked and vacuum hoses are checked for leaks, kinks, or other restrictions.

If the vehicle cruises at a speed a few mph above or below the engagement speed, this error can be corrected with a simple adjustment of the orifice tube in the transducer (Fig. 9-2C).

Never remove orifice tube from casting. It cannot be reinstalled once it has been removed.

1. To check cruise speed error, engage Cruise-Master at 55 mph (90 km/h).
2. If vehicle cruises **below** engagement speed, screw orifice tube **outward**.
3. If vehicle cruises **above** engagement speed, screw orifice tube **inward**.

Each 1/4 turn of the orifice tube will change cruise speed approximately one mph (one km/h). Snug-up lock nut after each adjustment.

If a Transducer is found to be defective and not simply out-of-adjustment, it must be replaced. During replacement, check the hoses which connect to the Transducer and replace any which are cracked or deteriorated.

POWER UNIT

Adjustment (Fig. 9-6C and 9-7C)

1. Before adjusting the Power Unit linkage, make sure ignition is OFF and fast idle cam is OFF and that the throttle is completely closed.
2. With rod hooked through tab on power unit, adjust length by turning link onto rod until dimension shown in Figures 9-6C and 9-7C is obtained.
3. Install link and link retainer.

If the Power Unit is found to be defective, replacement is required. Note the condition of the hoses and replace any which are cracked or deteriorated.

BRAKE RELEASE SWITCHES (Figs. 9-6C and 9-7C)

Adjustment

The design of the switch and valve mounting provides for automatic adjustment when the brake pedal is manually returned to its mechanical stop as follows:

1. With brake pedal depressed, insert switch and/or valve assembly into tubular clip until switch body and/or valve assembly seats on tube clip. Note that audible "clicks"

can be heard as threaded portion of switch and valve are pushed through the clip toward the brake pedal.

2. Pull brake pedal fully rearward against pedal stop, until audible "click" sounds can no longer be heard. Switch and/or valve assembly will be moved in tubular clip providing proper adjustment.

3. Release brake pedal, and then repeat step 2 to assure that no audible "click" sounds remain.

COLUMN MOUNTED ENGAGEMENT SWITCH

The engagement switch may be serviced by replacement of the lever assembly or repair of wiring.

COMPONENT PART REPLACEMENT TRANSDUCER

Replacement

1. Disconnect battery ground cable.
2. Disconnect speedometer cables at transducer.
3. Disconnect vacuum and wiring harness at transducer body.
4. Remove transducer to bracket screws and remove regulator.
5. To install, reverse Steps 1-4 above.

POWER UNIT

Replacement

1. Disconnect battery ground cable.
2. Disconnect vacuum line at power unit.
3. Remove power unit link retainer at accelerator lever stud.
4. Remove rod and link from power unit.
5. Remove power unit to bracket nut and washer and remove power unit assembly.
6. To install, reverse Steps 1-5 above.
7. Adjust the power unit as outlined in this section.

COLUMN MOUNTED ENGAGEMENT SWITCH Removal

1. Disconnect the battery ground cable.
2. Disconnect cruise master engagement switch wiring harness plug on steering column.
3. Remove plastic protector from cruise master wiring harness on column.
4. Remove steering wheel as described in section 3B.
5. Remove lock plate cover.
6. Remove screw securing turn signal lever and attach a 24" piece of follower wire to connector. Then remove lever and harness. (Leave follower wire in column to guide engagement harness back in).

Installation

1. Attach new engagement switch harness to follower wire and pull harness into column. Position turn signal lever on turn signal switch and tighten screw.
2. Install lock plate cover to lock plate.
3. Install steering wheel as described in section 3B.
4. Connect cruise control harness connector.
5. Connect battery ground cable.

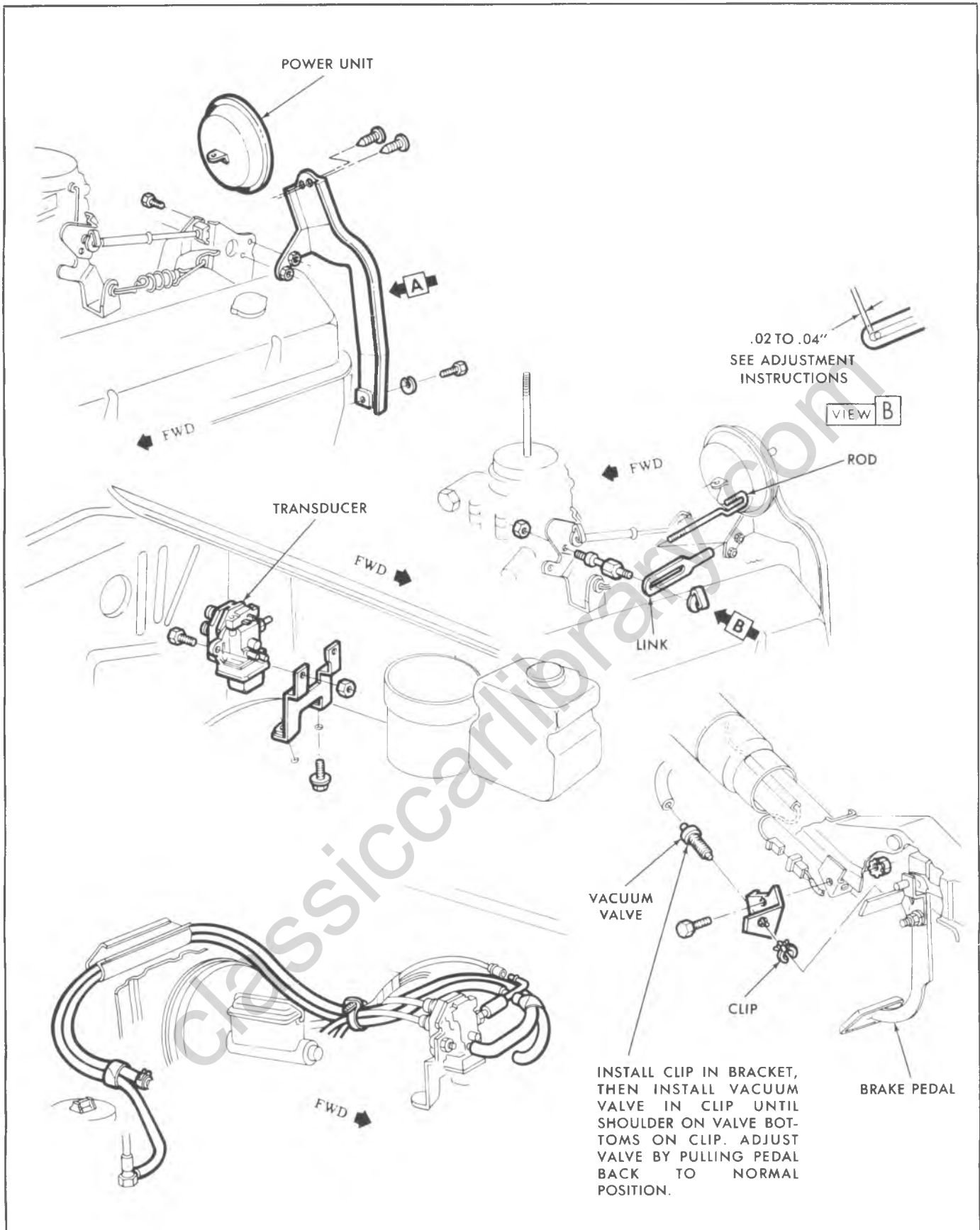


Fig. 9-6C--Cruise Master Installation--C-K Models

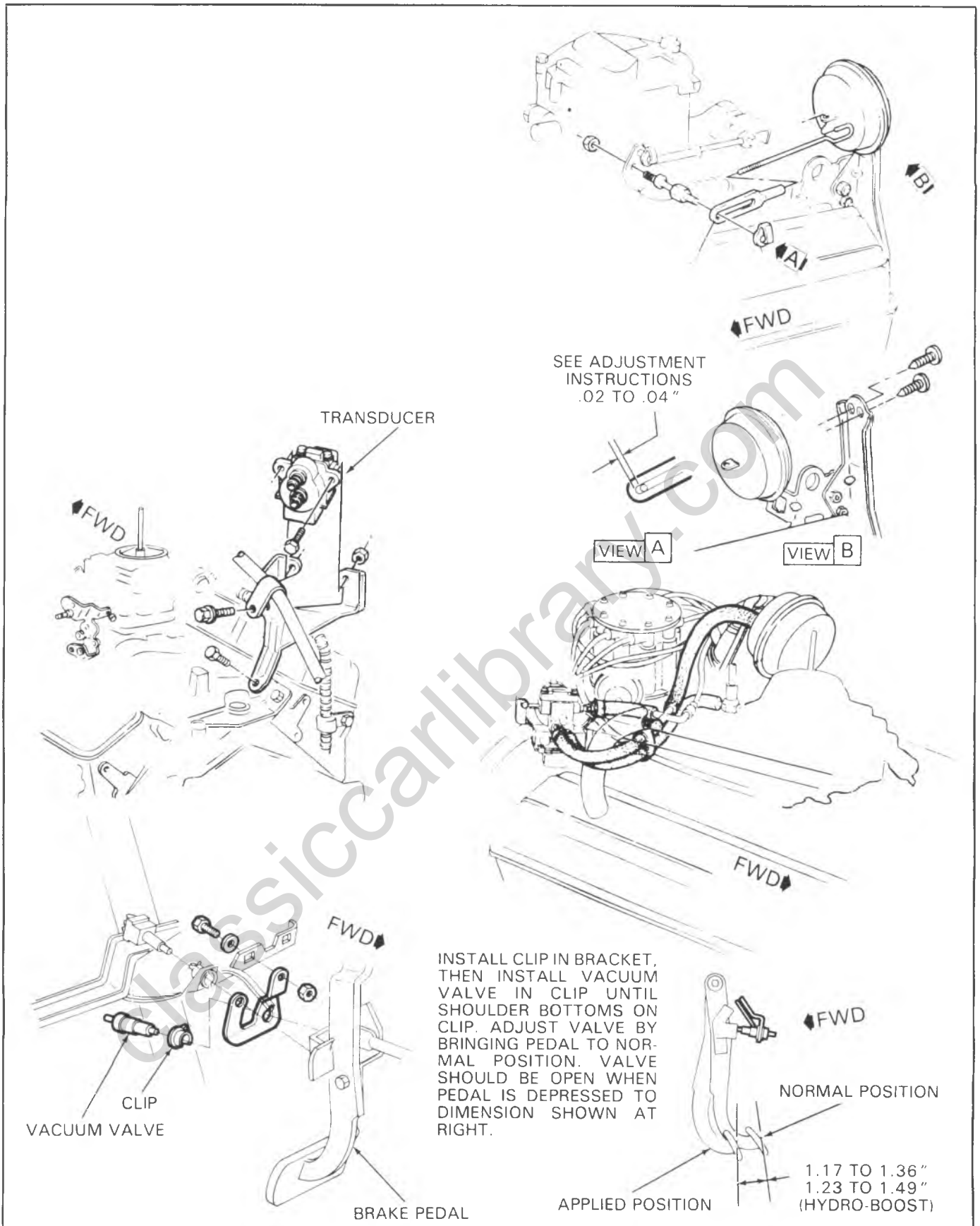


Fig. 9-7C--Cruise Master Installation--G Models

SPECIFICATIONS

CRUISE-MASTER

| | |
|--|--|
| Solenoid Resistance | 5 ohms \pm 1/4 ohm |
| Solenoid Wire Resistance | 40 ohms |
| Maximum allowable Vacuum Leakage rate for Servo unit | 5 inches of Vacuum Per Minute |
| | Not Greater than 1 inch of Vacuum per 10 seconds |
| Operational Test Speed | 55 MPH |

Fig. 9-8C—Cruise-Master Specifications Chart

classiccarlibrary.com

RADIO

GENERAL DESCRIPTION

Six types of radios are available: AM Pushbutton, AM/Stereo 8-Track Tape, AM/FM, AM/FM Stereo, AM/FM Stereo/Stereo tape, and AM/FM Stereo Cassette Tape. The left knob operates the on-off switch and volume control, the left ring operates the tone control. The right hand knob controls manual tuning. All AM/FM radios have five push buttons (10 station selections) five on AM and five on FM.

On models equipped with auxiliary speakers, a variable control located behind the manual tuning knob adjusts the volume of the front and rear speakers. Turn the control clockwise to increase rear speaker volume and decrease front speaker volume. Turn the control counterclockwise and the rear speaker volume decreases and the front speaker volume increases. Both speakers are controlled together by the volume control knob.

On models equipped with stereo radios, this control varies front and rear speaker volume to obtain the desired balance for stereo separation.

AM WITH STEREO 8-TRACK TAPE AND AM/FM STEREO WITH STEREO 8-TRACK TAPE

With the AM and AM/FM stereo radio and eight-track tape player combination units, the tape cartridge is inserted through the spring loaded dial face and power is automatically switched from the radio to the tape player.

Tape programs are changed by pushing the volume control knob.

To release the tape cartridge, depress the eject pushbutton and remove cartridge. With the tape cartridge

out, power is automatically returned to the radio.

NOTICE: DO NOT USE Silicone spray lubricants for switch, plunger or tape head lubrication, or damage may occur.

AM/FM STEREO WITH CASSETTE TAPE

The operation of the cassette player requires that the cartridge be inserted through the door endwise and positioned according to the outline on the door. The radio is automatically turned off.

To advance to the next selection, push the fast forward button at the right end of the tape door. Sound is off during the fast forward operation. To release fast forward button from locked in position, push eject button on left end of tape door.

Only 2 programs are available on cassettes and it is necessary to eject the cassette, turn it over and insert it again in the position outlined on the door.

30 or 60 minute cassettes produce the best sound and should be removed from the player when not in use. As with 8-track tapes, cassettes should be stored away from extreme heat or direct sunlight.

To maintain quality sound reproduction, the player pick-up head and capstan should be cleaned after every 100 hours of operation using a cotton swab dipped in rubbing alcohol. There are also cleaning tapes available for this purpose and the manufacturer's instructions for their use must be followed.

DIAGNOSIS

CASSETTE TAPE PLAYER

Diagnosis of radio portion of cassette-AM/FM is shown on the diagnosis charts. For cassette diagnosis, refer to Fig. 9-1R. If unit must be removed, it must be repaired by an authorized service station. See Section 8 for removal procedures and connections for speaker and power wiring.

EIGHT-TRACK STEREO TAPE PLAYER

The tape player trouble diagnosis guide is intended as an aid in locating minor faults which can be corrected without a specialized knowledge of electronics and without special test equipment. If the suggestions given here do not effect a correction, further testing should be done only by a trained radio technician having proper test equipment. It should first be determined if the owner's tape and not the player is at fault. Substituting a known good tape cartridge for the owner's is a simple check.

Because tape player service problems are generally corrected by a radio repair shop, there is a tendency for many technicians to remove a set when a problem is reported. Removal of the tape player can frequently be avoided if the diagnosis chart is used to eliminate problems which can be easily fixed or which are not caused by a faulty player.

In diagnosing radio/tape problems the main point to remember is that you now have both a radio and a tape player to diagnose as part of the stereo system. By inserting test tape, J-22683-01, you can quickly determine whether the tape speed is proper. Since only the pre-amps and audio are common to both radio and tape, by listening for distortion with the tape playing and comparing it to the radio signal, you can further isolate the problem to either radio or tape; See the Diagnosis Chart.

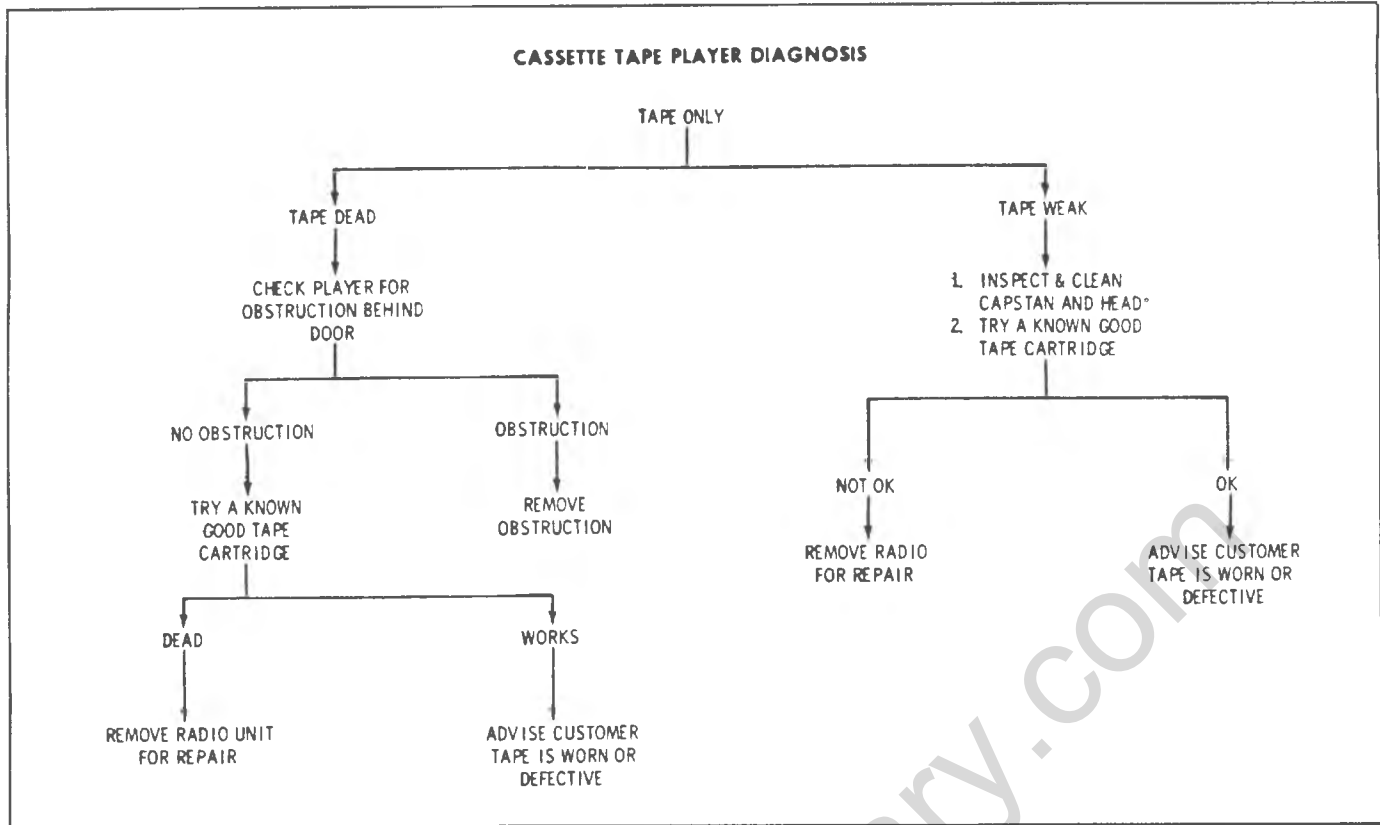


Fig. 9-1R--Cassette Tape Player Diagnosis

DIAGNOSIS AM/FM-CB RADIO COMBINATION

| PROBLEM | CHECK | ACTION |
|---|--------------------------------|--|
| No AM, FM or CB sound No CB channel display. | Check Fuse | Remove radio for repair. |
| No AM, FM or CB sound Channel display OK | Mode Switch Squelch control | Remove radio for repair |
| No AM, or FM sound; CB sound OK | Mode switch Squelch | Remove radio for repair |
| No CB sound and no channel display; AM/FM sound OK | Mode switch | Remove radio for repair |
| No CB sound, channel display OK; AM/FM OK. | Mode switch Squelch | Replace antenna Remove radio for repair |
| Irregular channel stepping & unit not coordinated with display | Cable connections | Remove radio for repair |
| Display segments missing or segment contrast not uniform | Mode switch | Remove radio for repair |
| Channel display won't change | Selector switch | Remove radio for repair |
| Channel display indicates only "0" | Power connector | Remove radio for repair |

Fig. 9-2R--AM/FM-CB Radio Diagnosis

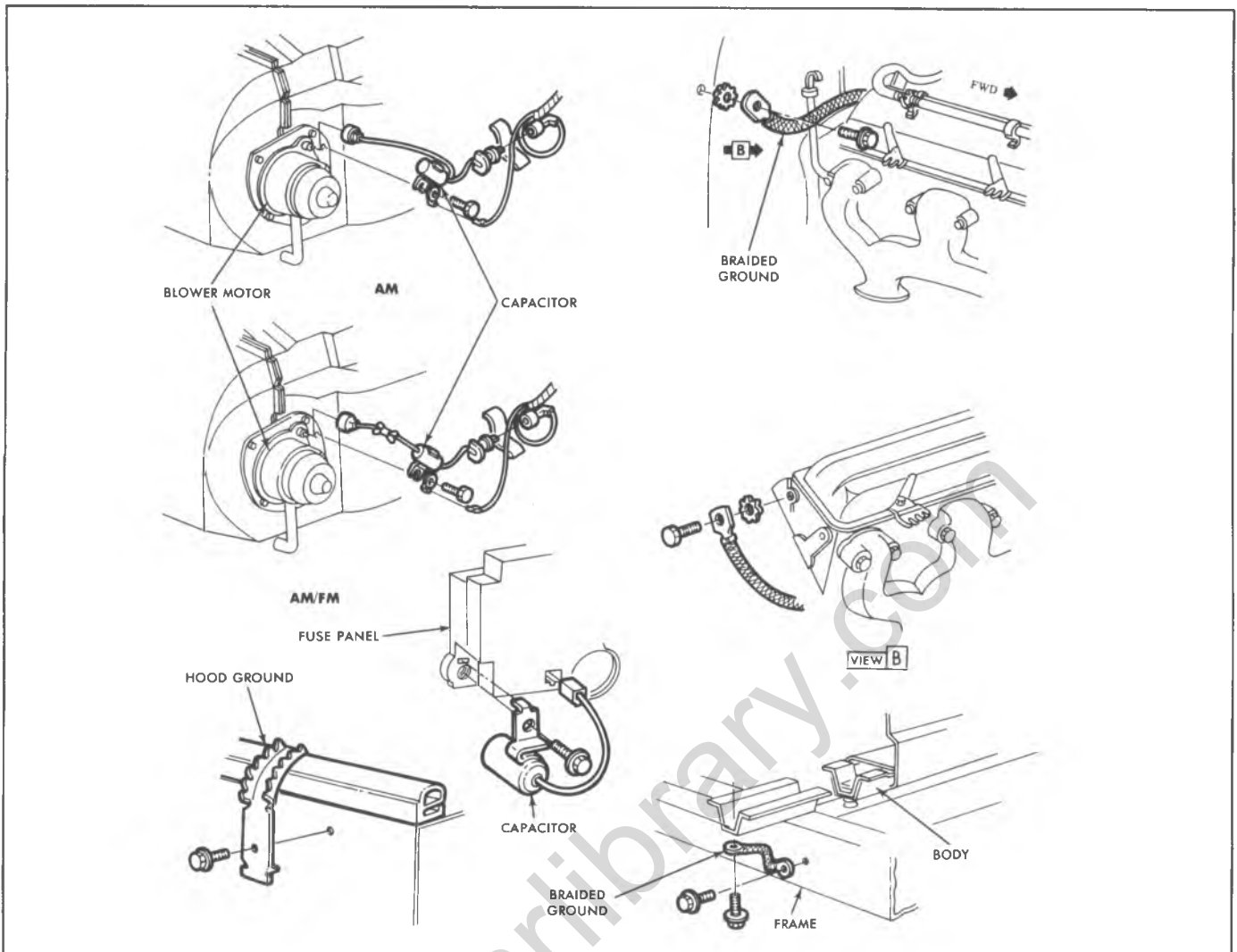


Fig. 9-3R--Radio Static Suppression--Typical

STATIC AND NOISE

Refer to figure 9-3R for radio static suppression on the vehicle. Ground strap connections must be clean and tight, spark plug cables must be TVRS type and in good condition and resistance type spark plugs used. Extra electrical equipment added to the car could cause static if not properly grounded or wiring was improperly routed. Radio and antenna lead-in grounding must be clean and tight. An improperly trimmed antenna adjusting screw could result in poor sensitivity and static/noise on AM stations only.

Weak FM station reception will be affected by near-by buildings, car speed, direction and windshield wiper operation. These "flutter," "swish" and "fading" conditions are characteristics of weak FM signals.

POPPING NOISE

Operating switches such as turn signal, pushing in cigarette lighter, operating stop lights, etc., may cause a popping noise on distant AM (weak) signals. Adjusting the antenna trimmer, if it is out of adjustment, will minimize the noise.

TESTING WINDSHIELD ANTENNA (Fig. 9-4R)

All C-K model trucks with factory installed radios are equipped with windshield antennas. To positively identify antenna failure and eliminate the possibility of unnecessary



Fig. 9-4R--Testing Windshield Antenna (Typical)

windshield replacement, Windshield Antenna Tester J-23520 should be used to determine continuity of the thin antenna wire.

When antenna failure is suspected, the following checks should be made before replacing the windshield.

1. Check Tester J-23520 for operation on any vehicle radio antenna that is operating normally to test for a weak or dead battery.

2. Check all antenna connectings to insure that antenna is electrically coupled to the radio.

3. Turn ignition switch to accessory position, turn radio "ON", select AM band if receiver is AM/FM and tune radio to an off station position.

4. Hold tester to antenna beginning at the upper corner of antenna:

NOTICE: The plastic shield must be on tester at all times to avoid scratching windshield.

a. If a shrill sound is emitted through the speaker when both antenna wires are tested, antenna is operational.

b. If no sound is emitted through one or both antenna wires, move tester along the wire toward center of windshield and down toward radio.

c. If a shrill sound is picked up, find exact location where the noise begins, this is the area of the defect. Replace windshield.

d. If no noise is heard over entire length of antenna, unplug antenna lead at radio and touch tester to antenna socket in radio.

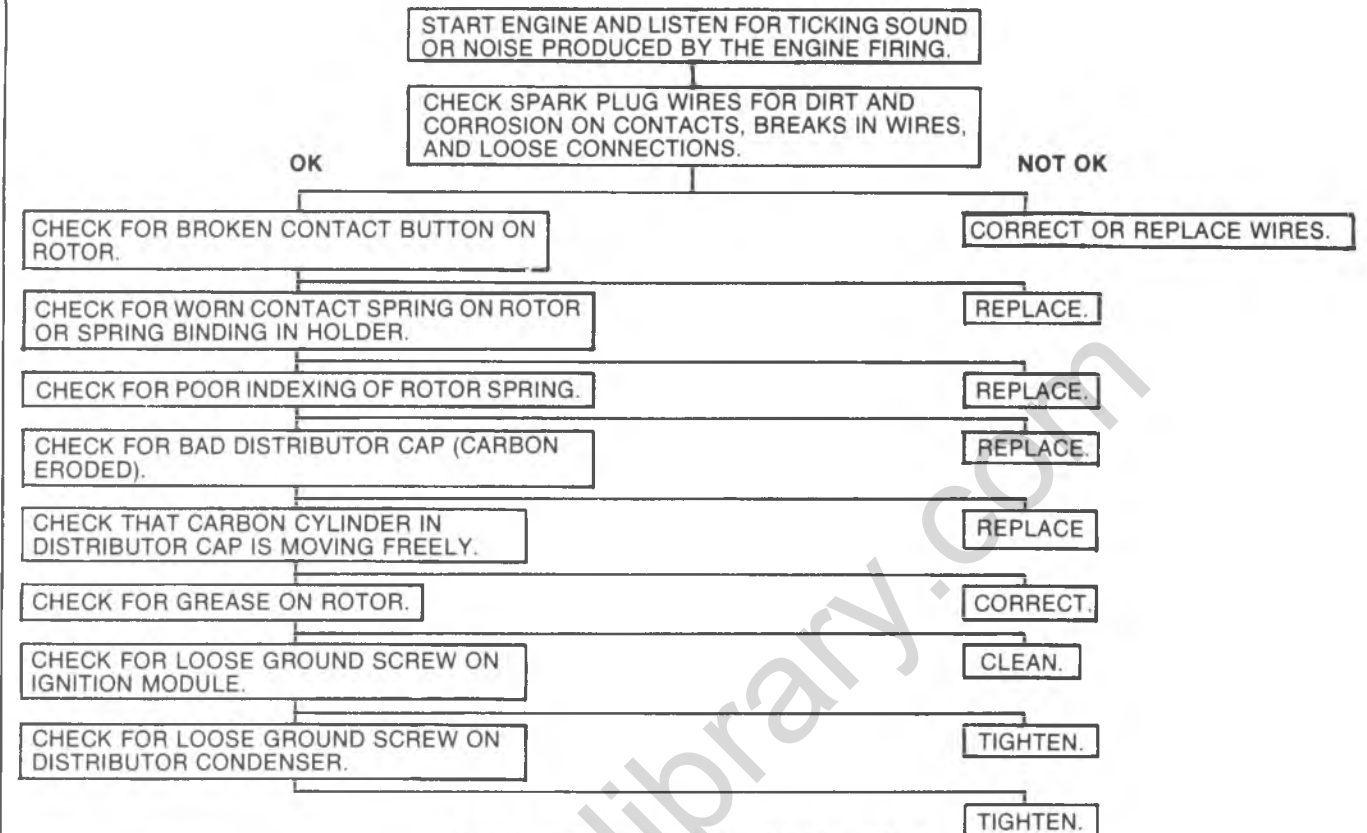
e. If radio now makes a shrill sound, check connectors and antenna lead for possible defect before replacing windshield.

f. If no noise is emitted, radio, speaker, or fuse is defective.

Make sure that antenna tester is turned off after completing antenna test.

classiccarylbrary.com

RADIO NOISE DIAGNOSIS IMPROPERLY OPERATING IGNITION SYSTEM (HEI)



LACK OF SHIELDING/GROUNDING

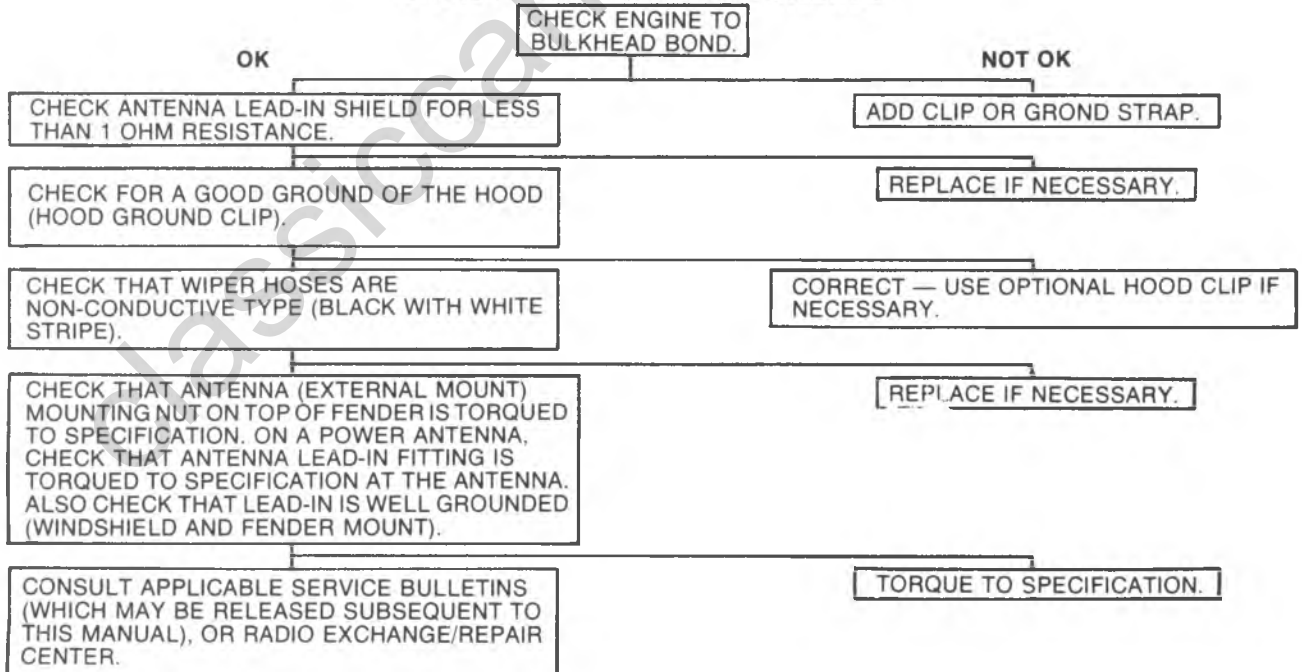


Fig. 9-5R--Radio Diagnosis, Chart A

RADIO NOISE — BLOWER MOTOR

TURN ON BLOWER MOTOR. NOISE APPEARS AS STATIC WHICH FOLLOWS BLOWER MOTOR SPEED (USUALLY ON FM).

CHECK IF A .25 MFD COAXIAL FEED-THROUGH CAPACITOR IS INSTALLED ON THE BLOWER MOTOR LEAD.

INSTALLED

NOT INSTALLED

SUBSTITUTE A .25 MFD COAXIAL CAPACITOR. (REFER TO "MAINTENANCE AND ADJUSTMENTS")

INSTALL A .25 MFD COAXIAL CAPACITOR. (REFER TO "MAINTENANCE AND ADJUSTMENTS")

NO NOISE

NOISE

NO NOISE

REPLACE CAPACITOR.

REPLACE BLOWER MOTOR.

STOP.

TAPE ONLY

TAPE DEAD

TAPE WEAK

CHECK PLAYER FOR OBSTRUCTION THROUGH DOOR.

INSPECT & CLEAN, MOVING PARTS AND HEAD*

NO OBSTRUCTION

OBSTRUCTION

TAPE NOT OK

TAPE OK

SUBSTITUTE KNOWN GOOD TAPE CARTRIDGE

REMOVE OBSTRUCTION

SUBSTITUTE WITH KNOWN GOOD TAPE CARTRIDGE.

STOP

DEAD

WORKS

SUBSTITUTE TAPE NOT OK

SUBSTITUTE TAPE OK

REMOVE PLAYER

INFORM CUSTOMER TO USE GOOD QUALITY TAPES

REMOVE UNIT

INFORM CUSTOMER TO USE GOOD QUALITY TAPE

Fig. 9-6R--Radio Diagnosis, Chart B

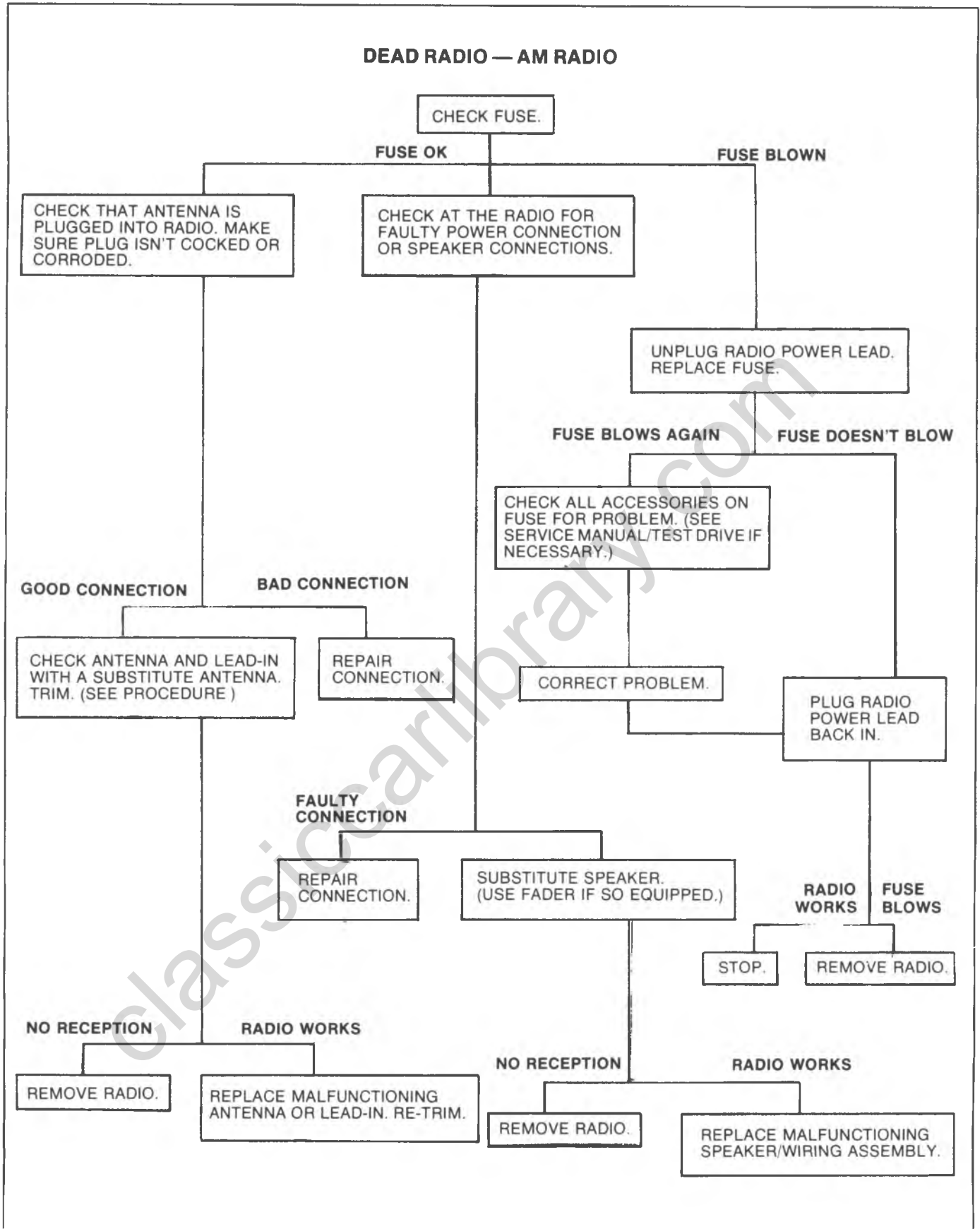


Fig. 9-7R--Radio Diagnosis, Chart C

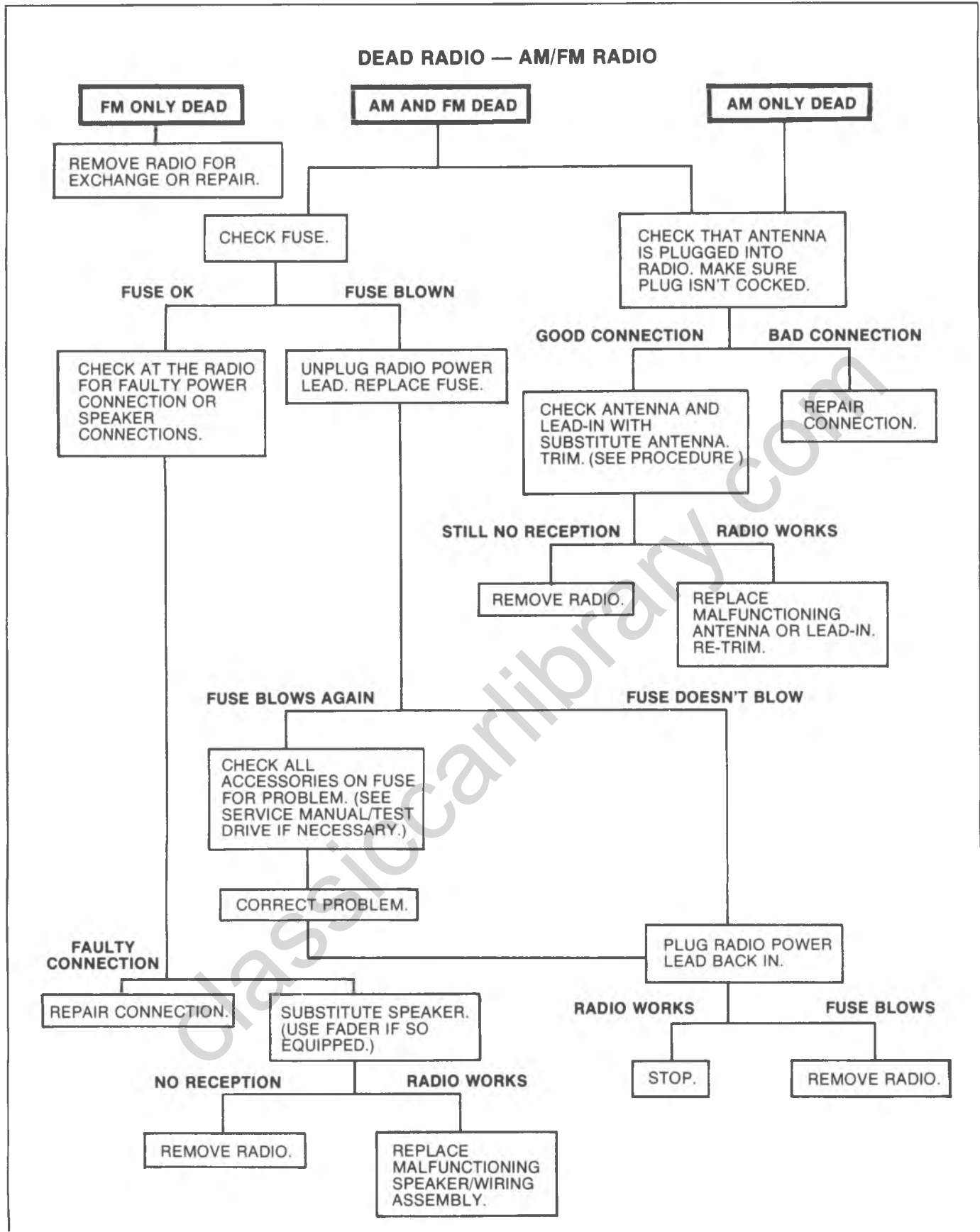


Fig. 9-8R--Radio Diagnosis, Chart D

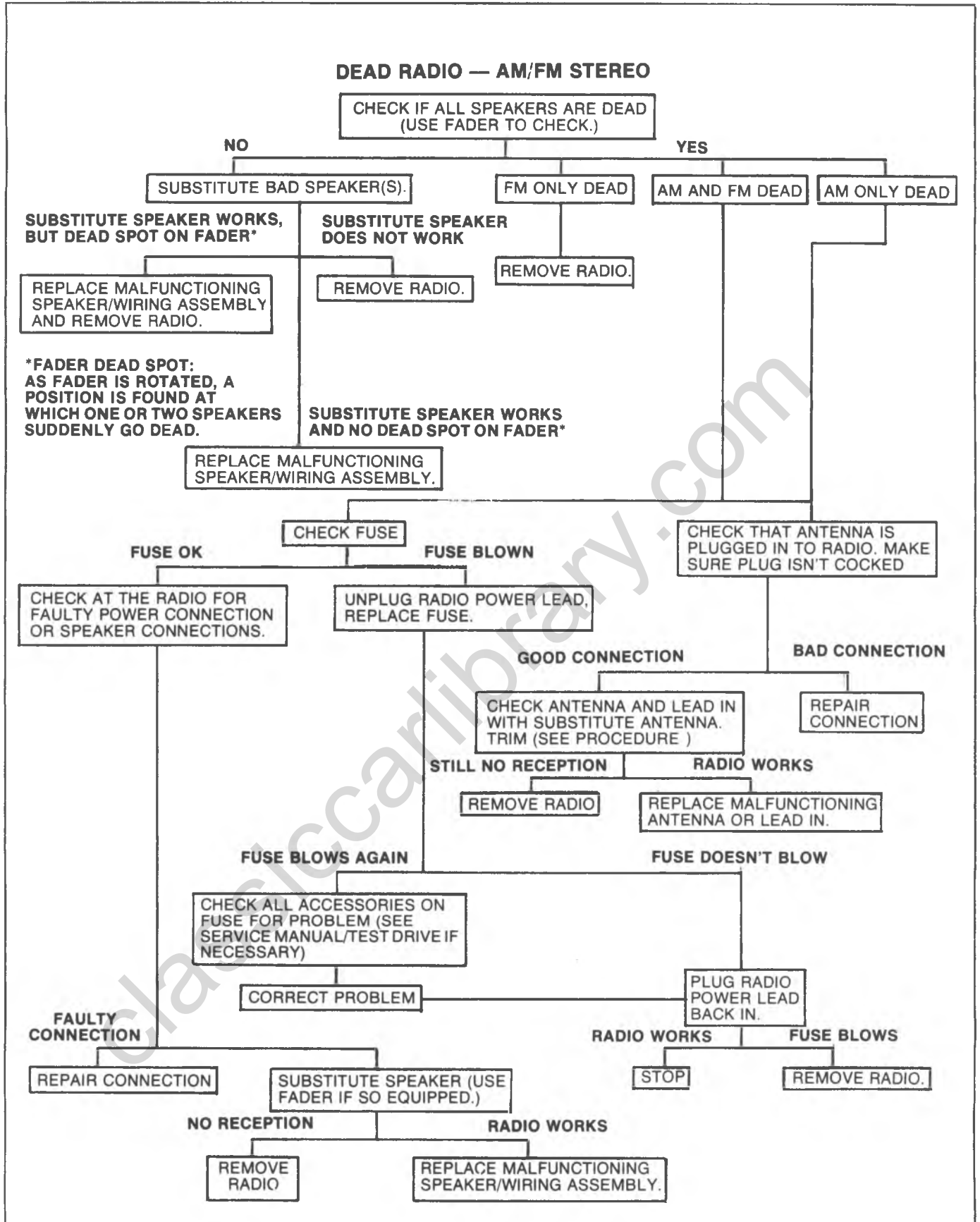
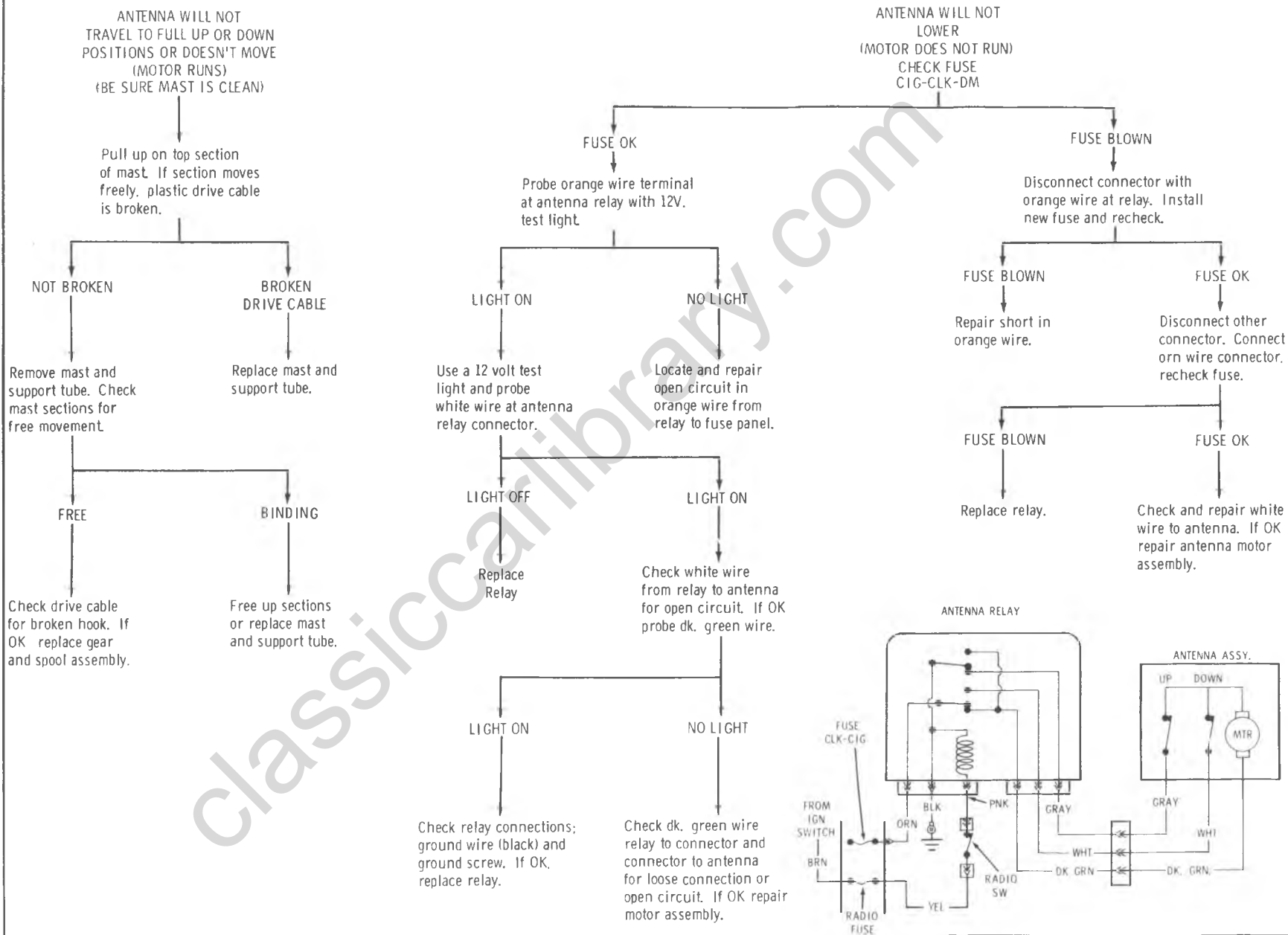


Fig. 9-9R--Radio Diagnosis, Chart E

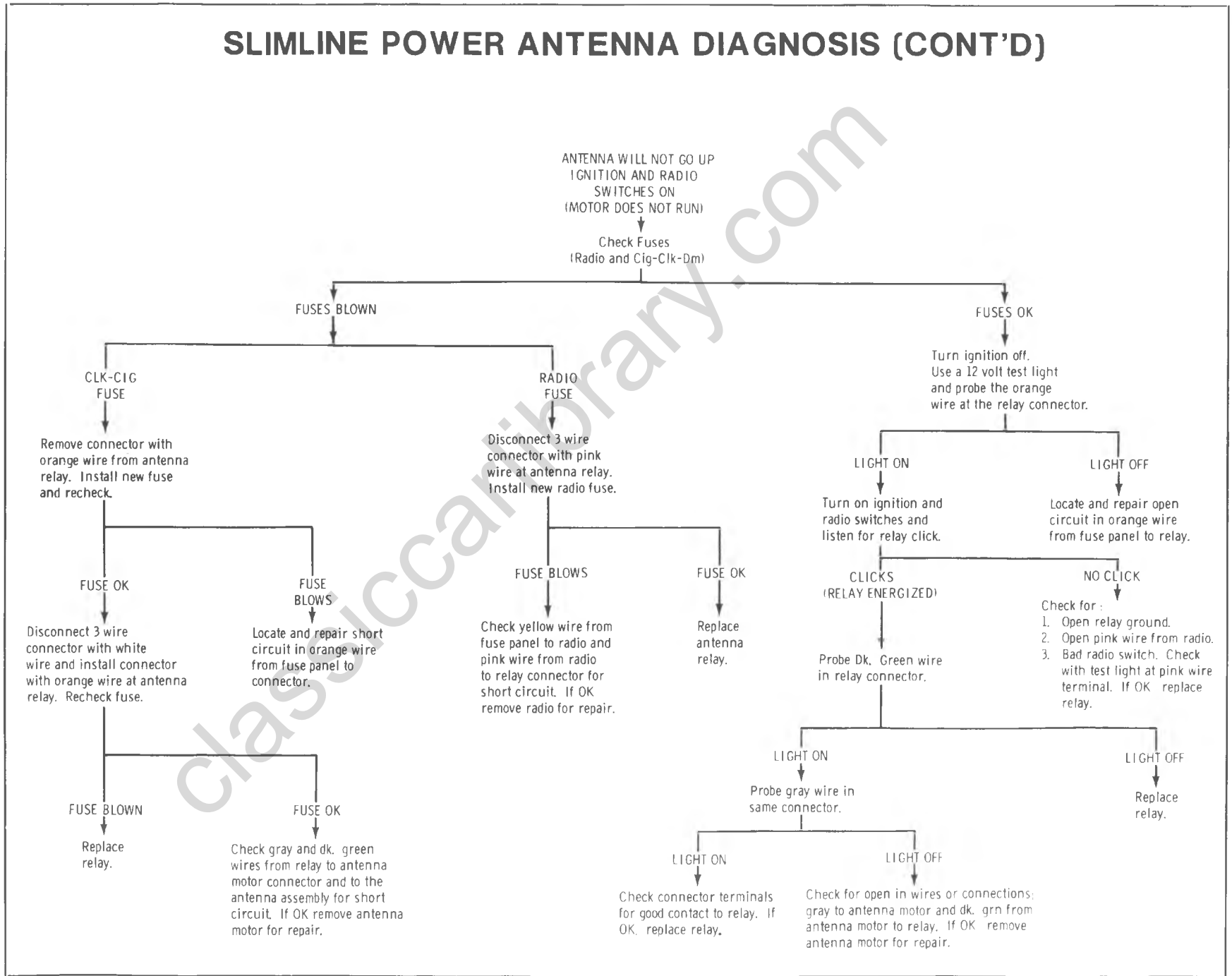
SLIMLINE POWER ANTENNA DIAGNOSIS

Fig. 9-10R--Slimline Power Antenna Diagnosis, Chart F



SLIMLINE POWER ANTENNA DIAGNOSIS (CONT'D)

Fig. 9-11R--Slimline Power Antenna Diagnosis, Chart G



POWER ANTENNA

General Description and Operation

The power antenna automatically raises the antenna mast to its full height whenever the radio and ignition are turned on. The antenna retracts into the fender when either the ignition or radio is turned off.

The power antenna drive unit is housed in a 2 piece plastic housing attached to the mast and tube assembly. A permanent magnet motor with worm drive moves the antenna mast up and down with a plastic cable attached to the top mast section. No clutch is used in this unit. Upper and lower travel limits are controlled by switches opened by armature shaft thrust as the mast reaches the end of its travel. A circuit breaker is used to protect the motor armature from over heating.

Two types of power antennas are used depending on the type of radio used in the car:

- 1) AM-FM Type
- 2) AM-FM-CB (Tri-Band) Type

The AM-FM antenna extends to a maximum height of 794 mm (31 1/4"). The AM-FM-CB (Tri-Band) antenna extends to a height of 914 mm (36"). The tri-band antenna has a load coil mounted on the center mast section to tune it to the CB radio band and a stub antenna lead taped to the support tube. The stub matches the antenna to the FM band and should not be removed except for replacement.

On Car Service

There is no on car service of the AM-FM antenna other

than cleaning of the mast sections. On the Tri-Band antenna the load coil and tip are servicable in the event of damage or loss. The load coil has an adjustable band to set SWR (Standing Wave Ratio) for CB operation. The SWR is preset on complete antenna assemblies but replacement load coils must be checked and/or adjusted using available SWR meters.

Checking SWR

NOTICE: SWR checking procedures require transmitter operation and FCC regulations governing CB radio operation apply. The following options are available.

- Have SWR test performed by a technician who has a CB license.
- Acquire a dealership CB radio operator's license which allows technicians to use license during business hours.
- Ask owner or an operator possessing a permanent CB Radio license to properly operate transmitter during the test.

Adjustments or repairs referred to in the procedure that follows are limited to the antenna itself or the antenna lead in and connections.

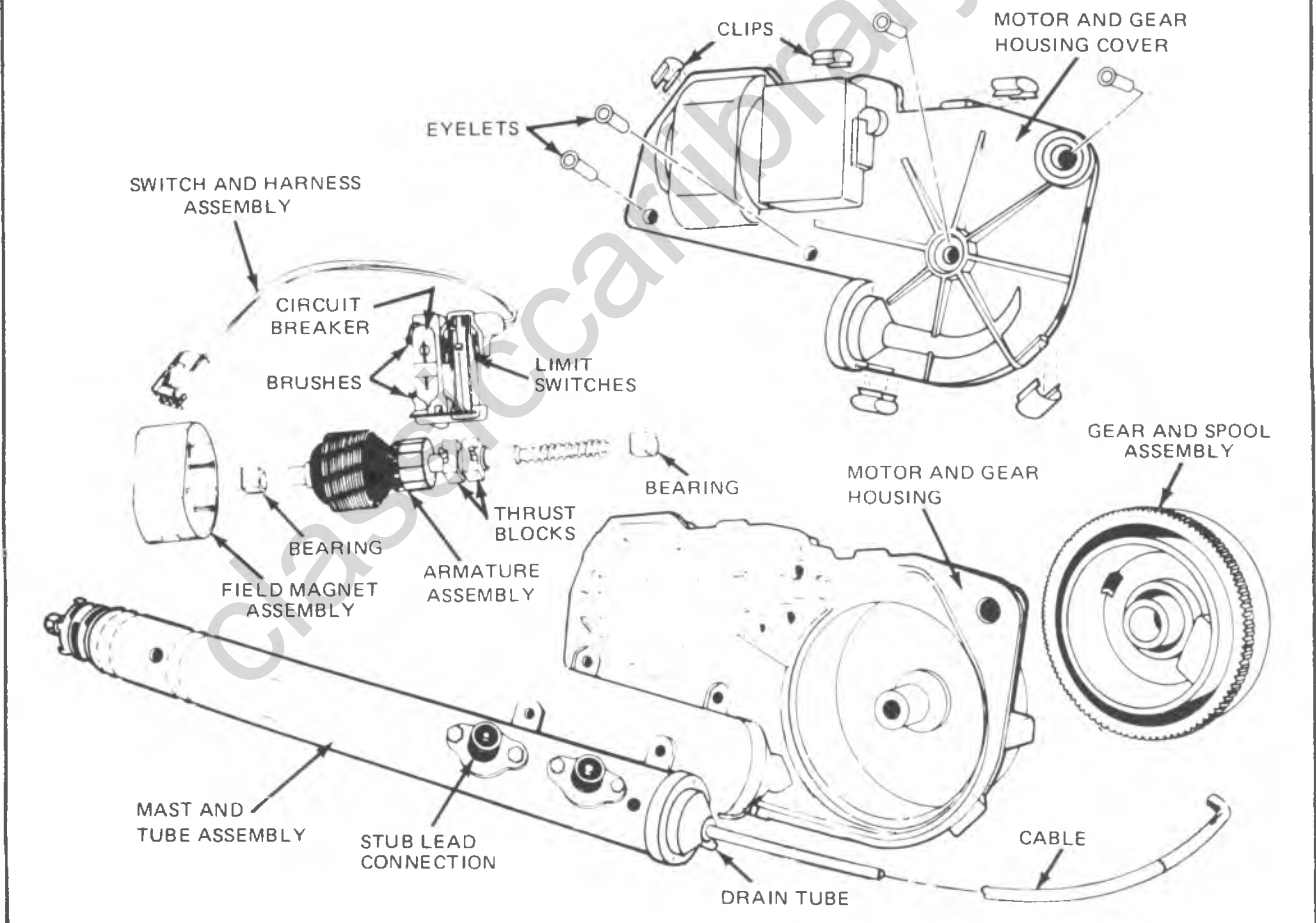


Fig. 9-12R--Slimline Power Antenna Diagnosis, Chart H

SWR (STANDING WAVE RATIO) CHECK

1. With Ignition and Radio off install an SWR meter as shown following meter manufacturers instructions.

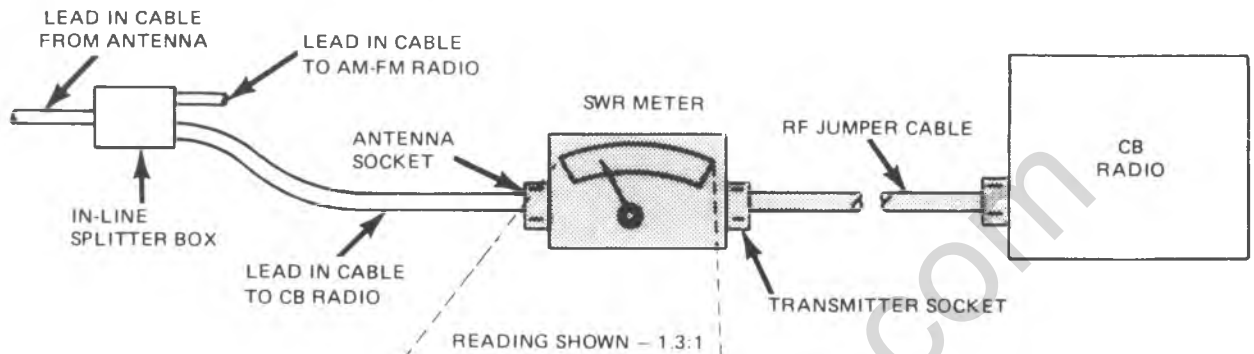
NOTICE: Operation of transmitter requires FCC CB Operators License.

When making this check, car should be at least 20 feet away from any building, hood closed and no one should be standing close to the antenna.

2. Turn on Ignition and Radio.

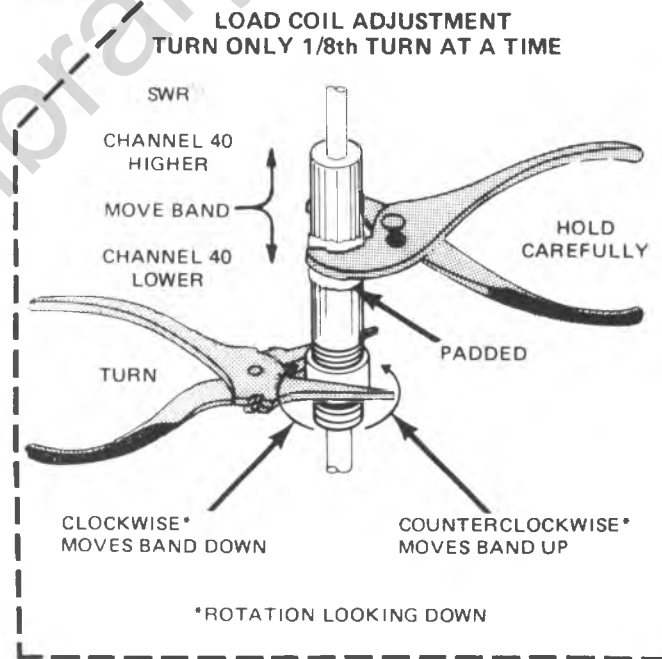
3. Check Antenna height – Must be fully extended.
914 mm (36") from fender to tip
286 mm (11-1/4") top of load coil to tip.

4. After adjustment is complete apply a small amount of thread cement to adjusting band.



POSSIBLE SWR READINGS

1. Initial readings taken on Channel 1, 20, 40
 - a. SWR of 2:1 or lower on Channel 20 and nearly equal on Channels 1 and 40 is considered good. No adjustment required.
 - b. SWR higher than 2:1 on Channel 20. Adjustment required.
 - c. Unequal SWR on Channels 1 and 40 (one channel in red) indicates adjustment required.



ANY READING IN THE RED BAND (ABOVE 3:1 SWR) CHECK FOR:

- Antenna mounting screws tight making a good ground connection
- Lead in cable connections to radio, splitter and antenna are tight. between antenna mounting surface and car sheet metal.
- Lead in cables not pinched and cutting the insulation.

Fig. 9-13R--Slimline SWR Check

ON VEHICLE SERVICE

MAINTENANCE AND ADJUSTMENTS

TAPE PLAYER MAINTENANCE

The only required maintenance on tape players is periodic cleaning of the tape player head and capstan. This service should be performed every 100 hours of operation. Since you can reach them through the tape door, you can leave the tape player in the truck.

To clean the head and capstan, use a cotton swab dipped in ordinary rubbing alcohol. Wipe the head and capstan as shown in Figure 9-15R.

No lubricants should be used since they will cause the player to operate improperly, especially at extreme temperatures.

Do not bring any magnetized tools near the tape head. If the head becomes magnetized, every cartridge played in the player will be degraded.

To operate the tape player, completely insert a cartridge into the unit. This turns the tape player on, automatically removes power from the radio, and switches the speakers from the radio to the tape player. This feature prevents accidental damage to the radio should the owner attempt to operate it while the tape player is in use.

After the tape player is in operation, the front panel controls of the player are then adjusted for the most pleasant stereo listening.

The tape player is equipped with a cartridge locking arm to hold the cartridge in a rigid position against the capstan drive for minimum wow and flutter. As the cartridge is withdrawn from the player, the on/off switch at the other side of the cartridge is not completely disengaged when the cartridge lock arm reaches a detent point on the cartridge. Always withdraw the cartridge just beyond the detent point for normal operation from the radio.

Tape cartridges should be handled carefully and should be kept clean and out of direct sunlight. A cartridge should not be left inserted fully in the player. This may cause permanent damage to the cartridge.

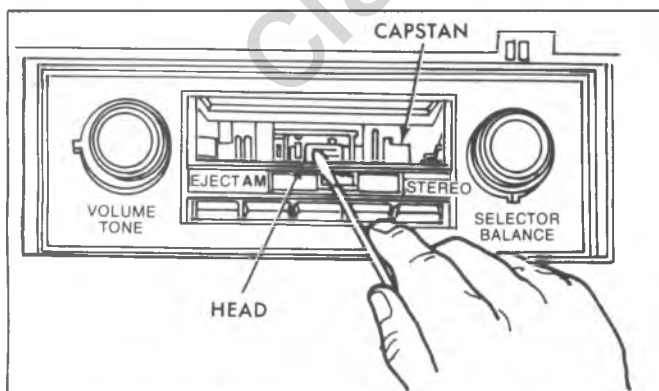


Fig. 9-15R--Cleaning Tape Player Head

ANTENNA TRIMMER ADJUSTMENT-ALL RADIOS (Fig. 9-6R)

The antenna trimmer adjustment must be made any time the radio is removed and installed, a new windshield or lead-in is installed or if weak, AM reception is noted. (Fig. 9-6R).

COMPONENT PART REPLACEMENT

RADIO OR RADIO TAPE REMOVAL

(Refer to Section 8).

RADIO DIAL LAMP REMOVAL

(Refer to Section 8).

RADIO SPEAKER REMOVAL

(Refer to Section 8).

ANTENNA

C-K Models

Antenna Replacement

Refer to Section 2 of this manual "Windshield Replacement" procedure.

Cable Replacement (Fig. 9-17R)

1. Disconnect battery ground cable.
2. Unsnap antenna cable from windshield.
3. Remove bracket to dash panel screws.
4. Disconnect cable at rear of radio receiver and remove cable assembly.

G Models

Antenna Replacement (Fig. 9-18R)

1. Unscrew mast nut. Prevent the cable assembly from turning by using two separate wrenches. Remove rod and mast assembly.
2. To install, insert rod and mast assembly into cable assembly and tighten mast nut. Prevent cable assembly from turning by using a second wrench.

Cable Assembly Replacement (Fig. 9-18R)

1. Disconnect battery ground cable.
2. Remove antenna assembly as described above.
3. Remove cable body nut and then remove seal, bezel, gasket and ring ground.

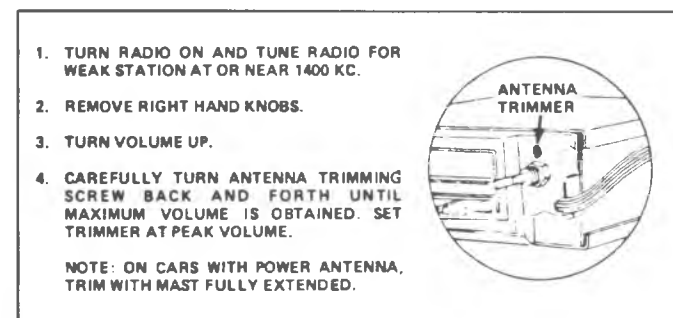


Fig. 9-16R--Trimming Radio

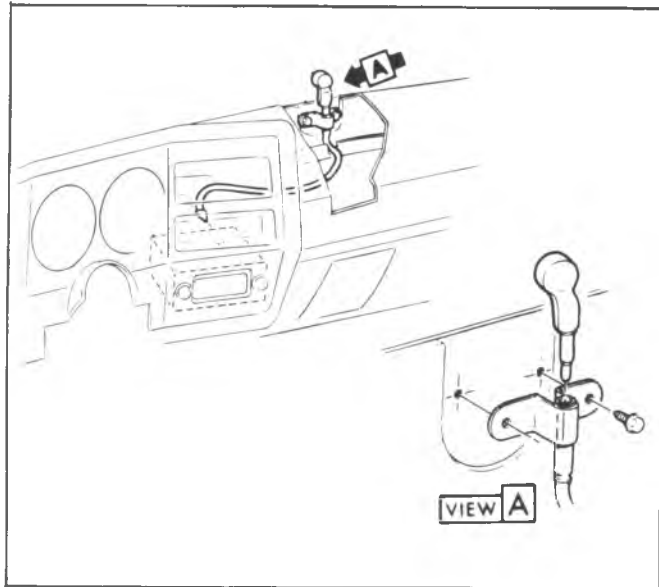


Fig. 9-17R--Antenna Lead (C-K Models)

4. Perform Steps 2-8 of "Radio Receiver Removal". Refer to Section 8.

5. Disconnect cable at rear of receiver.

6. Insert new cable through the dash panel (from the forward side).

7. Reverse Steps 1-5 above to complete installation.

Be sure cable grommet is properly positioned in dash panel.

POWER ANTENNA

DESCRIPTION AND OPERATION

The power antenna used on "G" models operates automatically whenever the radio is turned on. The drive gear unit on the automatic system consists of a drive gear and pulley assembly and a spool for storing the excess nylon drive cable when the mast is in the retracted position, plus two limit switches and a gear operated cam system to actuate the switches. The limit switches are used to open the motor circuits when the mast reaches the full up or down

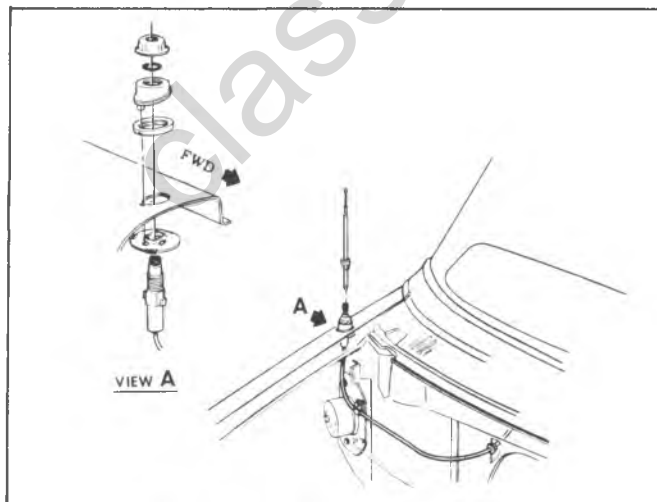


Fig. 9-18R--Antenna Installation (G Models)

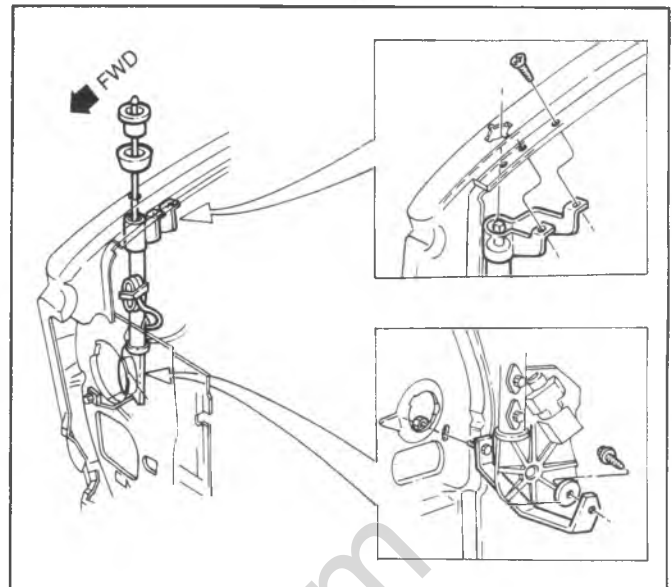


Fig. 9-19R--G Model Power Antenna

positions.

When the motor circuit is completed by the radio or ignition switch, the motor drives the gear and pulley to extend the drive cable and antenna.

The gear is coupled to the drive pulley by a torque limiting clutch that permits continued gear rotation when the mast reaches the limit of travel. The antenna mast fully retracts into the fender or extends 31-1/4" and has no intermediate position.

POWER ANTENNA - G MODELS

Replacement (Fig. 9-19R and 9-20R)

1. Lower antenna by turning off radio or ignition.
2. Disconnect battery ground cable.
3. Remove coolant recovery bottle.
4. Remove motor lower bracket retaining nut and upper bracket screws.
5. Disconnect electrical leads and remove antenna and motor assembly.

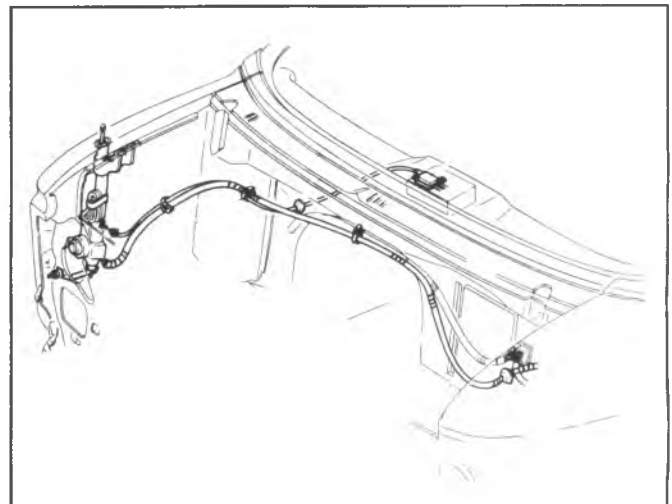


Fig. 9-20R--G Model Power Antenna Wiring

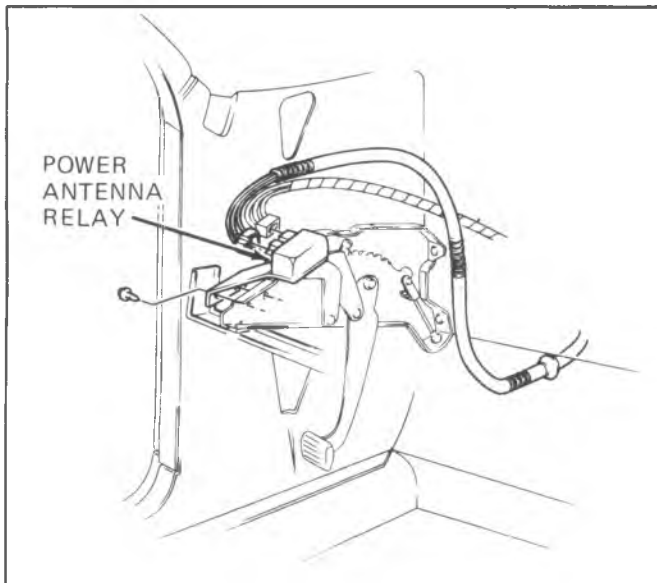


Fig. 9-21R-G Model Power Antenna Relay

6. To install, reverse steps 1-5 above.

POWER ANTENNA RELAY

The power antenna relay is bracket mounted to the parking brake assembly as illustrated in figure 9-21R.

classiccarlibrary.com

POWER ANTENNA DISASSEMBLY-SLIMLINE

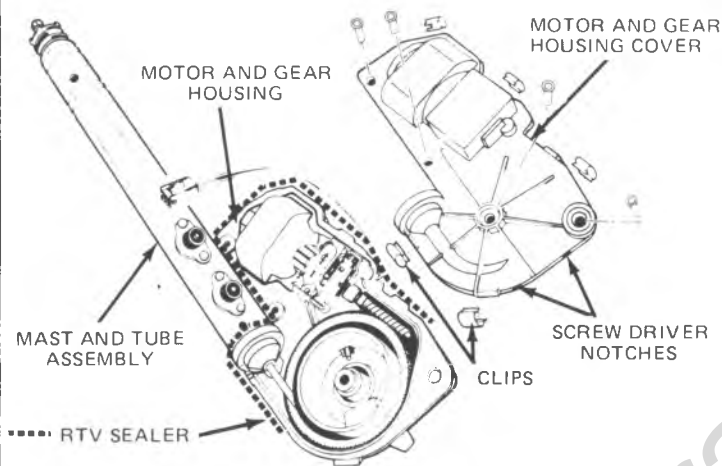
NOTICE: With the exception of load coil on the tri-band antenna, all service operations require opening the motor and gear housing. All disassembly will require a bolt and clip package.

1. REMOVE AND INSTALL MOTOR AND GEAR HOUSING COVER.

REMOVAL

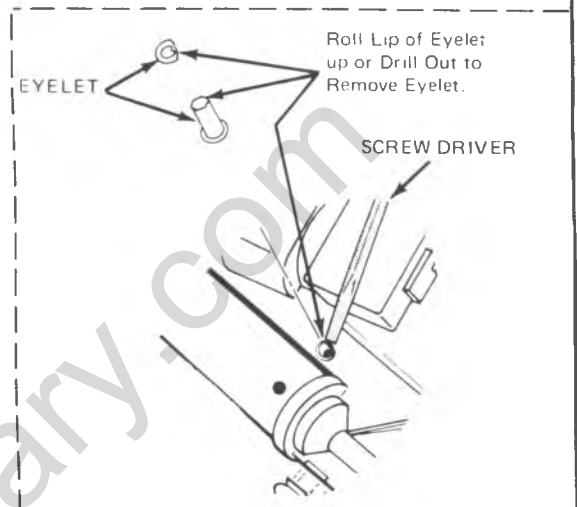
1. Remove parts shown.
2. Separate housing and cover as shown.

EYELETS



INSTALL

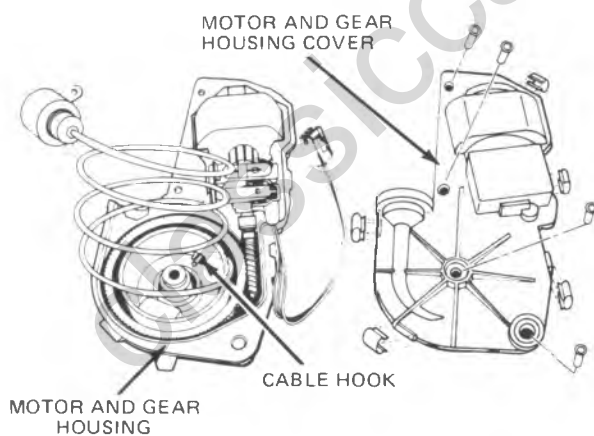
1. Remove loose or excess sealer and reassemble using 3 bolts and nuts, from service package and the 5 clips.
2. Apply RTV sealer around support tube and along seam on top half of housing.



2. REMOVE AND INSTALL MAST AND TUBE ASSEMBLY.

REMOVAL

1. Remove parts as shown.



Disengage cable from gear by rotating cable 90°

INSTALL

1. Reassemble as shown with mast extended to reduce length of cable.
2. Run motor to lower mast into support tube. Reseal housing and support tube.

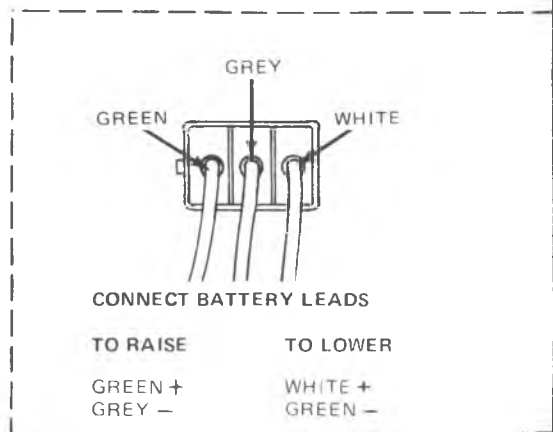


Fig. 9-22R--Slimline Disassembly I

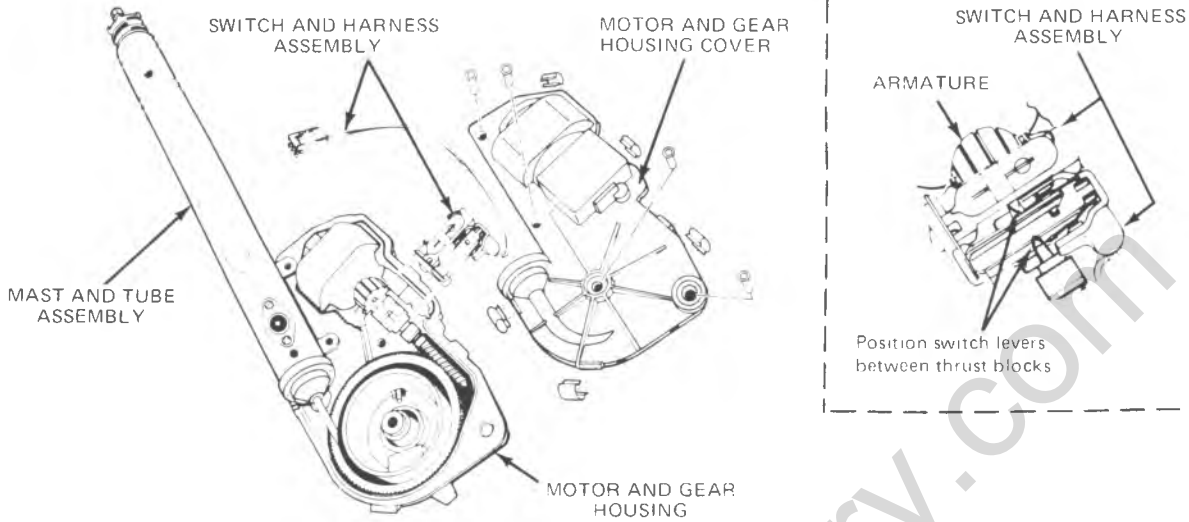
3. REMOVE AND INSTALL SWITCH AND HARNESS ASSEMBLY.

REMOVAL

1. Remove parts as shown.
2. Remove excess sealer where wire goes through housing.

INSTALL

1. Position switch.
2. Reseal area where wires come out of housing. Reseal housing.



4. REMOVE AND INSTALL ARMATURE AND MAGNET ASSEMBLY.

REMOVAL

1. Remove parts as shown.
2. Cleanout old grease.

INSTALL

1. Lubricate worm and gear with lithium soap grease such as Sun Oil Prestige # 2 or equivalent.
2. Apply drop of light oil to bearings.
3. Reassemble and seal housing.

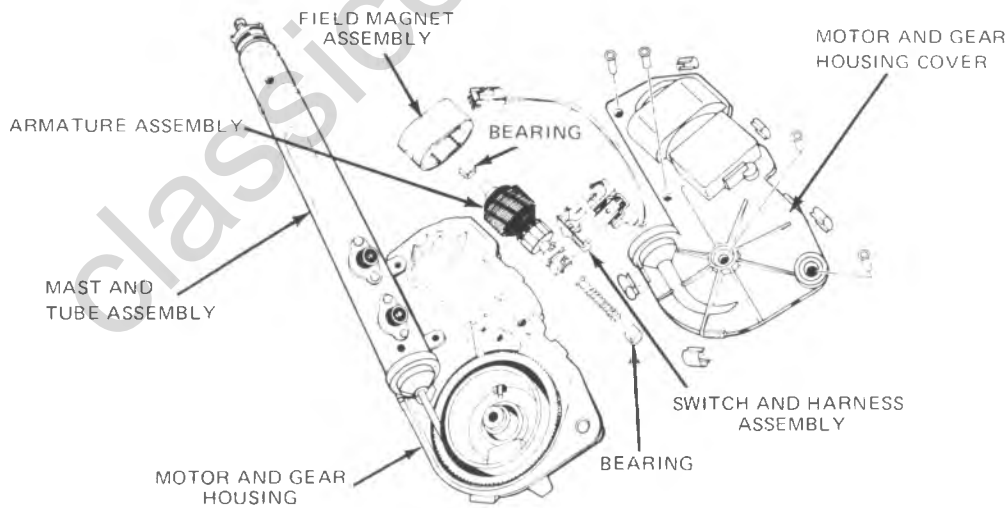


Fig. 9-23R--Slimline Disassembly II

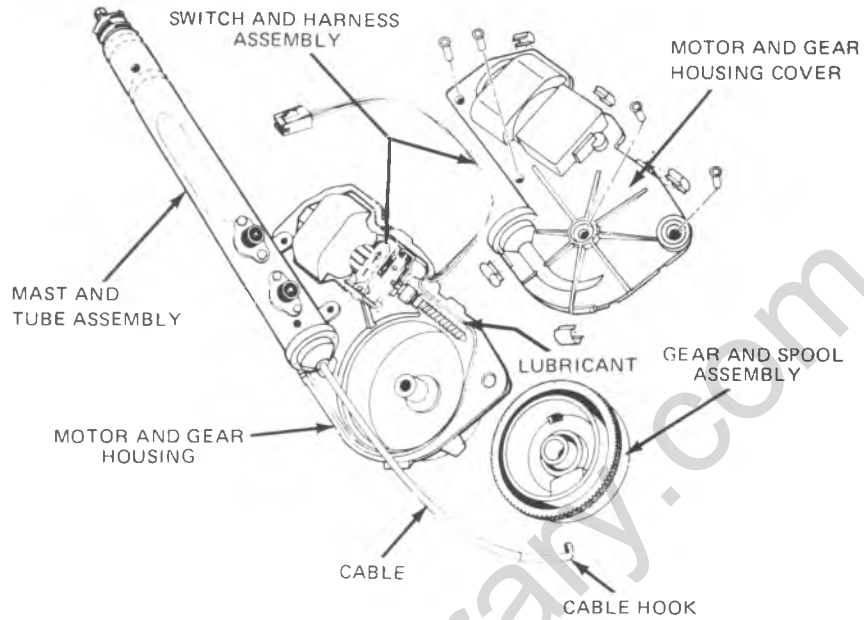
5. REMOVE AND INSTALL GEAR ASSEMBLY.

REMOVAL

1. Disassemble as shown.
2. Clean out old lubricant.

INSTALL

1. Apply lubricant to worm and gear.
2. Reassemble and seal housing.



6. REMOVE AND INSTALL CB LOAD COIL AND/OR TIP.

REMOVAL

1. Disconnect Neg. Battery Cable.
2. Turn on ignition and radio then connect battery long enough to raise antenna about half way.
3. Remove parts as shown using padded pliers.

INSTALL

1. Reassemble as shown using thread cement to lock in place.
2. Adjust S.W.R. (See SWR adjustment procedure)

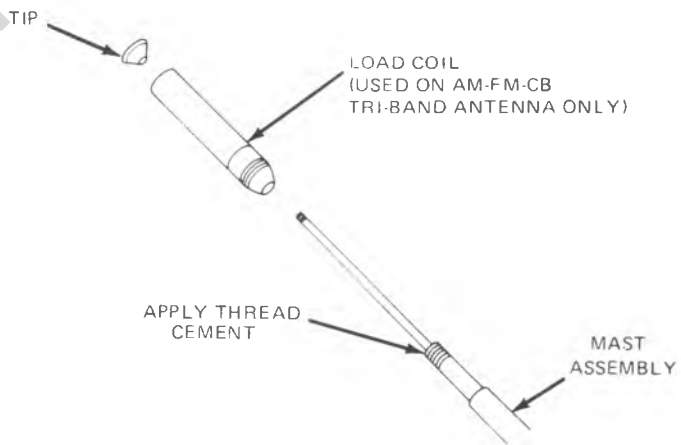


Fig. 9-24R--Slimline Disassembly III

classicalcarlibrary.com

SECTION 10

METRIC & FASTENER INFORMATION

USE OF METRIC AND CUSTOMARY NUTS, BOLTS AND SCREWS

Some of the 1980 model cars present special service requirements to the technician due to the use of both metric and customary (inch) type nuts, bolts and screws on the same car. Many are metric and some are very close in dimension to customary nuts, bolts and screws in the inch system. Mismatched or incorrect nuts, bolts and screws can result in damage, malfunction or possible personal injury. Nuts, bolts and screws removed from the car should be saved for re-use whenever possible. If they are not re-usable, care should be taken to select a replacement that matches the original.

General Motors Engineering Standards have adopted a portion of the standard metric fastener sizes defined by SI (Système International). This was done to reduce the number of sizes used and yet retain the best strength characteristics in each thread size. For example, the customary 1/4-20 and 1/4-28 screws are replaced by the metric M6.3 x 1 screw which has nearly the same diameter and 25.4 threads per inch. The thread pitch is in between the customary coarse and fine thread pitches.

Metric and customary thread notation differ slightly. The difference is illustrated below.

| CUSTOMARY | METRIC |
|---------------------------------------|---|
| 1/4 | M6.3 |
| Thread Major Diameter in Inches | Thread Major Diameter in Millimeters |
| 20 | 1 |
| Number of Threads per Inch | Distance Between Threads in Millimeters |




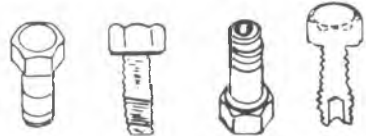





Care should be taken when servicing the car to guard against cross threading or improper retention due to interchanged metric and inch nuts and bolts.

When obtaining metric or customary nuts, bolts, and screws locally for servicing the car, care must be exercised in selecting parts that are equivalent to the original parts in dimensions, strength, and pitch of threads.

REUSE OF PREVAILING TORQUE NUT(S) AND BOLT(S)

PREVAILING TORQUE NUTS ARE THOSE NUTS WHICH INCORPORATE A SYSTEM TO DEVELOP AN INTERFERENCE BETWEEN NUT AND BOLT THREADS INTERFERENCE IS MOST COMMONLY ACHIEVED BY DISTORTING TOP OF ALL-METAL NUT, BUT ALSO MAY BE ACHIEVED BY DISTORTING AT MIDDLE OF HEX FLAT, BY NYLON PATCH ON THREADS, BY NYLON WASHER INSERT AT TOP OF NUT AND BY NYLON INSERT THROUGH NUT.

PREVAILING TORQUE BOLTS ARE THOSE BOLTS WHICH INCORPORATE A SYSTEM TO DEVELOP AN INTERFERENCE BETWEEN BOLT AND NUT OR TAPPED HOLE THREADS. INTERFERENCE IS ACHIEVED BY DISTORTING SOME OF THE THREADS (SEVERAL METHODS EXIST), BY APPLYING A NYLON PATCH OR STRIP OR BY ADHESIVE COATING ON THREADS.

| PREVAILING TORQUE NUTS | | | | PREVAILING TORQUE BOLTS | | | |
|--|--|--|--|--|--|---|--|
|  <p>TOP LOCK MANY TYPES</p> | |  <p>CENTER LOCK</p> | |  <p>DRY ADHESIVE COATING</p> | |  <p>OUT OF ROUND THREAD AREA</p> | |
|  <p>NYLON INSERT</p> | |  <p>NYLON PATCH</p> | |  <p>NYLON STRIP OR PATCH</p> | |  <p>THREAD PROFILE DEFORMED</p> | |
|  <p>NYLON WASHER INSERT</p> | | | | | | | |

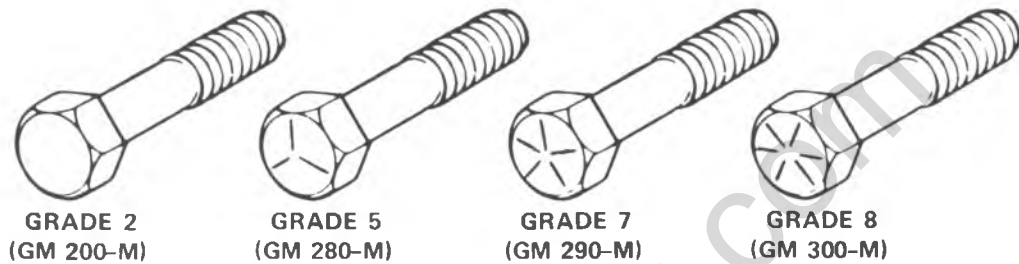
RECOMMENDATIONS FOR REUSE

- A. CLEAN, UNRUSTED PREVAILING TORQUE BOLTS AND NUTS MAY BE REUSED AS FOLLOWS:
- CLEAN DIRT AND OTHER FOREIGN MATERIAL OFF NUT AND BOLT.
 - INSPECT BOLT AND NUT TO ASSURE THERE ARE NO CRACKS, ELONGATION OR OTHER SIGNS OF ABUSE OR OVERTIGHTENING. LIGHTLY LUBRICATE THREADS. (IF ANY DOUBT, REPLACE WITH NEW PREVAILING TORQUE FASTENER OF EQUAL OR GREATER STRENGTH.)
 - ASSEMBLE PARTS AND START BOLT OR NUT.
 - OBSERVE THAT BEFORE FASTENER SEATS, IT DEVELOPS PREVAILING TORQUE PER CHART BELOW. (IF ANY DOUBT, INSTALL NEW PREVAILING TORQUE FASTENER OF EQUAL OR GREATER STRENGTH).
 - TIGHTEN TO TORQUE SPECIFIED IN SERVICE MANUAL.
- B. BOLTS AND NUTS WHICH ARE RUSTY OR DAMAGED SHOULD BE REPLACED WITH NEW PARTS OF EQUAL OR GREATER STRENGTH.

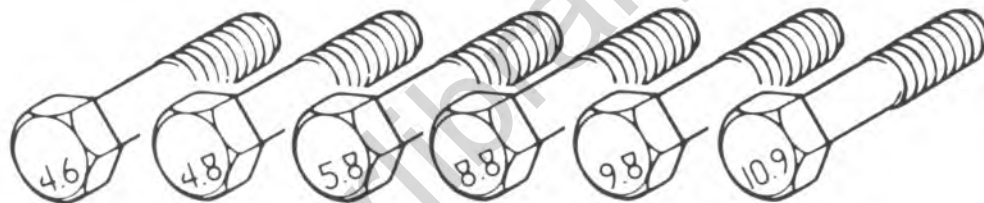
| | | METRIC SIZES | | | | | | | |
|--------------------------------|----------|--------------|------|------|------|------|------|------|------|
| | | 6 & 6.3 | 8 | 10 | 12 | 14 | 16 | 20 | |
| NUTS AND ALL METAL BOLTS | N•m | 0.4 | 0.8 | 1.4 | 2.2 | 3.0 | 4.2 | 7.0 | |
| | In. Lbs. | 4.0 | 7.0 | 12 | 18 | 25 | 35 | 57 | |
| ADHESIVE OR NYLON COATED BOLTS | N•m | 0.4 | 0.6 | 1.2 | 1.6 | 2.4 | 3.4 | 5.6 | |
| | In. Lbs. | 4.0 | 5.0 | 10 | 14 | 20 | 28 | 46 | |
| | | INCH SIZES | | | | | | | |
| | | .250 | .312 | .375 | .437 | .500 | .562 | .625 | .750 |
| NUTS AND ALL METAL BOLTS | N•m | 0.4 | 0.6 | 1.4 | 1.8 | 2.4 | 3.2 | 4.2 | 6.2 |
| | In. Lbs. | 4.0 | 5.0 | 12 | 15 | 20 | 27 | 35 | 51 |
| ADHESIVE OR NYLON COATED BOLTS | N•m | 0.4 | 0.6 | 1.0 | 1.4 | 1.8 | 2.6 | 3.4 | 5.2 |
| | In. Lbs. | 4.0 | 5.0 | 9.0 | 12 | 15 | 22 | 28 | 43 |

METRIC BOLT AND NUT IDENTIFICATION

Common metric fastener strength property classes are 9.8 and 10.9 with the class identification embossed on the head of each bolt. Customary (inch) strength classes range from grade 2 to 8 with line identification embossed on each bolt head. Markings correspond to two lines less than the actual grade (i.e. grade 7 bolt will exhibit 5 embossed lines on the bolt head). Some metric nuts will be marked with single digit strength identification numbers on the nut face. The following figure illustrates the different strength markings.



Customary (inch) bolts - Identification marks correspond to bolt strength - Increasing numbers represent increasing strength.

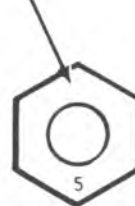


Metric Bolts - Identification class numbers correspond to bolt strength - Increasing numbers represent increasing strength.

MANUFACTURERS IDENTIFICATION



NUT STRENGTH IDENTIFICATION



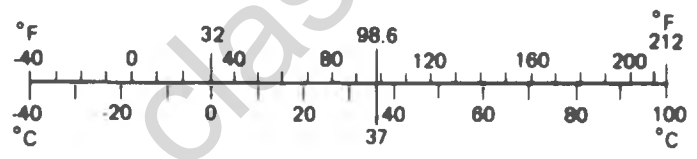
POSIDRIV SCREW HEAD



IDENTIFICATION MARKS (4)

SI METRIC-CUSTOMARY CONVERSION TABLE

| Multiply | by | to get equivalent number of: | Multiply | by | to get equivalent number of: |
|--------------------|---------------|---|---------------------------|------------|--|
| LENGTH | | | | | |
| Inch | 25.4 | millimeters (mm) | Foot/sec ² | 0.304 8 | meter/sec ² (m/s ²) |
| Foot | 0.304 8 | meters (m) | Inch/sec ² | 0.025 4 | meter/sec ² |
| Yard | 0.914 4 | meters | TORQUE | | |
| Mile | 1.609 | kilometers (km) | Pound-inch | 0.112 98 | newton-meters (N·m) |
| AREA | | | | | |
| Inch ² | 645.2 | millimeters ² (mm ²) | Pound-foot | 1.355 8 | newton-meters |
| Foot ² | 6.45 | centimeters ² (cm ²) | POWER | | |
| Yard ² | 0.836 1 | meters ² (m ²) | Horsepower | 0.746 | kilowatts (kW) |
| VOLUME | | | | | |
| Inch ³ | 16 387. | mm ³ | PRESSURE OR STRESS | | |
| Quart | 0.946 4 | liters | Inches of mercury | 3.377 | kilopascals (kPa) |
| Gallon | 3.785 4 | liters | Pounds/sq. in. | 6.895 | kilopascals |
| Yard ³ | 0.764 6 | meters ³ (m ³) | ENERGY OR WORK | | |
| MASS | | | | | |
| Pound | 0.453 6 | kilograms (kg) | BTU | 1 055. | joules (J) |
| Ton | 907.18 | kilograms (kg) | Foot-pound | 1.355 8 | joules |
| Ton | 0.907 | tonne (t) | Kilowatt-hour | 3 600 000. | joules (J = one W's) |
| FORCE | | | | | |
| Kilogram | 9.807 | newtons (N) | LIGHT | | |
| Ounce | 0.278 0 | newtons | Foot candle | 10.764 | lumens/meter ² (lm/m ²) |
| Pound | 4.448 | newtons | FUEL PERFORMANCE | | |
| TEMPERATURE | | | | | |
| Degree Fahrenheit | (°F-32) ÷ 1.8 | degree Celsius (C) | Miles/gal | 0.425 1 | kilometers/liter (km/l) |
| | | | Gal/mile | 2.352 7 | liters/kilometer (l/km) |
| | | | VELOCITY | | |
| | | | Miles/hour | 1.609 3 | kilometers/hr. (km/h) |



DECIMAL AND METRIC EQUIVALENTS

| Fractions | Decimal In. | Metric MM. | Fractions | Decimal In. | Metric MM. |
|-----------|----------------|---------------|-----------|----------------|---------------|
| 1/64 | .015625 | .39688 | 33/64 | .515625 | 13.09687 |
| 1/32 | .03125 | .79375 | 17/32 | .53125 | 13.49375 |
| 3/64 | .046875 | 1.19062 | 35/64 | .546875 | 13.89062 |
| 1/16 | .0625 | 1.58750 | 9/16 | .5625 | 14.28750 |
| 5/64 | .078125 | 1.98437 | 37/64 | .578125 | 14.68437 |
| 3/32 | .09375 | 2.38125 | 19/32 | .59375 | 15.08125 |
| 7/64 | .109375 | 2.77812 | 39/64 | .609375 | 15.47812 |
| 1/8 | .125 | 3.1750 | 5/8 | .625 | 15.87500 |
| 9/64 | .140625 | 3.57187 | 41/64 | .640625 | 16.27187 |
| 5/32 | .15625 | 3.96875 | 21/32 | .65625 | 16.66875 |
| 11/64 | .171875 | 4.36562 | 43/64 | .671875 | 17.06562 |
| 3/16 | .1875 | 4.76250 | 11/16 | .6875 | 17.46250 |
| 13/64 | .203125 | 5.15937 | 45/64 | .703125 | 17.85937 |
| 7/32 | .21875 | 5.55625 | 23/32 | .71875 | 18.25625 |
| 15/64 | .234375 | 5.95312 | 47/64 | .734375 | 18.65312 |
| 1/4 | .250 | 6.35000 | 3/4 | .750 | 19.05000 |
| 17/64 | .265625 | 6.74687 | 49/64 | .765625 | 19.44687 |
| 9/32 | .28125 | 7.14375 | 25/32 | .78125 | 19.84375 |
| 19/64 | .296875 | 7.54062 | 51/64 | .796875 | 20.24062 |
| 5/16 | .3125 | 7.93750 | 13/16 | .8125 | 20.63750 |
| 21/64 | .328125 | 8.33437 | 53/64 | .828125 | 21.03437 |
| 11/32 | .34375 | 8.73125 | 27/32 | .84375 | 21.43125 |
| 23/64 | .359375 | 9.12812 | 55/64 | .859375 | 21.82812 |
| 3/8 | .375 | 9.52500 | 7/8 | .875 | 22.22500 |
| 25/64 | .390625 | 9.92187 | 57/64 | .890625 | 22.62187 |
| 13/32 | .40625 | 10.31875 | 29/32 | .90625 | 23.01875 |
| 27/64 | .421875 | 10.71562 | 59/64 | .921875 | 23.41562 |
| 7/16 | .4375 | 11.11250 | 15/16 | .9375 | 23.81250 |
| 29/64 | .453125 | 11.50937 | 61/64 | .953125 | 24.20937 |
| 15/32 | .46875 | 11.90625 | 31/32 | .96875 | 24.60625 |
| 31/64 | .484375 | 12.30312 | 63/64 | .984375 | 25.00312 |
| 1/2 | .500 | 12.70000 | 1 | 1.00 | 25.40000 |

classiccarylbrary.com

INDEX

- A**
- ACCESSORIES 9-1
 ADAPTER ASSEMBLY, TRANSFER 7E-5
 AIR CLEANER OB-11, 6E-9
 AIR CONDITIONING 1B-1
 Diagnosis 1B-11
 Wiring 1B-20
 Performance Chart 1B-20
 Pressure Switch 1B-12
 AIR INJECTOR REACTOR PUMP 6E-16
 ALIGNMENT 3A-1
 ANTENNA, RADIO 9-24
 ANTI-THEFT SYSTEM 8B-8
 AUTOMATIC TRANSMISSION 7A-1
 AXLE
 Front 4C-1
 Rear 4B-1
 Shaft Type All 4B-13, 4B-18, 4B-20, 4B-21
 Bearing and Seal Type All .. 4B-14, 4B-19, 4B-20, 4B-22
- B**
- BACKING LAMP SWITCH 8C-7
 Automatic Transmission 8B-7
 Manual Transmission 8C-7
 BACK PRESSURE EGR VALVE 6E-4
 BALL JOINT 3C-20
 BATTERY 6D-5
 Boosting, Jump Starting 6D-8
 BELT TENSION CHART 0B-10
 BODY MOUNTS 2D-29
 BRAKES 5-1
 Disc 5-25
 Hydro-Boost 5-39
 Fluid Recommendations 0B-12
 Master Cylinder 5-22
 Power Cylinder 5-39
 Stop Lamp Switch 5-10
 Warning Light 5-20
 Wheel Cylinder 5-38
 BULBS 8A-10
 Replacement 8A-10
 BUMPERS 2B-1
 Headlamp Warning 8B-6
- C**
- CAMSHAFT IDENTIFICATION 6A6-29
 CAMSHAFT & BEARINGS
 In-Line 6A1-18
 Small Block 6A4-20
 Mark IV 6A5-19
 350 Diesel 6A6-29
 CANISTER PURGE — TVS 6E-3
 CAPACITIES 0B-13
 CARBURETOR
 Model 1ME 6C1-1
 Model 2SE 6C2-1
 Model M2MC 6C3-1
 Model M4MC 6C4-1
- Adjustment Chart
 Model 1ME 6C1-3
 Model 2SE 6C2-4
 Model M2MC 6C3-2
 Model M4MC 6C4-4
 Diagnosis Chart 6C-2
 CAR MODEL IDENTIFICATION 0A-2
 CASE, TRANSFER 7E-1
 CATALYTIC CONVERTER 6F-1
 CHARGING CIRCUIT OPERATION 6D-9
 CHASSIS LUBRICATION 0B-3
 CHASSIS SHEET METAL 2C-1
 CHASSIS SPRINGS
 Front 3C-15
 Rear 3D-4
 CIRCUIT PROTECTION 8B-4
 Circuit Breaker 8B-4
 Fuse 8B-4
 CLUSTER, SPEEDOMETER 8C-8
 CLUTCH 7C-1
 CLUTCH START SWITCH 8C-6
 CLUTCH, TORQUE CONVERTER 7A-1
 COIL, IGNITION 6D-39
 COMPRESSION TEST 6A6-5
 CONNECTING ROD & BEARINGS
 In-Line 6A1-20
 Small Block 6A4-22
 Mark IV 6A5-21
 350 Diesel 6A6-21
 CONTROL ARM
 Upper 3C-17
 Lower 3C-17
 COOLING SYSTEM 6B-1
 CRANKCASE VENTILATION (PCV) 6E-11
 CRANKSHAFT, ENGINE
 In-Line 6A1-30
 Small Block 6A4-32
 Mark IV 6A5-30
 350 Diesel 6A6-31
 CRUISE CONTROL 9-1
 Cruise Control Wiring 9-4
- D**
- DECIMAL, METERIC EQUIVALENTS 10-1
 DEFROSTER DUCTS, WINDSHIELD 1B-42
 DELAY PULSE WIPER/WASHER 8C-20
 DIAGNOSIS
 A/C System (All Series) 1B-11
 Air Injector Reactor (AIR) 6E-16
 Antenna (Power) 9-13
 Battery 6D-6
 Brakes
 General Diagnosis 5-2
 Carburetion 6C-2
 Charging System 6D-46
 Clutch 7C-1
 Cooling System 6B-6
 Cruise Control 9-3
 Diesel Engine 6A-10, 6D-26
 Distributor 6D-34

Early Fuel Evaporation System (EFE)..... 6E-3
 Engine, General..... 6A-2
 Engine, Cooling..... 6B-6
 Exhaust Gas Recirculation (EGR)..... 6E-5
 Front Suspension..... 3C-1
 Fuel Gage..... 8C-2
 Fuel System..... 6C-2
 Heater..... 1A-4
 High Energy Ignition..... 6D-35
 Lighting System..... 8A-3
 Positive Crankcase Ventilation (PCV)..... 6E-11
 Radio, CB..... 9-11
 Radio/Tape..... 9-11
 Rear Axle..... 4B-1
 Rear Axle Noises..... 4B-7, 4B-8
 Seat Belt Warning System..... 8B-6
 Shock Absorber..... 3C-5
 Starting System..... 6D-46
 Steering
 Linkage..... 3B1-1
 Manual Gear..... 3B2-1
 Pump and Gear (Power)..... 3B3-1
 Steering Column..... 3B4-1
 Tape Player/Radio..... 9-11
 Thermostatic Air Cleaner..... 6E-11
 Transmission-Manual..... 7B-1
 Automatic 350 and 350C Transmission..... 7A-7
 Torque Converter Clutch..... 7A-1
 Turn Signal Switch..... 3B4-2
 Valve Lifter..... 6A-2
DIESEL ENGINE
 Fuel Lines..... 6A6-7
 Injection Nozzle..... 6A5-15
 Injection Pump..... 6A6-9
 Electronic Controls..... 6D-18
DOWNSHIFT OR T.V. CABLE
 Automatic 350 and 350C Transmission..... 7A-12

E
EARLY FUEL EVAP. VALVE & ACTUATOR.... 6E-3
EFE CHECK VALVE..... 6E-3
EFE-TVS..... 6E-3
ELECTRICAL CHASSIS..... 8A-1
ELECTRICAL ENGINE..... 6D-1
ELECTRICAL CIRCUIT DIAGNOSIS..... 8A-1
ELECTRONIC SPARK TIMING/EGR-TVS.... 6E1-24
EMISSION CONTROL MAINTENANCE..... 0B-11
ENGINE
 Cooling System..... 6B-1
 Crankcase Ventilation (PCV)..... 0B-11, 6E-11
 Exhaust System..... 6F-1
 Fuel System..... 6C-1
 Identification..... 0A-1
 Mechanical..... 6A-1
 Oil Recommendations..... 0B-12
 Performance Specifications..... 6E-27
 Vacuum Hose Routing..... 6E-26
 Wiring..... 6D-34
EVAPORATIVE EMISSION CONTROL..... 6C5-10
EXHAUST GAS RECIRCULATION..... 6E-5
EGR/CANISTER PURGE-TVS..... 6E-5
EGR-TVS..... 6E-5
EGR THERMAL CONTROL VALVE..... 6E-5
EGR/EFE-TVS SWITCH..... 6E-5

F

FAN, ENGINE..... 6B-11
 FENDER ASSEMBLY..... 2C-9
 FRAME..... 2A-1
 FRONT AXLE..... 4C-1
 FRONT MARKER LIGHT..... 8A-40
 FRONT SUSPENSION..... 3C-1
 FRONT WHEEL ALIGNMENT..... 3A-1
 FRONT WHEEL BEARING..... 3C-14
FUEL GAGE
 Dash Unit..... 8C-10
 Tank Unit..... 6C5-3
FUEL PUMP..... 6C5-1
FUEL SYSTEM..... 6C5-1
FUEL TANK..... 6C5-3
FUSES..... 8B-4
FUSE PANEL..... 8A-1
FUSIBLE LINK REPLACEMENT..... 8B-4

G

GENERATOR..... 6D-8

H

HEADLAMPS
 Aiming..... 8A-9
 Headlamp Switch..... 8A-13
HEATER..... 1A-1
HIGH ENERGY IGNITION..... 6D-33
HOOD ASSEMBLY..... 2C-1
 Latch..... 2C-2
 Hinge..... 2C-1

I

IDENTIFICATION NO. VEHICLE..... 0A-1
IDLE SPEED SPECIFICATIONS
 Model 1ME..... 6C5-16
 Model 2SE..... 6C5-16
 Model M2MC..... 6C5-16
 Model M4MC..... 6C5-16
IGNITION COIL..... 6-39
IGNITION KEY WARNING..... 8A-56
IGNITION LOCK..... 3B4-21
IGNITION SWITCH OPERATION CIRCUIT... 8A-21
IGNITION SWITCH..... 3B4-22
IGNITION TIMING..... 6D-34
INFORMATION CHARTS
 Automatic 350 and 350C Transmission..... 7A-21
 Fan Clutch..... 6B-11
 Fan Blade..... 6B-11
 Engine Performance Specifications..... 6E-27
INSTRUMENT PANEL AND GAGES
 Instrument Panel Illumination..... 8C-8
INJECTION NOZZLE..... 6A6-15
INJECTION PUMP..... 6A6-7
INTAKE MANIFOLD
 In-Line..... 6A1-10
 Small Block..... 6A4-5
 Mark IV..... 6A5-6
 350 Diesel..... 6A6-10

K

KNUCKLE, STEERING..... 3C-21, 3C-29, 3C-31

L

LAMP BULB REPLACEMENT 8A-9
 LAMP BULB SPECIFICATIONS 8A-16
 LIFT POINTS 0B-15
 LINKAGE, STEERING 3B1-1
 LOWER CONTROL ARM 3C-16
 LUBRICATION 0B-3

M

MAINTENANCE CHART 0B-2
 MANIFOLD, ENGINE
 Intake
 In-Line 6A1-10
 Small Block 6A4-5
 Mark IV 6A5-6
 350 Diesel 6A6-10
 Exhaust
 In-Line 6A1-10
 Small Block 6A4-11
 Mark IV 6A5-10
 350 Diesel 6A6-4
 MASTER CYLINDER, BRAKE 5-22
 MODEL DESIGNATION 0A-2
 MOUNTINGS
 Engine
 In-Line 6A1-9
 Small Block 6A4-6
 Mark IV 6A5-6
 350 Diesel 6A6-4
 Body 2A-29
 MUFFLER 6F-1

N

NEUTRAL START AND BACK-UP LAMP
 Switch 3B4-23

O

OIL FILTER, ENGINE 0B-6
 OIL PRESSURE INDICATOR LIGHT 8C-6
 OIL PUMP, ENGINE
 In-Line 6A1-19
 Small Block 6A4-22
 Mark IV 6A5-21
 350 Diesel 6A6-20
 OIL RECOMMENDATIONS
 Engine 0B-6
 Transmission 7A-1
 Checking Level, Transmission 7A-31

P

PARKING BRAKE CONTROLS 5-16
 PERIODIC MAINTENANCE 0B-6
 PINION OIL SEAL 4B-13
 PISTONS, PINS, RINGS
 In-Line 6A1-24
 Small Block 6A4-27
 Mark IV 6A5-25
 350 Diesel 6A6-24
 PCV SYSTEM 6E-11
 POWER ANTENNA 9-24
 POWER DOOR LOCKS 2D-15
 POWER SEATS 8A-105
 POWER WINDOW 2D-13

PUMP, FUEL 6C5-1
 PUMP, OIL
 Engine 6A4-19
 In-Line 6A1-19
 Small Block 6A4-22
 Mark IV 6A5-21
 350 Diesel 6A6-20
 PUMP, POWER STEERING 3B3-13

R

RADIATOR 6B-11
 RADIO
 AM and AM-FM Stereo 8B-1
 Diagnosis 9-11
 Static Suppression 9-13
 Trimmer, Antenna 9-24
 WIRING 8A-85
 REAR AXLE 4B-1
 Bearing and/or Seal 4B-13
 Shaft 4B-13, 4B-18, 4B-20, 4B-21
 REAR MARKER LIGHT 8A-36
 REAR SUSPENSION 3D-1
 RELEASE BEARING, CLUTCH 7C-1
 RINGS, PISTON
 Engine
 In-Line 6A1-24
 Small Block 6A4-27
 Mark IV 6A5-25
 350 Diesel 6A6-24

S

SEAT BELT WARNING SYSTEM 8B-6
 SHEET METAL CHASSIS 2C-1
 SHOCK ABSORBERS
 Front 3C-14
 Rear 3D-2
 SIDE MARKER LIGHTS 8A-11
 SKID PLATE 7E-5
 SOLENOID, STARTER 6D-50
 SPARK PLUGS 6E-34, 6D-34, 6D-35
 SPEAKER, Radio 8B-3
 SPECIFICATIONS
 Battery 6D-58
 Brakes 5-48
 Clutch 7C-9
 Engine
 In-Line 6A1-31
 Small Block 6A4-34
 Mark IV 6A5-31
 350 Diesel 6A6-35
 Engine Performance Specification Chart 6E-27
 Front Wheel Alignment 3A-6
 Idle-All Carburetors 6C5-16
 Lamp Bulbs 8B-12
 Lug Nut Torque 0B-3, 3E-6
 Maintenance Service 0B-3
 Rear Axle 4B-25
 Steering
 Linkage 3B1-4
 Power Gear 3B3-12
 Wheels and Columns 3B4-18, 3B4-23
 SPEEDOMETER CLUSTER 8C-8
 SPEEDOMETER CABLE 8C-10
 SPRING, FRONT SUSPENSION
 Coil 3C-15

| | |
|-----------------------------|---------------------|
| SPRING, HOOD HINGE | 2C-1 |
| SPRING, REAR SUSPENSION | |
| Leaf | 3D-4 |
| STABILIZER SHAFT | |
| Front | 3C-15 |
| Rear | 3D-3 |
| STARTER | |
| Except Diesel | 6D-44 |
| Diesel | 6D-53 |
| STEERING | |
| Arm, Idler | 3B1-8 |
| Arm, Pitman | 3B1-9 |
| Column | 3B4-23 |
| Diagnosis | |
| Column | 3B4-2 |
| Linkage | 3B1-1 |
| Manual Gear | 3B2-1 |
| Pump and Gear (Power) | 3B3-1 |
| Knuckle | 3C-21, 3C-24, 3C-31 |
| STEERING WHEEL | |
| Standard | 3B4-18 |
| STEREO RADIO | 9-11 |
| STOP LIGHT SWITCH | 5-10 |
| STOWAWAY SPARE | 3E-5 |
| STRUT ROD | 7E-5 |
| SUSPENSION | |
| Front | 3C-1 |
| Rear | 3D-1 |
| SWITCH, Headlamp | 8A-13 |
| Ignition | 3B4-9 |
| Turn Signal | 3B4-6 |

T

| | |
|--------------------------------|-------|
| TAIL PIPE | 6F-1 |
| TANK, FUEL | 6C5-3 |
| TAPE PLAYER/RADIO | 9-11 |
| THERMOSTAT, ENGINE | 6B-10 |
| THERMOSTATIC AIR CLEANER | 6E-11 |
| TIE ROD | 3B1-4 |
| TIMING | |
| Adjustment | 6D-40 |
| Ignition | 6E-34 |
| TIRES | |
| Balance | 3E-7 |
| Rotation | 0B-8 |

| | |
|--|-------|
| TRANSFER CASE | 7E-1 |
| TRANSMISSION | |
| Automatic 350 and 350C Transmission | 7A-1 |
| Manual | |
| Three Speed | 7B-1 |
| Four Speed | 7B-1 |
| TUNE-UP | |
| Engine Performance Specification Chart | 6E-27 |
| T.V. CABLE SYSTEM | |
| Automatic 200 and 200C Transmission | 7A-14 |
| Automatic Transmission 250C | 7A-45 |
| Automatic 350 and 350C Transmission | 7A-68 |

U

| | |
|------------------------|------|
| UNIVERSAL JOINTS | 4A-1 |
|------------------------|------|

V

| | |
|-------------------------------------|-------|
| VEHICLE IDENTIFICATION | 0A-1 |
| VENTILATION, CRANKCASE (PCV) | 6E-11 |
| VACUUM HOSE ROUTING | |
| Engine Vacuum Hoses | 6E-26 |
| Air Conditioning Vacuum Hoses | 1B-5 |
| VIBRATION DIAGNOSIS | 3-15 |

W

| | |
|-----------------------------|--------|
| WATER PUMP | 6B-10 |
| WHEELS | 3E-1 |
| Alignment | 3A-1 |
| Balance | 3E-7 |
| Lug Nut Torque | 3E-9 |
| WHEEL BEARINGS | |
| Front | 3C-14 |
| Rear | 4B-11 |
| WHEEL CYLINDER, BRAKE | 5-38 |
| WHEEL, STEERING | |
| Standard | 3B4-18 |
| Deluxe | 3B4-18 |
| WINDSHIELD | |
| Antenna | 9-17 |
| WIPER | |
| CK, G Series | 8C-16 |
| P Series | 8C-36 |
| Switch | 8C-6 |

classiccarylbrary.com

classiccarylbrary.com

classiccarylbrary.com

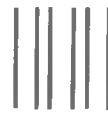
classiccaryllibrary.com

classiccarylbrary.com

classiccarylbrary.com

SUGGESTION CARDS

Outline your suggestions for improvement of this Service Manual on one of the attached cards and mail. No postage necessary. You may also use these cards to report errors in the Manual.

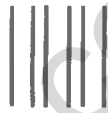
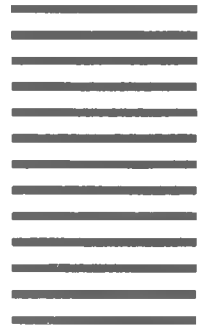


NO POSTAGE
NECESSARY
IF MAILED
IN THE
UNITED STATES

BUSINESS REPLY CARD
FIRST CLASS PERMIT NO. 302 WARREN, MICHIGAN

POSTAGE WILL BE PAID BY ADDRESSEE

CHEVROLET MOTOR DIVISION
GENERAL MOTORS CORPORATION
30007 VAN DYKE AVE.
WARREN, MICHIGAN 48090

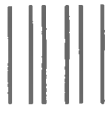


NO POSTAGE
NECESSARY
IF MAILED
IN THE
UNITED STATES

BUSINESS REPLY CARD
FIRST CLASS PERMIT NO. 302 WARREN, MICHIGAN

POSTAGE WILL BE PAID BY ADDRESSEE

CHEVROLET MOTOR DIVISION
GENERAL MOTORS CORPORATION
30007 VAN DYKE AVE.
WARREN, MICHIGAN 48090

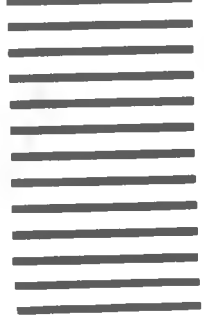


NO POSTAGE
NECESSARY
IF MAILED
IN THE
UNITED STATES

BUSINESS REPLY CARD
FIRST CLASS PERMIT NO. 302 WARREN, MICHIGAN

POSTAGE WILL BE PAID BY ADDRESSEE

CHEVROLET MOTOR DIVISION
GENERAL MOTORS CORPORATION
30007 VAN DYKE AVE.
WARREN, MICHIGAN 48090



1980 CHEVROLET SERVICE MANUAL
(PLEASE TYPE OR PRINT CLEARLY)

Suggestion Error Date _____

Manual No. and Title _____ Section and Page No. _____

Name _____ Title _____

Dealership
or
Company _____ Zone _____

Address _____ City & State _____ Zip Code _____

1980 CHEVROLET SERVICE MANUAL
(PLEASE TYPE OR PRINT CLEARLY)

Suggestion Error Date _____

Manual No. and Title _____ Section and Page No. _____

Name _____ Title _____

Dealership
or
Company _____ Zone _____

Address _____ City & State _____ Zip Code _____

1980 CHEVROLET SERVICE MANUAL
(PLEASE TYPE OR PRINT CLEARLY)

Suggestion Error Date _____

Manual No. and Title _____ Section and Page No. _____

Name _____ Title _____

Dealership
or
Company _____ Zone _____

Address _____ City & State _____ Zip Code _____

classiccarylbrary.com



classiccarlibrary.com