

Bob Hill

**LIGHT
DUTY
TRUCK**

**SERVICE
MANUAL**



ST 330-77

1977 CHEVROLET

FOREWORD

This manual includes procedures for diagnosis, maintenance and adjustments, minor service operations, and removal and installation for components of Chevrolet Light Duty Trucks. Procedures involving disassembly and assembly of major components for these vehicles are contained in the 1977 Chevrolet Passenger Car and Light Duty Truck Overhaul Manual. Wiring diagrams for 1977 trucks are contained in a separate Wiring Diagram Booklet.

The Section Index on the contents page enables the user to quickly locate any desired section. At the beginning of each section containing more than one major subject is a Table of Contents, which gives the page number on which each major subject begins. An Index is placed at the beginning of each major subject within the section.

Summaries of Special Tools, when required, and specifications are found at the end of major sections.

This manual should be kept in a handy place for ready reference. If properly used, it will enable the technician to better serve the owners of Chevrolet built vehicles.

All information, illustrations and specifications contained in this literature are based on the latest product information available at the time of publication approval. The right is reserved to make changes at any time without notice.

IMPORTANT SAFETY NOTICE

Proper service and repair is important to the safe, reliable operation of all motor vehicles. The service procedures recommended and described in this service manual are effective methods of performing service operations. Some of these service operations require the use of tools specially designed for the purpose. The special tools should be used when and as recommended.

It is important to note that this manual contains various Warnings, and Cautions which should be carefully read in order to minimize the risk of personal injury to service personnel or the possibility that improper service methods will be followed which may damage the vehicle or render it unsafe. It is also important to understand that these Warnings, and Cautions are not exhaustive. We could not possibly know, evaluate and advise the service trade of all conceivable ways in which service might be done or of the possible hazardous consequences of each way. Consequently, we have not undertaken any such broad evaluation. Accordingly, anyone who uses a service procedure or tool which is not recommended by the manufacturer must first satisfy himself thoroughly that neither his safety nor vehicle safety will be jeopardized by the service method he selects.

1977 LIGHT DUTY TRUCK (SERIES 10-35) CHASSIS SERVICE MANUAL

CAUTION

This vehicle contains some parts dimensioned in the metric system as well as in the customary system. Some fasteners are metric and are very close in dimension to familiar customary fasteners in the inch system. It is important to note that, during any vehicle maintenance procedures, replacement fasteners must have the same measurements and strength as those removed, whether metric or customary. (Numbers on the heads of metric bolts and on surfaces of metric nuts indicate their strength. Customary bolts use radial lines for this purpose, while most customary nuts do not have strength markings.) Mismatched or incorrect fasteners can result in vehicle damage or malfunction, or possibly personal injury. Therefore, fasteners removed from the vehicle should be saved for re-use in the same locations whenever possible. Where the fasteners are not satisfactory for re-use, care should be taken to select a replacement that matches the original. For information and assistance, see your authorized dealer.

SECTION	NAME
0A	GENERAL INFORMATION
0B	LUBRICATION
1A	HEATER
1B	MANUAL AIR CONDITIONING
2A	FRAME
2B	BUMPERS
2C	SHEET METAL
2D	BODY
3A	FRONT ALIGNMENT
3B	STEERING
3C	FRONT SUSPENSION
3D	REAR SUSPENSION
3E	WHEELS AND TIRES
4A	PROPSHAFT
4B	DRIVE AXLE
4C	FOUR WHEEL DRIVE
5	BRAKES
6A	ENGINE MECHANICAL
6B	ENGINE COOLING
6C	FUEL SYSTEM
6D	ENGINE ELECTRICAL
6E	ENGINE EMISSION
6F	ENGINE EXHAUST
7A	AUTOMATIC TRANSMISSION
7B	MANUAL TRANSMISSION
7C	CLUTCH
8	CHASSIS ELECTRICAL
9	ACCESSORIES

SECTION 0A

GENERAL INFORMATION

CONTENTS OF THIS SECTION

Truck Model Identification.....	0A-1	Service Parts Identification Plate.....	0A-3
Vehicle Identification Number and Rating Plate...	0A-1	Keys and Locks.....	0A-3
Engine Number.....	0A-1	Towing.....	0A-3
Unit and Serial Number Locations.....	0A-1		

TRUCK MODEL IDENTIFICATION

All 10-30 series models are identified by the model system shown in the chart on the following page. Basically the designation consists of 7 characters, 2 letters followed by five numbers. The first letter indicates a model and the second identifies the chassis type. The first number designates the GVW range, the second and third identify the cab-to-axle dimension or model type and the last two identify the cab or body style.

VEHICLE IDENTIFICATION NUMBER AND RATING PLATE

A combination vehicle identification number and rating plate used on all models (fig. 0A-1) is located on the left door lock pillar of C-K-G models. On Forward Control models, it is attached to the dash and toe panel.

The vehicle identification number stamped on the plate decodes into the information shown in Figure 0A-2.

ENGINE NUMBER

The engine number indicates manufacturing plant, month and day of manufacture, and transmission type. A typical engine number would be F1210TFA, which would breakdown thus:

- F - Manufacturing Plant (F-Flint, T-Tonawanda)
- 12 - Month of Manufacture (December)
- 10 - Day of Manufacture (tenth)
- T - Truck
- FA - Transmission and engine type

UNIT AND SERIAL NUMBER LOCATIONS

For the convenience of service technicians and engineers when writing up certain business papers such as Warranty Reports, Product Information Reports, or reporting product failures in any way, the location of the various unit numbers have been indicated. These unit numbers and their prefix or suffix are necessary on these papers for various reasons - such as accounting, follow-up on production, etc.

The prefixes on certain units identify the plant in which the unit was manufactured and thereby permits proper follow-up of the plant involved to get corrections made when necessary.

Always include the prefix in the number.

Axles

Chevrolet Built

- On 10 Series, the Code is stamped on Front of Right Rear Axle Tube.
- On 20-30 Series, the Code is stamped on Upper Surface of the Right Rear Axle Tube.

Dana Built

- On Front Axles, code is stamped on Front Surface of Left Axle Tube.
- On Rear Axles, code is stamped on Rear Surface of Right Axle Tube.

Transmissions

- On 3-Speed Transmissions (except Tremec), the Unit Number is located on Lower Left Side of Case Adjacent to Rear of Cover.
- On Tremec Transmissions, Unit Number is located on Upper Forward Mounting Flange of Case.
- On 70 mm 4-Speed Transmissions, Unit Number is stamped on Upper Center Front of Case. On Borg Warner 4-Speeds, Unit Number is located on Left Side of Case Rearward of Side Cover. Muncie 4-Speeds, Unit Number is located on Rear Face of Case below Retainer.
- On Turbo Hydra-Matic 350 Transmission, Unit Number is Located on Right Rear Vertical Surface of Oil Pan.
- On the Turbo Hydra-Matic 400 Transmission, Serial Number is Located on the Light Blue Plate on the Right Side of the Transmission.

Engines

- 6-Cylinder Engine Unit Number Located on Pad at Right Hand Side of Cylinder Block at Rear of Distributor.
- 8-Cylinder Engine Unit Number Located on Pad at Front, Right Hand Side of Cylinder Block.

Generators

Generator Unit Serial Number is located on the Drive End Frame Below the Part Number.

Batteries

Battery Code Number is Located on Cell Cover Top of Battery.

TRUCK MODEL IDENTIFICATION

1. C = Chevrolet; T = GMC Truck **C C 10703 + E63 + LG9**
2. Chassis Type _____
3. GVW Range _____
4. CA Dimension/Model Type _____
5. Cab or Body Style _____
6. Body Ordering Code _____
7. Engine Ordering Code _____

②

Chassis Type

- C—Conventional 4 x 2
- G—Forward Control 4 x 2 (Body-Frame Integral)
- K—Conventional 4 x 4 (Four Wheel Drive)
- P—Forward Control 4 x 2 (Conventional)

③

- Series/GVW Range**
- 1—4800 to 7300
 - 2—6400 to 8400
 - 3—6400 to 14,500

⑤

Cab or Body Style

- 03—Conventional Cab (C-K models); Cutaway Van, Hi-Cube Van (G models)
- 05—Chevy Van, Vandura
- 06—Suburban/Sportvan, Rally Wagon with Panel Rear Doors
- 16—Blazer, Jimmy
- 32—Motor Home Chassis
- 42—Forward Control Chassis, Step-Van, Value Van
- 43—Bonus Cab, Crew Cab

④

CA Dimension/Model Type

- 05—Blazer, Jimmy, Step-Van, Value Van
- 07—42"/Pickup, Chassis-Cab
- 08—FC or Motor Home Chassis, Step-Van, Value Van
- 09—56"/Suburban, Chassis-Cab, Pickup
- 10—60"/FC Chassis, Chevy Van, Vandura, Sportvan, Rally Wagon, Chassis-Cab, Step-Van, Value Van
- 11—Motor Home Chassis
- 13—Chevy Van, Vandura, Sportvan, Rally Wagon, Cutaway Van, Hi-Cube Van
- 14—84"/FC or Motor Home Chassis, Chassis-Cab, Step-Van, Value Van
- 16—Cutaway Van, Hi-Cube Van
- 18—Motor Home Chassis

⑥

Body Code

- ZW9—Base Body
- Z58—Blazer, Jimmy w/White Top
- Z59—Blazer, Jimmy w/Black Top
- Z64—RV Cutaway Van
- E31—Hi-Cube Van (10' Steel 96" Wide)
- E32—Step-Van, Value Van (Steel)
- E33—Step-Van, Value Van (Aluminum)
- E34—Hi-Cube Van (10' Steel 82" Wide)
- E36—Hi-Cube Van (96" Wide 10' Aluminum)
- E38—Hi-Cube Van (12' Steel 96" Wide)
- E39—Hi-Cube Van (96" Wide 12' Aluminum)
- E55—Suburban (w/End Gate)
- E62—Stepside (Fenderside) Pickup
- E63—Fleetside (Wide Side) Pickup
- E94—Beauville Sportvan, Rally STX

⑦

Engine Code

- LD4—250 Six
- L25—292 Six
- LG9—305-2 V8
- LS9—350-4 V8
- LF4—400-4 V8
- LF8—454-4 V8

MFD. BY GENERAL MOTORS CORPORATION

GVWR

GAWR FRONT GAWR REAR

VIN

CAMPER LOADING DATA

CWR DIM A DIM B

INFLATION DATA FOR TIRES FURNISHED WITH VEHICLE

FRONT PRESSURE

REAR PRESSURE

WARRANTY VOIDED IF LOADED IN EXCESS OF RATINGS

SEE OWNERS MANUAL FOR OTHER LOADING AND INFLATION DATA

Fig. 0A-1--Vehicle Identification Number and Rating Plate Information

SERVICE PARTS IDENTIFICATION

V.I.N. W/BASE SE

V.I.N. - VEHICLE IDENTIFICATION NUMBER

NOTE: THE SPECIAL EQUIPMENT LISTED BELOW HAS BEEN INSTALLED ON THIS VEHICLE FOR PROPER IDENTIFICATION OF REPLACEMENT PARTS. BE SURE TO SPECIFY THE APPLICABLE OPTION NUMBERS.

OPTION NO.	DESCRIPTION	OPTION NO.	DESCRIPTION

IMPORTANT: RETAIN THIS PLATE AS A PERMANENT RECORD

Fig. 0A-3--Service Parts Identification Plate

wheelbase, and all Production options or Special Equipment on the vehicle when it was shipped from the factory including paint information. **ALWAYS REFER TO THIS INFORMATION WHEN ORDERING PARTS.**

KEYS AND LOCKS

Two separate identifiable keys (with different cross section) are provided for the lock cylinders of each vehicle. The key codes are stamped on the "knock out" plug in the key head.

- Key with square head (stamped "E") - or ignition switch only.
- Key with oval head (stamped "H") - or all other locks.

TOWING

Proper lifting or towing equipment is necessary to prevent damage to the vehicle during any towing operation. State (Provincial in Canada) and local laws applicable to vehicles in tow must be followed.

All Except Four Wheel Drive Trucks

Normally this vehicle may be towed on all four wheels, at speeds of less than 35 MPH, for distances up to 50 miles, provided the driveline, axle and transmission, and steering system are otherwise normally operable. Use only towing equipment specifically designed for this purpose, following the instructions of the equipment manufacturer. A separate safety chain system must be used. For such towing the steering must be locked, transmission in neutral and parking brake released. Attachments must be made to main structural members of the vehicle. Do not attach to bumpers or associated brackets. Remember that power brake and power steering assists will not be available when engine is inoperative.

The rear wheels must be raised off the ground or the drive shaft disconnected when the transmission is not operating properly or when a speed of 35 MPH or distance of 50 miles will be exceeded.

CAUTION: *If a truck is towed on its front wheels only, the steering wheel must be secured with the wheels in a straight ahead position.*

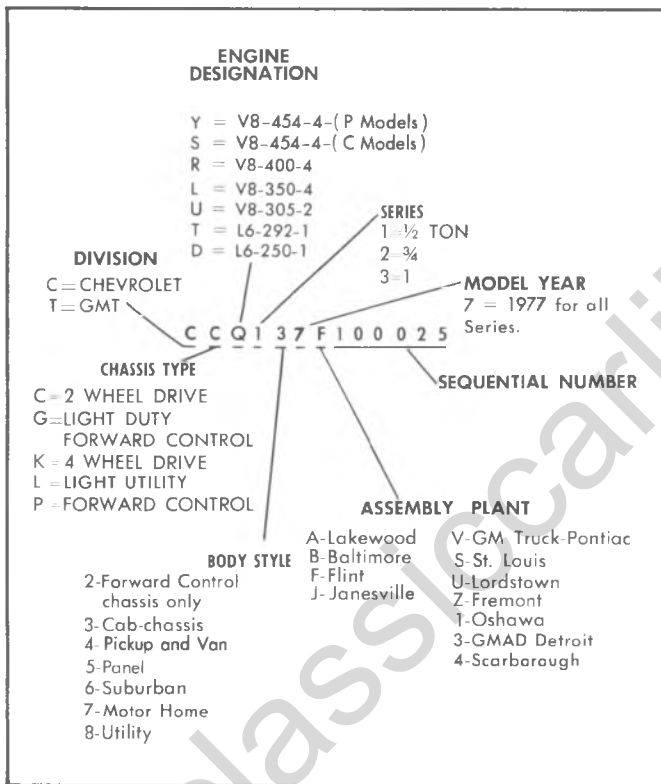


Fig. 0A-2--Vehicle Identification Number

Starters

Starter Serial Number and Production Date are Stamped on Outer Case, Toward Rear.

SERVICE PARTS IDENTIFICATION PLATE

The Service Parts Identification Plate (fig. 0A-3) is provided on all Truck models. On most series it will be located on the inside of the glove box door, or, on Forward Control series, it will be located on an inner body panel. The plate lists the vehicle serial number,

TIPS FOR TOWING FOUR WHEEL DRIVE VEHICLES

FRONT WHEELS OFF THE GROUND	
FULL TIME (4 X 4) AUTOMATIC TRANSMISSION	PART TIME (4 X 4) MANUAL TRANSMISSION
1. TRANSFER CASE IN NEUTRAL 2. TRANSMISSION IN PARK 3. MAXIMUM SPEED 35 MPH 4. MAXIMUM DISTANCE 50 MILES NOTE: For distances over 50 miles, disconnect rear propshaft at rear axle carrier and secure in safe position.	1. TRANSFER CASE IN 2 H 2. TRANSMISSION IN NEUTRAL 3. MAXIMUM SPEED 35 MPH 4. MAXIMUM DISTANCE 50 MILES NOTE: For distances over 50 miles, disconnect the rear propshaft at rear axle carrier and secure in safe position.
REAR WHEELS OFF THE GROUND	
CAUTION: When towing a vehicle in this position, the steering wheel should be secured to keep the front wheels in a straight ahead position.	
FULL TIME (4 X 4)	PART TIME (4 X 4)
1. TRANSFER CASE IN NEUTRAL 2. TRANSMISSION IN PARK 3. MAXIMUM SPEED 35 MPH 4. MAXIMUM DISTANCE 50 MILES NOTE: For distances over 50 miles, disconnect front propshaft at front axle carrier and secure in safe position.	1. TRANSFER CASE IN 2 H 2. TRANSMISSION IN NEUTRAL 3. MAXIMUM SPEED 35 MPH 4. MAXIMUM DISTANCE 50 MILES NOTE: For distances over 50 miles, disconnect the front propshaft at front axle carrier and secure in safe position.
ALL FOUR WHEELS ON GROUND	
FULL TIME (4 X 4)	PART TIME (4 X 4)
1. TRANSFER CASE IN NEUTRAL 2. TRANSMISSION IN PARK NOTE: Do not exceed speed as per State laws for towing vehicles.	1. TRANSFER CASE IN 2 H 2. TRANSMISSION IN NEUTRAL 3. MAXIMUM SPEED 35 MPH 4. MAXIMUM DISTANCE 50 MILES NOTE: For speeds or distances greater than above, both propshafts must be disconnected at the axle carrier end and secured in a safe position. It is recommended that both propshafts be removed and stored in the vehicle. NOTE: Do not exceed speeds as per State laws for towing vehicles.

Keyliner--Towing Chart 0A-2

Four Wheel Drive Trucks

It is recommended that the truck be towed with the front wheels off the ground. The truck can be towed, however, with the rear wheels off the ground if there is damage in the rear wheel area. Refer to Chart on "Tips for Towing Four Wheel Drive Vehicles".

STEEL TUBING REPLACEMENT

In the event that replacement of steel tubing is required on brake line, fuel line, evaporative emission, and transmission cooling lines, only the recommended steel replacement tubing should be used.

Only special steel tubing should be used to replace brake lines. That is, a double layer and brazed steel tubing meeting G.M. Specification 123M. Further, any other steel tubing should be replaced only with the released steel tubing or its equivalent. Under no condition should copper or aluminum tubing be used to replace steel tubing. Those materials do not have satisfactory fatigue durability to withstand normal vehicle vibrations.

All steel tubing should be flared using the upset (double lap) flare method.

VEHICLE LOADING

Vehicle loading must be controlled so weights do not exceed the numbers shown on the Vehicle Identification

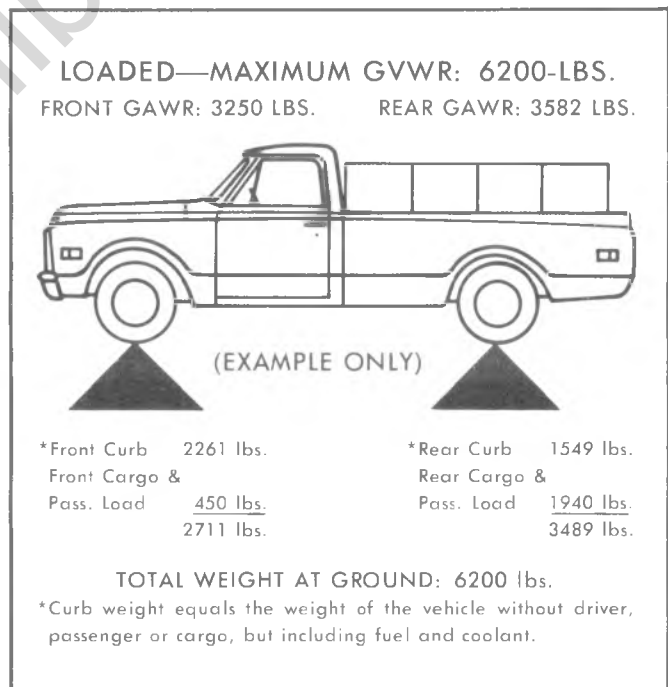


Fig. 0A-4--Typical Vehicle Loaded Condition

Number and Rating Plate for the vehicle.

A typical example of a truck in a loaded condition is shown in Figure 0A-4. Note that the axle or GVW capabilities are not exceeded.

SECTION OB LUBRICATION

INDEX

Maintenance Schedule.....	OB-1	Rear Axle.....	OB-4
Engine.....	OB-1	Propeller Shaft Slip Joints.....	OB-4
Oil and Filter Recommendations.....	OB-1	Universal Joints.....	OB-4
Drive Belts.....	OB-2	Wheel Bearings.....	OB-4
Positive Crankcase Ventilation (P.C.V.).....	OB-2	Brake Master Cylinder.....	OB-5
Air Injection Reactor System (A.I.R.).....	OB-3	Brake and Clutch Pedal Springs.....	OB-5
Controlled Combustion System (C.C.S.).....	OB-3	Parking Brake.....	OB-5
Evaporation Control System (E.C.S.).....	OB-3	Steering.....	OB-5
Early Fuel Evaporation (E.F.E.) System.....	OB-3	Hood Latch and Hood Hinge.....	OB-5
Air Cleaner.....	OB-3	Body Lubrication.....	OB-6
Fuel Filter.....	OB-3	Speedometer Adapter.....	OB-6
Accelerator Linkage.....	OB-3	Complete Maintenance Schedule.....	OB-6
Automatic Transmission.....	OB-3	Recommended Fluids Lubricants.....	OB-17
Manual Transmission.....	OB-4	Lubrication Diagrams.....	OB-18
Transmission Shift Linkage.....	OB-4	Conventional and Forward Control Models.....	OB-18
Clutch.....	OB-4	1/2 Ton G Models.....	OB-19

MAINTENANCE SCHEDULE

A separate maintenance folder has been provided with each vehicle which contains a complete schedule and brief explanation of the safety, emission control, lubrication and general maintenance it requires. The maintenance folder information is supplemented by this section of this manual, as well as the separate vehicle and emissions warranty booklet also furnished with each vehicle. Read all three publications for a full understanding of vehicle maintenance requirements.

The time or mileage intervals for lubrication and maintenance services outlined in this section are intended as a general guide for establishing regular maintenance and lubrication periods for trucks with light and heavy duty emission control systems (see chart). Sustained heavy duty and high speed operation or operation under adverse conditions may require more frequent servicing.

LIGHT AND HEAVY DUTY EMISSION CLASS VEHICLES
Light Duty Vehicle C10-Pickup (exc. over 6000 lbs. GVW)
Heavy Duty C10-Pickup (over 6000 lbs. GVW) C10-Suburban C-10-Utility C20-30 All models All K models All P models

ENGINE

Oil and Filter Recommendations

The letter designation "SE" has been established to correspond with the requirements of GM 6136-M. "SE" engine oils will be better quality and perform better than those identified with "SA" through "SD" designations and are recommended for all light-duty gasoline trucks regardless of model year and previous engine oil quality recommendations.

Oil Change Period

- Use only SE engine oil.

ENGINE OIL PERFORMANCE AND ENGINE SERVICE CLASSIFICATION SYSTEM

Letter Designation	GM Specification	Applicable Model Year
SA	None	None
SB	None	None
SC	GM 4745-M	1967 and Prior Years
SD	GM 6041-M (1968 Release)	1970 and Prior Years
SE	GM 6136-M 1972	1977 and Prior Years

- **Light Duty Emission Vehicles**-Change oil each 12 months or 7,500 miles. If more than 7,500 miles are driven in a 12 month period, change oil each 7,500 miles.

- **Heavy Duty Emission Vehicles**-Change oil each 4 months or 6,000 miles. If more than 6,000 miles are driven in a 4-month period, change oil each 6,000 miles.

- Change oil each 3 months or 3,000 miles (2 months or 3,000 miles on Heavy Duty Emission Vehicles), whichever occurs first, under the following conditions:

- Driving in dusty conditions.
- Trailer pulling or camper use.
- Motor Home use.
- Extensive idling.
- Short-trip operation at freezing temperatures (engine not thoroughly warmed-up).

- Operation in dust storms may require an immediate oil change.

- For Light Duty Emission Vehicles replace the oil filter at the first oil change, and every second oil change thereafter, if mileage (7,500 miles is the determining factor. If time (12 month) is the determining factor, then change oil filter with every oil change. For Heavy Duty Emission Vehicles, replace the oil filter at the first oil change and every other oil change thereafter using 6,000 miles or 12 month as the determining factors. AC oil filters (or equivalent) provide excellent engine protection.

The above recommendations apply to the first change as well as subsequent oil changes. The oil change interval for the engine is based on the use of SE oils and quality oil filters. Oil change intervals longer than those listed above will seriously reduce engine life and may affect the manufacturer's obligation under the provisions of the New Vehicle Warranty.

A high quality SE oil was installed in the engine at the factory. It is not necessary to change this factory-installed oil prior to the recommended normal change period. However, check the oil level more frequently during the break-in period since higher oil consumption is normal until the piston rings become seated.

NOTE: Non-detergent and other low quality oils are specifically not recommended.

Oil Filter Type and Capacity

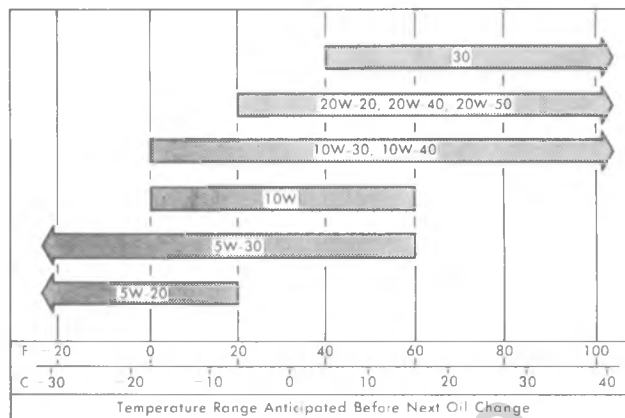
- Throwaway type, 1 quart U.S. measure, .75 quart Imperial measure.
- 250 and 292 cu. in., AC Type PF-25, 305, 350, 400 and 454 cu. in., AC Type PF-35.

Crankcase Capacity (Does Not Include Filter)

- 292 L6 Engine; 5 quarts U.S. measure, 4.25 quarts Imperial measure.
- All other engines; 4 quarts U.S. measure, 3.25 quarts Imperial measure.

Recommended Viscosity

To help assure good cold and hot starting, as well as maximum engine life, fuel economy, and oil economy, select the proper oil viscosity for the temperature range anticipated from the following chart:



NOTE: SAE 5W-30 oils are recommended for all seasons in vehicles normally operated in Canada. SAE 5W-20 oils are not recommended for sustained high-speed driving.

Checking Oil Level

The engine oil should be maintained at proper level. The best time to check it is before operating the engine or as the last step in a fuel stop. This will allow the oil accumulation in the engine to drain back in the crankcase. To check the level, remove the oil gauge rod (dipstick), wipe it clean and reinsert it firmly for an accurate reading. The oil gauge rod is marked "FULL" and "ADD". The oil level should be maintained in the safety margin, neither going above the "FULL" line nor below "ADD" line.

NOTE: The oil gauge rod is also marked "Use SE Engine Oil" as a reminder to use only SE oils.

Supplemental Engine Oil Additives

The regular use of supplemental additives is specifically not recommended and will increase operating costs. However, supplemental additives are available that can effectively and economically solve certain specific problems without causing other difficulties. For example, if higher detergency is required to reduce varnish and sludge deposits resulting from some unusual operational difficulty, a thoroughly tested and approved additive - "G.M. Super Engine Oil Supplement" (or equivalent) - is available.

Drive Belts

Drive belts should be checked every 7,500 miles or 12 months (6,000 miles or 4 months Heavy Duty Emission Vehicles) for proper tension. A loose belt will affect water pump and generator operation.

Positive Crankcase Ventilation Valve (P.C.V.)

Every 30,000 miles (24,000 miles Heavy Duty Emission Vehicles) or 24 months the valve should be replaced. Connecting hoses, fittings and flame arrestor should be cleaned. At every oil change the system should

be tested for proper function and serviced, if necessary (Also see maintenance schedule at end of this section.)

Air Injection Reactor System

(A.I.R.)--Controlled Combustion

System (E.C.S.)

The Air Injection Reactor system should have the drive belt inspected for wear and tension every 24 months or 30,000 miles (4 months or 6,000 miles Heavy Duty Emission Vehicles), whichever occurs first. In addition, complete effectiveness of either system, as well as full power and performance, depends upon idle speed, ignition timing, and idle fuel mixture being set according to specification. A quality tune-up which includes these adjustments should be performed periodically to assure normal engine efficiency, operation and performance.

Evaporation Control System (E.C.S.)

Every 30,000 miles (24,000 miles Heavy Duty Emission Vehicles) or 24 months, (more often under dusty conditions) the filter in the base of the canister must be replaced and the canister inspected.

Early Fuel Evaporation (E.F.E.) System

First 7,500 miles or 12 months check valve for freedom of operation. A binding condition must be corrected. Check hoses for cracking, abrasion or deterioration. Replace parts as necessary.

Air Cleaner

CAUTION: Do not remove the engine air cleaner unless temporary removal is necessary during repair or maintenance of the vehicle. When the air cleaner is removed backfiring can cause fire in the engine compartment.

NOTE: Under prolonged dusty driving conditions, it is recommended that these operations be performed more often.

Replace the engine air cleaner element under normal operating conditions every 30,000 miles (12,000 miles Heavy Duty Emission Vehicles except California 350-400 engines, replace every 24,000 miles).

Fuel Filter

Light Duty Emission Vehicles-Replace filter element located in carburetor inlet every 12 months or 15,000 miles whichever occurs first, or, if an in-line filter is also used, replace both filters every 30,000 miles.

Heavy Duty Emission Vehicles-Replace filter element in carburetor inlet every 12 months or 12,000 miles, whichever comes first, except California 350-400 engines should be replaced every 24 months or 24,000 miles.

Accelerator Linkage

Lubricate with engine oil every 15,000 miles (12,000 miles Heavy Duty Emission Vehicles) as follows:

1. On V8 engine, lubricate the ball stud at the carburetor lever.

2. On L6 engine, lubricate the two ball studs at the carburetor lever and lubricate the lever mounting stud. Do not lubricate the accelerator cable.

AUTOMATIC TRANSMISSION

Fluid Recommendations

Use automatic transmission fluids identified with the mark DEXRON® II.

Check the fluid level at each engine oil change period.

Automatic transmissions are frequently overfilled because the fluid level is checked when the fluid is cold and the dipstick indicates fluid should be added. However, the low reading is normal since the level will rise as the fluid temperature increases. A level change of over 3/4 inch will occur as fluid temperature rises from 60°F to 180°F.

Overfilling can cause foaming and loss of fluid through the vent. Slippage and transmission failure can result.

Fluid level too low can cause slipping, particularly, when the transmission is cold or the vehicle is on a hill.

Check the transmission fluid level with engine running, the shift lever in **PARK** and the vehicle level.

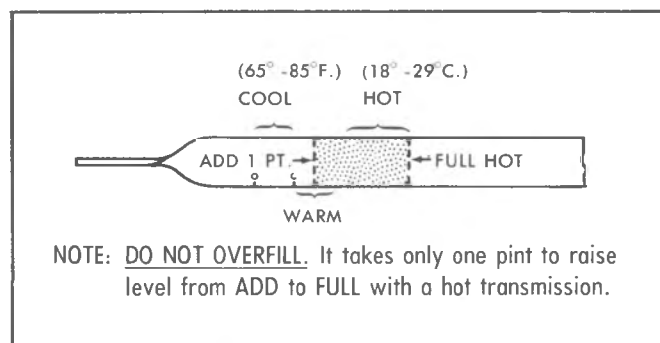
NOTE: If the vehicle has recently been operated for an extended period at high speed or in city traffic in hot weather or the vehicle is being used to pull a trailer, an accurate fluid level cannot be determined until the fluid has cooled down - usually about 30 minutes after the vehicle has been parked.

Remove the dipstick and touch the transmission end of the dipstick cautiously to find out if the fluid is cool, warm or hot.

Wipe it clean and re-insert until cap seats. Remove dipstick and note readings.

- If the fluid feels cool, about room temperature 65°F to 85°F the level should be 1/8 to 3/8 inch below the **ADD** mark. The dipstick has two dimples below the "ADD" mark to show this range (fig. 0B-1).

- If it feels warm, the level should be close to the **ADD** mark (either above or below).



NOTE: DO NOT OVERFILL. It takes only one pint to raise level from ADD to FULL with a hot transmission.

Fig. 0B-1--Automatic Transmission Dipstick

- If it feels hot (cannot be held comfortably), the level should be between the **ADD** and **FULL** marks.

Drain Intervals

The transmission operating temperature resulting from the type of driving conditions under which your vehicle is used is the main consideration in establishing the proper frequency of transmission fluid changes.

Change the transmission fluid and filter every 15,000 miles (12,000 miles Heavy Duty Emission Vehicles), if the vehicle is usually driven under one or more of the following conditions which are considered severe transmission service:

- In heavy city traffic.
- Where the outside temperature regularly reaches 90 °F.
- In very hilly or mountainous areas.
- Frequent trailer pulling.
- Commercial uses, such as taxi, police car or delivery service.

If you do not use your vehicle under any of these conditions, change the fluid and filter every 60,000 miles (24,000 miles Heavy Duty Emission Vehicles).

To Change Turbo Hydra-Matic 400 and Turbo Hydra-Matic 350 fluid, remove fluid from the transmission sump, add approximately 7.5 pints U.S. measure (6.25 pints Imperial measure) for the Turbo Hydra-Matic 400 and 2-1/2 qts. U.S. measure (2 qts. Imperial measure) for the Turbo Hydra-Matic 350 of fresh fluid, to return level to proper mark on the dipstick.

Every 60,000 Miles (24,000 miles Heavy Duty Emission Vehicles)—the Turbo Hydra-Matic 400 transmission sump filter should be replaced.

3-AND 4-SPEED MANUAL TRANSMISSION

Lubricant

Every 12 months or 7,500 miles (4 months or 6,000 miles Heavy Duty Emission Vehicles), whichever occurs first, check lubricant level and add lubricant, if necessary, to fill to level of filler plug hole with SAE 80W or SAE 80W-90 GL-5 Gear Lubricant. If temperatures below +32 °F are expected, use SAE 80W GL-5 Gear Lubricant only. For those vehicles normally operated in Canada, use SAE 80W GL-5 Gear Lubricant only.

TRANSMISSION SHIFT LINKAGE

(MANUAL AND AUTOMATIC)

Every 7,500 miles or 12 months (6,000 miles or 4 months Heavy Duty Emission Vehicles), lubricate shift linkage and, on Manual transmission floor control, lever contacting faces with water resistant EP chassis lubricant which meets General Motors Specification GM6031-M.

Clutch

The clutch pedal free travel should be checked at regular intervals.

Lubricate the clutch cross-shaft at fitting (on Series 10 Forward Control models also lubricate the clutch

linkage idler lever at fitting) every 7,500 miles or 12 months (6,000 miles or 4 months Heavy Duty Emission Vehicles) with water resistant EP chassis lubricant which meets General Motors Specification GM 6031-M.

REAR AXLES

Standard

Every 12 months or 7,500 miles (4 months or 6,000 miles Heavy Duty Emission Vehicles), whichever occurs first, check lubricant level and add lubricant, if necessary, to fill to level of filler plug hole. Use SAE 80W or SAE 80W-90 GL-5 Gear Lubricant. For those vehicles normally operated in Canada, use SAE 80W GL-5 Gear Lubricant.

Positive Locking or Positraction

Every 12 months or 7,500 miles (4 months or 6,000 miles Heavy Duty Emission Vehicles), whichever occurs first, check lubricant level and add SAE 80W or SAE 80W-90 GL5 gear lubricant, if necessary, to fill to level of filler plug hole.

PROPELLER SHAFT SLIP JOINTS

Propeller shaft slip joints should be lubricated every 7,500 miles or 12 months (6,000 miles or 4 months Heavy Duty Emission Vehicles) with water resistant EP chassis lubricant which meets General Motors Specification GM 6031-M.

UNIVERSAL JOINTS

All universal joints are the needle bearing type. Lubricate those universal joints (depending on truck model) equipped with lube fittings every 7,500 miles or 12 months (6,000 miles or 4 months Heavy Duty Emission Vehicles) with water resistant EP chassis lubricant which meets General Motors Specification GM 6031-M. More frequent lubes may be required on heavy duty or "Off the Road" operations.

WHEEL BEARINGS

Front

NOTE: Use wheel bearing lubricant GM Part No. 1051344 or equivalent which meets all requirements of General Motors Specification GM 6031-M.

Due to the weight of the tire and wheel assembly it is recommended that they be removed from hub before lubricating bearings to prevent damage to oil seal. Then remove the front wheel hub to lubricate the bearings. The bearings should be thoroughly cleaned before repacking with lubricant.

Front wheels are equipped with tapered roller

bearings on all trucks. Wheel bearings should be lubricated every 30,000 miles (24,000 miles Heavy Duty Emission Vehicles) - lubricate every 12,000 miles in four wheel drive trucks. Do not mix wheel bearing lubricants.

CAUTION: "Long fibre" type greases should not be used on roller bearing front wheels.

Rear

The rear wheel bearings receive their lubrication from the rear axle. When installing bearings which have been cleaned, prelube with wheel bearing grease.

BRAKE MASTER CYLINDER

Check master cylinder fluid level in both reservoirs every 7,500 miles or 12 months (6,000 miles or 4 months Heavy Duty Emission Vehicles). If the fluid is low in the reservoir, it should be filled to a point about 1/4" from the top rear of each reservoir with Delco Supreme No. 11 Hydraulic Brake Fluid or equivalent.

BRAKE AND CLUTCH PEDAL SPRINGS

Lubricate brake and clutch pedal springs every 7,500 miles or 12 months (6,000 miles or 4 months Heavy Duty Emission Vehicles) with engine oil for all models.

PARKING BRAKE

Every 7,500 miles or 12 months (6,000 miles or 4 months Heavy Duty Emission Vehicles) clean and lubricate all parking brake pivot points with water resistant EP chassis lubricant which meets General Motors Specification GM 6031-M.

STEERING

Manual Steering Gear

The steering gear is factory-filled with steering gear lubricant. Seasonal change of this lubricant should not be performed and the housing should not be drained-no lubrication is required for the life of the steering gear.

Every 30,000 miles (36,000 miles Heavy Duty Emission Vehicles), the gear should be inspected for seal leakage (actual solid grease-not just oily film). If a seal is replaced or the gear is overhauled, the gear housing should be refilled with No. 1051052 (13 oz. container) Steering Gear Lubricant which meets GM Specification GM4673-M or its equivalent.

NOTE: Do not use EP Chassis Lube, which meets GM Specification GM 6031-M, to lubricate the gear. **DO NOT OVER-FILL** the gear housing.

Power Steering System

Check the fluid level in the pump reservoir at each oil change period. Add GM Power Steering Fluid (GM 1050017 or equivalent) as necessary to bring level into proper range on filler cap indicator depending upon fluid temperature.

If at operating temperature (approximately 150 °F-hot to the touch), fluid should be between "HOT" and "COLD" marks.

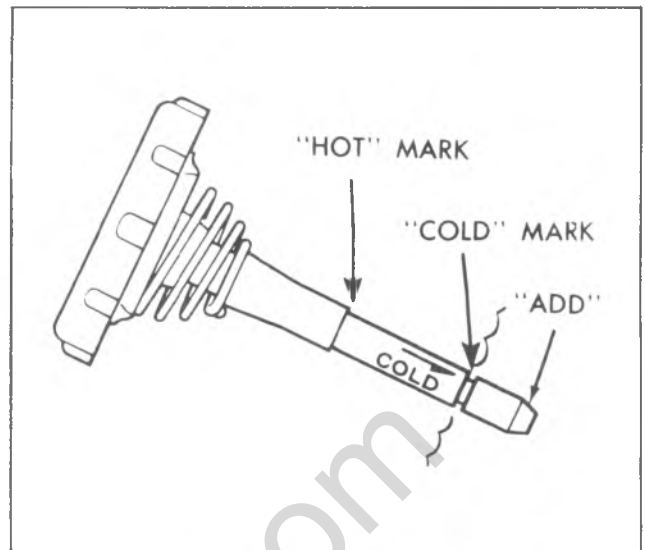


Fig. 0B-2--Power Steering Filler Cap Indicator

If at room temperature (approximately 70 °F), fluid should be between "ADD" and "COLD" marks. Fluid does not require periodic changing.

Linkage and Suspension

Maintain correct front end alignment to provide easy steering, longer tire life, and driving stability.

Check control arm bushings and ball joints for wear. Lubricate tie rods, upper and lower control arms, and ball joints at fittings with water resistant EP chassis lubricant which meets General Motors Specification GM 6031-M every 7,500 miles or 12 months (6,000 miles or 4 months Heavy Duty Emission Vehicles).

Lubricate every 3,000 miles or 3 months (2 months Heavy Duty Emission Vehicles), whichever occurs first, under the following conditions:

- Driving in dusty or muddy conditions.
- Extensive off-road use.

NOTE: Ball joints must be at +10 °F. or more before lubricating.

Keep spring to axle U bolts and shackle bolts properly tightened (see Specifications Section for torque recommendations). Check U bolt nuts after the first 1,000 miles of operation if the U bolt or U bolt nuts are changed in service.

HOOD LATCH AND HOOD HINGE

Every 7,500 miles or 12 months (6,000 miles or 4 months Heavy Duty Emission Vehicles), whichever occurs first, lubricate hood latch assembly and hood hinge assembly as follows:

1. Wipe off any accumulation of dirt or contamination on latch parts.
2. Apply lubriplate or equivalent to latch pilot bolt and latch locking plate.
3. Apply light engine oil to all pivot points in release mechanism, as well as primary and secondary latch mechanisms.
4. Lubricate hood hinges.

5. Make hood hinge and latch mechanism functional check to assure the assembly is working correctly.

BODY LUBRICATION

Normal use of a truck causes metal-to-metal movement at certain points in the cab or body. Noise, wear and improper operation at these points will result when a protective film of lubricant is not provided.

For exposed surfaces, such as door checks, door lock bolts, lock striker plates, dovetail bumper wedges, etc. apply a thin film of light engine oil.

Where oil holes are provided in body parts a dripless oil can be safely used, but any lubricant should be used sparingly, and after application all excess should be carefully wiped off.

The seat adjusters and seat track, ordinarily overlooked, should be lubricated with water resistant EP chassis lubricant which meets General Motors Specification GM 6031-M.

There are other points on bodies which may occasionally require lubrication and which are difficult to service. window regulators and controls are confined in the space between the upholstery and the outside door panel. Easy access to the working parts may be made by removing the trim. Door weatherstrips and rubber hood bumpers should be lightly coated with a rubber lubricant.

UNDERBODY MAINTENANCE

Corrosive materials used for ice and snow removal and dust control accumulate on the underbody. If

allowed to remain, these materials can result in accelerated rusting and deterioration of underbody components such as fuel lines, frame and floor pan, exhaust system, etc. At least once each year, preferably after a winter's exposure these corrosive materials should be removed by flushing the underbody with plain water. Particular attention should be given to cleaning out those areas where mud and other foreign materials collect.

SPEEDOMETER ADAPTER

On vehicles so equipped, lubricate adapter at fitting with water resistant EP chassis grease which meets General Motors Specification GM 6031-M every 7,500 miles or 12 months (6,000 miles or 4 months Heavy Duty Emission Vehicles).

COMPLETE VEHICLE MAINTENANCE SCHEDULE

Three separate Maintenance Schedules are used for the 1977 truck models. Two schedules (L-6 Schedule and V-8 Schedule) are used on the Light Duty Emission Vehicles while a third schedule applies only to Heavy Duty Emission Vehicles.

Presented on the following pages are the Maintenance Schedules, followed immediately by the schedule explanation. Section "A" (Lubrication and General Maintenance) and Section "B" (Safety Maintenance) are the same for both L-6 and V-8 Schedules; however, Section "C" (Emission Control Maintenance) differs.

COMPLETE VEHICLE MAINTENANCE SCHEDULE I

Series 10 with V-8 Engine and Light Duty Emission System

This Maintenance Schedule is applicable to all Chevrolet engines which do not contain the letter "U" in the engine identification code (which begins with the numeral "7") shown in the upper left corner of the under hood "Vehicle Emission Control Information" label. (Example: 712Y2).

When To Perform Services (Months or Miles, Whichever Occurs First)	Item No.	Services
SECTION A—Lubrication and General Maintenance		
Every 12 Months or 7,500 Miles	A-1	Chassis Lubrication
	A-2	•*Fluid Levels Check
	A-3	*Engine Oil Change
See Explanation	A-4	*Oil Filter Change
	A-5	Tire Rotation
	A-6	Rear Axle Lube Change
Every 12 Months	A-7	Air Conditioning Check
Every 12 Months or 15,000 Miles	A-8	*Cooling System Check
Every 30,000 Miles	A-9	Wheel Bearing Repack
	A-10	Manual Steering Gear Check
	A-11	Clutch Cross Shaft Lubrication
Every 60,000 Miles	A-12	*Auto. Trans. Fluid & Filter Change
SECTION B—Safety Maintenance		
Every 12 Months or 7,500 Miles	B-1	Owner Safety Checks
	B-2	Tire, Wheel and Disc Brake Check
	B-3	*Exhaust System Check
	B-4	Suspension and Steering Check
	B-5	Brake and Power Steering Check
Every 12 Months or 15,000 Miles	B-6	*Drive Belt Check
	B-7	Drum Brake and Parking Brake Check
	B-8	Throttle Linkage Check
	B-9	Underbody Flush & Check
SECTION C—Emission Control Maintenance		
At First 6 Months or 7,500 Miles— Then at 18 Month/22,500 Mile Intervals as Indicated in Log	C-1	Thermo. Controlled Air Cleaner Check
	C-2	Carburetor Choke Check
	C-3	Engine Idle Speed Adjustment
	C-4	EFE System Check
	C-5	Carburetor Mounting Torque
	C-6	Vacuum Advance System, Hoses Check
Every 12 Months or 15,000 Miles	C-7	Fuel Filter Replacement
	C-8	PCV System Check —PCV Valve & Filter Replacement
Every 22,500 Miles	C-9	Spark Plug Wires Check
	C-10	Idle Speed-Up Solenoid Check
	C-11	Spark Plug Replacement
	C-12	Engine Timing Adjustment & Dist. Check
	C-13	Carburetor Vacuum Break Adjustment (1)
Every 24 Months or 30,000 Miles	C-14	ECS System Check & Filter Replacement
	C-15	Fuel Cap, Tank and Lines Check
Every 30,000 Miles	C-16	Air Cleaner Element Replacement

•Also A Safety Service

*Also An Emission Control Service

(1) Applies to 305 CID engine only

Your 1977 Chevrolet has been certified to meet emission standards at either high or low altitude as designated on the underhood Vehicle Emission Control Information Label. Vehicle driveability will be optimum at the altitude designated on the Label but will be satisfactory at all altitudes.

The exhaust emission control systems used on 1977 model GM vehicles are not designed for conversion to allow the vehicles to meet emission standards when operated at other than the altitude designated on the Label. However, for some GM vehicles, conversion to meet emission standards at other than the designated altitude is possible and is permitted by government regulations. Information regarding conversion of your vehicle, if permitted, can be obtained from: (Customer Services Manager, Chevrolet Central Office—Detroit, Michigan 48202). Include your Vehicle Identification Number in your request.

COMPLETE VEHICLE MAINTENANCE SCHEDULE II

Series 10 with L-6 Engine and Light Duty Emission System

This Maintenance Schedule is applicable to all Chevrolet engines which contain the letter "U" in the engine identification code (which begins with the numeral "7") shown in the upper left corner of the under hood "Vehicle Emission Control Information" label. (Example: 712F1U).

When To Perform Services (Months or Miles, Whichever Occurs First)	Item No.	Services
SECTION A—Lubrication and General Maintenance		
Every 12 Months or 7,500 Miles	A-1	Chassis Lubrication
	A-2	●*Fluid Levels Check
	A-3	*Engine Oil Change
See Explanation	A-4	*Oil Filter Change
	A-5	Tire Rotation
	A-6	Rear Axle Lube Change
Every 12 Months	A-7	Air Conditioning Check
Every 12 Months or 15,000 Miles	A-8	*Cooling System Check
Every 30,000 Miles	A-9	Wheel Bearing Repack
	A-10	Manual Steering Gear Check
	A-11	Clutch Cross Shaft Lubrication
Every 60,000 Miles	A-12	*Auto. Trans. Fluid & Filter Change
SECTION B—Safety Maintenance		
Every 12 Months or 7,500 Miles	B-1	Owner Safety Checks
	B-2	Tire, Wheel and Disc Brake Check
	B-3	*Exhaust System Check
	B-4	Suspension and Steering Check
	B-5	Brake and Power Steering Check
Every 12 Months or 15,000 Miles	B-6	*Drive Belt Check
	B-7	Drum Brake and Parking Brake Check
	B-8	Throttle Linkage Check
	B-9	Underbody Flush & Check
SECTION C—Emission Control Maintenance		
See Explanation	C-1	Carburetor Choke Check
At First 6 Months or 7,500 Miles— Then at 24 Month/30,000 Mile Intervals as Indicated in Log	C-2	Thermo. Controlled Air Cleaner Check
	C-3	Engine Idle Speed Adjustment
	C-4	EFE System Check
	C-5	Carburetor Mounting Torque
Every 12 Months or 15,000 Miles	C-6	Vacuum Advance System, Hoses Check
	C-7	Fuel Filter Replacement
		PCV System Check
Every 15,000 Miles	C-8	—PCV Valve & Filter Replacement
Every 15,000 Miles	C-9	Spark Plug Wires Check
Every 30,000 Miles	C-10	Idle Stop Solenoid Check
	C-11	Spark Plug Replacement
	C-12	Engine Timing Adjustment & Dist. Check
	C-13	Air Cleaner Element Replacement
Every 24 Months or 30,000 Miles	C-14	ECS System Check & Filter Replacement
	C-15	Fuel Cap, Tank and Lines Check

●Also A Safety Service

*Also An Emission Control Service

Your 1977 Chevrolet has been certified to meet emission standards at either high or low altitude as designated on the underhood Vehicle Emission Control Information Label. Vehicle driveability will be optimum at the altitude designated on the Label but will be satisfactory at all altitudes.

The exhaust emission control systems used on 1977 model GM vehicles are not designed for conversion to allow the vehicles to meet emission standards when operated at other than the altitude designated on the Label. However, for some GM vehicles, conversion to meet emission standards at other than the designated altitude is possible and is permitted by government regulations. Information regarding conversion of your vehicle, if permitted, can be obtained from: (Customer Services Manager, Chevrolet Central Office—Detroit, Michigan 48202). Include your Vehicle Identification Number in your request.

EXPLANATION OF COMPLETE 1977 VEHICLE MAINTENANCE SCHEDULE

Presented below is a brief explanation of each of the services listed in the preceding Complete Vehicle Maintenance Schedule.

NORMAL VEHICLE USE—The owner's maintenance instructions contained in this maintenance schedule are based on the assumption that your vehicle will be used as designed:

- to carry passengers and cargo within the limitations indicated on the VIN plate affixed to the edge of the driver's door,
- on reasonable road surfaces within legal operating limits,
- on a daily basis, as a general rule, for at least several miles, and
- on unleaded fuel.

Unusual operating conditions will require more frequent vehicle maintenance as specified in the respective sections included below.

After each of the following maintenance services is performed, it is recommended that you insert the month, day and mileage in the maintenance schedule under the appropriate "Owner Service Log" column.

SECTION A—LUBE & GENERAL MAINTENANCE

ITEM NO. SERVICES

A-1 CHASSIS—Lubricate all grease fittings in front suspension and steering linkage. Also lubricate transmission shift linkage, hood latch, hood and door hinges, and parking brake cable guides and linkage, clutch linkage, propeller shaft slip joint, universal joints and brake and clutch pedal springs. Lubricate suspension and steering linkage every 3 months or 3,000 miles when operating under dusty or muddy conditions and in extensive off-road use.
Also see Item B-8.[†]

A-2 FLUID LEVELS—Check level of fluid in brake master cylinder[†], power steering pump[†], battery, engine^{*}, axle, transmission^{*} and windshield washer[†]. Check test indicator on battery (if so equipped). Engine coolant should be checked for proper level and freeze protection to at least -20°F (-29°C) or to the lowest temperature expected during the period of vehicle operation.^{*} Proper engine coolant also provides corrosion protection.

Any significant fluid loss in any of these systems or units could mean that a malfunction is developing and corrective action should be taken immediately. A low fluid level in the brake master cylinder front reservoir could also be an indicator that the disc brake pads need replacing.

A-3 ENGINE OIL*—Change each 12 months or 7,500 miles, whichever occurs first under normal driving conditions, or each 3 months or 3,000 miles when the vehicle is operated under the following conditions: (a) driving in dusty conditions, (b) trailer pulling, (c) extensive idling or (d) short-trip operation at freezing temperatures (with engine not thoroughly warmed-up). See your Owner's and Driver's Manual for additional details on engine oil.

A-4 ENGINE OIL FILTER*—Replace at the first oil change and every other oil change thereafter, if mileage (7,500 miles) is the determining factor. If time (12 months) is the determining factor, then change oil filter with every oil change.

A-5 TIRES—To equalize wear, rotate tires as indicated in Owner's and Driver's Manual and adjust tire pressures. Steel-belted radial tires should be rotated at first 7,500 miles and then at every 15,000 miles thereafter. Bias-belted tires should be rotated every 7,500 miles.

A-6 REAR AXLE—Change lubricant every 7,500 miles on all type rear axles or final drives when using vehicle to pull a trailer.

A-7 AIR CONDITIONING—Check condition of air conditioning system hoses and refrigerant charge at sight glass (if so equipped). Replace hoses and/or refrigerant if need is indicated.

A-8 COOLING SYSTEM*—At 12-month or 15,000-mile intervals, wash radiator cap and filler neck with clean water, pressure test system and radiator cap for proper pressure holding capacity, tighten hose clamps and inspect condition of all cooling and heater hoses. Replace hoses if checked, swollen or otherwise deteriorated. Clean exterior of radiator core and air conditioning condenser. Every 24 months or 30,000 miles, drain, flush, and refill the cooling system with a new coolant solution as described in your Owner's and Driver's Manual.

A-9 WHEEL BEARINGS—Clean and repack front wheel bearings with a lubricant as specified in the "Recommended Fluids & Lubricants" chart in this folder.

[†]Also a Safety Service
^{*}Also an Emission Control Service

A-10 MANUAL STEERING GEAR—Check for seal leakage around the pitman shaft and housing. If leakage is evident (solid grease oozing out—not just oily film), it should be corrected immediately.

A-11 CLUTCH CROSS SHAFT—Lubricate clutch cross shaft lever.

A-12 AUTOMATIC TRANSMISSION FLUID*—Under normal driving conditions, change the transmission fluid and service the sump filter every 60,000 miles. Under unusual conditions such as constant driving in heavy city traffic, trailer pulling, and commercial applications, services should be performed at 15,000-mile intervals. See your Owner's and Driver's Manual for further details on transmission care.

SECTION B—SAFETY MAINTENANCE

NOTE: Items B-1 (a) thru (v) can be checked by the owner or driver, while items B-2 thru B-9 should only be checked by a qualified mechanic. It is particularly important that any safety systems which may have been adversely affected in an accident be checked and repaired as necessary before the vehicle is returned to use.

B-1 SAFETY CHECKS TO BE PERFORMED BY OWNER OR DRIVER—The following checks should be made regularly during operation at no greater interval than 12 months or 7,500 miles, whichever occurs first, and more often when the need is indicated. Any deficiencies should be brought to the attention of your dealer or another service outlet, as soon as possible, so the advice of a qualified mechanic is available regarding the need for repairs or replacements.

(a) **STEERING COLUMN LOCK (EXCEPT VAN)** — Check for proper operation by attempting to turn key to LOCK position in the various transmission gear ranges when the vehicle is stationary. Key should turn to LOCK position only when transmission control is in PARK on automatic transmission models. Key should be removable only in LOCK position.

(b) **PARKING BRAKE**—Check parking brake holding ability by parking on a fairly steep hill and restraining the vehicle with the parking brake only.

CAUTION: Before making checks (c) or (d) below, be sure to have a clear distance ahead and behind the vehicle, set the parking brake and firmly apply the foot brake. Do not depress ac-

celerator pedal. Be prepared to turn off ignition switch immediately if engine should start.

- (c) **STARTER SAFETY SWITCH (AUTOMATIC TRANSMISSION VEHICLES)**—Check starter safety switch by attempting to start the engine with the transmission in each of the driving gears. The starter should operate only in the Park ("P") or Neutral ("N") positions.
- (d) **STARTER SAFETY SWITCH (MANUAL TRANSMISSION VEHICLES)**—To check, place the shift lever in neutral, depress the clutch halfway, and attempt to start. The starter should operate only when clutch is fully depressed.
- (e) **TRANSMISSION SHIFT INDICATOR**—Check to be sure automatic transmission shift indicator accurately indicates the shift position selected.
- (f) **STEERING**—Be alert to any changes in steering action. The need for inspection or servicing may be indicated by increased effort to turn the steering wheel, excessive free play or unusual sounds when turning or parking.
- (g) **WHEEL ALIGNMENT AND BALANCE**—In addition to uneven or abnormal tire wear, the need for wheel alignment service may be indicated by a pull to the right or left when driving on a straight and level road. The need for wheel balancing is usually indicated by a vibration of the steering wheel or seat while driving at normal highway speeds.
- (h) **BRAKES**—Be alert to illumination of the brake warning light or changes in braking action, such as repeated pulling to one side, unusual sounds either when braking or between brake applications, or increased brake pedal travel. Any of these could indicate the need for brake system inspection and/or service.
- (i) **EXHAUST SYSTEM**—Be alert to any change in the sound of the exhaust system or a smell of fumes which may indicate a leak or overheat condition requiring inspection and/or service. (See also Engine Exhaust Gas Caution and Catalytic Converter information in Owner's and Driver's Manual and Item B-3 in this folder.)
- (j) **WINDSHIELD WIPERS AND WASHERS**—Check operation of wipers, as well as condition and alignment of wiper blades. Check amount and direction of fluid sprayed by washers during use.
- (k) **DEFROSTER**—Check performance by moving controls to "DEF" and noting amount of air directed against the windshield.

- (l) **REARVIEW MIRRORS AND SUN VISORS**—Check that friction joints are properly adjusted so mirrors and sun visors stay in the selected position.
- (m) **HORN**—Blow the horn occasionally to be sure that it works. Check all button locations.
- (n) **LAP AND SHOULDER BELTS**—Check belts, buckles, latch plates, retractors, reminder systems, guide loops, clips and anchors for proper operation or damage. Check to make certain that anchor mounting bolts are tight.
- (o) **SEAT ADJUSTERS**—Check that seat adjusters (and swivel seat lock, if present) securely engage by pushing forward and backward (and twisting) whenever seat is adjusted.
- (p) **SEAT BACK LATCHES**—Check to see that seat back latches are holding by pulling forward on the top of each folding seat back.
- (q) **LIGHTS AND BUZZERS**—Check all instrument panel illuminating and warning lights, seat belt reminder light and buzzer (if so equipped), interior lights, license plate lights, side marker lights, headlamps, parking lamps, tail lamps, brake lights, turn signals, backup lamps, and hazard warning flashers. Have headlamp aim checked every 12 months or 15,000 miles, or more often if light beams seem to be aimed improperly.
- (r) **GLASS**—Check for broken, scratched, dirty or damaged glass on vehicle that could obscure vision or become an injury hazard.
- (s) **DOOR LATCHES**—Check for positive closing, latching and locking.
- (t) **HOOD LATCHES**—Check to make sure hood closes firmly by lifting on the hood after each closing. Check also for broken, damaged or missing parts which might prevent secure latching.
- (u) **FLUID LEAKS**—Check for fuel, water, oil or other fluid leaks by observing the ground beneath the vehicle after it has been parked for a while. (Water dripping from air conditioning system after use is normal.) If gasoline fumes or fluid are noticed at *any time*, the cause should be determined and corrected without delay because of the possibility of fire.
- (v) **SPARE AND JACK**—Check that spare tire assembly and jack equipment are securely stowed at all times.

B-2 TIRES, WHEELS AND DISC BRAKES—Check disc, brake pads for wear and surface condition of

rotors while wheels are removed during tire rotation (see Item A-5). Check tires for excessive wear or damage. Make certain wheels are not bent or cracked and that wheel nuts have been tightened to torque value specified in Owner's and Driver's Manual. Check tire inflation pressure (including spare tire) when tires are "cold" at least monthly, or more often if daily visual inspection indicates the need.

B-3 EXHAUST SYSTEM*—Check complete exhaust system including catalytic converter and nearby body areas for broken, damaged, missing or mispositioned parts, open seams, holes, loose connections or other deterioration which could permit exhaust fumes to seep into the passenger compartment or cause a heat buildup in floor pan. Any necessary corrections should be made immediately. To help continue integrity, exhaust system pipes and resonators rearward of the muffler must be replaced whenever a new muffler is installed. (Also see Item B-1 (i).

B-4 SUSPENSION AND STEERING—Check for damaged, loose or missing parts, or parts showing visible signs of excessive wear or lack of lubrication in front and rear suspension and steering system. Questionable parts noted should be replaced by a qualified mechanic without delay.

B-5 BRAKES AND POWER STEERING—Check lines and hoses for proper attachment, leaks, binding, cracks, chafing, deterioration, etc. Any questionable parts noted should be replaced or repaired immediately. When abrasion or wear is evident on lines or hoses, the cause must be corrected.

B-6 ENGINE DRIVE BELTS*—Check belts driving fan, AIR pump, generator, power steering pump and air conditioning compressor for cracks, fraying, wear and tension. Adjust or replace as necessary.

B-7 DRUM BRAKES AND PARKING BRAKE—(See Item B-2 for disc brake check.) Check drum brake linings for wear or cracks and other internal brake components at each wheel (drums, wheel cylinders, etc.). Parking brake adjustment also should be checked whenever drum brake linings are checked.

NOTE: More frequent brake checks should be made if driving conditions and habits result in frequent brake application.

B-8 THROTTLE LINKAGE—Lubricate as covered in Owner's and Driver's Manual. Check for damaged or missing parts, interference or binding. Any deficiencies should be corrected without delay by a qualified mechanic.

B-9 UNDERBODY—Corrosive material used for ice and snow removal and dust control can accumulate on the underbody. If allowed to remain, these materials can result in accelerated rusting and deterioration of underbody components such as fuel lines, frame and floor pan, exhaust system, etc. At least once each year, preferably after a winter's exposure, these corrosive materials should be removed by flushing the underbody with plain water. Particular attention should be given to cleaning out those areas where mud and other foreign materials collect.

SECTION C—EMISSION CONTROL MAINTENANCE

L-6 ENGINE

NOTE: Additional recommended maintenance instructions relating to vehicle use, evidence of maintenance, and service replacement parts are included in the New Car Warranty Information folder.

- C-1 CARBURETOR CHOKE AND HOSES** — Check choke mechanism and vacuum break for proper operation. Any binding condition which may have developed due to petroleum gum formation on the choke shaft or from damage should be corrected. Check carburetor choke hoses for proper connection, cracking, abrasion or deterioration and correct or replace as necessary. Check operation at 6 months or 7,500 miles, 24 months or 30,000 miles and every 12 months or 15,000 miles thereafter.
- C-2 THERMOSTATICALLY CONTROLLED AIR CLEANER** — Inspect installation to make certain that all hoses and ducts are connected and correctly installed. Also check valve for proper operation.
- C-3 ENGINE IDLE SPEED** — Adjust engine idle speed accurately (following the specifications shown on the label under the hood). Adjustments must be made with test equipment known to be accurate.
- C-4 EARLY FUEL EVAPORATION (EFE) SYSTEM**—Check valve for proper operation. A binding condition must be corrected. Check thermal vacuum switch for proper operation. Check hoses for cracking, abrasion or deterioration. Replace parts as necessary.
- C-5 CARBURETOR MOUNTING**—At designated intervals torque carburetor attaching bolts and/or nuts

to compensate for compression of the gasket.

- C-6 VACUUM ADVANCE SYSTEM AND HOSES** — Check system for proper operation and hoses for proper connection, cracking, abrasion or deterioration. Replace parts as necessary.
- C-7 FUEL FILTER**—Replace filter in carburetor at designated intervals or more frequently if clogged.
- C-8 POSITIVE CRANKCASE VENTILATION SYSTEM (PCV)** —Check the PCV system for satisfactory operation at 15,000-mile intervals, and clean filter. Replace the PCV valve at 30,000-mile intervals and blow out PCV valve hose with compressed air. Replace deteriorated hoses.

The PCV filter (located in the air cleaner) should be replaced whenever the air cleaner element is replaced.

- C-9 SPARK PLUG WIRES**—Clean exterior of wires; remove any evidence of corrosion on end terminals. Inspect spark plug wires for evidence of checking, burning, or cracking of exterior insulation and tight fit at distributor cap and spark plugs or other deterioration. If corrosion cannot be removed or other conditions above are noted, replace wire.
- C-10 IDLE STOP SOLENOID**—Check for proper operation. An inoperative solenoid must be replaced.
- C-11 SPARK PLUGS**—Replace plugs at designated intervals with type specified in Owner's and Driver's Manual.
- C-12 TIMING AND DISTRIBUTOR CAP** — Adjust ignition timing following the specifications shown on label under the hood. Also, carefully inspect the interior and exterior of the distributor cap and rotor for cracks, carbon tracking and terminal corrosion. Clean or replace as necessary.
- C-13 AIR CLEANER ELEMENT**—Replace the engine air cleaner element at designated intervals. The PCV filter should be replaced at the same interval. Operation of vehicle in dusty areas will necessitate more frequent replacement. Your dealer can be of assistance in determining the proper replacement frequency for the conditions under which you operate your vehicle.

CAUTION: Do not operate the engine without the air cleaner unless temporary removal is necessary during repair or maintenance of the vehicle. When the air cleaner is removed, back-firing can cause fire in the engine compartment.

C-14 EVAPORATOR CONTROL SYSTEM (ECS)—Check all fuel and vapor lines and hoses for proper connections and correct routing as well as condition. Remove canister and check for cracks or damage. Replace damaged or deteriorated parts as necessary. Replace filter in lower section of canister.

C-15 FUEL CAP, FUEL LINES AND FUEL TANK —

1. Inspect the fuel tank, cap and lines for damage which could cause leaks.
2. Remove fuel cap and inspect gasket for an even imprint from the filler neck, and any indications of physical damage.
3. Replace any damaged or deteriorated parts.

SECTION C—EMISSION CONTROL MAINTENANCE

V-8 ENGINE

NOTE: Additional recommended maintenance instructions relating to vehicle use, evidence of maintenance, and service replacement parts are included in the New Vehicle Warranty Information folder.

- C-1 THERMOSTATICALLY CONTROLLED AIR CLEANER** — Inspect installation to make certain that all hoses and ducts are connected and correctly installed. Also check valve for proper operation.
- C-2 CARBURETOR CHOKE AND HOSES** — Check choke mechanism and vacuum break for proper operation. Any binding condition which may have developed due to petroleum gum formation on the choke shaft or from damage should be corrected. Check carburetor choke hoses for proper connection, cracking, abrasion or deterioration and correct or replace as necessary.
- C-3 ENGINE IDLE SPEED** — Adjust engine idle speed accurately (following the specifications shown on the label under the hood). Adjustments must be made with test equipment known to be accurate.
- C-4 EARLY FUEL EVAPORATION (EFE) SYSTEM**—Check valve for proper operation. A binding condition must be corrected. Check thermal vacuum switch for proper operation. Check hoses for cracking, abrasion or deterioration. Replace parts as necessary.
- C-5 CARBURETOR MOUNTING**—At designated intervals,

torque carburetor attaching bolts and/or nuts to compensate for compression of the gasket.

C-6 VACUUM ADVANCE SYSTEM AND HOSES — Check system for proper operation and hoses for proper connection, cracking, abrasion or deterioration. Replace as necessary.

C-7 FUEL FILTER—Replace filter in carburetor at designated intervals or more frequently if clogged.

C-8 POSITIVE CRANKCASE VENTILATION SYSTEM (PCV) —Check the PCV system for satisfactory operation at 15,000-mile intervals, and clean filter. Replace the PCV valve at 30,000-mile intervals and blow out PCV valve hose with compressed air. Replace deteriorated hoses.

The PCV filter (located in the air cleaner) should be replaced whenever the air cleaner element is replaced.

C-9 SPARK PLUG WIRES—Clean exterior of wires; remove any evidence of corrosion on end terminals. Inspect spark plug wires for evidence of checking, burning, or cracking of exterior insulation and tight fit at distributor cap and spark plugs or other deterioration. If corrosion cannot

be removed or other conditions above are noted, replace wire.

C-10 IDLE SPEED-UP SOLENOID—Check for proper operation. An inoperative solenoid must be replaced.

C-11 SPARK PLUGS—Replace plugs at 22,500-mile intervals with type specified in Owner's and Driver's Manual.

C-12 TIMING AND DISTRIBUTOR GAP — Adjust ignition timing following the specifications shown on label under hood. Also, carefully inspect the interior and exterior of the distributor cap and rotor for cracks, carbon tracking and terminal corrosion. Clean or replace as necessary.

C-13 CARBURETOR VACUUM BREAK ADJUSTMENT — Inspect vacuum break linkage for proper operation. A binding condition must be corrected. Check hoses for proper connection, cracking, abrasion or deterioration. Replace parts as necessary. Adjust vacuum break at specified intervals following procedure and specifications found in appropriate service manual.

C-14 EVAPORATION CONTROL SYSTEM (ECS)—Check all fuel and vapor lines and hoses for proper con-

nections and correct routing as well as condition. Remove canister and check for cracks or damage. Replace damaged or deteriorated parts as necessary. Replace filter in lower section of canister.

C-15 FUEL CAP, FUEL LINES AND FUEL TANK—

1. Inspect the fuel tank, cap and lines for damage which could cause leaks.
2. Remove fuel cap and inspect gasket for an even imprint from the filler neck, and any indications of physical damage.
3. Replace any damaged or deteriorated parts.

C-16 AIR CLEANER ELEMENT—Replace the engine air cleaner element at designated intervals. Operation of vehicle in dusty areas will necessitate more frequent replacements. Your dealer can be of assistance in determining the proper replacement frequency for the conditions under which you operate your vehicle.

CAUTION: Do not operate the engine without the air cleaner unless temporary removal is necessary during repair or maintenance of the vehicle. When the air cleaner is removed, back-firing can cause fire in the engine compartment.

ClassicCars.com

COMPLETE VEHICLE MAINTENANCE SCHEDULE

Heavy Duty Emission System

When To Perform Services (Months or Miles, Whichever Occurs First)	Item No.	Services (For Details, See Numbered Paragraphs)
Every 4 months or 6,000 miles	1	Chassis Lubrication
	2	●Fluid Levels
	3	*Engine Oil
	4	Air Conditioning System
Every 6,000 miles	5	Tire Rotation
At 1st oil change – then every 2nd	6	*Engine Oil Filter
Every 12,000 miles	7	Rear Axle
Every 12 months or 12,000 miles	8	Cooling System
Every 24,000 miles	9	Wheel Bearings**
	10	Automatic Transmission
Every 36,000 miles	11	Manual Steering Gear
Every 4 months or 6,000 miles	12	Owner Safety Checks
	13	Tires and Wheels
	14	Exhaust System
	15	*Engine Drive Belts
	16	Suspension and Steering
	17	Brakes and Power Steering
Every 6,000 miles	18	Disc Brakes
Every 12 months or 12,000 miles	19	Drum Brakes and Parking Brake
	20	Throttle Linkage
	21	Underbody
At 1st 4 months or 6,000 miles – then at 12 month/12,000 mile intervals	22	Carburetor Choke and Hoses (1)
	23	Engine Idle Speed Adjustment (1)
	24	Carburetor Mounting (1)
Every 12 months or 12,000 miles	25	Thermostatically Controlled Air Cleaner (1)
	26	Manifold Heat Valve (1)
Every 12,000 miles	27	Spark Plugs (2)
	28	Engine Timing Adjust. & Distributor Check (2)
Every 12 months or 12,000 miles	29	EGR System
	30	Carburetor Fuel Inlet Filter (1)
	31	Engine Idle Mixture (1)
	32	Throttle Return Control (1)
	33	Idle Stop Solenoid
	34	PCV System
Every 24 months or 24,000 miles	35	ECS System
	36	Fuel Cap, Tank and Lines
Every 12,000 miles	37	Air Cleaner Element (2)
Every 12 months or 12,000 miles	38	Spark Plug and Ignition Coil Wires (1)

*Also an Emission Control Service ●Also a Safety Service

**On 4-Wheel Drive Vehicles, lubricate wheel bearings every 12,000 miles.

(1) All except California 350 CID & 400 CID engines which receive this service at 24 months or 24,000 miles.

(2) All except California 350 CID & 400 CID engines which receive this service at 24,000 miles.

EXPLANATION OF COMPLETE 1977 VEHICLE MAINTENANCE SCHEDULE

Presented below is a brief explanation of each of the services listed in the preceding Complete Vehicle Maintenance Schedule.

NORMAL VEHICLE USE—The owner's maintenance instructions contained in this maintenance schedule are based on the assumption that your vehicle will be used as designed:

- to carry passengers and cargo within the limitations indicated on the VIN plate,
- on reasonable road surfaces within legal operating limits, and
- on a daily basis, as a general rule, for at least several miles.

Unusual operating conditions will require more frequent vehicle maintenance as specified in the respective sections included below.

After each of the following maintenance services is performed, it is recommended that you insert the month, day and mileage in the maintenance schedule under the appropriate "Owner Service Log" column.

LUBE & GENERAL MAINTENANCE

ITEM NO. SERVICES

- 1 CHASSIS** — Lubricate all grease fittings in front suspension, steering linkage, and constant velocity universal joint. Also lubricate transmission and transfer case shift linkage, hood latch, hood and door hinges, parking brake cable guides and linkage, clutch linkage, propeller shaft slip joint, universal joints, and brake and clutch pedal springs. Lubricate suspension and steering linkage every 2 months or 3,000 miles when operating under dusty or muddy conditions and in extensive off-road use. See your Owner's and Driver's Manual for additional services required on four wheel drive models. Also see Item 20.[▲]
- 2 FLUID LEVELS**—Check level of fluid in brake master cylinder[▲], power steering pump[▲], battery, engine, axles, transmission, transfer case and windshield washer[▲]. Check test indicator on battery (if so equipped). Check coolant for proper level regularly (daily if necessary, depending on severity of service), and every 4 months or 6000 miles for freeze protection to at least -20°F (-29°C) or to the lowest temperature expected during the period of vehicle operation. Proper

[▲]Also a Safety Service

*Also an Emission Control Service

engine coolant also provides corrosion protection.

Any significant fluid loss in any of these systems or units could mean that a malfunction is developing and corrective action should be taken immediately. On vehicles with disc brakes, a low fluid level in the brake master cylinder front reservoir could also be an indicator that the disc brake pads need replacing.

- 3 ENGINE OIL*** — Change each 4 months or 6,000 miles, whichever occurs first, or each 2 months or 3,000 miles when the vehicle is operated under the following conditions: (a) driving in dusty conditions, (b) trailer pulling, (c) extensive idling or (d) short-trip operation at freezing temperatures (with engine not thoroughly warmed-up). See Owner's and Driver's Manual for additional details.
- 4 AIR CONDITIONING**—Check condition of air conditioning system hoses and refrigerant charge at sight glass (if so equipped). Replace hoses and/or refrigerant if need is indicated.
- 5 TIRES**—To equalize wear, rotate tires and adjust tire pressures as indicated in Owner's and Driver's Manual.
- 6 ENGINE OIL FILTER*** — Replace at the first oil change and every other oil change thereafter, if mileage (6,000 miles) is the determining factor. If time (4 months) is the determining factor, then change oil filter with every oil change.
- 7 REAR AXLE**—On 20 and 30 Series trucks, change lubricant every 24,000 miles. Change lubricant every 12,000 miles on all type rear axles under severe operating conditions.
FRONT AXLE AND TRANSFER CASE—Check every 6,000 miles. See Owner's and Driver's Manual for further information.
- 8 COOLING SYSTEM** — At 12-month or 12,000-mile intervals, wash radiator cap and filler neck with clean water, pressure test system and radiator cap for proper pressure holding capacity, tighten hose clamps and inspect condition of all cooling and heater hoses. Replace hoses if checked, swollen or otherwise deteriorated. Clean exterior of radiator core and air conditioning condenser. Every 24 months or 24,000 miles, drain, flush, and refill the cooling system with a new coolant solution as described in your Owner's and Driver's Manual.
- 9 WHEEL BEARINGS**—Clean and repack front wheel bearings with a lubricant as specified in the "Recommended Fluids & Lubricants" chart in this folder.

10 AUTOMATIC TRANSMISSION FLUID—Under normal driving conditions, change the transmission fluid and service the sump filter every 24,000 miles. Under unusual conditions such as constant driving in heavy city traffic during hot weather, trailer pulling, etc., these services should be performed at 12,000-mile intervals. See your Owner's and Driver's Manual for further details on transmission care.

11 MANUAL STEERING GEAR—Check for seal leakage around the pitman shaft and housing. If leakage is evident (solid grease oozing out—not just oily film), it should be corrected immediately.

SAFETY MAINTENANCE

NOTE: Items 12(a) thru (v) can be checked by the owner or driver while Items 13 thru 22 should only be checked by a qualified mechanic. It is particularly important that any safety systems which may have been adversely affected in an accident be checked and repaired as necessary before the vehicle is returned to use.

12 SAFETY CHECKS TO BE PERFORMED BY OWNER OR DRIVER—The following checks should be made regularly during operation at no greater interval than 4 months or 6,000 miles, whichever occurs first, and more often when the need is indicated. Any deficiencies should be brought to the attention of your dealer or another service outlet, as soon as possible, so the advice of a qualified mechanic is available regarding the need for repairs or replacements.

- (a) STEERING COLUMN LOCK (IF SO EQUIPPED)** — Check for proper operation by attempting to turn key to LOCK position in the various transmission gear ranges when the vehicle is stationary. Key should turn to LOCK position only when transmission control is in PARK on automatic transmission models or in reverse on manual transmission models. Key should be removable only in LOCK position.
- (b) PARKING BRAKE**—Check parking brake holding ability by parking on a fairly steep hill and restraining the vehicle with the parking brake only.

CAUTION: Before making the checks (c) or (d) below, be sure to have a clear distance ahead and behind the vehicle, set the parking brake and firmly apply the foot brake. Do not depress accelerator pedal. Be prepared to turn off ignition switch immediately if engine should start.

- (c) **STARTER SAFETY SWITCH (AUTOMATIC TRANSMISSION)**—Check starter safety switch by attempting to start the engine with the transmission in each of the driving gears. The starter should operate only in the Park (“P”) or Neutral (“N”) positions.
- (d) **STARTER SAFETY SWITCH (MANUAL TRANSMISSION)**—To check, place the shift lever in neutral, depress the clutch halfway, and attempt to start. The starter should operate only when clutch is fully depressed.
- (e) **TRANSMISSION SHIFT INDICATOR**—Check to be sure automatic transmission shift indicator accurately indicates the shift position selected.
- (f) **STEERING**—Be alert to any changes in steering action. The need for inspection or servicing may be indicated by increased effort to turn the steering wheel, excessive free play or unusual sounds when turning or parking.
- (g) **WHEEL ALIGNMENT AND BALANCE**—In addition to uneven or abnormal tire wear, the need for wheel alignment service may be indicated by a pull to the right or left when driving on a straight and level road. The need for wheel balancing is usually indicated by a vibration of the steering wheel or seat while driving at normal highway speeds.
- (h) **BRAKES**—Be alert to illumination of the brake warning light or changes in braking action, such as repeated pulling to one side, unusual sounds when braking or increased brake pedal travel. Any of these could indicate the need for brake system inspection and/or service.
- (i) **EXHAUST SYSTEM**—Be alert to any change in the sound of the exhaust system or a smell of fumes which may indicate a leak requiring inspection and/or service. (See also Engine Exhaust Gas Caution in Owner’s and Driver’s Manual and Item 14 in this folder.)
- (j) **WINDSHIELD WIPER AND WASHER**—Check operation of wipers, as well as condition and alignment of wiper blades. Check amount and direction of fluid sprayed by washers during use.
- (k) **DEFROSTER**—Check performance by moving controls to “DEF” and noting amount of air directed against the windshield.
- (l) **REARVIEW MIRRORS AND SUN VISORS**—Check that friction joints are properly adjusted so mirrors and sun visors stay in the selected position.
- (m) **HORN**—Blow the horn occasionally to be sure that it works. Check all button locations.
- (n) **LAP AND SHOULDER BELTS**—Check belts, buckles, latch plates, retractors, reminder systems, guide loops, clips and anchors for proper operation or damage. Check to make certain that anchor mounting bolts are tight.
- (o) **SEAT ADJUSTERS**—Check that seat adjusters (and swivel seat lock, if so equipped) securely engage by pushing forward and backward (and twisting) whenever seat is adjusted.
- (p) **SEAT BACK LATCHES (IF SO EQUIPPED)**—Check to see that seat back latches are holding by pulling forward on the top of each folding seat back.
- (q) **LIGHTS AND BUZZERS**—Check all instrument panel illuminating and warning lights, seat belt reminder light and buzzer (if so equipped), interior lights, license plate lights, side marker lights, headlamps, parking lamps, identification or clearance lights, tail lamps, brake lights, turn signals, backup lamps, and hazard warning flashers. Have headlamp aim checked every 12 months or 15,000 miles, or more often if light beams seem to be aimed improperly.
- (r) **GLASS**—Check for broken, scratched, dirty or damaged glass on vehicle that could obscure vision or become an injury hazard.
- (s) **DOOR LATCHES**—Check for positive closing, latching and locking.
- (t) **HOOD LATCHES**—Check to make sure hood closes firmly by lifting on the hood after each closing. Check also for broken, damaged or missing parts which might prevent secure latching.
- (u) **FLUID LEAKS**—Check for fuel, water, oil or other fluid leaks by observing the ground beneath the vehicle after it has been parked for a while. (Water dripping from air conditioning system after use is normal.) If gasoline fumes or fluid are noticed *at any time*, the cause should be determined and corrected without delay because of the possibility of fire.
- (v) **SPARE AND JACK**—Check that spare tire assembly and jack equipment are securely stowed at all times.
- 13 TIRES AND WHEELS**—Check tires for excessive wear or damage. Make certain wheels are not bent or cracked and that wheel nuts have been tightened to torque value specified in Owner’s and Driver’s Manual. Check tire inflation pressure (including spare tire) when tires are “cold” at least monthly, or more often if daily visual inspection indicates the need.
- 14 EXHAUST SYSTEM**—Check complete exhaust system and nearby body areas for broken, damaged, missing or mispositioned parts, open seams, holes, loose connections or other deterioration which could permit exhaust fumes to seep into the passenger compartment. Any necessary corrections should be made immediately. To help continue integrity, exhaust system pipes and resonators rearward of the muffler must be replaced whenever a new muffler is installed. Also see Item 12(i).
- 15 ENGINE DRIVE BELTS***—Check belts driving fan, AIR pump, generator, power steering pump and air conditioning compressor for cracks, fraying, wear and tension. Adjust or replace as necessary.
- 16 SUSPENSION AND STEERING**—Check for damaged, loose or missing parts, or parts showing visible signs of excessive wear or lack of lubrication in front and rear suspension and steering system. Questionable parts noted should be replaced by a qualified mechanic without delay.
- 17 BRAKES AND POWER STEERING**—Check lines and hoses for proper attachment, binding, leaks, cracks, chafing, deterioration, etc. Any questionable parts noted should be replaced or repaired immediately. When abrasion or wear is evident on lines or hoses, the cause must be corrected.
- 18 DISC BRAKES**—Check brake pads for wear and surface condition of rotors while wheels are removed during tire rotation. (See Item 5.)
- NOTE: More frequent brake checks should be made if driving conditions and habits result in frequent brake application.
- 19 DRUM BRAKES AND PARKING BRAKE**—Check drum brake linings for wear or cracks and other internal brake components at each wheel (drums, wheel cylinders, etc.). Parking brake adjustment also should be checked whenever drum brake linings are checked.
- NOTE: More frequent brake checks should be made if driving conditions and habits result in frequent brake application.

- 20 THROTTLE LINKAGE** — Lubricate as covered in Owner's and Driver's Manual. Check for damaged or missing parts, interference or binding. Any deficiencies should be corrected without delay by a qualified mechanic.
- 21 UNDERBODY**—Corrosive material used for ice and snow removal and dust control can accumulate on the underbody. If allowed to remain, these materials can result in accelerated rusting and deterioration of underbody components such as fuel lines, frame and floor pan, exhaust system, etc. At least once each year, preferably after a winter's exposure, these corrosive materials should be removed by flushing the underbody with plain water. Particular attention should be given to cleaning out those areas where mud and other foreign materials collect.

EMISSION CONTROL MAINTENANCE

NOTE: Additional recommended maintenance instructions relating to vehicle use, evidence of maintenance, and service replacement parts are included in the New Vehicle Warranty Information Folder.

- 22 CARBURETOR CHOKE AND HOSES** — Check choke mechanism for proper operation. Any binding condition which may have developed due to petroleum gum formation on the choke shaft or from damage should be corrected. Check carburetor choke hoses for proper connection, cracking, abrasion or deterioration and correct or replace as necessary.
- 23 ENGINE IDLE SPEED ADJUSTMENT** — Adjust engine idle speed accurately (following the specifications shown on the label under the hood). Adjustments must be made with test equipment known to be accurate.
- 24 CARBURETOR MOUNTING**—At designated intervals, torque carburetor attaching bolts and/or nuts to compensate for compression of gasket.
- 25 THERMOSTATICALLY CONTROLLED AIR CLEANER** — Inspect installation to make certain that all hoses and ducts are connected and correctly installed. Also, check valve for proper operation.
- 26 MANIFOLD HEAT VALVE** — Some engines are equipped with a manifold heat valve which should be inspected and repaired as necessary to insure free operation.
- 27 SPARK PLUGS** — Replace at designated intervals with type specified in Owner's and Driver's Manual.
- 28 ENGINE TIMING ADJUSTMENT & DISTRIBUTOR CHECK** — Adjust ignition timing following the specifications shown on label under the hood. Also, carefully inspect the interior and exterior of the distributor cap and rotor for cracks, carbon tracking and terminal corrosion. Clean or replace as necessary.
- 29 EXHAUST GAS RECIRCULATION SYSTEM (EGR)** — At 12 month/12,000 mile intervals, inspect and if deposits exist, clean the EGR valve. Inspect the EGR passages in the inlet manifold and clean as required. A damaged EGR valve must be repaired or replaced. Check thermal switch for proper operation. A malfunctioning switch must be replaced. Check hoses for proper connection, cracking, abrasions, or deterioration and replace as required.
- 30 CARBURETOR FUEL INLET FILTER** — Replace filter at designated intervals or if clogged.
- 31 ENGINE IDLE MIXTURE**—At designated intervals or in case of a major carburetor overhaul, or when poor idle quality exists, adjust mixture by a mechanical method (lean drop), following the specifications shown on the label under the hood.
- 32 THROTTLE RETURN CONTROL (TRC) SYSTEM** — Check hoses for proper connections, cracking, abrasion, or deterioration and replace as necessary. Check for proper operation of system.
- 33 IDLE STOP SOLENOID** — Check for proper operation. An inoperative solenoid must be replaced.
- 34 POSITIVE CRANKCASE VENTILATION SYSTEM (PCV)** — Check the PCV system for satisfactory operation at 12-month or 12,000-mile intervals. Replace the PCV valve at 24-month or 24,000-mile intervals, blow out PCV valve hose with com-

pressed air and replace the filter. The PCV valve should be replaced at 12-month or 12,000-mile intervals when the vehicle is used in operations involving heavy dust, extensive idling, trailer pulling, and short trip use at freezing temperatures where engine does not become thoroughly warmed up. The PCV filter should be replaced at 12-month / 12,000-mile intervals under dusty driving conditions.

- 35 EVAPORATION CONTROL SYSTEM (ECS)**—Check all fuel and vapor lines and hoses for proper connections and correct routing as well as condition. Remove canisters and check for cracks or damage. Replace damaged or deteriorated parts as necessary. Replace filter in lower section of canister. If vehicle is equipped with two canisters, filter is located in lower canister only.
- 36 FUEL CAP, FUEL LINES AND FUEL TANK** — Inspect the fuel tank, cap and lines for damage which could cause leakage. Inspect fuel cap for correct sealing ability and indications of physical damage. Replace any damaged or malfunctioning parts.
- 37 AIR CLEANER ELEMENT** — Replace the engine air cleaner element at designated intervals. Operation of vehicle in dusty areas will necessitate more frequent element replacement. Your dealer can be of assistance in determining the proper replacement frequency for the conditions under which you operate your vehicle.

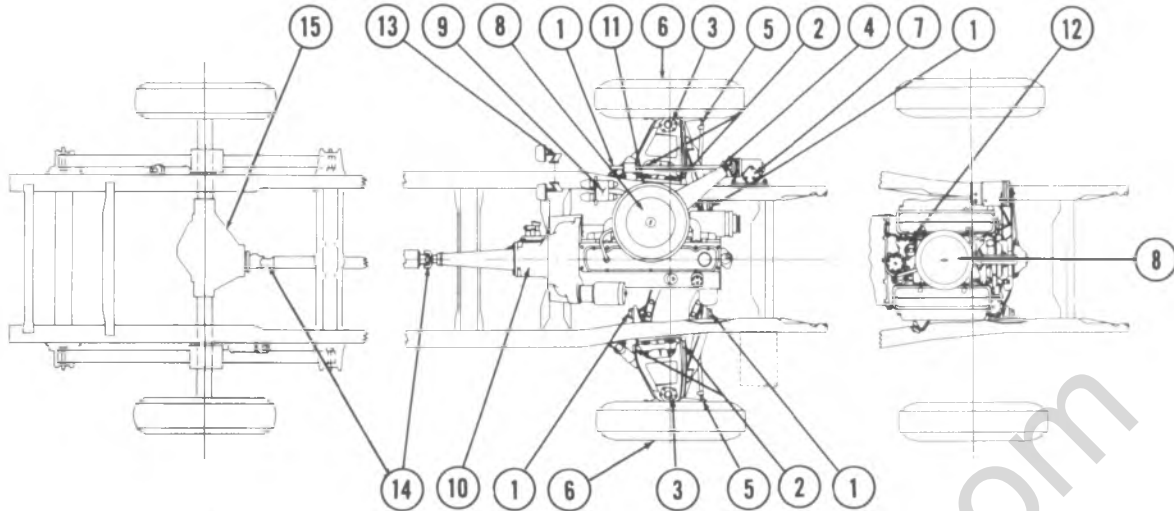
CAUTION: Do not operate the engine without the air cleaner unless temporary removal is necessary during repair or maintenance of the vehicle. When the air cleaner is removed, backfiring can cause fire in the engine compartment.

- 38 SPARK PLUG AND IGNITION COIL WIRES** — Clean exterior of wires; remove any evidence of corrosion on end terminals. Inspect spark plug and ignition coil wires for evidence of checking, burning, or cracking of exterior insulation and tight fit at distributor cap and spark plugs, or other deterioration. If corrosion cannot be removed, or other conditions above are noted, replace wire.

RECOMMENDED FLUIDS & LUBRICANTS

USAGE	FLUID/LUBRICANT
Power steering system and pump reservoir	GM power steering fluid Part No. 1050017 or equivalent
Differential—standard & posi-traction front axle & part time Transfer case	SAE-80W or SAE-80W-90 GL-5 gear lubricant(SAE-80W in Canada)
Full Time transfer case	Engine oil
Manual steering gear	Lubricant GM Part No. 1051052 or equivalent.
Manual transmission	SAE-80W or SAE-80W-90 GL-5 gear lubricant (SAE-80W in Canada)
Brake system and master cylinder	Delco Supreme 11 fluid or DOT-3
Clutch linkage (Man. trans. only) a. Pivot points b. Push rod to clutch fork joint, and cross shaft pressure fitting	Engine oil Chassis grease meeting requirements of GM 6031-M
Manual transmission shift linkage, column shift	Engine oil
Shift linkage, floor shift	Engine oil
Hood Latch assembly a. Pivots and spring anchor b. Release pawl	Engine oil Chassis grease
Hood and Door hinges	Engine oil
Automatic transmission shift linkage	Engine oil
Chassis lubrication	Chassis grease meeting requirements of GM 6031-M
Constant Velocity Universal Joint	GM Lubricant Part No. 1050679 or grease meeting requirements of GM 6040-M
Automatic transmission	DEXRON® II automatic transmission fluid
Parking brake cables	Chassis grease
Front wheel bearings	Wheel bearing lubricant GM Part No. 1051344 or equivalent.
Body door hinge pins, tailgate hinge and linkage, folding seat, fuel door hinge, rear compartment lid hinges	Engine oil
Windshield washer solvent	GM Optikleen washer solvent Part No. 1051515 or equivalent
Battery	Colorless, odorless, drinking water
Engine coolant	Mixture of water and a high quality Ethylene Glycol base type anti-freeze conforming to GM Spec. 1899-M

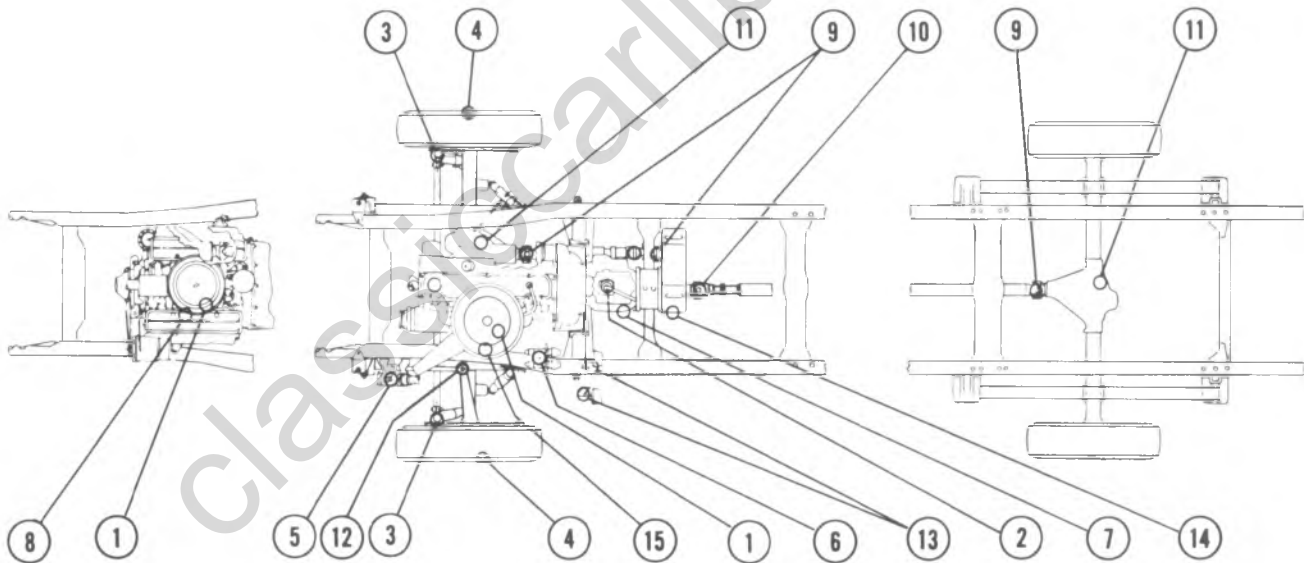
CONVENTIONAL AND FORWARD CONTROL MODELS



LUBRICATION POINTS

- | | | |
|---|---|-----------------------------------|
| 1 Lower Control Arms | 6 Wheel Bearings | 11 Throttle Bell Crank – L-6 |
| 2 Upper Control Arms | 7 Steering Gear | 12 Carburetor Linkage – V-8 |
| 3 Upper and Lower Control Arm Ball Joints | 8 Air Cleaner – Element | 13 Brake and Clutch Pedal Springs |
| 4 Intermediate Steering Shaft (PA10) | 9 Master Cylinder | 14 Universal Joints |
| 5 Tie Rod Ends | 10 Transmission – Manual
– Automatic | 15 Rear Axle |

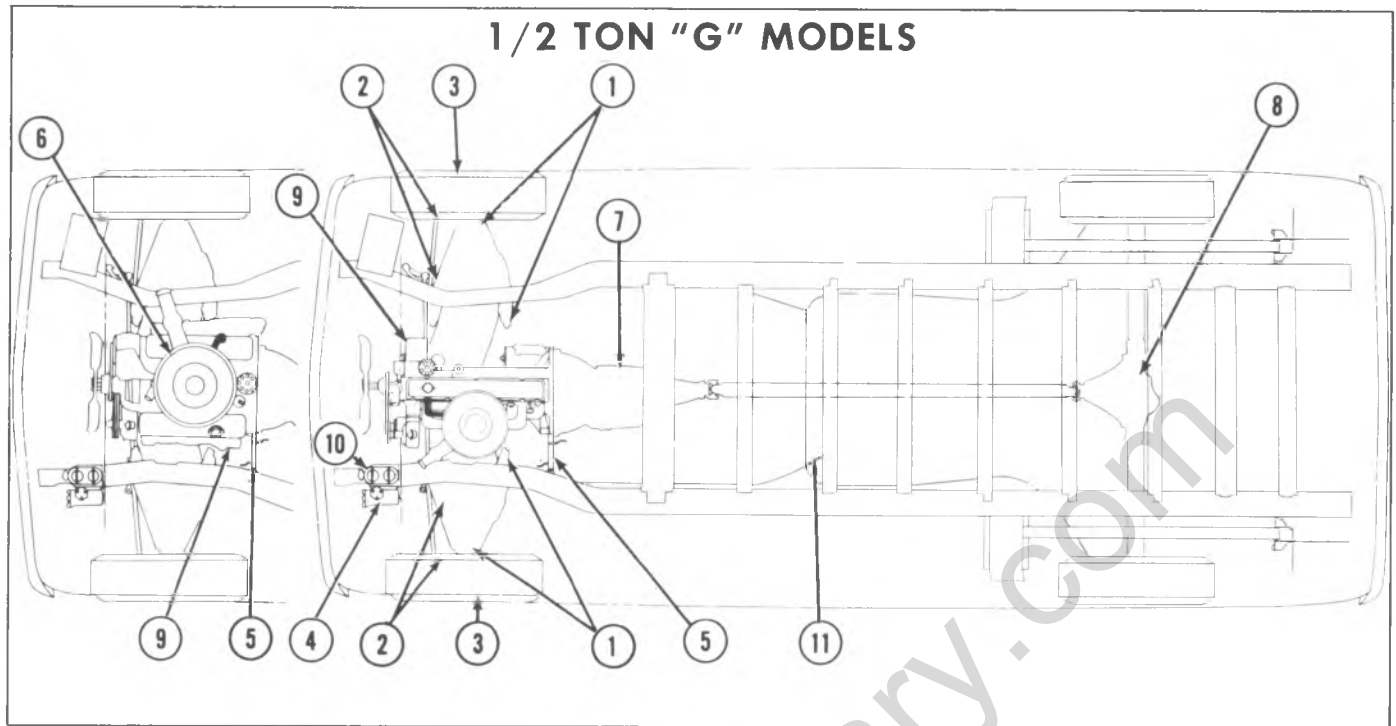
FOUR WHEEL DRIVE MODELS



LUBRICATION POINTS

- | | | |
|--------------------------|--|-----------------------------------|
| 1 Air Cleaner | 6 Master Cylinder | 11 Front and Rear Axle |
| 2 Control Linkage Points | 7 Transmission – Manual
– Automatic | 12 Drag Link |
| 3 Tie Rod Ends | 8 Carburetor Linkage – V-8 | 13 Brake and Clutch Pedal Springs |
| 4 Wheel Bearings | 9 Universal Joints | 14 Transfer Case |
| 5 Steering Gear | 10 Propeller Shaft Slip Joints | 15 Throttle Bell Crank – L-6 |

Fig. 0B-3--Lubrication Points Conventional Four Wheel Drive



LUBRICATION POINTS

- 1 Control Arm Bushings and Ball Joints
- 2 Tie Rod Ends
- 3 Wheel Bearings
- 4 Steering Gear
Clutch Cross-Shaft

- 5 Trans. Control Shaft
- 6 Air Cleaner - Element
- 7 Transmission - Manual
- Automatic

- 8 Rear Axle
- 9 Oil Filter
- 10 Brake Master Cylinder
- 11 Parking Brake Linkage

Fig. 0B-4--Lubrication Points 1/2 Ton G-Van

classiccarylbrary.com

SECTION 1A HEATER

CONTENTS OF THIS SECTION

Standard Heater	1A-1
Auxiliary Heater	1A-14
Specifications	1A-18

STANDARD HEATER

INDEX

General Description	1A-1	Heater Hoses	1A-10
System Components	1A-1	Center Distributor Duct - G Models	1A-10
System Controls	1A-3	Left Distributor Duct - G Models	1A-10
Diagnosis	1A-4	Defroster Duct	1A-10
On Vehicle Service		Control Assembly	1A-10
Blower Motor	1A-9	Control Cables	1A-11
Heater Distributer and Core Assembly	1A-9	Blower Switch	1A-12
		Resistor Unit	1A-13

GENERAL DESCRIPTION

Heating components are attached to the dash panel on the right side of the vehicle. The blower and air inlet assembly and water hoses are located on the forward side of the dash panel while the heater core and distributor duct are on the passenger side.

which outside air is heated and then mixed in varying amounts with cooler outside air to attain the desired air temperature. The system consists basically of three parts: (1) the blower and air inlet assembly, (2) the heater distributor assembly and (3) the heater control assembly.

The heater system is an air mix type system in

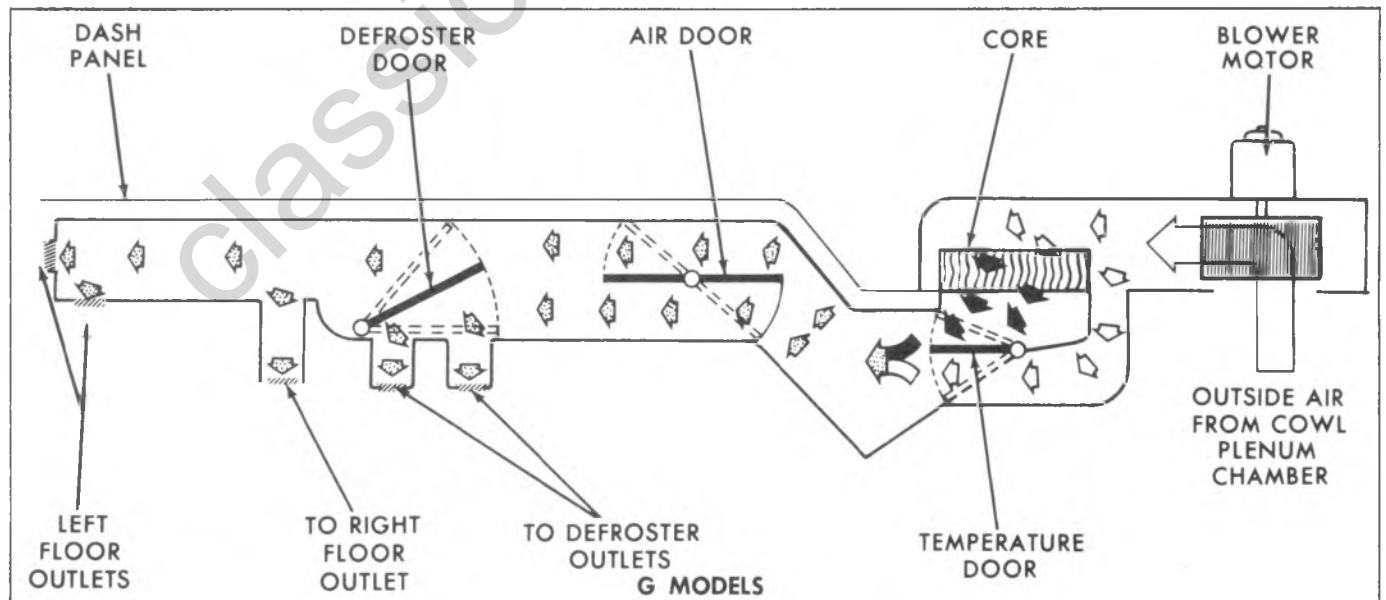


Fig. 1A-1-Heater Air Flow Schematic-G Models

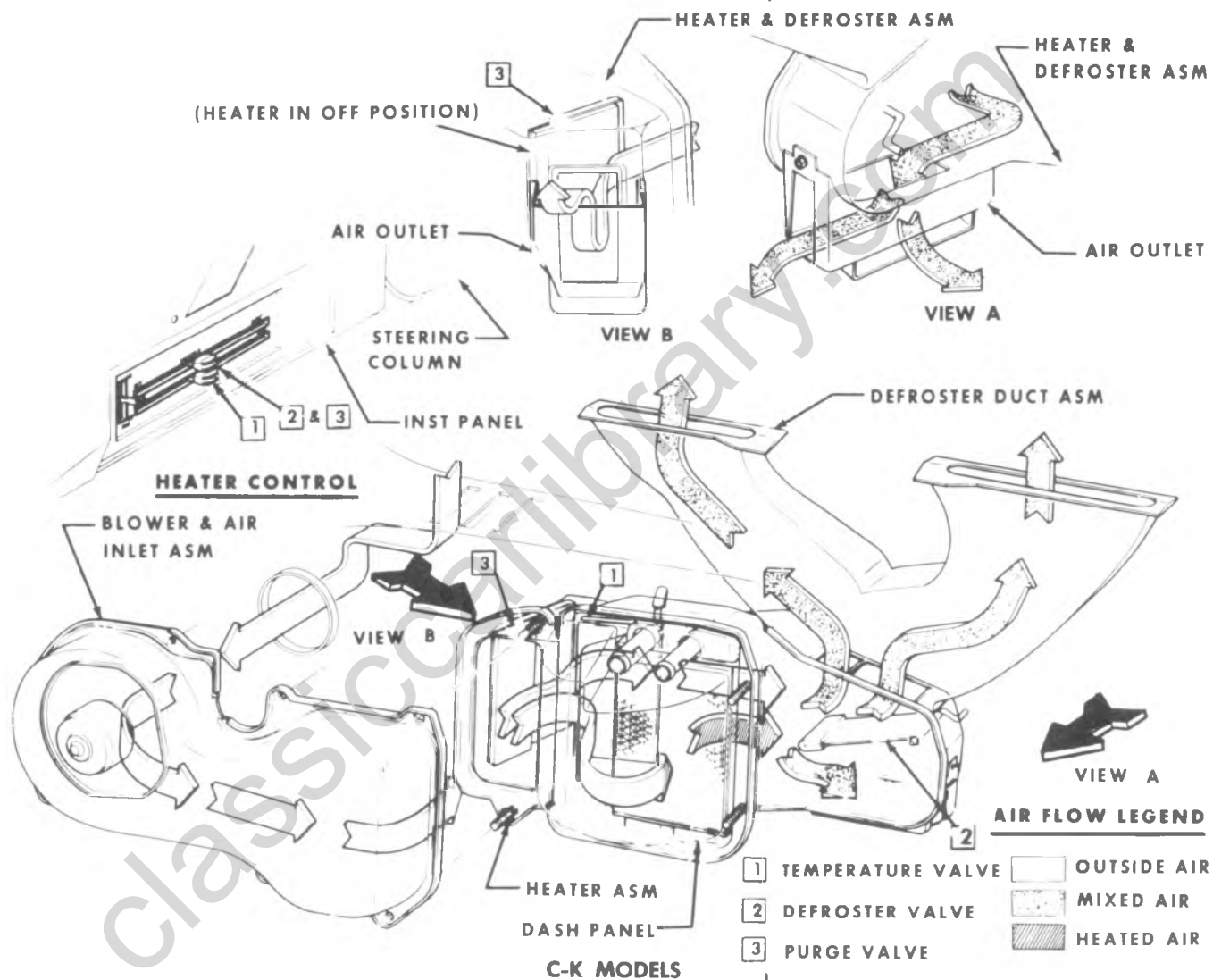


Fig. 1A-2-Heater Air Flow Schematic-C-K Models

BLOWER AND AIR INLET ASSEMBLY

The blower and air inlet assembly draws outside air through the outside air inlet grille located forward of the windshield reveal molding and channels the air into the heater distributor assembly. The operation of the blower motor is controlled by the FAN switch on the heater control. The motor is connected in series with the FAN switch and also the blower resistor assembly. Located in the fuse block, in series between the blower motor and the battery, is a 25 amp. fuse C-K models - a 20 amp fuse on G models.

HEATER DISTRIBUTOR ASSEMBLY

The heater distributor assembly houses the heater core and the doors necessary to control mixing and channeling of the air. Since the unit has no water valve, water circulation keeps the core hot at all times. That portion of the air passing through the core receives maximum heat from the core. Air entering the distributor assembly is channeled as follows:

C-K Models

Air entering the distributor can be directed out the purge door opening, on the right end of the distributor assembly, by the purge door. If the purge door is closed, then air is directed through and/or around the heater core by the temperature door. Air is then directed into the passenger compartment through the heater (floor) outlets and/or the defroster (dash) outlets by the defroster door. The temperature of the outlet air is dependent on the ratio of heated to unheated air (controlled by the temperature door).

G Models

Air flow is controlled by three doors in the distributor assembly. The air door can be adjusted to vary airflow. If air is allowed to enter the distributor assembly, it is then directed through and/or around the heater core by the temperature door. Air is directed into the passenger compartment through the heater (floor) and/or defroster (dash) outlets by the defroster door. The temperature of the outlet air is dependent of the

ratio of heated to unheated air (controlled by the temperature door).

CONTROLS

C-K Models (Fig. 1A-3)

These controls are mounted in the center of the dash, above the radio assembly. The control incorporates two levers which make use of bowden cables to control positioning of the purge, temperature and defroster doors.

Temperature Lever

This lever control the positioning of the TEMPERATURE door in the heater distributor assembly. All incoming "outside" air is directed around the heater core in the COLD position or through the core in the HOT position. The desired outlet temperature is obtained by blending the heated and unheated air according to the setting of the temperature lever.

Heater-Def Lever

The HEATER-DEF lever controls the position of the DEFROSTER door and the PURGE door. In the OFF position, the blower is "on" and incoming air is directed up under the dash through the purge door opening. As the lever is moved to the right of the OFF position, the door closes, directing airflow on into the distributor assembly. With the lever at HEATER, the DEFROSTER door directs almost all airflow to the heater (floor) outlets - a small amount of air is directed to the defroster (dash) outlets. In the DEF position, most airflow is diverted to the defroster outlets. Moving the lever part way, as desired, will split airflow between the floor and defroster outlets.

Fan Control

The blower fan lever is located at the left hand side of the control assembly. The blower motor will operate as soon as the ignition switch is turned to the RUN position. The control has three positions only; LO, MED, HI. There is no OFF position.

G Models (Fig. 1A-4)

The controls are located in the instrument panel, just to the right of the instrument cluster. In operation, two levers control all heating operations.

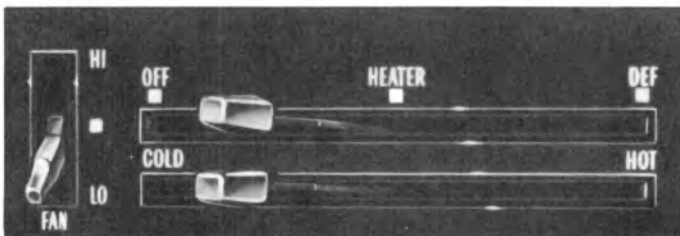


Fig. 1A-3--Heater Control--C-K Models

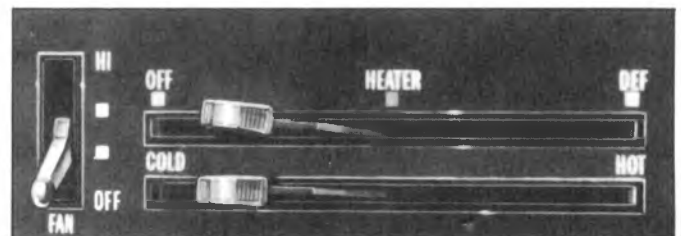


Fig. 1A-4--Heater Control--G Models

Temperature Lever

This lever controls the positioning of the TEMPERATURE door in the heater distributor assembly. All incoming "outside" air is directed around the heater core in the COLD position or through the core in the HOT position. The desired outlet temperature is obtained by blending heated and unheated air according to the setting of the temperature lever.

Heater-Def Lever

The HEATER-DEF lever controls positioning of the AIR and DEFROSTER doors in the heater distributor assembly. In the OFF position, no air is allowed to enter

the system. Moving the lever to the right (toward HEATER) opens the air door with the AIR door being fully open at the HEATER position. Incoming air is directed to the heater outlets (with slight air bleed to the defroster outlets). Moving the lever between HEATER and DEF, directs increasing amounts of air to the defroster outlets until all air is directed to the defroster outlets in the DEF position.

Fan Control

The blower fan lever is located on the left hand side of the control assembly. When the lever is fully down, the blower motor is inoperative. Moving the lever upward actuates the three speed blower motor (LOW-MED-HI).

classiccarylbrary.com

DIAGNOSIS

TROUBLE	CAUSE AND CORRECTION
Temperature of heater air at outlets too low to heat up passenger compartment.	1. See "Insufficient Heat Diagnostic Chart".
Temperature of heater air at outlets adequate but the vehicle will not build up sufficient heat.	<p>Check for body leaks such as:</p> <ol style="list-style-type: none"> 1. Floor side kick pad ventilators partially open. 2. Leaking grommets in dash. 3. Leaking welded seams along rocker panel and windshield. 4. Leaks through access holes and screw holes. 5. Leaking rubber molding around door and windows. 6. Leaks between sealing edge of blower and air inlet assembly and dash, and between sealing edge of heater distributor assembly and dash.
Inadequate defrosting action.	<ol style="list-style-type: none"> 1. Check that DEFROST lever completely opens defroster door in DEF position - Adjust if necessary. 2. Insure that temperature and air doors open fully - Adjust. 3. Look for obstructions in defroster ducts - Remove any obstructions. 4. Check for air leak in ducting between defroster outlet on heater assembly and defroster duct under instrument panel - Seal area as necessary. 5. Check position of bottom of nozzle to heater locating tab - Adjust. 6. Check position of defroster nozzle openings relative to instrument panel openings. Mounting tabs provide positive position if properly installed.
Inadequate circulation of heated air through vehicle.	<ol style="list-style-type: none"> 1. Check heater air outlet for correct installation - Reinstall. 2. Inspect floor carpet to insure that carpet lies flat under front seat and does not obstruct air flow under seat, and also inspect around outlet ducts to insure that carpet is well fastened to floor to prevent cupping of air flow - Correct as necessary.
Erratic heater operation.	<ol style="list-style-type: none"> 1. Check coolant level - Fill to proper level. 2. Check for kinked heater hoses - relieve kinks or replace hoses. 3. Check operation of all bowden cables and doors - Adjust as necessary. 4. Sediment in heater lines and radiator causing engine thermostat to stick open - flush system and clean or replace thermostat as necessary. 5. Partially plugged heater core - backflush core as necessary.
Hard operating or broken controls.	<ol style="list-style-type: none"> 1. Check for loose bowden cable tab screws or mis-adjusted bowden cables - Correct as required. 2. Check for sticking heater system door(s) - Lubricate as required using a silicone spray.

INSUFFICIENT HEAT DIAGNOSIS

Position the controls so that the:
 Temperature lever is on full heat.
 Selector or heater lever is on Heater.
 Fan switch is on Hi.

*CHECK DUMP DOOR OUTLET FOR AIR FLOW

NO AIR FLOW

CHECK DEFROSTER OUTLETS FOR AIR FLOW
 (If in doubt as to High or Low air flow set selector on DEF which is High and compare. Reset selector on Heater)

NO OR LOW AIR FLOW

CHECK HEATER OUTLET AIR FLOW
 (If in doubt, switch fan switch from Hi to Lo)

CHANGE IN AIR FLOW

NORMAL AIR FLOW

Check heater outlet temperature with 220° F range thermometer

(approximate outlet air temperatures)

Outlet Air	145	150	155	165
Ambient Air	0	25	40	75

NORMAL TEMPERATURE

Remove all obstructions under front seat
 Car does not build up heat - operate vent controls and see that the air vent doors close completely, if not, adjust.

LOW TEMPERATURE

(Check the system temperature after repairing the item checked to complete the diagnosis.)
 Check coolant level; if low, fill. Look for or feel all radiator and heater hoses and connections for leaks. Repair or replace. Check the radiator cap for damage and replace if required.
 Check heater and radiator hoses for kinks - straighten and replace as necessary.
 Check temperature door for max heat position. Adjust if necessary.

HEATER CORE

Feel temperatures of heater inlet and outlet hoses.

WARM INLET AND OUTLET HOSES

Check engine thermostat.

HOT INLET AND WARM OUTLET HOSES

Check pulleys, belt tension, etc., for proper operation. Replace or service as necessary.

Remove hoses from heater core. Reverse flush with tap water. If plugged, repair or replace.

AIR FLOW

Adjust dump door for no air flow.

HIGH AIR FLOW

Adjust defroster door for low air flow.

LITTLE OR NO CHANGE IN AIR FLOW

LOW OR NO AIR FLOW

**Check shutoff door position for full system air flow. Adjust if necessary.

LOW AIR FLOW

Check heater outlet for obstruction - remove.

Check motor voltage at closest motor line connection with a voltmeter.

UNDER 10 VOLTS

Check battery volts - under 10 volts, recharge then recheck motor voltage.

Check wiring and connections for under 10 volts from motor to fan switch. Repair or replace last point of under 10 volt reading.

Apply external ground, (jumper wire) to motor case. INCREASED AIR FLOW - repair ground.

SAME AIR FLOW - remove motor and check for obstruction in system opening. If none, REPLACE MOTOR. If obstruction, remove material and re-install motor.

OVER 10 VOLTS

NO AIR FLOW

CHECK FUSE

FUSE BLOWN - replace fuse.

AIR FLOW - system okay.

BLOWS FUSE

Remove positive lead from motor and replace fuse.

FUSE REMAINS OK - remove motor and check for obstruction in system opening, if none, REPLACE MOTOR. If obstruction, remove material and re-install motor.

BLOWS FUSE - check for shorted wire in blower electric circuit - See Heater Circuit Diagnostic Chart.

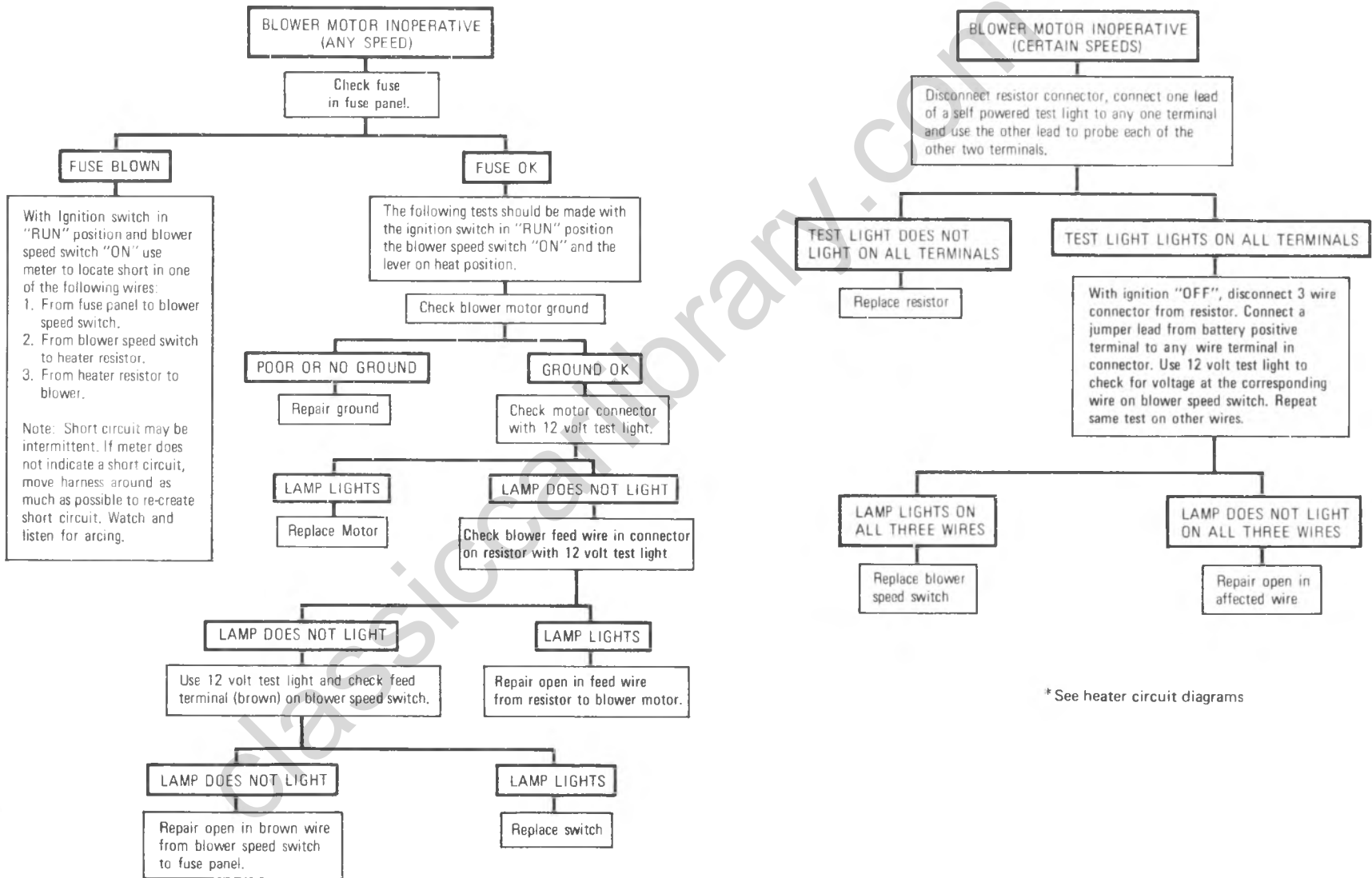
FUSE OK

FUSE OK - See Heater Circuit Diagnostic Chart.

*CHECK FOR C-K MODELS ONLY

**CHECK FOR G MODELS ONLY

HEATER CIRCUIT DIAGNOSIS*



* See heater circuit diagrams

Fig. 1A-5: Heater Circuit Diagnosis

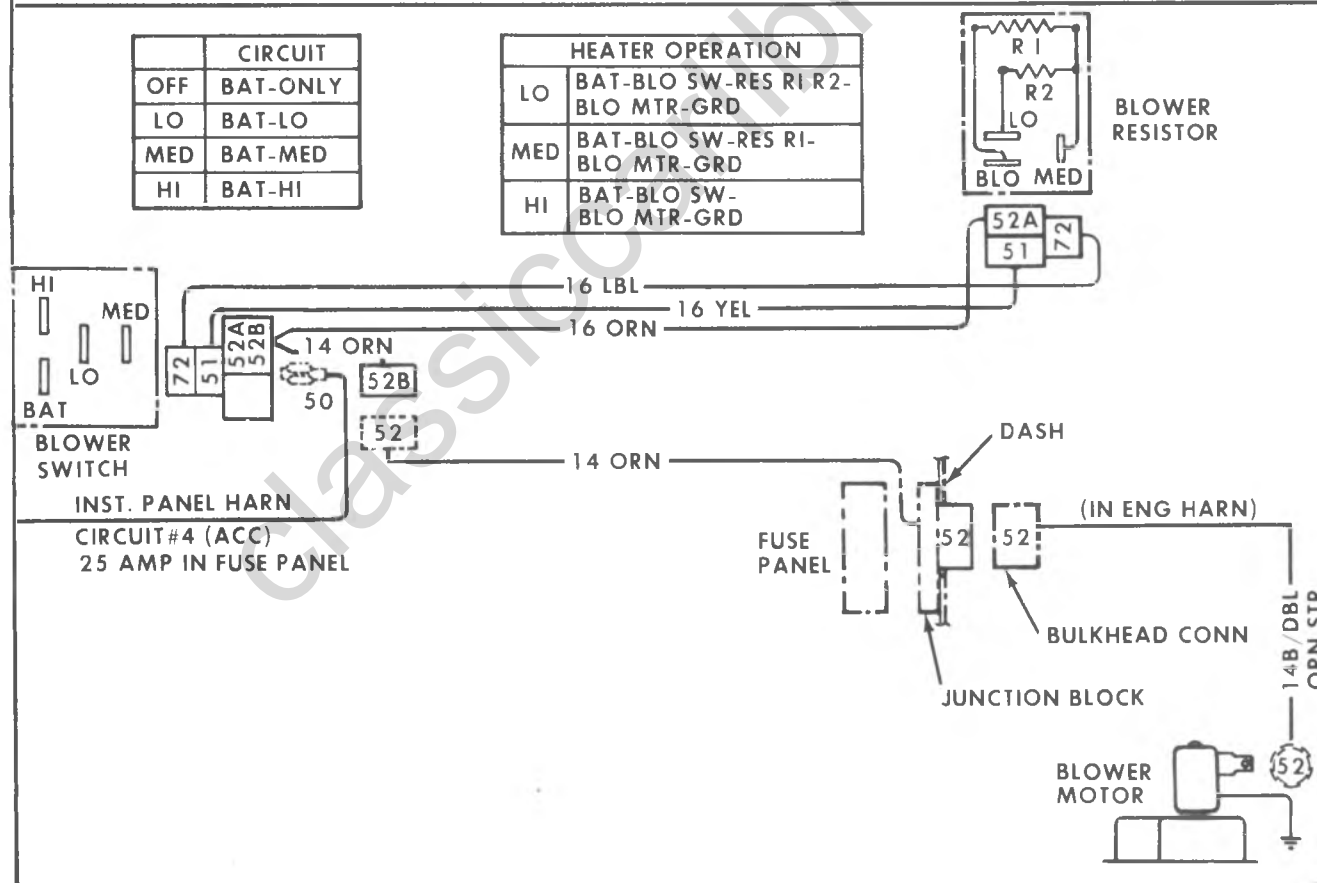
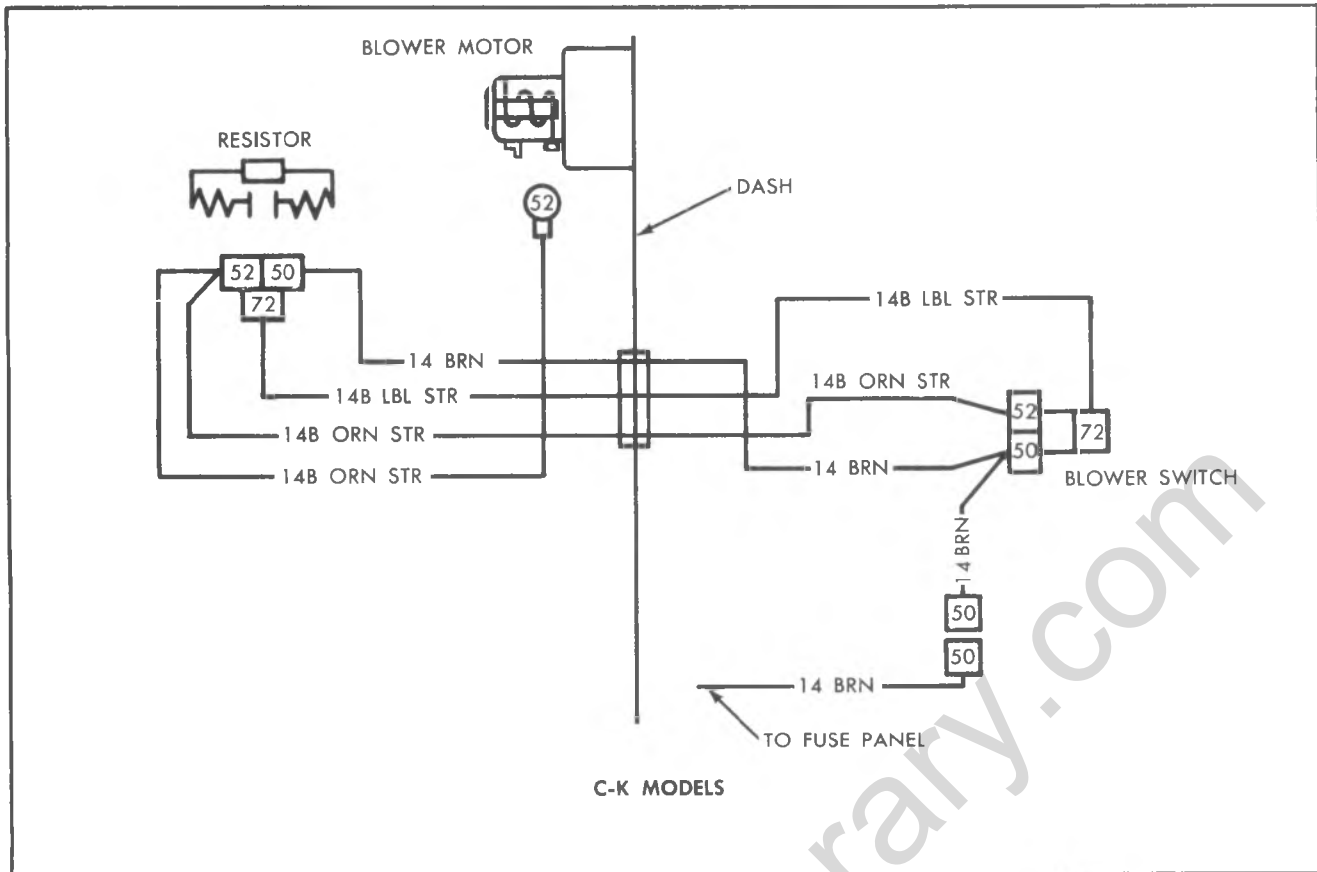


Fig. 1A-6--Heater Wiring Diagrams

ON VEHICLE SERVICE

BLOWER MOTOR

Removal (Fig. 1A-7)

1. Disconnect battery ground cable.
- G Models** - Remove the battery.
2. Disconnect the blower motor lead wire.
3. Remove the five blower motor mounting screws and remove the motor and wheel assembly. Pry gently on the blower flange if the sealer acts as an adhesive.
4. Remove the blower wheel to motor shaft nut and separate the wheel and motor assemblies.
5. To install a new motor, reverse Steps 1-4 above.

NOTE: The following precautions should be taken to assure proper installation:

- a. Assemble the blower wheel to the motor with the open end of the wheel away from the blower motor.

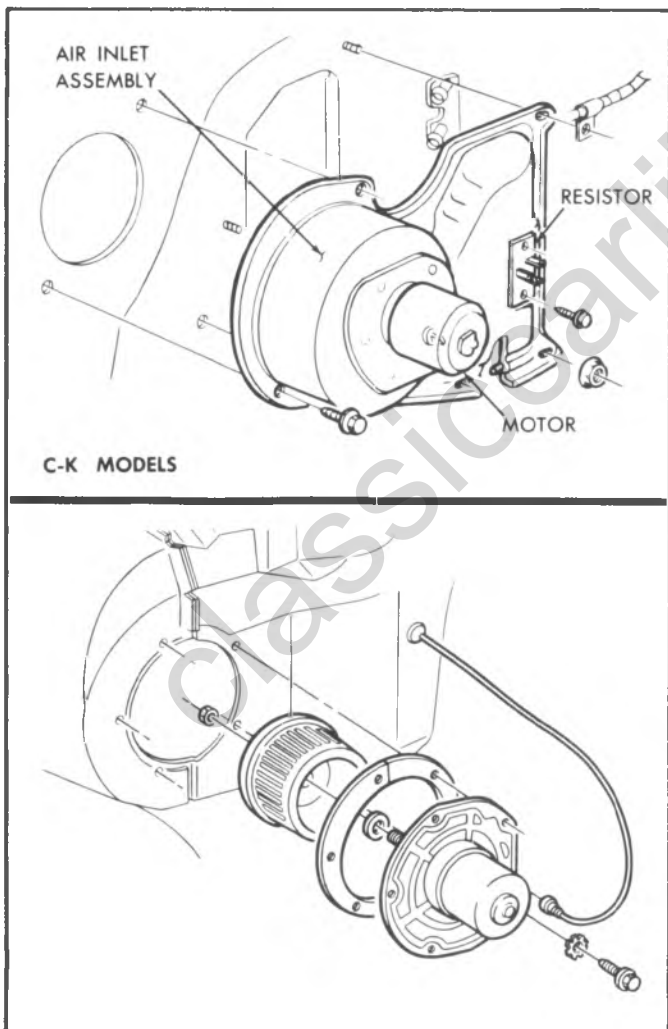


Fig. 1A-7-Blower Motor Assembly

- b. If the motor mounting flange sealer has hardened, or is not intact, remove the old sealer and apply a new bead of sealer to the entire circumference of the mounting flange.

- c. Check blower operations: blower wheel should rotate freely with no interference.

HEATER DISTRIBUTOR AND CORE ASSEMBLY

C-K Models

Replacement (Fig. 1A-8)

1. Disconnect the battery ground cable.
2. Disconnect the heater hoses at the core tubes and drain engine coolant into a clean pan. Plug the core tubes to prevent coolant spillage at removal.
3. Remove the nuts from the distributor duct studs projecting into the engine compartment.
4. Remove the glove box and door assembly.
5. Disconnect the Air-Defrost and Temperature door cables.
6. Remove the floor outlet and remove the defroster duct to heater distributor duct screw.
7. Remove the heater distributor to dash panel screws. Pull the assembly rearward to gain access to wiring harness and disconnect all harnesses attached to the unit.
8. Remove the heater-distributor from the vehicle.
9. Remove the core retaining straps and remove the core.
10. To install, reverse Steps 1-9 above.

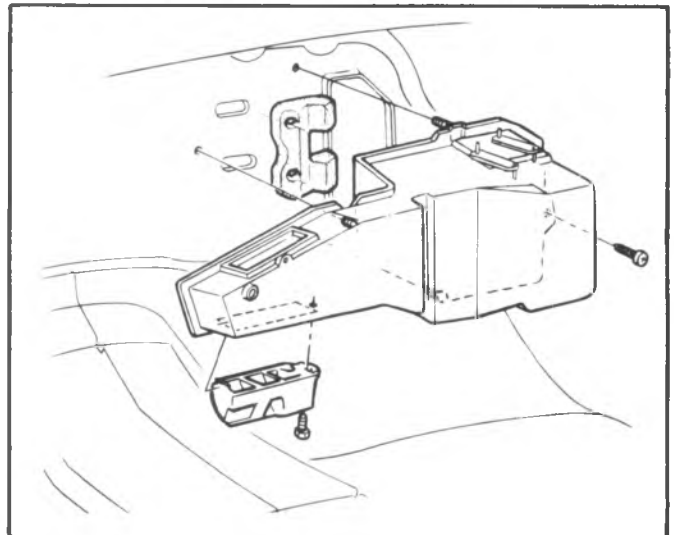


Fig. 1A-8-Heater Distributor Assembly-C-K Models

NOTE: Be sure core to case and case to dash panel sealer is intact before assembling unit.

G Models

Replacement (Fig. 1A-9)

1. Disconnect the battery ground cable.
2. Place a clean pan under the vehicle and then disconnect the heater core inlet and outlet hoses at the core connections (see "Heater Hoses-Replacement" later in this section). Quickly plug the heater hoses and support them in a raised position. Allow the coolant in the heater core to drain into the pan on the floor.
3. Disconnect the right hand air distributor hose from the heater case and rotate it up out of the way.
4. Pry off the temperature door cable eyelet clip and then remove the bowden cable attaching screw.
5. Remove the distributor duct to heater case screws and pull the duct rearward out of the heater case retainer.
6. Remove the four heater case to dash screws and then remove the heater case and core as an assembly. Tilt the case assembly rearward at the top while lifting up until the core tubes clear the dash openings.
7. Remove the core retaining strap screws and remove the core.
8. To install a new core, reverse Steps 1-7 above.

NOTE: Be sure core to case and case to dash panel sealer is intact before assembling unit.

HEATER HOSES

Heater hoses are routed from the thermostat housing or inlet manifold and water pump (radiator on some automatic transmission vehicles) to the core inlet and outlet pipes as shown in Figure 1A-10. Hoses are attached at each end with screw type clamps.

Replacement

The heater core can be easily damaged in the area

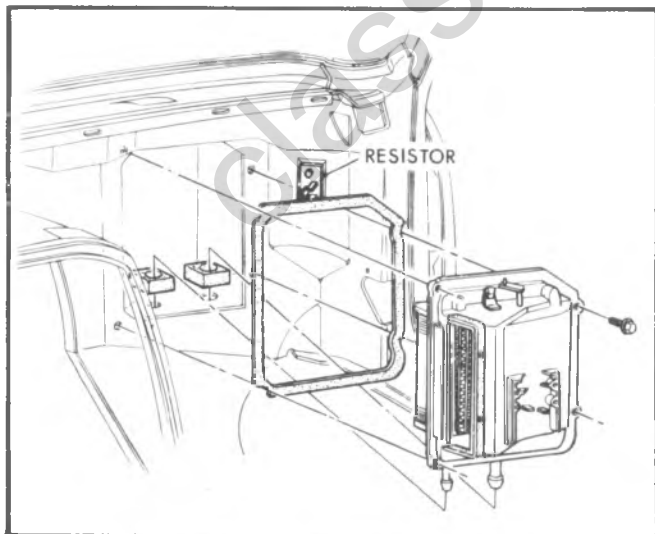


Fig. 1A-9-Heater Distributor - G Models

of the core tube attachment seams whenever undue force is exerted on them. Whenever the heater core hoses do not readily come off the tubes, the hoses should be cut just forward of the core tubes. The portion of the hose remaining on the core tube should then be split longitudinally. Once the hoses have been split, they can be removed from the tubes without damage to the core.

CENTER DISTRIBUTOR DUCT - G Models

Replacement (Fig. 1A-11)

1. Disconnect the battery ground cable.
2. Unsnap the engine cover front latches. Remove the two cover to floorpan screws and remove the cover.
3. Remove the heater core case and core as an assembly (see "Heater Distributor and Core-Replacement").
4. Disconnect the right hand heater outlet hose and the two defroster hoses from the distributor duct.
5. Disconnect the air and defroster door cables by prying off the eyelet clips and removing the cable attaching screws.
6. Pull the center distributor duct to the right and remove it from the vehicle.
7. To install, reverse Steps 1-6 above.

NOTE: Check cable and door operation; cables should be free from kinks or binding and doors should close properly. If cable adjustment is necessary, see "Bowden Cable-Adjustment."

LEFT DISTRIBUTOR DUCT - G Models

Replacement (Fig. 1A-11)

1. Disconnect the battery ground cable.
2. Unsnap the engine cover front latches. Remove the two cover to floorpan screws and remove the cover.
3. Remove the duct bracket screw and remove the duct.
4. To install, reverse Steps 1-3.

NOTE: All three bowden cables are routed under the duct. It may be necessary to hold the cables down as the duct is being installed. Be sure the left duct is fully installed over the center duct.

DEFROSTER DUCT

The defroster hose and outlet assemblies are illustrated in Figure 1A-12.

CONTROL ASSEMBLY

C-K Models

Replacement (Fig. 1A-13)

1. Disconnect the battery ground cable.
2. Remove the instrument panel bezel.
3. Disconnect the bowden cables and the blower switch wiring harness.

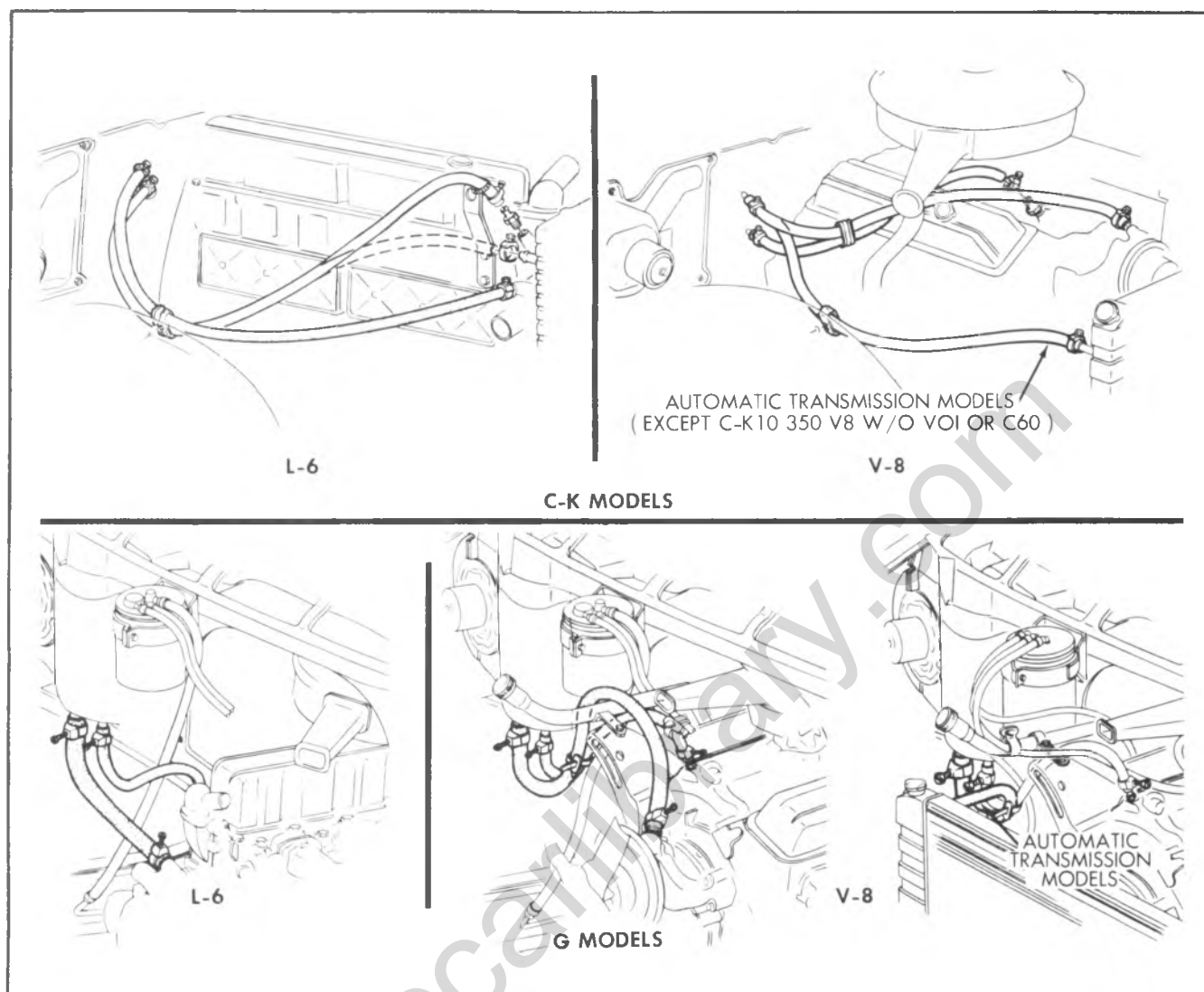


Fig. 1A-10--Heater Hose Routings

CAUTION: Be careful not to kink the bowden cables.

4. Remove the control through the opening above the control.
5. If a new unit is being installed, transfer the blower switch to the new unit.
6. To reinstall, reverse Steps 1-4 above.

G Models

Replacement (Fig. 1A-14)

1. Disconnect the battery ground cable.
2. Remove the ignition switch from the instrument panel (see Section 3B of this manual).
3. Remove the control to instrument panel mounting screws and carefully lower the control far enough to gain access to the bowden cable attachments.

CAUTION: Care should be taken to prevent kinking the bowden cables while lowering the control.

4. Disconnect the three bowden cables, the control illumination bulb, the blower switch connector and remove the control from the vehicle.

5. Remove the blower switch screws and remove the blower switch.

6. To install, reverse Steps 1-5 above.

CONTROL CABLES

C-K Models

Replacement

1. Disconnect the battery ground cable.
2. Remove the instrument panel bezel.
3. Remove the control to instrument panel screws.
4. Raise or lower control as necessary to remove cable push nuts and tab attaching screws.
5. Remove glove box and door as an assembly.
6. Remove cable push nut and tab attaching screw at door end of cable.
7. Remove cable from retaining clip and remove cable assembly.

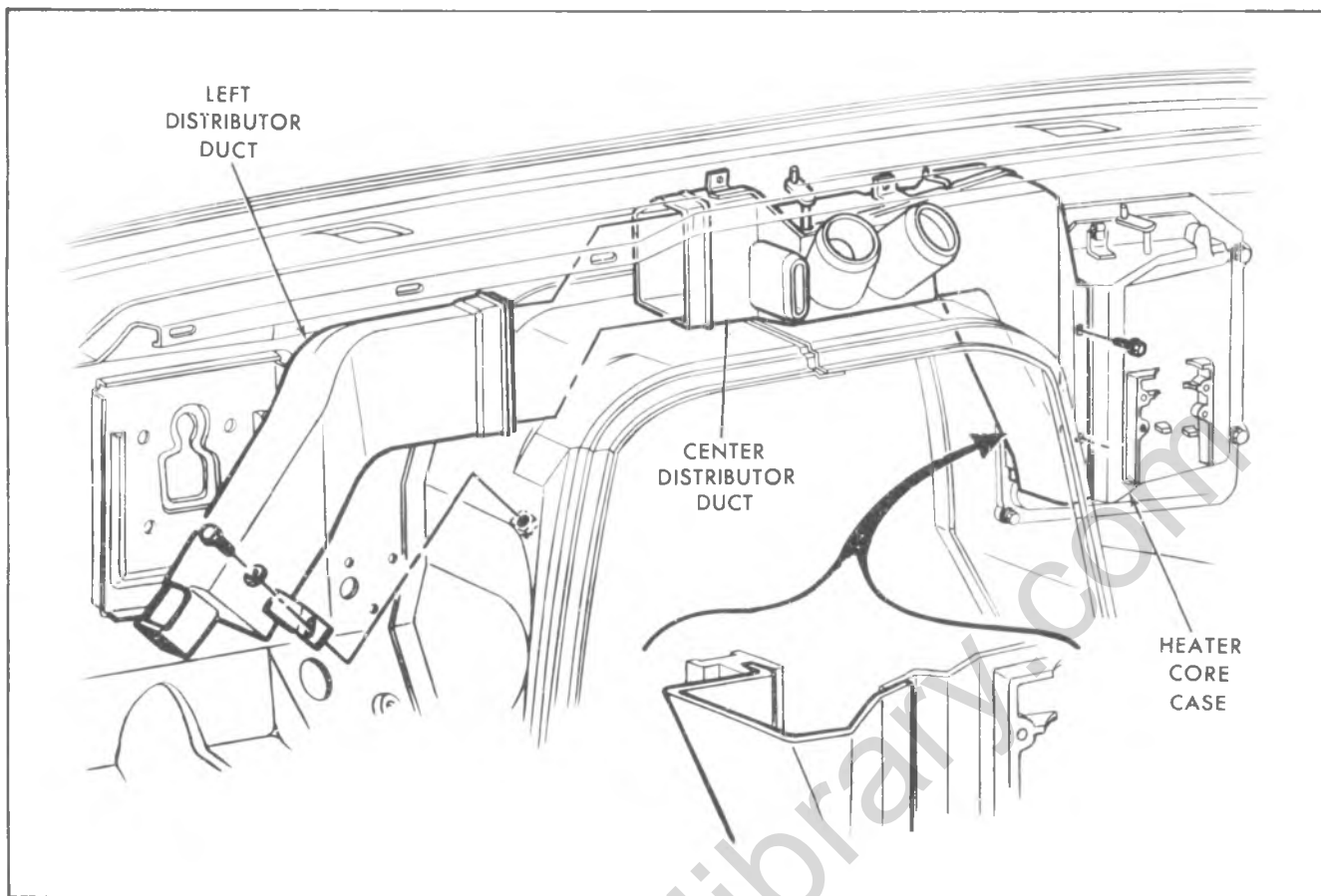


Fig. 1A-11-Distributor Ducts-G Models

8. To install, reverse Steps 1-7 above.

CAUTION: Be careful not to kink the cable during installation. Be sure to route the cable as when removed. Check cable adjustment.

G Models

Replacement (Fig. 1A-15)

1. Disconnect the battery ground cable.
2. Unsnap the engine cover front latches. Remove the two cover to floorpan screws and remove the cover.
3. Remove the left distributor duct attaching screw and remove the duct.
4. Pry off the cable eyelet clip at both the door and control lever. Remove the cable attaching screw at both door and control locations.
5. Attach a 4' piece of wire to the door end of the cable. Place protective tape around the cable mounting tab and attached wire and carefully pull the cable from the vehicle. Remove the tape and disconnect the 4' piece of wire.
6. To install, attach the new cable to the 4' piece of wire. Tape the mounting tab and attached wire. Carefully pull the new cable into position.
7. Reverse Steps 1-4.

NOTE: If cable adjustment is required, see below.

Adjustment

1. Disconnect the battery ground cable.
2. **G Model Air and Defroster Door Cables** - Unsnap the engine cover front latches. Remove the two cover to floorpan screws and remove the engine cover.
3. **C-K Models** - Remove glove box and door as an assembly.
3. Pry off the appropriate cable eyelet clip and disconnect the cable from the door.
4. Remove the cable retaining screw.
5. While holding the cable with pliers, rotate the mounting tab on the cable to lengthen or shorten the cable, whichever is required.

NOTE: Do not pinch the cable too tightly or damage to the cable could result.

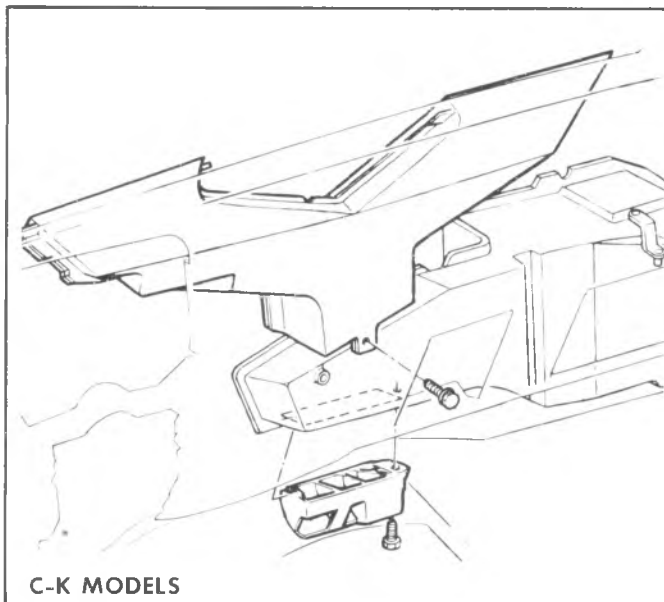
6. Install the cable, reversing Steps 1-4 above.

BLOWER SWITCH

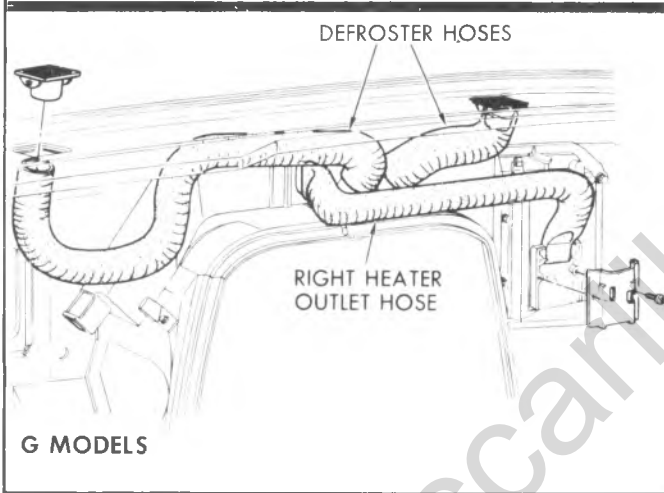
C-K Models

Replacement (Fig. 1A-13)

1. Disconnect the battery ground cable.
2. Remove the instrument panel bezel.
3. Remove the control to instrument panel screws and lower the control onto the radio.



C-K MODELS



G MODELS

Fig. 1A-12--Defroster Outlets

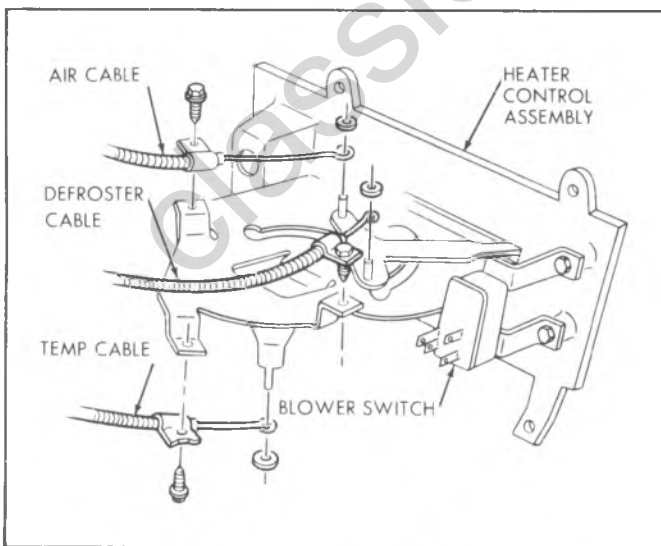


Fig. 1A-13--Control Assembly--C-K Models

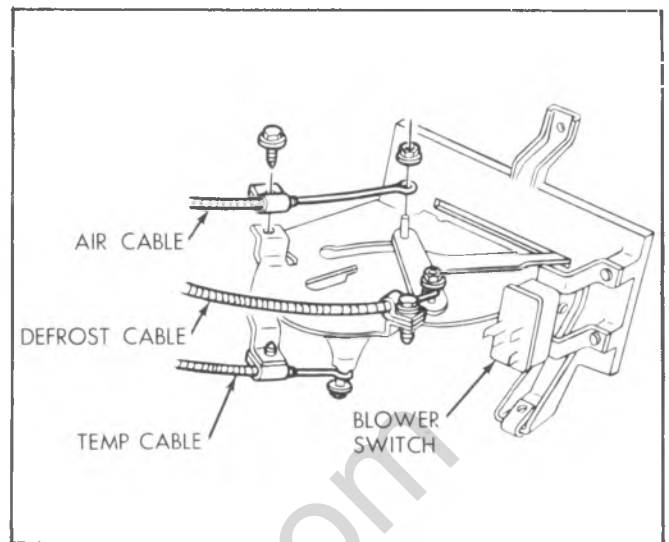


Fig. 1A-14--Control Assembly--G Models

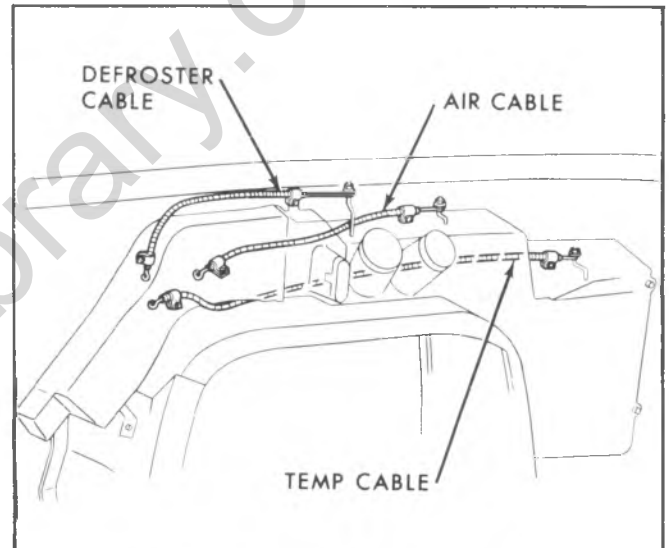


Fig. 1A-15--Control Cable Routing--G Models

4. Disconnect the switch electrical harness.
5. Remove the switch attaching screws and remove the switch.
6. To install, reverse Steps 1-5 above.

G Models

Replacement (Fig. 1A-14)

1. Disconnect the battery ground cable.
2. Disconnect the blower switch wiring harness connector at the switch.
3. Remove the two switch attaching screws and remove the switch assembly.
4. To install a new switch, reverse Steps 1-3 above.

RESISTOR

Replacement (Figs. 1A-7 and 1A-9)

1. Disconnect the wiring harness at the resistor connector.

2. Remove the two resistor mounting screws and remove the resistor.

3. To install a new resistor, reverse Steps 1 and 2 above.

AUXILIARY HEATER

INDEX

General Description	1A-14
Control	1A-15
Diagnosis	1A-15
On Vehicle Service	1A-15
Specifications	1A-18

GENERAL DESCRIPTION

An auxiliary heater is available as a dealer installed accessory to provide additional heating capacity for the rearmost extremities of the C-K (06) and G (05 and 06) models.

This unit operates entirely independent of the standard heater and is regulated through its own controls at the instrument panel.

This system consists of a separate core and fan unit mounted as shown in Figures 1A-16 and 1A-17.

Heater hoses extend from the unit to the front of the vehicle where they are connected to the standard heater hoses with "tees". An "on-off" water valve is installed in the heater core inlet line in the engine compartment. This valve must be operated manually—"on" for cold weather, "off" in warm weather. The purpose of the valve is to cut off coolant flow to the

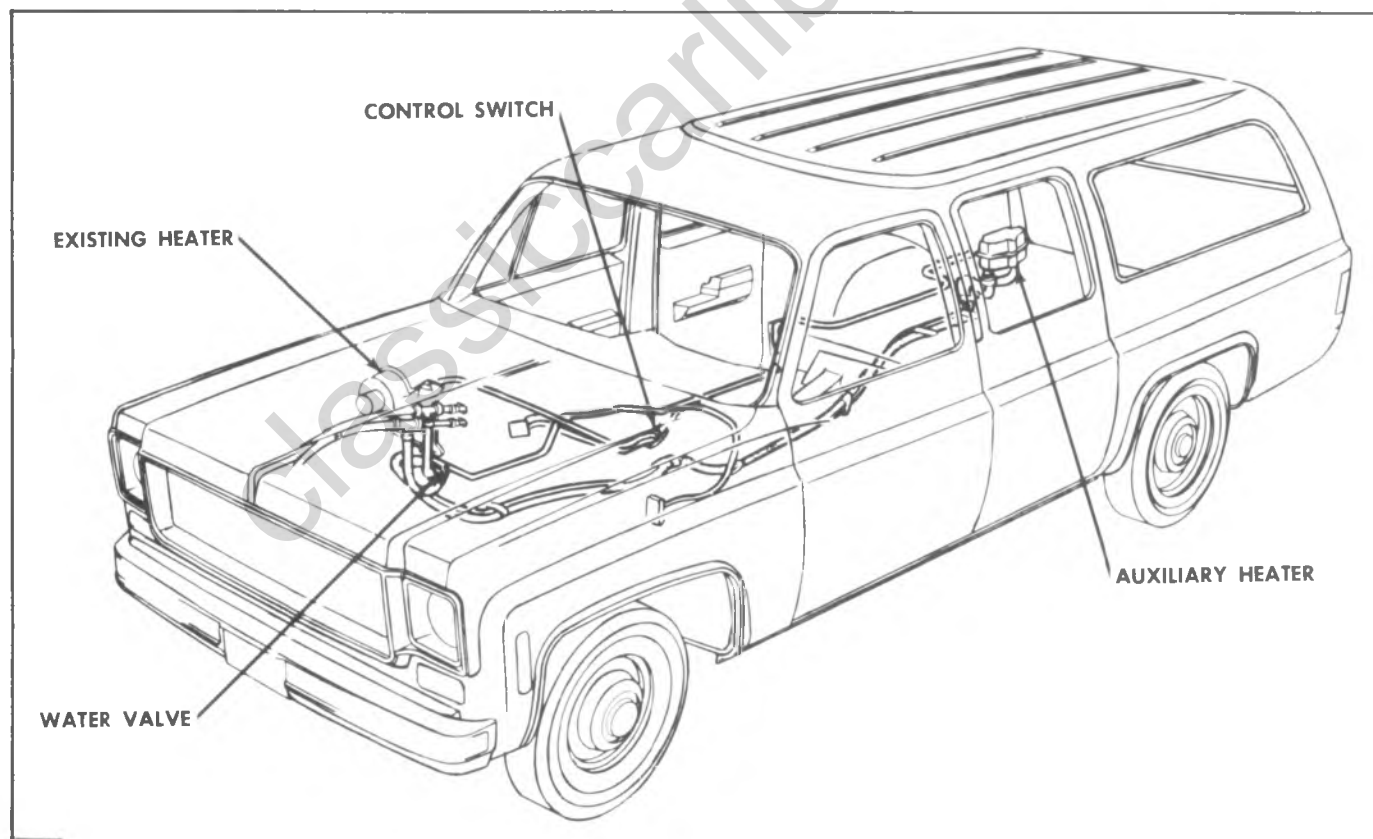


Fig. 1A-16--Auxiliary Heater Installations (C-K Models)

auxiliary core during warm weather and eliminate the radiant heat that would result.

CONTROLS

Two methods of control are employed with this system:

Water Valve (Fig. 1A-18)

When heat is desired, the water valve must be in the "on" position (valve located in the engine compartment

in the core inlet line). During the summer months, this valve should be placed in the "off" position.

Fan Switch (Fig. 1A-19)

The three speed fan switch (LOW-MED-HI) is located in the instrument panel, to the right of the steering column. Full down, the blower is inoperative; fully up the blower is on HI.

DIAGNOSIS

Refer to the "Standard Heater" section of this manual for diagnostic information; see Electrical Diagram Figure 1A-20.

NOTE: If the heater blower motor is inoperative on C-K models (equipped with Overhead Air Conditioning), check that the connectors have not been interchanged with one another.

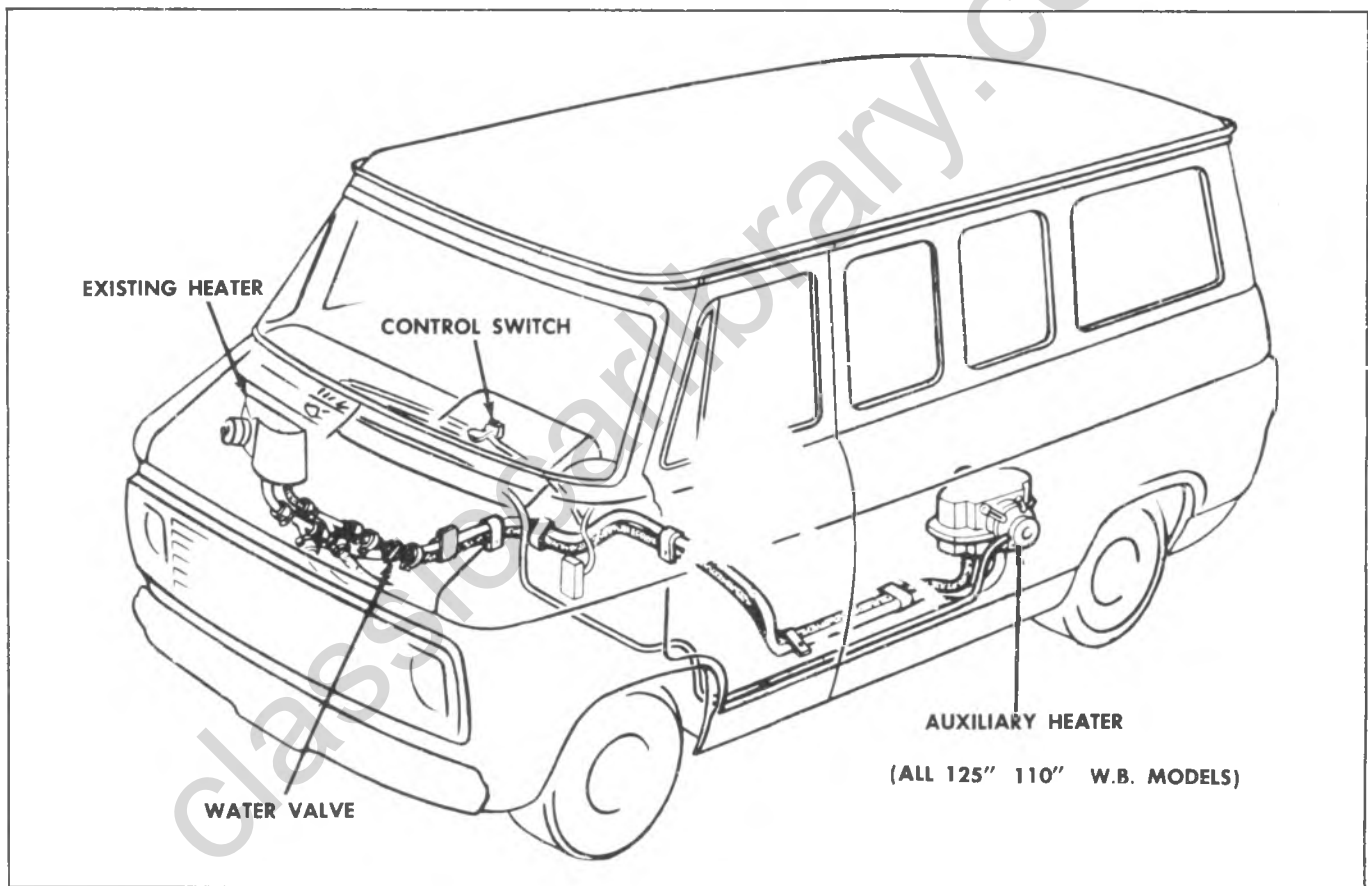


Fig. 1A-17--Auxiliary Heater Installations (G Models)

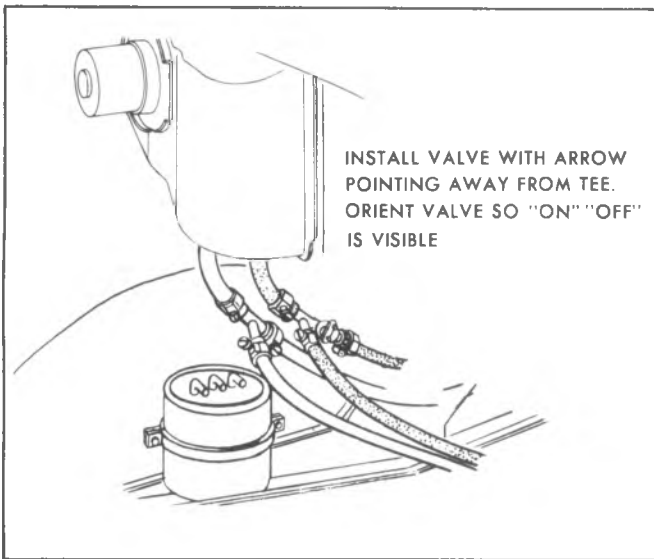


Fig. 1A-18-Water Valve Installation - G Model Shown as Typical

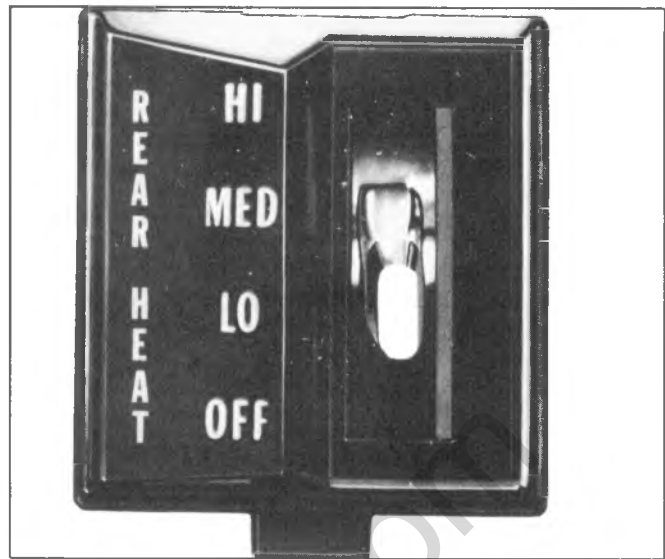


Fig. 1A-19-Auxiliary Heater Control

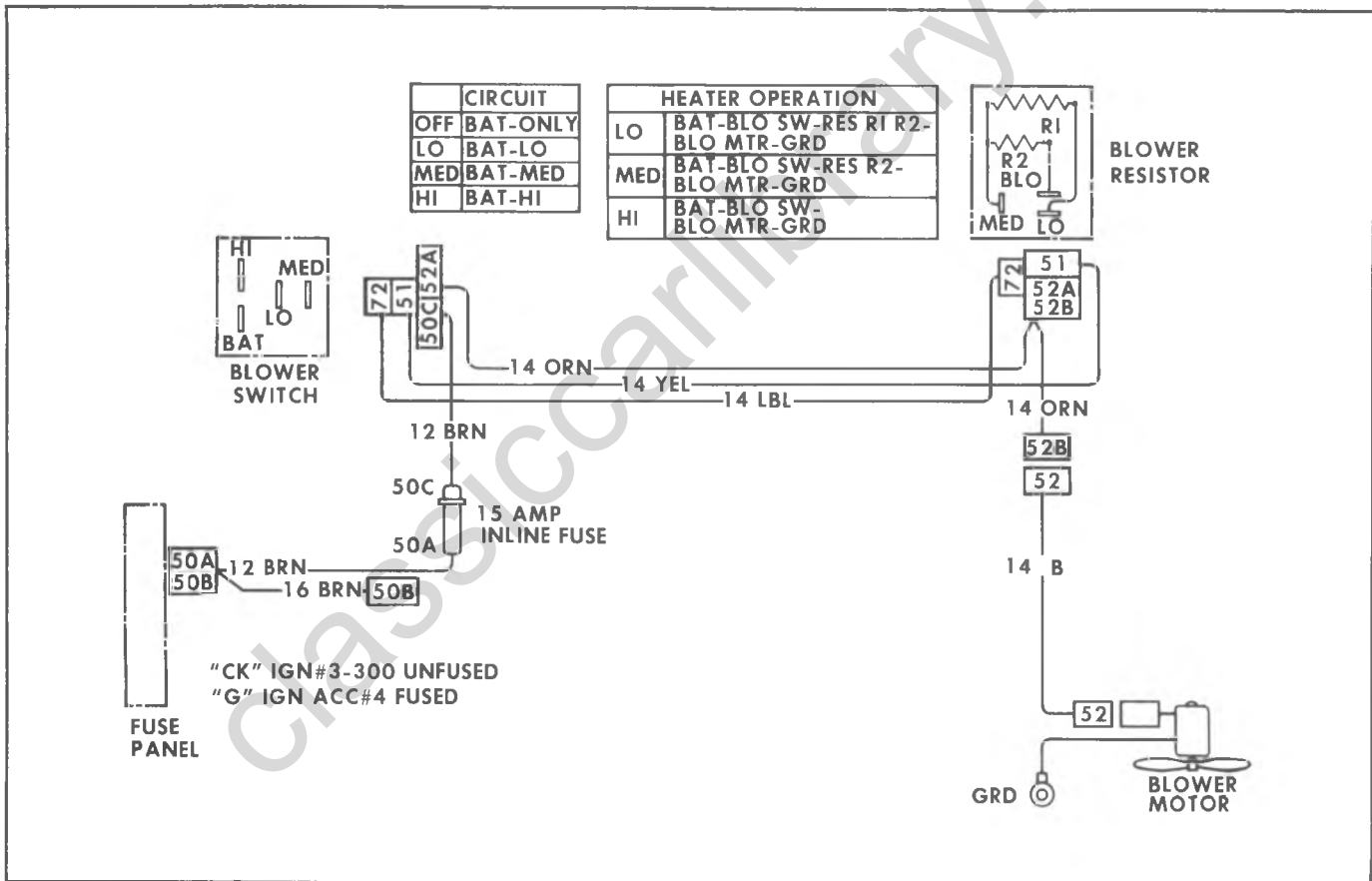


Fig. 1A-20-Electrical Diagram - All Models

ON VEHICLE SERVICE

Since a detailed list of installation instructions is included with the auxiliary heater unit, replacement procedures will not be repeated in this section.

CAUTION: *G Models--When replacing heater hoses, maintain a 1/2" minimum clearance between hose clip and upper control arm, a*

1-1/2" minimum clearance between hoses and propshaft and a 1-1/4" minimum clearance between the auxiliary heater core lines and the exhaust pipe as shown in Figure 1A-22. All

Models--Draw hoses tight to prevent sag or rub against other components. Be sure to route hoses through all clamps as originally installed.

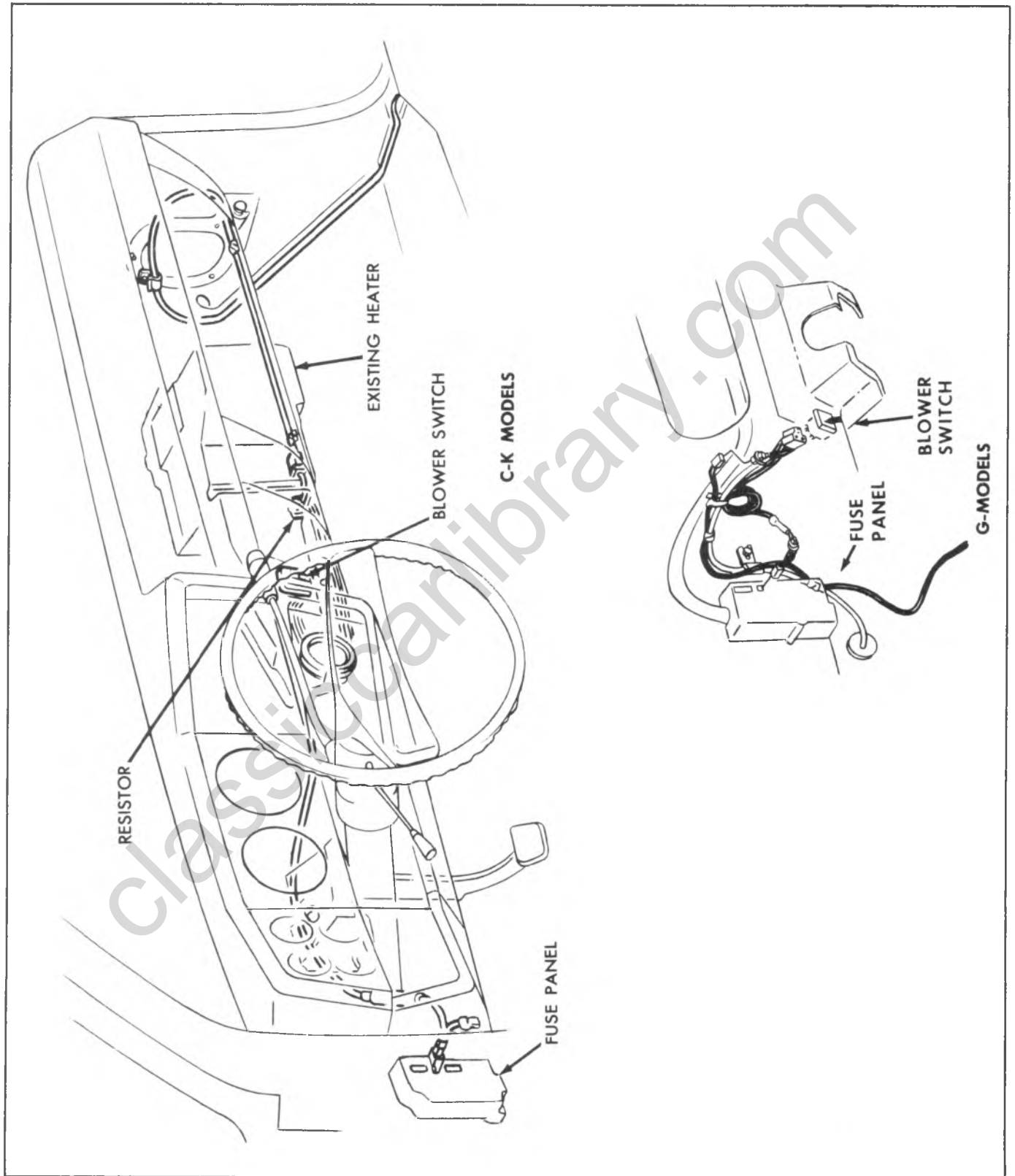


Fig. 1A-21--Control and Resistor Mountings

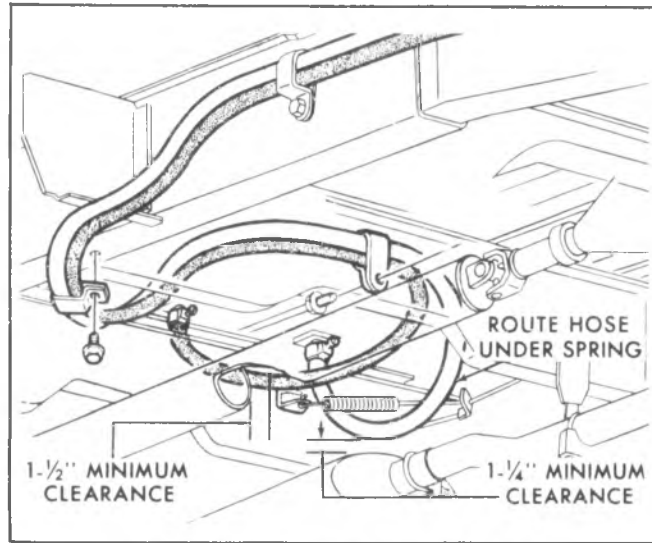


Fig. 1A-22-Heater Hose Routing - G Models

SPECIFICATIONS

SECTION 1A

HEATER

	<u>Volts</u>	<u>Amps. (Cold)</u>	<u>RPM (Cold)</u>
Blower Motor			
C-K Models	13.5	6.25 Max.	2550 Min. 2950 Max.
G Models	13.5	7.1 Max.	2850 Min. 3250 Max.

Fuses

C-K Models	20 Amp.
G Models	20 Amp.

AUXILIARY HEATER

	<u>Volts</u>	<u>Amps. (Cold)</u>	<u>RPM (Cold)</u>
Blower Motor	13.5	9.6 Max.	2700 Min.

SECTION 1B

AIR CONDITIONING

CONTENTS

General Description.....	1B-2	Evaporator Core.....	1B-44
Four-Season System (C-K Models).....	1B-2	Blower Motor Switch.....	1B-45
C60 System (G Models).....	1B-2	Fuse.....	1B-45
Overhead Systems (C-K-G Models).....	1B-2	C60 System--G Models.....	1B-45
Motor Home Chassis System.....	1B-2	Condenser.....	1B-45
Basic Air Conditioner.....	1B-2	Receiver-Dehydrator.....	1B-45
Main Units of the System.....	1B-5	Sight Glass Replacement.....	1B-46
System Control.....	1B-12	A/C Air Distributor Duct.....	1B-46
Diagnosis.....	1B-16	A/C Center and Right Dash Outlets.....	1B-47
Refrigerant System.....	1B-16	Heater, Air Distributor and Extension Ducts..	1B-48
Compressor Diagnosis.....	1B-16	Heater Core Case and Core.....	1B-48
Vacuum System Diagnosis.....	1B-17	Expansion Valve.....	1B-48
Insufficient Cooling.....	1B-19	Blower Motor.....	1B-48
Electrical System Diagnosis.....	1B-21	Evaporator Core.....	1B-49
Air Conditioning System Capacity.....	1B-17	Air Inlet Valve.....	1B-49
Performance Test.....	1B-17	Temperature Door Cable.....	1B-49
Performance Data.....	1B-30	Control.....	1B-49
Checking Oil.....	1B-30	Blower Switch.....	1B-50
Refrigerant Quick-Check Procedure.....	1B-32	Amplifier Circuit Board.....	1B-50
On Vehicle Service.....	1B-33	Resistors.....	1B-50
Thermostatic Switch.....	1B-33	Blower Motor Relay.....	1B-50
Potentiometer (G Models).....	1B-33	Resistors.....	1B-50
Expansion Valve.....	1B-34	Blower Motor Relay.....	1B-50
Engine Idle Compensator.....	1B-34	Discharge Pressure Switch.....	1B-50
Compressor.....	1B-35	Vacuum Tank.....	1B-51
Four Season System--C-K Models.....	1B-36	Circuit Breaker.....	1B-51
Condenser.....	1B-36	Overhead System--G Models.....	1B-51
Accumulator.....	1B-37	Blower-Evaporator Shroud.....	1B-51
Blower Assembly.....	1B-37	Blower Motor Assemblies.....	1B-51
Evaporator Core.....	1B-37	Expansion Valves.....	1B-52
Expansion Tube.....	1B-38	Evaporator Core.....	1B-53
Selector Duct and Heater Core.....	1B-38	Resistor.....	1B-54
Kick Panel Air Valve.....	1B-39	Blower Switch.....	1B-54
Plenum Air Valve.....	1B-39	Rear Blower Relay.....	1B-54
Control Assembly.....	1B-39	Tie Relay.....	1B-54
Temperature Door Cable Adjustment.....	1B-40	Dash Mounted System--Motor Home Units.....	1B-54
Master Switch and/or Blower Switch.....	1B-40	Condenser.....	1B-54
Vacuum Tank.....	1B-40	Receiver-Dehydrator.....	1B-55
Blower Resistor Unit.....	1B-41	Sight Glass.....	1B-55
Thermostatic Switch.....	1B-41	Blower-Evaporator Assembly.....	1B-55
Discharge Pressure Switch.....	1B-41	Blower Assembly.....	1B-56
Fuse.....	1B-42	Expansion Valve, Evaporator Case or Core.....	1B-56
Overhead System--C-K Models.....	1B-42	Thermostatic and/or Blower Switches.....	1B-57
Rear Duct.....	1B-42	Resistor.....	1B-57
Blower Motor Resistor.....	1B-42	Fuse.....	1B-57
Blower Motor Assembly.....	1B-42	Specifications.....	1B-57
Expansion Valve.....	1B-44	Special Tools.....	1B-58

GENERAL DESCRIPTION

FOUR-SEASON SYSTEM (C-K MODELS)

Both the heating and cooling functions are performed by this system. Air entering the vehicle must pass through the cooling unit (evaporator) and through (or around) the heating unit, in that order, and the system is thus referred to as a "reheat" system.

The evaporator provides maximum cooling of the air passing through the core when the air conditioning system is calling for cooling. A thermostatic switch, located on the blower-evaporator case, acts to control compressor operation by sensing the evaporator inlet line temperature.

System operation is as follows" Air, either outside air or recirculated air, enters the system and is forced through the system by the blower. As the air passes through the evaporator core, it receives maximum cooling if the air conditioning controls are calling for cooling. After leaving the evaporator, the air enters the Heater and Air Conditioner Selector Duct Assembly where, by means of diverter doors, it is caused to pass through or to bypass the heater core in the proportions necessary to provide the desired outlet temperature. Conditioned air then enters the vehicle through either the floor distributor duct or the dash outlets. When, during cooling operations, the air is cooled by the evaporator to below comfort level, it is then warmed by the heater to the desired temperature. During "heating only" operations, the evaporator will not be in operation and ambient air will be warmed to the desired level in the same manner.

The dash outlets are rectangular in design. The outlets can be rotated horizontally or vertically to direct air as desired. Under the left distributor duct is located a floor cooler which can be rotated to provide cooling air or shut off completely.

C60 SYSTEM (G MODELS)

This system performs both the heating and cooling functions; however, the heating and cooling systems operate independently of one another -- the system provides either heating or cooling and thus is referred to as a "parallel system".

In the air conditioning modes, air (either a mixture of inside and outside at NORM or inside air only at MAX) enters the system and passes through the evaporator core (receiving maximum cooling) and is then directed into the passenger compartment through the dash outlets and foot coolers.

A thermister clipped to the evaporator core is used to control compressor operation by sensing air temperature as it leaves the evaporator core. As the core temperature increases the resistance of the thermister to 400 ohms, the amplifier (on the control) furnishes current to energize the compressor clutch coil. As the evaporator cools down, the temperature of the thermister

decreases which biases the amplifier off and compressor clutch coil is de-energized.

The dash outlets are rectangular in design and can be rotated horizontally or vertically to direct air as desired. Foot coolers are provided on both driver and passenger side.

In the heater-defrost modes, the air conditioning outside air door is closed. The heater air door is open and outside air is allowed to pass through the heater core (receiving maximum heating) and is then directed into the passenger compartment through the heater and/or defroster outlets.

OVERHEAD SYSTEMS (C-K-G MODELS)

These systems (C69 on C-K-G Models) operate in conjunction with the Four-Season System (C-K Models) or C60 System (G Models)--they do not operate independently.

NOTE: Overhead system kits are available for non-factory installation on C-K Models, providing the vehicle is equipped with the front system.

These units are self contained, operating on inside (recirculated) air only. Air is drawn into the unit, passed through the evaporator core and then directed into the passenger compartment through the air distributor duct.

System control is through the front system. The only control on the overhead system is a three speed blower switch.

MOTOR HOME CHASSIS SYSTEM

This system performs the cooling functions only. When heating (above ambient temperatures) is desired, the vehicle heater must be used. When air conditioning is desired, the heater should be completely shut off.

This self-contained unit is bracket mounted to the dash by the body manufacturer. It operates on inside (recirculated) air only. Air is drawn into the unit, passed through the evaporator core (receiving maximum cooling) and then directed into the vehicle through adjustable outlets.

A thermostatic switch, located on the face plate is used to control compressor operation by sensing air temperature as it leaves the evaporator core.

BASIC AIR CONDITIONER

When we look at an air conditioning unit, we will always find a set of coils or a finned radiator core through which the air to be cooled passes. This is known as the "evaporator". The refrigerant boils in the evaporator. In boiling, or course, the refrigerant absorbs heat and changes into a vapor. By piping this vapor outside the car we can bodily carry out the heat that caused its creation.

Once we get vapor out of the evaporator, all we have to do is remove the heat it contains. Since heat is

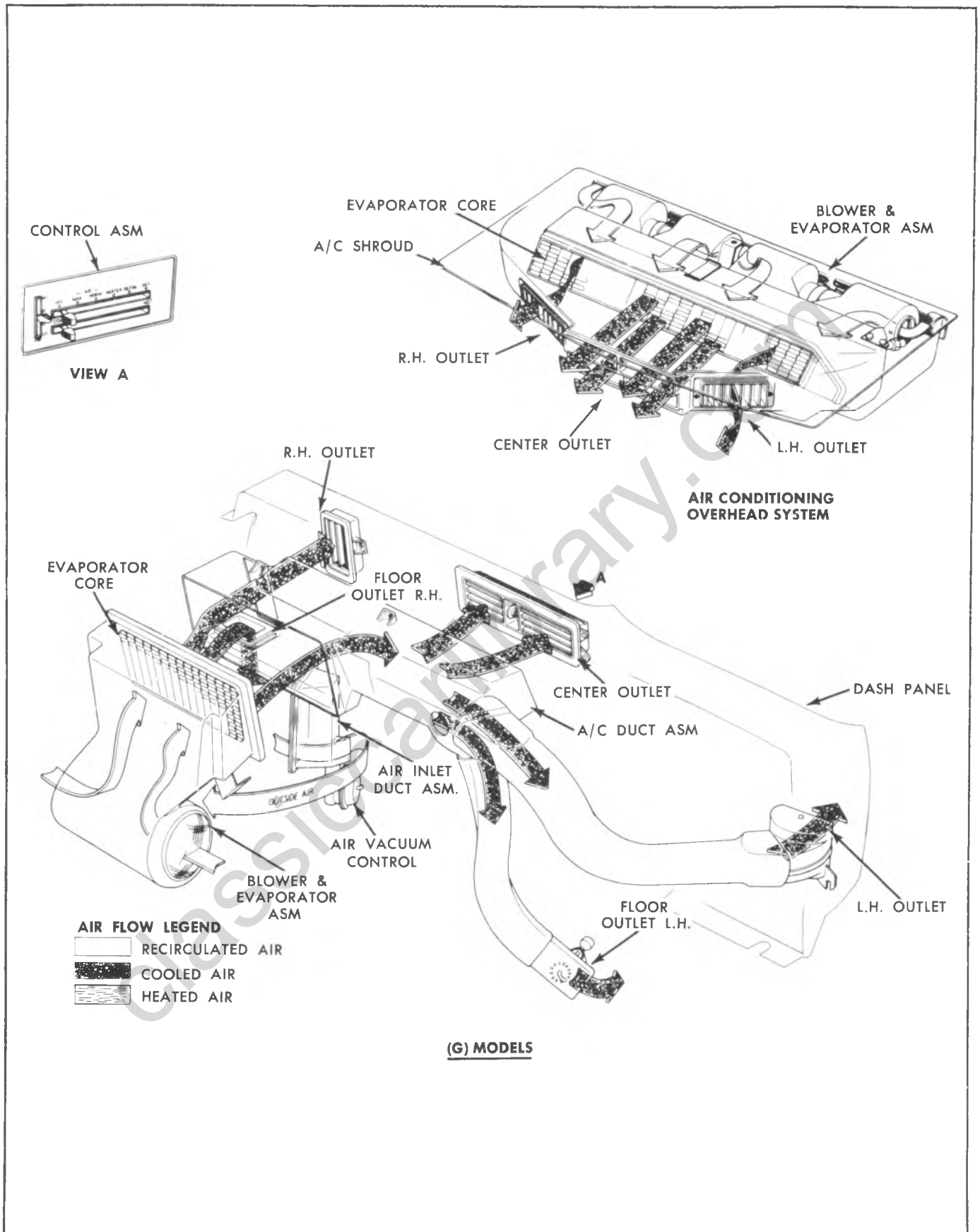
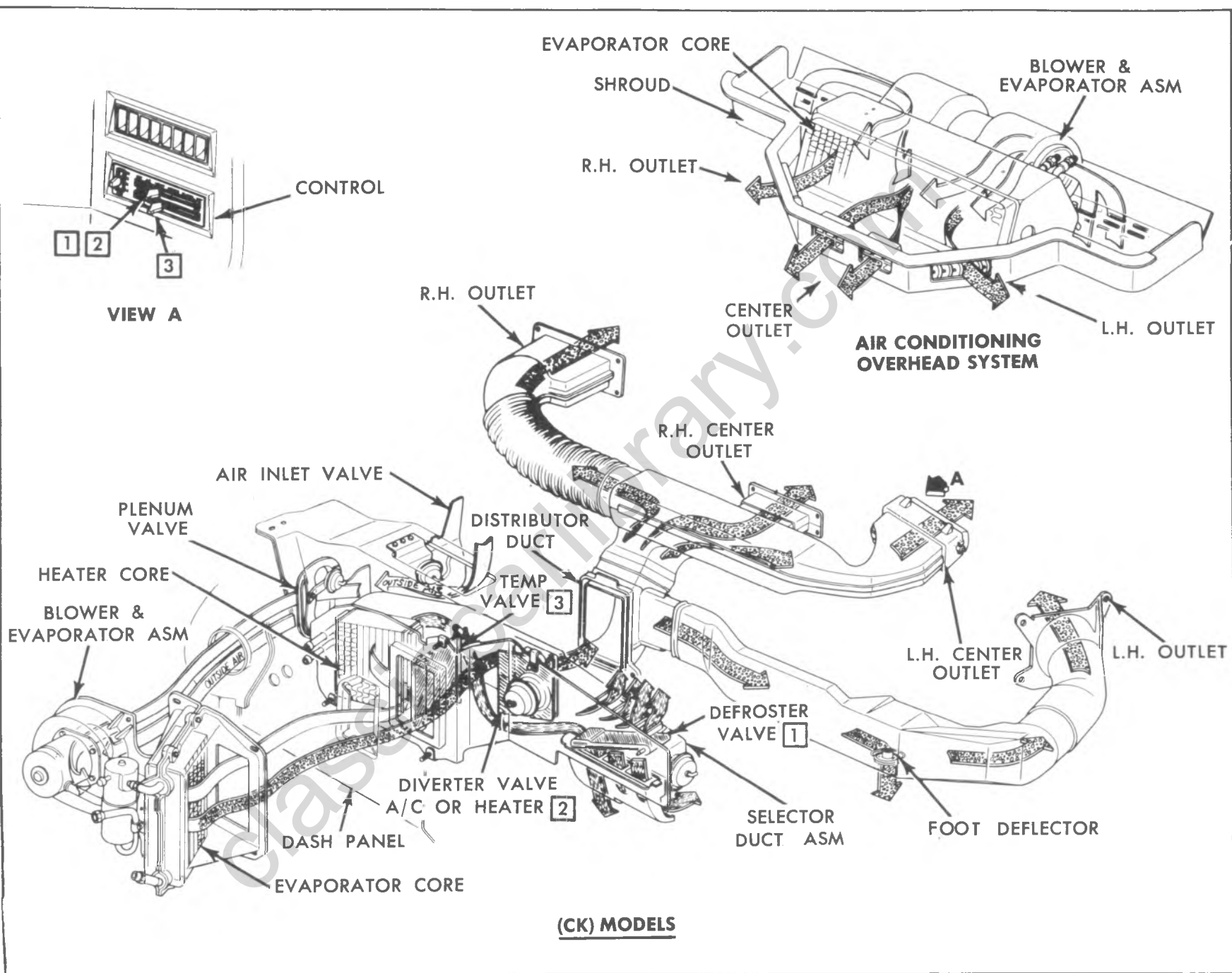


Fig. 1B-1--Airflow Chart G-Models



(CK) MODELS

Fig. 1B-2-Airflow Chart - CK Models

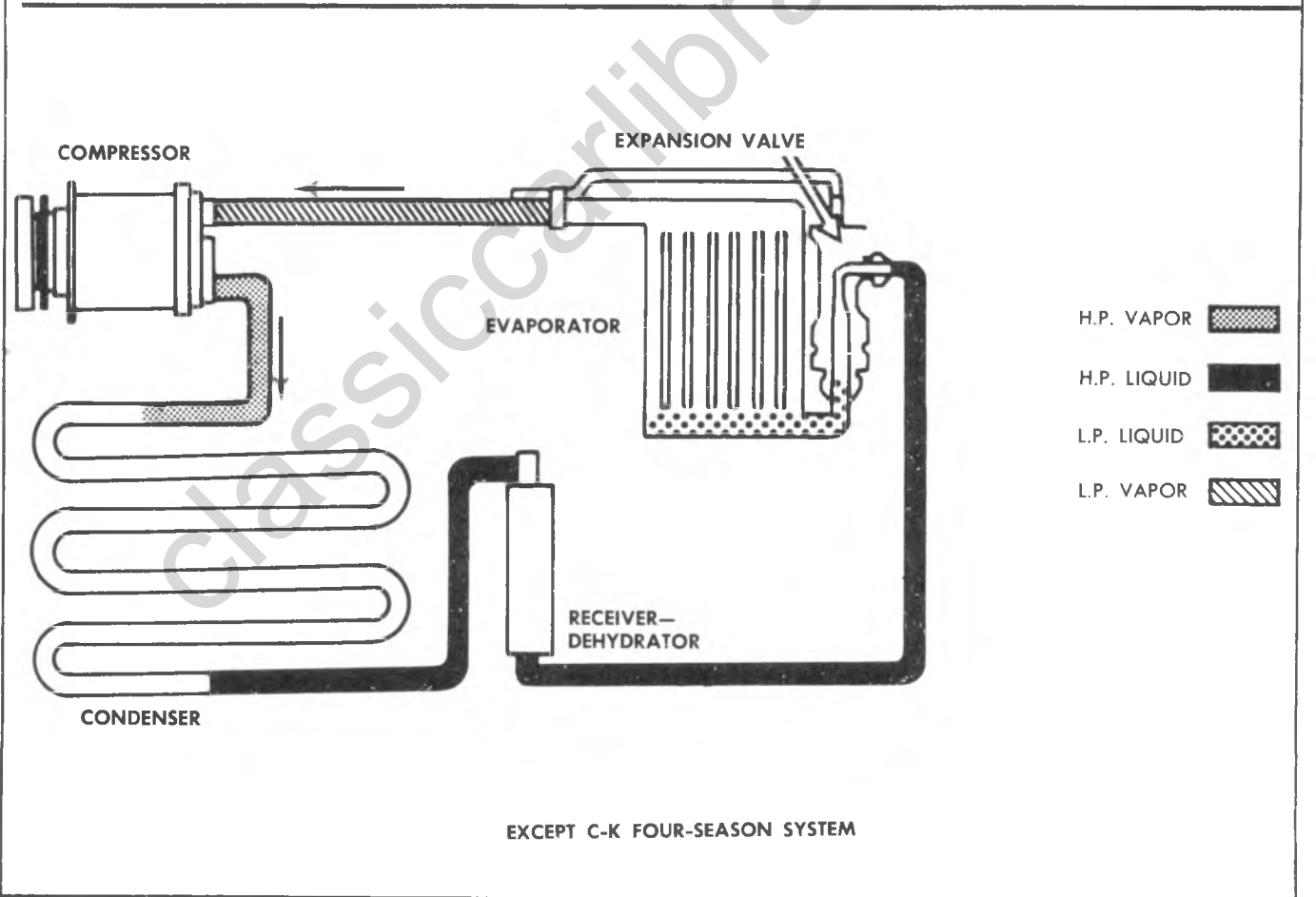
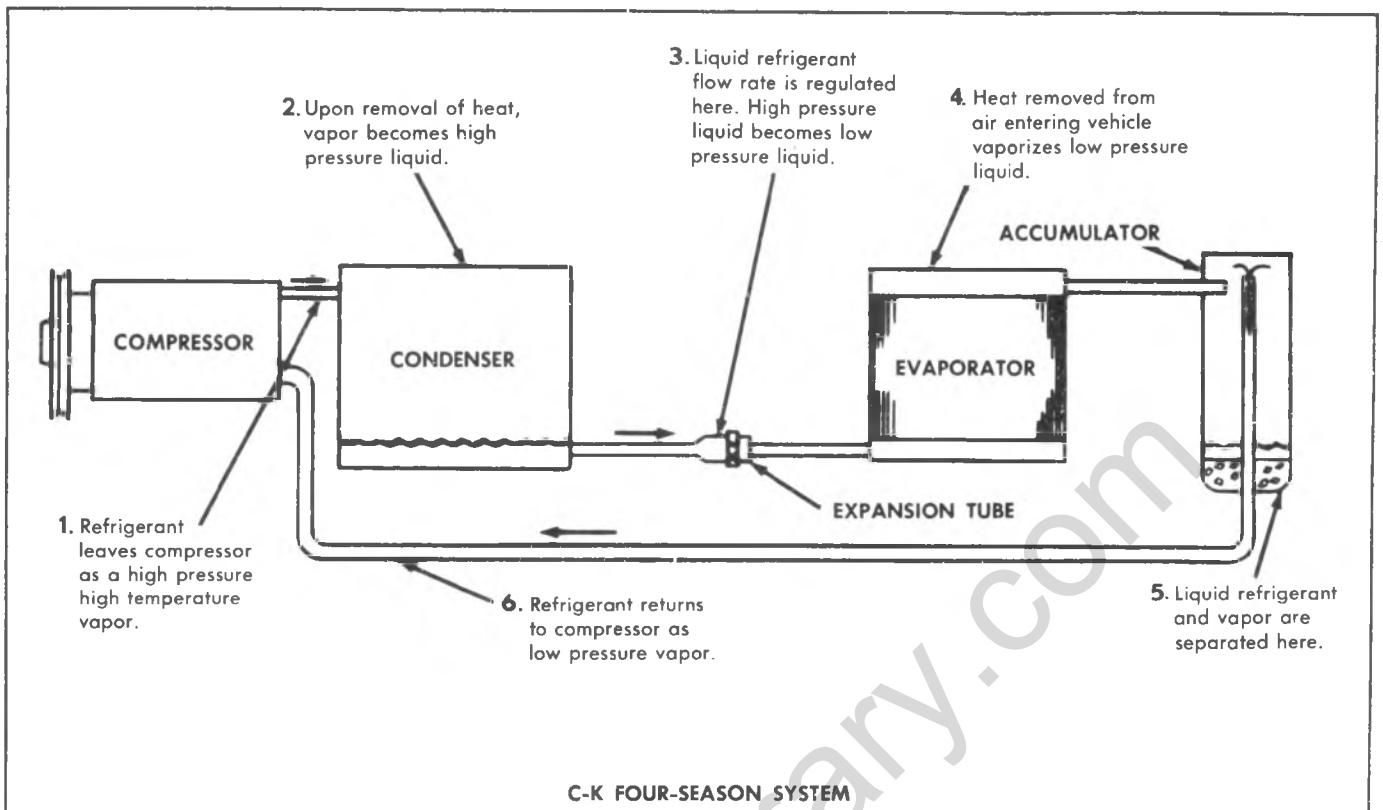


Fig. 1B-3--Basic Refrigeration Cycle

the only thing that expanded the refrigerant from a liquid to a vapor in the first place, removal of that same heat will let the vapor condense into a liquid again. Then we can return the liquid refrigerant to the evaporator to be used over again.

Actually, the vapor coming out of the evaporator is very cold. We know the liquid refrigerant boils at temperatures considerably below freezing and that the vapors arising from it are only a shade warmer even though they do contain quantities of heat. Consequently, we can't expect to remove heat from sub-freezing vapors by "cooling" them in air temperatures that usually range between 15°C and 38°C (60°F and 100°F)...heat refuses to flow from a cold object toward a warmer object.

But with a pump, we can squeeze the heat-laden vapor into a smaller space. And, when we compress the vapor, we also concentrate the heat it contains. In this way, we can make the vapor hotter without adding any heat. Then we can cool it in comparatively warm air.

That is the only responsibility of a compressor in an air conditioning system. It is not intended to be a pump just for circulating the refrigerant. Rather, its job is to exert pressure for two reasons. Pressure makes the vapor hot enough to cool off in warm air. At the same time, the compressor raises the refrigerant's pressure above the condensing point at the temperature of the surrounding air so it will condense.

As the refrigerant leaves the compressor, it is still a vapor although it is not quite hot and ready to give up the heat that it absorbed in the evaporator. One of the easiest ways to help refrigerant vapor discharge its heat is to send it through a radiator-like component known as a condenser.

The condenser really is a very simple device having no moving parts. It does exactly the same job as the familiar radiator in a typical home steam-heating system. There, the steam is nothing more than water vapor. In passing through the radiator, the steam gives up its heat and condenses back into water.

The purpose of the condenser, as the name implies, is to condense the high pressure, high temperature refrigerant vapor discharged by the compressor into a high pressure liquid refrigerant. This occurs when the high pressure, high temperature refrigerant is subjected to the considerably cooler metal surfaces of the condenser. This is due to the fundamental laws, which state that "heat travels from the warmer to the cooler surface," and that "when heat is removed from vapor, liquid is produced."

When the refrigerant condenses into a liquid, it again is ready for boiling in the evaporator. So, we run a pipe from the condenser back to the evaporator.

MAIN UNITS OF THE SYSTEM

These three units then; the evaporator, the compressor, and the condenser...are the main working parts in any typical air conditioning system. We have the evaporator where the refrigerant boils and changes into a vapor, absorbing heat as it does so. We have the pump or compressor to put pressure on the refrigerant so it can get rid of its heat. And we have a condenser outside the

car body to help discharge the heat into the surrounding air.

Now let's look at the compressor in detail, and some of the components that work with these main units to complete the air conditioning system.

AXIAL SIX-CYLINDER COMPRESSOR

The prime purpose of the compressor (fig. 1B-4) is to take the low pressure refrigerant vapor produced by the evaporator and compress it into a high pressure, high temperature vapor which will be sent on to the condenser.

It utilizes the principle that "when a vapor is compressed, both its pressure and temperature are raised" which we have already discussed. The axial six cylinder compressor is mounted above the engine in a special rubber mounted bracket and is belt driven from the engine through an electromagnetic clutch pulley on the compressor.

The compressor has three double-acting pistons, making it a six cylinder compressor. The compressor has a 1.5 inch bore and 1.1875 inch stroke, giving it a total displacement of 12.6 cu. in. Identification of the compressor is by model and serial number stamped on a plate on top of the compressor.

Clutch-Pulley

The movable part of the clutch drive plate is in front of the pulley and bearing assembly. The armature plate, the movable member, is attached to the drive hub through driver springs and is riveted to both members. The hub of the drive plate is pressed over a square drive key located in the compressor shaft. A spacer and retainer ring are assembled to the shaft and the assembly is held in place with a self-locking nut. The pulley rim, power element ring and pulley hub are formed into a final assembly by molding a frictional material between the rim and the hub with the power element ring imbedded in the forward face of the assembly.

A two-row ball bearing is pressed into the pulley hub and held in place by a retainer ring. The entire pulley and bearing assembly is then pressed over the front head of the compressor and secured by a retainer ring.

Clutch coil

The coil is molded into the coil housing with a filled epoxy resin and must be replaced as a complete assembly. Three protrusions on the rear of the housing fit into alignment holes in the compressor front head. A retainer ring secures the coil and housing in place. The coil has 3.85 ohms resistance at 26.7°C (80°F) ambient temperature and will require no more than 3.2 amperes at 12 volts D.C. Since the clutch coil is not grounded internally, a ground lead is required as well as a "hot" lead.

Compressor Connector

Compressor connectors, are attached to the compressor rear head by means of a single bolt and lock washer.

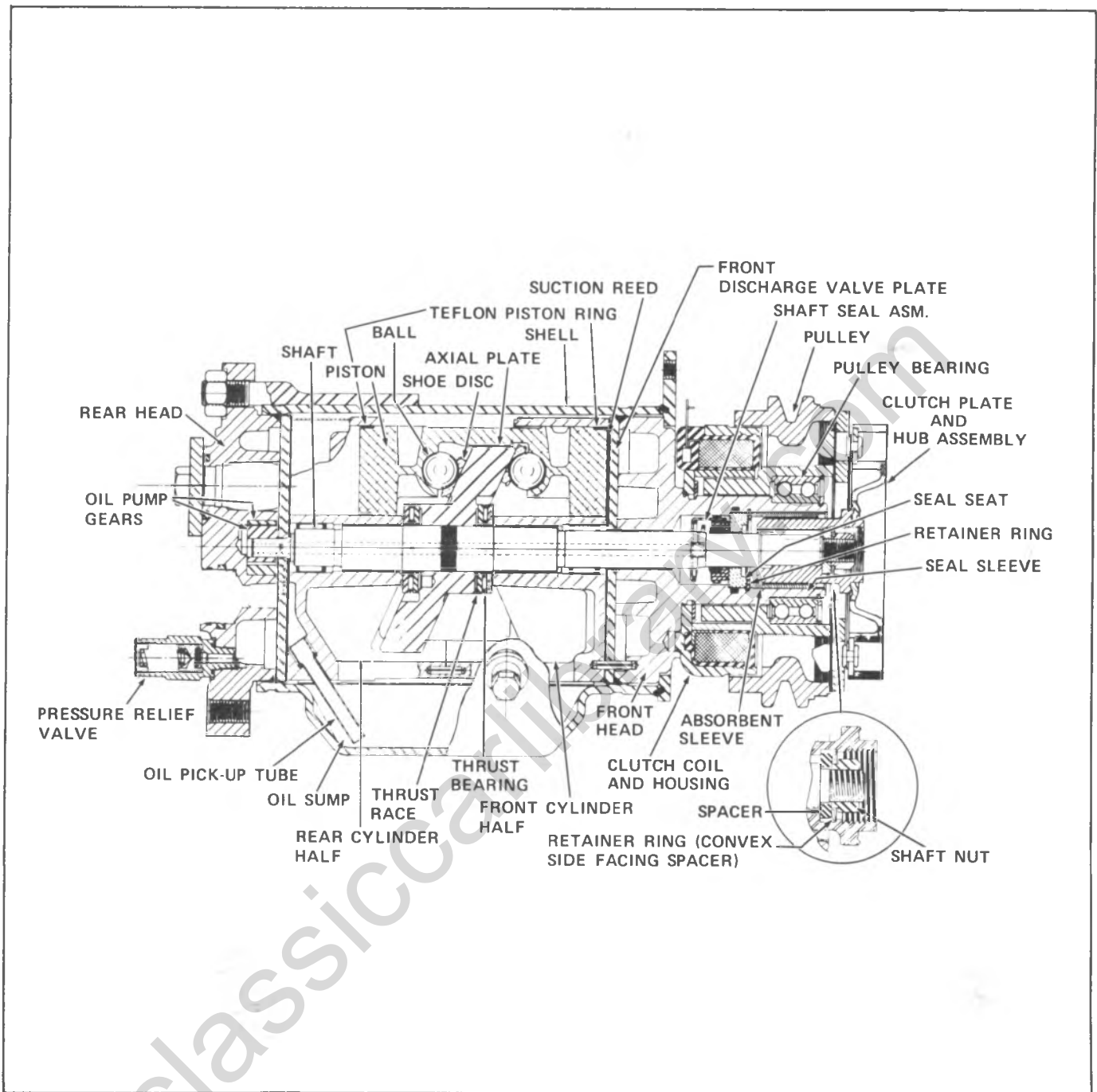


Fig. 1B-4--Axial Six Cylinder Compressor--Cross Sectional View

All have inlet and outlet connections connected by a strap to form an integral unit.

G Models have gauge fittings located on the muffler and compressor inlet line. Motor Home Chassis unit fittings are located on the inlet and outlet lines. C-K model gauge fittings are located on the accumulator and evaporator inlet line. All fittings are equipped with a valve core.

Pressure Relief Valve

The pressure relief valve, located on the compressor

rear head, is simply a safety valve designed to open automatically if the system pressure should reach a predetermined level high enough to cause system damage. After the pressure drops to a safe level the valve will close. After such an occurrence, the system should be thoroughly checked to discover and correct the cause of the abnormal pressure increase, and then should be purged, evacuated and charged.

RADIAL FOUR CYLINDER COMPRESSOR

A Radial four cylinder compressor (Fig. 1B-5) is

used on a vehicle with a six cylinder engine.

The compressor is mounted to the engine by mounting brackets (Fig. 1B-6) and is belt driven by the engine when the electromagnetic clutch assembly on the compressor is energized by the air conditioning controls.

The purpose of the compressor is to pump low pressure, low temperature refrigerant vapor produced by the evaporator and compress it into a high pressure, high temperature vapor which can then be readily condensed back to a liquid state by the condenser.

The compressor has a displacement of 10.0 cu. in. The compressor has variations in the pulley rim diameter specified for the respective vehicle applications.

The basic compressor mechanism is a modified scotch yoke with four cylinders located radially in the same plane. Opposed pistons are pressed into a yoke which rides upon a slider block located on the shaft eccentric. Rotation of the shaft provides reciprocating piston motion with no "connecting rods". The mechanism is completely balanced with counterweights. Needle bearings are used for the shaft journals and the shaft eccentric. Pistons and yokes, along with the main cylinder housing and front cover, are made from aluminum to provide light weight. Teflon piston rings are used to provide both a gas compression seal and piston-to-bore bearing surface. The outer shell is a simple steel band which encloses a large annular discharge muffler space.

Two O-rings provide a seal between the compressor shell and the compressor cylinder. A rubber seal ring seals the front head to the cylinder assembly and the shaft seal assembly provides a front head to shaft seal.

Refrigerant flows into the crankcase from the connector block at the rear, is drawn through the reeds attached to the piston top during the suction stroke, and is discharged outward through the discharge valve plate which is held in place at the top of the cylinder by a snap ring. Discharge gas flows out of the compressor muffler cavity through the connector block at the rear.

Clutch Coil

The clutch coil is molded into the steel coil housing and must be replaced as a complete assembly. Three protrusions on the rear of the housing fit into alignment holes in the compressor front head. The coil is secured to the front head by a pressed fit between the coil housing and neck portion of the front head. The coil has 3.65 ohms resistance at 26.7°C (80°F) ambient and will require no more than 3.2 amperes at 12 volts D.C. The clutch coil has two terminals for the power and ground leads.

Clutch-Pulley

The movable part of the clutch drive plate is in front of and adjacent to the rotor and bearing assembly. The armature plate, the movable member, is attached to the drive hub through driver springs riveted to both members. The hub of the drive plate is pressed on the compressor shaft and keyed to the shaft by a square drive key. A self-locking nut threads on the end of the

shaft and is tightened against the shaft. The rotor and hub is a welded assembly and contains six threaded holes for mounting the pulley rim. The pulley rim is secured to the rear portion of the rotor by six screws and six special lock washers.

A two-row ball bearing is pressed into the rotor hub and held in place by three punch stakes, 120° apart, into the rotor hub near the hub bore. The entire clutch coil, pulley rim, rotor and bearing assembly is pressed on the front head of the compressor and secured by a retainer ring.

When power is supplied to the clutch coil the armature plate of the drive plate and hub assembly electromagnetically engages the slotted portion of the rotor face which then drives the crankshaft through the drive plate leaf springs and hub.

Refrigerant Lines

Special refrigerant hose lines are required to carry the refrigerant liquid and vapor between the various system components. The hose line with the smallest diameter is called the high pressure liquid line. It is routed from the condenser or receiver-dehydrator to the evaporator or thermostatic expansion valve. The large diameter hose line connecting the compressor and evaporator (or accumulator) is the low pressure vapor line. The large diameter hose between the compressor and condenser is the high pressure vapor discharge line.

These hoses are constructed with a synthetic material core covered by a woven fabric and coated for extra protection. This hose is so constructed to withstand the extreme pressures and temperatures found in the modern refrigeration system. **None but special refrigerant type hoses should be used.**

All systems make use of swaged type connections (hose to metal fittings) with metal to metal fittings being made using "O" rings. Care must be taken when making these connections that they not be turned down too tightly or damage to the "O" rings may result.

Flexible refrigerant hoses should not be permitted to contact the hot engine manifold nor should they be bent into a radius of less than 4 times their diameter.

Muffler

A muffler, located in the high pressure line from the compressor to the condenser, serves as a surge chamber for high pressure gas to reduce the noise level of the system while in operation. The muffler is actually a welded portion of the compressor connector assembly. It is found on all truck air conditioning systems.

Fan Slip Clutch

A special engine fan is used on most systems. It is a 19.5 inch six or seven bladed fan, limited by means of a viscous clutch to a maximum speed of 3400-3700 rpm, regardless of the speed of the engine. The silicone fluid in the clutch transmits only enough torque to drive the fan at this limited speed, thus avoiding excessive noise

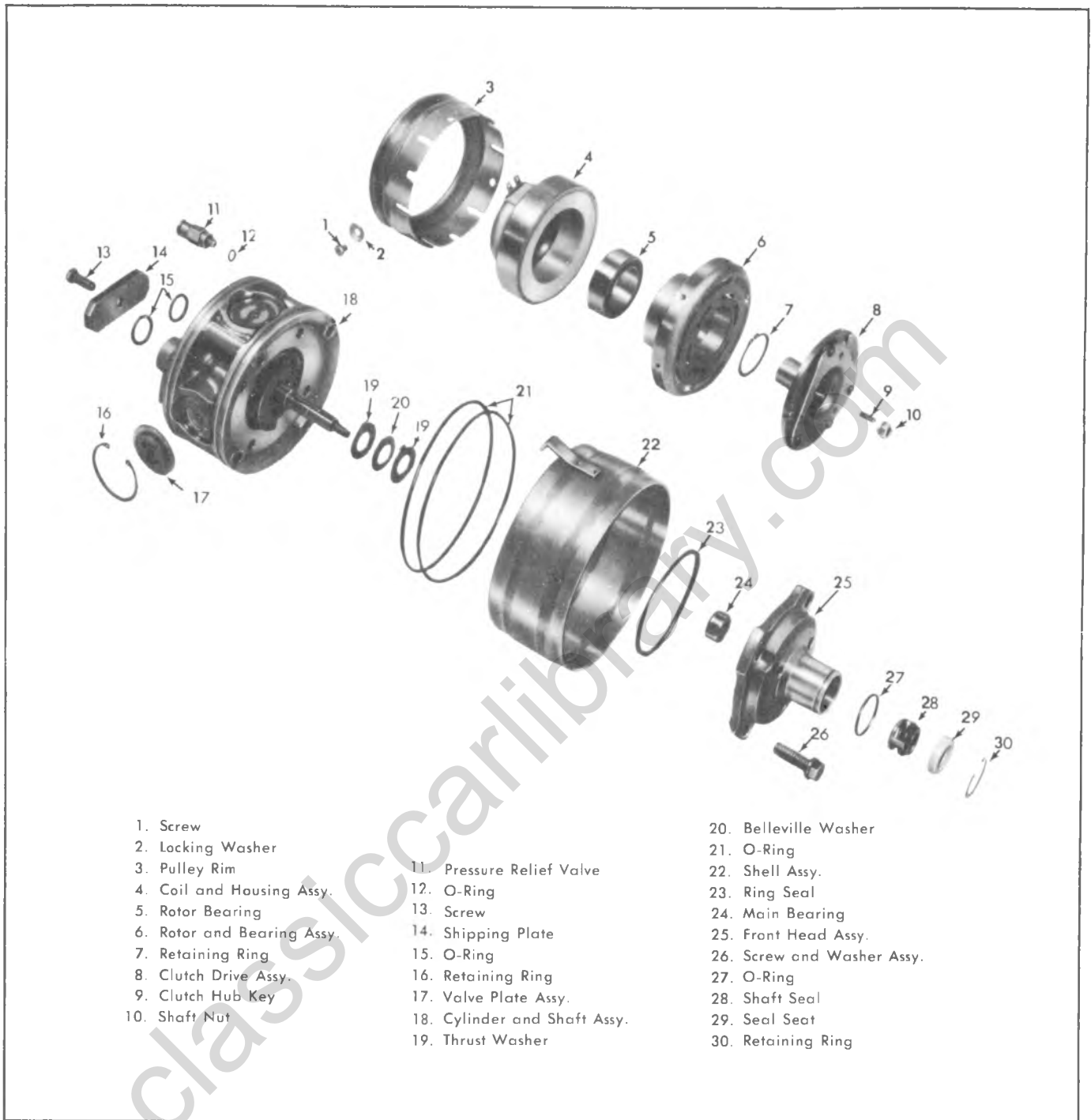


Fig. 1B-5-Radial Four Cylinder Compressor-Exploded View

and power consumption by the fan at higher engine speeds.

Condenser

In a properly charged system, the condenser delivers sub-cooled liquid. This is because all the vapor condenses before the end of the condenser and the remaining portion of the condenser subcools the liquid.

Receiver-Dehydrator (G and Motor Home Chassis Models)

The receiver-dehydrator, serving as a reservoir for storage of high pressure liquid produced in the condenser, incorporates a screen sack filled with the dehydrating agent.

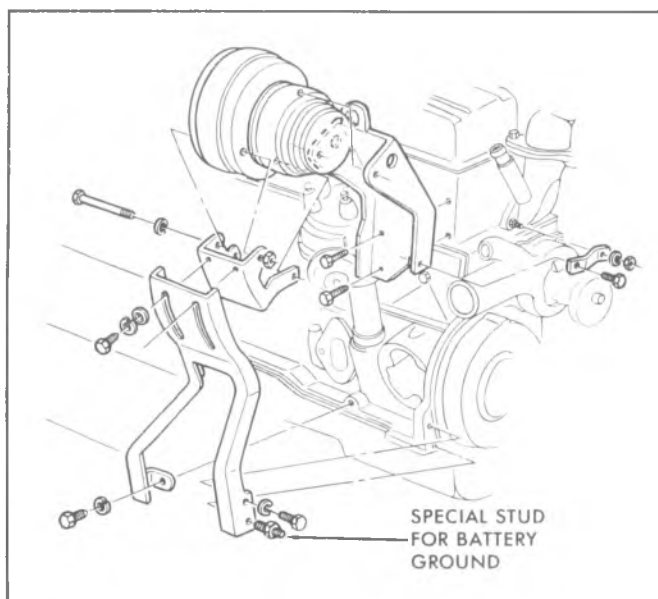


Fig. 1B-6--Compressor Mounting - L6 Engine

The receiver-dehydrator, used primarily as a liquid storage tank, also functions to trap minute quantities of moisture and foreign material which may have remained in the system after installation or service operations. A refrigerant sight glass is built into the receiver-dehydrator to be used as a quick check of the state and condition of charge of the entire system. The receiver-dehydrator is mounted near the condenser.

Sight Glass (G and Motor Home Chassis Models)

While having no real function to perform in the system, the sight glass is a valuable aid in determining whether or not the refrigerant charge is sufficient and for eliminating some guess work in diagnosing difficulties. The sight glass, is built into the receiver-dehydrator outlet connection and is designed and located so that a shortage of refrigerant at this point will be indicated by the appearance of bubbles beneath the glass. The dust cap provided should be kept in place when the sight glass is not in use.

Thermostatic Expansion Valve (Fig. 1B-7)

C-K Overhead, G C60 and Overhead and Motor Home Chassis systems use a thermostatic expansion valve in place of a float system.

The valve consists primarily of the power element, body, actuating pins, seat and orifice. At the high pressure liquid inlet, is a fine mesh screen which prevents dirt, filings or other foreign matter from entering the valve orifice.

When the valve is connected in the system, high pressure liquid refrigerant enters the valve through the screen from the receiver-dehydrator or condenser and passes on to the seat and orifice. Upon passing through the orifice the high pressure liquid becomes low pressure liquid. The low pressure liquid leaves the valve and flows into the evaporator core where it absorbs heat from the evaporator core and changes to a low pressure vapor,

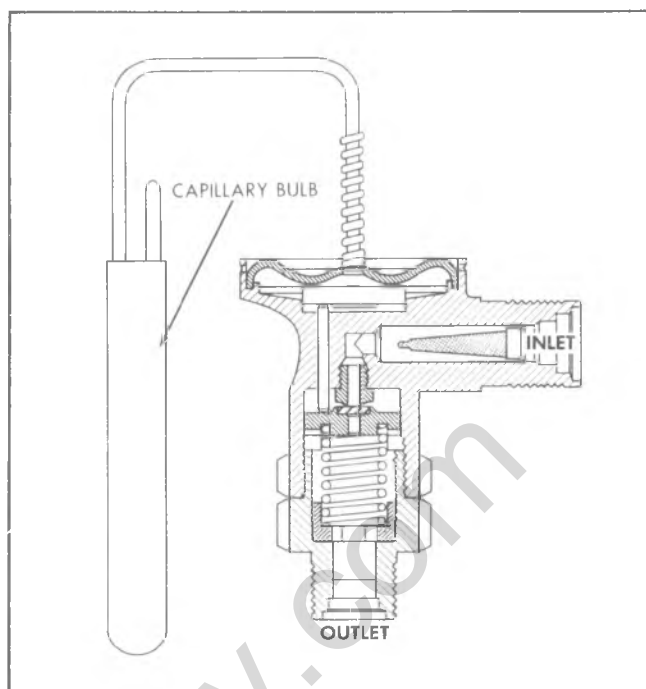


Fig. 1B-7--Expansion Valve

and leaves the evaporator core as such. The power element bulb is clamped to the low pressure vapor line just beyond the outlet of the evaporator (fig. 1B-7).

The operation of the valve is quite simple. It is a matter of controlling opposing forces produced by a spring and the refrigerant pressures. For example: The pressure in the power element is trying to push the seat away from the orifice, while the adjusting spring is trying to force the seat toward the orifice. These opposing pressures are established in the design of the valve so that during idle periods the adjusting spring tension and the refrigerant pressure in the cooling coil are always greater than the opposing pressure in the power element. Therefore, the valve remains closed. When the compressor is started, it will reduce the pressure and temperature of the refrigerant in the cooling coil to a point where the vapor pressure in the power element becomes the stronger. The seat then moves off the orifice and liquid starts to flow through the valve orifice into the cooling coil.

The purpose of the power element is to help determine the quantity of liquid that is being metered into the cooling coil. As the temperature of the low pressure line changes at the bulb, the pressure of the vapor in the power element changes, resulting in a change of the position of the seat. For example if the cooling coil gets more liquid than is required, the temperature of the low pressure line is reduced and the resultant lowering of the bulb temperature reduces the pressure of the vapor in the power element, allowing the seat to move closer to the orifice. This immediately reduces the amount of liquid leaving the valve. Under normal operation, the power element provides accurate control of the quantity of refrigerant to the cooling coil.

To employ our tire pump analogy once more for clarity, it is the same situation that would exist if you were inflating a tire with a very slow leak. Providing you pumped the air into the tire as fast as it leaked out, you would be able to maintain pressure even though the air would merely be circulating through the tire and leaking out through the puncture.

Accumulator-C-K Models (Fig. 1B-8)

The accumulator is located at the evaporator outlet. Its most important function is not to "accumulate" although this too is important. Its primary function is to separate liquid retained from vapor, retain the liquid and release the vapor to the compressor.

Thus, in an ideal accumulator with no oil bleed hole, and in a correctly designed system, no liquid can get to the compressor.

In an actual accumulator, there is some entrained liquid in the vapor stream to the compressor. The measure of a good accumulator is how well it separates vapor from liquid and how little entrained liquid is released to the compressor. Also, in an actual accumulator, an oil bleed hole is required to prevent trapping of oil in the bottom of the accumulator; this oil bleed hole bleeds some liquid refrigerant as well.

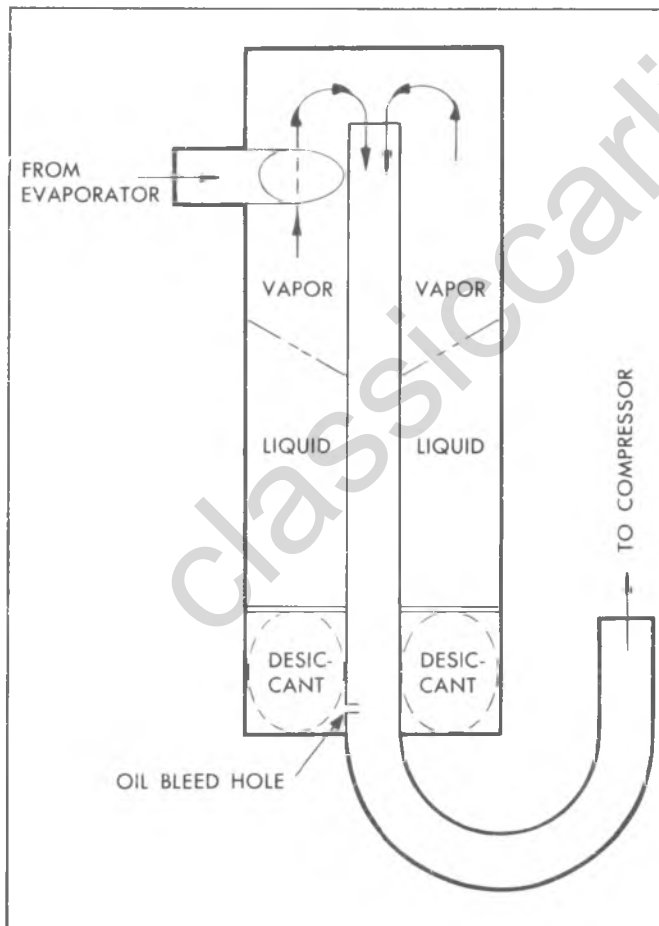


Fig. 1B-8--Accumulator

Therefore, flow out of the accumulator to the compressor consists mostly of vapor with the addition of entrained liquid and liquid flow through the oil bleed hole.

A bag of desiccant (dehydrating agent) is located in the base of the accumulator as a moisture collecting device.

NOTE: There is no sight glass in the accumulator-clutch cycle system.

Expansion Tube-C-K Models

Expansion tube flow rate depends on pressure difference and on subcooling; however, the flow rate is more sensitive to subcooling.

The expansion tube is located in the evaporator inlet line (fig. 1B-9).

Thermostatic Switch

System temperature is controlled by running the compressor intermittently, automatically turning it on and off as necessary to maintain proper temperatures. The compressor is started and stopped through the use of an electro-magnetic clutch and a thermostat affected by variations in temperature.

The thermostatic switch incorporates a metallic tube which contains a highly expansive gas. This tube is inserted into the evaporator inlet line (C-K Four-Season System) or is located in the air stream as it leaves the evaporator (Motor Home Chassis Unit). The tube leads to a bellows operated switch. As air temperature rises, the gas inside the tube expands, travels through the tube to the bellows and closes the electrical switch which engages the compressor clutch.

As soon as the compressor starts running, the temperature begins to go down. As the air being cooled gets colder, the gas in the thermostatic tube begins to reduce the pressure on the switch bellows. This allows the



Fig. 1B-9--Expansion Tube

switch contact to open and the compressor clutch disengages.

Low Refrigerant Charge Protection System

C-K-G Models

The compressor discharge pressure switch performs the function of shutting off the compressor when it senses low refrigerant pressure. The switch is located in the evaporator inlet line (high pressure). The switch electrically is wired in series between the compressor clutch and the master switch on the control. When the switch senses low pressure it breaks contact and opens the circuit to the compressor clutch, thus shutting off the A/C system and preventing compressor failure or seizure.

The compressor discharge pressure switch also performs the function of the ambient switch as the pressure at the switch varies directly with ambient temperatures. The compressor should **not** run below -3.9°C (25°F) ambient or 37 psi at the switch. The compressor should run in A/C modes above 7.2°C (45°F) ambient or 42 psi at the switch.

The switch interacts with other switches so that in an A/C system where the compressor will **not** operate above 7.2°C (45°F) ambient the following components should be checked for continuity:

1. Compressor discharge pressure switch.
2. Master switch (on control head).

If both switches show proper continuity, check the harness for shorts or improper ground conditions.

SYSTEM CONTROLS

FOUR-SEASON SYSTEM (C-K MODELS) FIG. 1B-10

The system selector lever (air control lever) determines the mode of operation: OFF, MAX, NORM, BI-LEVEL, VENT, HEATER, DEF. When the system selector lever is placed in the MAX, NORM, BI-LEVEL or DEF. positions, electrical circuit connection is made to the compressor clutch through the control panel switch and the discharge pressure switch. If the compressor discharge pressure switch is closed (ambient temperature above approximately 5.5°C (42°F), the compressor will run. In the OFF, or ECONOMY, (VENT or HEATER) positions, the compressor is not energized.

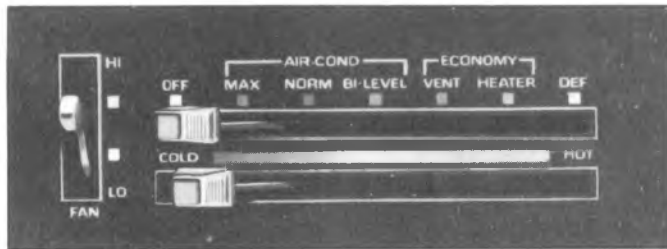


Fig. 1B-10. Four-Season System Controls (C-K Models)

The system selector lever also determines the direction of outlet air flow. Moving the lever from mode to mode varies the position of a sliding-type vacuum valve on the control. The position of the vacuum valve will supply vacuum to, or vent, vacuum diaphragms which position the upper and lower mode and defroster air doors in the selector duct assembly. The position of these air doors determines if output air flow is from heater outlet (OFF), the heater outlet with slight air flow from defroster nozzles (HEATER), heater and A/C outlets (VENT), A/C outlets only at MAX and NORM, heater, A/C and defroster outlets (BI-LEVEL) or the defroster nozzles with slight air flow from the heater outlet (DEF).

When the system is in MAX A/C mode and the temperature lever is at full COLD the air inlet door is positioned to reduce the supply of outside air from approximately 100% to approximately 20%. The remainder of the air input 80% to the A/C system is then taken from the interior of the passenger compartment. This recirculation of interior air (recirc operation) provides a source of fast cool down of interior temperatures.

A switch connected to the selector lever overrides the blower (FAN) switch (in MAX A/C) and automatically provides high blower speed.

Temperature Control

The temperature lever determines the temperature of outlet airflow by positioning the temperature door in the selector duct assembly, through the motion of a bowden cable linking the control panel lever to the temperature door.

NOTE: An engine thermal switch prevents LO blower operation until the temperature at the switch reaches 35°C (95°F). This blower delay can be by-passed by placing the fan switch in any of the other three positions.

Fan Switch

The blower (FAN) switch provides a means of selecting the amount of airflow from the system by regulating the speed of the blower motor. There are, however, limitations to the control of blower speed. To provide constant ventilation, the blower motor electrical circuitry prevents the blower motor from being shut off when the ignition switch is on. Therefore, the blower speeds available are HI, LO and two medium speeds.

The control master switch incorporates an "override" function which overrides the blower speed switch and automatically provides HI blower speed when the system selector lever is in MAX and the temperature lever is set to full COLD.

System Operation - CK Truck

System operation is as illustrated in Fig. 1B-11.

Vacuum Schematic - CK Truck

The CK Truck air conditioning vacuum schematic is illustrated in Figure 1B-12.

SYSTEM OPERATION - CK TRUCK

SELECTOR LEVER POSITION	COMPRESSOR	BLOWER SPEEDS AVAIL	AIR SOURCE	AIR ENTERS VEHICLE	HEATER A/C DOOR-OPEN TO:	HEATER DEFROSTER DOOR-OPEN TO:
OFF	OFF	LOW	OUTSIDE	FLOOR OUTLETS	HEATER	HEATER
MAX A/C	ON	HI	INSIDE%	DASH OUTLETS	A/C	HEATER
NORM A/C	ON	ALL	OUTSIDE	DASH OUTLETS	A/C	HEATER
BI-LEVEL	ON	ALL	OUTSIDE	FLOOR AND DASH OUTLETS	A/C & HEATER	HEATER
VENT	OFF	ALL	OUTSIDE	DASH OUTLETS	A/C	HEATER
HTR	OFF	ALL	OUTSIDE	FLOOR OUTLETS	HEATER	HEATER
DEF	ON	ALL	OUTSIDE	DEFROST OUTLETS	HEATER	DEFROST

NOTE % 100% Inside air is not available, some bleed through of outside air is allowed.

Fig. 1B-11-System Operation - CK Truck

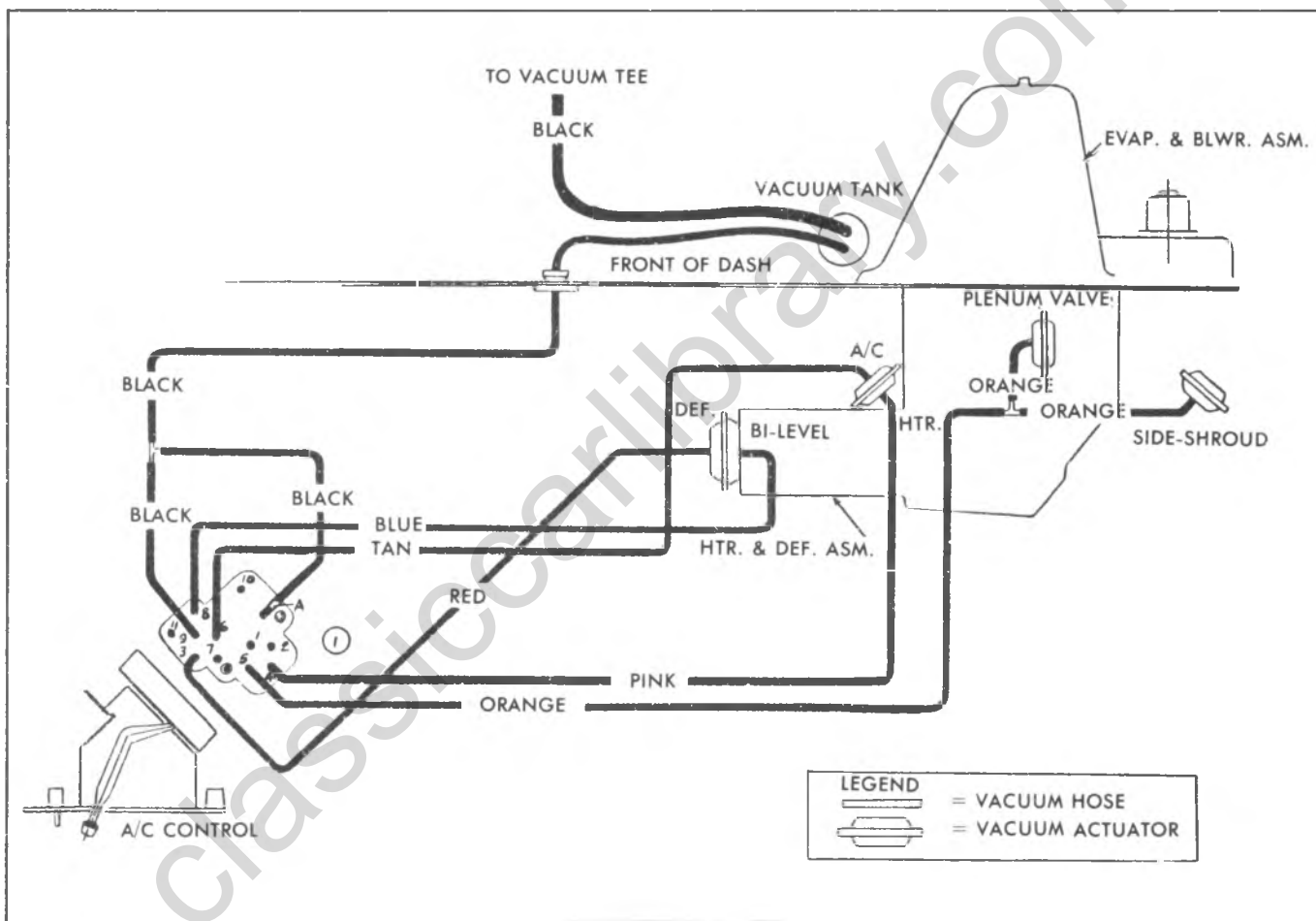


Fig. 1B-12-Air Conditioning Vacuum Schematic - CK Truck

OVERHEAD SYSTEM (C-K MODELS)

This system operates in conjunction with the Four-Season System. Since refrigerant flow is controlled by the front system, the only control provided for on the overhead system is a three-speed fan switch (LOW, MED, HI). The fan switch is mounted in the instrument panel, to the right of the steering column (fig. 1B-13).

In the OFF position, the blower is inoperative;

however, refrigerant is circulating in the system if the Four-Season System is ON. In any of the three blower positions (LOW, MED, HI), the blower will be operative regardless if the Four-Season System is ON.

NOTE: To obtain maximum cooling, the Four-Season System should be on A/C, temperature



Fig. 1B-13--Overhead Unit Control (C-K Models)

lever on COLD, blower switch on HI and the overhead unit blower switch should be on HI.

C60 SYSTEM (G MODELS)--FIG. 1B-14

The system selector lever (air control lever) determines the mode of operation: OFF, MAX, NORM, HEAT, DEFOG or DEF. When the system selector lever is placed in the A/C, positions, electrical circuit connection is made to the compressor clutch through the control panel switch and the discharge pressure switch. If the switch is closed (ambient temperature above 4.4°C.), the compressor will run. In the OFF, HEAT, DEFOG or DEF positions, the compressor is not energized.

The system selector lever also determines the direction of outlet air flow. Moving the lever from mode to mode varies the position of a rotary vacuum valve on the control. The position of the vacuum valve will supply vacuum to, or vent, vacuum diaphragms which position the air and defroster doors in the heater distributor duct and the outside air door in the right side of the cowl plenum. The position of these doors determines if output air flow is from the A/C outlets using recirc air (MAX), or recirc and outside air (NORM), the heater outlet (HEAT), heater and defroster outlets (DEFOG), or the defroster nozzles with slight air flow from the heater outlet (DEF).

Temperature Control

(A/C Modes)

The temperature lever activates a potentiometer on the control assembly (connected in series with the

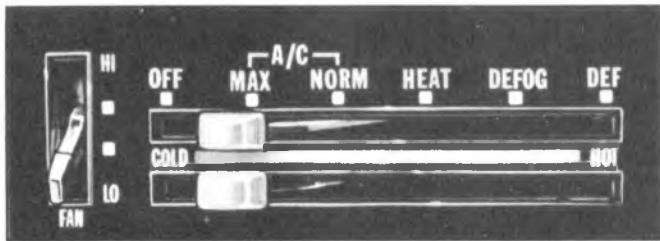


Fig. 1B-14--C60 System Controls (G Models)

amplifier on the control and thermister on the evaporator) to control compressor operation.

(Heater-Defrost Modes)

The temperature lever determines the temperature of outlet air flow by positioning the temperature door in the heater distributor assembly, through the motion of a bowden cable linking the control panel lever to the temperature door.

Fan Switch

The blower (FAN) switch provides a means of selecting the amount of air flow from the system by regulating the speed of the heater or A/C blower motor. There is no OFF position on the fan switch; however the blower is inoperative if the selector lever is placed in the OFF position. If the selector lever is placed in any of the heater or A/C modes, the appropriate blower is operative. The blower speeds available are LO, M1, M2 and HI.

OVERHEAD SYSTEM (G MODELS)

This system operates in conjunction with the C60 system. Since refrigerant is controlled by the C60 system, the only control provided on the rear overhead system is a three speed blower switch (fig. 1B-15).

In the OFF position, the blower is inoperative; however, refrigerant is circulating in the system if the front system is ON. To operate the rear overhead system, simply select the desired blower speed (LOW, MED, HI).

When air circulation only is desired, the rear A/C

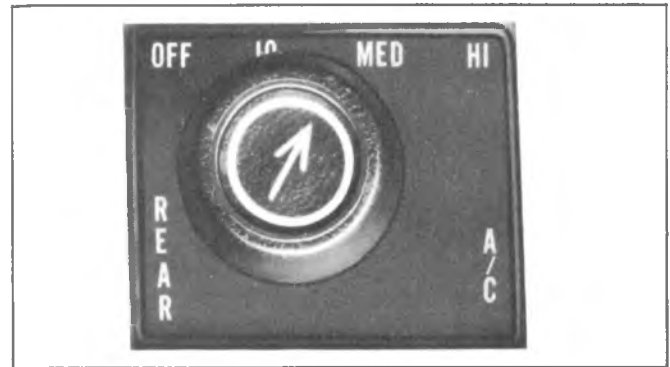


Fig. 1B-15--Overhead Unit Control (G Models)

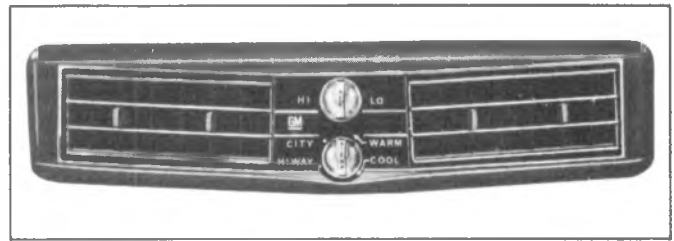


Fig. 1B-16--Motor Home Unit Control

Metal Tube O.D.	Thread and Fitting Size	Alum. Tubing Torque*
1/4	7/16	6
3/8	5/8	12
1/2	3/4	18
5/8	7/8	24
3/4	1-1/16	30

*Foot Pounds

blower motor may be operated independent of the front A/C blower motor and without the cooling function.

DASH MOUNTED UNIT (MOTOR HOME CHASSIS UNITS)

This system is self contained and is mounted below the dash by the body manufacturer. System controls consist of an AIR knob and TEMP knob located in the center of the unit face plate (fig. 1B-16).

Air Knob

Turning the AIR knob clockwise operates a three speed (LOW-MED-HI) blower motor.

Temp Knob

This knob is used to control the degree of cooling desired. Fully clockwise at CITY provides maximum cooling, while turning the knob to HIWAY provided adequate cooling for highway operation.

NOTE: Reduced cooling could be encountered when operating at highway speeds with the controls at the CITY setting. The heater must be fully off to obtain maximum cooling.

REFRIGERANT LINE CONNECTIONS

"O" Rings

Always replace the "O" ring when a connection has been broken. When replacing the "O" ring, first dip it in clean refrigeration oil. Always use a backing wrench on "O" ring fittings to prevent the pipe from twisting and damaging the "O" ring. Do not overtighten. Correct torque specifications are as follows:

CAUTION: Where steel to aluminum connections are being made, use torque for aluminum tubing.

Hose Clamps

When hose clamp connections are encountered, special procedures are necessary for both removal and installation.

Removal

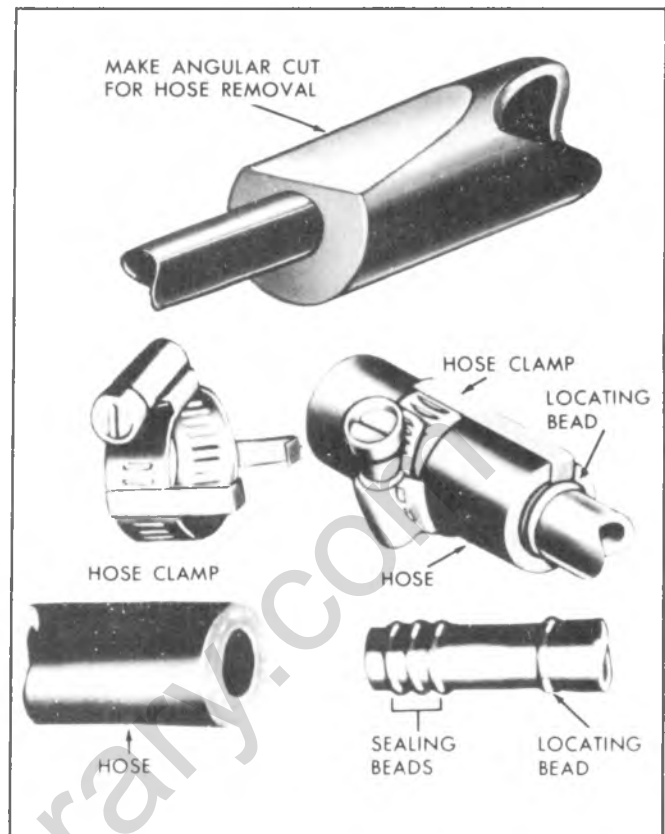


Fig. 1B-17-Hose Clamp Connections

1. Carefully, with a sharp knife, make an angle cut in the hose as shown in Figure 1B-17. This should loosen the hose so that it may be worked off the fittings.

2. Cut off slit end of hose.

CAUTION: Use only approved refrigeration hose. Never use heater hose. Use extreme care not to nick or score the sealing beads when cutting off the hose. Cutting the hose lengthwise may result in this problem.

Installation

1. Coat tube and hose with clean refrigeration oil.

2. Carefully insert hose over the three beads on the fitting and down as far as the fourth, or locating bead. Hose must butt against this fourth bead.

CAUTION: Use no sealer of any kind.

3. Install clamps on hose, hooking the locating arms over the cut end of the hose.

4. Tighten the hose clamp screw to 35-42 in. lbs. torque. **DO NOT RETORQUE.** The clamp screw torque will normally decrease as the hose conforms to the force of the clamp. The screw should be retorqued only if its torque falls below 10 in. lbs. In this case, retorqued to 20-25 in. lbs. Further tightening may damage the hose.

DIAGNOSIS

REFRIGERANT SYSTEM

The following is a description of the type of symptom each refrigerant component will evidence if a defect occurs:

COMPRESSOR

A compressor defect will appear in one of four ways: Noise, seizure, leakage, or low discharge pressure.

NOTE: Resonant compressor noises are not cause for alarm; however, irregular noise or rattles may indicate broken parts or excessive clearances due to wear. To check seizure, de-energize the magnetic clutch and check to see if drive plate can be rotated. If rotation is impossible, compressor is seized (See "False Compressor Seizure"). To check for a leak, refer to leak testing in the service manual. Low discharge pressure may be due to a faulty internal seal of the compressor, or a restriction in the compressor.

Low discharge pressure may also be due to an insufficient refrigerant charge or a restriction elsewhere in the system. These possibilities should be checked prior to servicing the compressor. If the compressor is inoperative, but is not seized, check to see if current is being supplied to the magnetic clutch coil terminals.

CONDENSER

A condenser may be defective in two ways: it may leak, or it may be restricted. A condenser restriction will result in excessive compressor discharge pressure. If a partial restriction is present, sometimes ice or frost will form immediately after the restriction as the refrigerant expands after passing through the restriction. If air flow through the condenser or radiator is blocked, high discharge pressures will result. During normal condenser operation, the outlet pipe will be slightly cooler than the inlet pipe.

RECEIVER-DEHYDRATOR

A defective receiver-dehydrator may be due to a restriction inside the body of the unit. A restriction at the inlet to the receiver-dehydrator will cause high head pressures. Outlet tube restrictions will be indicated by low head pressures and little or no cooling. An excessively cold receiver-dehydrator outlet may be indicative of a restriction.

EXPANSION VALVE

A malfunction of the expansion valve will be caused by one of the following conditions: valve stuck open, valve stuck closed, broken power element, a restricted screen or an improperly located or installed power element bulb. The first three conditions require valve

replacement. The last two may be corrected by replacing the valve inlet screen and by properly installing the power element bulb.

Attachment of the expansion valve bulb to the evaporator outlet line is very critical. The bulb must be attached tightly to the line and must make good contact with the line along the entire length of the bulb. A loose bulb will result in high low side pressures and poor cooling.

Indications of expansion valve trouble are provided by Performance Tests; consult Diagnostic Charts.

VALVE STUCK OPEN

NOISY COMPRESSOR.

No Cooling - Freeze Up.

VALVE STUCK CLOSED, BROKEN POWER ELEMENT OR PLUGGED SCREEN

Very Low Suction Pressure.

No Cooling.

POORLY LOCATED POWER ELEMENT BULB

Normal Pressure.

Poor Cooling.

Diagnosis for Defective Valve

The following procedure must be followed to determine if a malfunction is due to a defective expansion valve.

1. Check to determine if the system will meet the performance test as outlined previously. If the expansion valve is defective, the low pressure readings (evaporator pressure) will be above specifications.

2. The loss of system performance is not as evident when the compressor head pressure is below 200 psi. Therefore, it may be necessary to increase the system head pressure by partially blocking the condenser. Disconnect the blower lead wire and repeat the "performance check" to determine if the evaporator pressure can be obtained.

3. The system will also indicate a low refrigerant charge by bubbles occurring in the sight glass.

EVAPORATOR

When the evaporator is defective, the trouble will show up as an inadequate supply of cool air. A partially plugged core due to dirt, a cracked case, or a leaking seal will generally be the cause.

REFRIGERANT LINE RESTRICTIONS

Restrictions in the refrigerant lines will be indicated as follows:

1. Suction Line - A restricted suction line will cause low suction pressure at the compressor, low discharge pressure and little or no cooling.

2. Discharge Line - A restriction in the discharge line generally will cause the pressure relief valve to open.

3. Liquid Line - A liquid line restriction will be

evidenced by low discharge and suction pressure, and insufficient cooling.

Sight Glass Diagnosis (G and Motor Home Chassis Units)

At temperatures higher than 21°C (70 degrees F), the sight glass may indicate whether the refrigerant charge is sufficient. A shortage of liquid refrigerant is indicated after above five minutes of compressor operation by the appearance of slow-moving bubbles (vapor) or a broken column of refrigerant under the glass. Continuous bubbles may appear in a properly charged system on a cool day. This is a normal situation. If the sight glass is generally clear and performance is satisfactory, occasional bubbles do not indicate refrigerant shortage.

If the sight glass consistently shows foaming or a broken liquid column, it should be observed after partially blocking the air to the condenser. If under this condition the sight glass clears and the performance is otherwise satisfactory, the charge shall be considered adequate.

In all instances where the indications of refrigerant shortage continues, additional refrigerant should be added in 1/4 lb. increments until the sight glass is clear. An additional charge of 1/2 lb. should be added as a reserve after the glass clears. In no case should the system be overcharged.

VACUUM SYSTEM DIAGNOSIS

(C-K-G FOUR-SEASON SYSTEM)

Start the engine and allow it to idle - move the selector lever to each position and refer to the vacuum diagrams and operational charts for proper airflow, air door functioning and vacuum circuits. If air flow is not out of the proper outlets at each selector lever position, then proceed as follows:

1. **Check for good hose connections**-at the vacuum actuators, control head valve, reservoir, tees, etc.

2. **Check the vacuum source circuit as follows:**

Install vacuum tee and gauge (with restrictor) at the vacuum tank outlet (see Vacuum Diagram). Idle the engine and read the vacuum (a normal vacuum is equivalent to manifold vacuum) at all selector lever positions.

a. **Vacuum Less Than Normal At All Positions -**

Remove the tee and connect the vacuum gauge line directly to the tank - read the vacuum. If still low, then the problem lies in the feed circuit, the feed circuit to the tank or in the tank itself. If vacuum is now normal, then the problem lies downstream.

b. **Vacuum Less Than Normal at Some Positions -**

If vacuum was low at one or several of the selector lever positions, a leak is indicated in these circuits.

c. **Vacuum Normal at All Positions -**

If vacuum was normal and even at all positions, then the malfunction is probably caused by

improperly connected or plugged lines or a defective vacuum valve or valves.

3. **Specific Vacuum Circuit Check**

Place the selector lever in the malfunctioning position and check for vacuum at the pertinent vacuum actuators. If vacuum exists at the actuator but the door does not move, then the actuator is defective or the door is mechanically bound. If low or no vacuum exists at the actuator, then the next step is to determine whether the cause is the vacuum harness or the vacuum valve. Check the vacuum harness first.

4. **Vacuum Harness Circuit Check**

a. Disconnect the vacuum harness at the control head.

b. The black line (#1) should show engine vacuum - if not, trace back through connector to vacuum tank.

c. To check any individual circuit place the selector lever at the involved circuit position and check for vacuum presence.

CHECKING SYSTEM OPERATION

1. Operate system for a maximum of five minutes at maximum cooling, high blower speed and with engine operating at 2000 RPM (exhaust should be vented if inside).

2. When system is stabilized, the pressure gauges on the charging station should read pressures corresponding to values listed under PERFORMANCE DATA.

3. When correct system pressures are observed, check system charge as described under "Refrigerant Quick Check Procedure".

4. Feel outlet air distribution to ensure that cold air is being distributed.

5. Disconnect gauge lines and cap fittings.

CAUTION: *When removing gauge lines from fittings, be sure to remove the adapters from the fittings rather than the gauge lines from the adapters.*

PERFORMANCE TEST

Under normal circumstances, it will not be necessary to Performance Test a system as outlined below; however, in certain instances, the following procedure may be advantageous in diagnosing system malfunction.

The following fixed conditions must be adhered to in order to make it possible to compare the performance of the system being tested with the standards below:

1. Doors and window closed. (Vehicle inside or in shade.)

2. Hood up and engine exhaust suitably ventilated.

3. Vehicle in NEUTRAL with engine running at 2000 rpm.

4. Air Conditioning controls set for -

- Maximum cooling.
- High blower speed

COMPRESSOR DIAGNOSIS

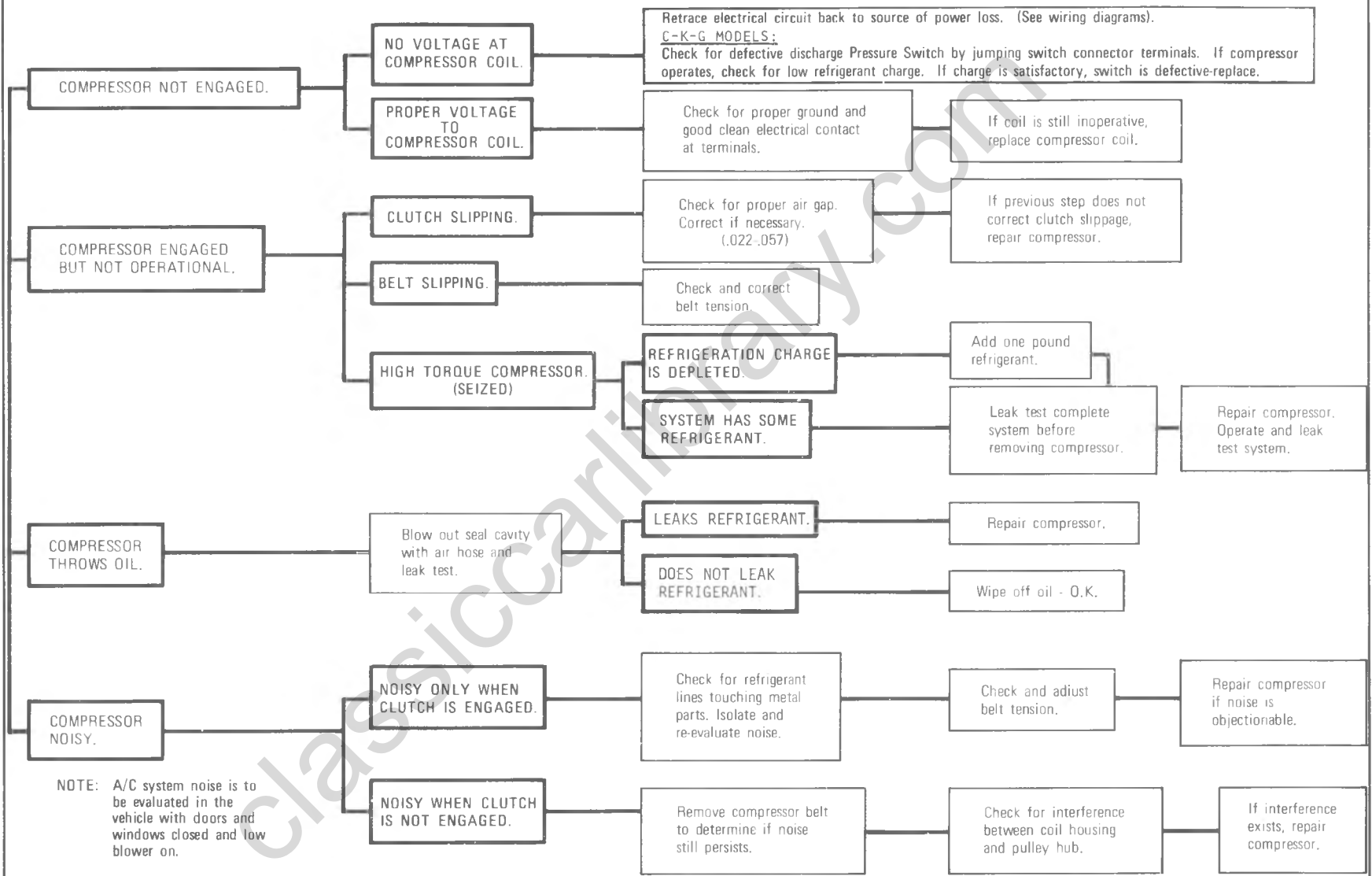
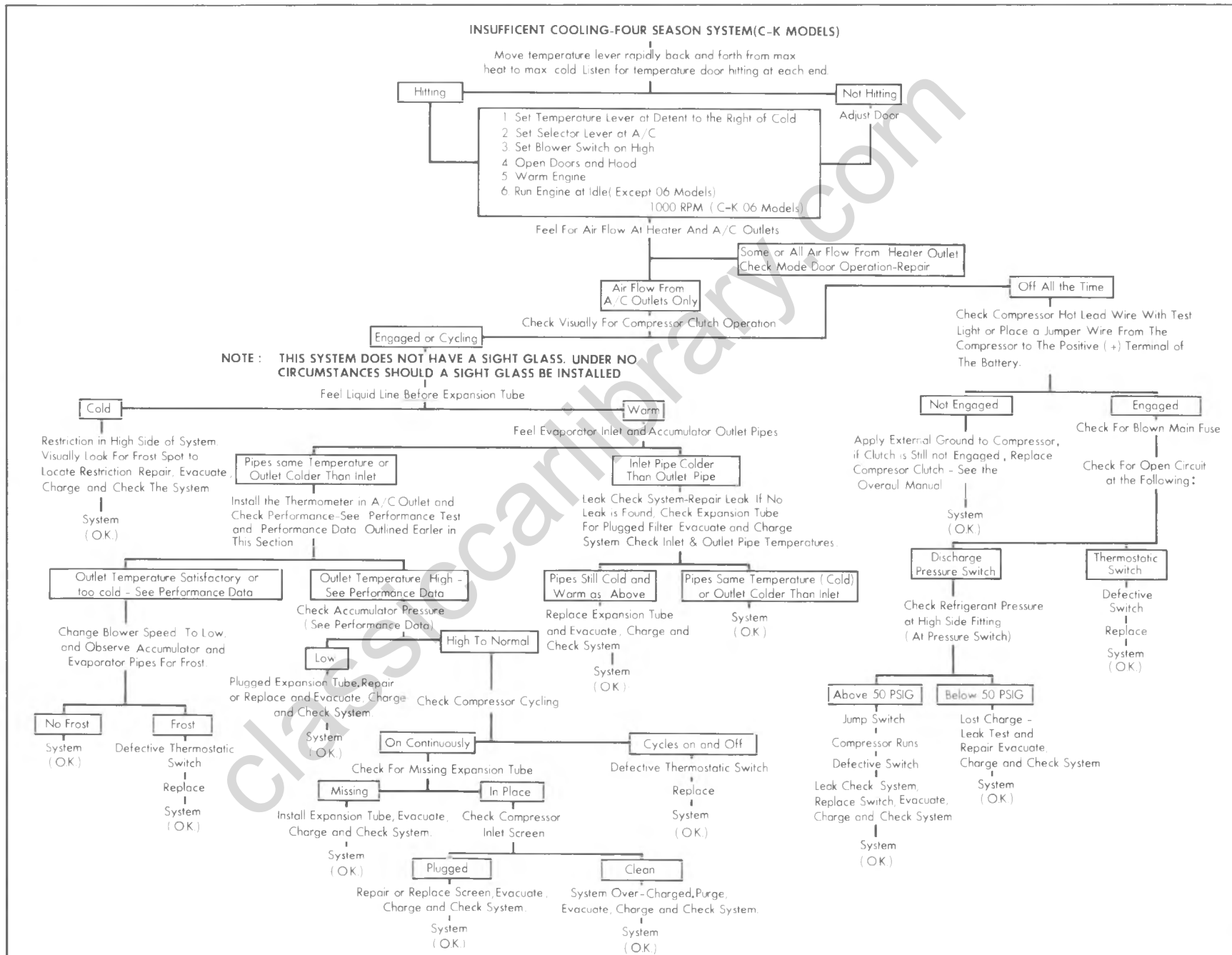


Fig. 1B-18-Compressor Diagnosis

Fig. 1B-19--Insufficient Cooling--C-K Four-Season System



INSUFFICIENT COOLING DIAGNOSIS CHART (EXCEPT C-K FOUR-SEASON SYSTEM)

The following procedures should be applied before performance testing an A/C System.

1. Check for proper belt installation and tension with J-23600.
2. Check for proper clutch coil terminal connector installation.
3. Check for clutch air Gap (.022-.057).
4. Check for broken, burst, or cut hoses. Also check for loose fittings on all components.

5. Check for condenser air blockage due to foreign material.
6. Check for proper air ducting hose connections.
7. Check heater temperature door adjustment, adjust if incorrect.
8. Check evaporator sealing for air leak, repair if leaking.
9. Install pressure gages and thermometer and make performance test.

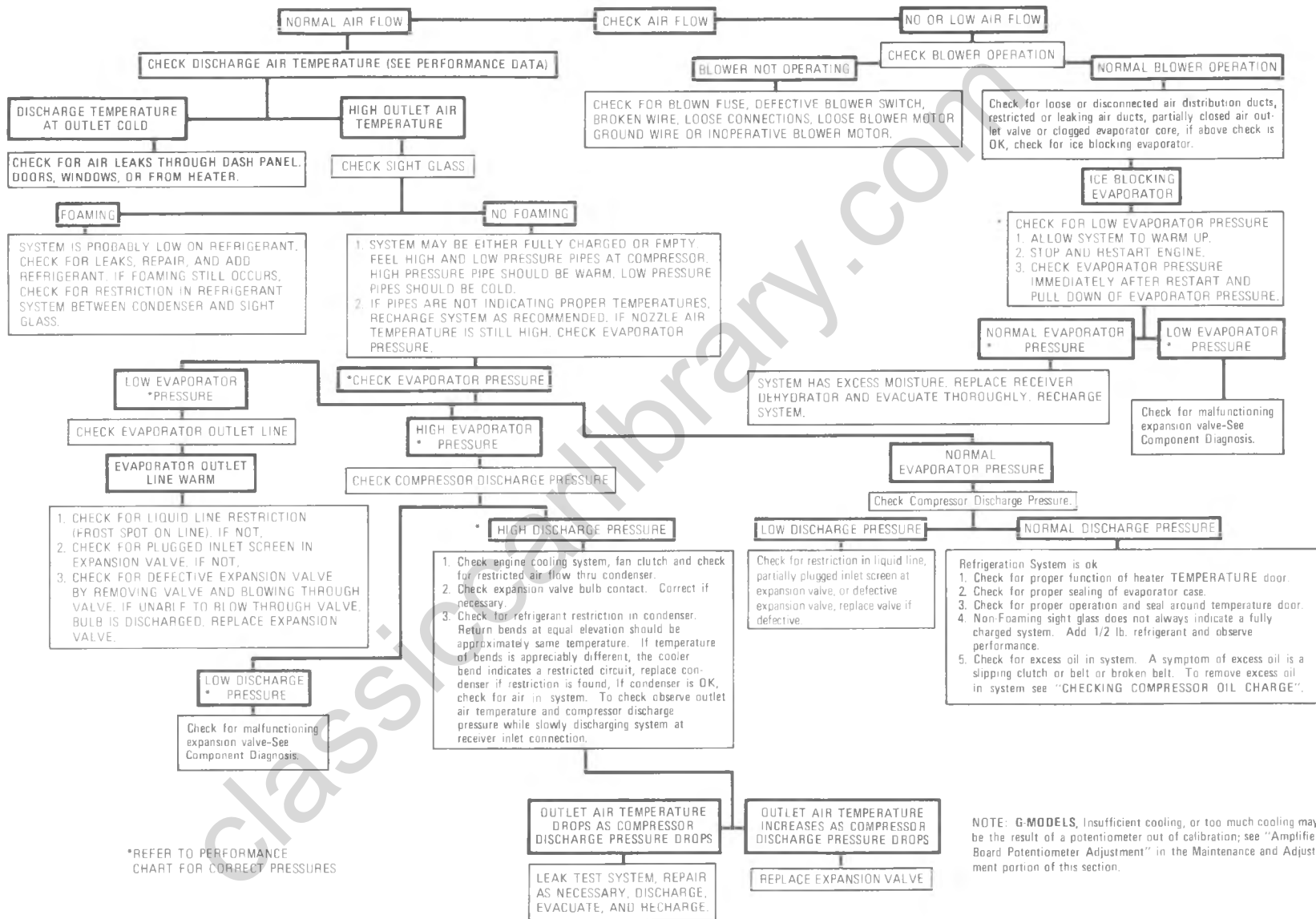


Fig. 1B-20-Insufficient Cooling Diagnosis-Except C-K Four-Season System

ELECTRICAL SYSTEM DIAGNOSTIC CHART

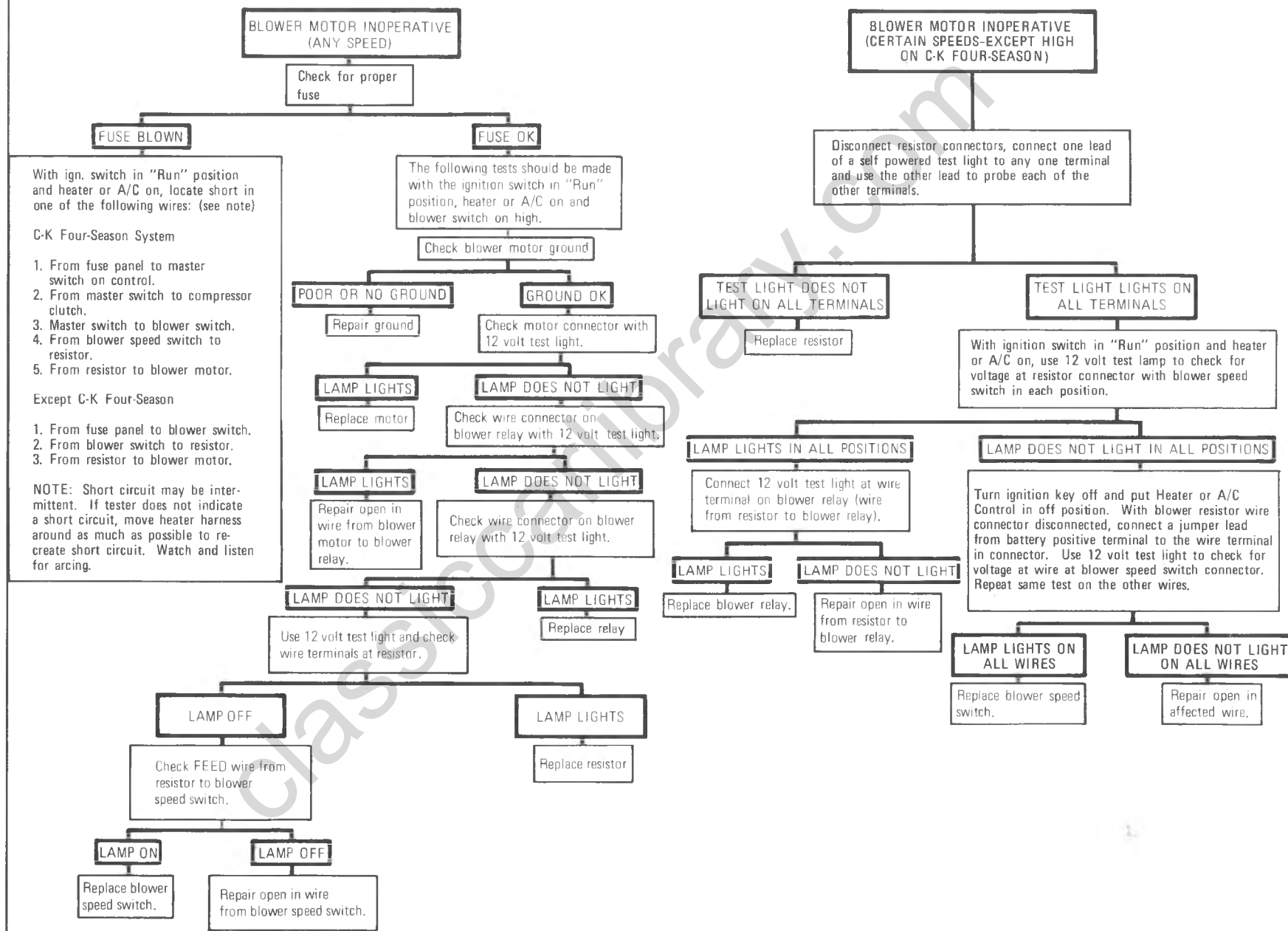


Fig. 1B-21—Electrical System Diagnosis Chart

ELECTRICAL SYSTEM DIAGNOSTIC CHART

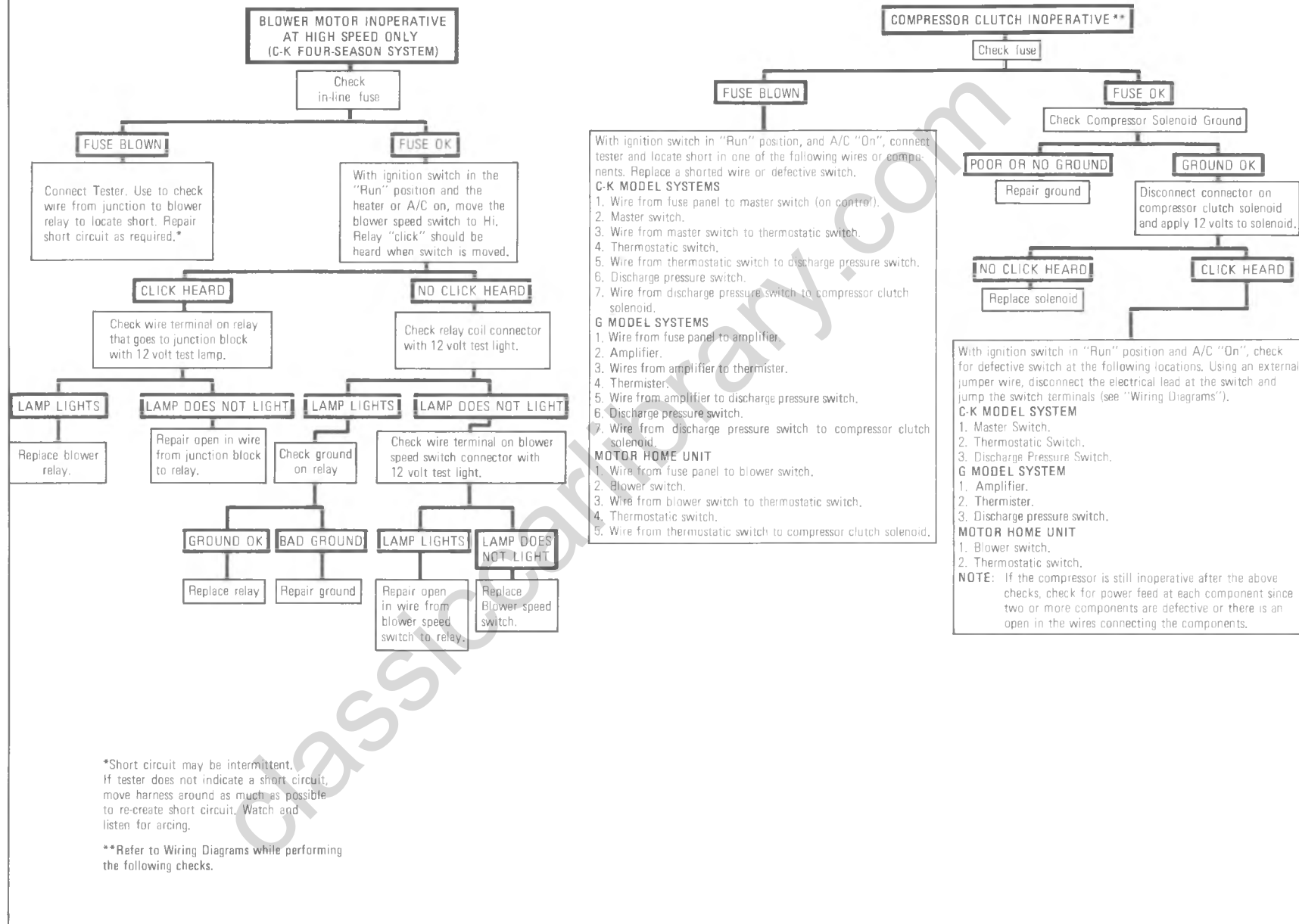
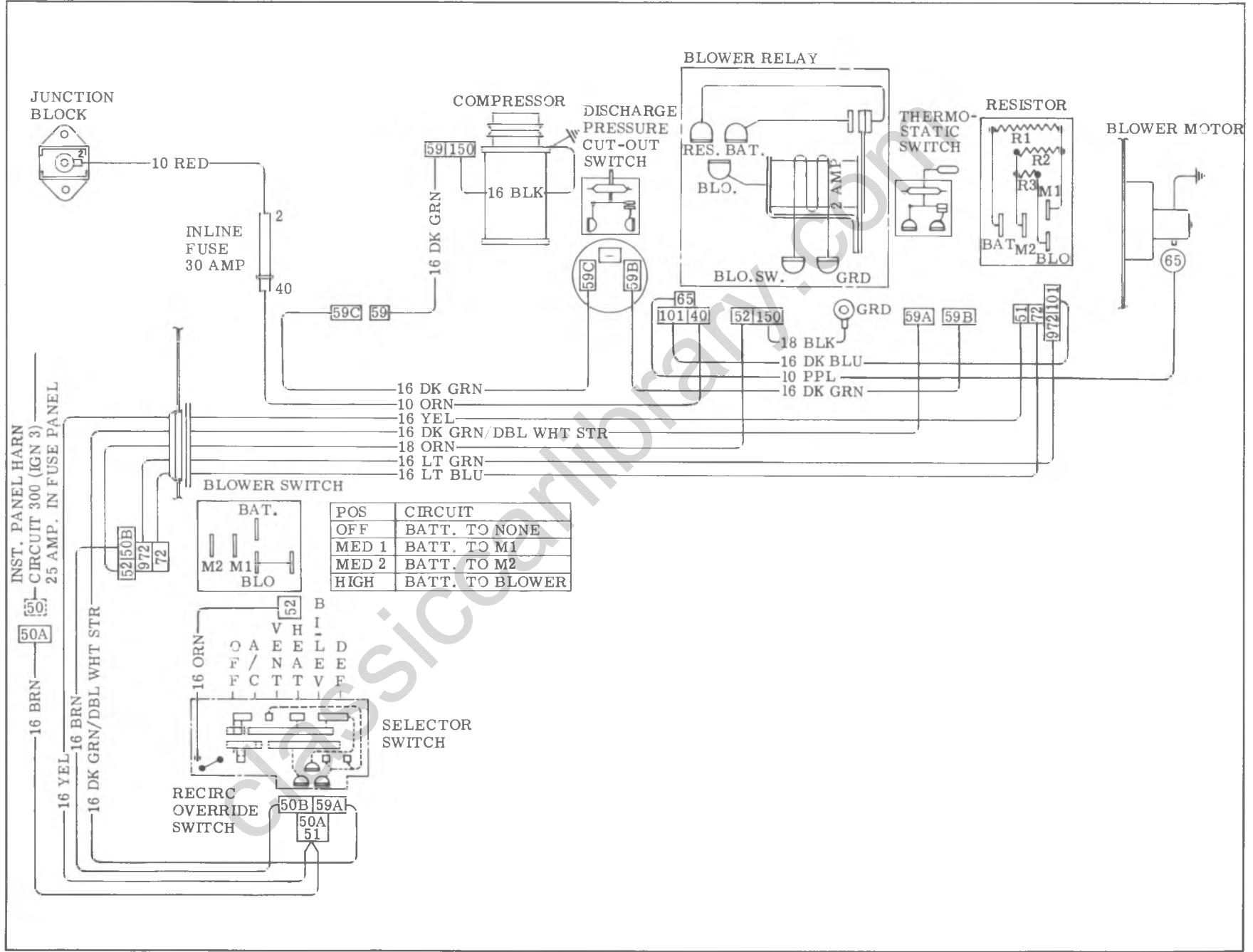


Fig. 1B-22: Electrical System Diagnosis Chart

Fig. 1B-23: Four-Season System Wiring Diagram (C-K Models)



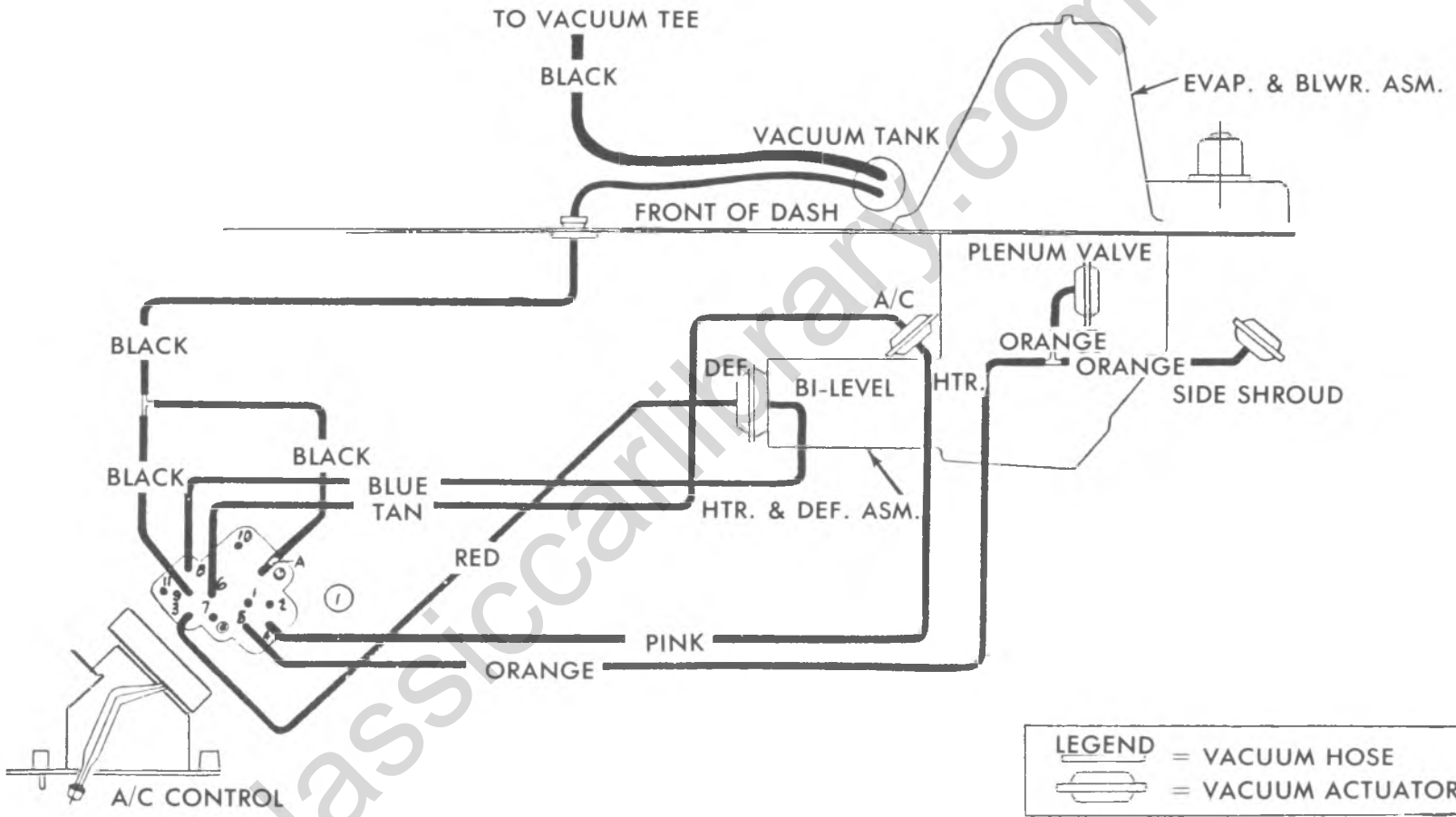


Fig. 1B-24--Four-Season System Vacuum Diagram (C-K Models)

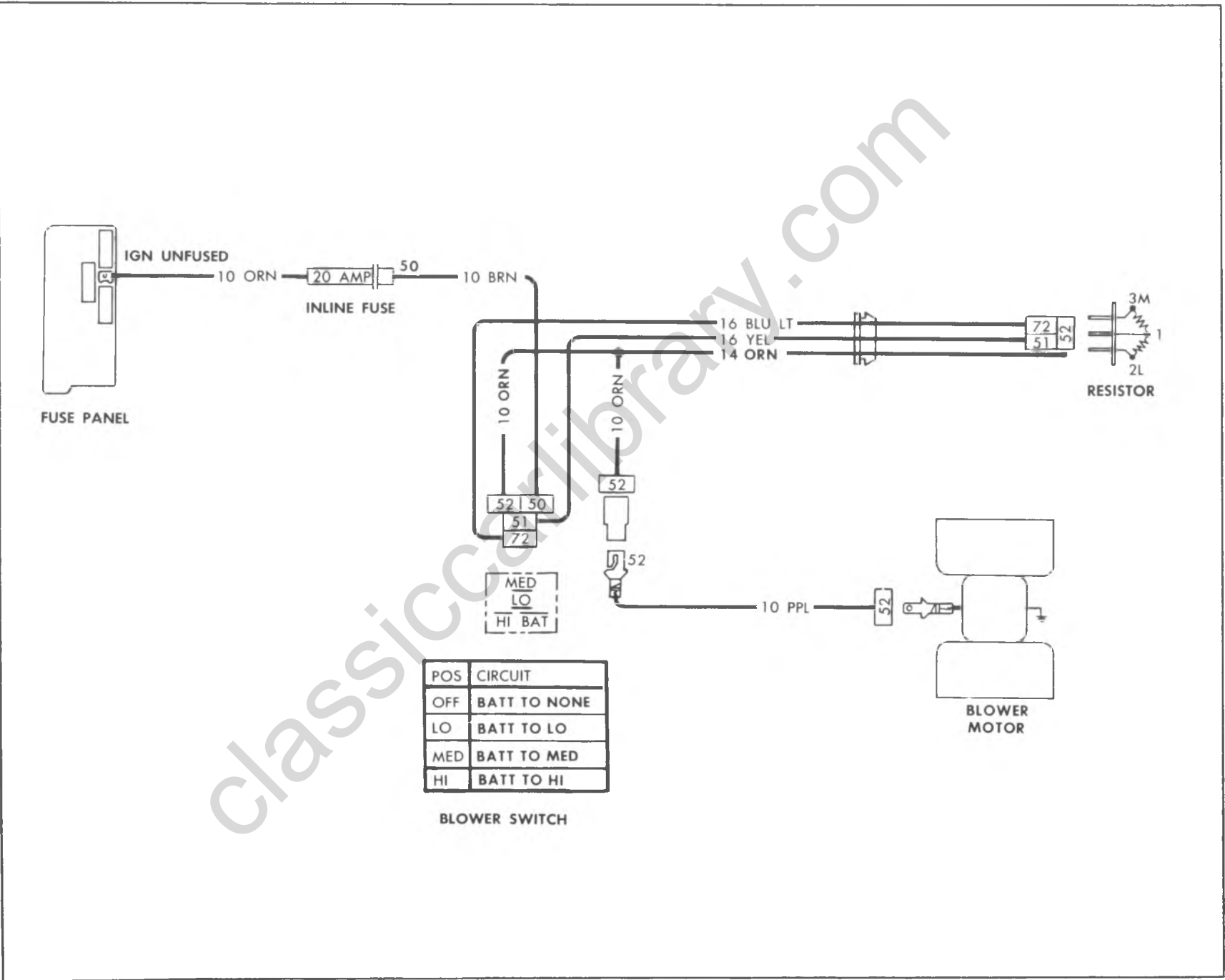
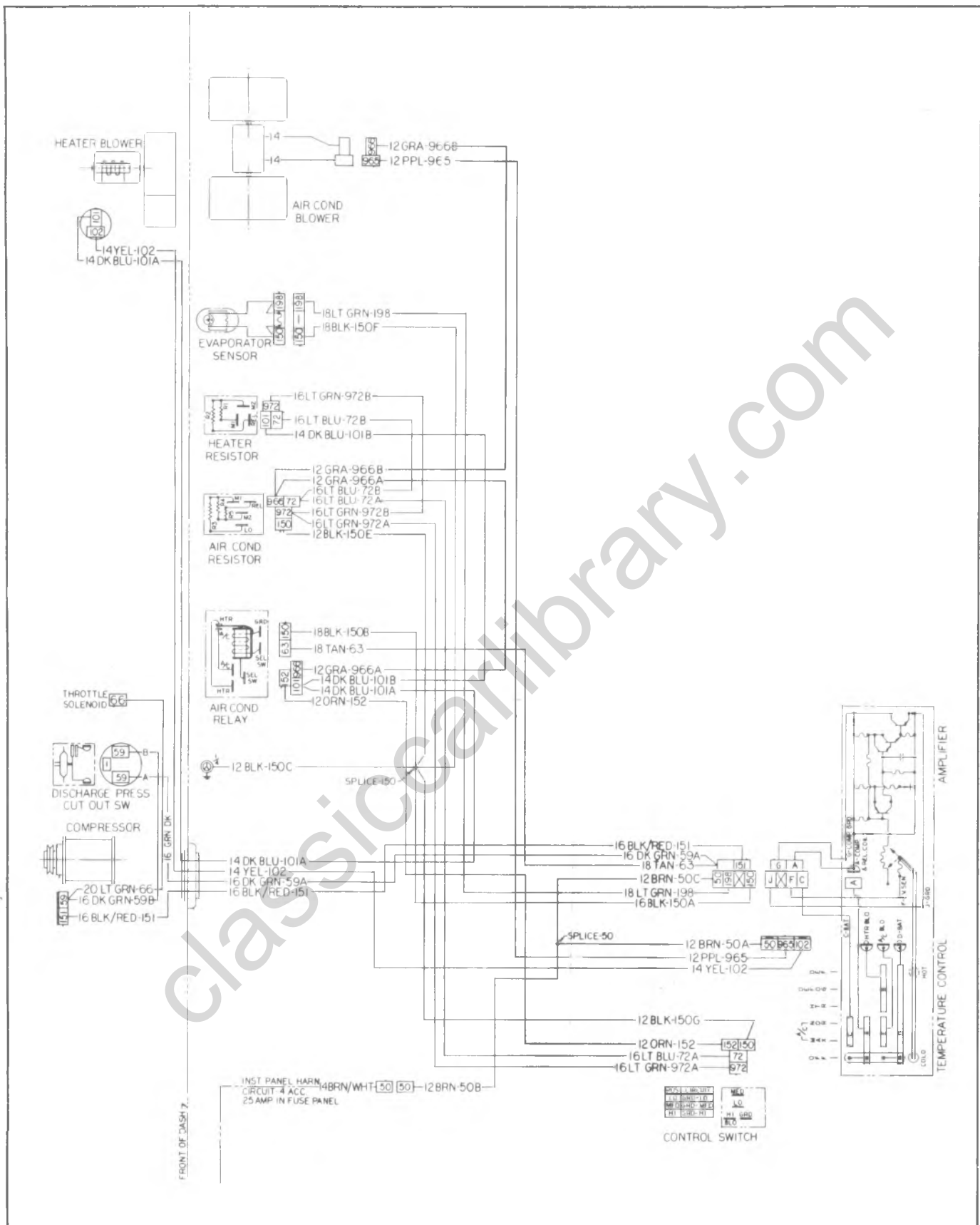


Fig. 1B-25: Overhead System Wiring Diagram (C-K Models)



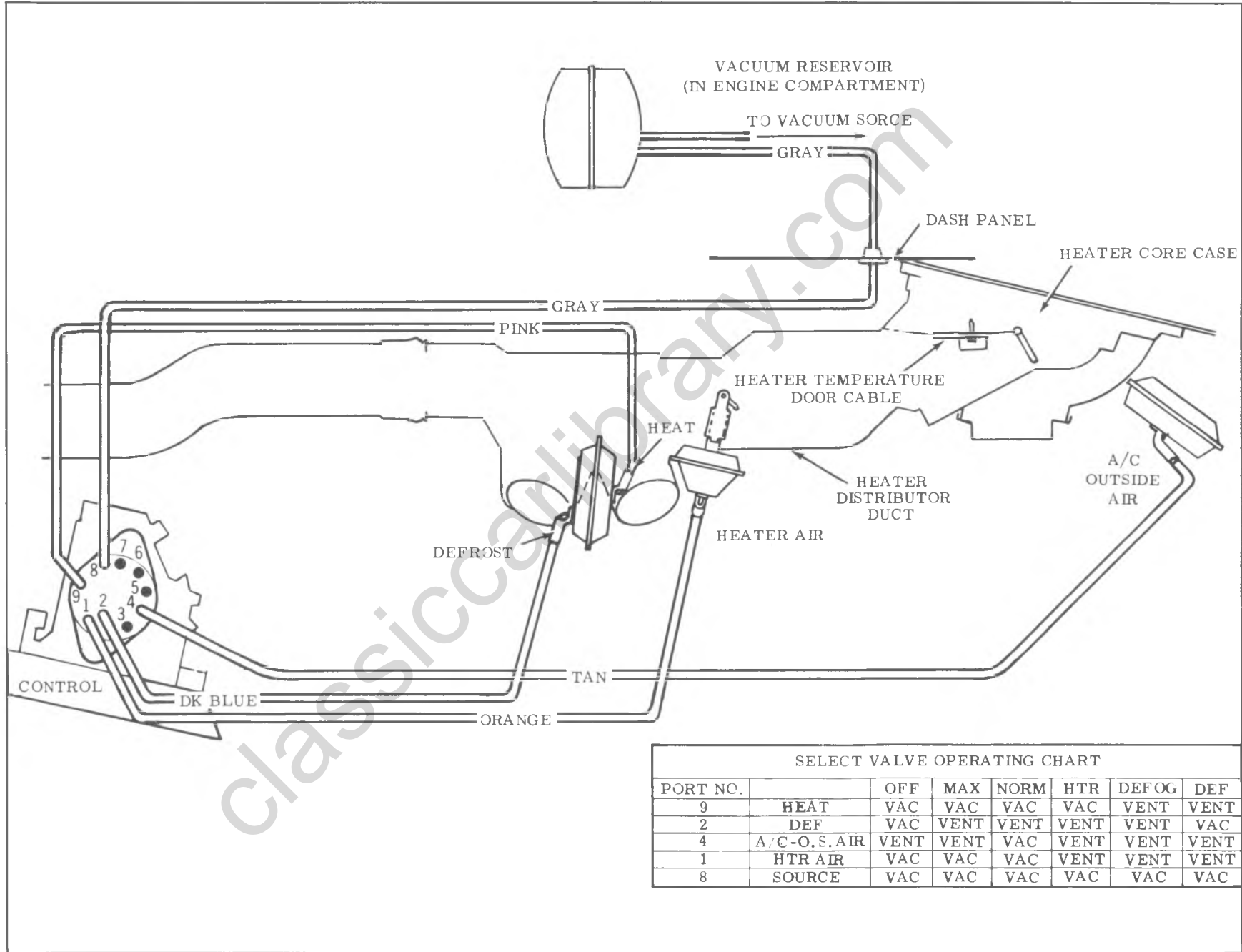


Fig. 1B-27-C60 System Vacuum Diagram (G Models)

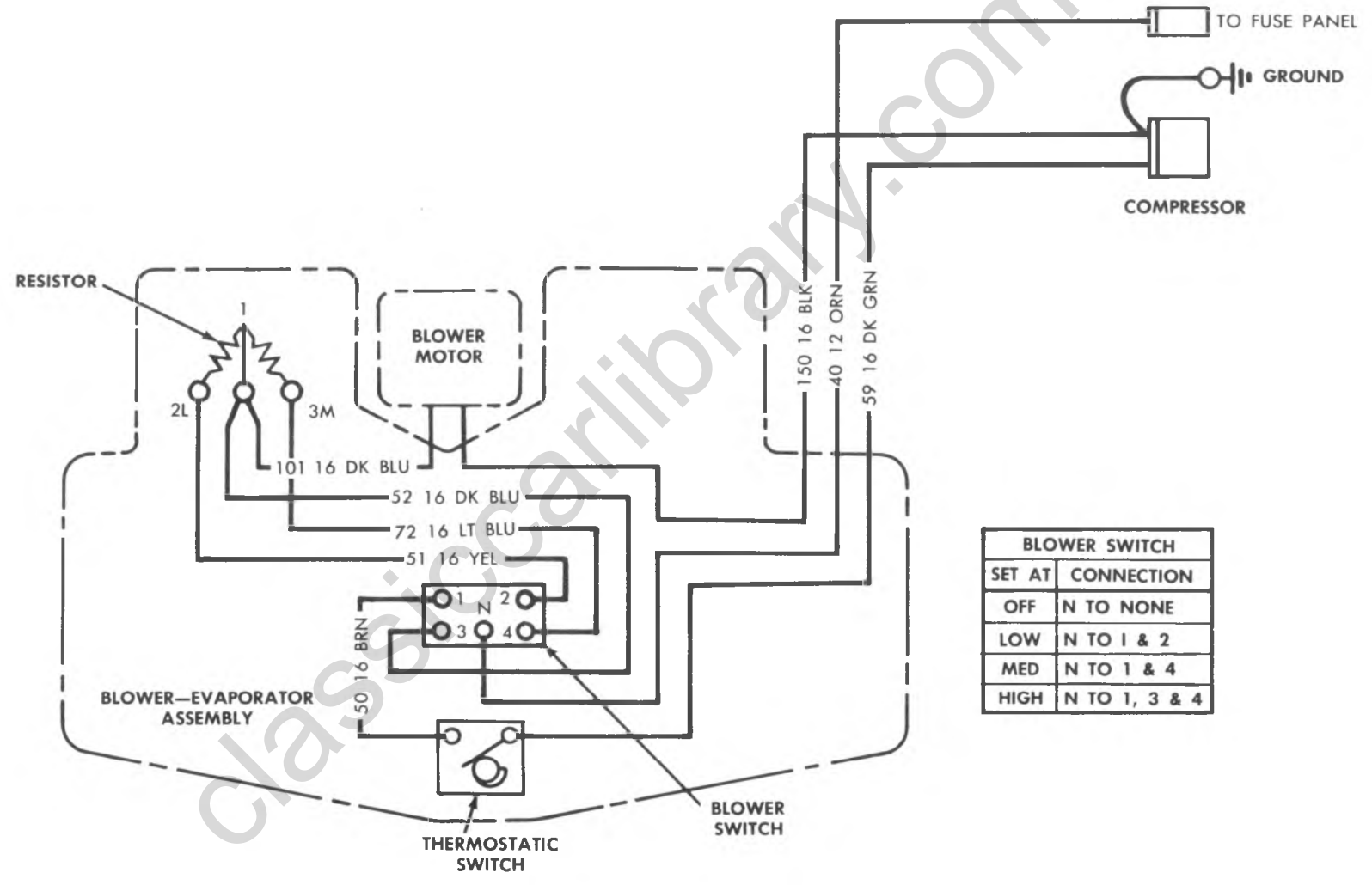


Fig. 1B-29--Motor Home Chassis Wiring Diagram

5. TEMP control set at "COLD" and all air conditioning outlets open.

6. Gauge set installed.

7. System settled out (run-in approximately 10 minutes).

8. A thermometer placed in front of vehicle grille and another in the right hand diffuser outlet.

NOTE: On Overhead Systems, place a third thermometer in the rear unit center outlet.

9. An 18" fan placed in front of the vehicle and blowing into the condenser.

NOTE: Higher temperatures and pressures will occur at higher ambient temperatures. In areas of high humidity it is possible to have thermometer and gauge readings approach but not reach the figures listed in the performance tables and still have a satisfactory operating unit. However, it is important to remember that low pressure has a direct relationship to nozzle outlet temperature. If pressure is too low, ice will gradually form on the evaporator fins, restricting air flow into the passenger area and resulting in insufficient or no cooling.

PERFORMANCE DATA

The following Performance Data define normal operation of the system under the above conditions. Relative humidity does not appear in the tables because after running the prescribed length of time on recirculated air and maximum cooling, the relative humidity of the air passing over the evaporator core will remain at approximately 35% to 40% regardless of the ambient temperature or humidity.

CHECKING OIL

In the six cylinder compressor it is not recommended that the oil be checked as a matter of course.

Four-Season Air Conditioning (C-K Models)

(Refrigerant Charge - 3 Lbs. - 12 oz.)					
Temperature of Air Entering Condenser	70°	80°	90°	100°	110°
Engine rpm	2000				
Compressor Head Pressure *	150-205	170-220	190-240	220-270	240-290
Accumulator Pressure *	20-26	20-28	21-29	22-30	23-32
Discharge Air Temp. at Right Hand Outlet *	41-47	41-47	42-50	43-51	43-51

Overhead System (C-K Models)

(Refrigerant Charge - 5 lbs.-4 oz.)					
Temperature of Air Entering Condenser	70°	80°	90°	100°	110°
Engine rpm	2000				
Compressor Head Pressure *	135-185	160-210	195-245	230-280	270-320
Accumulator Pressure *	22-28	22-30	30-38	33-41	37-47
Discharge Air Temp. at Right Hand Outlet *	42-48	42-48	50-58	54-62	57-67
Rear Center Outlet *	43-49	47-53	50-58	55-63	58-68

C60 System (G Models)

(Refrigerant Charge - 3 lbs.)						
Temperature of Air Entering Condenser	70°	80°	90°	100°	110°	120°
Engine rpm	2000 RPM					
Compressor Head Pressure*	10-60	20-70	140-190	160-210	190-240	210-260
Suction Pressure*	3-9	3-9	3-9	4-10	7-14	10-18
Discharge Air Temp. at Right Upper Outlet*	42-48	42-48	43-49	45-57	49-56	53-60

Generally, compressor oil level should be checked only where there is evidence of a major loss of system oil such as might be caused by:

- A broken refrigerant hose
- A severe hose fitting leak
- A very badly leaking compressor seal
- Collision damage to the system components

As a quick check on compressor oil charge, operate the engine at **idle** on maximum cold for approximately 10 minutes, turn off the engine and momentarily crack open the oil drain plug on bottom of the compressor letting a slight amount of oil drain out. Retighten plug. Again slightly crack open the plug. If oil comes out, the compressor has the required amount of oil.

Overhead System (G Models)

(Refrigerant Charge — 5 lbs.-4 oz.)						
Temperature of Air Entering Condenser	70°	80°	90°	100°	110°	120°
Engine rpm	2000					
Compressor Head Pressure*	50-200	160-210	200-250	225-275	250-300	280-320
Suction Pressure*	13-19	13-21	16-24	19-27	23-31	26-34
Discharge Air Temp. at Right Front Upper Outlet*	38-44	38-44	39-47	45-53	50-58	54-62

Rear system temperatures at center outlet run 5 - 10° higher than front system.

Dash Mounted Unit (Motor Home Chassis)

(Refrigerant Charge — 3 lbs.-4 oz.)						
Temperature of Air Entering Condenser	70°	80°	90°	100°	110°	120°
Engine rpm	2000					
Compressor Head Pressure*	110-120	135-145	160-170	190-200	220-230	260-270
Suction Pressure psi*	6	7	9	10	10	13
Discharge Air Temperature*	40-45	41-46	41-46	42-47	44-49	44-49

*Just prior to compressor clutch disengagement.

NOTE: The oil may appear foamy. This is considered normal.

To further check the compressor oil charge, should the above test show insufficient oil, it is necessary to remove the compressor from the vehicle, drain and measure the oil as outlined under "Checking Compressor Oil Charge."

Checking Compressor Oil Charge

1. Run the system for 10 minutes at 500-600 engine rpm with controls set for maximum cooling and high blower speed.

2. Turn off engine, discharge the system, remove compressor from vehicle, place it in a horizontal position with the drain plug downward. Remove the drain plug and, tipping the compressor back and forth and rotating the compressor shaft, drain the oil into a clean container, measure and discard the oil.

3. Add new refrigeration oil to the compressor as follows.

a. If the quantity drained was 4 fluid oz. or more, add the same amount of new refrigeration oil to the replacement compressor.

b. If the quantity drained was less than 4 fluid oz., add 6 fluid oz. of new refrigeration oil to the replacement compressor.

c. If a new service compressor is being installed, drain all oil from it and replace only the amount specified in Steps 3a and 3b above.

d. If a field repaired compressor is being installed, add one additional fluid oz. to the compressor.

4. In the event that it is not possible to idle the compressor as outlined in Step 1 to effect oil return to it, proceed as follows:

a. Remove the compressor, drain, measure and discard the oil.

b. If the amount drained is more than 1-1/2 fluid oz. and the system shows no signs of a major leak, add the same amount to the replacement compressor.

c. If the amount drained is less than 1-1/2 fluid oz. and the system appears to have lost an excessive amount of oil, add 6 fluid oz. of clean refrigeration oil to replacement compressor, 7 fluid oz. to a repaired compressor.

If the oil contains chips or other foreign material, replace the receiver-dehydrator (expansion tube on C-K models) and flush or replace all component parts as necessary. Add the full specified volume of new refrigeration oil to the replacement compressor.

5. Add additional oil in the following amounts for any system components being replaced.

- Evaporator Core 3 fluid oz.
- Condenser 1 fluid oz.
- Receiver-Dehydrator 1 fluid oz.
- Accumulator 1 fluid oz.

CAUTION: When adding oil to the compressor, it will be necessary to tilt the rear end of the compressor up so that the oil will not run out of the suction and discharge ports. Do not set the

compressor on the shaft end.

REFRIGERANT QUICK-CHECK PROCEDURE

The following procedure can be used to quickly determine whether or not an air conditioning system has a proper charge of refrigerant. This check can be made in a manner of minutes thus facilitating system diagnosis by pinpointing the problem to the amount of charge in the system or by eliminating this possibility from the overall checkout.

C-K Models

1. Engine must be warm (thermostat open).
2. Hood and body doors open.
3. Selector lever set at A/C.
4. Temperature lever at first detent to the right of COLD (set for outside air).
5. Blower on HI.
6. Engine idling at 1000 RPM.
7. Feel temperature of evaporator inlet and accumulator outlet pipes with compressor engaged (fig. 52).
 - a. If both are cold this is a proper condition.
 - b. If inlet pipe is cooler than outlet pipe, system is low on charge.
 - Add a slight amount of refrigerant until both pipes feel the same (system stabilized – 3-5 minutes).
 - Then add 15 oz. (1 can) additional refrigerant.

G Models and Motor Home Chassis Units

Start engine and place on fast idle. Set controls for maximum cold with blower on high.

Bubbles present in sight glass.

System low on charge. Check with leak detector. Correct leak, if any, and fill system to proper charge.

No appreciable temperature differential noted at compressor.

System empty or nearly empty. Turn off engine and connect Charging Station. Induce 1/2# of refrigerant in system (if system will not accept charge, start engine and draw 1/2# in through low pressure side). Check system with leak detector.

If refrigerant in sight glass remains clear for more than 45 seconds (before foaming and then settling away from sight glass) an overcharge is indicated. Verify with a performance check.

No bubbles. Sight glass clear.

System is either fully charged or empty. Feel high and low pressure pipes at compressor. High pressure pipe should be warm, low pressure pipe should be cold.

Temperature differential noted at compressor.

Even though a differential is noted, there exists a possibility of overcharge. An overfilled system will result in poor cooling during low speed operation (as a result of excessive head pressure). An overfill is easily checked by disconnecting the compressor clutch connector while observing the sight glass.

If refrigerant foams and then settles away from sight glass in less than 45 seconds, it can be assumed that there is a proper charge of refrigerant in system. Continue checking out system using performance checks outlined previously.

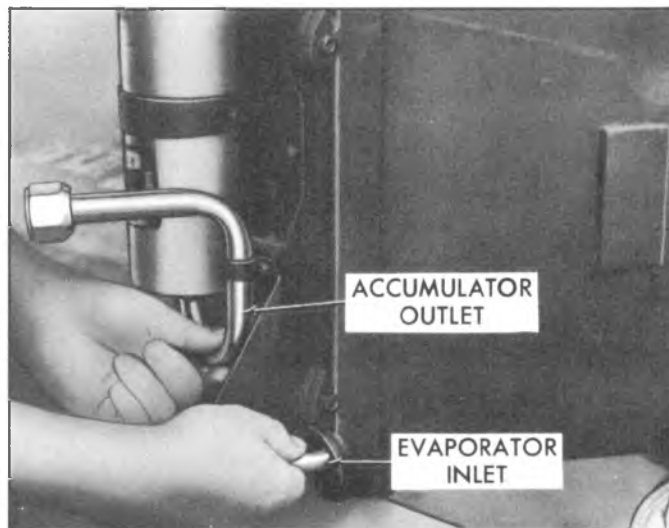


Fig. 1B-30—Checking Evaporator Inlet and Accumulator Outlet Temperatures

ON VEHICLE SERVICE

THERMOSTATIC SWITCH

C-K Systems and Motor Home Chassis Units make use of a thermostatic switch with either an air or evaporator inlet line sensing capillary. This capillary controls the switch by sensing the temperature of the air leaving the evaporator core (Motor Home Units) or temperature of the core fins (C-K models).

Checking for Proper Operation

Motor Home Chassis Units

1. Install the gauge set and set up the vehicle as described under "Performance Test."

2. Movement of the temperature control knob should result in a definite change in suction pressure and cycling of the compressor clutch.

- If compressor continued to operate regardless of the knob adjustment, it indicates that the switch points are fused which will lead to evaporator freeze-up. Replace the switch.

- If the compressor does not operate, regardless of the position of the knob, a loss of the power element charge is indicated (provided that it has been established that power is supplied to the switch). This, of course, results in no cooling. Replace the switch.

C-K Models

1. Install the gauge set and set up the vehicle as described under "Performance Test".

2. Set the control at A/C, HI blower, max COLD and run the engine at 2000 rpm.

- The thermostatic switch should cycle the compressor off when the low limit of the outlet air temperature is reached (see Performance Data). If it does

not, the switch points are fused which will lead to evaporator freeze up. Replace the switch.

- If the compressor does not operate, a loss of power element charge is indicated (provided that it has been established that power is supplied to the switch). This, of course, results in no cooling. Replace the switch.

NOTE: Do not attempt to run a Performance Check with the system disassembled since inaccurate readings would be the result. ALWAYS reinstall switch and capillary and any duct work before running a performance check.

AMPLIFIER BOARD POTENTIOMETER (Fig. 1B-31)

To cure a "too cold" or "not cold enough" capacity complaint, the sensor should be simulated by a $400 \pm 1\%$, 1/2 Watt resistor. By connecting the resistor as shown in Figure 1B-31, the control pot can be rotated until the compressor clutch energizes. The procedure is as follows:

1. Remove the headlamp switch knob and then remove the instrument panel bezel.

2. Remove the control to instrument panel screws.

3. Remove the left foot cooler bracket to instrument panel reinforcement screws and remove the foot cooler and duct.

4. With the system in the vehicle and the engine running, disconnect the terminals F and J from the connector at the control wiring harness connector.

5. Connect a 400 ohm $\pm 1\%$, 1/2 Watt resistor across terminals F and J.

6. Set the control temperature lever at COLD and

then adjust by rotating the pot until the compressor clutch engages.

7. Reverse the adjustment by carefully rotating the pot until the compressor clutch just disengages.

8. Reverse Steps 1-4 above and check system operation.

EXPANSION VALVE (Fig. 1B-32)

An expansion valve is used on C-K Model Overhead Systems, all G Model systems and Motor Home Chassis Units.

A malfunction of the expansion valve will be caused by one of the following conditions; valve stuck open, valve stuck closed, broken power element, a restricted screen or an improperly located or installed power element bulb.

Attachment of the expansion valve bulb to the evaporator outlet pipe is very critical. The bulb must be attached tightly to the pipe and must make good contact with the pipe along the entire length of the bulb. A loose bulb will result in high "high side" pressures and poor cooling.

Indications of expansion valve trouble provided by the Performance Test are as follows"

VALVE STUCK OPEN

Noisy Compressor.

No Cooling - Freeze Up.

VALVE STUCK CLOSED, PLUGGED SCREEN OR BROKEN POWER ELEMENTS

Very Low Suction Pressure.

No Cooling.



Fig. 1B-31--Amplifier Board Potentiometer Adjustment

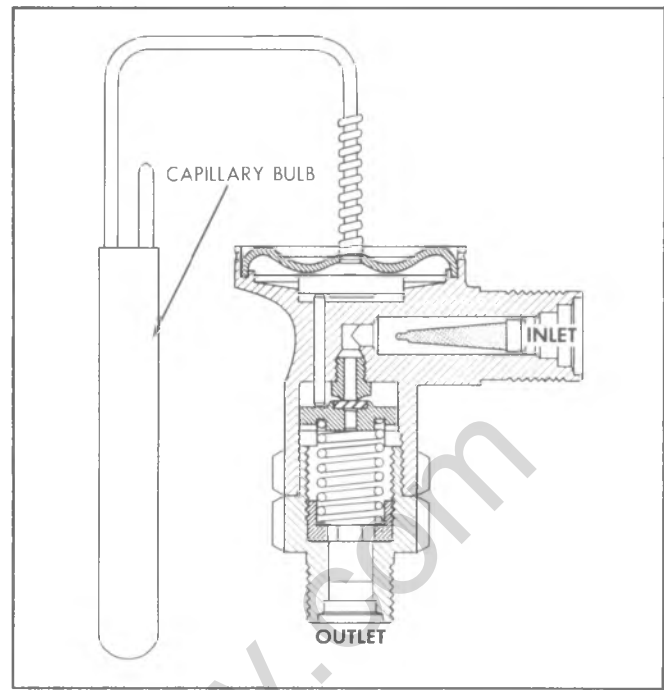


Fig. 1B-32--Expansion Valve

POORLY LOCATED POWER ELEMENT BULB

Normal Pressure.

Poor Cooling.

Check for Defective Valve

The following procedure must be followed to determine if a malfunction is due to a defective expansion valve.

1. Check to determine if the system will meet the performance test as outlined previously. If the expansion valve is defective, the low pressure readings will be above specification.

2. The loss of system performance is not as evident when the high side pressure is below 200 PSI. Therefore, it may be necessary to increase the system high side pressure by partially blocking the condenser. Disconnect the blower lead wire and repeat the "Performance Check" to determine if the low side pressure can be obtained.

3. The system will also indicate a low refrigerant charge by bubbles occurring in the sight glass.

ENGINE IDLE COMPENSATOR

This additional aid to prevent stalling during prolonged hot weather periods is included with all air conditioned vehicles. The idle compensator is a thermostatically controlled air bleed which supplies additional air to the idle mixture. On V-8 engines, with

factory installed air conditioning systems, the compensator is located within the carburetor and is accessible when the engine air cleaner is removed.

COMPRESSOR

Removal (Fig. 1B-33)

C-K Models

1. Purge the refrigerant from the system.

2. Remove connector attaching bolt and connector. Cap or plug open connections at once.

3. Disconnect electrical lead to clutch actuating coil.

4. Loosen brace and pivot bolts and detach belt.

5. Remove the nuts and bolts attaching the

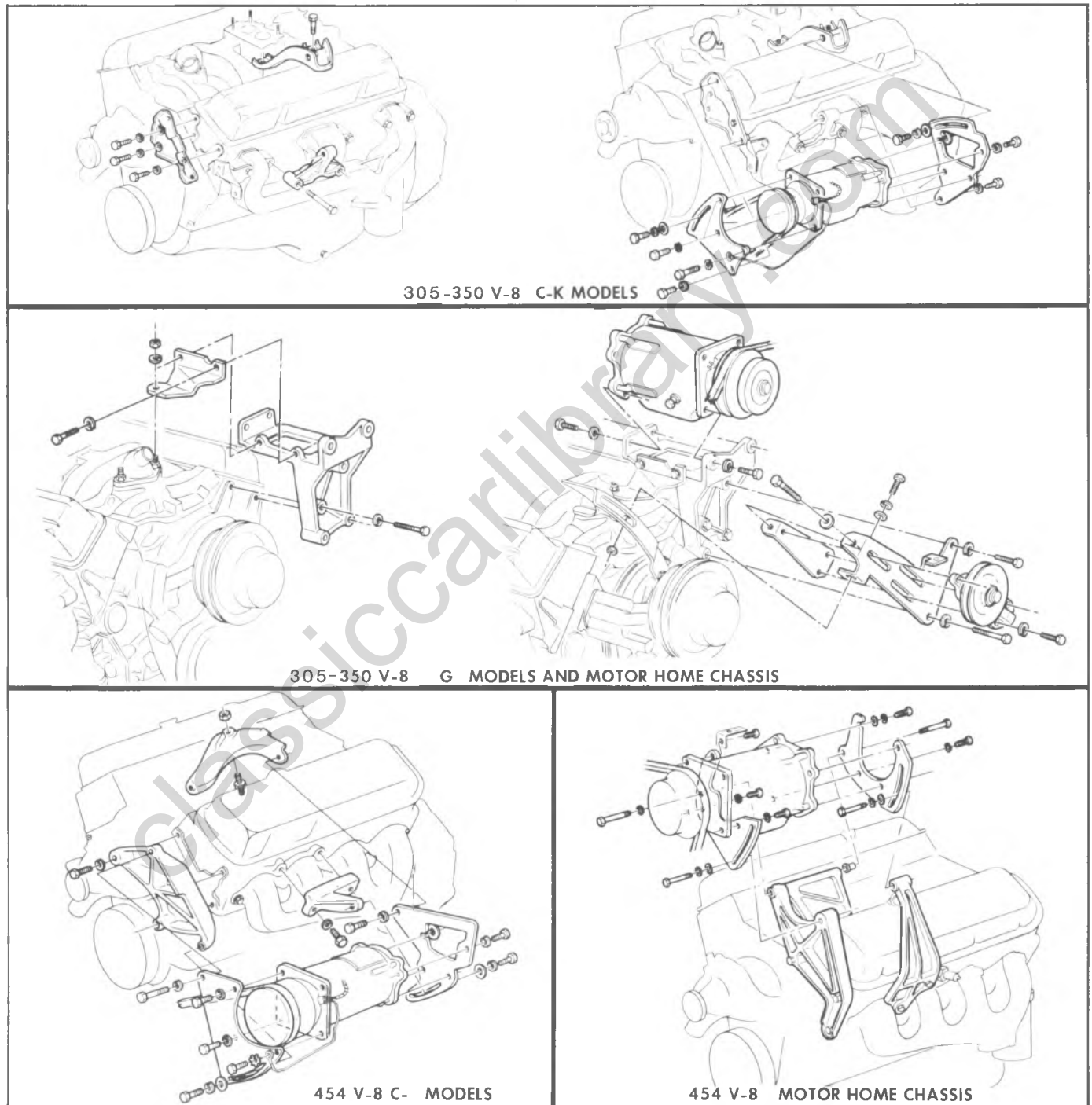


Fig. 1B-33-Compressor Mountings

compressor brackets to the mounting bracket. Remove the compressor.

6. Before beginning any compressor disassembly, drain and measure oil in the compressor. Check for evidence of contamination to determine if remainder of system requires servicing. Compressor servicing information is located in the Overhaul Manual.

Installation

1. If oil previously drained from the compressor upon removal shows no evidence of contamination, replace a like amount of fresh refrigeration oil into the compressor before reinstallation. If it was necessary to service the entire system because of excessive contamination in the oil removed, install a full charge of fresh refrigeration oil into the compressor.

2. Position compressor on the mounting bracket and install all nuts, bolts and lock washers.

3. Install the connector assembly to the compressor rear head, using new "O" rings coated with clean refrigeration oil.

4. Connect the electrical lead to the coil and install and adjust compressor belt.

5. Evacuate, charge and check the system.

G and Motor Home Chassis Models

Removal (Fig. 1B-33)

1. Disconnect battery ground cable.

2. Disconnect compressor clutch connector.

3. Purge the system of refrigerant.

4. Release the belt tension at the idler pulley and remove the belt from the compressor pulley. On some vehicles it may be necessary to remove the crankshaft pulley in order to remove the belt.

5. **G Models**—Remove the two bolts and two clamps that hold the engine cover and remove the cover.

6. Remove the air cleaner to aid access to the compressor.

7. Remove fitting and muffler assembly and cap or plug all open connections.

8. Remove the nuts and bolts attaching the compressor to the bracket.

9. Remove the engine oil tube support bracket bolt and nut from the compressor, also compressor clutch ground lead.

Before beginning any compressor disassembly, drain and measure oil in the compressor. Check for evidence of contamination to determine if remainder of system requires servicing. Compressor Servicing information is located in the Overhaul Manual.

Installation

1. If the oil drained from the compressor showed no evidence of contamination replace a like amount of fresh refrigeration oil into the compressor before reinstallation. If it was necessary to service the entire system because of excessive contamination in the oil removed, install a full charge of fresh refrigeration oil into the compressor. (See Checking Compressor Oil Charge in the Diagnosis Section of this Service Manual.)

2. Position compressor on the mounting bracket and install all nuts, bolts, lock washers, and ground wire.

3. Install the connector assembly to the compressor rear head, using new "O" ring coated with clean refrigeration oil.

4. Connect the electrical lead to the coil and install and adjust compressor belt, using idler pulley. See "Compressor Belt Tension Adjustment."

5. Evacuate, charge and check the system.

6. Replace air cleaner. On G models, replace the engine cover.

7. Connect the battery ground cable.

Compressor Belt Tension Adjustment

Adjust the compressor belt to the specifications shown in the Tune-Up chart in the Engine section of the Service Manual.

NOTE: On some G and Motor Home Chassis models it may be necessary to increase idler pulley slack adjustment. This may be accomplished by (1) Remove and discard the idler adjustment bolt. (2) Remove the idler backing plate and elongate all 3 adjusting slots 1/2 inch inboard or outboard as required. (3) Reinstall the idler assembly and adjust belt tension using a lever (screwdriver, etc.) to move the pulley outboard until proper belt tension is reached. If the belt is being replaced it may be necessary to remove and replace the throttle cable during the belt replacement. If so check throttle cable adjustment upon completion. It may also be necessary to remove the crankshaft pulley to install a new compressor belt.

FOUR-SEASON SYSTEM--C-K MODELS

CONDENSER

Replacement (Fig. 1B-34)

1. Disconnect battery ground cable.

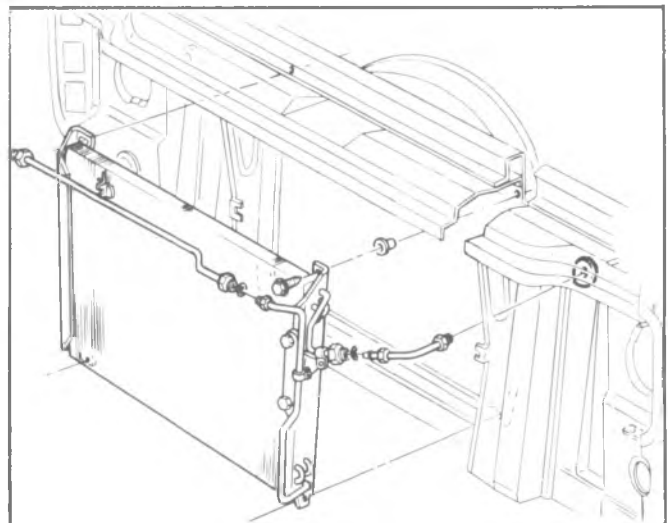


Fig. 1B-34--Condenser Installation (C-K Models)

2. Purge the system of refrigerant.
3. Remove the grille assembly.
4. Remove the radiator grille center support.
5. Remove the left grille support to upper fender support (2) screws.
6. Disconnect the condenser inlet and outlet lines and the outlet tube line at the right end of the condenser. Cap or plug all open connections at once.
7. Remove the condenser to radiator support screws.
8. Bend the left grille support outboard to gain clearance for condenser removal.
9. Remove the condenser assembly by pulling it forward and then lowering it from the vehicle.
10. To install a new condenser, reverse Steps 1-9 above. Add one fluid ounce of clean refrigeration oil to a new condenser.

NOTE: Use new "O" rings, coated with clean refrigeration oil, when connecting all refrigerant lines.

11. Evacuate, charge and check the system.

ACCUMULATOR

Replacement (Fig. 1B-35)

1. Disconnect the battery ground cable and the compressor clutch connector.
2. Purge the system of refrigerant.

WARNING: Be sure system is completely purged of refrigerant before completely disconnecting refrigerant lines. Visually check the accumulator for frost. The presence of frost indicates that the system is not fully discharged. To complete purging, connect the vacuum line to the vacuum pump, turn on the vacuum pump and open vacuum control valve. An alternate method would be to place warm water soaked cloths (not exceeding 51°C (125°F) around the accumulator to boil off any remaining refrigerant.

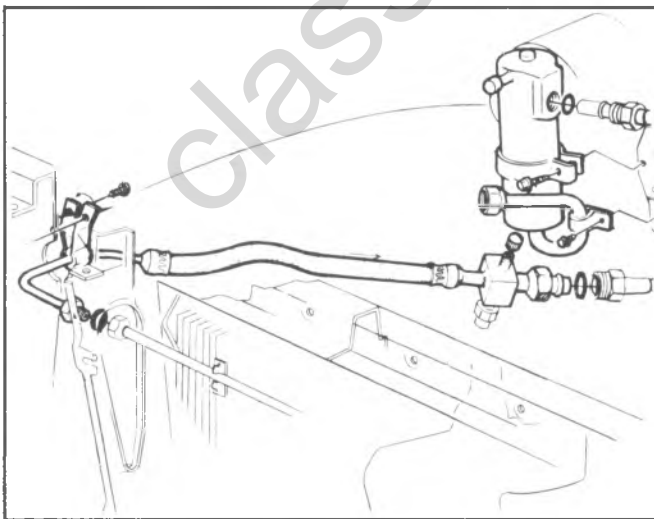


Fig. 1B-35--Accumulator Installation (C-K Models)

3. Disconnect the accumulator inlet and outlet lines and cap or plug the open connections at once.
4. Remove the accumulator bracket screws and remove the accumulator from the vehicle.
5. Drain any excess refrigerant oil from the accumulator into a clean container. Measure and discard the oil.
6. If a new accumulator is being installed, add one ounce of clean refrigeration oil to the new accumulator **PLUS** an amount equal to that drained in Step 5 above.
7. To install the new accumulator, reverse Steps 1-4 above. Connect all lines using new "O" rings, coated with clean refrigeration oil.

CAUTION: Do not uncap the new unit until ready to fasten the inlet and outlet line to the unit.

8. Evacuate charge and check the system.

BLOWER ASSEMBLY

Replacement

1. Disconnect the battery ground cable.
2. Disconnect the blower motor lead and ground wires.
3. Disconnect the blower motor cooling tube.
4. Remove the blower to case attaching screws and remove the blower assembly. Pry the blower flange away from the case carefully if the sealer acts as an adhesive.
5. Remove the nut attaching the blower wheel to the motor shaft and separate the assemblies.
6. To install, reverse Steps 1-5 above; replace sealer as necessary.

EVAPORATOR CORE

Replacement (Fig. 1B-36)

1. Disconnect the battery ground cable.
2. Purge the system of refrigerant.
3. Remove the nuts from the selector duct studs projecting through the dash panel.
4. Remove the cover to dash and cover to case screws and remove the evaporator case cover.
5. Disconnect the evaporator core inlet and outlet lines and cap or plug all open connectins at once.
6. Remove the thermostatic switch and the expansion tube assemblies.
7. Remove the evaporator core assembly.
8. To install, reverse Steps 1-7 above. Add three ounces of clean refrigeration oil to a new evaporator core.

CAUTION: Be sure to install the thermostatic switch capillary in the same position as when removed. See Thermostatic switch replacement.

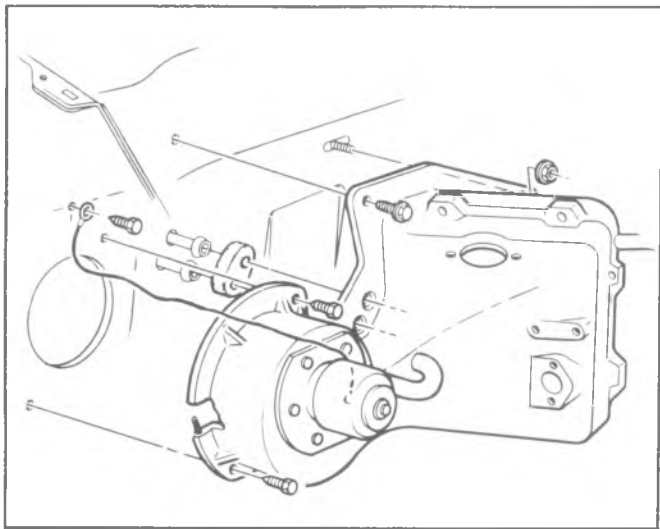


Fig. 1B-36-Blower-Evaporator (C-K Models)

NOTE: Use new "O" rings, coated with clean refrigeration oil, when connecting refrigerant lines.

Be sure cover to case and dash panel sealer is intact before reinstalling cover.

9. Evacuate, charge and check the system.

EXPANSION TUBE

The expansion tube is located in the evaporator core inlet line.

Replacement (Fig. 1B-37)

1. Purge the system of refrigerant.

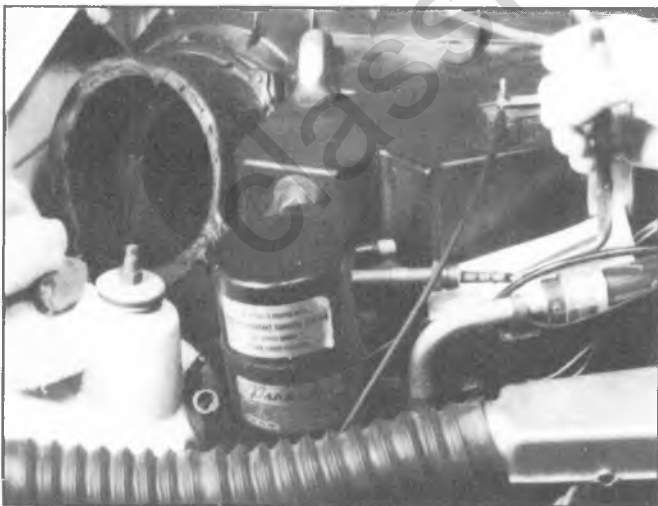


Fig. 1B-37-Expansion Tube - Typical

2. Disconnect the condenser to evaporator line at the evaporator inlet. Cap the open line at once.

3. Using needle-nose pliers, remove the expansion tube from the evaporator core inlet line (fig. 1B-37).

4. Remove the expansion tube "O" ring from the core inlet line.

5. To install, reverse Steps 1-4 above.

NOTE: Install the expansion tube using a new "O" ring coated with clean refrigeration oil, by inserting the short screen end of the tube into the evaporator inlet line.

6. Evacuate, charge and check the system.

SELECTOR DUCT AND HEATER CORE ASSEMBLY

Replacement (Figs. 1B-38 and 1B-39)

1. Disconnect the battery ground cable.
2. Drain the radiator and remove the heater hoses from the core tubes. Plug the core tubes to prevent coolant spillage during removal.

3. Remove the glove box and door as an assembly.

4. Remove the center duct to selector duct and instrument panel screws and remove the center lower and center upper ducts.

5. Disconnect the bowden cable at the temperature door.

6. Remove the nuts from the three selector duct studs projecting through the dash panel.

7. Remove the selector duct to dash panel screw (inside vehicle).

8. Pull the selector duct assembly rearward until the core tubes clear the dash panel. Lower the selector assembly far enough to gain access to all vacuum and electrical harnesses.

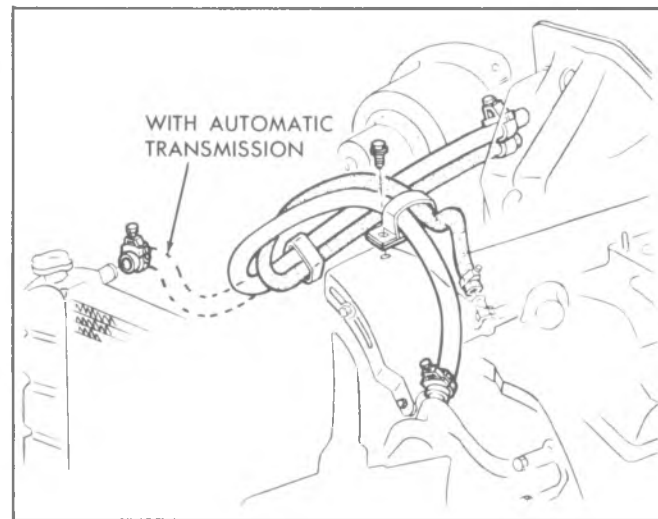


Fig. 1B-38-Heater Hose Routings (C-K Models)

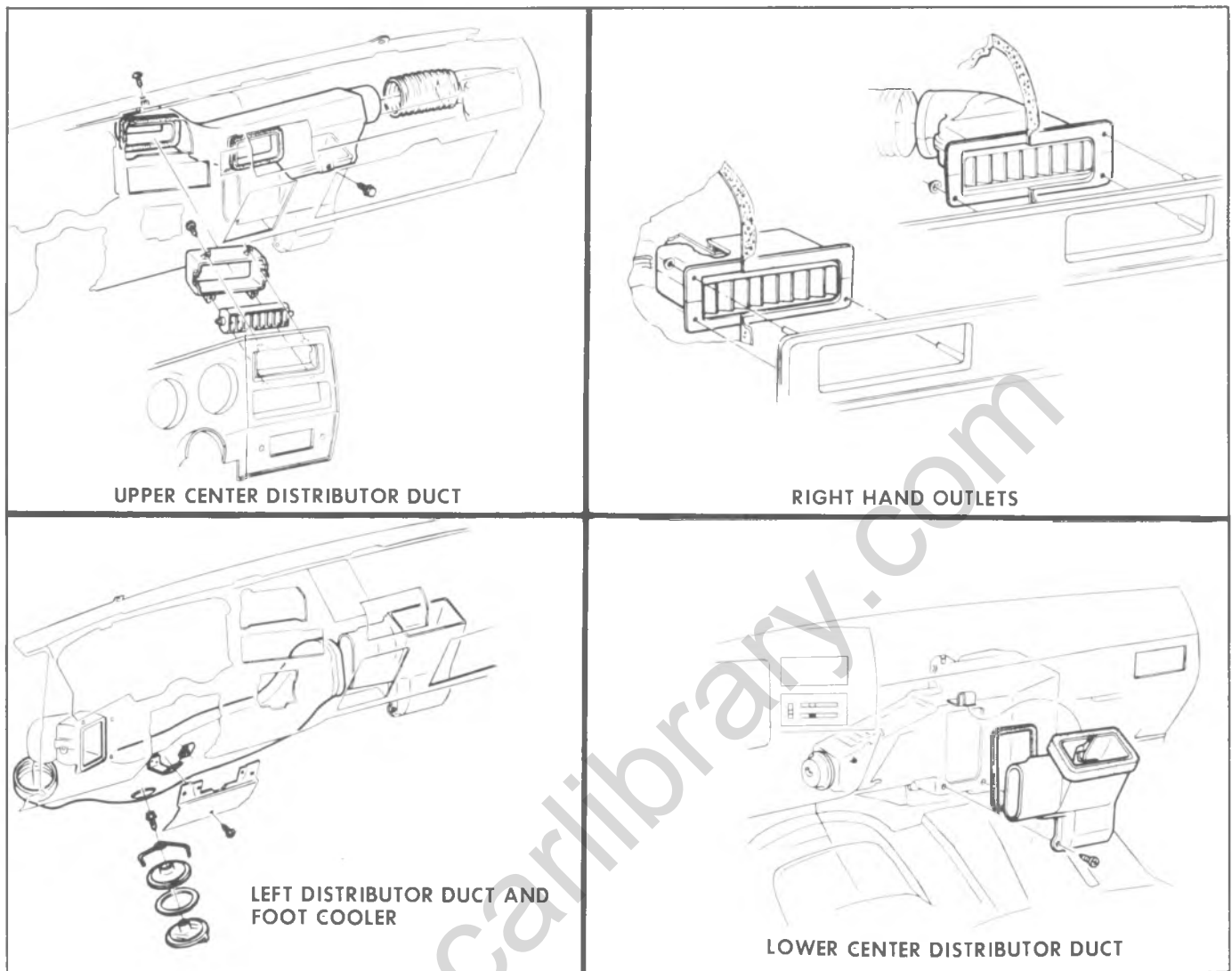


Fig. 1B-39 -Air Selector and Ducts (C-K Models)

9. Disconnect the vacuum and electrical harness and remove the selector duct assembly.

10. Remove the core mounting strap screws and remove the core.

11. To install, reverse Steps 1-10 above.

12. Refill coolant system and connect the battery ground strap. Check temperature door cable adjustment.

KICK PAD VALVE

Replacement (Fig. 1B-40)

1. Disconnect the vacuum hose at the actuator.
2. Unhook the valve return spring at the actuator end.
3. Remove the actuator bracket mounting screws.
4. Remove the cam to actuator arm screw and separate the actuator and bracket from the cam.
5. Remove the actuator to bracket nuts and separate the actuator and bracket.

6. To install reverse Steps 1-5 above.

PLENUM VALVE

Replacement (Fig. 1B-40)

1. Raise the hood.
2. Remove the cowl plastic grille.
3. Remove the three cowl to valve assembly screws and remove the valve assembly from the vehicle.
4. Remove the actuator arm push nut.
5. Remove the actuator to valve nuts and separate the valve and actuator.
6. To install, reverse Steps 1-5 above.

CONTROL ASSEMBLY

Removal (Fig. 1B-41)

1. Disconnect the battery ground cable.
2. Remove the radio as outlined in Section 9 of this manual.
3. Remove the instrument panel bezel.

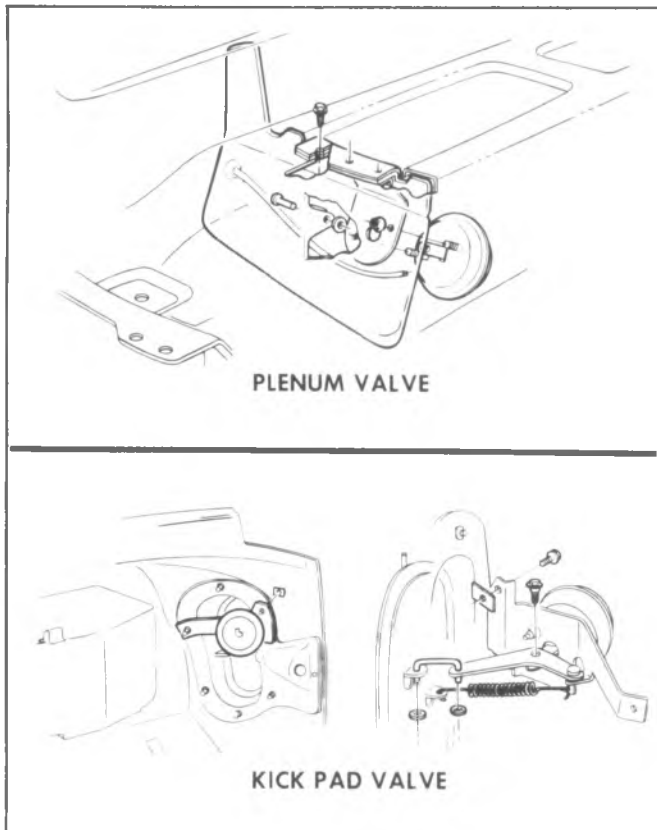


Fig. 1B-40-Air Inlet Valves (C-K Models)

4. Remove the control to instrument panel screws and lower the control far enough to gain access to the control assembly.

CAUTION: Be careful not to kink the bowden cable.

5. Disconnect the bowden cable, vacuum harness and electrical harness at the control.

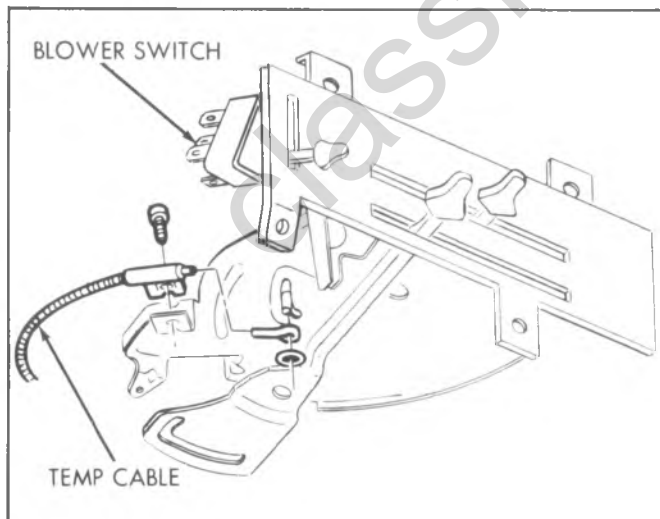


Fig. 1B-41-Control Assembly (C-K Four-Season System)

6. Remove the control.
7. If a new unit is being installed, transfer the master blower switches to the new control.
8. To reinstall, reverse Steps 1-6 above. Check control operation.

TEMPERATURE DOOR CABLE ADJUSTMENT

1. Remove glove box and door assembly.
2. Loosen the cable attaching screw at the selector duct assembly.
3. Make sure the cable is installed in the bracket on the selector duct assembly.
4. Place temperature lever in full COLD position and hold while tightening cable attaching screw.

MASTER SWITCH AND/OR BLOWER SWITCH

The master switch is located on rear of the control assembly.

Replacement

1. Disconnect the battery ground cable.
2. Remove the instrument panel bezel.
3. Remove the control to instrument panel screws and allow control to rest on top of the radio.
4. Remove the switch to control screws, disconnect the electrical harness (and vacuum harness on master switch) at the switch and remove the switch assembly.
5. To install a new switch, reverse Steps 1-4 above.

VACUUM TANK

The vacuum tank is mounted to the engine side of the dash panel above the blower assembly (fig. 1B-42).

Replacement

1. Disconnect the vacuum lines at the tank.
2. Remove the tank to dash panel screws and remove the tank.

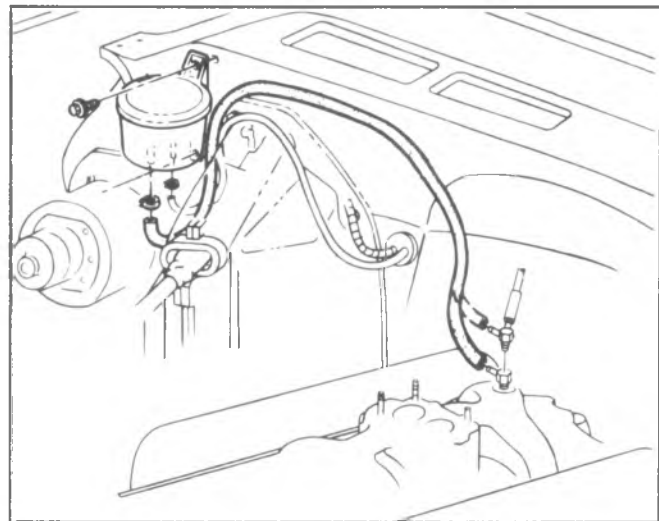


Fig. 1B-42-Vacuum Tank (C-K Models)

3. To install, reverse Steps 1 and 2 above.

BLOWER MOTOR RESISTOR

The blower motor resistor is located in the blower side of the blower-evaporator case (fig. 1B-43).

Replacement

1. Disconnect the wiring harness at the resistor.
2. Remove the resistor to case attaching screws and remove the resistor.
3. Place the new resistor in position and install the attaching screws.
4. Connect the resistor wiring harness.

BLOWER MOTOR RELAY

The blower motor relay is located on the blower side of the blower-evaporator case.

Replacement

1. Disconnect the wiring harness at the relay.
2. Remove the relay to case attaching screws and remove the relay.
3. Place the new relay in position and drive the mounting screws.
4. Connect the relay wiring harness.

THERMOSTATIC SWITCH

The thermostatic switch is mounted on the bracket which supports the inlet tube in position at the evaporator case. The switch sensing capillary is attached by means of a clamp to the evaporator inlet tube.

Removal

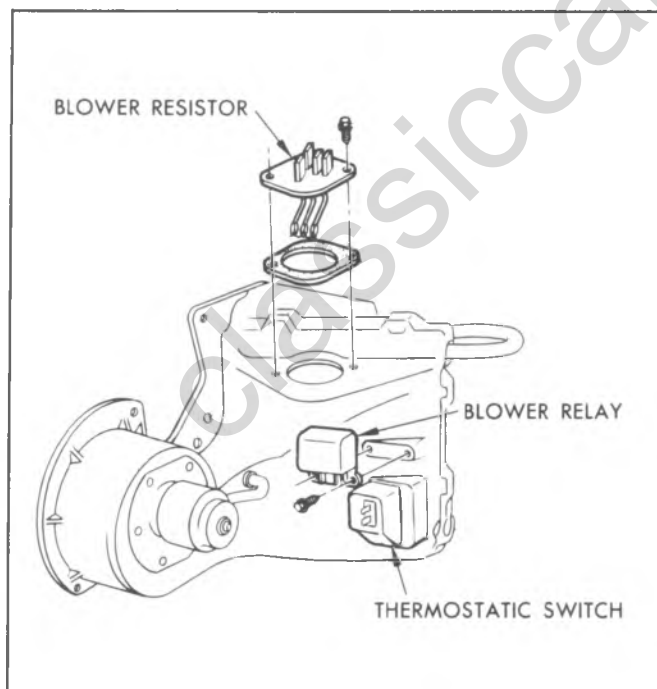


Fig. 1B-43--Resistor, Relay and Thermostatic Switch
(C-K Models)

1. Remove electrical connectors to the switch.
2. Remove screws to loosen body from evaporator case.
3. A capillary line (small tube) extends from the switch with the other end attached to the evaporator inlet pipe (1/2" O.D.) with two clamps. This end is covered with an insulation material. Carefully remove the insulation and loosen clamps enough to pull the formed end of the capillary tube out from under the clamps. Solvent clean pipe area to remove remaining insulation material and dirt.
4. Identify area by marking the capillary tube location on the inlet pipe from where it was removed. **The replacement switch's tube should be installed at this location.**

Installation

1. Mount switch body to previous location. Do not over-torque screws. The recommended reassembly torque is 15-20 in. lbs. Do not damage or distort the switch body, as this may affect switch calibration.
2. Mount formed end of capillary tube to the inlet pipe in SAME POSITION AS THE ORIGINAL tube. DO NOT INSTALL NEW TUBE MORE THAN 1/2" in either direction of previously marked location.
3. Adjust each clamp before tightening so that width of the clamp covers the capillary tube's formed end. Tighten to 1.69 to 2.25 N·m (15 to 20 in. lbs.) of torque. Do not overtorque.
4. Re-cover tube and pipe with insulation material. If original insulation is damaged, replace with same type material. (GMPD Part No. 3014431 or equivalent).
5. Reconnect electrical terminals.

DISCHARGE PRESSURE SWITCH

The discharge pressure switch is located in the condenser to evaporator line (fig. 1B-44).

Replacement

1. Disconnect the battery ground cable.

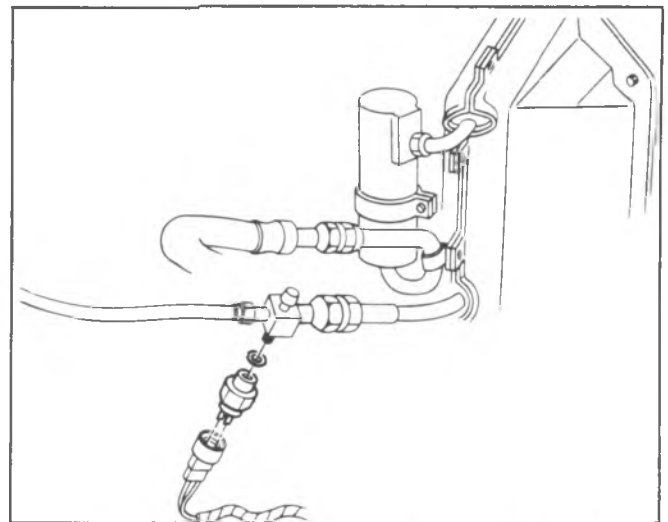


Fig. 1B-44--Discharge Pressure Switch (C-K Models)

2. Purge the system of refrigerant.
3. Disconnect the wiring harness at the switch.
4. Remove the switch from the refrigerant line.
5. To replace, reverse Steps 1-4 above.

NOTE: Be sure to use new "O" rings, coated with clean rebrigeration oil, when installing the switch.

6. Evacuate charge and check system operation.

FUSE

A 25 amp fuse, located in the junction block protects the entire air conditioning system except for the blower circuit, the fuse for the blower circuit is located in the electrical wiring between the junction block and the blower relay (fig. 1B-45).

OVERHEAD SYSTEM--C-K MODELS

The Overhead System is used in conjunction with the Four-Season System. Since replacement of Four-Season System components has been covered previously, only those components peculiar to the Overhead System will be covered in this section.

REAR DUCT

This duct covers the blower-evaporator assembly, at

the rear of the vehicle, and incorporates four adjustable air outlets (fig. 1B-46).

Replacement

1. Disconnect the battery ground cable.
2. Disconnect the drain tube from the rear duct.
3. Remove the screws securing the duct to the roof panel and rear header brackets.
4. Remove the duct.
5. To install, reverse Steps 1-4 above.

BLOWER MOTOR RESISTOR

The blower motor resistor is located on the cover side of the Four-Season System blower-evaporator as shown in Figure 1B-47.

Replacement

1. Disconnect battery ground cable.
2. Disconnect the electrical harness at the resistor.
3. Remove the resistor attaching screws and remove the resistor.
4. To install a new resistor, reverse Steps 1-3 above.

BLOWER MOTOR ASSEMBLY

Removal (Fig. 1B-48)

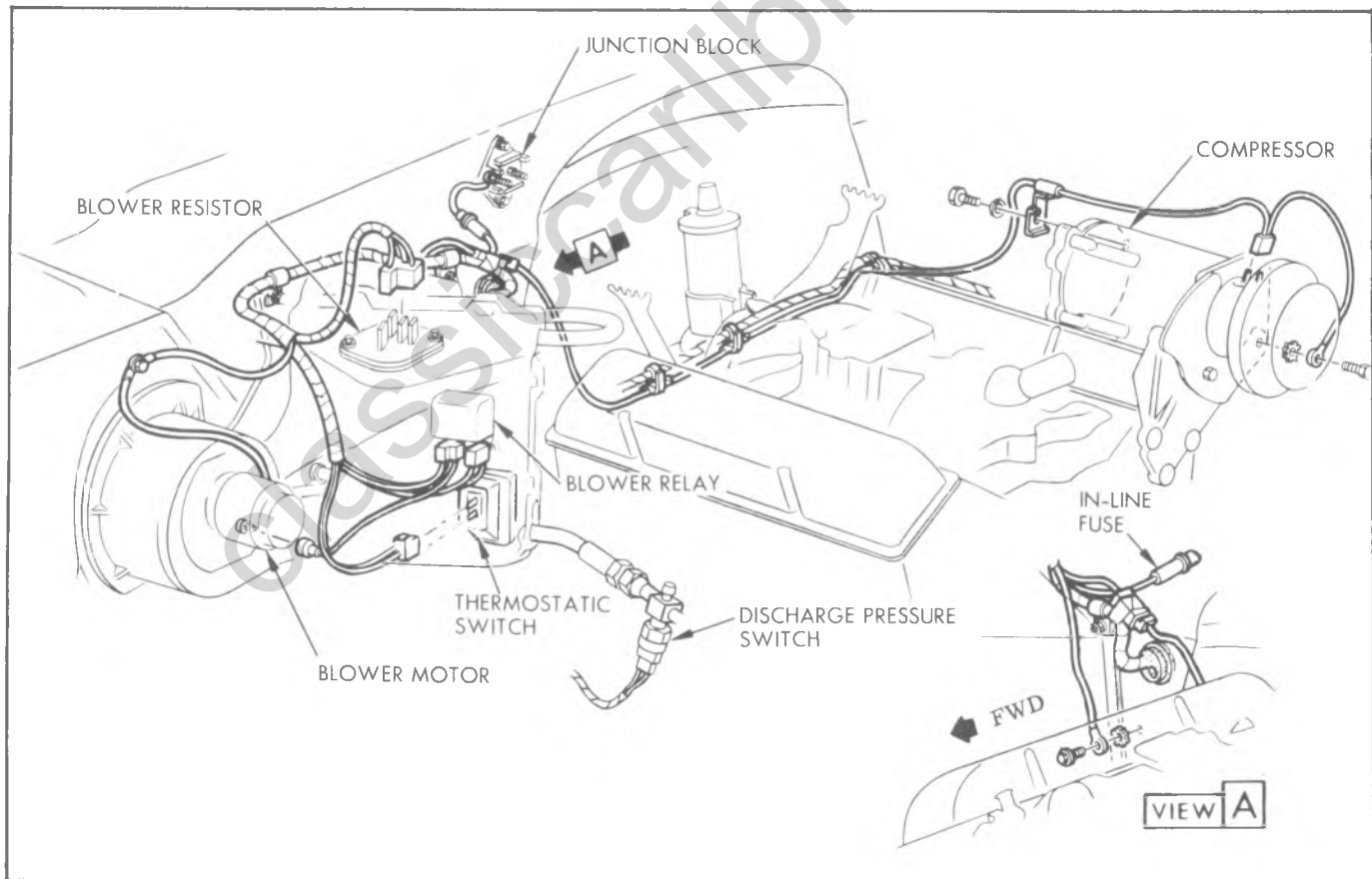


Fig. 1B-45-Engine Compartment Wiring Harness (C-K Models)

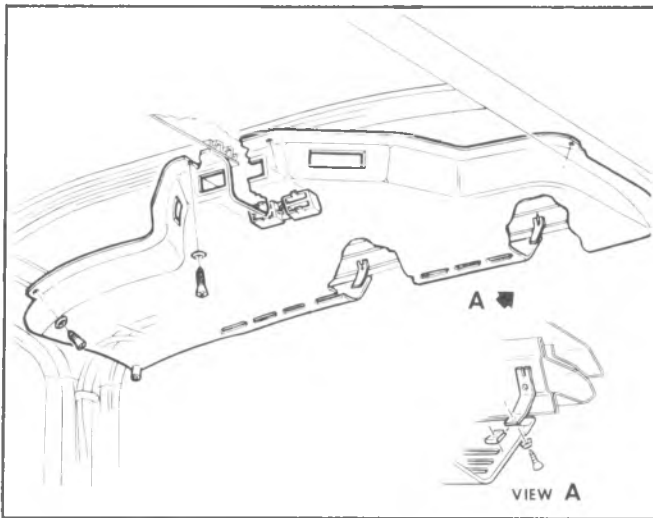


Fig. 1B-46-Rear Duct (C-K Overhead System)

1. Disconnect the battery ground cable.
2. Remove the rear duct as outlined previously.
3. Disconnect the blower motor ground strap.
4. Disconnect the blower motor lead wire.
5. Remove the lower to upper blower-evaporator case screws and lower the lower case and motor assembly.

CAUTION: Before removing the case screws, support the lower case to prevent damage to the case or motor assemblies.

6. Remove the motor retaining strap and remove the motor and wheels. Remove the wheels from the motor shaft.

Installation

1. Place the blower wheels onto the motor shaft making sure the wheel tension springs are installed on hub of wheels.

CAUTION: Be sure that the blower wheels are installed as shown in Figure 1B-49.

2. Install the blower motor retaining strap and foam.
3. Place the blower motor and wheel assembly into the lower case. Align the blower wheels so that they do not contact the case.
4. Place the lower case and blower motor assembly in position in the vehicle and install the lower to upper case screws.

NOTE: Rotate the blower wheels to make sure that they do not rub on the case.

5. Install the center ground wire and connect the blower lead wire.
6. Install the rear duct assembly as described previously.

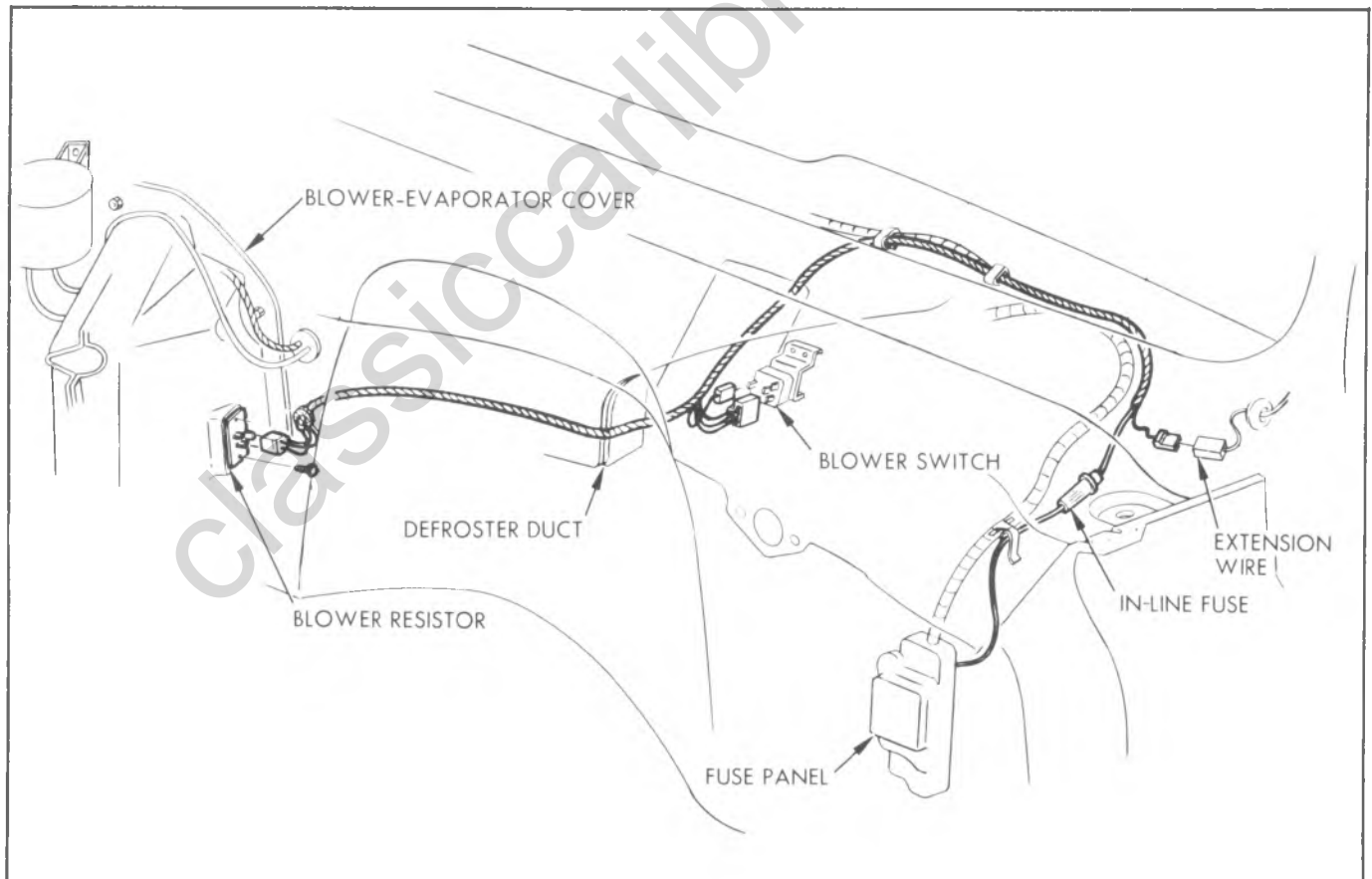


Fig. 1B-47-Overhead System Front Wiring (C-K Models)

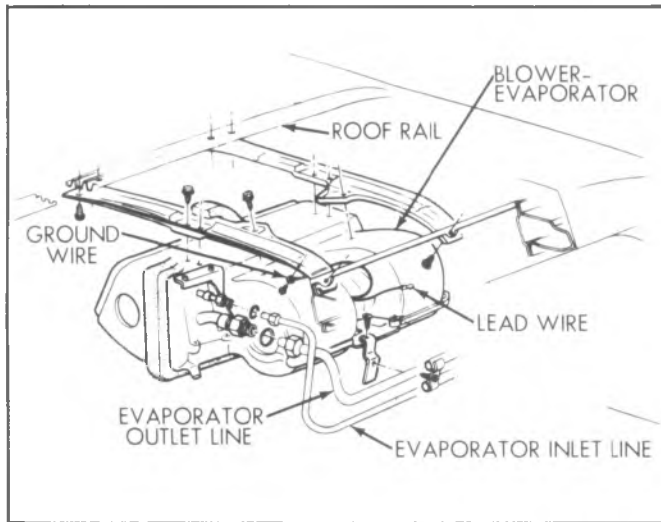


Fig. 1B-48-Blower-Evaporator (C-K Overhead System)

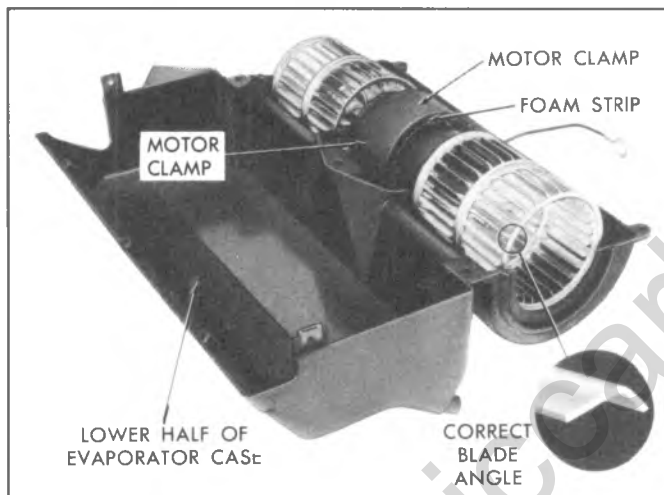


Fig. 1B-49-Blower Motor (C-K Overhead System)

7. Connect the battery ground cable.

EXPANSION VALVE

This system incorporates an expansion valve which does not utilize an external equalizer line (fig. 1B-50).

Removal

1. Disconnect battery ground cable.
2. Purge the system of refrigerant.
3. Remove the rear duct as outlined previously.
4. Disconnect the blower motor lead and ground wires.
5. Remove the lower to upper blower-evaporator case screws and lower the lower case and motor assembly.

CAUTION: Before removing the case screws, support the lower case and motor assemblies.

6. Remove the expansion valve sensing bulb clamps.

7. Disconnect the valve inlet and outlet lines and remove the expansion valve assembly. Cap or plug the open connections at once.

Installation

1. Remove caps or plugs from system connections and install the new valve assembly using new "O" rings coated with clean refrigeration oil.
2. Install the sensing bulb, making sure that the bulb makes good contact with the core outlet line.
3. Install the lower case and blower motor assemblies. Connect the blower motor lead and ground wires.
4. Install the rear duct as outlined previously.
5. Connect the battery ground cable.
6. Evacuate, charge and check the system.

EVAPORATOR CORE (Fig. 1B-50)

Removal

1. Disconnect the battery ground cable.
2. Purge the system of refrigerant.
3. Remove the rear duct as outlined previously.
4. Disconnect the blower motor lead and ground wire connections.
5. Disconnect the refrigerant lines at the rear of the blower-evaporator assembly. Cap or plug the open connections at once.
6. Remove the blower-evaporator support to roof rail screws, lower the blower-evaporator assembly and place it on a work bench upside down.
7. Remove the lower to upper case screws and remove the lower case assembly. Remove the support to upper case screws and remove the upper case from the evaporator core.
8. Remove the expansion valve inlet and outlet lines and cap or plug the open connections at once. Remove the expansion valve capillary bulb from the evaporator outlet line and remove the valve.
9. Remove the plastic pins holding the screen to the core and remove the screen.

Installation

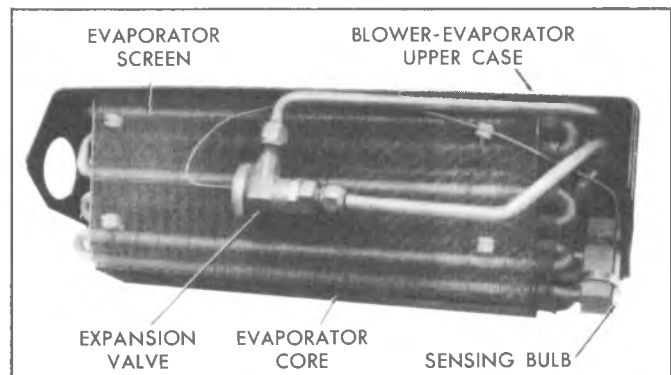


Fig. 1B-50-Expansion Valve (C-K Overhead System)

1. Install the wire screen to the front of the core and insert the plastic pins.

2. Install the expansion valve inlet and outlet lines using new "O" rings coated with clean refrigeration oil. Install the sensing bulb to the evaporator outlet line as shown in Figure 1B-50; make sure the bulb has good contact with the line.

NOTE: Add 3 oz. clean refrigeration oil when installing a new core.

3. Install the upper case and supports to the core.
4. Install the lower core case and blower assembly.
5. Install the blower-evaporator assembly to the roof and install the support to roof rail screws.
6. Connect the refrigerant lines to the blower-evaporator unit using new "O" rings coated with clean refrigeration oil.
7. Connect the blower lead and ground wires.
8. Install the rear duct as outlined previously.
9. Connect the battery ground cable.
10. Evacuate, charge and check the system.

BLOWER MOTOR SWITCH

The three-speed (LO-MED-HI) blower motor switch is located in the instrument panel, just to the left of the ash tray (fig. 1B-50).

Replacement

1. Disconnect the battery ground cable.
2. Remove the switch retaining screws.
3. Disconnect the wiring harness at the switch and remove the switch.
4. To install, reverse Steps 1-3 above.

FUSE

The Four Season portion of this system is protected by a 25 amp fuse in the junction block.

The rear blower high speed circuit is protected by a

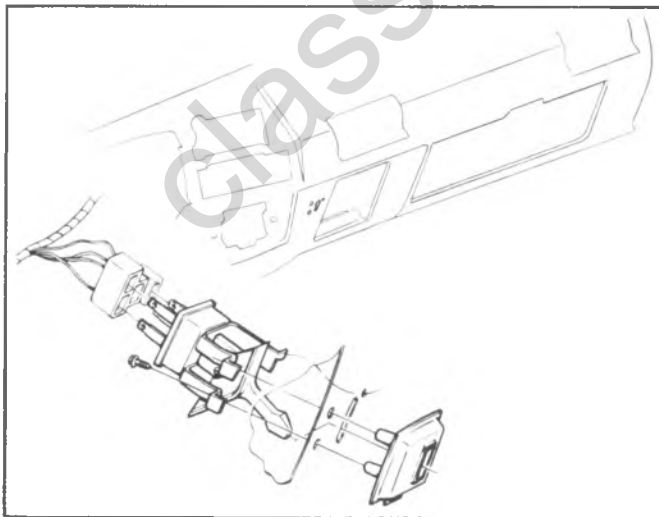


Fig. 1B-51-Blower Switch (C-K Overhead System)

20 amp in-line fuse, located between the junction block and the rear blower motor switch.

C60 SYSTEM--G MODELS

CONDENSER

Replacement (Fig. 1B-52)

1. Remove the battery ground cable and compressor clutch connector.
 2. Purge the system of refrigerant.
 3. Remove the left and right hand headlamp bezels and parking lamp lens. Place a piece of protective tape over upper surface of the front bumper. Remove the grille to radiator support screws and remove the grille.
 4. Remove the screws from radiator center brace and remove the brace.
 5. Remove the upper radiator supports. Move the upper edge of the radiator rearward to gain access to condenser attachment.
 6. Remove the condenser to radiator support nuts and bolts.
 7. Disconnect the condenser inlet and outlet lines and remove the condenser. Cap or plug the open connections at once.
 8. Remove the condenser mounting brackets from the condenser.
 9. To install, reverse Steps 1-8 above. Add 1 fluid ounce of clean refrigeration oil to a new condenser.
- CAUTION:** Use new "O" rings, coated with clean refrigeration oil, when connecting all refrigerant lines.
10. Evacuate, charge and check the system.

RECEIVER-DEHYDRATOR

Replacement (Fig. 1B-52)

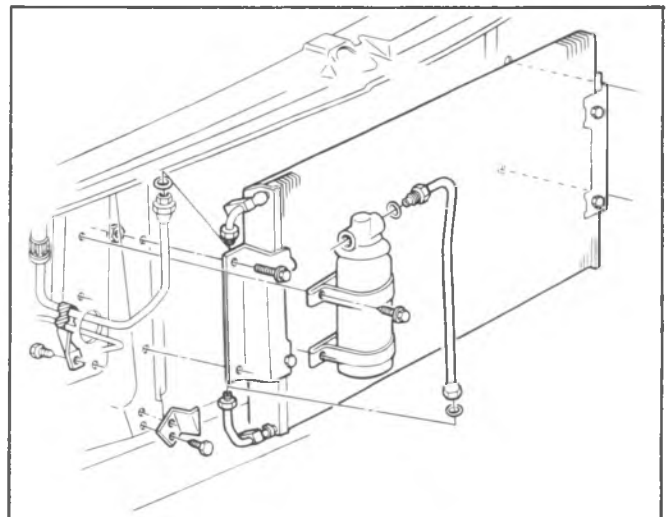


Fig. 1B-52-Condenser (G Models)

1. Disconnect the battery ground cable, and the compressor clutch connector.
2. Purge the system of refrigerant.
3. Remove left and right hand headlamp bezel and parking lamp lens. Place a piece of protective tape over the upper surface of the front bumper. Remove the grille to radiator support screws and remove the grille.
4. Disconnect the receiver-dehydrator inlet and outlet lines and cap or plug the connections at once.
5. Remove the receiver-dehydrator bracket attaching screws.
6. Remove the receiver-dehydrator from the vehicle.
7. If a new receiver-dehydrator is being installed, add 1 fluid ounce of clean refrigeration oil to the new unit.
8. Connect the inlet and outlet lines using new "O" rings coated with clean refrigeration oil.

CAUTION: Do not uncap the new unit until ready to fasten the inlet and outlet lines to the unit.

9. Install receiver-dehydrator by reversing Steps 1-6 above.

10. Evacuate, charge and check the system.

SIGHT GLASS REPLACEMENT

If damage to the sight glass should occur, a new sight glass kit should be installed. The kit contains the sight glass, seal and retainer. (See Figure 1B-53).

1. Purge system.
2. Remove the sight glass retainer nut using a screwdriver and remove old glass and "O" ring seal.
3. Install the new glass and seal and retainer nut, being careful not to turn the nut past the face of the housing. To do so may damage the "O" ring seal.
4. Evacuate, charge and check the system.

A/C AIR DISTRIBUTOR DUCT

Replacement (Fig. 1B-54)

1. Disconnect the battery ground cable.
2. Remove screws securing the blower-evaporator shield; remove the shield. Remove the shield bracket to instrument panel reinforcement screws and remove the bracket.
3. Remove the heater intermediate duct to A/C distributor duct screw and remove the duct.

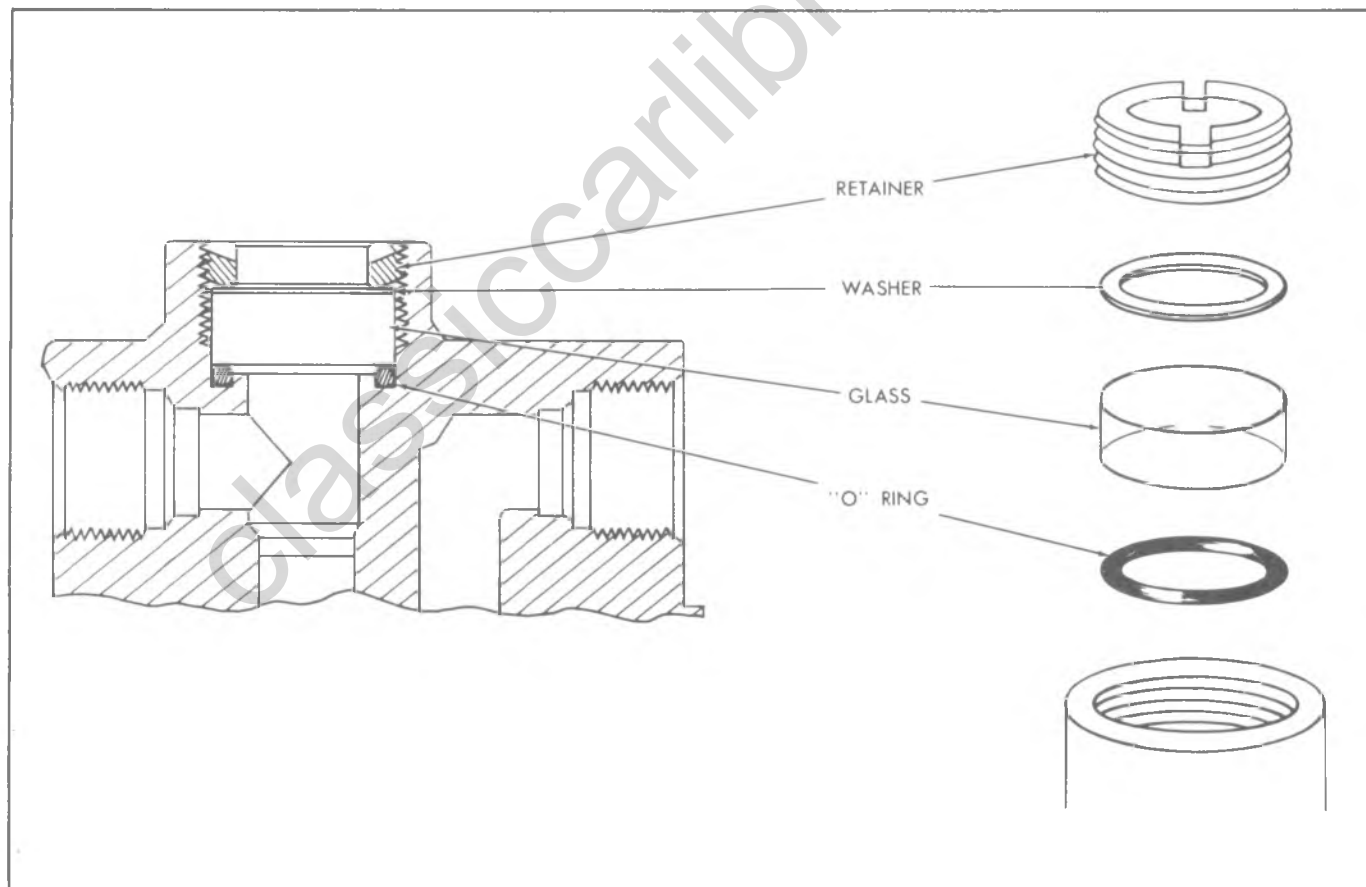


Fig. 1B-53-Sight Glass Replacement

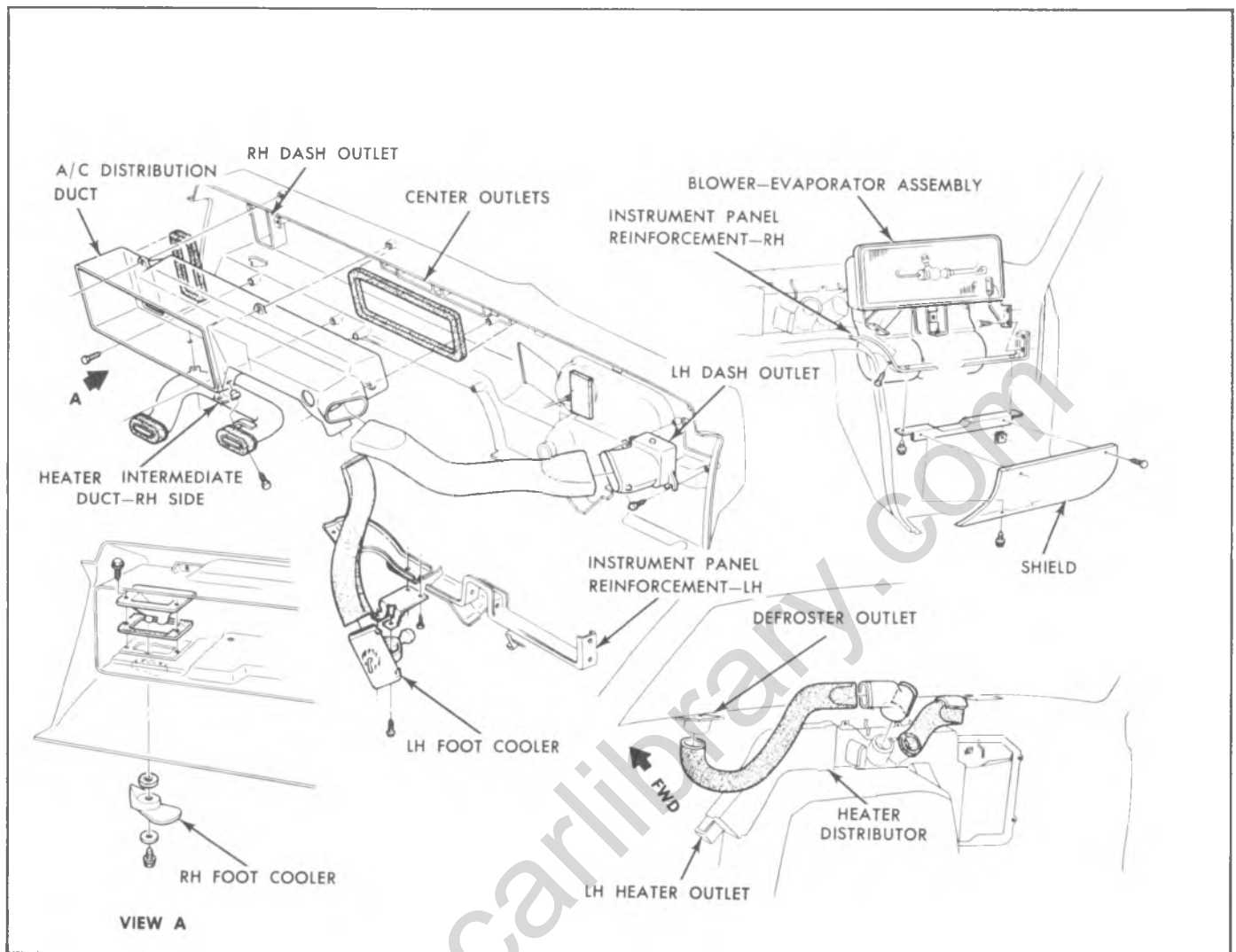


Fig. 1B-54-Air Distributor Ducts (C60 System - G Models)

4. Unsnap the engine cover latches, remove the lower tab mounting bolts and remove the engine cover.

5. Loosen both steering column instrument panel reinforcement screws; remove one screw.

6. Remove the left foot cooler bracket to instrument panel reinforcement screws, disconnect the outlet from the duct and remove the outlet and bracket assembly.

7. Disconnect the speedometer cable.

8. Remove the instrument panel to lower reinforcement attaching screws. Rotate the instrument panel up to gain access to the air distribution duct.

9. Disconnect the blower resistor electrical harness.

10. Remove the duct to instrument panel attaching screws and remove the duct assembly.

11. If a new duct is being installed, transfer the blower resistor to the new duct. Reverse Steps 1-10 above.

NOTE: Make sure all ducts and seals are installed properly.

A/C CENTER AND RIGHT DASH OUTLETS

Replacement (Fig. 1B-54)

1. Follow Steps 1-10 of "A/C Air Distributor Duct-Replacement".

2. Remove the outlet to instrument panel screws and remove the outlet.

3. To install, reverse Steps 1-2 above.

A/C LEFT DASH OUTLET

Replacement (Fig. 1B-54)

1. Follow Steps 1-8 of "A/C Air Distributor Duct-Replacement".

2. Remove the outlet to instrument panel screws and remove the outlet.

- To install, reverse Steps 1-2 above.

HEATER AIR DISTRIBUTOR AND EXTENSION DUCT - G MODEL

Replacement (Fig. 1B-54)

- Disconnect battery ground cable.
- Remove engine cover.
- Remove evaporator-blower shield.
- Remove shield bracket.
- Remove left floor outlet deflector and bracket.
- Loosen steering column to instrument panel reinforcement screws. Remove one screw. Torque both screws on installation.
- Disconnect speedometer cable at meter.
- Remove instrument panel to lower reinforcement attaching screws.
- Move instrument panel assembly rearward. Disconnect radio antenna and electrical connector. Support instrument panel at right visor. Disconnect electrical connector at brake switch.
- Remove blower-evaporator support bracket to door pillar and forward engine housing attaching screws. Move rearward to gain access.
- Disconnect vacuum lines and electrical connectors. Remove heater distributor duct assembly.
- Transfer duct and relays.
- To reassemble, Reverse Steps 1-12.

HEATER CORE CASE AND CORE-G MODEL

Replacement (Fig. 1B-54)

- Follow Steps 1-10 of "Heater Air Distributor and Extension Duct Replacement" procedure.
- Remove battery.
 - Disconnect heater hoses at heater core (drain pan below hoses) refill radiator upon completion.
 - Remove air inlet valve assembly.
 - Remove temperature door control cable at heater case.
 - Remove heater assembly.
 - Remove heater core. Reseal heater case.
 - To reassemble, Reverse Steps 1-16.

EXPANSION VALVE

Replacement (Fig. 1B-55)

- Purge the system of refrigerant.
- Follow Steps 1-8 of Distributor Duct Replacement.
- Loosen the expansion valve sensing bulb clamps and remove the bulb from the evaporator core.
- Disconnect the expansion valve inlet and outlet lines and remove the expansion valve assembly. Cap or plug all open connections at once.
- To install a new expansion valve, reverse Steps 1-4 above.

NOTE: Use new "O" rings, coated with clean refrigeration oil when connecting all lines.

Make sure expansion valve sensing bulb makes good physical contact with the evaporator core connector block.

- Evacuate, charge and check system operation.

A/C BLOWER MOTOR

Replacement (Fig. 1B-55)

- Purge the system of refrigerant.
- Follow Steps 1-8 of "A/C Air Distributor Duct Replacement".
- Disconnect evaporator inlet and outlet lines. Cap or plug open connections at once.
- Remove the blower-evaporator support bracket to door pillar and forward engine housing screws and lower the blower-evaporator assembly. Disconnect electrical connections, pull drain hose through the dash panel and remove the blower-evaporator as an assembly.
- Separate the front and rear case halves.
- Remove the blower motor retaining strap and insulator strip and remove the motor and blower wheels as an assembly.
- Mark the blower wheel locations (L and R) and then remove the blower wheels from the motor shaft.
- To reinstall, reverse Steps 1-7 above.

NOTE: Install blower wheels in proper position (L and R) as marked at removal (blade angle as shown in Figure 1B-55). Be sure to install insulation around motor before installing motor clamp. Check blower operation that wheels do not rub on case.

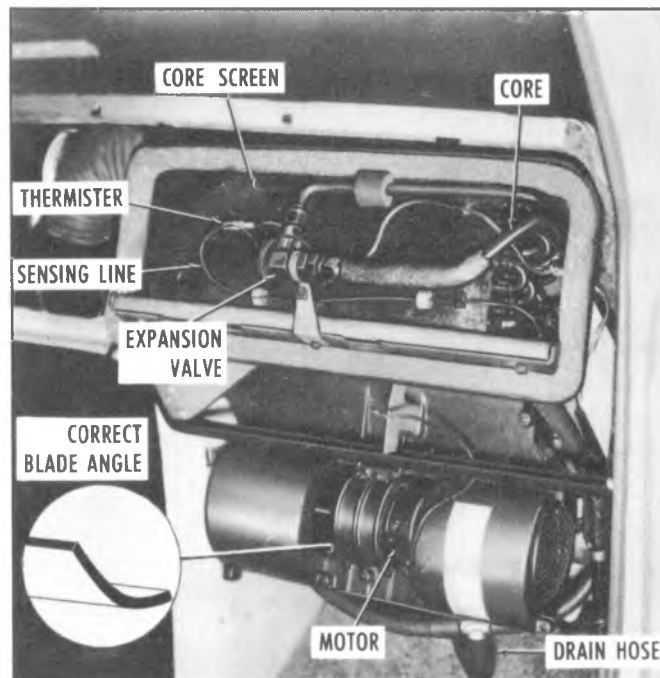


Fig. 1B-55-Blower and Evaporator (C60 System - G Models)

When making evaporator core connections, use new "O" rings coated with clean refrigeration oil.

9. Evacuate, charge and check system operation.

EVAPORATOR CORE

Replacement (Fig. 1B-55)

1. Purge the system of refrigerant.
2. Follow Steps 1-8 of "A/C Air Distributor Duct Replacement".
3. Disconnect evaporator inlet and outlet connections. Cap or plug open connections at once.
4. Remove the blower-evaporator support bracket to door pillar and forward engine housing screws and lower the blower-evaporator assembly. Disconnect the electrical connections, pull drain hose through the dash panel and remove the blower-evaporator as an assembly.
5. Remove the expansion valve sensing bulb clamps and disconnect the line from the evaporator core. Disconnect the expansion valve inlet and outlet lines and remove the expansion valve. Cap or plug all open connections at once.
6. Remove the evaporator core line clamp screws. Remove the core to case attaching screws and remove the evaporator core assembly.
7. To install a new core, reverse Steps 1-6 above. Transfer the core screen to the new core. NOTE: Add three ounces of new refrigeration oil to a new core. Use new "O" rings, coated with clean refrigeration oil, when connecting all refrigerant lines. Transfer thermister to the new evaporator.

NOTE: Make sure the expansion valve sensing bulb makes good contact with the core connector block.

8. Evacuate, charge and check system operation.

AIR INLET VALVE - G MODEL

Replacement (Fig. 1B-56)

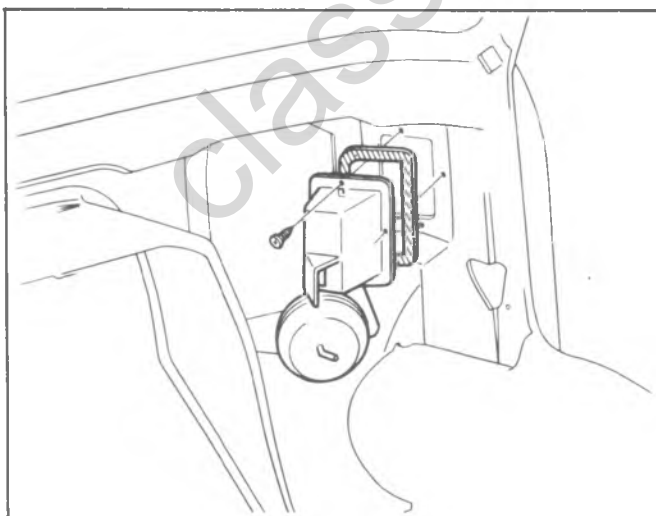


Fig. 1B-56-Air Inlet Valve (G Model C60 System)

Follow Steps 1-10 of "Heater Air Distributor and Extension Duct Extension Duct Replacement" procedure.

11. Remove duct assembly. Disconnect vacuum hose.
12. Remove vacuum valve.
13. To reassemble. Reverse Steps 1-12.

TEMPERATURE DOOR CABLE - G MODEL

Replacement

Follow Steps 1-10 of "Heater Air Distributor and Extension Duct Replacement" procedure.

11. Disconnect temperature door control cable at heater case.
12. Disconnect temperature door control cable at control.
13. Make up new cable.
14. To reassemble. Reverse Steps 1-13.

CONTROL

Replacement (Fig. 1B-57)

1. Disconnect the battery ground cable.
2. Remove the headlamp switch control knob.
3. Remove the instrument panel bezel.
4. Remove the control to instrument panel attaching screws.
5. Remove the temperature cable eyelet clip and mounting tab screw.
6. Pull the control through the instrument panel opening as follows: First pull the lower right mounting tab through the opening, then the upper tab and finally the lower right tab.
7. Disconnect electrical and vacuum connections and remove the control assembly.

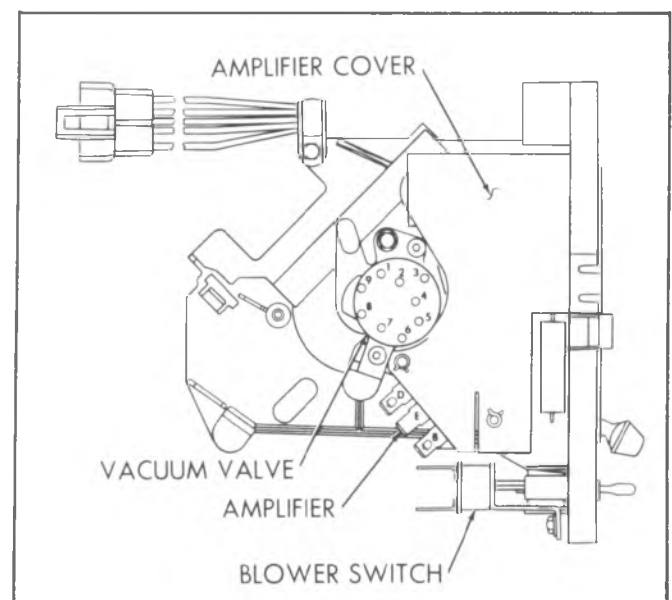


Fig. 1B-57-Control (G Model C60 System)

8. To install, reverse Steps 1-7 above. Check temperature door operation; adjust if necessary.

BLOWER SWITCH

Replacement (Fig. 1B-57)

1. Disconnect the battery ground cable.
2. Remove the left foot cooler outlet assembly at the instrument panel attachment.
3. Disconnect the switch electrical harness.
4. Remove the switch mounting screws and remove the switch.
5. To install, reverse Steps 1-4 above.

AMPLIFIER CIRCUIT BOARD

REPLACEMENT (Fig. 1B-57)

1. Remove the control assembly as outlined under "Control-Replacement".
2. Remove the potentiometer gear from the pot shaft.
3. Remove amplifier board cover retainers and lay the cover back.
4. Remove the circuit board attaching screws and remove the circuit board and pot assembly.
5. To install, reverse Steps 1 and 4 above.

RESISTORS

The heater blower motor resistor is mounted in the right hand plenum (in the same position as without air conditioning). The A/C blower motor resistor is mounted in the forward face of the A/C air distribution duct (fig. 1B-57).

Replacement

1. Follow Steps 1-8 of "A/C Air Distributor Duct-Replacement".
2. Disconnect electrical harness at the resistor.
3. Remove the resistor mounting screws and remove the resistor.

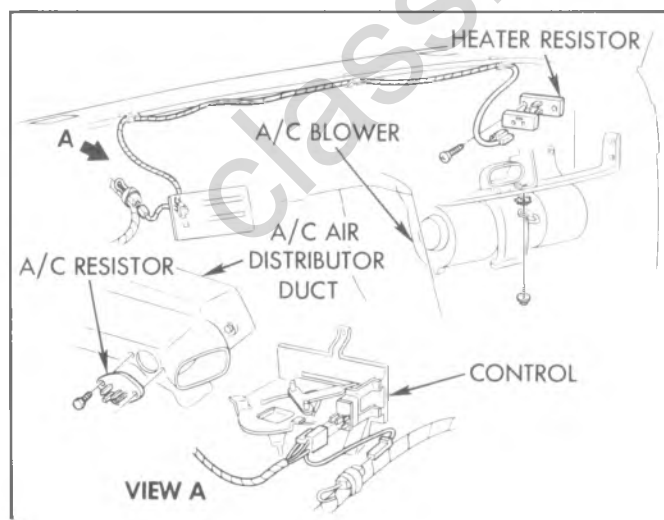


Fig. 1B-58-Resistors (G Model C60 System)

4. To install, reverse Steps 1-3 above.

BLOWER MOTOR RELAY

The blower motor relay is attached to the left end of the heater air distributor duct (fig. 1B-59).

Replacement

1. Follow Steps 1-8 of "A/C Air Distributor Duct-Replacement".
2. Disconnect electrical harness at the relay.
3. Remove the relay mounting screw and remove the relay.
4. To install, reverse Steps 1-3 above.

DISCHARGE PRESSURE SWITCH

Replacement (Fig. 1B-60)

1. Raise the hood.
2. Purge the system of refrigerant.

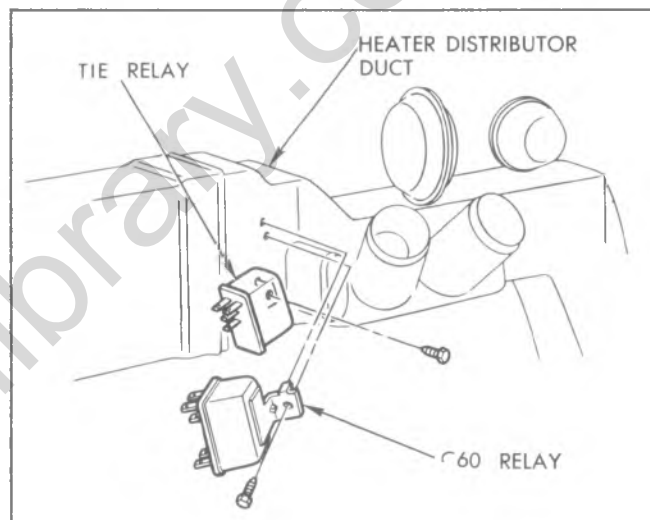


Fig. 1B-59-Relays (C60 and Tie Relay with C69)

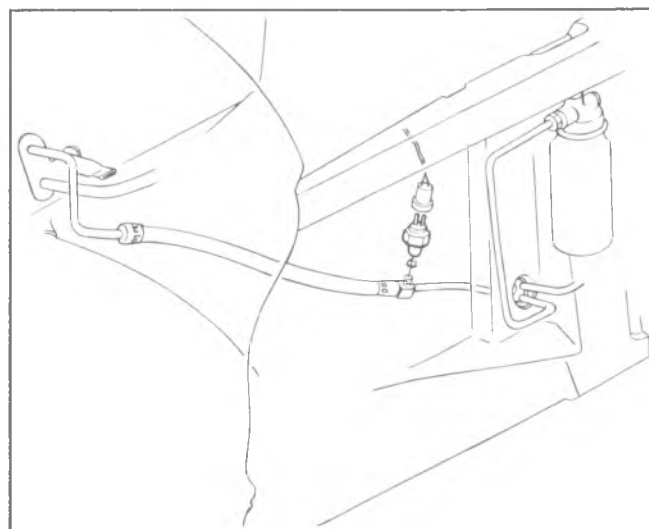


Fig. 1B-60-Discharge Pressure Switch (G Models)

3. Disconnect the electrical harness at the switch.
4. Remove the switch from the refrigerant line.
5. To install, reverse Steps 1-4 above.

NOTE: Use a new "O" ring coated with clean refrigeration oil, when installing switch.

6. Evacuate, charge and check system operation.

VACUUM TANK

Replacement (Fig. 1B-61)

1. Raise the hood.
2. Disconnect the vacuum harness at the tank.
3. Remove the tank attaching screws and remove the tank.
4. To install, reverse Steps 1-3 above.

CIRCUIT BREAKER

The entire air conditioning system is protected by a 45 amp circuit breaker located on the left side of the dash, in the engine compartment.

OVERHEAD SYSTEM--G MODELS

This system is used in conjunction with the C60 system. Since replacement of the C60 System Components has been covered previously, only those components peculiar to the Overhead system will be covered in this section.

BLOWER-EVAPORATOR SHROUD

This shroud covers the blower-evaporator at the rear of the vehicle, and incorporates four air outlets.

Replacement (Fig. 1B-63)

1. Disconnect the battery ground cable.
2. Disconnect the drain tubes at the rear corners of the shroud.
3. Remove the screws securing the shroud to the unit and roof panel.

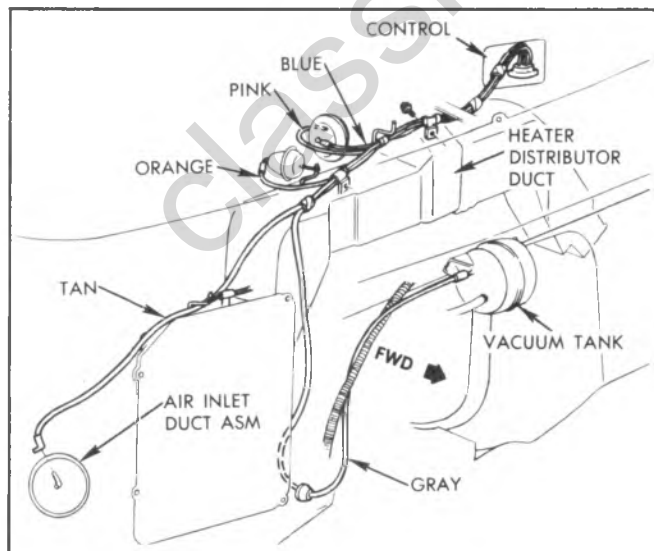


Fig. 1B-61--Vacuum Harness (G Models)

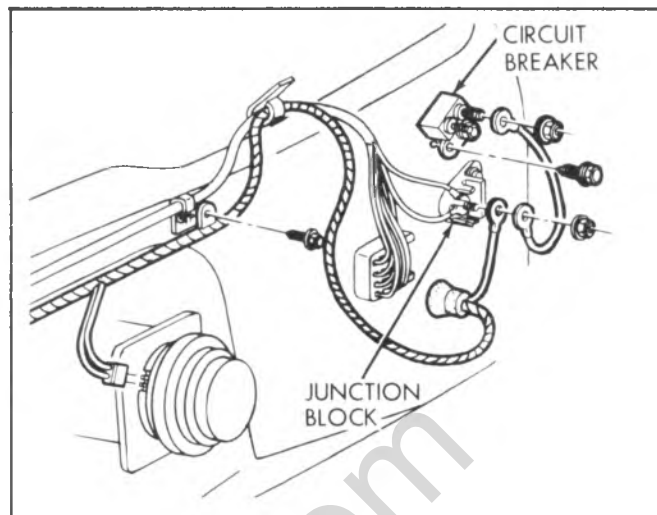


Fig. 1B-62--Circuit Breaker

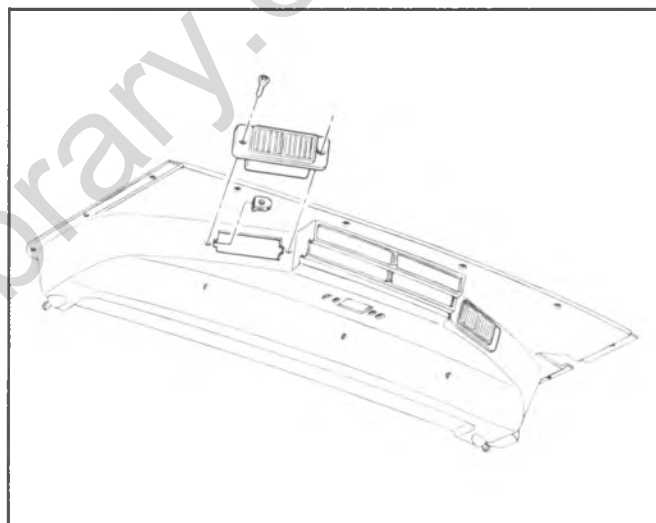


Fig. 1B-63--Blower-Evaporator Shroud (G Overhead System)

4. Remove the shroud from the side and rear retaining flanges and remove the shroud.
5. To install, reverse Steps 1-4 above.

BLOWER MOTOR ASSEMBLIES

Removal (Fig. 1B-64)

1. Disconnect the battery ground cable and compressor clutch connector.
2. Remove the blower-evaporator shroud as outlined previously.
3. Remove the blower motor ground straps at the center connector between the motors.
4. Disconnect the blower motor lead wires.

WARNING: Before removing the case screws, support the lower case to prevent damage to the case or motor assemblies.

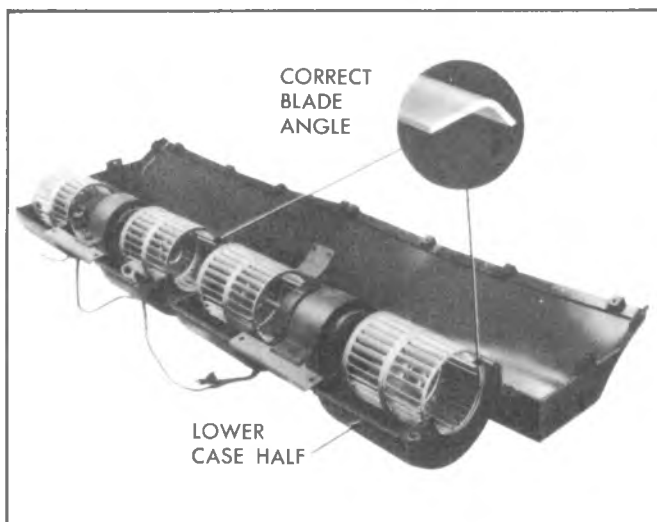


Fig. 1B-64--Blower Motors (G Overhead System)

5. Remove the lower to upper blower-evaporator case screws and lower the lower case and motor assemblies.
6. Remove the motor retaining strap and remove the motor and wheels. Remove the wheels from the motor shaft.

Installation

1. Place the blower wheels onto the motor shaft.

CAUTION: Be sure that the blower wheels are installed as shown in Figure 1B-64.

2. Install the blower motor retaining strap and foam strip.
3. Place the two blower motor and wheel assemblies into the lower case. Align the blower wheels so that they do not contact the case.
4. Place the lower case and blower motor assemblies in position in the vehicle and install the blower to upper case screws.

NOTE: Rotate the blower wheels to make sure that they do not rub on the case.

5. Install the center ground wires and connect the blower lead wires.
6. Install the blower-evaporator shroud assembly as described previously.
7. Connect the battery ground cable and compressor clutch connector.

EXPANSION VALVES

This system incorporates two expansion valves. These valve do not use an external equalizer line (fig. 1B-65).

Removal (Inner Valve)

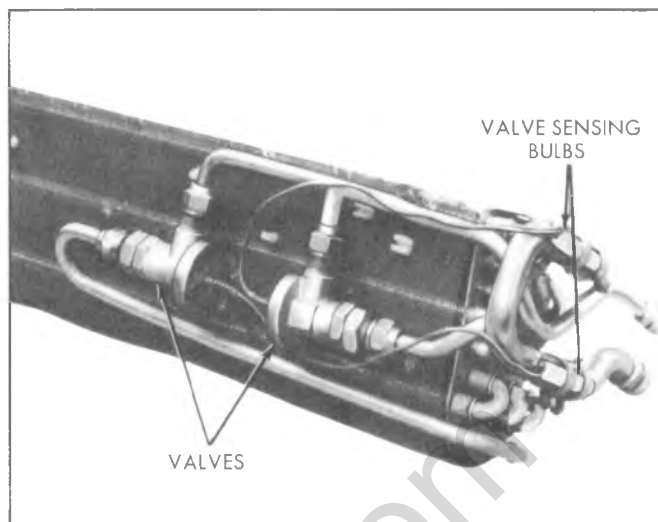


Fig. 1B-65--Expansion Valves (G Overhead System)

1. Disconnect the battery ground cable and compressor clutch connector.
2. Purge the system of refrigerant.
3. Remove the blower-evaporator shroud as outlined previously.

WARNING: Before removing the lower case screws, support the case to prevent damage to the case or motor assemblies.

4. Disconnect the center ground wire and the lower motor lead wires. Remove the lower to upper case screws and lower the lower case and blower motor assemblies.
5. Disconnect the valve sensing bulb from the core outlet line.
6. Disconnect the core inlet and outlet lines and remove the valve assembly. Cap or plug the open connections at once.

Installation (Inner Valve)

1. Remove caps or plugs from system connections and install the new valve assembly using new "O" rings coated with clean refrigeration oil.
2. Install the sensing bulb, making sure that the bulb makes good contact with the core outlet line.
3. Install the lower case and blower motor assemblies.
4. Install the blower-evaporator shroud as outlined previously.
5. Connect the battery ground cable and compressor clutch connector.
6. Evacuate, charge and check the system.

Removal (Outer Valve)

1. Disconnect the battery ground cable and compressor clutch connector.
2. Purge the system of refrigerant.

3. Remove the blower-evaporator shroud as outlined previously.
4. Disconnect the blower motor ground straps and leads.
5. Disconnect the refrigerant lines at the rear of the blower-evaporator assembly. Cap or plug all open connections at once.
6. Remove the blower-evaporator to roof panel attachments and lower the blower-evaporator assembly. Remove the assembly and place on a work bench upside down.
7. Remove the lower to upper case screws and remove the lower case assembly. Remove the upper shroud from the upper case and then remove the upper case from the core.
8. Remove the expansion valve bulb from the evaporator outlet line. Remove the expansion valve inlet and outlet lines and cap or plug the open connections at once. Remove the valve.

Installation (Outer Valve)

1. Remove the caps or plugs from the refrigerant connections and install the new valve using new "O" rings coated with clean refrigeration oil. Install the sensing bulb, making sure that the bulb makes good contact with the core outlet line.
2. Install the upper case to the core making sure the sealing strips are positioned correctly. Install the upper shroud on the upper case.
3. Install the lower case and blower assemblies.
4. Install the blower-evaporator to the roof panel.
5. Connect the refrigerant lines at the rear of the blower-evaporator unit using new "O" rings coated with clean refrigeration oil.
6. Connect the blower lead wires and ground straps.
7. Install the blower-evaporator shroud as described previously.
8. Connect the battery ground cable and the compressor clutch connector.
9. Evacuate, charge and check the system.

EVAPORATOR CORE

Removal (Fig. 1B-66)

1. Disconnect the battery ground cable and compressor clutch connector.
2. Purge the system of refrigerant.
3. Remove the blower-evaporator shroud as outlined previously.
4. Disconnect the blower motor leads and ground wire.
5. Disconnect the refrigerant lines at the rear of the blower-evaporator assembly. Cap or plug open connections at once.

WARNING: Before removing the blower-evaporator unit, support the case to prevent damage to components.

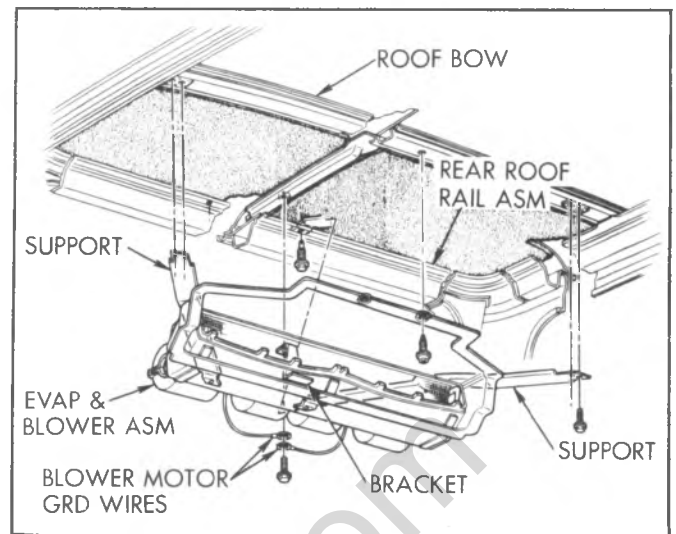


Fig. 1B-66-Blower-Evaporator (G Overhead System)

6. Remove the blower-evaporator to roof panel attachments and lower the blower-evaporator assembly. Remove the assembly and place it on a work bench upside down.
7. Remove the lower to upper case screws and remove the lower case assembly. Remove the upper shroud and upper case from the evaporator core.
8. Remove the expansion valve inlet and outlet lines and cap or plug the open connections at once. Remove the expansion valve capillary bulbs from the evaporator outlet line and remove the valves.
9. Remove the plastic pins holding the screen to the core and remove the screen.

Installation

1. Install the wire screen to the front of the new core and insert the plastic pins.
2. Install the expansion valve inlet and outlet lines using new "O" rings coated with clean refrigeration oil. Install the sensing bulbs to the evaporator outlet line. Make sure the bulbs have good contact with the line.

NOTE: Add 3 oz. clean refrigeration oil when installing a new core.

3. Install the upper case and upper shroud to the core.
4. Install the lower core case and blower assemblies.
5. Install the blower-evaporator to the roof panel.
6. Connect the refrigerant lines to the blower-evaporator unit using new "O" rings coated with clean refrigeration oil.
7. Connect the blower lead wires and ground straps.
8. Install the blower-evaporator shroud as outlined previously.
9. Connect the battery ground cable and the compressor clutch connector.

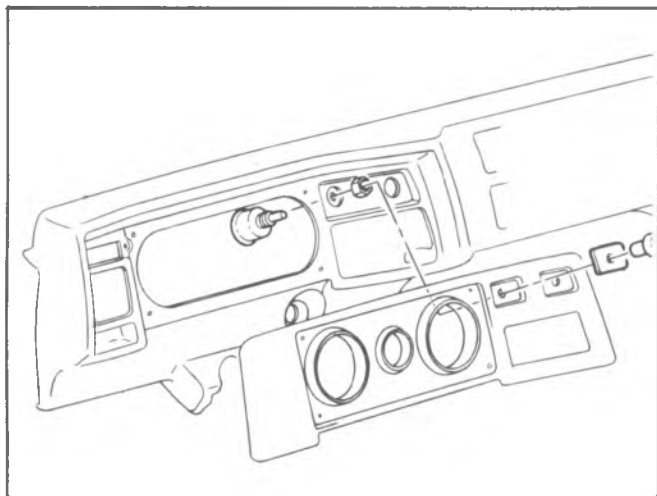


Fig. 1B-67--Rear Blower Motor Switch

10. Evacuate, charge and check the system.

RESISTOR

See "Resistor" in the G Model C60 System Section of this manual (fig. 1B-58).

BLOWER SWITCH

Replacement (Fig. 1B-67)

1. Disconnect the battery ground cable.
2. Remove the headlamp and blower switch control knobs.
3. Remove the instrument panel bezel.
4. Disconnect the wiring harness at the switch.
5. Remove the switch locknut and remove the switch.
6. To install, reverse Steps 1-5 above.

REAR BLOWER RELAY

The rear blower relay is attached to the instrument panel reinforcement, just left of the steering column (fig. 1B-68).

Replacement

1. Disconnect battery ground cable.
2. Disconnect relay wiring harness at the relay.
3. Remove the relay attaching screw and remove the relay.

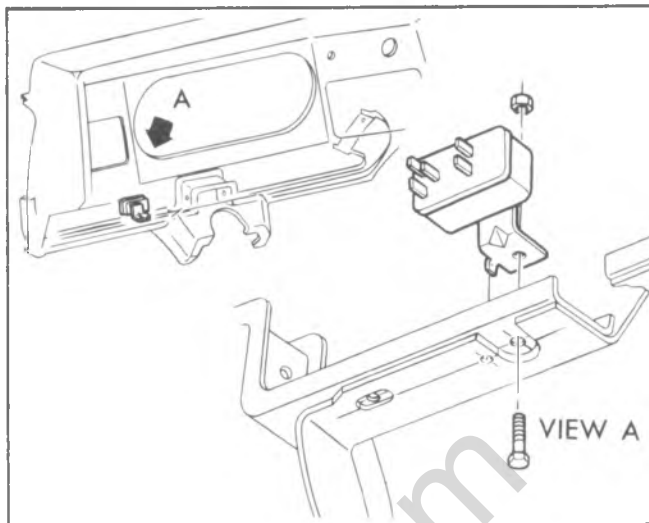


Fig. 1B-68--Rear Blower Motor Relay

4. To install, reverse Steps 1-3 above. Check system operation.

TIE RELAY

Replacement (Fig. 1B-59)

1. Disconnect the battery ground cable.
2. Remove screws securing the blower-evaporator shield; remove the shield. Remove the shield bracket to instrument panel reinforcement screws and remove the bracket.
3. Remove the heater intermediate duct to A/C distributor duct screw and remove the duct.
4. Unsnap the engine cover latches, remove the lower tab mounting bolts and remove the engine cover.
5. Loosen both steering column instrument panel reinforcement screws; remove one screw.
6. Remove the left foot cooler bracket to instrument panel reinforcement screws, disconnect the outlet from the duct and remove the outlet and bracket assembly.
7. Disconnect the speedometer cable.
8. Remove the instrument panel to lower reinforcement attaching screws. Rotate the instrument panel up to gain access to the relay.
9. Disconnect electrical harness at the relay.
10. Remove the relay mounting screw and remove the relay.
11. To install, reverse Steps 1-10 above.

DASH MOUNTED SYSTEM--MOTOR HOME CHASSIS

This system is installed on the vehicle and checked at assembly. The blower-evaporator is then disconnected and shipped with the chassis unit to the body supplier. For this reason, it will only be possible to give basic

replacement procedures on some components.

CONDENSER

Replacement (Fig. 1B-69)

1. Disconnect the battery ground cable.

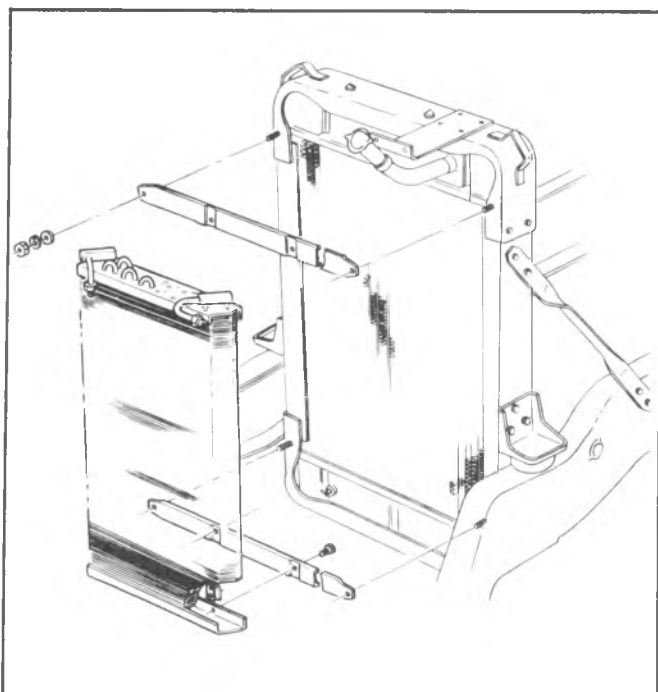


Fig. 1B-69--Condenser (Motor Home Chassis Unit)

2. Purge the system of refrigerant.
3. Disconnect the condenser inlet and outlet lines and cap or plug all open connections at once.
4. Remove the condenser to radiator support screws and remove the condenser.
5. To install a new condenser, reverse Steps 1-4 above. Add one fluid ounce of clean refrigeration oil to a new condenser.

NOTE: Use new "O" rings, coated with clean refrigeration oil, when connecting all refrigerant lines.

6. Evacuate, charge and check the system.

RECEIVER-DEHYDRATOR

Replacement (Fig. 1B-70)

1. Disconnect the battery ground cable.
2. Purge the system of refrigerant.
3. Disconnect the inlet and outlet lines at the receiver-dehydrator and cap or plug the open lines at once.
4. Remove the receiver-dehydrator bracket attaching screws and remove the bracket and receiver-dehydrator.
5. To install a new receiver-dehydrator, reverse Steps 1-4 above. Add one fluid ounce of clean refrigeration oil to a new receiver-dehydrator.

NOTE: Use new "O" rings, coated with clean refrigeration oil, when connecting all refrigerant lines.

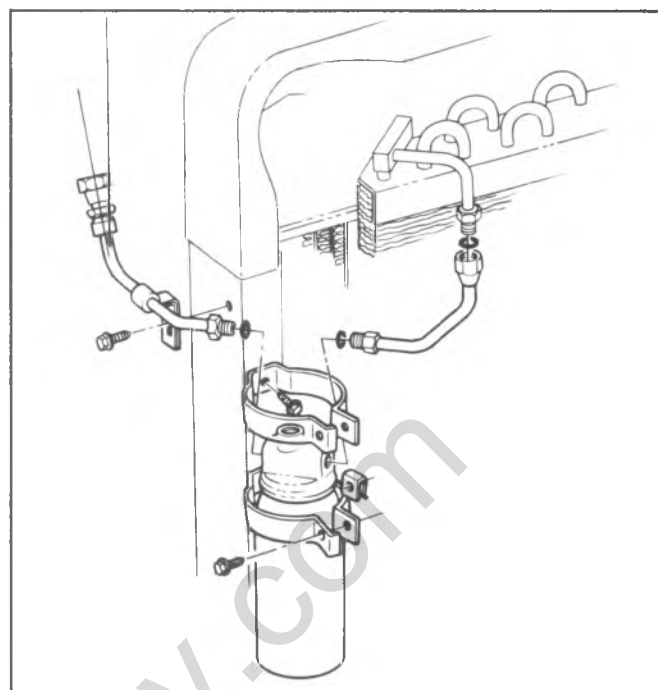


Fig. 1B-70--Receiver-Dehydrator (Motor Home Chassis Unit)

6. Evacuate, charge and check the system.

SIGHT GLASS REPLACEMENT

Refer to "Sight Glass Replacement" in the G Model C60 System Section of this manual.

BLOWER-EVAPORATOR ASSEMBLY (Fig. 1B-71)

Removal

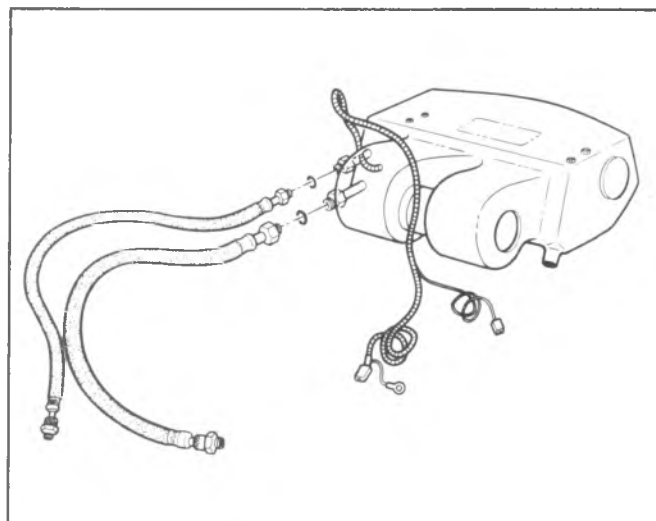


Fig. 1B-71--Blower-Evaporator (Motor Home Chassis Units)

1. Disconnect battery ground cable.
2. Purge system of refrigerant.
3. Disconnect inlet and outlet refrigerant lines from the back of unit. Cap or plug all open connections at once.
4. Disconnect drain tubes from evaporator case.
5. Disconnect electrical connector from compressor. Remove the terminal (See Figure 1B-72) and allow connector to hang on ground wire.
6. Remove screws securing grommet retainer to dash panel. Remove wire from grommet through slit.
7. Disconnect electrical lead at connector.
8. Remove unit mounting bolts. Remove unit from vehicle, carefully pulling compressor electrical lead through dash panel.

Once the unit has been removed from the vehicle, continue with component replacement as follows:

BLOWER ASSEMBLY

Removal (Fig. 1B-73)

1. Remove the cover plate and separate the upper and lower case halves. Remove blower motor mounting strap screw and remove strap.
2. Remove blower assembly. Remove the wheels from the motor shaft.

Installation

1. Install the blower wheels on the motor so that the lower blades curve toward the dash panel side of the unit when the motor is placed in the case as illustrated in Figure 1B-73.
2. Place the motor in the bracket with the electrical connector side of the motor to the right side of the bracket. Attach the mounting strap. Align blower wheels so that they do not contact case.
3. Assemble the case halves and attach the cover plate.

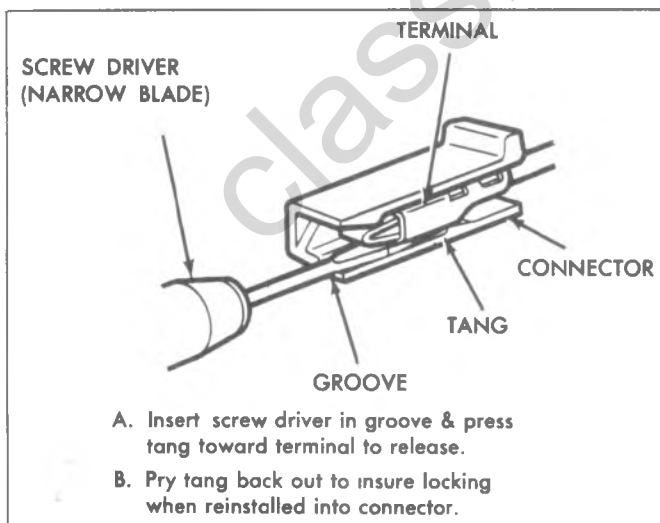


Fig. 1B-72--Terminal Removal

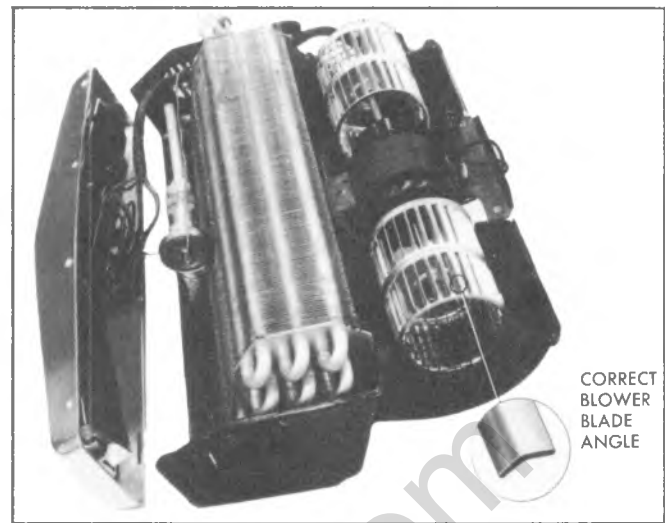


Fig. 1B-73--Blower Assembly (Motor Home Chassis Unit)

4. Reverse Steps 1-8 on the "Blower-Evaporator Assembly" removal procedure.
5. Evacuate, charge and check the system.

EXPANSION VALVE, EVAPORATOR AND/OR EVAPORATOR CASE

Removal (Fig. 1B-74)

1. Remove the cover plate and separate upper and lower case halves.
2. Remove inlet and outlet lines from the expansion valve. Remove sensing bulb from the evaporator outlet manifold. Remove expansion valve. Cap or plug open connections at once.
3. Remove evaporator core retaining screws and remove core.

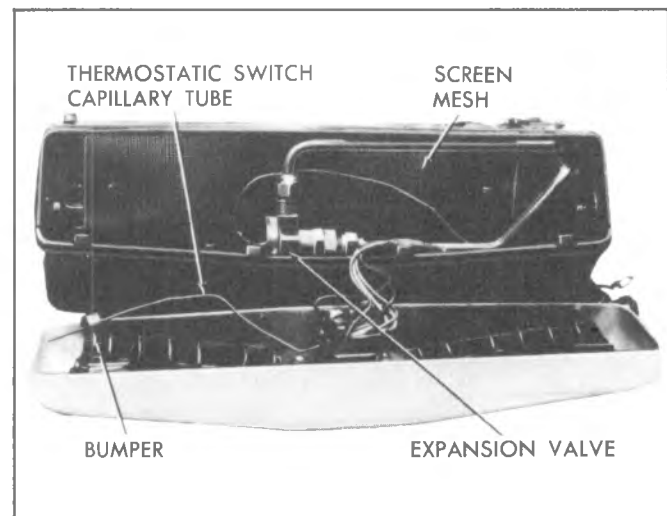


Fig. 1B-74--Expansion Valve (Motor Home Chassis Unit)

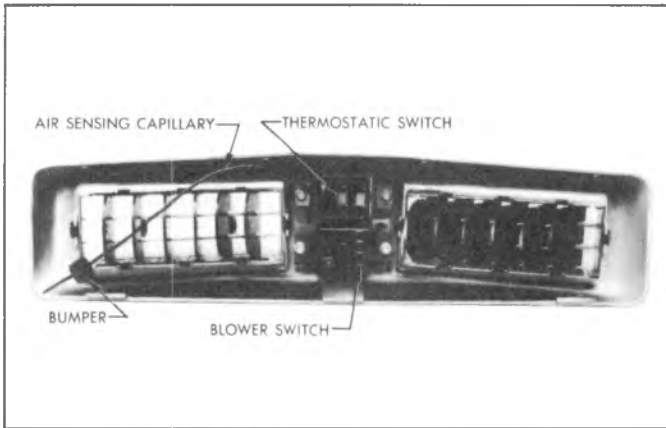


Fig. 1B-75-Thermostatic and Blower Switches

4. Remove blower motor and harness assembly from case.

Installation

1. Reverse applicable steps in the removal procedure.

CAUTION: Use new "O" rings coated with clean refrigeration oil when connecting lines. Add 3 oz. of new refrigeration oil to a new core.

2. Reverse steps 1-8 of the "Blower Evaporator Assembly" removal procedure.
3. Evacuate, charge and check the system.

THERMOSTATIC AND/OR BLOWER SWITCHES

Replacement

1. Remove the cover plate assembly from the evaporator case.
2. Remove two screws securing either switch to the cover plate and remove appropriate switch (fig. 1B-75).
3. Install replacement switch, reinstall cover plate and reverse steps 1-8 of the "Blower-EVaporator Assembly" removal procedure.

NOTE: When installing thermostatic switch, be sure to position sensing capillary as when unit was removed.

RESISTOR

The blower motor resistor is located on the top of the unit. The entire unit must be removed to replace the resistor.

FUSE

This Unit does not incorporate an in-line fuse. The lead wire is connected to the Heater Wiring Harness and operates off the 20 amp Heater Fuse.

SPECIFICATIONS

AIR CONDITIONING

Compressor

Make	Frigidaire		
Type	6 Cylinder Axial		
Displacement	12.6 Cu. In.		
Rotation	Clockwise		

C-K Four-Season System	3 lbs.
C-K-G Overhead Systems	5 lbs. 4 oz.
G Floor System	3 lbs. 4 oz.
Motor Home Chassis Unit	3 lbs. 4 oz.

	<u>Volts</u>	<u>Amps. (Cold)</u>	<u>RPM (Cold)</u>
Blower Motor			
C-K Four Season	12.0	12.8 Max.	3400 Min.
C-K-G Overhead, G Floor and Motor Home Units	12.0	13.7 Max.	3400 Min.

Torque Specifications

Compressor Suction and Discharge	
Connector Bolt	25 ft. lbs.
Rear Head to Shell Stud Nuts	23 ft. lbs.
Shaft Mounting Nut	20 ft. lbs.
Compressor Mounting Bracket Bolts	25 ft. lbs.
Front Bracket to Compressor Bolts	20 ft. lbs.
Belt Tension	See Tune Up Chart

Compressor Clutch Coil

Ohms (at 80°F)	3.70
Amps. (at 80°F)	3.33 @ 12 volts

Fuses

Fuse Block—

C-K Systems	25 Amp.
Motor Home Chassis Unit	20 Amp.

In-Line—

C-K Systems	25 Amp.
Motor Home Chassis Unit	None

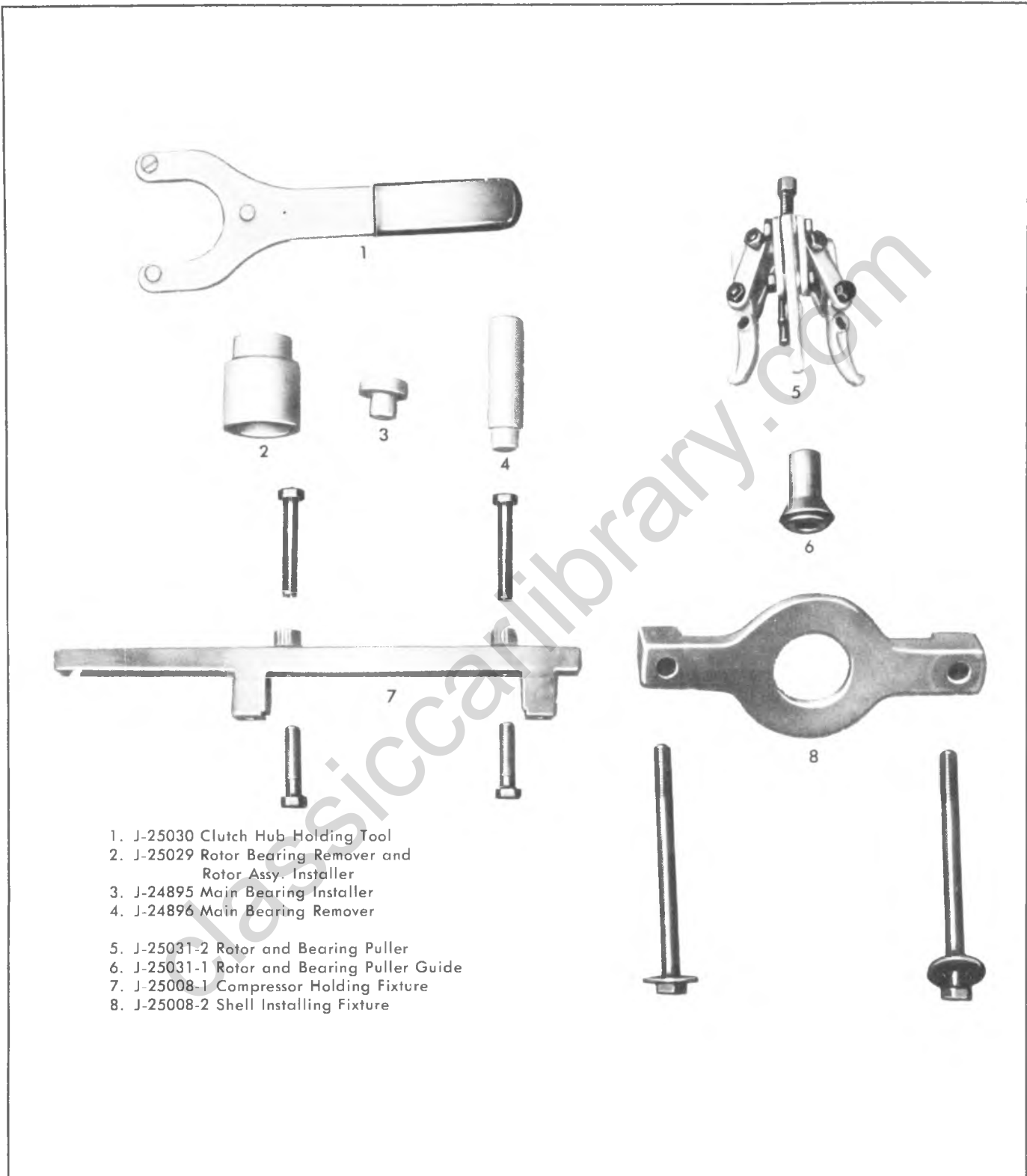
Circuit Breaker

G Model Systems	45 Amp.
-----------------------	---------

System Capacities

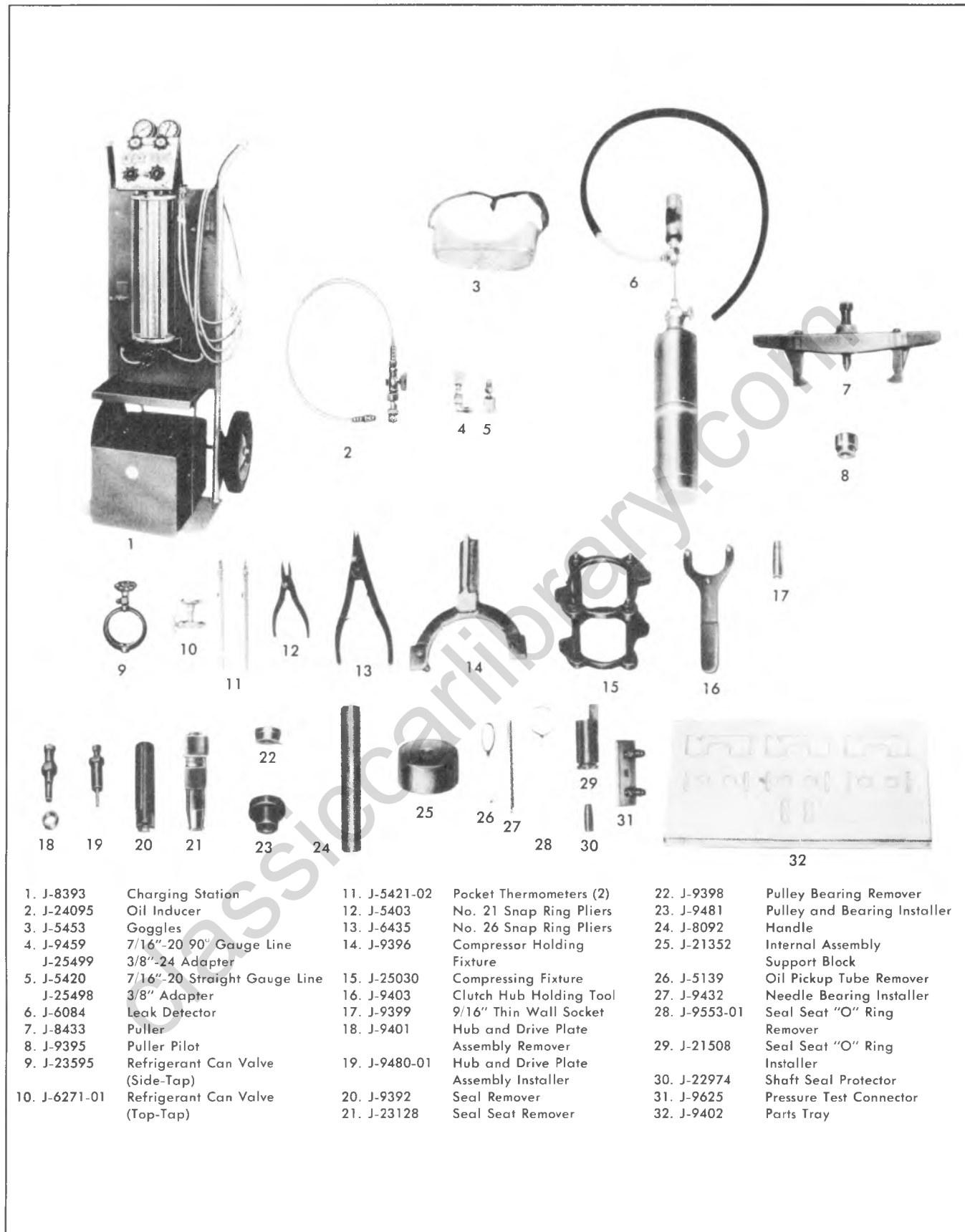
Refrigerant 12

SPECIAL TOOLS



- 1. J-25030 Clutch Hub Holding Tool
- 2. J-25029 Rotor Bearing Remover and Rotor Assy. Installer
- 3. J-24895 Main Bearing Installer
- 4. J-24896 Main Bearing Remover
- 5. J-25031-2 Rotor and Bearing Puller
- 6. J-25031-1 Rotor and Bearing Puller Guide
- 7. J-25008-1 Compressor Holding Fixture
- 8. J-25008-2 Shell Installing Fixture

Fig. 1B-76-Air Conditioning Special Tools



- | | | | | | |
|---------------|----------------------------------|---------------|--|---------------|---------------------------------|
| 1. J-8393 | Charging Station | 11. J-5421-02 | Pocket Thermometers (2) | 22. J-9398 | Pulley Bearing Remover |
| 2. J-24095 | Oil Inducer | 12. J-5403 | No. 21 Snap Ring Pliers | 23. J-9481 | Pulley and Bearing Installer |
| 3. J-5453 | Goggles | 13. J-6435 | No. 26 Snap Ring Pliers | 24. J-8092 | Handle |
| 4. J-9459 | 7/16"-20 90° Gauge Line | 14. J-9396 | Compressor Holding Fixture | 25. J-21352 | Internal Assembly Support Block |
| J-25499 | 3/8"-24 Adapter | 15. J-25030 | Compressing Fixture | 26. J-5139 | Oil Pickup Tube Remover |
| 5. J-5420 | 7/16"-20 Straight Gauge Line | 16. J-9403 | Clutch Hub Holding Tool | 27. J-9432 | Needle Bearing Installer |
| J-25498 | 3/8" Adapter | 17. J-9399 | 9/16" Thin Wall Socket | 28. J-9553-01 | Seal Seat "O" Ring Remover |
| 6. J-6084 | Leak Detector | 18. J-9401 | Hub and Drive Plate Assembly Remover | 29. J-21508 | Seal Seat "O" Ring Installer |
| 7. J-8433 | Puller | 19. J-9480-01 | Hub and Drive Plate Assembly Installer | 30. J-22974 | Shaft Seal Protector |
| 8. J-9395 | Puller Pilot | 20. J-9392 | Seal Remover | 31. J-9625 | Pressure Test Connector |
| 9. J-23595 | Refrigerant Can Valve (Side-Tap) | 21. J-23128 | Seal Seat Remover | 32. J-9402 | Parts Tray |
| 10. J-6271-01 | Refrigerant Can Valve (Top-Tap) | | | | |

Fig. 1B-77-Air Conditioning Special Tools

classicalibrary.com

SECTION 2A

FRAME

CONTENTS

General Description	2A-1
On-Vehicle Service.....	2A-1
Maintenance and Inspection	2A-1
Underbody Inspection.....	2A-1
Frame Inspection	2A-1
Frame Alignment.....	2A-1
Underbody Alignment.....	2A-3
Excessive Body Damage.....	2A-3

GENERAL DESCRIPTION

Light duty 10-30 Series frames are of the ladder channel section riveted type.

Figure 2A-1 thru 2A-4 illustrates typical light duty truck frames with crossmembers, body mounts and suspension attaching brackets. This section also includes general instructions for checking frame alignment and recommendations on frame repair.

The G-Van frame side rails, cross sills and outriggers are part of the underbody assembly which is a welded unit.

Misalignment of the underbody can affect door opening fits and also influence the suspension system, causing suspension misalignment. It is essential, therefore, that underbody alignment be exact to within 1/16" of the specified dimensions.

ON-VEHICLE SERVICE

MAINTENANCE AND INSPECTION

UNDERBODY INSPECTION

Raise the vehicle on a hoist (preferably a twin-post type).

Check for obvious floor pan deterioration.

Check for loose dirt and rust around the inside of the floor pan reinforcement member access holes. This is the first indication that corrosion may exist in hidden areas, and that repairs might be required before the final cleaning and protective treatment is performed.

Using a chisel, ensure that the drain provisions in the floor pan reinforcement members are open.

There are drain holes in the body side panels also. These holes can be opened by using a punch or drift. The side panel drain holes are in the rear section of the rocker panels, and in the lower rear quarter panels.

FRAME INSPECTION

Raise the vehicle on a hoist (preferably a twin-post type).

Check for obvious floor pan deterioration.

Check for loose dirt and rust around the inside of the frame rails, on top and at the ends where corrosion

may exist in hidden areas. Check especially in the frame box sections for accumulation of debris.

FRAME ALIGNMENT

Horizontal frame checking can be made with tramming gauges applied directly to the frame or by transferring selected points of measurement from the frame to the floor by means of a plum bob and using the floor layout for measuring. Figure 2A-2 or 2A-4 may be used as a general guide in the selection of checking points; however, selection of these points is arbitrary depending on accessibility and convenience. An important point to remember is that for each point selected on one side of the frame, a corresponding point on the opposite side of the frame must be used for vertical checks, opposite and alternate sides for horizontal checks.

Vehicle Preparation

Points to remember when preparing vehicle for frame checking:

1. Place vehicle on a level surface.
2. Inspect damaged areas for obvious frame misalignment to eliminate unnecessary measuring.

3. Support vehicle so that frame sidemembers are parallel to the ground.

Tramming Sequence (Fig. 2A-1)

1. Dimensions to bolts and/or holes in frame extend to dead center of the hole or bolt.
2. Dimensions must be within $3/16''$.
3. If a tram bar is used, for horizontal alignment "X" - check from opposite and alternate reference points AA, BB and CC, as illustrated by the lines in Figure 2A-1. Error will result if a tram bar is not level and centered at the reference points.
4. Obtain vertical dimensions and compare the differences between these dimensions with the dimensions as shown in figure 2A-3 or 2A-4.

Horizontal Check

1. Measure frame width at front and rear. If widths correspond to specifications, draw centerline full length of vehicle halfway between lines indicating front and rear widths. If frame widths are not correct, layout centerline as shown in Step 4.
2. Measure distance from centerline to corresponding points on each side of frame layout over entire

length. Opposite side measurement should correspond within $3/16''$.

3. Measure diagonals marked A, B and C. If the lengths of intersecting diagonals are equal and these diagonals intersect the centerline, frame area included between these points of measurement may be considered in alignment.

4. If front or rear end of frame is damaged and width is no longer within limits, frame centerline may be drawn through the intersection of any two previously drawn pairs of equal, intersecting diagonals.

Vertical Check

Vertical dimensions are checked with a tramming bar from indicated points on the frame (figs. 2A-2 and 2A-4). For example, if the tram bar is set at point B with a vertical pointer length of $8-1/4$ inches, and at point E with a vertical pointer length of $5-1/4$ inches (a height difference of 3 inches), the tram bar should be parallel with the frame. If the area is twisted or misaligned in any way, tram bar will not be parallel. Placing the tram bar vertical pointers on opposite sides of the frame side rail is preferable in that frame twist will show up during this vertical check. Figures 2A-2 and 2A-4 show typical

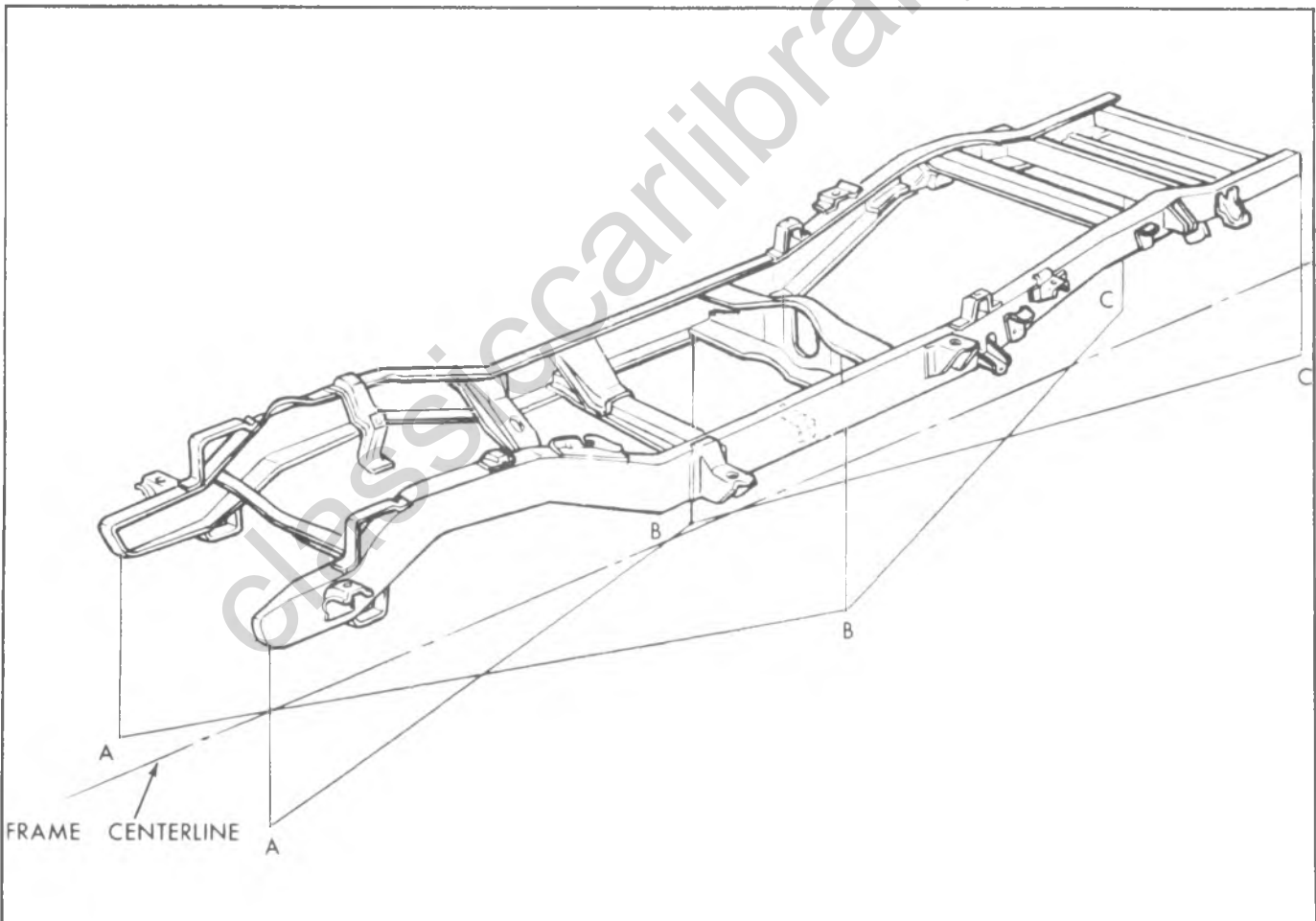


Fig. 2A-1--Frame Horizontal Checking--Typical

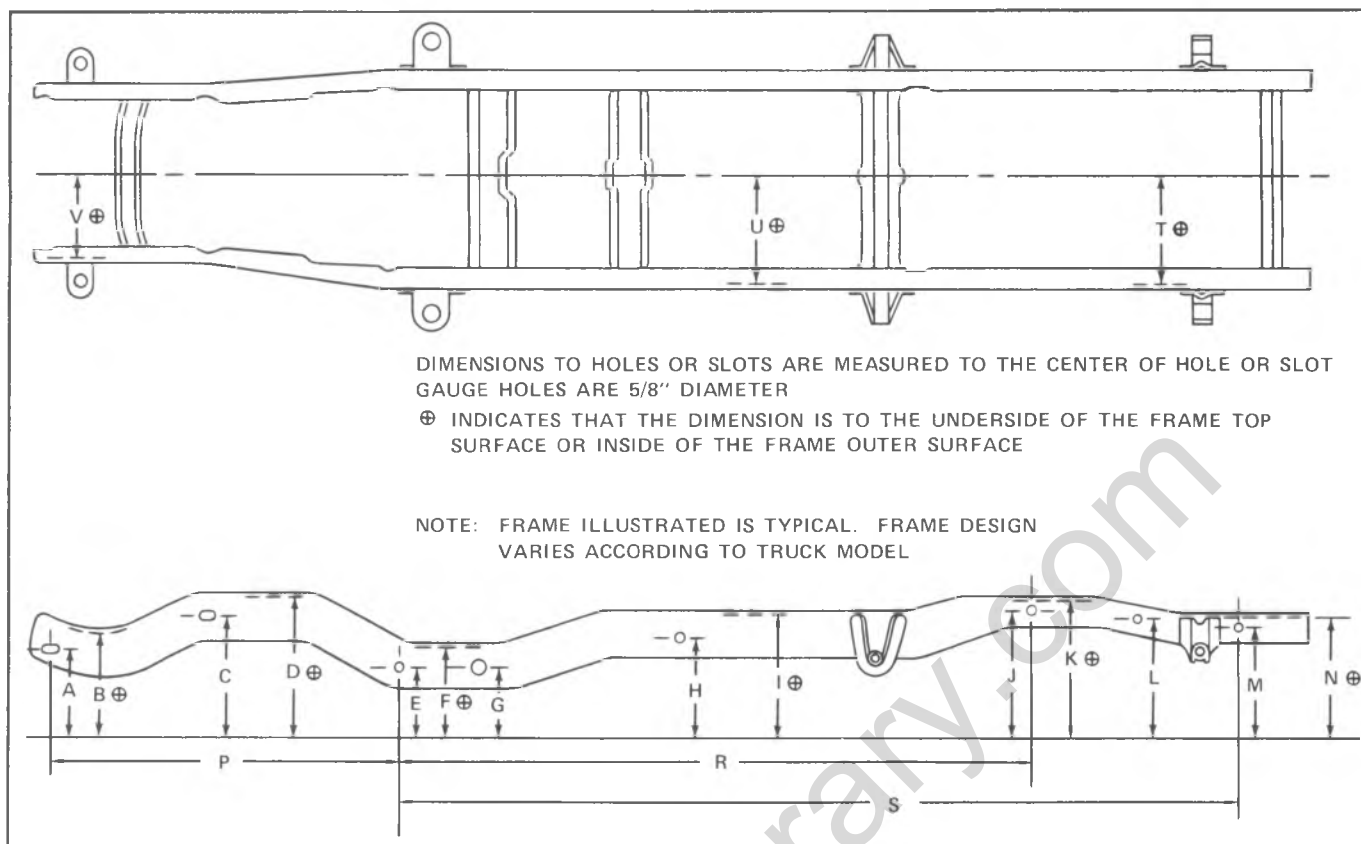


Fig. 2A-2-C-K-P Series Truck Frame

checking points, with dimensions for various frames shown in figure 2A-3.

Frame Repair

Welding

Before welding up a crack in frame, a hole should be drilled at the starting point of the crack to prevent spreading. Widen V groove crack to allow complete weld penetration.

NOTE: Do not weld into corners of frame or along edges of side rail flanges. Welding at these points will tend to weaken the frame and encourage new cracks.

Bolting

Wherever rivets or failed bolts are replaced, bolt hole must be as near the O.D. of the bolt as possible to prevent bolt from working and wearing. Drill out and line ream hole (or holes) to the bolt O.D.

UNDERBODY ALIGNMENT

One method of determining the alignment of the underbody is with a tram gauge which should be sufficiently flexible to obtain all necessary measurements up to three quarters the length of the vehicle. A good tramming tool is essential for analyzing and determining the extent of collision misalignment present in underbody construction.

MEASURING

To measure the distance accurately between any two reference points on the underbody, two specifications are required.

1. The horizontal dimension between the two points to be trammed.
2. The vertical dimension from the datum line to the points to be trammed.

The tram bar should be on a parallel to that of the body plane. The exception to this would be when one of the reference locations is included in the misaligned area; then the parallel plane between the body and the tram bar may not prevail. After completion of the repairs, the tram gauge should be set at the specified dimension to check the accuracy of the repair operation.

EXCESSIVE BODY DAMAGE

If damage is so extensive that key locations are not suitable as reference points, repair operations should always begin with the underbody area. All other components should be aligned progressively from this area. Unlike the conventional type of frame design, the unitized type of body construction seldom develops the two conditions of "twist" and "diamond" in the underbody area as a result of front or rear end collisions, therefore, there usually is an undamaged area suitable as a beginning reference point.

Model	A	B	C	D	E	F	G	H	I	J	K	L	M	N	P	R	S	T	U	V
CA107	13-3/8	15-1/4	16	19-7/8	12	13	10	14-7/8	17-3/4	17-3/4	19-7/8	16-3/4	15-5/8	17-3/4	69-5/8	76-1/2	110	16-7/8	16-7/8	14
CA109	13-3/8	15-1/4	16	19-7/8	12	13	10	14-7/8	17-3/4	17-3/4	19-7/8	16-3/4	15-5/8	17-3/4	69-5/8	86-1/2	120	16-7/8	16-7/8	14
CA209	13-3/8	15-1/4	17	19-7/8	12	13	10	14-7/8	17-3/4	17-3/4	19-7/8	16-3/4	15-5/8	17-3/4	69-5/8	86-1/2	120	16-7/8	16-7/8	14
CA ²¹⁰ ₃₁₀	13-3/4	15-1/4	16	18-1/2	10	13	10	14-1/4	17-3/4	17-3/4	19-7/8		15-5/8	17-3/4	69-7/8	105	131	16-7/8	16-7/8	14
CA314	13-3/8	14-7/8	16	18-1/2	10	13	10	14-1/4	17-3/4	17-3/4	19-7/8		15-5/8	17-3/4	69-7/8	129	155-1/2	16-7/8	16-7/8	14
KA107	13-3/8	15-1/4	17	19-7/8	12-1/2	13	10	14-7/8	17-3/4	17-3/4	19-7/8	16-3/4	15-5/8	17-3/4	69-5/8	76-1/2	110	16-7/8	16-7/8	14
KA ¹⁰⁹ ₂₀₉	13-3/8	15-1/4	17	19-7/8	12-1/2	13	10	14-7/8	17-3/4	17-3/4	19-7/8	16-3/4	15-5/8	17-3/4	69-5/8	86-1/2	120	16-7/8	16-7/8	14
PA100	7-5/8	9-3/8	11	14-5/8	9-1/2	13	10			9-1/2	13		10-7/8	13	71-7/8	36	89	16-7/8	16-7/8	14
PA ²⁰⁸ ₃₀₈	7-5/8	9-3/8	11-5/8	14-5/8	9-1/2	13	10	9-1/2	13	9-1/2	13		10-7/8	13	72-1/4	59	131	16-7/8	16-7/8	14
PA ²¹⁰ ₃₁₀	7-5/8	9-3/8	11-5/8	14-5/8	9-1/2	13	10	9-1/2	13	9-1/2	13	10-7/8	10-7/8	13	71-7/8	67	153	16-7/8	16-7/8	14
PA314	7-5/8	9-3/8	11-5/8	14-5/8	9-1/2	13	10	9-1/2	13	9-1/2	13	10-7/8	10-7/8	13	71-7/8	91	177	16-7/8	16-7/8	14
CA105	13-3/8	15-1/4	17	19-7/8	12	13	10		14-1/4	20	17-3/4	15-5/8	17-3/4	69-5/8	46	88	16-7/8	16-7/8	14	
KA105	13-3/8	15-1/4	17	19-7/8	12-1/2	13	10		14-1/4	20	17-3/4	15-5/8	17-3/4	69-5/8	46	88	16-7/8	16-7/8	14	
PE 31132 (137)	9-1/8	11-1/2	10-7/8		9-1/2	13	10	9-1/2	13	9-1/2	13	10-7/8	10-7/8	13	68-1/2	71	157	16-7/8	16-7/8	14
PE 31432 (157)	9-1/8	11-1/2	10-7/8		9-1/2	13	10	9-1/2	13	9-1/2	13	9-7/8	10-7/8	13	68-1/2	92-1/2	178-1/2	16-7/8	16-7/8	14
PE 31832	9-1/8	11-1/2	10-7/8		9-1/2	13	10	9-1/2	13	9-1/2	13	10-7/8	10-7/8	13	68-1/2	112	240-3/16	16-7/8	16-7/8	14

Fig. 2A-3--C-K-P Series Frame Reference Dimensions

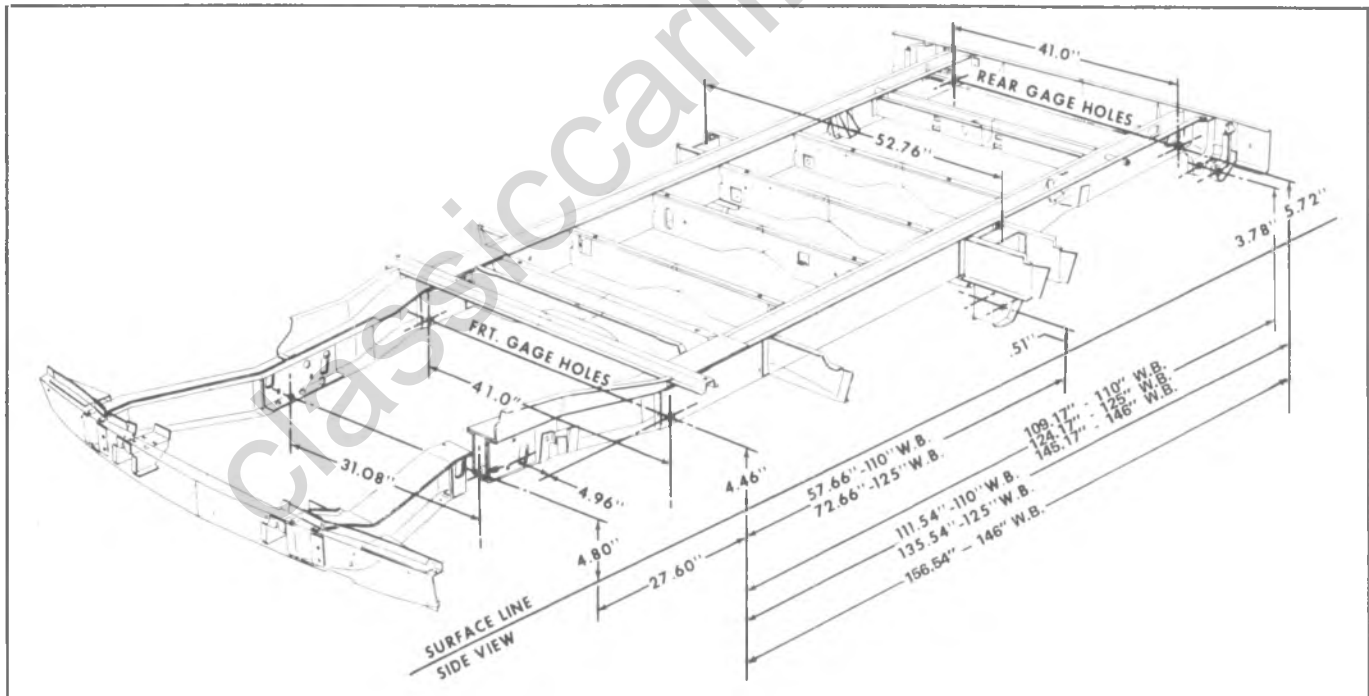


Fig. 2A-4-G Van Truck Reference Dimensions

SECTION 2B BUMPERS

CONTENTS

General Description.....	2B-1	Rear Step Bumper - C and K Models.....	2B-2
Service Procedures - 10 thru 30 Series.....	2B-1	Front Bumper G Series.....	2B-2
Front Bumper - C, K and P Models.....	2B-1	Rear Bumper G Series.....	2B-2
Rear Bumper - C and K Models.....	2B-1	Specifications.....	2B-3

GENERAL DESCRIPTION

All 1977 truck front and rear bumpers are of a single piece design. Bumper attachments are the standard bracket and brace to frame mountings. This

section contains procedures for the removal and installation of face bar, brackets, braces and license plate brackets.

SERVICE PROCEDURES—10 THRU 30 SERIES

FRONT BUMPER-C, K AND P MODELS

Removal Fig. 2B-1, 2B-2

1. Remove bolts securing two bumper brackets to frame.
2. Remove bolts securing bumper face bar to frame, and left and right bumper braces and remove bumper from vehicle.
3. If necessary, disassemble bumper by removing bolts attaching brackets and braces to bumper face bar.
4. If equipped with bumper guards (Fig. 2B-2) remove remaining nuts and bolts.

Installation

Assemble and install front bumper following the removal procedure in reverse order.

REAR BUMPER-C AND K MODELS (FIG 2B-3)

Removal

1. Remove bolts attaching bumper to each bumper brace. Disconnect license lamp wiring on suburban and panels and pickup.
2. Remove bolts attaching bumper to frame.
3. Remove bumper from vehicle.
4. If necessary, replace body splash shield.

Installation

Install rear bumper following removal procedure in

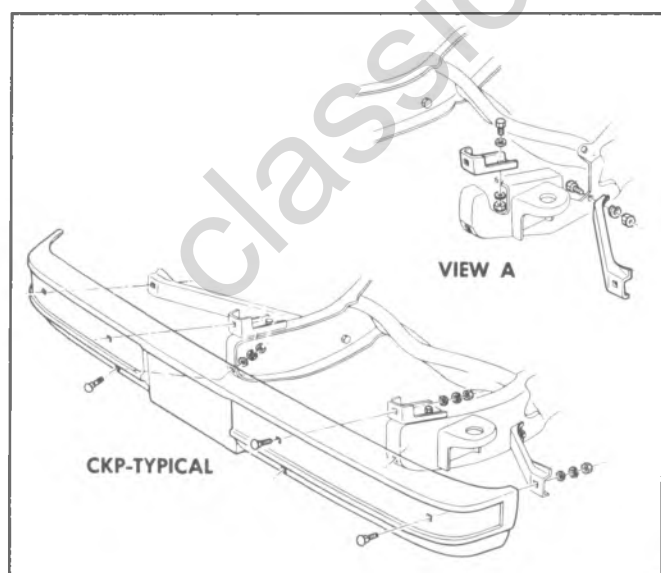


Fig. 2B-1--Front Bumper-C, K and P Models

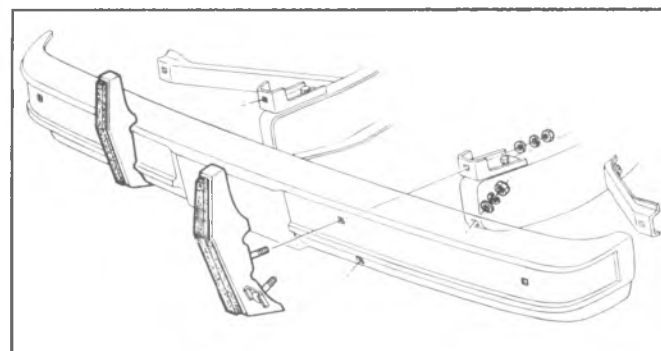


Fig. 2B-2--C, K Model Front Bumper Guards

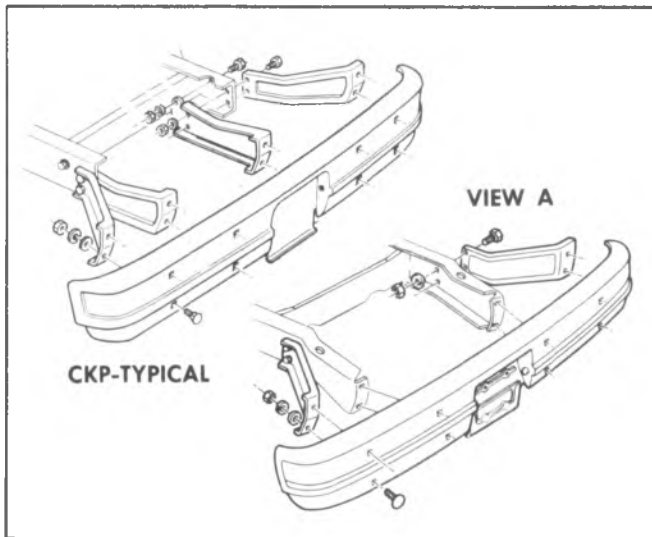


Fig. 2B-3-Rear Bumper - C, K Models

reverse order. Connect license lamp wiring on suburban panel, and pickup models.

REAR STEP BUMPER C AND K MODELS

Removal (Fig. 2B-4)

1. Disconnect license lamp wiring.
2. Remove bolts connecting bumper to brackets.
3. Remove bumper assembly.
4. Remove bolts securing bumper brace to frame and remove brace.

Installation

Install rear step bumper by reversing removal procedure. Connect license lamp wiring.

FRONT BUMPER - G MODELS

Removal Fig. 2B-5, 2B-6

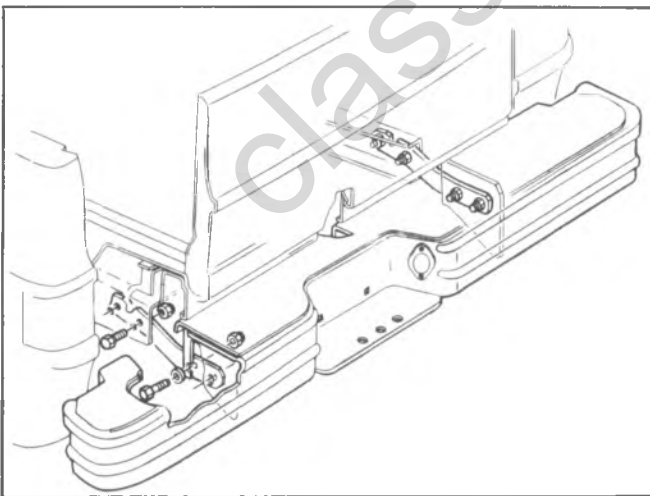


Fig. 2B-4-Rear Step Bumper C and K Models

1. Remove nuts securing bumpers to brackets and braces from left and right side. Remove bumper.
2. Remove the license plate support nut and bolts.
3. If necessary to remove the braces and brackets, remove screws securing brackets and braces to sheet metal.

NOTE: The bumper may be removed with the brackets and braces attached.

4. If equipped with bumper guards (Fig. 2B-6) they may be removed from the face bar at this time.

Installation

Reverse removal steps to install bumpers.

REAR BUMPER-G MODELS

Removal Fig. 2B-7, 2B-8

1. Remove nuts securing bumper to brackets and braces and remove bumper.
2. Remove brackets and braces from vehicle.

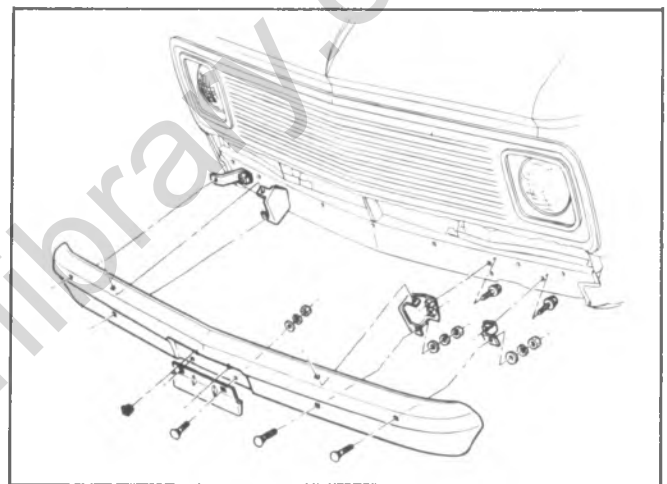


Fig. 2B-5-Front Bumper - G Models

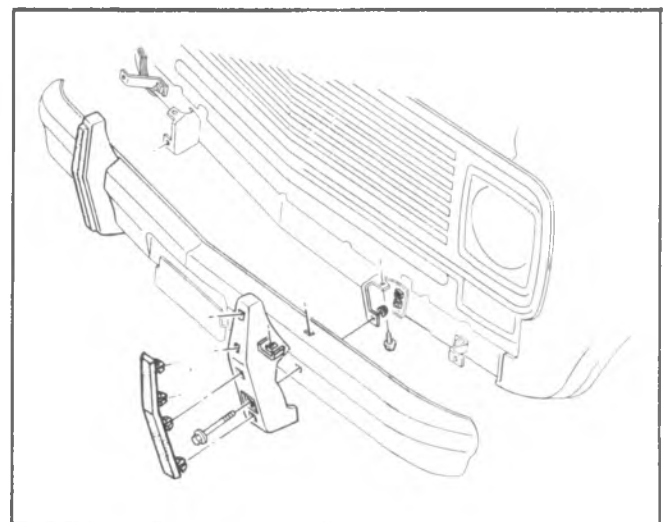


Fig. 2B-6-G-Models Front Bumper Guards

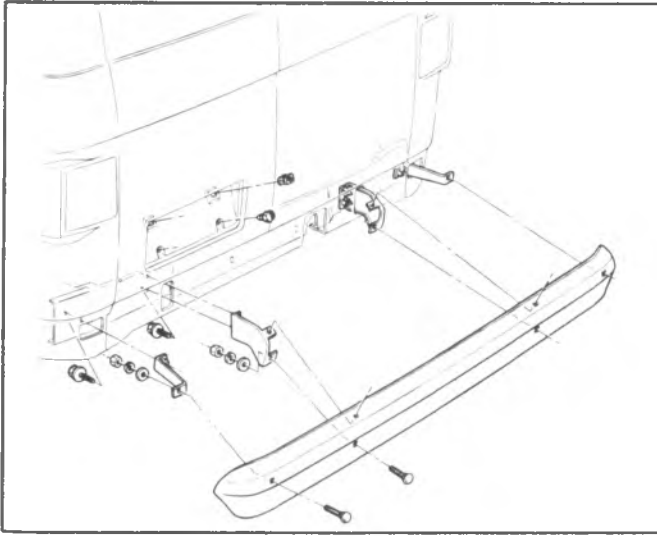


Fig. 2B-7--Rear Bumper-G Models

NOTE: The bumper may be removed with brackets and braces attached if necessary.

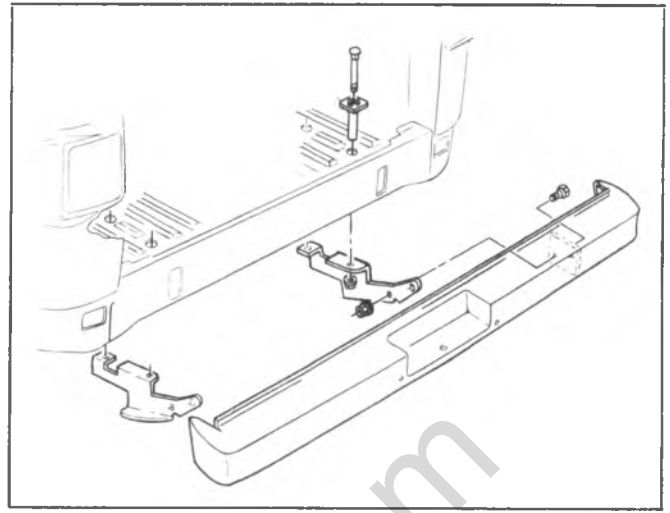


Fig. 2B-8--G-Model Rear Step Bumper

Installation

Install in reverse order of removal.

classiccarylbrary.com

SPECIFICATIONS

TORQUE SPECIFICATIONS C, P AND K

Front Bumper35 ft.-lbs.
Front Bumper Bracket and Brace70 ft.-lbs.
Rear Bumper to Outer Bracket35 ft.-lbs.
Rear Bumper Outer Bracket and Brace50 ft.-lbs.
License Plate Bracket18 ft.-lbs.
Gravel Deflector85 in.-lbs.
Rear Step Bumper to Bracket or Frame40 ft.-lbs.

TORQUE SPECIFICATIONS G

Front Face Bar to Bracket24 ft.-lbs.
Bracket to Cross Sill24 ft.-lbs.
License Plate Bracket to Face Bar100 in.-lbs.
Rear Face Bar to Brackets55 ft.-lbs.
Bracket to Floor55 ft.-lbs.

classiccarlibrary.com

SECTION 2C

CHASSIS SHEET METAL

CONTENTS

General Description.....	2C-1	Hood Assembly.....	2C-4
On Vehicle Service	2C-1	Front Sheet Metal - CK Series	2C-6
Hood Assembly - CK Series.....	2C-1	Radiator Support.....	2C-8
Hood Hinge Spring Replacement.....	2C-1	Front Fender.....	2C-8
Hood Hinge.....	2C-1	Front Fender and Skirt	2C-8
Hood Lock Assembly.....	2C-2	Front Fender Skirt	2C-9
Hood Assembly.....	2C-2	Running Board	2C-9
Hood Assembly - G Series	2C-3	Front Sheet Metal - G Series.....	2C-9
Hood Hinge.....	2C-3	Sheet Metal Checking.....	2C-10
Hood Lock Assembly.....	2C-3	Fender Skirt - P Series.....	2C-10
Hood Bumper.....	2C-4	Wood Grain Applique Installation Procedure	2C-10
		Specifications.....	2C-12

GENERAL DESCRIPTION

CK Series

The chassis sheet metal assembly is attached to the frame and body at adjustment points. The front of the assembly is supported by two mounts located at the frame side rails. Fore and aft and side adjustment is allowed by oversize holes at the fender rear attaching point and chassis sheet metal mounts. Special shims at the rear locations allow adjustment of the rear of the assembly. The lower rear edge of the assembly is attached to the body at the rocker panel by bolts on each side. Shims are used at this location to provide in and out adjustment at the rear of the fender. The bolts that retain the sheet metal braces must be torqued to the required torques. If these bolts are loose, the braces will

not provide additional support for the sheet metal assembly.

G Series

The front end sheet metal design does not include the radiator support and fenders as loose items inasmuch that these items are welded together as an integral part of the body.

Front end sheet metal includes the hood assembly, hood hinges, hood lock catch and support, a hood rod assembly which supports the hood, a bolted radiator-upper tie bar, and series designation plates and hoods emblems. Refer to figure 13 for sheet metal checking.

Refer to Section 6B for Radiator and Grille service procedures, Section 2B for Bumpers, and Section 1A for Heater.

ON VEHICLE SERVICE

HOOD ASSEMBLY - CK SERIES

Hood Hinge Spring Replacement

For Hinge Spring Replacement, a tool can be made to dimensions as shown in Figure 2C-1.

1. Raise and safely support the hood in full open position.
2. As shown in Figure 2C-2, engage hooked end of tool to spring, then carefully pull forward to engage or disengage spring from hinge assembly.

Hood Hinge (Fig. 2C-2)

Removal

1. Prop the hood in the extreme open position and place protective covering over the cowl and fenders.
2. Scribe position of hinge attachment on hood rear reinforcement and remove two bolts.
3. Remove hood hinge spring as described above.
4. Scribe position of hinge attachment on fender assembly and remove bolts.
5. Remove hinge.

Installation

1. Install hinge assembly to fender and align within scribe marks. Install bolts.

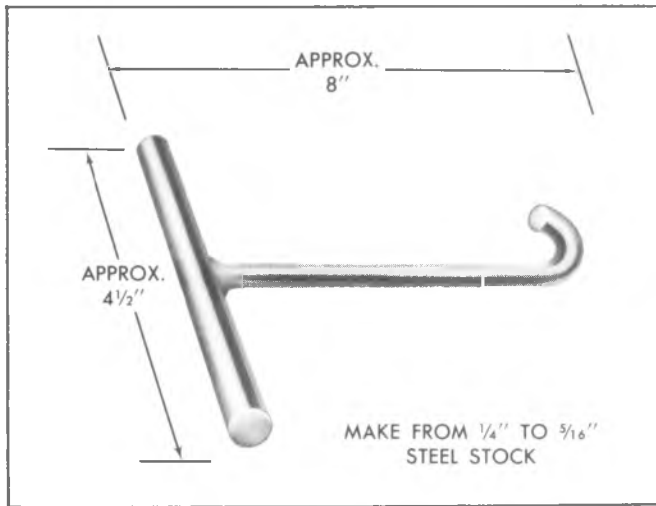


Fig. 2C-1--Hood Hinge Spring Remover/Installer

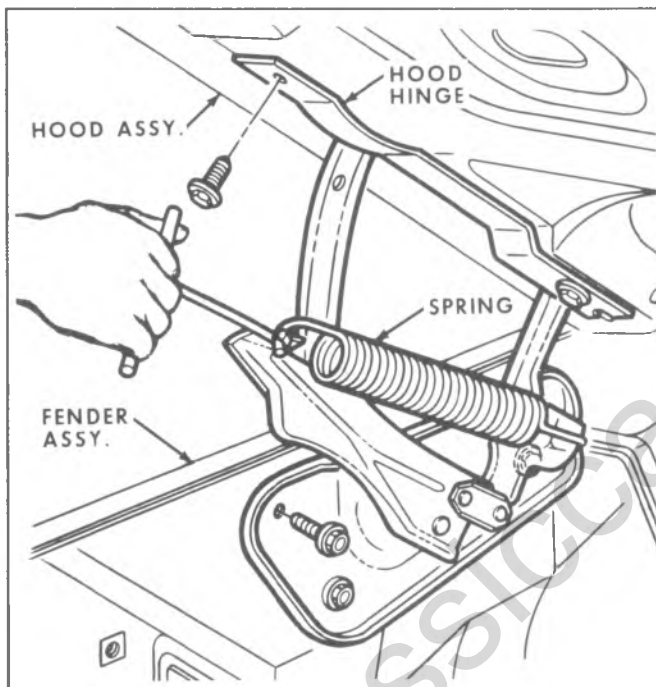


Fig. 2C-2--Hood Hinge and Spring—CK Series

2. Install hood hinge spring.
3. Install bolts and align hood. See Hood Alignment in this section.

Hood Lock Assembly

A bolt-type hood lock is used as shown in Figure 2C-3. The lock bolt, located on the hood dovetails with the mounted striker plate, preventing upward or downward movement of the hood while the vehicle is in

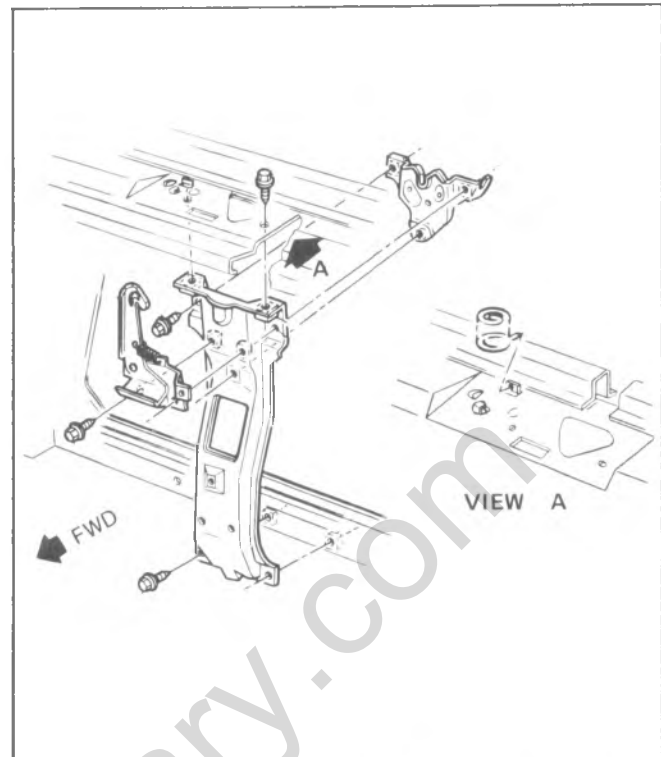


Fig. 2C-3--Hood Lock Catch and Support—CK Series

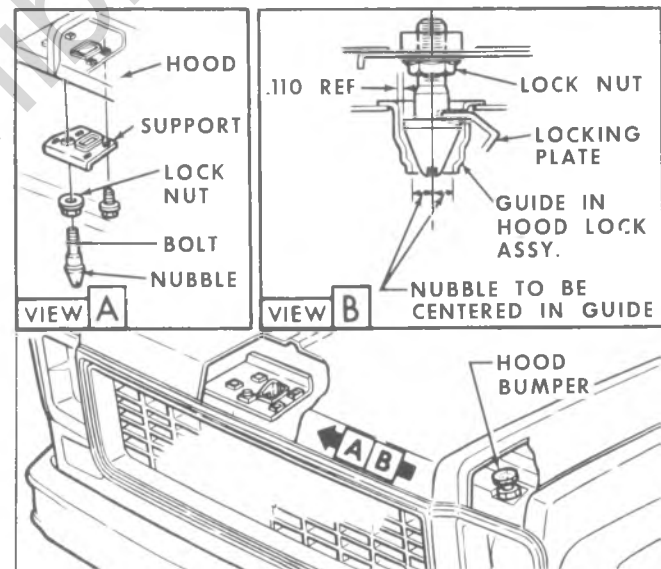


Fig. 2C-4--Hood Lock Bolt and Bumper—CK Series

motion. Integral with the striker plate is the combination lock release lever and safety catch.

Replacement

1. Open hood and remove the four bolts holding the combination lock support and lock bolt.

NOTE: If original hood lock assembly is to be

replaced, scribe a line around lock for alignment on installation.

2. Place hood lock assembly in position.
3. Adjust as outlined under Adjustments.

Adjustment (Fig. 2C-4)

1. Loosen lock nut on lock bolt and adjust lock bolt approximately $2 \frac{7}{16}$ inches from bottom of lock bolt to bottom of support.

2. Adjust tightness of support screws so they are just snug enough to hold support in position.

3. Adjust support fore and aft until nubble enters center of elongated guide. Bending nubble to accomplish this adjustment may seriously effect lock operation and safety latch engagement and is, therefore, not recommended.

4. Tighten screws to 140 pound inches.

5. Adjust lock bolt to obtain a secure hood closure and reasonable lock release effort.

Hood Bumper Adjustment

Hood Bumpers must be adjusted until hood and fender line up flush at front corner. Adjust hood lock bolt to obtain a minimum load of 45 pounds to a maximum load of 55 pounds on each bumper after hood is firmly slammed.

Hood Assembly

Removal

1. Open hood and prop in full open position.

NOTE: If hood is to be reinstalled and present alignment is satisfactory, mark each hinge in relation to hood, to assure original alignment.

2. Remove two (2) cap screws which attach each hinge to hood; then with a helper remove hood from vehicle.

Installation

1. If original hood is to be installed, position hood to hinges and install four cap screws snug which attach hinges to hood.

NOTE: If a new hood is to be installed, perform procedures as outlined under Alignment, directly below.

2. Shift hood on hinges to location marks made before removal of hood, then tighten attaching cap screws at hinges firmly. Close hood and check fit. If necessary to align hood perform procedure as outlined under "Alignment" which follows.

Alignment (Fig. 2C-2)

1. Loosen hood hinge bolts. Note that rear most bolt hole in hinge is slotted to allow hood trailing edge to move up and down.

2. Adjust hood rear bumper bolt so that bumper is flush with fender. Nut must be threaded completely onto bolt before torquing to maintain design height.

3. Perform hood lock adjustment as outlined in this section if necessary.

Hood Assembly - G Series

The alignment of the hood is controlled by the position of the hood hinges and the height of the two bumpers located one at each side of the radiator support. The adjustment at the hood lock must be made after the hinges and bumpers are properly adjusted (refer to Hood Lock Adjustment fig. 2C-6). To align the hood and lock proceed as follows:

Hood Hinge (Fig. 2C-5)

The body mounted portion of the hood hinges are slotted to provide up and down movement. The hood mounted end is slotted to provide forward and rearward movement.

Hood support rod assembly must operate freely without binding in assembled position.

Hood Lock Assembly

A bolt-type hood lock is used as shown in Figure 2C-6. The lock bolt, located on the hood, dovetails with the mounted striker plate, preventing upward or downward movement of the hood while the vehicle is in motion. Integral with the striker plate is the combination lock release lever and safety catch.

1. Scribe a line around the entire hinge plate to be repositioned.

2. Loosen the appropriate screws and shift the position of the hood into correct alignment using the scribe marks to check amount of movement. Check alignment by tightening screws and closing the hood.

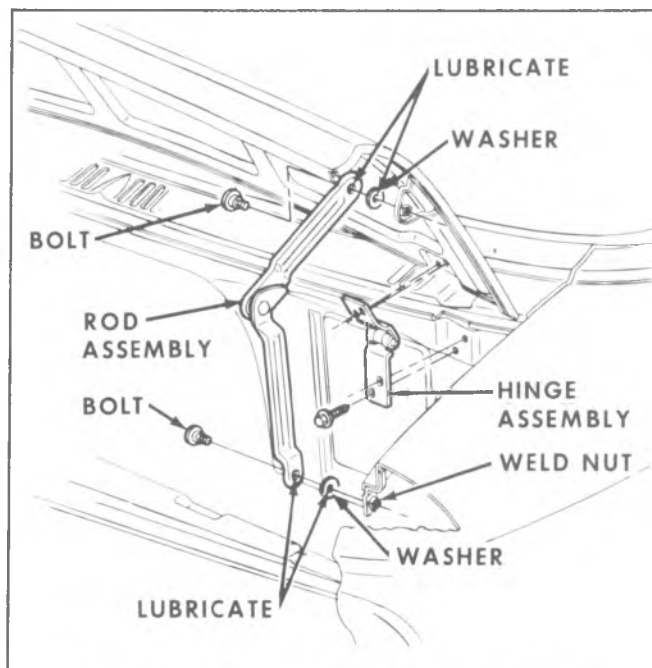


Fig. 2C-5—Hood Hinge and Rod Assembly—G Series

Replacement

1. Open hood and remove the four bolts holding the combination lock catch and lock bolt.

NOTE: If original hood lock assembly is to be replaced, scribe a line around lock for alignment on installation.

2. Place hood lock assembly in position.
3. Adjust as outlined under Adjustments.

Adjustment

CAUTION: Hood lock assembly to be adjusted fore and aft until hood lock bolt enters center of elongated guide. Bending bolt to accomplish this adjustment may seriously effect lock operation and safety catch engagement and is, therefore not recommended.

1. Adjust lock bolt as shown in Figure 2C-7.
2. Open hood and adjust tightness of catch

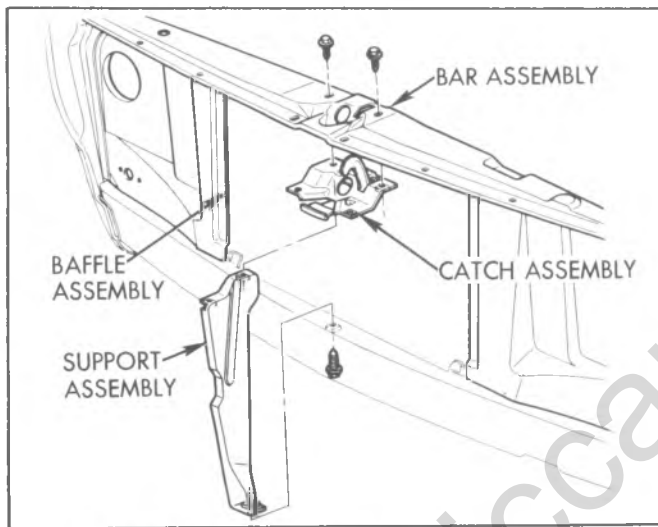


Fig. 2C-6--Hood Lock Catch Assembly—G Series

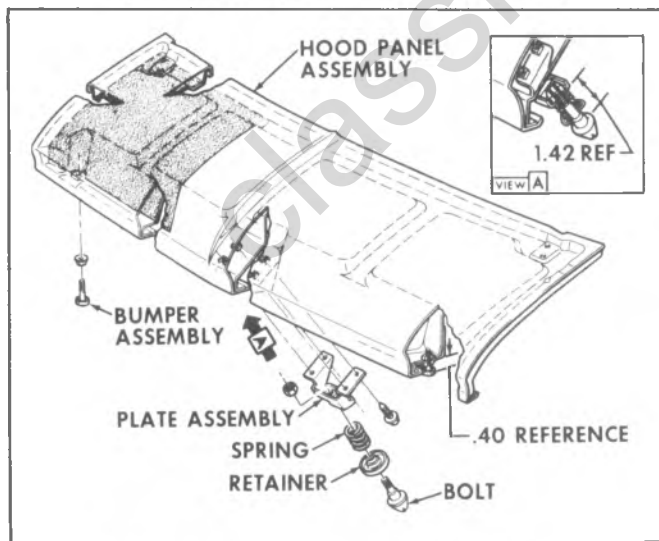


Fig. 2C-7--Hood, Bumpers and Latch—G Series

assembly so that it is just "snug" enough to hold lock bolt in position.

3. Close hood in a normal manner.
4. Raise hood again; lock bolt assembly will have shifted to operating position. Tighten bolts fully. Further adjustment may be made at lock bolt support, if necessary.
5. Adjust lock bolt to obtain a secure hood closure and reasonable lock release effort.

HOOD LATCH CABLE RELEASE - CK MODELS (FIG. 2C-8)

Replacement

1. Release the hood from below, using a suitable rod, by pressing on the hood release tab at the right side of the lock assembly.
2. Remove the cable at the lock assembly.
3. Remove hood release handle to kickpad attaching screws.
4. Remove hood release cable.
5. To install, reverse steps 2 through 4 above.

HOOD EMBLEM - CK MODELS (FIG. 2C-9)

Hood Bumper (Fig. 2C-7)

Adjust hood bumpers so that hood top surface is flush with the fender and grille top surfaces. Refer to Figure 13 for correct sheet metal adjustment dimensions.

Hood Assembly (Fig. 2C-7)

Removal

1. Lay a fender cover along cowl top to prevent hood from scratching painted surfaces.
2. Open hood and prop in full open position.

NOTE: If hood is to be reinstalled and present alignment is satisfactory, mark each hinge in relation to hood, to assure original alignment.

3. Remove rod assembly (see fig. 2C-5).
4. Remove two cap screws which attach each hinge to hood; then with a helper remove hood from vehicle.

Installation

1. If original hood is to be installed, position hood to hinges with helper and install four cap screws snug which attach hinges to hood.
2. Install rod assembly.

NOTE: If a new hood is to be installed, perform procedures as outlined under Alignment, directly below.

3. Shift hood on hinges to location marks made before removal of hood, then tighten attaching cap screws at hinges firmly. Close hood and check fit. If

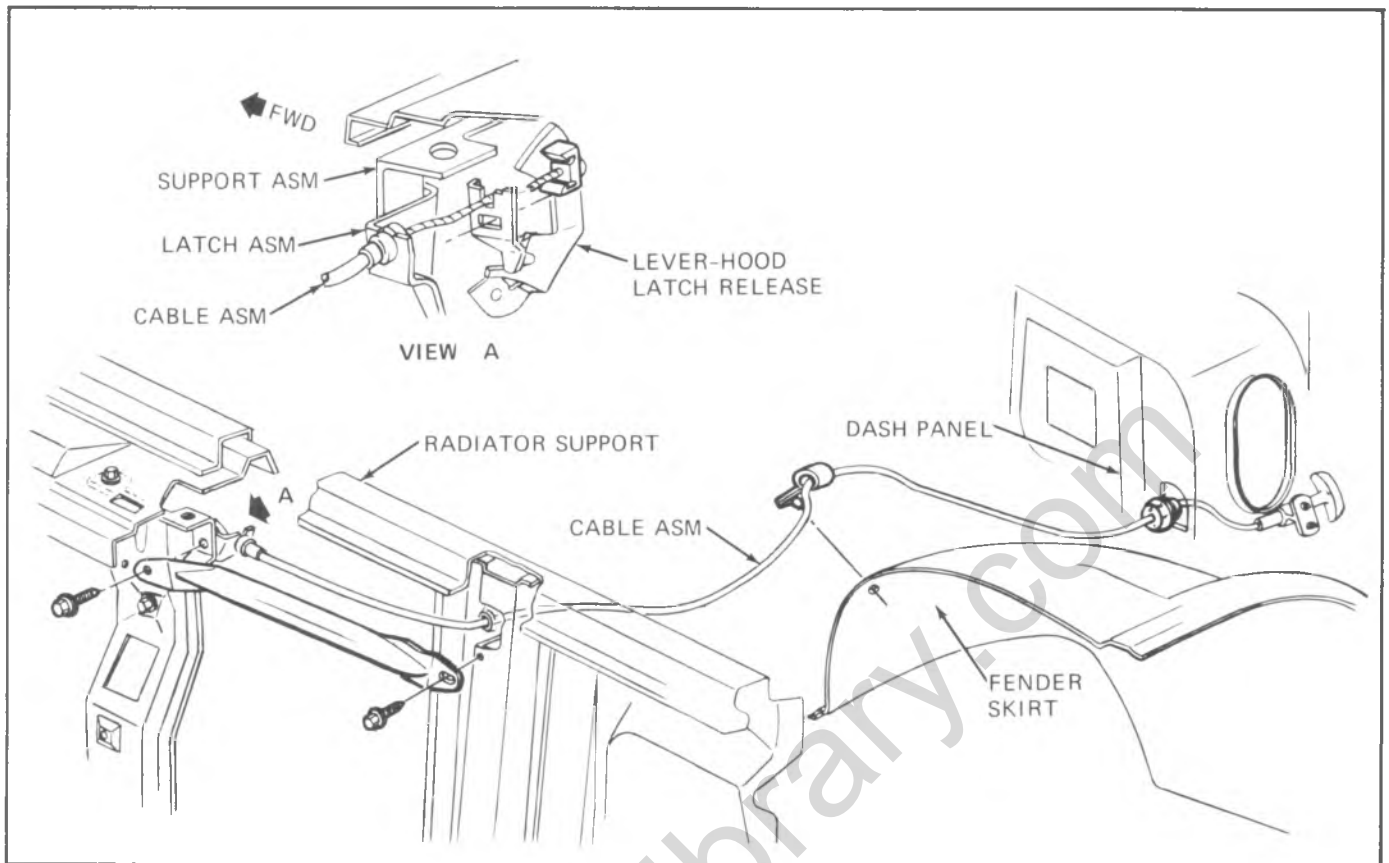


Fig. 2C-8- Hood Release Cable - CK Models

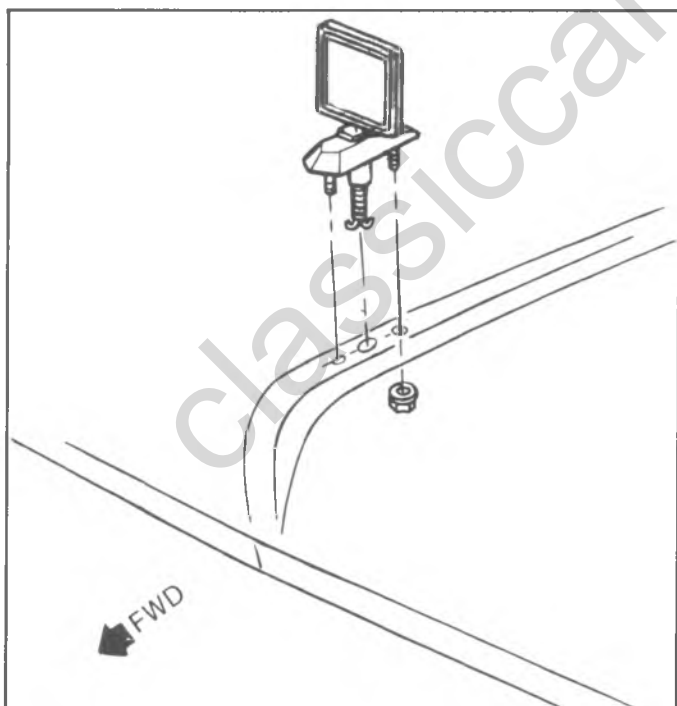


Fig. 2C-9- Hood Emblem - CK Models

necessary to align hood perform procedure as outlined under "Alignment" which follows.

Alignment

1. Loosen hood hinge bolts. Note that rear bolt holes in hinge is slotted to allow hood trailing edge to move up and down.
2. Adjust hood bumpers so that hood and adjacent surfaces are flush.
3. Perform hood lock adjustment as outlined in this section if necessary.

NOTE: Hood Lock Assembly to be adjusted fore and aft until nubble (part of Hood Lock Bolt Support Assembly) enters center of elongated guide (Socket). Bending nubble to accomplish this adjustment may seriously effect lock operation and

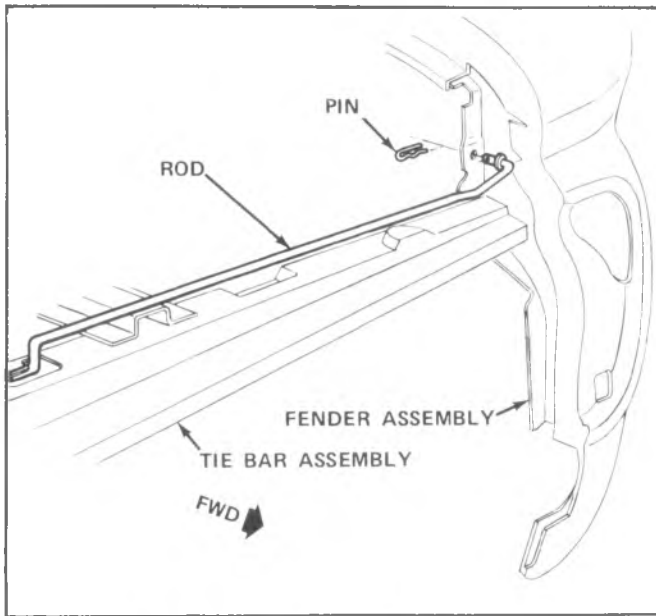


Fig. 2C-10--Hood Rod Support - G-Series

safety catch engagement and is, therefore, **NOT RECOMMENDED**.

Hood Rod Support - G-Series

Refer to Fig. 2C-10 for removal and installation of hood rod support.

CARBURETOR OUTSIDE AIR INLET

SNORKELS (Fig. 2C-11)

Removal

1. Raise hood and remove carburetor air duct from air snorkel by sliding duct rearward.
2. Remove two (2) screws attaching air snorkel to radiator support and remove from vehicle.

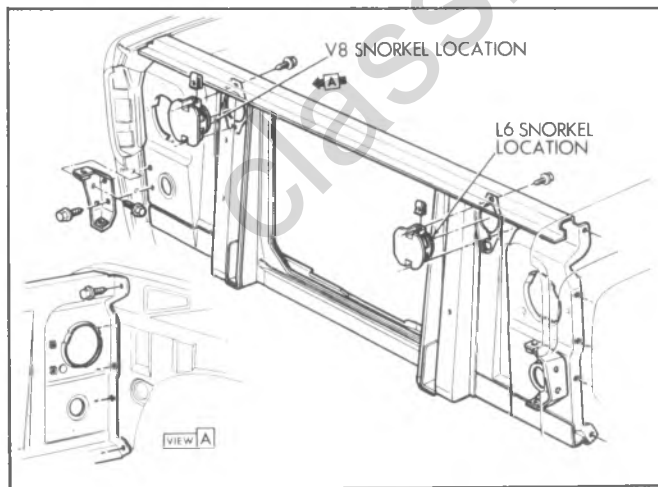


Fig. 2C-11--Carburetor Outside Air Inlet Snorkels—CK Series

RADIATOR GRILLE MOLDING - CK MODELS (FIG. 2C-12)

FRONT SHEET METAL ASSEMBLY-CK SERIES

Removal of entire front sheet metal assembly including radiator involves disassembly of mounts, disconnecting radiator hoses and removal of front bumper. Vehicles equipped with air conditioning and/or power steering will require special handling.

Refer to appropriate sections of this manual for instructions.

Shims which are found at various locations should be recorded to ease installation of sheet metal assembly.

Refer to Figure 2C-13 for sheet metal clearance.

Removal

1. Drain radiator and remove radiator hoses. Disconnect oil cooler lines if so equipped.
2. Disconnect wire connectors at the dash and toe panel and wire connector to horn and voltage regulator.
3. Disconnect battery and generator wires.
4. Remove front bumper bolts and remove bumper.
5. Remove bolts attaching fender upper edge to cowl door frame.
6. Remove fan shroud.
7. Working from underneath rear of fender, remove attachment from each fender at the hinge pillar.

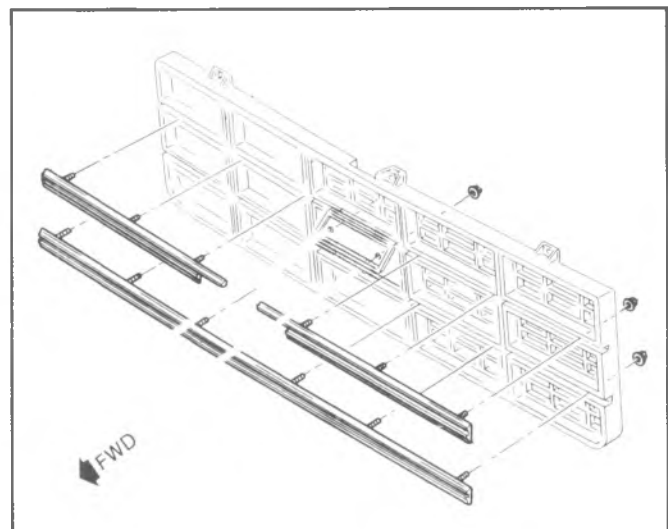


Fig. 2C-12--Radiator Grille Molding - CK Models

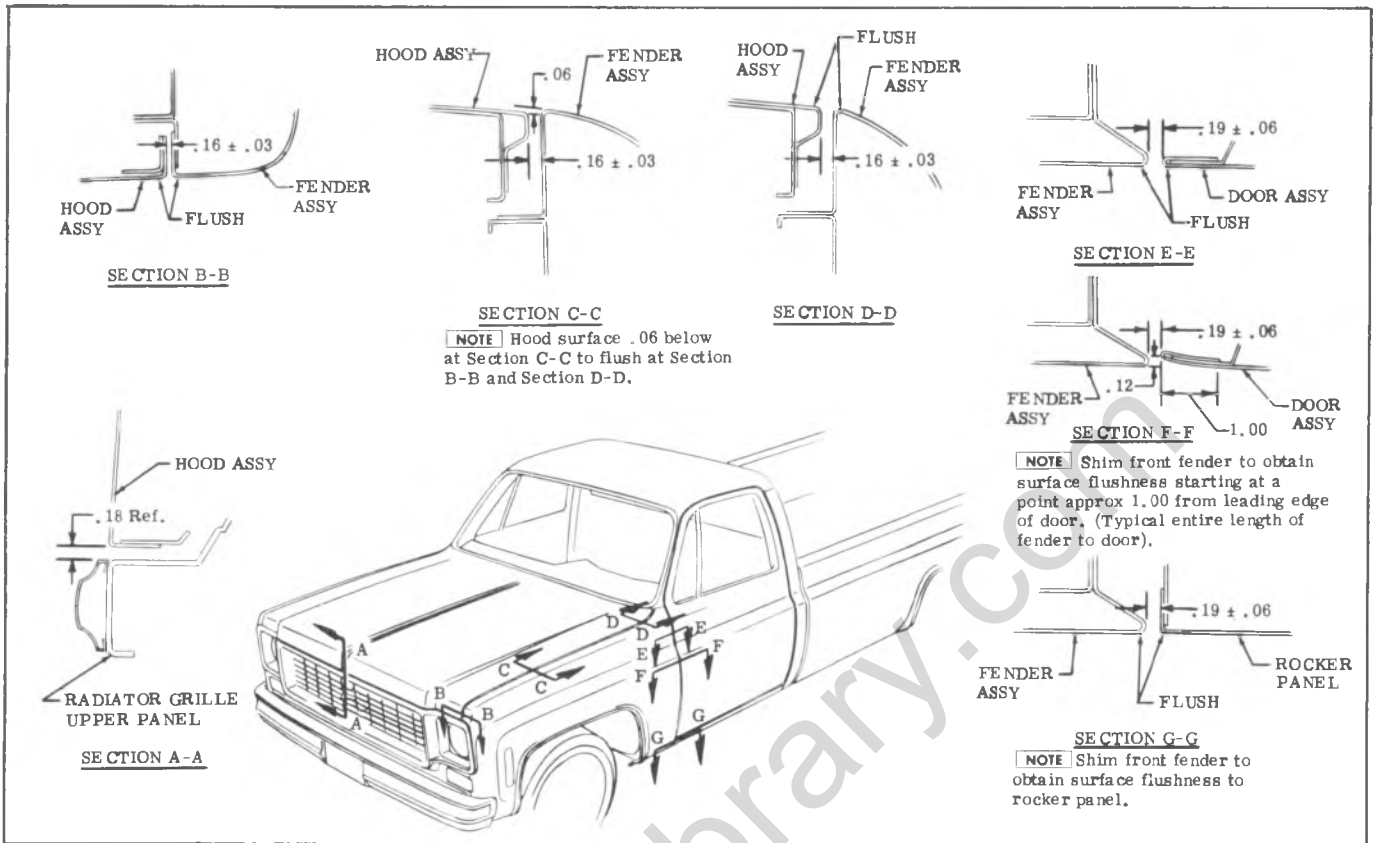


Fig. 2C-13-Sheet Metal Clearance—CK Series

8. Remove bolt from each radiator support mounting.

9. Remove bolts at each fender skirt to cab underbody (fig. 2C-14).

10. With a helper, remove front sheet metal assembly, with radiator, battery, horn and voltage regulator attached.

Installation

1. With a helper place sheet metal assembly in position.

NOTE: Install all bolts loosely to facilitate aligning after complete installation.

2. Install fender bolts at cowl.

3. Install combination bolt and flat washer assembly into each fender reinforcement while inserting shims required between fender reinforcement and body (See Figure 2C-15).

4. Install two bolts and shims required at each fender rear lower edge to hinge pillar.

5. Install bolt in each fender skirt to underbody.

6. Install bolts at steering column skirt reinforcement, final torque 25 ft. lbs.

7. Tighten each radiator support mounting bolt 33 ft. lbs.

8. Torque bolts at fender to cowl 25 ft. lbs.

9. Install front bumper.

10. Connect wire connectors at dash and toe panel. Attach generator and regulator wires.

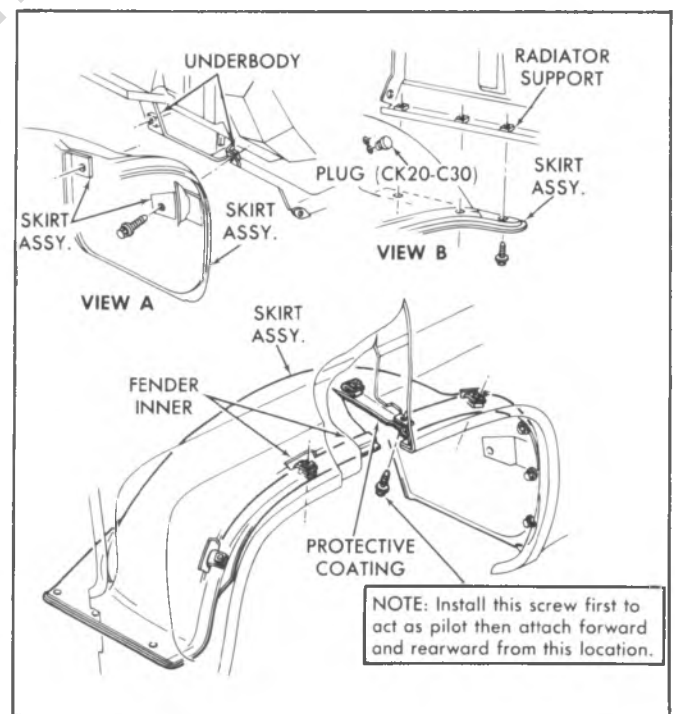


Fig. 2C-14-Fender Skirt Assembly—CK Series

11. Connect upper and lower radiator hoses. Connect oil cooler lines to the radiator on models so equipped.

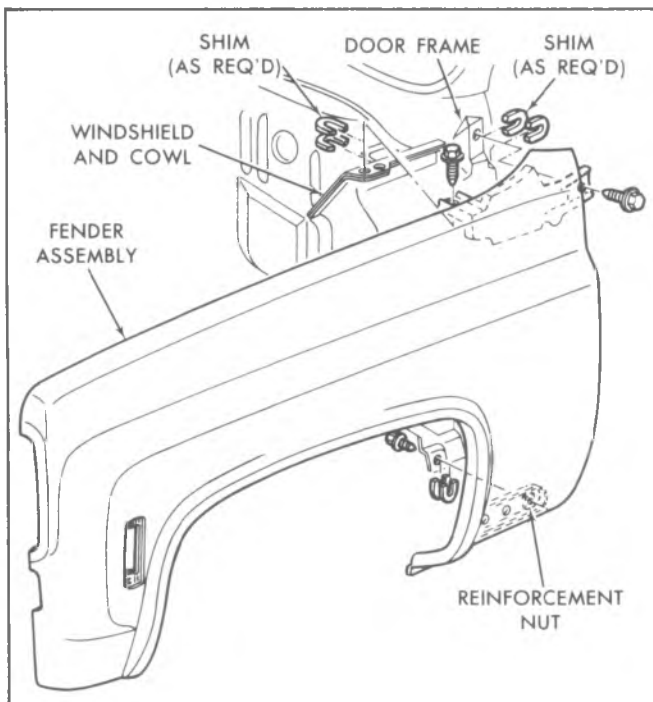


Fig. 2C-15--Front Fender Assembly—CK Series

12. Connect battery and fill radiator. Start engine and check for leaks.

Radiator Support

Removal

1. Remove hood as described in this section.
2. Drain radiator, saving coolant, loosen attachments and remove radiator and coolant recovery tank.
3. Disconnect and remove battery.
4. Remove battery tray with battery hanger.
5. Remove wiring from radiator support.
6. Disconnect fan shroud and lay back on engine.
7. Remove both head lamp assemblies.
8. Remove grille assembly.
9. Remove upper and lower radiator grille panels. (Fig. 2C-16).
10. Remove screws securing front fenders to radiator support.
11. Remove screws securing fender skirts to radiator support bottom. (Fig. 2C-14).
12. Remove bolt securing center grille support to radiator support.
13. Remove bolts securing hood catch assembly to radiator support.
14. Remove radiator support bolts secured to frame.
15. Tilt radiator support rearward and lift up and off.

Installation

1. Rotate radiator support into position and loosely install attachments to frame.
2. Connect center grille support to radiator support.

3. Connect hood latch plate.
4. Connect radiator support brackets to fenders.
5. Connect support to fenders.
6. Connect screws from underside of fender skirts to support bottom.
7. Attach grille upper panel to fenders loosely.
8. Attach grille lower panel to fenders.
9. Tighten radiator support bolts.
10. Place battery tray in position and fasten to radiator support.
11. Install radiator coolant recovery tank hoses and shroud.
12. Connect removed wiring to radiator support.
13. Install both head lamp assemblies.
14. Tighten all previously installed bolts and screws.
15. Install battery and connect leads and wires.
16. Install grille assembly.
17. Fill radiator with coolant as specified in Section 13.
18. Install hood on previously marked outline.

FRONT FENDER (FIG. 2C-15)

Removal

1. Remove hood and hinge assembly.
2. Remove head lamp bezel, wiring and attachments from fender.
3. Remove screws attaching upper and lower radiator grille panels.
4. Remove screws attaching fender wheel opening flange to skirt.
5. Remove skirt to fender bolts, located inboard on underside of skirt.
6. Remove two (2) screws attaching support bracket to fender.
7. Remove five (5) screws attaching radiator support to front fender.
8. Remove bolt and shim attaching trailing edge of fender to hinge pillar.
9. Remove two bolts and shims at top rear of fender attaching to cowl.

Installation

To install, reverse the removal procedure using sealing tape between filler panel and fender. Check sheet metal alignment.

FRONT FENDER AND SKIRT (FIGS. 2C-14 AND 2C-15)

Removal

1. Remove hood and hood hinge assembly.
2. Disconnect and remove battery (right side or auxiliary left side).
3. Remove head lamp bezel, wiring and attachments from fender.
4. Remove screws attaching upper and lower radiator grille panels.
5. Remove screws attaching skirt to radiator support.

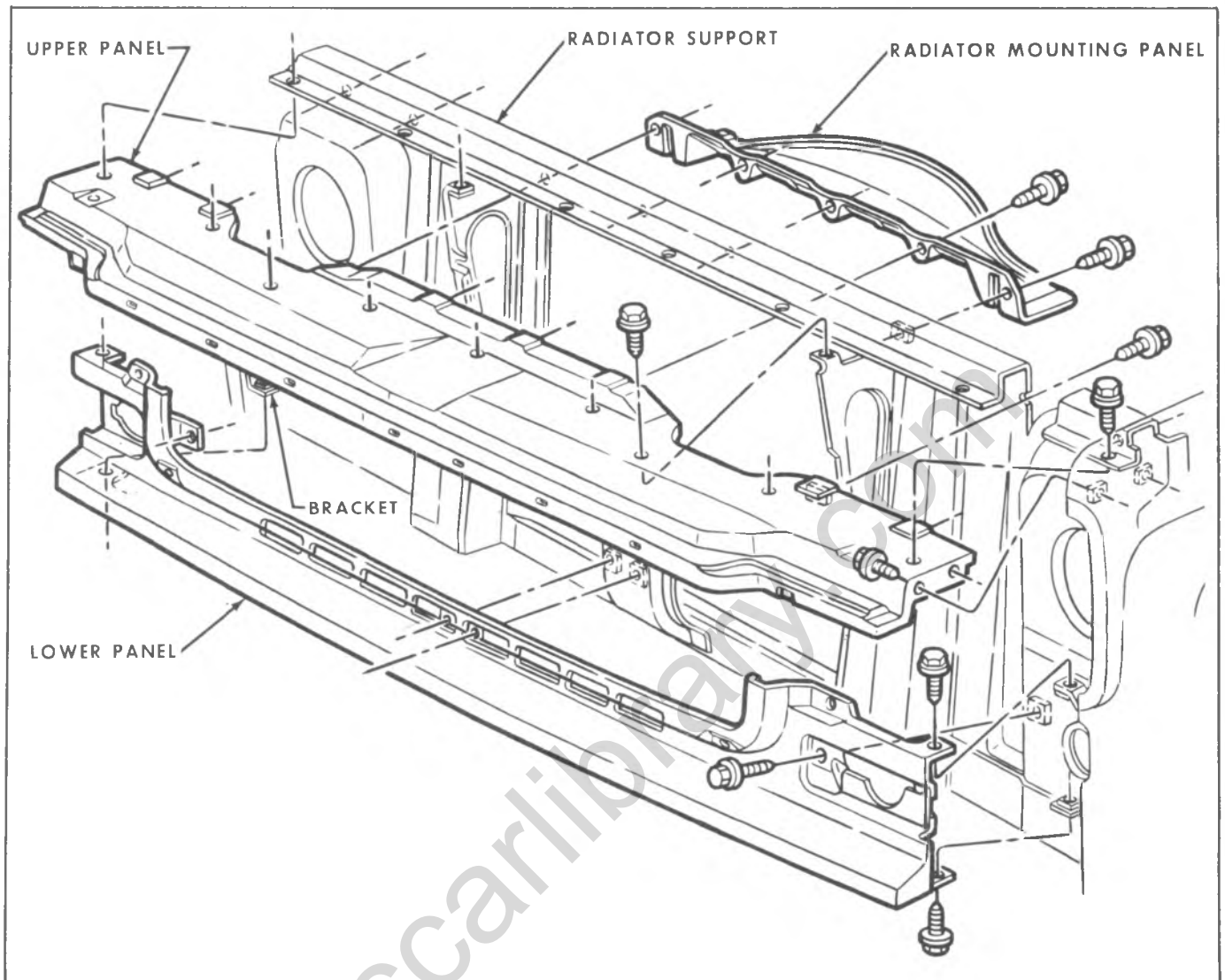


Fig. 2C-16--Radiator Upper and Lower Grille Panels—CK Series

6. Remove two (2) top rear fender bolts and shims.
7. Remove bolt and shims at bottom of fender.
8. Remove bolt and shim(s) attaching skirt to underbody.
9. Remove two (2) screw attaching support bracket to fender.
10. Remove five (5) screws attaching radiator support to front fender.
11. Lift fender and skirt from truck.

Installation

Install front fender and skirt assembly in reverse order of removal.

FRONT FENDER SKIRT

Refer to figure 2C-14 for removal and installation of Front Fender Skirt.

RUNNING BOARDS

Refer to figure 2C-17 for removal and installation of running boards.

Front Sheet Metal Assembly - G Series

The front end sheet metal components not covered in this section are covered in the Body Section 1B.

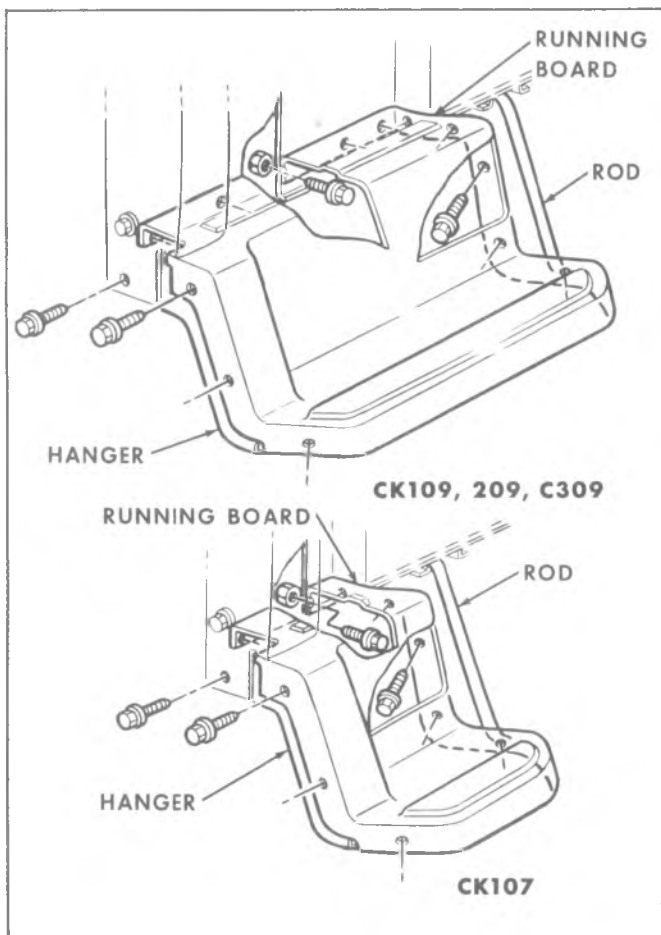


Fig. 2C-17-Running Boards—CK Series

SHEET METAL CHECKING

Refer to the sheet metal checking illustration figure 2C-18 for proper gaps and hood adjustments.

Fender Skirt - P Series

Refer to figure 2C-19 for removal and installation of fender skirt, brackets, rear supports and hangers.

WOOD GRAIN APPLIQUE

INSTALLATION PROCEDURE

General

The wood grain applique (transfer film) is a vinyl material with a pressure sensitive adhesive backing. The transfers are serviced in pre-cut panels. The transfers are designed with an appealing wood grain pattern and a 50 degree or semi-gloss finish.

Preparation of the surface to which the transfer will be applied is very important. In cases where body metal repair has been made it is necessary to prime and color coat these areas to blend with the undamaged surface.

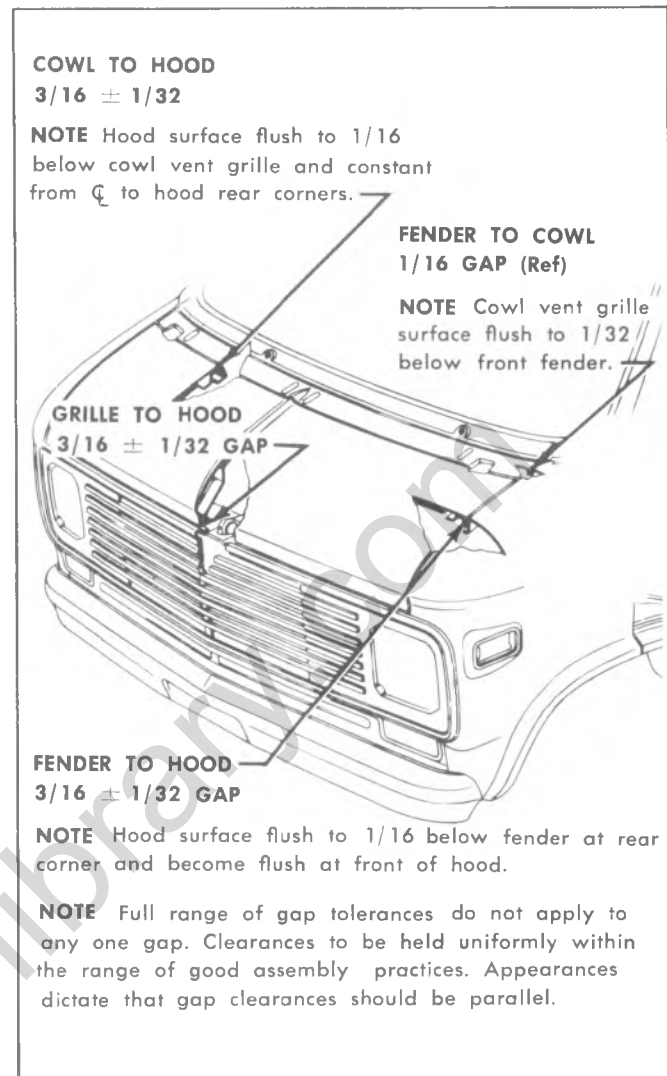


Fig. 2C-18-Front End Sheet Metal Checking—G Series

Apply the transfer film to color coated panels only, never to bare metal or primer.

The surface must be free of any imperfections that might high-light through the film. Remove dirt nibs and other foreign material in the paint by light sanding with 600 grit sandpaper.

The temperature of the body must be maintained at a moderate level between approximately 70 and 90 degrees. Too warm a body will cause the wood grain film to stick prematurely while too cool a body will reduce the adhesion of the wood grain film. Cool the body panel with cool water when too warm and heat the body panel with a heat gun or a heat lamp when too cold.

Transfers should not be replaced in temperatures below 65 degrees Fahrenheit. The transfer should not be subjected to temperature greater than 175 °F and should not be left at or near this temperature for extended periods of time.

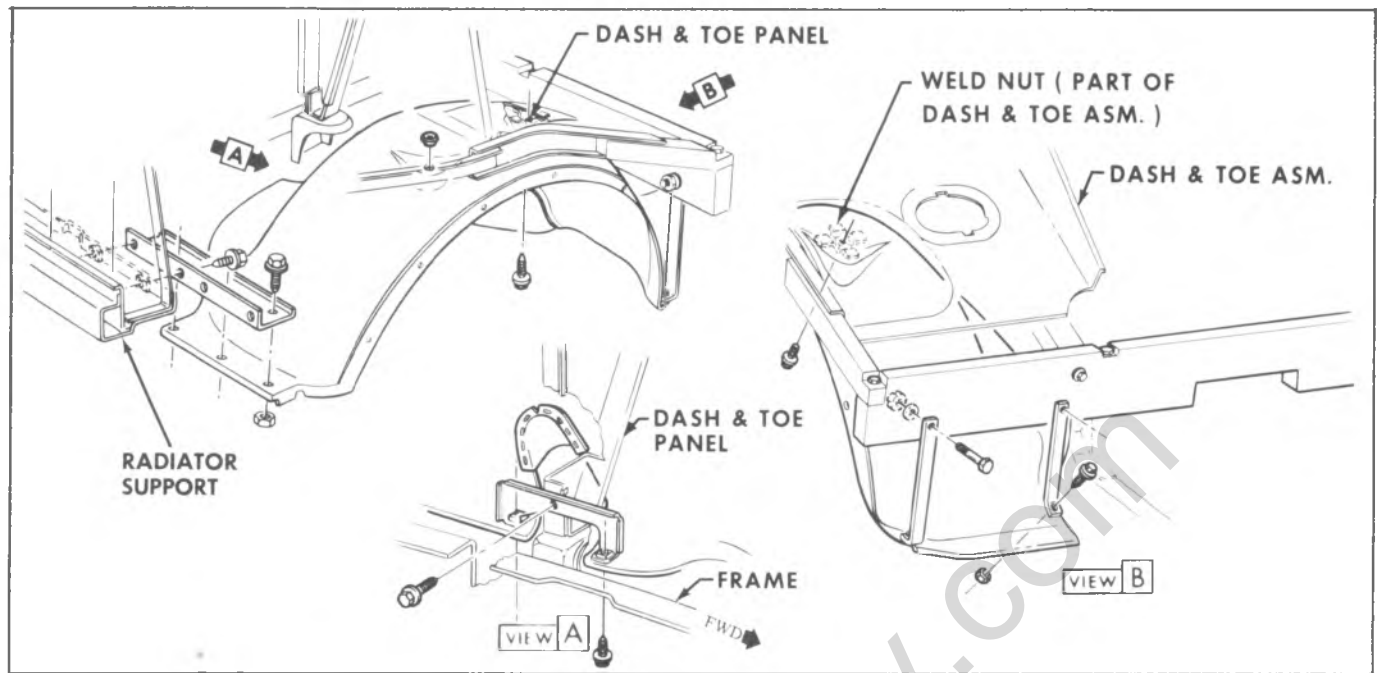


Fig. 2C-19 -Fender Skirt, Dash and Toe Pan—P Series

Shelf life of the transfer material is 90 days at a temperature not to exceed 105 F.

Removal

Remove the moldings from the affected panel. The transfer film may then be removed by lifting an edge and peeling the material from the painted surface. Exercise care so as not to damage the paint. Application of heat to the transfer and the panel by means of a heat gun or heat lamp will aid in the removal.

Installation

1. With a solvent dampened sponge, clean entire surface to be covered with applique.
2. Wipe area dry with a clean cloth.
3. Prior to application of transfer, wet down the complete transfer surface of the fender with a solution of 1/4 oz. of neutral detergent cleaner (must not contain oils, perfumes, or bleaches) per gallon of clear water. It is essential that no substitute for this solution be used and that the specified proportions be maintained.
4. While entire area is still wet with solution,

remove paper backing from transfer and align upper edge with pierced holes in fender and press on lightly.

5. Start at center of transfer and squeeze outboard from middle to edges removing all air bubbles and wetting solution to assure a satisfactory bond. Use teflon-backed plastic squeegee only.

6. Notch applique at fender rear contour bend areas with scissors. Also notch out front marker lamp.

7. Fold ends of applique over fender flanges using squeegee. Heat the wrap-around area of applique with a heat lamp or gun to approximately 90°F and press with squeegee to secure entire edge surface.

8. If the wrap-around of the transfer has trouble sticking to fender edges, brush vinyl adhesive onto the fender or transfer area. Allow the adhesive to set for one minute then press transfer to fender for adhesion.

9. Inspect transfer installation from critical angle using adequate light reflection to detect any irregularities that may have developed during installation. Remove all air or moisture bubbles by piercing each at an acute angle with a fine pin or needle and by pressing the bubble down.

10. Install previously removed parts and clean up vehicle as required.

SPECIFICATIONS

SHEET METAL

SECTION 2C

TORQUE SPECIFICATIONS

	CK	G	P
Lock Support to Hood	150 in. lbs.	150 in. lbs.	
Lock Bolt Nut	30 ft. lbs.	40 ft. lbs.	
Bumper Bolt Nut	85 in. lbs.	150 in. lbs.	
Hood Hinge	35 ft. lbs.	18 ft. lbs.	
Hood Lock Catch	150 in. lbs.	18 ft. lbs.	
Lock Support to Rad. Support	18 ft. lbs.	18 ft. lbs.	
Rad. Support to Frame	35 ft. lbs.		30 ft. lbs.
Rad. Support to Fender	150 in. lbs.		
Fender Skirt to Fender	150 in. lbs.		150 in. lbs.
Fender to Cowl	35 ft. lbs.		
Rad. Grille Panel	150 in. lbs.		

SECTION 2D

BODY

The following caution applies to one or more steps in the assembly procedure of components in this portion of the manual as indicated at appropriate locations by the terminology "See Caution on page 1 of this Section".

CAUTION: *THIS FASTENER IS AN IMPORTANT ATTACHING PART IN THAT IT COULD AFFECT THE PERFORMANCE OF VITAL COMPONENTS AND SYSTEMS, AND/OR COULD RESULT IN MAJOR REPAIR EXPENSE. IT MUST BE REPLACED WITH ONE OF THE SAME PART NUMBER OR WITH AN EQUIVALENT PART IF REPLACEMENT BECOMES NECESSARY. DO NOT USE A REPLACEMENT PART OF LESSER QUALITY OR OF SUBSTITUTE DESIGN. TORQUE VALUES MUST BE USED AS SPECIFIED DURING REASSEMBLY TO ASSURE PROPER RETENTION OF THIS PART.*

CONTENTS OF THIS SECTION

General Description.....	2D-1
C-K Models.....	2D-1
G Models.....	2D-1
On Vehicle Service.....	2D-4
Specifications.....	2D-61,62
Special Tools.....	2D-63

GENERAL DESCRIPTION

On the following pages, service procedures will be given for components on all 10-20-30 series trucks in C, K and G models. Reference will be made, both in text and illustrations, to vehicle model lines and to individual model numbers within these model lines.

As an aid to identification of specific models, the following general descriptions are given.

Chassis/Cabs

All chassis cabs use "03" as the model identification. See figure 2D-1. Two-wheel drive units come in C10, C-20 and C-30 series. Four-wheel drive units may be either K-10 or K-20. Optional pickup boxes are available.

Crew Cab/Chassis

Model number "63" designates the crew cab/chassis models. See figure 2D-2. Optional pickup boxes are available.

Coach

The four-door coach model number is "06". See figure 2D-3. Base models have rear cargo doors. An optional endgate with moveable window is available.

Utility

Utility models are designated with the number "16". See figure 2D-4. An optional removable roof is also available.

Vans

G-Series Vans are available in three model number designations. See figures 2D-5 and 2D-6. Vans without body windows use number "05"; vans with body windows are "06" models; "03" vans have an open cargo area, as shown in figure 2D-6.

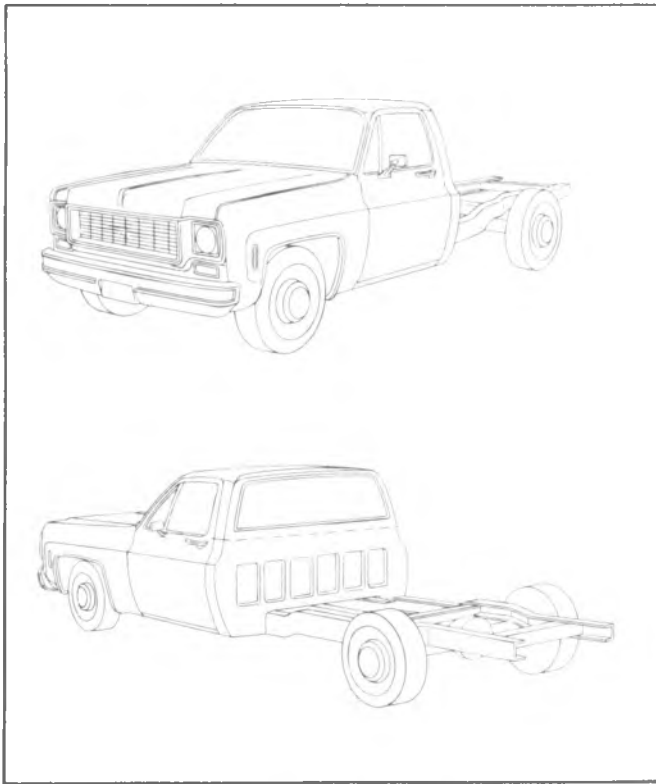


Fig. 2D-1--Typical Chassis/Cab

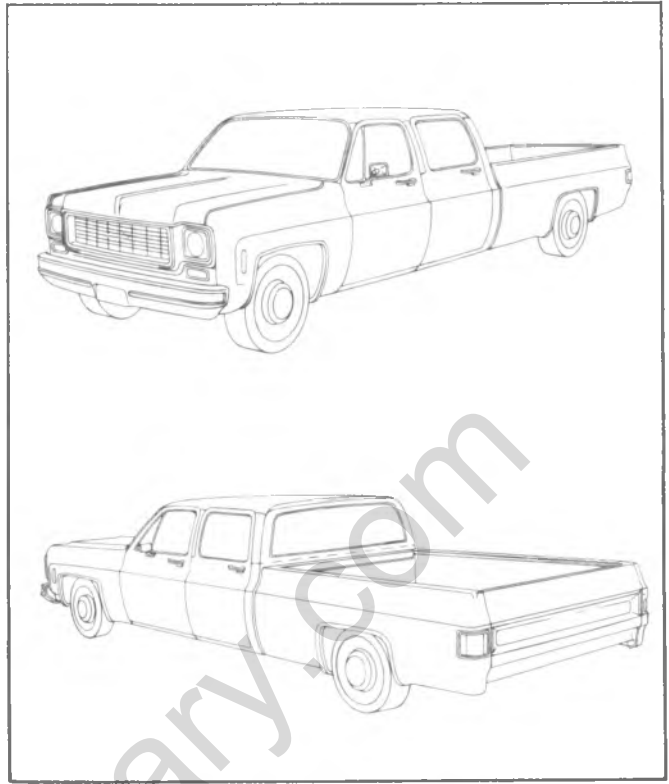


Fig. 2D-2--Typical Crew Cab/Chassis



Fig. 2D-3--Typical Coach

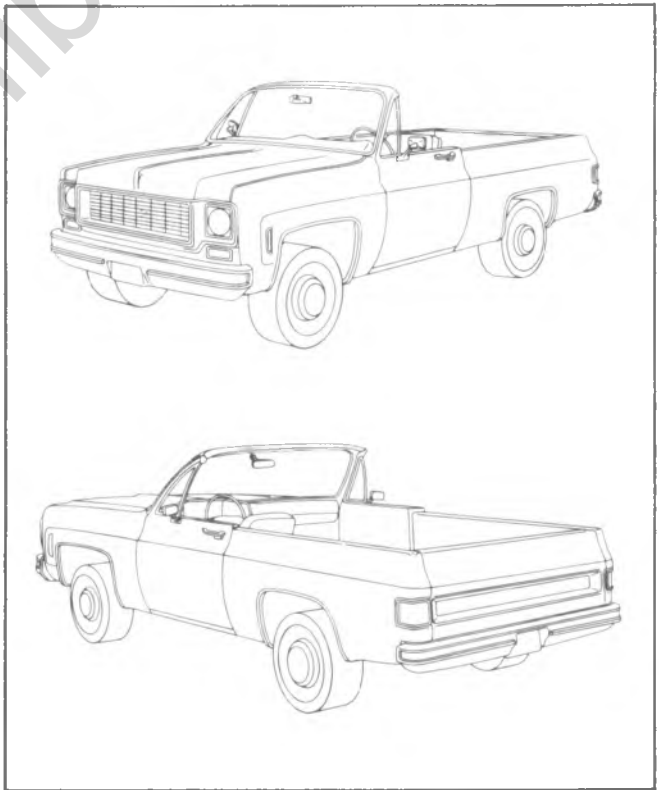


Fig. 2D-4--Typical Utility Vehicle

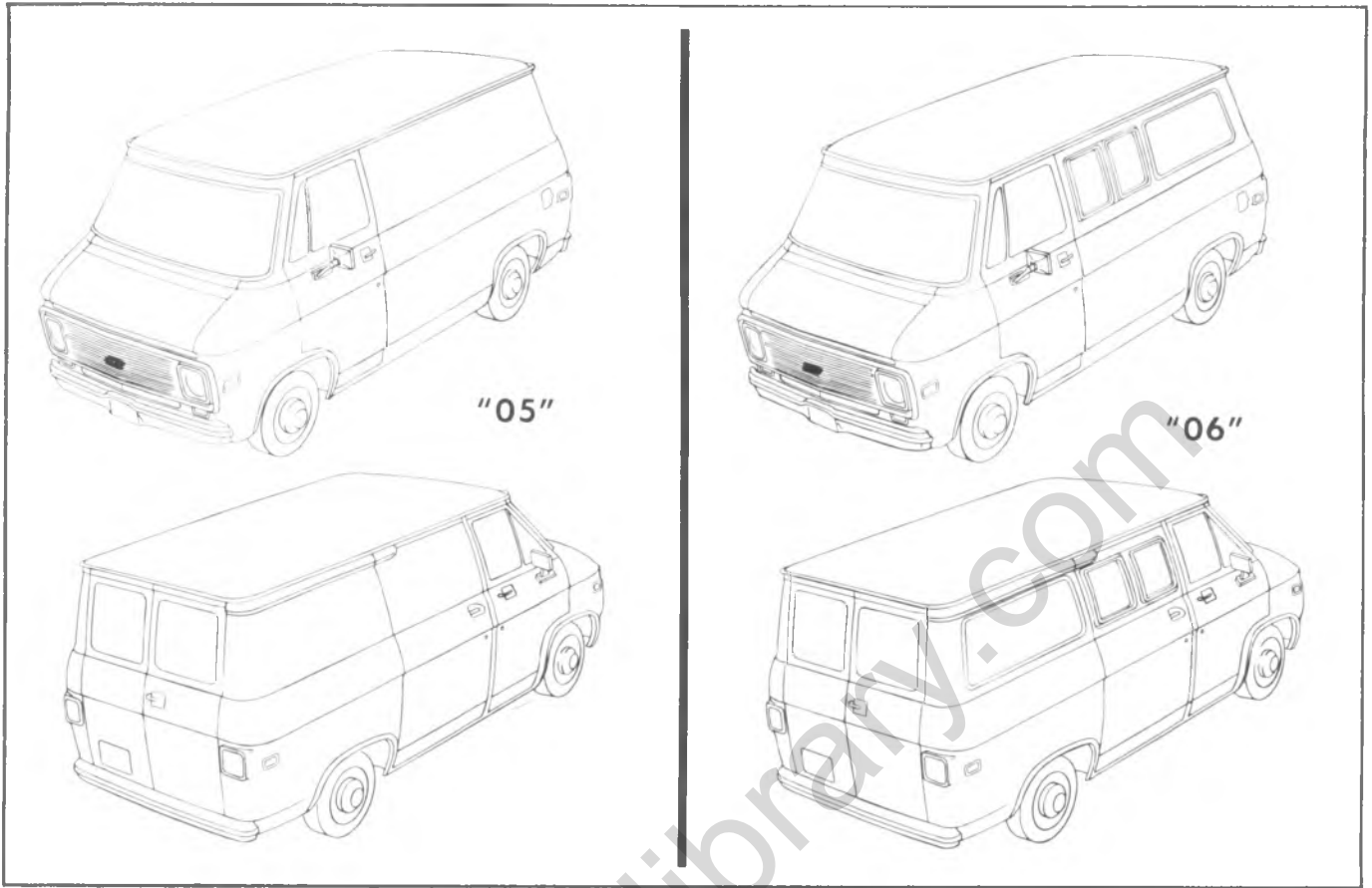


Fig. 2D-5-Typical "05" and "06" Vans

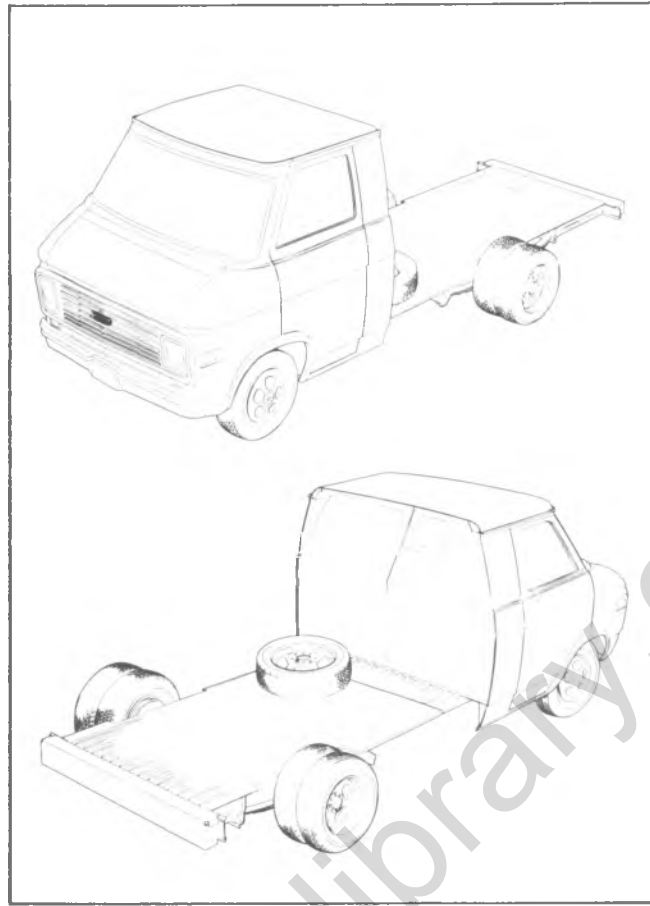


Fig. 2D-6--Typical "03" Van

ON VEHICLE SERVICE

C-K MODELS

INDEX

Front End			
Windshield Wipers.....	2D-5		
Glove Box.....	2D-5		
Rear View Mirrors.....	2D-6		
Body Glass			
Windshield Glass.....	2D-7		
Stationary Body Glass.....	2D-9		
Side Doors			
Adjustments.....	2D-11		
Front Side Door.....	2D-12		
Replacement.....	2D-12		
Hinges.....	2D-12		
Ventilator.....	2D-12		
Window and Regulator.....	2D-14		
Locks, Handles, Rods.....	2D-16		
Weatherstrip.....	2D-17		
Rear Side Doors.....	2D-17		
Replacement.....	2D-17		
Hinges.....	2D-17		
Stationary Glass.....	2D-18		
Window and Regulator.....	2D-19		
Locks, Handles, Rods.....	2D-19		
Weatherstrip.....	2D-20		
Rear Doors			
Adjustments.....	2D-20		
Locks, Handles, Rods.....	2D-20		
Hinges.....	2D-20		
Gates			
Endgates.....	2D-24		
Tailgates.....	2D-28		
Removable Top - Folding Top (Utility).....	2D-29		
Seats.....	2D-30		
Body Mounting.....	2D-34		

FRONT END

WINDSHIELD WIPERS

Windshield wiper units on all models are of the two-speed electric type. A single wiper motor unit, mounted to the left side of the dash panel inside the engine compartment, powers both wiper blades. The wiper blade operating link rods and pivot mountings on these models are located in the outside air inlet plenum chamber.

Arm Adjustment

To adjust sweep of blades, turn on wipers and note sweep of arms. If necessary, remove one or both arms as follows: Pull outer end of arm away from glass which will trip lock spring at base of arm and release spring from undercut of pivot shaft. While holding arm in this position, pull outward on cap section at base of arm to remove arm. Arm can be reinstalled in any one of several positions due to serrations on pivot shaft and in arm cap. See figure 2D-7.

Wiper Arm Pivot Shafts and Linkage

Removal

1. Remove windshield wiper arms from pivot shafts. Procedure for removing arms is explained previously under "Arm Adjustment".

2. Remove two nut and lock washer assemblies from the connector link to motor drive arm via the plenum access hole.

3. Remove two screws from each transmission

pivot shaft assembly to windshield frame. Remove wiper linkage and transmission from plenum.

Installation

1. Place wiper linkage and transmission into position. Secure assembly with two screws at each transmission.

2. Attach end of cross rod to drive arm of motor assembly. Secure rod.

3. Before installing wiper arms, operate wiper motor momentarily which should rotate pivot shafts to park position. Install arms and shafts.

INSTRUMENT PANEL COMPARTMENT AND LOCK

Replacement

Removal of the entire assembly including door may be accomplished by removing four screws which attach hinge just below box. See figure 2D-8. The outer door panel may be removed, leaving the compartment intact, by removal of four screws. Access to the door stop

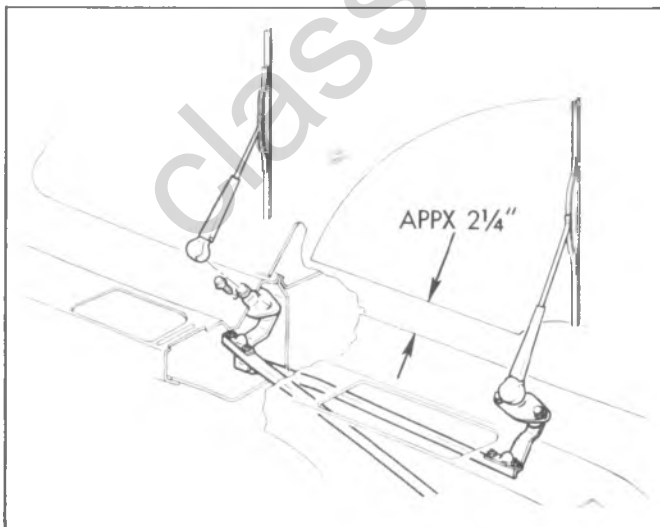


Fig. 2D-7--Windshield Wipers

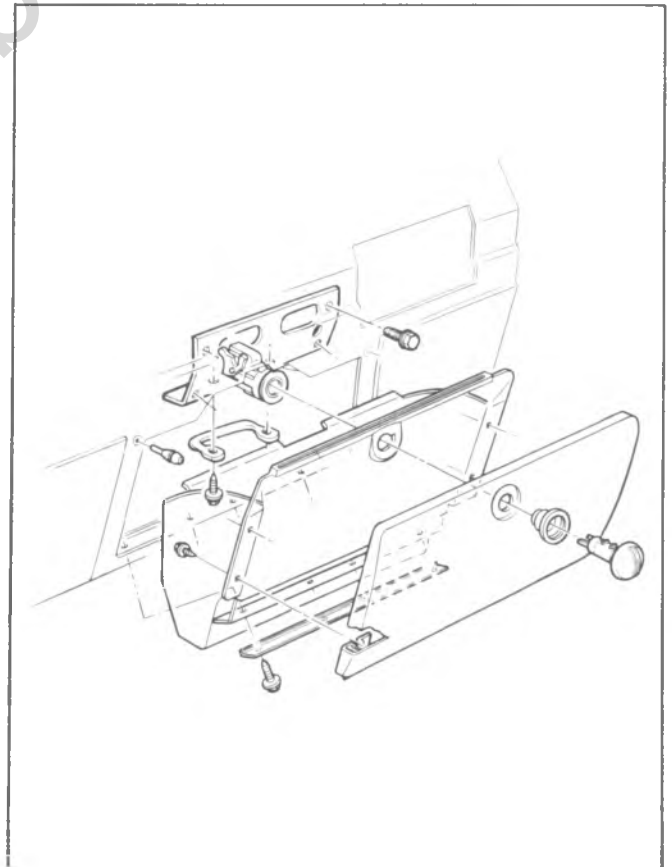


Fig. 2D-8--Glove Box

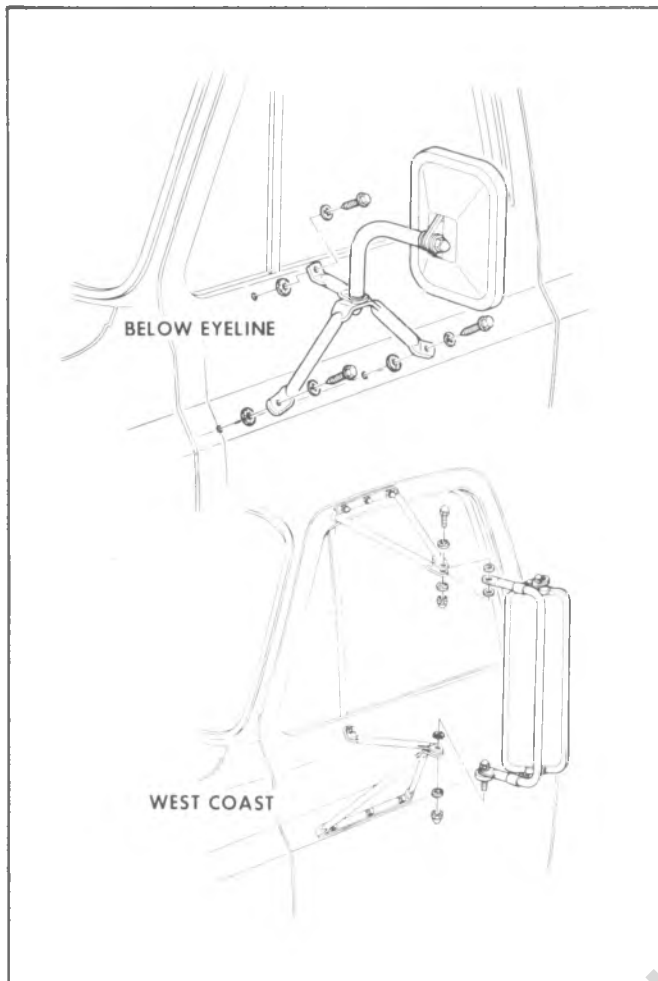


Fig. 2D-10--Rear View Mirrors

bumper is gained by reaching into compartment opening with door partially open.

Adjustment

Engagement of lock in striker may be adjusted by loosening striker retaining screws and moving the striker to desired position.

OUTSIDE REAR VIEW MIRRORS

Rear view mirror installations are shown in figure 2D-9, 2D-10 and 2D-11. Occasional tightening of mounting and assembly bolts and screws will sharply decrease occurrence of failure due to door slamming or road shock.

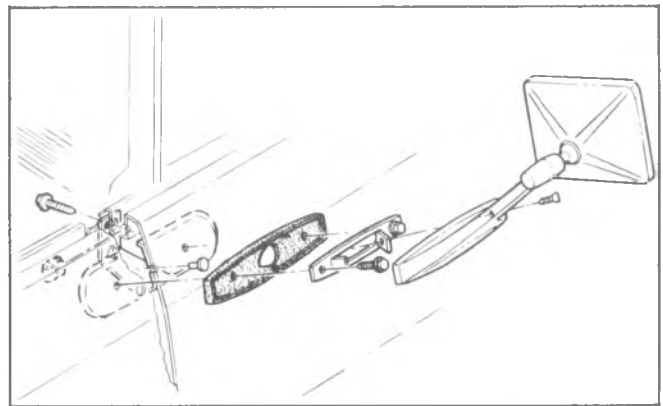


Fig. 2D-9--Rear View Mirror Base

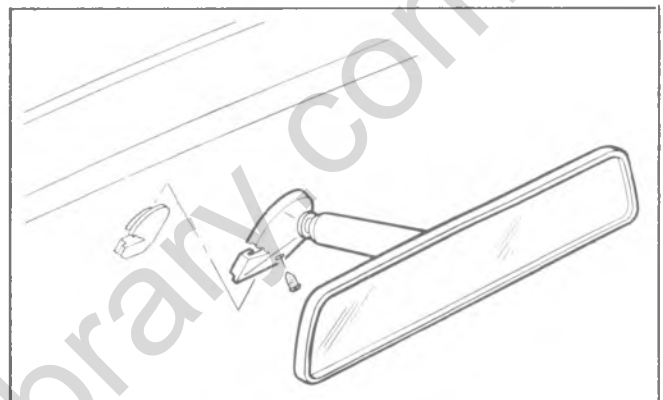


Fig. 2D-11--Inside Rear View Mirror

NOTE: Camper mirror installation is similar to the below eyeline mirror installation.

INSIDE REAR VIEW MIRROR - FIGURE 2D-11

Replacement

1. Remove screw retaining mirror to its glass-mounted bracket and remove mirror.
2. Install mirror into its mounting bracket. Torque screw to specifications.

COWL VENT VALVE - FIGURE 2D-12

Two styles are shown in Figure 2D-12. Removing the attaching screws allows removal of the valve from the side panels.

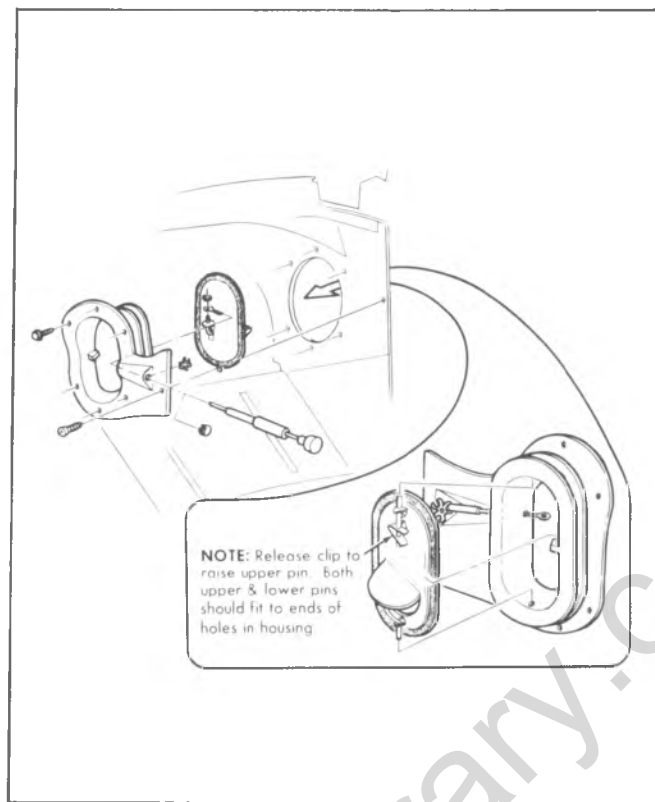


Fig. 2D-12-Cowl Vent Valves

BODY GLASS

WARNING: Always wear gloves when handling glass.

WINDSHIELD GLASS

The windshield is a one-piece type and is retained in the windshield opening by a molded rubber weatherstrip. See figure 2D-13.

When replacing a cracked windshield glass, it is very important that the cause of the glass breakage be determined and the condition corrected before a new glass is installed. Otherwise, it is highly possible that a small obstruction or high spot somewhere around the windshield opening will continue to crack or break the newly installed windshield especially when the strain on the glass caused by this obstruction is increased by such conditions as wind pressures, extremes of temperature, motion of the vehicle, etc.

NOTE: The procedure for removal of the

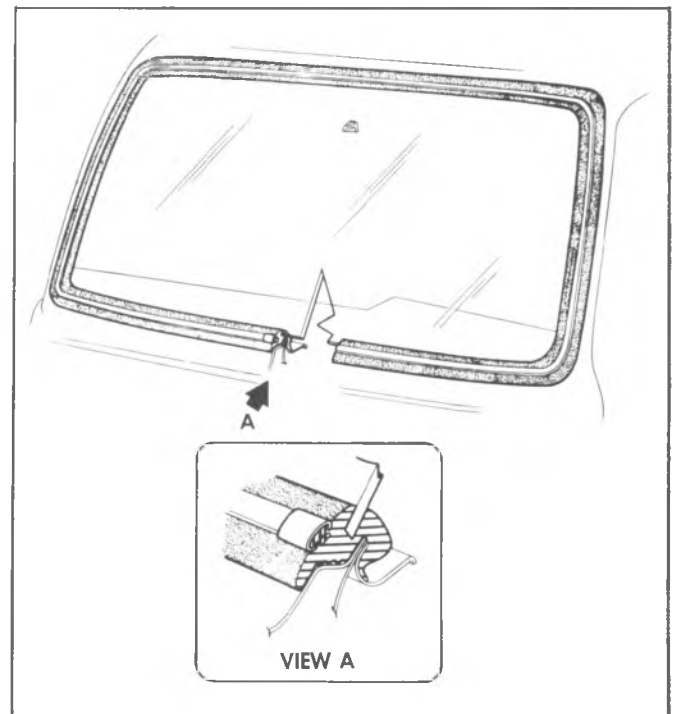


Fig. 2D-13-Typical Windshield

windshield applies to other stationary glass applications, such as in figures 2D-20 and 2D-21.

Removal

1. Before removing the windshield, mark the location of the break on the windshield rubber channel and the body. Protect the paint finish inside of the cab. Mask around the windshield opening and outside, lay a suitable covering across the hood and fenders.

NOTE: The windshield glass rubber weatherstrip is one piece. The glass is held in a channel within the weatherstrip.

2. **On vehicles without reveal moldings,** "unzip" the locking strip shown in figure 2D-18.

3. **On vehicles with reveal moldings,** remove reveal molding with tools show in figure 2D-19.

4. To free windshield rubber channel of weatherstrip loosen the lip of the windshield weatherstrip from the pinchweld flange along the top and at the sides by



Fig. 2D-14--Applying Pressure to Windshield



Fig. 2D-15--Assisting Weatherstrip over Flange

applying firm, controlled pressure to the edge of the glass. At the same time assist the lip of the rubber weatherstrip channel over the pinchweld flange with a flat bladed tool. See figures 2D-14 and 2D-15.

5. With the aid of an assistant outside the cab, remove the windshield from the opening. See figure 2D-16.

Checking Windshield Opening

Due to the expanse and contour of the windshield it is imperative in the event of a stress crack that the windshield opening be thoroughly checked before installing a replacement windshield. The replacement glass is used as a template.

1. Check for the following conditions at the previously marked point of fracture.

- a. Chipped edges on glass.
- b. Irregularities in body opening.
- c. Irregularities in rubber channel weatherstrip.

2. Check flange area for solder, weld high spots, or hardened spot-weld sealer. Remove all high spots.

3. Check windshield glass to opening, by supporting glass with six spacers contained in packet J-22577. See figure 2D-17.

CAUTION: Do not strike glass against body metal. Chipped edges on the glass can lead to future breaks.

4. With the windshield supported and centered in its opening, check the relationship of the glass to the body opening flange around the entire perimeter of the glass.

5. Check the relationship of glass to opening as follows:

- a. Inside edge of glass to body flange.
- b. Outer edge of glass to parallel body metal.

6. Mark areas of body metal or flange to be reformed remove glass and correct as necessary.



Fig. 2D-16--Removing Windshield from Opening



Fig. 2D-17-Checking Windshield Opening

7. Recheck windshield in its opening and if satisfactory proceed as follows:

Installation

1. Place a protective covering over front fenders and hood, then apply soapy water to all grooves of the weatherstrip.

2. Install weatherstrip centrally to the body opening, with the pinchweld flange in the inner weatherstrip groove. See figure 2D-18.

NOTE: Because of the configuration of the weatherstrip and of the importance of centrally locating the weatherstrip in the body opening, it is **not recommended** to use the "cord-type" installation technique.

3. Position the lower edge of the windshield glass into the outer weatherstrip groove. Gently push the glass "into" the weatherstrip, assisting rubber over edge of glass.

4. When glass is in position, lock the weatherstrip to the glass as follows:

a. Base Weatherstrip - Bend the "locking strip" over and use a thin bladed tool to lock weatherstrip tightly against windshield. See figure 2D-18 for detail.

b. Optional Weatherstrip - Use J-2189-24 and J-2189-23 in Handle J-2189 to install flexible reveal molding into locking slot of weatherstrip, as shown in figure 2D-19. This will expand the weatherstrip to a tight

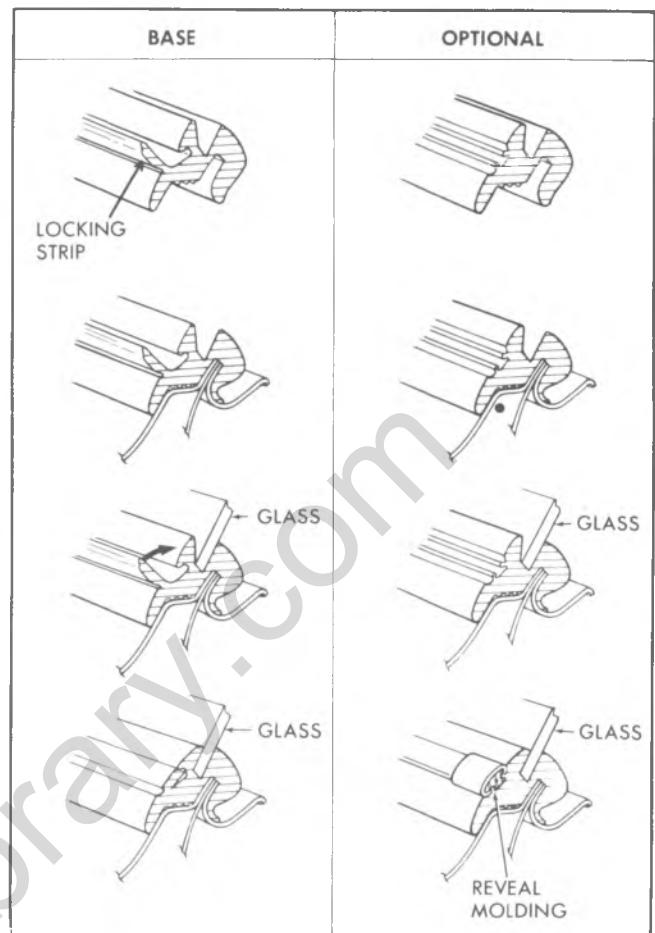


Fig. 2D-18-Locking the Weatherstrip to the Glass

fit against the windshield. Install reveal molding so that joint is at center of lower edge of windshield. Cover the joint with the molding cap.

STATIONARY BODY GLASS

Replacement

The method used to remove the windshield glass may be applied to other stationary glass, such as shown in figures 2D-20 and 2D-21. Remember to check for cause of breakage, and to always wear gloves when handling glass. Installation procedures are similar to G-Van windshield. Refer to figures 2D-94 and 2D-95, later in this section.



Fig. 2D-19--Installing Reveal Molding

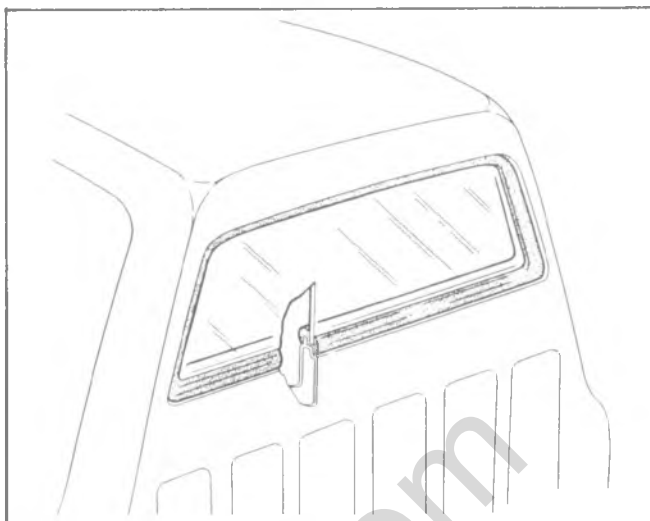


Fig. 2D-20--Back Window Glass - (03, 63)

classiccarylbrary.com

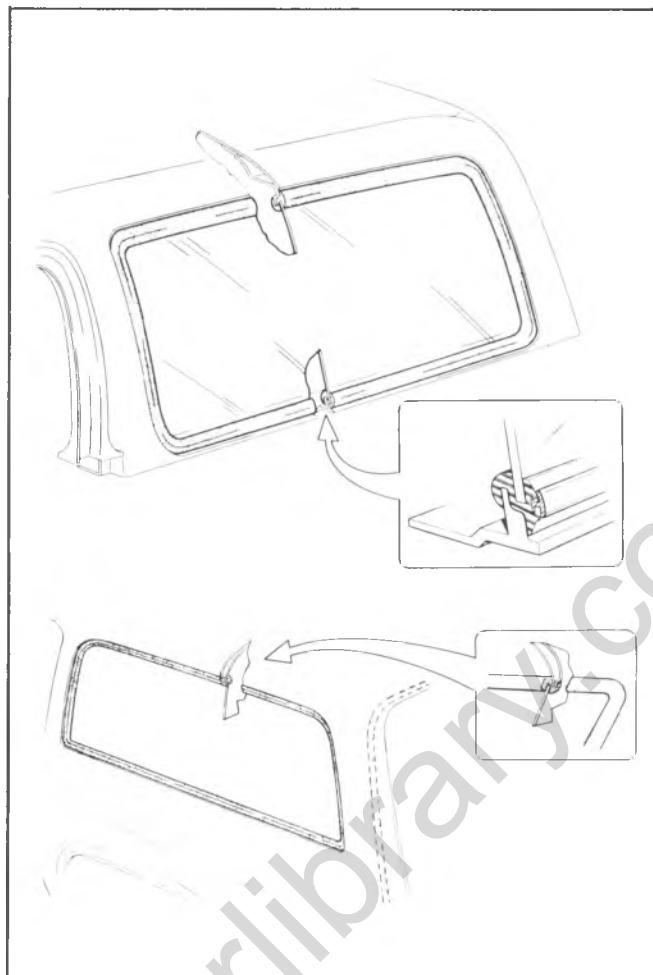


Fig. 2D-21--Body Side Window - (14 and 06)

BODY SIDE DOORS

DOOR ADJUSTMENTS

Doors can be adjusted for alignment of clearance in the cab door opening, and for proper latching. Door alignment adjustments are made at the striker bolt, and at door hinges. The door, when properly located in door opening, will have .19 inch clearance at the top and side edges, and .25 inch clearance at the bottom. The door should be adjusted in the opening so the edge of the door across the top and also at the lock side is parallel with the body opening as nearly as possible.

Hinge Adjustment

Door hinge bolt holes are oversized to make adjustment possible. Alignment adjustments can be made by loosening the proper hinge bolts, aligning door to proper position, and tightening bolts securely. See figure 2D-22, for typical adjustments.

Striker Bolt Adjustment

With the use of J-23457, shown in figure 2D-23, the striker bolt can be adjusted in any of three ways. See figure 2D-24.

1. **Up and down** - To adjust striker up or down, loosen bolt, adjust to desired height, and tighten bolt securely.

NOTE: This adjustment is important to assure that the right proportion of door's weight will rest on striker bolt when door is closed. If bolt is positioned too high on pillar, rapid wear will occur to the lock cam; if too low, an extra load will be placed on door hinges as well as pull door downward and out of alignment.

2. **In and Out** - To adjust striker in and out, loosen bolt, adjust horizontally to desired position and tighten bolt securely.

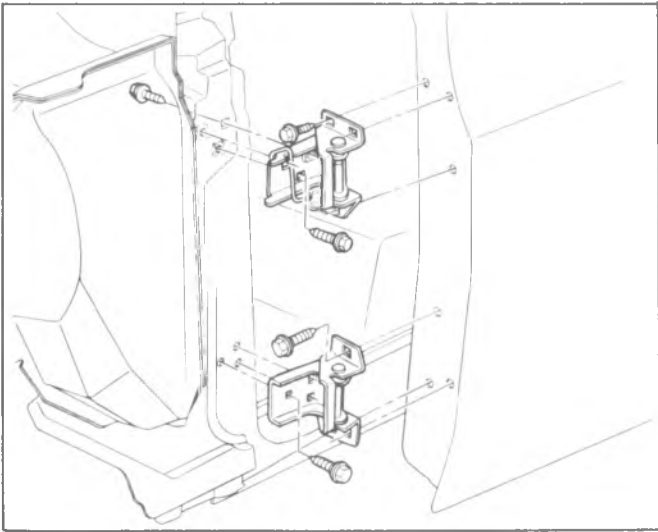


Fig. 2D-22--Door Hinge

3. **Forward and Rearward**--To make this adjustment, loosen striker bolt, shim to desired position, and tighten bolt securely.

FRONT DOOR ASSEMBLY

Replacement

Remove the door assembly from the body by removing the hinges from the door.

DOOR HINGE

The door check is part of the front door upper hinge. The front door torque rod check holds the door in either of two positions between full open and closed. The



Fig. 2D-23--Loosening Striker Bolt

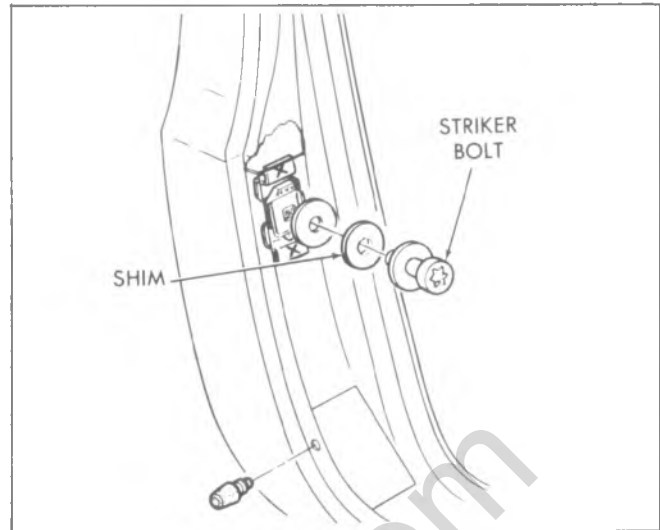


Fig. 2D-24--Typical Striker Bolt Adjustment

front door check-hinge assembly is replaced as a complete unit as follows. See figure 2D-22.

Removal

1. Loosen front fender rear bolts.
2. With special Tool J-22585 remove 3 bolts securing front door upper hinge to cowl pillar.
 - a. Remove the door to upper hinge retaining bolts.
 - b. With aid of an assistant to support weight of door, remove the door to lower hinge retaining bolts and remove door.

Installation

1. Install hinge snugly on pillar in same location as hinge removed.
2. With the aid of an assistant fasten the door to the hinge.
3. Adjustment of the door lock and striker plate should be made after the door is positioned in the opening.

DOOR TRIM PANELS - CK MODELS

Door trim panel installation is illustrated in Fig. 2D-25.

DOOR VENTILATOR ASSEMBLY--Fig. 2D-26

Removal

NOTE: The channel between the door window glass and door vent is removed as part of the vent assembly.

1. Regulate the door window glass to the full down position.
2. Remove clip from the window regulator handle, and knob from lock rod.
3. Remove arm rest screws and rim panel. See figure 2D-27.

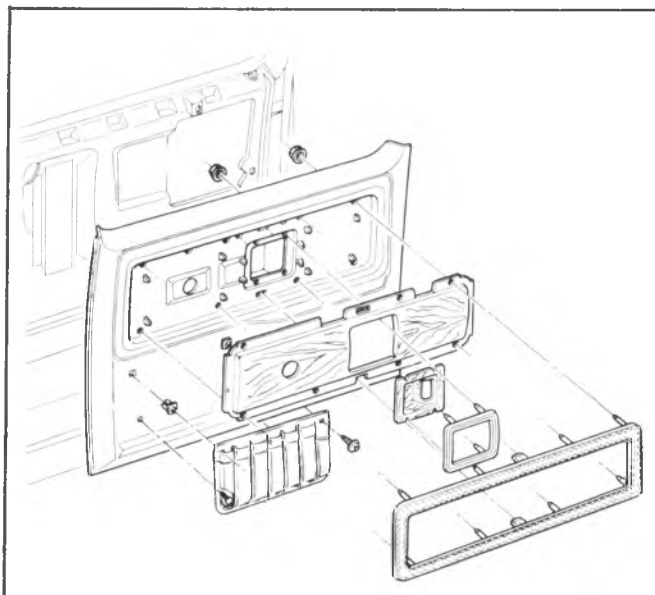


Fig. 2D-25--Door Trim Panel

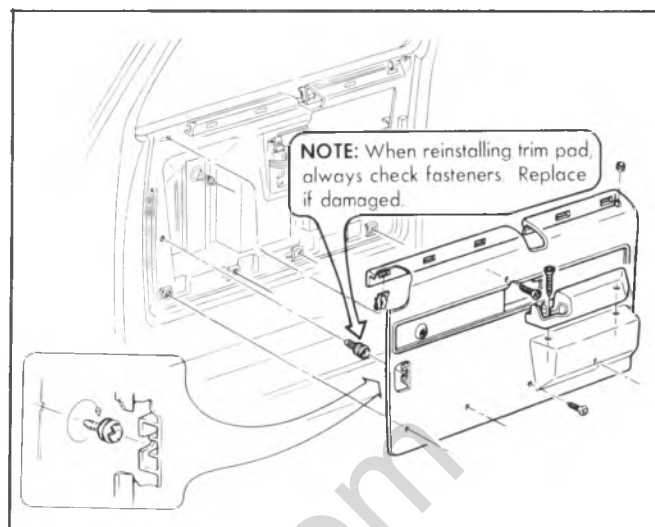


Fig. 2D-27--Door Trim Pad

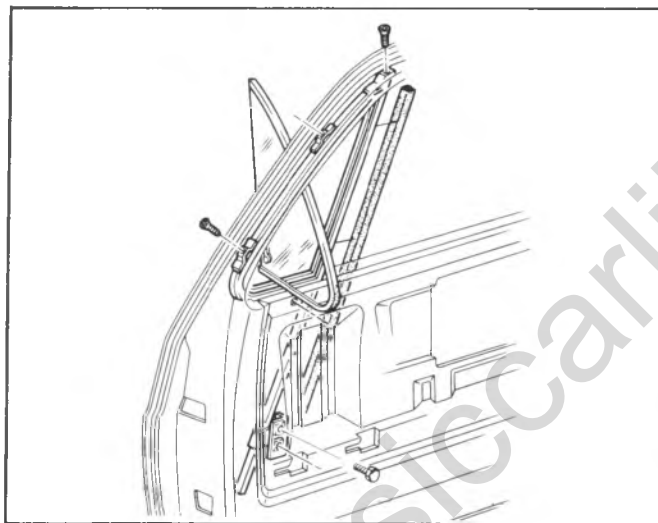


Fig. 2D-26--Door Ventilator Assembly



Fig. 2D-28--Removing Ventilator Assembly

4. Remove screws attaching ventilator lower assembly to door panel.

5. Loosen inner to outer panel attaching screw through access hole just rearward of the lower vent pivot.

6. Slide door window glass rearward away from ventilator.

7. Remove three screws at the upper front of the door frame.

8. Turn vent assembly 90° and carefully remove by guiding up and out. See figure 2D-28.

Ventilator Glass Replacement

1. Using an oil can or similar means, squirt prepsol or equivalent on the glass filler all around the glass channel or frame to soften the old seal. When the seal has softened, remove the glass from the channel.

2. Thoroughly clean the inside of the glass channel with sandpaper, removing all rust, etc.

3. Using new glass channel filler, cut the piece to be installed two inches longer than necessary for the channel. Place this piece of filler (soapstoned side of filler away from glass) evenly over the edge of the glass which will fit in the channel. The extra filler extending beyond the rear edge of the glass should be pinched together to hold it in place during glass installation.

NOTE: One side of this filler (the outside of the roll) is soapstoned. This is the side which goes into the metal channel.

4. Brush the inside of the metal glass channel freely with ordinary engine oil. This will enable the glass and filler to slide freely into the channel. Push the glass with the filler around it into the channel until it is firmly seated. After the glass is firmly in place, the oil softens the filler, causing it to swell, thereby making a watertight

seal. Trim off the excess filler material around the channel and at the ends of the channel.

NOTE: Glass should be installed so that rear edge is parallel to the division post. Allow full cure before water testing.

Installation

NOTE: Replace the door window glass and regulate to the full down position before installing the door ventilator assembly.

1. Lower the ventilator assembly into the door frame.
2. Make certain the rubber lip is positioned inside the inner and outer panel before tightening screws.
3. Slide door glass forward engaging glass in vent channel.
4. Reinstall all screws and tighten.
5. Install and tighten the three screws at the upper front of the door.



Fig. 2D-29--Adjusting Tension

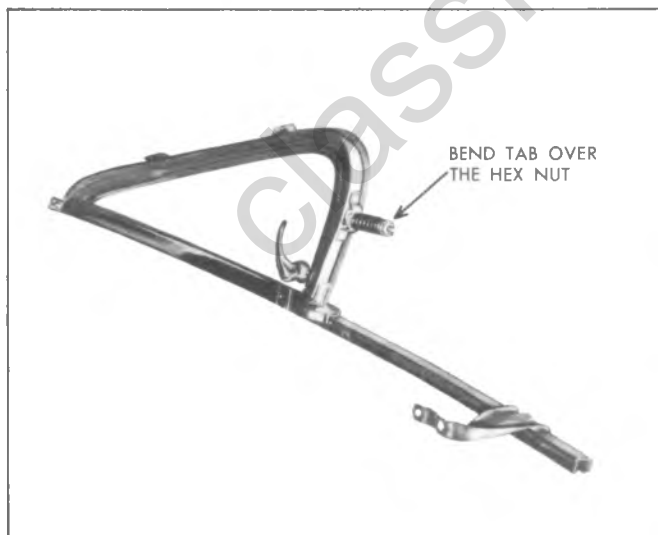


Fig. 2D-30--Bend Tabs Over Hex Nut

Adjustment

1. Adjust the ventilator by placing wrench on adjusting nut thru access hole and turning vent window to the desired tension. See figure 2D-29.
2. After making adjustment bend tabs over the hex nut on base of assembly. See figure 2D-30.
3. Install arm rest screws and trim panel.
4. Install window regulator handle.

DOOR WINDOW ASSEMBLY--FIG. 2D-31

Replacement

1. Completely lower glass to bottom of door.
2. Remove window regulator handles using tool J-7797, and remove remote control push button knob.
3. Remove door arm rest and trim pad.
4. Mask or cover upper portion of door window frame. Remove ventilator assembly as previously outlined.
5. Slide glass forward until front roller is in line with notch in sash channel. Disengage roller from channel.
6. Push window forward and tilt front portion of window up until rear roller is disengaged. See figure 2D-32.
7. Put window assembly in normal position (level) and raise straight up and out.
8. Reverse above procedure for installation.

WINDOW REGULATOR-MANUAL--FIG. 2D-31

Replacement

1. Remove ventilator assembly and door window as outlined previously.
2. Remove screws attaching regulator to door inner panel.
3. Remove regulator assembly through door opening.

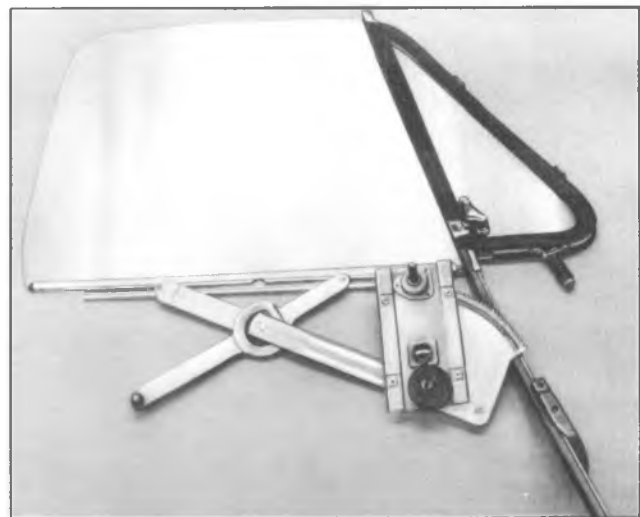


Fig. 2D-31--Door Window and Regulator

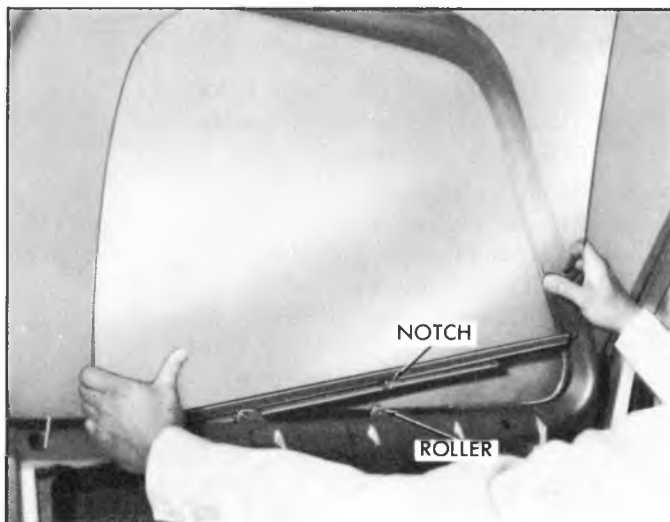


Fig. 2D-32-Removing Door Glass

4. Install regulator by reversing above steps. Lubricate regulator gear with lubriplate or equivalent.

WINDOW REGULATOR - POWER - CK MODELS

In the case that window will not operate, check electrical connections first. Figure 2D-33 illustrates location of junctions, switch, relay and circuit breaker.

Replacement

CAUTION: *Electrical connectors must be removed from window lift motor before performing any operation on the regulator. Figure 2D-34 illustrates location of regulator on door and wiring.*

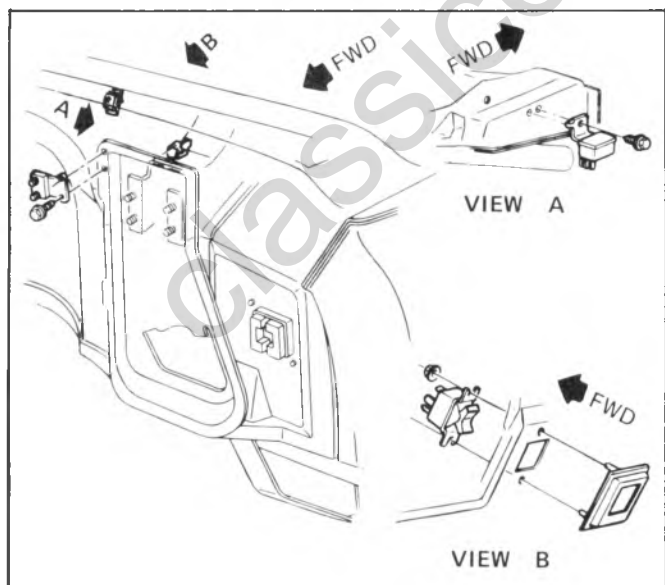


Fig. 2D-33-Power Window Switch, Relay and Breaker Assembly

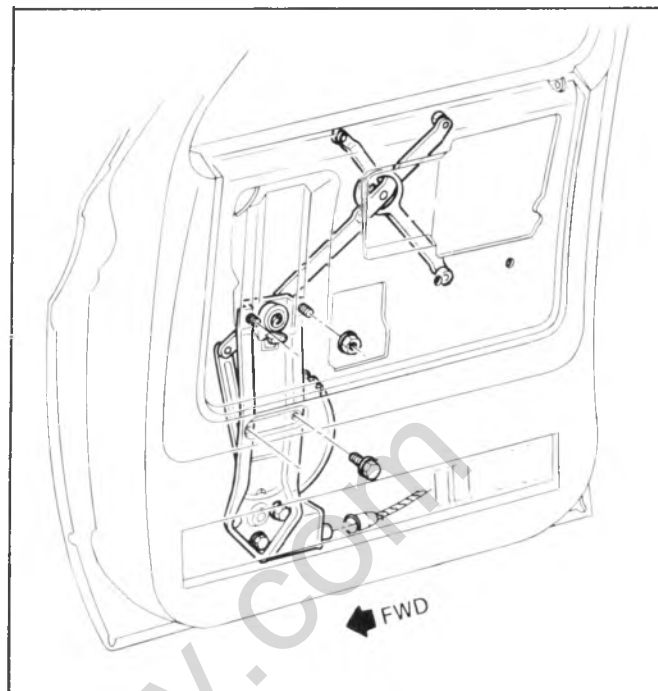


Fig. 2D-34-Power Windw Regulator, Motor and Connector

1. Disconnect battery ground cable.
2. Remove door upper trim panel.
3. Remove arm rest bracket and pull assist handle bracket.
4. Remove remote control bolts and lay control assembly aside for access.
5. Remove glass outer seal.
6. Remove rear glass run channel.
7. Remove regulator to door panel attaching nuts and screws, and pull rear of glass up as far as possible and rotate clockwise approximately 90° to remove glass from door.
8. Disconnect harness from regulator.
9. Rotate motor regulator approximately 90° to access hole in door.

WARNING: Step 10 must be performed when regulator is removed from door. The regulator lift arms are under tension from the counterbalance spring and can cause serious injury if the motor is removed without locking the sector gear in position.

10. Drill a hole through the regulator sector gear and back plate. DO NOT drill hole closer than 1/2" to edge of sector gear or back plate. Install a pan head sheet metal tapping screw (No. 10 - 12 x 3/4) in drilled hole to lock sector gear in position.
11. Remove motor to regulator attaching screws.
12. Remove motor from regulator.
13. Prior to installation, lubricate the motor drive gear and regulator sector teeth.

NOTE: The lubrication used must be cold weather approved to a minimum of minus 20° fahrenheit.

14. Install regulator motor to regulator. Make sure the motor pinion gear teeth mesh properly with the sector gear teeth before installing the three motor attaching screws.

15. Remove screw locking sector gear in a fixed position.

16. Insert regulator into door in such a position that motor connector can be installed onto motor.

17. Reinstall regulator into door.

LOCKS, HANDLES AND RODS

The door lock, handles and control rods are shown in figure 2D-32 as they would be installed in the vehicle. Note the clips which attach the three control rods to the lock assembly.

NOTE: All clips which attach control rods to lock assembly must be replaced whenever removed.

Door Lock Assembly

Replacement

1. Raise window to gain access to lock.
2. Remove regulator handle.
3. Remove remote control push button knob.
4. Remove trim panel.
5. Remove clip from inside handle rod-to-lock.
6. Remove clip from outside handle rod-to-lock. This is best accomplished by inserting a long screwdriver through the daylight opening, as shown in figure 2D-35.
7. Remove screws which attach lock assembly to door panel.
8. Remove lock and remote control rod as an assembly.
9. To install lock assembly, reverse above steps. Be sure to replace all clips removed earlier.

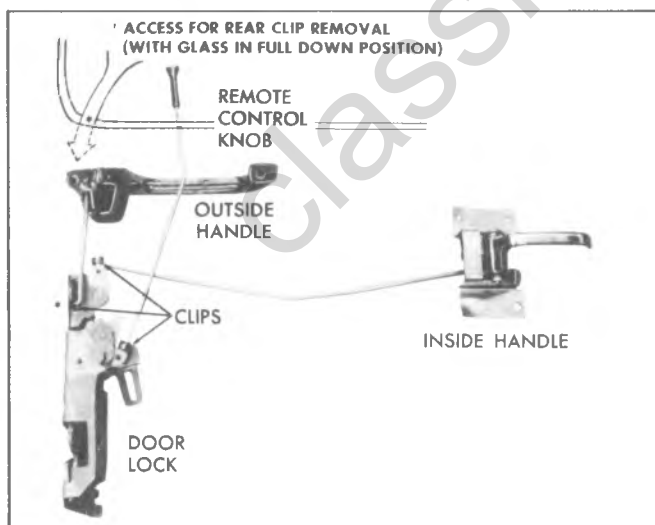


Fig. 2D-35--Lock, Handles and Rods

Door Outside Handle--Fig. 2D-36

Replacement

1. Raise window to gain access to lock.
2. Remove window regulator handle.
3. Remove remote control rod.
4. Remove trim panel.
5. Remove clip from outside handle rod-to-lock. This is best accomplished by inserting a long screwdriver through the daylight opening, as shown in figure 2D-35.
6. Remove screws which retain outside handle to door panel.
7. Remove handle and control rod.
8. Reverse above procedures to install outside handle.

Door Lock Cylinder -Fig 2D-36 -

Replacement

1. Raise door window.
2. Remove window regulator handle, remote control knob and trim panel.
3. Use a screwdriver or other suitable tool to slide the lock cylinder retaining clip out of engagement with the lock cylinder.
4. Remove lock cylinder.
5. To install, reverse the above steps.

Door Inside Handle

Replacement

1. Remove window regulator handle, remote control push button knob and trim panel.
2. Disconnect control rod from inside handle, as shown in figure 2D-37.
3. Remove screws retaining inside handle to door.
4. Remove inside handle.
5. Reverse above steps to install.

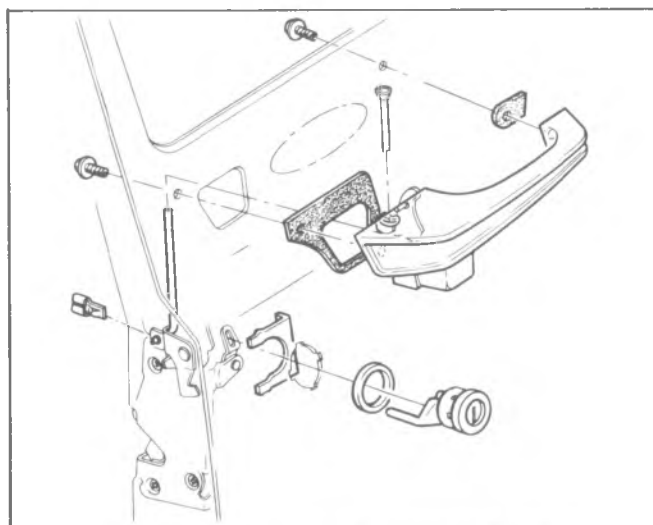


Fig. 2D-36--Outside Handle and Lock Cylinder

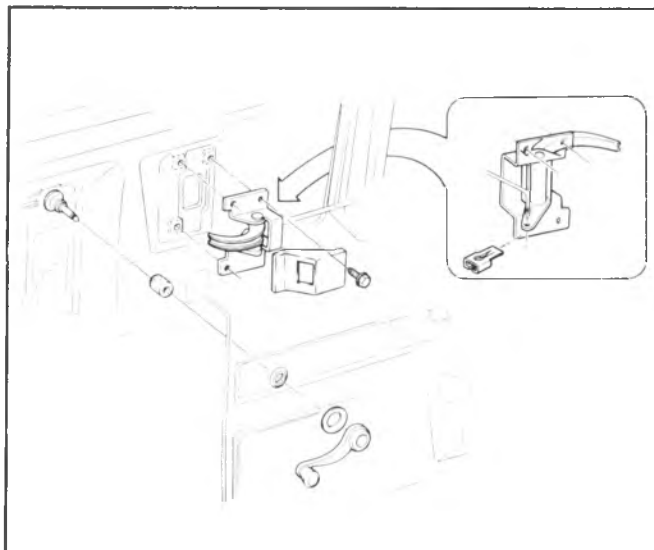


Fig. 2D-37--Inside Handle

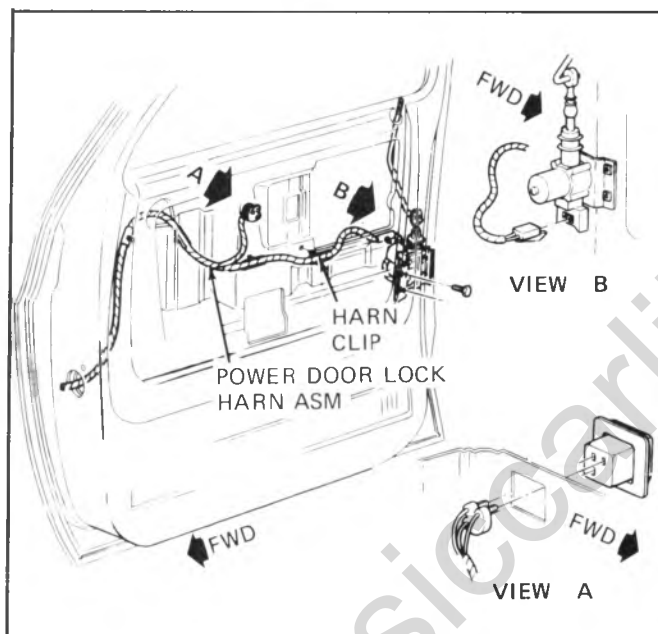


Fig. 2D-38--Power Door Lock Assembly

POWER DOOR LOCKS - CK MODELS (Fig. 2D-38)

Replacement

1. Disconnect battery ground cable.
2. Remove door trim panel (fig. 2D-25) to gain access to power door lock motor. If equipped with optional trim, remove pull handle assist bracket.
3. Disconnect electrical connector from motor.
4. Remove screws attaching motor to door inner panel.
5. Remove door lock lever from rubber mount at top of motor actuator and remove motor through access hole.

6. To install, reverse steps 1 through 5 above.

DOOR TO BODY OPENING WEATHERSTRIP-FIGS. 2D-39, 2D-40

Side door sealing incorporates an inner seal. The inner seal is mounted on the body opening welding flange and goes completely around the periphery of the opening. The molded weatherstrip material is snapped in place.

Success of weatherstrip replacement depends entirely upon the quality of the cement used and the care with which it is applied. All rust, road dirt and grease or oil must be completely removed as should all old cement and bits of old weatherstrip. After removing all foreign material from door opening surface proceed as follows:

1. Open door and block open.
2. Remove sill plate retaining screws and remove sill plate.
3. Remove side door inner weatherstrip seal.
4. Install molded corner of inner weatherstrip, starting at the bottom of the door opening.
5. Trim inner weatherstrip with a notch and butt ends together.
6. Reinstall sill plate and sill plate retaining screws.

REAR SIDE DOOR (06 AND 63 ONLY)

Adjustments and Hinge Replacement

The procedures for hinge replacement, and for hinge and striker bolt adjustment are similar to those detailed in the front door adjustment procedure. Access to the hinges of the rear door is shown in figure 2D-41.

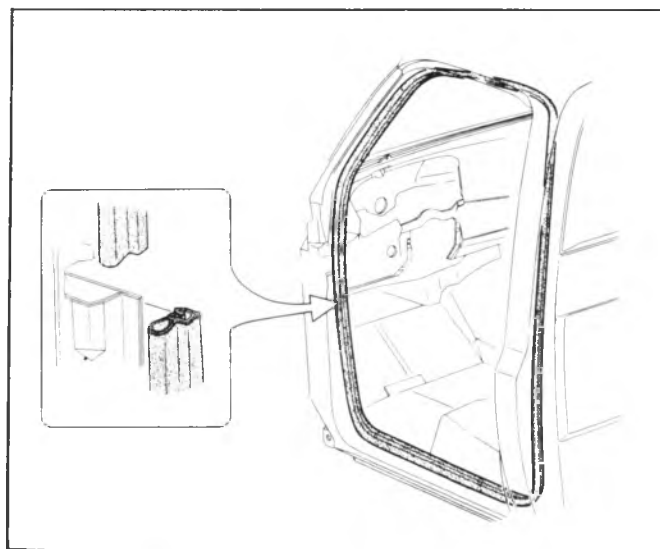


Fig. 2D-39--Door Weatherstrip (03-63-06)

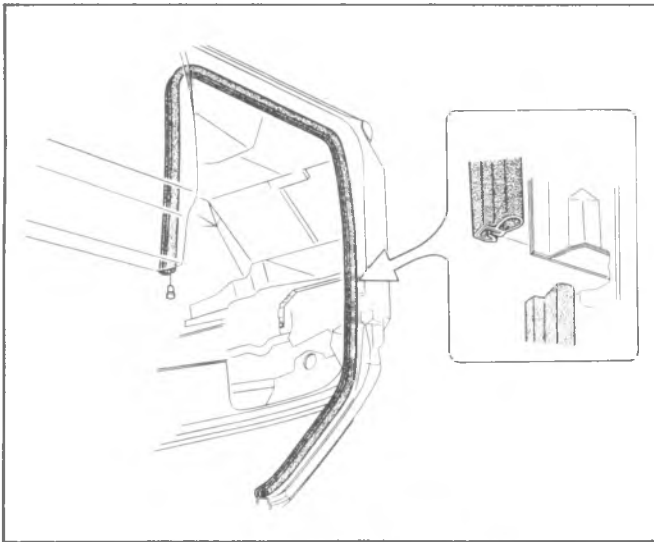


Fig. 2D-40--Door Weatherstrip (14)

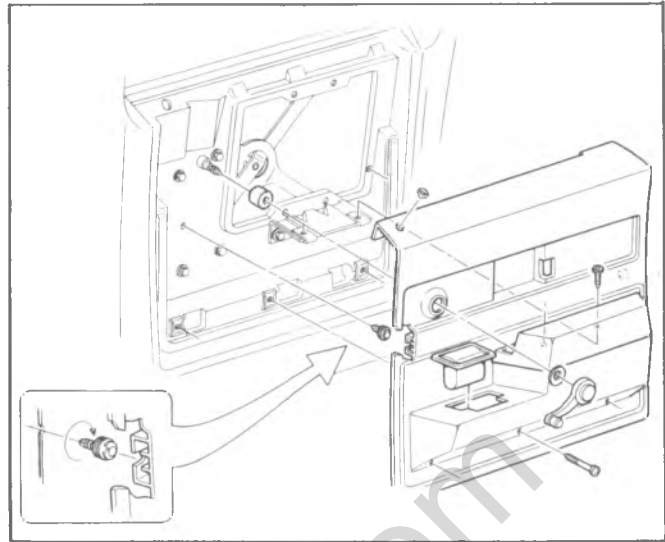


Fig. 2D-42--Side Rear Door Trim Pad

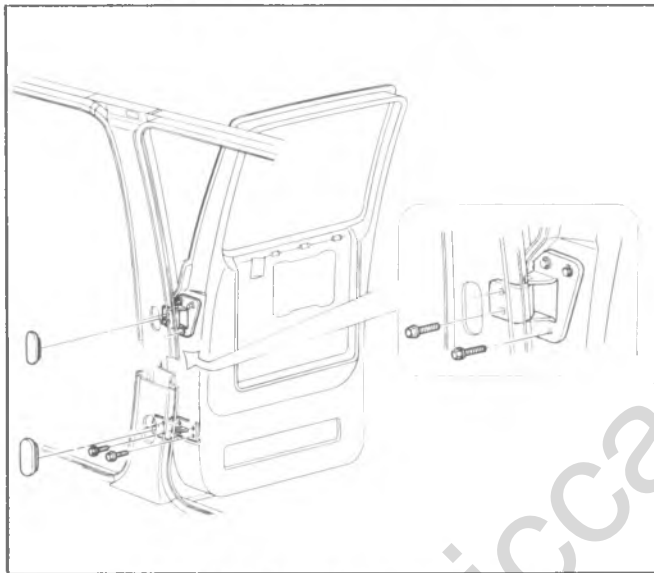


Fig. 2D-41--Rear Door Hinge Location

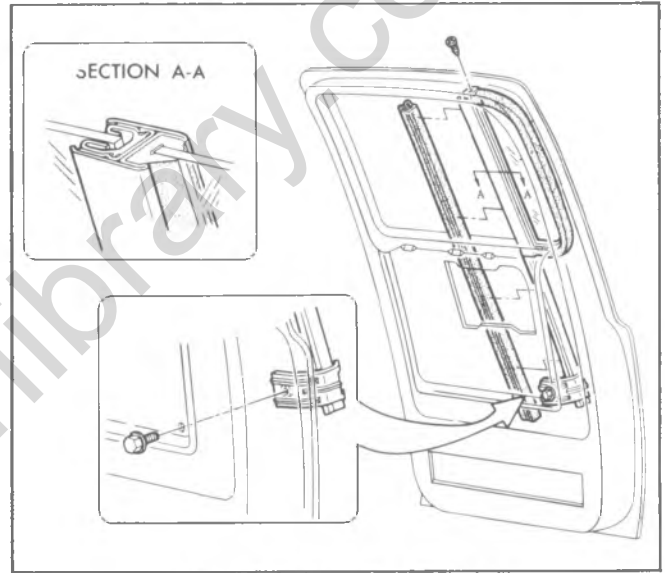


Fig. 2D-43--Glass Run Channel

STATIONARY GLASS--REAR DOOR

Replacement

1. Lower window to full down position.
2. Remove remote control knob and window regulator handle.
3. Remove screws retaining door rim pad, and remove trim pad. See figure 2D-42.
4. Remove glass run channel by removing screws retaining channel to door. See figure 2D-43.
5. Remove stationary glass.
6. Replace glass by reversing above procedure.

Glas Run Channel Adjustment s

Figure 2D-44 illustrates the front run channel. At the lower end, a slotted bracket provides for in-and-out adjustment. The screw and locknut at that bracket allow fore-and-aft adjustment. Together, this allows proper

alignment of the glass to the rear glass run channel for full up and down travel.

WINDOW GLASS--FIG. 2D-45

Replacement

1. Lower glass to full down position.
2. Remove remote control push button knob, window regulator handle and trim pad.
3. Remove stationary glass as previously outlined. Remove screws from rear division channel, and slide channel rearward in the opening.
4. Raise glass as far as possible, then slide glass until the roller is in line with the notch in the sash channel. See figure 2D-45. Disengage roller from channel.
5. Tilt window outboard and move until other roller can be removed from channel.
6. Raise window up and out.

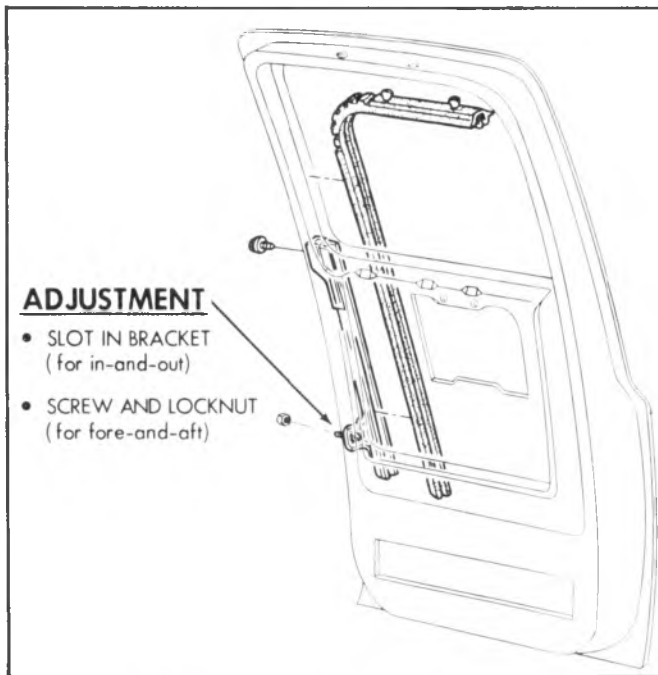


Fig. 2D-44--Glass Run Channel Adjustment

- Reverse above procedure for installation.

WINDOW REGULATOR ASSEMBLY--FIG. 2D-45

Replacement

- Remove trim pad, stationary glass, and window glass as outlined earlier.
- Remove screws attaching regulator assembly to door inner panel.
- Remove regulator assembly through opening in door.

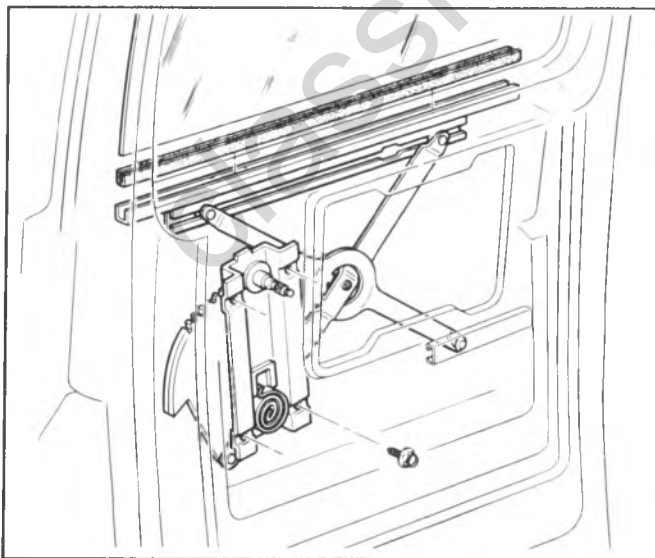


Fig. 2D-45--Window Glass and Regulator Assembly

- Install regulator by reversing above procedure. Lubricate regulator gear with lubriplate or equivalent.

LOCKS HANDLES AND RODS

Lock Assembly--Fig. 2D-46

Replacement

- Remove window regulator handle and remote control push button knob.
- Remove trim pad.
- Disengage three clips which retain control rods to lock assembly.
 - Inside handle control rod.
 - Remote control lower rod.
 - Outside handle control rod.
- Remove screws retaining lock assembly to door panel, then remove lock assembly.
- Install lock by reversing above procedure. Be sure to replace all clips removed with new clips on installation.

Inside Handle--Fig. 2D-46

Replacement

- Remove regulator handle, remote control knob and trim pad as outlined previously.
- Disconnect control rod from inside handle by removing clip as shown in figure 2D-46.
- Remove inside handle by removing four screws which secure handle to door panel.
- Replace handle by reversing above procedure. Install new clip when installing control rod.

Remote Control--Fig. 2D-47

Replacement

- Remove regulator handle, remote control knob and trim pad.
- Disconnect remote control lower rod from door lock assembly.

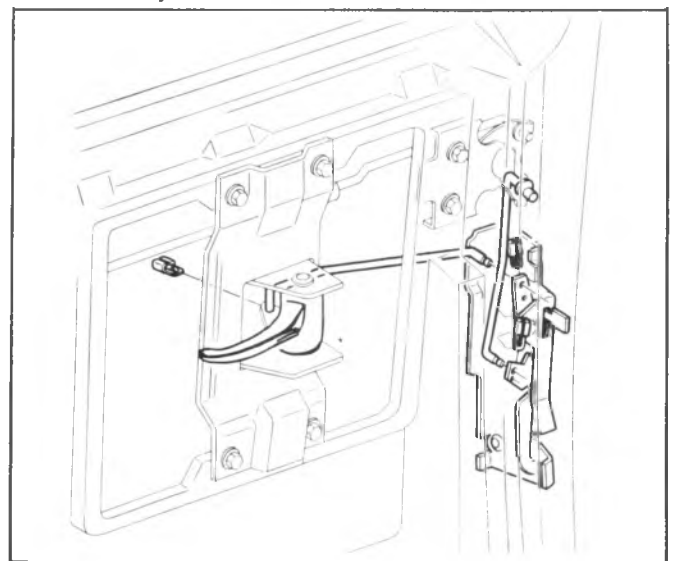


Fig. 2D-46--Lock Assembly and Inside Handle

3. Remove two screws securing each remote control lever to door panel.
4. Remove remote control levers and rods through door opening.
5. Replace by reversing above procedure.

Outside Handle--Fig. 2D-48

Replacement

1. Remove regulator handle, remote control rod and trim pad.
2. Disengage outside handle control rod from lock assembly by removing clip, as shown in figure 2D-43.
3. Remove two screws securing outside handle to door panel.
4. Remove handle assembly.
5. Replace by reversing above procedure. Be sure to use new clip when attaching control rod to lock assembly.

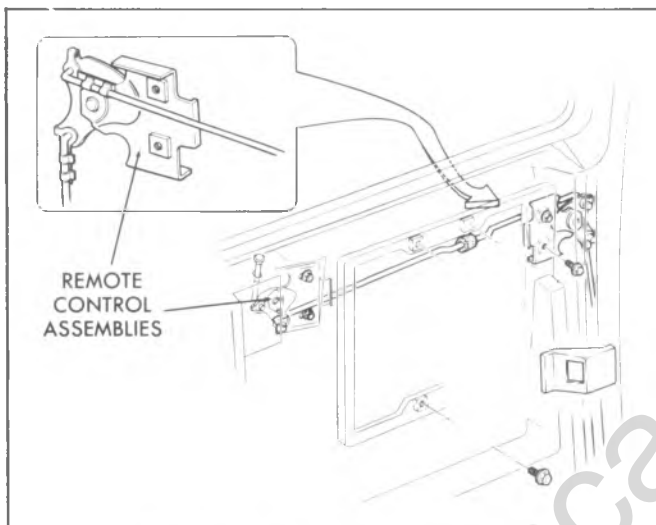


Fig. 2D-47--Remote Control Assembly

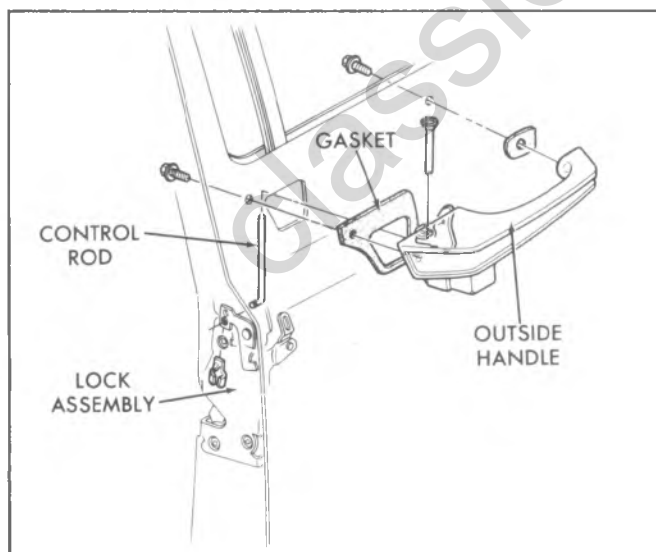


Fig. 2D-48--Outside Handle

WEATHERSTRIP--FIG. 2D-49

The procedure outlined in Front Door Weatherstrip may be applied to the Rear Side Door Weatherstrip, shown in figure 2D-49.

REAR DOORS (06 ONLY)

Adjustments

Rear doors may be adjusted in the body opening by loosening hinge bolts and repositioning door, then retightening bolts. See figure 2D-53 for hinge bolt location. Rear door wedges and strikers should be adjusted as shown in figure 2D-48.

Glass Run Channel Adjustment

Figure 2D-50 illustrates the front run channel. At the lower end, a slotted bracket provides for in-and-out adjustment. The screw and locknut at that bracket allow fore-and-aft adjustment.

Together, this allows proper alignment of the glass to the rear glass run channel for full up and down travel.

LOCKS, HANDLES AND RODS

The rear door lock, outside handle, lock cylinder, control rods and latch are shown in figures 2D-51 and 2D-52. The rods can be disconnected from the lock, latch or handle by disengaging the retaining clips, as shown. The lock cylinder is removed in the same manner as the front side door lock cylinder.

REAR DOOR--Fig. 2D-53

Replacement

1. Remove bolts securing check arm bracket to body pillar.
2. Remove upper and lower hinge bolts, and with aid from an assistant, remove the rear door.

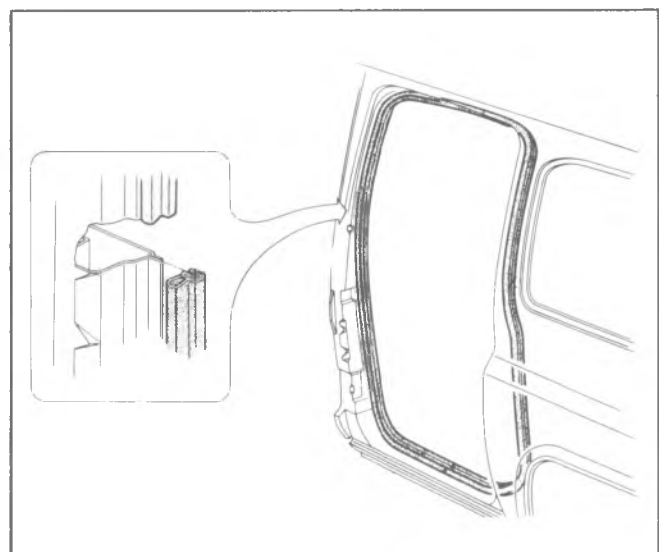


Fig. 2D-49--Side Rear Door Weatherstrip

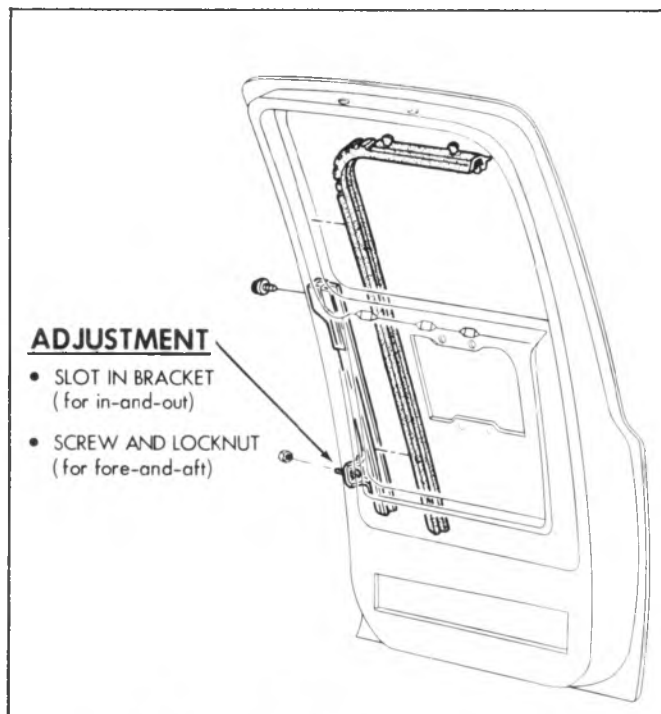


Fig. 2D-50--Glass Run Channel Adjustment

3. Reverse above steps for reinstallation.

REAR DOOR CHECK STRAP

Model 06

Figure 2D-53 shows the cloth check strap used for rear doors. The door may be completely opened by removing the strap pin from the bracket. The bracket

attaches to the pillar with three screws; the strap is fastened to the door panel with two screws and an attaching bar.

REAR DOOR--STRIKER AND WEDGE ADJUSTMENTS

Figure 2D-54 illustrates the rear door latch strikers and door wedges. Be sure that adjustments are as shown to insure proper latching of the rear doors.

CHECK ARM--FIG. 2D-53

Replacement

1. Remove bolts securing check arm bracket to body pillar.
2. Remove check arm access cover.
3. With one hand supporting housing assembly and insulator on the inside of the door panel, remove bolts securing housing assembly to door.
4. Remove housing, insulator and check arm.
5. To separate check arm from bracket, remove holding pin connecting the two parts.
6. To install check arm, reverse the procedure above.

WEATHERSTRIP

Weatherstrip installation is shown in figure 2D-55. Proper installation is dependent on completely cleaning all foreign material from old installation and using a quality cement on the new installation.

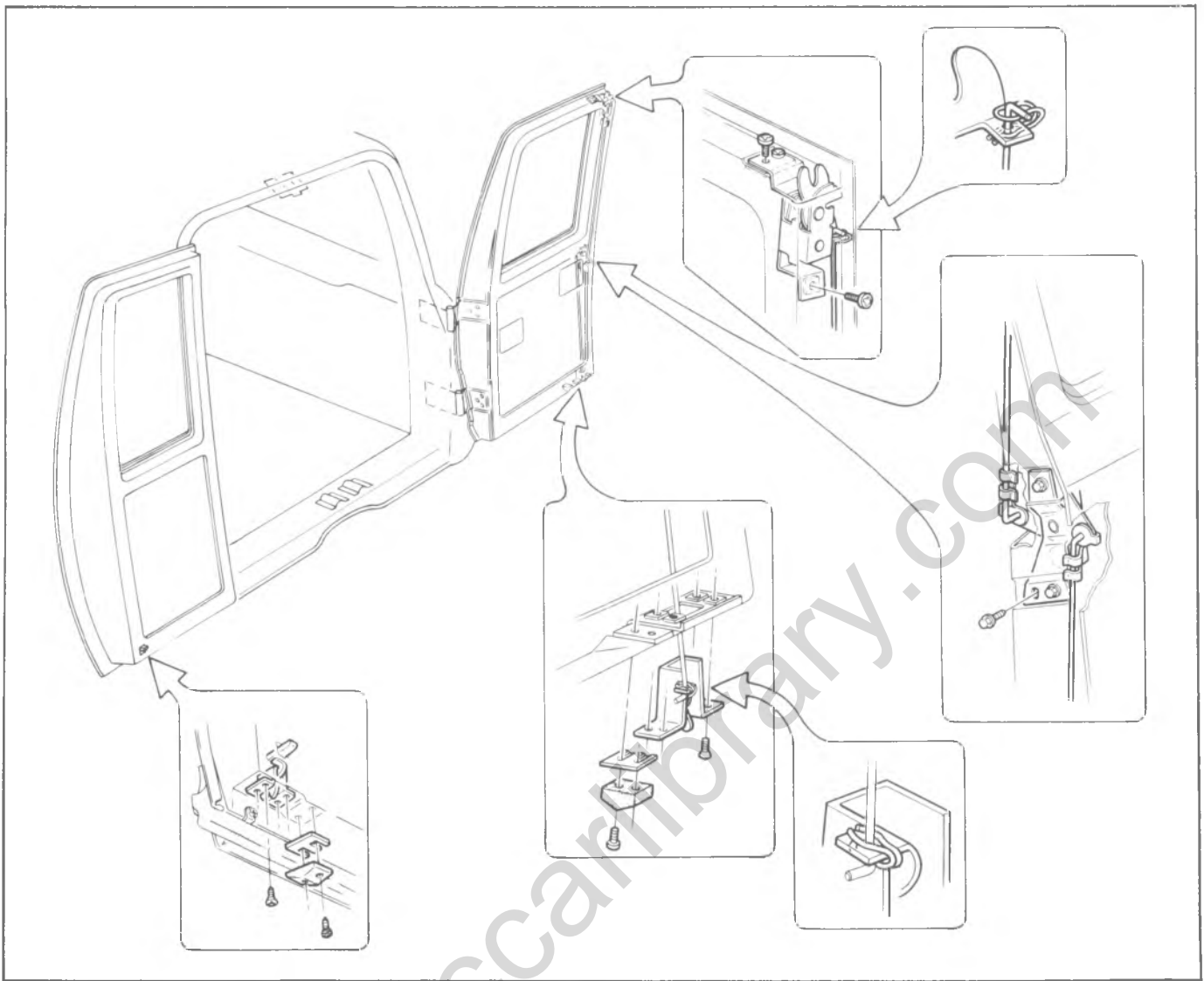


Fig. 2D-51--Rear Door Controls

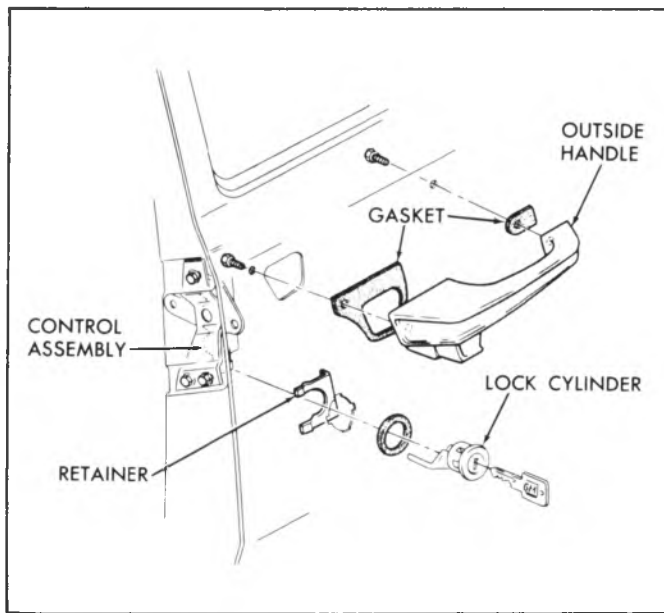


Fig. 2D-52-Rear Door Outside Handle and Lock Cylinder

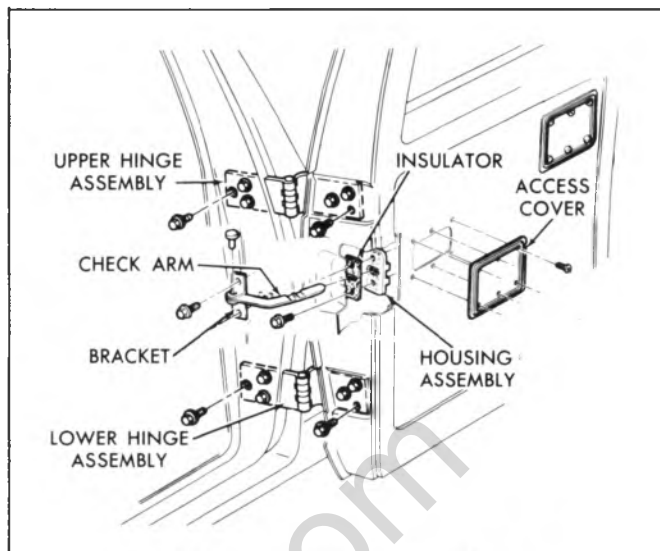


Fig. 2D-53-Rear Door Hinges and Check Arm

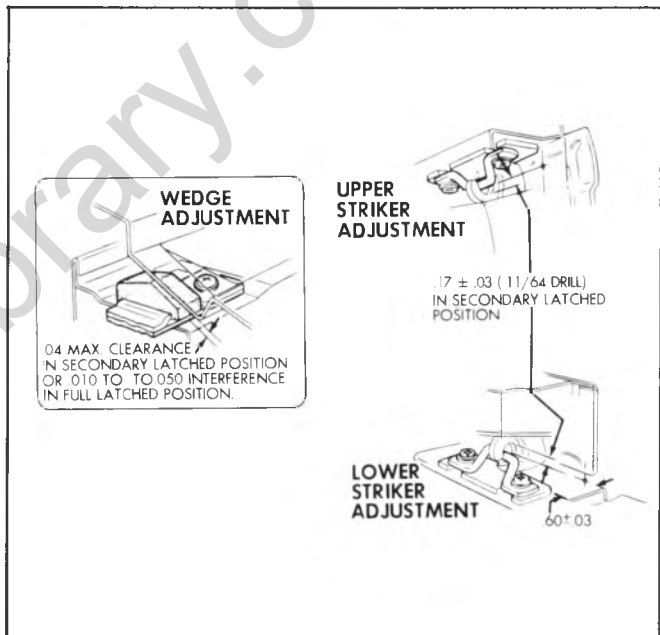


Fig. 2D-54-Wedge and Striker Adjustments

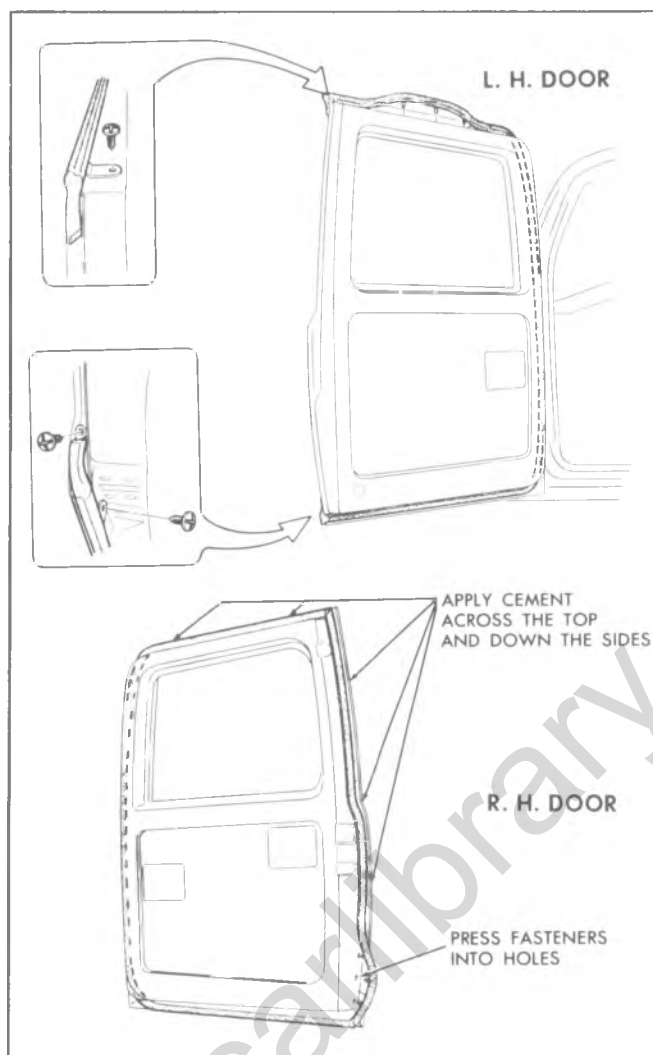


Fig. 2D-55-Weatherstrip--L.H. and R.H. Rear Door

ENDGATES (06 AND 14)

Coach models (06) and utility models (14) use endgates of similar, yet distinct design. Separate procedures follow for service on each of these endgates.

ENDGATE ASSEMBLY - (06) MODELS ONLY

Replacement

1. Lower endgate, and removed hinge access covers. See figure 2D-56.
2. Remove endgate-to-hinge bolts.
3. Remove L.H. torque rod bracket, shown in figure 2D-57.
4. If equipped with electric powered window, disconnect wiring harness.
5. Lift endgate to almost closed position and remove support cables.
6. Remove endgate with torque rod.

7. To install, reverse removal procedure.

HINGES

Replacement

If necessary to remove hinges, remove endgate as outlined previously, and proceed as follows:

1. Remove bolts from each of the hinge assemblies on the underside of the body. See figure 2D-56.
2. Remove hinge assemblies. If the hinge pins are to be removed, note the position of bushings so they may be reinstalled in the same position.
3. Reverse procedure to install.

ENDGATE DISASSEMBLY

1. Remove access cover shown in figure 2D-58, to gain access to interior components.
2. Detach remote control rods from lock assembly by removing clips.

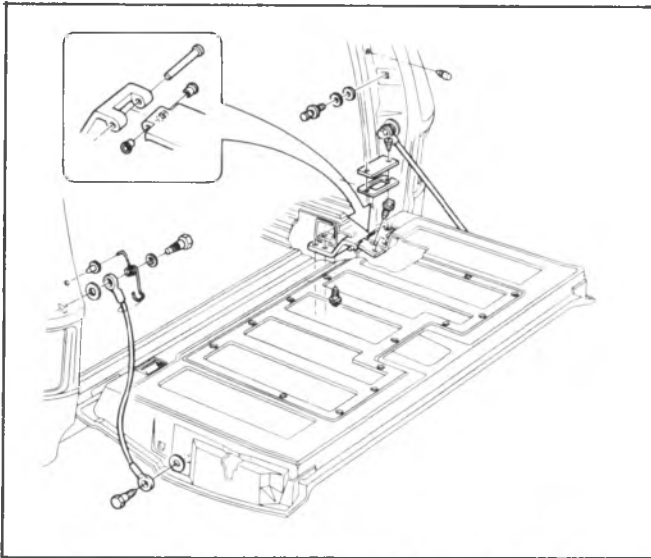


Fig. 2D-56--Endgate, Hinges and Supports--(06 Only)

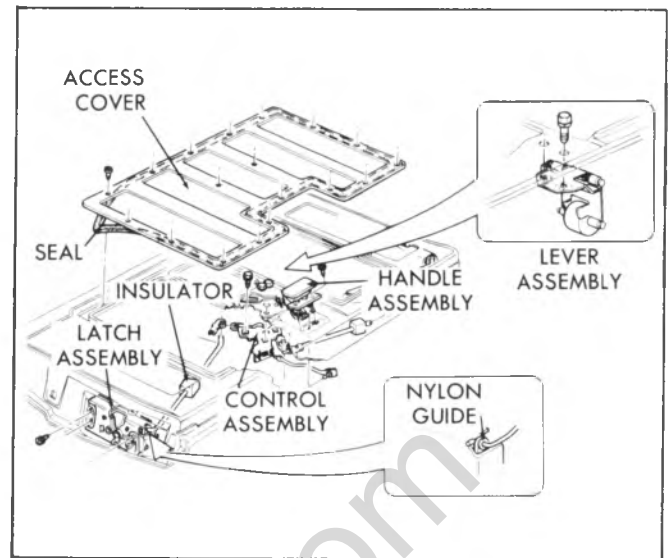


Fig. 2D-58--Latch and Remote Controls--(06 Only)

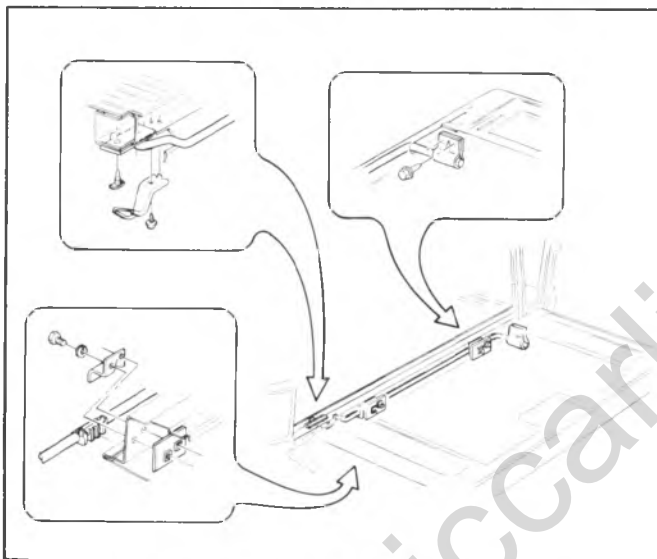


Fig. 2D-57--Torque Rod--(06 Only)

3. Remove bolts securing lock assembly, and remove lock assembly.

4. Remove handle assembly bolts and remove inside handle.

5. Remove R.H. torque rod bracket screws, figure 2D-57, then remove torque rod from endgate.

6. Remove screws connecting cam assemblies to sash assembly, figure 2D-59, then remove cam assemblies.

7. Remove glass from endgate.

8. Unclip and remove inner and outer seal assemblies.

9. Remove screws connecting window regulator assembly to endgate, figure 2D-59, and remove regulator.

10. For endgates with electric window, secure the window regulator lift arms before removing the electric motor, when the window glass has been removed or disengaged from the lift arms.

WARNING: Step 10 must be performed if the window is removed or disengaged from the regulator lift arms. The lift arms are under tension from the counter-balance spring, and can cause injury if the motor is removed without locking the sector gears in position.

a. Drill a 1/8 inch hole through the sector gear and back plate, as shown in figure 2D-59. Install a sheet metal tapping screw into the hole to lock the sector gears in position.

b. Remove the regulator motor attaching screws and remove the motor assembly.

11. From inside the endgate, remove the nuts fastening the outside handle to endgate and remove the outside handle. See figure 2D-60.

NOTE: If equipped with power tailgate window, detach wiring harness from motor.

12. Remove side bolts connecting left and right glass channels to endgate and remove channels.

13. Remove side latch bolts and remove side latches with control rods. See figure 2D-58.

NOTE: Detach wiring harness from R.H. latch if so equipped.

14. Separate side latch from control rod by pulling control rod thru nylon guide.

15. Reverse the above procedure for reassembly and installation.

Adjustments

Loosen bolts, adjust at either endgate hinge position or endgate latch, then retighten bolts.

ENDGATE ASSEMBLY--(14) MODELS ONLY

Replacement

1. Lower endgate, then remove four bolts securing

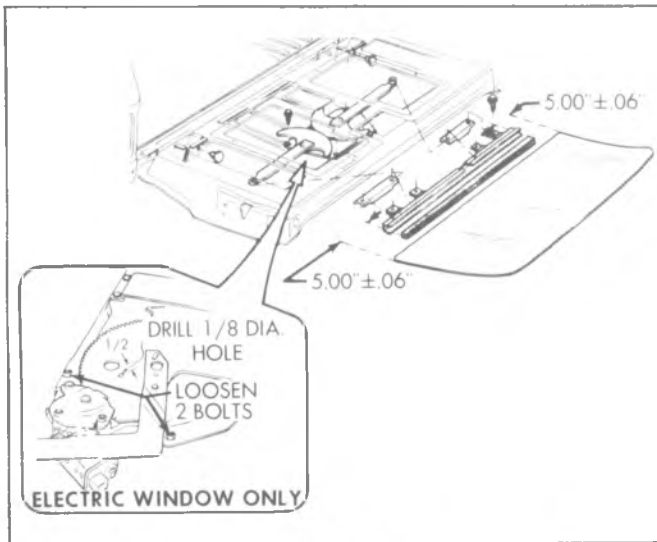


Fig. 2D-59--Window Glass and Regulator--(06 Only)

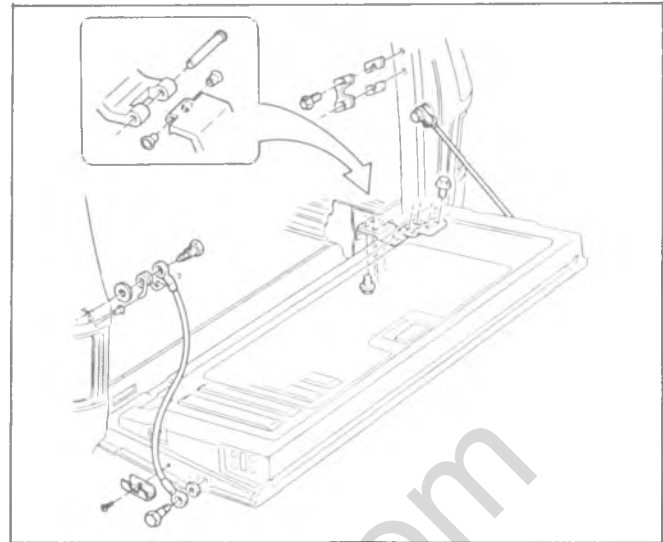


Fig. 2D-61--Endgate, Hinges and Support (14)

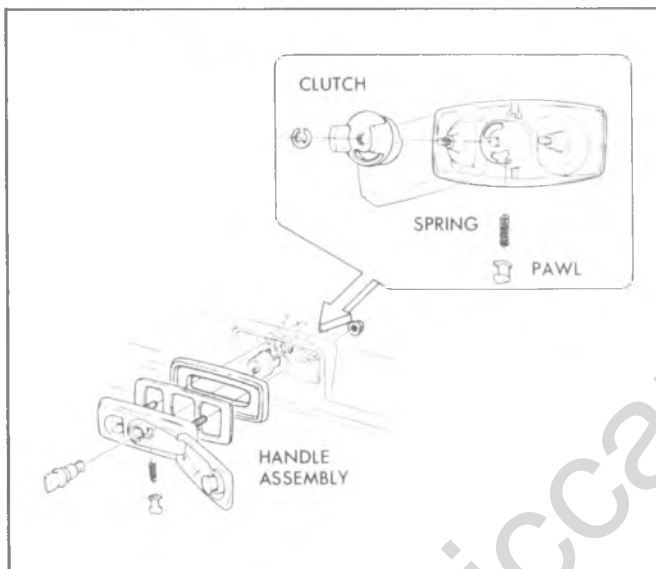


Fig. 2D-60--Outside Handle (06 and 14)



Fig. 2D-62--Pulling Hinge Away From Body (14)

hinge to body on each side. See figure 2D-61. Disconnect wiring harness, if so equipped.

2. Disconnect torque rod anchor plate on each side. It is necessary to remove lower bolt only, then let plate swing down. See figure 2D-65.

3. With an assistant, raise endgate part way, then disconnect support cables from endgate. See figure 2D-61.

4. Remove endgate by pulling disconnected hinge from body, figure 2D-62, then grasping torque rod with one hand and pulling torque rod over gravel deflector, as shown in figure 2D-63.

5. Individual components may be removed from the endgate now, or after reinstallation.

6. To install endgate, reverse the above procedure.

HINGE

Replacement

1. Lower endgate and disconnect hinge to be replaced by removing hinge-to-body bolts. See figure 2D-61.

2. At the other hinge, **loosen** the hinge-to-body bolts.

3. On the hinge to be replaced, remove the hinge-to-endgate bolts.

4. Pull the endgate away from the body several inches and withdraw hinge from body. Then lift endgate slightly to allow removal of hinge from endgate. See figure 2D-62.

5. To install hinge, reverse the above procedure. Be

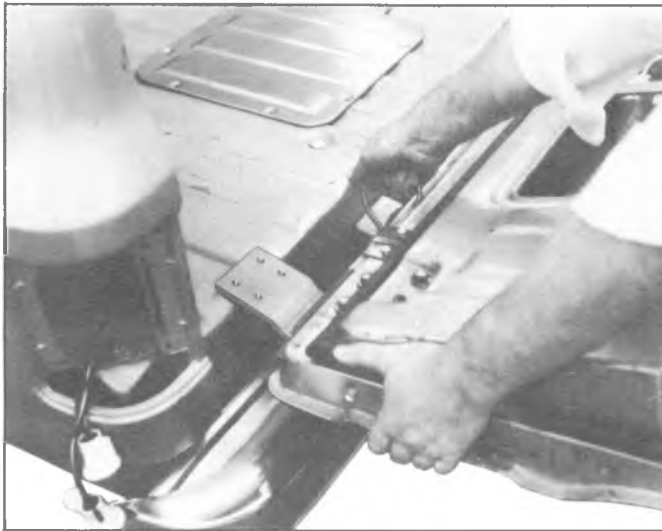


Fig. 2D-63--Grasping Torque Rod (14)

sure to install hinge into endgate first, then into the body.

TORQUE ROD

Replacement

1. Lower endgate and remove access cover, as shown in figure 2D-64.
2. Disconnect torque rod anchor plate. It is necessary to remove the lower bolt only, then let plate swing down. See figure 2D-65.
3. Loosen four bolts retaining endgate hinge to body.
4. Move endgate slightly away from body.
5. Remove torque rod retaining bracket on lower edge of endgate. See figure 2D-65.
6. Remove torque rod retaining clip on side edge of endgate.

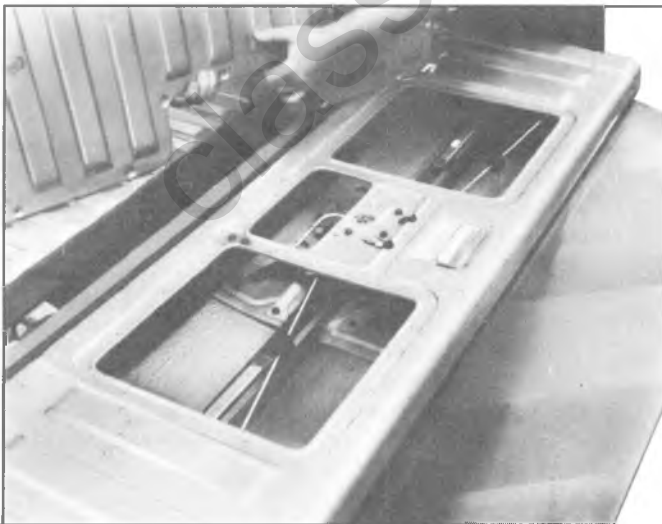


Fig. 2D-64--Removing Access Cover (14)

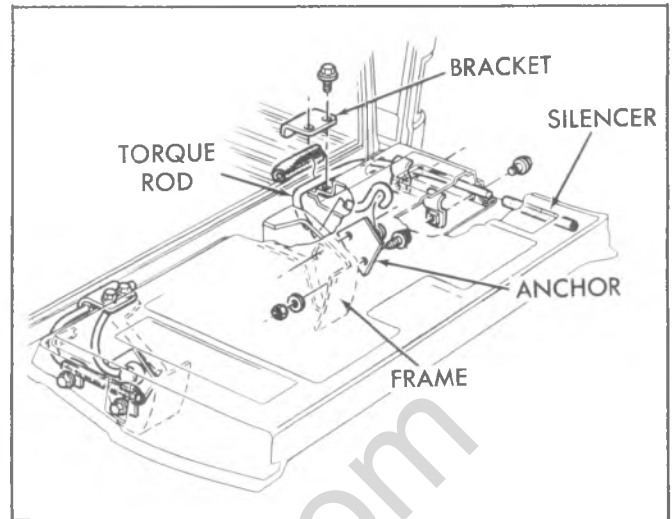


Fig. 2D-65--Torque Rod Installation (14)

7. Lift torque rod up and slide from endgate as shown in figure 2D-66.
8. Reverse the procedure above for installation.

ENDGATE DISASSEMBLY

1. Lower endgate and remove access cover.
2. Disconnect side latch remote control rods from center control by removing retaining clips. See figure 2D-67.
3. Remove four screws from each side latch, and withdraw latch and control rod from endgate, as shown in figure 2D-68.
4. Disconnect control rod from latch.
5. Refer to figure 2D-69 for installation of latch control and blockout rod.
6. Disconnect blockout rod from control assembly by detaching spring and removing two screws retaining rod to inner panel.
7. Disconnect inside handle control rod from



Fig. 2D-66--Removing Torque Rod (14)

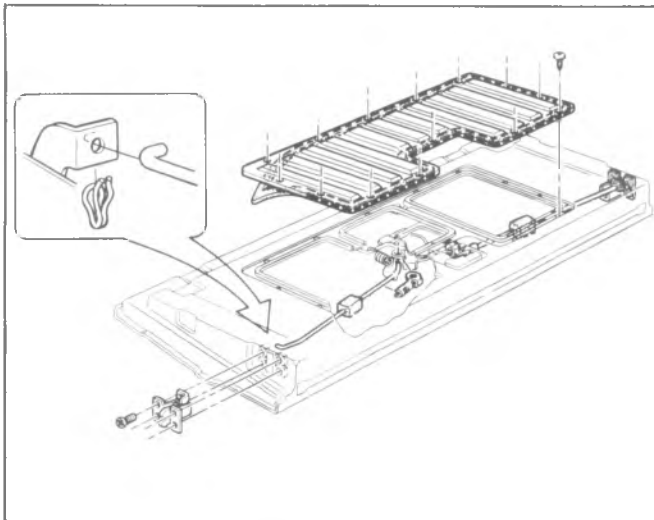


Fig. 2D-67--Latches and Rods

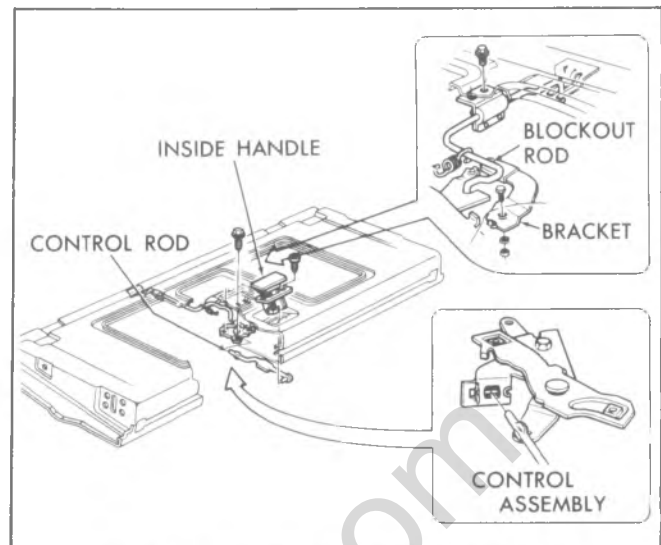


Fig. 2D-69--Control Assembly and Blockout Rod

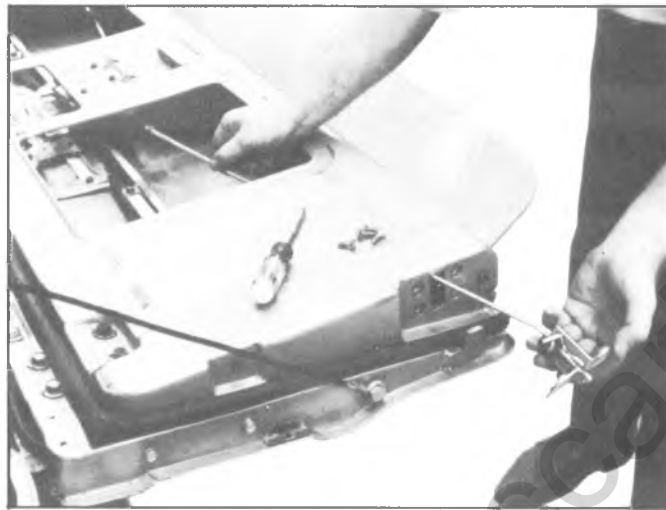


Fig. 2D-68--Removing Side Latch



Fig. 2D-70--Removing Control Assembly and Inside Handle

control assembly, then remove screws which secure inside handle to inner panel.

8. Remove three screws which retain remote control assembly to inner panel.

9. Remove control assembly and inside handle as shown in figure 2D-70.

10. Refer to figure 2D-71 for window and regulator installation.

11. Roll window to up position.

12. Disconnect sash from regulator as shown in figure 2D-72.

13. Remove glass from endgate.

14. Remove four regulator attaching screws and withdraw regulator from endgate as shown in figure 2D-73.

15. Remove outside handle by removing nuts from inside of outer panel. See figure 2D-74.

16. Reverse the above steps for reassembly.

TAILGATES (03, 63 and 14)

Replacement

Utility vehicles (14) without removable tops utilize a tailgate shown in figure 2D-75. Chassis/cab (03 and 63) models have optional pickup units which utilize tailgates as shown in figures 2D-75 and 2D-76.

The tailgate shown in figure 2D-75 can be removed by disconnecting both links from the tailgate, removing screws attaching both trunnions to body, and lifting the tailgate off the vehicle.

The tailgate shown in figure 2D-76 can be separated from the vehicle by removing the bolt and lock washer from each trunnion in carrier box, and removing the tailgate.

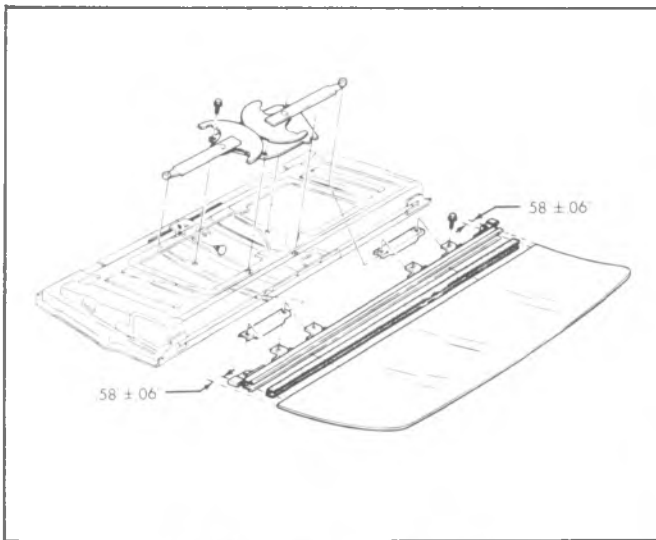


Fig. 2D-71--Window and Regulator

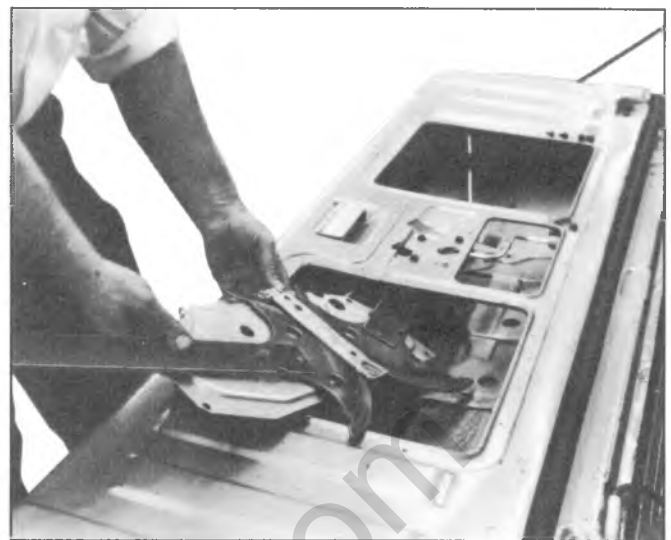


Fig. 2D-73--Removing Regulator

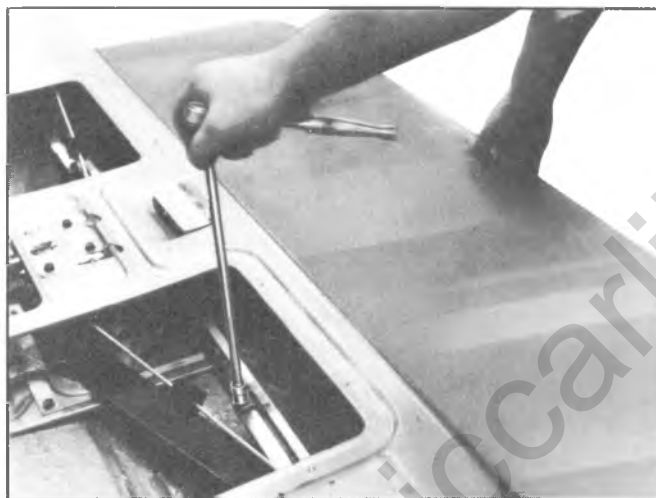


Fig. 2D-72--Disconnecting Sash from Regulator

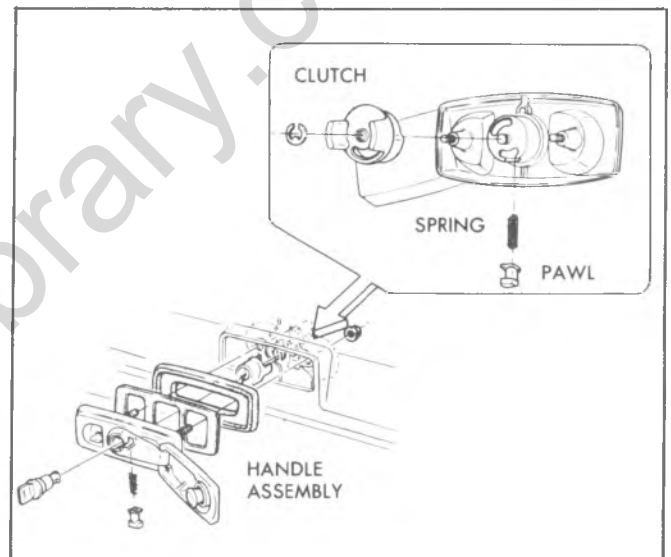


Fig. 2D-74--Outside Handle

REMOVABLE TOP-FOLDING TOP (16 ONLY)

Removal

1. Remove the bracket-to-roof bolt from each of the top-to-header panel attaching brackets as shown in Figure 2D-77.
2. Remove the bolts which retain the top to the body side panels, shown in figure 2D-78.
3. Lower the rear window into the endgate, and lower endgate.
4. Lower the door windows.
5. Slide top rearward approximately 18" to expose the bottom rear top-to-pickup box attaching holes.
6. To prevent possible flexing of the sides on removal, connect the sides of the top with support braces as follows.
 - a. Fabricate 2 braces 72" long from wood or square aluminum tubing. Drill two (2) 3/8" diameter holes, 63 inches apart in the brace.

- b. Attach one brace to the holes exposed in Step 7.
- c. Slide top forward to expose the front bottom top-to-pickup box attaching holes.
- d. Attach the second brace to these holes.
7. With assistance, lift the top and move it rearward for removal.

Mandatory Assembly Sequence (Fig. 2D-78)

Removable top must be clamped in direction of arrow A at pints X and Y. Clamp load must be great enough to force the removable top against the steel cab at the attachment locations. After clamping, bolting must start with the rear vertical bolt (1) and then going forward, install (2), (3) and (4). When all but the front bolt (5) are in place, release the clamp and drive the front bolt. Then drive the horizontal bolts into the steel cab.

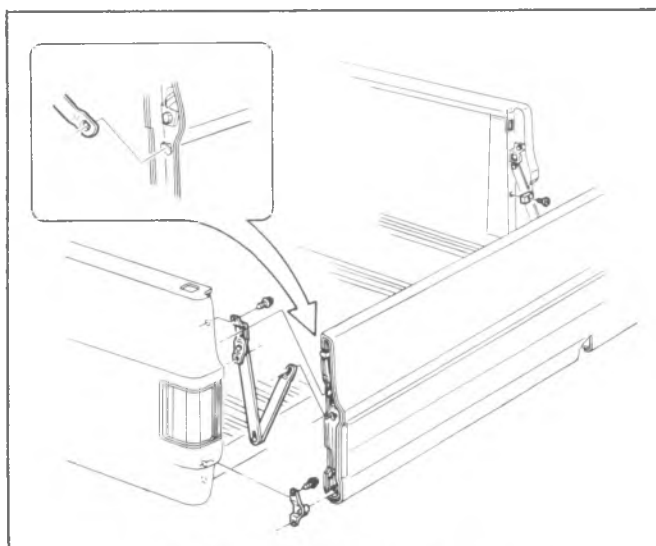


Fig. 2D-75-Tailgate (14, 03 and 63)

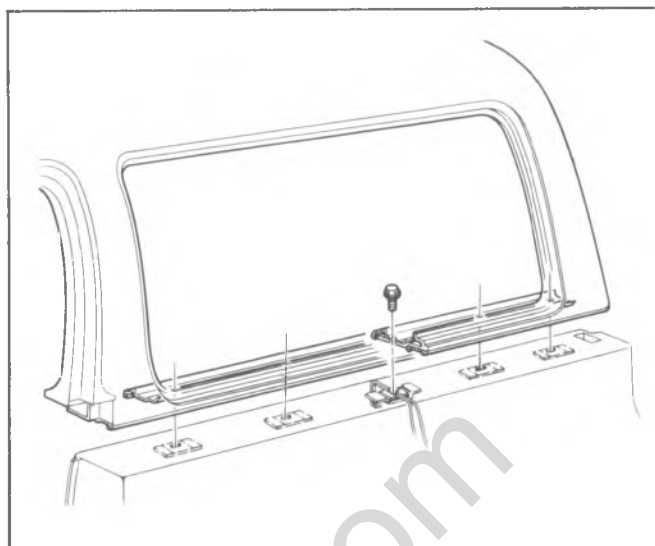


Fig. 2D-77-Roof-to-Header Brackets

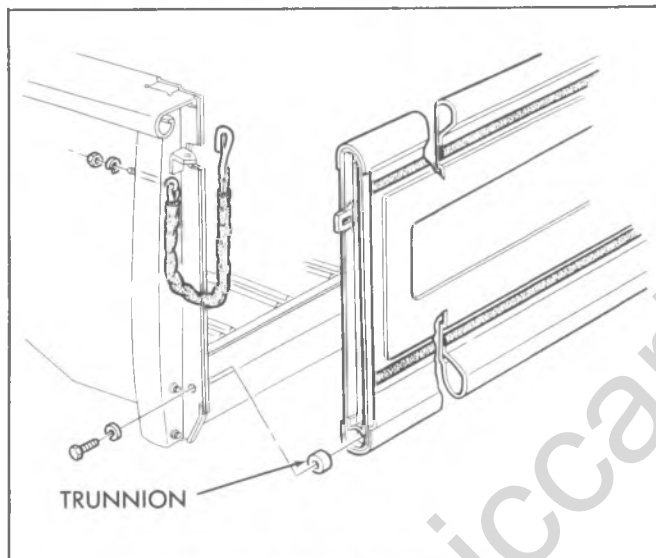


Fig. 2D-76-Tailgate (03 and 63)

SEATS

Care and Cleaning of Interior Soft Trim

Dust and loose dirt that accumulate on interior fabric trim should be removed frequently with a vacuum cleaner, whisk broom or soft brush. Vinyl or leather trim should be wiped clean with a damp cloth. Normal cleanable trim soilage, spots or stains can be cleaned with the proper use of trim cleaners available through General Motors dealers or other reputable supply outlets. Before attempting to remove spots or stains from upholstery, determine as accurately as possible the nature and age of the spot or stain. Some spots or stains can be removed satisfactorily with water or mild soap solution (refer to accompanying "Removal of Specific Stains"). For best results, spots or stains should be removed as soon as possible. Some types of stains or soilage such as lipsticks, some inks, certain types of grease, mustard, etc., are extremely difficult and, in some

cases, impossible to completely remove. When cleaning this type of stain or soilage, care must be taken not to enlarge the soiled area. It is sometimes more desirable to have a small stain than an enlarged stain as a result of careless cleaning.

CAUTION: When cleaning interior soft trim such as upholstery or carpeting, do not use volatile cleaning solvents such as: acetone, lacquer thinners, carbon tetrachloride, enamel reducers, nail polish removers; or such cleaning materials as laundry soaps, bleaches or reducing agents (except as noted in the instructions on stain removal). Never use gasoline or naphtha for any cleaning purpose. These materials may be toxic or flammable, or may cause damage to interior trim.

Cleaning Fabrics with Cleaning Fluid

This type of cleaner should be used for cleaning stains containing grease, oil or fats. Excess stain should be gently scraped off trim with a clean dull knife or scraper. Use very little cleaner, light pressure, and clean cloths (preferably cheese cloth). Cleaning action with cloth should be from outside of stain towards center and constantly changing to a clean section of cloth. When stain is cleaned from fabric, immediately wipe area briskly with a clean absorbent towel or cheese cloth to help dry area and prevent a cleaning ring. If ring forms, immediately clean entire area or panel section of the trim assembly.

NOTE: Sometimes a difficult spot may require a second application of cleaning fluid followed

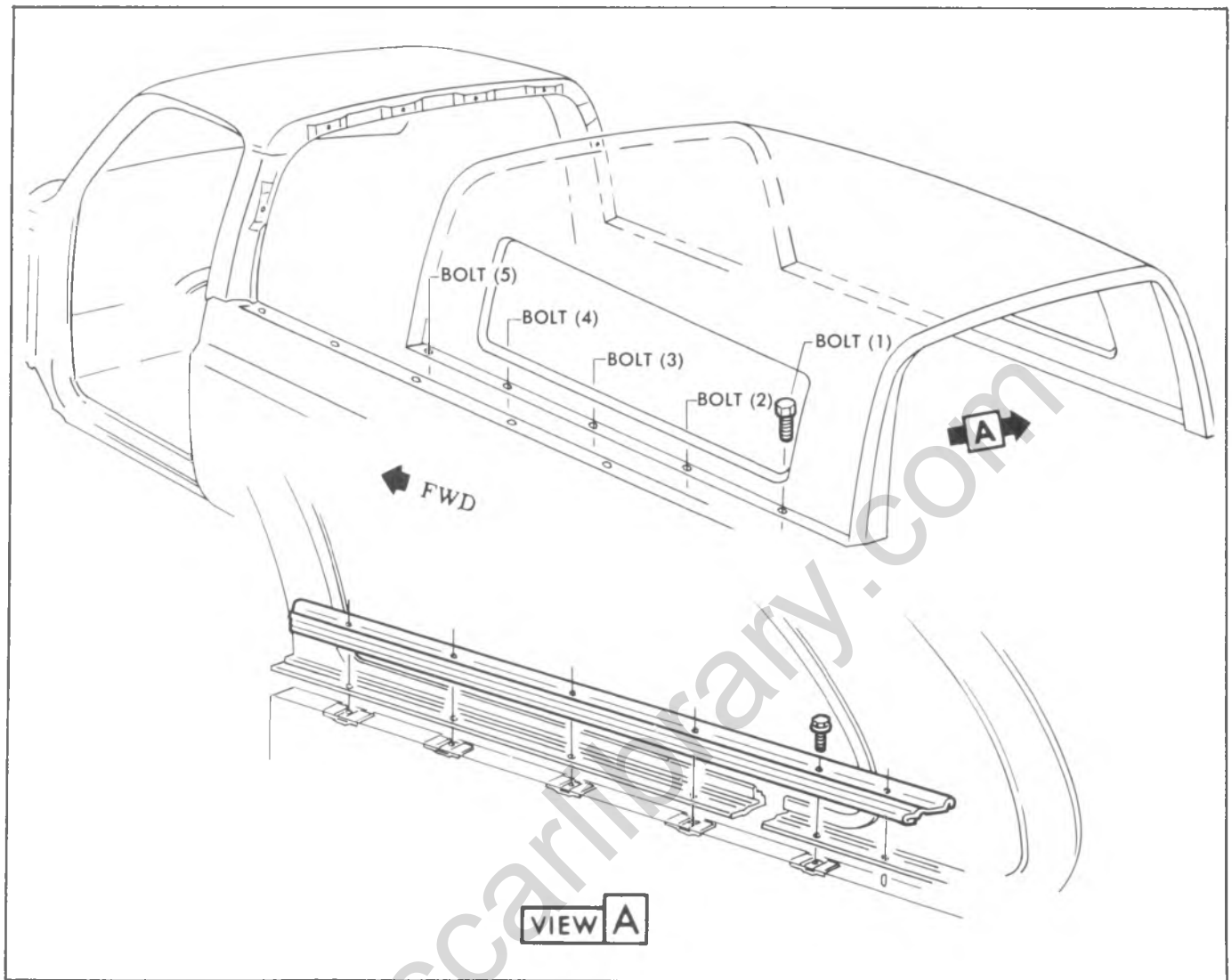


Fig. 2D-78--Removable Top

immediately by a soft brush to completely remove the spot.

Cleaning Fabrics with Detergent Foam Cleaners

This type of cleaner is excellent for cleaning general soilage from fabrics and for cleaning a panel section where a minor cleaning ring may be left from spot cleaning. Vacuum area to remove excess loose dirt.

Always clean at least a full trim panel or section of trim. Mask adjacent trim along stitch or weld lines. Mix detergent type foam cleaners in strict accordance with directions on label of container. Use foam only on a clean sponge or soft bristle brush. Do not wet fabric excessively or rub harshly with brush. Wipe clean with a slightly damp absorbent towel or cloth. Immediately after cleaning fabric, dry fabric, with a dry towel or hair dryer. Rewipe fabric with dry absorbent towel or cloth to

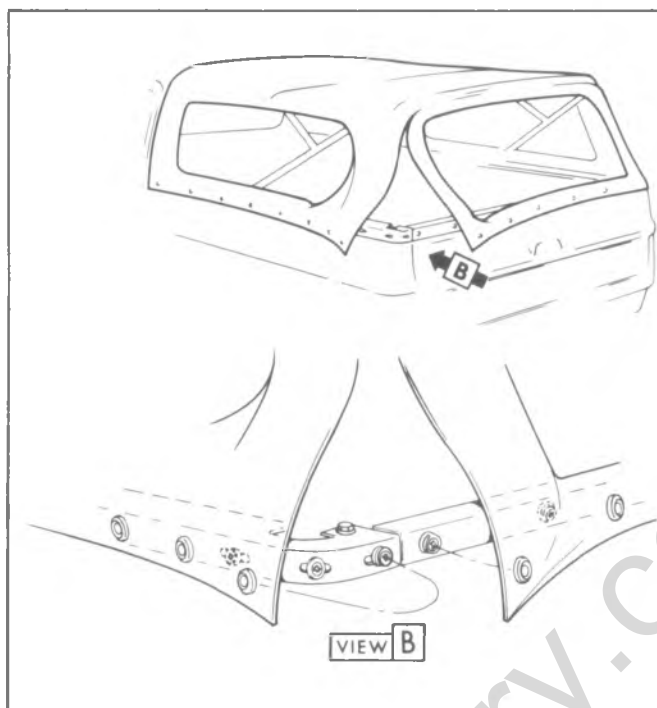


Fig. 2D-79--Folding Top Assembly

classiccarlibrary.com

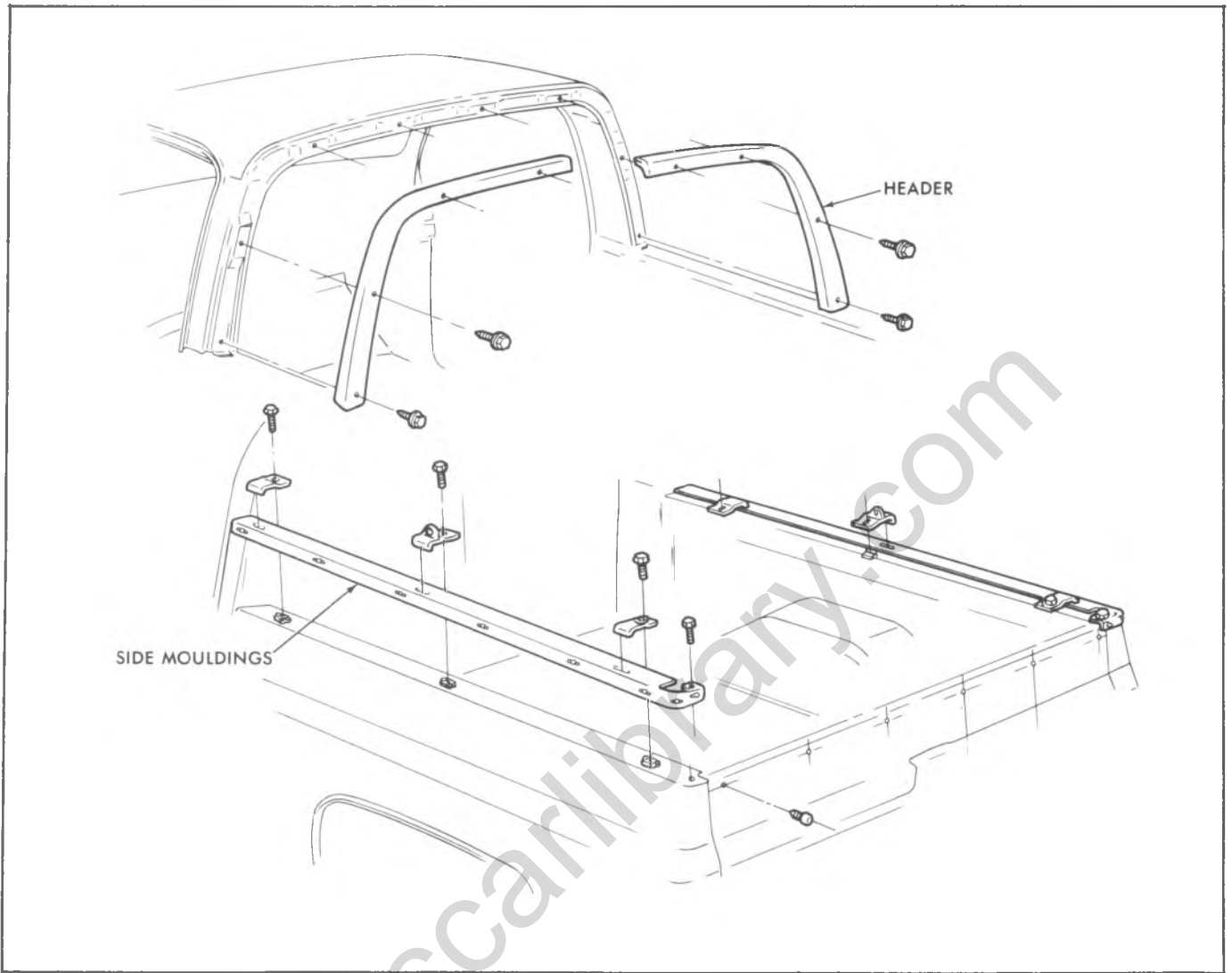


Fig. 2D-80--Folding Top Side Moldings and Header

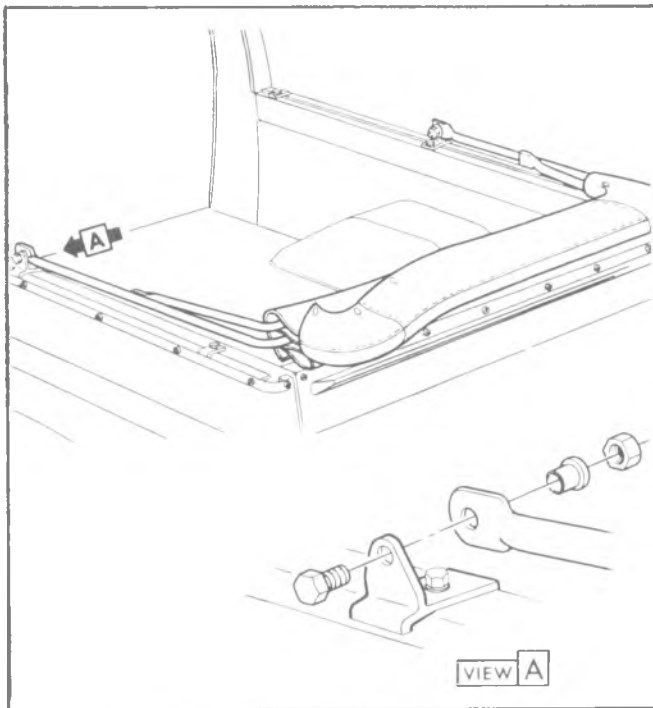


Fig. 2D-81--Folding Top Assembly and Storage

restore the luster of the trim and to eliminate any dried residue.

Removal of Specific Stains

Candy

Chocolate, use cloth soaked in lukewarm water; other than chocolate, use very hot water. Dry. If necessary, clean lightly with fabric cleaning fluid.

Chewing Gum

Harden gum with ice cube and scrape off with dull knife. Moisten with fabric cleaning fluid and scrape again.

Fruit Stains, Coffee, Soft Drinks, Ice Cream and Milk

Wipe with cloth soaked in cold water. If necessary clean lightly with fabric cleaning fluid. Soap and water is not recommended as it might set the stain.

Catsup

Wipe with cloth soaked in cool water. If further cleaning is necessary, use a detergent foam cleaner.

Grease, Oil, Butter, Margarine and Crayon

Scrape off excess with dull knife. Use fabric cleaning fluid.

Paste or Wax Type Shoe Polish

Light application of fabric cleaning fluid.

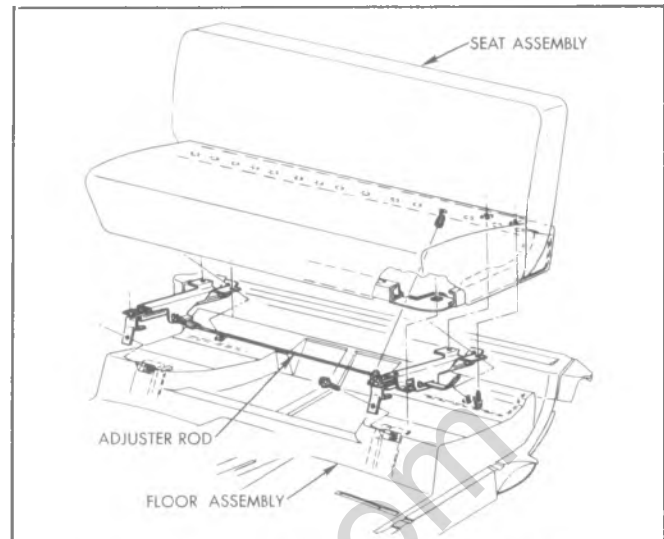


Fig. 2D-82--Front Bench Seat (03, 06 and 63)

Tar

Remove excess with dull knife, moisten with fabric cleaning fluid, scrape again, rub lightly with additional cleaner.

Blood

Wipe with clean cloth moistened with cold water. Use no soap.

Urine

Sponge stain with lukewarm soap suds from mild neutral soap and clean cloth, rinse with cloth soaked in cold water, saturate cloth with one part household ammonia water and 5 parts water, apply for 1 minute, rinse with clean, wet cloth.

Vomitus

Sponge with clean cloth dipped in clean, cold water. Wash lightly with lukewarm water and mild neutral soap. If odor persists, treat area with water-baking soda solution (1 teaspoon baking soda to one cup of tepid water). Rub again with cloth and cold water. Finally, if necessary, clean lightly with fabric cleaning fluid.

SEAT MOUNTING

Typical Seat Mounting provisions are shown in figures 2D-82 through 2D-90.

CAUTION: See *CAUTION* on page 1 of this section regarding fasteners used on seats and seat belts.

BODY MOUNTING

The sequence of mounting attachments is shown in figures 2D-91 through 2D-94.

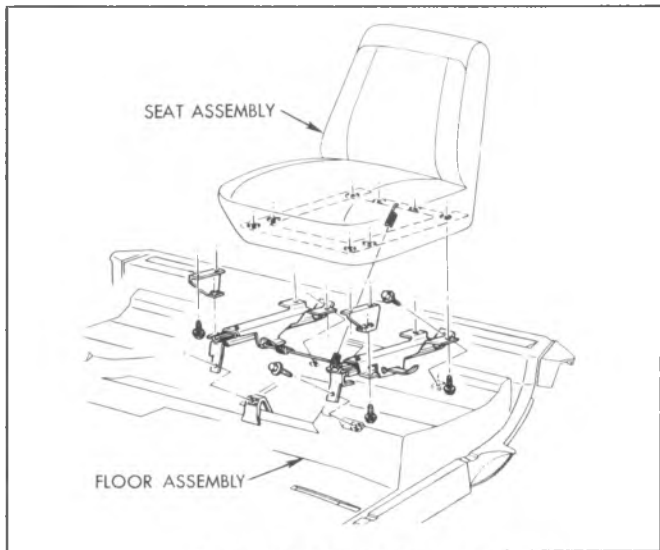


Fig. 2D-83--Driver's Bucket Seat (03)

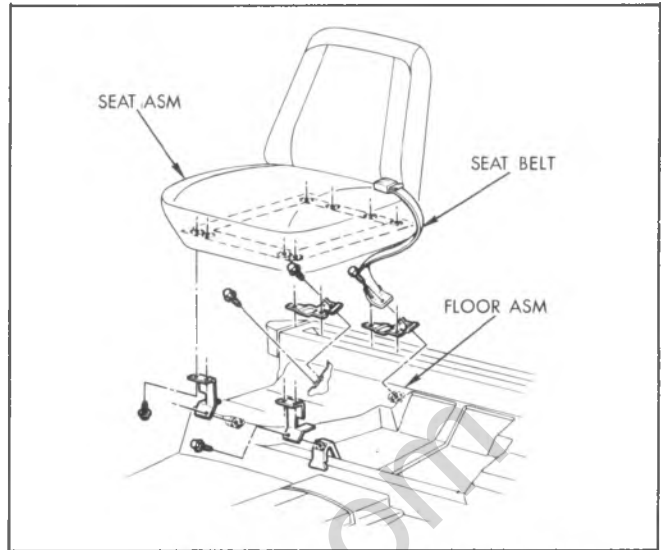


Fig. 2D-84--Passenger's Bucket Seat (03)

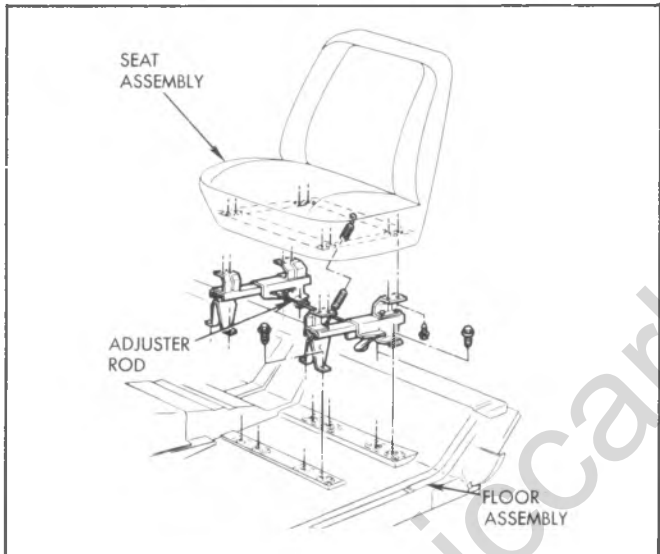


Fig. 2D-85--Driver's Bucket Seat (14)

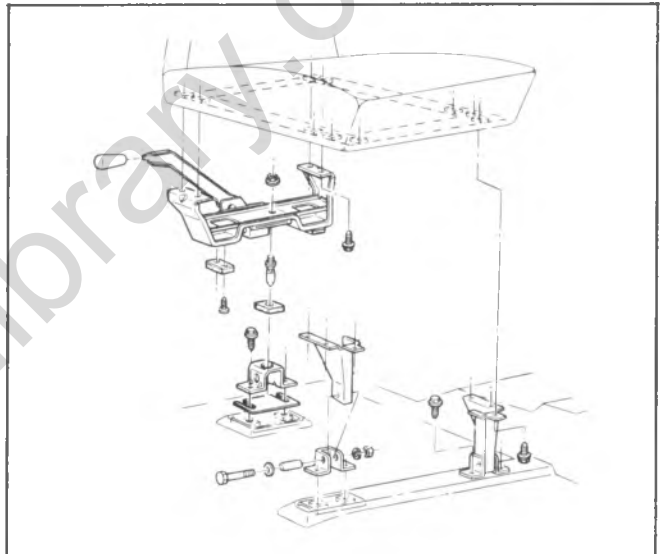


Fig. 2D-86--Passenger's Bucket Seat (14)

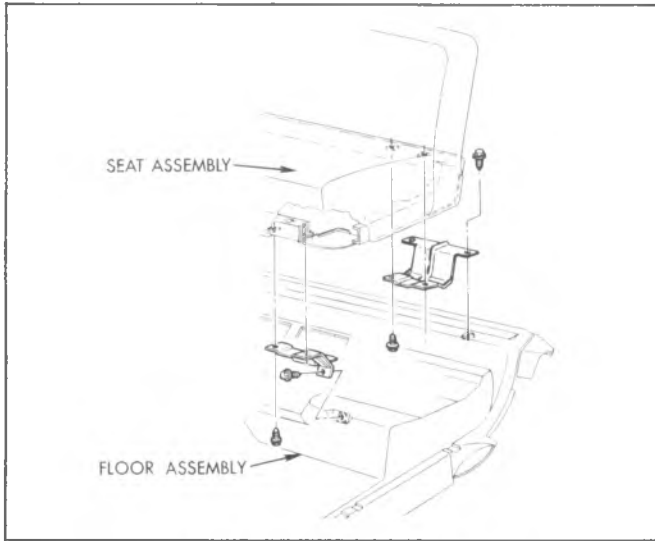


Fig. 2D-87-Rear Bench Seat (63)

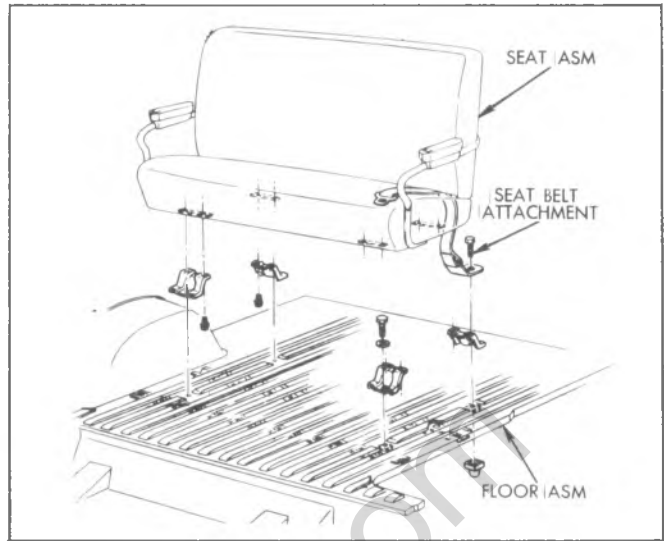


Fig. 2D-88-Rear Bench Seat (06)

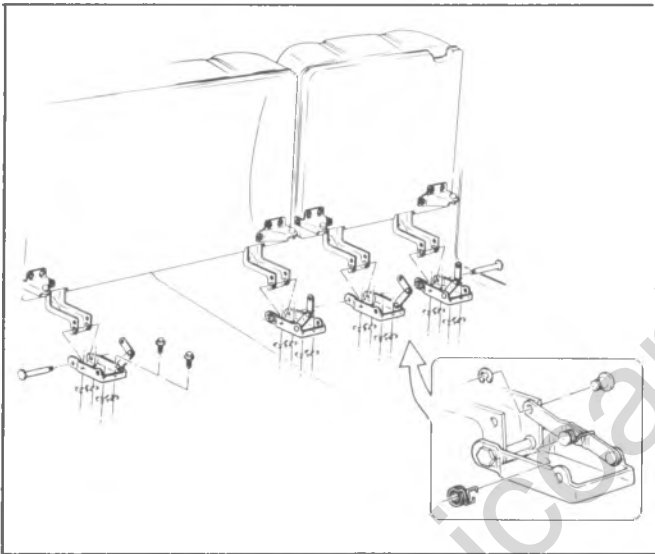


Fig. 2D-89-Rear Folding Seat (06)

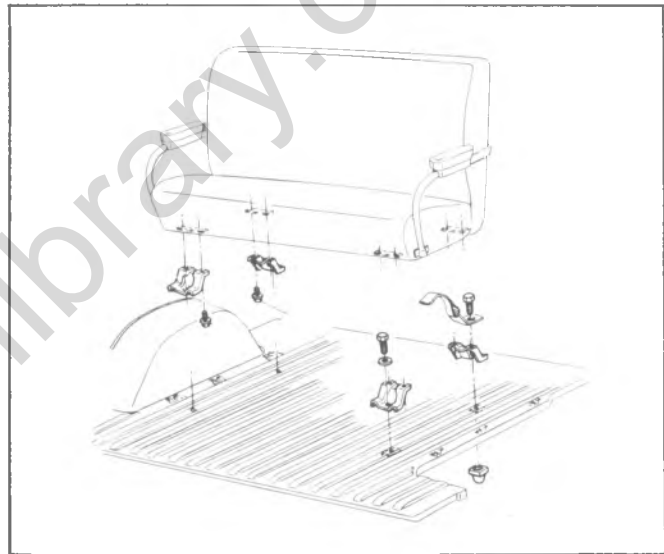


Fig. 2D-90-Rear Bench Seat (14)

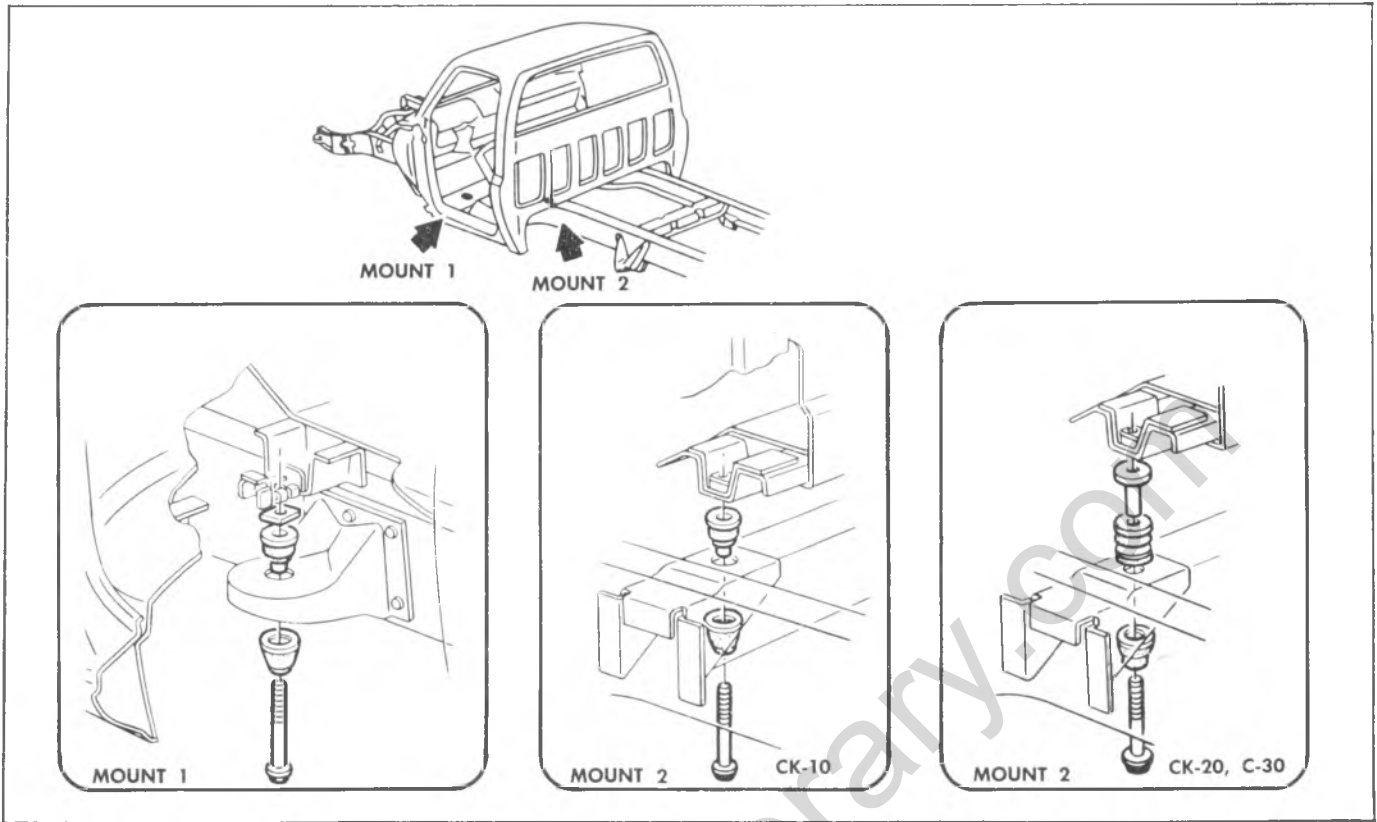


Fig. 2D 91 Body Mounting (03)

Classiccarlibrary.com

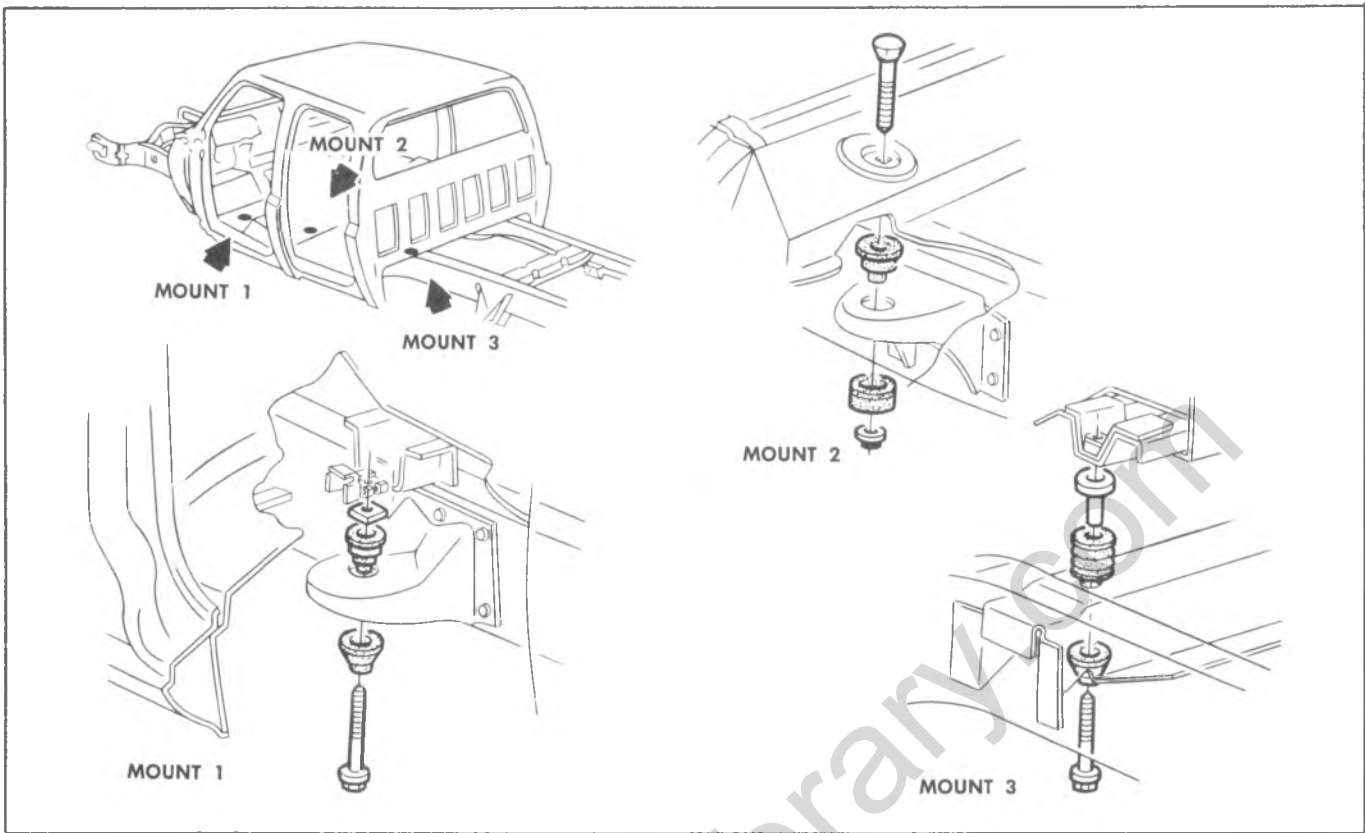


Fig. 2D-92--Body Mounting (63)

classiccarslibrary.com

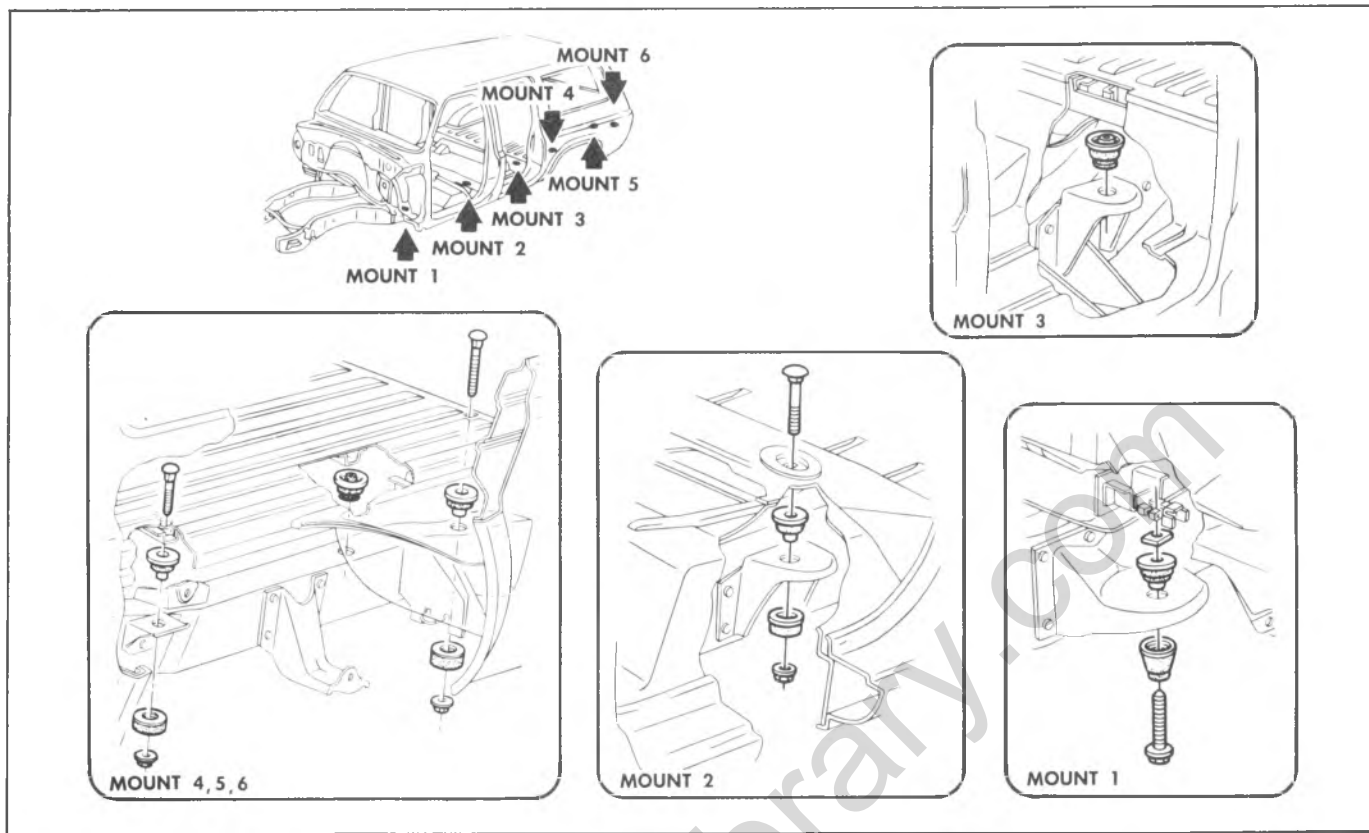


Fig. 2D-93-Body Mounting (06)

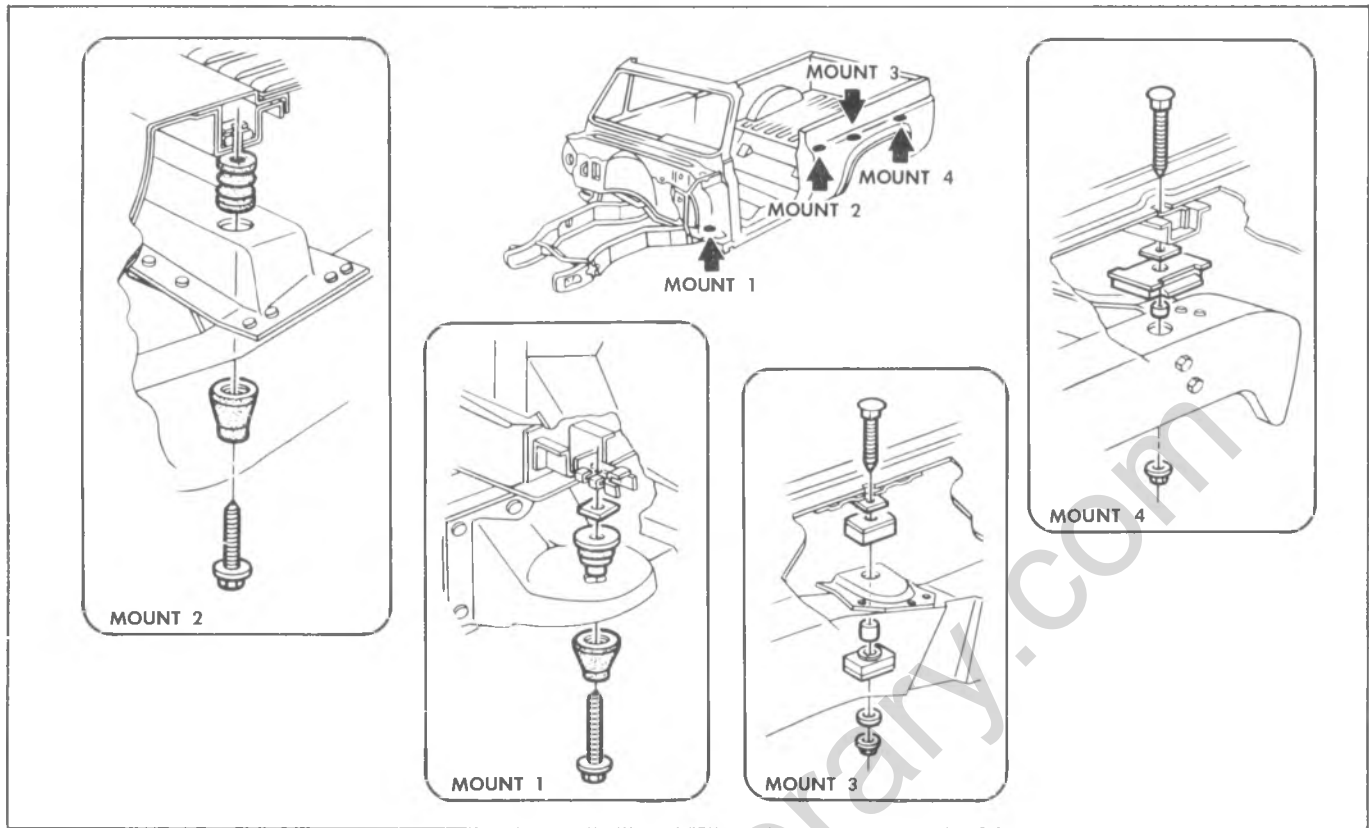


Fig. 2D-94-Body Mounting (14)

G MODELS

INDEX

Front End		Locks, Handles, Rods	2D-48
Windshield Wipers.....	2D-41	Sliding Side Door	
Cowl Ventilator Grille.....	2D-41	Description	2D-49
Side Ventilator Valve	2D-41	Adjustments.....	2D-51
Rear View Mirror	2D-42	Front Latch.....	2D-51
Body Glass		Rear Latch.....	2D-51
Windshield Glass.....	2D-43	Upper Rear Hinge.....	2D-51
Stationary Glass.....	2D-45	Strikers	2D-51
Swingout Glass.....	2D-45	Rear Door	
Front Door		Hinge	2D-55
Adjustments.....	2D-45	Remote Control.....	2D-55
Replacement.....	2D-46	Latches and Rods.....	2D-55
Weatherstrip.....	2D-46	Adjustments.....	2D-55
Hinges.....	2D-46	Seats	
Ventilator	2D-47	Drivers Seat.....	2D-57
Window and Regulator.....	2D-48	Passenger Seat.....	2D-58
		Rear Seats	2D-58

FRONT END

WINDSHIELD WIPERS

Windshield wiper units on all models are of the two-speed electric type. A single wiper motor unit, mounted to dash panel at top and to left of engine cover inside cab, powers both wiper blades. The wiper blade operating link rods and pivot mountings on these models are located in the outside air inlet plenum chamber.

Arm Adjustment

To adjust sweep of blades turn on wipers, then note sweep of arms. If necessary, remove one or both arms as follows: Pull outer end of arm away from glass which will trip lock spring at base of arm and release spring from undercut of pivot shaft. While holding arm in this position, pull outward on cap section at base of arm to remove arm. Arm can be reinstalled in any one of several positions due to serrations on pivot shaft and in arm cap. See figure 2D-95.

WIPER ARM PIVOT SHAFTS AND LINK ROD—FIG. 2D-96

Removal

1. Remove windshield wiper arms from pivot shafts. Procedure for removing arms is explained previously under "Arm Adjustments."

2. Remove screws which attach outside air cowl ventilator grille to cowl. Carefully remove grille from cowl.

3. At center of cowl, remove two attaching nuts which attach link rod to motor drive. Disengage link rods from pins.

4. Remove screws which attach each arm transmission pivot shaft assembly to cowl. Remove pivot shaft assembly with link rod from plenum chamber.

Installation

1. Place pivot shaft assembly with link rod into position at cowl bracket. Secure assembly to bracket with two screws.

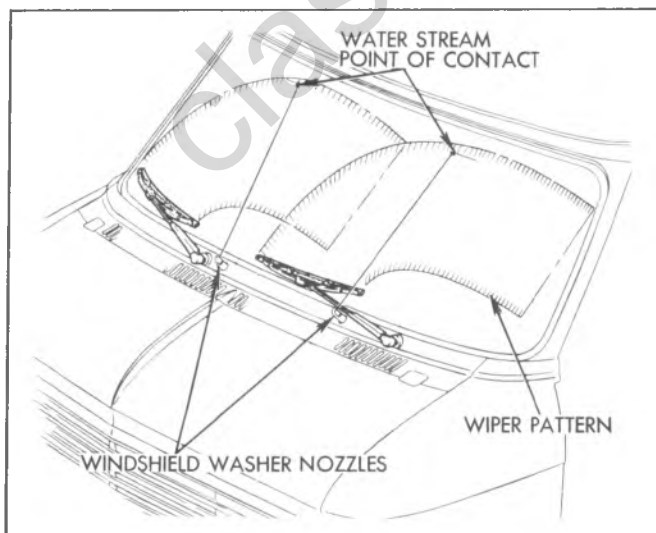


Fig. 2D-95--Wiper Pattern

2. Attach end of link rod to motor drive and arm. Secure rod with the two attaching nuts.

3. Install outside air cowl ventilator grille to top of cowl.

4. Before installing wiper arms, operate wiper motor momentarily which should rotate pivot shafts to park position. Install arms.

COWL VENTILATOR GRILLE

Replacement

1. Remove windshield wiper blades.
2. Remove screws retaining grille, figure 2D-97.
3. Remove grille and seal.
4. Reverse above steps to install grille.

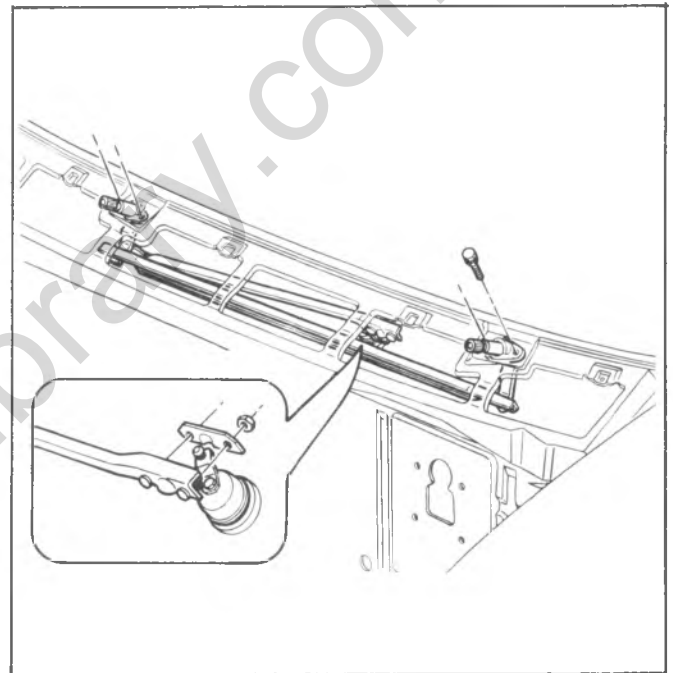


Fig. 2D-96--Windshield Wiper Linkage

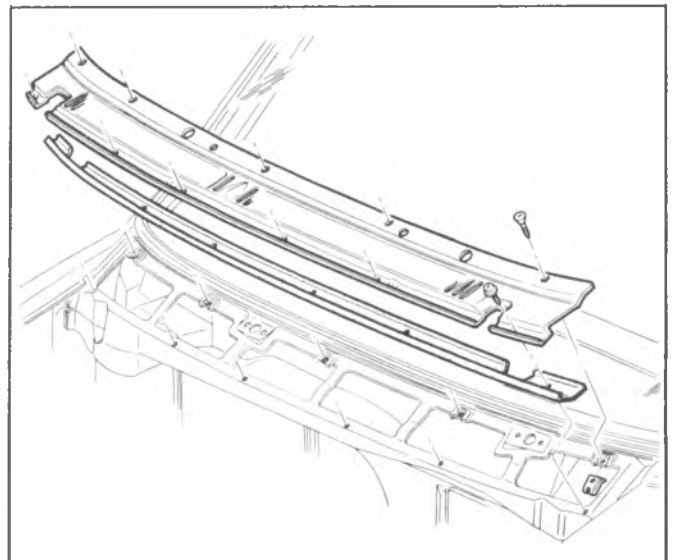


Fig. 2D-97--Cowl Ventilator Grille

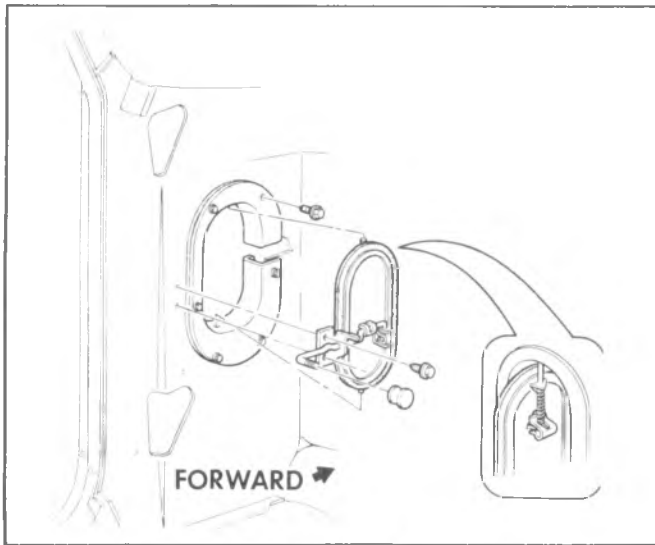


Fig. 2D-98--Side Cowl Ventilator

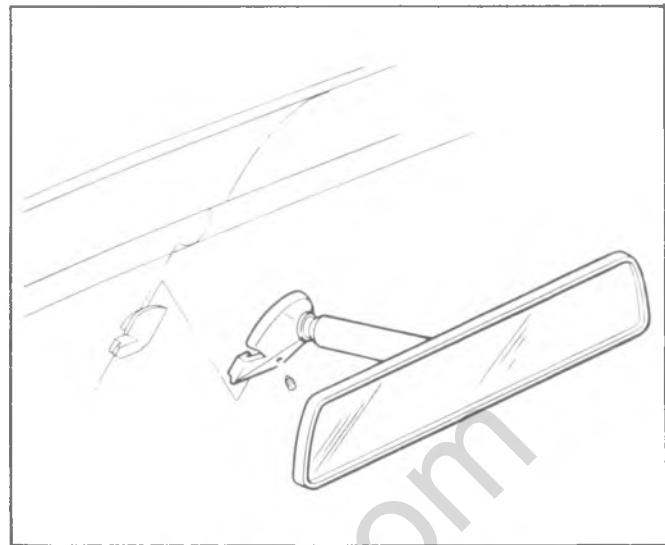


Fig. 2D-99--Inside Rear View Mirror

Replacement

1. Remove screws retaining valve guide to panel, as shown in figure 2D-98.
2. Remove valve assembly by depressing pins at top and bottom of valve.
3. Reverse the above steps for installation.

REAR VIEW MIRRORS

Inside Rear View Mirror

Replacement

The inside mirror may be removed by removing screw retaining mirror to its glass-mounted bracket, and lifting mirror off bracket.

Outside Rear View Mirrors

Outside rear view mirror installations are shown in figure 2D-100. Occasional tightening of mounting and assembly bolts and screws will sharply decrease occurrence of failure due to door slamming or road shock.

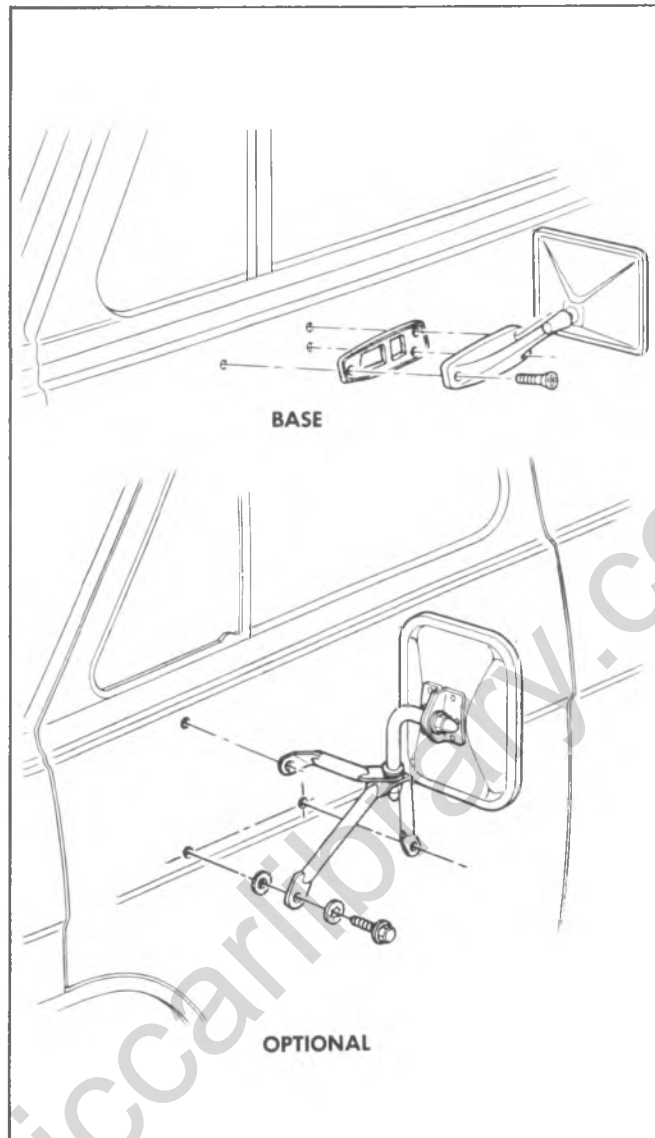


Fig. 2D-100--Outside Rear View Mirrors

BODY GLASS

WARNING: Always wear gloves when handling glass.

WINDSHIELD GLASS

The windshield is a one-piece type and is retained in the windshield opening by a moulded rubber weatherstrip. This weatherstrip is sealed in the windshield opening and sealed to the windshield glass. See figure 2D-101.

When replacing a cracked windshield glass, it is very important that the cause of the glass breakage be determined and the condition corrected before a new

glass is installed. Otherwise, it is highly possible that a small obstruction or high spot somewhere around the windshield opening will continue to crack or break the newly installed windshield, especially when the strain on the glass caused by this obstruction is increased by such conditions as wind pressures, extremes of temperature, motion of the vehicle, etc.

The procedure for removal of the windshield applies to the complete windshield assembly and to other stationary glass, such as in figure 2D-104.

Removal

NOTE: Refer to figures 2D-14 to 2D-16 in the "C-K Models" portion of this section for illustration of removal technique.



Fig. 2D-101--Windshield Glass

1. Before removing the windshield, mark the location of the break on the windshield rubber channel and the body. Protect the paint finish inside of the cab. Mask around the windshield opening and outside, lay a suitable covering across the hood and fenders.

NOTE: The windshield glass rubber weatherstrip is one piece. The glass is held in a channel within the weatherstrip.

2. Do not try to remove reveal moldings while windshield is in body opening. Remove reveal molding from custom weatherstrip retention groove after windshield is removed from body opening.

3. To free windshield rubber channel of weatherstrip loosen the lip of the windshield weatherstrip from the pinchweld flange along the top and at the sides by applying firm, controlled pressure to the edge of the glass. At the same time assist the lip of the rubber weatherstrip channel over the pinchweld flange with a flat bladed tool.

Checking Windshield Opening

Due to the expanse and contour of the windshield it is imperative in the event of a stress crack that the windshield opening be thoroughly checked before installing a replacement windshield. The replacement glass is used as a template.

1. Check for the following conditions at the previously marked point of fracture.

- a. Chipped edges on glass.
- b. Irregularities in body opening.
- c. Irregularities in rubber channel weatherstrip.

2. Remove all sealer from flange and body around windshield opening.

3. Check flange area for solder, weld high spots, or hardened spot-weld sealer. Remove all high spots.

4. Check windshield glass to opening, by supporting glass with six spacers contained in packet J-22577, as shown in figure 2D-102.

CAUTION: Do not strike glass against body metal. Chipped edges on the glass can lead to future breaks.

NOTE: It is necessary to modify the spacers by cutting off 3/16" from the back of the spacer with a knife, as shown in figure 2D-102.

With the windshield supported and centered in its opening, check the relationship of the glass to the body opening flange around the entire perimeter of the glass.

6. Check the relationship of glass to opening as follows:

- a. Inside edge of glass to body flange.
- b. Outer edge of glass to parallel body metal.

7. Mark areas of body metal or flange to be reformed, remove glass and correct as necessary.

8. Recheck windshield in its opening and if satisfactory proceed as follows:

Installation

1. Apply sealer to weatherstrip and install on glass.

2. Install a cord around periphery of weatherstrip, leaving a loop at the top and the loose ends at the bottom. See figure 2D-103.

3. Place protective covering over plenum grille, front fenders and hood.

4. Place windshield and weatherstrip assembly in opening. With one technician lightly pushing in on windshield, another technician within the cab should pull on the cord as follows:

- a. Pull on loose ends until each is within 2" of its respective upper corner.
- b. Pull on loop until cord is within 2" of the upper corners.

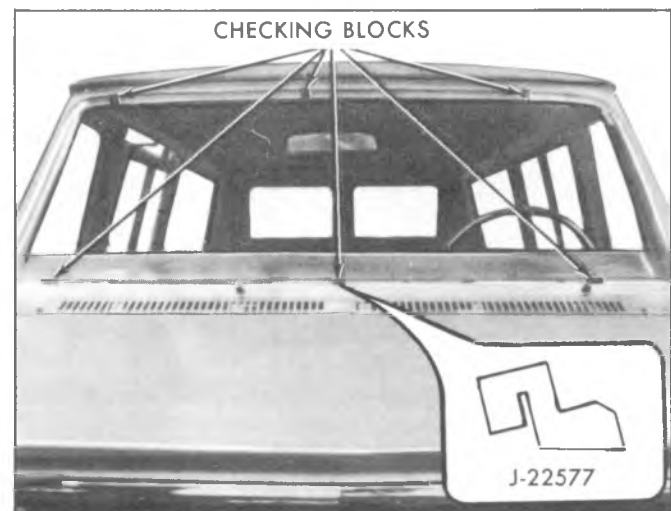


Fig. 2D-102--Checking Windshield Opening

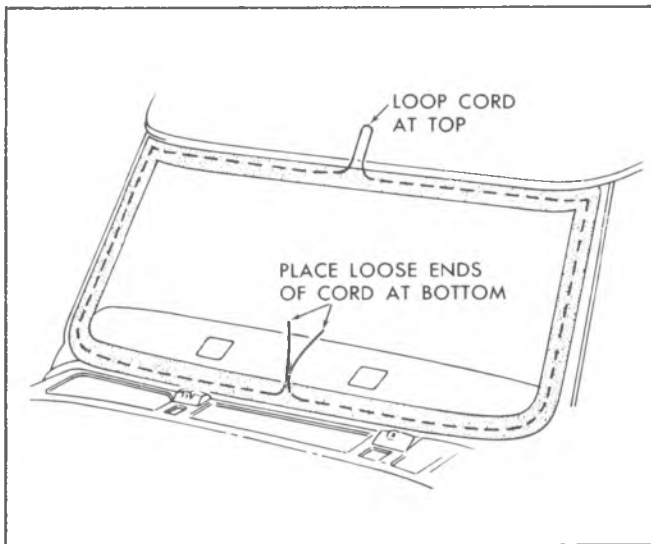


Fig. 2D-103--Cord Installation

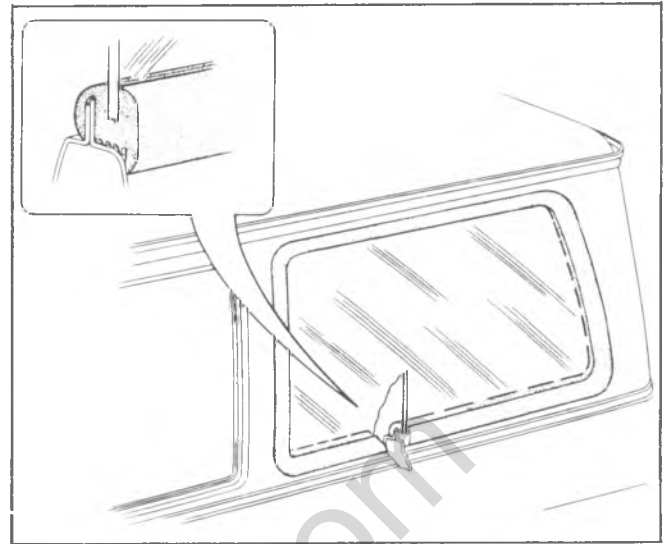


Fig. 2D-104--Body Window Glass

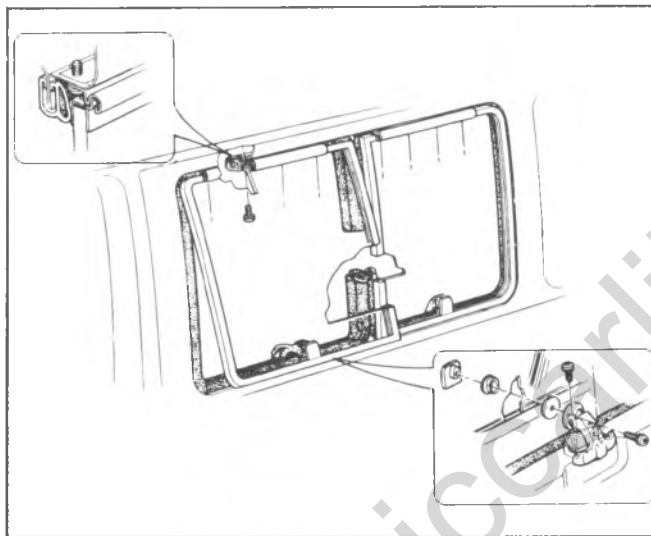


Fig. 2D-105--Swingout Window

c. Finish seating corners by simultaneously pulling on both ends of the cord at each corner. This will insure proper positioning of the critical upper corners.

d. Seal windshield to weatherstrip and weatherstrip to body.

SWINGOUT WINDOW

Removal

1. Swing out the window. See figure 2D-105.
2. Remove screws retaining latch to body.
3. Remove window hinge retaining screws and window.
4. Remove latch from glass.

Installation

1. Install latch to glass using escutcheon, spacer, washer latch and screw. Torque to specifications.
2. Place window into opening and install hinge retaining screws and window.
3. Install latch to glass.

LATCH SWINGOUT WINDOW

Replacement

1. Swing out the window.
2. Remove latch to body and latch to window screws and remove latch.
3. Reverse above steps for installation.

FRONT DOOR

DOOR ADJUSTMENTS

Doors can be adjusted for alignment of clearance in the cab door opening, and for proper latching. Door alignment adjustments are made at the striker bolt, and at door hinges. The door, when properly located in door opening, will have equal clearance around its perimeter. The door should be adjusted in the opening so the edge

of the door across the top and also at the lock side is parallel with the body opening as nearly as possible.

Hinge Adjustment

Door hinge bolt holes are oversized to make adjustment possible. Alignment adjustments can be made by loosening the proper hinge bolts, aligning door to proper position, and tightening bolts securely. See figure 2D-106, for typical adjustments.

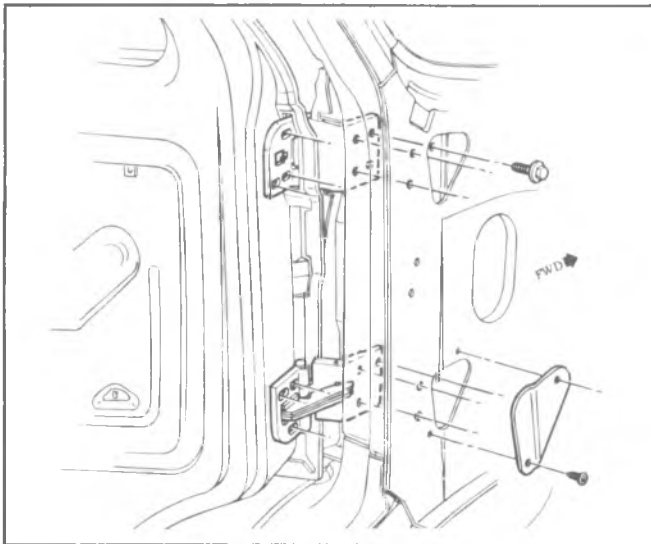


Fig. 2D-106-Door Hinge

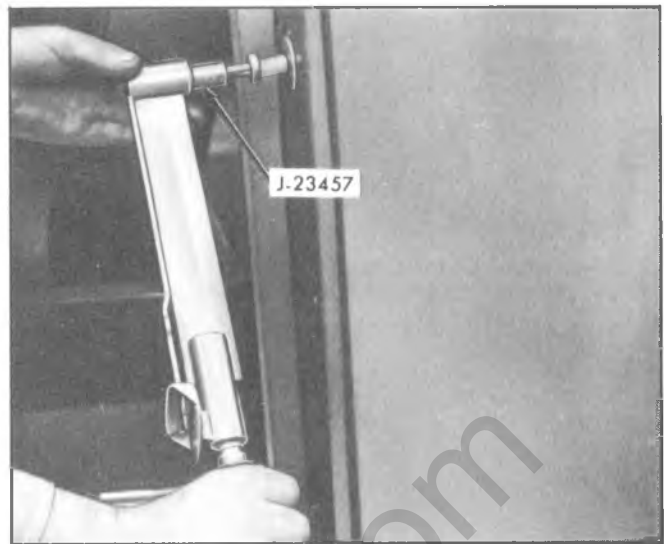


Fig. 2D-107-Loosening Striker Bolt

Striker Bolt Adjustment

With the use of J-23457, shown in figure 2D-107, the striker bolt can be adjusted in any of three ways. See figure 2D-108.

1. **Up and down**—To adjust striker up or down, loosen bolt, adjust to center of lock entry, and tighten bolt securely.

NOTE: This adjustment is important to assure that the right proportion of door's weight will rest on striker bolt when door is closed. If bolt is positioned too high on pillar, rapid wear will occur to the lock cam; if too low, an extra load will be placed on door hinges as well as pull door downward and out of alignment.

2. **In and Out**—To adjust striker in and out, loosen bolt, adjust horizontally to match the door surface to the body surface, and tighten bolt securely.

3. **Forward and Rearward**—To make this adjustment, loosen striker bolt, shim to desired position, and tighten bolt securely.

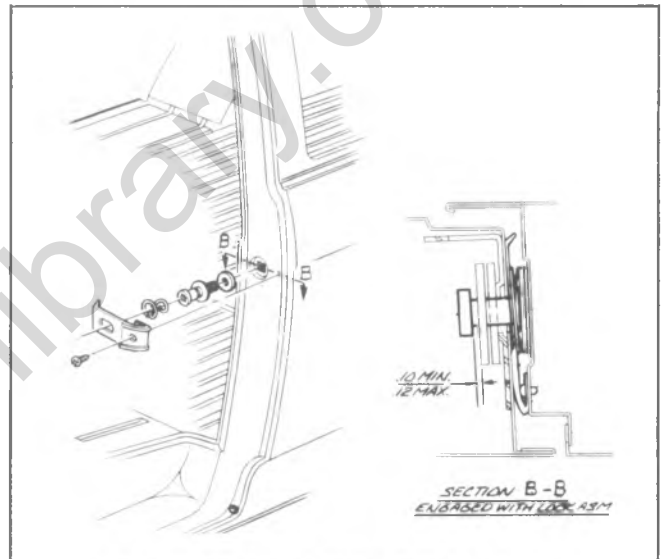


Fig. 2D-108-Typical Striker Bolt Adjustment

5. Install hinge access hole covers.

DOOR HINGE

Remove

1. Remove hinge access hole cover from door hinge pillar.
2. If removing one hinge, support door in such a manner that weight is taken off other hinge, and that the door will not move.
3. Remove hinge screws from both body and from door and remove hinge. See figure 2D-106.

Installation

1. Install hinge to door and body. Snug bolts.
2. Remove door supports.
3. Adjust door as outlined under "Door Adjustment".
4. Torque bolts to specifications.

DOOR WEATHERSTRIP

Success of weatherstrip replacement depends entirely upon the quality of the cement used and the care with which it is applied. All rust, road dirt and grease or oil must be completely removed as should all old cement and bits of old weatherstrip. After removing all foreign material from door opening surface, wipe down with prepsol or its equivalent. Use only a good quality cement which is made specially for weatherstrip installation, following the manufacturer's directions. Proceed as follows:

1. Open door and block open.
2. Remove side door weatherstrip.
3. Remove used adhesive from door with adhesive or cement remover, and remove all plastic nails.
4. Apply adhesive to door.
5. Position weatherstrip by locating part number at

top of vent window, making sure that plastic nails align with holes in door.

6. Install weatherstrip by pressing each nail into the door.

TRIM PANEL, ARM REST AND HANDLES

Removal

1. Remove screws retaining arm rest to trim panel.
2. Remove door handles with Tool J-7797 and pull from shaft.
3. Remove trim panel screws and remove panel. If seal is damaged, replace seal.

Installation

1. Install trim panel.
2. Install arm rest. Install door handle washers and handles.

DOOR VENTILATOR ASSEMBLY

Removal

NOTE: The channel between the door window glass and door vent is removed as part of the vent assembly.

1. Regulate the door window glass to the full down position.
2. Remove door handles with Tool J-7797.
3. Remove trim panel.
4. Remove rear window run channel screws.
5. Slide door window glass rearward away from ventilator.
6. Remove three screws at the upper front of the door, as shown in figure 2D-109.
7. Turn the vent assembly 90° and carefully remove by guiding up out, as shown in figure 2D-109.

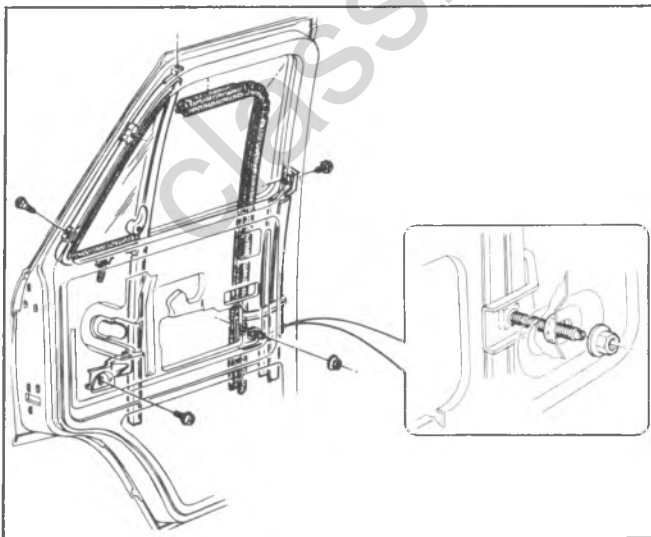


Fig. 2D-109--Ventilator Assembly

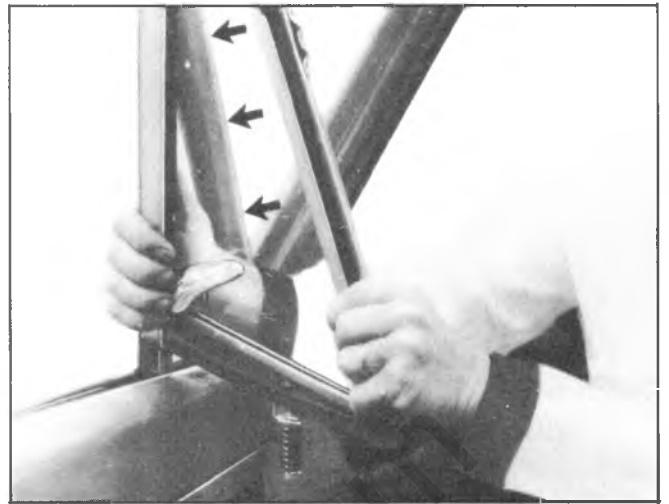


Fig. 2D-110--Removing Ventilator

Ventilator Glass Replacement

1. Using an oil can or similar means, squirt prepsol on the glass filler all around the glass channel or frame to soften the old seal. When the seal has softened, remove the glass from the channel.
2. Thoroughly clean the inside of the glass channel with sandpaper, removing all rust, etc.
3. Using new glass channel filler, cut the piece to be installed two inches longer than necessary for the channel. Place this piece of filler (soapstoned side of filler away from glass) evenly over the edge of the glass which will fit in the channel. The extra filler extending beyond the rear edge of the glass should be pinched together to hold it in place during glass installation.

NOTE: One side of this filler (the outside of the roll) is soapstoned. This is the side which goes into the metal channel.

4. Brush the inside of the metal glass channel freely with ordinary engine oil. This will enable the glass and filler to slide freely into the channel.

NOTE: Glass should be installed so that rear edge is parallel to the division post. Allow full cure before water testing.

Installation

NOTE: Replace the door window glass and regulate to the full down position before installing the door ventilator assembly.

1. Lower the ventilator assembly into the door frame. Center into position.
2. Make certain the rubber lip is positioned before tightening screws.
3. Slide door glass forward engaging glass in vent channel.
4. Reinstall all screws and tighten.

5. Install and tighten the three screws at the upper front of the door.

Adjustment

1. Adjust the ventilator adjusting nut by turning clockwise to increase operating tension, as shown in figure 2D-111.

2. After making adjustment bend tabs over the hex nut.

3. Install trim panel.

4. Install door and window regulator handles.

DOOR WINDOW ASSEMBLY

Replacement

1. Completely lower glass to bottom of door.

2. Remove inside door and window regulator handles using Tool J-7797.

3. Remove door arm rest and trim pad.

4. Mask or cover upper portion of door window frame. Remove ventilator assembly as previously outlined.

5. Slide glass forward until front roller is in line with notch in sash channel. Disengage roller from channel. See figure 2D-112.

6. Push window forward and tilt front portion of window up until rear roller is disengaged.

7. Put window assembly in normal position (level) and raise straight up and out.

8. Reverse above procedure for installation.

WINDOW REGULATOR

Replacement

1. Wind window all the way up.

2. Remove inside door handles with Tool J-7797.

3. Remove door trim pad.

4. Remove screws securing regulator to inner panel.

5. Push regulator out of door opening while holding rear of assembly, then slide assembly to the

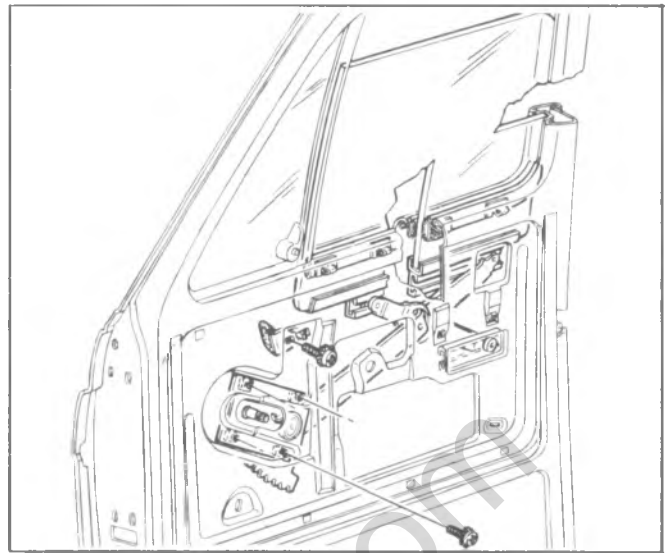


Fig. 2D-112--Window and Regulator

notches in the carrier channel and out through the door access hole.

6. Install regulator in reverse order of removal, lubricate regulator gears with lubriplate or equivalent.

DOOR LOCK—FIGURE 2D-113

Removal

1. Raise window.

2. Remove inside handles with Tool J-7797.

3. Remove trim panel.

4. Remove remote control sill knob.

5. From outside the door remove screws retaining lock to door edge and lower the lock assembly.

6. Remove screws retaining remote control.

7. Remove screws securing glass run guide channel.

8. Remove lock, push button rod and remote control rod as an assembly.

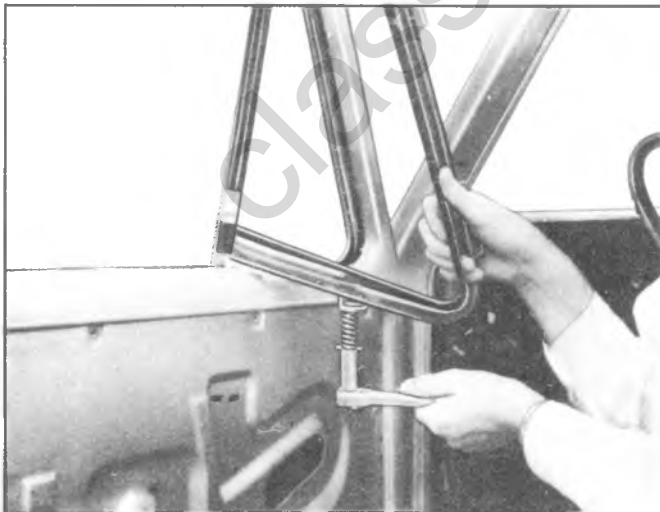


Fig. 2D-111--Adjusting Ventilator Tension

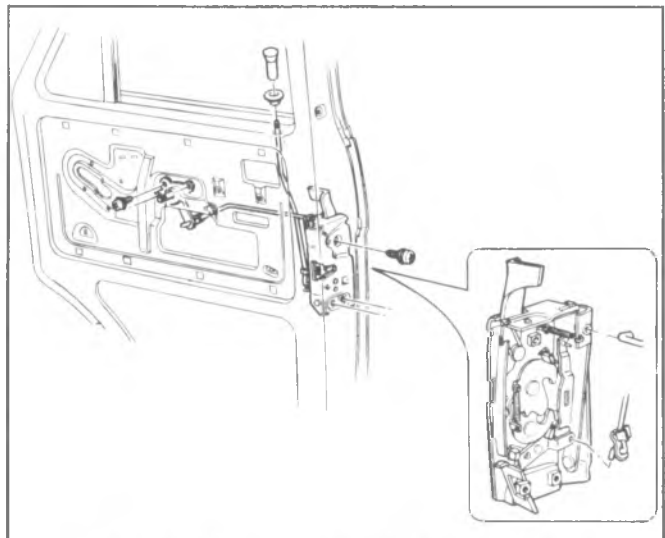


Fig. 2D-113--Lock and Remote Control Assembly

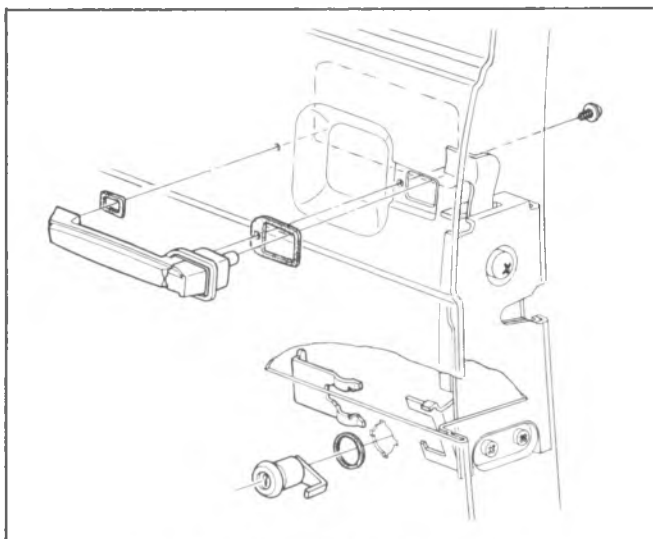


Fig. 2D-114--Lock Cylinder Assembly

Installation

1. Transfer remote rod with clip to new lock.
2. Connect remote door handle rod to lock after lock is positioned.
3. Secure lock screws.

4. Secure remote handle.
5. Check all controls for proper operation before reinstalling trim and handles.
6. Install remote control sill knob.

REMOTE CONTROL AND CONNECTING

ROD--Fig. 2D-113

Replacement

1. Raise door window and remove door trim pad.
2. Remove bolts securing remote control to door inner panel.
3. Pivot remote inboard slightly, to disengage connecting rod, and remove remote control from door.

NOTE: Connecting rod can be removed at this point by disconnecting spring clip from lock.

4. To install, reverse removal procedure.

LOCK CYLINDER ASSEMBLY--FIG. 2D-114

Replacement

1. Raise door window and remove door trim pad.
2. With a screwdriver, or other suitable tool, slide lock cylinder retaining clip (on door outer panel) out of engagement and remove lock cylinder.
3. To install, reverse removal procedure.

SLIDING SIDE DOOR

DESCRIPTION

The weight of the sliding side door is supported by the upper rear hinge-and-roller assembly, and by the lower front catch-and-roller assembly. The front and rear latches retain the door in the locked position, while the rear wedge assembly restricts door vibration on rough road surfaces.

ADJUSTMENTS

CAUTION: See *CAUTION* on page 1 of this section regarding all sliding door fasteners and adjustments found below.

The side door can be adjusted for alignment and/or clearance in the body opening and for proper latching. When properly positioned in the body opening, the door should have equal clearances around its perimeter. Adjustments for door positioning and proper latching can be made at the locations shown in figure 2D-115.

Up and Down

Up and down adjustments are provided by means of slotted holes located at the upper front roller, view B of figure 2D-112; at the lower front catch-and-roller, view D; and at the upper rear hinge-and-roller assembly, view A. To reposition the door up or down:

1. Partially open door and loosen front latch striker on pillar.

2. Remove upper rear hinge cover, shown in figure 2D-116.
3. Loosen upper rear hinge-to-door bolts.
4. Loosen rear lock striker and door wedge assembly.
5. Align rear edge of door up or down, then tighten upper rear hinge-to-door bolts to specifications.
6. Loosen upper front roller bracket-to-door bolts.
7. Partially close door and align front edge of door up or down by loosening front lower hinge-to-door bolts. When door is correctly positioned, tighten bolts to specifications.
8. Position upper front roller in center of track, then tighten roller bracket to door.
9. Adjust front and rear strikers and rear wedge assembly as outlined in their respective procedures later in this section.

In and Out

Front in and out adjustments are provided by means of an adjustable lower roller mounting bracket, view D of figure 2D-115, and by a slotted upper bracket, view B of figure 2D-115. Rear in and out adjustment is provided by adjusting the rear latch striker, view E of figure 2D-115. To position the door in or out:

1. Loosen front latch striker.
2. Loosen upper front roller from its bracket.
3. Loosen lower front roller bracket-to-arm bolts.

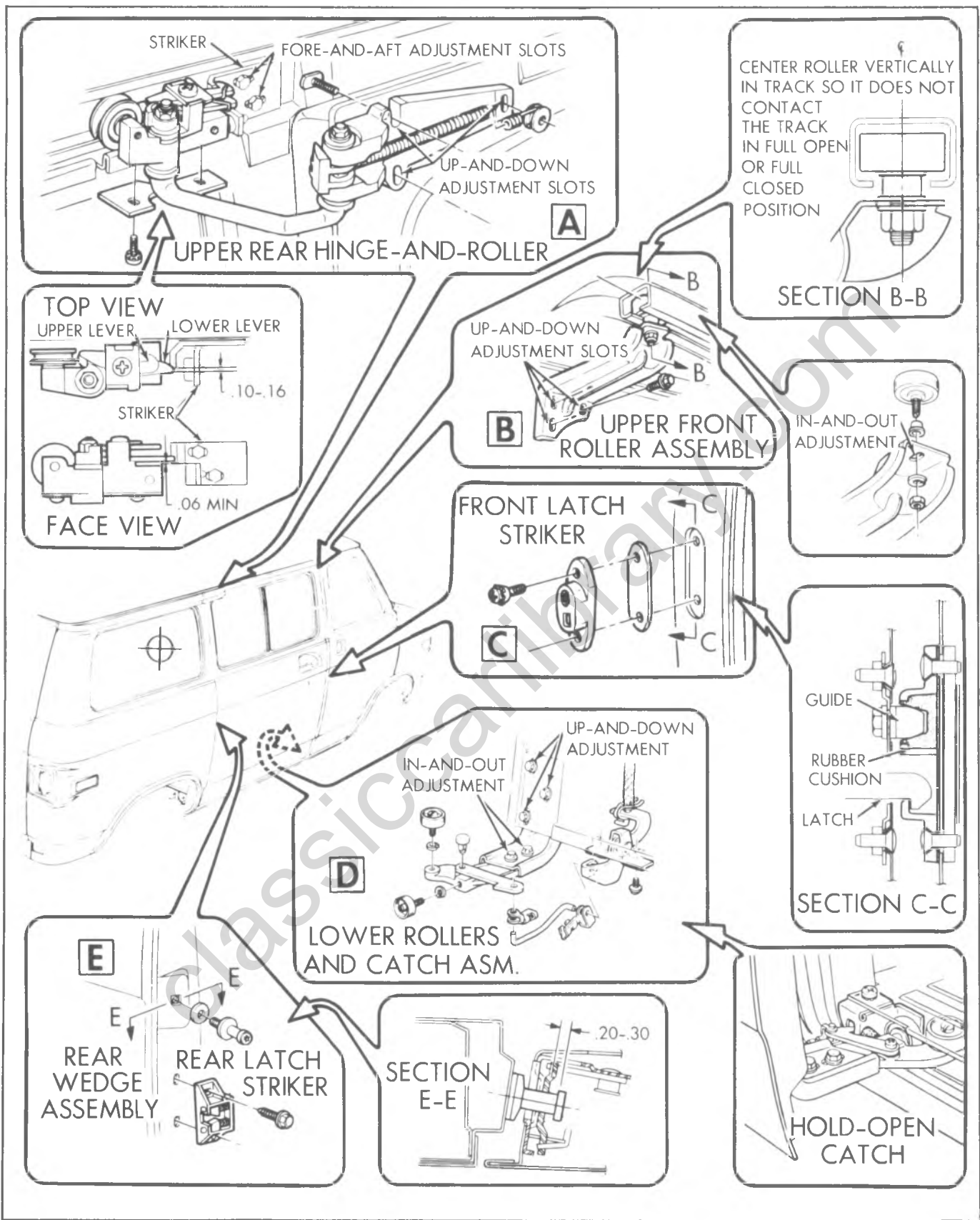


Fig. 2D-115-Sliding Side Door Adjustment Locations

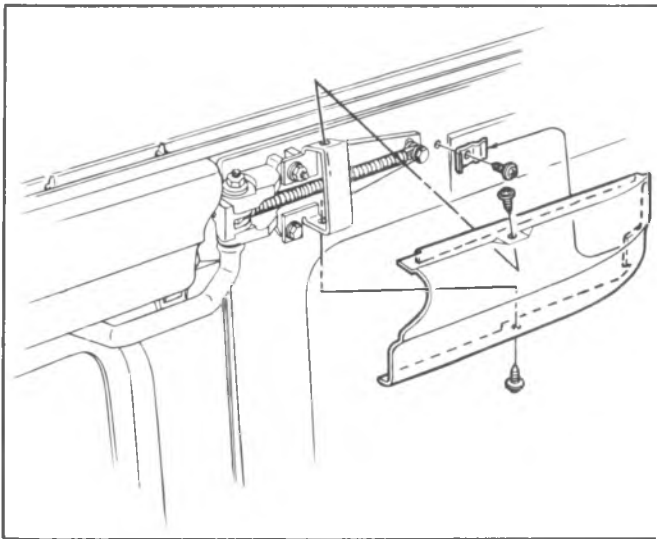


Fig. 2D-116--Hinge Cover

4. Adjust front of door in or out, then tighten bolts to specifications.

5. Adjust door hold open catch bracket, rear wedge assembly, rear latch striker, upper front roller and front latch striker as outlined later in "Adjustments".

Fore and Aft

Fore and aft adjustment is provided at the upper rear hinge striker by means of a slotted bracket mounted to the body, view A of figure 2D-115.

1. Partially open door and remove front latch striker and rear lock striker.

2. Loosen rear wedge assembly.

3. Remove upper rear track cover.

4. Loosen upper rear hinge striker.

5. Move door assembly forward or rearward, then tighten striker bolts to specifications.

6. Reinstall upper rear track cover.

7. Reinstall front and rear latch strikers.

8. Adjust latch strikers and rear wedge assembly as outlined below.

Latch Striker Adjustments

Front Striker

1. Loosen front latch striker screws, view C of figure 2D-115.

2. Visually align latch-to-striker relationship and adjust if necessary.

3. Slide door slowly toward striker. The guide on the door, just above the latch, must fit snugly within the rubber-lined opening on the striker assembly.

4. Assure that the latch engages fully into the striker. Add or delete shims behind the striker as necessary.

5. Tighten striker screws to specified torque.

Rear Striker

1. Loosen striker with J-23457.

2. Loosen rear wedge assembly.

3. Center the striker vertically to door striker opening.

4. Adjust the striker laterally to match outer panel to the body panel surfaces, view E of figure 2D-116.

5. Apply grease to the striker.

6. Gently push the door in until the rear lock contacts the striker enough to make an impression in the grease.

7. Open the door and measure the distance from the rear of the striker head to the impression. The distance should be between .20 inch and .30 inch. Refer to view E of figure 2D-115.

8. Adjust position of striker by adding or deleting shims between the striker and the pillar.

9. Adjust rear wedge assembly as outlined later in this section, and torque all fasteners to specifications.

Upper Rear Hinge-To-Striker Adjustment

CAUTION: *If door has been removed and is being reinstalled, adjust striker-to-lower hinge lever before closing door. Failure to do so may cause possible lever breakage.*

The upper rear hinge must be positioned as shown in view A of figure 2D-116, in order to insure proper latching.

1. The hinge lower lever must contact the striker at least .06 inch above the lower edge of the striker tang.

2. The lower lever must extend at least .10 inch outboard of the striker tang. Add or delete shims between the striker and the body as necessary.

3. If necessary to shim roller away from guide, shims are added between the nylon block and hinge and between roller and hinge. They must be installed in pairs. For example, if one shim is added behind the nylon block another must be added behind the roller.

Door Hold-Open Catch Adjustment

This catch, mounted on the lower front roller bracket, holds the door in the full open position. See figure 2D-117. The catch engages a striker installed at the rear of the lower roller channel, view D of figure 2D-115.

1. Loosen the screws retaining the catch rod bracket to bottom of door.

2. Adjust catch-to-striker engagement by sliding the bracket laterally. Catch should fully engage striker.

Rear Wedge Assembly Adjustment

1. Loosen screws attaching rear wedge assembly to the body pillar, then close the door to the fully latched position.

2. Center the wedge assembly on the door wedge, as shown in figure 2D-118, and scribe a line around the wedge assembly.

3. Open the door, and move the wedge assembly 3/16 inch.

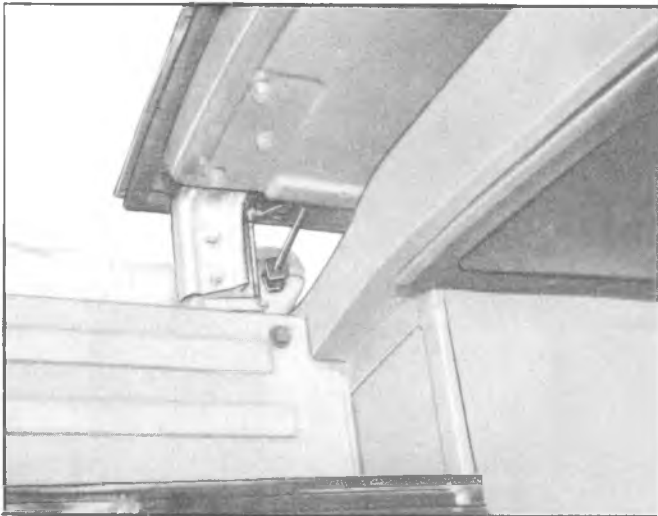


Fig. 2D-117--Hold-Open Catch

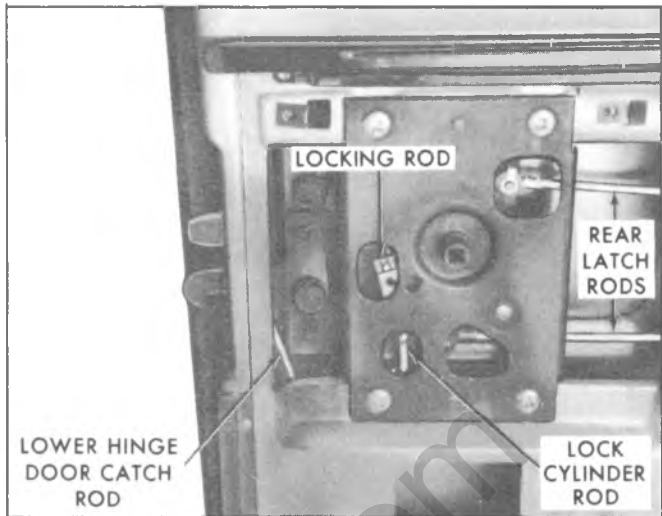


Fig. 2D-119--Sliding Door Front Latch

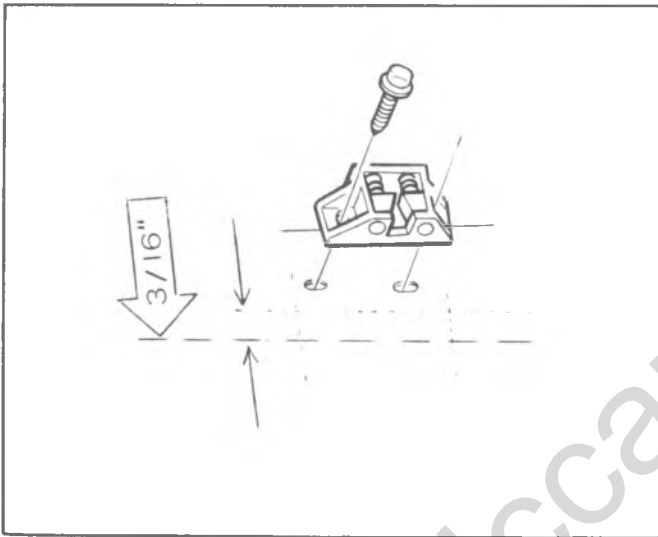


Fig. 2D-118--Adjusting the Rear Wedge Assembly

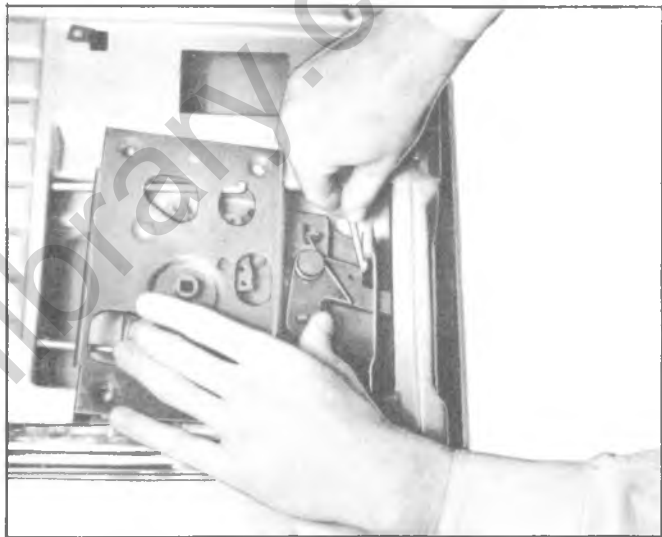


Fig. 2D-120--Disconnecting Lower Latch Rod from Latch

FRONT LATCH ASSEMBLY

Removal

1. Remove trim panel, if so equipped.
2. Remove access cover.
3. Unscrew door lock knob from rod.
4. Disconnect the following rods from latch, shown in figure 2D-119.
 - a. Rear latch rods.
 - b. Lock cylinder rod.
 - c. Door lock rod.
5. Remove door handle.
6. Remove screws retaining latch assembly to door.
7. Slide latch rearward and lift front of latch. Disconnect rod leading to lower hinge door catch by pushing rod out of hole and rotating rod clear of latch. See figure 2D-119.
8. Remove latch assembly from door.

Installation

1. Install latch assembly into door by working latch assembly behind the lower hinge door catch.
2. Connect lower hinge door catch, lock cylinder rod, door lock rod, and both rear latch rods.
3. Install latch assembly-to-door attaching screws. Torque to specifications.
4. Install door lock knob and door handle.
5. Install access cover and trim panel.
6. Adjust door front striker as outlined earlier under "Adjustments".

REAR LATCH AND/OR LATCH ACTUATING RODS

Removal

1. Remove trim panel (if so equipped).
2. Remove front latch assembly access cover.

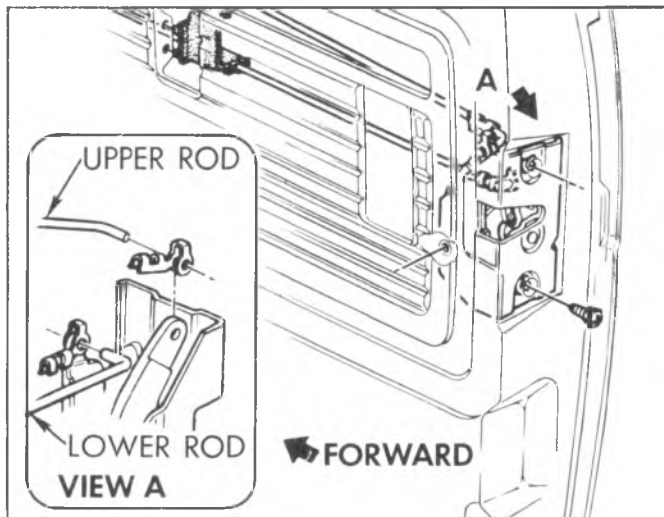


Fig. 2D-121--Sliding Door Rear Latch

3. Disconnect rear latch rods from front latch assembly, shown in figure 2D.
4. Remove rear latch attaching screws. See figure 2D-121.
5. Slide rear latch toward front of door until rod clips become exposed. Disconnect rod clips and remove latch from door.

Installation

1. Connect rods to latch and install latch to door. Torque screws to specifications.
2. Connect rods to front latch assembly.
3. Install access covers and trim panels (if so equipped).
4. Adjust rear latch striker as outlined earlier under "Adjustments".

UPPER REAR HINGE

Removal

1. Remove the hinge cover and rear track cover. See figures 2D-116 and 2D-122.
2. Open the door.

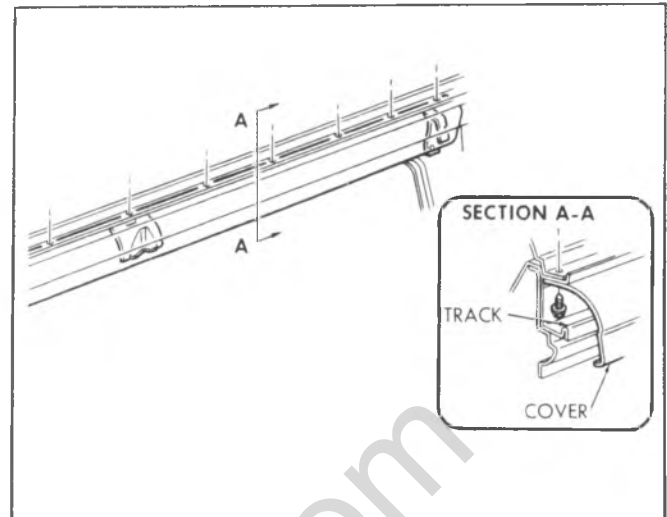


Fig. 2D-122--Rear Track Cover

3. Disengage spring from bolt, using a spring removal tool.
4. Close the door.
5. Remove the hinge assembly.

Installation

NOTE: When holding hinge assembly as in figure 2D-124, the lower latch must engage cam.

1. Install hinge assembly to door. Torque bolts to specifications.
2. Check and adjust latch to striker position as outlined under "Adjustments".
3. Open the door and reconnect the hinge spring.
4. Install the rear track cover and hinge cover.
5. Check the operation of the door hinge.

STRIKERS

The front and rear strikers are shown in figure 2D-115. The rear striker can be removed with J-23457 as in figure 2D-107, and the front striker can be removed by removing attaching screws. Refer to "Adjustments" when reinstalling.

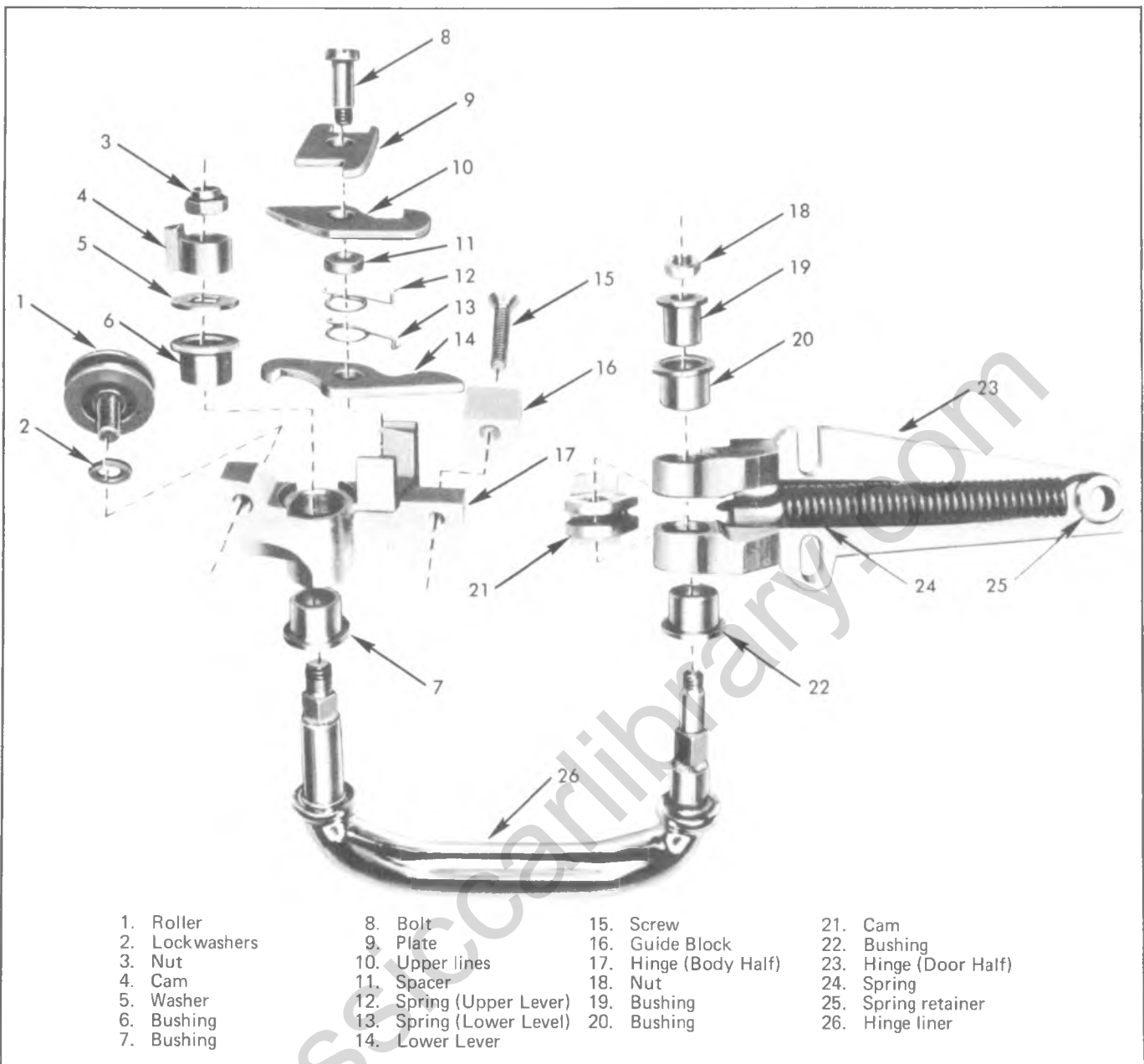


Fig. 2D-123-Upper Rear Hinge Components

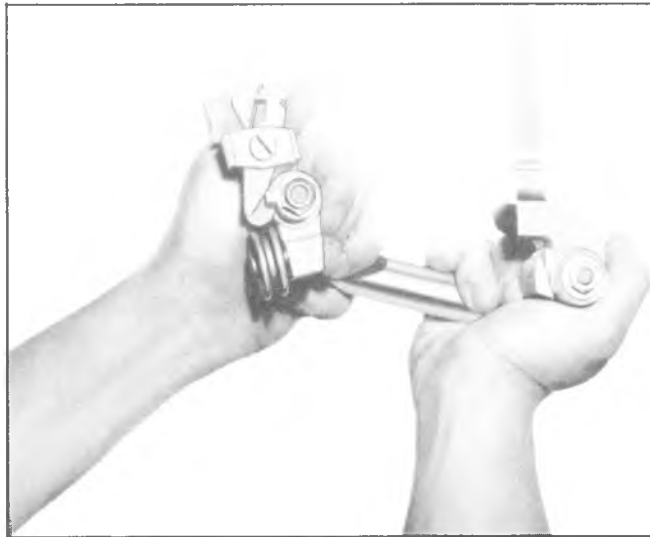


Fig. 2D-124--Checking Assembly of Hinge

REAR DOORS

REAR DOOR HINGE STRAP

Replacement

1. Remove strap release pin. See figure 2D-125.
2. Remove screws retaining strap to door.
3. Install strap to door. Torque retaining screws to specifications.

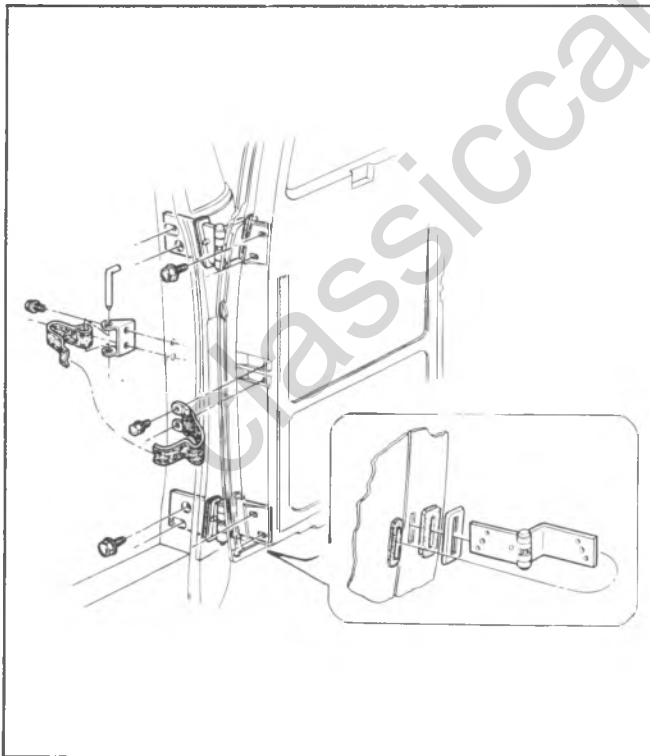


Fig. 2D-125--Rear Door Hinges and Strap

REAR DOOR HINGE

Removal

1. Open door. Support door so that when hinge screws are removed door weight will be on support.
2. Remove hinge strap release pin.
3. Remove hinge-to-door bolts and remove door assembly.
4. Remove hinge-to-body bolts and hinge.

Installation

1. Install grommet into door hinge opening (if removed).
2. Install hinge into door. Snug bolts.
3. Install seal and retainer on body half of hinge (if removed).
4. Install hinge into body opening and install bolts.
5. Take care to compress seal between body and retainer and snug bolts.
6. Install hinge strap and its retaining pin.
7. Adjust door and torque hinge bolts to specification.

REAR DOOR REMOTE CONTROL

Removal

1. Remove trim panel.
2. Disengage upper and lower latch rods from control by removing retaining clips. See figure 2D-126.
3. Remove remote control by removing its retaining screws.

Installation

1. Install remote control screws loosely.
2. Attach upper and lower control rods.
3. Rotate remote control lever clockwise, and hold

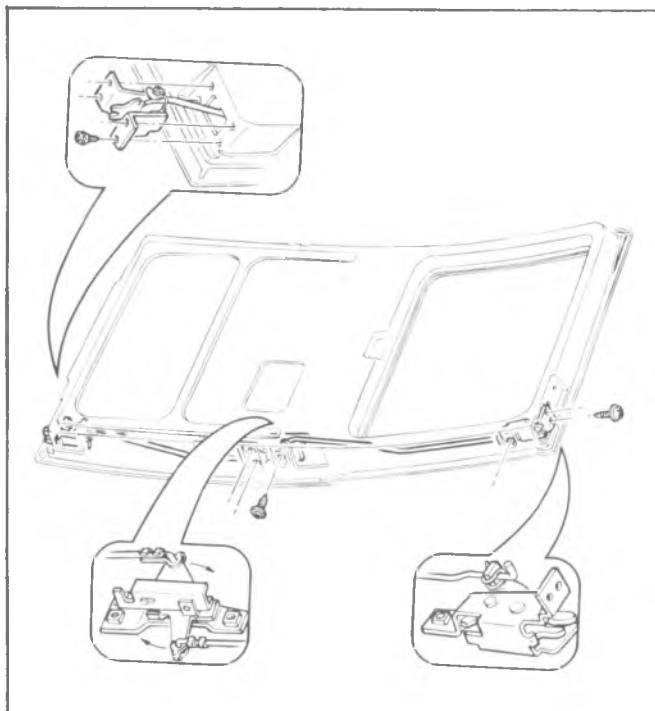


Fig. 2D-126--Remote Control and Latch

in this position while torquing the screws to specifications.

4. Install the trim panel.

REAR DOOR UPPER OR LOWER LATCHES AND/OR LATCH RODS

Removal

1. Remove trim panel.
2. Disengage rod from remote control assembly. See figure 2D-126.
3. Remove latch retaining screws and withdraw latch and control rod.
4. Remove spring clip retaining rod to latch.

Installation

1. Install latch rod to latch.

NOTE: When reinstalling the lower latch rod to control, the short straight section attaches to the latch.

2. Install latch and rod assembly into door and connect rod to remote control.
3. Install latch retaining screws and torque to specifications.

4. Adjust latch to strikers.

REAR DOOR OUTSIDE HANDLE

Removal

1. Remove trim panel.
2. Remove door handle retaining screws, handle and gaskets. See figure 2D-127.

Installation

1. Apply grease to remote control where handle plunger makes contact.
2. Install handle and gaskets. Torque screws to specifications.
3. Install trim panel.

REAR DOOR LOCK CYLINDER

Removal

1. Remove trim panel.
2. Remove remote control.
3. Remove lock cylinder retainer and lock cylinder.

Installation

1. Install lock cylinder and retainer.
2. Install remote control. Torque screws to specifications.
3. Install trim panel.

REAR DOOR GLASS AND WEATHERSTRIP

Removal and installation procedures are the same as for the stationary body side windows. Refer to those procedures for rear door glass and weatherstrip replacement.

REAR DOOR ADJUSTMENTS

NOTE: Door adjustments are provided by slotted holes, at hinge attachment, in body and door.

1. Remove or loosen door strikers and wedges.
2. Loosen door hinge bolts and adjust door to

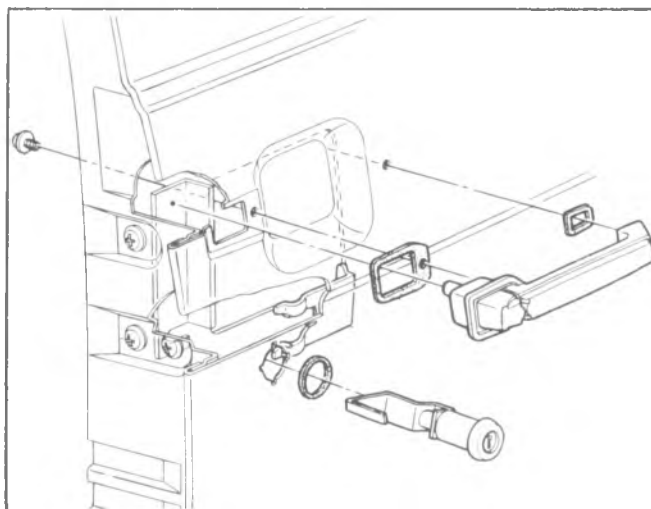


Fig. 2D-127--Outside Handle and Lock Cylinder

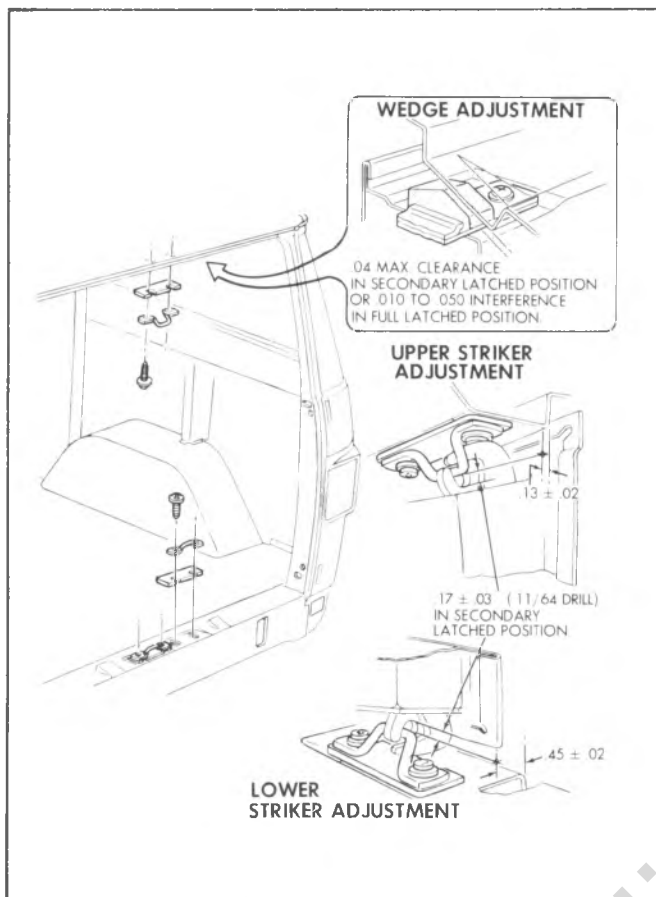


Fig. 2D-128--Rear Door Striker and Wedge Adjustment

provide equal clearances between body and door around perimeter of door.

3. Adjust door in and out so that door panel is flush with body.

4. Install door strikers and wedges and adjust as outlined under door striker adjustment.

REAR DOOR STRIKER AND WEDGE ADJUSTMENT

CAUTION: See *CAUTION* on page 1 of this section regarding *Rear Door Striker fasteners*.

1. Adjust striker by adding or deleting shims as necessary to obtain dimension as shown in figure 34G. This dimension can be checked by applying grease to the latch and slowly closing door until striker fully engages latch. Then open door and measure from grease impression to bottom of latch slot. Torque to specifications.

2. Adjust door wedge by adding or deleting shims as necessary so that wedge contact ramp on body when door is closed. See figure 2D-128.

SEATS

CAUTION: See *CAUTION* on page 1 of this section regarding *fasteners used on seats and seat belts*.

DRIVERS SEAT

Seat Adjuster

Replacement

1. Remove seat by removing nuts securing seat adjuster to seat riser.
2. Remove adjuster from seat. See figure 2D-129.
3. Install seat adjuster to seat. Torque bolts to specifications.

4. Install seat onto seat riser, and torque nuts to specifications.

SEAT RISER

Replacement

1. Remove seat and adjusters as an assembly by removing nuts securing seat to riser.
2. Remove nuts securing seat riser to floor.
3. Install seat riser to floor. Torque nuts to specifications.

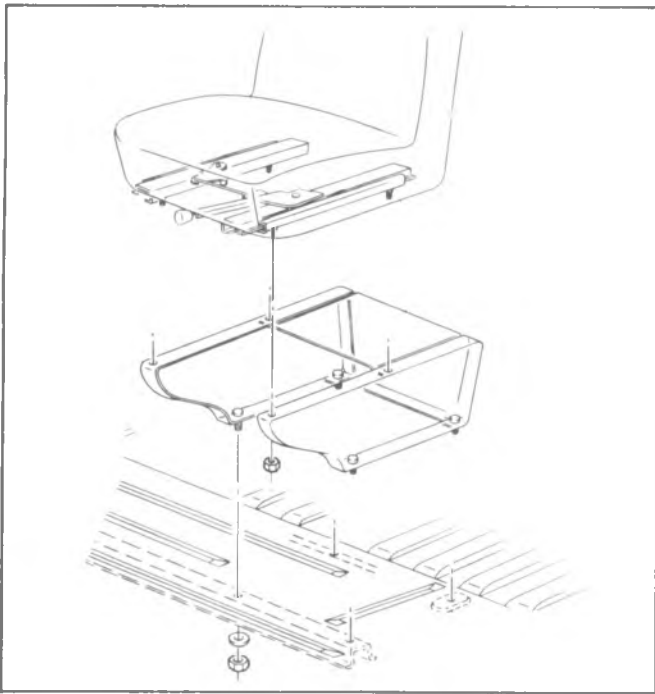


Fig. 2D-129-Driver's Seat

4. Install seat and torque nuts to specifications.

PASSENGER SEAT-MOUNTING BRACKETS

Removal

1. Remove seat and brackets from seat riser. See figure 2D-130.
2. Remove brackets from seat.

Installation

1. Install brackets to seat. Torque to specifications.
2. Install seat to seat riser. Torque to specifications.

SEAT RISER

Removal

1. Remove seat and mounting bracket as an assembly.
2. Remove riser from floor.

Installation

1. Install riser to floor. Torque nuts to specifications.
2. Install seat riser. Torque nuts to specifications.

All models equipped with 2nd, 3rd and 4th bench seat assemblies feature a quick release mechanism which facilitates removal of the seats for added cargo space.

Instead of the conventional clamp and bolt method of seat retention, cam type latch assemblies and hooked retainers, which fit onto anchor pins in floor anchor

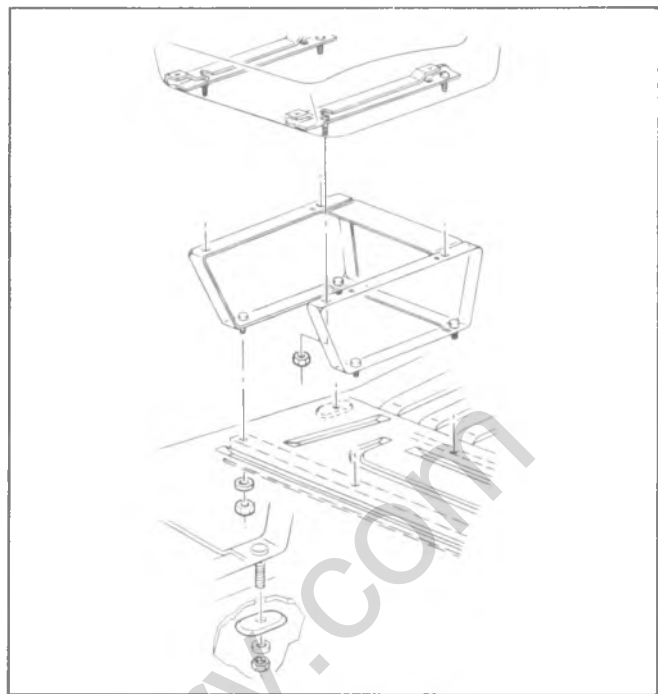


Fig. 2D-130-Passenger Seat

plates are used. When the latch assemblies are depressed, their cams and the hooks of the retainers are drawn tightly onto the anchor pins for secure seat attachment.

Removal is accomplished using the following procedure:

1. Pull up on quick release latches located at lower front of seat legs (right and left hand sides).
2. Tilt up front of seat and push seat rearward to clear anchor pins located beneath floor at front and rear of seat legs.
3. Lift seat up and remove from van.
4. To replace, reverse steps 1 to 3.

CAUTION: When replacing seats make sure that seat retainer hooks are fully engaged with anchor pins and latching assembly is fully depressed into place.

SWIVEL BUCKET SEATS - G MODELS

Refer to the illustration in Figure 2D-132 for swivel Bucket Seat Assembly installation.

ROOF VENT - G MODELS

Roof vent installation is illustrated in Figure 2D-133.

CARE AND CLEANING OF SEATS

Instructions on care and cleaning of interior soft trim may be found in "C-K Models--Seats", earlier in this section.

2D-59

BODY

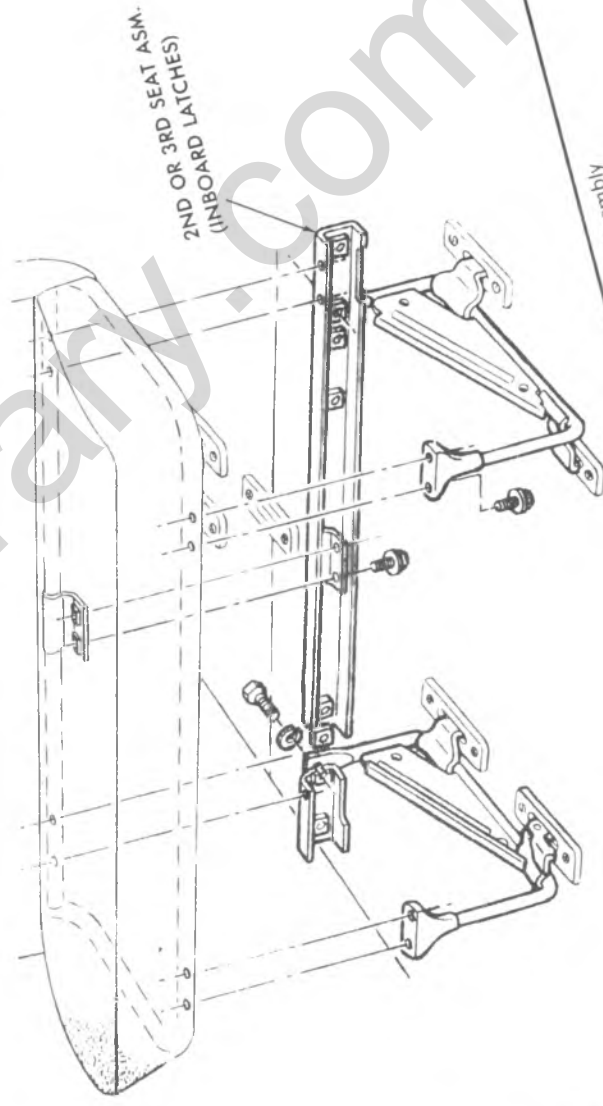
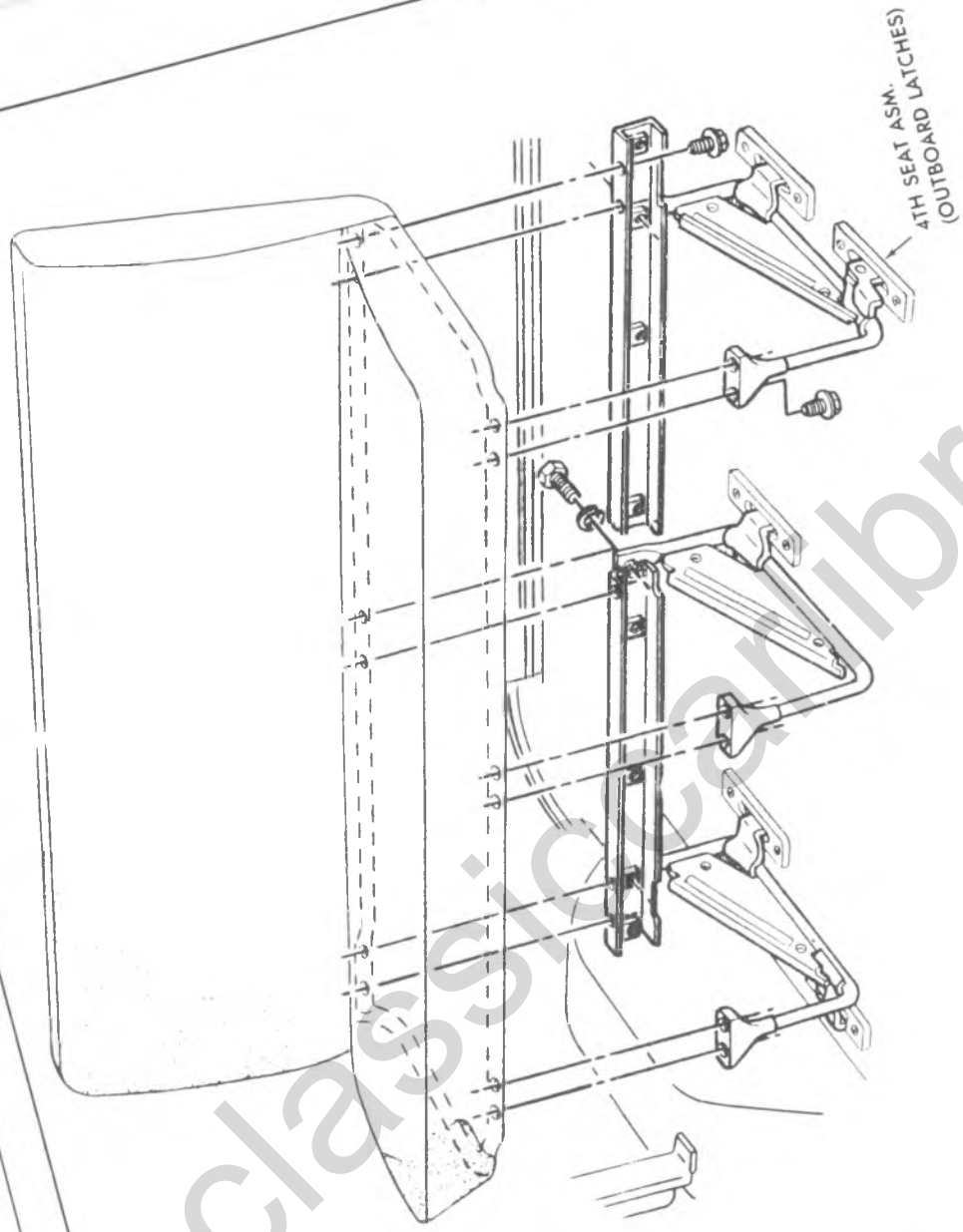


Fig. 2D-131. Quick Release Seat Assembly

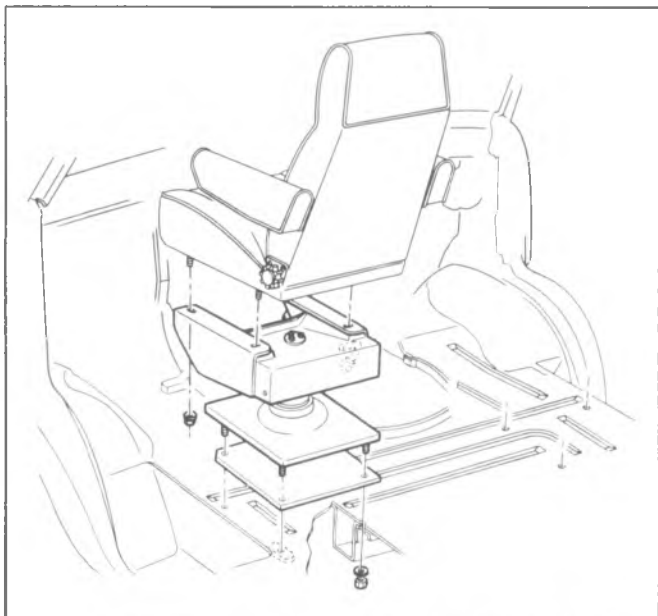


Fig. 2D-132--Swivel Bucket Seat Assembly - G Series

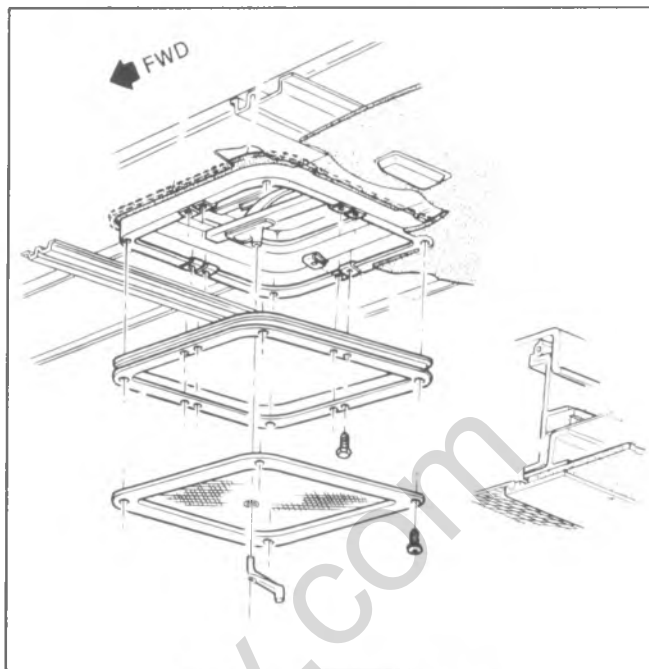


Fig. 2D-133-Roof Vent - G Series

classiccarylbrary.com

SPECIFICATIONS

BODY

SECTION 2D

C AND K MODELS

FRONT END

Windshield Wiper Linkage to Plenum	25 in. lb.
Sunshade Support	20 in. lb.
Inside Rear View Mirror to Bracket	45 in. lb.
Outside Rear View Mirror to Door Panel –	
Base Mirror	25 in. lb.
West Coast Mirror—Lower Bracket to Door	20 in. lb.
—Upper Bracket to Door	45 in. lb.

DOORS

Window Regulator Assembly to Door Panel	85 in. lb.
Remote Control Door Lock to Door Panel	45 in. lb.
Lock Striker to Body Pillar	45 ft. lb.
Outside Door Handle	85 in. lb.
Inside Door Handle	85 in. lb.
Hinges to Body and Door	35 ft. lb.
Front Door—Window Run Channel	
Upper Screw Assembly	85 in. lb.
Lower Bolt Assembly	18 in. lb.
Front Door—Ventilator Assembly	
Top Vent Screw	18 in. lb.
Side Vent Screws and Spacers	25 in. lb.
Lower Vent Channel Bolts	40 in. lb.
Side Rear Door—Run Channel	
Front Upper to Door	40 in. lb.
Rear Upper to Door	20 in. lb.
Front and Rear Lower to Door	85 in. lb.
Lock Lever to Door	85 in. lb.
Rear Door—Lock Striker (06)	95 in. lb.
Rear Door—Latch L.H. and R.H. to Door (06)	85 in. lb.
Rear Door—Latch Control Assembly to Door (06)	
—Upper Assembly	85 in. lb.
—Lower Assembly	90 in. lb.
Rear Door—Weatherstrip L.H. (06)	18 in. lb.

END GATE (14)

Hinges—Body Half and Gate Half	35 ft. lb.
Support Assembly—Body to End Gate	25 ft. lb.
Torque Rod—Retainer Assembly	85 in. lb.
—Anchor Assembly	18 ft. lb.
Latch Assembly to End Gate	85 in. lb.
Latch Control Assembly to End Gate	40 in. lb.
Access Cover	18 in. lb.
Handle to Latch Control Assembly	55 in. lb.
Glass Channel Assembly to End Gate	85 in. lb.
Cap Assembly to Channel Assembly	24 in. lb.
Striker—Body Mounted	18 ft. lb.

END GATE (06)

Hinges—Hinge to Body	35 ft. lb.
—Hinge to End Gate	20 ft. lb.
Support Cable Bolts	25 ft. lb.
Torque Rod—Silencer Bracket	40 in. lb.
—End Support Bracket	90 in. lb.
Latch Assembly to End Gate	20 ft. lb.
Latch Remote Control Assembly to End Gate	40 in. lb.
Access Cover	18 in. lb.
Outside Handle	55 in. lb.
Glass Channel	45 in. lb.

TAILGATE (03, 63—with E63)

Trunnion Assembly	18 ft. lb.
Linkage and Striker Assembly—Support	25 in. lb.

TAILGATE (03, 63—with E62)

Trunnion Assembly	35 ft. lb.
Chain Support Assembly	90 in. lb.

SEATS

Front Bench Seat	
Adjuster-to-Seat	155 in. lb.
Adjuster-to-Floor	25 ft. lb.
Front Bucket Type (14, 03)	
Driver	
Adjuster-to-Seat	18 ft. lb.
Adjuster-to-Floor	25 ft. lb.
Passenger (03)	
Support-to-Seat	18 ft. lb.
Support-to-Floor (Front)	25 ft. lb.
Support-to-Floor (Rear)	40 ft. lb.
Passenger (14)	
Latch Support-to-Seat (Rear)	18 ft. lb.
Striker-to-Floor (Rear)	25 ft. lb.
Support (Upper)-to-Seat (Front)	18 ft. lb.
Support (Lower)-to-Floor (Front)	25 ft. lb.
Support (Upper)-to-Support (Lower)	30 ft. lb.
Rear Bench (06, 14)	
Support-to-Seat	18 ft. lb.
Support-to-Floor	50 ft. lb.
Rear Bench (63)	
Support-to-Seat	150 in. lb.
Support-to-Floor	35 in. lb.
Folding Rear Seat (06)	
Support Asm-to-Floor	150 in. lb.
Seat-to-Support Asm	18 in. lb.

BODY MOUNTING (C-K MODELS)—FT. LBS.

Model	#1	#2	#3	#4	#5	#6
(03)	45	45	—	—	—	—
(06)	35	35	—	35	—	35
(14)	55	45	35	35	—	—
(63)	55	35	55	—	—	—

G MODELS

MIRRORS AND SUNSHADE

Inside Rear View Mirror to Bracket	15 in. lb.	Remote Control (front latch) to Door	90 in. lb.
Outside Rear View Mirror to Panel	40 in. lb.	Rear Latch to Door	90 in. lb.
Sunshade Support to Header Panel	15 in. lb.	Rear Plate to Door	90 in. lb.

SLIDING SIDE DOOR

Lower Front Roller and Roller Support	
Support-to-Door	24 ft. lb.
Support to Roller Bracket	24 ft. lb.
Roller to Roller Bracket	20 ft. lb.
Catch to Roller Bracket	45 in. lb.

SIDE WINDOW (SWINGOUT)

Latch to Body	40 in. lb.	Upper Front Roller Bracket	
Latch to Glass	40 in. lb.	Bracket to Door	24 ft. lb.
Hinge to Body	40 in. lb.	Roller to Bracket	20 ft. lb.

FRONT SIDE DOORS

Door Hinges	30 ft. lb.	Upper Left Hinge (Door Half)	
Door Hinge Access Hole Cover	18 in. lb.	Hinge to Door	25 ft. lb.
Door Lock Striker	45 ft. lb.	Upper Left Hinge (Body Half)	
Door Lock to Door	20 ft. lb.	Roller to Hinge	20 ft. lb.
Outside Door Handle	45 in. lb.	Guide Block to Hinge	40 in. lb.
		Lever Arm-to-Hinge Retaining Nut	120 in. lb.
		Lever Retaining Screw	40 in. lb.
		Striker to Body	20 ft. lb.
		Rear Striker Bolt (Body Mounted)	45 ft. lb.
		Front Striker Retaining Screws (Body Mounted)	90 in. lb.

REAR DOOR

Hinge Strap to Door	45 in. lb.	Seat Belt to Seat	37 ft. lb.
Hinge Strap Bracket to Body	45 in. lb.	Passenger and Drivers	
Hinge (to body and door)	30 ft. lb.	Seat to Adjuster (Mounting Bracket)	18 ft. lb.
Remote Control Retaining Screws	85 in. lb.	Seat to Riser	18 ft. lb.
Latch-to-Door Retaining Screws	90 in. lb.	Seat Riser-to-Floor	50 ft. lb.
Door Strikers-to-Body	90 in. lb.	Bench Seats	
Outside Door Handle	45 in. lb.	Seat to Seat Support	18 ft. lb.
		Seat Support to Floor Clamps	40 ft. lb.

SEATS

SPECIAL TOOLS

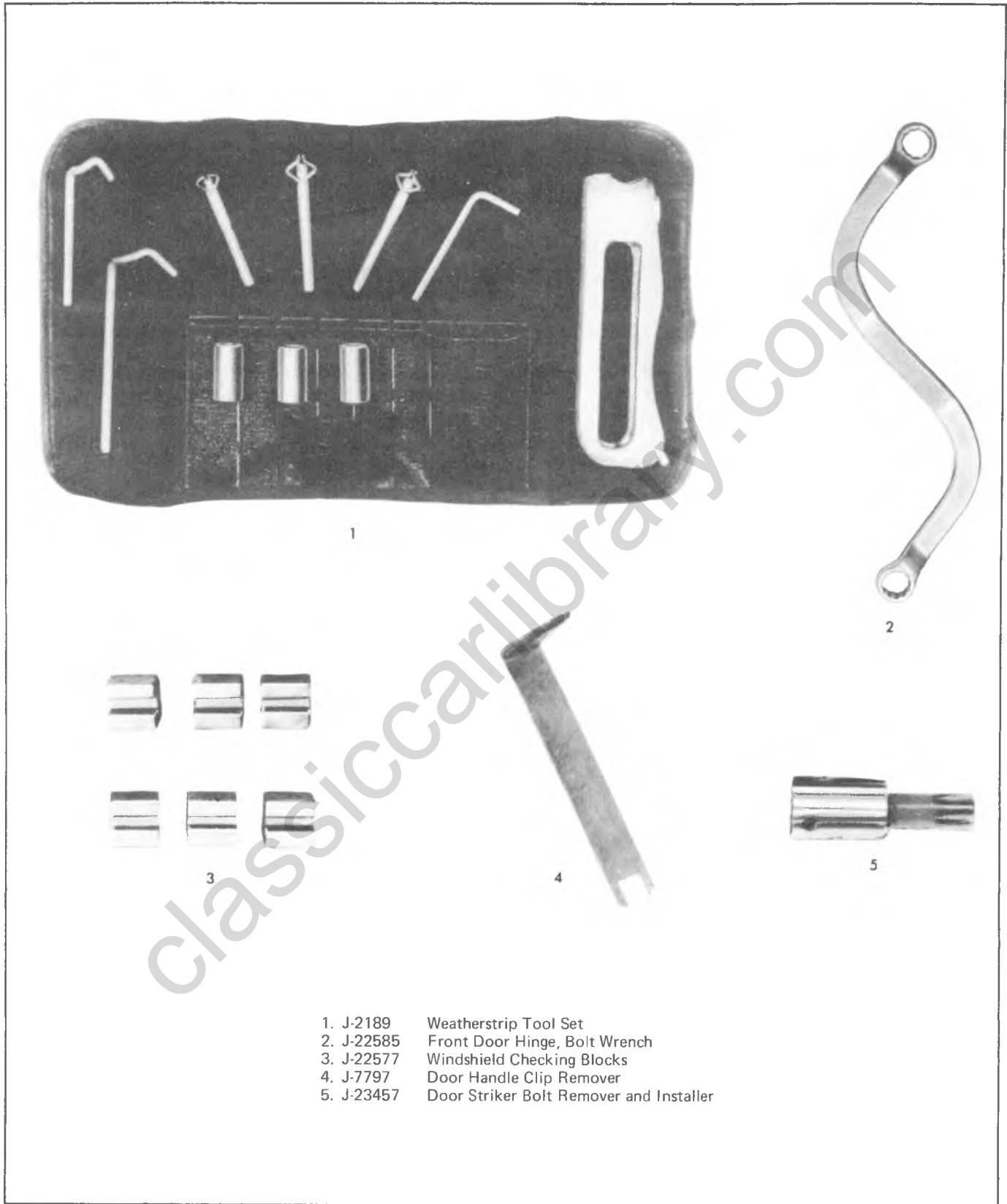


Fig. 2D-134--Special Tools

classicalibrary.com

SECTION 3A

FRONT ALIGNMENT

CONTENTS

General Description	3A-1
Maintenance and Adjustments	3A-2
Specifications	3A-6

GENERAL DESCRIPTION

FRONT ALIGNMENT

The term "front alignment" refers to the angular relationships between the front wheels, the front suspension attaching parts and the ground.

The pointing in or "toe-in" of the front wheels, the tilt of the front wheels from vertical (when viewed from the front of the vehicle) and the tilt of the suspension members from vertical (when viewed from the side of the vehicle), all these are involved in front alignment. The various factors that enter into front alignment are covered here each one under its own heading.

CASTER

Caster is the tilting of the front steering axis either forward or backward from the vertical (when viewed from the side of the vehicle). A backward tilt is said to be positive (+) and a forward tilt is said to be negative (-).

On the short and long arm type suspension you cannot see a caster angle without a special instrument, but you can understand that if you look straight down from the top of the upper control arm to the ground you would find that the ball joints do not line up (fore and aft) when a caster angle other than 0° is present. If you had a positive caster angle the lower ball joint would be slightly ahead (toward the front of the vehicle) of the upper ball joint center line. In short then, caster is the forward or backward tilt of the steering axis as viewed

from a side elevation. Caster is designed into the front axle assembly on all K series vehicles (four-wheel drive), and is non-adjustable. See caster copy under ADJUSTMENTS.

CAMBER

Camber is the tilting of the front wheels from the vertical when viewed from the front of the vehicle. When the wheels tilt outward at the top, the camber is said to be positive (+). When the wheels tilt inward at the top, the camber is said to be negative (-). The amount of tilt is measured in degrees from the vertical and this measurement is called the camber angle. Camber is designed into the front axle assembly of all K series vehicles and is non-adjustable. See camber copy under ADJUSTMENTS.

TOE-IN

Toe-in is the turning in of the front wheels. The actual amount of toe-in is normally only a fraction of an inch. The purpose of a toe specification is to ensure parallel rolling of the front wheels. (Excessive toe-in or toe-out will cause tire wear). Toe-in also serves to offset the small deflections of the wheel support system which occurs when the vehicle is rolling forward. In other words, even when the wheels are set to toe-in slightly when the vehicle is standing still, they tend to roll parallel on the road when the vehicle is moving. See toe-in copy under ADJUSTMENTS.

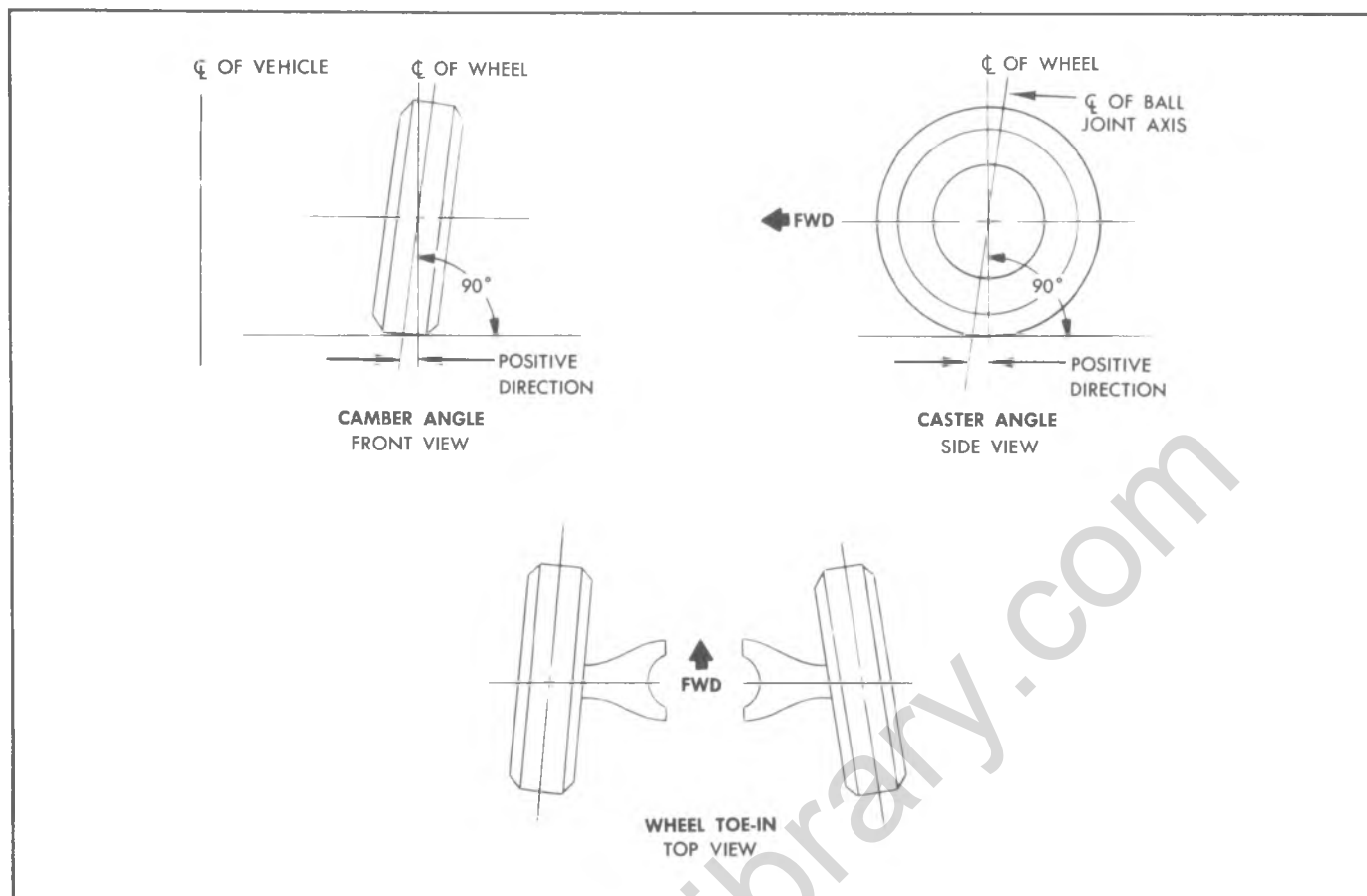


Fig. 3A-1-Caster - Camber - Toe-In

MAINTENANCE AND ADJUSTMENTS

PRELIMINARY CHECKS PRIOR TO ADJUSTING FRONT ALIGNMENT

Before making any adjustment affecting caster, camber or toe-in, the following checks and inspections should be made to insure correctness of alignment readings and alignment adjustments.

1. Check all tires for proper inflation pressures and approximately the same tread wear.
2. Check front wheel bearings for looseness (.001-.008 end play is correct) and adjust if necessary.
3. Check for looseness of ball joints, tie rod ends and steering relay rods; if excessive looseness is noted, it must be corrected before adjusting.
4. Check for run-out of wheels and tires.
5. Check vehicle trim heights; if out of specifications and a correction is to be made, the correction must be made before adjusting caster, camber or toe-in.
6. Check for steering gear looseness at frame.
7. Check for improperly operating shock absorbers.
8. Check for loose control arms.

9. Check for loose or missing stabilizer bar attachments.

10. Consideration must be given to excess loads, such as tool boxes. If this excess load is **normally** carried in the vehicle, it should remain in the vehicle during alignment checks.

11. Consider the condition of the equipment being used to check alignment and follow the manufacturer's instructions.

12. Regardless of equipment used to check alignment, the vehicle must be on a level surface both fore and aft and transversely.

13. Steering and vibration complaints are not always the result of improper alignment. An additional item to be checked is the possibility of tire lead due to worn or improperly manufactured tires. "Lead" is the deviation of the vehicle from a straight path on a level road without hand pressure on the steering wheel. Section 3E of this manual, "Wheels and Tires", contains

a procedure for determining the presence of a tire lead problem.

FRONT ALIGNMENT REQUIREMENTS

Satisfactory vehicle operation may occur over a wide range of front end wheel alignment settings. Nevertheless, should settings vary beyond certain tolerances, readjustments of alignment is advisable. The specifications stated in column 1 of the chart in the specifications section of this manual should be used by owners, dealers and repairmen as guidelines in vehicle diagnosis either for repairs under the new vehicle warranty or for maintenance service at customer's request. These specifications provide an acceptable all-around operating range in that they prevent abnormal tire wear caused by wheel alignment.

Governmental Periodic Motor Vehicle Inspection programs usually include wheel alignment among items that are inspected. To provide useful information for such inspections, the specifications stated in column 2 of the wheel alignment chart are given and these are well within the range of safe vehicle operation.

In the event the actual settings are beyond the specifications set forth in column 1 or 2 (whichever is applicable), or whenever for other reasons the alignment is being reset, the specifications given in column 3 of the wheel alignment chart should be used.

NOTE: It is good practice to set front end alignment to specifications while the vehicle is in its **normally loaded** condition. Trucks which are **consistently operated with heavy loads should have toe-in adjusted with the truck under heavy load.** This procedure should result in longer tire life.

ALIGNMENT ADJUSTMENTS

NOTE: A normal shim pack will leave at least two (2) threads of the bolt exposed beyond the nut. If two (2) threads cannot be obtained, check for damaged control arms and related parts. The difference between front and rear shim packs must not exceed .30 inches. Front shim pack must be at least .24 inches.

Access to Shim Packs

G10-20 Models, C10 Models with 3/4" Nut:

With vehicle on front end rack, jack at frame and raise the wheel off the ground. This will allow the upper control arm to pivot down far enough to use a socket on the nuts and permit shim removal.

G30 Models, C20 and 30 Models with 7/8" Nut:

Remove the upper control arm bumper; then follow the same procedure as above. Reinstall the upper control arm bumper when alignment is completed.

Caster

All caster specifications are given assuming a frame angle of zero. Therefore, it will be necessary to know the angle of the frame (whether "up" in rear or "down" in rear) before a corrected caster reading can be determined. Camber and toe can be read "as is" from the alignment equipment.

How to Determine Caster (Fig. 3A-4)

1. With the vehicle on a level surface, determine the frame angle "B" in Fig. 3A-4, using a bubble protractor or inclinometer.

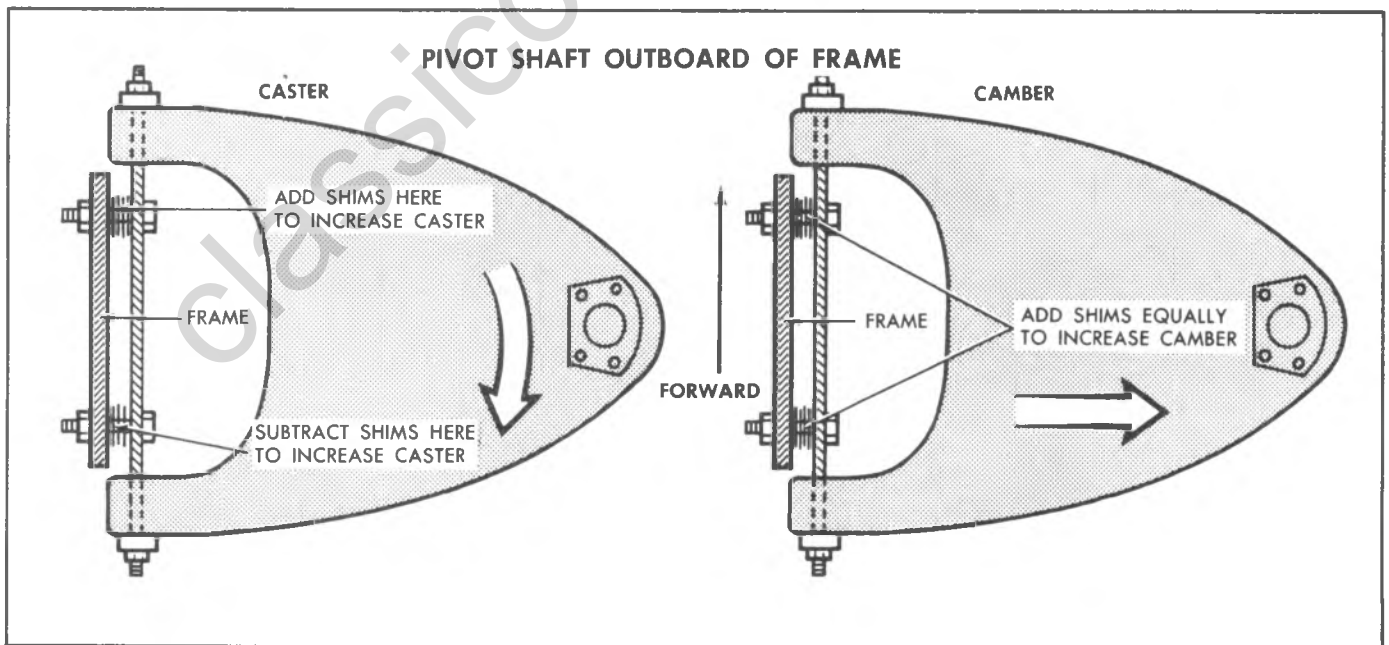


Fig. 3A-2--Caster - Camber Adjustment

2. Draw a graphic as in Fig. 3A-4 that is representative of the frame angle (either "up" in rear or "down" in rear).

3. Determine the caster angle from the alignment equipment and draw a line that is representative of the caster reading.

4. To determine an "actual (corrected) caster reading" with various frame angles and caster readings, one of the following rules applies:

a. A **DOWN IN REAR** frame angle must be **SUBTRACTED** from a **POSITIVE** caster reading.

b. An **UP IN REAR** frame angle must be **ADDED** to a **POSITIVE** caster reading.

c. A **DOWN IN REAR** frame angle must be **ADDED** to a **NEGATIVE** caster reading.

d. An **UP IN REAR** frame angle must be **SUBTRACTED** from a **NEGATIVE** caster reading.

How to Adjust Caster

5. Add or subtract as necessary to arrive at the corrected caster angle.

6. Measure dimension "A" (bump stop bracket to frame) and check the specifications for that dimension.

7. Correct the actual caster angle, as arrived at in Step 4, as necessary to keep within the specifications by

adding or subtracting shims from the front or rear bolt on the upper control arm shaft, shown in Figure 3A-2.

Camber

1. Determine the camber angle from the alignment equipment.

2. Add or subtract shims from both the front and rear bolts to affect a change.

Toe-In

1. Determine the wheel toe-in from the alignment equipment.

2. Change the length of both tie rod sleeves to affect a toe change.

Toe-in can be increased or decreased by changing the length of the tie rods. A threaded sleeve is provided for this purpose.

When the tie rods are mounted ahead of the steering knuckle they must be decreased in length in order to increase toe-in. When the tie rods are mounted behind the steering knuckle they must be lengthened in order to increase toe-in.

See Section 3B for proper tie rod clamp orientation and positioning.

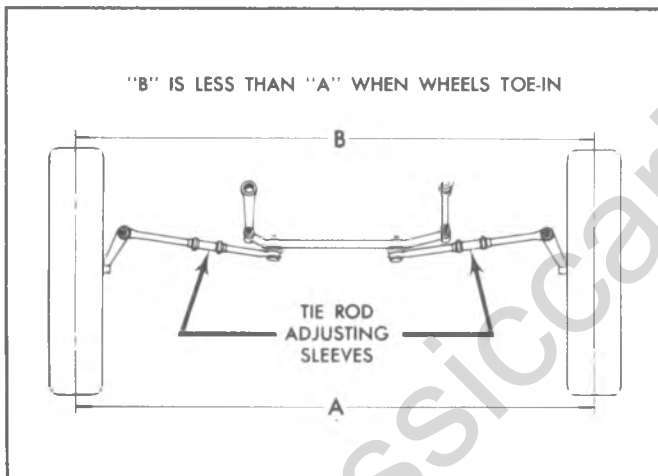


Fig. 3A-3-Toe-In Adjustment

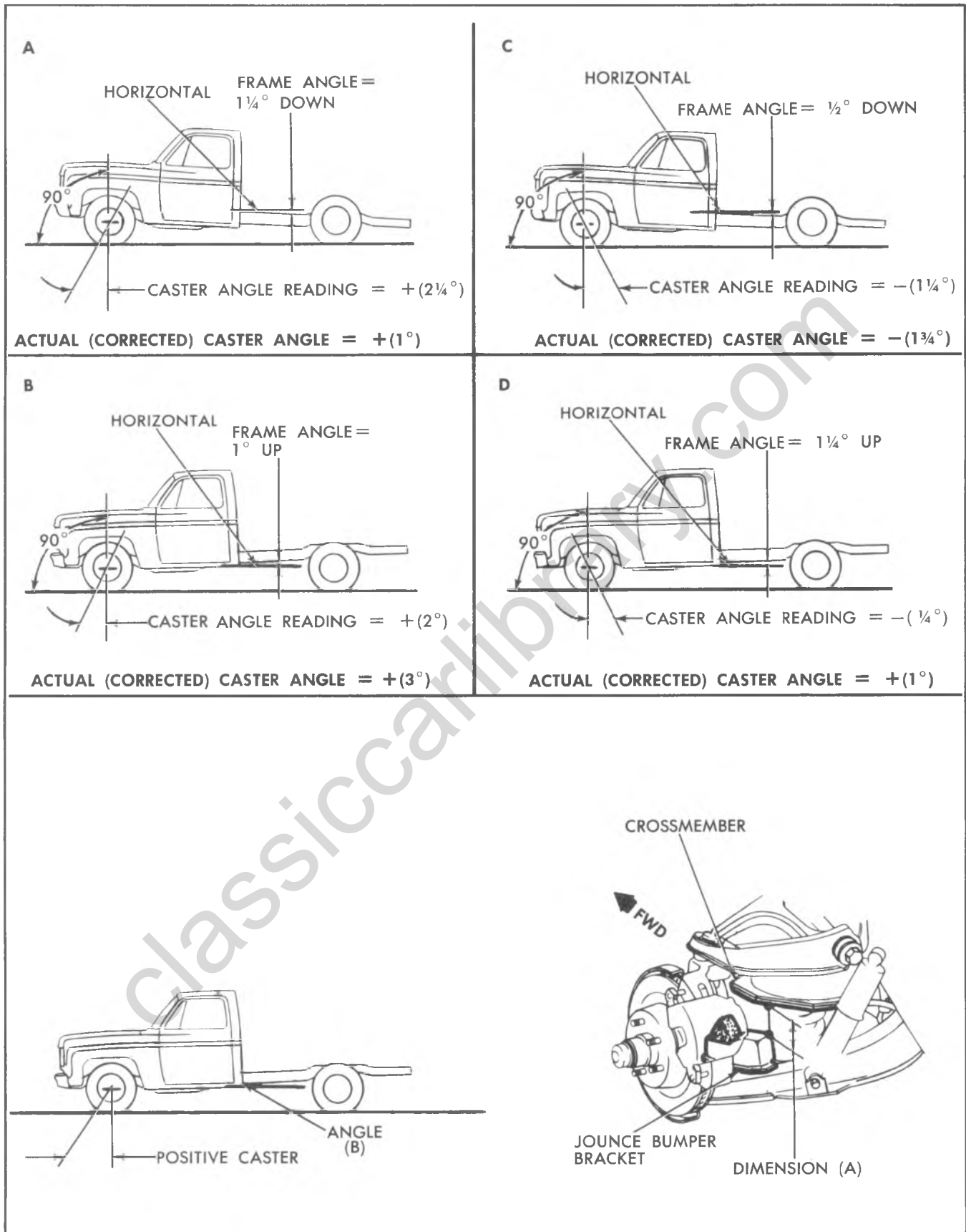


Fig. 3A-4--Determining Caster

SPECIFICATIONS

WHEEL ALIGNMENT SPECIFICATIONS

MODELS	CASTER*										
	DIMENSION "A" IN INCHES*										
	2 1/2"	2 3/4"	3"	3 1/4"	3 1/2"	3 3/4"	4"	4 1/4"	4 1/2"	4 3/4"	5"
C10			+2°	+1 1/2°	+1 1/4°	+1°	+3/4°	+1/2°	+1/4°	0°	-1/2°
C20,C30	+1 1/2°	+1 1/4°	+1°	+3/4°	+1/2°	+1/4°	0°	-1/4°	-1/2°	-3/4°	-1°
K10,K20,K30	(8°) (NO ADJUSTMENT PROVISION)										
G10,G20,G30	+2 1/4°	+2°	+1 1/2°	+1 1/4°	+1°	+3/4°	+1/2°	+1/4°	0°	-1/4°	-1/2°
P10,P20,P30	+2 1/2°	+2 1/4°	+2°	+1 3/4°	+1 1/2°	+1°	+3/4°	+1/2°	+1/4°	0°	-1/4°
MOTOR HOME (32)	+5 3/4	+5 1/2	+5	+5	+4 1/2	+4 1/4	+4	+4	+3 1/2	+3 1/4	+3

CAMBER													
C10,C20,C30	+1/4												
K10,K20,K30	NO ADJUSTMENT PROVISION												
G10,G20,G30	+1/4°												
P10	Camber on P-Truck is dependent on dimension 'A'. After measuring dimension 'A' set camber as follows:												
	2 1/2"	2 3/4"	3"	3 1/4"	3 1/2"	3 3/4"	4"	4 1/4"	4 1/2"	4 3/4"	5"	5 1/4"	5 1/2"
	0	0	+1/4°	+1/4°	+1/4°	+1/4°	+1/4°	0°	0°	0°	-1/4°	-1/2°	-3/4°
P20,P30	0	0	+1/4°	+1/4°	+1/4°	+1/4°	+1/4°	+1/4°	0°	0°	-1/4°	-1/2°	-3/4°
MOTOR HOME (32)	0	0	+1/4°	+1/4°	+1/4°	+1/4°	0°	0°	0°	-1/4°	-1/2°	-3/4°	-1°

TOE-IN	
C10,C20,C30	3/16"
K10,K20,K30	0
G10,G20,G30	3/16"
P10,P20,P30	3/16"
MOTORHOME P30 (32)	5/16"

	ALIGNMENT TOLERANCES		
	WARRANTY REPAIR CHECKING	RESETTING TARGET	PERIODIC MOTOR VEHICLE INSPECTION
CASTER	±1°	±1/2°	±2°
CAMBER	±3/4°	±1/2°	±1 1/2°
TOE-IN	±1/8"	±1/16"	±3/8°

SECTION 3B

STEERING

The following caution applies to one or more steps in the assembly procedure of components in this portion of the manual as indicated at appropriate locations by the terminology "See Caution on page 1 of this Section".

CAUTION THIS FASTENER IS AN IMPORTANT ATTACHING PART IN THAT IT COULD AFFECT THE PERFORMANCE OF VITAL COMPONENTS AND SYSTEMS, AND/OR COULD RESULT IN MAJOR REPAIR EXPENSE. IT MUST BE REPLACED WITH ONE OF THE SAME PART NUMBER OF WITH AN EQUIVALENT PART IF REPLACEMENT BECOMES NECESSARY. DO NOT USE A REPLACEMENT PART OF LESSER QUALITY OR SUBSTITUTE DESIGN. TORQUE VALUES MUST BE USED AS SPECIFIED DURING REASSEMBLY TO ASSURE PROPER RETENTION OF THIS PART.

CONTENTS

General Description.....	3B-2	Steering Gear.....	3B-40
Diagnosis.....	3B-3	Pitman Shaft Oil Seal Replacement.....	3B-41
Steering Linkage.....	3B-3	Directional Signal Switch.....	3B-41
Manual Steering Gear.....	3B-5	Lock Cylinder.....	3B-43
Steering Column (C and K).....	3B-7	Ignition Switch.....	3B-45
Electrical Analyzer J-23980.....	3B-7	Steering Column.....	3B-45
Collision Diagnosis.....	3B-7	Removal.....	3B-46
Automatic Column.....	3B-9	Column Disassembly (Except Tilt).....	3B-47
Manual Column.....	3B-12	Column Assembly (Except Tilt).....	3B-47
Tilt Column.....	3B-13	Column Disassembly-Tilt.....	3B-50
Signal Switch.....	3B-14	Column Assembly-Tilt.....	3B-53
Power Steering System.....	3B-15	Column Installation-Mandatory Sequence.....	3B-55
External Leakage.....	3B-26	Steering Column Service G and P.....	3B-56
Maintenance and Adjustments.....	3B-31	Upper Bearing G and P.....	3B-56
Lubrication.....	3B-31	Lower Bearing P.....	3B-56
Adjustments.....	3B-31	Directional Switch.....	3B-56
Steering Gear-Manual.....	3B-31	Tilt Column Bearing Housing.....	3B-57
Steering Gear High Point Centering.....	3B-32	Column Removal.....	3B-58
Steering Wheel Alignment.....	3B-32	Disassembly Standard Column.....	3B-59
Steering Column Lower Bearing Adjustment.....	3B-32	Assembly Standard Column.....	3B-60
Shifter Tube Adjustment.....	3B-32	Disassembly Tilt Column.....	3B-61
Power Steering Gear.....	3B-33	Assembly Tilt Column.....	3B-61
Belt Tension.....	3B-34	Column Installation P Series.....	3B-65
Fluid Level.....	3B-35	Column Installation G Series.....	3B-66
Bleeding System.....	3B-35	Steering Linkage.....	3B-66
System Checks.....	3B-36	Tie Rod.....	3B-66
Component Replacement and Repairs.....	3B-37	Relay Rod.....	3B-69
Steering Wheel.....	3B-37	Idler Arm.....	3B-70
Steering Coupling.....	3B-37	Pitman Arm.....	3B-70
Flexible Type.....	3B-37	Steering Connecting Rod.....	3B-71
Intermediate Steering Shafts with Pot Joint		Power Steering System.....	3B-71
Couplings.....	3B-38	Power Gear.....	3B-71
Intermediate Steering Shaft with Universal		Pump.....	3B-72
Joint Couplings.....	3B-39	Hoses.....	3B-73
		Special Tools.....	3B-78

GENERAL DESCRIPTION

The steering gear is of the recirculating ball type. This gear provides for ease of handling by transmitting forces from the wormshaft to the pitman shaft through the use of ball bearings.

The steering column is connected to the steering gear by a flexible coupling. This coupling incorporates a capturing strap which is designed to prevent column-to-

coupling deflection from exceeding the length of the coupling alignment pins.

The trucks incorporate "Forward Steering" whereas the steering linkage is located forward of the front crossmember. Steering effort is transmitted to left and right hand adjustable tie rod through a relay rod. The relay rod is connected to an idler arm on the right and to the pitman arm on the left.

classiccarylbrary.com

CONDITION	POSSIBLE CAUSE	CORRECTION
<p>Excessive Play or Looseness in Steering System.</p>	<p>Front wheel bearings loosely adjusted.</p> <p>Worn steering shaft couplings.</p> <p>Worn upper ball joints.</p> <p>Steering wheel loose on shaft, loose pitman arm, tie rods, steering arms or steering linkage ball studs.</p> <p>Steering gear thrust bearings loosely adjusted.</p> <p>Excessive over-center lash in steering gear.</p> <p>Worn intermediate rod or tie rod sockets.</p>	<p>Adjust bearings to obtain proper end play.</p> <p>Replace part.</p> <p>Check and replace if necessary.</p> <p>Tighten to specified torque, or replace if necessary.</p> <p>Adjust preload to specification.</p> <p>Adjust preload to specification.</p> <p>Replace worn part.</p>
<p>Excessive looseness in tie rod or intermediate rod pivots, or excessive vertical lash in idler support.</p>	<p>Seal damage and leakage resulting in loss of lubricant, corrosion and excessive wear.</p>	<p>Replace damaged parts as necessary. Properly position upon reassembly.</p>

Fig. 3B-1-Steering Linkage Diagnosis

CONDITION	POSSIBLE CAUSE	CORRECTION
<p>Hard Steering – Excessive Effort Required at Steering Wheel.</p>	<p>Low or uneven tire pressure.</p> <p>Steering linkage or bolt joints need lubrication.</p> <p>Tight or frozen intermediate rod, tie rod or idler socket.</p> <p>Steering gear to column misalignment.</p> <p>Steering gear adjusted too tightly.</p> <p>Front wheel alignment incorrect. (manual gear)</p>	<p>Inflate to specified pressures.</p> <p>Lube with specified lubricant.</p> <p>Lube replace or reposition as necessary.</p> <p>Align column.</p> <p>Adjust over-center and thrust bearing preload to specification.</p> <p>Check alignment and correct as necessary.</p>
<p>Poor Returnability.</p>	<p>Steering linkage or ball joints need lubrication.</p> <p>Steering gear adjusted too tightly.</p> <p>Steering gear to column misalignment.</p> <p>Front wheel alignment incorrect. (Caster)</p>	<p>Lube with specified lubricant.</p> <p>Adjust over-center and thrust bearing preload to specifications.</p> <p>Align column.</p> <p>Check alignment and correct as necessary.</p>

Fig. 3B-2--Steering Linkage Diagnosis

CONDITION	POSSIBLE CAUSE	CORRECTION
Rattle or Chuck in Steering Gear.	<p>Insufficient or improper lubricant in steering gear.</p> <p>Pitman arm loose on shaft or steering gear mounting bolt loose.</p> <p>Loose or worn steering shaft bearing.</p> <p>Excessive over-center lash or worm thrust bearings adjusted too loose.</p> <p>NOTE: On turns a slight rattle may occur, due to the increased lash between ball nut and pitman shaft as gear moves off the center of "high point" position. This is normal and lash must not be reduced to eliminate this slight rattle.</p>	<p>Add lube specified.</p> <p>Tighten to specified torque.</p> <p>Replace steering shaft bearing.</p> <p>Adjust steering gear to specified preloads.</p>
Poor Returnability	<p>Steering column misaligned.</p> <p>Insufficient or improper lubricant in steering gear or front suspension.</p> <p>Steering gear adjusted too tight.</p> <p>Front wheel alignment incorrect (Caster)</p>	<p>Align column.</p> <p>Lubricate as specified.</p> <p>Adjust over-center and thrust bearing preload to specifications.</p> <p>Adjust to specifications.</p>

Fig. 3B-3-Manual Gear Diagnosis

CONDITION	POSSIBLE CAUSE	CORRECTION
<p>Excessive Play or Looseness in Steering System.</p>	<p>Front wheel bearings loosely adjusted.</p> <p>Worn upper ball joints.</p> <p>Steering wheel loose on shaft, loose pitman arm, tie rods, steering arms or steering linkage ball nuts.</p> <p>Excessive over-center lash.</p> <p>Worm thrust bearings loosely adjusted.</p>	<p>Adjust to obtain proper end play.</p> <p>Check and replace ball joints if necessary.</p> <p>Tighten to specification, replace if worn or damaged.</p> <p>Adjust over-center preload to specifications.</p> <p>Adjust worm thrust bearing preload to specifications.</p>
<p>Hard Steering – Excessive Effort Required at Steering Wheel</p>	<p>Low or uneven tire pressure.</p> <p>Insufficient or improper lubricant in steering gear or front suspension.</p> <p>Steering shaft flexible coupling misaligned.</p> <p>Steering gear adjusted too tight.</p> <p>Front wheel alignment incorrect. (Manual Gear)</p>	<p>Inflate to specified pressures.</p> <p>Lubricate as specified. Re-lubricate at specified intervals.</p> <p>Align column and coupling.</p> <p>Adjust over-center and thrust bearing preload to specifications.</p> <p>Adjust to specifications.</p>

Fig. 3B-4-Manual Gear Diagnosis

DIAGNOSIS C AND K STEERING COLUMNS

This section contains diagnostic information to help locate the cause of the problem in the column. Reference should be made to the correct method of column disassembly, repair, adjustment and reassembly. Damaged, broken or deformed parts must be replaced with the correct replacement.

GENERAL INFORMATION

All C and K models are equipped with function locking energy absorbing Steering Columns. The columns are of five basic designs as follows:

1. **Synchromesh** - The synchromesh column is used on models with the standard transmission and column mounted shift levers. The shift tube, within the outer column jacket, includes two lower shift levers for connection to the transmission control linkage.

2. **Floor Shift** - This column is used on models equipped with a manual transmission with the shift lever on the floor. This column does not incorporate a shift tube.

3. **AUTOMATIC TRANSMISSION** - Available with column shift only, Locks the transmission and steering wheel while in park position and the lock cylinder is in "Lock" position.

4. **TILT WHEEL OPTION** - The upper end and steering shaft of this column is specifically designed to accommodate the optional tilt steering wheel. It is available with either manual (the fourth column type) or automatic transmission on (the fifth column type).

To perform diagnostic procedures on the steering column upper end components, it is not necessary to remove the column from the vehicle.

The steering wheel, horn components, directional signal switch, ignition switch and lock cylinder may be removed with the column remaining in the vehicle as described in the Service Manual under "Component Part Replacement".

CAUTION: *The outer mast jacket shift tube, steering shaft and instrument panel mounting bracket are designed as energy absorbing units. Because of the design of these components, it is absolutely necessary to handle the column with care when performing any service operation. Avoid hammering, jarring, dropping or leaning on any portion of the column. When reassembling the column components, use only the specified screws, nuts and bolts and tighten to specified torque. Care should be exercised not to use over-length screws or bolts as they may prevent a portion of the column from compressing under impact.*

COLLISION DIAGNOSIS

To determine if the energy absorbing steering column components are functioning as designed, or if repairs are required, a close inspection should be made. An inspection is called for in all cases where damage is

evident or whenever the vehicle is being repaired due to a front end collision. Whenever a force has been exerted on the steering wheel or steering column, or its components, inspection should also be made. If damage is evident, the affected parts must be replaced.

The inspection procedure for the various steering column components on C and K trucks is as follows:

Column Support Bracket

Damage in this area will be indicated by separation of the mounting capsules from the bracket. The bracket will have moved forward toward the engine compartment and will usually result in collapsing of the jacket section of the steering column.

COLUMN JACKET

Inspect jacket section of column for looseness, and/or bends.

SHIFTER SHAFT

Separation of the shifter shaft sections will be internal and cannot be visually identified. Hold lower end of the "shifter shaft" and move "shift lever" on column through its ranges and up and down. If there is little or no movement of the "shifter shaft", the plastic joints are sheared.

Steering Shaft

If the steering shaft plastic pins have been sheared, the shaft will rattle when struck lightly from the side and some lash may be felt when rotating the steering wheel while holding the rag joint. It should be noted that if the steering shaft pins are sheared due to minor collision with no appreciable damage to other components, that the vehicle can be safely steered; however, steering shaft replacement is recommended.

Because of the differences in the steering column types, be sure to refer to the set of instructions below which apply to the column being serviced.

METHOD TO DETERMINE COLUMN COLLAPSE

Measure distance between top of neutral-start switch window opening and the bottom of the upper jacket. The correct value is shown below:

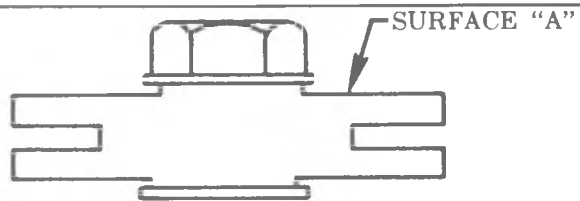
- a. C-Truck 5 11/16" to 5 1/2".
- b. K-Truck 5 11/16" to 5 1/2".

STEERING COLUMN ELECTRICAL ANALYZER J-23980 FOR C AND K SERIES COLUMNS

A new tool has been developed to help the technician analyze the steering column wiring harness for electrical problems. The tool in actuality eliminates the steering column, related wiring and components; and replaces them with the tool itself. In this way disassembly

Instrument Panel Bracket Capsule Damage

NOTE: The bolt head must not contact surface "A". If contact is made, the capsule shear load will be increased. If this condition exists replace the bracket.



AUTOMATIC TRANSMISSION COLUMNS

LOCK SYSTEM – WILL NOT UNLOCK

Cause	Solution
A. Lock bolt damaged.	A. Replace lock bolt.
B. Defective lock cylinder.	B. Replace or repair lock cylinder.
C. Damaged housing.	C. Replace housing.
D. Damaged or collapsed sector.	D. Replace sector.
E. Damaged rack.	E. Replace rack.
F. Shear Flange on sector shaft collapsed.	F. Replace.

LOCK SYSTEM - WILL NOT LOCK

Cause	Solution
A. Lock bolt spring broken or defective.	A. Replace spring.
B. Damaged sector tooth, or sector installed incorrectly.	B. Replace, or install correctly.
C. Defective lock cylinder.	C. Replace lock cylinder
D. Burr or lock bolt or housing.	D. Remove Burr.
E. Damaged housing.	E. Replace housing.
F. Transmission linkage adjustment incorrect.	F. Readjust (see Sec. 7).
G. Damaged rack.	G. Replace rack.
H. Interference between bowl and coupling (tilt).	H. Adjust or replace as necessary.
I. Ignition switch stuck.	I. Readjust or replace.
J. Actuator rod restricted or bent.	J. Readjust or replace.

LOCK SYSTEM – HIGH EFFORT

Cause	Solution
A. Lock cylinder defective.	A. Replace lock cylinder.
B. Ignition switch defective.	B. Replace switch.
C. Rack preload spring broken or deformed.	C. Replace spring.
D. Burrs on sector, rack, housing, support, tang of shift gate or actuator rod coupling.	D. Remove Burr.
E. Bent sector shaft.	E. Replace shaft.
F. Distorted rack.	F. Replace rack
G. Misalignment of housing to cover (tilt only).	G. Replace either or both.

Fig. 3B-5-Automatic Transmission Column Diagnosis

of the column is not performed until the problem has been determined to be in the column. By moving the tester switch, (with the key in the "on" position), the various functions may be checked. The switch positions are "OFF", "HORN", "LEFT TURN", "RIGHT TURN", "KEY BUZZER", and "HAZARD". (Trucks

do not incorporate a Key Buzzer Switch) if the systems function properly while using the tester, then the malfunction has been narrowed to the column wiring or components. When this has been determined then the column may be serviced to correct the malfunction.

To use the tool just unfasten the harmonica

LOCK SYSTEM – HIGH EFFORT (CONT'D.)	
Cause	Solution
H. Distorted coupling slot in rack (tilt). I. Bent or restricted actuator rod. J. Ignition switch mounting bracket bent.	H. Replace rack. I. Straighten remove restriction or replace. J. Straighten or replace.
HIGH EFFORT LOCK CYLINDER – BETWEEN "OFF" AND "OFF-LOCK" POSITIONS	
Cause	Solution
A. Burr on tang of shift gate. B. Distorted rack.	A. Remove burr. B. Replace rack.
STICKS IN "START" POSITION	
Cause	Solution
A. Actuator rod deformed. B. Any high effort condition.	A. Straighten or replace. B. Check items under high effort section.
KEY CAN NOT BE REMOVED IN "OFF-LOCK" POSITION	
Cause	Solution
A. Ignition switch is not set correctly. B. Defective lock cylinder.	A. Readjust ignition switch. B. Replace lock cylinder.
LOCK CYLINDER CAN BE REMOVED WITHOUT DEPRESSING RETAINER	
Cause	Solution
A. Lock cylinder with defective retainer. B. Lock cylinder without retainer. C. Burr over retainer slot in housing cover.	A. Replace lock cylinder. B. Replace lock cylinder. C. Remove burr.
LOCK BOLT HITS SHAFT LOCK IN "OFF" AND "PARK" POSITIONS	
Cause	Solution
A. Ignition switch is not set correctly.	A. Readjust ignition switch.
IGNITION SYSTEM – ELECTRICAL SYSTEM WILL NOT FUNCTION	
Cause	Solution
A. Defective fuse in "accessory" circuit. B. Connector body loose or defective. C. Defective wiring.	A. Replace fuse. B. Tighten or replace. C. Repair or replace.

Fig. 3B-6--Automatic Transmission Column Diagnosis

IGNITION SYSTEM – ELECTRICAL SYSTEM – WILL NOT FUNCTION (CONT'D.)	
Cause	Solution
D. Defective ignition switch. E. Ignition switch not adjusted properly.	D. Replace ignition switch. E. Readjust ignition switch.
SWITCH WILL NOT ACTUATE MECHANICALLY	
Cause	Solution
A. Defective ignition switch.	A. Replace ignition switch.
SWITCH CAN NOT BE SET CORRECTLY	
Cause	Solution
A. Switch actuator rod deformed. B. Sector to rack engaged in wrong tooth (tilt).	A. Repair or replace switch actuator rod. B. Engage sector to rack correctly.
NOISE IN COLUMN	
Cause	Solution
A. Coupling bolts loose. B. Column not correctly aligned. C. Coupling pulled apart. D. Sheared intermediate shaft plastic joint. E. Horn contact ring not lubricated. F. Lack of grease on bearings or bearing surfaces. G. Lower shaft bearing tight or frozen. H. Upper shaft tight or frozen. I. Shaft lock plate cover loose. J. Lock plate snap ring not seated. K. Defective buzzer dog cam on lock cylinder. L. One click when in "off-lock" position and the steering wheel is moved.	A. Tighten pinch bolts to specified torque. B. Realign column. C. Replace coupling and realign column. D. Replace or repair steering shaft and realign column. E. Lubricate with lubriplate. F. Lubricate bearings. G. Replace bearing. Check shaft and replace if scored. H. Replace housing assembly. I. Tighten three screws or, if missing, replace. CAUTION: Use specified screws. (15 in. lbs.) J. Replace snap ring. Check for proper seating in groove. K. Replace lock cylinder. L. Normal condition - lock bolt is seating.

Fig. 3B-7--Automatic Transmission Column Diagnosis

HIGH STEERING SHAFT EFFORT

Cause	Solution
<ul style="list-style-type: none"> A. Column assembly misaligned in vehicle. B. Improperly installed or deformed dust seal. C. Tight or frozen upper or lower bearing. D. Flash on I.D. of shift tube from plastic joint. 	<ul style="list-style-type: none"> A. Realign. B. Remove and replace. C. Replace affected bearing or bearings. D. Replace shift tube.

HIGH SHIFT EFFORT

Cause	Solution
<ul style="list-style-type: none"> A. Column not aligned correctly in car. B. Improperly installed dust seal. C. Lack of grease on seal or bearing areas. D. Burr on upper or lower end of shift tube. E. Lower bowl bearing not assembled properly (tilt). F. Wave washer with burrs (tilt only). 	<ul style="list-style-type: none"> A. Realign. B. Remove and replace. C. Lubricate bearings and seals. D. Remove burr. E. Reassemble properly. F. Replace wave washer.

IMPROPER TRANSMISSION SHIFTING

Cause	Solution
<ul style="list-style-type: none"> A. Sheared shift tube joint. B. Improper transmission linkage adjustment. C. Loose lower shift lever. D. Improper gate plate. E. Sheared lower shift lever weld. 	<ul style="list-style-type: none"> A. Replace shift tube assembly. B. Readjust linkage. C. Replace shift tube assembly. D. Replace with correct part. E. Replace tube assembly.

LASH IN MOUNTED COLUMN ASSEMBLY

Cause	Solution
<ul style="list-style-type: none"> A. Instrument panel mounting bolts loose. B. Broken weld nuts on jacket. C. Instrument panel bracket capsule sheared. D. Instrument panel to jacket mounting bolts loose. E. Loose shoes in housing (tilt only). F. Loose tilt head pivot pins (tilt only). G. Loose shoe lock pin in support (tilt only). 	<ul style="list-style-type: none"> A. Tighten to specifications. (20 ft. lbs.) B. Replace jacket assembly. C. Replace bracket assembly. D. Tighten to specifications. (15 ft. lbs.) E. Replace. F. Replace. G. Replace.

MISCELLANEOUS

Cause	Solution
<ul style="list-style-type: none"> A. Housing loose on jacket - will be noticed with ignition in "Off-Lock" and a torque applied to the steering wheel. B. Shroud loose on shift bowl. 	<ul style="list-style-type: none"> A. Tighten four mounting screws - (60 in. lbs.) B. Bend tabs on shroud over lugs on bowl.

Fig. 3B-8-Automatic Transmission Column Diagnosis

MANUAL TRANSMISSION COLUMNS

GENERAL INFORMATION

All of the preceding diagnosis information for automatic transmission will apply to the manual transmission. The following information is supplied in addition to and specifically for manual transmission columns.

DRIVER CAN LOCK STEERING IN SECOND GEAR

Cause	Solution
A. Defective upper shift lever.	A. Replace shift lever.
B. Defective shift lever gate.	B. Replace shift lever gate.
C. Loose relay lever on shift tube.	C. Replace shift tube assembly.
D. Use of upper shift lever prior to 1969 model year.	D. Replace with current lever.

HIGH SHIFT EFFORT

Cause	Solution
A. Column not aligned correctly in car.	A. Realign column.
B. Lower bowl bearing not assembled correctly.	B. Reassemble correctly.
C. Improperly installed seal.	C. Remove and replace.
D. Wave washer in lower bowl bearing defective.	D. Replace wave washer.
E. Improper adjustment of lower shift levers.	E. Readjust (see Sec. 7).
F. Lack of grease on seal, bearing areas or levers.	F. Lubricate seal, levers and bearings.
G. Damaged shift tube in bearing areas.	G. Replace shift tube assembly.

IMPROPER TRANSMISSION SHIFTING

Cause	Solution
A. Loose relay lever on shift tube.	A. Replace shift tube assembly.

TILT COLUMNS

GENERAL INFORMATION

All of the preceding diagnosis will generally apply to tilt columns. The following is supplied in addition to and specifically for tilt columns.

HOUSING SCRAPPING ON BOWL

Cause	Solution
A. Bowl bent or not concentric with hub.	A. Replace bowl.

Fig. 3B-9—Manual Transmission Column Diagnosis

STEERING WHEEL LOOSE	
Cause	Solution
<ul style="list-style-type: none"> A. Excessive clearance between holes in support or housing and pivot pin diameters. B. Defective or missing anti-lash spring in spheres. C. Upper bearing seat not seating in bearing. D. Upper bearing inner race seat missing. F. Loose support screws. G. Bearing preload spring missing or broken. 	<ul style="list-style-type: none"> A. Replace either or both. B. Add spring or replace both. C. Replace both. D. Install seat. F. Tighten to 60 in. lbs. G. Replace preload spring.
STEERING WHEEL LOOSE EVERY OTHER TILT POSITION	
Cause	Solution
<ul style="list-style-type: none"> A. Loose fit between shoe and shoe pivot pin. 	<ul style="list-style-type: none"> A. Replace both.
NOISE WHEN TILTING COLUMN	
Cause	Solution
<ul style="list-style-type: none"> A. Upper tilt bumper worn. B. Tilt spring rubbing in housing. 	<ul style="list-style-type: none"> A. Replace tilt bumper. B. Lubricate.
STEERING COLUMN NOT LOCKING IN ANY TILT POSITION	
Cause	Solution
<ul style="list-style-type: none"> A. Shoe seized on its pivot pin. ivot pin. B. Shoe grooves may have burrs or dirt. C. Shoe lock spring weak or broken. 	<ul style="list-style-type: none"> A. Replace shoe and pivot pin. B. Replace shoe. C. Replace lock spring.
STEERING WHEEL FAILS TO RETURN TO TOP TILT POSITION	
Cause	Solution
<ul style="list-style-type: none"> A. Pivot pins are bound up. B. Wheel tilt spring is defective. C. Turn signal switch wires too tight. 	<ul style="list-style-type: none"> A. Replace pivot pins. B. Replace tilt spring. C. Reposition wires.

Fig. 3B-10--Tilt Column Diagnosis

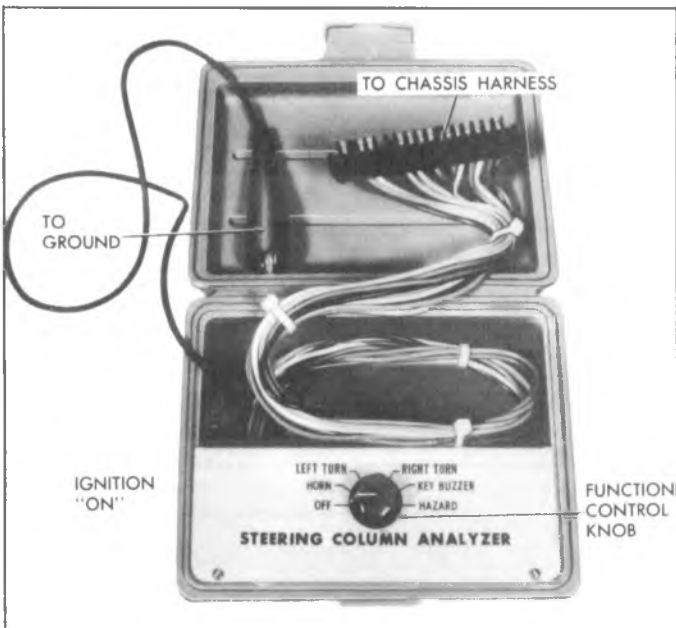


Fig. 3B-11-Steering Column Electrical Analyzer J-23980

connector on the column and plug the harness from J-23980 into the vehicle chassis harness. The "A", "B", and "C" terminals on the tester will overhang the chassis connector. This does not affect the test results. These terminals are for vehicles with cornering lights. Connect the single black jumper to a good ground. The tester is now ready for use (Fig. 3B-11).

TURN SIGNAL DIAGNOSIS C AND K SERIES

When a complaint is made involving the turn signal system, it must first be determined whether the problem is mechanical or electrical. If mechanical, the switch itself is at fault and must be repaired or replaced. If electrical, J-23980 should be used to determine whether the switch, or the chassis wiring is in need of repair or replacement.

This diagnostic procedure has been designed to guide the mechanic through the proper diagnosis and repair of the turn signal system. The service section is to be used where assembly and/or disassembly procedures are required. The wiring diagram, found in Section 12, should be used to trouble shoot the chassis and body wiring after the problem has been isolated.

The nature of the customer complaint will generally point to the problem area.

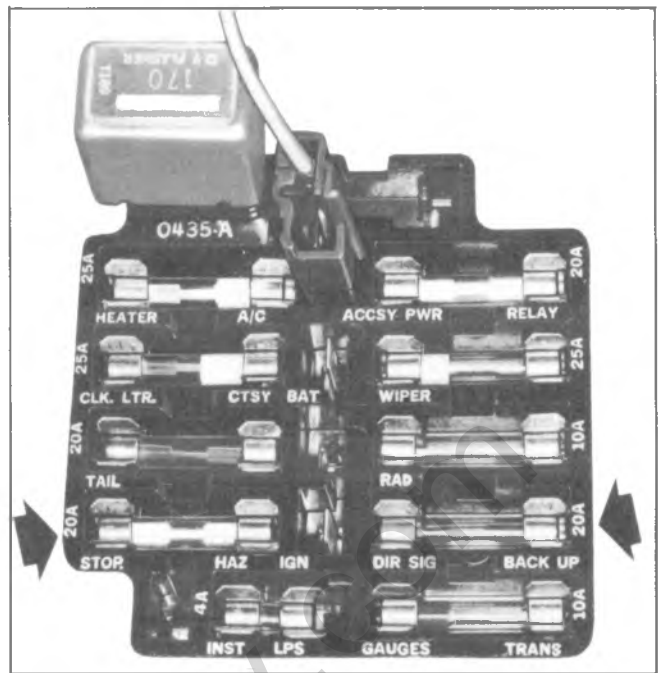


Fig. 3B-12-Checking Fuses on Fuse Block

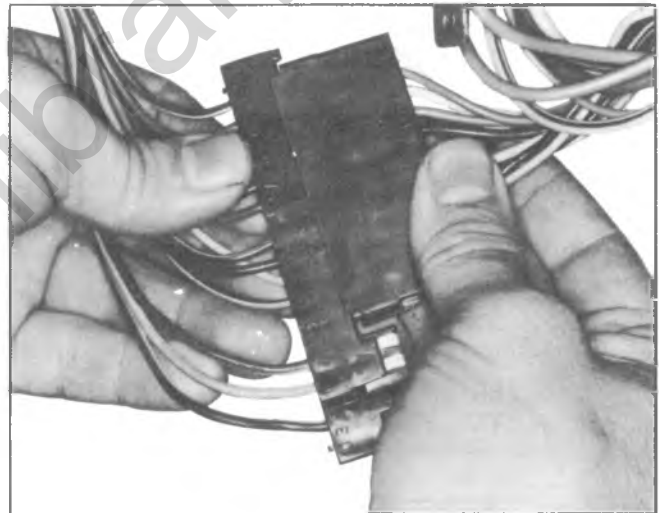


Fig. 3B-13-Checking Harmonica Connector on Column

Electrical

Chassis Electrical

The most common turn signal system problems are generally electrical and may easily, be fixed by the replacement of fuses, bulbs or flashers

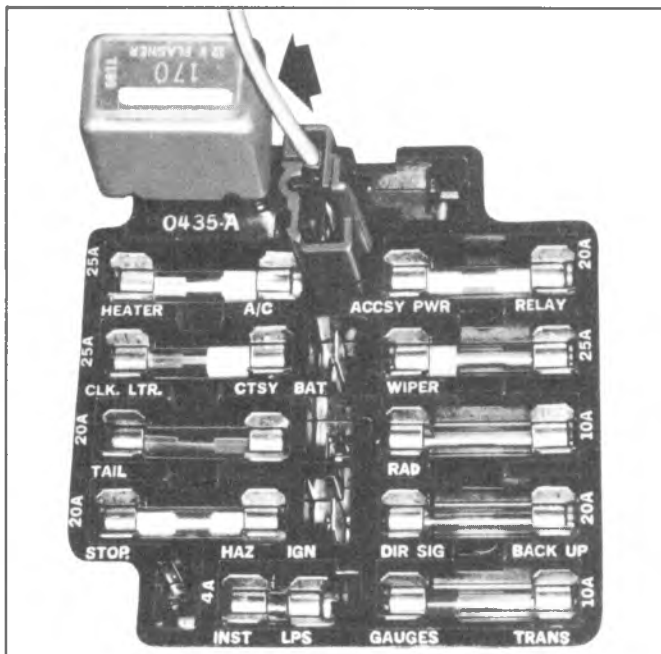


Fig. 3B-14--Checking Hazard Warning Flasher

First make these checks and replace any non-operative components.

1. **Check fuses** (Figure 3B-12). Replace if blown. If new fuse blows, replace flasher in system. (There are 2 flashers in the signal switch system. The hazard warning flasher and turn signal flasher are located on the fuse block.

2. Check for secure connection at the chassis to switch connector. This is the harmonica connector on the column (Figure 3B-13). Secure if loose. Check all individual wire terminals for proper seating in the connector bodies. Terminals should be locked in place.

3. Depress hazard warning button and check all lights in signal switch system. Replace any which do not work. If all lamps light when hazard warning is depressed, but flashing does not occur, replace hazard warning flasher. (On fuse block) (Figure 3B-14).

4. If all directional lamps light when lane change or turn indicator is actuated, but no flashing occurs, replace the turn signal flasher.

The above four steps will, in most cases, cure the common signal switch system troubles. If the system is still not operating correctly, use J-23980 to determine whether the chassis wiring or the signal switch itself is at fault.

Mechanical

1. If the customer's complaint indicates the problem is in the switch, function check as to return from full left and full right turns.

Actuate the turn lever into a full turn position in either direction, then turn the steering wheel (motor on - power steering) at least 1/4 turn in the direction indicated and then back to center. Do this

in both directions. If the lever does not return to the neutral position, disassemble the upper part of the column until the switch is visible.

2. Check the return from lane change by holding the lever in lane change and releasing (both left and right). If the lever does not return to neutral, disassemble the upper part of the column.

3. If the hazard warning button cannot be depressed or released, the switch must be replaced.

Switch Visual Inspection

1. With the upper part of the column disassembled so that the signal switch is visible (Figure 3B-15) check for missing springs. Replace any spring that is missing, inspecting the molded pins which secure them. If these pins are broken, the switch must be replaced.

2. Check the position of the switch in the bowl. If it appears cocked or crooked, loosen the securing screws (3) and visually inspect the switch. If any of the plastic is broken or badly deformed, the switch must be replaced.

3. If the switch appears undamaged, replace it being careful to seat the pilot into the housing, tighten the screws to 25 lbs. in. of torque.

POWER STEERING SYSTEM DIAGNOSIS

Complaints of faulty steering are frequently the result of problems other than the steering gear or pump. Those areas of the steering system which can be easily checked and quickly corrected without disassembly and overhaul of any major components should be attempted first.

Conditions such as hard or loose steering, road shock or vibrations are not always due to the steering gear or pump, but are often related instead to such factors low tire pressure and front end alignment. These factors should be checked and corrected before any

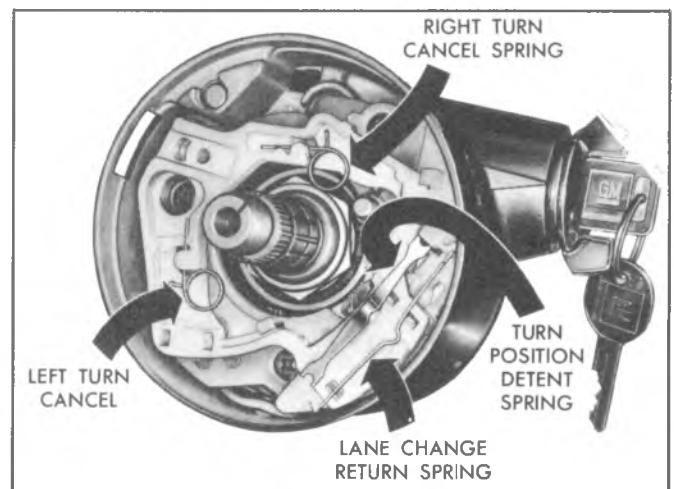


Fig. 3B-15--Checking Turn Signal Switch Visually

SIGNAL SWITCH DIAGNOSIS		
CONDITION	POSSIBLE CAUSE	CORRECTION
Turn signal will not cancel	<ul style="list-style-type: none"> A. Loose switch mounting screws B. Switch or anchor bosses broken C. Broken, missing or out of position detent, return or cancelling spring D. Uneven or incorrect cancelling cam to cancelling spring interference. (.120)/side 	<ul style="list-style-type: none"> A. Tighten to specified torque (25 in-lbs) B. Replace switch C. Reposition or replace springs as required D. Adjust switch position <ul style="list-style-type: none"> 1. If interference is correct and switch will still not cancel, replace switch. 2. If interference cannot be corrected by switch adjustment, replace cancelling cam.
Turn signal difficult to operate	<ul style="list-style-type: none"> A. Actuator rod loose B. Yoke broken or distorted C. Loose or misplaced springs D. Foreign parts and/or materials E. Switch mounted loosely 	<ul style="list-style-type: none"> A. Tighten mounting screw (12 in-lb) B. Replace switch C. Reposition or replace springs D. Remove foreign parts and/or material E. Tighten mounting screws (25 in-lbs)
Turn signal will not indicate lane change	<ul style="list-style-type: none"> A. Broken lane change pressure pad or spring hanger B. Broken, missing or misplaced lane change spring C. Jammed base or wires 	<ul style="list-style-type: none"> A. Replace switch B. Replace or reposition as required C. Loosen mounting screws, reposition base or wires and retighten screws (25 in-lbs)
Turn signal will not stay in turn position	<ul style="list-style-type: none"> A. Foreign material or loose parts impeding movement of yoke B. Broken or missing detent or cancelling springs C. None of the above 	<ul style="list-style-type: none"> A. Remove material and/or parts B. Replace spring C. Replace switch
Hazard switch cannot be turned off	<ul style="list-style-type: none"> A. Foreign material between hazard support cancelling leg and yoke 	<ul style="list-style-type: none"> A. Remove foreign material <ul style="list-style-type: none"> 1. No foreign material impeding function of hazard switch – replace turn signal switch

Fig. 3B-16--Turn Signal Switch Diagnosis

SIGNAL SWITCH DIAGNOSIS		
CONDITION	POSSIBLE CAUSE	CORRECTION
Hazard switch will not stay on or difficult to turn off	<ul style="list-style-type: none"> A. Loose switch mounting screws B. Interference with other components C. Foreign material D. None of the above 	<ul style="list-style-type: none"> A. Tighten mounting screws (25 in-lbs) B. Remove interference C. Remove foreign material D. Replace switch
No turn signal lights	<ul style="list-style-type: none"> A. Defective or blown fuse B. Inoperative turn signal flasher C. Loose chassis to column connector D. Disconnect column to chassis connector. Connect new switch to chassis and operate switch by hand. If vehicle lights now operate normally, signal switch is inoperative E. If vehicle lights do not operate check chassis wiring for opens, grounds, etc. 	<ul style="list-style-type: none"> A. Replace fuse and check operation B. Replace turn signal flasher C. Connect securely, check operation D. Replace signal switch E. Repair chassis wiring as required using manual as guide
Turn indicator lights on, but not flashing	<ul style="list-style-type: none"> A. Inoperative turn flasher B. Loose chassis to column connection C. Inoperative turn signal switch D. To determine if turn signal switch is defective, substitute new switch into circuit and operate switch by hand. If the vehicle's lights operate normally, signal switch is inoperative E. If the vehicle's lights do not operate, check light sockets for high resistance connections, the chassis wiring for opens, grounds, etc. 	<ul style="list-style-type: none"> A. Replace turn flasher Note: There are two flashers in the system. Consult manual for location. B. Connect securely and check operation C. Replace turn signal switch D. Replace signal switch E. Repair chassis wiring as required using manual as guide

Fig. 3B-17--Turn Signal Switch Diagnosis

SIGNAL SWITCH DIAGNOSIS		
CONDITION	POSSIBLE CAUSE	CORRECTION
Front or rear turn signal lights not flashing	<p>A. Burned out fuse</p> <p>B. Burned out or damaged turn signal bulb</p> <p>C. High resistance connection to ground at bulb socket</p> <p>D. Loose chassis to column connector</p> <p>E. Disconnect column to chassis connector. Connect new switch into system and operate switch by hand. If turn signal lights are now on and flash, turn signal switch is inoperative.</p> <p>F. If vehicle lights do not operate, check chassis wiring harness to light sockets for opens, grounds, etc.</p>	<p>A. Replace fuse and check operation</p> <p>B. Replace bulb</p> <p>C. Remove or repair defective connection and check operation</p> <p>D. Connect securely and check operation</p> <p>E. Replace turn signal switch.</p> <p>F. Repair chassis wiring as required using manual as guide</p>
Stop light not on when turn indicated	<p>A. Burned out fuse</p> <p>B. Loose column to chassis connection</p> <p>C. Disconnect column to chassis connector. Connect new switch into system without removing old. Operate switch by hand. If brake lights work with switch in the turn position, signal switch is defective</p> <p>D. If brake lights do not work check connector to stop light sockets for grounds, opens, etc.</p>	<p>A. Replace fuse and check operation</p> <p>B. Connect securely and check operation</p> <p>C. Replace signal switch</p> <p>D. Repair connector to stop light circuits using manual as guide.</p>
Turn indicator panel lights not flashing	<p>A. Burned out bulbs</p> <p>B. High resistance to ground at bulb socket</p> <p>C. Opens, grounds in wiring harness in front turn signal bulb socket to indicator lights</p>	<p>A. Replace bulbs</p> <p>B. Replace socket</p> <p>C. Locate and repair as required. Use shop manual as guide.</p>

Fig. 3B-18-Turn Signal Switch Diagnosis

SIGNAL SWITCH DIAGNOSIS		
CONDITION	POSSIBLE CAUSE	CORRECTION
Turn signal lights flash very slowly	<p>A. Inoperative turn signal flasher</p> <p>B. System charging voltage low</p> <p>C. High resistance ground at light sockets</p> <p>D. Loose chassis to column connection</p> <p>E. Disconnect column to chassis connector. Connect new switch into system without removing old. Operate switch by hand. If flashing occurs at normal rate, the signal switch is defective.</p> <p>F. If the flashing rate is still extremely slow, check chassis wiring harness from the connector to light sockets for grounds, high resistance points, etc.</p>	<p>A. Replace turn signal flasher</p> <p>B. Increase voltage to specified. See Sec. 6Y</p> <p>C. Repair high resistance grounds at light sockets</p> <p>D. Connect securely and check operation</p> <p>E. Replace signal switch</p> <p>F. Locate and repair as required. Use manual as guide. See Section 12</p>
Hazard signal lights will not flash — turn signal functions normally	<p>A. Blown fuse</p> <p>B. Inoperative hazard warning flasher</p> <p>C. Loose chassis to column connection</p> <p>D. Disconnect column to chassis connector. Connect new switch into system without removing old. Depress the hazard warning button and observe the hazard warning lights. If they now work normally, the turn signal switch is defective.</p> <p>E. If the lights do not flash, check wiring harness "K" lead (brown) for open between hazard flasher and harmonica connector. If open, fuse block is defective.</p>	<p>A. Replace fuse and check operation</p> <p>B. Replace hazard warning flasher</p> <p>C. Connect securely and check operation</p> <p>D. Replace the turn signal switch</p> <p>E. Replace fuse block (See Sec. 12)</p>

Fig. 3B-19--Turn Signal Switch Diagnosis

adjustment or disassembly of the power steering gear or pump is attempted.

System Checks

Many factors affect power operation of the steering system, of which the most common are:

1. Fluid level and condition.
2. Drive belt tension.
3. Loose component mountings.
4. Loose pump pulley.

These factors must be checked and corrected before making any further diagnosis of the steering system. The need for proper diagnosis cannot be over-emphasized.

After the source of the problem has been found, determine the cause. For example, if the oil level in the reservoir is found to be low, refill and check the entire hydraulic system for oil leaks. Refilling the reservoir will not necessarily correct problem.

Fluid Level

1. Run engine to normal operating temperature, then shut engine off. Remove reservoir filler cap and check oil level to "hot" mark on dipstick.

2. If oil level is low, add hydraulic fluid to proper level on dipstick and replace filler cap.

NOTE: When adding or making a complete fluid change, always use GM power steering fluid or equivalent.

3. When checking fluid level after the steering system has been serviced, air must be bled from the system. Proceed as follows:

a. With wheels turned all the way to the left, add power steering fluid to "Cold" mark on dipstick.

b. Start engine, and running at fast idle, recheck fluid level. Add fluid if necessary to "Cold" mark on dipstick.

c. Bleed system by turning wheels from side to side without hitting stops. Maintain fluid level just above internal pump casting. Fluid with air in it will have a light tan or red appearance. This air must be eliminated from fluid before normal steering action can be obtained.

d. Return wheels to center position and continue to run engine for two or three minutes, then shut engine off.

e. Road test car to make sure steering functions normally and is free from noise.

f. Recheck fluid level as described in steps 1 and 2, making sure fluid level is at "hot" mark on dipstick after the system has stabilized at its normal operating temperature approximately 170° to 190°F.

Belt Adjustment

When adjusting a power steering pump belt, never pry against the pump reservoir or pull against the filler neck. To increase belt tension move the pump outward by prying against the pump housing casting extension directly behind the pump drive pulley.

A belt that has been previously tensioned is considered to be a used belt and should be tightened to

75 pounds. A belt that has never been tensioned is considered to be a new belt and should be tightened to 125 pounds.

Place belt tension gage, J-23600 or equivalent midway between the pulleys on drive belt being checked. If the belt tension is incorrect proceed as follows:

1. When power steering pump is driven by a single belt:

a. Loosen the pump attaching bolts and adjust the belt to correct tension by moving the pump outward, away from the engine.

b. Snug all pump mounting bolts and remove pry bar.

c. Tighten all pump mounting bolts to specified torque.

d. Check belt tension and remove the belt tension gage.

Hydraulic System Checks

The following procedure outlines methods to identify and isolate power steering hydraulic circuit difficulties. The test provides means of determining whether power steering system hydraulic parts are actually faulty. This test will result in readings indicating faulty hydraulic operation, and will help to identify the faulty component.

Before performing hydraulic circuit test, carefully check belt tension, fluid level and condition of driving pulley.

Power Steering Hydraulic System Test

Engine must be at normal operating temperature. Inflate front tires to correct pressure. All tests are made with engine idling, check idle adjustment and if necessary adjust engine idle speed to correct specifications listed in Section 6C and proceed as follows:

1. With engine NOT running disconnect pressure hose from pump and install Tool J-5176 using a spare pressure hose between gauge and pump. Gauge must be between shut-off valve and pump. Open shut-off valve.

2. Remove filler cap from pump reservoir and check fluid level. Fill pump reservoir to full mark on dipstick. Start engine and, momentarily holding steering wheel against stop, check connections at Tool J-5176 for leakage.

3. Bleed system as outlined under Maintenance and Adjustments.

4. Insert thermometer (Tool J-5421) in reservoir filler opening. Move steering wheel from stop to stop several times until thermometer indicates that hydraulic fluid in reservoir has reached temperature of 150° to 170°F.

CAUTION: To prevent scrubbing flat spots on tires, do not turn steering wheel more than five times without rolling vehicle to change tire-to-floor contact area.

5. Start engine and check fluid level adding any fluid if required. When engine is at normal operating temperature, the initial pressure read on the gauge (valve open) should be in the 80-125 PSI range. Should this

CONDITION	POSSIBLE CAUSE	CORRECTION
<p>SYSTEM NOISE</p> <p>There is some noise in all power steering systems.</p> <p>Common complaints are listed as follows:</p>		
Pump noise-"chirp".	Loose belt.	Adjust belt tension to specification.
Belt squeal.	Loose belt.	Adjust belt tension to specification.
Gear noise ("hissing" sound)	There is some noise in all power steering systems. One of the most common is a hissing sound most evident at standstill parking. There is no relationship between this noise and performance of the steering. "Hiss" may be expected when steering wheel is at end of travel or when slowly turning at standstill.	Do not replace valve unless "hiss" is extremely objectionable. Slight "hiss" is normal and in no way affects steering. A replacement valve will also exhibit slight noise and is not always a cure for the objection. Investigate clearance around flexible coupling rivets. Be sure steering shaft and gear are aligned so flexible coupling rotates in a flat plane and is not distorted as shaft rotates. Any metal-to-metal contacts through flexible coupling will transmit "hiss" into passenger compartment.
Rattle.	Pressure hose touching other parts of car. Loose pump pulley nut Pump vanes not installed properly. Pump vanes sticking in rotor slots.	Adjust hose position. Replace nut, torque to specs. Install properly. Free up by removing burrs, varnish or dirt.
Gear noise (rattle or chuckle).	Improper over-center adjustment NOTE: A slight rattle may occur on turns because of increased clearance off the "high point". This is normal and clearance must not be reduced below specified limits to eliminate this slight rattle. Loose pitman arm. Gear loose on frame.	Adjust to specifications. Tighten to specifications Check gear-to-frame mounting bolts. Tighten bolts to 70 foot-pounds.
Rattle or chuckle.	Steering linkage looseness.	Check linkage pivot points for wear. Replace if necessary.
Groan.	Low oil level.	Fill reservoir to proper level.
Groan.	Air in the oil. Poor pressure hose connection.	Bleed system by operating steering from right to left - full turn. Check connections, torque to specs.
Growl.	Excessive back pressure caused by hoses or steering gear. (restriction)	Locate restriction and correct. Replace part if necessary.

Fig. 3B-20--Power Steering System Diagnosis

CONDITION	POSSIBLE CAUSE	CORRECTION
Pump growl Note: Most noticeable at full wheel travel and stand still parking	Scored pump pressure plates, thrust plate or rotor. Extreme wear of pump cam ring.	Replace affected parts, flush system. Replace affected parts.
Swish in pump	Defective pump flow control valve	Replace valve
Whine in pump	Pump shaft bearing scored.	Replace housing and shaft, flush system
Squawk in gear (not belt)	Dampener "O" ring on valve spool cut	Replace "O" ring.
SYSTEM OPERATION Excessive wheel kick-back or loose steering.	Backlash in steering linkage. Air in system. Excessive "over-center" lash. Loose thrust bearing preload adjustment. Worn poppet valve (Gear) Steering gear loose on frame. Steering gear flexible coupling too loose on shaft or rubber disc mounting screws loose. Steering linkage ball studs worn enough to be loose. Front wheel bearings incorrectly adjusted or worn.	Adjust parts affected or replace worn parts. Add oil to pump reservoir and bleed by operating steering. Check all connections. Adjust to specification. Adjust to specification. Replace poppet valve. Tighten attaching bolts to 70 foot-pounds. Tighten flange pinch bolts to 30 foot-pounds, if serrations are not damaged. Tighten upper flange to coupling nuts to 20 foot-pounds. Replace loose components. Adjust bearings or replace with new parts as necessary.
Poor return of steering.	Tires under-inflated. Lower coupling flange rubbing against steering gear adjuster plug. Steering wheel rubbing against directional signal housing. Tight or frozen steering shaft bearings. Steering linkage or ball joints binding. Steering gear to column misalignment. Tie rod pivots not centralized. Lack of lubricant in suspension ball joints and steering linkage	Inflate to specified pressure. Loosen pinch bolt and assemble properly. Adjust steering jacket. Replace bearings. Replace affected parts. Align steering column. Adjust tie rod ends as required to center pivots. Lubricate and relubricate at proper intervals

Fig. 3B-21--Power Steering System Diagnosis

CONDITION	POSSIBLE CAUSE	CORRECTION
Poor return of steering. (Cont'd.)	Steering gear adjustments over specifications. Sticky or plugged valve spool. Rubber spacer binding in shift tube. Improper front suspension alignment. Tight steering shaft bearings.	Check adjustment with pitman arm disconnected. Readjust if necessary. Remove and clean or replace valve. Make certain spacer is properly seated. Lubricate inside diameter with silicone lubricant. Check and adjust to specifications. Replace bearings.
Car leads to one side or the other. (Keep in mind road condition and wind. Test car on flat road going in both directions)	Front suspension misaligned Steering shaft rubbing ID of shift tube. Unbalanced or badly worn steering gear valve. NOTE: If this is cause, steering effort will be very light in direction of lead and heavy in opposite direction. Steering linkage not level.	Adjust to specifications. Align column. Replace valve. Adjust as required.
Steering wheel surges or jerks when turning with engine running especially during parking.	Low oil level in pump. Loose pump belt. Sticky flow control valve. Insufficient pump pressure. Steering linkage hitting engine oil pan at full turn.	Check oil level, add as necessary. Adjust tension to specification. Inspect for varnish or damage, replace if necessary. Check pump pressure. (See pump pressure test). Replace relief valve if defective. Correct clearance.
Momentary increase in effort when turning wheel fast to right or left.	Pump belt slipping. Low oil level in pump. High internal leakage.	Tighten or replace belt. Check oil level, add as necessary. Check pump pressure (Test)
Hard steering or lack of assist.	High internal leakage. (Gear or pump) Loose pump belt. Low oil level in reservoir.	Check pump pressure. (See pump pressure test). Adjust belt tension to specification. Fill to proper level. If excessively low, check all lines and joints for evidence of external leakage, torque to specs.

Fig. 3B-22--Power Steering System Diagnosis

CONDITION	POSSIBLE CAUSE	CORRECTION
<p>Hard Steering or lack of assist (Continued)</p>	<p>Lack of lubricant in suspension or ball joints.</p> <p>Tires not properly inflated.</p> <p>Steering gear to column misalignment.</p> <p>Steering gear adjusted too tight.</p> <p>Excessive friction in steering linkage.</p> <p>Lower coupling flange rubbing against steering gear adjuster plug.</p> <p>Sticky flow control valve.</p> <p>Frame bent.</p> <p>Front springs weak and sagging.</p> <p>Insufficient oil pressure.</p>	<p>Lubricate, relubricate at proper intervals.</p> <p>Inflate to recommended pressure.</p> <p>Align steering column.</p> <p>Test steering system for binding with front wheels off floor. Adjust as necessary.</p> <p>Check tie rod pivot points for excessive friction. Replace the affected pivot.</p> <p>Loosen pinch bolt and assemble properly.</p> <p>Replace or clean valve.</p> <p>Check frame for proper alignment or cracking. Repair or replace as necessary.</p> <p>Check standing height. Weak or sagging springs should be replaced with new ones.</p> <p>If above checks do not reveal cause of hard steering, diagnose hydraulic system to determine problem.</p>
<p>Low oil pressure due to restriction in hoses:</p>	<p>Check for kinks in hoses.</p> <p>Foreign object stuck in hose.</p>	<p>Remove kink.</p> <p>Remove hoses and remove restricting object or replace hose.</p>
<p>Low oil pressure due to steering gear: (See pump pressure test)</p>	<p>Pressure loss in cylinder due to worn piston ring or scored housing bore.</p> <p>Leakage at valve rings, valve body to worm seal.</p> <p>Loose fit of spool in valve body or leaky valve body.</p> <p>Damaged poppet valve.</p>	<p>Remove gear from car for disassembly and inspection of ring and housing bore. Replace affected parts.</p> <p>Remove gear from car for disassembly and replace seals.</p> <p>Replace valve.</p> <p>Replace valve.</p>

Fig. 3B-23 -Power Steering System Diagnosis

CONDITION	POSSIBLE CAUSE	CORRECTION
<p>Low oil pressure due to steering pump: (See pump pressure test.)</p> <p>Note: Steering system external leakage</p> <p>Foaming milky power steering fluid, low level and possible low pressure.</p>	<p>Loose belt.</p> <p>Low oil level.</p> <p>Air in the oil.</p> <p>Defective hoses or steering gear.</p> <p>Flow control valve stuck or inoperative.</p> <p>Loose screw in end of flow control valve.</p> <p>Cracked or broken thrust or pressure plate.</p> <p>Pressure plate not flat against cam ring.</p> <p>Extreme wear of cam ring.</p> <p>Scored pressure plate, thrust plate or rotor.</p> <p>Vanes not installed properly.</p> <p>Vanes sticking in rotor slots.</p> <p>Air in the fluid, and loss of fluid due to internal pump leakage causing overflow.</p>	<p>Adjust tension to specification</p> <p>Fill reservoir to proper level.</p> <p>Locate source of leak and correct. Bleed system.</p> <p>Correct as necessary.</p> <p>Remove burrs or dirt or replace.</p> <p>Tighten.</p> <p>Replace part.</p> <p>Replace pressure plate.</p> <p>Replace parts, flush system</p> <p>Replace parts. (If rotor, replace with rotating group kit), flush system</p> <p>Install properly. Radius edge to outside.</p> <p>Free-up by removing burrs, varnish or dirt.</p> <p>Check for leak and correct. Bleed system. Extremely cold temperatures will cause system aeration should the oil level be low. If oil level is correct and pump still foams, remove pump from vehicle and separate reservoir from housing. Check welsh plug and housing for cracks. If plug is loose or housing is cracked, replace housing.</p>

Fig. 3B-24--Power Steering System Diagnosis

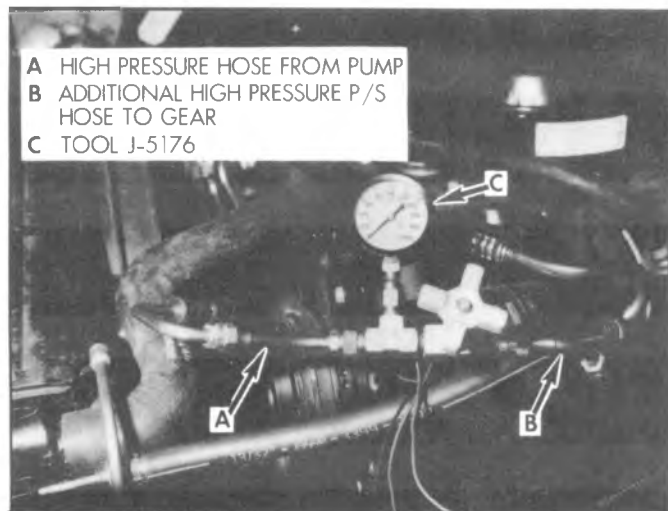


Fig. 3B-25-Checking Power Steering Pressures

pressure be in excess of 200 PSI - check the hoses for restrictions and the poppet valve for proper assembly.

6. Close gate valve fully 3 times. Record the highest pressures attained each time.

CAUTION: Do not leave valve fully closed for more than 5 seconds as the pump could be damaged internally.

a. If the pressures recorded are within the listed specs and the range of readings are within 50 PSI, the pump is functioning within specs. (EX. Spec. 900 - 1500 PSI - readings - 1270 - 1275 - 1280).

b. If the pressures recorded are high, but do not repeat within 50 PSI, the flow controlling valve is sticking. Remove the valve, clean it and remove any burrs using crocus cloth or fine hone. If the system contains some dirt, flush it. If it is exceptionally dirty, both the pump and the gear must be completely disassembled, cleaned, flushed and reassembled before further usage.

c. If the pressures recorded are constant, but more than 100 PSI, below the low listed spec., replace the flow control valve and recheck. If the pressures are still low, replace the rotating group in the pump.

7. If the pump checks within specifications, leave the valve open and turn (or have turned) the steering wheel into both corners. Record the highest pressures and compare with the maximum pump pressure recorded. If this pressure cannot be built in either (or one) side of the gear, the gear is leaking internally and must be disassembled and repaired. See the current Overhaul Manual.

8. Shut off engine, remove testing gauge, spare hose, reconnect pressure hose, check fluid level and/or make needed repairs.

Power Steering System External Leakage

General Procedure

1. Wipe suspected area dry.
2. Check for overfilled reservoir.
3. Check for oil aeration and overflow.

4. Check hose connections - tighten if necessary.

5. Verify exact point of leakage.

Example: Torsion bar, stub shaft and adjuster seals are close together; exact leakage point could be confused.

Example: The point oil drips from is not necessarily the leakage point - oil overflowing from reservoir for instance.

6. When service is required:

A. Clean leakage area upon disassembly.

B. Replace leaking seal.

C. Check component sealing surfaces for damage.

D. Reset bolt torque to specifications where required.

Some of the customer complaints associated with the power steering system may be reported as:

1. Oil leakage on garage floor.

2. Oil leaks visible on steering gear, pump, or anywhere else on the left side of engine compartment.

3. Growling noise especially when parking or when engine is cold.

4. Loss of power when parking.

5. Heavy steering effort.

For the purpose of trouble shooting complaints of this nature, assume that there is an external leak in the power steering system.

Leakage Diagnosis (Fig. 3B-26)

This section is a guide, which when used in conjunction with your service manual will enable you, a service mechanic, to locate, identify, and repair leaks in the power steering system. It contains:

A. Diagram of the complete power steering system with the areas of potential leakage identified.

B. Recommended procedure for locating external leakage in the vehicle.

C. Areas of leakage to be checked, which can be serviced at once.

D. Part replacement recommendations.

E. Diagram of the actual areas where leakage will be observed and the action recommended to repair this leakage.

Leakage Check

The purpose of the diagnostic procedure is to pinpoint the location of the leak. The method outlined in this manual can be followed to locate the leak and repair it.

In some cases you will be able to locate the leak easily. However, seepage type leaks may be more difficult to isolate. For seepage leaks, the following method is recommended.

A. With the vehicle's engine off, wipe the complete power steering system dry (gear, pump, hoses, and connections).

B. Check oil level in pump's reservoir and adjust as directed in maintenance section.

C. Start engine and turn steering wheel from stop to stop several times. Do not hold in corner for any length of time as this can damage the power steering

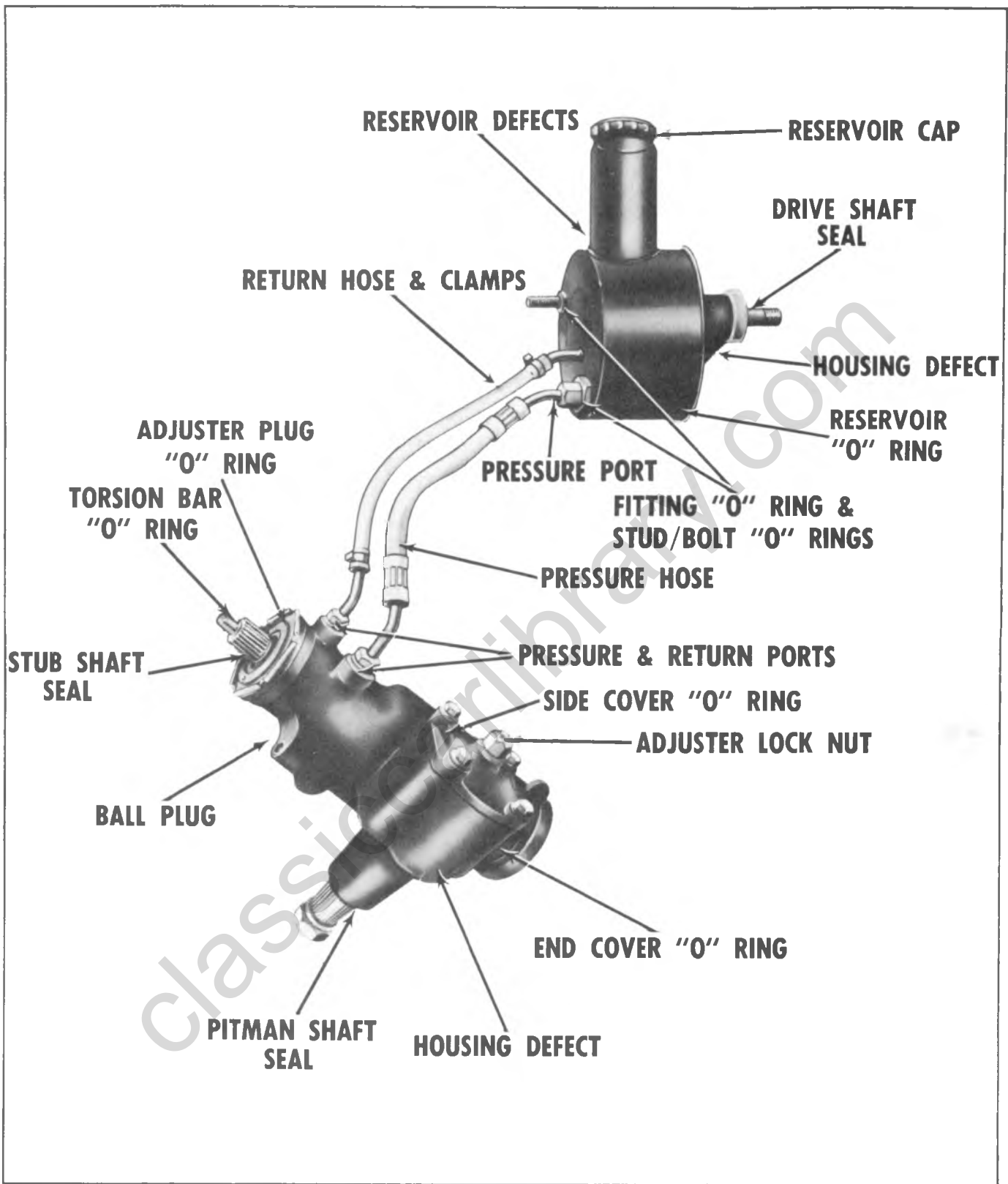


Fig. 3B-26--Power Steering System Potential Leakage Areas

pump. It is easier if someone else operates the steering wheel while you search for the seepage.

D. Find the exact area of leakage.

E. Refer to the diagnostic chart to find the recommended method of repair.

Quick Fixes

The purpose of this section is to acquaint you with the types of leakage which can be repaired very easily. It contains information on reservoir oil level, the hoses and the hose connections.

An overfilled pump reservoir can be a cause for leakage complaint. The oil in the steering system expands as heated during normal usage. If overfilled the excess is forced through the breather cap hole and may be sprayed over the engine by air blast. Operate the engine and steering system until normal operating temperature is obtained. Remove the reservoir cap and check the graduated level on the dipstick. Adjust the oil level as required.

Seepage at the hose connections can be a cause for leakage complaint and can be due to loose connection nuts. If leakage is observed at the hose connections, and the nut is not cross threaded, tighten the nuts at the gear to 30 foot pounds.

The nut at the power steering pump should be tightened to 40 foot pounds. If tightening to this torque does not stop the leak, refer to the diagnostic chart.

If either the return hose or the pressure hose leaks, replace the hose.

Component Replacement

Lip seals, which seal rotating shafts, require special treatment. This type of seal is used on the steering gear at the pitman shaft, at the stud shaft, and on the drive shaft of the pump. When leakage occurs in one of these areas, always replace the seal(s), after inspecting and thoroughly cleaning the sealing surfaces. Replace the shaft only if very severe pitting is found. If the corrosion in the lip seal contact zone is slight, clean the surface of the shaft with crocus cloth. Replace the shaft only if the leakage cannot be stopped by smoothing with crocus cloth first.

Housing or Cover Seepage - Both the power steering gear and pump assemblies are leakage checked before shipment. However, occasionally oil seepage may occur from the gear or pump other than the seal areas. If this type of leakage is found, replace the leaking part.

The following diagrams have been prepared to show the potential areas of leakage. If leakage occurs in the zones shown, replace the part listed using the service manual as a guide.

Steering Gear Leakage Diagrams (Fig. 3B-27)

Pay particular attention to the exact source of leakage as an improper diagnosis will result in an ineffective repair.

1. Replace adjuster plug "O" RING SEAL.
2. Replace dust and stub shaft seals. Refer to above on stub shaft seal ride.
3. Replace rotary valve assembly.
4. Seat ball flush with punch and restake. If seepage persists, replace housing.
5. Replace both pitman shaft seals. Refer to above on seal ride area of pitman shaft.
6. Replace end plug "O" ring seal.
7. Tighten nut to 35 pounds foot. Replace nut if leakage persists.
8. Replace side cover "O" ring seal.
9. If leakage persists upon tightening the fitting nut (30 foot pounds), replace brass connector and reface hose tube flare. If leakage is due to damaged threads (cross threaded), replace brass connector. Repair fitting nut or replace hose as required. If housing threads are badly stripped, replace housing.

Pump Leakage Diagrams (Fig. 3B-28)

10. Tighten hose fitting nut to 40 pounds foot. If leakage persists, replace discharge fitting and reface hose tube flare or replace hose as required.
11. Tighten fitting to 35 pounds foot. If leakage persists, replace both "O" ring seals.
12. Replace reservoir "O" ring.
13. Replace drive shaft seal. Refer to above on seal ride area of drive shaft.
14. Replace reservoir.
15. Check oil level. If leakage persists with the level right and the cap tight, replace the cap.

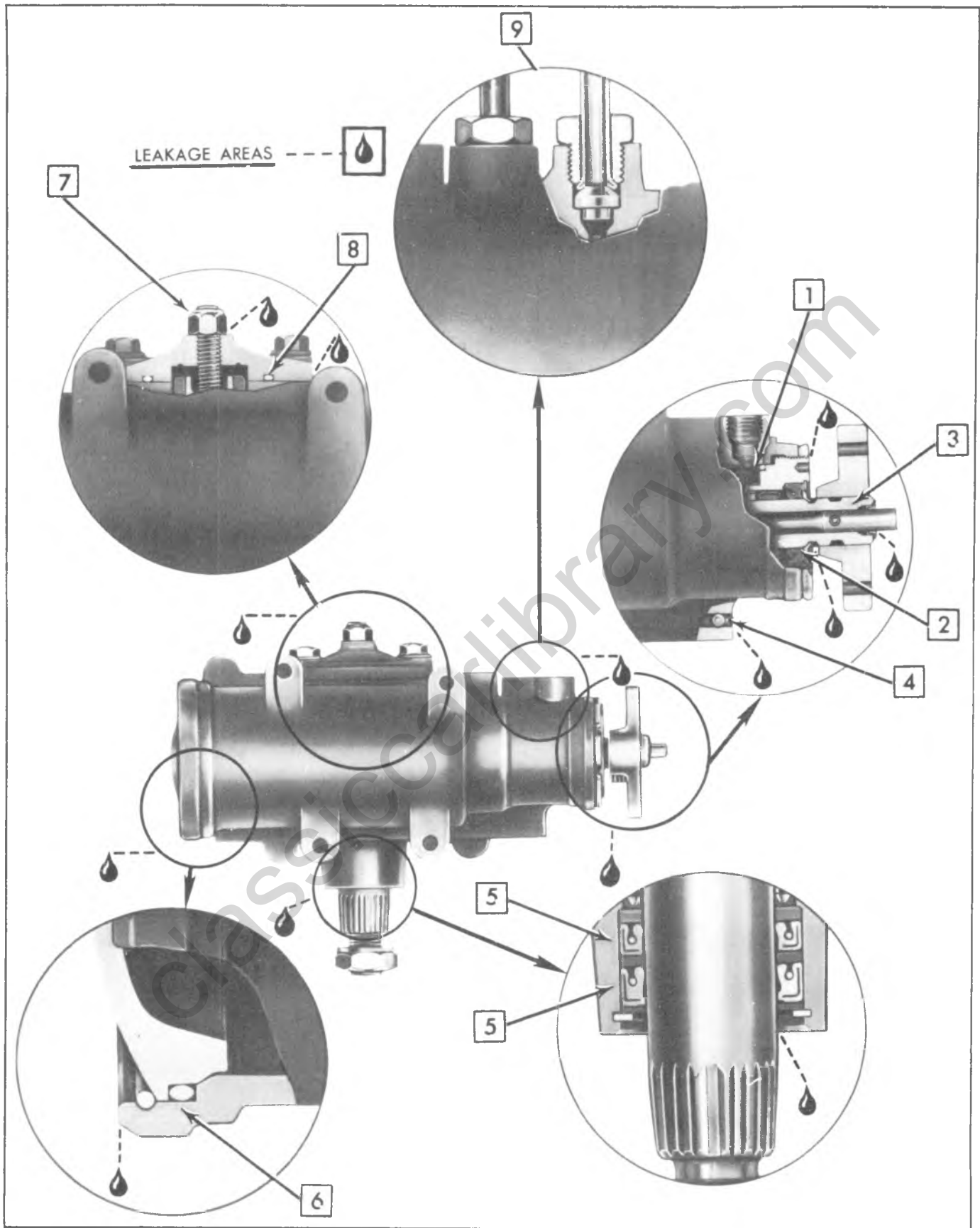


Fig. 3B-27--Power Steering Gear Leakage

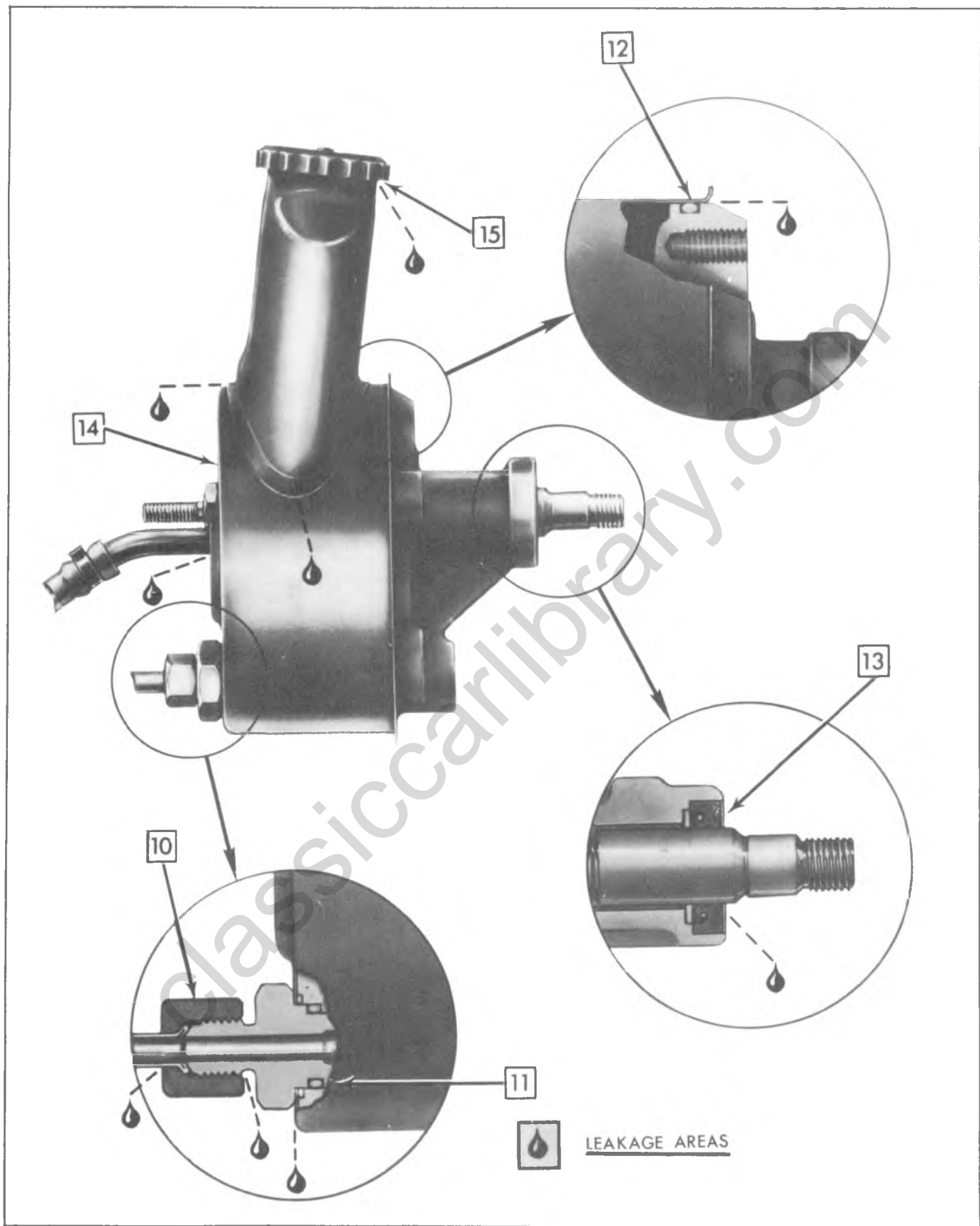


Fig. 3B-28--Power Steering Pump Leakage

MAINTENANCE AND ADJUSTMENTS

Lubrication

The manual steering gear is factory-filled with steering gear lubricant. Seasonal change of this lubricant should not be performed and the housing should not be drained—**no lubrication is required for the life of the steering gear.**

Every 36,000 miles, the manual gear should be inspected for seal leakage (**actual solid grease - not just oily film**). If a seal is replaced or the gear is overhauled, the gear housing should be refilled with **1051052 (13 oz. container) Steering Gear Lubricant which meets GM Specification GM 4673M, or its equivalent.**

NOTE: Do not use EP Chassis Lube, which meets GM Specification GM 6031M, to lubricate the gear **DO NOT OVER-FILL** the gear housing.

The steering linkage under normal conditions should be lubricated with any water resistant EP type chassis lubricant every 7,500 miles or six months, whichever occurs first. Lubricate every 3,000 miles or two months whichever occurs first when operating in dusty or muddy conditions or if the vehicle is used "off-road". Lubrication points and additional information on the chassis lubricant recommended can be found in Section 0--General Information and lubrication.

Adjustments

CAUTION: See Caution on page one of this section regarding the fasteners referred to in steps 9d and 10.

Manual Steering Gear

CAUTION: See CAUTION on page 1 of this section regarding the fastener referred to in step 10.

Before any adjustments are made to the steering gear attempt to correct complaints of loose or hard steering, or other wheel disturbances, a careful check should be made of front end alignment, shock absorbers, wheel balance and tire pressure for possible steering system problems. See Diagnosis in sections 3A and 3B.

Correct adjustment of steering gear is very important. While there are but two adjustments to be made, the following procedure must be followed step-by-step in the order given.

1. Disconnect the battery ground cable.
2. Raise the vehicle.
3. Remove the pitman arm nut. Mark the relationship of the pitman arm to the pitman shaft. Remove the pitman arm with Tool J-6632 or J-5504 as shown in Figure 3B-50.
4. Loosen the steering gear adjuster plug locknut and back the adjuster plug off 1/4 turn (fig. 3B-29).
5. Remove the horn shroud or button cap.

6. Turn the steering wheel gently in one direction until stopped by the gear; then turn back one-half turn.

CAUTION: Do not turn the steering wheel hard against the stops when the steering linkage is disconnected from the gear as damage to the ball guides could result.

7. Measure and record "bearing drag" by applying a torque wrench with a socket on the steering wheel nut and rotating through a 90° arc (fig. 3B-30).

NOTE: Do not use a torque wrench having a maximum torque reading of more than 50 inch pounds.

8. Adjust "thrust bearing preload" by tightening the adjuster plug until the proper "thrust loading

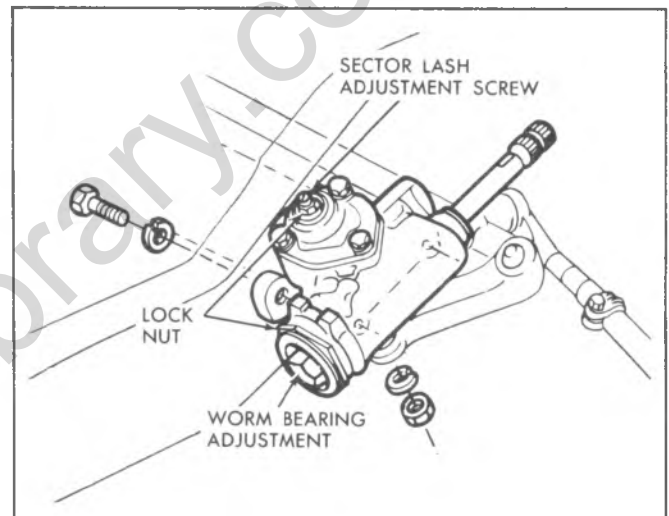


Fig. 3B-29--Steering Gear Adjustment Points-Typical

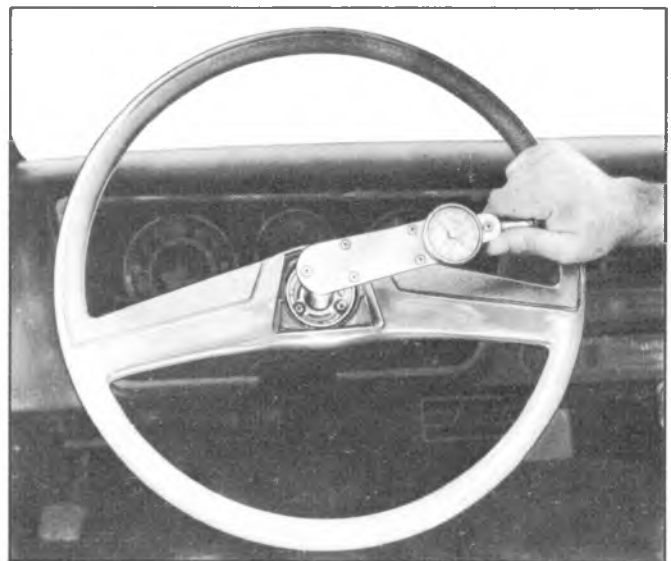


Fig. 3B-30--Checking Torque at Steering Wheel

preload" is obtained (See specifications section). When the proper preload has been obtained, tighten the adjuster plug locknut to specifications and recheck torque. If the gear feels "lumpy" after adjustment, there is probably damage in the bearings due to severe impact or improper adjustment; the gear must be disassembled and inspected for replacement of damaged parts.

9. Adjust "over-center preload" as follows:

a. Turn the steering wheel gently from one stop all the way to the other carefully counting the total number of turns. Turn the wheel back exactly half-way, to center position.

b. Turn the lash adjuster screw clockwise to take out all lash between the ball nut and pitman shaft sector teeth and then tighten the locknut.

c. Check the torque at the steering wheel, taking the highest reading as the wheel is turned through center position. See the Specifications Section for proper over-center preload.

d. If necessary, loosen locknut and readjust lash adjuster screw to obtain proper torque. Tighten the locknut to specifications and again check torque reading through center of travel.

NOTE: If maximum specification is exceeded, turn lash adjuster screw counterclockwise, then come up on adjustment by turning the adjuster in a clockwise motion.

10. Reassemble the pitman arm to the pitman shaft, lining up the marks made during disassembly. Torque the pitman shaft nut to specifications.

CAUTION: If a clamp type pitman arm is used, spread the pitman arm just enough, with a wedge, to slip the arm onto the pitman shaft. Do not spread the clamp more than required to slip over pitman shaft with hand pressure. Do not hammer the pitman arm onto the pitman shaft. Be sure to install the hardened steel washer before installing the nut.

11. Install the horn button cap or shroud and connect the battery ground cable.

12. Lower the vehicle to the floor.

Steering Gear High Point Centering

1. Set front wheels in straight ahead position. This can be checked by driving vehicle a short distance on a flat surface to determine steering wheel position at which vehicle follows a straight path.

2. With front wheels set straight ahead, check position of mark on wormshaft designating steering gear high point. This mark should be at the top side of the shaft at 12 o'clock position and lined up with the mark in the coupling lower clamp.

3. On C, G and P series if gear has been moved off high point when setting wheel in straight ahead position. Loosen adjusting sleeve clamps on both left and right hand tie rods, then turn both sleeves an equal number of turns in the same direction to bring gear back on high point.

NOTE: Turning the sleeves an unequal number of

turns or in different directions will disturb the toe-in setting of the wheels.

4. On K series if the gear has been moved off high point when setting wheels in straight ahead position. Loosen adjusting sleeve clamps on the connecting rod then turn sleeve to bring gear back on high point.

5. Readjust toe-in as outlined in Section 3A (if necessary).

6. Be sure to properly orient sleeves and clamps as shown in figures 3B-104, 3B-106 and 3B-109 when fastening and torquing clamps to proper specifications.

Steering Wheel Alignment

NOTE: On all series vehicles check steering gear for high point centering before checking steering wheel alignment.

1. Set wheels in straight ahead position by driving vehicle a short distance.

2. Note steering wheel position. If off more than 1 inch from center (fig. 3B-31), remove steering wheel as outlined under "Steering Wheel - Removal", center high point on gear, reposition and reinstall the wheel.

Steering Column Lower Bearing Adjustment G and P Series

1. Loosen clamp on steering shaft.

2. Applying 50 lb. force to the steering wheel end of the steering shaft, adjust clamp to obtain clearances indicated in Figure 3B-32.

3. Tighten clamp bolt to specified torque.

Shifter Tube Adjustment G and P Series

3-Speed Transmission

1. Loosen adjusting ring attaching screws and clamp bolt.

2. Rotate adjusting ring to give .005" end play between adjusting ring and first and reverse shifter lever (fig. 3B-33).

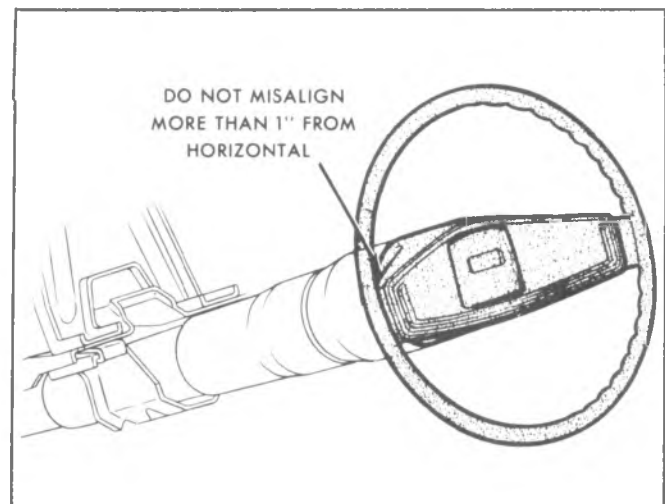


Fig. 3B-31--Steering Wheel Alignment

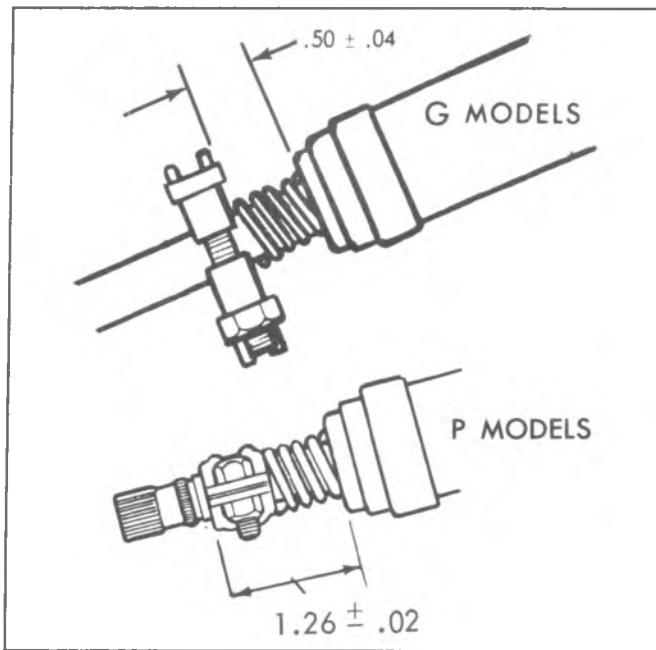


Fig. 3B-32-Steering Column Lower Bearing Adjustment

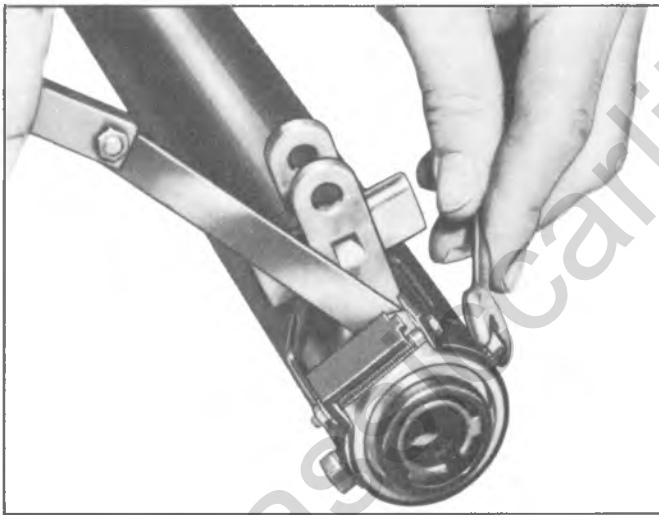


Fig. 3B-33-Shift Tube Adjustment-3 Speed Manual Transmission

3. Tighten attaching screws and clamp bolt.

Automatic Transmission

1. Place the shift tube lever in "Neutral" or "Drive".
2. Loosen adjusting ring clamp screws and rotate the shift tube adjusting ring to obtain .33" to .36" clearance between the shift tube lever and adjusting ring (fig. 3B-34).
3. Tighten the adjusting ring clamp screws to 70 in. lbs.

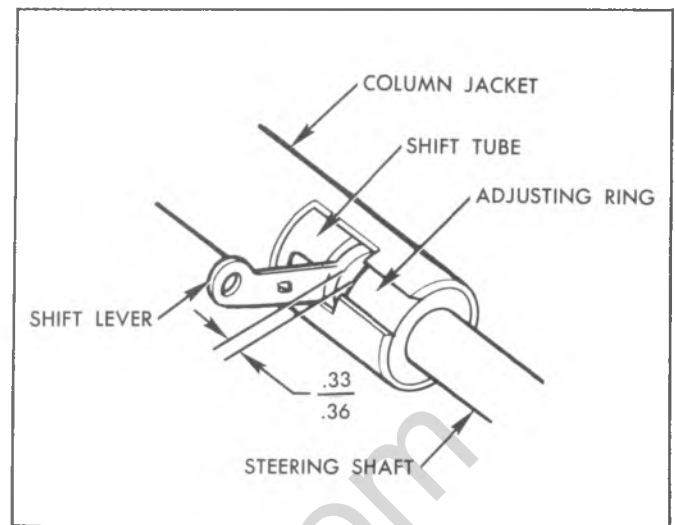


Fig. 3B-34-Shift Tube Adjustment-Automatic Transmission

Power Steering Gear Adjustment Procedure

Adjustment of the steering gear in the vehicle is discouraged because of the difficulty encountered in adjusting the worm thrust bearing preload and the confusing effects of the hydraulic fluid in the gear. Since a gear adjustment is made only as a correction and not as a periodic adjustment, it is better to take the extra time and make the adjustment correctly the first time.

Since a handling stability complaint can be caused by improperly adjusted worm bearings as well as an improper gear over-center adjustment, it is necessary that the steering gear assembly be removed from the vehicle and both thrust bearing and over-center preload be checked and corrected as necessary. An in-vehicle check of the steering gear will not pin-point a thrust bearing looseness.

Thrust Bearing Adjustment

If a gear is known to contain the new thrust bearing parts, thrust bearing adjustment in service is simplified. Recommended procedure:

1. Drain power steering fluid from gear by rotating the stub shaft full travel in both directions several times.
2. Loosen and remove adjuster plug lock nut (Fig. 3B-35 and 3B-36).
3. Using spanner wrench J-7624, turn the adjuster plug in (clockwise) until the plug and thrust bearing are firmly bottomed approximately 20 foot-pounds (Fig. 3B-37).
4. Mark the housing even with one of the holes in the face of the adjuster plug (Fig. 3B-38).
5. Measure back (CCW direction) 1/2 inch and place a second mark on the housing (Fig. 3B-39).
6. Turn adjuster plug counterclockwise until the hole in the face of the adjuster plug, which was even

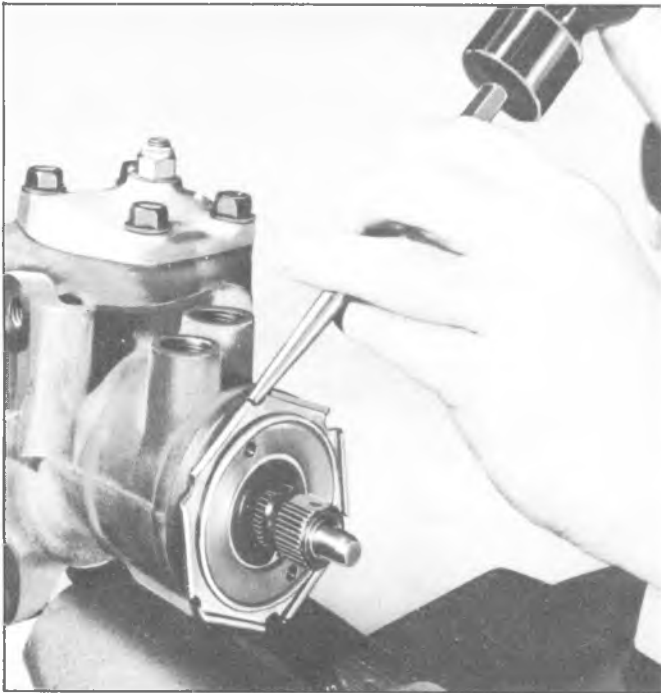


Fig. 3B-35--Loosening Lock Nut



Fig. 3B-36--Removing Lock Nut

with the first mark is in line with second mark (Fig. 3B-40).

7. Tighten lock nut securely. Hold (or have held) adjuster plug to maintain alignment of hole with mark (Fig. 3B-41).

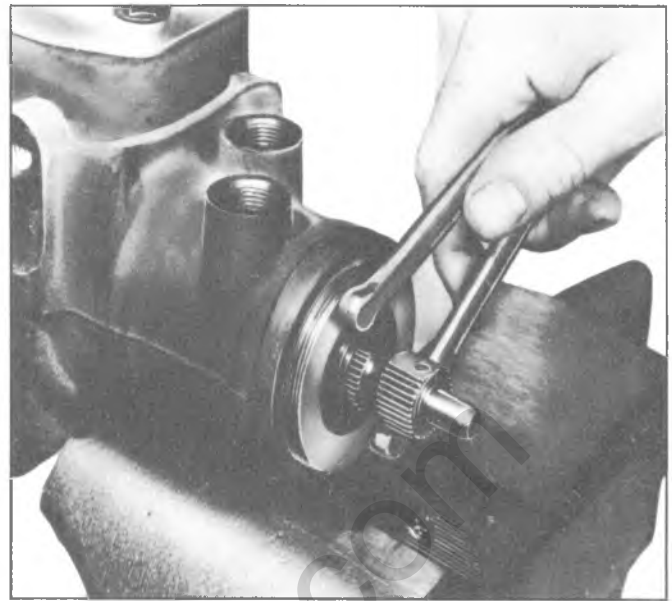


Fig. 3B-37--Bottoming Adjuster Plug

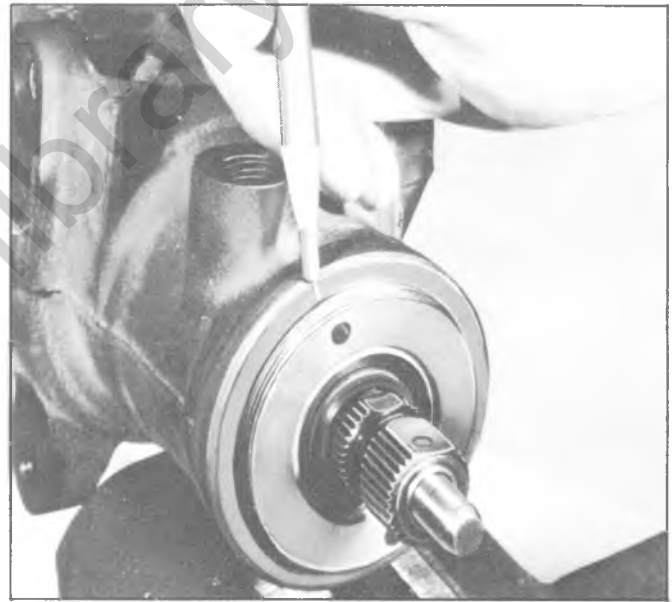


Fig. 3B-38--Marking Housing

Pump Belt Tension

1. Loosen pivot bolt and pump brace adjusting nuts.

CAUTION: Do not move pump by prying against reservoir or by pulling on filler neck.

2. Move pump, with belt in place until belt is tensioned to specifications as indicated by Tool J-23600 (Fig. 3B-42).

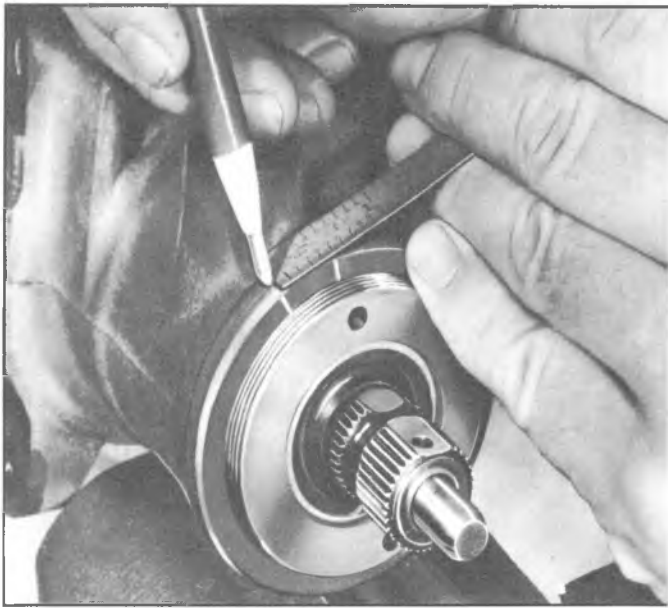


Fig. 3B-39--Measure Back and Remark Housing



Fig. 3B-41--Tighten Lock Nut



Fig. 3B-40--Align Hole With Second Mark

3. Tighten pump brace adjusting nut. Then tighten pivot bolt nut.

Fluid Level

1. Check oil level in the reservoir by checking the dipstick when oil is at operating temperature. On models equipped with remote reservoir, the oil level should be maintained approximately 1/2 to 1 inch from top with wheels in full left turn position.

2. Fill, if necessary, to proper level with GM Power Steering Fluid or equivalent.



Fig. 3B-42--Checking Belt Tension with J-23600

Bleeding Hydraulic System

1. Fill oil reservoir to proper level and let oil remain undisturbed for at least two minutes.
2. Start engine and run only for about two seconds.
3. Add oil if necessary.
4. Repeat above procedure until oil level remains constant after running engine.

5. Raise front end of vehicle so that wheels are off the ground.
6. Increase engine speed to approximately 1500 rpm.
7. Turn the wheels (off ground) right and left, lightly contacting the wheel stops.
8. Add oil if necessary.
9. Lower the vehicle and turn wheels right and left on the ground.
10. Check oil level and refill as required.
11. If oil is extremely foamy, allow vehicle to stand a few minutes with engine off and repeat above procedure.
 - a. Check belt tightness and check for a bent or loose pulley. (Pulley should not wobble with engine running.)

b. Check to make sure hoses are not touching any other parts of the truck, particularly sheet metal except where design calls for a clamp.

c. Check oil level, filling to proper level if necessary, following operations 1 through 10. This step and Step "D" are extremely important as low oil level and/or air in the oil are the most frequent causes of objectional pump noise.

d. Check the presence of air in the oil. If air is present, attempt to bleed system as described in operations 1 through 10. If it becomes obvious that the pump will not bleed after a few trials, proceed as outlined under Hydraulic System Checks.

Hydraulic System Checks

The following procedure outlines methods to identify and isolate power steering hydraulic circuit difficulties. The test provides means of determining whether power steering system hydraulic parts are actually faulty. This test will result in readings indicating faulty hydraulic operation, and will help to identify the faulty component.

Before performing hydraulic circuit test, carefully check belt tension, fluid level and condition of driving pulley.

Power Steering Hydraulic System Test

Engine must be at normal operating temperature. Inflate front tires to correct pressure. All tests are made with engine idling, check idle adjustment and if necessary adjust engine idle speed to correct specifications listed in Section 6C and proceed as follows:

1. With engine **NOT** running disconnect pressure hose from pump and install Tool J-5176 using a spare pressure hose between gauge and pump. Gauge must be between shut-off valve and pump (Fig. 3B-43). Open shut-off valve.

2. Remove filler cap from pump reservoir and check fluid level. Fill pump reservoir to full mark on dip stick. Start engine and, momentarily holding steering wheel against stop, check connections at Tool J-5176 for leakage.

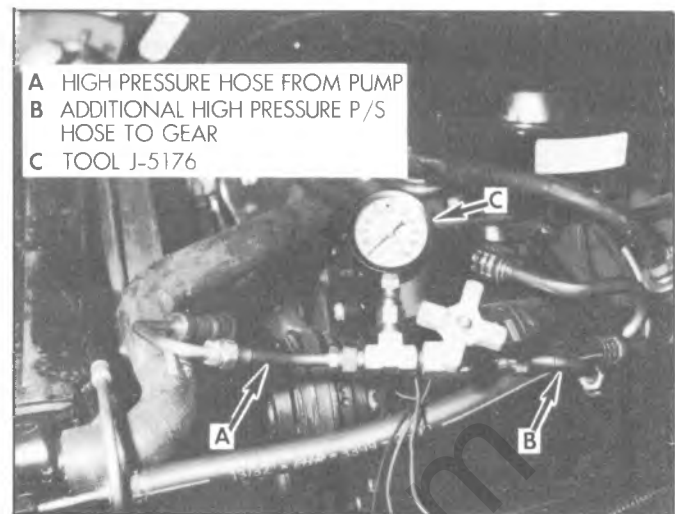


Fig. 3B-43-Checking Power Steering Pressures

3. Bleed system as outlined under Maintenance and Adjustments.

4. Insert thermometer (Tool J-5421) in reservoir filler opening. Move steering wheel from stop to stop several times until thermometer indicates that hydraulic fluid in reservoir has reached temperature of 150° to 170 F.

CAUTION: To prevent scrubbing flat spots on tires, do not turn steering wheel more than five times without rolling vehicle to change tire-to-floor contact area.

5. Start engine and check fluid level adding any fluid if required. When engine is at normal operating temperature, the initial pressure read on the gage (valve open) should be in the 80-125 PSI range. Should this pressure be in excess of 200 PSI - check the hoses for restrictions and the poppet valve for proper assembly.

6. Close gate valve fully 3 times. Record the highest pressures attained each time.

CAUTION: Do not leave valve fully closed for more than 5 seconds as the pump could be damaged internally.

a. If the pressures recorded are within the listed specs and the range of readings are within 50 PSI, the pump is functioning within specs. (Ex. Spec. 1250 - 1350 PSI - readings - 1270 - 1275 - 1280).

b. If the pressures recorded are high, but do not repeat within 50 PSI, the flow controlling valve is sticking. Remove the valve, clean it and remove any burrs using crocus cloth or fine hone. If the system contains some dirt, flush it. If it is exceptionally dirty, both the pump and the gear must be completely disassembled, cleaned, flushed and reassembled before further usage.

c. If the pressures recorded are constant, but more than 100 PSI, below the low listed spec., replace the flow control valve and recheck. If the pressures are still low, replace the rotating group in the pump.

7. If the pump checks within specifications, leave

the valve open and turn (or have turned) the steering wheel into both corners. Record the highest pressures and compare with the maximum pump pressures and compare with the maximum pump pressure recorded. If this pressure cannot be built in either (or one) side of the gear, the gear is leaking internally and must be disassembled and repaired. See the current Overhaul Manual.

8. Shut off engine, remove testing gauge, spare hose, reconnect pressure hose, check fluid level and/or make needed repairs.

COMPONENT REPLACEMENT AND REPAIRS

Steering Wheel

Removal G and P Series

1. Disconnect battery ground cable.
2. Remove horn button or shroud, receiving cup, belleville spring and bushing and mark steering wheel to steering shaft relationship.
3. Remove snap ring, steering shaft nut and washer.
4. Use Tool J-2927 to remove wheel (Fig. 3B-44).

Installation

CAUTION: See *CAUTION* on page 1 of this section regarding the fastener referred to in step 2.

Directional signal control assembly must be in neutral position when assembling steering wheel to prevent damage to cancelling cam and control assembly.

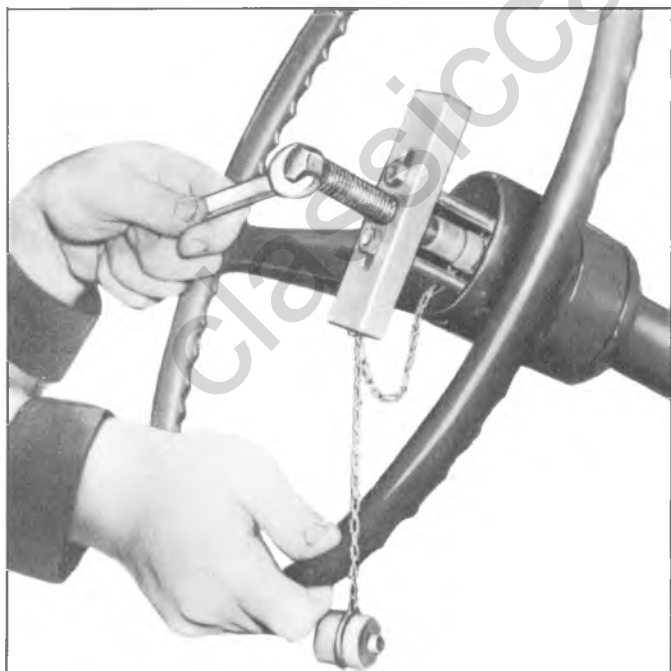


Fig. 3B-44-Steering Wheel Removal-Typical

1. Place the steering wheel onto the steering shaft, aligning the marks made at removal.
2. Position into place and secure to proper torque with washer and nut. Install snap ring.
3. Install belleville spring, receiving cup, bushing and attaching screws.
4. Install horn button assembly.
5. Connect battery ground cable.

Removal C and K Series

1. Disconnect battery ground cable.
2. Remove horn button cap.
3. Remove snap ring and steering wheel nut.
4. Using tool J-2927, thread puller anchor screws into holes provided on steering wheel. Turn center bolt of tool clockwise to remove wheel.

NOTE: Do not hammer on puller. The tool centering adapters need not be used.

Installation

CAUTION: See *CAUTION* on page 1 of this section regarding the fasteners referred to in step 1.

1. With turn signal in neutral position, align marks and set wheel onto steering shaft. Torque steering shaft nut to specifications and install snap ring.

CAUTION: Do not over torque shaft nut or steering wheel rub may result.

2. Place steering wheel horn button on wheel and snap into proper position.
3. Connect battery ground cable.

Steering Coupling (Flexible Type Fig. 3B-45)

Removal

1. Remove the coupling to steering shaft flange bolt nuts.
2. Remove the coupling clamp bolt.

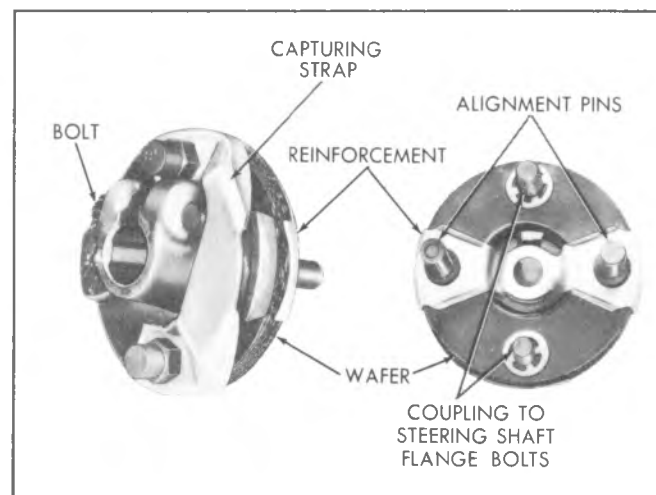


Fig. 3B-45-Flexible Type Steering Coupling-Manual

NOTE: This is a special bolt and will require a 12 pt. socket or box wrench.

3. Remove the steering gear to frame bolts and lower the steering gear far enough to remove the flexible coupling.

NOTE: It is not necessary to disconnect the pitman arm from the pitman shaft.

4. Tap lightly on the flexible coupling with a soft mallet to remove the coupling from the steering gear wormshaft.

Installation

CAUTION: See **CAUTION** on page 1 of this section regarding the fasteners referred to in steps 2, 4 and 5.

1. Install the flexible coupling onto the steering gear wormshaft, aligning the flat on the shaft with the flat in the coupling.

NOTE: Push the coupling onto the wormshaft until the coupling reinforcement bottoms against the end of the worm.

2. Install the special bolt into the split clamp and torque to specifications.

NOTE: The bolt must pass through the shaft undercut.

3. Place the steering gear into position, guiding the flexible coupling bolts into the proper holes in the steering shaft flange.

4. Install and tighten the steering gear to frame bolts.

5. Install the coupling to flange bolt nuts and washers and torque to specifications. Be sure to maintain a coupling to flange dimension of .250" to .375". The coupling alignment pins should be centered in the flange slots.

Intermediate Steering Shafts With Pot Joint Couplings

Removal (Fig. 3B-46)

1. Remove the lower shaft flange to flexible coupling bolts.

2. Remove upper shaft to intermediate coupling bolt

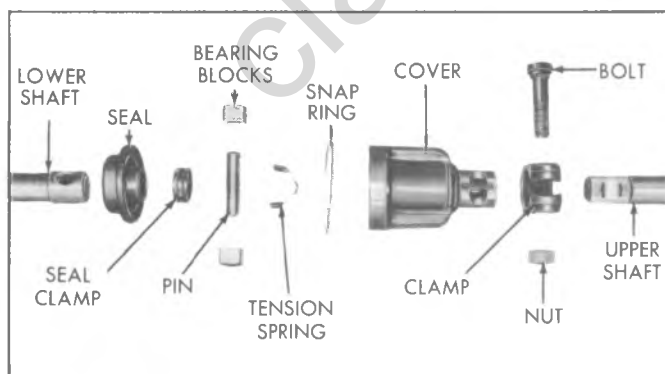


Fig. 3B-46--Steering Shaft Intermediate Coupling

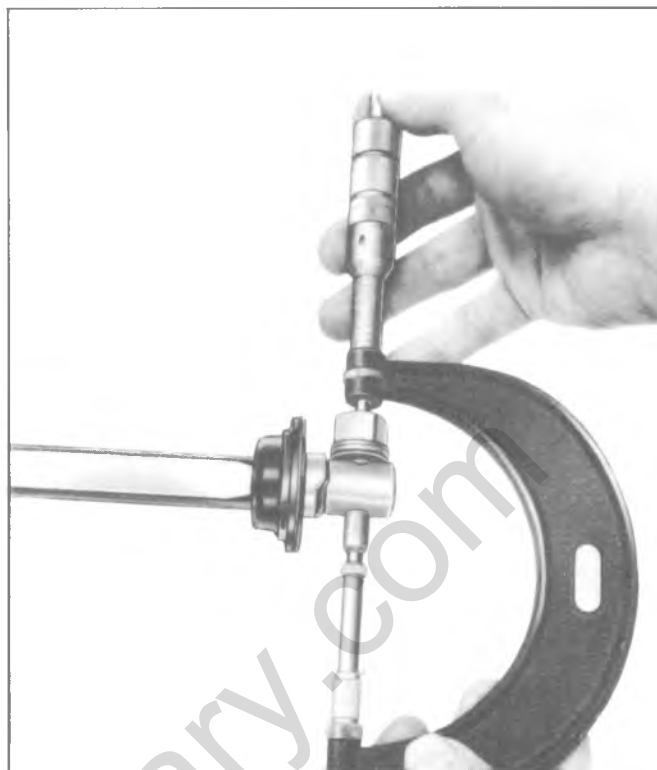


Fig. 3B-47--Checking Coupling Pin Centering

3. If necessary, remove the steering gear to frame bolts and lower the steering gear far enough to remove the intermediate shaft assembly.

NOTE: It is not necessary to remove the pitman arm from the pitman shaft.

Disassembly

1. Mark cover to shaft relationship. Pry off snap ring and slide cover from shaft.

2. Remove bearing blocks and tension spring from pivot pin.

3. Clean grease off pin and end of shaft. Scribe location mark on pin on same side as chamfer in shaft.

4. Supporting shaft assembly securely, with chamfer up, press pin out of shaft with arbor press.

CAUTION: Do not drive pin out with hammer. This will cause sticky or binding bearings when reassembled.

5. Remove seal clamp and slide seal off end of shaft.

Assembly

1. Be sure all parts are free of dirt. Slide seal onto steering shaft. With lip of seal against step in shaft clamp seal.

2. Press pin back into shaft from chamfered side. Locate pin in shaft using scribe mark as reference.

CAUTION: Pin must be centered within .012 in. or binding in the coupling will result.

3. Check centering of pin (fig. 3B-47).

- a. Place just enough 3/8" flat washers on pin to prevent bearing block from bottoming when installed.
- b. Measure distance from end of pin to top of bearing with micrometer.
- c. Remove bearing and washers and place same bearing and washers on other end of pin. Measure distance from end of pin to top of bearing. If micrometer readings in Steps b and c differ more than .012, repeat last part of Step 2 and recheck.
4. Apply a liberal amount of wheel bearing grease to inside and outside of bearing blocks and inside of cover.
5. Position tension spring and bearing blocks on pin.
6. Slide cover over bearing blocks aligning reference mark on cover with mark on shaft. Install seal into end of cover and secure with snap ring retainer.

Installation

CAUTION: See **CAUTION** on page 1 of this section regarding the fasteners referred to in steps 1, 3 and 4.

1. Install the intermediate shaft assembly onto the steering shaft, aligning the flat on the shaft with the flat in the coupling. Install the pot joint clamp bolt and torque to specifications.
2. Lift the steering gear into position, guiding the flexible coupling bolts into the shaft flange holes.
3. Install the steering gear to frame bolts and torque to specifications.
4. Install the flexible coupling to steering shaft flange bolt lockwashers and nuts. Check that the coupling alignment pins are centered in the flange slots and then torque the coupling bolts to specifications.

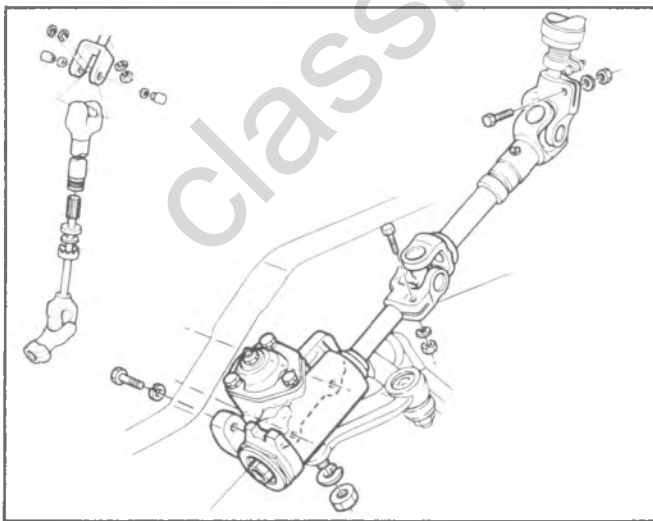


Fig. 3B-48--Intermediate Steering Shaft-P Series

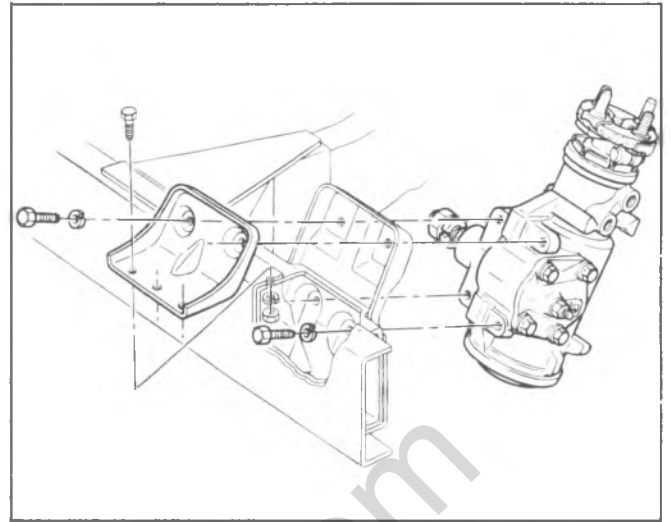


Fig. 3B-49--Steering Gear Mounting-Motor Home-Typical

Intermediate Steering Shaft With Universal Joint Couplings

Removal (Fig. 3B-48)

1. Set front wheels in straight ahead position. This can be done by driving the vehicle a short distance on a flat surface.
2. Mark upper universal joint yoke to steering shaft relationship and lower yoke to steering gear wormshaft relationship.
3. Remove both upper and lower universal yoke pinch bolts.
4. Remove steering gear to frame bolts and lower the gear.

NOTE: It is not necessary to disconnect the pitman arm from the steering gear pitman shaft.

5. Remove the intermediate steering shaft and universal joint assembly.

Disassembly

1. If the upper or lower half of the intermediate steering shaft is to be replaced, proceed as follows:
 - a. With the shaft assembly on a bench, straighten the tangs on the dust cap. Separate the upper and lower portions of the shaft assembly.
 - b. Remove the felt washer, plastic washer and dust cap. Discard the felt washer.
2. If the trunion assemblies are to be replaced, proceed as follows:
 - a. Remove the snap rings retaining the trunion bushings in one of the yokes.
 - b. Support the yoke on a bench vise and drive out one bushing by tapping on the opposite bushing using a soft drift and hammer.
 - c. Support the other side of the yoke and drive out the remaining bushing as in Step b above.
 - d. Move the yoke on the trunion as necessary to separate the upper and lower yokes.
 - e. Remove the trunion from the lower yoke as

outlined in Steps a through d above. Remove and discard the seals.

Assembly

1. If the yoke trunnions were removed, reassemble as follows:

- Place the new trunnion into the lower yoke.
- Place new seals onto the trunnion and then press the new bushings into the yoke and over the trunnion hubs far enough to install the snap rings.
- Install the snap rings.
- Repeat Steps a through c to attach the upper yoke to the trunnion.

2. Reassemble the intermediate shaft assembly as follows:

- Place the dust cap, plastic washer and a new felt seal over the shaft on the lower yoke assembly.
- Align the arrow on the lower yoke assembly shaft with the arrow on the upper yoke assembly tube and push the two assemblies together.
- Push the dust cap, plastic washer and felt washer into position on the lower end of the upper yoke assembly and bend the tangs of the dust cap down against the yoke tube.

Installation

CAUTION: See *CAUTION* on page 1 of this section regarding the fasteners referred to in steps 1, 3 and 4.

1. Align the marks made at removal and assemble the intermediate shaft lower yoke onto the steering gear wormshaft. Install the pinch bolt and torque to specifications.

NOTE: The pinch bolt must pass through the shaft undercut. If a new yoke was installed, the slit in the yoke should be up (12 o'clock position).

2. Raise the steering gear into position while guiding the upper yoke assembly onto the steering shaft.

NOTE: The marks on the coupling and steering shaft must align. If a new yoke was installed, assemble the upper yoke to the steering shaft with the steering wheel in straight ahead position (gear must be on high point).

3. Install the steering gear to frame bolts and torque to specifications.

4. Install the upper yoke to steering shaft pinch bolt and torque to specifications.

NOTE: The pinch bolt must pass through the shaft undercut.

Steering Gear

Removal

1. Set the front wheels in straight ahead position by driving vehicle a short distance on a flat surface.

2. Remove the flexible coupling to steering shaft flange bolts (C-K models) or the lower universal joint pinch bolt (P models). Mark the relationship of the universal yoke to the wormshaft.

3. Mark the relationship of the pitman arm to the

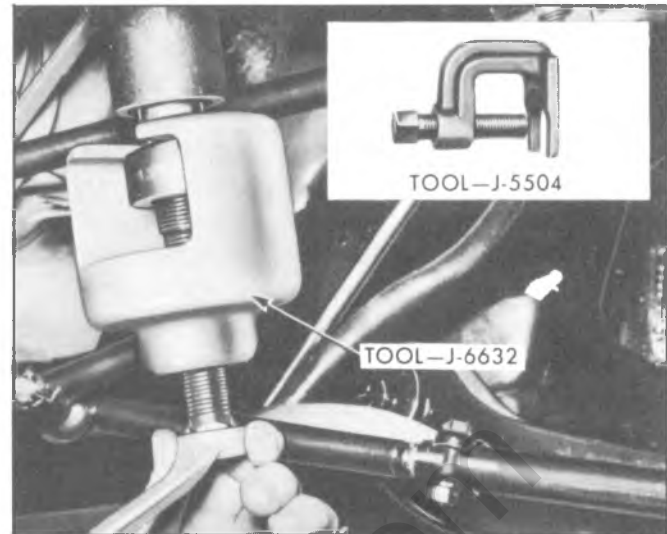


Fig. 3B-50-Removing Pitman Arm-Typical

pitman shaft. Remove the pitman shaft nut or pitman arm pinch bolt and then remove the pitman arm from the pitman shaft using Puller J-6632 (fig. 3B-50).

4. Remove the steering gear to frame bolts and remove the gear assembly.

5. **C-K Models** - Remove the flexible coupling pinch bolt and remove the coupling from the steering gear wormshaft.

Installation

CAUTION: See *CAUTION* on page 1 of this section regarding the fasteners referred to in steps 1a, 1c, 1d, 1e, 2b, 2c and 3.

1. C-K Models

a. Install the flexible coupling onto the steering gear wormshaft, aligning the flat in the coupling with the flat on the shaft. Push the coupling onto the shaft until the wormshaft bottoms on the coupling reinforcement. Install the pinch bolt and torque to specifications.

NOTE: The coupling bolt must pass through the shaft undercut.

b. Place the steering gear in position, guiding the coupling bolt into the steering shaft flange.

c. Install the steering gear to frame bolts and torque to specifications.

d. If flexible coupling alignment pin plastic spacers were used, make sure they are bottomed on the pins, torque the flange bolt nuts to specifications and then remove the plastic spacers.

e. If flexible coupling alignment pin plastic spacers were not used, center the pins in the slots in the steering shaft flange and then install and torque the flange bolt nuts to specifications.

2. P Models

a. Place the steering gear in position, guiding the wormshaft into the universal joint assembly and lining up the marks made at removal.

NOTE: If a new gear was installed, line up the

mark on the wormshaft with the slit in the universal joint yoke.

b. Install the steering gear to frame bolts and torque to specifications.

c. Install the universal joint pinch bolt and torque to specification.

NOTE: The pinch bolt must pass through the shaft undercut.

3. Install the pitman arm onto the pitman shaft, lining up the marks made at removal. Install the pitman shaft nut or pitman arm pinch bolt and torque to specifications.

CAUTION: *If a clamp type pitman arm is used, spread the pitman arm just enough, with a wedge, to slip the arm onto the pitman shaft. Do not spread the clamp more than required to slip over pitman arm onto the pitman shaft. Be sure to install the hardened steel washer before installing the nut.*

Pitman Shaft Seal Replacement

Manual Steering Gear

A faulty seal may be replaced without removal of steering gear from C, G and P trucks by removing pitman arm as outlined under Maintenance and Adjustments - Steering Gear Adjustments and proceed as follows:

NOTE: On K series vehicles remove the gear from the vehicle first.

1. Rotate the steering wheel from stop to stop, counting the total number of turns. Then turn back exactly half-way, placing the gear on center (the wormshaft flat should be at the 12 o'clock position).

2. Remove the three self-locking bolts attaching side cover to the housing and lift the pitman shaft and side cover assembly from the housing.

3. Pry the pitman shaft seal from the gear housing using a screwdriver and being careful not to damage the housing bore.

CAUTION: *Inspect the lubricant in the gear for contamination. If the lubricant is contaminated in any way, the gear must be removed from the vehicle and completely overhauled as outlined in the Overhaul Manual.*

4. Coat the new pitman shaft seal with Steering Gear Lubricant meeting GM Specification GM4673M (or equivalent). Position the seal in the pitman shaft bore and tap into position using a suitable size socket.

5. Remove the lash adjuster lock nut. Remove the side cover from the pitman shaft assembly by turning the lash adjuster screw clockwise.

6. Place the pitman shaft in the steering gear such that the center tooth of the pitman shaft sector enters the center tooth space of the ball nut.

7. Fill the steering gear housing with Steering Gear Lubricant meeting GM Specification GM4673M (or equivalent).

8. Install a new side cover gasket onto the gear housing.

9. Install the side cover onto the lash adjuster screw by reaching through the threaded hole in the side cover with a small screwdriver and turning the lash adjuster screw counter-clockwise until it bottoms and turns back in 1/4 turn.

10. Install the side cover bolts and torque to specifications.

11. Install the lash adjuster screw locknut, perform steering gear adjustment and install the pitman arm as outlined under "Maintenance and Adjustments".

NOTE: On K series install the gear into the vehicle using previously outlined procedure.

Directional Signal Switch

The directional signal switch can be removed with the steering column in the vehicle and without disturbing any of the column mountings.

C and K Series

Removal

1. Remove the steering wheel as outlined under "Steering Wheel - Removal".

2. Remove the column to instrument panel trim cover.

3. Position screwdriver blade into cover slot. Pry up and out to free cover from lock plate.

4. Screw the center post of Lock Plate Compressing Tool J-23653 onto the steering shaft as far as it will go. Compress the lock plate by turning the center post nut clockwise (fig. 3B-51). Pry the round wire snap ring out of the shaft groove and discard the ring. Remove Tool J-23653 and lift the lock plate off the end of the shaft.

CAUTION: *If the column is being disassembled on the bench, with the snap ring removed the shaft could slide out of the lower end of the mast jacket, damaging the shaft assembly.*

5. Slide the directional signal cancelling cam,

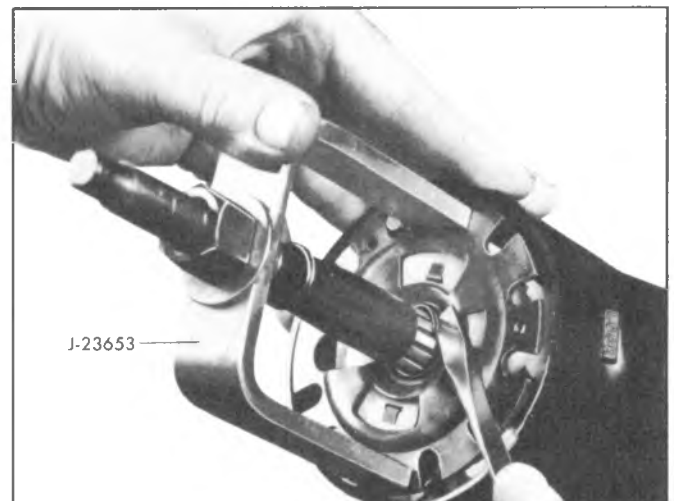


Fig. 3B-51--Removing Lock Plate Retaining Ring

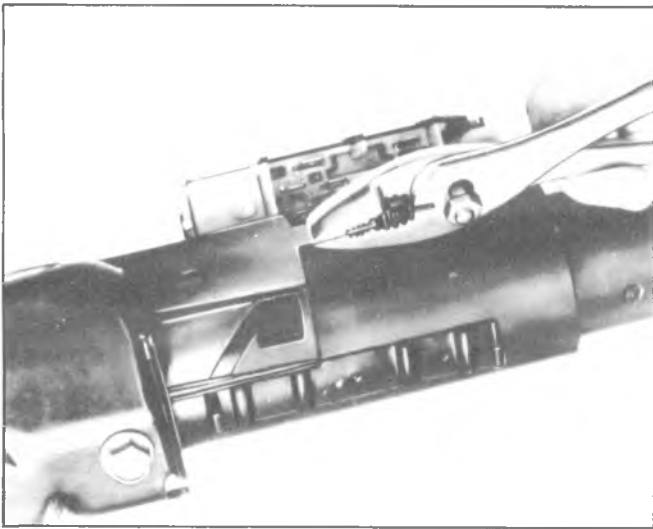


Fig. 3B-52-Removing Directional Signal Wire Protector

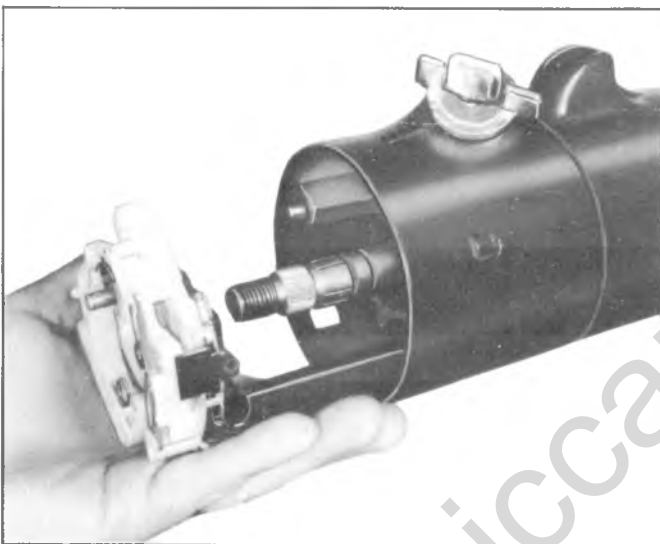


Fig. 3B-53-Removing Directional Signal Switch Assembly

upper bearing preload spring and thrust washer off the end of the shaft.

6. Remove the directional signal lever screw and remove the lever.

7. Push the hazard warning knob in and unscrew the knob.

8. Remove the three switch mounting screws.

9. **All Columns** - Pull the switch connector out of the bracket on the jacket and feed switch connector through column support bracket and pull switch straight up, guiding the wiring harness through the column housing and protector.

10. Remove wire protector by pulling downward out of column with pliers using tab provided (fig. 3B-52).

Tilt Column - Position the direction signal and shifter housing in the "low" position. Remove the

harness cover by pulling toward the lower end of the column, be careful not to damage the wires.

11. Remove the three switch mounting screws and pull the switch straight up, guiding the wiring harness and cover through the column housing (fig. 3B-53).

Installation

CAUTION: *It is extremely important that only the specified screws, bolts and nuts be used at assembly. Use of overlength screws could prevent a portion of the assembly from compressing under impact.*

1. **All except Tilt** - Be sure that the wiring harness is in the protector. Feed the connector and cover down through the housing and under the mounting bracket (column in vehicle).

Tilt - Feed the connector down through the housing



Fig. 3B-54-Installing Switch Connector Onto Jacket Clips



Fig. 3B-55-Installing Snap Ring

and under the mounting bracket. Then install the cover on the harness.

2. Install the three mounting screws and clip the connector to the bracket on the jacket (fig. 3B-54).

3. Install the column to instrument panel trim plate.

4. Install the hazard warning knob and directional signal lever.

5. Make certain that the switch is in "Neutral" and the hazard warning knob is out. Slide the thrust washer, upper bearing preload spring and cancelling cam onto the upper end of the shaft.

6. Place the lock plate onto the end of the shaft. Screw the center post of Lock Plate Compressing Tool J-23653 onto the steering shaft as far as it will go. Place a NEW snap ring over the center post. Place the "C" bar over the center post and then compress the lock plate by turning the nut clockwise. Slide the new snap ring down the tapered center post and into the shaft groove (fig.3B-55). Remove Tool J-23653.

CAUTION: Always use a new snap ring when reassembling.

7. Place cover on the lock plate and snap into position.

8. Install the steering wheel as outlined under "Steering Wheel-Installation".



Fig. 3B-56--Lock Cylinder Removal

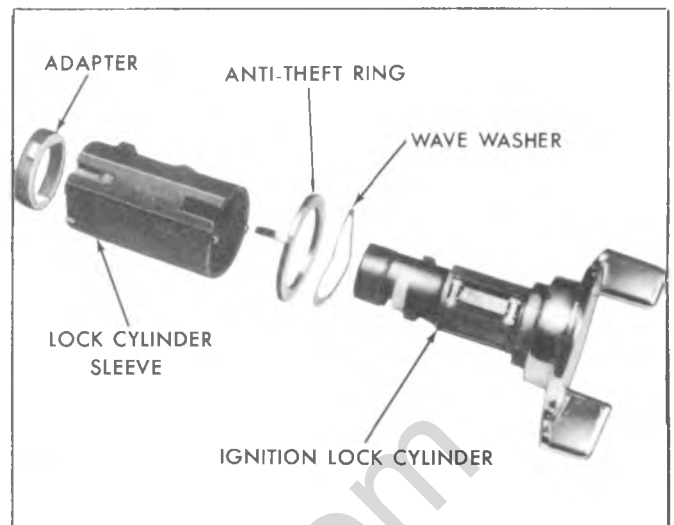


Fig. 3B-57--Ignition Lock Cylinder-Exploded

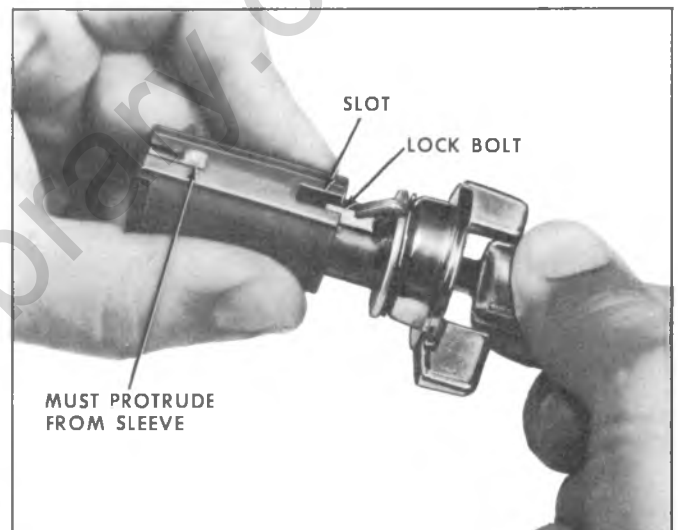


Fig. 3B-58--Ignition Lock Cylinder Assembly

Lock Cylinder (C and K Series)

The lock cylinder is located on the upper right hand side of the column. The lock cylinder should be removed in the "RUN" position only.

Removal

1. Remove the steering wheel as outlined under "Steering Wheel - Removal".

2. Remove the directional signal switch as outlined under "Directional Signal Switch - Removal".

NOTE: It is not necessary to completely remove the directional signal switch from the column. Pull the switch rearward far enough to slip it over the end of the shaft - do not pull the harness out of the column.

3. Insert a small screwdriver or similar tool into the turn signal housing slot as shown in Figure 3B-56. Keeping the tool to the right side of the slot, break the

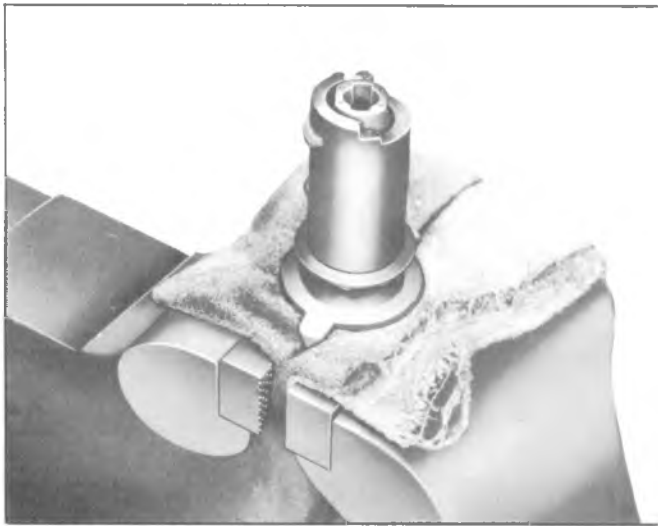


Fig. 3B-59--Ignition Lock Cylinder Installed in a Vise

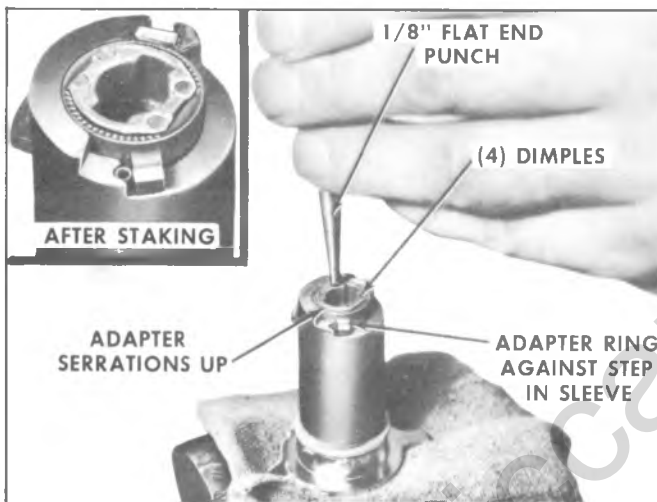


Fig. 3B-60--Installing Adapter Ring

housing flash loose and at the same time depress the spring latch at the lower end of the lock cylinder. With the latch depressed, the lock cylinder can be removed from the housing.

Assembly (Fig. 3B-57)

1. Place the key part way into the lock cylinder assembly. Place the wave washer and anti-theft ring onto the lower end of the lock cylinder.

NOTE: If the key is installed all the way into the lock cylinder, the plastic keeper in the lock cylinder protrudes and prevents installation of the sleeve assembly.

2. Make sure that the plastic keeper in the sleeve assembly protrudes from the sleeve (fig. 3B-58).

3. Align the lock bolt on the lock cylinder and the tab on the anti-theft washer and the slot in the sleeve assembly (fig. 3B-58). Push the sleeve all the way onto

the lock cylinder assembly, push the ignition key the rest of the way in and rotate the lock cylinder clockwise.

4. Rotate the lock counter-clockwise into "LOCK" position.

5. Place the lock in a brass jawed vise or between two pieces of wood (fig. 3B-59).

NOTE: If a vise is used, place cloth around the knob to prevent marring the knob surface.

6. Place the adapter ring onto the lower end of the cylinder so that the finger of the adapter is located at the step in the sleeve and the serrated edge of the adapter is visible after assembly to the cylinder and before "staking" (fig. 3B-60). The key must be free to rotate at least 1/3 of a circle (120°).

NOTE: Tap the adapter onto the cylinder until it is stopped at the bottom of the cylinder flats (cylinder will extend above adapter approximately 1/16").

7. Using a small flat punch, at least 1/8" in diameter, stake the lock cylinder over the adapter ring in four places just outboard of the four dimples as shown in Figure 3B-60.

8. Check lock operation before reinstalling vehicle.

Installation

1. Hold the lock cylinder sleeve and rotate the knob clockwise against the stop. Insert the cylinder into the housing bore with the key on the cylinder sleeve aligned with the keyway in the housing. Push the cylinder into abutment of cylinder and sector. Hold an .070" drill between the lock bezel and housing. Rotate the cylinder counterclockwise, maintaining a light pressure until the drive section of the cylinder mates with the sector. Push in until the snap ring pops into the grooves and lock cylinder is secured in the housing. Remove the .070" drill. Check lock cylinder for freedom of rotation.

2. Install the Direction Signal Switch and Steering Wheel as outlined previously in this section.

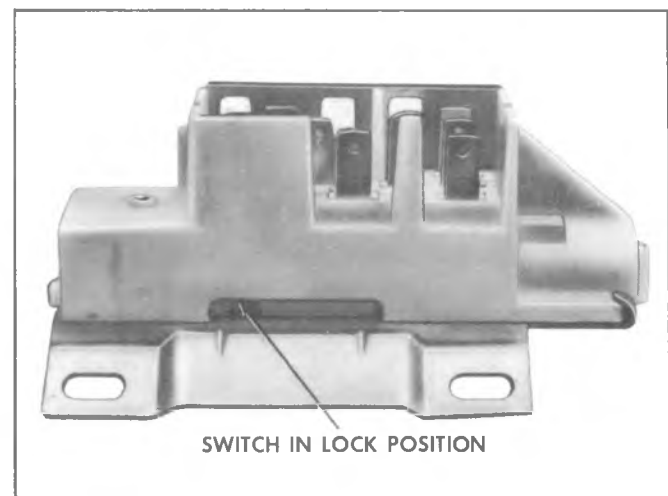


Fig. 3B-61--Ignition Switch Assembly

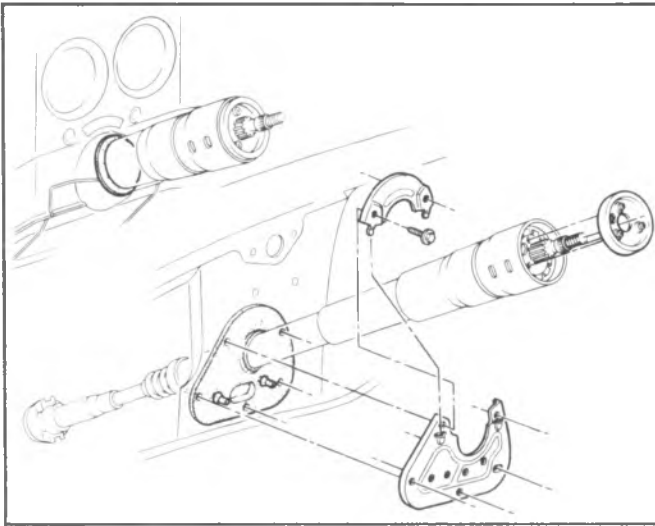


Fig. 3B-62--Steering Column Cover and Seal

Ignition Switch (C and K Series)

The ignition switch is mounted on top of the column jacket near the front of the dash. For anti-theft reasons, the switch is located inside the channel section of the brake pedal support and is completely inaccessible without first lowering the steering column (see steering column removal).

The switch is actuated by a rod and rack assembly. A portion of the rack is toothed and engages a gear on the end of the lock cylinder, thus enabling the rod and rack to be moved axially (with respect to the column) to actuate the switch when the lock cylinder is rotated.

Removal

1. Lower the steering column as outlined under "Steering Column Removal" later in this section. It is not necessary to remove the steering wheel.

CAUTION: *If the steering column is not removed from the vehicle, be sure that it is properly supported, before proceeding.*

2. The switch should be positioned in "Lock" position before removing. If the lock cylinder has already been removed, the actuating rod to the switch should be pulled up until there is a definite stop, then moved down one detent, which is the "Lock" position.

3. Remove the two switch screws and remove the switch assembly.

Installation

1. Before replacing the switch, be sure that the lock is in the "Lock" position (fig. 3B-61); if it is not, a screwdriver (placed in the locking rod slot) can be used to move the switch to "Lock".

2. Install the activating rod into the switch and assemble the switch on the column; tighten the mounting screws.

CAUTION: *Use only the specified screws since over-length screws could prevent a portion of the assembly from compressing under impact.*

3. Reinstall the steering column assembly following the "Mandatory Installation Sequence" outlined later in this section.

Steering Column

All models which are equipped with the Function Locking Energy Absorbing Steering Columns are one of five basic designs.

1. **Synchromesh** - The synchromesh column is used on models with the standard transmission and column mounted shift levers. The shift tube, within the outer column jacket, includes two lower shift levers for connection to the transmission control linkage. This column does not lock the transmission when the lock cylinder is in the "lock" position.

2. **Floor Shift** - This column is used on models equipped with a manual transmission with the shift lever on the floor. This column does not lock the transmission when the lock cylinder is in the "lock" position.

3. **Automatic Column Shift** - This column has a single lower shift lever for shifting the automatic transmission.

The transmission is locked in Park when the lock cylinder is in "Lock".

4. **Tilt Column Option automatic transmission** - The upper end and steering shaft of this column is specifically designed to accommodate the optional tilt steering wheel. The lower portion of the column is the same as in item number 3.

5. **Tilt Column Option Manual Transmission** - This column is the same as the automatic transmission tilt column except incorporating provisions for the manual transmission shifting and the transmission is not locked when the lock cylinder is in "Lock" position.

To perform service procedures on the steering column upper end components, it is not necessary to remove the column from the vehicle.

The steering wheel, horn components, directional signal switch, and ignition lock cylinder may be removed with the column remaining in the vehicle as described earlier in this section.

CAUTION: *The outer mast jacket shift tube, steering shaft and instrument panel mounting bracket are designed as energy absorbing units. Because of the design of these components, it is absolutely necessary to handle the column with care when performing any service operation. Avoid hammering, jarring, dropping or leaning on any portion of the column. When reassembling the column components, use only the specified screws, nuts and bolts and tighten to specified torque. Care should be exercised in using over-length screws or bolts as they may prevent a portion of the column from compressing under impact.*

Inspection

To determine if the energy absorbing steering column components are functioning as designed, or if repairs are required, a close inspection should be made.

Inspection is called for in all cases where damage is evident or whenever the vehicle is being repaired due to a front end collision. Whenever a force has been exerted on the steering wheel or steering column, or its components, inspection should also be made. If damage is evident, the affected parts must be replaced.

The inspection procedure for the various steering column components on all C and K Series Trucks is as follows:

Column Support Bracket

Damage in this area will be indicated by separation of the mounting capsules from the bracket. The bracket will have moved forward toward the engine compartment and will usually result in collapsing of the jacket section of the steering column.

Column Jacket

Inspect jacket section of column for looseness, and/or bends.

Shifter Shaft

Separation of the shifter shaft sections will be internal and cannot be visually identified. Hold lower end of the "shifter shaft" and move "shift lever" on column through its ranges and up and down. If there is little or no movement of the "shifter shaft", the plastic joints are sheared.

Steering Shaft

If the steering shaft plastic pins have been sheared, the shaft will rattle when struck lightly from the side and some lash may be felt when rotating the steering wheel while holding the rag joint. It should be noted that if the steering shaft pins are sheared due to minor collision the vehicle can be safely steered; however, steering shaft replacement is recommended.

Because of the differences in the steering column

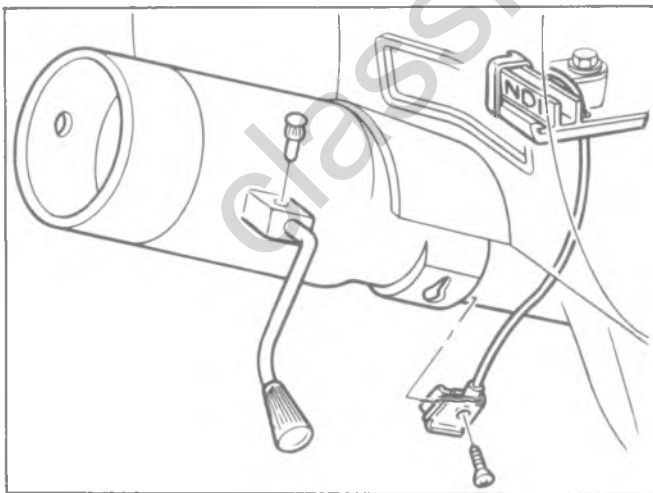


Fig. 3B-63-Automatic Transmission Indicator Connection-CK-Typical

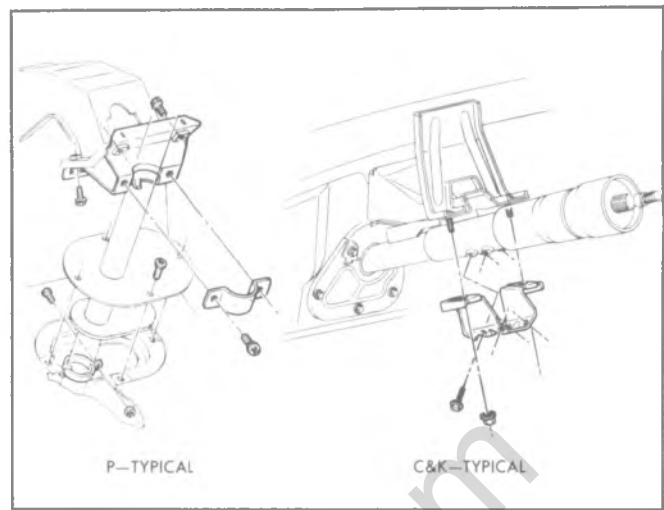


Fig. 3B-64-Steering Column to Dash Panel-C,K P Typical

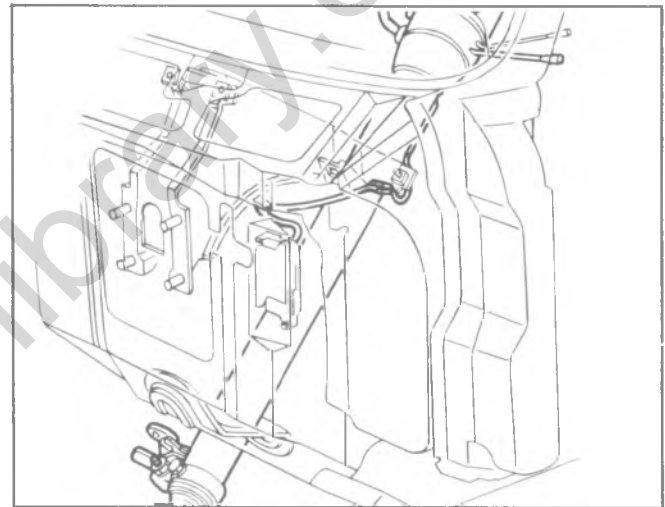


Fig. 3B-65-Steering Columns to Dash Panel-G

types, be sure to refer to the set of instructions below which apply to the column being serviced.

C and K Columns

Removal

NOTE: Front of dash mounting plates must be loosened whenever the steering column is to be lowered from the instrument panel.

1. Disconnect the battery ground cable.
2. Remove the steering wheel as outlined under "Steering Wheel Removal".
3. Remove the nuts and washers securing the flanged end of the steering shaft to the flexible coupling.
4. Disconnect the transmission control linkage from the column shift tube levers.
5. Disconnect the steering column harness at the connector. Disconnect the neutral-start switch and back-up lamp switch connectors if so equipped.

6. Remove the floor pan trim cover screws and remove the cover.
7. Remove the screws securing the two halves of the floor pan cover; then remove the screws securing the halves and seal to the floor pan and remove the covers (fig. 3B-64 and 3B-65).
8. Remove the transmission indicator cable, if so equipped (fig. 3B-63).
9. Move the front seat as far back as possible to provide maximum clearance.
10. Remove the two column bracket-to-instrument panel nuts and carefully remove from vehicle. Additional help should be obtained to guide the lower shift levers through the firewall opening.

C and K Series Except Tilt Columns- (Fig. 3B-66)

Disassembly

NOTE: G and P Series columns differ from those shown in Figures 3B-66 thru 3B-74.

1. Remove the four dash panel bracket-to-column screws and lay the bracket in a safe place to prevent damage to the mounting capsules.
2. Place the column in a vise using both weld nuts of either Set A or B as shown in Figure 3B-67. The vise jaws must clamp onto the sides of the weld nuts indicated by arrows shown on Set B.

CAUTION: Do not place the column in a vise by clamping onto one weld nut of both sets A and B or by clamping onto the sides not indicated by arrows, since damage to the column could result.

3. Remove the Directional Signal Switch, Lock Cylinder, and Ignition Switch as outlined previously in this section.
4. **Column Shift Models** - Drive out the upper shift lever pivot pin and remove the shift lever.
5. Remove the upper bearing thrust washer. Remove the four screws attaching the turn signal and ignition lock housing to the jacket and remove the housing assembly (fig. 3B-68).
6. Remove the thrust cap from the lower side of the housing.
7. Lift the ignition switch actuating rod and rack assembly, the rack preload spring and the shaft lock bolt and spring assembly out of the housing (fig. 3B-69).
8. Remove the shift lever detent plate (shift gate).
9. Remove the ignition switch actuator sector through the lock cylinder hole by pushing firmly on the block tooth of the sector with a blunt punch or screwdriver (fig. 3B-70).
10. Remove the gearshift lever housing and shroud from the jacket assembly (transmission control lock tube housing and shroud on floor shift models).
11. Remove the shift lever spring from the gearshift lever housing (lock tube spring on floor shift models).
12. Pull the steering shaft from lower end of the jacket assembly.

13. Remove the two screws holding the back-up switch or neutral-safety switch to the column and remove the switch.

14. Remove the lower bearing retainer clip (fig. 3B-71).

15. **Automatic and Floorshift Columns** - Remove the lower bearing retainer, bearing adapter assembly, shift tube thrust spring and washer. The lower bearing may be removed from the adapter by light pressure on the bearing outer race. Slide out the shift tube assembly.

Manual Transmission - Column Shift - Remove the lower bearing adapter, bearing and the first reverse shift lever. The lower bearing may be removed from the adapter by light pressure on the bearing outer race. Remove the three screws from bearing at the lower end and slide out the shift tube assembly. Remove the gearshift housing lower bearing from the upper end of the mast jacket.

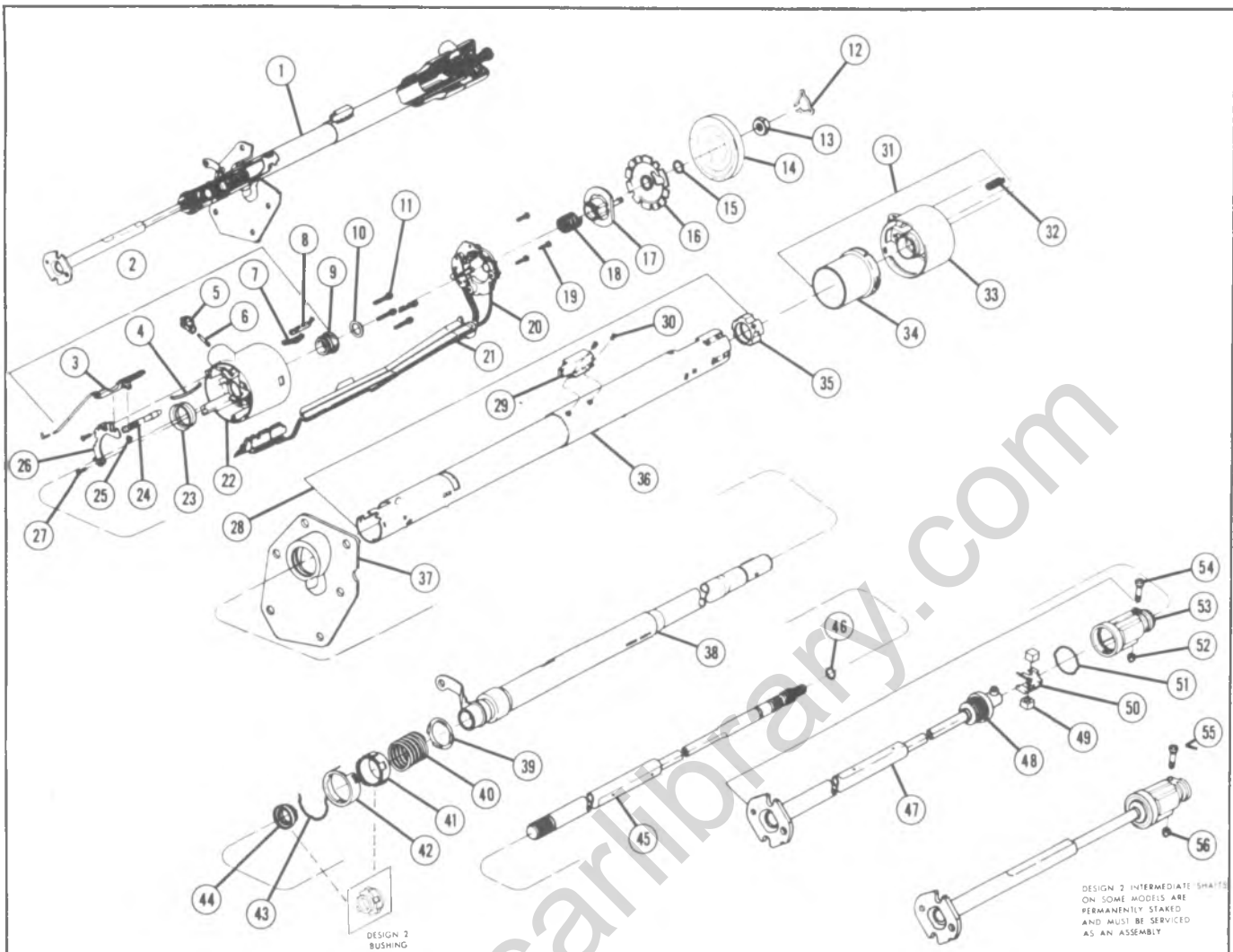
Assembly-All Except Tilt Columns

NOTE: Apply a thin coat of lithium soap grease to all friction surfaces.

1. Install the sector into the turn signal and lock cylinder housing. Install the sector in the lock cylinder hole over the sector shaft with the tang end to the outside of the hole. Press the sector over the shaft with a blunt tool.
2. Install the shift lever detent plate onto the housing.
3. Insert the rack preload spring into the housing from the bottom side. The long section should be toward the handwheel and hook onto the edge of the housing (fig. 3B-72).
4. Assemble the locking bolt onto the crossover arm on the rack and insert the rack and lock bolt assembly into the housing from the bottom with the teeth up (toward hand-wheel) and toward the centerline of the column (fig. 3B-69). Align the 1st tooth on the sector with the 1st tooth on the rack; if aligned properly, the block teeth will line up when the rack assembly is pushed all the way in.
5. Install the thrust cup on the bottom hub of the housing.
6. Install the gearshift housing lower bearing. Insert the bearing from the very end of the jacket. Aligning the indentations in the bearing with the projections on the jacket (fig. 3B-73).

CAUTION: If the bearing is not installed correctly, it will not rest on all of the stops provided.

7. Install the shift lever spring into the gearshift lever (or lock tube) housing. Install the housing and shroud assemblies onto the upper end of the mast jacket. Rotate the housing to be sure it is seated in the bearing.
8. With the shift lever housing in place, install the turn signal and lock cylinder housing onto the jacket. The gearshift housing should be in "Park" position and the rack pulled downward. Be sure the turn signal housing is seated on the jacket and drive the four screws.



Key No. Part Name

- 1 - COLUMN ASM
- 2 - HOUSING ASM
- 3 - RACK ASM
- 4 - SPRING
- 5 - SECTOR
- 6 - SHAFT
- 7 - CLIP
- 8 - SWITCH
- 9 - BEARING
- 10 - WASHER
- 11 - SCREW (4)
- 12 - RETAINING RING
- 13 - NUT
- 14 - COVER ASM (SHIPPED SEPARATELY)
- 15 - RING
- 16 - LOCK
- 17 - CAM ASM
- 18 - SPRING
- 19 - SCREW (3)

Key No. Part Name

- 20 - SWITCH ASM
- 21 - PROTECTOR WIRE
- 22 - HOUSING
- 23 - CUP
- 24 - BOLT ASM
- 25 - WASHER
- 26 - GATE
- 27 - SCREW (2)
- 28 - JACKET ASM
- 29 - SWITCH ASM, IGNITION
- 30 - SCREW (2)
- 31 - BOWL ASM
- 32 - SPRING
- 33 - BOWL
- 34 - SHROUD
- 35 - BEARING
- 36 - JACKET ASM
- 37 - SEAL-DASH
- 38 - TUBE ASM

Key No. Part Name

- 39 - WASHER
- 40 - SPRING
- 41 - ADAPTER
- 42 - RETAINER
- 43 - BEARING
- 44 - RING
- 45 - SHAFT ASM
- 46 - CLIP
- 47 - SHAFT ASM
- 48 - COUPLING ASM
- 49 - BOLT
- 50 - NUT
- 51 - RING
- 52 - SPRING
- 53 - BEARING (2)
- 54 - ABRASION SHIELD
- 55 - BOLT
- 56 - NUT

Fig. 3B-66--Typical Standard Column

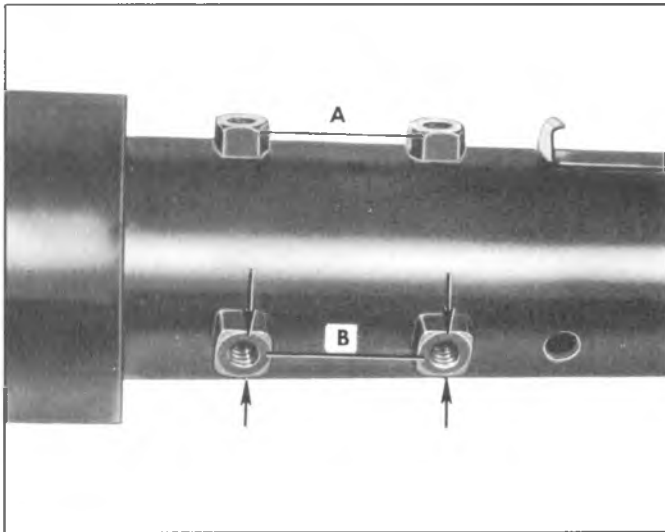


Fig. 3B-67-Installing Steering Column in Vise

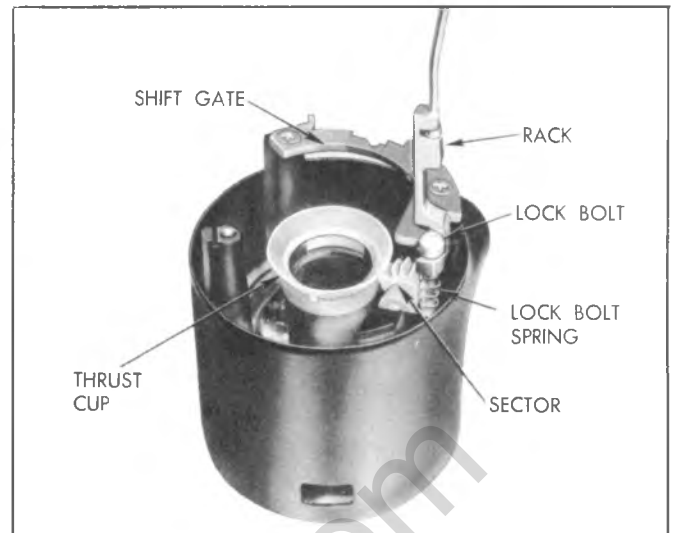


Fig. 3B-69-Turn Signal Housing Assembly

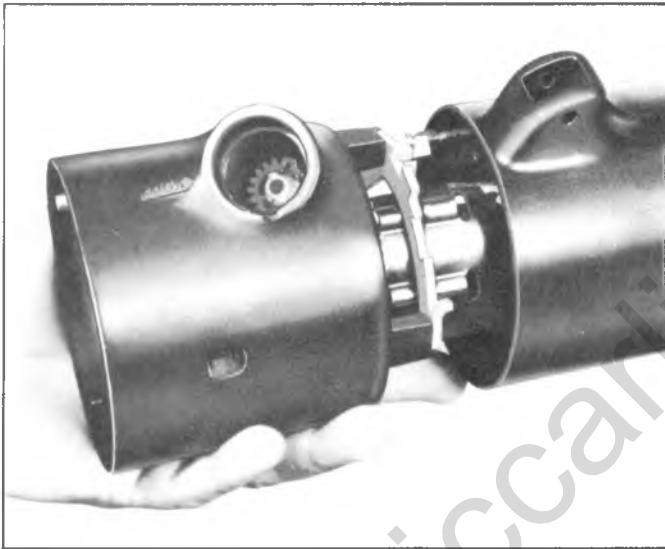


Fig. 3B-68-Removing Turn Signal Housing

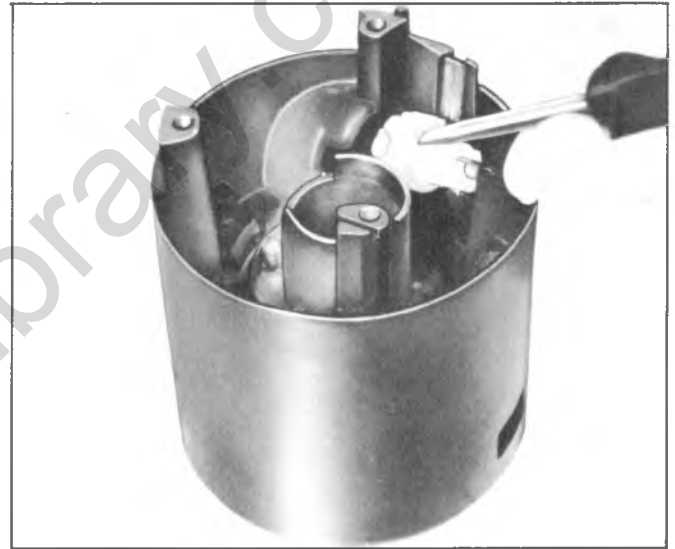


Fig. 3B-70-Removing Ignition Switch Actuator Sector

9. Press the lower bearing into the adapter assembly.

10. Insert the shift tube assembly into the lower end of the jacket and rotate until the upper shift tube key slides into the housing keyway.

11. **Automatic and Floor shift Columns** - Assemble the spring and lower bearing and adapter assembly into the bottom of the jacket. Holding the adapter in place, install the lower bearing reinforcement and retainer clip. Be sure the clip snaps into the jacket and reinforcement slots.

12. **Manual Transmission - Column Shift** - Loosely attach the three screws in the jacket and shift tube bearing.

Assemble the 1st-Reverse lever and lower bearing and adapter assembly into the bottom of the jacket. Holding the adapter in place, install the bearing reinforcement and retaining clip. Be sure the

retaining clip snaps into the jacket and reinforcement slots.

Place a .005" shim between the 1st-Reverse lever and lever spacer and turn the upper shift tube bearing down and tighten the three screws. Remove the shim (fig. 3B-74).

13. Install the neutral-safety or back-up switch as outlined in Section 12 of this manual.

14. Slide the steering shaft into the column and install the upper bearing thrust washer.

15. Install the turn signal switch, lock cylinder assembly and ignition switch as previously outlined in this section.

16. Install the shift lever and shift lever pivot pin.

17. Remove the column from the vise.

18. Install the dash bracket to the column; torque the screws to specifications.

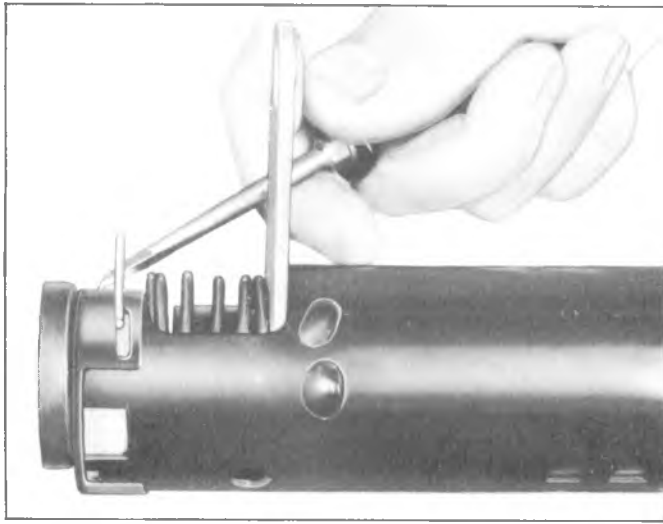


Fig. 3B-71--Removing Lower Bearing Retainer

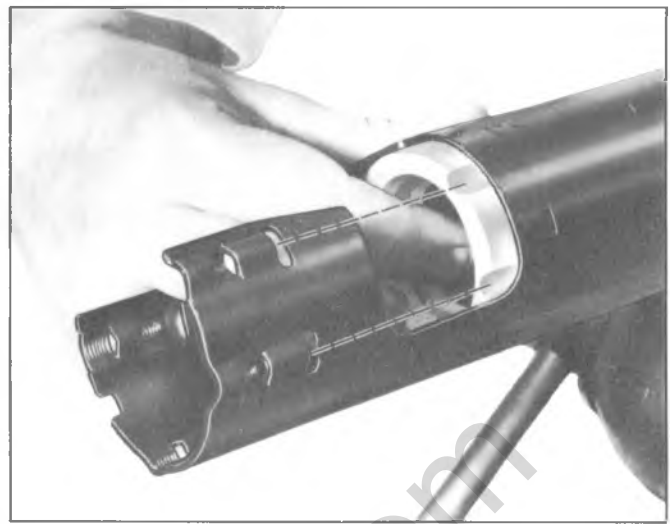


Fig. 3B-73--Installing Gearshift Housing Lower Bearing

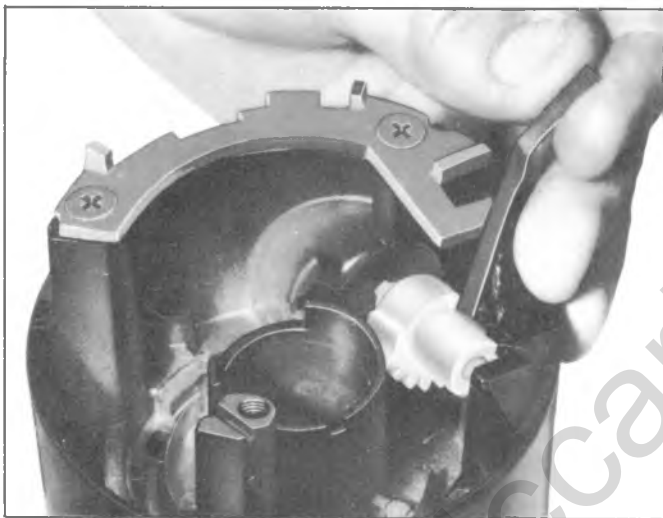


Fig. 3B-72--Installing Rack Preload Spring



Fig. 3B-74--Adjusting Lower Bearing-Typical

Disassembly-Tilt Columns (Fig. 3B-75)

NOTE: Steps 3-14 may be performed with the steering column in the vehicle.

1. Remove the four screws retaining the dash mounting bracket to the column and set the bracket aside to protect the breakaway capsules.

2. Mount the column in a vise using both weld nuts of either Set A or B as shown in Figure 3B-67. The vise jaws must clamp onto the sides of the weld nuts indicated by arrows shown on Set B.

CAUTION: Do not place the column in a vise by clamping onto only one weld nut, by clamping onto one weld nut of both Sets A and B or by clamping onto the sides not indicated by arrows, since damage to the column could result.

3. Remove the directional signal switch, lock

cylinder and ignition switch as outlined previously in this section.

4. Remove the tilt release lever. Drive out the shift lever pivot pin and remove the shift lever from the housing.

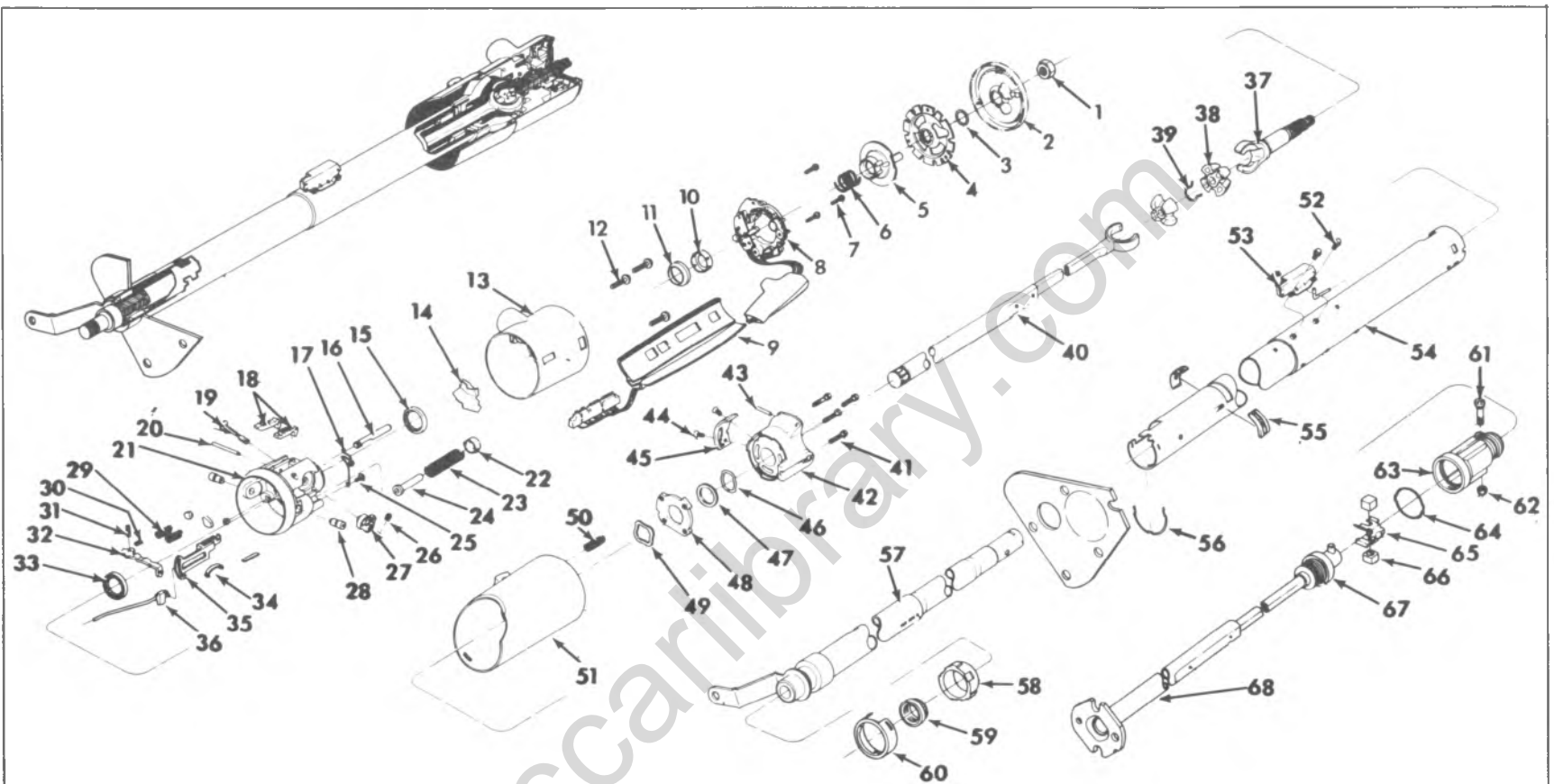
5. Remove the three turn signal housing screws and remove the housing.

6. Install the tilt release lever and place the column in the full "up" position. Remove the tilt lever spring retainer using a **3 phillips screwdriver that just fits into the slot opening. Insert the phillips screwdriver in the slot, press in approximately 3/16", turn approximately 1/8 turn counterclockwise until the ears align with the grooves in the housing and remove the retainer, spring and guide (fig. 3B-76).**

7. Remove the pot joint to steering shaft clamp bolt and remove the intermediate shaft and pot joint assembly.

Push the upper steering shaft in sufficiently to

Fig. 3B-75-Tilt Steering Column Assembly-CK Typical



- | | | | |
|--------------------------------|---------------------------------|------------------------------------|---------------------------------|
| 1. Shaft Nut | 17. Lock Bolt Spring | 35. Ignition Switch Rack | 53. Ignition Switch |
| 2. Cover | 18. Lock Shoes | 36. Ignition Switch Rod | 54. Mast Jacket |
| 3. Lock Plate Retaining Ring | 19. Sector Shaft | 37. Upper Steering Shaft | 55. Neutral-Safety or Back-Up |
| 4. Lock Plate | 20. Lock Shoe Pin | 38. Centering Spheres | 56. Retainer |
| 5. Cancelling Cam | 21. Bearing Housing | 39. Center Sphere Spring | 57. Shift Tube |
| 6. Bearing Preload Spring | 22. Tilt Lever Spring Retainer | 40. Lower Steering Shaft | 58. Lower Bearing Adapter |
| 7. Turn Signal Screws | 23. Tilt Lever Spring | 41. Bearing Housing Support Screws | 59. Lower Bearing |
| 8. Turn Signal Switch | 24. Tilt Lever Spring Guide | 42. Bearing Housing Support | 60. Lower Bearing Reinforcement |
| 9. Protector Cover | 25. Lock Bolt Spring Screw | 43. Pin | 61. Pot Joint Bolt |
| 10. Upper Bearing Seat | 26. Sector Snap Ring | 44. Shift Tube Index Plate Screws | 62. Nut |
| 11. Upper Bearing Race | 27. Sector | 45. Shift Tube Index Plate | 63. Pot Joint Cover |
| 12. Turn Signal Housing Screws | 28. Bearing Housing Pivot Pins | 46. Support Retaining Ring | 64. Seal Retaining Ring |
| 13. Turn Signal Housing | 29. Shoe Release Springs | 47. Support Thrust Washer | 65. Bearing Spring |
| 14. Tilt Lever Opening Shield | 30. Spring | 48. Support Plate Lock | 66. Bearing Blocks |
| 15. Upper Bearing | 31. Shoe Release Lever Pin | 49. Support Wave Washer | 67. Pot Joint Seal |
| 16. Shaft Lock Bolt | 32. Shoe Release Lever | 50. Gearshift Lever Spring | 68. Intermediate Shaft |
| | 33. Lower Bearing | 51. Gearshift Lever Housing | |
| | 34. Ignition Switch Rack Spring | 52. Ignition Switch Screws | |

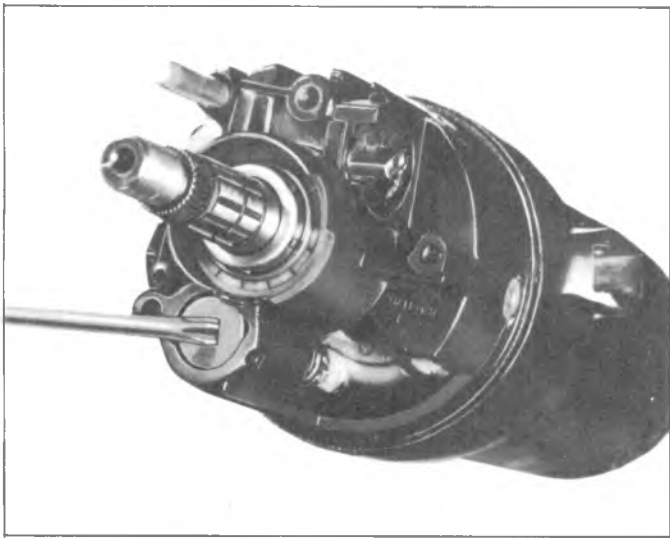


Fig. 3B-76--Removing Tilt Lever Spring Retainer



Fig. 3B-78--Removing Shift Tube



Fig. 3B-77--Removing Bearing Housing Pivot Pins

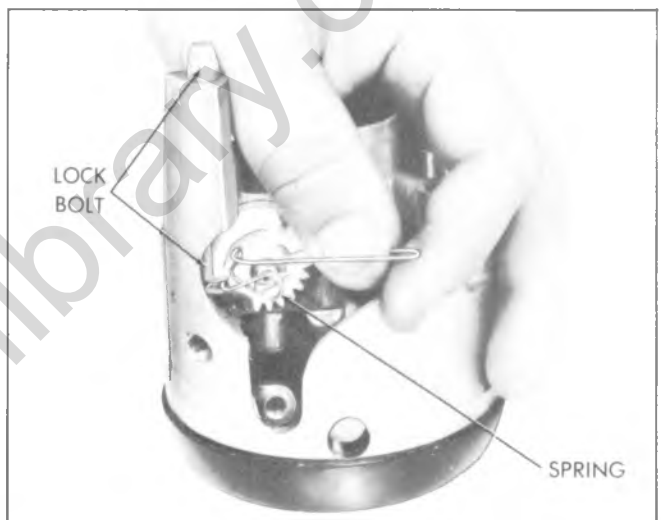


Fig. 3B-79--Replacing Lock Bolt Spring

classiccarlibrary.com

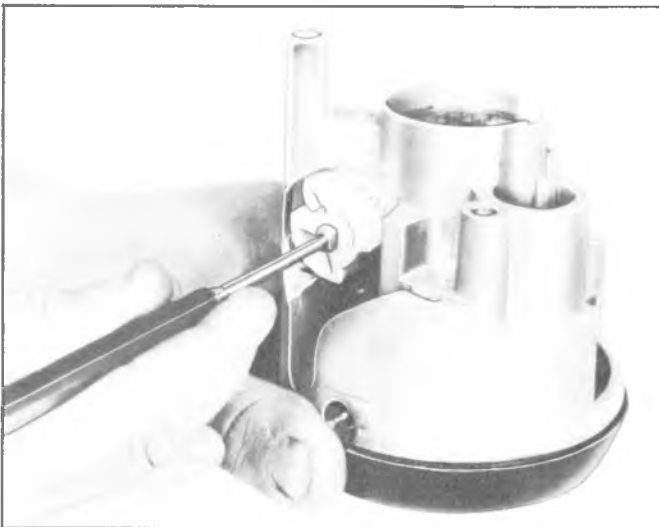


Fig. 3B-80--Removing Sector Drive Shaft

remove the steering shaft upper bearing inner race and seat. Pry off the lower bearing retainer clip and remove the bearing reinforcement, bearing and bearing adapter assembly from the lower end of the mast jacket.

8. Remove the upper bearing housing pivot pins using Tool J-21854-1 (fig. 3B-77).

9. Install the tilt release lever and disengage the lock shoes. Remove the bearing housing by pulling upward to extend the rack full down, and then moving the housing to the left to disengage the ignition switch rack from the actuator rod.

10. Remove the steering shaft assembly from the upper end of the column.

11. Disassemble the steering shaft by removing the centering spheres and the anti-lash spring.

12. Remove the transmission indicator wire, if so equipped.

13. Remove the four steering shaft bearing housing support to gearshift housing screws and remove the bearing housing support. Remove the ignition switch actuator rod.

14. Remove the shift tube retaining ring with a screwdriver and then remove the thrust washer.

15. Install Tool J-23072 into the lock plate, making sure that the tool screws have good thread engagement in the lock plate. Then, turning the center screw clockwise, force the shift tube from the housing (fig. 3B-78). Remove the shift tube (transmission control lock tube on floor shift models) from the lower end of the mast jacket. Remove Tool J-23072.

CAUTION: When removing the shift tube, be sure to guide the lower end through the slotted opening in the mast jacket. If the tube is allowed to interfere with the jacket in any way, damage to the tube and jacket could result.

16. Remove the bearing housing support lock plate by sliding it out of the jacket notches, tipping it down toward the housing hub at the 12 o'clock position and

sliding it under the jacket opening. Remove the wave washer.

17. **All Columns** - Remove the shift lever housing from the mast jacket (transmission control lock tube housing on floor shift models). Remove the shift lever spring by winding the spring up with pliers and pulling it out. On floor shift models, remove the spring plunger.

18. Disassemble the bearing housing as follows:

a. Remove the tilt lever opening shield.

b. Remove the lock bolt spring by removing the retaining screw and moving the spring clockwise to remove it from the bolt (fig. 3B-79).

c. Remove the snap ring from the sector drive shaft. With a small punch, lightly tap the drive shaft from the sector (fig. 3B-80). Remove the drive shaft, sector and lock bolt. Remove the rack and rack spring.

d. Remove the tilt release lever pin with a punch and hammer. Remove the lever and release lever spring. To relieve the load on the release lever, hold the shoes inward and wedge a block between the top of the shoes (over slots) and bearing housing.

e. Remove the lock shoe retaining pin with a punch and hammer. Remove the lock shoes and lock shoe springs.

NOTE: With the tilt lever opening on the left side and shoes facing up, the four slot shoe is on the left.

f. Remove the bearings from the bearing housing only if they are to be replaced. Remove the separator and balls from the bearings. Place the housing on work bench and with a pointed punch against the back surface of the race, carefully hammer the race out of the housing until a bearing puller can be used. Repeat for the other race.

Assembly-Tilt Columns

Apply a thin coat of lithium grease to all friction surfaces.

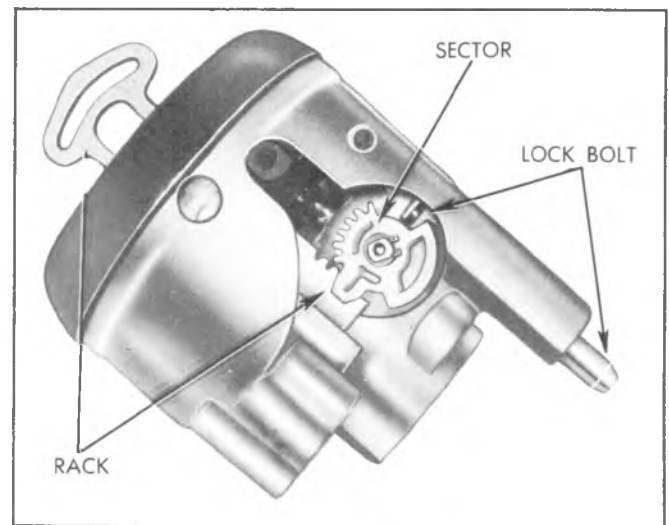


Fig. 3B-81--Installing Lock Bolt and Rack Assemblies

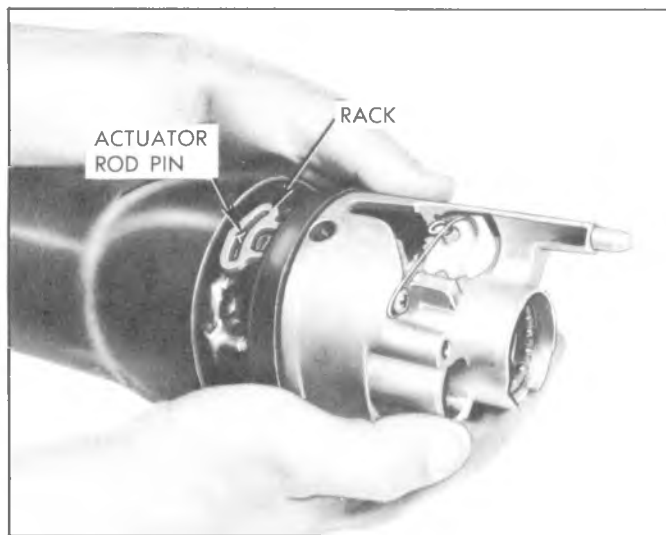


Fig. 3B-82--Installing Bearing Housing

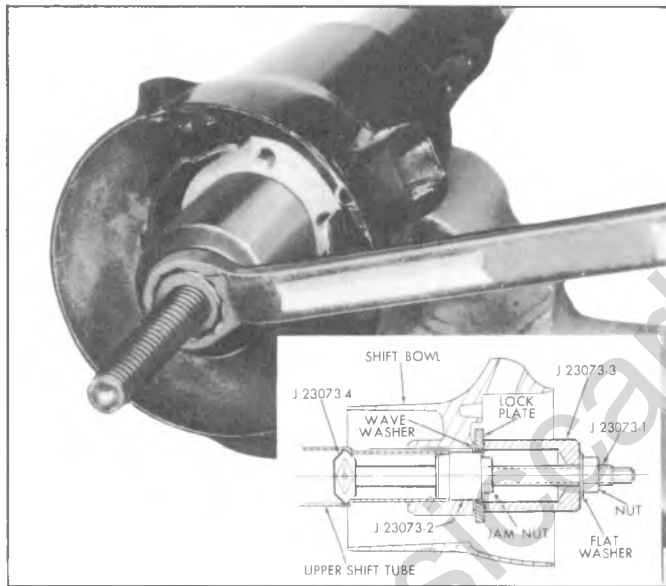


Fig. 3B-83--Installing Shift Tube

1. If the bearing housing was disassembled, repeat the following steps:

a. Press the bearings into the housing, if removed, using a suitable size socket. Be careful not to damage the housing or bearing during installation.

b. Install the lock shoe springs, lock shoes and shoe pin in the housing. Use an approximate .180" rod to line up the shoes for pin installation.

c. Install the shoe release lever, spring and pin.

NOTE: To relieve the load on the release lever, hold the shoes inward and wedge a block between the top of the shoes (over slots) and bearing housing.

d. Install the sector drive shaft into the housing. Lightly tap the sector onto the shaft far enough to install the snap ring. Install the snap ring.

e. Install the lock bolt and engage it with the sector cam surface. Then install the rack and spring. The block tooth on the rack should engage the block tooth on the sector (fig. 3B-81). Install the external tilt release lever.

f. Install the lock bolt spring and retaining screw (fig. 3B-76). Tighten the screw to 35 in. lbs.

2. Install the shift lever spring into the housing by winding it up with pliers and pushing it into the housing. On floor shift models, install the plunger, slide the gearshift lever housing onto the mast jacket.

3. Install the bearing support lock plate wave washer.

4. Install the bearing support lock plate. Work it into the notches in the jacket by tipping it toward the housing hub at the 12 o'clock position and sliding it under the jacket opening. Slide the lock plate into the notches in the jacket.

5. Carefully install the shift tube into the lower end of the mast jacket. Align keyway in the tube with the key in the shift lever housing. Install the wobble plate end of Tool J-23073 into the upper end of the shift tube far enough to reach the enlarged portion of the tube. Then install the adapter over the end of the tool, seating it against the lock plate. Place the nut on the threaded end of the tool and pull the shift tube into the housing (fig. 3B-83). Remove Tool J-23073.

CAUTION: Do not push or tap on the end of the shift tube. Be sure that the shift tube lever is aligned with the slotted opening at the lower end of the mast jacket or damage to the shift tube and mast jacket could result.

6. Install the bearing support thrust washer and retaining ring by pulling the shift lever housing up far enough to compress the wave washer.

7. Install the bearing support by aligning the "V" in the support with the "V" in the jacket. Insert the screws through the support and into the lock plate and torque to 60 lbs. in.

8. Align the lower bearing adapter with the notches in the jacket and push the adapter into the lower end of the mast jacket. Install lower bearing, bearing reinforcement and retaining clip, being sure that the clip is aligned with the slots in the reinforcement, jacket and adapter.

9. Install the centering spheres and anti-lash spring in the upper shaft. Install the lower shaft from the same side of the spheres that the spring ends protrude.

10. Install the steering shaft assembly into the shift tube from the upper end. Carefully guide the shaft through the shift tube and bearing.

11. Install the ignition switch actuator rod through the shift lever housing and insert in the slot in the bearing support. Extend the rack downward from the bearing housing.

12. Assemble the bearing housing over the steering shaft and engage the rack over the end of the actuator rod (fig. 3B-82).

13. With the external release lever installed, hold the lock shoes in the disengaged position and assemble

the bearing housing over the steering shaft until the pivot pin holes line up.

14. Install the pivot pins.

15. Place the bearing housing in the full "up" position and install the tilt lever spring guide, spring and spring retainer. With a suitable screwdriver, push the retainer in and turn clockwise to engage in the housing.

16. Install the upper bearing inner race and race seat.

17. Install the tilt lever opening shield.

18. Remove the tilt release lever, install the turn signal housing and torque the three retaining screws to 45 lbs. in.

19. Install the tilt release lever and shift lever. Drive the shift lever pin in.

20. Install the lock cylinder, turn signal switch and ignition switch as outlined previously in this section.

21. Align the groove across the upper end of the pot joint with the flat on the steering shaft. Assemble the intermediate shaft assembly to the upper shaft. Install the clamp and bolt and torque the nut to specifications.

NOTE: The clamp bolt must pass through the shaft under cut.

22. Install the neutral-safety switch or back-up switch as outlined in Section 12 of this manual.

23. Install the four dash panel bracket to column screws and torque to specifications.

CAUTION: Be sure that the slotted openings in the bracket (for the mounting capsules) face the upper end of the steering column.

COLUMN INSTALLATION- MANDATORY SEQUENCE

C and K SERIES VEHICLES (Fig. 3B-84)

Mandatory Instructions

1. Assemble lower dash cover (A) and upper dash cover (B) to seal (C) with "Carrots" (part of seal).
2. Attach bracket (D) to jacket and tighten four bolts (E) to specified torque.

Mandatory Installation Sequence

1. Position column in body and position flange to rag joint and install lock washers and nuts (F) (May be tightened to specified torque at this time).

NOTE: Coupling (G) on manual steering must be installed prior to column installation.

2. Loosely assemble (2) capsules nuts (H) at the instrument panel bracket (D).
3. Position lower clamp (J) and tighten attaching nuts (K) to specified torque.
4. Tighten two nuts (H) at capsules to specified torque.
5. Install seal (C) and covers (A and B) to dash.
6. Install attaching screws (L) and tighten to specified torque.
7. Tighten two nuts (F) at capsules to specified torque if not already done.

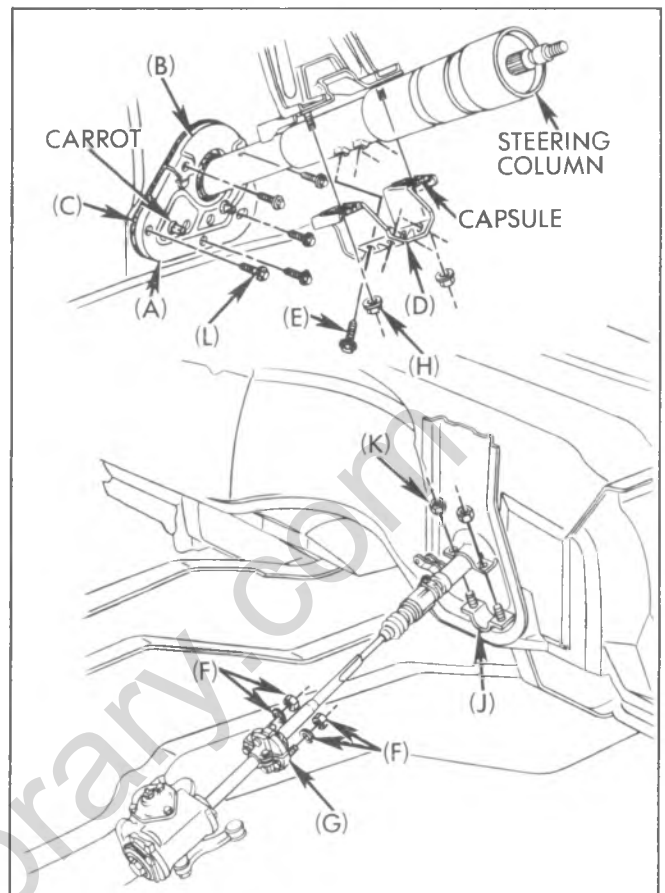


Fig. 3B-84-Steering Column Installation-CK

8. Remove plastic spacers from flexible coupling pins.
9. Install transmission indicator cable on column automatics.
10. Install the instrument panel trim cover.
11. Connect the transmission control linkage at the shift tube levers.
12. Install the steering wheel as outlined previously in this section.
13. Connect the battery ground cable.

Mandatory System Requirements

1. Pot joint operating angle must be $1\ 1/2^\circ \pm 4^\circ$.
2. Flexible coupling must not be distorted greater than $\pm .06$ due to pot joint bottoming, in either direction.

STEERING COLUMN SERVICE FOR G AND P SERIES

STEERING COLUMN UPPER BEARING- G AND P SERIES

Standard Column

Removal

1. Remove steering wheel as outlined in this section.
2. Remove directional signal cancelling cam.
3. Pry out upper bearing.

Installation

CAUTION: See *CAUTION* on page 1 of this section regarding the fasteners referred to in step 1.

1. Replace all component parts in reverse order of removal making sure that directional switch is in neutral position before installing steering wheel. Torque steering wheel nut to specifications.

Tilt Column

The upper bearings on the tilt column are spun into the bearing housing assembly. If the bearings indicate need of replacement, the entire bearing housing must be replaced. See "Tilt Steering Column - Disassembly and Assembly" for the correct replacement procedure.

STEERING COLUMN LOWER BEARING P SERIES

Removal

1. Remove the intermediate steering shaft and universal joint assembly as outlined earlier in this section. Remove the preload spring clamp and spring from the end of the steering shaft.
2. Pry out the lower bearing assembly.

Installation

CAUTION: See *CAUTION* not on page 1 of this section regarding fasteners referred to in step 2.

1. Place the new bearing over the end of the steering shaft and press into position in the column.
2. Install the preload spring and clamp and torque the clamp bolt nut to specifications while maintaining the dimension shown in Fig. 3B-32. Reinstall the intermediate shaft and universal joint assembly as outlined under "Intermediate Steering Shaft with Universal Joint Couplings - Installation".

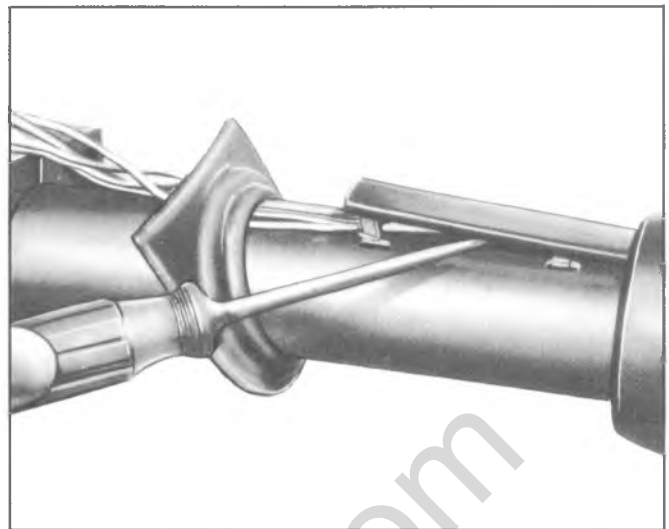


Fig. 3B-85--Removing Wiring Harness Protector

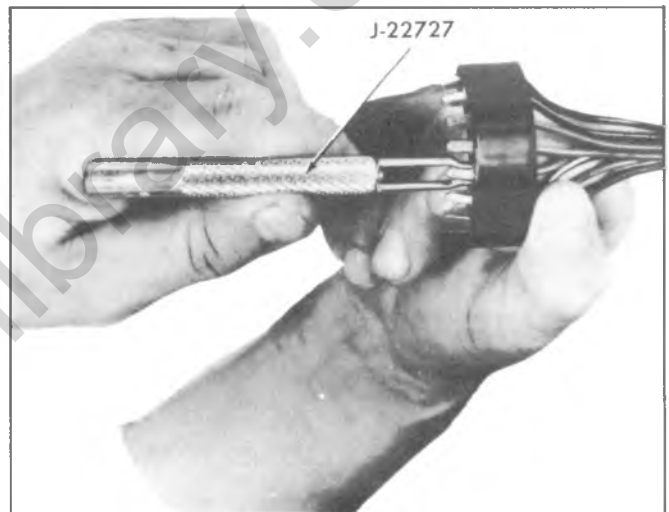


Fig. 3B-86--Removing Wires from Connector

DIRECTIONAL SIGNAL SWITCH- G AND P SERIES COLUMNS

If the directional signal switch must be replaced, the steering column does not have to be removed from the vehicle.

Removal

1. Remove the steering wheel as outlined under "Steering Wheel - Removal".
2. Remove the directional signal switch cancelling cam and spring.
3. Remove the column to instrument panel trim plate (if so equipped).
4. Disconnect the directional signal switch wiring harness at the half-moon connector.
5. Pry the wiring harness protector out of the column retaining slots as shown in Figure 3B-85.
6. Mark the location of each wire in the half-moon connector and then remove each individual wire from

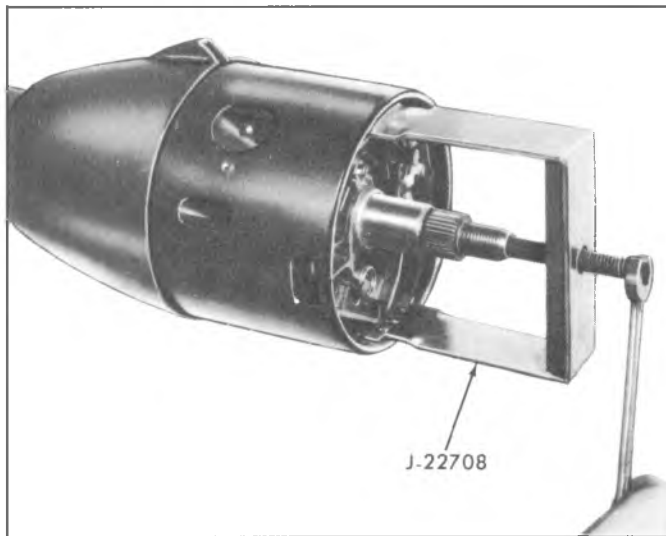


Fig. 3B-87--Removing Directional Signal Housing Cover

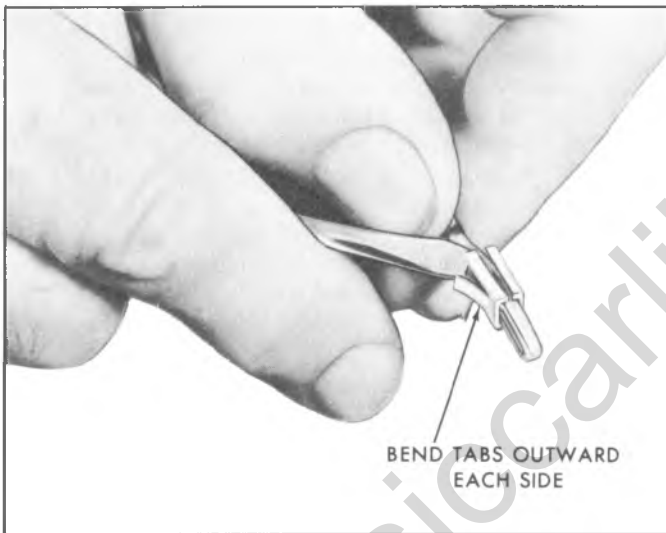


Fig. 3B-88--Preparing Wire Retaining Tabs for Installation

the connector using Tool J-22727 (fig. 3B-86). Insert the tool into the lower end of the connector and push in until the tool bottoms on the connector. Remove the tool and then pull the wire from the connector.

7. Remove the directional signal lever screw and remove the lever.

8. Push in on the hazard warning light knob and then unscrew and remove the knob.

9. Tilt Columns Only

a. Automatic Transmission Models - Remove the PRNDL dial screws and remove the dial and indicator needle. Remove the cap and dial illumination bulb from the housing cover.

b. Unscrew and remove the tilt release lever.

c. Assemble Tool J-22708 inside the directional signal housing cover; push in until the tangs lock inside

the cover flange (fig. 3B-87). Turn the tool center screw clockwise to pull the cover from the housing.

10. Remove the three directional signal switch mounting screws and then carefully remove the switch assembly from the column while guiding the wiring harness through the opening in the shift lever housing.

Installation

CAUTION: See CAUTION on page 1 of this section regarding the fasteners referred to in step 9.

1. Wrap the ends of the directional signal switch wires with tape and then guide them through the opening at the lower left hand side of the bearing housing (tilt columns) out the lower end of the shift lever housing and under the dash seal.

2. Place the directional signal switch in position and install the three mounting screws; torque to 25 lbs. in. after screw head has been firmly seated.

3. Tilt Columns Only-

a. Align the openings in the directional signal switch cover with the proper lever positions and tap the cover into place using a plastic hammer.

b. Install the tilt release lever.

c. Automatic Transmission Model - Install the PRNDL dial, pointer, dial illumination bulb and cap.

4. Install the directional signal switch lever and hazard warning knob.

5. Bend the wire retaining tabs slightly outward on each wire in the wiring harness as shown in Figure 3B-88; this will provide proper retention of the wire in the half-moon connector.

6. Install each wire in its marked location in the half-moon connector. Push in until square part of clip is flush with the bottom side of the connector. Connect the directional signal switch wiring harness.

7. Snap the wiring harness protector into the column retaining slots.

8. Install the directional signal cancelling cam and spring.

9. Install the steering wheel as outlined under "Steering Wheel - Installation".

10. Install the column to instrument panel trim plate (if so equipped).

TILT COLUMN BEARING HOUSING ASSEMBLY - G AND P SERIES

Removal (Column in Vehicle)

1. Disconnect the battery ground cable.

2. Remove the steering wheel as outlined under "Steering Wheel - Removal".

3. Remove the directional signal switch as outlined under "Directional Signal Switch - Removal".

4. **Column Shift Models** - Using a suitable size punch, drive out the shift lever pivot pin and remove the shift lever.

5. Install the tilt release lever and place the column in the full "up" position. Remove the tilt lever spring and retainer using a screwdriver that just fits into the slot opening. Insert the screwdriver into the slot, push in

approximately 3/16", rotate clockwise approximately 1/8 turn until the retainer ears align with the grooves in the housing and remove the retainer and spring.

6. Remove the steering shaft bearing locknut using Socket J-22599. Remove the upper bearing race seat and race.

7. Remove the two bearing housing pivot pins using Tool J-21854.

8. Pull up on the tilt release lever (to disengage the lock shoes) and remove the bearing housing.

If the bearing housing is being replaced or it is necessary to disassemble the bearing housing, proceed as follows:

a. Press the upper and lower bearings out of the housing.

b. Using Puller J-5822 and Slide Hammer J-2619, pull the bearing races from the housing.

c. Remove the tilt release lever.

d. Drive out the shoe release pivot pin using Tool J-22635 or a suitable punch. Remove the lever spring and remove the wedge.

e. Using a suitable size punch, drive out the lock shoe retaining pin. Remove the shoes and shoe springs.

If the upper steering shaft, lower steering shaft, or centering spheres are being removed, proceed as follows:

9. To remove the steering shaft assembly through the upper end of the column. If it is necessary to disassemble the shaft, proceed as follows:

a. To remove the lower steering shaft first disconnect the shaft at the pot joint coupling clamp.

b. Turn the upper shaft 90° to the lower shaft and slide the upper shaft and centering spheres from the lower shaft.

c. Rotate the centering spheres 90° and remove the centering spheres and preload spring from the upper shaft.

If the bearing housing support is being replaced, proceed as follows:

10. Remove the four bearing housing support screws and remove the support.

Assembly

CAUTION: See caution note on page 7 of this section regarding the fasteners referred to in steps 3, 9 and 11.

1. Assemble the steering shaft as follows:

a. Lubricate and assemble the centering spheres and preload spring.

b. Install the spheres into the upper (short) shaft and rotate 90°.

c. Install the lower shaft 90° to the upper shaft and over the centering spheres. Slowly straighten the shafts while compressing the preload spring.

2. Install the shaft assembly into the housing from the upper end.

3. Install the lower shaft to the pot joint coupling clamp. Install the coupling clamp bolt and torque to specifications.

NOTE: The coupling bolt must pass through the shaft undercut.

4. Assemble the bearing housing as follows:

a. Press the new upper and lower bearing races into the bearing housing.

b. Lubricate and install the bearings into the bearing races.

c. Place the lock shoe springs in position in the housing. Install each shoe in place and compress the spring until a suitable size straight punch can be used to hold the shoe in position (it may be necessary to acquire assistance to install the shoes). Once the shoes are in place, drive in the shoe retaining pin.

d. Install the shoe release lever and drive in the pivot pin.

e. Install the tilt release lever.

f. Lubricate the shoes and release lever.

5. Install the bearing housing assembly to the support. Hold the tilt release lever in the "up" position until the shoes have fully engaged the support. Lubricate and install the bearing housing pivot pins. Press the pins in flush with the housing.

6. Place the housing in the full "up" position and then install tilt spring and retainer (tapered end of spring first). Push into the housing approximately 3/16" and rotate counterclockwise 1/8 turn.

7. Lubricate and install the upper bearing race, race seat and locknut. Tighten the locknut (using Socket J-22599) to remove the lash and then carefully further tighten 1/16 to 1/8 of a turn (column must be in straight ahead position).

8. Remove the tilt release lever.

9. Install the directional signal switch as outlined under "Directional Signal Switch - Installation".

10. Column Shift Models - Install the shift lever and pivot pin.

11. Install the steering wheel as outlined under "Steering Wheel - Installation".

12. Check electrical and mechanical functioning of column.

STEERING COLUMN-G AND P SERIES

Removal (Fig. 3B-89)

1. Disconnect the battery ground cable.

2. Column Shift Models - Disconnect transmission shifter rods at the lower end of the column.

3. **G Models** - Remove the intermediate steering shaft flange to flexible coupling bolts.

P Models - Remove the intermediate steering shaft upper universal yoke to steering shaft pinch bolt. Mark the coupling to shaft relationship.

4. Remove column clamp screw(s) on engine side of firewall, if equipped, and remove or slide the clamp down the column.

5. From inside the vehicle, remove the screws from the toe pan cover and slide the cover and seal up the column.

6. Remove the steering wheel as outlined under "Steering Wheel-Removal", and reinstall the shaft nut and washer.

7. All Columns - Disconnect the directional signal wiring harness. Standard Column with Automatic

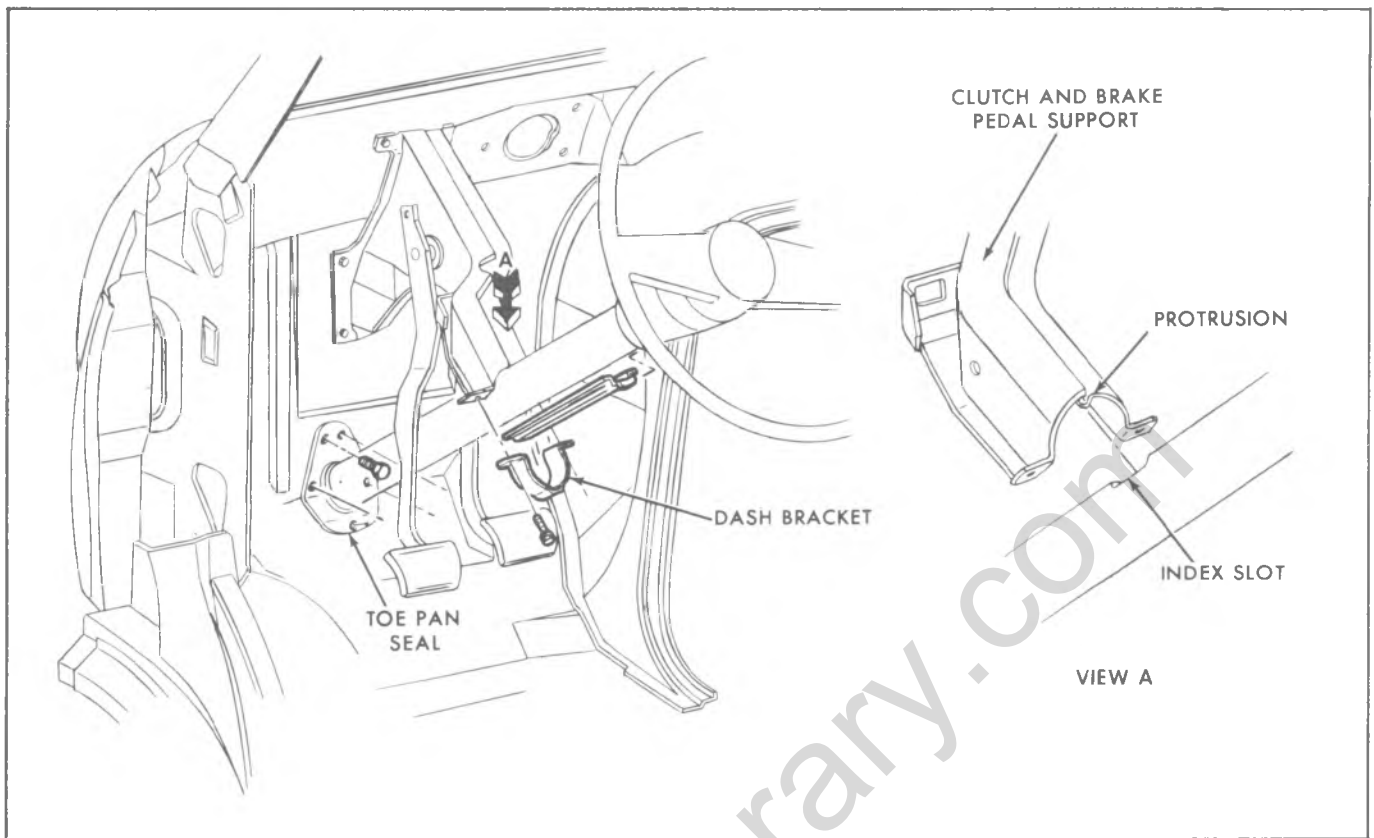


Fig. 3B-89--Steering Column Installation-G Series

Transmission - Disconnect the conductor tube (for transmission indicator) at the instrument panel.

Tilt Column with Automatic Transmission - Disconnect the single wire at the fuse block and unclip it from the parking brake bracket.

8. Remove the cap screws from the column support bracket at the dash panel.

9. Carefully lower and then withdraw the column assembly, rotating so that the shift levers clear the toe pan opening.

Standard Column (Fig. 3B-90)

Disassembly

NOTE: For floor shift transmission models, omit Steps 4, 14, 15 and 16.

1. Remove the steering wheel nut and lock washer and then slide the steering shaft assembly from the lower end of the column.

2. G Models - Remove the lower bearing preload spring and clamp from the steering shaft.

P Models - Remove the lower bearing preload spring and clamp.

3. Remove the back-up lamp switch.

4. Drive out the shift lever pivot pin and remove the shift lever.

5. Remove the directional signal cancelling cam.

Remove the directional signal switch lever.

6. Remove the column wiring harness cover.

7. Remove the directional signal switch screws.

8. Rotate the directional signal switch housing counterclockwise and remove the housing from the column.

NOTE: The housing and switch cannot be fully removed from the column until the shift lever housing is removed.

9. Remove the plastic thrust washer assembly and then remove the shift lever housing (or extension housing) from the column.

10. Separate the directional signal switch, switch control support assembly, directional signal housing and shift lever housing (or housing extension) assemblies.

11. Press the steering shaft upper bearing out of the switch contact support.

12. Remove the shift lever housing (or extension housing) seat and bushing from the upper end of the column.

13. Remove the bolt and screws from the adjusting ring clamp and remove the clamp, adjusting ring and lower bearing. Press the lower bearing out of the adjusting ring.

14. 3-Speed Columns - Remove 1st-reverse shift lever and lever spacer.

Automatic Columns - Remove the selector plate clamping ring screws (3).

15. Place the column upright on the floor, supporting it with two pieces of wood. Place a block of wood on the upper end of the shift tube. Press down on

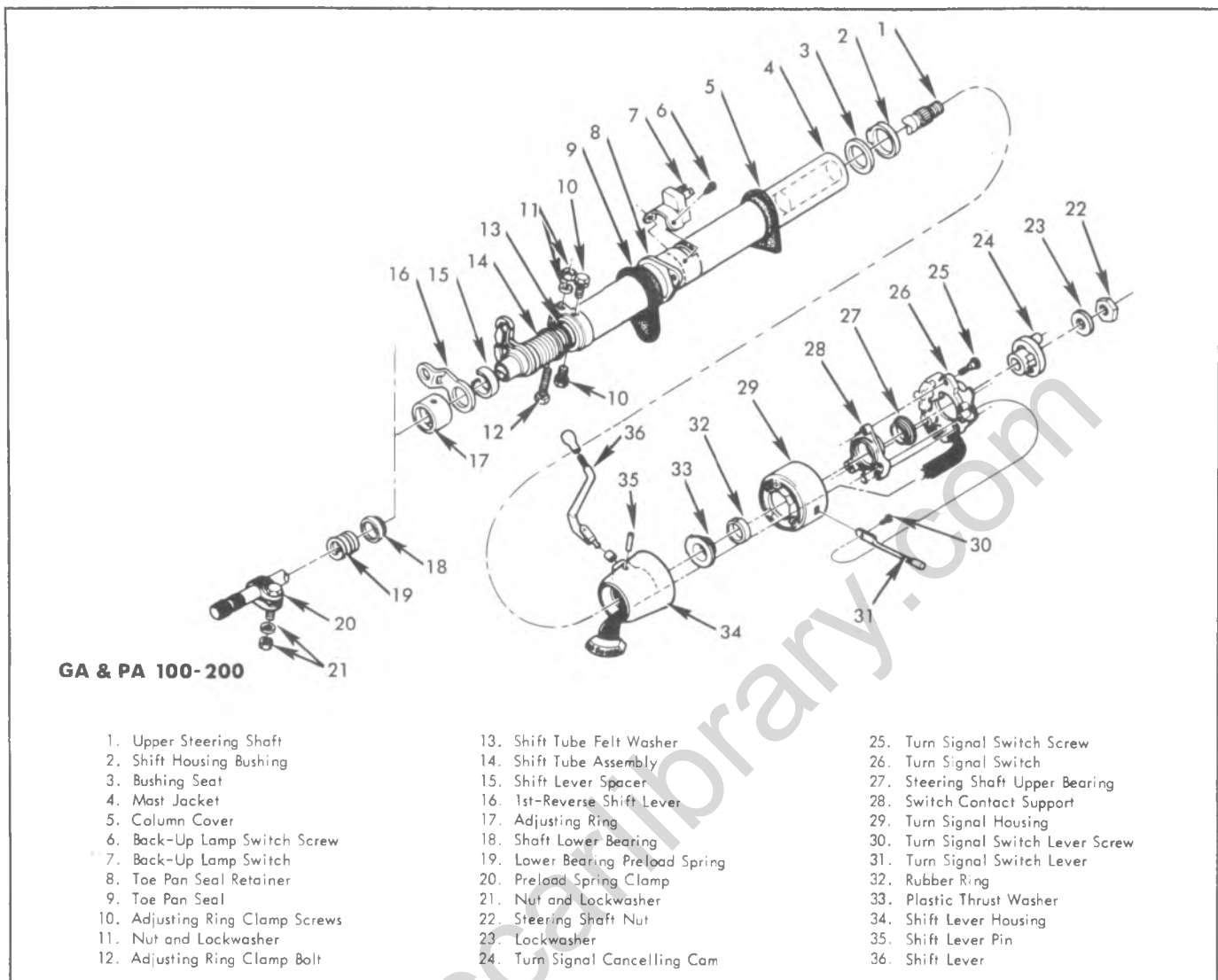


Fig. 3B-90--Standard Column--Typical G & P

the shift lever with foot while tapping on the wood block to withdraw the tube from the column jacket.

NOTE: In some tolerance stack-up cases it may be necessary to use a press. Be careful not to damage the tube or jacket.

16. Remove the felt seal from the shift tube.

17. Remove firewall clamp, toe pan seal and dash panel seals from the jacket.

Assembly

NOTE: In the following assembly sequence use any general purpose lithium soap grease for lubricating those components so indicated.

1. Install the dash panel seal, toe panel and firewall clamps over the end of the jacket.

2. Lubricate all bearing surfaces on the shift tube.

3. Place the felt seal onto the shift tube (next to spring) and then place the shift tube in the jacket.

4. 3-Speed Columns - Temporarily install spacer, 1st-reverse shift lever and lower adjusting ring. Place a

block of wood on top of the adjusting ring and tap until the shift tube bottoms. Remove adjusting ring, shift lever and spacer.

Automatic Columns - Align the three holes in the selector plate with the three holes in the jacket, position the clamping ring and install the three screws.

NOTE: The shift tube spring retainer must be bottomed against the jacket stops.

5. 3-Speed Columns-Lubricate and install the spacer and 1st-reverse shift lever (tang of lever towards top of column).

6. Install lower bearing in the adjusting ring and then install the adjusting ring, clamp and screws.

7. Install the shift lever housing (or extension housing) seat and bushing to upper end of housing.

8. Thread directional signal switch wiring harness through the switch and lever (or extension) housings, lubricate the inner diameter of the shift housing, and

then place the shift lever (or extension) housing onto the upper end of the column.

9. Install the switch housing plastic washer assembly. Press the upper bearing into the switch contact support.

10. Install the directional signal switch housing, contact support, bearing and switch and torque the switch screws to 25 lbs. in.

11. Install the column wiring harness cover and back-up lamp switch.

12. Install the directional signal and gearshift levers.

13. Adjust the shift tube as outlined under "Shifter Tube Adjustment."

14. Loosely install the lower bearing preload spring and clamp.

15. Slide the steering shaft assembly up through the column assembly. Install the directional signal cancelling cam, steering shaft nut and lock washer.

Tilt Column (Fig. 3B-91)

Disassembly

1. If the column is removed from the vehicle, place the column in a bench vise using Holding Fixtures J-22573 (fig. 3B-92).

CAUTION: *Clamping the column directly in a vise, could result in a damaged column.*

2. Remove the directional signal switch as outlined under "Directional Signal Switch-Removal".

3. Remove the lower steering shaft and pot joint assembly and lower bearing and adapter assembly as outlined under "Lower Bearing and Adapter-Removal".

4. Column Shift Models - Using a suitable size punch, drive out the shift lever pivot pin and remove the shift lever.

5. Install the tilt release lever and place the column in the full "up" position. Remove the tilt lever spring and retainer using a screwdriver that just fits into the slot opening (fig. 3B-93). Insert the screwdriver clockwise approximately 1/8 turn until the retainer ears align with the grooves in the housing and remove the retainer and spring.

6. Remove the steering shaft bearing locknut using socket J-22599. Remove the upper bearing race seat and race.

7. Remove the two bearing housing pivot pins using Tool J-21854 (fig. 3B-94).

8. Pull up on the tilt release lever (to disengage the lock shoes) and remove the bearing housing. If it is necessary to disassemble the bearing housing, proceed as follows:

a. Press the upper and lower bearings out of the housing.

b. Using Puller J-5822 and Slide Hammer J-2619 pull the bearing races from the housing (fig. 3B-95).

c. Remove the tilt release lever.

d. Drive out the shoe release lever pivot pin using Tool J-22635 or a suitable punch (fig. 3B-96). Remove the lever spring and remove the wedge.

e. Using a suitable size punch, drive out the lock shoe retaining pin. Remove the shoes and shoe springs.

9. Remove the steering shaft assembly through the upper end of the column. If it is necessary to disassemble the shaft proceed as follows:

a. Turn the upper shaft 90° to the lower shaft and slide the upper shaft and centering spheres from the lower shaft.

b. Rotate the centering spheres 90° and remove the center spheres and preload spring from the upper shaft.

10. Remove the four bearing housing support screws and remove the support.

Column Shift Models - If the shift tube index plate must be removed, remove the two retaining screws and remove the plate.

11. Remove the shift tube retaining ring with a screwdriver (fig. 3B-97). Remove the thrust washer.

12. Remove the neutral-safety or back-up lamp switch screws and remove the switch.

13. Rework Shift Tube Removing Tool J-22551 by removing 1/2" from the pilot end of the tool (Fig. 3B-98). This allows the shift tube to be pushed further out of the housing and will not affect the use of the tool on other columns.

14. Remove the shift tube assembly using Tool J-22551 (fig. 3B-99). Insert the hooked end of the tool into the notch in the shift tube just below the shift lever housing key. Pilot the sleeve over the threaded end of the tool and into the upper end of the shift tube. Force the shift tube out of the housing by turning the nut onto the tool. If the shift tube is not completely free when the nut is bottomed on the threads, complete the removal by hand.

CAUTION: *Do not hammer or pull on the shift tube during removal. On column shift models, guide the lower shift lever through the slotted opening in the column to prevent damage to the tube or column.*

15. Remove the lock plate by sliding out of the column notches, tipping the plate downward toward the housing (to compress the wave washer) and then removing as shown in Figure 3B-100. Remove the wave washer.

16. Remove the shift lever housing.

17. Column Shift Models - Remove the shift lever spring by winding the spring up with pliers.

18. If necessary, remove the dash panel seal, mounting plate and the instrument panel seal from the column jacket.

Assembly

NOTE: When lubricating components during the following installation sequence, use any general purpose lithium soap grease.

1. Install the dash panel seal, mounting plate and the instrument panel seal on the column.

2. Column Shift Models - Press a new shift lever spring into the shift lever housing.

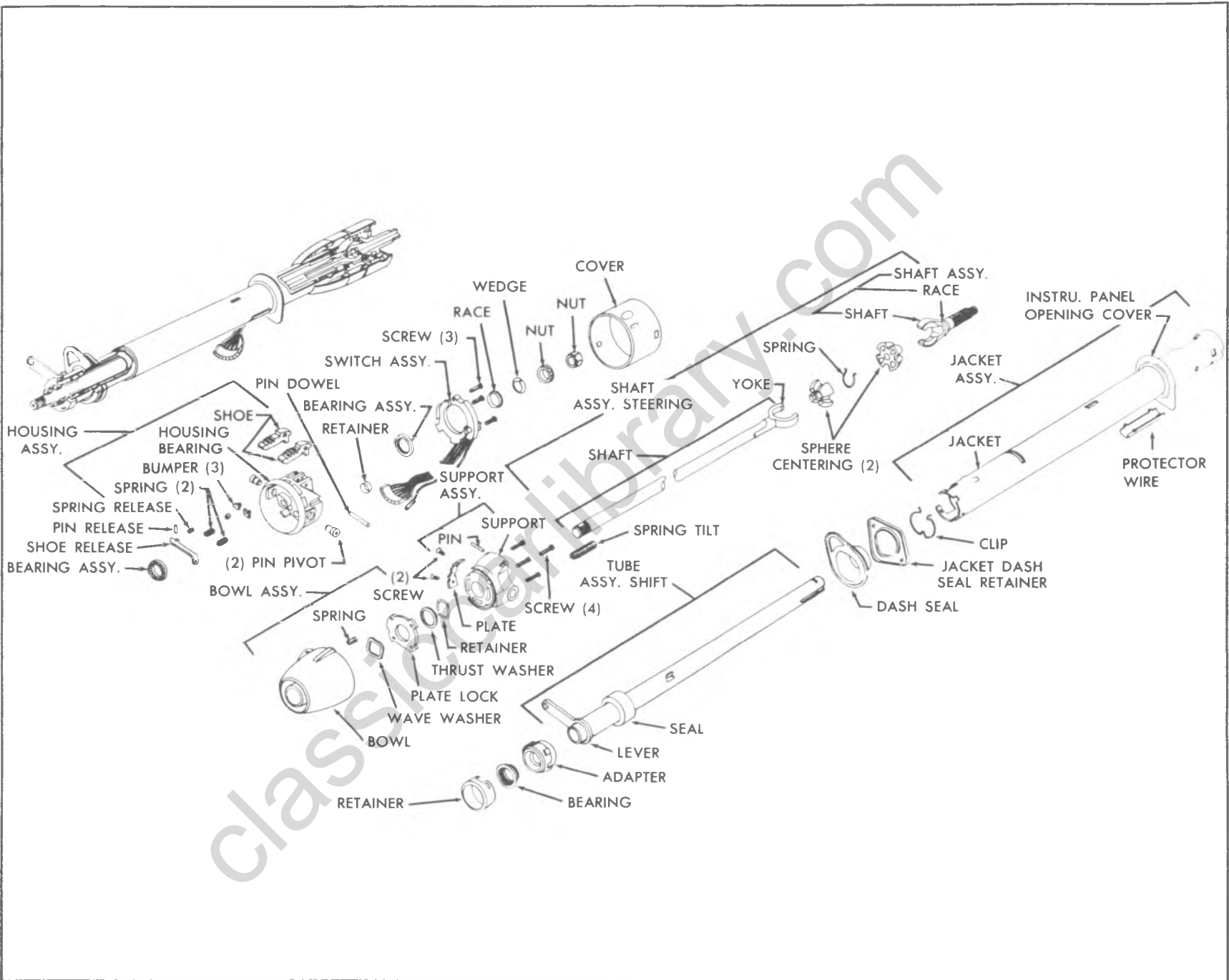


Fig. 3B-91--Tilt Steering Column-G P

classmate.com

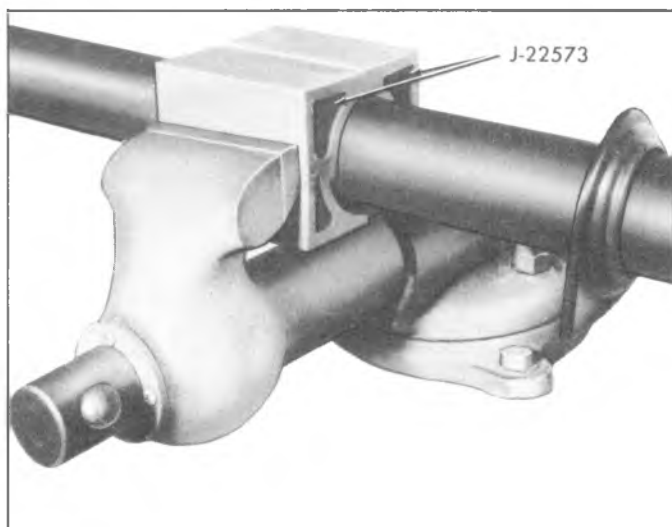


Fig. 3B-92--Securing Column with J-22573

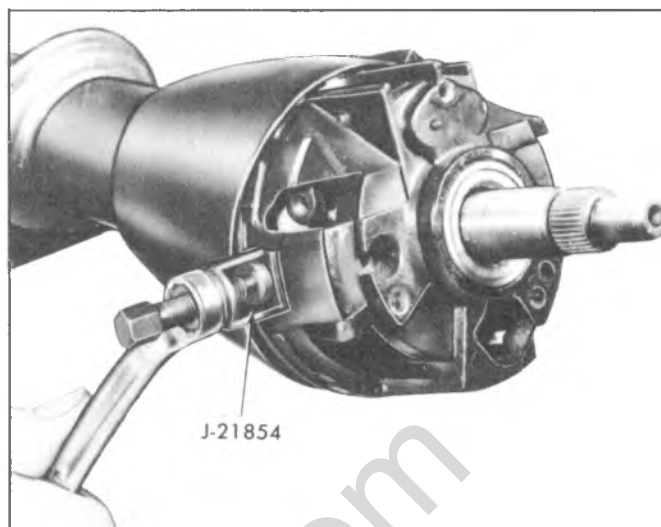


Fig. 3B-94--Removing Bearing Housing Pivot Pin

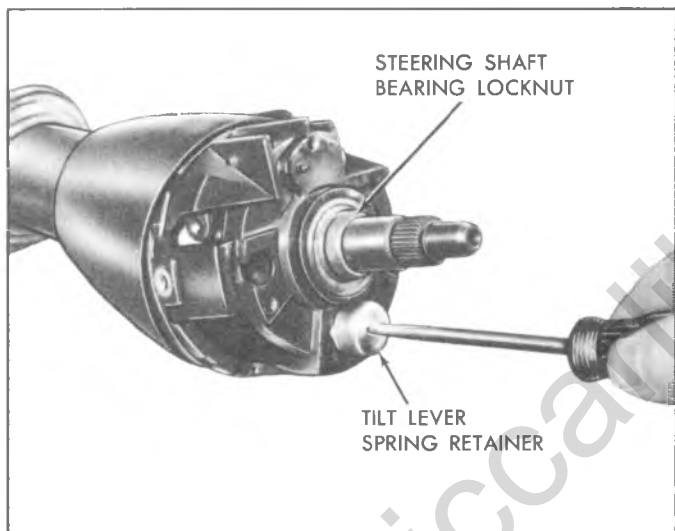


Fig. 3B-93--Removing Tilt Spring and Retainer

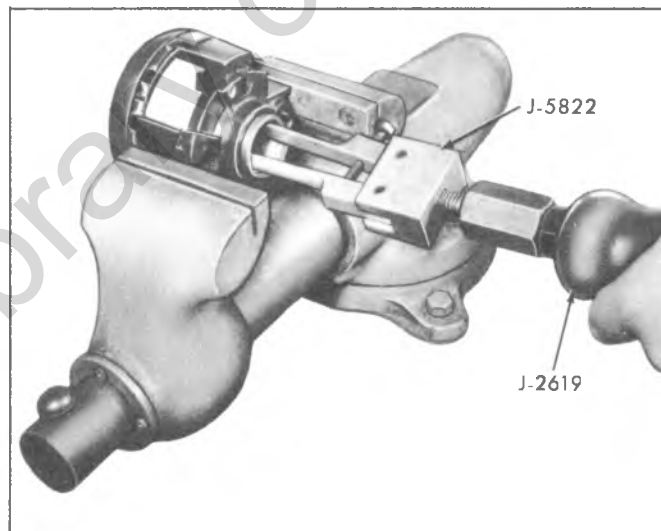


Fig. 3B-95--Removing Bearing Race

3. Slide the shift lever housing over the upper end of the column.

4. Place the wave washer and lock plate in position. Work the lock plate into the notches by tipping the plate toward the housing (compressing the wave washer) at the open side of the column. Lubricate the lock plate and upper end of the shift tube.

5. Carefully install the shift tube into the lower end of the column (make sure the foam seal is at lower end of the shift tube). Align the keyway in the tube with the key in the shift lever housing and complete installation of the shift tube using Tool J-22549 (fig. 3B-101). The shift lever housing key must bottom in the shift tube slot to be fully installed. Remove Tool J-22549 from the column. Lubricate and push foam seal in flush with column housing.

CAUTION: Do Not hammer or force the tube when installing in the column.

6. Pull up on the shift lever housing (to compress the wave washer) and install the thrust washer and retaining ring. Be sure the ring is seated in both slots of the shift tube.

7. Lubricate the I.D. of the bearing housing support and install the support, aligning the bolt holes in the support with the bolt holes in the lock plate. Install the four support screws and torque to 45 in. lbs.

8. Assemble the steering shaft as follows:

a. Lubricate and assemble the centering spheres and preload spring.

b. Install the spheres into the upper (short) shaft and rotate 90°.

c. Install the lower shaft 90° to the upper shaft and over the centering spheres. Slowly straighten the shafts while compressing the preload spring.

9. Install the shaft assembly into the housing from the upper end.

10. Install the lower bearing and adapter, bearing

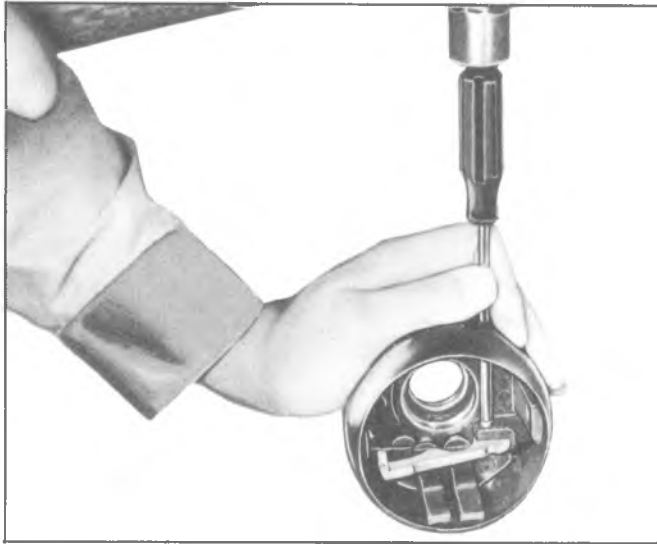


Fig. 3B-96-Removing Release Lever Pivot Pin

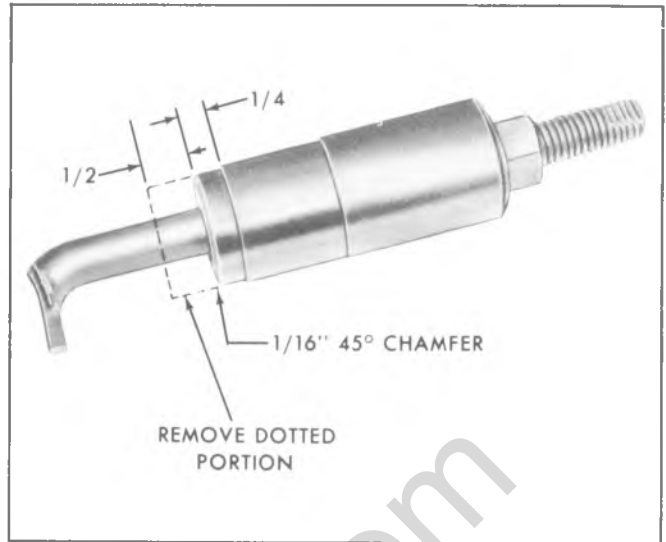


Fig. 3B-98-Revised Shift Tube Removing Tool
J-22551

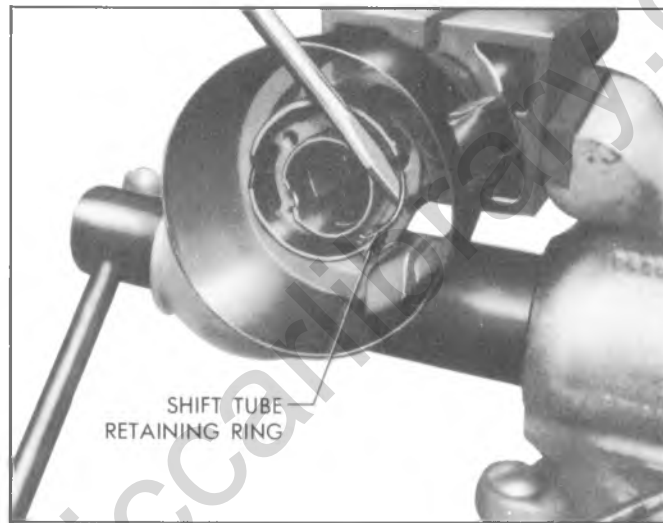


Fig. 3B-97-Removing Shift Tube Retaining Ring

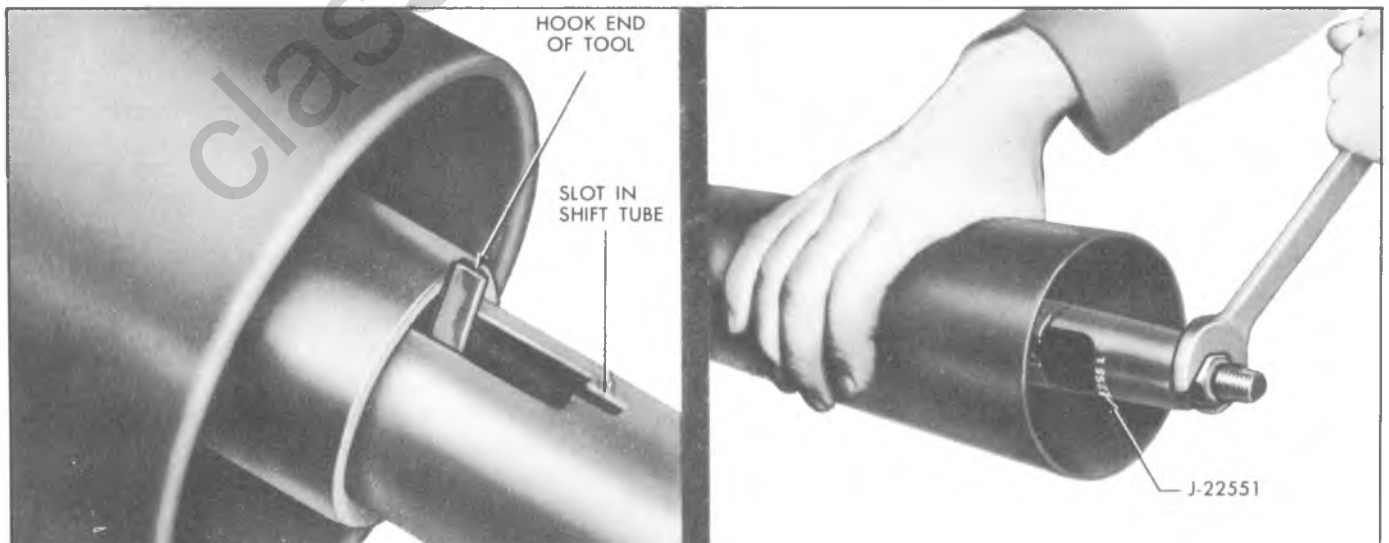


Fig. 3B-99-Removing Shift Tube Assembly

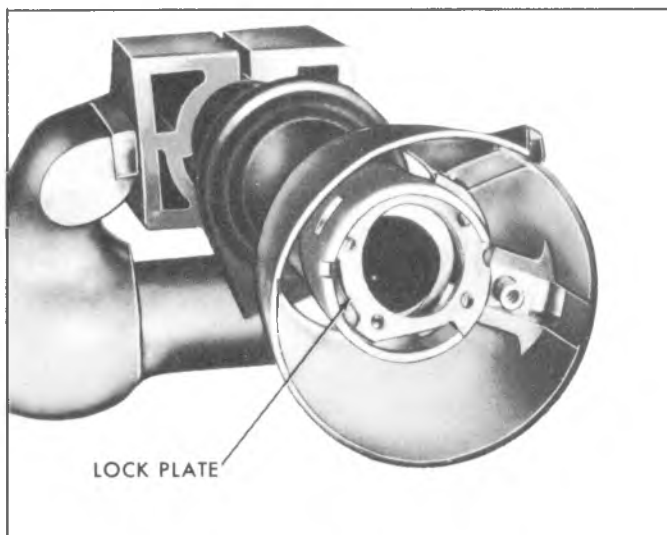


Fig. 3B-100-Removing Lock Plate Assembly

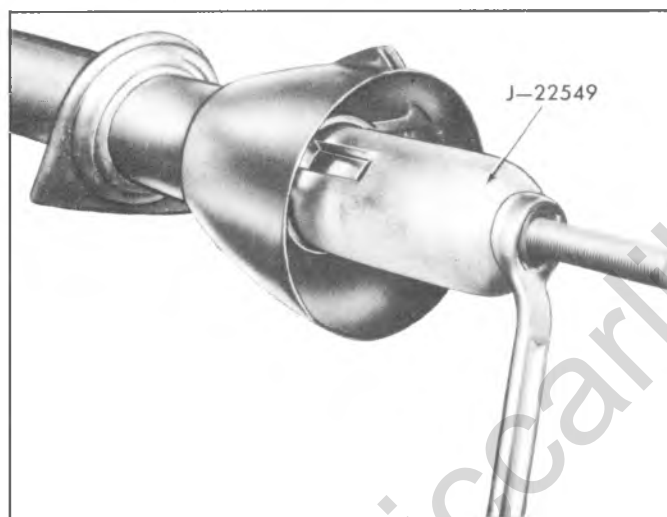


Fig. 3B-101-Installing Shift Pin Tube

reinforcement, wire clip, pot joint coupling and lower shaft as described under "Lower Bearing Installation".

11. Assemble the bearing housing as follows:

a. Press the new upper and lower bearing races into the bearing housing.

b. Lubricate and install the bearings into the bearing races.

c. Place the lock shoe springs in position in the housing. Install each shoe in place and compress the spring until a suitable size straight punch can be used to hold the shoes in position (it may be necessary to acquire assistance to install the shoes). Once the shoes are in place, drive in the shoe retaining pin.

d. Install the shoe release lever and drive in the pivot pin.

e. Install the tilt release lever.

f. Lubricate the shoes and release lever.

12. Install the bearing housing assembly to the support. Hold the tilt release lever in the "up" position

until the shoes have fully engaged the support. Lubricate and install the bearing housing pivot pins. Press the pins in flush with the housing.

13. Place the housing in the full "up" position and then install tilt spring and retainer (tapered end of spring first). Push into the housing approximately $3/16$ " and rotate counter clockwise $1/8$ turn.

14. Lubricate and install the upper bearing upper race, race seat and locknut. Tighten the locknut (using Socket J-22599) to remove the lash and then further tighten $1/16$ to $1/8$ of a turn (column must be in straight ahead position).

15. Remove the tilt release lever.

16. Install the directional signal switch as outlined under "Directional Signal Switch-Installation".

17. Column Shift Models - Install the shift lever and pivot pin.

18. Install the neutral-safety or back-up lamp switch.

19. Remove the column from the bench vise.

COLUMN INSTALLATION

Mandatory Sequence P Series (Fig. 3B-89)

CAUTION: See CAUTION note on page 1 of this section regarding the fasteners referred to in steps 1, 2, 3 and 10.

1. Applying 50 lbs. force on the steering wheel end of the steering shaft, adjust the lower bearing preload to allow steering shaft end play as indicated in Figure 3B-38. Tighten the shaft clamp on pot joint bolt to specifications.

2. From the passenger side of the dash panel, carefully insert the lower end of the steering column through the toe panel opening.

Guide the steering shaft into the universal yoke, lining up the marks made at removal. Install the

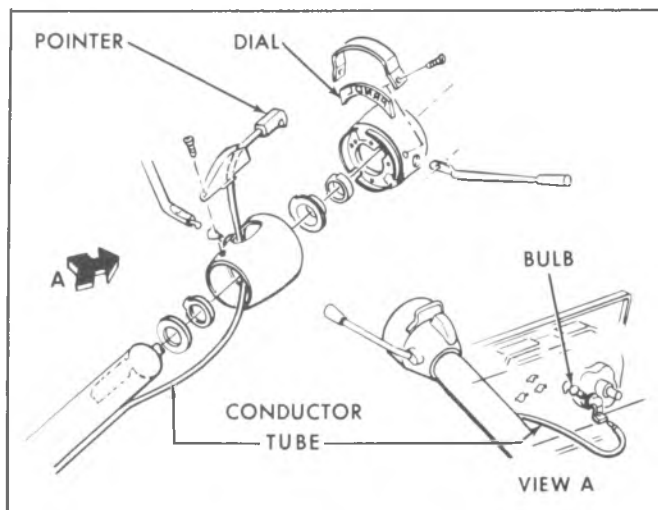


Fig. 3B-102-Conductor Tube for Automatic Transmission Indicator

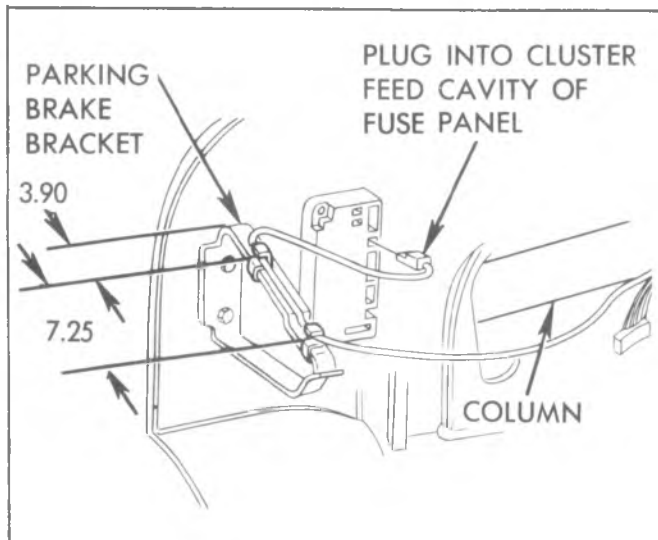


Fig. 3B-103-Tilt Column Shift Indicator Light

yoke pinch bolt and torque to specifications. The pinch bolt must pass through the shaft undercut.

3. Position and attach the lower clamp mounting bracket to the firewall. Locate the steering column protrusions against the toe pan bracket while at the same time, aligning protrusion in brake and clutch pedal support with index slot in the steering column, as shown in Figure 3B-89. Install the column to bracket clamp and torque the clamp bolt to specifications.

NOTE: The toe pan bracket must not override the protrusions on the steering column.

4. Position the steering column to dash panel bracket, install the attaching bolts and torque to specifications.

5. If plastic spacers were used on the flexible coupling alignment pins, remove the spacers after all bolts have been properly torqued.

6. Install the seal at the toe pan and then install the toe pan bracket screws; torque to specifications.

7. Install the dash panel trim plate (if so equipped).

8. Connect the transmission shift linkage on column shift models.

9. All Columns - Connect the directional signal wiring harness.

Standard Column with Automatic Transmission - Connect the conductor tube (for transmission indicator) at the instrument panel (fig. 3B-102).

10. Install steering wheel as outlined under "Steering Wheel-Installation".

11. Connect battery ground cable.

Mandatory Installation Sequence-G Series

CAUTION: See *CAUTION* on page 1 of this section regarding the fasteners referred to in steps 3 and 10.

1. Adjust the column lower bearing preload by applying a force on the steering wheel end of the

steering shaft (A). Position the spring and clamp to maintain the dimension as shown in Figure 3B-38.

2. Install the plastic spacers onto the flexible coupling alignment pins.

3. From inside the vehicle, carefully insert the lower end of the column through the toe pan opening guiding the steering shaft flange onto the flexible coupling. Install and torque the glange to coupling bolts.

4. Locate the index slot in the column jacket with the protrusion on the clutch and brake pedal support.

5. Loosely install the column dash bracket and screws.

6. Push the column down until the steering shaft flange bottoms on the plastic spacers on the flexible coupling and then torque the dash bracket screws.

7. Remove the plastic spacer from the alignment pins using a wire hook. Check the rag joint to steering shaft flange clearance (.25" to .325"), if not within specifications, the dash bracket screws must be loosened and the column raised or lowered as required. Retorque the bracket screws.

CAUTION: The alignment pin plastic spacers must be removed before the vehicle can be driven.

8. Push the tow pan seal to the toe pan, install and torque the mounting screws.

9. All Columns - Connect the directional signal switch wiring harness.

Automatic Columns-Connect the conductor tube (for transmission indicator) to the instrument panel.

10. Install the steering wheel as outlined under "Steering Wheel Installation".

11. Connect the transmission linkage.

12. Connect the battery ground cable.

STEERING LINKAGE

CAUTION: See *CAUTION* on page 1 of this section regarding all fasteners referred to in servicing steering linkage components.

Tie Rods

Removal

1. Raise vehicle on hoist.
2. Remove cotter pins from ball studs and remove castellated nuts.

3. To remove outer ball stud, tap on steering arm at tie rod end with a hammer while using a heavy hammer or similar tool as a backing (fig. 3B-105).

4. Remove inner ball stud from relay rod using same procedure as described in Step 3.

5. To remove tire rod ends from tie rod, loosen clamp bolts and unscrew end assemblies.

Installation

CAUTION: See the *CAUTION* on page 1 of this section regarding the fasteners referred to in steps 4 and 6.

NOTE: Tie rod adjuster components often become rusted in service. In such cases, it is recommended

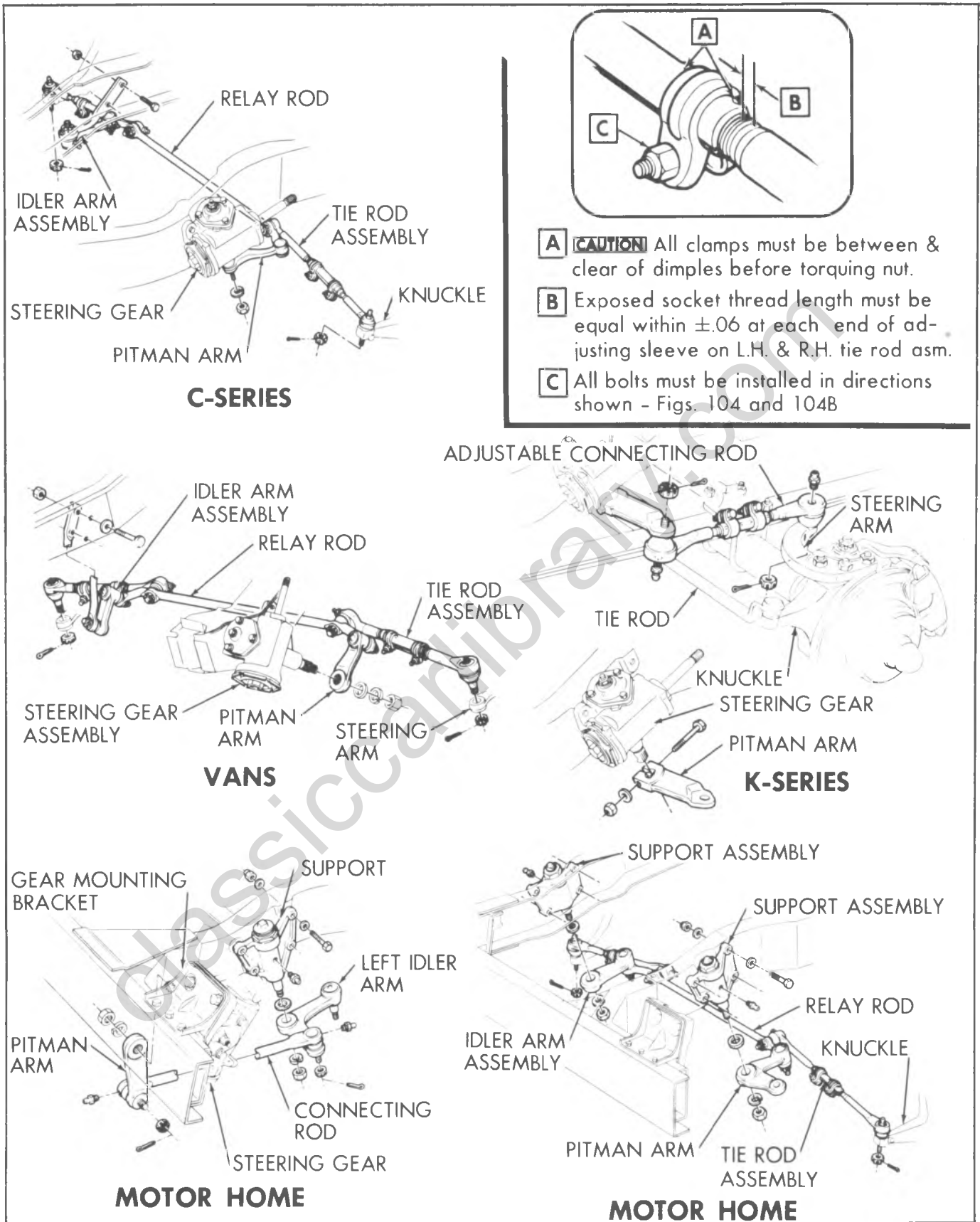


Fig. 3B-104-Steering Linkage



Fig. 3B-105-Ball Stud Removal-Typical

that if the torque required to remove the nut from the bolt after breakaway exceed 7 pounds, discard the nuts and bolts. Apply penetrating oil between the clamp and tube and rotate the clamps until they move freely. Install new bolts and nuts having the same part number to assure proper clamping at the specified nut torque.

CAUTION: As a guide to correct orientation of the inner tie rod end relative to the outer tie rod end, rotate both ends to the extremes of travel in the same direction before clamping. The position of each tie rod end must be maintained as the clamps are tightened to ensure free movement of each joint. Return the rod assembly to midposition of its travel. This should result in the inner and outer ball studs being retained in a parallel relationship with the intermediate (relay) rod and steering knuckle (arm) respectively. The following procedure should be used when installing tie rods.

1. If the tie rod ends were removed, lubricate the tie rod threads with EP Chassis lube and install ends on tie rod making sure both ends are threaded an equal distance from the tie rod.
2. Make sure that threads on ball studs and in ball stud nuts are perfectly clean and smooth. Check condition of ball stud seals; replace if necessary.

NOTE: Tool J-24434 may be used to install ball stud seals.

- If threads are not clean and smooth, ball studs may turn in tie rod ends when attempting to tighten nut.
3. Install ball studs in steering arms and relay rod.

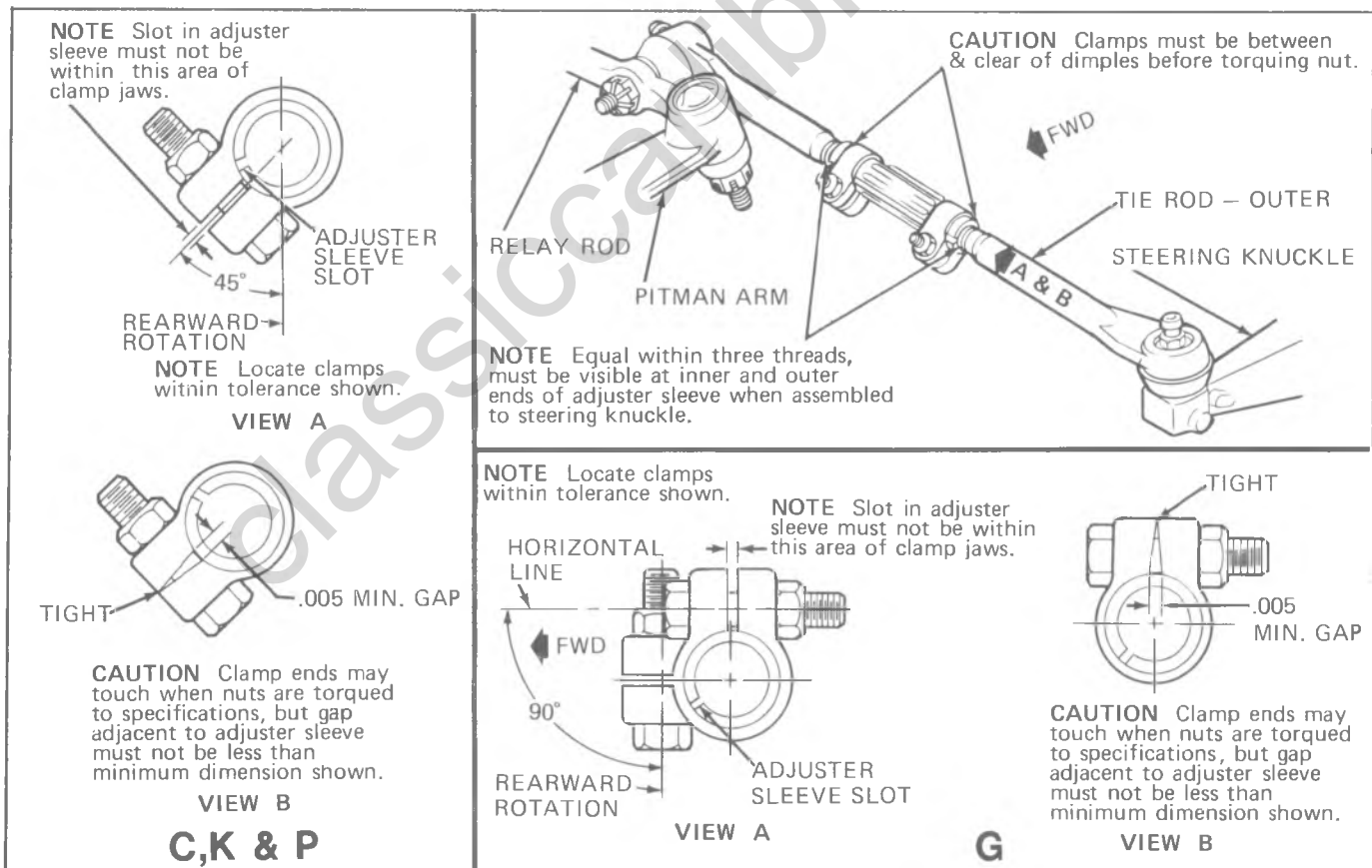


Fig. 3B-106-Tie Rod Clamp Relationship

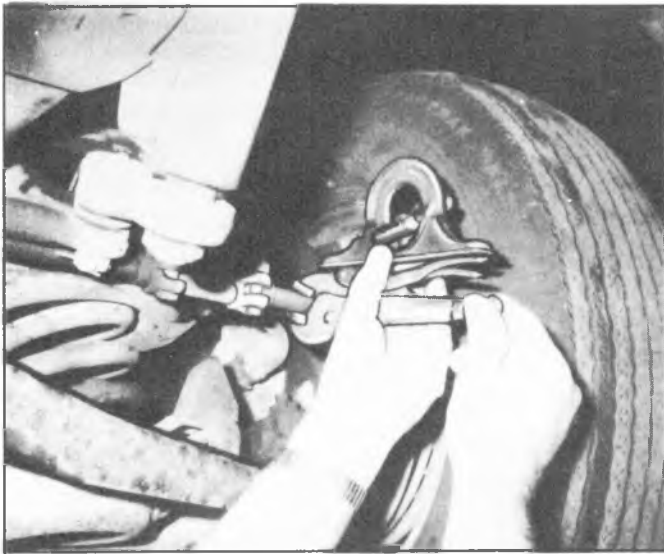


Fig. 3B-107--Tie Rod Inspection

4. Install bass stud nut, tighten to specifications and install new cotter pins; see Specifications Section at rear of this Section. Lubricate tie rod ends.

NOTE: Never back off nut to align the cotter pin, always tighten nut to next slot that lines up with hole in stud.

5. Adjust toe-in as described in Section 3A.

CAUTION: Before tightening the tie rod adjusting sleeve clamp bolts, be sure that the following conditions have been met:

- The sleeve clamps must be positioned between the locating dimples at either end of the sleeve.
- The clamps must be positioned within the angular travel indicated in Figure 3B-106.
- The relationship of the clamp slot with the slit in the sleeve should be maintained as shown in Figure 3B-106.
- Rotate both inner and outer tie rod housing rearward to the limit of ball joint travel before tightening clamps. Tighten clamps to specifications. Return tie rod assembly to the center of travel.
- All procedures for alignment, adjustment and assembly of tie rods applies to each side.
- Check each assembly to be sure that a total travel of at least 35° can be obtained using a bubble protractor and a pair of vise grips (Fig. 3B-107).

Inspection

To ensure proper installation, it is necessary to perform the following inspection after any change of toe setting or removal of any ball stud:

- Check the total rotation of the tie rod assembly using the following procedure:
 - Lubricate inner and outer tie rod ends.
 - Attach vise grip pliers to the outer tie rod end.
 - Rotate outer tie rod end counterclockwise (up) to maximum position. Attach bevel protractor as shown

in Figure 3B-107. Center protractor bubble indicator and record reading.

d. Rotate tie rod end clockwise (down) to maximum position. Center protractor bubble indicator and record reading.

e. Compare protractor readings obtained in Steps c and d. Total rotation of tie rod assembly should measure at least 35°.

f. If rotation is less than 35°, loosen one tie rod sleeve clamp and rotate both tie rod ends to their maximum limit **both ends must be rotated in the same direction**

g. Tighten tie rod clamp and again rotate both ends to their maximum limits, repeating Steps c and d. This recheck of total rotation will result in a minimum of 35° travel.

h. After obtaining the correct amount of rotation (35° or greater), position the outer tie rod end approximately midway in this travel.

If rotating checks, outlined above, reveal a rough or lumpy feel, the inner or outer tie rod end assembly may have excessive wear and should be replaced.

If all of the above mentioned conditions are met, proper tie rod installation is assured.

Relay Rod

Removal

- Raise vehicle on hoist.
- Remove inner ends of the tie rods from relay rod as described under "Tie Rod-Removal".
- Remove the cotter pins from the pitman and idler arm ball studs at the relay rod. Remove the castellated nuts.
- Remove the relay rod from the pitman and idler arms by tapping on the relay rod ball stud bosses with a hammer, while using a heavy hammer as a backing (fig. 3B-105).
- Remove the relay rod from the vehicle.

Installation

CAUTION: See the **CAUTION** on page 1 of this section regarding the fasteners referred to in steps 2 and 3.

- Make sure that threads on the ball studs and in the ball stud nuts are perfectly clean and smooth. Check condition of ball stud seals; replace if necessary.

NOTE: If threads are not clean and smooth, ball studs may turn in sockets when attempting to tighten nut.

- Install the relay rod to the idler arm and pitman arm ball studs, making certain the seals are in place. Install and torque the nut to specifications and then install the cotter pin.

NOTE: Never back off the nut to align cotter pin, always tighten nut to next slot that lines up with hole in stud.

- Install the tie rods to the relay rod as previously

described under "Tie Rod- Installation". Lubricate the tie rod ends.

4. Lower the vehicle to the floor.

5. Adjust toe-in (see Section 3A) and align steering wheel as described previously in this section under "Steering Wheel Alignment and High Point Centering".

Idler Arm

Use of the proper diagnosis and checking procedure is essential to prevent needless replacement of good idler arms.

1. Raise the vehicle in such a manner as to allow the front wheels to rotate freely and the steering mechanism freedom to turn. Position the wheels in a straight ahead position.

2. Using a push pull type spring scale located as near the relay rod end of the idler arm as possible, exert a 25 lb. force upward and then downward while noticing the total distance the end of the arm moves. This distance should not exceed $\pm 1/8$ inch for a total acceptable movement of $1/4$ inch (Figure 3B-108). It is necessary to ensure that the correct load is applied to the arm since it will move more when higher loads are applied. It is also necessary that a scale or ruler be rested against the frame and used to determine the amount of movement since observers tend to over-estimate the actual movement when a scale is not used. The idler arm should always be replaced if it fails this test.

NOTE: Jerking the right front wheel and tire assembly back and forth thus causing an up and down movement in the idler arm is not an acceptable method of checking since there is no control on the amount of force being applied.

Caution should be used in assuming shimmy complaints are caused by loose idler arms. Before

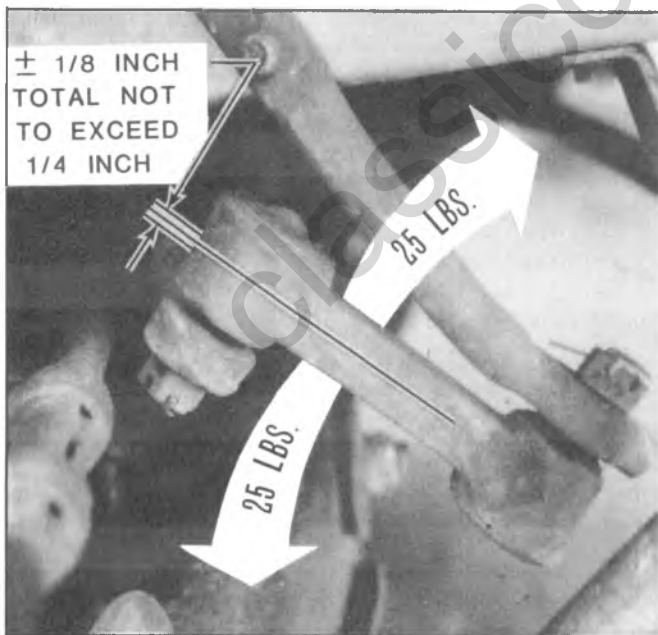


Fig. 3B-108-Checking Idler Movement

suspecting suspension or steering components, technicians should eliminate shimmy excitation factors, such as dynamic imbalance, run-out or force variation of wheel and tire assemblies and road surface irregularities.

Removal

1. Raise vehicle on a hoist.

2. Remove the cotter pin and castellated nut from ball stud at the relay rod. Remove the ball stud from the relay rod by tapping on the relay rod boss with a hammer, while using a heavy hammer as a backing (fig. 3B-105).

3. Remove the idler arm to frame bolt and remove the idler arm assembly.

Installation

CAUTION: See the CAUTION on page 1 of this section regarding the fasteners referred to in steps 1 and 3.

1. Position the idler arm on the frame and install the mounting bolts (special plain washers under bolt heads); torque the nuts to specifications.

2. Make sure that the threads on the ball stud and in the ball stud nut are perfectly clean and smooth. Check condition of ball stud seal; replace if necessary.

NOTE: If threads are not clean and smooth, ball stud may turn in the socket when attempting to tighten nut.

3. Install the idler arm ball stud in the relay rod, making certain the seal is positioned properly; install the nut and torque to specifications.

NOTE: Never back off nut to align cotter pin, always tighten nut to the next slot that lines up with the hole in the stud.

4. Install cotter pin.

5. Lower the vehicle to the floor.

Pitman Arm

Removal

1. Raise vehicle on hoist.

2. Remove cotter pin from pitman arm ball stud and remove nut.

3. Remove pitman arm or relay rod from ball stud by tapping on side of rod or arm (in which the stud mounts) with a hammer while using a heavy hammer or similar tool as a backing (fig. 3B-105). Pull on linkage to remove from stud.

4. Remove pitman arm nut from pitman shaft or clamp bolt from pitman arm, and mark relation of arm position to shaft.

5. Remove pitman arm, using Tool J-6632 or J-5504 (Fig. 3B-50).

Installation

CAUTION: See the CAUTION on page 1 of this section regarding the fasteners referred to in steps 3 and 4.

1. Install pitman arm on pitman shaft, lining up the marks made upon removal.

CAUTION: *If a clamp type pitman arm is used, spread the pitman arm just enough, with a wedge, to slip arm onto pitman shaft. Do not spread pitman arm more than required to slip over pitman shaft with hand pressure. Do not hammer or damage to steering gear may result. Be sure to install the hardened steel washer before installing the nut.*

2. Make sure that threads on ball studs and in ball stud nuts are clean and smooth. Check condition of ball stud seals; replace if necessary.

NOTE: If threads are not clean and smooth, ball studs may turn in sockets when attempting to tighten nut.

3. Install pitman shaft nut or pitman arm clamp bolt and torque to specifications.

4. Position ball stud onto pitman arm or relay rod. Install nut and torque to specifications.

5. Install cotter pin.

NOTE: Never back off nut to align cotter pin, always tighten nut to next slot that lines up with hole in stud.

6. Lubricate ball studs.

7. Lower the vehicle to the floor.

Steering Connecting Rod

Removal

1. Remove cotter pins from ball studs and remove castellated nuts.

2. Remove ball studs from steering arm and pitman arm boss with a heavy hammer and striking other side of boss with lighter hammer (similar to method shown in (fig. 3B-105).

Installation

CAUTION: *See the CAUTION on page 1 of this section regarding the fasteners referred to in step 3.*

1. Make sure that threads on ball studs and in ball stud nuts are clean and smooth. Check condition of ball stud seals—replace if necessary.

NOTE: If threads are not clean and smooth, ball studs may turn in connecting rod when attempting to tighten nut.

2. Install ball studs in steering arm and pitman arm. Be sure to install the long end of the connecting rod assembly to the pitman arm.

3. Install ball stud nuts and torque to specifications.

NOTE: Never back off nut to align cotter pin, always tighten nut to next slot that lines up with hole in stud.

4. Install cotter pins and lubricate ball studs.

NOTE: For proper alignment and orientation of connecting rod clamps see figure 3B-109.

POWER STEERING SYSTEM

Power Steering Gear

Removal

1. Disconnect hoses at gear. When hoses are disconnected, secure ends in raised position or prevent drainage of oil. Cap or tape the ends of the hoses to prevent entrance of dirt.

2. Install two plugs in gear fittings to prevent entrance of dirt.

3. Remove the flexible coupling to steering shaft flange bolts (G, C and K models) or the lower universal joint pinch bolt (P models). Mark the relationship of the universal yoke to the stub shaft.

4. Mark the relationship of the pitman arm to the pitman shaft. Remove the pitman shaft nut or pitman arm pinch bolt and then remove the pitman arm from the pitman shaft using Puller J-6632 (fig. 3B-50).

5. Remove the steering gear to frame bolts and remove the gear assembly.

6. G, C and K Models - Remove the flexible coupling pinch bolt and remove the coupling from the steering gear stub shaft.

Installation (Fig. 3B-110)

CAUTION: *See CAUTION on page 1 of this section regarding the fasteners referred to in steps 1, 3, 4 and 5.*

1. Install the flexible coupling onto the steering gear stub shaft, aligning the flat in the coupling with the flat on the shaft. Push the coupling onto the shaft until the stub shaft bottoms on the coupling reinforcement. Install the pinch bolt and torque to specifications.

NOTE: The coupling bolt must pass through the shaft undercut.

2. Place the steering gear in position, guiding the coupling bolt into the steering shaft flange.

3. Install the steering gear to frame bolts and torque to specifications.

4. If flexible coupling alignment pin plastic spacers were used, make sure they are bottomed on the pins, tighten the flange bolt nuts to specifications and then remove the plastic spacers.

5. If flexible coupling alignment pin plastic spacers were not used, center the pins in the slots in the steering shaft flange and then install and torque the flange bolt nuts to specifications.

P Models

a. Place the steering gear in position, guiding the stub shaft into the universal joint assembly and lining up the marks made at removal.

NOTE: If a new gear was installed, line up the mark on the stub shaft with the mark on the universal yoke.

b. Install the steering gear to frame bolts and torque to specifications.

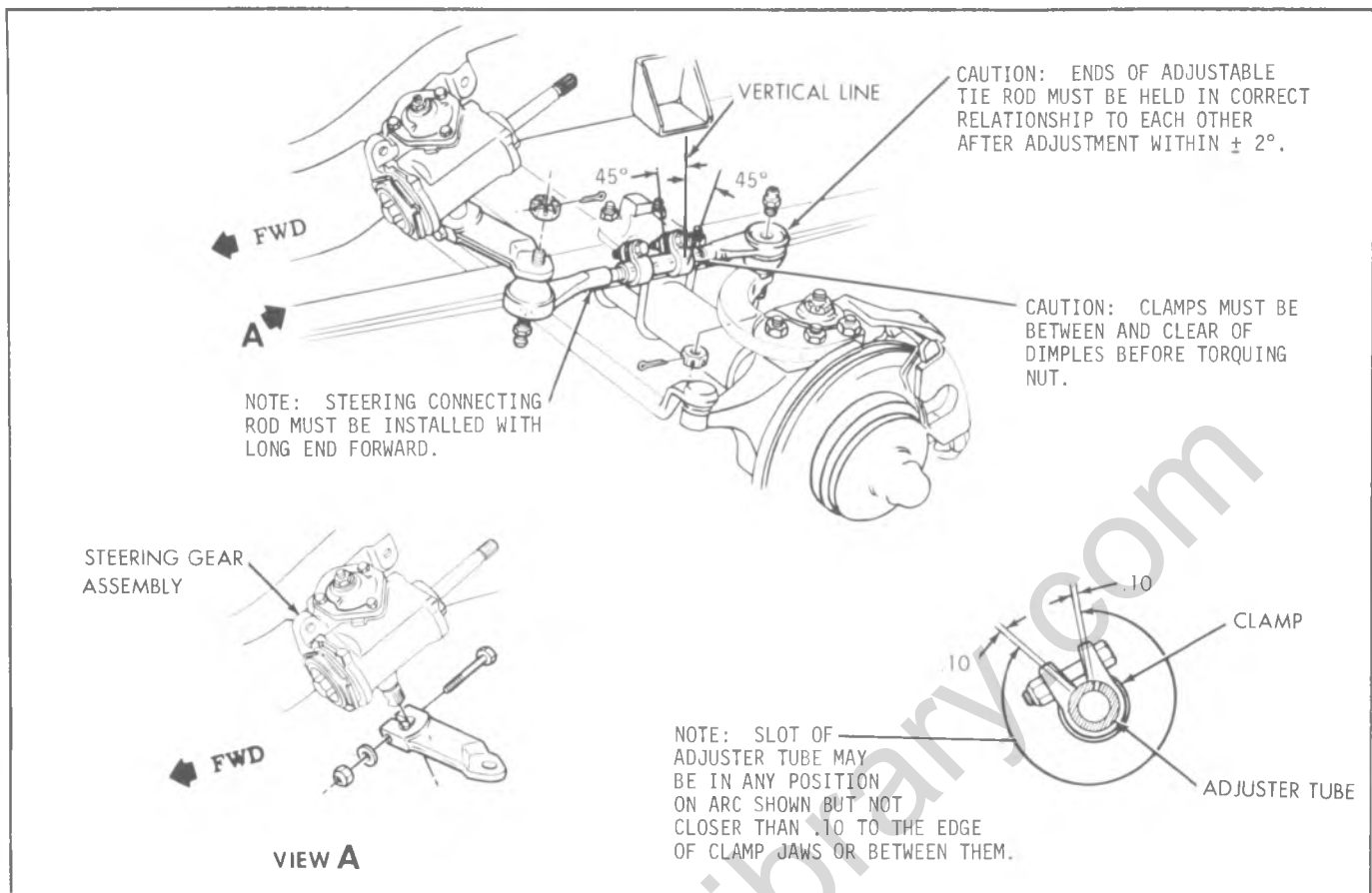


Fig. 3B-109--Adjustable Connecting Rod Assembly-K Series

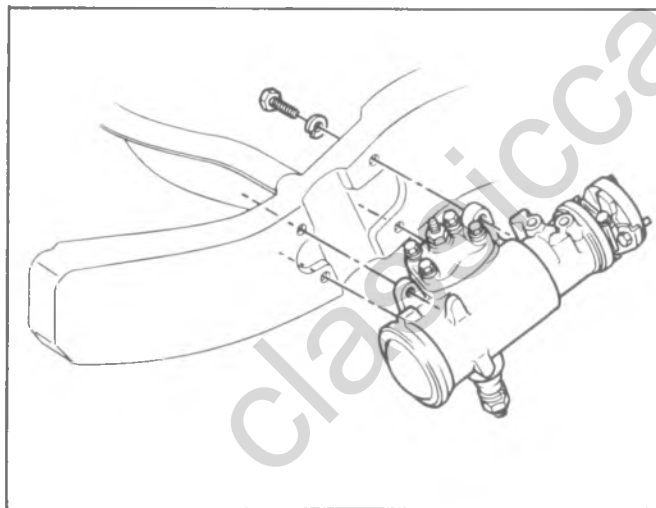


Fig. 3B-110--Power Steering Gear Mounting-Typical

c. Install the universal joint pinch bolt and torque to specification.

NOTE: The pinch bolt must pass through the shaft undercut.

All Models

6. Install the pitman arm onto the pitman shaft, lining up the marks made at removal. Install the pitman shaft nut or pitman arm pinch bolt and torque to specifications.

7. Remove the plugs and caps from the steering gear and hoses and connect the hoses to the gear. Tighten the hose fittings to specified torque.

Power Steering Pump (Fig. 3B-111 through 3B-117)

Removal

1. Disconnect hoses at pump. When hoses are disconnected, secure ends in raised position to prevent drainage of oil. Cap or tape the ends of the hoses to prevent entrance of dirt.

On Models with remote reservoir, disconnect reservoir hose at pump and secure in raised position. Cap hose pump fittings.

2. Install two caps at pump fittings to prevent drainage of oil from pump.

3. Loosen bracket-to-pump mounting nuts.

4. Remove pump belt.

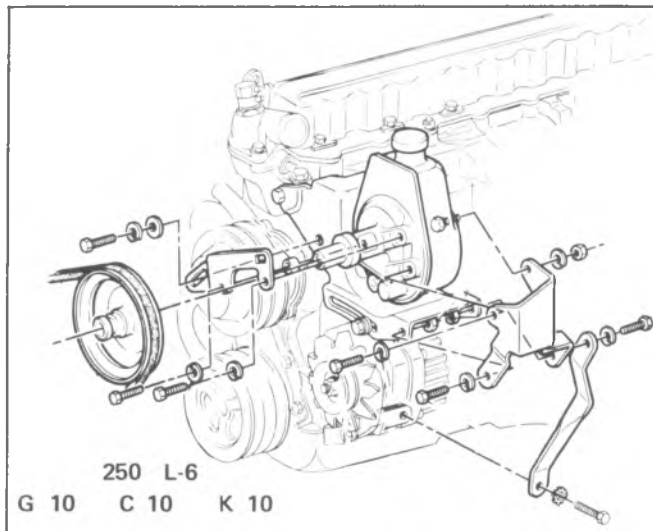


Fig. 3B-111--Power Steering Pump-250 L-6

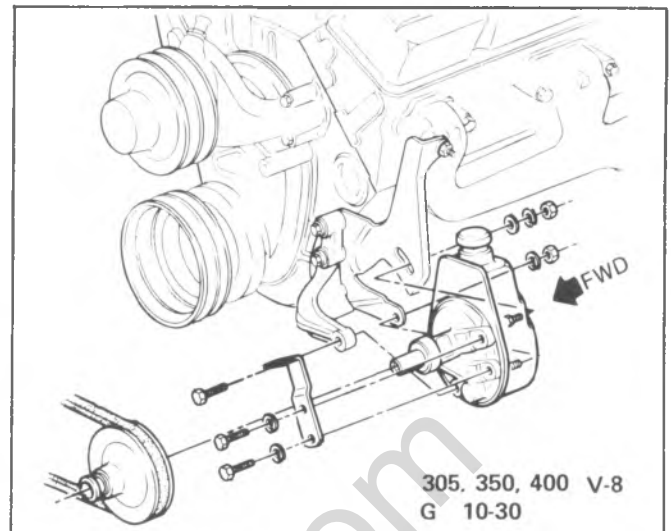


Fig. 3B-113--Power Steering Pump-G Series

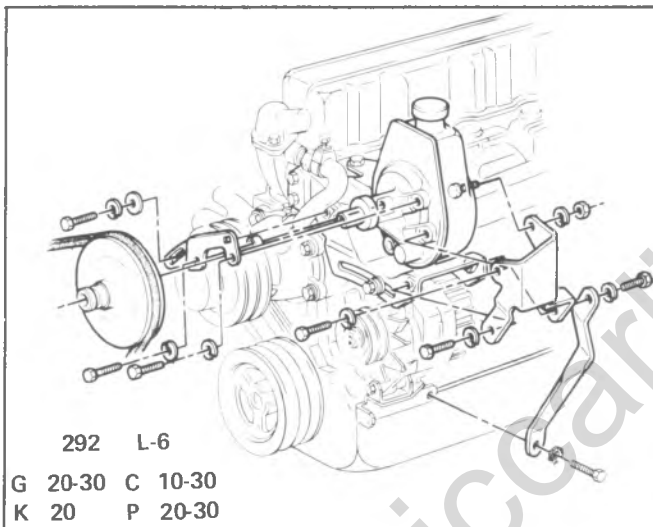


Fig. 3B-112--Power Steering Pump 292 L-6

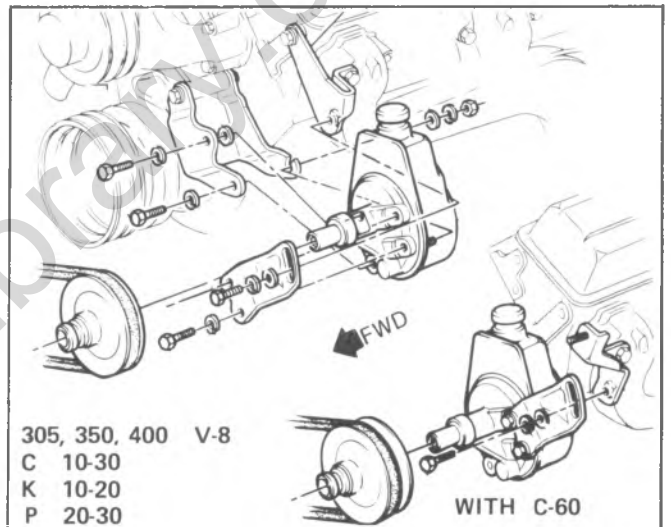


Fig. 3B-114--Power Steering Pump-C, K P Series

5. Remove pump from attaching parts and remove pump from vehicle.

Installation

1. Position pump assembly on vehicle and install attaching parts loosely.
2. Connect and tighten hose fittings.
3. Fill reservoir. Bleed pump by turning pulley backward (counter-clockwise as viewed from front) until air bubbles cease to appear.
4. Install pump belt over pulley.
5. Tension belt as outlined under "Pump Belt Tension-Adjustment" in this section.
6. Bleed as outlined under "Bleeding Power Steering Systems."

Power Steering Hoses

When servicing the power steering hoses be sure to align the hoses in their correct position as shown in Figs. 3B-118-3B-133.

It is important that the power steering hoses be installed correctly. Hoses installed out of position may be subjected to chafing or other abuses during sharp turns. Do not twist hoses unnecessarily during installation.

CAUTION: Do not start engine with any power steering hose disconnected.

Bleeding Power Steering Systems

When a power steering pump or power gear has been installed, the air that has entered the system must be bled out before the vehicle is again operated. If air is allowed to remain in the power steering fluid system, moisy and unsatisfactory operation of the system will result. Bleed air from the hydraulic system as follows:

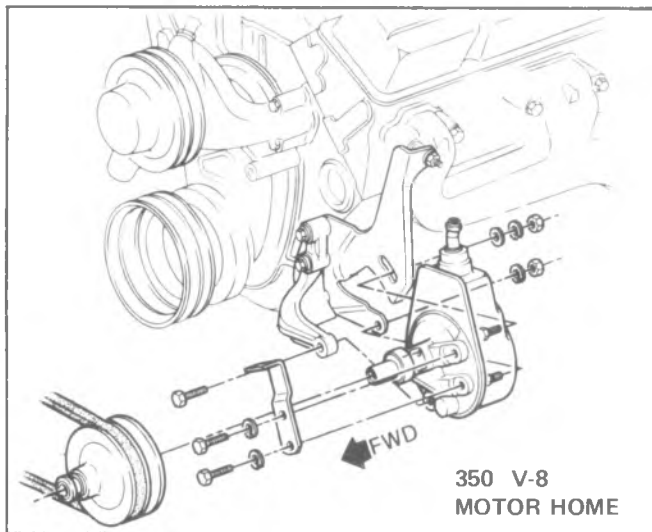


Fig. 3B-115-Power Steering Pump-350 V-8 Motor Home

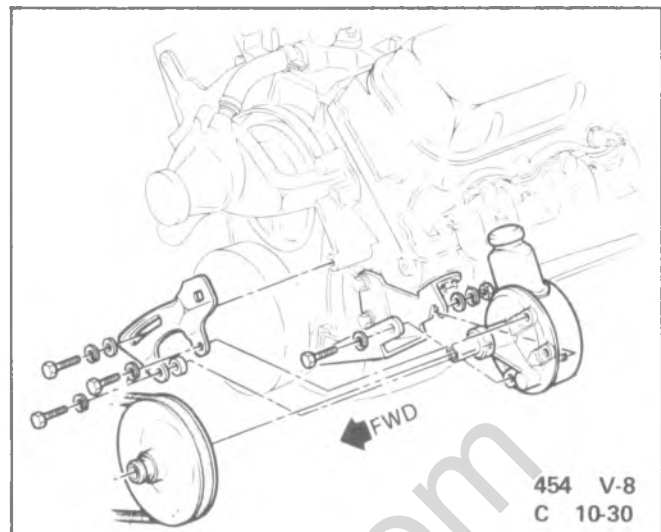


Fig. 3B-116-Power Steering Pump-454 V-8

NOTE: When power steering fluid is added to power steering system, only clean new power steering fluid should be used.

1. Fill oil reservoir to proper level and let oil remain undisturbed for at least two minutes.
2. Start engine and run momentarily.
3. Add oil, if necessary.
4. Repeat above procedure until oil level remains constant after running engine.
5. Raise front end of vehicle so that wheels are off the ground.
6. Turn the wheels (off ground) right and left, lightly contacting the wheel stops.
7. Add oil if necessary.
8. Lower the vehicle and turn wheels right and left on the ground.
9. Check oil level and refill as required.
10. If oil is extremely foamy, allow vehicle to stand a few minutes with engine off and repeat above procedure.
 - a. Check belt tightness and check for a bent pulley. (Pulley should not wobble with engine running.).
 - b. Check to make sure hoses are not touching any other parts of the vehicle, particularly sheet metal.
 - c. Check oil level, filling to proper level if necessary, following operations 1 through 10. This step and Step "d" are extremely important as low oil level and/or air in the oil are the most frequent causes of objectionable pump noises.
 - d. Check the presence of air in the oil. Air will show up as milky appearing oil. If air is present, attempt to bleed system as described in operations 1 through 10.
11. The presence of trapped air in the system will cause the fluid level in the pump to rise when the engine is turned off. Continue to bleed system until this condition no longer occurs.

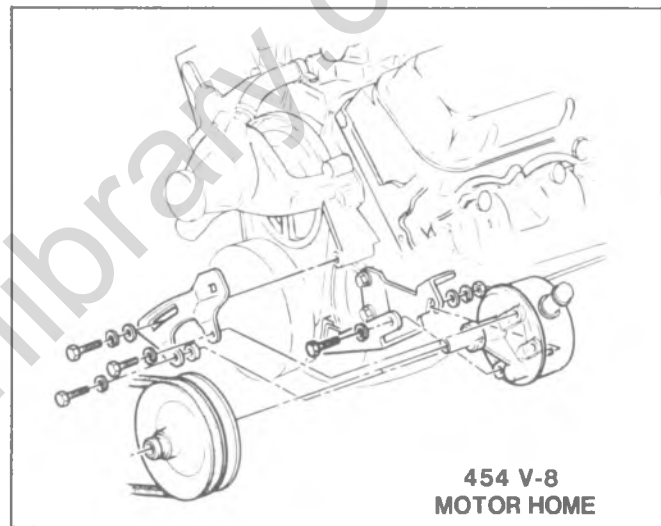


Fig. 3B-117-Power Steering Pump-454 V-8 Motor Home

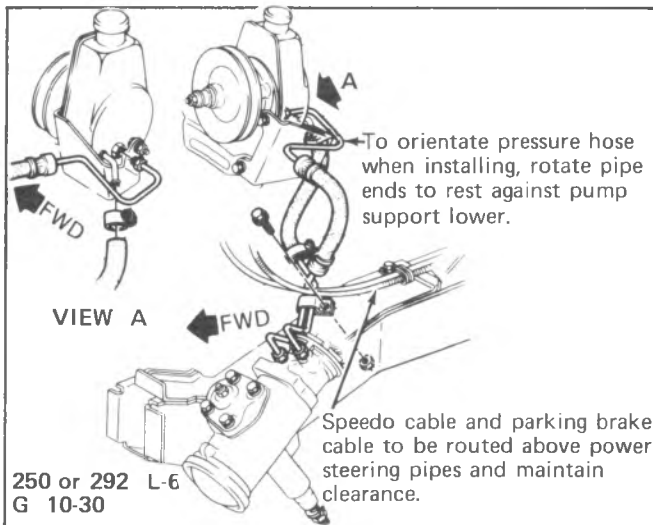


Fig. 3B-118--Power Steering Hose Routing

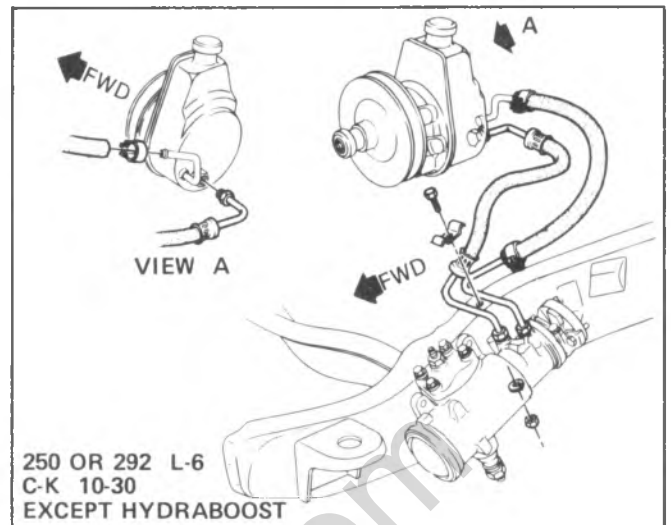


Fig. 3B-119--Power Steering Hose Routing

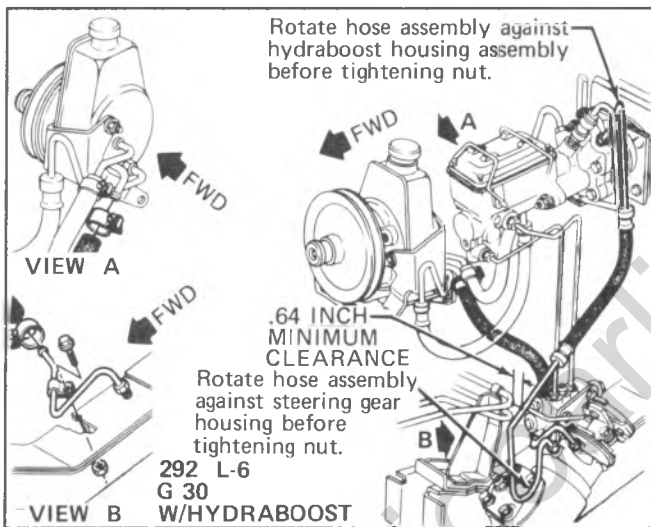


Fig. 3B-120--Power Steering Hose Routing

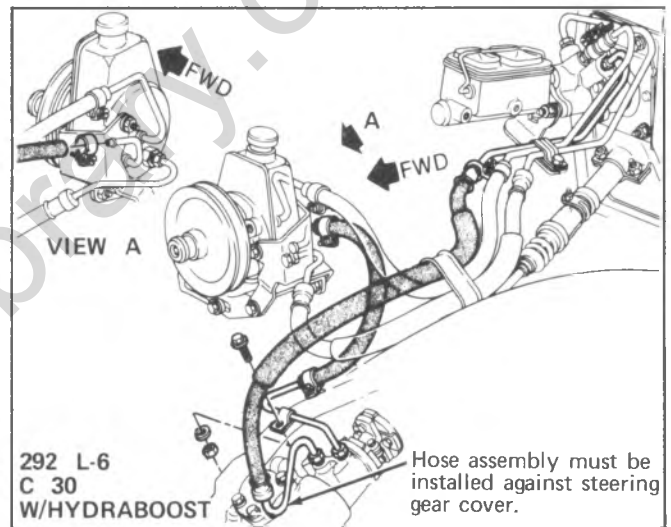


Fig. 3B-121--Power Steering Hose Routing

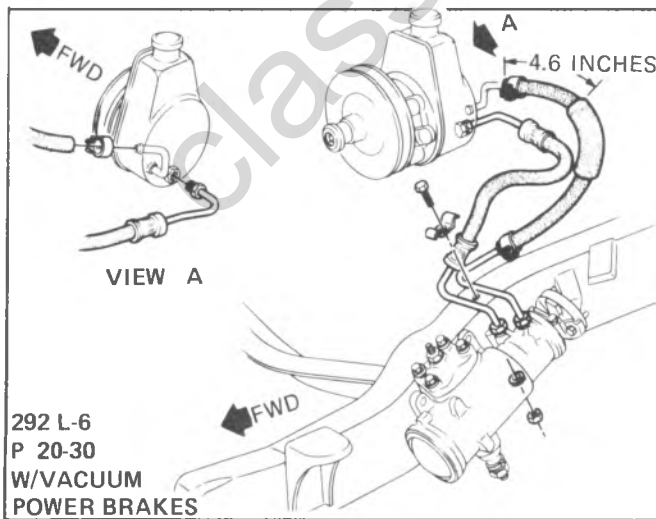


Fig. 3B-122--Power Steering Hose Routing

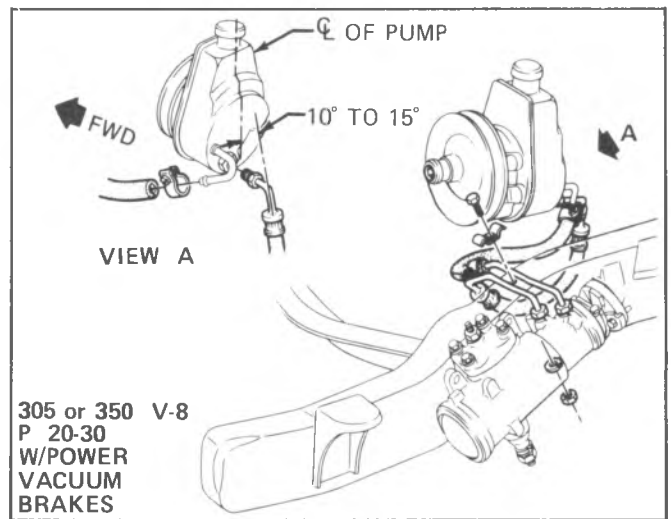


Fig. 3B-123--Power Steering Hose Routing

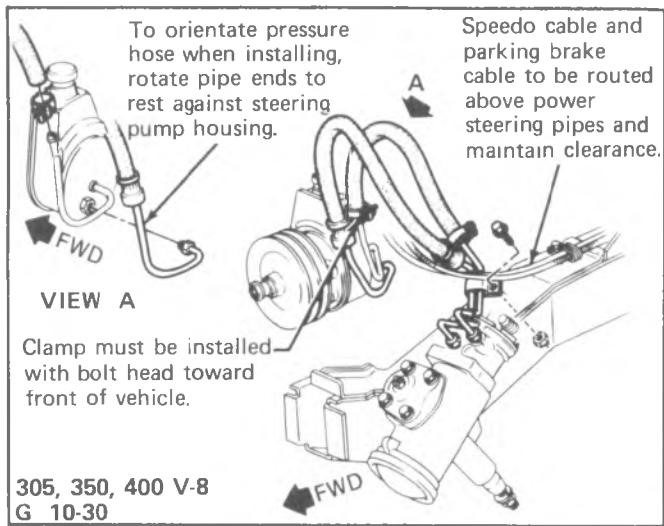


Fig. 3B-124--Power Steering Hose Routing

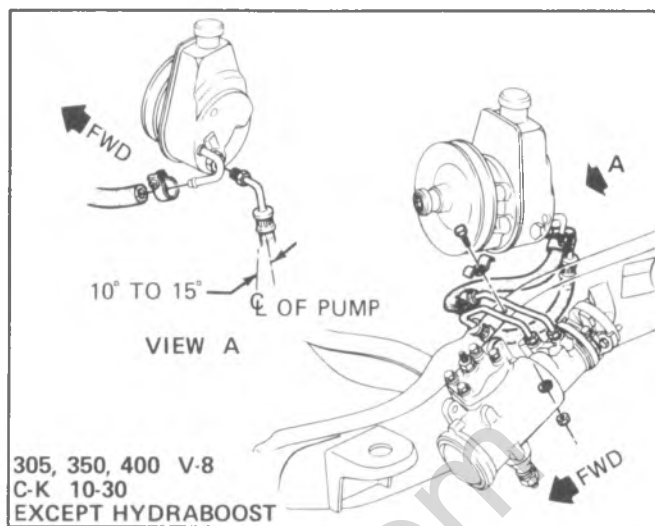


Fig. 3B-125--Power Steering Hose Routing

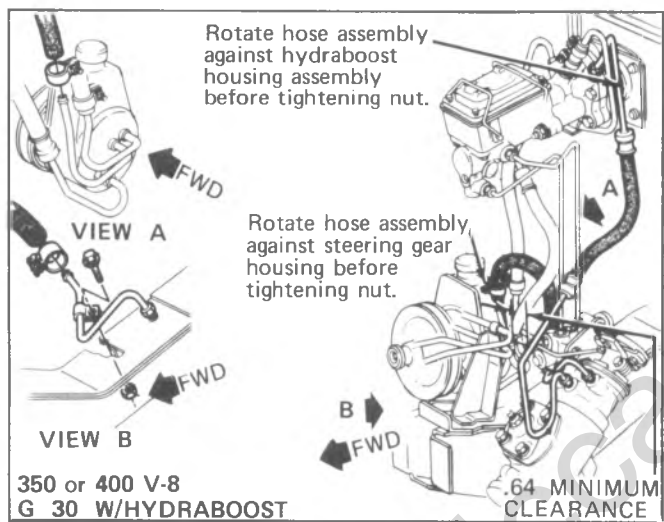


Fig. 3B-126--Power Steering Hose Routing

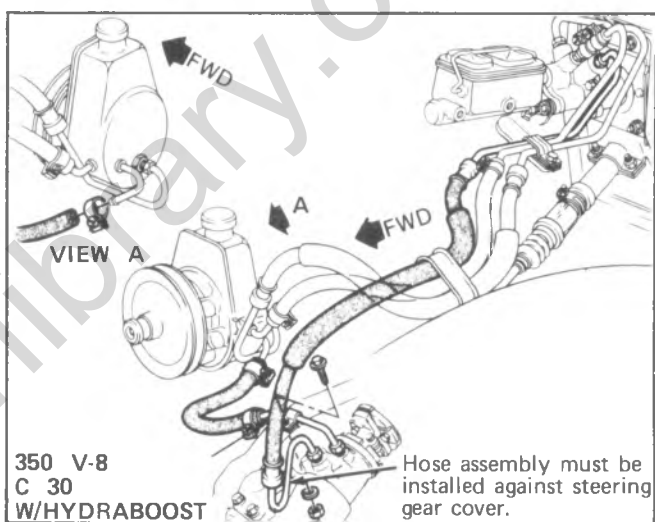


Fig. 3B-127--Power Steering Hose Routing

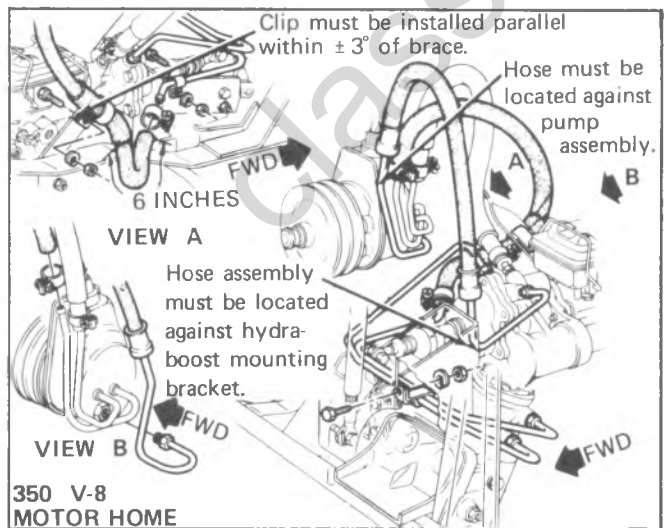


Fig. 3B-128--Power Steering HOse Routing

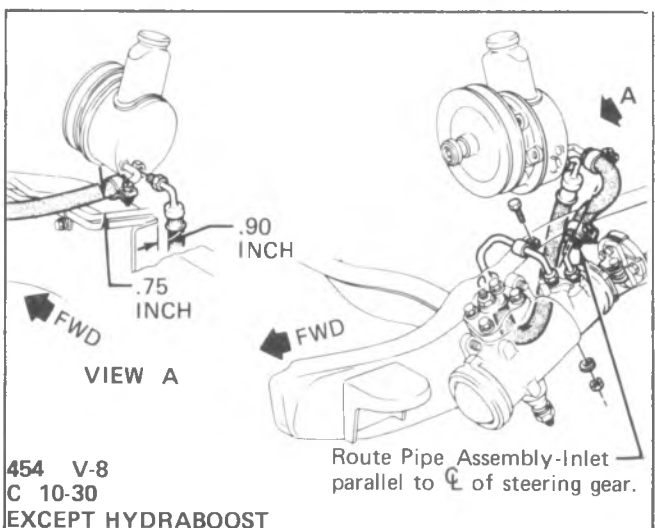


Fig. 3B-129--Power Steering Hose Routing

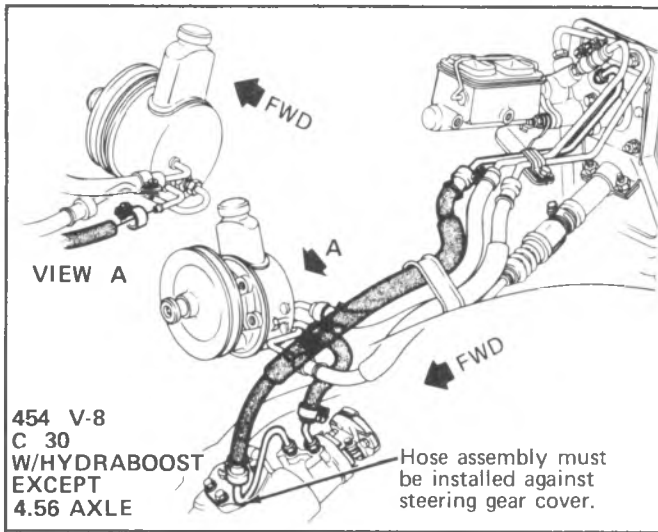


Fig. 3B-130-Power Steering Hose Routing

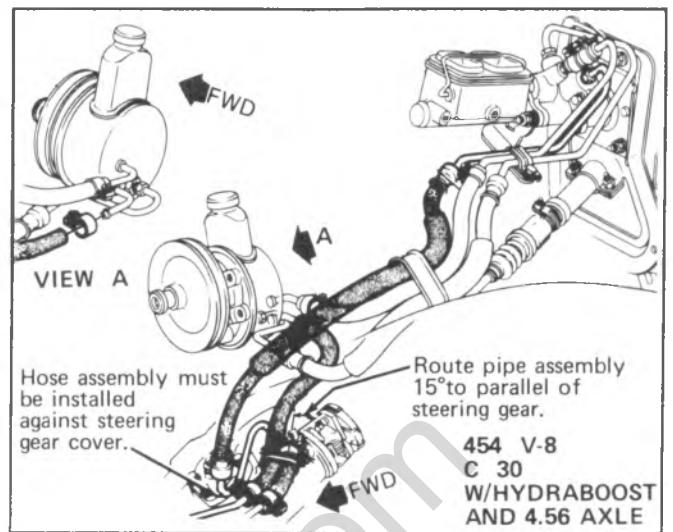


Fig. 3B-131-Power Steering Hose Routing

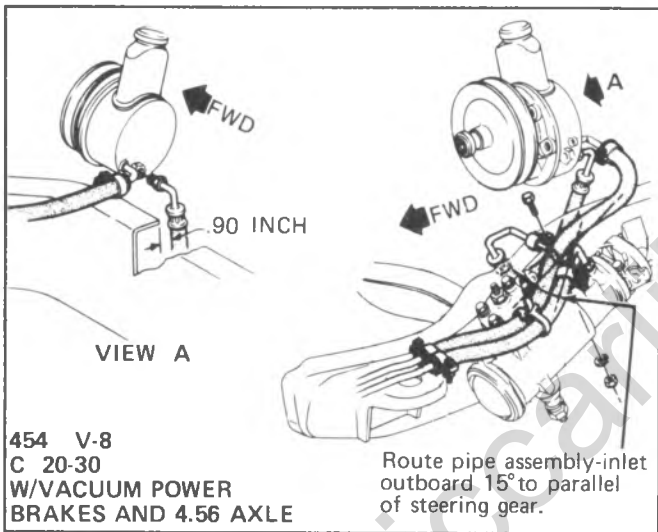


Fig. 3B-132-Power Steering Hose Routing

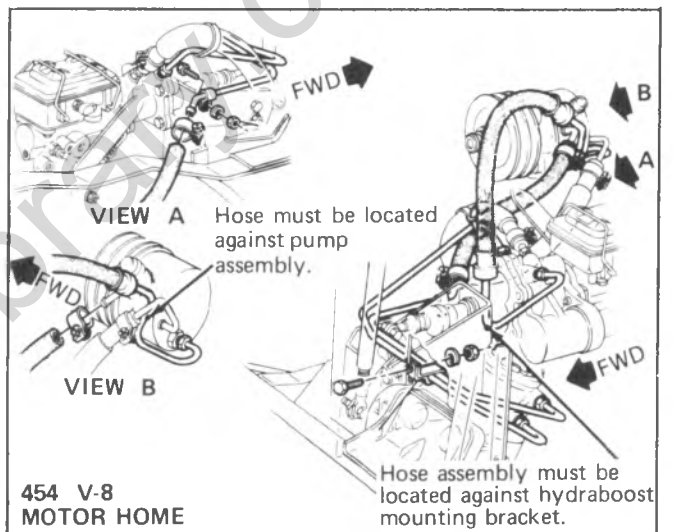


Fig. 3B-133-Power Steering Hose Routing

SPECIFICATIONS

STEERING GEAR RATIOS

Vehicle	Manual		Power	
	Gear Ratio	Overall Ratio	Gear Ratio	Overall Ratio
G10-20	24:1	29.4:1 to 36.7:1	14:1	21.4:1 to 26.7:1
G30	24:1	29.4:1 to 36.4:1	14:1	21.4:1 to 26.5:1
P10	24:1	29.1:1 to 35.5:1	17.5:1	21.2:1 to 25.7:1
P20-30	24:1	29.1:1 to 35.3:1	17.5:1	21.2:1 to 25.7:1
Motor Home	—	—	14:1	16.0:1 to 21.9:1
C 10	24:1	29.1:1 to 37.0:1	16:1 to 13:1	16.9:1 to 20.2:1
C20-30	24:1	29.4:1 to 36.3:1	16:1 to 13:1	17.2:1 to 20.6:1
K10-20	24:1	24.6:1 to 28.0:1	16:1 to 13:1	13.2:1 to 17.2:1

MANUAL STEERING GEAR

Components	G10 - 30	C10 - 30 P10	K10 - 20	P20 - 30
Thrust Bearing Preload	6 to 11 lbs. in.	4 to 6 lbs. in.		9 to 12 lbs. in.
Adjuster Plug Lock Nut	85 lbs. ft.			
Over Center Preload	5 to 11 lbs. in.*	4 to 10 lbs. in.*		9 to 13 lbs. in.*
Over Center Lock Nut	25 lbs. ft.			
Total Steering Gear Preload	18 lbs. in. Max.	14 lbs. in. Max.		25 lbs. in. Max.

*In excess of thrust bearing preload.

POWER STEERING GEAR

Components	All C, P, K and G
Steering Gear Ball Drag	3 lbs. in. Max.
Thrust Bearing Preload	1/2 to 2 lbs. in.*
Adjuster Plug Locknut	80 lbs. ft.
Over-Center Preload	5 lbs. in.
Over-Center Adjusting Screw Locknut	35 lbs. ft.
Total Steering Gear Preload	14 lbs. in. Max.

*In excess of ball drag.

**In excess of ball drag and thrust bearing preload.

POWER STEERING PUMP PRESSURES

Vehicle	Pressure
C10-30	1200 - 1300 psi
G10-20	900 - 1000 psi
G30	1200 - 1300 psi
P10-30	1200 - 1300 psi
Motor Home & K	1350 - 1450 psi

Special Tools



- | | | | | | |
|-----|---------|--------------------------------------|-----|----------|-------------------------------------|
| 1. | J-6632 | Pitman Arm Puller | 19. | J-6222 | Shaft Seal Protector |
| 2. | J-5504 | Pitman Arm Puller | 20. | J-23600 | Belt Tension Gauge |
| 3. | J-23073 | Shift Tube Installer | 21. | J-8947 | Rack-Piston Seal Compressor |
| 4. | J-23072 | Shift Tube Remover | 22. | J-5755 | Wormshaft Bearing Race Installer |
| 5. | J-5176 | Oil Pressure Gauge | 23. | J-2619 | Slide Hammer |
| 6. | J-5822 | Wormshaft Bearing Cup Remover | 24. | J-8092 | Handle |
| 7. | J-8433 | Pump Pulley Remover (Cast Pulley) | 25. | J-6278 | Pitman Shaft Bearing Remover |
| 8. | J-21854 | Column Pivot Pin Remover | 26. | J-6278-2 | Pitman Shaft Bearing Installer |
| 9. | J-23653 | Lock Plate Compressor | 27. | J-7079-2 | Handle |
| 10. | J-5421 | Thermometer | 28. | J-8524-1 | Adjuster Plug Bearing Installer |
| 11. | J-5860 | Torque Wrench Adapter | 29. | J-8524-2 | Adjuster Plug Bearing Remover |
| 12. | J-21239 | Pump Pulley Remover (Stamper Pulley) | 30. | J-6219 | Pitman Shaft Seal Installer |
| 13. | J-2927 | Steering Wheel Puller | 31. | J-22407 | Pitman Shaft Bearing Installer |
| 14. | J-1614 | Sector Shaft Bushing Remover | 32. | J-8937 | Ball Seal Remover |
| 15. | J-7539 | Ball Retainer | 33. | J-6217 | Connector Seat Installer |
| 16. | J-7624 | Spanner Wrench | 34. | J-23980 | Steering Column Electrical Analyzer |
| 17. | J-4245 | #23 Internal Pliers | 35. | | Torque Wrenches |
| 18. | J-22670 | Pump Shaft Seal Installer | | | |

Fig. 3B-134--Special Tools C & K

SPECIAL TOOLS

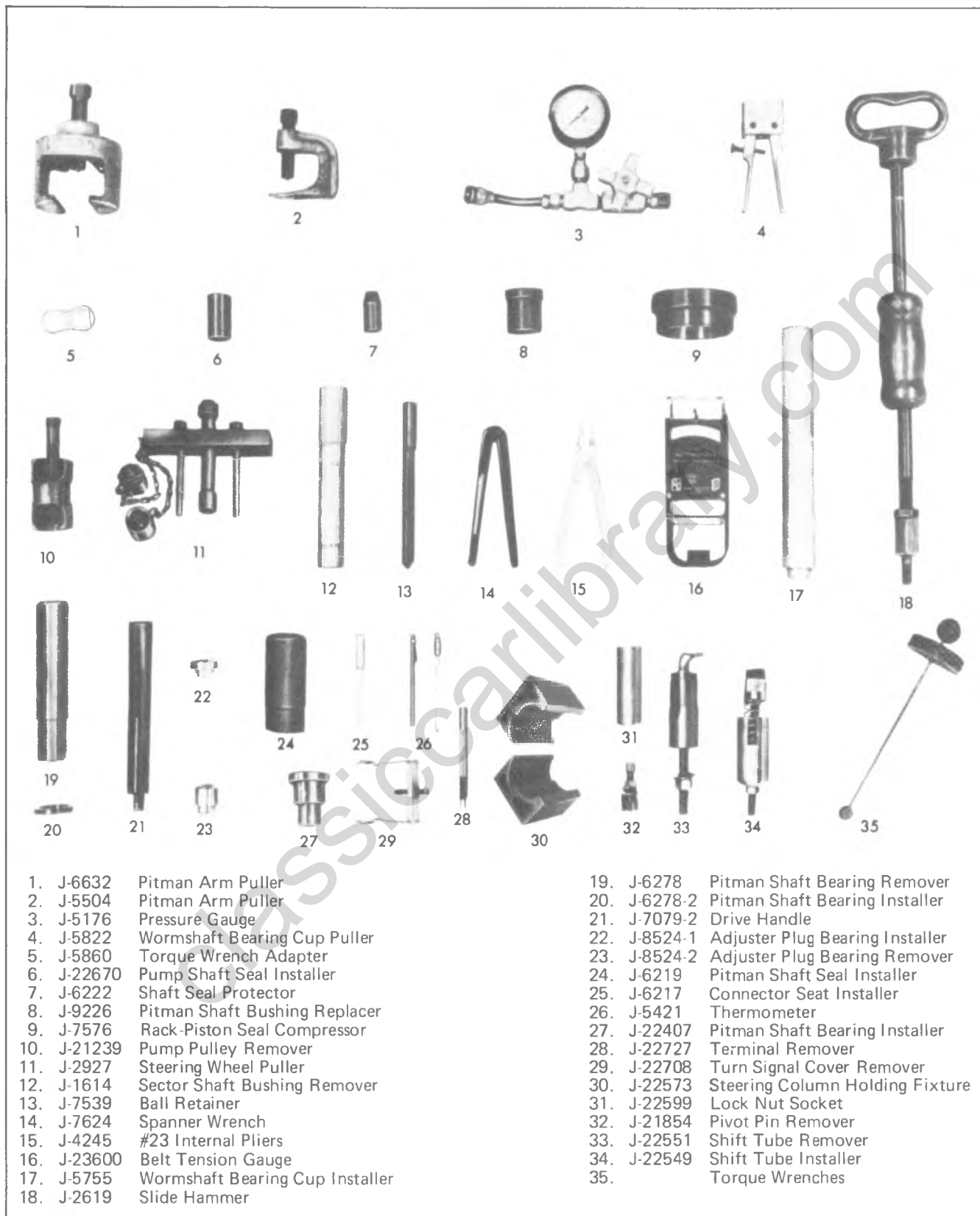


Fig. 3B-135--Special Tools G & P

SECTION 3C

FRONT SUSPENSION

The following caution applies to one or more steps in the assembly procedure of components in this portion of the manual as indicated at appropriate locations by the terminology "See Caution on page 1 of this section".

CAUTION: *THIS FASTENER IS AN IMPORTANT ATTACHING PART IN THAT IT COULD AFFECT THE PERFORMANCE OF VITAL COMPONENTS AND SYSTEMS, AND/OR COULD RESULT IN MAJOR REPAIR EXPENSE. IT MUST BE REPLACED WITH ONE OF THE SAME PART NUMBER OF WITH AN EQUIVALENT PART IF REPLACEMENT BECOMES NECESSARY. DO NOT USE A REPLACEMENT PART OF LESSER QUALITY OR SUBSTITUTE DESIGN. TORQUE VALUES MUST BE USED AS SPECIFIED DURING REASSEMBLY TO ASSURE PROPER RETENTION OF THIS PART.*

CONTENTS OF THIS SECTION

Front Suspension (C-G-P Series).....	3C-1
Front Suspension (K-Series).....	3C-24

FRONT SUSPENSION, TWO-WHEEL DRIVE

INDEX

General Description.....	3C-1	Upper Control Arm Shaft.....	3C-17
Maintenance and Adjustments	3C-3	Lower Control Arm Shaft.....	3C-17
Diagnosis	3C-4	Upper Control Arm	3C-18
Component Parts Replacement.....	3C-15	Lower Control Arm.....	3C-19
Wheel Hubs, Bearings	3C-15	Ball Joint.....	3C-21
Shock Absorber	3C-15	Steering Knuckle	3C-23
Stabilizer.....	3C-16	Suspension Unit.....	3C-23
Coil Spring	3C-16	Specifications.....	3C-38
		Special Tools	3C-39

GENERAL DESCRIPTION

C-G-P Series

The C-G-P Series trucks incorporate an independent coil spring front suspension system, as shown in Figures 3C-1 and 3C-2. The control arms are of unequal length (S.L.A. Type).

This suspension system consists of upper and lower control arms pivoting on steel threaded or rubber bushings on upper and lower control arm shafts. The lower control arms are attached to the crossmember. The upper control arms are attached to a frame bracket.

These control arms are connected to the steering knuckle through pivoting ball joints.

A coil spring is located between the lower control arm and a formed seat in the suspension crossmember, thus the lower control arm is the load carrying member. Double acting shock absorbers are also attached to the lower control arms and connect with the frame to the rear on the upper end. The front wheel bearings are tapered roller type and are used on all models.

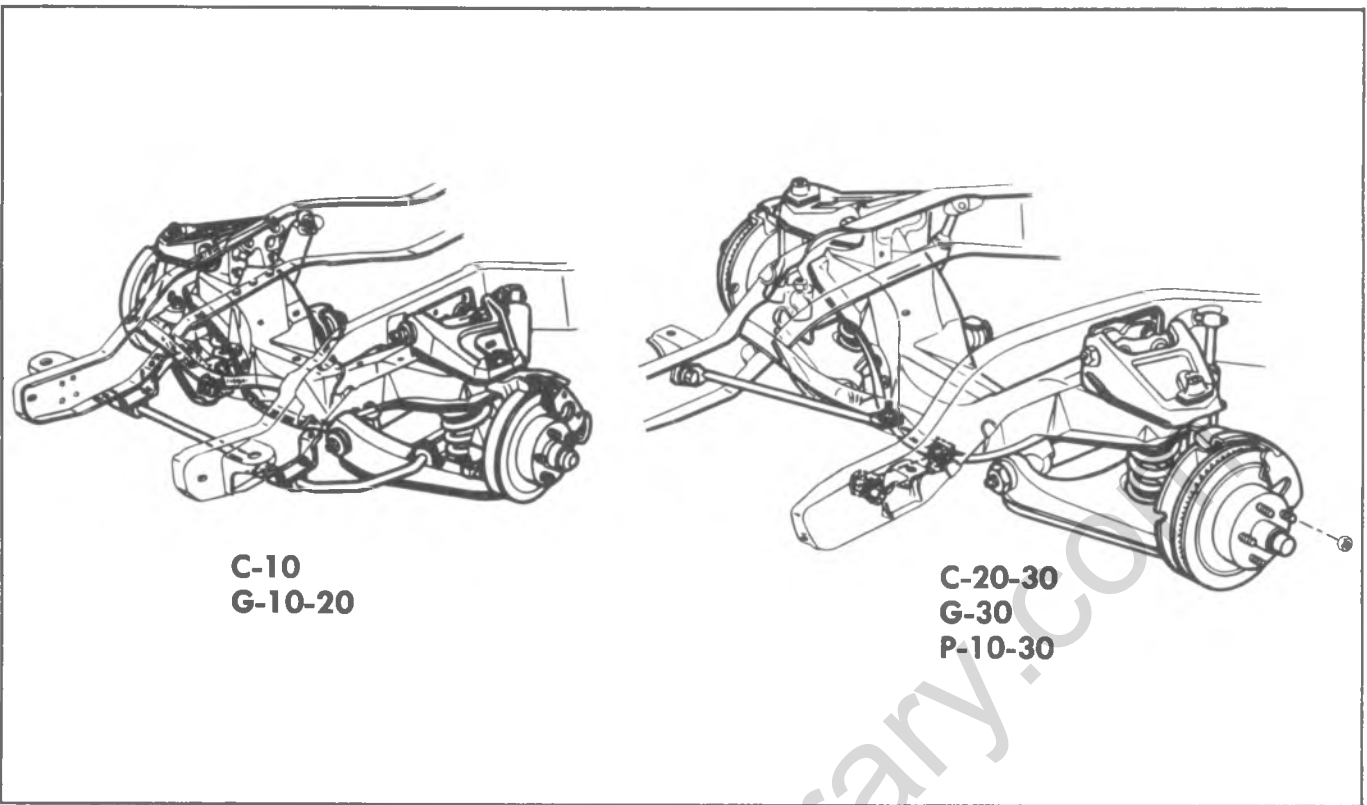


Fig. 3C-1--Front Suspension, C-P Series

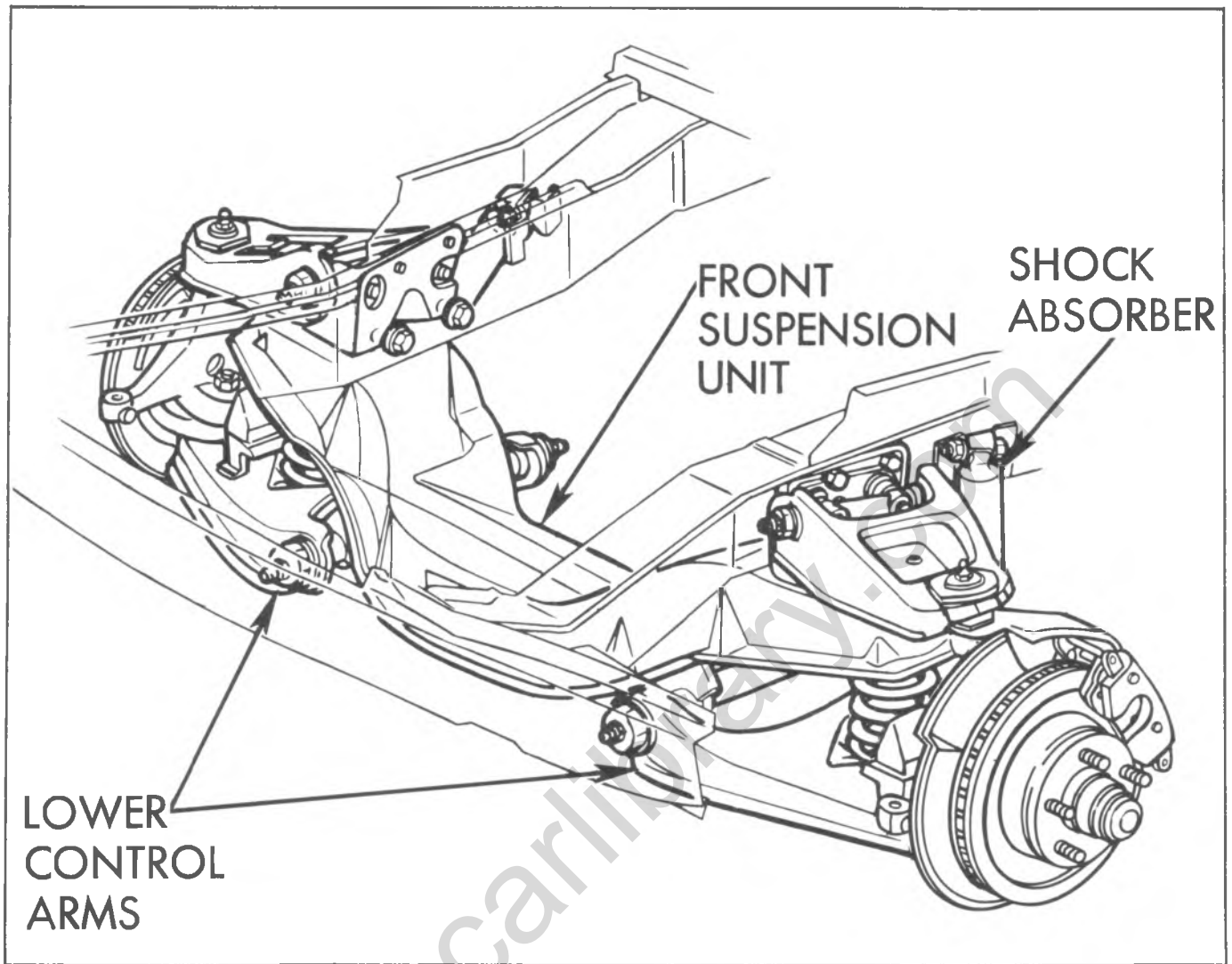


Fig. 3C-2--Front Suspension - G-30-Typical

MAINTENANCE AND ADJUSTMENTS

CAUTION: See *CAUTION* on page 1 of this section regarding the fasteners referred to in the maintenance and adjustment procedures below.

WHEEL BEARINGS-CHECK ADJUSTMENT

CAUTION: Tapered roller bearings are used on all series vehicles and they have a slightly loose feel when properly adjusted. A design feature of front wheel taper roller bearings is that they must *NEVER* be pre-loaded. Damage can result by the steady thrust on roller ends which comes from preloading.

1. Raise vehicle and support at front lower control arm.

2. Spin wheel to check for unusual noise or roughness.

3. If bearings are noisy, tight, or excessively loose, they should be cleaned, inspected and relubricated prior to adjustment. If it is necessary to inspect bearings, see "Wheel Hubs, Bearings" under "Component Parts Replacement."

NOTE: To check for tight or loose bearings, grip the tire at the top and bottom and move the wheel assembly in and out on the spindle. Measure movement of hub assembly. If movement is less than .001" or greater than .005", adjust bearings per adjustment procedure.

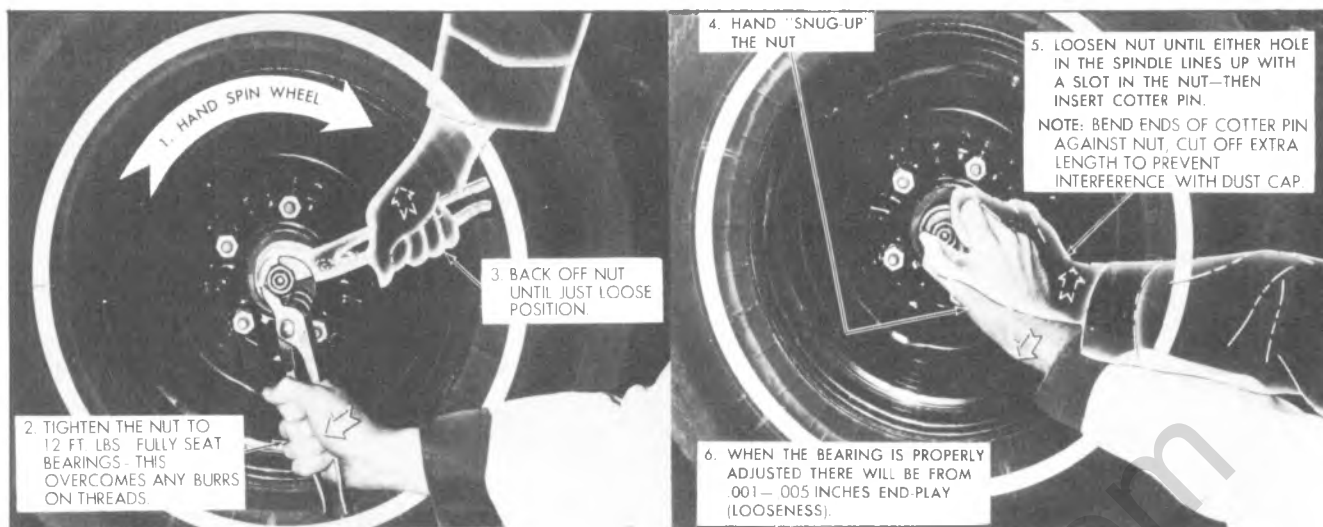


Fig. 3C-3—Wheel Bearing Adjustment

ADJUSTMENT OF WHEEL BEARINGS (FIG. 3C-3)

1. Remove hub cap or wheel disc from wheel.
2. Remove dust cap from hub.
3. Remove cotter pin from spindle and spindle nut.
4. Tighten the spindle nut to 12 ft. lbs. while turning the wheel assembly forward by hand to fully seat the bearings. This will remove any grease or burrs which could cause excessive wheel bearing play later. See Fig. 3C-3.
5. Back off the nut to the "just loose" position.
6. Hand tighten the spindle nut. Loosen spindle

nut until either hole in the spindle lines up with a slot in the nut. (Not more than 1/2 flat).

7. Install new cotter pin. Bend the ends of the cotter pin against nut, cut off extra length to ensure ends will not interfere with the dust cap.

8. Measure the looseness in the hub assembly. There will be from .001 to .005 inches end play when properly adjusted.

9. Install dust cap on hub.

10. Replace the wheel cover or hub cap.

11. Lower vehicle to floor.

12. Perform the same operation for each front wheel.

DIAGNOSIS

SHOCK ABSORBER DIAGNOSIS

ON VEHICLE CHECKS

(Follow the Procedures Outlined Below in the Order Indicated).

Preliminary Inspection and Ride Test:

Tire Pressure

Check tire pressure compare to vehicle specifications and adjust as required. Poor vehicle control and ride complaints are caused in many cases by improper tire inflation.

Special Suspension Equipment

Check Service Parts Identification Sticker for any special suspension equipment; such as, a heavy duty suspension. Vehicles equipped with this type of option have a somewhat stiffer or harsh ride, and this should be

kept in mind during the following tests. If complaint about stiffness should occur while vehicle is still new (under 5,000 miles), owner should be advised to have ride rechecked after 7,000 to 8,000 miles.

Vehicle Load Conditions

Note any exceptional load conditions under which the owner normally operates the vehicle; such as, large tool boxes full of tools, pick up bed full etc. If exceptional loading is apparent, check the distribution of this weight. Note if it is all toward one side of the vehicle or at the extreme rear of the vehicle. Reposition load as required to obtain a more uniform weight distribution.

Check Vehicle Ride and Handling

After completing previous checks, ride vehicle with owner to determine if problem has been corrected or to definitely establish type of problem that still exists. If

HARD STEERING	
<u>Probable Cause</u>	<u>Probable Remedy</u>
<ul style="list-style-type: none"> a. Ball joints and steering linkage need lubrication b. Low or uneven front tire pressure c. Power steering partially or not operative d. Steering gear not properly adjusted e. Incorrect front wheel alignment (manual steering) 	<ul style="list-style-type: none"> a. Lubricate ball joints and linkage b. Inflate tires to the proper recommended pressure c. Check power steering components for proper operation d. Adjust steering gear e. Check and align front suspension
POOR DIRECTIONAL STABILITY	
<ul style="list-style-type: none"> a. Ball joints and steering linkage need lubrication b. Low or uneven front or rear tire pressure c. Loose wheel bearings d. Steering Gear not on high point e. Incorrect front wheel alignment (caster) f. Broken springs g. Malfunctioning shock absorber. h. Broken stabilizer bar, or missing link 	<ul style="list-style-type: none"> a. Lubricate at proper intervals b. Inflate tires to the proper recommended pressure c. Adjust wheel bearings d. Adjust steering gear e. Check and align front suspension f. Replace springs g. Diagnose shock absorbers. h. Replace stabilizer or link
FRONT WHEEL SHIMMY (SMOOTH ROAD SHAKE)	
<ul style="list-style-type: none"> a. Tire and wheel out of balance, or out of round b. Worn or loose wheel bearings c. Worn tie rod ends d. Worn ball joints e. Malfunctioning shock absorber 	<ul style="list-style-type: none"> a. Balance tires, check run-out b. Adjust wheel bearings c. Replace tie rod end d. Replace ball joints e. Diagnose shock absorbers
VEHICLE PULLS TO ONE SIDE (NO BRAKING ACTION)	
<ul style="list-style-type: none"> a. Low or uneven tire pressure b. Front or rear brake dragging c. Broken or sagging front spring d. Incorrect front wheel alignment (Camber) 	<ul style="list-style-type: none"> a. Inflate tires to the proper recommended pressure b. Adjust brakes c. Replace spring d. Check and align front suspension
EXCESSIVE PLAY IN STEERING	
<ul style="list-style-type: none"> a. Incorrect steering gear adjustment b. Worn steering gear parts 	<ul style="list-style-type: none"> a. Adjust steering gear b. Overhaul Gear

Fig. 3C-4--Front Suspension Diagnosis Chart A

NOISE IN FRONT END

Probable Cause

- a. Ball joints and steering linkage need lubrication
- b. Shock absorber loose or bushings worn
- c. Worn control arm bushings
- d. Worn tie rod ends
- e. Worn or loose wheel bearings
- f. Loose stabilizer bar
- g. Loose wheel nuts
- h. Spring improperly positioned
- i. Loose suspension bolts

Probable Remedy

- a. Lubricate at recommended intervals
- b. Tighten bolts and/or replace bushings
- c. Replace bushings
- d. Replace tie rod ends
- e. Adjust or replace wheel bearings
- f. Tighten all stabilizer bar attachments
- g. Tighten the wheel nuts to proper torque
- h. Reposition
- i. Torque to specifications or replace

WHEEL TRAMP

- a. Tire and wheel out of balance
- b. Tire and wheel out of round
- c. Blister or bump on tire
- d. Improper shock absorber action

- a. Balance wheels
- b. Replace tire
- c. Replace tire
- d. Replace shock absorber

EXCESSIVE OR UNEVEN TIRE WEAR

- a. Underinflated or overinflated tires
- b. Improper toe-in
- c. Wheels out of balance
- d. Hard Driving
- e. Over loaded vehicle

- a. Inflate tire to proper recommended pressure
- b. Adjust toe-in
- c. Balance wheels
- d. Instruct driver
- e. Instruct driver

SCUFFED TIRES

- a. Toe-in incorrect
- b. Excessive speed on turns
- c. Tires improperly inflated
- d. Suspension arm bent or twisted

- a. Adjust toe-in to specifications
- b. Advise driver
- c. Inflate tires to proper recommended pressure
- d. Replace arm

CUPPED TIRES

- a. Front shock absorbers defective
- b. Worn ball joints
- c. Wheel bearings incorrectly adjusted or worn
- d. Wheel and tire out of balance
- e. Excessive tire or wheel runout

- a. Replace shock absorbers
- b. Replace ball joints
- c. Adjust or replace wheel bearings
- d. Balance wheel and tire
- e. Compensate for runout

Fig. 3C-5--Front Suspension Diagnosis Chart B

"DOG" TRACKINGProbable CauseProbable Remedy**LEAF TYPE REAR SPRING**

- | | |
|---|---|
| <ul style="list-style-type: none"> a. Rear leaf spring broken b. Bent rear axle housing c. Frame or underbody out of alignment | <ul style="list-style-type: none"> a. Replace spring b. Replace housing c. Align frame |
|---|---|

COIL TYPE REAR SPRING

- | | |
|---|---|
| <ul style="list-style-type: none"> a. Damaged rear suspension arm and/or worn bushings b. Frame out of alignment c. Bent rear axle housing | <ul style="list-style-type: none"> a. Replace suspension arm and/or bushings b. Align frame c. Replace housing |
|---|---|

RETURNABILITY POOR

- | | |
|---|---|
| <ul style="list-style-type: none"> a. Steering column alignment b. Steering linkage needs lubrication c. Idler arm bushing worn d. Steering gear adjustment e. Power steering gear valve spool binding f. Obstruction within power steering gear g. Improper caster setting (negative) | <ul style="list-style-type: none"> a. See Section 3b in shop manual for proper alignment b. Lubricate chassis c. Replace idler arm d. Adjust gear as outlined in Section 3b of shop manual e. See Section 3b in shop manual f. See Section 3b in shop manual g. Check and reset if necessary |
|---|---|

ERRATIC STEERING ON BRAKE APPLICATION

- | | |
|---|--|
| <ul style="list-style-type: none"> a. Low or uneven tire pressure b. Front wheel bearing incorrectly adjusted c. Brakes incorrectly or unevenly adjusted d. Front spring sagged e. Steering gear off high point f. Incorrect or uneven caster g. Leaking wheel cylinders | <ul style="list-style-type: none"> a. Inflate tires to proper recommended pressure b. Adjust bearing as necessary c. Adjust brakes as necessary d. Check shop manual for proper riding heights and replace spring if necessary e. Check and correct steering if necessary f. Check and adjust caster as necessary g. Replace (See sec. 5) |
|---|--|

Fig. 3C-6--Front Suspension Diagnosis Chart C

BALL JOINT DIAGNOSTIC PROCEDURE

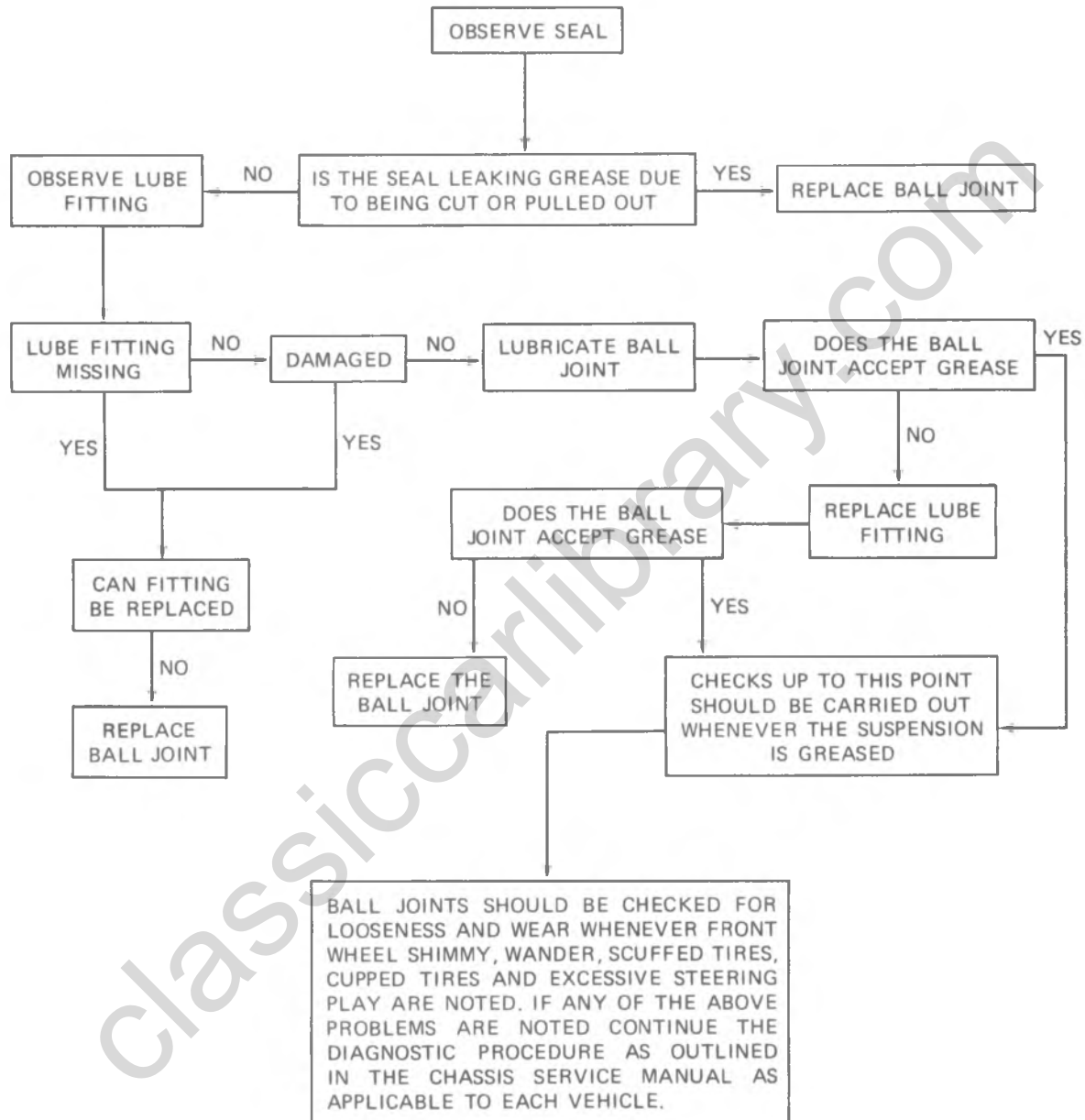


Fig. 3C-7-Ball Joint Diagnostic Procedure

problem still exists (poor handling, bottoming, noise, ride sway, etc.), proceed.

Inspecting and Testing the Shocks

Three procedures are included in this step. They are (a) Bounce Test, (b) Inspecting Shock Mountings for Noise (Looseness) and (c) Manually Operating Shocks to Determine if Shocks are Weak, Leaking Hydraulic Fluid, and/or if Shocks have an Internal Noise Condition.

IMPORTANT: Test procedures (b) and (c) require vehicle to be on a hoist that supports wheels or rear axle housing and front lower control arms.

Bounce Test

NOTE: This is only a comparison type test to help locate the suspected shock or noise condition before proceeding.

Test each front and rear shock by bouncing each corner of the vehicle. This can usually be done by lifting up and pushing down on the end of the bumper near each corner of the vehicle until maximum movement up and down is reached. Then let go of bumper and observe if the up and down motion stops very quickly. If up and down motion continues longer at one corner when compared to opposite corner (example, both front shocks), the one having the longer up and down motion may be suspect. **Do Not** compare front to rear. If complaint is noise, this test should help to locate the suspected area.

Inspecting Shock Mountings

If noisy and/or loose shock mountings are suspected, place vehicle on hoist that supports wheels and check all mountings for the following conditions:

- (1) Worn or defective grommets
- (2) Loose mounting nuts
- (3) Possible interference condition
- (4) Bump stops missing

If no apparent defects are noted in this step but noise condition still exists when vehicle is bounced up and down, proceed.

Inspecting Shocks for Leaks and Manually Operating Shocks

This procedure is sub-divided into two general areas, (1) Inspecting Shocks for Loss of Hydraulic Fluid and (2) Manually Operating Shock. It should aid the technician to localize defective shocks caused by internal noise in the shock, weak, leaking, etc.

1. Inspecting Shocks for Possible Loss of Hydraulic Fluid

(a) Disconnect each shock lower mounting as required and pull down on the shock until it is fully extended.

(b) Inspect shocks for leaks in seal cover area. Shock fluid is a very thin hydraulic fluid and has a characteristic odor and dark brown tint (Figure 3C-8).

Certain precautions should be observed when inspecting shocks for leaks:

- shocks may have glossy paint on them. Do not confuse this paint with a leak condition.
- a slight trace of shock fluid around the seal cover area is **not** cause for replacement. The shock seal is engineered to permit a slight seepage to lubricate the rod. The shock absorber has reserve fluid to compensate for the slight seepage.
- shocks are sometimes incorrectly diagnosed as leakers due to oil spray originating from some other source. If in doubt, wipe the wet area from and manually operate shock as described in Step (2). Fluid will reappear if shock is leaking.

2. Manually Operating Shocks

NOTE: It may be necessary with certain types of shock mountings to fabricate a bracket that can be installed on a shock to enable a technician to securely grip the shock when manually operating the shock. See Figure 3C-9 for suggested methods of providing temporary grip.

This test should help the mechanic to isolate the following shock defects:

- binding condition internally
- verify leaking shock
- improper or defective valving

(a) If suspected problem is in front shocks, disconnect both front shock lower mountings and stroke each shock as follows: Grip the lower end of the shock securely and pull down (rebound stroke) then push up (compression stroke). The control arms will limit the movement of the front shocks during the compression stroke. Compare the rebound resistance between both front shocks, then compare the compression resistance. If a noticeable difference can be felt during either stroke, usually the shock having the least resistance is at fault.

(b) If shock has an internal noise condition,

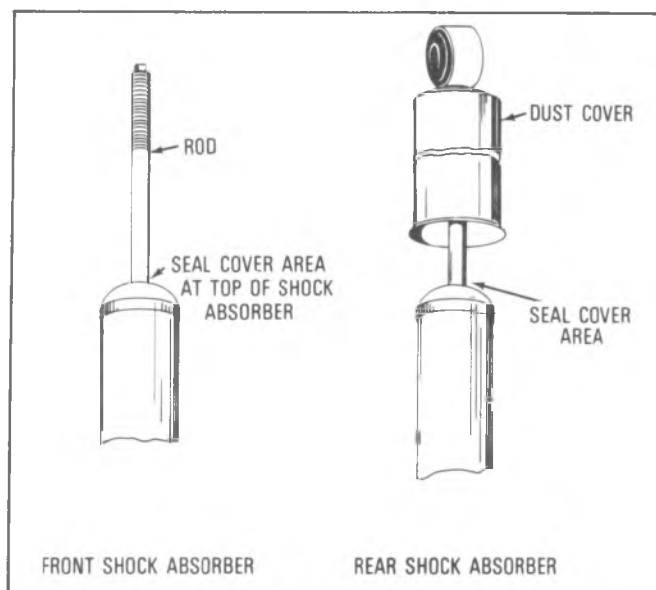


Fig. 3C-8-Seal Cover Area of Shock

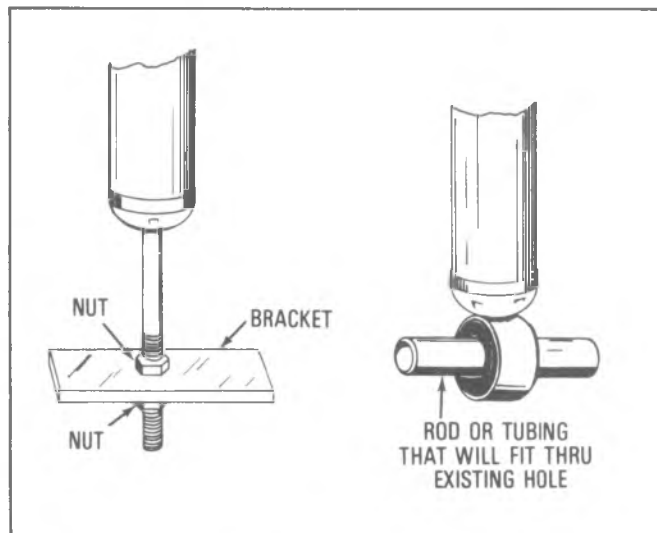


Fig. 3C-9--Gripping Methods

extend shock fully, then exert an extra pull. If noisy shock should be replaced.

Other noise conditions that require shock replacement are:

- a grunt or squeal after one full stroke in both directions
- a clicking noise on fast reverse
- a skip or lag at reversal near mid-stroke

IMPORTANT: When air adjustable shocks are being manually operated, the air line must be disconnected at the shock absorber.

BENCH CHECKS

The bench checks are recommended if the proper type hoist is not available to perform the "on car" tests, or if there is still some doubt as to whether the shocks are defective. In addition, the bench test allows a more thorough visual inspection.

Bench check procedures are discussed for three general types of shocks.

SPIRAL GROOVE RESERVOIR

IMPORTANT: If this type of shock has been stored or allowed to lay in a horizontal position for any length of time, an air void will develop in the pressure chamber of the shock absorber. This air void if not purged, can cause a technician to diagnose the shock as defective. To purge the air from the pressure chamber, proceed as follows: (Refer to Figure 3C-10)

- Holding the shock in its normal vertical position (top end up), fully extend shock.
- Hold the top end of the shock **down** and fully collapse the shock.
- Repeat Steps (a) and (b) at least five (5) times to assure air is purged.

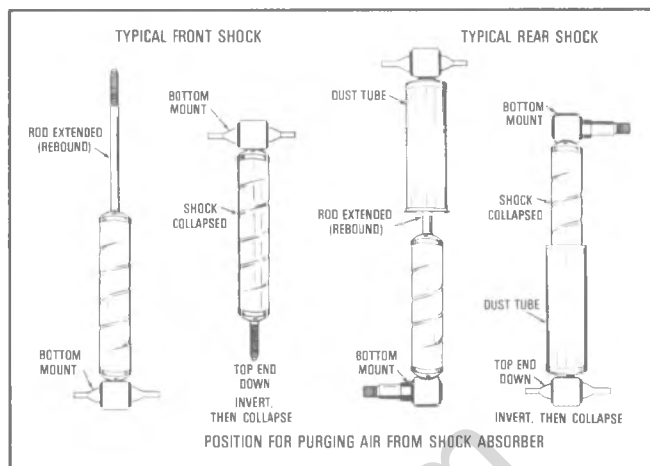


Fig. 3C-10--Position for Purging Air From Shocks

Bench Test Procedure

1. This is a comparison type test. If possible, obtain a new or known good shock with same part number as shock under test.

2. With shocks in vertical position (top end up), clamp bottom mounts in vise.

CAUTION: Do not clamp on reservoir tube or mounting threads.

3. Manually pump each shock by hand at various rates of speed and compare resistance of suspected shock with the new one.

NOTE: Rebound resistance (extending the shock) is normally stronger than the compression resistance (approximately 2:1). However, resistance should be smooth and constant for each stroking rate.

4. Observe or listen for the following conditions that will indicate a defective shock:

- a skip or lag when reversing stroke at mid travel.
- seizing or binding condition except at extreme end of either stroke.
- a noise, such as a grunt or squeal, after completing one full stroke in both directions.
- a clicking type noise at fast reversal.
- fluid leakage.

5. To check for a loose piston, completely extend shock to full rebound; then exert an extra hard pull. If a give is felt, a loose piston is indicated and shock should be replaced.

PLIACELL OR GENETRON

Pliacell and Genetron are some of the trade names used to indicate a gas-filled cell in the shock reservoir. The reservoirs of Pliacell and Genetron shocks are smooth, compared to the spiral groove type. The cell takes the place of air in the reservoir. Thus, aeration or foaming of the fluid is eliminated, as air and fluid cannot mix.

Due to this feature, these shocks should be bench checked in an **inverted position** (top end down). If, when

stroked, a lag is noticed, it means the gas-filled cell has been ruptured, and the shock should be replaced. If no lag is noticed, the remainder of the bench check is the same as given in the Spiral Groove Reservoir, Section 1, Bench Check Procedure.

AIR ADJUSTABLE SHOCKS

This type of shock contains an air chamber like the spiral groove reservoir type, and must have the air purged from the working chamber. See Section 1, Spiral Groove Reservoir. After air has been purged from shock, proceed as follows:

(a) Clamp lower shock mounting ring in vise in vertical position with larger diameter tube at the top.

(b) Pump unit by hand at different rates of speed. Smooth resistance should be felt through the length of the stroke. Since the units are normally pressurized, the sound of air bubbles or a gurgling noise is **normal**.

(c) The remainder of the bench check is the same as given in the Spiral Groove Reservoir, Section 1, Bench Check Procedure.

BEARINGS AND RACES

BENCH DIAGNOSTIC PROCEDURE

This section describes common types of bearing distress and their causes. Illustrations are included to

help diagnose the cause of distress and comments are provided to help make effective repairs.

Consider The Following Factors When

Diagnosing Bearing Distress:

1. Note General Condition of all parts during teardown and examinations.

2. Classify the failure with the aid of these illustrations where possible.

3. Determine the cause. Recognizing the cause will permit correction of the problem and prevent a repeat failure of the same type.

4. Make all repairs following recommended procedures.

Common Causes For Bearing Distress

Include The Following:

1. Improper adjustment or preloading.
2. Mounting or teardown abuse.
3. Improper mounting methods.
4. Inadequate or wrong lubricants.
5. Entrance of dirt or water.
6. Wear from dirt or metal chips.
7. Corrosion or rusting.
8. Seizing or smearing from overload.
9. Overheating causing tempering.
10. Fretting of bearing seats.
11. Brinelling from impact loads and shipping.
12. Manufacturing defects.

BEARINGS AND RACES

FRONT WHEEL, PINION, DIFFERENTIAL SIDE AND REAR WHEEL ROLLER BEARINGS

DIAGNOSIS

	EXCESS NOISE COMPLAINT DIAGNOSTIC PROCEDURE
Road Test	<ol style="list-style-type: none"> 1. Check tires for irregular wear 2. Check tire pressure 3. Check lubricant level 4. Drive to warm-up rear axle 5. Test at various speeds in drive, float, coast and cornering
Tire Noises	<ol style="list-style-type: none"> 1. Change tire pressure to minimize noises 2. Drive over different road surfaces 3. Smooth black-top minimizes tire noise 4. Cross switch tires, if necessary 5. Snow tire treads and studs caused added noises
Engine or Exhaust Noises	<ol style="list-style-type: none"> 1. Drive slightly above speed where noise occurs, place transmission in neutral 2. Let engine speed drop to idle 3. Stop car 4. Run engine at various speeds
Test for Wheel Bearing Noise	<ol style="list-style-type: none"> 1. Drive car at low speed on a smooth road 2. Turn car to develop left and right motions, traffic permitting 3. Noise should change due to cornering loads 4. Jack-up wheels to verify roughness at wheels
Test for Differential Bearing Noise	<ol style="list-style-type: none"> 1. Drive car at low speed on a smooth road 2. Constant low pitch bearing noise may be heard 3. Noise should not change in reversing turns 4. Noise pattern should vary with wheel speed
Test for Pinion Bearing Noise	<ol style="list-style-type: none"> 1. Roughness or whine noise should increase with speed 2. Noise pitch should be higher than differentials 3. Test on smooth road to minimize tire noises 4. Test at various speeds in drive, float, and coast 5. Rear pinion bearing noise may be louder on acceleration 6. Front pinion bearing noise may be louder on deceleration 7. Gear noises tend to peak in a narrow speed range

Fig. 3C-11--Bearing Diagnosis Chart

FRONT WHEEL BEARING DIAGNOSIS

CONSIDER THE FOLLOWING FACTORS WHEN DIAGNOSING BEARING CONDITION:

1. GENERAL CONDITION OF ALL PARTS DURING DISASSEMBLY AND INSPECTION.
2. CLASSIFY THE FAILURE WITH THE AID OF THE ILLUSTRATIONS.
3. DETERMINE THE CAUSE.
4. MAKE ALL REPAIRS FOLLOWING RECOMMENDED PROCEDURES.

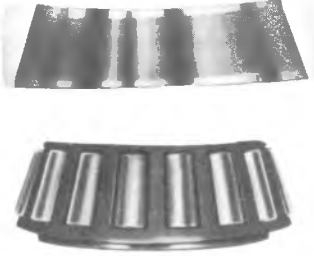

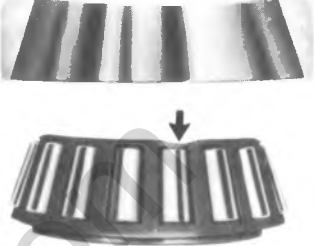



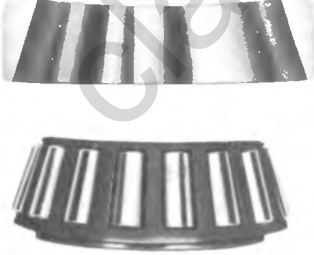


 <p>ABRASIVE ROLLER WEAR</p> <p>PATTERN ON RACES AND ROLLERS CAUSED BY FINE ABRASIVES.</p> <p>CLEAN ALL PARTS AND HOUSINGS. CHECK SEALS AND BEARINGS AND REPLACE IF LEAKING, ROUGH OR NOISY.</p>	 <p>GALLING</p> <p>METAL SMEARS ON ROLLER ENDS DUE TO OVERHEAT, LUBRICANT FAILURE OR OVERLOAD (WAGON'S)</p> <p>REPLACE BEARING - CHECK SEALS AND CHECK FOR PROPER LUBRICATION.</p>	 <p>BENT CAGE</p> <p>CAGE DAMAGE DUE TO IMPROPER HANDLING OR TOOL USAGE.</p> <p>REPLACE BEARING.</p>
 <p>ABRASIVE STEP WEAR</p> <p>PATTERN ON ROLLER ENDS CAUSED BY FINE ABRASIVES.</p> <p>CLEAN ALL PARTS AND HOUSINGS. CHECK SEALS AND BEARINGS AND REPLACE IF LEAKING, ROUGH OR NOISY.</p>	 <p>ETCHING</p> <p>BEARING SURFACES APPEAR GRAY OR GRAYISH BLACK IN COLOR WITH RELATED ETCHING AWAY OF MATERIAL USUALLY AT ROLLER SPACING.</p> <p>REPLACE BEARINGS - CHECK SEALS AND CHECK FOR PROPER LUBRICATION.</p>	 <p>BENT CAGE</p> <p>CAGE DAMAGE DUE TO IMPROPER HANDLING OR TOOL USAGE.</p> <p>REPLACE BEARING.</p>
 <p>INDENTATIONS</p> <p>SURFACE DEPRESSIONS ON RACE AND ROLLERS CAUSED BY HARD PARTICLES OF FOREIGN MATERIAL.</p> <p>CLEAN ALL PARTS AND HOUSINGS. CHECK SEALS AND REPLACE BEARINGS IF ROUGH OR NOISY.</p>	 <p>CAGE WEAR</p> <p>WEAR AROUND OUTSIDE DIAMETER OF CAGE AND ROLLER POCKETS CAUSED BY ABRASIVE MATERIAL AND INEFFICIENT LUBRICATION.</p> <p>CLEAN RELATED PARTS AND HOUSINGS. CHECK SEALS AND REPLACE BEARINGS.</p>	 <p>MISALIGNMENT</p> <p>OUTER RACE MISALIGNMENT DUE TO FOREIGN OBJECT.</p> <p>CLEAN RELATED PARTS AND REPLACE BEARING. MAKE SURE RACES ARE PROPERLY SEATED.</p>

Fig. 3C-12-Bearing Diagnosis Illustration A

FRONT WHEEL BEARING DIAGNOSIS (CONT'D)








 <p>CRACKED INNER RACE</p> <p>RACE CRACKED DUE TO IMPROPER FIT, COCKING, OR POOR BEARING SEATS.</p> <p>REPLACE BEARING AND CORRECT BEARING SEATS.</p>	 <p>FATIGUE SPALLING</p> <p>FLAKING OF SURFACE METAL RESULTING FROM FATIGUE.</p> <p>REPLACE BEARING -- CLEAN ALL RELATED PARTS.</p>	 <p>BRINELLING</p> <p>SURFACE INDENTATIONS IN RACEWAY CAUSED BY ROLLERS EITHER UNDER IMPACT LOADING OR VIBRATION WHILE THE BEARING IS NOT ROTATING.</p> <p>REPLACE BEARING IF ROUGH OR NOISY.</p>
 <p>FRETTAGE</p> <p>CORROSION SET UP BY SMALL RELATIVE MOVEMENT OF PARTS WITH NO LUBRICATION.</p> <p>REPLACE BEARING. CLEAN RELATED PARTS. CHECK SEALS AND CHECK FOR PROPER LUBRICATION.</p>	 <p>STAIN DISCOLORATION</p> <p>DISCOLORATION CAN RANGE FROM LIGHT BROWN TO BLACK CAUSED BY INCORRECT LUBRICANT OR MOISTURE.</p> <p>RE USE BEARINGS IF STAINS CAN BE REMOVED BY LIGHT POLISHING OR IF NO EVIDENCE OF OVER HEATING IS OBSERVED.</p> <p>CHECK SEALS AND RELATED PARTS FOR DAMAGE.</p>	 <p>HEAT DISCOLORATION</p> <p>HEAT DISCOLORATION CAN RANGE FROM FAINT YELLOW TO DARK BLUE RESULTING FROM OVERLOAD (WAGON'S) OR INCORRECT LUBRICANT.</p> <p>EXCESSIVE HEAT CAN CAUSE SOFTENING OF RACES OR ROLLERS.</p> <p>TO CHECK FOR LOSS OF TEMPER ON RACES OR ROLLERS A SIMPLE FILE TEST MAY BE MADE. A FILE DRAWN OVER A TEMPERED PART WILL GRAB AND CUT METAL, WHEREAS, A FILE DRAWN OVER A HARD PART WILL GLIDE READILY WITH NO METAL CUTTING.</p> <p>REPLACE BEARINGS IF OVER HEATING DAMAGE IS INDICATED. CHECK SEALS AND OTHER PARTS.</p>
 <p>SMEARS</p> <p>SMEARING OF METAL DUE TO SLIPPAGE. SLIPPAGE CAN BE CAUSED BY POOR FITS, LUBRICATION, OVERHEATING, OVERLOADS OR HANDLING DAMAGE.</p> <p>REPLACE BEARINGS, CLEAN RELATED PARTS AND CHECK FOR PROPER FITS AND LUBRICATION</p>		

Fig. 3C-13--Bearing Diagnosis, Illustration B

COMPONENT PARTS REPLACEMENT

WHEEL HUBS, BEARINGS (Fig. 3C-14)

Removal C, G and P Series

1. Raise vehicle on hoist and remove wheel and tire assembly. Remove dust cap from end of hub and withdraw cotter pin.
2. Remove the brake caliper and hang by wire to the suspension.

CAUTION: Do not allow the caliper assembly to hang by the brake flex line.

3. Remove hub and disc assembly.
4. Remove outer bearing from hub. The inner bearing will remain in the hub and may be removed by prying out the inner grease seal.
5. Wash all parts in cleaning solvent.

Inspection

1. Check all bearings for cracked bearing cages, worn or pitted rollers.
2. Check bearing races for cracks or scoring, check brake discs for out-of-round or scored conditions and check bearing outer races for looseness in hubs.

Repairs

Replacement of Bearing Cups

If necessary to replace an outer race, drive out old race from the hub with a brass drift inserted behind race in notches in hub. Install new race by driving it into hub with the proper race installer J-8457, J-8458, J-8849 or J-9276-2. Remove and install the inner race in the same manner.

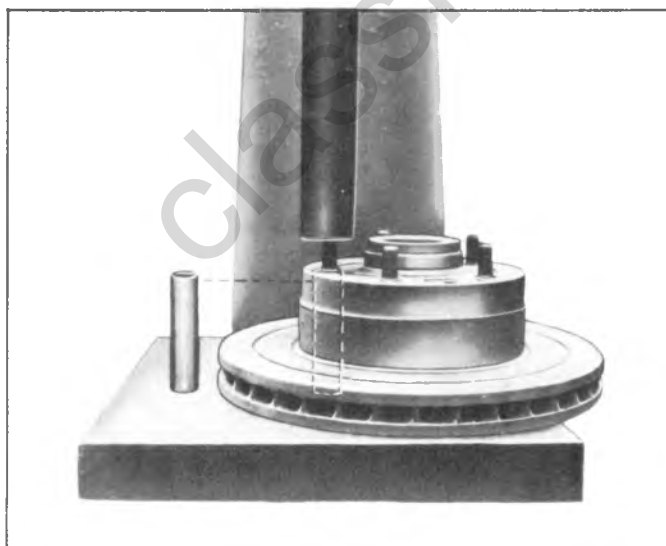


Fig. 3C-14--Pressing Hub Bolt

CAUTION: Use care when installing new race to start it squarely into hub, to avoid distortion and possible cracking.

Thoroughly lubricate bearing assemblies with new high melting point wheel-bearing lubricant. Remove any excess lubricant.

NOTE: Be sure bearing parts have been thoroughly cleaned and air-dried.

Wheel Stud Replacement (Fig. 3C-14)

NOTE: Use a piece of water pipe or other similar tool to support the hub while pressing a wheel stud either in or out.

Installation

CAUTION: See CAUTION on page 1 of this section regarding the fasteners referred to in steps 3, 4 and 5.

1. Pack inner and outer wheel bearings with recommended grease (see Section 0).
2. Place inner bearing in hub and install new seal assembly, tapping into place with soft hammer.
3. Position hub and disc on spindle and install outer bearing, pressing it firmly into position in hub. Install hub washer and finger tighten nut.
4. Install brake caliper see section 5.
5. Install wheel and tire, and adjust wheel bearings as outlined under Wheel Bearings—Adjust. then lower vehicle to floor.

SHOCK ABSORBER

Removal (Fig. 3C-15)

1. Raise vehicle on hoist.
2. Remove nuts and eye bolts securing upper and lower shock absorber eyes.
3. Withdraw shock absorber and inspect rubber

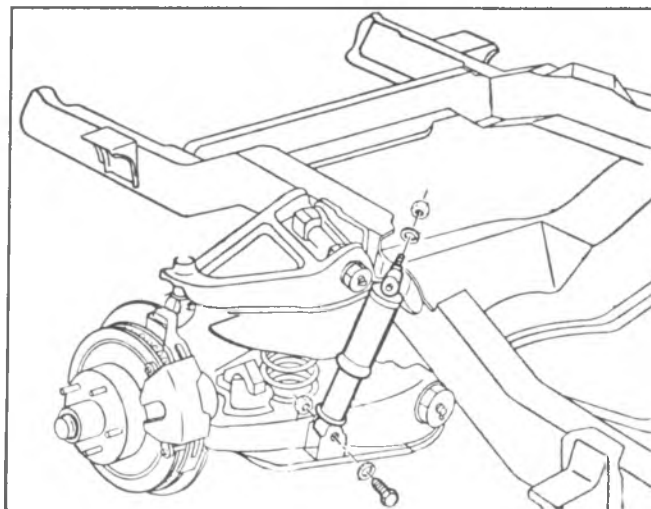


Fig. 3C-15--Shock Absorber Attachments

eye bushings. If defective, replace shock absorber assembly.

Installation

Place shock absorber into position over mounting bolts or into mounting brackets. Install eye bolts and nuts and torque as shown in Specifications Section. Lower vehicle to floor.

STABILIZER BAR

Removal (Fig. 3C-16)

1. Raise vehicle on hoist and remove nuts and bolts attaching stabilizer brackets and bushings at frame location.
2. Remove brackets and bushings at lower control arms and remove stabilizer from vehicle.

Inspection

Inspect rubber bushings for excessive wear or aging—replace where necessary. Use rubber lubricant when installing bushings over stabilizer bar.

Installation

CAUTION: See *CAUTION* on page 1 of this section regarding the fasteners referred to in step 2.

NOTE: Slit in bar to frame bushings should be facing forward.

1. Place stabilizer in position on frame and install frame brackets over bushings. Install nuts and bolts loosely.
2. Install brackets over bushings at lower control arm location. Be sure brackets are positioned properly over bushings. Torque all nuts and bolts to specifications.
3. Lower vehicle to floor.

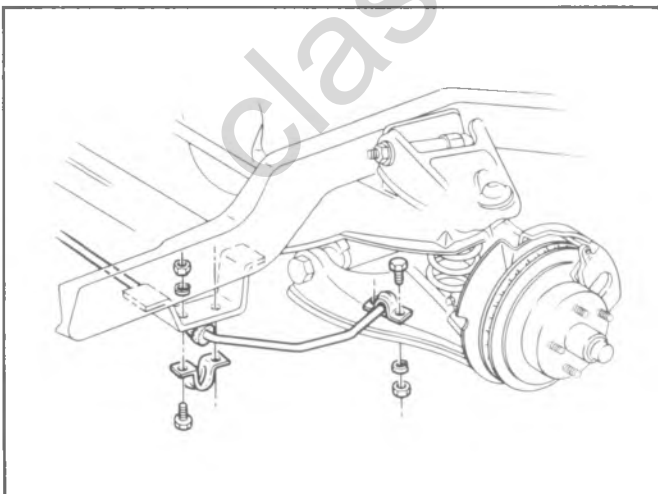


Fig. 3C-16--Stabilizer Bar - C, P and G Typical

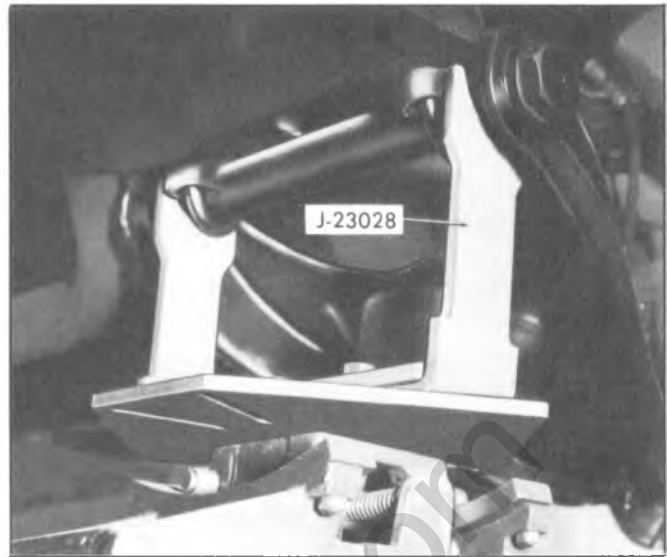


Fig. 3C-17--Removing Coil Spring with Tool J-23028

COIL SPRING

Removal (Fig. 3C-17)

1. Place vehicle on hoist and place jack stands under frame, allowing control arms to hang free.
2. Disconnect shock absorber at lower end and move aside. Disconnect the stabilizer bar attachments to the lower control arm.
3. Bolt Tool J-23028 to a suitable jack.
4. Place tool under cross-shaft so that the cross-shaft seats in the grooves of the tool. As a safety precaution install and secure a chain through the spring and lower control arm.
5. Raise the jack to remove tension on the lower control arm cross-shaft and remove the two "U" bolts securing the cross-shaft to crossmember.

WARNING: The crossshaft and lower control arm keeps the coil spring compressed. Use care when lowering.

6. Lower control arm by slowly releasing the jack until spring can be removed. Be sure all compression is relieved from spring.
7. Remove spring.

Installation

CAUTION: See *CAUTION* on page 1 of this section regarding the fasteners referred to steps 3 and 4.

1. Properly position spring on the control arm, and lift control arm using jack and tool J-23028.
2. Position control arm cross-shaft to crossmember and install "U" bolts and attaching nuts. Make certain front indexing hole in cross-shaft is lined up with crossmember attaching saddle stud.

3. Torque nut to specifications.
4. Install shock absorber to lower control arm and install stabilizer bar.
5. Remove tool J-23028 and safety chain.
6. Lower vehicle to floor.

UPPER CONTROL ARM INNER PIVOT SHAFT AND/OR BUSHING REPLACEMENT

C20-30, G30 and P10-30 (Steel Bushings)

Pivot Shaft Removal

1. Raise vehicle and remove tire and wheel assembly.
2. Support the lower control arm with a floor jack.

NOTE: Position jack under the ball joint assembly or as near as possible and still have good support.

3. Loosen the upper control arm shaft end nuts before loosening the shaft to frame attaching nuts.
4. Loosen the shaft to frame nuts and remove the caster and camber shims.

NOTE: Tape the shims together as they are removed and mark for position.

5. Remove the pivot shaft to frame nuts but do not allow the arm to swing too far away from the frame.

NOTE: Use a safety chain to retain the arm in a close relationship to the frame. See Fig. 3C-18.

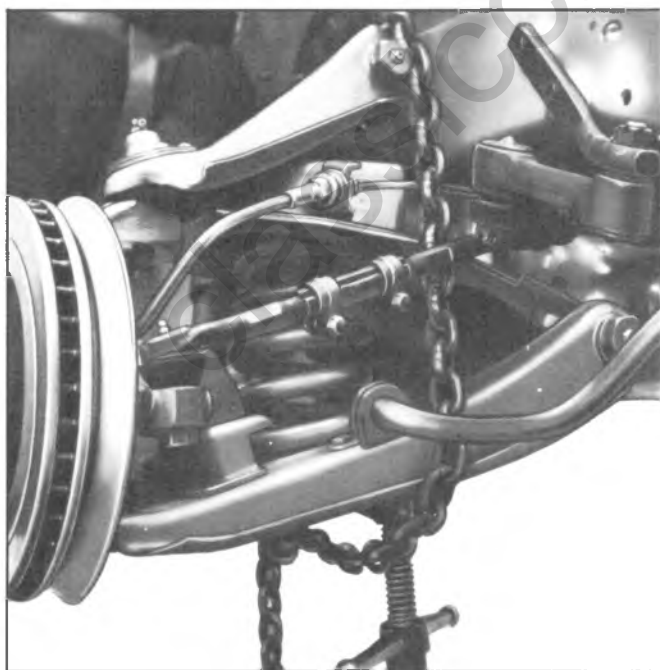


Fig. 3C-18-Removing Inner Pivot Shaft

6. Remove the shaft end nuts and remove shaft from arm.

Bushing Replacement (Steel Bushings)

1. Remove grease fittings from bushing outer ends and unscrew bushings from control arm and shaft.
2. Slide new seal on each end of shaft and insert shaft into control arm.
3. Start new bushings on shaft and into control arm. Adjust shaft until it is centered in control arm, then turn bushings in and torque to specifications. Figure 3C-19 shows correct final positioning of shaft. Check shaft for free rotation and install grease fittings.

Installation

CAUTION: See *CAUTION* on page 1 of this section regarding the fasteners referred to in steps 3, 5 and 6.

NOTE: When installing the upper control arm be sure to properly position the special aligning washers to the pivot shaft with convex and concave sides together.

1. Install the shaft to the control arm and install end nuts. Do not torque nuts at this time.
2. Position cross shaft to frame bolts and start cross shaft nuts.
3. Torque the shaft end nuts. See Fig. 3C-19 for proper spacing.

NOTE: The shaft should rotate by hand after the nuts are torqued.

4. Install caster and camber shim in their appropriate places.
5. Torque the cross-shaft to frame nuts.
6. Remove the safety chain and install the tire.
7. Lower vehicle to the floor.

LOWER CONTROL ARM INNER PIVOT SHAFT AND/OR BUSHING REPLACEMENT

C20-30, G30, P10-30 (Steel Bushings)

Lower-Removal (Fig. 3C-18)

1. Raise vehicle and support the frame so that control arms hang free.
2. Position an adjustable floor jack under the control arm inboard of spring and into depression in lower arm.
3. Install a chain over upper arm (Fig. 3C-18). Inboard of stabilizer and outboard of shock absorber as a safety measure.
4. Disconnect shock absorber at lower control arm.
5. Loosen shaft end nuts.
6. Remove "U" bolts.
7. Lower jack just enough to get at shaft.
8. Remove shaft end nuts and remove shaft.

Bushing Replacement (Steel Bushings)

1. Remove grease fittings from ends of bushings and unscrew bushings from shaft and control arm. Remove shaft and seals.

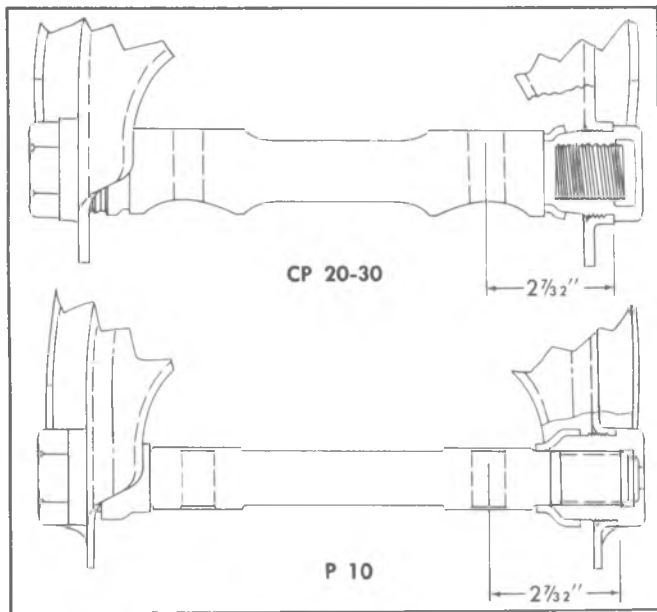


Fig. 3C-19--Positioning U.C.A. Shaft (Steel Bushings)

2. Slide new seal on each end of shaft and insert shaft into control arm.

3. Start new bushings on shaft and into control arm. Adjust shaft until it is centered in control arm, then turn bushings in and torque to specifications. Check shaft for free rotation. Figure 3C-20 shows correct final positioning of shaft.

Installation

CAUTION: See *CAUTION* on page 1 of this section regarding the fasteners referred to in steps 4 and 5.

1. Install shaft to control arm and install end nuts. Do not torque nuts at this time.
 2. Raise jack and position shaft into crossmember saddle. Be sure to index hole in shaft to mate with bolt head in saddle.
 3. Install "U" bolts. Do not torque nuts at this time.
 4. Torque cross-shaft end nuts.
- NOTE:** The shaft should rotate by hand after the nuts are torqued.
5. Torque "U" bolt nuts.
 6. Remove safety chain.
 7. Lower vehicle to floor.

UPPER CONTROL ARM ASSEMBLY

All Removal

1. Raise vehicle on hoist, remove wheel and tire assembly and support lower control arm assembly with adjustable jackstand.
2. Remove cotter pin from upper control arm ball stud and loosen stud nut one turn.
3. Loosen upper control arm ball stud in steering knuckle, using Tool J-23742 position as shown in Figure

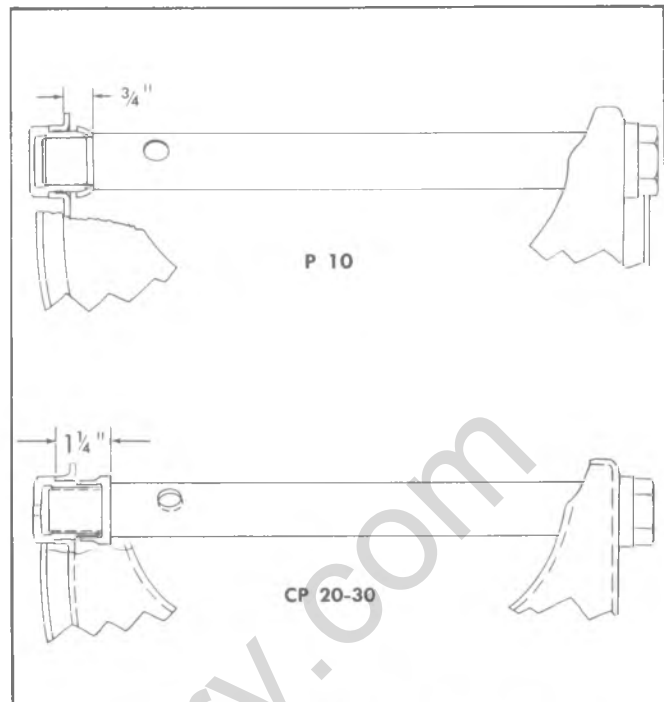


Fig. 3C-20--Positioning L.C.A. Shaft (Steel Bushings)

3C-21. Remove the nut from the ball stud and raise upper arm to clear steering knuckle.

NOTE: It is necessary to remove the brake caliper assembly and wire it to the frame to gain clearance for tool J-23742. See section 5 for proper procedure.

4. Remove nuts securing control arm shaft to frame. Withdraw control arm assembly.

NOTE: Tape shims together and tag for proper relocation when control arm is reinstalled.

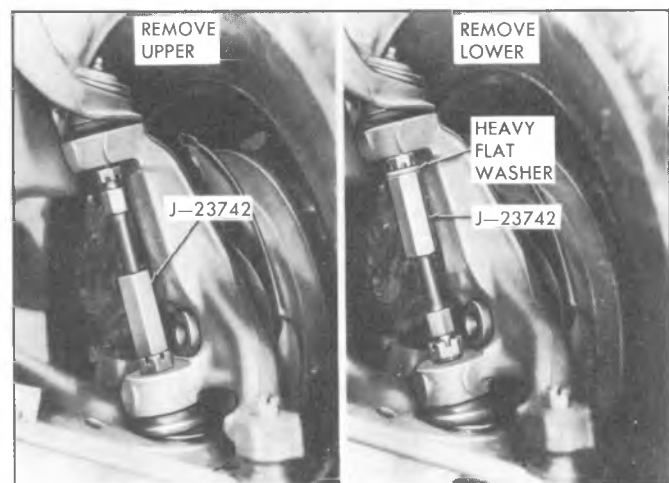


Fig. 3C-21--Disconnecting Ball Joints from Knuckle

Upper Control Arm Inner Pivot Shaft and/or Bushing Replacement

C10, G10-20 (Rubber Bushings)

Removal (Fig. 3C-22)

1. Remove the upper control arm using the preceding procedure and mount the control arm in a vise.
2. Install remover J-24435-1, receiver J-24435-3 and "C" clamps J-24435-7 as shown in Figure 3C-22.
3. Tighten the clamp to draw out the old bushing. Discard old bushing.
4. The pivot shaft may now be removed from the control arm assembly.
5. Reposition the control arm in the vise and repeat the removal procedure on the remaining bushing.

Bushing Installation

1. Again using "C" clamp J-24435-7 and installers J-24435-4 (outer) and J-24435-5 (inner) tighten clamp to install bushing onto control arm.
2. Install pivot shaft into inside diameter of first installed bushing.
3. Install remaining bushing as shown in Figure 3C-23 and described in step 1.
4. Remove tools and install control arm on vehicle following procedure described below. Torque all fasteners to proper specifications.

Upper Control Arm Installation

CAUTION: See CAUTION on page 1 of this section regarding the fasteners referred to in steps 1, 2 and 3.

NOTE: When installing the upper control arm be sure to position the special aligning washers to the pivot shaft with concave and convex sides together.

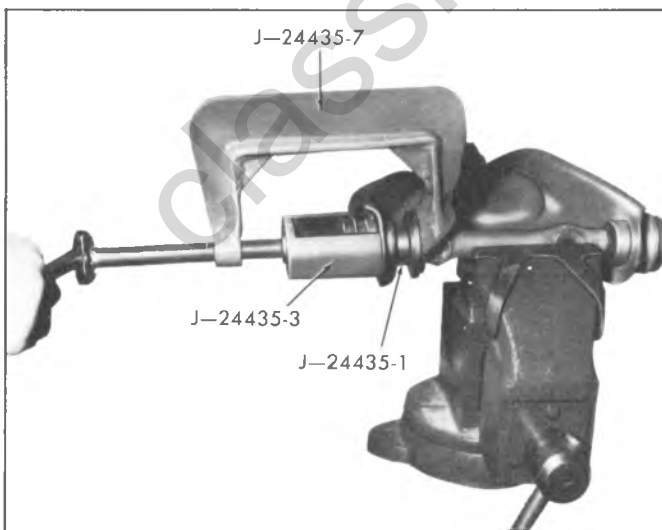


Fig. 3C-22--U.C.A. Rubber Bushing Removal

1. Place control arm in position on bracket and install nuts. Before tightening nuts, insert caster and camber shims in the same order as when removed. Torque the nuts to specifications.

NOTE: A normal shim pack will leave at least two (2) threads of the bolt exposed beyond the nut. If two (2) threads cannot be obtained: Check for damaged control arms and related parts. Difference between front and rear shim packs must not exceed .30 inches. Front shim pack must be at least .24 inches.

Always tighten the thinner shim packs' nut first for improved shaft to frame clamping force and torque retention.

2. Insert ball joint stud into steering knuckle and install nut. Torque stud nut to specifications and install cotter pin.
3. Install brake caliper assembly if removed (see section 5).
4. Remove adjustable support from under lower control arm. Install wheel and tire assembly.
5. Lower the vehicle to the floor.

LOWER CONTROL ARM ASSEMBLY

Removal

1. Raise vehicle on hoist and remove spring as outlined under spring removal.

NOTE: Support the inboard end of the control arm after spring removal.

2. Remove cotter pin from lower ball stud and loosen stud nut one turn.
3. Install Ball Stud Remover J-23742, position large cup end of the tool over the upper ball stud nut and piloting the threaded end of tool on end of the lower ball stud. Extend bolt from Tool J-23742 to loosen lower

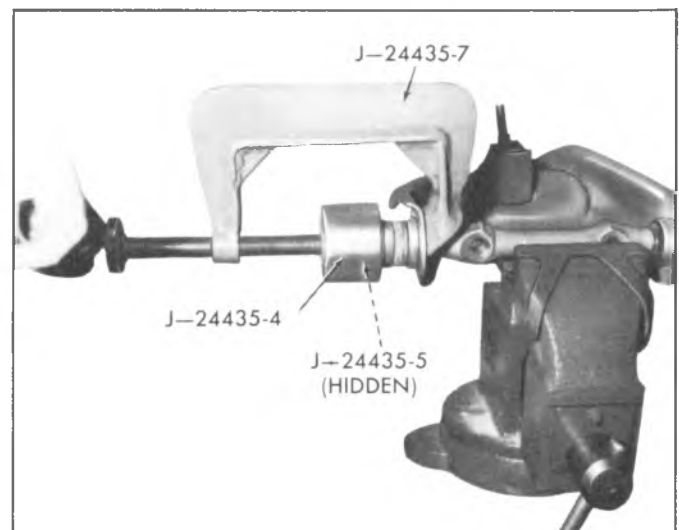


Fig. 3C-23--U.C.A. Rubber Bushing Installation

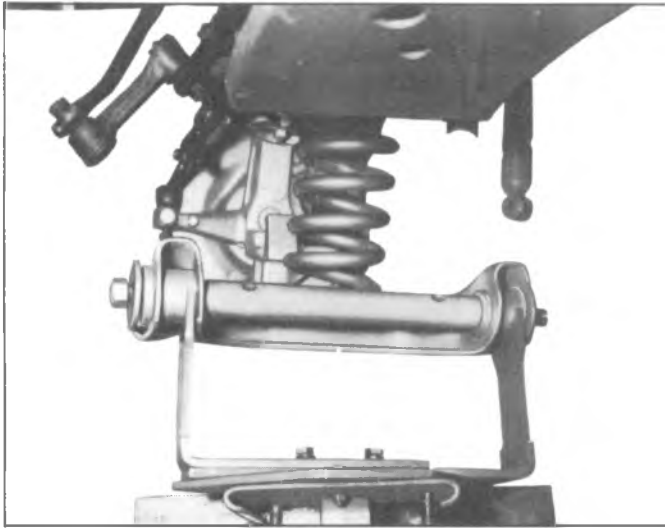


Fig. 3C-24--Lowering Control Arm for Bushing Replacement

ball stud in steering knuckle. When stud is loosened, remove tool and nut from lower stud.

NOTE: It is necessary to remove the brake caliper assembly and wire it to the frame to gain clearance for tool J-23742. See section 5 for proper procedure.

4. Remove the lower control arm.

Lower Control Arm Inner Pivot Shaft and/or Bushing Replacement-On Vehicle

C10, G10-20 (Rubber Bushings)

Removal (Figs. 3C-24, 3C-25)

NOTE: If just bushings or pivot shaft are to be replaced the lower control arm does not have to be removed from the vehicle.

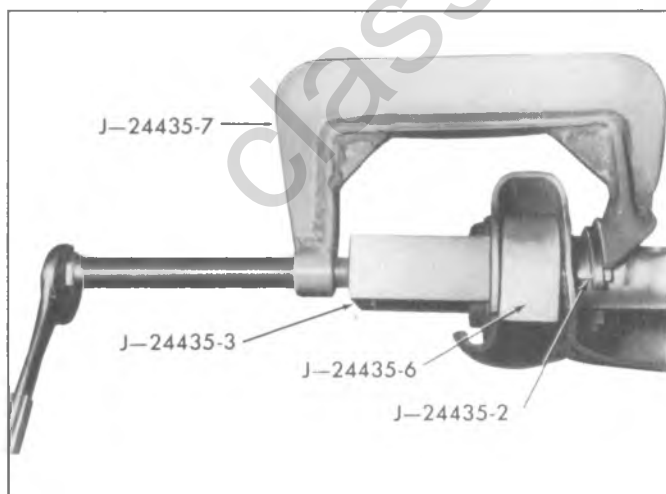


Fig. 3C-25--L.C.A. Rubber Bushing Removal

1. Raise vehicle on hoist and support the frame so that the control arms hang free.
2. Position an adjustable floor jack under the lower control arm inboard of spring and into depression of control arm.
3. Install a chain over the upper arm inboard of the stabilizer and outboard of shock absorber as a safety measure.
4. Disconnect shock and stabilizer bar attachments at lower control arm.
5. Loosen shaft end nuts.
6. Remove "U" bolts that retain the inboard end of the lower control arm.
7. Lower jack SLOWLY to release spring compression (Fig. 3C-24) and gain clearance to remove bushings.

WARNING: Be sure all compression is released from coil springs.

8. Remove the stakes on the front bushing using tool J-22717 or equivalent tool.
9. Bushings may now be replaced. Install "C" clamps J-24435-7 and receiver J-24435-3 with remover J-24435-2 and spacer J-24435-6 as shown in Figure 3C-25.
10. Tighten the "C" clamp to remove the bushing.
11. Remove tools and discard old bushing.
12. Pivot shaft may now be removed if necessary.
13. Remove second bushing (leave pivot shaft in to pilot tool) by the same method as in steps 8-12.

Bushing Installation (Fig. 3C-26)

CAUTION: See CAUTION on page 1 of this section regarding the fasteners referred to in step 5.

1. Install new bushings as shown in Figure 3C-26 using spacer J-24435-6, installer J-24435-4 and "C" clamp J-24435-7.
2. Turn clamp in until bushing seats firmly.

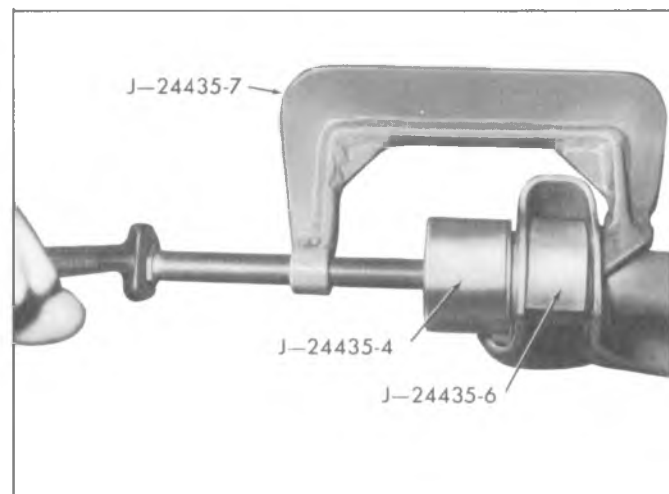


Fig. 3C-26--L.C.A. Rubber Bushing Installation

CAUTION: Be sure spacer J-24435-6 is in position as shown in Figure 3C-26 to avoid collapsing control arm during assembly.

3. Install one bushing then insert the pivot shaft and install second bushing.
4. Stake front bushing at least in two places when installed.
5. Install the lower control arm to the vehicle as described under "Lower Control Arm - Installation", being sure to torque all fasteners to the proper specification.

Lower Control Arm Installation

CAUTION: See CAUTION on page 1 of this section regarding the fasteners referred to in steps 2 and 3.

1. Install lower ball stud through steering knuckle and tighten nut.
2. Install spring and control arm as outlined under spring installation.
3. Torque lower control arm ball stud to specifications and install cotter pin.
4. Install brake caliper assembly if removed (see section 5).
5. Lower the vehicle to the floor.

BALL JOINT SERVICE—ON VEHICLE

Ball Joint—Inspection

The upper ball stud is spring loaded in its socket. This minimizes looseness at this point and compensates for normal wear. If the upper stud has any perceptible lateral shake, or if it can be twisted in its socket with the fingers, the upper ball joint should be replaced.

Upper—Removal

1. Raise vehicle on hoist. If a frame hoist is used, it will be necessary to support the lower control arm with a floor jack.

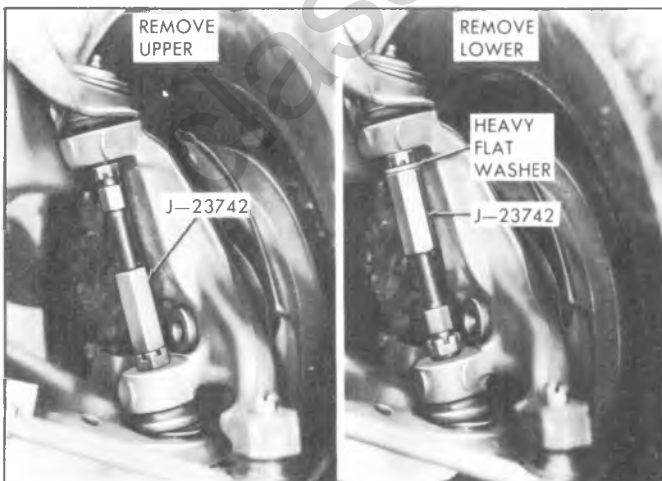


Fig. 3C-27—Disconnecting Ball Joints—Typical

2. Remove cotter pin from upper ball stud and loosen stud nut (two turns) but do not remove nut.
3. Install J-23742 between the ball studs as shown in Figure 3C-27.

NOTE: It is necessary to remove the brake caliper assembly and wire it to the frame to gain clearance for tool J-23742. See section 5 for the proper procedure.

CAUTION: Before proceeding with Step 4, be sure lower control arm is supported as pointed out in Step 1.

4. Extend bolt from Tool J-23742 to loosen ball stud in steering knuckle. When stud is loose, remove tool and stud nut.
5. Center punch rivet heads and drill out rivets.
6. Remove the ball joint assembly.

Installation

CAUTION: See CAUTION on page 1 of this section regarding the fasteners referred to in steps 1, 3 and 6.

1. Install new service ball joint, using bolts and nuts supplied with joint, to upper arm. Torque nuts to 45 ft. lbs.
2. Mate ball stud to steering knuckle and install stud nut.
3. Torque the ball stud nut as follows:
 - A. 10 Series 40–60 ft. lbs. plus additional torque to align cotter pin not to exceed 90 ft. lbs. Never back off to align cotter pin.
 - B. 20–30 Series 80–100 ft. lbs. plus additional torque to align cotter pin not to exceed 130 ft. lbs. Never back off to align cotter pin.
4. Install new cotter pin.
5. Install lube fitting and lube new joint.
6. Install brake caliper assembly if removed (see section 5).
7. Install tire and wheel assembly.
8. Lower the vehicle to the floor.

Ball Joint—Inspection

Lower

Lower ball joints are a loose fit when not connected to the steering knuckle. Wear may be checked without disassembling the ball stud, as follows:

1. Support weight of control arms at wheel hub and drum.
2. Accurately measure distance between tip of ball stud and tip of grease fitting below ball joint.
3. Move support to control arm to allow wheel hub and drum to hang free. Measure distance as in Step 2. If the difference in measurements exceeds .094" (3/32") for all models, ball joint is worn and should be replaced (Fig. 3C-28).

Lower—Removal

1. Raise vehicle on a hoist. If a frame hoist is used it will be necessary to support the lower control arm with a floor stand.

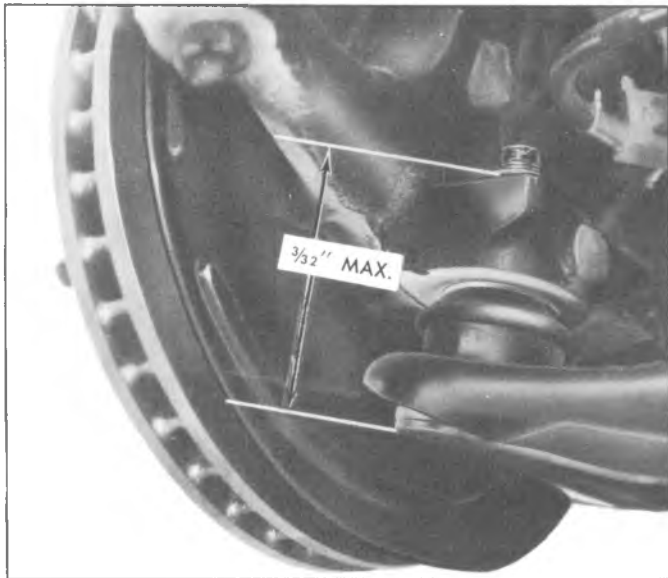


Fig. 3C-28-Checking Lower Ball Joint

2. Remove the tire and wheel assembly.
3. Remove the lower stud cotter pin and loosen (two turns) but do not remove the stud nut.
4. Install J-23742 between the ball studs as shown in Figure 3C-27.

NOTE: It is necessary to remove the brake caliper assembly and wire it to the frame to gain clearance for tool J-23742. See section 5 for proper procedure.

CAUTION: Before proceeding with Step 5, be sure lower control arm is supported as pointed out in Step 1.

5. Extend bolt from Tool J-23742 to loosen ball stud in steering knuckle. When stud is loosened, remove tool and ball stud nut.
6. Pull the brake disc and knuckle assembly up off

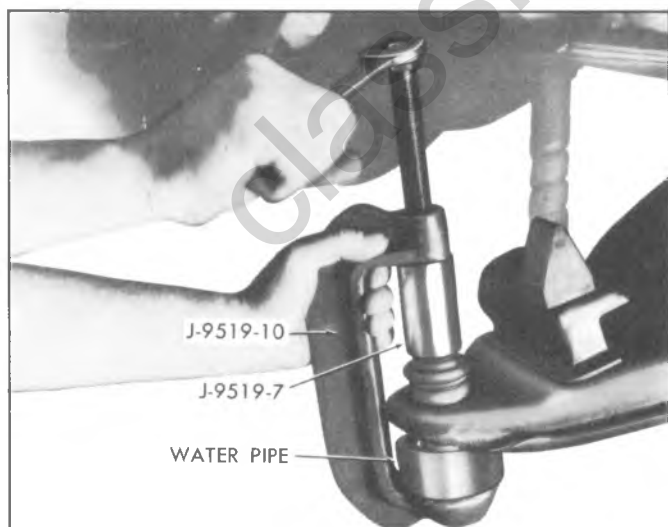


Fig. 3C-29-Ball Joint Removal

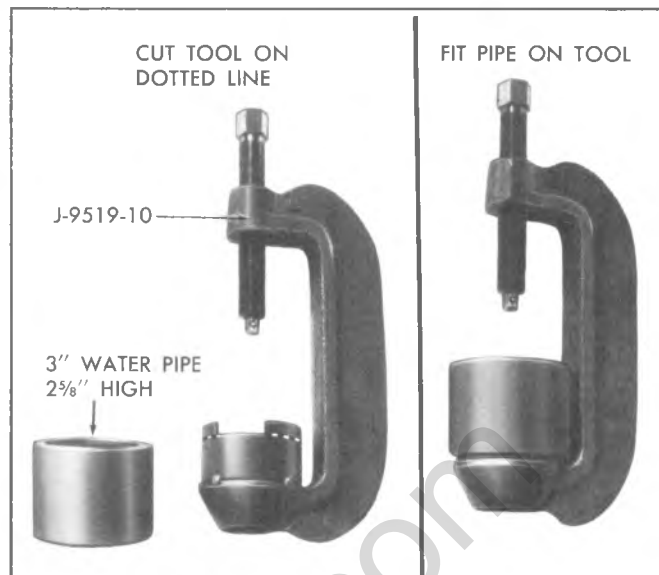


Fig. 3C-30-Alteration to Tool J-9519-10

the ball stud and support the upper arm with a block of wood so that assembly is out of working area.

CAUTION: Do not put stress on the brake line flex hose.

7. Install Tools J-9519-10 and J-9519-7 as shown in Fig. 3C-29.

NOTE: It will be necessary to alter Tool J-9519-10 as illustrated in Fig. 3C-30 and install a 3" I.D. pipe as shown if working on a 20 or 30 series vehicle.

8. Turn hex head screw until ball joint is free of control arm.
9. Remove tools and the ball joint.

Installation (Fig. 3C-31)

CAUTION: See CAUTION on page 1 of this section regarding the fasteners referred to in steps 4, 5 and 7.

1. Start the new ball joint into the control arm and install J-9519 and J-9519-9 as shown.

NOTE: Position bleed vent in rubber boot facing inward.

2. Turn hex head screw until ball joint is seated in control arm.
3. Lower the upper arm and mate the steering knuckle to the lower ball stud.
4. Install brake caliper assembly if removed (see Section 5).
5. Install ball stud nut and torque as follows. All Series, 80–100 ft. lbs. plus additional torque to align cotter pin hole not to exceed 130 ft. lbs. maximum. Never back off to align cotter pin.
6. Install a lube fitting and lube the joint.

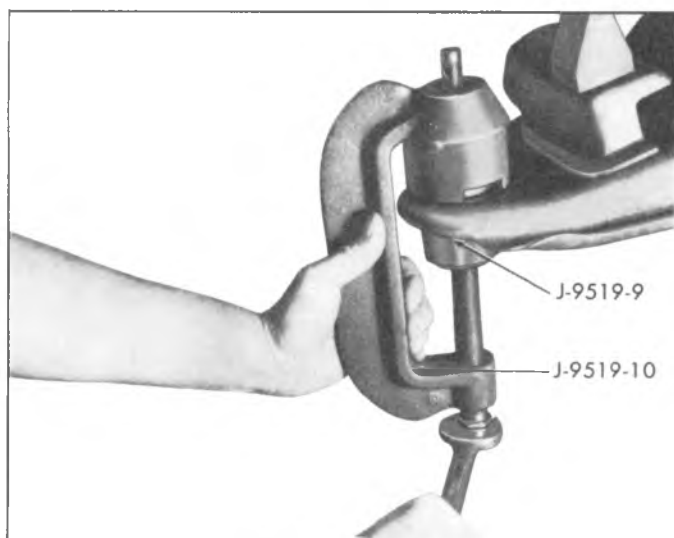


Fig. 3C-31--Installing Ball Joint

7. Install tire and wheel assembly and lower vehicle to floor.

STEERING KNUCKLE

It is recommended that vehicle be raised and supported as on a twin-post hoist so that the front coil spring remains compressed, yet the wheel and steering knuckle assembly remain accessible. If a frame hoist is used, support lower control arm with an adjustable jackstand to safely retain spring in its curb height position.

Removal

1. Raise vehicle on hoist and support lower control arm as noted above.
2. Remove wheel and tire assembly.
3. Remove caliper as outlined under "Front Wheel Hub - Removal".
4. Remove disc splash shield bolts securing the shield to the steering knuckle. Remove Shield.
5. Refer to Section 3B-Steering for service removal operations.
6. Remove upper and lower ball stud cotter pins and loosen ball stud nuts. Free steering knuckle from ball studs by installing Special Tool J-23742. Remove ball stud nuts and withdraw steering knuckle.

Installation

CAUTION: See *CAUTION* on page 1 of this section regarding the fasteners referred to in steps 2, 3, 4 and 5.

1. Place steering knuckle in position and insert upper and lower ball studs into knuckle bosses.

CAUTION: Steering knuckle hole, ball stud and nut should be free of dirt and grease before tightening nut.

2. Install ball stud nuts and tighten nut to specifications. (See Specification Section.)

CAUTION: If necessary, tighten one more

notch to insert cotter pins. Do not loosen nut to insert cotter pin. Refer to Ball Joint text for proper nut installation sequence.

3. Reverse remaining removal procedure, and tighten splash shield mounting bolt. Tighten two caliper assembly mounting bolts to 35 ft. lb. torque.

4. Adjust wheel bearings as outlined under Front Wheel Bearing Adjustment.

5. Tighten wheel nuts to 75 ft. lb.

CROSSMEMBER AND SUSPENSION UNIT

Component parts of the front suspension may be serviced separately as outlined in the preceding service operations. However, if extensive service is to be performed to crossmember, frame, etc., the unit can be removed and installed as follows:

Removal (Fig. 3C-32)

1. Place vehicle on hoist and remove the shock absorber from the lower control arm.
2. Remove idler arm and pitman arm.
3. Support engine and remove front engine mount center bolts.
4. Separate main brake feeder line from crossmember tee.
5. Remove bolts retaining crossmember hangers to frame side rails.
6. If equipped with brake support struts remove bolts retaining struts to crossmember and frame and remove.

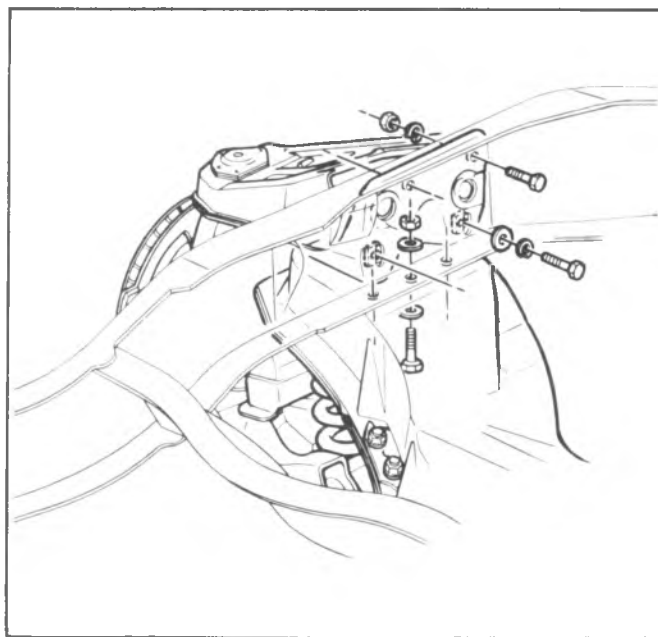


Fig. 3C-32--Suspension Unit to Frame

7. Remove bolts securing crossmember to frame bottom rail and lower the assembly from vehicle.

Installation

CAUTION: See *CAUTION* on page 1 of this section regarding the fasteners referred to in steps 1, 2, 3, 4, 5, 6 and 7.

1. Jack crossmember into position under frame and install frame bottom rail mounting bolts.
2. Install bolts securing crossmember hanger to frame and torque nuts. See specifications.
3. Position engine on front mount and install mounting bolt and torque (see Section 6).

4. Install the shock absorber.
5. Install brake support struts if previously removed.
6. Connect front brake main feeder line and bleed brakes as described in Section 5.
7. Install idler arm and pitman arm (see Section 9).
8. Check and Adjust front end alignment as outlined under "Maintenance and Adjustments" in this section.
9. Lower the vehicle to the floor.

FRONT SUSPENSION, FOUR-WHEEL DRIVE

SERIES K10, K20, K30

INDEX

General Description.....	3C- 24	Spindle.....	3C-30
Maintenance and Adjustments.....	3C- 27	Steering Knuckle (K10, K20).....	3C-31
Ball Joint Adjustment.....	3C- 27	Steering Knuckle (K30).....	3C-33
Bearing Lubrication.....	3C- 28	Shock Absorber.....	3C-36
Wheel Bearing Adjustment.....	3C- 28	Stabilizer Bar.....	3C-36
Component Replacement.....	3C- 29	Leaf Spring.....	3C-37
Hubs, Free-Wheeling (K10, K20).....	3C- 29	Specifications.....	3C-38
Hubs, Locked (K10, K20, K30).....	3C- 30	Special Tools.....	3C-39

GENERAL DESCRIPTION

Front drive axles used on K10, K20, and K30 trucks have several styles of wheel-end construction.

At the wheel ends of the axle tubes, two types of steering knuckle attachment are used. Figures 3C-1K and 3C-2K show the K10 and K20 knuckle attached with ball joints. Figure 3C-3K shows the king-pin attachment used in K30. The tapered upper king pin fits in a tapered nylon bushing. The lower king pin is part of the bearing cap, and this king pin rides in a tapered roller bearing.

All trucks with full-time four-wheel drive use a locked hub, as shown in Figure 3C-1K (for K10, K20), and in Figure 3C-3K (for K30). A free-wheeling hub is used on trucks equipped with part-time four-wheel drive. The free-wheeling hub (for K10, K20) is shown in Figure 3C-2K. This hub allows the driver to manually engage or disengage the hub from the axle shafts.

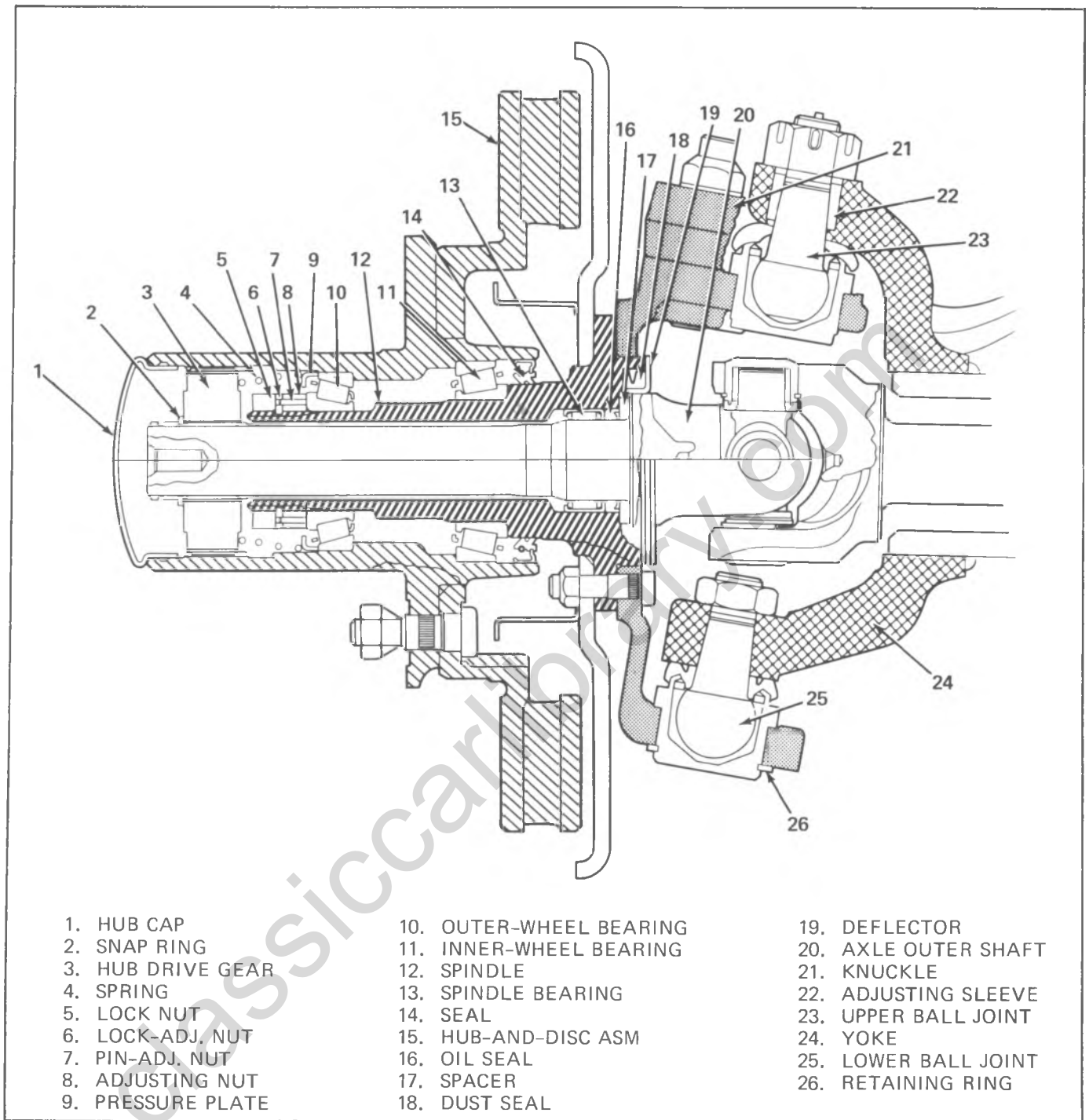


Fig. 3C-1K-K10, K20 with Locked Hub and Ball Joints

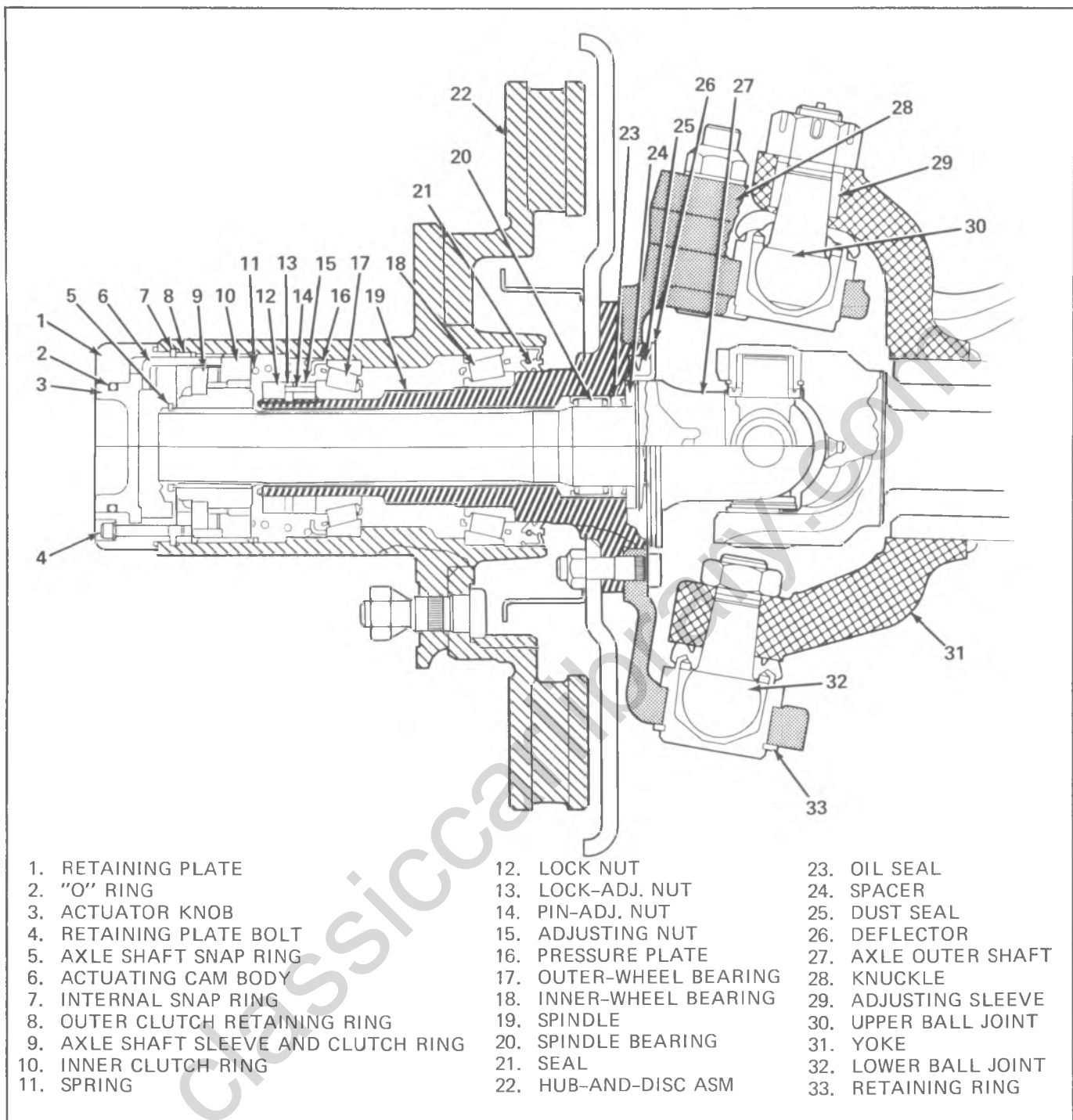


Fig. 3C-2K- K10, K20 with Free-Wheeling Hub and Ball Joints

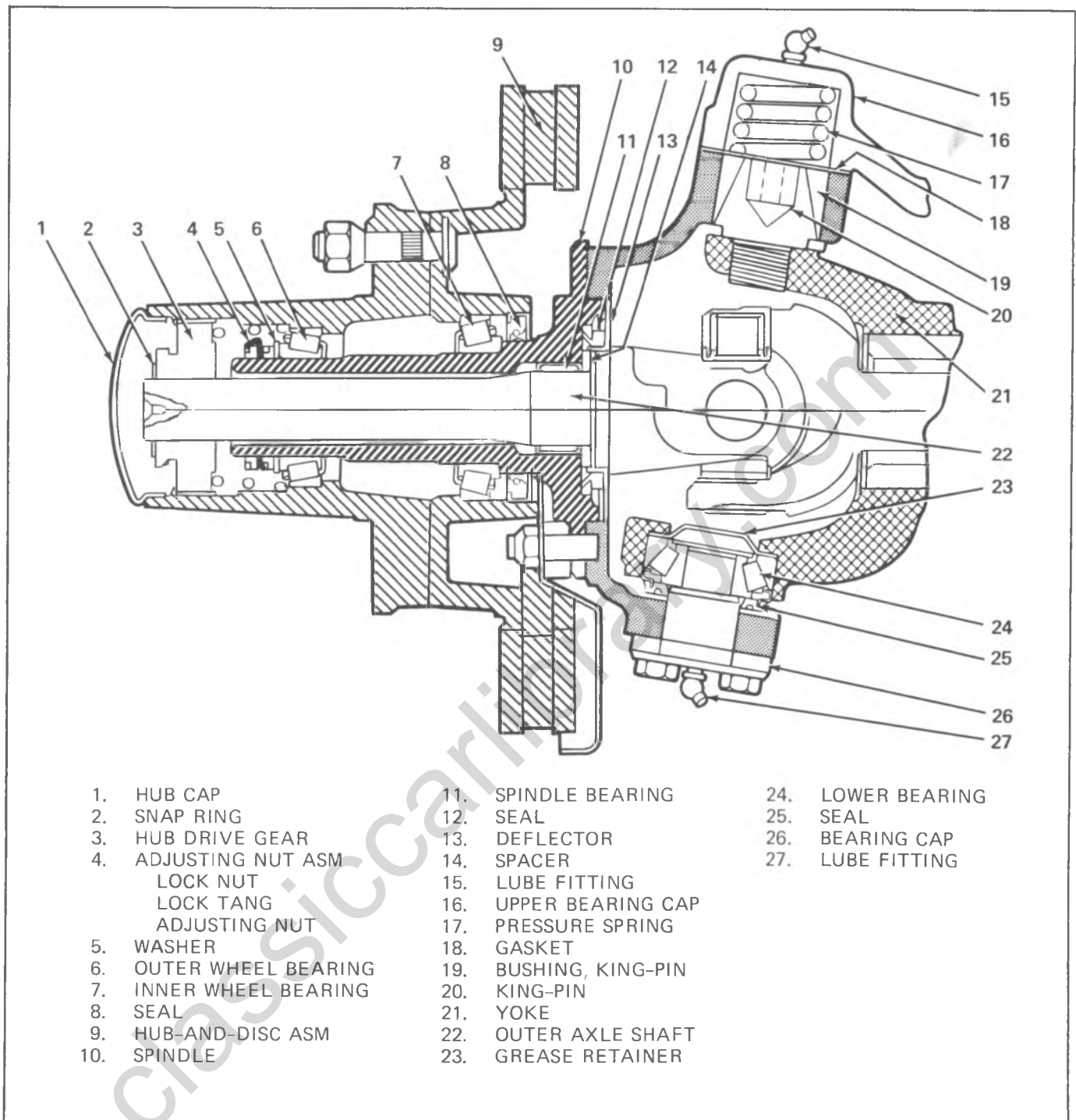


Fig. 3C-3K--K30 with Locked Hub and King-Pins

MAINTENANCE AND ADJUSTMENTS

BALL JOINT ADJUSTMENT (K10, K20)

Front axle ball joint adjustment is generally necessary only when there is excessive play in steering, irregular wear on tires or persistent loosening of the tie rod is observed.

1. Raise vehicle on hoist then place jack stands just inside of front springs.

2. Disconnect connecting rod and tie rod to allow

independent movement of each steering knuckle.

3. Apply a fish-scale to the tie rod mounting hole of the steering knuckle arm. With the knuckle assembly in the straight-ahead position, determine the right angle pull required to keep the knuckle assembly turning after initial break-away. This pull should not exceed 25 lbs., for each knuckle assembly, in either direction. See Figure 3C-4K.

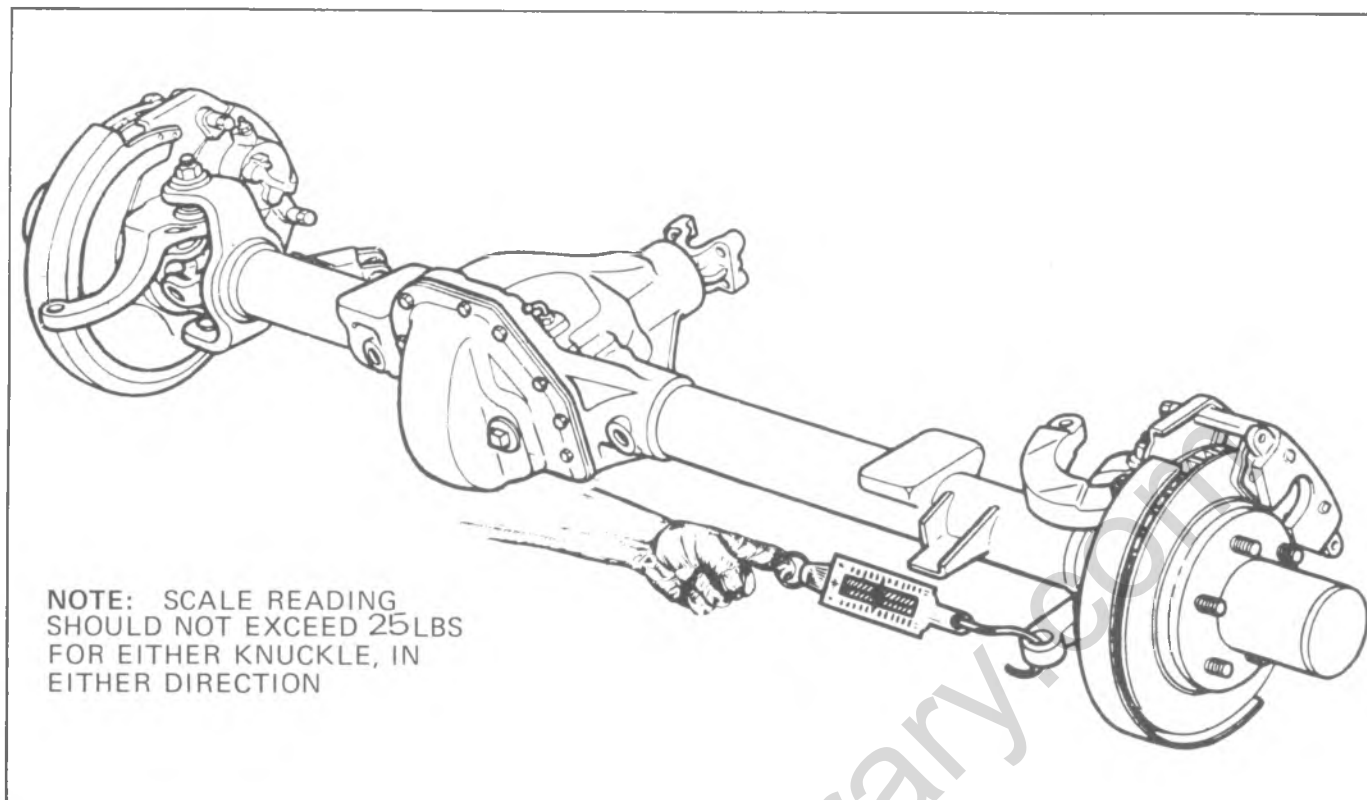


Fig. 3C-4K--Determining Front Axle Ball Joint Adjustment

4. If the effort exceeds 25 lbs., remove the upper ball stud nut, and loosen the ball stud adjusting sleeve as required. Re-torque the ball stud nut and recheck the turning effort.

BEARING LUBRICATION

Front Wheel Bearings

Spindle Bearings

Whenever front wheel bearings are lubricated, the spindle needle bearings should also be lubricated, with the same chassis grease. Under normal conditions, the lubrication interval should be 12,000 miles; off-road use such as in mud or water will require shorter intervals. The spindle bearings are accessible after removing the spindle, as shown in Figure 3C-6K.

WHEEL BEARING ADJUSTMENT

1. After lubricating the wheel bearings and the spindle bearings, install the hub-and-disc, and the outer wheel bearing to the spindle.

2. Torque the inner adjusting nut to 50 foot pounds, while rotating the hub-and-disc to seat the bearings. Use Tool J-6893 and Adapter J-23446 or J-6893-01 for K10, K20; use J-26878 for K30. Back off the inner adjusting nut and re-torque to 35 ft. lbs. while the hub is being rotated.

3. Back off the inner adjusting nut again 3/8 turn maximum.

a. For K10 and K20, assemble adjusting nut lock by aligning nearest hole in lock with adjusting nut pin. Install outer lock nut and torque to 50 ft. lbs. (minimum).

b. For K30, assemble lockwasher and outer locknut. Torque outer locknut to 65 ft. lbs. (minimum). Bend one ear of lockwasher over the inner nut a minimum of 30°. Bend one ear of lockwasher over the outer nut a minimum of 60°.

NOTE: Hub assembly should have .001 to .010 inch end play, for all K10, K20 and K30 models.

4. If vehicle is equipped with locked hubs, install the hub cap assembly. If the vehicle is equipped with free-wheeling hubs, refer to free-wheeling hub assembly and installation procedures.

COMPONENT REPLACEMENT

HUB REPLACEMENT

CAUTION: See **CAUTION** on page 1 of this section regarding the fasteners in the following procedures for hub replacement.

FREE-WHEELING HUBS

K10, K20 (PART-TIME)

Hub Removal

1. Turn actuator lever to set hub to "LOCK" position (Fig. 3C-5K) and raise vehicle on hoist.
2. Remove six retaining plate bolts and remove retaining plate actuating knob and "O" ring.
3. Remove internal snap ring, outer clutch retaining ring and actuating cam body.
4. Relieve pressure on the axle shaft snap ring and remove snap ring.
5. Remove the axle shaft sleeve and clutch ring assembly and inner clutch ring and bushing assembly.
6. Remove pressure spring and spring retainer plate.
7. Remove the wheel bearing outer lock nut, lock ring, and wheel bearing inner adjusting nut using Tool J-6893 and Adapter J-23446 or Tool J-6893-01.

NOTE: If the disc or other brake components require repairs or replacement, refer to Section 5.

8. Remove the hub-and-disc assembly, outer wheel bearing and the spring retainer plate.
 - a. Remove the oil seal and inner bearing cone from the hub using a brass drift and tapping with a hammer. Discard the oil seal.



Fig. 3C-5K--Hub Key Position - Typical

- b. Remove the inner and outer bearing cups using a brass drift and hammer.
- c. Clean, inspect and lubricate all parts as required.

Servicing Actuating Parts

1. Remove actuator knob and "O" ring from retaining plate, discard "O" ring and replace with a new "O" ring during assembly.
2. Slide inner clutch ring and bushing assembly from axle sleeve and clutch ring assembly.
3. Wash all parts in solvent and air dry.
4. Inspect all parts for wear, cracks or broken teeth.
5. Replace all "O" rings during assembly.
6. Place new "O" ring seal on actuator knob. Apply Lubri-plate, or equivalent, to "O" ring and place actuator knob in retaining plate.

Installation of Hub

NOTE: All parts should be lubricated for normal operation during assembly with an ample amount of high speed grease. Lubrication **MUST** be applied to prevent deterioration before the unit is placed in service.

1. Assemble the outer wheel bearing cup into the wheel hub using Installer J-6368 and Driver Handle J-8092.
2. Assemble the inner wheel bearing cup into the wheel hub using Installer J-23448 and Driver Handle J-8092.
3. Pack the wheel bearing cone with a high melting point type wheel bearing grease and insert the cone into the cup.
4. After lubricating the wheel bearings, install the hub-and-disc and the bearings to the spindle.
5. Torque the inner adjusting nut to 50 foot pounds, while rotating the hub-and-disc to seat the bearings. Use Tool J-6893 and Adapter J-23446 or J-6893-01. Back off the inner adjusting nut and retorquer to 35 ft. lbs. while the hub is being rotated.
6. Back off the inner adjusting nut again 3/8 turn maximum. Assemble the adjusting nut lock by aligning the nearest hole in lock with the adjusting nut pin. Install outer lock nut and torque to 50 ft. lbs. (minimum).

NOTE: Hub assembly should have .001 to .010 inch end play.

7. Install spring retainer plate (flange side facing bearing) over spindle nuts and seat retainer against bearing outer cup.
8. Install pressure spring into position. Large O.D. seats against spring retaining plate.

NOTE: Spring is an interference fit. When spring is seated, spring extends past the spindle nuts by approximately 7/8".

9. Place inner clutch ring and bushing assembly

into axle shaft sleeve and clutch ring assembly and install as an assembly onto the axle shaft. Press in on assembly and install axle shaft snap ring.

NOTE: Install 7/16 x 20 bolt in axle shaft end and pull outward on axle shaft to aid in installing snap rings.

10. Install actuating cam body (cams facing outward), outer clutch retaining ring and internal snap ring.

11. Install "O" ring on retaining plate and install actuating knob and retaining plate.

NOTE: Install actuating knob with knob in "LOCK" position--grooves in knob must fit into actuator cam body.

12. Install six cover bolts and seals, and torque to 30 ft. lbs.

13. Turn knob to "FREE" position to check for proper operation.

14. Lower vehicle to floor.

LOCKED HUBS

K10, K20, K30 (FULL-TIME)

Removal and Service

1. Remove the hub cap and snap ring.
2. Remove the drive gear and, on K10 and K20, the pressure spring. Place a hand over the drive gear and use a screwdriver to pry the gear out.
3. Remove the wheel bearing outer lock nut, lock ring, and wheel bearing inner adjusting nut using Tool J-6893 and Adapter J-23446 or tool J-6893-01 for K10, K20; use J-26878 for K30.

NOTE: If the disc or other brake components require repairs or replacement, refer to Section 5.

4. Remove the hub-and-disc assembly, outer wheel bearing and the spring retainer plate.
 - a. Remove the oil seal and inner bearing cone from the hub using a brass drift and tapping with a hammer. Discard the oil seal.
 - b. Remove the inner and outer bearing cups using a brass drift and hammer.
 - c. Clean, inspect and lubricate all parts as required.

Installation

1. Assemble the outer wheel bearing cup into the wheel hub.
 - a. Use installer J-6368 and Driver Handle J-8092 for K10, K20.
 - b. Use J-8608 for K-30.
2. Assemble the inner wheel bearing cup into the wheel hub.
 - a. Use J-23448 and Driver Handle J-8092 for K10, K20.
 - b. Use J-22306 for K-30.
3. Pack the wheel bearing cone with a high melting point type wheel bearing grease.
 - a. Insert the cone into the cup.

b. Install new grease seal into inboard end of hub. Use J-24428 for K30.

4. After lubricating the wheel bearings, install the hub-and-disc and the bearings to the spindle.

5. Torque the inner adjusting nut to 50 ft. lbs. while rotating the hub-and-disc, to seat the bearings. Back off the inner adjusting nut and retorque to 35 ft. lbs. while the hub is being rotated.

6. Back off the inner adjusting nut again 3/8 turn maximum.

a. **For K10 and K20** assemble the adjusting nut lock by aligning the nearest hole in lock with the adjusting nut pin. Install outer lock nut and torque to 50 ft. lbs. (minimum).

b. **For K30**, assemble lockwasher and outer locknut. Torque outer locknut to 65 ft. lbs. (minimum). Bend one ear of lockwasher over the inner nut a minimum of 30°. Bend one ear of lockwasher over outer nut, a minimum of 60°.

NOTE: Hub assembly should have .001 to .010 inch end play, for all K10, K20 and K30 models.

CAUTION: See *CAUTION* on page 1 of this section.

7. Install the pressure spring (on K10 and K20), drive gear, snap ring and hub cap.

SPINDLE

Removal

1. Remove the hub-and-disc assembly as outlined earlier.
2. Remove the spindle retaining bolts.
3. Remove the spindle and bronze thrust washer by tapping the end of the spindle lightly with a soft hammer to break it loose from the knuckle as shown in Figure 3C-6K. Replace the thrust washer if excessive wear has occurred.

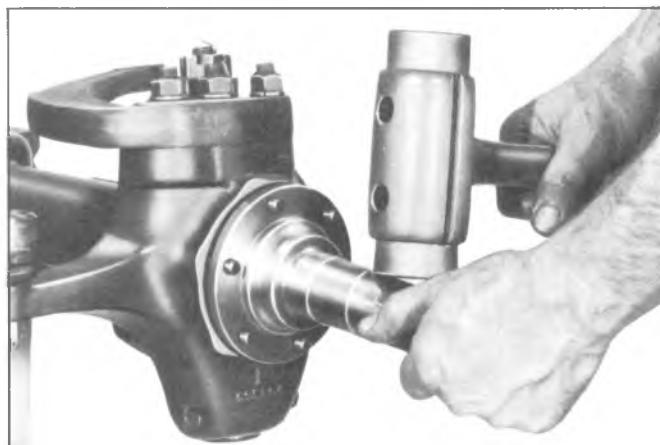


Fig. 3C-6K--Removing Spindle and Thrust Washer

Servicing Spindle Components

1. Secure the spindle in a vise by locating on the high step diameter. Be sure that the machined surface of the spindle will not be damaged by the vise jaws.
2. Remove the oil seal.
3. Remove the needle roller bearing.
4. Place the spindle in a vise on the high step and install needle roller bearing.
 - a. Use J-23445 and Drive Handle J-8092 for K10, K20.
 - b. Use J-21465-17 for K-30.
5. Install grease seal onto slinger with lip toward spindle.
6. Relubricate the needle bearing and the spindle end with a high melting point type wheel bearing grease.

Installation

1. Install the bronze thrust washer over the axle shaft with the chamfer toward the slinger and install the spindle as shown in Figure 3C-7K.
2. Assemble spindle to knuckle.

NOTE: Torque spindle nuts to 25 ft. lbs. (K10, 20); torque to 60 ft. lbs. (K30).

CAUTION: See *CAUTION* on page 1 of this section.

NUCKLE

K10, K20, (WITH BALL JOINTS)

Removal

1. Remove hub and spindle components as outlined earlier.
2. If the steering arm is to be removed, disconnect the tie rod.
 - a. Remove cotter pin.
 - b. Loosen tie rod nuts and tap on nut with a soft hammer to break the studs loose from the knuckle arm.
 - c. Remove nuts and disconnect the tie rod.

CAUTION: If it is necessary to remove the

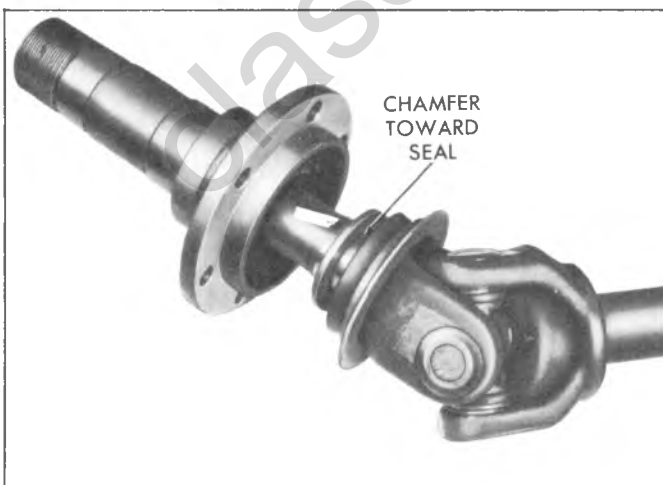


Fig. 3C-7K--Installing Spindle and Thrust Washer

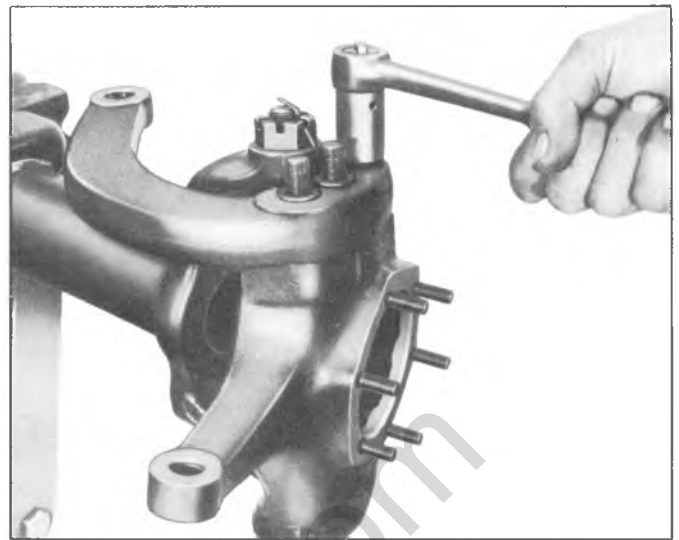


Fig. 3C-8K--Removing Steering Arm Nuts

steering arm, discard the self-locking nuts (Fig. 3C-8K) and replace with new nuts at assembly.

3. Remove the cotter pin from the upper ball socket nut.
4. Remove the retaining nuts from the upper and lower ball sockets as shown in Figure 3C-9K.
5. Remove the knuckle assembly from the yoke by inserting a suitable wedge-shaped tool between the lower ball stud and the yoke and tapping on the tool to release the knuckle assembly. Repeat as required at the upper ball stud location.

Ball Joint Service

CAUTION: Do not remove the yoke upper ball stud adjusting sleeve unless new ball studs are being installed. If it is necessary to loosen the sleeve to remove the knuckle, do not loosen it more than two threads using Spanner J-23447 as shown in Figure 3C-14K. The nonhardened

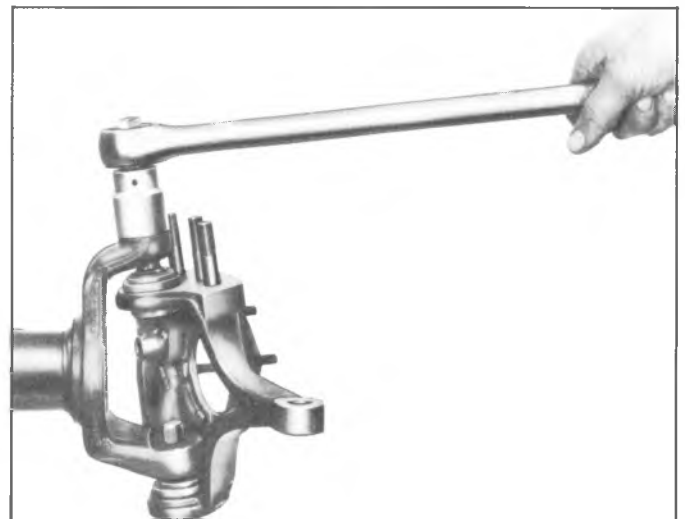


Fig. 3C-9K--Removing Ball Socket Retaining Nut

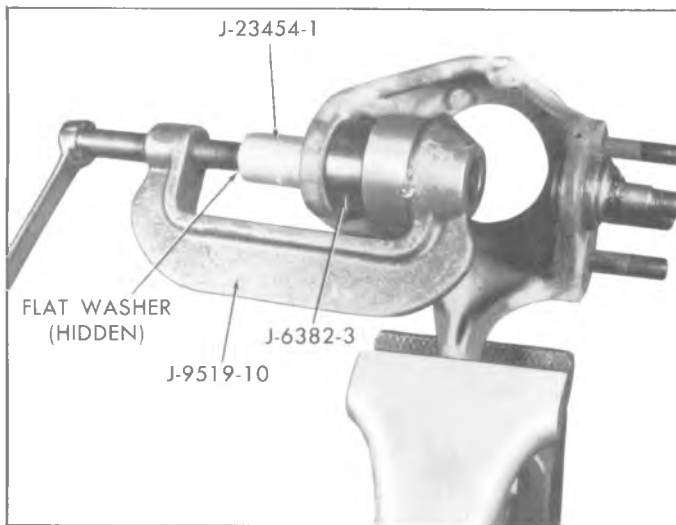


Fig. 3C-10K--Removing Lower Ball Joint

threads in the yoke can be easily damaged by the hardened threads in the adjusting sleeve if caution is not used during knuckle removal.

NOTE: Remove the lower ball joint snap ring before beginning. Lower ball joint must be removed before any service can be performed on the upper ball joint.

1. Remove the lower ball joint using tools J-9519-10, J-23454-1, and sleeve J-6382-3 or equivalent as shown in Figure 3C-10K.

NOTE: If Tool J-6382-3 is not available, a suitable tool may be fabricated from 2-1/2" O.D. steel tubing with 3/16" wall thickness, cut 2-1/2" long.

2. Remove the upper ball joint using tools J-9519-10, J-23454-1, and sleeve J-6382-3 or equivalent as shown in Figure 3C-11K.

3. Install the lower ball joint into the knuckle. Make sure that the lower ball joint (the joint without

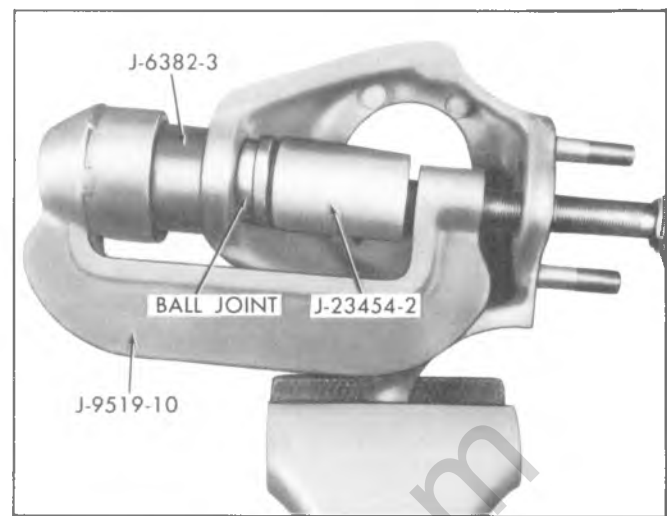


Fig. 3C-12K--Installing Lower Ball Joint

cotter pin hole in the stud end) is straight. Press the stud into the knuckle until properly seated using tools J-9519-10, J-23454-2, and J-6382-3 or equivalent as shown in Figure 3C-12K and install snap ring.

4. Install the upper ball joint into the knuckle. Press the stud into the knuckle until properly seated using Tools J-9519-10, J-23454-2, and J-6382-3 or equivalent as shown in Figure 3C-13K.

Installation

CAUTION: See **CAUTION** on page 1 of this section regarding the fasteners in the following steps.

1. Position the knuckle and sockets to the yoke. Install new nuts finger tight to the upper (the nut with the cotter pin slot) and lower ball socket studs.

2. Push up on the knuckle (to keep the ball socket from turning in the knuckle) while tightening the lower socket retaining nut. Torque lower nut to 70 ft. lbs.

3. Torque the yoke upper ball stud adjusting sleeve to 50 ft. lbs. using Spanner J-23447. See Figure 3C-14K.

4. Torque the upper ball socket nut to 100 ft. lbs.

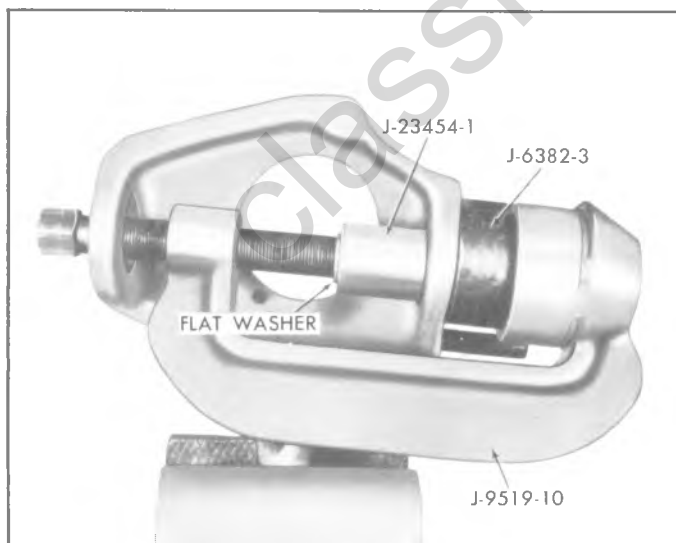


Fig. 3C-11K--Removing Upper Ball Joint

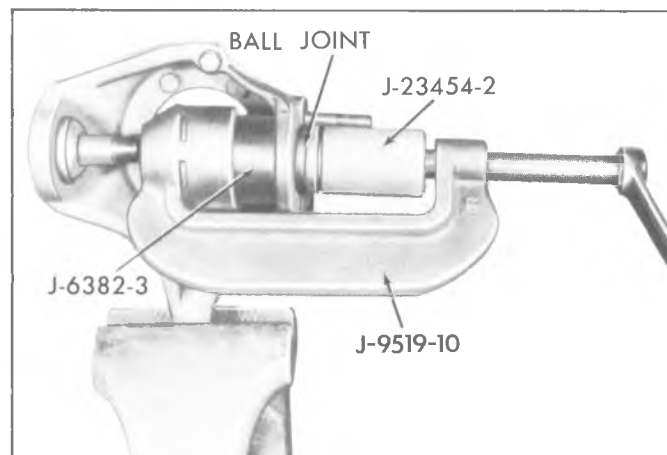


Fig. 3C-13K--Installing Upper Ball Joint

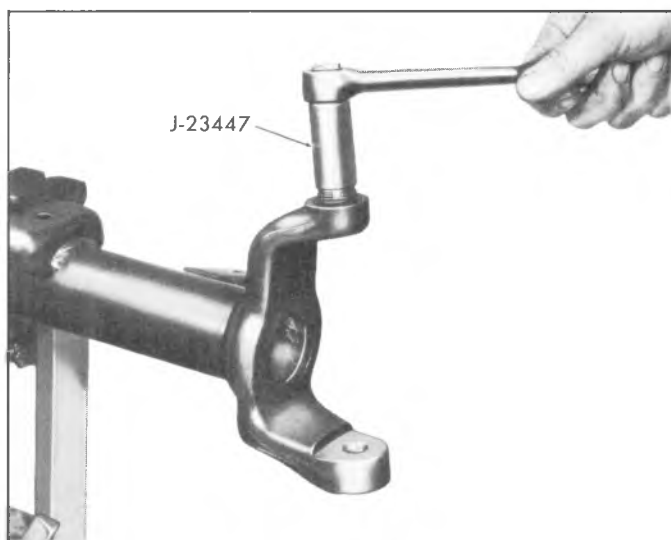


Fig. 3C-14K--Ball Stud Adjusting Sleeve

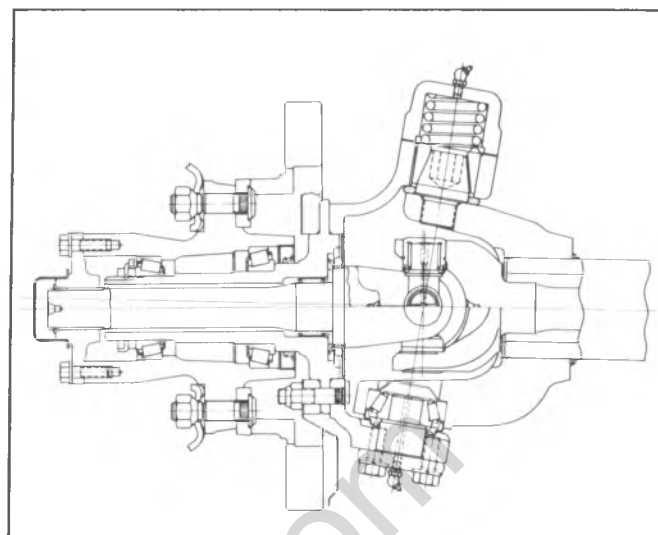


Fig. 3C-16K--Knuckle with King Pins

as shown in Figure 3C-15K. After torquing the nut, do not loosen to install cotter pin, apply additional torque, if necessary, to line up hole in stud with slot in nut.

5. If the tie rod and steering arm were removed:

a. Assemble the steering arm using the three stud adapters and three new self-locking nuts. Torque the nuts to 90 ft. lbs.

b. Assemble the tie rod to the knuckle arm. Torque the tie rod nuts to 45 ft. lbs. and install cotter pin.

KNUCKLE

K30 (WITH KING PINS)

Removal (Fig. 3C-16K)

1. Remove the hub and spindle as outlined earlier. If necessary, tap lightly with a rawhide hammer to free it from the knuckle. Check bronze spacer located between

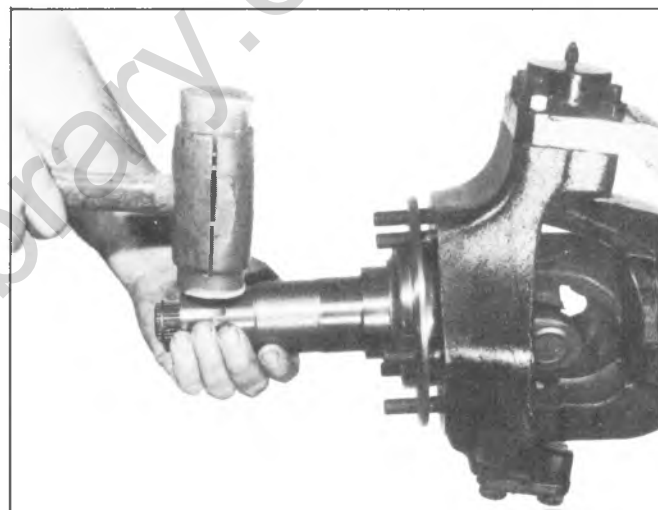


Fig. 3C-17K--Removing Spindle

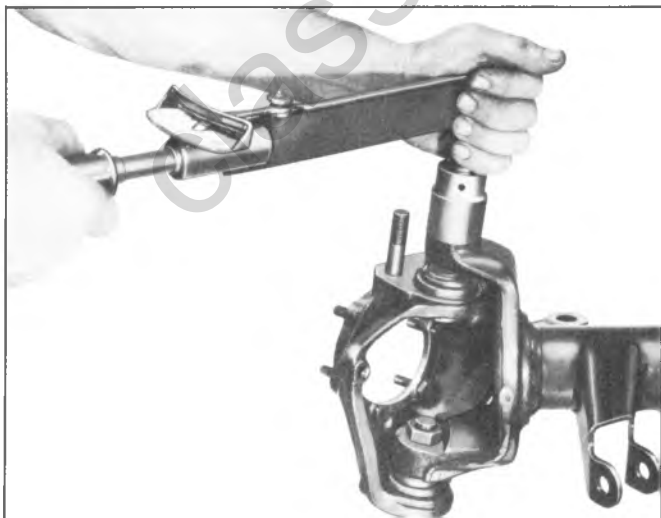


Fig. 3C-15K--Torquing Upper Ball Socket Nut

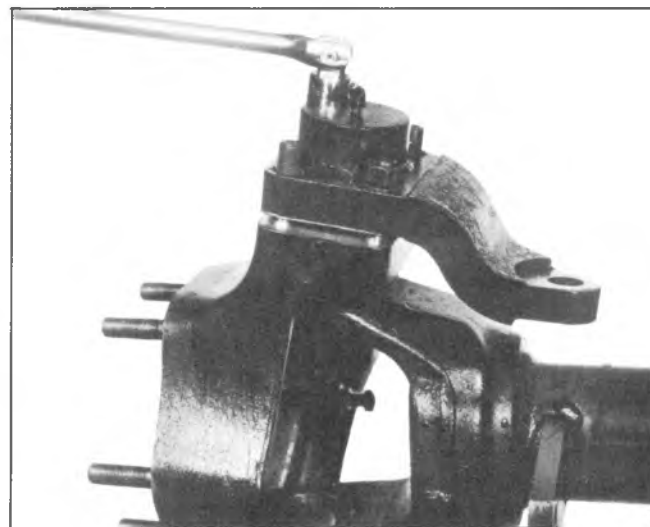


Fig. 3C-18K--Removing Nuts Alternately

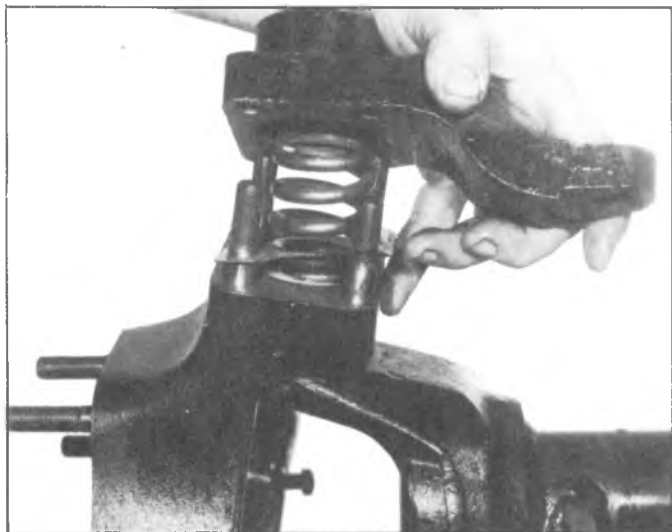


Fig. 3C-19K--Removing Cap, Spring and Gasket

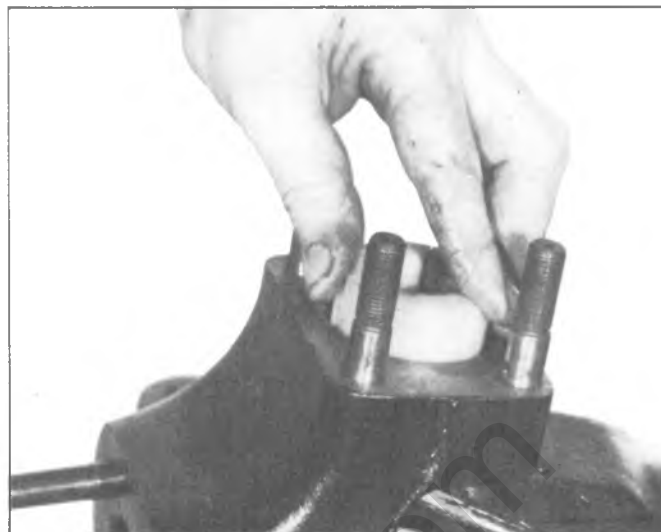


Fig. 3C-21K--Removing Tapered Bushing

axle shaft joint assembly and bearing. If wear is evident, replace with a new one. See Figure 3C-17K.

2. Remove four nuts from upper king pin cap. Remove nuts alternately as compression spring will force cap up. Refer to Figure 3C-18K.

3. Remove cap, compression spring, and gasket, as shown in Figure 3C-19K. Discard gasket, replace with new one at time of assembly.

4. From the underside of the knuckle, remove four cap screws from the lower king pin bearing cap. Remove the bearing cap-and-lower king pin. See Figure 3C-20K.

5. Remove upper king pin tapered bushing and knuckle from yoke. Remove king-pin felt seal. See Figure 3C-21K. Remove knuckle.

6. Remove upper king-pin from yoke with large breaker bar and J-26871, as seen in Figure 3C-22K.

NOTE: Torque specification is 500-600 ft. lbs.

7. Remove lower king pin bearing cup, cone,

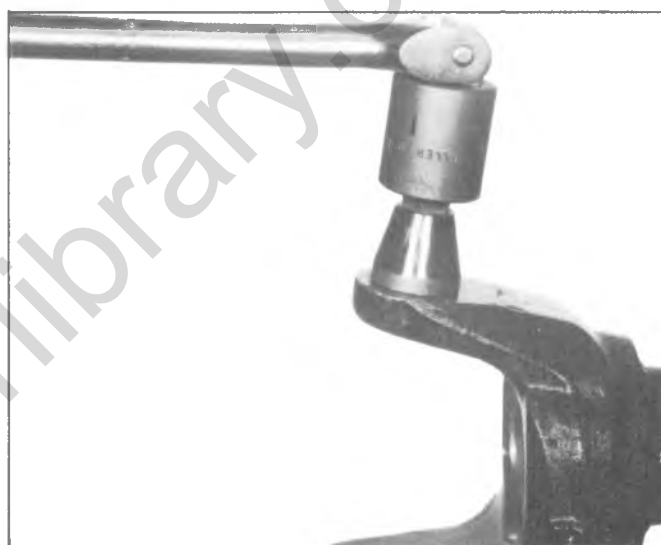


Fig. 3C-22K--Removing Upper King Pin

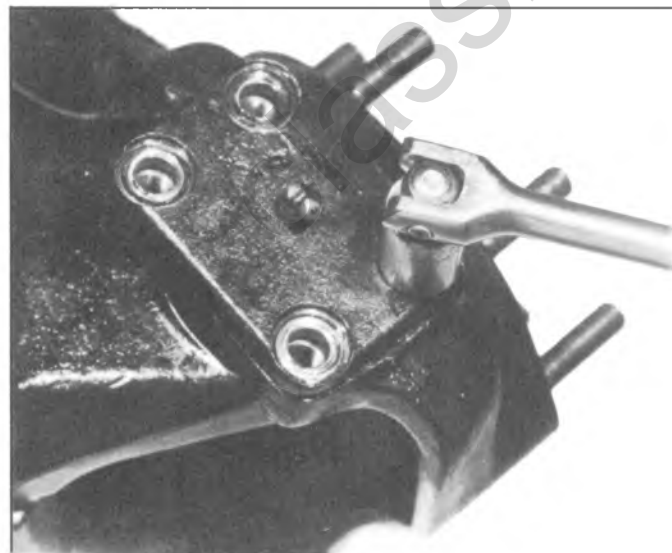


Fig. 3C-20K--Removing Lower Bearing Cap



Fig. 3C-23K--Removing Cup, Cone and Seal

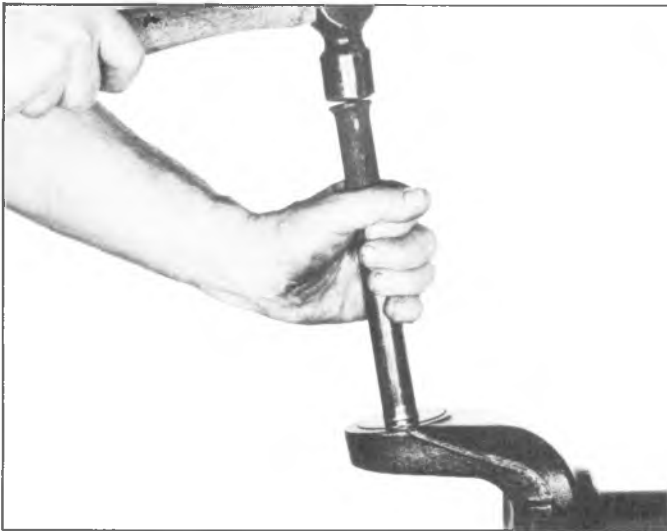


Fig. 3C-24K--Installing Grease Retainer

grease retainer, and seal all at the same time, as shown in Figure 3C-23K. Discard seal and replace with new one at time of assembly. If grease retainer is damaged, replace with new one at time of assembly.

Installation

CAUTION: See *CAUTION* on page 1 of this section regarding the fasteners in the following steps.

1. Assemble new grease retainer and lower king pin bearing cup, using J-7817, as shown in Figure 3C-24K.

2. Fill the area in grease retainer with specified grease, then grease the bearing cone and install. Install



Fig. 3C-25K--Installing Oil Seal

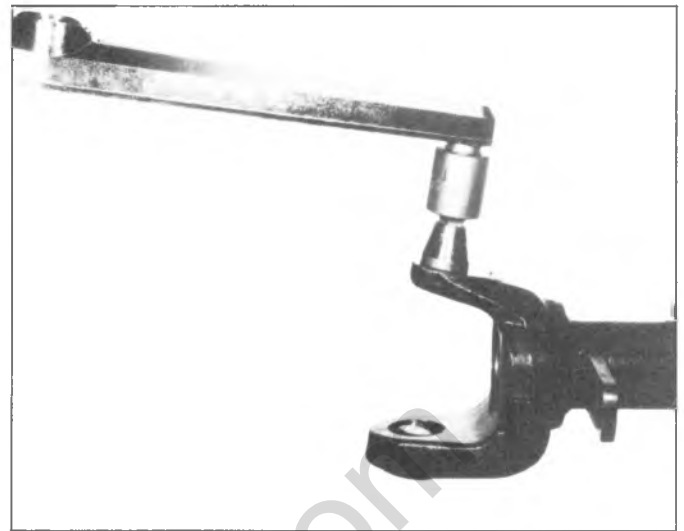


Fig. 3C-26K--Installing Upper King-Pin

new lower king pin bearing oil seal, using J-22281, as shown in Figure 3C-25K.

NOTE: Do not distort oil seal. It will protrude slightly from the surface of yoke flange when fully installed.

3. Install upper king-pin, using J-26871 as shown in Figure 3C-26K. Torque to 500-600 ft. lbs.

4. Assemble felt seal to king pin, assemble knuckle, assemble tapered bushing over king pin, as shown in Figure 3C-27K.

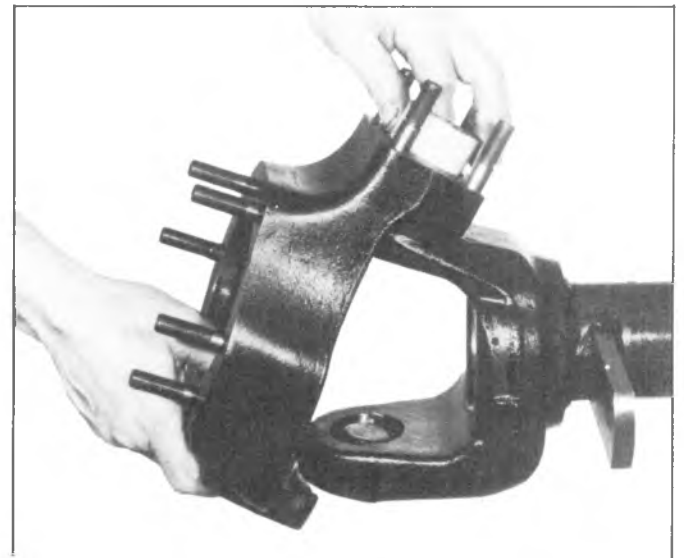


Fig. 3C-27K--Installing Knuckle to Yoke

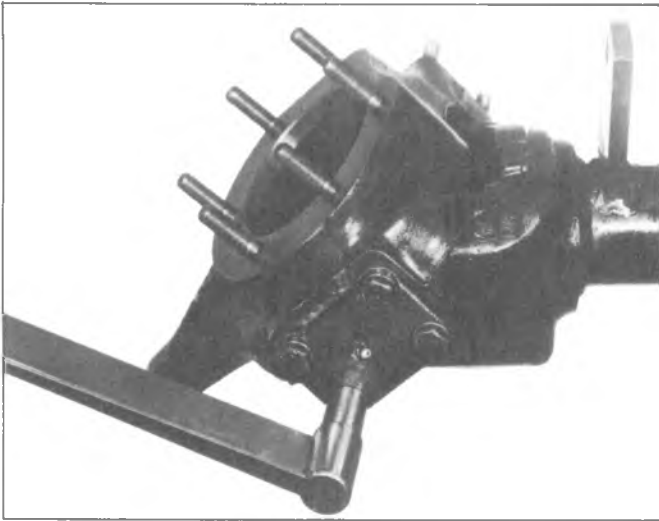


Fig. 3C-28K--Installing Lower Bearing Cap-and-King Pin

5. Assemble lower bearing cap-and-king pin with four cap screws. Tighten cap screws alternately and evenly; see Figure 3C-28K. Torque cap screws to 70-90 ft. lbs.

6. Assemble compression spring on upper king pin bushing. Assemble bearing cap, with new gasket, over four studs. Tighten nuts alternately and evenly. Torque nuts to 70-90 Lb. Ft. See Figure 3C-29K.

SHOCK ABSORBER

Removal (Fig. 3C-30K)

1. Raise vehicle on hoist.
2. Remove nuts and eye bolts securing upper and lower shock absorber eyes.
3. Withdraw shock absorber and inspect rubber eye bushings. If defective, replace shock absorber assembly.

Installation

Place shock absorber into position over mounting

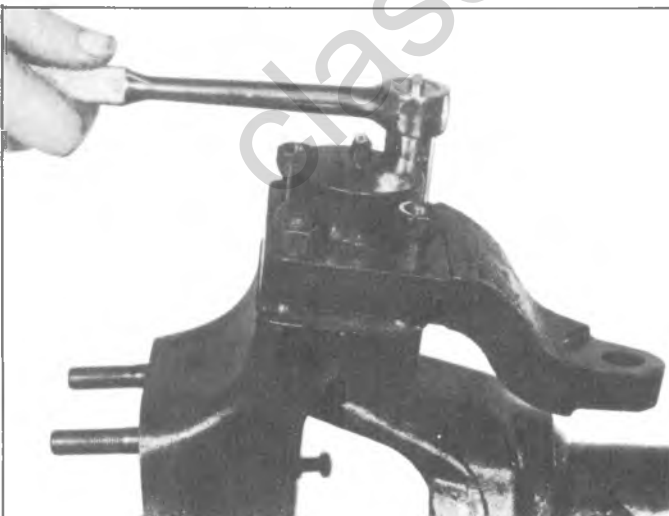


Fig. 3C-29K--Installing Bearing Cap/Steering Arm

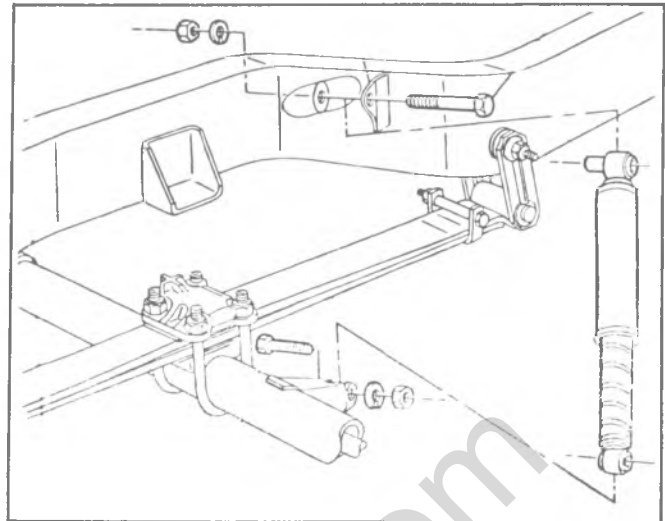


Fig. 3C-30K--Shock Absorber Attachment

bolts or into mounting brackets. Install eye bolts and nuts and torque as shown in Specifications Section. Lower vehicle to floor.

STABILIZER BAR-TYPICAL

Removal (Fig. 3C-31K)

1. Raise vehicle on hoist and remove nuts and bolts attaching stabilizer brackets and bushings at frame location.
2. Remove brackets and bushings at lower spring anchor plates and remove stabilizer from vehicle.

Inspection

Inspect rubber rushings for excessive wear or aging—replace where necessary. Use rubber lubricant when installing bushings over stabilizer bar.

Installation

CAUTION: See *CAUTION* on page 1 of this section regarding the fasteners referred to in step 2.

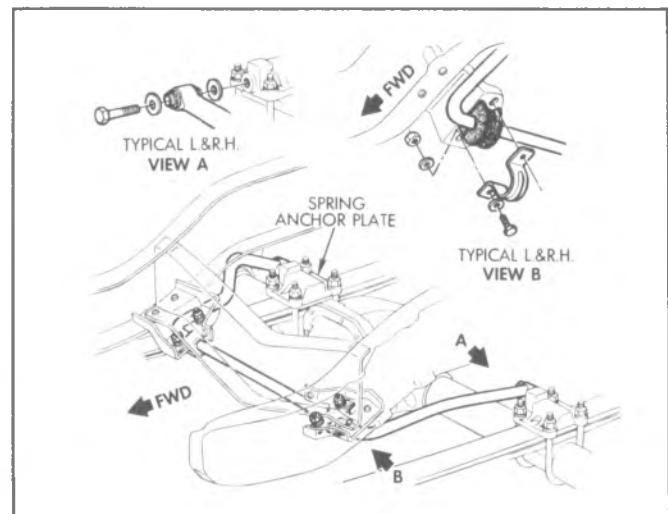


Fig. 3C-31K--Stabilizer Bar Attachment

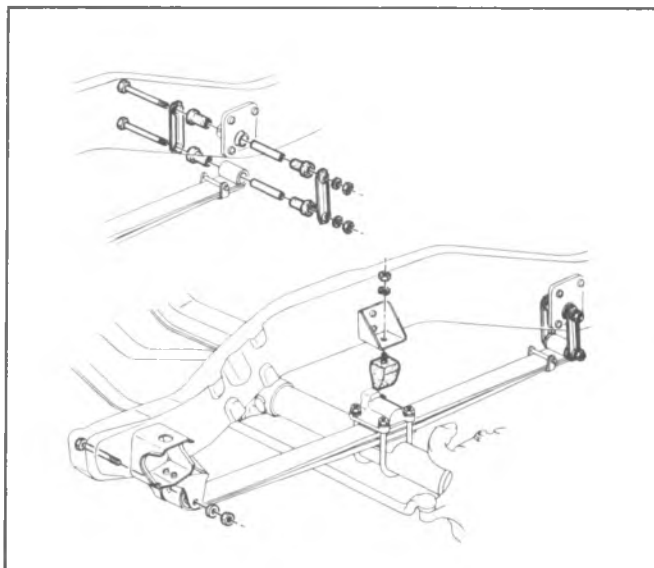


Fig. 3C-32K--Leaf Spring Assembly

NOTE: Slit in bar to frame bushings should be facing forward.

1. Place stabilizer in position on frame and install frame brackets over bushings. Install nuts and bolts loosely.
2. Install brackets over bushings at lower control arm location. Be sure brackets are positioned properly over bushings. Torque all nuts and bolts to specifications.
3. Lower vehicle to floor.

LEAF SPRING AND BUSHINGS

Removal

1. Raise vehicle on hoist.
2. Place adjustable lifting device under axle.
3. Position axle so that all tension is relieved from spring.
4. Remove shackle upper retaining bolt.

5. Remove front spring eye bolt.
6. Remove spring-to-axle u-bolt nuts and remove spring, lower plate and spring pads.
7. Remove shackle to spring bolt and remove bushings and shackle.

Bushing Replacement

1. Place spring on press and press out bushing using a suitable rod, pipe, or tool.
2. Press in new bushing; assure that tool presses on steel outer shell of bushing. Install until bushing protrudes an equal amount on each side of spring.

Spring Inserts (Liners) or Leaf Replacement

1. Place spring in vise and remove clips.
2. Remove center bolt. Open vise slowly, allowing spring to expand.
3. Wire brush, clean, and inspect for broken leaves.
4. Replace leaf or liners.

Installation

CAUTION: See CAUTION note on page one of this section regarding the fasteners referred to in steps 5 and 6.

1. Install spring shackle bushings into spring and attach shackle. Do not tighten bolt.
2. Position spring upper cushion on spring.
3. Insert front of spring into frame and install bolt. Do not tighten.
4. Install shackle bushings into frame and attach rear shackle. Do not tighten bolt.
5. Install lower spring pad and spring retainer plate. Torque bolts to specifications.
6. Torque front and rear spring eye and shackle bolts to specifications.
7. Remove stands and lower vehicle to floor.

SPECIFICATIONS

FRONT SUSPENSION BOLT TORQUE (Ft. Lbs.) \$

	CP-10	CP-20-30	K-All	G-10-20	G-30
Lower Control Arm Shaft U-Bolt	85	85	—	45	85
Upper Control Arm Shaft Nuts	70	105	—	70	105
Control Arm Rubber Bushings	140	—	—	140	—
Upper Control Arm Bushing Steel \$\$		New 190 Used 115	—	w/Spacer 160 No Spacer 95	w/Spacer 190 No Spacer 115
Lower Control Arm Bushing Steel \$\$		New 280 Used 130	—	w/Spacer 280 No Spacer 130	w/Spacer 280 No Spacer 130
Upper Ball Joint Nut	*50	**90	**100	*50	**90
Lower Ball Joint Nut	**90	**90	***80	**90	**90
Crossmember to Side Rail	65	65	—	65	65
Crossmember to Bottom Rail	100	100	—	100	100
Crossmember Brake Support Struts		60			60
Stabilizer Bar to Control Arm	25	25	ANCHOR PLATE — 130		25
Stabilizer Bar to Frame	25	25	.55		25
Shock Absorber Upper End	140	140	65		75
Shock Absorber Lower End	60	60	65		75
Brake Splash Shield to Knuckle	120 In. Lbs.	120 In. Lbs.	120 In. Lbs.		120 In. Lbs.
Wheel Bearing Adjustment	—	—	Inner # - 35 Outer - 50		—
Wheel Bearing Preload	Zero	Zero	Zero		Zero
Wheel Bearing End Movement	.001 - .005"	.001 - .005"	.001 - .010"		.001 - .005
Caliper Mounting Bolt	35	35	35		35
Spring - Front Eye Bolt	—	—	90		—
Spring - Rear Eye Bolt	—	—	50		—
Spring - To Rear Shackle Bolt	—	—	50		—
Spring - To Axle U-Bolt	—	—	150		—
Spring - Front Support to Frame	—	—	25		—
Suspension Bumper	15	15	25		15
Stabilizer to Spring Plate	—	—	130		—

* Plus additional torque to align cotter pin. Not to exceed 90 ft. lbs. maximum.

** Plus additional torque to align cotter pin. Not to exceed 130 ft. lbs. maximum.

*** Plus additional torque to align cotter pin.

Back nut off to align cotter pin at nearest slot.

\$ All specifications are given in foot pounds of Torque unless indicated otherwise.

\$\$ C10, G10-20 Rubber Bushings; C20-30, G30, P10-30 Steel Bushings.

SPECIAL TOOLS

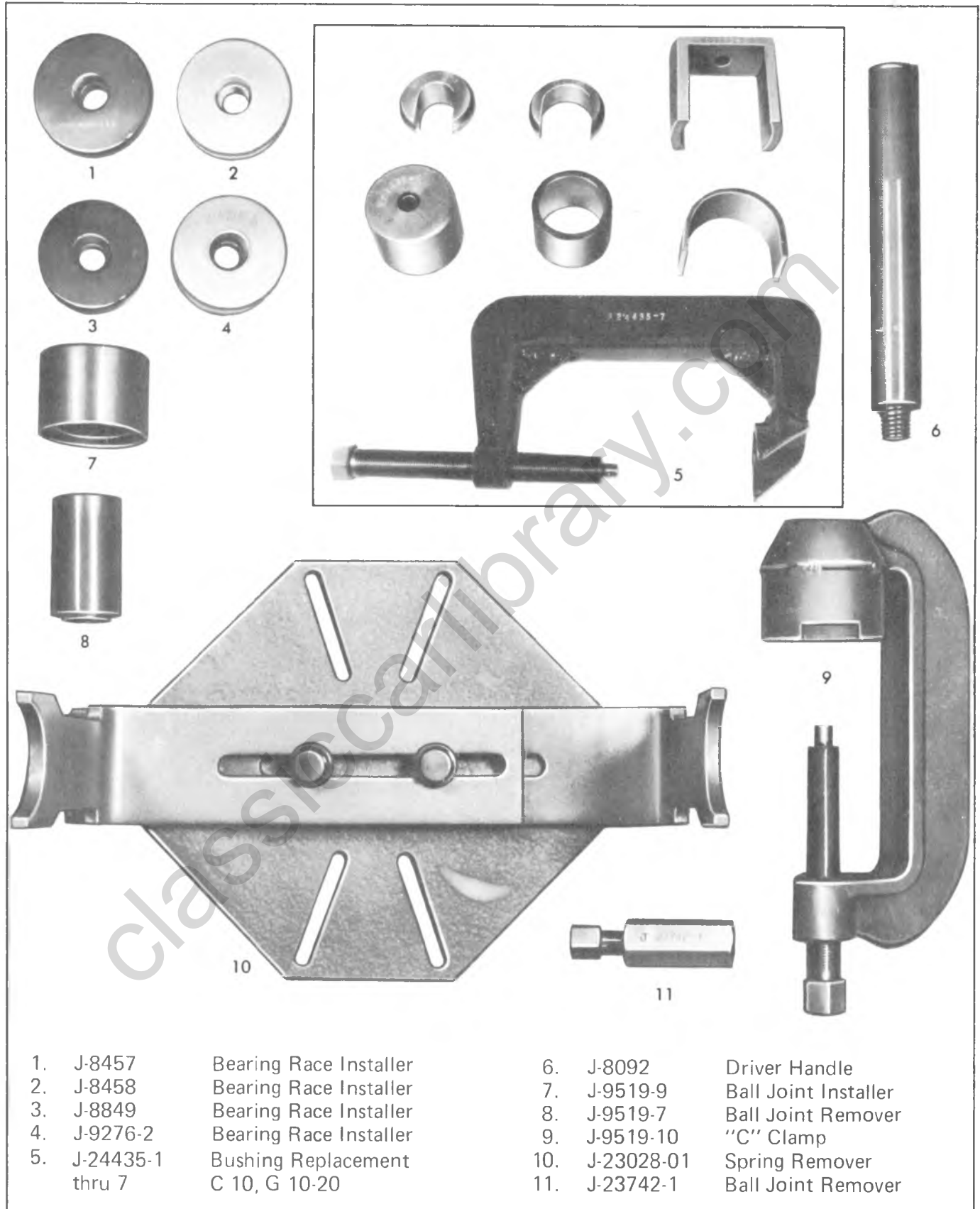


Fig. 3C-ST-- Special Tools

classiccarylbrary.com

SECTION 3D

REAR SUSPENSION

The following caution applies to one or more steps in the assembly procedure of components in this portion of the manual as indicated at the appropriate locations by the terminology "See Caution on page 1 of this Section".

CAUTION: *THIS FASTENER IS AN IMPORTANT ATTACHING PART IN THAT IT COULD AFFECT THE PERFORMANCE OF VITAL COMPONENTS AND SYSTEMS, AND/OR COULD RESULT IN MAJOR REPAIR EXPENSE. IT MUST BE REPLACED WITH ONE OF THE SAME PART NUMBER OR WITH AN EQUIVALENT PART IF REPLACEMENT BECOMES NECESSARY. DO NOT USE A REPLACEMENT PART OF LESSER QUALITY OR SUBSTITUTE DESIGN. TORQUE VALUES MUST BE USED AS SPECIFIED DURING REASSEMBLY TO ASSURE PROPER RETENTION OF THIS PART.*

INDEX

General Description.....	3D-1
Component Parts Replacement.....	3D-2
Shock Absorbers.....	3D-2
Stabilizer Shaft.....	3D-3
Leaf Spring Assembly.....	3D-4
Specifications.....	3D-8

GENERAL DESCRIPTION

All 10-30 series vehicles use a leaf spring/solid rear axle suspension system. Typical systems are illustrated in Fig. 3D-1, 3D-2 and 3D-3.

The rear axle assembly is attached to multi-leaf springs by "U" bolts. The spring front eyes are attached to the frame at the front hangers, through rubber bushings. The rear ends of the springs are attached to the frame by the use of shackles which allow the spring to "change its length" while the vehicle is in motion. Control arms are not used with leaf springs.

Ride control is provided by two identical direct double acting shock absorbers angle-mounted between the frame and brackets attached to the axle tubes.

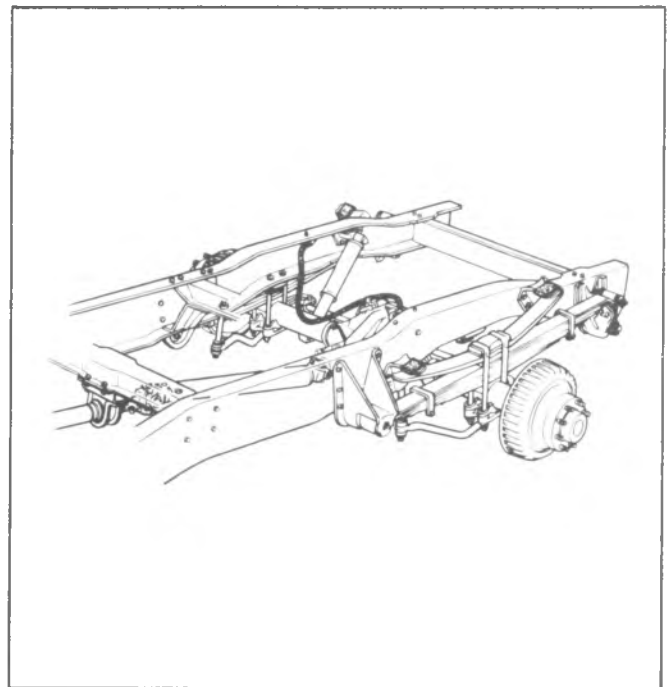


Fig. 3D-1—Typical C-30 H.D. Truck Rear Suspension

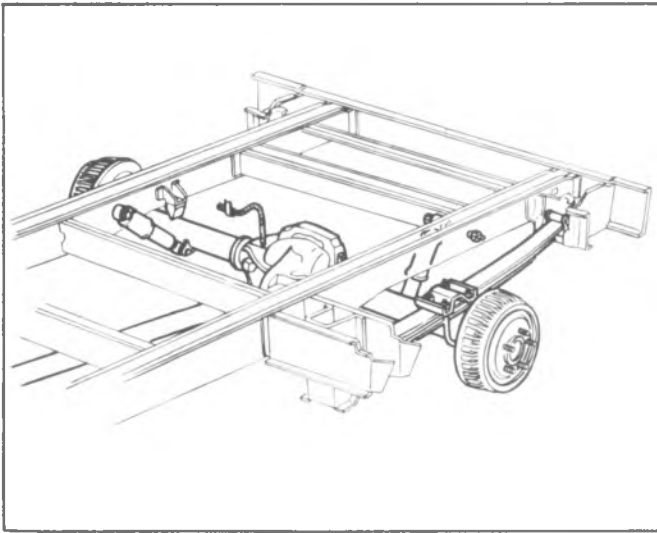


Fig. 3D-2--Typical G-Truck Rear Suspension

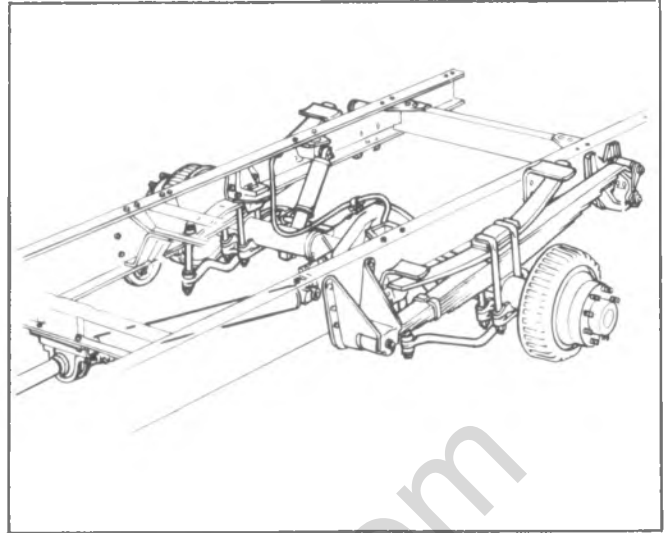


Fig. 3D-3--Typical P-30 H.D. Truck Rear Suspension

COMPONENT PARTS REPLACEMENT

SHOCK ABSORBERS

Replacement

Refer to Figs. 3D-4 through 3D-8 for specific vehicle mounting provisions.

1. Raise vehicle on hoist, and support rear axle.
2. If equipped with air lift shock absorbers, bleed air from lines. Disconnect line from shock absorber.
3. At the upper mounting location, disconnect

shock absorber by removing nut and washers shown, and bolt on G-models.

4. At the lower mounting location, remove nut, washers and bolt as shown.
5. Remove shock absorbers from vehicle.
6. To install shock absorber, place into position and reattach at upper mounting location. Be sure to install nuts and washers as shown.

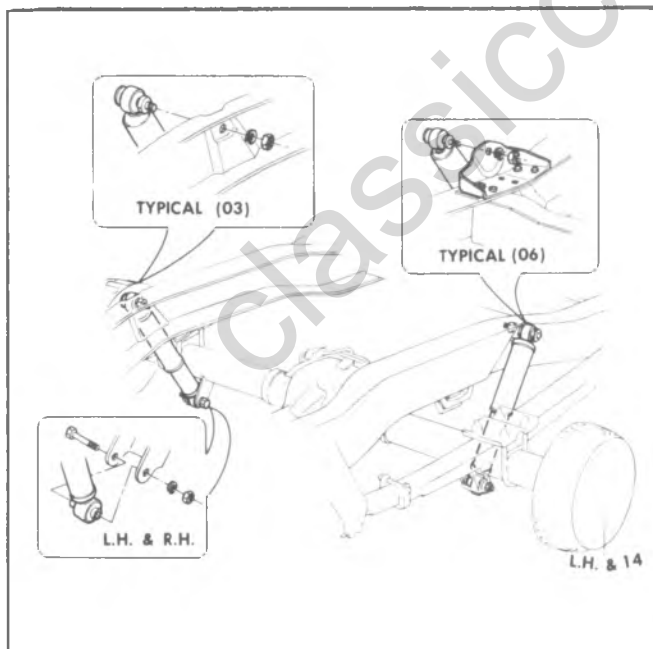


Fig. 3D-4--Shock Absorber-CK-10, CK-20 (03, 06)

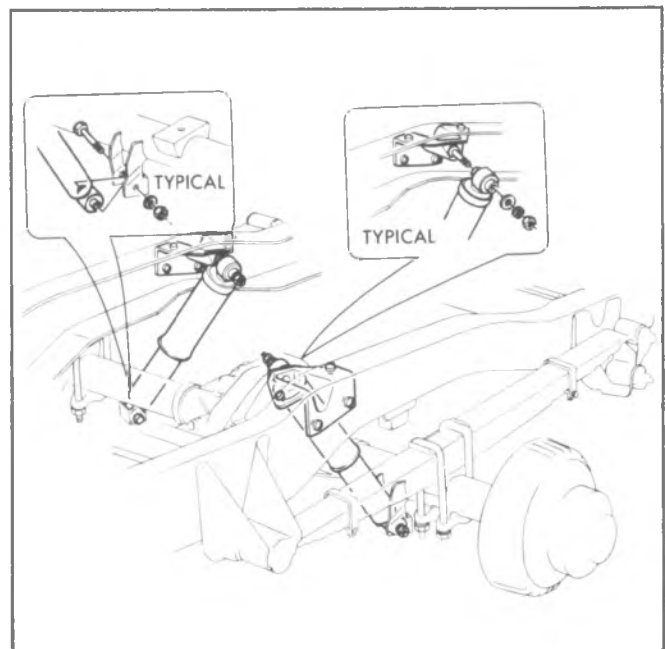


Fig. 3D-5--Shock Absorber-CK-20 (43), CK30

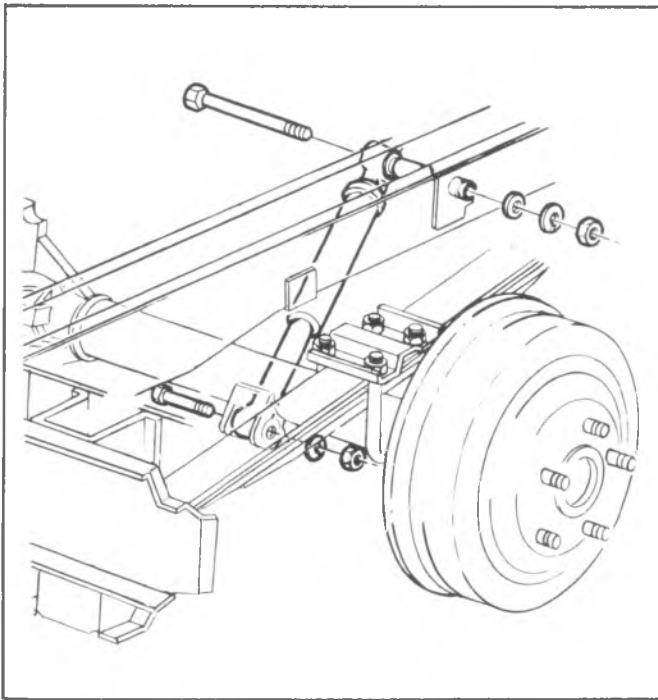


Fig. 3D-6--Shock Absorber-G-10, 20, 30

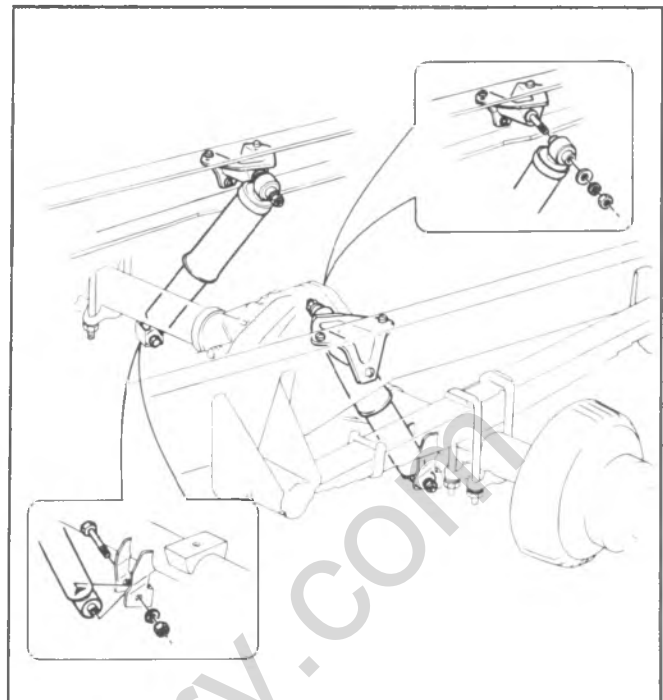


Fig. 3D-8--Shock Absorber-P30

7. Align lower end of shock absorber with axle bracket, and install bolt, washers and nut, as shown.
8. Tighten nuts to specifications.

CAUTION: See *CAUTION* on page 1 of this section regarding shock absorber fasteners.

9. If equipped with airlift shock absorbers, inflate to 10-15 pounds minimum air pressure.

10. Lower vehicle and remove from hoist.

STABILIZER SHAFTS

Refer to Fig. 3D-9, 3D-10 and 3D-11 for specific rear stabilizer shaft mounting on C and P models.

Replacement

1. Raise vehicle on hoist and support rear axle.

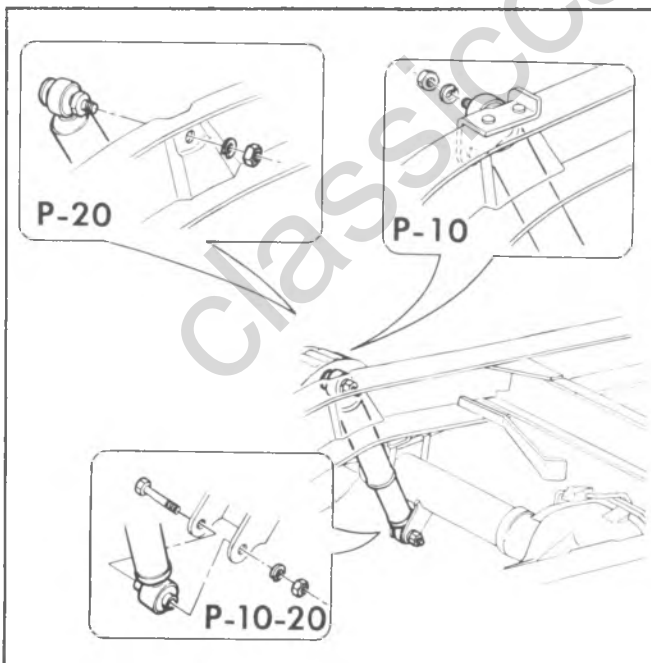


Fig. 3D-7--Shock Absorber-P-10, 20

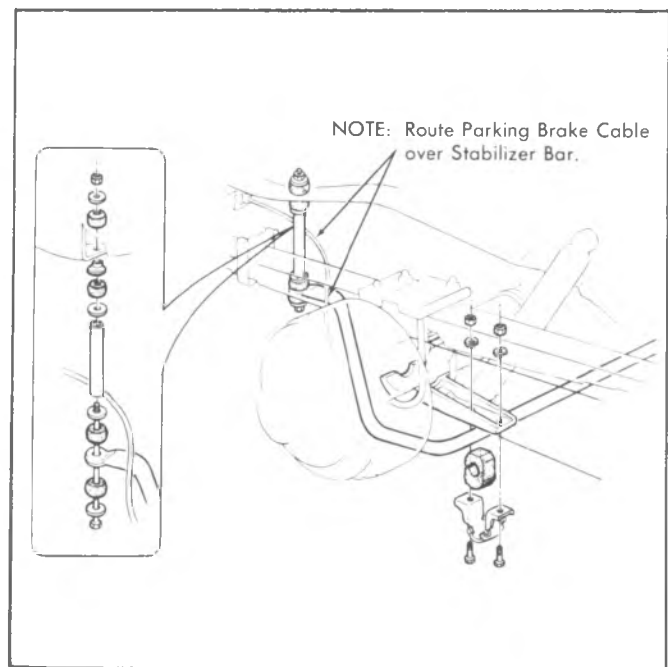


Fig. 3D-9--Rear Stabilizer Shaft-C-20(03)

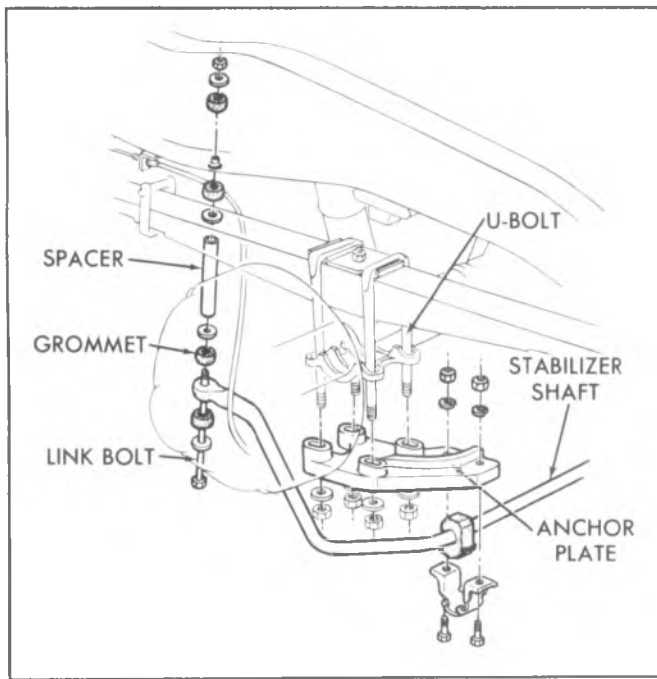


Fig. 3D-10-Rear Stabilizer Shaft-C-20(43), C-30

2. Remove nut, washer and grommet from link bolt at the frame side member on each side.
3. Withdraw link bolt, washers, grommets and spacer.
4. Remove brackets from anchor plates by removing attaching screws.
5. Remove stabilizer shafts.
6. Reverse above steps to install stabilizer shaft. On installation, position shaft so parking brake cable is routed over stabilizer.
7. Torque all bolts to specifications.

CAUTION: See *CAUTION* on page 1 of this section, regarding stabilizer fasteners.

8. Lower hoist and remove vehicle.

LEAF SPRING ASSEMBLY

Refer to Figs. 3D-12, 3D-13, 3D-14 and 3D-15 for specific leaf spring mounting provisions of C, K, G and P models. Fig. 3D-17 illustrates a typical U-bolt anchor plate installation with the mandatory tightening sequence.

CAUTION: See *CAUTION* on page 1 of this section, regarding leaf spring fasteners.

Removal

1. Raise vehicle on hoist so that tension in spring is relieved.
2. Loosen, but do not remove, spring-to-shackle retaining nut.
3. Remove nut and bolt securing shackle to spring hanger.
4. Remove nut and bolt securing spring to front hanger.
5. Remove "U" bolt retaining nuts, withdraw "U"

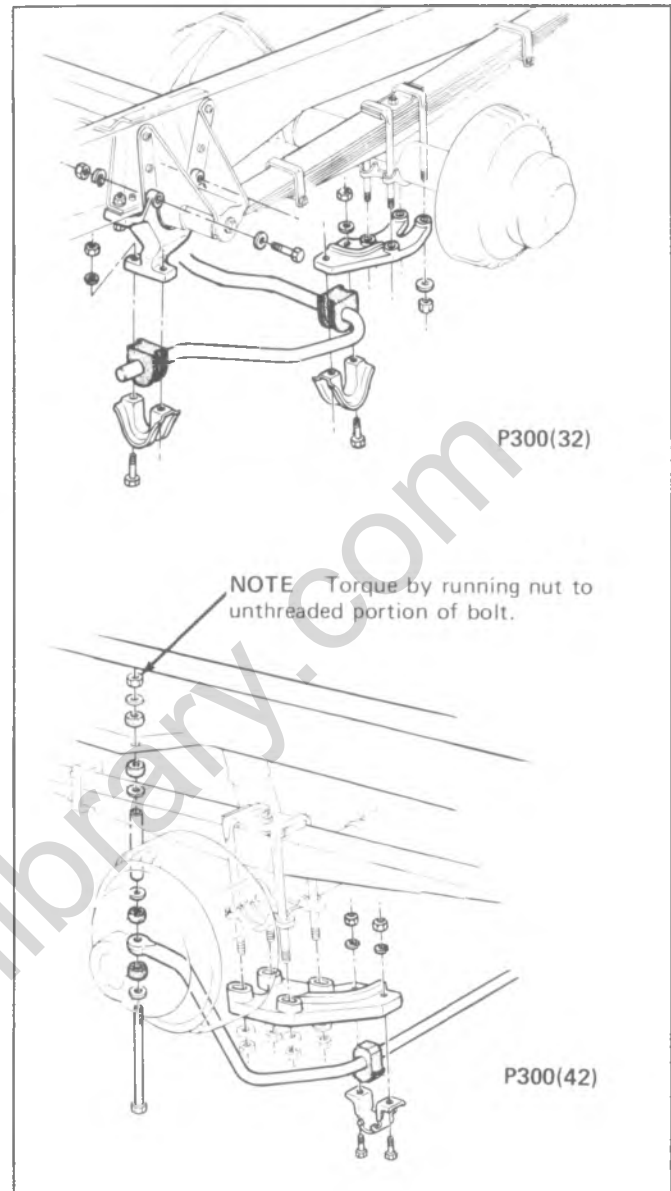


Fig. 3D-11-Rear Stabilizer Shaft-P30

bolts and spring plate from spring-to-axle housing attachment.

6. Withdraw spring from vehicle.
7. Inspect spring. Replace bushings, repair or replace spring unit as outlined in this section.

Bushing Replacement

1. Place spring on press and press out bushing using a suitable rod, pipe or tool as shown in Fig. 3D-16.
2. Press in new bushing; assure that tool presses on steel outer shell of bushing.

NOTE: Rear Spring, Front Eye—Heavy Duty leaf springs on C20 and C30 trucks use a staked-in-place front eye bushing. Before this bushing is pressed out of the spring, the staked locations must be straightened with a chisel or drift. After a new bushing is installed, it must be staked in three equally spaced locations.

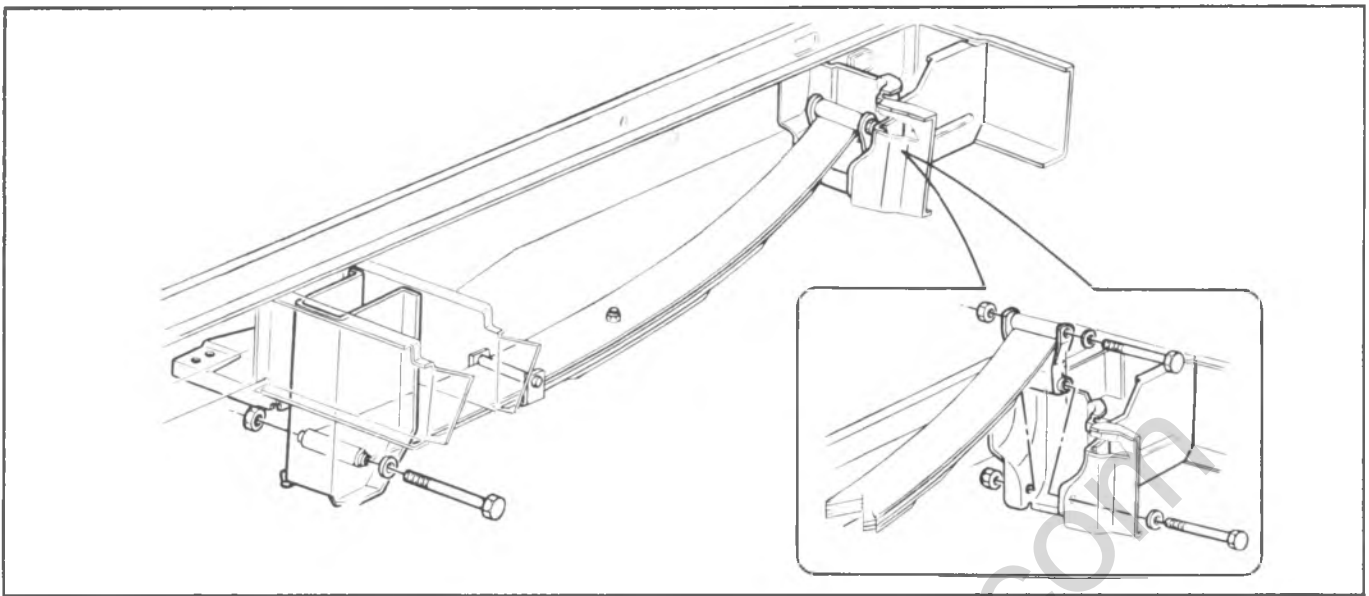


Fig. 3D-12-Rear Spring Installation-G Models

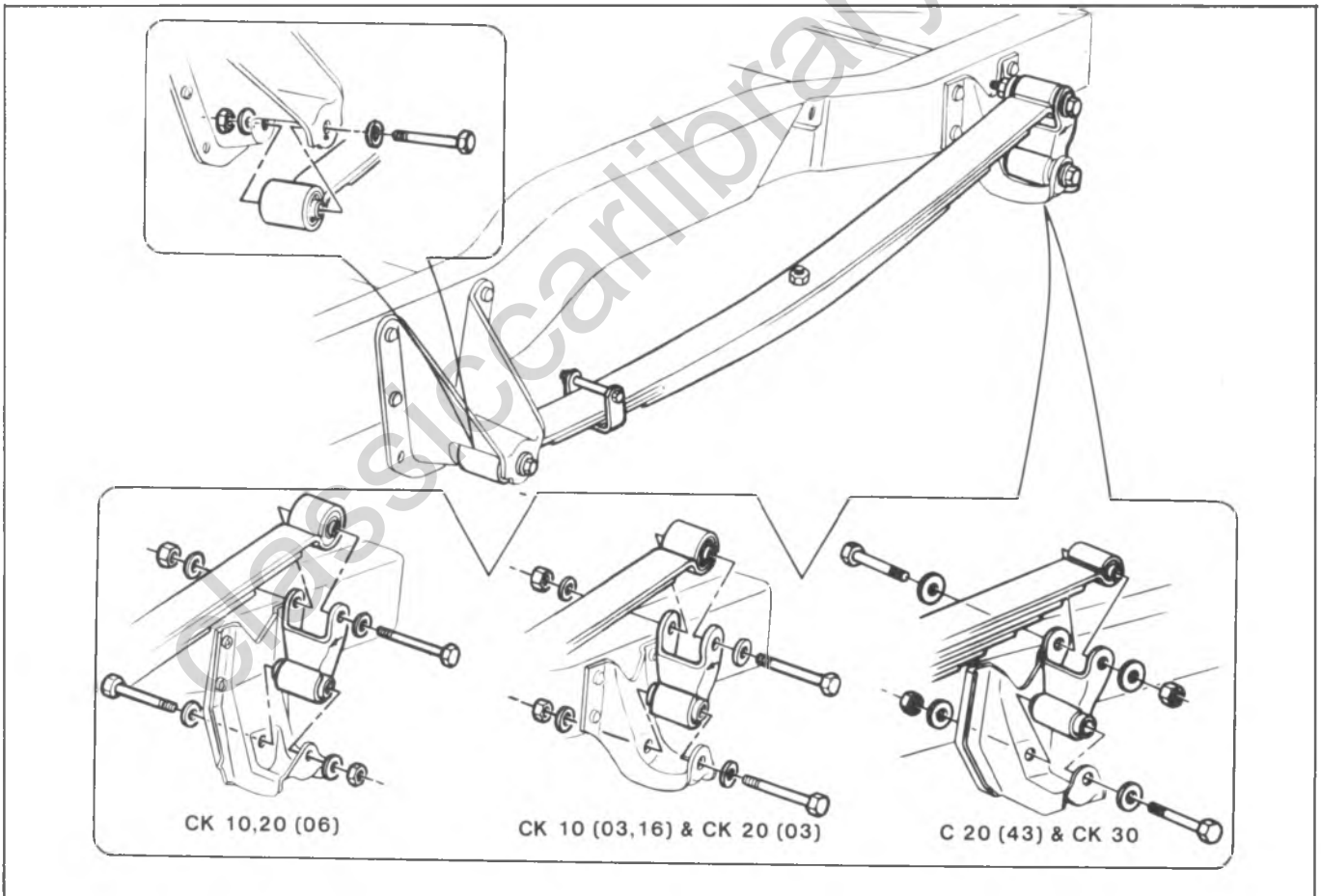


Fig. 3D-13-Rear Spring Installation-C-K Models

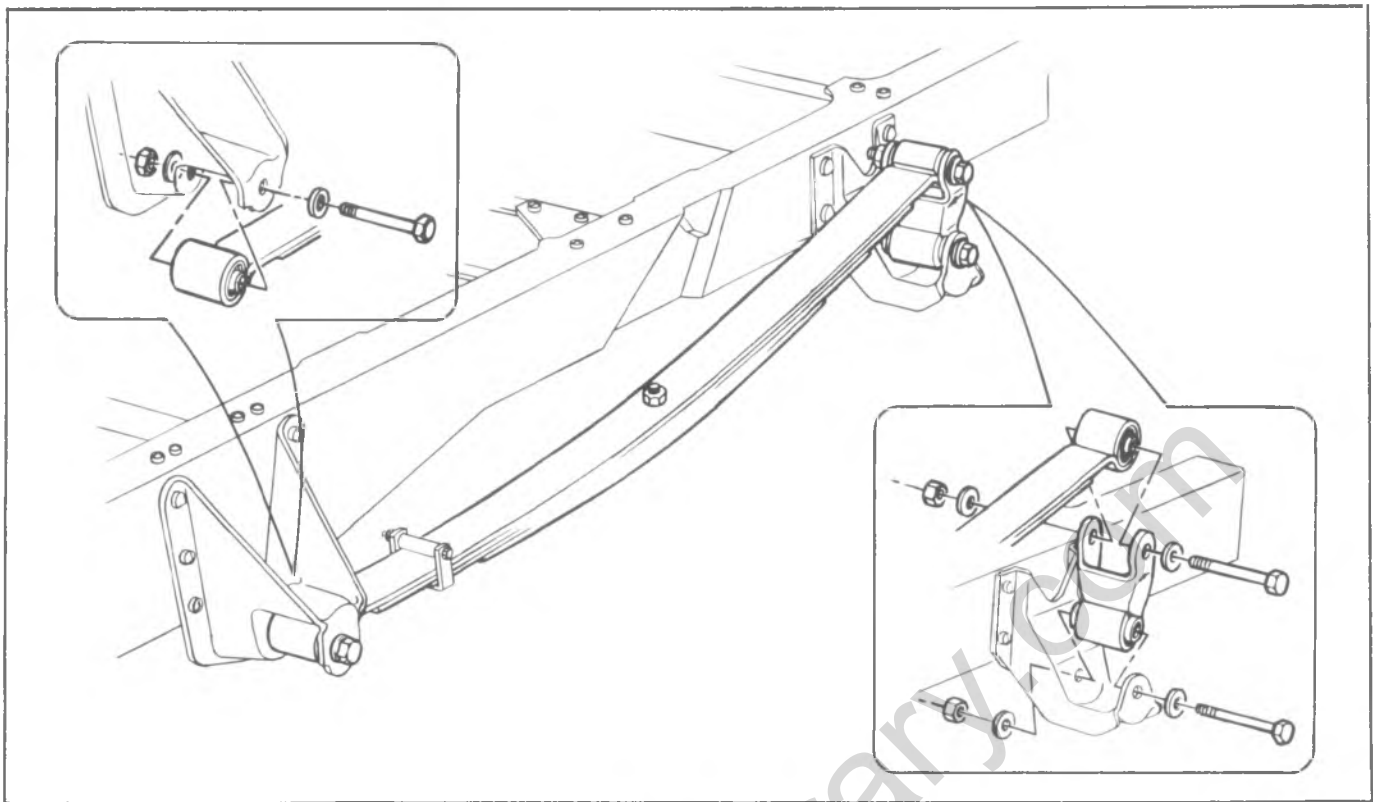


Fig. 3D-14-Rear Spring Installation-P10,20

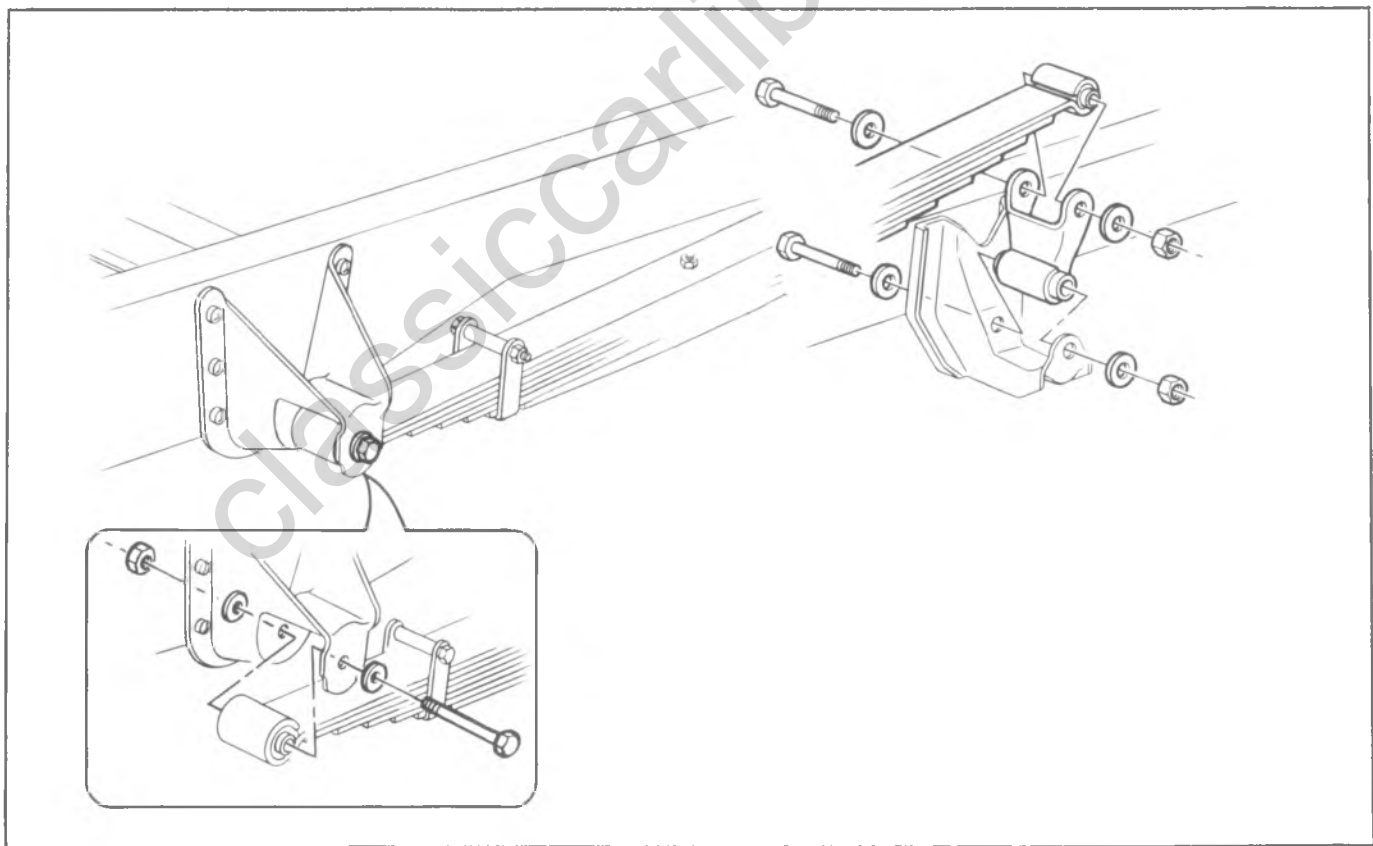


Fig. 3D-15-Rear Spring Installation-P30

Spring Leaf Replacement

1. Place spring assembly in a bench mounted vise and remove spring clips.
2. Position spring in vise jaws, compressing leaves at center and adjacent to center bolts.
3. File peened end of center bolt and remove nut. Open vise slowly to allow spring assembly to expand.
4. Wire brush and clean spring leaves. Inspect spring leaves to determine if replacement is required; also replace defective spring leaf liners at this time.
5. Align center holes in spring leaves by means of a long drift and compress spring leaves in a vise.
6. Remove drift from center hole and install a new center bolt. Peen bolt to retain nut.
7. Align spring leaves by tapping with hammer, then bend spring clips into place or install bolts and spacer if so equipped.

NOTE: Spring clips should be bent sufficiently to maintain alignment, but not tight enough to bind spring action.

Leaf Spring Installation

1. Position spring assembly to axle. Make sure spring is in position at both spring hangers.

NOTE: The shackle assembly must be attached to the rear spring eye before installing shackle to rear hanger.

2. Install spring retainer plate and "U" bolts. Loosely install retaining nuts, but do not torque at this time.
3. Jack frame as required to align spring and shackle with spring hangers.
4. Install shackle bolt and nut and again reposition spring, if necessary to align front eye. Install front eye bolt and nut. Torque hanger and shackle fasteners to specifications.

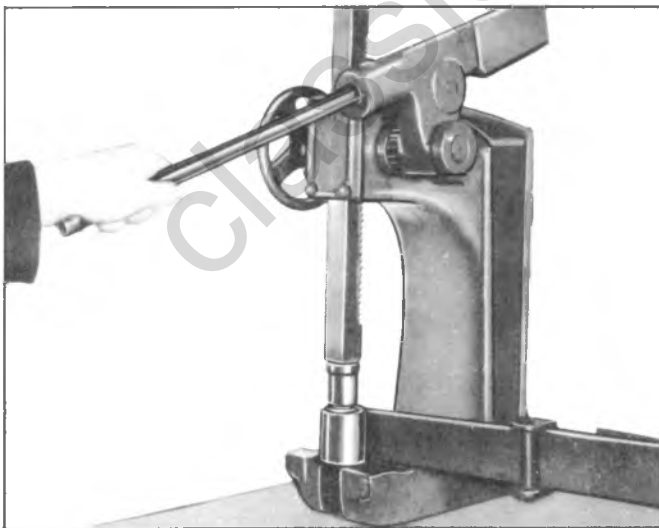


Fig. 3D-16--Pressing Out Bushing

NOTE: Make certain that the bolts are free-turning in their bushings prior to torquing.

5. Lower vehicle so that weight of vehicle is on suspension components and torque U-bolt nuts to specifications.
6. Lower vehicle and remove from hoist.

U-Bolt and Anchor Plate Installation

Fig. 3D-17 illustrates the mandatory sequence of tightening U-bolt nuts. Tighten diagonally opposite nuts to 40-50 foot pounds, then tighten all nuts as shown to specifications.

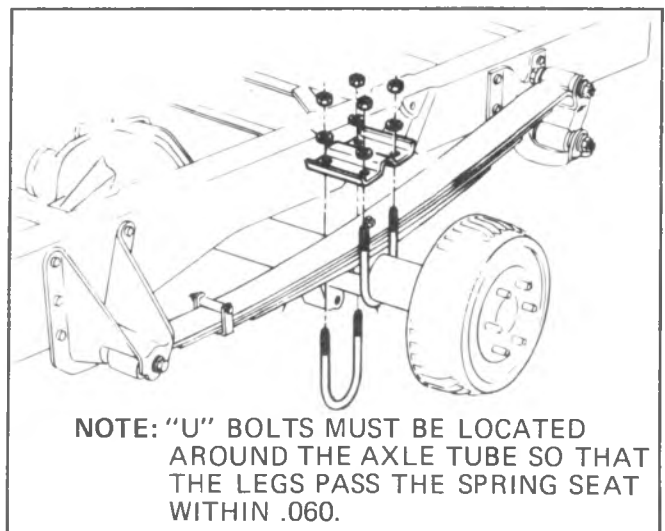
CAUTION: See *CAUTION* on page 1 of this section, regarding "U"-Bolt fasteners.

SHACKLE REPLACEMENT

1. Raise vehicle on hoist. Place adjustable lifting device under axle.
2. Remove load from spring by jacking frame.
3. Loosen spring-to-shackle retaining bolt, but do not remove.
4. Remove shackle-to-frame bracket retaining bolt then remove shackle bolt from spring eye.
5. Position shackle to spring eye and loosely install retaining bolt. Do not torque retaining bolt at this time.
6. Position shackle to frame bracket and install retaining bolt.
7. Rest vehicle weight on suspension components and torque both shackle bolt retaining nuts to specifications.

CAUTION: See *CAUTION* on page 1 of this section, regarding these fasteners.

8. Lower vehicle and remove from hoist.



NOTE: "U" BOLTS MUST BE LOCATED AROUND THE AXLE TUBE SO THAT THE LEGS PASS THE SPRING SEAT WITHIN .060.

Fig. 3D-17--U-Bolt Installation

SPECIFICATIONS

TORQUE SPECIFICATIONS

	C-K	G	P
Spring-to-Axle "U" Bolt Nuts	140	G10 120 G20 120 G30 150	P10 140 P20 140 P30 170 (Exc. w/3/4" Bolt) 200 (W/3/4" Bolt)
Leaf Spring —Front Bushing Bolt	110	90/135* (G316...90)	110
—Rear Shackle Bolt	110	90/135* (G316...90)	110
Shock Absorber —Upper Attachment	140	75	P10 25 P20 140 P30 50
—Lower Attachment	115	75	115
Propeller Shaft To Rear Axle (Strap)	12-17	12-17	12-17
To Rear Axle ("U" Bolt)	18-22	18-22	18-22
Bearing Support-to-Hanger	20-30	20-30	20-30
Hanger-to-Frame	40-50	—	—
Rear Stabilizer-to-Anchor Plate	20-30	—	20-30

* 90 Ft. Lbs. when tightening the nut.
135 Ft. Lbs. when tightening the bolt.

classiccarylbrary.com

classiccarylbrary.com

SECTION 3E

WHEELS AND TIRES

INDEX

General Description.....	3E-1
Maintenance.....	3E-2
Wheel Replacement Consideration.....	3E-2
Wheel Nut Torques.....	3E-2
Tire Inspection and Rotation.....	3E-2
Tire Inflation Pressure.....	3E-2
Service Operations.....	3E-6
Correcting Irregular Tire Wear.....	3E-6
Wheel Removal and Installation.....	3E-7
Tire Mounting and Demounting.....	3E-8
Dual Wheel Attachment P300 Models.....	3E-9

GENERAL DESCRIPTION

The 1977 truck is equipped with a wide range of tube or tubeless type tires and wheels selected according to the truck Gross Vehicle Weight Rating (GVWR) and type of service. The dual rear wheel option is available on Series 30 trucks. The factor installed bias belted tires are selected to provide the best all around tire performance for all normal operations. All tires are manufactured for use on wheels of specific size, configuration and load carrying capacity. When replacing a worn or damaged tire it is essential that you use a replacement tire of the same size and load rating as that with which the vehicle was equipped when manufactured. Use of any other size of tire may seriously affect ride, handling, ground clearance, tire clearance and speedometer calibration. Similarly, use of wheels with offsets other than recommended, or use of what are commonly referred to as "reversed rims" may seriously overload wheel bearings or other axle components causing rapid wear or failure of these parts and void the vehicle warranty. To achieve best all around vehicle handling performance belted tires and bias ply tires should not be mixed on the same truck. Because of possible adverse effects on vehicle handling, do not mix radial ply tires with other type tires on the same vehicle.

NOTE: On four-wheel drive vehicles all tires must be of equal size (but not necessarily ply rating) and of same tread configuration.

TUBELESS TIRES

These tire have an inner liner which, if punctured, tends to cling to the penetrating object forming a partial seal until the object is removed from the tire. It is essential to conduct a periodic pressure check according to the tire inflation tables on the following pages plus a visual tire inspection to detect imbedded objects which might otherwise go unnoticed and cause serious casing damage.

TUBE TIRES

Some commercial vehicles are equipped (at customer option) with synthetic rubber tires and tubes.

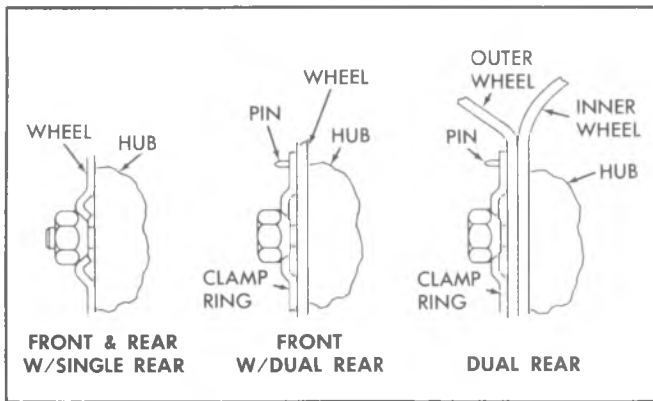


Fig. 1--Wheel Attachments

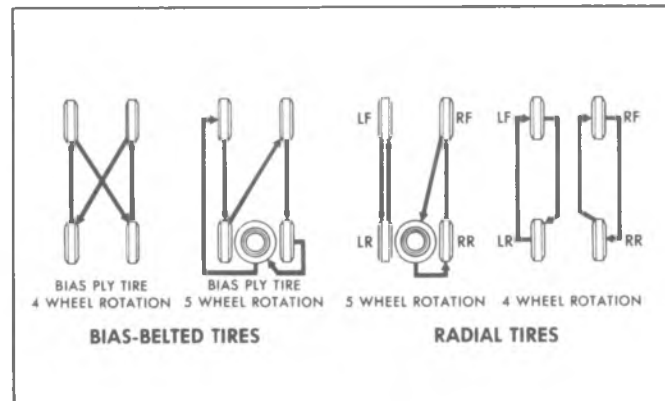


Fig. 2--Tire Rotation

MAINTENANCE

WHEEL REPLACEMENT CONSIDERATIONS

Wheels must be replaced if bent, heavily rusted, leak air, or if lug nuts continually loosen. Do not straighten bent wheels or use inner tubes in leaking wheels used with tubeless tires. The wheels originally equipped on the vehicle will provide optimum life up to the maximum load and inflation pressures as shown in the Wheel Code and Limits Chart. Maximum loads, maximum inflation pressures, wheel identification codes, and wheel sizes are stamped on each wheel.

When replacing wheels for any reason, the replacement wheels should be equivalent in load capacity, inflation pressure capacity, diameter, width, offset, and mounting configurations to those originally installed on the vehicle.

A wheel of improper size or type may adversely affect load carrying capacity, wheel and bearing life, brake cooling, speedometer/odometer calibration, vehicle ground clearance, and tire clearance to the body and chassis. Replacement with "used" wheels which may have been subjected to harsh operating conditions or very high mileage is not recommended. These wheels may fail prematurely without any prior visual indication.

NOTE: The use of wheels and/or tires with higher load carrying capacity than originally equipped on the vehicle does not necessarily increase the GAWR's or the GVWR of the vehicle. Wheels having diameters ranging from 16 inch through 19.5 inch diameter that have also been certified for radial tire application up to the maximum load and maximum tire pressure wheel limits shown in the Wheel Code and Limits Chart have the word "radial" stamped on the rim. Wheels in the 16 inch through 19.5 inch diameter range without the "radial" identification stamp are not to be used with radial tires.

WHEEL NUT TORQUES

On a new vehicle or after the wheel has been changed, the wheel nut torque must be checked at 100, 1,000 and 6,000 miles and every 6,000 miles thereafter.

TIRE INSPECTION AND ROTATION

Front and rear tires perform different jobs and can wear differently depending on the type of roads driven, individual driving habits, etc. To obtain maximum tire life, tires should be inspected and rotated regularly.

Bias-belted tires should be rotated every 7,500 miles (passenger car type tires); 6,000 miles (truck type tires). Radial tires should be rotated at the first 7,500 miles and then at least every 15,000 miles thereafter (passenger car type tires); first 6,000 miles then every 12,000 miles (truck type tires). For the longest tire life, any time irregular wear is noticed, the tires should be inspected and rotated and the cause of the uneven wear corrected. Be certain to check wheel nut tightness and to adjust the tire pressures, front and rear, after rotation to agree with those recommended in the tire inflation charts.

The outer tire on a dual wheel will skid or drag on a turn because of the difference in the turning radii of the inner and outer tires. This results in faster wear of the outer tire. In general, the tire with the largest diameter or least wear would be at the outside of each dual wheel. In addition, when trucks are operated continuously on high crown roads an increase in air pressure of from 5 to 10 PSI in the outside tire of each dual produces maximum tire life.

INFLATION PRESSURE

The maximum cold inflation pressures for the factory installed tires are listed on the VIN plate. Tires must be inflated to these pressures when the GVWR or an axle GAWR is reached. Improper tire inflation pressures for the load the vehicle is carrying can adversely affect tire life and vehicle performance.

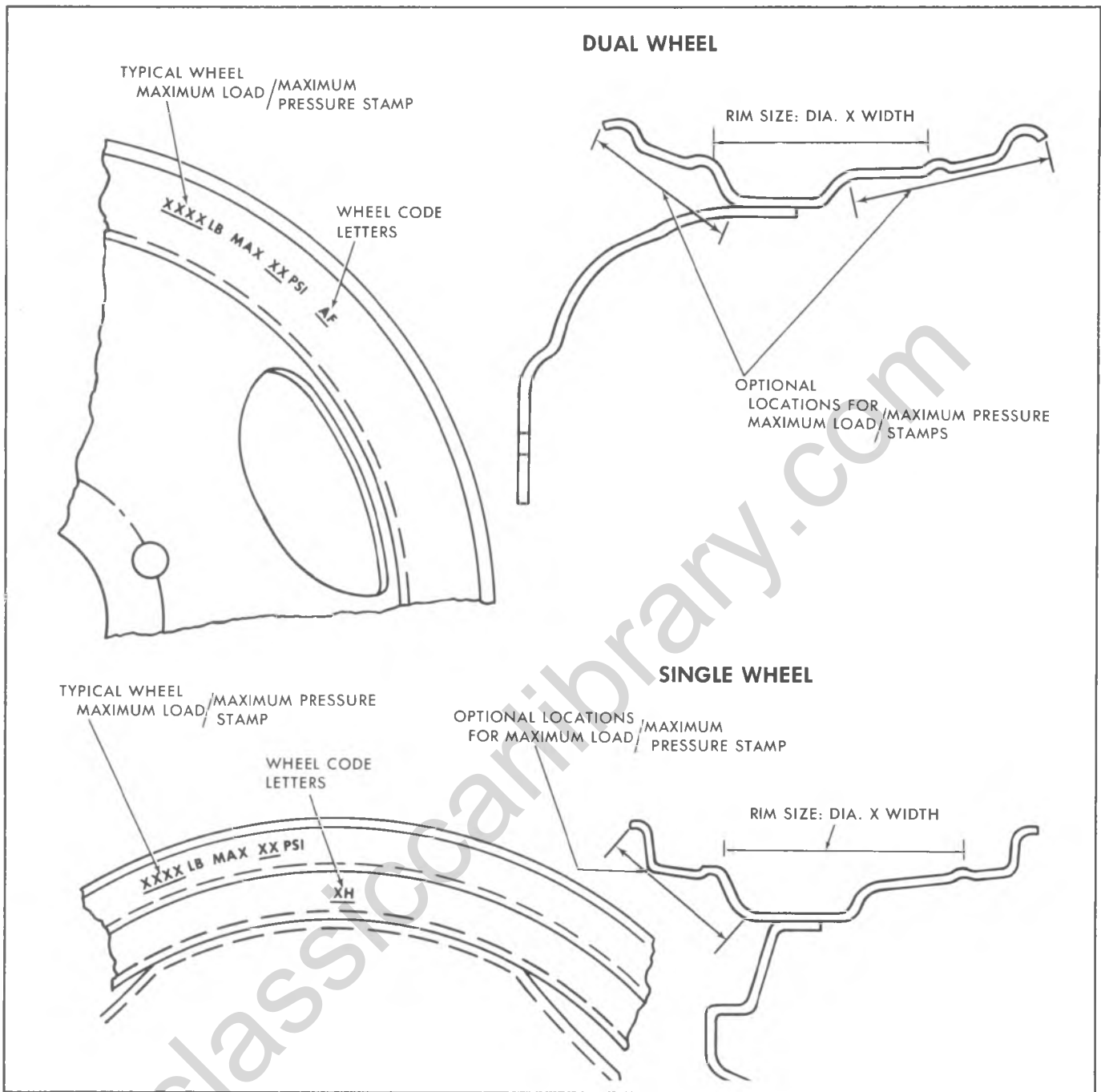


Fig. 3--Wheel Code Location

Too low an air pressure can result in tire overloading, abnormal tire wear, adverse vehicle handling, and reduced fuel economy. The tire flexes more and can build up excessive heat, weakening the tire and increasing susceptibility to damage or failure. Too high an air pressure can result in abnormal wear, harsh vehicle ride, and increased susceptibility to damage from road hazards. Lower inflation pressures should be used only with reduced vehicle loads and the rear tire pressure

should be equal to or greater than the front pressure on single wheel application. After determining the load on each tire by weighing the vehicle on a scale, the correct cold inflation pressures for the actual tire loads can be obtained from the Tire/Wheel Load and Inflation Pressure Chart shown in this section.

Tire inflation pressures should be checked at least monthly when the tires are "cold" and when changing the load the vehicle is carrying.

TIRE/WHEEL LOAD & INFLATION PRESSURE

PASSENGER TYPE TIRES FOR LIGHT TRUCKS USED IN HIGHWAY SERVICE

Wheel Code		Tire Size	Load Range	Tire Load Limits at Various Inflation Pressures									
Regular	Rally/Spoke			24	26	28	30	32	34	36	38	40	
XU, XH, DT	XT	E78-15	B	1081	1127	1181	1227	<u>1270</u>					
XH, DT	XT	F78-15	B	1163	1218	1272	1318	<u>1360</u>					
XU, XH, DT	BC, CR, XT	G78-15	B	1254	1309	1363	1418	<u>1470</u>					
XU, XH, DT	BC, CR, XT	G78-15	D	1254	1309	1363	1418	<u>1470</u>	1527	1572	1618	<u>1663</u>	
XH, DT	XT	GR78-15	B	1254	1309	1363	1418	<u>1470</u>					
XU, XH, DT	BC, CR	H78-15	B	1372	1436	1500	1554	<u>1605</u>					
AX, FT	BC, CR	H78-15	D	1372	1436	1500	1554	<u>1605</u>	1663	1718	1772	<u>1827</u>	
FT	XT	J78-15	B	1436	1500	1563	1627	<u>1690</u>					
FT	XT	JR78-15	B	1436	1500	1563	1627	<u>1690</u>					
AX, FT	AH, BM, DS, CS	L78-15	B	1527	1590	1663	1727	<u>1790</u>					
AX, FT	AH, BM, DS, CS	LR78-15	C	1527	1590	1663	1727	<u>1790</u>	1854	1905			
AX, FT	AH, BM, DS, CS	L78-15	D	1527	1590	1663	1727	<u>1790</u>	1854	1905	1972	<u>2025</u>	
—	AH, BM, DS, CS	LR60-15	B	1527	1590	1663	1727	<u>1790</u>					
XU, XH, DT	—	8.25-15	D	1254	1309	1363	1418	<u>1470</u>	1527	1572	1618	<u>1663</u>	

NOTE: The load at maximum inflation pressure stamped on the tire sidewall of passenger tires will differ from the load shown in this table. This is in accordance with Tire and Rim Association standards requiring a reduced loading factor of approximately 91% for passenger type tires used on trucks and multipurpose passenger vehicles.

TIRES FOR LIGHT TRUCKS USED IN HIGHWAY SERVICE

TIRES USED AS SINGLES

Wheel Code		Tire Size	Load Range	Tire Load Limits at Various Inflation Pressures									
Regular	Rally			30	35	40	45	50	55	60	65	70	75
TUBE TYPE TIRES MOUNTED ON 5° TAPERED BEAD SEAT RIMS													
XL, BR	—	6.50-16	C	1270	1390	1500	1610						
AX, FT	—	7.00-15	C	1350	1480	1610	<u>1720</u>						
AX, FT	—	7.00-15	D	1350	1480	1610	<u>1720</u>	1830	1940	<u>2040</u>			
XL, BR	—	7.00-16	C	1430	1560	1680	<u>1800</u>						
AM	—	7.50-16	C	1620	1770	1930	<u>2060</u>						
AM	—	7.50-16	D	1620	1770	1930	<u>2060</u>	2190	2310	<u>2440</u>			
AM	—	7.50-16	E	1620	1770	1930	<u>2060</u>	2190	2310	<u>2440</u>	2560	2670	<u>2780</u>
TUBELESS TIRES MOUNTED ON 15° TAPERED BEAD SEAT DROP CENTER RIMS													
FA	—	8.19-5	D	—	—	—	—	2110	2270	2410	2540	2680	<u>2800</u>

WIDE BASE TUBELESS TIRES USED AS SINGLES

Wheel Code		Tire Size	Load Range	Tire Load Limits at Various Inflation Pressures									
Regular	Rally/Spoke			20	22	24	26	28	30	32	34	36	38
BS	AH, BM, DS, CS	10-15	B			1540	1620	1690	<u>1760</u>				
BS	AH, BM, DS, CS	10-15	C			1540	1620	1690	<u>1760</u>	1830	1890	1960	<u>2020</u>
30 35 40 45 50 55 60 65 70 75													
XH, DT	XT	C78-15LT	C	1080	1180	1280	<u>1370</u>						
XH, DT	XT	G78-15LT	C	1310	1430	1550	<u>1660</u>						
FT, AX	—	7.00-15LT	C	1350	1480	1610	<u>1720</u>						
BU, DK, FK	—	8.00-16.5	C	1360	1490	1610	<u>1730</u>						
DK, FK	—	8.00-16.5	D	1360	1490	1610	<u>1730</u>	1840	1945	<u>2045</u>			
DK, FK	—	8.00-16.5	E	1360	1490	1610	<u>1730</u>	1840	1945	<u>2045</u>	2145	2240	<u>2330</u>
BU, FK	—	8.00R-16.5	C	—	1360	1490	1610	<u>1730</u>					
DK, FK	—	8.00R-16.5	D	—	1360	1490	1610	<u>1730</u>	1840	1945	<u>2045</u>		
DK, FK	—	8.75-16.5	C	1570	1720	1850	<u>1990</u>						
DK, FK	—	8.75-16.5	D	1570	1720	1850	<u>1990</u>	2110	2240	<u>2350</u>			
FK	—	8.75-16.5	E	1570	1720	1850	<u>1990</u>	2110	2240	<u>2350</u>	2470	2570	<u>2680</u>
DK, FK	—	8.75R-16.5	D	—	1570	1720	1850	<u>1990</u>	2110	2240	<u>2350</u>		
FK	—	8.75R-16.5	E	—	1570	1720	1850	<u>1990</u>	2110	2240	<u>2350</u>	2470	<u>2570</u> *
DJ	—	9.50-16.5	D	1860	2030	2190	2350	2500	2650	<u>2780</u>			
DJ	—	9.50-16.5	E	1860	2030	2190	2350	2500	2650	<u>2780</u>	2920	3050	<u>3170</u>
BH	—	10-16.5	C	1840	2010	2170	<u>2330</u>						
BH	—	10-16.5	D	1840	2010	2170	<u>2330</u>	2480	2620	<u>2750</u>			

* 2680 @ 80 psi

**TIRE/WHEEL LOAD & INFLATION PRESSURE
TIRES FOR LIGHT TRUCKS USED IN HIGHWAY SERVICE (Cont'd)**

TIRES USED AS DUALS

Wheel Code		Tire Size	Load Range	Tire Load Limits at Various Inflation Pressures									
Regular	Rally			30	35	40	45	50	55	60	65	70	75
TUBE TYPE TIRES MOUNTED ON 5° TAPERED BEAD SEAT RIMS													
YW	—	6.50-16	C	1120	1225	1320	1420						
YW	—	7.00-16	C	1260	1365	1475	1580						
YW	—	7.00-16	D	1260	1365	1475	1580	1685	1780	1870			
YW	—	7.50-16	C	1430	1565	1690	1815						
YW	—	7.50-16	D	1430	1565	1690	1815	1930	2040	2140			
DW, FJ	—	8.75-16.5	C	1380	1515	1630	1750						
DW, FJ	—	8.75-16.5	D	1380	1515	1630	1750	1855	1970	2070			
DW, FJ	—	8.75-16.5	E	1380	1515	1630	1750	1855	1970	2070	2175	2260	2360

TUBELESS TIRES MOUNTED ON 15° TAPERED BEAD SEAT DROP CENTER RIMS

Wheel Code	Tire Size	Load Range	30	35	40	45	50	55	60	65	70	75
CM	8-17.5	D	1445	1575	1700	1820	1935	2050	2155			
FB, UH	8-19.5	D	—	—	1850	1990	2110	2230	2350	2460		
UH	8-19.5	E	—	—	1850	1990	2110	2230	2350	2460	2570	2680 (#)

WIDE BASE TUBELESS TIRES USED AS DUALS

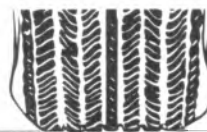
Wheel Code		Tire Size	Load Range	Tire Load Limits at Various Inflation Pressures									
Regular	Rally			30	35	40	45	50	55	60	65	70	75
FJ, DW	—	8.00-16.5	C	1195	1310	1415	1520						
FJ, DW	—	8.00-16.5	D	1195	1310	1415	1520	1620	1710	1800			
FJ, DW	—	8.00R-16.5	C	—	1195	1310	1415	1520					
FJ, DW	—	8.00R-16.5	D	—	1195	1310	1415	1520	1620	1710	1800		
FJ, DW	—	8.75-16.5	C	1380	1515	1630	1750						
FJ, DW	—	8.75-16.5	D	1380	1515	1630	1750	1855	1970	2070			
FJ, DW	—	8.75-16.5	E	1380	1515	1630	1750	1855	1970	2070	2175	2260	2360
FJ, DW	—	8.75R-16.5	D	—	1380	1515	1630	1750	1855	1970	2070		
FJ, DW	—	8.75R-16.5	E	—	1380	1515	1630	1750	1855	1970	2070	2175	2260 *

(#) 2780 @ 80 PSI

*2360 @ 80 PSI

1. The "cold" tire inflation pressure rating applies to the tire pressure when the vehicle has not been driven for three hours or more, or driven less than one mile.
2. It is normal for tire pressures to increase 4-8 PSI, or more, when the tires become "hot" from driving. Do not "bleed" or reduce tire inflation pressures after driving your vehicle. Bleeding serves to reduce "cold" inflation pressure and increase tire flexing which can result in tire damage and failure.
3. For sustained driving over 75 mph with passenger car type tires, cold inflation pressures should be increased 4 PSI above the recommended cold inflation pressures in the Tire/Wheel Load and Inflation Pressure Chart for the load being carried up to a maximum of 32 PSI for load range B tires, 36 PSI for load range C, and 40 PSI for load range D. Sustained speeds above 75 mph are not recommended when the 4 PSI adjustment exceeds the maximum pressures stated above.
4. For sustained driving over 65 mph with truck type tires* cold inflation pressures should be increased 10 PSI above those specified in the Tire/Wheel Load and Inflation Pressure charts for the load being carried. Do not exceed the maximum wheel capacity shown in the Wheel Code & Limits Chart. Sustained speeds above 65 MPH are not recommended where the 10 PSI pressure increase would exceed this maximum wheel capacity.

For special operating conditions such as carrying slide-in campers or other high center of gravity loads, cold inflation pressures may be increased up to 10 PSI above those shown in the table. The total increase in cold inflation pressures, however, must not exceed the maximum wheel capacity shown on the Wheel Code & Limits Chart.



PROPERLY INFLATED RADIAL TIRE



PROPERLY INFLATED BIAS OR BIAS-BELTED TIRE

5. When using passenger car type snow tires cold inflation pressures should be increased 4 PSI (truck type snow tires, 10 PSI) above the recommended pressures for the load being carried. However, do not exceed the maximum wheel capacity shown in the Wheel Code & Limits Chart. Sustained speeds above 75 MPH with passenger car type snow tires (65 MPH with truck type snow tires) are not recommended.
6. Always use a tire pressure gauge (a pocket type gauge is recommended) when checking inflation pressures. Radial tires may have the appearance of being under-inflated when at recommended cold inflation.

7. Be sure to re-install the tire inflation valve caps, if so equipped, to prevent dirt and moisture from entering the valve core which could cause air leakage.

- * Passenger car tires have 15 inch or smaller wheel size and have no "LT" designation molded in sidewall. Light truck type tires have "LT" molded in the sidewall and/or are larger than 15 inch in wheel size.

Load Range	Replaces Ply Rating
A	2
B	4
C	6
D	8
E	10

WHEEL CODE AND LIMITS

CODE	SIZE OF WHEEL	WHEEL LIMITS	
		MAX. LOAD (LBS)	MAX. PRESS (PSI)
DT	15 x 6JJ	1670	55
XH	15 x 6JJ	1670	55
XU	15 x 6JJ	1670	55
FT	15 x 6JJ	1910	70
AX	15 x 6JJ	2040	70
XT	15 x 6½JJ	1690	40
BC	15 x 7JJ	1670	40
CR	15 x 7JJ	1670	40
AH	15 x 8JJ	1910	40
BM	15 x 8JJ	1910	40
BS	15 x 8JJ	1760	40
CS	15 x 8JJ	2030	40
DS	15 x 8JJ	2030	40
BR	16 x 5K	1800	55
XL	16 x 5K	1800	55
YW	16 x 6KS	2440	75
AM	16 x 6½LS	2780	85
BU	16,5 x 6	1730	55
DK	16,5 x 6	2350	70
DW	16,5 x 6	2680	85
FJ	16,5 x 6	2680	85
FK	16,5 x 6,75	2680	85
DJ	16,5 x 6,75	3170	85
BH	16,5 x 8,25	2750	70
CM	17,5 x 5,25	2155	70
FB	19,5 x 6	2540	80
UH	19,5 x 6	2780	95
FA	19,5 x 6,75	2850	90

SERVICE OPERATIONS

CAUTION: Servicing of tires mounted on multi-piece rims requires proper tools, safety equipment and specialized training. Severe injuries can result from improper servicing techniques. It is recommended that tires on multi-piece rims be serviced only by competent personnel with proper equipment or by competent truck tire repair shops.

CORRECTING IRREGULAR TIRE WEAR

Heel and Toe Wear

This is a saw-toothed effect where one end of each tread block is worn more than the other. The end that wears is the one that first grips the road when the brakes are applied.

Heel and toe wear is less noticeable on rear tires than on front tires, because the propelling action of the rear wheels creates a force which tends to wear the opposite end of the tread blocks. The two forces, propelling and braking, make for more even wear of the rear tires, whereas only the braking forces act on the front wheels, and the saw-tooth effect is more noticeable.

A certain amount of heel and toe wear is normal. Excessive wear is usually due to high speed driving and excessive use of brakes. The best remedy, in addition to cautioning the owner on his driving habits, is to interchange tires regularly.

Side Wear

This may be caused by incorrect wheel camber, underinflation, high cambered roads or by taking corners at too high a rate of speed. The first two causes are the most common. Camber wear can be readily identified because it occurs only on one side of the treads, whereas underinflation causes wear on both sides. Camber wear requires correction of the camber first and then interchanging tires. There is, of course, no correction for high cambered roads. Cornering wear is discussed further on.

Misalignment Wear

This is wear due to excessive toe-in or toe-out. In either case, tires will revolve with a side motion and scrape the tread rubber off. If misalignment is severe, the rubber will be scraped off of both tires; if slight, only

one will be affected. The scraping action against the face of the tire causes a small feather edge of rubber to appear on one side of the tread and this feather edge is certain indication of misalignment. The remedy is readjusting toe-in, or rechecking the entire front end alignment if necessary.

Uneven Wear

Uneven or spotty wear is due to such irregularities as unequal caster or camber, bent front suspension parts, out-of-balance wheels, brake drums out of round, brakes out of adjustment or other mechanical conditions. The remedy in each case consists of locating the mechanical defect and correcting it.

Cornering Wear

When a truck makes an extremely fast turn, the weight is shifted from an even loading on all wheels to an abnormal load on the tires on the outside of the curve and a very light load on the inside tires, due to centrifugal force. This unequal loading may have two unfavorable results.

First the rear tire on the inside of the curve may be relieved of so much load that it is no longer geared to the road and it slips, grinding off the tread on the inside half of the tire at an excessive rate. This type of tire shows much the same appearance of tread wear as tire wear caused by negative camber.

Second the transfer of weight may also overload the outside tires so much that they are laterally distorted resulting in excessive wear on the outside half of the tire, producing a type of wear like that caused by excessive positive camber.

Cornering wear can be most easily distinguished from abnormal camber wear by the rounding of the outside shoulder or edge of the tire and by the roughening of the tread surface which denotes abrasion.

Cornering wear often produces a fin or raised portion along the inside edge of each row in the tread pattern. In some cases this fin is almost as pronounced as a toe-in fin, and in others, it tapers into a row of tread blocks to such an extent that the tire has a definite "step wear" appearance.

The only remedy for cornering wear is proper instruction of operators. Driving more slowly on curves and turns will avoid grinding rubber off tires. To offset normal cornering wear as much as possible tires should be interchanged at regular intervals.

Wheel and Tire Balancing

It is desirable from the standpoints of tire wear and vehicle ride and handling ease to maintain proper balance of wheel and tire assemblies on all models. This may be accomplished by either of the two types of balancing systems in correct use which balance wheels either on the vehicle or off. The "on the vehicle" type, however, is the more desirable in that all rolling components (brake drums, bearings, seals, etc.) are

included in the balancing procedure and thereby have any existing unbalance corrected.

Truck Wheel Balance Weights

All 1977 truck wheels equipped with a tubular side ring (rolled flange rim) on the outboard side of the wheel rims require special design weights to fit. Dynamic balancing can be accomplished through use of these special balance weights which are designed only for installations on the outboard side of these wheels. Conventional weights fit only the inboard side of these wheels.

Static Balance

Static balance (sometimes called still balance) is the equal distribution of weight of the wheel and tire assembly about the axis of rotation in such a manner that the assembly has no tendency to rotate by itself, regardless of its position. For example: A wheel with chunk of dirt on the rim will always rotate by itself until the heavy side is at the bottom. Any wheel with a heavy side like this is statically out of balance. Static unbalance of a wheel causes a hopping or pounding action (up and down) which frequently leads to wheel "flutter" and quite often to wheel "tramp".

Dynamic Balance

Dynamic balance (sometimes called running balance) means that the wheel must be in static balance, and also run smoothly at all speeds.

To insure successful, accurate balancing, the following precautions must be observed:

- Wheel and tire must be clean and free from all foreign matter.
- The tires should be in good condition and properly mounted with the balance mark on the tire, if any, lined up with the valve.
- Bent wheels that have runout over 1/16" should be replaced.
- Inspect tire and wheel assembly to determine if an eccentric or out-of-round condition exists. Note that this condition, if severe, cannot be "balanced out". An assembly which has an out-of-round condition exceeding 3/16" on tire sizes through 19.5" is not suitable for use on the front of the vehicle. Its use on the rear should be governed by its general condition and whether the roundness defect seriously detracts from overall ride quality.
- When balancing wheels and tires, it is recommended that the instructions covering the operation of the wheel balancer being used be closely followed.
- When balancing truck type nylon tires, tires must be hot (run for several miles) before raising vehicle to balance so that flat spot is eliminated. A tire which is flat spotted will be incorrectly balanced.

WHEEL REMOVAL AND INSTALLATION

Jacking Instructions

Place vehicle jack supplied or recommended as follows: To raise a rear wheel, place jack under axle

housing; to raise front wheel of C, G, P models, place jack under lower control arm pivot; to raise front wheel of K models, place jack under front axle near spring seat.

Dual and Single Wheels

When installing the tire and wheel on the vehicle, the following procedure should be followed:

After wheel nuts are put on loosely, turn the wheel until one nut is at the top of the bolt circle; tighten the nut just snug. Snug up the remaining nuts criss-cross to minimize runout, then tighten the nuts to the recommended torque alternately and evenly to avoid excessive runout.

When installing wheels on vehicles with dual rear wheels:

1. Install inner and outer wheel and clamp ring on rear, or wheel and clamp ring on front (be sure pins on clamp ring face outboard).

2. Install and snug nuts finger tight.

3. Torque nuts to specified torque in sequence shown in Figure 4.

Lateral runout should not exceed 1/8" on front wheel or 3/16" on rear wheel.

Matching Side and Lock Rings

Side and lock rings of different rim types are not interchangeable. Some may appear to be, but they do not fit properly on the rim base. Serious accidents have resulted from the use of mismatched rings. Rim base and rings must be matched according to manufacturer, size and type. This information is stamped on each part.

Installing Synthetic Tubes

CAUTION: When tube and flap are not properly lubricated and mounted, they will stretch thin in the tire bead and rim region.

This will cause premature failure.

1. Before installing tube in tire, clean inside of casing thoroughly.

2. Insert tube in tire and inflate until it is nearly rounded out.

3. Inspect rim for rust scale and bent flanges—clean rust scale and straighten flanges where necessary.

4. Using a brush or cloth swab, apply a solution of neutral vegetable oil soap to the inside and outside of

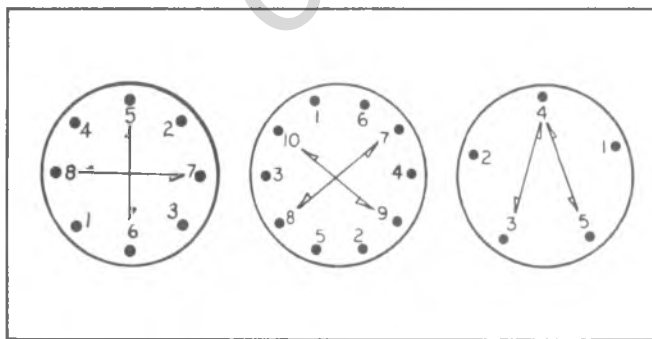


Fig. 4—Wheel Nut Tightening Sequence

tire beads and also the the rim side of the tube. Do not allow soap solution to run down into tire.

5. When mounting tire and tube on a drop center rim, follow the standard procedure. Be sure tire is centered on rim so that beads are out of rim well before inflating. Do not allow tire to hang loosely on wheel while inflating.

6. Center valve and pull it firmly against the rim. Hold in this position and inflate until tire beads are firmly seated on rim against flanges.

7. Completely deflate tire by removing valve core.

8. Reinflate tire to recommended pressure.

TUBELESS TIRES

Tubeless tires mounted on one piece full drop center rims are standard on some trucks. These tires have a safety inner liner which if punctured, tends to cling to the penetrating object forming a partial seal until the object is removed from the tire.

The mounting and demounting of tubeless truck tires will present no problem when a rubber lubricant, such as Ru-Glyde or equivalent is applied to tire beads and rim flanges. Ru-Glyde or equivalent in addition to materially assisting in mounting and demounting also prevents rusting at the tire sealing area and thus prevents tires from adhering to the wheel.

CAUTION: A hammer, or tools with sharp edges, should never be used to demount or mount tubeless tires as damage to rim flange or tire sealing bead may result.

Inspection for Leaks

1. With wheel assembly removed from vehicle, inflate the tire to recommended operating pressure.

2. Check for leaks at rim bead by placing wheel and tire horizontal and allowing water to stand in groove between rim and tire. Check for large leaks by lowering assembly into water tank or running water over tire.

Demounting

1. Remove valve core to completely deflate tire. With tire lying flat on floor, loosen beads from rim seats by walking around on tire with heels at points close to rim. With wide side of rim down, apply tire lubricant to top bead. With stops toward rim, insert spoon ends of two tire irons about 10" apart. While standing on tire to hold bead in gutter, pull one tool toward center of rim.

2. Hold one iron in position with foot and pull second iron toward center of rim. Progressively work bead off rim, taking additional bites if necessary.

3. Stand assembly in vertical position. Lubricate second bead. At top of assembly insert straight end of tire iron between bead and back flange of rim at about a 45 degree angle.

4. Turn iron so that it is perpendicular to rim. Pry second bead off.

Mounting

All tubeless tires will be mounted as follows:

1. Inspect rim to insure bead seats are clean and

smooth. Then place rim on floor with wide side down and lubricate first bead of tire and upper bead seat of rim.

2. Push first bead into well of rim and onto rim as far as possible. Using straight end of tire iron and with stop resting on rim flange, work remaining section of first bead over rim.

3. Hold second bead in well by standing on tire. When necessary, push section of bead into rim well and anchor with vise-grip pliers by pinching pliers on rim flange. Using spoon end of tire iron with stop toward rim, work progressively around bead using small bites until bead slips over flange onto rim base. If necessary,

insert second tire iron and lubricate last 6" of bead before completing.

4. Check valve to be certain that hex nut at the valve base is tight. Inflate tire to recommended operating pressure. Check assembly for air leaks.

ATTACHMENT OF DUAL WHEELS ON P300 MODELS

To assure secure attachment of the dual disc wheels, it is important that all dirt or rust scale be removed from the mating surface of the wheels, hub, and clamp ring as well as the stud and nut. **POWER DRIVE NUTS THEN MANUALLY INSPECT TORQUE AT 130-180 FT. LBS. MANUAL TORQUE ONLY: 150-200 FT. LB.**

Classiccarlibrary.com

Classiccarlibrary.com

SECTION 4A

PROPSHAFT

The following caution applies to one or more steps in the assembly procedure of components in this portion of the manual as indicated at appropriate locations by the terminology "See Caution on page 1 of this Section".

CAUTION: *THIS FASTENER IS AN IMPORTANT ATTACHING PART IN THAT IT COULD AFFECT THE PERFORMANCE OF VITAL COMPONENTS AND SYSTEMS, AND/OR COULD RESULT IN MAJOR REPAIR EXPENSE. IT MUST BE REPLACED WITH ONE OF THE SAME PART NUMBER OF WITH AN EQUIVALENT PART IF REPLACEMENT BECOMES NECESSARY. DO NOT USE A REPLACEMENT PART OF LESSER QUALITY OR SUBSTITUTE DESIGN. TORQUE VALUES MUST BE USED AS SPECIFIED DURING REASSEMBLY TO ASSURE PROPER RETENTION OF THIS PART.*

CONTENTS

General Description	4A-1
Universal Joints.....	4A-1
Propeller Shaft.....	4A-2
Diagnosis.....	4A-3
On Car Service.....	4A-5
Specifications	4A-15

GENERAL DESCRIPTION

Universal Joints

The simple universal joint is basically two Y-shaped yokes connected by a crossmember called a spider. The spider is shaped like an X and arms that extend from it are called trunnions. See figure 4A-1.

The spider allows the two yoke shafts to operate at

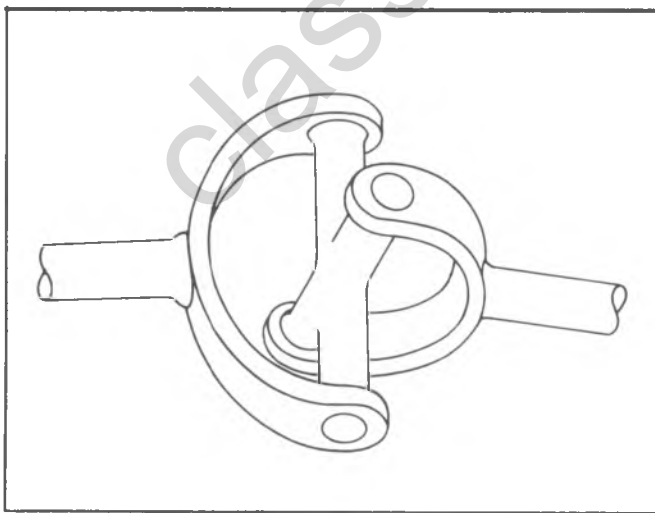


Fig. 4A-1-Simple Universal Joint

an angle to each other. When torque is transmitted at an angle, through this type of joint, the driving yoke rotates at a constant speed while the driven yoke speeds up and slows down twice per revolution. This changing of velocity (acceleration) of the driven yoke increases as the angle between the two yoke shafts increases. This is the prime reason why single universal joints are not used for angles greater than three to four degrees. At four degrees, for example the change of velocity is .5%. At ten degrees it is 3%. If the universal joint were set at 30 degrees and the driving yoke were turning at 1000 RPM the velocity of the driven yoke would change from 856 RPM to 1155 RPM in one quarter of a revolution. In the remaining quarter revolution the velocity would change from 1155 RPM to 866 RPM.

On a one-piece drive shaft this problem can be eliminated by arranging two simple universal joints so that the two driving yokes are rotated 90 degrees to each other. However the angle between the drive and driven yokes must be very nearly the same on both joints for this to work. Refer to figure 4A-2. This allows the alternate acceleration and deceleration of one joint to be offset by the alternate deceleration and acceleration of the second joint. When the two joints do not run at approximately the same angle, operation can be rough and an objectionable vibration can be produced.

Universal joints are designed to consider the effects

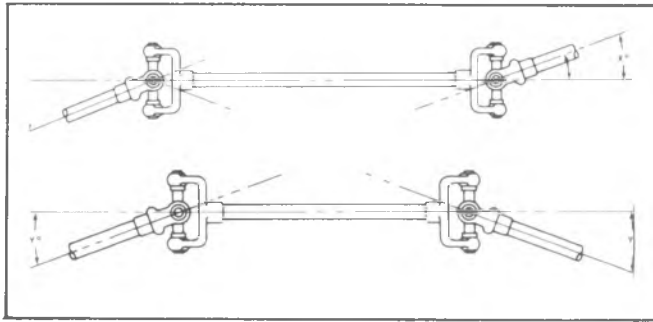


Fig. 4A-2--Universal Joints Arranged for Constant Velocity

of various loadings and rear axle windup, during acceleration. Within the design angle variations the universal joints will operate safely and efficiently. However, when the design angles are exceeded the operational life of the joints may decrease.

The bearings used in universal joints are the needle roller type. The needle rollers are held in place on the trunnion by round bearing cups. The bearing cups are held in the yoke by either (depending on the manufacturer) snaprings or plastic injection. These joints usually are lubricated for life and cannot be lubricated while on the vehicle.

Constant Velocity Joint—Double Cardan Joint

As mentioned previously, the simple universal joint will operate efficiently through small angles only. Also, two simple universal joints phased properly and operating through the same angle will transmit constant velocity. When a large angle is encountered in a driveline, a simple universal joint will introduce two vibrations in each revolution. It is in this situation that a constant velocity joint is used.

Essentially, the constant velocity joint is two simple universal joints closely coupled by a coupling yoke, phased properly for constant velocity.

A centering ball socket between the joints maintains the relative position of the two units. This centering device causes each of the two units to operate through one-half of the complete angle between the drive shaft and differential carrier. See figure 4A-3.

NOTE: The ball/socket on this Constant Velocity joint requires periodic lubrication. A lubrication fitting is provided for this purpose, and is illustrated later in this section.

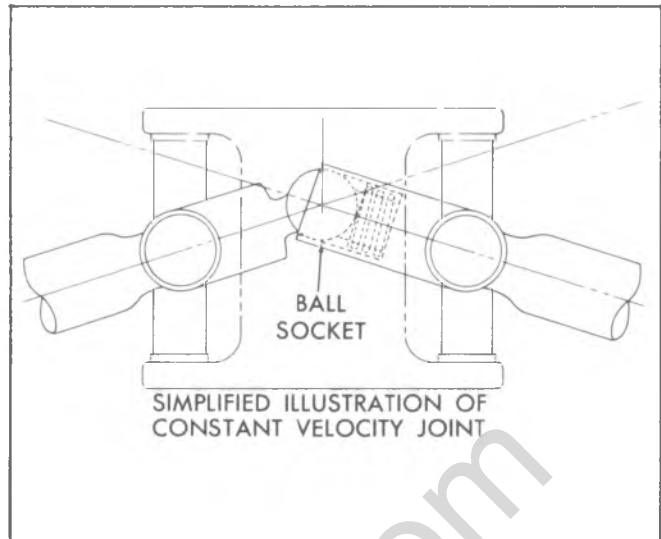


Fig. 4A-3--Ball-Socket Location

Propeller Shafts

The propeller shaft is a steel tube which is used to transmit power from the transmission output shaft to the differential. To accommodate various model, wheelbase and transmission combinations, drive shafts differ in length, diameter and the type of splined yoke. On some models the drive shaft is made up of concentric steel tubes with rubber elements between.

Each shaft is installed in the same manner. A universal joint and splined slip yoke are located at the transmission end of the shaft, where they are held in alignment by a bushing in the transmission rear extension. The slip yoke permits fore and aft movement of the drive shaft as the differential assembly moves up and down. The spline is lubricated internally by transmission lubricant or grease. An oil seal at the transmission prevents leakage and protects the slip yoke from dust, dirt and other harmful material.

Since the drive shaft is a balanced unit, it should be kept completely free of undercoating and other foreign material which would upset shaft balance.

Both one piece and two piece propeller shafts are used depending on the model. All are tubular and use needle bearing type universal joints.

On models that use a two piece shaft, the shaft is supported near its splined end in a rubber cushioned ball bearing which is mounted in a bracket attached to a frame crossmember. The ball bearing is permanently lubricated and sealed.

Four wheel drive models use a front propeller shaft incorporating a constant velocity joint.

PROPELLER SHAFT AND UNIVERSAL JOINT DIAGNOSIS

Checking and Correcting

Propeller Shaft Unbalance

1. Place vehicle on a twin post hoist so that the rear wheels are free to rotate.
2. Remove both rear tire and wheel assemblies and brake drums.

CAUTION: Use care not to apply brakes with drums removed.

3. Visually inspect propshaft, U-Joints and attach-

ments for mud undercoating or other discrepancies. Make necessary corrections prior to running.

4. With vehicle running in gear at the indicated speed where disturbance is at its peak, observe the intensity of the disturbance.

5. Stop engine and disconnect drive shaft from companion flange. Reinstall shaft by rotating it 180° from its original position. Determine which position of the companion flange gives the best balance.

6. Install rear drums and wheels, and road test vehicle for final check of balance. If balance is still unacceptable, replace drive shaft.

DIAGNOSTIC CHART

COMPLAINT	POSSIBLE CAUSE	CORRECTION
Leak at front slip yoke. <div style="border: 1px solid black; padding: 5px; width: fit-content;"> NOTE: An occasional drop of lubricant leaking from splined yoke is normal and requires no attention. </div>	a. Rough outside surface on splined yoke. b. Defective transmission rear oil seal.	a. Replace seal if cut by burrs on yoke. Minor burrs can be smoothed by careful use of crocus cloth or honing with a fine stone. Replace yoke if outside surface is rough or burred badly. b. Replace transmission rear oil seal. c. Bring transmission oil up to proper level after correction.
Knock in drive line, clunking noise when car is operated under floating condition at 10 mph in high gear or neutral.	a. Worn or damaged universal joints. b. Side gear hub counterbore in differential worn oversize.	a. Disassemble universal joints, inspect and replace worn or damaged parts. b. Replace differential case and/or side gears as required.
Ping, Snap or Click in drive line. <div style="border: 1px solid black; padding: 5px; width: fit-content;"> NOTE: Usually occurs on initial load application after transmission has been put into gear, either forward or reverse. </div>	a. Loose upper or lower control arm bushing bolts. b. Loose companion flange.	a. Tighten bolts to specified torque. b. Remove companion flange, turn 180° from its original position, apply white lead to splines and reinstall. Tighten pinion nut to specified torque.

Fig. 4A-4--Diagnosis Chart A

COMPLAINT	POSSIBLE CAUSE	CORRECTION
<p>Roughness, Vibration or Body Boom at any speed.</p> <p>NOTE: With tachometer installed in car, determine whether propeller shaft is cause of complaint by driving through speed range and note the engine speed (rpm) at which vibration (roughness) is most pronounced. Then, shift transmission to a different gear range and drive car at same engine speed (rpm) at which vibration was noted before. Note the effect on the vibration.</p> <p>If vibration occurs at the same engine speed (rpm), regardless of transmission gear range selected, drive shaft assembly is <u>not</u> at fault, since the shaft speed (rpm) varies.</p> <p>If vibration decreased, or is eliminated, in a different gear range but at the same engine speed (rpm), check the possible causes:</p>	<ul style="list-style-type: none"> a. Bent or dented drive shaft. b. Undercoating on drive shaft. c. Tire unbalance. (30-80 mph, not throttle conscious) d. Excessive U-bolt torque. e. Tight universal joints. f. Worn universal joints. g. Burrs or gouges on companion flange. Check snap ring locating surfaces on flange yoke. h. Drive shaft or companion flange unbalance. i. Excessive looseness at slip yoke spline. j. Drive shaft runout (50-80 mph throttle conscious) 	<ul style="list-style-type: none"> a. Replace. b. Clean drive shaft. c. Balance or replace as required. d. Check and correct to specified torque. e. Impact yokes with a hammer to free up. Overhaul joint if unable to free up or if joint feels rough when rotated by hand. f. Overhaul, replacing necessary parts. g. Rework or replace companion flange. h. Check for missing balance weights on drive shaft. Remove and reassemble drive shaft to companion flange, 180° from original position. i. Replace necessary parts. j. Check drive shaft runout at front and rear. Should be less than specified. If above, rotate shaft 180° and recheck. If still above specified, replace shaft.
<p>Roughness usually at low speeds, light load, 15-35 mph.</p>	<ul style="list-style-type: none"> a. U-bolt clamp nuts excessively tight. 	<ul style="list-style-type: none"> a. Check and correct torque to that specified. If torque was excessive or if brenelled pattern on trunnions is evident, replace joints.
<p>Scraping noise.</p>	<ul style="list-style-type: none"> a. Slinger, companion flange, or end yoke rubbing on rear axle carrier. 	<ul style="list-style-type: none"> a. Straighten slinger to remove interference.
<p>Roughness on heavy acceleration (short duration.)</p>	<ul style="list-style-type: none"> a. Double cardan joint ball seats worn. Ball seat spring may be broken. 	<ul style="list-style-type: none"> a. Replace joint and shaft assembly.
<p>Roughness -- above 35 mph felt and/or heard.</p>	<ul style="list-style-type: none"> a. Tires unbalanced or worn. 	<ul style="list-style-type: none"> a. Balance or replace as required.

Fig. 4A-5--Diagnosis Chart B

UNIT REPAIR

PROPELLER SHAFT

Two methods are used to retain the propeller shaft to the differential pinion flange. One method utilizes "U" bolts, and the other is a strap attachment. Refer to figures 4A-6 and 4A-7.

Removal

1. Raise vehicle on hoist. Mark relationship of shaft to companion flange and disconnect the rear universal joint by removing trunnion bearing "U" bolts or straps. Tape bearing cups to trunnion to prevent dropping and loss of bearing rollers.

2. For models with two-piece shafts remove bolts retaining bearing support to hanger.

3. Slide propeller shaft forward disengaging trunnion from axle flange, then slide assembly rearward disengaging from transmission.

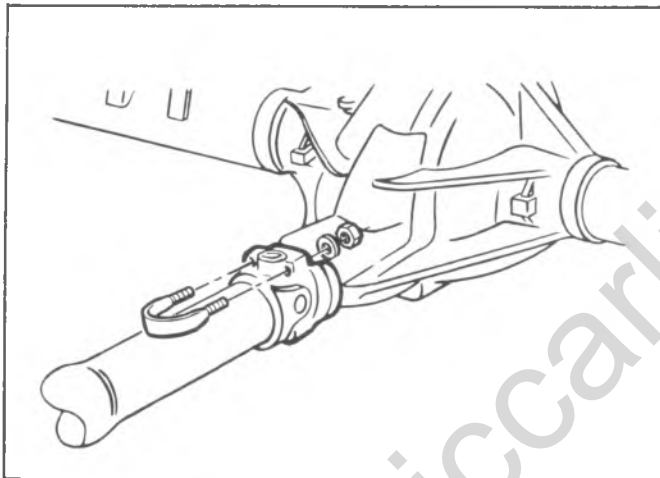


Fig. 4A-6--U-Bolt Attachment

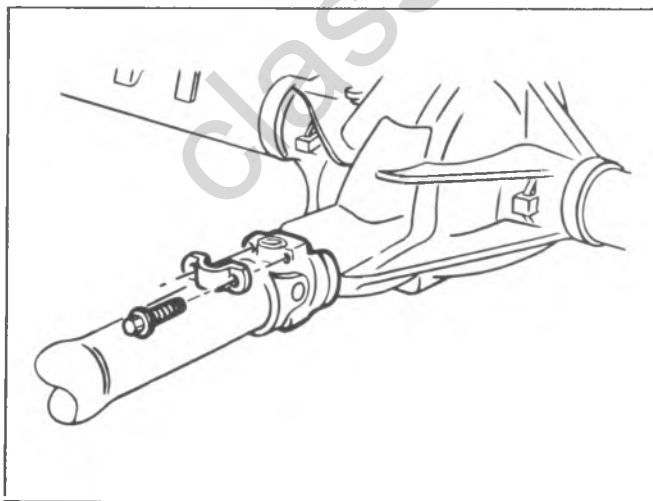


Fig. 4A-7--Strap Attachment

NOTE: For models using strap or U-bolt attachments to transmission or transfer case use same removal procedure as above.

Universal Joints

On models with between center slip propshaft it is important that components are marked prior to disassembly for proper phasing. Arrows are stamped on assemblies as shown in Fig. 4A-8.

NOTE: The universal joints are of the extended-life design and do not require periodic inspection or lubrication; however, when these joints are disassembled, repack bearings and lubricate reservoir at end of trunnions with high-melting point wheel bearing lubricant use care not to damage or dislodge seals from trunnion.

Snap Ring Type

Disassembly

1. Remove bearing lock rings from trunnion yoke.
2. Support trunnion yoke on a piece of 1-1/4" I.D. pipe on an arbor bed.

NOTE: Due to length of the propeller shaft it may be more convenient to use a bench vise, for removal and installation, instead of an arbor press. In this case, proceed with disassembly and assembly procedure as with an arbor press Fig. 4A-9 and 4A-10.

3. Using a suitable socket or rod, press on trunnion

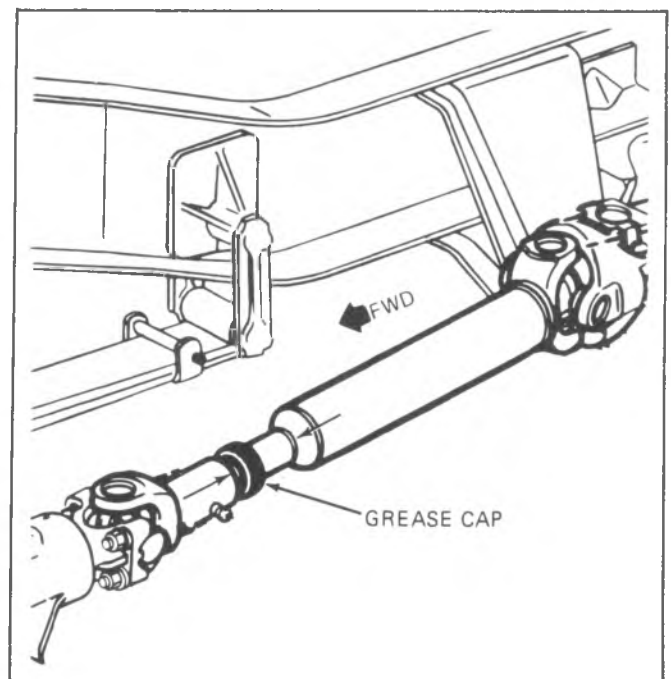


Fig. 4A-8--Proper Alignment

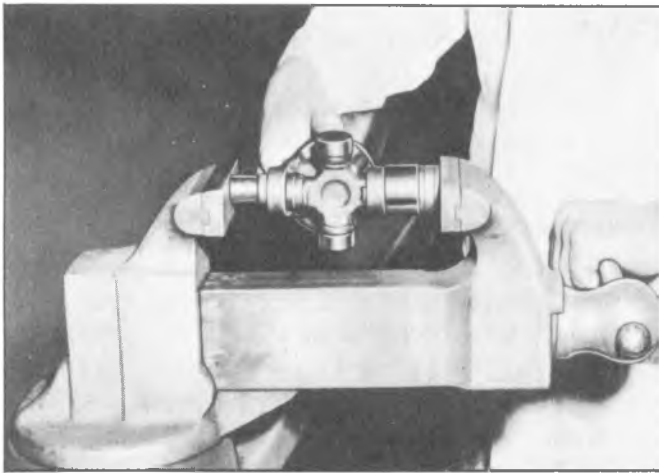


Fig. 4A-9-Bearing Cup Removal with Vise

until bearing cup is almost out. Grasp cup in vise and work cup out of yoke. See figures 4A-9 and 4A-10.

NOTE: The bearing cup cannot be fully pressed out.

4. Press trunnion in opposite direction and remove other cup as in Step 3.

5. Clean and inspect dust seals, bearing rollers, and trunnion. Relubricate bearings as indicated in Section 0.

NOTE: In addition to packing the bearings, make sure that the lubricant reservoir at the end of each trunnion is completely filled with lubricant. In filling these reservoirs, pack lubricant into the hole so as to fill from the bottom (use of squeeze bottle is recommended). This will prevent air pockets and ensure an adequate supply of lubricant.

Reassembly Fig. 4A-11

1. Position trunnion into yoke. Partially install one bearing cup into yoke. Start trunnion into bearing cup.

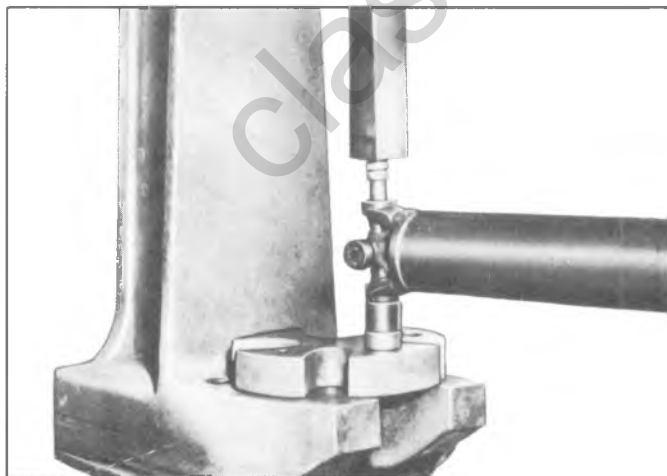


Fig. 4A-10-Bearing Cup Removal with Press

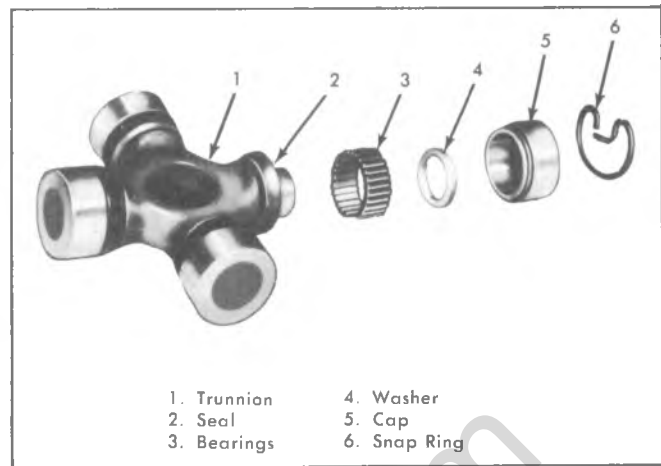


Fig. 4A-11--Universal Joint Repair Kit

Partially install other cup. Align trunnion into cup, and press cups into yoke.

2. Install lock rings.

Injected Plastic Type

Disassembly

NOTE: Never clamp drive shaft tubing in a vise as the tube may be dented. Always clamp on one of the yokes, and support the shaft horizontally. Avoid damaging the slip yoke sealing surface. Nicks may damage the bushing or cut the seal lip.

1. Support the drive shaft in a horizontal position in line with the base plate of a press. Place the universal joint so that the lower ear of the shaft yoke is supported on a 1-1/8" socket. Place the cross press, J-9522-3, on the open horizontal bearing cups, and press the lower bearing cup out of the yoke ear as shown in figure 4A-12. This will shear the plastic retaining the lower bearing cup.

2. If the bearing cup is not completely removed, lift the cross and insert Spacer J-9522-5 between the seal

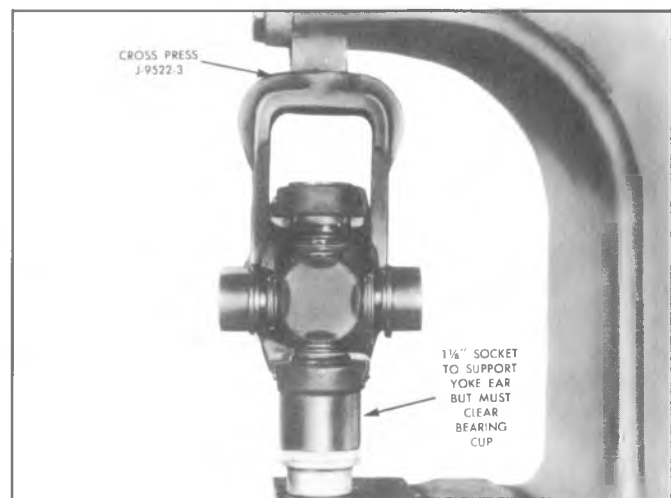


Fig. 4A-12--Pressing Out Bearing Cup

and bearing cup being removed, as shown in figure 4A-13.

Complete the removal of the bearing cup, by pressing it out of the yoke.

3. Rotate the drive shaft, shear the opposite plastic retainer, and press the opposite bearing cup out of the yoke as before, using Spacer J-9522.

4. Disengage cross from yoke and remove.

NOTE: Production universal joints cannot be reassembled. There are no bearing retainer grooves in production bearing cups. Discard all universal joint parts removed.

5. Remove the remains of the sheared plastic bearing retainer from the ears of the yoke. This will aid in reassembly of the service joint bearing cups. It usually is easier to remove plastic if a small pin or punch is first driven through the injection holes.

6. If the front universal joint is being serviced, remove the pair of bearing cups from the slip yoke in the same manner.

Reassembly

A universal joint service kit is used when reassembling this joint. See figure 4A-14. This kit includes one pregreased cross assembly, four service bearing cup assemblies with seals, needle rollers, washers, grease and four bearing retainers.

Make sure that the seals are in place on the service bearing cups to hold the needle rollers in place for handling.

1. Remove all of the remains of the sheared plastic bearing retainers from the grooves in the yokes. The sheared plastic may prevent the bearing cups from being pressed into place, and this prevent the bearing retainers from being properly seated.

2. Install one bearing cup part way into one side of the yoke, and turn this yoke ear to the bottom.

3. Insert cross into yoke so that the trunnion seats freely into bearing cup as shown in figure 4A-15.

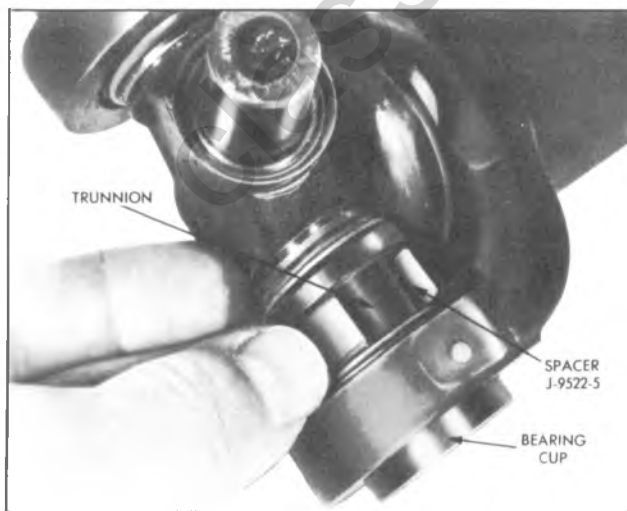


Fig. 4A-13--Using Spacer to Remove Bearing Cup

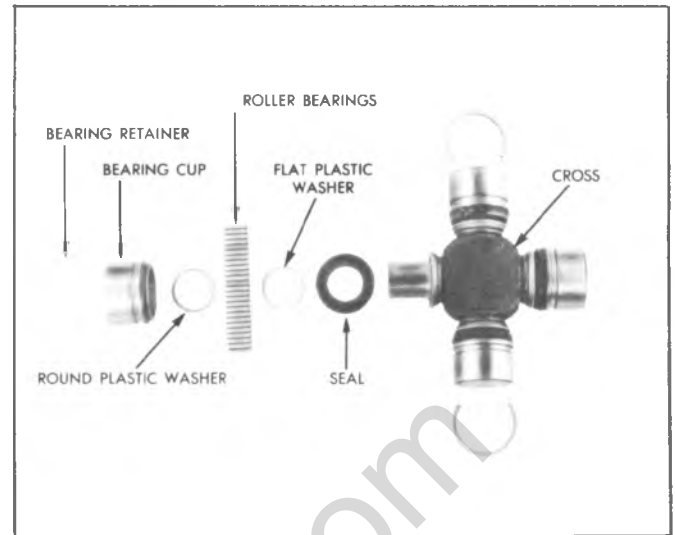


Fig. 4A-14--Repair Kit

4. Install opposite bearing cup part way. Make sure that both trunnions are started straight and true into both bearing cups.

5. Press against opposite bearing cups, working the cross all of the time to check for free movement of the trunnions in the bearings. If there seems to be a hang-up, stop pressing and recheck needle rollers, to determine if one or more of them has been tipped under the end of the trunnion.

6. As soon as one bearing retainer groove clears the inside of the yoke, stop pressing and snap the bearing retainer into place as shown in figure 4A-16.

7. Continue to press until the opposite bearing retainer can be snapped into place. If difficulty is encountered, strike the yoke firmly with a hammer to aid in seating bearing retainers. This springs the yoke ears slightly. See figure 4A-17.

8. Assemble the other half of the universal joint in the same manner.



Fig. 4A-15--Installing Trunnion into Yoke

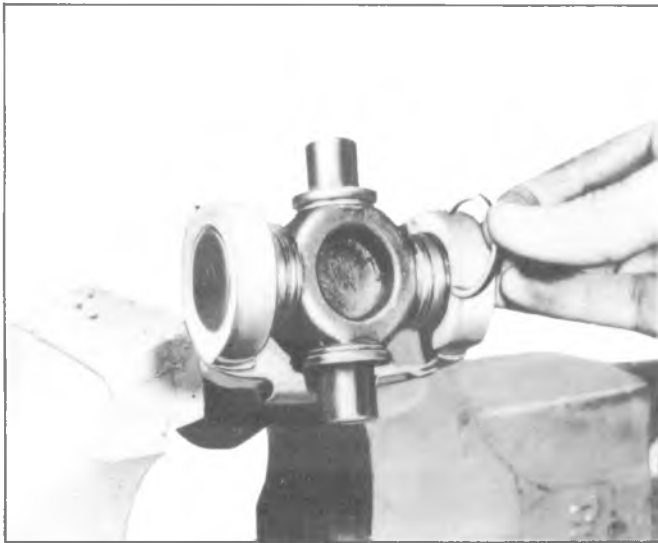


Fig. 4A-16--Installing Snap Ring to Retain Trunnion

9. Check the freedom of rotation of both sets of trunnions of the cross. If too tight, again rap the yoke ears as described above. This will loosen the bearings and help seat the bearing retainers.

CENTER SUPPORT BEARING—FIG. 4A-18

CAUTION: See *CAUTION* on page 1 of this section regarding Center Support Bearing fasteners.

1. Remove dust shield.
2. Remove strap retaining rubber cushion from bearing support.
3. Pull support bracket from rubber cushion and pull cushion from bearing.
4. Pull bearing assembly from shaft.



Fig. 4A-17--Seating Snap Rings

5. Assemble bearing support as follows:
 - a. Install inner deflector on propeller shaft, if removed, and prick punch deflector at two opposite points to make sure it is tight on shaft.
 - b. Fill space between inner dust shield and bearing with lithium soap grease.
 - c. Start bearing and slinger assembly straight on shaft journal. Support propeller shaft and, using suitable length of pipe over splined end of shaft, press bearing and inner slinger against shoulder on shaft.
 - d. Install dust shield over shaft, small diameter first and press into position against outer slinger.
 - e. Install rubber cushion onto bearing.
 - f. Install bracket onto cushion.
 - g. Install retaining strap.

Installation of Propshafts

NOTE: When reinstalling propshafts, it is necessary to place the shafts into particular positions to assure proper operation. This is called phasing.

All models with 32 splines use an alignment key, as shown in figure 4A-19, to obtain proper phasing. The shafts can mate only in the correct position.

G and K models with 16 splines must be phased as shown in figure 4A-20.

1. For models with one piece propeller shafts, slide shaft into transmission and attach rear U-joint to axle.
2. For C-P models with two-piece propeller shafts, proper phasing is accomplished with the alignment key, shown in figure 4A-19.
3. For G-K models with two piece shafts, install front half into transmission and bolt support to crossmember.
 - a. Slide grease cap and gasket onto rear splines.
 - b. Rotate shaft so front U-joint trunnion is in correct position. See figure 4A-20.
 - c. Take rear propeller shaft and before installing, align U-joint trunnions as shown in figure 4A-20. Attach rear U-joint to axle. Tighten grease cap.
 - d. Torque bearing support to crossmember and U-joint to axle attachments.

CONSTANT VELOCITY UNIVERSAL JOINT (Snap Ring Type) RETENSION

Disassembly

1. Remove auxiliary front propeller shaft from vehicle.
2. Remove rear trunnion snap rings from center yoke. Remove grease fitting.
3. Place propeller shaft in vice as shown in figure 4A-21. Drive one rear trunnion bearing cap from center yoke as shown in figure 4A-21 until it protrudes approximately 3/8".

NOTE: Keep rear portion of propeller shaft up to avoid interference of rear yoke half with center yoke.

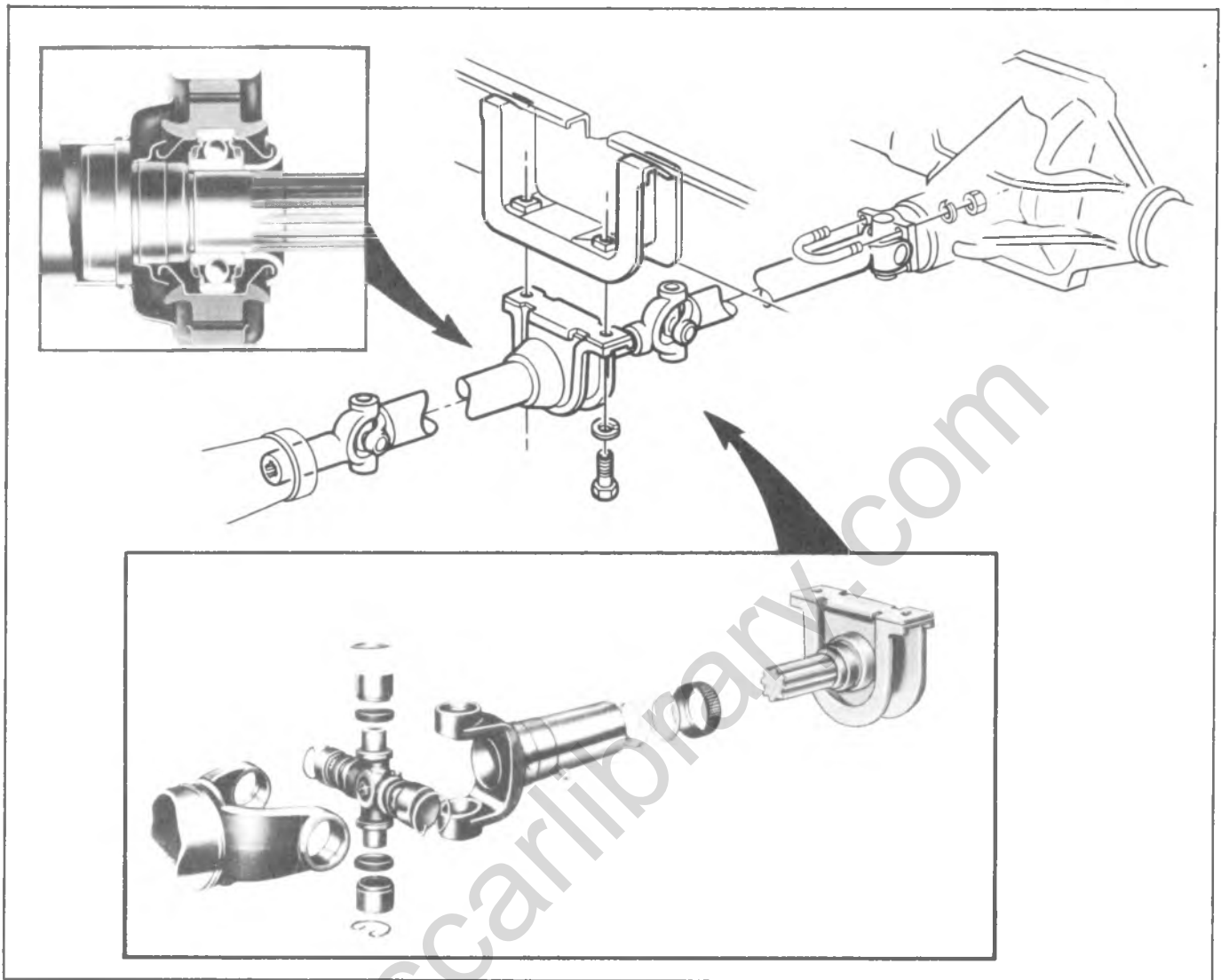


Fig. 4A-18-Propeller Shaft, Universal Joint and Bearing Support

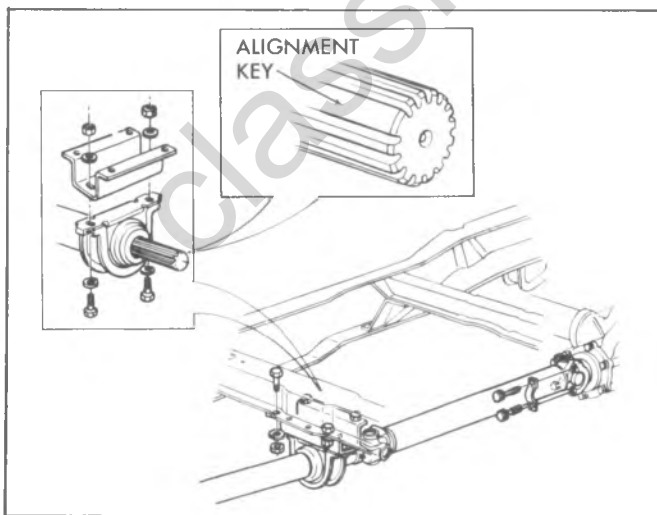


Fig. 4A-19-Alignment Key

4. Once the bearing cup protrudes $3/8''$, release vice. Grasp protruding portion of cup in vice and strike center yoke as shown in Figure 4A-22 until cup is removed. Remove cup seal by prying off with a thin screwdriver.

5. Repeat steps 3 and 4 for remaining bearing cup.

6. Once the center yoke cups have been removed, remove rear yoke half bearing cups. Remove rear trunnion.

7. Gently pull rear yoke half from prop shaft. Remove all loose needle bearings. Remove spring seal.

8. Remove front trunnion from center and front yoke in same manner as described in Steps 2, 3 and 4.

NOTE: Before front trunnion can be removed all four (4) bearing caps must be removed.

Assembly

1. Clean and inspect all needle bearings, cups, seals, fittings, trunnions and yokes. Assemble all needle bearings in caps (27 per cap); assemble needle bearings

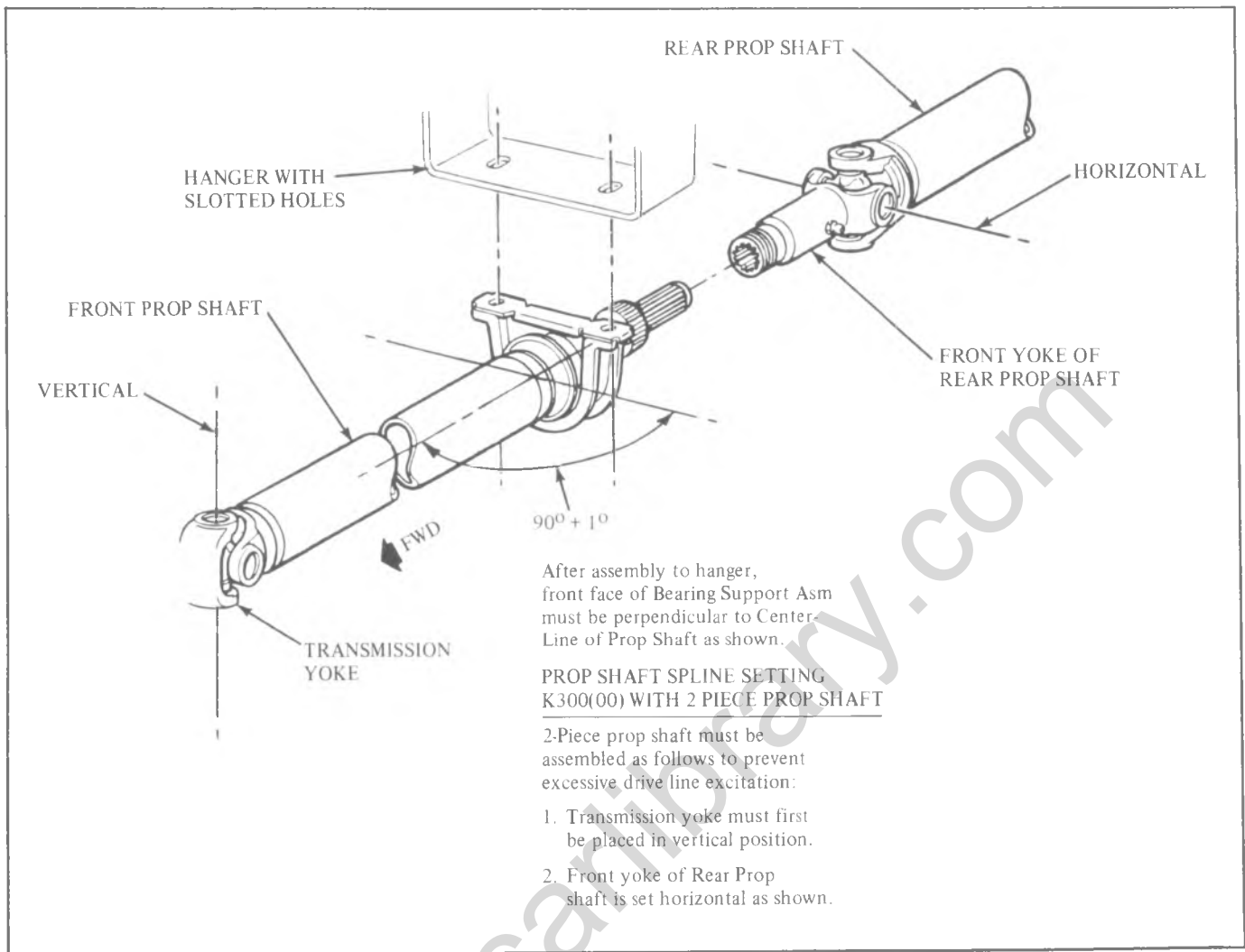


Fig. 4A-20-Alignment for Phasing

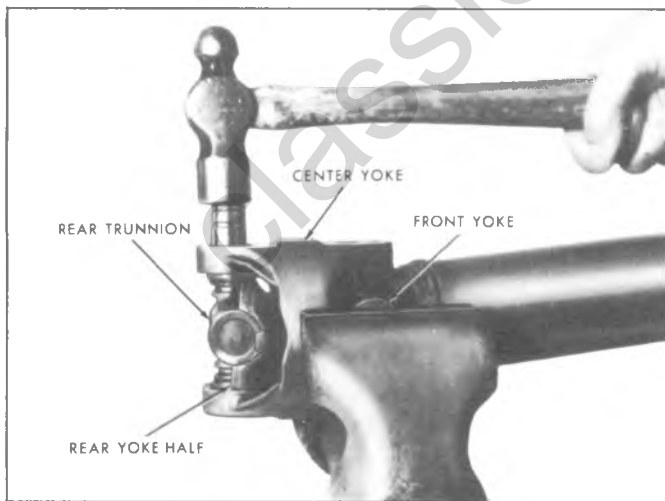


Fig. 4A-21-Driving Out Bearing Cups

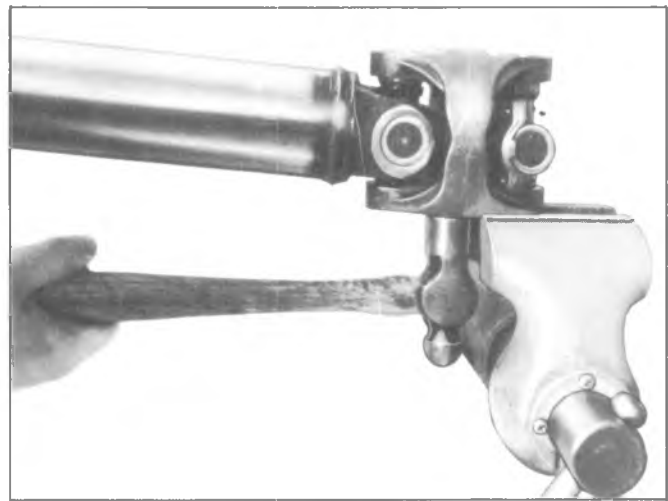


Fig. 4A-22-Bearing Cup Removal

in front yoke (28 total). Retain bearings with a heavy grease. Assemble seals to bearing cups.

2. Place front trunnion in drive shaft. Place center yoke on front trunnion. Install one bearing cup and seal assembly in front yoke. Drive in to a depth that the snap ring can be installed. Install snap ring. Install remaining cup and seal in front yoke. Install snap ring.

3. Install front trunnion bearing cups in center yoke in same manner.

4. With front trunnion completely installed, install seal on prop shaft (large face first). Gently slip rear yoke half on prop shaft using care not to upset rollers. Insert rear trunnion in center yoke. Install rear yoke half bearing caps on rear trunnion. Install one rear trunnion bearing cap in center yoke and press into yoke until snap ring can be installed. Install remaining cap and snap ring.

5. Grease universal as outlined in Section 0 at all three (3) fittings (2 conventional type and one in rear yoke half) that requires a needle nose grease gun adapter.

6. Install propeller shaft with constant velocity joint next to transfer case. Torque U-bolts to specifications. The lubrication fitting at this location is shown in figure 4A-23.

DOUBLE CARDAN TYPE-CV JOINT

Inspection

An inspection kit including two bearing caps and two snap rings is available to allow the removal of the two trunnion caps shown at location 1, in figure 4A-24. **Mark the flange yoke and coupling yoke for reassembly in the same position, as shown in figure 4A-25.**

NOTE: To service the trunnion caps, use the appropriate procedures given in the beginning of this Section.

When both bearing cups are free, disengage the flange yoke and trunnion from the centering ball. Note

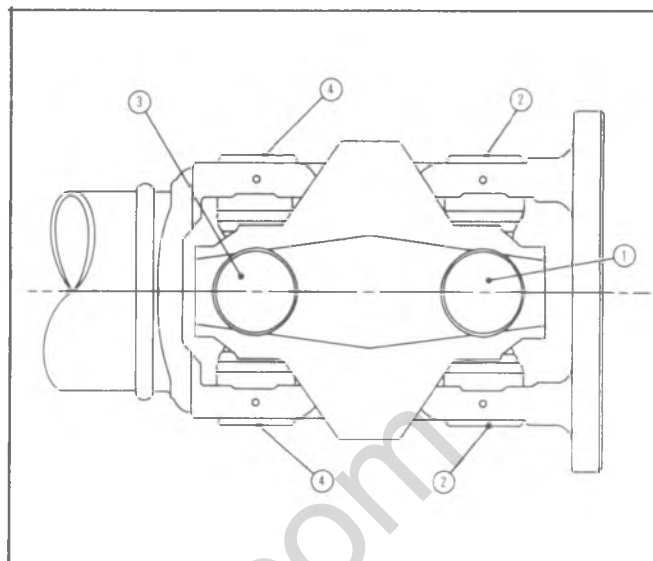


Fig. 4A-24--Bearing Cap Removal Sequence

that the ball socket is part of the flange yoke assembly, while the centering ball is pressed onto a stud and is part of the ball stud yoke. See figure 4A-26. Pry the seal from the ball socket and remove washers, spring and the three ball seats as illustrated in figure 4A-27.

1. Clean and inspect ball seat insert bushing for wear. If bushing is worn, replace flange yoke and cross assembly.

2. Clean and inspect seal and ball seats along with spring and washers. If any parts show indication of excessive wear or are broken, replace the entire set with a service kit.

NOTE: Whenever the seal is removed to inspect ball seat parts, it should be discarded and replaced with a new seal.

3. Remove all plastic from groove of coupling yoke.

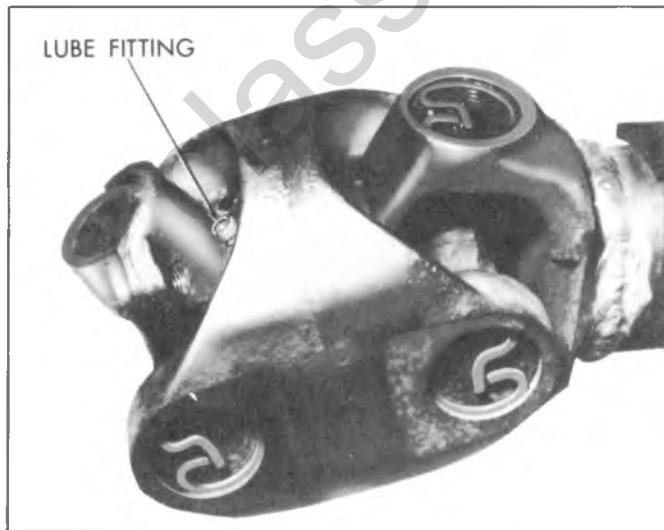


Fig. 4A-23--Lubrication Fitting

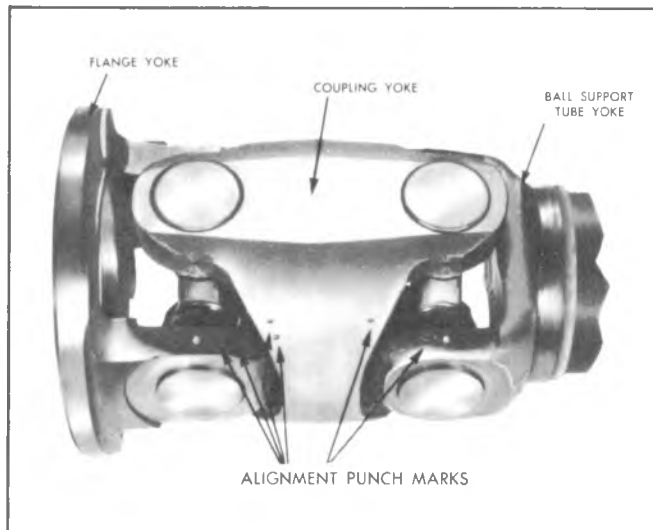


Fig. 4A-25--Reassembling Coupling Yoke

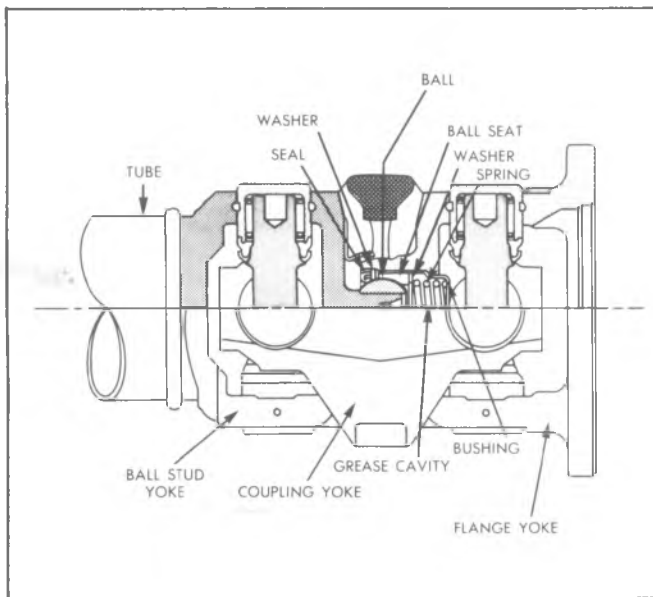


Fig. 4A-26--Cross Sectional View of CV Joint

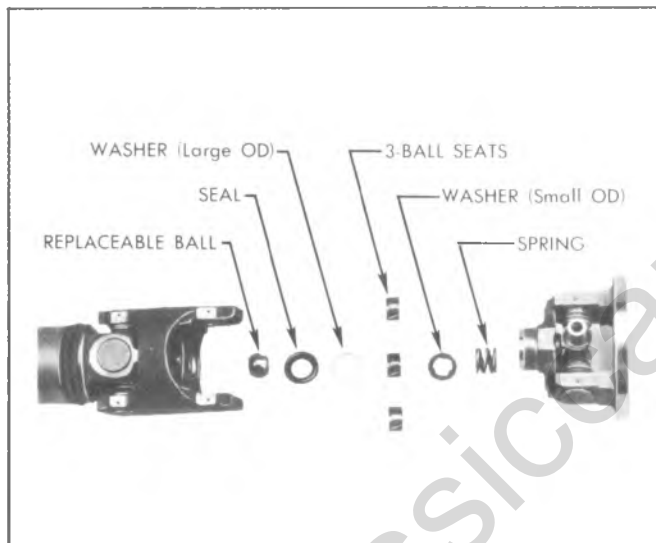


Fig. 4A-27--Exploded View of Centering Ball Mechanism

4. Inspect the centering ball surface. If it shows signs of wear beyond smooth polish, replace it.

Centering Ball Replacement

1. Place fingers of inner part of Tool J-23996 under ball as shown in figure 4A-28.

2. Place outer cylinder of Tool J-23996 over outside of ball as shown in figure 4A-29.

3. Thread nut on Tool j-23996 and draw ball off stud, using wrench as shown in figure 4A-30.

4. Place the replacement ball on stud.

5. Using Tool J-23996, drive ball onto stud as in figure 4A-31, until the ball can be seen to seat firmly against the shoulder at the base of the stud. This is important as the center of the double Cardan joint is

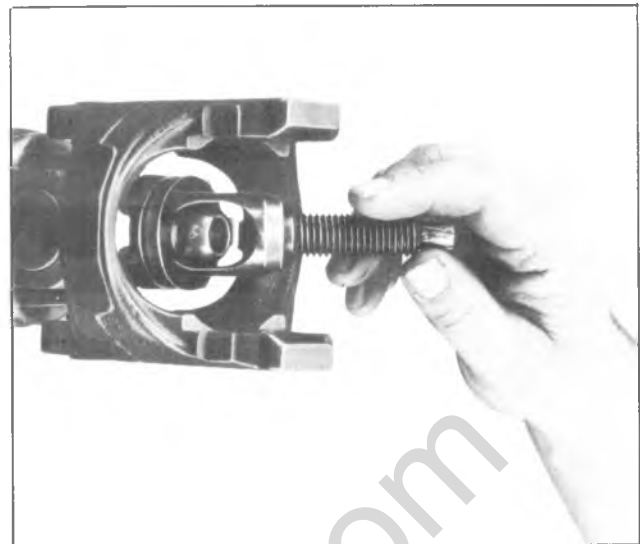


Fig. 4A-28--Installing Tool J-23996 Over Ball

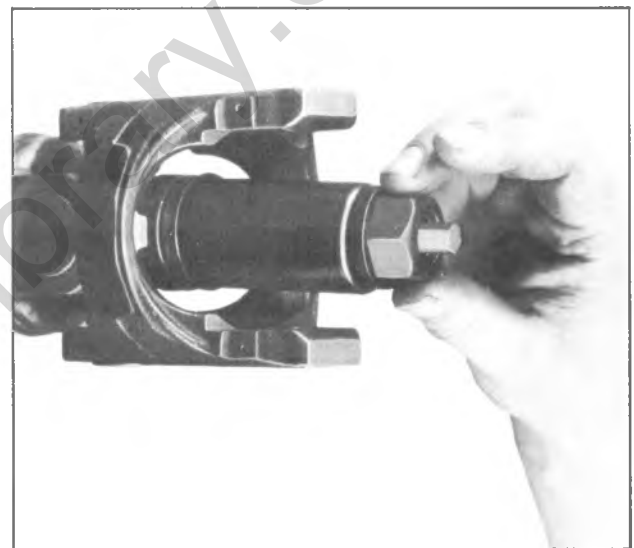


Fig. 4A-29--Installing Outer Cylinder of Tool J-23996 Over Ball

determined by the ball seating tightly in the proper location.

6. Using grease provided in the ball seat kit, lubricate all parts and insert them into the clean ball seat cavity in the following order: spring, washer (smallest OD), three ball seats (with largest opening outward to receive ball), washer (largest OD) and seal.

7. Lubricate seal lip and press seal flush with Tool J-23694, as shown in figure 4A-32. Sealing lip should tip inward.

8. Fill cavity with grease provided in kit.

9. Install flange yoke to centering ball as shown in figure 4A-33, making sure alignment marks are correctly positioned. Install trunnion and bearing caps as previously outlined.

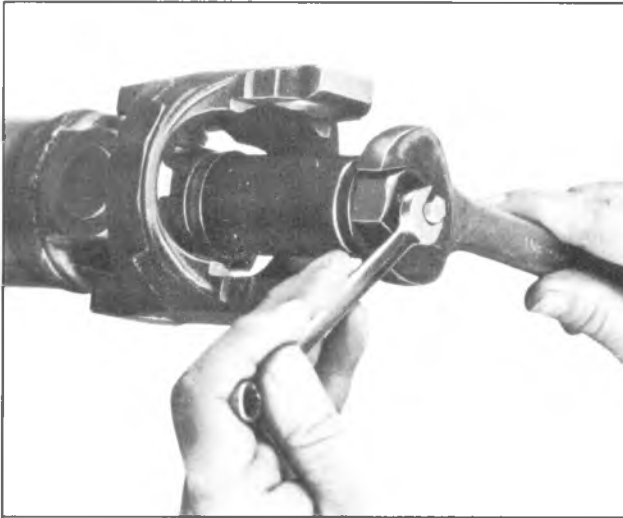


Fig. 4A-30--Removing Centering Ball



Fig. 4A-32--Installing Centering Ball Seal

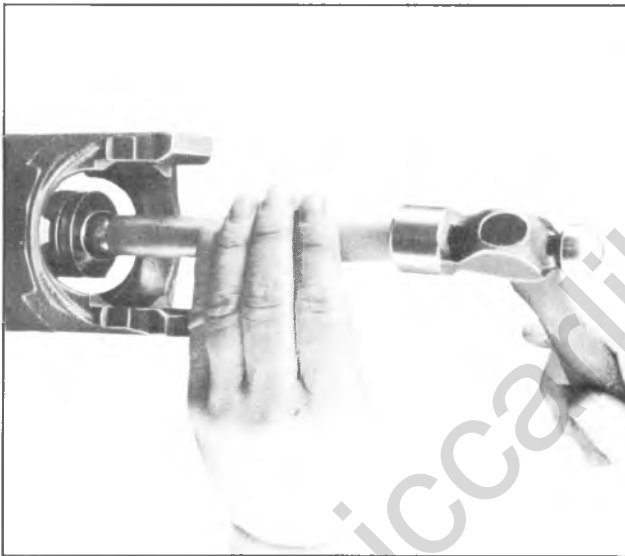


Fig. 4A-31--Installing Centering Ball

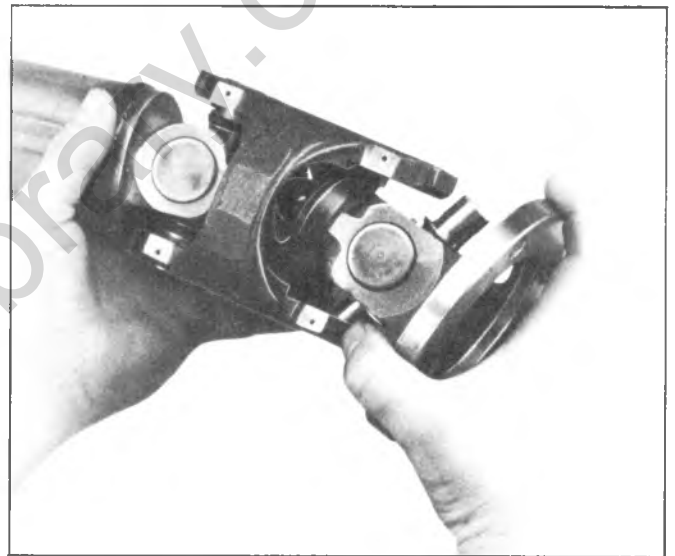


Fig. 4A-33--Reassembling Flange Yoke

LUBRICATION

The front axle propshaft found on all four-wheel drive trucks requires special lubrication procedures at two locations: The C/V joint, and the slip yoke.

All Constant Velocity Joints (C/V)

The constant velocity (C/V) joint, located at the transfer case end of the front propshaft, must be lubricated periodically with special lubricant, **1050679, or equivalent**. If the fitting cannot be seen from beneath the vehicle Figure 4A-34 shows how the fitting may be lubricated from above the C/V joint, with a special adapter J-25512-2 on the end of a flex hose.

Slip Spline

- **Dana Style Propshaft** First loosen the screw-on grease cap, shown in Figure 4A-35 and slide the collar back to reveal the sealing area. Apply chassis lubricant

at the fitting until grease begins to leave through the vent hole. Cover the vent hole with your finger and continue applying lubricant until it can be seen leaving at the slip yoke seal. Reinstall the grease cap.

NOTE: If the slip spline is dry or corroded, it may be necessary to disconnect the propshaft from the truck, remove the slip yoke, and wire brush the affected areas. Wipe clean before reinstallation. When installing the propshaft to transfer case attaching bolts, torque to specification (20-30 ft. lbs.).

- **GM Style Propshaft** Apply chassis lubricant at the fitting until grease begins to leave through the vent hole.

NOTE: If the slip spline is dry or corroded, it may be necessary to disconnect the propshaft from the

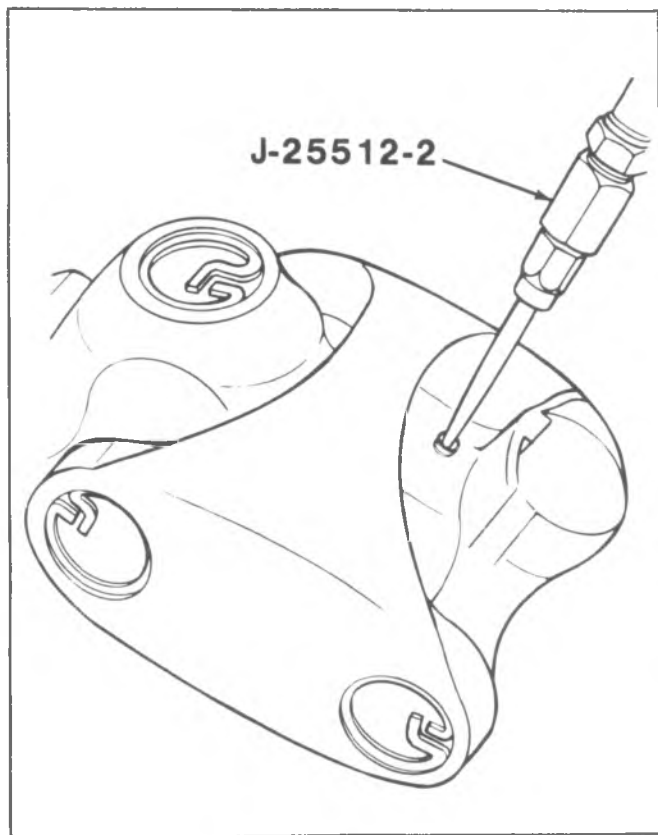
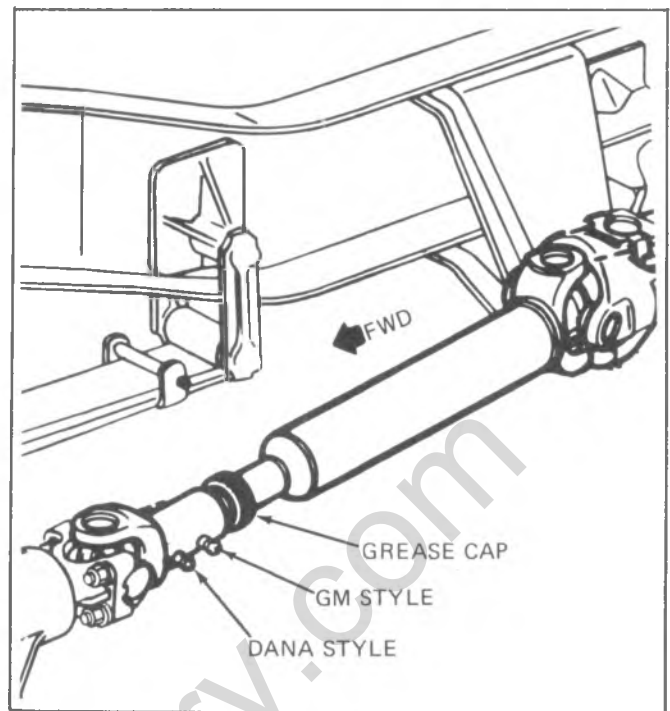


Fig. 4A-34-Dana Style Propshaft



Slip Yoke Lubrication

truck, remove the slip yoke, and wire brush the affected areas.

Wipe clean before reinstallation. When installing the propshaft to transfer case front output flange attaching bolts, torque to specification (70-80 ft. lbs.).

SPECIFICATIONS

PROPELLER SHAFT

	CK	G	P
Propeller Shaft			
To Rear Axle (Strap)	12-17	12-17	12-17
To Rear Axle ("U" Bolt)	18-22	—	18-22
Bearing Support-to-Hanger	20-30	20-30	20-30
Hanger-to-Frame	40-50	—	—
To Transfer Case			
Dana Style	20-30		
GM Style	70-80		

Torque Specifications (Ft.-Lbs.)

UNIVERSAL JOINT ATTACHMENT TORQUE SPECIFICATIONS	
Strap Attachments	15 Ft.-Lbs.
"U" Bolt Attachment	20 Ft.-Lbs.

Classiccarlibrary.com

classicalibrary.com

SECTION 4B

REAR AXLE

The following caution applies to one or more steps in the assembly procedure of components in this portion of the manual as indicated at appropriate locations by the terminology "See Caution on Page 1 of this Section".

CAUTION: *THIS FASTENER IS AN IMPORTANT ATTACHING PART IN THAT IT COULD AFFECT THE PERFORMANCE OF VITAL COMPONENTS AND SYSTEMS, AND/OR COULD RESULT IN MAJOR REPAIR EXPENSE. IT MUST BE REPLACED WITH ONE OF THE SAME PART NUMBER OR WITH AN EQUIVALENT PART IF REPLACEMENT BECOMES NECESSARY. DO NOT USE A REPLACEMENT PART OF LESSER QUALITY OR SUBSTITUTE DESIGN. TORQUE VALUES MUST BE USED AS SPECIFIED DURING REASSEMBLY TO ASSURE PROPER RETENTION OF THIS PART.*

CONTENTS

General Description.....	4B-1
Differential Diagnosis.....	4B-7
General Diagnostic Procedure.....	4B-10
Differential and Rear Axle Bearing Diagnosis.....	4B-11
On-Vehicle Service.....	4B-13
8-1/2" and 8-7/8" Ring Gear.....	4B-13
Chevrolet 10-1/2" Ring Gear.....	4B-18
Dana 10-1/2" Ring Gear.....	4B-21
Dana 9-3/4" Ring Gear.....	4B-21
Chevrolet 12-1/4" Ring Gear.....	4B-21
Specifications.....	4B-24
Special Tools.....	4B-25

GENERAL DESCRIPTION

A differential is an arrangement of gears that divides the torque between the axle shafts and allows them to rotate at different speeds. A basic differential consists of a set of four gears. Two of these gears are called differential side gears, and the other two are differential pinion gears. Some differentials have more than two pinion gears. Each side gear is splined to an axle shaft. Consequently, each axle shaft must turn when its side gear rotates.

The differential pinion gears are mounted on a differential pinion shaft, and the gears are free to rotate on this shaft. The pinion shaft is fitted into a bore in the differential case and is at right angles to the axle shafts.

Power flow through the differential is as follows: The drive pinion rotates the ring gear. The ring gear, being bolted to the differential case, rotates the case. The differential pinion, as it rotates with the case, forces the pinion gears against the side gears. When both wheels have equal traction, the pinion gears do not rotate on the pinion shaft because the input force on the pinion gear

is equally divided between the two side gears. See figure 4B-1. Consequently, the pinion gears revolve with the pinion shaft, but do not rotate around the shaft itself. The side gears, being splined to the axle shafts and in mesh with the pinion gears, rotate the axle shafts.

If a vehicle were always driven in a straight line, the ring and pinion gears would be sufficient. The axle shaft could then be solidly attached to the ring gear and both driving wheels would turn at equal speeds.

However, if it became necessary to turn a corner, the tires would scuff and slide because the outer wheel would travel further than the inner wheel, as in figure 4B-2. To prevent tire scuffing and sliding, the differential becomes effective and allows the axle shafts to rotate at different speeds.

As the inner wheel slows down, the side gear splined to that axle shaft also slows down. At this point, the pinion gears act as balancing levers by maintaining equal speeds of rotation of the axle shafts. See figure 4B-3. If the vehicle speed remains constant and the inner

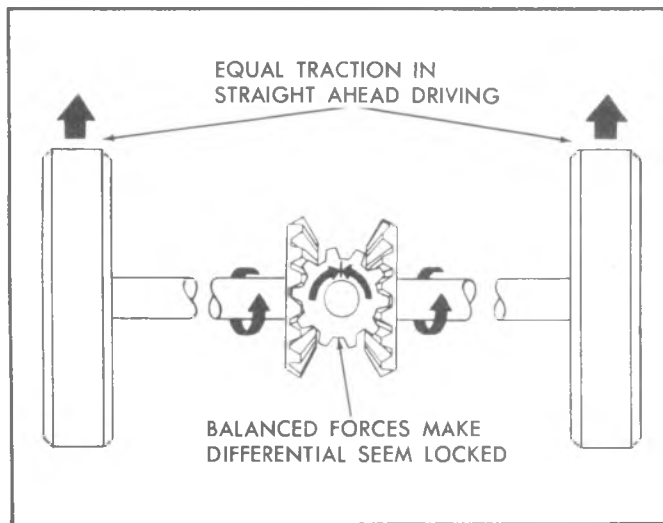


Fig. 4B-1--Differential Inactive

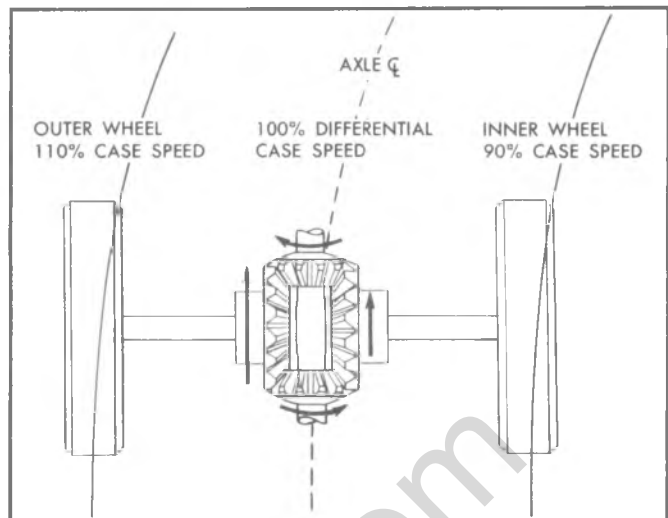


Fig. 4B-3--Differential Action on Turns

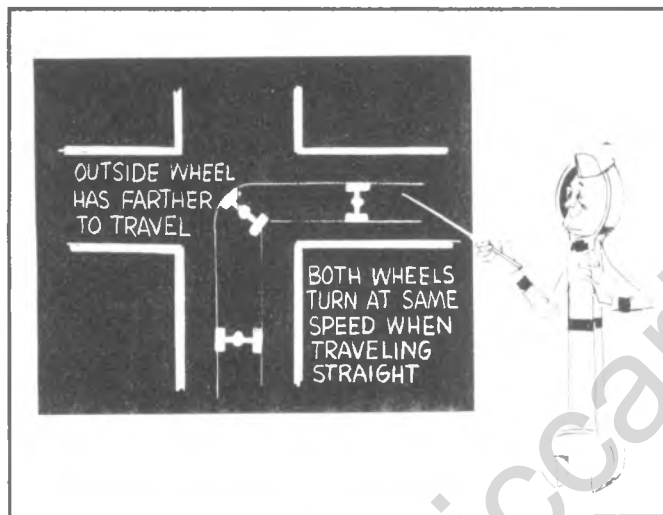


Fig. 4B-2--Need for Differential Action

wheel slows to 90% of vehicle speed, the outer wheel speeds up to 110%. If the inner wheel slows to 75%, the outer wheel would turn 125%. If one wheel stopped, the other wheel would turn 200%.

Six distinct axles comprise the truck line-up. These six, categorized by ring gear diameter, are a) 8-1/2" and b) 8-7/8" Ring Gear, c) Chevrolet 10-1/2" Ring Gear, d) Dana 10-1/2" Ring Gear, e) Dana 9-3/4" Ring Gear and f) Chevrolet 12-1/4" Ring Gear.

8-1/2" and 8-7/8" Ring Gear Axle

The axle shown in figure 4B-4 is a semifloating, fabricated constructed type consisting of a cast carrier with large bosses on each end into which two welded steel tubes are fitted. The carrier contains an overhung hypoid pinion and ring gear. The differential is a two pinion arrangement.

The axle housing is made up of two steel welded tubes pressed into the crossbore of the cast carrier. Each

tube is puddle welded to the carrier. Welded-on brackets provide attachment points for suspension components such as shock absorbers and leaf springs. A welded flange is provided for brake flange plate attachment.

An overhung hypoid drive pinion is supported by two preloaded tapered roller bearings. The pinion shaft is sealed by means of a molded, spring loaded, rubber seal. The seal is mounted on the pinion flange which is splined and bolted to the hypoid pinion shaft.

The hypoid ring gear is bolted to a one-piece differential case which is supported by two preloaded tapered roller bearings.

Chevrolet 10-1/2" Ring Gear Axle

The axle shown in figure 4B-5 is of the full floating type with hypoid ring gear and drive pinion. The full floating construction enables easy removal of axle shafts without removing truck load and without jacking up the axle. The differential carrier is heavily ribbed to provide rigid support for the differential assembly.

The straddle-mounted drive pinion is supported at the front by two opposed tapered roller bearings. The pinion straddle bearing is a roller bearing assembly consisting of an outer race and roller assembly. A precision ground diameter on the pinion pilot functions as an inner race.

Side bearing preload and ring gear-to-pinion backlash are controlled by side bearing adjusting nuts threaded into the carrier near the axle tubes. Pinion depth is controlled by a shim located between the pinion bearing retainer assembly and the differential carrier.

Dana 10-1/2" Ring Gear Axle

The Dana axle shown in figure 4B-6 is a Salisbury-type similar in design to the 8-7/8" ring gear axle in figure 4B-4. It does differ in several points, however. The axle shafts are full floating; the carrier must be spread to remove the differential; and the drive pinion incorporates two shim packs. The inner pack controls pinion

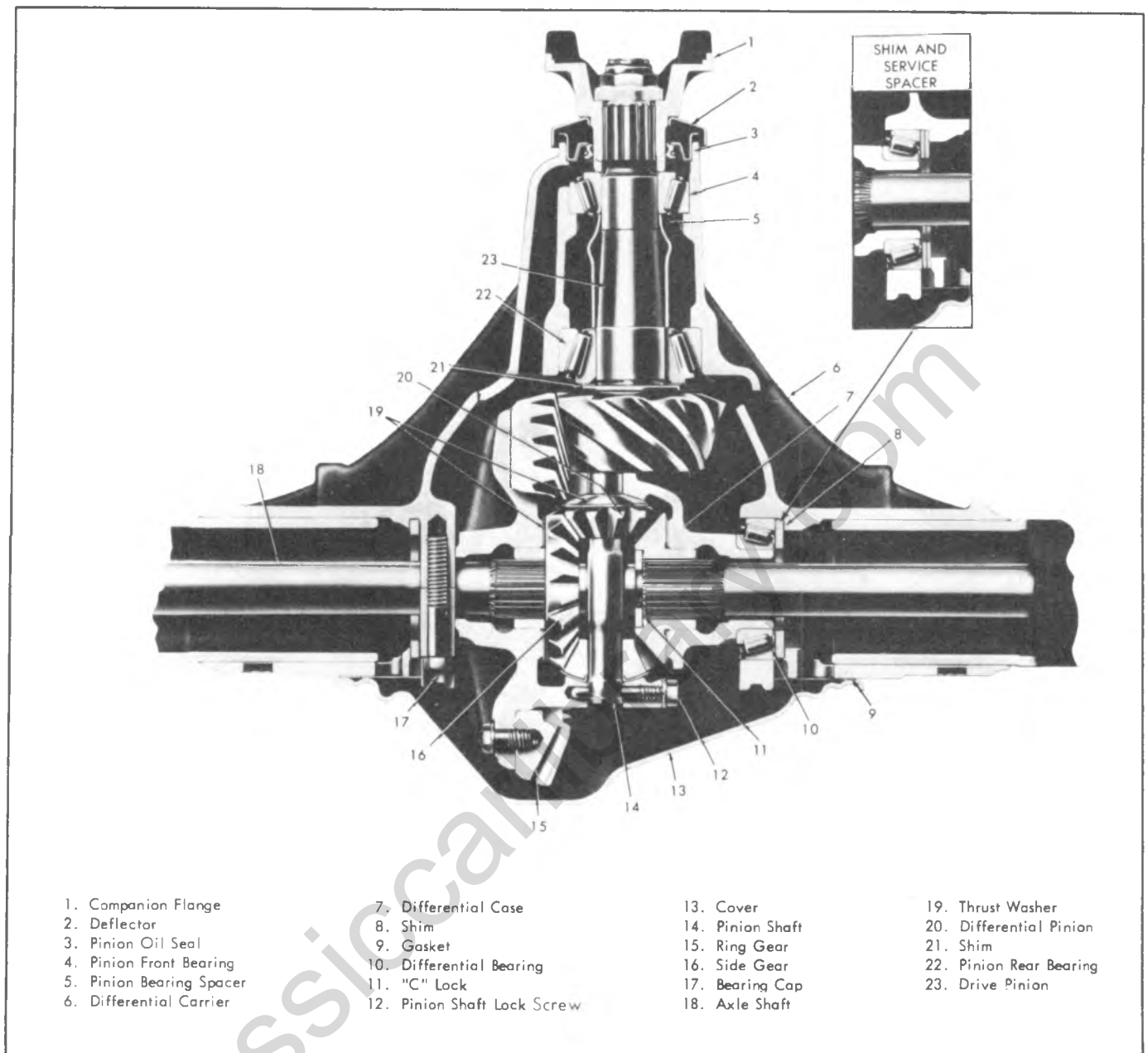


Fig. 4B-4--8-1/2" and 8-7/8" Ring Gear Axle Cross-Section Typical

depth, while the outer pack controls pinion bearing preload.

Dana 9-3/4" Ring Gear Axle

The Dana axle shown in figure 4B-7 is similar to the unit shown in 4B-6; however, the differential side bearing shims are located between the case and the side bearings.

Chevrolet 12-1/4" Ring Gear Axle

(11,000 Pound Capacity)

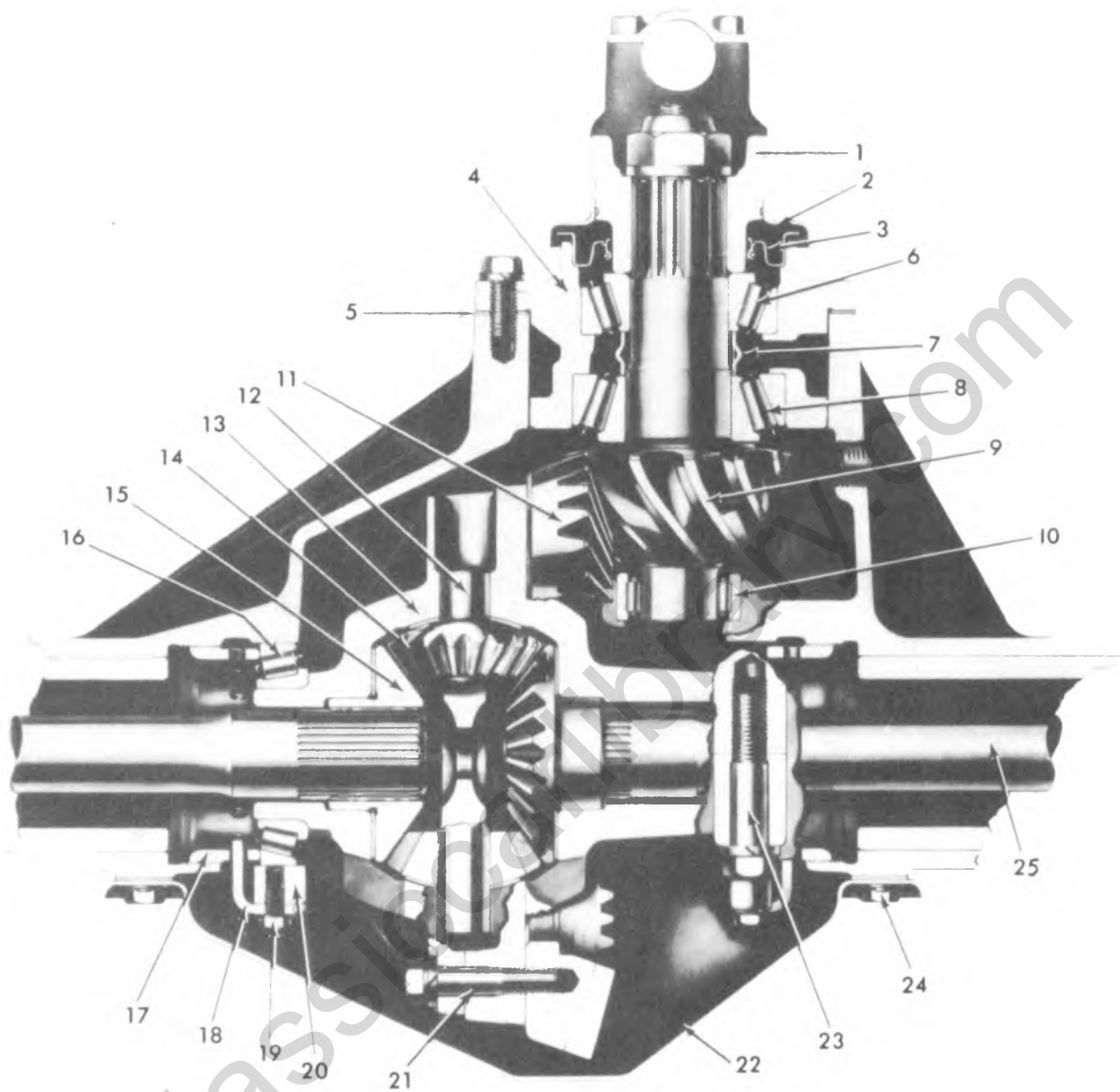
The 11,000 lb. capacity, single-speed hypoid axle, illustrated in figure 4B-8, has a straddle mounted drive

pinion which is supported at the rear by a straight roller bearing. The pinion front bearing consists of a double row ball bearing.

The differential is a conventional four-pinion type. Thrust washers are used between the side gears and case and also between differential pinions and the differential case.

A thrust pad mounted on the end of an adjusting screw threaded into the carrier housing limits deflection of the ring gear under high torque conditions.

Involute splines are incorporated in the axle shaft flange and in the wheel hubs. This design provides for the driving torque to be transmitted from the axle shaft to the hub through the mating splines.



- | | | |
|-------------------------|--------------------------------|----------------------------|
| 1. Companion Flange | 10. Straddle Bearing | 19. Retainer Screw |
| 2. Oil Deflector | 11. Ring Gear | 20. Bearing Cap |
| 3. Oil Seal | 12. Differential Spider | 21. Case to Ring Gear Bolt |
| 4. Bearing Retainer | 13. Differential Case | 22. Differential Cover |
| 5. Shim | 14. Differential Pinion | 23. Bearing Cap Bolt |
| 6. Pinion Front Bearing | 15. Differential Side Gear | 24. Cover Screw |
| 7. Collapsible Spacer | 16. Side Bearing | 25. Axle Shaft |
| 8. Pinion Rear Bearing | 17. Side Bearing Adjusting Nut | |
| 9. Drive Pinion | 18. Adjusting Nut Retainer | |

Fig. 4B-5--Chevrolet 10-1/2" Ring Gear Axle Cross-Section

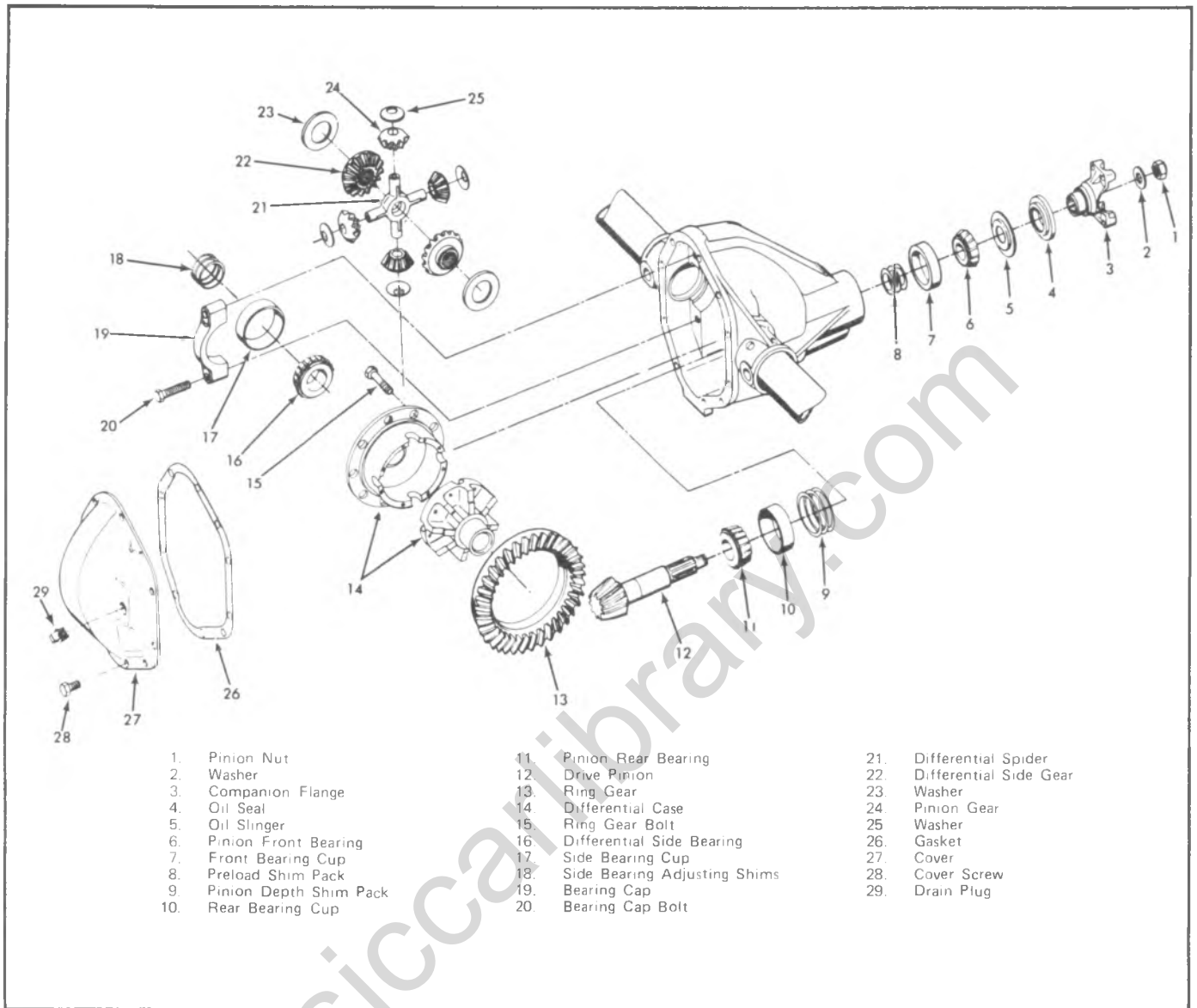


Fig. 4B-6--Dana 10-1/2" Ring Gear Axle Exploded View

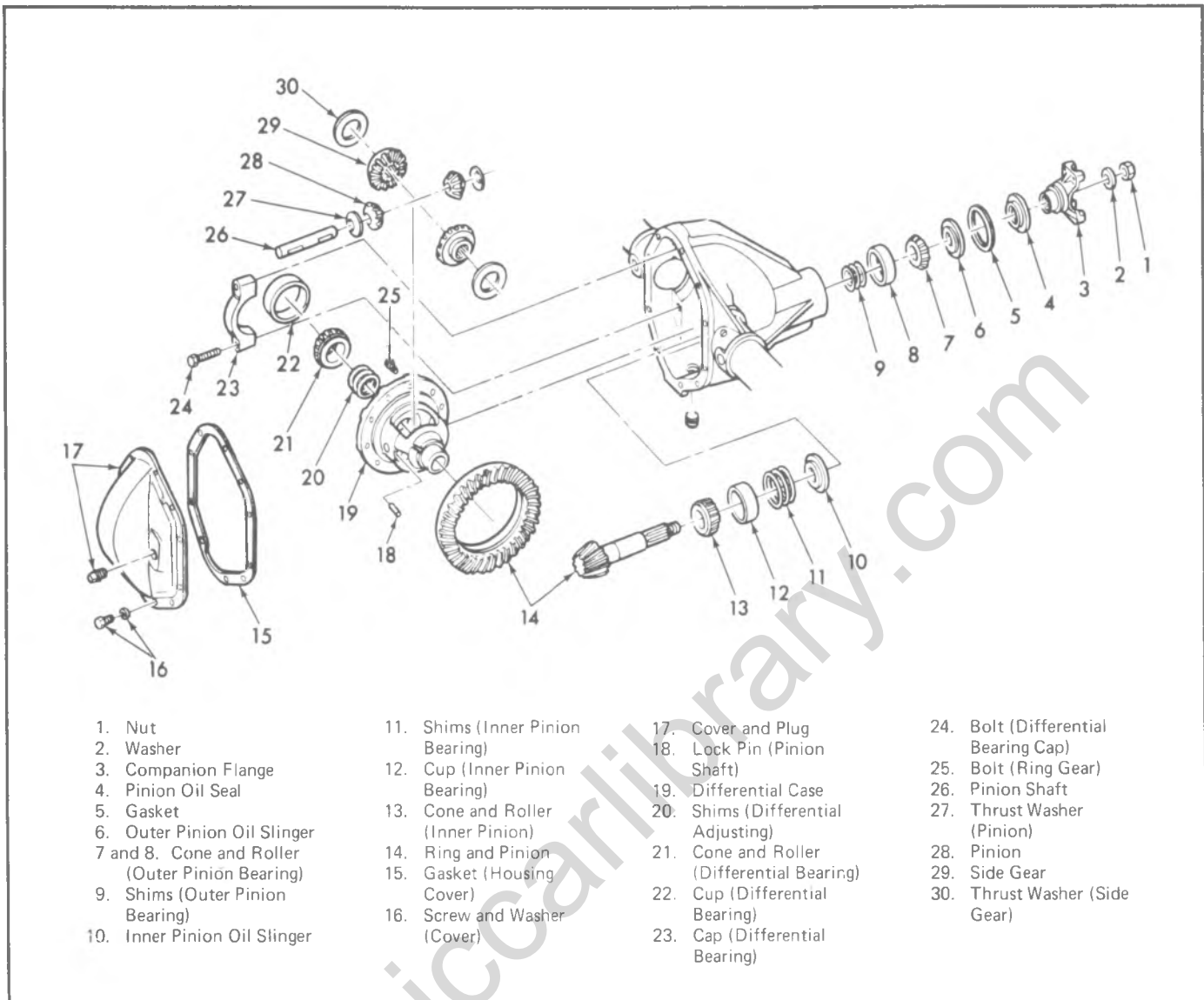


Fig. 4B-7--Dana 9-3/4" Ring Gear Axle Exploded View

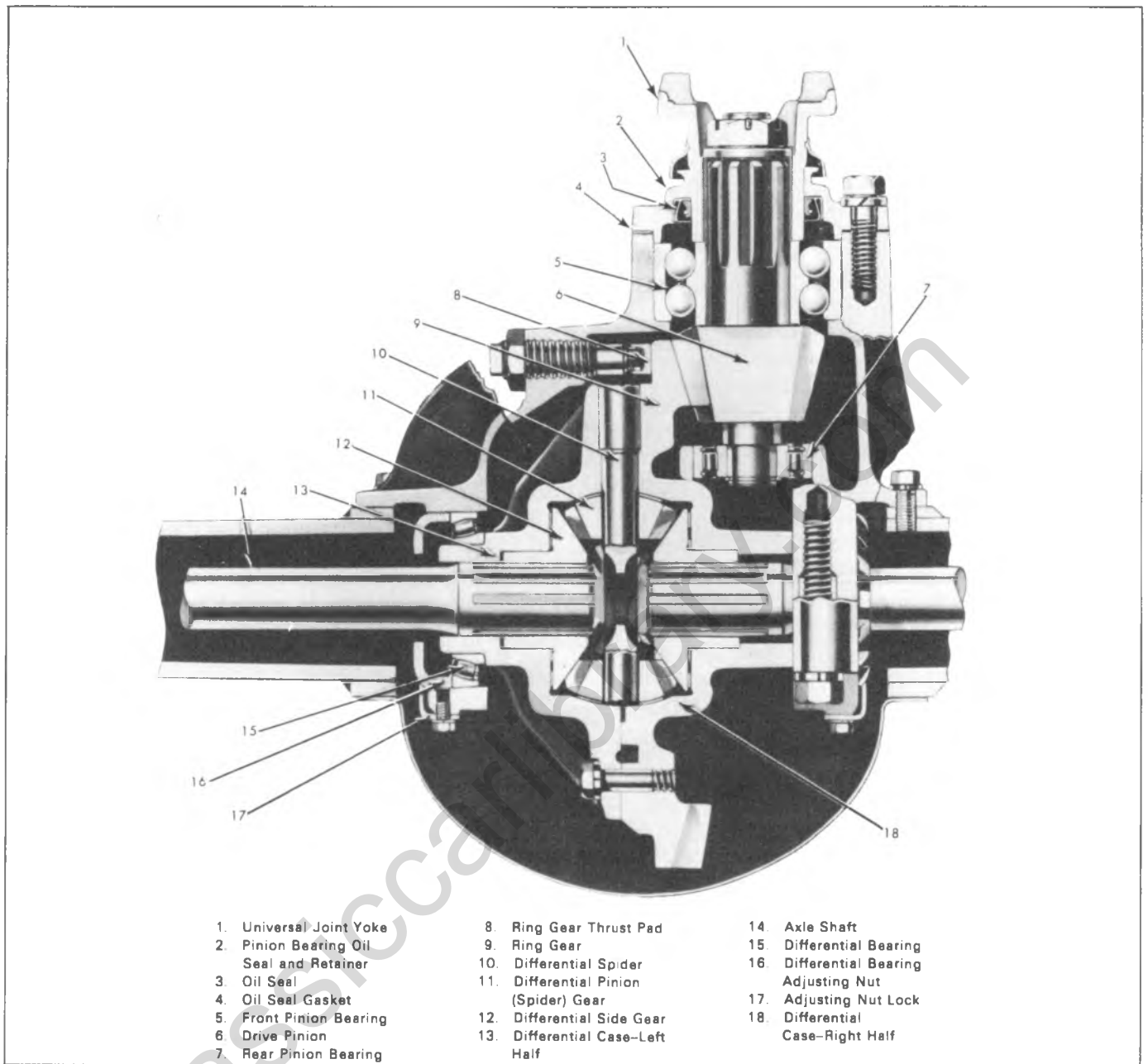


Fig. 4B-8 Chevrolet 12-1/4" Ring Gear Axle—11,000# Capacity

DIFFERENTIAL DIAGNOSIS

STANDARD DIFFERENTIAL Noise

The most essential part of rear axle service, as with any mechanical repair, is proper diagnosis of the problem, and, in axle work one of the most difficult areas to diagnosis is noise. Locating a broken axle shaft, or broken differential gear, presents little or no problem,

but, locating and isolating axle noise can be an entirely different matter.

Degree of Noise

Any gear driven unit, and especially an automotive drive axle where engine torque multiplication occurs at a 90° turn in the drive line, produces a certain amount of noise. Therefore, an interpretation must be made for each vehicle to determine whether the noise is normal or if a problem actually exists. A normal amount of noise

must be expected and cannot be eliminated by conventional repairs or adjustment. See figure 4B-9.

Acceptable noise can be defined as a slight noise heard only at a certain speed or under unusual or remote conditions. For example, this noise tends to reach a "peak" at speeds from 40 to 60 miles per hour depending on road and load conditions, or on gear ratio and tire size. This slight noise is in no way indicative of trouble in the axle assembly.

Drive line noises may baffle even the best diagnostician. Vehicle noises coming from tires, transmission, propeller shaft, universal joints, and front or rear wheel bearings, are often mistaken for axle noise. Such practices as: raising tire pressure to eliminate tire noise (although this will not silence tread noise of mud and snow tires), listening for the noise at varying speeds and road surfaces, on drive, float, and coast conditions will aid in locating the source of alleged axle noises. Thus, every effort should be made to isolate the noise to a specific drive line component instead of making a random guess that could be a costly waste of time.

Elimination of External Noises

When a rear axle is suspected of being noisy, it is advisable to make a thorough test to determine whether the noise originates in the tires, road surface, front wheel bearings, engine, transmission, or rear axle assembly. Noise which originates in other places cannot be corrected by adjustment or replacement of parts in the rear axle assembly.

Road Noise—Some road surfaces, such as brick or rough-surfaced concrete, cause noise which may be mistaken for tire or rear axle noise. Driving on a different type of road, such as smooth asphalt or dirt, will quickly show whether the road surface is the cause of noise. Road noise usually is the same on drive or coast.

Tire Noise—Tire noise may easily be mistaken for rear axle noise, even though the noisy tires may be located on the front wheels. Tires worn unevenly, or

having surfaces on non-skid divisions worn in saw-tooth fashion, are usually noisy and may produce vibrations which seem to originate elsewhere in the vehicle. This is particularly true with low tire pressure.

Test for Tire Noise—Tire noise changes with different road surfaces, but rear axle noise does not. Temporarily inflating all tires to approximately 50 pounds pressure, **for test purposes only** will materially alter noise caused by tires but will not affect noise caused by the rear axle. Rear axle noise usually ceases when coasting at speeds under 30 miles per hour; however, tire noise continues but with lower tone as vehicle speed is reduced. Rear axle noise usually changes when comparing "pull" and "coast" but tire noise remains about the same.

Engine and Transmission Noises—Sometimes a noise which seems to originate in the rear axle is actually caused by the engine or transmission. To determine which unit is actually causing the noise, observe approximate car speeds and conditions under which the noise is most pronounced; then stop vehicle in a quiet place to avoid interfering noises. With transmission in neutral, run engine slowly up and down through engine speeds corresponding to vehicle speed at which the noise was most pronounced. If a similar noise is produced with vehicle standing, it is caused by the engine or transmission and not the rear axle.

Front Wheel Bearing Noise—Loose or rough front wheel bearings will cause noise which may be confused with rear axle noises; however, front wheel bearing noise does not change when comparing "pull" and "coast". Light application of brake, while holding vehicle speed steady, will often cause wheel bearing noise to diminish, as this takes some weight off the bearing. Front wheel bearings may be easily checked for noise by jacking up the wheels and spinning them, and also by shaking wheels to determine if bearings are excessively loose.

Body Boom Noise or Vibration

Objectional "body boom" noise or vibration at 55-65 mph can be caused by an unbalanced propeller shaft. Excessive looseness at the spline can contribute to this unbalance.

Other items that may also contribute to the noise problem are as follows:

1. Undercoating or mud on the shaft, causing unbalance.
2. Shaft or companion flange balance weights missing.
3. Shaft damage, such as bending, dents, or nicks.
4. Tire-type roughness. Switch tires from a known good car to determine tire fault.

If, after making a comprehensive check of the vehicle, all indications point to the rear axle, further diagnostic steps are necessary to determine the axle components at fault. True axle noises generally fall into two categories: gear noise and bearing noise.

Rear Axle Noises

If a careful test of vehicle shows that noise is not caused by external items it is then reasonable to assume



Fig. 4B-9--Noise Level

that noise is caused by rear axle assembly. The rear axle should be tested on a smooth level road to avoid road noise. It is not advisable to test rear axle for noise by running with rear wheels jacked up.

Noises in rear axle assembly may be caused by a faulty propeller shaft, faulty rear wheel bearings, faulty differential or pinion shaft bearings, misalignment between two U-joints, or worn differential side gears and pinions; noises may also be caused by mismatched, improperly adjusted, or scored ring and pinion gear set.

Rear Wheel Bearing Noise—A rough rear wheel bearing produces a vibration or growl which continues with vehicle coasting and transmission in neutral. A brinelled rear wheel bearing causes a knock or click approximately every two revolutions of rear wheel, since the bearing rollers do not travel at the same speed as the rear axle and wheel. With rear wheels jacked up, spin rear wheels by hand while listening at hubs for evidence of rough or brinelled wheel bearing.

Differential Side Gear and Pinion Noise—Differential side gears and pinions seldom cause noise since their movement is relatively slight on straight ahead driving. Noise produced by these gears will be most pronounced on turns.

Pinion Bearing failures can be distinguished because they rotate at higher speeds than differential side bearings and axle shaft bearings. Rough or brinelled pinion bearings produce a continuous low pitched whirring or scraping noise starting at relatively low speed.

Side Bearings produce a constant rough noise of a lower pitch than pinion bearings. Side bearing noise may also fluctuate in the above wheel bearing test.

NOTE: Bearing Diagnosis Charts appear later in this section.

Gear Noise

There are two basic types of gear noise. The first type is produced by broken, bent, or forcibly damaged gear teeth and is usually quite audible over the entire speed range and presents no particular problem in diagnosis.

For example, hypoid gear tooth scoring as seen in figure 4B-10 generally results from the following: insufficient lubricant improper breakin, improper lubricant, insufficient gear backlash, improper ring and

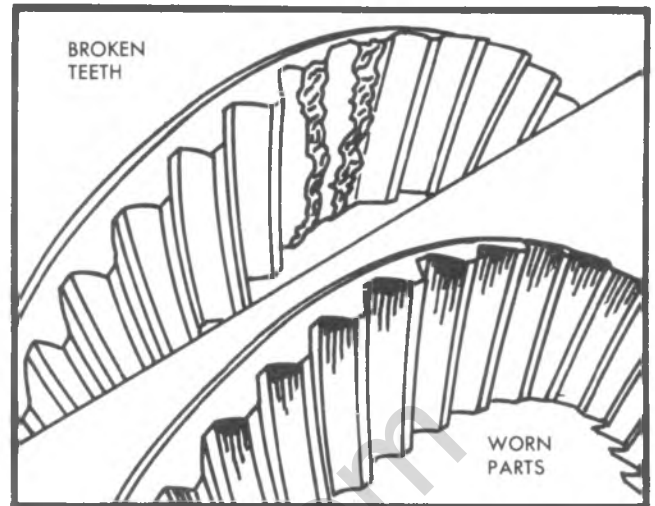


Fig. 4B-10—Two Causes of Gear Noise

pinion gear alignment, or loss of drive pinion nut torque. The scoring will progressively lead to complete erosion of the gear tooth, or gear tooth pitting and eventual fracture if the initial scoring condition is not corrected. Another cause of hypoid tooth fracture is extended overloading of the gear set which will produce fatigue fracture, or shock loading which will result in sudden failure.

Differential pinion and side gears rarely give trouble. Common causes of differential failure are shock loading, extended overloading, and seizure of the differential pinions to the cross shaft resulting from excessive wheel spin and consequent lubrication breakdown.

The second type of gear noise pertains to the mesh pattern of the gear teeth. This form of abnormal gear noise can be recognized as it produces a cycling pitch (whine) and will be very pronounced in the speed range at which it occurs, appearing under either "drive", "float" or "coast" conditions. "Drive" is acceleration or heavy pull. "Coast" is with a closed throttle and vehicle in gear and "float" is using just enough throttle to keep the car from driving the engine—the vehicle slows down gradually but engine still pulls slightly. Gear noise tends to peak in a narrow speed range or ranges, and will tend to remain constant in pitch. Bearing noise will vary in pitch with vehicle speeds. See figure 4B-11.

**A GENERAL DIAGNOSTIC PROCEDURE FOR
ISOLATING REAR AXLE NOISE PROBLEMS**

Problem	Cause
1. Noise is the same in drive or coast	1. a) Road noise b) Tire noise c) Front wheel bearing noise
2. Noise changes on a different type of road	2. a) Road noise b) Tire noise
3. Noise tone lowers as car speed is lowered	3. Tire noise
4. Similar noise is produced with car standing and driving	4. a) Engine noise b) Transmission noise
5. Vibration	5. a) Rough rear wheel bearing b) Unbalanced or damaged propeller shaft c) Tire unbalance d) Worn universal joint in propeller shaft e) Mis-indexed propeller shaft at companion flange f) Companion flange runout too great
6. A knock or click approximately every two revolutions of rear wheel	6. A brinelled rear wheel bearing
7. Noise most pronounced on turns	7. Differential side gear and pinion
8. A continuous low pitch whirring or scraping noise starting at relatively low speed	8. Pinion bearing
9. Drive noise, coast noise or float noise	9. Ring and pinion gear
10. Clunk on acceleration or deceleration	10. Worn differential cross shaft in case
11. Grunt on stops	11. No grease in propeller shaft slip yoke
12. Groan in Forward or Reverse	12. Wrong lube in differential
13. Chatter on turns	13. a) Wrong lube in differential b) Clutch plates worn
14. Clunk or knock on rough road operation	14. Excessive end play of axle shafts to differential cross shaft

Fig. 4B-11--Diagnosis of Noise Problems

DIFFERENTIAL AND REAR AXLE BEARING DIAGNOSIS

CONSIDER THE FOLLOWING FACTORS WHEN DIAGNOSING BEARING CONDITION:

1. GENERAL CONDITION OF ALL PARTS DURING DISASSEMBLY AND INSPECTION.
2. CLASSIFY THE FAILURE WITH THE AID OF THE ILLUSTRATIONS.
3. DETERMINE THE CAUSE.
4. MAKE ALL REPAIRS FOLLOWING RECOMMENDED PROCEDURES.





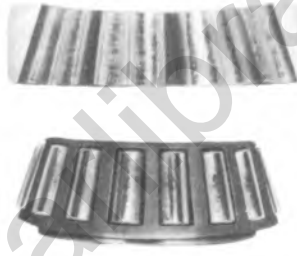




 <p>ABRASIVE ROLLER WEAR</p> <p>PATTERN ON RACES AND ROLLERS CAUSED BY FINE ABRASIVES</p> <p>CLEAN ALL PARTS AND HOUSINGS. CHECK SEALS AND BEARINGS AND REPLACE IF LEAKING, ROUGH OR NOISY.</p>	 <p>GALLING</p> <p>METAL SMEARS ON ROLLER ENDS DUE TO OVERHEAT, LUBRICANT FAILURE OR OVERLOAD (WAGON'S)</p> <p>REPLACE BEARING - CHECK SEALS AND CHECK FOR PROPER LUBRICATION.</p>	 <p>BENT CAGE</p> <p>CAGE DAMAGE DUE TO IMPROPER HANDLING OR TOOL USAGE.</p> <p>REPLACE BEARING.</p>
 <p>ABRASIVE STEP WEAR</p> <p>PATTERN ON ROLLER ENDS CAUSED BY FINE ABRASIVES.</p> <p>CLEAN ALL PARTS AND HOUSINGS. CHECK SEALS AND BEARINGS AND REPLACE IF LEAKING, ROUGH OR NOISY.</p>	 <p>ETCHING</p> <p>BEARING SURFACES APPEAR GRAY OR GRAYISH BLACK IN COLOR WITH RELATED ETCHING AWAY OF MATERIAL USUALLY AT ROLLER SPACING.</p> <p>REPLACE BEARINGS - CHECK SEALS AND CHECK FOR PROPER LUBRICATION.</p>	 <p>BENT CAGE</p> <p>CAGE DAMAGE DUE TO IMPROPER HANDLING OR TOOL USAGE.</p> <p>REPLACE BEARING.</p>
 <p>INDENTATIONS</p> <p>SURFACE DEPRESSIONS ON RACE AND ROLLERS CAUSED BY HARD PARTICLES OF FOREIGN MATERIAL.</p> <p>CLEAN ALL PARTS AND HOUSINGS. CHECK SEALS AND REPLACE BEARINGS IF ROUGH OR NOISY.</p>	 <p>CAGE WEAR</p> <p>WEAR AROUND OUTSIDE DIAMETER OF CAGE AND ROLLER POCKETS CAUSED BY ABRASIVE MATERIAL AND INEFFICIENT LUBRICATION.</p> <p>CLEAN RELATED PARTS AND HOUSINGS. CHECK SEALS AND REPLACE BEARINGS.</p>	 <p>MISALIGNMENT</p> <p>OUTER RACE MISALIGNMENT DUE TO FOREIGN OBJECT.</p> <p>CLEAN RELATED PARTS AND REPLACE BEARING. MAKE SURE RACES ARE PROPERLY SEATED.</p>

Fig. 4B-12--Differential and Axle Bearing Diagnosis Chart A

DIFFERENTIAL AND REAR AXLE BEARING DIAGNOSIS (CONT'D)








 <p style="text-align: center;">CRACKED INNER RACE</p> <p>RACE CRACKED DUE TO IMPROPER FIT, COCKING, OR POOR BEARING SEATS.</p> <p>REPLACE BEARING AND CORRECT BEARING SEATS.</p>	 <p style="text-align: center;">FATIGUE SPALLING</p> <p>FLAKING OF SURFACE METAL RESULTING FROM FATIGUE.</p> <p>REPLACE BEARING - CLEAN ALL RELATED PARTS.</p>	 <p style="text-align: center;">BRINELLING</p> <p>SURFACE INDENTATIONS IN RACEWAY CAUSED BY ROLLERS EITHER UNDER IMPACT LOADING OR VIBRATION WHILE THE BEARING IS NOT ROTATING.</p> <p>REPLACE BEARING IF ROUGH OR NOISY.</p>
 <p style="text-align: center;">FRETTAGE</p> <p>CORROSION SET UP BY SMALL RELATIVE MOVEMENT OF PARTS WITH NO LUBRICATION.</p> <p>REPLACE BEARING. CLEAN RELATED PARTS. CHECK SEALS AND CHECK FOR PROPER LUBRICATION.</p>	 <p style="text-align: center;">STAIN DISCOLORATION</p> <p>DISCOLORATION CAN RANGE FROM LIGHT BROWN TO BLACK CAUSED BY INCORRECT LUBRICANT OR MOISTURE.</p> <p>RE-USE BEARINGS IF STAINS CAN BE REMOVED BY LIGHT POLISHING OR IF NO EVIDENCE OF OVERHEATING IS OBSERVED.</p> <p>CHECK SEALS AND RELATED PARTS FOR DAMAGE.</p>	 <p style="text-align: center;">HEAT DISCOLORATION</p> <p>HEAT DISCOLORATION CAN RANGE FROM FAINT YELLOW TO DARK BLUE RESULTING FROM OVERLOAD (WAGON'S) OR INCORRECT LUBRICANT.</p> <p>EXCESSIVE HEAT CAN CAUSE SOFTENING OF RACES OR ROLLERS.</p> <p>TO CHECK FOR LOSS OF TEMPER ON RACES OR ROLLERS A SIMPLE FILE TEST MAY BE MADE. A FILE DRAWN OVER A TEMPERED PART WILL GRAB AND CUT METAL, WHEREAS, A FILE DRAWN OVER A HARD PART WILL GLIDE READILY WITH NO METAL CUTTING.</p> <p>REPLACE BEARINGS IF OVER HEATING DAMAGE IS INDICATED. CHECK SEALS AND OTHER PARTS.</p>
 <p style="text-align: center;">SMEARS</p> <p>SMEARING OF METAL DUE TO SLIPPAGE. SLIPPAGE CAN BE CAUSED BY POOR FITS, LUBRICATION, OVERHEATING, OVERLOADS OR HANDLING DAMAGE.</p> <p>REPLACE BEARINGS, CLEAN RELATED PARTS AND CHECK FOR PROPER FITS AND LUBRICATION.</p>		

Fig. 4B-13--Differential and Axle Bearing Diagnosis Chart B

ON-VEHICLE SERVICE

8-1/2 and 8-7/8 RING GEAR AXLE

AXLE ASSEMBLY

Construction of the axle assembly is such that service operations may be performed with the housing installed in the vehicle or with the housing installed in a holding fixture. The following removal and installation procedure is necessary only when the housing requires replacement.

CAUTION: See *CAUTION* on page 1 of this section, regarding Axle Assembly fasteners.

Removal

1. Raise vehicle on hoist.
2. Support rear axle assembly with suitable lifting device, so that tension is relieved in springs and shock absorbers.
3. Remove trunnion bearing "U" bolts from the axle companion flange, separate trunnion from flange, position propeller shaft to one side and tie it to frame side rail.

NOTE: Secure trunnion bearing caps to trunnion, using masking tape or a large rubber band, to prevent loss of bearings.

4. Disconnect shock absorbers at lower attachment points and position out of the way.
5. Disconnect axle vent hose from vent connector and position vent hose to one side.
6. Disconnect hydraulic brake hose at connector on axle housing. Remove brake drum, disconnect parking brake cable at actuating levers and at flange plate. Refer to Section 5 for cable removal and brake details. Remove axle "U" bolt nuts, "U" bolts, spacers and clamp plates.
7. Lower axle assembly and remove from vehicle.

Installation

1. Position axle assembly under vehicle and align with springs.
2. Install spacer, clamp plate and "U" bolts to axle assembly, loosely install retaining nuts to "U" bolts.
3. Position shock absorbers in lower attachment brackets and loosely install nut to retain shock.
4. Connect axle vent hose to vent connector at carrier.
5. Connect hydraulic brake hose to connector on axle housing, connect parking brake cable to actuating levers. Install brake drum and wheel and tire assembly—bleed brakes and adjust parking brake as outlined in applicable portion of Section 5.
6. Reassemble the propeller shaft to companion flange, making sure that bearing caps are indexed in flange seat. Torque bearing cap retaining nuts to specifications.
7. Position vehicle so that weight is placed on

suspension components and torque affected parts to specifications.

8. Lower vehicle and remove from hoist.

AXLE SHAFT

Removal

1. Raise vehicle on hoist. Remove wheel and tire assembly and brake drums.
2. Clean all dirt from area of carrier cover.
3. Drain lubricant from carrier by removing cover.
4. Remove the differential pinion shaft lock screw and the differential pinion shaft as shown in figure 4B-14.
5. Push flanged end of axle shaft toward center of vehicle and remove "C" lock from button end of shaft.
6. Remove axle shaft from housing, being careful not to damage oil seal.

NOTE: Axles equipped with 8-7/8" ring gears and Eaton Locking differentials use a thrust block on the pinion shaft which affects the removal of axle shafts as noted below.

1. Raise the vehicle on a hoist. Remove both rear wheel and tire assemblies and both rear brake drums.
2. Remove the rear cover and drain the lubricant.
3. Rotate the case **to the position shown in figure 4B-15**. Support the pinion shaft so that it cannot fall into the case, then remove the lock screw.
4. Carefully withdraw the pinion shaft part-way out, as shown in figure 4B-16. Rotate the case until the shaft touches the housing.
5. Reach into the case with a screwdriver or similar tool, and rotate the C-lock until its open end points directly inward, as shown in figure 4B-17. The axle shaft cannot be pushed inward until the C-lock is properly positioned.

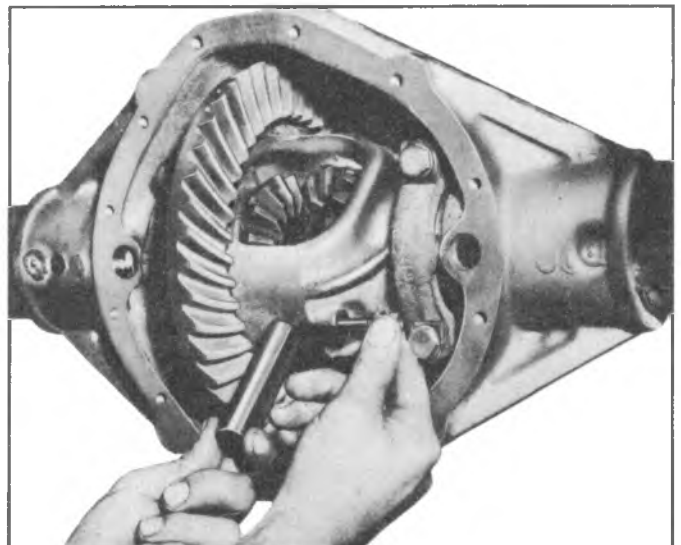


Fig. 4B-14--Differential Pinion Shaft Removal

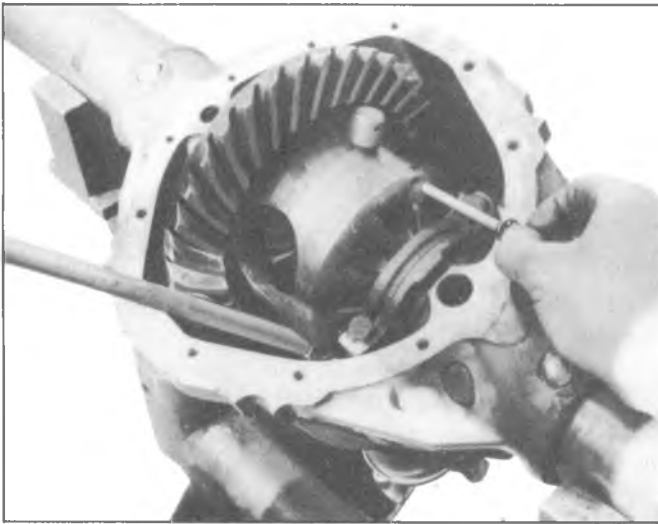


Fig. 4B-15--Removing Lock Screw

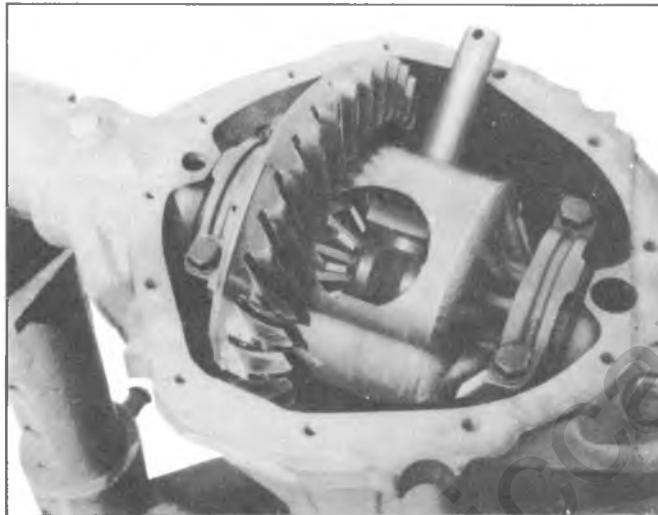


Fig. 4B-16--Positioning Case For Best Clearance

Do not force or hammer the axle shaft in an attempt to gain clearance.

6. When the C-lock is positioned to pass through the end of the thrust block, push the axle shaft inward as shown in figure 4B-18, and remove the C-lock. Remove the axle shaft and repeat steps 5 and 6 for the opposite axle shaft.

7. When installing C-locks keep the pinion shaft partially withdrawn. Place the C-lock in the same position shown in figure 4B-17. Carefully withdraw the axle shaft until the C-lock is clear of the thrust block. When both locks are installed, install the pinion shaft and lock screw.

Oil Seal/Bearing—Replacement Fig. 4B-19

1. Remove oil seal by using button end of axle shaft. Insert button end behind the steel case of the oil seal, then pry seal out of bore being careful not to

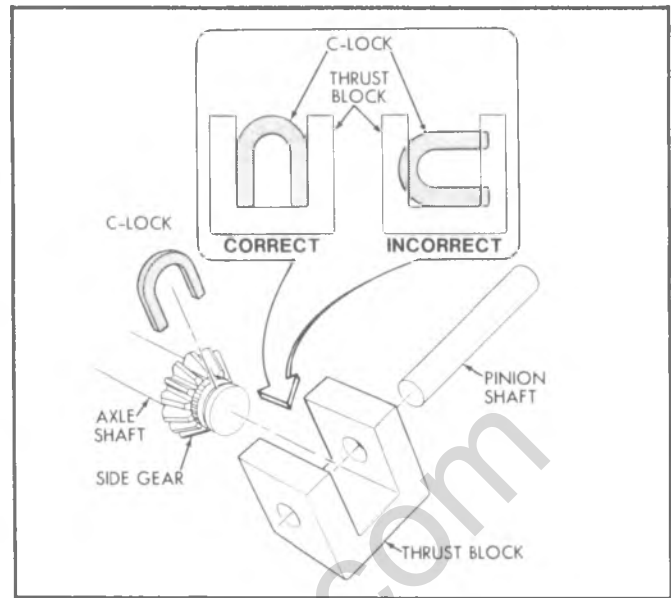


Fig. 4B-17--Correct C-Lock Position

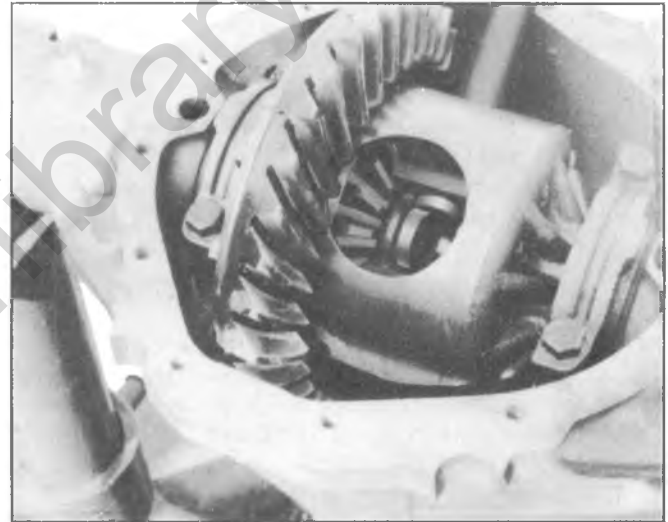


Fig. 4B-18--Push Axle Shaft Inward

damage seal. If both seal and bearing are being replaced proceed to step 2.

2. Using J-23689, insert into bore so that tool grasps behind the bearing. See figure 4B-20. Slide washer against outside of seal (or bearing) and turn nut finger tight against washer. Attach Slide Hammer J-2619 and remove bearing and seal.

3. Back off nut and remove bearing and seal from tool.

4. Lubricate cavity between seal lips with wheel bearing lubricant and also lubricate new bearing with wheel bearing lubricant.

5. To reinstall bearing, use J-23690 Installer. Install bearing until tool bottoms against tube as illustrated in figure 4B-21.

6. To install oil seal, place seal on J-21128 and drive into bore until tool bottoms against end of tube.

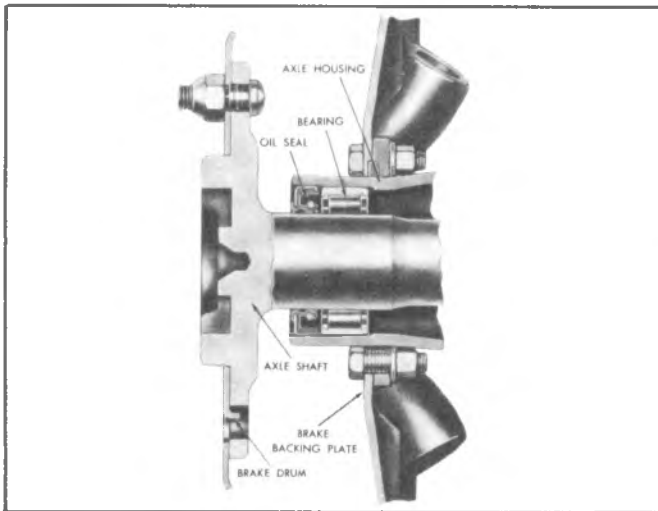


Fig. 4B-19--Oil Seal and Wheel Bearing

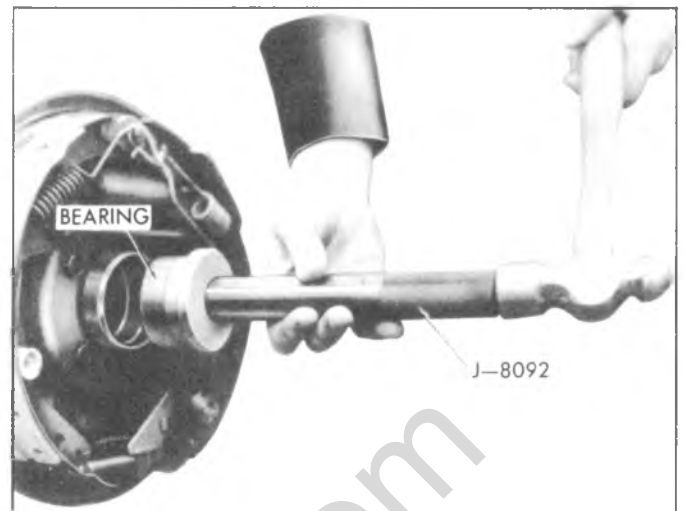


Fig. 4B-21--Wheel Bearing Installation

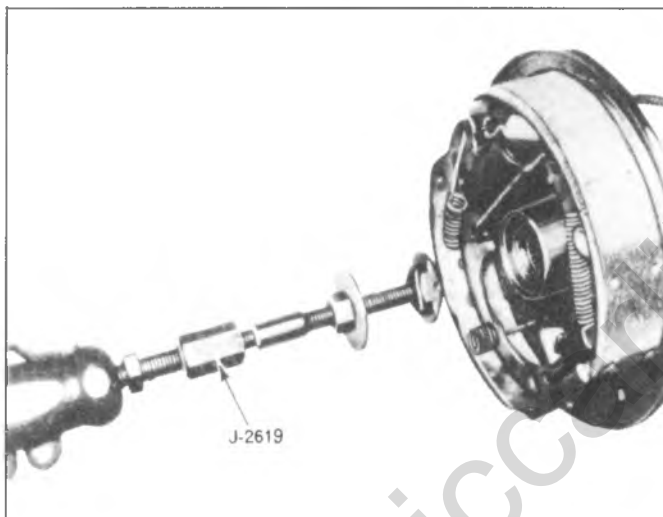


Fig. 4B-20--Wheel Bearing Removal

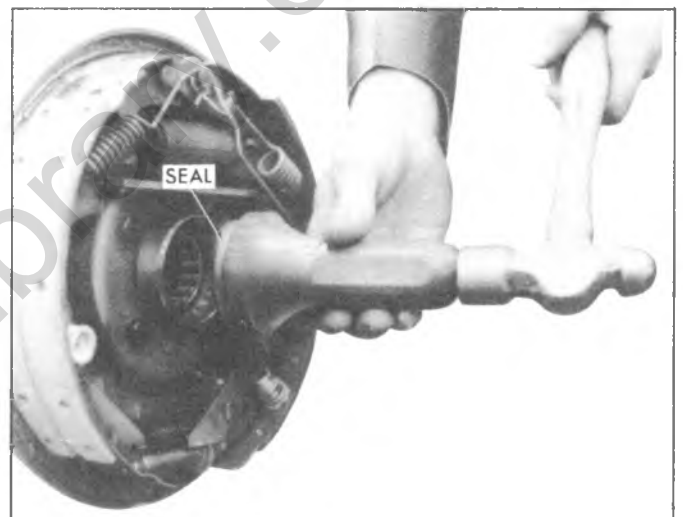


Fig. 4B-22--Seal Installation

See figure 4B-22. This tool installs the seal flush with the end of the tube.

Brake Backing Plate—Replacement

1. Remove brake line at wheel cylinder inlet and disassemble brake components from flange plate. Refer to Section 5 for brake disassembly procedure.
2. Remove bolts retaining flange plate to axle, and remove flange plate.
3. Install new flange plate to axle housing and torque nuts to specifications.
4. Install brake components on flange and connect hydraulic line to wheel cylinder inlet. See Section 5 for brake assembly, bleeding and adjustment procedures.

Axle Shaft—Installation

1. Slide axle shaft into place.

CAUTION: Exercise care that splines on end of

shaft do not damage oil seal and that they engage with splines of differential side gear.

2. Install axle shaft "C" lock on button end of axle shaft and push shaft outward so that shaft lock seats in counterbore of differential side gear.
3. Position differential pinion shaft through case and pinions, aligning hole in shaft with lock screw hole. Install lock screw.
4. Using a new gasket, install carrier cover.

CAUTION: Make sure both gasket surfaces on carrier and cover are clean before installing new gasket. Torque carrier cover bolts in a crosswise pattern to ensure uniform draw on cover gasket.

5. Fill axle with lubricant as specified in Section 0 of this manual to a level even with the bottom of filler hole.
6. Install brake drum and wheel and tire assembly.

7. Lower vehicle and remove from hoist.

Wheel Bolt—Replacement

1. Raise vehicle on hoist allowing axle to hang freely.
2. Remove wheel and tire and brake drum.
3. Using Tool J-5504 or J-6627 press out stud as shown in figure 4B-23.
4. Place new stud in axle flange hole. Slightly start stud serrations in hole by firmly pressing back of stud with your hand.
5. Install a lug nut with flat side first (tapered face outboard). Tighten on lug nut drawing stud into flange until stud head is bottomed on back side of flange.
6. Remove lug nut.
7. Reinstall brake drum and wheel and tire.
8. Lower vehicle and remove from hoist.

PINION FLANGE, DUST DEFLECTOR AND/OR OIL SEAL

Removal

1. Raise vehicle on hoist.
2. Disconnect propeller shaft from axle.
3. Position propeller shaft to one side and tie it to frame side rail.
4. Measure the torque required to rotate the pinion, as shown in figure 4B-24. Record the torque for later reference.
5. Scribe a line down pinion stem, pinion nut, and flange to aid on reinstallation. Make sure lines show the relationship of components accurately. Count the number of exposed threads on pinion stem, and record for later reference. See figure 4B-25.
6. Install Tool J-8614-11 on pinion flange and remove pinion flange self-locking washer faced nut as shown in figure 4B-26. (Position J-8614-11 on flange so that the four notches are toward flange.) Save scribed nut for reinstallation.

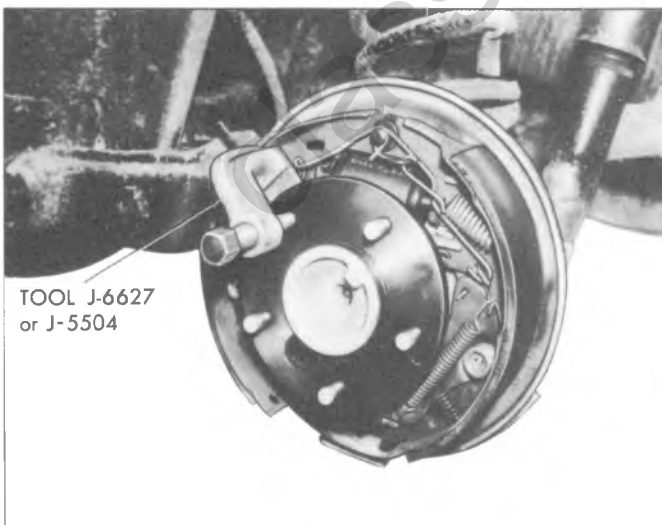


Fig. 4B-23—Pressing Out Wheel Stud

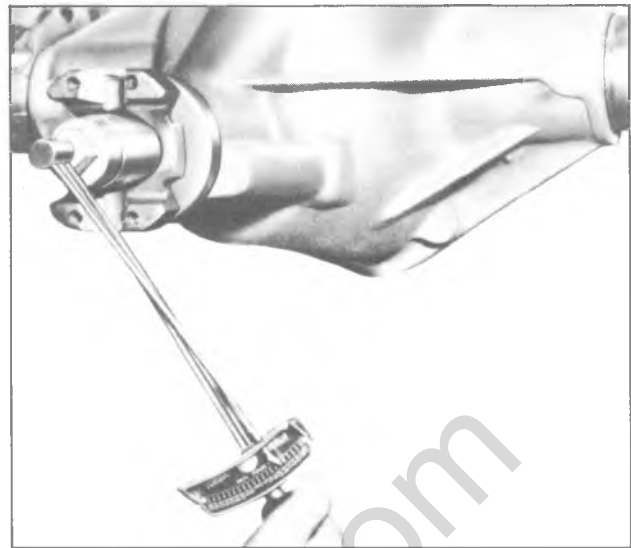


Fig. 4B-24—Measuring Pinion Rotating Torque

7. Thread pilot end of Tool J-8614-3 into small O.D. end of J-8614-2. Then with J-8614-11 installed as in Step 6, insert J-8614-2 into J-8614-11 and turn it 45 degrees to locked position. Remove flange by turning J-8614-3 while holding J-8614-11 as shown in figure 4B-27.

8. Pry old seal out of bore, using a screw driver or a hammer and chisel.

Inspection

1. Inspect pinion flange for smooth oil seal surface. worn drive splines, damaged ears, and for smoothness of bearing contact surface. Replace if necessary.
2. If deflector requires replacement, remove by tapping from flange. clean up stake points; install new deflector, and stake deflector at three new equally spaced positions.

NOTE: Staking operation must be performed in

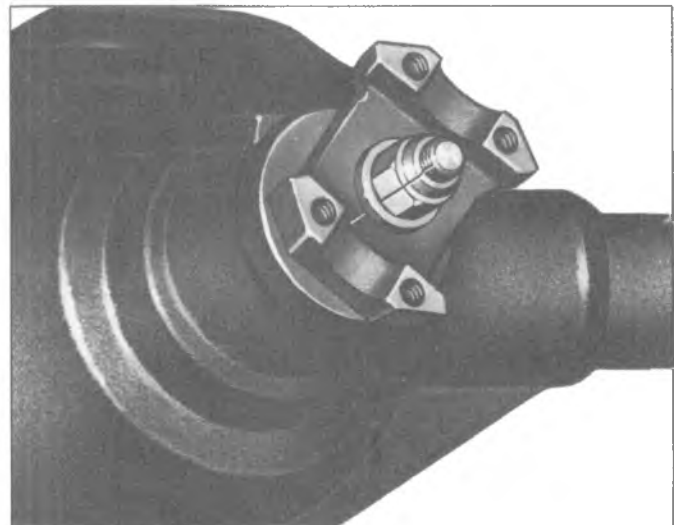


Fig. 4B-25—Scribe Marks

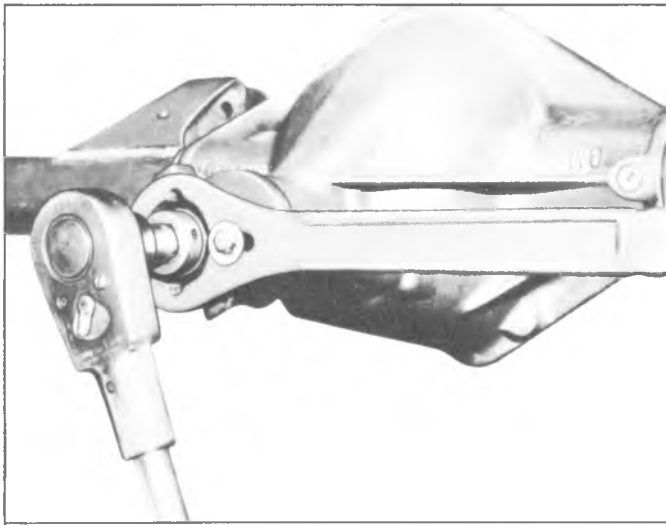


Fig. 4B-26--Removing Nut from Drive Pinion

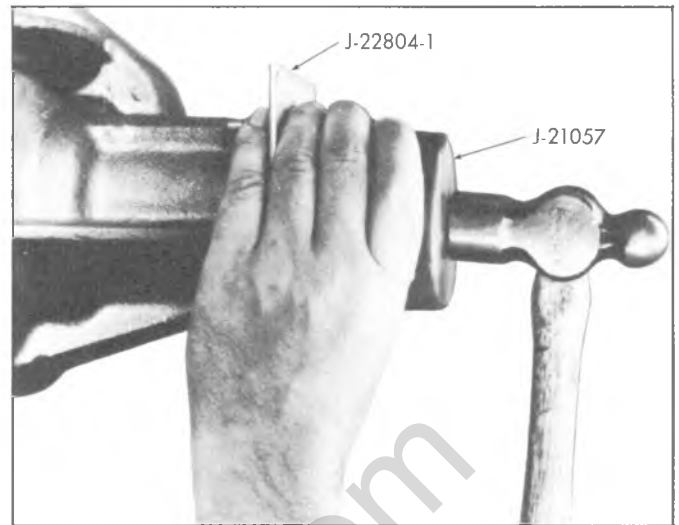


Fig. 4B-28--Pinion Oil Seal Installation

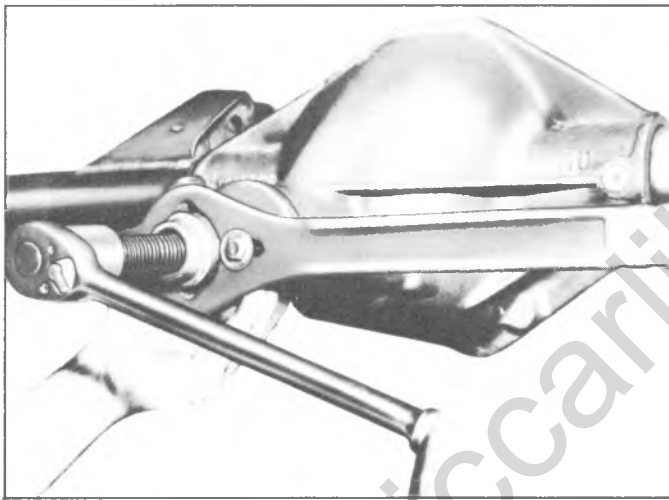


Fig. 4B-27--Drive Pinion Flange Removal

such a manner that the seal operating surface is not damaged.

Installation

1. Lubricate cavity between the seal lips of the pinion flange oil seal with a lithium-base extreme pressure lubricant.

2. Position seal in bore and place gauge plate J-22804-1 over seal and against seal flange. The gauge plate assures proper seating of seal in carrier bore.

3. Use J-21057, as shown in figure 4B-28, to press seal into carrier bore until gauge plate is flush with the carrier shoulder and seal flange. Turn gauge plate 180° from installed position; seal must be square in carrier bore to seal properly against pinion flange.

4. Pack the cavity between end of pinion splines and pinion flange with a non-hardening sealer (such as Permatex Type A or equivalent) prior to installing washer and nut on pinion.

5. Using J-8614-11 as shown in figure 4B-29, install flange onto pinion. Install washer and nut, and tighten nut to original position. Refer to scribe marks and number of exposed threads, recorded earlier.

NOTE: Do not attempt to hammer the flange onto pinion shaft. To do so may damage the ring gear and pinion.

6. Measure rotating torque of pinion and compare with torque recorded before removal. Tighten pinion nut in additional **small** increments until the torque necessary to rotate the pinion exceeds the original figure by 1 to 5 inch pounds. **Do not** exceed the original torque by more than 5 inch pounds.

7. Reattach propeller shaft and torque to specifications. Reinstall brake drums and wheels.

CAUTION: See *CAUTION* on page 1 of this section regarding the fasteners referred to in step 7.

8. Lower vehicle and remove from hoist.

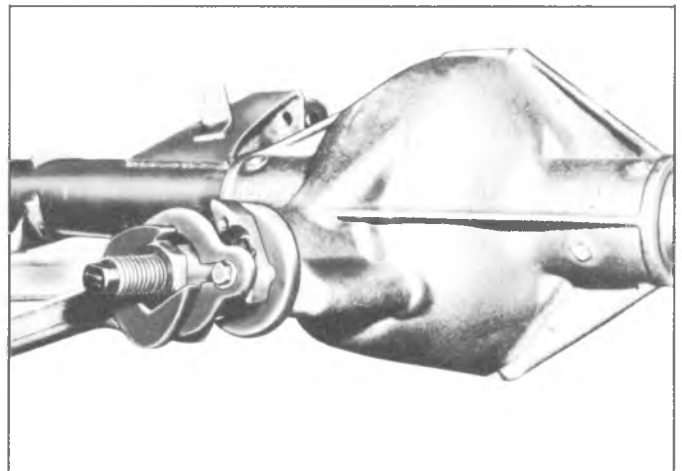


Fig. 4B-29--Installing Pinion Flange

CHEVROLET 10-1/2 RING GEAR AXLES

AXLE ASSEMBLY

Service operations on these axle assemblies may be performed with the housing installed in the vehicle or with the housing installed in a holding fixture. There may be occasions, however, when it will be necessary to remove the complete housing assembly. The following axle assembly removal and installation procedure, therefore, is necessary only when housing replacement is required.

CAUTION: All axle attachments are important attaching parts. See **CAUTION** on page 1 of this section.

Removal

1. Raise vehicle, place stand jacks under frame side rails, and remove rear wheels.
2. Remove two trunnion bearing "U" bolts from the rear yoke, split rear universal joint, position propeller shaft to one side, and tie it to the frame side rail.

NOTE: The bearings can be left on the trunnion and held in place with tape.

3. Remove hub and drum assembly and disconnect parking brake cable at lever and at flange plate. See Section 5 for cable removal.
4. Disconnect hydraulic brake hose at connector on rear axle housing. Refer to Section 5.
5. Disconnect shock absorbers at axle brackets.
6. Support axle assembly with hydraulic jack, remove spring "U" bolts, and lower axle assembly to the floor.

Installation

1. Place axle assembly under vehicle, raise into position, install spring "U" bolts, anchor plates and nuts, and tighten securely.
2. Connect and secure shock absorbers to axle brackets.
3. Connect brake hose at connector on rear axle housing.
4. Connect parking brake cable at lever and flange plate. Install hub and drum assembly. Bleed brake hydraulic system and adjust parking brake.

NOTE: Before reinstalling wheel hub and drum assembly replace hub oil seal.

5. Reassemble the rear universal joint, making sure that "U" bolts are drawn up tight and locked properly. Caution should be taken not to overtighten "U" bolt nuts and cause bearing cups to become distorted.
6. Install rear wheels, remove stand jacks, and lower vehicle.
7. Test operation of brakes and rear axle.

AXLE SHAFT

Replacement

1. Remove bolts that attach the axle shaft flange to the wheel hub. See figure 4B-30.
2. Rap on flange with a soft-faced hammer to loosen shaft. Grip the rib on end of flange with a pair of locking pliers and twist to start shaft removal. Remove shaft from axle tube.
3. Thoroughly clean both the axle shaft flange and the end of the wheel hub.

NOTE: Any lubricant on these surfaces tends to loosen axle shaft flange bolts.

4. Place a new gasket over the axle shaft and position the axle shaft in the housing so that the shaft splines enter the differential side gear. Position gasket so that holes are in alignment and install flange-to-hub attaching bolts. Torque bolts to specifications.

HUB AND DRUM ASSEMBLY—FIG. 4B-31

Removal

1. Remove axle shaft as outlined earlier.
2. Disengage tang of retainer from slot or flat of locknut, then remove locknut from housing tube, using J-2222, as shown in figure 4B-32.
3. Disengage tang of retainer from slot or flat of adjusting nut and remove retainer from housing tube.
4. Use appropriate tool as specified in Step 2 to remove adjusting nut from housing tube.

NOTE: Remove thrust washer from housing tube.

5. Pull hub and drum assembly straight off axle housing.
6. Remove oil seal, and discard.

Bearing/Cup—Removal

1. Use a hammer and long drift to knock the inner bearing, cup and oil seal from the hub assembly.

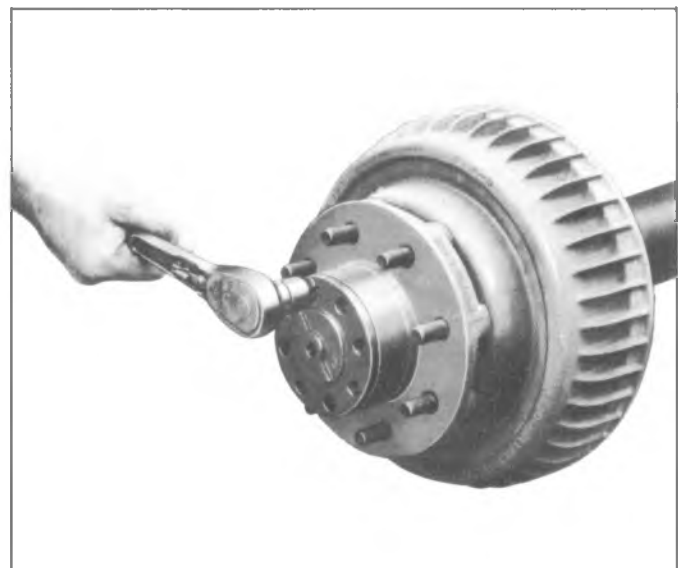


Fig. 4B-30--Removing Flange-to-Hub Bolts

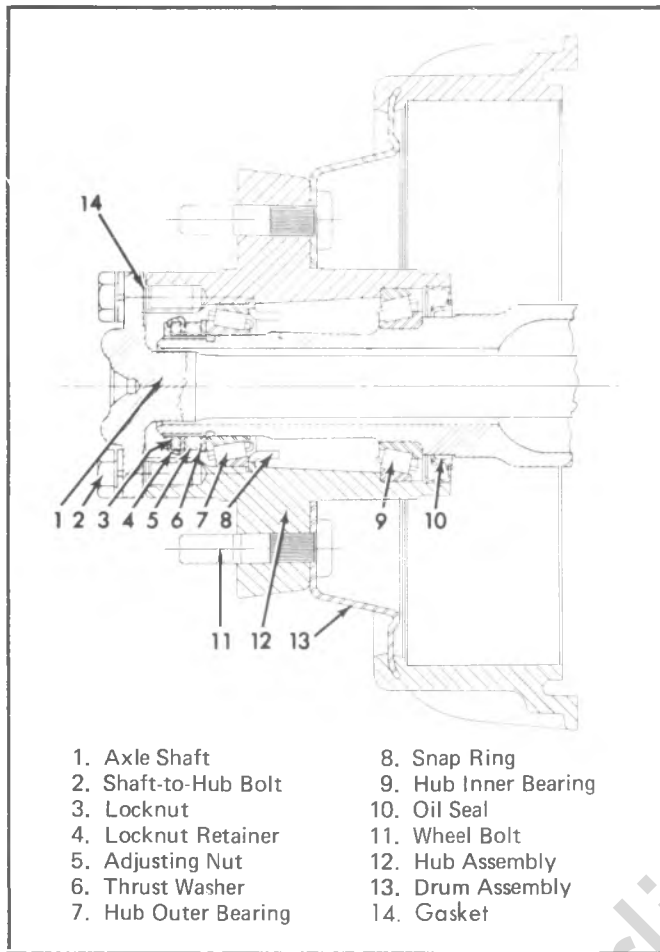


Fig. 4B-31-Hub and Drum Assembly—10-1/2" Axles

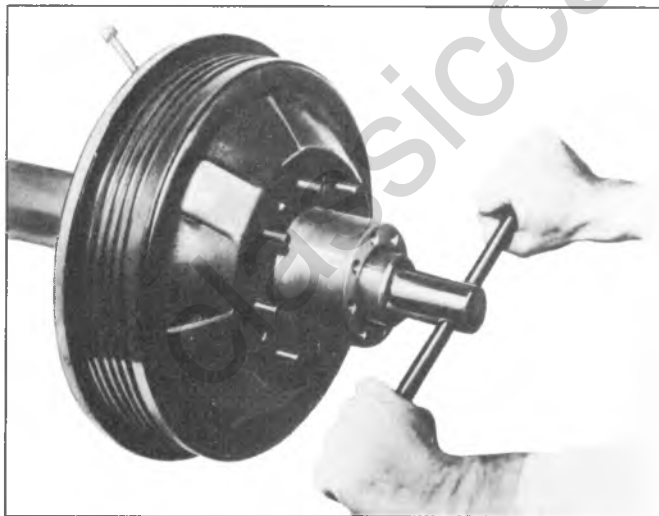


Fig. 4B-32-Removing Lock Nut—Typical

2. Remove **outer** bearing snap ring with a pair of pliers.
3. With J-24426 on Handle J-8092, as shown in figure 4B-33, drive **outer** bearing and cup from the hub assembly.



Fig. 4B-33-Removing Outer Bearing and Cup

Inspection and Cleaning of Bearings

1. Inspect bearing rollers for excessive wear, chipped edges, and other damage. Slowly move rollers around cone to detect any flat or rough spots on rollers or cone.
2. Examine bearing cups in hub for pits, cracks, and other damage.
3. Examine axle shaft flange studs, wheel studs, hub splines, hub bore, and tapped holes for evidence of damage. Clean up threads or replace parts where required.

4. Examine oil seal sleeve for evidence of wear or roughness, check axle housing oil deflector and brake drum oil deflector for evidence of damage. Replace parts where required.

5. Examine brake drum for excessive scoring and other damage. To replace brake drum refer to "Brake Drum Replacement."

6. Immerse bearing cone and roller assemblies in cleaning solvent. Clean with stiff brush to remove old lubricant. Blow bearings dry with compressed air, directing air stream across bearing. Do not spin bearings while blowing them dry.

7. Thoroughly remove all lubricant from axle housing tube and from inside the hub, wipe dry. Make sure all particles of gasket are removed from outer end of hub, axle shaft, and hub cap.

8. Scrape old sealing compound out of oil seal bore in the hub.

Bearing/Cup—Installation

1. Place **outer** bearing into hub.
2. Install cup of outer bearing into hub by using Handle J-8092 and J-8608, **installed upside-down**. Be sure J-8608 is upside down on driver handle, so that chamfer does **not** contact bearing cup.
3. Drive cup **beyond** the snap ring groove.
4. Using a pair of pliers, install snap ring into the groove.

5. Drive cup back **against** snap ring by using J-24426, as shown in figure 4B-33.

6. To install **inner** bearing cup, use J-24427 on Handle J-8092. Drive cup into place until it seats against shoulder of hub bore.

7. Install new oil seal with J-24428.

Drum—Non-Demountable-Type—Fig. 4B-31

Replacement

Construction of the nondemountable-type hub and drum assembly is such that replacement cannot be accomplished with the hub assembly installed on the vehicle.

1. Separate the drum and hub by removing the drum-to-hub retaining bolts, hub stud nuts, or by pressing out the wheel studs, as applicable.

2. Position brake drum to hub assembly, making certain that all drain holes are in alignment.

3. Apply a light, even coating of sealing compound to the hub oil deflector contact surface, and position deflector to drum.

4. Install drum-to-hub retaining bolts, hub stud nuts, or press wheel studs into drum, as applicable.

Wheel Bolt

Replacement

Wheel bolts are serrated and may also be swaged in place; however, replacement procedure remains the same for both types of installation.

Press bolts out of hub flange and press new bolts into place, making sure they are a tight fit. If all bolts are removed, be sure that hub oil deflector is in position under bolt heads. See figure 4B-34.

Installation of Hub and Drum Assembly

1. Using a high melting point EP bearing lubricant, liberally pack bearings and apply a light coat on I.D. of hub bearing contact surface and O.D. of axle housing tube.

2. Make sure inner bearing, oil seal, axle housing oil deflector, and inner bearing race and oil seal are properly positioned.

3. Install hub and drum assembly on axle housing, exercising care so as not to damage oil seal or dislocate other internal components.

4. Install thrust washer so that tang on I.D. of washer is in keyway on axle housing.

5. Install adjusting nut and complete the installation as directed under "Bearing Adjustment."

BEARING ADJUSTMENT

Before checking bearing adjustment, make sure brakes are fully released and do not drag.

Check bearing play by grasping tire at top and pulling back and forth, or by using a pry bar under tire. If bearings are properly adjusted, movement of brake drum in relation to brake flange plate will be barely noticeable and wheel will turn freely. If movement is excessive, adjust bearing as follows:

1. Remove axle shaft and raise vehicle until wheel is free to rotate.

2. Disengage tang of retainer from locknut and remove both locknut and retainer from axle housing tube.

3. Using J-2222, tighten inner adjusting nut to specified torque at the same time rotating hub to make sure all bearing surfaces are in contact. Then back off inner nut to specified amount of turn-back.

See figure 4B-35, and refer to Specifications Section for torque values.

4. Install tang retainer against the inner adjusting nut. Align inner adjusting nut so short tang of retainer will engage nearest slot on inner adjusting nut.

5. Install outer locknut and tighten to correct specified torque. Then bend long tang of retainer into

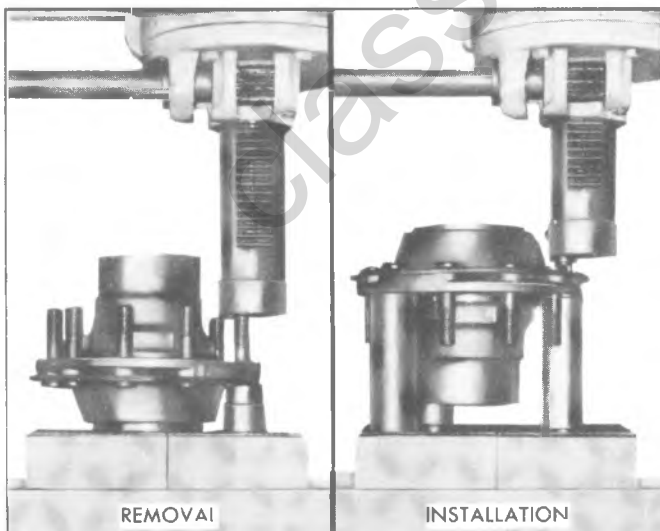


Fig. 4B-34—Wheel Bolt Replacement

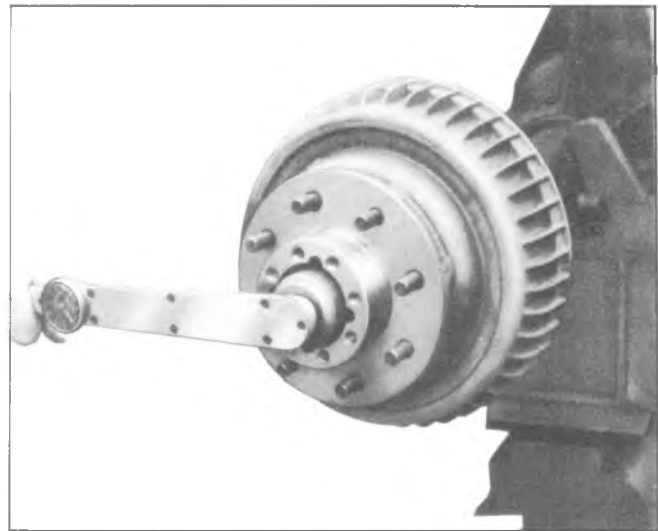


Fig. 4B-35 Tightening Adjusting Nut—Typical

slot of outer nut. This method of adjustment will result in the proper bearing adjustment.

DRIVE PINION OIL SEAL

Replacement

NOTE: The pinion oil seal may be replaced with the carrier assembly installed in the vehicle.

1. Disconnect propeller shaft.
2. Scribe a line down the pinion stem, pinion nut and companion flange.
3. Use J-8614-11 to remove the pinion nut and the companion flange.
4. Pry the oil seal from the bore, using care not to damage the machined surfaces. Thoroughly clean all foreign material from contact area.
5. Lubricate the cavity between the seal lips with a high melting point bearing lubricant.
6. Install a new pinion oil seal into the bore, using J-24434.
7. Reinstall the companion flange, pinion nut and propeller shaft.

CAUTION: See *CAUTION* on page 1 of this section, regarding the above fasteners.

DANA 10-1/2 RING GEAR AXLE DANA 9-3/4 RING GEAR AXLE

Procedures for service to axle assembly, axle shafts, hub and drum components and bearing adjustments are identical to those listed for "Chevrolet 10-1/2 Ring Gear Axle".

Drive pinion oil seal replacement requires different special tools for the Dana axles. Follow the same procedure listed for "Chevrolet 10-1/2" Ring Gear Axle"; use J-24384 for seal replacement on Dana 10-1/2" Ring Gear Axles, and use J-22281 for pinion oil seal replacement on Dana 9-3/4" Ring Gear Axles.

12-1/4 RING GEAR AXLE

AXLE ASSEMBLY

The axle assembly removal and installation is identical to the procedure given earlier for "Chevrolet 10-1/2" Ring Gear Axle".

AXLE VENT

Replacement

Service replacement axle housing assemblies are not equipped with an axle vent; therefore, always make sure that a new vent assembly is installed when replacing the housing. If axle vent requires replacement, pry old vent from housing being sure that entire vent is removed. Prick punch around carrier hole to insure fit of replacement vent. Tap new vent into housing using a soft-faced hammer. Vent should be positioned in housing so that flat surface is toward centerline of differential carrier. See figure 4B-36.

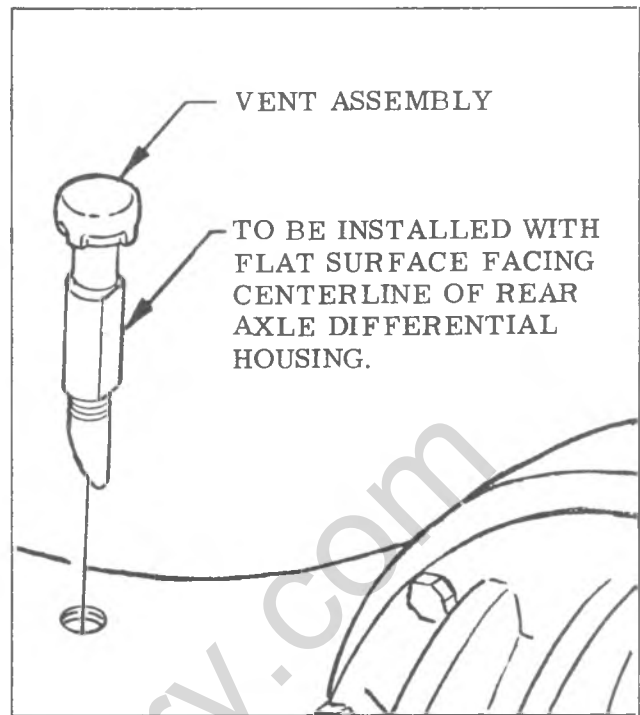


Fig. 4B-36—Typical Axle Vent Installation

AXLE SHAFT

Replacement

1. Remove hub cap, and install Tool J-8117 in tapped hole on shaft flange.
2. Install slide hammer, Tool J-2619, and remove axle shaft.
3. Thoroughly remove old gasket material from hub and hub cap. Clean shaft flange and mating surfaces in the wheel hub.
4. Install axle shaft so that the flange splines index into hub splines. Tap shaft into position, using J-8117 and J-2619.
5. Install new gasket, position flange to hub and install attaching bolts. Torque bolts to specifications.

HUB AND DRUM ASSEMBLY

Removal

Use the procedure given for "Chevrolet 10-1/2" Ring Gear Axle", and use J-0870 to remove the adjusting nut.

Bearing Cup—Removal

1. Cut a suitable length of 1/2 inch steel bar stock for press-out tool.
2. Place bar stock tool behind inner bearing cup, index tool in provided notches, and press out cup with an arbor press.
3. Use J-22380, as shown in figure 4B-37, to remove outer bearing retainer ring.
4. Remove the outer bearing by driving on the axle shaft spacer, using the splined flange cut from an old axle shaft, as shown in figure 4B-38.



Fig. 4B-37-Removing Hub Outer Bearing Retainer Ring

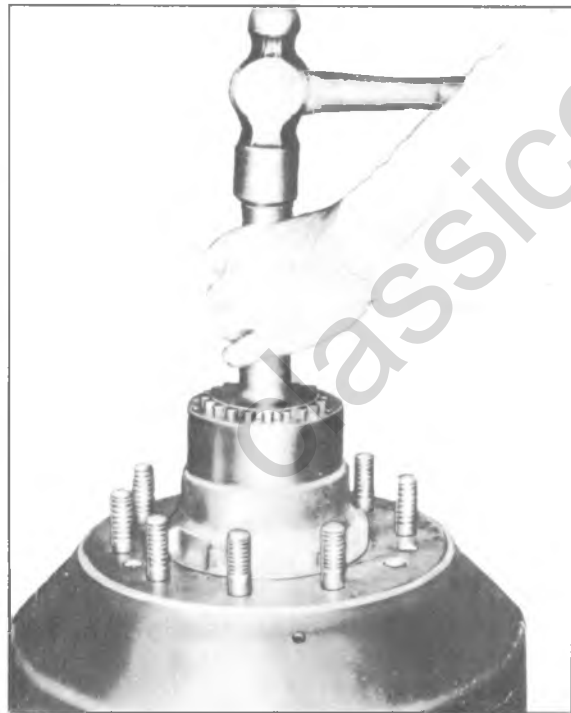


Fig. 4B-38-Removing Hub Outer Bearing

Inspection and Cleaning of Bearings

Refer to procedures listed for "Chevrolet 10-1/2" Ring Gear Axle.

Bearing Cup—Installation

1. To install **outer** bearing, place axle shaft spacer in hub, followed by the outer bearing. The larger O.D. of the bearing goes toward the outer end of the hub.
2. Position outer bearing cup in hub with the thin edge of the cup toward the outer end of the hub.
3. Press the cup into the hub, using J-8114 and Handle J-8092.
4. Withdraw cup installer, then install retainer ring, using J-22380 as shown in figure 4B-37. Press the cup into contact with the retainer ring as shown in figure 4B-38.

NOTE: The bearing cup-to-retainer ring seating procedure is essential to assure that an accurate wheel bearing adjustment will be obtained, and that the adjustment will not loosen during vehicle operation.

5. To install **inner** bearing, use J-8093 with Handle J-8092 to drive cup into hub bore, as shown in figure 4B-39.
6. Install new oil seal, using J-22354 as shown in figure 4B-40.

DRUM—DEMOUNTABLE-TYPE

Replacement

The demountable-type drum may be separated from the hub and removed from the vehicle without disturbing the axle shaft and hub. The drum is held to the hub by countersunk, slotted screws, which are easily removed with a screw driver.

WHEEL BOLT REPLACEMENT

Refer to figure 4B-34 and to procedure listed under "Chevrolet 10-1/2" Ring Gear Axle.

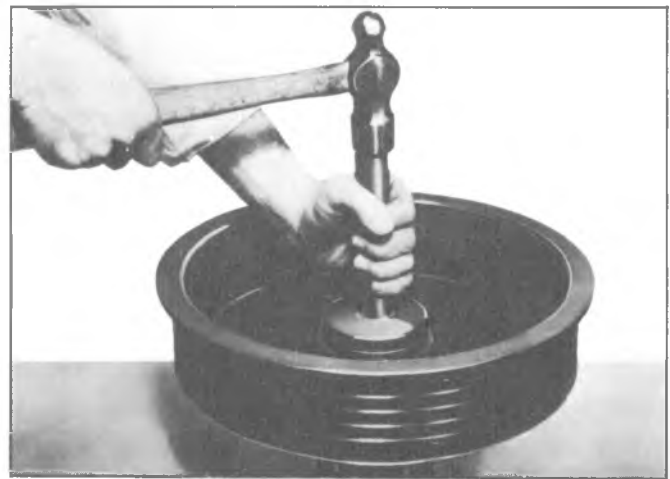


Fig. 4B-39-Installing Hub Inner Bearing Cup



Fig. 4B-40--Installing Hub Oil Seal

INSTALLATION OF HUB AND DRUM ASSEMBLY

1. Using a high melting point EP bearing lubricant, liberally pack bearings and apply a light coat on I.D. of hub bearing contact surface and O.D. of axle housing tube.

2. Make sure inner bearing, oil seal, axle housing oil deflector, and inner bearing race and oil seal are properly positioned.

3. Install hub and drum assembly on axle housing, exercising care so as not to damage oil seal or dislocate other internal components.

4. Place outer bearing cone and roller assembly on axle housing and press firmly into hub with hand.

5. Install adjusting nut and complete the installation as directed under "Bearing Adjustment".

BEARING ADJUSTMENT

Before checking bearing adjustment, make sure brakes are fully released and do not drag.

Check bearing play by grasping tire at top and pulling back and forth, or by using a pry bar under tire. If bearings are properly adjusted, movement of brake drum in relation to brake flange plate will be barely noticeable and wheel will turn freely. If movement is excessive, adjust bearing as follows:

1. Remove axle shaft and raise vehicle until wheel is free to rotate.

2. Disengage tang of retainer from locknut and remove both locknut and retainer from axle housing tube.

3. Use J-0870 to tighten inner adjusting nut at the

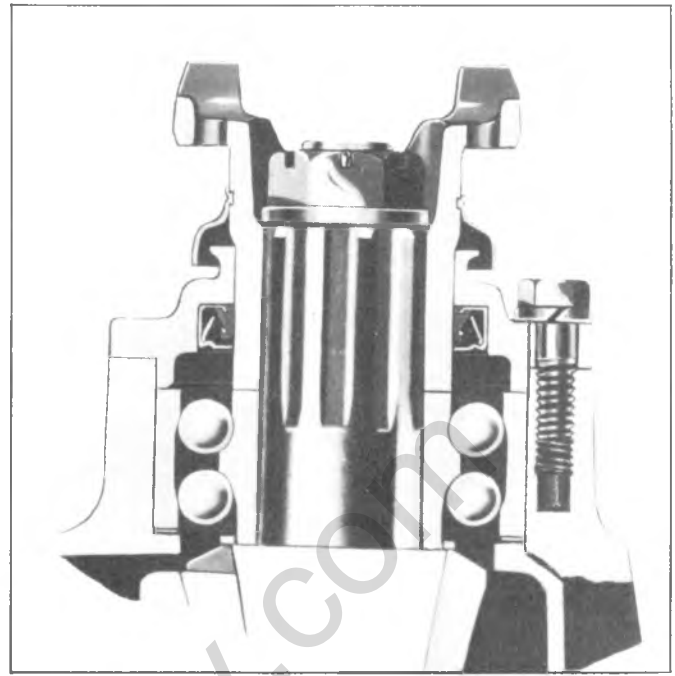


Fig. 4B-41--Pinion Oil Seal—12-1/4" Axle

same time rotating hub to make sure all bearing surfaces are in contact. Then back off inner nut to specified amount of turn-back Fig. 4B-35.

4. Install tanged retainer against the inner adjusting nut. Align inner adjusting nut so short tang of retainer will engage nearest slot on inner adjusting nut.

5. Install outer locknut and tighten to correct specified torque. Then bend long tang of retainer into slot of outer nut. This method of adjustment will result in the proper bearing adjustment.

DRIVE PINION OIL SEAL

Replacement

NOTE: The pinion oil seal may be replaced with the carrier assembly installed in the vehicle.

1. Disconnect propeller shaft.
2. Scribe a line down the pinion stem, pinion nut and companion flange.

3. Use J-8614-11 to remove the pinion nut and the companion flange.

4. Remove the bolts retaining the oil seal retainer to the carrier, and remove the retainer. See figure 4B-41.

5. Pry the oil seal from the bore, using care not to damage the machined surfaces. Thoroughly clean all foreign material from contact area.

6. Lubricate the cavity between the seal lips with a high melting point bearing lubricant.

7. Install a new pinion oil seal into the bore, using J-22281. Be sure seal bottoms against shoulder in bore.

8. Install the bearing retainer to the carrier.

9. Reinstall the companion flange, pinion nut and propeller shaft.

CAUTION: See CAUTION on page 1 of this section, regarding the above fasteners.

SPECIFICATIONS

DIFFERENTIAL SPECIFICATIONS

	8 1/2"	8 7/8"	Dana 10 1/2" 9 3/4"	Chevrolet 10 1/2"	12 1/4"
Gear Backlash Preferred	.005"-.008"	.005"-.008"	.004"-.009"	.005"-.008"	.005"-.008"
Min. and Max.	.003"-.010"	.003"-.010"	.004"-.009"	.003"-.012"	.003"-.012"
Pinion Bearing Preload (In.-Lbs.)					
— New	15-30	15-30	20-40	25-35	
— Used	5-10	5-10	10-20	5-15	

BOLT TORQUES (FT.-LBS.)▲

Carrier Cover	20	20	35	30	—
Ring Gear	80	50	110	120	105
Differential Bearing Caps	55	55	85	135	205

BOLT TORQUES (FT.-LBS.)▲

	8 1/2"	8 7/8"	Dana 10 1/2" 9 3/4"	Chevrolet 10 1/2"	12 1/4"
Filler Plugs	25	18	10	18	10
Differential Pinion Lock	20"#	20"#	—	—	—
Drive Pinion Nut		—	*	*	220
Differential Carrier to Axle Housing		—	—	—	85
Differential Bearing Adjusting Lock		—	—	20	15
Pinion Bearing Cage To Carrier		—	—	65	165
Thrust Pad Lock Nut		—	—	—	135
Brack Backing Plate	35	35	105	105	155
Axle Shaft To Hub Bolts		—	115	115	15

▲Except where noted otherwise.

*Torque as necessary to obtain correct preload.

Ring Gear Size	Lubricant Capacity
8 1/2"	4.2 Pints
8 7/8"	3.5 Pints
Chevrolet 10 1/2"	5.4 Pints
Dana 10 1/2"	7.2 Pints
Dana 9 3/4"	6.0 Pints
12 1/4"	14.0 Pints

SPECIAL TOOLS

8 5/8" R.G. AXLE ONLY

10 1/2" R.G. AXLE ONLY

12 1/4" R.G. AXLE ONLY

1. J-21548	Trunnion Seal Installer	16. J-24430	Differential Side Bearing Installer
2. J-23690	Axle Shaft Bearing Installer	17. J-23322	Pinion Straddle Bearing Installer
3. J-23689	Axle Shaft Bearing Remover	18. J-24426	Outer Wheel Bearing Cup Tool
4. J-21128	Axle Shaft Seal Installer	19. J-24432	Pinion Rear Bearing Cup Installer
5. J-21057	Pinion Oil Seal Installer	20. J-24427	Inner Wheel Bearing Cup Installer
6. J-22804-1	Pinion Seal Gauge Plate	21. J-8608	Outer Wheel Bearing Cup Installer
7. J-5748	Positraction Torque Measuring Adapter	22. J-24384	Pinion Oil Seal Installer - Dana
8. J-6627	Wheel Bolt Remover	23. J-24428	Wheel Hub Oil Seal Installer
9. J-8092	Driver Handle	24. J-24434	Pinion Oil Seal Installer - Chevrolet
10. J-5853	Torque Wrench - Inch/Pound	25. J-870	Wheel Bearing Nut Wrench
11. J-8614-II	Companion Flange Holder	26. J-22380	Tru-Arc Pliers
12. J-2619	Slide Hammer	27. J-22354	Wheel Oil Seal Installer
13. J-2222	Wheel Bearing Nut Wrench	28. J-22281	Pinion Oil Seal Installer
14. J-24429	Adjusting Nut Wrench	29. J-8114	Wheel Bearing Outer Cup Installer
15. J-24433	Pinion Rear Bearing Installer	30. J-8093	Wheel Bearing Inner Cup Installer

Fig. 4B-42-Special Tools

classicalibrary.com

SECTION 4C

FRONT WHEEL DRIVE

The following caution applies to one or more steps in the assembly procedure of components in this portion of the manual as indicated at appropriate locations by the terminology "See Caution on page 1 of this Section".

CAUTION: *THIS FASTENER IS AN IMPORTANT ATTACHING PART IN THAT IT COULD AFFECT THE PERFORMANCE OF VITAL COMPONENTS AND SYSTEMS, AND/OR COULD RESULT IN MAJOR REPAIR EXPENSE, IT MUST BE REPLACED WITH ONE OF THE SAME PART NUMBER OR WITH AN EQUIVALENT PART IF REPLACEMENT BECOMES NECESSARY. DO NOT USE A REPLACEMENT PART OF LESSER QUALITY OR SUBSTITUTE DESIGN. TORQUE VALUES MUST BE USED AS SPECIFIED DURING REASSEMBLY TO ASSURE PROPER RETENTION OF THIS PART.*

CONTENTS

General Description.....	4C-1
Diagnosis.....	4C-2
Front Axle Assembly.....	4C-5
Removal.....	4C-5
Installation.....	4C-5
Repair Axle Joint Components.....	4C-6
Specifications.....	4C-6

GENERAL DESCRIPTION

The front axle is a hypoid gear axle unit equipped with steering knuckles. Axle assembly number and production date are stamped on left tube of assembly. Conventional truck service brakes are provided on all 4-wheel drive units.

K10-20 Models use the Dana (44 Series) which incorporates a 8-1/2" ring gear. A new 4500 lb. capacity unit is used on the K-30 Model. The K-30 axle assembly is a Dana (60 Series) which incorporates a 9-3/4" ring gear.

DIAGNOSIS

BEARINGS AND RACES

FRONT WHEEL, PINION, DIFFERENTIAL SIDE AND REAR WHEEL ROLLER BEARINGS

DIAGNOSIS

	EXCESS NOISE COMPLAINT DIAGNOSTIC PROCEDURE
Road Test	<ol style="list-style-type: none"> 1. Check tires for irregular wear 2. Check tire pressure 3. Check lubricant level 4. Drive to warm-up rear axle 5. Test at various speeds in drive, float, coast and cornering
Tire Noises	<ol style="list-style-type: none"> 1. Change tire pressure to minimize noises 2. Drive over different road surfaces 3. Smooth black-top minimizes tire noise 4. Cross switch tires, if necessary 5. Snow tire treads and studs caused added noises
Engine or Exhaust Noises	<ol style="list-style-type: none"> 1. Drive slightly above speed where noise occurs, place transmission in neutral 2. Let engine speed drop to idle 3. Stop car 4. Run engine at various speeds
Test for Wheel Bearing Noise	<ol style="list-style-type: none"> 1. Drive car at low speed on a smooth road 2. Turn car to develop left and right motions, traffic permitting 3. Noise should change due to cornering loads 4. Jack-up wheels to verify roughness at wheels
Test for Differential Bearing Noise	<ol style="list-style-type: none"> 1. Drive car at low speed on a smooth road 2. Constant low pitch bearing noise may be heard 3. Noise should not change in reversing turns 4. Noise pattern should vary with wheel speed
Test for Pinion Bearing Noise	<ol style="list-style-type: none"> 1. Roughness or whine noise should increase with speed 2. Noise pitch should be higher than differentials 3. Test on smooth road to minimize tire noises 4. Test at various speeds in drive, float, and coast 5. Rear pinion bearing noise may be louder on acceleration 6. Front pinion bearing noise may be louder on deceleration 7. Gear noises tend to peak in a narrow speed range

Fig. 4C-1-Bearing Diagnosis

FRONT WHEEL BEARING DIAGNOSIS

CONSIDER THE FOLLOWING FACTORS WHEN DIAGNOSING BEARING CONDITION

- 1 GENERAL CONDITION OF ALL PARTS DURING DISASSEMBLY AND INSPECTION
- 2 CLASSIFY THE FAILURE WITH THE AID OF THE ILLUSTRATIONS
- 3 DETERMINE THE CAUSE
- 4 MAKE ALL REPAIRS FOLLOWING RECOMMENDED PROCEDURES

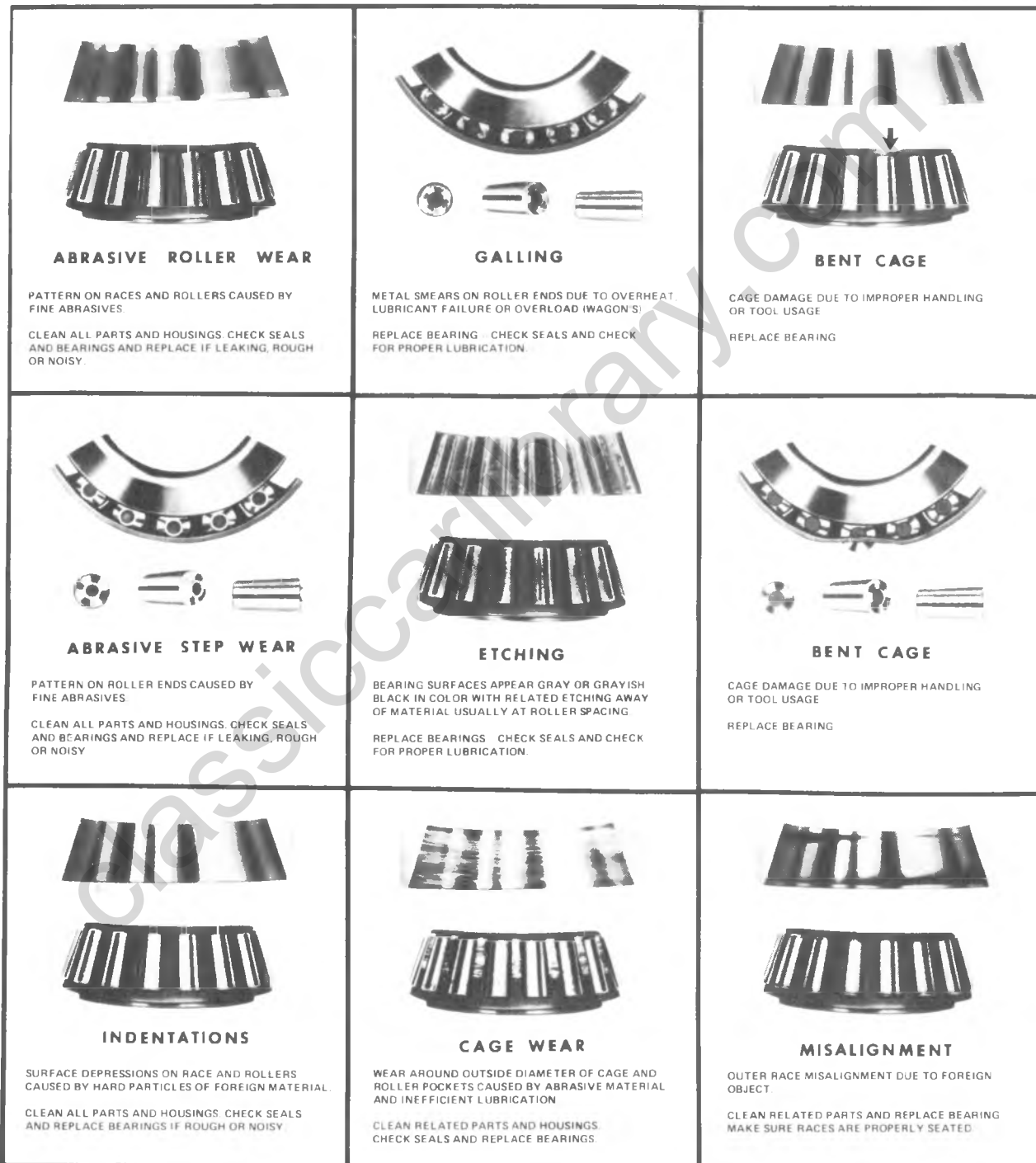


Fig. 4C-2--Bearing Diagnosis Cont'd.

FRONT WHEEL BEARING DIAGNOSIS (CONT'D)



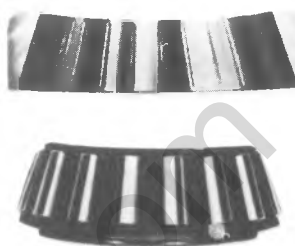

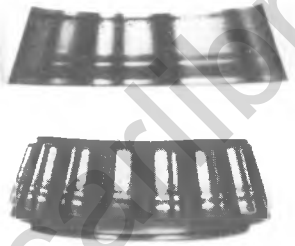
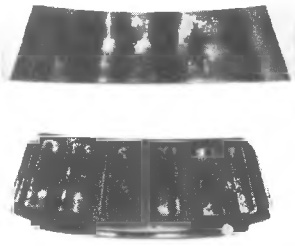

 <p>CRACKED INNER RACE</p> <p>RACE CRACKED DUE TO IMPROPER FIT, COCKING, OR POOR BEARING SEATS.</p> <p>REPLACE BEARING AND CORRECT BEARING SEATS.</p>	 <p>FATIGUE SPALLING</p> <p>FLAKING OF SURFACE METAL RESULTING FROM FATIGUE.</p> <p>REPLACE BEARING - CLEAN ALL RELATED PARTS.</p>	 <p>BRINELLING</p> <p>SURFACE INDENTATIONS IN RACEWAY CAUSED BY ROLLERS EITHER UNDER IMPACT LOADING OR VIBRATION WHILE THE BEARING IS NOT ROTATING.</p> <p>REPLACE BEARING IF ROUGH OR NOISY.</p>
 <p>FRETTAGE</p> <p>CORROSION SET UP BY SMALL RELATIVE MOVEMENT OF PARTS WITH NO LUBRICATION.</p> <p>REPLACE BEARING. CLEAN RELATED PARTS. CHECK SEALS AND CHECK FOR PROPER LUBRICATION.</p>	 <p>STAIN DISCOLORATION</p> <p>DISCOLORATION CAN RANGE FROM LIGHT BROWN TO BLACK CAUSED BY INCORRECT LUBRICANT OR MOISTURE.</p> <p>RE USE BEARINGS IF STAINS CAN BE REMOVED BY LIGHT POLISHING OR IF NO EVIDENCE OF OVER HEATING IS OBSERVED.</p> <p>CHECK SEALS AND RELATED PARTS FOR DAMAGE.</p>	 <p>HEAT DISCOLORATION</p> <p>HEAT DISCOLORATION CAN RANGE FROM FAINT YELLOW TO DARK BLUE RESULTING FROM OVER LOAD (WAGON'S) OR INCORRECT LUBRICANT.</p> <p>EXCESSIVE HEAT CAN CAUSE SOFTENING OF RACES OR ROLLERS.</p> <p>TO CHECK FOR LOSS OF TEMPER ON RACES OR ROLLERS A SIMPLE FILE TEST MAY BE MADE. A FILE DRAWN OVER A TEMPERED PART WILL GRAB AND CUT METAL, WHEREAS, A FILE DRAWN OVER A HARD PART WILL GLIDE READILY WITH NO METAL CUTTING.</p> <p>REPLACE BEARINGS IF OVER HEATING DAMAGE IS INDICATED. CHECK SEALS AND OTHER PARTS.</p>
 <p>SMEARS</p> <p>SMEARING OF METAL DUE TO SLIPPAGE. SLIPPAGE CAN BE CAUSED BY POOR FITS, LUBRICATION, OVERHEATING, OVERLOADS OR HANDLING DAMAGE.</p> <p>REPLACE BEARINGS, CLEAN RELATED PARTS AND CHECK FOR PROPER FITS AND LUBRICATION.</p>		

Fig. 4C-3-Bearing Diagnosis Cont'd.

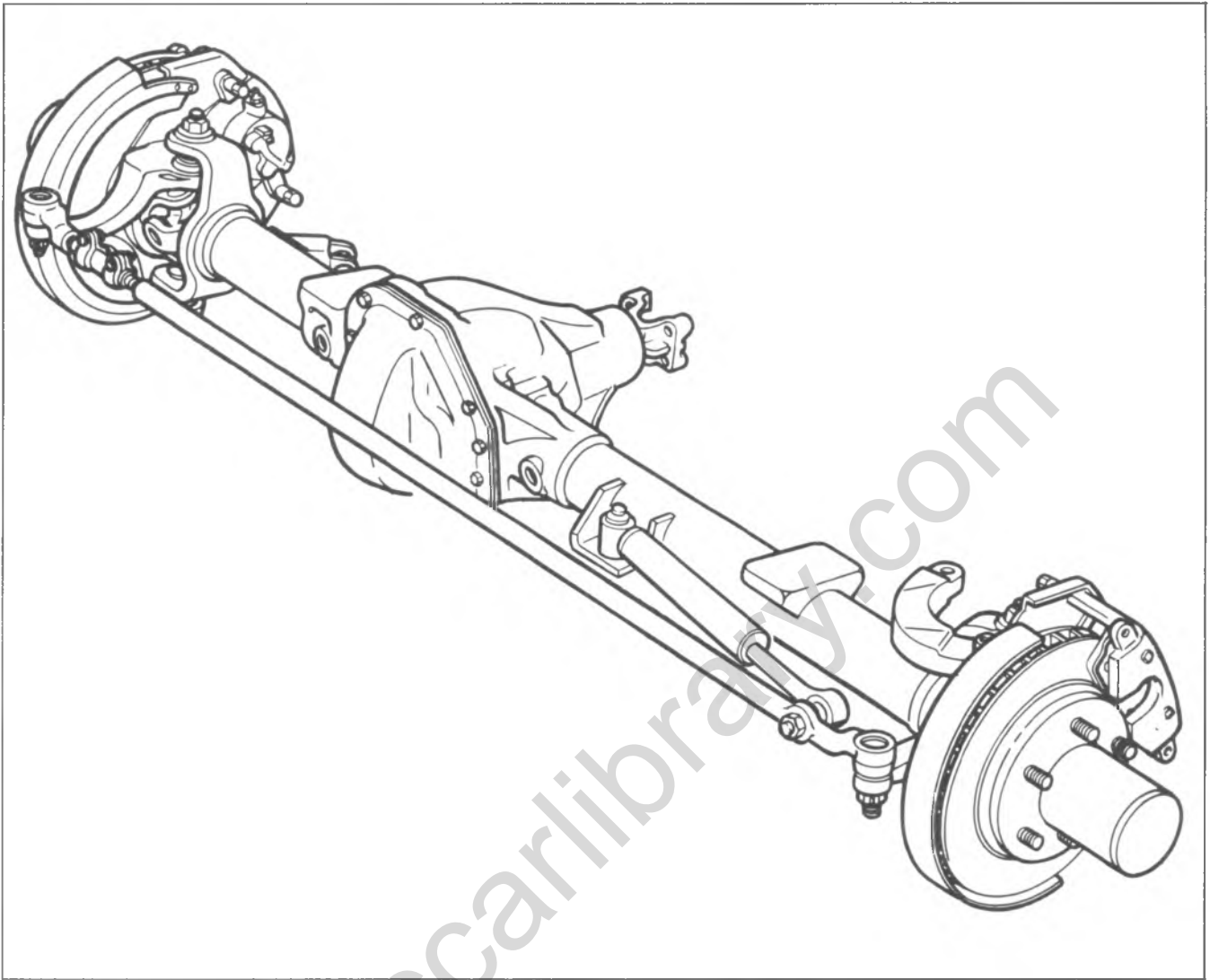


Fig. 4C-4--Front Drive Axle Typical

FRONT AXLE ASSEMBLY (Refer to Fig. 4C-4)

Removal

1. Disconnect propeller shaft from front axle differential.
2. Raise front of vehicle on hoist until weight is removed from front springs. Support truck with jack stands behind front springs.
3. Disconnect connecting rod from steering arm.
4. Disconnect brake hoses from frame fittings and cap all fitting ends or cover with a rag to prevent contamination.
5. Disconnect shock absorbers from axle brackets.
6. Disconnect axle vent tube clip at the differential housing (see fig. 4C-5).
7. Dismount "U" bolts from axle to separate axle from truck springs.
8. Raise truck to clear axle assembly and roll front axle out from under the truck.

Installation

CAUTION: See *CAUTION* on page 1 of this section regarding the fasteners referred to in steps 3, 5, 6 and 8.

1. Truck should be on jack stands as in Step 2 of removal instructions.
2. Place axle in position under truck.
3. Install "U" bolts attaching axle to front springs.
4. Attach shock absorbers to axle brackets.
5. Connect brake hoses to frame fittings bleed the brake system (see Section 5).
6. Attach connecting rod to steering arm.
7. Remove jack stands and lower front of truck.
8. Assemble propeller shaft to front axle differential.
9. Lower vehicle to floor.

Disassembly

Refer to Section 3B for hub, spindle and knuckle removal and installation procedures.

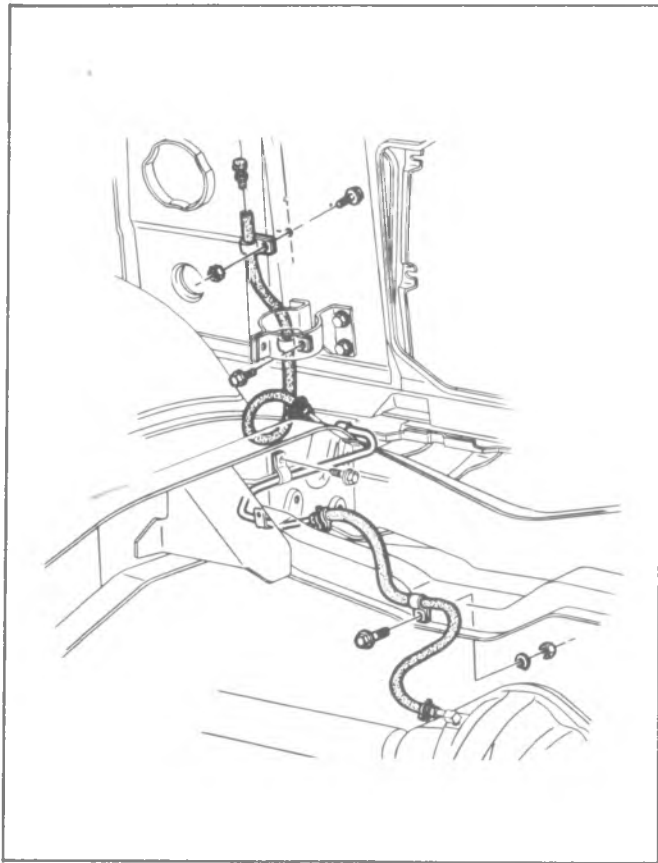


Fig. 4C-5--Axle Vent Hose Routing Typical

1. Securely mount the axle assembly in a suitable holding fixture.

2. If the vehicle is not equipped with RPO F76 freewheeling hubs, remove the hub cap and snap ring.

3. Remove the drive gear and pressure spring. Place a hand over the drive gear and use a screwdriver to pry the gear out.

4. Remove the wheel bearing outer lock nut, lock ring, and wheel bearing inner adjusting as outlined in Section 3B.

5. Remove the disc assembly outer wheel bearing and the spring retainer plate.

NOTE: If the disc or other brake components require repairs or replacement, refer to Section 5.

Repair The Axle Joint Components:

1. Remove the lock rings after removing pressure from the trunnion bearings by squeezing the ends of the bearing in a vise.

2. Support the shaft yoke in a bench vise or on a short length of pipe.

3. Using a brass drift and a soft hammer, drive on end of one trunnion bearing just far enough to drive opposite bearing from yoke.

4. Support the other side of the yoke in the vise and drive the other bearing out by tapping on the end of the trunnion using a brass drift.

5. Remove trunnion.

6. Clean and inspect bearings. Lubricate with a high melting point type wheel bearing grease.

7. Replace trunnion and press new or relubricated bearings into yoke and over trunnion hubs far enough to install lock rings.

8. Hold trunnion in one hand and tap yoke lightly to seat bearings against lock rings.

Assembly

Reverse disassembly procedure.

SPECIFICATIONS

FOUR WHEEL DRIVE

Axle			Bolt Torques (Ft.-Lbs.)
Gear Backlash Preferred	.004"-.009"	Carrier Cover	35
Min. and Max.	.004"-.009"	Ring Gear	110
New Pinion Bearing Preload	20-40 in.-lbs.	Differential Bearing Caps	85
Used Pinion Bearing Preload	10-20 in.-lbs.	Filler Plugs	10
		Drive Pinion Nut	255
		Brake — Backing Plate — K10, K20	35
		Brake — Backing Plate — K30	105
		Axle Shaft to Hub Bolts — K10, K20	60
		Axle Shaft to Hub Bolts — K30	90

SECTION 5

BRAKES

The following warning and caution notes apply to one or more steps in the assembly procedure of components in this portion of the manual as indicated at appropriate locations by the terminology "See Warning/Caution on page 1 of this section".

Warning: When servicing wheel brake parts, do not create dust by grinding or sanding brake linings or by cleaning wheel brake parts with a dry brush or with compressed air. (A water dampened cloth should be used.) Many wheel brake parts contain asbestos fibers which can become airborne if dust is created during servicing. Breathing dust containing asbestos fibers may cause serious bodily harm."

CAUTION: *THIS FASTENER IS AN IMPORTANT ATTACHING PART IN THAT IT COULD AFFECT THE PERFORMANCE OF VITAL COMPONENTS AND SYSTEMS AND/OR COULD RESULT IN MAJOR REPAIR EXPENSE. IT MUST BE REPLACED WITH ONE OF THE SAME PART NUMBER OR WITH AN EQUIVALENT PART IF REPLACEMENT BECOMES NECESSARY. DO NOT USE A REPLACEMENT PART OF LESSER QUALITY OR SUBSTITUTE DESIGN. TORQUE VALUES MUST BE USED AS SPECIFIED DURING REASSEMBLY TO ASSURE PROPER RETENTION OF THIS PART.*

CONTENTS

General Description	5-1	Delco Disc Brake Shoe and Lining	5-26
Diagnosis	5-2	Bendix Disc Brake Shoe and Lining	5-31
On-Vehicle Service	5-10	Caliper Overhaul	5-33
Pedal Travel	5-10	Rotor Servicing	5-36
Stop Light Switch	5-10	Brake Drum Shoe and Lining	5-37
Bleeding and Flushing Brakes	5-10	Standard Drum Brake	5-37
Brake Pipes	5-10	Propeller Shaft Brake	5-40
Brake Hoses	5-14	RPO H22 Rear Drum Brakes	5-41
Bleeding Hydro-Boost Power Steering System	5-15	Brake Drums	5-43
Parking Brake Pedal or Handle	5-15	Wheel Cylinder	5-44
Parking Brake Adjustment	5-15	Power Brake Unit	5-44
Parking Brake (Propshaft) Internal Expanding ...	5-22	Vacuum Booster	5-44
Parking Brake Cable	5-22	Hydro-Boost Unit	5-45
Combination Valve	5-22	Specifications	5-47
Brake Pedal	5-23	Brake System Description	5-47
Brake Pedal Rod	5-24	Brake System Application	5-48
Master Cylinder	5-24	Torque Specifications	5-52
		Special Tools	5-53

GENERAL DESCRIPTION

All vehicles are equipped with a dual hydraulic brake system.

The split system consists basically of two separate brake systems. When a failure is encountered on either, the other is adequate to stop the vehicle. If one system is not functioning, it is normal for the brake pedal lash and pedal effort to substantially increase. This occurs because of the design of the master cylinder which incorporates an actuating piston for each system. When the rear system loses fluid, its piston will bottom against

the front piston. When the front system loses fluid, its piston will bottom on the end of the master cylinder body. The pressure differential in one of the systems causes an uneven hydraulic pressure balance between the front and rear systems. The combination valve (near the master cylinder) detects the loss of pressure and illuminates the brake alarm indicator light on the instrument panel. The pressure loss is felt at the brake pedal by an apparent lack of brakes for most of the

brake travel and then, when failed chamber is bottomed, the pedal will harden.

If a vehicle displays these symptoms, it is a good indication that one of the systems contains air or has failed, and it is necessary to bleed or repair the brakes.

MASTER CYLINDER

The system is designed with a separate hydraulic system for the front and rear brakes using a dual master cylinder. The cylinder has two separate reservoirs and outlets in a common body casting.

COMBINATION VALVE

All models have a combination valve. The front and rear hydraulic lines are routed through this combination "metering" and "brake failure warning switch" to their appropriate wheel cylinders or caliper.

The metering portion of the combination valve tends to "hold off" front hydraulic pressure until the rear brake system overcomes the pull back springs; then pressure is allowed to flow with the result being a good distribution of braking effort.

The brake failure warning switch portion of the combination valve "senses" a loss of hydraulic pressure,

if a failure should occur, and turns "on" a red light in the dash to warn the operator of the failure.

DISC BRAKES FRONT

All models have disc brakes on the front. The one piece caliper mounts on the steering knuckle/steering arm, which is also a one piece casting, and astride the brake disc. The caliper is the single piston design which is said to be a sliding caliper sliding piston. No front brake adjustment is necessary once the system is in operation and the pedal has been stroked to "seat" the shoes to the caliper.

DISC BRAKES REAR (JF9)

Rear disc brakes operate in the same manner as front disc brakes except the caliper is mounted to a support attached to the axle flange.

DRUM BRAKES REAR

The rear brakes are duo servo and self adjusting. Brake adjustment takes place when the brakes are applied with a firm pedal effort while the vehicle is backing up. Applying the brakes moves the actuator which turns the star wheel and lengthens the adjuster screw assembly. This action moves the shoes outward until clearance between the lining and drum is within proper limits.

DIAGNOSIS

INSPECTION AND TESTING BRAKES

Testing Brakes

CAUTION: *New linings must be protected from severe use for several hundred miles.*

Brakes should be tested on dry, clean, reasonably smooth and level roadway. A true test of brake performance cannot be made if roadway is wet, greasy or covered with loose dirt so that all tires do not grip the road equally. Testing will also be adversely affected if roadway is crowned so as to throw weight of vehicle toward wheels on one side or if roadway is so rough that wheels tend to bounce.

Test brakes at different vehicle speeds with both light and heavy pedal pressure; however, avoid locking the wheels and sliding the tires on roadway. Locked wheels and sliding tires do not indicate brake efficiency since heavily braked but turning wheels will stop vehicle

in less distance than locked wheels. More tire-to-road friction is present with a heavily braked turning tire than with a sliding tire.

External Conditions that Affect Brake Performance

1. **Tires**--Tires having unequal contact and grip on road will cause unequal braking. Tires must be equally inflated and tread pattern of right and left tires must be approximately equal.
2. **Vehicle Loading**--When vehicle has unequal loading, the most heavily loaded wheels require more braking power than others. A heavily loaded vehicle requires more braking effort.
3. **Front Wheel Bearings**--A loose front wheel bearing permits the drum to tilt and have spotty contact with the brake shoe linings causing erratic action.
4. **Front End Alignment**--Misalignment of the front end, particularly in regard to limits on camber and theoretical king pin inclination, will cause the brakes to pull to one side.

CONDITION	POSSIBLE CAUSE	CORRECTION
Pulls	1. Incorrect tire pressures.	1. Inflate evenly on both sides to the recommended pressures.
	2. Front end out of line.	2. Check and align to manufacturer's specifications.
	3. Unmatched tires on same axle. For radial tire lead refer to Section 3E.	3. Tires with approximately the same amount of tread should be used on the same axle.
	4. Restricted brake pipes or hoses.	4. Check for soft hoses and damaged lines. Replace with new hoses and new double-walled steel brake tubing.
	5. Malfunctioning caliper assembly.	5. Check for stuck or sluggish pistons, proper lubrication. Remove and rebuild caliper.
	6. Defective or damaged shoe and lining (grease or brake fluid on lining or bent shoe).	6. Install new shoe and lining in complete axle sets.
	7. Malfunctioning rear brakes.	7. Check for inoperative auto adjusting mechanism, defective lining (grease or brake fluid on lining) or defective wheel cylinders. Repair as necessary.
	8. Loose suspension parts.	8. Check and torque all suspension mountings to specifications.
	9. Loose calipers.	9. Check and torque bolts to specifications.
Noise (high pitched squeak without brake applied).	1. Front linings worn out.	1. Replace linings.
Brake roughness or chatter (Pedal Pulsates)	1. Excessive lateral runout.	1. Check per instructions and replace or machine rotor, if not within specifications.
	2. Parallelism not within specifications.	2. Check per instructions and replace or machine the rotor, if not within specifications.
	3. Wheel Bearings not adjusted.	3. Adjust wheel bearings to correct specifications.
	4. Rear drums out of round.	4. Check runout and, if not within specifications, turn the drums (not over maximum of 0.060 on the diameter).

CONDITION	POSSIBLE CAUSE	CORRECTION
Brake roughness or chatter (Pedal Pulsates) — Continued	5. Shoe reversed (steel against iron).	5. Replace shoe and lining and machine rotor within specifications.
Excessive Pedal Effort	1. Malfunctioning power brake.	1. Check power brake and repair if necessary.
	2. Partial system failure.	2. Check front and rear brake system and repair, if necessary. Also, check and repair brake warning light circuit if a failed system is found and light did not function.
	3. Excessively worn shoe and lining.	3. Check and replace in axle sets.
	4. Piston in caliper stuck or sluggish.	4. Remove caliper and rebuild.
	5. Fading brakes due to incorrect lining.	5. Remove and replace with original equipment lining (or equivalent).
Excessive Pedal Travel	1. Partial brake system failure.	1. Check both front and rear system for a failure and repair. Also check and repair warning light circuit. It should have indicated a failure.
	2. Insufficient fluid in master cylinder.	2. Fill reservoirs with approved brake fluid. Check for leaks. Check warning light.
	3. Air trapped in system.	3. Bleed system.
	4. Rear brake not adjusting.	4. Adjust rear brakes and repair auto adjusters.
	5. Bent shoe and lining.	5. Replace axle set of shoe and lining.
Dragging Brakes (A very light drag is present in all disc brakes immediately after pedal is released.)	1. Master cylinder pistons not returning correctly.	1. With reservoir cover off, check for fluid spurt at bypass holes as pedal is depressed. Adjust push rod, if necessary, or rebuild master cylinder.
	2. Restricted brake pipes or hoses.	2. Check for soft hoses or damaged pipes and replace with new hoses and new double-walled steel brake tubing.

CONDITION	POSSIBLE CAUSE	CORRECTION
Dragging Brakes (A very light drag is present in all disc brakes immediately after pedal is released.) — Continued	3. Incorrect parking brake adjustment on rear brakes.	3. Check and readjust to correct specifications.
	4. Check valve installed in outlet to front disc brakes.	4. Check master cylinder outlet and remove check valve if present.
Grabbing or Uneven Braking Action	1. All conditions listed under "PULLS".	1. All corrections listed under "PULLS".
	2. Malfunction of combination valve.	2. Replace and bleed system.
	3. Malfunction of power brake unit.	3. Check operation and repair, if necessary.
	4. Binding brake pedal mechanism.	4. Check and lubricate, if necessary. Possibly replace pedal bushing and/or spacer.
Pulsation (roughness) Felt during normal brake application.	1. Uneven pad wear caused by caliper not sliding due to improper clearance or dirt.	1. Remove caliper and correct as necessary.
	2. Uneven rotor wear causing a thickness variation between the two braking surfaces.	2. Machine rotors as follows: <ol style="list-style-type: none"> a. Machine rotors to obtain a circumferential thickness variation no greater than .0005" in 360° and a lateral runout no greater than .004" (max. rate of change not exceed .001" in 30°). b. Check caliper freeness. With rotor removed, install caliper and mounting bolts (pins). Check for .005"-.012" clearance at both top and bottom of caliper. If less than .005" is found, file with a flat file until at least .005" is obtained. DO NOT EXCEED A MAXIMUM of .012" per end or .024" total clearance. Caliper clearance to inboard and outboard reaction pads must be equal within .004" both at the top and bottom of the caliper. This is to ensure correct alignment of caliper to knuckle during a brake application. c. Remove caliper after freeness check. Clean pins and sleeves, replace "O" rings, and apply a light coating of silicone grease or equivalent to all contact points and "O" rings.

CAUSE	SYMPTOM												
	Excessive Brake Pedal Travel	Brake Pedal Gradually Increases	Excessive Brake Pedal Effort	Brakes Slow to Respond	Brakes Slow to Release	Brakes Drag (Side to Side)	Uneven Braking Action (Front to Rear)	Scraping Noise from Brakes	Brakes Squeak During Application	Brakes Squeak During	Brakes Chatter During Stop	Brakes Groan (Roughness) at End of Stop	Brake Tell-tale Glows During Stop
Leaking Brake Line or Connection	X	XX							X				XX
Leaking Wheel Cylinder or Piston Seal	X	XX		X				X					X
Leaking Master Cylinder	X	XX											X
Air In Brake System	XX								X				XX
Contaminated or Improper Brake Fluid					X	X	X						X
Leaking Vacuum System			XX	X									
Restricted Air Passage in Power Head			X		XX	X							
Damaged Power Head			X	X	X	X	X						
Improperly Assembled Power Head Valving			X	X	X	X	XX						
Worn Out Brake Lining - Replace			X	X				X	X	X	X	X	X
Uneven Brake Lining Wear - Replace and Correct	X			X				X	X	X	X	XX	X
Glazed Brake Lining			XX		X			X	X		X	X	
Incorrect Lining Material - Replace			X	X				X	X		X	X	X
Contaminated Brake Lining - Replace				XX				XX	XX	X	X	X	X
Linings Damaged by Abusive Use - Replace			X	XX				X	X	X	X	X	X
Excessive Brake Lining Dust			X	XX				XX	XX		X	XX	X
Heat Spotted or Scored Brake Drums or Rotors				X				X	X		X	X	XX
Out-of-Round or Vibrating Brake Drums											X	XX	
Out-of-Parallel Brake Rotors												XX	
Excessive Rotor Run-Out												X	
Faulty Automatic Adjusters	X							X	X	X			X
Incorrect Wheel Cylinder Sizes			X	X				X	X				
Weak or Incorrect Brake Shoe Retention Springs				X		X	XX	X	X	XX	X	XX	
Brake Assembly Attachments - Missing or Loose	X							X	X	X	X	X	X
Insufficient Brake Shoe Guide Lubricant						X	X	X	X	XX	XX		
Restricted Brake Fluid Passage or Sticking Wheel Cylinder Piston		X	X		X	X	X	X	X				
Faulty Metering Valve	X		X	X	X	X	X		X				X
Brake Pedal Linkage Interference or Binding			X		X	XX	XX						
Improperly Adjusted Parking Brake							X						
Drums Tapered or Threaded										XX			
Incorrect Front End Alignment								XX					
Incorrect Tire Pressure								X	X				
Incorrect Wheel Bearing Adjustment	X									X		X	
Loose Front Suspension Attachments								X		XX		X	X
Out-of-Balance Wheel Assemblies												XX	
Operator Riding Brake Pedal	X	X	X					X		X			X
Improperly Adjusted Master Cylinder Push Rod	X					X	XX						X
Sticking Wheel Cylinder or Caliper Piston			X		X	X	X	X	X				
Faulty Proportioning Valve			X		X	X	X						

XX - Indicates more probable causes

X - Indicates causes

DIAGNOSIS - HYDRO - BOOST SYSTEM

NOTE: Before checking the hydraulic power booster for the source of trouble, refer to the trouble diagnosis procedures for Standard Brakes. After these possible causes have been eliminated, check for the probable cause and remedy as outlined below:

Normal Operating Characteristics

Brake pedal application of the Hydro-boost system differs in some respects from a vacuum type power brake system in the following manner:

1. On pedal application until booster run-out, slight power steering pump noise may be heard.
2. Pedal application through run-out will not necessarily be smooth due to the internal ratio change. It is possible to push the pedal past run-out because of the higher pedal ratio. At run-out of the vacuum booster the pedal just becomes hard.
3. On the first full application of the brake pedal, a slight hissing sound may be heard. The hiss is the accumulator charging and the noise should go away in a short period of time.
4. On a spike brake application, a slight pedal kick-back may be felt.
5. If the vehicle is started with the pedal depressed, the pedal will fall away slightly then return back to approximately the original position.

NO BOOST - HARD PEDAL

Preliminary Check

With the engine stopped, depress the brake pedal several times to eliminate all accumulator reserve from the system.

Hold the brake pedal depressed with medium pressure (25 to 35 lbs.), start the engine. If the unit is operating correctly, the brake pedal will fall slightly and then push back against the driver's foot, remaining at about the same position. If the booster is not operating correctly, the trouble may be one of the following causes:

Probable Cause	Remedy
1. Loose or broken power steering pump belt.	1. Tighten or replace the belt.
2. No fluid in power steering reservoir.	2. Fill reservoir and check for external leaks.
3. Leaks in power steering, booster or accumulator hoses.	3. Replace defective parts.
4. Leaks at tube fittings, power steering, booster or accumulator connections.	4. Tighten fittings or replace tube seats, if defective.
5. External leakage at accumulator.	5. Replace booster.
6. Faulty booster piston seal causing leakage at booster flange vent.	6. Replace all booster seals.
7. Faulty booster input rod seal with leakage at input rod end.	7. Replace all booster seals.
8. Faulty booster cover seal with leakage between housing and cover.	8. Replace all booster seals.
9. Faulty booster spool plug seal.	9. Replace all booster seals.
10. Internal leakage in booster.	10. Replace booster.
11. Contamination in power steering fluid.	11. Flush power steering system and replace with new fluid.
12. Hydraulic lines routed incorrectly.	12. Re-route lines.

DIAGNOSIS - HYDRO - BOOST SYSTEM

SLOW BRAKE PEDAL RETURN

Probable Cause	Remedy
1. Excessive seal friction in booster.	1. Replace all booster seals.
2. Faulty spool action.	2. Clean spool and replace all booster seals.
3. Broken piston return spring.	3. Replace spring.
4. Restriction in return line from booster to pump reservoir.	4. Replace line.
5. Broken spool return spring.	5. Replace spring.
6. Excessive pedal pivot friction.	6. Lubricate pivot bushings with Delco Brake Lube #5450032 (or equivalent) or replace bushings.

GRABBY BRAKES

Probable Cause	Remedy
1. Broken spool return spring.	1. Replace spring.
2. Faulty spool action caused by contamination in system.	2. Inspect, clean and replace all booster seals.
3. No cargo body on chassis.	3. Normal condition.

BOOSTER CHATTERS - PEDAL VIBRATES

Probable Cause	Remedy
1. Power steering pump belt slips.	1. Tighten belt.
2. Low fluid level in power steering pump reservoir.	2. Fill reservoir and check for external leaks.
3. Faulty spool operation caused by contamination in system.	3. Inspect, clean and replace all booster seals.
4. Excessive contamination in power steering fluid.	4. Flush power steering fluid from system and replace with new power steering fluid.
5. Air in power steering fluid.	5. Allow vehicle to stand for approximately one hour; then bleed power steering hydraulic system as described earlier in this section.

DIAGNOSIS - HYDRO-BOOST SYSTEM

POWER STEERING PUMP NOISE ON BRAKE APPLY

Probable Cause	Remedy
1. Insufficient fluid in pump reservoir.	1. Fluid level decreases approximately 1/2" on brake apply-refill to proper level. If fluid is foamy, let vehicle stand for approximately one hour; then bleed power steering hydraulic system as outlined earlier in this section.

BRAKE PEDAL PULLS DOWN SLIGHTLY ON ENGINE START

Probable Cause	Remedy
1. Restriction in gear or booster return lines.	1. Replace lines or reposition lines to eliminate restriction.

ACCUMULATOR LEAKDOWN - SYSTEM DOES NOT HOLD CHARGE

Preliminary Check

Start engine and turn the steering wheel until the wheels contact the wheel stops lightly. Hold for a maximum of five seconds. Then release the steering wheel and turn off the engine.

Depress and release the brake pedal. There should be a minimum of three power assisted brake applications before a hard pedal is obtained.

Re-start the engine and turn the steering wheel until the wheels contact the wheel stops lightly. There should be a light hissing sound as the accumulator is charged. Hold steering wheel lightly against stop for a maximum of five seconds. Then release the steering wheel, and turn off the engine.

Wait one hour and apply brake pedal (do not re-start the engine). There should still be a minimum of three power assisted brake applications before obtaining a hard pedal.

If either of these preliminary checks shows that the accumulator is not holding its charge, the trouble may be one of the following causes.

Probable Cause	Remedy
1. External leakage at accumulator.	1. Replace booster assembly.
2. Internal leakage in accumulator.	2. Replace booster.
3. Internal leakage at booster accumulator valve (if accumulator is not leaking externally or internally).	3. Replace all booster seals and accumulator valves.

ON-VEHICLE SERVICE

PEDAL TRAVEL

At reasonably frequent intervals, the brakes should be inspected for pedal travel, which is the distance the pedal moves toward the floor from a fully-released position. Inspection should be made with the brake pedal firmly depressed (approximately 90 lbs.) while the brakes are cold.

C-K-G Manual 4.5"

C-K-G Power 3.5"

P (Except JF9) 3.5"

P (JF9) 6.0"

On power brake-equipped vehicles, pump the pedal a minimum of 3 times with the engine off before making pedal travel checks. This exhausts all vacuum from the power booster.

STOP LIGHT SWITCH

Adjustment

The stop light switch is mounted on a flange protruding from the brake pedal support.

1. Release the brake pedal to its normal position.

2. Adjust switch by turning in or out as necessary.

Electrical contact should be made when the brake pedal is depressed 1.0-1.24" (C-K models), .70" (G-P models) from its fully released position.

3. Tighten switch locknut, if so equipped, and connect electrical harness.

BLEEDING AND FLUSHING BRAKE SYSTEM

Bleeding Brake Hydraulic System

A bleeding operation is necessary to remove air whenever it is introduced into the hydraulic brake system.

It may be necessary to bleed the hydraulic system at all four wheel cylinders if air has been introduced through low fluid level or by disconnecting brake pipes at master cylinder. If brake pipe is disconnected at any wheel cylinder, then that wheel cylinder only need be bled. If pipes are disconnected at any fitting located between master cylinder and wheel cylinders, then all wheel cylinders served by the disconnected pipe must be bled.

Manual Bleed

If the vehicle is equipped with power brakes, deplete the vacuum reserve by applying the brakes several times.

1. Fill master cylinder with brake fluid and keep at least one-half full of fluid during bleeding operation.

Bleed right rear brake, left rear brake, right front brake and left front brake.

2. With the proper size box end wrench or Tool J-21472 over bleeder valve, attach bleeder tube to valve and allow tube to hang submerged in brake fluid in a clean glass jar (fig. 5-1).

3. Open the bleeder valve and fully depress the brake pedal.

4. Close bleeder valve and release brake pedal.

5. Repeat steps 3 and 4 until all air is evacuated.

Check and refill master cylinder reservoir as required to prevent air from being drawn through master cylinder.

6. Repeat the bleeding procedure at all wheels if the entire system is to be bled.

7. Check the brake pedal, feel for "sponginess" and repeat entire bleeding procedure if necessary.

Flushing Brake Hydraulic System

It is recommended that the entire hydraulic system be thoroughly flushed with clean brake fluid whenever new parts are installed in the hydraulic system.

Flushing is also recommended if there is any doubt as to the grade of fluid in the system. If fluid has been used which contains the slightest trace of mineral oil, all rubber parts that have been subjected to the contaminated fluid should be replaced.

BRAKE PIPES

Replacement (Figs. 5-2 thru 5-4)

WARNING: NEVER USE COPPER TUBING BECAUSE COPPER IS SUBJECT TO FATIGUE CRACKING AND CORROSION WHICH COULD RESULT IN BRAKE FAILURE.

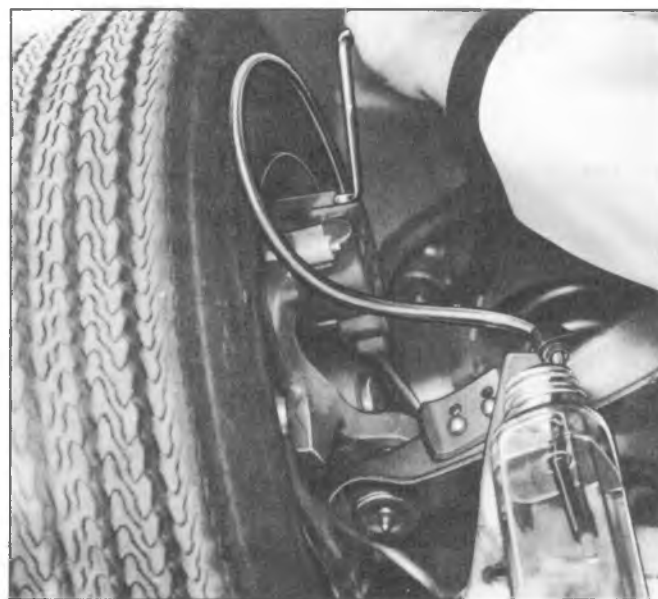


Fig. 5-1--Bleeding Wheel Cylinder

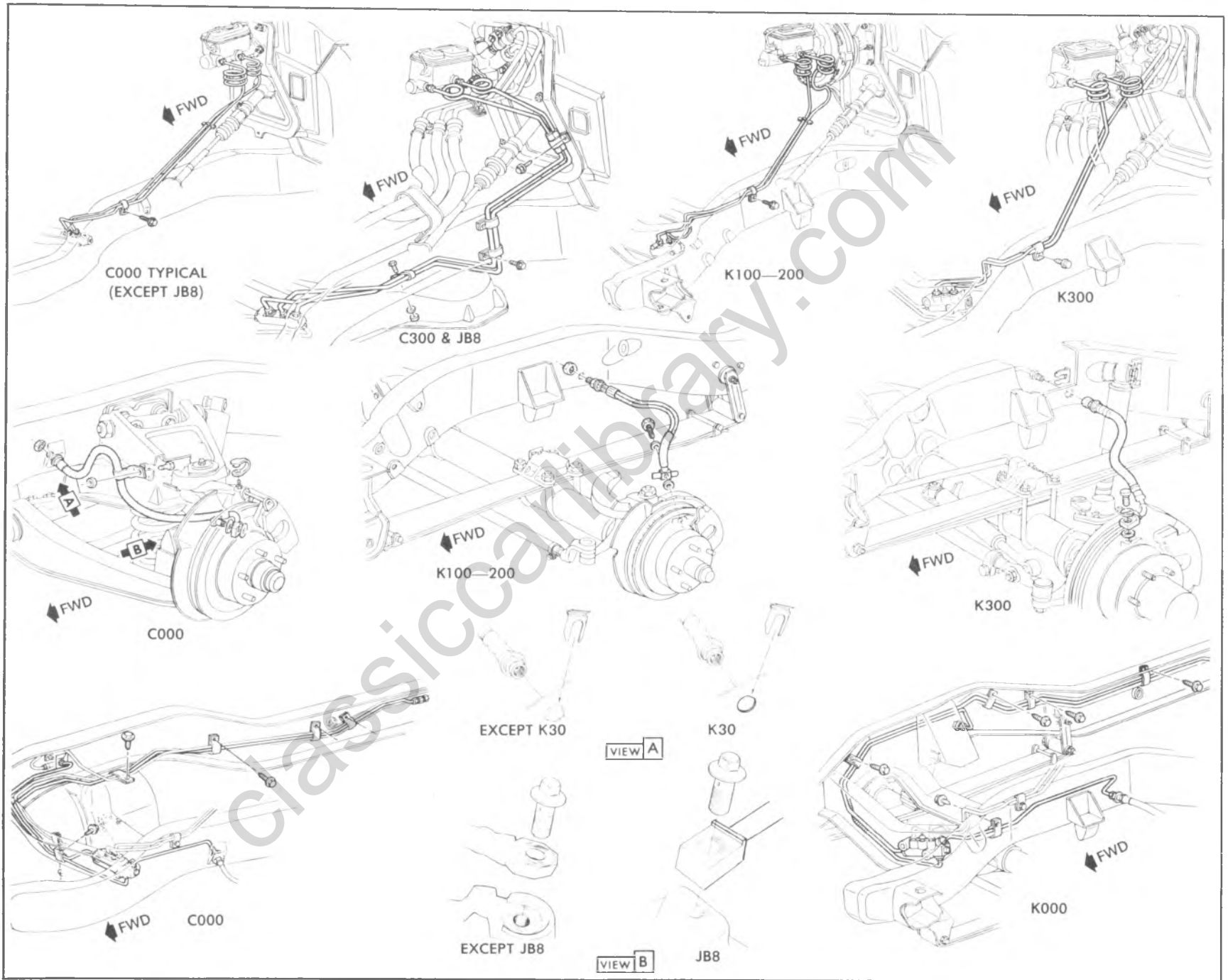


Fig. 5-2: Front Brake Pipes and Hoses—C-K Models

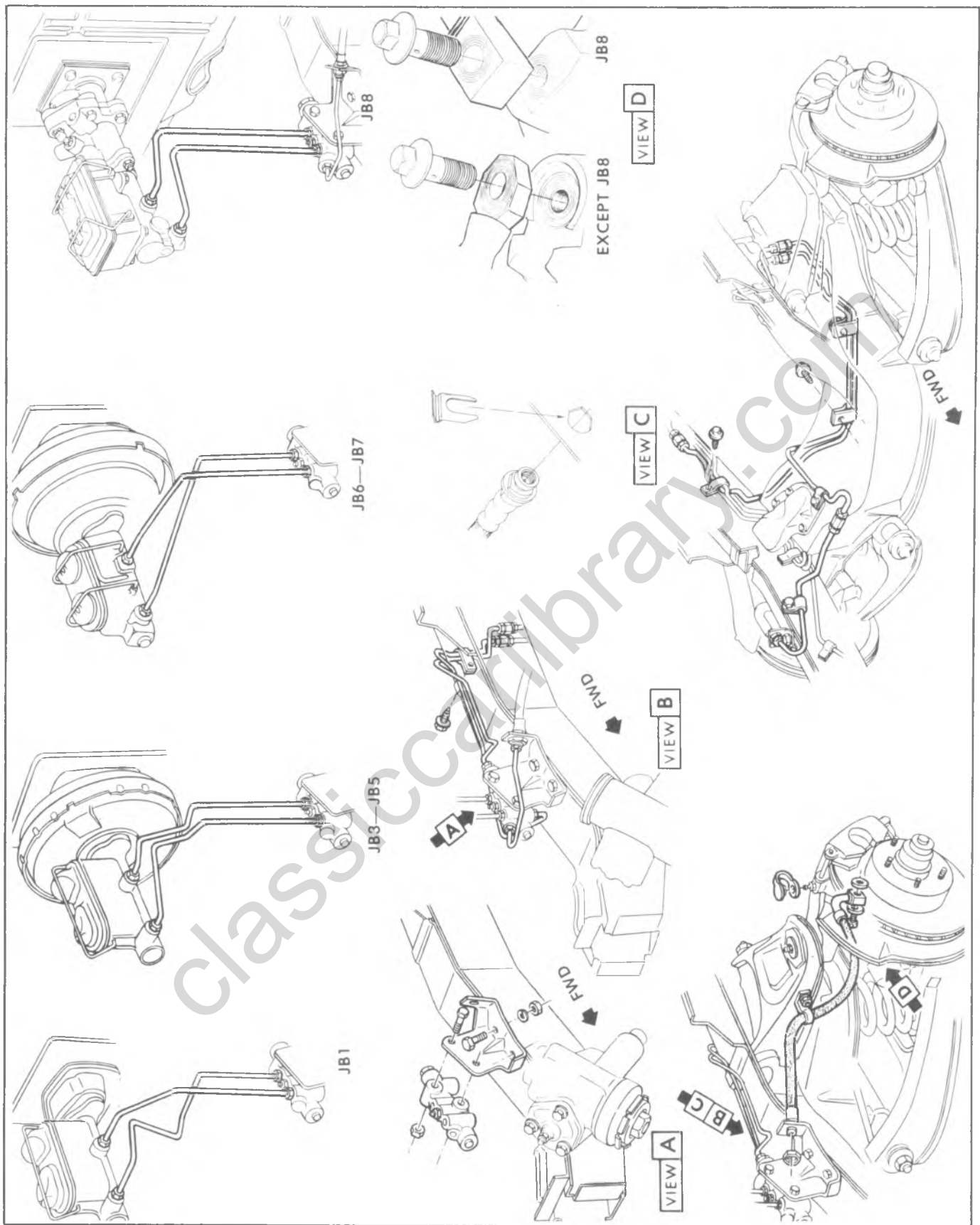
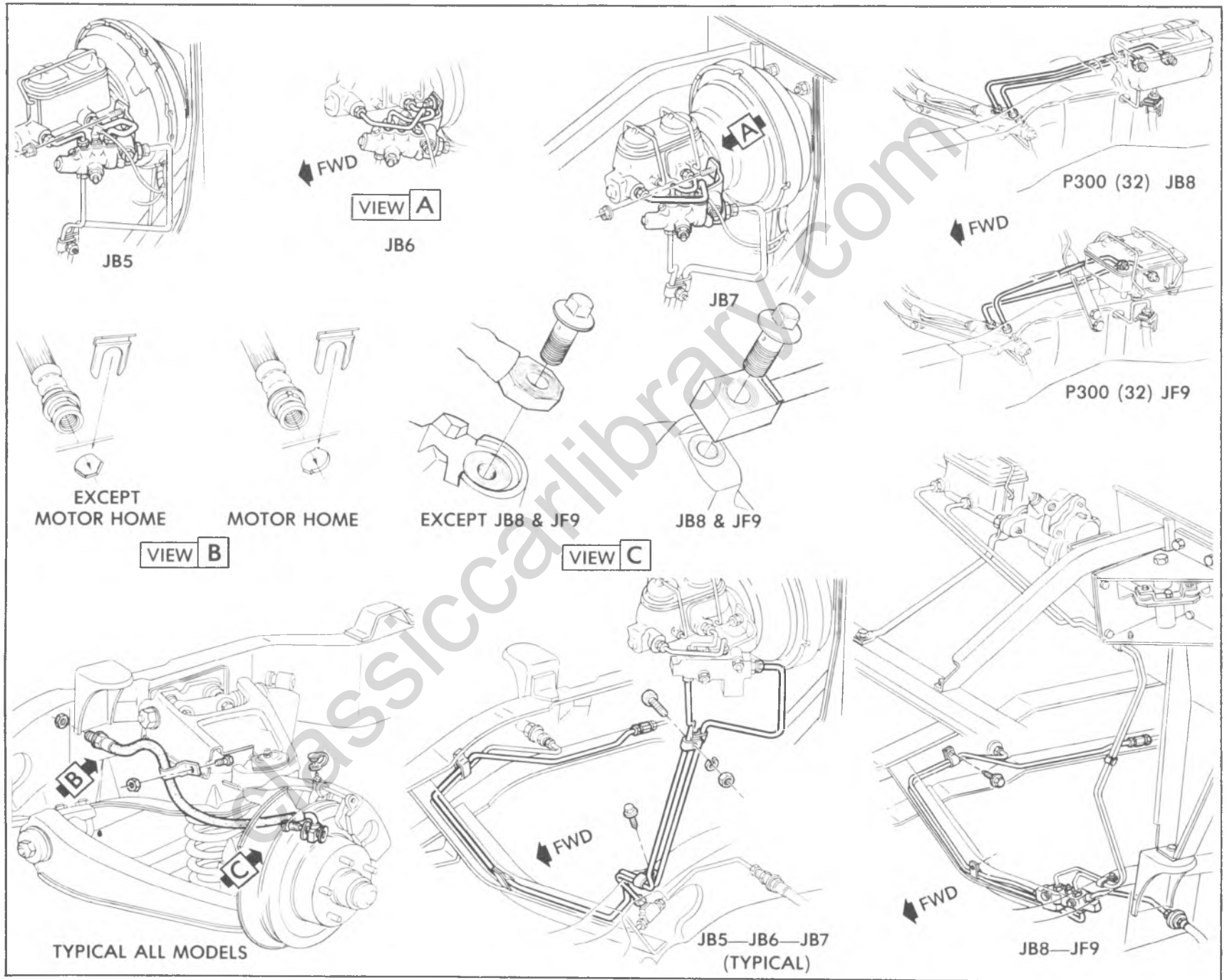


Fig. 5-3-Front Brake Pipes and Hoses--G Models

Fig. 5-4: Front Brake Pipes and Hoses—P Models



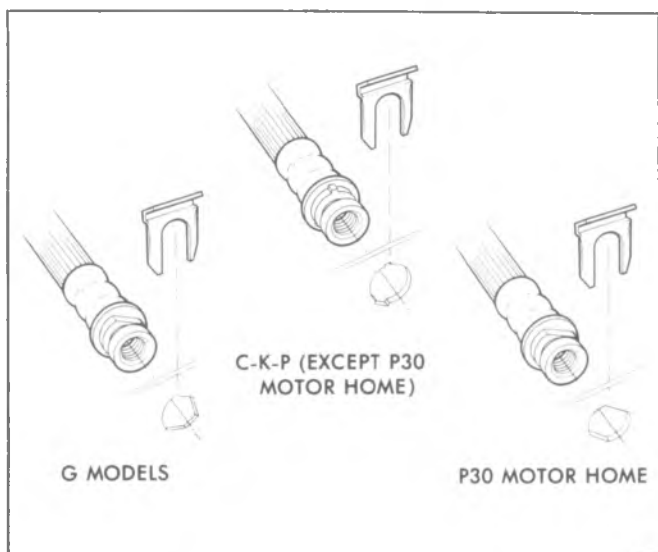


Fig. 5-5--Typical Rear Hose Fittings

1. Procure the recommended tubing and steel fitting nuts of the correct size. (Outside diameter of tubing is used to specify size.)

2. Cut tubing to length. Correct length may be determined by measuring old pipe using a cord and adding 1/8" for each double flare.

3. Double flare tubing ends using a suitable flaring tool such as J-23530. Follow instructions included in tool set.

Make sure fittings are installed before starting second flare.

WARNING: DOUBLE FLARING TOOL MUST BE USED AS SINGLE FLARING TOOLS CANNOT PRODUCE A FLARE STRONG ENOUGH TO HOLD THE NECESSARY PRESSURE.

4. Bend pipe assembly to match old pipe using a tubing bender. Clearance of .75" must be maintained to all moving or vibrating parts.

BRAKE HOSES

Inspection

The flexible hydraulic brake hose which transmits hydraulic pressure from the steel brake pipe on the frame to the rear axle and to the calipers should be inspected every 4 months or 6,000 miles (heavy duty emission vehicles), every 12 months or 7,500 miles (light duty emission vehicles). The brake hose assembly should be checked for road hazard damage, for cracks and chafing of the outer cover, and for leaks and blisters. A light and mirror may be needed for an adequate

inspection. If any of the above conditions are observed on the brake hose, it will be necessary to replace it.

Front Brake Hose

Removal (figs. 5-2 thru 5-4)

1. Raise vehicle on hoist.
2. Clean dirt and foreign material from both hose end fittings.
3. Disconnect brake pipe from hose fitting using a back-up wrench on fitting. Be careful not to bend frame bracket or brake pipe. It may be necessary to soak the connections with penetrating oil.
4. Remove "U" clip from female fitting at bracket and remove hose from bracket.
5. Remove bolt from caliper end of hose. Remove hose from caliper, and discard the two copper gaskets on either side of fitting block.

Installation

1. Use new copper gaskets on both sides of fitting block, wet bolt threads with brake fluid, then with fitting orientation flange engaged with the caliper orientation ledge on JB8 and JF9 (hose located in caliper gate on all except JB8 and JF9), fasten hose to caliper; torque to specifications.
2. With weight of vehicle on suspension, pass female fitting through frame or frame bracket. Fitting fits the bracket in only one position. With least amount of twist in hose, install fitting in this position. There should be no kinks in hose.
3. Install "U" clip to female fitting at frame bracket.
4. Attach brake pipe to hose fitting using a backup wrench on fitting; torque to specifications.
5. Inspect to see that hose doesn't make contact with any part of suspension. Check in extreme right hand and extreme left hand turn conditions. If hose makes any contact, remove and correct.
6. Bleed brake system.
7. Lower vehicle from hoist.

Rear Brake Hose

Removal

1. Raise vehicle on hoist.
2. Remove all three brake pipes from hose, two at junction block and, with the use of a back-up wrench, one on the female fitting at bracket. Be careful not to bend bracket or pipes; use penetrating oil if necessary.
3. Remove "U" clip and take female fitting out of bracket (fig. 5-5).
4. Observe position at which junction block is mounted to the axle. When installing new hose be sure this junction block is in the same position.
5. Remove bolt attaching junction block to axle.

Installation

1. Thread both rear axle pipes into junction block.
2. Bolt junction block to axle and then torque rear pipes into block.
3. Pass female end of hose through bracket;

female fitting will fit bracket in only 1 position (except G models), 2 positions (G models). Without twisting hose, position female end in bracket.

4. Install "U" clip.
5. Attach pipe to female fitting using a back-up wrench on fitting; torque to specification, again be careful not to bend bracket or pipe. Check to see that hose installation did not loosen frame bracket. re-torque bracket if necessary.
6. Bleed system.
7. Lower vehicle from hoist.

BLEEDING HYDRO-BOOST/POWER

STEERING HYDRAULIC SYSTEM

The following procedure should be used to bleed the power steering hydraulic system on hydro-boost vehicles.

NOTE: If the power steering fluid has foamed due to low fluid level, it will be necessary to park the vehicle for approximately one hour (reservoir cap loose) so that the foam can dissipate.

1. Raise the front of the vehicle on a hoist so that the tires are clear of the floor.
2. Check reservoir and fill with GM Power Steering Fluid (or equivalent).

NOTE: Leave the reservoir cap off during entire bleed procedure.

3. Install a remote control starter switch so that engine can be cranked but not started.

CAUTION: *Whenever the engine is cranked remotely at the starter, with a special jumper or other means, the distributor primary lead must be disconnected from the negative post on the coil.*

4. Crank engine for 4 to 5 second intervals while pouring fluid into the reservoir.
5. Fill reservoir and crank as in step 4 until system will no longer accept fluid. It is normal that fluid may spill when cranking stops (it is the result of air in the system trying to escape). To prevent spilling, crank engine.
6. Remove remote control starter switch. Reinstall distributor primary lead.
7. Start engine and allow to run 2 seconds.
8. Check and refill fluid reservoir if necessary.
9. Start engine and depress the brake pedal several times while rotating the steering wheel from stop to stop.
10. Turn engine off and then pump brake pedal 4-5 times to deplete accumulator pressure.
11. Check and refill fluid reservoir if necessary.
12. Repeat Steps 9, 10 and 11. Install pump reservoir cap.
13. Remove vehicle from hoist.

PARKING BRAKE PEDAL OR HANDLE

Removal (Fig. 5-9)

1. Place parking brake pedal or handle in the released position.

2. Remove nuts from the engine compartment on C, K and G models or bolts from mounting bracket on P models.

NOTE: Take notice of the spacers on P models for reinstallation.

3. Disconnect the release handle rod at the parking brake assembly end (C-K models).
4. Remove the bolts from the underside of the dash and lower the brake assembly (C-K-G Models).
5. **C-K-G Models**-Disconnect the cable ball from the parking brake clevis and remove the assembly.
- P Models**-Remove the clevis pin and disconnect the cable from the brake assembly; remove the assembly.

Installation

Reverse the removal procedure. Torque all bolts and nuts. After installing the clevis-pin, use a new cotter pin to secure the clevis pin. Adjust the cable if necessary as outlined below.

CAUTION: See "Caution" on Page 1 of this section.

PARKING BRAKE ADJUSTMENT

Adjustment of parking brake cable is necessary whenever holding ability is not adequate or whenever the center brake cables have been disconnected.

NOTE: The service brake must be properly adjusted as a base for parking brake adjustment; conversely the parking brake must be properly adjusted for the service brake to function as intended.

Inspection

If complete release of the parking brake is not obtained, unless it is forcibly returned to its released position, or if application effort is high, check parking brake assembly for free operation. If operation is sticky or a bind is experienced, correct as follows:

1. Clean and lubricate brake cables and equalizer with Delco Brake Lube (or equivalent).
2. Inspect brake assembly for straightness and alignment (replace if necessary).
3. Clean and lubricate parking brake assembly with Delco Brake Lube (or equivalent).
4. Checking routing of cables for kinks or binding.

Adjustment-Foot Pedal Type

NOTE: Before adjusting parking brake, check service brake condition and adjustment.

1. Raise vehicle on hoist.
2. Loosen the equalizer adjusting nut.
3. Apply parking brake 4 notches from fully released position.
4. Tighten the equalizer nut until a moderate drag is felt when the rear wheels are rotated forward.

CAUTION: See "Caution" on Page 1 of this section.

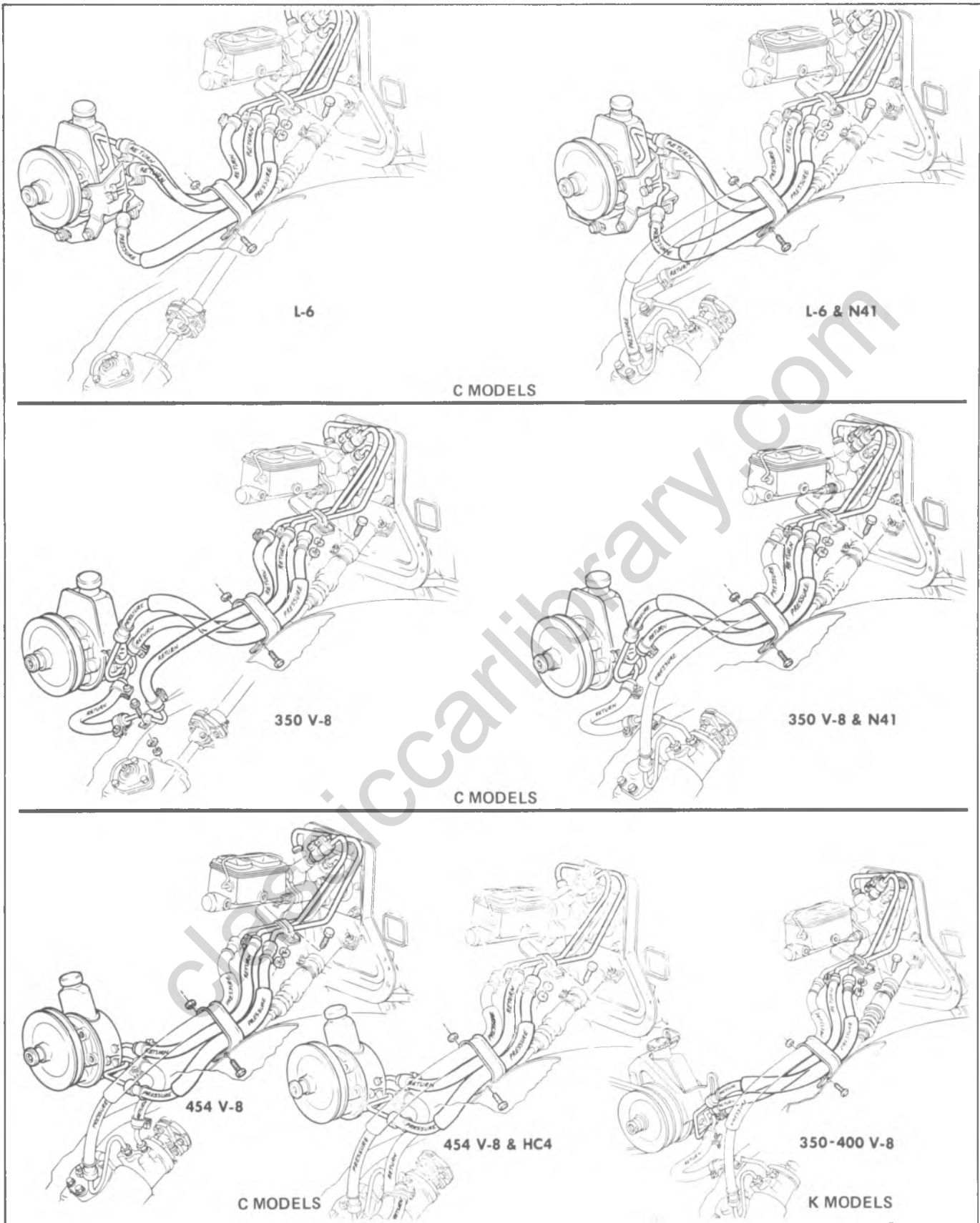


Fig. 5-6--Power Steering Hose Routing--C-K Models

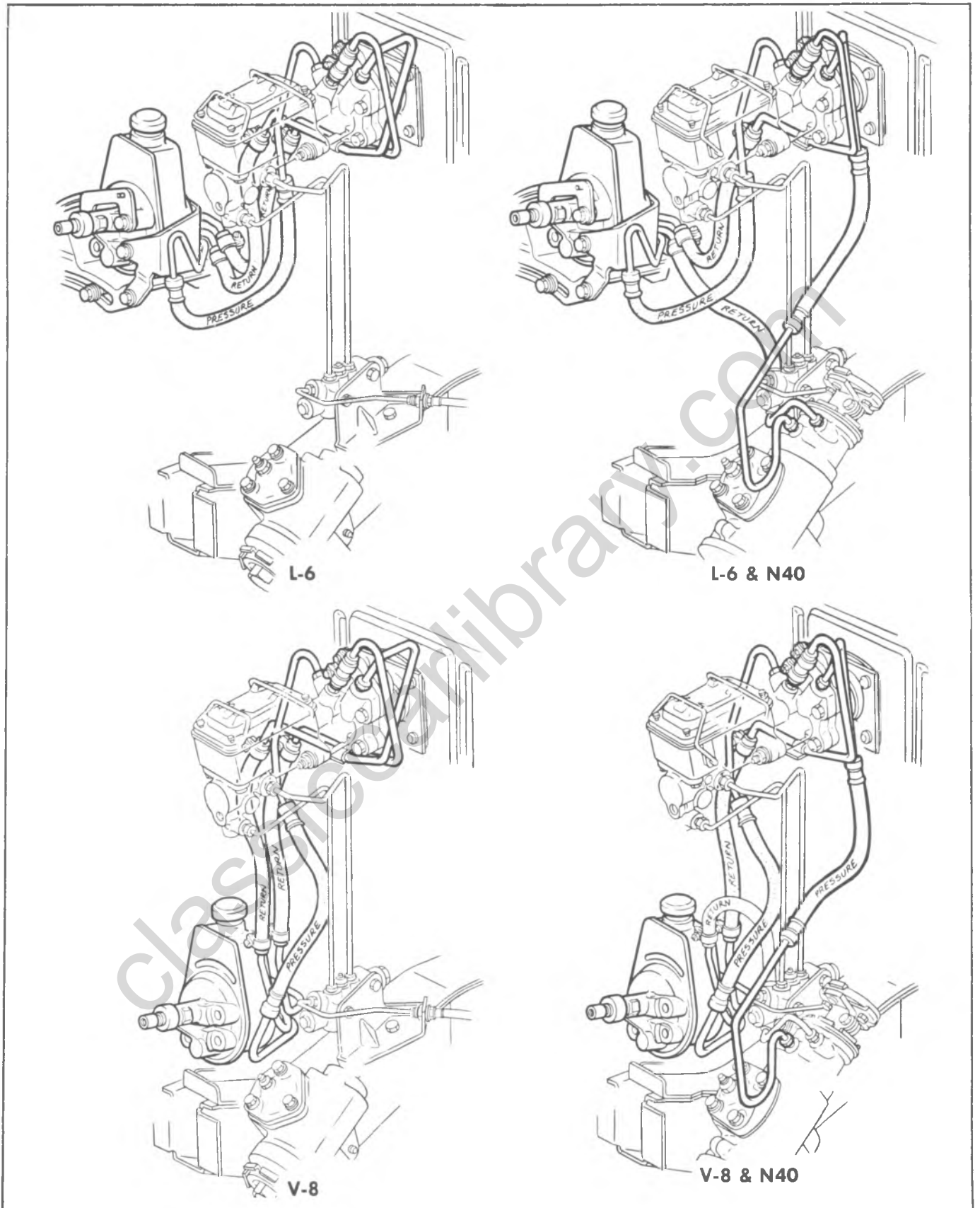


Fig. 5-7--Power Steering Hose Routing--G Models

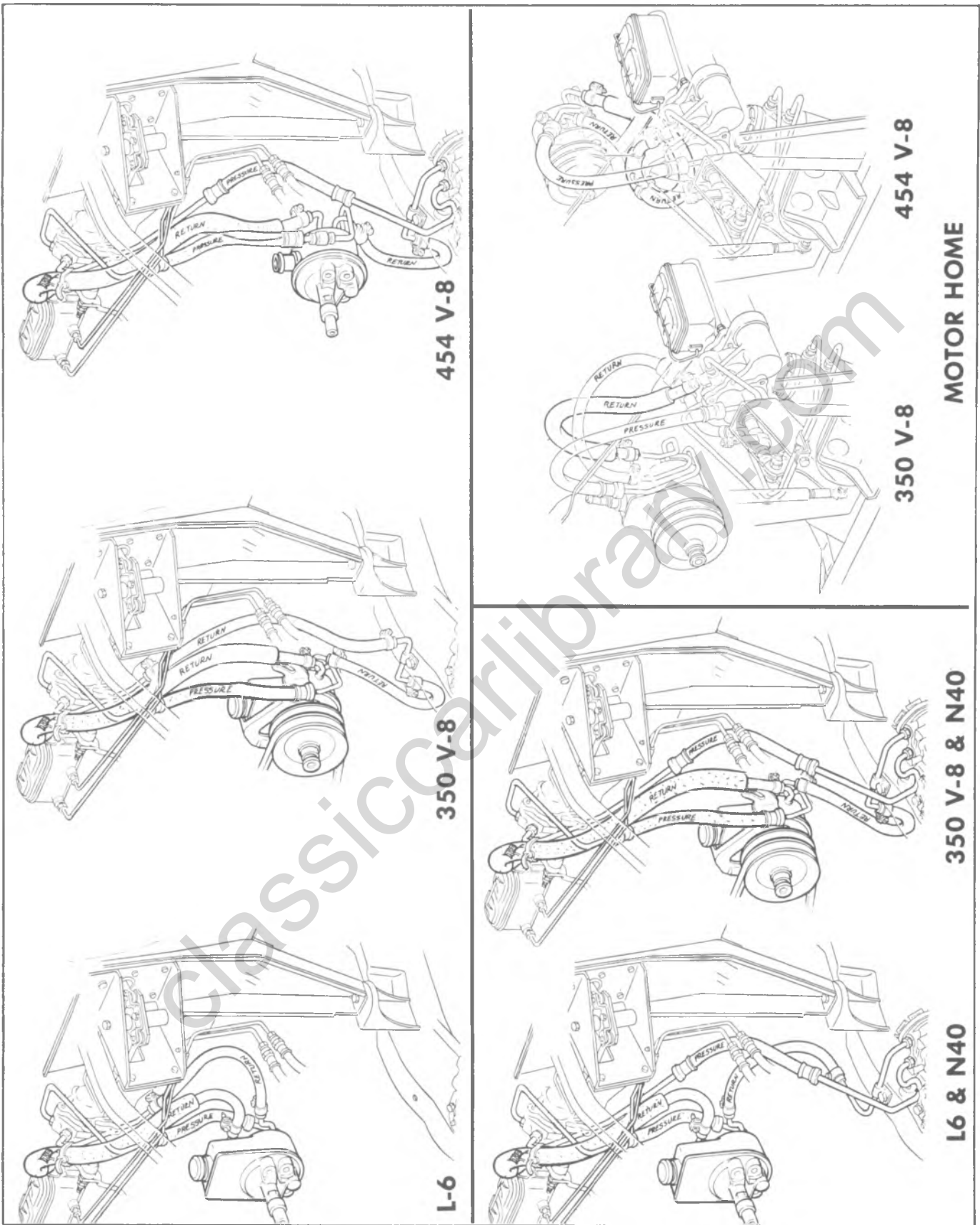


Fig. 5-8--Power Steering Hose Routing--P Models

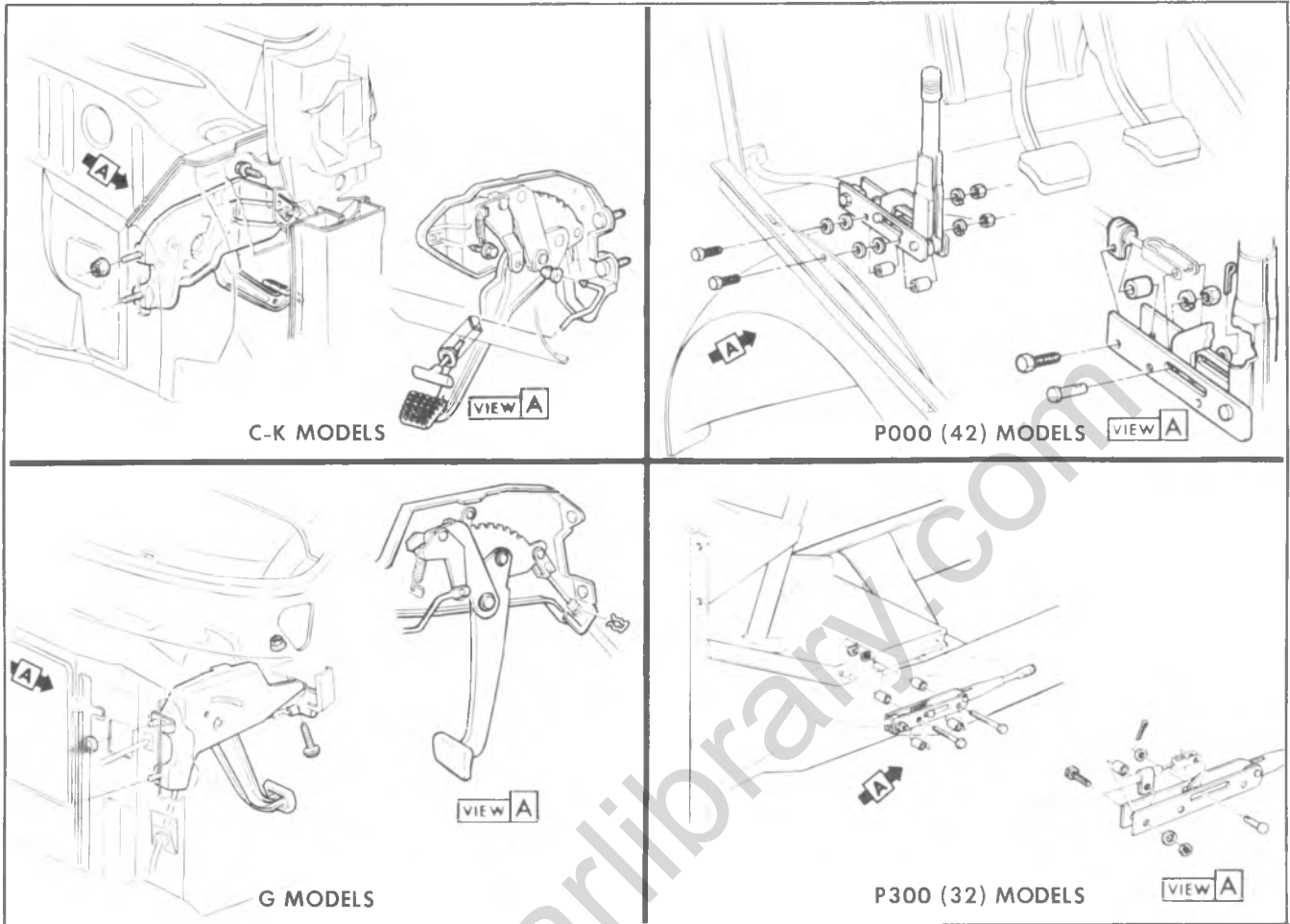


Fig. 5-9 -Parking Brake Assembly--Typical

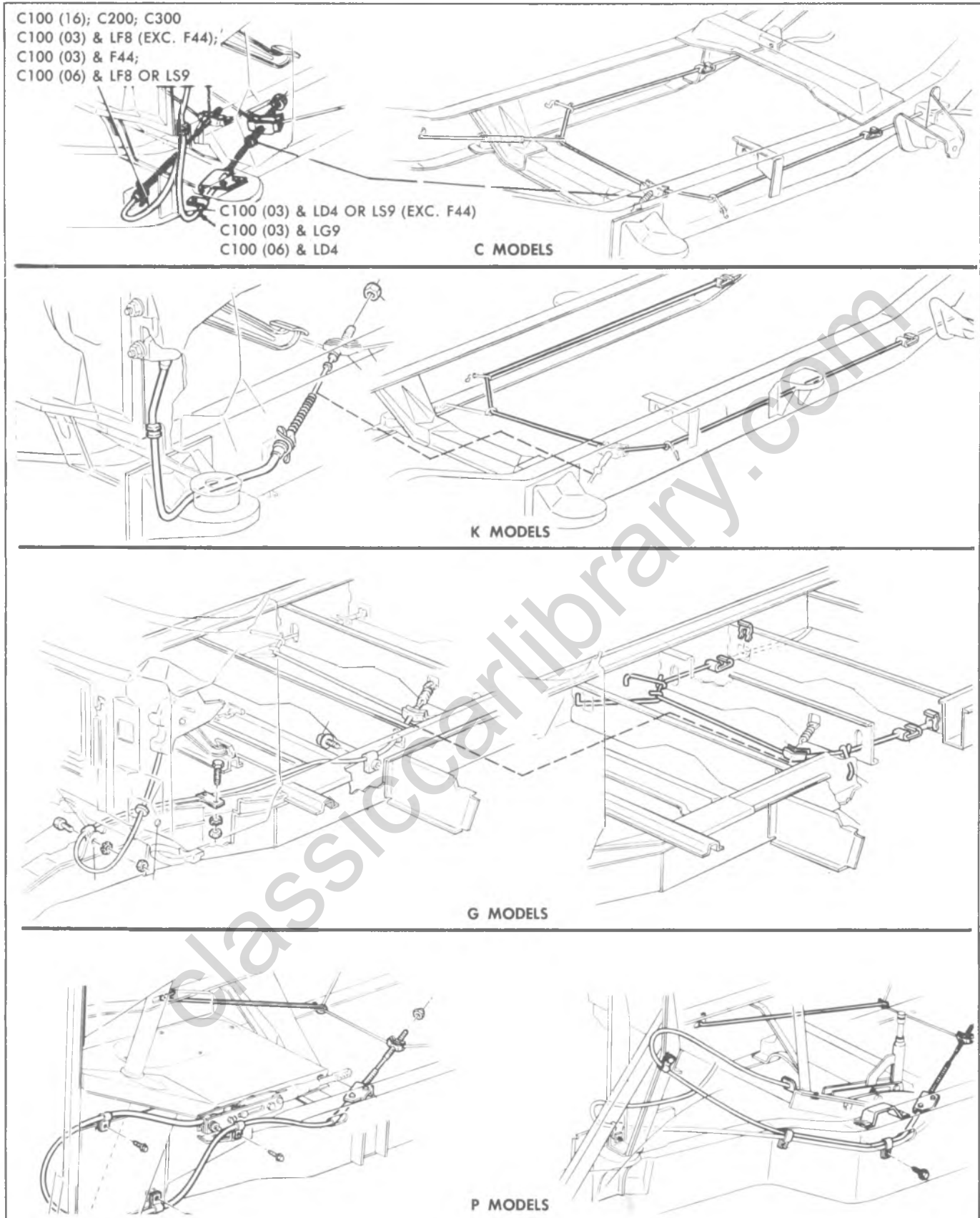


Fig. 5-10- Parking Brake System--Typical

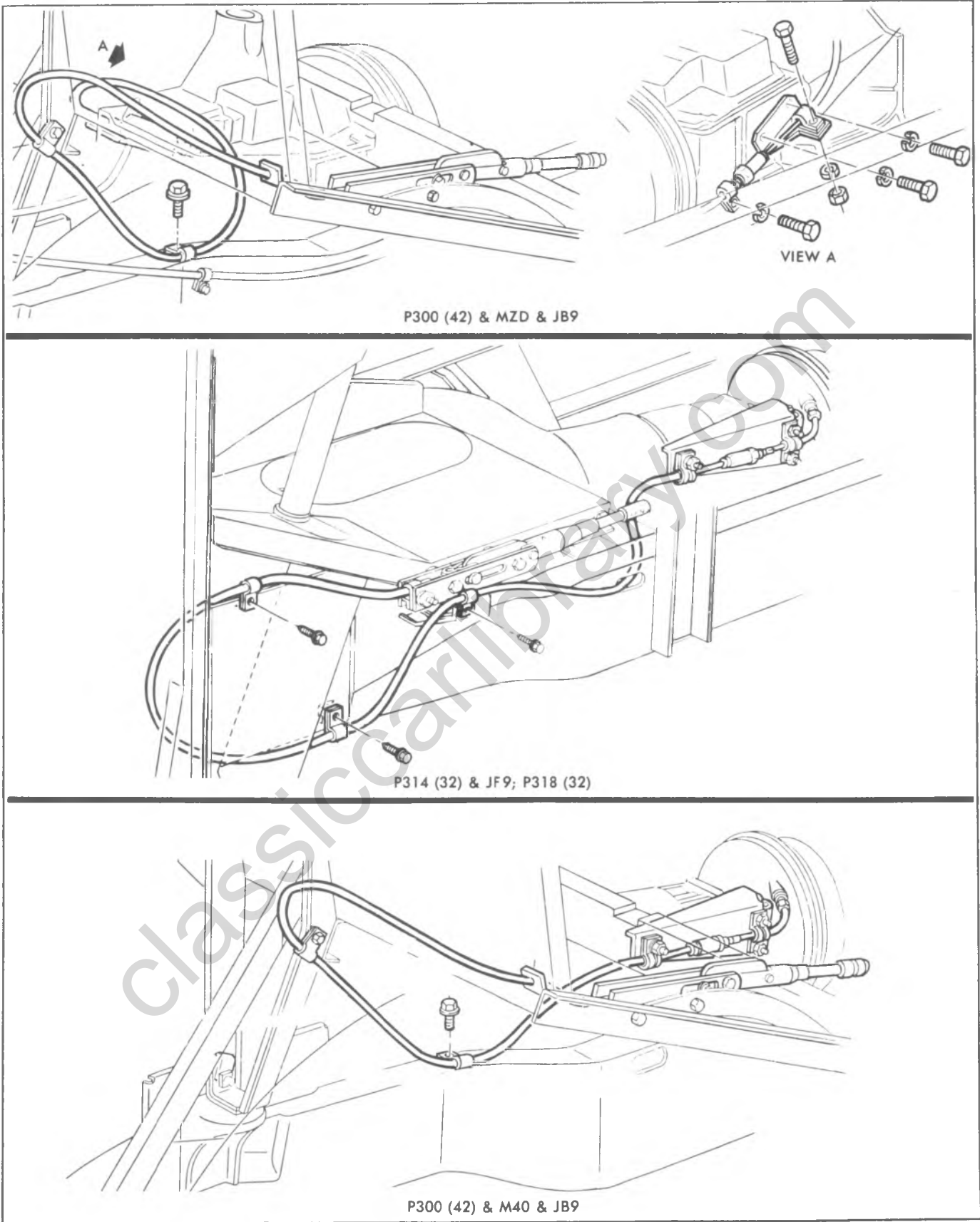


Fig. 5-11--Parking Brake System (Propshaft)

5. Fully release parking brake and rotate the rear wheels. No drag should be present.
6. Remove vehicle from hoist.

Adjustment--Orscheln Lever Type

1. Turn adjusting knob on parking brake lever counterclockwise to stop.
2. Apply parking brake.
3. Raise vehicle on a hoist.
4. Loosen nut at intermediate cable equalizer and then adjust nut to give light drag at rear wheels.

CAUTION: See "Caution" on Page 1 of this section.

5. Readjust parking brake lever knob to give a definite snap-over-center feel.

PARKING BRAKE (PROPELLER SHAFT)-

INTERNAL EXPANDING

Adjustment-Drum On

1. Jack up at least one rear wheel. Block wheels and release hand brake.
2. Remove cotter pin and clevis pin connecting pull rod and relay lever. This will assure freedom for full shoe release.

CAUTION: It may be necessary to knock out lanced area in brake drum with punch and hammer to gain entry into adjusting screw through brake drum. Be sure all metal has been removed from parking brake compartment.

3. Rotate brake drum to bring one of access holes into line with adjusting screw at bottom of shoes (manual transmission), top of shoes (automatic transmission).
4. Expand shoes by rotating adjusting screws with screwdriver inserted through hole in drum. Move outer end of screwdriver away from drive shaft. Continue adjustment until shoes are tight against drum and drum cannot be rotated by hand. Back off adjustment ten notches and check drum for free rotation.
5. Place parking brake lever in fully released position. Take up slack in brake linkage by pulling back on cable just enough to overcome spring tension. Adjust clevis of pull rod or front cable to line up with hole in relay levers.
 - a. Insert clevis pin and cotter pin, then tighten clevis locknut.
 - b. Install a new metal hole cover in drum to prevent contamination of brake.
 - c. Lower rear wheels. Remove jack and wheel blocks.

CAUTION: See "Caution" on Page 1 of this section.

Adjustment--Drum Off

1. With parking brake drum off, use special Tool J-21177 or J-22364, Drum to Brake Shoe Clearance Gauge, to check diameter of drum clearance surface.
2. Turn the tool to the opposite side and fit over

brake shoes by turning the star wheel until the gauge just slides over the linings.

3. Rotate the gauge around the brake shoe lining surface to insure proper clearance.
4. Install propeller shaft flange at mainshaft as outlined in transmission section.
5. Lower rear wheels. Remove jack and wheel blocks.

PARKING BRAKE CABLES

Front Parking Brake Cable Replacement

1. Raise vehicle on hoist.
2. Remove adjusting nut from equalizer.
3. Remove retainer clip from rear portion of front cable at frame and from lever arm.
4. Disconnect front brake cable from parking brake pedal or lever assemblies. Remove front brake cable. On some models it may assist installation of new cable if a heavy cord is tied to other end of cable in order to guide new cable through proper routing.
5. Install cable by reversing removal procedure.
6. Adjust parking brake.

Center Parking Brake Cable Replacement

1. Raise vehicle on hoist.
2. Remove adjusting nut from equalizer.
3. Unhook connector at each end and disengage hooks and guides.
4. Install new cable by reversing removal procedure.
5. Adjust parking brake.
6. Apply parking brake 3 times with heavy pressure and repeat adjustment.

Rear Parking Brake Cable Replacement

1. Raise vehicle on hoist.
2. Remove rear wheel and brake drum.
3. Loosen adjusting nut at equalizer.
4. Disengage rear cable at connector.
5. Bend retainer fingers.
6. Disengage cable at brake shoe operating lever.
7. Install new cable by reversing removal procedure.
8. Adjust parking brake.

COMBINATION VALVE

Testing Electrical Circuit of Combination Valve

1. Disconnect wire from switch terminal and use a jumper to connect wire to a good ground.
2. Turn ignition key on "On" - warning lamp should light. If lamp does not light, bulb is burned out or electrical circuit is defective. Replace bulb or repair electrical circuit as necessary.
3. When warning lamp lights, turn ignition switch off. Disconnect jumper and reconnect wire to switch terminal.

Testing Warning Light Switch Portion of Combination Valve

1. Raise vehicle on hoist. Attach a bleeder hose to

a rear brake bleed screw and immerse the other end of the hose in a container partially filled with clean brake fluid. Be sure master cylinder reservoir is full.

2. Turn ignition switch to "On"; open bleeder screw while a helper applies moderate pressure to the brake pedal; warning lamp should light. Close bleeder screw before helper releases brake pedal. Reapply brake pedal with moderate-to-heavy pressure; light should go out.

3. Attach the bleeder hose to a front brake bleeder screw and repeat above test. Warning lamp action should be the same as in Step No. 2. Turn ignition switch off.

4. If warning lamp does not light during Steps 2 and 3 but does light when a jumper is connected to ground, the warning light switch portion of the combination valve is defective. Do not attempt to disassemble the combination valve. If any portion of the combination valve is defective, it must be replaced with a new combination valve.

5. Lower vehicle to floor. Check and refill master cylinder to proper level.

Replacement

The combination valve is not repairable and must be serviced as a complete assembly.

1. Disconnect hydraulic lines at combination valve. Plug lines to prevent loss of fluid and entrance of dirt. Disconnect warning switch wiring harness from valve switch terminal.

2. Remove combination valve.

3. Install combination valve by reversing removal steps.

4. Bleed entire brake system. Do not move vehicle until a firm brake pedal is obtained.

BRAKE PEDAL

NOTE: The brake pedal mounting is an integral design with the clutch pedal (except automatic transmission), necessitating the removal of the clutch pedal before removing the brake pedal.

Removal (Fig. 5-12)

1. Remove the pull back spring from the body or brake pedal support bracket.

2. **Manual Transmission Vehicles**-Remove the clutch pedal as outlined under "Clutch Pedal" in Section 7C.

Automatic Transmission Vehicles-Remove pedal pivot bolt nut or pivot pin retainer and remove bolts or pin and bushings.

3. **P Models**-Remove the sleeve assembly screw attachment and remove sleeve.

4. Disengage the push rod from the master cylinder and remove the pedal.

Inspection

Clean all parts and inspect for wear, cracks or any other damage that might impair operation; replace if required.

Installation

Reverse the above procedure and make certain the

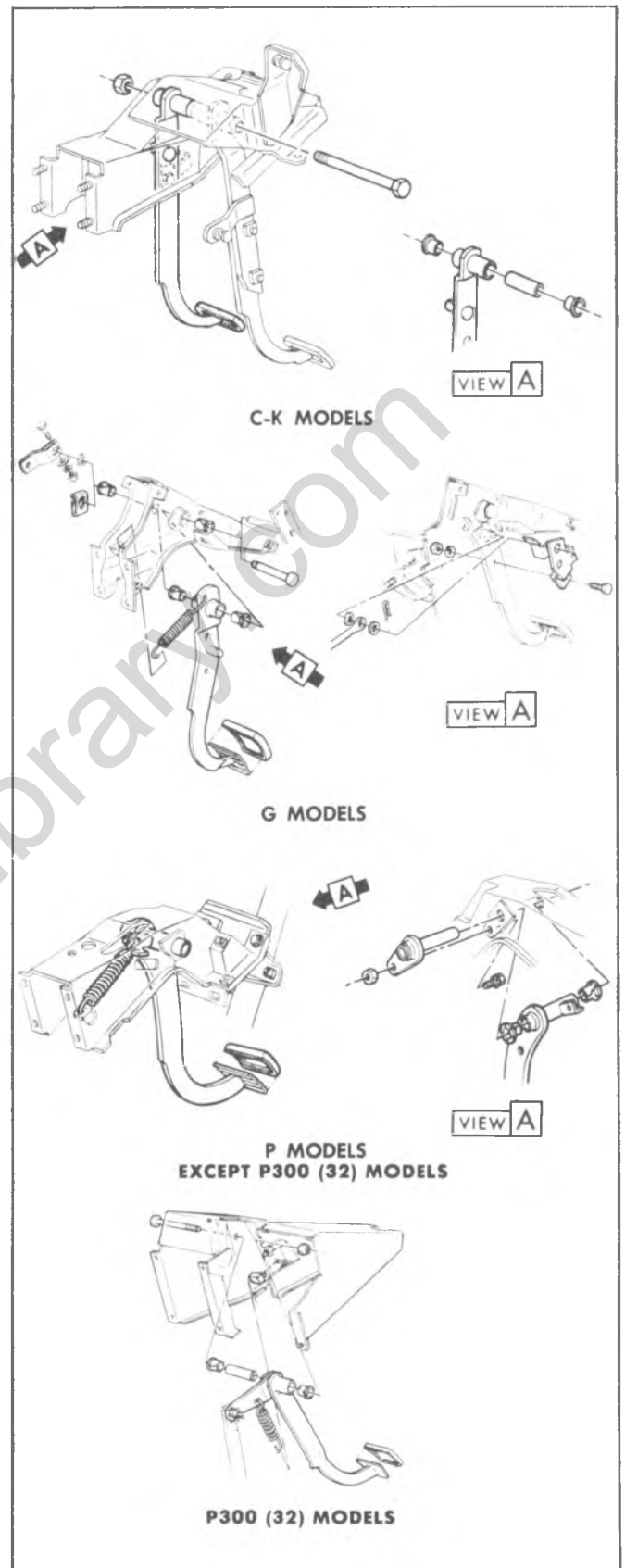


Fig. 5-12--Brake Pedal Installation

brake pedal is secure and adjusted properly before operating the vehicle. Lubricate pedal pivot bushings and pivot pin, bolt or sleeve with Delco Brake Lube (or equivalent). Adjust stoplamp switch.

CAUTION: See "Caution" on Page 1 of this section.

BRAKE PEDAL ROD

P30(32) Models

Replacement (Fig. 5-13)

1. Remove the cotter pin, nut, special washers and bolt at the brake pedal lever end of rod; discard the cotter pin.
2. Remove the boot to floorpan screws.
3. Raise the vehicle on a hoist.
4. Remove the cotter pin, nut, special washers and bolt at the lower end of the rod and remove the pedal rod assembly. Discard the cotter pin.
5. To install a new rod, adjust the rod length to 31.00" (center of upper attachment to center of lower attachment).
6. Lubricate the pedal rod bolts and special washers with Delco Brake Lube (or equivalent).
7. Install the rod up through the floorpan opening and install the lower pivot bolt, special washers and nut. Tighten the nut to 22-30 ft. lbs. and install a NEW cotter pin.
8. Push the boot up to the floorpan.
9. Lower the vehicle from the hoist.
10. Install the rod upper pivot bolt, special washers and nut. Tighten the nut to 22-30 ft. lbs. and install a NEW cotter pin.

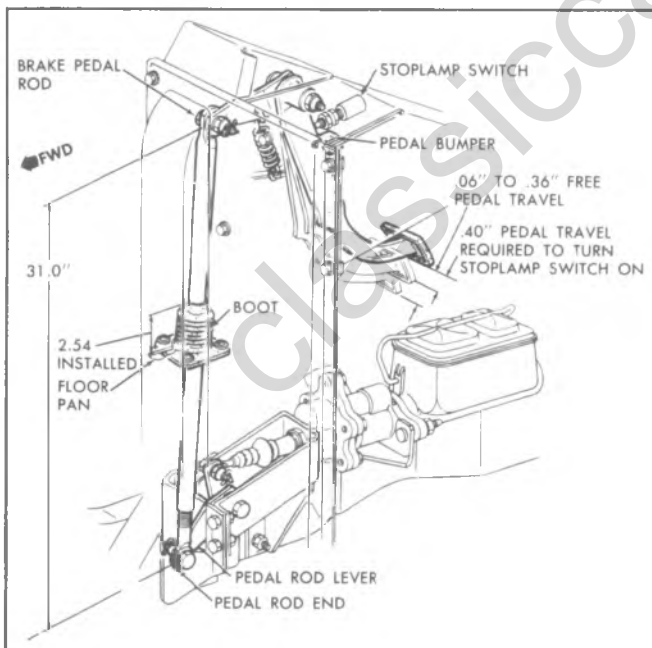


Fig. 5-13-Brake Pedal and Stop Lamp Adjustment
P30(32) Model

11. Fasten the boot to the floorpan and compress the boot to 2.54" installed height; tighten the boot to 2.54" installed height; tighten the boot screws to 13-18 in. lbs. (Refer to Figure 5-13).

12. Adjust brake pedal and stoplamp switch as outlined previously.

P30(42) and G Models

Replacement

1. **G Models**-Remove the brake pedal striker screw and remove the striker. Remove the cotter pin and washer and disconnect the pedal rod from the brake pedal.
2. **P30(42) Models**-Remove the cotter pin nut and bolt to disconnect the pedal rod from the brake pedal.
3. Remove the pedal rod retainer bolt (at the rod pivot) and remove the retainer.
4. Remove the cotter pin and washer and remove the pedal rod.
5. To install a new rod, reverse Steps 1-4 above.

NOTE: Lubricate pivot points with Delco Brake Lube (or equivalent).

CAUTION: See "Caution" on Page 1 of this section.

6. Check brake pedal and stoplamp switch adjustments as outlined previously.

MASTER CYLINDER

Filling Brake Master Cylinder

The master cylinder must be kept properly filled to

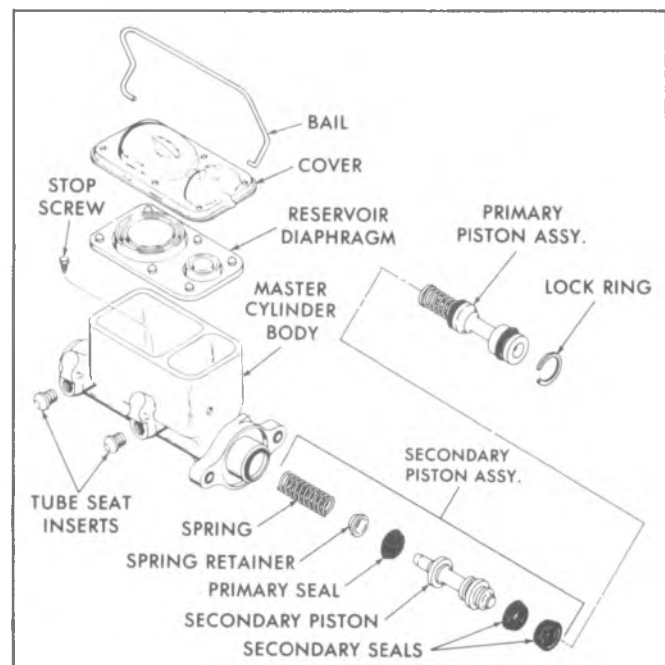


Fig. 5-14-Delco Master Cylinder--Exploded View

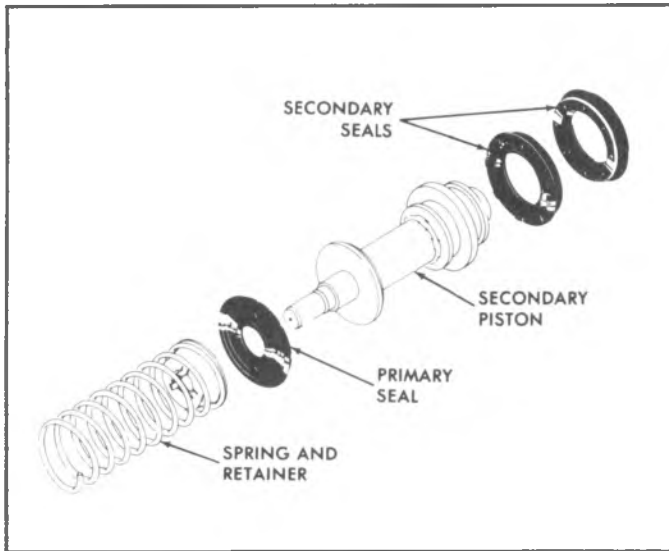


Fig. 5-15--Delco Secondary Piston - Exploded View

insure adequate reserve and to prevent air from entering the hydraulic system. However, because of expansion due to heat absorbed from brakes and from engine, master cylinder must not be overfilled.

The brake fluid reservoir is on the master cylinder which is located under the hood on the left side of the dash.

Thoroughly clean reservoir cover before removal to avoid getting dirt into reservoir. Remove cover and diaphragm. Add fluid as required to bring level to 1/4" (plus or minus 1/8") from the lowest portion of the top of each reservoir. Use Delco Supreme No. 11 Hydraulic Brake Fluid or equivalent.

Do not use shock absorber fluid or any other fluid which contains mineral oil. Do not use a container which has been used for mineral oil or a container which is wet from water. Mineral oil will cause swelling and distortion of rubber parts in the hydraulic brake system and water will mix with brake fluid, lowering the fluid boiling point. Keep all fluid containers capped to prevent water contamination.

Except Bendix Mini-Master Cylinder

Removal

1. Disconnect brake pipes from master cylinder and tape end of pipes to prevent entrance of dirt.
2. **Manual brake only**-Disconnect brake pedal from master cylinder push rod.
3. Remove two nuts holding master cylinder to dash or power cylinder and remove master cylinder from vehicle. Be careful not to drip brake fluid on exterior paint.

Disassembly (Figs. 5-14 and 5-15)

1. Clean outside of master cylinder thoroughly. Remove reservoir cover and diaphragm. Turn cylinder over and pump push rod by hand to drain all brake fluid. Always discard used fluid.
2. **Manual brake only**-Pull boot away from master

cylinder to uncover push rod retainer. The retainer has a small, depressed tab in the side. This tab must be pried up to release retainer.

3. Depress piston and remove secondary piston stop bolt from bottom of front fluid reservoir (if so equipped).

4. Place master cylinder in a vise so that lock ring can be removed from groove in the inside diameter of bore. Remove lock ring and primary piston assembly. Remove secondary piston, secondary piston spring and retainer by blowing air through the outlet port.

5. Place master cylinder in vise, so that outlet holes are up. Enlarge hole in tube fitting insert using a 13/64" drill. Place a heavy washer over outlet on master cylinder and thread a 1/4-20 x 3/4" screw into the insert. Tighten screw until insert is unseated. Remove insert, screw, and washer.

6. Remove primary seal, and secondary seal from secondary piston.

7. Use clean brake fluid to clean all metal brake parts thoroughly. Air dry and place cleaned parts on clean paper or lint free clean cloth.

Do not use anti-freeze alcohol, gasoline, kerosene, or any other cleaning fluid that might contain even a trace of mineral oil.

Inspection

Inspect cylinder bore for scoring or corrosion. It is best to replace a corroded cylinder. Corrosion can be identified as pits or excessive roughness.

Polish any discolored or stained area with crocus cloth by revolving cylinder on cloth supported by finger.

Rinse cylinder in clean brake fluid. Shake excess rinsing fluid from cylinder. Do not use a rag to dry cylinder, as lint from rag cannot be kept from cylinder bore surfaces.

Make certain that compensating port in cylinder is clear.

If scratches or corroded spots are too deep to be polished satisfactorily, the cylinder should be replaced.

Assembly

1. Place brass tube fitting insert (new parts) in outlet holes so that it is in a position to be pressed into outlet hole. The recommended method of inserting tube fitting insert is to thread a spare brake line tube nut into outlet hole and turn nut down until tube fitting insert bottoms. Remove tube nut and check outlet hole for loose burrs, which might have been turned up when tube fitting insert was pressed down.

2. Put new secondary seal in groove in end of secondary piston (fig. 5-15).

3. Assemble a new primary seal over end of secondary piston, so that flat side of the seal seats against flange of piston (fig. 5-15).

4. Assemble new secondary seal into groove on end of the secondary piston.

5. In order to insure correct assembly of the primary assembly, a complete primary piston assembly is included in the repair kits.

6. Coat bore of master cylinder with clean brake

fluid. Coat primary and secondary seals on secondary piston with clean brake fluid. Insert the secondary piston spring retainer into secondary piston spring. Place retainer and spring over end of secondary piston, so that retainer locates inside lip of primary cup.

7. Hold master cylinder with open end of bore down, push secondary piston into bore, so that spring will seat against closed end of bore.

8. Place master cylinder in a vise with open end of bore up. Coat primary and secondary seal on primary piston with clean brake fluid. Push primary piston assembly, spring end first, into bore of master cylinder. Hold the piston down and snap lock ring into position in groove in inside diameter of bore.

9. Install a new reservoir diaphragm in reservoir cover where needed, and install cover on master cylinder. Beaded side faces master cylinder casting to insure positive sealing. The bail wire is now pushed into position to hold reservoir cover.

10. **Manual brake only**-Assemble push rod through push rod retainer, if it has been disassembled. Push retainer over end of master cylinder. Assemble new boot over push rod and press it down over the push rod retainer.

Installation

CAUTION: Refer to "Caution" on Page 1 of this section regarding fasteners referred to in Steps 1 and 2 below.

1. **Manual brake only**-Connect push rod to brake pedal pin and install retainer while holding master cylinder in place.

2. Install master cylinder on dash or power cylinder; torque nuts to specifications.

3. Connect brake pipes to master cylinder.

4. Bleed hydraulic system.

5. Road test vehicle for proper brake performance.

Bendix Mini-Master Cylinder

NOTE: Removal, Inspection and Installation procedures are the same as described for "Except Bendix Mini-Master Cylinder".

Disassembly

1. Remove the reservoir cover and diaphragm, and drain the fluid from the reservoir.

2. Remove the four bolts that secure the body to the reservoir using Socket J-25085.

3. Remove the small "O" ring and the two compensating valve seals from the recessed areas on the bottom side of the reservoir.

NOTE: Do not remove the two small filters from the inside of the reservoir unless they are damaged and are to be replaced.

4. Depress the primary piston using a tool with a smooth rounded end. Then remove the compensating valve poppets and the compensating valve springs from

the compensating valve ports in the master cylinder body.

5. Using a small screwdriver, remove the snap ring at the end of the master cylinder bore. Then release the piston and remove the primary and secondary piston assemblies from the cylinder bore. It may be necessary to plug the front outlet port and to apply low air pressure to the front compensating valve port to remove the secondary piston assembly.

Assembly

1. Lubricate the secondary piston assembly and the master cylinder bore with clean brake fluid.

2. Assemble the secondary spring (shorter of the two springs) in the open end of the secondary piston actuator, and assemble the piston return spring (longer spring) on the projection at the rear of the secondary piston.

3. Insert the secondary piston assembly, actuator end first, into the master cylinder bore, and press assembly to the bottom of the bore.

4. Lubricate the primary piston assembly with clean brake fluid. Insert the primary piston assembly, actuator end first, into the bore.

5. Place the snap ring over a smooth round ended tool and depress the pistons in the bore.

6. Assemble the retaining ring in the groove in the cylinder bore.

7. Assemble the compensating valve seals and the small "O" ring seal in the recesses on the bottom of the reservoir. Be sure that all seals are fully seated.

8. While holding the pistons depressed, assemble the compensating valve springs and the compensating valve poppets in the compensating valve ports.

9. Holding the pistons compressed, position the reservoir on the master cylinder body and secure with the four mounting bolts. Tighten the bolts to 12-15 ft. lbs.

DELCO DISC BRAKE SHOE AND LINING

Lining Inspection

Inspect the brake linings every 7,500 miles and any time that the wheels are removed (tire rotation, etc.). Check both ends of the outboard shoe by looking in at each end of the caliper (fig. 5-18). These are the points at which the highest rate of wear normally occurs. However, at the same time, check the lining thickness on the inboard shoe to make sure that it has not worn prematurely. Look down through the inspection hole in the top of the caliper to view the inboard shoe. Whenever the thickness of any lining is worn to within .030" of rivet at either end of the shoe, all disc brake shoe and lining assemblies should be replaced at the same time (fig. 5-19).

Caliper Removal

WARNING: See "Warning" on Page 5-1 of this section.

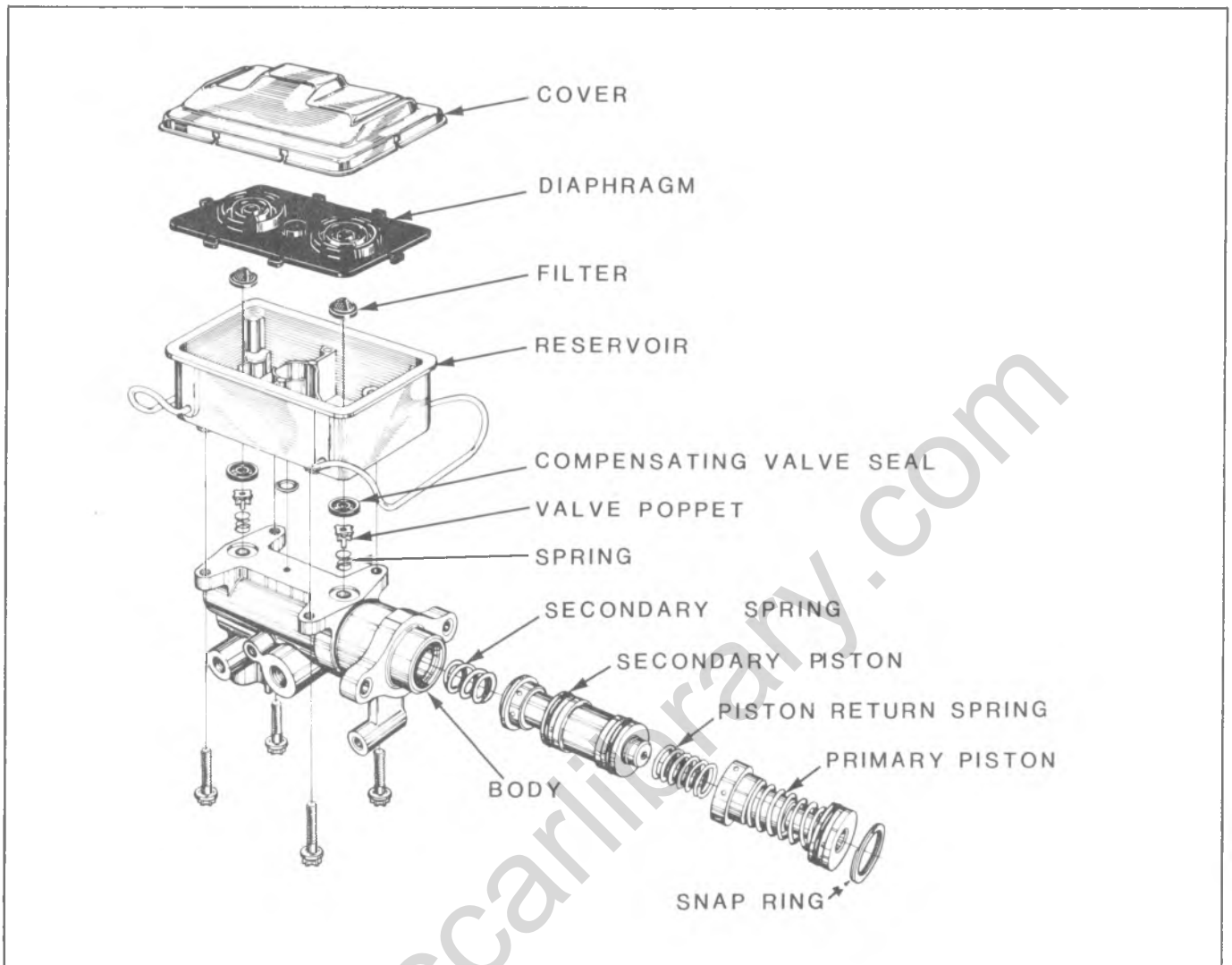


Fig. 5-16--Bendix Mini-Master Cylinder--Exploded View

1. Remove two thirds of the total fluid capacity from the front master cylinder reservoir. Removal of the fluid is necessary to prevent reservoir overflow when the caliper piston is pushed back in its bore to remove the caliper. This may be done by breaking the front line connection at the master cylinder and bleeding down the fluid level. Do not remove the brake line or completely empty the reservoir or it will be necessary to bleed the hydraulic system. Discard -- do not attempt to reuse -- the brake fluid removed.

2. Raise the vehicle on a hoist and remove the wheel covers and wheel assemblies. Position a 7 inch "C" clamp on the caliper so that solid side of the clamp rests against the metal part of the outboard shoe (fig. 5-20). Tighten the "C" clamp until the caliper moves away from the vehicle far enough to push the piston to the bottom of the piston bore. This will allow the shoes to back off from the rotor surfaces. Remove the "C" clamp.

3. It is not necessary to disconnect the brake hose from shoe and lining replacement. Remove the two mounting bolts which attach the caliper to the support bracket (fig. 5-21). Lift the caliper off the rotor and remove the inboard shoe. *Dislodge the outboard shoe and position the caliper on the front suspension arm so that the brake hose will not support the weight of the caliper. Remove the shoe support spring from the cavity in the piston.*

4. Using Tool J-22835, remove the sleeves from the inboard ears of the caliper (fig. 5-22). Next, remove the rubber bushings from the grooves in each of the four caliper ears.

Cleaning and Inspection

1. Thoroughly clean the holes and the bushing

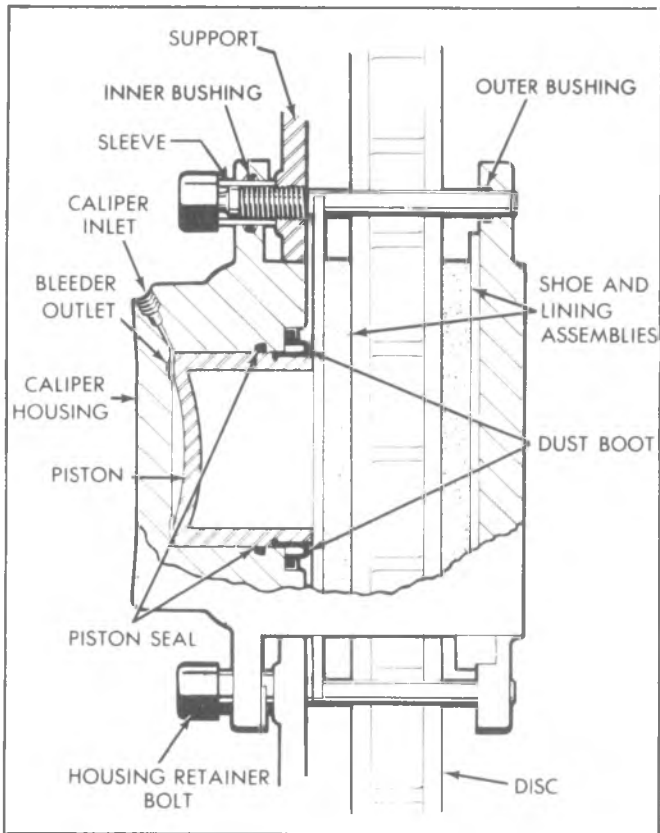


Fig. 5-17--Delco Single Piston Disc Brake

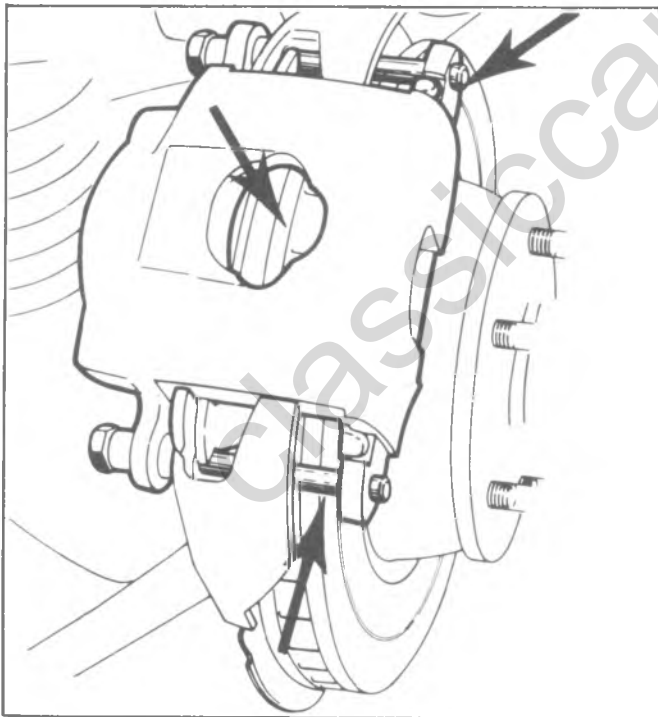


Fig. 5-18--Lining Inspection

grooves in the caliper ears. Wipe all dirt from the mounting bolts. Do not use abrasives on the bolts since

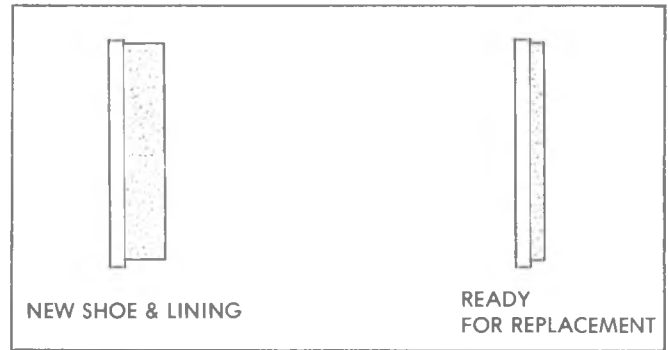


Fig. 5-19--New and Worn Linings

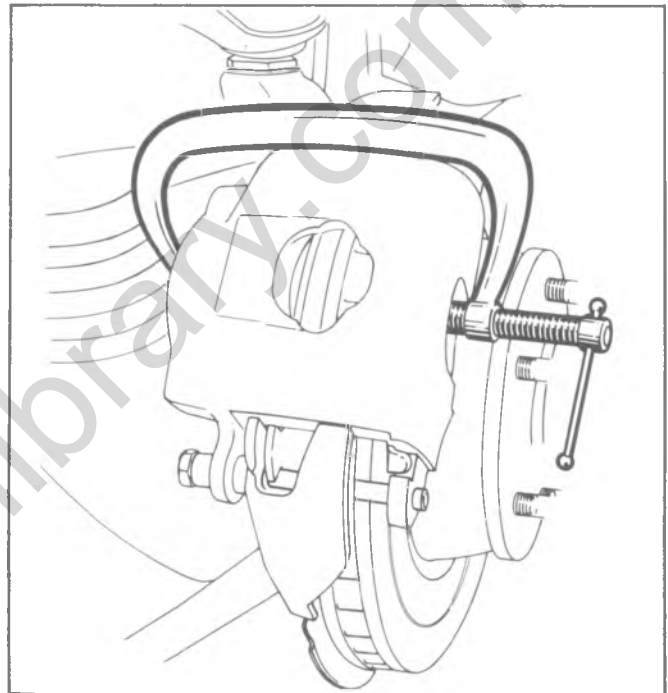


Fig. 5-20--Use of "C" Clamp

this will damage the plating. If the bolts are corroded, or damaged, they should be replaced.

2. Examine the inside of the caliper for evidence of fluid leakage. If leakage is noted, the caliper should be overhauled. Wipe the inside of the caliper clean, including the exterior of the dust boot. Check the boot for cuts, cracks or other damage. Make sure that the boot is properly engaged in the groove in the piston and also in the caliper counter-bore (fig. 5-24).

CAUTION: Do not use compressed air to clean the inside of the caliper since this may cause the dust boot to become unseated.

3. If the vehicle has a brake problem and diagnosis points to the rotor, it should be inspected and checked for runout at this time.

Caliper Installation

1. Install rubber bushings in all four caliper ears.

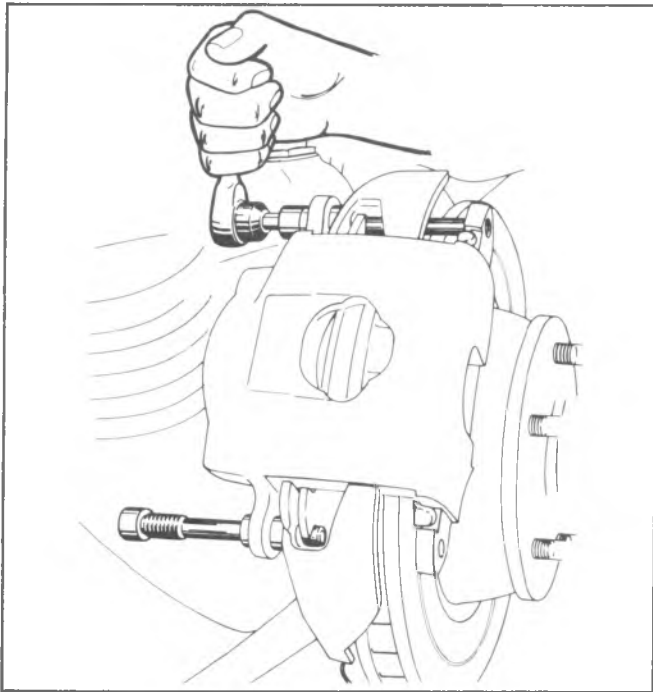


Fig. 5-21-Removing Mounting Bolts

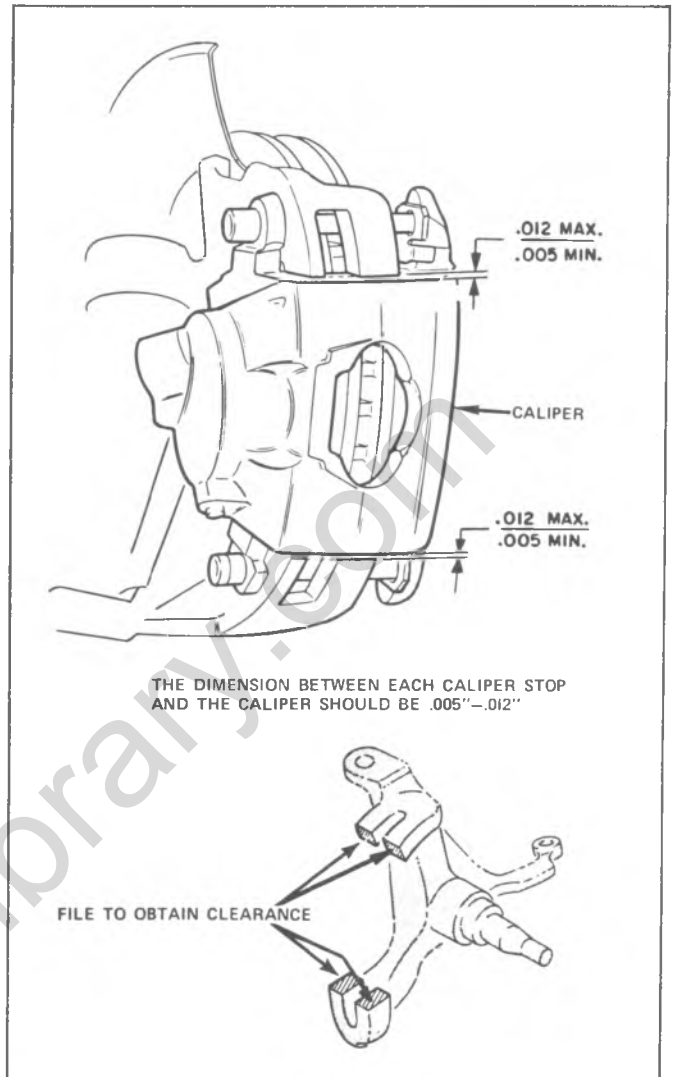


Fig. 5-23-Caliper to Stop Clearance

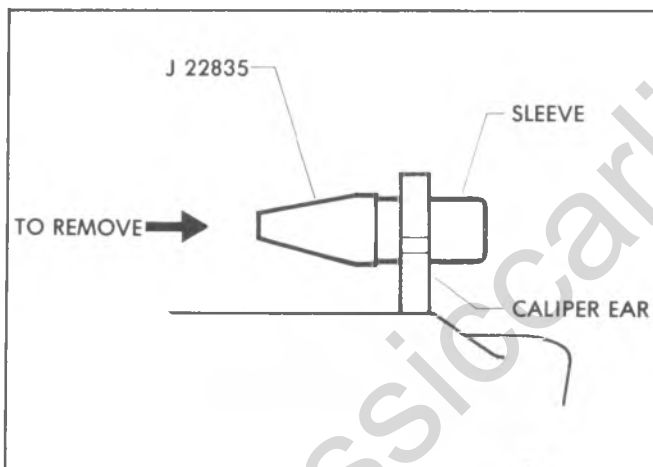


Fig. 5-22-Removing Sleeves

CAUTION: It is essential that the new sleeves and rubber bushings be used in order to insure the proper functioning of the sliding caliper design.

2. Use Tool, J-22835, to install the sleeves (fig. 5-25). Position the sleeves so that the end toward the shoe and lining assemblies is flush with the machined surface of the ear.

3. Install the shoe support spring by replacing the single tang end of the spring over the notch in the center of the edge of the shoe. Then press the two tangs at the spring end of the inboard shoe spring over the bottom edge of the shoe so that they engage the shoe securely, as shown in Figure 5-26.

4. Position the inboard shoe and lining assembly (with spring attached) in the caliper so that the ear end

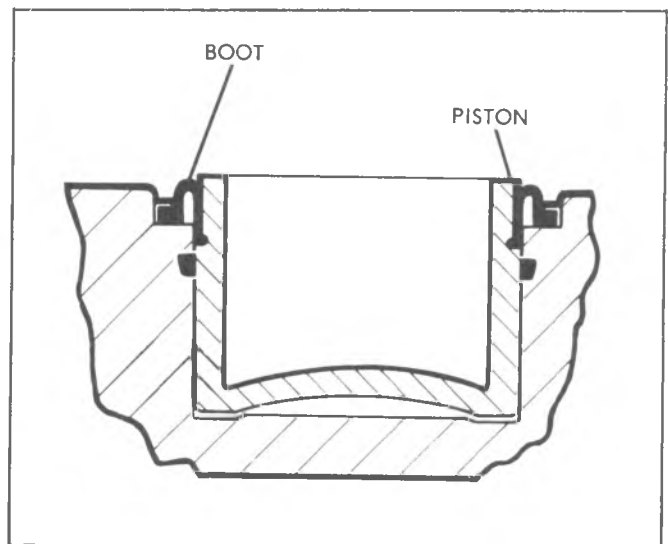


Fig. 5-24-Boot Installation

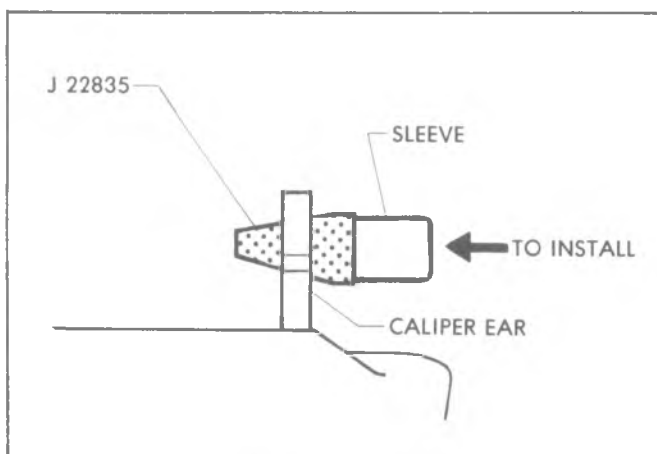


Fig. 5-25--Sleeve Installation

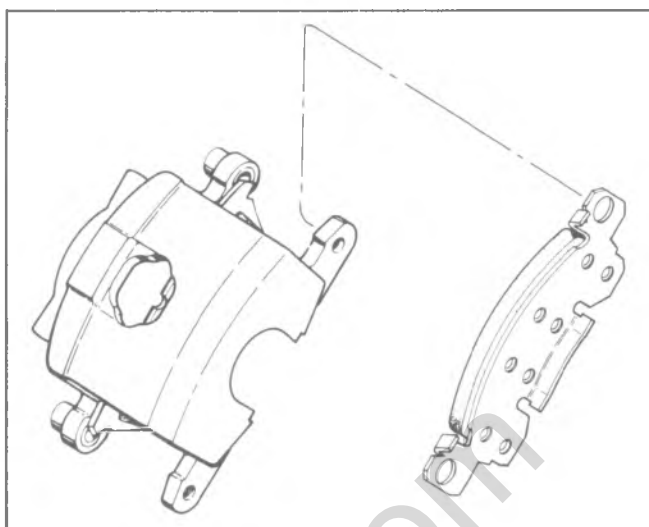


Fig. 5-28- Installing Outboard Shoe

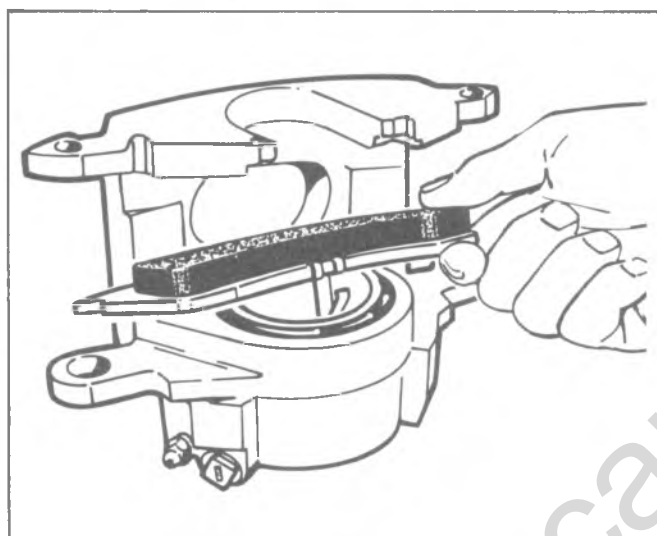


Fig. 5-26--Inserting Shoe Support Spring

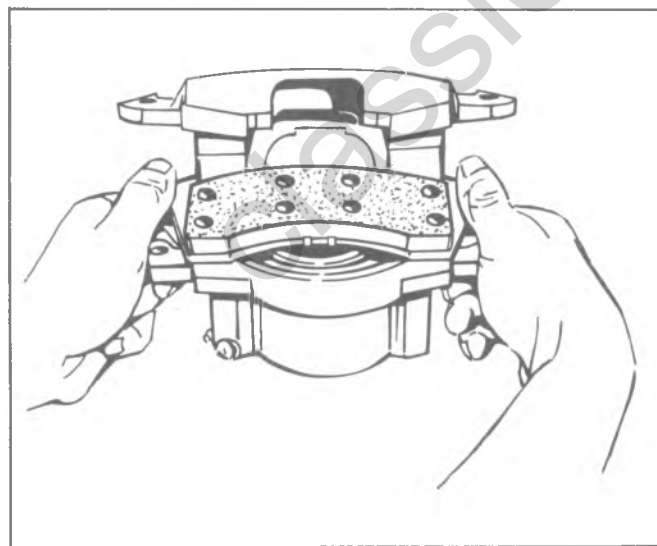


Fig. 5-27--Installing Inboard Shoe

of the shoe and lining is down and the bottom end up at an angle with the spring resting on the piston I.D. (fig. 5-27). Press down on both ends of the shoe until the shoe is in a flat position, resting on the piston. The spring end of the inboard shoe support spring should be resting on the I.D. of the piston.

CAUTION: *On inboard shoes there is a specific left hand and right hand shoe. When properly installed the wear sensor will be toward rear of caliper.*

5. Position the outboard shoe in the caliper, with the ears at the top of the shoe over the caliper ears and the tab at the bottom of the shoe engaged in the caliper cut-out (see fig. 5-28). Be sure to note right and left brake shoes. 6. Position the caliper over the rotor, lining up the holes in the caliper ears with the holes in the mounting bracket.

CAUTION: *When reinstalling caliper be sure you haven't turned it over, end over end. This would cause a severe twist in the brake hose. After positioning caliper on disc, observe brake hose being sure it is not twisted.*

Start the bolts through the sleeves in the inboard caliper ears and through the mounting bracket, making sure that the ends of the bolts pass under the retaining ears on the inboard shoe (fig. 5-29). Push bolts on through to engage the holes in the outboard shoes and the outboard caliper ears at the same time, threading the bolts into the mounting bracket. Torque the bolts to 35 ft. lbs.

CAUTION: *See "Caution" on Page 1 of this section.*

7. Add fresh approved brake fluid to the master cylinder reservoirs to bring the level up to within 1/8 inch of the top.

8. Pump brake pedal to seat linings against rotor.

9. Clinch upper ears of outboard shoe by positioning channel lock pliers with one jaw on top of

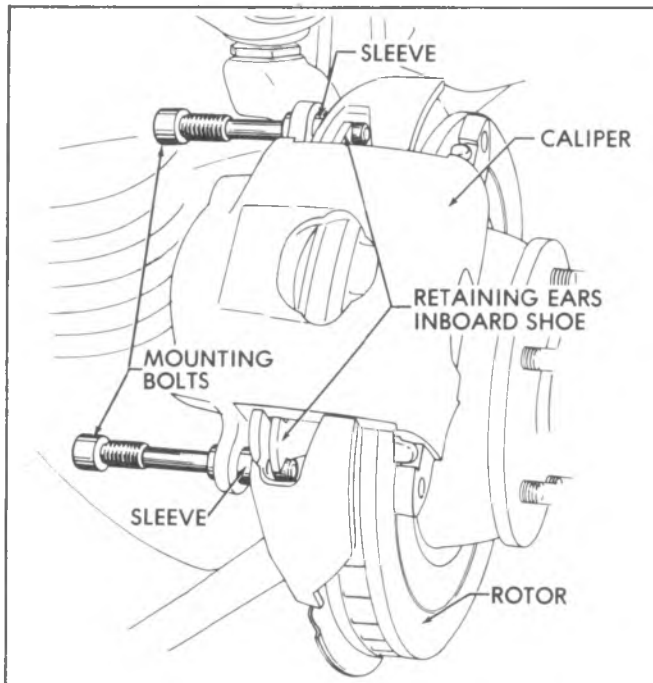


Fig. 5-29--Installing Mounting Bolts

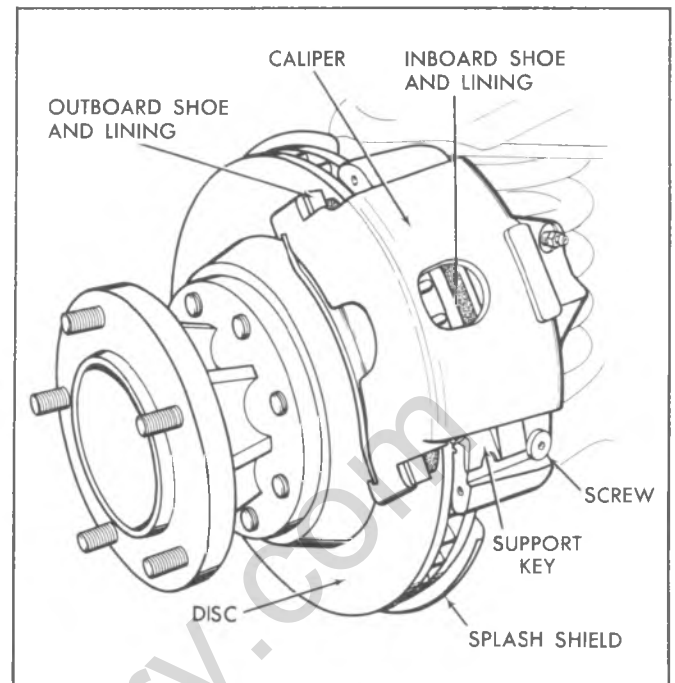


Fig. 5-31--Bendix Disc Brake Caliper Assembly

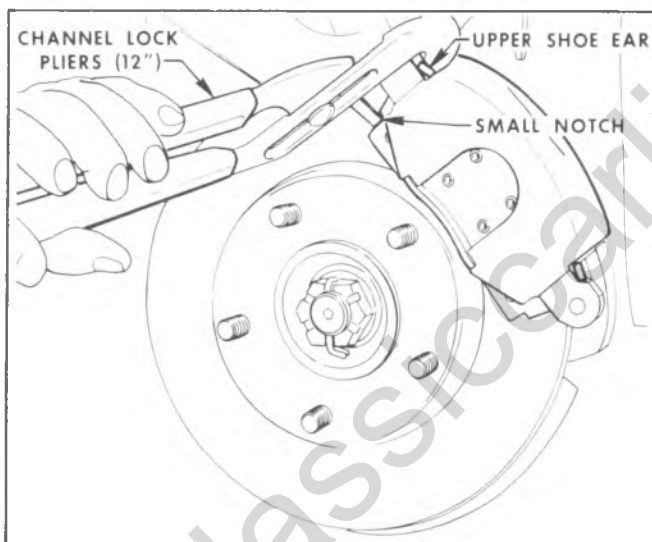


Fig. 5-30--Clinching Outboard Shoe

upper ear and one jaw in notch on bottom of shoe opposite upper ear (fig. 5-30).

10. After clinching, ears are to be flat against caliper housing with no radial clearance.

11. If radial clearance exists, repeat clinching procedure.

Completion

1. Replace the shoe and linings on the other front wheel disc brake in exactly the same manner as just described. Relining is to be done in full axle sets only. When completed, reinstall the wheel and tire assemblies. Torque wheel nuts to specifications. Install wheel covers and lower the vehicle to the floor.

CAUTION: See "Caution" on Page 1 of this section.

2. Whenever the front wheel disc brakes are relined, the rear drum brakes should be checked also.

BENDIX DISC BRAKE SHOE AND LINING

The brake linings should be inspected any time the wheels are removed. Check both ends of the outboard shoe by looking in at each end of the caliper (fig. 5-31). This is the point at which the highest rate of wear normally occurs. At the same time, check the lining thickness on the inboard shoe by looking down through the inspection hole in the top of the caliper; see "Brake Inspection" portion of this section. The inboard shoe is installed with the ends of the shoe resting in the steering knuckle. The large tab at the bottom of the outboard shoe is bent over at the right angle and fits in the cutout in the outboard section of the caliper.

NOTE: The inboard shoe does not incorporate a lining wear sensor as with standard disc brakes.

Removal

WARNING: See "Warning" on page 1 of this section.

1. Remove master cylinder cover and observe brake fluid level in front reservoir is more than 1/3 full, siphon the necessary amount out to bring the level to 1/3 full. This step is taken to avoid reservoir overflow when the caliper piston is pushed back into its bore. Discard the brake fluid removed. Never reuse brake fluid.

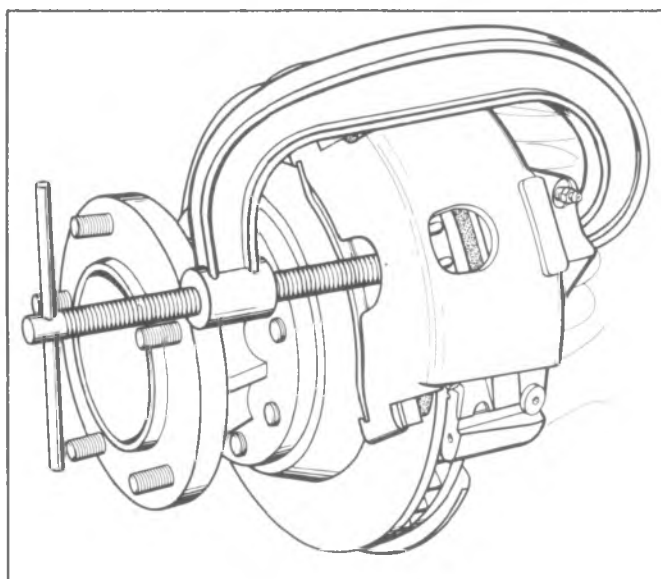


Fig. 5-32--Pushing Piston into Bore Using a "C" Clamp

2. Raise the front of the vehicle on a hoist and remove the front wheels.

3. Push the piston back into its bore. This can be accomplished by using a "C" clamp as shown in Figure 5-32.

4. Remove the bolt at the caliper support key. Using a brass punch, remove the key and spring (fig. 5-33).

5. Lift the caliper off the disc and support in a raised position with a heavy wire (fig. 5-34).

CAUTION: Do not support the weight of the caliper on the brake hose.

6. Remove the inboard shoe from the steering

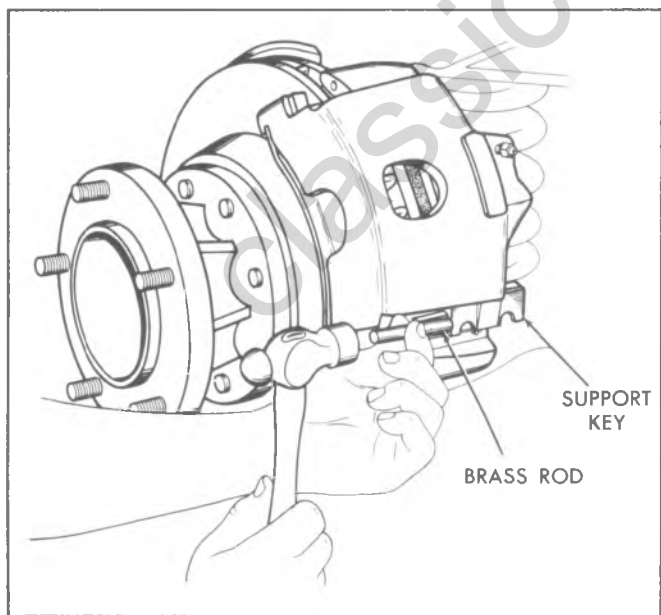


Fig. 5-33--Removing the Caliper Support Key

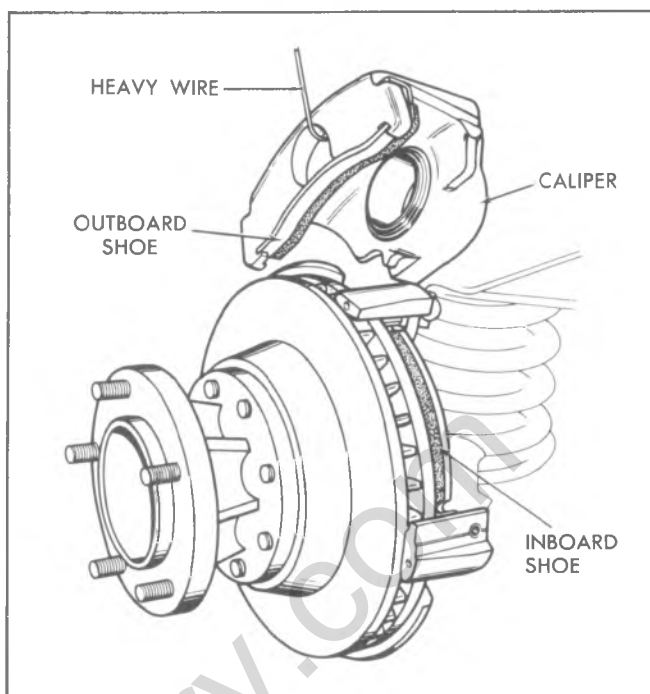


Fig. 5-34--Removing Caliper from the Disc

knuckle. Remove and discard the inboard shoe clip. Remove the outboard shoe from the caliper. It may be necessary to tap the shoe to loosen it in the caliper housing.

CAUTION: Mark disc pad positions if pads are to be reinstalled.

Cleaning and Inspection

NOTE: The shoes should be replaced when the lining is worn to approximately 1/32" thickness over the rivet heads. Replace shoes in axle sets.

1. Examine the inside of the caliper for evidence of fluid leakage. If leakage is noted, the caliper should be overhauled.

2. Wipe the inside of the caliper clean, including the exterior of the dust boot. Check the boot for cuts, cracks or other damage.

CAUTION: Do not use compressed air to clean the inside of the caliper.

3. Use a wire brush to remove any rust or corrosion from the machined surfaces of the steering knuckle and caliper. It is important to clean those areas of the caliper and spindle assembly that are in contact during the sliding action of the caliper.

Installation

CAUTION: If original disc pads are being reinstalled, they must be installed in original positions (as marked at removal).

1. Lubricate the caliper and steering knuckle sliding surfaces and the support spring with Delco Silicone Lube (or equivalent).

2. Install a NEW inboard shoe clip in the steering

knuckle. Be sure the tabs are positioned correctly and the loop-type spring positioned away from the rotor. Install the lower end of the inboard shoe into the groove provided in the steering knuckle (against the spring clip). Slide the upper end of the shoe into position. Be sure the clip remains in position.

3. Position the outboard shoe in the caliper with the ears at the top of the shoe over the caliper ears and the tab at the bottom of the shoe engaged in the caliper cutout. If assembly is difficult, a "C" clamp may be used. Be careful not to mar the lining.

4. With both shoes installed, lift up the caliper and rest the bottom edge of the outboard lining on the outer edge of the brake disc to make sure there is no clearance between the tab at the bottom of the outboard shoe and the caliper abutment. The outboard shoe should fit tightly in the caliper and should not rattle.

5. Position the caliper over the brake disc, guiding the upper caliper groove onto the mating surface of the steering knuckle. Position the caliper to the lower steering knuckle sliding surface.

NOTE: Make sure that the brake hose is not twisted or kinked.

6. Place the spring over the caliper support key, install the assembly between the steering knuckle and lower caliper groove. Tap into place (until the key retaining screw can be installed) using a brass punch and a light hammer (fig. 5-35).

7. Install the screw and torque to 12 to 18 ft. lbs.

CAUTION: The bolt boss must fit fully into the circular cutout in the key.

See "Caution" on Page 1 of this section.

8. Reinstall the front wheel and tire assembly.

9. Add brake fluid to the master cylinder reservoir to bring the fluid level up to within 1/4 inch of the top.

NOTE: Before moving the vehicle, pump the brake pedal several times to make sure that it is firm. Do

not move vehicle until a firm pedal is obtained. Check master cylinder fluid level again after pumping the brake pedal.

CALIPER OVERHAUL

Delco

Removal

1. Removal of the caliper for overhaul is the same as for shoe and lining replacement except that it will be necessary to disconnect the brake hose; (Refer to front brake hose replacement).

2. First, disconnect the hose from the steel brake pipe and cap the fittings to prevent dirt from entering the pipe or the hose. Then, remove the U-shaped retainer from the hose fitting. Withdraw the hose from the frame support bracket and remove the caliper -- with hose attached -- to a work bench for overhaul.

Disassembly

1. Before beginning disassembly, thoroughly clean the exterior of the caliper using brake cleaner. Place the caliper on a clean work surface.

2. Remove the brake hose from the caliper, discarding the copper gasket. Check the hose for worn spots, cracks or other signs of deterioration, discard the hose, if damaged, to be replaced with a new hose at reassembly. Drain brake fluid from the caliper.

3. Use clean shop towels to pad the interior of the caliper.

WARNING: DO NOT PLACE THE FINGERS IN FRONT OF THE PISTON IN AN ATTEMPT TO CATCH OR PROTECT IT WHEN APPLYING COMPRESSED AIR. THIS COULD RESULT IN SERIOUS INJURY.

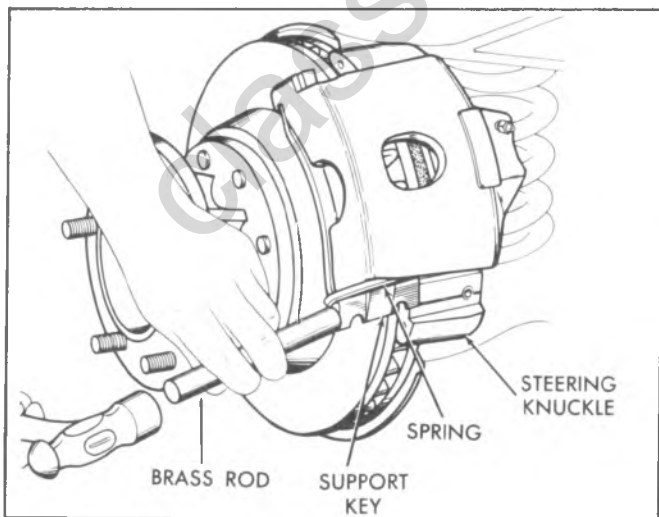


Fig. 5-35--Installing the Caliper Support Key

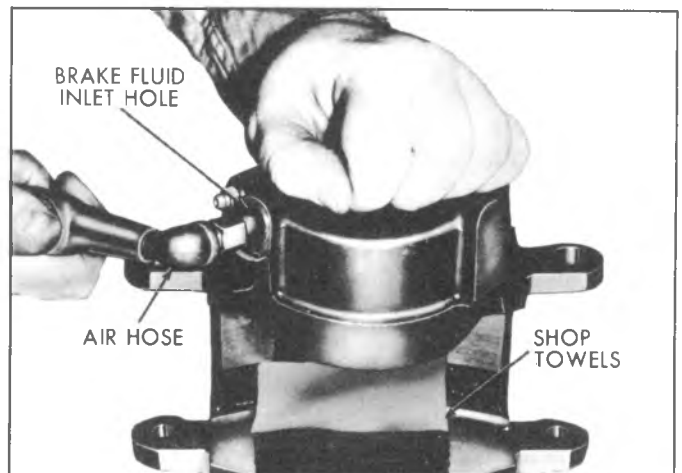


Fig. 5-36--Removing Piston

Remove the piston by directing compressed air into the caliper inlet hole (fig. 5-36).

CAUTION: Use just enough air pressure to ease the piston out of the bore. If the piston is blown out, even with padding provided, it may become damaged.

4. Use a screwdriver to pry the boot out of the caliper. Extend the screwdriver across the caliper bore, under the boot, and pry up. Be careful not to scratch the caliper bore.

5. Use a piece of wood or plastic -- a plastic toothpick is ideal -- to remove the piston seal from its groove in the caliper bore. **DO NOT USE A METAL TOOL OF ANY TYPE FOR THIS OPERATION.**

6. Remove the bleeder valve from the cliper.

Cleaning and Inspection

1. The boot, piston seal, rubber bushings and sleeves are to be replaced each time the caliper is overhauled. Discard, do not bother to clean and inspect, these parts.

2. Clean all other parts in clean denatured alcohol or brake cleaner. Use dry, filtered compressed air to dry parts and blow out all passages in the caliper and bleeder valves.

The use of lubricated shop air will leave a film of mineral oil on the metal parts. This may damage rubber parts when they come in contact after reassembly.

3. Check the mounting for corrosion, breaks in the plating or other damage. Do not use abrasives in an attempt to clean the pins -- replace them.

4. Carefully examine the piston outside diameter for scoring, nicks, corrosion and worn or damaged chrome plating. If any surface defects are detected, replace the piston.

5. Check the bore in the caliper for the same defects as the piston with the exception of plating damage. The piston bore is not plated and stains or minor corrosion can be polished with crocus cloth. Do not use emery cloth. Thoroughly clean the caliper after the use of crocus cloth. If the bore cannot be cleaned up in this manner, replace the caliper.

Reassembly

1. Lubricate the bore in the caliper and the new piston seal with clean brake fluid. Position the seal in the caliper bore groove. Lubricate the piston with clean brake fluid and assemble a new boot into the groove in the piston so that the fold faces the open end of the piston. Insert the piston into the caliper bore, using care not to unseat the seal and force down to the bottom in the bore. This will require a force of 50 to 100 pounds. Position the outside diameter of the boot in the caliper counterbore and seat with Tool J-22904 (fig. 5-37).

2. Check the boot installation to make sure that the retaining ring molded into the boot is not bent and that the boot is installed fully, below the caliper face, and evenly all around. Otherwise dirt or moisture may enter the bore and cause damage or corrosion.

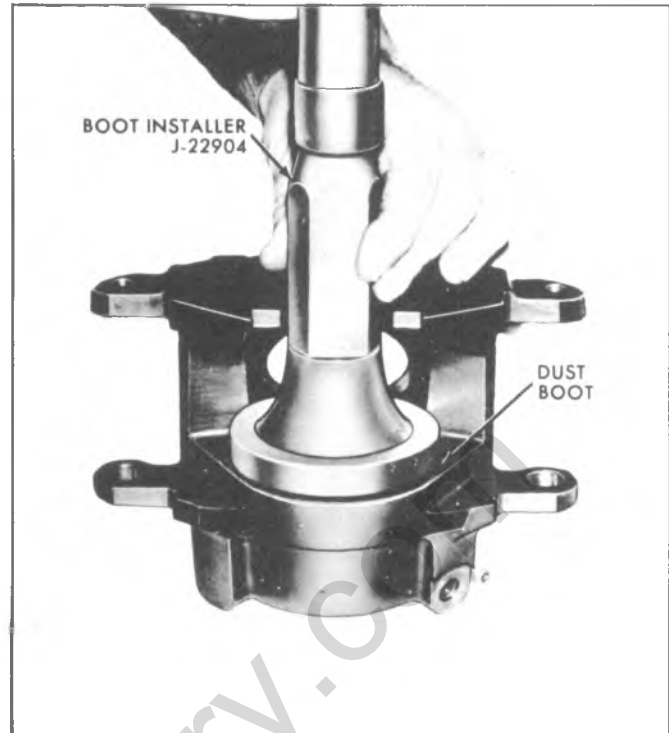


Fig. 5-37--Seating Boot

3. Install the brake hose in the caliper inlet using a new copper gasket.

Installation

1. Installation of the caliper and mounting parts (rubber bushing, sleeves, shoe and lining assemblies and pins) is the same as for lining replacement except for the following:

a. The brake hose must be connected to the brake pipe at the frame or frame bracket.

Use extreme care to orient the hose so that the keyed hose end fitting aligns with the slot in the bracket without twisting or kinking the hose.

b. After overhaul -- or any time that the brake hose or line is disconnected -- the calipers must be bled.

Bendix

Removal

CAUTION: Clean dirt from hose to caliper connection before proceeding with removal.

1. Remove the hose to caliper bolt and cap or tape the open connections to prevent dirt from entering the hose or caliper. Discard the copper gaskets.

2. Remove the caliper assembly as described under "Shoe and Linings-Removal".

Disassembly (Fig. 5-38)

1. Clean the exterior of the caliper using clean brake fluid and place on a clean work surface.

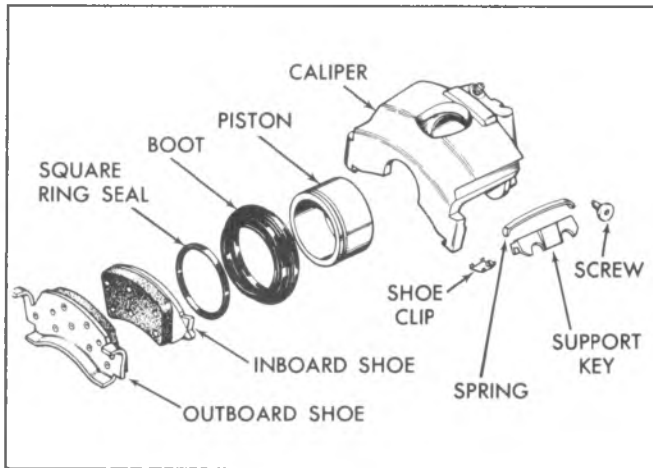


Fig. 5-38--Bendix Brake Caliper Assembly

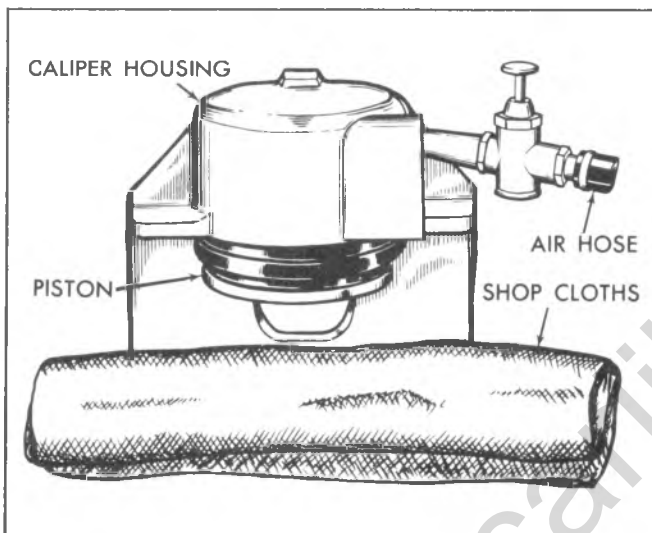


Fig. 5-39--Removing the Caliper Piston

2. Drain the brake fluid from the caliper.

WARNING: Do not place the fingers in front of the piston in an attempt to catch or protect it when applying compressed air.

3. Using clean shop cloths, pad the interior of the caliper and remove the piston by directing compressed air into the caliper inlet hole (fig. 5-39).

CAUTION: Use just just enough air pressure to ease the piston out of the bore. Do not blow piston out of the bore. If the piston is seized or cocked or does not come out readily, release the air pressure and use a soft (brass) hammer to rap sharply on and around the end of the piston. Reapply air pressure to remove the piston.

NOTE: An alternate method of removing the piston is to stroke the brake pedal (gently) while the hydraulic lines are still connected. This will push the piston out of the caliper bore.

4. Remove the boot from the piston bore.
5. Using a small piece of wood or plastic, remove the square ring seal from the piston bore.

CAUTION: Do not use a metal tool of any kind for this operation as it may damage the bore.

6. Remove the bleeder valve from the caliper.

Cleaning and Inspection

CAUTION: The dust boot and piston seal are to be replaced whenever the caliper is overhauled. Discard these parts.

1. Clean all parts (other than those mentioned above in clean brake fluid. Use dry, filtered, compressor air to blow out all passages in the caliper and bleeder valve.

CAUTION: The use of lubricated shop air will leave a film of mineral oil on the metal parts. This may damage rubber parts when they come in contact after reassembly.

2. Check the sliding surfaces of the caliper, steering knuckle and support spring for rust or corrosion. Clean up any surface defects with crocus cloth.

3. Carefully examine the outside surface of the piston for scoring, nicks, corrosion and worn or damaged plating. If any surface defects are detected, replace the piston.

CAUTION: The piston outside diameter is the primary sealing surface in the caliper assembly. It is manufactured and plated to close tolerances. Refinishing by any means or the use of any abrasive is not acceptable practice.

4. Check the bore in the caliper for the same defects as the piston. The piston bore, however, is not plated and stains or minor corrosion can be polished with crocus cloth.

CAUTION: Do not use emery cloth or any other form of abrasive. Thoroughly clean the caliper after the use of crocus cloth. If the bore cannot be cleaned up in this manner, replace the caliper.

Assembly

1. Lubricate the caliper piston bore and the NEW piston seal with the clean brake fluid. Position the square ring seal in the caliper bore groove.

2. Lubricate both sealing lips of the dust boot and the piston with a light film of clean brake fluid. Place the new boot over Piston Installer Tool J-24548. This is most easily accomplished by placing the boot large diameter over the tool first, then riding the smaller diameter onto the tool. The large diameter lip must then be slid off the tool to make ready for installation into the bore groove. Install the boot (large bead) into the piston bore groove by reaching inside of Tool J-24548 and pressing the boot bead into the groove (fig. 5-40).

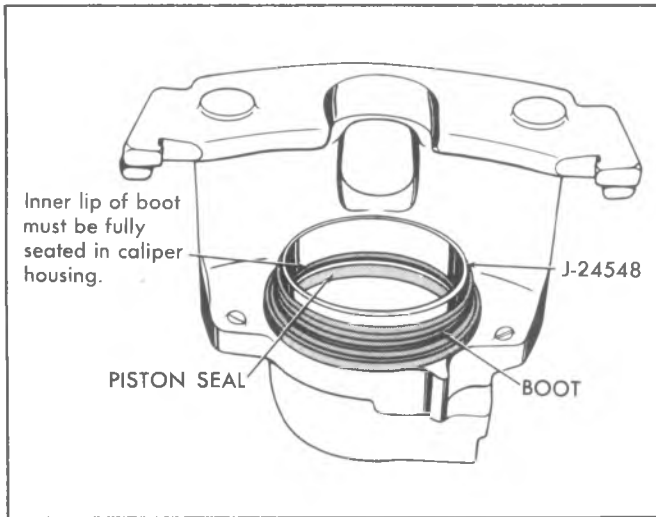


Fig. 5-40--Installing Caliper Piston Boot

CAUTION: Be sure boot is fully seated in the groove before proceeding.

3. Place the piston inside of Tool J-24548, force the piston halfway into the piston bore using a wood hammer handle or "C" clamp (fig. 5-41); remove Tool J-24548. Check to be sure the boot was not unseated at piston installation. Make sure the outer bead of the boot is seated in the piston outer groove.

Installation

NOTE: Installation of the caliper and mounting parts is the same for: "Shoe and Lining-Disc Brake" except for steps given below:

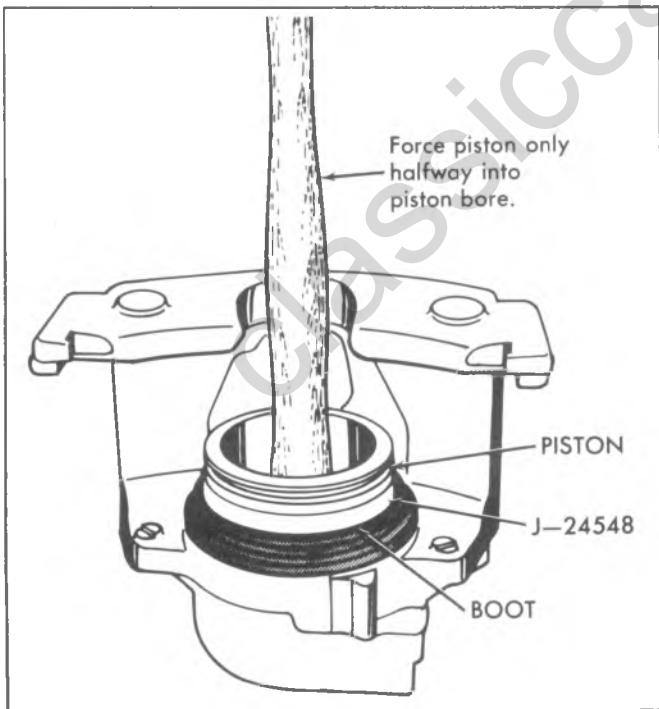


Fig. 5-41--Installing Piston in Caliper

1. Connect the brake hose to the caliper using NEW copper gaskets.

CAUTION: Hose must be properly positioned to prevent hose twist or misalignment.

2. Bleed the caliper assemblies as outlined earlier in this section.

ROTOR SERVICING

Checking Lateral Runout

1. Lateral runout is the movement of the rotor from side to side as it rotates on the steering knuckle spindle. This could be described as "rotor wobble".

2. The movement of the rotor from side to side in the lateral plane causes the brake shoe and lining and pistons to be knocked back into their bores. This results in additional pedal travel required and a vibration during the braking action.

3. To check lateral runout, first tighten the wheel bearings until all of the play is out of the bearings. Fasten a dial indicator to some portion of the suspension so that the point of the stylus contacts the rotor face approximately one inch from the rotor edge (fig. 5-42). Set the dial at zero. Move the rotor one complete rotation, checking the indicator as the rotor moves.

4. Lateral runout should not be over .004" total indicator reading.

Parallelism Check

1. Parallelism is the measurement of the thickness of the rotor at four or more points around the circumference of the rotor. All measurements must be made at the same distance in from the edge of the rotor.

2. A rotor that varies over .0005" causes pedal vibration, as well as front end vibration during brake applications. A rotor that does not meet these

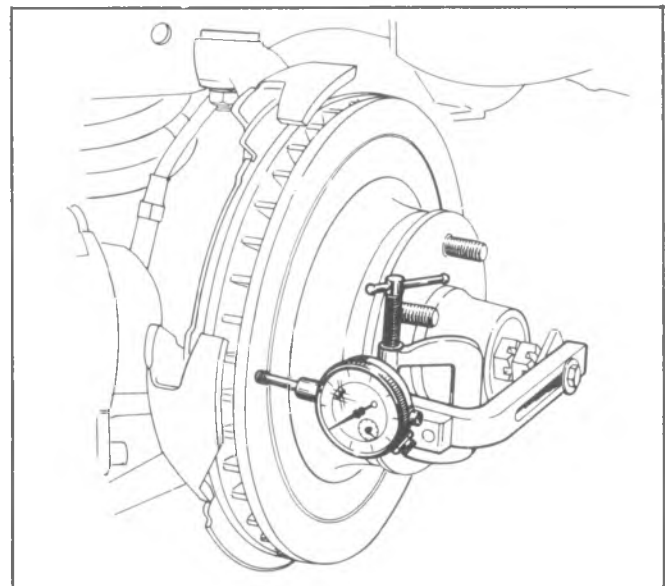


Fig. 5-42--Checking Rotor for Lateral Runout

specifications may be refinished to specifications if precision equipment is available.

Rotor Tolerance and Surface Finish

In manufacturing the brake rotor, tolerances of the rubbing surfaces for flatness, for parallelism and for lateral runout are held very closely. The maintenance of these close controls on the shape of the rubbing surfaces is necessary to prevent brake roughness.

In addition to these tolerances, the surface finish must be held to a specified range. The control of the rubbing surface finish is necessary to avoid pulls and erratic performance and to extend lining life.

Light scoring of the rotor surfaces not exceeding .015" in depth, which may result from normal use, is not detrimental to brake operation.

Machining

Since accurate control of the rotor tolerances is necessary for proper performance of the disc brakes, machining of the rotor should be done only with precision equipment.

WARNING: ALL BRAKE ROTORS HAVE A MINIMUM THICKNESS DIMENSION CAST INTO THEM. THIS DIMENSION IS THE MINIMUM WEAR DIMENSION AND NOT A REFINISH DIMENSION. DO NOT USE A BRAKE ROTOR THAT WILL NOT MEET THE SPECIFICATIONS, AS SHOWN BELOW, AFTER REFINISHING. REPLACE WITH NEW BRAKE ROTOR.

ROTOR THICKNESS	
MINIMUM AFTER REFINISHING	REPLACEMENT (DISCARD)
1.480	1.465
1.230	1.215
.980	.965

Wheel Bolt Replacement (Disc Brakes)

1. Remove hub and rotor assembly from vehicle.
2. Mark rotor to hub location and remove bolts attaching hub to rotor.
3. The wheel bolts on disc brakes can be pressed out from the outside of the hub and installed from inside the rotor by pressing into place. No drilling or cutting is required.
4. Reinstall assembly and adjust wheel bearings.

DRUM BRAKE SHOE AND LINING

Service Brake

Adjustment

1. Using a punch, knock out lanced area in brake drum. If this is done with the drum installed on the vehicle, the drum must be removed and all metal cleaned out of the brake compartment. Be sure to procure a new **metal** hole cover and install it in the drum after adjustment to prevent dirt and water from getting into the brakes. Use J-6166 to turn brake adjusting screw; expand brake shoes at each wheel until the wheel can just be turned by hand. The drag should be equal at all wheels.

2. Back off brake adjusting screw at each wheel 30 notches. If shoes still drag lightly on drum, back off adjusting screw one or two additional notches. Brakes should be free of drag when screw has been backed off approximately 12 notches. Heavy drag at this point indicates tight parking brake cables.

3. Install metal adjusting hole cover in brake drum.

4. Check parking brake adjustment.

Removal and Inspecting

WARNING: See "Warning" on Page 1 of this section.

1. Raise vehicle on hoist. Remove wheel and brake drum. It may be necessary to back off the brake shoe adjustment before the brake drums can be removed. To back off shoe adjustment, rotate shoe adjusting screw downward.

NOTE: On JB6, JB7 and JB8 equipped vehicles, it is necessary to remove the axle shafts to remove the hub and drum assembly; refer to Section 4B of this manual.

2. Unhook the primary and secondary shoe return springs using large pliers.

3. Remove shoe hold down springs.

4. Lift up on actuator, unhook actuating link from anchor pin, then remove.

5. Spread shoes to clear wheel cylinder connecting links, remove parking brake strut and spring, disconnect cable from parking brake lever, remove shoes from the backing plate.

6. Separate the brake shoes by removing adjusting-screw and lock spring. Remove parking brake lever and secondary brake shoe.

7. Clean all dirt out of brake drum. Inspect drums and replace or recondition if required.

8. Clean all dirt from brake assemblies and inspect for any unusual condition.

9. Wheel cylinders having torn, cut, or heat-cracked boots should be completely overhauled.

Inspection for leakage may be accomplished at the boot center hole after removal of link pin. Fluid

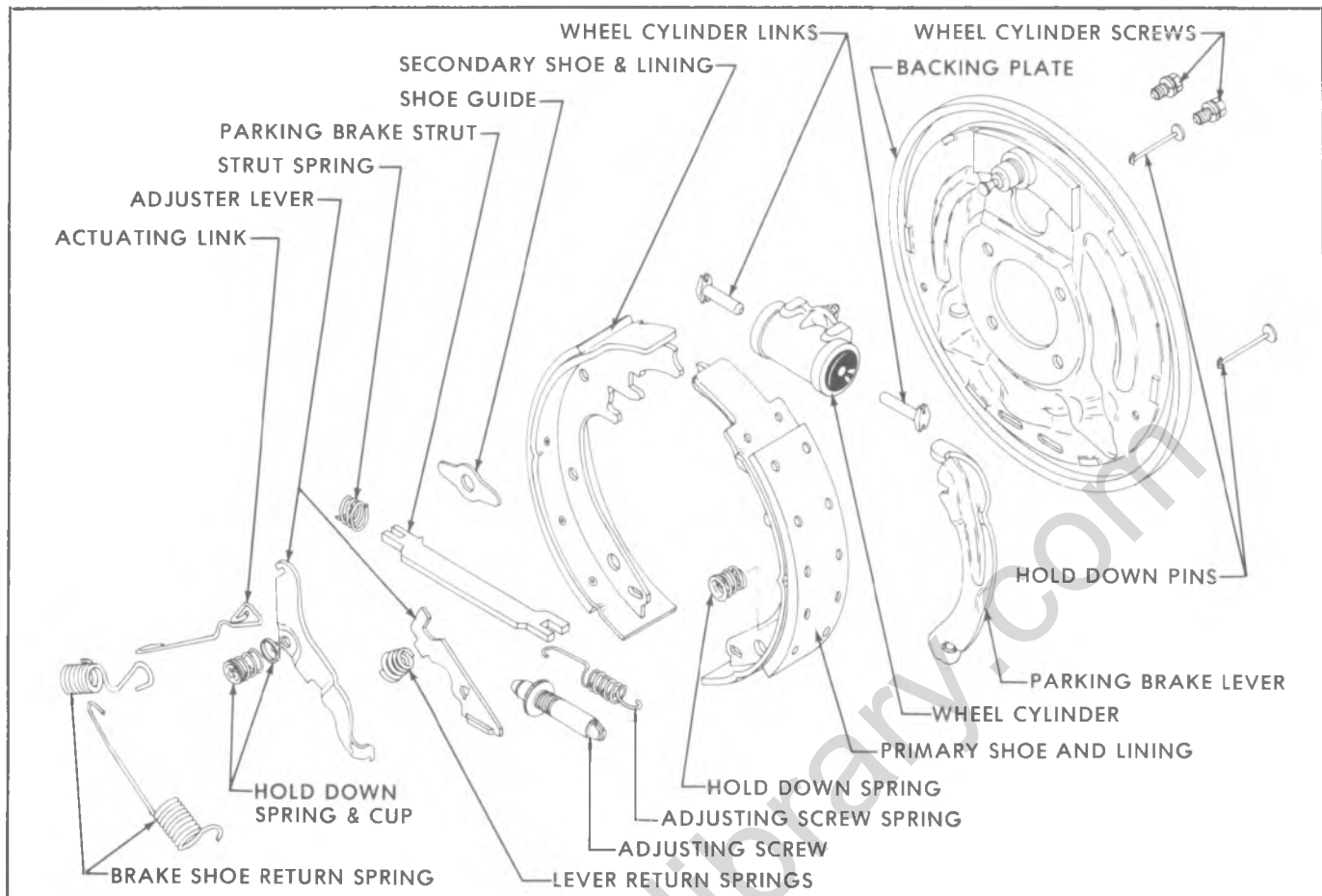


Fig. 5-43--Typical Drum Brake Assembly

coatings on piston within cylinder and on end of link pin removed from boot are normal, as cylinder contains a porous PISTON WHICH IS IMPREGNATED WITH A CORROSION INHIBITING FLUID. Fluid spilling from boot center hole, after link pin is removed, indicates cup leakage and necessity for completely over-hauling cylinder.

10. Inspect backing plate for oil leakage past wheel bearing oil seals. Correct any leak by installation of new seals (See Section 4B).

11. Check all backing plate attaching bolts to make sure they are tight. Using fine emery cloth, clean all rust and dirt from shoe contact surfaces on plate.

Relining Brake Shoes

If old brake shoes are to be relined, inspect shoes for distortion and for looseness between the rim and web; these are the causes for discarding any shoe. If shoes are serviceable, be governed by the following points in installing new linings:

1. Remove old linings by drilling out rivets. Punching rivets out will distort shoe rim. Thoroughly clean surface of shoe rim and file off any burrs or high spots.

2. Use GM brake lining (or equivalent) and the rivets included in lining package which are of the correct size. The rivets must fit the holes with the solid body of

rivet extending through the shoe rim, but no farther.

Keep hands clean while handling brake lining.

3. Start riveting at center of shoe and lining and work toward the ends. Use a roll set for riveting; a star set might split the tubular end and then the rivet would not fill the hole. The primary lining is shorter than secondary lining; therefore, the rivet holes at each end of the shoe rim are not used.

4. After riveting is completed, lining must seat snugly against shoe with no more than .005" separation midway between rivets. Check with a .004" (go) and a .006" (No Go) feeler gage.

Installation and Adjustment

1. Lubricate fulcrum end of parking brake lever with Delco Brake Lubricant or equivalent, then attach lever to secondary shoe. Make sure that lever is free moving.

2. Connect brake shoes together with adjusting screw spring, then place adjusting screw in position. When installing the adjusting screw spring and adjusting screw, make sure the spring does not touch the starwheel portion of the adjusting screw; and, also, when installing adjusting screw, make sure right hand thread adjusting screw is on left side of vehicle and left hand thread adjusting screw is on right side of vehicle. Make certain starwheel lines up with adjusting hole in backing plate.

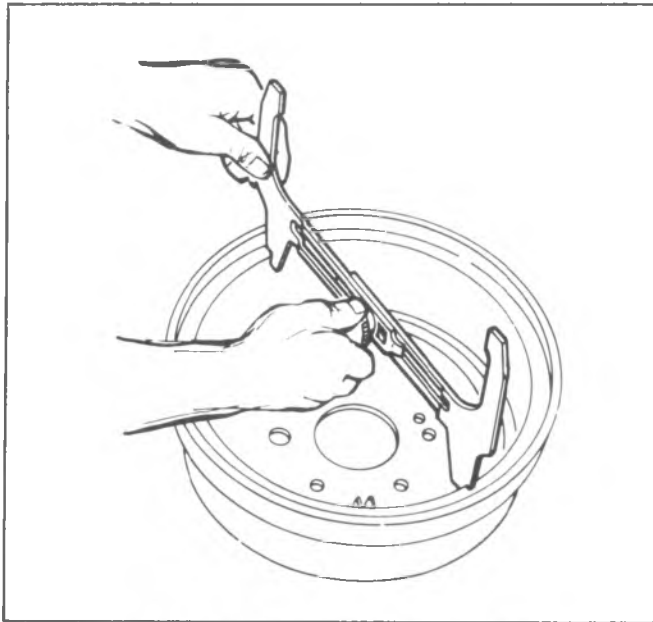


Fig. 5-44-Measuring Brake Drum I.D.

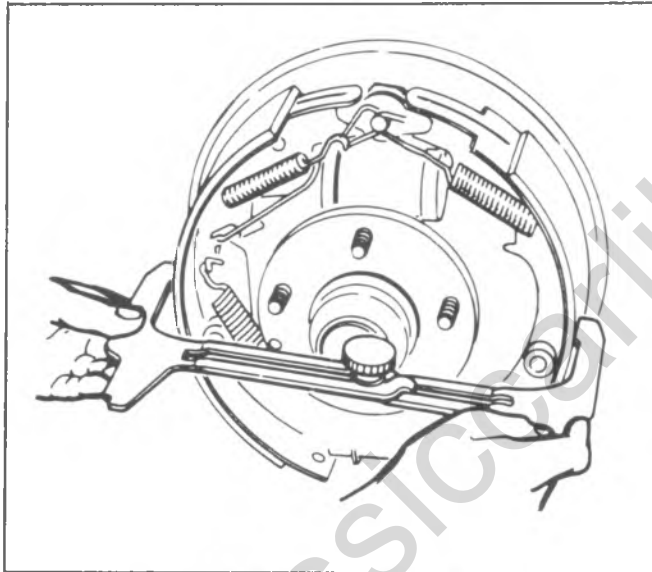


Fig. 5-45-Adjusting Brake Shoes

3. Lubricate shoe contact surfaces on backing plate with a thin coating of Delco Brake Lubricant or equivalent. Sparingly apply same lubricant where brake cable contacts backing plate.

4. Place brake shoes on backing plate, at the same time engaging shoes with wheel cylinder links. The primary shoe (short lining) goes toward front of vehicle. Connect cable to parking brake lever and install strut and spring between lever and primary shoe.

5. Install actuator, actuator return spring and actuating link. If old brake shoe return springs are nicked, distorted or of doubtful strength (discolored from heat), it is advisable to install new parts.

6. Install shoe hold down springs.

7. Install the primary and secondary shoe return springs using large pliers. Be careful not to distort springs.

8. Measure brake drum I.D. using inside caliper portion of Tool J-21177 (fig. 5-44). Adjust brake shoes to dimension obtained on outside caliper portion of Tool J-21177 (fig. 5-45).

9. Install brake drums and wheels.

10. If any hydraulic connections were disturbed, bleed hydraulic system.

11. Adjust parking brake.

12. Inspect all brake pipes, hoses and connections for evidence of fluid leakage. Tighten any leaking connection. Then apply heavy pedal pressure to brake pedal and recheck connections.

13. Check fluid level in master cylinder and add fluid if necessary.

14. Check brake pedal for proper feel and for proper return.

15. Remove vehicle from hoist and road test for proper brake action. Brakes must not be severely applied immediately after installation of new brake shoes or linings. Severe application may permanently damage new linings and may score brake drums. When linings are new, they must be given moderate use for several hundred miles of burnishing.

Repair Brake Lining

This procedure is to be used when brake action is unequal, severe, hard, noisy or otherwise unsatisfactory and when brake linings have had little wear.

1. Check fluid in master cylinder and add fluid if necessary.

2. Check brake pedal for proper feel and for proper return.

3. Raise vehicle on hoist and remove all wheels.

4. Remove all brake drums. Brake pedal must not be operated while drums are removed.

WARNING: See "Warning" on page 1 of this section.

5. Clean all dirt out of brake drums. Inspect drums and replace or recondition if required.

6. Clean all dirt from brake assemblies, then inspect brake linings for uneven wear, oil soaking, loose rivets or imbedded foreign particles. If linings are oil soaked, replacement is required.

7. If linings are otherwise serviceable, tighten or replace loose rivets and thoroughly clean all steel or other imbedded particles from surfaces and rivet counterbores of linings.

8. Check all backing plate bolts to make sure they are tight. (Refer to Section 4B for wheel stud replacement procedure.)

9. Measure brake drum I.D. using inside caliper portion of Tool J-21177. Adjust brake shoes to dimension obtained on outside caliper portion of Tool J-21177 (figs. 5-44 and 5-45).

10. Install drum and wheel and tire assemblies.

11. Remove vehicle from hoist and road test for proper brake action. Brakes must not be severely applied immediately after installation. Severe application may

permanently damage new linings and may score brake drums. When linings are new, they must be given moderate use for several hundred miles of burnishing.

Propeller Shaft Brake

Removal (Fig. 5-46)

1. Remove the propeller shaft; see Section 4A.
2. Remove the brake drum.

NOTE: It may be necessary to back off the shoe adjustment before removing the drum.

On automatic transmission models, the exhaust crossover pipe may be in the way. If so, loosen the transmission rear mounting bolts and jack the transmission sufficiently for brake drum to clear the pipe.

3. Remove the two pull back springs.
4. Remove the guide plate from anchor pin.
5. Remove shoe hold down cups, springs, and washers from hold down pins--remove pins.
6. Pull brake shoe and lining assemblies away from anchor pin and remove the strut and spring.
7. Lift the brake shoes and linings with the adjusting nut and bolt and connecting spring off the flange plate.
8. Move the shoes toward each other until the adjusting bolt and connecting spring drop off.

9. Remove the clip holding the brake lever to the primary shoe (shoe with short lining).

10. Compress the spring on the brake cable and remove the cable from the lever.

11. If necessary to remove the anchor pin, straighten the washer from pin hex and reinforcement. Remove reinforcement and washer with anchor pin.

12. If necessary to remove the cable, compress tangs on cable and pull assembly out of the hole in the flange plate.

13. If necessary to remove the flange plate, remove the transmission flange nut and transmission output flange. Remove bolts holding the flange plate to bearing retainer and remove the flange plate.

Inspection

Replace any worn or broken parts.

Installation

CAUTION: Refer to "Caution" on Page 1 of this section when installing fasteners in steps 1, 2 and 4 below.

1. Place the flange plate in position on the rear bearing retainer and fasten with four bolts. Torque bolts to 24 foot pounds.

2. Install transmission output flange on spline of mainshaft and fasten with flange nut. Torque nut to 100 ft. lbs.

3. Install cable assembly from back of flange plate.

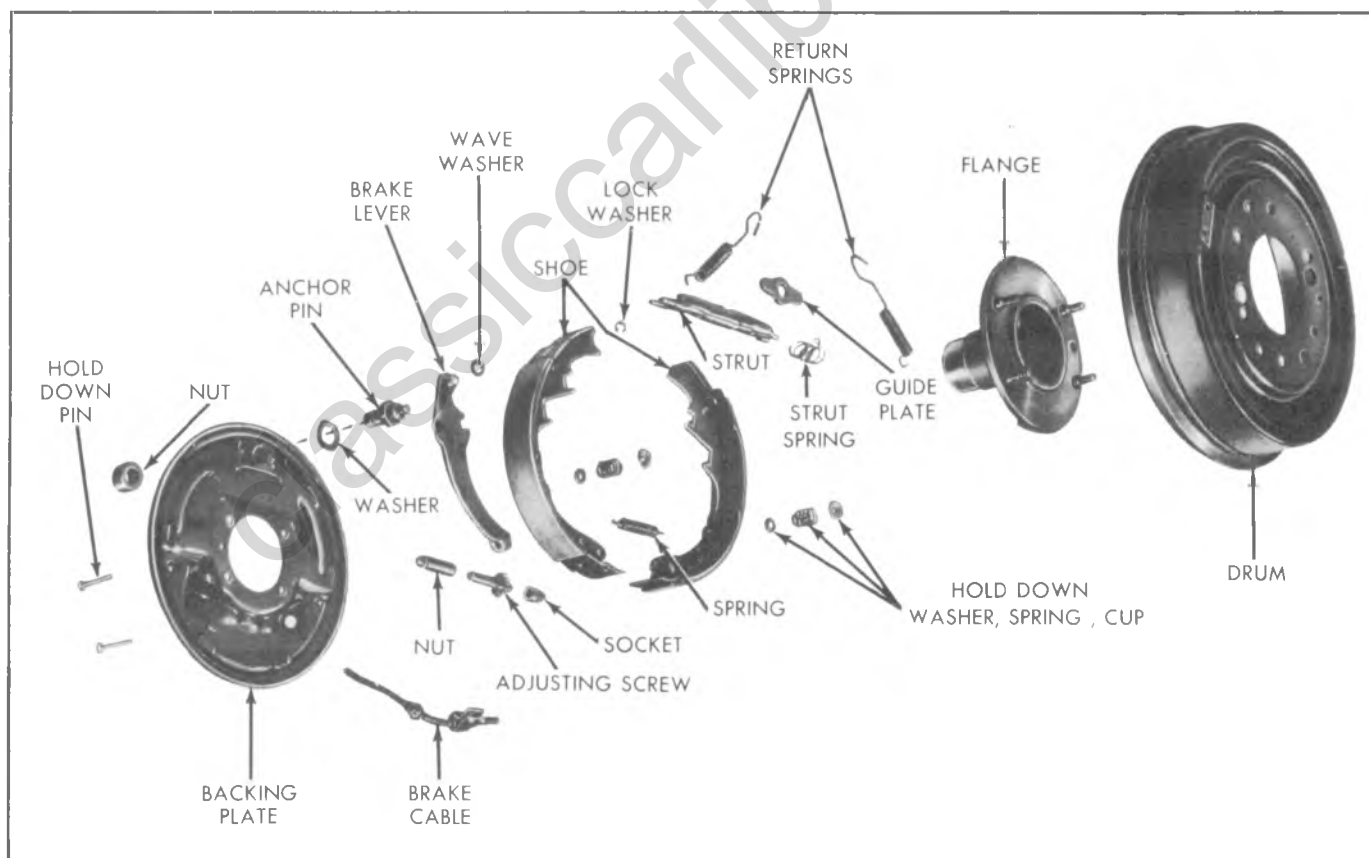


Fig. 5-46 Propshaft Parking Brake Components

Push retainer through hole in flange plate until tangs securely grip the inner side of the plate.

4. Place washer and reinforcement over the threaded end of anchor pin. Hold anchor pin nut (flat side against flange on flange plate) in position behind flange plate and insert threaded end of anchor pin from front side. Thread the anchor pin into nut and tighten securely (140 foot pounds torque). Bend tang of washer over reinforcement and side of washer over hex of anchor pin.

5. Install lever on cable by compressing spring and inserting cable in channel of lever. Release spring.

6. Install primary shoe (short lining) to lever as follows: Place pin in lever, place washer on pin and push pin through hole in primary shoe. Fasten parts together by installing the clip in groove of pin.

7. Fasten two brake shoes and linings together by installing connecting spring. Move the shoes toward each other and install adjusting screw.

8. Lubricate the flange plate contact surfaces with a very light coat of Delco Brake Lube (or equivalent).

9. Place shoe and linings in position on flange plate.

NOTE: When facing the brake assembly, the shoe with the short lining should be to the left with the lever assembled to it (automatic transmission), to the right (manual transmission).

10. Pull brake shoes apart and install strut lever and spring between them. The loop on the strut spring should be in the "up" position.

11. Install hold down pins, washers, springs and cups from flange plate to shoes.

12. Place guide plate on anchor pin.

13. Install pull back springs.

14. Remove the "knock out" plug (if necessary) and install a new metal plug in the brake drum adjusting hole.

15. Install the brake drum.

16. Install the propeller shaft.

RPO H22 Rear Drum Brakes

Removal (Fig. 5-47)

WARNING: See "Warning" on Page 1 of this section.

1. Raise the vehicle on a hoist.
2. Retract self adjusters if necessary and remove brake drums.

3. Using Tool J-22348, remove the brake shoe pull back springs (fig. 5-48).

4. Loosen the actuating lever cam cap screw and while holding the star wheel end of the actuating lever past the star wheel, remove the cap screw and cam.

5. Remove the brake shoe hold down springs and pins by compressing the spring with Tool J-22348 and, at the same time, pushing the pin back through the flange

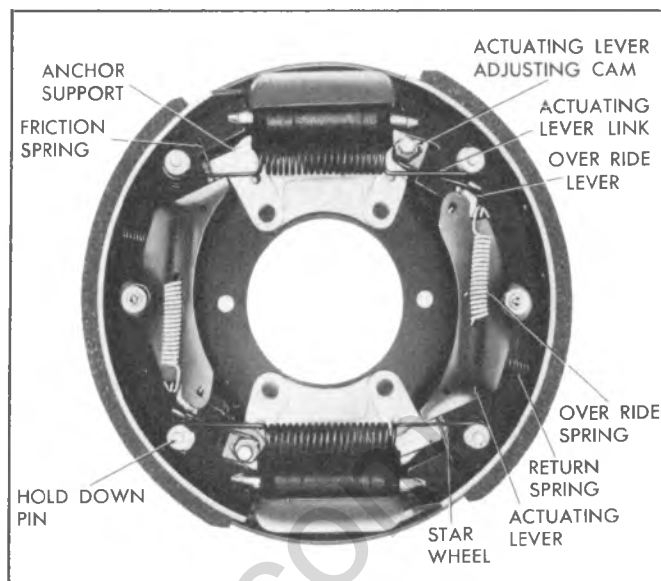


Fig. 5-47--Rear Brake-Used with RPO H-22

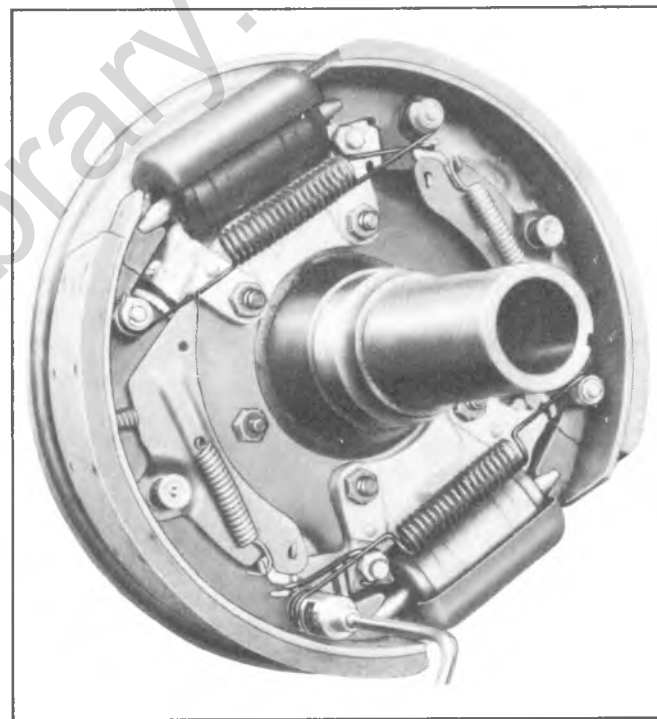


Fig. 5-48--Removing Pull Pack Spring with Tool J-22348

plate toward the tool. Then, keeping the spring compressed, remove the lock from the pin with a magnet (fig. 5-49).

6. Lift off the brake shoe and self adjuster as an assembly.

7. The self adjuster can now be removed from the brake shoe by removing the hold down spring and pin.

NOTE: The actuating lever, override lever and spring are an assembly. It is recommended that they not be disassembled for service purposes unless

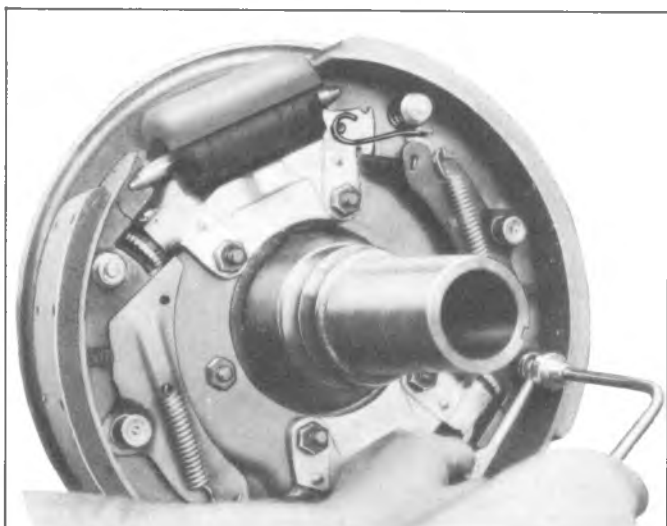


Fig. 5-49-Removing Hold Down Pins Using J 22348

they are broken. It is much easier to assemble and disassemble the brakes leaving them intact.

8. Thread the adjusting screw out of the anchor support and remove and discard the friction spring.

9. Clean all dirt out of brake drum. Inspect drums for roughness, scoring or out-of-round. Replace or recondition drums as necessary.

NOTE: See Section on "BRAKE DRUMS".

10. Carefully pull lower edges of wheel cylinder boots away from cylinders. If brake fluid flows out, overhaul of the wheel cylinders is necessary.

NOTE: A slight amount of fluid is nearly always present and acts as a lubricant for the piston.

11. Inspect flange plate for oil leakage past axle shaft oil seals. Install seals if necessary.

12. Check all flange plate attaching bolts to make sure they are tight (150 ft. lbs. torque). Clean all dirt and rust from shoe contact faces on flange plate using emery cloth.

13. Thoroughly clean adjusting screws and threads in the anchor brackets.

Installation

1. Put a light film of Delco Brake Lube (or equivalent) on shoe bearing surfaces of brake flange plate and on threads of adjusting screw.

2. Thread adjusting screw completely into anchor bracket without friction spring to be sure threads are clean and screw turns easily. Then remove screw, position a new friction spring on screw and reinstall in anchor bracket.

CAUTION: See "Caution" on Page 1 of this section.

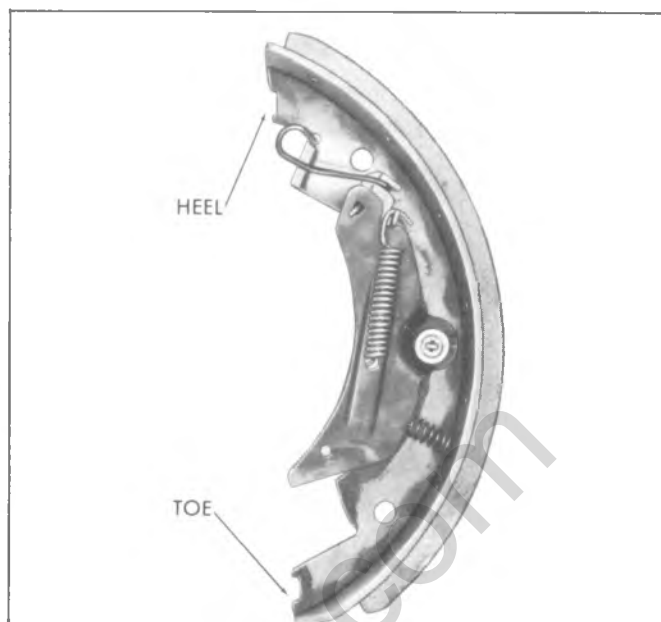


Fig. 5-50-Brake Shoe and Self Adjuster Assembly



Fig. 5-51-Measuring Points for Shoe Centering

3. Assemble self adjuster assembly to brake shoe and position actuating lever link on override lever.

4. Position hold down pins in flange plate.

5. Install brake shoe and self adjuster assemblies onto hold down pins, indexing ends of shoes with wheel cylinder push rods and legs of friction springs.

NOTE: Make sure the toe of the shoe is against the adjusting screw (fig.5-50).

6. Install cup, spring and retainer on end of hold

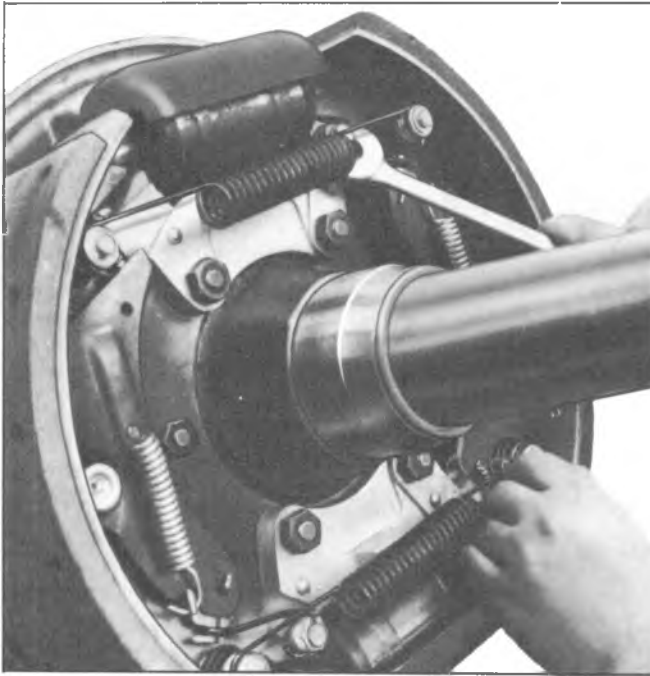


Fig. 5-52--Positioning Actuator Lever

down pin. Using Tool J-22348, compress the spring. With spring compressed, push the hold down pin back through the flange plate toward the tool and install the lock on the pin.

7. Using Tool J-22348, install brake shoe return springs.

8. Holding the star wheel end of the actuating lever as far as possible past the star wheel, position the adjusting lever cam into the actuating lever link and assemble with cap screw.

9. Check the brake shoes for being centered by measuring the distance from the lining surface to the edge of the flange plate at the points shown in Figure 5-51. To center the shoes, tap the upper or lower end of the shoes with a plastic mallet until the distances at each end become equal.

10. Locate the adjusting lever .020" to .039" above the outside diameter of the adjusting screw thread by loosening the cap screw and turning the adjusting cam.

NOTE: To determine .020" to .039", turn the adjusting screw 2 full turns out from the fully retracted position. Hold a .060" plug gage (from J-9789-01 Universal Carburetor Gage Set) at a 90° angle with the star wheel edge of the actuating lever. Turn the adjusting cam until the actuating lever and threaded area on the adjusting screw just touch the gage (figs. 5-52 and 5-53).

11. Secure the adjusting cam cap screw and retract the adjusting screw.

12. Install brake drums and wheels and remove vehicle from jack stands.

13. Adjust the brakes by making several forward

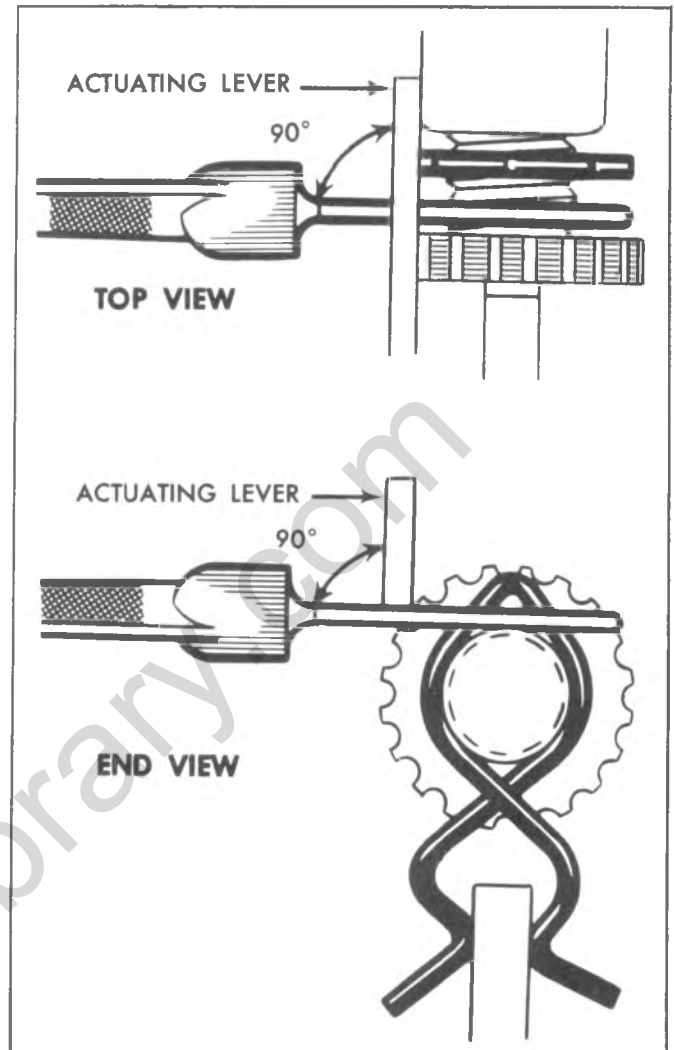


Fig. 5-53--Pull Gage Positioning for Correct Actuator Lever Adjustment

and reverse stops until a satisfactory brake pedal height results.

BRAKE DRUMS

Inspection and Reconditioning

WARNING: See "Warning" on Page 1 of this section.

Whenever brake drums are removed, they should be thoroughly cleaned and inspected for cracks, scores, deep grooves and out-of-round.

Cracked, Scored, or Grooved Drum

A cracked drum is unsafe for further service and must be replaced. Do not attempt to weld a cracked drum.

Smooth up any slight scores. Heavy or extensive scoring will cause excessive brake lining wear, and it will

probably be necessary to rebore in order to true up the braking surface.

If the brake linings are slightly worn and the drum is grooved, the drum should be polished with fine emery cloth but should not be turned. At this stage, eliminating the grooves in drum would necessitate removal of too much metal, while if left alone, the grooves and lining ridges match and satisfactory service can be obtained.

If brake linings are to be replaced, a grooved drum should be turned for use with new linings. A grooved drum, if used with new lining, will not only wear the lining, but will make it difficult, if not impossible to obtain efficient brake performance.

Out-Of-Round or Tapered Drum

An out-of-round drum makes accurate brake shoe adjustment impossible and is likely to cause excessive wear of other parts of brake mechanism due to its eccentric action. An out-of-round drum can also cause severe and irregular tire tread wear as well as pulsating brake pedal. When the braking surface of a brake drum exceeds the factory specification limits in taper (and/or) being out-of-round, the drum should be turned to true up the braking surface. Out-of-round as well as taper and wear can be accurately measured with an inside micrometer fitted with proper extension rods.

When measuring a drum for out-of-round, taper and wear, take measurements at the open and closed edges of machined surface and at right angles to each other.

Turning Brake Drums

If a drum is to be turned, only enough metal should be removed to obtain a true, smooth braking surface. If a drum does not clean-up when turned to a maximum diameter as shown in the general specification, it must be replaced. Removal of more metal will affect dissipation of heat and may cause distortion of the drum.

All brake drums have a maximum diameter cast into them. This diameter is the maximum wear diameter and not a refinish diameter. Do not refinish a brake drum that will not meet the specifications, as shown below, after refinishing.

DRUM DIAMETERS		
ORIGINAL	MAXIMUM REFINISH	REPLACEMENT (DISCARD)
11.000	11.060	11.090
12.000	12.060	12.090
13.000	13.060	13.090

Brake Drum Balance

During manufacture, brake drums are balanced within three ounce inches. These weights must not be removed.

WHEEL CYLINDER

Removal

1. Remove wheel, drum and brake shoes. Be careful not to get grease or dirt on brake lining.
2. Remove wheel cylinder from backing plate.

Disassembly

1. Inspect cylinder bore for scoring or corrosion. It is best to replace a corroded cylinder.
2. Polish any discolored or stained area with crocus cloth by revolving cylinder on cloth supported by a finger.
3. Rinse cylinder in clean brake fluid.
4. Shake excessive rinsing fluid from cylinder. Do not use a rag to dry cylinder, as lint from the rag cannot be kept from cylinder bore surfaces.

Assembly

1. Lubricate cylinder bore and counterbore with clean brake fluid and insert spring-expander assembly.
2. Install new cups. (Be sure cups are lint and dirt free.) Do not lubricate cups prior to assembly.
3. Install new pistons.
4. Press new boots into cylinder counterbores by hand. Do not lubricate boots prior to assembly.

Installation

1. Install wheel cylinder on brake backing plate and connect brake pipe to hose. Torque rear wheel brake pipe to wheel cylinder to specifications.
2. Install brake shoes, drum and wheel; then flush and bleed hydraulic system.

POWER BRAKE UNIT

Vacuum Booster

Replacement (Fig. 5-54)

CAUTION: See "Caution" on page 1 of this section when installing fasteners referred to in steps 6, 7 and 9 below.

1. Remove two nuts holding master cylinder to power cylinder and position it away from power cylinder.

CAUTION: Do not disconnect hydraulic brake lines; be careful not to bend or kink pipes.

2. Disconnect the vacuum hose from the vacuum check valve on the front housing of the power head. Plug vacuum hose to prevent dust and dirt from entering hose.
3. Disconnect the power brake push rod from the brake pedal.
4. Remove the four nuts from the mounting studs which hold the power brake to the cowl.

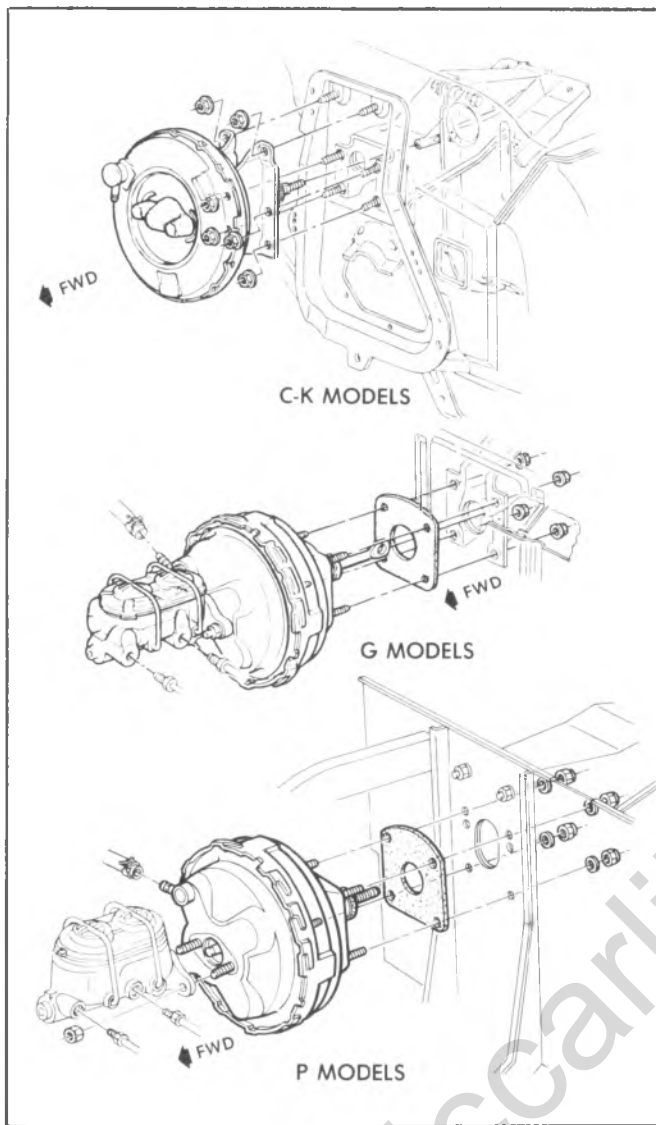


Fig. 5-54--Vacuum Booster Installation

5. Carry the power brake to a clean work area and clean the exterior of the power brake prior to disassembly.

6. Mount power brake assembly to cowl and torque nuts to specified torque.

7. Connect power brake push rod to brake pedal.

8. Connect vacuum hose to vacuum check valve.

9. Connect master cylinder to power cylinder and torque nuts to specifications.

Hydro-Boost Unit

Replacement (fig. 5-55)

1. Depress and release the brake pedal several times (engine not running) to be sure that all pressure is discharged from the accumulator prior to disconnecting the hoses from the booster.

2. **P30(32) Models**-Raise the vehicle on a hoist.
3. Clean all dirt from the booster at the hydraulic line connections and master cylinder.

4. Remove the nuts and lockwashers that secure the master cylinder to the booster and the support bracket. Support the master cylinder, being careful to avoid kinking or bending the hydraulic lines attached to the master cylinder. Cover the end of the master cylinder with a clean cloth.

NOTE: It should not be necessary to disconnect the hydraulic lines from the master cylinder.

5. Disconnect the hydraulic lines from the booster ports. Plug all lines and the booster ports to prevent loss of fluid and to keep out foreign material.

6. **P30(42) and C-K-G Models-**

a. Remove booster pedal push rod cotter pin and washer and disconnect the push rod from the brake pedal (C and K models) or booster bracket pivot lever (G and P models). ♦

b. Remove the booster support bracket on C and K models, support braces on G and P30(42) models.

c. Remove the booster bracket to dash panel or support bracket nuts and remove the booster assembly.

7. **P30(32) Models-**

a. Remove the cotter pin, nut, bolt and washers that secure the operating lever to the vertical brake rod.

b. Remove the six nuts, lock washer and bolts that secure the booster linkage bracket to the front and rear support brackets, and remove the booster from the vehicle by sliding the booster off the rear support studs.

c. Remove the cotter pin, nut, washer and bolt that secures the operating lever to the pedal rod.

d. Remove the brake pedal rod lever nut and bolt and then remove the lever, sleeve and bushings.

8. To install, reverse Steps 1-7 above. Torque all hydraulic lines and attaching bolts to specifications.

NOTE: Lubricate pedal rod and linkage pivot bolts, pins, sleeves and bushings with Delco Brake Lube (or equivalent).

CAUTION: See "Caution" on Page 1 of this section.

9. Bleed the booster/power steering hydraulic system as described earlier in this section.

10. Check brake pedal and stoplamp switch adjustment.

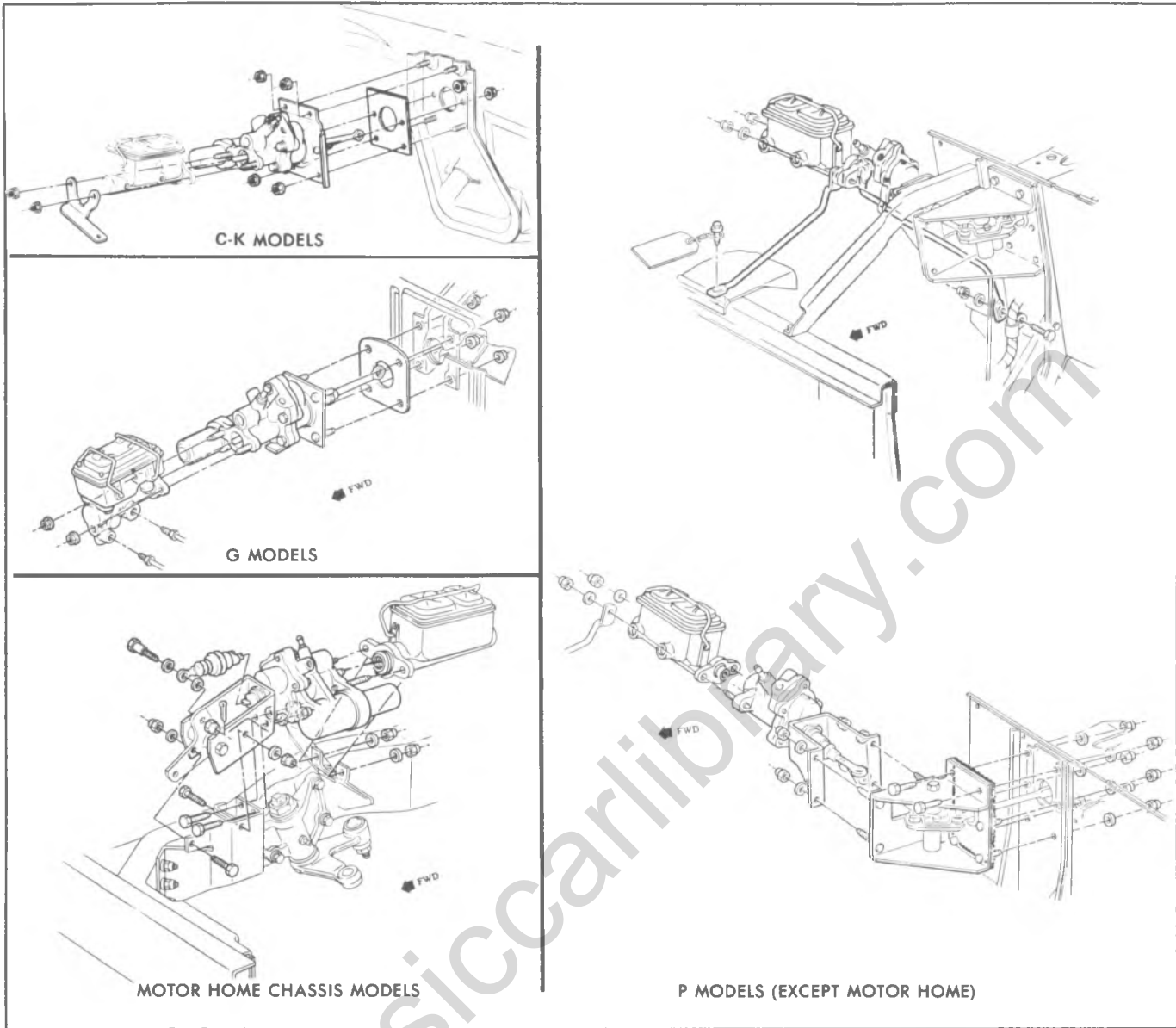


Fig. 5-55--Booster Installation (Hydroboost)

SPECIFICATIONS

BRAKE SYSTEM DESCRIPTION

<u>SYSTEM</u>	<u>FRONT BRAKES</u>	<u>REAR BRAKES</u>	<u>BRAKE ASSIST</u>
JB1	Disc 11.86 x 1.28	Drum 11.00 x 2.00	None (Manual Brakes)
JB3	Disc 11.86 x 1.28	Drum 11.00 x 2.00	Vacuum - Single Diaphragm
JB5	Disc 11.86 x 1.28	Drum 11.15 x 2.75	Vacuum - Dual Diaphragm
JB6	Disc 12.50 x 1.28	Drum 11.15 x 2.75	Vacuum - Dual Diaphragm
JB7	Disc 12.50 x 1.28	Drum 13.00 x 2.50	Vacuum - Dual Diaphragm
JB8	Disc 12.50 x 1.53	Drum 13.00 x 3.50	Hydraulic - Hydroboost
JF9	Disc 14.25 x 1.53	Disc 13.75 x 1.53	Hydraulic - Hydroboost

BRAKE SYSTEM APPLICATION

<u>MODEL</u>	<u>TON RATING</u>	<u>WHEELBASE</u>	<u>GVW RATING</u>	<u>MERCHANDIZING OPTION</u>	<u>BRAKE SYSTEM</u>
C10516	1/2	106.5	6050	Base	JB5
C10703		117.5	4900	Base	JB1
			5300-5600	J50	JB3
			5300-5600	J55*	JB5*
			6050-6200	J55	JB5
C10903		131.5	4900	Base	JB1
			5300-5600	J50	JB3
			5300-5600	J55*	JB5*
			6050-6200	J55	JB5
C10906		129.5	6050-7000	Base	JB5
C20903	3/4	131.5	6400-7100	Base	JB6
			6400-7100	J55*	JB7*
			7500-8200	J55	JB7
C20906		129.5	7100	Base	JB6
			7100	J55*	JB7*
			7500-8200	J55	JB7
C20943		164.5	7500-8200	Base	JB7
C20963			8200	Base	JB7
C30903	1	131.5	6600-8200	Base	JB7
			6600-8200	J55*	JB8*
			9000-10000	J55	JB8
C30943		164.5	9000-10000	Base	JB8
C31003		135.5	6600-8200	Base	JB7
			6600-8200	J55*	JB8*
			9000-10000	J55	JB8
C31403		159.5	6600-8200	Base	JB7
			6600-8200	J55*	JB8*
			9000-10000	J55	JB8

*Optional Heavy Duty Brakes.

BRAKE SYSTEM APPLICATION (continued)

<u>MODEL</u>	<u>TON RATING</u>	<u>WHEELBASE</u>	<u>GVW RATING</u>	<u>MERCHANDIZING OPTION</u>	<u>BRAKE SYSTEM</u>
K10516	1/2	106.5	6200	Base	JB5
K10703		117.5	6200	Base	JB5
K10903		131.5	6200	Base	JB5
K10906		129.5	6200-7300	Base	JB5
K20903	3/4	131.5	6800 6800 7500-8400	Base J55* J55	JB6 JB7* JB7
K20906		129.5	6800 6800 7500-8400	Base J55* J55	JB6 JB7* JB7
K30903	1	131.5	8600-10000	Base	JB8
K30943		164.5	9200-10000	Base	JB8
K31003		135.5	8600-10000	Base	JB8
K31403		159.5	8600-10000	Base	JB8

*Optional Heavy Duty Brakes.

BRAKE SYSTEM APPLICATION (continued)

MODEL	TON RATING	WHEELBASE	GVW RATING	MERCHANDIZING OPTION	BRAKE SYSTEM
G11005	1/2	110	4800 4800 5400-5600	Base J50* J50	JB1 JB3* JB3
G11006			5400-5600	Base	JB3
G11305		125	4900 4900 5400-5600	Base J50* J50	JB1 JB3* JB3
G11306			5600	Base	JB3
G21005	3/4	110	6400	Base	JB5
G21006			6400	Base	JB5
G21305		125	6400	Base	JB5
G21306			6400	Base	JB5
G31005	1	110	6400-7100 6400-7100 7700-8100	Base J55* J55	JB6 JB7* JB7
G31305		125	6600-7400 6600-7400 7900-8400	Base J55* J55	JB6 JB7* JB7
G31306			6600-7400 6600-7400 7900-8400	Base J55* J55	JB6 JB7* JB7
G31303			7400-8400 8900	Base R05	JB7 JB8
G31603		146	8900-10500	Base	JB8

*Optional Heavy Duty Brakes.

BRAKE SYSTEM APPLICATION (continued)

<u>MODEL</u>	<u>TON RATING</u>	<u>WHEELBASE</u>	<u>GVW RATING</u>	<u>MERCHANDIZING OPTION</u>	<u>BRAKE SYSTEM</u>
P10542	1/2	102	6200	Base	JB5
P20842	3/4	125	6800 6800 7500-8000	Base J55* J55	JB6 JB7* JB7
P21042		133	6800 6800 7500-8000	Base J55* J55	JB6 JB7* JB7
P30842	1	125	7600-8200 7600-8200 9000-10000 12000-14000	Base J55* J55 H22 or H23	JB7 JB8* JB8 JF9
P30832			10500-12500	Base	JB8
P31042		133	7600-8200 7600-8200 9000-10000 12000-14000	Base J55* J55 H22 or H23	JB7 JB8* JB8 JF9
P31132		137	10500-12500	Base	JB8
P31432		158.5	10500-12500 14500	Base HF7 or HF8	JB8 JF9
P31442		157	7600-8200 7600-8200 9000-10000 12000-14000	Base J55* J55 H22 or H23	JB7 JB8* JB8 JF9
P31832		178	14500	Base	JF9

*Optional Heavy Duty Brakes.

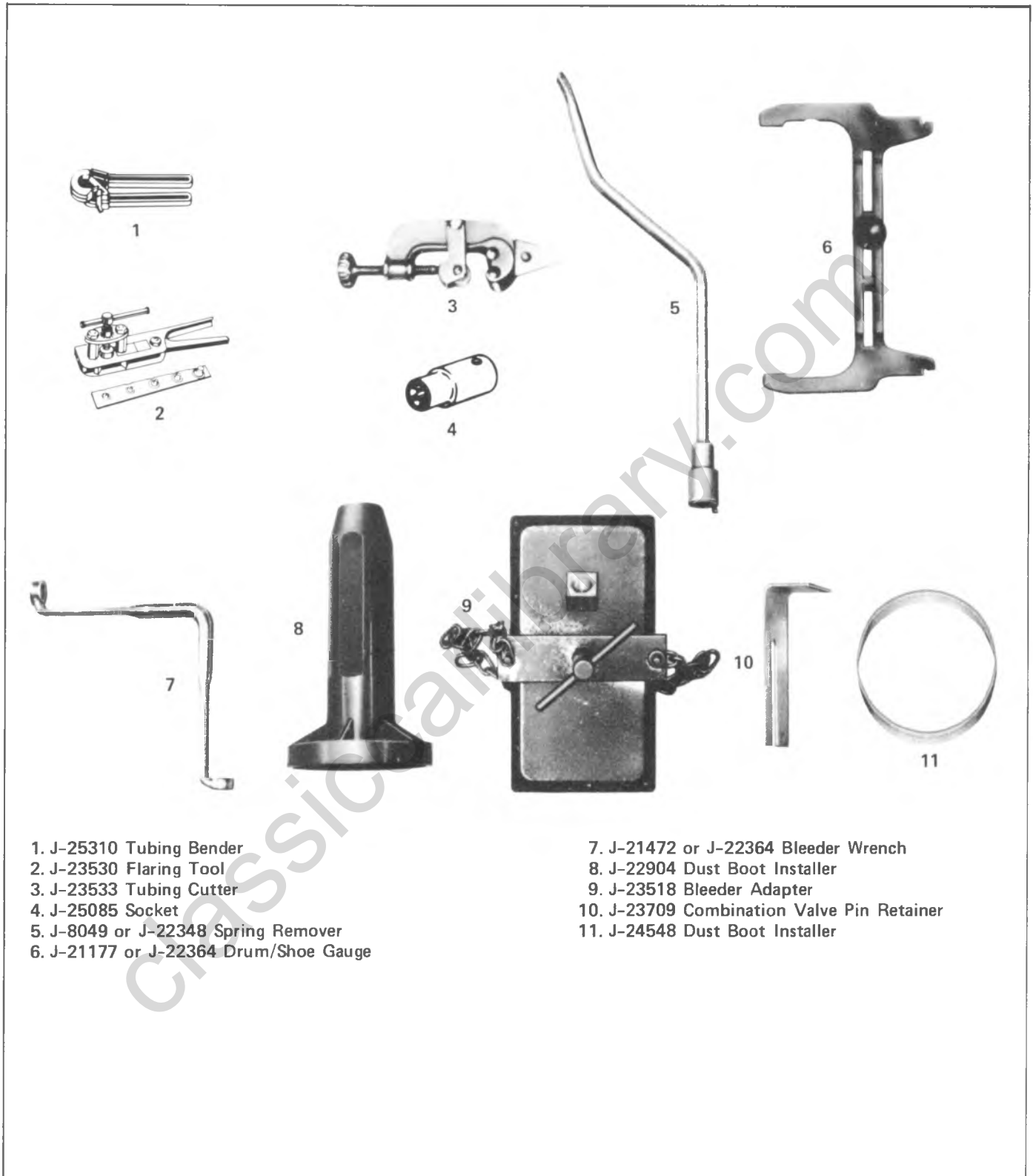
	C	K	G	P
Master Cylinder - to Dash or Booster	**25 ft. lbs.	**25 ft. lbs.	25 ft. lbs.	25 ft. lbs.
Booster to Dash or Frame	**25 ft. lbs.	**25 ft. lbs.	25 ft. lbs.	25 ft. lbs.
Combination Valve - Mounting Bolts	150 in. lbs.	150 in. lbs.	17 ft. lbs.	17 ft. lbs.
- Bracket	-	-	25 ft. lbs.	25 ft. lbs.
Caliper - Mounting Bolt	35 ft. lbs.			
- Support Plate to Knuckle	140 in. lbs.			
Brake Pedal - Bracket to Dash	25 ft. lbs.	25 ft. lbs.	150 in. lbs.	25 ft. lbs.
- Bracket to I.P.	25 in. lbs.	25 in. lbs.	-	-
- Pivot Bolt Nut	25 ft. lbs.	25 ft. lbs.	-	45 ft. lbs.
- Sleeve to Bracket	-	-	-	100 in. lbs.
- Stoplamp Switch Bracket	25 ft. lbs.	25 ft. lbs.	25 ft. lbs.	-
- Push Rod to Pedal	-	-	-	25 ft. lbs.
- Push Rod Adjusting Nut	-	-	-	22 ft. lbs.
Parking Brake - to Dash	100 in. lbs.	100 in. lbs.	100 in. lbs.	-
- to I.P., Kick Panel or Floorpan	150 in. lbs.	150 in. lbs.	100 in. lbs.	18 ft. lbs.
- Cable Clips - Screws	150 in. lbs.	-	100 in. lbs.	150 in. lbs.
- Bolts	150 in. lbs.	-	18 ft. lbs.	55 in. lbs.
Propshaft Parking Brake - Adjusting Nut	-	-	-	30 ft. lbs.
- Bracket to Trans.	-	-	-	20 ft. lbs.
- Cable Clip to Frame	-	-	-	150 in. lbs.
- Cable Clip to Dash	-	-	-	55 in. lbs.
- Cable Clip to Trans. Brkt.	-	-	-	20 ft. lbs.
- Flange Plate	-	-	-	30 ft. lbs.
- Drum	-	-	-	80 ft. lbs.
Wheel Cylinder to Flange Plate Bolt	50 in. lbs. (180 in. lbs. on JB5, JB6, JB7 and JB8)			
Rear Brake Anchor Pin	140 ft. lbs. (230 ft. lbs. JB7 and JB8)			
Front Brake Hose - to Caliper	22 ft. lbs.			
- to Frame Nut	58 in. lbs.			
- Bracket Bolt	150 in. lbs.	-	150 in. lbs.	150 in. lbs.
Rear Brake Hose - to Axle Bracket	150 in. lbs.	150 in. lbs.	90 in. lbs.	150 in. lbs.
- Bracket to Axle	150 in. lbs.*	150 in. lbs.*	-	150 in. lbs.*
Brake Line - Attaching Nuts	150 in. lbs.			
- Retaining Clips - Screws	150 in. lbs.	150 in. lbs.	100 in. lbs.	150 in. lbs.
- Bolts	-	-	150 in. lbs.	18 ft. lbs.
Brake Bleeder Valves	60 in. lbs.			
Hydro-Boost - Pedal Rod - P30(32) Models	-	-	-	25 ft. lbs.
- Pedal Rod Boot - P30(32)Models	-	-	-	15 in. lbs.
- Pivot Lever Rod Retainer	-	-	-	25 ft. lbs.
- Pivot Lever Bolt	-	-	-	45 ft. lbs.
- Booster Brackets	-	-	-	25 ft. lbs.
- Booster Brace at Dash or Rad. Supt.	-	-	-	150 in. lbs.
- Power Steering Pump to Booster Line	25 ft. lbs.			
- Booster to Gear Line	25 ft. lbs.			
- Return Line at Booster & Gear	25 ft. lbs.			
- Return Line Clamp Screw	15 in. lbs.			
- Line Clamp to Bracket Screw	150 in. lbs.			
- Hose Clamp to Skirt Screw	40 in. lbs.	-	-	-
- Line Clamp to Frame Bolt	150 in. lbs.	-	-	18 ft. lbs.

*20 ft. lbs. (CKP20-30)

**32 ft. lbs. — Master Cylinder to Booster

Master Cylinder or Booster to Dash Reinforcement

SPECIAL TOOLS



1. J-25310 Tubing Bender
 2. J-23530 Flaring Tool
 3. J-23533 Tubing Cutter
 4. J-25085 Socket
 5. J-8049 or J-22348 Spring Remover
 6. J-21177 or J-22364 Drum/Shoe Gauge

7. J-21472 or J-22364 Bleeder Wrench
 8. J-22904 Dust Boot Installer
 9. J-23518 Bleeder Adapter
 10. J-23709 Combination Valve Pin Retainer
 11. J-24548 Dust Boot Installer

Fig. 5-56--Special Tools

classiccarylbrary.com

SECTION 6A

ENGINE MECHANICAL

CONTENTS OF THIS SECTION

Engine Identification	6A-1
Diagnosis	6A-3
6 Cylinder Engine	6A-7
8 Cylinder Engine	6A-43

ENGINE IDENTIFICATION

All engines have a portion of the VIN number and a build date code stamped on the cylinder case.

The 6-cylinder stamping is on the right hand side on the distributor pad. An optional code location is at the left rear of the cylinder and case on the bellhousing/converter housing mounting surface (Fig. 6A-1).

Small block 8-cylinder engines have the stamping on

top front of right hand bank of cylinder and case. The optional location is rear of the oil filter on the left side of the engine (Fig. 6A-1).

The Mark IV 8-cylinder engines (big block) have the same stamping locations as the small blocks with the addition of a stamping location in front of the engine, above the timing chain cover (Fig. 6A-2).

DIAGNOSIS

ENGINE FAILS TO START

- | | |
|--|---|
| <ul style="list-style-type: none"> a. Check for sufficient fuel to operate engine. b. Carburetor flooded and/or fuel level in carburetor bowl not correct. c. Dirt and water in gas line or carburetor. d. Sticking choke. e. Faulty fuel pump. f. Corroded or loose battery terminal connections and/or weak battery. g. Broken or loose ignition wires and/or faulty ignition switch. | <ul style="list-style-type: none"> h. Excessive moisture on plugs, caps or ignition system. i. Damaged distributor rotor or cracked distributor cap. j. Fouled spark plugs and/or improper spark plug gap. k. Weak or faulty coil. l. Faulty solenoid or starting motor. m. Park or neutral switch inoperative. |
|--|---|

ENGINE LOPES WHILE IDLING

- | | |
|---|--|
| <ul style="list-style-type: none"> a. Check for air leaks between intake manifold and head. b. Check for blown head gasket. c. Check for worn timing gears, chain or sprockets. d. Check for worn camshaft lobes. | <ul style="list-style-type: none"> e. Check for overheated engine. f. Check for plugged crankcase vent valve. g. Check for faulty fuel pump. h. Check for leaky EGR valve. |
|---|--|

ENGINE MISSES WHILE IDLING

- | | |
|--|---|
| <ul style="list-style-type: none"> a. Check, inspect and regap spark plugs. Replace as necessary. b. Remove moisture from spark plug wires and/or distributor cap. c. Check for broken or loose ignition wires. Repair or replace as necessary. d. Check condition of cylinders for uneven compression. Repair as necessary. | <ul style="list-style-type: none"> e. Check for weak or faulty HEI system coil as outlined in Section 6D of this manual. f. Inspect condition of distributor cap and rotor. Replace if damaged or cracked. g. Check carburetor for internal obstructions, incorrect idle speed, faulty altitude compensator, sticking choke or enrichment system and adjust, repair or replace as necessary. |
|--|---|

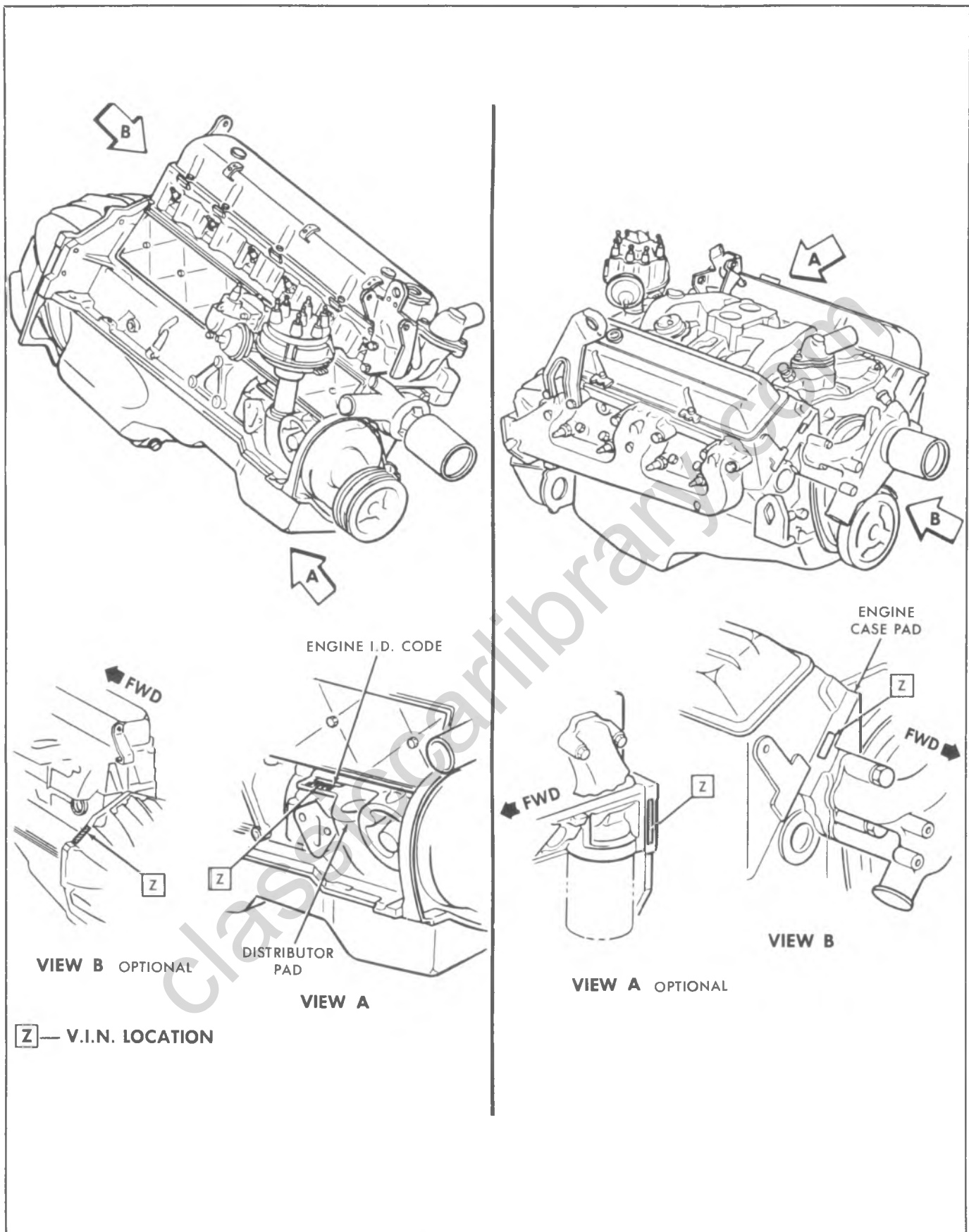


Fig. 6A-1--VIN Locations L-6 Small V-8

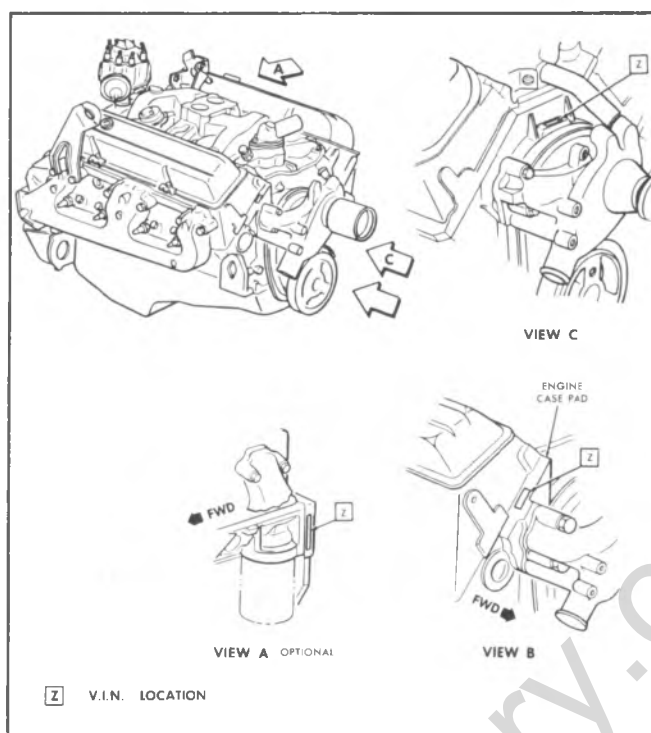


Fig. 6A-2-VIN Locations (MK IV V-8)

- h. Inspect carburetor fuel filter for presence of water and/or impurities and correct as necessary.
- i. Check carburetor mounting gasket for air leaks. Repair as necessary.
- j. Check distributor spark advance mechanism for proper operation. Repair or replace as necessary.
- k. Inspect valve train components. Adjust, repair and/or replace as necessary.
- l. Check engine for low compression. Repair as necessary.
- m. Check operation of exhaust gas recirculation valve. Repair or replace as necessary.
- n. Check ignition timing, and condition of ignition system as outlined in Section 6D of this manual. Correct as necessary.
- o. Check for vacuum leaks. Correct as necessary.
- p. Check operation of EFE valve as outlined in Section 6E of this manual. Repair or replace as necessary.

ENGINE MISSES AT VARIOUS SPEEDS

- a. Inspect carburetor fuel filter for presence of water and/or impurities. Correct as necessary.
- b. Check fuel system for leaks, plugged fuel lines, incorrect fuel pump pressure and/or plugged carburetor jets. Correct as necessary.
- c. Check ignition timing. Correct as necessary.
- d. Check for excessive play in distributor shaft. Repair or replace as necessary.
- e. Check for weak or faulty H.E.I. system coil as outlined in Section 6D of this manual.
- f. Check, inspect and regap spark plugs. Replace as necessary.
- g. Detonation and pre-ignition may be caused by using sub-standard fuel. Correct as necessary.
- h. Check for weak valve springs and condition of camshaft lobes. Repair or replace as necessary.
- i. Check engine operating temperature. Correct as necessary.
- j. Check operation of exhaust gas recirculation valve. Repair or replace as necessary.
- k. Inspect distributor cap for evidence of carbon tracking. Replace if necessary.
- l. Check for faulty altitude compensator and incorrect carburetor adjustments. Correct as necessary.
- m. Check for vacuum leaks. Correct as necessary.
- n. Check operation EFE valve as outlined in Section 6E of this manual. Repair or replace as necessary.

ENGINE STALLS

- a. Check carburetor for incorrect and/or misadjusted idle speed, float level, leaking needle and seat, air valve, sticking choke or enrichment system and secondary vacuum break operation. Adjust, repair or replace as necessary.
- b. Inspect carburetor fuel filter for presence of water and/or impurities. Correct as necessary.
- c. Check H.E.I. system as outlined in Section 6D of this manual.

- d. Check, inspect and regap spark plugs. Replace as necessary.
- e. Check distributor spark advance mechanism for proper operation. Repair or replace as necessary.
- f. Inspect exhaust system for restrictions. Correct as necessary.
- g. Check carburetor mounting gasket for air leaks. Repair as necessary.
- h. Check and adjust valve lash.
- i. Check for burned, warped or sticking valves. Repair or replace as necessary.
- j. Check engine for low compression. Repair as necessary.

- k. Check engine operating temperature. Correct as necessary.
- l. Check for loose, corroded or leaking wiring connections (bulk-head connectors, etc.). Repair as necessary.
- m. Check operation of exhaust gas recirculation system. Repair or replace as necessary.
- n. Check fuel system for leaks and/or obstructions. Repair as necessary.
- o. Check for vacuum leaks. Correct as necessary.
- p. Check operation of EFE valve as outlined in Section 6E of this manual. Repair or replace as necessary.

ENGINE HAS LOW POWER

- a. Check for weak or faulty H.E.I. system coil as outlined in Section 6D of this manual.
- b. Check ignition timing. Correct as necessary.
- c. Check for excessive play in distributor shaft. Repair or replace as necessary.
- d. Check, inspect and regap spark plugs. Replace as necessary.
- e. Check carburetor for incorrect and/or misadjusted idle speed, float level, leaking needle and seat, air valve and sticking choke or enrichment system. Adjust, repair or replace as necessary.
- f. Inspect carburetor fuel filter for presence of water and/or impurities. Correct as necessary.
- g. Check fuel pump for leaks and proper operation. Correct as necessary.
- h. Check for sticking valves, weak valve springs, incorrect valve timing, lifter noise and worn camshaft lobes. Adjust, repair or replace as necessary.
- i. Check for excessive piston to bore clearance. Correct as necessary.
- j. Check condition of cylinders for uneven compression and/or blown head gasket. Repair as necessary.

- k. Check power steering flow control valve operation. Repair or replace as necessary.
- l. Check for clutch slippage (vehicles with manual transmissions) and adjust or replace as necessary.
- m. Check hydraulic brake system for proper operation. Correct as necessary.
- n. Check engine operating temperature. Correct as necessary.
- o. Check pressure regulator valve (automatic transmission) for proper operation. Repair as necessary.
- p. Check transmission fluid level. Correct as necessary.
- q. Loss of power may be caused by using sub-standard fuel. Correct as necessary.
- r. Check operation of EFE valve as outlined in Section 6E of this manual. Repair or replace as necessary.
- s. Check operation of diverter valve (A.I.R. system). Repair or replace as necessary.
- t. Check for engine vacuum leaks. Correct as necessary.

ENGINE DIESELING ON SHUT OFF

- a. Check base idle speed for improper adjustment and correct as necessary.
- b. Check ignition timing and reset to specifications if required.
- c. Check idle mixture setting and correct as necessary.

- d. Check accelerator and choke linkage operation and correct as necessary.
- e. Check engine operating temperature and correct as necessary.
- f. Check thermac valve for sticking and correct as necessary.

ENGINE DETONATION

- a. Check for overadvanced ignition timing and/or faulty ignition system and correct as necessary.
- b. Check for loose or improper application of spark plugs, or spark plugs with cracked or broken ceramic cores and replace as necessary.
- c. Check for the use of sub-standard fuel and correct as necessary.
- d. Check for foreign material in fuel lines and/or carburetor and correct as necessary.

- e. Check for restricted fuel delivery to carburetor (pinched lines, faulty fuel tank cap or pick-up) and correct as necessary.
- f. Check fuel pump operation and replace if necessary.
- g. Check EFE system operation and repair or replace as necessary.
- h. Check EGR system operation and correct as necessary.

- i. Check thermostatically controlled air cleaner operation and correct as necessary.
- j. Check P.C.V. system operation and correct as necessary.
- k. Check for vacuum leaks and repair or replace as necessary.

- l. Check engine operating temperature and correct as necessary.
- m. Check for excessive combustion chamber deposits and correct as necessary.
- n. Check for leaking, sticking, or broken valves and repair or replace as necessary.

EXTERNAL OIL LEAKAGE

- a. Check for improperly seated or fuel pump gasket. Replace as necessary.
- b. Check for improperly seated or broken push rod cover gasket. Replace as necessary.
- c. Check for improperly seated or broken oil filter gasket. Replace as necessary.
- d. Check for broken or improperly seated oil pan gasket. Replace as necessary.
- e. Inspect gasket surface of oil pan to be bent or distorted. Repair or replace as necessary.
- f. Check for improperly seated or broken timing chain cover gasket. Replace as necessary.
- g. Inspect timing cover oil seal. Replace if necessary.

- h. Check for worn or improperly seated rear main bearing oil seal. Replace if necessary.
- i. Inspect for loose oil line plugs. Repair or replace if necessary.
- j. Check for engine oil pan drain plug improperly seated. Correct as necessary.
- k. Inspect camshaft rear bearing drain hole for obstructions. Correct as necessary.
- l. Check for loose rocker arm cover. Broken or distorted cover correct as necessary.
- m. Check EFE valve switch for leakage. Replace if necessary.
- n. Check oil pressure switch for leakage. Replace if necessary.

EXCESSIVE OIL CONSUMPTION DUE TO OIL ENTERING COMBUSTION CHAMBER

THROUGH HEAD AREA

- a. Check for intake valve seats to be damaged, missing or loose. Repair or replace as necessary.
- b. Check for worn valve stems or guides. Repair as necessary.
- c. Inspect for plugged oil drain back holes in head. Correct as necessary.
- d. Inspect PCV system operation. Correct as necessary.

EXCESSIVE OIL CONSUMPTION DUE TO OIL ENTERING COMBUSTION CHAMBER BY

PASSING PISTON RINGS

- a. Check engine oil level too high. Correct as necessary.
- b. Check for piston ring gaps not staggered and correct as necessary.
- c. Check for incorrect size rings installed and correct as necessary.
- d. Check for piston rings out of round, broken or scored and replace as necessary.
- e. Inspect insufficient piston ring tension due to engine overheating and replace as necessary.
- f. Check for ring grooves or oil return slots clogged and corrected as necessary.
- g. Inspect rings sticking in ring grooves of piston and correct as necessary.
- h. Inspect ring grooves worn excessively in piston and correct as necessary.
- i. Inspect compression rings installed upside down and correct as necessary.
- j. Check for excessively worn or scored cylinder walls and correct as necessary.
- k. Inspect oil too thin and replace if necessary.
- l. Inspect mis-match of oil ring expander and rail and correct as necessary.

NO OIL PRESSURE WHILE IDLING

- a. Check faulty oil gauge sending unit, and correct as necessary.
- b. Check for oil pump not functioning properly. (Regulator ball stuck in position by foreign material) and correct as necessary.
- c. Inspect for excessive clearance at main and connecting rod bearings and correct as necessary.
- d. Inspect for loose camshaft bearings and correct as necessary.
- e. Inspect leakage at internal oil passages and correct as necessary.

NO OIL PRESSURE WHILE ACCELERATING

- a. Check low oil level in oil pan and correct as necessary.
- b. Inspect leakage at internal oil passages and correct as necessary.
- c. Check oil pump suction screen loose or fallen off and correct as necessary.

BURNED, STICKING OR BROKEN VALVES

- a. Check for weak springs and replace as necessary.
- b. Check for improper valve lifter clearance and adjust as necessary.
- c. Check for improper valve guide clearance and/or worn valve guides and correct as necessary.
- d. Check for out-of-round valve seats or incorrect valve seat width and correct as necessary.
- e. Check for deposits on valve seats and/or gum formation on stems or guides and correct as necessary.
- f. Check for warped valves or faulty valve forgings and correct as necessary.
- g. Check for exhaust back pressure and correct as necessary.
- h. Check improper spark timing and correct as necessary.
- i. Check excessive idling and correct as necessary.

NOISY VALVES

- a. Check and adjust valve lash if necessary.
- b. Check for excessively worn, dirty or faulty valve lifters. Replace if necessary.
- c. Check for worn valve guides. Repair as necessary.
- d. Check for excessive run-out of valve seat or valve face. Repair as necessary.
- e. Check for worn camshaft lobes. Replace camshaft if necessary.
- f. Inspect for pulled or loose rocker arm studs. Repair or replace as necessary.
- g. Check for bent push rods. Replace if necessary.
- h. Inspect for broken valve spring. Replace if necessary.

NOISY PISTONS AND RINGS

- a. Check for excessive piston to bore clearance. Correct as necessary.
- b. Inspect for improper fit of piston pin. Correct as necessary.
- c. Inspect for excessive accumulation of carbon in combustion chamber or on piston tops. Clean and/or repair as necessary.
- d. Check for connecting rods alignment. Correct as necessary.
- e. Inspect for excessive clearance between rings and grooves. Repair or replace as necessary.
- f. Check for broken piston rings. Replace as necessary.

BROKEN PISTONS AND/OR RINGS

- a. Check for undersize pistons. Replace if necessary.
- b. Check for wrong type and/or size rings installed. Replace if necessary.
- c. Check for tapered or eccentric cylinder bores. Correct as necessary.
- d. Check connecting rod alignment. Replace if necessary.
- e. Check for excessively worn ring grooves. Replace if necessary.
- f. Check for improperly assembled piston pins. Replace as necessary.
- g. Check for insufficient ring gap clearance. Correct as necessary.
- h. Inspect for engine overheating. Correct as necessary.
- i. Check for sub-standard fuel. Correct as necessary.
- j. Check ignition timing. Correct as necessary.

NOISY CONNECTING RODS

- a. Check connecting rods for improper alignment and correct as necessary.
- b. Check for excessive bearing clearance and correct as necessary.
- c. Check for eccentric or out-of-round crankshaft journals and correct as necessary.
- d. Check for insufficient oil supply and correct as necessary.
- e. Check for low oil pressure and correct as necessary.
- f. Check for connecting rod bolts not tightened correctly and correct as necessary.

NOISY MAIN BEARINGS

- a. Check low oil pressure and/or insufficient oil supply and correct as necessary.
- b. Check for excessive bearing clearance and correct as necessary.
- c. Check for excessive crankshaft end play and correct as necessary.
- d. Check for eccentric or out-of-round crankshaft journals and correct as necessary.
- e. Check for sprung crankshaft and replace if necessary.
- f. Check for excessive belt tension and adjust as necessary.
- g. Check for loose torsional damper and replace as necessary.

NOISY VALVE LIFTERS

- a. Check for broken valve springs and replace as necessary.
- b. Check for worn or sticking rocker arms and repair or replace as necessary.
- c. Check for worn or bent push rods and replace as necessary.
- d. Check for valve lifters incorrectly fitted to bore size and correct as necessary.
- e. Check faulty valve lifter plunger or push rod seat and replace lifters as necessary.
- f. Check for plungers excessively worn causing fast leakdown under pressure and replace as necessary.
- g. Check for excessively worn camshaft lobes and replace if necessary.
- h. Check valve lifter oil feed holes plugged causing internal breakdown and correct as necessary.
- i. Check faulty valve lifter check ball. (nicked, flat spot, or out of round) and replace as necessary.
- j. Check rocker arm retaining nut to be installed upside down and correct as necessary.
- k. Check for end of push rod excessively worn or flaked and replace as necessary.

6 Cylinder Engine**Contents**

General Description	6A-7	Valves	6A-24
Engine Lubrication	6A-8	Torsional Damper	6A-24
On Vehicle Service	6A-15	Crankcase Front Cover	6A-25
Engine Mounts	6A-15	Oil Seal (Front Cover).....	6A-26
Manifold Assembly-Non-Integrated Head.....	6A-16	Camshaft.....	6A-27
Exhaust Manifold-Integrated Head.....	6A-16	Camshaft Bearings.....	6A-29
Rocker Arm Cover.....	6A-17	Oil Pan.....	6A-30
Valve Mechanism.....	6A-17	Oil Pump.....	6A-30
Valve Stem Oil Seal and/or Valve Spring.....	6A-17	Connecting Rod Bearings.....	6A-31
Valve Lifters	6A-18	Crankshaft Main Bearings.....	6A-32
Cylinder Head	6A-20	Oil Seal (Rear Main).....	6A-35
Rocker Arm Studs.....	6A-22	Piston and Connecting Rod Assemblies.....	6A-36
Valve Guides.....	6A-23	Engine Assembly.....	6A-40
Valve Seats	6A-23	Crankshaft	6A-41

GENERAL DESCRIPTION**CYLINDER BLOCK**

The cylinder block is made of cast iron and has 6 cylinders arranged "In-Line". Seven main bearings support the crankshaft which is retained by recessed bearing caps that are machined with the block for proper alignment and clearances. Cylinders are completely encircled by coolant jackets.

CYLINDER HEAD

The cast iron cylinder head provides a compression ratio of 8.3:1. It is cast with individual intake and exhaust ports for each cylinder. Valve guides are integral and rocker arms are retained on individual threaded studs pressed into head. Most 250 heads have integrated

inlet manifold while the 292 uses separate inlet manifolds.

CRANKSHAFT AND BEARINGS

The crankshaft is cast nodular iron and is supported by seven main bearings. Number seven bearing is the end thrust bearing. Main bearings are lubricated from oil holes which intersect the main oil gallery located on the right side of the block. The cam bearings are also fed oil by intersecting holes with main oil gallery. The lifters are located in the main oil gallery.

A damper assembly, on the forward end of the crankshaft, dampens any engine torsional vibrations. The

outer ring of the damper is grooved for the accessory drive belts.

CAMSHAFT AND DRIVE

The cast iron camshaft is supported by four bearings and is gear driven. A cast iron crankshaft gear drives the aluminum camshaft gear. Cam lobes are ground, hardened and tapered with the high side toward the rear. This, coupled with a spherical face on the lifters, causes the valve lifters to rotate.

PISTONS AND CONNECTING RODS

The pistons are made of a cast aluminum alloy using two compression rings and one oil control ring.

Piston pins are offset .060" toward the thrust side (right hand side) to provide a gradual change in thrust pressure against the cylinder wall as the piston travels its path. Pins are chromium steel and have a floating fit in the pistons. They are retained in the connecting rods by a press fit.

Connecting rods are made of forged steel. Full pressure lubrication is directed to the connecting rods by drilled oil passages from the adjacent main bearing journal. Oil holes at the connecting rod journals are located so that oil is supplied to give maximum lubrication just prior to full bearing load.

VALVE TRAIN

A very simple ball pivot-type train is used. Motion is transmitted from the camshaft through the hydraulic lifters and push rods to the rocker arms. The rocker arm pivots on its ball and transmits the camshaft motion to the valve. The rocker arm ball is retained by a self locking nut.

HYDRAULIC VALVE LIFTERS

Hydraulic Valve Lifters are used to keep all parts of the valve train in constant contact for quiet operation.

The hydraulic lifter assembly consists of: the lifter body, which rides in the cylinder block boss, a plunger, a push rod seat, a metering valve, a plunger spring, a check ball and spring, a check ball retainer and a push rod seat retainer.

When the lifter is riding on the low point (base circle) of the cam, the plunger spring keeps the plunger and push rod seat in contact with the push rod.

When the lifter body begins to ride up the cam lobe, the check ball cuts off the transfer of oil from the reservoir below the plunger. The plunger and lifter body then rise as a unit, pushing up the push rod and opening

the valve. A very small amount of oil will leak out between the plunger and the body.

As the lifter body rides down the other side of the cam, the plunger follows with it until the valve closes. The lifter body continues to follow the cam to its low point, but the plunger spring keeps the plunger in contact with the push rod. The ball check valve will then move off its seat and the lifter reservoir will be refilled with oil.

INTAKE MANIFOLD

The intake manifold is of cast iron, single level design for efficient fuel distribution. The 250 manifold is an integral unit with the head, except K10 and C10 with F44, while the 292 uses a separate component. The carburetor pad is centrally located with a passage running underneath the pad (E.F.E.), through which exhaust gases are forced, to promote faster fuel vaporization when the engine is cold. An EGR port is also cast into the manifold for the induction of a metered amount of exhaust gases into the air and fuel mixture which has entered through the carburetor.

EXHAUST MANIFOLD

A single four port, underslung, center take down manifold of cast iron is used to direct exhaust gases from the combustion chambers. A heat shield is mounted to the manifold that is used to route heated air to the air cleaner for better fuel vaporization.

ENGINE SERVICE

NOTE: The following information is important in preventing engine damage and in providing reliable engine performance.

When raising or supporting the engine for any reason, do not use a jack under the oil pan, any sheet metal or crankshaft pulley. Due to the small clearance between the oil pan and the oil pump screen, jacking against the oil pan may cause it to be bent against the pump screen, resulting in a damaged oil pickup unit.

It should be kept in mind, while working on the engine, that the 12-volt electrical system is capable of violent and damaging short circuits. When performing any work where electrical terminals could possibly be grounded, the ground cable of the battery should be disconnected at the battery.

Any time the carburetor or air cleaner is removed, the intake opening should be covered. This will protect against accidental entrance of foreign material which could follow the intake passage into the cylinder and cause extensive damage when the engine is started.

Engine Lubrication

Full pressure lubrication, through a full flow oil filter is furnished by a gear-type oil pump. The distributor, driven by a helical gear on the camshaft, drives the oil pump. The main oil gallery feeds oil,

through drilled passages, to the camshaft and crankshaft to lubricate the bearings. The main oil gallery also feeds the valve lifters; which, through hollow push rods, feed the individually mounted rocker arms (Fig. 6A-3).

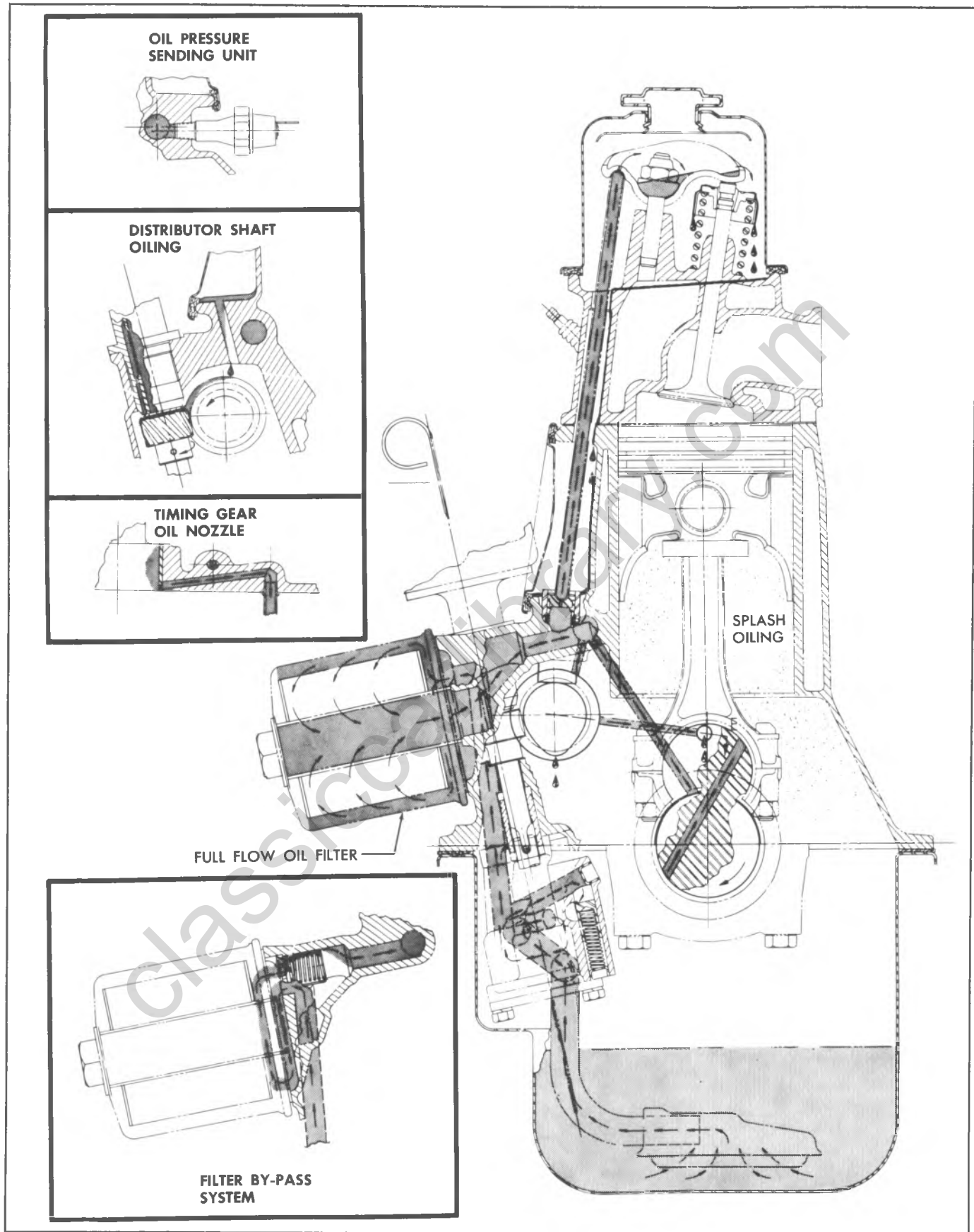


Fig. 6A-3-In-Line Engine Lubrication

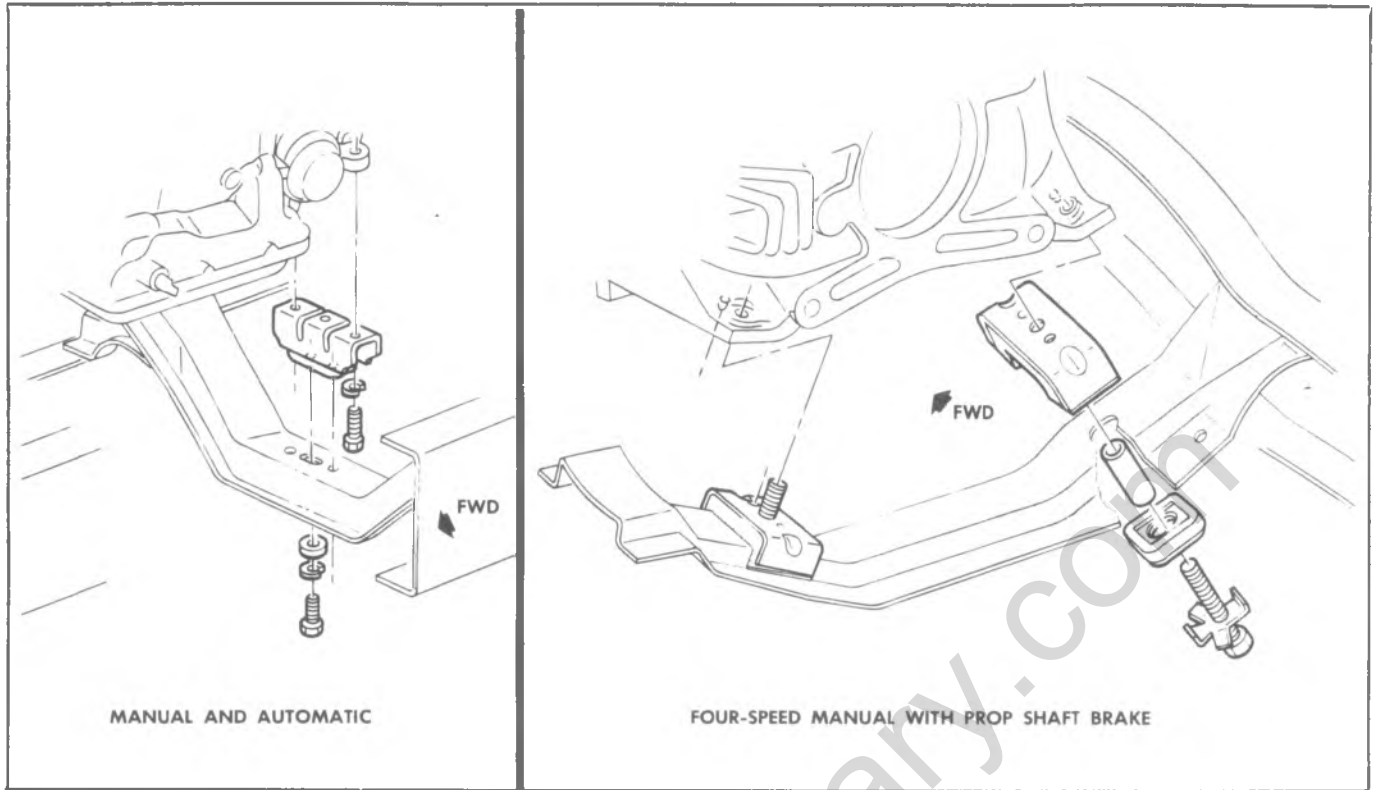


Fig. 6A-4--P Series Engine Rear Mount

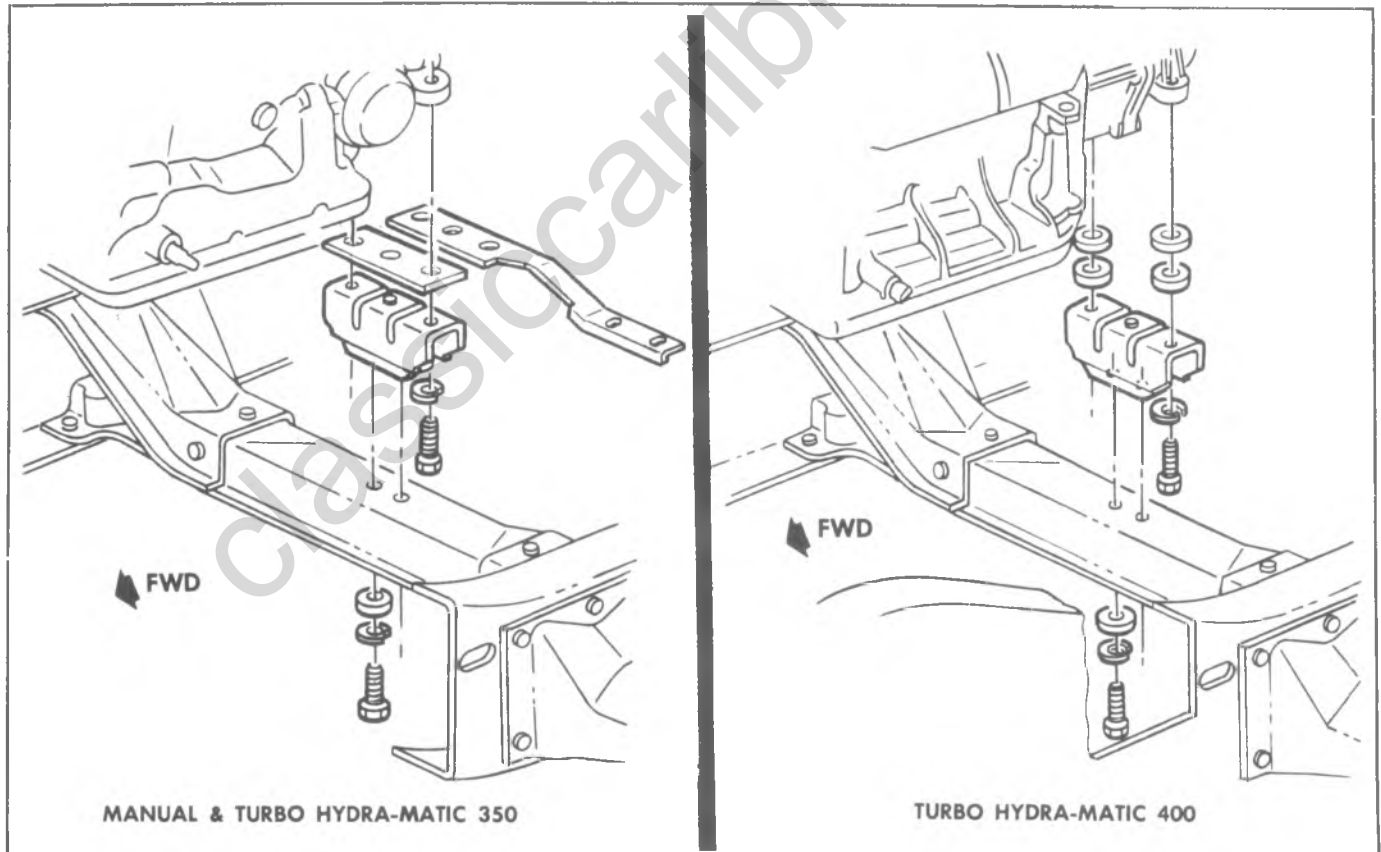


Fig. 6A-6-C Series Engine Rear Mounts

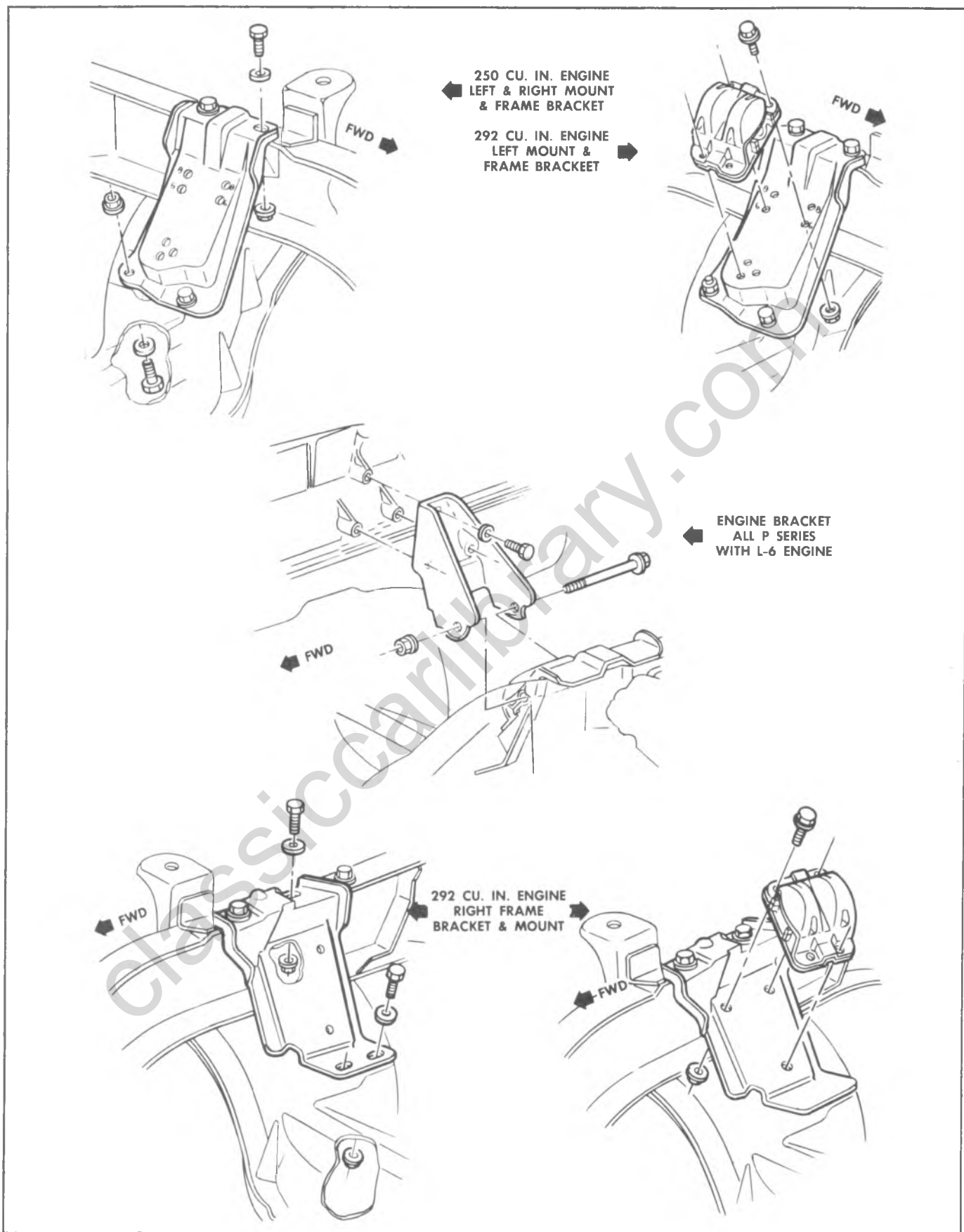


Fig. 6A-5-P Series Engine Front Mount

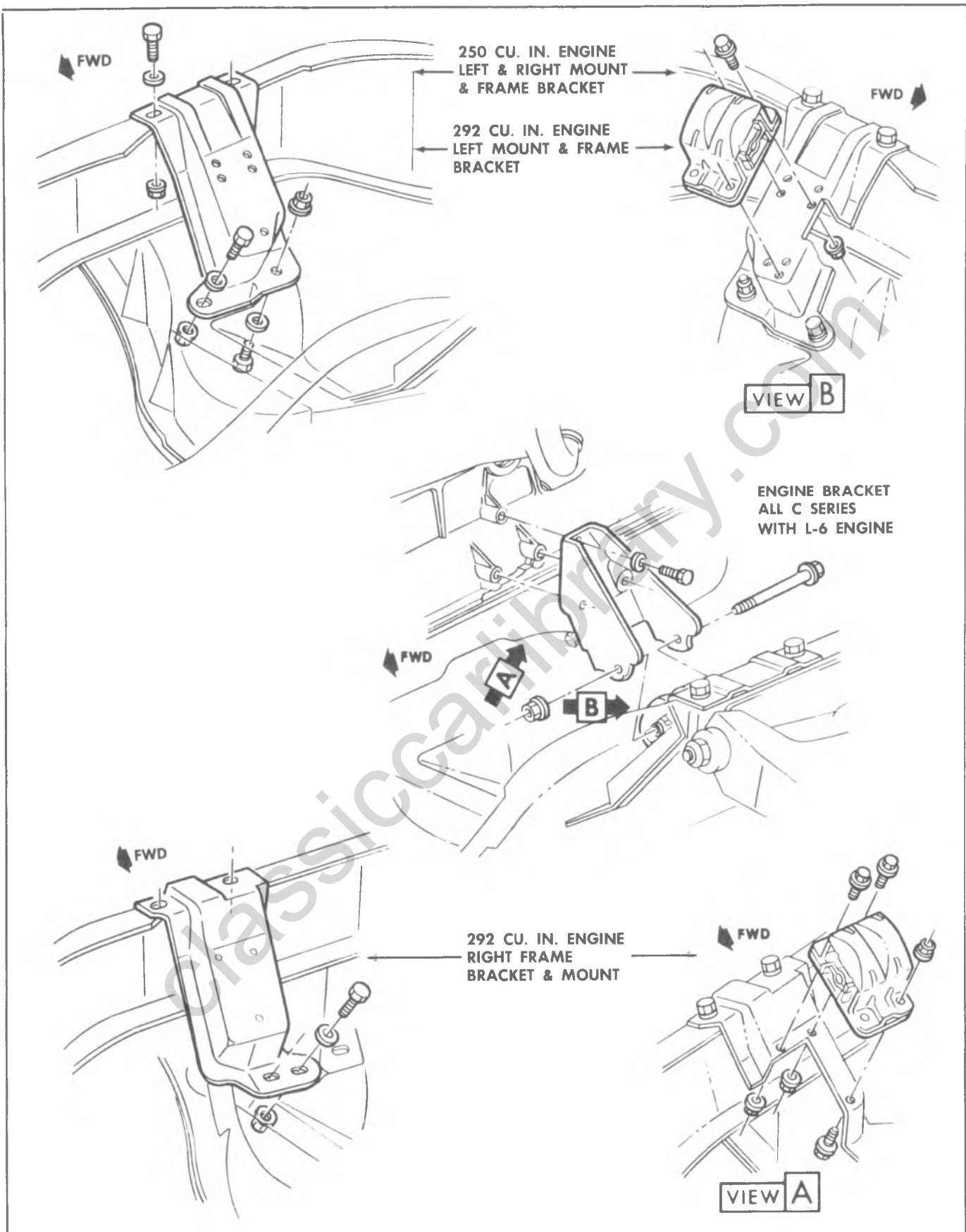


Fig. 6A-7--C Series Engine Front Mount

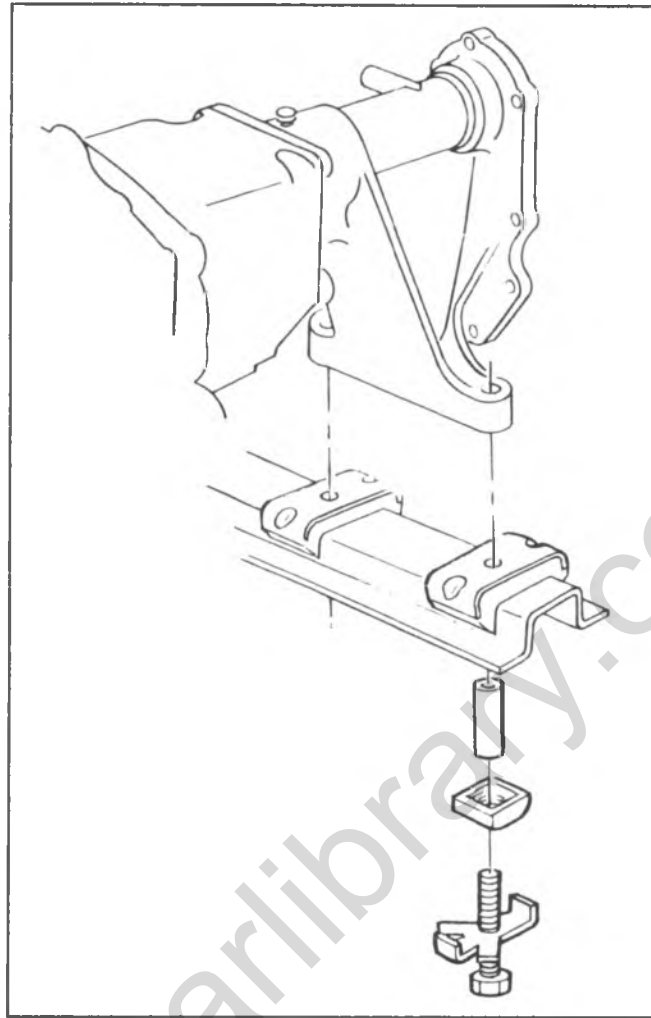


Fig. 6A-8-K Series Engine Rear Mount

classiccarlibrary.com

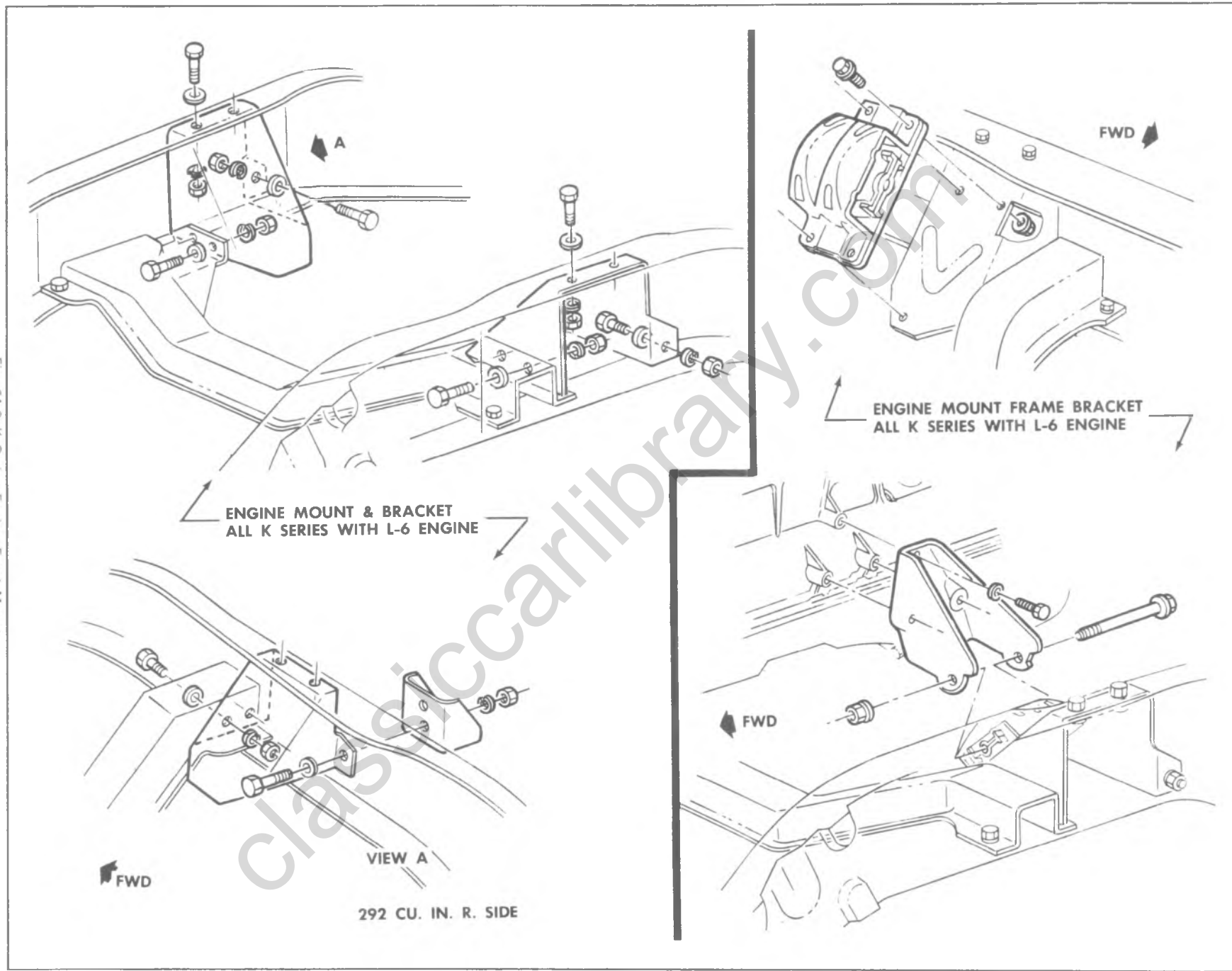


Fig. 6A-9-K Series Engine Front Mount

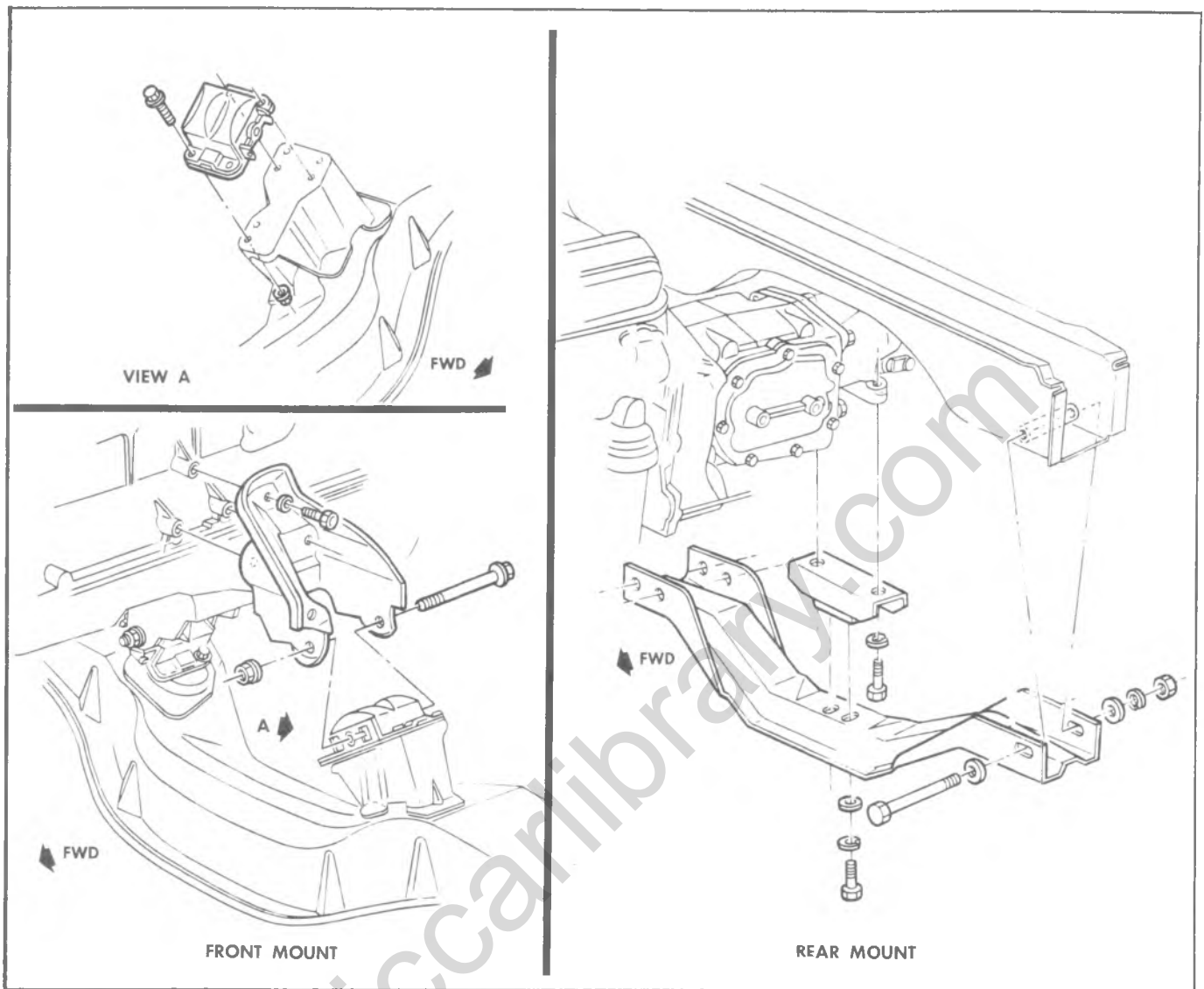


Fig. 6A-10-G Series Engine Mounts

ON VEHICLE SERVICE

ENGINE MOUNTS

Engine mounts (Fig. 6A-4 - 6A-10) are the non-adjustable type and seldom require service. Broken or deteriorated mounts should be replaced immediately, because of the added strain placed on other mounts and drive line components.

Checking Engine Mounts

Front Mount

Raise the engine to remove weight from the mounts and to place a slight tension in the rubber. Observe both mounts while raising engine. If an engine mount exhibits:

a. Hard rubber surface covered with heat check cracks;

b. Rubber separated from a metal plate of the mount; or

c. Rubber split through center,

Replace the mount. If there is relative movement between a metal plate of the mount and its attaching points, lower the engine on the mounts and tighten the screws or nuts attaching the mount to the engine, frame, or bracket.

Rear Mount

Raise the vehicle on a hoist. Push up and pull down on the transmission tailshaft while observing the transmission mount. If the rubber separates from the metal plate of the mount or if the tailshaft moves up but not down (mount bottomed out) replace the mount. If there is relative movement between a metal plate of the

mount and its attaching point. Tighten the screws or nuts attaching the mount to the transmission or crossmember.

Front Mount Replacement

1. Remove engine mount through bolt.
2. Raise engine and remove mount to frame bracket attaching bolts. Remove mount.

CAUTION: Raise engine only enough for sufficient clearance. Check for interference between rear of engine and cowl panel.

3. Install new engine mount to frame bracket and torque attaching bolts to specifications.
4. Install engine mount through bolt and torque to specification.

Rear Mount Replacement

1. Support engine weight to relieve rear mounts.
2. Remove crossmember-to-mount bolts.
3. On P Series with manual transmission and propeller shaft parking brake, remove mount attaching bolts from frame outrigger and clutch housing and remove rear mounting cushions.
4. Remove mount-to-transmission bolts, then remove mount.
5. On P Series with manual transmission and propeller shaft parking brake, install new mounting cushions and bolts.
6. Install new mount on transmission.
7. While lowering transmission, align and start crossmember-to-mount bolts.
8. Torque bolts to specifications then bend lock tabs to bolt head as applicable.

MANIFOLD ASSEMBLY - NON-INTEGRATED HEAD

Removal

1. Remove air cleaner.
2. Disconnect both throttle controls at bellcrank and remove throttle return spring.
3. Disconnect fuel and vacuum lines at carburetor.
4. Disconnect crankcase ventilation hose at rocker arm cover.
5. Disconnect vapor hose at canister.
6. Disconnect exhaust pipe at manifold flange and discard packing.
7. Remove manifold attaching bolts and clamps then remove manifold assembly and discard gaskets.
8. Check for cracks in manifold castings.
9. Separate manifold by removing one bolt and two nuts at center of assembly.

Installation

1. Clean gasket surfaces on cylinder head and manifolds.
2. Lay a straight edge along the full length of the exhaust port faces and measure any gaps between the straight edge and the port faces. If at any point a gap of .030 or more exists, it is likely that the manifold has distorted to a point where it will not seat properly. If a

good exhaust seal is to be expected, the exhaust manifold must be replaced.

3. Reinstall the one bolt and two nuts at the center of the manifold to finger tight.
4. Position a new gasket over manifold end studs on the cylinder head.
5. Install manifold assembly bolts and clamps while holding manifold assembly in place by hand.
6. Clean, oil and torque all manifold assembly to cylinder head bolts and nuts to 35 lbs. ft.
7. Complete torquing the inlet to exhaust manifold bolt and two nuts at the center of the manifold to 30 lb. ft.
8. Connect exhaust pipe to manifold using a new packing.
9. Connect crankcase ventilation hose at rocker arm cover.
10. Connect vapor hoses at canister.
11. Connect fuel and vacuum lines a carburetor.
12. Connect throttle controls at bellcrank and install throttle return spring.
13. Install air cleaner, start engine, check for leaks and adjust carburetor idle speed.

EXHAUST MANIFOLD ASSEMBLY - INTEGRATED HEAD

Removal

1. Disconnect negative battery cable.
2. Remove air cleaner.
3. Remove power steering pump and/or A.I.R. pump brackets, if so equipped.
4. Raise vehicle on hoist and disconnect exhaust pipe at manifold and converter bracket at transmission mount. If equipped with manifold converter, disconnect exhaust pipe from converter, remove converter.
5. Lower vehicle.
6. Remove rear heat shield and accelerator cable bracket.
7. Remove exhaust manifold bolts.
8. Remove exhaust manifold, check EFE Valve to see if free and check manifold for cracks.

Installation

NOTE: If a new exhaust manifold is being installed, the E.F.E. valve and actuator and rod assembly must be transferred from the old component.

1. Clean gasket surface and position new gasket on exhaust manifold.
2. Install manifold bolts, while holding manifold assembly in place.
3. Torque all cylinder head to manifold bolts to specifications (Fig. 6A-11).
4. Install rear heat shield and accelerator cable bracket.
5. Raise vehicle on hoist.
6. Connect exhaust pipe at manifold flange and converter bracket at transmission mount. If equipped with manifold converter, loosely install Manifold

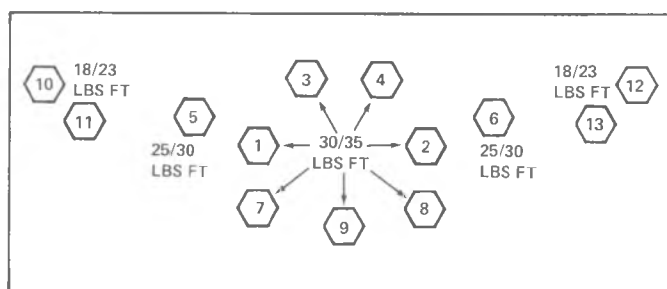


Fig. 6A-11-Cylinder Head To Exhaust Manifold Tightening Sequence

Converter, attach exhaust pipe and align exhaust system. Torque attaching bolts to specification.

7. Lower vehicle.
8. Install power steering pump and/or A.I.R. pump and brackets, if so equipped. Tighten drive belt using strand tension gauge.
9. Install air cleaner.
10. Connect negative battery cable.
11. Start engine and check for leaks.

ROCKER ARM COVER

Removal

1. Disconnect crankcase ventilation hose(s) at rocker arm cover.
2. Remove air cleaner.
3. Disconnect all wires, fuel and vacuum pipes from rocker arm cover clips.
4. Disconnect air injection hose from check valve of AIR pipe (where so equipped).
5. Remove rocker arm cover by rotating out from under air pipe.

CAUTION: Do not pry rocker arm cover loose. Gaskets adhering to cylinder head and rocker arm cover may be sheared by bumping front end of rocker arm cover rearward with palm of hand or rubber mallet.

Installation

1. Clean gasket surfaces on cylinder head with degreaser. Using RTV, install rocker arm cover and torque bolts to specification.

NOTE: All loose RTV sealer, or pieces causing installation interference must be removed from both cylinder head and cover seal surfaces prior to applying new sealer.

- A 1/8" bead of RTV sealer should be placed all around the rocker cover sealing surface of the cylinder head. (When going around attaching bolt holes, always go around the inboard side of the holes). Install cover and torque bolts to specification while RTV is wet (within 10 min.).
2. Connect wires, fuel and vacuum pipes at rocker arm cover clips.
 3. Install air cleaner.

4. Connect crankcase ventilation hoses and AIR hoses.

VALVE MECHANISM

Removal

1. Remove rocker arm cover as outlined.
2. Remove rocker arm nuts, rocker arm balls, rocker arms and push rods.

NOTE: Place rocker arms, rocker arm balls and push rods in a rack so that they may be reinstalled in the same location.

Installation and Adjustment

NOTE: Whenever new rocker arms and/or rocker arm balls are being installed, coat bearing surfaces of rocker arms and rocker arm balls with "Molykote" or its equivalent.

1. Install push rods. Be sure push rods seat in lifter socket.
2. Install rocker arms, rocker arm balls and rocker arm nuts. Tighten rocker arm nuts until all lash is eliminated.
3. Adjust valves when lifter is on base circle of camshaft lobe as follows:
 - a. Mark distributor housing, with chalk, at number one and number six positions (plug wire) then disconnect plug wires at spark plugs and coil and remove distributor cap and plug wire assembly (if not previously done).
 - b. Crank engine until distributor rotor points to number one cylinder position. The following valves can be adjusted with engine in number one firing position:
 - Number one cylinder-Exhaust and Intake.
 - Number two cylinder-Intake
 - Number three cylinder-Exhaust
 - Number four cylinder-Intake
 - Number five cylinder-Exhaust
 - c. Back out adjusting nut until lash is felt at the push rod then turn in adjusting nut until all lash is removed. This can be determined by checking push rod end play while turning adjusting nut (Fig. 6A-12). When play has been removed, turn adjusting nut in one full additional turn (to center lifter plunger).
 - d. Crank engine until distributor rotor points to number six position. The following valves can be adjusted with engine in number six firing position:
 - Number two cylinder-Exhaust
 - Number three cylinder-Intake
 - Number four cylinder-Exhaust
 - Number five cylinder-Intake
 - Number six cylinder-Intake and Exhaust
4. Install distributor cap and spark plug wire assembly.
5. Install rocker arm cover as outlined.
6. Adjust carburetor idle speed.

VALVE STEM OIL SEAL AND/OR VALVE SPRING

Replacement

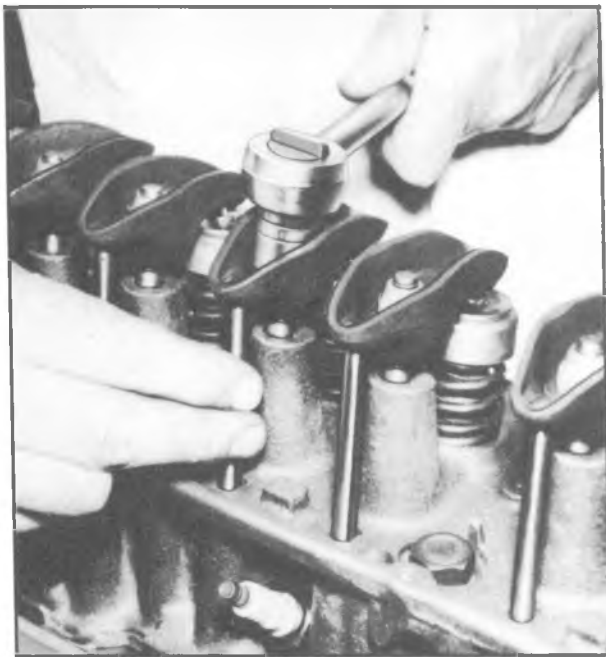


Fig. 6A-12--Valve Adjustment

6. To replace, set the valve spring, valve shield and valve can in place. Compress the spring with Tool J-5892 and install oil seal in the lower groove of the stem, making sure the seal is flat and not twisted.

NOTE: A light coat of oil on the seal will help prevent twisting.

7. Install the valve locks and release the compressor tool, making sure the locks seat properly in the upper groove of the valve stem.

NOTE: Grease may be used to hold the locks in place while releasing the compressor tool.

8. Install spark plug, and torque to 15 lb. ft.

9. Install and adjust valve mechanism as previously outlined.

VALVE LIFTERS

Hydraulic valve lifters very seldom require attention. The lifters are extremely simple in design. Readjustments are not necessary, and servicing of the lifters requires only that care and cleanliness be exercised in the handling of parts.

Locating Noisy Lifters

Locate a noisy valve lifter by using a piece of garden hose approximately four feet in length. Place one end of the hose near the end of each intake and exhaust valve with the other end of the hose to the ear. In this manner the sound is localized, making it easy to determine which lifter is at fault.

Another method is to place a finger on the face of the valve spring retainer. If the lifter is not functioning properly, a distinct shock will be felt when the valve returns to its seat.

The general types of valve lifter noise are as follows:

1. Hard Rapping Noise - Usually caused by the plunger becoming tight in the bore of the lifter body to such an extent that the return spring can no longer push the plunger back up to working position. Probable causes are:

a. Excessive varnish or carbon deposit causing abnormal stickiness.

b. Galling or "pickup" between plunger and bore of lifter body, usually caused by an abrasive piece of dirt or metal wedging between plunger and lifter body.

2. Moderate Rapping Noise - Probable causes are:

a. Excessively high leakdown rate.

b. Leaky check valve seat.

c. Improper adjustment.

3. General Noise Throughout the Valve Train - This will, in most cases, be caused by either insufficient oil supply or improper adjustment.

4. Intermittent Clicking Probable causes are:

a. A microscopic piece of dirt momentarily caught between ball seat and check valve ball.

b. In rare cases, the ball itself may be out-of-round or have a flat spot.

c. Improper adjustment.

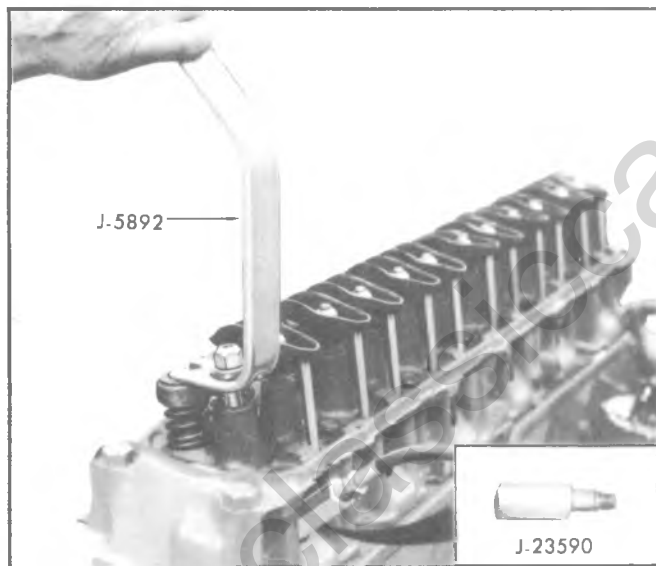


Fig. 6A-13--Compressing Valve Spring

1. Remove rocker arm cover as previously outlined.

2. Remove spark plug, rocker arm and push rod on the cylinder(s) to be serviced.

3. Install air line adapter Tool J-23590 to spark plug port and apply compressed air to hold the valves in place.

4. Using Tool J-5892 to compress the valve spring, remove the valve locks, valve cap, valve shield and valve spring and damper (fig. 6A-13).

5. Remove the valve stem oil seal.

In most cases where noise exists in one or more lifters, all lifter units should be removed, disassembled, cleaned in a solvent, reassembled, and reinstalled in the engine. If dirt, varnish, carbon, etc., is shown to exist in one unit, it more than likely exists in all the units, thus it would only be a matter of time before all lifters caused trouble.

Removal

1. Remove rocker arm cover and loosen rocker arms sufficiently to remove the push rods. Place push rods in a rack so that they may be returned to their original location.

2. Mark distributor housing, with chalk, at number one and number six position (plug wire) then disconnect plug wires at spark plugs and coil and remove distributor cap and plug wire assembly.

3. Crank engine until distributor rotor points to number one position, then disconnect distributor primary lead at coil and remove distributor.

4. REMOVE PUSH ROD COVERS (discard gaskets).

5. Remove valve lifters.

NOTE: Place valve lifters in a rack so that they may be installed in the same location.

Disassembly

1. Hold the plunger down with a push rod, and using the blade of a small screw driver, remove the push rod seat retainer.

2. Remove the push rod seat and metering valve (fig. 6A-14).

3. Remove the plunger, ball check valve assembly and the plunger spring.

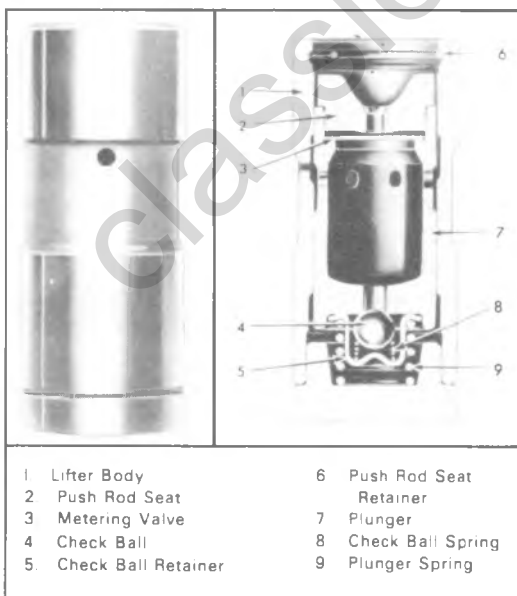


Fig. 6A-14--Hydraulic Valve Lifter



Fig. 6A-15--Removing Ball Check Valve

4. Remove the ball check valve and spring by prying the ball retainer loose from the plunger with the blade of a small screw driver (fig. 6A-15).

Cleaning and Inspection

Thoroughly clean all parts in cleaning solvent, and inspect them carefully. If any parts are damaged or worn, the entire lifter assembly should be replaced. If the lifter body wall is scuffed or worn, inspect the cylinder block lifter bore, if the bottom of the lifter is scuffed or worn inspect the camshaft lobe, if the push rod seat is scuffed or worn inspect the push rod.

An additive containing EP lube, such as EOS, or equivalent, should always be added to crankcase oil for run-in when any new camshaft or lifters are installed. All damaged or worn lifters should be replaced.

Assembly

1. Place the check ball on small hole in bottom of the plunger.

2. Insert check ball spring on seat in ball retainer and place retainer over ball so that spring rests on the ball. Carefully press the retainer into position in plunger with the blade of a small screw driver (fig. 6A-16).

3. Place the plunger spring over the ball retainer and slide the lifter body over the spring and plunger, being careful to line up the oil feed holes in the lifter body and plunger.

4. Fill the assembly with SAE 10 oil, then insert the end of a 1/8" drift pin into the plunger and press down solid. At this point oil holes in the lifter body and plunger assembly will be aligned (fig. 6A-17).



Fig. 6A-16--Installing Ball Check Valve

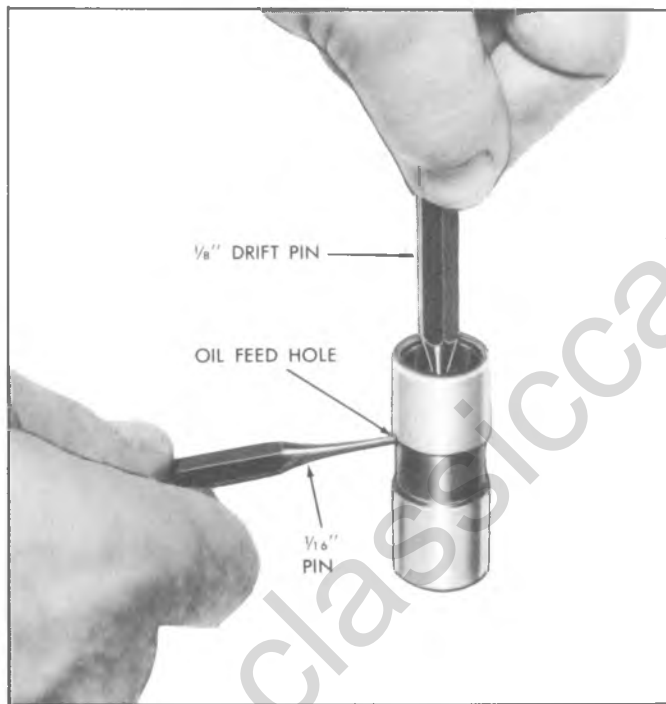


Fig. 6A-17--Assembling Hydraulic Lifter

CAUTION: Do not attempt to force or pump the plunger.

5. Insert a 1/16" drift pin through both oil holes to hold the plunger down against the lifter spring tension (fig. 6A-17).

6. Remove the 1/8" drift pin, refill assembly with SAE 10 oil.

7. Install the metering valve and push rod seat (fig. 6A-14).

8. Install the push rod seat retainer, press down on the push rod seat and remove the 1/16" drift pin from

the oil holes. The lifter is now completely assembled, filled with oil and ready for installation.

NOTE: Before installing lifters, coat the bottom of the lifter with "Molykote" or its equivalent.

Installation

1. Install valve lifters.

NOTE: Whenever new valve lifters are being installed, coat foot of valve lifters with "Molykote" or its equivalent.

2. Install push rod covers, using new gaskets, and torque bolts to specifications.

3. Install distributor, positioning rotor to number one cylinder position, then connect primary lead at distributor.

4. Install push rods and adjust valve mechanism as outlined.

5. Adjust ignition timing and carburetor idle speed.

CYLINDER HEAD ASSEMBLY

Removal

1. Remove manifold assembly as previously outlined.

2. Remove rocker arm cover and valve mechanism as previously outlined.

3. Drain cooling system (block).

4. Remove fuel and vacuum line from retaining clip at water outlet, then disconnect wires from temperature sending units.

5. Disconnect air injection hose at check valve (if so equipped).

6. Disconnect radiator upper hose at water outlet housing and battery ground strap at cylinder head.

7. Remove cylinder head bolts, cylinder head and gasket. Place cylinder head on two blocks of wood to prevent damage.

Disassembly

1. With the cylinder head removed, use tool J-8062 to compress the valve springs and remove the valve keys (fig. 6A-18). Release the compressor tool and remove rotators or spring caps, spring shields (if so equipped) springs and spring damper, then remove oil seals and valve spring shims.

2. Remove valves from cylinder head and place them in a rack in their proper sequence so that they can be assembled in their original positions.

Cleaning

1. Clean all deposits from combustion chambers and valve ports using Tool J-8089 (fig. 6A-19).

2. Thoroughly clean the valve guides using Tool J-8101 (fig. 6A-20).

3. Clean all carbon and sludge from push rods, rocker arms and push rod guides.

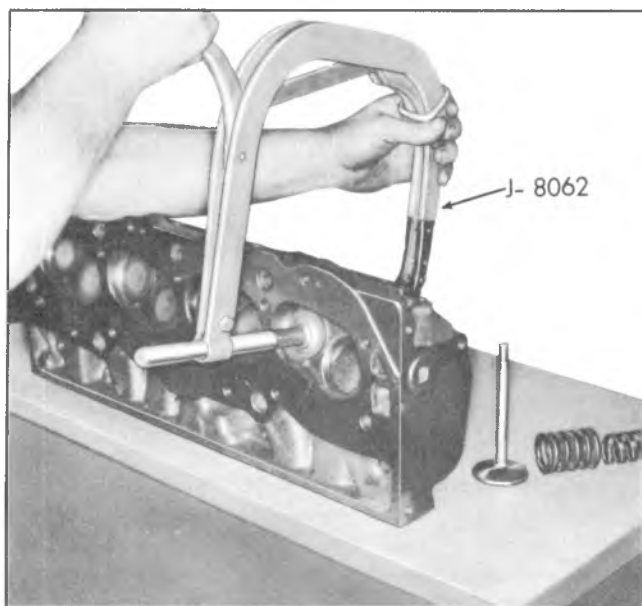


Fig. 6A-18-Compressing Valve Spring (Typical)

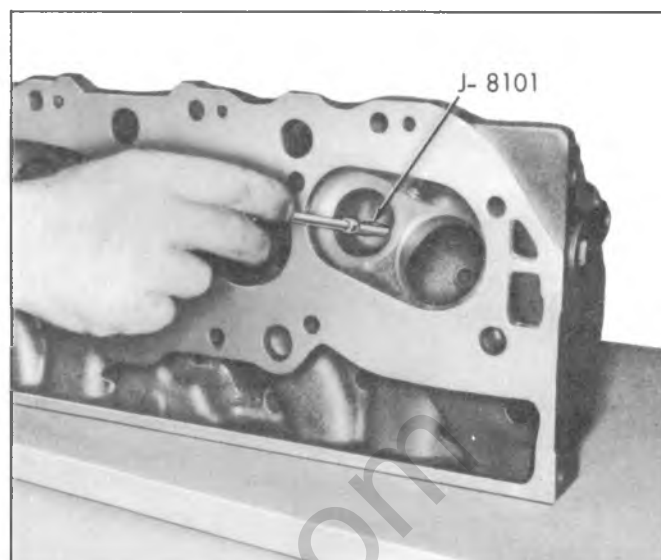


Fig. 6A-20-Cleaning Valve Guides (Typical)

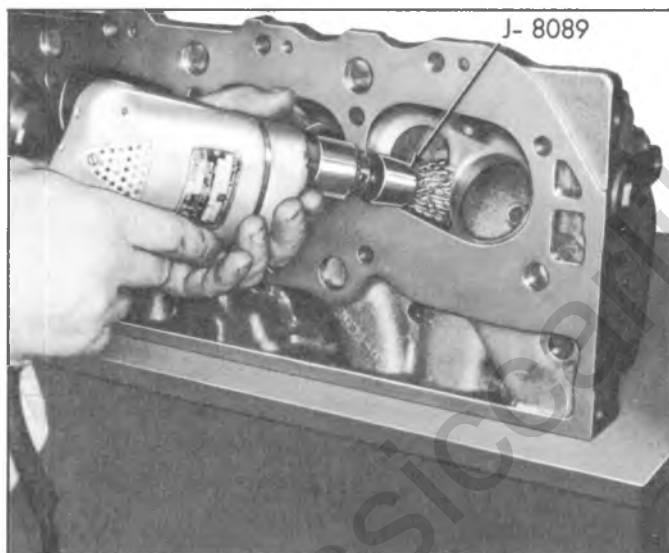


Fig. 6A-19-Cleaning Combustion Chambers (Typical)

4. Clean valve stems and heads on a buffing wheel.
5. Clean carbon deposits from head gasket mating surface.

Inspection

1. Inspect the cylinder head for cracks in the exhaust ports, combustion chambers, or external cracks to the water chamber.
2. Inspect the valves for burned heads, cracked faces or damaged stems.

NOTE: Excessive valve stem to bore clearance will cause excessive oil consumption and may cause valve breakage. Insufficient clearance will result in

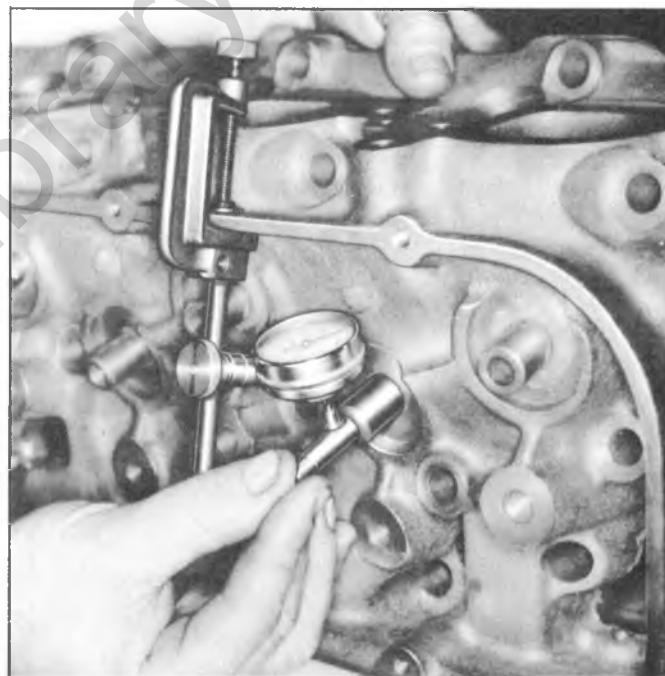


Fig. 6A-21-Measuring Valve Stem Clearance (Typical)

noisy and sticky functioning of the valve and disturb engine smoothness.

3. Measure valve stem clearance (fig. 6A-21) as follows: Clamp a dial indicator on one side of the cylinder head rocker arm cover gasket rail, locating the indicator so that movement of the valve stem from side to side (crosswise to the head) will cause a direct movement of the indicator stem. The indicator stem must contact the side of the valve stem just above the valve guide. With the valve head dropped about 1/16" off the valve seat; move the stem of the valve from side to side using light pressure to obtain a clearance reading.



Fig. 6A-22--Checking Valve Spring Tension

If clearance exceeds specifications it will be necessary to ream valve guides for oversize valves as outlined.

4. Check valve spring tension with Tool J-8056 spring tester (fig. 6A-22).

NOTE: Springs should be compressed to the specified height and checked against the specifications chart. Springs should be replaced if not within 10 lbs. of the specified load (without dampers).

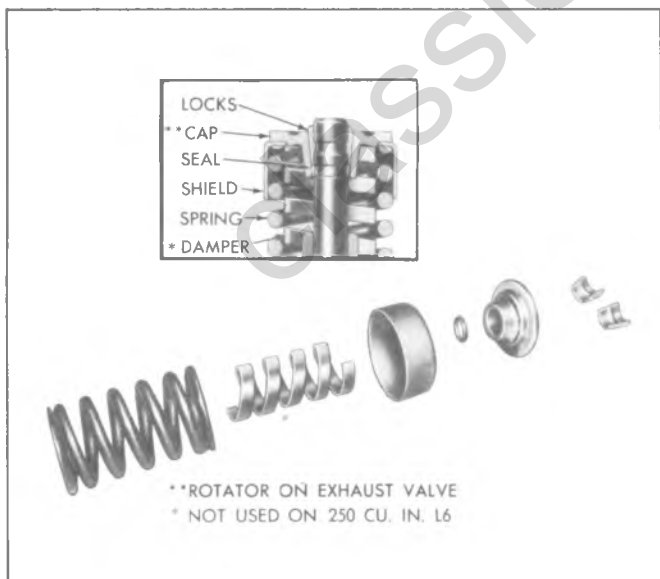


Fig. 6A-23--Valve Spring Installation

5. Inspect rocker arm studs for wear or damage.

Assembly

1. Insert valves in the proper ports.
2. Set the valve spring shim, valve spring (with damper, if used) valve shield and valve cap or rotator in place (fig. 6A-23).
3. Compress the spring with Tool J-8062.
4. Install oil seal in the lower groove of the stem, making sure that the seal is flat and not twisted.
5. Install the valve locks and release the compressor tool, making sure that the locks seat properly in the upper groove of the valve stem.

Installation

CAUTION: The gasket surfaces on both the head and the block must be clean of any foreign matter and free of nicks or heavy scratches. Cylinder bolt threads in the block and threads on the cylinder head bolt must be cleaned. (Dirt will affect bolt torque.) Do not use gasket sealer or composition steel asbestos gasket.

1. Place the gasket in position over the dowel pins with the bead up.
2. Carefully guide cylinder head into place over dowel pins and gasket.
3. Coat threads of cylinder head bolts with sealing compound and install finger tight.
4. Tighten cylinder head bolts a little at a time in the sequence shown on the torque sequence chart until the specified torque is reached.
5. Connect radiator upper hose and engine ground strap.
6. Connect temperature sending unit wires and install fuel and vacuum lines in clip at water outlet.
7. Fill cooling system.
8. Install manifold assembly as previously outlined.
9. Install and adjust valve mechanism as previously outlined.
10. Install and torque rocker arm cover.
11. Connect AIR pipe (if so equipped).

ROCKER ARM STUDS

Replacement

Rocker arm studs that have damaged threads or are loose in cylinder heads should be replaced with new studs available in .003" and .013" oversize. Studs may be installed after reaming the holes as follows:

1. Remove old stud by placing Tool J-5802-A over the stud, installing nut and flat washer and removing stud by turning nut (fig. 6A-24).
2. Ream hole for oversize stud using Tool J-5715 for .003" oversize or Tool J-6036 for .013" oversize (fig. 6A-25).

CAUTION: Do not attempt to install an oversize stud without reaming stud hole.

3. Coat press-fit area of stud with hypoid axle

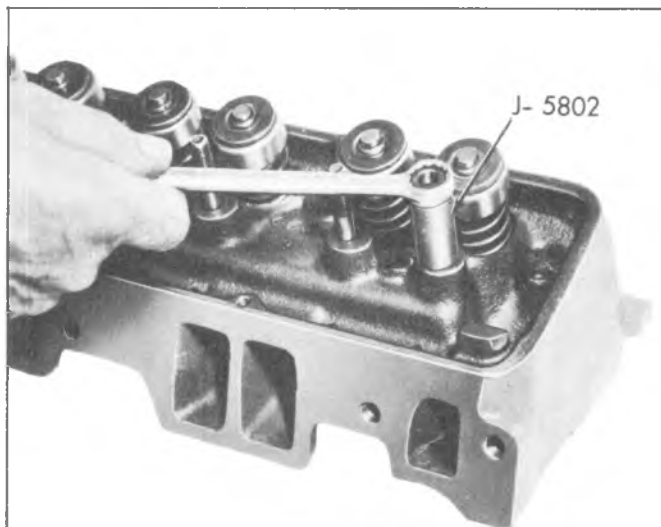


Fig. 6A-24--Removing Rocker Arm Stud (Typical)

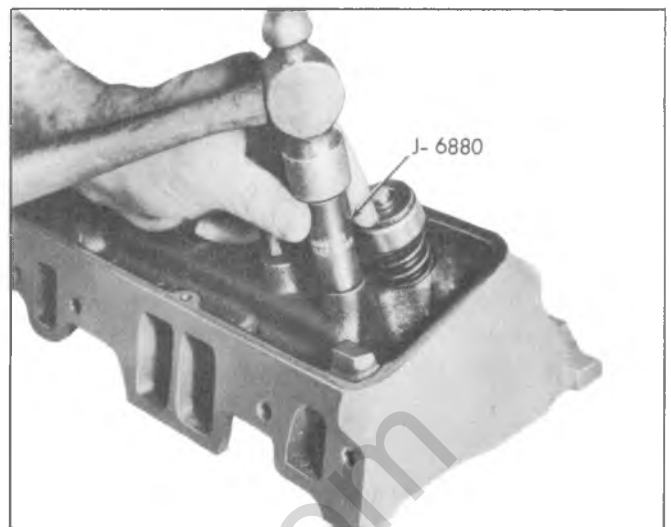


Fig. 6A-26--Installing Rocker Arm Stud (Typical)

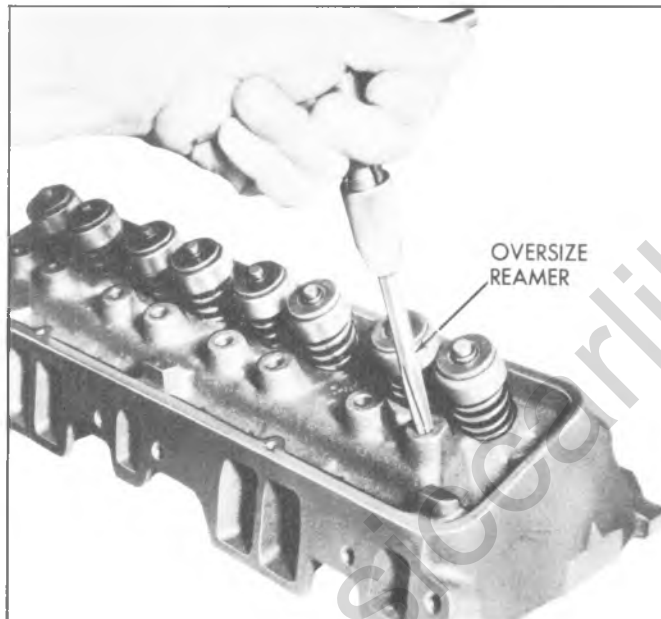


Fig. 6A-25--Reaming Rocker Arm Stud Bore (Typical)

lubricant. Install new stud, using Tool J-6880 as a guide. Gauge should bottom on head (fig. 6A-26).

VALVE GUIDE BORES

Valves with oversize stems are available (see specifications). To ream the valve guide bores for oversize valves, use Tool Set J-5830 (fig. 6A-27).

VALVE SEATS

Reconditioning the valve seats is very important, because the seating of the valves must be perfect for the engine to deliver the power and performance built into it.

Another important factor is the cooling of the valve heads. Good contact between each valve and its seat in



Fig. 6A-27--Reaming Valve Guide (Typical)

the head is imperative to insure that the heat in the valve head will be properly carried away.

Several different types of equipment are available for reseating valve seats. The recommendations of the manufacturer of the equipment being used should be carefully followed to attain proper results.

Regardless of what type of equipment is used, however, it is essential that valve guide bores be free from carbon or dirt to ensure proper centering of pilot in the guide.

Reconditioning

1. Install expanding pilot in the valve guide bore and expand pilot.

2. Place roughing stone or forming stone over pilot and just clean up the valve seat. Use a stone cut to specifications.

3. Remove roughing stone or forming stone from pilot, place finishing stone, cut to specifications, over pilot and cut just enough metal from the seat to provide a smooth finish. Refer to specifications.

4. Narrow down the valve seat to the specified width.

NOTE: This operation is done by grinding the port side with a 30 degree stone to lower seat and a 60 degree stone to raise seat.

5. Remove expanding pilot and clean cylinder head carefully to remove all chips and grindings from above operations.

6. Measure valve seat concentricity (fig. 6A-28).

VALVES

Valves that are pitted can be refaced to the proper angle, insuring correct relation between the head and stem on a valve refacing mechanism. Valve stems which show excessive wear, or valves that are warped excessively should be replaced. When a valve head which is warped excessively is refaced, a knife edge will be ground on part or all of the valve head due to the amount of metal that must be removed to completely reface. Knife edges lead to breakage, burning or pre-ignition due to heat localizing on this knife edge. If the edge of the valve head is less than 1/32" thick after grinding, replace the valve.

Several different types of equipment are available for refacing valves. The recommendations of the manufacturer of the equipment being used should be carefully followed to attain proper results.

Reconditioning

1. If necessary, dress the valve refacing machine



Fig. 6A-28--Measuring Valve Seat Concentricity
(Typical)

grinding wheel to make sure it is smooth and true. Set check at angle specified for valve. Refer to specifications.

2. Clamp the valve stem in the chuck of the machine.

3. Start the grinder and move the valve head in line with the grinder wheel.

4. Turn the feed screw until the valve head just contacts wheel. Move valve back and forth across the wheel and regulate the feed screw to provide light valve contact.

5. Continue grinding until the valve face is true and smooth all around the valve. If this makes the valve head thin (1/32" min.) the valve must be replaced as the valve will overheat and burn.

6. Remove valve from chuck and place stem in "V" block. Feed valve squarely against grinding wheel to grind any pit from rocker arm end of stem.

NOTE: Only the extreme end of the valve stem is hardened to resist wear. Do not grind end of stem excessively.

7. After cleaning valve face and cylinder head valve seat of grinding particles, make pencil marks about 1/4" apart across the valve face, place the valve in cylinder head and give the valve 1/2 turn in each direction while exerting firm pressure on head of valve.

8. Remove valve and check face carefully. If all pencil marks have not been removed at the point of contact with the valve seat, it will be necessary to repeat the refacing operation and again recheck for proper seating.

9. Grind and check the remaining valves in the same manner.

TORSIONAL DAMPER

Removal

1. Drain radiator and remove as outlined in Section 6B.

2. Remove fan belt and (if so equipped) accessory drive pulley and belt.

3. Install Tool J-23523 to damper and turn puller screw to remove damper (fig. 6A-29). Remove tool.

Installation

1. Coat front cover oil seal contact area of damper with engine oil.

CAUTION: It is necessary to use installer Tool J-22197 to prevent the inertia weight section from walking off the hub during installation of damper.

NOTE: The damper on the 292 L-6 should be pulled on by using special tool J-23523 or equivalent.

2. Attach damper installer Tool J-22197 to damper. Tighten fingers of tool to prevent weight from moving (fig. 6A-30).

3. Position damper on crankshaft and drive into

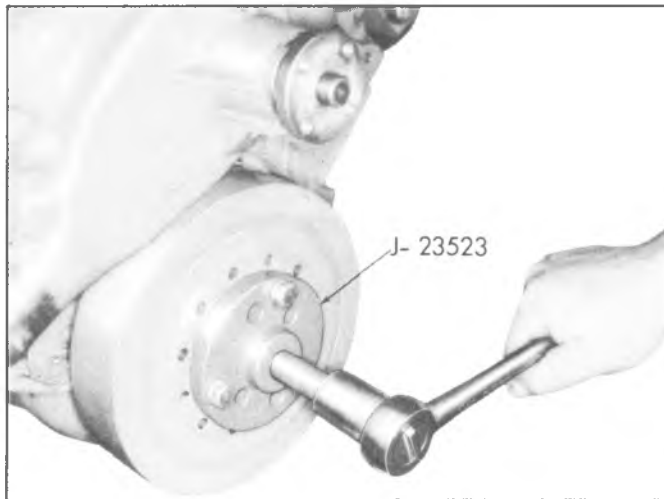


Fig. 6A-29--Removing Torsional Damper

position, using J-5590 until it bottoms against crankshaft gear (fig. 6A-30). Remove installer tool.

4. Install fan belt and adjust using strand tension gauge.
5. If so equipped, install accessory drive pulley and belt.
6. Install radiator core as outlined in Section 6B.
7. Fill cooling system and check for leaks.

CRANKCASE FRONT COVER (TIMING GEAR COVER)

Removal (without removing oil pan)

1. Remove torsional damper as outlined.
2. Remove the two, oil pan-to-front cover attaching screws.

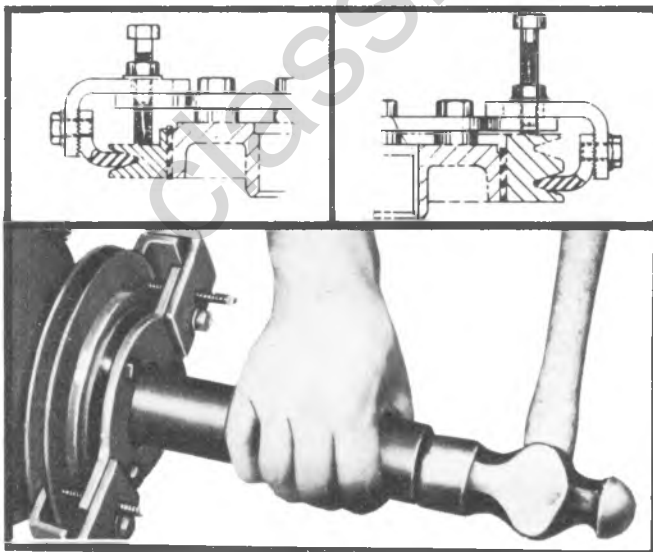


Fig. 6A-30--Installing Torsional Damper

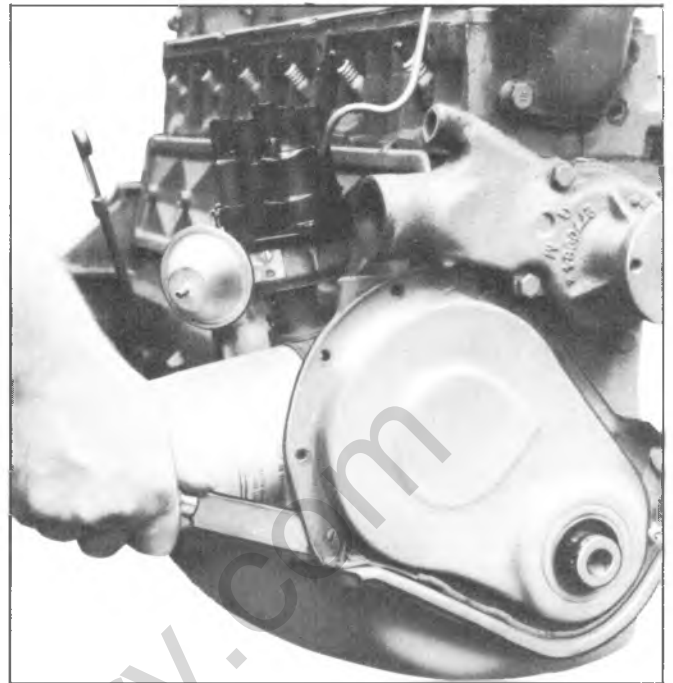


Fig. 6A-31--Cutting Tabs on Oil Pan Front Seal

3. Remove the front cover-to-block attaching screws.
4. Pull the cover slightly forward only enough to permit cutting of oil pan front seal.
5. Using a sharp knife or other suitable cutting tool, cut oil pan front seal flush with cylinder block at both sides of cover (fig. 6A-31).
6. Remove front cover and attached portion of oil pan front seal. Remove front cover gasket.

Installation

1. Clean gasket surfaces on block and crankcase front cover.

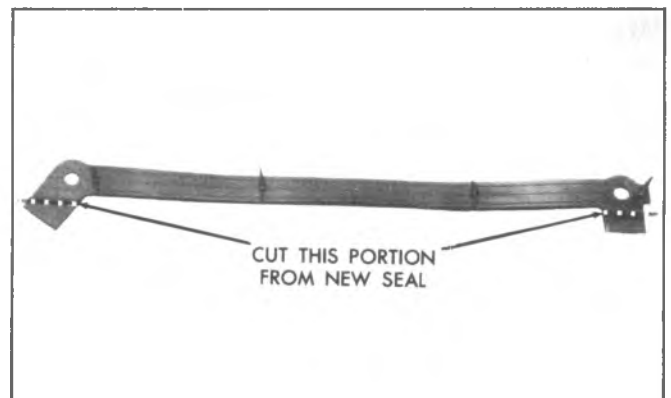


Fig. 6A-32--Oil Pan Front Seal Modification

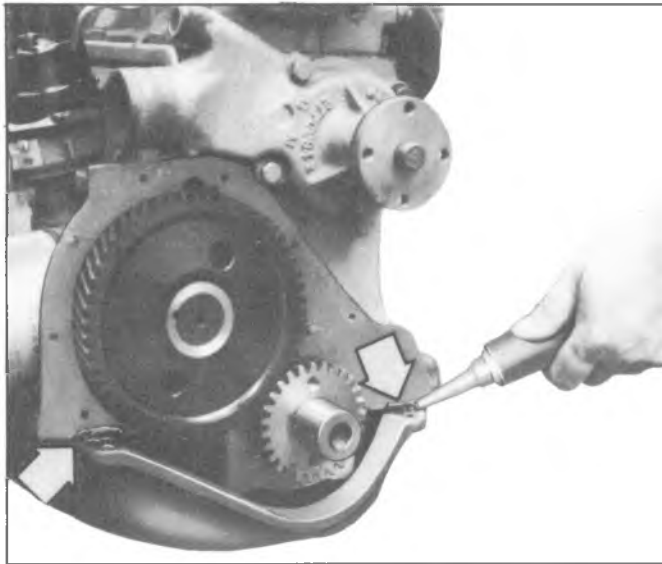


Fig. 6A-33--Applying Front Cover Sealant

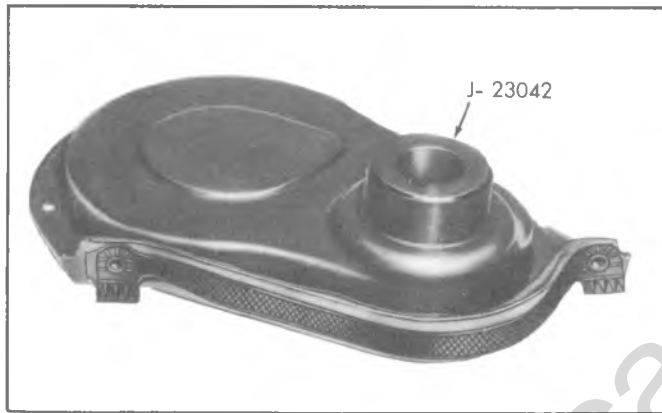


Fig. 6A-34--J-23042 Centering Tool In Cover

2. Cut tabs from the new oil pan front seal (fig. 6A-32) use a sharp instrument to ensure a clean cut.

3. Install seal to front cover, pressing tips into holes provided in cover.

4. Coat the gasket with gasket sealer and place in position on cover.

5. Apply a 1/8 inch bead of silicone rubber sealer part 1051435 (or equivalent) to the joint formed at the oil pan and cylinder block (fig. 6A-33).

6. Install centering Tool J-23042 in crankcase front cover seal (fig. 6A-34).

NOTE: It is important that centering tool be used to align crankcase front cover so that torsional damper installation will not damage seal and so that seal is positioned evenly around balancer.

7. Install crankcase front cover to block. Install and partially tighten the two, oil pan-to-front cover screws.

8. Install the front cover-to-block attaching screws.

9. Remove centering Tool J-23042 and torque all cover attaching screws to specifications.

10. Install torsional damper as outlined.

OIL SEAL (FRONT COVER)

Replacement

With Cover Installed

1. With torsional damper removed, pry old seal out of cover from the front with a screw driver, being careful not to damage the seal surface on the cover.

2. Install new seal so that open end is toward the inside of the cover and drive it into position with tool J-23042 (fig. 6A-35).

With Cover Removed

1. With cover removed, pry old seal out of cover from the front with screw driver, being careful not to distort cover.

2. Install new seal so that open end of the seal is

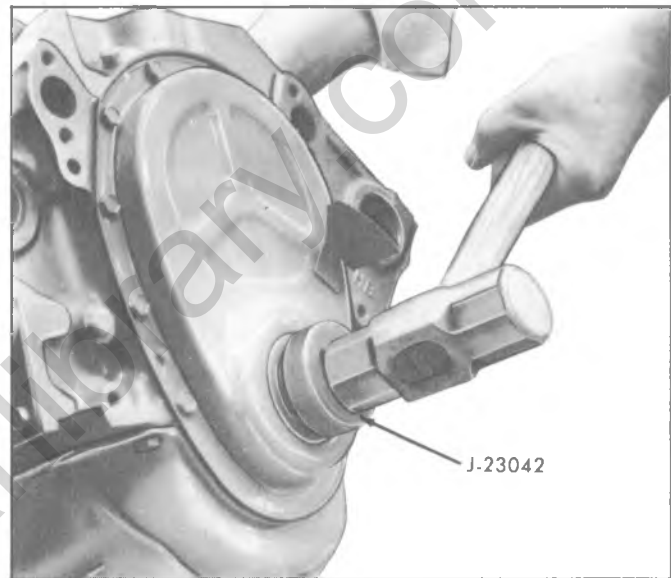
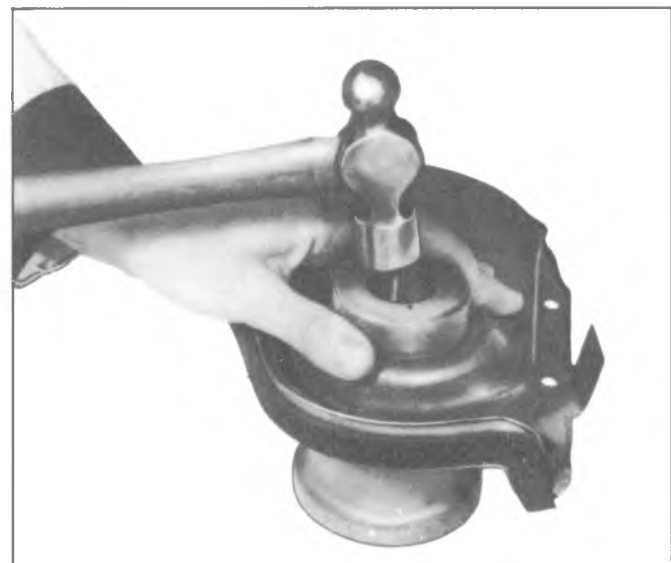
Fig. 6A-35--Installing Oil Seal (Cover Installed)
(Typical)

Fig. 6A-36--Installing Oil Seal (Cover Removed)

toward the inside of cover and drive it into position with Tool J-23042 (fig. 6A-36).

CAUTION: Support cover at sealing area. (Tool J-971 may be used as support.)

CAMSHAFT

Measuring Lobe Lift

NOTE: This procedure is similar to that used for checking valve timing. If improper valve operation is indicated, measure the lift of each push rod in consecutive order and record the readings.

1. Remove valve mechanism as outlined.
2. Position indicator with ball socket adapter (Tool J-8520) on push rod (fig. 6A-37).
3. Rotate the crankshaft slowly in the direction of rotation until the lifter is on the heel of the cam lobe. At this point, the push rod will be in its lowest position.
4. Set dial indicator on zero, then rotate the crankshaft slowly, or attach an auxiliary starter switch and "bump" the engine over, until the push rod is in the fully raised position.

CAUTION: Whenever the engine is cranked remotely at the starter, with a special jumper cable or other means, the "BATT" positive lead must be disconnected from the coil.

5. Compare the total lift recorded from the dial indicator with specifications.
6. Continue to rotate the crankshaft until the indicator reads zero. This will be a check on the accuracy of the original indicator reading.

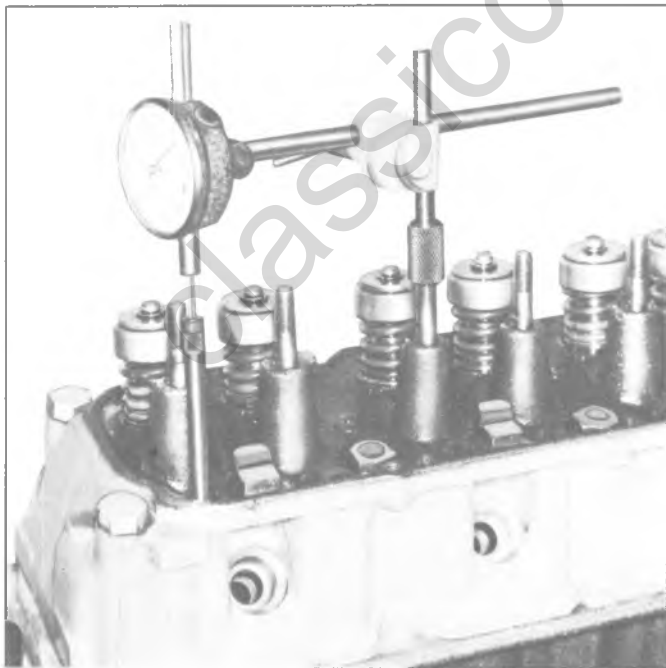


Fig. 6A-37--Measuring Camshaft Lobe Lift

7. If camshaft readings for all lobes are within specifications, remove dial indicator assembly.

8. Install and adjust valve mechanism as outlined.

Removal

1. Remove engine, following procedure on page 6A of this section.
2. Remove lifters as previously outlined.
3. Remove crankcase front cover as previously outlined.
4. Remove fuel pump.
5. Align timing gear marks then remove the two camshaft thrust plate bolts by working through holes in camshaft gear (fig. 6A-38).
6. Remove the camshaft and gear assembly by pulling it out through the front of the block.

NOTE: Support camshaft carefully when removing so as not to damage the camshaft bearings.

Inspection

The camshaft bearing journals should be measured with a micrometer for an out-of-round condition. If the journals exceed .001" out-of-round, the camshaft should be replaced.

The camshaft should also be checked for alignment. The best method is by use of "V" blocks and a dial indicator (fig. 6A-39). The dial indicator will indicate the exact amount the camshaft is out of true. If it is out more than .0015" dial indicator reading, the camshaft should be replaced.

Inspect the camshaft gear and thrust plate for wear or damage. Measure the camshaft end play. This should be .001" to .005" (fig. 6A-40).

Gear Replacement

1. If the inspection indicated that the camshaft, gear or thrust plate should be replaced, the gear must be

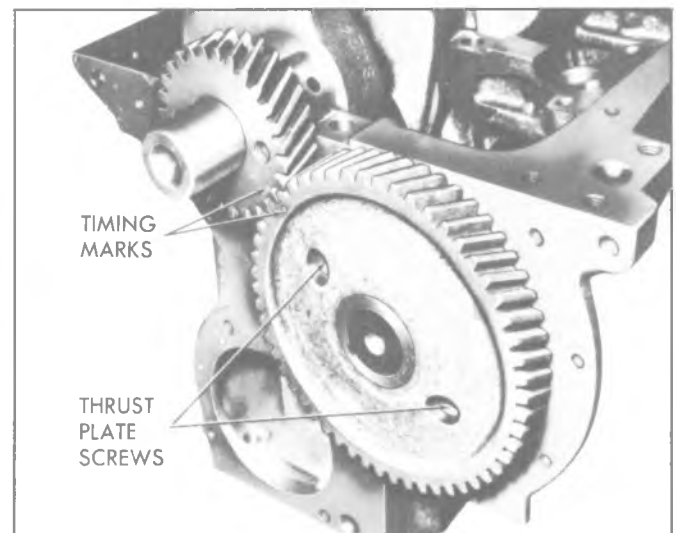


Fig. 6A-38--Timing Gear Marks

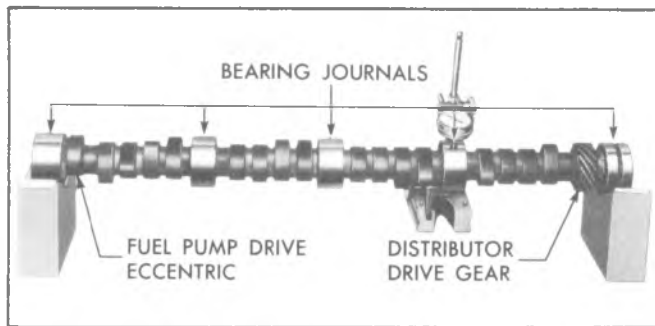


Fig. 6A-39--Checking Camshaft Alignment (Typical)

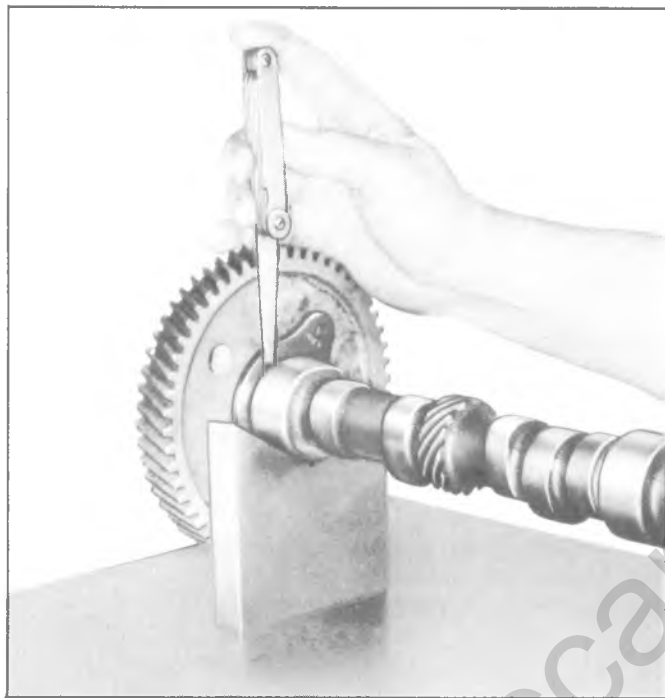


Fig. 6A-40--Measuring Camshaft End Play

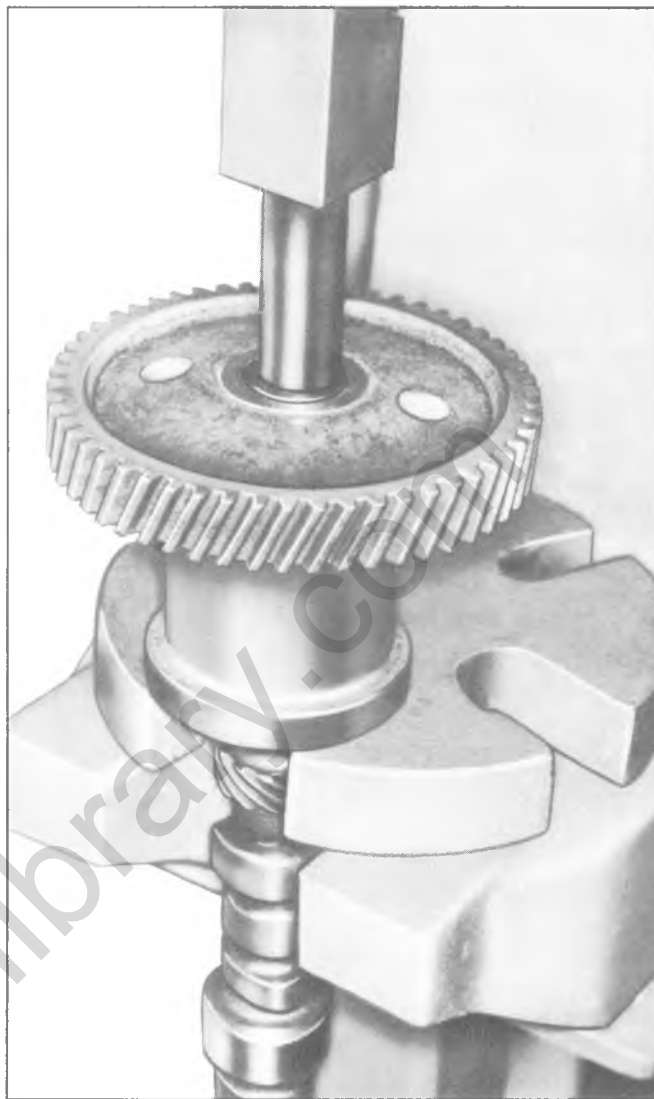


Fig. 6A-41--Removing Camshaft Gear

removed from the camshaft. This operation requires the use of camshaft gear removed J-971.

2. Place the camshaft through the gear remover, place end of remover on table of a press and press shaft out of gear (fig. 6A-41).

CAUTION: Thrust plate must be positioned so that woodruff key in shaft does not damage it when the shaft is pressed out of gear. Also support the hub of the gear or the gear will be seriously damaged.

3. To assemble camshaft gear thrust plate and gear spacer ring to camshaft firmly support camshaft at back of front journal in an arbor press.

4. Place gear spacer ring and thrust plate over end of shaft, and install woodruff key in shaft keyway. Install camshaft gear and press it onto the shaft until it bottoms against the gear spacer ring. The end clearance of the thrust plate should be .001" to .005" (fig. 6A-40).

Installation

1. Install the camshaft and gear assembly in the engine block, being careful not to damage camshaft bearings or camshaft.

2. Turn crankshaft and camshaft so that the valve timing marks on the gear teeth will line up (fig. 6A-38). Push camshaft into position. Install camshaft thrust plate-to-block bolts and torque to specifications.

3. Check camshaft and crankshaft gear run out with a dial indicator (fig. 6A-42). The camshaft gear run out should not exceed .004" and the crankshaft gear run out should not exceed .003".

4. If gear run out is excessive, the gear will have to be removed and any burrs cleaned from the shaft or the gear will have to be replaced.

5. Check the backlash between the timing gear teeth with a dial indicator (fig. 6A-43). The backlash should be not less than .004" nor more than .006".

6. Install fuel pump.

7. Install crankcase front cover.

8. Install lifters.

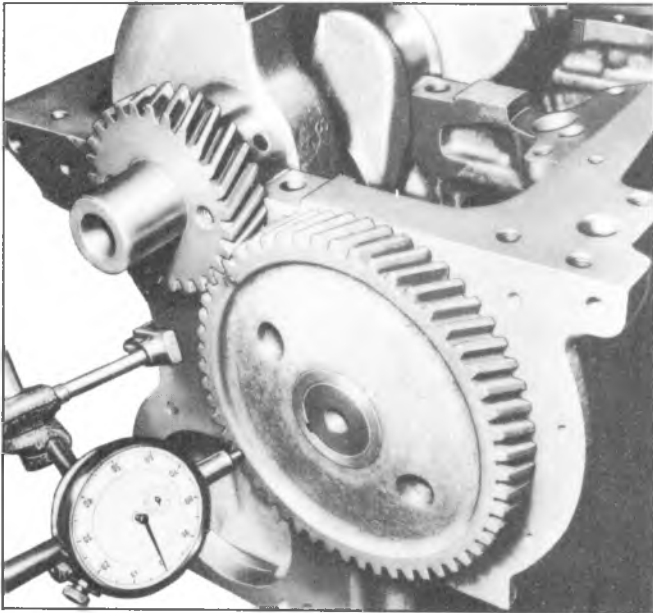


Fig. 6A-42-Checking Camshaft Gear Runout

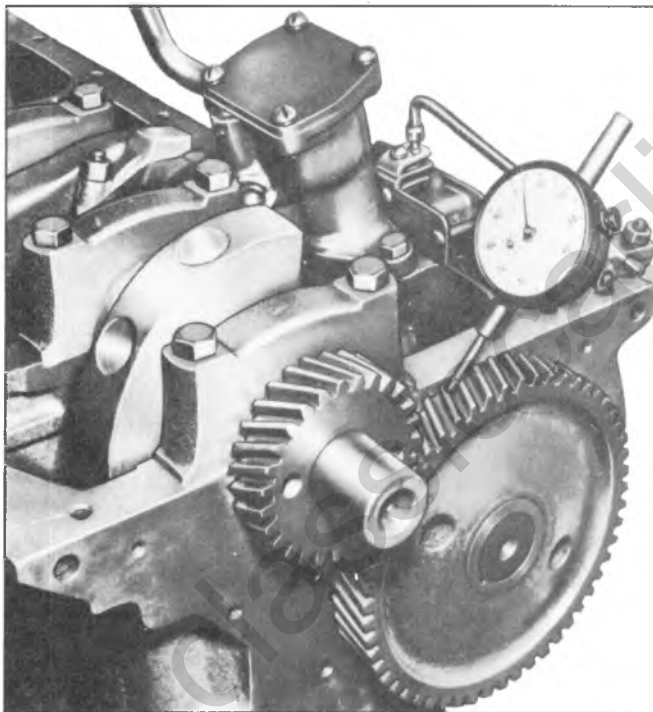


Fig. 6A-43-Checking Timing Gear Backlash

9. Install engine in vehicle.

CAMSHAFT BEARINGS

Removal

1. Remove camshaft as previously outlined.

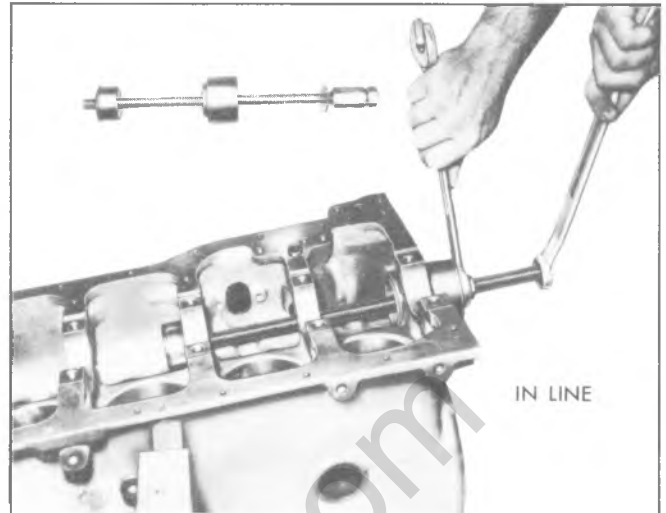


Fig. 6A-44-Replacing Camshaft Center Bearing

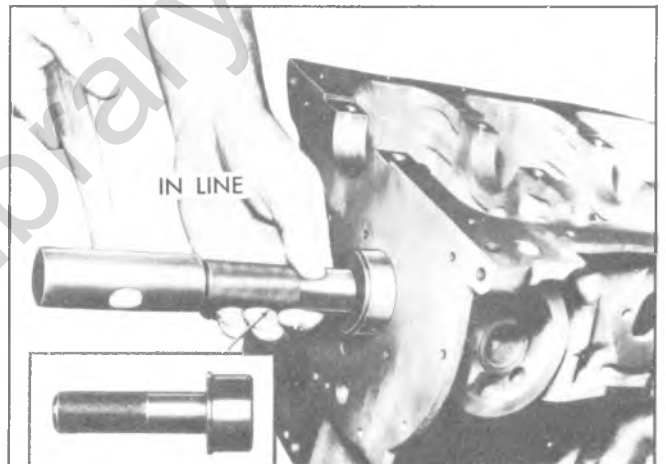


Fig. 6A-45-Replacing Camshaft Front Bearing

2. Remove oil pan and oil pump as described on page 6A-30 of this section.

3. Drive camshaft rear plug from cylinder block.

NOTE: This procedure is based on removal of the bearings nearest center of the engine first. With this method a minimum amount of turns are necessary to remove all bearings.

4. Using Tool Set J-6098, with nut and thrust washer installed to end of threads, index pilot in camshaft front bearing and install puller screw through pilot.

5. Install remover and installer tool with shoulder toward bearing, making sure a sufficient amount of threads are engaged.

6. Using two wrenches, hold puller screw while turning nut. When bearing has been pulled from bore, remove remover and installer tool and bearing from puller screw (fig. 6A-44).

7. Remove remaining bearings (except front and rear) in the same manner. It will be necessary to index pilot in camshaft rear bearing to remove the rear intermediate bearing.

8. Assemble remover and installer tool on driver handle and remove camshaft front and rear bearings by driving towards center of cylinder block (fig. 6A-45).

Installation

NOTE: The camshaft front and rear bearings should be installed first. These bearings will act as guides for the pilot and center the remaining bearings being pulled into place.

1. Assemble remover and installer tool on driver handle and install camshaft front and rear bearings by driving towards center of cylinder block (fig. 6A-45).

2. Using Tool Set J-6098, with nut and thrust washer installed to end of threads, index pilot in camshaft front bearings and install puller screw through pilot.

3. Index camshaft bearing in bore, then install remover and installer tool on puller screw with shoulder toward bearing.

CAUTION: All cam bearing oil holes must be aligned with oil holes in cam bore.

4. Using two wrenches, hold puller screw while turning nut. After bearing has been pulled into bore, remove the remover and installer tool from puller screw and check alignment of oil hole in camshaft bearing.

5. Install remaining bearings in the same manner. It will be necessary to index pilot in the camshaft rear bearing to install the rear intermediate bearing.

6. Install a new camshaft rear plug.

NOTE: Plug should be installed flush to 1/32" deep and be parallel with rear surface of cylinder block.

OIL PAN

Removal

1. Disconnect battery negative cable.
2. Raise vehicle on hoist and drain engine oil.
3. Remove starter.
4. Remove flywheel splash shield or converter housing underpan, as applicable.
5. Remove "through" bolts from engine front mounts.
6. Raise front of engine, reinstall mount through bolts and lower engine.
7. Remove oil pan bolts.
8. Remove oil pan.

Installation

1. Thoroughly clean all gasket sealing surfaces.
2. Using a new gasket, install rear seal in rear main bearing cap.
3. Install front seal on crankcase front cover, pressing tips into holes provided in cover (fig. 6A-46).

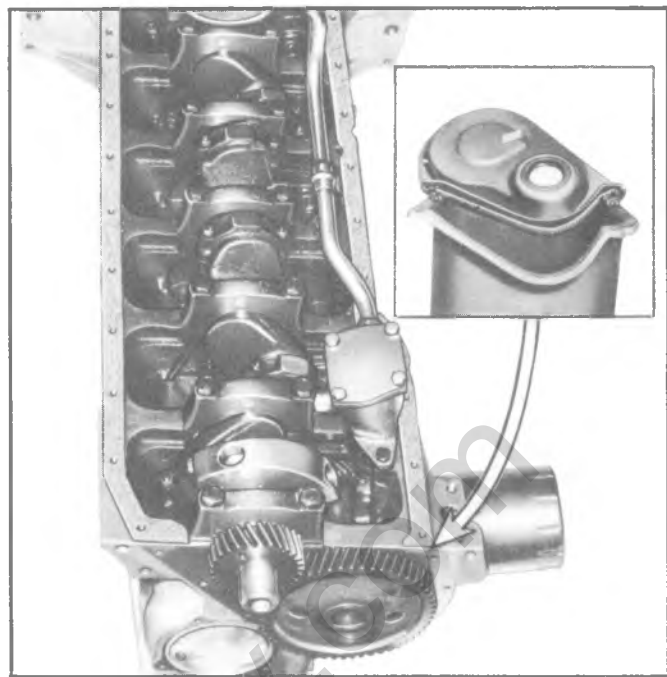


Fig. 6A-46--Pan Gaskets and Seals

4. Install side gaskets to engine block, using a gasket sealer with sufficient body to act as a retainer.

5. Install oil pan, torquing the retaining bolts to specifications.

6. Raise engine sufficiently to allow removal of "through" bolts - lower engine and install mount "through" bolts. Torque bolts to specifications.

7. Install flywheel splash shield or converter housing underpan, as applicable.

8. Install starter.

9. Lower vehicle and fill crankcase with oil.

10. Connect battery negative cable, start engine and check for leaks.

OIL PUMP

Removal

1. Remove oil pan as outlined.
2. Remove two flange mounting bolts, pickup pipe bolt, then remove pump and screen as an assembly.

Disassembly

1. Remove the pump cover attaching screws, the pump cover and the pump cover gasket (fig. 6A-47).

NOTE: Mark gear teeth so they may be reassembled with the same teeth indexing.

2. Remove the idler gear and the drive gear and shaft from the pump body.

3. Remove the pressure regulator valve retaining pin, pressure regulator valve and related parts.

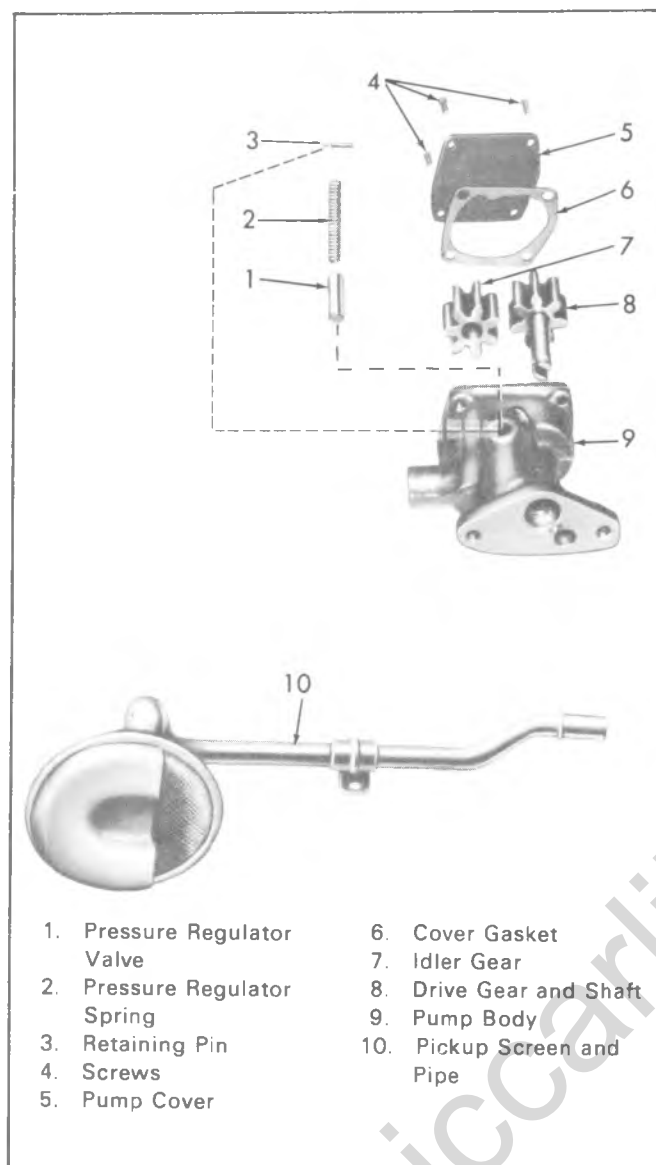


Fig. 6A-47--Oil Pump (L6 Exploded)

4. If the pickup screen and pipe assembly need replacing, mount the pump in a soft-jawed vise and extract pipe from pump.

CAUTION: Do not disturb the pickup screen on the pipe. This is serviced as an assembly.

Cleaning and Inspection

1. Wash all parts in cleaning solvent and dry with compressed air.
2. Inspect the pump body and cover for cracks or excessive wear.
3. Inspect pump gears for damage or excessive wear.
4. Check the drive gear shaft for looseness in the pump body.
5. Inspect inside of pump cover for wear that would permit oil to leak past the ends of the gears.
6. Inspect the pickup screen and pipe assembly for damage to screen, pipe or relief grommet.

7. Check the pressure regulator valve for fit.

NOTE: The pump gears and body are not serviced separately. If the pump gears or body are damaged or worn, replacement of the entire oil pump assembly is necessary.

Assembly

1. If the pickup screen and pipe assembly was removed, it should be replaced with a new part. Loss of press fit condition could result in an air leak and loss of oil pressure. Mount the pump in a soft-jawed vise, apply sealer to the end of pipe and tap the pipe in place with a plastic hammer using Tool J-8369.

CAUTION: Be careful of twisting, shearing or collapsing pipe while installing in pump. Pickup screen must be parallel to bottom of oil pan when oil pump is installed.

2. Install the pressure regulator valve and related parts.
3. Install the drive gear and shaft in the pump body.
4. Install the idler gear in the pump body with the smooth side of gear towards pump cover opening.
5. Install the pump, with new gasket, and torque attaching screws to specifications.
6. Turn drive shaft by hand to check for smooth operation.

CONNECTING ROD BEARINGS

Connecting rod bearings are of the precision insert type and do not utilize shims for adjustment. **DO NOT FILE RODS OR ROD CAPS.** If clearances are found to be excessive a new bearing will be required. Bearings are available in standard size and .001" and .002" undersize for use with new and used standard size crankshafts, and in .010" and .020" undersize for use with reconditioned crankshafts.

Inspection and Replacement

1. With oil pan and oil pump removed, remove the connecting rod cap and bearing.
2. Inspect the bearings for evidence of wear or damage. (Bearings showing the above should not be installed.)
3. Wipe the bearings and crankpin clean of oil.
4. Measure the crankpin for out-of-round or taper with a micrometer. If not within specifications replace or recondition the crankshaft. If within specifications and a new bearing is to be installed, measure the maximum diameter of the crankpin to determine new bearing size required.
5. If within specifications measure new or used bearing clearances with Plastigage or its equivalent.

NOTE: If a bearing is being fitted to an out-of-round crankpin, be sure to fit to the maximum diameter of the crankpin. If the bearing is fitted to

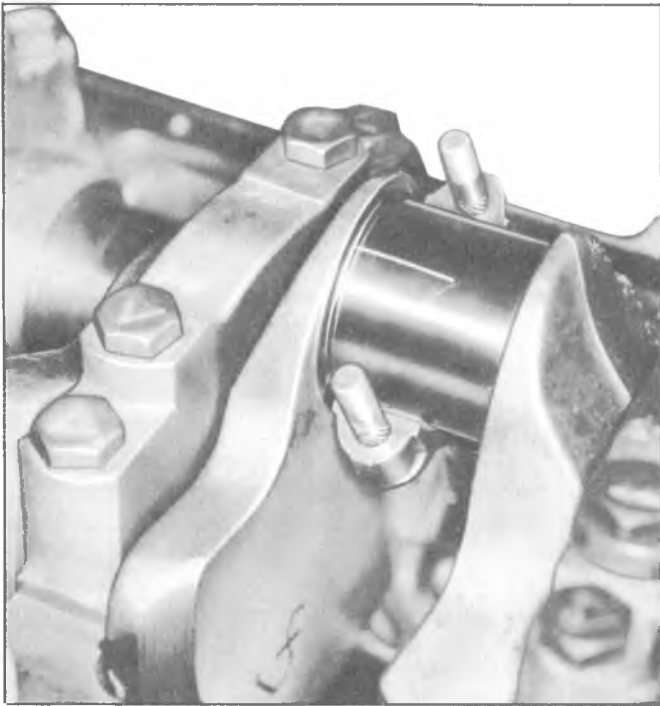


Fig. 6A-48-Gauging Plastic on Crankpin

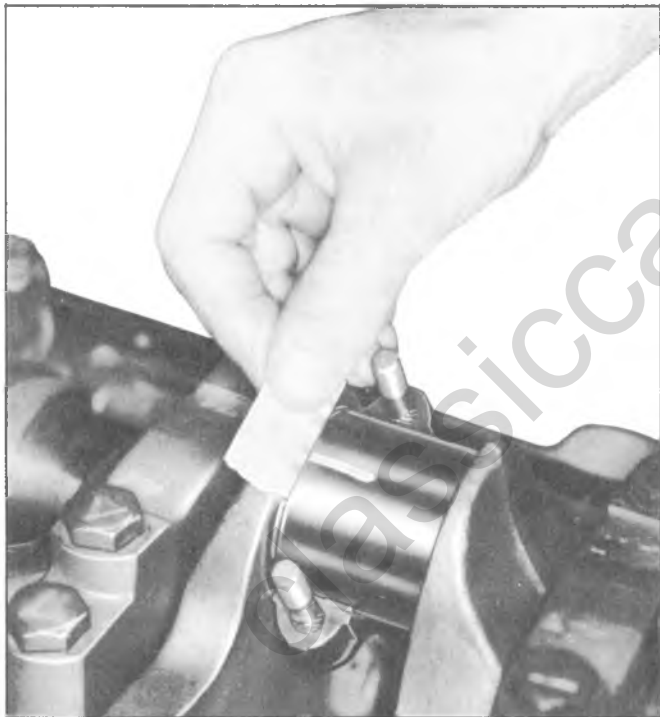


Fig. 6A-49-Measuring Gauging Plastic

the minimum diameter and the crankpin is out-of-round .001" interference between the bearing and crankpin will result in rapid bearing failure.

a. Place a piece of gauging plastic the full width of the crankpin as contacted by the bearing (parallel to the crankshaft)(fig. 6A-48).

b. Install the bearing in the connecting rod and cap.



Fig. 6A-50-Measuring Connecting Rod Side Clearance

c. Install the bearing cap and evenly torque nuts to specifications.

CAUTION: Do not turn the crankshaft with the gauging plastic installed.

d. Remove the bearing cap and using the scale on the gauging plastic envelope, measure the gauging plastic width at the widest point (fig. 6A-49).

6. If the clearance exceeds specifications, select a new, correct size, bearing and remeasure the clearance.

7. Coat the bearing surface with oil, install the rod cap and torque nuts to specifications.

8. When all connecting rod bearings have been installed, tap each rod lightly (parallel to the crankpin) to make sure they have clearance.

9. Measure all connecting rod side clearances between the connecting rod cap and side of crankpin (fig. 6A-50).

CRANKSHAFT MAIN BEARINGS

Main bearings are of the precision insert type and do not utilize shim for adjustment. If clearances are found to be excessive, a new bearing, both upper and lower halves, will be required. Bearings are available in standard size and .001", .002", .009", .010" and .020" undersize.

Selective fitting of both rod and main bearing inserts is necessary in production in order to obtain close tolerances. For this reason you may find one half of a standard insert with one half of a .001" undersize insert which will decrease the clearance .0005" from using a full standard bearing.

When a production crankshaft cannot be precision fitted by this method, it is then ground .009" undersize **on main journals only**. A .009" undersize bearing and .010" undersize bearing may be used for precision fitting in the same manner as previously described. Any engine fitted with a .009" undersize crankshaft will be identified by the following markings.

- ".009" will be stamped on the crankshaft counterweight forward of the center main journal.

- A figure "9" will be stamped on the block at the left front oil pan rail.

NOTE: If, for any reason, main bearings caps are replaced, shimming may be necessary. Laminated shims for each cap are available for service. Shim requirement will be determined by bearing clearance.

Inspection

In general, the lower half of the bearing (except No.1 bearing) shows a greater wear and the most distress from fatigue. If upon inspection the lower half is suitable for use, it can be assumed that the upper half is also satisfactory. If the lower half shows evidence of wear or damage, both upper and lower halves should be replaced. Never replace one half without replacing the other half.

Checking Clearance

To obtain the most accurate results with "Plastigage", (or its equivalent) a wax-like plastic material which will compress evenly between the bearing and journal surfaces without damaging either surface, certain precautions should be observed. If the engine is out of the vehicle and upside down, the crankshaft will rest on the upper bearings and the total clearance can be measured between the lower bearing and journal. If the engine is to remain in the vehicle, the crankshaft should be supported both front and rear (damper and flywheel) to remove the clearance from the upper bearing. The



Fig. 6A-51--Gauging Plastic on Journal (Typical)

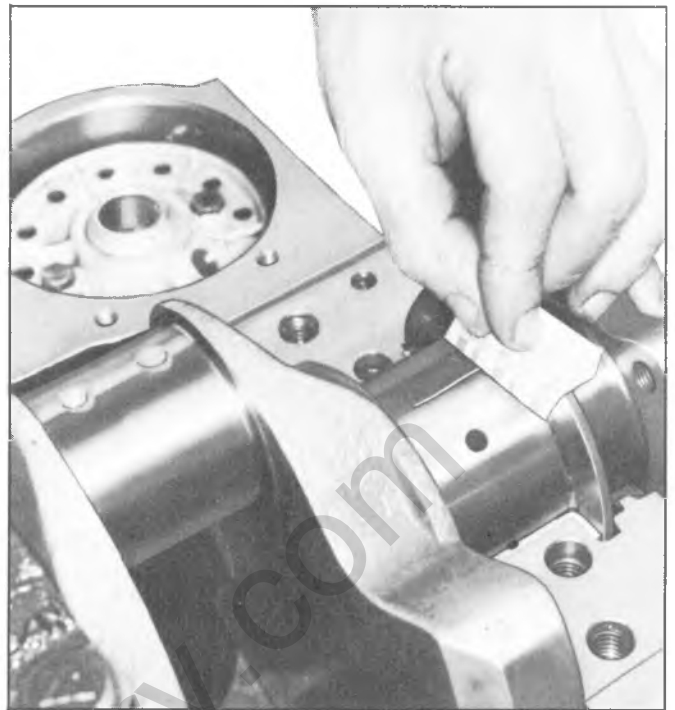


Fig. 6A-52--Measuring Gauging Plastic (Typical)

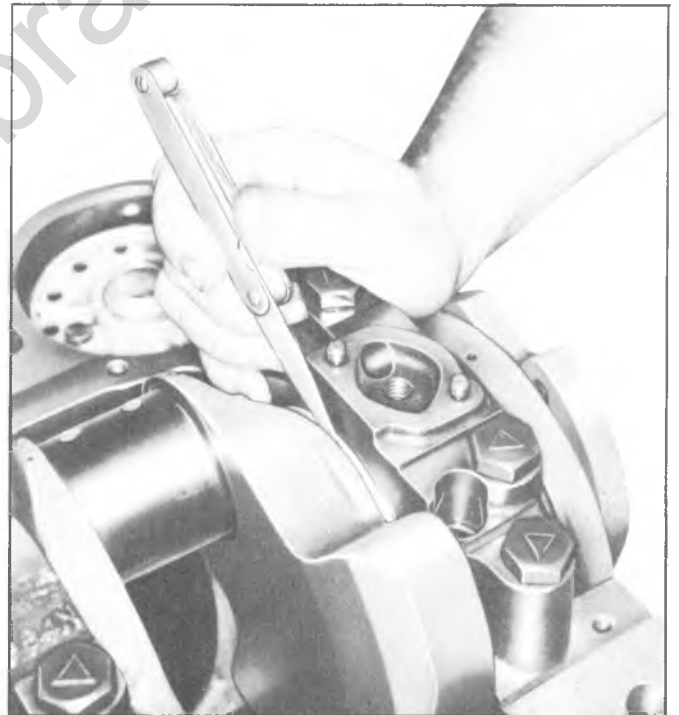


Fig. 6A-53--Measuring Crankshaft End Play (Typical)

total clearance can then be measured between the lower bearing and journal.

NOTE: To assure the proper seating of the crankshaft all bearing cap bolts should be at their specified torque. In addition, preparatory to checking fit of bearings, the surface of the

crankshaft journal and bearing should be wiped clean of oil.

1. With the oil pan and oil pump removed, and staring with the rear main bearing, remove bearing cap and wipe oil from journal and bearing cap.

2. Place a piece of gauging plastic the full width of the bearing (parallel to the crankshaft) on the journal (fig. 6A-51).

CAUTION: Do not rotate the crankshaft while the gauging plastic is between the bearing and journal.

3. Install the bearing cap and evenly torque the retaining bolts to specifications.

4. Remove bearing cap. The flattened gauging plastic will be found adhering to either the bearing shell or journal.

5. On the edge of gauging plastic envelope there is a graduated scale which is correlated in thousandths of an inch. Without removing the gauging plastic, measure its compressed width (at the widest point) with the graduations on the gauging plastic envelope (fig. 6A-52).

NOTE: Normally, main bearing journals wear evenly and are not out-of-round. However, if a bearing is being fitted to an out-of-round journal (.001" max.), be sure to fit to the maximum diameter of the journal.

If the bearing is fitted to the minimum diameter and the journal is out-of-round .001", interference between the bearing and journal will result in rapid bearing failure. If the flattened gauging plastic tapers toward the middle or ends, there is a difference in clearance indicating taper, low spot or other irregularity of the bearing or journal. Be sure to measure the journal with a micrometer if the flattened gauging plastic indicates more than .001" difference.

6. If the bearing clearance is within specifications, the bearing insert is satisfactory. If the clearance is not within specifications, replace the insert. Always replace both upper and lower insert as a unit.

NOTE: If a new bearing cap is being installed and clearance is less than .001", inspect for burrs or nicks; if none are found then install shims as required.

7. A standard, .001" or .002" undersize bearing may produce the proper clearance. If not, it will be necessary to regrind the crankshaft journal for use with the next undersize bearing.

8. Proceed to the next bearing. After all bearings have been checked, rotate the crankshaft to see that there is no excessive drag.

9. Measure crankshaft end play (see specifications) by forcing the crankshaft to the extreme front position. Measure at the front end of the rear main bearing with a feeler gauge (fig. 6A-53).

10. Install a new rear main bearing oil seal in the cylinder block and main bearing cap.

Replacement

NOTE: Main bearings may be replaced with or without removing the crankshaft.

With Crankshaft Removed

1. Remove and inspect the crankshaft.
2. Remove the main bearings from the cylinder block and main bearing caps.
3. Coat bearing surfaces of new, correct size, main bearings with oil and install in the cylinder block and main bearing caps.
4. Install the crankshaft.

Without Crankshaft Removal

1. With oil pan, oil pump and spark plugs removed, remove cap on main bearing requiring replacement and remove bearing from cap.
2. The rear main journal has no oil hole. Replace the rear main bearing upper half as follows:
 - a. Use a small drift punch and hammer to start the upper bearing half rotating out of block.
 - b. Use a pair of pliers (with taped jaws) to hold the bearing thrust surface to the oil slinger and rotate the crankshaft to remove bearing (fig. 6A-54).
 - c. Oil new selected size upper bearing and insert plain (unnotched) end between crankshaft and indented or notched side of block.
 - d. Use pliers as in removing to rotate bearing into place. The last 1/4 movement may be done by holding just the slinger with the pliers or tap in place with a drift punch.

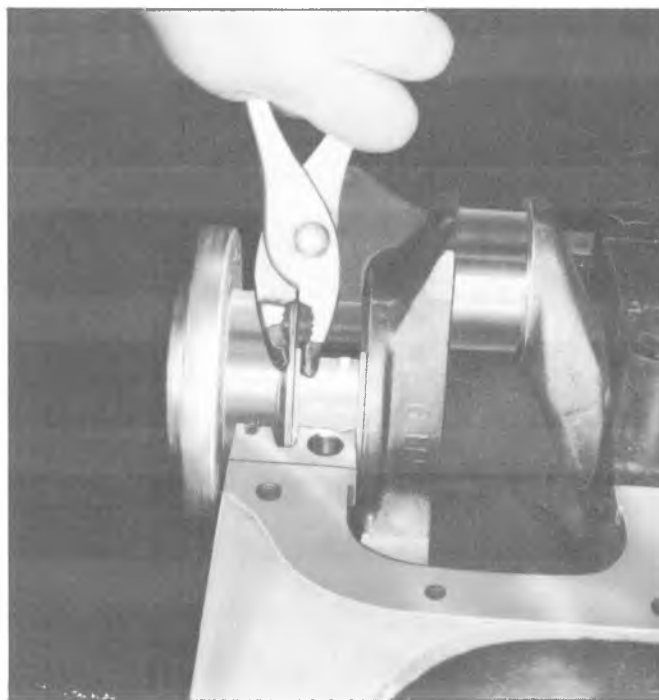


Fig. 6A-54--Replacing Upper Main Bearing

3. All other crankshaft journals have oil holes. Replace the main bearing upper half as follows:

a. Install a main bearing removing and installing tool in oil hole in crankshaft journal.

NOTE: If such a tool is not available, a cotter pin may be bent as required to do the job.

b. Rotate the crankshaft clockwise as viewed from the front of engine. This will roll upper bearing out of block.

c. Oil new selected size upper bearing and insert plain (unnotched) end between crankshaft and indented or notched side of block. Rotate the bearing into place and remove tool from oil hole in crankshaft journal.

4. Oil new lower bearing and install in bearing cap.

5. Install main bearing cap with arrows pointing toward front of engine.

6. Torque main bearing cap bolts to specifications.

OIL SEAL (REAR MAIN)

Replacement

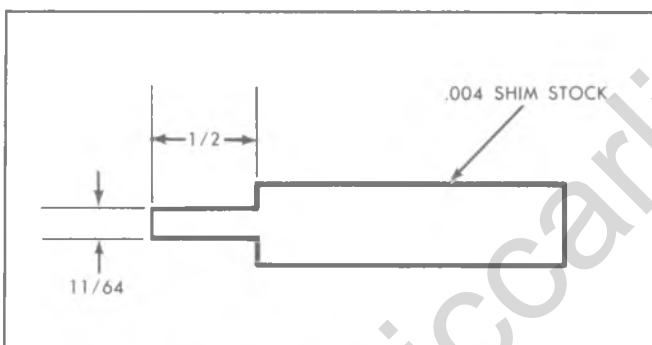


Fig. 6A-55--Oil Seal Installation Tool

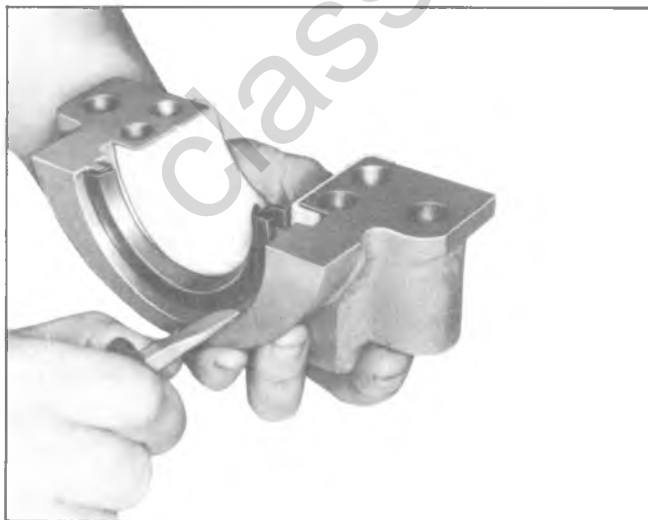


Fig. 6A-56--Removing Oil Seal Lower Half (Typical)

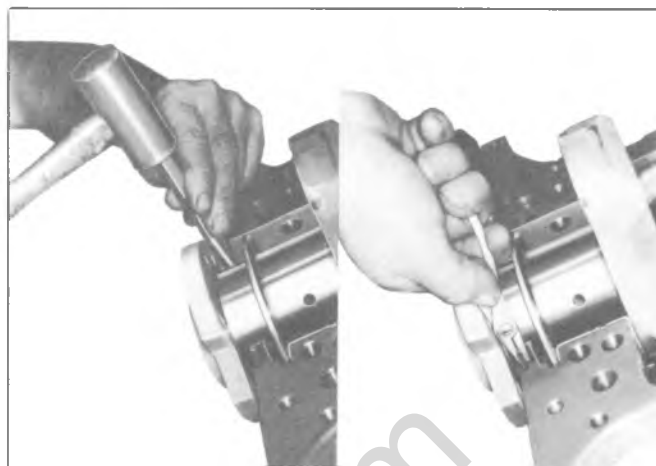


Fig. 6A-57--Removing Oil Seal Upper Half (Typical)

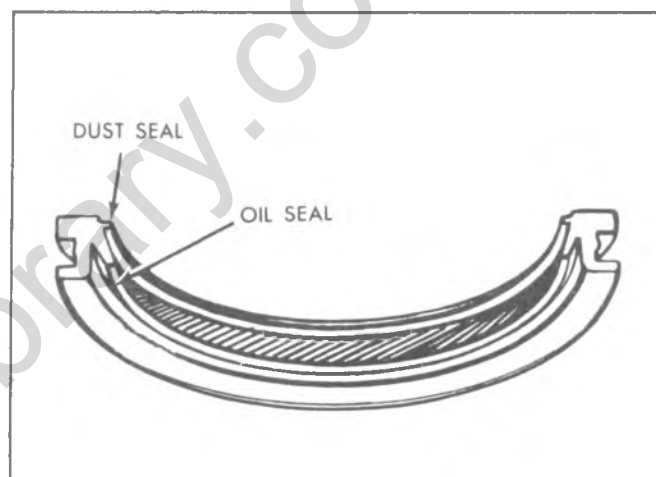


Fig. 6A-58--Crankshaft Oil Seal (Rear Main)

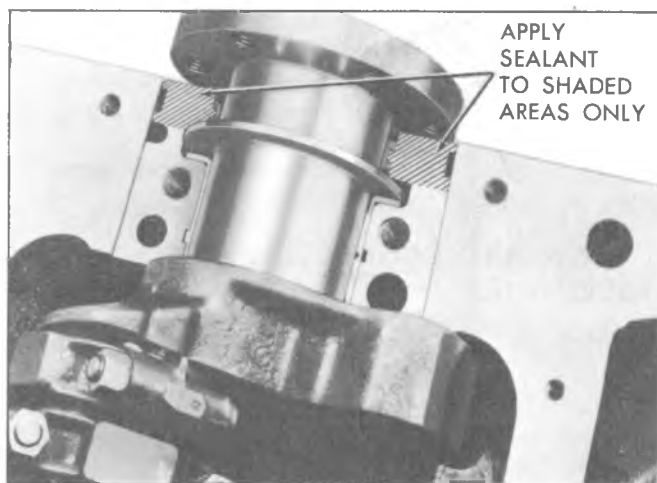


Fig. 6A-59--Sealing Bearing Cap (Typical)

NOTE: Always replace the upper and lower seal as a unit. Install seal with lip facing front of engine.

The rear main bearing oil seal can be replaced (both halves) without removal of the crankshaft. Extreme care should be exercised when installing this seal to protect

the sealing bead located in the channel on the outside diameter of the seal. An installation tool (fig. 6A-55) can be used to protect the seal bead when positioning seal as follows:

1. With the oil pan and oil pump removed, remove the rear main bearing cap.
2. Remove oil seal from the bearing cap by prying from the bottom with a small screw driver (fig. 6A-56).
3. To remove the upper half of the seal, use a small hammer to tap a brass pin punch on one end of seal until it protrudes far enough to be removed with pliers (fig. 6A-57).
4. Clean all sealant and foreign material from cylinder case bearing cap and crankshaft, using a nonabrasive cleaner.
5. Inspect components for nicks, scratches, burrs and machining defects at all sealing surfaces, case assembly and crankshaft.
6. Coat seal lips and seal bead with light engine oil - keep oil off seal mating ends.
7. Position tip of tool between crankshaft and seal seat in cylinder case.
8. Position seal between crankshaft and tip of tool so that seal bead contacts tip of tool.

NOTE: Make sure that oil-seal lip is positioned toward front of engine (fig. 6A-58).

9. Roll seal around crankshaft using tool as a "shoe-horn" to protect seal bead from sharp corner of seal seat surface in cylinder case.

CAUTION: Installation tool must remain in position until seal is properly positioned with both ends flush with block.

10. Remove tool, being careful not to withdraw seal.
11. Install seal half in bearing cap, again using tool as a "shoe-horn", feeding seal into cap using light pressure with thumb and finger.
12. Install bearing cap to case with sealant applied to the cap-to-case interface being careful to keep sealant off the seal split line (fig. 6A-59).
13. Install the rear main bearing cap (with new seal) and torque to specifications.

PISTON AND CONNECTING ROD ASSEMBLIES

Removal

1. With oil pan, oil pump and cylinder head removed, use a ridge reamer to remove any ridge and/or deposits from the upper end of the cylinder bore.

NOTE: Before ridge and/or deposits are removed, turn crankshaft until piston is at the bottom of stroke and place a cloth on top of piston to collect the cuttings. After ridge and/or deposits are removed, turn crankshaft until piston is at top of stroke and remove cloth and cuttings.

2. Inspect connecting rods and connecting rod caps for cylinder identification. If necessary, mark them.

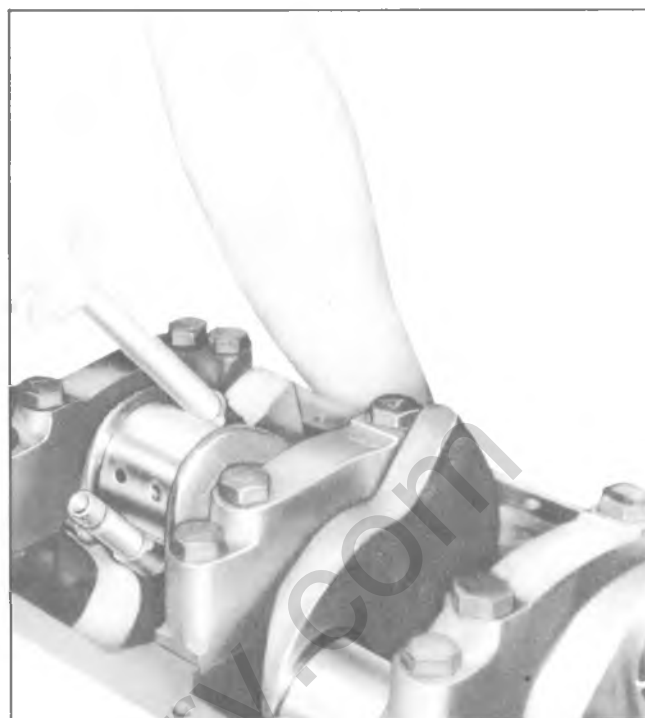


Fig. 6A-60-Removing Connecting Rod Piston Assembly

3. Remove connecting rod cap and install Tool J-5239 (3/8") or J-6305 (11/32") on studs. Push connecting rod and piston assembly out of top of cylinder block (fig. 6A-60).

NOTE: It will be necessary to turn the crankshaft slightly to disconnect some of the connecting rod and piston assemblies and push them out of the cylinder.

Disassembly

1. Remove connecting rod bearings from connecting rods and caps.

NOTE: If connecting rod bearings are being reused, place them in a rack so they may be reinstalled in their original rod and cap.

2. Remove piston rings by expanding and sliding them off the pistons. Tools J-8020 (3-9/16"), J-8021 (3-7/8"), J-8032 (4"), J-22249 (3-15/16"), J-22147 (-3/32"), and J-22250 (4-1/4") are available for this purpose.

3. Place connecting rod and piston assembly on tool J-24086. Using an arbor press and piston pin remover, J-24086, press the piston pin out of connecting rod and piston (fig. 6A-61).

Cleaning and Inspection

Connecting Rods

Wash connecting rods in cleaning solvent and dry with compressed air.

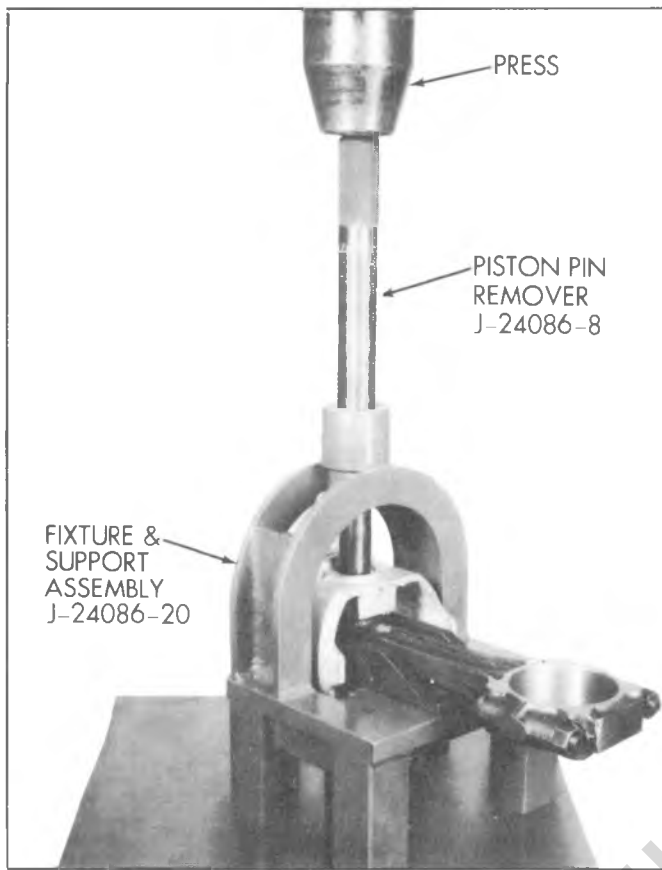


Fig. 6A-61--Removing Piston Pin

Check for twisted or bent rods and inspect for nicks or cracks. Replace connecting rods that are damaged.

Pistons

Clean varnish from piston skirts and pins with a cleaning solvent. **DO NOT WIRE BRUSH ANY PART OF THE PISTON.** Clean the ring grooves with a groove cleaner and make sure oil ring holes and slots are clean.

Inspect the piston for cracked ring lands, skirts or pin bosses, wavy or worn ring lands, scuffed or damaged skirts, eroded areas at top of the piston. Replace pistons that are damaged or show signs of excessive wear.

Inspect the grooves for nicks or burrs that might cause the rings to hang up.

Measure piston skirt (across center line of piston pin) and check clearance as outlined under "Piston Selection".

Piston Pins

The piston pin clearance is designed to maintain adequate clearance under all engine operating conditions. Because of this, the piston and piston pin are a matched set and not serviced separately.

Inspect piston pin bores and piston pins for wear. Piston pin bores and piston pins must be free of varnish or scuffing when being measured. The piston pin should be measured with a micrometer and the piston pin bore should be measured with a dial bore gauge or an inside micrometer. If clearance is in excess of the .001" wear

limit, the piston and piston pin assembly should be replaced.

ASSEMBLY

1. Lubricate piston pin holes in piston and connecting rod to facilitate installation of pin.

2. Place connecting rod in piston and hold in place with piston pin guide and piston pin. Place connecting rod and piston assembly on fixture and support assembly (fig. 6A-62).

NOTE: See figure 6A-63 for correct size of piston pin guide.

3. Using piston pin installer, J-24086-9, press the piston pin into the piston and connecting rod (Fig. 6A-64).

NOTE: The piston pin installer is a variable insertion length tool designed to be applicable to all GM piston assemblies. The insertion length is varied by rotating the hub on the shaft much like adjusting a micrometer. An alpha-numeric scale is used to determine the desired length for a given piston pin assembly. Refer to figure 6A-63 for correct setting.

CAUTION: After installer hub bottoms on support assembly, do not exceed 6000 psi

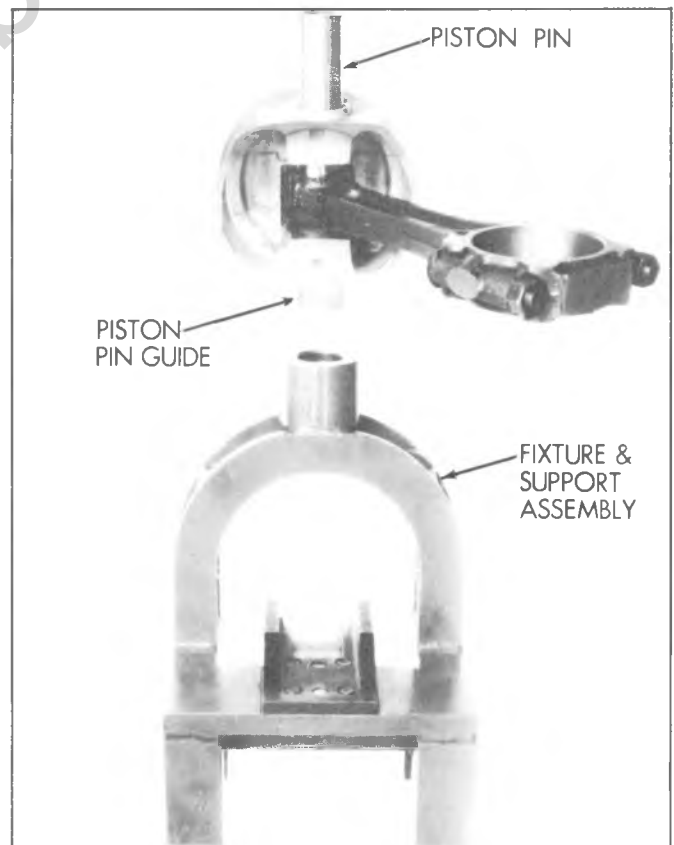


Fig. 6A-62--Piston Assembly Fixture Support Assembly

CYL.	DISPLACEMENT	PIN GUIDE	INSTALLER SETTING	PIN SIZE
4	85 cu. in./1.4 Litre	Gold J-24086-6	I-6	.905"
	97 cu. in./1.6 Litre			
	110 cu. in./1.8 Litre	Blue J-24086-5	I-7	.866"
	140 cu. in./2.3 Litre	Violet J-24086-7	I-7	.927"
6	250 cu. in./4.1 Litre	Violet J-24086-7	G-8	.927"
	292 cu. in./4.8 Litre			
8	Small Block 283, 302, 305, 307, 350, 400	Violet J-24086-7	G-8	.927"
	Mark IV 366, 396, 402, 427, 454	Gray J-24086-3	G-7	.990"

Fig. 6A-63--Piston Pin Tool Specifications



Fig. 6A-64--Installing Piston Pin

pressure, as this could cause structural damage to the tool.

4. Remove piston and connecting rod assembly from tool and check piston for freedom of movement on piston pin.

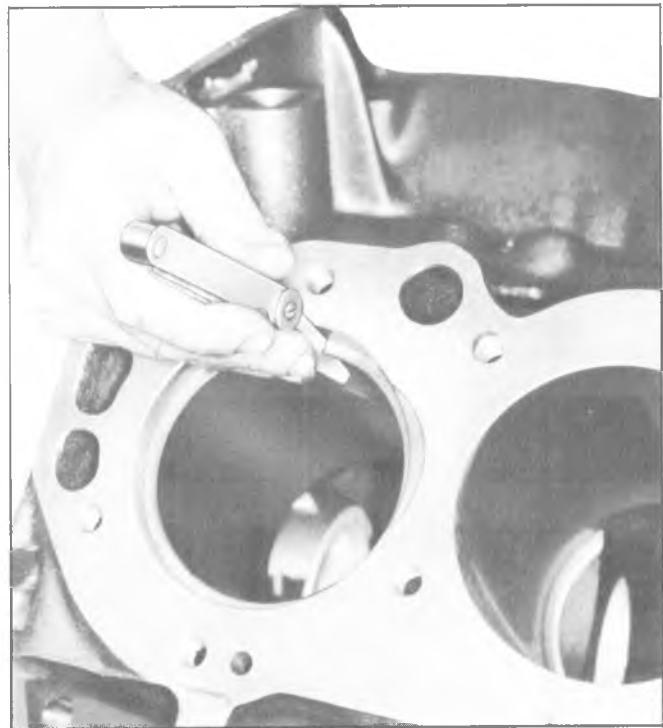


Fig. 6A-65--Measuring Ring Gap



Fig. 6A-66--Checking Ring in Groove

Piston Rings

All compression rings are marked on the upper side of the ring. When installing compression rings, make sure the marked side is toward the top of the piston. The top ring is chrome faced, or treated with molybdenum for maximum life.

The oil control rings are of three piece type, consisting of two segments (rails) and spacer.

1. Select rings comparable in size to the piston being used.

2. Slip the compression ring in the cylinder bore; then press the ring down into the cylinder bore about 1/4" (above ring travel). Be sure ring is square with cylinder wall.

3. Measure the space or gap between the ends of the ring with a feeler gauge (fig. 6A-65).

4. If the gap between the ends of the ring is below specifications, remove the ring and try another for fit.

5. Fit each compression ring to the cylinder in which it is going to be used.

6. If the pistons have not been cleaned and inspected as previously outlined, do so.

7. Slip the outer surface of the top and second compression ring into the respective piston ring groove and roll the ring entirely around the groove (Fig. 6A-66) to make sure that the ring is free. If binding occurs at any point the cause should be determined, and if caused by ring groove, remove by dressing with a fine cut file. If the binding is caused by a distorted ring, check a new ring.

8. Install piston rings as follows (fig. 6A-67).

NOTE: Tools J-8020 (3-9/16"), J-8021 (3-7/8"), J-8032 (4"), J-22249 (3-15/16"), J-22147 (4-3/32"),

and (J-22250 (4-1/4")) are available for this purpose.

a. Install oil ring spacer in groove and insert anti-rotation tang in oil hole.

b. Hold spacer ends butted and install lower steel oil ring rail with gap properly located.

c. Install upper steel oil ring rail with gap properly located.

d. Flex the oil ring assembly to make sure ring is free. If binding occurs at any point, the cause should be determined, and if caused by ring groove, remove by dressing groove with a fine cut file. If binding is caused by a distorted ring, check a new ring.

e. Install second compression ring expander then ring with gaps properly located.

f. Install top compression ring with gap properly located.

9. Proper clearance of the piston ring in its piston ring groove is very important to provide proper ring action and reduce wear. Therefore, when fitting new rings, the clearances between the surfaces of the ring groove should be measured (fig. 6A-68). (See Specifications.)

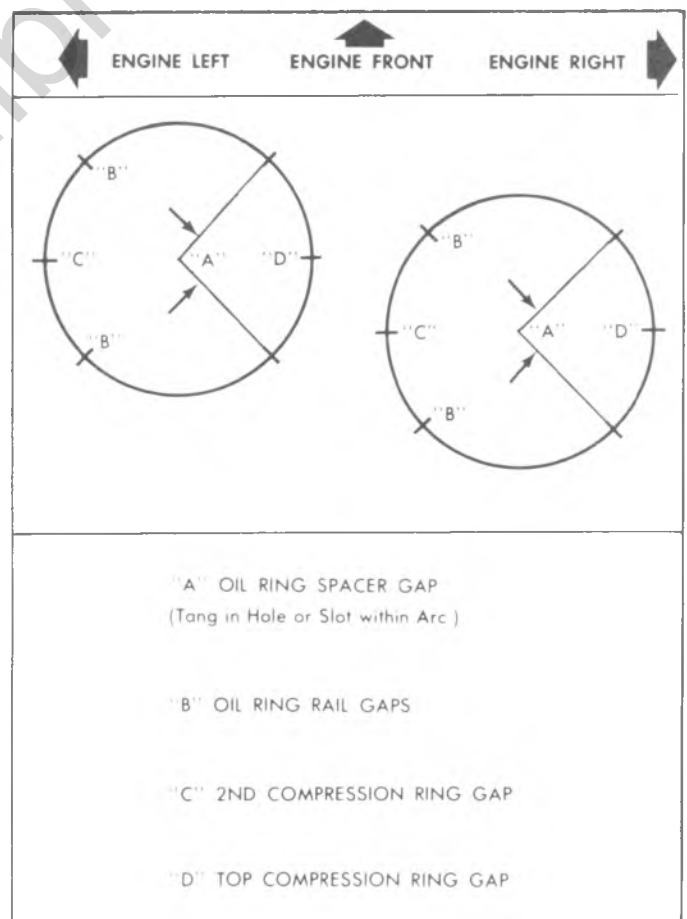


Fig. 6A-67--Ring Gap Location



Fig. 6A-68--Measuring Ring Groove Clearance



Fig. 6A-70--Installing Connecting Rod and Piston Assembly

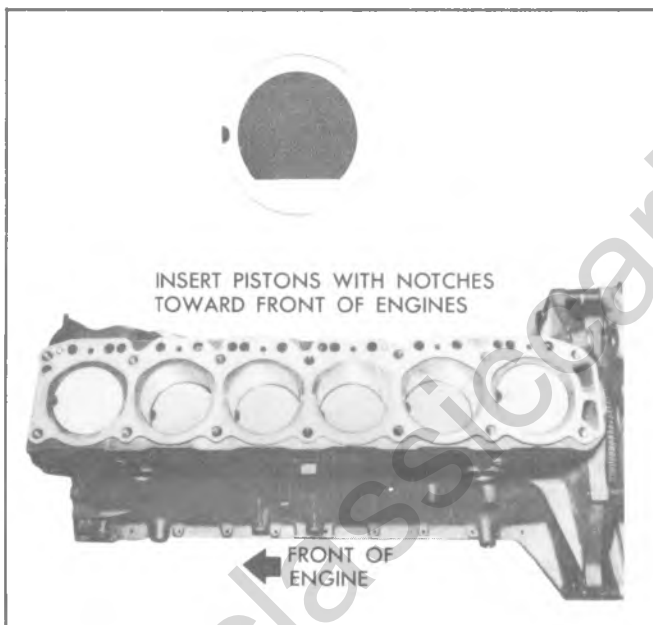


Fig. 6A-69--Pistons - Installed Position

Installation

NOTE: Cylinder bores must be clean before piston installation. This may be accomplished with a hot water and detergent wash or with a light honing as necessary. After cleaning, the bores should be swabbed several times with light engine oil and a clean dry cloth.

1. Lubricate connecting rod bearings and install in rods and rod caps.
2. Lightly coat pistons, rings and cylinder walls with light engine oil.

3. With bearing caps removed, install Tool J-5239 (3/8") or J-6305 (11/32") on connecting rod bolts.

CAUTION: Be sure ring gaps are properly positioned as previously outlined.

4. Install each connecting rod and piston in its respective bore. Pistons must have notches facing front of engine (fig. 6A-69).

Use Tool J-8037 to compress the rings (fig. 6A-70). Guide the connecting rod into place on the crankshaft journal with Tool J-5239 (3/8") or J-6305 (11/32"). Use a hammer handle and light blows to install the piston into the bore. Hold the ring compressor firmly against the cylinder block until all piston rings have entered the cylinder bore.

5. Remove Tool J-5239 or J-6305.
6. Install the bearing caps and torque nuts to specifications.

NOTE: If bearing replacement is required refer to "Connecting Rod Bearings".

Be sure to install new pistons in the same cylinders for which they were fitted, and used pistons in the same cylinder from which they were removed. If a connecting rod is ever transposed from one block or cylinder to another, new bearings should be fitted and the connecting rod should be numbered to correspond with the new cylinder number.

ENGINE ASSEMBLY

Removal

1. Remove Hood.
2. Disconnect battery cables at battery.
3. Remove air cleaner.
4. Drain radiator and block.

5. Disconnect radiator and heater hoses and remove radiator and fan shroud.
6. Disconnect wires at:
 - Starter Solenoid
 - Delcotron
 - Temperature switch
 - Oil Pressure Switch
 - Coil
7. Disconnect:
 - Accelerator linkage at inlet manifold.
 - Fuel line, from tank, at fuel pump.
 - Hoses at fuel vapor storage canister (if applicable).
 - Vacuum line to power brake unit at manifold, if so equipped.
8. Remove power steering pump and lay aside, if so equipped.
9. Raise vehicle on hoist.
10. Drain crankcase.
11. Disconnect exhaust pipe at manifold and, if so equipped, converter bracket at transmission rear mount.
12. Remove starter.
13. Remove flywheel splash shield or converter housing cover as applicable.
14. On vehicles with automatic transmissions, remove converter to flywheel attaching bolt.
15. Remove mount "through" bolts.
16. Remove bell housing bolts.
17. Lower vehicle on hoist.
18. Raise transmission using floor jack.
19. Attach engine lifting devices, raise engine.
20. Remove motor mount to engine brackets.
21. Remove engine assembly.

Installation

1. Position engine assembly in vehicle.
2. Attach motor mount to engine brackets and lower engine in place.
3. Remove engine lifting device.
4. Remove transmission floor jack.
5. Raise vehicle on hoist.
6. Install mount "through" bolts. Torque to specification.
7. Install bell housing bolts. Torque to specifications.
8. On vehicles with automatic transmissions, install converter to flywheel attaching bolts. Torque to specification.
9. Install flywheel splash shield or converter housing cover as applicable. Torque attaching bolts to specifications.
10. Install starter.
11. Connect exhaust pipe at manifold and converter bracket at transmission rear mount.
12. Lower vehicle on hoist.
13. Reinstall power steering pump, if so equipped.
14. Connect:
 - Accelerator linkage at inlet manifold.
 - Fuel line, from tank, at fuel pump.
 - Hoses at fuel vapor storage canister.

• Vacuum line to power brake unit at manifold, if equipped.

15. Connect wires at:
 - Starter Solenoid
 - Delcotron
 - Temperature Switch
 - Oil Pressure Switch
 - Coil

16. Install radiator and fan shroud and reconnect radiator and heater hoses.

17. Fill cooling system.

18. Fill crankcase with oil. See owner's manual for specifications.

19. Install air cleaner.

20. Install hood.

21. Connect battery cables.

NOTE: To avoid possible arcing of battery, connect positive battery cable first.

22. Start engine, check for leaks and check timing.

CRANKSHAFT

Removal

1. Remove engine as previously outlined. Remove clutch, if applicable, and flywheel and mount engine on stand.
2. Remove the oil dipstick and oil dipstick tube.
3. Remove the spark plugs.
4. Remove crankshaft pulley and torsional damper.
5. Remove oil pan and oil pump.
6. Remove crankcase front cover.
7. Check the connecting rod caps for cylinder number identification. If necessary, mark them.
8. Remove the connecting rod caps and push the pistons to the top of bores.
9. Remove main bearing caps and lift crankshaft out of cylinder block.
10. Remove rear main bearing oil seal and main bearings from cylinder block and main bearing caps.

Cleaning and Inspection

1. Wash crankshaft in solvent and dry with compressed air.
2. Measure dimensions of main bearing journals and crankpins with a micrometer for out-of-round, taper or undersize. (See Specifications.)
3. Check crankshaft for run-out of supporting at the front and rear main bearings journals in "V" blocks and check at the front and rear intermediate journals with a dial indicator. (See Specifications.)
4. Replace or recondition the crankshaft if out of specifications.

Gear Replacement

Remove crankshaft gear using Tool J-8105 and install using Tool J-5590 (fig. 6A-71).

Installation

1. Install rear main bearing oil seal in cylinder

block and rear main bearing cap grooves. Install with lip of seal toward front of engine. Where seal has two lips install lip and helix towards front of engine.

2. Lubricate lips of seal with engine oil. Keep oil off parting line surface.

3. Install main bearings in cylinder block and main bearing caps then lubricate bearing surface with engine oil.

4. Install crankshaft, being careful not to damage bearing surfaces.

5. Apply a thin coat of brush-on type oil sealing compound to block mating surface and corresponding surface of cap only (fig. 6A-22). Do not allow sealer on crankshaft or seal.

6. Install main bearing caps with arrows pointing toward front of engine.

7. Torque all except rear main bearing cap bolts to

specifications. Torque rear main bearing cap bolts to 10-12 ft. lbs. then tap end of crankshaft, first rearward then forward with a lead hammer. This will line up rear main bearing and crankshaft thrust surfaces. Retorque all main bearing cap bolts to specifications.

8. Measure crankshaft end play with a feeler gauge. Force crankshaft forward and measure clearance between the front of the rear main bearing and the crankshaft thrust surface.

9. Install flywheel and torque to specifications. A wood block placed between the crankshaft and cylinder block will prevent crankshaft from rotating.

NOTE: Align dowel hole in flywheel with dowel hole in crankshaft. On vehicles equipped with automatic transmissions, install flywheel with the converter attaching pads towards transmission.

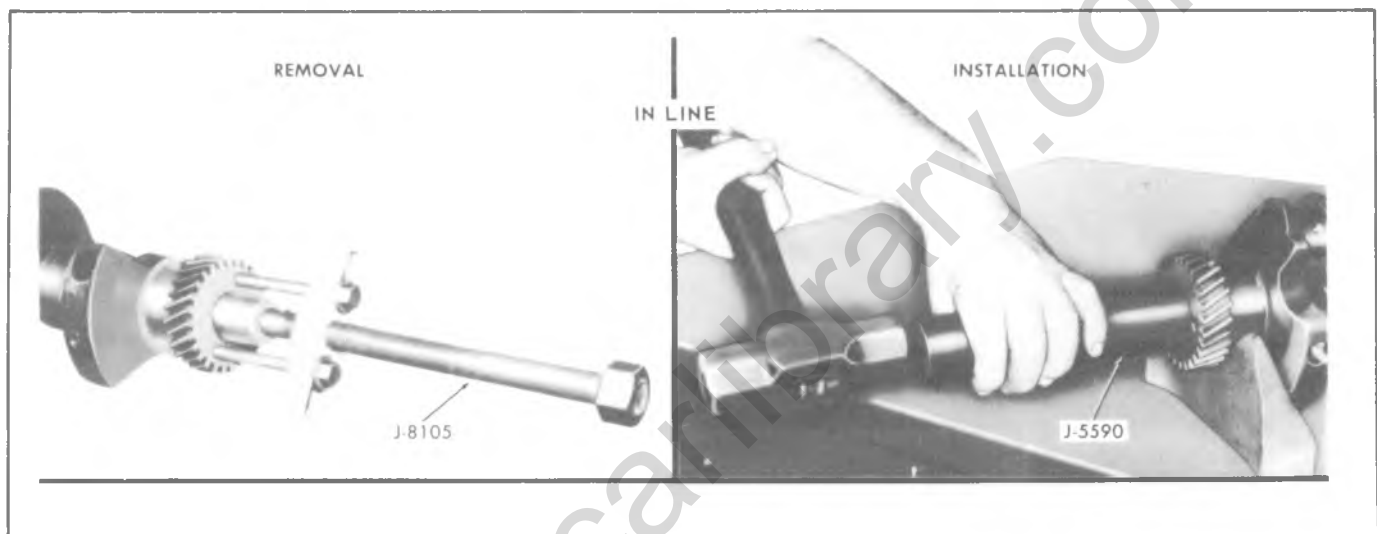


Fig. 6A-71--Gear Replacement

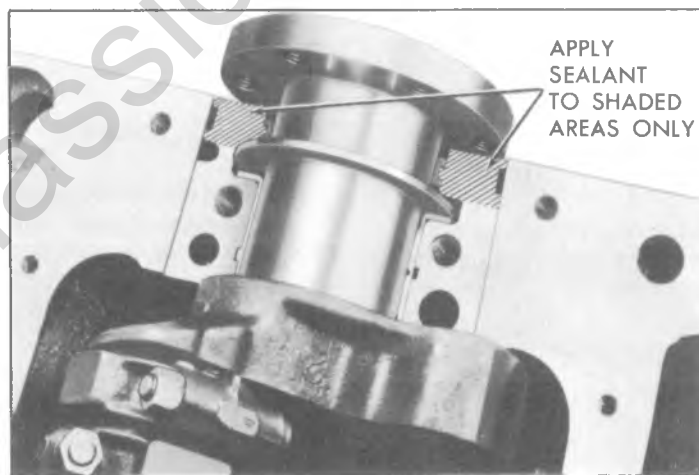


Fig. 6A-72--Sealing Bearing Cap

8 Cylinder Engine

Contents

General Description	6A-43	Valves	6A-64
Engine Lubrication	6A-44	Torsional Damper	6A-64
On Vehicle Service	6A-44	Crankcase Front Cover	6A-65
Engine Mounts	6A-44	Oil Seal (Front Cover)	6A-66
Intake Manifold	6A-53	Camshaft	6A-67
Exhaust Manifold	6A-53	Camshaft Bearings	6A-68
Rocker Arm Cover	6A-54	Oil Pan	6A-70
Valve Mechanism	6A-55	Oil Pump	6A-70
Valve Stem Oil Seal and/or		Connecting Rod Bearings	6A-72
Valve Spring	6A-56	Main Bearings	6A-72
Valve Lifters	6A-57	Oil Seal (Rear Main)	6A-75
Cylinder Head Assembly	6A-59	Connecting Rod Piston Asemblies	6A-76
Rocker Arm Studs	6A-62	Engine Assembly	6A-80
Valve Guide Bores	6A-63	Crankshaft	6A-81
Valve Seats	6A-63	Sprocket or Gear Replacement	6A-81

GENERAL DESCRIPTION

CYLINDER BLOCK

The cylinder block is made of cast iron and has 8 cylinders arranged in a "V" shape with 4 cylinders in each bank. Five main bearings support the crankshaft which is retained by bearing caps that are machined with the block for proper alignment and clearances. Cylinders are completely encircled by coolant jackets.

CYLINDER HEAD

The cast iron cylinder heads provide a compression ratio of 8.5:1. They are cast with individual intake and exhaust ports for each cylinder. Valve guides are integral, and rocker arms are retained on individual studs.

CRANKSHAFT AND BEARINGS

The crankshaft is cast nodular iron and is supported by five main bearings. Number five bearing is the end thrust bearing.

Main bearings are lubricated from oil holes which intersect the camshaft bearings. The camshaft bearings are fed oil by the main oil gallery which is rifle drilled down the center of the block, above the camshaft. Two additional oil galleries are on either side of the main oil gallery to provide an oil supply for the hydraulic lifters.

A torsional damper on the forward end of the crankshaft dampens any engine torsional vibrations.

CAMSHAFT AND DRIVE

The cast iron camshaft is supported by five bearings and is chain driven. A steel crankshaft gear drives the

timing chain which in turn drives the camshaft through a bakelite fabric composition gear with steel hub.

Cam lobes are ground, hardened and tapered with the high side toward the rear. This, coupled with a spherical face on the lifter, causes the valve lifters to rotate.

Camshaft bearings are lubricated through oil holes which intersect the main oil gallery. The main oil gallery is rifle drilled down the center of the block, above the camshaft.

PISTONS AND CONNECTING RODS

The pistons are made of cast aluminum alloy using two compression rings and one oil control ring. Piston pins are offset 1/16" toward the thrust side (right hand side) to provide a gradual change in thrust pressure against the cylinder wall as the piston travels its path. Pins are Chromium steel and have a floating fit in the pistons. They are retained in the connecting rods by a press fit.

Connecting rods are made of forged steel. Full pressure lubrication is directed to the connecting rods by drilled oil passages from the adjacent main bearing journal. Oil holes at the connecting rod journals are located so that oil is supplied to give maximum lubrication just prior to full bearing load.

VALVE TRAIN

A very simple ball pivot-type train is used. Motion is transmitted from the camshaft through the hydraulic lifter and push rod to the rocker arm. The rocker arm

pivots on its ball and transmits the camshaft motion to the valve. The rocker-arm ball is retained by a nut.

HYDRAULIC VALVE LIFTERS

Hydraulic Valve Lifters are used to keep all parts of the valve train in constant contact.

The hydraulic lifter assembly consists of: the lifter body, which rides in the cylinder block boss, a plunger, a push rod seat, a metering valve, a plunger spring, a check ball and spring, a check ball retainer and a push rod seat retainer.

When the lifter is riding on the low point of the cam, the plunger spring keeps the plunger and push rod seat in contact with the push rod.

When the lifter body begins to ride up the cam lobe, the check ball cuts off the transfer of oil from the reservoir below the plunger. The plunger and lifter body then rise as a unit, pushing up the push rod and opening the valve.

As the lifter body rides down the other side of the cam, the plunger follows with it until the valve closes. The lifter body continues to follow the cam to its low point, but the plunger spring keeps the plunger in contact with the push rod. The ball check valve will then move off its seat and the lifter reservoir will remain full.

INTAKE MANIFOLD

The intake manifold is of cast iron double level design for efficient fuel distribution. The carburetor pad is centrally located with a passage running underneath the pad (E.F.E.) through which exhaust gases are forced to promote faster fuel vaporization when the engine is cold. An EGR port is also cast into the manifold for the mixture of exhaust gases with the fuel air mixture.

EXHUAUST MANIFOLDS

Two cast iron exhaust manifolds are used to direct exhaust gases from the combustion chambers to the exhaust system. The right hand side manifold receives a heat shield that is used to route heated air to the air cleaner for better fuel vaporization.

COMBUSTION CHAMBERS

Combustion Chambers are cast to insure uniform shape for all cylinders. Spark plugs are located between the intake and exhaust valves.

The contoured wedge shape of the combustion chamber minimizes the possibility of detonation, facilitates breathing and provides swirling turbulence for smooth, complete combustion.

ENGINE LUBRICATION

Full pressure lubrication through a full flow oil filter, is furnished by a gear-type oil pump. The distributor, driven by a helical gear on the camshaft, drives the oil pump. The main oil gallery feeds oil, through drilled passages, to the camshaft and crankshaft

to lubricate the bearings. The valve lifter oil gallery feeds the valve lifters which, through hollow push rods, feed the individually mounted rocker arms (fig. 6A-1V and 6A-2V).

ON VEHICLE SERVICE

ENGINE MOUNTS

Engine mounts (fig. 6A-3V - 6A-8V) are the non-adjustable type and seldom require service. Broken or deteriorated mounts should be replaced immediately, because of the added strain placed on other mounts and drive line components.

Checking Engine Mounts

Front Mount

Raise the engine to remove weight from the mounts and to place a slight tension in the rubber. Observe both mounts while raising engine. If an engine mount exhibits:

- a. Hard rubber surface covered with heat check cracks;
- b. Rubber separated from a metal plate of the mount; or

- c. Rubber split through center

Replace the mount. If there is relative movement between a metal plate of the mount and its attaching points, lower the engine on the mounts and tighten the screws or nuts attaching the mount to the engine, frame, or bracket.

Rear Mount

Raise the vehicle on a hoist. Push up and pull down on the transmission tailshaft while observing the transmission mount. If the rubber separates from the metal plate of the mount or if the tailshaft moves up but not down (mount bottomed out) replace the mount. If there is relative movement between a metal plate of the mount and its attaching point, tighten the screws or nuts attaching the mount to the transmission or crossmember.

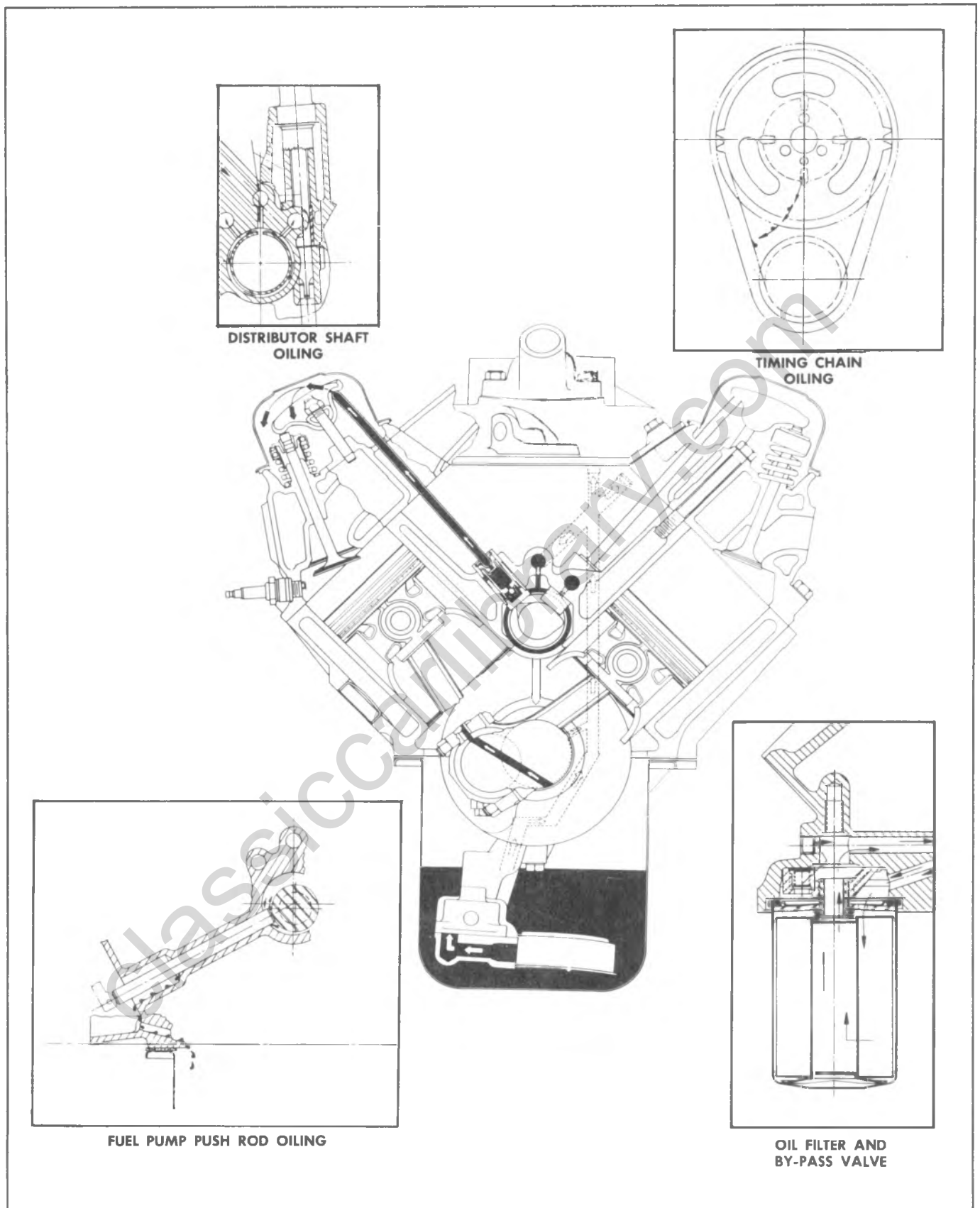


Fig. 6A-1V--"Small V-8" Engine Lubrication

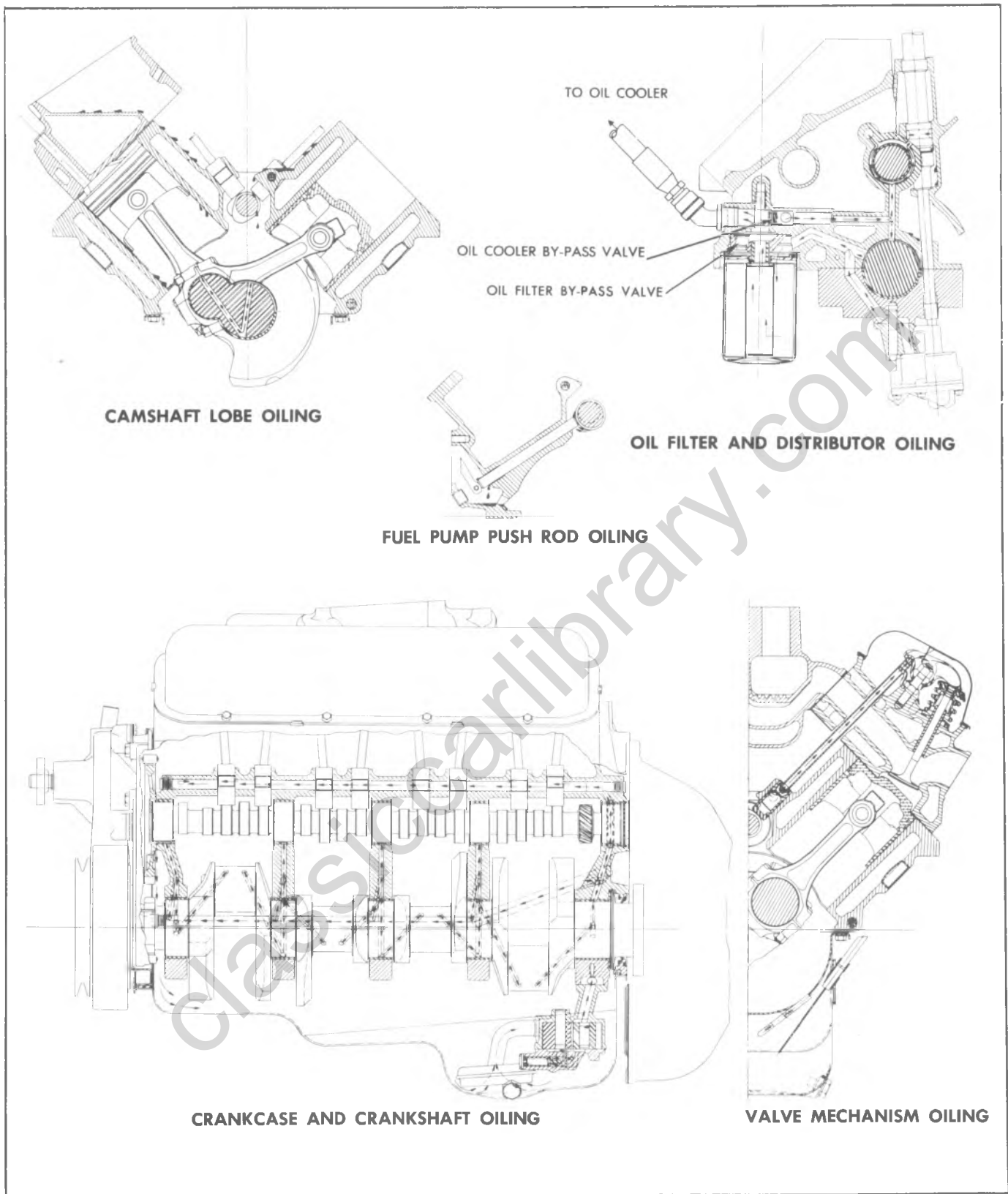


Fig. 6A-2V--"Mark IV" Engine Lubrication

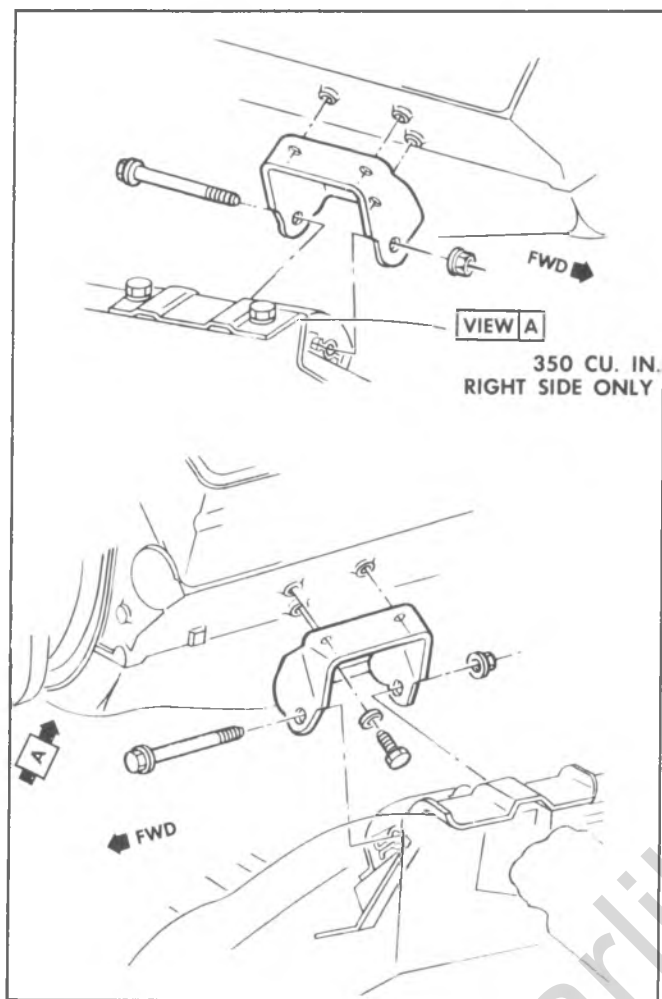


Fig. 6A-3V-'P' Series Engine Mount Bracket

Front Mount Replacement

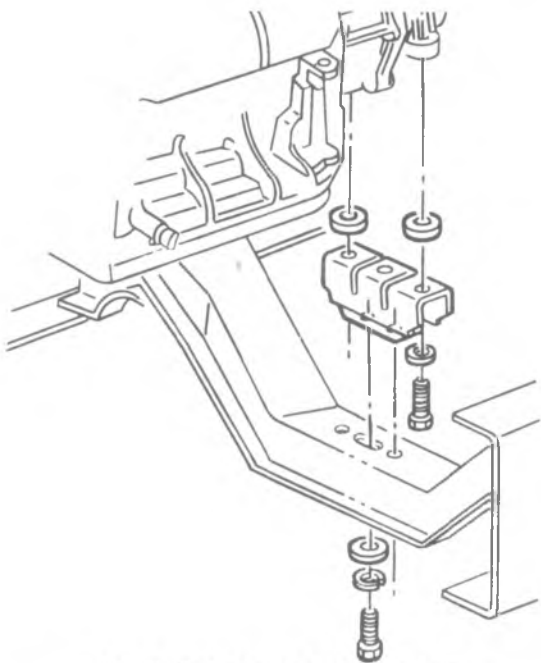
1. Remove mount retaining bolt from below frame mounting bracket.
2. Raise front of engine and remove mount-to-engine bolts and remove mount.

CAUTION: Raise engine only enough for sufficient clearance. Check for interference between rear of engine and cowl panel.

3. Replace mount to engine and lower engine into place.
4. Install retaining bolt and torque all bolts to specifications.

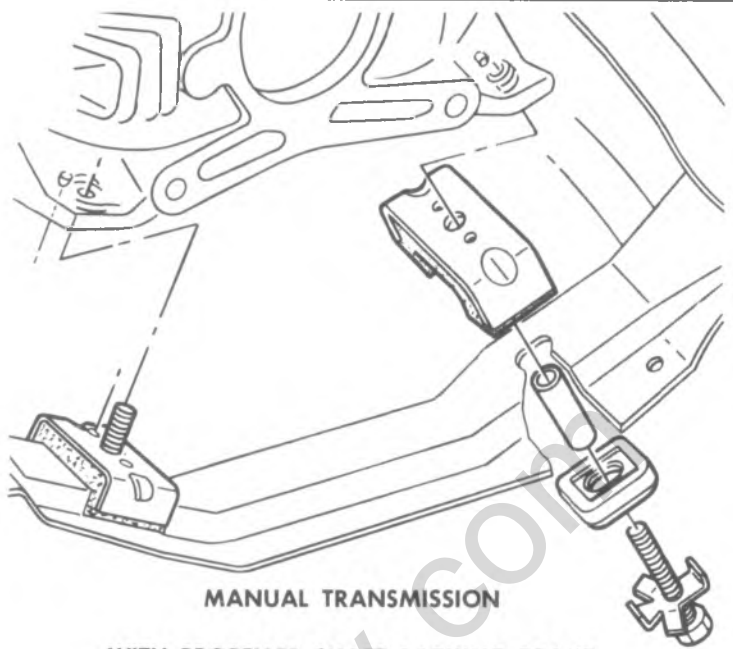
Rear Mount Replacement

1. Support engine weight to relieve rear mounts.
2. Remove crossmember-to-mount bolts.
3. On P Series with manual transmission and propeller shaft parking brake, remove mount attaching bolts from frame outrigger and clutch housing and remove rear mounting cushions.



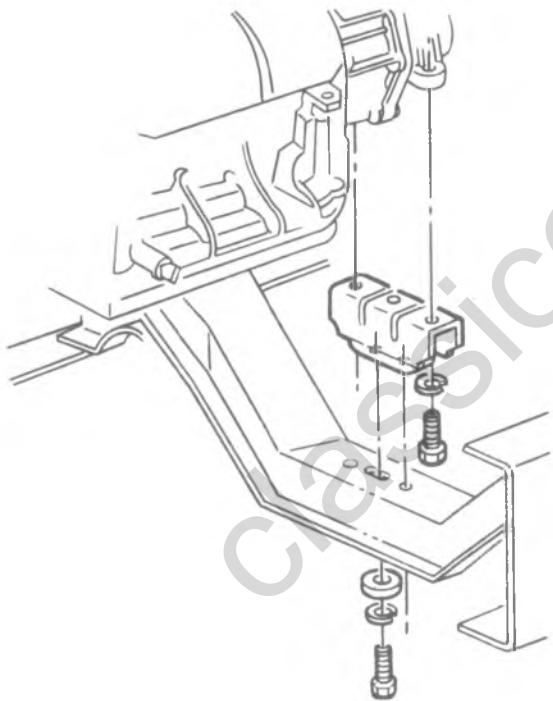
ALL TURBO HYDRA-MATIC 400
(EXCEPT MOBILE HOME CHASSIS)

WITHOUT PROPELLER SHAFT PARKING BRAKE



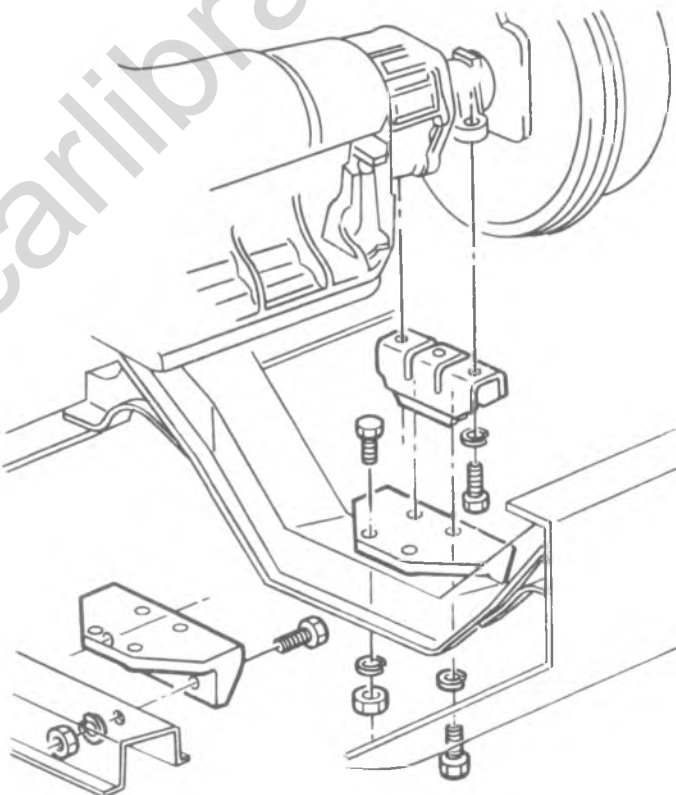
MANUAL TRANSMISSION

WITH PROPELLER SHAFT PARKING BRAKE



ALL MANUAL TRANSMISSION
ALL TURBO HYDRA-MATIC 350
ALL MOBILE HOME CHASSIS

WITHOUT PROPELLER SHAFT PARKING BRAKE



AUTOMATIC TRANSMISSION

WITH PROPELLER SHAFT PARKING BRAKE

Fig. 6A-4V--"P" Series Engine Rear Mount

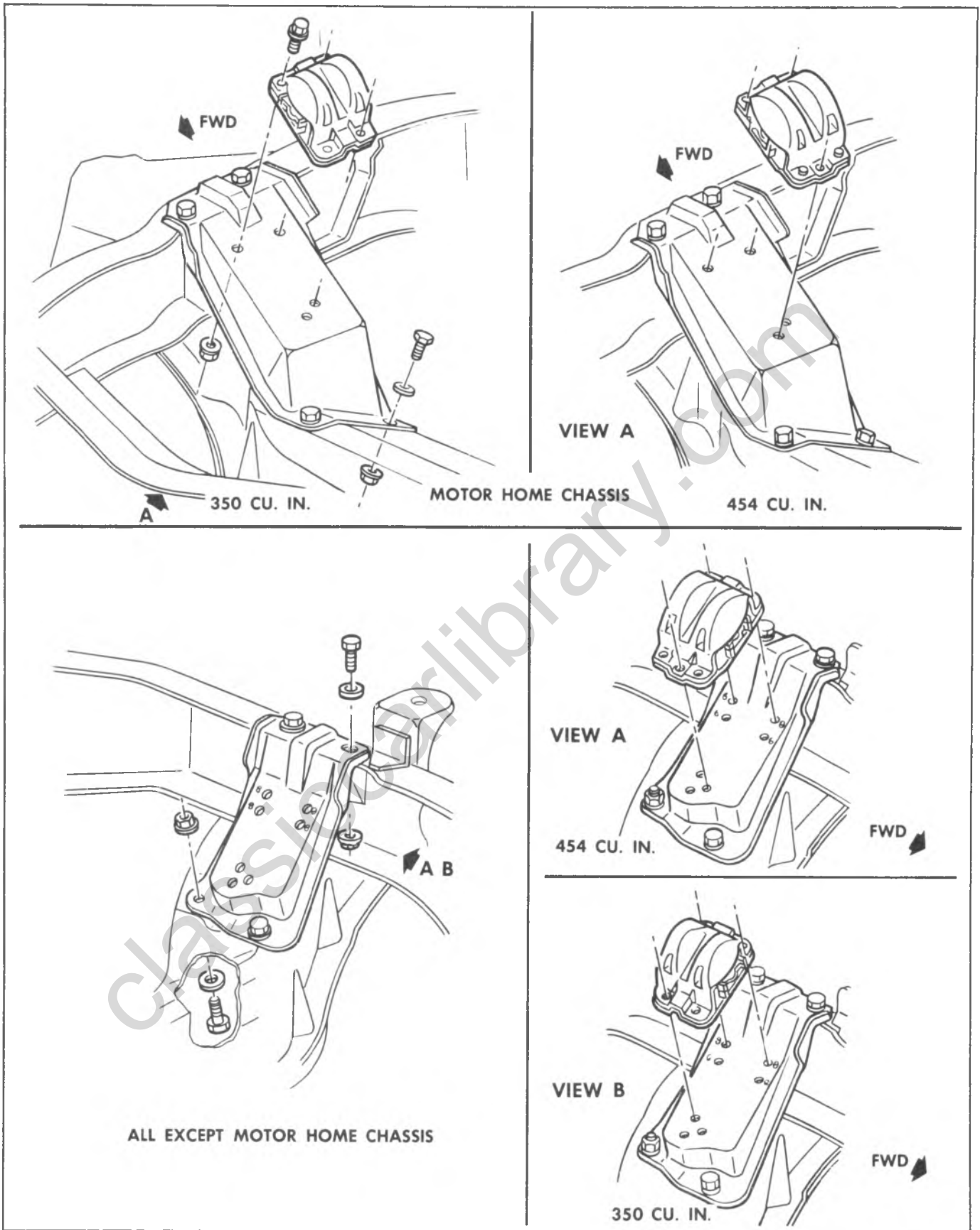


Fig. 6A-5V--"P" Series Engine Front Mount

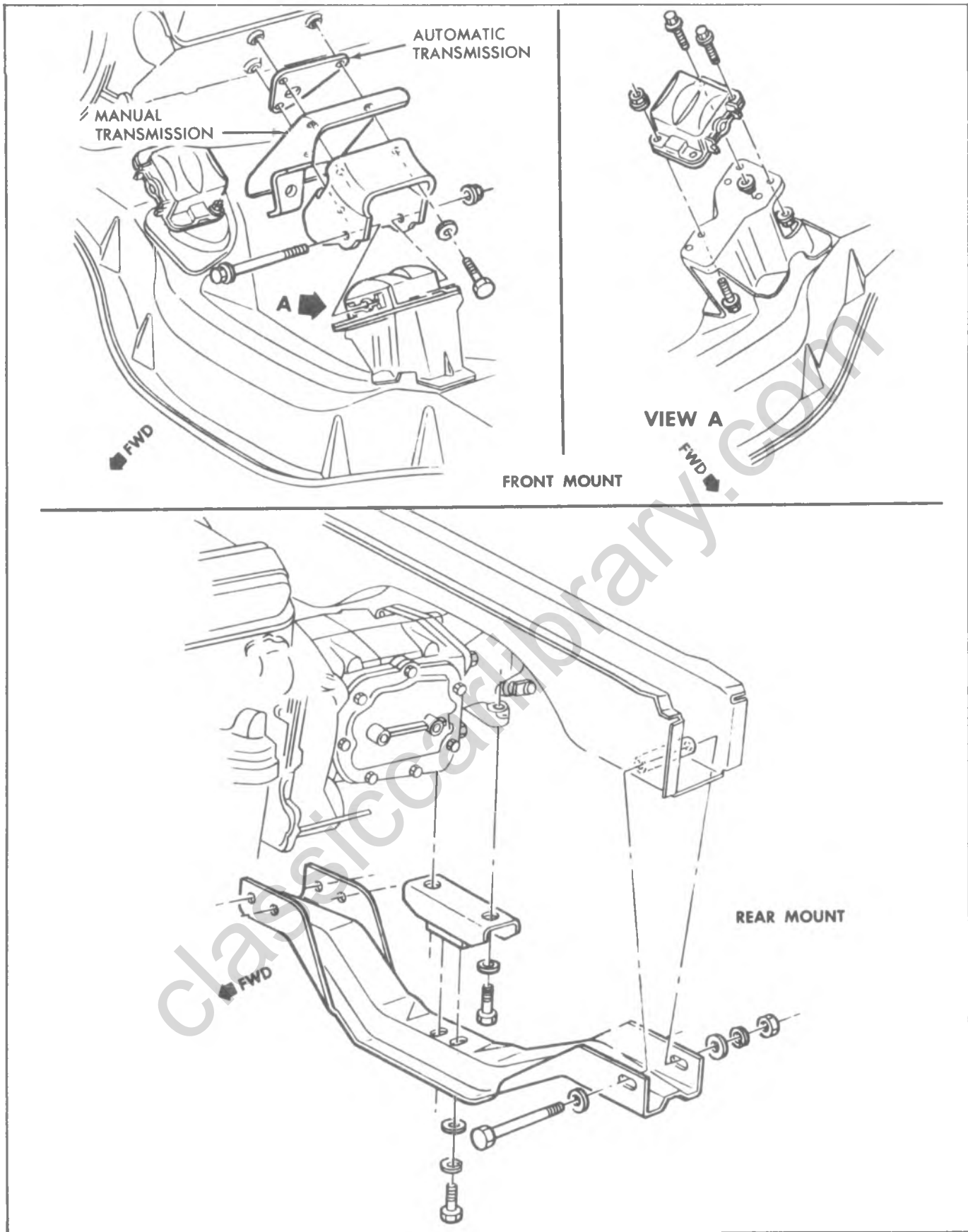


Fig. 6A-6V-"G" Series Engine Mounts

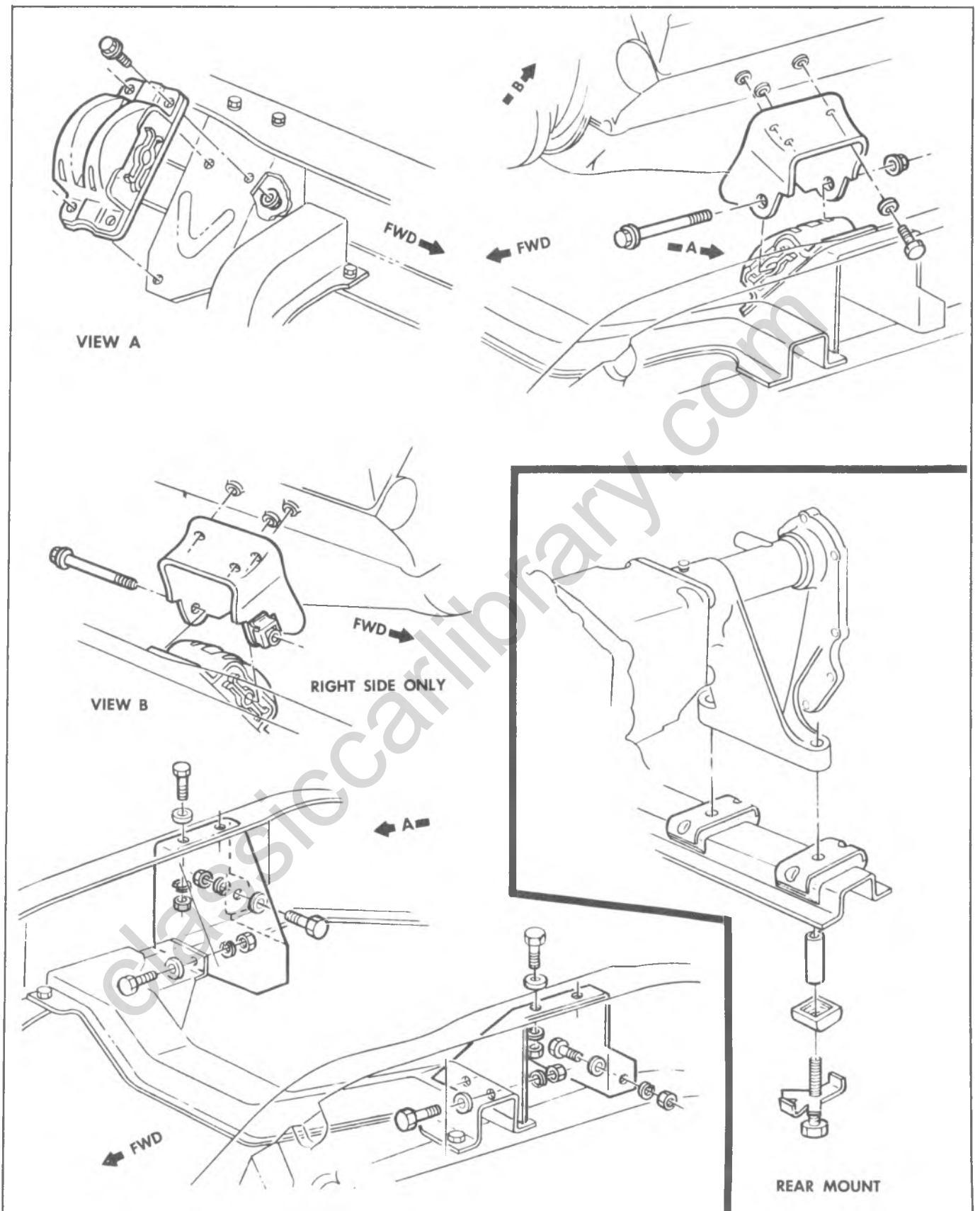


Fig. 6A-7V--"K" Series Engine Mounts

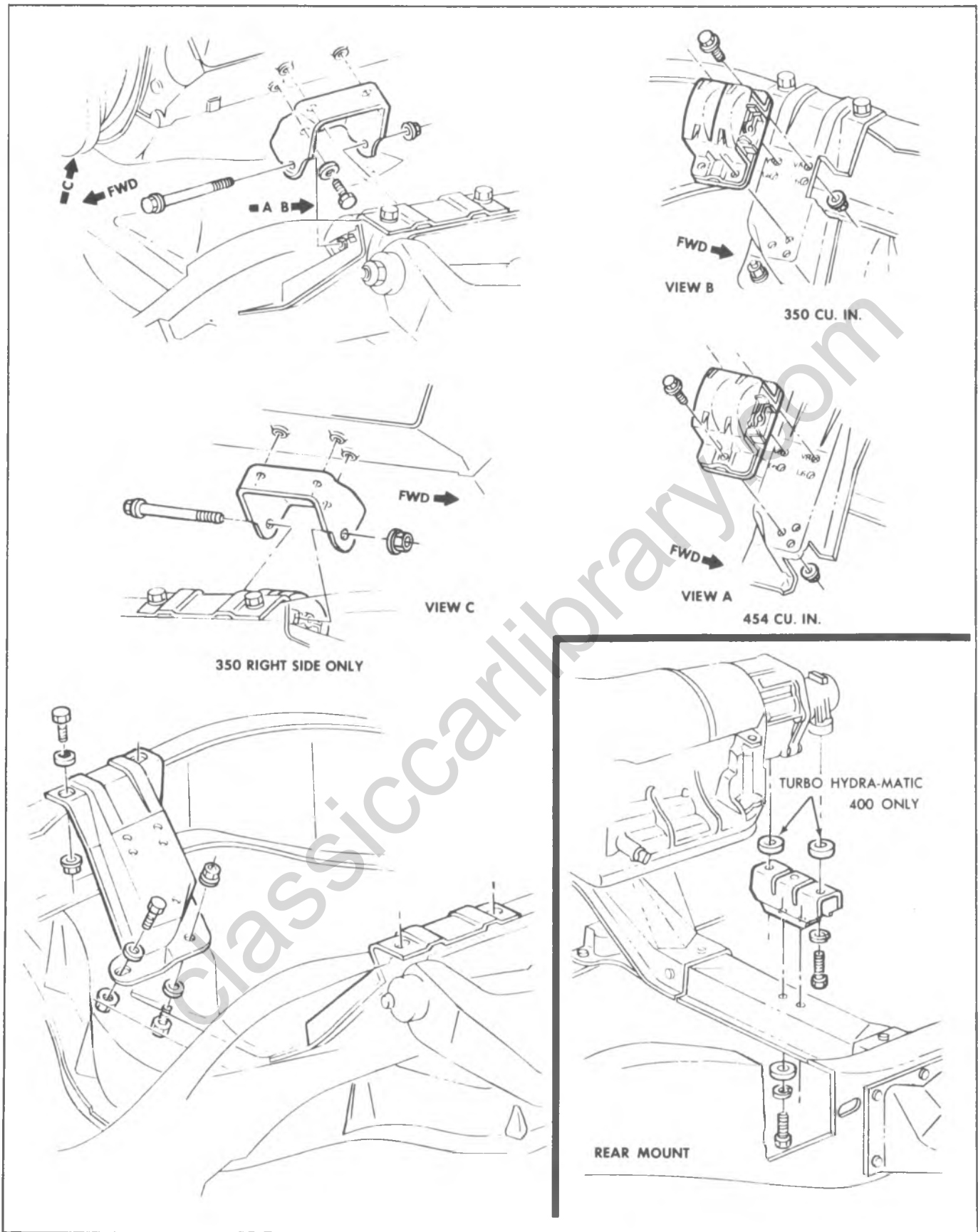


Fig. 6A-8V--"C" Series Engine Mounts

4. Remove mount-to-transmission bolts, then remove mount.

5. On P Series with manual transmission and propeller shaft parking brake, install new mounting cushions and bolts.

6. Install new mount on transmission.

7. While lowering transmission, align and start crossmember-to-mount bolts.

8. Torque bolts to specifications then bend lock tabs to bolt head as applicable.

INTAKE MANIFOLD

Removal

1. Drain radiator and remove air cleaner.
2. Disconnect:
 - Battery negative cable at battery.
 - Radiator upper hose and heater hose at manifold.
 - Water pump by-pass at water pump (Mark IV only).
 - Accelerator linkage at carburetor.
 - Fuel line at carburetor.
 - Crankcase ventilation lines.
 - Spark advance hose at distributor.
3. Remove distributor cap and mark rotor position with chalk, then remove distributor.
4. Remove (as required) air cleaner bracket, air compressor and bracket, accelerator return spring and bracket, and accelerator bellcrank.
5. Remove generator upper mounting bracket.
6. Remove manifold attaching bolts, then remove manifold and carburetor as an assembly. Discard gaskets and seals.
7. If manifold is to be replaced, transfer:
 - Carburetor and carburetor attaching bolts.
 - Temperature sending unit.
 - Thermostat with housing (use new gasket).
 - Heater hose and water pump by-pass adapters.
 - EGR Valve (use new gasket) (if applicable).
 - TVS switch (if applicable).
 - Vacuum fitting(s).
 - Choke spring assembly (where applicable).

Installation

1. Clean gasket and seal surfaces on manifold, block, and cylinder heads.
2. Install manifold seals on block and gaskets on cylinder heads (fig. 6A-9V). Use sealer at water passages and where seals butt to gaskets.
3. Install manifold and torque bolts to specifications in the sequence outlined in fig. 6A-10V.
4. Install (if removed) air cleaner bracket, air compressor and bracket, accelerator bellcrank.
5. Install distributor, positioning rotor at chalk mark, then install distributor cap.
6. Connect:
 - Spark advance hose at distributor.
 - Crankcase ventilation lines.

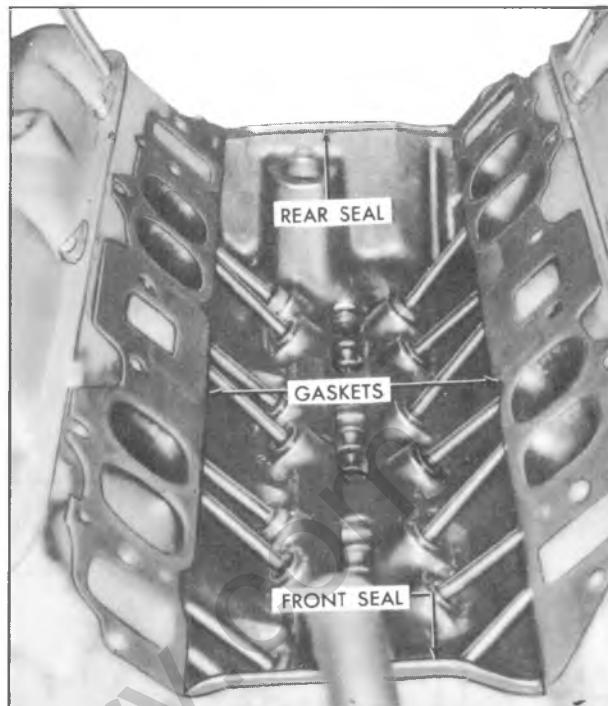


Fig. 6A-9V--Intake Manifold Gasket Seal Location

- Fuel line at carburetor.
 - Accelerator linkage at carburetor.
 - Water pump by-pass at water pump (Mark IV only).
 - Battery negative cable at battery.
7. Install air cleaner.
 8. Fill with coolant, start engine, adjust ignition timing and carburetor idle speed and check for leaks.

EXHAUST MANIFOLD

Removal

1. Remove carburetor heat stove pipe.
2. On Small V8 engine, remove the spark plug wiring heatshields.
3. On Mark IV V8 engine, remove spark plugs.
4. Disconnect exhaust pipe from manifold and hang exhaust pipe from frame with wire.
5. Remove end bolts then remove center bolts and remove manifold.

Installation

NOTE: If installing a new right side manifold, the carburetor heat stove must be transferred from the old unit (fig. 6A-11V 6V-12V).

1. Clean mating surfaces on manifold and head, then install manifold in position and install bolts (fingertight).
2. Torque manifold bolts to specifications in the sequence shown on torque chart at end of section.
3. Connect exhaust pipe to manifold. Use new gasket or packing.

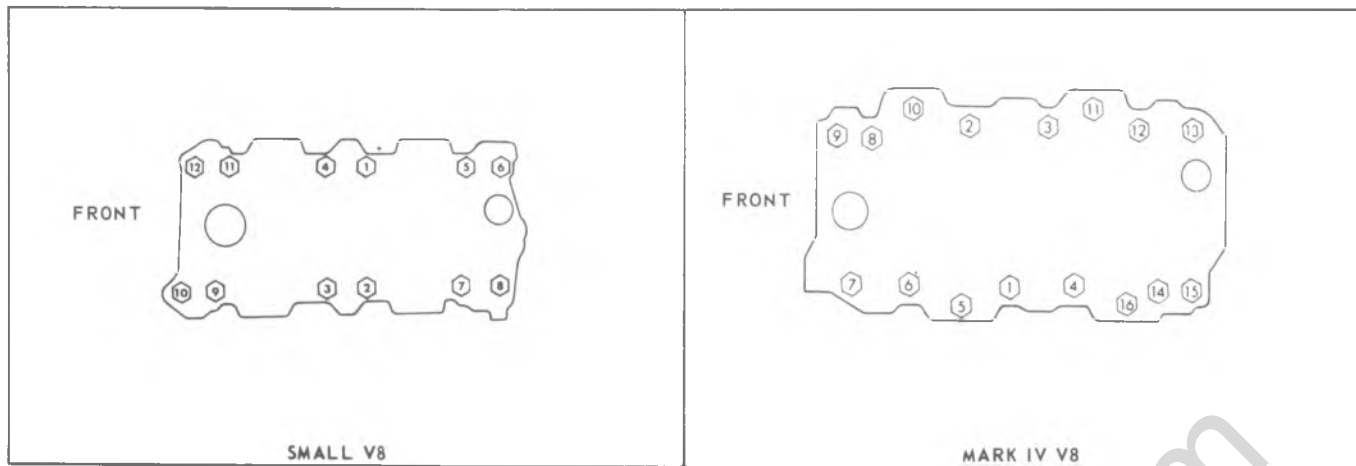


Fig. 6A-10V-Intake Manifold Torque Sequence

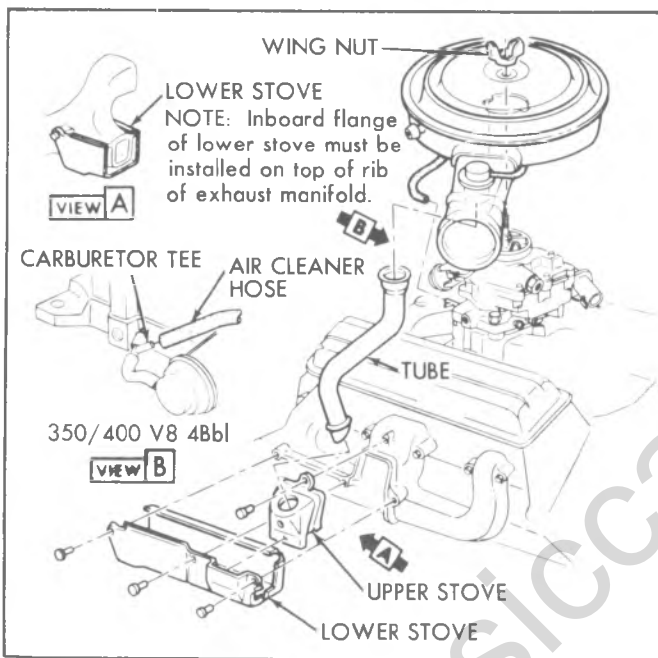


Fig. 6A-11V-Carburetor Heat Stove Assembly—Small V-8

4. On Mark IV V8 engines, install spark plugs. Torque plugs to specifications.
5. Install carburetor heat stove pipe.
6. On Small V8 engine, install spark plug wiring heatshields.
7. Start engine and check for leaks.

ROCKER ARM COVER

Removal (All)

1. Remove air cleaner.
2. Disconnect crankcase ventilation hoses at rocker arm covers.

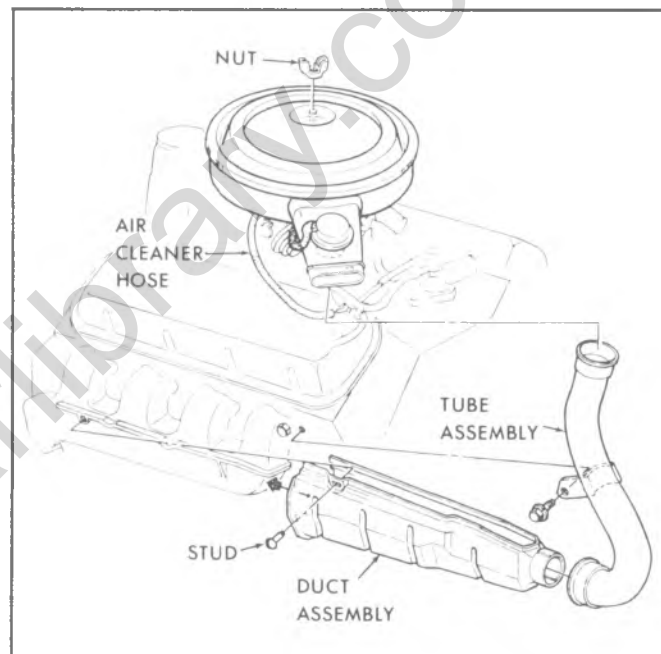


Fig. 6A-12V-Carburetor Heat Stove Assembly—Mark IV

3. Disconnect electrical wiring harness from rocker arm clips.
4. Remove carburetor heat stove pipe from right exhaust manifold.
5. If the vehicle is equipped with air conditioning, remove the A/C compressor rear brace on small V-8 (fig. 6A-13V) or upper brace on Mark IV (fig. 6A-14V).
6. Remove rocker arm cover to head attaching bolts and remove rocker arm cover.

CAUTION: Do not pry rocker arm cover loose. Gaskets adhering to cylinder head and rocker arm cover may be sheared by bumping front

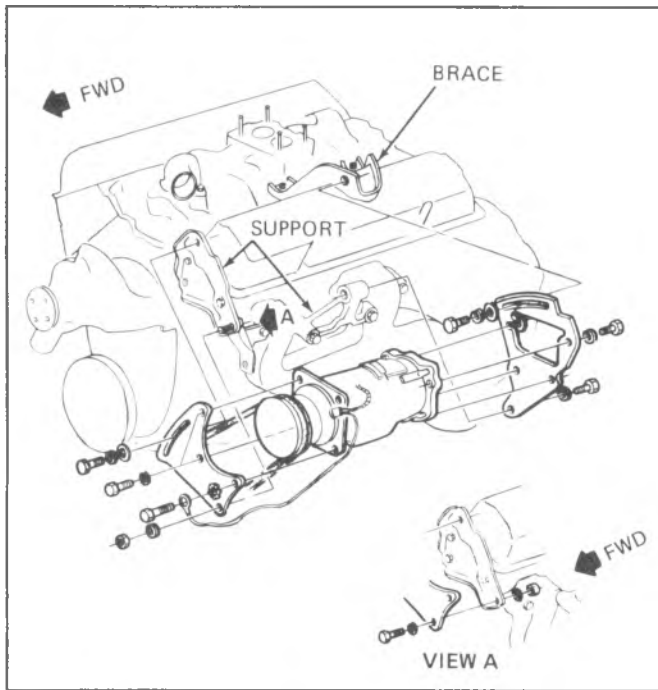


Fig. 6A-13V-A/C Compressor mounting—Small V-8

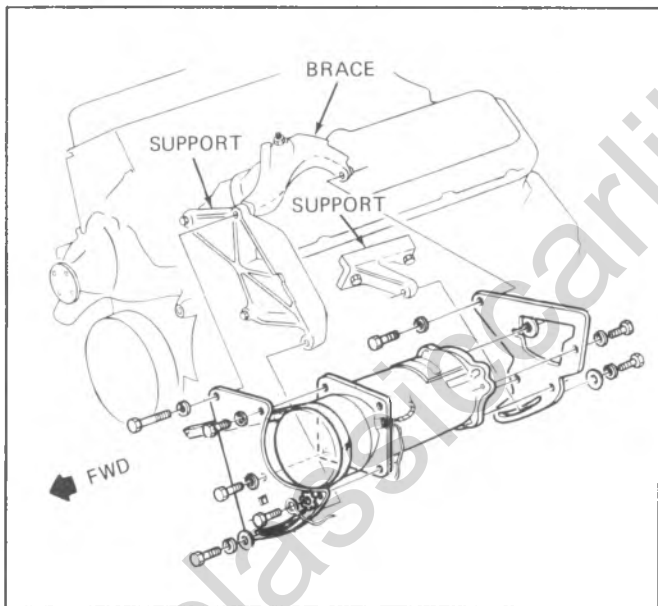


Fig. 6A-14V-A/C Compressor mounting—Mark IV

end of rocker arm cover rearward with palm of hand or a rubber mallet.

Installation (Small V-8)

1. Clean gasket surfaces on cylinder head and rocker arm cover with degreaser then, using a new gasket, place rocker arm cover on the head, install retaining bolts and torque to specifications.
2. On A/C equipped vehicles, install the A/C compressor rear brace. Adjust pulley belt to specifications.
3. Install carburetor heat stove pipe.

4. Connect electrical wiring harness at clips on rocker arm cover.
5. Connect crankcase ventilation hoses.
6. Install air cleaner, start engine and check for leaks.

Installation (Mark IV)

1. Clean sealing surface on cylinder head with degreaser then, using RTV, place rocker arm cover on the head, install retaining bolts and torque to specification.

NOTE: All loose RTV sealer, or pieces causing installation interference, must be removed from both cylinder head and cover seal surfaces prior to applying new sealer.

A 1/8" bead of RTV sealer should be placed all around the rocker cover sealing surface of the cylinder head. (When going around the attaching bolt holes, always flow the RTV on the inboard side of the holes). Install cover and torque bolts to specification while RTV is wet (within 10 min.).

2. On A/C equipped vehicles, install the A/C compressor upper brace. Adjust pulley belt to specification.
3. Install carburetor heat stove pipe.
4. Connect electrical wiring harness at clips on rocker arm cover.
5. Connect crankcase ventilation hoses.
6. Install air cleaner, start engine and check for leaks.

VALVE MECHANISM

Removal

1. Remove rocker arm covers as previously outlined.
2. Remove rocker arm nuts, rocker arm balls, rocker arms and push rods.

NOTE: Place rocker arms, rocker arm balls and push rods in a rack so they may be reinstalled in the same locations.

Installation and Adjustment

NOTE: Whenever new rocker arms and/or rocker arm balls are being installed, coat bearing surfaces of rocker arms and rocker arm balls with "Molykote" or its equivalent.

1. Install push rods. Be sure push rods seat in lifter socket.
2. Install rocker arms, rocker arm balls and rocker arm nuts. Tighten rocker arm nuts until all lash is eliminated.
3. Adjust valves when lifter is on base circle of camshaft lobe as follows:
 - a. Crank engine until mark on torsional damper lines up with center or "O" mark on the timing tab fastened to the crankcase front cover and the engine is in the number 1 firing position. This may be determined by placing fingers on the number 1 valve as the mark on

the damper comes near the "O" mark on the crankcase front cover. If the valves are not moving, the engine is in the number 1 firing position. If the valves move as the mark comes up to the timing tab, the engine is in number 6 firing position and should be turned over one more time to reach the number 1 position.

b. With the engine in the number 1 firing position as determined above, the following valves may be adjusted.

- Exhaust--1, 3, 4, 8
- Intake--1, 2, 5, 7

c. Back out adjusting nut until lash is felt at the push rod then turn in adjusting nut until all lash is removed. This can be determined by checking push rod side play while turning adjusting nut (fig. 6A-15V). When play has been removed, turn adjusting nut in one full additional turn (to center lifter plunger).

d. Crank the engine one revolution until the pointer "o" mark and torsional damper mark are again in alignment. This is number 6 firing position. With the engine in this position the following valves may be adjusted.

- Exhaust--2, 5, 6, 7
- Intake--3, 4, 6, 8

4. Install rocker arm covers as previously outlined.
5. Start engine and adjust carburetor idle speed.

VALVE STEM OIL SEAL and/or VALVE SPRING

Removal

1. Remove rocker arm cover as previously outlined.

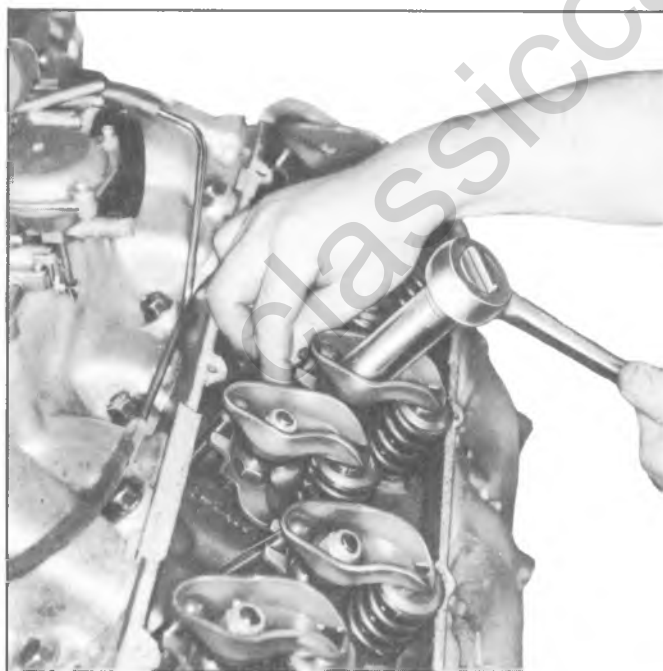


Fig. 6A-15V--Valve Adjustment - Typical

2. Remove spark plug, rocker arm and push rod on the cylinder(s) to be serviced.

3. Install air line adapter Tool J-23590 to spark plug port and apply compressed air to hold the valves in place.

4. Using Tool J-5892 to compress the valve spring, remove the valve locks, valve cap and valve spring and damper (fig. 6A-16V).

5. Remove the valve stem oil seal.

Installation

Small V8 Engines

1. Set the valve spring and damper, valve shield and valve cap in place. Compress the spring with Tool J-5892 and install oil seal in the lower groove of the stem, making sure the seal is flat and not twisted.

NOTE: A light coat of oil on the seal will help prevent twisting.

2. Install the valve locks and release the compressor tool making sure the locks seat properly in the upper groove of the valve stem.

NOTE: Grease may be used to hold the locks in place while releasing the compressor tool.

3. Install spark plug and torque to specification.
4. Install and adjust valve mechanism as previously outlined.

Mark IV V8 Engines

1. Install new valve stem oil seal (coated with oil) in position over valve guide.

NOTE: Seal installation instructions are supplied

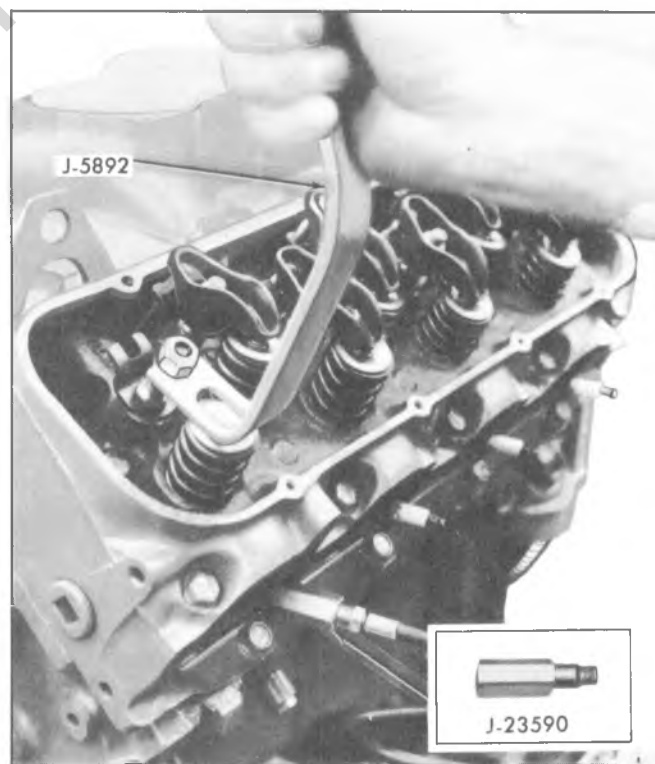


Fig. 3A-16V--Compressing Valve Spring

with each service kit. Install seal following procedures outlined on the supplied instruction sheet.

2. Set the valve spring and damper and valve cap in place.

3. Compress the spring with Tool J-5892 and install the valve locks then release the compressor tool, making sure the locks seat properly in the groove of the valve stem.

NOTE: Grease may be used to hold the locks in place while releasing the compressor tool.

4. Install spark plug and torque to specifications.

5. Install and adjust valve mechanism as previously outlined.

VALVE LIFTERS

Hydraulic valve lifters very seldom require attention. The lifters are extremely simple in design, readjustments are not necessary, and servicing of the lifters requires only that care and cleanliness be exercised in the handling of parts.

Locating Noisy Lifters

Locate a noisy valve lifter by using a piece of garden hose approximately four feet in length. Place one end of the hose near the end of each intake and exhaust valve with the other end of the hose to the ear. In this manner, the sound is localized making it easy to determine which lifter is at fault.

Another method is to place a finger on the face of the valve spring retainer. If the lifter is not functioning properly, a distinct shock will be felt when the valve returns to its seat.

The general types of valve lifter noise are as follows:

1. **Hard Rapping Noise**--Usually caused by the plunger becoming tight in the bore of the lifter body to such an extent that the return spring can no longer push the plunger back up to working position. Probable causes are:

a. Excessive varnish or carbon deposit causing abnormal stickiness.

b. Galling or "pick-up" between plunger and bore of lifter body, usually caused by an abrasive piece of dirt or metal wedging between plunger and lifter body.

2. **Moderate Rapping Noise**--Probable causes are:

a. Excessively high leakdown rate.

b. Leaky check valve seat.

c. Improper adjustment.

3. **General Noise Throughout the Valve Train**--This will, in most cases, be caused by either insufficient oil supply or improper adjustment.

4. **Intermittent Clicking**--Probable causes are:

a. A microscopic piece of dirt momentarily caught between ball seat and check valve ball.

b. In rare cases, the ball itself may be out-of-round or have a flat spot.

c. Improper adjustment.

In most cases where noise exists in one or more

lifters all lifter units should be removed, disassembled, cleaned in a solvent, reassembled, and reinstalled in the engine. If dirt, corrosion, carbon, etc. is shown to exist in one unit, it more likely exists in all the units, thus it would only be a matter of time before all lifters caused trouble.

Removal

1. Remove intake manifold as previously outlined.

2. Remove valve mechanism as previously outlined.

3. Remove valve lifters.

NOTE: Place valve lifters in a rack so that they may be reinstalled in the same location.

Installation

1. Install valve lifters.

NOTE: Whenever new valve lifters are being installed, coat foot of valve lifters with "Molykote" or its equivalent.

2. Install intake manifold as previously outlined.

3. Install and adjust valve mechanism as outlined.

Disassembly

1. Hold the plunger down with a push rod, and using the blade of a small screw driver, remove the push rod seat retainer.

2. Remove the push rod seat and metering valve (fig. 6A-17V).

3. Remove the plunger, ball check valve assembly and the plunger spring.

4. Remove the ball check valve and spring by

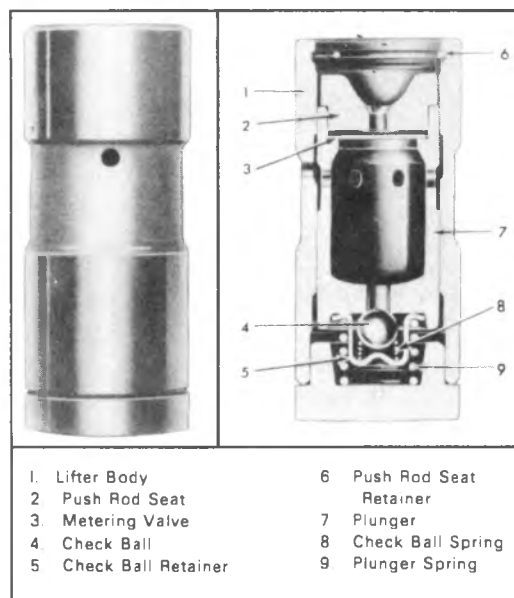


Fig. 6A-17V--Hydraulic Valve Lifter



Fig. 6A-18V--Removing Ball Check Valve



Fig. 6A-19V--Installing Ball Check Valve

prying the ball retainer loose from the plunger with the blade of a small screw driver (fig. 6A-18V).

Cleaning and Inspection

Thoroughly clean all parts in cleaning solvent, and inspect them carefully. If any parts are damaged or worn, the entire lifter assembly should be replaced. If the lifter body wall is scuffed or worn, inspect the cylinder block lifter bore. If the bottom of the lifter is scuffed or worn, inspect the camshaft lobe. If the push rod seat is scuffed or worn, inspect the push rod. An additive containing EP lube, such as EOS, or equivalent, should always be added to crankcase oil for run-in when any new camshaft or lifters are installed. All damaged or worn lifters should be replaced.

Assembly

1. Place the check ball on small hole in bottom of the plunger.

2. Insert check ball spring on seat in ball retainer and place retainer over ball so that spring rests on the ball. Carefully press the retainer into position in plunger with the blade of a small screw driver (fig. 6A-19V).

3. Place the plunger spring over the ball retainer and slide the lifter body over the spring and plunger, being careful to line up the oil feed holes in the lifter body and plunger.

4. Fill the assembly with SAE 10 oil, then insert the end of a 1/8" drift pin into the plunger and press down solid. At this point, oil holes in the lifter body and plunger assembly will be aligned (fig. 6A-20V).

CAUTION: Do not attempt to force or pump the plunger.

5. Insert a 1/16" drift pin through both oil holes to

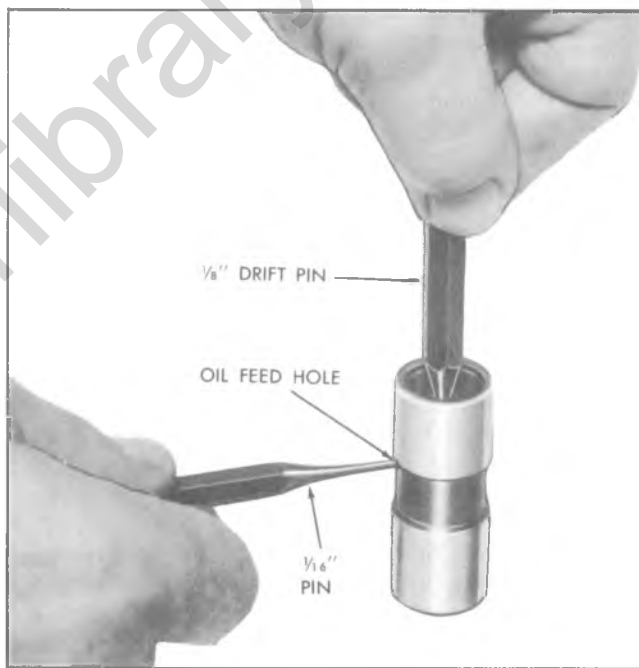


Fig. 6A-20V--Assembly Hydraulic Lifter

hold the plunger down against the lifter spring tension (fig. 6A-20V).

6. Remove the 1/8" drift pin, refill assembly with SAE 10 oil.

7. Install the metering valve and push rod seat (fig. 6A-17V).

8. Install the push rod seat retainer, press down on the push rod seat and remove the 1/16" drift pin from the oil holes. The lifter is now completely assembled, filled with oil and ready for installation.

NOTE: Before installing lifters, coat the bottom of the lifter with "Molykote" or its equivalent.

CYLINDER HEAD ASSEMBLY

Removal

1. Remove intake manifold as previously outlined.
2. Remove generator lower mounting bolt and lay unit aside.
3. Remove exhaust manifolds as previously outlined.
4. If vehicle is equipped with A/C, remove A/C compressor and forward mounting bracket. Lay unit aside.

NOTE: On vehicles equipped with A.I.R., disconnect the rubber hosing at the injection tubing check valve (fig. 6A-21V). In this manner, the tubing will not have to be removed from the exhaust manifold.

5. Remove valve mechanism as previously outlined.
6. Drain cylinder block of coolant.
7. Remove cylinder head bolts, cylinder head and gasket. Place cylinder head on two blocks of wood to prevent damage.

Disassembly

1. With cylinder head removed, remove valve rocker arm nuts, balls and rocker arms (if not previously done).
2. Using Tool J-8062, compress the valve springs (fig. 6A-22V) and remove valve keys. Release the compressor tool and remove rotators or spring caps,

spring shields (if so equipped) springs and spring damper, then remove oil seals and valve spring shims.

3. Remove valves from cylinder head and place them in a rack in their proper sequence so that they can be assembled in their original positions.

Cleaning

1. Clean all carbon from combustion chambers and valve ports using Tool J-8089 (fig. 6A-23V).
2. Thoroughly clean the valve guides using Tool J-8101 (fig. 6A-24V).
3. Clean all carbon and sludge from push rods, rocker arms and push rod guides.
4. Clean valve stems and heads on a buffing wheel.
5. Clean carbon deposits from head gasket mating surface.

Inspection

1. Inspect the cylinder head for cracks in the exhaust ports, combustion chambers, or external cracks to the water chamber.
2. Inspect the valves for burned heads, cracked faces or damaged stems.

NOTE: Excessive valve stem to bore clearance will cause excessive oil consumption and may cause valve breakage. Insufficient clearance will result in noisy and sticky functioning of the valve and disturb engine smoothness.

3. Measure valve stem clearance (fig. 6A-25V) as follows: Clamp a dial indicator on one side of the cylinder head rocker arm cover gasket rail, locating the indicator so that movement of the valve stem from side

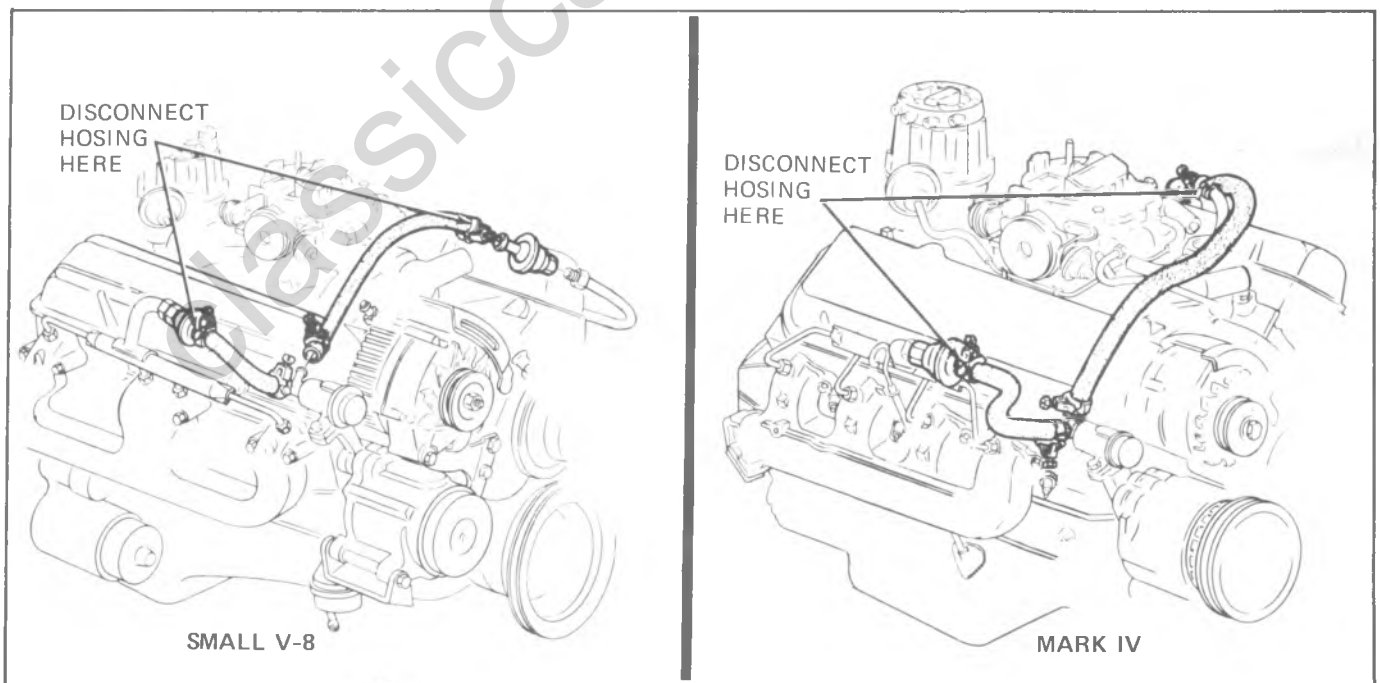


Fig. 6A-21V--A.I.R. Hose Routing

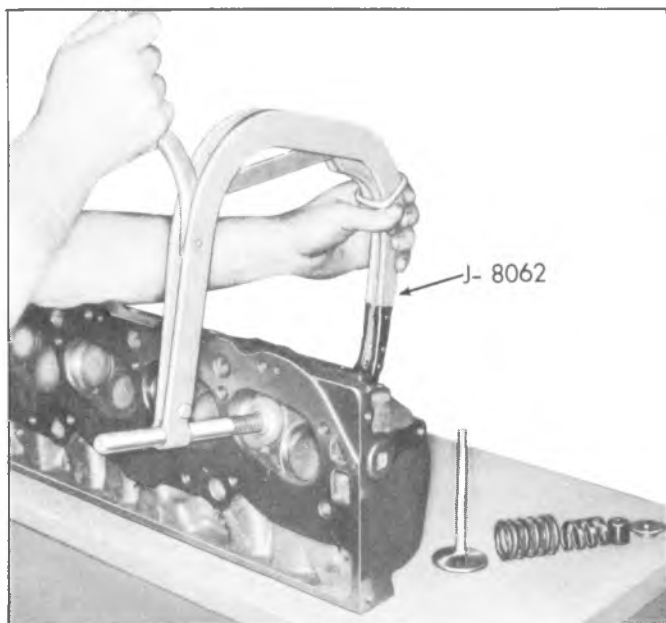


Fig. 6A-22V--Compressing Valve Spring (Typical)

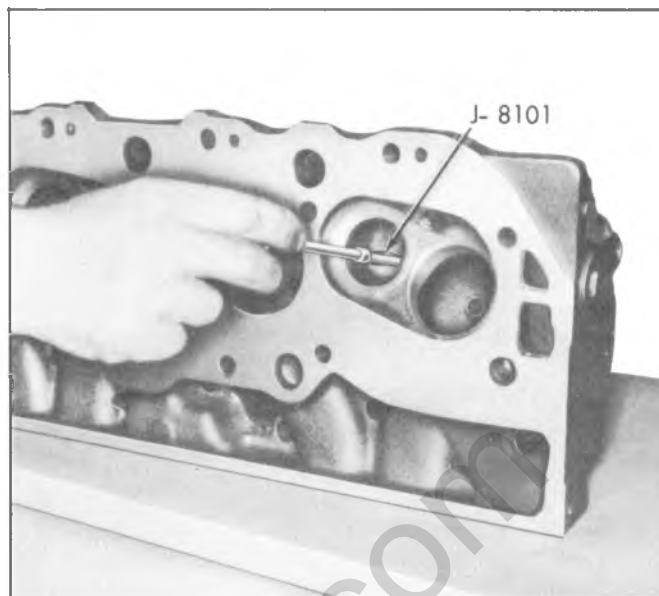


Fig. 6A-24V--Cleaning Valve Guides (Typical)

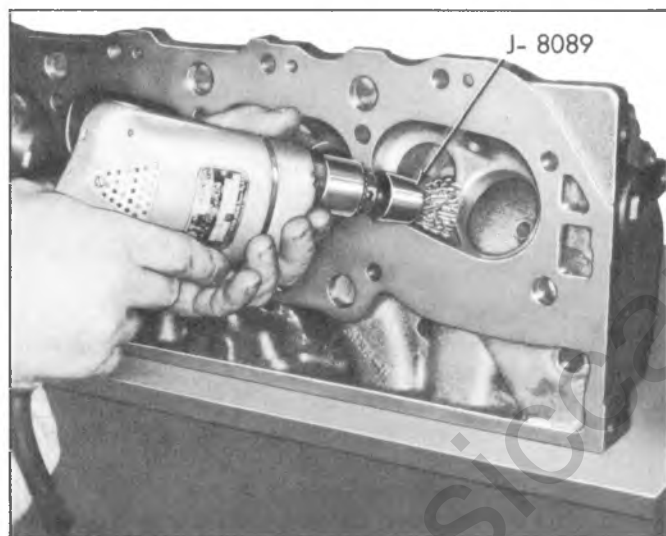


Fig. 6A-23V--Cleaning Combustion Chambers (Typical)

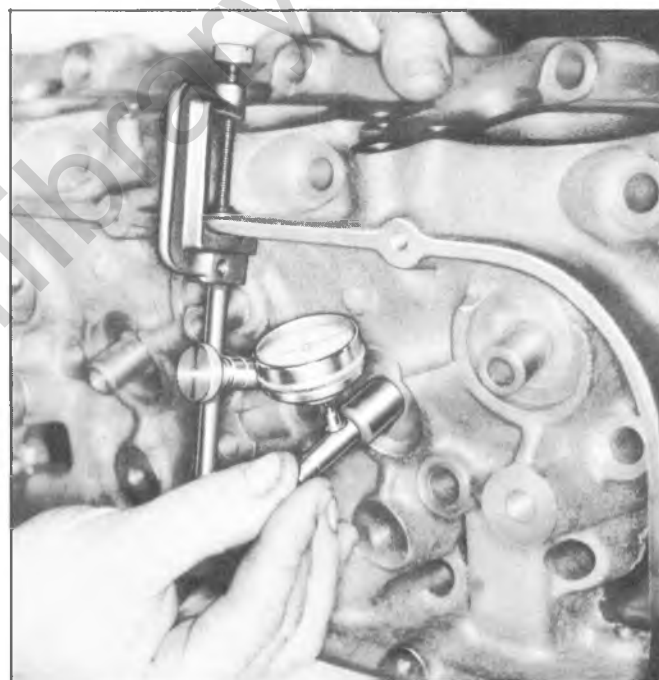


Fig. 6A-25V--Measuring Valve Stem Clearances (Typical)

to side (crosswise to the head) will cause a direct movement of the indicator stem. The indicator stem must contact the side of the valve stem just above the valve guide. With the valve head dropped about 1/16" off the valve seat; move the stem of the valve from side to side using light pressure to obtain a clearance reading. If clearance exceeds specifications it will be necessary to ream valve guides for oversize valves as outlined.

4. Check valve spring tension with Tool J-8056 spring tester (fig. 6A-26V).

NOTE: Springs should be compressed to the specified height and checked against the specifications chart. Springs should be replaced if not within 10 lbs. of the specified load (without dampers).

5. Inspect rocker arm studs for wear or damage.

Inspect push rod guides on Mark IV V8 engines for wear or damage.

Assembly

1. Insert a valve in the proper port.



Fig. 6A-26V--Checking Valve Spring Tension

2. Assemble the valve spring and related parts as follows:

Small V8

CAUTION: *On engines using exhaust valve rotators, make sure that the proper (shorter) springs are used on exhaust valves.*

a. Set the valve spring shim, valve spring (with damper if used), valve shield and valve cap or rotator in place (fig. 6A-27V).

b. Compress the spring with Tool J-8062.

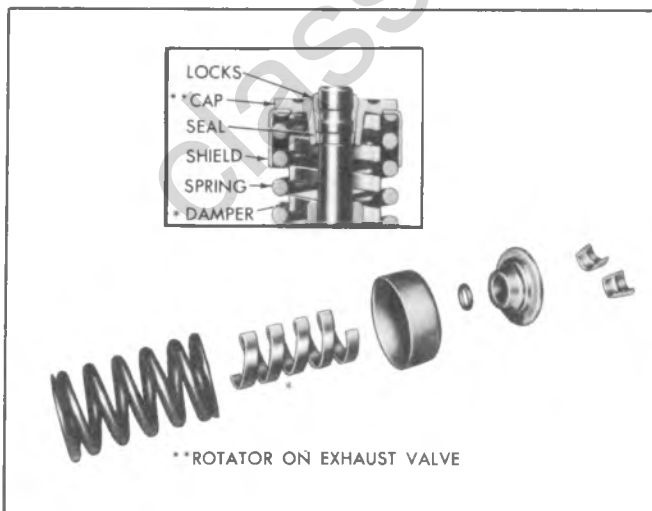


Fig. 6A-27V--Valve Spring Installation (Small V-8)

c. Install oil seal in the lower groove of the stem, making sure that the seal is flat and not twisted.

d. Install the valve locks and release the compressor tool making sure that the locks seat properly in the upper groove of the valve stem.

Mark IV V8

a. Install valve spring shim on valve spring seat then install a new valve stem oil seal over valve and valve guide.

b. Set the valve spring (with damper); and valve cap in place (fig. 6A-28V).

c. Compress the spring with Tool J-8062.

d. Install the valve locks and release the

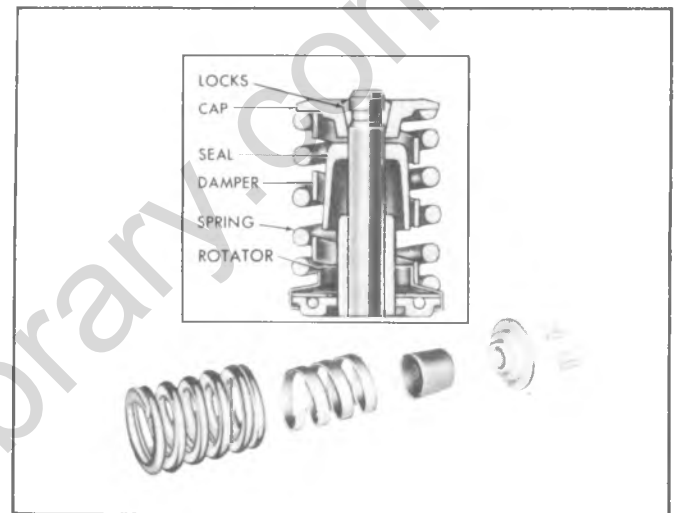


Fig. 6A-28V--Exhaust Valve Spring Installation (Mark IV)

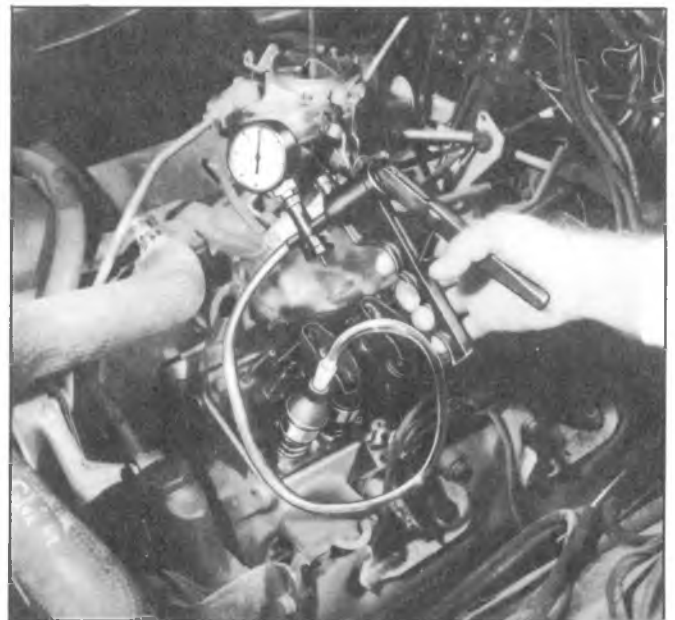


Fig. 6A-29V--Checking Valve Stem Oil Seals (Small V-8)

compressor tool, making sure the locks seat properly in the groove of the valve stem.

NOTE: Grease may be used to hold the locks in place, while releasing the compressor tool.

3. Install the remaining valves.
4. On Small V8 engines check each valve stem oil seal by placing Valve Seal Leak Detector (Tool J-23994) over the end of the valve stem and against the cap. Operate the vacuum pump and make sure no air leaks past the seal (fig. 6A-29V).
5. Check the installed height of the valve springs, using a narrow thin scale. A cutaway scale will help (fig. 6A-30V). Measure from the top of the shim or the spring seat to the top of the valve spring or valve spring shield (fig. 6A-31V). If this is found to exceed the specified height, install a valve spring seat shim approximately 1/16" thick. At no time should the spring be shimmed to give an installed height under the minimum specified.

Installation

CAUTION: The gasket surfaces on both the head and the block must be clean of any foreign matter and free of nicks or heavy scratches. Cylinder bolt threads in the block and threads on the cylinder head bolts must be clean. (Dirt will affect bolt torque).

1. On engines using a STEEL gasket, coat both sides of a new gasket with a good sealer. Spread the

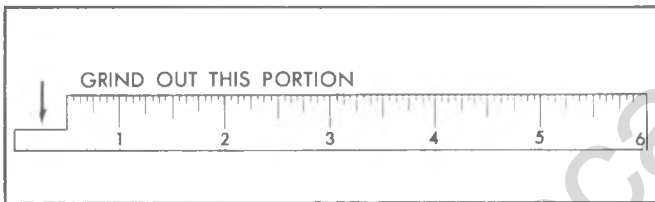


Fig. 6A-30V--Cutaway Scale

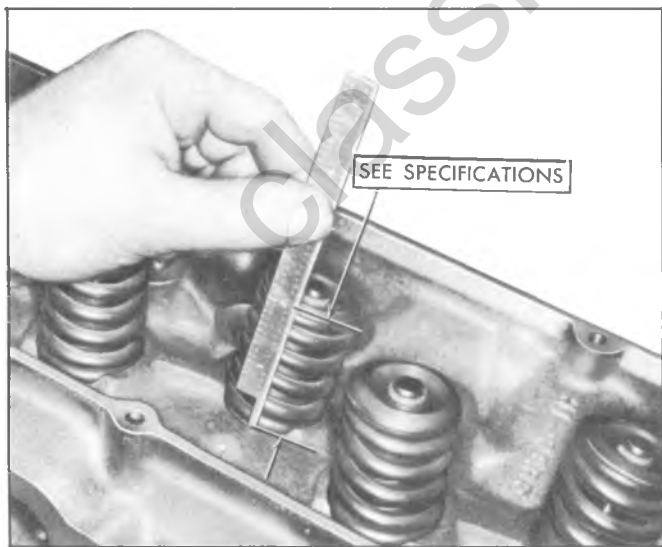


Fig. 6A-31V--Measuring Valve Spring Installed Height

sealer thin and even. One method of applying the sealer that will assure the proper coat is with the use of a paint roller. Too much sealer may hold the gasket away from the head or block.

CAUTION: Use no sealer on engines using a composition STEEL ASBESTOS gasket.

2. Place the gasket in position over the dowel pins with the bead up.
3. Carefully guide the cylinder head into place over the dowel pins and gasket.
4. Coat threads of cylinder head bolts with sealing compound and install bolts finger tight.
5. Tighten each cylinder head bolt a little at a time in the sequence shown in the torque sequence chart until the specified torque is reached.
6. Install exhaust manifolds as previously outlined.
7. Install intake manifold as previously outlined.
8. Install and adjust valve mechanism as previously outlined.

ROCKER ARM STUDS

Replacement

Mark IV

The push rod guides are related to the cylinder head by the rocker arm studs (fig. 6A-32V). Replace where necessary and torque rocker arm studs to specifications.

NOTE: Coat Threads on cylinder head end of rocker arm studs with sealer before assembly to cylinder head.

Small V8

Rocker arm studs that have damaged threads or are

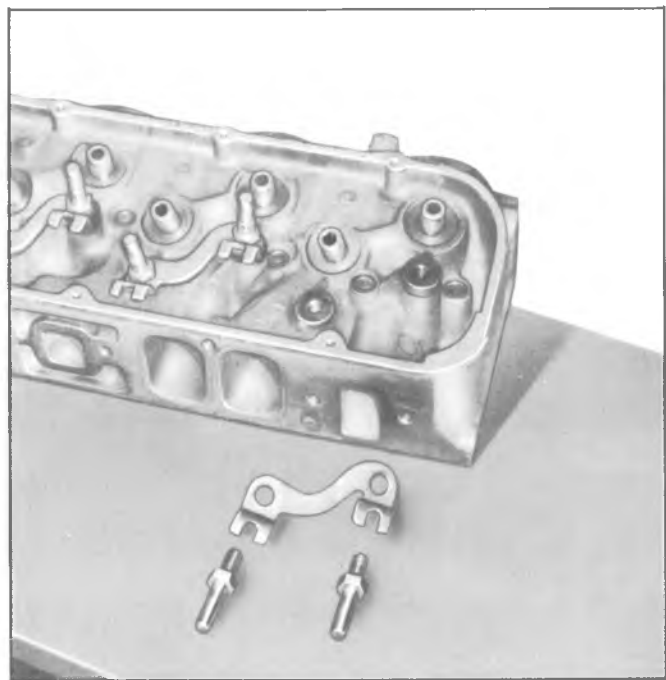


Fig. 6A-32V--Rocker Arm Stud Push Rod Guide

loose in cylinder heads should be replaced with new studs available in .003" and .013" oversize. Studs may be installed after reaming the holes as follows:

1. Remove old stud by placing Tool J-5802-1 over the stud, installing nut and flat washer and removing stud by turning nut (fig. 6A-33V).

2. Ream hole for oversize stud using Tool J-5715 for .003" oversize or Tool J-6036 for .013" oversize (fig. 6A-34V).

CAUTION: Do not attempt to install an oversize stud without reaming stud hole.

3. Coat press-fit area of stud with hypoid axle

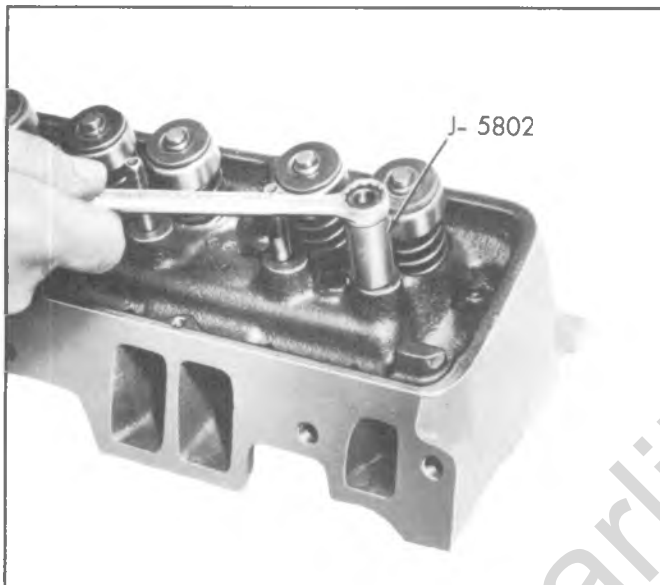


Fig. 6A 33V--Removing Rocker Arm Stud (Small V8)

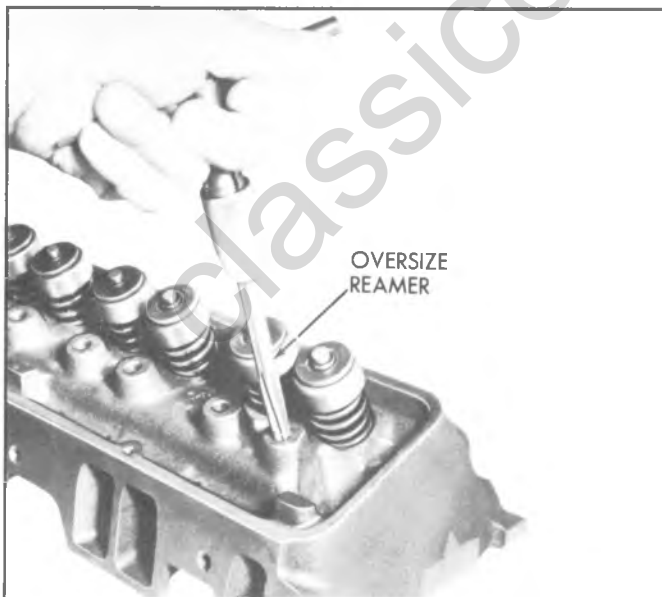


Fig. 6A-34V--Reaming rocker arm stud bore

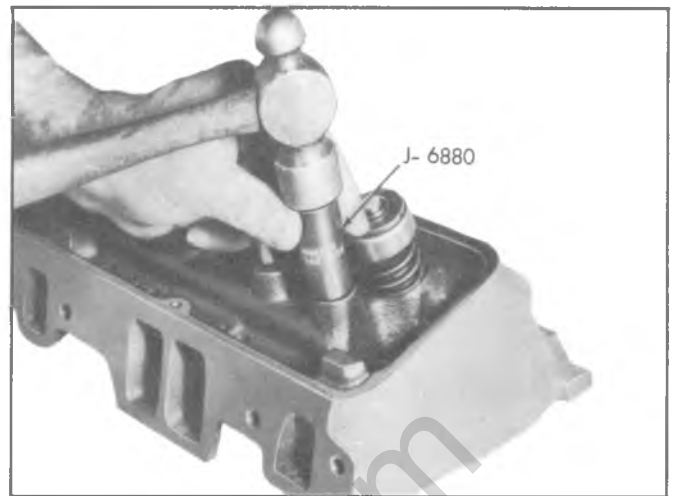


Fig. 6A-35V--Installing Rocker Arm Stud (Small V8)

lubricant. Install new stud, using Tool J-6880 as a guide. Gauge should bottom on head (fig. 6A-35V).

VALVE GUIDE BORES

Valves with oversize stems are available (see specifications). To ream the valve guide bores for oversize valves use Tool Set J-5830 for Small V8 or J-7049 for Mark IV V8.

VALVE SEATS

Reconditioning the valve seats is very important, because the seating of the valves must be perfect for the engine to deliver the power and performance built into it.

Another important factor is the cooling of the valve heads. Good contact between each valve and its seat in the head is imperative to insure that the heat in the valve head will be properly carried away.

Several different types of equipment are available for reseating valves seats. The recommendations of the manufacturer of the equipment being used should be carefully followed to attain proper results.

Regardless of what type of equipment is used, however, it is essential that valve guide bores be free from carbon or dirt to ensure proper centering of pilot in the guide.

Reconditioning

1. Install expanding pilot in the valve guide bore and expand pilot.
2. Place roughing stone or forming stone over pilot and just clean up the valve seat. Use a stone cut to specifications.
3. Remove roughing stone or forming stone from pilot, place finishing stone, cut to specifications, over pilot and cut just enough metal from the seat to provide a smooth finish. Refer to specifications.
4. Narrow down the valve seat to the specified width.

NOTE: This operation is done by grinding the port side with a 30 degree stone to lower seat and a 60 degree stone to raise seat.

5. Remove expanding pilot and clean cylinder head carefully to remove all chips and grindings from above operations.

6. Measure valve seat concentricity (fig. 6A-36V).

NOTE: Valve seats should be concentric to within .002" total indicator reading.

VALVES

Valves that are pitted can be refaced to the proper angle, insuring correct relation between the head and stem on a valve refacing mechanism. Valve stems which show excessive wear, or valves that are warped excessively should be replaced. When a valve head which is warped excessively is refaced, a knife edge will be ground on part or all of the valve head due to the amount of metal that must be removed to completely reface. Knife edges lead to breakage, burning or pre-ignition due to heat localizing on this knife edge. If the edge of the valve head is less than 1/32" thick after grinding, replace the valve.

Several different types of equipment are available for refacing valves. The recommendation of the manufacturer of the equipment being used should be carefully followed to attain proper results.

Reconditioning

1. If necessary, dress the valve refacing machine grinding wheel to make sure it is smooth and true. Set chuck at angle specified for valve. Refer to specifications.

2. Clamp the valve stem in the chuck of the machine.

3. Start the grinder and move the valve head in line with the grinder wheel.

4. Turn the feed screw until the valve head just contacts wheel. Move valve back and forth across the

wheel and regulate the feed screw to provide light valve contact.

5. Continue grinding until the valve face is true and smooth all around the valve. If this makes the valve head thin (1/32" min.) the valve must be replaced as the valve will overheat and burn.

6. Remove valve from chuck and place stem in "V" block. Feed valve squarely against grinding wheel to grind any pit from rocker arm end of stem.

NOTE: Only the extreme end of the valve stem is hardened to resist wear. Do not grind end of stem excessively.

7. After cleaning valve face and cylinder head valve seat of grinding particles, make pencil marks about 1/4" apart across the valve face, place the valve in cylinder head and give the valve 1/2 turn in each direction while exerting firm pressure on head of valve.

8. Remove valve and check face carefully. If all pencil marks have not been removed at the point of contact with the valve seat, it will be necessary to repeat the refacing operation and again recheck for proper seating.

9. Grind and check the remaining valves in the same manner.

TORSIONAL DAMPER

Removal

1. Remove fan belt, fan and pulley.
2. Remove the radiator shroud assembly as outlined in Section 6B.

NOTE: If additional operations (such as camshaft removal) are not being performed, the radiator removal will not be necessary.

3. Remove accessory drive pulley then remove damper retaining bolt.

4. Install Tool J-23523 on damper then, turning puller screw, remove damper (fig. 6A-37V).



Fig. 6A-36V--Measuring Valve Seat Concentricity

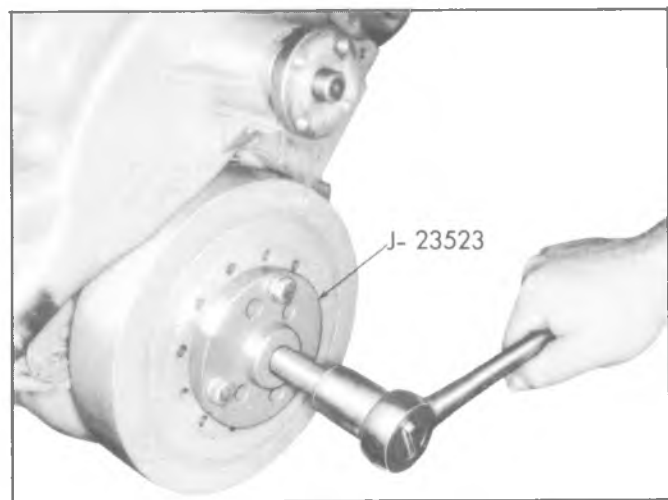


Fig. 6A-37V--Removing Torsional Damper (Typical)

NOTE: Tool J-23523 has holes forming two patterns. A two bolt and a three bolt pattern. The holes for the two bolt pattern must be elongated for use on the Mark IV V8 engines.

Installation

CAUTION: The inertial weight section of the torsional damper is assembled to the hub with a rubber type material. The installation procedures (with proper tool) must be followed or movement of the inertia weight section on the hub will destroy the turning of the torsional damper.

1. Coat front cover seal contact area (on damper) with engine oil.
2. Place damper in position over key on crankshaft.
3. Pull damper onto crankshaft as follows:
 - a. Install appropriate threaded end of Tool J-23523 into crankshaft.

CAUTION: Install tool in crankshaft so that at least 1/2" of thread engagement is obtained.

- b. Install plate, thrust bearing and nut to complete tool installation.
- c. Pull damper into position as shown in Figure 6A-38V.
- d. Remove tool from crankshaft then install damper retaining bolt and torque to specifications.
4. Install accessory drive pulley.
5. Install radiator shroud as outlined in Section 6B.
6. Install fan and pulley to water pump hub and tighten securely.
7. Install fan belt and adjust to specifications using strand tension gauge.

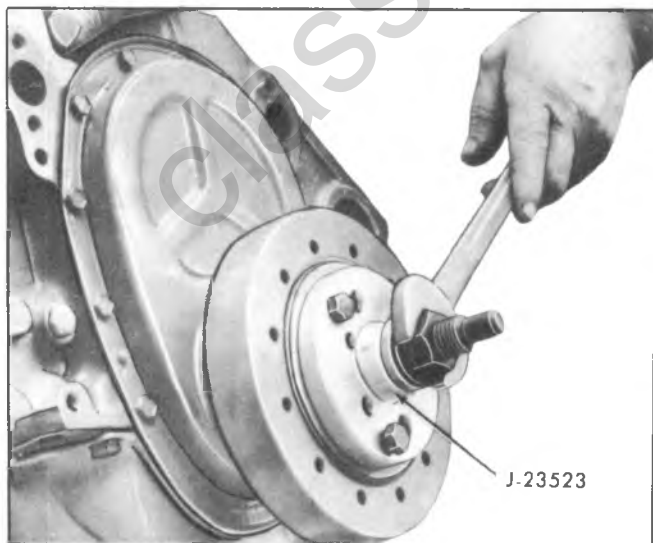


Fig. 6A-38V--Installing Torsional Damper

8. Fill cooling system, start engine and check for leaks.

CRANKCASE FRONT COVER

Removal

Small V8 Engine

1. Remove torsional damper as previously outlined.
2. Remove water pump as outlined in Section 6B.
3. Remove crankcase front cover attaching screws and remove front cover and gasket, then discard gasket.

Mark IV V8 Engine

1. Remove torsional damper and water pump as outlined.
2. Remove the two, oil pan-to-front cover attaching screws.
3. Remove the front cover-to-block attaching screws.
4. Pull the cover slightly forward only enough to permit cutting of oil pan front seal.
5. Using a sharp knife or other suitable cutting tool, cut oil pan front seal flush with cylinder block at both sides of cover (fig. 6A-39V).
6. Remove front cover and attaching portion of oil pan front seal. Remove front cover gasket.

Installation

Small V8 Engine

1. Clean gasket surface on block and crankcase front cover.
2. Use a sharp knife or other suitable cutting tool,

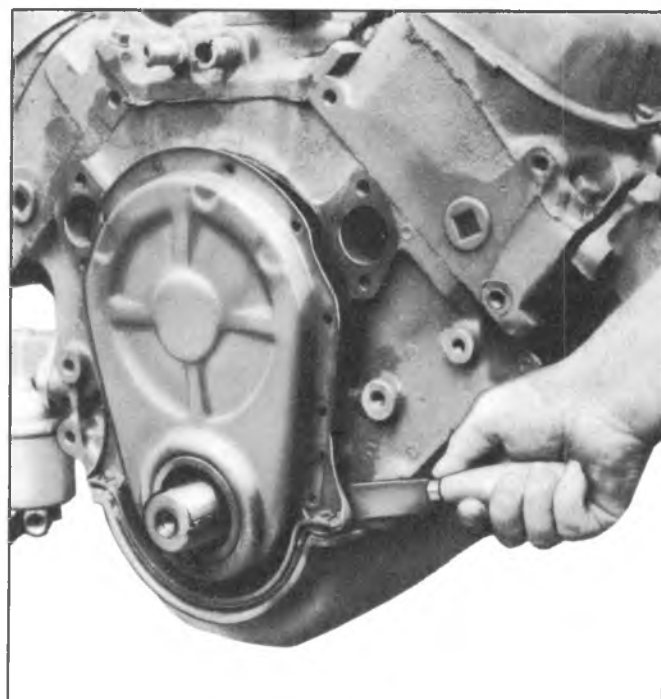


Fig. 6A-39V--Cutting Tabs on Oil Pan Front Seal

to remove any excess oil pan gasket material that may be protruding at the oil to engine block junction.

3. Apply a 1/8 inch bead of silicone rubber sealer, part **1051435 (or equivalent)** to the joint formed at the **oil pan and cylinder block**.

4. Coat the cover gasket with gasket sealer and place in position on cover.

5. Install cover-to-oil pan seal, lightly coat bottom of seal with engine oil, and position cover over crankshaft end.

6. Loosely install the cover-to-block, upper attaching screws.

7. Tighten screws alternately and evenly while pressing downward on cover so that dowels in block are aligned with corresponding holes in cover.

NOTE: Position cover so that dowels enter holes in cover without binding. Do not force cover over dowels so that cover flange or holes are distorted.

8. Install remaining cover screws and torque to specifications.

9. Install torsional damper and water pump as previously outlined.

Mark IV V8 Engine

1. Clean gasket surface on block and crankcase front cover.

2. Cut tabs from the new oil pan front seal (fig. 6A-40V), use a sharp instrument to ensure a clean cut.

3. Install seal to front cover, pressing tips into holes provided in cover.

4. Coat the gasket with gasket sealer and place in position on cover.

5. Apply a 1/8 inch bead of silicone rubber sealer, part **1051435 (or equivalent)** to the joint formed at the **oil pan and cylinder block (fig. 6A-41V)**.

6. Position crankcase front cover over crankshaft.

7. Press cover downward against oil pan until cover is aligned and installed over dowel pins on block.

8. Install and partially tighten the two, oil pan-to-front cover attaching screws.

9. Install the front cover-to-block attaching screws.

10. Torque all screws to specifications.

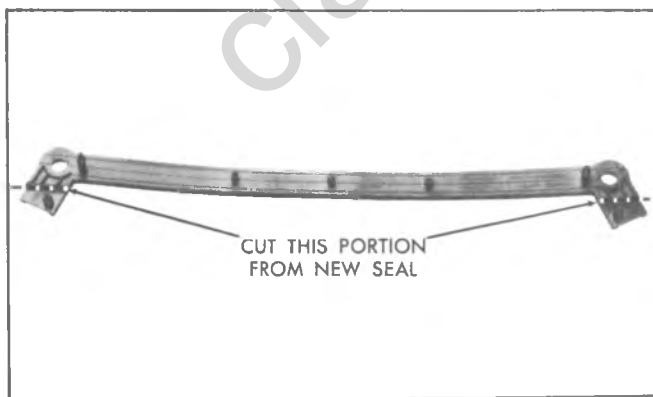


Fig. 6A-40V--Oil Pan Front Seal Modification

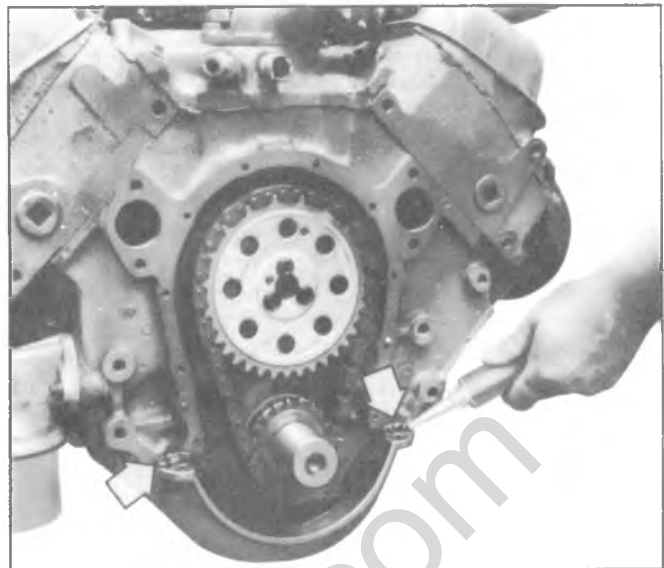


Fig. 6A-41V--Applying Front Cover Sealer

11. Install torsional damper and water pump as previously outlined.

OIL SEAL (FRONT COVER)

Replacement

With Cover Removed

1. With cover removed, pry oil seal out of cover from the front with a large screw driver.

2. Install new seal so that open end of the seal is toward the inside of cover and drive it into position with Tool J-23042 on Small V8 engines or Tool J-22102 on Mark IV V8 engines (fig. 6A-42V).



Fig. 6A-42V--Installing Oil Seal (Cover Removed)

CAUTION: Support cover at seal area. (Tool J-971 may be used as support).

With Cover Installed

1. With torsional damper removed, pry seal out of cover from the front with a large screw driver, being careful not to damage the surface on the crankshaft.

2. Install new seal so that open end of seal is toward the inside of cover and drive it into position with Tool J-23042 on Small V8 engines or Tool J-22102 on Mark IV V8 engines (fig. 6A-43V).

CAMSHAFT

Measuring Lobe Lift

NOTE: Procedure is similar to that used for checking valve timing. If improper valve operation is indicated, measure the lift of each push rod in consecutive order and record the readings.

1. Remove the valve mechanism as previously outlined.

2. Position indicator with ball socket adapter (Tool J-8520) on push rod (fig. 6A-44V).

NOTE: Make sure push rod is in the lifter socket.

3. Rotate the crankshaft slowly in the direction of rotation until the lifter is on the heel of the cam lobe. At this point, the push rod will be in its lowest position.

4. Set dial indicator on zero, then rotate the crankshaft slowly, or attach an auxiliary starter switch and "bump" the engine over, until the push rod is fully raised position.

CAUTION: Whenever the engine is cranked remotely at the started, with a special jumper cable or other means, the distributor primary lead must be disconnected from the coil.

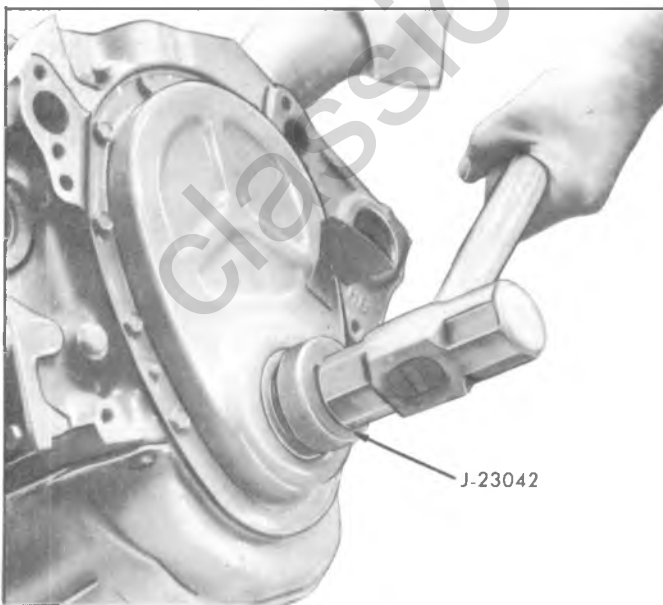


Fig. 6A-43V--Installing Oil Seal (Cover Installed)

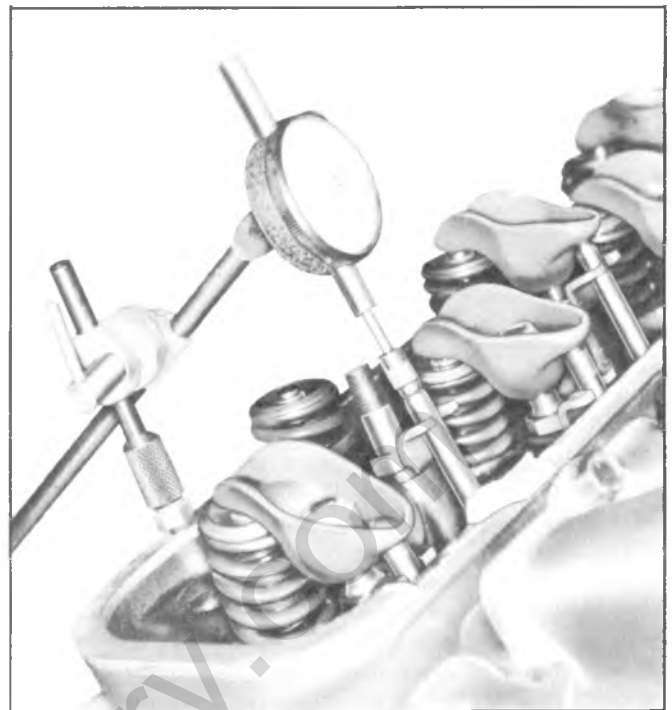


Fig. 6A-44V--Measuring Camshaft Lobe Lift

5. Compare the total lift recorded from the dial indicator with specifications.

6. If camshaft readings for all lobes are within specifications, remove dial indicator assembly.

7. Install and adjust valve mechanism as outlined.

Removal

1. Remove valve lifters as previously outlined.

2. Remove crankcase front cover as previously outlined.

3. Remove grille as outlined in Section 6B.

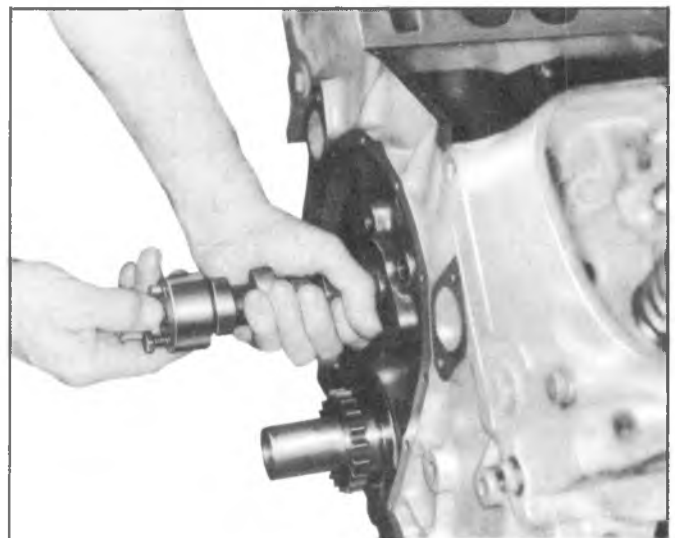


Fig. 6A-45V--Removing Camshaft

4. Remove fuel pump push rod as outlined in Section 6C.

5. Complete camshaft removal as follows:

NOTE: Sprocket is a light fit on camshaft. If sprocket does not come off easily a light blow on the lower edge of the sprocket (with a plastic mallet) should dislodge the sprocket.

6. Install two 5/16" x 18 x 4" bolts in camshaft bolt holes then remove camshaft (fig. 6A-45V).

CAUTION: All camshaft journals are the same diameter and care must be used in removing camshaft to avoid damage to bearings.

Inspection

The camshaft bearing journals should be measured with a micrometer for an out-of-round condition. If the journals exceed .001" out-of-round, the camshaft should be replaced.

The camshaft should also be checked for alignment. The best method is by use of "V" blocks and a dial indicator (fig. 6A-46V). The dial indicator will indicate the exact amount the camshaft is out of true. If it is out more than .0015" dial indicator reading, the camshaft should be replaced.

Installation

NOTE: Whenever a new camshaft is installed coat camshaft lobes with "Molykote" or its equivalent.

Whenever a new camshaft is installed, replacement of all valve lifters is recommended to insure durability of the camshaft lobes and lifter feet.

1. Lubricate camshaft journals with engine oil and install camshaft.

2. Install timing chain on camshaft sprocket. Hold the sprocket vertically with the chain hanging down and align marks on camshaft and crankshaft sprockets. (Refer to fig. 6A-47V 6A-48V).

3. Align dowel in camshaft with dowel hole in camshaft sprocket then install sprocket on camshaft.

4. Draw the camshaft sprocket onto camshaft using the mounting bolts. Torque to specifications.

5. Lubricate timing chain with engine oil.

6. Install fuel pump push rod as outlined in Section 6C.

7. Install grille as outlined in Section 6B.

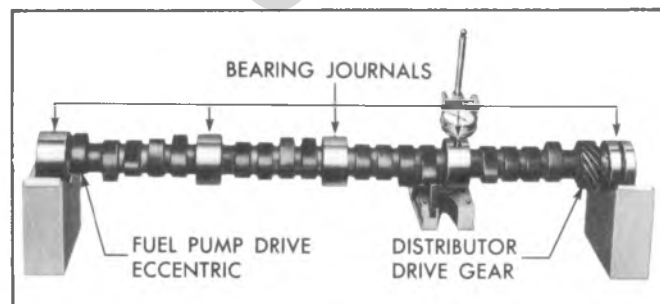


Fig. 6A-46V--Checking Camshaft Alignment

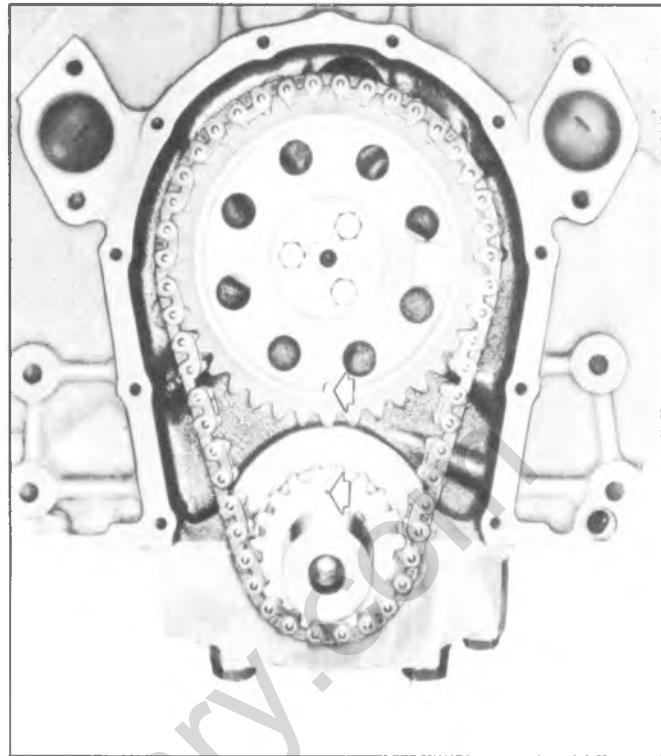


Fig. 6A-47V--Timing Sprocket Alignment Marks

8. Install crankcase front cover as previously outlined.

9. Install valve lifters as previously outlined.

CAMSHAFT BEARINGS

Removal

Camshaft bearings can be replaced while engine is disassembled for overhaul or without complete disassembly of the engine. To replace bearings without complete disassembly remove the camshaft and crankshaft leaving cylinder heads attached and pistons in place. Before removing crankshaft, tape threads of connecting rod bolts to prevent damage to crankshaft. Fasten connecting rods against sides of engine so they will not be in the way while replacing camshaft bearings.

1. With camshaft and crankshaft removed, drive camshaft rear plug from cylinder block.

NOTE: This procedure is based on removal of the bearings nearest center of the engine first. With this method a minimum amount of turns are necessary to remove all bearings.

2. Using Tool J-6098, with nut and thrust washer installed to end of threads, index pilot in camshaft front bearing and install puller screw through pilot.

3. Install remover and installer tool with shoulder toward bearing, making sure a sufficient amount of threads are engaged.

4. Using two wrenches, hold puller screw while turning nut. When bearing has been pulled from bore, remove remover and installer tool and bearing from puller screw (fig. 6A-49V).



Fig. 6A-48V-Installing Timing Chain

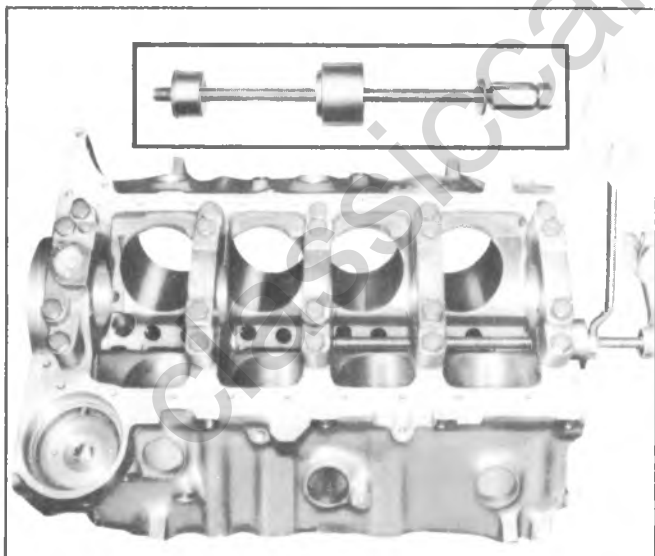


Fig. 6A-49V-Removing Camshaft Bearings

5. Remove remaining bearings (except front and rear) in the same manner. It will be necessary to index pilot in camshaft rear bearing to remove the rear intermediate bearing.

6. Assemble remover and installer tool on driver

handle and remove camshaft front and rear bearings by driving towards center of cylinder block (fig. 6A-50V).

Installation

The camshaft front and rear bearings should be installed first. These bearings will act as guides for the pilot and center the remaining bearings being pulled into place.

1. Assemble remover and installer tool on driver handle and install camshaft front and rear bearings by driving towards center of cylinder block (fig. 6A-50V).

2. Using Tool Set J-6098, with nut then thrust washer installed to end of threads, index pilot in camshaft front bearing and install puller screw through pilot.

3. Index camshaft bearing in bore (with oil hole aligned as outlined below), then install remover and installer tool on puller screw with shoulder toward bearing.

a. Small V8 Engines--Number one cam bearing oil hole must be positioned so that oil holes are equidistant from 6 o'clock position. Number two through number four bearing oil holes must be positioned at 5 o'clock position (toward left side of engine and at a position even with bottom of cylinder bore). Number five bearing oil hole must be in 12 o'clock position.

b. Mark IV V8 Engines--Number one through number four cam bearing oil hole must be aligned with oil holes in cam bearing bore. The number five bearing bore is annulus and cam bearing must be positioned at or near the 6 o'clock position.

4. Using two wrenches, hold puller screw while turning nut. After bearing has been pulled into bore, remove the remover and installer tool from puller screw and check alignment of oil hole in camshaft bearing (fig. 6A-49V).

5. Install remaining bearings in the same manner.

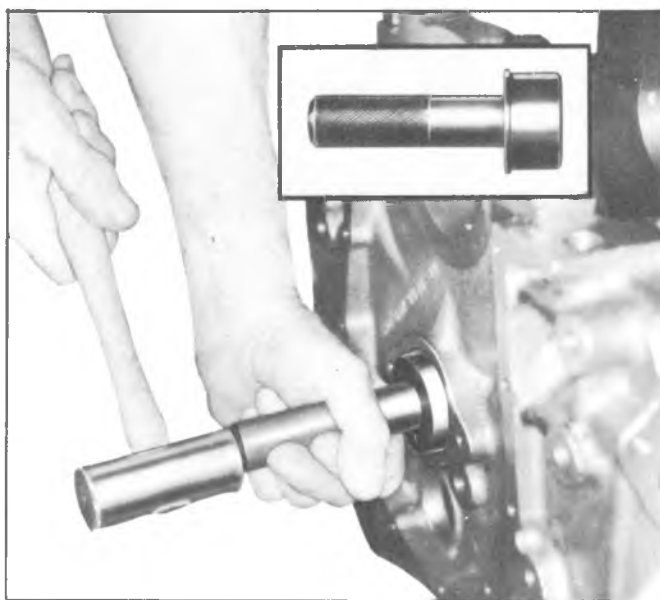


Fig. 6A-50V-Replacing Camshaft Front Bearing

It will be necessary to index pilot in the camshaft rear bearing to install the rear intermediate bearing.

6. Install a new camshaft rear plug.

NOTE: Plug should be installed flush to 1/32" deep and be parallel with rear surface of cylinder block.

OIL PAN

Removal

1. Drain engine oil.
2. Remove oil dip stick and tube.
3. Remove exhaust crossover pipe.
4. On vehicles equipped with automatic transmission remove converter housing under pan.
5. Remove starter brace and inboard bolt, swing starter aside.
6. Remove oil pan and discard gaskets and seals.

Installation

1. Thoroughly clean all gasket and seal surfaces on oil pan, cylinder block, crankcase front cover and rear main bearing cap.
2. Install new oil pan side gaskets on cylinder block using gasket sealer as a retainer. Install new oil

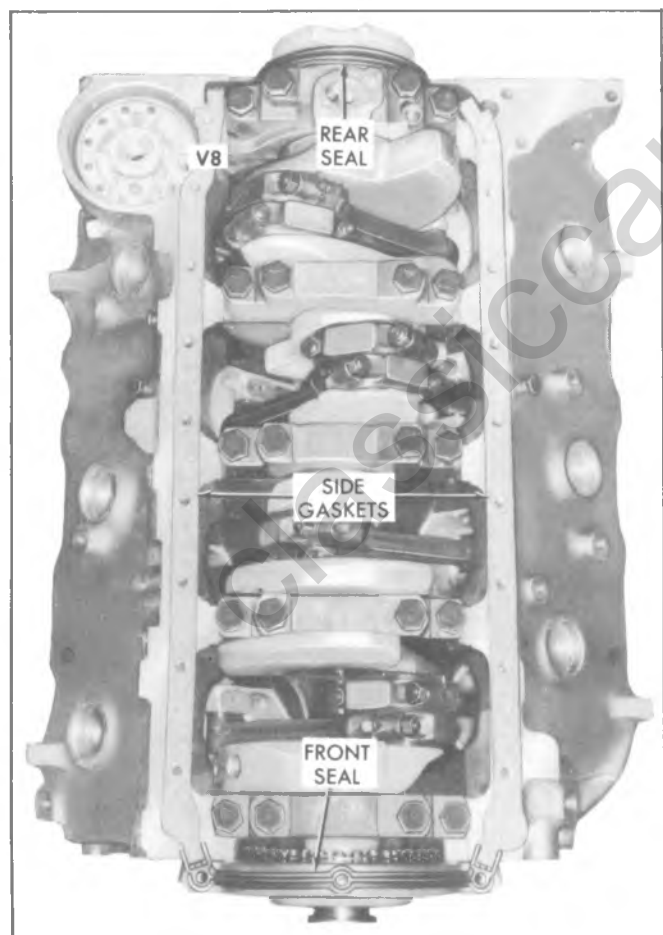


Fig. 6A-51V-Oil Pan Gaskets Seals

pan rear seal in rear main bearing cap groove, with ends butting side gaskets. Install new oil pan front seal in groove in crankcase front cover with ends butting side gaskets (fig. 6A-51V).

3. Install oil pan and torque bolts to specifications.
4. Install starter brace and attaching bolts. Torque bolts to specifications.
5. Install converter housing under pan.
6. Install exhaust crossover pipe.
7. Install oil dip stick tube and dip stick.
8. Fill with oil, start engine and check for leaks.

OIL PUMP

Removal

1. Remove oil pan as previously outlined.
2. Remove pump to rear main bearing cap bolt and remove pump and extension shaft.

Disassembly (Figures 6A-52V and 6A-53V)

1. Remove the pump cover attaching screws and the pump cover.

NOTE: Mark gear teeth so they may be reassembled with the same teeth indexing.

2. Remove the idler gear and the drive gear and shaft from the pump body.
3. Remove the pressure regulator valve retaining pin, pressure regulator valve and related parts.
4. If the pickup screen and pipe assembly need replacing, mount the pump in a soft-jawed vise and extract pipe from pump.

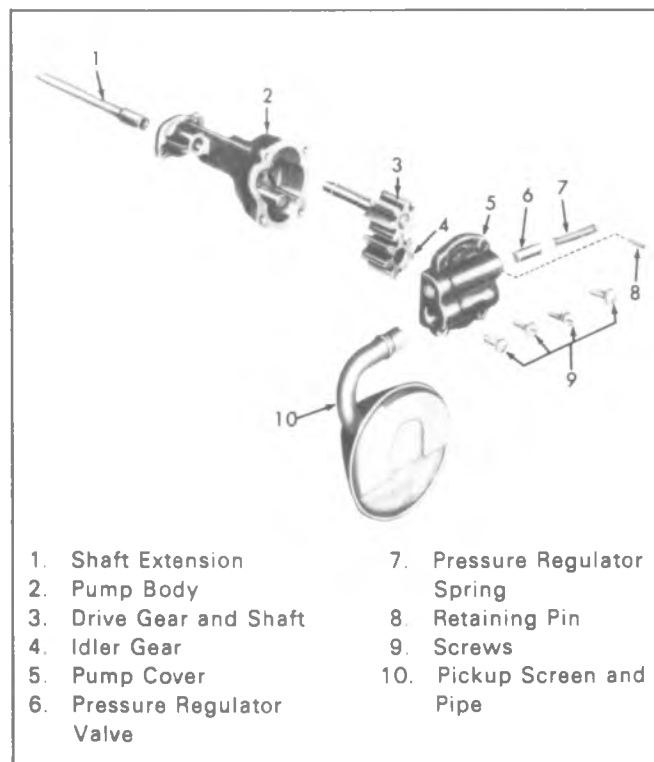


Fig. 6A-52V-Oil Pump - Small V8

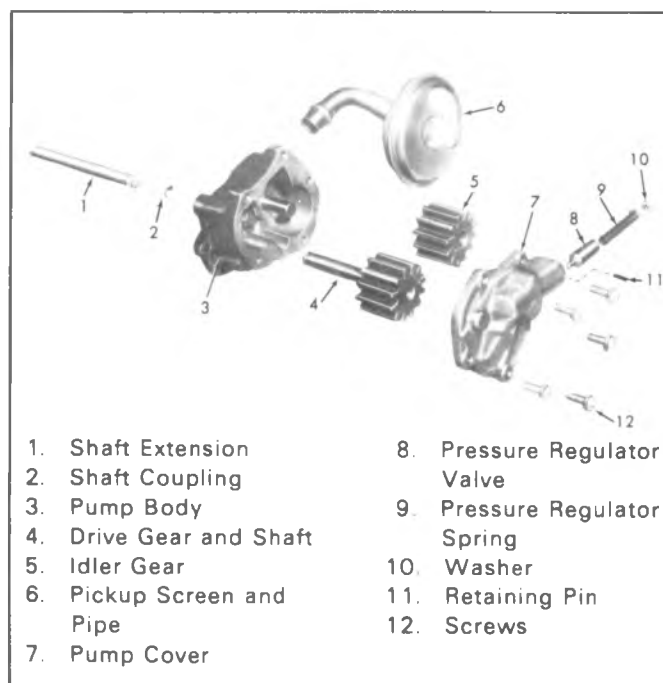


Fig. 6A-53V--Oil Pump - Mark IV

CAUTION: Do not disturb the pickup screen on the pipe. This is serviced as an assembly.

Cleaning and Inspection

1. Wash all parts in cleaning solvent and dry with compressed air.
2. Inspect the pump body and cover for cracks or excessive wear.
3. Inspect pump gears for damage or excessive wear.
4. Check the drive gear shaft for looseness in the pump body.
5. Inspect inside of pump cover for wear that would permit oil to leak past the ends of the gears.
6. Inspect the pickup screen and pipe assembly for damage to screen, pipe or relief grommet.
7. Check the pressure regulator valve for fit.

NOTE: The pump gears and body are not serviced separately. If the pump gears or body are damaged or worn, replacement of the entire oil pump assembly is necessary.

Assembly (Figures 6A-52V and 6A-53V)

1. If the pickup screen and pipe assembly was removed, it should be replaced with a new part. Loss of press fit condition could result in an air leak and loss of oil pressure. Mount the pump in a soft-jawed vise, apply sealer to end of pipe, and using Tool J-8369 for "Small V8" (fig. 6A-54V) or Tool J-22144 for "Mark IV V8" (fig. 6A-55V) tap the pipe in place with a plastic hammer.

CAUTION: Be careful of twisting, shearing or collapsing pipe while installing in pump.

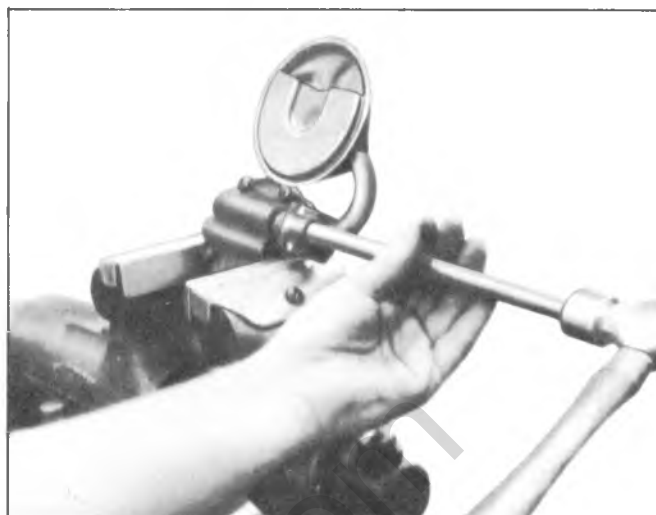


Fig. 6A-54V--Installing Screen - Small V8

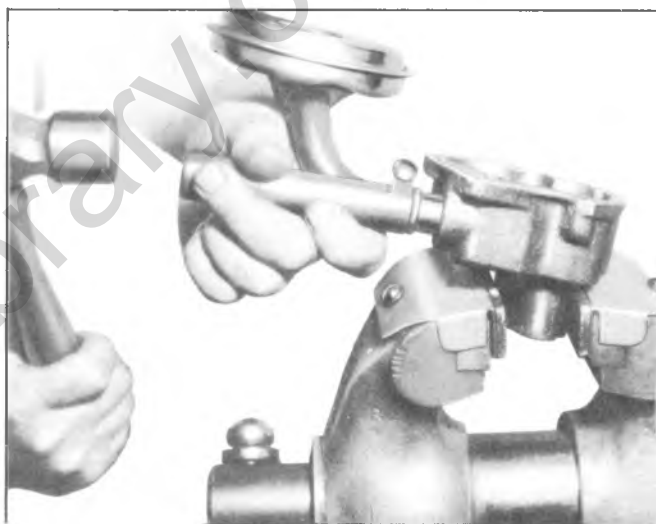


Fig. 6A-55V--Installing Screen - Mark IV

2. Install the pressure regulator valve and related parts.
3. Install the drive gear and shaft in the pump body.
4. Install the idler gear in the pump body with the smooth side of gear towards pump cover opening.
5. Install the pump cover and torque attaching screws to specifications.
6. Turn drive shaft by hand to check for smooth operation.

Installation

1. Assemble pump and extension shaft to rear main bearing cap, aligning slot on top end of extension shaft with drive tang on lower end of distributor drive shaft.
2. Install pump to rear bearing cap bolt and torque to specifications.

NOTE: Installed position of oil pump screen is with bottom edge parallel to oil pan rails.

3. Install oil pan previously outlined.

CONNECTING ROD BEARINGS

Connecting rod bearings are of the precision insert type and do not utilize shims for adjustment. **DO NOT FILE RODS OR ROD CAPS.** If clearances are found to be excessive a new bearing will be required. Bearings are available in standard size and .001" and .002" undersize for use with new and used standard size crankshafts, and in .010" and .020" undersize for use with reconditioned crankshafts.

Inspection and Replacement

1. With oil pan and oil pump removed, remove the connecting rod cap and bearing.
2. Inspect the bearing for evidence of wear or damage. (Bearings showing the above should not be installed.)
3. Wipe the bearings and crankpin clean of oil.
4. Measure the crankpin for out-of-round or taper with a micrometer. If not within specifications replace or recondition the crankshaft. If within specifications and a new bearing is to be installed, measure the maximum diameter of the crankpin to determine new bearing size required.
5. If within specifications measure new or used bearing clearances with Plastigage or its equivalent.

NOTE: If a bearing is being fitted to an out-of-round crankpin, be sure to fit to the maximum diameter of the crankpin. If the bearing is fitted to

the minimum diameter and the crankpin is out-of-round .001" interference between the bearing and crankpin will result in rapid bearing failure.

- a. Place a piece of gauging plastic the full width of the crankpin as contacted by the bearing (parallel to the crankshaft) (fig. 6A-56V).
- b. Install the bearing in the connecting rod and cap.
- c. Install the bearing cap and evenly torque nuts to specifications.

CAUTION: Do not turn the crankshaft with the gauging plastic installed.

- d. Remove the bearing cap and using the scale on the gauging plastic envelope, measure the gauging plastic width at the widest point (fig.6A-57V).
6. If the clearance exceeds specifications, select a new, correct size, bearing and remeasure the clearance.
7. Coat the bearing surface with oil, install the rod cap and torque nuts to specifications.
8. When all connecting rod bearings have been installed tap each rod lightly (parallel to the crankpin) to make sure they have clearance.
9. Measure all connecting rod side clearances (see specifications) between connecting rod caps (fig. 6A-58V).

MAIN BEARINGS

Main bearings are of the precision insert type and do not utilize shims for adjustment. If clearances are found to be excessive, a new bearing, both upper and lower halves, will be required. Bearings are available in standard size and .001", .002", .009", .010" and .020" undersize.

Selective fitting of both rod and main bearing



Fig. 6A-56V-Gauging Plastic On Crankpin

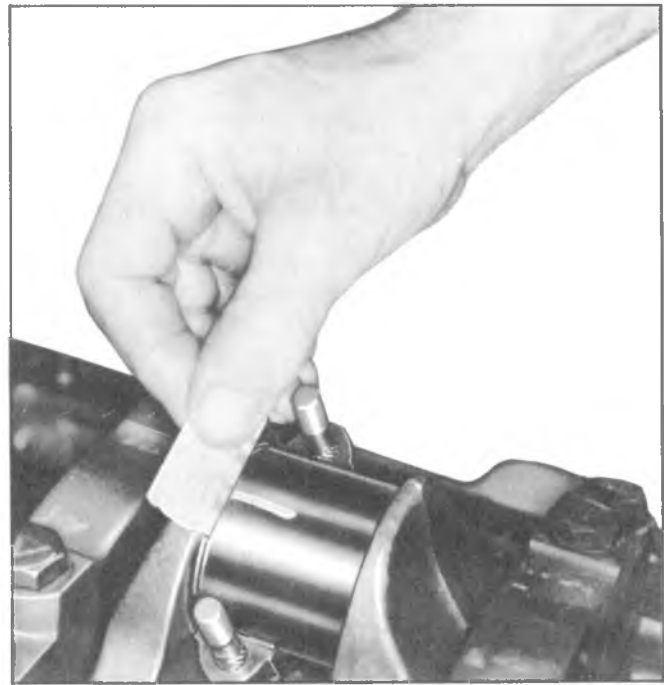


Fig. 6A-57V-Measuring Gauging Plastic



Fig. 6A-58V--Measuring Connecting Rod Side Clearance

inserts is necessary in production in order to obtain close tolerances. For this reason you may find one half of a standard insert with one half of a .001" undersize insert which will decrease the clearance .0005" from using a full standard bearing.

When a production crankshaft cannot be precision fitted by this method, it is then ground .009" undersize on main journals only. A .009" undersize bearing and .010" undersize bearing may be used for precision fitting in the same manner as previously described. Any engine fitted with a .009" undersize crankshaft will be identified by the following markings.

- ".009" will be stamped on the crankshaft counterweight forward of the center main journal.
- A figure "9" will be stamped on the block at the left front oil pan rail.

NOTE: If, for any reason, main bearing caps are replaced, shimming may be necessary. Laminated shims for each cap are available for service. Shim requirement will be determined by bearing clearance.

Inspection

In general, the lower half of the bearing (except No. 1 bearing) shows a greater wear and the most distress from fatigue. If upon inspection the lower half is suitable for use, it can be assumed that the upper half is also satisfactory. If the lower half shows evidence of wear or damage, both upper and lower halves should be replaced. Never replace one half without replacing the other half.

Checking Clearance

To obtain the most accurate results with "Plasti-gage", (or its equivalent) a wax-like plastic material which will compress evenly between the bearing and journal surfaces without damaging either surface, certain precautions should be observed.

If the engine is out of the vehicle and upside down, the crankshaft will rest on the upper bearings and the total clearance can be measured between the lower bearing and journal. If the engine is to remain in the vehicle, the crankshaft should be supported both front and rear (damper and flywheel) to remove the clearance from the upper bearing. The total clearance can then be measured between the lower bearing and journal.

NOTE: To assure the proper seating of the crankshaft, all bearing cap bolts should be at their specified torque. In addition, preparatory to checking fit of bearings, the surface of the crankshaft journal and bearing should be wiped clean of oil.

1. With the oil pan and oil pump removed, and starting with the rear main bearing, remove bearing cap and wipe oil from journal and bearing cap.

2. Place a piece of gauging plastic the full width of the bearing (parallel to the crankshaft) on the journal (fig. 6A-59V).

CAUTION: Do not rotate the crankshaft while the gauging plastic is between the bearing and journal.

3. Install the bearing cap and evenly torque the retaining bolts to specifications.

4. Remove bearing cap. The flattened gauging plastic will be found adhering to either the bearing shell or journal.

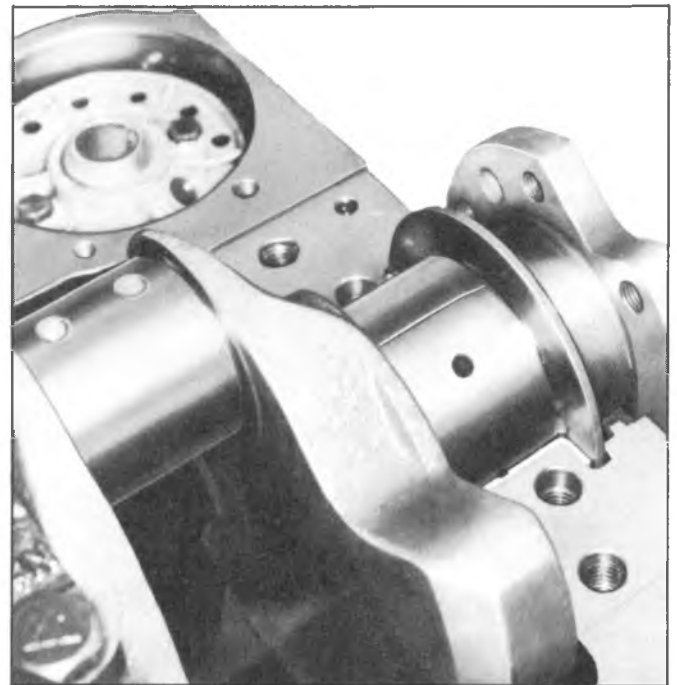


Fig. 6A-59V--Gauging Plastic on Journal

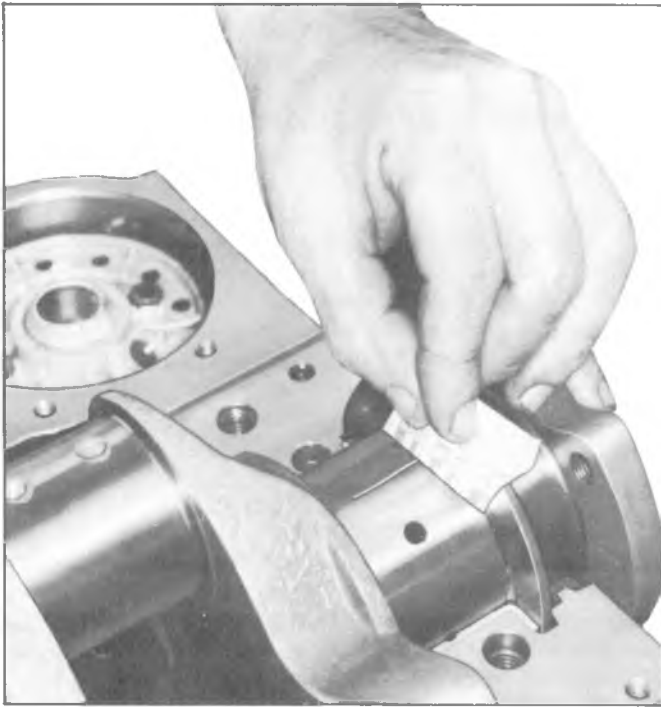


Fig. 6A-60V—Measuring Gauging Plastic

5. On the edge of gauging plastic envelope there is a graduated scale which is correlated in thousandths of an inch. Without removing the gauging plastic, measure its compressed width (at the widest point) with the graduations on the gauging plastic envelope (fig. 6A-60V).

NOTE: Normally main bearing journals wear evenly and are not out-of-round. However, if a bearing is being fitted to an out-of-round (.001" max.), be sure to fit to the maximum diameter of the journal: If the bearing is fitted to the minimum diameter and the journal is out-of-round .001", interference between the bearing and journal will result in rapid bearing failure. If the flattened gauging plastic tapers toward the middle or ends, there is a difference in clearance indicating taper, low spot or other irregularity of the bearing or journal. Be sure to measure the journal with a micrometer if the flattened gauging plastic indicates more than .001" difference.

6. If the bearing clearance is within specifications, the bearing insert is satisfactory. If the clearance is not within specifications, replace the insert. Always replace both upper and lower inserts as a unit.

NOTE: If a new bearing cap is being installed and clearance is less than .001", inspect for burrs or nicks; if none are found then install shims as required.

7. A standard, .001" or .002" undersize bearing may produce the proper clearance. If not, it will be necessary to regrind the crankshaft journal for use with the next undersize bearing.

8. Proceed to the next bearing. After all bearings

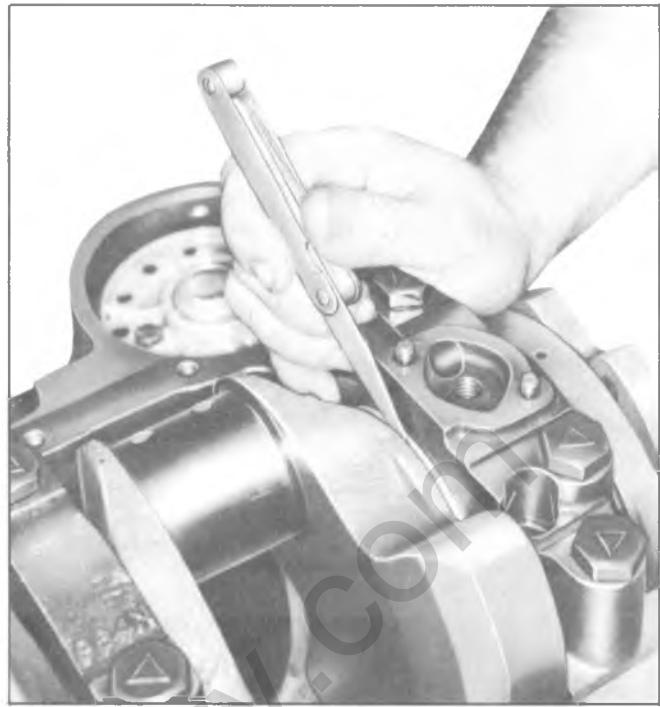


Fig. 6A-61V—Measuring Crankshaft End Play

have been checked rotate the crankshaft to see that there is no excessive drag.

9. Measure crankshaft end play (see specifications) by forcing the crankshaft to the extreme front position. Measure at the front end of the rear main bearing with a feeler gauge (fig. 6A-61V).

10. Install a new rear main bearing oil seal in the cylinder block and main bearing cap.

Replacement

NOTE: Main bearings may be replaced with or without removing the crankshaft.

With Crankshaft Removal

1. Remove and inspect the crankshaft.
2. Remove the main bearings from the cylinder block and main bearing caps.
3. Coat bearing surfaces of new, correct size, main bearings with oil and install in the cylinder block and main bearing caps.
4. Install the crankshaft.

Without Crankshaft Removal

1. With oil pan, oil pump and spark plugs removed, remove cap on main bearing requiring replacement and remove bearing from cap.
2. Install a main bearing removing and installing tool in oil hole in crankshaft journal.

NOTE: If such a tool is not available, a cotter pin may be bent as required to do the job.

3. Rotate the crankshaft clockwise as viewed from the front of engine. This will roll upper bearing out of block.
4. Oil new selected size upper bearing and insert

plain (unnotched) end between crankshaft and indented or notched side of block. Rotate the bearing into place and remove tool from oil hole in crankshaft journal.

5. Oil new lower bearing and install in bearing cap.

6. Install main bearing cap with arrows pointing toward front of engine.

7. Torque main bearing cap bolts to specifications.

OIL SEAL (REAR MAIN)

Replacement

NOTE: Always replace the upper and lower seal as a unit. Install seal with lip facing front of engine.

The rear main bearing oil seal can be replaced (both halves) without removal of the crankshaft. Extreme care should be exercised when installing this seal to protect the sealing bead located in the channel on the outside diameter of the seal. An installation tool (fig. 6A-62V) can be used to protect the seal bead when positioning seal as follows:

1. With the oil pan and oil pump removed, remove the rear main bearing cap.
2. Remove oil seal from the bearing cap by prying from the bottom with a small screw driver (fig. 6A-63V).
3. To remove the upper half of the seal, use a

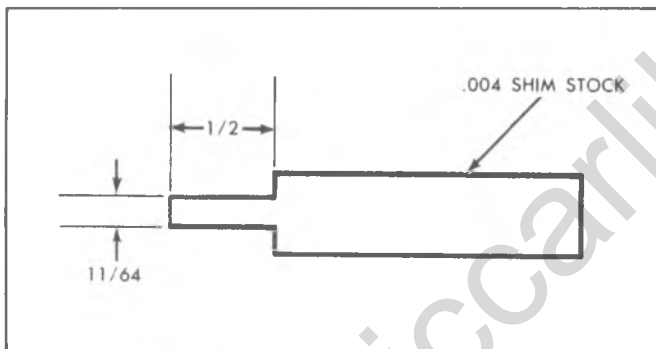


Fig. 6A-62V--Oil Seal Installation Tool



Fig. 6A-63V--Removing Oil Seal - Lower Half

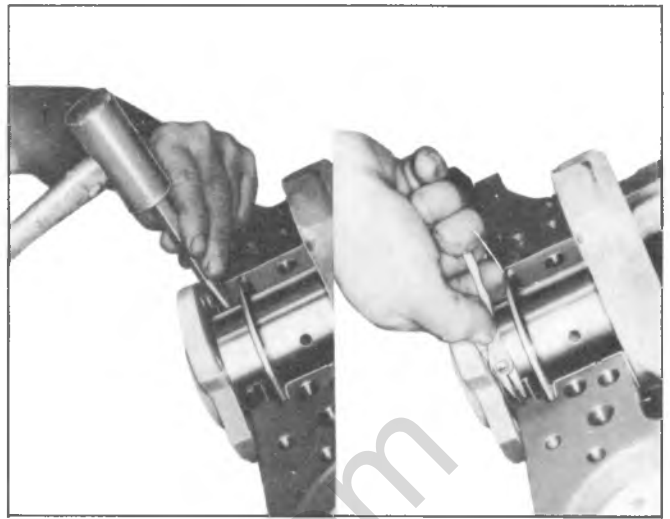


Fig. 6A-64V--Removing Oil Seal - Upper Half

small hammer to tap a brass pin punch on one end of seal until it protrudes far enough to be removed with pliers (fig. 6A-64V).

4. Clean all sealant and foreign material from cylinder case bearing cap and crankshaft, using a non-abrasive cleaner.

5. Inspect components for nicks, scratches, burrs and machining defects at all sealing surfaces, case assembly and crankshaft.

6. Coat seal lips and seal bead with light engine oil - keep oil off seal mating ends.

7. Position tip of tool between crankshaft and seal seat in cylinder case.

8. Position seal between crankshaft and tip of tool so that seal bead contacts tip of tool.

NOTE: Make sure that oil-seal lip is positioned toward front of engine (fig. 6A-65V).

9. Roll seal around crankshaft using tool as a

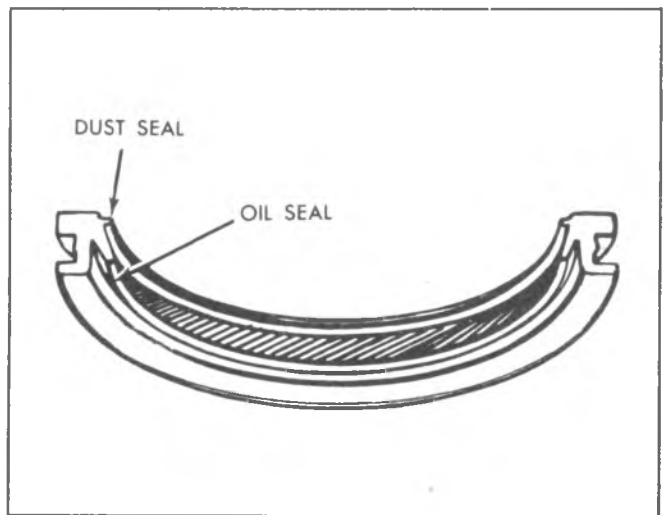


Fig. 6A-65V--Crankshaft Oil Seal - Rear Main

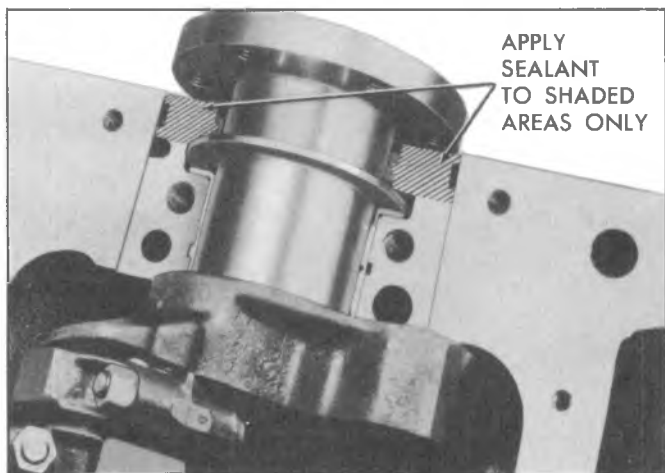


Fig. 6A-66V-Sealing Bearing Cap

"shoe-horn" to protect seal bead from sharp corner of seal seat surface in cylinder case.

CAUTION: Installation tool must remain in position until seal is properly positioned with both ends flush with block.

10. Remove tool, being careful not to withdraw seal.

11. Install seal half in bearing cap, again using tool as a "shoe-horn", feeding seal into cap using light pressure with thumb and finger.

12. Install bearing cap to case with sealant applied to the cap-to-case interface being careful to keep sealant off the seal split line (fig. 6A-66V).

13. Install the rear main bearing cap (with new seal) and torque to specifications.

CONNECTING ROD AND PISTON ASSEMBLIES

Removal

1. With oil pan, oil pump and cylinder head removed, use a ridge reamer to remove any ridge and/or deposits from the upper end of the cylinder bore.

NOTE: Before ridge and/or deposits are removed, turn crankshaft until piston is at the bottom of stroke and place a cloth on top of piston to collect the cuttings. After ridge and/or deposits are removed, turn crankshaft until piston is at top of stroke and remove cloth and cuttings.

2. Inspect connecting rods and connecting rod caps for cylinder identification. If necessary mark them.

3. Remove connecting rod cap and install Tool J-5239 (3/8") or J-6305 (11/32") on studs. Push connecting rod and piston assembly out of top of cylinder block (fig. 6A-67V).

NOTE: It will be necessary to turn the crankshaft slightly to disconnect some of the connecting rod

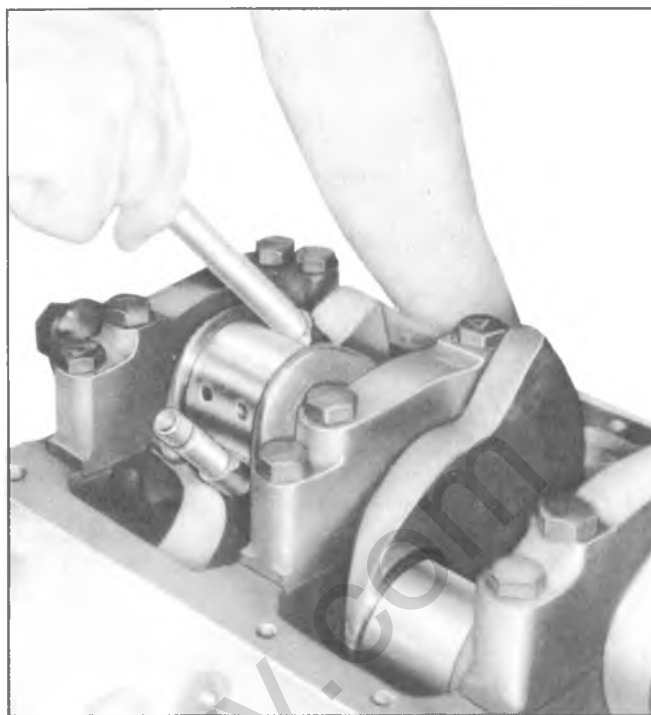


Fig. 6A-67V-Removing Connecting Rod Piston Assembly

and piston assemblies and push them out of the cylinder.

Disassembly

1. Remove connecting rod bearings from connecting rods and caps.

NOTE: If connecting rod bearings are being reused, place them in a rack so they may be reinstalled in their original rod and cap.

2. Remove piston rings by expanding and sliding them off the pistons. Tools J-8020 (3-9/16"), J-8021 (3-7/8"), J8032 (4"), J-22249 (3-15/16"), J-22147 (4-3/32"), and J-22250 (4-1/4") are available for this purpose.

3. Place connecting rod and piston assembly on Tool J-24086-20. Using an arbor press and piston pin remover, J-24086-8, press the piston pin out of connecting rod and piston (fig. 6A-68V).

Cleaning and Inspection

Connecting Rods

Wash connecting rods in cleaning solvent and dry with compressed air.

Check for twisted or bent rods and inspect for nicks or cracks. Replace connecting rods that are damaged.

Pistons

Clean varnish from piston skirts and pins with a cleaning solvent. **DO NOT WIRE BRUSH ANY PART OF THE PISTON.** Clean the ring grooves with a groove cleaner and make sure oil ring holes and slots are clean.

Inspect the piston for cracked ring lands, skirts or pin bosses, wavy or worn ring lands, scuffed or damaged

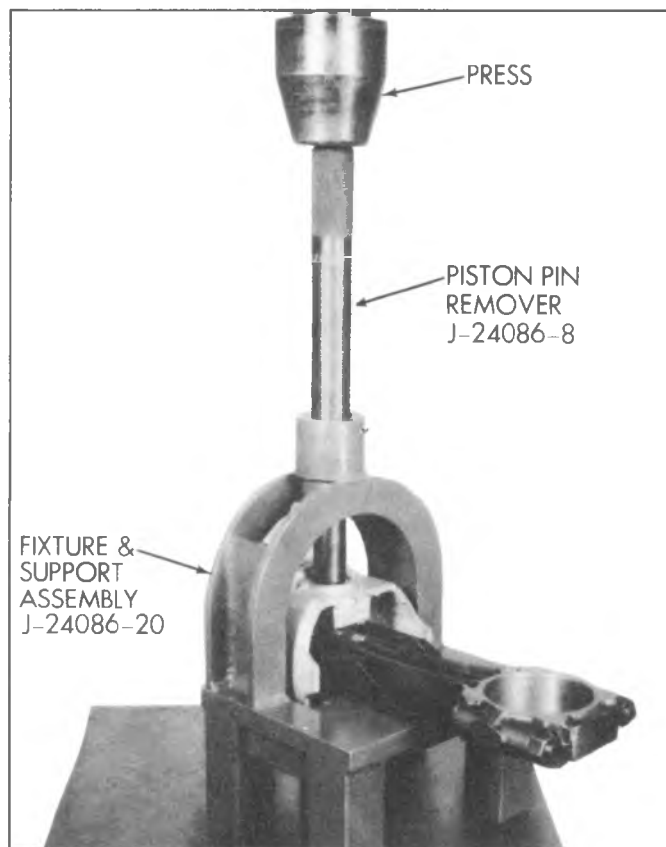


Fig. 6A-68V--Removing Piston Pin

skirts, eroded areas at top of the piston. Replace pistons that are damaged or show signs of excessive wear.

Inspect the grooves for nicks or burrs that might cause the rings to hang up.

Measure piston skirt (across center line of piston pin) and check clearance as outlined under "Piston Selection".

Piston Pins

The piston pin clearance is designed to maintain adequate clearance under all engine operating conditions. Because of this, the piston and piston pin are a matched set and not serviced separately.

Inspect piston pin bores and piston pins for wear. Piston pin bores and piston pins must be free of varnish or scuffing when being measured. The piston pin should be measured with a micrometer and the piston pin bore should be measured with a dial bore gauge or an inside micrometer. If clearance is in excess of the .001" wear limit, the piston and piston pin assembly should be replaced.

Assembly

1. Lubricate piston pin holes in piston and connecting rod to facilitate installation of pin.
2. Place connecting rod in piston and hold in place

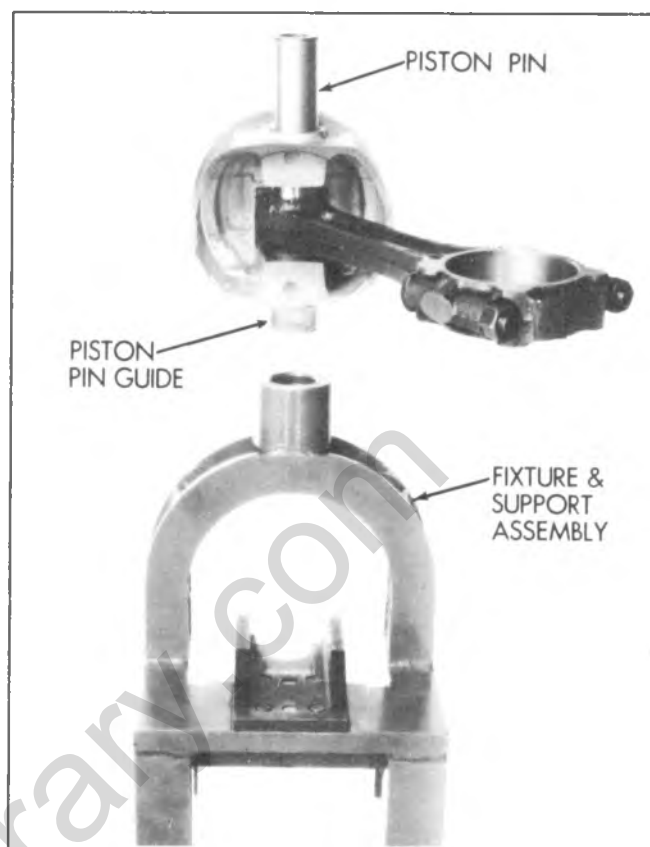


Fig. 6A-69V--Piston Pin Ready for Installation

with piston pin guide and piston pin. Place assembly on fixture and support assembly (fig. 6A-69V).

NOTE: See figure 6A-70V for correct size of piston pin guide.

3. Using piston pin installer, J-24086-9, press the piston pin into the piston and connecting rod (fig. 6A-71V).

NOTE: The piston pin installer is a variable insertion length tool designed to be applicable to all GM Piston assemblies.

The insertion length is varied by rotating the hub on the shaft much like adjusting a micrometer. An alpha-numeric scale is used to determine the desired length for a given piston pin assembly. Refer to figure 6A-70V for correct setting.

CAUTION: After installer hub bottoms on support assembly, do not exceed 6000 psi pressure, as this could cause structural damage to the tool.

4. Remove piston and connecting rod assembly from tool and check piston for freedom of movement on piston pin.

Piston Rings

All compression rings are marked on the upper side of the ring. When installing compression rings, make sure the marked side is toward the top of the piston. The

CYL.	DISPLACEMENT	PIN GUIDE	INSTALLER SETTING	PIN SIZE
4	85 cu. in./1.4 Litre	Gold J-24086-6	I-6	.905"
	97 cu. in./1.6 Litre			
	110 cu. in./1.8 Litre	Blue J-24086-5	I-7	.866"
	140 cu. in./2.3 Litre	Violet J-24086-7	I-7	.927"
6	250 cu. in./4.1 Litre	Violet J-24086-7	G-8	.927"
	292 cu. in./4.8 Litre			
8	Small Block 283, 302, 305, 307, 350, 400	Violet J-24086-7	G-8	.927"
	Mark IV 366, 396, 402, 427, 454	Gray J-24086-3	G-7	.990"

Fig. 6A-70V--Piston Pin Tool Specification

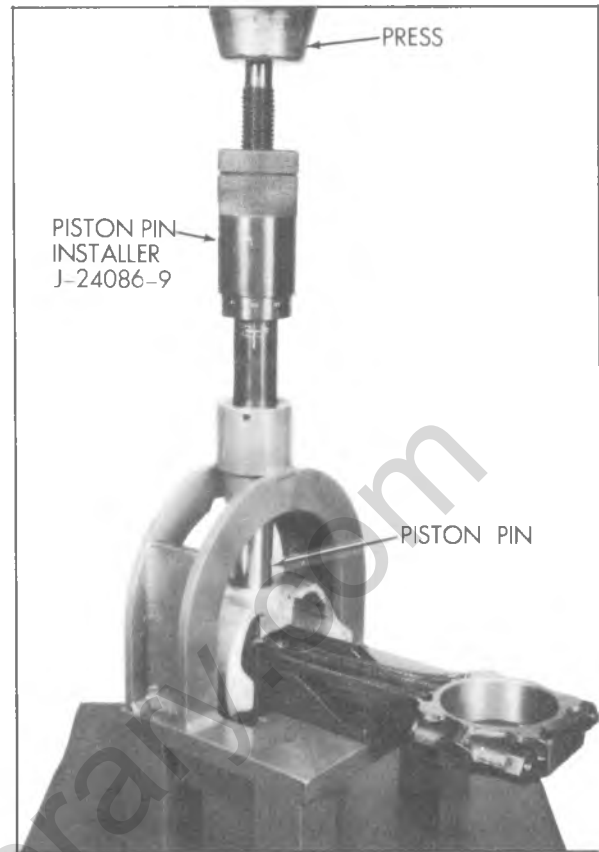


Fig. 6A-71V--Installing Piston Pin

top ring is chrome faced, or treated with molybdenum for maximum life.

The oil control rings are of three piece type, consisting of two segments (rails) and a spacer.

1. Select rings comparable in size to the piston being used.

2. Slip the compression ring in the cylinder bore; then press the ring down into the cylinder bore about 1/4 inch (above ring travel). Be sure ring is square with cylinder wall.

3. Measure the space or gap between the ends of the ring with a feeler gauge (fig. 6A-72V).

4. If the gap between the ends of the ring is below specifications, remove the ring and try another for fit.

5. Fit each compression ring to the cylinder in which it is going to be used.

6. If the pistons have not been cleaned and inspected as previously outlined, do so.

7. Slip the outer surface of the top and second compression ring into the respective piston ring groove and roll the ring entirely around the groove (fig. 6A-73V) to make sure that the ring is free. If binding occurs at any point the cause should be determined, and if caused by ring groove, remove by dressing with a fine cut file. If the binding is caused by a distorted ring, check a new ring.

8. Install piston rings as follows (fig. 6A-74V).

NOTE: Tools J-8020 (3-9/16"), J-8021 (3-7/8"),

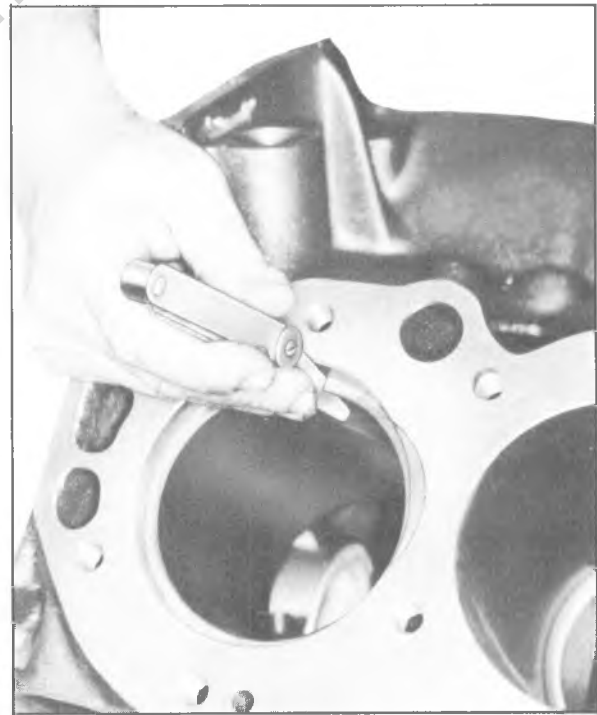


Fig. 6A-72V--Measuring Ring Gap

J8032 (4"), J-22249 (3-15/16"), J-22147 (4-3/32"), and J-22250 (4-1/4") are available for this purpose.



Fig. 6A-73V--Checking Ring in Groove

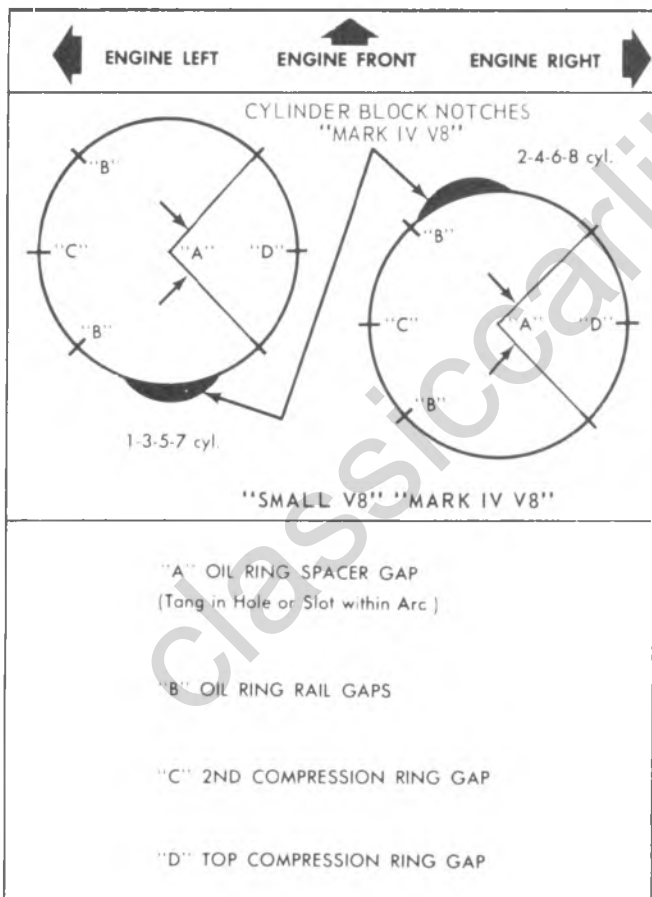


Fig. 6A-74V--Ring Gap Location

a. Install oil ring spacer in groove and insert anti-rotation tang in oil hole.

b. Hold spacer ends butted and install lower steel oil ring rail with gap properly located.

c. Install upper steel oil ring rail with gap properly located.

d. Flex the oil ring assembly to make sure ring is free. If binding occurs at any point the cause should be determined, and if caused by ring groove, remove by dressing groove with a fine cut file. If binding is caused by a distorted ring, check a new ring.

e. Install second compression ring expander then ring with gaps properly located.

f. Install top compression ring with gap properly located.

9. Proper clearance of the piston ring in its piston ring groove is very important to provide proper ring action and reduce wear. Therefore, when fitting new rings, the clearances between the surfaces of the ring and groove should be measured (fig. 6A-75V). (See Specifications).

Installation

NOTE: Cylinder bores must be clean before piston installation. This may be accomplished with a hot water and detergent wash or with a light honing as necessary. After cleaning, the bores should be swabbed several times with light engine oil and a clean dry cloth.

1. Lubricate connecting rod bearings and install in rods and rod caps.

2. Lightly coat pistons, rings and cylinder walls with light engine oil.

3. With bearing caps removed, install Tool J-5239 (3/8") or J-6305 (11/32") on connecting rod bolts.



Fig. 6A-75V--Measuring Ring Groove Clearance

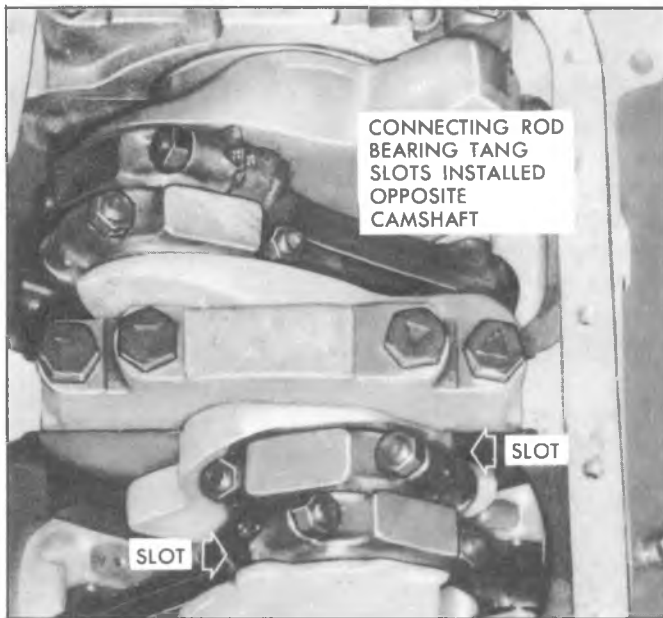


Fig. 6A-76V--Connecting Rods - Installed Position



Fig. 6A-77V--Installing Connecting Rod Piston Assembly

CAUTION: Be sure ring gaps are properly positioned as previously outlined.

4. Install each connecting rod and piston assembly in its respective bore. Install with connecting rod bearing tang slots on side opposite camshaft (fig. 6A-76V). Use Tool J-8037 to compress the rings (fig. 6A-77V). Guide the connecting rod into place on the crankshaft journal with Tool J-5239 (3/8") or J-6305 (11/32"). Use a hammer handle and light blows to install the piston into the bore. Hold the ring compressor firmly against the cylinder block until all piston rings have entered the cylinder bore.

5. Remove Tool J-5239 or J-6305.

6. Install the bearing caps and torque nuts to specifications.

NOTE: If bearing replacement is required refer to "Connecting Rod Bearings".

Be sure to install new pistons in the same cylinders for which they were fitted, and used pistons in the same cylinder from which they were removed. Each connecting rod and bearing cap should be marked, beginning at the front of the engine. On V8 engines 1,3,5 and 7 in the left bank and, 2,4,6 and 8 in the right bank. The numbers on the connecting rod and bearing cap must be on the same side when installed in the cylinder bore. If a connecting rod is ever transposed from one block or cylinder to another, new bearings should be fitted and the connecting rod should be numbered to correspond with the new cylinder number.

ENGINE ASSEMBLY

Removal

1. Remove hood.
2. Disconnect battery cables at battery.
3. Remove air cleaner.
4. Drain radiator and block.
5. Disconnect radiator and heater hoses and remove radiator and fan shroud.
6. Disconnect wires at:
 - Starter Solenoid
 - Delcotron
 - Temperature switch
 - Oil Pressure Switch
 - Coil
7. Disconnect:
 - Accelerator linkage at inlet manifold.
 - Fuel line, from tank, at fuel pump.
 - Hoses at fuel vapor storage canister (if applicable).
 - Vacuum line to power brake unit at manifold, if so equipped.
8. Remove power steering pump and lay aside, if so equipped.
9. Raise vehicle on hoist.
10. Drain crankcase.
11. Disconnect exhaust pipe at manifold and, if so equipped, converter bracket at transmission rear mount.
12. Remove starter.
13. Remove flywheel splash shield or converter housing cover as applicable.
14. On vehicles with automatic transmission, remove converter to flywheel attaching bolt.
15. Remove mount "through" bolts.
16. Remove bell housing bolts.
17. Lower vehicle on hoist.
18. Raise transmission using floor jack.
19. Attach engine lifting devices, raise engine.
20. Remove motor mount to engine brackets.
21. Remove engine assembly.

Installation

1. Position engine assembly in vehicle.
2. Attach motor mount to engine brackets and lower engine in place.
3. Remove engine lifting device.
4. Remove transmission floor jack.
5. Raise vehicle on hoist.
6. Install mount "through" bolts. Torque to specifications.
7. Install bell housing bolts. Torque to specifications.
8. On vehicles with automatic transmissions, install converter to flywheel attaching bolts. Torque to specifications.
9. Install flywheel splash shield of converter housing cover as applicable. Torque attaching bolts to specifications.
10. Install starter.
11. Connect exhaust pipe at manifold and converter bracket at transmission rear mount.
12. Lower vehicle on hoist.
13. Reinstall power steering pump, if so equipped.
14. Connect:
 - Accelerator linkage at inlet manifold.
 - Fuel line, from tank, at fuel pump.
 - Hoses at fuel vapor storage canister.
 - Vacuum line to power brake unit at manifold, if equipped.
15. Connect wires at:
 - Starter Solenoid
 - Delcotron
 - Temperature Switch
 - Oil Pressure Switch
 - Coil
16. Install radiator and fanshroud and reconnect radiator and heater hoses.
17. Fill cooling system.
18. Fill crankcase with oil. See owner's manual for specifications.
19. Install air cleaner.
20. Install hood.
21. Connect battery cables.

NOTE: To avoid possible arcing of battery, connect positive battery cable first.

22. Start engine, check for leaks and check timing.

CRANKSHAFT

The crankshaft can be removed while the engine is disassembled for overhaul, as previously outlined or without complete disassembly as outlined below.

Removal

1. With the engine removed from the vehicle and the transmission and/or clutch housing removed from the engine, mount engine in stand and clamp securely.
2. Remove the oil dip stick and oil dip stick tube, (if applicable).
3. Remove the starting motor, clutch assembly (if equipped) and flywheel.
4. Remove the spark plugs.

5. Remove crankshaft pulley and torsional damper.
6. Remove oil pan and oil pump.
7. Remove crankcase front cover, and if so equipped, remove timing chain and camshaft sprocket.
8. Check the connecting rod caps for cylinder number identification. If necessary mark them.
9. Remove the connecting rod caps and push the pistons to top of bores.
10. Remove main bearing caps and lift crankshaft out of cylinder block.
11. Remove rear main bearing oil seal and main bearings from cylinder block and main bearing caps.

Cleaning and Inspection

1. Wash crankshaft in solvent and dry with compressed air.
2. Measure dimensions of main bearing journals and crankpins with a micrometer for out-of-round, taper or undersize. (See Specifications.)
3. Check crankshaft for run-out by supporting at the front and rear main bearings journals in "V" blocks and check at the front and rear intermediate journals with a dial indicator. (See Specifications.)
4. Replace or recondition the crankshaft if out of specifications.

**SPROCKET OR GEAR REPLACEMENT
(REFER TO FIG. 6A-78V)**

- On "Small V8" engines, remove crankshaft sprocket using Tool J-5825, install using Tool J-5590.
- On Mark IV V8 engines, remove crankshaft sprocket using Tool J1619, install using Tool J-21058.

Installation

1. Install rear main bearing oil seal in cylinder block and rear main bearing cap grooves. Install with lip of seal toward front of engine. Where seal has two lips install lip with helix towards front of engine.

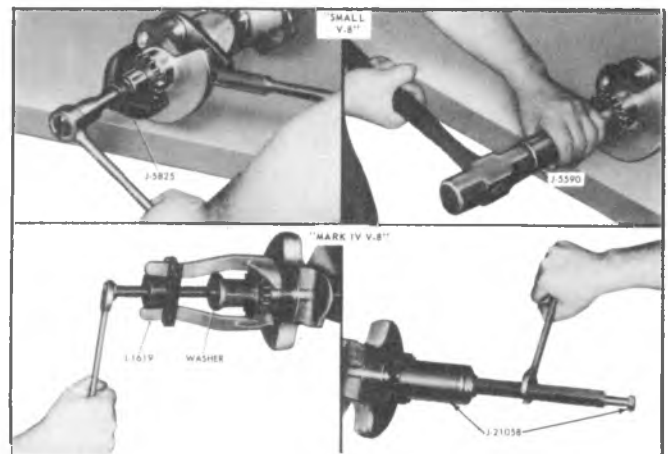


Fig. 6A-78V--Sprocket or Gear Replacement

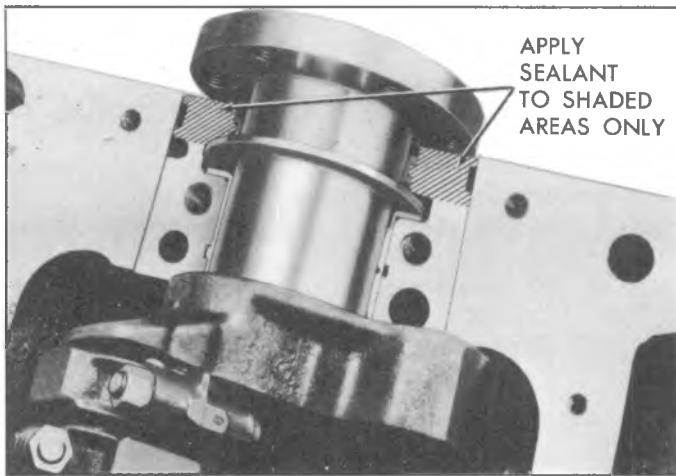


Fig. 6A-79V--Sealing Bearing Cap Block

2. Lubricate lips of seal with engine oil. Keep oil off parting line surface.

3. Install main bearings in cylinder block and main bearing caps then lubricate bearing surface with engine oil.

4. Install crankshaft, being careful not to damage bearing surfaces.

5. Apply a thin coat of brush-on type oil sealing compound to block mating surface and corresponding surface of cap only (fig. 6A-79V). Do not allow sealer on crankshaft or seal.

6. Install main bearing caps with arrows pointing toward front of engine.

7. Torque all except rear main bearing cap bolts to specifications. Torque rear main bearing cap bolts to 10-12 ft. lbs. then tap end of crankshaft, first rearward then forward with a lead hammer. This will line up rear main bearing and crankshaft thrust surfaces. Retorque all main bearing cap bolts to specifications.

8. Measure crankshaft end play with a feeler gauge. Force crankshaft forward and measure clearance between the front of the rear main bearing and the crankshaft thrust surface.

9. Install flywheel and torque to specifications. A wood block placed between the crankshaft and cylinder block will prevent crankshaft from rotating.

NOTE: Align dowel hole in flywheel with dowel hole in crankshaft. On vehicles equipped with automatic transmissions, install flywheel with the converter attaching pads towards transmission.

SPECIFICATIONS

GENERAL DATA:										
Type		In Line			V-8					
Displacement (cu. in.)		250	292	305	350	400	454			
Bore		3.875			3.736	4	4.125	4.250		
Stroke		3.53	4.12	3.48		3.75	4			
Compression Ratio		8.25:1	8.0:1	8.5:1						
Firing Order		1-5-3-6-2-4			1-8-4-3-6-5-7-2					
CYLINDER BORE:										
Diameter		3.8745-3.8775		3.7350-3.7385	3.9995-4.0025	4.1246-4.1274	4.2495-4.2525			
Out of Round	Production	.0005 Max.			.001 Max.					
	Service	.002 Max.								
Taper	Production	Thrust Side	.0005 Max.							
		Relief Side	.0005 Max.	.001 Max.						
	Service	.005 Max.								
PISTON:										
Clearance	Production	.0005-.0015	.0026-.0036	.0007-.0017	.0007-.0017	.0014-.0024	.0024			
	Service	.0025 Max.	.0045 Max.	.0027 Max.		.0035 Max.				
PISTON RING:										
C O M P R E S S I O N	Clearance Groove	Production	Top	.0012-.0027	.0020-.0040	.0012-.0032			.0017-.0032	
			2nd	.0012-.0032						
			Service	Hi Limit Production + .001						
	Gap	Production	Top	.010-.020						
			2nd	.010-.020	.010-.025			.010-.020		
				Service	Hi Limit Production + .01					
O I L	Groove Clearance	Production	.005 Max.	.005-.0055	.002-.007			.0005-.0065		
		Service	Hi Limit Production + .001							
	Gap	Production	.015-.055							
		Service	Hi Limit Production + .01							
PISTON PIN:										
Diameter		.9270-.9273					.9895-.9898			
Clearance	Production	.00015-.00025		.00025-.00035		.00025-.00035		.00025-.00035		
	Service	.001 Max.								
Fit in Rod		.0008-.0016 Interference								

CRANKSHAFT:		250	292	305	350	400	454	
Main Journal	Diameter	All 2.2983-2.2993		#1 2.4484-2.4493	#1-2-3-4 2.6484-2.6493	#1 2.7485-2.7494		
				#2-3-4 2.4481-2.4490		#2-3-4 3.7481-2.7490		
				#5 2.4479-2.4488	#5 2.6479-2.6488	#5 2.7478-2.7488		
	Taper	Production	.0002 (Max.)					
		Service	.001 (Max.)					
	Out of Round	Production	.0002 (Max.)					
		Service	.001 (Max.)					
Main Bearing Clearance	Production	All .0003	All .0008	#1 .0008-.0020		#1-2-3-4 .0013-.0025		
		-	-	#2-3-4 .0011-.0023				
		.0029	.0034	#5 .0017-.0032		#5 .0024-.0040		
	Service	#1 - .002 (Max.) All Others .0035 (Max.)						
Crankshaft End Play		.002-.006				.006-.010		
Crank-pin	Diameter		1.999-1.2000	2.099-2.100	2.199-2.200		2.1985-2.1995	
	Taper	Production	.0003 (Max.)					
		Service	.001 (Max.)					
	Out of Round	Production	.0002 (Max.)					
Service		.001 (Max.)						
Rod Bearing Clearance	Production	.0007-.0027		.0013-.0035		.0009-.0025		
	Service	.0035 (Max.)						
Rod Side Clearance		.0006-.0017		.008-.014		.013-.023		

CAMSHAFT:			250	292	305	350	400	454	
Lobe Lift $\pm .002''$	Intake		.2217	.2315	.2485	.2600		.2343	
	Exhaust		.2217	.2315	.2733			.2343	
Journal Diameter	1.8677-1.8697			1.8682-1.8692			1.9482-1.9492		
Camshaft Runout	.0015 Max.								
Camshaft End Play	.001-.005								
VALVE SYSTEM:									
Lifter	Hydraulic								
Rocker Arm Ratio	1.75:1			1.50:1			1.70:1		
Valve Lash	Intake	One Turn Down From Zero Lash							
	Exhaust								
Face Angle (Int. & Exch.)	45°								
Seat Angle (Int. & Exh.)	46°								
Seat Runout (Int. & Exh.)	.002 (Max.)								
Seat Width	Intake	1/32-1/16							
	Exhaust	1/16-3/32							
Stem Clearance	Production	Int.	.0015-.0032			.0010-.0027		.0012-.0029	
		Exh.							
	Service	Hi Limit Production + .001 Intake - + .002 Exhaust							
Valve Spring (Outer)	Free Length		2.08		2.03			2.12	
	Pressure lbs. @ in.	Closed	55-64 @ 1.66	85-93 @ 1.69	76-84 @ 1.70 Intake @ 1.61 Exhaust			74-86 @ 1.88	
		Open	180-192 @ 1.27	174-184 @ 1.30	194-206 @ 1.25 Intake @ 1.16 Exhaust			288-312 @ 1.38	
	Installed Height $\pm 1/32''$		1-21/32	1-5/8	1-23/32 Intake 1-19/32 Exhaust			1-7/8	
Damper	Free Length		1.94	1.94	1.86			1.86	
	Approx. # of Coils		4	4	4			4	

SECTION 6B

ENGINE COOLING

INDEX

General Description.....	6B-1	Heater Core.....	6B-6
Diagnosis.....	6B-2	Fan Belt Adjustment.....	6B-6
Maintenance and Adjustments.....	6B-4	Radiator Cap.....	6B-6
Coolant Level.....	6B-4	Thermostat.....	6B-6
Coolant System Checks.....	6B-4	Replacement.....	6B-6
Periodic Maintenance.....	6B-4	Thermostatic Fan Clutch Replacement.....	6B-6
Cleaning.....	6B-5	Water Pump.....	6B-7
Reverse Flushing.....	6B-5	Removal.....	6B-7
Radiator.....	6B-5	Installation.....	6B-8
Cylinder Block and Cylinder Head.....	6B-5		

GENERAL DESCRIPTION

All light duty trucks have pressure type engine cooling systems with thermostatic control of coolant circulation. The cooling system is sealed by a pressure type radiator filler cap.

The pressure type radiator filler cap (fig. 6B-1) is designed to operate the cooling system at higher than atmospheric pressure. The higher pressure raises the boiling point of the coolant which increases the efficiency of the radiator.

The radiator filler cap contains a pressure relief valve and a vacuum relief valve. The pressure relief valve is held against its seat by a spring, which when compressed, allows excessive pressure to be relieved out the radiator overflow.

The vacuum valve is also held against its seat by a spring which when compressed, opens the valve relieving the vacuum created when the system cools.

The cooling systems water pump is of the centrifugal vane impeller type (figs. 6B-2 and 6B-3). The

bearings are permanently lubricated during manufacture and are sealed to prevent the loss of lubricant or the entry of dirt and water. The pump requires no care other than to make certain the air vent at the top of the housing and the drain holes in the bottom do not become plugged with dirt or grease.

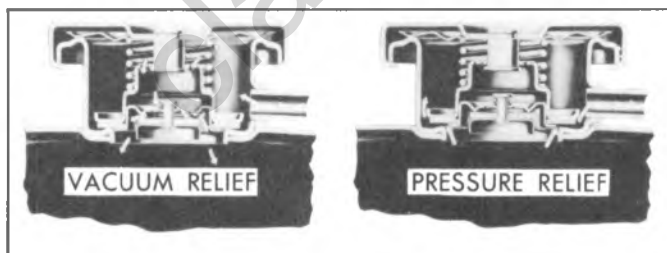


Fig. 6B-1--Radiator Pressure Cap

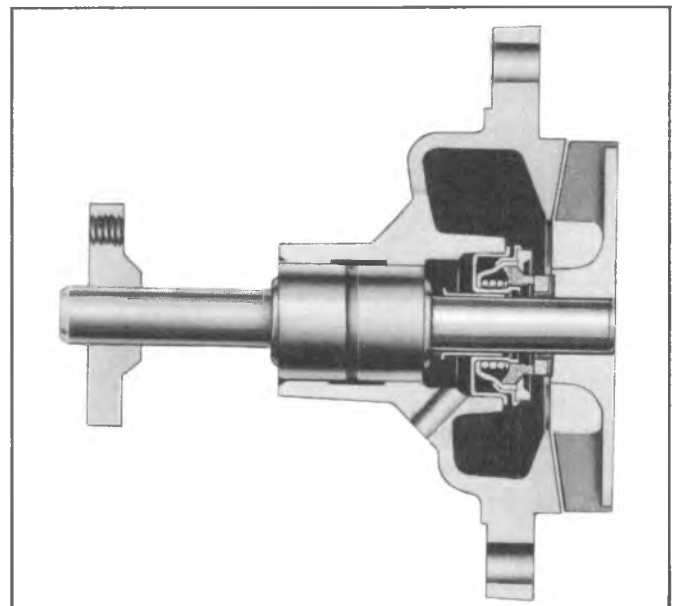


Fig. 6B-2--Water Pump—Typical L-6

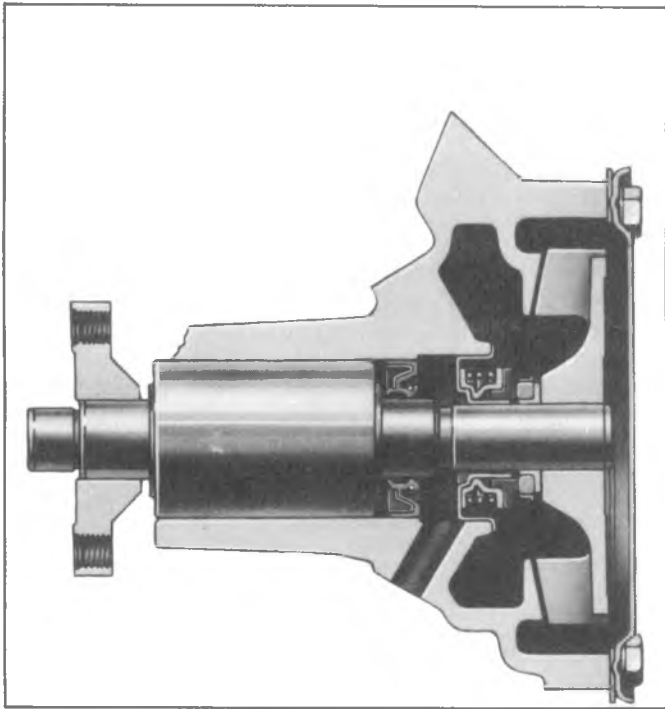


Fig. 6B-3--Water Pump—Typical V8

Water pump components are not serviced separately; therefore, in the event of water pump failure, it will be necessary to replace the complete assembly - removal and installation procedures are covered in this section.

DIAGNOSIS

If the cooling system requires frequent addition of coolant in order to maintain the proper level, check all units and connections in the cooling system for evidence of leakage. Inspection should be made with cooling system cold. Small leaks which may show dampness or dripping can easily escape detection when the engine is hot, due to the rapid evaporation of coolant. Tell-tale stains of grayish white or rusty color, or dye stains from anti-freeze, at joints in cooling system are almost always sure signs of small leaks even though there appears to be no damage.

Air may be drawn into the cooling system through leakage at the water pump seal or through leaks in the coolant recovery system. Gas may be forced into the cooling system through leakage at the cylinder head gasket even though the leakage is not sufficient to allow water to enter the combustion chamber.

COOLING SYSTEM CHECKS

To check for exhaust leaks into the cooling system, drain the system until the coolant level stands just above the top of the cylinder head, then disconnect the radiator upper hose and remove the thermostat and fan belt. Start the engine and quickly accelerate several times. At the same time note any appreciable water rise or the appearance of bubbles which are indicative of exhaust gases leaking into the cooling system.

Water pump operation may be checked by running the engine while squeezing the radiator upper hose. A

pressure surge should be felt. Check for a plugged vent-hole in pump.

Test for restriction in the radiator, by warming the engine up and then turning the engine off and feeling the radiator. The radiator should be hot along the left side and warm along the right side, with an even temperature rise from right to left. Cold spots in the radiator indicate clogged sections.

An operational check of the thermostat can be made by hanging thermostat on a hook in a 33% glycol solution 25° above the temperature stamped on the thermostat valve. Submerge the valve completely and agitate the solution thoroughly. Under this condition the valve should open. Remove the thermostat and place in a 33% glycol solution 10° below temperature indicated on the valve. With valve completely submerged and water agitated thoroughly, the valve should close completely.

Coolant Loss

1. Check for crack in block. Pull engine oil dipstick to check for water in crankcase.

2. Remove rocker arm covers and check for cracked cylinder head.

3. Remove cylinder heads and check gaskets. While heads are off, check for cracks in heads or block.

Overheating

1. Check to see that the radiator cap seats in radiator filler neck and releases at specified pressure (15 lbs.).
2. Check coolant level.
3. Check temperature sending unit and/or gauge.
4. Check engine thermostat.
5. Check fan belt for excessive looseness.
6. Check for punctures in radiator, ruptured or disconnected hoses, loose pressure cap or use of low boiling point antifreeze. These conditions prevent cooling system from maintaining proper pressure.
7. Clean debris from radiator and/or condenser.
8. Check engine operation to make sure tune-up is not needed. Improper timing may cause overheating.
9. Check for driving conditions which may cause overheating. Prolonged idling, start and stop driving in long lines of traffic on hot days, climbing steep grades on hot days, etc. will occasionally cause coolant to boil.
10. Clean cooling system.
11. Remove cylinder heads and check water passages in heads and block for obstructions.

FAN CLUTCH

1. NOISE

Fan noise is sometimes evident under the following normal conditions: a. when clutch is engaged for maximum cooling, and b. during first few minutes after start-up until the clutch can re-distribute the silicone fluid back to its normal disengaged operating condition after overnight settling.

However, fan noise or an excessive roar will generally occur continuously under all high engine speed conditions (2500 r.p.m. and up) if the clutch assembly is locked up due to an internal failure. If the fan cannot be rotated by hand or there is a rough grating feel as the fan is turned, the clutch should be replaced.

2. LOOSENESS

Under various temperature conditions, there is a visible lateral movement that can be observed at the tip of the fan blade. This is a normal condition due to the type of bearing used. Approximately 1/4" maximum lateral movement measured at the fan tip is allowable. This is not cause for replacement.

3. SILICONE FLUID LEAK

The operation of the unit is generally not affected by small fluid leaks which may occur in the area around the bearing assembly. However, if the degree of leakage appears excessive, proceed to item 4.

4. ENGINE OVERHEATING

A. Start with a cool engine to ensure complete fan clutch disengagement. Refer to Item b, paragraph 1.

B. If the fan and clutch assembly free-wheels with no drag (revolves over 5 times when spun by hand), the clutch should be replaced. If clutch performs properly with a slight drag go to step C.

NOTE: Testing a fan clutch by holding the small hub with one hand and rotating the aluminum housing in a clockwise/counterclockwise motion will cause the clutch to free-wheel, which is a normal condition when operated in this manner. This should not be considered a test by which replacement is determined.

C. Use dial type thermometer, J6742-01, or similar type.

NOTE: J6742-01 reads to 180 degrees F, therefore, allow approximately 3/16" pointer movement for each 10 degrees over 180 degrees.

CAUTION: Check for adequate clearance between fan blades and thermometer sensor before starting engine.

Position thermometer so that the thermometer sensor is centered in the space between the fan blades and radiator. This can be achieved by inserting the sensor through one of the existing holes in the fan shroud or fan guard, or by placing between the radiator and the shroud. On some models, it may be necessary to drill a 3/16" hole in the fan shroud to insert J6742-01.

D. Cover radiator grille sufficiently to induce a high engine temperature. Start engine and turn on air conditioning if equipped. Maintain a position in front of the vehicle to observe the thermometer reading. With a rod, broom handle, or etc., push on the accelerator linkage to maintain approximately 3000 r.p.m. Use tachometer if available.

E. Observe thermometer reading when clutch engages. It will take approximately 5 to 10 minutes for the temperature to become high enough to allow engagement of the fan clutch. This will be indicated by an increase or roar in fan air noise and by a drop in the thermometer reading of approximately 5-15 degrees F. If the clutch did not engage by the temperature specified below, the unit should be replaced.

165° All vehicles except as listed below.

170° Corvette without A/C.

190° Corvette with A/C.

NOTE: Be sure fan clutch was disengaged at beginning of test.

CAUTION: Do not continue test past a thermometer reading as specified to prevent engine overheating.

If no sharp increase in fan noise or temperature drop was observed and the fan noise level was constantly high from start of test to 165 degrees F, the unit should be replaced.

F. As soon as the clutch engages, remove the radiator grille cover and turn off the air conditioning to assist in engine cooling. The engine should be run at approximately 1500 r.p.m.

G. After several minutes the fan clutch should disengage, as indicated by a reduction in fan speed and roar.

MAINTENANCE AND ADJUSTMENTS

COOLANT LEVEL

NOTE: With the coolant recovery system, the coolant level is checked by observing the liquid level in the reservoir. The radiator cap need not be removed. The coolant level should be at the "Cold Full" mark when cooling system cools and coolant is at ambient temperature. After the vehicle has been driven sufficiently to obtain normal operating temperatures, the level should be at the "Hot Full" mark.

The radiator coolant level should only be checked when the engine is cool, particularly on cars equipped with air conditioning. If the radiator cap is removed from a hot cooling system, serious personal injury may result.

Coolant level in crossflow radiators without the coolant recovery system should be maintained three inches below the bottom of the filler neck when the system is cold. When a surge radiator supply tank is used the coolant level should be maintained at the one-half full level in the supply tank. It is very important that the correct fluid level be maintained. The sealing ability of the radiator cap is affected when the cooling level is too high.

All passenger car cooling systems are pressurized with a 15 pound pressure cap which permits safe engine operation at coolant temperatures of up to 258 °F.

When the radiator cap is removed or loosened, the system pressure drops to atmospheric, and the heat which had caused water temperature to be higher than 212 °F, will be dissipated by conversion of water to steam. Inasmuch as the steam may form in the engine water passages, it will blow coolant out of the radiator upper hose and tank top, necessitating coolant replacement. Engine operating temperatures higher than the normal boiling point of water are in no way objectionable so long as the coolant level is satisfactory when the engine is cool.

Upon repeated coolant loss, the pressure radiator cap and seat should be checked for sealing ability. Also, the cooling system should be checked for loose hose connections, defective hoses, gasket leaks, etc.

Cooling System Checks

1. Test for restriction in the radiator, by warming the engine up and then turning the engine off and feeling the radiator. The radiator should be hot along the left side and warm along the right side, with an even temperature rise from right to left. Cold spots in the radiator indicate clogged sections.

2. Water pump operation may be checked by running the engine while squeezing the radiator upper

hose. A pressure surge should be felt. Check for a plugged vent-hole in pump.

NOTE: A defective head gasket may allow exhaust gases to leak into the cooling system. This is particularly damaging to the cooling system as the gases combine with the water to form acids which are harmful to the radiator and engine.

WARNING: If you siphon coolant from the radiator, do not use mouth to start siphoning action. The coolant solution is **POISONOUS** and can cause death or serious illness if swallowed.

3. To check for exhaust leaks into the cooling system, drain coolant from the system until the coolant level stands just above the top of the cylinder head, then disconnect the radiator upper hose and remove the thermostat and fan belt. Start the engine and quickly accelerate several times. At the same time note any appreciable water rise or the appearance of bubbles which are indicative of exhaust gases leaking into the cooling system.

Periodic Maintenance

It is the owner's responsibility to keep the freeze protection at a level commensurate with the area in which the vehicle will be operated. Regardless of whether freezing temperatures are or are not expected, cooling system protection should be maintained at least to -20 °F to provide adequate corrosion protection and proper temperature indicating light operation. With glycol content less than requirement for -20 °F protection, coolant boiling point is less than the temperature indicating light setting. When adding solution due to loss of coolant for any reason or in areas where temperatures lower than -20 °F may occur, a sufficient amount of an ethylene glycol base coolant that meets GM Specification 1899-M should be used.

Every two years the cooling system should be serviced by flushing with plain water, then completely refilled with a fresh solution of water and a high-quality, inhibited (permanent-type) glycol base coolant meeting GM Specification 1899-M and providing freezing protection at least to -20 °F. At this time, also add GM Cooling System Inhibitor and Sealer or equivalent. In addition, such an inhibitor and sealer should be added every fall thereafter.

NOTE: Alcohol or methanol base coolants or plain

water are not recommended for your engine at any time.

Two common causes of corrosion are: (1) air suction—Air may be drawn into the system due to low liquid level in the radiator, leaky water pump or loose hose connections, defective pressure cap or loose overflow hose connection to radiator on recovery bottle; (2) exhaust gas leakage—Exhaust gas may be blown into the cooling system past the cylinder head gasket or through cracks in the cylinder head and block.

Cleaning

A good cleaning solution should be used to loosen the rust and scale before reverse flushing the cooling system. There are a number of cleaning solutions available and the manufacturer's instructions with the particular cleaner being used should always be followed.

An excellent preparation to use for this purpose is GM Cooling System Cleaner or its equivalent. The following directions for cleaning the system applies only when this type cleaner is used.

WARNING: If you siphon coolant from the radiator, do not use mouth to start siphoning action. The coolant solution is POISONOUS and can cause death or serious illness if swallowed.

1. Drain coolant from the cooling system, including the cylinder block.

NOTE: The V8 cylinder block drain plugs are located on both sides of the block about halfway back and on the lower edge near the oil pan rail.

The 6-cylinder block drain is located on the left side of the engine at about centerline of the block and adjacent to the flywheel housing.

2. Remove thermostat and replace thermostat housing.

3. Add the liquid portion (No. 1) of the cooling system cleaner.

4. Fill the cooling system with water to a level of about 3 inches below the top of the overflow pipe.

5. Cover the radiator and run the engine at moderate speed until engine coolant temperature reaches 180 degrees.

6. Remove cover from radiator and continue to run the engine for 20 minutes. Avoid boiling.

7. While the engine is still running, add the powder portion (No. 2) of the cooling system cleaner and continue to run the engine for 10 minutes.

WARNING: Be careful not to scald your hands.

8. At the end of this time, stop the engine, wait a few minutes and then open the drain cocks.

NOTE: Dirt and bugs may be cleaned out of the radiator air passages by blowing out with air pressure from the back of the core. Do not bend radiator fins.

Reverse Flushing

Reverse flushing should always be accomplished after the system is thoroughly cleaned as outlined above. Flushing is accomplished through the system in a direction opposite to the normal flow. This action causes the water to get behind the corrosion deposits and force them out.

Radiator

1. Remove the radiator upper and lower hoses and replace the radiator cap.

2. Attach a lead-away hose at the top of the radiator.

3. Attach a new piece of hose to the radiator outlet connection and insert the flushing gun in this hose.

4. Connect the water hose of the flushing gun to a water outlet and the air hose to an air line.

CAUTION: Apply air gradually as a clogged radiator will stand only 20 p.s.i. pressure.

5. Turn on the water and when the radiator is full, turn on the air in short blasts, allowing the radiator to fill between blasts of air.

6. Continue this flushing until the water from the lead-away hose runs clear.

Cylinder Block and Cylinder Head

1. With the thermostat removed, attach a lead-away hose to the water pump inlet and a length of new hose to the water outlet connection at the top of the engine.

NOTE: Disconnect the heater hose and cap connections at engine when reverse flushing engine.

2. Insert the flushing gun in the new hose.

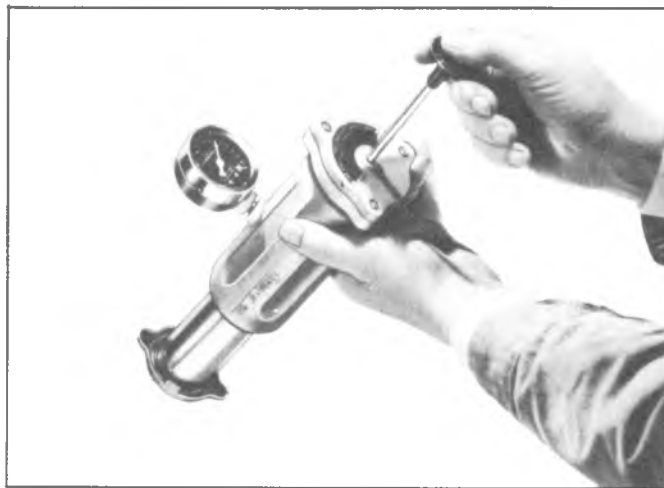


Fig. 6B-4.-Pressure Checking Radiator Cap

3. Turn on the water and when the engine water jacket is full, turn on the air in short blasts.

4. Continue this flushing until the water from the lead-away hose runs clear.

Heater Core

1. Remove water outlet hose from heater core pipe.
2. Remove inlet hose from engine connection.
3. Insert flushing gun and flush heater core. Care must be taken when applying air pressure to prevent damage to the core.

Fan Belt Adjustment

1. Loosen bolts at Delcotron mounting.
2. Pull Delcotron away from engine until desired tension reading is obtained with a strand tension gauge. Refer to Engine Tune-Up Specifications.
3. Tighten all Delcotron bolts securely.

Radiator Cap

The radiator cap should be washed with clean water and pressure checked at regular tune-up intervals. Inspect rubber seal on cap for tears or cracks. Install radiator cap on tester (fig. 6B-4). If the pressure cap will not hold pressure or does not release at the proper pressure, replace the cap.

Thermostat

The thermostat consists of a restriction valve actuated by a thermostatic element. This is mounted in the housing at the cylinder head water outlet above the water pump. Thermostats are designed to open and close at predetermined temperatures and if not operating properly should be removed and tested as follows:

Replacement

1. Remove radiator to water outlet hose.
2. Remove thermostat housing bolts and remove



Fig. 6B-5--Replacing Thermostat

water outlet and gasket from thermostat housing (fig. 6B-5).

3. Inspect thermostat valve to make sure it is in good condition.

4. Place thermostat in a 33% glycol solution 25° above the temperature stamped on the thermostat valve.

5. Submerge the valve completely and agitate the water thoroughly. Under this condition the valve should open fully.

6. Remove the thermostat and place in a 33% glycol solution 10° below temperature indicated on the valve.

7. With valve completely submerged and water agitated thoroughly, the valve should close completely.

8. If thermostat checks satisfactorily, re-install, using a new housing gasket.

9. Refill cooling system.

THERMOSTATIC FAN CLUTCH

REPLACEMENT

All mating surfaces (water pump hub and fan clutch hub) should be inspected for smooth mating surfaces and reworked as necessary to eliminate burrs or other imperfections. Except for the fan belt, components should be assembled to the engine (See Water Pump Removal and Installation Procedures). Radial run-out should be checked as follows:

1. Secure the fan blade to prevent rotation. (See Figure 6B-6).

2. Mount a dial indicator (.001 graduations) to the engine and place the indicator pointer on the fan blade spider. Preferably on the longest band or space on the spider. (See Figure 6B-7).

3. Rotate the water pump pulley in one direction and note the total amount of indicator needle movement. This represents the total radial run-out. Mark the point on the pulley at which the highest reading is obtained.

4. If the total indicator reading is less than .006 inch, the assembly is within specification. Install fan belt and adjust.

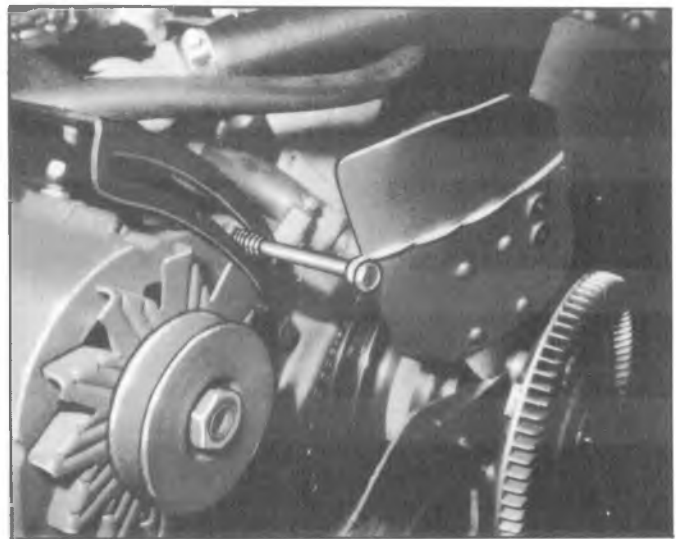


Fig. 6B-6--Securing Fan Blade

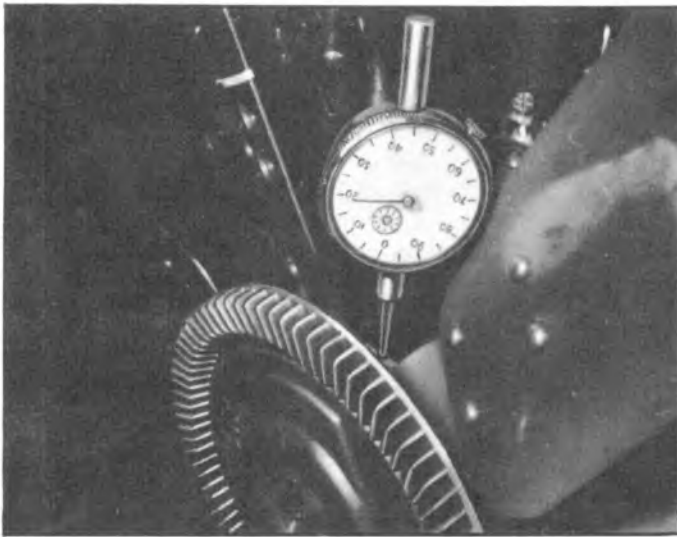


Fig. 6B-7--Checking Run-Out

If the total indicator run-out exceeds .006 inch, proceed to Step 5.

5. Divide the total indicator reading in half and obtain this thickness from shim stock (1/2 x 3/4) and rework per Figure 6B-8. Place this shim pack between the water pump pulley and fan clutch hub at the bolt closest to the point marked on the pulley in Step 3. If the mark on the pulley is between two bolts so that it is difficult to determine which bolt is closest, place two shim packs; one under each bolt on either side of the mark. (See Figure 6B-9).

Bolt Torque Sequence

a. When one shim pack is used, first, torque the bolt over which the shim pack has been placed; second, the bolt opposite the first; and finally, the other two. Recommended torque is 25 lbs. ft.

b. When two shim packs are used, each bolt must be torqued partially; then to full torque alternating between opposite bolts; then the other two bolts in the same manner. Recommended torque is 25 lbs. ft.

NOTE: Excessive run-out may result if the above sequence and recommended torque is not used.

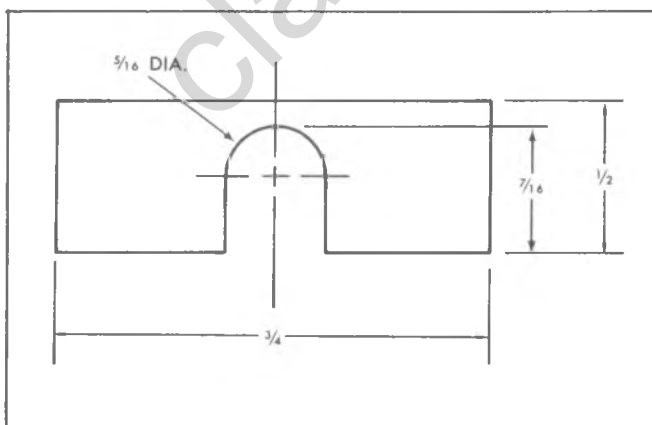


Fig. 6B-8--Shim Fabrication Dimensions

6. Recheck total indicator run-out to verify that run-out is within .006 inch. Install fan belt and adjust.

Water Pump

Removal

WARNING: If you siphon coolant from the radiator, do not use mouth to start siphoning action. The coolant solution is **POISONOUS** and can cause death or serious illness if swallowed.

1. Drain coolant from the radiator and break loose the fan pulley bolts.
2. Disconnect heater hose, radiator lower hose and by pass hose (as required) at water pump.
3. Remove Delcotron upper brace (V8 only), loosen swivel bolt, and remove fan belt. On Mark IV engines disconnect power steering and air conditioning belts and swivel power steering pump to one side.
4. Remove fan blade assembly attaching bolts, fan and pulley.

CAUTION: If a fan blade is bent or damaged in any way, no attempt should be made to repair and reuse the damaged part. A bent or damaged fan assembly should always be replaced with a new fan assembly.

It is essential that fan assemblies remain in proper balance and proper balance cannot be assured once a fan assembly has been bent or damaged. A fan assembly that is not in proper balance could fail and fly apart during subsequent use creating an extremely dangerous condition.

NOTE: Thermostatic fan clutches must be kept in an "in-car" position. When removed from the car

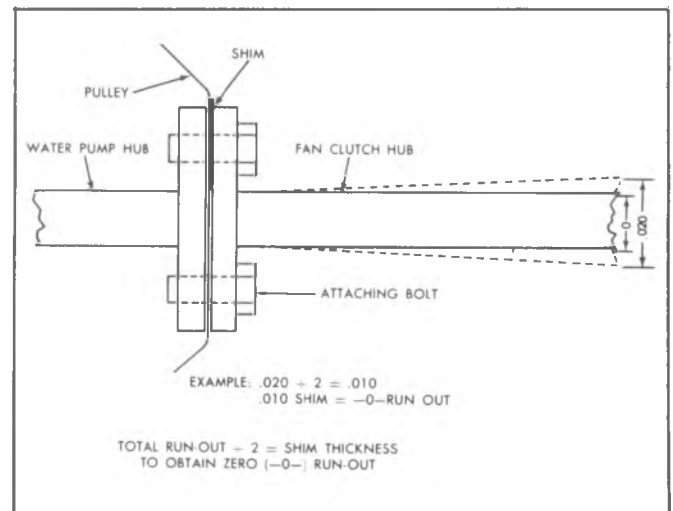


Fig. 6B-9--Determining Shim Placement

the assembly should be supported so that the clutch disc remains in a vertical plane to prevent silicone fluid leakage.

5. Remove pump-to-cylinder block and power steering-to-pump bolts and remove pump and old gasket from engine.

CAUTION: *On in line engines, pull the pump straight out of the block first, to avoid damage to impeller.*

Installation

1. Install pump assembly on cylinder block then, using a new sealer-coated pump-to-block gasket, tighten bolts to specifications.

2. Install pump pulley and fan on pump hub and tighten bolts to specifications.

NOTE: A guide stud (5/16"-24 bolt with the head removed) installed in one hole of the fan hub will aid in aligning hub, pulley and fan. Remove stud after starting the remaining three bolts. On Mark IV engines install power steering and air conditioning bolts.

3. Connect hoses and fill cooling system.

4. Install Delcotron upper brace (V8 only), and install fan belt. Install power steering pump bolt.

NOTE: Grind a slight taper to threaded end of bolt. This will serve as a pilot during installation and also serve to pick-up threads on nut.

5. Adjust belts to specifications as previously outlined.

6. Start engine and check for leaks.

classiccarylbrary.com

SECTION 6C

FUEL SYSTEM

CONTENTS

General Description.....	6C-1	Fuel Pump	6C-42
Carburetion	6C-1	Fuel Tank.....	6C-44
Model 1ME Carburetor.....	6C-1	Fuel Feed and Vapor Lines	6C-50
Model 2GC/2GV Carburetor.....	6C-11	Evaporative Control System (ECS)	6C-50
Model M4MC/M4ME/4MV Carburetor.....	6C-21	Accelerator Controls	6C-51
Fuel Supply.....	6C-42	Special Tools	6C-54
Fuel Filter.....	6C-42		

GENERAL DESCRIPTION

Carburetor

All engines are equipped with either a 1-barrel, 2-barrel, or 4-barrel carburetor attached to the intake manifold.

FUEL FILTER

All light duty emissions engines have a pleated paper fuel filter and check valve assembly located in the carburetor inlet.

All vehicles have a woven plastic fuel filter in the fuel tank on the lower end of the pick-up pipe.

FUEL PUMP

The fuel pump is located on the right front of the engine.

FUEL TANK AND FEED PIPES

All filler necks with light duty emissions have restrictors to prevent the entry of leaded fuel nozzles.

In all series the tank is vented during filling by an internal baffle inside the filler.

In all series the tank outlet consists of a combination fuel pickup, filter and fuel gage tank unit. The tank unit can be removed by removing a cam ring which retains the unit.

The fuel feed pipes are coated, welded steel tubing. Connections from the tank unit to the line and from the line to the fuel pump are made with synthetic rubber hose attached with spring clamps.

EVAPORATIVE CONTROL SYSTEM (ECS)

The Evaporative Control System is a closed system that prevents gasoline vapors in the fuel tank and carburetor from entering the atmosphere.

CARBURETION

ALL NEW 1977 CHEVROLETS ARE CERTIFIED BY THE UNITED STATES DEPARTMENT OF HEALTH, EDUCATION AND WELFARE AS CONFORMING TO THE REQUIREMENTS OF THE REGULATIONS FOR THE CONTROL OF AIR POLLUTION FROM NEW MOTOR VEHICLES. THIS CERTIFICATION IS CONTINGENT ON CERTAIN ADJUSTMENTS BEING SET TO FACTORY STANDARDS. FOR THIS REASON, THE FACTORY PROCEDURE FOR SETTING IGNITION TIMING, AND SLOW IDLE MUST BE FOLLOWED EXACTLY WHEN ADJUSTMENTS ARE MADE.

MODEL 1ME CARBURETOR

GENERAL DESCRIPTION

The Monojet, carburetor (Fig. 6C-1) is a single bore downdraft carburetor using a triple venture in conjunction with a plain tube nozzle.

Fuel flow through the main metering system is controlled by a main well air bleed and a variable orifice jet. A power enrichment system is used to provide good

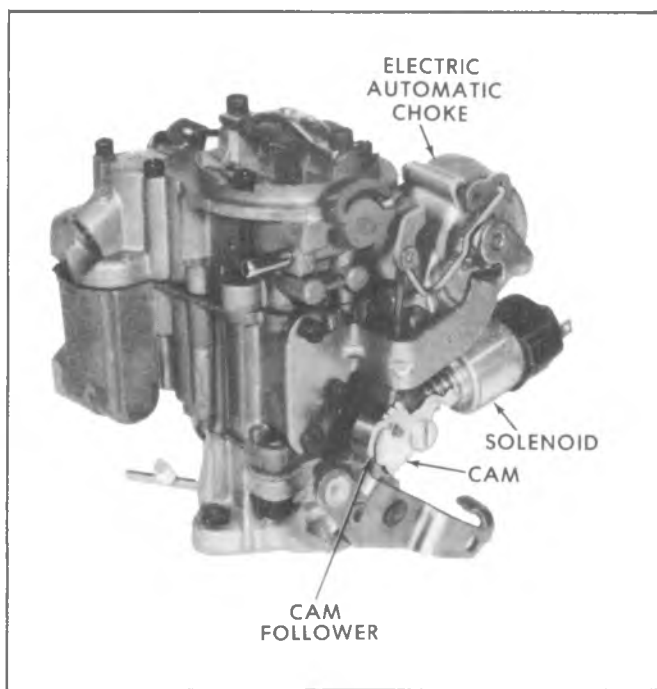


Fig. 6C-1--Model 1ME Carburetor-Rear View

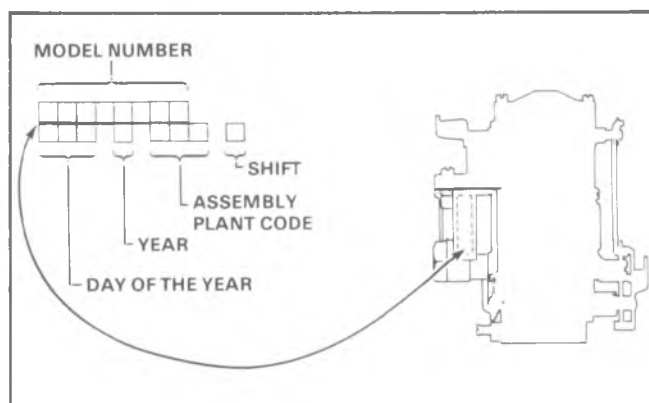


Fig. 6C-2--Model 1ME Carburetor Identification

the float bowl. The carburetor has internally balanced venting through a vent hole in the air horn, which leads from the float bowl into the bore beneath the air cleaner.

The carburetor model identification is stamped on a vertical portion of the float bowl, adjacent to the fuel inlet nut (Fig. 6C-2).

If replacing the float bowl, follow the manufacturer's instructions contained in the service package so that the identification number can be transferred to the new float bowl.

An electrically operated idle stop solenoid is used on all models.

Dual throttle return springs are used on all carburetors.

The throttle lever has a spun-in plastic bushing, this is used as the bearing surface for the dual throttle return springs.

NOTE: The spun-in plastic return spring bushing will withstand normal cleaning time in an approved cold immersion type carburetor cleaner. The bushing is not serviced separately and should not be removed from the carburetor throttle lever.

An Exhaust Gas Recirculation system (EGR) is used on light duty emission and heavy duty emission 454 CID Calif. to control oxides of nitrogen. The vacuum supply port necessary to operate the recirculation valve is located in the throttle body and connects through a channel to a tube which is located at the top of the air horn casting. See Idle System (Fig. 6C-4) for port location and operation.

Six basic systems of operation are used: float, idle, main metering, power enrichment, pump and choke. 6C-3 through 9).

performance during moderate to heavy acceleration and at higher engine speeds.

The idle system, on certain models, incorporates a hot idle compensator (A.T. only) to maintain smooth engine idle during periods of extreme hot engine operation.

The model 1ME incorporates an integral automatic choke system which uses an electrically heated choke coil. The vacuum diaphragm unit is mounted externally on the air horn and connects to the thermostatic coil lever through a connecting line.

The electric choke coil is contained in a choke housing mounted on a bracket attached to the float bowl.

An integral, pleated-paper fuel inlet filter is mounted in the fuel bowl behind the fuel inlet nut to give maximum filtration of incoming fuel. A check valve on light duty emissions is used in the filter inlet to prevent fuel draining from the fuel system after roll-over.

Other features of the Monojet carburetor include an aluminum throttle body for decreased weight and improved heat distribution and a thick throttle body to bowl insulator gasket to keep excessive engine heat from

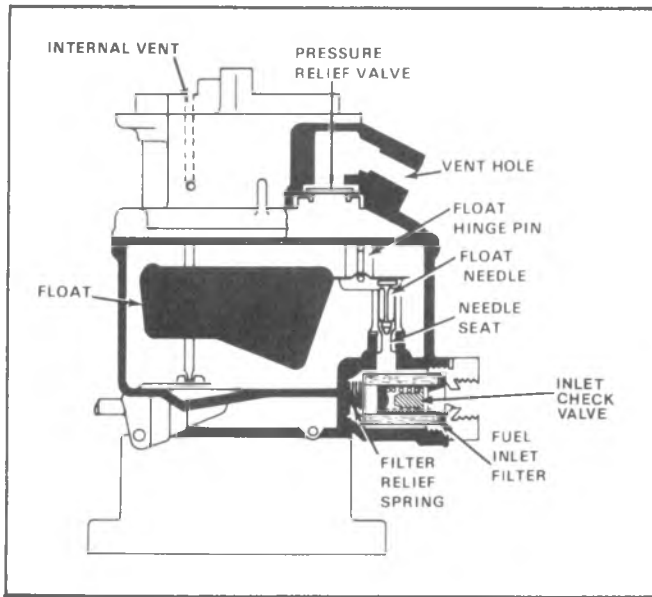


Fig. 6C-3-Float System

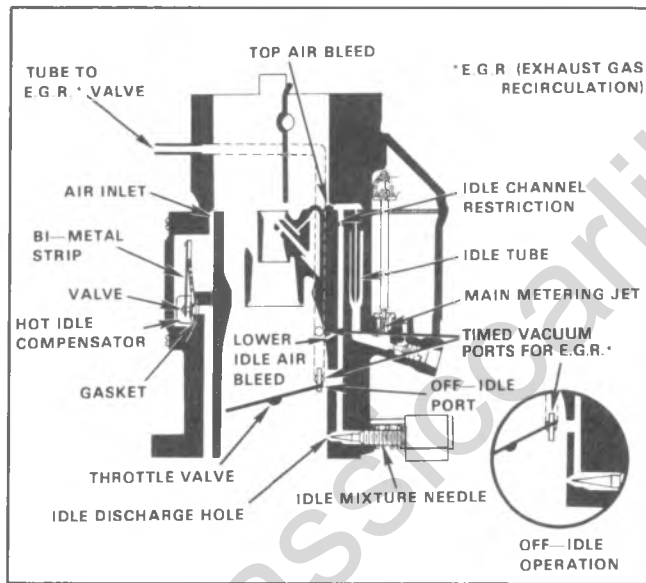


Fig. 6C-4-Idle System

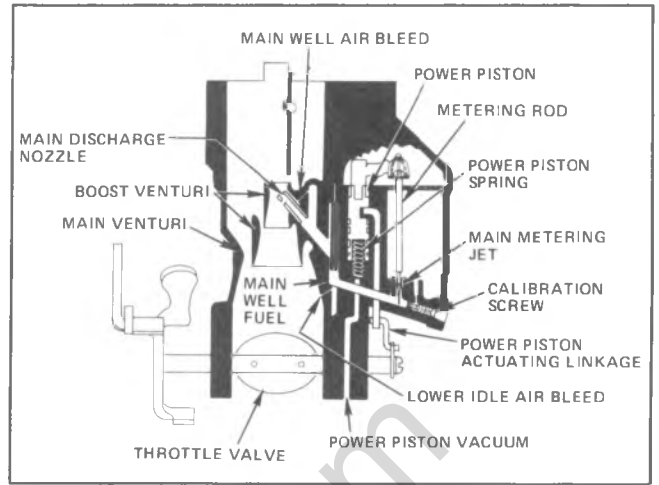


Fig. 6C-5--Main Metering System

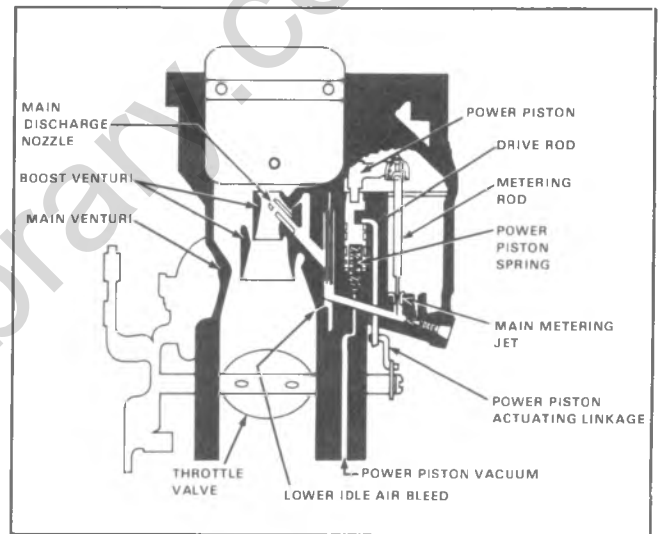


Fig. 6C-6--Power Enrichment System

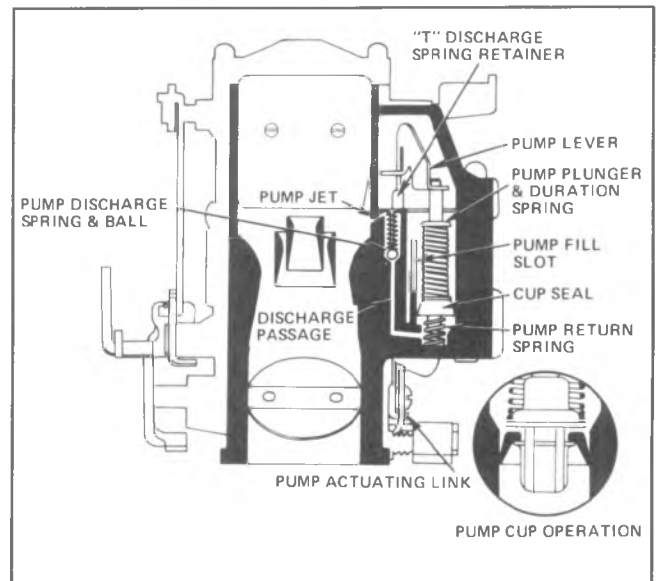


Fig. 6C-7--Pump System

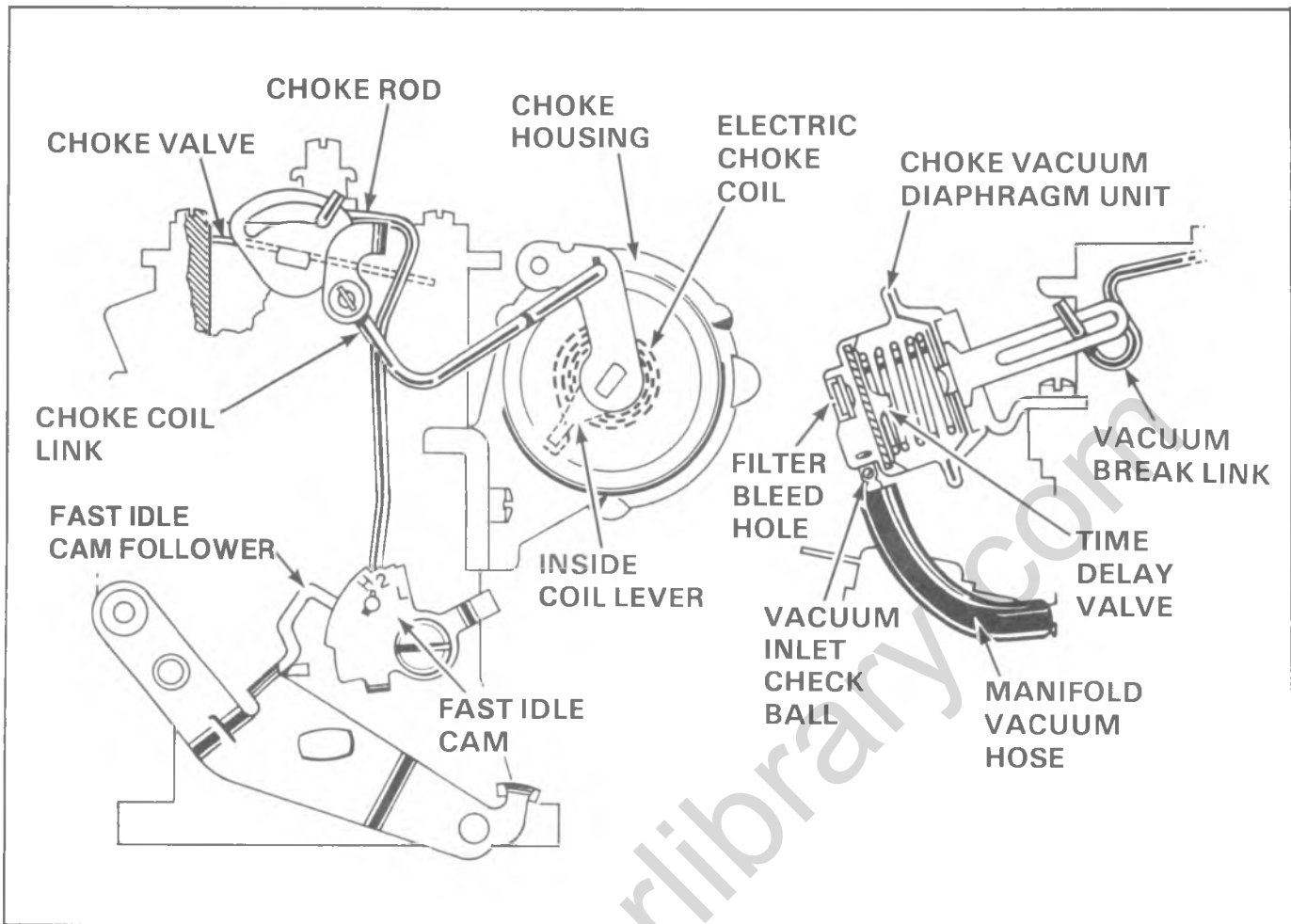


Fig. 6C-8.-Choke System

ON-VEHICLE SERVICE

TIME CARBURETOR ADJUSTMENTS

Refer to figure 6C-9 for the following adjustments:

- Float Level
- Metering Rod
- Fast Idle

Refer to figure 6C-10 for the following adjustments:

- Choke Coil Lever
- Automatic Choke
- Choke Rod (Fast Idle Cam)

Choke Checking Procedure

1. Remove air cleaner. With engine off, hold throttle half open. Open and close choke several times. Watch linkage to be certain all links are connected and there are no signs of damage.

2. If choke or linkage binds, sticks, or works

sluggishly, clean with Choke Cleaner X-20-A or equivalent. Use cleaner as directed on can. Refer to disassembly instructions for additional direction if cleaning does not correct.

3. Visually inspect carburetor to be certain all vacuum hoses are connected. Inspect hoses for cracks, abrasions, hardness or other signs of deterioration. Replace or correct as necessary.

4. Make sure vacuum break diaphragm shaft is fully extended when engine is off. If shaft is not fully extended, replace vacuum break assembly. Start engine - vacuum break diaphragm shaft should fully retract within 10 seconds. If unit fails to retract, replace vacuum break assembly.

5. Allow choke to cool so that when throttle is opened slightly choke blade fully closes.

NOTE: This check must be performed at an ambient temperature of 60 °F to 80 °F.

6. Start engine and determine time for choke

1

FLOAT LEVEL ADJUSTMENT

CARB. NO.	GAUGE
ALL WITH LIGHT DUTY EMISSIONS	3/8"

ALL WITH HEAVY DUTY EMISSIONS	5/16"

2

METERING ROD ADJUSTMENT

CARB. NO.	PLUG GAUGE
17057001 17057002 17057004 17057005 17057010 17057302	.008

17057303	.090

17057006 17057007	.070

17057008 17057009 17057308 17057309	.065

3

NOTE: MANUAL CHOKE MODELS WITH SMOOTH CONTOUR CAM SURFACE-ROTATE FAST IDLE CAM CLOCKWISE TO ITS FARTHEST UP POSITION.

CLEARANCE

FAST IDLE CAM STEPS

LIGHT DUTY EMISSIONS
2100 RPM
(IN NEUTRAL)

HEAVY DUTY EMISSIONS
2400 RPM
(IN NEUTRAL)

FAST IDLE ADJUSTMENT

Fig. 6C-9-1ME Carburetor Adjustments - 1 of 3

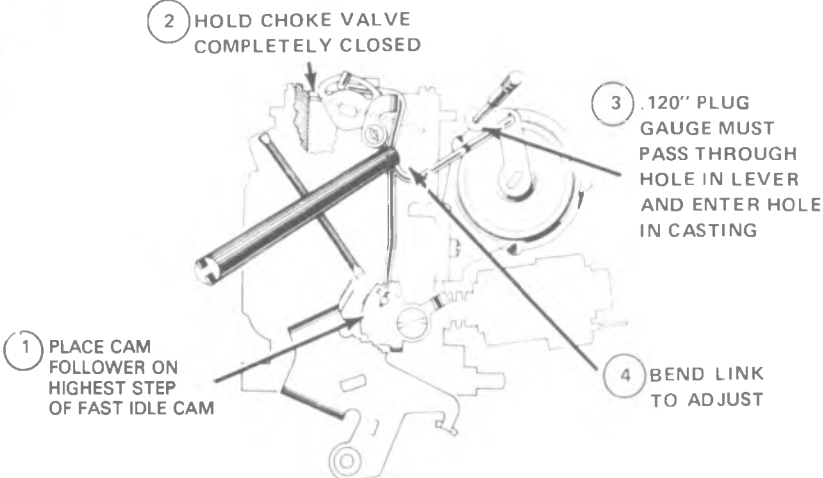
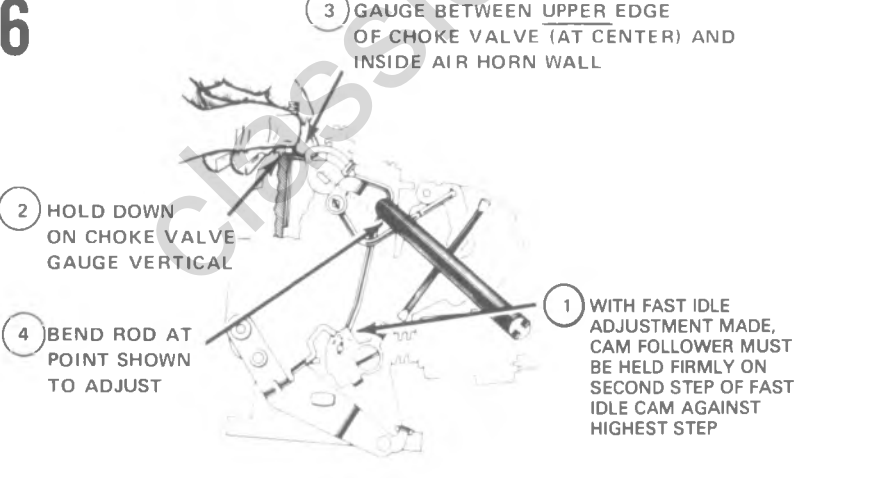
<p>4</p> <p>2 HOLD CHOKE VALVE COMPLETELY CLOSED</p>  <p>1 PLACE CAM FOLLOWER ON HIGHEST STEP OF FAST IDLE CAM</p> <p>3 .120" PLUG GAUGE MUST PASS THROUGH HOLE IN LEVER AND ENTER HOLE IN CASTING</p> <p>4 BEND LINK TO ADJUST</p> <p>CHOKER COIL LEVER ADJUSTMENT</p>	<p>CARB. NO.</p> <p>ALL</p>	<p>PLUG GAUGE</p> <p>.120</p>
<p>5</p> <p>1 LOOSEN THREE RETAINING SCREWS</p> <p>CHOKE HOUSING</p> <p>INDEX</p> <p>3 WITH CHOKE COIL LEVER LOCATED INSIDE COIL TANG (SEE INSET) SET MARK ON ELECTRIC CHOKE TO SPECIFIED POINT ON CHOKE HOUSING AND TIGHTEN SCREWS</p> <p>2 PLACE CAM FOLLOWER ON HIGH STEP OF CAM</p> <p>ELECTRIC CHOKE COIL</p> <p>INSIDE COIL LEVER</p> <p>INSET</p> <p>AUTOMATIC CHOKE ADJUSTMENT</p>	<p>CARB. NO.</p> <p>ALL</p>	<p>INDEX MARK</p> <p>INDEX</p>
<p>6</p> <p>3 GAUGE BETWEEN UPPER EDGE OF CHOKE VALVE (AT CENTER) AND INSIDE AIR HORN WALL</p>  <p>2 HOLD DOWN ON CHOKE VALVE GAUGE VERTICAL</p> <p>4 BEND ROD AT POINT SHOWN TO ADJUST</p> <p>1 WITH FAST IDLE ADJUSTMENT MADE, CAM FOLLOWER MUST BE HELD FIRMLY ON SECOND STEP OF FAST IDLE CAM AGAINST HIGHEST STEP</p> <p>CHOKER ROD (FAST IDLE CAM) ADJUSTMENT</p>	<p>CARB. NO.</p> <p>17057001 17057303 17057005</p> <hr/> <p>17057002 17057004 17057302 17057010</p> <hr/> <p>17057006 17057007 17057008 17057009 17057308 17057309</p>	<p>PLUG GAUGE</p> <p>.125 (.230 BOTTOM)</p> <hr/> <p>.110 (.190 BOTTOM)</p> <hr/> <p>.150 (.275 BOTTOM)</p>

Fig. 6C-10-1ME Carburetor Adjustments - 2 of 3

<p>7</p> <p>NOTE: HOLD GAUGE VERTICAL</p> <p>7 BEND ROD TO ADJUST</p> <p>6 GAUGE BETWEEN UPPER EDGE OF CHOKE VALVE (AT CENTER) AND INSIDE AIR HORN WALL</p> <p>5 ROD IN END OF SLOT</p> <p>NOTE: ON DELAY FEATURE MODELS PLUG END COVER WITH MASKING TAPE</p> <p>4 PUSH UP ON CHOKE COIL LEVER</p> <p>3 DIAPHRAGM PLUNGER OUT AND SEATED. (BUCKING SPRING COMPRESSED—WHERE USED)</p> <p>2 USE OUTSIDE VACUUM SOURCE TO SEAT DIAPHRAGM</p> <p>1 PLACE FAST IDLE CAM FOLLOWER ON HIGHEST STEP OF FAST IDLE CAM</p> <p>8 REMOVE MASKING TAPE, IF USED</p> <p>VACUUM BREAK ADJUSTMENT</p>	<table border="1"> <thead> <tr> <th>CARB. NO.</th> <th>PLUG GAUGE</th> </tr> </thead> <tbody> <tr> <td>17057001 17057303</td> <td>.150 (.275 BOTTOM)</td> </tr> <tr> <td>17057002 17057004 17057302</td> <td>.135 (.245 BOTTOM)</td> </tr> <tr> <td>17057005 17057006 17057007 17057008 17057009 17057308 17057309</td> <td>.180 (.325 BOTTOM)</td> </tr> </tbody> </table>	CARB. NO.	PLUG GAUGE	17057001 17057303	.150 (.275 BOTTOM)	17057002 17057004 17057302	.135 (.245 BOTTOM)	17057005 17057006 17057007 17057008 17057009 17057308 17057309	.180 (.325 BOTTOM)
CARB. NO.	PLUG GAUGE								
17057001 17057303	.150 (.275 BOTTOM)								
17057002 17057004 17057302	.135 (.245 BOTTOM)								
17057005 17057006 17057007 17057008 17057009 17057308 17057309	.180 (.325 BOTTOM)								
<p>8</p> <p>2 HOLDING DOWN ON CHOKE VALVE, GAUGE BETWEEN UPPER EDGE OF CHOKE VALVE AND INSIDE AIR HORN WALL</p> <p>3 BEND TANG TO ADJUST (SEE INSET)</p> <p>NOTE: HOLD GAUGE VERTICAL</p> <p>1 HOLD THROTTLE VALVE WIDE OPEN</p> <p>UNLOADER ADJUSTMENT</p>	<table border="1"> <thead> <tr> <th>CARB. NO.</th> <th>PLUG GAUGE</th> </tr> </thead> <tbody> <tr> <td>ALL WITH LIGHT DUTY EMISSIONS</td> <td>.325 (.600 BOTTOM)</td> </tr> <tr> <td>ALL WITH HEAVY DUTY EMISSIONS</td> <td>.275 (.500 BOTTOM)</td> </tr> </tbody> </table>	CARB. NO.	PLUG GAUGE	ALL WITH LIGHT DUTY EMISSIONS	.325 (.600 BOTTOM)	ALL WITH HEAVY DUTY EMISSIONS	.275 (.500 BOTTOM)		
CARB. NO.	PLUG GAUGE								
ALL WITH LIGHT DUTY EMISSIONS	.325 (.600 BOTTOM)								
ALL WITH HEAVY DUTY EMISSIONS	.275 (.500 BOTTOM)								
<p>9</p> <p>3 TO ADJUST BASE IDLE, TURN 1/8" HEX SCREW (SOLENOID NOT ENERGIZED)</p> <p>2 SET CURB IDLE TO SPECIFICATIONS-TURN ASSEMBLY IN OR OUT TO ADJUST R.P.M. (SOLENOID ENERGIZED)</p> <p>1 ENGINE MUST BE WARM-CHOKE WIDE OPEN-CAM FOLLOWER OFF STEPS OF CAM (SEE EMISSION LABEL)</p> <p>HEX WRENCH</p> <p>IDLE SPEED ADJUSTMENT</p>	<table border="1"> <tbody> <tr> <td>BASE IDLE — LDX 425 RPM (N) — M.T. (D) — A.T.</td> </tr> <tr> <td>CURB IDLE — LDX 750 RPM (N) M.T. EX CALIF. 850 RPM (N) M.T. CALIF. 550 RPM (D) A.T. NO A/C 49 STATES 600 RPM (D) A.T. A/C 49 STATES 600 RPM (D) A.T. H. A.T. AND CALIF.</td> </tr> <tr> <td>BASE IDLE — HDX 450 RPM (N)</td> </tr> <tr> <td>CURB IDLE — HDX 600 RPM (N)</td> </tr> </tbody> </table>	BASE IDLE — LDX 425 RPM (N) — M.T. (D) — A.T.	CURB IDLE — LDX 750 RPM (N) M.T. EX CALIF. 850 RPM (N) M.T. CALIF. 550 RPM (D) A.T. NO A/C 49 STATES 600 RPM (D) A.T. A/C 49 STATES 600 RPM (D) A.T. H. A.T. AND CALIF.	BASE IDLE — HDX 450 RPM (N)	CURB IDLE — HDX 600 RPM (N)				
BASE IDLE — LDX 425 RPM (N) — M.T. (D) — A.T.									
CURB IDLE — LDX 750 RPM (N) M.T. EX CALIF. 850 RPM (N) M.T. CALIF. 550 RPM (D) A.T. NO A/C 49 STATES 600 RPM (D) A.T. A/C 49 STATES 600 RPM (D) A.T. H. A.T. AND CALIF.									
BASE IDLE — HDX 450 RPM (N)									
CURB IDLE — HDX 600 RPM (N)									

Fig. 6C-11-1ME Carburetor Adjustments · 3 of 3

blade to reach full open position. (Start timer when engine starts).

7. If the choke blade fails to open fully within 3-1/2 minutes proceed with steps 8-9-10 below.

8. Check voltage at the choke heater connection. (Engine must be running). If the voltage is approximately 12-15 volts, replace the electric choke unit.

9. If the voltage is low or zero, check all wires and connections. If the connections at the oil pressure switch are faulty, the oil warning light will be off with the key "on" and engine off. If the fuse is blown, the radio or turn signal indicator will be inoperative. Repair wires or replace fuses as required.

10. If step 9 is good, replace oil pressure switch.

NOTE: No gasket is used between the choke cover and the choke housing due to grounding requirements.

Refer to figure 6C-11 for the following adjustments:

- Vacuum Break
- Unloader
- Idle Speed

Checking Solenoid

1. Turn on ignition, but do not start engine.
2. Open throttle to allow solenoid plunger to extend.
3. Hold throttle lever wide open, feel end of plunger and disconnect wire at solenoid.
4. Plunger should move. Some spring tension should be felt.
5. If plunger did not move, back out 1/8 hex screw (counterclockwise) one full turn and repeat steps 3 and 4.
6. If plunger moves in step 5, connect wire to solenoid and adjust idle speed.
7. If plunger did not move in step 5 insert test lamp (1893 bulb or smaller) between solenoid feed wire and ground.
8. If lamp lights, replace solenoid.
9. If lamp does not light, locate cause of open circuit in solenoid feed wire.

Idle Mixture

Idle mixture screw has been preset at the factory and capped. Do not remove the cap during normal engine maintenance.

Before suspecting the carburetor as the cause of poor engine performance or rough idle, check ignition system including distributor, timing, spark plugs and wires. Check air cleaner, evaporative emission system, EFE System, PCV system, EGR valve and engine compression. Also inspect intake manifold, vacuum hoses and connections for leaks and check torques of carburetor mounting bolts/nuts.

In the case of major carburetor overhaul, throttle body replacement, high idle CO as indicated by state or local emission inspection, the idle mixture may be adjusted. Adjusting mixture by other than the following method may violate Federal and/or California or other state laws.

Idle Mixture Adjustment

1. Set parking brake and block drive wheels.
2. Remove air cleaner for access to carburetor, but keep vacuum hoses connected.
3. Disconnect and plug other hoses as directed on Emission Control Information Label under the hood.
4. Engine must be at normal operating temperature, choke open, air conditioning off.
5. Connect an **ACCURATE** tachometer to engine.
6. Disconnect vacuum advance and plug hose. Check ignition timing. If necessary, adjust to specification shown on Emission Control Information Label. Reconnect vacuum advance.
7. Carefully remove cap from idle mixture screw. Be careful not to bend screw. Lightly seat screw, then back out just enough so engine will run.
8. Place transmission in Drive (automatics with light duty emissions) or Neutral (all manuals and automatics with heavy duty emissions).
9. Back screw out (richen) 1/8 turn at a time until maximum idle speed is obtained. Then set idle speed to value shown in Chart Column A of specifications. Repeat Step 9 to be certain you have maximum idle speed.
10. Turn screw in (lean) with 1/8 turn increments until idle speed reaches value shown in Chart Column B of specifications.
11. Reset idle speed to specification shown on Emission Control Information Label.
12. Check and adjust fast idle as described on the Emission Control Information Label.
13. Reconnect vacuum hoses. Install air cleaner.

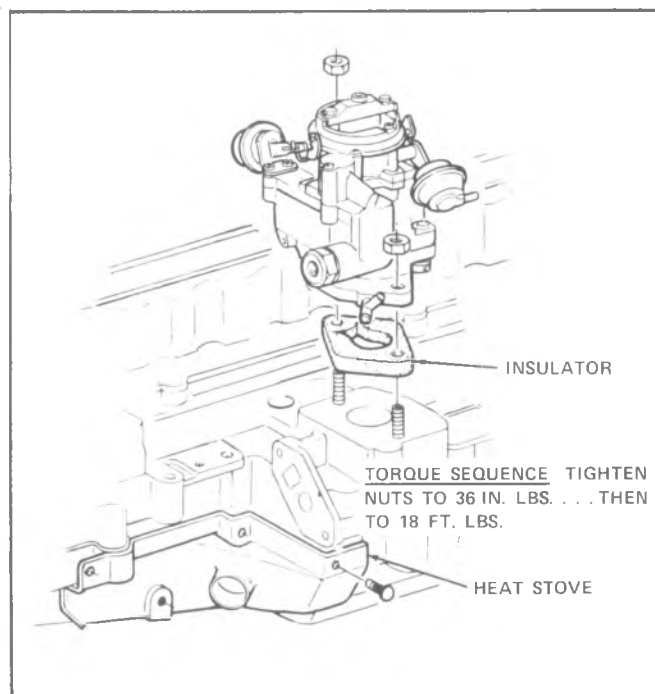


Fig. 6C-12-1ME Carburetor Replacement

14. Recheck idle speed. If necessary, reset to specification.

CARBURETOR REPLACEMENT (FIG. 6C-12)

Removal

Flooding, stumble on acceleration and other performance complaints are, in many instances, caused by presence of dirt, water, or other foreign matter in carburetor. To aid in diagnosing cause, carburetor should be carefully removed from engine without draining fuel from bowl. Contents of fuel bowl may then be examined for contamination as carburetor is disassembled. Check filter.

1. Remove air cleaner.
2. Disconnect fuel and vacuum lines from carburetor.
3. Disconnect electrical connector at choke.
4. Disconnect accelerator linkage.
5. Disconnect solenoid electrical connector.
6. Remove carburetor attaching nuts and remove carburetor and solenoid assembly attachment.
7. Remove insulator gasket.

Installation

It is good shop practice to fill carburetor bowl before installing carburetor. This reduces strain on starting motor and battery and reduces the possibility of backfiring while attempting to start engine. A small supply of fuel will enable carburetor to be filled and the operation of float and intake needle and seat to be checked. Operate throttle lever several times and check discharge from pump jets before installing carburetor.

1. Be certain throttle body and intake manifold sealing surface are clean.
2. Install carburetor insulator.
3. Install carburetor over manifold studs.
4. Install vacuum and fuel lines at carburetor
5. Install attaching nuts and tighten alternately to 16 pounds-feet (21 N·m).
6. Tighten fuel line.
7. Connect accelerator linkage.
8. Connect choke and solenoid electrical connectors.
9. Install air cleaner.
10. Check and adjust idle speed.

SOLENOID REPLACEMENT

An inoperative solenoid should be replaced.

Removal

1. Remove carburetor air cleaner.
2. Disconnect electrical connector at solenoid.
3. Unscrew and remove solenoid from float bowl assembly.

Installation

1. Hold choke valve wide open so that fast idle cam follower clears fast idle cam.
2. Install solenoid and turn in until it contacts lever tang.
3. Connect electrical connector.
4. Install air cleaner.
5. Check and adjust idle speed.

CHOKE COIL REPLACEMENT

Choke mechanism should be checked for free operation. A binding condition may have developed from petroleum gum formation on the choke shaft or from damage. Choke shafts can usually be cleaned without disassembly by using Carbon X(X55) or equivalent.

1. Remove air cleaner and disconnect choke electrical connector.
2. Remove screws attaching choke assembly to housing and remove choke as an assembly.
3. Install new choke and coil assembly.
4. Install screws and loosely tighten.
5. Adjust choke setting as specified and tighten screws.
6. Connect choke electrical connector.
7. Start engine, check operation of choke and then install air cleaner.

AIR HORN TIGHTENING SEQUENCE

Refer to Figure 6C-13 for proper air horn tightening sequence.

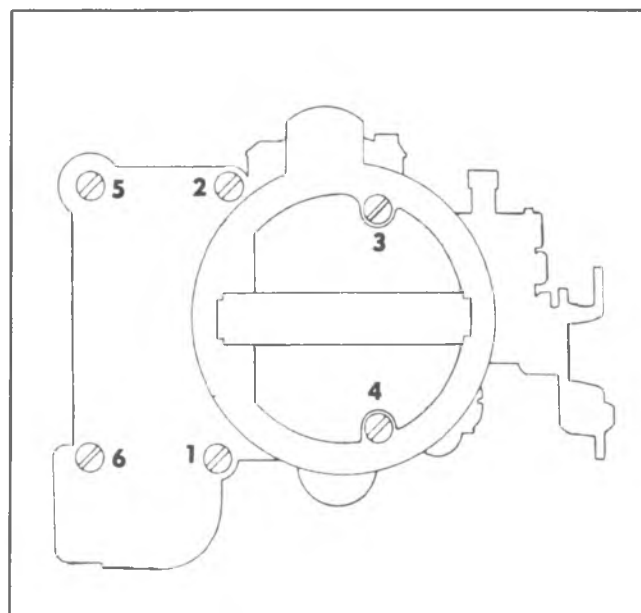


Fig. 6C-13--Air Horn Tightening Sequence

SPECIFICATIONS
IDLE MIXTURE
(LEAN DROP)
LIGHT DUTY EMISSIONS

ENGINE	COLUMN A SPEED BEFORE LEAN DROP	COLUMN B SPEED AFTER LEAN DROP
250 CID MANUAL TRANS. LOW ALTITUDE	900 RPM (N)	750 RPM (N)
250 CID AUTOMATIC TRANS. LOW ALT. NO A/C	575 RPM (D)	550 RPM (D)
250 CID AUTOMATIC TRANS. LOW ALT. A/C	620 RPM (D)	600 RPM (D)
250 CID AUTOMATIC TRANS. CALIFORNIA	630 RPM (D)	600 RPM (D)
250 CID AUTOMATIC TRANS. HIGH ALTITUDE	620 RPM (D)	600 RPM (D)
250 CID MANUAL TRANS. CALIFORNIA	1100 RPM (N)	850 RPM (N)

IDLE MIXTURE
(LEAN DROP)
HEAVY DUTY EMISSIONS

ENGINE	COLUMN A SPEED BEFORE LEAN DROP	COLUMN B SPEED AFTER LEAN DROP
250 CID	700 RPM (N)	600 RPM (N)
292 CID		

TORQUE SPECIFICATIONS
IME CARBURETOR

SCREW	TORQUE (IN. LBS.)	SCREW	TORQUE (IN. LBS.)
AIR HORN TO BOWL	45	FUEL INLET NUT	400
AIR CLEANER BRIDGE	70	FAST IDLE CAM	50
THROTTLE BODY TO BOWL	180	CHOKE LEVER	25
NEEDLE SEAT	45	PUMP LEVER	30*
METERING JET	40		

* Loctite AVV or equivalent

MODEL 2GC CARBURETOR

GENERAL DESCRIPTION

The Model 2GC carburetor (Figs. 6C-14 and 15) is equipped with an integral choke attached to the throttle body assembly.

All light duty emission models use a fuel inlet check valve to shut off fuel flow to the carburetor float bowl to prevent fuel leaks if a vehicle roll-over should occur.

All models (except California) use full vacuum for distributor advance obtained through a tube pressed into the float bowl (choke side location "h"). On California models, timed vacuum for distributor advance is supplied through this same tube (location "h").

An Exhaust Gas Recirculation (E.G.R.) system is used to meet emission requirements for oxides of Nitrogen (NOx). In addition, a cup restriction is added in the float bowl behind the Exhaust Gas Recirculation (E.G.R.) vacuum tube (location "j"), to delay E.G.R. valve operation for improved engine performance as the throttle valves are opened.

A electrically operated solenoid is used on all 2GC

models equipped with automatic transmission and air conditioning. The solenoid is used to maintain proper idle speed when the air conditioning is in operation.

Fuel for the pump system is obtained through a hole located in a raised cast-in boss on the floor of the float bowl which prevents the entry of dirt into the accelerator pump fuel inlet passage. The pump plunger head is designed with an expander spring beneath the pump cup to maintain good pump wall contact during pump operation.

The end of the pump plunger stem is upset in manufacturing to provide the "clipless" retaining in feature. The pump plunger assembly may be removed from the inner lever by twisting upset end with small pliers until it breaks. The service pump assembly has a grooved end and is provided with a retaining clip.

The carburetor part number is stamped on the flat section of the float bowl next to the fuel inlet nut. (Fig. 6C-17). When servicing the carburetor unit, refer to the On-Car Service section for proper procedures and specifications.

Incorporated in the Model 2GC carburetor are six basic systems. They are Float, Idle, Main Metering, Power, Pump and Choke (Figs. 6C-17 through 23).

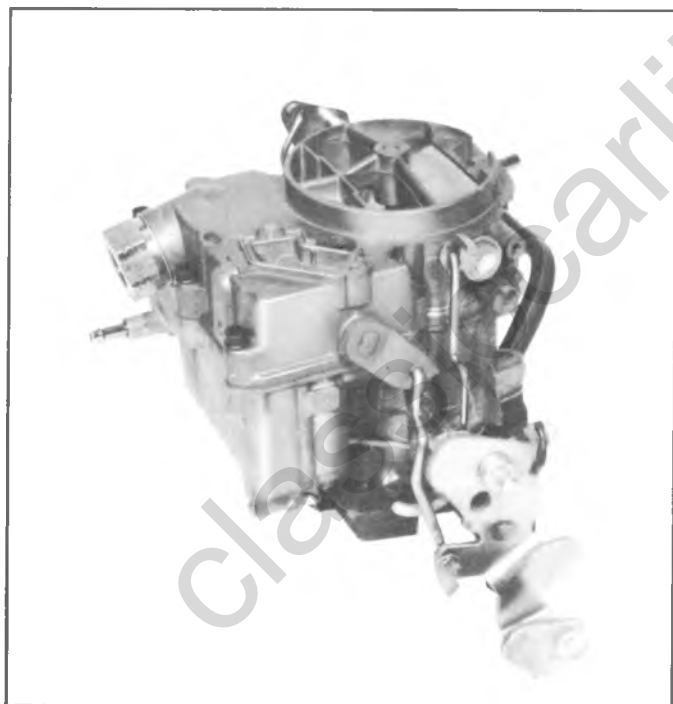


Fig. 6C-14--Model 2GC Carburetor

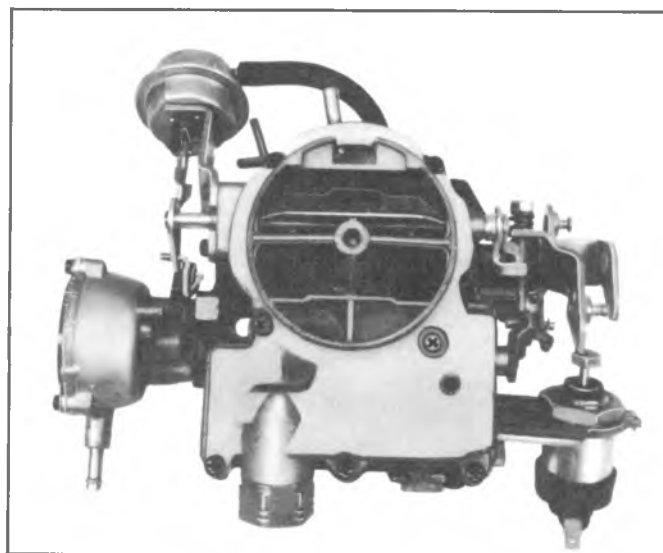


Fig. 6C-15--Model 2GC Carburetor with Solenoid

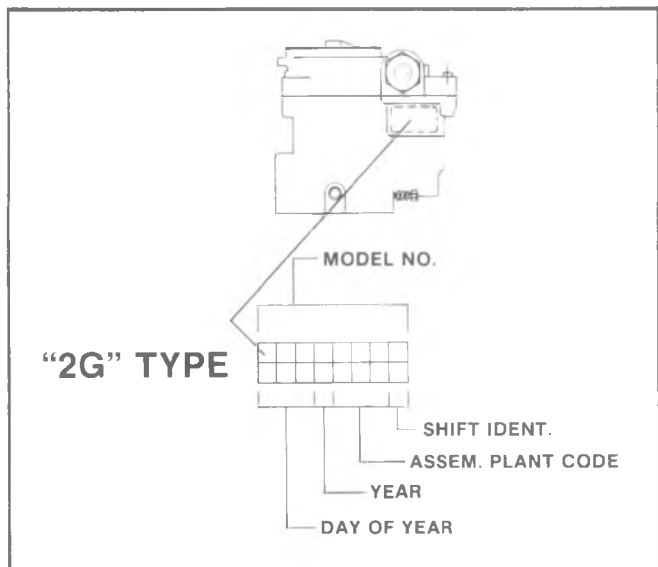


Fig. 16--Model 2GC Carburetor Identification

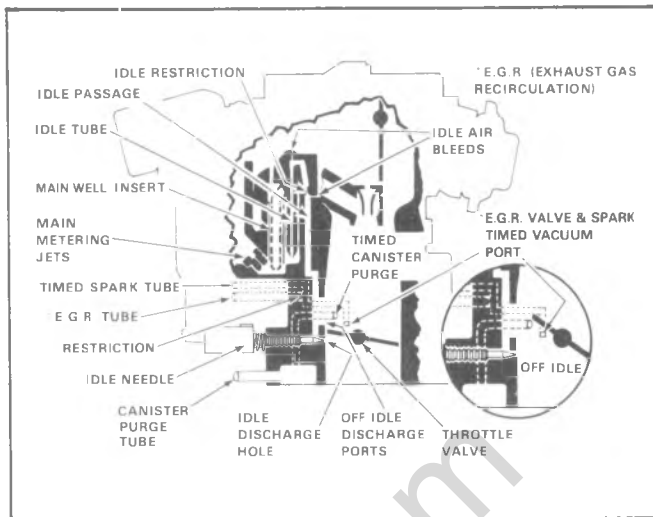


Fig. 6C-19--Idle System-California

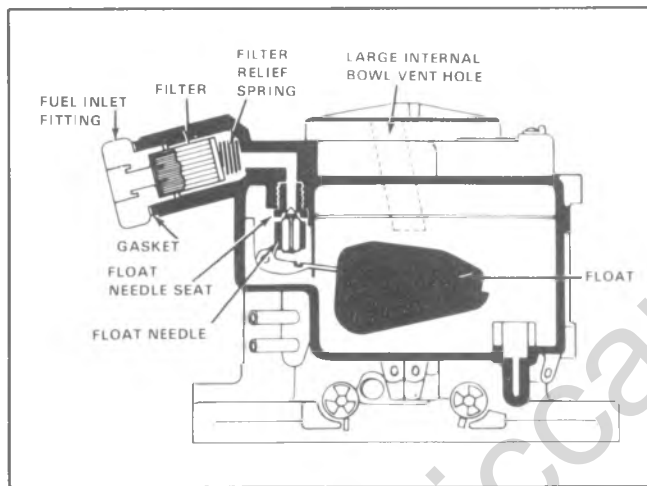


Fig. 6C-17--Float System

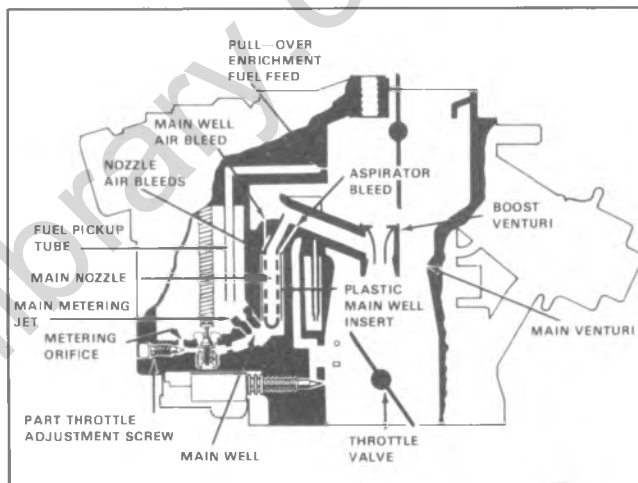


Fig. 6C-20--Main Metering System

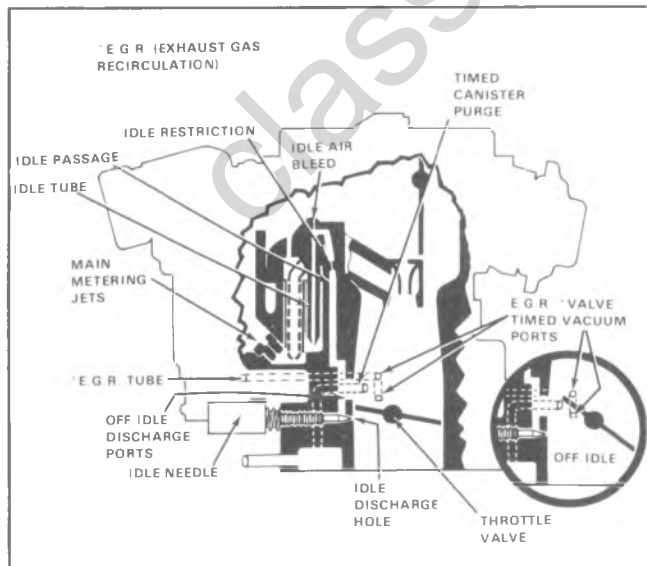


Fig. 6C-18--Idle System-except California

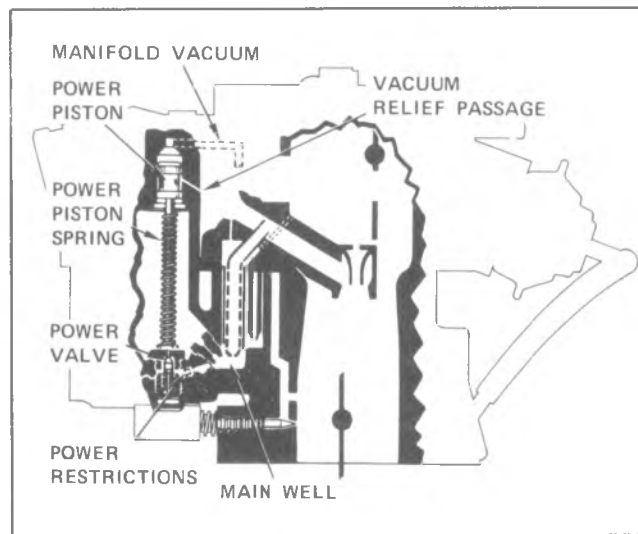


Fig. 6C-21--Power System

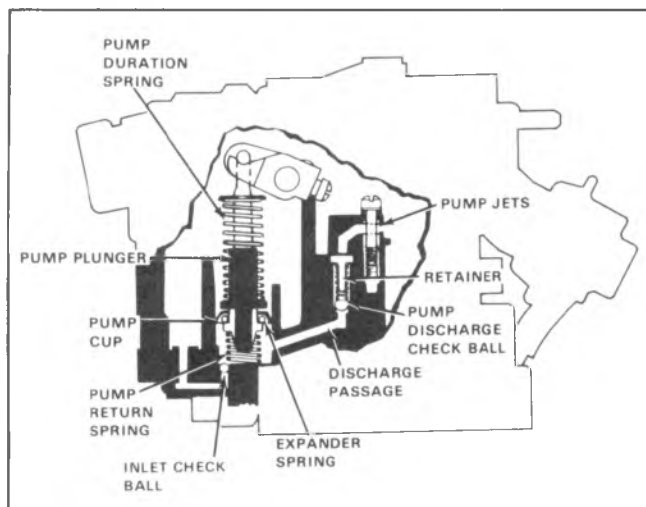


Fig. 6C-22--Pump System

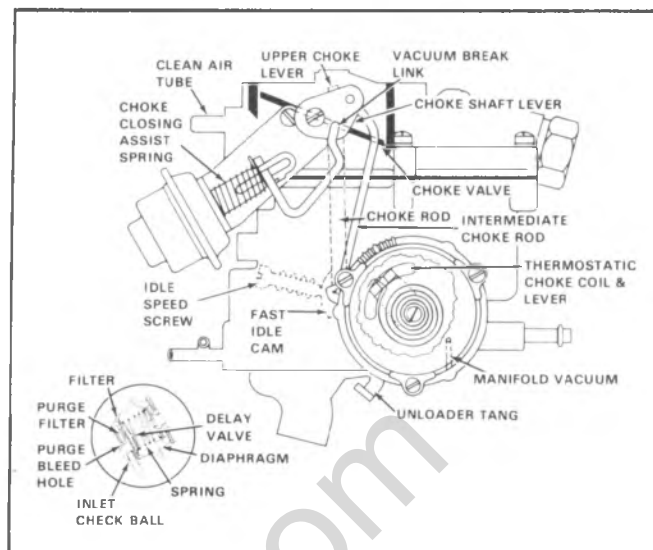


Fig. 6C-23--Choke System-2GC

ON-VEHICLE SERVICE

CARBURETOR ADJUSTMENTS

Refer to figure 6C-24 for the following adjustments:

- Float Level
- Float Drop
- Pump Rod

Refer to figure 6C-25 for the following adjustments:

- Choke Coil Lever
- Automatic Choke Coil-2GC
- Choke Coil Rod-2GV

Checking Carburetor Choke

1. Remove air cleaner. With engine off, hold throttle half open. Open and close choke several times. Watch linkage to be certain all links are connected and there are no signs of damage.

2. If choke or linkage binds, sticks, or works sluggishly, clean with Choke Cleaner X-20-A or equivalent. Use cleaner as directed on can. Refer to disassembly instructions for additional direction if cleaning does not correct.

3. Visually inspect carburetor to be certain all vacuum hoses are connected. Inspect hoses for cracks, abrasions, hardness or other signs of deterioration. Replace or correct as necessary.

4. Make sure vacuum break diaphragm shaft is fully extended when engine is off. If shaft is not fully extended, replace vacuum break assembly. Start engine - Vacuum break diaphragm shaft should fully retract

within 10 seconds. If unit fails to retract, replace vacuum break assembly.

Refer to figure 6C-26 for the following adjustments:

- Choke Rod (Fast Idle Cam)
- Vacuum Break
- Unloader

Refer to figure 6C-27 for the following adjustments:

- Idle Speed Adjustment-without solenoid.
- Idle Speed Adjustment-with solenoid.

Checking Solenoid

1. Turn on ignition, but do not start engine. Turn A/C to "on" position.

2. Open throttle to allow solenoid to extend, close throttle

3. Disconnect lead at solenoid. Solenoid plunger should drop away from throttle lever.

4. Connect solenoid lead. Plunger should move out and contact the throttle lever. Solenoid may not be strong enough to open the throttle, but the plunger should move.

5. If plunger does not move in and out as lead is disconnected and connected, insert test light (1893 bulb or smaller) between the solenoid feed wire and ground.

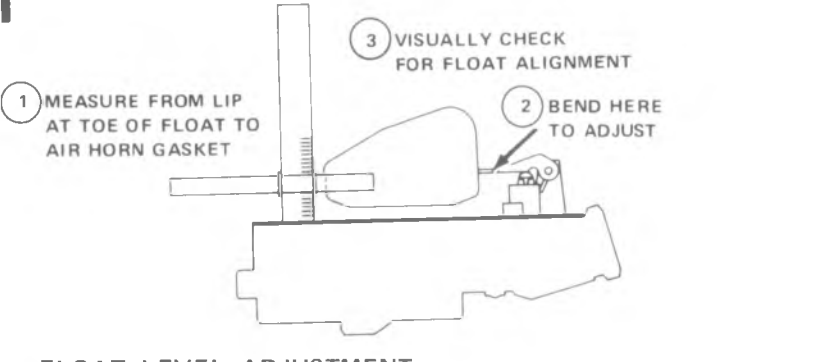
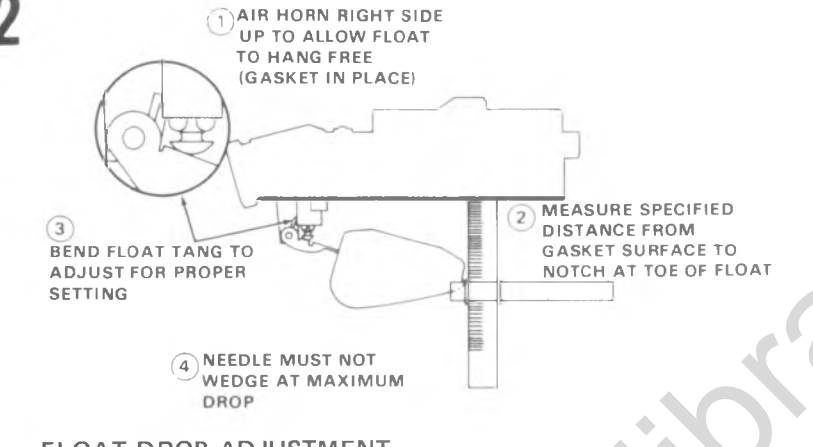
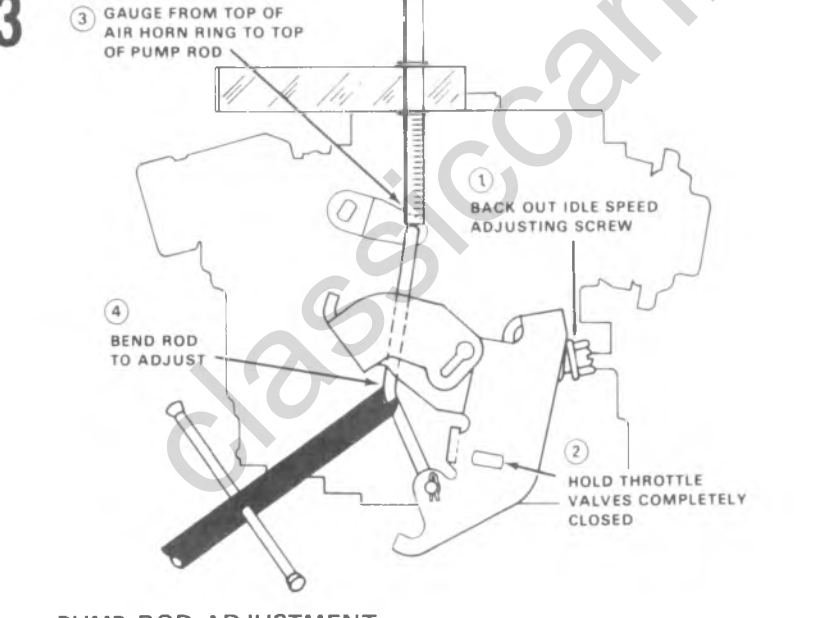
6. If light lights, replace solenoid.

7. If light does not light, locate cause of open circuit in solenoid feed wire.

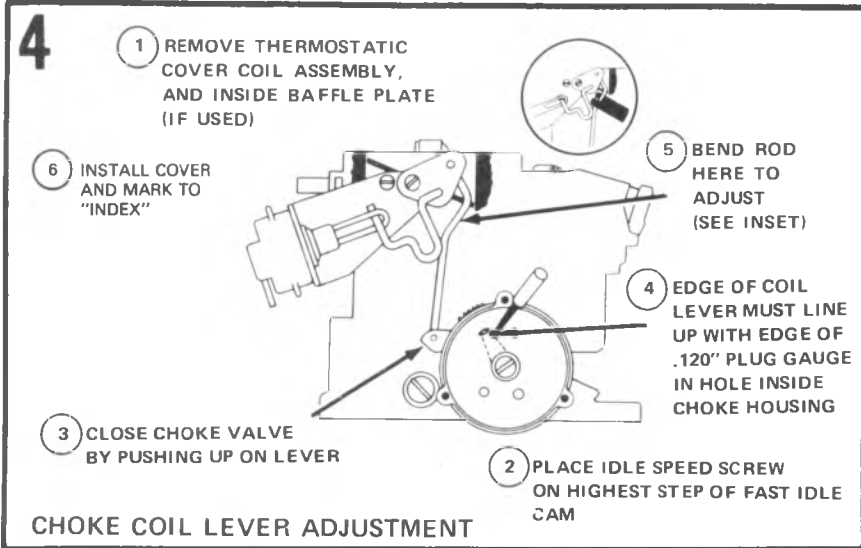
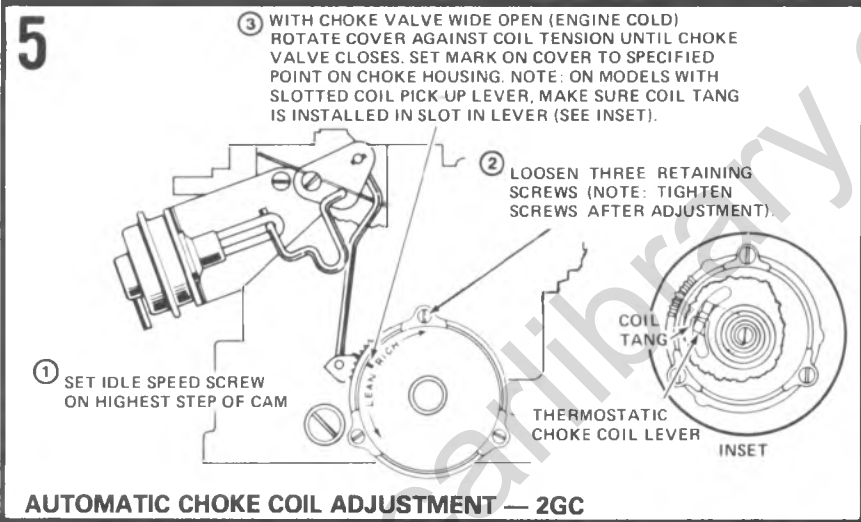
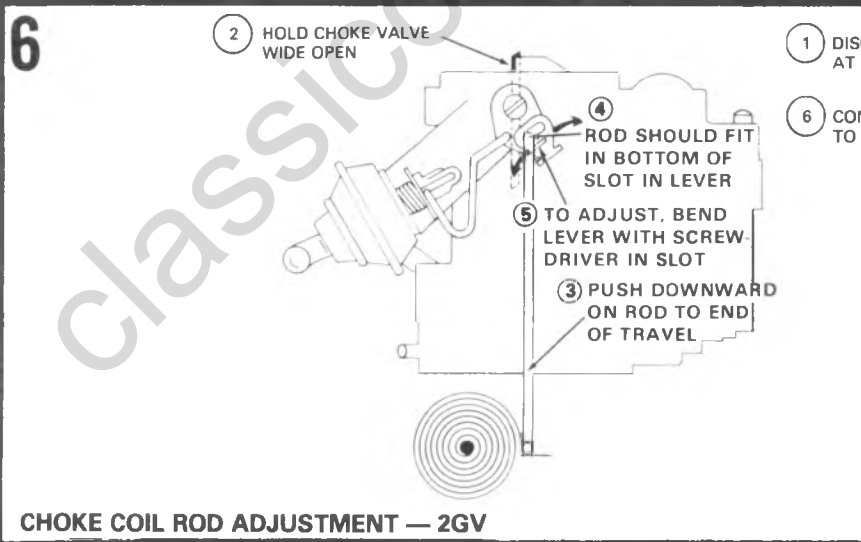
Idle Mixture

Idle mixture screws have been preset at the factory and capped. Do not remove the caps during normal engine maintenance.

Before suspecting the carburetor as the cause of poor engine performance or rough idle, check ignition system including distributor, timing, spark plugs and

<p>1</p>  <p>FLOAT LEVEL ADJUSTMENT</p>	<p>CARB. NO.</p> <p>ALL</p>	<p>GAUGE</p> <p>19/32"</p>
<p>2</p>  <p>FLOAT DROP ADJUSTMENT</p>	<p>CARB. NO.</p> <p>ALL</p>	<p>GAUGE</p> <p>1-9/32"</p>
<p>3</p>  <p>PUMP ROD ADJUSTMENT</p>	<p>CARB. NO.</p> <p>ALL</p>	<p>GAUGE</p> <p>1-21/32"</p>

MODEL 2V/2GC CARB. ADJUSTMENTS

<p>4</p> <p>1 REMOVE THERMOSTATIC COVER COIL ASSEMBLY, AND INSIDE BAFFLE PLATE (IF USED)</p> <p>2 PLACE IDLE SPEED SCREW ON HIGHEST STEP OF FAST IDLE CAM</p> <p>3 CLOSE CHOKE VALVE BY PUSHING UP ON LEVER</p> <p>4 EDGE OF COIL LEVER MUST LINE UP WITH EDGE OF .120" PLUG GAUGE IN HOLE INSIDE CHOKE HOUSING</p> <p>5 BEND ROD HERE TO ADJUST (SEE INSET)</p> <p>6 INSTALL COVER AND MARK TO "INDEX"</p>  <p>CHOKE COIL LEVER ADJUSTMENT</p>	<p>CARB. NO.</p> <p>ALL</p>	<p>PLUG GAUGE</p> <p>.120</p>
<p>5</p> <p>1 SET IDLE SPEED SCREW ON HIGHEST STEP OF CAM</p> <p>2 LOOSEN THREE RETAINING SCREWS (NOTE: TIGHTEN SCREWS AFTER ADJUSTMENT)</p> <p>3 WITH CHOKE VALVE WIDE OPEN (ENGINE COLD) ROTATE COVER AGAINST COIL TENSION UNTIL CHOKE VALVE CLOSURES. SET MARK ON COVER TO SPECIFIED POINT ON CHOKE HOUSING. NOTE: ON MODELS WITH SLOTTED COIL PICK UP LEVER, MAKE SURE COIL TANG IS INSTALLED IN SLOT IN LEVER (SEE INSET).</p>  <p>AUTOMATIC CHOKE COIL ADJUSTMENT — 2GC</p>	<p>CARB. NO.</p> <p>ALL</p>	<p>INDEX MARK</p> <p>INDEX</p>
<p>6</p> <p>1 DISCONNECT ROD AT LEVER</p> <p>2 HOLD CHOKE VALVE WIDE OPEN</p> <p>3 PUSH DOWNWARD ON ROD TO END OF TRAVEL</p> <p>4 ROD SHOULD FIT IN BOTTOM OF SLOT IN LEVER</p> <p>5 TO ADJUST, BEND LEVER WITH SCREW DRIVER IN SLOT</p> <p>6 CONNECT ROD TO LEVER</p>  <p>CHOKE COIL ROD ADJUSTMENT — 2GV</p>		

MODEL 2GC/2GV CARB. ADJUSTMENTS

<p>7</p> <p>③ BEND TANG TO ADJUST (SEE INSET # 2 or # 3)</p> <p>② GAUGE BETWEEN UPPER EDGE OF CHOKE VALVE AND WALL OF AIR HORN</p> <p>① IDLE SPEED SCREW ON 2ND STEP OF FAST IDLE CAM AGAINST HIGH STEP</p> <p>L - LOW STEP 2 - 2ND STEP H - HIGH STEP</p> <p>INSET # 1</p> <p>INSET # 2</p> <p>INSET # 3</p> <p>CHOKE ROD (FAST IDLE CAM) ADJUSTMENT</p>	<p>CARB. NO.</p> <p>ALL</p>	<p>PLUG GAUGE</p> <p>.260</p>
<p>8</p> <p>③ STEM PULLED OUT UNTIL SEATED</p> <p>④ GAUGE BETWEEN UPPER EDGE OF CHOKE VALVE AND WALL OF AIR HORN</p> <p>① PLACE IDLE SPEED SCREW ON HIGHEST STEP OF FAST IDLE CAM</p> <p>⑤ BEND ROD TO ADJUST</p> <p>VACUUM DIAPHRAGM SEATED</p> <p>NOTE: PLUG END COVER WITH A PIECE OF MASKING TAPE MAKING SURE TO COVER PURGE BLEED HOLE. REMOVE TAPE AFTER ADJUSTMENT.</p> <p>② USE OUTSIDE VACUUM SOURCE</p> <p>VACUUM BREAK ADJUSTMENT</p>	<p>CARB. NO.</p> <p>ALL EXCEPT 17056137</p> <p>17056137</p>	<p>PLUG GAUGE</p> <p>.130 BELOW 22,500 MI</p> <p>.160 ABOVE 22,500 MI</p> <p>.190</p>
<p>9</p> <p>② GAUGE BETWEEN UPPER EDGE OF CHOKE VALVE AND WALL OF AIR HORN</p> <p>③ BEND TANG TO ADJUST SEE INSET</p> <p>① HOLD THROTTLE VALVE WIDE OPEN</p> <p>INSET</p> <p>CHOKE UNLOADER ADJUSTMENT</p>	<p>CARB. NO.</p> <p>ALL</p>	<p>PLUG GAUGE</p> <p>.325</p>

Fig. 6C-26-2GC Carburetor Adjustments · 3 of 4

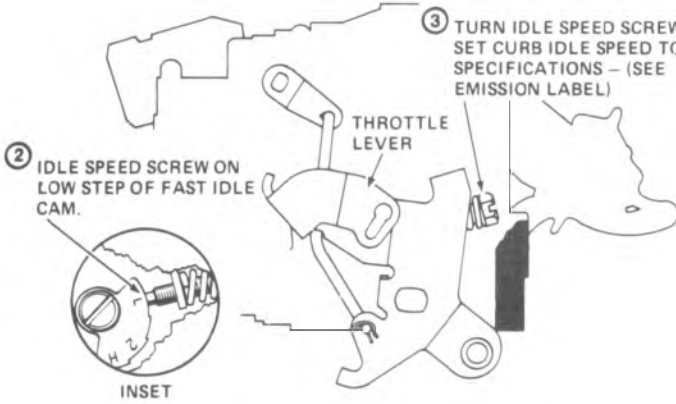
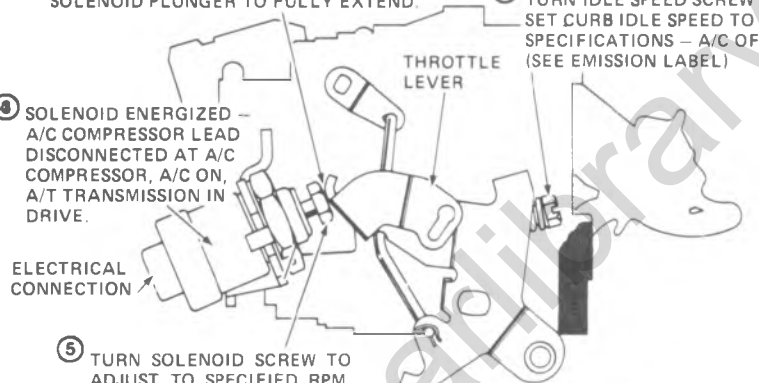
<p>10</p> <p>① PREPARE VEHICLE FOR ADJUSTMENTS – SEE EMISSION LABEL ON VEHICLE. NOTE: IGNITION TIMING SET PER LABEL.</p>  <p>② IDLE SPEED SCREW ON LOW STEP OF FAST IDLE CAM.</p> <p>③ TURN IDLE SPEED SCREW TO SET CURB IDLE SPEED TO SPECIFICATIONS – (SEE EMISSION LABEL)</p> <p>THROTTLE LEVER</p> <p>INSET</p> <p>IDLE SPEED ADJUSTMENT — WITHOUT SOLENOID</p>	<p>LIGHT DUTY EMISSIONS MANUAL TRANSMISSION 600 RPM (N) AUTOMATIC TRANSMISSION 500 RPM (D)</p> <hr/> <p>HEAVY DUTY EMISSIONS 700 RPM (N)</p>
<p>11</p> <p>④ OPEN THROTTLE SLIGHTLY TO ALLOW SOLENOID PLUNGER TO FULLY EXTEND.</p>  <p>② TURN IDLE SPEED SCREW TO SET CURB IDLE SPEED TO SPECIFICATIONS – A/C OFF (SEE EMISSION LABEL)</p> <p>THROTTLE LEVER</p> <p>④ SOLENOID ENERGIZED – A/C COMPRESSOR LEAD DISCONNECTED AT A/C COMPRESSOR, A/C ON, A/T TRANSMISSION IN DRIVE.</p> <p>ELECTRICAL CONNECTION</p> <p>⑤ TURN SOLENOID SCREW TO ADJUST TO SPECIFIED RPM. (RECONNECT A/C COMPRESSOR LEAD AFTER ADJUSTMENT)</p> <p>① PREPARE VEHICLE FOR ADJUSTMENTS – SEE EMISSION LABEL ON VEHICLE. NOTE: IGNITION TIMING SET PER LABEL.</p> <p>IDLE ADJUSTMENT — WITH SOLENOID</p>	<p>LIGHT DUTY EMISSIONS MANUAL TRANSMISSION IDLE SPEED SCREW - 600 RPM (N) SOLENOID SCREW - 700 RPM (N)</p> <p>AUTOMATIC TRANSMISSION IDLE SPEED SCREW - 500 RPM (D) SOLENOID SCREW - 650 RPM (D)</p>

Fig. 6C-27-2GC Carburetor Adjustments-4 of 4

wires. Check air cleaner, evaporative emission system, EFE System, PCV system, EGR valve and engine compression. Also inspect intake manifold, vacuum hoses and connections for leaks and check torques of carburetor mounting bolts/nuts.

In the case of major carburetor overhaul, throttle body replacement, high idle CO as indicated by state or local emission inspection, the idle mixture may be adjusted. Adjusting mixture by other than the following method may violate Federal and/or California or other state laws.

Idle Mixture Adjustment

1. Set parking brake and block drive wheels.
2. Remove air cleaner for access to carburetor, but keep vacuum hoses connected.
3. Disconnect and plug other hoses as directed on Emission Control Information Label under the hood.
4. Engine must be at normal operating temperature, choke open, air conditioning off.
5. Connect an **ACCURATE** tachometer to engine.
6. Disconnect vacuum advance and plug hose. Check ignition timing. If necessary, adjust to specification shown on Emission Control Information Label. Reconnect vacuum advance.
7. Carefully remove caps from idle mixture screws. Be careful not to bend screws. Lightly seat screws then back out **EQUALLY** just enough so engine will run.
8. Place transmission in Drive (automatics on light duty emissions) or Neutral (all manuals and automatics with heavy duty emissions).
9. Back each screw out (richen) 1/8 turn at a time until maximum idle speed is obtained. Then set idle speed to value shown in Chart Column A of specifications. Repeat Step 9 to be certain you have maximum idle speed.
10. Turn each screw in (lean) with 1/8 turn increments until idle speed reaches value shown in Chart Column B of specifications.
11. Reset idle speed to specification shown on Emission Control Information Label.
12. Check and adjust fast idle as described on the Emission Control Information Label.
13. Reconnect vacuum hoses. Install air cleaner.
14. Recheck idle speed. If necessary, reset to specification.

CARBURETOR REPLACEMENT (FIG.6C-28)

Removal

Flooding, stumble on acceleration and other performance complaints are, in many instances, caused by presence of dirt, water, or other foreign matter in carburetor. To aid in diagnosis, carburetor should be carefully removed from engine without draining fuel from bowl. Contents of fuel bowl may then be examined for contamination as carburetor is disassembled. Check filter.

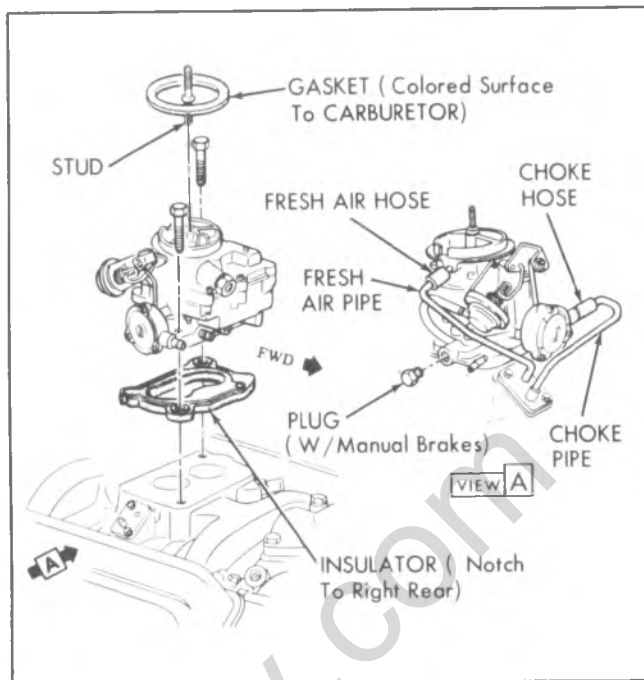


Fig. 6C-28--Carburetor and Choke Pipes
V8,2Bb1

1. Remove air cleaner and gasket.
2. Disconnect solenoid wire if equipped.
3. Disconnect fuel and vacuum lines from carburetor.
4. Disconnect fresh air hose and choke hose from choke system.
5. Disconnect accelerator linkage.
6. If equipped with automatic transmission, disconnect downshift cable.
7. If equipped with cruise control, disconnect linkage.
8. Remove carburetor attaching bolts and remove carburetor and insulator.

Installation

1. Fill carburetor bowl before installing carburetor.
2. With clean sealing surfaces on carburetor and intake manifold, install new insulator.
3. Position carburetor over insulator and install bolts. Tighten bolts alternately to 145 inch pounds.
4. Connect downshift cable as required.
5. Connect cruise control cable as required.
6. Connect accelerator linkage.
7. Connect choke system.
8. Connect fuel pipe and vacuum hoses.
9. Connect solenoid wire as required.
10. Install air cleaner.
11. Check and adjust idle speed.

AIR HORN TIGHTENING SEQUENCE

Refer to figure 6C-29 for air horn tightening sequence.

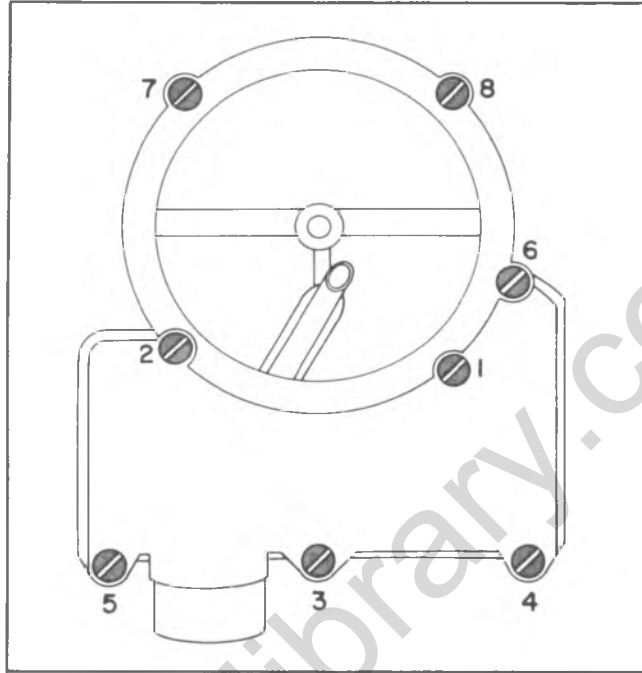


Fig. 6C-29 Air Horn Tightening Sequence

SPECIFICATIONS
IDLE MIXTURE
(LEAN DROP)
LIGHT DUTY EMISSIONS

ENGINE	COLUMN A SPEED BEFORE LEAN DROP	COLUMN B SPEED AFTER LEAN DROP
305 CID MANUAL TRANS.	650 RPM (N)	600 RPM (N)
305 CID AUTOMATIC TRANS.	530 RPM (D)	500 RPM (D)

IDLE MIXTURE
(LEAN DROP)
HEAVY DUTY EMISSIONS

ENGINE	COLUMN A SPEED BEFORE LEAN DROP	COLUMN B SPEED AFTER LEAN DROP
305 CID	800 RPM (N)	700 RPM (N)

TORQUE SPECIFICATIONS
2GC CARBURETOR

SCREW	TORQUE (IN. LBS.)
THROTTLE BODY THROTTLE BODY TO BOWL	72
BOWL CLUSTER	46
FAST IDLE CAM	58
METERING JET	40
CHOKE HOUSING CHOKE LEVER	14
CHOKE HSG. TO THROTTLE BODY	46
CHOKE HOUSING COVER	26
AIR HORN AIR HORN TO BOWL	46
VACUUM BREAK UNIT	26
CHOKE SHAFT	14
FUEL INLET NUT	400
NEEDLE SEAT	45

MODEL M4MC/M4ME/4MV CARBURETOR

GENERAL DESCRIPTION

The Model M4MC/M4ME/4MV carburetor (Figs. 6C-30, 31 and 32) are two stage carburetor of downdraft



Fig. 6C-30-Model M4MC Carburetor

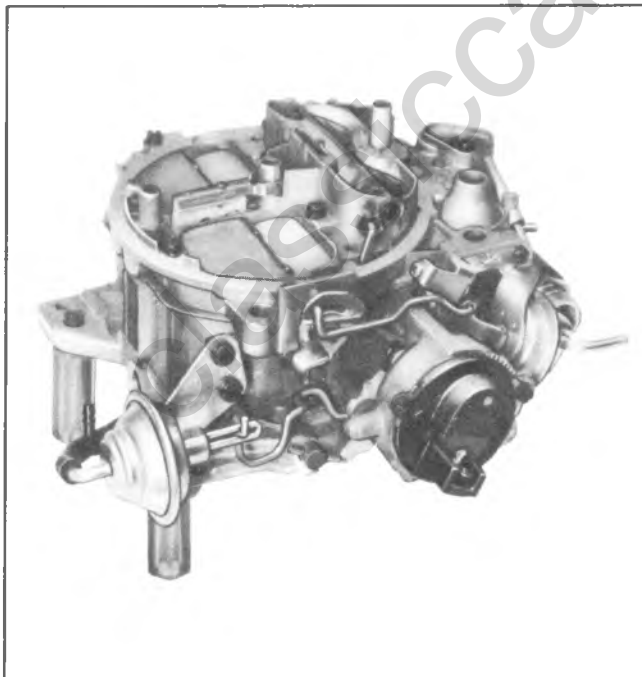


Fig. 6C-31-Model M4ME Carburetor

design. The triple venturi system is used on the primary side of the carburetor with 1-3/8 inch throttle valve bores.

The secondary side has two 2-1/4 inch bores. Using the air valve principle in the secondary side, fuel is metered in direct proportion to the air passing through the secondary bores. A baffle is attached to the secondary side of the air horn above the main well bleed tubes to deflect incoming air to improve secondary nozzle operation on heavy acceleration.

The solenoid is used on air conditioned equipped vehicles with automatic transmission and light duty emissions to increase idle speed slightly when the air conditioning is in operation. This allows the engine to idle at the same speed when the air conditioning is in operation, as when it is off.

The float assembly is used along with a windowless type needle seat for better fuel handling in the float bowl. Also, a plastic filler block is used above the float chamber to reduce fuel slosh in this area. A fuel inlet filter check valve is used on light duty emission models to shut off fuel flow to the carburetor float bowl to prevent fuel leaks if a vehicle roll over should occur.

The main metering system on all models uses separate main wells to feed each fuel nozzle for improved fuel flow in the venturi system.

Adjustable Part Throttle-M4MC/M4ME

In order to provide a close tolerance adjustment in the main metering system, an adjustment is provided to very accurately set the depth of the metering rods in the main metering jets.

The adjustment feature consists of a pin pressed in the side of the power piston which extends through a slot in the side of the piston well. When the power piston is

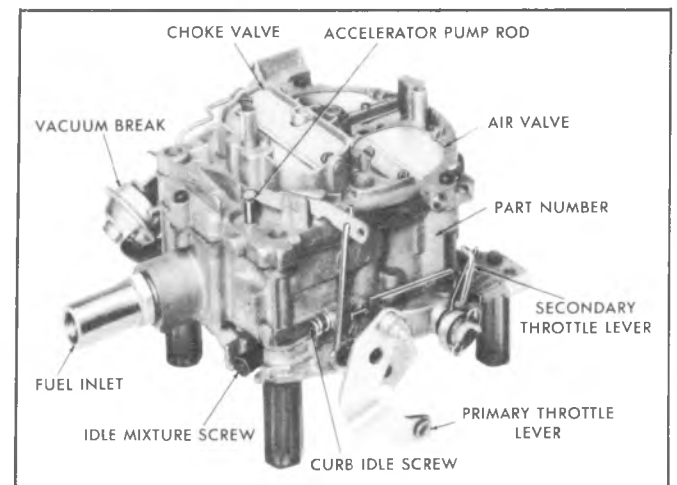


Fig. 6C-32-Model 4MV Carburetor

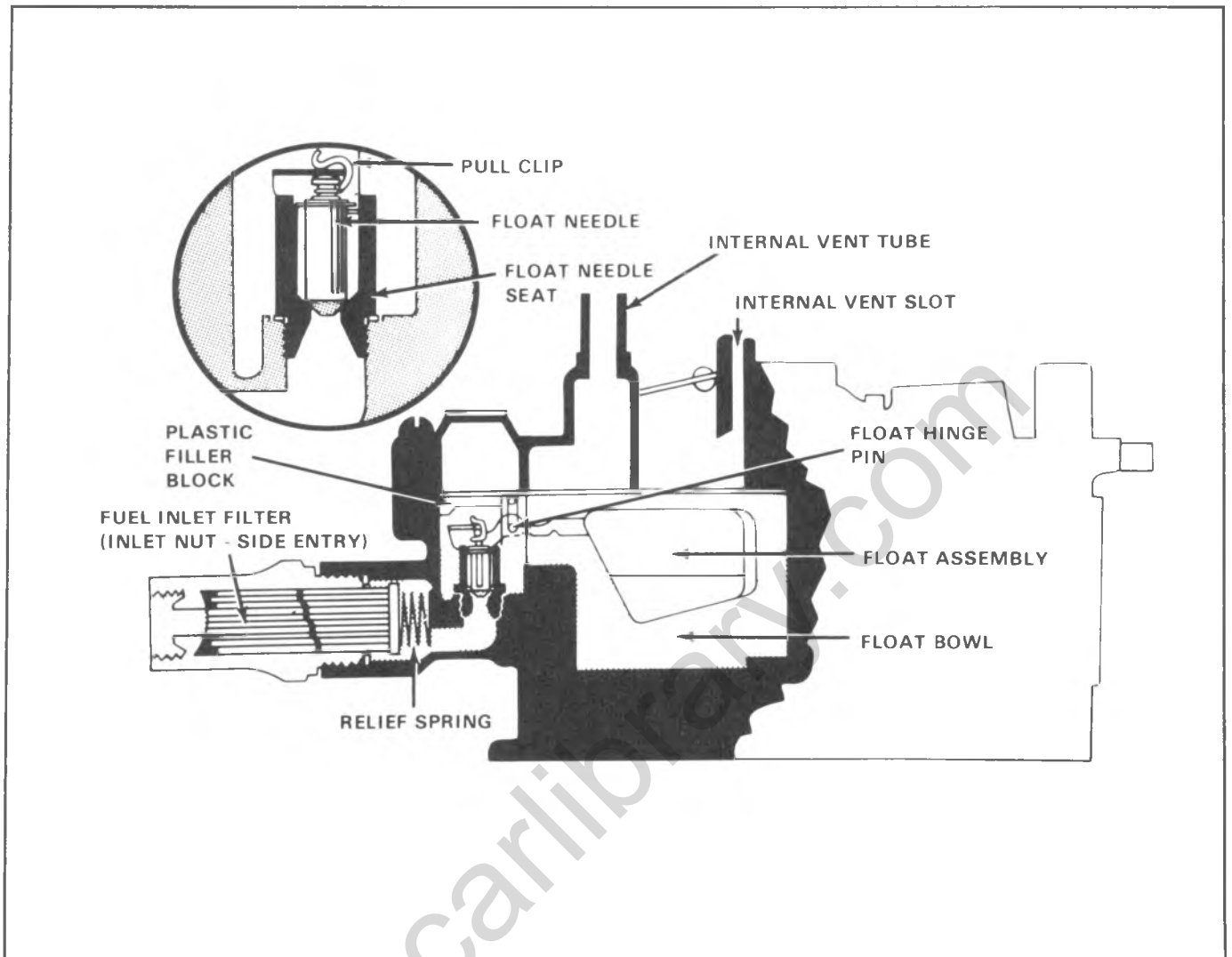


Fig. 6C-34--Float System

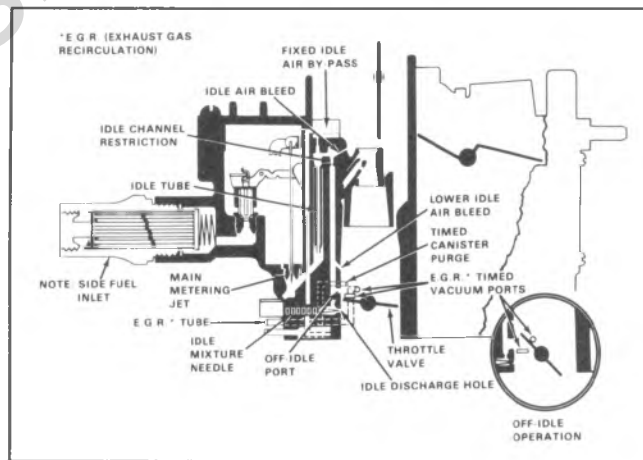


Fig. 6C-35--Idle System

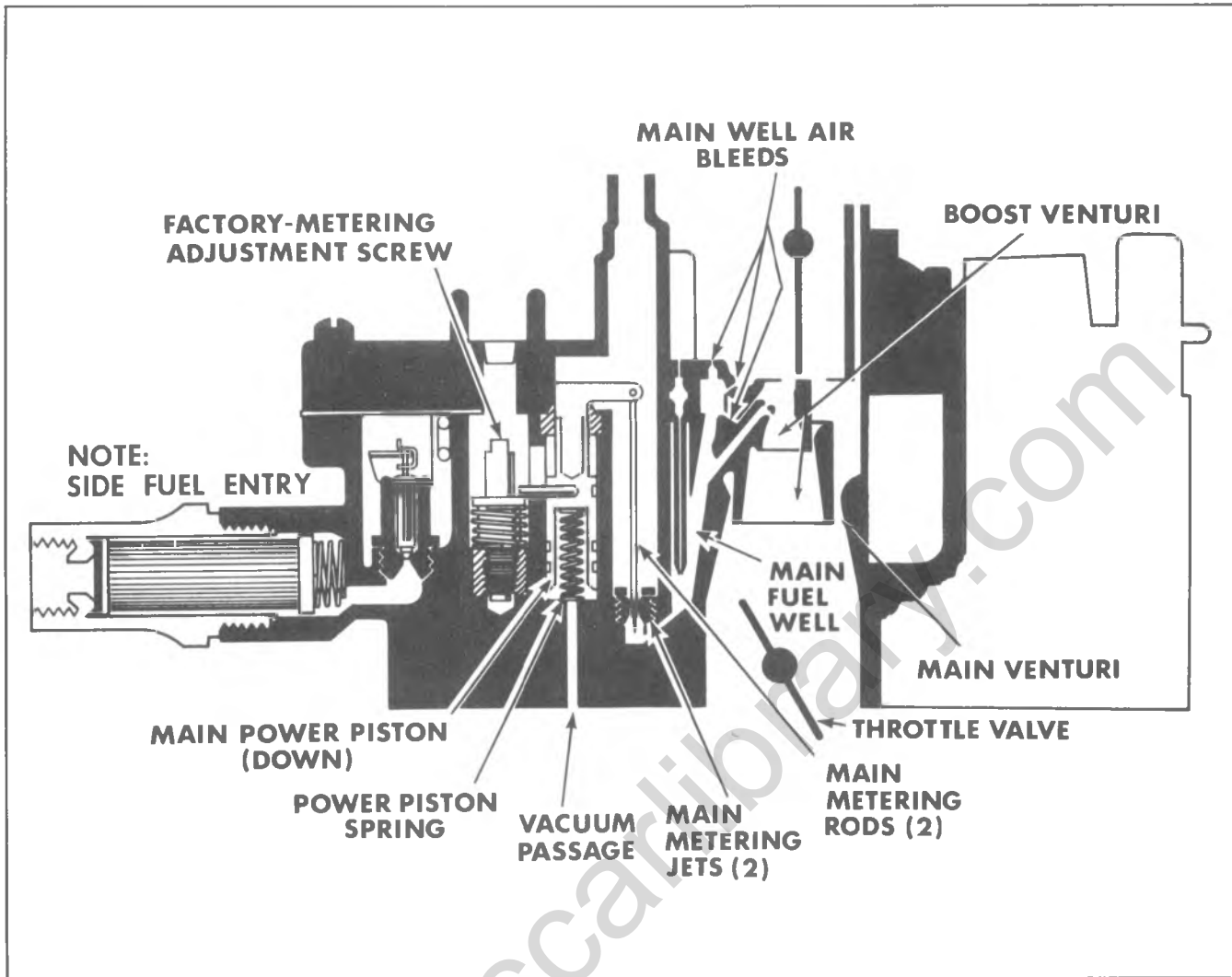


Fig. 6C-36--Main Metering System-M4MC/M4ME

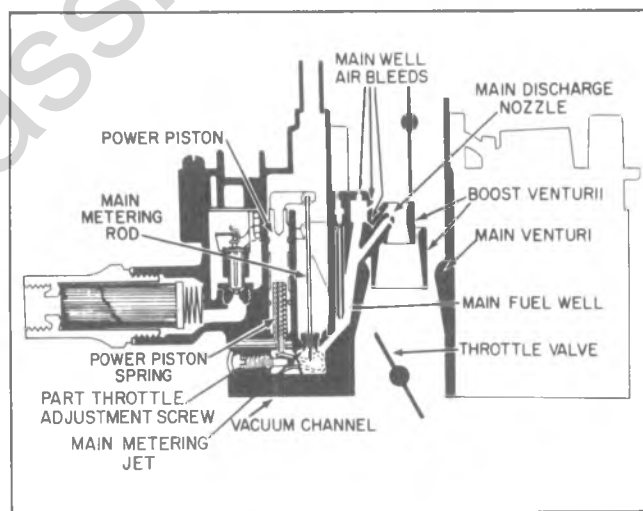


Fig. 6C-37--Main Metering System-4MV

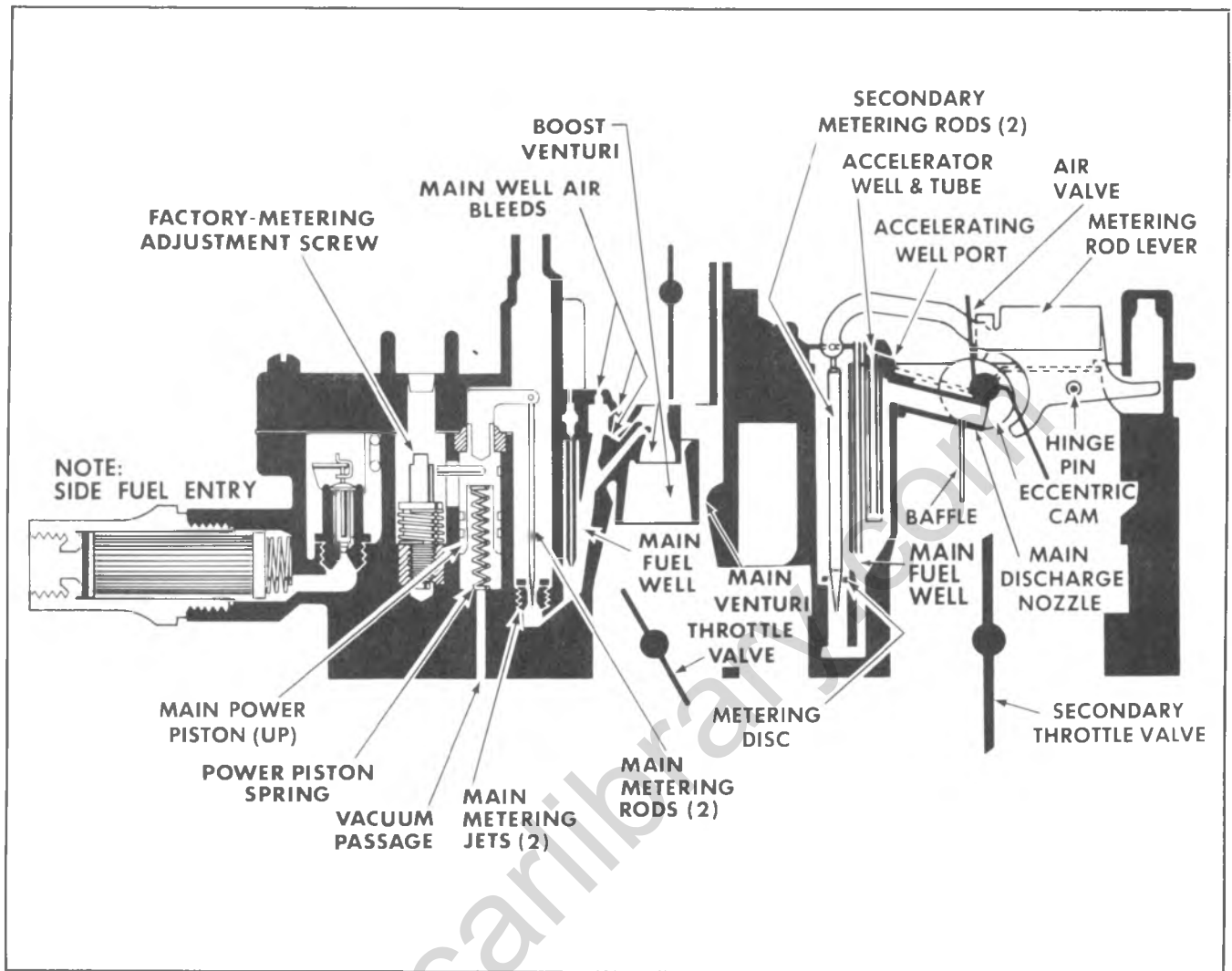


Fig. 6C-38--Power System-M4MC/M4ME

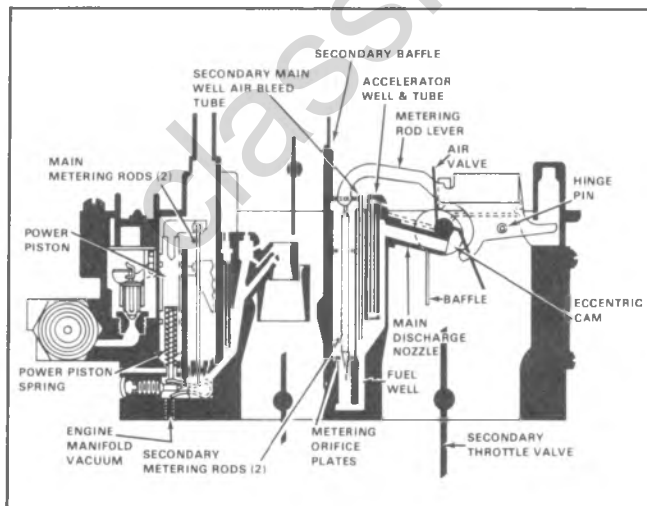


Fig. 6C-39--Power System-4MV

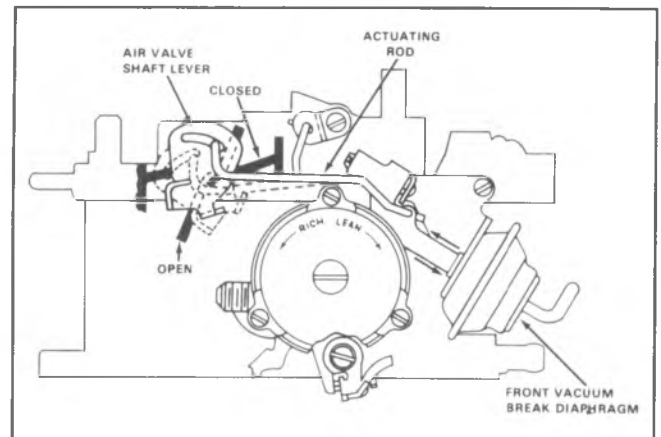


Fig. 6C-40--Air Valve Dashpot-M4MC/M4ME

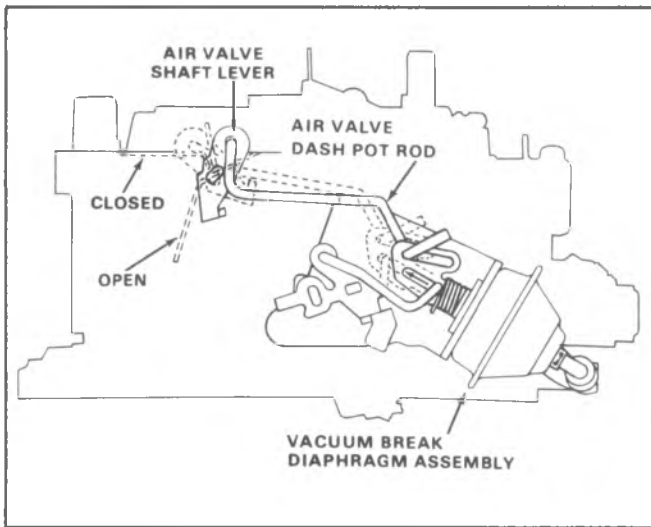


Fig. 6C-41--Air Valve Dashpot-4MV

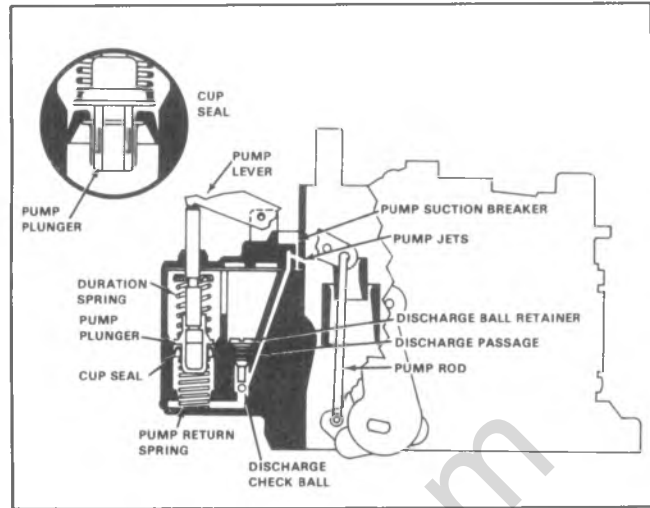


Fig. 6C-43--Accelerating Pump System-4MV

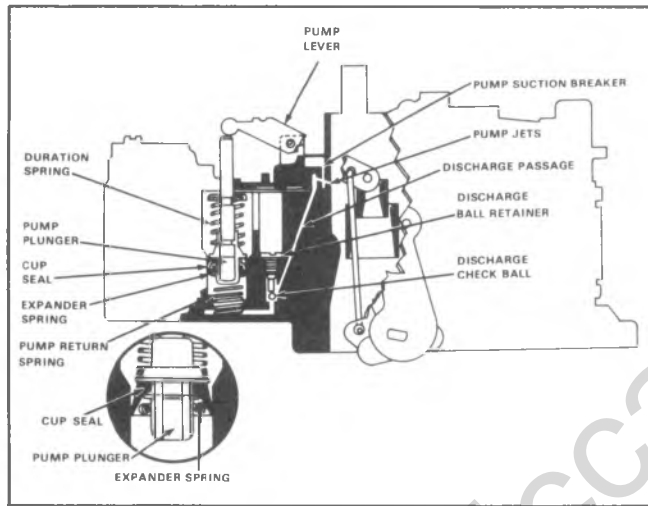


Fig. 6C-42--Accelerating Pump System-M4MC/M4ME

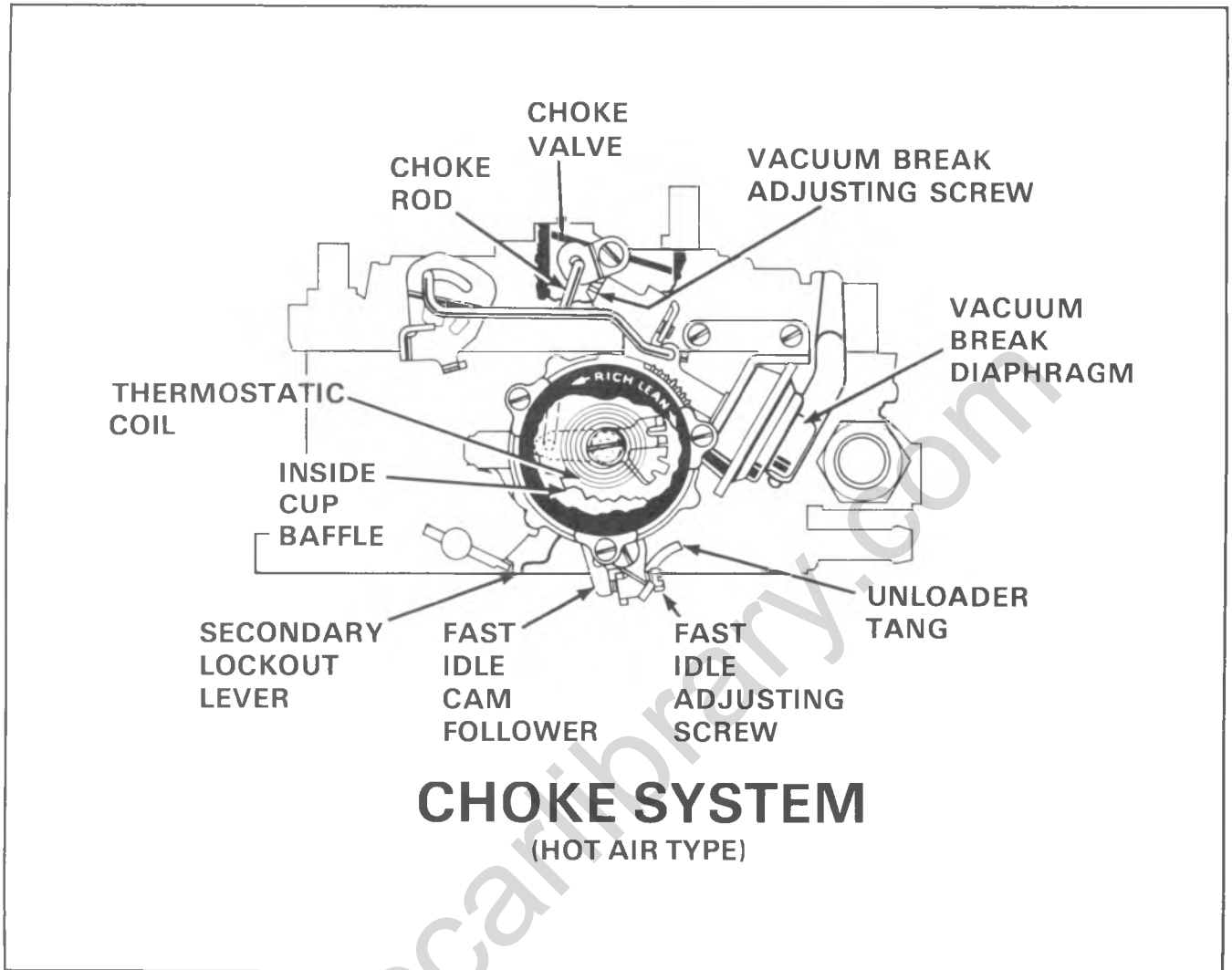


Fig. 6C-44-Choke System-M4MC

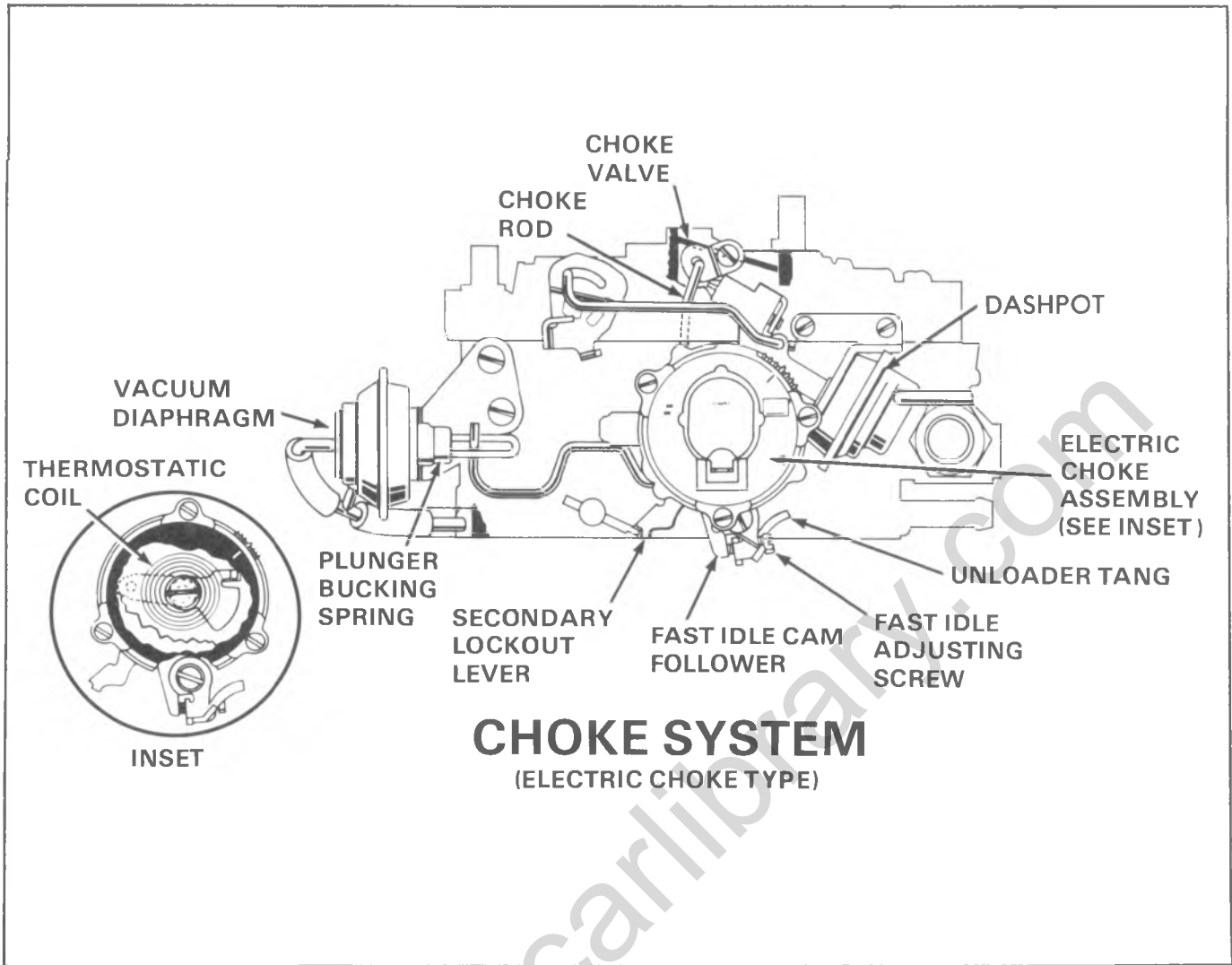


Fig. 6C-45--Choke System-M4ME

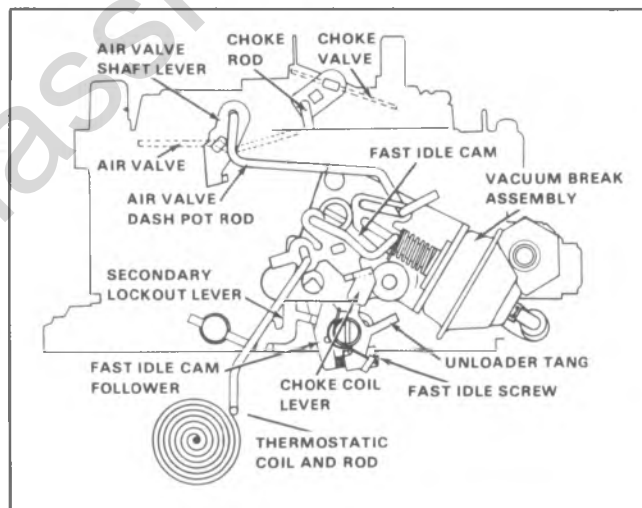


Fig. 6C-46--Choke System-4MV

ON-VEHICLE SERVICE

M4MC/M4ME/4MV CARBURETOR ADJUSTMENTS

Refer to figure 6C-47 for the following adjustments:

- Float
- Pump

Refer to figure 6C-48 for the following adjustments:

- Fast Idle
- Choke Coil Lever
- Choke Rod (Fast Idle Cam)-M4MC/M4ME

Refer to figure 6C-49 for the following adjustments:

- Choke Rod (Fast Idle Cam)-4MV
- Air Valve Rod-M4MC/M4ME
- Air Valve Rod-4MV

Refer to figure 6C-50 for the following adjustments:

- Vacuum Break
- Rear Vacuum Break
- Vacuum Break-4MV

Refer to figure 6C-51 for the following adjustments:

- Automatic Choke Coil-M4MC
- Automatic Choke Coil-M4ME
- Automatic Choke Coil Rod-4MV

Checking Carburetor Choke

1. Remove air cleaner. With engine off, hold throttle half open. Open and close choke several times. Watch linkage to be certain all links are connected and there are no signs of damage.

2. If choke or linkage binds, sticks or works sluggish, clean with choke cleaner X-20-A or equivalent. Use cleaner as directed on can. Refer to disassembly instructions for additional direction if cleaning does not correct.

3. Visually inspect carburetor to be certain all vacuum hoses are connected. Inspect hoses for cracks, abrasions, hardness or other signs of deterioration. Replace or correct as necessary.

4. Make sure vacuum break diaphragm shaft is fully extended when engine is off. If shaft is not fully extended, replace vacuum break diaphragm shaft should fully retract within 10 seconds. If unit fails to retract, replace vacuum break assembly.

Refer to figure 6C-52 for the following adjustments:

- Unloader-M4MC/M4ME
- Unloader-4MV
- Secondary Lockout

Refer to figure 6C-53 for the following adjustments:

- Secondary Closing

- Secondary Opening
- Air Valve Spring

Refer to figure 6C-54 for the following adjustments:

- Air Valve Spring
- Idle Speed-Without Solenoid
- Idle Speed-With Solenoid

Checking Solenoid

1. Turn on ignition, but do not start engine.
2. Turn A/C to "on" position.
3. Open throttle to allow solenoid to extend, close throttle.
4. Disconnect lead at solenoid. Solenoid plunger should drop away from throttle lever.
5. Connect solenoid lead. Plunger should move out and contact the throttle lever. Solenoid may not be strong enough to open the throttle, but the plunger should move.
6. If plunger does not move in and out as lead is disconnected and connected, insert test light (1893 bulb or smaller) between the solenoid feed wire and ground.
7. If light lights, replace solenoid.
8. If light does not light, locate cause of open circuit in solenoid feed wire.

Idle Mixture

Idle mixture screws have been present at the factory and capped. Do not remove the caps during normal engine maintenance.

Before suspecting the carburetor as the cause of poor engine performance or rough idle, check ignition system including distributor, timing, spark plugs and wires. Check air cleaner, evaporative emission system, EFE System, PCV system, EGP valve and engine compression. Also inspect intake manifold, vacuum hoses and connections for leaks and check torques of carburetor mounting bolts/nuts.

In the case of major carburetor overhaul, throttle body replacement, high idle CO as indicated by state or local emission inspection, the idle mixture may be adjusted. Adjusting mixture by other than the following method may violate Federal and/or California or other state laws.

Idle Mixture Adjustment

1. Set parking brake and block drive wheels.
2. Remove air cleaner for access to carburetor, but keep vacuum hoses connected.
3. Disconnect and plug other hoses as directed on Emission Control Information Label under the hood.
4. Engine must be at normal operating temperature, choke open, air conditioning off.
5. Connect an **ACCURATE** tachometer to engine.
6. Disconnect vacuum advance and plug hose. Check ignition timing. If necessary, adjust to specification shown on Emission Control Information Label. Reconnect vacuum advance.
7. Carefully remove caps from idle mixture screws.

<p>1</p> <p>③ GAUGE FROM TOP OF CASTING TO TOP OF FLOAT – GAUGING POINT 3/16" BACK FROM END OF FLOAT AT TOE (SEE INSET)</p> <p>① HOLD RETAINER FIRMLY IN PLACE</p> <p>② PUSH FLOAT DOWN LIGHTLY AGAINST NEEDLE</p> <p>④ REMOVE FLOAT AND BEND FLOAT ARM UP OR DOWN TO ADJUST</p> <p>⑤ VISUALLY CHECK FLOAT ALIGNMENT AFTER ADJUSTING</p> <p>(INSET) TOE GAUGING POINT (3/16" BACK FROM TOE)</p> <p>FLOAT ADJUSTMENT</p>	<p>CARB. NO.</p> <p>17057202 17057204 17057502 17057582 17057584 17057503 17057504</p> <p>17057209 17057218 17057222 17057518 17057522 17057586 17057588 17057219 17057519 17057512 17057517</p> <p>17056212 17057221 17056217</p> <p>17057213 17057215 17057216 17057525 17057514 17057529 17057229 7045583 7045585 7045586</p>	<p>GAUGE</p> <p>15/32"</p> <p>7/16"</p> <p>3/8"</p> <p>11/32"</p>
<p>2</p> <p>③ GAUGE FROM TOP OF CHOKE VALVE WALL. NEXT TO VENT STACK. TO TOP OF PUMP STEM AS SPECIFIED</p> <p>④ BEND PUMP LEVER TO ADJUST</p> <p>② ROD IN SPECIFIED HOLE OF PUMP LEVER</p> <p>① THROTTLE VALVES COMPLETELY CLOSED</p> <p>IF NECESSARY, BEND SECONDARY CLOSING TANG AWAY TO CLOSE PRIMARY VALVES. THEN RE ADJUST</p> <p>PUMP ADJUSTMENT</p>	<p>CARB. NO.</p> <p>ALL EXCEPT 17057586 17057588</p> <p>17057586 17057588</p>	<p>GAUGE</p> <p>9/32"</p> <p>9/32"</p> <p>HOLE LOC.</p> <p>INNER</p> <p>OUTER</p>

Fig. 6C-47-M4MC/M4ME/4MV Carburetor Adjustments-1 of 8

NOTE*: ANGLE GAUGE METHOD CAN BE USED

<p>3</p> <p>1 LOOSEN THREE RETAINING SCREWS AND REMOVE THE THERMOSTATIC COVER AND COIL ASSEMBLY FROM CHOKE HOUSING</p> <p>CHOKE VALVE CLOSED</p> <p>2 PUSH UP ON THERMOSTATIC COIL TANG (COUNTERCLOCKWISE) UNTIL CHOKE VALVE IS CLOSED</p> <p>3 ROD AT BOTTOM OF SLOT</p> <p>4 INSERT SPECIFIED PLUG GAUGE</p> <p>5 LOWER EDGE OF LEVER SHOULD JUST CONTACT SIDE OF PLUG GAUGE</p> <p>6 BEND CHOKE ROD AT THIS POINT TO ADJUST (SEE INSET)</p> <p>7 INSTALL COVER AND REFER TO AUTOMATIC CHOKE ADJUSTMENT</p> <p>CHOKE COIL LEVER ADJUSTMENT — M4MC/M4ME</p>	<p>CARB. NO.</p> <p>ALL</p>	<p>PLUG GAUGE</p> <p>.120"</p>			
<p>4</p> <p>1 POSITION TRANSMISSION IN PARK OR NEUTRAL</p> <p>2 HOLD CAM FOLLOWER ON HIGHEST STEP OF FAST IDLE CAM</p> <p>3 DISCONNECT AND PLUG VACUUM HOSE AT EGR VALVE</p> <p>4 TURN FAST IDLE SCREW TO OBTAIN SPECIFIED FAST IDLE RPM</p> <p>FAST IDLE ADJUSTMENT</p>	<p>LIGHT DUTY EMISSIONS MANUAL TRANSMISSION 1300 RPM (N)</p>	<p>AUTOMATIC TRANSMISSION 1600 RPM (N)</p>	<p>HEAVY DUTY EMISSIONS 350/400 CID 1600 RPM (N)</p>	<p>454 1700 RPM (N)</p>	
<p>5</p> <p>5 GAUGE BETWEEN UPPER EDGE OF CHOKE VALVE & INSIDE AIR HORN WALL (SEE NOTE*)</p> <p>NOTE: HOLD GAUGE VERTICAL</p> <p>6 BEND TANG ON FAST IDLE CAM TO ADJUST</p> <p>4 CLOSE CHOKE BY PUSHING UPWARD ON CHOKE COIL LEVER</p> <p>3 PLACE CAM FOLLOWER ON SECOND STEP OF CAM NEXT TO HIGH STEP</p> <p>1 MAKE FAST IDLE ADJUSTMENT</p> <p>2 REMOVE THERMOSTATIC COVER</p> <p>7 INSTALL COVER AND REFER TO AUTOMATIC CHOKE ADJUSTMENT</p> <p>CHOKE ROD (FAST IDLE CAM) ADJUSTMENT — M4MC/M4ME</p>	<p>CARB. NO.</p>	<p>PLUG GAUGE</p>	<p>ANGLE GAUGE</p>	<p>ALL WITH LIGHT DUTY EMISSIONS</p> <p>.325</p> <p>46°</p>	<p>ALL WITH HEAVY DUTY EMISSIONS</p> <p>.285</p> <p>46°</p>

Fig. 6C-48-M4MC/M4ME/4MV Carburetor Adjustments - 2 of 8

6

② PLACE SPECIFIED GAUGE BETWEEN WALL AND UPPER EDGE OF CHOKE VALVE

③ BEND CHOKE ROD TO OBTAIN GAUGE DIMENSION OPENING

① POSITION CAM FOLLOWER ON SECOND STEP OF CAM

④ RECHECK FAST IDLE ADJUSTMENT

CHOKE ROD (FAST IDLE CAM) ADJUSTMENT — 4MV

CARB. NO.	PLUG GAUGE	ANGLE
7045583 7045585 7045586 17056212 17056217	.290	
ALL OTHERS	.220	42°

7

③ PLACE GAUGE BETWEEN ROD AND END OF SLOT IN LEVER

② AIR VALVE COMPLETELY CLOSED

① SEAT CHOKE VACUUM DIAPHRAGM USE OUTSIDE VACUUM SOURCE

④ BEND HERE FOR SPECIFIED CLEARANCE BETWEEN ROD AND END OF SLOT IN LEVER

NOTE: PLUG PURGE BLEED HOLE WITH TAPE (WHERE USED). REMOVE AFTER ADJUSTMENT

AIR VALVE ROD ADJUSTMENTS — M4MC/M4ME

CARB. NO.	PLUG GAUGE
ALL	.015"

② AIR VALVES MUST BE COMPLETELY CLOSED

④ BEND ROD HERE TO OBTAIN SPECIFIED CLEARANCE BETWEEN ROD AND END OF SLOT IN LEVER

③ PLACE .015 GAUGE BETWEEN ROD AND END OF SLOT IN LEVER

① SEAT DIAPHRAGM USING OUTSIDE VACUUM SOURCE

AIR VALVE ROD ADJUSTMENT — 4MV

Fig. 6C-49--M4MC/M4ME/4MV Carburetor Adjustments-3 of 8

NOTE*: ANGLE GAUGE METHOD CAN ALSO BE USED

8		NOTE: HOLD GAUGE VERTICALLY		5 PLACE GAUGE BETWEEN UPPER EDGE OF CHOKE VALVE AND INSIDE WALL OF AIR HORN (SEE NOTE*) 3 SEAT DIAPHRAGM USING OUTSIDE VACUUM SOURCE NOTE: PLUG PURGE BLEED HOLE WITH A PIECE OF MASKING TAPE ON DELAY FEATURE MODELS. REMOVE AFTER ADJUSTMENT. 4 PUSH INSIDE CHOKE COIL LEVER COUNTERCLOCKWISE UNTIL TANG ON VACUUM BREAK LEVER CONTACTS TANG ON VACUUM BREAK PLUNGER STEM	CARB. NO.	PLUG GAUGE	ANGLE GAUGE		
8 TURN SCREW TO ADJUST 2 PLACE CAM FOLLOWER ON HIGHEST STEP OF FAST IDLE CAM 1 REMOVE THERMOSTATIC COVER 7 INSTALL COVER AND REFER TO AUTOMATIC CHOKE ADJUSTMENT VACUUM BREAK ADJUSTMENT -M4MC					17057202	.160 (.215 BOTTOM)	27°		
					17057204				
					17057218				
					17057222				
9 BEND ROD TO ADJUST NOTE: PLUG PURGE BLEED HOLE WITH A PIECE OF MASKING TAPE ON DELAY FEATURE MODELS. REMOVE AFTER ADJUSTMENT. 2 SEAT REAR VACUUM BREAK DIAPHRAGM USING OUTSIDE VACUUM SOURCE 1 REMOVE COVER AND PLACE CAM FOLLOWER ON HIGHEST STEP OF FAST IDLE CAM 6 BEND ROD TO ADJUST 5 GAUGE BETWEEN AIR HORN WALL & UPPER EDGE OF CHOKE VALVE (SEE NOTE*) 4 ROD IN BOTTOM OF SLOT 7 INSTALL COVER AND REFER TO AUTOMATIC CHOKE ADJUSTMENT 3 PUSH UP ON CHOKE COIL LEVER DIAPHRAGM PLUNGER PULLED OUT UNTIL SEATED — BUCKING SPRING COMPRESSED ON MODELS WHERE USED REAR VACUUM BREAK ADJUSTMENT -M4ME					17057221	.160	27°		
					10 4 GAUGE BETWEEN AIR HORN WALL AND UPPER EDGE OF CHOKE VALVE 1 VACUUM PLUNGER MUST BE FULLY SEATED USING OUTSIDE VACUUM SOURCE 3 LIGHTLY ROTATE CHOKE COIL LEVER COUNTERCLOCKWISE UNTIL END OF ROD IS IN END OF SLOT IN LEVER 5 BEND ROD TO ADJUST 2 OPEN PRIMARY THROTTLE VALVES SO THAT FAST IDLE CAM FOLLOWER CLEARS FAST IDLE CAM VACUUM BREAK ADJUSTMENT - 4MV		CARB. NO.	PLUG GAUGE	ANGLE GAUGE
							17057213	.115	25.3°
							17057215		
17057216									
					17057529	.110	25.3°		
					17057229				
					7045583	.120	26.5°		
					7045585				
					7045586				
					17056212				
					17056217				
					17057514				
17057525									

Fig. 6C-50--M4MC/M4ME/4MV Carburetor Adjustments - 4 of 8

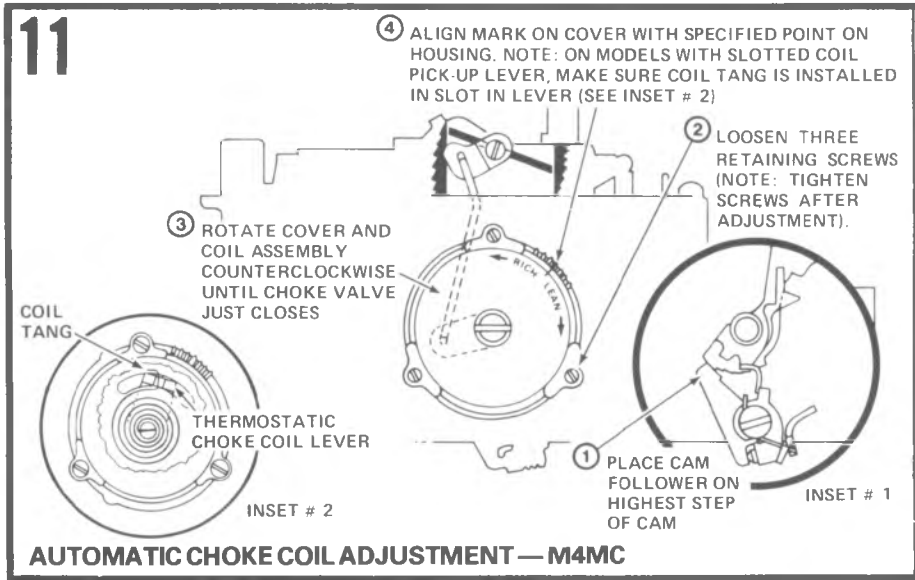
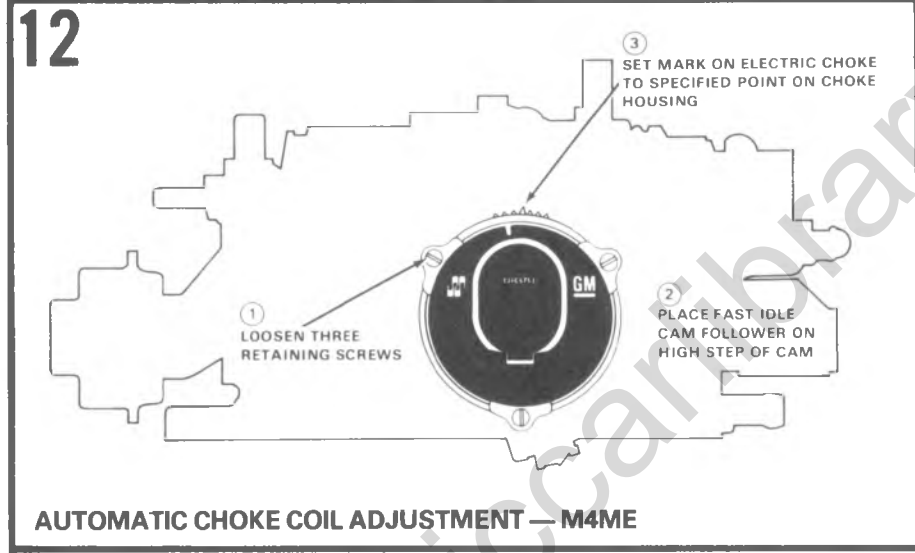
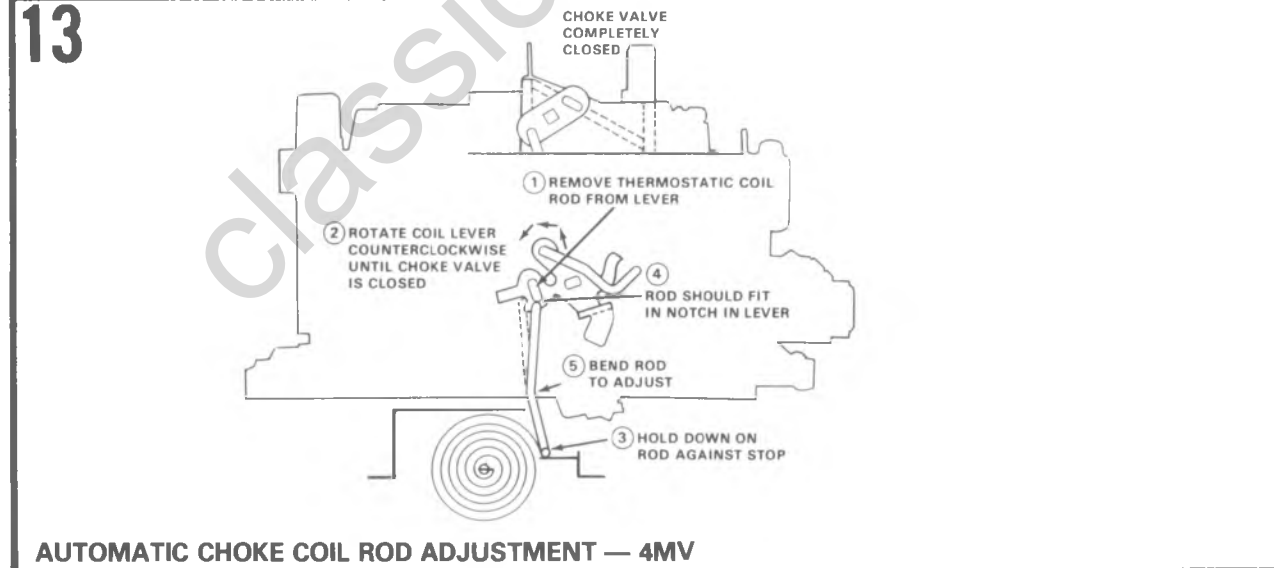
<p>11</p>  <p>④ ALIGN MARK ON COVER WITH SPECIFIED POINT ON HOUSING. NOTE: ON MODELS WITH SLOTTED COIL PICK-UP LEVER, MAKE SURE COIL TANG IS INSTALLED IN SLOT IN LEVER (SEE INSET # 2)</p> <p>③ ROTATE COVER AND COIL ASSEMBLY COUNTERCLOCKWISE UNTIL CHOKE VALVE JUST CLOSES</p> <p>② LOOSEN THREE RETAINING SCREWS (NOTE: TIGHTEN SCREWS AFTER ADJUSTMENT).</p> <p>① PLACE CAM FOLLOWER ON HIGHEST STEP OF CAM</p> <p>COIL TANG</p> <p>THERMOSTATIC CHOKE COIL LEVER</p> <p>INSET # 2</p> <p>INSET # 1</p> <p>AUTOMATIC CHOKE COIL ADJUSTMENT — M4MC</p>	<p>CARB. NO.</p> <p>17057503 17057519</p> <p>17057202 17057204 17057218 17057222 17057502 17057504 17057518 17057522 17057582 17057584 17057586 17057588</p> <p>17057209 17057219</p> <p>17057512 17057517</p>	<p>INDEX MARK</p> <p>ONE NOTCH LEAN</p> <p>2 NOTCHES LEAN</p> <p>3 NOTCHES LEAN</p> <p>INDEX</p>
<p>12</p>  <p>③ SET MARK ON ELECTRIC CHOKE TO SPECIFIED POINT ON CHOKE HOUSING</p> <p>② PLACE FAST IDLE CAM FOLLOWER ON HIGH STEP OF CAM</p> <p>① LOOSEN THREE RETAINING SCREWS</p> <p>AUTOMATIC CHOKE COIL ADJUSTMENT — M4ME</p>	<p>CARB. NO.</p> <p>17057221</p>	<p>INDEX MARK</p> <p>2 NOTCHES COUNTER-CLOCKWISE</p>
<p>13</p>  <p>CHOKE VALVE COMPLETELY CLOSED</p> <p>① REMOVE THERMOSTATIC COIL ROD FROM LEVER</p> <p>② ROTATE COIL LEVER COUNTERCLOCKWISE UNTIL CHOKE VALVE IS CLOSED</p> <p>④ ROD SHOULD FIT IN NOTCH IN LEVER</p> <p>⑤ BEND ROD TO ADJUST</p> <p>③ HOLD DOWN ON ROD AGAINST STOP</p> <p>AUTOMATIC CHOKE COIL ROD ADJUSTMENT — 4MV</p>		

Fig. 6C-51--M4MC/M4ME/4MV Carburetor Adjustments-5 of 8

NOTE*: ANGLE GAUGE METHOD CAN ALSO BE USED

<p>14</p> <p>④ GAUGE BETWEEN UPPER EDGE OF CHOKE VALVE AND AIR HORN WALL (SEE NOTE*)</p> <p>③ ON WARM ENGINE, CLOSE CHOKE VALVE BY PUSHING UP ON TANG ON INTERMEDIATE CHOKE LEVER (HOLD IN POSITION WITH RUBBER BAND)</p> <p>⑤ BEND TANG TO ADJUST</p> <p>② HOLD THROTTLE VALVES WIDE OPEN</p> <p>① CHECK INDEX MARK POSITION (STEP 11 OR 12)</p> <p>UNLOADER ADJUSTMENT — M4MC/M4ME</p>	<p>CARB. NO.</p> <p>17057221 17057209</p>	<p>PLUG GAUGE</p> <p>.325</p>	<p>ANGLE GAUGE</p> <p>46°</p>
<p>15</p> <p>③ GAUGE BETWEEN AIR HORN WALL AND UPPER EDGE OF CHOKE VALVE (SEE NOTE*)</p> <p>① PUSH UP OR DOWN ON LEVER TOWARDS CLOSED CHOKE</p> <p>② HOLD PRIMARY THROTTLE VALVES WIDE OPEN</p> <p>④ BEND TANG TO ADJUST</p> <p>UNLOADER ADJUSTMENT — 4MV</p>	<p>CARB. NO.</p> <p>17057213 17057215 17057216 17057529 17057229</p> <p>17057525 17057514</p> <p>17056212 17056217 7045583 7045585 7045586</p>	<p>PLUG GAUGE</p> <p>.205</p> <p>.225</p> <p>.295</p>	<p>ANGLE GAUGE</p> <p>40°</p> <p>43°</p>
<p>16</p> <p>CHOKE VALVE</p> <p>PUSH DOWN ON TAIL OF CAM (STEP 2)</p> <p>LOCKOUT LEVER</p> <p>CHOKE VALVE CLOSED</p> <p>THROTTLE VALVES CLOSED</p> <p>BEND PIN TO ADJUST</p> <p>.015 MAX CLEARANCE</p> <p>① SECONDARY LOCKOUT LEVER SIDE CLEARANCE</p> <p>HOLD CHOKE VALVE WIDE OPEN BY PUSHING DOWN ON TAIL OF FAST IDLE CAM</p> <p>CHECK LOCKOUT PIN FOR CLEARANCE</p> <p>FILE END OF PIN FOR CLEARANCE (CHECK FOR NO BURRS AFTER FILING)</p> <p>② SECONDARY LOCKOUT OPENING CLEARANCE</p> <p>GAUGE</p> <p>SECONDARY LOCKOUT ADJUSTMENT</p>	<p>CARB. NO.</p> <p>ALL</p>	<p>PLUG GAUGE</p> <p>.015"</p>	

Fig. 6C-52-M4MC/M4ME/4MV Carburetor Adjustments · 6 of 8

<p>17</p> <p>1 ENGINE IDLE SET TO PROPER IDLE R.P.M.</p> <p>2 CHOKE VALVE WIDE OPEN-CAM FOLLOWER OFF STEPS OF FAST IDLE CAM</p> <p>3 LEVER AGAINST TANG</p> <p>4 SPECIFIED CLEARANCE</p> <p>5 BEND TANG TO ADJUST</p> <p>SECONDARY CLOSING ADJUSTMENT</p>	<p>CARB. NO.</p> <p>ALL</p>	<p>PLUG GAUGE</p> <p>.020"</p>
<p>18</p> <p>1 OPEN PRIMARY THROTTLE UNTIL ACTUATING LINK CONTACTS TANG</p> <p>2 LINK SHOULD BE IN CENTER OF SLOT</p> <p>3 BEND TANG TO ADJUST</p> <p>SECONDARY OPENING ADJUSTMENT</p>		
<p>19</p> <p>1 LOOSEN LOCK SCREW USING SPECIAL HEX WRENCH</p> <p>2 TURN TENSION ADJUSTING SCREW COUNTERCLOCKWISE UNTIL AIR VALVE OPENS PART WAY</p> <p>3 MANUALLY HOLD AIR VALVE CLOSED AND TURN TENSION ADJUSTING SCREW CLOCKWISE SPECIFIED NUMBER OF TURNS AFTER SPRING CONTACTS PIN</p> <p>4 HOLD ADJUSTING SCREW AND TIGHTEN LOCK SCREW</p> <p>AIR VALVE SPRING ADJUSTMENT</p>	<p>CARB. NO.</p> <p>17057525</p> <p>17056212 17056217</p> <p>ALL OTHERS</p>	<p>NUMBER OF TURNS</p> <p>3/4"</p> <p>7/16"</p> <p>7/8"</p>

Fig. 6C-53--M4MC/M4ME/4MV Carburetor Adjustments - 7 of 8

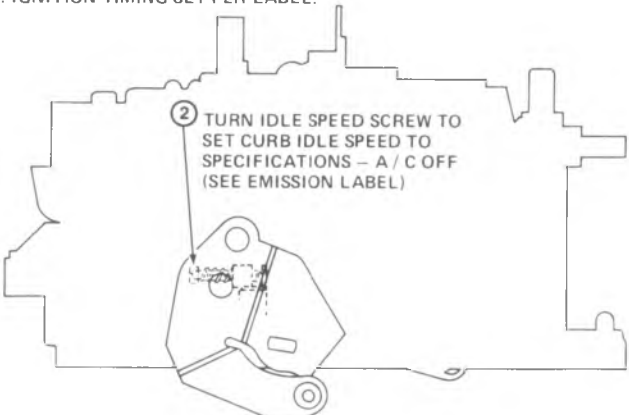
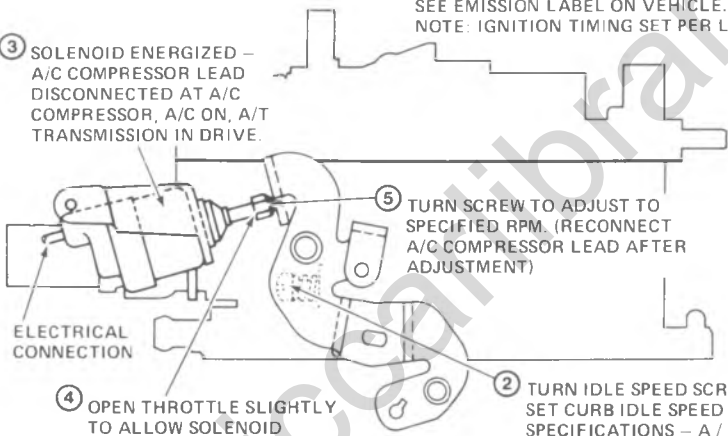
<p>20</p> <p>① PREPARE VEHICLE FOR ADJUSTMENTS – SEE EMISSION LABEL ON VEHICLE. NOTE: IGNITION TIMING SET PER LABEL.</p>  <p>② TURN IDLE SPEED SCREW TO SET CURB IDLE SPEED TO SPECIFICATIONS – A / C OFF (SEE EMISSION LABEL)</p> <p>IDLE SPEED ADJUSTMENT — WITHOUT SOLENOID</p>	<p>LIGHT DUTY EMISSIONS</p> <p>MANUAL TRANSMISSION 700 RPM (N)</p> <hr/> <p>LIGHT DUTY EMISSIONS AUTOMATIC TRANSMISSION (ALL EXCEPT HIGH ALTITUDE & 454 CID) 500 RPM (D)</p> <p>(HIGH ALTITUDE & 454 CID) 600 RPM (D)</p> <p>HEAVY DUTY EMISSIONS 700 RPM</p>
<p>21</p> <p>① PREPARE VEHICLE FOR ADJUSTMENTS – SEE EMISSION LABEL ON VEHICLE. NOTE: IGNITION TIMING SET PER LABEL.</p> <p>③ SOLENOID ENERGIZED – A/C COMPRESSOR LEAD DISCONNECTED AT A/C COMPRESSOR, A/C ON, A/T TRANSMISSION IN DRIVE.</p>  <p>ELECTRICAL CONNECTION</p> <p>④ OPEN THROTTLE SLIGHTLY TO ALLOW SOLENOID PLUNGER TO FULLY EXTEND.</p> <p>⑤ TURN SCREW TO ADJUST TO SPECIFIED RPM. (RECONNECT A/C COMPRESSOR LEAD AFTER ADJUSTMENT)</p> <p>② TURN IDLE SPEED SCREW TO SET CURB IDLE SPEED TO SPECIFICATIONS – A / C OFF (SEE EMISSION LABEL)</p> <p>IDLE SPEED ADJUSTMENT — WITH SOLENOID</p>	<p>LIGHT DUTY EMISSIONS AUTOMATIC TRANSMISSION & AIR CONDITIONING</p> <p>(ALL EXCEPT HIGH ALTITUDE & 454 CID)</p> <p>IDLE SPEED SCREW – 500 RPM (D) SOLENOID SCREW – 650 RPM (D)</p> <p>(HIGH ALTITUDE & 454 CID) IDLE SPEED SCREW – 600 RPM (D) SOLENOID SCREW – 650 RPM (D)</p>

Fig. 6C-54-M4MC/M4ME/4MV Carburetor Adjustments - 8 of 8

Be careful not to bend screws. Lightly seat screws then back out **EQUALLY** just enough so engine will run.

8. Place transmission in Drive (automatics with light duty emissions) or Neutral (all manuals and automatics with heavy duty emissions).

9. Back each screw out (richen) 1/8 turn at a time until maximum idle speed is obtained. Then set idle speed to value shown in Chart Column A of specifications. Repeat Step 9 to be certain you have maximum idle speed.

10. Turn each screw in (lean) with 1/8 turn increments until idle speed reaches value shown in Chart Column B of specifications.

11. Reset idle speed to specification shown on Emission Control Information Label.

12. Check and adjust fast idle as described on the Emission Control Information Label.

13. Reconnect vacuum hoses. Install air cleaner.

14. Recheck idle speed. If necessary, reset to specification.

Choke Valve Angle Gauge (Fig. 6C-55)

1. Choke valve angle measuring gauge J-26701 tool may be used with carburetor on or off engine. If off engine, place carburetor on holding fixture so that it will remain in the same position when gauge is in place.

2. Rotate degree scale until zero (0) is opposite pointer.

3. With choke valve completely closed, place magnet squarely on top of choke valve.

4. Rotate bubble until it is centered.

5. Rotate scale so that degree specified for the particular adjustment is opposite pointer.

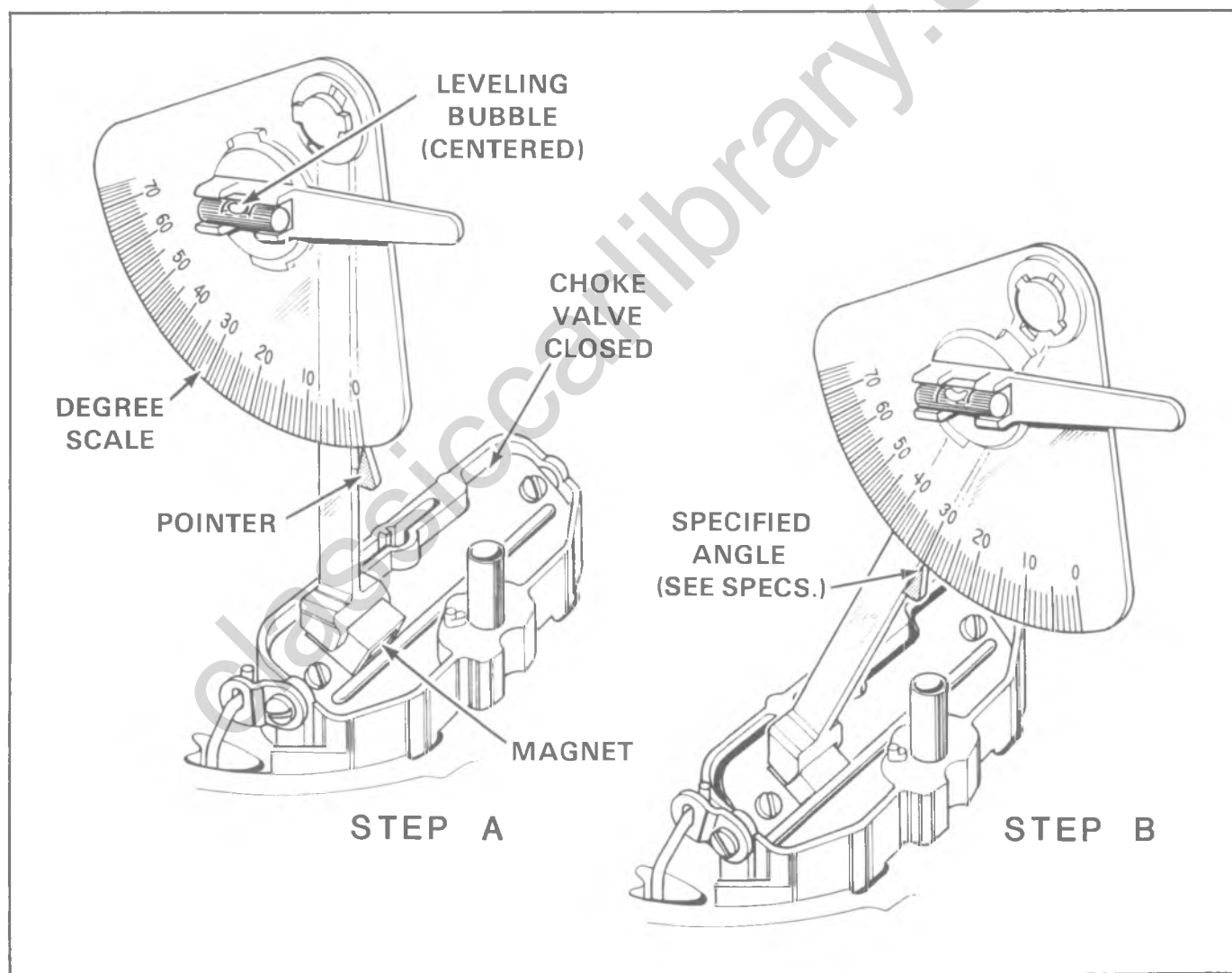


Fig. 6C-55-Choke Valve Angle Gauge

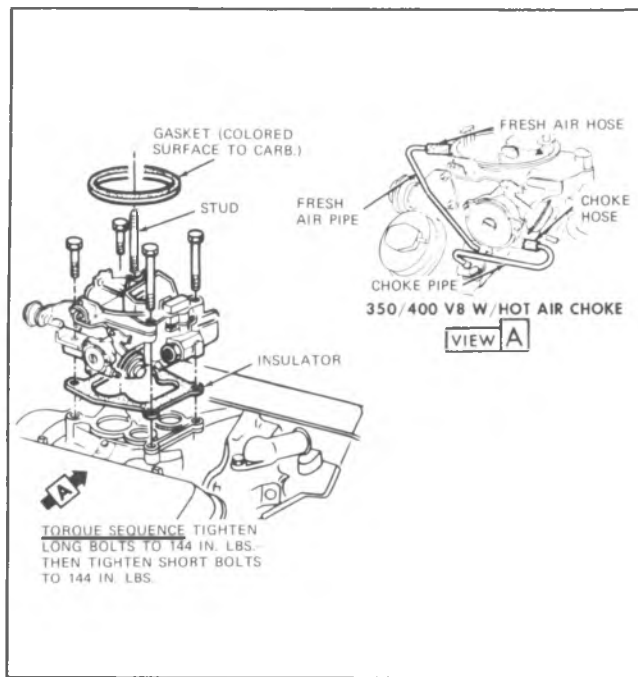


Fig. 6C-56--Carburetor and Choke Pipes-M4MC/
M4ME

6. Adjust the choke linkage to center the bubble. This completes adjustment.

CARBURETOR REPLACEMENT

Model M4MC/M4ME (Fig. 6C-56)

Removal

Flooding, stumble on acceleration and other performance complaints are in many instances, caused by presence of dirt, water, or other foreign matter in carburetor. To aid in diagnosis, carburetor should be carefully removed from engine without draining fuel from bowl. Contents of fuel bowl may then be examined for contamination as carburetor is disassembled. Check filter.

1. Remove air cleaner and gasket.
2. Disconnect wire at solenoid, if equipped.
3. Disconnect fuel pipe and vacuum lines.
4. Disconnect fresh air hose (hot air choke) or electrical connector (electric choke) from choke system.
5. Disconnect accelerator linkage.
6. If equipped with automatic transmission, disconnect downshift cable.
7. If equipped with cruise control, disconnect linkage.
8. Remove carburetor attaching bolt, carburetor and insulator.

Installation

1. Clean sealing surfaces on intake manifold and carburetor.
2. Fill carburetor bowl before installing carburetor.

3. Install carburetor and new insulator with attaching bolts. Tighten bolts alternately to 144 pound inches.
4. Connect downshift cable as required.
5. Connect cruise control cable as required.
6. Connect accelerator linkage.
7. Connect choke system.
8. Connect fuel pipe and vacuum hoses.
9. Connect solenoid as required.
10. Install air cleaner.
11. Check and adjust idle speed.

Model 4MV (Fig. 6C-57)

Removal

Flooding, stumble on acceleration and other performance complaints are, in many instances, caused by presence of dirt, water, or other foreign matter in carburetor. To aid in diagnosis, carburetor should be carefully removed from engine without draining fuel from bowl. Contents of fuel bowl may then be examined for contamination as carburetor is disassembled. Check filter.

1. Remove air cleaner and gasket.
2. Disconnect fuel and vacuum lines from carburetor.
3. Remove clip from choke linkage.
4. Disconnect accelerator linkage.
5. If equipped with automatic downshift cable, disconnect cable.
6. Remove carburetor attaching bolts and remove carburetor.

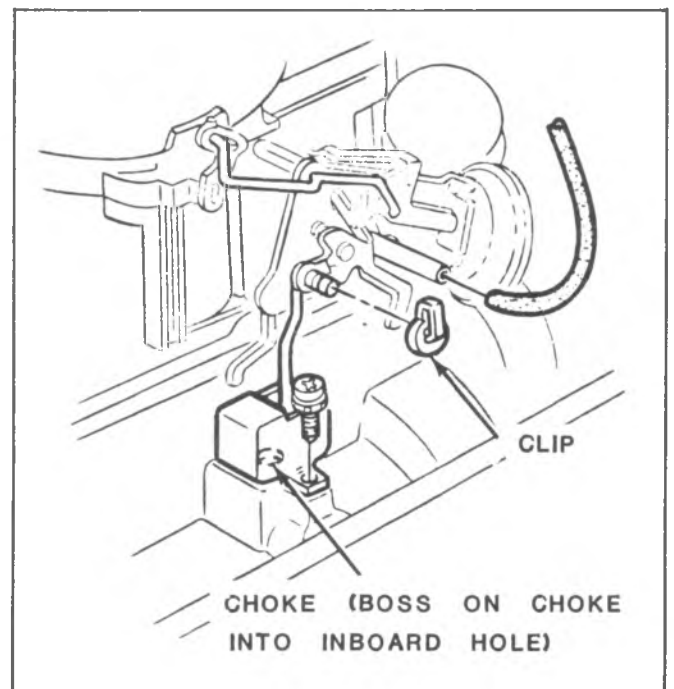


Fig. 6C-57--Carburetor Choke-4MV

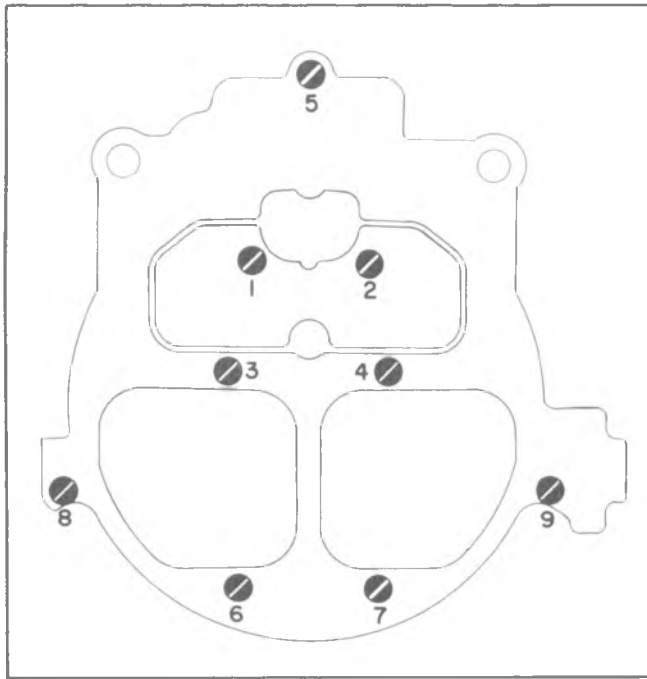


Fig. 6C-58--Air Horn Tightening Sequence

7. Remove insulator.

Installation

1. Clean sealing surfaces on intake manifold and carburetor.
2. Fill carburetor bowl before installing carburetor.
3. Install carburetor and new insulator with attaching bolts. Tighten bolts alternately to 144 pound inches.
4. Connect downshift cable as required.
5. Connect accelerator linkage.
6. Connect choke linkage and install clip.
7. Connect solenoid as required.
8. Install air cleaner.
9. Check and adjust idle speed.

AIR HORN TIGHTENING SEQUENCE

Refer to figure 6C-58 for air horn tightening sequence.

SPECIFICATIONS
IDLE MIXTURE (LEAN DROP)
LIGHT DUTY EMISSIONS

ENGINE	COLUMN A SPEED BEFORE LEAN DROP	COLUMN B SPEED AFTER LEAN DROP
350 CID MANUAL TRANS. LOW ALT & CALIF.	800 RPM (N)	700 RPM (N)
350 CID AUTOMATIC TRANS. LOW ALT. & CALIF.	550 RPM (D)	500 RPM (D)
350 CID AUTOMATIC TRANS. HIGH ALTITUDE	650 RPM (D)	600 RPM (D)
454 CID AUTOMATIC TRANS.	650 RPM (D)	600 RPM (D)

IDLE MIXTURE (LEAN DROP)
HEAVY DUTY EMISSIONS

ENGINE	COLUMN A SPEED BEFORE LEAN DROP	COLUMN B SPEED AFTER LEAN DROP
350 CID EXCEPT CALIFORNIA	875 RPM (N)	700 RPM (N)
350 CID CALIFORNIA	800 RPM (N)	
400 CID	770 RPM (N)	
454 CID EXCEPT CALIFORNIA	800 RPM (N)	
454 CID CALIFORNIA	750 RPM (N)	

TORQUE SPECIFICATIONS

M4MC/M4ME CARBURETOR

SCREW	TORQUE (IN. LBS.)
THROTTLE BODY THROTTLE BODY TO BOWL	46
CHOKE HOUSING CHOKE LEVER	14
CHOKE HOUSING ATTACHING	46
CHOKE HOUSING COVER	26
AIR HORN	
AIR HORN TO BOWL 10-32	46
AIR HORN TO BOWL 8-32	26
AIR HORN TO THROTTLE BODY	46
CHOKE LEVER	14
VACUUM BREAK UNIT	26
FUEL INLET NUT	400
NEEDLE SEAT	45
METERING JET	40
SOLENOIS BRACKET	71

4MV CARBURETOR

SCREW	TORQUE (IN. LBS.)
AIR HORN TO BOWL 10-32	46
AIR HORN TO BOWL 8-32	26
AIR HORN TO THROTTLE BODY	46
THROTTLE BODY TO BOWL	46
VACUUM BREAK UNIT	26
SOLENOID BRACKET	71
FUEL INLET NUT	400
METERING JET	40
NEEDLE SEAT	45

FUEL SUPPLY

FUEL FILTER

GENERAL DESCRIPTION

All engine fuel filters are located in the carburetor fuel inlet. These fuel filter elements are of pleated paper. Elements are placed in the inlet hole with the gasket surface outward. A spring holds the element outward, sealing it by compressing a gasket surface against the inlet fitting.

ON-VEHICLE SERVICE

The carburetor inlet fuel filter should be replaced every 15,000 miles or 12 months.

After assembling any filter element in the carburetor, always start the engine and check for leaks in the fuel line and fittings before installing the air cleaner.

Other Filters or Strainers

A woven plastic filter is located on the lower end of the fuel pickup pipe in the gas tank. This filter prevents dirt from entering the fuel line and also stops water unless the filter becomes completely submerged in water. This filter is self cleaning and normally required no maintenance. Fuel stoppage at this point indicates that the gas tank contains an abnormal amount of sediment or water; the tank should therefore be removed and thoroughly cleaned.

Fuel Filter Replacement

Light Duty Emissions

A plugged fuel filter and/or check valve will restrict fuel flow.

1. Disconnect fuel line connection at fuel inlet filter nut.

2. Remove fuel inlet filter nut from carburetor.
3. Remove filter and spring.
4. If removed, install check valve in fuel inlet filter.

CAUTION: The fuel inlet check valve must be installed in the filter to meet Motor Vehicle Safety Standards (M.V.S.S.) for roll-over. New service replacement filter include the check valve.

5. Install fuel inlet filter spring, filter, and check valve assembly in carburetor. Check valve end of filter faces toward fuel line.

NOTE: Ribs on closed end of filter element prevent filter from being installed incorrectly unless forced.

6. Install new gasket on fuel inlet filter nut and install nut in carburetor. Tighten nut to 18 pound feet.

CAUTION: Tightening beyond specified torque can damage gasket.

7. Install fuel line and tighten connection.

Heavy Duty Emissions

A plugged fuel filter will shut off fuel flow into carburetor.

1. Disconnect fuel line-connection at inlet fuel filter nut.
2. Remove inlet fuel filter nut from carburetor.
3. Remove filter element and spring.
4. Install element spring and filter element in carburetor.
5. Install new gasket on inlet fitting nut and install nut in carburetor and tighten securely.
6. Install fuel line and tighten connector.

FUEL PUMP

GENERAL DESCRIPTION

The fuel pump (Figs. 6C-59 through 61)) is a diaphragm type pump and is actuated by the rocker arm through a link and a push rod.

Some vehicles have a fuel pump which has a metering outlet for a vapor return system. Any vapor which forms is returned to the fuel tank along with hot fuel through a separate line. This greatly reduces any possibility of vapor lock by keeping cool fuel from the tank constantly circulating through the fuel pump.

ON-VEHICLE SERVICE

Inspection and Test

If the fuel system is suspected of delivering an

improper amount of fuel to the carburetor, it should be inspected and tested in the vehicle, as follows:

Inspection of Fuel System

1. Make certain that there is gasoline in the tank.
2. With the engine running, inspect for leaks at all gasoline feed hose connections from fuel tank to carburetor. Tighten any loose connections. Inspect all hoses for flattening or kinks which would restrict the flow of fuel. Air leaks or restrictions on suction side of mechanical fuel pump will seriously affect pump output.
3. Inspect for leaks at fuel pump diaphragm flange.
4. Disconnect feed pipe near carburetor. Ground distributor terminal of coil with jumper wire so that engine can be cranked without firing. Place suitable

container at end of pipe and crank engine a few revolutions. If no gasoline, or only a little flows from pipe, the feed line is clogged or fuel pump is inoperative. Before condemning the fuel pump, disconnect feed line at both ends and blow through it with air hose to make certain that fuel pump is operating within specifications.

Fuel Pump Pressure Test

1. Disconnect gasoline line near carburetor and connect a suitable pressure gage (such as Pressure-Leakdown Tester J-22109).

2. Start engine and check pressure with engine running at slow idle speed. Fuel pump pressure should be as specified at the end of this section. On vehicles equipped with a vapor return system, squeeze off the return hose so that an accurate reading can be obtained.

3. If fuel pump pressure is below minimum, pump must be replaced.

Fuel Pump Flow Test

1. Disconnect fuel line from carburetor. Run fuel line into a suitable measuring container.

2. While observing the sweep second hand of a clock or watch, run the engine at idle until there is one pint of fuel in the container. One pint should be pumped in 30 seconds or less.

3. If flow is below minimum, check for restriction in the line.

Diagnosis

Complete diagnosis of all possible causes of the trouble prior to replacement of the fuel pump will save time, expense and possible causes of the trouble prior to replacement of the fuel pump will save time, expense and possibly prevent a repeat complaint.

Low Pressure Complaint

The only way to check fuel pump pressure is by connecting an accurate pressure gauge to the fuel line at carburetor level. Never replace a fuel pump without first making that simple check.

Not Enough Fuel Flow Complaint

When an engine has a "starving-out" condition, many mechanics jump to the conclusion that the fuel pump is not pumping enough fuel. Many times the "starving-out" condition is actually due to a weakness in the ignition system, since these two troubles are very hard to separate. Even when an engine is starving for fuel, the cause is more likely to be a plugged fuel filter or a restricted fuel line than a malfunctioning fuel pump.

Removal

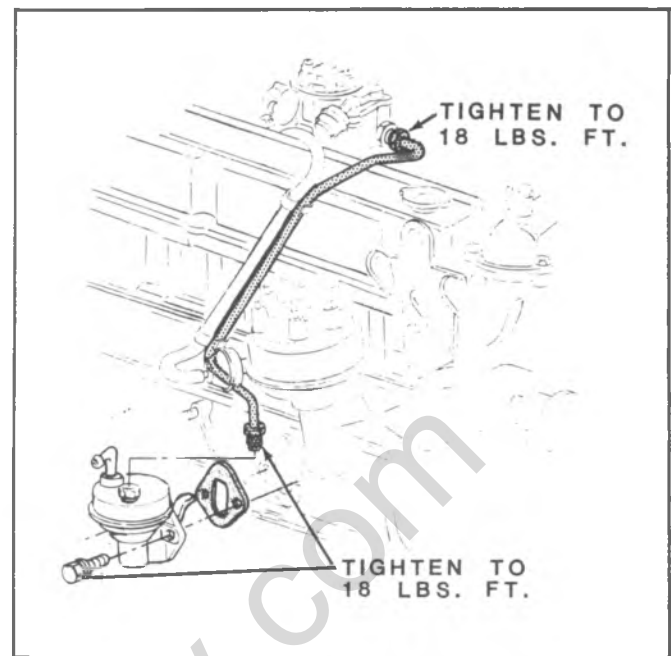


Fig. 6C-59--Fuel Pump-L6

1. Disconnect fuel inlet hose from pump. Disconnect vapor return hose, if so equipped.
2. Disconnect fuel outlet pipe.
3. Remove two 1/2 inch hex head bolts, using a 3/8 inch drive deep socket and a ratchet handle.
4. Remove fuel pump.

Installation

1. Install new fuel pump with new gasket.
2. Install two 1/2 inch hex head bolts, turning them alternately and evenly.
3. Install fuel outlet pipe. If it is difficult to start fitting, time can be saved by disconnecting upper end of pipe from carburetor. Tighten fitting securely, meanwhile holding fuel pump nut with a wrench. Install and tighten fitting at carburetor, if removed.
4. Install fuel inlet hose. Install vapor return hose, if so equipped.
5. Start engine and check for leaks.

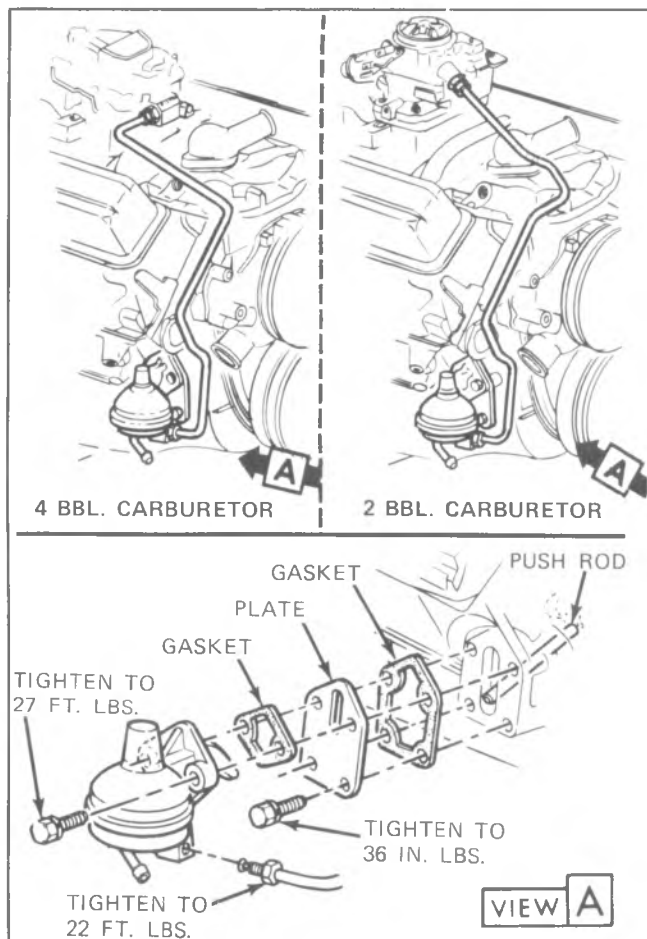


Fig. 6C-60--Fuel Pump-305/350/400 V8

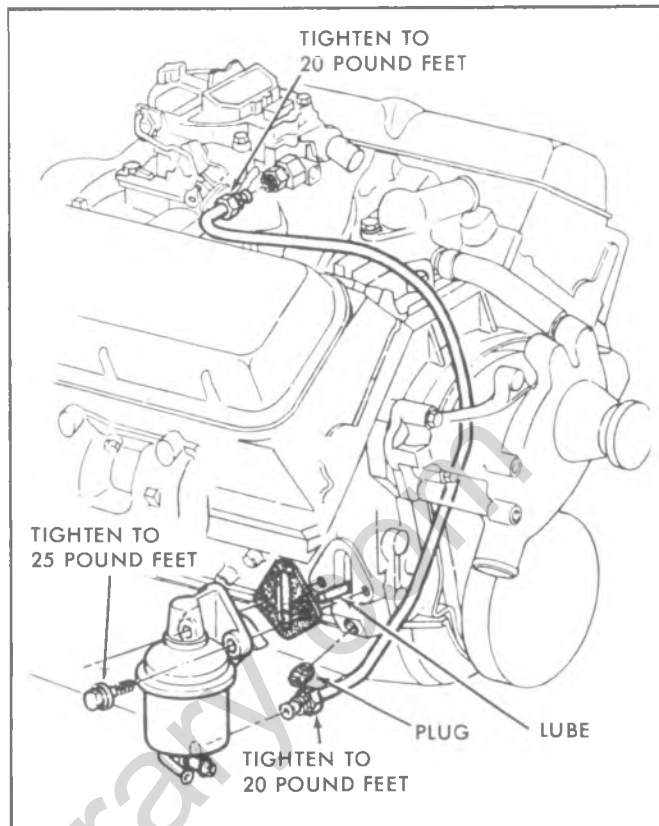


Fig. 6C-61--Fuel Pump-454 V8

FUEL TANK

ON-VEHICLE SERVICE

Outside Frame Rail Fuel Tank-

Cab and Crewcab (Figs. 6C-62 and 63)

1. Drain tank.
2. Disconnect fuel lines, meter wire and ground lead.
3. Remove strap supports (lines, vent) and clip.
4. Loosen clamps from filler neck and vent line.
5. Remove strap bolts and lock washers from tank front and rear locations on inside frame rail.
6. Remove tank from frame simultaneously disengaging filler neck hose from filler neck (Fig. 6C-64).
7. Remove meter assembly from fuel tank using Tool J-24187 (Fig. 6C-65).
8. Reverse removal procedure to install fuel tank.

Center and Auxiliary Fuel Tank -

CK 10 and 20 (06, 16) (Figs. 6C-66, 67, 68)

Fuel Tank-Van (Fig. 6C-69)

1. Drain tank.
2. Raise vehicle on hoist.
3. Unclamp upper filler neck and vent tube hose.
4. Unclamp gauge unit hoses at frame end.
5. Support tank and remove support straps.
6. Lower tank and disconnect meter wire.
7. Remove tank.
8. Install in the reverse order, using new antisqueak material.
9. Lower vehicle and remove from hoist.

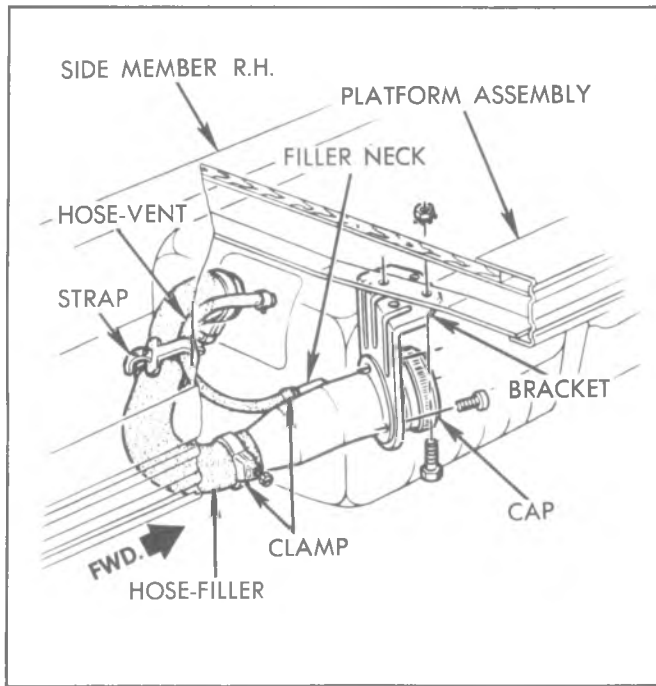


Fig. 6C-64--Filler Neck-Cab Stake Body

equipped). Apply air pressure in the direction fuel normally flows through line.

9. Use low air pressure to clean pipes on tank unit.

10. Clean filter on fuel tank unit, if required. Install fuel tank gauge unit, (with new gasket) into tank and install tank. Connect tank unit wires and all fuel lines, except pump to carburetor line (see "Removal of Tank" for proper procedure).

11. Connect a hose to fuel line at carburetor; insert other end of hose into a one gallon fuel can.

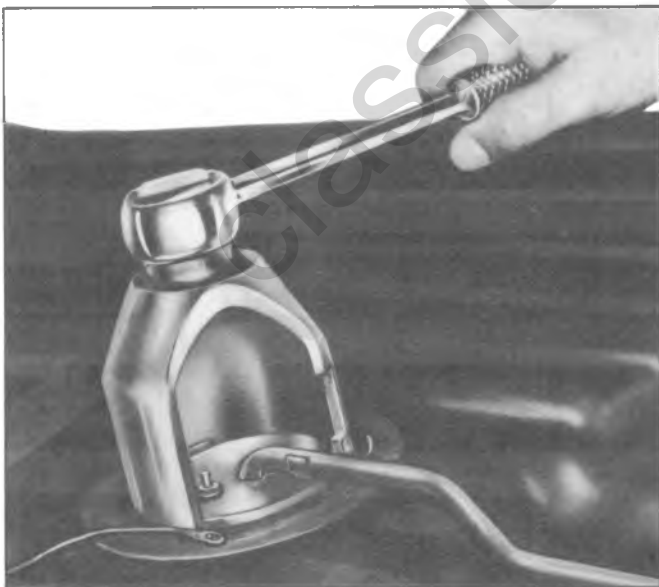


Fig. 6C-65--Removing Meter Assembly

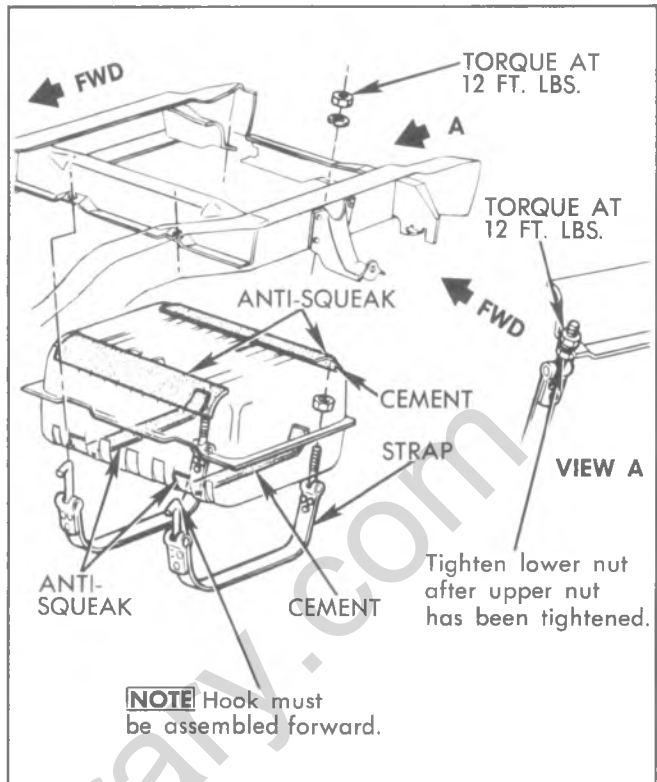


Fig. 6C-66--Fuel Tank, CK 10-20 (06, 16)

12. Connect battery cable. Make sure distributor feed wire is disconnected.

13. Put six gallons of clean fuel in tank and operate starter to pump two quarts of fuel into fuel can. This will purge fuel pump.

14. Remove hose and connect fuel line to carburetor.

15. Connect distributor feed wire.

16. Check all connections for leaks.

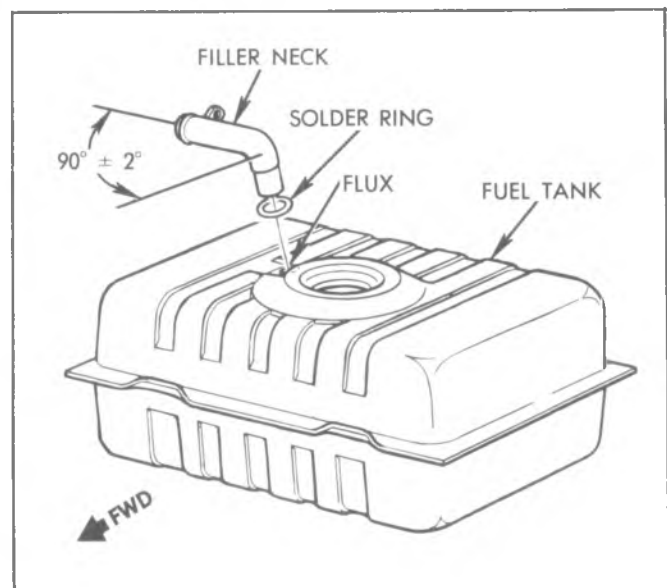


Fig. 6C-67--Fuel Tank, CK 10-20 (06, 16)

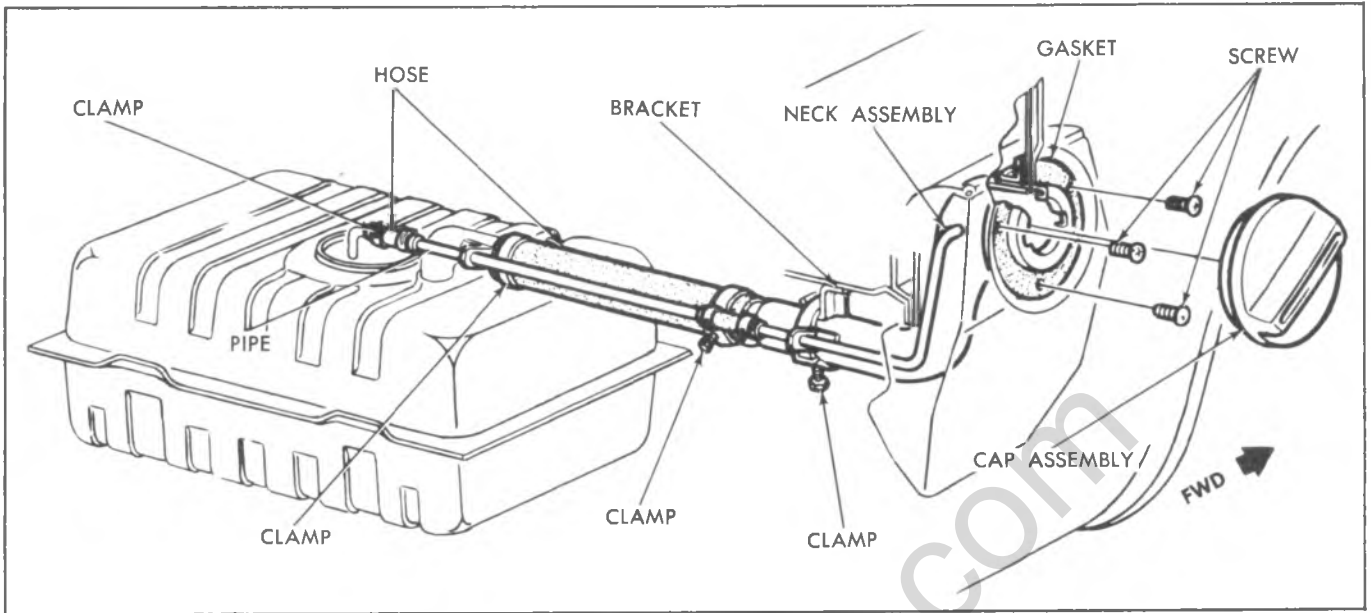


Fig. 6C-68-Filler Neck, CK10-20 (06, 16)

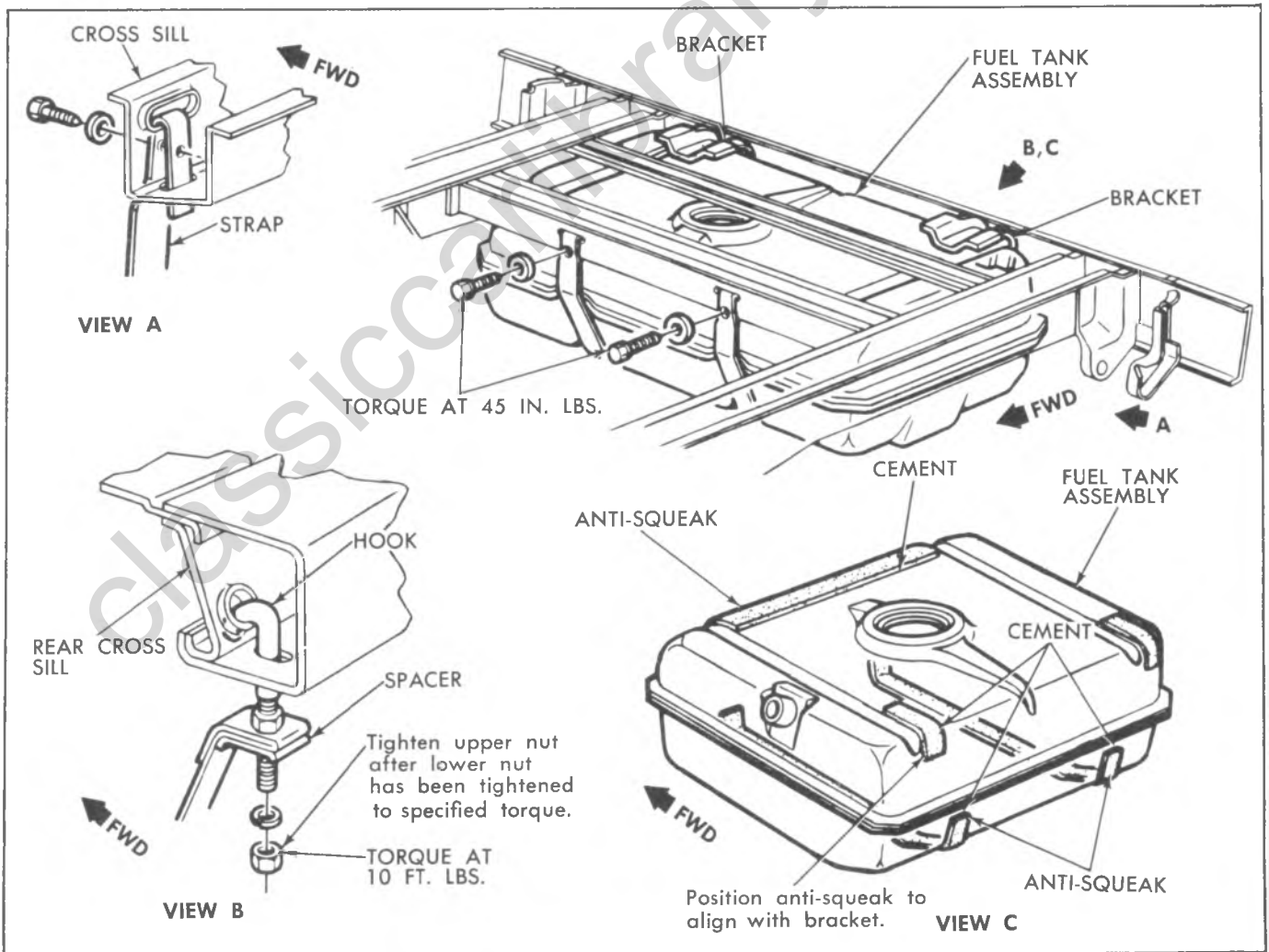


Fig. 6C-69-Fuel Tank and Mounting - Van

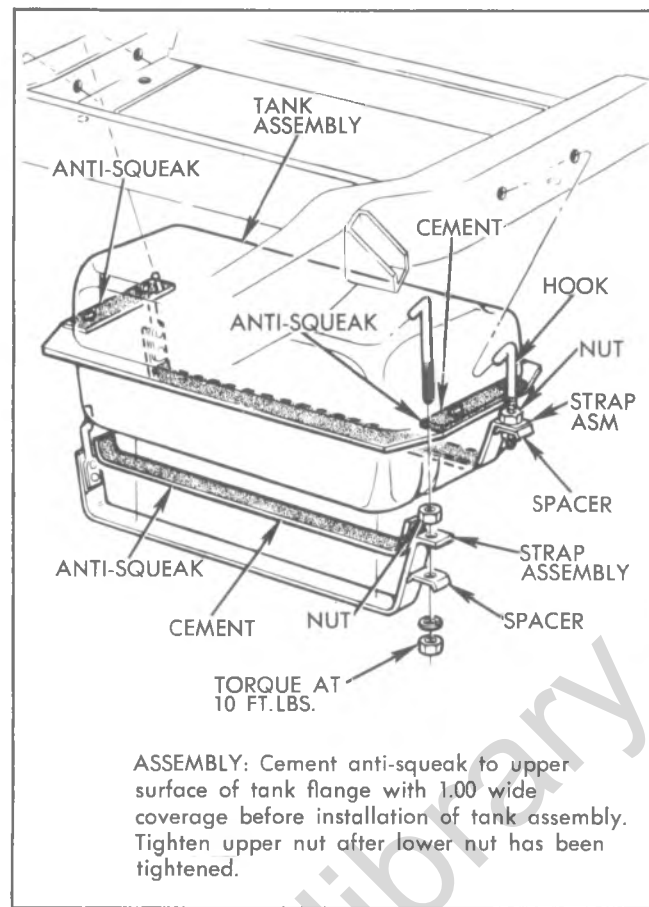


Fig. 6C-70--Fuel Tank and Mounting - P10

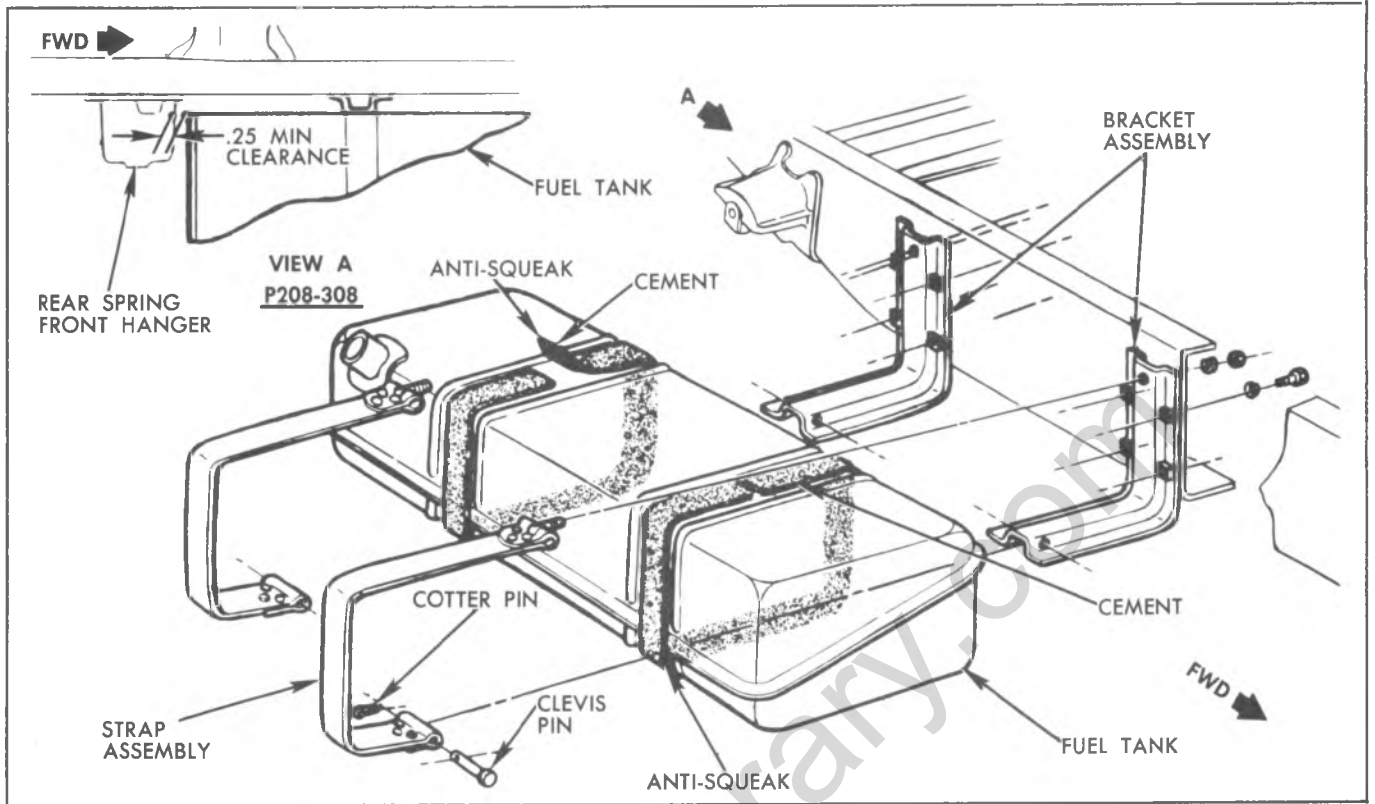


Fig. 6C-71--Fuel Tank and Mounting - P20, 30

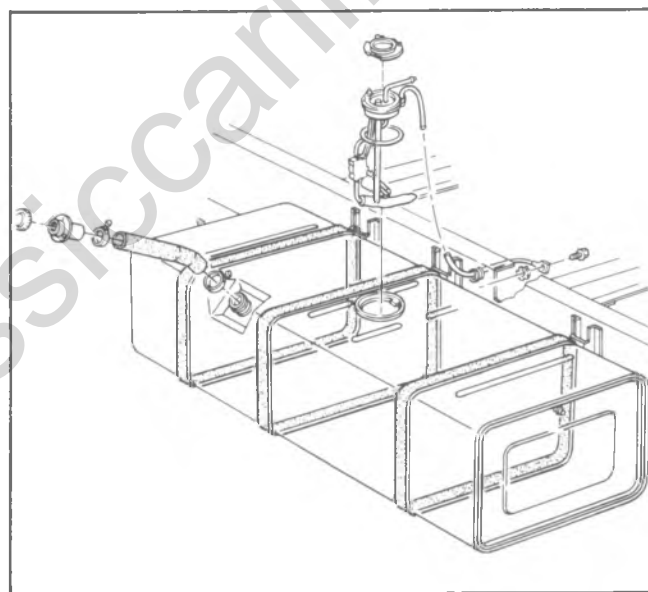


Fig. 6C-72--Fuel Tank (50 Gal.) Meter and Filler Neck - P30

FUEL FEED AND VAPOR PIPES

GENERAL DESCRIPTION

Fuel feed pipes are secured to the underbody with clamp and screw assemblies. Flexible hoses are located at fuel tank fuel, vapor and return lines and fuel pump. The pipes should be inspected occasionally for leaks, kinks or dents. If evidence of dirt or foreign material is found in carburetor, fuel pump or pipes, pipe should be disconnected and blown out. Dirt or foreign material may be caused by a damaged or omitted fuel strainer in fuel tank.

ON-VEHICLE SERVICE

Replacement

If replacement of fuel feed pipe, vapor pipe or return pipe is required, use only double wrap and brazed

steel tubing meeting GM Specification 123M or its equivalent. Under no condition use copper or aluminum tubing to replace steel tubing. Those materials do not have satisfactory fatigue durability to withstand normal vehicle vibrations.

Repair

1. Do not use fuel hose for pipe repair within 4 inches of any part of the exhaust system.

2. In repairable areas, cut fuel hose 4 inches longer than the portion of pipe removed. Use only hose stated for fuel usage by the manufacturer.

If more than a 6-inch length of pipe is removed, use a combination of steel pipe and hose so that hose lengths will not be longer than 10 inches.

3. The fuel hose should extend 2 inches on each pipe and be clamped at each end. Pipes must be properly secured to the frame to prevent chafing.

EVAPORATIVE CONTROL SYSTEM (ECS)

GENERAL DESCRIPTION

All light duty emissions and some heavy duty emission vehicles are equipped with a system designed to prevent escape of fuel vapor to the atmosphere. Vapor generated by evaporation of fuel in the tank, previously exhausted to atmosphere, is transferred by an emission line to the engine compartment. During periods of operation, vapors are fed directly to the engine for consumption. During periods of inoperation, an activated charcoal canister located in the emission line stores any vapor generated for consumption during the next period of operation.

The amount of vapor drawn into the engine at any time is too small to have any effect on fuel economy or engine operation.

With this closed system it is extremely important that only vapors be transferred to the engine. To avoid the possibility of liquid fuel being drawn into the system, these following features are included as part of the total system:

1. A fuel tank overflow protector is provided on all series to assure adequate room for expansion of liquid fuel volume with temperature changes.

2. A one point fuel tank venting system is provided on all series to assure that the tank will be vented under any conceivable vehicle attitude.

3. To protect the tank from mechanical damage in the event of excessive internal or external pressures resulting from the operation of this closed system, a pressure-vacuum relief valve, located in the gas cap, will control the tank internal pressure.

ON-VEHICLE SERVICE

Maintenance requirement is only that the oiled fiberglass filter assembled in the bottom of the canister,

be replaced every 24 months or 30,000 miles (light duty emissions), 24,000 miles (heavy duty emissions). Under extremely dusty conditions, more frequent attention may be required.

Canister and Filter

Removal

1. Note installed position of hoses on canister.
2. Disconnect hoses from top of canister.
3. Loosen clamps and remove canister.
4. If replacing filter, pull out filter from bottom of canister with your fingers.

Inspection

1. Check hose connection openings. Assure that they are open.
2. Check operation of purge valve by applying vacuum to the valve. A good valve will hold vacuum.

Installation

1. Install new filter.
2. Install canister and tighten clamp.
3. Connect hoses in same order.

Canister Purge Valve

Disassembly

1. Disconnect lines at valve.
2. Snap off valve cap (slowly remove cap as diaphragm is under spring tension). Remove diaphragm, spring retainer and spring.
3. Replace parts as necessary. Check orifice openings.

Assembly

1. Install spring, spring retainer, diaphragm and cap.
2. Connect lines to valve.

ACCELERATOR CONTROL

GENERAL

The accelerator control system is cable type. There are no linkage adjustments. A reference between the bottom of accelerator pedal and floor pan should be used only as a check for bent bracket assembly. Check torque references.

Check for correct opening and closing positions by operating accelerator pedal and if any binding is present, check routing of cable.

ACCELERATOR CONTROL CABLE

Refer to figures 6C-73 through 76 for removal and installation of accelerator control cable.

ACCELERATOR PEDAL

Refer to figures 6C-77 through 80 for removal and installation of accelerator pedal.

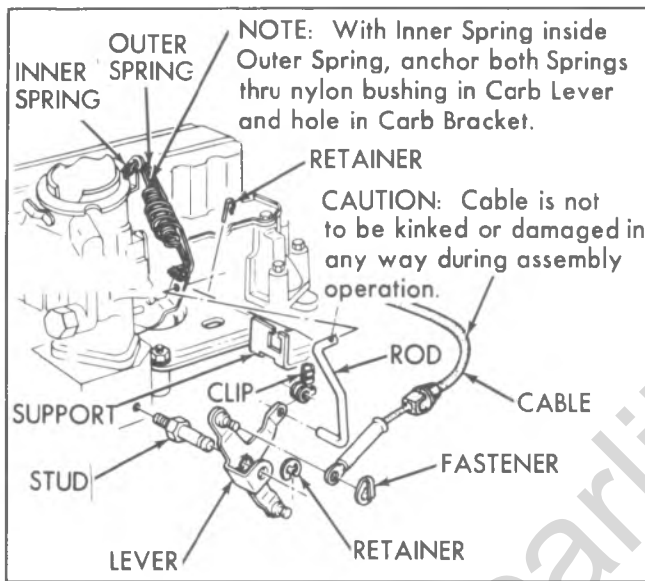


Fig. 6C-73--Accelerator Controls L6-Light Duty Emissions

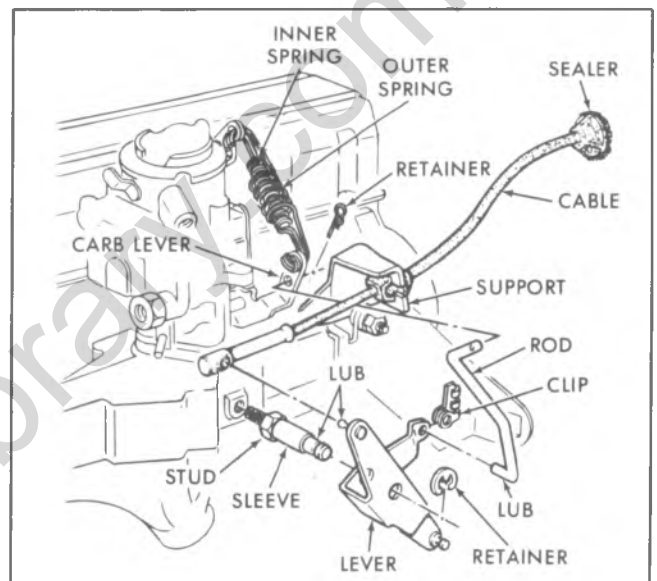


Fig. 6C-74--Accelerator Controls L6-Heavy Duty Emissions.

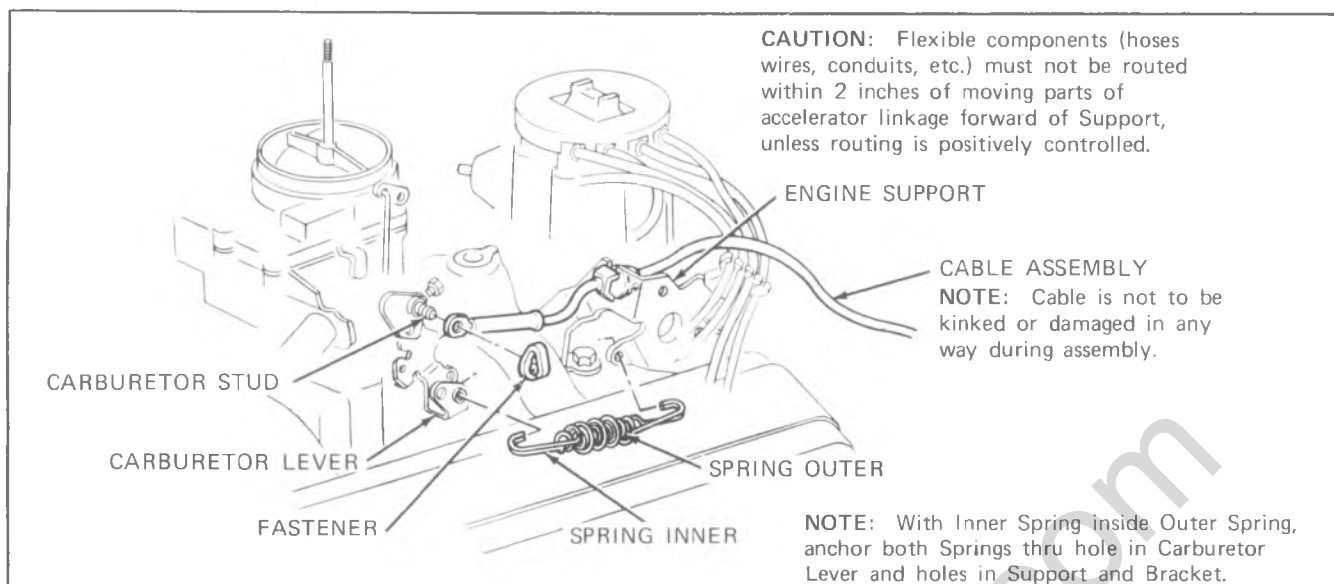


Fig. 6C-75--Accelerator Controls V8-2Bbl.

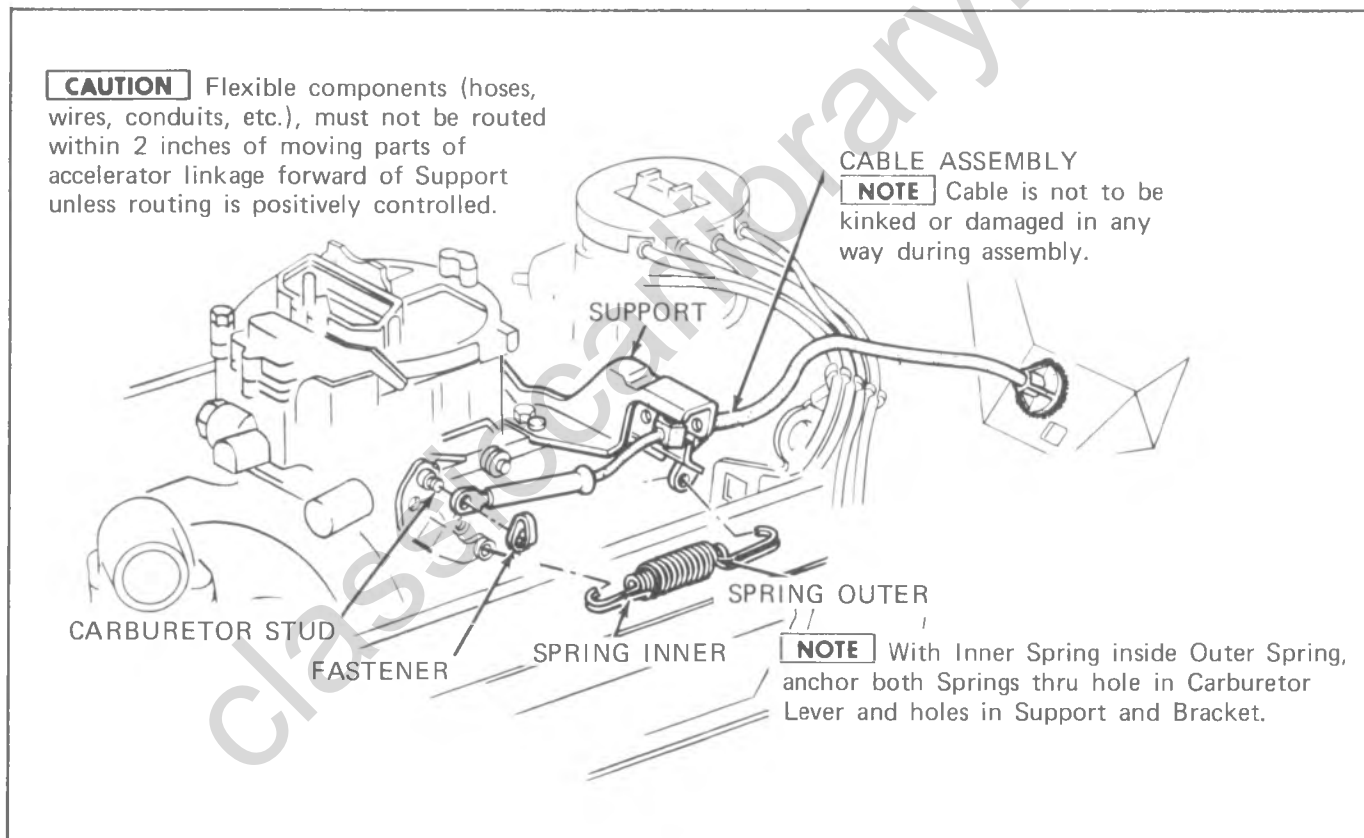


Fig. 6C-76--Accelerator Controls V8-4Bbl.

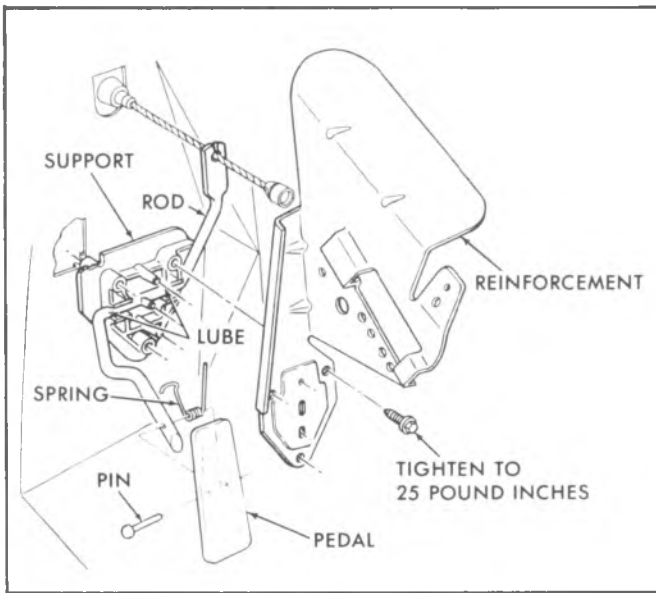


Fig. 6C-77--Accelerator Pedal-CK

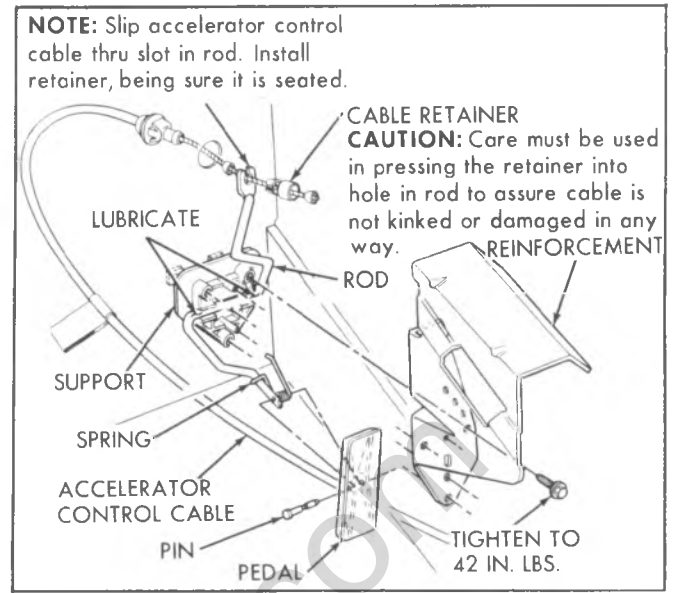


Fig. 6C-79--Accelerator Pedal-P42

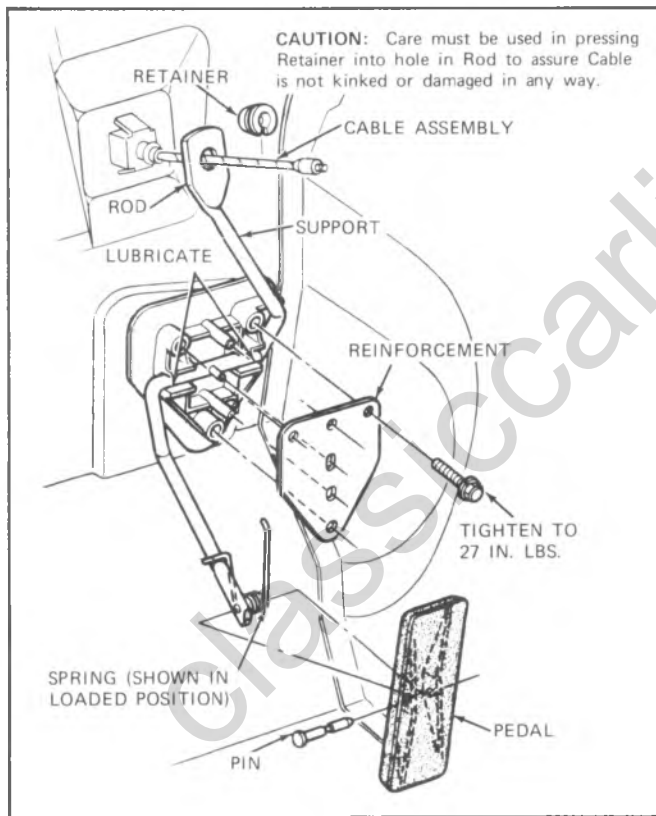


Fig. 6C-78--Accelerator Pedal-G

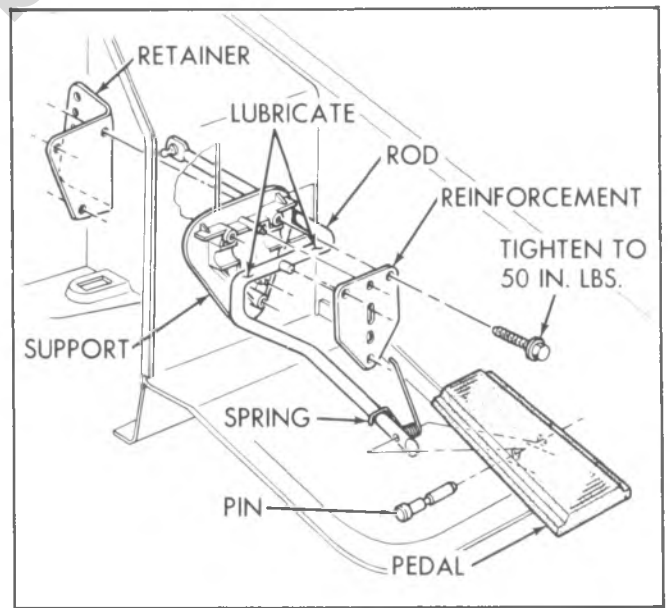


Fig. 6C-80--Accelerator Pedal-P32

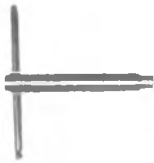
SPECIAL TOOLS



J9789-02 UNIVERSAL CARBURETOR GAUGE SET



J9789-118 CARBURETOR HOLDING STAND



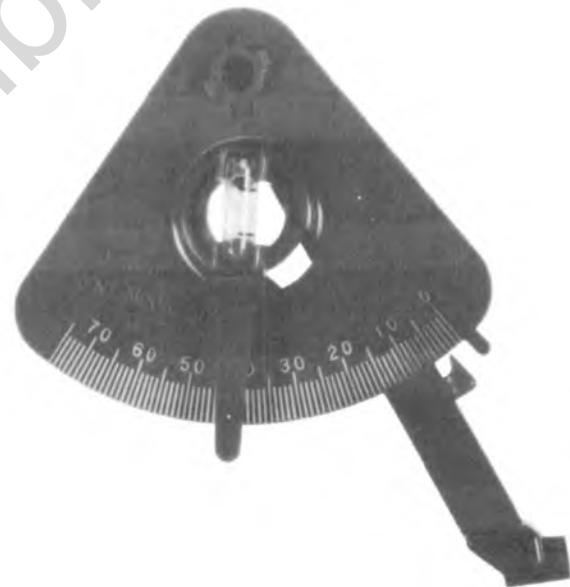
J9789-111 BENDING TOOL



J25322 PUMP LEVER PIN DRIVE PUNCH



J23417 CHOKE LEVER INSTALLING TOOL



J26701 CHOKE VALVE ANGLE GAUGE

Fig. 6C-81--Special Tools

SECTION 6D

ENGINE ELECTRICAL

CONTENTS

Electric Choke Heater	6D-1	Unit Repair	6D-21
Battery	6D-2	Special Tools	6D-25
General Description	6D-2	Distributor	6D-25
Common Causes of Failure	6D-4	General Description	6D-25
Care of Battery	6D-4	Diagnosis	6D-27
Battery Rating	6D-5	On-Vehicle Service	6D-33
Selecting a Replacement Battery	6D-5	Maintenance and Adjustments	6D-33
Safety Precautions	6D-5	Component Part Replacement	6D-33
Charging Procedures	6D-5	Spark Plugs	6D-33
Testing Procedures	6D-6	General Description	6D-37
Installing Batteries	6D-7	Diagnosis	6D-38
Diagnosis	6D-7	On-Vehicle Service	6D-41
Battery Test Procedure	6D-7	Component Part Replacement	6D-42
Maintenance Free Battery	6D-7	Ignition Switch	6D-42
General Information	6D-7	General Description	6D-42
Green Dot Visible	6D-7	Starter System	6D-43
Dark-Green Dot Not Visible	6D-7	General Description	6D-43
Testing Procedure	6D-7	Starter Motor	6D-43
Visual Inspection	6D-7	Solenoid	6D-46
State of Charge Indicator	6D-7	Diagnosis	6D-48
Removing Surface Charge	6D-8	No Cranking Action	6D-48
Load Test	6D-8	Cranking Speed Abnormally Low	6D-48
Charging Procedure	6D-8	Voltage Test	6D-48
Battery Charging Guide	6D-8	Amperage Test	6D-49
Charging and Testing Adapters	6D-8	On-Vehicle Service	6D-50
10 SI Series Generator	6D-8	Component Part Replacement	6D-50
General Description	6D-8	Starting Motor	6D-50
Diagnosis	6D-10	Checking Pinion Clearance	6D-50
Static Checks	6D-10	Bench Test	6D-50
Indicator Lamp Circuit Check	6D-11	Unit Repair	6D-51
Undercharged Battery Condition	6D-11	Disassembly	6D-51
Overcharged Battery Condition	6D-12	Cleaning and Inspection	6D-51
Generator Output Test	6D-12	Testing and Repairs	6D-51
Other Harness Checks	6D-12	Assembly	6D-54
Diagnosis Charts	6D-14	Pinion Clearance Check	6D-55
On-Vehicle Service	6D-20	Starting Solenoid	6D-55
Generator Replacement	6D-20	Specifications	6D-56
Pulley Replacement	6D-20		

ELECTRIC CHOKE HEATER-OIL PRESSURE SWITCH

MK IV V-8 AND 6 CYL ENGINES

All MK IV and 6 cylinder engines have a two-terminal oil pressure switch (sending unit) for controlling current to the electric choke heater. This switch and its associated circuitry provide for the illumination of the "Oil" tell tale lamp in the event of loss of oil pressure or loss of voltage at the choke heater.

The diagram in Figure 6D-1A shows how the dual function is accomplished. The "Bulb Check" feature is same as present system. That is, with ignition switch in "Run" position with engine off. This circuit will also indicate continuity in the choke heater and its connector.

If "Oil" tell tale lamp illuminates with engine running,

it could indicate one or more of the following:

1. Loss of oil pressure.
2. Loss of choke heater voltage.
3. Blown GAUGE fuse.

ELECTRIC CHOKE HEATER CHECKING PROCEDURE

1. Allow choke to cool so that when throttle is opened slightly, choke blade fully closes.

NOTE: This check must be performed with engine not running and at an ambient temperature of 60°C to 27°C.

2. Start engine and determine time for choke blade to reach full open position. (Start timer when engine starts).

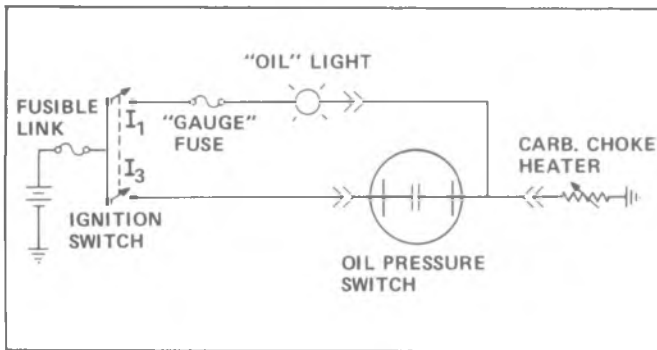


Fig. 6D-1A--Electric Choke Heater Diagram

3. If the choke blade fails to open fully within 3.5 minutes, proceed with steps 4-5-6 below.

4. Check voltage at the choke heater connection. (Engine must be running). If the voltage is approximately 12-15 volts, replace the electrical choke unit.

5. If the voltage is low or zero, check all wires and connections. If any connections in the oil pressure switch circuitry are faulty or if the oil pressure switch is failed open, the oil warning light will be on with the engine running. Repair wires or connections as required.

6. If all wiring and connections are good, replace oil pressure switch.

NOTE: No gasket is used between the choke cover and the choke housing because of grounding requirements.

BATTERY

GENERAL DESCRIPTION

The battery (fig. 6D-1B) is made up of a number of separate elements, each located in an individual cell in a hard rubber case. Each element consists of an assembly of positive plates and negative plates containing dissimilar active materials and kept apart by separators. The elements are immersed in an electrolyte composed of dilute sulfuric acid. Plate straps located on the top of each element connect all the positive plates and all the negative plates into groups. The elements are connected in series electrically by connectors that pass directly through the case partitions between cells. The battery top is a one piece cover. The cell connectors, by passing through the cell partitions, connect the elements along the shortest practical path (fig. 6D-2B). With the length of the electrical circuit inside the battery reduced to a

minimum, the internal voltage drop is decreased resulting in improved performance, particularly during engine cranking at low temperatures.

The terminals of this type battery, passing through the side of the case, are positioned out of the "wet" area surrounding the vent holes. Normal spillage, spewing, condensation, and road splash are not as likely to reach or remain on the vertical sides where the terminals are located. This greatly decreases the cause of terminal corrosion. Also, construction of the terminals is such that the mating cable connector seals the junction and provides a permanently tight and clean connection. Power robbing resistance in the form of corrosion is thereby eliminated at these maintenance-free connections.

The hard, smooth, one piece cover greatly reduces the tendency for corrosion to form on the top of the battery. The

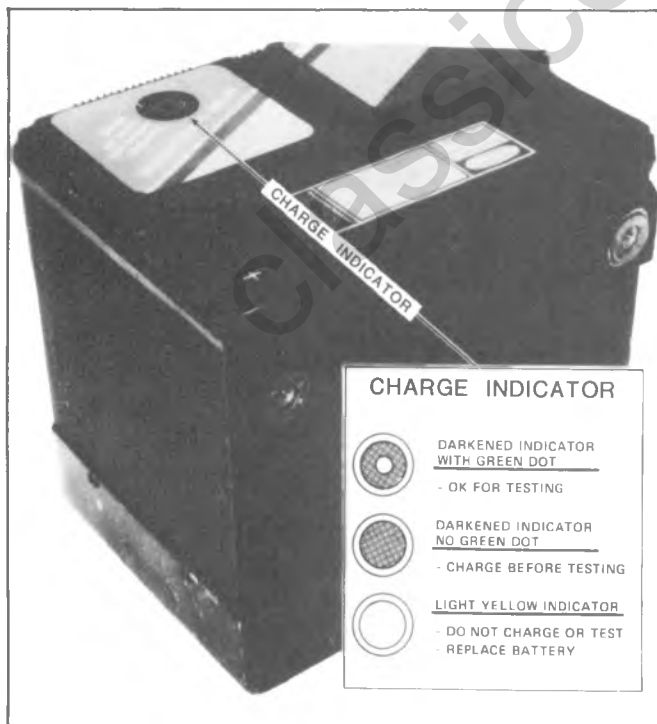


Fig. 6D-1B--Battery

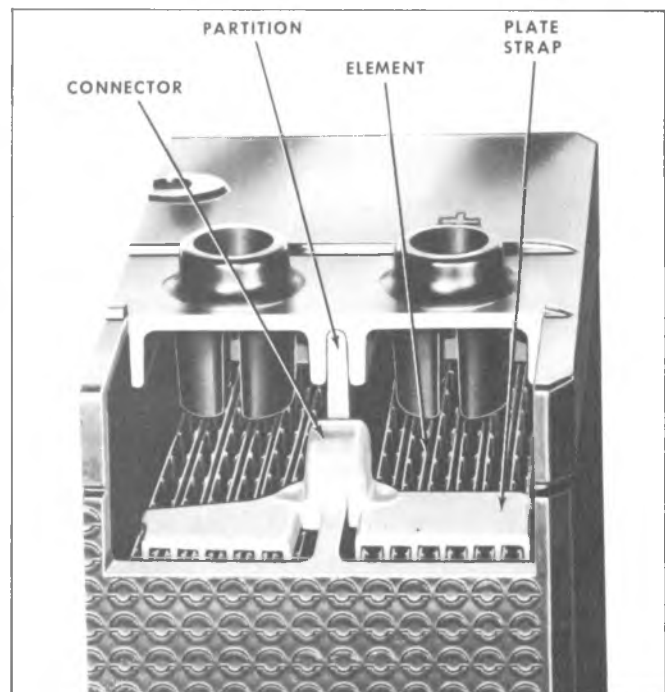


Fig. 6D-2B--Internal View of Battery

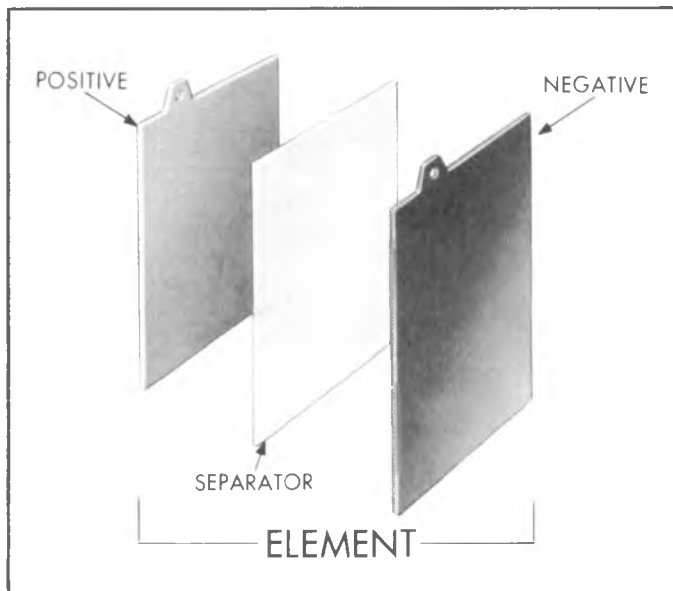


Fig. 6D-3B—Battery Element (Simple)

cover is bonded to the case forming an air-tight seal between the cover and case.

Electrical energy is released by chemical reactions between the active materials in the two dissimilar plates and the electrolyte whenever the battery is being "discharged." Maximum electrical energy is released only when the cells are being discharged from a state of full charge.

As the cells discharge, chemical changes in the active materials in the plates gradually reduce the potential electrical energy available. "Recharging" the battery with a flow of direct current opposite to that during discharge reverses the chemical changes within the cells and restores them to their active condition and a state of full charge.

The lead-acid storage battery is an electrochemical device for converting chemical energy into electrical energy. It is not a storage tank for electricity as is often believed, but instead, stores electrical energy in chemical form.

Active materials within the battery react chemically to produce a flow of direct current whenever lights, radio, cranking motor, or other current consuming devices are connected to the battery terminal posts. This current is produced by chemical reaction between the active materials of the PLATES and the sulfuric acid of the ELECTROLYTE.

The battery performs three functions in automotive applications:

1. It supplies electrical energy for the cranking motor and for the ignition system as the engine is started.
2. It supplies current for the lights, radio, heater, and other accessories when the electrical demands of these devices exceed the output of the generator.
3. The battery acts as a voltage stabilizer in the electrical system. Satisfactory operation of the vehicle is impossible unless the battery performs each of these functions.

The simplest unit of a lead-acid storage battery is made up of two unlike materials, a positive plate and a negative plate, kept apart by a porous separator. This assembly is called an "ELEMENT" (Fig. 6D-3B).

When this simple element is put in a container filled with a sulphuric acid and water solution called "electrolyte", a

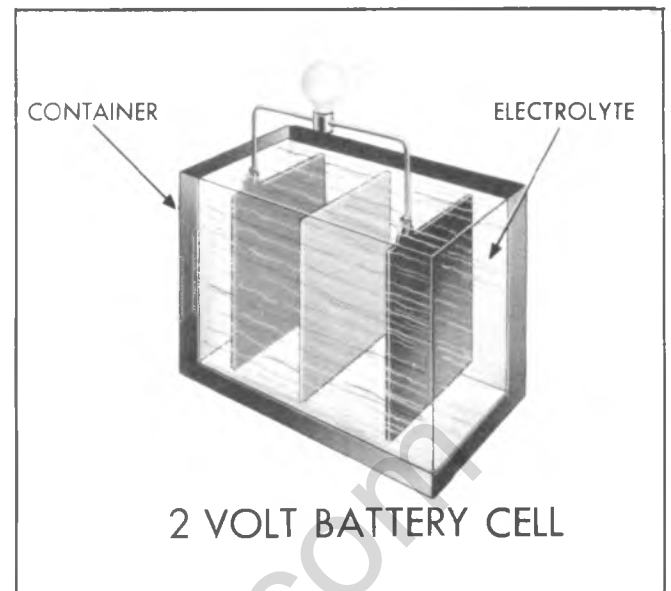


Fig. 6D-4B—Two Volt Battery Cell

two-volt "cell" is formed. Electricity will flow when the plates are connected to an electrical load (Fig. 6D-4B).

An element made by grouping several positive plates together and several negative plates together with separators between them also generates two-volts but can produce more total electrical energy than a simple cell (Fig. 6D-5B).

When six cells are connected in series, a "battery" of cells is formed which produces six times as much electrical pressure as a simple cell, or a total of 12 volts (Fig. 6D-6B).

If the battery continuously supplies current, it becomes run-down or discharged. This is where the generator gets into the act. The generator restores the chemical energy to the battery. This is done by sending current through the battery in a direction opposite to that during discharge. The generator current reverses the chemical actions in the battery and restores it to a charged condition.

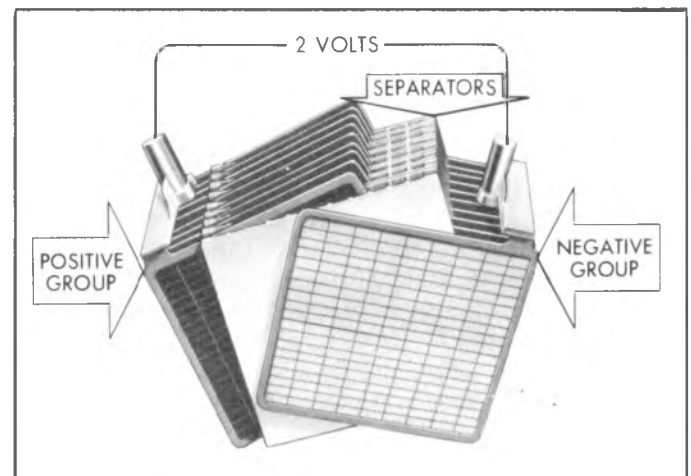


Fig. 6D-5B—Battery Element (Compound)

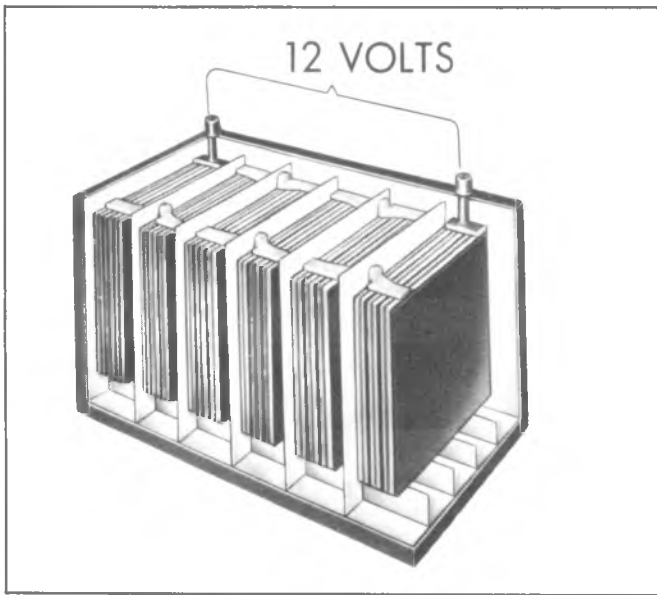


Fig. 6D-6B--Typical 12 Volt Battery Cell Arrangement

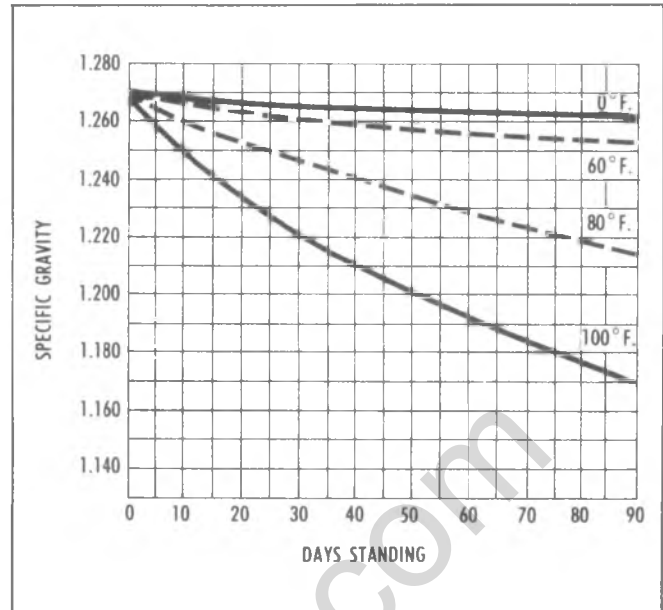


Fig. 6D-7B-- Rate of Self-Discharge

COMMON CAUSES OF FAILURE

Since the battery is a perishable item which requires periodic servicing, a good maintenance program will insure the longest possible battery life. If the battery tests good but fails to perform satisfactorily in service for no apparent reason, the following are some of the more important factors that may point to the cause of the trouble.

1. Vehicle accessories inadvertently left on overnight to cause a discharge condition.
2. Slow speed driving of short duration, to cause an undercharged condition.
3. A vehicle electrical load exceeding the generator capacity.
4. Defect in the charging system such as high resistance, slipping fan belt, faulty generator or voltage regulator.
5. Battery abuse, including failure to keep the battery top clean, cable attaching bolts clean and tight, and improper addition of water to the cells.

CARE OF BATTERY

Battery Storage

A wet charged battery will not maintain its charged condition during storage, and must be recharged periodically. During storage, even though the battery is not in use, a slow reaction takes place between the chemicals inside the battery which causes the battery to lose charge and "wear out" slowly. This reaction is called "self-discharge." The rate at which self-discharge occurs varies directly with temperature of the electrolyte.

Note from Figure 6D-7B that an battery stored in an area at 100°F (38°C) for 60 days has a much lower specific gravity and consequently a lower state of charge than one stored in an area at 60°F (16°C) for the same length of time.

To minimize self-discharge, a wet battery should be stored in as cool a place as possible, provided the electrolyte does not freeze.

A wet battery which has been allowed to stand idle for a long period of time without recharging may become so badly damaged by the growth of lead sulfate crystals (sulfation) in the plates that it can never be restored to a

normal charged condition. An battery in this condition not only loses its capacity but also is subject to changes in its charging characteristics. These changes, due to self-discharge, are often serious enough to prevent satisfactory performance in a vehicle.

Periodic recharging, therefore, is necessary to maintain a wet charged battery in a satisfactory condition while in storage. See paragraph "Charging Wet battery in Storage."

Charging Wet battery in Storage

Before placing a battery on charge, always check the battery charge indicator.

The battery should be brought to a fully charged condition only when darkened indicator with no green dot appears by charging as covered under heading of "Battery Charging."

Trickle charging should not be used to maintain a battery in a charged condition when in storage. The low charge rate method applied every 30 days is the best method of maintaining a wet charged battery in a fully charged condition without damage.

Electrolyte Freezing

The freezing point of electrolyte depends on its specific

VALUE OF SPECIFIC GRAVITY @ 30°F	FREEZING TEMP. °F °C	VALUE OF SPECIFIC GRAVITY @ 80°F	FREEZING TEMP. °F °C
1.100	18 - 8	1.220	-33 -36
1.120	13 -11	1.240	-50 -46
1.140	8 -13	1.260	-75 -59
1.160	1 -17	1.280	-92 -69
1.180	-6 -21	1.300	-95 -71
1.200	-17 -27		

gravity. The following table gives the freezing temperatures of electrolyte at various specific gravities.

Since freezing may ruin a wet battery, it should be protected against freezing by keeping it in a charged condition. This is true whether the wet battery is in storage or in service.

Carrier and Hold-Down

The battery carrier and hold-down should be clean and free from corrosion before installing the battery. The carrier should be in sound mechanical condition so that it will support the battery securely and keep it level.

To prevent the battery from shaking in its carrier, the hold-down bolts should be tight (60-80 in. lbs.). However, the bolts should not be tightened to the point where the battery case or cover will be placed under a severe strain.

Cleaning

The external condition of the battery should be checked periodically for damage such as cracked cover, case and vent plugs or for the presence of dirt and corrosion. The battery should be kept clean. An accumulation of acid film and dirt may permit current to flow between the terminals, which will slowly discharge the Battery. For best results when cleaning batteries, wash first with a diluted ammonia or a soda solution to neutralize any acid present; then flush with clean water. Care must be taken to keep vent plugs tight, so that the neutralizing solution does not enter the cells.

BATTERY RATING

A battery generally has two classifications of ratings: (1) a 20 hour rating at 80 F and, (2) a cold rating at 0 F which indicates the cranking load capacity. The Ampere/Hour rating found on batteries was based on the 20 hour rating. That is, a battery capable of furnishing three (3) amperes for 20 hours while maintaining a specified average individual cell voltage would be classified as a 60 ampere hour battery (e.g. 3 amperes \times 20 hours = 60 A.H.) a PWR (Peak Watt Rating) has been developed as a measure of the battery's cold cranking ability. The numerical rating is embossed on each case at the base of the battery. This value is determined by multiplying the maximum current by the maximum voltage. The PWR should not be confused with the ampere hour rating since two batteries with the same ampere hour rating can have quite different watt ratings. For battery replacement, a unit of at least equal power rating must be selected.

SELECTING A REPLACEMENT BATTERY

Long and troublefree service can be more assured when the capacity or wattage rating of the replacement battery is at least equal to the wattage rating of the battery originally engineered for the application by the manufacturer.

The use of an undersize battery may result in poor performance and early failure. Figure 6D-8B shows how battery power shrinks while the need for engine cranking power increases with falling temperatures. Sub-zero temperatures reduce capacity of a fully charged battery to 45% of its normal power and at the same time increase cranking load to 3-1/2 times the normal warm weather load.

Hot weather can also place excessive electrical loads on the battery. Difficulty in starting may occur when cranking is attempted shortly after a hot engine has been turned off or stalls. In fact, modern high compression engines can be as difficult to start under such conditions as on the coldest

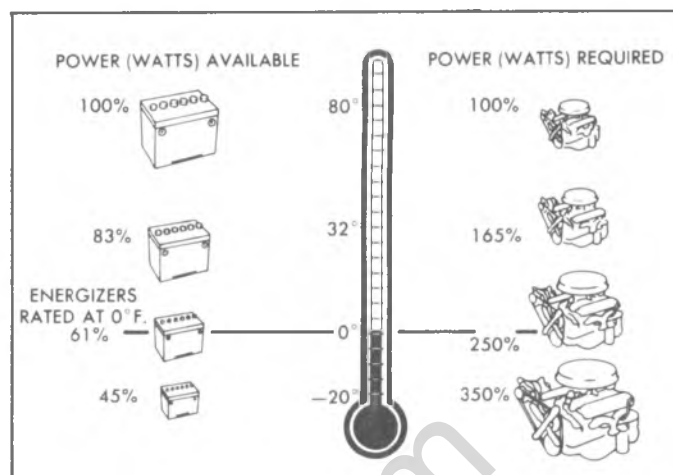


Fig. 6D-8B--Battery Power vs Falling Temperature

winter day. Consequently, good performance can be obtained only if the battery has ample capacity to cope with these conditions.

A battery of greater capacity should be considered if the electrical load has been increased through the addition of accessories or if driving conditions are such that the generator cannot keep the battery in a charged condition.

On applications where heavy electrical loads are encountered, a higher output generator that will supply a charge during low speed operation may be required to increase battery life and improve battery performance.

SAFETY PRECAUTIONS

When batteries are being charged, an explosive gas mixture forms in each cell. Part of this gas escapes through the holes in the vent holes and may form an explosive atmosphere around the battery itself if ventilation is poor. This explosive gas may remain in or around the battery for several hours after it has been charged. Sparks or flames can ignite this gas causing an internal explosion which may shatter the battery (Fig. 6D-9B).

The following precautions should be observed to prevent an explosion:

1. Do not smoke near batteries being charged or which have been very recently charged.
2. Do not break live circuits at the terminals of batteries because a spark usually occurs at the point where a live circuit is broken. Care must always be taken when connecting or disconnecting booster leads or cable clamps on fast chargers. Poor connections are a common cause of electrical arcs which cause explosions.

CHARGING PROCEDURES

Before charging a battery the electrolyte level must be checked and adjusted if needed. Battery charging consists of applying a charge rate in amperes for a period of time in hours. Thus, a 10-ampere charge rate for seven hours would be a 70 ampere-hour (A.H.) charging input to the battery. Charging rates in the three to 20 ampere range are generally satisfactory. No particular charge rate (except that charge rate should not exceed 20 amperes) or time can be specified for an battery due to the following factors:

1. The size, or electrical capacity in ampere-hours (A.H.), of the battery.

EXAMPLE: A completely discharged 70 A.H. battery

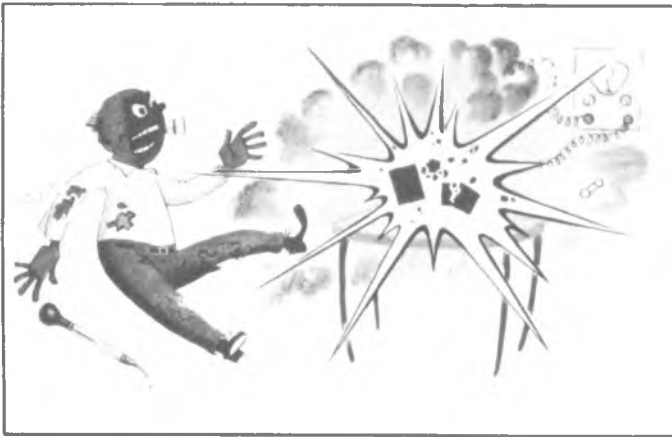


Fig. 6D-9B--Sparks or Flames

requires almost twice the recharging as a 40 A.H. battery.

2. Temperature of the battery electrolyte.

EXAMPLE: About two hours longer will be needed to charge a 0°F (-18°C) battery than a 80°F (27°C) battery.

3. Battery state-of-charge at the start of the charging period.

EXAMPLE: A completely discharged battery requires twice as much charge in ampere-hours as a one-half charged battery.

4. Battery age and condition.

EXAMPLE: A battery that has been subjected to severe service will require up to 50% more ampere-hour charging input than a relatively new battery.

The following basic rule applies to any battery charging situation:

If the charge indicator is dark and the green dot is not visible, charge battery until dot appears, but not more than 60 ampere-hours (for example 15 amperes for four hours). Do not exceed a charging rate of 20 amperes during charging.

NOTE: Some chargers are constant current chargers while others are constant voltage chargers. If a constant voltage charger is used for charging the battery and the green dot fails to appear after prolonged charging, it may be necessary to tip the battery slightly from side to side a few times for the green dot to appear.

If the charge indicator is light replace battery. **DO NOT** attempt to charge or "jump" when charge indicator is light.

NOTE: A battery that failed prematurely, and exhibited a light charge indicator condition, may indicate a need for checking the charging system of the vehicle.

For the most satisfactory charging, the lower charging rates in amperes are recommended.

An "emergency boost charge", consisting of a high charging rate for a short period of time, may be applied as a temporary expedient in order to crank an engine. However, this procedure usually supplies insufficient battery reserve to crank a second and third time. Therefore, the "emergency boost charge" must be followed by a subsequent charging period of sufficient duration to restore the battery to a satisfactory state of charge. Refer to the charging guide in this section.

When out of the vehicle, the sealed side terminal battery will require adapters (Fig. 6D-10B) for the terminals to provide a place for attachment of the charging leads. Adapters are available through local parts service.

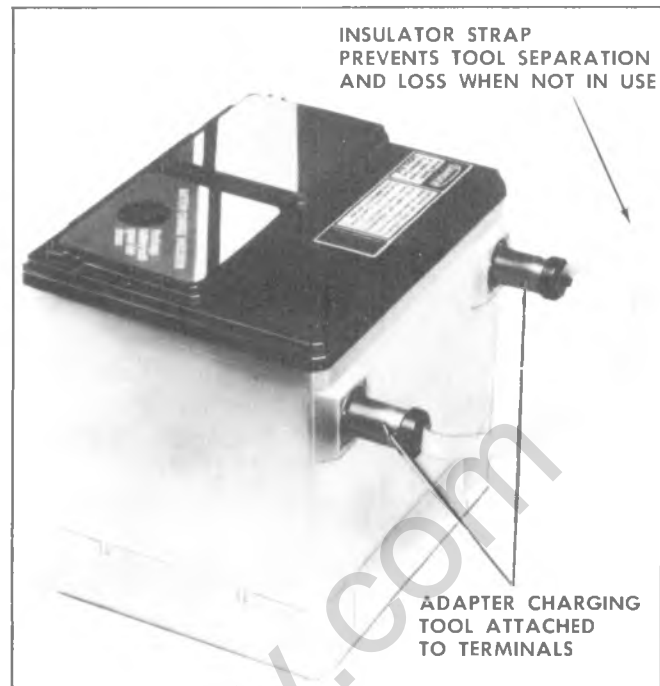


Fig. 6D-10B--Charging and Testing Adapters

When the side terminal battery is in the vehicle, the studs provided in the wiring harness are suitable for attachment of the charger's leads.

CAUTION: Exercise care when attaching charger leads to side terminal studs to avoid contact with vehicle metal components which would result in damage to the battery.

TESTING PROCEDURES

Testing procedures are used to determine whether the battery is (1) good and usable, (2) requires recharging or (3) should be replaced. Analysis of battery conditions can be accomplished by performing a visual inspection, instrument test and the full charge hydrometer test. Refer to test procedure chart in this section.

Visual Inspection

The first step in testing the battery should be a visual inspection, which very often will save time and expense in determining battery condition.

- Check the outside of the battery for a broken or cracked case or a broken or cracked cover. If any damage is evident, the battery should be replaced.

- Observe battery state of charge indicator to determine condition of battery.

- Check for loose cable connections. Correct as required before proceeding with tests.

Instrument Test

A number of suppliers have approved testing equipment available. These testers have a programmed test procedure consisting of a series of timed discharge and charge events, requiring approximately 2 to 3 minutes, that will determine the condition of the battery with a high degree of accuracy. When using these testers, the procedure recommended by the tester manufacturer should be followed.

INSTALLING BATTERIES

To install a battery properly, it is important to observe the following precautions:

- Connect grounded terminal of battery last to avoid short circuits which may damage the electrical system. Do not connect primary lead until secondary negative cable wire has been grounded to sheet metal.

- Be sure there are no foreign objects in the carrier, so that the new battery will rest properly in the bottom of the carrier.

- Tighten the hold-down evenly until snug (60-80 in. lbs.). Do not draw down tight enough to distort or crack the case or cover.

- Be sure the cables are in good condition and the terminal bolts are clean and tight. Make sure the ground cable is clean and tight at engine block or frame.

- Check polarity to be sure the battery is not reversed with respect to the generating system.

Do not over torque cable terminal studs.

Replacement

1. Disconnect battery negative cable and then the positive cable.

2. Remove battery hold-down clamp bolt and clamp.

3. Remove battery from tray.

4. Position new battery, which has been properly activated, in the battery tray.

5. Install battery hold down clamp and bolt.

NOTE: Recommended hold-down bolt torque is 70 in. lbs.

6. Install battery positive and negative cables and tighten terminal bolts to 70 in. lbs. torque.

DIAGNOSIS

BATTERY TEST PROCEDURE

To determine the ability of a battery to function properly requires testing. The accuracy of the testing changes with temperature, specific gravity, age of the battery, etc. Therefore, an accurate test has more than one step:

Step 1. Visual inspection.

Step 2. Specific gravity check (hydrometer)

Step 3. Programmed Instrument Test

Step 4. Load Test.

CAUTION: *Wear safety glasses. Do not break live circuits at battery terminals. When testing be certain to remove gases at battery cover caused by charging.*

MAINTENANCE FREE BATTERY

GENERAL INFORMATION

The state of charge indicator located on top of the battery (Fig. 6D-1B) is to be used with accepted diagnostic procedures only. It is not to be used to determine if the battery is good or bad, or charged or discharged. The indicator is actually a built-in hydrometer in one cell of the battery and provides visual information only for battery testing.

On rare occasions, the state of charge indicator will turn light yellow. Normally, a battery with this condition is capable of further service but the indicator can no longer provide information for battery testing. A light yellow indicator is by no means a command to replace the battery. However, if a problem exists, such as failing to crank, the battery must be replaced. Do not charge, test or jump start.

It is important when observing the state of charge indicator, that the battery be relatively level and have a clean indicator top to see the correct indication. An electric light or flashlight may be required in some poorly-lit areas to verify the correct indication. Under normal operation, two indications can be observed:

GREEN DOT VISIBLE

Any green appearance in the indicator is interpreted as a "green dot" and the battery is ready for testing. On rare occasions following prolonged cranking, the green dot may still be visible even though the battery is in a discharged condition. Should this occur, charge battery as described in Charging Procedure portion of this manual.

DARK-GREEN DOT NOT VISIBLE

If there is a cranking complaint, the battery should be tested as described in the Testing Procedure that follows:

TESTING PROCEDURE

VISUAL INSPECTION

Check for obvious damage, such as cracked or broken case or cover, that could permit loss of electrolyte. If obvious physical damage is noted, replace battery. Determine cause of damage and correct as needed.

STATE OF CHARGE INDICATOR (Fig. 6D-1B)

Green Dot Visible

If the indicator is dark and has a green dot in the center, the battery is OK for testing. Proceed to step 3. On rare occasions, such as after prolonged cranking, the green dot may still be visible even though the battery is in a state of discharge. Should this situation occur, charge battery as described in Charging Procedure portion of this manual.

Dark-Green Dot Not Visible

If the indicator is dark but the green dot is not visible, charge the battery as described in Charging Procedure portion of this manual and proceed to Remove Surface Charge step.

Light or Yellow

On rare occasions the indicator will turn light yellow and the battery must not be tested. Replace the battery. Do not charge, test or jump start.

REMOVE SURFACE CHARGE

Connect a 300-ampere load across battery terminals for 15 seconds to remove surface charge.

NOTE: If battery is out of vehicle, use adapters as shown in Charging and Testing Adapters portion of this manual.

LOAD TEST

a. Connect a voltmeter and a specified load as indicated below across terminals of battery.

BATTERY TYPE	AMPS FOR LOAD TEST
85-5	170
85-4	130
87-5	210

b. Read voltage on voltmeter after 15 seconds with load connected, then disconnect load.

c. If minimum voltage is *9.6 volts or more, battery is good.

d. If minimum voltage is less than *9.6 volts, replace battery.

*This voltage is to be used for battery ambient temperature 21°C (70°F) and above. For temperatures below 21°C (70°F), use the following:

MINIMUM VOLTAGE	TEMPERATURE	
	F	C
9.6	70	21
9.5	60	16
9.4	50	10
9.3	40	4
9.1	30	- 1
8.9	20	- 7
8.7	10	-12
8.5	0	-18

BATTERY CHARGING PROCEDURE

Charging equipment for ordinary batteries is suitable for Maintenance- Free type batteries.

Do not charge a battery if the green dot is visible except on rare occasions following prolonged cranking when the battery is discharged but the green dot still appears. Should this situation occur, a boost-charge of 20 ampere-hours is recommended.

Do not charge a battery if the state of charge indicator is light yellow.

BATTERY CHARGING GUIDE

Stop charging battery when green dot appears in state of charge indicator or when the maximum charge rate shown below is reached:

BATTERY TYPE	SLOW CHARGING RATE	FAST CHARGING RATE
85-4	5A @ 10 Hours	20A @ 2½ Hours
85-5	10A @ 5 Hours	30A @ 1½ Hours
87-5	5A @ 15 Hours	20A @ 3¾ Hours
	10A @ 7½ Hours	30A @ 2½ Hours
		40A @ 2 Hours
		50A @ 1½ Hours

To avoid damage, charging rate must be reduced or temporarily halted if battery case feels hot (52°C) (125°F) or if violent gassing or spewing of electrolyte through the vent holes occur.

After charging in accordance with the tables, the green dot may appear in the state of charge indicator after slightly tipping the battery from side to side a few times. If the green dot does not appear, the battery is still sufficiently charged for testing.

CHARGING AND TESTING ADAPTERS

Freedom type batteries should be charged or tested on-the-vehicle, using existing terminals. However, when the battery is out-of-the-vehicle, adapters similar to the AC-Delco adapters Kit #ST-238 shown in Figure 6D-10B are required.

THE CHARGING SYSTEM

10-SI SERIES GENERATOR SYSTEM

GENERAL DESCRIPTION

The 10-SI series generator shown in Figure 6D-1C is typical of a variety of models. A solid state regulator having an integrated circuit is built into the end frame. Although models are available with different outputs at idle and different maximum outputs, their basic operating principles are the same.

The generator consists primarily of two end frame assemblies, a rotor assembly and a stator assembly. A typical cross-sectional view is shown in Figure 6D-1C. The rotor assembly is supported in the drive end frame by a ball bearing

and in the slip ring end frame by a roller bearing. These rotor bearings contain a supply of lubricant sufficiently adequate to eliminate the need for periodic lubrication. Two brushes carry current through the two slip rings to the field coil mounted on the rotor and under normal conditions will provide long periods of attention - free service. No periodic adjustments or maintenance are required on the generator assembly.

The stator windings are assembled on the inside of a laminated core that forms part of the generator frame. A

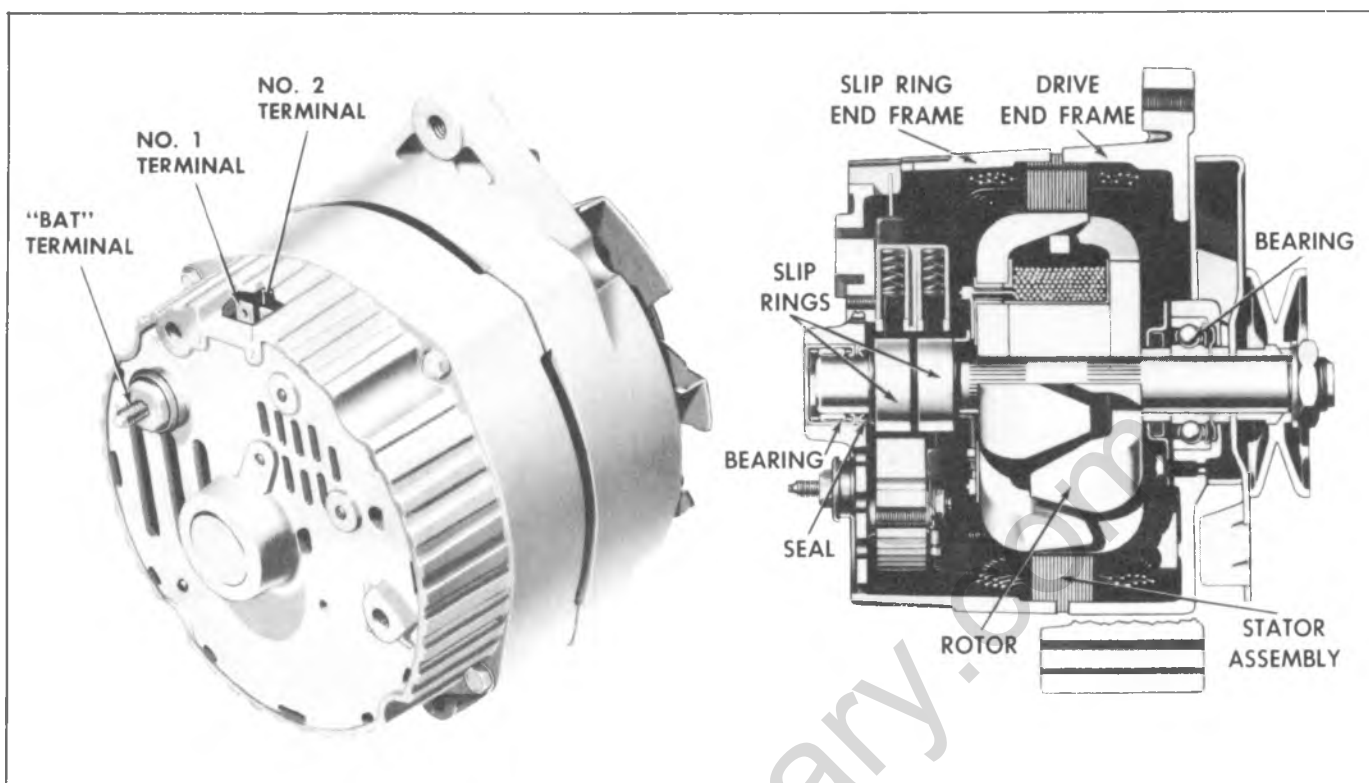


Fig. 6D-1C--10-SI Series Generator

rectifier bridge connected to the stator windings contains six diodes, (three positive and three negative) molded into an assembly which is connected to the stator windings. This rectifier bridge changes the stator a.c. voltages to d.c. voltage which appears at the output terminal. The blocking action of the diodes prevent battery discharge back through the generator. Because of this blocking action, the need for a cutout relay in the circuit is eliminated. Generator field current is supplied through a diode trio which is also connected to the stator windings.

A capacitor, or condenser, mounted in the end frame protects the rectifier bridge and diode from high voltages, and suppresses radio noise.

The typical passenger car integral charging system is made up of two components--a generator with a built-in solid state voltage regulator and battery. These components work together to supply electrical power for ignition, lights, radio, cranking motor, etc. A typical wiring diagram is illustrated in Figure 6D-2C. The basic operating principles are explained as follows.

When the switch is closed, current from the battery flows through the indicator lamp to the generator No. 1 terminal, through resistor R1, diode D1, and the base-emitter of transistor TR1 to ground, and then back to the battery. This turns on transistor TR1, and current flows through the generator field coil and TR1 back to the battery. The indicator lamp then turns on. Resistor R5 carries some of the indicator lamp current and is shown in figure 6D-2C.

With the generator operating, a.c. voltage is generated in the stator windings, and the stator supplies d.c. field

current through the diode trio, the field, TR1, and then through the grounded diodes in the rectifier bridge back to the stator. Also, the six diodes in the rectifier bridge change the stator a.c. voltages to a d.c. voltage which appears between ground and the generator "BAT" terminal. As generator speed increases, current is provided for charging the battery and operating electrical accessories. Also, with the generator operating, the same voltage appears at the "BAT" and No. 1 terminals, and the indicator lamp goes out to indicate the generator is producing voltage.

The No. 2 terminal on the generator is always connected to the battery, but the discharge current is limited to a negligible value by the high resistances of R2 and R3. As the generator speed and voltage increase, the voltage between R2 and R3 increases to the point where zener diode D2 conducts. Transistor TR2 then turns on and TR1 turns off. With TR1 off, the field current and system voltage decrease, and D2 then blocks current flow, causing TR1 to turn back on. The field current and system voltage increase, and this cycle then repeats many times per second to limit the generator voltage to a pre-set value.

Capacitor C1 smooths out the voltage across R3, resistor R4 prevents excessive current through TR1 at high temperatures, and diode D3 prevents high-induced voltages in the field windings when TR1 turns off.

Resistor R2 is a thermister which causes the regulated voltage to vary with temperature, thus providing optimum voltage for charging the battery.

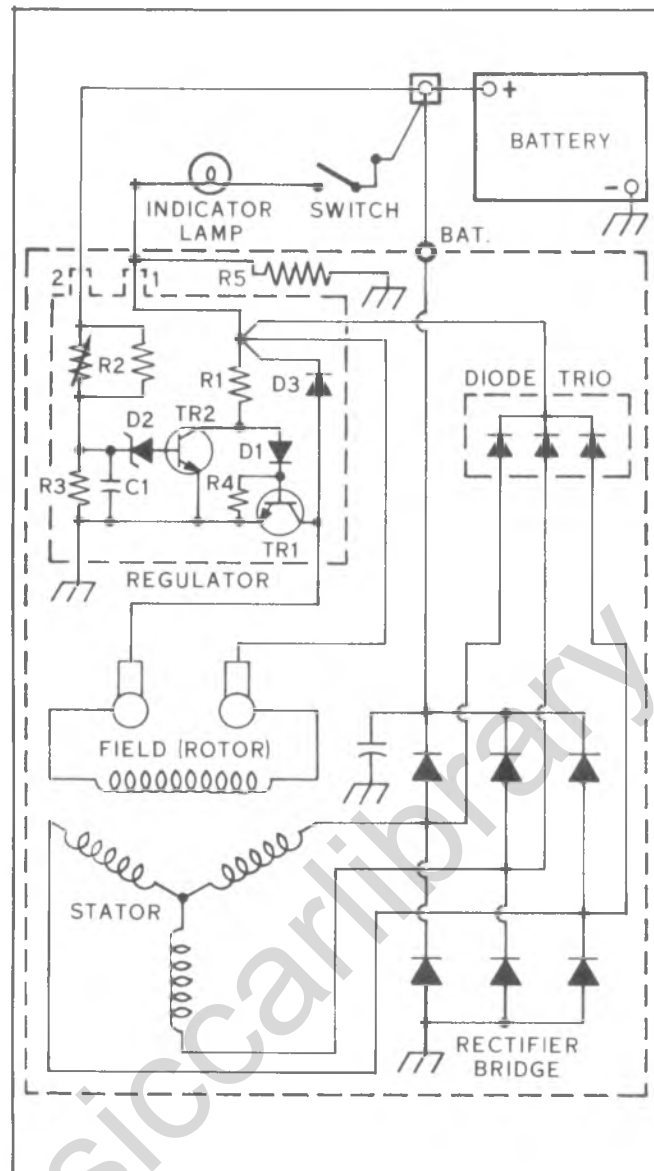


Fig. 6D-2C--Integral Charging System Circuitry

DIAGNOSIS

Most charging system troubles show up as a faulty indicator lamp, an undercharged or an overcharged battery. Since the battery itself may be defective, it should be checked first to determine its condition. Also, in the case of an undercharged battery, check for battery drain caused by grounds or by accessories being left on.

A basic wiring diagram showing lead connections is presented in Figure 6D-3C. The following precautions must be observed when working on the charging circuit. Failure to observe these precautions will result in serious damage to the electrical equipment.

- Do not polarize the generator.
- Do not short across or ground any of the terminals in the charging circuit except as specifically instructed in these procedures.
- Never operate the generator with the output terminal open circuited.

- Make sure the generator and battery are of the same ground polarity.

- When connecting a charger or a booster battery to the vehicle battery, connect negative terminal to negative terminal and positive terminal to positive terminal.

STATIC CHECK

Before making any electrical checks, visually inspect all connections, including slip-on connectors, to make sure they are clean and tight. Inspect all wiring for cracked, frayed or broken insulation. Be sure generator mounting bolts are tight and unit is properly grounded. Check for loose fan belt.

NOTE: In some circuits an ammeter may be used instead of an indicator lamp. In this case, the section pertaining to faulty indicator lamp operation may be omitted from the trouble shooting procedure.

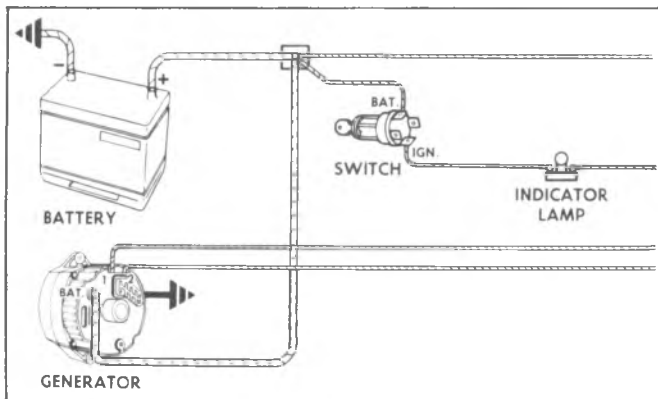


Fig. 6D-3C--Basic Wiring Diagram

INDICATOR LAMP CIRCUIT CHECK

Check the indicator lamp for normal operation as shown below.

If the indicator lamp operates normally, proceed to "Undercharged Battery" or "Overcharged Battery" section. Otherwise, proceed to either one of the following three abnormal conditions.

1. Switch Off, Lamp On—In this case, disconnect the two leads from the generator No. 1 and No. 2 terminals. If the lamp stays on, there is a short between these two leads. If the lamp goes out, replace the rectifier bridge as covered in the "Chassis Overhaul Manual". This condition will cause an undercharged battery.

Switch	Lamp	Engine
OFF	OFF	STOPPED
ON	ON	STOPPED
ON	OFF	RUNNING

2. Switch On, Lamp Off, Engine Stopped—This condition can be caused by the defects listed in step 1 above, by reversal of the No. 1 and No. 2 leads at these two terminals, or by an open in the circuit. This condition can cause an undercharged battery. To determine where an open exists, proceed as follows:

a. Check for a blown fuse, or fusible link, a burned out bulb, defective bulb socket, or an open in No. 1 lead circuit between generator and ignition switch.

b. If no defects have been found, proceed to Undercharged Battery section.

3. Switch On, Lamp On, Engine Running—The possible causes of this condition are covered in the "UNDERCHARGED BATTERY" section.

UNDERCHARGED BATTERY CONDITION CHECK

This condition, as evidenced by slow cranking and low specific gravity readings, can be caused by one or more of the following conditions even though the ammeter may be operating normally.

1. Insure that the undercharged condition has not been caused by accessories having been left on for extended

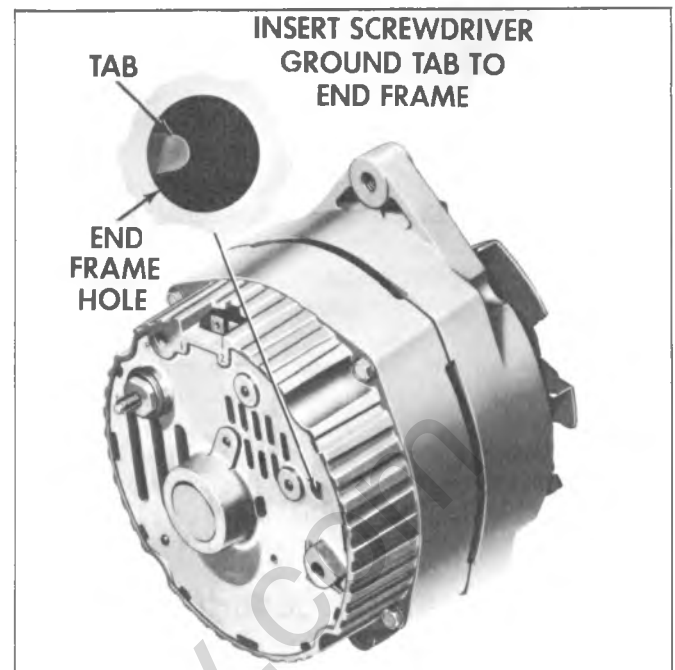


Fig. 6D-4C--Generator End View

periods.

2. Check the drive belt for proper tension.

3. Check battery. Test is not valid unless battery is good and fully charged.

4. Inspect the wiring for defects. Check all connections for tightness and cleanliness, including the slip connectors at the generator and firewall, and the cable clamps and battery posts.

5. With ignition switch "on" connect a voltmeter from generator "BAT" terminal to ground, generator No. 1 terminal to ground and generator No. 2 terminal to ground. A zero reading indicates an open between voltmeter connection and battery.

NOTE: An open No. 2 lead circuit on generators will cause uncontrolled voltage, battery overcharge and possible damage to battery and accessories. Generators supplied for current applications have a built-in feature which avoids overcharge and accessory damage by preventing the generator from turning on if there is an open in the wiring harness connected to the No. 2 generator terminal. Opens in the wiring harness connected between the No. 2 generator terminal and battery may be between the terminals, at the crimp between the harness wire and terminal, or in the wire.

6. If previous Steps 1 through 5 check satisfactorily, check generator as follows:

a. Disconnect battery ground cable.

b. Connect an ammeter in the circuit at the "BAT" terminal of the generator.

c. Reconnect battery ground cable.

d. Turn on radio, windshield wipers, lights high beam and blower motor high speed. Connect a carbon pile across the battery.

e. Operate engine at moderate speed as required, and adjust carbon pile as required, to obtain maximum current output.

f. If ampere output is within 10 percent of rated output

as stamped on generator frame, generator is not defective; recheck Steps 1 through 5.

g. If ampere output is not within 10 percent of rated output, ground the field winding by inserting a screwdriver into the test hole (Fig. 6D-4C).

CAUTION: Tab is within 3/4 inch (19mm) of casting surface. Do not force screwdriver deeper than one inch (25mm) into end frame.

h. Operate engine at moderate speed as required, and adjust carbon pile as required to obtain maximum current output.

i. If output is within 10 percent of rated output, replace regulator as covered in the Chassis Overhaul Manual and check field winding.

j. If output is not within 10 percent of rated output, check the field winding, diode trio, rectifier bridge, and stator as covered in the Chassis Overhaul Manual.

k. Remove ammeter from generator and turn accessories off.

OVERCHARGED BATTERY CONDITION CHECK

1. Determine battery condition. Test is not valid if battery is not good and fully charged.

2. Connect a voltmeter from generator No. 2 terminal to ground. If reading is zero, No. 2 lead circuit is open.

3. If battery and No. 2 lead circuit check good, but an obvious overcharge condition exists as evidenced by excessive battery water usage, proceed as follows:

a. Separate end frames as covered in generator "Disassembly" section in the Chassis Overhaul Manual. Check field winding for shorts. If shorted replace rotor and regulator.

b. Connect ohmmeter using lowest range scale from brush lead clip to end frame as shown in Step 1, Figure 6D-5C, then reverse lead connections.

c. If both readings are zero, either the brush lead clip is grounded, or regulator is defective.

d. A grounded brush lead clip can result from omission of insulating washer (Fig. 6D-5C), omission of insulating sleeve over screw, or damaged insulating sleeve. Remove screw to inspect sleeve. If satisfactory, replace regulator as covered in the Chassis Overhaul Manual.

GENERATOR OUTPUT TEST

To check the generator in a test stand, proceed as follows:

1. Make connections as shown in Figure 6D-6C, except leave the carbon pile disconnected. Use a fully charged battery and a 10 ohm resistor rated at six watts or more between the generator No. 1 terminal and the battery.

2. Slowly increase the generator speed and observe the voltage.

3. If the voltage is uncontrolled with speed and increases above 16 volts, check for a grounded brush lead clip as covered under heading of "OVERCHARGED BATTERY", Step 3. If not grounded, replace the regulator.

NOTE: The battery must be fully charged when making this check.

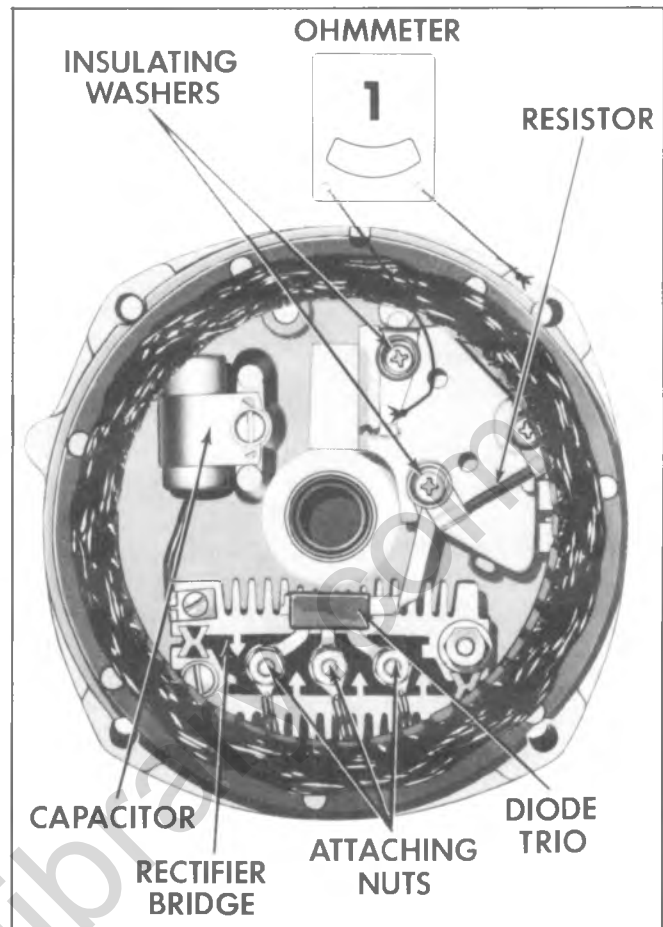


Fig. 6D-5C--Slip Ring End Frame

4. Connect the carbon pile as shown.

5. Operate the generator at moderate speed as required and adjust the carbon pile as required to obtain maximum current output.

6. If output is within ten percent of rated output as stamped on generator frame, generator is good.

7. If output is not within ten percent of rated output, ground generator field (Fig. 6D-4C).

8. Operate generator at moderate speed and adjust carbon pile as required to obtain maximum output.

9. If output is within ten percent of rated output, replace regulator as covered in "Regulator Replacement" section.

10. If output is not within ten percent of rated output, check the field winding, diode trio, rectifier bridge and stator as previously covered.

OTHER HARNESS CHECKS

Wires in the charging system may be checked for continuity by use of an ohmmeter or a test light (12 volt). Connect the test so the wire in question is in series in the test circuit.

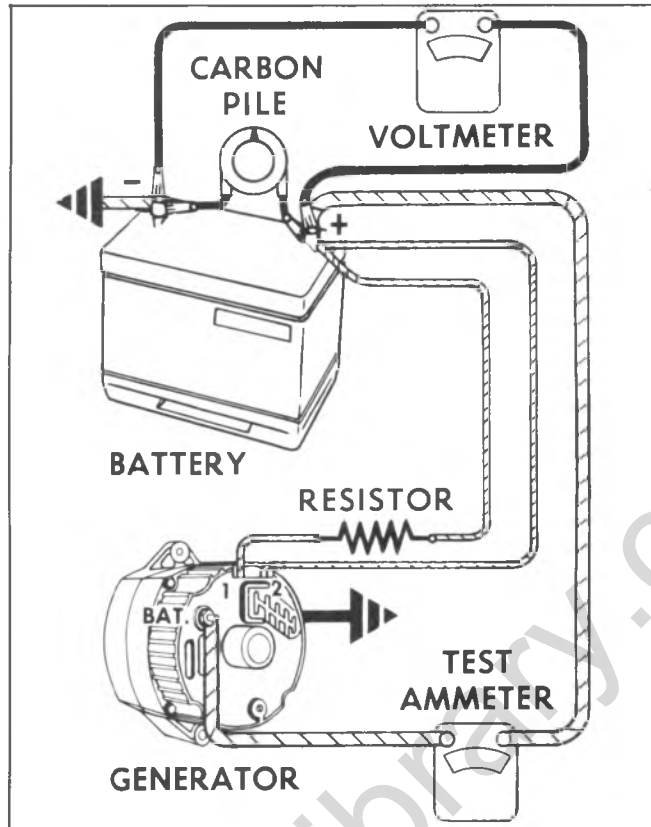
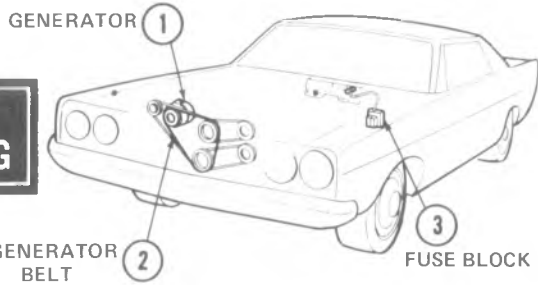


Fig. 6D-6C--Generator Output Test

classiccarlibrary.com

Chart 1

PROBLEM:
generator light ON engine RUNNING




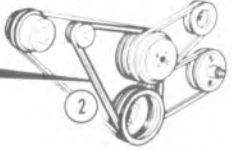











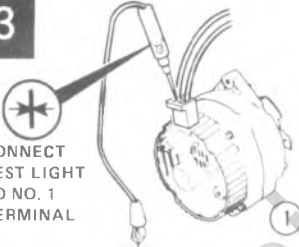

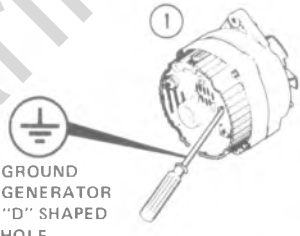




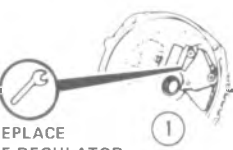
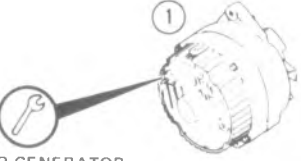
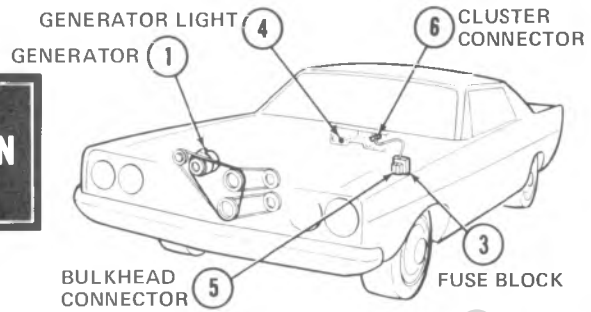
STEP	SEQUENCE	RESULT
<p>1</p>  <p>CHECK GENERATOR BELT</p>	 <p>REPLACE IF NECESSARY ADJUST TENSION TO 80 LBS.</p>  <p>START ENGINE</p>	 <p>GENERATOR LIGHT OFF</p> <p>STOP</p>  <p>GENERATOR LIGHT ON (DIM OR BRIGHT)</p> <p>GO TO STEP 2</p>
<p>2</p>  <p>TURN ENGINE OFF</p>  <p>IGNITION ON</p>	 <p>CHECK ALL INDICATOR LIGHTS</p>  <p>IF ALL LIGHTS OFF</p>  <p>CHECK FOR CAUSE AND REPLACE GAUGES FUSE</p>  <p>START ENGINE</p>	 <p>GENERATOR LIGHT OFF</p> <p>STOP</p>  <p>GENERATOR LIGHT ON</p> <p>GO TO STEP 3</p>
<p>3</p>  <p>CONNECT TEST LIGHT TO NO. 1 TERMINAL</p>	 <p>TEST LIGHT 1/2 BRIGHT</p>  <p>GROUND GENERATOR "D" SHAPED HOLE</p>	 <p>TEST LIGHT FULLY BRIGHT</p> <p>GO TO STEP 4</p>  <p>TEST LIGHT 1/2 BRIGHT</p> <p>GO TO STEP 5</p>
<p>4</p>  <p>TEST VOLTAGE REGULATOR WITH APPROVED TESTER</p>	 <p>OK</p>  <p>REPLACE VOLTAGE REGULATOR</p>	<p>GO TO STEP 5</p> <p>STOP</p>
<p>5</p>  <p>REPAIR GENERATOR</p>		<p>STOP</p>

Chart 2

PROBLEM:
generator light OFF ignition ON
engine NOT RUNNING



STEP	SEQUENCE	RESULT
1	<p>IGNITION ON</p> <p>CHECK ALL INDICATOR LIGHTS</p> <p>IF ALL LIGHTS OFF</p> <p>REPLACE GAUGES FUSE</p>	<p>STOP</p> <p>IF NEW FUSE BLOWS GO TO STEP 2</p> <p>IF FUSE DOES NOT BLOW GO TO STEP 3</p>
2	<p>CHECK FOR PINCHED OR GROUNDED WIRE IN GAUGES CIRCUITS</p> <p>REPAIR IF NECESSARY</p> <p>REPLACE GAUGES FUSE</p>	<p>STOP</p> <p>GENERATOR LIGHT ON</p> <p>GO TO STEP 3</p> <p>GENERATOR LIGHT OFF</p>
3	<p>REPAIR OPEN IN NO. 18 PINK WIRE (INDICATOR FEED WIRE)</p>	<p>STOP</p> <p>GENERATOR LIGHT ON</p> <p>GO TO STEP 4</p> <p>GENERATOR LIGHT OFF</p>
4	<p>CHECK GENERATOR INDICATOR BULB AND SOCKET ASSY.</p> <p>REPLACE IF NECESSARY</p>	<p>STOP</p> <p>GENERATOR LIGHT ON</p> <p>GO TO STEP 5</p> <p>GENERATOR LIGHT OFF</p>
5	<p>DISCONNECT BROWN/WHITE WIRE</p> <p>GROUND NO. 1 TERMINAL WIRE</p>	<p>GO TO STEP 6</p> <p>GENERATOR LIGHT ON</p> <p>GO TO STEP 7</p> <p>GENERATOR LIGHT OFF</p>

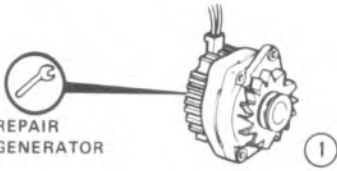

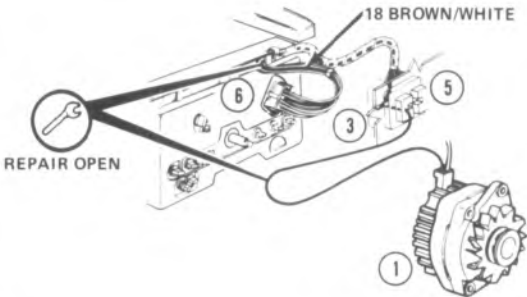

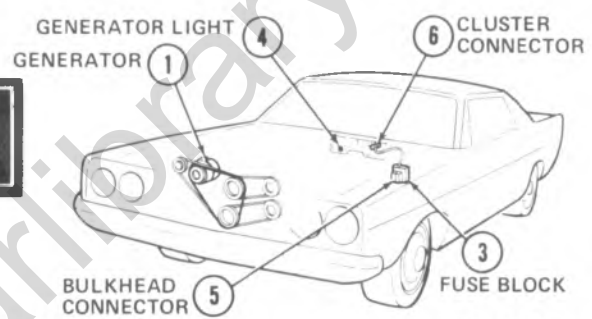
STEP	SEQUENCE	RESULT
6		
7		

Chart 3

PROBLEM:
generator light ON ignition OFF



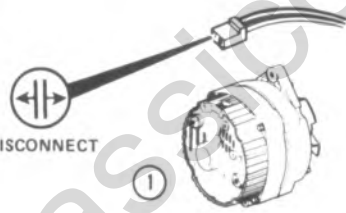
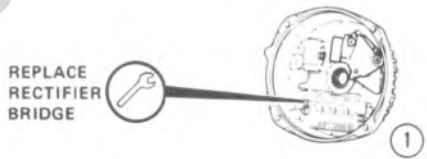

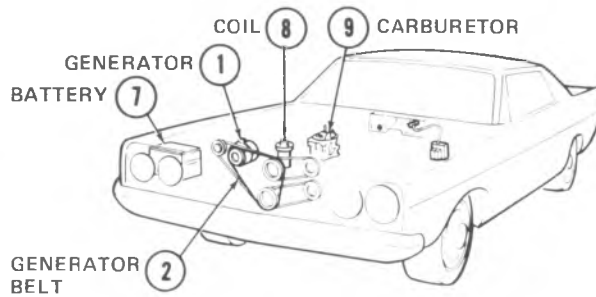
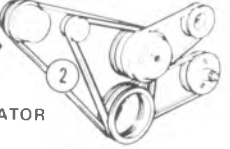
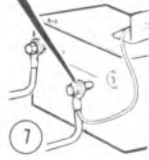
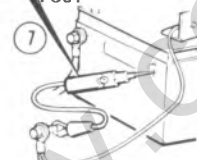
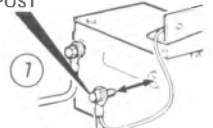
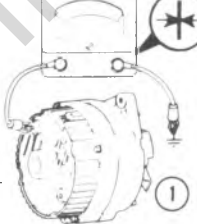
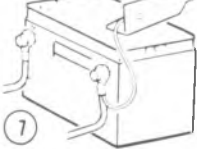
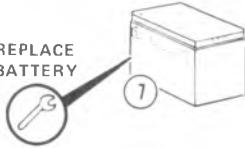
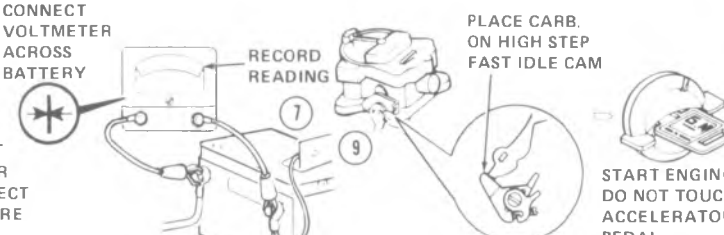

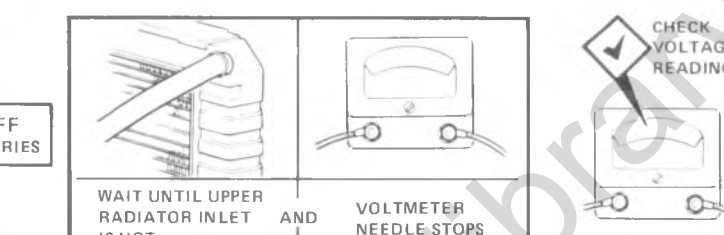
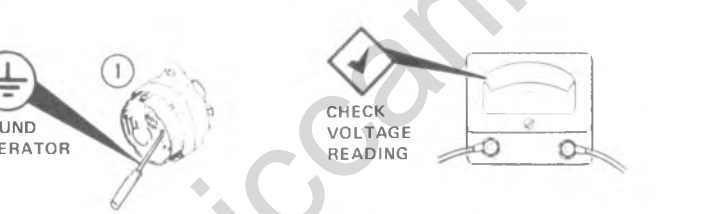
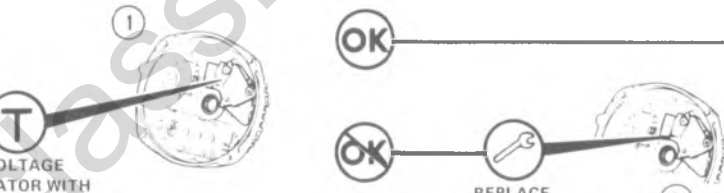

STEP	SEQUENCE	RESULT
1	 <p data-bbox="751 1223 850 1298"> GENERATOR LIGHT ON </p> <p data-bbox="751 1361 850 1436"> GENERATOR LIGHT OFF </p> <p data-bbox="900 1223 1131 1361"> REPAIR SHORT BETWEEN NO. 1 (BROWN) WIRE AND NO. 2 (RED) WIRE </p>	<p data-bbox="1230 1234 1296 1298">STOP</p> <p data-bbox="1230 1372 1296 1436">GO TO STEP 2</p>
2		

Chart 4

PROBLEM:
battery UNDERCHARGED



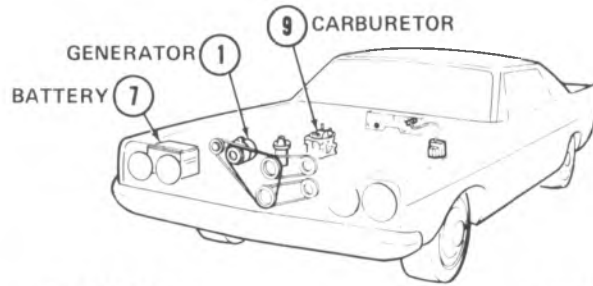
STEP	SEQUENCE	RESULT
<p>1</p> <p>CHECK GENERATOR BELT</p>  <p>REPLACE IF NECESSARY ADJUST TENSION TO 80 LBS.</p> <p>MAKE SURE NO ACCESSORIES WERE LEFT ON, IGNITION OFF, DOORS CLOSED, UNDER HOOD LIGHTS DISCONNECTED</p>	<p>DISCONNECT NEGATIVE CABLE</p>  <p>CONNECT TEST LIGHT BETWEEN CABLE & BATTERY POST</p> 	<p>TEST LIGHT ON → GO TO STEP 2</p> <p>TEST LIGHT OFF → NO DRAIN ON BATTERY → GO TO STEP 3</p>
<p>2</p> <p>TAP CABLE AGAINST POST</p>  <p>TEST LIGHT ON</p>	<p>TRACE & CORRECT CONTINUOUS DRAIN ON BATTERY</p>	<p>TEST LIGHT OFF → STOP</p> <p>TEST LIGHT ON → GO TO STEP 3</p>
<p>3</p> <p>RECONNECT NEGATIVE CABLE</p> <p>CONNECT JUMPER (-) TERMINAL AND GROUND</p> <p>(ON H.E.T. DISCONNECT FEED WIRE)</p>	<p>CONNECT VOLTMETER (+) TERMINAL AND GROUND</p>  <p>CRANK ENGINE LONG ENOUGH FOR STABILIZED READING</p>	<p>NEEDLE ABOVE 9.0 VOLTS → GO TO STEP 6</p> <p>NEEDLE BELOW 9.0 VOLTS → GO TO STEP 4</p>
<p>4</p> <p>CHECK VOLTAGE ACROSS POST WHILE CRANKING</p>	<p>IF READING IS WITHIN .5 VOLT OF VOLTAGE AT GEN. → TEST BATTERY USING BATTERY LOAD TEST PROCEDURE</p> <p>IF READING IS NOT WITHIN .5 VOLT OF READING AT GEN. CHECK FOR BATTERY CABLE AND STARTER TO DELCOTRON CIRCUIT RESISTANCE</p> 	<p>BATTERY OK CHARGE AS SPECIFIED BY TEST → GO TO STEP 6</p> <p>BATTERY NOT OK → GO TO STEP 5</p>
<p>5</p> <p>REPLACE BATTERY</p> 		<p>GO TO STEP 6</p>


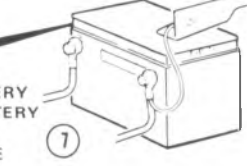
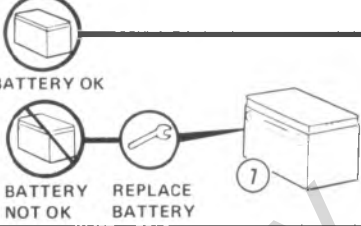

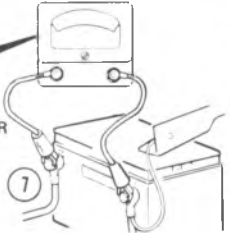
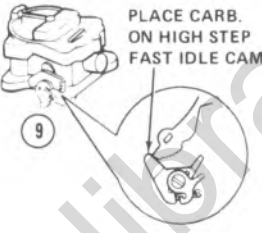


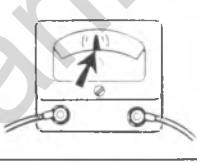
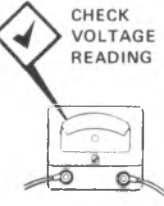

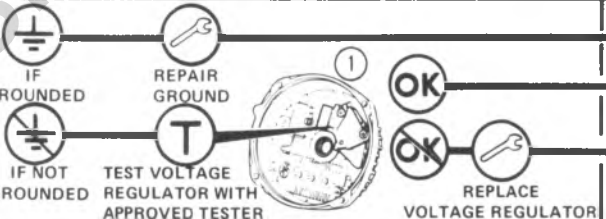

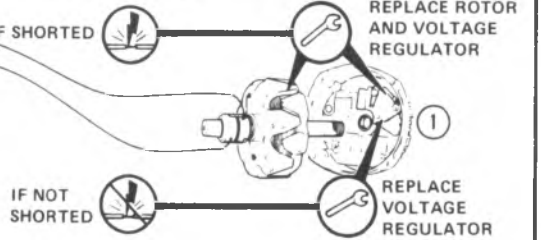
STEP	SEQUENCE	RESULT
<p>6</p>	<p>CONNECT VOLTMETER ACROSS BATTERY</p> <p>DISCONNECT COIL JUMPER OR RECONNECT HEI FEED WIRE</p> <p>RECORD READING</p> <p>PLACE CARB. ON HIGH STEP FAST IDLE CAM</p> <p>START ENGINE DO NOT TOUCH ACCELERATOR PEDAL</p> 	<p>GO TO STEP 7</p>
<p>7</p>	<p>TURN ON ACCESSORIES</p> <p>HEADLIGHTS-HI</p> <p>A/C - HI</p> <p>RADIO</p> <p>BLOWER TYPE DEFOGGER</p> <p>CHECK VOLTAGE READING</p> 	<p>IF VOLTAGE READS LOWER THAN PREVIOUS READING GO TO STEP 9</p> <p>IF VOLTAGE READS HIGHER THAN PREVIOUS READING GO TO STEP 8</p>
<p>8</p>	<p>TURN OFF ACCESSORIES</p> <p>WAIT UNTIL UPPER RADIATOR INLET IS HOT AND VOLTMETER NEEDLE STOPS</p> <p>CHECK VOLTAGE READING</p> 	<p>IF METER READS UNDER 12.5 GO TO STEP 9</p> <p>IF METER READS OVER 15.5 GO TO STEP 10</p> <p>IF METER READS 12.5 TO 15.5 SEE NOTE STOP</p>
<p>9</p>	<p>GROUND GENERATOR</p> <p>CHECK VOLTAGE READING</p> 	<p>IF VOLTAGE READS HIGHER THAN PREVIOUS READING GO TO STEP 10</p> <p>IF VOLTAGE READS LOWER THAN PREVIOUS READING GO TO STEP 11</p>
<p>10</p>	<p>TEST VOLTAGE REGULATOR WITH APPROVED TESTER</p> <p>REPLACE VOLTAGE REGULATOR</p> 	<p>GO TO STEP 11</p> <p>STOP</p>
<p>11</p>	<p>OVERHAUL GENERATOR</p> 	<p>STOP</p>

NOTE: IF NOTHING HAS BEEN FOUND RE-EDUCATE OWNER ON EXCESSIVE IDLING, SLOW OR SHORT DISTANCE DRIVING WITH ALL ACCESSORIES ON.

Chart 5

PROBLEM:
battery OVERCHARGED
(uses too much water)



STEP	SEQUENCE	RESULT
<p>1</p>  <p>TEST BATTERY USING BATTERY LOAD TEST PROCEDURE</p> 		<p>GO TO STEP 2</p> <p>GO TO STEP 2</p>
<p>2</p>  <p>CONNECT VOLTMETER ACROSS BATTERY</p> 	<p>PLACE CARB. ON HIGH STEP FAST IDLE CAM</p>  <p>START ENGINE DO NOT TOUCH ACCELERATOR PEDAL</p> 	<p>GO TO STEP 3</p>
<p>3</p> <p>TURN OFF ALL ACCESSORIES</p>	 <p>WAIT UNTIL UPPER RADIATOR INLET IS HOT</p>  <p>AND VOLTMETER NEEDLE STOPS</p>	<p>CHECK VOLTAGE READING</p>  <p>READING IS 12.5 to 15.5</p> <p>STOP</p> <p>READING IS NOT 12.5 to 15.5</p> <p>PERFORM NEXT TWO STEPS 4 & 5</p>
<p>4</p>  <p>CHECK FOR GROUNDED BRUSH LEAD CLIP</p>		<p>GO TO STEP 5</p> <p>GO TO STEP 5</p> <p>GO TO STEP 5</p>
<p>5</p> <p>CHECK FOR SHORTED FIELD WINDINGS</p>  <p>OHMMETER</p>		<p>STOP</p>

ON-VEHICLE SERVICE

GENERATOR ASSEMBLY

Replacement (Fig. 6D-7C)

1. Disconnect the battery ground cable at battery.
2. Disconnect wiring leads at generator.
3. Remove generator brace bolt, then detach drive belt (belts).
4. Support the generator and remove generator mount bolt and remove from vehicle.
5. Reverse the removal procedure to install then adjust drive belt(s) as outlined in Section 6A of this manual.

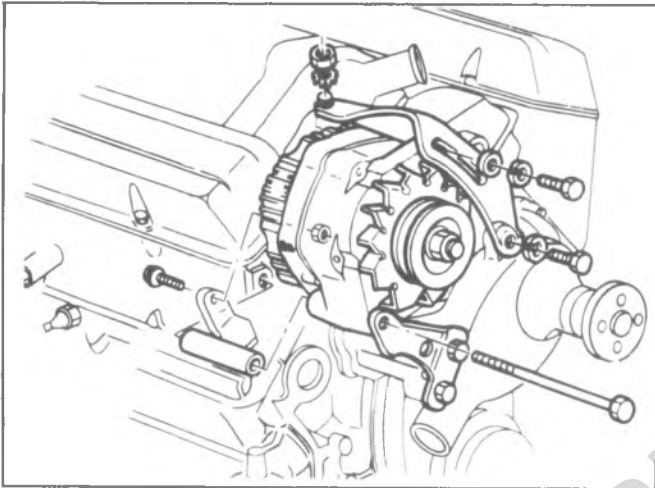


Fig. 6D-7C--Generator Installation Typical

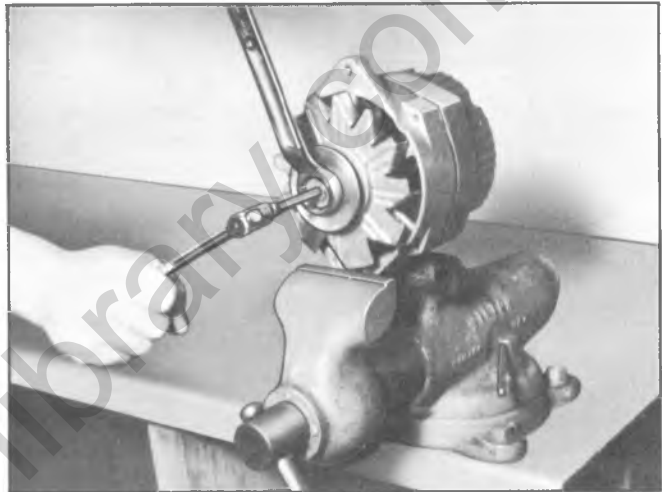


Fig. 6D-8C--Pulley Removal

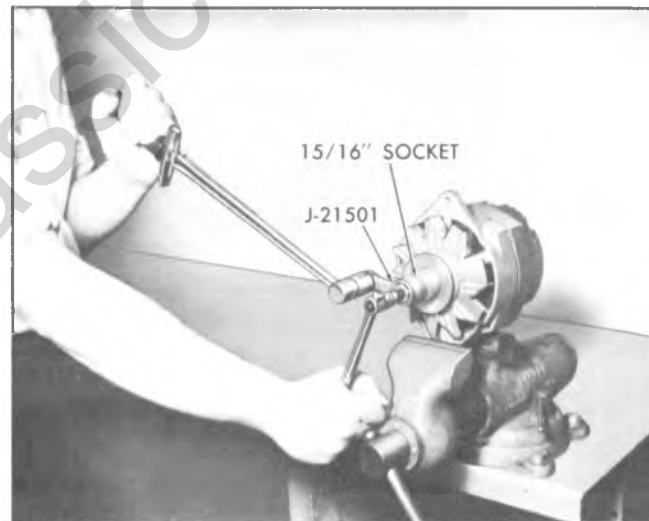


Fig. 6D-9C--Torquing Pulley Nut

UNIT REPAIR

DISASSEMBLY (FIG. 6D-1C)

1. Hold generator in a vise, clamping the mounting flange lengthwise.

2. Remove the four thru-bolts and separate the slip ring end frame and stator assembly from the drive end and rotor assembly by prying apart with a screwdriver at the stator slot.

NOTE: A scribe mark will help locate the parts in the same position during assembly.

3. Place a piece of tape over the slip ring end frame bearing to prevent entry of dirt and other foreign material, and also a piece of tape over the shaft at the slip ring end.

CAUTION: *Brushes may drop onto the rotor shaft and become contaminated with bearing lubricant. Clean brushes prior to installing with a non-toxic cleaner such as trichlorethylene or a soft dry cloth.*

4. Remove the stator lead attaching nuts and separate stator from end frame.

NOTE: At this point, with the two end frames separated the stator disconnected and the rotor removed electrical checks of the rotor, rectifier bridge, stator and diode trio brush lead clip may be made without further disassembly. Refer to the specific checks as outlined in this section.

5. Remove screw attaching diode trio to brush holder assembly and remove diode trio from end frame.

6. Remove the rectifier bridge attaching screw and the "BAT" terminal screw, and disconnect the capacitor lead. Remove rectifier bridge from the end frame.

7. Remove two attaching screws, and remove brush holder and regulator assemblies.

NOTE: Two insulators are assembled over the top of the brush retaining clips and the two screws have special insulating sleeves over the screw body.

8. Remove retaining screw and capacitor from end of frame.

9. Remove slip ring end frame bearing (if necessary). Refer to bearing replacement covered in this section.

10. Remove pulley retaining nut and slide washer, pulley, fan and spacer from shaft.

a. Single groove pulley--place 15/16" box wrench on the shaft nut and insert a 5/16" allen wrench into the shaft end hole to hold the shaft while removing the nut (fig. 6D-8C).

b. Double groove pulley--place a 15/16" socket (with wrench flats on the drive end or use adapter J-21501 and a box wrench on the pulley retaining nut, insert a 5/16" allen wrench through the socket and adapter into hex hole in the shaft to hold the shaft while removing the nut.

11. Remove rotor and spacers from the drive end frame assembly.

12. Remove drive end frame bearing retainer plate screws, plate, gasket, bearing, and slinger from end frame (if necessary).

CLEANING AND INSPECTION

With generator completely disassembled the components should be cleaned and inspected. Be sure testing equipment is in good working order before attempting to check the generator.

1. Wash all metal parts except stator and rotor assemblies.

2. Clean bearings and inspect for sealing, pitting or

roughness.

3. Inspect rotor slip rings, they may be cleaned with 400 grain polishing cloth. Rotate rotor for this operation to prevent creating flat spots on slip rings.

4. Slip rings which are out of round may be trued in a lathe to .002" maximum indicator reading. Remove only enough material to make the rings smooth and concentric. Finish with 400 grain polishing cloth and blow dry.

5. Slip rings are not replaceable--excessive damage will require rotor assembly replacement.

6. Inspect brushes for wear. If they are worn halfway, replace. Inspect brush springs for distortion or weakening. If brushes appear satisfactory and move freely in brush holder, springs may be reused.

TESTING

Where specified, conduct the following tests using an ohmmeter with a 1-1/2 volt cell and use the lowest range scale for the readings.

Rotor Field Winding Checks (Fig. 6D-10C)

The rotor may be checked electrically with a 110-volt test lamp or an ohmmeter.

Open Circuit

Connect one test lamp or ohmmeter lead to each slip ring. If the lamp fails to light or if the ohmmeter reading is high, the windings are open.

Short Circuit

The windings are checked for shorts by connecting a 12 volt battery and an ammeter in series with the two slip rings. Note the ammeter reading. An ammeter reading above the specified field amperage draw indicates shorted windings. Refer to Specifications at the end of this manual.

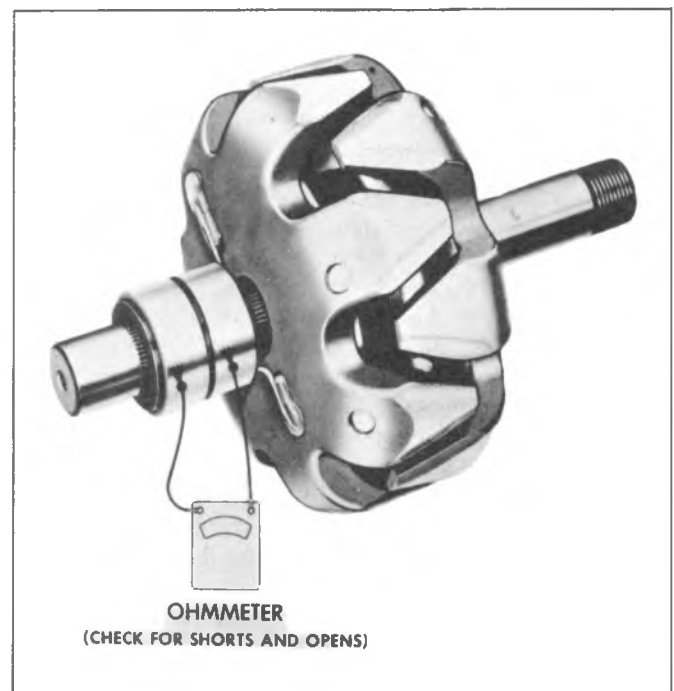


Fig. 6D-10C--Checking Rotor

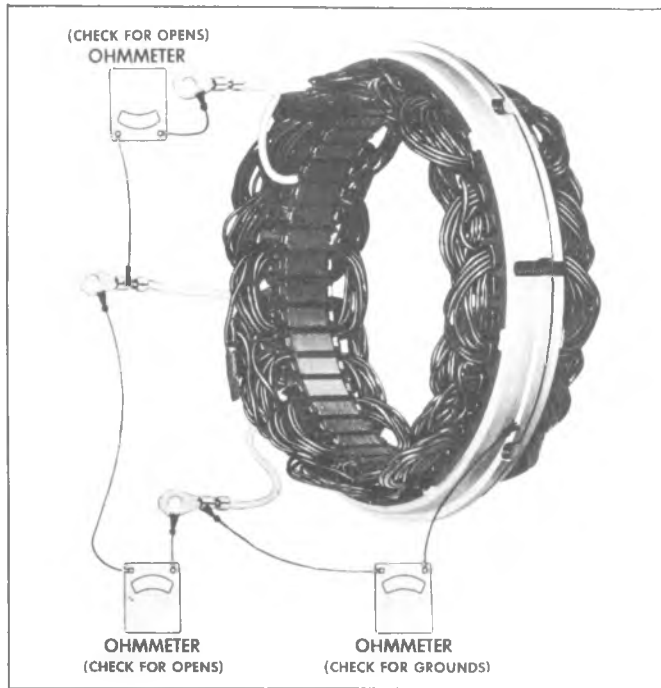


Fig. 6D-11C--Checking Stator

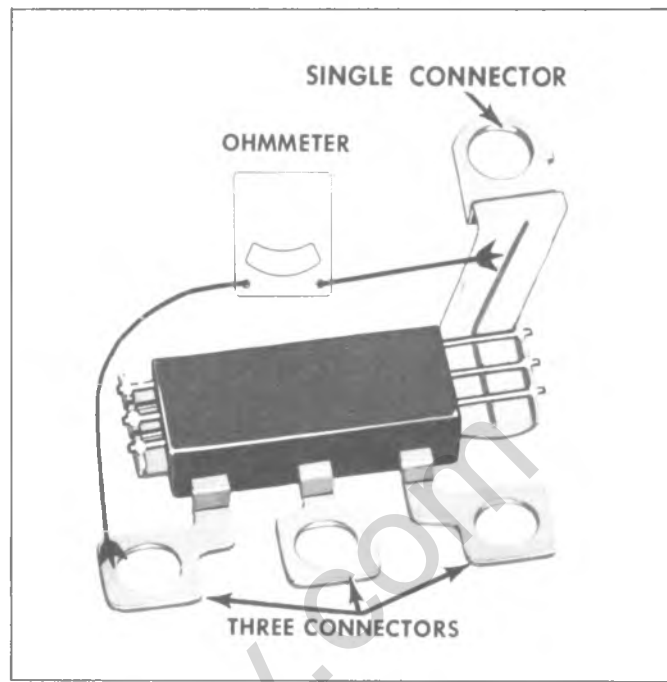


Fig. 6D-12C--Diode Trio Checks

Stator Checks (Fig. 6D-11C)

Grounds

Connect a 110-volt test lamp or an ohmmeter from any stator lead to the stator frame. If test lamp lights or if ohmmeter reads low, the windings are grounded.

Open Circuit

If lamp fails to light or if ohmmeter reads high when successively connected between each pair of stator leads, the windings are open.

Short Circuit

A short in the stator windings is difficult to locate without special test equipment due to the low resistance of the windings. However, if all other electrical checks are normal and the generator fails to supply rated output, shorted stator windings are indicated. Also, look for heat discoloration on the windings.

Diode Trio (Fig. 6D-12C)

With the diode trio unit remove from the end frame, connect an ohmmeter to the single connect and to one of the three connectors. Observe the reading, then reverse the ohmmeter leads to the same connectors. A good diode trio will give one high and one low reading. If both readings are the same, replace the diode trio. Repeat this test between the single connector and each of the other two connectors.

NOTE: There are two diode trio units differing in appearance used in the generator but they are completely interchangeable.

CAUTION: Do not use high voltage such as 110 volt test lamp to check the diode trio.

Rectifier Bridge Check (Fig. 6D-13C)

Connect an ohmmeter to the grounded heat sink and one of the three terminals. Then reverse the lead connections to the grounded heat sink and same terminal. If both readings are the same, replace the bridge. A good rectifier bridge will give one high and one low reading. Repeat this same test

between the grounded heat sink and the other two terminals, and between the insulated heat sink and each of the three terminals. When this is done all six diodes are checked with

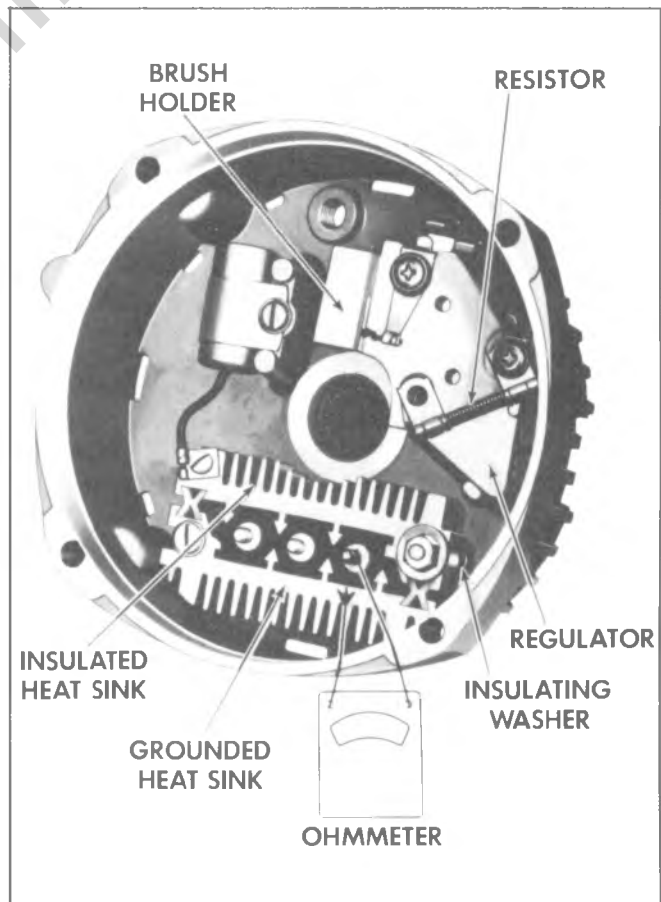


Fig. 6D-13C--Rectifier Bridge Checks

two readings taken for each diode.

NOTE: The diodes are not replaced individually. The entire rectifier bridge is replaced if one or more diodes are defective.

CAUTION: Do not use high voltage to check the rectifier bridge, such as a 110 volt test lamp.

Voltage Reg./Brush Lead Clip Check (Fig. 6D-5C)

Connect an ohmmeter from the brush lead clip to the end frame as shown in Step 1, Figure 6D-7C. Then reverse lead connections. If both readings are zero, either the brush lead clip is grounded or the regulator is defective.

A grounded brush lead clip can result from omission of the insulating washer, omission of the insulating sleeve on the screw, or a damaged insulating sleeve. Remove the screw and inspect the sleeve. If it is satisfactory, replace the regulator unit.

REPAIRS

Brush Holder and Regulator Replacement (Fig. 6D-5C)

1. If not previously removed, remove the three stator lead attaching nuts, the stator, diode trio brush lead screw and diode trio from the end frame.

2. Remove the remaining two screws from the brush holder and regulator and remove these units from the end frame.

NOTE: The two screws retaining the brush clips have insulating washers over the tops of the brush clips and special insulating sleeves over the screw body above the threads. If they are damaged or missing a ground will result causing uncontrolled or no output.

3. Replace defective unit and reassemble using reverse of removal procedures.

NOTE: The screw nearest regulator terminals does not have an insulating washer, but may or may not have an insulating sleeve.

Slip Ring Servicing

If the slip rings are dirty, they may be cleaned and finished with 400 grain or finer polishing cloth. Spin the rotor, and hold the polishing cloth against the slip rings until they are clean.

CAUTION: The rotor must be rotated in order that the slip rings will be cleaned evenly. Cleaning the slip rings by hand without spinning the rotor may result in flat spots on the slip rings, causing brush noise.

Slip rings which are rough or out of round should be trued in a lathe to .002 inch maximum indicator reading. Remove only enough material to make the rings smooth and round. Finish with 400 grain or finer polishing cloth and blow away all dust.

Drive End Frame-Bearing Replacement/Lubrication

1. The drive end frame bearing can be removed by detaching the retainer plate bolts and separating retainer plate and seal assembly from end frame, and then pressing bearing out using suitable tube or pipe on outer race.

2. Refill bearing one-quarter full with Delco-Remy No. 1948791 grease or equivalent. Do not overfill.

3. Press bearing into end frame using tube or pipe as in Step 1 with bearing and slinger assembled as shown in Figure 6D-8C.

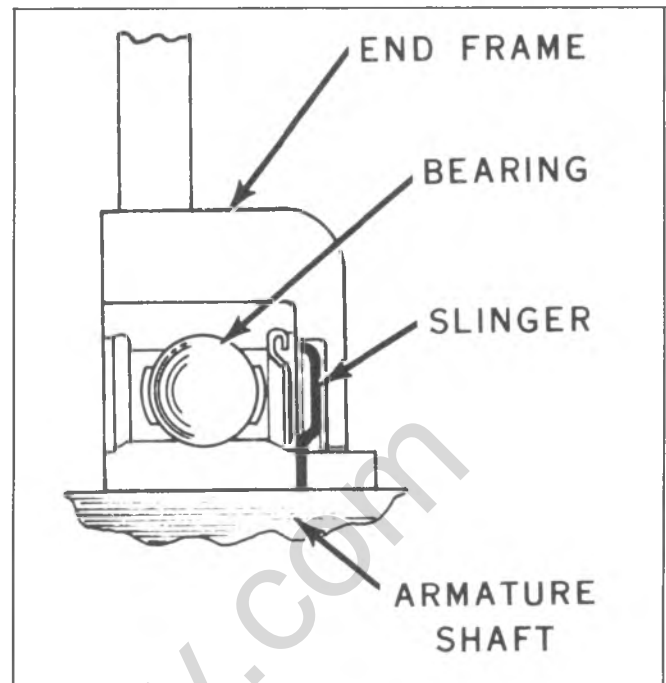


Fig. 6D-14C-Drive End Bearing Cross Section

4. Install retainer plate. Use new retainer plate if felt seal is hardened or excessively worn.

NOTE: Stake retainer plate bolts to plate.

Slip Ring End Frame-Bearing Replacement

1. Replace the bearing if the grease supply is exhausted. Make no attempt to re-lubricate and reuse the bearing.

2. Press out from outside of housing, using suitable tool over outer race of bearing.

3. To install, place a flat plate over the bearing and press in from outside of housing until bearing is flush with the outside of the end frame. Support inside of end frame around bearing bore with a suitable tool to prevent distortion. Use extreme care to avoid misalignment.

4. Install new seal whenever bearing is replaced. Lightly coat the seal lip with oil and press seal into the end frame with the seal lip toward the inside of the end frame.

REASSEMBLY

1. Install rotor in drive end frame and attach spacer, fan, pulley, washer, and nut.

2. Using adapter J-21501, insert an allen wrench into hex shaped hole at end of shaft and torque the shaft nut to 40-50 ft. lbs. (fig. 6D-9C).

3. Install capacitor and retaining screw in slip ring end frame.

4. Position brush holder and regulator assemblies in end frame and install two retaining screws.

NOTE: The two screws retaining the brush clips have insulating washers over the top of the brush clips and special insulating sleeves over the screw body above the threads. If the third screw does not have an insulating sleeve, it must not be interchanged with either of the other two screws.

5. Position rectifier bridge to end frame. Install attaching screw and the "BAT" terminal screw. Connect capacitor lead to bridge.

6. Position diode trio on rectifier bridge terminal and

install screw attaching brush lead clip to brush holder.

CAUTION: *Insulating washer on the screw must be assembled over top of the connector.*

7. Position stator in end frame. Connect stator leads to rectifier bridge terminals and install attaching nuts.

8. Position slip ring end frame to drive end frame and install four thru bolts.

NOTE: Remove tooth pick from brush holder at opening in slip ring end frame before operating machine on vehicle.

SPECIAL TOOLS

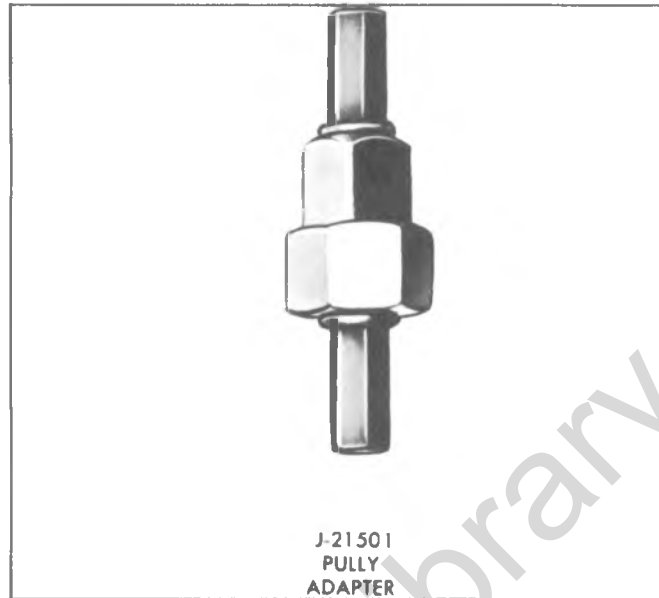


Fig. 6D-15C--Special Tool

IGNITION SYSTEM

DISTRIBUTOR

GENERAL DESCRIPTION

There are two types of HEI distributors. The 8 cylinder distributor (Fig. 6D-1i) combines all ignition components in one unit. The ignition coil is in the distributor cap and connects directly to the rotor. The 6 cylinder distributor (Fig. 6D-2i) has an external mounted coil. Both operate basically in the same manner as a conventional ignition system except the module and pick-up coil of the HEI system replace the contact points of the conventional system.

The High Energy Ignition is a pulse triggered, transistor controlled, inductive discharge ignition system. The magnetic pick-up assembly located inside the distributor contains a permanent magnet, a pole piece with internal teeth, and a pick-up coil. When the teeth of the timer core rotating inside the pole piece line up with teeth of the pole piece, an induced voltage in the pick-up coil signals the all electronic module to open the coil primary circuit. The primary current decreases and a high voltage is induced in the ignition coil secondary winding which is directed through the rotor and high voltage leads to fire the spark plugs. The capacitor in the distributor is for radio noise suppression.

The module automatically controls the dwell period, stretching it with increasing engine speed. The HEI system also features a longer spark duration, made possible by the higher amount of energy stored in the coil primary. This is

desirable for firing lean and EGR diluted mixtures.

Ignition Coil

In the 8 cylinder HEI system, the ignition coil is built into the distributor cap. In the 6 cylinder HEI system, the ignition coil is mounted externally. The coil is somewhat smaller physically than a conventional coil, but has more primary and secondary windings. It is built more like a true transformer with the windings surrounded by the laminated iron core. A conventional coil has the iron core inside the windings. Although the HEI coil operates in basically the same way as a conventional coil, it is more effective in generating higher secondary voltage when the primary circuit is broken.

Electronic Module

The electronic module is a solid state unit containing five complete circuits which control spark triggering, switching, current limiting, dwell control and distributor pick-up. Dwell angle is controlled by a transistor circuit within the module and is varied in direct relation to engine speed.

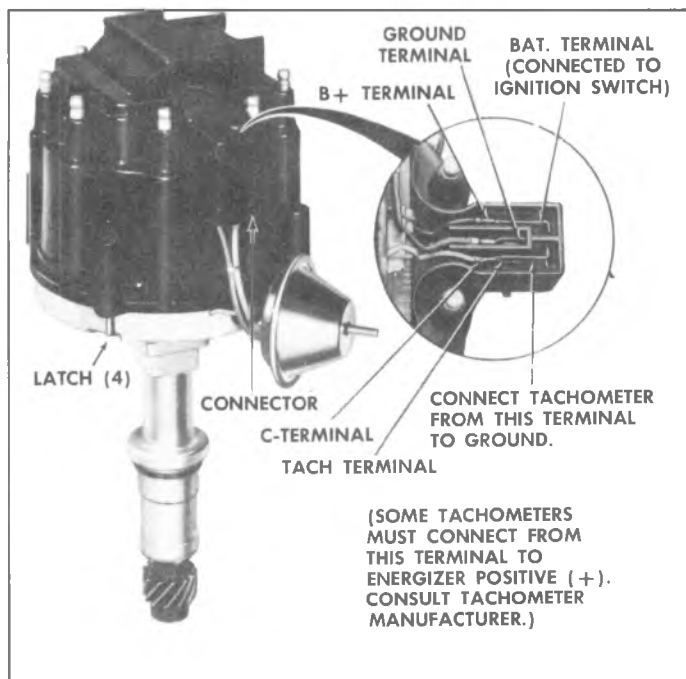


Fig. 6D-11-8 Cylinder HEI Distributor

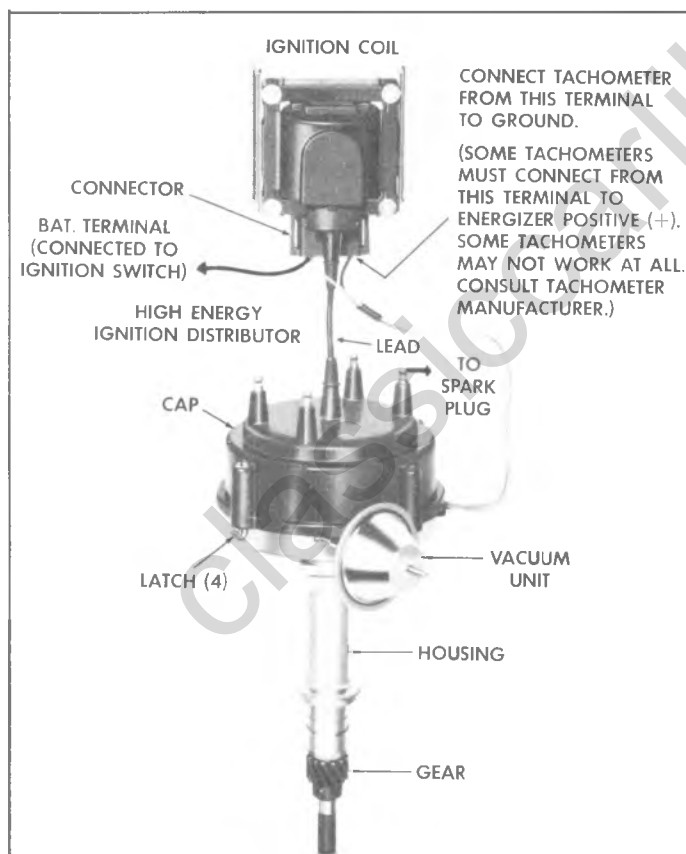


Fig. 6D-2i-6 Cylinder HEI Distributor

Pick-Up Assembly

The pick-up assembly consists of the following:

1. A rotating timer core with external teeth which is turned by the distributor shaft.
2. A stationary pole piece with internal teeth.
3. A pick-up coil and magnet which are located between the pole piece and a bottom plate.

Centrifugal and Vacuum Advance

The centrifugal and vacuum advance mechanisms are basically the same types of units that provide spark advance in the breaker-type system. Centrifugal advance is achieved through the rotation of the timer core in relation to the distributor shaft. Vacuum advance is achieved by attaching the pick-up coil and pole piece to the vacuum advance unit actuating arm.

Wiring (Fig. 6D-3i)

The pick-up coil is connected to transistors in the electronic module. The electronic module is connected to the primary windings in the coil. As the distributor shaft turns the timer core teeth out of alignment with the teeth of the pole piece a voltage is created in the magnetic field of the pick-up coil.

The pick-up coil sends this voltage signal to the electronic module, which determines from RPM when to start current building in the primary windings of the ignition coil.

Each time the timer core teeth align with the pole piece teeth the pick-up coil magnetic field is changed creating a different voltage. The pick-up coil sends this different voltage signal the electronic module which electronically shuts off the ignition coil primary circuit. This in turn collapses the coil magnetic field, induces high secondary voltage and fires one spark plug.

The electronic module delivers full battery voltage to the ignition coil which is limited to five to six amperes. There is no primary resistance wire in the HEI system. The electronic module triggers the closing and opening of the primary circuit instantaneously with no energy lost due to breaker point arcing or capacitor charging time lag. The capacitor in the HEI unit functions only as a radio noise suppressor.

This instantaneous and efficient circuit triggering enables the HEI system to deliver up to approximately 35,000 volts through the secondary wiring to the spark plugs.

Because of the higher voltage, the HEI system has larger diameter (8 millimeter) spark plug wires with silicone insulation. The silicone wire is gray in color, more heat resistant than standard black wire and less vulnerable to deterioration. Silicone insulation is soft, however, and must not be mishandled.

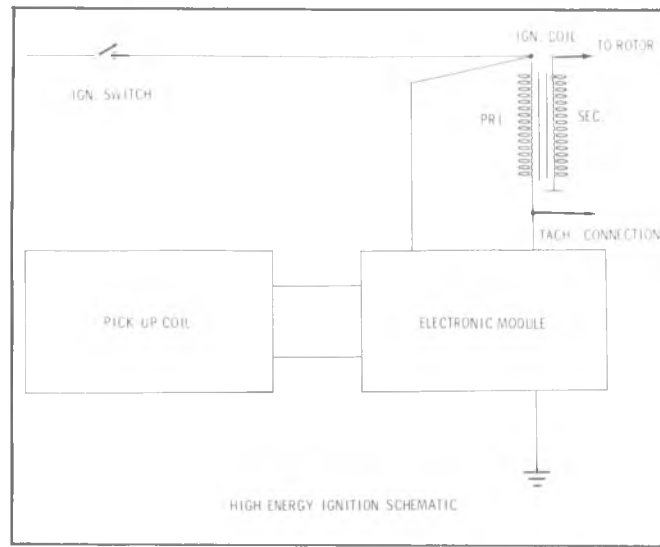


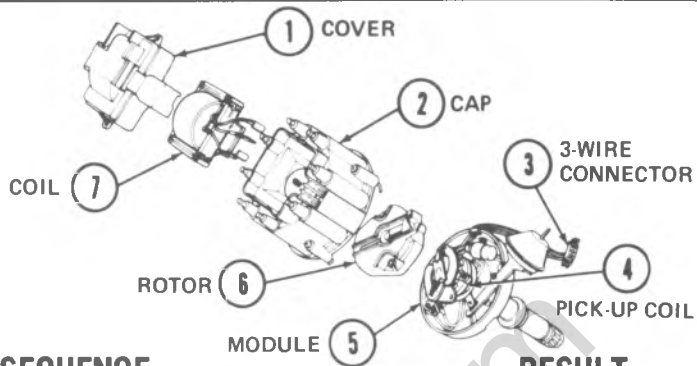
Fig. 6D-3i--High Energy Ignition Basic Wiring

classiccarslibrary.com

DIAGNOSIS

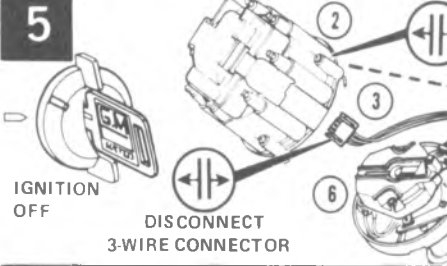
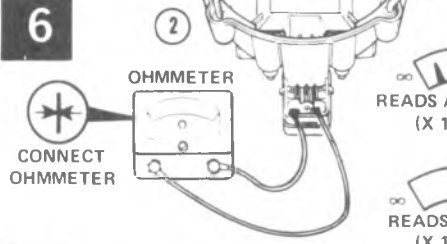
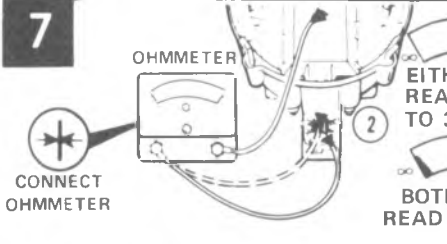
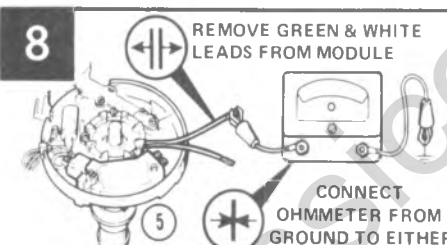
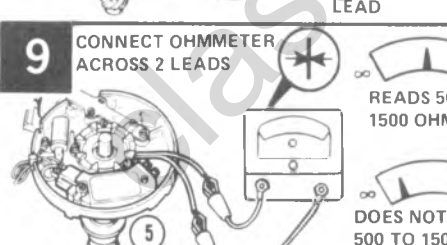
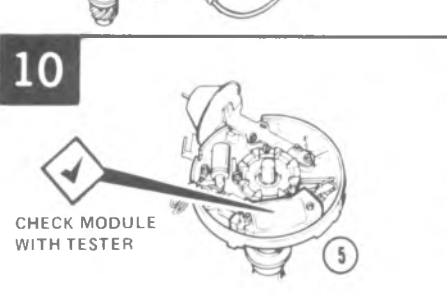
HIGH ENERGY IGNITION SYSTEM V8 engine

PROBLEM:
engine **CRANKS** but
WILL NOT START



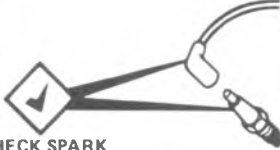


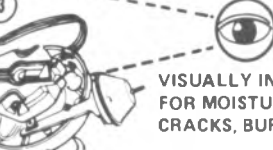

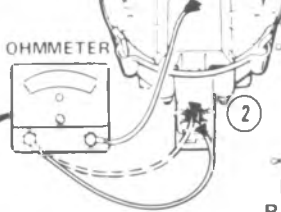
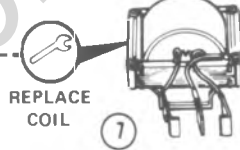
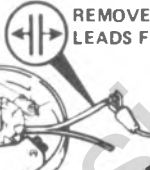

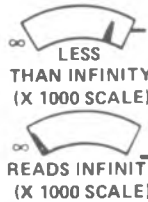

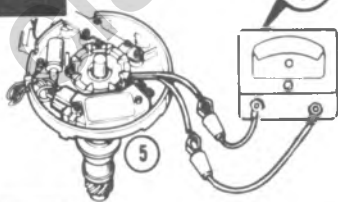


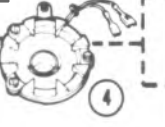
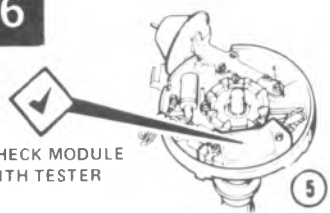
STEP	SEQUENCE	RESULT
<p>1</p>		<p>TEST LIGHT ON 4</p> <p>TEST LIGHT OFF 3</p>
<p>2</p>	<p>TEST LIGHT OFF</p> <p>REPAIR LEAD OR CONNECTOR</p> <p>TEST LIGHT ON</p> <p>TEST LIGHT ON</p>	<p>STARTS STOP</p> <p>NO START 5</p> <p>NO START 5</p>
<p>3</p>	<p>REPAIR OR REPLACE AS NECESSARY</p> <p>TEST LIGHT ON</p>	<p>STARTS STOP</p> <p>NO START 4</p>
<p>4</p> <p>REMOVE A SPARK PLUG WIRE, INSERT EXTENSION AND PERFORM SPARK TEST</p> <p>USING INSULATED PLIERS HOLD SPARK PLUG WIRE 1/4" AWAY FROM ENG. BLOCK WHILE CRANKING ENGINE</p>		<p>NO SPARK 2</p> <p>SPARK</p> <p>PROBLEM IS NOT IGNITION SYSTEM CHECK</p> <ul style="list-style-type: none"> • FUEL SYSTEM • PLUGS • FLOODED

HIGH ENERGY IGNITION SYSTEM V8 engine

STEP	SEQUENCE	RESULT
5	 <p>REMOVE CAP ASSY.</p> <p>IGNITION OFF</p> <p>DISCONNECT 3-WIRE CONNECTOR</p> <p>VISUALLY INSPECT FOR MOISTURE, DUST, CRACKS, BURNS, ETC.</p> <p>REPAIR AS NECESSARY</p>	<p>STARTS → STOP</p> <p>NO START → 6</p>
6	 <p>OHMMETER</p> <p>CONNECT OHMMETER</p> <p>READS ABOVE 1 OHM (X 1 SCALE)</p> <p>REPLACE COIL</p> <p>READS 0 TO 1 OHM (X 1 SCALE)</p>	<p>STARTS → STOP</p> <p>NO START → 8</p> <p>NO START → 7</p>
7	 <p>OHMMETER</p> <p>CONNECT OHMMETER</p> <p>EITHER TEST READS 6,000 TO 30,000 OHMS</p> <p>BOTH TESTS READ INFINITY</p> <p>REPLACE COIL</p>	<p>STARTS → STOP</p> <p>NO START → 8</p> <p>NO START → 8</p>
8	 <p>REMOVE GREEN & WHITE LEADS FROM MODULE</p> <p>CONNECT OHMMETER FROM GROUND TO EITHER LEAD</p> <p>LESS THAN INFINITY (X 1000 SCALE)</p> <p>REPLACE COIL (PICK-UP)</p> <p>READS INFINITE (X 1000 SCALE)</p>	<p>STARTS → STOP</p> <p>NO START → 10</p> <p>NO START → 9</p>
9	 <p>CONNECT OHMMETER ACROSS 2 LEADS</p> <p>READS 500 TO 1500 OHMS</p> <p>REPEAT STEPS 8 AND 9 WHILE MOVING VAC. ADVANCE WITH SCREWDRIVER. IF READING IS STILL OK</p> <p>DOES NOT READ 500 TO 1500 OHMS</p> <p>REPLACE COIL (PICK-UP)</p>	<p>STARTS → STOP</p> <p>NO START → 10</p> <p>NO START → 10</p>
10	 <p>CHECK MODULE WITH TESTER</p> <p>OK IF OK</p> <p>IF NOT OK REMOVE AND REPLACE MODULE</p>	<p>REPEAT STEPS 5 THRU 9</p> <p>STOP</p>

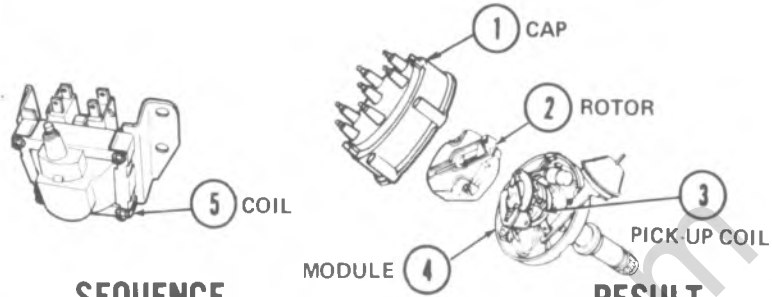
HIGH ENERGY IGNITION SYSTEM V8 engine


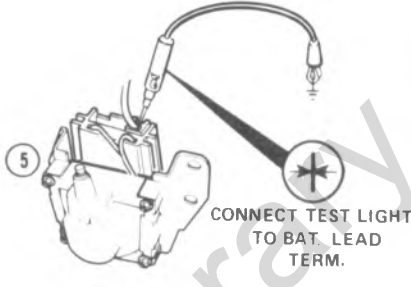



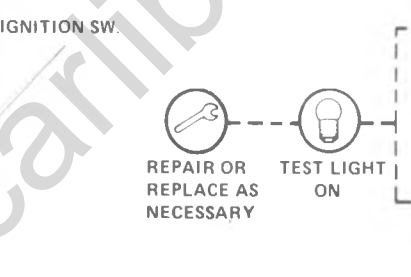



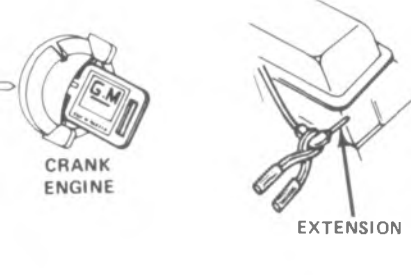



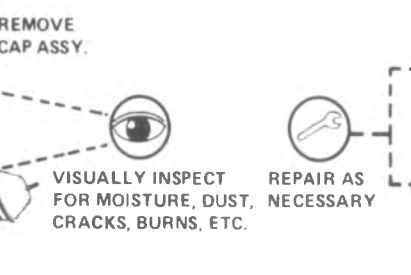



PROBLEM: engine RUNS ROUGH or CUTS OUT

STEP	SEQUENCE	RESULT
<p>1</p>  <p>CHECK SPARK PLUGS & PLUG WIRES</p>	<p>OK</p> <p>REPAIR OR REPLACE</p>	<p>2</p> <p>RUNS SMOOTH</p> <p>RUNS ROUGH</p> <p>2</p>
<p>2</p>  <p>IGNITION OFF</p> <p>DISCONNECT 3-WIRE CONNECTOR</p>  <p>REMOVE CAP ASSY.</p>  <p>VISUALLY INSPECT FOR MOISTURE, DUST, CRACKS, BURNS, ETC.</p> <p>REPAIR AS NECESSARY</p>	<p>RUNS SMOOTH</p> <p>RUNS ROUGH</p>	<p>STOP</p> <p>3</p>
<p>3</p>  <p>CONNECT OHMMETER</p>  <p>OHMMETER</p> <p>EITHER TEST READS 6,000 TO 30,000 OHMS</p> <p>BOTH TESTS READ INFINITY</p>  <p>REPLACE COIL</p>	<p>RUNS SMOOTH</p> <p>RUNS ROUGH</p>	<p>4</p> <p>STOP</p> <p>4</p>
<p>4</p>  <p>REMOVE GREEN & WHITE LEADS FROM MODULE</p>  <p>CONNECT OHMMETER FROM GROUND TO EITHER LEAD</p>  <p>LESS THAN INFINITY (X 1000 SCALE)</p> <p>REPLACE COIL (PICK-UP)</p>  <p>READS INFINITE (X 1000 SCALE)</p>	<p>RUNS SMOOTH</p> <p>RUNS ROUGH</p>	<p>STOP</p> <p>6</p> <p>5</p>
<p>5</p> <p>CONNECT OHMMETER ACROSS 2 LEADS</p>   <p>READS 500 TO 1500 OHMS</p> <p>REPEAT STEPS 4 AND 5 WHILE MOVING VAC. ADVANCE WITH SCREWDRIVER. IF READING IS STILL OK</p>  <p>DOES NOT READ 500 TO 1500 OHMS</p> <p>REPLACE COIL (PICK-UP)</p> 	<p>RUNS SMOOTH</p> <p>RUNS ROUGH</p>	<p>6</p> <p>STOP</p> <p>6</p>
<p>6</p>  <p>CHECK MODULE WITH TESTER</p>	<p>OK IF OK</p> <p>REPEAT STEPS 1 THRU 5</p> <p>REMOVE AND REPLACE MODULE</p> <p>STOP</p>	<p>STOP</p>

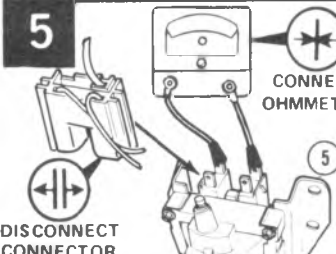
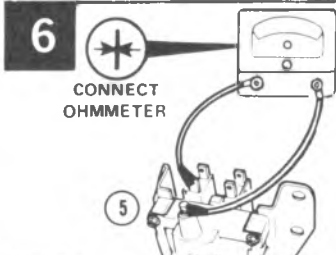
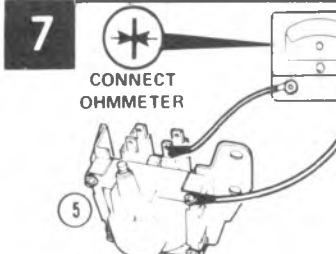
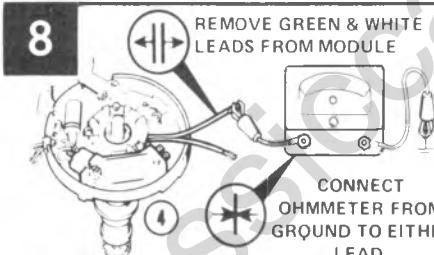
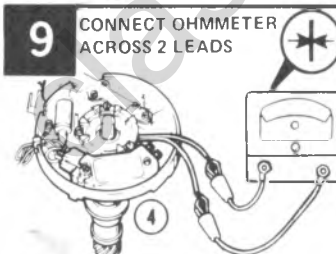
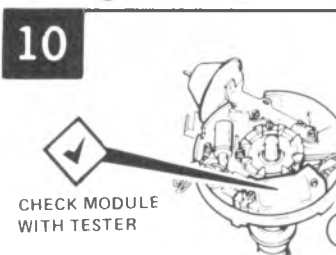
HIGH ENERGY IGNITION SYSTEM L-6 engines

PROBLEM:
engine **CRANKS** but
WILL NOT START



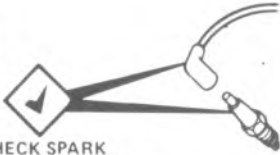
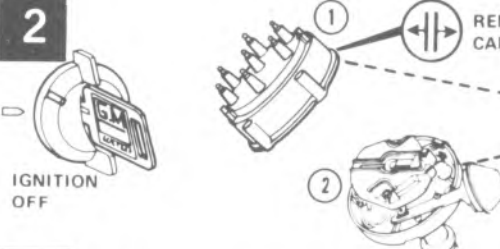
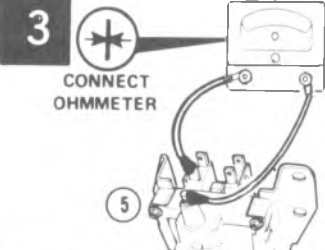
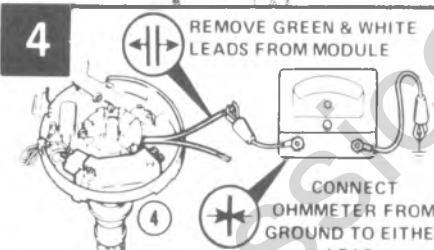
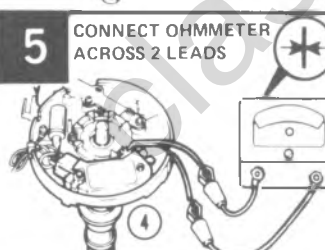

STEP	SEQUENCE	RESULT
<p>1</p>  <p>IGNITION ON</p> <p>AUTO TRANS. PRND12 LEVER IN PARK</p> <p>MANUAL TRANS. LEVER IN NEUTRAL</p>	 <p>5 COIL</p> <p>CONNECT TEST LIGHT TO BAT. LEAD TERM.</p>	<p>3</p>  <p>TEST LIGHT ON</p> <p>2</p>  <p>TEST LIGHT OFF</p>
<p>2</p>  <p>5 COIL</p> <p>BAT. TERM.</p> <p>CHECK</p> <p>IGNITION SW.</p>	 <p>REPAIR OR REPLACE AS NECESSARY</p> <p>TEST LIGHT ON</p>	<p>STARTS  </p> <p>NO START  3</p>
<p>3</p> <p>REMOVE A SPARK PLUG WIRE, INSERT EXTENSION AND PERFORM SPARK TEST</p> <p>USING INSULATED PLIERS HOLD SPARK PLUG WIRE 1/4" AWAY FROM ENG. BLOCK WHILE CRANKING ENGINE</p>	 <p>CRANK ENGINE</p> <p>EXTENSION</p>	<p>4</p> <p>NO SPARK </p> <p>SPARK </p> <p>PROBLEM IS NOT IGNITION SYSTEM CHECK</p> <ul style="list-style-type: none"> • FUEL SYSTEM • PLUGS • FLOODED
<p>4</p>  <p>IGNITION OFF</p>	 <p>1 REMOVE CAP ASSY.</p> <p>2 VISUALLY INSPECT FOR MOISTURE, DUST, CRACKS, BURNS, ETC.</p> <p>REPAIR AS NECESSARY</p>	<p>STARTS  </p> <p>NO START  5</p>

HIGH ENERGY IGNITION SYSTEM L-6 engines

STEP	SEQUENCE	RESULT	
5	 <p>CONNECT OHMMETER</p> <p>DISCONNECT CONNECTOR</p>	<p>READS ABOVE 1 OHM (X 1 SCALE)</p> <p>REPLACE COIL</p>	<p>STARTS → STOP</p> <p>NO START → 8</p>
	<p>READS 0 TO 1 OHM (X 1 SCALE)</p>	<p>STARTS → STOP</p> <p>NO START → 6</p>	
6	 <p>CONNECT OHMMETER</p>	<p>READS 6,000 TO 30,000 OHMS</p> <p>REPLACE COIL</p>	<p>STARTS → STOP</p> <p>NO START → 8</p>
	<p>READS MORE THAN 30,000 OHMS OR LESS THAN 6,000 OHMS</p>	<p>STARTS → STOP</p> <p>NO START → 8</p>	
7	 <p>CONNECT OHMMETER</p>	<p>LESS THAN INFINITY</p> <p>REPLACE COIL</p>	<p>STARTS → STOP</p> <p>NO START → 8</p>
	<p>READS INFINITE (X 1000 SCALE)</p>	<p>STARTS → STOP</p> <p>NO START → 8</p>	
8	 <p>REMOVE GREEN & WHITE LEADS FROM MODULE</p> <p>CONNECT OHMMETER FROM GROUND TO EITHER LEAD</p>	<p>LESS THAN INFINITY (X 1000 SCALE)</p> <p>REPLACE COIL (PICK-UP)</p>	<p>STARTS → STOP</p> <p>NO START → 10</p>
	<p>READS INFINITE (X 1000 SCALE)</p>	<p>STARTS → STOP</p> <p>NO START → 9</p>	
9	 <p>CONNECT OHMMETER ACROSS 2 LEADS</p>	<p>READS 500 TO 1500 OHMS</p> <p>REPEAT STEPS 8 AND 9 WHILE MOVING VAC. ADVANCE WITH SCREW DRIVER. IF READING IS STILL OK</p> <p>REPLACE COIL (PICK-UP)</p>	<p>STARTS → STOP</p> <p>NO START → 10</p>
	<p>DOES NOT READ 500 TO 1500 OHMS</p>	<p>STARTS → STOP</p> <p>NO START → 10</p>	
10	 <p>CHECK MODULE WITH TESTER</p>	<p>OK IF OK</p> <p>NO OK IF NOT OK</p> <p>REMOVE AND REPLACE MODULE</p>	<p>REPEAT STEPS 5 THRU 9</p> <p>STOP</p>

HIGH ENERGY IGNITION SYSTEM L-6 engines

PROBLEM: engine RUNS ROUGH or CUTS OUT

STEP	SEQUENCE	RESULT
1	 <p>CHECK SPARK PLUGS & PLUG WIRES</p> <p>OK</p> <p>NO OK</p> <p>REPAIR OR REPLACE</p>	<p>2</p> <p>STOP</p> <p>RUNS SMOOTH</p> <p>2</p> <p>RUNS ROUGH</p>
2	 <p>IGNITION OFF</p> <p>REMOVE CAP ASSY.</p> <p>VISUALLY INSPECT FOR MOISTURE, DUST, CRACKS, BURNS, ETC.</p> <p>REPAIR AS NECESSARY</p>	<p>STOP</p> <p>RUNS SMOOTH</p> <p>3</p> <p>RUNS ROUGH</p>
3	 <p>CONNECT OHMMETER</p> <p>READS 6,000 TO 30,000 OHMS</p> <p>READS MORE THAN 30,000 OHMS OR LESS THAN 6,000 OHMS</p> <p>REPLACE COIL</p>	<p>4</p> <p>STOP</p> <p>RUNS SMOOTH</p> <p>4</p> <p>RUNS ROUGH</p>
4	 <p>REMOVE GREEN & WHITE LEADS FROM MODULE</p> <p>CONNECT OHMMETER FROM GROUND TO EITHER LEAD</p> <p>LESS THAN INFINITY (X 1000 SCALE)</p> <p>REPLACE COIL (PICK-UP)</p> <p>READS INFINITE (X 1000 SCALE)</p>	<p>STOP</p> <p>RUNS SMOOTH</p> <p>6</p> <p>RUNS ROUGH</p> <p>5</p>
5	 <p>CONNECT OHMMETER ACROSS 2 LEADS</p> <p>READS 500 TO 1500 OHMS</p> <p>DOES NOT READ 500 TO 1500 OHMS</p> <p>REPEAT STEPS 4 AND 5 WHILE MOVING VAC. ADVANCE WITH SCREWDRIVER. IF READING IS STILL OK</p> <p>REPLACE COIL (PICK-UP)</p>	<p>6</p> <p>STOP</p> <p>RUNS SMOOTH</p> <p>6</p> <p>RUNS ROUGH</p>
6	 <p>CHECK MODULE WITH TESTER</p> <p>IF OK</p> <p>IF NOT OK</p> <p>REMOVE AND REPLACE MODULE</p>	<p>REPEAT STEPS 1 THRU 5</p> <p>STOP</p>

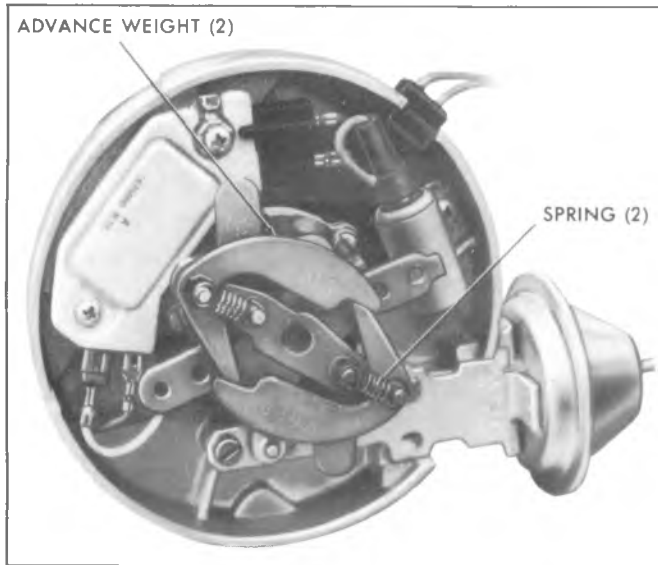


Fig. 6D-6i--Distributor Centrifugal Advance

of cap aligned with notch in housing and secure with four latches.

5. Connect wiring harness connector to terminals on side of distributor cap. Connector will fit only one way.

6. Adjust ignition timing as described in Specification Chart in Section 6E of this manual.

Distributor

Disassembly (Figs. 6D-6i and 6D-8i)

1. Remove distributor as described above.
2. Remove rotor from distributor shaft by removing two screws.
3. Remove two advance springs, weight retainer, and advance weights.
4. Remove two screws holding module to housing and move module to a position where connector may be removed from 'B' and 'C' terminals.
5. Remove wires from "W" and "G" terminals of module.
6. Remove roll pin from drive gear.

CAUTION: *Distributor gear should be supported in such a way that no damage will occur to distributor shaft while removing pin.*

7. Remove gear, shim and tanged washer from distributor shaft. Remove any burrs that may have been caused by removal of pin.

8. Remove distributor shaft from housing.

9. Remove washer from upper end of distributor housing.

10. Remove lock ring at top of housing and remove pole piece and plate assembly and felt washer.

NOTE: No attempt should be made to service the shaft bushings in the housing.

11. Remove vacuum advance mechanism by removing two screws.

12. Disconnect capacitor lead and remove capacitor by removing one screw.

13. Remove wiring harness from distributor housing.

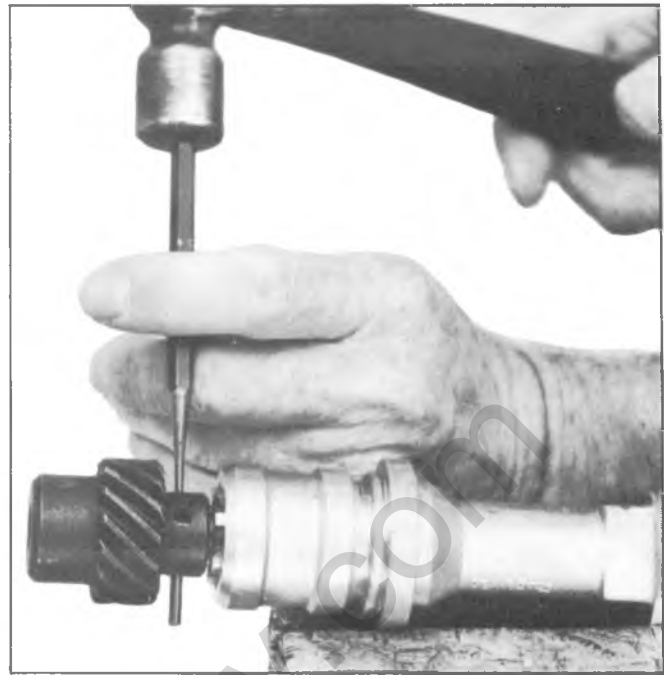


Fig. 6D-7i--Roll Pin Removal

Assembly (Figs. 6D-6i - 6D-9i)

1. Position vacuum advance unit to housing and secure with two screws.
2. Position felt washer over lubricant reservoir at top of housing.
3. Lubricate felt wick with a few drops of motor oil and install replacement pole piece and plate assembly over upper bushing and vacuum advance unit. Make sure the connector or retainer (bow) that holds the white and green electrical leads together is color coded yellow.
4. Install lock ring pole piece and plate assembly.
5. Place distributor shaft (with rotor attached) in distributor housing.

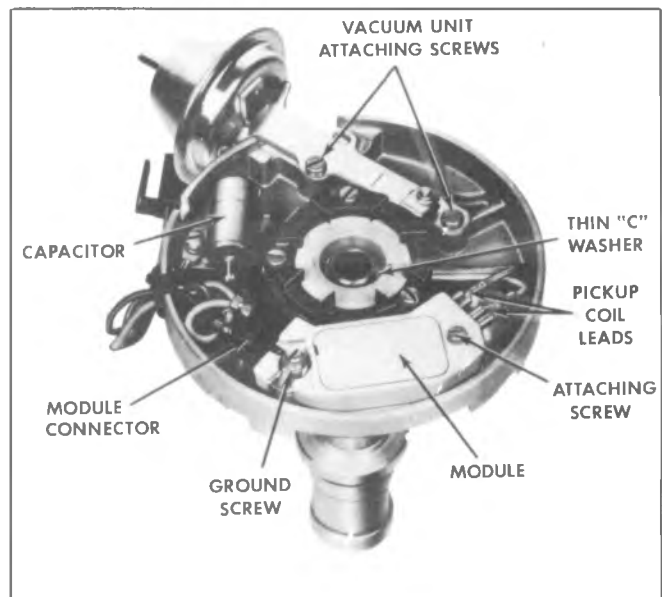


Fig. 6D-8i--Top View of Distributor Housing

6. On 8 cylinder distributors, install tanged washer, shim and drive gear on distributor shaft.

7. On 6 cylinder distributors, install drive gear on distributor shaft.

8. Align holes of drive gear with hole of distributor shaft so that locating mark on drive gear is in line with tip of rotor. Support distributor shaft on a wooden block or other suitable object and install roll pin. Make sure distributor is supported in such a way that no damage will occur to distributor shaft while installing roll pin.

9. Check to make sure shaft is not binding by spinning shaft a few times by hand.

10. Position capacitor to housing and loosely install one mounting screw.

11. Install connector to "B" and "C" terminals on module with tab on top.

12. Apply special silicone lubricant liberally to bottom of module and secure with two screws.

13. Position wiring harness with grommet in housing notch.

14. Connect pink wire to capacitor stud, and black wire to capacitor mounting screw. Tighten screw.

15. Connect white wire from pick-up coil to terminal "W" module.

16. Connect green wire from pick-up coil to terminal "G" of module.

17. Install centrifugal advance weights, weight retainer (dimple facing down), and springs.

18. Install rotor and secure with two screws.

CAUTION: *Notch on side of rotor must engage tab on cam weight base.*

19. Install distributor as described above.

Electronic Module

Replacement (Fig. 6D-8i)

The electronic module is serviced by complete replacement only. When replacing the module a liberal coating of special silicone grease **MUST** be applied to the metal mounting surface on which the module will be installed. If this grease is not applied, the module will not cool properly, which can cause the module to malfunction. A tube of this special silicone grease is supplied with each replacement module.

1. Raise hood and remove air cleaner.

2. Release distributor cap and place aside in an out-of-the-way place.

3. Remove two screws and remove rotor from distributor shaft.

4. Remove two screws holding module to housing and move module to a position where electrical connector may be removed from B and C terminals of module.

5. Use needle nose pliers or similar tool to remove pole piece and plate assembly electrical leads from W (White) and G (Green) terminals of module. Do not remove leads by pulling on the wires as damage to the leads may occur.

6. Install replacement module in reverse order of removal. During installation, make sure a liberal amount of special silicone grease is applied to the metal mounting surface of module to insure proper cooling.

7. Check operation of new module by starting and running vehicle.

Pole Piece and Plate Assembly

Replacement (Figs. 6D-7i - 6D-9i)

The pole piece and plate assembly is serviced by complete replacement only. The three screws securing stationary pole piece and permanent magnet should not be disturbed except under extreme conditions since the pole piece is adjusted by the factory to critical dimensions. During replacement, make sure the replacement pole piece and plate assembly is the correct specified part. One quick method of assuring a correct part is to observe the connector or retainer (bow) that holds the white and green electrical leads together is color coded yellow. The correct pole piece and plate assembly for all 6 and 8 cylinder engines is color coded yellow.

1. Remove distributor as described previously in this section.

2. Support distributor gear on a block of wood or other suitable object (Fig. 6D-7i) and drive roll pin from drive gear. Make sure distributor is supported in such a way that no damage will occur to distributor shaft while removing roll pin.

3. On 8 cylinder distributors, remove drive gear, shim and tanged washer from distributor shaft.

4. On 6 cylinder distributors, remove drive gear from distributor shaft.

5. Remove any burrs that may have been caused by removal of roll pin and remove shaft (with rotor attached) from distributor housing.

6. Use needle nose pliers or similar tool to remove pole piece and plate assembly electrical leads from W (white) and G (Green) terminals of module. Do not remove leads by pulling on the wires as damage to the leads may occur.

7. Remove lock ring from top of pole piece and plate assembly (Fig. 6D-8i) and remove pole piece and plate assembly from distributor housing.

8. Lubricate felt wick with a few drops of motor oil and install replacement pole piece and plate assembly over upper bushing and vacuum advance unit. Make sure the connector or retainer (bow) that holds the white and green electrical leads together is color coded yellow.

9. Install lock ring (Fig. 6D-8i) and then connect green electrical lead of pole piece and plate assembly to G terminal of module. Then connect white lead of pole piece and plate assembly to W terminal of module.

10. Place distributor shaft (with rotor attached) in distributor housing.

11. On 8 cylinder distributors, install tanged washer, shim and drive gear on distributor shaft.

12. On 6 cylinder distributors, install drive gear on distributor shaft.

13. Align holes of drive gear with hole of distributor shaft so that locating mark on drive gear is in line with tip of rotor. Support distributor shaft on a wooden block or other suitable object and install roll pin. Make sure distributor is supported in such a way that no damage will occur to distributor shaft while installing roll pin.

14. Check to make sure shaft is not binding by spinning shaft a few times by hand.

15. Install distributor as described previously in this section.

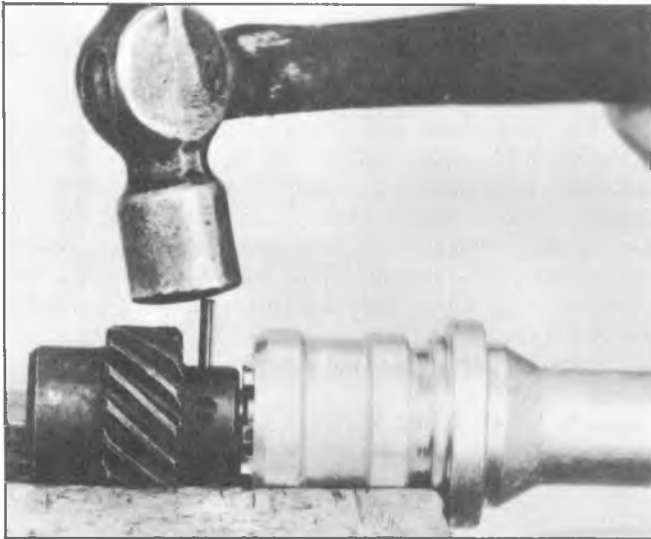


Fig. 6D-9i--Roll Pin Installation

Ignition Coil-8 Cylinder

Removal (Fig. 6D-10i)

1. Disconnect battery wire and harness connector from distributor cap.
2. Remove three screws securing coil cover to distributor cap.
3. Remove four screws securing ignition coil to distributor cap.
4. Remove ground wire from coil.
5. Push coil leads from under side of connectors and remove coil from distributor cap.

Installation (Fig. 6D-10i)

1. Position coil into distributor cap with terminals over connector at side of cap.
2. Push coil lead wires into connector on side of cap as follows: black (ground) in center; brown next to vacuum advance unit; pink opposite vacuum advance unit.
3. Secure ignition coil with four screws. Place ground wire under coil mounting screw.
4. Install coil cover onto distributor cap and secure with three screws.

Ignition Coil-6 Cylinder

Removal (Fig. 6D-5i)

1. Disconnect ignition switch to coil lead at coil.
2. Disconnect coil to distributor leads at coil.
3. Remove 4 screws securing coil to side of engine and remove coil.

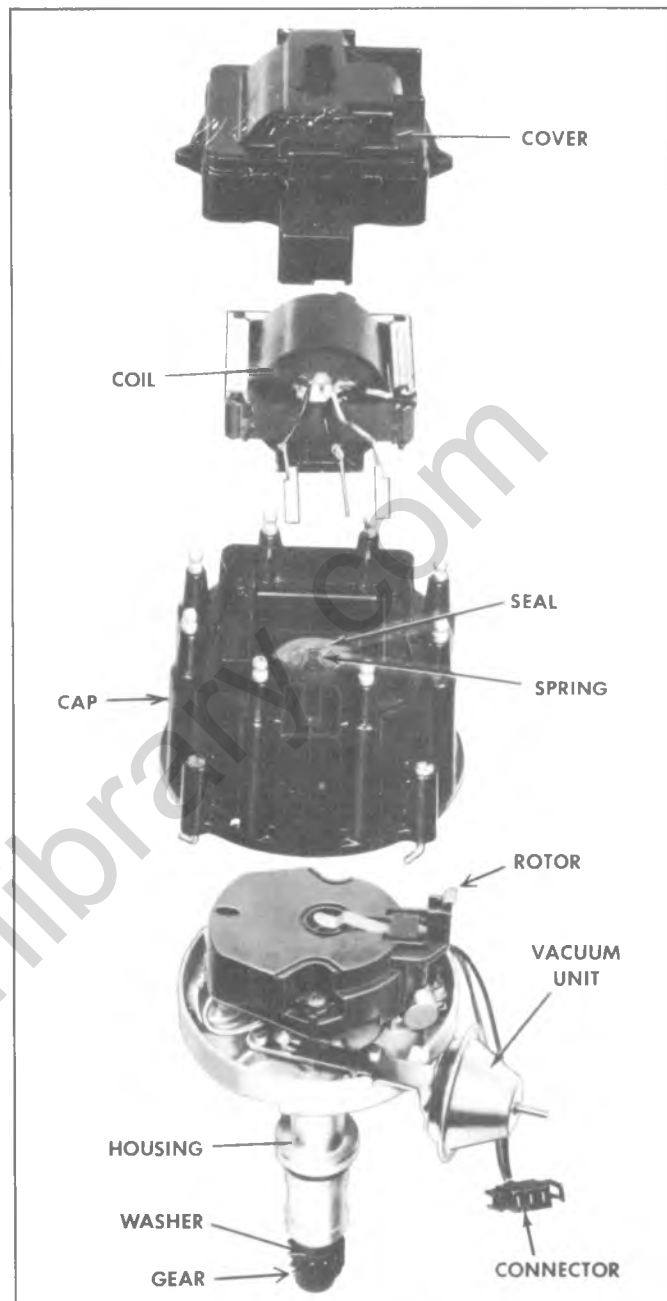


Fig. 6D-10i--Exploded View of 8 Cylinder HEI Distributor

Installation (Fig. 6D-5i)

1. Install coil to side of engine with 4 screws.
2. Connect coil to distributor leads at coil.
3. Connect ignition switch to coil lead at coil.

SPARK PLUGS

GENERAL DESCRIPTION

The spark plug (Fig. 6D-11i) consists of a metal shell in which is fastened a porcelain insulator and an electrode extending through the center of the insulator. The metal shell has a short electrode attached to one side and bent in toward the center electrode. There are threads on the metal shell that allow it to be screwed into a tapped hole in the cylinder head. The two electrodes are of special heavy wire, and there is a specified gap between them. The electric spark jumps this gap to ignite the air-fuel mixture in the combustion chamber, passing from the center, or insulated, electrode. The seals between the metal base, porcelain, and center electrode, as well as the porcelain itself, must be able to withstand the high pressure and temperature created in the combustion chamber during the power stroke.

Some spark plugs have been supplied with a built-in resistor which forms part of the center electrode. The purpose of this resistor is to reduce radio and television interference from the ignition system as well as to reduce spark-plug-electrode erosion caused by excessively long sparking. We have been talking of the high-voltage surge from the ignition-coil secondary as though it were a single powerful surge that almost instantly caused the spark to jump across the spark

plug gap. Actually, the action is more complex than that. There may be a whole series of preliminary surges before a full-fledged spark forms. At the end of the sparking cycle the spark may be quenched and may reform several times. All this takes place in only a few ten-thousandths of a second. The effect is that the ignition wiring acts like a radio transmitting antenna; the surges of high voltage send out impulses that causes radio and television interference. However, the resistors in the spark plugs tend to concentrate the surges in each sparking cycle, reduce their number, and thus reduce the interference and also the erosive effect on the plug electrodes.

Heat Range System

The "heat range" of a spark plug is determined primarily by the length of the lower insulator. The longer this is, the hotter the plug will operate; the shorter it is, the cooler the plug will operate (Fig. 9-12i).

Spark plugs, to give good performance in a particular engine, must operate within a certain temperature range (neither too hot nor too cool). If the spark plug remains too cool, oil, soot, and carbon compounds will deposit on the insulator causing fouling and missing. If the plug runs too hot, electrodes will wear rapidly, and under extreme conditions, premature ignition (pre-ignition) of the fuel mixture may result.

Frequently, the wrong type of spark plugs, one with an improper heat range for the engine, may have been installed when replacing spark plugs originally fitted by the engine manufacturer and such misapplication may lead to poor performance. The heat range system makes it possible to select the type of spark plug that will operate within the correct temperature range for each specific engine.

Where abnormal operating conditions cause chronic carbon or oil fouling of the plugs, the use of a type one number higher (a "hotter" type) than recommended will generally remedy the trouble; and by the same formula, where chronic pre-ignition or rapid electrode wear is experienced, a type with one number lower (a "cooler" type) will generally



Fig. 6D-11i--Cross-Section of Spark Plug

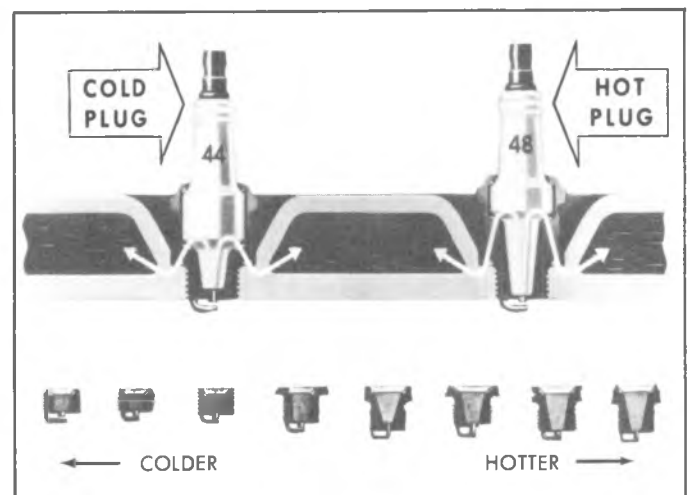


Fig. 6D-12i--Spark Plug Heat Range System

be found satisfactory.

The last digit of the type number indicates the heat range position of the plug in the heat range system. Read the numbers as you would a thermometer--the higher the last digit, the "hotter" the spark plug will operate in the engine; the lower the last digit, the "cooler" the spark plug will operate.

Spark Plug Reach and Threads

Spark plugs are manufactured in a number of thread sizes and "reaches." Reach is the distance from the gasket seat to the end of the shell. Spark Plugs have a type number on the insulator which designates plug thread size as well as the relative position in the heat range system as previously explained.

DIAGNOSIS

Under normal operating conditions, spark plugs wear out due to the destructive action, under intense heat, of sulphur and lead compounds in the fuel and the bombardment of the electric spark on the electrodes.

It is reasonable to expect over 22,000 miles of useful life from a spark plug. However, operating conditions are an

important factor and life expectancy of the spark plug will vary with the type of service in which the engine is used.

The same type of spark plug used in two different engines of the same make and model may frequently show wide variation in appearance. The cause of such differences lies in the condition of the engine, its piston rings, carburetor setting, kind of fuel used, and under what conditions the engine is operated, namely, sustained high speeds or heavy loads; or continual low speed, stop-and-go driving or light loads.

Spark Plugs are frequently blamed for faulty engine operation which they do not cause. Replacement of old spark plugs by new may temporarily improve poor engine performance because of the lessened demand new plugs make on the ignition system. This cannot permanently cure poor engine performance caused by worn rings or cylinders, weak coil, worn contact points, faulty carburetion or other engine ills.

On the following pages are pictures of some commonly encountered appearances and causes of spark plug problems.



Normal Operation



Deposit Fouling "A"



Deposit Fouling "B"



Carbon Fouling

NORMAL OPERATION

Brown to grayish-tan deposits and slight electrode wear indicate correct spark plug heat range and mixed periods of high and low speed driving. **SPARK PLUGS HAVING THIS APPEARANCE MAY BE REINSTALLED. IF MISFIRING PERSISTS, SPARK PLUGS SHOULD BE REPLACED.**

When reinstalling spark plugs, be sure to use new gaskets on spark plugs that utilize engine seat gaskets.

DEPOSIT FOULING—"A"

Red, brown, yellow and white colored coatings which accumulate on the insulator are by-products of combustion and come from the fuel and lubricating oil, both of which today generally contain additives. Most powdery deposits have no adverse effect on spark plug operation; however, they may cause intermittent missing under severe operating conditions, especially at high speeds and heavy load. **SPARK PLUGS HAVING THIS APPEARANCE SHOULD BE REPLACED.**

DEPOSIT FOULING—"B"

Most powdery deposits, as shown in "A", have no adverse effect on the operation of the spark plug as long as they remain in the powdery state. However, under certain conditions of operation, these deposits melt and form a shiny yellow glaze coating on the insulator which, when hot, acts as a good electrical conductor. This allows the current to follow the deposits instead of jumping the gap, thus shorting out the spark plug.

Glazed deposits can be avoided by not applying sudden load, such as wide open throttle acceleration, after sustained periods of low speed and idle operation. **SPARK PLUGS HAVING THIS APPEARANCE SHOULD BE REPLACED.**

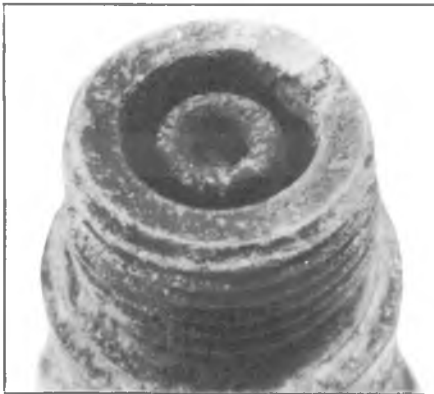
CARBON FOULING

Dry, fluffy black carbon deposits may result from overrich carburetion, excessive hand choking, a faulty automatic choke, or a sticking manifold heat valve. A clogged air cleaner can restrict air flow to the carburetor causing rich mixtures. Poor ignition output (faulty breaker points, weak coil or condenser, worn ignition cables) can reduce voltage and cause misfiring. Fouled spark plugs are the result—not the cause—of this problem. **AFTER THE CAUSE HAS BEEN ELIMINATED, SPARK PLUGS HAVING THIS APPEARANCE SHOULD BE REPLACED.**

Excessive idling, slow speeds under light load also can keep spark plug temperatures so low that normal combustion deposits are not burned off. In such a case a hotter type spark plug will better resist carbon deposits.



Detonation

Insufficient
Installation Torque

Pre-ignition



Improper Installation

DETONATION

Overadvanced ignition timing, or the use of low octane fuel will result in detonation commonly referred to as engine knock.

This causes severe shock inside the combustion chamber resulting in damage to the adjacent parts which include spark plugs. A common result of detonation is to have the sidewire of a spark plug torn off.

INSTALL A NEW PLUG OF THE RECOMMENDED HEAT RANGE AFTER PROBLEM HAS BEEN CORRECTED.

INSUFFICIENT INSTALLATION TORQUE

Failure to install a spark plug with sufficient torque results in poor contact between the spark plug and the engine seat. The lack of proper heat transfer, resulting from poor seat contact, causes excessive overheating of the spark plug and, in many cases, severe damage as shown.

A NEW SPARK PLUG OF THE RECOMMENDED HEAT RANGE SHOULD BE INSTALLED IN ACCORDANCE WITH AC INSTALLATION INSTRUCTIONS.

PRE-IGNITION

Pre-ignition, causing burned or blistered insulator tip and badly eroded electrodes, indicates excessive overheating. Cooling system stoppages or sticking valves can also result in pre-ignition. Lean fuel-air mixtures are an additional cause.

INSTALL A NEW PLUG OF THE RECOMMENDED HEAT RANGE AFTER PROBLEM HAS BEEN CORRECTED.

Sustained high speed, heavy load service can produce high temperatures which will cause pre-ignition and, in this instance a colder spark plug should be used.

IMPROPER INSTALLATION

Dirty threads in an engine head will result in the plug seizing before it is actually seated. This results in poor heat transfer and causes the spark plug to overheat.

To insure proper seating of a new spark plug in the head, dirty cylinder head threads should be cleaned with a greased thread chaser of the proper size.

ELIMINATE THE CAUSE AND INSTALL A NEW PLUG OF THE RECOMMENDED HEAT RANGE.



Oil Fouling



Heat Shock Failure

OIL FOULING

Wet, oily deposits with a minor degree of electrode wear may be caused by oil pumping past worn rings. "Break-in" of a new or recently overhauled engine before rings are fully seated may also result in this condition. Other possibilities of introduction of oil into the combustion chamber are a porous vacuum booster pump diaphragm or excessive valve stem guide clearances.

A HOTTER TYPE SPARK PLUG WILL REDUCE OIL DEPOSITS, but too hot a spark plug can cause pre-ignition and, consequently, severe engine damage. An engine overhaul may be necessary in severe cases to obtain satisfactory service.

HEAT SHOCK FAILURE

Heat shock is a common cause of broken and cracked insulator tips. Over-advanced ignition timing and low grade fuel are usually responsible for heat shock failures. Rapid increase in tip temperature under severe operating conditions causes the heat shock and fracture results.

Another common cause of chipped or broken insulator tips is carelessness in regapping by either bending the centerwire to adjust the gap, or allowing the gapping tool to exert pressure against the tip of the center electrode or insulator when bending the side electrode to adjust the gap.

ELIMINATE THE CAUSE AND INSTALL A NEW PLUG OF THE RECOMMENDED HEAT RANGE.

ON-VEHICLE SERVICE

COMPONENT PART REPLACEMENT

Spark Plug

Removal

1. To disconnect wires, pull only on the boot and gently twist boot while pulling away. Pulling on the wire might cause separation of the core of the wire. Remove spark plugs and gaskets using a 5/8" deep socket on the 5/8" hex tapered plugs. Use care in this operation to avoid cracking spark plug insulators.

2. Carefully inspect the insulator and electrodes of all spark plugs. Replace any spark plug which has a cracked or broken insulator. If the insulator is worn away around the center electrode, or the electrodes are burned or worn, the spark plug is worn out and should be discarded.

Cleaning

Spark plugs which have carbon or oxide deposits should be cleaned in a blast type spark plug cleaner. Scraping with a pointed tool will not properly remove the deposits and may damage the insulator. If spark plugs have a wet or oily deposit dip them in a degreasing solvent and then dry thoroughly with dry compressed air. Oily plugs will cause the cleaning compound to pack in the shell. Carefully follow the

instructions of the manufacturer of the cleaner being used, cleaning each plug until the interior of shell and the entire insulator are clean; however, avoid excessive blasting.

Examine interior of plug in good light. Remove any cleaning compound with compressed air. If traces of carbon oxide remain in plug, finish the cleaning with a light blasting operation. Clean firing surfaces of center and side electrodes with several strokes of a fine file.

When spark plugs have been thoroughly cleaned, carefully inspect for cracks or other defects which may not have been visible before cleaning.

Adjusting Spark Plug Gap (Fig. 6D-13i)

Use round wire feeler gages to check the gap between spark plug electrodes of used plugs. Flat feeler gages will not give a correct measurement if the electrodes are worn. Adjust gap by bending the side electrodes only. Adjust gaps to specifications. Setting spark plug gap to other than specification to effect changes in engine performance is not recommended.



Fig. 6D-13i--Checking Spark Plug Gap

IGNITION SWITCH GENERAL DESCRIPTION

The electrical switching portion of the assembly is separate from the key and lock cylinder. However, both are synchronized and work in conjunction with each other through the action of the actuator rod assembly. For a complete explanation of the key and lock cylinder, and the actuator rod assembly, refer to the Steering section of this manual.

The ignition switch is key operated through the actuator rod assembly to close the ignition primary circuit and to energize the starting motor solenoid for cranking. The ignition switch used on all cars have five positions: OFF, LOCK, ACCESSORY, RUN and START. OFF is the center position of the key-lock cylinder, and LOCK is the next position to the left. ACCESSORY is located one more detent to the left of LOCK. Turning the key to the right of the OFF position until spring pressure is felt will put the ignition switch in the RUN position, and when turned fully to the right against spring pressure, the switch will be in the START position.

In the RUN position, the ignition primary circuit is activated through a resistance wire. The ignition resistor wire is used in the ignition running circuit to reduce the voltage to the ignition coil. The resistor wire is bypassed when the engine is being started. The purpose of this is to compensate for the drop in voltage which occurs as the result of the heavy drain on the battery during starting, and to provide a hotter spark for starting.

All ignition switches have five terminals which are connected in different combinations for each of the three operating positions. A brass plate, inside the switch, has three contacts which connect these terminals. Figure 12i shows the positions of the contacts in all positions as viewed from the key side of the switch. There is also a ground pin in the switch which contacts the "ground" terminal when the ignition switch is in the START position. This pin contacts the IGN. terminal when in the OFF position.

Installation of Spark Plugs

When installing spark plugs, make sure that all surfaces on plugs and in cylinder heads are clean. When installing the 5/8" hex tapered seat spark plugs, tighten to 15 lb. ft., using a 5/8" deep socket, an extension and a torque wrench.

CAUTION: *If tapered seat spark plugs are over-tightened, there is a possibility they can crack and be more difficult to remove at the next tune-up.*

Ignition Start and Run Circuit

The ignition switch is fed from the battery to the BAT. terminal of the switch. When the ignition switch is in the OFF position, no current flows through the switch. When the ignition switch is turned to the ACC. position, the BAT. terminal is connected to the ACC. terminal. This permits operation of accessories when the engine is not running.

When the ignition switch is turned to the START position, the BAT. terminal is connected to the SOL. and IGN. terminals. When the clutch or automatic transmission neutral start switches are closed, current flows to the starter solenoid. This energizes the solenoid windings. The solenoid has two sets of windings: a "pull-in" winding and a "hold-in" winding. Both windings are used to create the magnetic field to actuate the the solenoid plunger and move the starter pinion into engagement with the flywheel. As the solenoid plunger reaches the end of its travel, it closes a switch which connects battery voltage to the starter motor. With battery voltage applied to both terminals of the "pull-in" windings, the "pull-in" winding is no longer energized, so that only the "hold-in" winding keeps the starter solenoid engaged.

NOTE: The instrument panel warning lights are fed from the ignition terminal of the ignition switch and have battery voltage applied to them when the ignition switch is in the START and RUN position. These circuits are explained in the Chassis Electrical Section.

When the ignition switch is released from the START to the RUN position, the IGN. terminal is still connected to the BAT. terminal, but the solenoid is no longer energized and so the feed for the coil from the IGN. terminal on the ignition switch, through the ignition resistor wire and to the coil, dropping the battery voltage at the coil to approximately nine volts. With the ignition switch in the RUN position, the BAT. terminal is connected to the IGN. terminal and the ACC. terminal. This permits operation of all accessories and the ignition system.

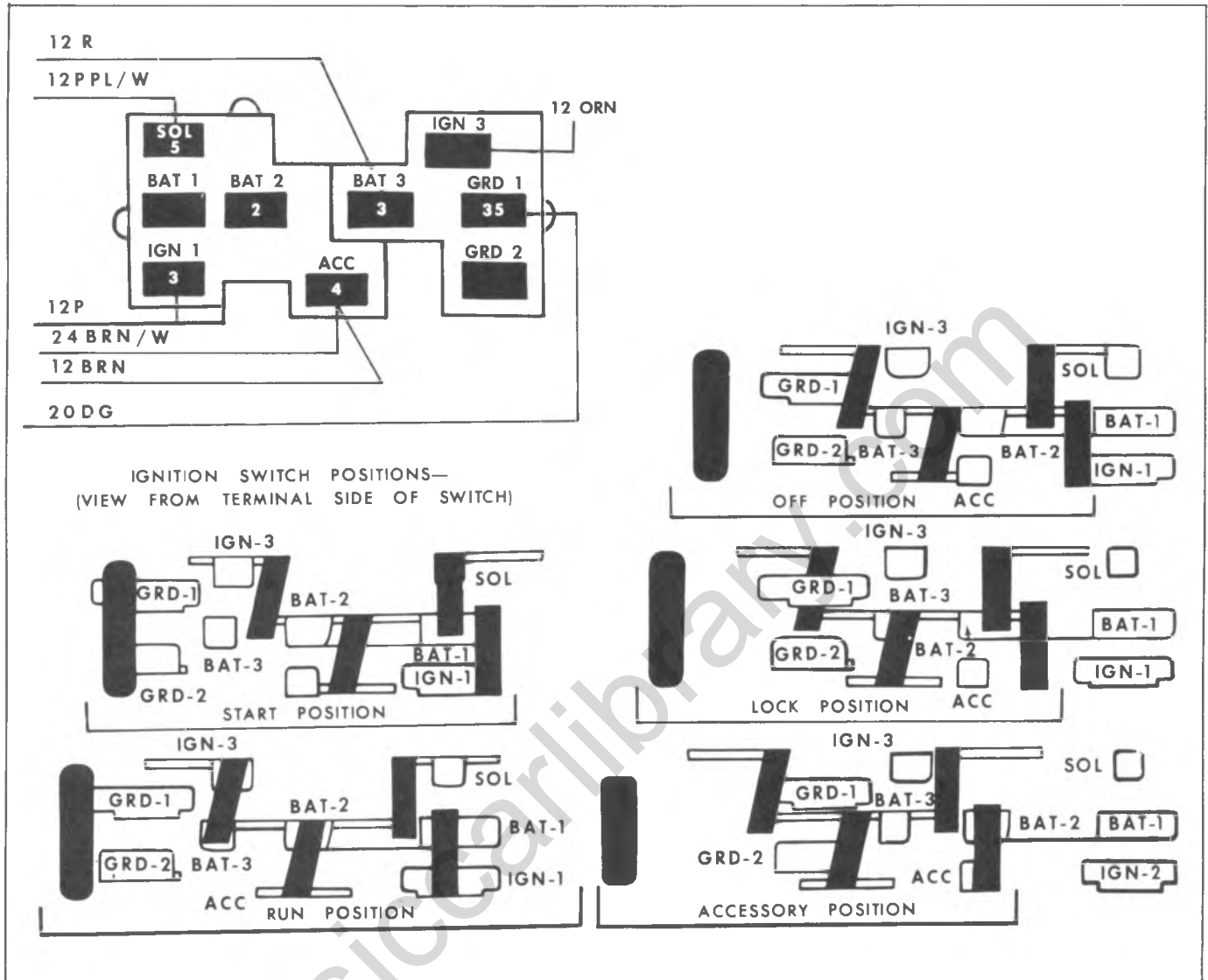


Fig. 6D-14i—Ignition Switch Circuit

STARTER SYSTEM GENERAL DESCRIPTION

The function of the starting system, composed of the starting motor, solenoid and battery, is to crank the engine. The battery supplies the electrical energy, the solenoid completes the circuit to the starting motor, and the motor then does the actual work of cranking the engine.

The starting motor (fig. 6D-1s) consists primarily of the drive mechanism, frame, armature, brushes, and field windings. The starting motor is a pad mounted 12-volt extruded frame type, having four pole shoes and four fields, connected with the armature. The aluminum drive end housing is extended to enclose the entire shift lever and plunger mechanism, protecting them from dirt, splash, and icing. The drive end frame also includes a grease reservoir to provide improved lubrication of the drive end bearing. The flange mounted solenoid switch operates the overrunning clutch drive by means of a linkage to the shaft lever.

The starting system is made up of the cranking motor with its drive mechanism, the starter motor solenoid and the battery. These units are connected together and work as a team to crank the engine. The simplified diagram (Fig. 6D-2s) shows the electrical components in a typical starting system. Although modern day applications use more circuitry and controls than shown in Figure 6D-1s, the function of the components is always the same--to convert electrical energy from the battery into mechanical energy at the starter motor to crank the engine.

STARTER MOTOR

To understand the operating principles of a starter motor, think of a straight wire conductor located in the magnetic field of a horseshoe-shaped magnet. Current is flowing through the wire as shown in Figure 6D-3s. There will be two separate magnetic fields--the one produced by the

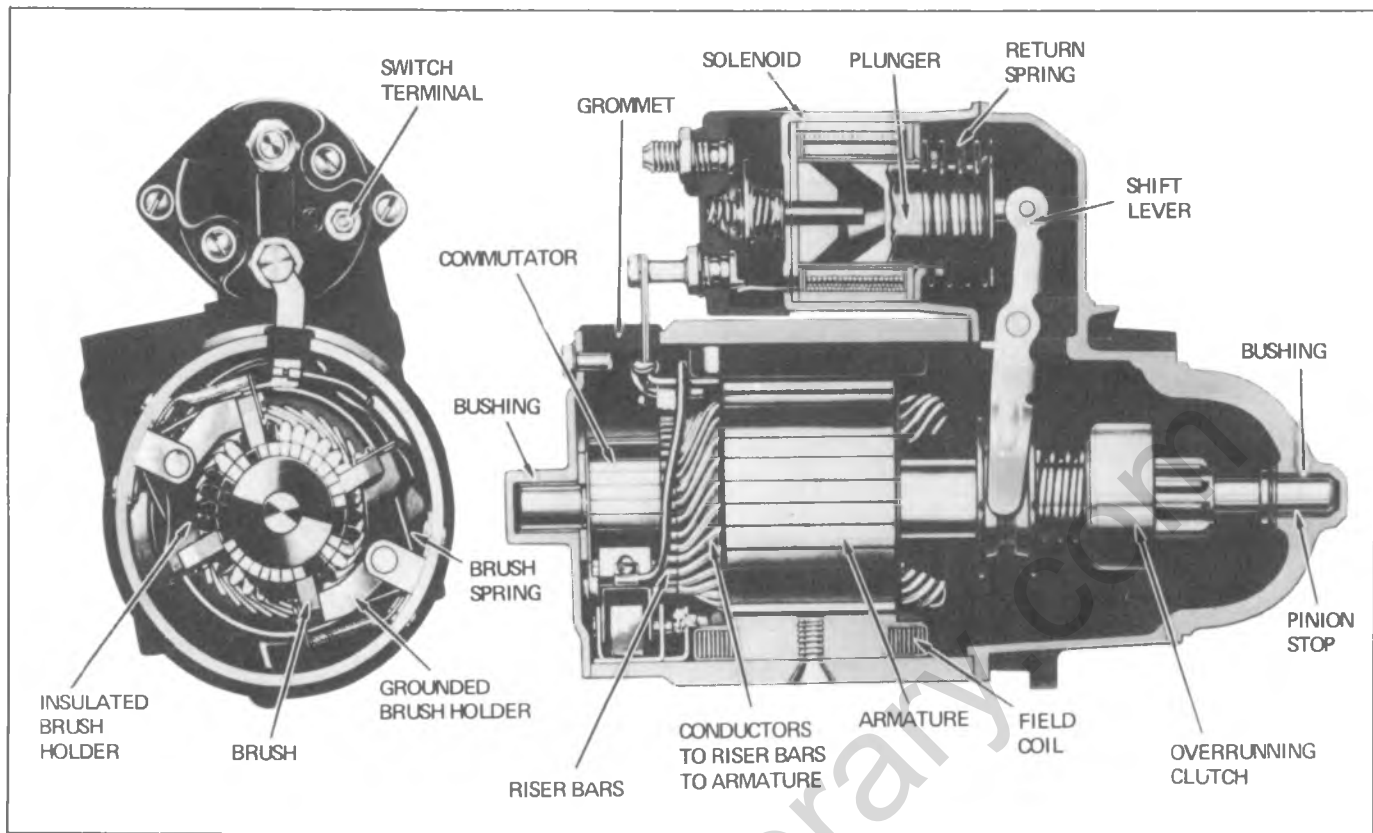


Fig. 6D-1s--Starting Motor Cross Section (Typical)

horseshoe magnet and the one produced by the current flow through the conductor.

Since magnetic lines always leave a North pole and enter a South pole, the direction of the magnetic lines between the two poles of the horseshoe magnet will be upward as shown. The current-carrying conductor will produce a magnet field shown as circles around the wire. The net result is more magnetic lines on the left hand side of the wire than on the

right (Fig. 6D-4s).

With a strong field on one side of the conductor and a weak field on the other side, the conductor will move from the strong to the weak field, or from left to right. This magnetic force makes the cranking motor operate.

A basic motor is shown in Figure 6D-5s. A loop of wire is placed between two iron pole pieces and is connected to two separate commutator bars. Riding on the commutator

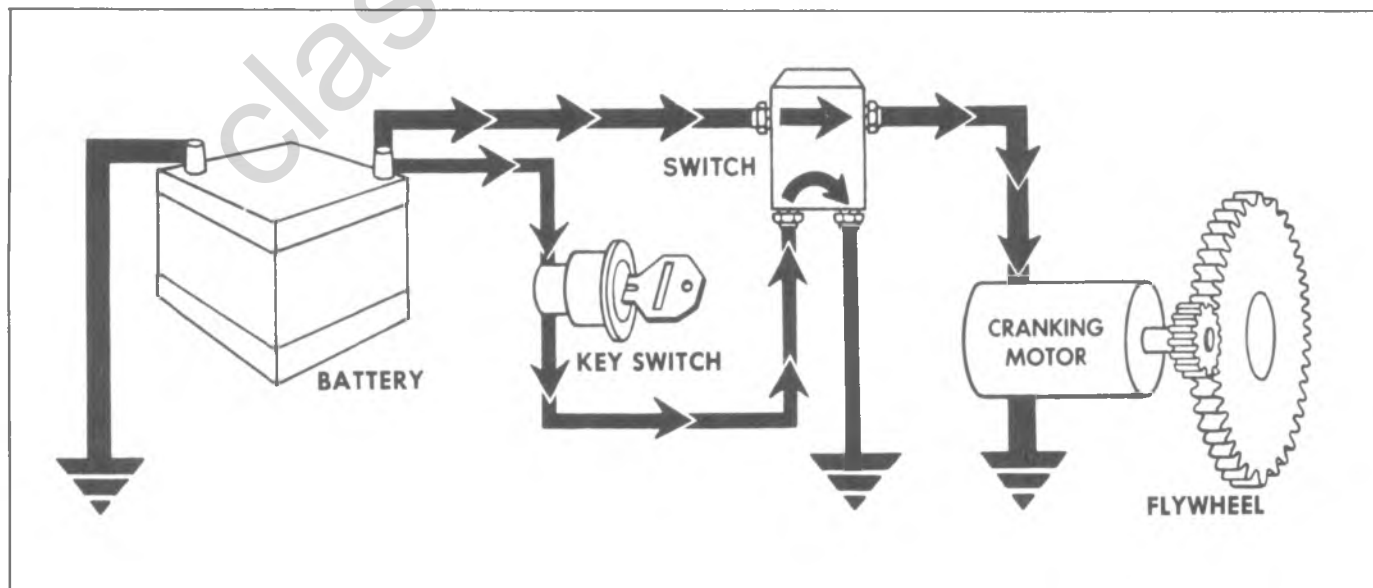


Fig. 6D-2s--Typical Cranking System

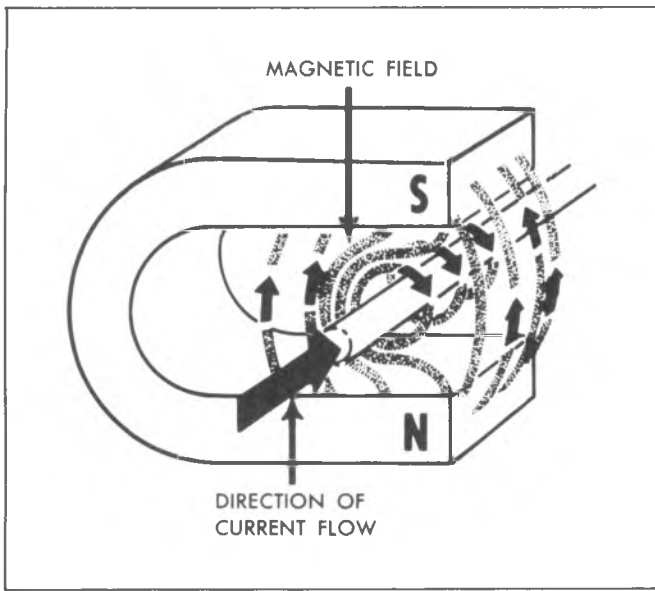


Fig. 6D-3s--Magnetic Field of a Horseshoe Magnet

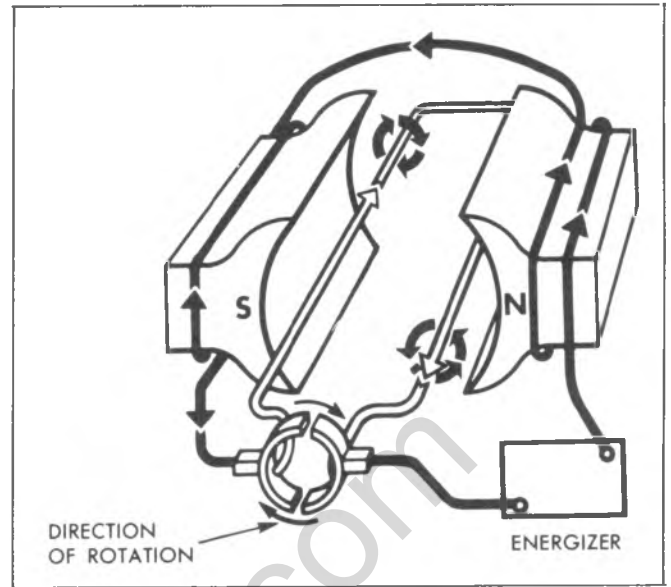


Fig. 6D-5s--Basic Motor

bars are two brushes, which are connected to the battery and to the windings located over the pole pieces.

Current flow can be traced from the battery through the pole piece windings, to a brush and commutator bar, through the loop of wire to the other commutator bar and brush, and then back to the battery. The magnetic fields create a turning or rotational effect in the same clockwise direction as shown in Figure 6D-6s.

The basic motor we have used in our illustrations has no practical value. It would produce very little torque to crank an engine. It has served, however, to show the fundamental principles that operate a starter motor.

In the simplest terms, the armature is rotated by a concentration of magnetic lines on one side of the armature conductor and a lack of magnetic lines on the other side of the conductor.

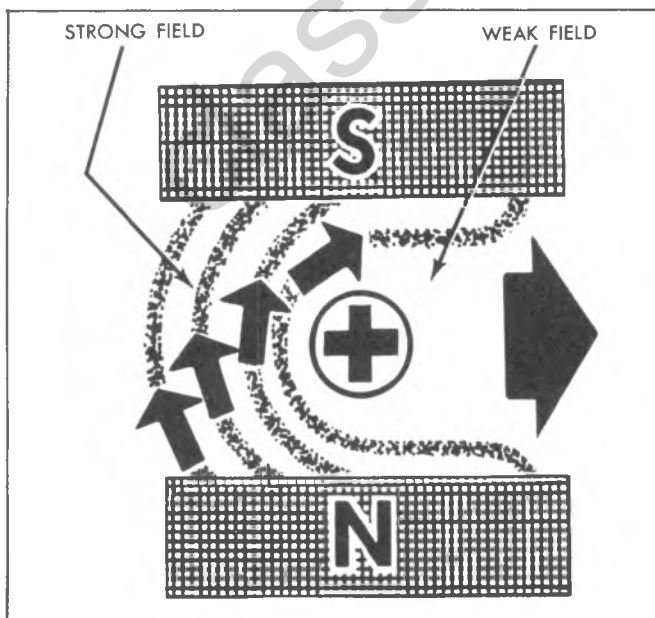


Fig. 6D-4s--Magnetic Force

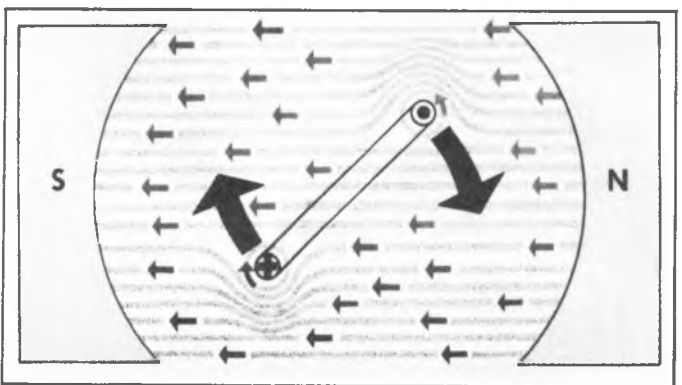


Fig. 6D-6s--Magnetic Field Rotational Effect

Construction

A cross-sectional view of a typical starter motor with a solenoid is shown in figure 6D-1s.

The starting motor assembly is made up of field coils placed over pole pieces which are attached to the inside of a heavy iron frame, an armature, an overrunning clutch-type drive mechanism, and a solenoid.

The iron frame and pole shoes not only provide a place for the field coils, but also provide a path for the magnetic lines produced by the field coil windings.

Armature

The armature assembly (Fig. 6D-7s), consists of a stack of iron laminations placed over a steel shaft, a commutator assembly and the armature winding. The windings are heavy copper ribbon that are assembled into slots in the iron laminations. The winding ends are soldered or welded to the commutator bars which are electrically insulated from each other and from the iron shaft.

The armature is supported by bushings in the end frames. Brushes are supported on the field frame and ride on the commutator bars.

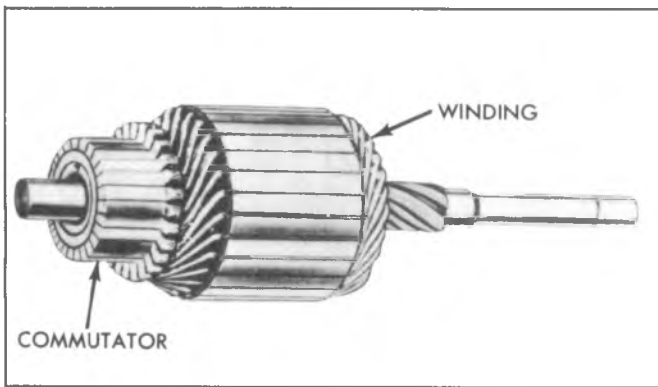


Fig. 6D-7s--Armature Assembly

Drive Mechanism

The starting motor drive mechanism (Fig. 6D-8s) is a roll-type overrunning clutch that is assembled onto the armature shaft. Through this drive component power is transmitted from the armature to the engine during the starting cycle.

The overrunning clutch drive contains a pinion which is made to move along the shaft by means of a shift lever to engage the engine ring gear for cranking. A gear reduction is provided between the pinion and ring gear to meet the cranking requirements of the engine. With this gear reduction, the motor operates to crank the engine at speeds required for starting.

The overrunning clutch drive has a shell and sleeve assembly which is splined internally to match the spiral splines on the armature shaft. The pinion is located inside the shell along with spring-loaded rollers that are wedged against the pinion and a taper inside the shell. The springs may be either a helical or accordion type. Four rolls are used. A collar and spring, located over the sleeve, are the other major clutch components.

When the shift lever is operated by the solenoid, it moves the collar endwise along the shaft. The spring pushes the pinion into mesh with the ring gear. If a tooth abutment occurs, the spring compresses until the switch is closed, at which time the armature rotates and the tooth abutment is cleared. The compressed spring then pushes the pinion into mesh and cranking begins.

Torque is transmitted from the shell to the pinion by the

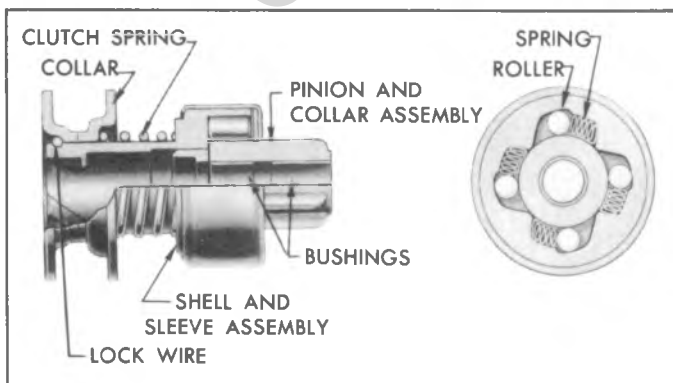


Fig. 6D-8s--Overrunning Clutch Assembly

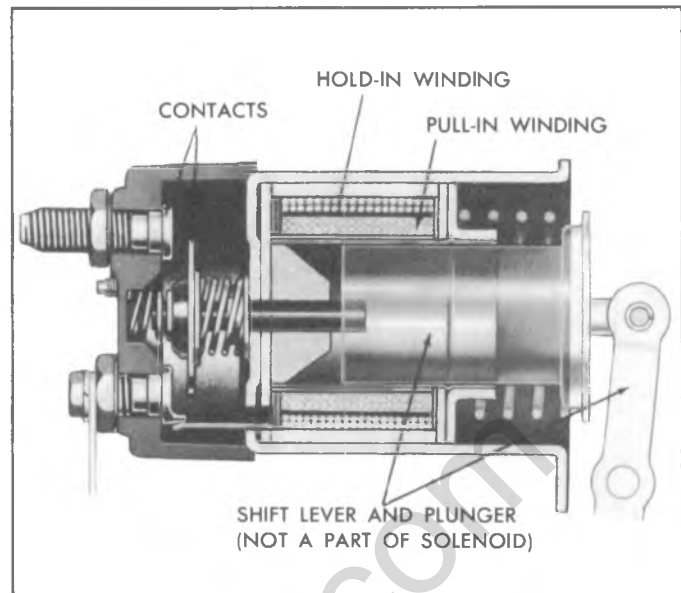


Fig. 6D-9s--Solenoid Cross Section

rolls which are wedged tightly between the pinion and taper cut into the shell.

When the engine starts, the ring gear drives the pinion faster than the armature and the rolls move away from the taper, allowing the pinion to overrun the shell. The start switch should be opened immediately when the engine starts to avoid prolonged overrun. When the shift lever is moved back by the return spring, the pinion moves out of mesh and the cranking cycle is completed.

SOLENOID

A sectional view of a typical solenoid is shown in Figure 6D-9s. It performs two functions in the starting system. First, it is used to provide a circuit of short length and low resistance between the battery and motor. Since the motor may draw several hundred amperes during operation, heavy cables of short length are needed to reduce the voltage drop in the circuit.

If a solenoid switch were not used and the high motor currents were carried directly through the start switch, cables of excessive size would be required to limit the voltage drop to an acceptable value.

Since the start switch is usually some distance from the battery and solenoid switch, the long leads connected to the switch can be of reasonable size since they conduct only the small current drawn by the solenoid switch winding (Fig. 6D-10s).

Second, when the start switch is closed, the solenoid moves the pinion into mesh, and the cranking cycle begins. When the start switch is opened, the cranking cycle ends. The neutral safety switch in this type of circuit is closed only when the transmission shift lever is in the proper position, thereby preventing cranking of the engine with the transmission in gear.

The solenoid switch consists basically of two windings mounted around a hollow cylinder containing a moveable core or plunger (Fig. 6D-9s). A shift lever is connected to the plunger. When the push rod and contact disc is pushed into firm contact with the battery and motor terminals of the solenoid, with the motor windings connected directly to the battery, cranking takes place.

The two windings in the solenoid are called the hold-in winding and the pull-in winding (Fig. 6D-11s).

The hold-in winding contains many turns of fine wire and the pull-in winding the same number of turns of larger wire. When the start switch is closed, current flows from the battery to the solenoid (S) terminals, through the hold-in winding to ground, and then back to the battery. Current also flows through the solenoid (M) terminal and then through the motor windings to the ground.

The magnetism created by each winding adds together to form a strong magnetic field that attracts the plunger into the core. Plunger movement shifts the pinion into mesh with the ring gear and also moves the contact disc to close the circuit between the solenoid battery (B) and Motor (M) terminals. With the motor windings connected directly to the battery through the contact disc, cranking takes place.

The pull-in winding operates to assist the hold-in winding in pulling the plunger into the core. Once the plunger movement has been completed, much less magnetism is needed to hold the plunger in the cranking position. With the contact disc contacting the battery and motor terminals of the solenoid, the pull-in winding is shorted and no current flows through it. This design feature reduces current draw on the battery and also reduces the amount of heat created in the solenoid.

When the start switch is opened, current flows for a very brief instant through the contact disc to the solenoid motor (M) terminal, through the pull-in winding in a reverse direction to the solenoid (S) terminal and then through the hold-in winding in a normal direction back to the battery. The magnetisms created by each winding oppose and cancel out each other and the return spring moves the entire shifting mechanism to the at-rest position, to complete the cranking cycle.

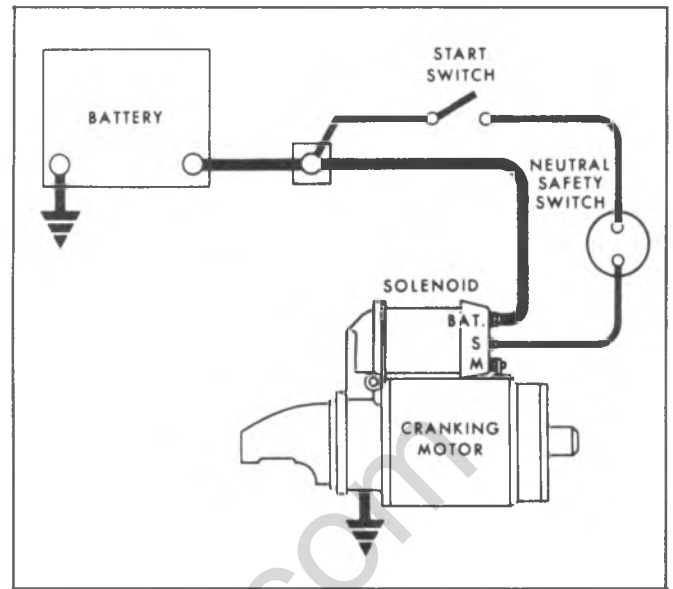


Fig. 6D-10s--Start Switch Circuit (Typical)

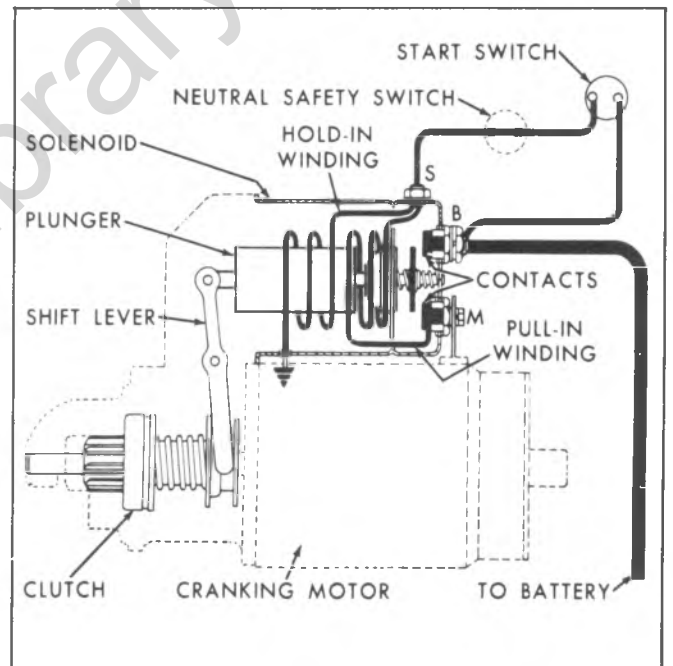


Fig. 6D-11s--Solenoid Windings

DIAGNOSIS

NO CRANKING ACTION

1. Make sure that control lever is neutral (N) or park (P) position or that clutch pedal is depressed on manual transmission.

2. Make quick check of battery and cables. If battery is low, the solenoid usually will produce a clattering noise, because a nearly discharged battery will not sustain the voltage required to hold solenoid plunger in after solenoid switch as been closed.

3. If starter motor spins and drive pinion engages ring gear but does not drive it, overrunning clutch is slipping. Remove motor to replace drive assembly.

4. If starter motor does not operate, note whether solenoid plunger is pulled into solenoid when solenoid circuit is closed. Ordinarily the plunger makes a loud click when it is pulled in. If plunger is pulled in, solenoid circuit is okay and trouble is in solenoid switch, cranking motor, or cranking motor circuit. The starter motor must be removed for repairs to switch or motor.

5. If plunger does not pull into solenoid when ignition switch is turned to "START", the solenoid circuit is open, or solenoid is at fault.

6. To find reason why plunger does not pull into solenoid, connect jumper between solenoid battery terminal and terminal on solenoid switch to which purple wire is connected. If cranking motor operates, solenoid is okay; trouble is in ignition switch, neutral start switch, or in wires and connections between these units.

7. If starter motor still does not operate, remove motor for inspection and test of solenoid switch.

CRANKING SPEED ABNORMALLY LOW

Abnormally low cranking speed may be caused by low battery or defective cables, defective solenoid switch, defective cranking motor, or an internal condition of engine.

1. Make quick check of battery. If low battery is indicated, test battery. If defective cables are indicated, test cables.

NOTE: Check generator belt tension for cause of low battery.

2. If battery and cables are okay, test cranking motor and solenoid switch.

3. If starter motor and solenoid switch test okay, the trouble is due to an internal condition of engine. This may be due to use of engine oil which is too heavy for prevailing temperatures.

VOLTAGE TEST OF STARTING SYSTEM AND SOLENOID SWITCH

The voltage across the starter motor and switch while cranking the engine gives a good indication of any excessive resistance.

NOTE: Engine must be at normal operating temperature when test is made.

1. Inspect battery and cables to make certain that battery has ample capacity for cranking and ignition.

2. Connect jumper wire to distributor terminal of coil and to ground on engine, so that engine can be cranked without firing.

3. Connect voltmeter positive lead to the motor terminal on solenoid switch; connect voltmeter negative lead to ground (Fig. 6D-12s).

4. Turn ignition switch on, crank engine and take voltmeter reading as quickly as possible. If cranking motor turns engine at normal cranking speed with voltmeter reading

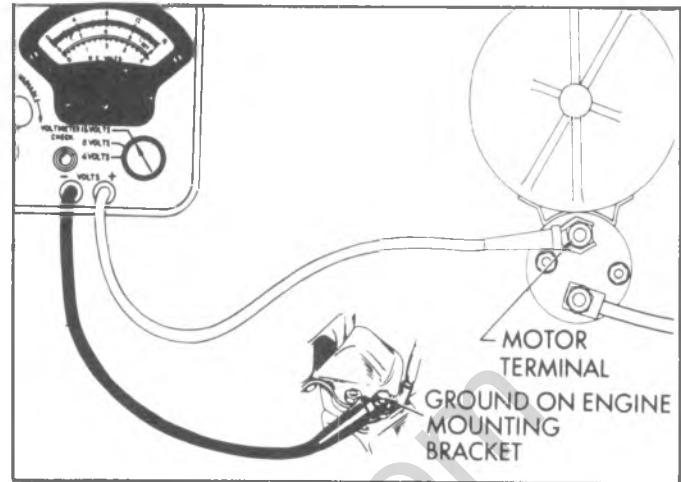


Fig. 6D-12s—Cranking Voltage Test Connections

9 or more volts, the motor and switch are satisfactory. If cranking speed is below normal and voltmeter reading is 9 volts or greater, the cranking motor is defective.

CAUTION: Do not operate starter motor more than 30 seconds at a time without pausing to allow motor to cool for at least two minutes; otherwise, overheating and damage to motor may result.

5. If starter motor turns engine at low rate of speed with voltmeter reading less than 9 volts, test solenoid switch contacts as follows:

6. With voltmeter switch turned to any scale above 12 volts, connect voltmeter negative lead to the motor terminal of solenoid switch, and connect positive lead to battery terminal of switch (Fig. 6D-13s).

7. Turn ignition switch on and crank engine. Immediately turn voltmeter switch to low scale and take reading as quickly as possible, then turn switch back to higher scale and stop engine.

The voltmeter will read not more than 2/10 volt if switch contacts are satisfactory. If voltmeter reads more than 2/10 volt, switch should be repaired or replaced.

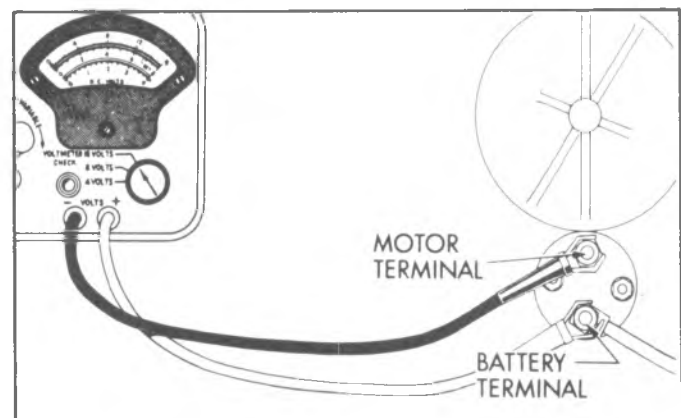


Fig. 6D-13s—Solenoid Switch Contact Test Connections

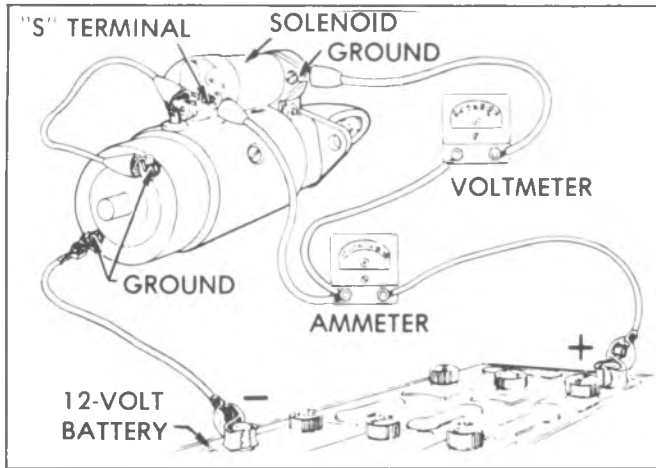


Fig. 6D-14s--Amperage Test of Solenoid

AMPERAGE TEST OF SOLENOID SWITCH WINDINGS

- (1) Current draw of both windings in parallel.
- (2) Current draw of hold-in winding alone.
 1. Remove screw from solenoid motor terminal and bend field leads slightly until clear of terminal. Then ground solenoid motor terminal with a heavy jumper wire (Fig. 6D-14s).
 2. Connect a 12-volt battery, a variable resistance, and an ammeter of 100 amperes capacity in series with solenoid "S" terminal. Connect a heavy jumper wire from solenoid base to ground post of battery.
 3. Connect a voltmeter between base of solenoid and small solenoid "S" terminal.
 4. Slowly adjust resistance until voltmeter reads 10 volts and note ammeter reading. This shows current draw of both windings in parallel. Refer to Delco-Remy bulletin for specifications on the starter being tested.
 5. Remove jumper wire from solenoid motor terminal and re-adjust resistance until voltmeter reads 10 volts, then note ammeter reading. This shows current draw of hold-in winding alone. Refer to Delco-Remy bulletin for specifications.
 6. If solenoid windings do not test within specifications given, solenoid switch assembly should be replaced.

ON-VEHICLE SERVICE

MAINTENANCE AND ADJUSTMENTS

Lubrication

No periodic lubrication of the starting motor or solenoid is required. Since the starting motor and brushes cannot be inspected without disassembling the unit, no service is required on these units between overhaul periods.

COMPONENT PART REPLACEMENT

STARTING MOTOR

Replacement

The following procedure is a general guide for all vehicles and will vary slightly depending on series and model.

1. Disconnect battery ground cable at battery.
2. Raise vehicle to a good working height.
3. Disconnect all wires at solenoid terminals.

NOTE: Reinstall the nuts as each wire is disconnected as thread size is different but may be mixed and stripped.

4. Loosen starter front bracket (nut on V-8 and bolt on L-4) then remove two mount bolts.

NOTE: On V-8 engines incorporating the solenoid heat shield, remove the front bracket upper bolt and detach bracket from starter motor.

5. Remove the front bracket bolt or nut and rotate bracket clear of work area then lower starter from vehicle by lowering front end first -- (hold starter against bell housing and sort of roll end-over-end).

6. Reverse the removal procedure to install. Tighten the mount bolts first, then tighten the brace bolt.

7. Check operation of starter on vehicle.

CHECKING PINION CLEARANCE

Whenever the starter motor is disassembled and reassembled, the pinion clearance should be checked. This is to make sure that proper clearance exists between the pinion and pinion stop retainer when pinion is in cranking position. Lack of clearance would prevent solenoid starter switch from closing properly; too much clearance would cause improper pinion engagement in ring gear.

1. Connect a source of approximately 6 volts (3 battery cells or a 6 volt battery) between the solenoid "S" terminal and ground.

CAUTION: Do not use more than 6 volts or the motor will operate. As a further precaution to prevent motoring, connect a heavy jumper wire from the solenoid motor terminal to ground.

2. After energizing the solenoid, push the pinion away from the stop retainer as far as possible and use feeler gauge to check clearance between pinion and retainer (Fig. 6D-15s).

3. If clearance is not between .010" and .140" it indicates excessive wear of solenoid linkage, shift lever mechanism, or improper assembly of these parts.

NOTE: Pinion clearance cannot be adjusted. If clearance is not correct, motor must be disassembled and checked for the above mentioned defects. Any defective parts must be replaced.

BENCH TEST OF STARTING MOTOR

To obtain full performance data on a cranking motor, or to determine the cause of abnormal operation, the motor should be removed from the engine and be submitted to a no-load test with equipment designed for such tests. A high current carrying variable resistance should be connected into the circuit so that the specified voltage at the starter motor may be obtained, since a small variation in the voltage will produce a marked difference in the current draw.

(a) No-Load Test. Connect the starter motor in series with a 12 volt-battery and an ammeter capable of indicating several hundred amperes. If an RPM indicator is available, set it up to read armature RPM. Check current draw and armature RPM at the specified voltage.

1. Low no-load speed and high current draw may result from:

(a) Tight, dirty, or worn bearings, bent armature shaft or loose field pole screws which would allow the armature to drag.

(b) Shorted armature. Check armature further on growler.

(c) A grounded armature or field.

Check for grounds by raising the grounded brushes and insulating them from the commutator. If the starter motor has shunt field coils which are grounded to the field frame, disconnect these fields from ground. Then check with a test lamp between the insulated terminal and the frame. If lamp lights, raise other brushes from commutator and check fields separately to determine whether it is the fields or armature that is grounded:

2. Failure to operate with high current draw may result from:

(a) A direct ground in the terminal or fields.

(b) Frozen shaft bearings which prevent the armature from turning.

3. Failure to operate with no current draw may result from:

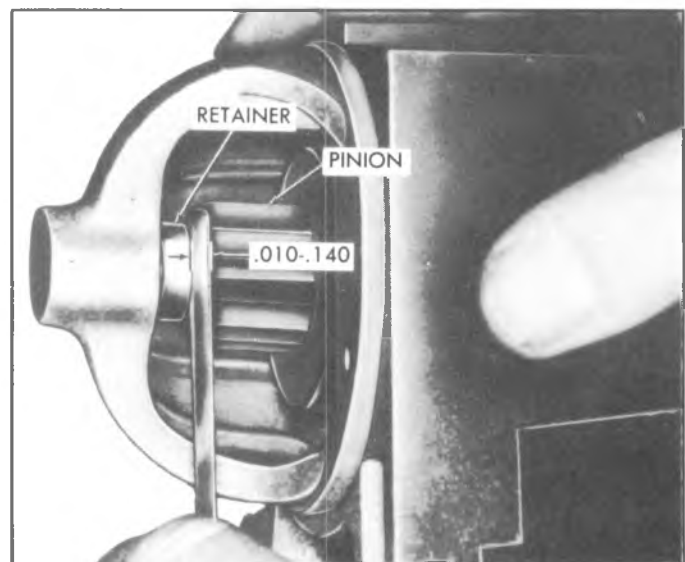


Fig. 6D-15s--Checking Pinion Clearance

(a) Open field circuit. Inspect internal connections and trace circuits with test lamp.

(b) Open armature coils. Inspect the commutator for badly burned bars.

(c) Broken or weakened brush springs, worn brushes, high mica on the commutator, or other causes which would prevent good contact between the brushes and commutator. Any of these conditions will cause burned commutator bars.

4. Low no-load speed with low current draw indicates:

(a) An open field winding. Raise and insulate ungrounded brushes from commutator and check fields with

test lamp.

(b) High internal resistance due to poor connections, defective leads, dirty commutator and causes listed under item 3 (c).

5. High no-load speed with high current draw indicates shorted fields. There is no easy way to detect shorted fields, since the field resistance is already low. If shorted fields are suspected, replace the fields and check for improvement in performance.

UNIT REPAIR

DISASSEMBLY (Figs. 6D-1S and 6D-16S)

1. Disconnect the field coil connector(s) from the motor solenoid terminal.

2. Remove through bolts.

3. Remove commutator end frame, field frame assembly and armature assembly from drive housing.

4. Remove overrunning clutch from armature shaft as follows:

a. Slide two piece thrust collar off end of armature shaft.

b. Slide a standard half-inch pipe coupling or other metal cylinder of suitable size (an old pinion of suitable size can be used if available) onto shaft so end of coupling or cylinder butts against edge of retainer (fig. 6D-17S). Tap end of coupling with hammer, driving retainer towards armature end of snap ring.

c. Remove snap ring from groove in shaft using pliers or other suitable tool. If the snap ring is too badly distorted during removal, it may be necessary to use a new one when reassembling clutch.

d. Slide retainer and clutch from armature shaft.

5. Disassemble brush rigging from field frame.

a. Release "V" spring from slot in brush holder support.

b. Remove support pin.

c. Lift brush holders, brushes and spring upward as a unit.

d. Disconnect leads from each brush.

e. Repeat operation for other set of brushes.

CLEANING AND INSPECTION

With the starting motor completely disassembled except for removal of field coils, the component parts should be cleaned and inspected as described below. Field coils need be removed only where defects in the coils are indicated by the tests described in this section.

1. Clean all starting motor parts, but do not use grease dissolving solvent for cleaning the overrunning clutch, armature, and field coils since such a solvent would dissolve the grease packed in the clutch mechanism and would damage armature and field coil insulation.

2. Test overrunning clutch action. The pinion should turn freely in the overrunning direction and must not slip in the cranking direction. Check pinion teeth to see that they have not been chipped, cracked, or excessively worn. Check the spring for normal tension and drive collar for wear. If necessary, the spring or collar can be replaced by forcing the collar toward the clutch and removing lock ring from end of tube.

3. Check brush holders to see that they are not deformed or bent, but will properly hold brushes against the commutator.

4. Check the condition of the brushes and if pitted or worn to one-half their original length, they should be replaced.

5. Check fit of armature shaft in bushing of drive housing. Shaft should fit snugly in the bushing. If the bushing is worn, it should be replaced. Apply a silicone lubricant to this bushing before reassembly. Avoid excessive lubrication.

6. Check fit of bushing in commutator end frame. If this bushing is damaged or worn excessively, the end frame assembly must be replaced. Apply a silicone lubricant to this bushing before reassembly. Avoid excessive lubrication. Lubricant forced onto the commutator would gum and cause poor commutation with a resulting decrease in cranking motor performance.

CAUTION: *Some starter motor models use a molded armature commutator design and no attempt to undercut the insulation should be made or serious damage may result to the commutator. Undercutting reduces the bonding of the molding material which holds the commutator bars and since the molding material is softer than the copper bars, it is not necessary to undercut the material between the bars of the molded commutator.*

7. Inspect armature commutator. If commutator is rough or out of round, it should be turned down and undercut. Inspect the points where the armature conductors join the commutator bars to make sure that it is a good firm connection. A burned commutator bar is usually evidence of a poor connection. See "Turning the Commutator," described under Testing and Repairs.

TESTING AND REPAIRS

Armature Test For Shorts

Check the armature for short circuit by placing on growler and holding hack saw blade over armature core while armature is rotated (fig. 6D-18S). If saw blade vibrates, armature is shorted. Recheck after cleaning between the commutator bars. If saw blade still vibrates, replace the armature.

Armature Test For Ground

Place one lead on the armature core or shaft and the other on the commutator (fig. 6D-19S). If the lamp lights, the armature is grounded and must be replaced.

Field Coil Test For Open Circuit

Place one lead on the insulated brush and the other to the field connector bar (fig. 6D-20S). If the lamp does not light, the field coils are open and will require replacement.

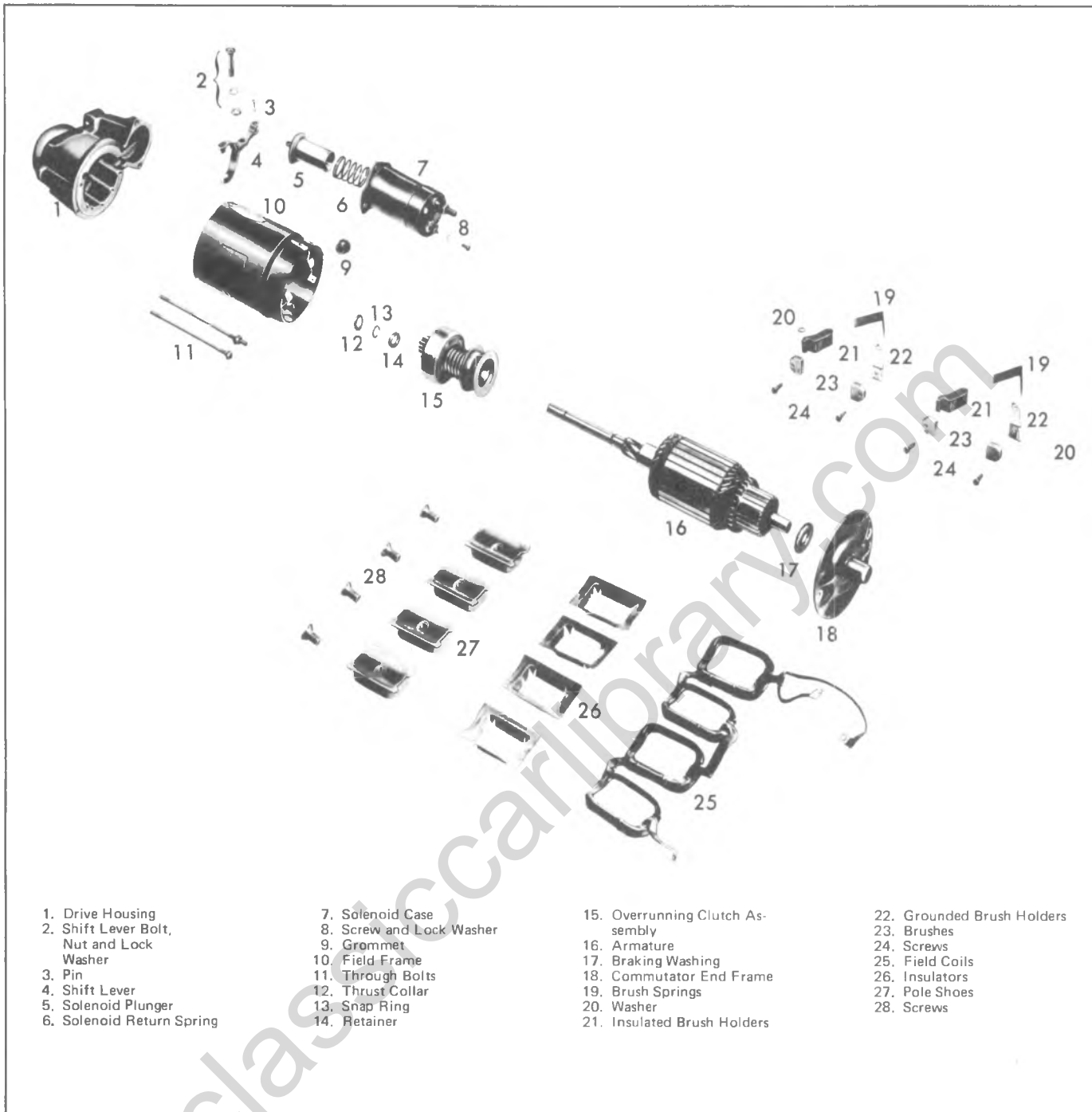


Fig. 6D-16S--Starting Motor Parts Layout

Field Coil Test For Ground

NOTE: Be sure to disconnect the shunt coil before performing this test (when applicable).

Place one lead on the connector bar and the other on the grounded brush (fig. 21S). If the lamp lights, the field coils are grounded.

Field Coil Replacement

Field coils may be removed from the field frame using a pole shoe screwdriver and a pole shoe spreader. The spreader prevents distortion of the field frame. Careful installation of field coils is necessary to prevent shorting or

grounding of the field coils as the pole shoe screws are tightened in place. Formed insulators are used to protect the field leads from grounding to the frame and must be replaced with assembly.

Loose Electrical Connections

When an open soldered connection of the armature to commutator leads is found during inspection, it may be resoldered provided resin flux is used for soldering. Acid flux should never be used on electrical connections.

When inspection shows commutator roughness, it should be cleaned as follows:

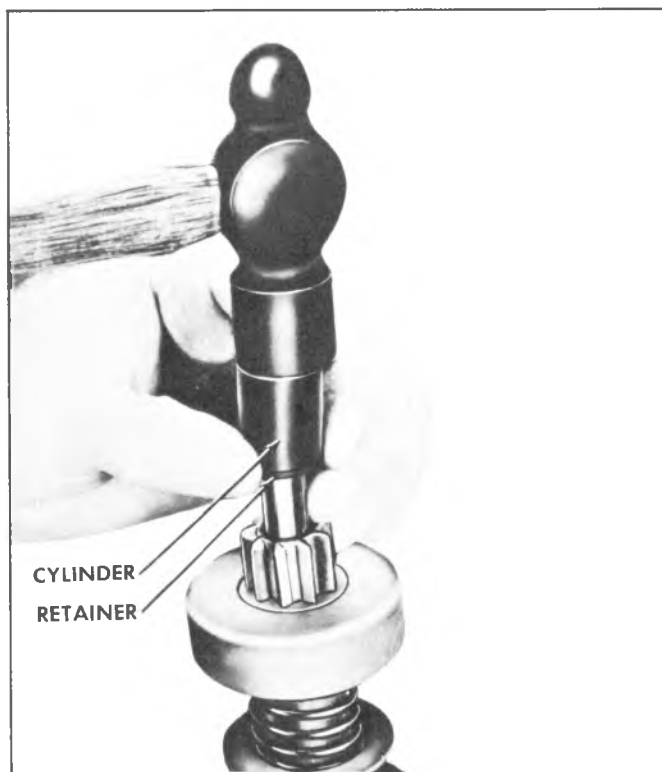


Fig. 6D-17S--Driving Retainer Off Snap Ring

Turning The Commutator

1. Turn down commutator in a lathe until it is thoroughly cleaned.

CAUTION: Some starter motor models use a molded armature commutator design and no attempt to undercut the insulation should be made or serious damage may result to the commutator. Undercutting reduces the bonding of the molding material which holds the commutator bars and since the molding material is softer than the copper bars, it is not necessary to undercut the material between the bars of the molded commutator.

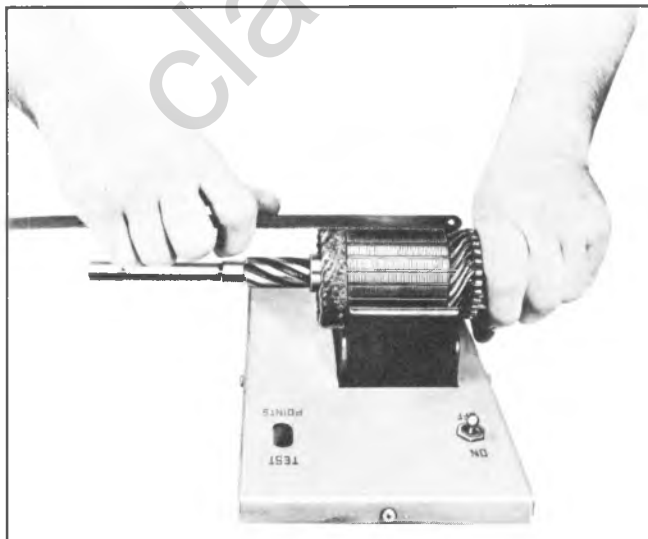


Fig. 6D-18S--Armature Short Circuit Test

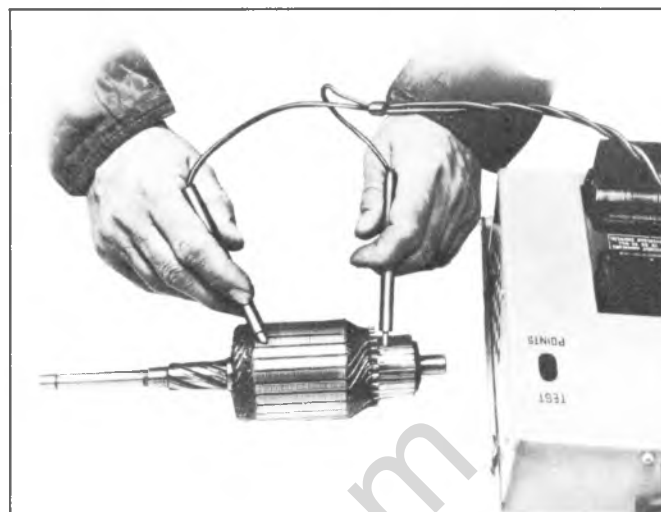


Fig. 6D-19S--Armature Ground Test

2. Undercut insulation between commutator bars $1/32"$. This undercut must be the full width of insulation and flat at the bottom; a triangular groove will not be satisfactory. After undercutting, the slots should be cleaned out carefully to remove any dirt and copper dust.

3. Sand and the commutator lightly with No. 00 sandpaper to remove and slight burrs left from undercutting.

4. Recheck armature on growler for short circuits.

Brush Holder Replacement

If brush holders are damaged, they can be replaced by special service units.

Overrunning Clutch

The overrunning clutch (roll clutch design) used in the various starting motors is (fig. 6D-22S) designed to be serviced as a complete unit.



Fig. 6D-20S--Field Coil Open Circuit Test



Fig. 6D-21S--Field Coil Ground Test

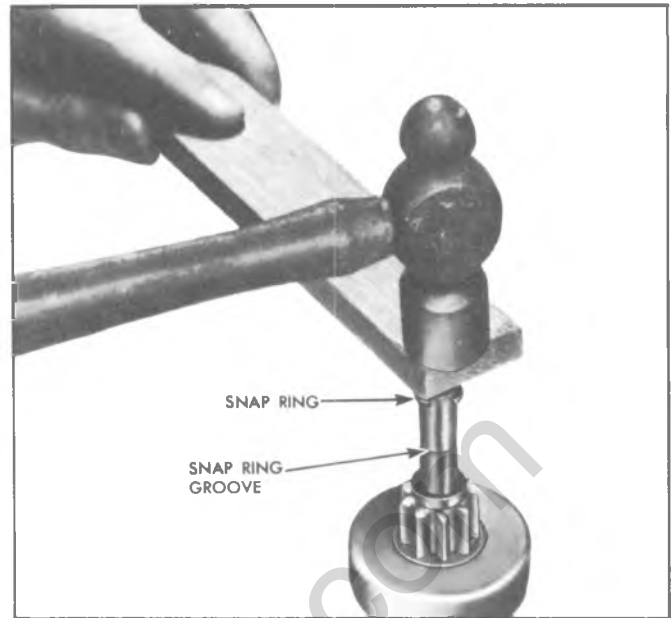


Fig. 6D-23S--Forcing Snap Ring Over Shaft

ASSEMBLY

After all parts have been thoroughly tested and inspected and worn or damaged parts replaced, the starter should be reassembled.

1. Assemble brush rigging to field frame.
 - a. Assemble brushes to brush holders.
 - b. Assemble insulated and grounded brush holder together with the "V" spring and position as unit on the support pin. Push holders and spring to bottom of support and rotate spring to engage the "V" in slot in support.
 - c. Attach ground wire to grounded brush and field lead wire to insulated brush.
 - d. Repeat for other set of brushes.
2. Assemble overrunning clutch assembly to armature shaft.
 - a. Lubricate drive end of armature shaft with silicone lubricant.
 - b. Slide clutch assembly onto armature shaft with pinion outward.
 - c. Slide retainer onto shaft with cupped surface facing end of shaft (away from pinion).
 - d. Stand armature on end of wood surface with commutator down. Position snap ring on upper end of shaft

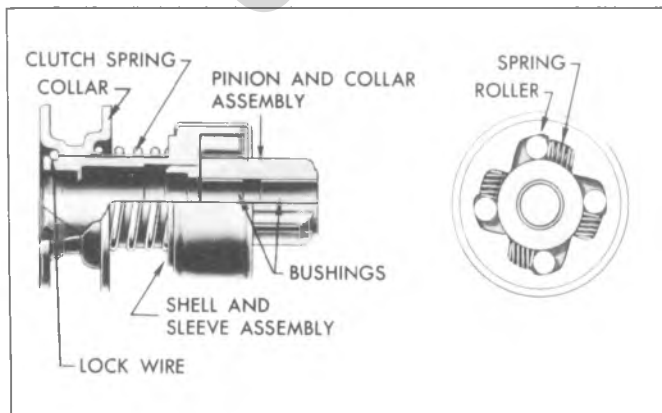


Fig. 6D-22S--Roll Type Clutch Cross-Section

and hold in place with block of wood. Tap wood block with hammer forcing snap ring over end of shaft (fig. 6D-23S). Slide snap ring down into groove.

- e. Assemble thrust collar on shaft with shoulder next to snap ring.
- f. Place armature flat on work bench, and position retainer and thrust collar next to snap ring. Then using two pair of pliers at the same time (one pair on either side of shaft), grip retainer and thrust collar and squeeze until snap ring is forced into retainer (fig. 6D-24S).

3. Lubricate the drive housing bushing with a silicone

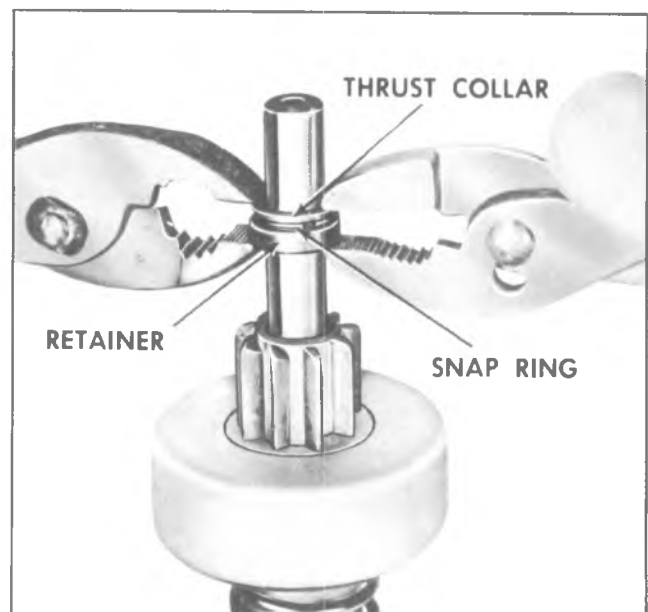


Fig. 6D-24S--Forcing Snap Ring Into Retainer

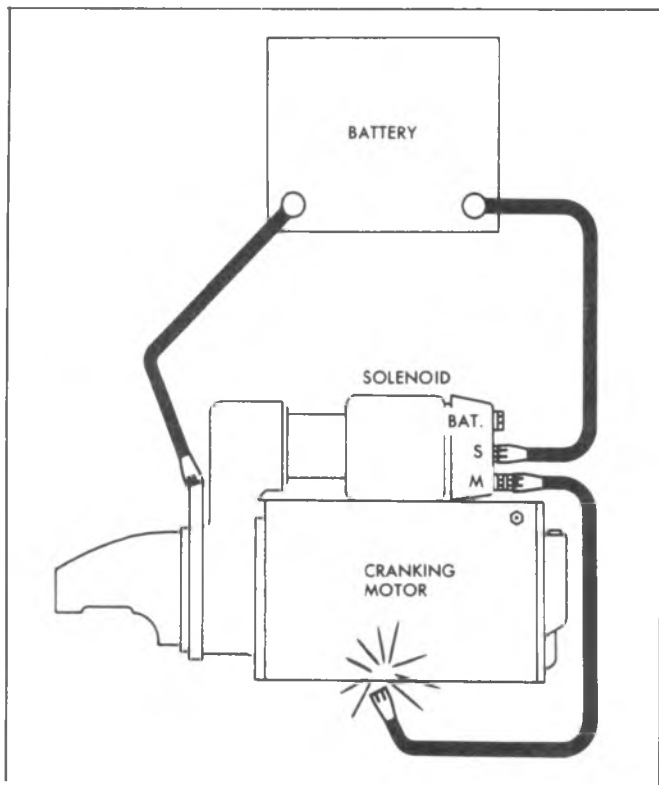


Fig. 6D-25S--Circuit for Checking Pinion Clearance

lubricant. Make sure thrust collar is in place against snap ring and retainer and slide armature and clutch assembly into place in drive housing engaging shift lever with clutch.

4. Position field frame over armature and apply special sealing compound between frame and solenoid case. Position frame against drive housing using care to prevent damage to the brushes.

5. Lubricate the bushing in the commutator end frame with a silicone lubricant. Place leather brake washer on armature shaft and slide commutator end frame onto shaft.

6. Reconnect the field coil connectors to the "motor" solenoid terminal.

7. After overhaul is completed, perform "Pinion Clearance Check".

PINION CLEARANCE CHECK

1. Connect a battery, of the same voltage as the solenoid, from the solenoid switch terminal to the solenoid frame or ground terminal (fig. 6D-25S).

NOTE: Disconnect the motor field coil connector for this test.

2. Momentarily flash a jumper lead from the solenoid motor terminal to the solenoid frame or ground terminal. The pinion will now shift into cranking position and will remain there until the jumper lead is disconnected.

3. Push the pinion back towards the commutator end to eliminate slack movement.

4. Measure the distance between the pinion and pinion stop (fig. 6D-15S). If clearance is not within specified limits (.010-.140) it may indicate excessive wear of solenoid linkage shift lever yoke buttons or improper assembly of the shift lever mechanism. Worn or defective parts should be replaced.

STARTING SOLENOID

Removal

1. Remove the outer screw and washer from the motor connector strap terminal.
2. Remove the two screws retaining solenoid housing to end frame assembly.
3. Twist solenoid clockwise to remove flange key from keyway slot in housing; then remove solenoid assembly.

Replacement of Contacts (Fig. 6D-26S)

1. With solenoid removed from motor, remove nuts and washers from switch and motor connector strap terminals.
2. Remove the two solenoid end cover retaining screws and washers and remove end cover from solenoid body.
3. Remove nut and washer from battery terminal on end cover and remove battery terminal. Remove resistor by-pass terminal and contactor.
4. Remove motor connector strap terminal and solder new terminal in position.
5. Using a new battery terminal, install terminal washer and retaining nut to end cover. Install by-pass terminal and contactor.
6. Position end cover over switch and motor terminals and install end cover retaining screws. Also install washers and nuts on the solenoid switch and starting motor terminals.
7. Bench test solenoid for proper operation.

Installation

1. With solenoid return spring installed on plunger, position solenoid body to drive housing and turn counterclockwise to engage the flange key in the keyway slot.
2. Install two screws retaining solenoid housing to end frame.
3. Install outer screw and washer securing motor connector strap terminal.
4. Install starter motor as previously described.

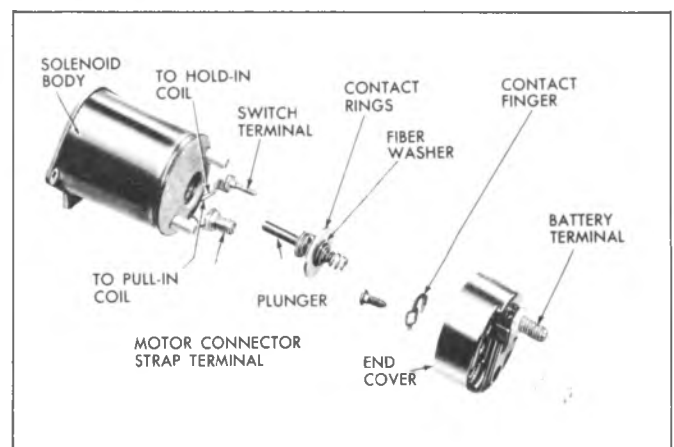


Fig. 6D-26S--Exploded View of Solenoid

SPECIFICATIONS

GENERATOR

MODEL NO.	APPLICATION	DELCO REMY SPEC. NO.	FIELD CURRENT AMPS 27°C (80°F) @ 12 VOLTS	COLD OUTPUT* AMPS @ 5000 RMP	RATED HOT OUTPUT** AMPS
1102394 1102491 1102889	All L-6 (Base) (Except G-20, 30 & P-Truck) All C-K-G Truck Base V-8 (Except K31303 & G30003)	4519	4-4.5	33	37
1102485 1102841 1102887	292 L-6 (L25) (Base) (G-20, 30 & P-Truck) All P-Truck Base V-8 (Except P31832)	4521	4-4.5	38	42
1102480 1102486 1102886 1102888	P31832 Truck (Base) All L-6 or V-8 with RPO K76 454 V-8 (F18) (Base) K31303 & G30003 Truck Base V-8	4522	4-4.5	57	61
1101016 1101028	Optional (COPO)	4525	4-4.5	76	80

*Generator temperature approximately 27°C. (80°F.).

**Ambient temperature 27°C. (80°F.).

Note: The only difference between generators within each group above is the position end frame is rotated.

SPECIFICATIONS

DISTRIBUTOR & SPARK PLUGS

Distributor and spark plug specifications are shown in the Emission Control Chart in Section 6E Specifications.

BATTERY

MODEL NO.	APPLICATION	COLD CRANK RATE @ 0°F (-18°C)	AMPS FOR LOAD TEST	25 AMP. RESERVE CAPACITY (MINUTES)
85-4	250 L-6 (LD4)	275 Amps	130	60
85-5	292 L-6 (L25) 305 V-8 (LG9) 350 V-8 (LS9) 400 V-8 (LF4)	350 Amps	170	80
89-5	454 V-8 (LF8) RPO UA1	465 Amps	230	125
87-5	RPO TP2	430 Amps	210	100

STARTING MOTOR

MODEL NO.	APPLICATION	SPEC. NO.	VOLTS	FREE SPEED AMPERES	RPM
1108778	250 L-6 (LD4) (C & K-10)	3573	9	50-80*	5500-10500
1108779	250 L-6 (LD4) (G-Van)	3573	9	50-80*	5500-10500
1108780	292 L-6 (L25)	2438	9	50-80*	3500-6000
1109056	305 V-8 (LG9) (C & K)	3573	9	50-80*	5500-10500
1109798	305 V-8 (LG9) (G-Van)	3573	9	50-80*	5500-10500
1109052	350 V-8 (LS9)	3563	9	65-95*	7500-10500
1108776	400 V-8 (LF4) 454 V-8 (LF8)	3563	9	65-95*	7500-10500

*Includes Solenoid

classiccarylbrary.com

SECTION 6E

ENGINE EMISSION CONTROLS

CONTENTS

General Description.....	6E-1
General Description of Emission	
Control Components.....	6E-1
Engine Performance Diagnosis Charts.....	6E-10
Early Fuel Evaporation-EFE.....	6E-16
Exhaust Gas Recirculation-EGR.....	6E-18
Positive Crankcase Ventilation System-PCV.....	6E-24
Thermostatic Air Cleaner-TAC.....	6E-25
Air Injection Reactor-AIR.....	6E-31
Throttle Return Control-TRC.....	6E-35
Vacuum Advance Control.....	6E-37

GENERAL DESCRIPTION

The normal operation of the engine results in the release of several compounds to the atmosphere. Federal Government and State of California legislation has placed limitations on the quantities of three compounds which can be emitted. The three controlled compounds are:

- Hydrocarbons - HC
- Carbon Monoxide - CO
- Oxides of Nitrogen - NOx

The Federal regulations have been revised for 1977 requiring that some vehicles sold for initial licensing, registration, or titling at altitudes greater than 1219 meters (4000 feet) be capable of meeting emission standards at such altitudes. In most cases, the revised Federal and California regulations make it necessary to have specific engines and emission control systems for vehicles sold in areas above 1219 meters, areas below 1219 meters, and California.

The emission control section will consist of a general description of emission control components and subsystems, followed by vacuum hose schematics or each engine type, diagnosis and service procedure section.

The emission control systems include:

- Carburetor Calibration
- Distributor Calibration
- Catalytic Converter (Light Duty Emissions)
- Early Fuel Evaporation (EFE) (Light Duty Emissions)
- Exhaust Gas Recirculation (EGR) (Lt. Duty Emissions 454 Calif. H-Duty Emissions)
- Positive Crankcase Ventilation (PCV)
- Choke Calibration
- Thermostatic Air Cleaner(TAC)
- Evaporation Control System (ECS)

The emission control systems for some engines may use an additional emission control device called Air Injection Reaction (AIR).

GENERAL DESCRIPTION OF EMISSION CONTROL COMPONENTS

CARBURETOR CALIBRATION

While the carburetor's main function is to provide the engine with a combustible air/fuel mixture, the carburetor calibration is critical to maintaining proper emission levels.

The carburetor's idle, off-idle, main metering, power enrichment, and accelerating pump systems are calibrated to provide the best possible combination of engine performance, fuel economy and exhaust emission control. Carburetor adjustments and service must be performed using the recommended procedures to insure engine exhaust emission levels remain within legislated limits.

See Section 6C, Fuel System, for carburetor adjustment specifications and recommended service procedures.

DISTRIBUTOR CALIBRATION

The distributor is an integral part of the engine ignition system and the distributor calibration is an important part of exhaust emission control.

The initial timing centrifugal advance and vacuum advance are calibrated to provide the best engine performance and fuel economy at varying speeds and loads while remaining within exhaust emission limits. Distributor diagnostics and service procedures are in Section 6D, Engine Electrical.

CATALYTIC CONVERTER

The catalytic converter on a light duty emission vehicle is an emission control device added to the exhaust system to reduce hydrocarbon and carbon

monoxide pollutants from the exhaust gas stream. The converter contains material which is coated with a catalytic material containing platinum and palladium.

THE CATALYTIC CONVERTER REQUIRES THE USE OF UNLEADED FUEL ONLY.

Periodic maintenance of the exhaust system is not required; however, if the vehicle is raised for other service, it is advisable to check the general condition of the underfloor catalytic converter, pipes and mufflers.

Refer to Section 6F, Engine Exhaust System, for catalytic converter service procedures and diagnostics.

EARLY FUEL EVAPORATION SYSTEM (EFE)

Light Duty Emissions

The EFE system is used to provide a source of rapid heat to the engine induction system during cold driveway. Rapid heating is desirable because it provides for quick fuel evaporation and more uniform fuel distribution to aid cold driveability. It also reduces the length of time carburetor choking is required making reductions in exhaust emission levels possible.

EFE systems uses a valve which increases the exhaust gas flow under the intake manifold during cold engine operation. The valve is vacuum operated and is controlled by a thermal vacuum switch (TVS) which applies vacuum when the coolant temperature is below the calibration valve.

Diagnosis and service procedures of the EFE system can be found in this section.

EXHAUST GAS RECIRCULATION SYSTEM (EGR)

Light Duty Emissions and 454-Calif. Heavy Duty Emission.

The Exhaust Gas Recirculation System meters exhaust gas into induction system for recirculation through the combustion cycle to reduce oxides of nitrogen emissions.

The EGR valve remains closed during periods of engine idle and deceleration to prevent rough idle from excessive exhaust gas dilution in the idle air/fuel mixtures.

All exhaust gas recirculation systems perform the same function, however, differences in operation of system will be covered in the Service Procedure Section.

Diagnosis and service procedure of EGR system can be found in this section.

CLOSED POSITIVE CRANKCASE VENTILATION SYSTEM (PCV)

All engines have closed Positive Crankcase Ventilation System to provide more complete scavenging of crankcase vapors.

An engine which is operated without any crankcase ventilation can be damaged seriously. Therefore, it is important to replace the ventilator valve periodically.

NOTE: If an engine is idling too slow or rough, this may be caused by a clogged ventilator valve or plugged hose; therefore, never adjust the carburetor idle without first checking the PCV valve and hose.

After installing a new PCV valve, readjust engine idle if necessary.

With this system, any blow-by in excess of the system capacity (from a badly-worn engine, sustained heavy load, etc.) is exhausted into the air cleaner and is drawn into the engine.

Diagnosis and service procedures for the PCV system can be found in this section.

CHOKE SYSTEM

An automatic choke system maintains proper engine performance during engine warm-up. Modifications to the choke system have been necessary in recent years to meet the lower legislated exhaust emission levels.

THERMOSTATIC AIR CLEANER (TAC)

The Thermostatic Air Cleaner (TAC) is on all engines. The TAC uses a damper assembly in the air cleaner inlet, controlled by a vacuum motor to mix pre-heated and non pre-heated air entering the air cleaner to maintain a controlled air temperature into the carburetor. The vacuum motor is modulated by a temperature sensor in the air cleaner. The pre-heating of the air cleaner inlet air allows leaner carburetor and choke calibrations resulting in lower emission levels, while maintaining good driveability. Diagnostics and service procedures for the thermostatic air cleaner can be found in this section.

AIR INJECTION REACTOR SYSTEM

An air injection reactor (AIR) is used on some engines to provide additional oxygen to continue the combustion process after the exhaust gases leave the combustion chamber. An engine driven pump provides pressurized air which is injected into the exhaust port of the cylinder head or exhaust pipe and then into the exhaust system. The AIR system operates at all times and will bypass air only for a short duration of time during deceleration and at high speeds. The diverter valve performs the bypass function, and the check valve protects the air pump from damage by preventing a back flow of exhaust gas.

Diagnosis and service procedures for air injection reactor system is in this section.

VACUUM CONTROLS

Various types of vacuum controls are used in the emission control system to modify or control the operation of the various emission control components to optimize emission control effectiveness, while minimizing any negative effect on driveability.

Refer to the vacuum hose schematics (Figs. 6E-1 through 6E-14) for usage of these systems.

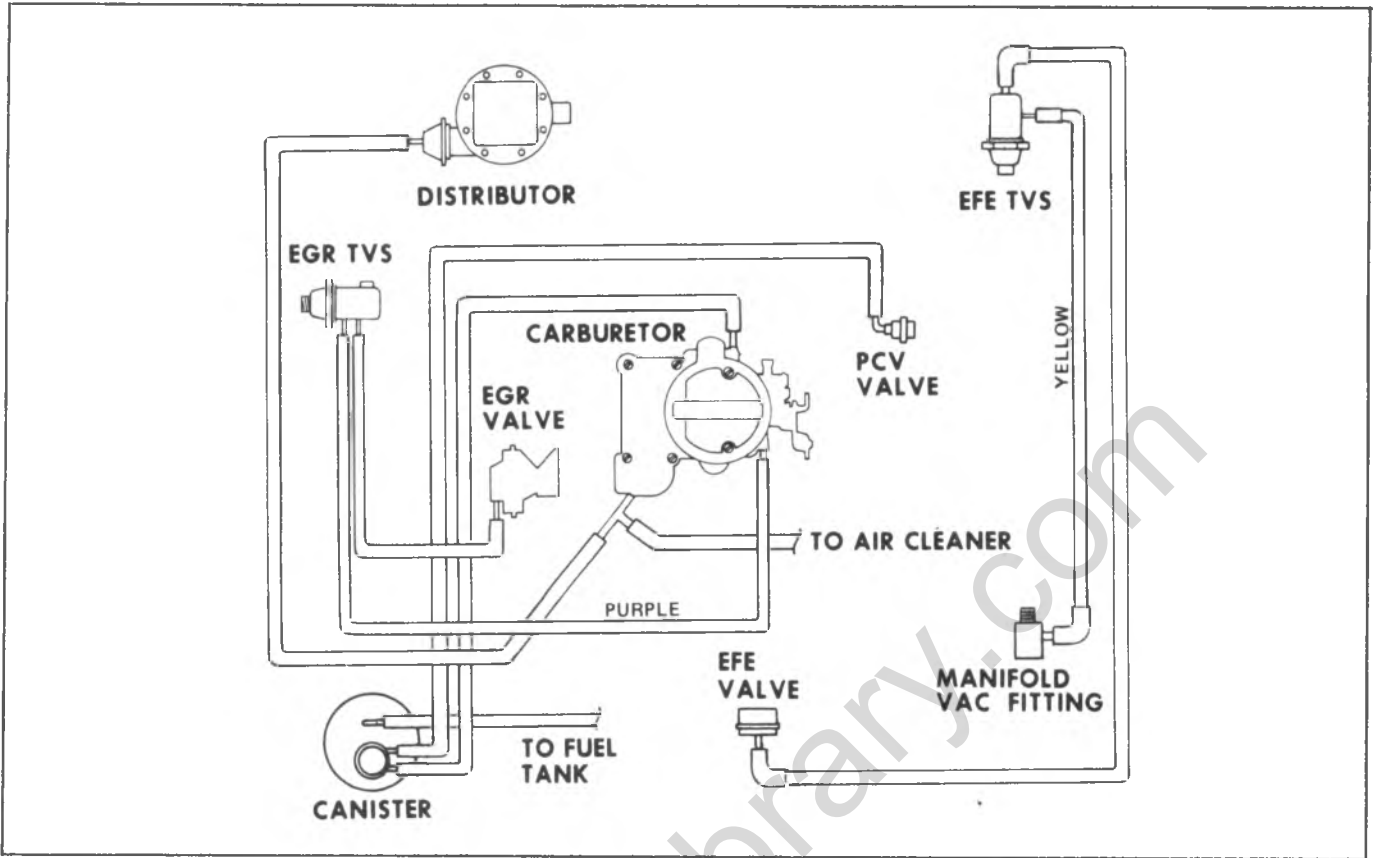


Fig. 6E-1-Vacuum Hose Schematic-L6 250 CID - LD Emissions

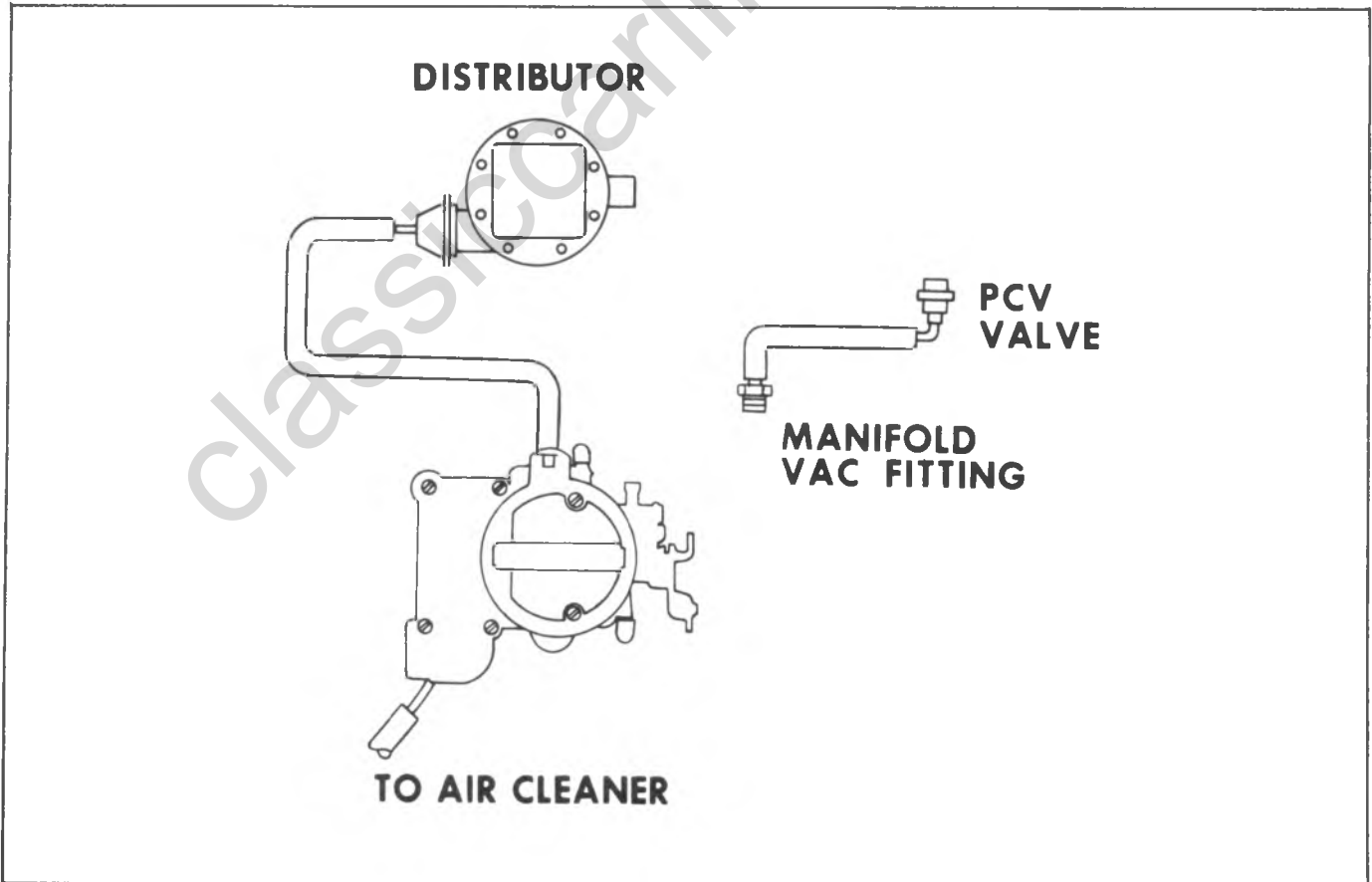


Fig. 6E-2-Vacuum Hose Schematic - L6 250/292 CID-Except Calif. - HD Emissions

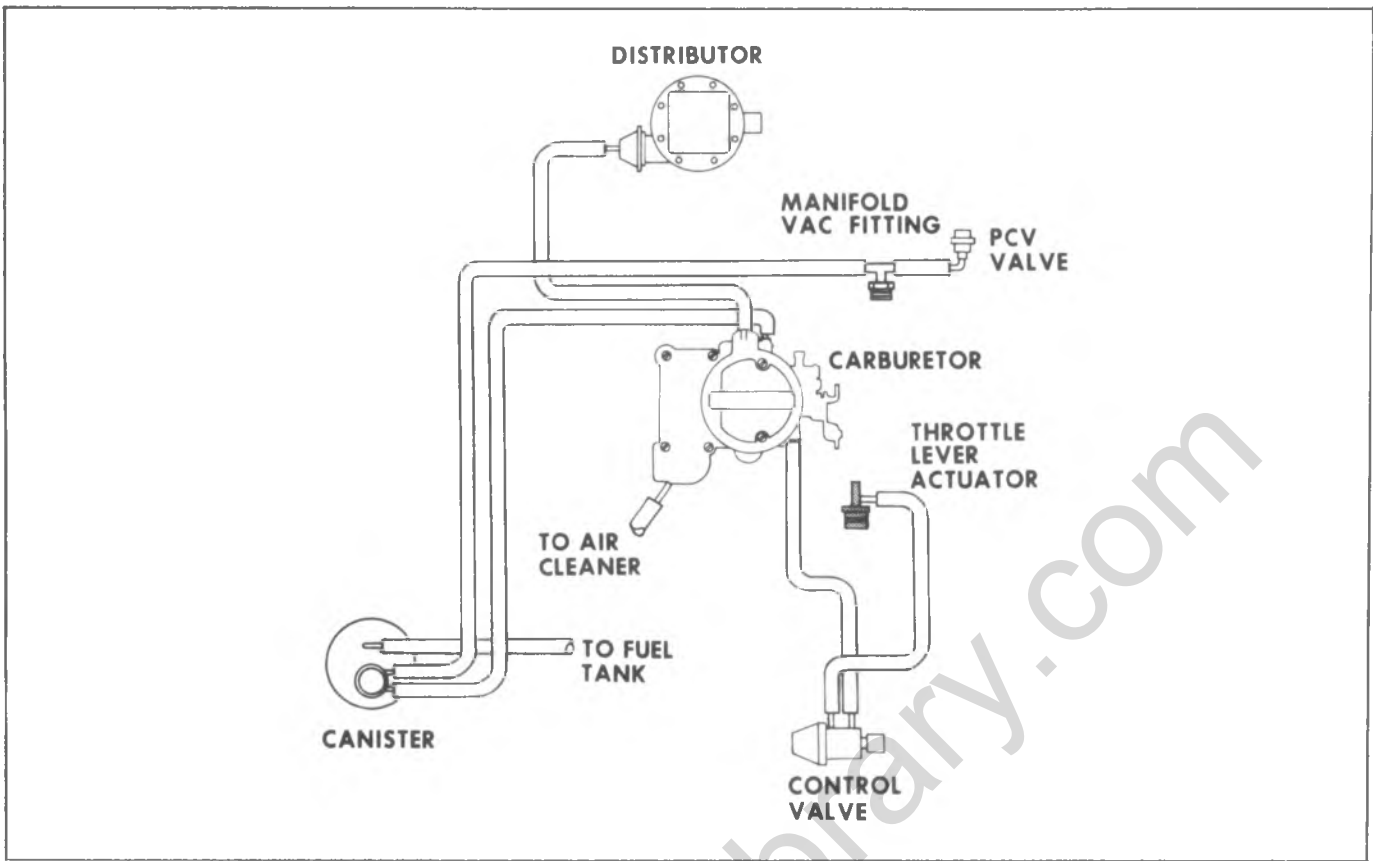


Fig. 6E-3--Vacuum Hose Schematic-L6 292 CID - Calif. - HD Emissions

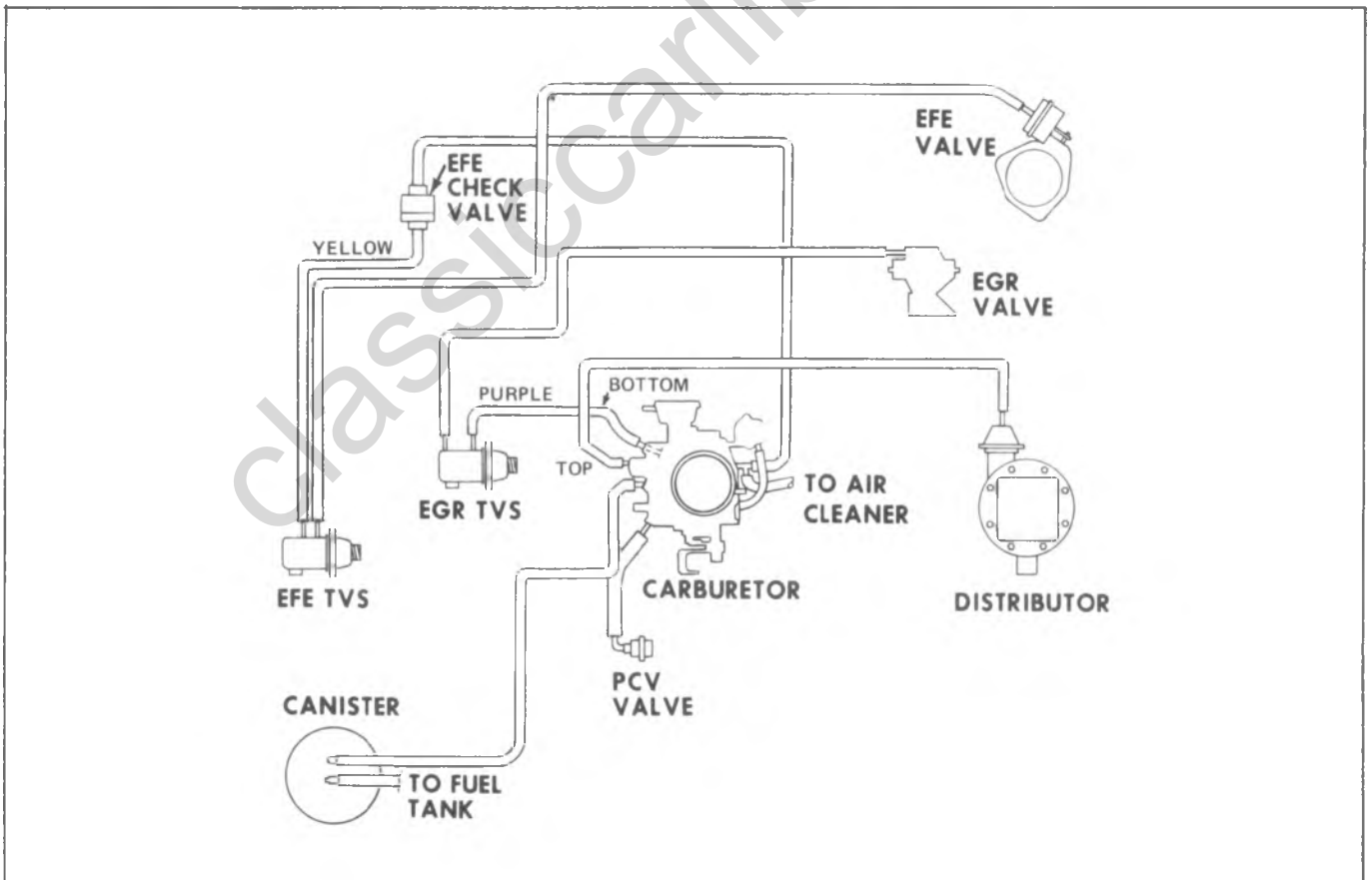


Fig. 6E-4--Vacuum Hose Schematic-V8 305 CID Low Altitude - LD Emissions

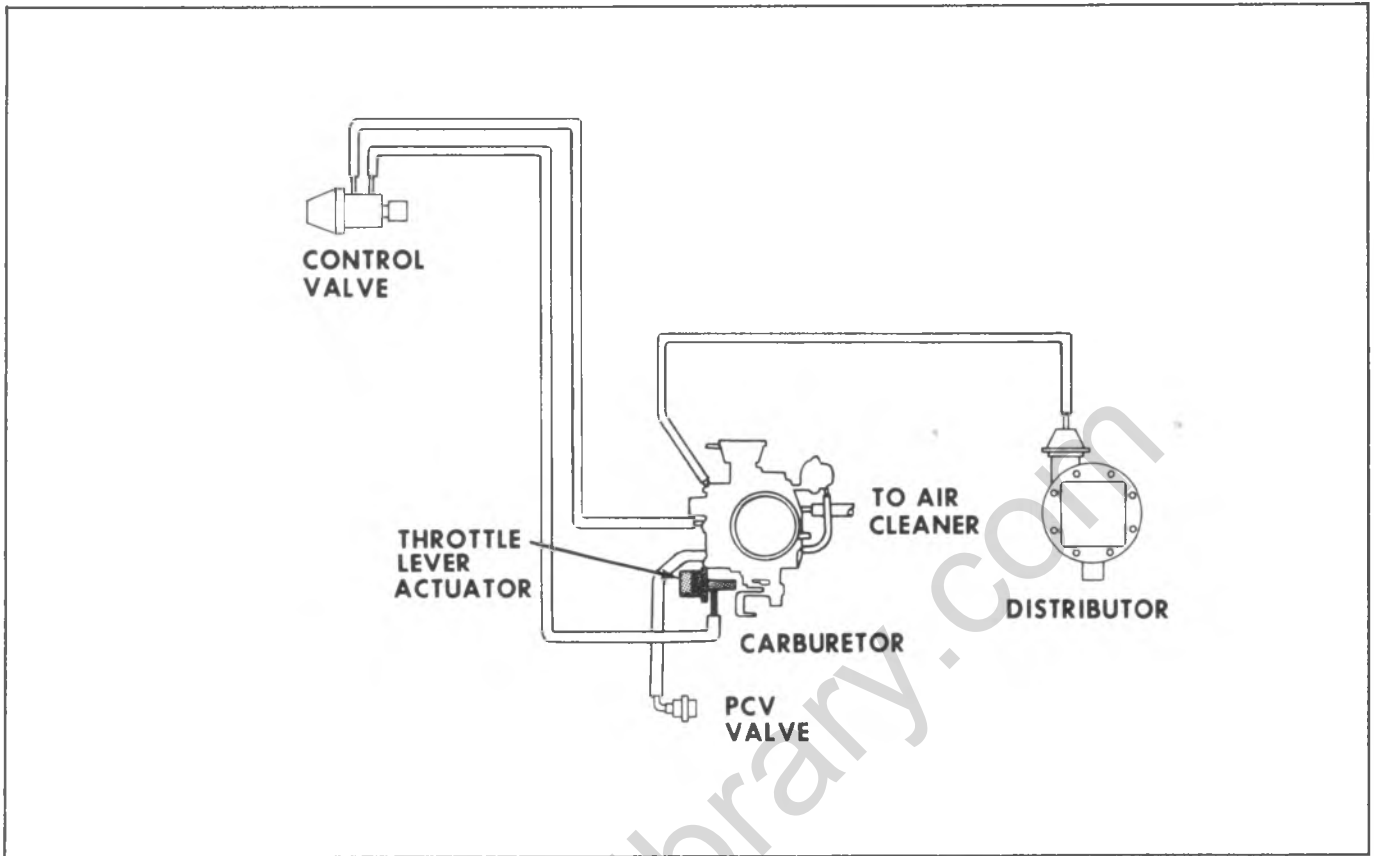


Fig. 6E-5--Vacuum Hose Schematic-V8 305 CID - HD Emissions

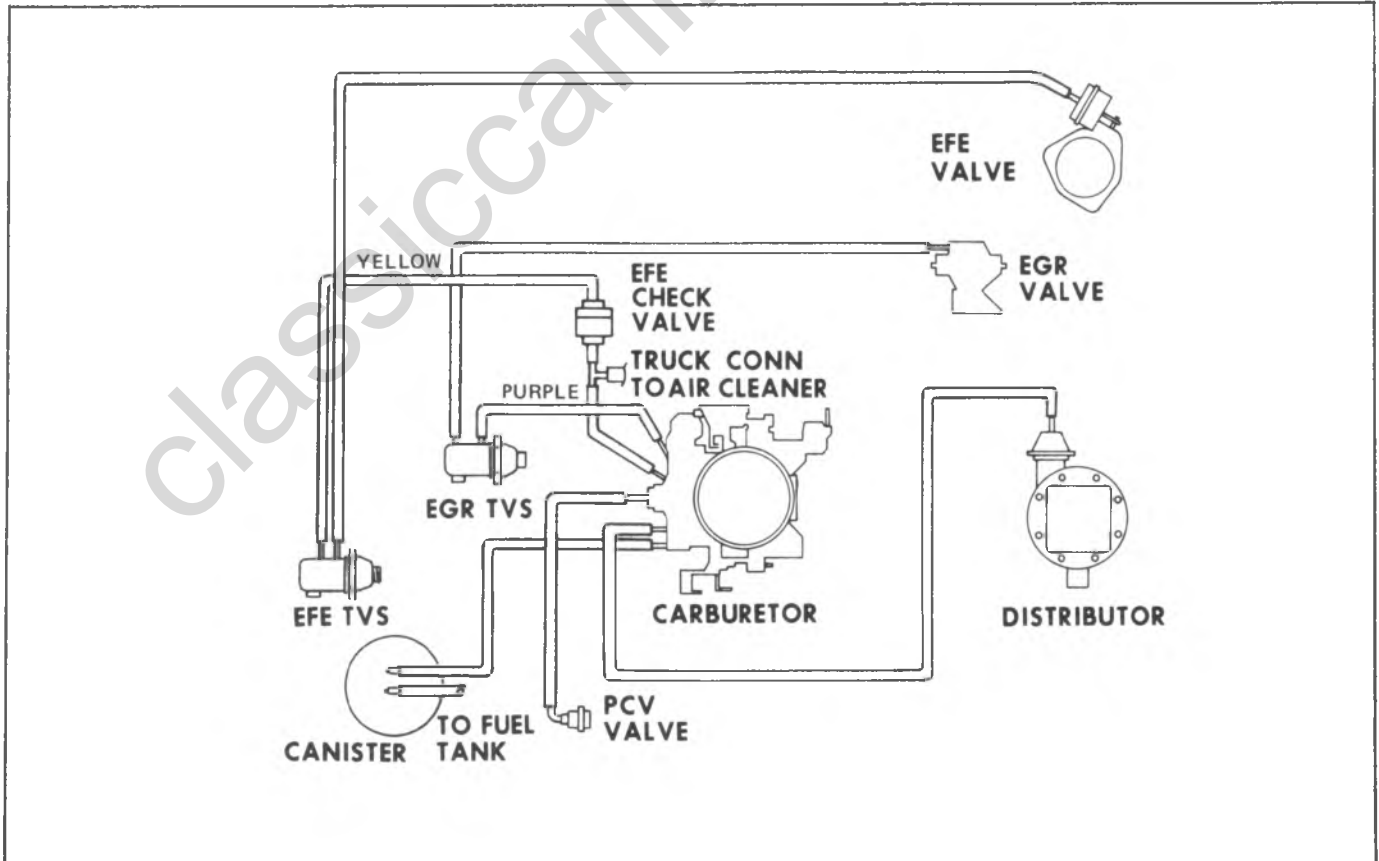


Fig. 6E-6--Vacuum Hose Schematic-V8 350 CID Low Altitude G10 - LD Emissions

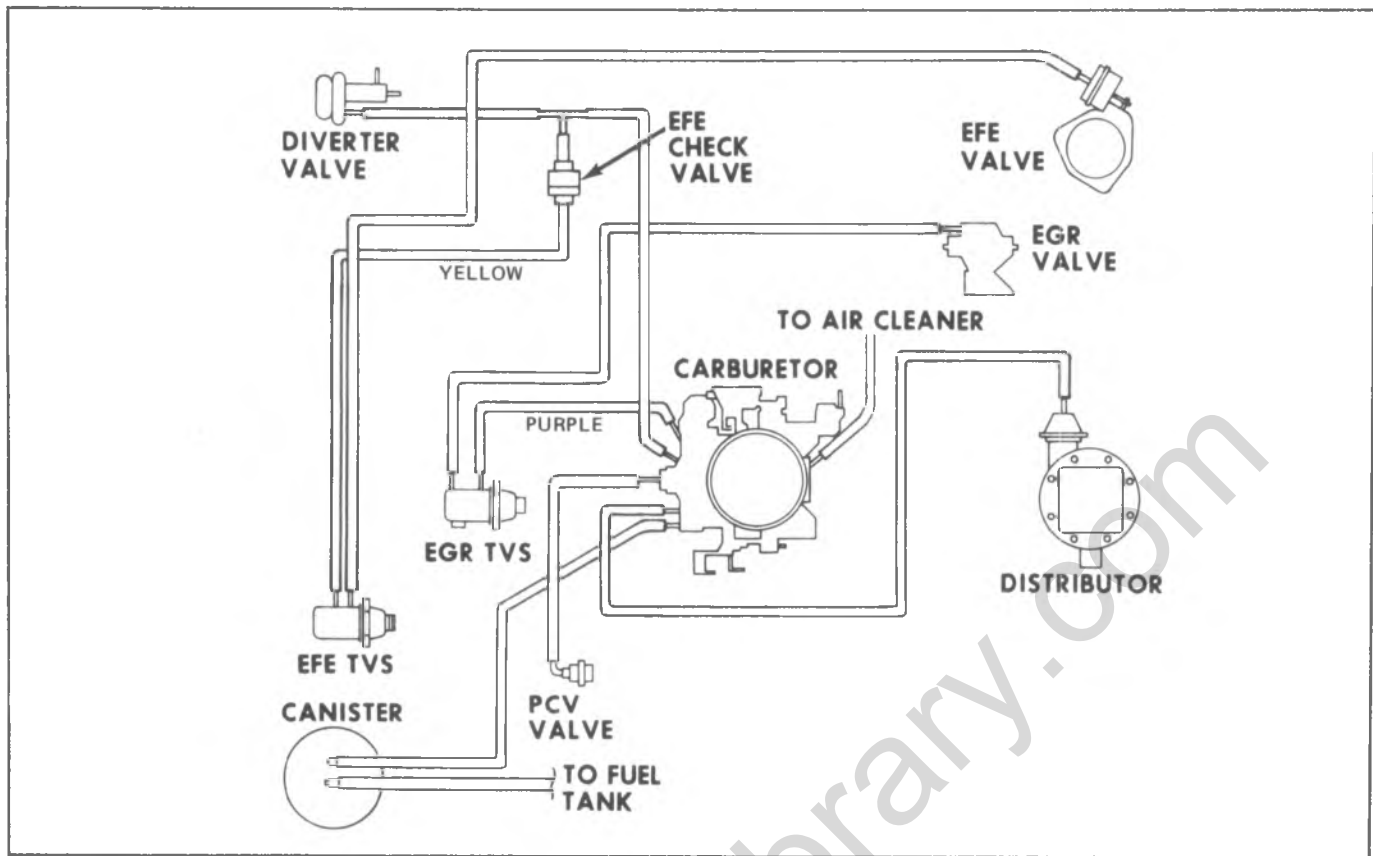


Fig. 6E-7--Vacuum Hose Schematic-V8 350 CID High Altitude&Calif.-LD Emissions

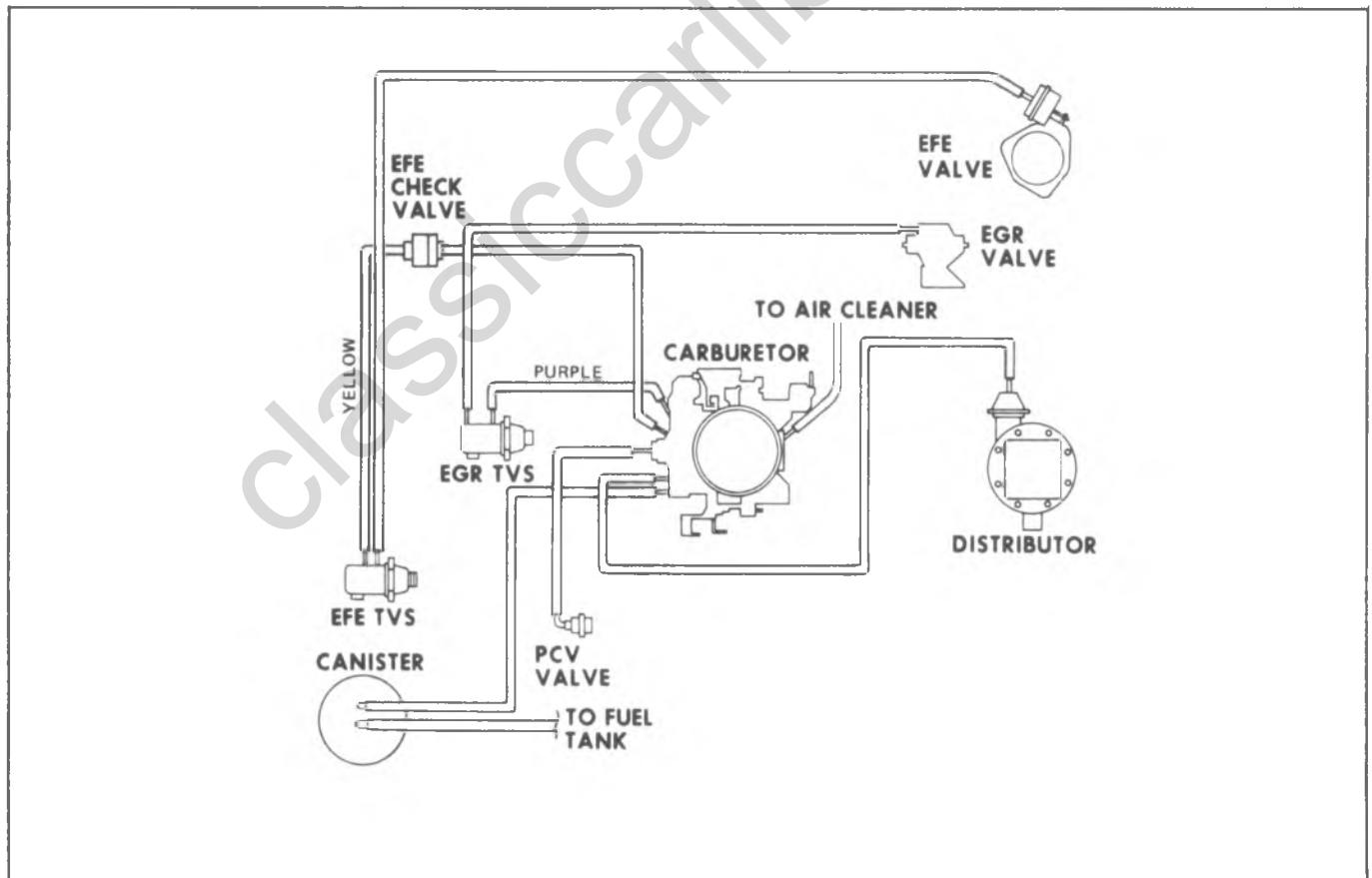


Fig. 6E-8--Vacuum Hose Schematic-V8 350 CID Low Altitude C10-LD Emissions

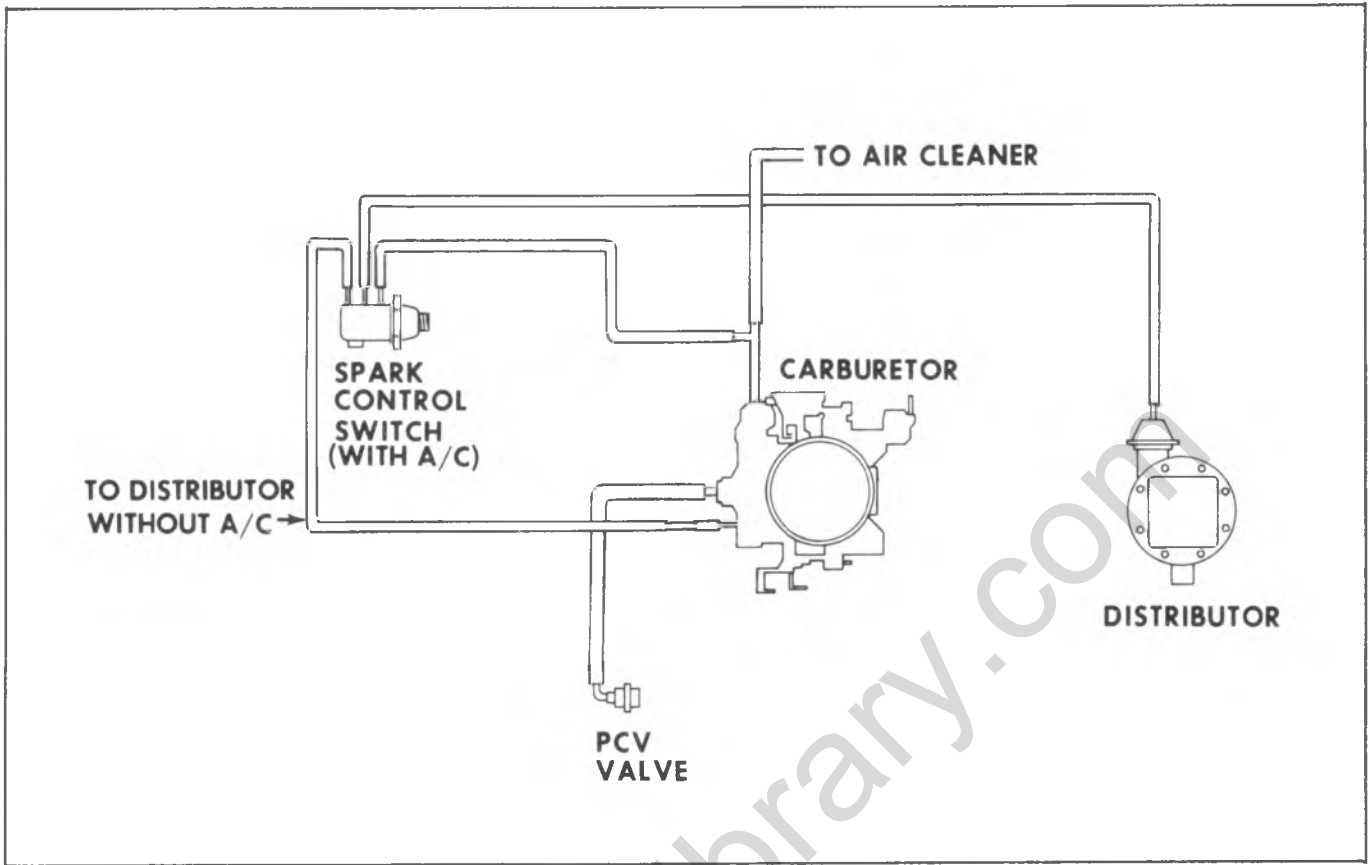


Fig. 6E-9--Vacuum Hose Schematic-V8 350/400 CID Except Calif.-HD Emissions

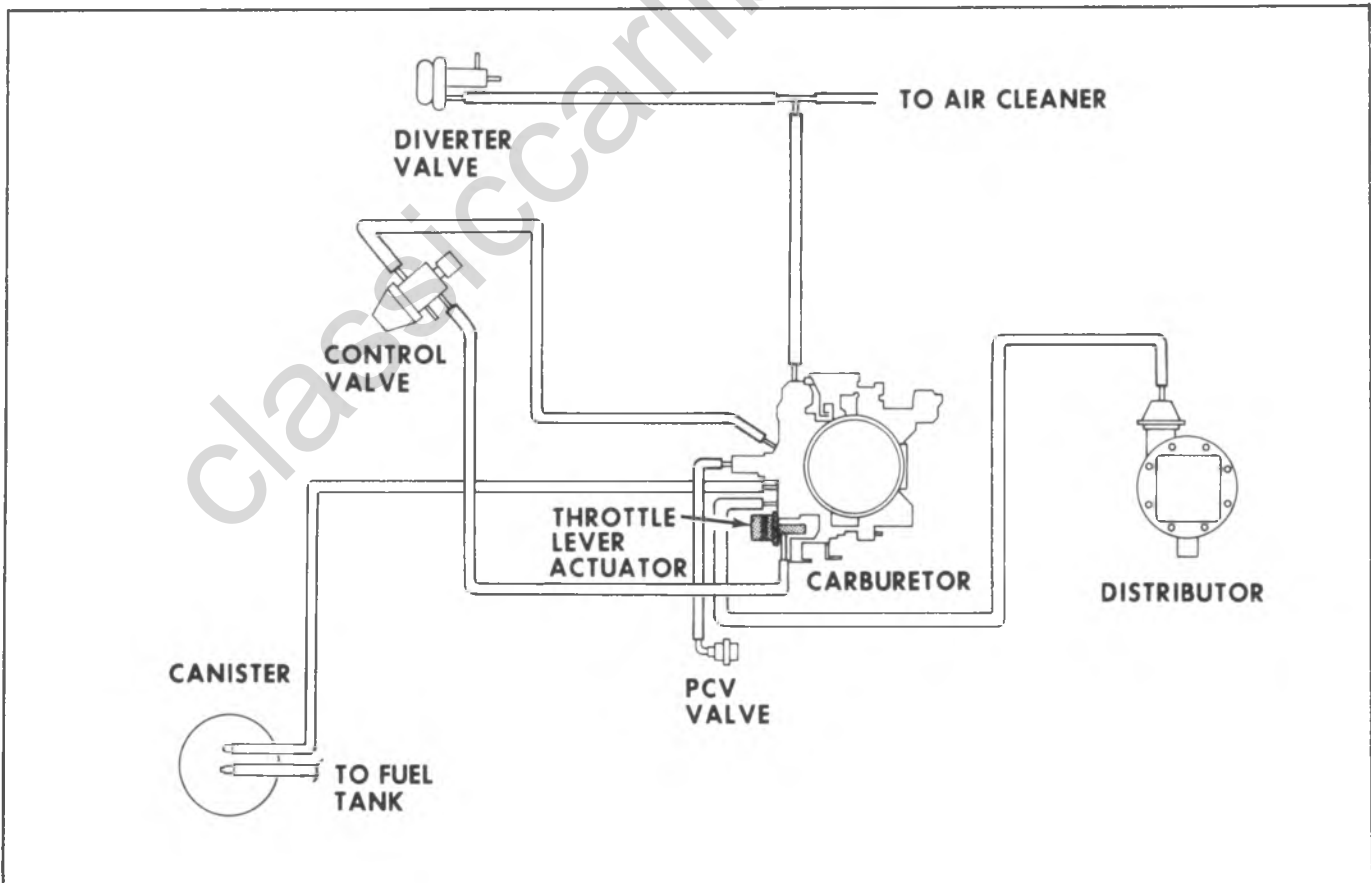


Fig. 6E-10--Vacuum Hose Schematic-V8 350/400 CID Calif. (C,K, G20, G30 w/o A/C)-HD Emissions

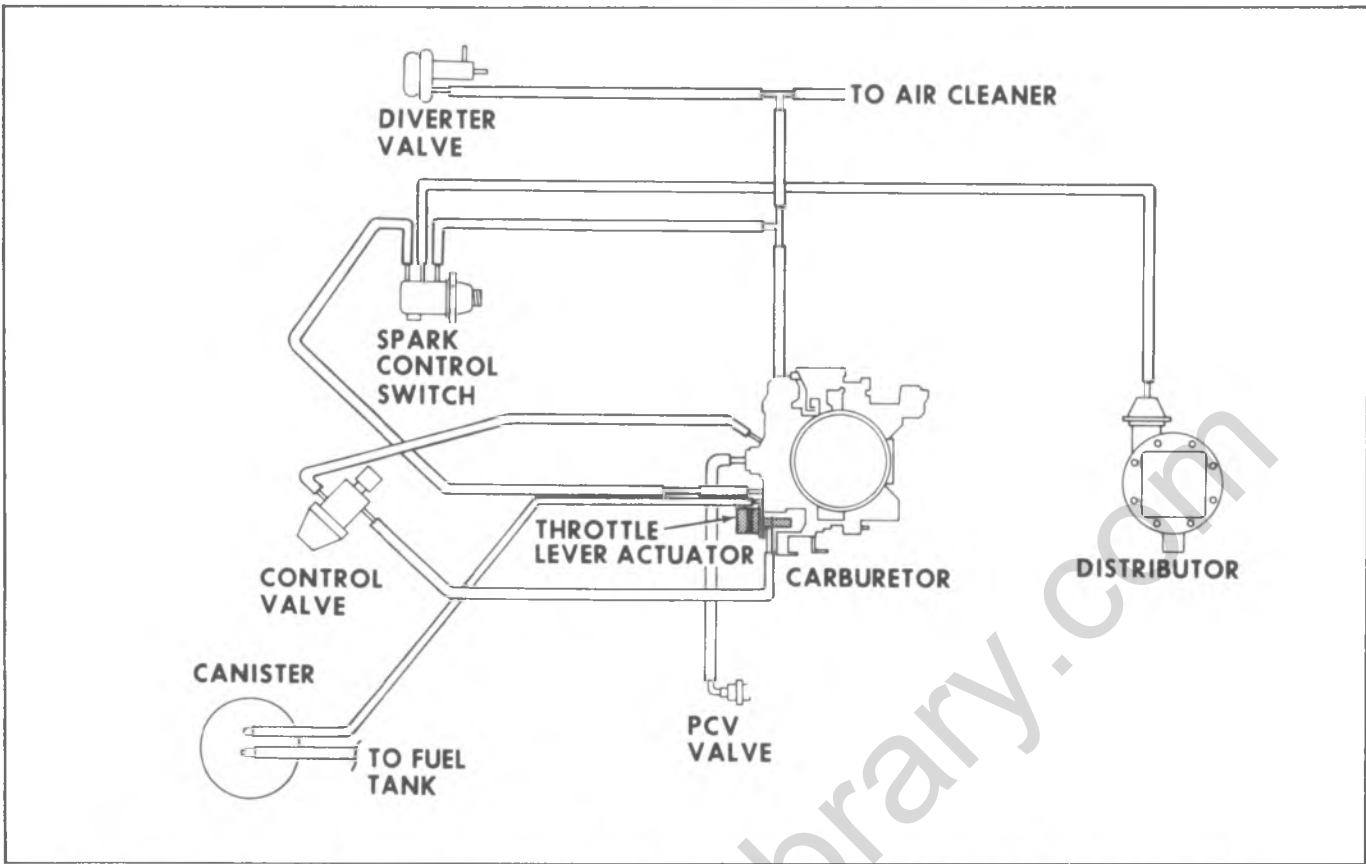


Fig. 6E-11--Vacuum Hose Schematic-V8 350/400 CID Calif. 10, 20&30 w A/C, V8 400 CID Calif. G20&30 w A/C-HD Emissions

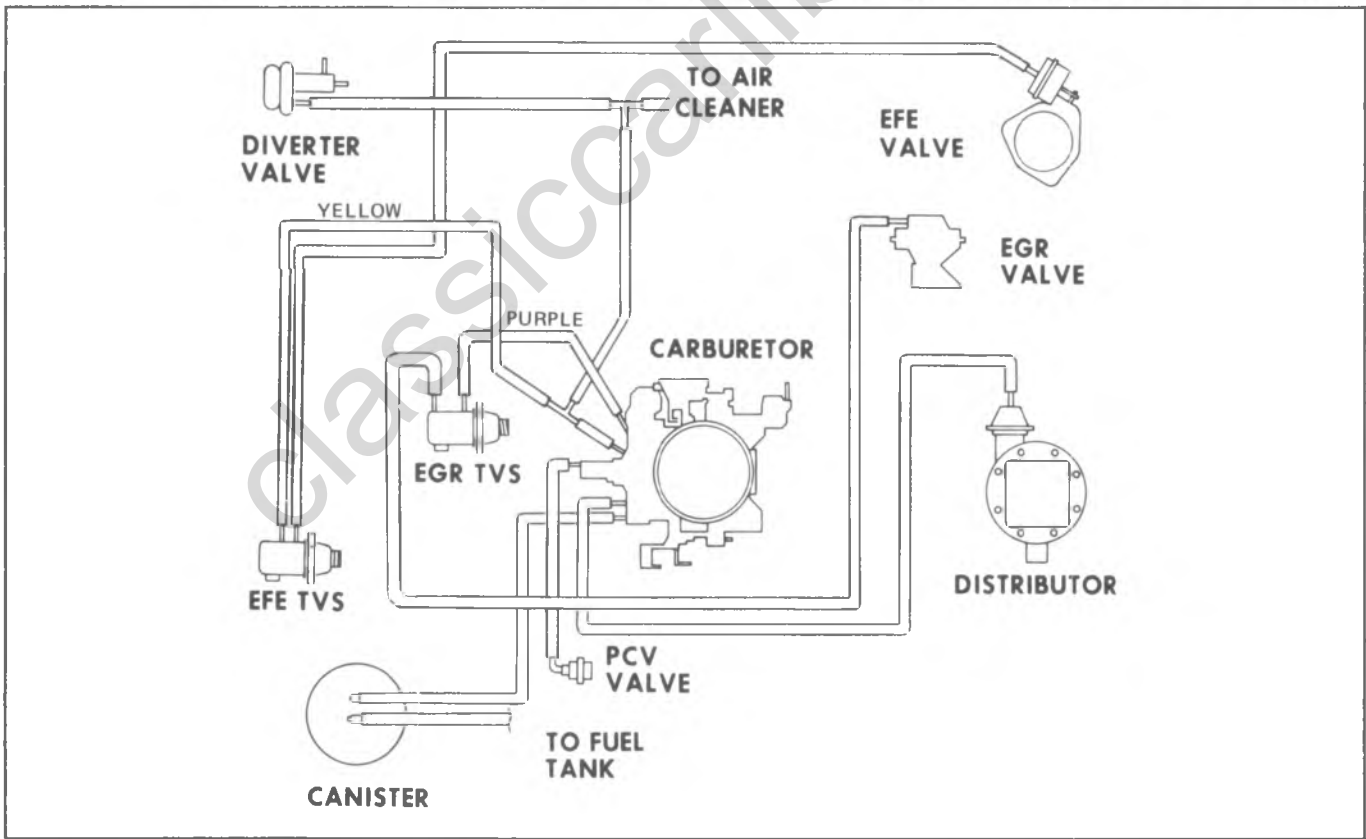


Fig. 6E-12--Vacuum Hose Schematic-V8 454 CID-LD Emissions

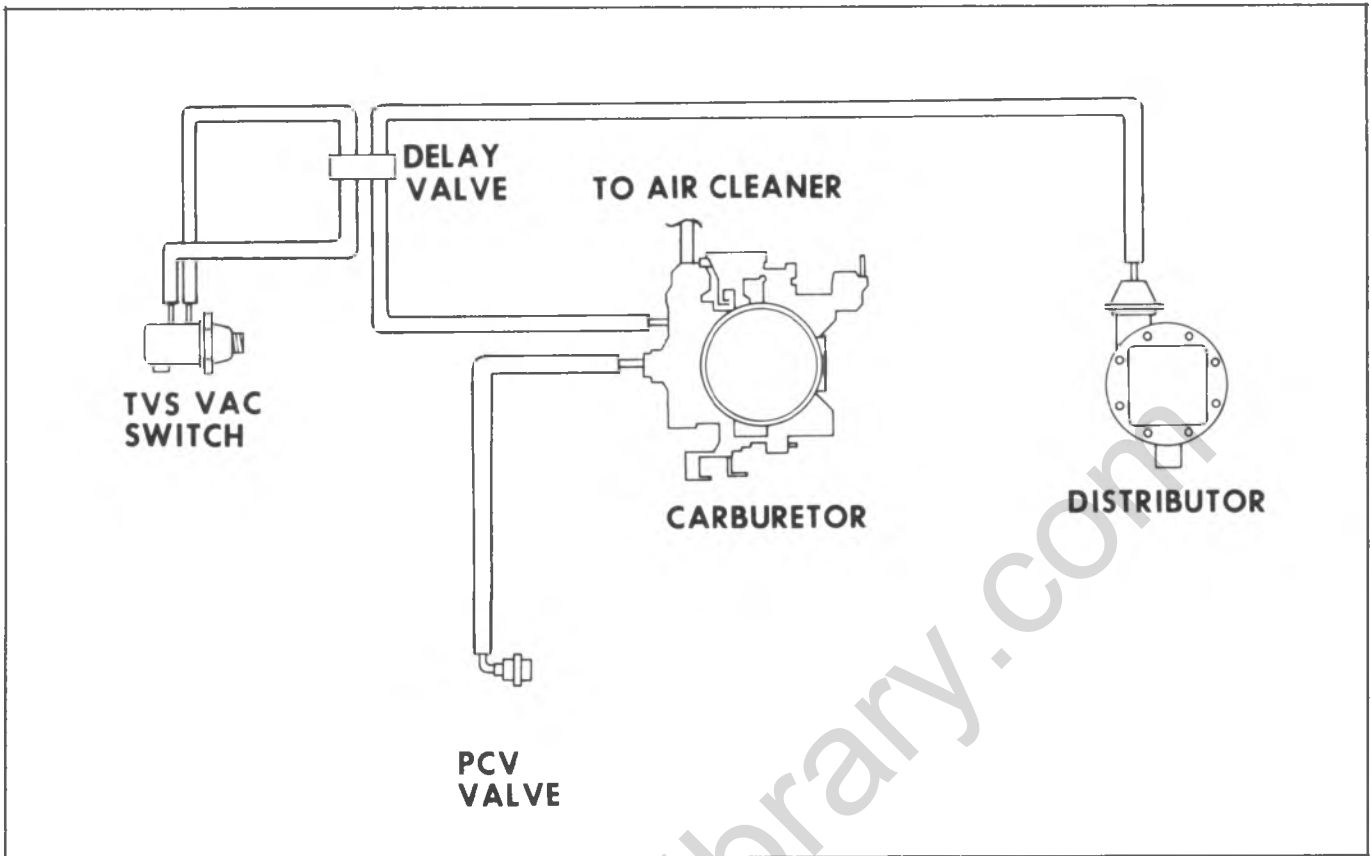


Fig. 6E-13--Vacuum Hose Schematic V8 454 CID Except Calif · HD Emissions

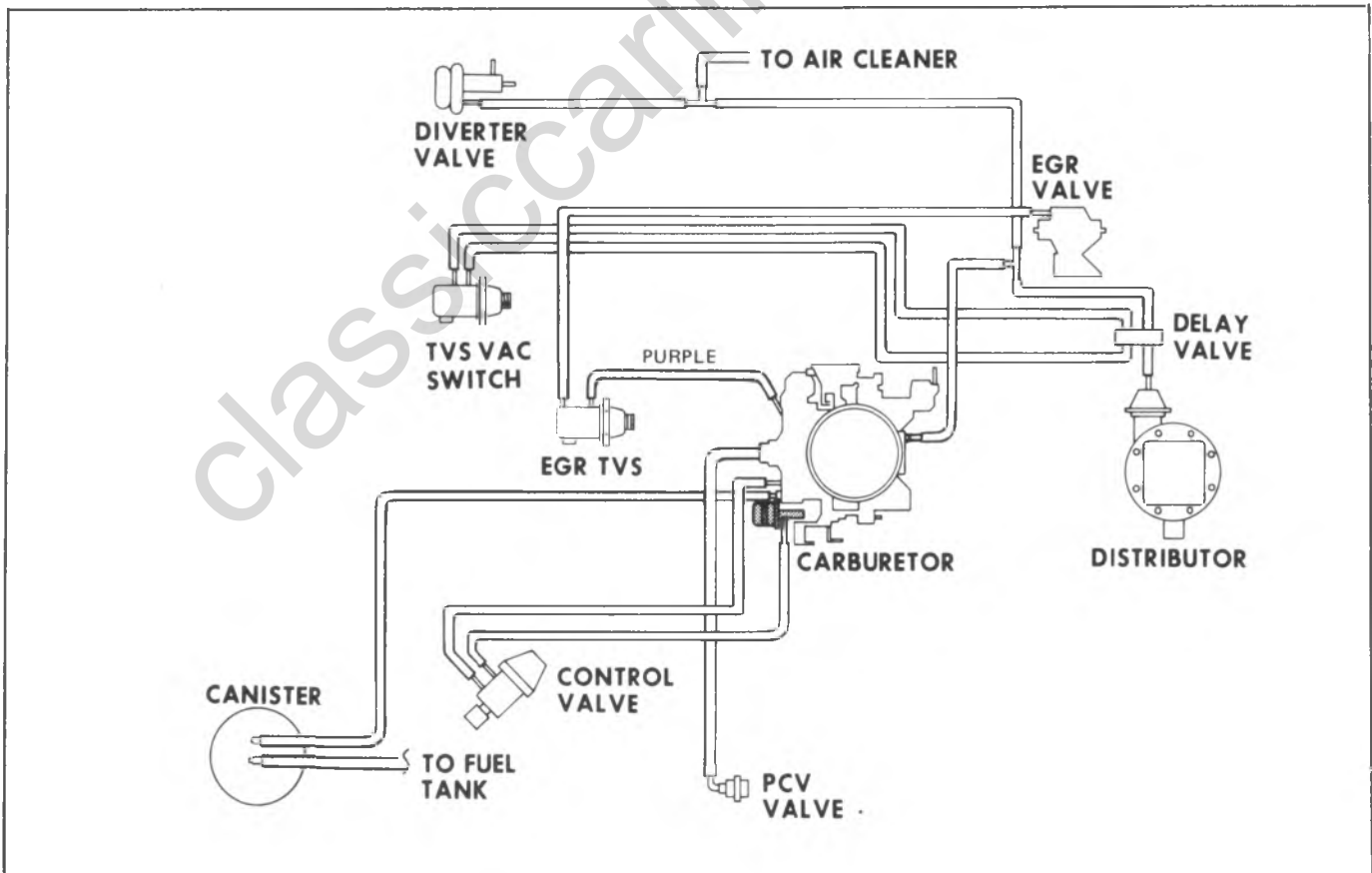


Fig. 6E-14--Vacuum Hose Schematic-V8 454 CID Calif · HD Emissions

ENGINE PERFORMANCE DIAGNOSIS CHARTS

INTRODUCTION

Engine Performance Diagnosis procedures are guides that will lead to the most probable causes of engine performance complaints. They consider all of the parts of the fuel, ignition, and mechanical systems that could cause a particular complaint, and then outline repairs in a logical sequence.

Each Symptom is defined, and it is vital that the correct one be selected based on the complaints reported or found.

Review the Symptoms and their definition to be sure that only the correct terms are used.

The words used may not be what you are used to in all cases, but because these terms have been used interchangeably for so long, it was necessary to decide on the most common usage and then define them. If the definition is not understood, and the exact Symptom is not used, the Diagnostic procedure will not work.

It is important to keep two facts in mind:

1. The procedures are written to diagnose problems on vehicles that have "run well at one time" and that time and wear have created the condition.

2. All possible causes cannot be covered, particularly with regard to emission controls that affect vacuum advance. If doing the work prescribed does not correct the complaint, then either the wrong Symptom was used, or a more detailed analysis will have to be made.

All of the Symptoms can be caused by worn out or defective parts such as Spark Plugs, Ignition Wiring, etc. If time and/or mileage indicate that parts should be replaced, it is recommended that it be done.

SYMPTOM DEFINITIONS

Dieseling - Engine continues to run after the switch is turned off. It runs unevenly and may make knocking noises.

Detonation - A mild to severe ping, usually worse

under acceleration. The engine makes sharp metallic knocks that change with throttle opening.

Stalls - The engine quits running. It may be at idle or while driving.

Loads - The engine misses due to excessively rich fuel/air mixture. Usually occurs during cold engine operation and is characterized by black smoke being emitted from the tail pipe.

Rough Idle - The engine runs unevenly at idle. If bad enough, it may make the vehicle shake.

Miss - Steady pulsation or jerking that follows engine speed, usually more pronounced as engine load increases. Not normally felt above 1500 RPM or 30 MPH. The exhaust has a steady spitting sound at idle or low speed.

Hesitation - Momentary lack of response as the accelerator is depressed. Can occur at all vehicle speeds. Usually most severe when first trying to make the vehicle move, as from a stop sign. May cause the engine to stall if severe enough.

Sag - The engine responds initially, then flattens out or slows down, and then recovers. May cause the engine to stall if severe enough.

Surges - Engine Power variation under steady throttle or cruise. Feels like the vehicle speeds up and slows down with no change in the accelerator pedal position. Can occur at any speed.

Sluggish - Engine delivers limited power under load or at high speed. Won't accelerate as fast as normal; loses too much speed going up hills; or has less top speed than normal

Poor Gas Mileage - Gas mileage significantly less than the average for the vehicle and drivetrain combination in question.

Cuts Out - Temporary complete loss of power. The engine quits at sharp, irregular intervals. May occur repeatedly, or intermittently. Usually worse under heavy acceleration.

Backfire - Explosion type noise emanating from the exhaust system. Usually occurs during deceleration.

ENGINE PERFORMANCE SPECIFICATION INFORMATION - LD EMISSION LT. DUTY TRUCK

ENGINE AND CODE	IGNITION TIMING B.T.D.C. DEGREES	SPARK PLUG TYPE & GAP	CURB IDLE (RPM)	BASE IDLE (RPM)	FAST IDLE (RPM) (N)	CARBURETOR IDENTIFICATION 17057----	EMISSION CONTROL DEVICES	EGR VALVE MODEL	EMISSION LABEL CODE	DISTRIBUTOR		VACUUM AND MECHANICAL ADVANCE			
										DISTRIBUTOR 1110----	VACUUM MODEL 1973----	VACUUM ADVANCE @ INCHES OF VACUUM (IN CRANK DEGREES)	MECHANICAL ADVANCE (CRANK DEGREES) @ ENGINE RPM		
250 CID L-6 ENGINE 1 BBL 1 ME CARBURETOR RPO LD4															
49 STATES M. T. TBA C10 3 SP. TBF G10	8° @ 750	R46TS .035	750 (N)	425 (N) - M. T. (D) - A. T.	2100	001	EGR PCV TAC ECS UFC EFE	17050492	CF	678	550	0° @ 4" Hg 24° @ 15" Hg	0° @ 1000 7° @ 1600 20° @ 4200		
49 STATES M. T. TBA C10 4 SP. TBF G10 & E63								7043058							
H. ALTITUDE M. T. TBA C10 3 SP. TBF G10								17050492						DD	
49 STATES A. T. TBB C10 TBH G10	12° @ 550 12° @ 600							550 (D) NO A/C 600 (D) A/C	002 NO A/C 004 A/C	7043052	CF	674	517	0° @ 4" Hg 18° @ 12" Hg	0° @ 1100 7° @ 2300 16° @ 4200
H. ALTITUDE A. T. TBB C10 TBH G10	12° @ 600							600 (D)	010	17050492	DD				
CALIFORNIA M. T. TBI C10 TBJ G10	6° @ 850							850 (D)	303	7044383	CH	692	517	0° @ 4" Hg 18° @ 12" Hg	0° @ 1100 7° @ 1600 20° @ 4200
CALIFORNIA A. T. TBD C10 TBK G10	10° @ 600							600 (D)	302	7043052		682	549	0° @ 4" Hg 15° @ 12" Hg	0° @ 1100 7° @ 2300 16° @ 4200
305 CID V-8 ENGINE 2 BBL 2GC CARBURETOR RPO LG9 SOLENOID WITH A/C 704----															
49 STATES M. T. UTA C10 UTC G10	8° @ 600	R45TS .045	600 (N)	700	—	113 NO A/C 123 A/C	EGR, PCV TAC, ECS UFC, EFE	4598	CK	1103252	517	0° @ 4" Hg 18° @ 12" Hg	0° @ 1000 10° @ 1700 20° @ 3800		
49 STATES A. T. UTB C10 UTD G10	8° @ 500		500 (D)	650	—	108 NO A/C 110 A/C	4366								

A. T. AUTOMATIC TRANSMISSION
M. T. MANUAL TRANSMISSION
EGR EXHAUST GAS RECIRCULATION
TAC THERMOSTATIC AIR CLEANER
ECS EVAPORATION CONTROL SYSTEM

UFC UNDERFLOOR CATALYTIC CONVERTER
PCV POSITIVE CRANKCASE VENTILATION
AIR AIR INJECTION REACTOR
SD SPARK DELAY
EFE EARLY FUEL EVAPORATION

ENGINE PERFORMANCE SPECIFICATION INFORMATION - LD EMISSION LT. DUTY TRUCK

ENGINE AND CODE	IGNITION TIMING B.T.D.C. DEGREES	SPARK PLUG TYPE & GAP	CURB IDLE (RPM)	SOLENOID WITH A/C (RPM)	FAST IDLE (RPM) (N)	CARBURETOR IDENTIFICATION 17057----	EMISSION CONTROL DEVICES	EGR VALVE MODEL 704-----	EMISSION LABEL CODE	DISTRIBUTOR		VACUUM AND MECHANICAL ADVANCE	
										DISTRIBUTOR 1103----	VACUUM MODEL 1973----	VACUUM ADVANCE @ INCHES OF VACUUM (IN CRANK DEGREES)	MECHANICAL ADVANCE (CRANK DEGREES) @ ENGINE RPM
350 CID V-8 ENGINE 4 BBL M4MC CARBURETOR RPO LS9													
49 STATES M. T. TWD C10 3 SP.	8° @ 700	R45TS .045	700 (N)	---	1300	209	EGR PCV TAC ECS UFC EFE AIR (CALIFORNIA)	3133	CM	253	517	0° @ 4" Hg 18° @ 12" Hg	0° @ 1100 12° @ 1600 22° @ 4600
49 STATES M. T. TWF C10 4 SP.													
49 STATES M. T. TKC G10 3 SP.													
49 STATES A. T. TKB C10	8° @ 500		500 (D)	650 (D)	1600	202 NO A/C 204 A/C		6154					
49 STATES A. T. TKD G10						218 NO A/C 222 A/C							
H. ALTITUDE A. T. TJR C10	6° @ 600		600 (D)	650 (D)	1600	582 NO A/C 584 A/C		3139	WS OR CR	246	517	0° @ 4" Hg 18° @ 12" Hg	0° @ 1200 12° @ 2000 22° @ 4200
H. ALTITUDE A. T. TJS G10						588 NO A/C 586 A/C							
CALIFORNIA M. T. TWJ C10	6° @ 700		700 (N)	---	1300	503		4090	CN	254	482	0° @ 6" Hg 15° @ 12" Hg	0° @ 1200 12° @ 2000 22° @ 4200
CALIFORNIA M. T. TWK G10						519							
CALIFORNIA A. T. TJK C10	6° @ 500	500 (D)	650 (D)	1600	502 NO A/C 504 A/C	6154							
CALIFORNIA A. T. TJL G10					518 NO A/C 522 A/C								
454 CID V-8 ENGINE 4 BBL M4ME CARBURETOR RPO LF8													
49 STATES A. T. TSM C10	4° @ 600	R45TS .045	600 (D)	---	1600	221	EGR, PCV TAC, ECS EFE, AIR	4046	CS	238	511	0° @ 10" Hg 15° @ 17" Hg	0° @ 1100 14° @ 2800 20° @ 4200

A. T. AUTOMATIC TRANSMISSION
 M. T. MANUAL TRANSMISSION
 EGR EXHAUST GAS RECIRCULATION
 TAC THERMOSTATIC AIR CLEANER
 ECS EVAPORATION CONTROL SYSTEM
 UFC UNDERFLOOR CATALYTIC CONVERTER
 PCV POSITIVE CRANKCASE VENTILATION
 AIR AIR INJECTION REACTOR
 EFE EARLY FUEL EVAPORATION

ENGINE PERFORMANCE SPECIFICATION INFORMATION - HD EMISSION LT. DUTY TRUCK

ENGINE AND CODE	IGNITION TIMING B.T.D.C. DEGREES	SPARK PLUG TYPE & GAP	CURB IDLE (RPM)	BASE IDLE (RPM)	FAST IDLE (RPM) (N)	CARBURETOR IDENTIFICATION 17057----	EMISSION CONTROL DEVICES	EGR VALVE MODEL	EMISSION LABEL CODE	DISTRIBUTOR		VACUUM AND MECHANICAL ADVANCE	
										DISTRIBUTOR 1110----	VACUUM MODEL 1973----	VACUUM ADVANCE @ INCHES OF VACUUM (IN CRANK DEGREES)	MECHANICAL ADVANCE (CRANK DEGREES) @ ENGINE RPM
250 CID L-6 ENGINE 1 BBL 1ME CARBURETOR RPO LD4													
49 STATES M. T. TAT C10	6° @ 600	R46T .035	600 (N)	450 (N)	2400	007	PCV, TAC	—	CT	679	520	0° @ 10" Hg 10° @ 13" Hg	0° @ 1100
49 STATES A. T. TAS C10						006							24° @ 2300 14° @ 4100
292 CID L-6 ENGINE 1 BBL 1ME CARBURETOR RPO L25													
49 STATES M. T. THH CKP TUB G	8° @ 600	R44T .035	600 (N)	450 (N)	2400	009	PCV TAC TRC (CALIFORNIA) ECS (CALIFORNIA)	—	CT	679	520	0° @ 10" Hg 10° @ 13" Hg	0° @ 1100
49 STATES A. T. THK CKP THL C30, P30 TUA G						008							14° @ 2300 24° @ 4100
CALIFORNIA M. T. THR CKP TUD G						309			0° @ 1100 6° @ 2000 14° @ 2300 24° @ 4100				
CALIFORNIA A. T. THT CKP THU C30, P30 TUC G						308							
305 CID V-8 ENGINE 2 BBL 2GC CARBURETOR RPO LG9 1103----													
49 STATES M. T. UTF - CK	6° @ 700	R44T .045	700 (N)	—	—	17056137	PCV TAC TRC	—	CT	237	516	0° @ 8" Hg 10° @ 13" Hg	0° @ 1000
49 STATES A. T. UTH - CK													10° @ 1700 20° @ 3800

A. T. AUTOMATIC TRANSMISSION
M. T. MANUAL TRANSMISSION
TAC THERMOSTATIC AIR CLEANER

ECS EVAPORATION CONTROL SYSTEM
PCV POSITIVE CRANKCASE VENTILATION
TRC THROTTLE RETURN CONTROL

ENGINE PERFORMANCE SPECIFICATION INFORMATION - HD EMISSION

LT. DUTY TRUCK

ENGINE AND CODE	IGNITION TIMING B.T.D.C. DEGREES	SPARK PLUG TYPE & GAP	CURB IDLE (RPM)	BASE IDLE (RPM)	FAST IDLE (RPM) (N)	CARBURETOR IDENTIFICATION 17057----	EMISSION CONTROL DEVICES	EGR VALVE MODEL	EMISSION LABEL CODE	DISTRIBUTOR		VACUUM AND MECHANICAL ADVANCE	
										DISTRIBUTOR	VACUUM MODEL	VACUUM ADVANCE @ INCHES OF VACUUM (IN CRANK DEGREES)	MECHANICAL ADVANCE (CRANK DEGREES) @ ENGINE RPM
350 CID V-8 ENGINE 4 BBL 4 MV/M4MC CARBURETOR RPO LS9													
49 STATES M. T. TXD-CK 20-30 TYX-C10-20 TYT-G20-30 TXK-G30	8° @ 700	R44T .045	700 (N)	—	1600	213		—	CT	1103274	1973482	0° @ 6" Hg 15° @ 12" Hg	0° @ 1200 15° @ 2700 20° @ 4200
49 STATES M. T. TXR-P20-30 TXX-P30						216							
49 STATES A. T. TXB-CK20-30 TYZ CK10-20 TYU-G20-30						213							
49 STATES A. T. TXT-P20-30 TWT-P30						216							
49 STATES A. T. TXU P30 (MOTOR HOME)						215							
CALIFORNIA M. T. TXC CK20-30 TYW CK10-20	2° @ 700	R44TX .060	700 (N)	—	1600	7045583	PCV TAC AIR (CALIFORNIA) STVS (CKG SERIES) TRC (CALIFORNIA) ECS (CALIFORNIA)	—	CU	1103250	1973516	0° @ 8" Hg 10° @ 13" Hg	0° @ 1150 17° @ 2900 22° @ 4200
CALIFORNIA M. T. TYS G20-30 TXJ G30						514							
CALIFORNIA M. T. TXM P20-30 TXY P30						7045586							
CALIFORNIA A. T. TXA CK20-30 TYY CK10-20						7045583							
CALIFORNIA A. T. TYR G20-30						514							
CALIFORNIA A. T. TXS P20-30 TWW P30						7045586							
CALIFORNIA A. T. TXW P30 (MOTOR HOME)						7045585							

A. T. AUTOMATIC TRANSMISSION
M. T. MANUAL TRANSMISSION
TAC THERMOSTATIC AIR CLEANER
ECS EVAPORATION CONTROL SYSTEM

PCV POSITIVE CRANKCASE VENTILATION
AIR AIR INJECTION REACTOR
STVS SPARK TVS
TRC THROTTLE RETURN CONTROL

ENGINE PERFORMANCE SPECIFICATION INFORMATION - HD EMISSION

LT. DUTY TRUCK

ENGINE AND CODE	IGNITION TIMING B.T.D.C. DEGREES	SPARK PLUG TYPE & GAP	CURB IDLE (RPM)	BASE IDLE (RPM)	FAST IDLE (RPM) (N)	CARBURETOR IDENTIFICATION 1705_____	EMISSION CONTROL DEVICES	EGR VALVE MODEL	EMISSION LABEL CODE	DISTRIBUTOR		VACUUM AND MECHANICAL ADVANCE		
										DISTRIBUTOR 1103 _____	VACUUM MODEL 1973_____	VACUUM ADVANCE @ INCHES OF VACUUM (IN CRANK DEGREES)	MECHANICAL ADVANCE (CRANK DEGREES) @ ENGINE RPM	
400 CID V-8 ENGINE 4 BBL M4MC CARBURETOR RPO LF4														
49 STATES A. T. TLU G20-30 TLM K20-30 TLS K10-20	4° @ 700	R44T .045	700 (N)	—	1600	7229	PCV TAC STVS AIR (CAL- IFORNIA) TRC (CAL- IFORNIA) ECS (CAL- IFORNIA)	—	CT	249	482	0° @ 6" Hg 15° @ 12" Hg	0° @ 1000 8° @ 1600 19° @ 3450	
CALIFORNIA A. T. TLT G20-30	2° @ 700					7525			CU	250	516	0° @ 8" Hg 10° @ 13" Hg	0° @ 1150 17° @ 2900 22° @ 4200	
CALIFORNIA A. T. TLR K10-20 TLL K20-30						7529								
454 CID V-8 ENGINE 4MV/M4MC M4MC CARBURETOR RPO LF8														
49 STATES M. T. TSC C20-30	8° @ 700	R44T .045	700 (N)	—	1700	6212	PCV TAC AIR (CAL- IFORNIA) EGR (CAL- IFORNIA) TSC (C SERIES) TRC (CAL- IFORNIA) ECS (CAL- IFORNIA)	—	CT	238	511	0° @ 10" Hg 15° @ 17" Hg	0° @ 1100 14° @ 2800 20° @ 4200	
49 STATES A. T. TSD C20-30 TSK C10-20 TRA P30 (MOTOR HOME)						6517								
49 STATES A. T. TRC P30						7512			17050064					
CALIFORNIA M. T. TRZ C20-30						7512			17050064	CU	240	481	0° @ 6" Hg 20° @ 15" Hg	0° @ 1100 4° @ 2800 20° @ 4200
CALIFORNIA A. T. TSA C20-30 TSL C10-20 TRB P30 (MOTOR HOME) NO A/C TSR P30 (MOTOR HOME) A/C						7517			17050064					
CALIFORNIA A. T. TRD P30														

A. T. AUTOMATIC TRANSMISSION
M. T. MANUAL TRANSMISSION
EGR EXHAUST GAS RECIRCULATION
TAC THERMOSTATIC AIR CLEANER
ECS EVAPORATION CONTROL SYSTEM

UFC UNDERFLOOR CATALYTIC CONVERTER
PCV POSITIVE CRANKCASE VENTILATION
AIR AIR INJECTION REACTOR
TSC THERMAL SPARK CONTROL
TRC THROTTLE RETURN CONTROL

EARLY FUEL EVAPORATION (EFE)

GENERAL

INSPECTION

- Visually inspect exhaust heat valve for damage or binding linkage.
- Check that linkage is connected and vacuum hoses are properly routed and connected (Figs. 6E-15 and 16).
- Move exhaust heat valve by hand. If binding or stuck, free with manifold heat valve lubricant, GM Part No. 1050422 or equivalent. If valve cannot be freed, replace valve.

CHECKING EFE SYSTEM

1. With engine cold, position transmission in neutral or park and apply parking brake.
2. Start engine and observe movement of actuator rod and exhaust heat valve. Valve should move to its closed position.
3. If valve does not close, disconnect hose at actuator and check for vacuum.
 - If there is vacuum, replace actuator.
 - If there is no vacuum, disconnect hose at TVS-to-vacuum source.
 - If there is vacuum at hose, replace TVS.
 - If there is no vacuum, check for deteriorated hose and vacuum source to determine lack of vacuum.
4. When coolant reaches 180 °F (82 °C) (V8), or oil reaches 150 °F (66 °C) (six cylinder), the exhaust heat valve should move to its open position.
5. If valve does not move, disconnect hose at actuator and check for vacuum.
 - If there is vacuum, replace TVS.
 - If there is no vacuum, replace actuator.

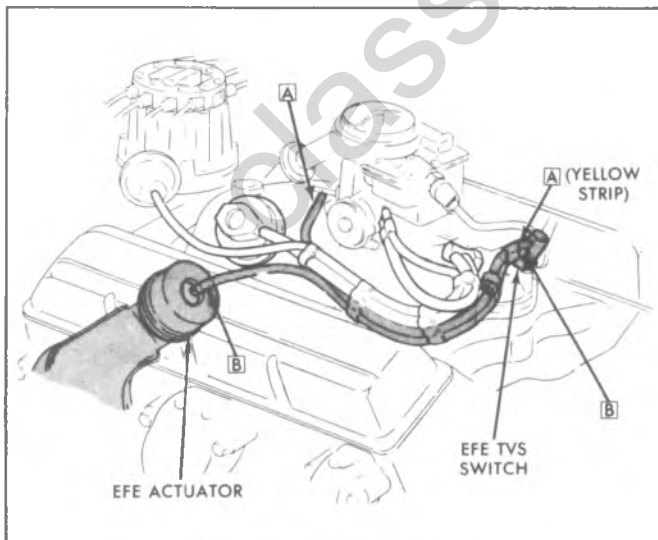


Fig. 6E-15--EFE System-V8

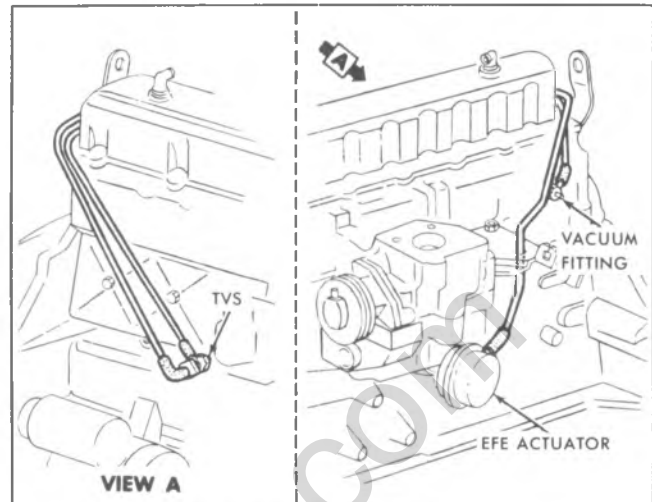


Fig. 6E-16--EFE System-L6

ON-VEHICLE SERVICE

THERMAL VACUUM SWITCH (TVS) - V8

Coolant Temperature

The TVS is located on the engine coolant outlet housing.

Replacement

1. Drain coolant below level of engine coolant outlet housing.
2. Disconnect hoses at TVS ports.
3. Remove TVS.
4. Apply a soft setting sealant uniformly on replacement TVS male threads. No sealant should be applied to sensor end of TVS.
5. Install TVS, tighten to 120 pound inches (14.N·m) and then hand torque clockwise as required to align TVS to accommodate hoses.
6. Connect hoses to TVS ports.
7. Add coolant as required.

THERMAL VACUUM SWITCH (TVS) - L6

Oil Temperature

The TVS is located on right hand oil gallery.

Replacement

1. Disconnect hoses at TVS ports.
2. Remove TVS switch.
3. Install TVS switch.
4. Connect hoses to TVS ports.

ACTUATOR AND ROD ASSEMBLY

The actuator and rod assembly is located on a bracket attached to right exhaust manifold on V8 engines (figs. 6E-17 and 6E-18) and on left side attached to exhaust manifold on L6 engine (fig. 6E-19).

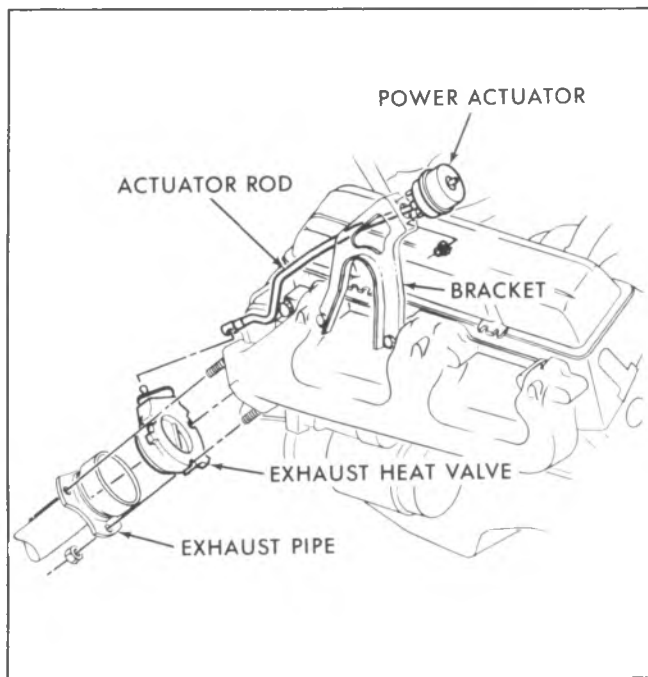


Fig. 6E-17--Actuator and Rod 305/350/400 V8

Replacement

1. Disconnect hose from actuator.
2. Remove 2 nuts attaching actuator-to-bracket.
3. Disconnect rod from valve and remove actuator and rod.
4. Install actuator and rod reversing steps 1 and 3. Tighten nuts to 25 pound inches (3 N·m).

EXHAUST HEAT VALVE - V8**Replacement**

1. Remove crossover exhaust pipe. Refer to Section 6F for removal and installation.

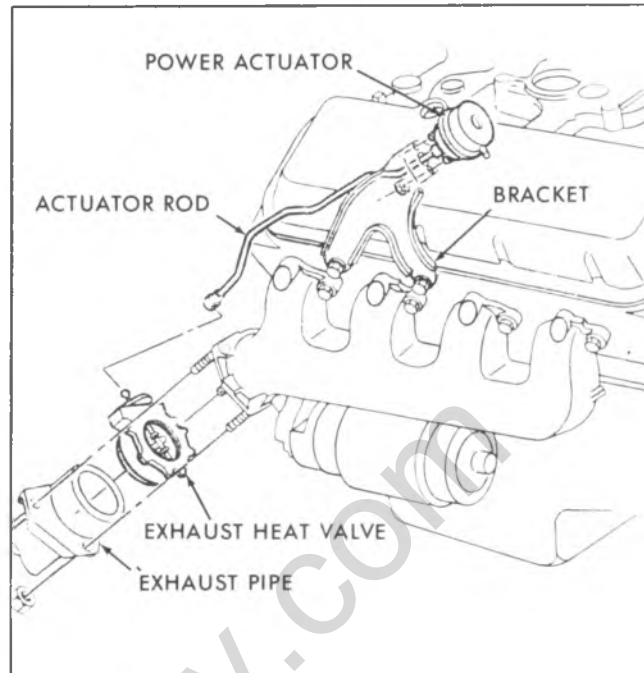


Fig. 6E-18--Actuator and Rod 454 V8

2. Disconnect rod from valve.
3. Remove valve.
4. Install valve and connect rod.
5. Install crossover exhaust pipe.

EXHAUST HEAT VALVE - L6**Replacement**

1. Remove 2 nuts attaching actuator bracket-to-valve and exhaust manifold.
2. Remove bracket and disconnect rod from valve.
3. Remove 2 additional nuts from valve and remove valve.
4. Install valve reversing Steps 1 through 3.

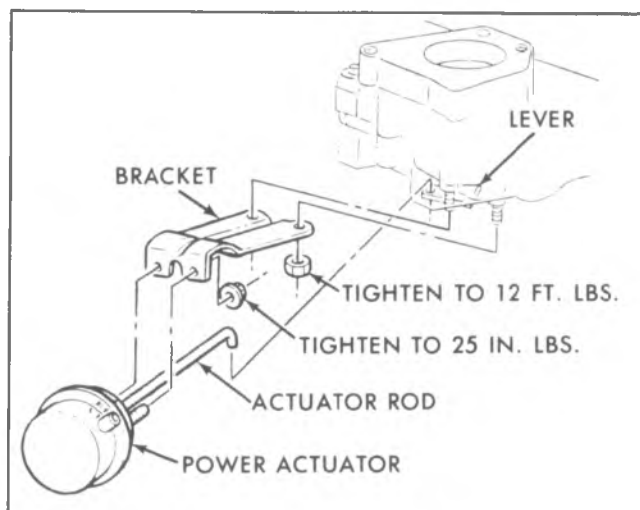


Fig. 6E-19-Actuator and Rod-L6

EXHAUST GAS RECIRCULATION (EGR)

ON-VEHICLE SERVICE

SYSTEM FUNCTIONAL TEST

1. Initial preparation.
 - a. Remove air cleaner so EGR valve diaphragm movement can be observed or felt.
- NOTE: When air cleaner is removed, it is recommended that the choke secondary vacuum break TVS be unclipped and removed from the air cleaner body rather than removing hoses.
- b. Plug intake manifold air cleaner vacuum fitting.
 - c. Connect a tachometer.
 - d. Warm up engine to operating temperature.
2. Open throttle part way and then release.
 3. Observe the EGR diaphragm for movement.

The valve should open slightly when the throttle is opened and close when it is released.
 4. Remove EGR hose from EGR valve and plug hose.
 5. Place cam follower on second step of fast idle cam and **note speed**
 6. Attach a vacuum hose between air cleaner vacuum fitting and the EGR valve (or use an external source in excess of 11 in. hg. [37kPa]) and **note speed change**. Speed should drop at least 200 RPM with A.T. or at least 150 RPM with M.T.

7. Summary.

- a. A successful function test must meet the following:
 - EGR diaphragm must move.

- Speed must drop when diaphragm moves.

FUNCTIONAL TEST OF INDIVIDUAL EGR SYSTEM COMPONENT PARTS

1. EGR VALVE (Valve can be left on or removed from the engine).
 - a. Depress the valve diaphragm.
 - b. With the diaphragm still depressed, plug the vacuum tube and release the diaphragm.
 - c. Observe diaphragm and/or pintle movement:
 - Valve is satisfactory if it takes over 20 seconds for the pintle to seat or for the diaphragm to achieve full travel.
 - Valve unsatisfactory and must be replaced if it takes less than 20 seconds for the pintle to seat or for diaphragm to achieve full travel.

GENERAL DESCRIPTION

EGR Valve

The EGR valve (Fig. 6E-20) contains a vacuum diaphragm, which is operated by intake manifold vacuum. The diaphragm vacuum signal supply port is located in the throttle body above the throttle valve, and is exposed to engine manifold vacuum in the off-idle and part throttle to wide open throttle operation. A .030 in. orifice in the valve vacuum tube serves to modulate flow.

BACK PRESSURE EGR VALVE

A back pressure EGR Valve (Fig. 6E-21) is used on all light duty emissions California and High Altitude V8 and L6 engines.

A small diaphragm control valve inside the EGR

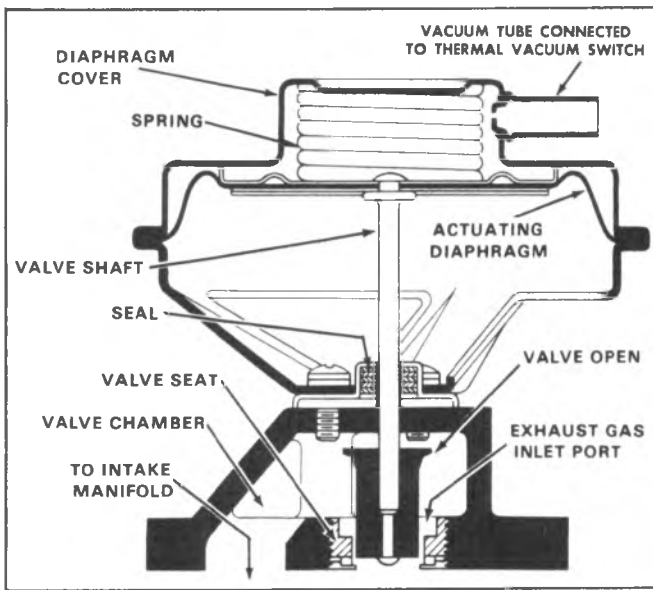


Fig. 6E-20-EGR Valve

valve assembly acts as a pressure regulator. The control valve receives an exhaust back pressure signal through the hollow shaft which exerts a force on the bottom of the control valve diaphragm, opposed by a light spring. A metal deflector plate prevents hot exhaust gases from flowing directly on the diaphragm.

Vacuum is applied to the EGR valve assembly from the carburetor spark port, to assure no exhaust gas recirculation at idle. During off-idle operation, manifold vacuum is applied to the vacuum chamber through a restriction in the signal tube. When engine load is light, and back pressure is low, the control valve is open, allowing air to flow from the 6 bleeds in the diaphragm plate, through the control valve orifice, into the vacuum chamber. The air bleeds off vacuum, decreasing the signal trying to open the EGR valve. Therefore, if back pressure does not close the control valve, sealing off the air flow, there will not be any vacuum built up to open the EGR valve for exhaust gas recirculation.

When power demands are made on the engine, and exhaust gas recirculation is needed, exhaust back pressure increases, closing the control valve, thereby shutting off air flow through the valve. Vacuum builds up in the vacuum chamber until the spring force holding the EGR valve closed is overcome.

Once the EGR valve opens, the exhaust pressure decreases because some of the exhaust gas is flowing into the intake manifold through the EGR passage. In actual operation, the system will reach a balanced condition providing optimum EGR operation.

Any increase in engine load will momentarily increase the exhaust signal, causing the control valve to

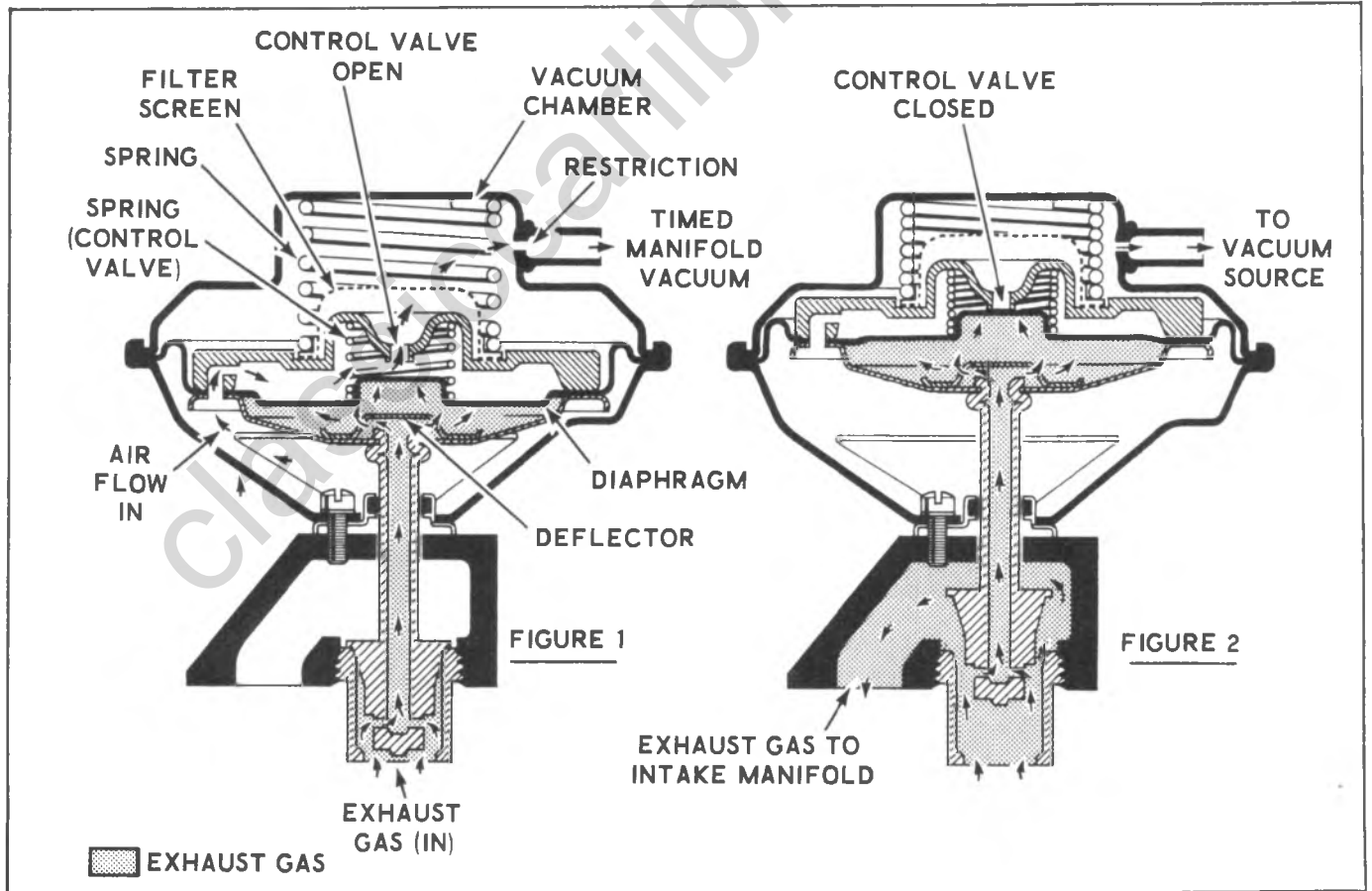


Fig. 6E-21-Back Pressure EGR Valve

close, allowing a stronger vacuum signal. The system will then stabilize at a greater EGR flow.

At maximum engine load, when manifold vacuum is nearly zero, momentarily, there will be no EGR operation. This is because of insufficient vacuum to pull the valve open, even though high exhaust back pressure has closed the control valve.

Thermal Vacuum Switch

A thermal vacuum switch shuts off vacuum to the EGR valve until coolant temperature is approximately 100 °F (38 °C) on L6 or 120 °F (49 °C) on V8.

DIAGNOSIS

Refer to Diagnosis Chart for diagnosis of exhaust gas recirculation system.

ON-VEHICLE SERVICE

Functional Test (on vehicle) - EGR Valve

1. With the engine running, the vehicle in "Park" or "Neutral", set the fast idle cam on second step to hold throttle open (approximately 1400 - 1600 RPM). Engine coolant temperature must be above 120 °F (49 °C).

2. Place finger beneath EGR valve in a manner to feel movement of diaphragm.

3. Disconnect the vacuum hose and watch for movement of the diaphragm downward (valve closed). This should be accompanied by increase in engine speed.

4. Reconnect the hose. Diaphragm should move upward (valve open). Engine RPM should decrease.

NOTE: A slight vibration of the diaphragm plate assembly may be noticed in back pressure models. This is due to the control valve modulating under light load and does not indicate an undesirable condition nor one requiring correction.

Failure Diagnosis

Diaphragm Doesn't Move:

1. Verify engine speed. Should be approximately 1400 - 1600 RPM.

2. Verify temperature: should be above 120 °F (49 °C).

3. Check for vacuum at hose. If no vacuum present, find cause for no vacuum. (Plugged or leaking hose or carburetor port, defective EFE/EGR switch).

4. In back pressure models, check control valve operation.

Diaphragm Moves With No Change In Engine RPM

Check manifold EGR passages for blockage.

Function Test (off vehicle) Control Valve (Back Pressure EGR Model Only)

1. Remove vacuum hose.

2. Remove two attaching bolts and EGR valve assembly from intake manifold, discard gasket.

3. Apply external vacuum [10" Hg. (34 kPa) or more] to signal tube. A constant vacuum supply must be used.

4. Valve should not open. If it does, control valve is stuck closed. Clean the valve. (See EGR valve cleaning).

5. With the vacuum still applied, direct a stream of air from a low pressure source into the valve exhaust gas intake.

6. Valve should open completely. If it does not open at all, control valve is stuck open or exhaust passages are plugged. Clean the valve (See EGR valve cleaning).

7. If EGR valve and control valve are both functioning properly, clean the mounting surfaces, then using a new gasket, install the valve to the intake manifold. Torque the bolts to 25 ft. lbs. (34 N·m).

8. Connect vacuum hose.

EGR Valve Cleaning

CAUTION: Do not wash valve assembly in solvents or degreaser - permanent damage to valve diaphragm may result. Also, sand blasting of the valve is not recommended since this can affect the operation of the valve.

1. Remove EGR valve and 2 attaching bolts, discarding the gasket.

2. Hold the valve assembly in hand, then tap lightly on the sides and end of the valve, and on the pintle itself using a small wood dowel, with a small plastic hammer to remove the exhaust deposits from the valve seat. Empty loose particles. **DO NOT PUT IN A VISE.**

3. With a wire wheel, buff the exhaust deposits from the mounting surface and around the valve.

4. Depress the valve diaphragm and look at the valve seating area through the valve outlet for cleanliness. If valve and/or seat are not completely clean, repeat step 3.

5. Look for exhaust deposits in the valve outlet. Remove deposit build up with a screwdriver.

6. Clean mounting surfaces of intake manifold and valve assembly, then using a new gasket install the valve assembly to the intake manifold. Torque the bolts to 25 ft. lbs. (34 N·m).

7. Connect vacuum hose.

EGR Passage

If inspection of EGR passages in the inlet manifold indicates excessive build-up of deposits, the passages should be cleaned. Care should be taken to ensure that all loose particles are completely removed to prevent them from clogging the EGR valve or from being ingested into the engine.

Replacement

1. Disconnect EGR valve (Fig. 6E-22 and 23).

2. Remove bolts securing valve to manifold.

3. Remove EGR valve from manifold.

4. Reassemble replacement valve to manifold, using a new gasket.

EXHAUST GAS RECIRCULATION SYSTEM DIAGNOSIS CHART

Condition	Possible Cause	Correction
Engine idles abnormally rough and/or stalls.	<p>EGR valve vacuum hoses misrouted.</p> <p>Leaking EGR valve.</p> <p>EGR valve gasket failed or loose EGR attaching bolts.</p> <p>EGR thermal control valve and/or EGR-TVS.</p> <p>Improper vacuum to EGR valve at idle.</p>	<p>Check EGR valve vacuum hose routing. Correct as required.</p> <p>Check EGR valve for correct operation.</p> <p>Check EGR attaching bolts for tightness. Tighten as required. If not loose, remove EGR valve and inspect gasket. Replace as required.</p> <p>Check vacuum into valve from carburetor EGR port with engine at normal operating temperature and at curb idle speed. Then check the vacuum out of the EGR thermal control valve to EGR valve. If the two vacuum readings are not equal within $\pm 1/2$ in. Hg. (1.7 kPa), then proceed to EGR vacuum control diagnoses.</p> <p>Check vacuum from carburetor EGR port with engine at stabilized operating temperature and at curb idle speed. If vacuum is more than 1.0 in. Hg., refer to carburetor idle diagnosis.</p>
Engine runs rough on light throttle acceleration, poor part load performance and poor fuel economy.	<p>EGR valve vacuum hose misrouted.</p> <p>Failed EGR vacuum control valve.</p> <p>EGR flow unbalanced due to deposit accumulation in EGR passages or under carburetor.</p> <p>Sticky or binding EGR valve.</p> <p>Wrong or no EGR gaskets.</p>	<p>Check EGR valve vacuum hose routing. Correct as required.</p> <p>Same as listing in "Engine Idles Rough" condition.</p> <p>Clean EGR passages of all deposits.</p> <p>Remove EGR valve and inspect. Clean or replace as required.</p> <p>Check and correct as required.</p>

EXHAUST GAS RECIRCULATION SYSTEM DIAGNOSIS CHART (CONT'D.)

Condition	Possible Cause	Correction
(Vehicle with back pressure EGR valve.) Engine stalls on decelerations.	Control valve blocked or air flow restricted. Restriction in EGR vacuum line. Sticking or binding EGR valve.	Check internal control valve function per service procedure. Check EGR vacuum lines for kinks bends, etc. Remove or replace hoses as required. Check EGR vacuum control valve function. Check EGR valve for excessive deposits causing sticky or binding operation. Clean or repair as required. Remove EGR valve and inspect clean or repair as required.
(Vehicle with a back pressure EGR valve.) Part throttle engine detonation.	Control valve blocked or air flow restricted. Insufficient exhaust gas recirculation flow during part throttle accelerations.	Check internal control valve function per service procedure. Check EGR valve hose routing. Check EGR valve operation. Repair or replace as required. Check EGR thermal control valve and/or EGR-TVS as listed in "Engine Idles Rough" section. Replace valve as required. Check EGR passages and valve for excessive deposit. Clean as required.
(Vehicle with a back pressure EGR valve.) (NOTE: Detonation can be caused by several other engine variables. Perform ignition and carburetor related diagnosis.)	Control valve blocked or air flow restricted.	Check internal control valve function per service procedure.
Engine starts but immediately stalls when cold.	EGR valve hoses misrouted. EGR system malfunctioning when engine is cold.	Check EGR valve hose routings. Perform check to determine if the EGR thermal control valve and/or EGR-TVS are operational. Replace as required.
(Vehicle with a back pressure EGR valve.) (NOTE: Stalls after start can also be caused by carburetor problems.)	Control valve blocked or air flow restricted.	Check internal control valve function per service procedure.

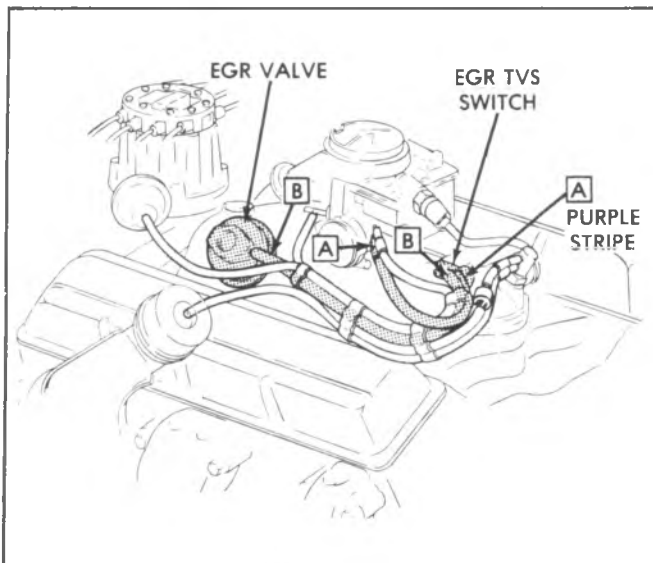


Fig. 6E-22--EGR System-V8

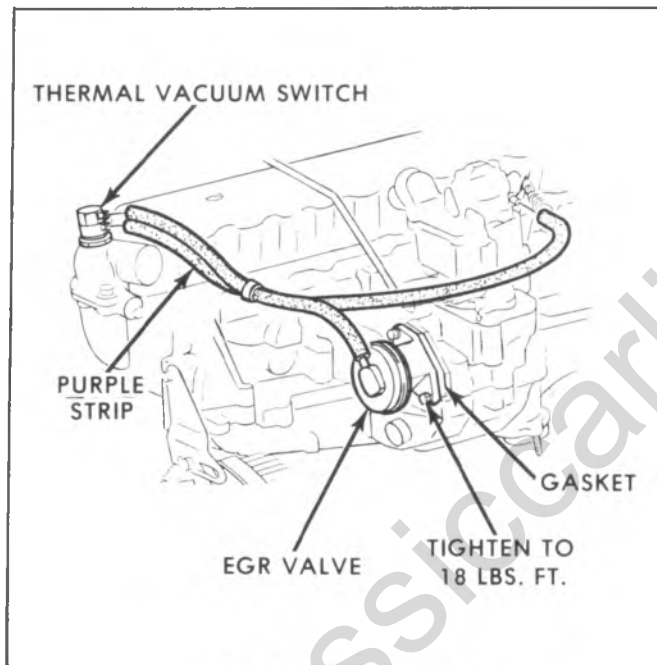


Fig. 6E-23--EGR System-L6

5. Torque clamp bolt to 13-18 lb. ft.
6. Connect carburetor vacuum signal line to tube at top of valve.

THERMAL VACUUM SWITCH (TVS)

Replacement

1. Disconnect vacuum lines (Figs. 6E-22 and 23) from the thermal vacuum switch.
2. Remove switch from thermostat housing.
3. Apply an approved sealer to threaded portion of switch.
4. Install switch in thermostat housing and torque to 100 lbs. in.
5. Rotate switch head as required to align for proper hose routing.

6. Install vacuum hoses to switch.

Functional Check

Hot

NOTE: This is to be performed as part of the emission maintenance routine at 12,000 miles or 12 months on heavy duty emission vehicles.

The EGR Thermal Vacuum Delay Switch should be open above coolant temperature 100 °F (38 °C) on L6 and 120 °F (49 °C) on V8 permitting the ported vacuum signal to reach the EGR valve above that temperature. Check as follows:

1. Remove EGR valve vacuum hose at EGR valve and connect hose to a vacuum gage.
2. Start engine. With transmission selector lever in Neutral or Park open throttle partially. (Do not overspeed engine.) As throttle is opened, the vacuum gage should respond with an increase in vacuum reading. (Note: Coolant temperature must be above 120 °F (49 °C) during this test. Allow about 3 minutes at idle to warm up a cold engine. If coolant is below 75 °F (24 °C) greater time may be required.)
3. If operation is satisfactory, remove gage and reconnect hose to EGR valve.
If gage does not respond to throttle opening, proceed to Step 4.
4. Remove Carb-to-switch hose from switch and connect hose to vacuum gage. Repeat Step 2.
5. If vacuum gage responds to throttle opening, then switch is defective. Remove switch and replace with new part.
If gage does not respond to throttle opening, then check for plugged hose or defective carburetor.

Cold

NOTE: This check may be performed in diagnosing complaint of stall after cold start or poor driveability immediately after cold start.

The EGR thermal vacuum delay switch should be closed below coolant temperature 100 °F (38 °C) on L6 on 120 °F (49 °C) on V8, thereby blocking the ported vacuum signal from reaching the EGR valve below that temperature. Check as follows:

1. Drain coolant below level of thermostat housing.
2. Disconnect vacuum lines and remove switch from thermostat housing.
3. Inspect switch to make sure it is in good condition.
4. Connect a vacuum hose to lower nipple of switch, marked "C" or "CARB". Connect a vacuum gage to upper nipple, marked "E" or "EGR".
5. Place switch in water at 85 °F (29 °C) and submerge completely for 2 minutes while agitating water thoroughly.
6. Apply 12 in. hg. (-41 kPa) vacuum to hose on lower nipple of switch. Under this condition, the switch should be closed.

NOTE: Leakage of up to 2in. hg. (-7kPa) of

vacuum in 2 minutes is allowable and does not constitute a defective switch.

7. If operation is satisfactory, re-install switch in thermostat housing. If switch is defective, replace with new part.

EGR SYSTEM - INSPECTION AND CLEANING

The following procedure is to be used for the inspection and cleaning of the EGR valve and passages.

Inspection

1. Remove air cleaner.
2. Remove EGR valve from intake manifold.
3. Look for deposits on the valve pintle.
4. Depress the valve diaphragm and inspect for deposits around the valve seating area thru the valve outlet.
5. With the diaphragm still depressed, plug the vacuum tube then release the diaphragm. If the pintle has not closed in 20 seconds, the EGR valve is OK. If the pintle is closed within 20 seconds, the valve must be replaced.
6. The valve requires cleaning if deposits exist.

Cleaning

1. Hold the valve assembly in hand. Then, using a light snapping action with a plastic hammer, tap on the end of the round pintle to remove the exhaust deposits from the valve seat. Empty loose particles.
2. Clean the mounting surface of the EGR valve with a wire wheel or wire brush, and the pintle with a wire brush.

3. Depress the valve diaphragm and check the seating area for cleanliness by looking thru the valve outlet. If pintle or seat are not completely clean, repeat step 1.

4. Inspect the valve outlet for deposits. Remove any deposit build-up with a screwdriver or other suitable sharp tool.

5. Clean mounting surface on the intake manifold with a wire wheel or wire brush.

NOTE: Do not use solvents for cleaning.

Intake Manifold Passages

1. Remove carburetor.
2. Remove the deposits from the EGR ports by hand turning a drill into the passage. Finish cleaning with a small screwdriver.

CAUTION: Do not use a power drill or file.

3. Brush any small particles down the EGR port and blow compressed air through the port.

NOTE: Do not use solvents for cleaning.

Reassembly

1. Reinstall carburetor using a new gasket and torque hold-down bolts to 10-15 ft. lbs.
2. Reinstall the EGR valve assembly to the intake manifold using a new gasket and torque bolt to 12-17 ft. lbs.
3. Connect fuel line and all vacuum hoses.
4. Warm up engine and reset idle rpm to specification if necessary per Emission Control Information label.
5. Perform functional check of EGR system to ensure correct operation.

POSITIVE CRANKCASE VENTILATION SYSTEM (PCV)

GENERAL DESCRIPTION

Ventilation air is drawn through a filter assembly located in the air cleaner, through a hose, down into the crankcase, up through the ventilator valve, through a hose and into the intake manifold. Intake manifold vacuum draws any fumes from the crankcase to be burned in the engine.

When air flow through the carburetor is high, added air from the Positive Crankcase Ventilation System has no noticeable effect on engine operation; however, at idle speed, air flow through the carburetor is so low that any large amount added by the ventilating system would upset the air-fuel mixture, causing rough idle.

For this reason, a flow control valve is used which restricts the ventilating system flow whenever intake manifold vacuum is high.

ON-VEHICLE SERVICE

1. Remove PCV valve from intake manifold or rocker arm shaft cover.
2. Run the engine at idle.
3. Place your thumb over end of valve to check for vacuum. If there is no vacuum at valve, check for plugged hoses or valve. Hoses may be cleared with compressed air.
4. Shut off the engine and remove PCV valve. Shake valve and listen for the rattle of check needle in valve. If valve does not rattle, replace valve.

THERMOSTATIC AIR CLEANER (TAC)

INSPECTION

Vacuum Motor Check

1. Check all hoses for proper hook-up. Check for kinked, plugged or damaged hoses.

2. With the engine "OFF", observe damper door position through snorkel opening. If position of snorkel makes observation difficult, use the aid of a mirror. At this point damper door should be in such a position that the heat stove passage is covered (snorkel passage open) (Fig. 6E-24). If not, check for binds in linkage.

3. Apply at least 7 in Hg. of vacuum to the diaphragm assembly through hose disconnected at sensor unit. Damper door should completely close snorkel passage when vacuum is applied. (Fig. 6E-24). If not, check to see if linkage is hooked up correctly and for a vacuum leak.

4. With vacuum applied, bend or clamp hose to trap vacuum in diaphragm assembly. Damper door should remain in position (closed snorkel passage) (Fig. 6E-24). If it does not, there is a vacuum leak in diaphragm assembly. Replace diaphragm assembly.

Sensor Check (Quick Check of System)

1. Start test with engine cold, air cleaner at a temperature below 79°F (26°C.). If the engine has been in recent use, allow it to cool. (Removing the air cleaner from the engine and placing it on the bench will aid in quickly cooling the sensor.)

2. Observe the damper door before starting the

engine: it should be in the open snorkel position (Fig. 6E-24).

3. Start the engine and allow it to idle. Immediately after starting the engine, the damper door should be in the closed snorkel passage position (Fig. 6E-24).

4. As the engine warms up, the damper door should start to allow outside air and heated air to enter the carburetor inlet.

5. The system is operating normally as described above. If the air cleaner fails to operate as above, or if correct operation of the air cleaner is still in doubt, proceed to the thermometer check (of sensor).

Thermometer Check of Sensor

1. Start test with air cleaner temperature below 79°F (26°C.). If engine has been run recently, remove air cleaner and place on bench (this will help quickly cool the air cleaner). Remove air cleaner cover and place thermometer as close as possible to the sensor. Let air cleaner cool until thermometer reads below 79°F (26°C.) about 5 to 10 minutes. Reinstall air cleaner on engine and continue to step 2 below.

2. Start and idle engine. Damper door should move to close the snorkel passage immediately if engine is cool enough. When damper door starts to open the snorkel passage (in a few minutes), remove air cleaner cover and read temperature gage. It must read 115°F. \pm 20°F (46°C. \pm 7°C).

3. If the damper door does not start to open up the snorkel passage at temperature indicated, temperature sensor is malfunctioning and must be replaced.

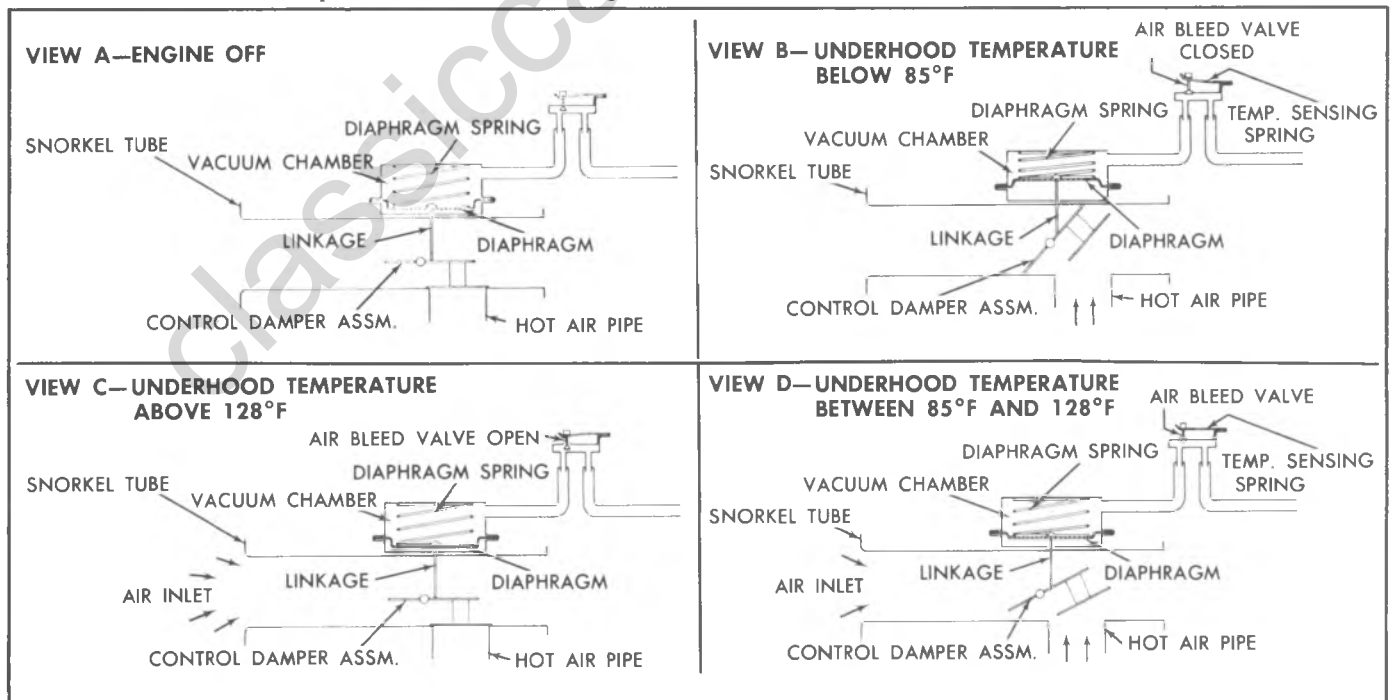


Fig. 6E-24—Air Cleaner Operation

ON VEHICLE SERVICE

Checking Air Cleaner

1. Inspect system to be sure all hoses and ducts are connected.
2. If engine is warm (above room temperature) remove air cleaner. Permit it to cool to room temperature.
3. Install cooled air cleaner. If air cleaner has cold air intake hose, disconnect it.
4. Start engine. Watch damper valve in air cleaner snorkel.
5. When engine is first started, valve should be closed. As air cleaner warms up, valve should slowly open.

NOTE: In hot weather the room temperature may be too hot for the snorkel valve to close when the engine is started. In this case, cool the temperature sensor in the air cleaner with a cool wet rag.

6. If valve doesn't close when the engine is started, check for vacuum at the diaphragm.
7. If vacuum is present, check for binding in the damper valve and operating link. If damper moves freely, replace diaphragm. (Failure of the diaphragm to close is more likely to result from mechanical bind due to a damaged or corroded snorkel assembly than from a failed diaphragm. This should be checked first, before replacing the diaphragm).
8. If no vacuum is present, check hoses for disconnects, cracks or pinches. Repair or replace as necessary.
9. If hoses are OK, replace temperature sensor in the air cleaner.

Air Cleaner Element Replacement

Paper Element

1. Remove air cleaner cover.
2. Remove element.
3. Install new element in air cleaner with either end up.
4. Install air cleaner cover. Do not over-torque wing nut.

Polywrap Element

1. Remove air cleaner cover.
2. Remove element.
3. Remove polywrap band from paper element and discard element (Fig. 6E-25).
4. Clean bottom section of air cleaner and inspect cover seal for tears or cracks. Replace seal if damaged.
5. Inspect band for tears and replace if damaged.
6. If band is serviceable, wash in kerosene or mineral spirits and squeeze out excess solvent (Fig. 6E-26).

NOTE: Never use a hot degreaser or any solvent containing acetone or similar solvent; also, never

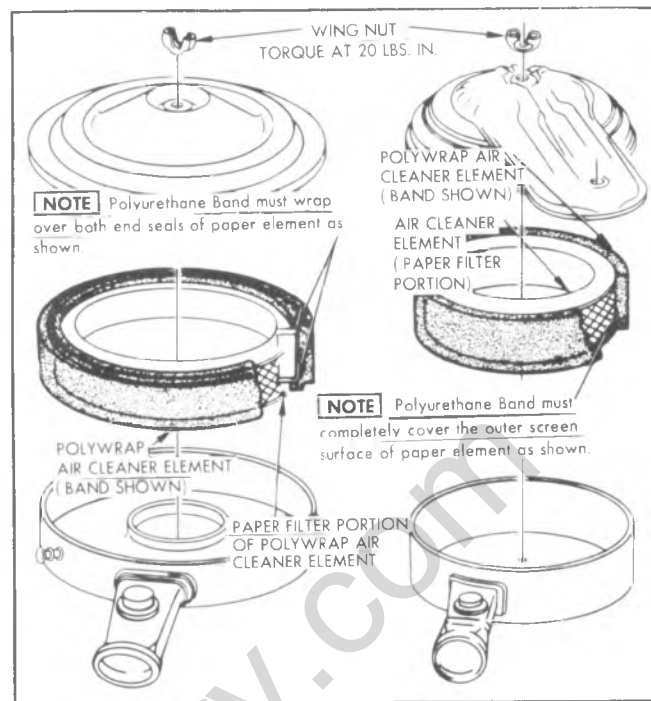


Fig. 6E-25--Polywrap Air Cleaner Element



Fig. 6E-26--Cleaning Polywrap Band

shake, swing or wring the element to remove excess solvent as this may tear the polyurethane material. Instead, "squeeze" the excess solvent from the element.

7. Dip band into light engine oil and squeeze out excess oil.
8. Install band around outer surface of new paper element.
9. Install element in bottom section of air cleaner with either end up.
10. Install air cleaner cover. Do not over-torque wing nuts(s).

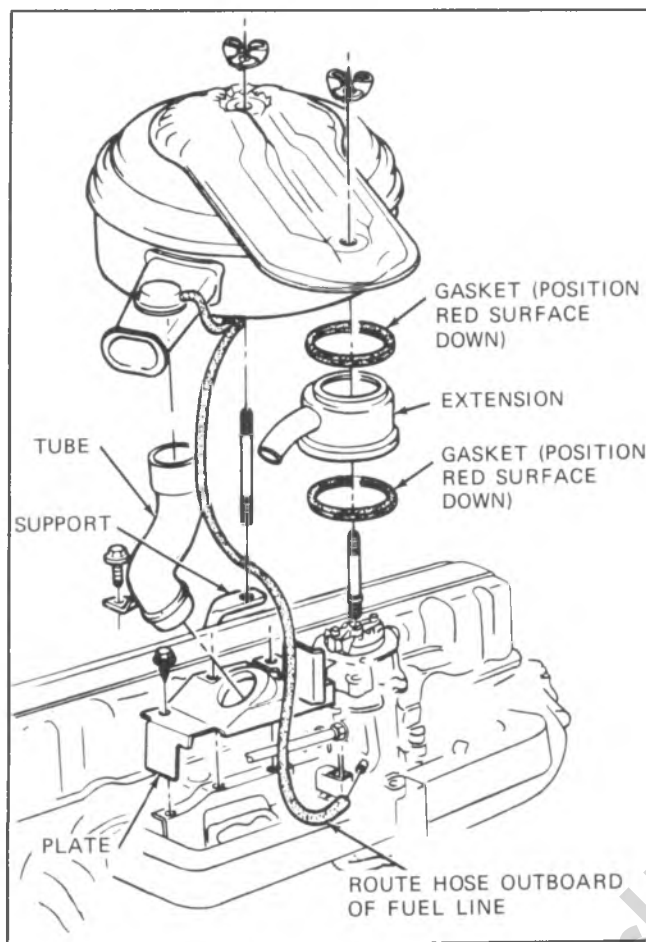


Fig. 6E-27--Air Cleaner-L6-Integrated Head

Air Cleaner Replacement

Refer to figures 6E-27 and 6E-28 for air cleaner used with in line L6 engine.

Refer to figure 6E-29 for air cleaner used on CK truck with 305/350/400 V8 engine.

Refer to figure 6E-30 for air cleaner used on G truck with V8 engine.

Refer to figure 6E-31 for air cleaner used with 454 V8 engine.

Refer to figure 6E-32 for air cleaner used of P20(42), P30(42) and P30(32) truck with 350 V8 engine and 4MV carburetor.

Carburetor Air Intake

Refer to figure 6E-33 and 6E-34 for repair or replacement of air intake.

Vacuum Motor

Removal

1. Remove air cleaner.
2. Disconnect vacuum hose from motor.
3. Drill out the two spot welds initially with a 1/6"

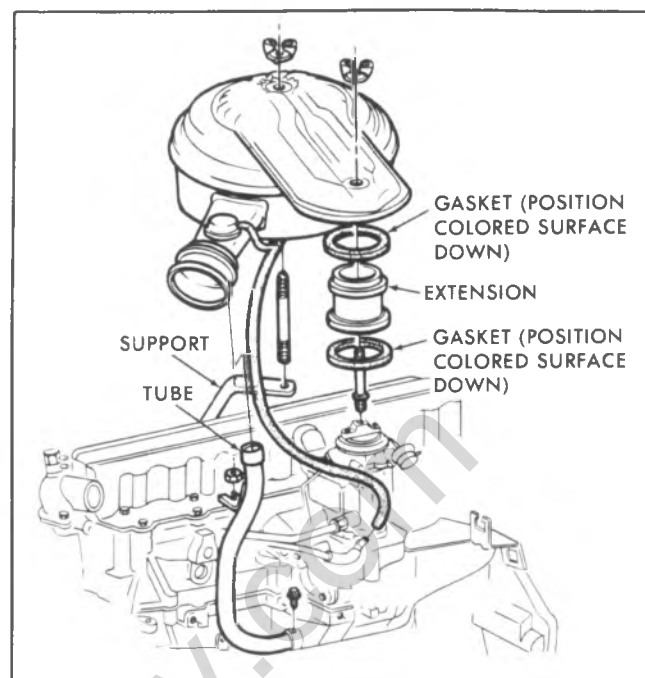


Fig. 6E-28--Air Cleaner-L6-Non-Integrated Head

hole, then enlarge as required to remove the retaining strap. Do not damage the snorkel tube.

4. Remove motor retaining strap.
5. Lift up motor, cocking it to one side to unhook the motor linkage at the control damper assembly.

Installation

1. Drill a 7/64" hole in snorkel tube at center of vacuum motor retaining strap (Fig. 6E-35).
2. Insert vacuum motor linkage into control damper assembly.
3. Use the motor retaining strap and sheet metal screw provided in the motor service package to secure the retaining strap and motor to the snorkel tube.
4. Make sure the screw does not interfere with the operation of the damper assembly. Shorten screw if required.
5. Connect vacuum hose to motor and install air cleaner.

Sensor

Removal

1. Remove air cleaner.
2. Detach hoses at sensor.
3. Pry up tabs on sensor retaining clip (Fig. 6E-36); remove clip and sensor from air cleaner. Note position of sensor for installation.

Installation

1. Install sensor and gasket assembly in original position.
2. Press retainer clip on hose connectors.
3. Connect vacuum hoses and install air cleaner on engine.

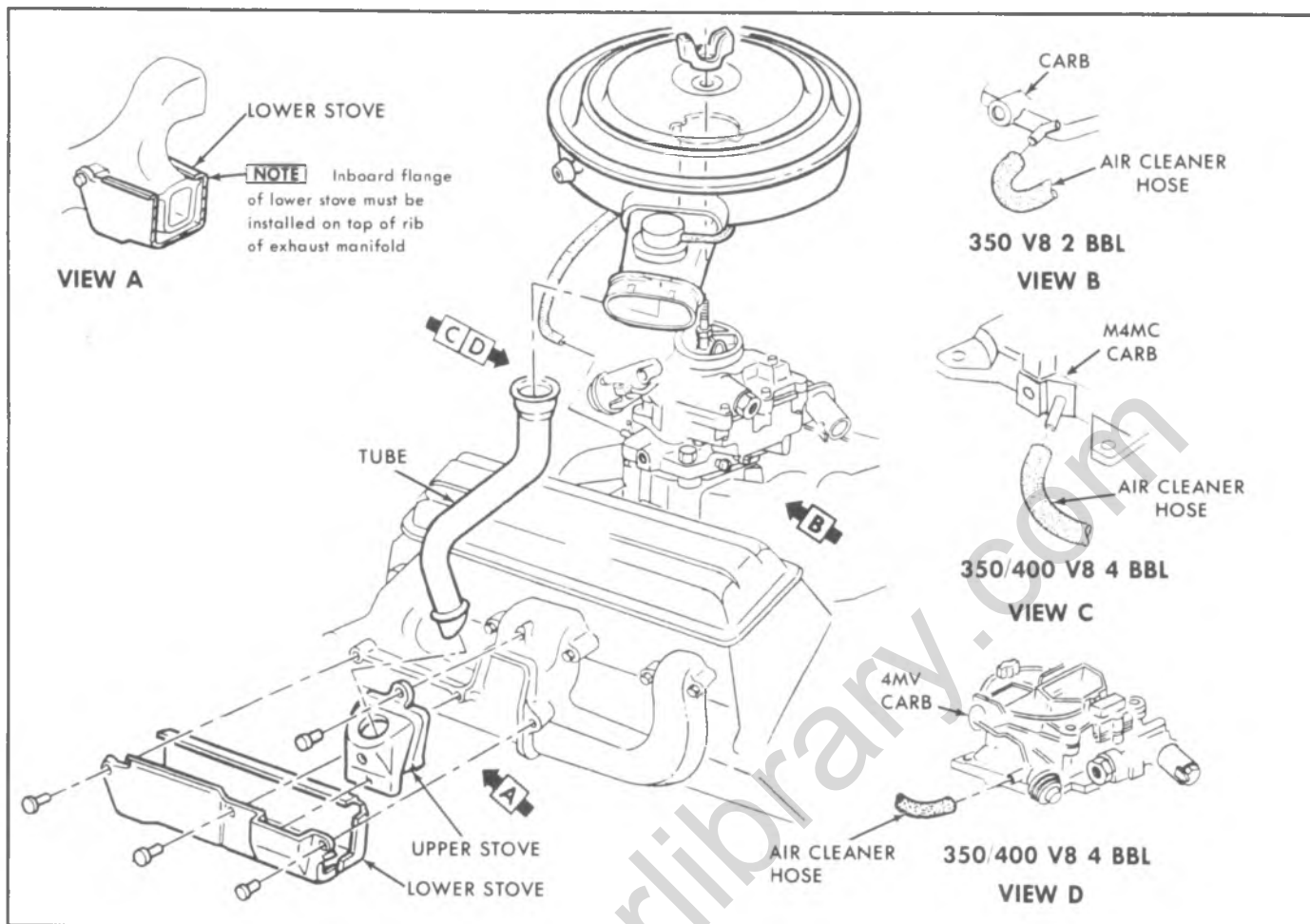


Fig. 6E-29-Air Cleaner-305/350/400 V8 CK

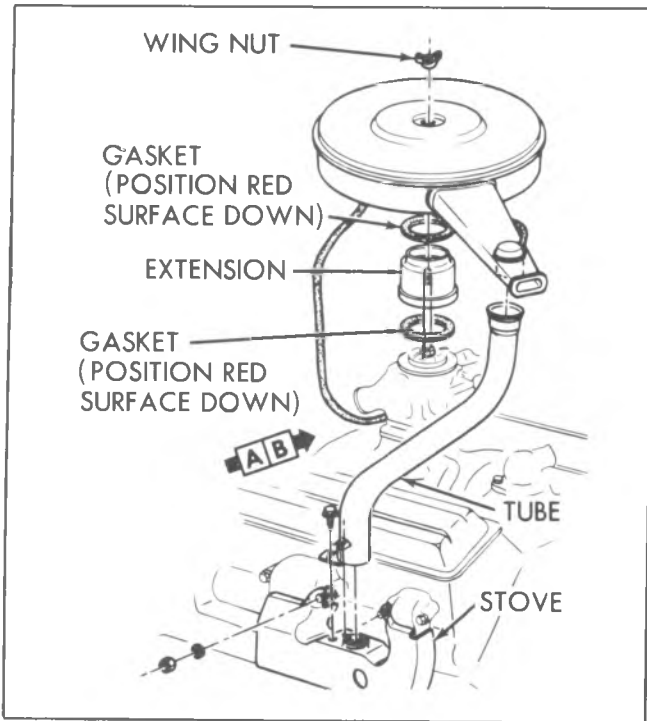


Fig. 6E-30--Air Cleaner-V8 G

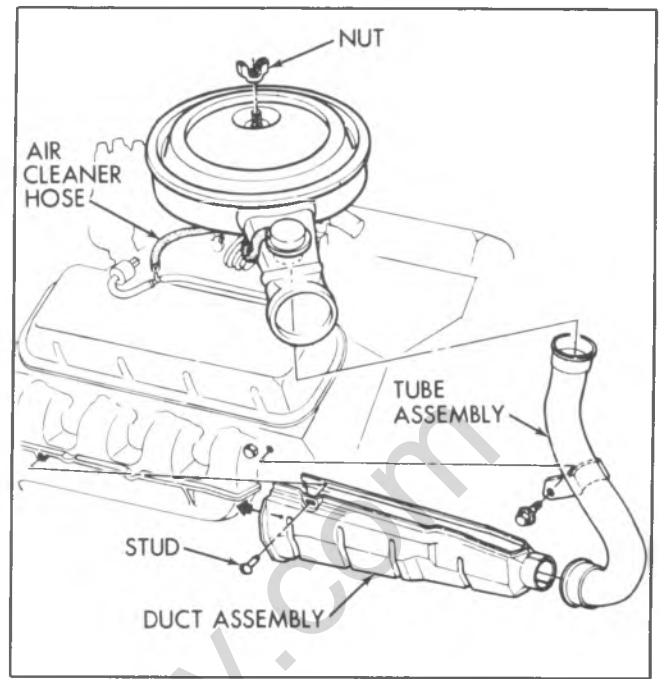


Fig. 6E-31--Air Cleaner-454 V8

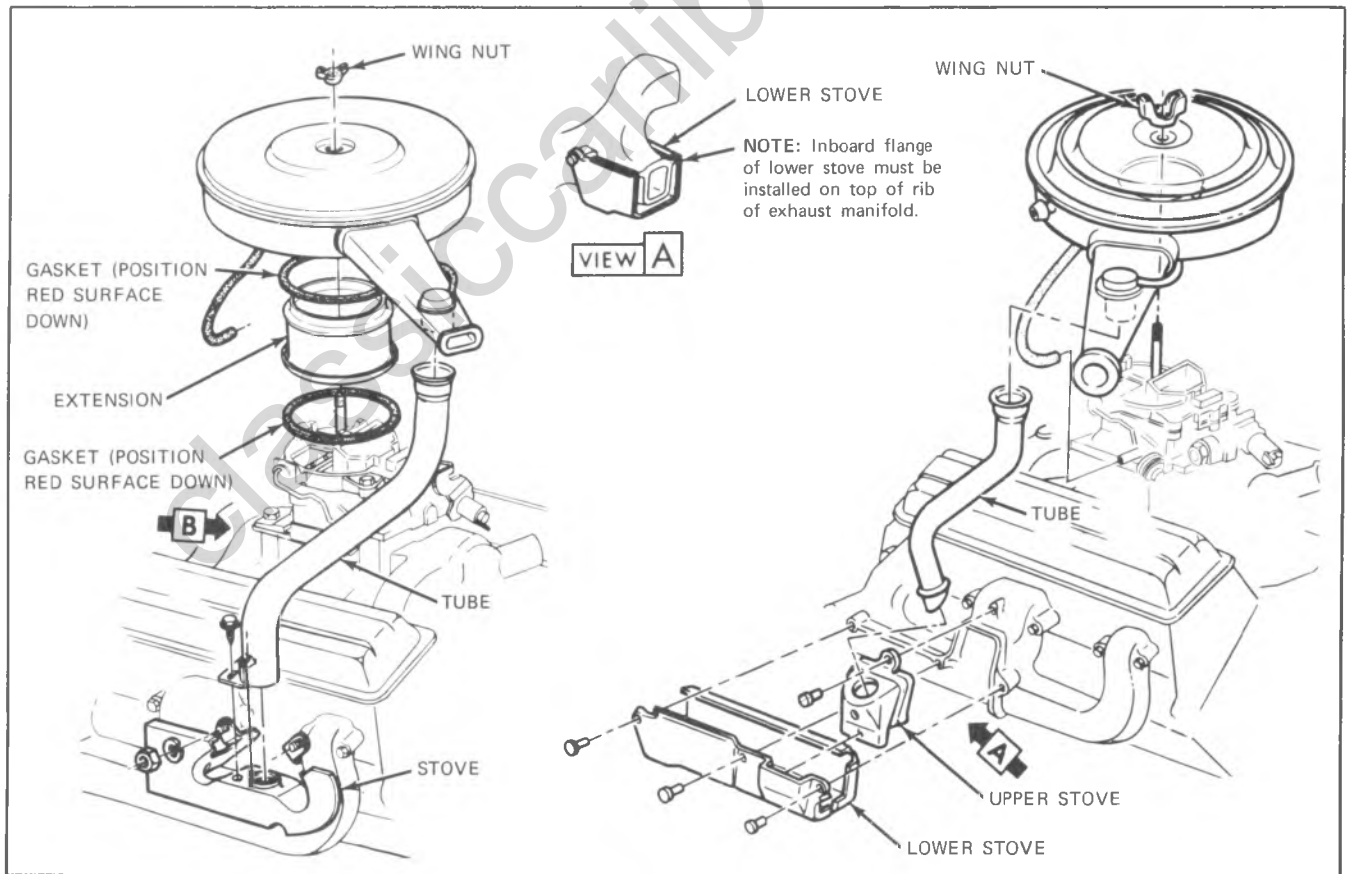


Fig. 6E-32--Air Cleaner-P20(42), P30(42), P30(32)-V8

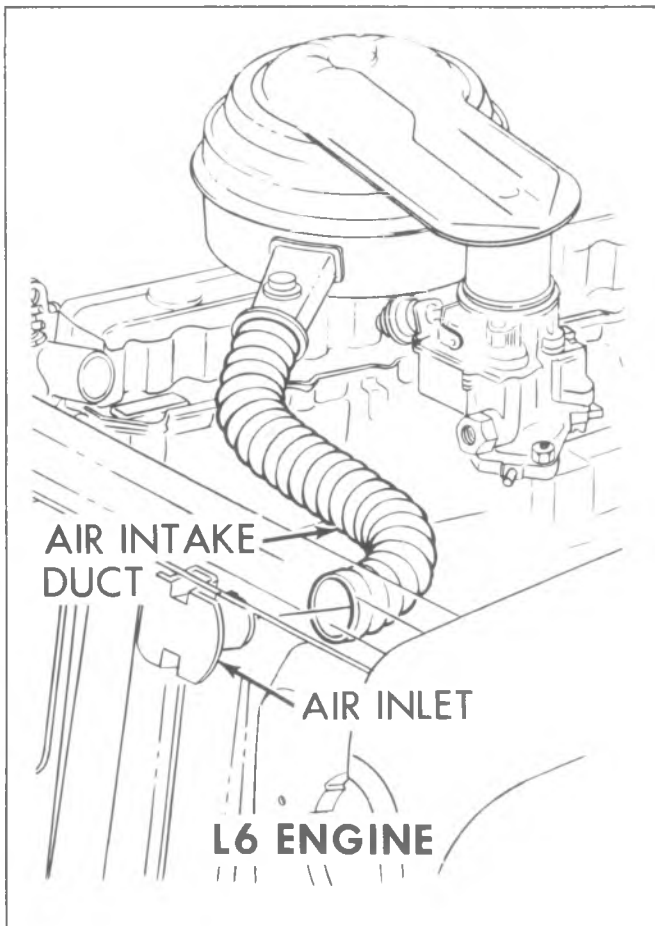


Fig. 6E-33--Carburetor Air Intake-L6

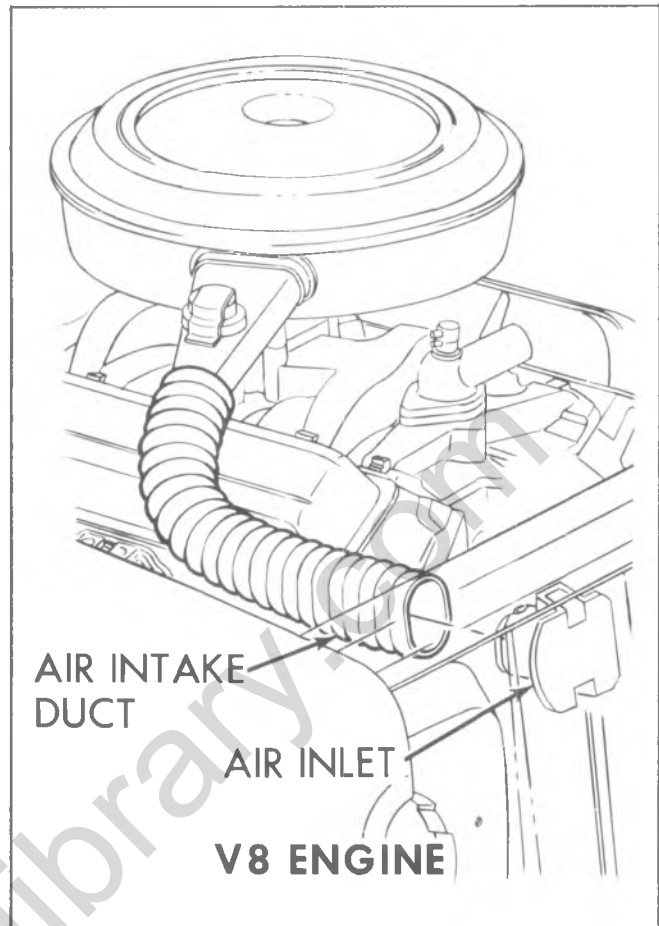


Fig. 6E-34--Carburetor Air Intake-V8

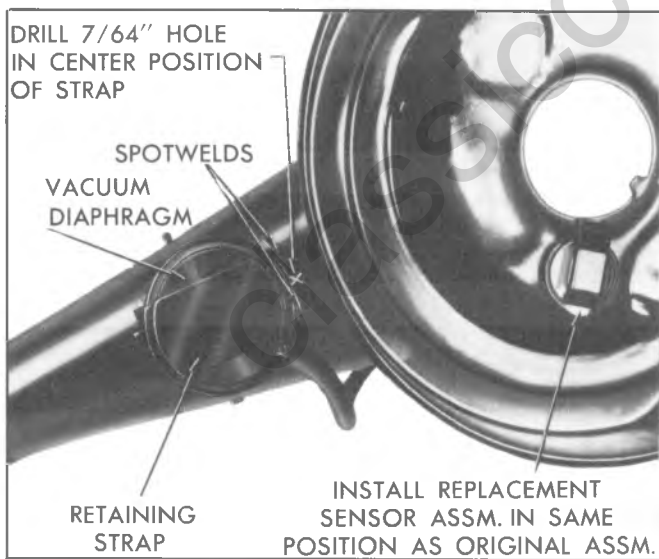


Fig. 6E-35--Vacuum Diaphragm Replacement



Fig. 6E-36--Removing Sensor Unit

AIR INJECTION REACTOR (AIR) SYSTEM

GENERAL DESCRIPTION

The Air Injection Reactor (A.I.R.) System consists of: an air injection pump (with necessary brackets and drive attachments), air diverter valve, a check valve and air pipe hose necessary to connect diverter valve (Figs. 6E-37 and 38).

The Air Injection Pump (Fig. 6E-39) with an integral filter, compresses the air and injects it through the air manifolds, into the exhaust system in the area of the exhaust valves. The fresh air helps burn the unburned portion of the exhaust gases in the exhaust system, thus minimizing exhaust contamination.

The diverter valve (Fig. 6E-40) when triggered by a

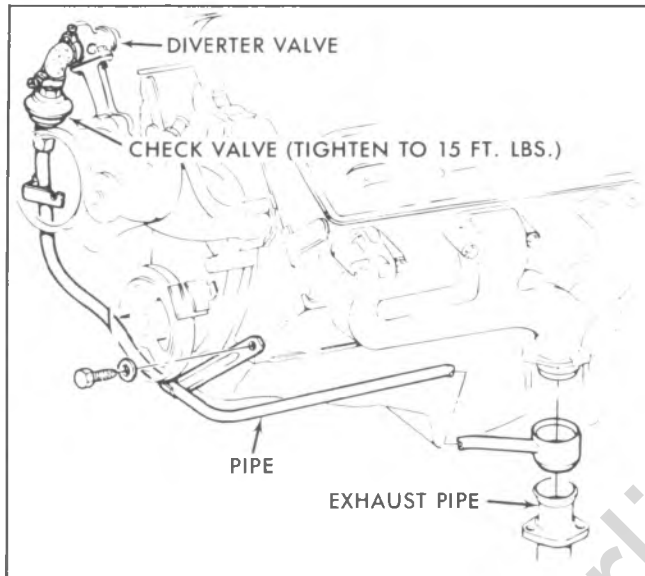


Fig. 6E-37-Air Pipe Installation-C10 and 350 V8 Cal

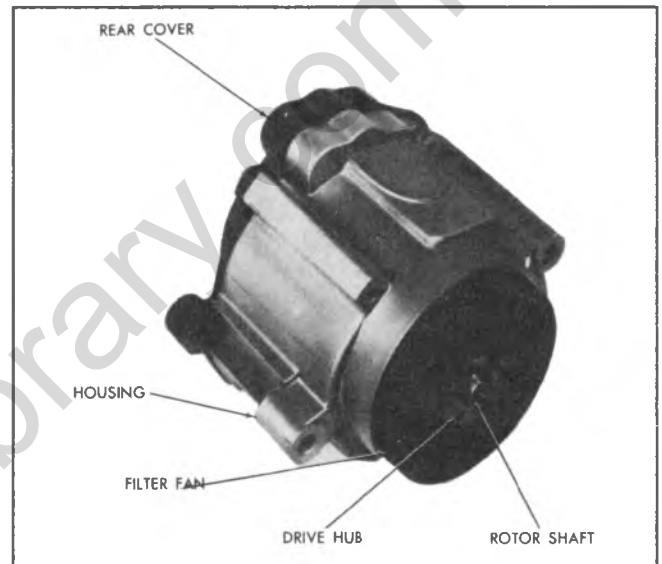


Fig. 6E-39-Air Injection Pump

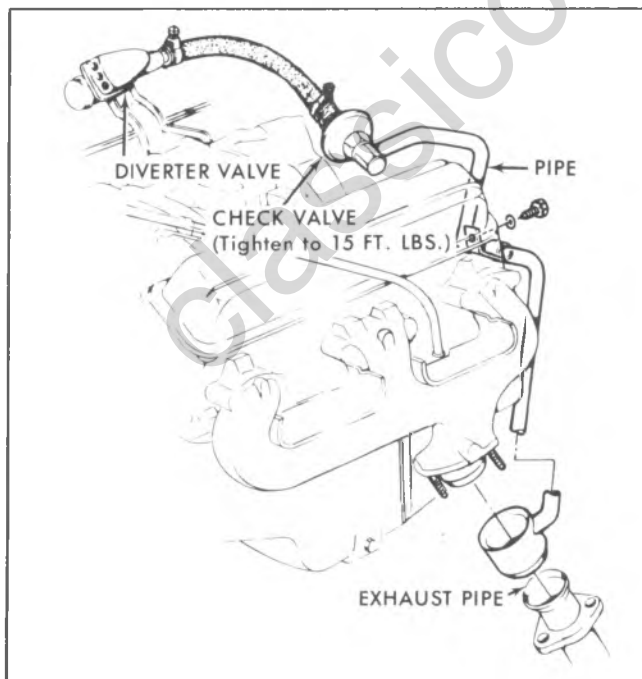


Fig. 6E-38-Air Pipe Installation G10 and 350 V8 Cal

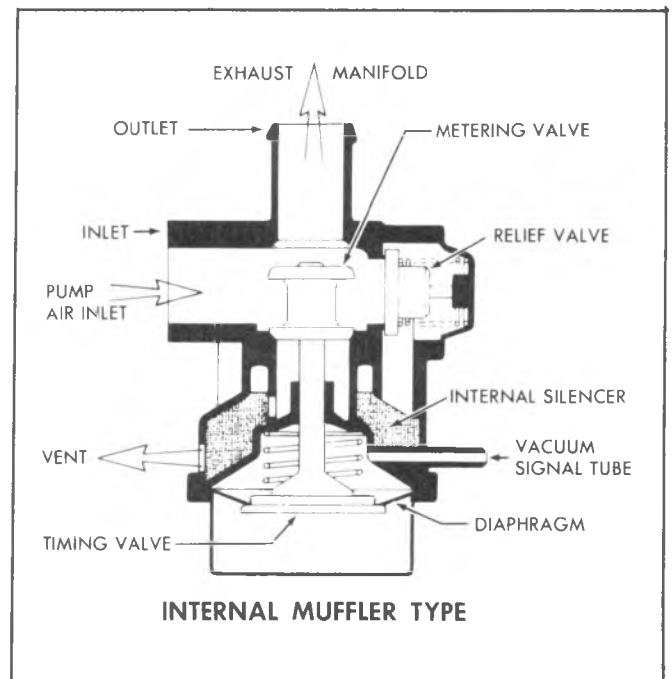


Fig. 6E-40-Diverter Valve

sharp increase in manifold vacuum, shuts off the injected air to the exhaust port areas and prevents backfiring during this richer period.

On engine overrun the total air supply is dumped through the muffler on the diverter valve. At high engine speeds the excess air is dumped through the pressure relief valve which is incorporated in the diverter valve.

The check valve (Fig. 6E-37 and 38) prevents exhaust gases from entering and damaging the air injection pump, as back flow can occur even under normal operating conditions.

ON-VEHICLE SERVICE

Drive Belt

Inspection

1. Inspect drive belt for wear, cracks or deterioration and replace if required.
2. Inspect belt tension and adjust if below 70 lbs. using a tension gauge.

Adjustment

Loosen pump mounting bolt and pump adjustment bracket bolt. Move pump until belt is properly tensioned then tighten adjustment bracket bolt and mounting bolt. Use a belt tension gauge to check adjustment.

CAUTION: Do not pry on the pump housing. Distortion of the housing will result in extensive damage to the Air Injection Pump.

Replace

1. Loosen pump mounting bolt and pump adjustment bracket bolt, then swing pump until drive belt may be removed.
2. Install a new drive belt and adjust as outlined above.

Pump Pulley

Replace

1. Hold pump pulley from turning by compressing drive belt then loosen pump pulley bolts.
2. Remove drive belt as outlined above then remove pump pulley.

Install

1. Install pump pulley with retaining bolts hand tight. Install and adjust drive belt as outlined above.
2. Hold pump pulley from turning by compressing drive belt then torque pump pulley bolts to 24 lb. ft. (32N·m).
3. Recheck drive belt tension and adjust if required.

Pump Filter

Replace

1. Remove drive belt and pump pulley as previously outlined.
2. Insert needle nose and pull fan from hub (Fig. 6E-41).

NOTE: Care should be taken to prevent fragments from entering the air intake hole. Do not insert a screwdriver between pump and filter. It is seldom possible to remove the filter without destroying it. Do not attempt to remove the metal hub.

Install

1. Install the new filter by drawing it on with the pulley and pulley bolts (Fig. 6E-42). Do not attempt to install a filter by hammering it on or pressing it on.
2. Draw the filter down evenly by alternately torquing the bolts. Make certain that the outer edge of the filter slips into the housing. The slight amount of interference with the housing bore is normal.

NOTE: The new filter may squeal upon initial operation until it's O.D. sealing lip has worn in.

Air Hoses and Tubes

Inspection

1. Inspect all hoses for deterioration or holes.
2. Inspect all tubes for cracks or holes.
3. Check all hose and tube connections.
4. Make repairs or replace parts as needed.
5. Check all tube and hose routing. Interference may cause wear.
6. If leak is suspected on the pressure side of the system or any tubes and/or hoses have been disconnected on the pressure side, the connections should be checked for leaks with soapy water solution.
7. With the pump running, bubbles will form if a leak exists.

Replace

To replace any hose and/or tube, note routing then remove hose(s) and/or tube(s) as required.

Install

1. Install new hose(s) and/or tube(s), routing them as when removed.
2. Tighten all connections.

Check Valve

Inspection

1. The check valve should be inspected whenever the hose is disconnected from the check valve or whenever check valve failure is suspected. (A pump that had become inoperative and had shown indications of having exhaust gases in the pump would indicate check valve failure.)
2. Blow through the check valve (toward the cylinder head) then attempt to suck back through check valve. Flow should only be in one direction (toward the exhaust manifold). Replace valve which does not function this way.

Replace

Disconnect pump outlet hose at check valve.

DIAGNOSIS

CONDITION	POSSIBLE CAUSE	CORRECTION
No air supply – accelerate engine to 1500 rpm and observe air flow from hoses. If the flow increases as the rpm's increase, the pump is functioning normally. If not, check possible cause.	<ol style="list-style-type: none"> 1. Loose drive belt. 2. Leaks in supply hose. 3. Leak at fittings. 4. Air expelled through by-pass valve. 4a. Connect a vacuum line directly from engine manifold vacuum to by-pass valve. 4b. Connect vacuum line from engine manifold vacuum source to by-pass valve through vacuum differential valve directly, by passing the differential vacuum delay and separator valve. 5. Check valve inoperative. 6. Pump failure. 	<ol style="list-style-type: none"> 1. Tighten to specifications. 2. Locate leak and repair 3. Tighten or replace clamps. 4a. If this corrects the problem go to step b. If not, replace air by-pass valve. 4b. If this corrects the problem, check differential vacuum, delay and separator valve and vacuum source line for plugging. Replace as required. If it doesn't, replace vacuum differential valve. 5. Disconnect hose and blow through hose toward check valve. If air passes, function is normal. If air can be sucked from check valve, replace check valve. 6. Replace pump.
Excessive pump noise, chirping, rumbling, knocking, loss of engine performance.	<ol style="list-style-type: none"> 1. Leak in hose. 2. Loose hose. 3. Hose touching other engine parts. 4. Vacuum differential valve inoperative. 5. By-pass valve inoperative 6. Pump mounting fasteners loose. 7. Pump failure. 8. Check valve inoperative. 	<ol style="list-style-type: none"> 1. Locate source of leak using soap solution and correct. 2. Reassemble and replace or tighten hose clamp. 3. Adjust hose position. 4. Replace vacuum differential valve. 5. Replace by-pass valve. 6. Tighten mounting screws as specified. 7. Replace pump. 8. Replace check valve.
Excessive belt noise.	<ol style="list-style-type: none"> 1. Loose belt 2. Seized pump 	<ol style="list-style-type: none"> 1. Tighten to spec. 2. Replace pump.
Excessive pump noise. Chirping	<ol style="list-style-type: none"> 1. Insufficient break-in 	<ol style="list-style-type: none"> 1. Run vehicle 10-15 miles at interstate speeds--recheck.
Centrifugal filter fan damaged or broken.	<ol style="list-style-type: none"> 1. Mechanical damage 	<ol style="list-style-type: none"> 1. Replace centrifugal filter fan.
Exhaust tube bent or damaged.	<ol style="list-style-type: none"> 1. Mechanical damage 	<ol style="list-style-type: none"> 1. Replace exhaust tube.
Poor idle or driveability.	<ol style="list-style-type: none"> 1. A defective A.I.R. system cannot cause poor idle or driveability. 	<ol style="list-style-type: none"> 1. Do not replace A.I.R. system.

Remove check valve from pipe assembly, being careful not to bend or twist the assembly.

Diverter Valve and Silencer Assembly

Inspection

1. Check condition and routing of all lines especially the signal line. All lines must be secure without crimps and not leaking. Replace deteriorated lines.
2. Disconnect signal line at valve. A vacuum signal must be available with engine running.
3. Check diverter valve attaching screws for tightness. Screws should be torqued to 85 lb. in. (10N·m).
4. Defective valves should be replaced (see Functional Test).

Replace

1. Disconnect vacuum signal line. Disconnect valve outlet hose.
2. Remove diverter valve from pump or elbow.

Install

1. Install diverter valve to pump or elbow with new gasket. Torque valve attaching screws to 85 lb. in. (9.5N·m).
2. Install outlet and vacuum signal hoses and check system for leaks.

Air Injection Pump

Inspection

Accelerate engine to approximately 1500 RPM and observe air flow from hose(s). If air flow increases as engine is accelerated, pump is operating satisfactorily. If air flow does not increase or is not present, proceed as follows:

1. Check for proper drive belt tension.

2. Check for a leaky pressure relief valve. Air may be heard leaking with the pump running.

NOTE: The AIR System is not completely noiseless. Under normal conditions, noise rises in pitch as engine speed increases. To determine if excessive noise is the fault of the Air Injection Reactor System, operate the engine with the pump drive belt removed. If excessive noise does not exist with the belt removed proceed as follows:

3. Check for a seized Air Injection Pump.
4. Check hoses, tubes and all connections for leaks and proper routing.

CAUTION: Do not oil AIR pump.

5. Check diverter valve.
6. Check AIR injection pump for proper mounting and bolt torque.
7. Repair irregularities in these components as necessary.
8. If no irregularities exist and the AIR injection pump noise is still excessive, remove and replace pump.

Replace

1. Disconnect the hoses at the pump.
2. Remove pump pulley as outlined.
3. Remove pump mounting bolts and remove pump.

Install

1. Install pump with mounting bolts loose.
2. Install pump pulley as outlined.
3. Install and adjust belt as outlined.
4. Connect the hoses at the pump.
5. Tighten mounting bolts to 20-35 lb. ft. (27 N·m - 48N·m).

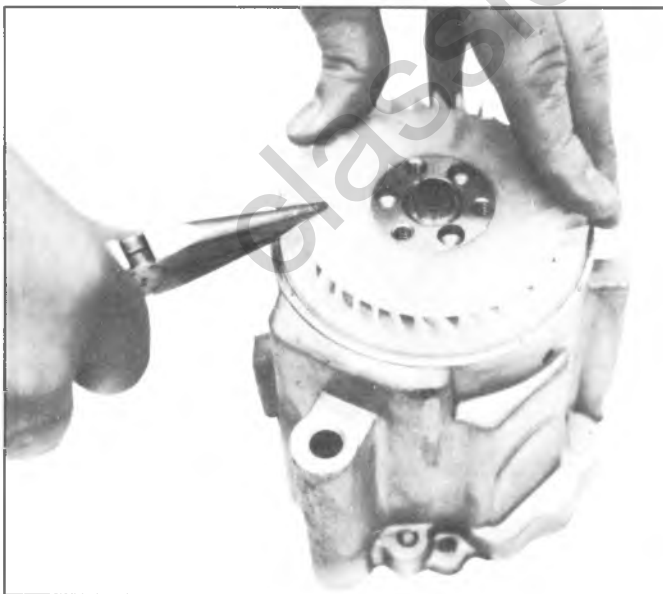


Fig. 6E-41--Removing Centrifugal Filter

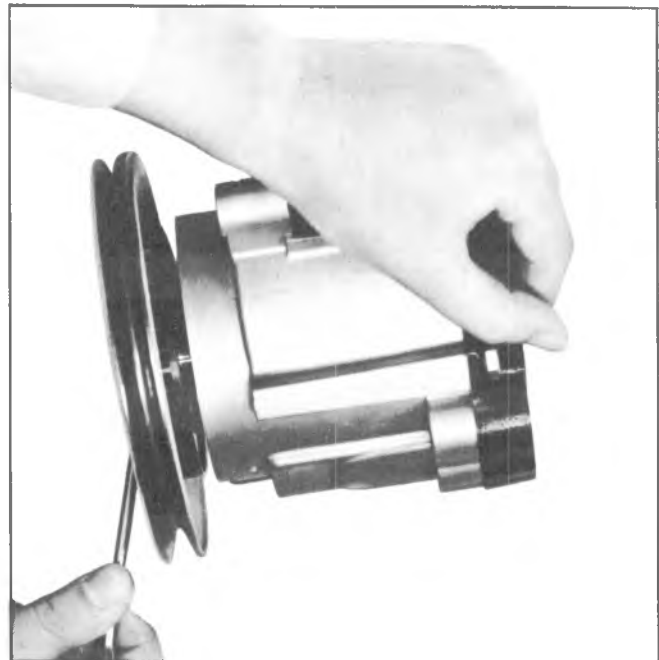


Fig. 6E-42--Installing Centrifugal Filter

THROTTLE RETURN CONTROL (TRC)

GENERAL DESCRIPTION

A throttle return control system (TRC) is used on 10-30 Series Trucks in California with heavy duty emissions systems. Also, 305 C.I.D. heavy duty emissions (except California) vehicles use the TRC system.

When the vehicle is coasting against the engine, the TRC valve will open at high manifold vacuum levels to allow vacuum to operate the throttle lever actuator. The throttle lever actuator pushes the throttle lever slightly open, thus reducing hydro-carbon emissions during coast down. When manifold vacuum drops below a pre-determined level (TRC valve set point) the control valve closes, the throttle actuator retracts, and the throttle lever returns to idle position.

ON-VEHICLE SERVICE

SYSTEM OPERATION

The TRC valve and actuator system should function to slightly open the throttle at high manifold vacuum overrun conditions (about 21-23 in. hg. [71-78kPa] depending on the particular engine application) and return to the curb idle position at lower manifold vacuums. Failure to function in this manner indicates the TRC valve or actuator is misadjusted, a vacuum leak exists, the valve vent is plugged or there is binding somewhere in the system.

Check hoses for cracking, abrasion, or deterioration and replace as necessary. Check system function for proper operation and adjust as as necessary.

CHECKING AND ADJUSTING SYSTEM

Control Valve (Figs. 6E-43,44, 45)

Checking and Adjusting

1. Disconnect valve-to-carburetor hose at the carburetor and connect to an external vacuum source with an accurate vacuum gage inserted near the valve.

2. Apply a minimum of 25 in. Hg. (84 kPa) vacuum to the control valve vacuum supply fitting and seal off the vacuum supply between the gage and the source. The vacuum gage reading will indicate the valve set point value.

If the gage reading is not within .5 in. Hg. (7kPa) of the specified value for the particular engine being checked, then the valve needs adjustment. If the trapped vacuum drops off faster than .1" Hg. per second, then the valve is leaking and must be replaced.

3. To adjust the valve set point:

- a. Gently pry off the conical plastic cover.
- b. Disengage the jam nuts by holding the larger

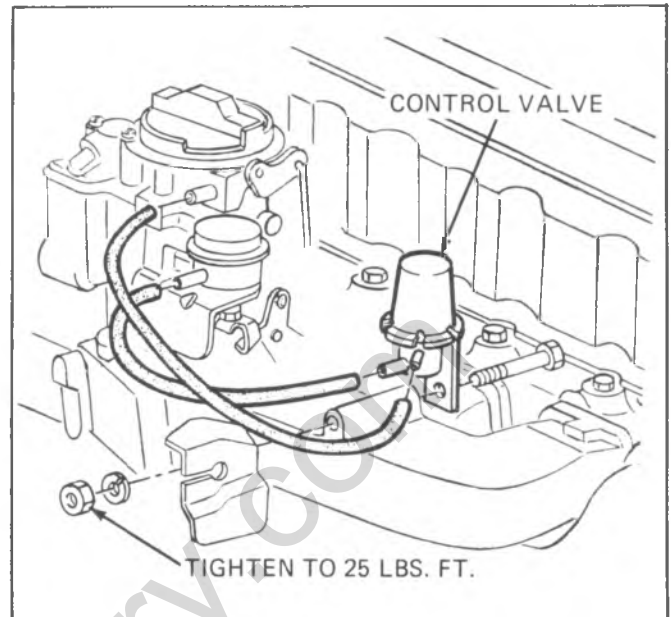


Fig. 6E-43--Control Valve - L6

nut and loosening the smaller nut. Adjust the valve by turning the larger nut in (clockwise) to raise the set point or out (counter-clockwise) to lower the set point value.

c. Recheck the valve set point per Step 2.

d. Repeat Steps b and c as necessary to obtain the proper set point value.

- 292-22.5 in. hg. \pm .5 (maroon)
- 305-22.5 in. hg. \pm .5 (orange)
- 350-21.5 in. hg. \pm .5 (black)
- 400-21.5 in. hg. \pm .5 (black)
- 454-23.0 in. hg. \pm .6 (green)

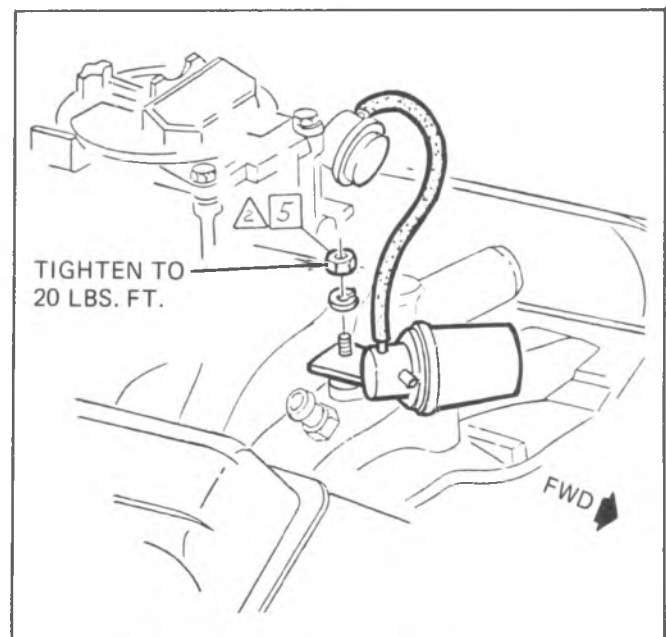


Fig. 6E-44--Control Valve-305/350/400 V8

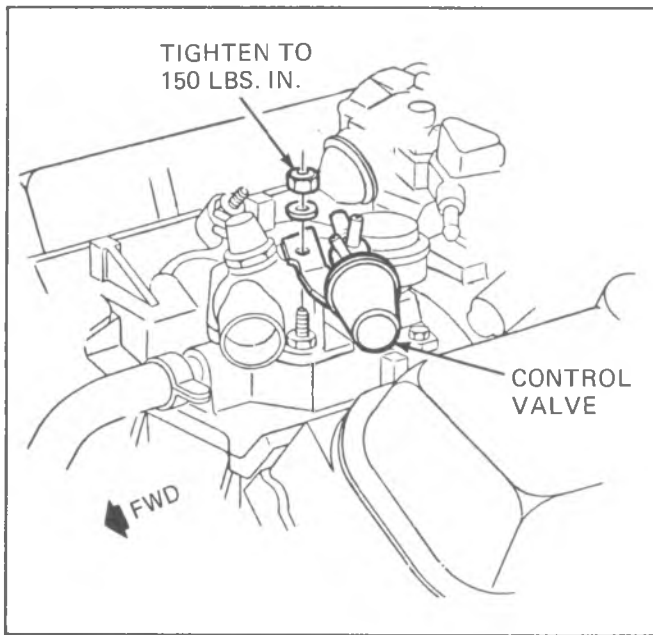


Fig. 6E-45--Control Valve-454 V8

- e. Hold the larger adjusting nut and retorque the smaller jam nut to 25-30 in. lbs. (3-3.4 N·m).
- f. Reinstall plastic cover.
- g. If the valve cannot be readjusted, it must be replaced.

Replacement

Disconnect vacuum hoses at control valve. Remove nut, washer and control valve. Reverse procedure to install, then check operation of new control valve.

Throttle Lever Actuator (Fig. 6E-46 and 47)

Check and Adjustment

Throttle Lever Actuator Checking and Adjusting Procedure

1. Disconnect valve-to-actuator hose at valve and connect to an external vacuum source equipped with a vacuum gage near the actuator.

NOTE: If an external vacuum source is not readily available, the actuator may be plumbed directly to manifold vacuum to extend the plunger.

2. Apply 20 in. hg. (68 kPa) vacuum to the actuator and seal off the vacuum source. If the vacuum gage reading drops, then the actuator is leaking and must be replaced.

3. To check the actuator for proper operation:

- a. Check the throttle lever, shaft, and linkage to be sure that they operate freely without binding or sticking.
- b. Start engine and run until warmed up and idle is stable. Turn air conditioning "off" if so equipped. Note idle RPM.

- c. Apply 20 in. hg. (68kPa) vacuum to the actuator. Manually open the throttle slightly and allow to close against the extended actuator plunger. Note the engine RPM.

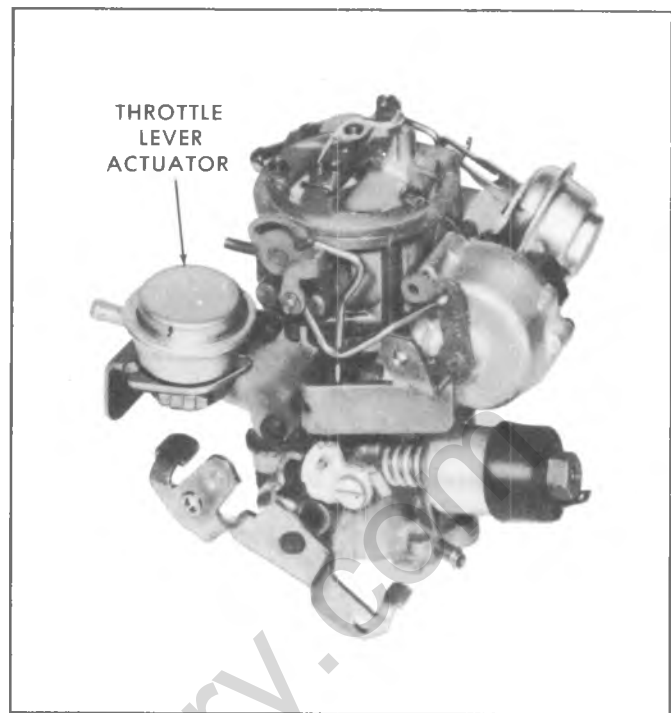


Fig. 6E-46--Throttle Lever Actuator-L6

- d. Release and reapply 20 in. hg. (68kPa) vacuum to the actuator and note the RPM to which the engine speed increased (do not assist the actuator).

- e. If the RPM obtained in Step d is not within 150 RPM of that obtained in c, then the actuator plunger may be binding due to dirt, corrosion, varnish, etc. If binding is indicated and cannot be corrected, then the actuator must be replaced.

- f. Release the vacuum from the actuator and the engine speed should return to within 50 RPM of the idle

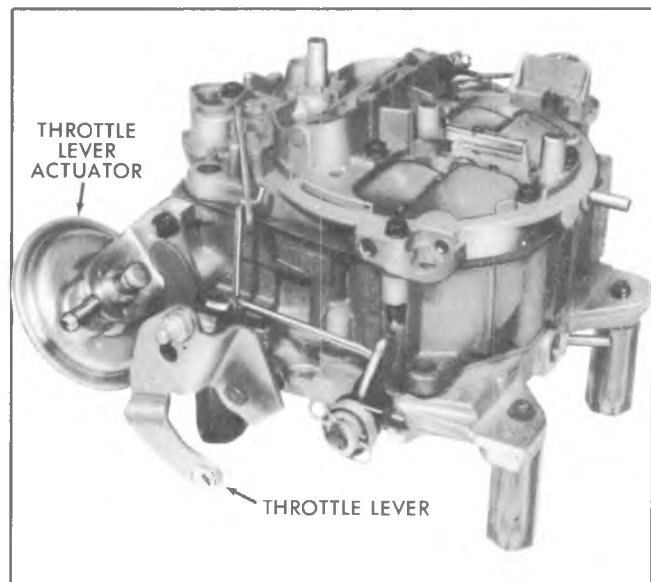


Fig. 6E-47--Throttle Lever Actuator-V8

speed noted in Step b. If it does not, the plunger may be binding due to dirt, corrosion, varnish, etc. If the problem cannot be corrected, the actuator must be replaced.

g. If the engine RPM noted in c is not within the specified TRC speed range, the TRC actuator must be adjusted.

4. To adjust the throttle lever actuator.

a. Apply 20 in. hg. (68kPa) vacuum to the actuator. Manually open the throttle slightly and allow to close against the extended actuator plunger.

b. To adjust the throttle lever actuator, turn the hex-end plunger on the actuator to obtain the specified speed.

- 292-1600 RPM
- 305-1600 RPM
- 350-1500 RPM
- 400-1500 RPM
- 454-1500 RPM

Replacement

Disconnect vacuum hose at actuator. Remove two screws and actuator (454 only). On all other applications unlock spider washer and loosen large nut to remove actuator from bracket. Reverse procedure to install new unit and refer to 4 above for proper speed adjustment.

VACUUM ADVANCE CONTROL

TRAPPED VACUUM SPARK

General Description

Trapped vacuum spark (Figs. 6E-13 and 14) is on all 454 CID engines with heavy duty emissions. A thermal vacuum switch (TVS) is mounted in the cylinder head sensing engine coolant temperature and a delay valve is between manifold vacuum, distributor and thermal vacuum switch.

When engine temperature is below specified valve, the manifold vacuum signal is routed through the delay valve to the distributor. Ports on TVS are blocked. The delay valve will keep the vacuum to the distributor at vacuum levels higher than manifold depression during vehicle acceleration. A small sintered iron bleed is provided in the delay valve to allow for a leak-down to enable restarts in case of engine stalls.

When engine temperature is above specified valve, the ports on TVS will be open to allow manifold vacuum

to the distributor. The delay valve in the mode of operation acts as a connector.

SPARK CONTROL SWITCH

General Description

Spark control switch (Figs. 6E-9 and 6E-11) system is used on some 350/400 CID engines with heavy duty emission to help protect the engine during an over-heat mode.

When coolant is at normal operating temperature, ported vacuum is directed through a thermal vacuum switch (TVS) to the distributor vacuum advance.

When coolant is above normal operating temperature, full vacuum is directed through the TVS to distributor vacuum advance. This advances the timing and allows the engine to run cooler. At this time, full vacuum is directed to the distributor vacuum advance at idle.

classiccarylbrary.com

SECTION 6F

ENGINE EXHAUST SYSTEM

GENERAL DESCRIPTION

For alignment purposes, the muffler outlet flange is notched and mates to a welded tab located on the outside diameter of the tailpipe. The exhaust pipes and muffler use locator tabs for alignment.

The C10 with light duty emissions (except 454 V8) and G10 vehicles have an exhaust system with a catalytic converter between the front exhaust pipe and the rear exhaust pipe.

The catalytic converter is an emission control device added to the exhaust system to reduce hydrocarbon and carbon monoxide pollutants from the exhaust gas stream.

The converter contains beads which are coated with a catalytic material containing platinum and palladium.

The catalytic converter requires the use of unleaded fuel only.

Periodic maintenance of the exhaust system is not required; however, if the vehicle is raised for other service, it is advisable to check the general condition of the catalytic converter, pipes and mufflers.

CAUTION: *When jacking or lifting vehicle from frame side rails, be certain lift pads do not contact catalytic converter as damage to converter will result.*

Classiccarlibrary.com

DIAGNOSIS EXHAUST SYSTEM

CONDITION	POSSIBLE CAUSE	CORRECTION
Leaking Exhaust Gases	Leaks at pipe joints.	Tighten U-bolt nuts at leaking joints to 30 foot-pounds.
	Damaged or improperly installed seals or packing.	Replace seals or packing as necessary.
	Loose exhaust pipe heat tube extension connections.	Replace seals or packing as required. Tighten stud nuts or bolts to specifications.
	Burned or rusted out exhaust pipe heat tube extensions.	Replace heat tube extensions as required.
Exhaust Noises	Leaks at manifold or pipe connections.	Tighten clamps at leaking connections to specified torque. Replace gasket or packing as required.
	Burned or blown out muffler.	Replace muffler assembly.
	Burned or rusted out exhaust pipe.	Replace exhaust pipe.
	Exhaust pipe leaking at manifold flange.	Tighten attaching bolts nuts to 17 foot-pounds.
	Exhaust manifold cracked or broken.	Replace manifold.
	Leak between manifold and cylinder head.	Tighten manifold to cylinder head stud nuts or bolts to specifications.
Loss of engine power and/or internal rattles in muffler.	Dislodged turning tubes and or baffles in muffler.	Replace muffler.
Loss of engine power.	Imploding (inner wall collapse) of exhaust pipe (C Truck)	Replace exhaust pipe.

ON-VEHICLE SERVICE

GENERAL

Exhaust System Pipes and Resonators Rearward of the Mufflers Must Be Replaced Whenever A New Muffler Is Installed.

NOTE: When a muffler is replaced use sealing compound at the clamped joint to prevent leaks.

Truck exhaust systems vary according to series and model designation. Series 10-30 trucks use a split-joint design system in which the exhaust pipe-to-muffler are clamped together and muffler-to-tailpipe connections are welded together. All mufflers and tailpipes are welded assemblies (no clamps).

NOTE: All 10-20-30 series exhaust systems are aluminized steel except: (1) "C" Series exhaust pipes and (2) stainless steel exhaust pipes on vehicles equipped with underfloor catalytic converters. Always use correct replacement parts when servicing these systems.

When installing a new exhaust pipe or muffler and tailpipe, on any model, care should be taken to have the correct alignment and relationship of the components to each other. Particular care should be given to the installation of the exhaust pipe and crossover pipe assembly on V-8 engine single exhaust systems. Incorrectly assembled parts of the exhaust system are frequently the cause of annoying noises and rattles due to improper clearances or obstructions to the normal flow of gases. Leave all clamp bolts and muffler bolts loose until all parts are properly aligned and then tighten, working from front to rear.

Exhaust system hangers, hanger brackets, and clamps which are damaged should be replaced to maintain proper exhaust system alignment.

NOTE: When reinstalling exhaust pipe to manifold, always use new packings and nuts. Be sure to clean manifold stud threads with a wire brush when installing the new nuts.

CONVERTER HEAT SHIELD

C 10 Series

Refer to Figure 6F-1 for converter heat shield.

CATALYTIC CONVERTER (FIGS. 6F-2 and 3)

C10 and G10 Series

Removal

1. Raise vehicle on hoist.
2. Remove clamps at front and rear of converter.
3. Cut converter pipes at front and rear of converter and remove converter.
4. On C10 models, remove support attaching converter-to-transmission.

5. Remove converter pipe-to-front-exhaust pipe and converter pipe-to-rear exhaust pipe.

Installation

1. With sealer on exhaust pipes, install pipes into converter.
2. On C10 model, loosely connect support attaching converter-to-transmission.
3. Install new "U" bolts and clamps at front and rear of converter.
4. Check all clearance and tighten clamps and support.
5. Lower vehicle and remove from hoist.

Catalyst Removal

If necessary, the catalyst in the converter can be replaced on the vehicle with Tool No. J-25077.

1. Install aspirator J-25077-2 (Fig. 6F-4).

NOTE: Separate hoses should be attached to the aspirator and the vibrator with maximum available pressure. Minimum of 60 psi in each hose.

2. Connect air supply line to aspirator to create a vacuum in the converter to hold beads in place when fill plug is removed.
3. Remove converter fill plug as follows:
 - a. Threaded plug - Remove with 3/4" hex wrench or Tool J-25077-3.
 - b. Pressed plug - Drive a small chisel between the converter shell and the fill plug. Use care not to damage converter shell (Fig. 6F-5). Continue to deform fill plug until it can be removed with pliers (Fig. 6F-6).

NOTE: Do not pry fill plug from converter as damage to fill plug sealing surfaces could result.

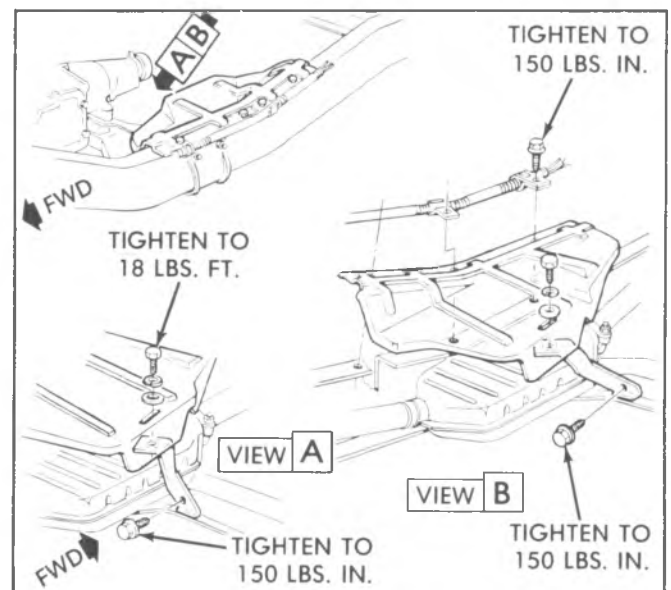


Fig. 6F-1--Heat Shield - C10 Series

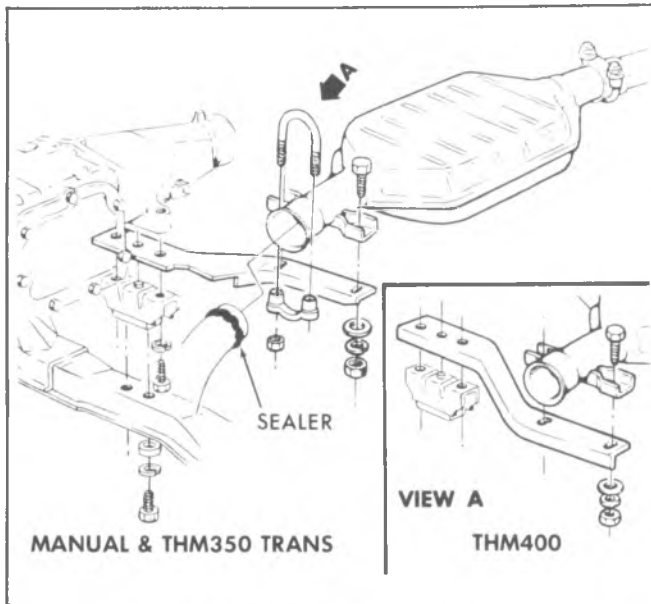


Fig. 6F-2--Catalytic Converter - C10 Series

4. Clamp on vibrator and catalyst container (Fig. 6F-7). Use adapter J-25077-6 if converter was built with pressed plug.

5. Disconnect air supply to aspirator and connect air supply to vibrator. Catalyst will now drain from the converter into the empty container.

6. When all the catalyst has been removed from the converter, disconnect air supply to vibrator and remove container from the converter.

7. Discard used catalyst.

Catalyst Replacement

1. Fill container with approved replacement catalyst.

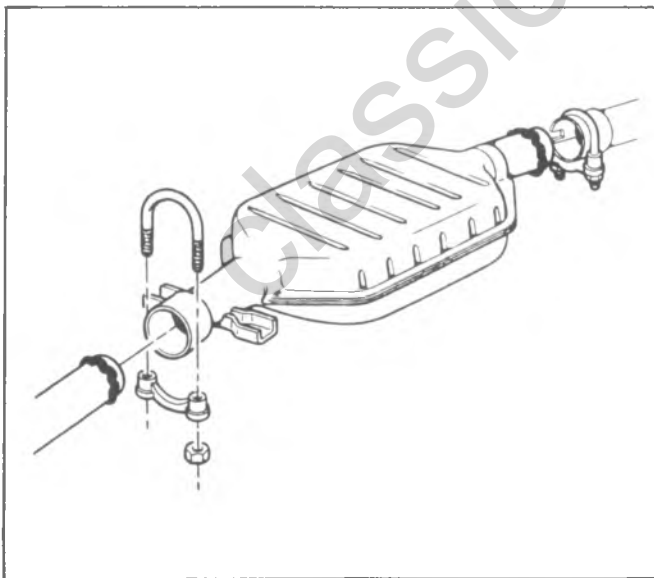


Fig. 6F-3--Catalytic Converter - G10 Series

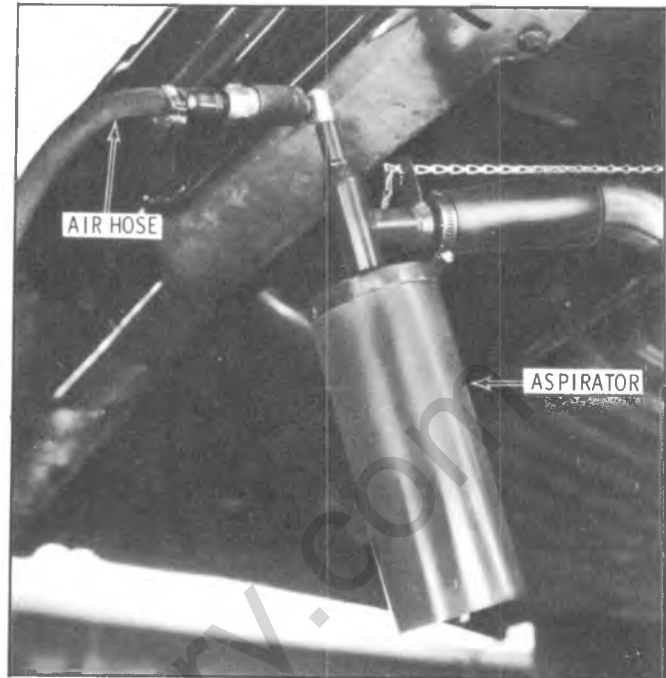


Fig. 6F-4--Installing Aspirator

2. Install fill tube extension to the fixture J-25077-1 (Fig. 6F-8). Use adapter J-25077-6 if converter was built with pressed plug.

3. Connect air supply to aspirator and vibrator.

4. Attach catalyst container to the fixture (6F-9).



Fig. 6F-5--Removing Pressed Plug



Fig. 6F-6--Removing Pressed Plug With Pliers

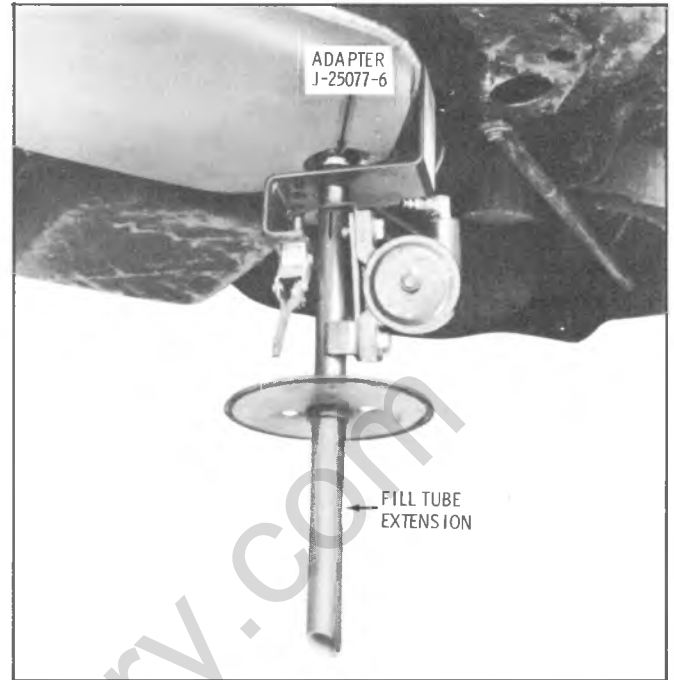


Fig. 6F-8--Installing Fill Tube Extension

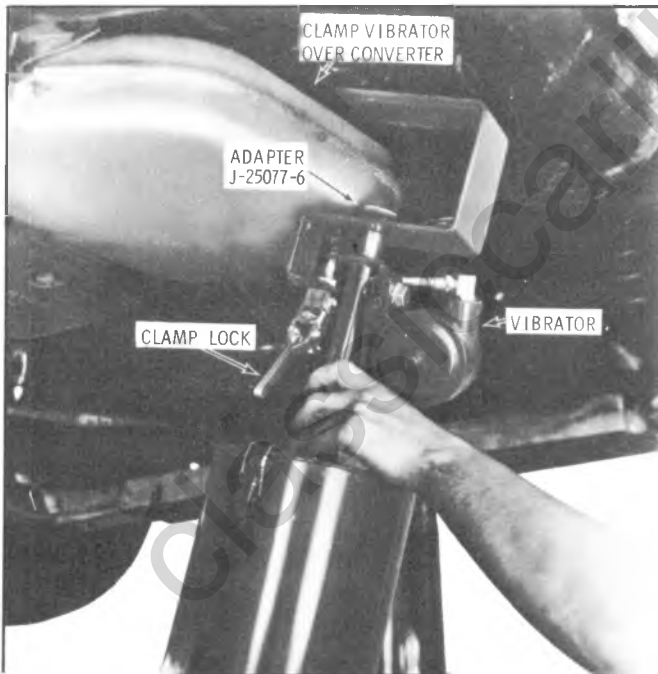


Fig. 6F-7--Installing Vibrator and Adapter

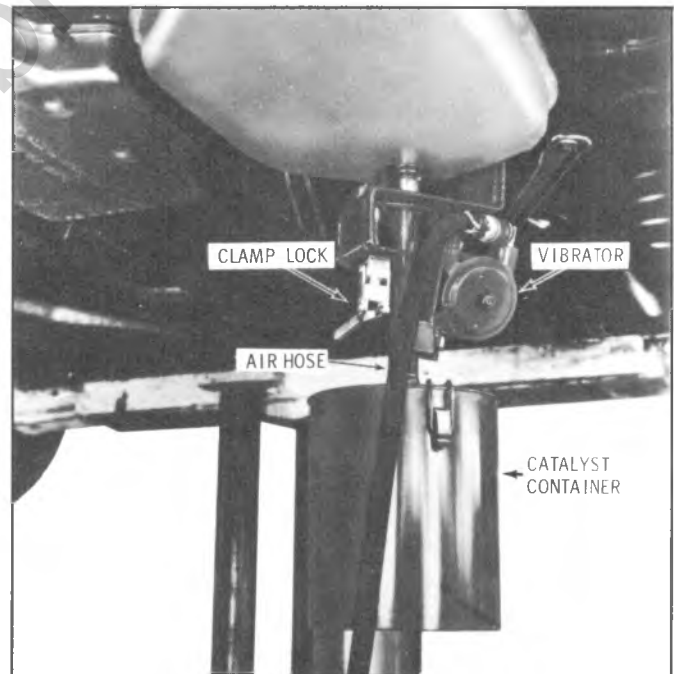


Fig. 6F-9--Installing Catalyst Container

5. After the catalyst stops flowing, disconnect air supply to the vibrator.

6. Remove vibrator and check that catalyst has filled converter flush with fill plug hole. Add catalyst if required.

7. Apply an anti-seize compound to the fill plug; install and tighten to 60 pound feet.

If built with a pressed plug, install service fill plug

(Fig. 6F-10), as follows: Install the bolt into the bridge and position the bridge into converter opening. Move bolt and bridge back and forth to dislodge catalyst beads until bridge is positioned (Fig. 6F-11).

8. Remove bolt from bridge then position the washer and fill plug, dished side out, over the bolt.

9. While holding the fill plug and washer against

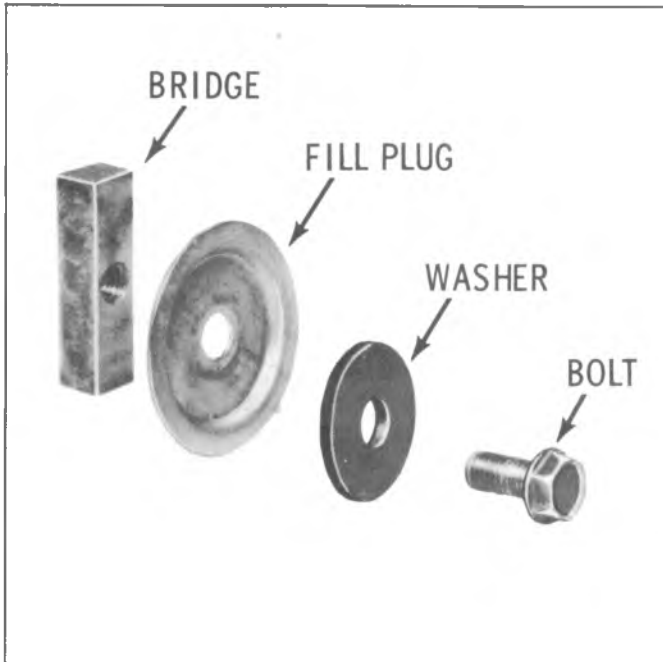


Fig. 6F-10--Service Fill Plug



Fig. 6F-12--Installing Fill Plug

the bolt head (Fig. 6F-12), thread the bolt 4 of 5 turns into the bridge. Release the fill plug and the aspirator will pull the fill plug into position.

NOTE: If fill plug is allowed to seat against the converter before installing bolt, the threaded hole in the bridge will fill with beads and it will be very difficult to start the bolt.

10. After making sure fill plug is correctly seated, tighten the bolt and torque to 28 ft. lbs. (Fig. 6F-13).

11. Disconnect air supply to aspirator and remove.

12. Start vehicle and check for leaks.

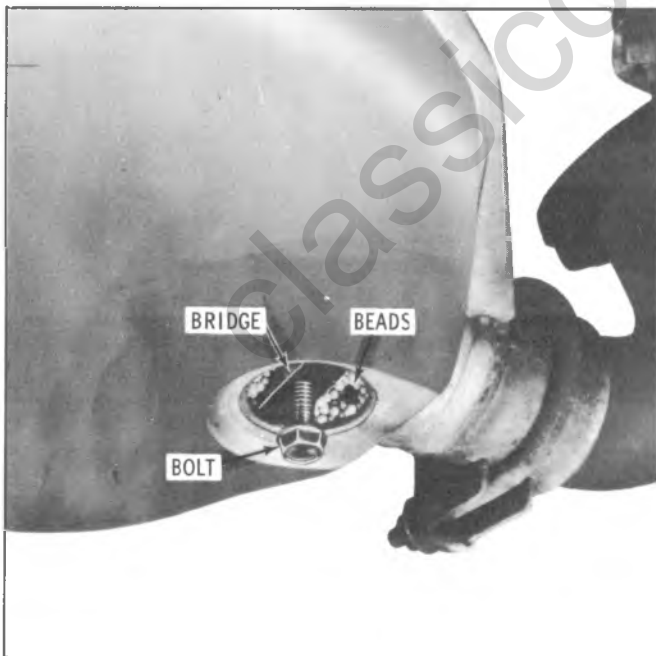


Fig. 6F-11--Positioning Fill Plug Bridge

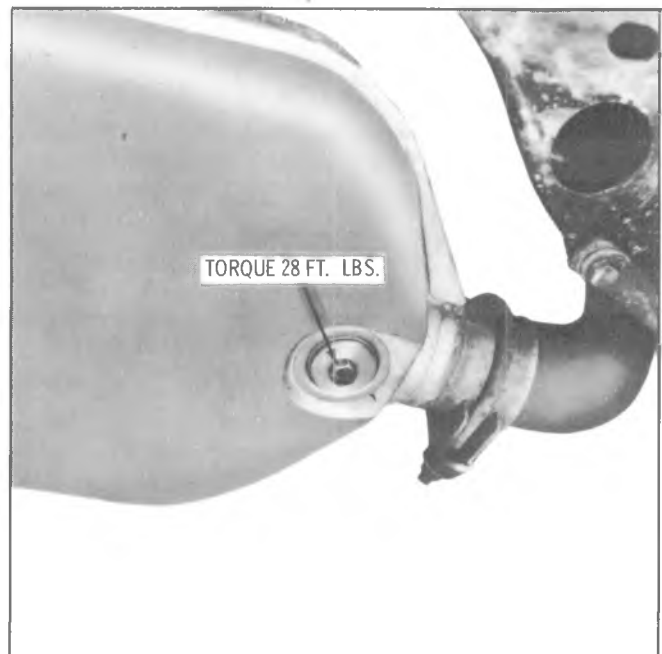


Fig. 6F-13--Fill Plug - Installed View

Bottom Cover

If, for any reason, the bottom cover of the converter is torn or severely damaged, it can be replaced with a repair kit.

Bottom Cover Replacement

1. Remove bottom cover by cutting close to the bottom outside edge (Figs. 6F-14 and 15). Do not remove the fill plug. The depth of the cut must be very shallow to prevent damage to the inner shell of the converter.

2. Remove insulation (Fig. 6F-16).

3. Inspect inner shell of the converter for damage. If there is damage in the inner shell, the converter assembly must be replaced (Fig. 6F-17).

4. Place new insulation in the replacement cover. Apply sealing compound, all around the cover after the insulation is in position. Apply extra sealer at the front and rear opening for the pipes (Fig. 6F-18).

5. Install replacement cover on converter (Fig. 6F-18).

6. Install cover retaining channels on both sides of the converter (Fig. 6F-19).

7. Attach 2 clamps over retaining channels at each end of the converter (Fig. 6F-20).

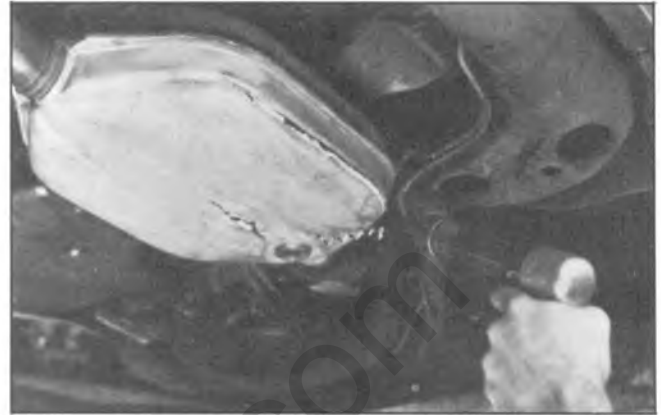


Fig. 6F-15--Removing Bottom Cover



Fig. 6F-14--Removing Bottom Cover

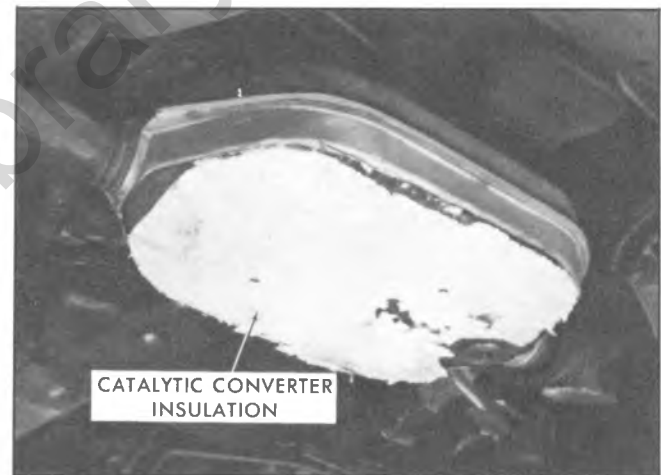


Fig. 6F-16--Catalytic Converter Insulation

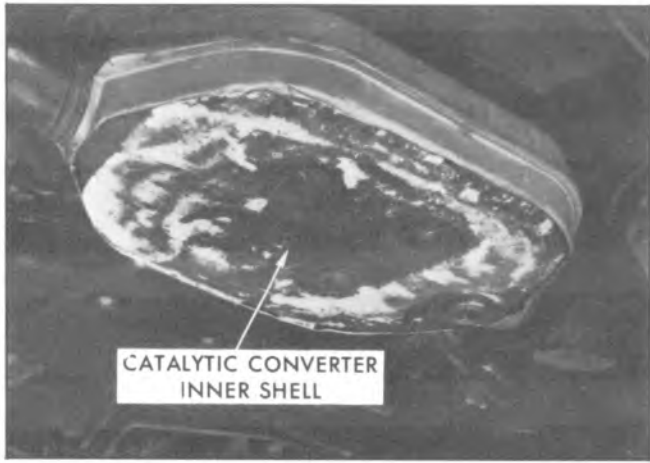


Fig. 6F-17--Catalytic Converter Inner Shell

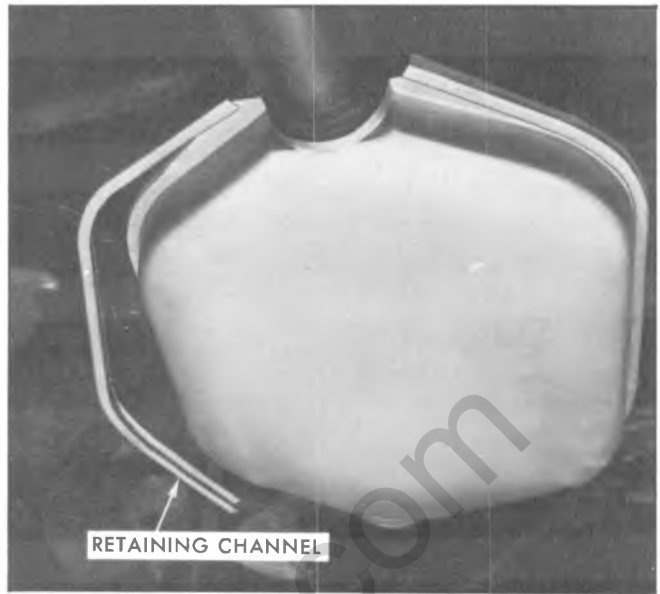


Fig. 6F-19--Installing Bottom Cover Retaining Channels

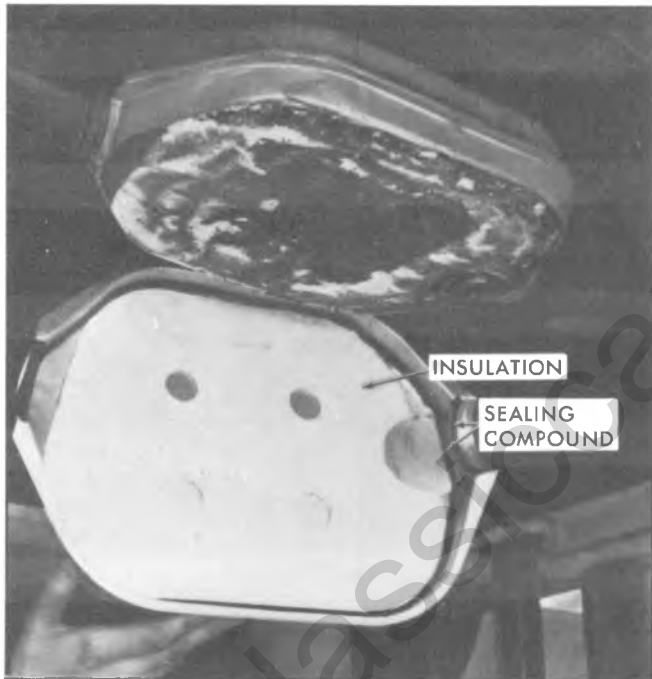


Fig. 6F-18--Installing Bottom Cover Replacement



Fig. 6F-20--Installing Bottom Cover Clamps

SPECIAL TOOLS



Fig. 6F-21·Special Tools

classicalibrary.com

SECTION 7A

AUTOMATIC TRANSMISSION

CONTENTS OF THIS SECTION

CBC 350 Transmission	7A-1
THM 400 Transmission	7A-21
Specifications	7A-37
Special Tools	7A-38

CBC 350 TRANSMISSION

INDEX

General Description	7A-1	Manual Linkage	7A-12
Maintenance and Adjustment	7A-4	Road Test	7A-12
Transmission Fluid	7A-4	Trouble Diagnosis	7A-13
Checking Transmission Mount	7A-5	Diagnosis Chart	7A-14
Shift Controls	7A-5	Service Operations	7A-18
Detent Downshift Cable	7A-7	Transmission Replacement (Except K Models) ..	7A-18
Neutral Start Switch	7A-7	Transmission Replacement (K Models)	7A-18
Diagnosis	7A-9	Extension Housing Oil Seal	7A-18
Sequence for Diagnosis	7A-9	Speedometer Driven Gear	7A-19
Fluid Checking Procedures	7A-9	Speedometer Drive Gear	7A-19
Fluid Leak Diagnosis	7A-9	Manual Shaft, Range Selector Inner Lever and	
Oil Pressure Check	7A-10	Parking Linkage	7A-19
Case Porosity Repair	7A-10	Governor	7A-19
Vacuum Modulator Diagnosis	7A-10	Vacuum Modulator and Modulator Valve	7A-19
Clutch Plate Diagnosis	7A-11	Valve Body Assembly	7A-20
Causes of Burned Clutch Plates	7A-11	1-2 Accumulator	7A-20
Governor Pressure Check	7A-12	Oil Cooler Pipes	7A-20

GENERAL DESCRIPTION

The CBC 350 transmission is a fully automatic unit consisting primarily of a 3-element hydraulic torque converter and two planetary gear sets. Four multiple-disc clutches, two roller clutches, and an intermediate overrun band provide the friction elements required to obtain the desired function of the two planetary gear sets.

The 3-element torque converter consists of a pump, turbine and a stator assembly. The stator is mounted on a one way roller clutch which will allow the stator to turn clockwise, but not counterclockwise. References to clockwise and counterclockwise are determined by looking toward rear of vehicle.

The torque converter is of welded construction and is serviced as a complete assembly. The unit is filled with oil and is attached to the engine crankshaft by a flywheel, thus always rotates at engine speed. The converter pump is an integral part of the converter housing, therefore, the pump blades, rotating at engine

speed, set the oil within the converter into motion and direct it to the turbine, causing the turbine to rotate.

As the oil passes throughout the turbine it is traveling in such a direction that if it were not redirected by the stator it would hit the rear of the converter pump blades and impede its pumping action. So at low turbine speeds, oil is redirected by the stator to the converter pump in such a manner that it actually assists the converter pump to deliver power, or multiply engine torque.

As turbine speed increases, the direction of oil leaving the turbine changes and flows against the rear side of the stator vanes in a clockwise direction. Since the stator is now impeding the smooth flow of oil, its roller clutch releases and it revolves freely on its shaft. Once the stator becomes inactive, there is no further multiplication of engine torque within the converter.

At this point, the converter is merely acting as a

fluid coupling as both the converter pump and turbine are being driven at approximately the same speed.

A hydraulic system pressurized by a gear type pump provides the working pressure required to operate the friction elements and automatic controls.

External control connections to the transmission are:

- Manual Linkage - To select the desired operating range.
 - Engine Vacuum - To operate the vacuum modulator.
 - Cable Control - To operate the detent valve.
- A vacuum modulator is used to automatically sense

any change in the torque input to the transmission. The vacuum modulator transmits this signal to the pressure regulator, which controls line pressure, so that all torque requirements of the transmission are met and smooth shifts are obtained at all throttle openings.

The detent valve is activated by a cable that is connected to the accelerator lever assembly. When the throttle is half open, the valve is actuated causing throttle downshift at speeds below 50 mph. When the throttle is fully open the detent valve is actuated causing the transmission to downshift from 3-1 at speeds below 40 mph and 3-2 below 75 mph.

classiccarlibrary.com

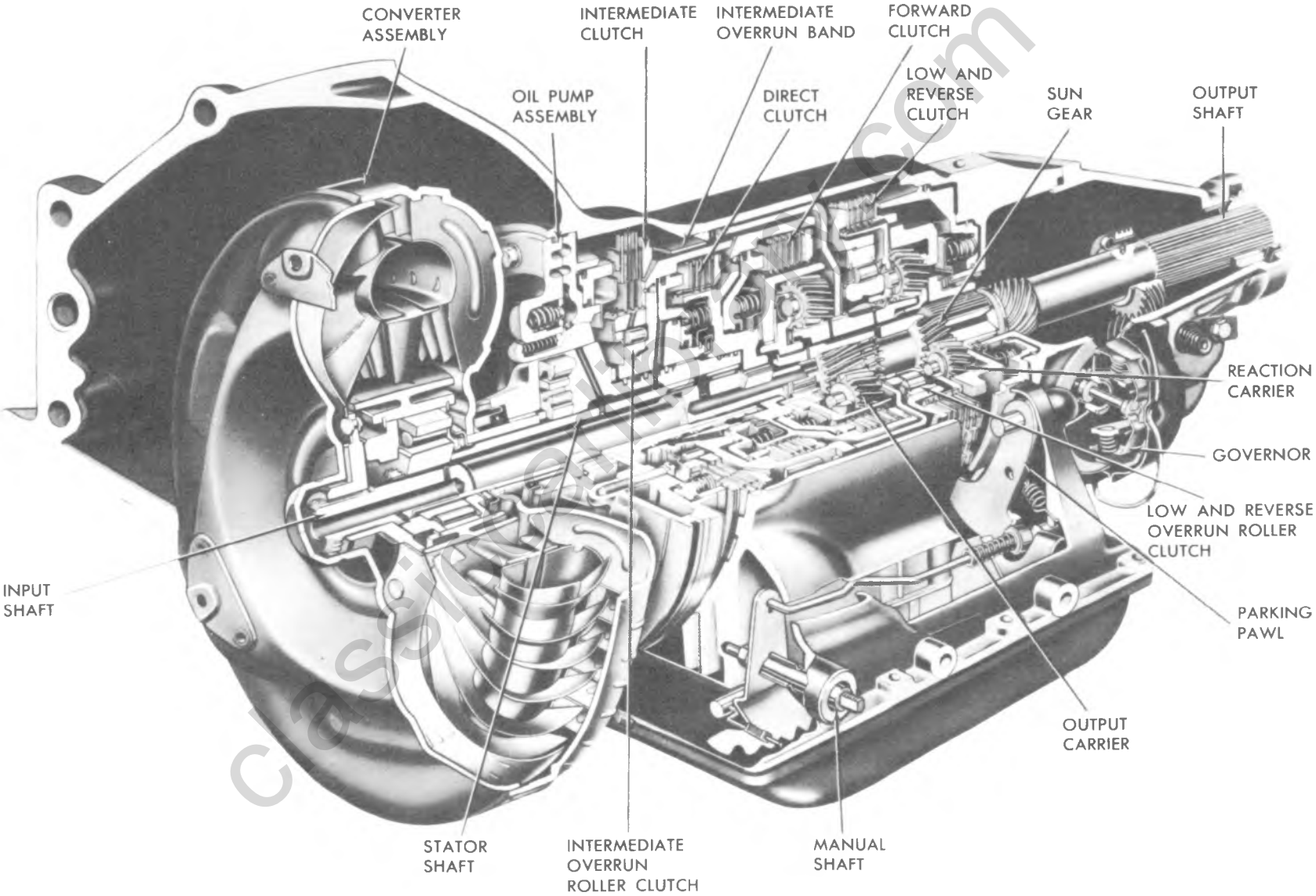


Fig. 7A-1B-CBC 350, Cross-Section View

MAINTENANCE AND ADJUSTMENTS

TRANSMISSION FLUID

Fluid Level and Capacity

The fluid level indicator is located in filler tube at right rear of engine. To bring the fluid level from the ADD mark to the FULL mark requires one pint of fluid. Fluid level should be checked at every engine oil change.

Fluid level should be to the FULL mark with the transmission fluid at normal operating temperature (200° F). With warm fluid (room temperature 70° F), the level will be 1/4 inch below the ADD mark on the dipstick. The normal operating temperature is obtained only after at least 15 miles of highway type driving or the equivalent of city driving.

Approximately 8 pints of fluid are required to refill transmission after oil pan has been drained. The fluid capacity of the CBC 350 transmission and converter assembly is approximately 21 1/2 pints but correct level is determined by the mark on the dipstick rather than by amount added. Use only DEXRON® or DEXRON® II automatic transmission fluid or its equivalent.

NOTE: An early stage to a darker color from the usual red color and/or a strong odor that is usually associated with overheated transmission fluid is normal, and is not a positive sign of required maintenance or transmission failure.

Checking Procedure and Adding Fluid

To determine proper fluid level at normal operating temperature, proceed as follows:

1. Position vehicle on a level surface, place selector lever in park (P), apply parking brake and have engine running at normal idle.
2. Remove fluid level indicator, wipe it clean and reinstall fully until cap seats.

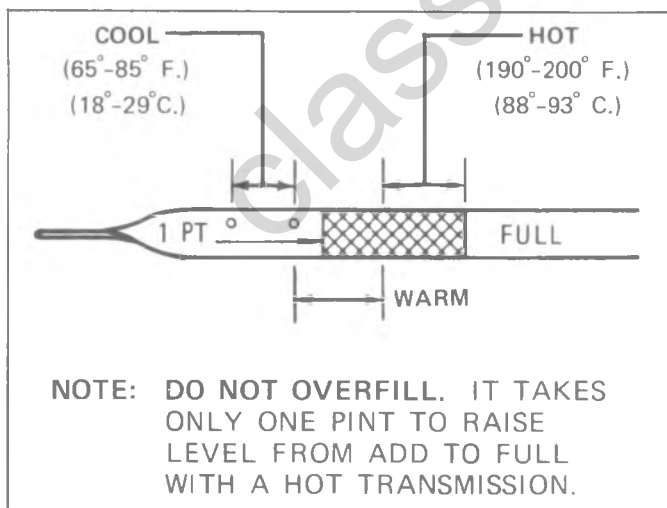


Fig. 7A-2B--Dipstick

3. Remove indicator and reading of fluid level should be at full "F" mark.

4. If additional fluid is required, add DEXRON® or DEXRON® II automatic transmission fluid or its equivalent to "F" mark on indicator.

If the vehicle cannot be driven sufficiently to bring the transmission to operating temperature and it becomes necessary to check the fluid level, the transmission may be checked at room temperature (70 degrees F) as follows:

1. Position selector lever in park (P), apply parking brake and start engine. **DO NOT RACE ENGINE.** Move selector lever through each range.

2. Immediately check fluid level with selector lever in Park, engine running and vehicle on LEVEL surface.

Fluid level on indicator should be 1/4 inch below the "ADD" mark.

3. If additional fluid is required, add enough fluid to bring level to 1/4" below the ADD mark on the dipstick. If transmission fluid level is correctly established at 70° F, it will appear at the FULL mark on the dipstick when the transmission reaches its normal operating temperature of 200° F.

CAUTION: DO NOT OVERFILL, as foaming and loss of fluid through the vent pipe might occur as fluid heats up.

If fluid is too low, especially when cold, complete loss of drive may result which can cause transmission failure.

Draining and Refilling Transmission

The oil pan should be drained and the strainer cleaned at the intervals detailed in section O-B of this manual, and fresh fluid added to obtain the proper level on indicator. Section O-B also details intervals for vehicles subjected to heavy city traffic during hot weather, or in commercial use, or when the engine is regularly idled for prolonged periods or when vehicle is used for towing.

Drain fluid immediately after operation before it has had an opportunity to cool.

WARNING: Transmission fluid temperature can exceed 350° F.

1. Raise vehicle.
2. Support transmission with suitable jack at the transmission.
3. With fluid receptacle placed under transmission oil pan, remove oil pan attaching bolts from front and side of pan.
4. Loosen rear pan attaching bolts approximately four (4) turns.
5. Carefully pry transmission oil pan loose with screwdriver, allowing fluid to drain.

6. Remove remaining screws and remove oil pan and gasket. Discard gasket.
7. Drain fluid from oil pan. Clean pan with solvent and dry thoroughly with clean compressed air.
8. Remove two (2) strainer-to-valve body screws, strainer and gasket. Discard gasket.
9. Thoroughly clean strainer assembly in solvent and dry thoroughly with clean compressed air.
10. Install new strainer-to-valve body gasket, strainer and two (2) screws.
11. Install new gasket on oil pan and install oil pan. Tighten its thirteen (13) attaching bolt and washer assemblies to 12 pound-feet torque.
12. Lower vehicle add approximately 5 pints U.S. measure (4 pints Imperial measure) of DEXRON® or DEXRON®II automatic transmission fluid or its equivalent through filler tube.
13. With selector lever in PARK position, apply hand brake, start engine and let idle (carburetor off fast idle step). **DO NOT RACE ENGINE.**
14. Move selector lever through each range and, with selector lever in PARK range, check the fluid level.
15. Add additional fluid to bring level to 1/4" below the ADD mark on the dipstick.

CAUTION: Do not overfill. Foaming can result if overfilled.

Adding Fluid to Fill Dry Transmission and Converter Assembly

In cases of transmission overhaul, when a complete fill is required, including converter (approximately 20 pints), proceed as follows:

1. Add 8 pints of transmission fluid through filler tube.
2. With manual control lever in park (P) position, start engine and place on cold idle cam. **DO NOT RACE ENGINE.** Move manual control lever through each range.
3. Immediately check fluid level with selector lever in park (P), engine running and vehicle on LEVEL surface and add additional fluid to bring level to 1/4" below the "ADD" mark on the dipstick. Do not overfill.

CHECKING TRANSMISSION MOUNT

Raise vehicle on a hoist. Push up and pull down on transmission tailshaft while observing transmission mount. If rubber separates from metal plate of mount or if tailshaft moves up but not down (mount bottomed out) replace mount. If there is relative movement between a metal plate of mount and its attaching point, tighten

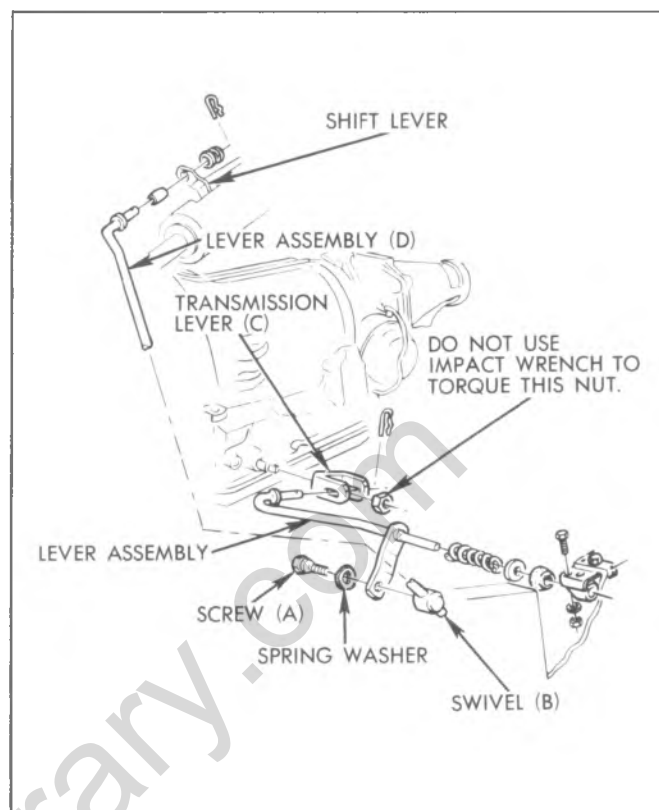


Fig. 7A-3B--Column Shift Linkage - CK Series

screws or nuts attaching mount to transmission or crossmember.

SHIFT CONTROLS

Column Shift Linkage - CK and P Series

(Figs. 7A-3B and 7A-4B)

1. The shift tube and lever assembly must be free in the mast jacket. See Section 3B for alignment of steering column assembly if necessary.
2. To check for proper shift linkage adjustment, lift the transmission selector lever towards the steering wheel. Allow the selector lever to be positioned in drive (D) by the transmission detent.

NOTE: Do not use the indicator pointer as a reference to position the selector lever. When performing linkage adjustment, pointer is adjusted last.

3. Release the selector lever. The lever should be inhibited from engaging low range unless the lever is lifted.
4. Lift the selector lever towards the steering wheel, and allow the lever to be positioned in neutral (N) by the transmission detent.
5. Release the selector lever. The lever should now be inhibited from engaging reverse range unless the lever is lifted.

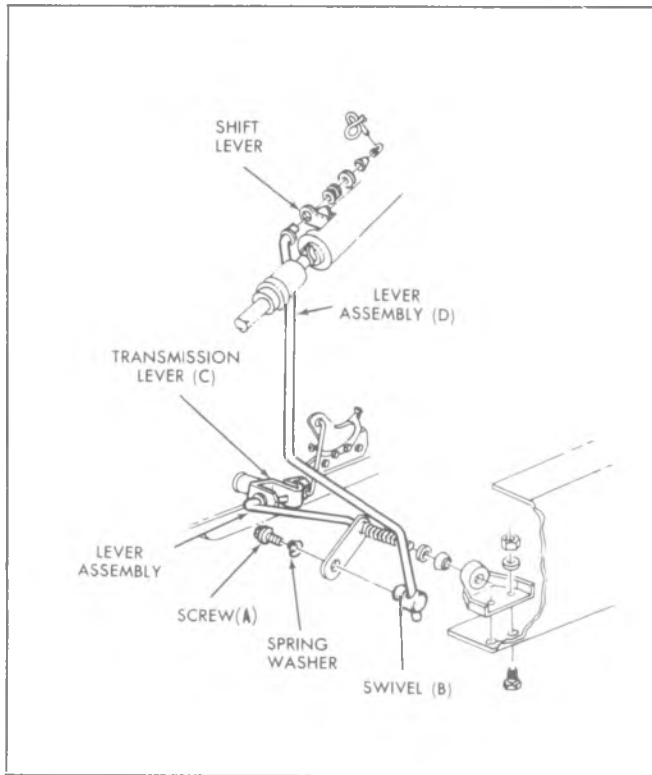


Fig. 7A-4B-Column Shift Linkage-P Series

6. A properly adjusted linkage will prevent the selector lever from moving beyond both the neutral detent, and the drive detent unless the lever is lifted to pass over the mechanical stop in the steering column.

7. If adjustment is required, remove screw (A) and spring washer from swivel (B).

8. Set transmission lever (C) in Neutral position by moving lever counterclockwise to L1 detent and then clockwise three (3) detent positions to Neutral.

9. Position transmission selector lever in Neutral position as determined by the mechanical stop in steering column assembly.

NOTE: Do not use the indicator pointer as a reference to position the selector lever. When performing linkage adjustment, pointer is adjusted last.

10. Assemble swivel, spring washer and screw to lever assembly (D) and tighten screw to 20 pound feet.

11. Readjust indicator needle if necessary to agree with the transmission detent positions. See Section 9.

12. Readjust neutral start switch if necessary to provide the correct relationship to the transmission detent positions. See Section 8.

13. Check operation (CK Series):

a. With key in "Run" position and transmission in "Reverse" be sure that key cannot be removed and that steering wheel is not locked.

b. With key in "Lock" position and shift lever in "Park", be sure that key can be removed, that steering

wheel is locked, and that transmission remains in "Park" when steering column is locked.

CAUTION: Any inaccuracies in the above adjustments may result in premature failure of the transmission due to operation without controls in full detent. Such operation results in reduced oil pressure and in turn partial engagement of the affected clutches. Partial engagement of the clutches with sufficient pressure to cause apparent normal operation of the vehicle will result in failure of the clutches or other internal parts after only a few miles of operation.

Column Shift Linkage - G Series

(Fig. 7A-5B)

1. The shift tube and lever assembly must be free in the mast jacket.

2. Set transmission lever (C) in "neutral" position by one of the following optional methods.

NOTE: Obtain "neutral" position by moving transmission lever (C) counter-clockwise to "L1" detent, then clockwise three detent positions to "neutral" or obtain "neutral" position by moving transmission lever (C) clockwise to the "park" detent then counter-clockwise two detents to "neutral".

3. Set the column shift lever in "neutral" position. This is obtained by rotating shift lever until it locks into mechanical stop in the column assembly.

NOTE: Do not use indicator pointer as a reference to position the shift lever.

4. Attach rod (A) to shaft assembly (B) as shown (Fig. 7A-5B).

5. Slide swivel (D) and clamp (E) onto rod (A) align the column shift lever and loosely attach as shown.

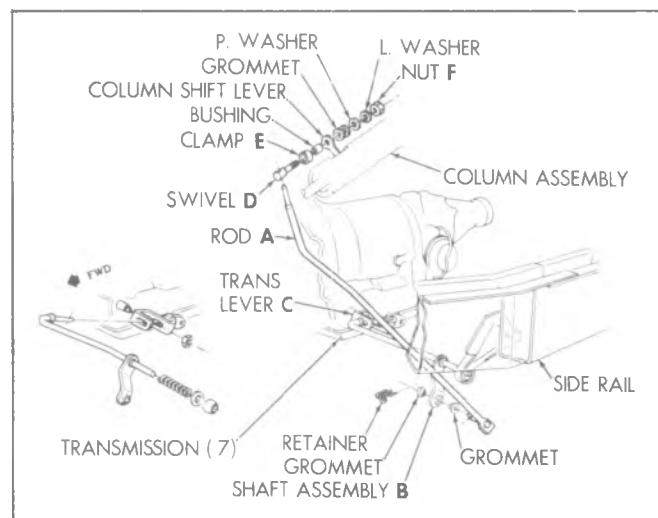


Fig. 7A-5B-Column Shift Linkage-G Series

6. Hold column lever against "neutral" stop "park" position side.
7. Tighten nut (F) to 18 foot pounds.
8. Readjust indicator needle if necessary to agree with the transmission detent positions.
9. Readjust neutral start switch if necessary to provide the correct relationship to the transmission detent positions.

CAUTION: *Any inaccuracies in the above adjustments may result in premature failure of the transmission due to operation without controls in full detent. Such operation results in reduced oil pressure and in turn partial engagement of the affected clutches. Partial engagement of the clutches with sufficient pressure to cause apparent normal operation of the vehicle will result in failure of the clutches or other internal parts after only a few miles of operation.*

DETENT DOWNSHIFT CABLE

(Figs. 7A-6B and 7A-7B)

Removal

1. Push up on bottom of snap-lock and release lock and detent downshift cable.
2. Disconnect cable from carburetor lever.

3. Compress locking tabs and disconnect snap-lock assembly from bracket.

4. Remove clamp around filler tube, remove screw and washer securing cable to transmission and disconnect detent downshift cable.

Installation

1. Install new seal on detent downshift cable. Lubricate seal with transmission fluid.

2. Connect transmission end of detent downshift cable and secure to transmission case with bolt and washer tightened to 75 inch pounds.

3. Route cable in front of filler tube and install clamp around filler tube, modulator pipe and detent downshift cable. Locate clamp approximately 2 inches above filler tube bracket.

4. Pass cable through bracket and engage locking tabs of snap-lock on bracket.

5. Connect cable to carburetor lever.

Adjustment

With snap-lock disengaged, position carburetor to wide open throttle (W.O.T.) position and push snap-lock downward until top is flush with rest of cable.

NEUTRAL START SWITCH

The adjustment of the neutral start switch is described in Section 8, Electrical.

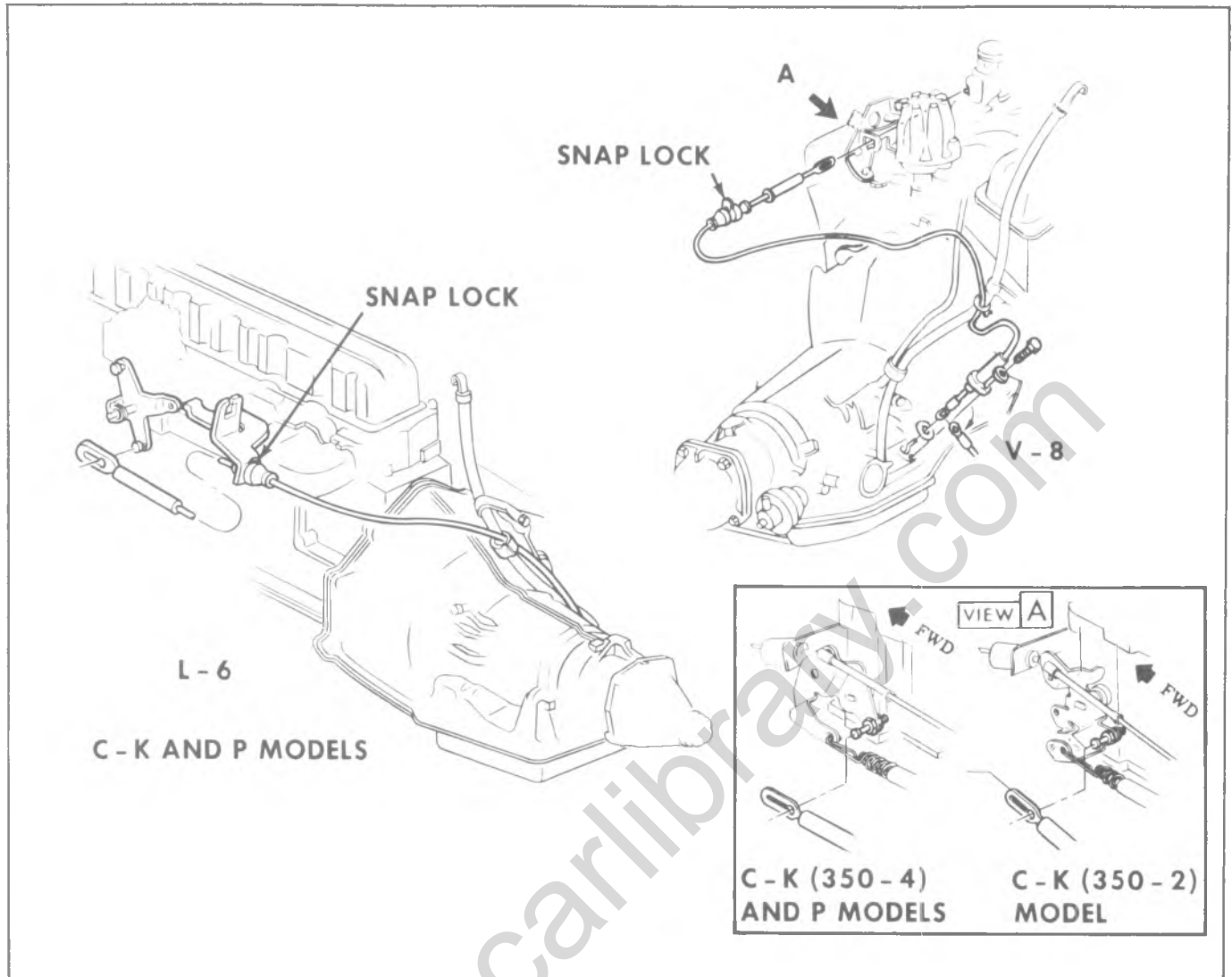


Fig. 7A 6B Detent Downshift Cable - C, K and P Series

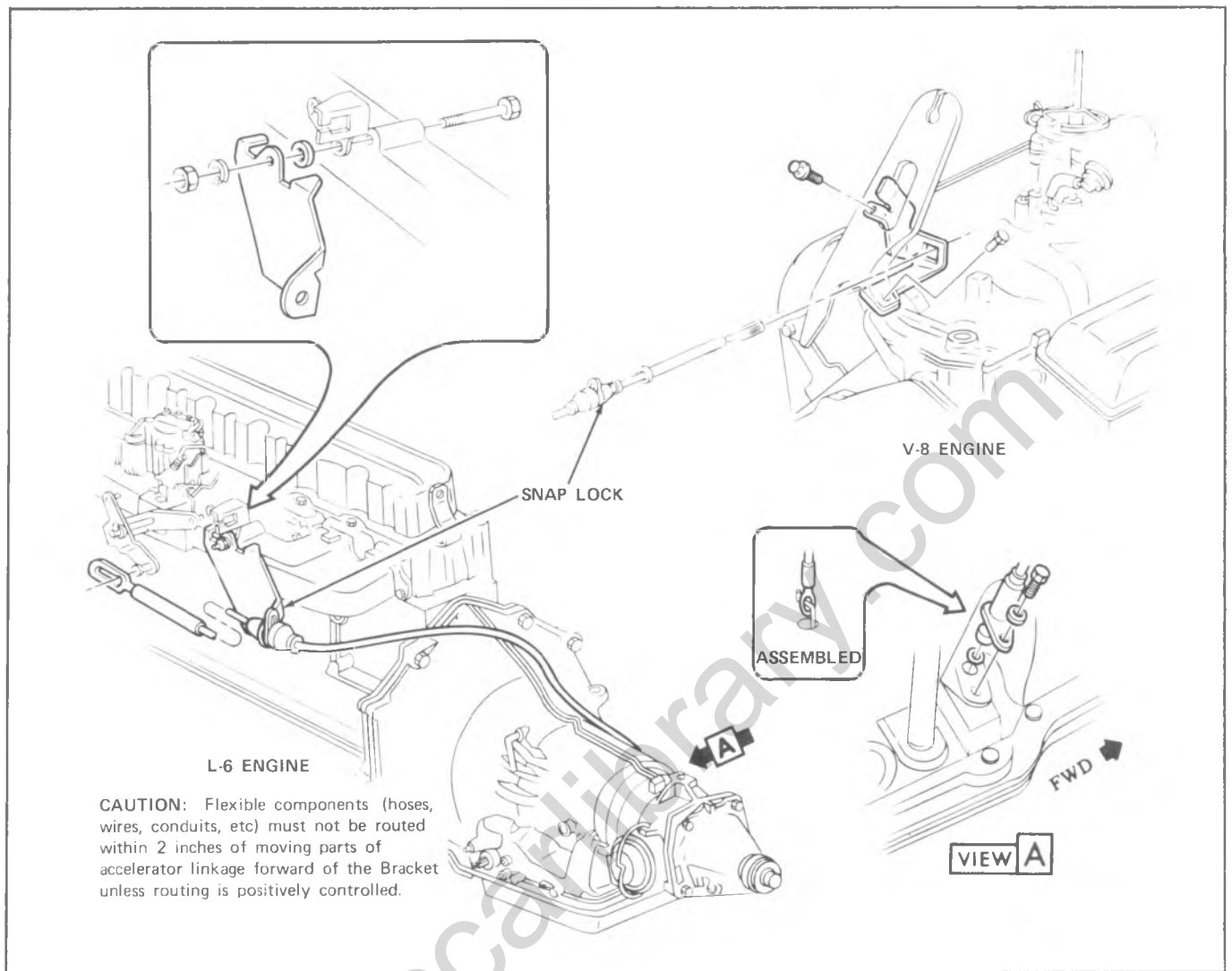


Fig. 7A-7B--Detent Downshift Cable - G Series

DIAGNOSIS

SEQUENCE FOR DIAGNOSIS

1. Check and correct fluid level.
2. Check detent cable adjustment.
3. Check and correct vacuum line and fittings.
4. Check and correct manual linkage.
5. Road test vehicle.
 - a. Install oil pressure gauge.
 - b. Road test using all selective ranges, noting when discrepancies in operation or oil pressure occur.
 - c. Attempt to isolate the unit or circuit involved in the malfunction.
 - d. If engine performances indicates an engine tune-up is required, this should be performed before road testing is completed or transmission correction

attempted. Poor engine performance can result in rough shifting or other malfunctions.

FLUID CHECKING PROCEDURES

Refer to Maintenance and Adjustment Section for fluid checking procedures.

FLUID LEAK DIAGNOSIS

Determining Source of Oil Leak

Before attempting to correct an oil leak, the actual source of the leak must be determined. In many cases, the source of the leak can be deceiving due to "wind flow" around the engine and transmission.

The suspected area should be wiped clean of all oil before inspecting for the source of the leak.

The use of a "Black Light" to locate the point at which the oil is leaking is helpful. Comparing the oil from the leak to that on the engine or transmission dipstick, when viewed by black light, will determine the source of the leak - engine or transmission.

Oil leaks around the engine and transmission are generally carried toward the rear of the vehicle by air stream. For example, a transmission oil filler tube to case leak will sometimes appear as a leak at the rear of the transmission. In determining the source of a leak, proceed as follows:

1. Degrease underside of transmission.
2. Road test to get unit at operating temperature.
3. Inspect for leak with engine running.
4. With engine off, check for oil leaks due to the raised oil level caused by drain back.

Possible Points of Oil Leak

1. Transmission Oil Pan Leak.
 - a. Attaching bolts not correctly torqued.
 - b. Improperly installed or damaged pan gasket.
 - c. Oil pan gasket mounting face not flat.
2. Extension Housing.
 - a. Attaching bolts not correctly torqued.
 - b. Rear seal assembly damaged or improperly installed.
 - c. Square seal, extension to case, damaged or improperly installed.
 - d. Porous casting. See subparagraph C.
3. Case Leak.
 - a. Filler pipe "O" ring seal damaged or missing; misposition of filler pipe bracket to engine.
 - b. Modulator assembly "O" ring seal damaged or improperly installed.
 - c. Detent cable connector "O" ring seal damaged or improperly installed.
 - d. Governor cover not tight, gasket damaged or leak between case face and gasket.
 - e. Speedometer gear "O" ring damaged.
 - f. Manual shaft seal damaged or improperly installed.
 - g. Line pressure tap plug loose.
 - h. Vent pipe (refer to item 5).
 - i. Porous casting. See Subparagraph C.
4. Leak at Front of Transmission.
 - a. Front pump seal leaks.
 1. Seal lip cut. Check converter hub, etc.
 2. Bushing moved and damaged, Oil return hole plugged.
 3. No oil return hole.
 - b. Front pump attaching bolts loose or bolt washer type seals damaged or missing.
 - c. Front pump housing "O" ring damaged or cut.
 - d. Converter leak in weld area.
 - e. Porous casting (pump).
5. Oil Comes Out Vent Pipe.
 - a. Transmission over-filled.
 - b. Water in oil.

c. Foreign material between pump and case or between pump cover and body.

d. Case - porous near converter bosses. Front pump cover or housing oil channels shy or stock near breather. See Subparagraph C.

e. Pump to case gasket mis-positioned.

OIL PRESSURE CHECK

While vehicle is stationary (service brake on), engine speed set to 1200 rmp, transmission oil pressure gauge attached as shown in Fig. 7A-10B, and vacuum modulator tube **disconnected** the transmission line pressure tap should read 167 psi in drive, 166 psi in L1 or L2, and 254 psi in reverse.

While vehicle is stationary (service brake on), engine speed set to maintain 12 inches hg. absolute manifold pressure, transmission oil pressure gauge attached, and vacuum modulator tube **connected** the transmission line pressure tap should read 85 psi in drive, 105 psi in L1 or L2, and 129 psi in reverse.

CASE POROSITY REPAIR

External oil leaks caused by case porosity can be successfully repaired with the transmission in the vehicle by using the following recommended procedures:

1. Road test and bring the transmission to operating temperature, approximately 180 degrees F.
2. Raise vehicle on a hoist or jack stand, engine running, and locate source of oil leak. Check for oil leaks in Low, Drive, and Reverse.
3. Shut engine off and thoroughly clean area to be repaired with a suitable cleaning solvent and a brush - air dry.

A clean, dry soldering acid brush can be used to clean the area and also to apply the epoxy cement.

4. Using instructions of the manufacturer, mix a sufficient amount of epoxy to make the repair. Make certain the area to be repaired is fully covered.

5. Allow cement to cure for 3 hours before starting engine.

6. Road test and check for leaks.

VACUUM MODULATOR DIAGNOSIS

A defective vacuum modulator can cause one or more of the following complaints.

1. Harsh upshifts and downshifts.
2. Delayed upshifts.
3. Soft upshifts and downshifts.
4. Slips in low, drive and reverse.
5. Transmission overheating.
6. Engine burning transmission oil.

If any one of the above complaints are encountered, the modulator must be checked.

Vacuum Diaphragm Leak Check

Insert a pipe cleaner into the vacuum connector pipe as far as possible and check for the presence of transmission oil. If oil is found, replace the modulator.

Gasoline or water vapor may settle in the vacuum side of the modulator. If this is found without the

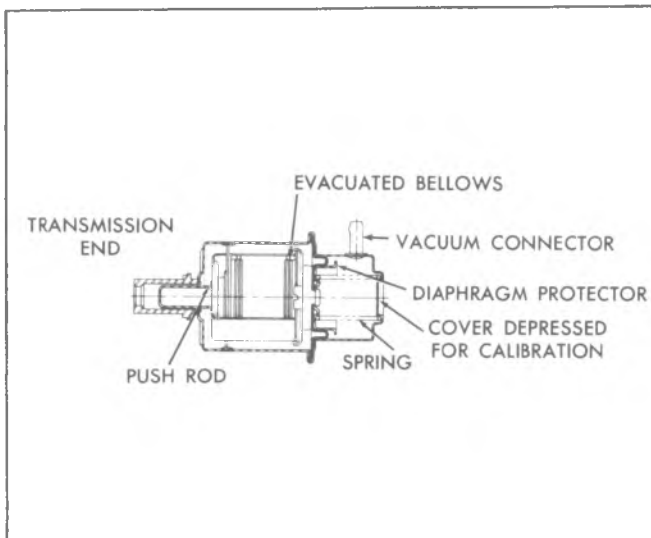


Fig. 7A-8B-Vacuum Modulator Assembly

presence of oil, the modulator is serviceable and should not be changed.

Atmospheric Leak Check

Apply a liberal coating of soap bubble solution to the vacuum connector pipe seam, the crimped upper to lower housing seam (Fig. 7A-8B). Using a short piece of rubber tubing, apply air pressure to the vacuum pipe by blowing into the tube and observe for leak bubbles. If bubbles appear, replace the modulator.

NOTE: Do not use any method other than human lung power for applying air pressure, as pressures over 6 psi may damage the modulator.

Spring Tension Comparison Check

Using tool J-24466, as shown in Figure 7A-9B, compare the load of a known good modulator with the assembly in question.

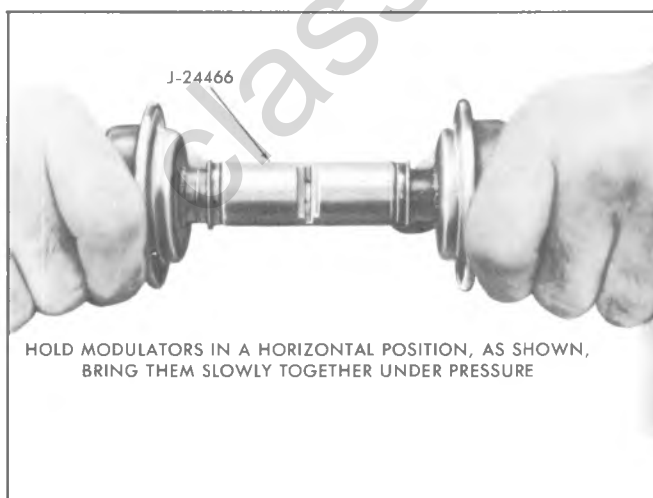


Fig. 7A-9B-Spring Tension Comparison

a. Install the modulator that is known to be acceptable on either end of the tool.

b. Install the modulator in question on the opposite end of the tool.

c. Holding the modulators in a horizontal position, bring them together under pressure until either modulator sleeve just touches the tool. The indicator in the gage will show white if the modulator is acceptable. A non-conforming modulator will cause the indicator to shift, thus showing blue. If white does not appear, the modulator in question should be replaced.

Sleeve Alignment Check

Roll the main body of the modulator on a flat surface and observe the sleeve for concentricity to the cam. If the sleeve is concentric and the plunger is free, the modulator is acceptable.

Once the modulator assembly passes all of the above tests, it is an acceptable part and may be re-used.

TRANSMISSION CLUTCH PLATES DIAGNOSIS

1. Lined Drive Plates.

a. Dry plates with compressed air and inspect the lined surface for:

1. pitting and flaking
2. wear
3. glazing
4. cracking
5. charring
6. chips or metal particles imbedded in lining.

If a lined drive plate exhibits any of the above conditions, replacement is required. Do not diagnose drive plates by color.

2. Steel Driven Plates

Wipe plates dry and check for heat discoloration. If the surface is smooth and an even color smear is indicated, the plate should be reused. If severe heat spot discoloration or surface scuffing is indicated, the plate must be replaced.

3. Clutch Release Springs

Evidence of extreme heat or burning in the area of the clutch may have caused the springs to take a heat set and would justify replacement of the springs.

CAUSES OF BURNED CLUTCH PLATES

1. FORWARD CLUTCH

a. Check ball in clutch housing damaged, stuck or missing.

b. Clutch piston cracked, seals damaged or missing.

c. Low line pressure.

d. Pump cover oil seal rings missing, broken or undersize; ring groove oversize.

e. Case valve body face not flat or porosity between channels.

2. INTERMEDIATE CLUTCH

a. Intermediate clutch piston seals damaged or missing.

- b. Low line pressure.
- c. Case valve body face not flat or porosity between channels.

3. DIRECT CLUTCH

- a. Restricted orifice in vacuum line to modulator (poor vacuum response).
- b. Check ball in direct clutch piston damaged, stuck or missing.
- c. Defective modulator bellows.
- d. Clutch piston seals damaged or missing.
- e. Case valve body face not flat or porosity between channels.
- f. Clutch installed backwards.

NOTE: Burned clutch plates can be caused by incorrect usage of clutch plates. Also, anti-freeze in transmission fluid can cause severe damage, such as large pieces of composition clutch plate material peeling off.

GOVERNOR PRESSURE CHECK

1. Install line Pressure Gage, to tap location shown in Fig. 7A-10B.
2. Disconnect vacuum line to moldulator.
3. With car on hoist (rear wheels, off ground), foot off brake, in drive, check line pressure at 1000 RPM.
4. Slowly increase engine RPM to 3000 RPM and determine if a line pressure drop occurs (7 PSI or more).
5. If no pressure drop occurs:
 - a. Inspect Governor
 1. Stuck valve.
 2. Free Weights.
 3. Restricted orifice in governor valve.
 - b. Governor Feed System
 1. Check screen in control valve assembly.
 2. Check for restrictions in feed line.
 3. Scored governor bore.

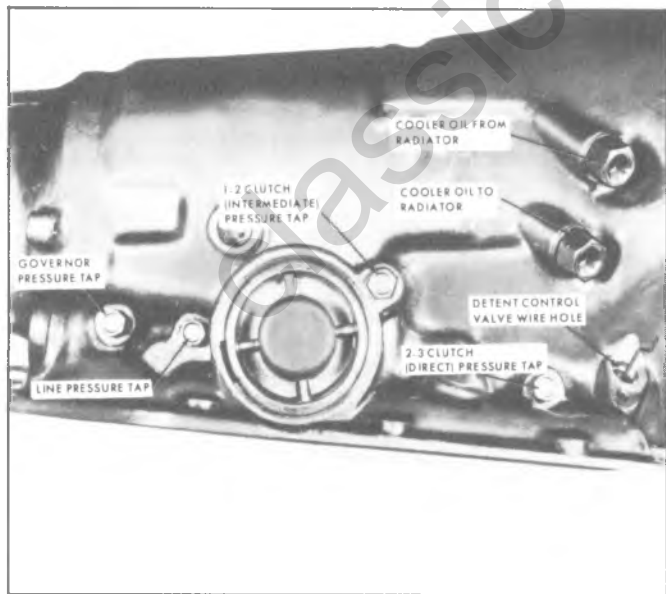


Fig. 7A-10B--Pressure Tap Locations

MANUAL LINKAGE

Manual linkage adjustment and the associated neutral safety switch are important from a safety standpoint. The neutral safety switch should be adjusted so that the engine will start in the Park and Neutral positions only.

With the selector lever in the Park position, the parking pawl should freely engage and prevent the vehicle from rolling. The pointer on the indicator quadrant should line up properly with the range indicators in all ranges.

ROAD TEST

Drive Range

Position selector lever in DRIVE RANGE and accelerate the vehicle from 0 MPH. A 1-2 and 2-3 shift should occur at all throttle openings. (The shift points will vary with the throttle opening). As the vehicle decreases in speed to 0 MPH, the 3-2 and 2-1 shifts should occur.

Low L2 Range

Position the selector lever in L2 RANGE and accelerate the vehicle from 0 MPH. A 1-2 shift should occur at all throttle openings. (No. 2-3 shift can be obtained in this range). The 1-2 shift point will vary with throttle opening. As the vehicle decreases in speed to 0 MPH, a 2-1 shift should occur.

The 1-2 shift in INTERMEDIATE RANGE is somewhat firmer than in DRIVE RANGE. This is normal.

Low L1 Range

Position the selector lever in L1 RANGE and accelerate the vehicle from 0 MPH. No upshift should occur in this range.

2ND Gear — Overrun Braking: (L2)

Position the selector lever in DRIVE RANGE, and with the vehicle speed at approximately 35 MPH, move the selector lever to L2 RANGE. The transmission should downshift to 2nd. An increase in engine RPM and an engine braking effect should be noticed. Line pressure should change from approximately 100 PSI to approximately 125 PSI in 2nd.

1ST Gear — Overrun Braking: (L1)

Position the selector lever in L2 RANGE at approximately 30 to 50 MPH, with throttle closed, move the selector lever to L1. A 2-1 downshift should occur in the speed range of approximately 45 to 30 MPH, depending on axle ratio and valve body calibration. The 2-1 downshift at closed throttle will be accompanied by increased engine RPM and an engine braking effect

should be noticed. Line pressure should be approximately 150 PSI. Stop vehicle.

Reverse Range: (R)

Position the selector lever in REVERSE POSITION and check for reverse operation.

TROUBLE DIAGNOSIS

Refer to Fig. 7A-11B, Diagnosis Chart, to determine a possible cause of a transmission problem.

Additional diagnosis of a malfunction is as follows:

No Drive in Drive Range

(Install pressure gauge)

- Low Oil Level - correct level and check for external leaks or defective vacuum modulator (leaking diaphragm will evacuate oil from unit).

- Manual Linkage - misadjusted, correct alignment to manual lever shift quadrant is essential.

- Low Oil Pressure - refer to LOW LINE PRESSURE below.

- Forward Clutch:

- a. Forward clutch does not apply - piston cracked; seals missing or damaged; clutch plates burned (see BURNED CLUTCH PLATES below).

- b. Pump feed circuit-to-forward clutch oil seal rings missing or broken on pump cover; leak in feed circuits; pump-to-case gasket mispositioned or damaged; clutch drum ball check stuck or missing.

- Low and Reverse Roller Clutch Assembly - broken spring, damaged cage or installed backwards.

High or Low Oil Pressure

(Refer to OIL PRESSURE CHECKS)

High Line Pressure

- Vacuum Leak:
 - a. Vacuum line disconnected.
 - b. Leak in line from engine to modulator.
 - c. Improper engine vacuum.
 - d. Leak in vacuum-operated accessory (hoses, vacuum advance, etc.).

- Modulator:

- a. Stuck modulator valve.
- b. Water in modulator.
- c. Damaged, not operating properly.

- Detent System - detent valve or cable stuck in detent position.

- Valve Body:

- a. Pressure regulator and/or boost valve stuck.
- b. Boost valve sleeve broken or defective.
- c. Incorrect pressure regulator valve spring.

Low Line Pressure

- Low transmission oil level.
- Defective vacuum modulator assembly.
- Strainer Assembly:
 - a. Blocked or restricted.
 - b. Gasket omitted or damaged.
- Oil Pump:

- a. Gear clearance, damaged, worn, gear installed backwards:

- b. Pump-to-case gasket mispositioned.
- c. Defective pump body and/or cover.

- Valve Body:

- a. Pressure regulator or boost valve stuck.
- b. Pressure regulator valve spring, too weak.

- Internal Circuit Leaks:

- a. Forward clutch leak (pressure low in Drive range, pressure normal in Neutral and Reverse).

1. Check pump oil seal rings.
2. Check forward clutch seals.

- b. Direct clutch leak (pressure low in Reverse, pressure normal in other ranges).

1. Check direct clutch outer seal.

2. Check 1-2 accumulator and 2-3 accumulator pistons and rings for damage or missing.

- Case Assembly - check ball missing from cored passage in case face.

1-2 Shift - Full Throttle Only

- Detent Valve - sticking or linkage misadjusted.
- Vacuum Leak - vacuum line or fittings leaking.

- Control Valve Assembly:

- a. Valve body gaskets - leaking, damaged or incorrectly installed.

- b. Detent valve train stuck.

- c. 1-2 valve stuck closed (in downshifted position).

- Case Assembly - refer to case porosity repair.

First Speed Only - No 1-2 Shift

- Detent (downshift) cable - binding.

- Governor Assembly:

- a. Governor valve sticking.

- b. Driven gear loose, damaged or worn (check for pin in case and length of pin showing; also, check output shaft drive gear for nicks or rough finish if driven gear shows damage).

- Control Valve Assembly:

- a. Valve body gaskets - leaking, damaged or incorrectly installed.

- b. Governor feed channels blocked.

- c. 1-2 shift valve train stuck closed (in downshifted position).

- Intermediate Clutch:

- a. Clutch piston seals - missing, improperly installed or cut.

- b. Intermediate roller clutch - broken spring or damaged cage.

- Case:

- a. Porosity between channels.

- b. Governor feed channel blocked; governor bore scored or worn, allowing cross pressure leak.

First and Second Speeds Only - No 2-3 Shift

- Control Valve Assembly:

- a. Valve body gaskets - leaking, damaged or incorrectly installed.

b. 2-3 shift valve train stuck closed (in downshifted position).

- Direct Clutch:

a. Pump hub - direct clutch oil seal rings - broken or missing.

b. Clutch piston seals - missing, improperly assembled or cut.

c. Clutch plates burned (see BURNED CLUTCH PLATES below).

No First Speed - Starts in Second Speed

(Locks up in L1 Range)

Intermediate Clutch:

1. Too many plates in intermediate clutch pack.
2. Incorrect intermediate clutch piston.

Drive in Neutral

- Manual Linkage - misadjusted, (correct alignment in manual lever shift quadrant is essential).

- Internal Linkage - manual valve disconnected or end broken.

- Oil Pump - line pressure leaking into forward clutch apply passage.

- Forward Clutch - incorrect clutch plate usage or burned clutches (see BURNED CLUTCH PLATES below).

No Motion in Reverse or Slips in Reverse

(Install pressure gauge)

- Low Oil Level - add oil.

- Manual Linkage - misadjusted (correct alignment in manual lever shift quadrant is essential).

- Low Oil Pressure - refer to LOW LINE PRESSURE above.

- Control Valve Assembly:

a. Valve body gaskets - leaking, damaged or incorrectly installed.

b. 2-3 shift valve train stuck open (in upshifted position).

- Intermediate Servo - piston or pin stuck so intermediate overrun band is applied.

- Low and Reverse Clutch - piston outer seal damaged or missing.

- Direct Clutch:

a. Outer seal damaged or missing.

b. Clutch plates burned (see BURNED CLUTCH PLATES below).

- Forward Clutch - clutch does not release (will cause DRIVE in NEUTRAL).

Slips in All Ranges or Slips on Start

(Install pressure gauge)

- Low Oil Level - add oil.

- Low Oil Pressure - refer to LOW LINE PRESSURE above.

- Forward clutch:

a. Clutch plates burned (see BURNED CLUTCH PLATES below).

b. Pump cover oil seal rings broken or worn.

- Case - cross leaks or porosity.

Slipping 1-2 Shift

(Install pressure gauge)

- Low Oil Level - add oil.

- Low Oil Pressure - refer to LOW LINE PRESSURE above.

- 2-3 Accumulator - oil ring damaged or missing.

- 1-2 Accumulator - oil ring damaged, missing or case bore damaged.

- Pump-to-Case Gasket - mispositioned or damaged.

- Intermediate Clutch:

a. Piston seals damaged or missing.

b. Clutch plates burned (See BURNED CLUTCH PLATES below).

- Case - porosity between channels.

Slipping 2-3 Shift

(Install pressure gauge)

- Low Oil Level - add oil.

- Low Oil Pressure - refer to LOW LINE PRESSURE above.

- Direct Clutch:

a. Piston seals leaks, damaged or missing.

b. Clutch plates burned (see BURNED CLUTCH PLATES below).

c. Inspect for proper number and type of clutch plates.

- Case - refer to case porosity repair.

Rough 1-2 Shift

(Install pressure gauge)

- High Oil Pressure - refer to HIGH LINE PRESSURE above.

- 1-2 Accumulator:

a. Oil rings damaged.

b. Piston stuck.

c. Broken or missing spring.

d. Bore damaged.

- Intermediate Clutch - check for burned and number (type) of plates.

- Case:

a. Check for correct number and location of check balls.

b. Porosity between channels.

Rough 2-3 Shift

(Install pressure gauge)

- High Oil Pressure - refer to HIGH LINE PRESSURE above.

- 2-3 Accumulator:

a. Oil ring damaged.

b. Piston stuck.

c. Broken or missing spring.

d. Piston bore damaged.

No Engine Braking in L2

(Install pressure gauge)

- Low Oil Pressure - pressure regulator and/or boost valve stuck.
- Intermediate Servo and 2-3 Accumulator:
 - a. Servo or accumulator oil rings or bores leaking or damaged.
 - b. Servo piston stuck or cocked.
- Intermediate Overrun Band - intermediate overrun band broken or burned (look for cause), not engaged or servo pin.

No Engine Braking in L1

(Install pressure gauge)

- Low Oil Pressure - pressure regulator and/or boost valves stuck.
- Manual Low Control Valve Assembly - stuck.
- Low and Reverse Clutch - piston inner seal damaged or missing.

No Part Throttle Downshift

(Install pressure gauge)

- Oil Pressure - vacuum modulator assembly, modulator valve or pressure regulator valve train (other malfunctions may also be noticed).
- Detent Valve and Linkage - sticks, disconnected or broken.
- 2-3 shift valve - stuck.

No Detent (Wide Open Throttle)

Downshift

- Detent cable or retainer not adjusted properly.
- Detent cable disconnected at transmission or throttle linkage.
- Valve Body:
 - a. Detent valve sticks.
 - b. Detent regulator valve sticks.
 - c. Incorrect spacer plate or gasket.

High or Low Shift Points

(Install pressure gauge)

- Oil Pressure:
 - a. Engine Vacuum - check at transmission end of modulator pipe.
 - b. Check vacuum line connections at engine and transmission.
 - c. Vacuum modulator assembly and valve and pressure regulator valve train.
- Governor:
 - a. Valve sticking.
 - b. Feed holes restricted or leaking.
- Detent Valve and Linkage - stuck open (will cause high shift points).
- Control Valve Assembly:
 - a. 1-2 shift valve train sticking.

- b. 2-3 shift valve train sticking.
- Case - refer to case porosity repair.

Won't Hold in Park

- Manual Linkage - misadjusted (correct alignment in manual lever shift quadrant is essential).
- Internal Linkage:
 - a. Inner lever and actuating rod assembly - defective or improperly installed.
 - b. Parking pawl - broken or inoperative.
 - c. Parking lock bracket loose, burred or rough edges or incorrectly installed.
 - d. Parking pawl disengaging spring missing, broken or incorrectly hooked.

Transmission Noisy

CAUTION: Before checking transmission for noise, make certain that the noise is not coming from the water pump, alternator, power steering, etc. These components can be isolated by removing the proper belt and running the engine not more than two minutes at one time.

Park, Neutral and all Driving Ranges

- Pump Cavitation:
 - a. Low oil level.
 - b. Plugged or restricted strainer.
 - c. Strainer-to-valve body gasket damaged.
 - d. Porosity in valve body intake area.
 - e. Water in oil.
 - f. Porosity or voids at transmission case (pump face) intake port.
 - g. Pump-to-case gasket off location.
- Pump Assembly:
 - a. Gears damaged.
 - b. Driving gear assembled backwards.
 - c. Crescent interference.
 - d. Oil seal rings damaged or worn.
- Converter:
 - a. Loose flexplate-to-converter bolts.
 - b. Converter damage.
 - c. Water in oil (causes whine).

First, Second and/or Reverse Gear

Planetary Gear Set:

1. Gears or thrust bearings damaged.
2. Input or output ring gear damaged.

During Acceleration - Any Gear

- Transmission or cooler lines grounded to underbody.
- Motor mounts loose or broken.

Squeal at Low Vehicle Speed

Speedometer driven gear shaft seal - requires lubrication or replacement.

Turbo Hydra-Matic 350 Diagnosis Chart

PROBLEM	CAR ROAD TEST	POSSIBLE CAUSE	ALL RANGES SLIPS	DRIVE SLIPS-NO 1ST GEAR	LINE PRESSURE-ALL LOW	LINE PRESSURE-ALL HIGH	1-2 INTERM. CL. PRES. HIGH	2-3 INTERM. CL. PRES. HIGH	NO 1-2 DIRECT CL. PRES. HIGH	NO 2-3 DIRECT CL. PRES. HIGH	1-2 U.S. UP-SHIFT	1-2 U.S. EARLY/LATE	SLIPS 1-2 UP-SHIFT @ W.O.T. ONLY	ROUGH 1-2 UP-SHIFT	NO 2-3 UP-SHIFT	2-3 U.S. UP-SHIFT	SLIPS 2-3 UP-SHIFT	ROUGH 2-3 UP-SHIFT	NO W.O.T. 2-3 UP-SHIFT	NO PART TH. 1-2 UP-SHIFT	NO FULL TH. DOWN SHIFT	2-3 UP-SHIFT DOWN SHIFT	HARSH DOWN-SHIFT	1-2 RANGE-NO W.O.T. ONLY	2-3 RANGE-NO W.O.T. ONLY	NEUTRAL-NO ENG. BRAKING	REVERSE-NO ENG. BRAKING	SLIPS IN REVERSE	PARK IN REVERSE	NOISY-NO REVERSE	1-2 ALL PARK-RATCHETS	REV & D. 2-3 SHIFTS	LOW COOLER NOISY	SPEWS OIL OUT	HUNTS OIL FLOW	HUNTS BETWEEN 2 & 3 AND 3 & 2				
LOW OIL LEVEL/WATER IN OIL			X	X	X		X		X																		X		X	X		X	X							
VACUUM LEAK					X	X		X	X	X			X							X																				
MODULATOR &/OR VALVE			X	X	*	X	X					X	X	X	X												X													
STRAINER &/OR GASKET			X	X	X		X		X																		X		X						X	X				
GOVERNOR-VALVE/SCREEN					X	X			X	X				X													X													
VALVE BODY-GASKET/PLATE			X	X	X		X	X	X	X		X	X	X	X											X		X												
PRES. REG. &/OR BOOST VALVE			X	X	X	X	X	X	X	X	X	X	X	X								X	X		X	X														
BALL (#1) SHY			X	X	*		X		X	X			X	X								O			X	X														
1-2 SHIFT VALVE						X		X	X	X	X												X				X													
2-3 SHIFT VALVE							X					X	X	X	X	X				X																				
MANUAL LOW CONT'L. VALVE																						X																		
DETENT VALVE & LINKAGE					X				X				X						X	X	X																		S	
DETENT REG. VALVE														X																										
2-3 ACCUMULATOR						X			X						X																									
MANUAL VALVE/LINKAGE			X	X	X																	X	X		X	X														
POROSITY/CROSS LEAK			X	X	X	X	X	X	X	X	X	X	X	X	X	X	X	X	X				X	X		X	X													
PUMP-GEARS			X	X	X		X		X					X														X												
PRIMING VALVE SHY			X	X	X																																			S
COOLER VALVE LEAK																																					X	X		
CLUTCH SEAL RINGS			X	X	X	X	X	X		X	X	X	X	X	X							X	X		X	X														
POROUS/CROSS LEAK			X	X	X	X	X	X	X	X	X	X	X	X	X	X	X	X	X						X	X												X	X	
GASKET SCREEN-PRESSURE			X	X	X																						X	X		X										
BAND-INTERM. O.R.																						X																		
CASE-POROUS/X LEAK			X	X	X	X	X	X	X	X	X	X	X	X	X	X	X	X	X			X			X	X													X	
1-2 ACCUMULATOR			X	X	X	X		X		X	X																													
INTERMED. SERVO			X	X	X	X				X													X																	
FORWARD CLUTCH ASS'Y			X																			X	X	X	L															
DIRECT CLUTCH ASS'Y							X					X	X												X	X														X
INTERMED. CL. ASS'Y						X		X				X																												X
L & REV. CL. ASS'Y																						X			X	X														
INT. ROLLER CL. ASS'Y							X		X														X																	
L. & R. ROLLER CL. ASS'Y			X																																					
PARK PAWL/LINKAGE																											X													
CONVERTER ASS'Y																												X		X										
GEAR SET & BEARINGS																												X	X											

Fig. 7A-11B-CBC 350 Diagnosis Chart

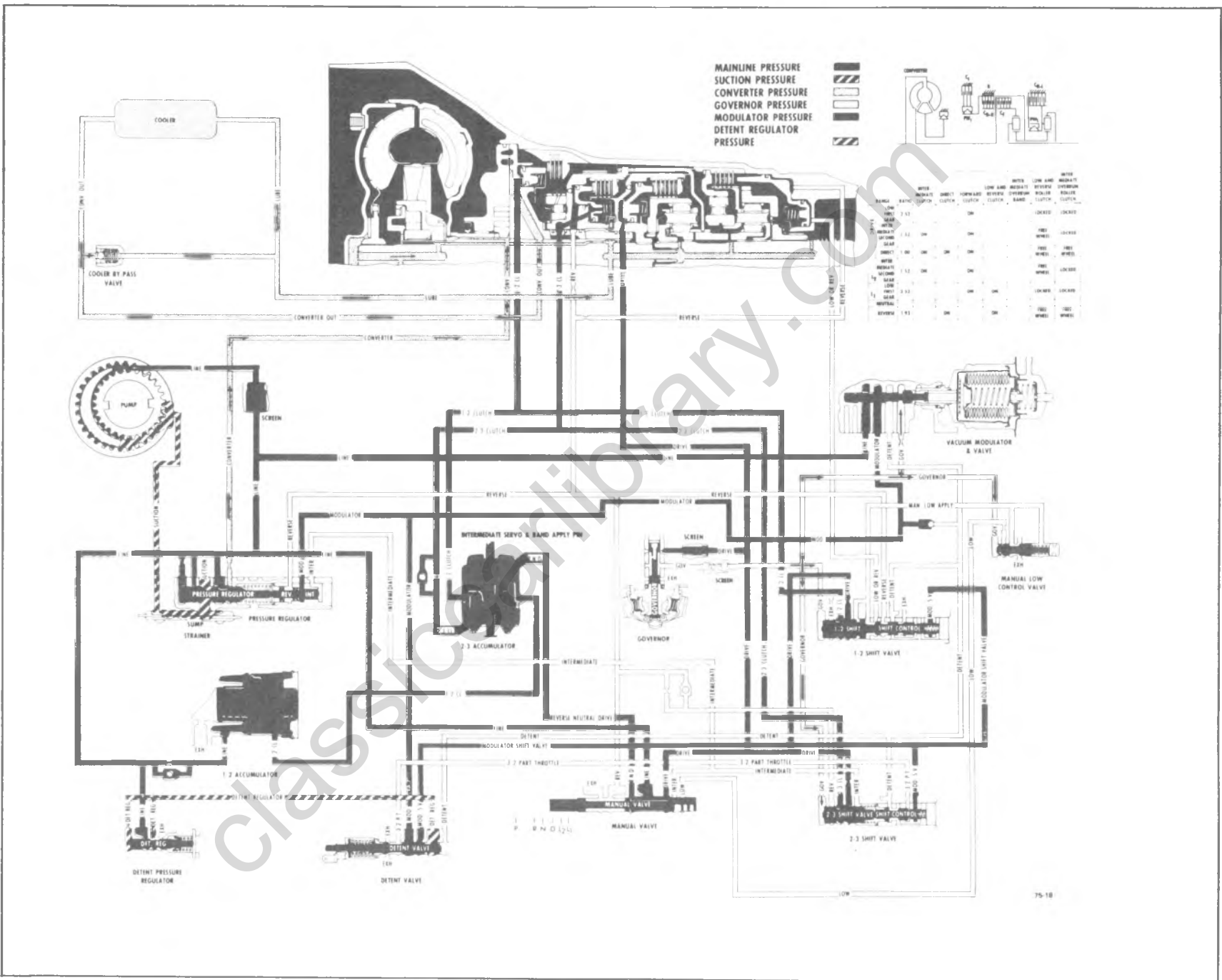


Fig. 7A-12B-CBC 350 Hydraulic Circuit

SERVICE OPERATIONS

TRANSMISSION REPLACEMENT

(All Except K Model)

NOTE: If necessary, the catalytic converter may have to be disconnected to provide adequate clearance for transmission removal. This procedure will include removal of the converter support bracket.

1. Before raising the vehicle, disconnect the negative battery cable detent downshift cable at carburetor and release the parking brake.

2. Raise vehicle on hoist.

3. Remove propeller shaft.

4. Disconnect speedometer cable, detent downshift cable, modulator vacuum line and oil cooler pipes at transmission.

5. Disconnect shift control linkage.

6. Support transmission with suitable transmission jack.

7. Disconnect rear mount from frame crossmember.

8. Remove two bolts at each end of frame crossmember. Remove crossmember.

9. Remove converter under pan.

10. Remove converter to flywheel bolts.

11. Lower transmission until jack is barely supporting it.

12. Remove transmission to engine mounting bolts and remove oil filler tube at transmission.

13. Raise transmission to its normal position, support engine with jack and slide transmission rearward from engine and lower it away from vehicle.

CAUTION: Use suitable converter holding tool when lowering transmission or keep rear of transmission lower than front so as not to lose converter.

The installation of the transmission is the reverse of the removal with the following added step. Before installing the flex plate to converter bolts, make certain that the attaching lugs on the converter are flush with the flex plate and the converter rotates freely by hand in this position. Then, hand start all three bolts and tighten finger tight before torquing to specification. This will insure proper converter alignment.

After installation of transmission, lower vehicle and remove vehicle from hoist. Check linkage for proper adjustment.

Check transmission fluid level.

TRANSMISSION REPLACEMENT

(K Model)

Removal

1. Disconnect battery cable.
2. Remove transmission dipstick.
3. Disconnect detent downshift cable at carburetor.

4. Remove transfer case shift lever knob and boot.

5. Raise vehicle on hoist.

6. Remove flywheel cover.

7. Remove torque converter to flywheel attaching bolts. (Secure the converter.)

8. Disconnect transmission shift linkage and speedometer cable.

9. Remove engine crossunder pipe to manifold bolts.

10. Disconnect vacuum modulator line, line to filler tube clip and detent downshift cable to filler tube strap.

11. Disconnect detent downshift cable at the transmission.

12. Disconnect transmission oil cooler lines at the transmission.

13. Remove transfer case adapter to crossmember bolts.

14. Raise engine as necessary.

15. Remove crossmember bolts and remove crossmember.

16. Remove exhaust system hanger bolts.

17. Disconnect rear propeller shaft at transfer case.

18. Disconnect parking brake cable.

19. Disconnect exhaust system. (Tie aside.)

20. Disconnect front propeller shaft at front axle. (Tie aside.)

21. Support transmission and transfer case with jack (use safety chains).

22. Remove transfer case to frame bracket bolts.

23. Remove transmission to engine bolts, remove transmission and transfer case.

24. Remove transfer case from transmission (includes: new "O" ring seal).

25. Move transmission to bench fixture.

26. Drain transmission.

27. Remove torque converter.

28. Remove and discard front pump seal.

29. Refill transfer case.

Installation

Reverse removal procedure to install.

EXTENSION HOUSING OIL SEAL

Removal

1. Remove propeller shaft.

2. Pry out lip oil seal with screwdriver or small chisel.

Installation

1. Coat outer casing of new lip oil seal with a non-hardening sealer and drive it into place with Installer J-21426.
2. Install propeller shaft and adjust fluid level.

SPEEDOMETER DRIVEN GEAR

Removal

1. Disconnect speedometer cable.
2. Remove retainer bolt, retainer, speedometer driven gear and O-ring seal.

Installation

Installation of speedometer driven gear is the reverse of REMOVAL. Install new O-ring seal (if required) and adjust the fluid level.

SPEEDOMETER DRIVE GEAR

Removal

1. Raise vehicle and support transmission with suitable transmission jack.
2. Remove propeller shaft.
3. Disconnect speedometer cable.
4. Disconnect transmission rear mount from frame crossmember.
5. Remove two bolts at each end of frame cross member and remove crossmember.
6. Remove extension housing.
7. Install Special Tools J-21427-01 and J-8105 on output shaft and remove speedometer drive gear. Remove retaining clip.

Installation

1. Place speedometer drive gear retaining clip into hole in output shaft.
2. Align slot in speedometer drive gear with retaining clip and install.
3. Install extension housing and tighten attaching bolts to 25 pound feet.
4. Connect speedometer cable.
5. Install crossmember to frame and transmission.
6. Install propeller shaft.
7. Remove transmission jack and lower vehicle.

MANUAL SHAFT, RANGE SELECTOR INNER LEVER AND PARKING LINKAGE ASSEMBLIES

Removal

1. Referring to draining procedures, drain transmission fluid from oil pan.
2. After oil pan and strainer have been removed, remove valve body assembly. Discard gaskets.
3. Remove manual shaft-to-case retainer and unthread jam nut holding range selector inner lever to manual shaft.

4. Remove jam nut and remove manual shaft from range selector inner lever and case.

NOTE: Do not remove manual shaft lip oil seal unless replacement is required.

5. Remove parking pawl actuating rod and range selector inner lever from case.
6. Remove bolts and parking lock bracket.
7. Remove parking pawl disengaging spring and, if necessary to replace park pawl or shaft, clean up bore in case and remove parking pawl shaft retaining plug, park pawl shaft and pawl.

Installation

Installation of parking linkage, selector lever and manual shaft is the reverse of REMOVAL. Install new plug (if required), new lip oil seal (if required) and new gaskets. Adjust the fluid level.

NOTE: Before installing the propeller shaft, liberally lubricate splines of the transmission yoke with a Lithium soap base lubricant. The lubricant should seep from the vent hole (rear cap of yoke) when installing yoke on transmission output shaft. It is essential that the vent hole is not obstructed.

GOVERNOR

Remove

1. Raise vehicle and disconnect speedometer cable at transmission.
2. Remove governor cover retainer and governor cover.

NOTE: Be careful not to damage cover and "O" ring seal.

3. Remove governor. Inspect weights and valve for freeness.

Install

1. Install governor.
2. Install governor cover using a brass drift around the outside flange of the cover.

NOTE: Do not distort cover on installation. Be sure "O" ring seal is not cut or damaged.

3. Install retainer.
4. Connect speedometer cable, lower vehicle and check transmission fluid level.

VACUUM MODULATOR AND MODULATOR

VALVE ASSEMBLY

Removal

1. Disconnect vacuum hose from vacuum modulator stem and remove vacuum modulator attaching screw and retainer.
2. Remove modulator assembly and its O-ring seal from case.

3. Remove modulator valve from case.

Installation

Installation of the modulator and modulator valve is the reverse of REMOVAL. Install a new O-ring seal and adjust the fluid level.

4. Remove tool and install oil pan bolts.

VALVE BODY ASSEMBLY

Removal

1. Referring to draining procedures, drain transmission fluid from oil pan.
2. After oil pan and strainer, have been removed, discard gaskets.
3. Remove detent spring and roller assembly from valve body and remove valve body-to-case bolts.
4. Remove valve body assembly while disconnecting manual control valve link from range selector inner lever and removing detent control valve link from the detent actuating lever.
5. Remove manual valve and link assembly from valve body assembly.

Installation

Installation of the valve body assembly is the reverse of REMOVAL. Install new gaskets to strainer and oil pan and adjust the fluid level.

1-2 ACCUMULATOR

Remove

1. Remove two transmission oil pan bolts below the 1-2 accumulator cover. Install J-23069 in place of bolts removed.

2. Press in on cover and remove retaining ring.
3. Remove cover "O" ring seal, spring and 1-2 accumulator.

Install

1. Install 1-2 accumulator piston.

NOTE: Rotating piston slightly when installing will help to get rings started in bore.

2. Position spring, "O" ring seal and cover in place.
3. Press in on cover with J-23069 and install retaining ring.
4. Remove tool and install oil pan bolts.

OIL COOLER PIPES

If replacement of transmission steel tubing cooler pipes is required, use only double wrapped and brazed steel tubing meeting GM specification 123M or its equivalent. Under no condition use copper or aluminum tubing to replace steel tubing. Those materials do not have satisfactory fatigue durability to withstand normal vehicle vibrations.

Steel tubing should be flared using the upset (double lap) flare method which is detailed in Section 5.

THM 400 TRANSMISSION

INDEX

General Description	7A-21	Manual Linkage	7A-28
Maintenance and Adjustment.....	7A-22	Trouble Diagnosis.....	7A-28
Checking Transmission Mount.....	7A-22	Service Operations	7A-34
Transmission Fluid	7A-22	Transmission Replacement	7A-34
Column Shift Linkage Adjustment.....	7A-24	Rear Seal	7A-34
Detent Switch Adjustment.....	7A-25	Governor	7A-34
Neutral Start Backup Lamp Switch Adjustment.....	7A-25	Modulator and Modulator Valve.....	7A-34
Diagnosis.....	7A-25	Parking Linkage.....	7A-34
Sequence for Diagnosis.....	7A-25	Control Valve Body.....	7A-35
Oil Checking Procedure	7A-25	Pressure Regulator Valve.....	7A-35
Oil Leak Diagnosis	7A-25	Oil Cooler Pipes.....	7A-35
Oil Pressure Check	7A-26	Other Service Operations.....	7A-36
Case Porosity Repair.....	7A-26	Specifications	7A-37
Vacuum Modulator Diagnosis	7A-27	Special Tools	7A-38

GENERAL DESCRIPTION

The THM 400 transmission is a fully automatic unit consisting primarily of a 3-element hydraulic torque converter and a compound planetary gear set. Three multiple-disc clutches, one gear unit, one roller clutch, and two bands provide the friction elements required to obtain the desired function of the compound planetary gear set.

The torque converter couples the engine to the planetary gears through oil and provides hydraulic torque multiplication when required. The compound planetary gear set produces three forward speeds and reverse.

The 3-element torque converter consists of a pump or driving member, a turbine or driven member, and a stator assembly. The stator is mounted on a one-way roller clutch which will allow the stator to turn clockwise but not counter-clockwise.

The torque converter housing is filled with oil and is attached to the engine crankshaft by a flex plate and always rotates at engine speed. The converter pump is an integral part of the converter housing, therefore the pump blades, rotating at engine speed, set the oil within the converter into motion and direct it to the turbine, causing the turbine to rotate.

As the oil passes through the turbine it is traveling in such a direction that if it were not re-directed by the stator it would hit the rear of the converter pump blades and impede its pumping action. So at low turbine speeds, the oil is re-directed by the stator to the converter pump in such a manner that it actually assists the converter pump to deliver power or multiply engine torque.

As turbine speed increases, the direction of the oil leaving the turbine changes and flows against the rear side of the stator vanes in a clockwise direction. Since the stator is now impeding the smooth flow of oil, its roller clutch releases and it revolves freely on its shaft. Once the stator becomes inactive, there is no further

multiplication of engine torque within the converter. At this point, the converter is merely acting as a fluid coupling as both the converter pump and turbine are being driven at approximately the same speed - or at one-to-one ratio.

A hydraulic system pressurized by a gear type pump provides the working pressure required to operate the friction elements and automatic controls.

External control connections to transmission are:

Manual Linkage - To select the desired operating range.

Engine Vacuum - To operate a vacuum modulator unit.

12 Volt Electrical - To operate an electrical detent solenoid.

A vacuum modulator is used to automatically sense any change in the torque input to the transmission. The vacuum modulator transmits this signal to the pressure regulator for line pressure control, to the 1-2 accumulator valve, and to the shift valves so that all torque requirements of the transmission are met and smooth shifts are obtained at all throttle openings.

The detent solenoid is activated by an electric switch on the carburetor. When the throttle is fully opened, the switch on the carburetor is closed, activating the detent solenoid and causing the transmission to downshift for passing speeds.

The selector quadrant has six selector positions: P, R, N, D, L2, L1.

P. PARK position positively locks the output shaft to the transmission case by means of a locking pawl to prevent the vehicle from rolling in either direction (not on CL model). The engine may be started in Park position.

R. REVERSE enables the vehicle to be operated in a reverse direction.

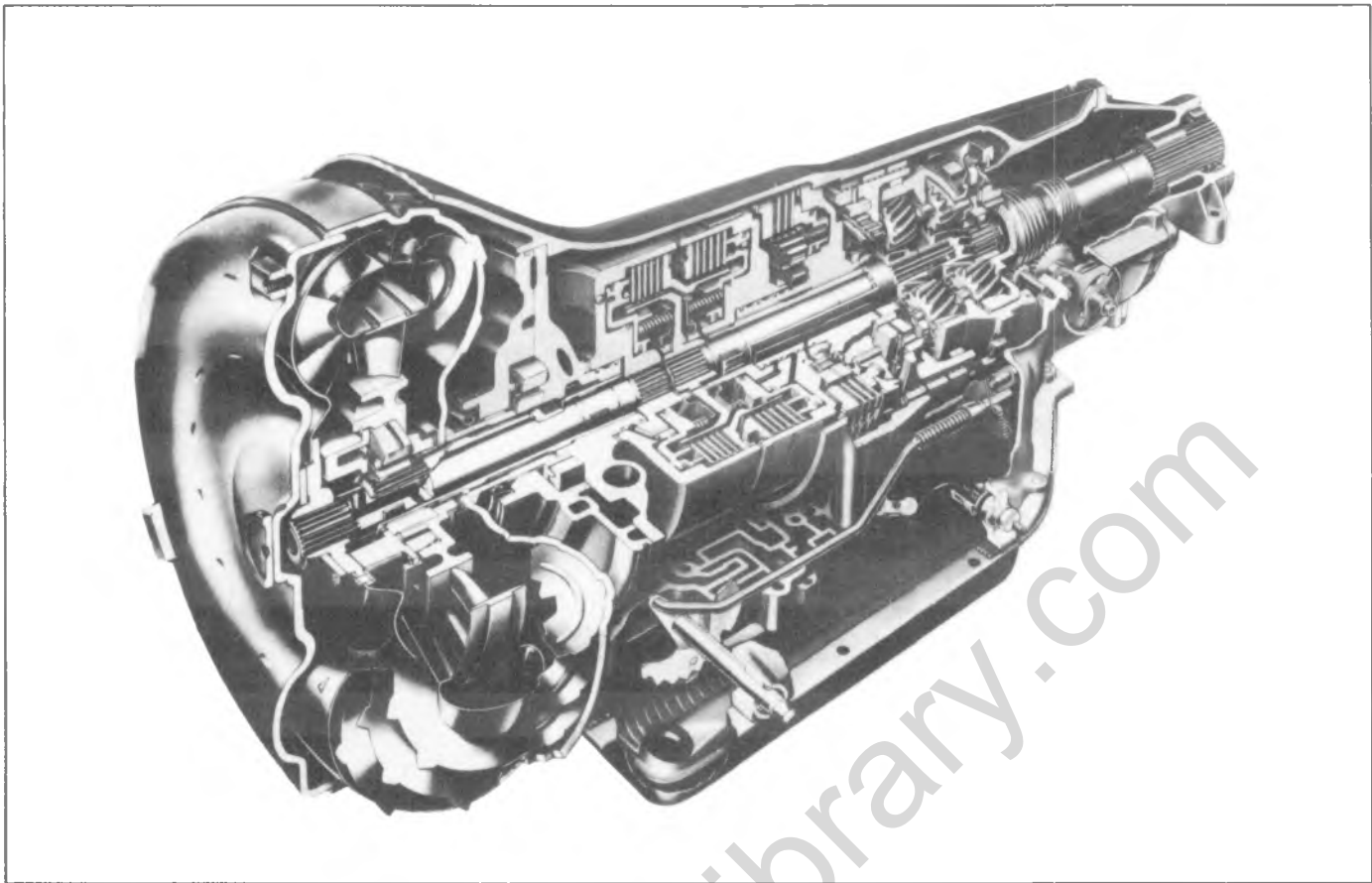


Fig. 7A-1C--THM 400, Cross-Section View

N. Neutral position enables the engine to be started and run without driving the vehicle.

D. DRIVE Range is used for all normal driving conditions and maximum economy. Drive Range has three gear ratios, from the starting ratio to direct drive. Detent downshifts are available by depressing the accelerator to the floor.

L2. L2 Range has the same starting ration as Drive Range, but prevents the transmission from shifting ration when extra performance is desired. L2 Range can also be used for engine braking. L2 Range can be selected at any vehicle speed, and the transmission will shift to second gear and remain in

second until the vehicle speed or the throttle are changed to obtain first gear operation in the same manner as in D Range.

L1. L1 Range can be selected at any vehicle speed, and the transmission will shift to second gear and remain in second until vehicle is reduced to approximately 40 MPH, depending on axle ratio. L1 Range position prevents the transmission from shifting out of first gear.

NOTE: It is very important that any communication concerning the THM 400 always contain the transmission serial and vehicle identification number.

MAINTENANCE AND ADJUSTMENTS

CHECKING TRANSMISSION MOUNT

Raise the vehicle on a hoist. Push up and pull down on the transmission extension while observing the transmission mount. If the rubber separates from the metal plate of the mount or if the extension moves up but not down (mount bottomed out), replace the mount. If there is relative movement between a metal plate of the mount and its attaching point, tighten the screws or

nuts attaching the mount to the transmission or crossmember.

TRANSMISSION FLUID

Fluid Level and Capacity

The fluid level indicator is located in the filler tube at the right rear of the engine. To bring the fluid level

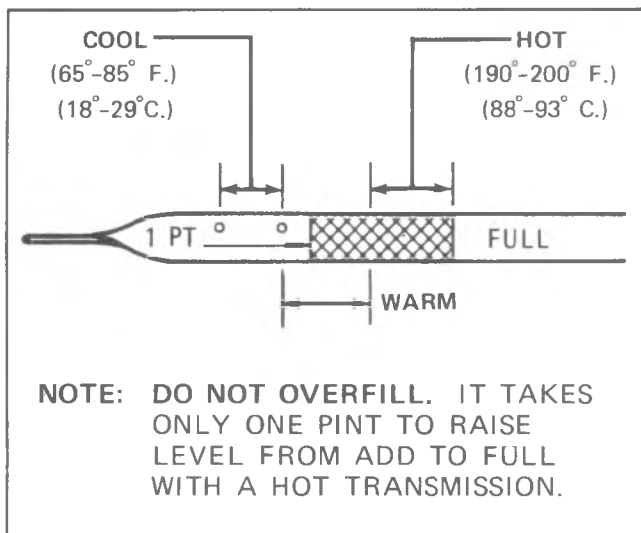


Fig. 7A 2C-Dipstick Markings

from the ADD mark to the FULL mark requires one pint of fluid. Fluid level should be checked at every engine oil change.

Fluid level should be to the FULL mark with the transmission fluid at normal operating temperature (180° F). With warm fluid (room temperature 70° F), the level will be 3/8 inch below the ADD mark on the dipstick. The normal operating temperature is obtained only after at least 15 miles of highway type driving or the equivalent of city driving.

Approximately 9 pints of fluid are required to refill transmission after oil pan has been drained. The fluid capacity of the THM 400 transmission and converter assembly is approximately 22 pints but correct level is determined by mark on the dipstick rather than by amount added. Use only DEXRON® or DEXRON® II automatic transmission fluid or its equivalent.

NOTE: An early stage to a darker color from the usual red color and/or a strong odor that is usually associated with overheated transmission fluid is normal, and is not a positive sign of required maintenance or transmission failure.

Checking Procedure and Adding Fluid

To determine proper fluid level at normal operating temperature (180° F), proceed as follows:

1. Position vehicle on a level surface, place selector lever in park (P), apply parking brake and have engine running at normal idle.
2. Remove fluid level indicator, wipe it clean and reinstall fully until cap seats.
3. Remove indicator and reading of fluid level should be at full "F" mark.
4. If additional fluid is required, add DEXRON® or DEXRON® II automatic transmission fluid or its equivalent to "F" mark on indicator.

If the vehicle cannot be driven sufficiently to bring the transmission to operating temperature and it becomes necessary to check the fluid level, the

transmission may be checked at room temperature (70 degrees F) as follows:

1. Position selector lever in park (P), apply parking brake and start engine. **DO NOT RACE ENGINE.** Move selector lever through each range.
2. Immediately check fluid level with selector lever in Park, engine running and vehicle on LEVEL surface. Fluid level on indicator should be 3/8 inch below the "ADD" mark.
3. If additional fluid is required, add enough fluid to bring level to 3/8 inch below the ADD mark on the dipstick. If transmission fluid level is correctly established at 70° F, it will appear at the FULL mark on the dipstick when the transmission reaches its normal operating temperature of 180° F.

CAUTION: DO NOT OVERFILL, as foaming and loss of fluid through the vent pipe might occur as fluid heats up.

If fluid is too low, especially when cold, complete loss of drive may result which can cause transmission failure.

Draining and Refilling Transmission

The oil pan should be drained and filter replaced and fresh fluid added to obtain the proper level on indicator, at the intervals detailed in section O-B of this manual. For vehicles subjected to heavy city traffic during hot weather, or in commercial use, when the engine is regularly idled for prolonged periods or when vehicle is used for towing, oil pan should be drained and filter replaced more frequently. See section O-B.

Drain fluid immediately after operation before it has had an opportunity to cool.

WARNING: Transmission fluid temperature can exceed 350 F.

1. Raise vehicle and support transmission with suitable jack at transmission.
2. With fluid receptacle placed under transmission oil pan, remove oil pan attaching bolts from front and side of pan.
3. Loosen rear pan attaching bolts approximately four (4) turns.
4. Carefully pry transmission oil pan loose with screwdriver, allowing fluid to drain.
5. Remove remaining screws and remove oil pan and gasket. Discard gasket.
6. Drain fluid from oil pan. Clean pan with solvent and dry thoroughly with clean compressed air.
7. Remove oil filter retainer bolt, oil filter assembly, O-ring seal from intake pipe and discard the filter and O-ring seal.
8. Install new O-ring seal on intake pipe and install new filter on pipe assembly.
9. With O-ring seal on intake pipe, install pipe and filter assembly, attaching filter to the control valve assembly with its retainer bolt, torquing to 10 pound feet.

10. Install new strainer-to-valve body gasket, strainer and two (2) screws.

11. Install new gasket on oil pan and install oil pan. Tighten its thirteen (13) attaching bolt and washer assemblies to 12 pound-feet.

12. Lower vehicle add approximately 5 pints U.S. measure (4 pints Imperial measure) of DEXRON® or DEXRON®II automatic transmission fluid or its equivalent through filler tube.

13. With selector lever in PARK position, apply hand brake, start engine and let idle (carburetor off fast idle step). **DO NOT RACE ENGINE.**

14. Move selector lever through each range and, with selector lever in PARK range, check the fluid level.

15. Add additional fluid to bring level to 1/4" below the ADD mark on the dipstick.

CAUTION: Do not overfill. Foaming can result if overfilled.

Adding Fluid to Fill Dry Transmission and Converter Assembly

In cases of transmission overhaul, when a complete fill is required, including converter (approximately 22 pints), proceed as follows:

1. Add 9 pints of transmission fluid through filler tube.

2. With manual control lever in park (P) position, start engine and place on cold idle cam. **DO NOT RACE ENGINE.** Move manual control lever through each range.

3. Immediately check fluid level with selector lever in park (P), engine running and vehicle on LEVEL surface and add additional fluid to bring level to 3/8-inch below the "ADD" mark on the dipstick. Do not overfill.

SHIFT CONTROLS

Column Shift Linkage - CK and P Series

(Figs. 7A-3C and 7A-4C)

1. The shift tube and lever assembly must be free in the mast jacket. See Section 3B for alignment of steering column assembly if necessary.

2. To check for proper shift linkage adjustment, lift the transmission selector lever towards the steering wheel. Allow the selector lever to be positioned in drive (D) by the transmission detent.

NOTE: Do not use indicator pointer as a reference to position the selector lever. When performing linkage adjustment, pointer is adjusted last.

3. Release the selector lever. The lever should be inhibited from engaging low range unless the lever is lifted.

4. Lift the selector lever towards the steering wheel and allow the lever to be positioned in neutral (N) by the transmission detent.

5. Release the selector lever. The lever should now be inhibited from engaging reverse range unless the lever is lifted.

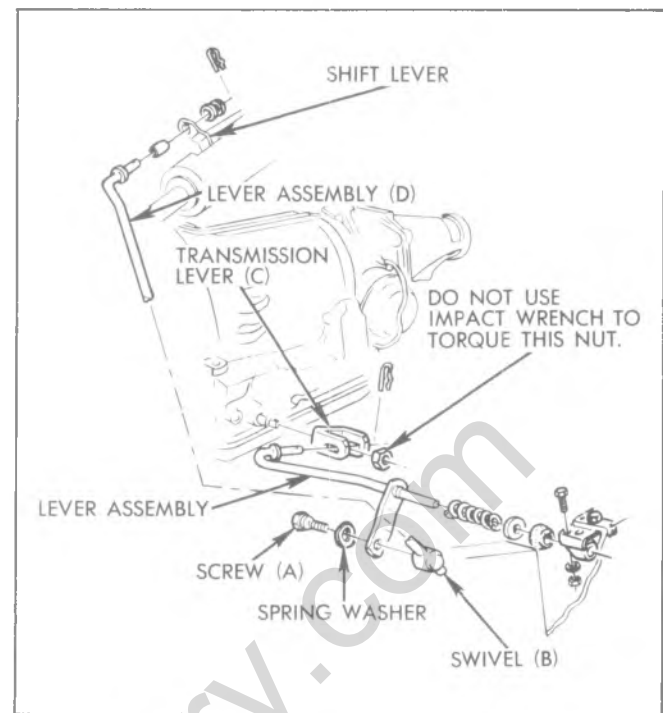


Fig. 7A-3C-Column Shift Linkage - CK Series

6. A properly adjusted linkage will prevent the selector from moving beyond both the neutral detent, and the drive detent unless the lever is lifted to pass over the mechanical stop in the steering column.

7. If adjustment is required, remove screw (A) and spring washer from swivel (B).

8. Set transmission lever (C) in Neutral position by moving lever counter-clockwise to L1 detent and then clockwise three (3) detent positions to Neutral.

9. Position transmission selector lever in Neutral position as determined by the mechanical stop in steering column assembly.

NOTE: Do not use the indicator pointer as a reference to position the selector lever. When performing linkage adjustment, pointer is adjusted last.

10. Assemble swivel, spring washer and screw to lever assembly (D) and tighten screw to 20 pound feet.

11. Readjust indicator needle if necessary to agree with the transmission detent positions. See Section 3B.

12. Readjust neutral start switch if necessary to provide the correct relationship to the transmission detent positions. See Section 8.

13. Check operation (CK Series):

a. With key in "Run" position and transmission in "Reverse" be sure that key cannot be removed and that steering wheel is not locked.

b. With key in "Lock" position and shift lever in "Park", be sure that key can be removed, that steering wheel is locked, and that transmission remains in "Park" when steering column is locked.

CAUTION: Any inaccuracies in the above adjustments may result in premature failure of

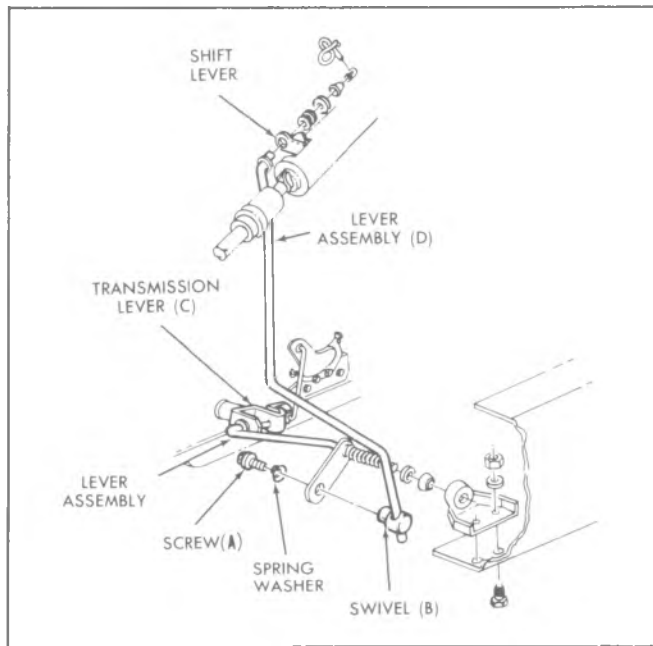


Fig. 7A-4C--Column Shift Linkage - P Series

the transmission due to operation without controls in full detent. Such operation results in reduced oil pressure and in turn partial engagement of the affected clutches. Partial engagement of the clutches with sufficient pressure to cause apparent normal operation of the vehicle will result in failure of the clutches or other internal parts after only a few miles of operation.

DETENT DOWNSHIFT SWITCH

1. Install switch as shown in Figure 7A-5C.
2. After installing the switch, press the switch

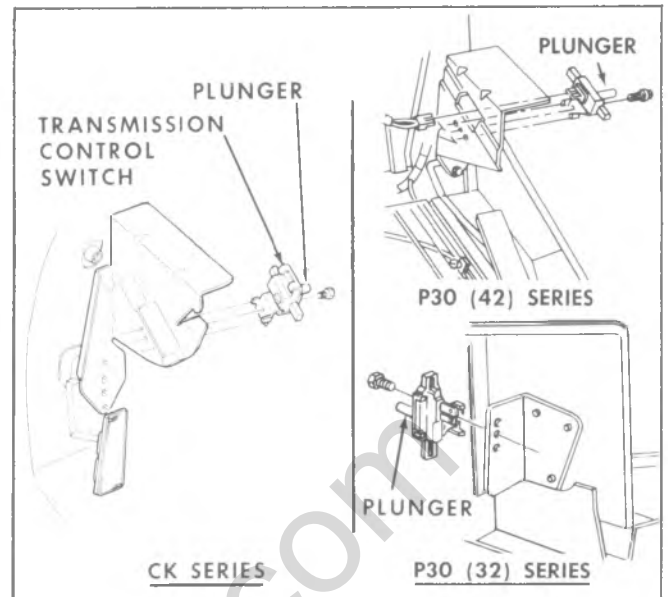


Fig. 7A-5C--Detent Downshift Switch

plunger as far forward as possible. This presets the switch for adjustment. The switch will then adjust itself with the first wide open throttle application of the accelerator pedal.

NEUTRAL START BACKUP LAMP SWITCH ADJUSTMENT

The neutral start backup lamp switch must be adjusted so that the car will start in the park or neutral position, but will not start in the other positions. For replacement and adjustment refer to Section 8 of this manual.

DIAGNOSIS

SEQUENCE FOR DIAGNOSIS

1. Check and correct oil level.
2. Check detent switch.
3. Check and correct vacuum line and fittings.
4. Check and correct manual linkage.
5. Install oil pressure gage.
6. Road test car.
 - a. Road test using all selective ranges, noting when discrepancies in operation or oil pressure occur.
 - b. Attempt to isolate the unit or circuit involved in the malfunction.
 - c. If engine performance indicates an engine tune up is required, this should be performed before road testing is completed or transmission correction

attempted. Poor engine performance can result in rough shifting or other malfunctions.

FLUID CHECKING PROCEDURES

Refer to Maintenance and Adjustment section for fluid checking procedure.

FLUID LEAK DIAGNOSIS

Determining Source of Oil Leak

Before attempting to correct an oil leak, the actual source of the leak must be determined. In many cases, the source of the leak can be deceiving due to "wind flow" around the engine and transmission.

The suspected area should be wiped clean of all oil before inspecting for the source of the leak. Red dye is used in the transmission oil at the assembly plant and will indicate if the oil leak is from the transmission.

The use of a "Black Light" to locate the point at which the oil is leaking is helpful. Comparing the oil from the leak to that on the engine or transmission dipstick, when viewed by black light, will determine the source of the leak - engine or transmission.

Oil leaks around the engine and transmission are generally carried toward the rear of the car by the air stream. For example, a transmission oil fill pipe to case leak will sometimes appear as a leak at the rear of the transmission. In determining the source of a leak, proceed as follows:

1. Degrease underside of transmission.
2. Road test to get unit at operating temperature. (180 degrees F.)
3. Inspect for leak with engine running.
4. With engine off, check for oil leaks due to the raised oil level caused by drain back.

Possible Points of Oil Leak

1. Transmission Oil Pan Leak
 - a. Attaching bolts not correctly torqued.
 - b. Improperly installed or damaged pan gasket.
 - c. Oil pan gasket mounting face not flat.
2. Case Extension
 - a. Attaching bolts not correctly torqued.
 - b. Rear seal assembly damaged or improperly installed.
 - c. Extension to case, gasket damage or improperly installed.
 - d. Porous casting. See paragraph C.
 - e. Output shaft "O" ring damaged.
3. Case Leak
 - a. Filler pipe "O" ring seal damaged or missing; misposition of filler pipe bracket to engine "loading" one side of "O" ring.
 - b. Modulator assembly "O" ring seal damaged or improperly installed.
 - c. Electrical connector "O" ring seal damaged or improperly installed.
 - d. Governor cover bolts not torqued, gasket damaged or leak between case face and gasket.
 - e. Speedometer gear "O" ring damaged.
 - f. Manual shaft lip seal damaged or improperly installed.
 - g. Parking pawl shaft cup plug damaged, improperly installed.
 - h. Line pressure band release tap plug loose.
 - i. Vent pipe (refer to item 5).
 - j. Porous casting. See subparagraph C.
4. Leak at Front of Transmission
 - a. Front pump seal leaks.
 1. Seal lip cut. Check converter hub for nicks, etc.
 2. Bushing moved forward and damaged.
 3. Garter spring missing from seal.
 - b. Front pump attaching bolts loose or bolt seals damaged or missing.
 - c. Front pump housing "O" ring damaged or cut.
 - d. Converter leak in weld area.
 - e. Porous casting (pump).

5. Oil Comes Out Vent Pipe
 - a. Transmission over-filled.
 - b. Water in oil.
 - c. Foreign matter between pump and case or between pump cover and body.
 - d. Case - porous, front pump cover mounting face shy of stock near breather. See subparagraph C.
 - e. Pump to case gasket mispositioned.
 - f. Incorrect dipstick.
 - g. Cut "O" ring or grommet on filter.
 - h. Pump - shy of stock on mounting faces, porous casting, breather hole plugged in pump cover.

OIL PRESSURE CHECK

Road or Normal Operating Conditions

While road testing (with the transmission oil pressure gage attached and the vacuum modulator tube **connected** the transmission pressure should check approximately as shown on Figure 7A-6C.

Vehicle Stationary - Engine at 1200 RPM

With the transmission oil pressure gauge attached and the vacuum modulator tube **disconnected** the transmission pressures should check approximately as shown in Fig. 7A-7C.

Vehicle Stationary - Engine at 1000 RPM

With the transmission oil pressure gauge attached and the vacuum modulator tube **connected** for normal modulator operation, the transmission pressure should check approximately as shown in Fig. 7A-8C.

NOTE: Pressures are not significantly affected by altitude or barometric pressure when the vacuum modulator tube is connected.

Case Porosity Repair

External leaks caused by case porosity have successfully been repaired with the transmission in the vehicle by using the following recommended procedures:

1. Road test and bring the transmission to operating temperature, approximately 180 degrees.
2. Raise vehicle on hoist or jack stand. engine running and locate source of oil leak. Check for leak in all operating positions. Use of a mirror is helpful in finding leaks.
3. Shut engine off and thoroughly clean area to be repaired with a cleaning solvent and a brush air dry.
4. Using instructions of the manufacturer, mix a sufficient amount of epoxy to make repair. Observe cautions of manufacturer in handling.
5. While the transmission case is still HOT apply the epoxy to the area to be repaired. A clean, dry soldering acid brush can be used to clean the area and also to apply the epoxy cement. Make certain the area to be repaired is fully covered.
6. Allow cement to cure for three hours before starting engine.

		Minimum	Maximum
L2-2nd Gear - Steady road load at approximately 25 mph		145 psi	155 psi
Gear	Selector Lever Position	Minimum	Maximum
1st	Drive		
2nd	("Zero" throttle to full throttle.)	60	150
3rd			
3rd	Drive Range, Zero Throttle at 30 mph	60	
Reverse	Rev. (Zero to full throttle)	95	260

Fig. 7A-6C-Oil Pressure Check - Road or Normal Operating Conditions

7. Road test and check for leaks.

VACUUM MODULATOR DIAGNOSIS

A defective vacuum modulator can be determined by performing the following procedures.

Vacuum Diaphragm Leak Check

Insert a pipe cleaner into the vacuum connector pipe as far as possible and check for the presence of transmission oil. If oil is found, replace the modulator.

Gasoline or water vapor may settle in the vacuum

side of the modulator. If this is found without the presence of oil, the modulator should not be changed.

Atmospheric Leak Check

Apply a liberal coating of soap bubble solution to the vacuum connector pipe seam, the crimped upper to lower housing seam, and the threaded screw seal (Fig. 7A-9C). Using a short piece of rubber tubing apply air pressure to the vacuum pipe by blowing into the tube and observe for leak bubbles. If bubbles appear, replace the modulator.

NOTE: Do not use any method other than human lung power for applying air pressure, as pressures over 6 psi may damage the modulator.

Approximate Altitude of Check (Ft. above sea level)	Drive Neutral Park	L1 or L2	Reverse
0	150	150	244
2,000	150	150	233
4,000	145	150	222
6,000	138	150	212
8,000	132	150	203
10,000	126	150	194
12,000	121	150	186
14,000	116	150	178

Fig. 7A-7C-Oil Pressure Check - Vehicle Stationary, Vacuum Tube Disconnected

Bellows Comparison Check

Using a comparison gauge, as shown in Figure 7A-10C, compare the load of a known good modulator with the assembly in question.

- Install the modulator that is known to be acceptable on either end of the gauge (Fig. 7A-11C).
- Install the modulator in question on the opposite end of the gauge. (Fig. 7A-12C).

Drive, Neutral, Park	L1 or L2	Reverse
60	150	107

Fig. 7A-8C-Oil Pressure Check - Vehicle Stationary, Vacuum Tube Connected

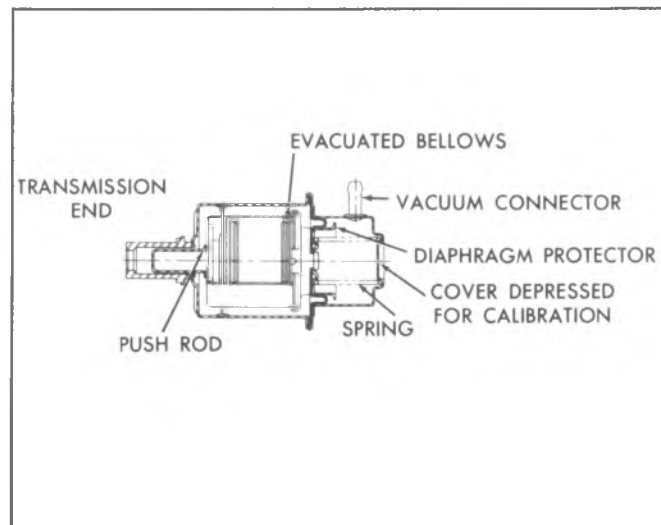


Fig. 7A-9C-Vacuum Modulator

c. Holding the modulators in a horizontal position, bring them together under pressure until either modulator sleeve end just touches the line in the center of the gauge (Fig. 7A-13C). The gap between the opposite modulator sleeve end and the gauge line should then be $1/16''$ or less. If the distance is greater than this amount, the modulator in question should be replaced.

Sleeve Alignment Check

Roll the main body of the modulator on a flat surface and observe the sleeve for concentricity to the can. If the sleeve is concentric and the plunger is free, the modulator is acceptable.

Once the modulator assembly passes all of the above tests, it is an acceptable part and should be re-used.

MANUAL LINKAGE

Manual linkage adjustment and the associated neutral safety switch are important from a safety standpoint. The neutral safety switch should be adjusted so that the engine will start in the Park and Neutral positions only.

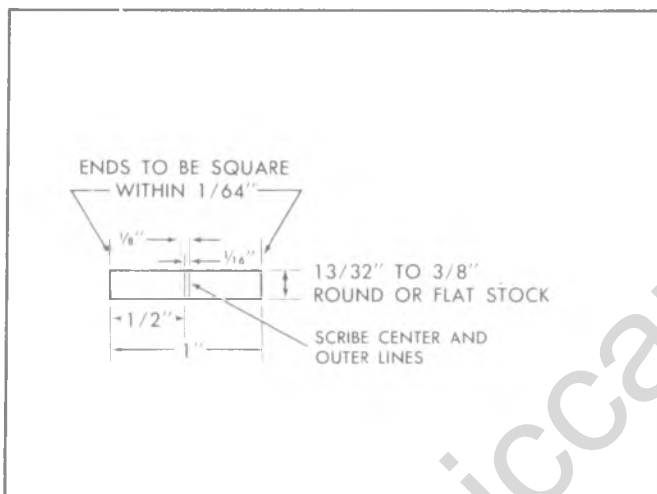


Fig. 7A-10C-Bellows Comparison Gauge

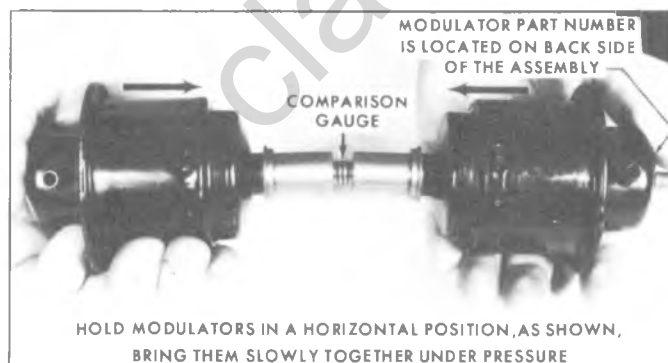


Fig. 7A-11C-Holding Modulators in Horizontal Position

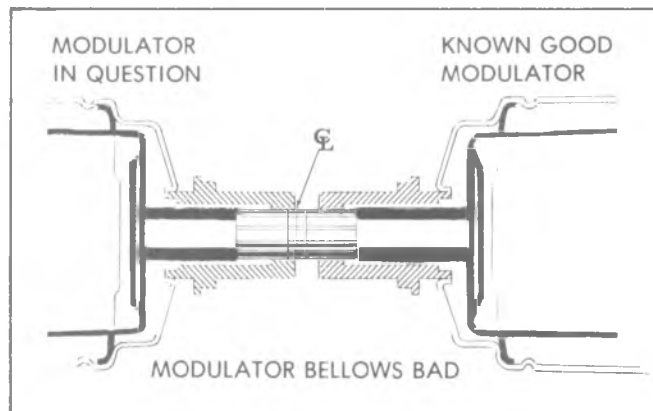


Fig. 7A-12C-Modulator Bellows - Bad

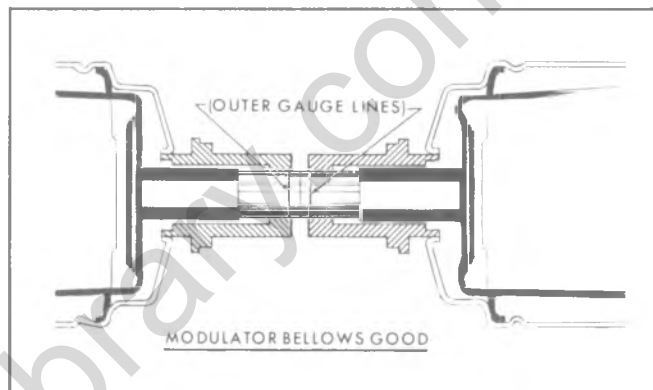


Fig. 7A-13C-Modulator Bellows (Good)

With the selector lever in the Park position, the parking pawl should freely engage and prevent the vehicle from rolling. The pointer on the indicator quadrant should line up properly with the range indicators in all ranges.

TROUBLE DIAGNOSIS

No Drive in Drive Range

(Install pressure gage)

- Low oil level - check for external leaks or defective vacuum modulator (leaking diaphragm will evacuate oil from unit).

- Manual linkage maladjusted (correct alignment in manual lever shift quadrant is essential); manual valve disconnected from manual lever pin.

- Low oil pressure - refer to LOW LINE PRESSURE below.

- Forward clutch:

- a. Clutch does not apply - piston cracked; seals missing, damaged; clutch plates burnt (see BURNED CLUTCH PLATES below).

- b. Pump feed circuit-to-forward clutch oil seal rings missing or broken on pump cover; leak or restriction in feed circuits; pump-to-case gasket mispositioned or damaged. Clutch drum ball check stuck or missing.

- Roller Clutch - broken springs, damaged cage or installed backwards.

High or Low Oil Pressure

(Refer to OIL PRESSURE CHECKS)

High Line Pressure

- Vacuum Leak:
 - a. Vacuum line disconnected.
 - b. Leak on line from engine to modulator.
 - c. Improper engine vacuum.
 - d. Leak in vacuum-operated accessory (hoses, vacuum advance, etc.).
- Modulator:
 - a. Stuck modulator valve.
 - b. Water in modulator.
 - c. Damaged, not operating properly.
- Detent System:
 - a. Detent switch actuated (plunger stuck) or shorted.
 - b. Detent wiring shorted.
 - c. Detent solenoid stuck open.
 - d. Detent feed orifice in spacer plate blocked or restricted.
 - e. Detent solenoid loose.
 - f. Detent valve bore plug damaged.
 - g. Detent regulator valve pin short.
- Oil Pump:
 - a. Pressure regulator and/or boost valve stuck.
 - b. Incorrect pressure regulator valve spring.
 - c. Too many pressure regulator valve spacers.
 - d. Pressure boost valve installed backwards or defective.
 - e. Pressure boost bushing broken or defective.
 - f. Pump casting bad.

Low Line Pressure

- Low transmission oil level.
- Defective vacuum modulator assembly.
- Filter Assembly:
 - a. Blocked or restricted.
 - b. "O" Ring seal on intake pipe and/or grommet omitted or damaged.
 - c. Split or leaking intake pipe.
 - d. Wrong filter assembly.
- Oil Pump:
 - a. Pressure regulator and/or boost valve stuck.
 - b. Pressure regulator valve spring too weak.
 - c. Not enough spacers in pressure regulator.
 - d. Gear clearance, damaged, worn, drive gear installed backwards.
 - e. Pump-to-case gasket mispositioned.
 - f. Defective or mismatched pump body/pump cover.
- Internal Circuit Leaks:
 - a. Forward clutch leak (pressure low in Drive range - pressure normal in Neutral and Reverse).
 1. Check pump oil seal rings.
 2. Check forward clutch seals.
 - b. Direct clutch leak (pressure low in Reverse, pressure normal in all other ranges).
 1. Check center support oil seal rings.
 2. Check direct clutch outer seal.
 3. Check rear servo and front accumulator pistons and rings for damage or missing.

6. Case Assembly:
 - a. Porosity in intake bore area.
 - b. Check case for intermediate clutch cup plug leak or blown out.
 - c. L1-reverse check ball mispositioned or missing (this will cause no reverse and no overrun braking in L1 range).

1-2 Shift-Full Throttle Only

- Detent switch sticking or defective (may stick in cold or wet weather). Can be detected by pulling connection at transmission and obtaining normal upshifts.
- Detent solenoid:
 - a. Loose.
 - b. Gasket leaking.
 - c. Sticks open.
- Control valve:
 - a. Valve body gaskets - leaking, damaged, incorrectly installed.
 - b. Detent valve train stuck.
 - c. 3-2 valve stuck.
- Case - porosity.

First Speed Only, No 1-2 Shift

- Governor:
 - a. Valve sticking.
 - b. Driven gear loose, damaged or worn (check for pin in case and length of pin showing); also check output shaft drive gear for nicks or rough finish if driven gear shows damage.
- Control valve:
 - a. 1-2 shift valve train stuck closed.
 - b. Governor feed channels blocked, leaking, pipes out of position, governor screen plugged.
 - c. Valve body gaskets leaking, damaged, incorrectly installed.
- Case:
 - a. Intermediate clutch cup plug leaking or blown out.
 - b. Porosity between channels.
 - c. Governor feed channel blocked; governor bore scored or worn, allowing cross pressure leak.
- Intermediate clutch:
 - a. Case center support - oil rings missing, broken, defective; orifice plug missing.
 - b. Clutch piston seals missing, improperly assembled, cut.

First and Second Speeds Only, No 2-3 Shift

- Detent solenoid - stuck open (detent shifts only - the 2-3 shift would occur at very high speeds, being interpreted as no 2-3 shift).
- Detent switch.
- Control valve:
 - a. 2-3 valve train stuck.

b. Valve body gaskets leaking, damaged, incorrectly installed.

- Direct clutch:

a. Center support oil rings missing, broken, defective.

b. Clutch piston seals missing, improperly assembled, cut; piston ball check stuck or missing.

Drive in Neutral

- Manual linkage maladjusted.

- Internal Linkage:

a. Manual valve disconnected or end broken.

b. Inside detent lever pin broken.

- Pump Assembly - transmission lube pressure leaking into forward clutch apply passage.

- Forward Clutch:

a. Burned plates - check cause.

b. Clutch doesn't release - will also cause no drive in Reverse.

No Drive in Reverse or Slips in Reverse

(Install pressure gauge)

- Low fluid level.

- Manual linkage maladjusted.

- Oil pressure - refer to LOW LINE PRESSURE above.

- Control valve:

a. Valve body gaskets leaking, damaged, incorrectly installed (Other malfunctions may also be indicated).

b. Low reverse ball check missing from case (this will also cause no overrun braking in L1 Range).

c. 2-3 valve train stuck open (this will also cause 1-3 upshift in Drive range).

d. Reverse feed passage restricted; also check case passages.

- Rear servo and accumulator:

a. Servo piston seal ring damaged or missing.

b. Short band apply pin (this may also cause no overrun braking or slips in overrun braking - L1 range). Refer to INSTALLATION OF REAR SERVO ASSEMBLY for pin selection procedure.

c. Defective rear servo piston or bore.

- Reverse or low band burnt, loose lining; apply pin or anchor pins not engaged; band broken.

- Direct clutch:

a. Outer seal damaged or missing.

b. Clutch plates burnt (see BURNED CLUTCH PLATES below).

- Forward clutch - clutch does not release (will also cause Drive in Neutral).

- Center support - oil seal rings or grooves damaged or worn.

Slips in all Ranges, Slips on Start

(Install pressure gauge)

- Low fluid level.

- Oil pressure - refer to LOW LINE PRESSURE above.

- Case - cross leaks, porosity.

- Forward and direct clutches slipping (if burnt, see BURNED CLUTCH PLATE below); oil seal rings on pump cover broken or worn.

Slips 1-2 Shift

(Install pressure gauge)

- Low fluid level.

- Oil pressure - refer to LOW LINE PRESSURE above.

- Front accumulator piston oil ring damaged or missing.

- Control valve:

a. 1-2 accumulator valve train sticking.

b. Porosity in valve body or case.

c. Valve body attaching bolts not properly torqued.

- Rear accumulator oil ring missing or damaged; case bore damaged.

- Pump-to-case gasket mispositioned.

- Case:

a. Intermediate clutch cup plug leaks excessively.

b. Porosity between channels.

c. Raised ridge around case center support bolt (does not allow control valve assembly to seat properly).

- Intermediate clutch:

a. Piston seals missing or damaged; clutch plates burnt (see BURNED CLUTCH PLATES below).

b. Center support - leak in feed circuit (oil rings damaged or grooves defective), excessive leak between tower and bushing, orifice bleed plug hole (.020 dia.) blocked, center support bolt not seated properly in case.

Rough 1-2 Shift

(Install pressure gauge)

- Oil pressure - refer to HIGH LINE PRESSURE above.

- Control valve:

a. 1-2 accumulator valve train.

b. Valve body-to-case bolts loose.

c. Wrong gaskets or off location, damaged.

- Case:

a. Intermediate clutch ball missing or not sealing.

b. Porosity between channels.

- Rear servo accumulator:

a. Oil rings damaged.

b. Piston stuck.

c. Broken or missing spring.

d. Bore damaged.

- Intermediate clutch - clutch plates burnt (see BURNED CLUTCH PLATES below).

Slips 2-3 Shift

(Install pressure gauge)

- Low fluid level.

- Oil pressure - refer to LOW LINE PRESSURE above.

- Control valve - accumulator piston pin (leak at swedge end).

- Case porosity.

- Direct clutch:
 - a. Piston seals leaking or ball check leaks.
 - b. Center support oil seal rings damaged; excessive leak between tower and bushing.

Rough 2-3 Shift

(Install pressure gauge)

- Oil Pressure - refer to HIGH LINE PRESSURE above.
- Front servo accumulator:
 - a. Front accumulator spring missing, broken.
 - b. Accumulator piston stuck.
- Direct clutch - air check for leak to outer area of clutch piston or center piston seal.
- Damaged center support.

No Engine Braking in L2 Range - 2nd Gear

- Front servo accumulator:
 - a. Servo or accumulator oil rings or bores leaking.
 - b. Servo piston cocked or stuck.
- Front band broken, burnt (check for cause), not engaged on anchor pin and/or servo pin.

No Engine Braking in L1 Range - 1st Gear

- Case assembly - L1-reverse check ball mispositioned or missing from case; case damaged at L1-reverse check ball area.
- Rear servo:
 - a. Oil seal ring, bore or piston damaged; leaking apply pressure.
 - b. Rear band apply pin short, improperly assembled.
- Rear band broken, burnt (check for cause), not engaged on anchor pins or servo pin.

NOTE: Items above will also cause slips in Reverse or no Reverse.

No Part Throttle Downshift

(Install pressure gauge)

- Oil pressure - refer to HIGH OR LOW OIL PRESSURE above.
- Control valve - 3-2 valve stuck spring missing or broken.

No Detent Downshifts

- Detent switch adjustments, connection (switch plunger activated approx. 7/8" at full throttle opening).
- Solenoid inoperative, connections.
- Control valve-detent valve train sticking.

Low or High Shift Points

(Install pressure gauge)

- Oil Pressure - refer to HIGH OR LOW OIL PRESSURE above.
- Governor:
 - a. Valve sticking.
 - b. Feed holes restricted or leaking; pipes damaged or mispositioned.
 - c. Feed line screen plugged.

- Detent switch.
- Detent solenoid stuck open, loose, etc. (will cause late shifts).
- Control valve:
 - a. Detent valve train.
 - b. 3-2 valve train (detent upshifts possible).
 - c. 1-2 shift valve train - 1-2 regulator valve stuck (this would cause a constant 1-2 shift point, regardless of throttle opening).
 - d. Spacer plate gaskets mispositioned; spacer plate orifice holes missing or blocked.
- Case porosity; intermediate clutch cup plug leaking, missing.

Won't Hold in Park

- Manual linkage maladjusted.
- Internal linkage:
 - a. Parking brake lever and actuator defective (check for chamfer on actuator rod sleeve).
 - b. Parking pawl broken.
 - c. Parking pawl bracket loose, burned, rough edges or incorrectly installed.
 - d. Parking pawl return spring missing, broken or incorrectly hooked.

Transmission Noisy

CAUTION: Before checking transmission for what is believed to be "transmission noise", make sure that the noise is not from the water pump, alternator, power steering, etc. These components can be isolated by removing the proper belt and running the engine no more than two minutes at one time.

Park, Neutral and all Driving Ranges

- Pump Cavitation:
 - a. Oil level low.
 - b. Plugged or restricted filter.
 - c. Intake pipe "O" ring damaged.
 - d. Intake pipe split, porosity in case intake pipe bore.
 - e. Water in oil.
 - f. Porosity or voids at transmission case (pump face) intake port.
 - g. Pump-to-case gasket off location.
- Pump Assembly:
 - a. Gears damaged or defective; driving gear installed backwards.
 - b. Crescent interference.
 - c. Oil seal rings damaged or worn.
- Converter:
 - a. Loose flywheel-to-converter bolts.
 - b. Damaged converter.

First, Second and/or Reverse Gears

Planetary Gear Set:

- a. Gears or thrust bearings damaged.

- b. Front internal gear ring damaged.

During Acceleration - Any Gear

- Transmission or cooler lines grounded to underbody.
- Motor mounts loose or broken.

Squeal at Low Vehicle Speed

Speedometer driven gear shaft seal - requires lubrication or replacement.

Burned Clutch Plates

- Forward clutch:
 - a. Check ball in clutch drum damaged, stuck or missing.
 - b. Clutch piston cracked, seals damaged or missing.
 - c. Low line pressure (see LOW LINE PRESSURE above).
 - d. Manual valve mispositioned (may also cause front band failure).
 - e. Restricted oil feed to forward clutch (clutch housing to inner and outer areas not drilled, restricted, porosity in pump, etc.).
 - f. Transmission case valve body face not flat or porosity between channels.
 - g. Manual valve bent and center land not ground properly.
 - h. Pump cover oil seal rings missing, broken or undersize, ring groove oversize.
- Intermediate Clutch:
 - a. Constant bleed orifice in center support missing.
 - b. Rear accumulator piston oil ring damaged or missing.

- c. 1-2 accumulator valve stuck in control valve assembly.
 - d. Intermediate clutch piston seals damaged or missing.
 - e. Center support bolt loose.
 - f. Low line pressure (see LOW LINE PRESSURE above).
 - g. Intermediate clutch cup plug in case missing.
 - h. Transmission case valve body face not flat or porosity between channels.
 - i. Manual valve bent and center land not ground properly.
- Direct Clutch:
 - a. Restricted orifice in vacuum line to modulator (poor vacuum response).
 - b. Check ball in clutch piston damaged, stuck or missing.
 - c. Defective modulator bellows.
 - d. Center support bolt loose (bolt may be tight in support but not holding support tight to the case).
 - e. Center support oil rings or grooves damaged or missing.
 - f. Clutch piston cracked, seals damaged or missing.
 - g. Front and rear servo pistons and/or seals damaged.
 - h. 3-2 valve, 3-2 valve spring or 3-2 spacer pin installed in wrong location in 3-2 valve train bore.
 - i. Manual valve bent and center land not ground properly.
 - j. Transmission case valve body not flat or porosity between channels.
 - k. Intermediate roller clutch installed backwards.
 - In addition, burned clutch plates can be caused by incorrect usage of clutch plates. Also, anti-freeze in transmission fluid can cause severe damage, such as large pieces of clutch plate material peeling off.

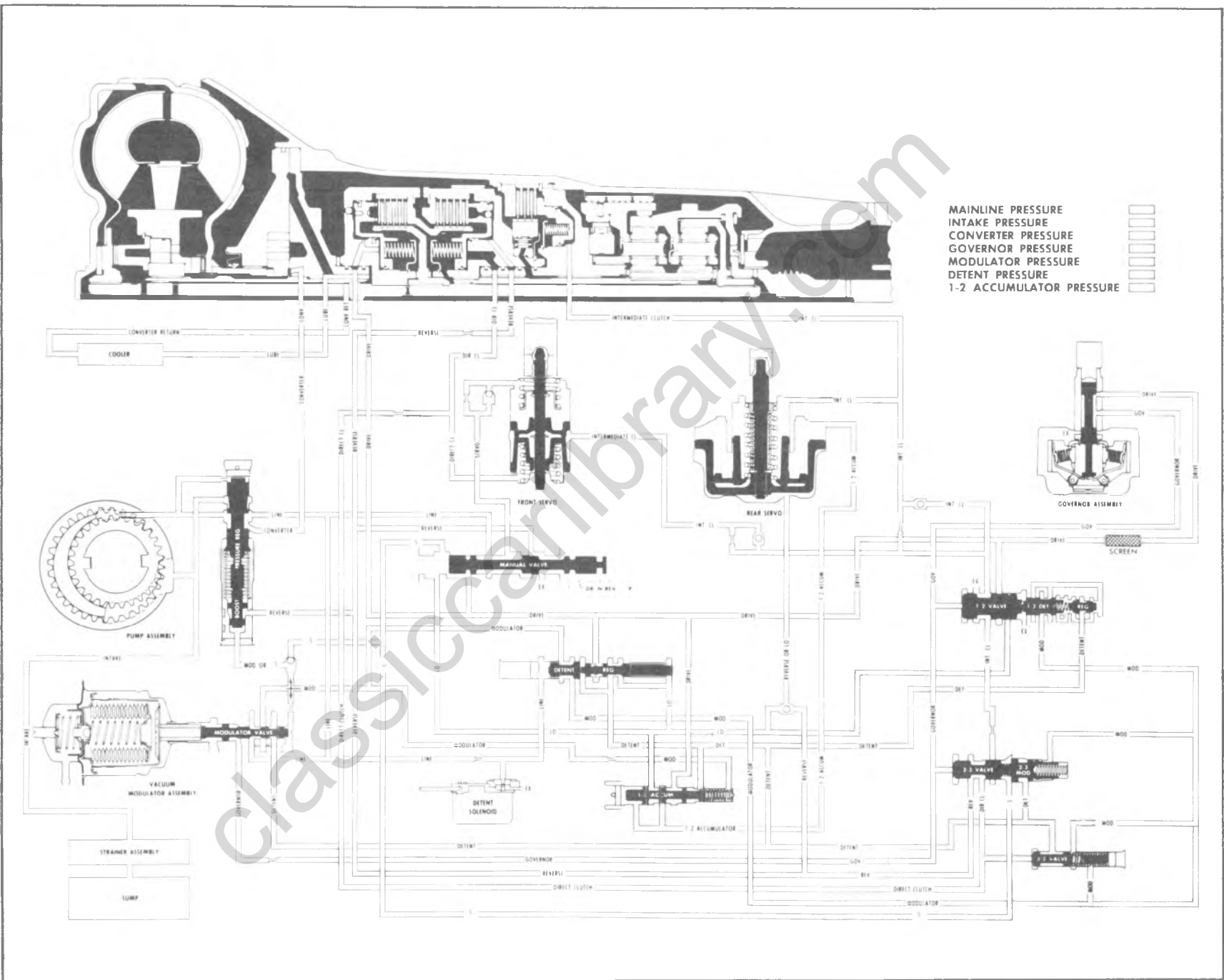


Fig. 7A-14C. THM 400 Hydraulic Circuit

SERVICE OPERATIONS

TRANSMISSION REPLACEMENT

NOTE: If necessary, the catalytic converter may have to be disconnected to provide adequate clearance for transmission removal. This procedure will include removal of the converter support bracket.

Removal

Before raising the truck, disconnect the battery and release the parking brake.

1. Raise truck on hoist.
2. Remove propeller shaft.
3. Disconnect speedometer cable, electrical lead to case connector, vacuum line at modulator, and oil cooler pipes.
4. Disconnect shift control linkage.
5. Support transmission with suitable transmission jack.
6. Disconnect rear mount from frame crossmember.
7. Remove two bolts at each end of the frame crossmember and remove crossmember.
8. Remove converter and pan.
9. Remove converter to flywheel bolts.
10. Loosen exhaust pipe to manifold bolts approximately 1/4 inch, and lower transmission until jack is barely supporting it.
11. Remove transmission to engine mounting bolts and remove oil filler tube at transmission.
12. Raise transmission to its normal position, support engine with jack and slide transmission rearward from engine and lower it away from vehicle.
13. Use converter holding Tool J-5384 when lowering transmission or keep rear of transmission lower than front so as not to lose converter.

Installation

The installation of the transmission is the reverse of the removal with the following additional steps.

1. Before installing the flex plate to converter bolts, make certain with the flex plate that the weld nuts on the converter as flush with the flex plate and the converter rotates freely by hand in this position. Then, hand start all bolts and tighten finger tight before torquing to specification. This will insure proper converter alignment.
2. Install transmission support crossmember to transmission and frame with taper on support sloping toward rear.
3. After installation of transmission, check linkage for proper adjustment.

4. Remove truck from hoist.

REAR SEAL

Removal

1. Remove propeller shaft.
2. Pry seal out with screw driver.

Installation

All Models Except CL

1. Use a non-hardening sealer on outside of seal body; and using Tool J-21359, drive seal in place.
2. Re-install propeller shaft.

Model CL

1. Use a non-hardening sealer on outside of seal body; and using Tool J-24057, drive seal in place.
2. Re-install propeller shaft.

GOVERNOR

Removal

1. Remove governor cover attaching screws, cover, and gasket.
2. Discard gasket.
3. Withdraw governor assembly from case.

Installation

Installation of the governor assembly is the reverse of the removal. Use a new gasket under the governor cover. Adjust fluid level.

MODULATOR AND MODULATOR VALVE

Removal

1. Remove modulator assembly attaching screw and retainer.
2. Remove modulator assembly from case. Discard "O" ring seal.
3. Remove modulator valve from case.

Installation

Installation of the modulator assembly and modulator valve is the reverse of the removal. Use a new "O" ring seal on the modulator assembly.

Adjust fluid level.

PARKING LINKAGE—10, 20 SERIES

Removal

1. Remove bottom pan and oil filter.
2. Unthread jam nut holding detent lever to manual shaft.
3. Remove manual shaft retaining pin from case.
4. Remove manual shaft and jam nut from case.

NOTE: Do not remove manual shaft seal unless replacement is required.

5. Remove parking actuator rod and detent lever assembly.
6. Remove parking pawl bracket attaching screws and bracket.
7. Remove parking pawl return spring.

NOTE: The following steps should be completed unless part replacement is required.

8. Remove parking pawl shaft retainer.
9. Remove parking pawl shaft, cup plug parking pawl shaft, and parking pawl.

Installation

Installation of the parking linkage is the reverse of the removal. Use new seal and cup plug, if removed, and new bottom pan gasket.

CONTROL VALVE BODY

Removal

1. Remove bottom pan and filter.
2. Disconnect lead wire from pressure switch assembly.
3. Remove control valve body attaching screws and detent roller spring assembly.

NOTE: Do not remove solenoid attaching screws.

CAUTION: *If the transmission is in the vehicle, the front servo parts may drop out as the control valve assembly is removed.*

4. Remove control valve body assembly and governor pipes. If care is taken in removing control valve body the six (6) check balls will stay in place above the spacer plate.
5. Remove the governor screen assembly from end of governor feed pipe or from the governor feed pipe hole in the case (Fig. 7A-15C). Clean governor screen in clean solvent and air dry.

CAUTION: *Do not drop manual valve.*

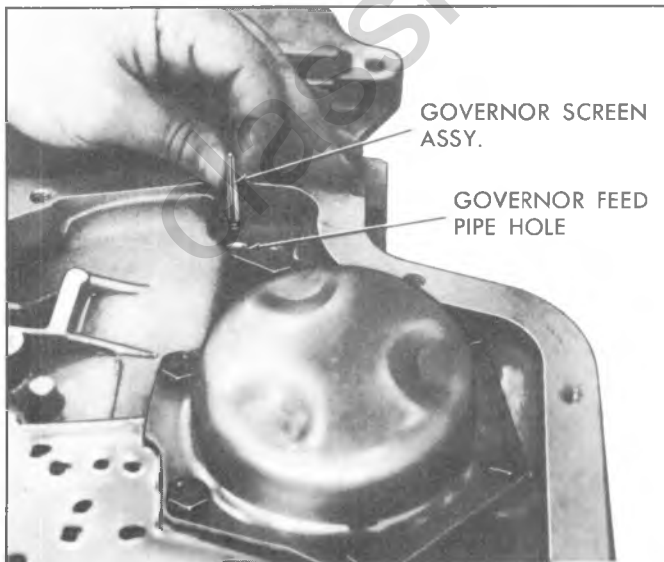


Fig. 7A-15C--Governor Screen Position

6. Remove the governor pipes and manual valve from control valve body.

Installation

Installation of control valve body is in reverse of removal. See Overhaul Manual. Adjust fluid level.

PRESSURE REGULATOR VALVE

Removal

1. Remove bottom pan and filter.
2. Compress regulator boost valve bushing against pressure regulator spring and remove snap ring, using J-5403 pliers.
3. Remove regulator boost valve bushing and valve.
4. Remove pressure regulator spring.
5. Remove spring retainer, washer spacer(s) is present, and regulator valve.

Installation

NOTE: A solid type pressure regulator valve must only be used in a pump cover with a squared-off pressure regulator boss (See Figure 7A-16C). A pressure regulator valve with oil holes and orifice cup plug may be used to service either type pump.

Installation of the pressure regulator valve is the reverse of the removal. Installing new gasket on oil pan and adjusting fluid level.

OIL COOLER PIPES

If replacement of transmission steel tubing cooler pipes is required, use only double wrapped and brazed steel tubing meeting GM specification 123M or its equivalent. Under no condition use copper or aluminum tubing to replace steel tubing. Those materials do not have satisfactory fatigue durability to withstand normal vehicle vibrations.

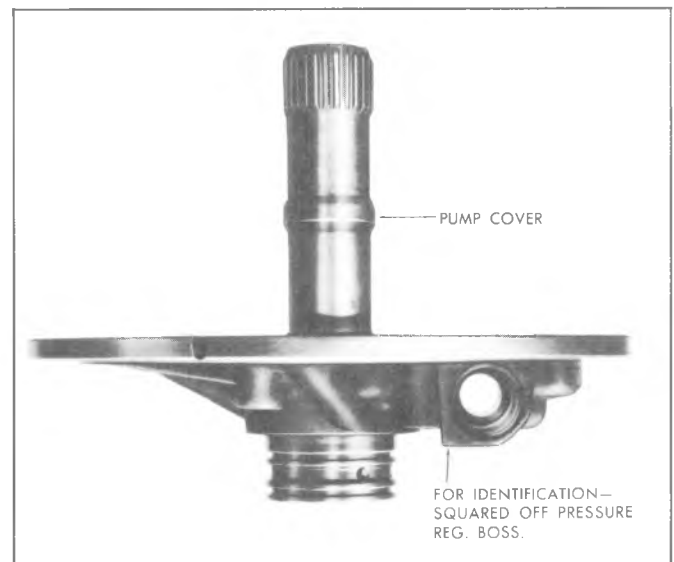


Fig. 7A-16C--Pressure Regulator Valve

Stell tubing should be flared using the upset (double lap) flare method which is detailed in Section 5.

OTHER SERVICE OPERATIONS

The following operations when done as single operations and not as part of a general overhaul should, as a practical matter, be performed with the transmission in the vehicle. Refer to the "Transmission Disassembly and Reassembly" section of the Overhaul Manual for service procedures.

1. Oil filler pipe and "O" ring seal.

2. Oil pan and gasket.
3. Down shift solenoid or connector.
4. Valve body spacer plate, gasket and check balls.
5. Front accumulator piston.
6. Rear servo and rear accumulator assembly.
7. Rear band apply checking with Tool J-21370.
8. Front servo assembly.
9. Speedo driven gear.
10. Case extension or gasket.
11. Filter and "O" ring.
12. Pressure switch assembly.

Classiccarlibrary.com

SPECIFICATIONS

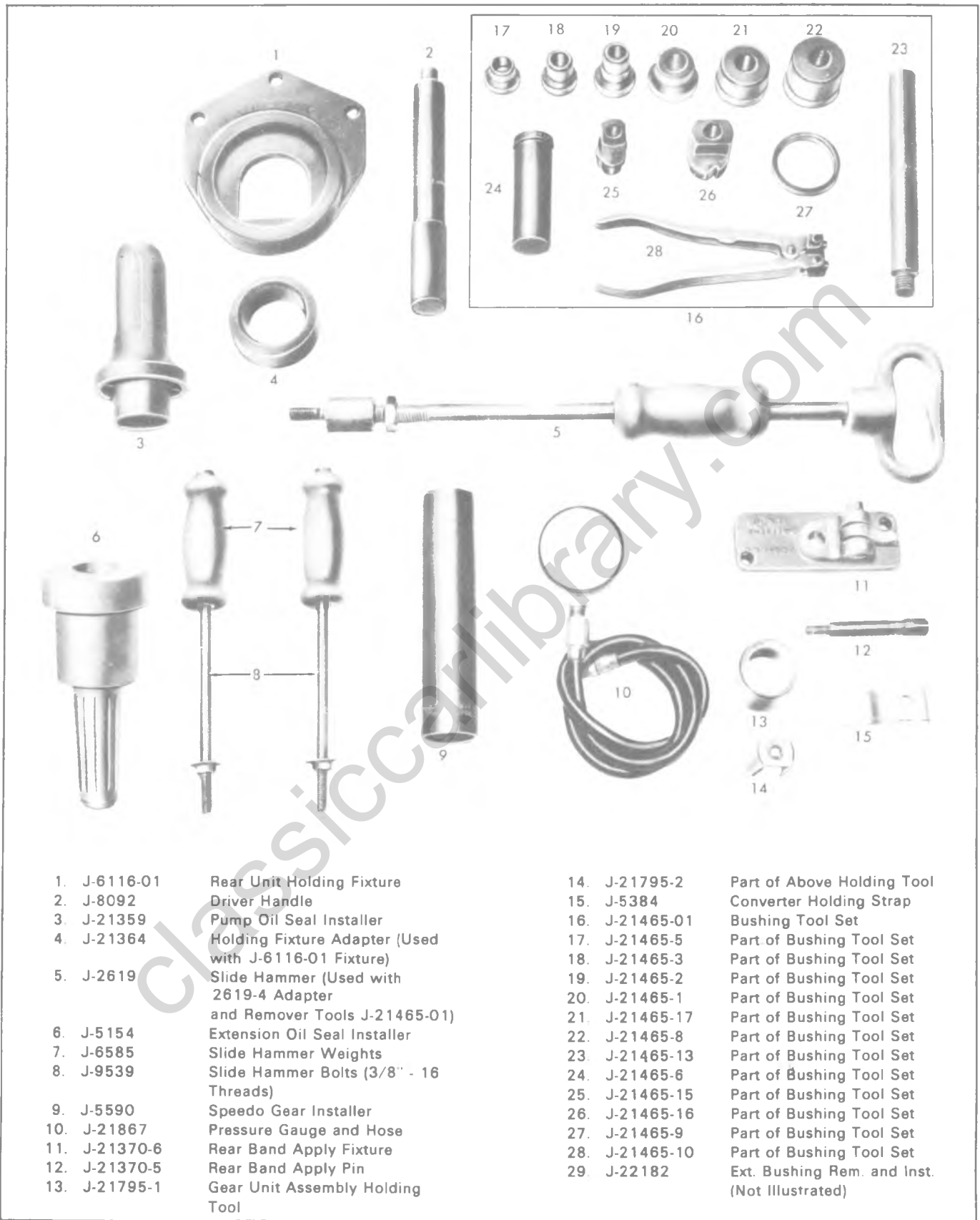
CBC 350

Pump Cover to Pump Body	17 ft. lbs.
Pump Assembly to Case	18-1/2 ft. lbs.
Valve Body and Support Plate	130 in. lbs.
Parking Lock Bracket	29 ft. lbs.
Oil Suction Screen	40 in. lbs.
Oil Pan to Case	130 in. lbs.
Extension to Case	25 ft. lbs.
Modulator Retainer to Case	130 in. lbs.
Inner Selector Lever to Shaft	25 ft. lbs.
Detent Valve Actuating Bracket	52 in. lbs.
Converter to Flywheel Bolts	35 ft. lbs.
Under Pan to Transmission Case	110 in. lbs.
Transmission Case to Engine	35 ft. lbs.
Oil Cooler Pipe Connectors to Transmission Case or Radiator	125 in. lbs.
Oil Cooler Pipe to Connectors	10 ft. lbs.
Detent Cable to Transmission	75 in. lbs.
Detent Cable to Carb	112 in. lbs.

THM 400

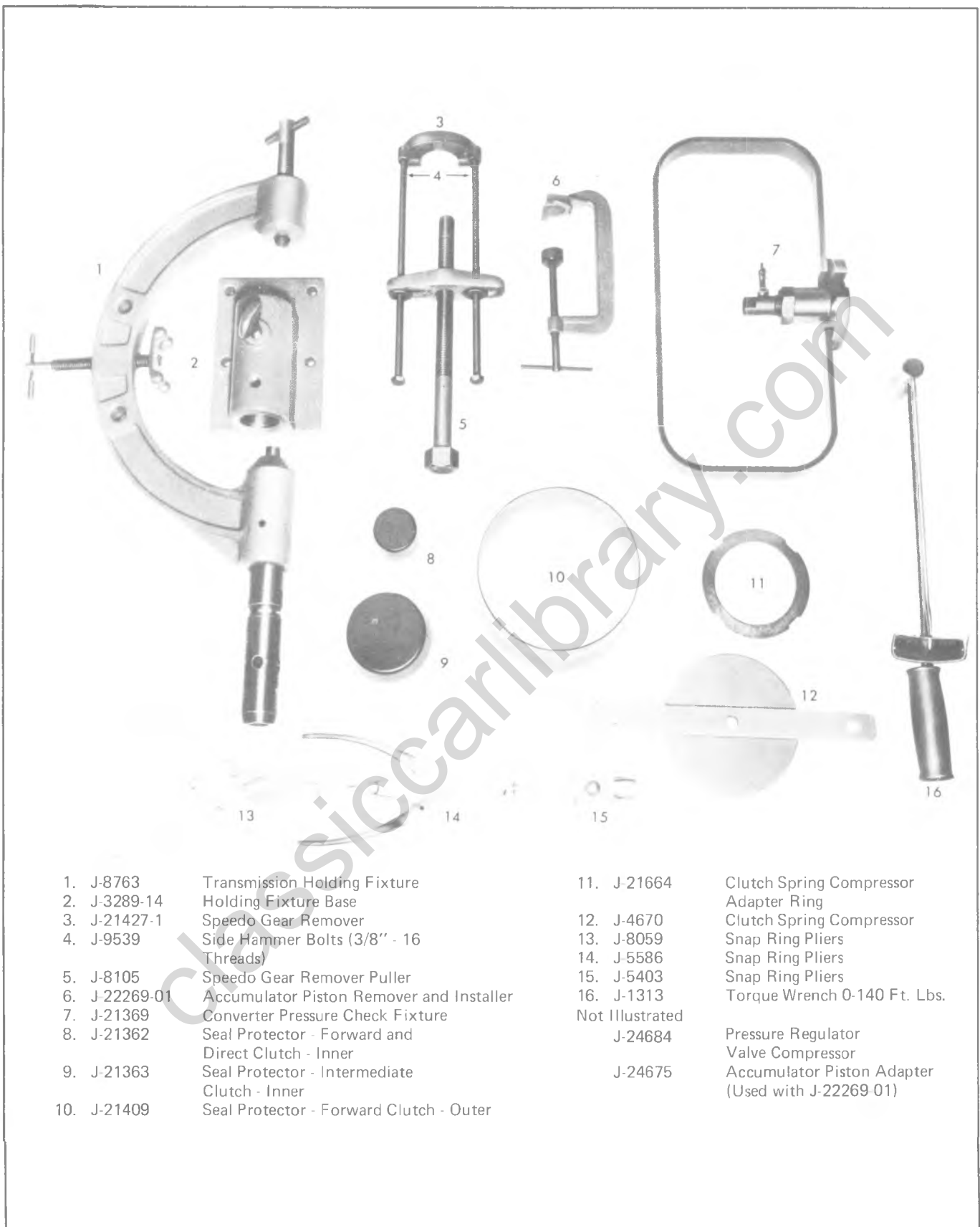
Pump Cover Bolts	18 ft. lbs.
Parking Pawl Bracket Bolts	18 ft. lbs.
Center Support Bolt	23 ft. lbs.
Pump to Case Attaching Bolts	18 ft. lbs.
Extension Housing to Case Attaching Bolts	23 ft. lbs.
Rear Servo Cover Bolts	18 ft. lbs.
Detent Solenoid Bolts	7 ft. lbs.
Control Valve Body Bolts	8 ft. lbs.
Bottom Pan Attaching Screws	12 ft. lbs.
Modulator Retainer Bolt	18 ft. lbs.
Governor Cover Bolts	18 ft. lbs.
Manual Lever to Manual Shaft Nut	8 ft. lbs.
Manual Shaft to Inside Detent Lever	18 ft. lbs.
Linkage Swivel Clamp Nut	43 ft. lbs.
Converter Dust Shield Screws	93 ft. lbs.
Transmission to Engine Mounting Bolts	35 ft. lbs.
Converter to Flywheel Bolts	35 ft. lbs.
Rear Mount to Transmission Bolts	40 ft. lbs.
Rear Mount to Crossmember Bolt	40 ft. lbs.
Crossmember Mounting Bolts	25 ft. lbs.
Oil Cooler Line	10 ft. lbs.
Line Pressure Take-Off Plug	13 ft. lbs.
Strainer Retainer Bolt	10 ft. lbs.
Oil Cooler Pipe Connectors to Transmission Case or Radiator	125 in. lbs.
Oil Cooler Pipe to Connector	10 in. lbs.
Downshift Switch to Bracket	22 in. lbs.

ClassicCarLib.com



- | | | | |
|---------------|--|----------------|---|
| 1. J-6116-01 | Rear Unit Holding Fixture | 14. J-21795-2 | Part of Above Holding Tool |
| 2. J-8092 | Driver Handle | 15. J-5384 | Converter Holding Strap |
| 3. J-21359 | Pump Oil Seal Installer | 16. J-21465-01 | Bushing Tool Set |
| 4. J-21364 | Holding Fixture Adapter (Used with J-6116-01 Fixture) | 17. J-21465-5 | Part of Bushing Tool Set |
| 5. J-2619 | Slide Hammer (Used with 2619-4 Adapter and Remover Tools J-21465-01) | 18. J-21465-3 | Part of Bushing Tool Set |
| 6. J-5154 | Extension Oil Seal Installer | 19. J-21465-2 | Part of Bushing Tool Set |
| 7. J-6585 | Slide Hammer Weights | 20. J-21465-1 | Part of Bushing Tool Set |
| 8. J-9539 | Slide Hammer Bolts (3/8" - 16 Threads) | 21. J-21465-17 | Part of Bushing Tool Set |
| 9. J-5590 | Speedo Gear Installer | 22. J-21465-8 | Part of Bushing Tool Set |
| 10. J-21867 | Pressure Gauge and Hose | 23. J-21465-13 | Part of Bushing Tool Set |
| 11. J-21370-6 | Rear Band Apply Fixture | 24. J-21465-6 | Part of Bushing Tool Set |
| 12. J-21370-5 | Rear Band Apply Pin | 25. J-21465-15 | Part of Bushing Tool Set |
| 13. J-21795-1 | Gear Unit Assembly Holding Tool | 26. J-21465-16 | Part of Bushing Tool Set |
| | | 27. J-21465-9 | Part of Bushing Tool Set |
| | | 28. J-21465-10 | Part of Bushing Tool Set |
| | | 29. J-22182 | Ext. Bushing Rem. and Inst. (Not Illustrated) |

Fig. 7A-2ST-THM 400 Special Tools



- | | | | |
|---------------|--|-----------------|---|
| 1. J-8763 | Transmission Holding Fixture | 11. J-21664 | Clutch Spring Compressor Adapter Ring |
| 2. J-3289-14 | Holding Fixture Base | 12. J-4670 | Clutch Spring Compressor |
| 3. J-21427-1 | Speedo Gear Remover | 13. J-8059 | Snap Ring Pliers |
| 4. J-9539 | Side Hammer Bolts (3/8" - 16 Threads) | 14. J-5586 | Snap Ring Pliers |
| 5. J-8105 | Speedo Gear Remover Puller | 15. J-5403 | Snap Ring Pliers |
| 6. J-22269-01 | Accumulator Piston Remover and Installer | 16. J-1313 | Torque Wrench 0-140 Ft. Lbs. |
| 7. J-21369 | Converter Pressure Check Fixture | Not Illustrated | |
| 8. J-21362 | Seal Protector - Forward and Direct Clutch - Inner | J-24684 | Pressure Regulator Valve Compressor |
| 9. J-21363 | Seal Protector - Intermediate Clutch - Inner | J-24675 | Accumulator Piston Adapter (Used with J-22269-01) |
| 10. J-21409 | Seal Protector - Forward Clutch - Outer | | |

Fig. 7A-3ST--THM 400 Special Tools

SECTION 7B

MANUAL TRANSMISSION

INDEX

General Description		Component Parts Replacement	
3-Speed 76mm Saginaw.....	7B-1	Transmissions.....	7B-17
3-Speed 77mm Tremac.....	7B-1	Replacement.....	7B-17
3-Speed 83mm Muncie.....	7B-1	Alignment.....	7B-19
4-Speed 117mm Muncie.....	7B-1	Oil Seal.....	7B-20
Maintenance and Adjustments		Speedo Gear.....	7B-21
Transmission Linkage.....	7B-10	Side Cover.....	7B-21
Transfer Case Linkage.....	7B-10	Shift Control Lever.....	7B-22
Diagnosis		Transfer Case.....	7B-22
Free Pedal Travel.....	7B-14	Removal.....	7B-22
Spin Down Time.....	7B-14	Installation.....	7B-22
Shift Linkage.....	7B-14	Specifications.....	7B-24
Shift Effort.....	7B-14	Special Tools.....	7B-25

GENERAL DESCRIPTION

THREE-SPEED TRANSMISSIONS

3-Speed 76 mm Saginaw

3-Speed 77mm Tremac

3-Speed 83mm H.D. Muncie

The three speed synchromesh transmissions (Figs. 7B-1 through 7B-5) are representative of a constant-mesh transmission design. Fundamental components of these units are the case, which houses the gears and shaft; the control cover, which houses the shifter mechanism; and the various shafts and gears. The input shaft has an integral main drive gear and rotates with the clutch driven plate; that is, the shaft rotates all the time the clutch is engaged and the engine is running. The input shaft is supported in the case by a ball bearing and at the front end by an oil impregnated bushing mounted in the engine crankshaft. The drive gear is in constant mesh with the countershaft drive gear. Since all gears in the countershaft cluster are integral to the shaft, they also rotate at the time the clutch is engaged. The countergear is carried on roller bearings at both ends and thrust is absorbed by thrust washers located between the countergear and thrust bosses in the case. The transmission mainshaft is held in line with the input shaft by a pilot bearing at its front end, which allows it to rotate or come to rest independently of the input shaft. It is carried at the rear by a ball bearing mounted in the front face of the extension housing.

Helical gears are incorporated throughout, including reverse gear. The mainshaft gears are free to rotate independently on the mainshaft and are in constant mesh with the countershaft gears. The reverse idler gear is carried on a bushing, finish bored in place, and thrust is taken on the thrust bosses of the case.

The transmissions are fully synchronized in all forward speeds; however, reverse gear is not. The synchronizer assemblies consist of a hub, sleeve, two key springs and three synchronizer keys. The synchronizer hubs are splined to the mainshaft and retained by snap rings. These assemblies permit gears to be selected without clashing, by synchronizing the speeds of mating parts before they engage.

Four of the transmission gears are rigidly connected to the countergear. These are the driven gear, second-speed gear, first-speed gear and reverse gear. The engine driven clutch gear drives the countergear through a constant mesh countershaft driven gear. The countergear rotates in a direction opposite, or counter, to the rotation of the clutch gear. Forward speed gears on the countergear remain in constant mesh with two nonsliding mainshaft gears giving first and second speed. Third speed is a direct drive with the clutch gear engaged directly to the mainshaft. Forward gears are engaged through two sliding synchronizer sleeves mounted on the mainshaft. Engagement of the constant mesh mainshaft gears to the mainshaft is accomplished through blocker ring-type synchronizers.

NOTE: The Muncie unit is similar to the Saginaw design but differs in that it has larger bearings, gears, input shaft and mainshaft.

FOUR-SPEED TRANSMISSION

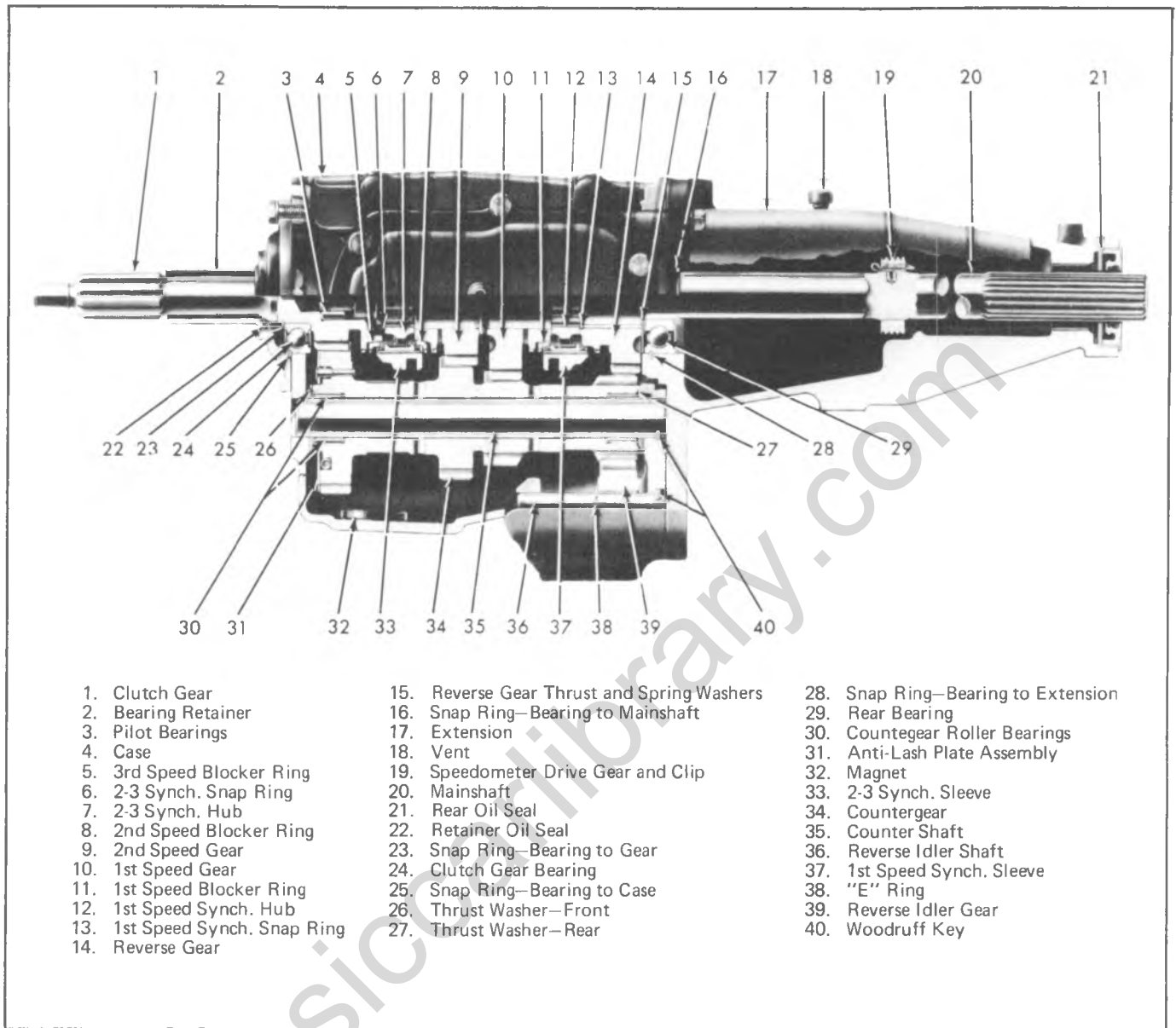
4-Speed 117mm Muncie

The Muncie Model CH 465 truck transmission (Figs. 7B-6 and 7B-7) uses a constant mesh first gear that engages with the second speed synchronizer sleeve. Second, third and fourth gears are synchronized. The clutch gear is supported by a heavy duty ball bearing.

The forward end of the mainshaft is supported by a loose collar-type bearing inside the clutch gear, while therear is carried on a ball bearing in the case. End play is taken up by the rear flange retaining nut. The countergear is supported at the rear by a single row ball bearing which takes the thrust load, and by a roller bearing at the front. Incorporated in the cover is a ball pin type interlock which prevents simultaneous engagement of two gears. As one rod is moved, it pushes a ball out that engages the other two rods to prevent their movement.

Gearshift levers on manual transmissions are located either on the steering column or on the floorboard. Regardless of location, the lever performs two operations: It selects the gear assembly to be moved, and moves it either forward or backward into the desired gear position. The transmission action is the same whether a floor-type shift lever or a steering column shift lever is used. When the shift lever is moved, the movement is carried by linkage to the transmission.

Classiccarlibrary.com



- | | | |
|--------------------------------|--|------------------------------------|
| 1. Clutch Gear | 15. Reverse Gear Thrust and Spring Washers | 28. Snap Ring—Bearing to Extension |
| 2. Bearing Retainer | 16. Snap Ring—Bearing to Mainshaft | 29. Rear Bearing |
| 3. Pilot Bearings | 17. Extension | 30. Countergear Roller Bearings |
| 4. Case | 18. Vent | 31. Anti-Lash Plate Assembly |
| 5. 3rd Speed Blocker Ring | 19. Speedometer Drive Gear and Clip | 32. Magnet |
| 6. 2-3 Synch. Snap Ring | 20. Mainshaft | 33. 2-3 Synch. Sleeve |
| 7. 2-3 Synch. Hub | 21. Rear Oil Seal | 34. Countergear |
| 8. 2nd Speed Blocker Ring | 22. Retainer Oil Seal | 35. Countershaft |
| 9. 2nd Speed Gear | 23. Snap Ring—Bearing to Gear | 36. Reverse Idler Shaft |
| 10. 1st Speed Gear | 24. Clutch Gear Bearing | 37. 1st Speed Synch. Sleeve |
| 11. 1st Speed Blocker Ring | 25. Snap Ring—Bearing to Case | 38. "E" Ring |
| 12. 1st Speed Synch. Hub | 26. Thrust Washer—Front | 39. Reverse Idler Gear |
| 13. 1st Speed Synch. Snap Ring | 27. Thrust Washer—Rear | 40. Woodruff Key |
| 14. Reverse Gear | | |

Fig. 7B-1--3-Speed 76mm, Cross-Section

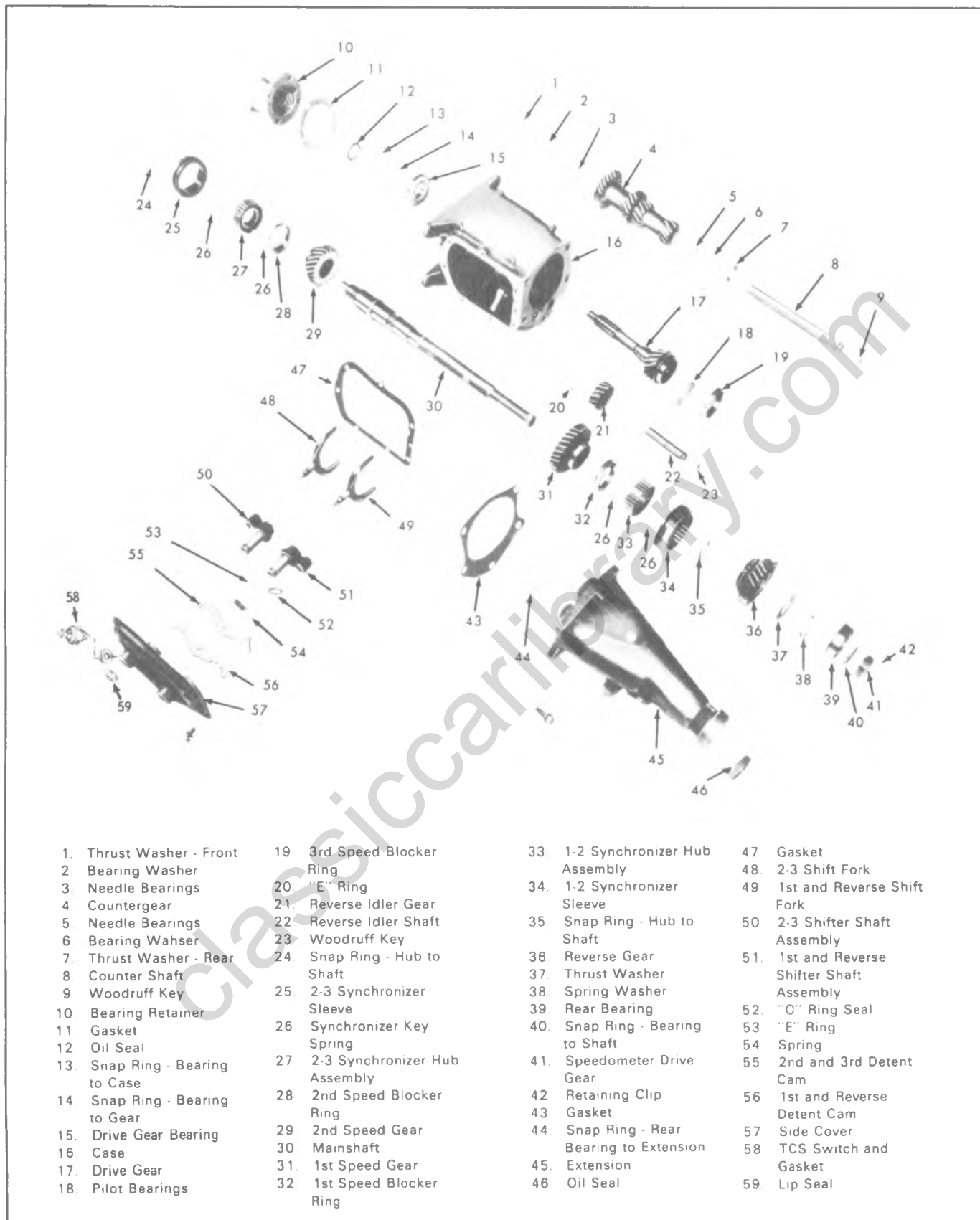
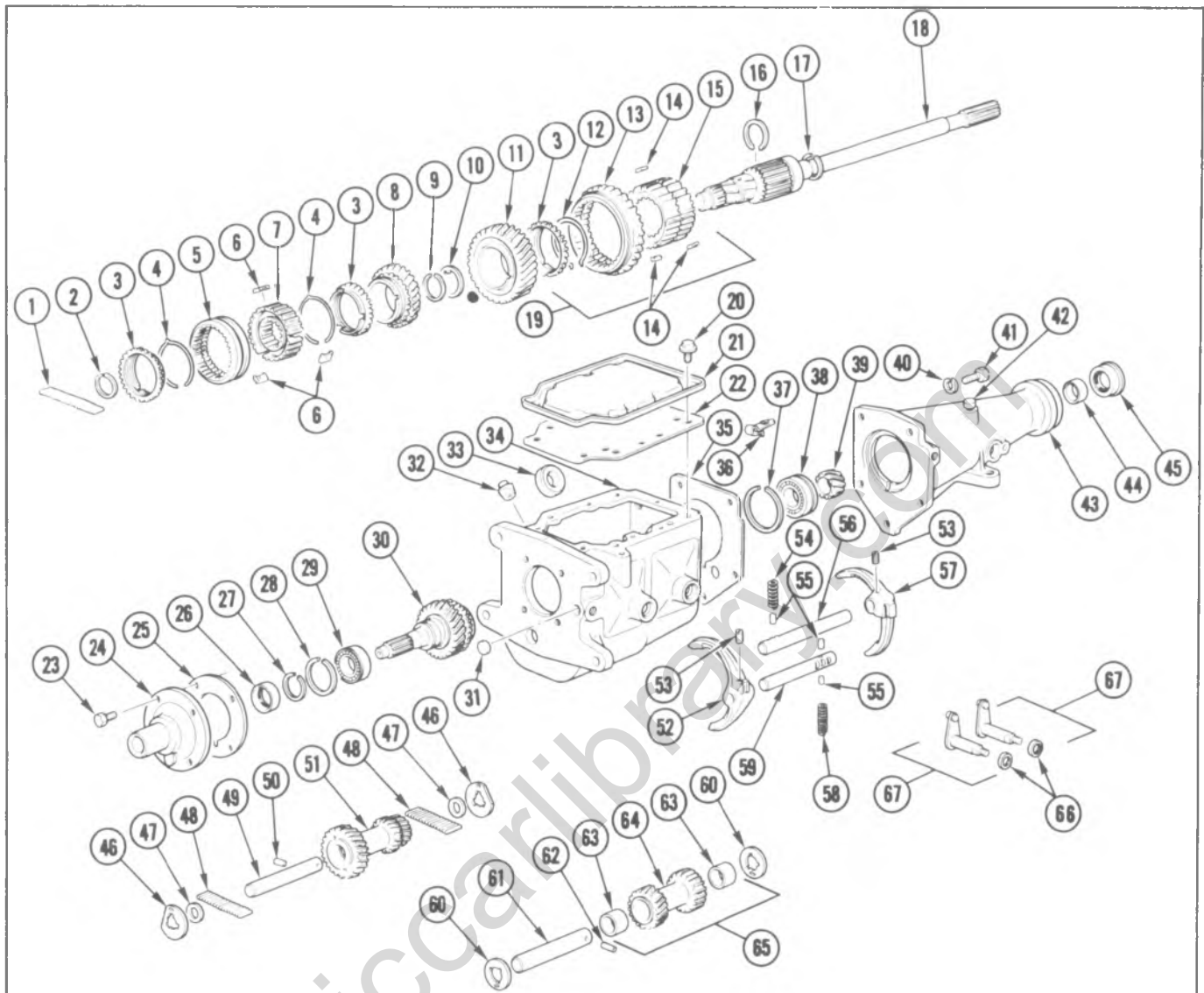
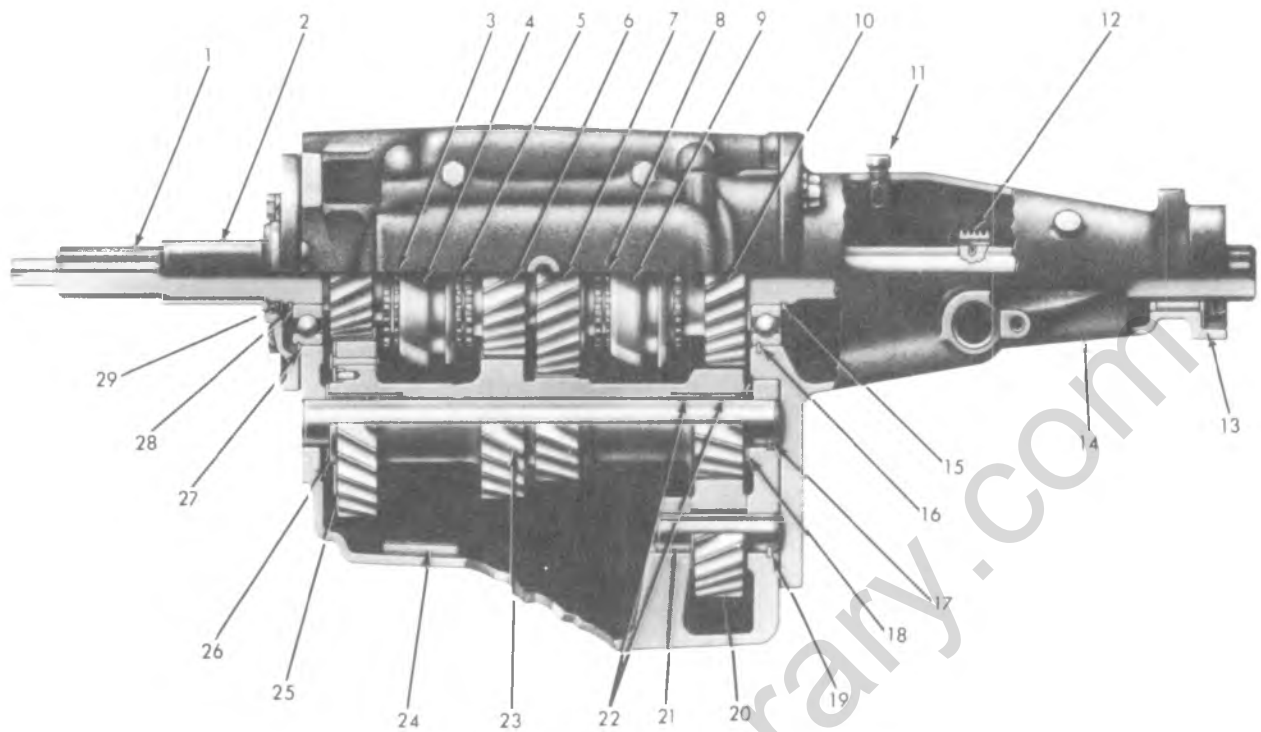


Fig. 7B-2-3 Speed 76mm, Exploded View



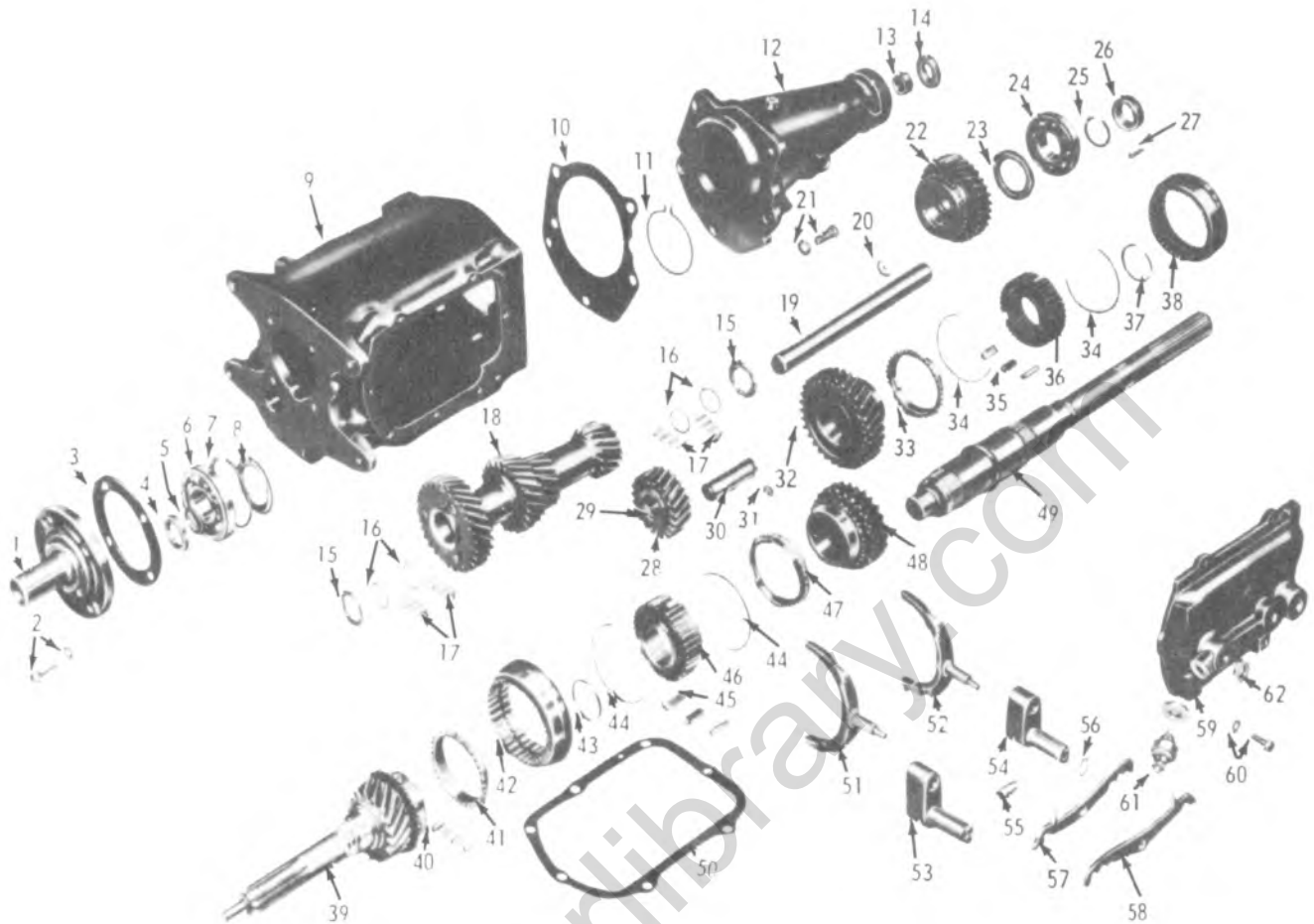
- | | |
|--|--|
| <ol style="list-style-type: none"> 1. MAINSHAFT ROLLER BEARINGS 2. 2ND & 3RD SYNCHRONIZER RETAINING RING 3. SYNCHRONIZER BLOCKER RINGS 4. 2ND & 3RD SYNCHRONIZER SPRING 5. 2ND & 3RD SYNCHRONIZER SLEEVE 6. 2ND & 3RD SYNCHRONIZER KEYS 7. 2ND & 3RD SYNCHRONIZER HUB 8. SECOND SPEED GEAR 9. 1ST SPEED GEAR RETAINING RING 10. 1ST SPEED GEAR TABBED WASHER 11. 1ST SPEED GEAR 12. REVERSE SYNCHRONIZER SPRING 13. 1ST & REVERSE SYNCHRONIZER SLEEVE & GEAR 14. REVERSE SYNCHRONIZER KEYS 15. 1ST & REVERSE SYNCHRONIZER HUB 16. 1ST & REVERSE SYNCHRONIZER RETAINING RING 17. REAR BEARING RETAINING RING 18. TRANSMISSION MAINSHAFT 19. REVERSE SYNCHRONIZER ASSEMBLY 20. ACCESS COVER BOLTS 21. ACCESS COVER 22. ACCESS COVER GASKET 23. BEARING RETAINER - TO CASE BOLTS 24. BEARING RETAINER - CLUTCH GEAR 25. GASKET - CLUTCH GEAR BEARING RETAINER 26. SEAL ASSEMBLY - CLUTCH GEAR BEARING RETAINER 27. CLUTCH GEAR BEARING RETAINING RING 28. CLUTCH GEAR BEARING LOCK RING 29. CLUTCH GEAR BEARING ASSEMBLY 30. CLUTCH GEAR 31. EXPANSION PLUG 32. FILLER PLUG 33. TRANSMISSION CASE MAGNET 34. CASE | <ol style="list-style-type: none"> 35. EXTENSION HOUSING TO CASE GASKET 36. SPEEDOMETER DRIVER GEAR RETAINING CLIP 37. TRANSMISSION REAR BEARING LOCK RING 38. MAINSHAFT BEARING ASSEMBLY 39. SPEEDOMETER DRIVE GEAR 40. EXTENSION TO CASE WASHER 41. EXTENSION TO CASE BOLT 42. TRANSMISSION EXTENSION VENTILATOR ASSEMBLY 43. EXTENSION HOUSING ASSEMBLY 44. EXTENSION HOUSING BUSHING 45. EXTENSION HOUSING OIL SEAL ASSEMBLY 46. COUNTERGEAR THRUST WASHER 47. COUNTERGEAR SPACER 48. COUNTERGEAR ROLLET BEARINGS 49. COUNTERGEAR SHAFT 50. COUNTERGEAR SPRING PIN 51. COUNTERGEAR 52. 2ND & 3RD SHIFTER FORK 53. SHIFTER FORK LOCKING SCREW 54. 1ST & 2ND SHIFTER INTERLOCK SPRING 55. SHIFTER INTERLOCK PIN 56. 1ST & REVERSE SHIFTER RAIL 57. 1ST & REVERSE SHIFTER FORK 58. 2ND & 3RD SHIFTER INTERLOCK SPRING 59. 2ND & 3RD SHIFTER RAIL 60. REVERSE IDLER GEAR THRUST WASHER 61. REVERSE IDLER GEAR SHAFT 62. SPRING PIN IDLER GEAR SHAFT 63. REVERSE IDLER GEAR BUSHING 64. REVERSE IDLER GEAR 65. REVERSE IDLER GEAR ASSEMBLY 66. SEAL TRANSMISSION SHIFTER 67. TRANSMISSION SHIFTER SHAFT & LEVER ASSEMBLY |
|--|--|

Fig. 7B-3-3-Speed 77mm, Exploded View



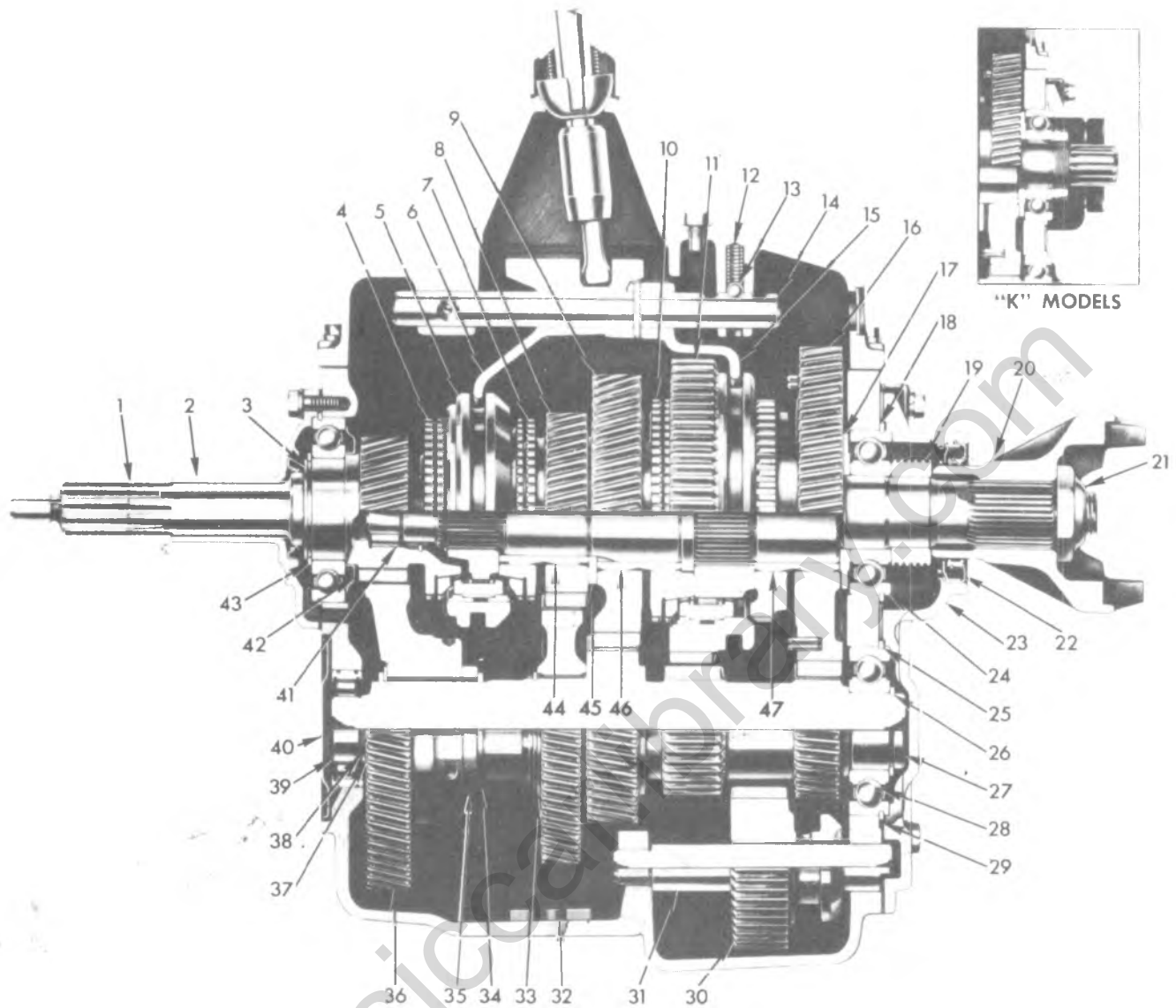
- | | | |
|---------------------------------|---|-----------------------------------|
| 1. Clutch Gear | 11. Vent | 21. Reverse Idler Shaft |
| 2. Clutch Gear Bearing Retainer | 12. Speedometer Gear and Clip | 22. Countergear Bearings |
| 3. 3rd Speed Synchronizer Ring | 13. Rear Extension Seal | 23. Countergear |
| 4. 2nd-3rd Speed Clutch Assy. | 14. Rear Extension | 24. Case Magnet |
| 5. 2nd Speed Synchronizer Ring | 15. Rear Bearing-to-Shaft Snap Ring | 25. Anti-Lash Plate Assy. |
| 6. 2nd Speed Gear | 16. Rear Bearing-to-extension Snap Ring | 26. Thrust Washer |
| 7. 1st Speed Gear | 17. Countergear Woodruff Key | 27. Clutch Gear Bearing |
| 8. 1st Speed Synchronizer Ring | 18. Thrust Washer | 28. Snap Ring |
| 9. 1st-Reverse Clutch Assy. | 19. Reverse Idler Shaft Woodruff Key | 29. Clutch Gear Retainer Lip Seal |
| 10. Reverse Gear | 20. Reverse Idler Gear | |

Fig. 7B-4 3-Speed 83mm. Cross-Section



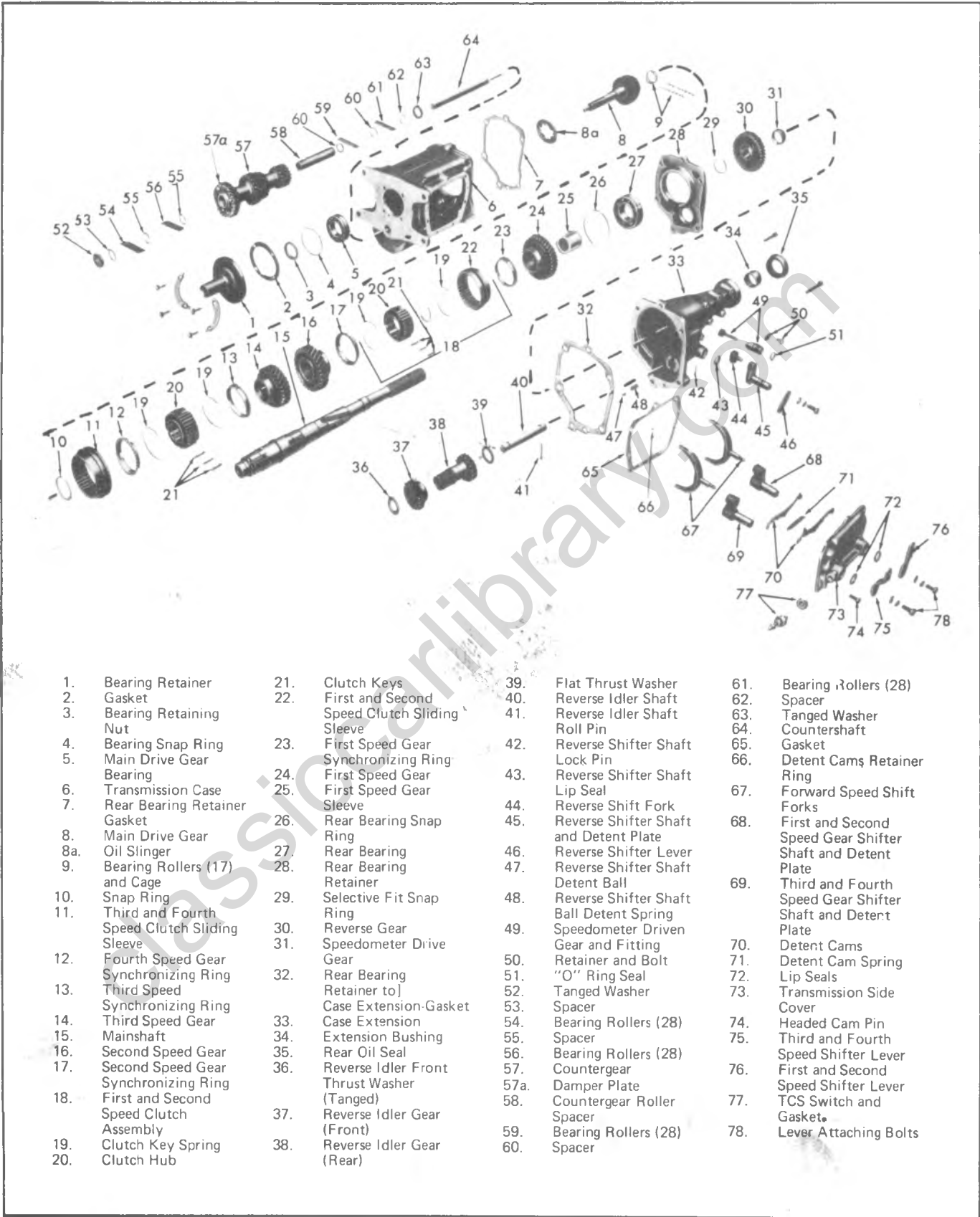
- | | | | |
|--|-----------------------------|--|---|
| 1 Bearing Retainer | 18 Countergear | 35 Synchronizer Keys | 50 Gasket |
| 2 Bolt and Lock Washer | 19 Countershaft | 36 1st and Reverse Synchronizer Hub Assembly | 51 2nd and 3rd Shifter Fork |
| 3 Gasket | 20 Woodruff Key | 37 Snap Ring | 52 1st and Reverse Shifter Fork |
| 4 Oil Seal | 21 Bolt (Extension-to-Case) | 38 1st and Reverse Synchronizer Collar | 53 2-3 Shifter Shaft Assembly |
| 5 Snap Ring (Bearing-to-Main Drive Gear) | 22 Reverse Gear | 39 Main Drive Gear | 54 1st and Reverse Shifter Shaft Assembly |
| 6 Main Drive Gear Bearing | 23 Thrust Washer | 40 Pilot Bearings | 55 Spring |
| 7 Snap Ring Bearing | 24 Rear Bearing | 41 3rd Speed Blocker Ring | 56 O-Ring Seal |
| 8 Oil Slinger | 25 Snap Ring | 42 2nd and 3rd Synchronizer Collar | 57 1st and Reverse Detent Cam |
| 9 Case | 26 Speedometer Drive Gear | 43 Snap Ring | 58 2nd and 3rd Detent Cam |
| 10 Gasket | 27 Retainer Clip | 44 Synchronizer Key Spring | 59 Side Cover |
| 11 Snap Ring (Rear Bearing-to-Extension) | 28 Reverse Idler Gear | 45 Synchronizer Keys | 60 Bolt and Lock Washer |
| 12 Extension | 29 Reverse Idler Bushing | 46 2nd and 3rd Synchronizer Hub | 61 TCS Switch and Gasket |
| 13 Extension Bushing | 30 Reverse Idler Shaft | 47 2nd Speed Blocker Ring | 62 Lip Seal |
| 14 Oil Seal | 31 Woodruff Key | 48 2nd Speed Gear | |
| 15 Thrust Washer | 32 1st Speed Gear | 49 Mainshaft | |
| 16 Bearing Washer | 33 1st Speed Blocker Ring | | |
| 17 Needle Bearings | 34 Synchronizer Key Spring | | |

Fig. 7B-5--3-Speed 83mm, Exploded View



- | | | | |
|---------------------------------------|-----------------------------------|------------------------------|-------------------------------|
| 1 Main Drive Gear | 11 Reverse Driven Gear | 24 Mainshaft Rear Bearing | 37 Thrust Washer |
| 2 Drive Gear Bearing Retainer | 12 Poppet Spring | 25 Rear Bearing Snap Ring | 38 Snap Ring |
| 3 Snap Ring-Outer | 13 Poppet Ball | 26 Snap Ring | 39 Front Countershaft Bearing |
| 4 3rd and 4th Synchronizer Ring | 14 Shift Rail | 27 Countershaft | 40 Countergear Front Cover |
| 5 3rd and 4th Synchronizer Collar | 15 1st and 2nd Shift Fork | 28 Countershaft Rear Bearing | 41 Pilot Bearing Rollers |
| 6 3rd and 4th Shift Fork | 16 1st Speed Gear | 29 Bearing Snap Ring | 42 Clutch Gear Oil Slinger |
| 7 3rd and 4th Speed Synchronizer Ring | 17 Thrust Washer | 30 Reverse Idler Gear | 43 Snap Ring |
| 8 3rd Speed Gear | 18 Bearing Snap Ring | 31 Reverse Idler Shaft | 44 3rd Speed Gear Bushing |
| 9 2nd Speed Gear | 19 Speedometer Drive Gear | 32 Case Magnet | 45 Thrust Washer |
| 10 1st and 2nd Synchronizer Assembly | 20 Output Yoke | 33 Snap Ring | 46 2nd Speed Gear Bushing |
| | 21 Flange Nut | 34 Snap Ring | 47 1st Speed Gear Bushing |
| | 22 Rear Bearing Retainer Oil Seal | 35 Spacer | |
| | 23 Rear Bearing Retainer | 36 Countergear | |

Fig. 7B-6-4-Speed, 117mm, Cross-Section



- | | | | |
|--|--|--|--|
| 1. Bearing Retainer | 21. Clutch Keys | 39. Flat Thrust Washer | 61. Bearing Rollers (28) |
| 2. Gasket | 22. First and Second Speed Clutch Sliding Sleeve | 40. Reverse Idler Shaft | 62. Spacer |
| 3. Bearing Retaining Nut | 23. First Speed Gear Synchronizing Ring | 41. Reverse Idler Shaft Roll Pin | 63. Tanged Washer |
| 4. Bearing Snap Ring | 24. First Speed Gear | 42. Reverse Shifter Shaft Lock Pin | 64. Countershaft Gasket |
| 5. Main Drive Gear Bearing | 25. First Speed Gear Sleeve | 43. Reverse Shifter Shaft Lip Seal | 65. Gasket |
| 6. Transmission Case | 26. Rear Bearing Snap Ring | 44. Reverse Shift Fork | 66. Detent Cam Retainer Ring |
| 7. Rear Bearing Retainer Gasket | 27. Rear Bearing | 45. Reverse Shifter Shaft and Detent Plate | 67. Forward Speed Shift Forks |
| 8. Main Drive Gear | 28. Rear Bearing Retainer | 46. Reverse Shifter Lever | 68. First and Second Speed Gear Shifter Shaft and Detent Plate |
| 8a. Oil Slinger | 29. Selective Fit Snap Ring | 47. Reverse Shifter Shaft Detent Ball | 69. Third and Fourth Speed Gear Shifter Shaft and Detent Plate |
| 9. Bearing Rollers (17) and Cage | 30. Reverse Gear | 48. Reverse Shifter Shaft Ball Detent Spring | 70. Detent Cam |
| 10. Snap Ring | 31. Speedometer Drive Gear | 49. Speedometer Driven Gear and Fitting | 71. Detent Cam Spring |
| 11. Third and Fourth Speed Clutch Sliding Sleeve | 32. Rear Bearing Retainer to Case Extension-Gasket | 50. Retainer and Bolt | 72. Lip Seals |
| 12. Fourth Speed Gear Synchronizing Ring | 33. Case Extension | 51. "O" Ring Seal | 73. Transmission Side Cover |
| 13. Third Speed Synchronizing Ring | 34. Extension Bushing | 52. Tanged Washer | 74. Headed Cam Pin |
| 14. Mainshaft | 35. Rear Oil Seal | 53. Spacer | 75. Third and Fourth Speed Shifter Lever |
| 15. Second Speed Gear | 36. Reverse Idler Front Thrust Washer (Tanged) | 54. Bearing Rollers (28) | 76. First and Second Speed Shifter Lever |
| 16. Second Speed Gear Synchronizing Ring | 37. Reverse Idler Gear (Front) | 55. Spacer | 77. TCS Switch and Gasket |
| 17. First and Second Speed Clutch Assembly | 38. Reverse Idler Gear (Rear) | 56. Bearing Rollers (28) | 78. Lever Attaching Bolts |
| 18. First and Second Speed Clutch Assembly | | 57. Damper Plate | |
| 19. Clutch Key Spring | | 57a. Counter gear Roller | |
| 20. Clutch Hub | | 58. Counter gear Roller | |
| | | 59. Bearing Rollers (28) | |
| | | 60. Spacer | |

Fig. 7B-7-4-Speed 117mm. Exploded View

MAINTENANCE AND ADJUSTMENTS

TRANSMISSION LINKAGE ADJUSTMENT

3-Speed Column Shift

(Figs. 7B-8, 7B-9, and 7B-10)

In cases where gearshift linkage has been disconnected or removed, proper adjustment sequence is important.

1. Set both shifter levers in neutral position. Install control rods to both second and third shifter lever and first and reverse shifter lever.

2. Align both shifter tube levers on mast jacket in the neutral position. Install gauge (3/16 to 7/32 in.) in holes of levers so that gearshift control lever is in neutral position.

3. Connect control rods to tube levers making sure clamps are properly adjusted so that tube levers and transmission shifter levers remain in their neutral positions while tightening.

4. Remove gauge and move selector lever through all positions to check adjustment and insure over-travel in all positions.

NOTE: If mast jacket lower dash clamp has been disturbed at its mounting on dash, its adjustment to the steering mainshaft should be checked as outlined in Section 3B of this manual.

TRANSFER CASE SHIFT CONTROL

LINKAGE ADJUSTMENT

Model 203 (Full-Time) Transfer Case (Fig. 7B-11)

Refer to Fig. 7B-11 for illustration of the shift controls and linkage adjustment procedures for the Model 203 (Full Time) Transfer Case.

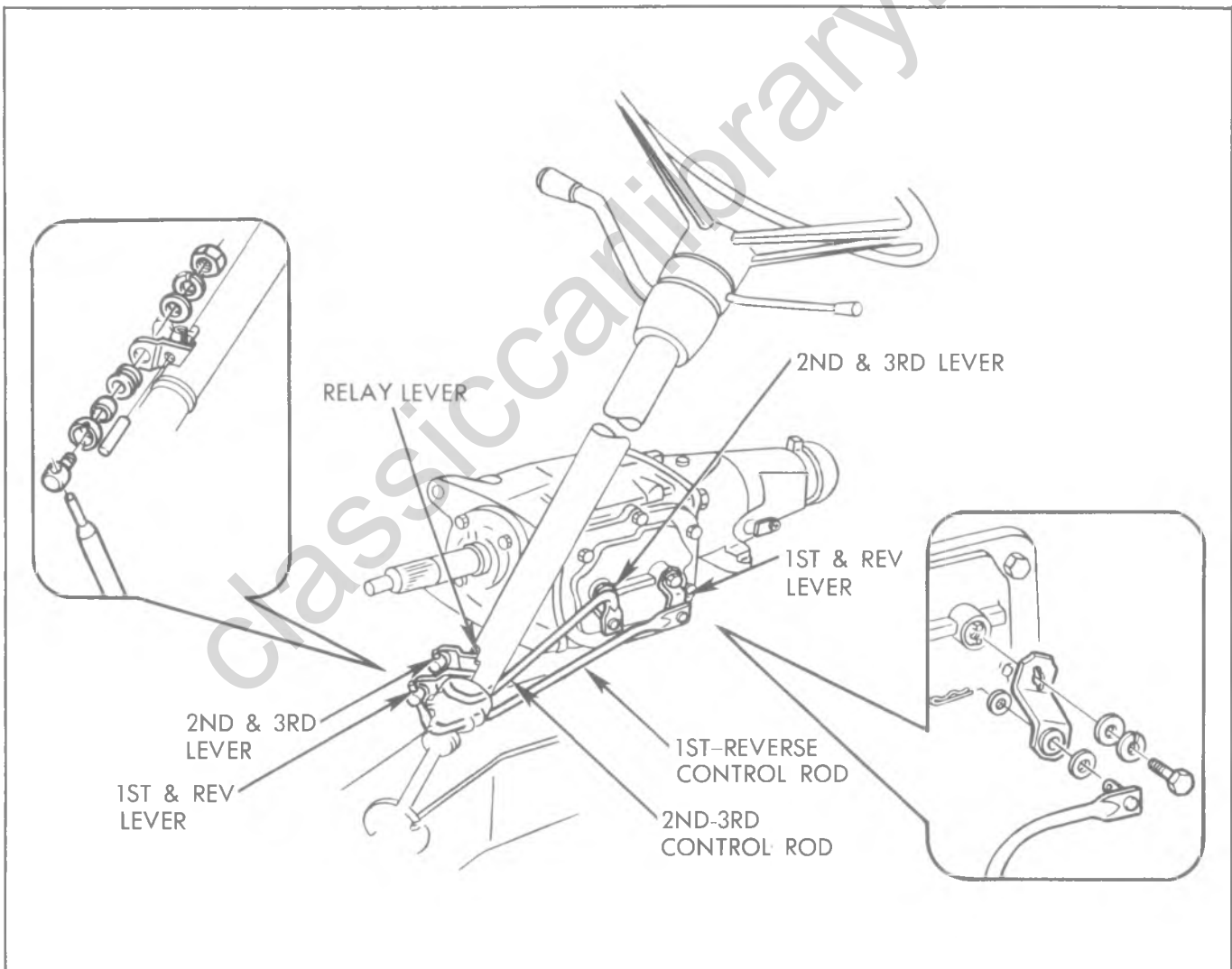


Fig. 7B-8-G-Truck Column Shift Linkage

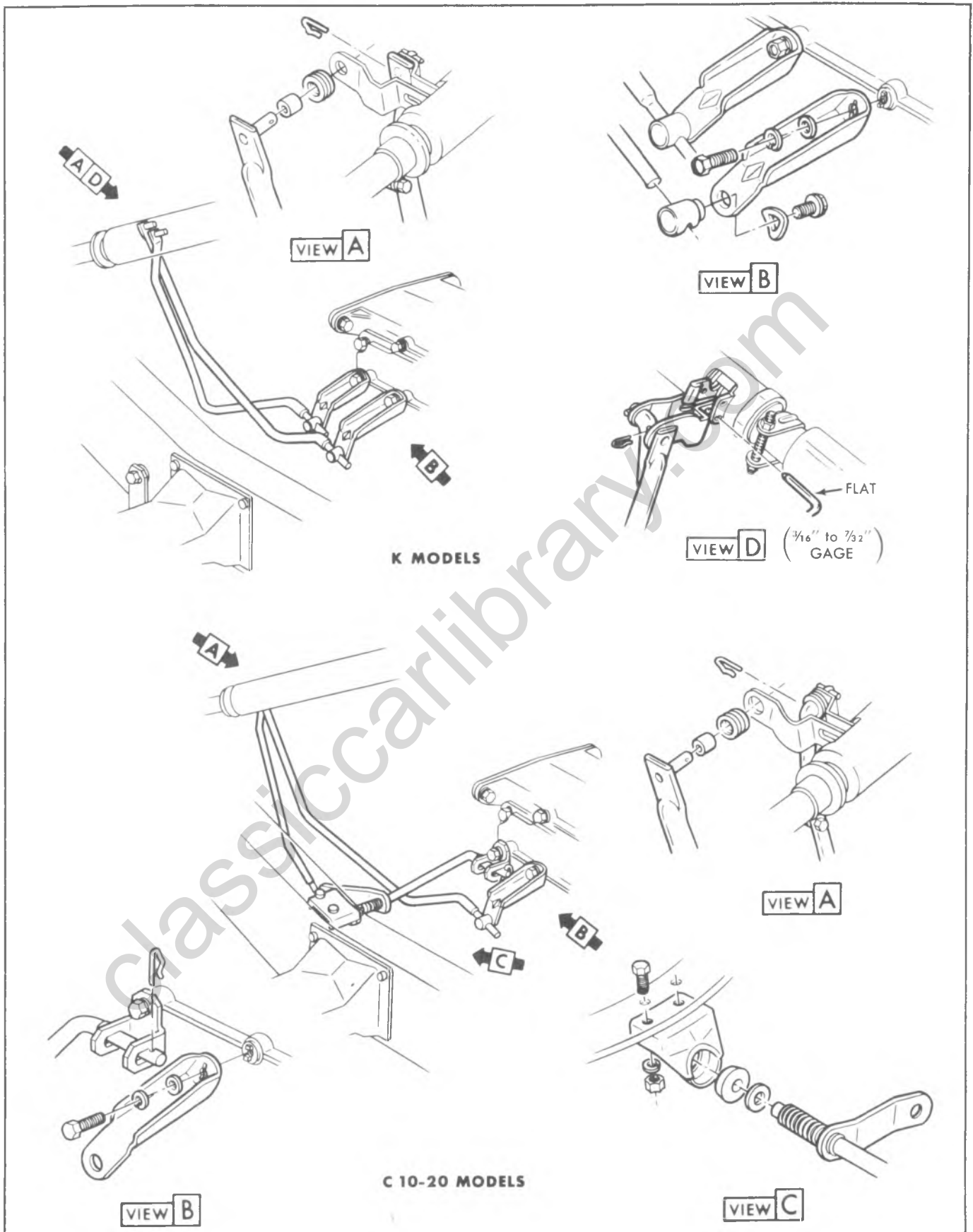


Fig. 7B-9-C and K-Truck Column Shift Linkage

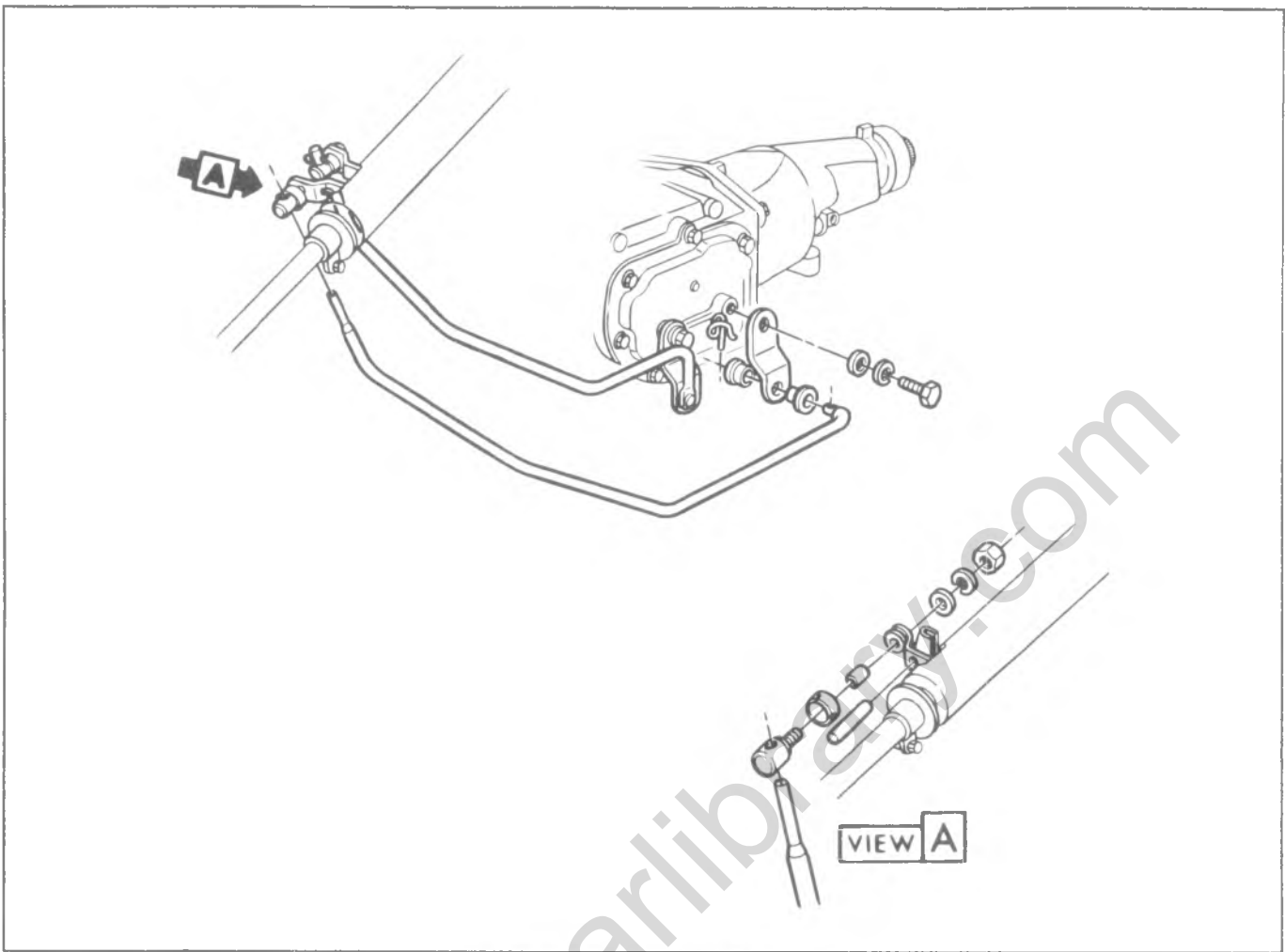


Fig. 7B-10-P-Truck Column Shift Linkage

classiccarslibrary.com

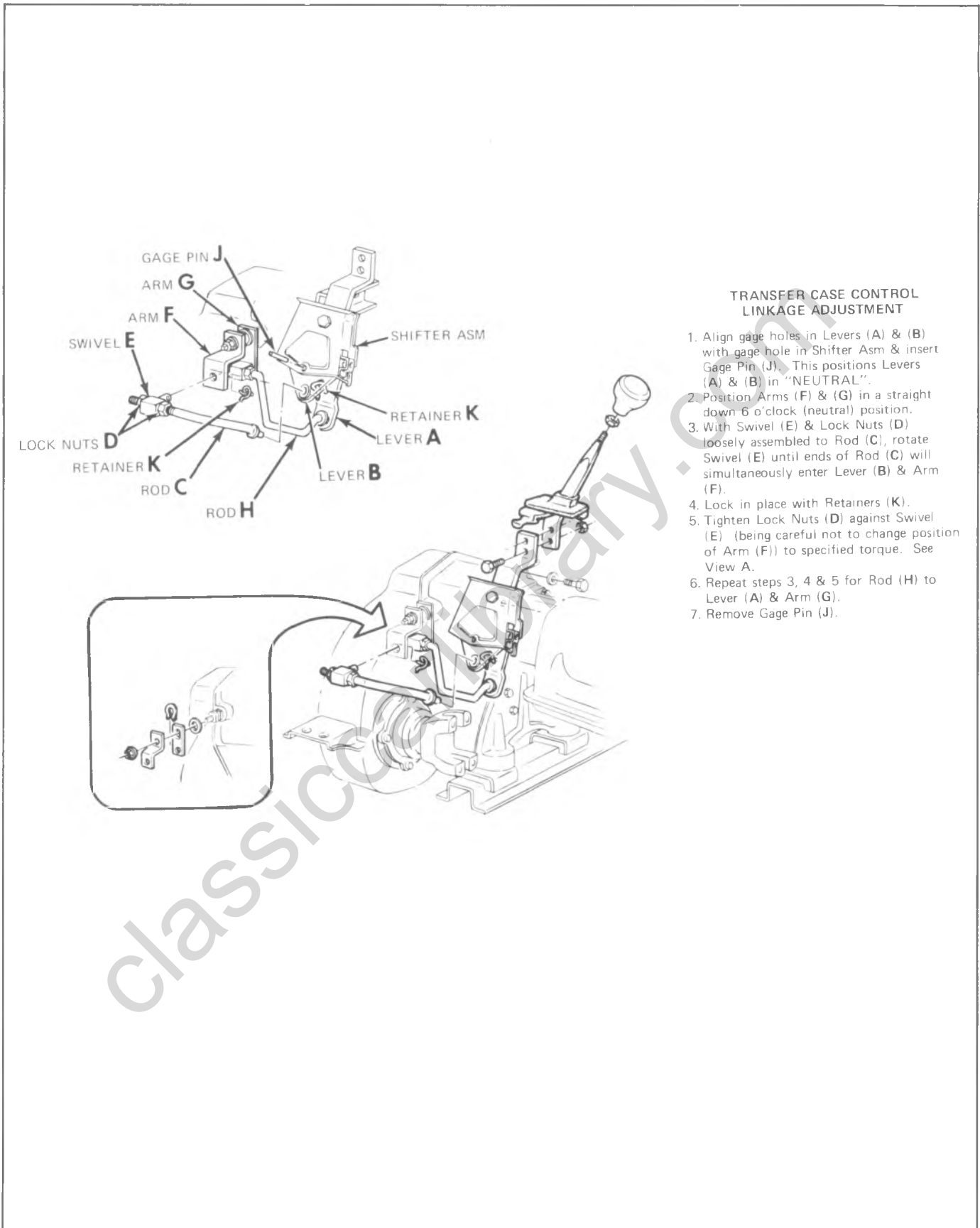


Fig. 7B-11 - Model 203 Transfer Case Controls

DIAGNOSIS

Preliminary Inspection

Before attempting to repair the clutch, transmission or related linkages for any reason other than an obvious failure, the problem and probable cause should be identified. A large percentage of clutch and manual transmission problems are manifested by shifting difficulties such as high shift effort, gear clash and grinding or transmission blockout. When any of these problems occur a careful analysis of these difficulties should be accomplished, and the following checks and adjustments performed in the presented sequence before removing the clutch or transmission for repairs.

CLUTCH ADJUSTMENT

Clutch Free Pedal Travel

1. The clutch free pedal travel adjustment should be made as outlined in Section 7C.
2. Check clutch linkage for lost motion caused by loose or worn swivels, deflection of mounting brackets or damaged cordon shaft.

Clutch Spin Down Time

1. Run the engine at a normal idle with transmission in neutral and clutch engaged.
2. Disengage the clutch, wait nine seconds and shift the transmission to reverse. No grinding noise should be heard. A grinding noise indicates incorrect clutch adjustment, lost motion clutch misalignment, or internal problems such as failed dampers, facings, cushion springs, diaphragm spring fingers, pressure plate drive straps, etc.

SHIFT LINKAGE ADJUSTMENT

Steering Column Shift Control

1. Remove the shift control rods from the column levers.
2. Check shift effort at the shift control lever knob. (Effort should not exceed 2 lbs. with transmission linkage removed.)
3. If binding is felt, refer to the adjustment procedure for the steering column lower bearing in Section 3B.
4. Lubricate all rod and swivel connections and recheck shift effort after installation.
5. If shift linkage is free from binding, the column levers should be checked for end play. A .005" feeler gauge should fit between the levers and control lever.
6. Connect control rods and check steering column control levers for alignment. In neutral, the column control lever tangs should line up with the slot in the main control lever.

Floor Shift Control

All swivels, rods and mountings should be checked for lost motion and repaired or replaced as necessary.

Transmission control levers should be checked for wear and repaired or replaced as necessary.

TRANSMISSION SHIFT EFFORT

Transmission Shift Effort Checking Procedures

1. Remove the shift rods at the transmission and align the sleeve, blocker ring and gear by shifting into the offending gear and then back into neutral.
2. Check the torque required to shift into gear with an inch pound torque wrench on the shift lever attaching bolt. If more than the specified torque (Fig. 7B-12) is required, the transmission shift lever should be checked for rust or dirt binding the lever.
3. Clean levers, lubricate and recheck the torque value.

NOTE: If at this point in the procedure, it is found that high shift effort or gear clashing still exists, an anti-chatter lubricant (positraction additive) should be used. The lubricant is available in plastic bottle and can be squirted into the transmission through the filler plug.

Transmission Internal Problems Related to Shift Effort

When the above procedures have been checked and the problem still exists, the transmission will have to be removed and disassembled for further diagnosis. There are three basic types of transmission internal problems reflected by shifting effort.

1. **Hard Shifting** - The effort to shift is excessive, but the gears engage. The lever moves with excessive effort throughout the entire travel range. If the static shift effort is high, (clutch depressed, engine not running) the synchronizer sleeve and hubs should be checked for a tight fit. With the three synchronizer keys removed, the sleeve should be loose on the hub. If the hub and sleeve are not a loose fit, replace the synchronizer assembly.
2. **Blockout** - The lever moves freely until the synchronizer is engaged. Synchronization should be heard to take place, but the gear will not engage. When it does engage, a double bump is generally felt in the lever. The synchronized blocker ring can be damaged by excessive force on gear cones that are finished improperly. The blocker ring material may stick to the

Shift Torque In. Lbs.	3-Saginaw	3-Muncie
	50	60

Fig. 7B-12--Shift Torque Chart

synchronizer gear cone causing it to be a yellowish brass color, in streaks, which results in hard shifts when present. The gear cone should be a bright silver color. Polish the gear cone with 400 grit paper to a bright silver when this condition is present. The blocker rings should be replaced if the thread is damaged or worn.

3. Clash - Gear clash is a sound which sometimes occurs when the sleeve and gear chamfers contact each other in the unsynchronized state. The characteristics of clash are a grating or loud buzzing sound from the transmission. The shift lever load will be lower, but a vibration should be felt. The noise (clash) can be for a short instant or long enough to keep the gear from being engaged. This condition should not be confused with hard shifting or reported as such. Hard shifting and clash are directly opposite conditions. When the clash is

slight, the load will build up on the shift lever and then fall off rapidly followed by the grating sound.

If the transmission has been clashing, the sleeve ends should be examined for chipping and burrs. If the sleeves are damaged, the synchronizer assemblies and blocker rings should be replaced. Synchronizer sleeve ends should have an angular surface. The surfaces should be even from side to side and the radii indicated should be very small. Any chipping will require synchronizer replacement.

Check the synchronizer load. When the keys are installed, the spring ends on one side of the hub should be hooked in one key and the spring on the opposite side of the synchronizer should not be hooked on the same key. A definite load should be felt when the sleeve is moved on the hubs with the keys and springs in proper position.

SHIFTING DIFFICULTY DIAGNOSIS

CONDITION	PROBABLE CAUSE	CORRECTION
High Shift Effort-Column Shift (Effort exceeds 2 ft. lbs. at lever knob with transmission linkage disconnected.)	Binding of column levers	Adjust column mechanism per Section 9, Steering of the Chassis Service Manual
	Lever end play exceeds .005 in.	Clean and lubricate all rod and swivel connections.
	Misalignment of column control levers.	Adjust levers
High Shift Effort-Floor Shift (crossover from 1st-2nd to 3rd-4th position cannot be accomplished without offset or step)	Improper linkage Adjustment	Adjust linkage
	Lost motion due to damaged or worn swivels, rods, grommets or mountings.	Repair or replace defective components.
	Loose lever attaching bolts	Tighten bolts and check levers for correct fit on shifter shafts.
	Binding	Clean and Adjust linkage
	Stiff shift lever boot	Replace boot
Gear Clash and binding	Improper linkage Adjustment	Adjust Shift linkage
Lost motion	Loose or worn swivels and grommets. Deflection of Mounting Brackets. Loose shift levers. Damaged Cordon Shaft	Replace defective parts

Fig. 7B-13-Shifting Difficulty Diagnosis Chart

MANUAL TRANSMISSION DIAGNOSIS

CONDITION	PROBABLE CAUSE	CORRECTION
Slips out of High Gear	<ul style="list-style-type: none"> a. Transmission loose on clutch housing b. Shift rods interfere with engine mounts or clutch throw-out lever c. Shift linkage does not work freely; binds d. Damaged mainshaft pilot bearing e. Main drive gear retainer broken or loose f. Dirt between transmission case and clutch housing g. Misalignment of transmission h. Stiff shift lever seal i. Pilot bearing loose in crankshaft j. Worn or improperly adjusted linkage 	<ul style="list-style-type: none"> a. Tighten mounting bolts b. Replace or bend levers and rods to eliminate interference c. Adjust and free up shift linkage d. Replace pilot bearing e. Tighten or replace main drive gear f. Clean mating surfaces g. Refer to TRANSMISSION ALIGNMENT h. Replace seal i. See Section 6 for brg. fits j. Adjust or replace linkage as required
Noisy in All Gears	<ul style="list-style-type: none"> a. Insufficient lubricant b. Worn countergear bearings c. Worn or damaged main drive gear and countergear d. Damaged main drive gear or main shaft bearings e. Worn or damaged countergear anti-lash plate 	<ul style="list-style-type: none"> a. Fill to correct level b. Replace countergear bearings and shaft c. Replace worn or damaged gears d. Replace damaged bearings or main drive gear e. Replace countergear
Noisy in High Gear	<ul style="list-style-type: none"> a. Damaged main drive gear bearing b. Damaged mainshaft bearing c. Damaged high speed gear synchronizer 	<ul style="list-style-type: none"> a. Replace damaged bearing b. Replace damaged bearing c. Replace synchronizer
Noisy in Neutral with Engine Running	<ul style="list-style-type: none"> a. Damaged main drive gear bearing b. Damaged or loose mainshaft pilot bearing c. Worn or damaged countergear anti-lash plate d. Worn countergear bearings 	<ul style="list-style-type: none"> a. Replace damaged bearing b. Replace pilot bearings. See Section 6 for bearing fits c. Replace countergear d. Replace countergear bearings and shaft
Noisy in all Reduction Gears	<ul style="list-style-type: none"> a. Insufficient lubricant b. Worn or damaged main drive gear or countergear 	<ul style="list-style-type: none"> a. Fill to correct level b. Replace faulty or damaged gears
Noisy in Second Only	<ul style="list-style-type: none"> a. Damaged or worn second-speed constant mesh gears b. Worn or damaged countergear rear bearings c. Damaged or worn second-speed synchronizer 	<ul style="list-style-type: none"> a. Replace damaged gears b. Replace countergear bearings and shaft c. Replace synchronizer
Noisy in Third Only (Four Speed)	<ul style="list-style-type: none"> a. Damaged or worn third-speed constant mesh gears b. Worn or damaged countergear bearings 	<ul style="list-style-type: none"> a. Replace damaged gears b. Replace damaged countergear bearings and shaft

Fig. 7B-14 Manual Transmission Diagnosis Chart A

MANUAL TRANSMISSION DIAGNOSIS (CONT'D.)

CONDITION	PROBABLE CAUSE	CORRECTION
Noisy in Reverse Only	a. Worn or damaged reverse idler gear or idler bushing b. Worn or damaged reverse gear on mainshaft c. Damaged or worn reverse countergear d. Damaged Shift mechanism	a. Replace reverse idler gear assembly b. Replace reverse gear c. Replace countergear assembly d. Inspect linkage and adjust or replace damaged parts
Excessive Backlash in all Reduction Gears	a. Worn countergear bearings b. Excessive end play in countergear	a. Replace bearings b. Replace countergear thrust washers
Main Drive Gear Bearing Retainer Burned or Scored by Input Shaft	a. Loose or damaged mainshaft pilot bearing b. Misalignment of transmission	a. Replace bearing. See Section 6 for bearing fit b. Align transmission
Leaks Lubricant	a. Excessive amount of lubricant in transmission b. Loose or broken main drive gear bearing retainer c. Main drive gear bearing retainer gasket damaged d. Side cover loose or gasket damaged e. Rear bearing retainer oil seal leaks f. Countershaft loose in case g. Shift lever seals leak	a. Drain to correct level b. Tighten or replace retainer c. Replace gasket d. Tighten cover or replace gasket e. Replace seal f. Replace case g. Replace seal

Fig. 7B 15--Manual Transmission Diagnosis Chart B

COMPONENT PARTS REPLACEMENT

INDEX

TRANSMISSION REPLACEMENT

3-Speed Transmission

(Except K Series)

Removal

1. Raise vehicle on suitable hoist and drain lubricant from transmission.
2. Disconnect speedometer cable, back-up lamp and TCS switch at transmission.
3. Remove shift controls from transmission.

NOTE: On vehicle equipped with Muncie 4-Speed transmission, remove the gearshift lever using Tool J-8109 as shown in Figure 7B-17. Press down firmly and rotate tool counterclockwise to release gearshift lever.

Place clean lint-free cloth or other suitable covering over opening on transmission to prevent entry of dirt or foreign material.

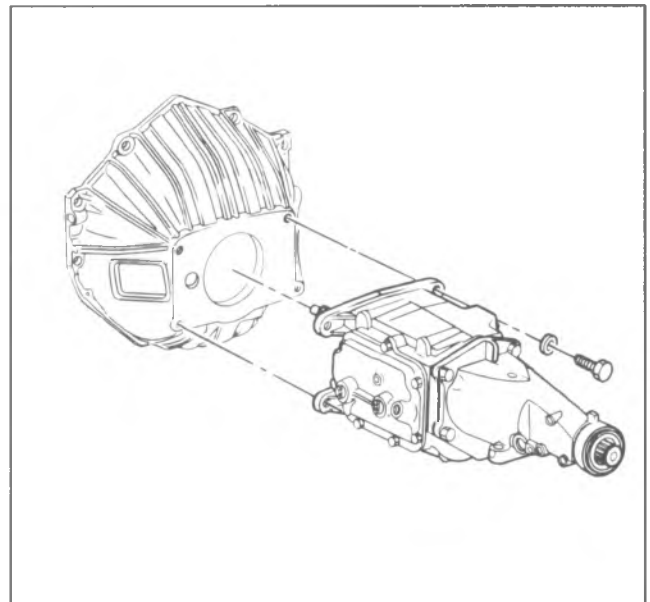


Fig. 7B-16--Typical Transmission Mounting

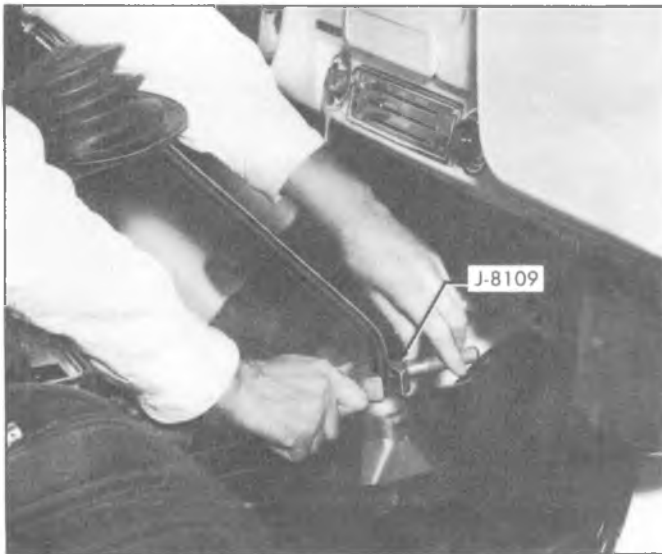


Fig. 7B 17--Removing Gearshift Lever

4. Disconnect parking brake lever and controls (when used) and back up lamp switch wire.

5. Disconnect propeller shaft from transmission as described in Section 4-A.

6. Position a suitable dolly or jack under the vehicle and adjust to carry the weight of the transmission.

7. Visually inspect to determine if other equipment, lines or brackets must be removed to permit removal of the transmission. Remove crossmember.

CAUTION: Be sure to support the clutch release bearing and support assembly during removal of the transmission main drive gear from the flywheel housing. This will prevent the release bearing from falling out of the flywheel housing when the transmission is removed.

8. Remove flywheel housing underpan and transmission-to-flywheel housing mounting bolts.

CAUTION: When removing the transmission, do not allow the weight of the transmission to hang on the clutch disc hub, as the disc may become distorted, seriously affecting clutch operation.

9. Move the transmission assembly straight away from the engine, using care to keep the transmission main drive gear shaft in alignment with the clutch disc hub. See Fig. 7B-16.

10. When the transmission is free from the engine, lower the transmission and move from under the vehicle.

11. If desired, a careful check of clutch components should be made after the transmission has been removed. If the clutch requires repair, refer to Section 7C before transmission is reinstalled in the vehicle.

3-Speed Transmission

(Except K Series)

Installation

1. Apply a light coating of high temperature

grease to the main drive gear bearing retainer and splined portion of transmission main drive gear shaft to assure free movement of clutch and transmission components during assembly.

CAUTION: Do not apply an excessive amount of grease in the above areas, as under normal operation this grease could be thrown onto clutch facings resulting in clutch problems.

2. Shift the transmission into high gear. Mount transmission on dolly or jack and move into position under the vehicle.

CAUTION: Avoid springing the clutch when the transmission is being installed to the engine. Do not force the transmission into the clutch disc hub. Do not let the transmission hang unsupported in the splined portion of the clutch disc.

3. Install flywheel housing-to-transmission mounting bolts and washers. Tighten bolts to specifications.

4. Align the transmission main drive gear shaft with the clutch disc hub by rotating the transmission companion flange or output yoke. Move the transmission forward, guiding the main drive gear shaft into the clutch disc splines.

5. Install crossmember.

6. Connect propeller shaft to transmission as described in Section 4A. Remove transmission jack.

7. Connect parking brake lever and control (if used). Adjust brakes as outlined in Section 5.

8. Install flywheel housing underpan. Tighten cap screws firmly.

9. Reconnect speedometer cable to adapter at transmission, connect back-up lamp switch wire and TCS switch.

10. Reinstall shift controls on transmission.

NOTE: On vehicle equipped with 3-speed transmission, reconnect shift levers to transmission side cover. On vehicle equipped with Muncie 4-Speed transmission, install gearshift lever using Tool J-8109 as shown in Figure 7B-17. Press down firmly and rotate clockwise to install gearshift lever. Install transmission floor pan cover and floor mat.

11. If other equipment (exhaust pipe, support brackets, etc.) was removed, reinstall these parts.

12. Refill transmission with lubricant recommended in Section 0-B of this manual.

13. If necessary, adjust clutch or transmission control linkage to achieve proper transmission operation.

3-Speed Transmission

"K" Series

Replacement

1. Raise vehicle on hoist.

2. Drain transfer case and transmission. Disconnect the speedometer cable from speedometer driven gear fitting, and TCS switch connections.

3. Disconnect propeller shafts front U-joint yoke at case, and tie up out of way.

4. Remove bolt holding the shift lever control assembly to the adapter assembly. Push assembly to one side and tie up out of way.

5. Support transfer case in a suitable cradle. Remove bolts attaching transfer case to adapter.

6. Remove bolts attaching transfer case to frame bracket at right side of case and remove case from adapter.

7. Disconnect shift control rods from the shifter levers at the transmission.

8. Support rear portion of engine. Remove two (2) adapter mount bolts.

9. Remove the 2 top transmission to clutch housing cap screws and insert 2 transmission guide pins, Tool J-1126 in these holes.

10. Remove flywheel under pan. Remove the 2 lower transmission-to-clutch housing cap screws.

11. Slide the transmission and adapter assembly straight back on guide pins until the clutch gear is free of splines in the clutch disc.

NOTE: The use of the 2 guide pins during this operation will support the transmission and prevent damage to the clutch disc through springing.

12. Remove the transmission and adapter as an assembly from under the body.

13. Remove adapter from transmission.

14. To install, reverse removal procedure.

4-Speed Transmission

K Series

Removal

1. Remove attaching screws from transfer case shift lever boot retainer and remove retainer.

2. Remove floor mat or carpeting from compartment.

3. Remove attaching screws from transmission shift lever boot retainer. Slide boot and retainer up lever and remove transmission shift lever using Tool J-8109 as shown in Figure 7B-17.

4. If necessary, remove center floor outlet from heater distributor duct. If equipped with a center console, remove console before proceeding to next step.

5. Remove transmission floor cover attaching screws and cover. Rotate cover approximately 90° to clear transfer case shift lever while lifting cover from vehicle.

6. Disconnect shift lever link assembly from transfer case shift rail connecting rod. Remove shift lever attaching bolt and shift lever control from adapter.

7. Disconnect back-up lamp wiring from switch and remove attaching clamp from top cover bolt.

8. Raise and support vehicle on hoist. Support engine with suitable floor stand. Drain transfer case and transmission assemblies.

9. Disconnect speedometer cable from transfer case. Disconnect back-up lamp switch wiring and TCS switch.

10. Disconnect prop shaft at rear of transfer case and tie up away from work area.

11. Disconnect front prop shaft from transfer case and tie up away from work area.

12. Open lock tabs and remove transmission mount-to-frame crossmember bolts. Also remove transfer case-to-frame bracket attaching bolts.

13. Support transmission and transfer case assembly with suitable floor stand.

14. Remove frame to crossmember bolts and remove crossmember from vehicle. Rotate crossmember to clear frame rails.

15. Remove flywheel housing cover. On V-8 engine models, remove exhaust crossover pipe.

16. Remove transmission to flywheel housing attaching bolts.

NOTE: Remove upper bolts first and install transmission guide pins J-1126. Use of the guide pins will prevent damage to the clutch assembly.

17. Slide transmission rearward until main drive gear clears the clutch assembly and lower assembly from vehicle.

4-Speed Transmission

K Series

Installation

1. Position transmission, with transfer case attached to the flywheel housing. Install bolts attaching transmission to flywheel housing.

2. Install flywheel housing cover and attaching bolts. On V-8 models, install exhaust crossover pipe.

3. Position frame crossmember and install retaining bolts. Install bolts retaining adapter assembly to crossmember and transfer case to frame rail bracket. Torque all bolts to specification.

4. Torque front and rear transfer case yoke lock nuts to specifications.

5. Install front and rear propshafts to transfer case output yokes.

6. Connect the speedometer cable, back-up lamp wiring and TCS switches.

7. Fill transmission and transfer case to proper level with lubricant specified in Section 0-B.

8. Install transfer case shift lever assembly and attaching bolt. Connect shift lever link to shift rail bar.

9. Install transmission floor cover and attaching bolts.

10. Install heater distributor duct center outlet.

NOTE: On models with center console, install console and retaining bolts.

11. Install floor mat, transfer case shift lever retainer and attaching screws.

12. Install transmission shift lever.

TRANSMISSION ALIGNMENT

In some instances where "excessive" gear whine or high gear hop out, particularly at 50 MPH and up, are encountered; and after all other probable causes have

been checked, an alignment check of the transmission and clutch housing may be helpful.

A special tool, on which a dial indicator is mounted, is necessary to check the transmission case rear bore alignment. This tool may be made from a new or good used clutch gear which has a good bearing surface on the crankshaft pilot end and at the front main bearing location.

The splines on the clutch gear shaft and the teeth on the clutch gear should be ground off so the shaft may be rotated in a clutch disc hub without interference when assembled in the car. Weld a piece of 1/4" rod in the mainshaft pilot bore long enough to extend out the case rear bore. Assemble a good bearing on the clutch gear shaft and secure it with the clutch gear bearing snap ring. Attach a suitable dial indicator to the rod.

1. Remove the transmission from the vehicle and completely disassemble, except for the reverse idler gear.

NOTE: In any case where the clutch gear pilot or pilot bearing is excessively loose or worn, the pilot bearing should be replaced before checking the transmission case rear bore alignment by the dial indicator method.

2. Carefully install the special tool with the dial indicator in the transmission case with the face of the indicator to the rear of the case and with the tracing finger contacting the I.D. of the case rear bore. Secure in place with a clutch gear bearing retainer.

3. Assemble the transmission case to the clutch housing and tighten the four transmission mounting bolts securely.

NOTE: Be sure to clean off any paint or other foreign material on the mating faces of the clutch housing and transmission as any foreign material on these faces will change alignment; also, check carefully for dings or burrs on these mating surfaces and remove carefully as necessary.

4. Dial indicate the transmission case rear bore and record the indicator readings in the 12, 3, 6 and 9 o'clock positions.

NOTE: It is best to start the reading at the 3, 6, 9 or 12 o'clock position closest to the point where the indicator plunger reaches its maximum outward travel. Set the dial indicator at "0" at this location and then record the 3, 6, 9 and 12 o'clock readings in rotation.

5. Install temporary slotted shims between the transmission case and the clutch housing in the quantities and at the bolt locations as necessary to bring misalignment at the transmission case rear bore to a maximum of .005" indicator reading in either the vertical or horizontal direction.

EXAMPLE: If the maximum indicator reading is at the 12 o'clock position, put shims on the two bottom bolts.

6. After the position and quantity of shims has been determined and recorded the transmission case may be removed.

NOTE: The clutch housing should then be stamped, showing the position where shims are to be installed and the thickness of shims at each location.

7. Inspect the external clutching teeth of the clutch gear and second speed gear. Inspect the second and third speed clutch internal clutching teeth. If the teeth are worn or tapered, even slightly, the gears should be replaced. Reassemble the transmission.

8. Install the transmission assembly to the clutch housing, using the correct number of shims at the proper locations as previously determined. Shims are available by unit part number with each unit consisting of the following shims:

4--.002" shims Identification--two corners cut off.

2--.005" shims Identification--one corner cut off.

1--.010" shims Identification--all corners square.

NOTE: These special shims have a tab on one end for ease of installation. Do not slot the shims for the permanent installation.

REAR OIL SEAL REPLACEMENT

1. Drain lubricant from transmission.

2. Disconnect propeller shaft from transmission as described in Section 4A.

3. On 3-speed transmissions, perform the following replacement procedures:

a. Remove slip joint yoke from rear of transmission mainshaft.

b. Pry seal out of extension housing or remove oil seal using oil seal remover (J-5859) and slide hammer (J-2619) as shown in Figure 7B-18.

c. Coat outer diameter of new oil seal with sealing cement. Install new oil seal using extension housing oil seal installer (J-5154).

d. Install slip joint yoke on rear of transmission mainshaft.

4. On Muncie 4-speed transmissions, perform the following:

a. Remove parking brake from rear of transmission as described in Section 5.

b. Disconnect speedometer cable and remove speedometer driven gear from mainshaft rear bearing cap.

c. Using flange or yoke holding tool, remove the

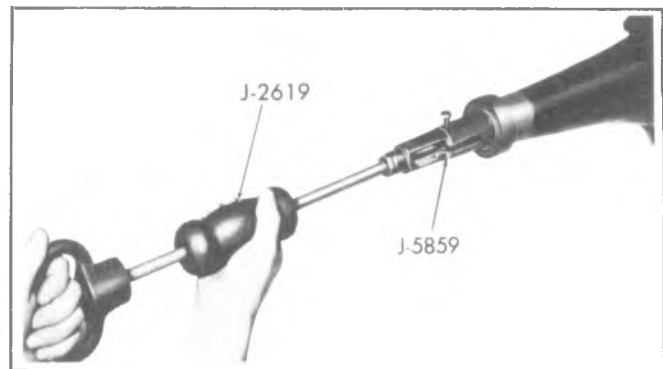


Fig. 7B-18--Removing Rear Oil Seal

output yoke or companion flange nut. Pull output yoke or companion flange nut off the mainshaft.

d. Remove mainshaft rear bearing cap and gasket. Discard gasket.

e. Remove oil seal from rear bearing cap. Discard oil seal.

f. Coat outer diameter of new oil seal with sealing cement. Install oil seal in rear bearing cup using a suitable installer. Drive seal flush with outside of rear bearing cap, being careful not to damage seal. Use Installer J-22834 with Adapter J-22834-1 as required, as shown in Fig. 7B-19.

g. Clean all gasket surfaces, then install the rear bearing cap with a new gasket on the transmission. Tighten cap screws firmly.

h. Install output yoke or companion flange or mainshaft. Using a flange or yoke holding tool install retaining nut. Torque the retaining nut to specification.

i. Install speedometer driven gear, then connect speedometer cable.

5. Reconnect propeller shaft to transmission as described in Section 4A.

6. Refill transmission with lubricant recommended in Section 0-B.

SPEEDOMETER DRIVEN GEAR REPLACEMENT

Disconnect speedometer cable, remove lock plate to housing bolt and lock washer and remove lock plate. Insert screw driver in lock plate slot in fitting and pry fitting, gear and shaft from housing. Pry "O" ring from groove in fitting.

Install new "O" ring in groove in fitting, coat "O" ring and driven gear shaft with transmission lubricant and insert shaft.

Hold the assembly so slot in fitting is toward lock plate boss on housing and install in housing. Push fitting

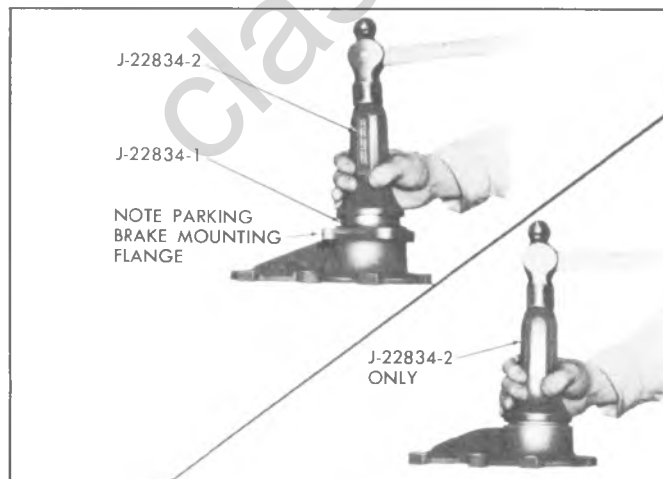


Fig. 7B-19--Replacing Rear Bearing Retainer Oil Seal

into housing until lock plate can be inserted in groove and attached to housing.

TRANSMISSION SIDE COVER

Replacement/Repair (Fig. 7B-20)

1. Disconnect control rods from levers, back-up lamp wiring and TCS switch.

2. Shift transmission into neutral detent positions before removing cover. Remove cover assembly from transmission case carefully and allow oil to drain.

3. Remove the outer shifter levers.

4. Remove both shift forks from shifter shaft assemblies. Remove both shifter shaft assemblies from cover. Seals around shifter shaft may now be pried out if replacement is required because of damage.

5. Remove detent cam spring and pivot retainer "C" ring. Remove both detent cams.

6. With detent spring tang projecting up over the 2nd and 3rd shifter shaft cover opening, install the first and reverse detent cam onto the detent cam pivot pin. With the detent spring tang projecting up over the first and reverse shifter shaft cover hole install the 2nd and 3rd detent cam.

7. Install detent cam retaining "C" ring to pivot shaft, and hook spring into detent cam notches.

8. Install both shifter shaft assemblies in cover being careful not to damage seals. Install both shift forks to shifter shaft assemblies, lifting up on detent cam to allow forks to fully seat into position.

9. Install outer shifter levers, flat washers, lock washers and bolts.

10. Shift shifter levers into neutral detent (center) position and slide cover into place making sure the shift forks are aligned with their respective mainshaft clutch sliding sleeves.

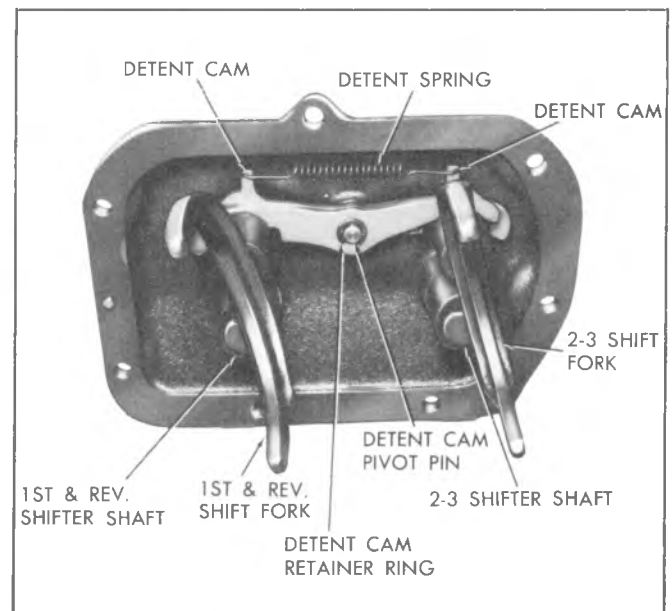


Fig. 7B-20--Transmission Side Cover Assembly

11. Install cover attaching bolts and tighten evenly to specified torque. Install TCS switch and connect wiring.

12. Remove filler plug and add lubricant specified in Section 0-B to level of filler plug hole.

TRANSMISSION FLOOR SHIFT CONTROL LEVER REPLACEMENT

1. On K-Series models remove transfer case shift lever boot retainer attaching screws and retainer from compartment floor.

2. Remove floor covering from vehicle.

3. Remove transmission shift lever boot retainer attaching screws.

4. Slide boot and retainer up on shift lever and remove the transmission shift lever using Tool J-8109 as shown in Figure 7B-17.

5. To install, reverse removal procedure Steps 1-4.

TRANSFER CASE REPLACEMENT

Removal (Fig. 7B-21)

1. Raise and support vehicle on hoist. Drain transfer case.

2. Disconnect speedometer cable, back-up lamp and TCS switch.

3. Remove skid plate and crossmember supports as necessary.

4. Disconnect rear prop shaft from transfer case and tie up away from work area.

5. Disconnect front prop shaft from transfer case and tie up shaft away from work area.

6. Disconnect shift lever rod from shift rail link. On full time 4 wheel drive models, disconnect shift levers at transfer case.

7. Support transfer case and remove bolts attaching transfer case to transmission adapter.

8. Move transfer case to rear until input shaft clears adapter and lower assembly from vehicle.

Installation

1. Support transfer case in suitable stand and position case to transmission adapter. Install bolts attaching case to adapter and torque to 45 ft. lbs.

2. Remove stand as required and install bolts attaching transfer case to frame rail. Bend lock tabs after assembly.

3. Install connecting rod to shift rail link or connect shift levers to transfer case, as applicable.

4. Connect front prop shaft to transfer case front output shaft.

5. Connect rear prop shaft to transfer case rear output shaft.

6. Install crossmember support and skid plate, if removed.

7. Connect speedometer cable, back-up lamp and TCS switch.

8. Fill transfer case to proper level with lubricant specified in section 0-B.

9. Lower and remove vehicle from hoist.

CAUTION: Check and tighten all bolts to specified torques.

NOTE: Before connecting prop shafts to companion flanges be sure locknuts are torqued to specifications.

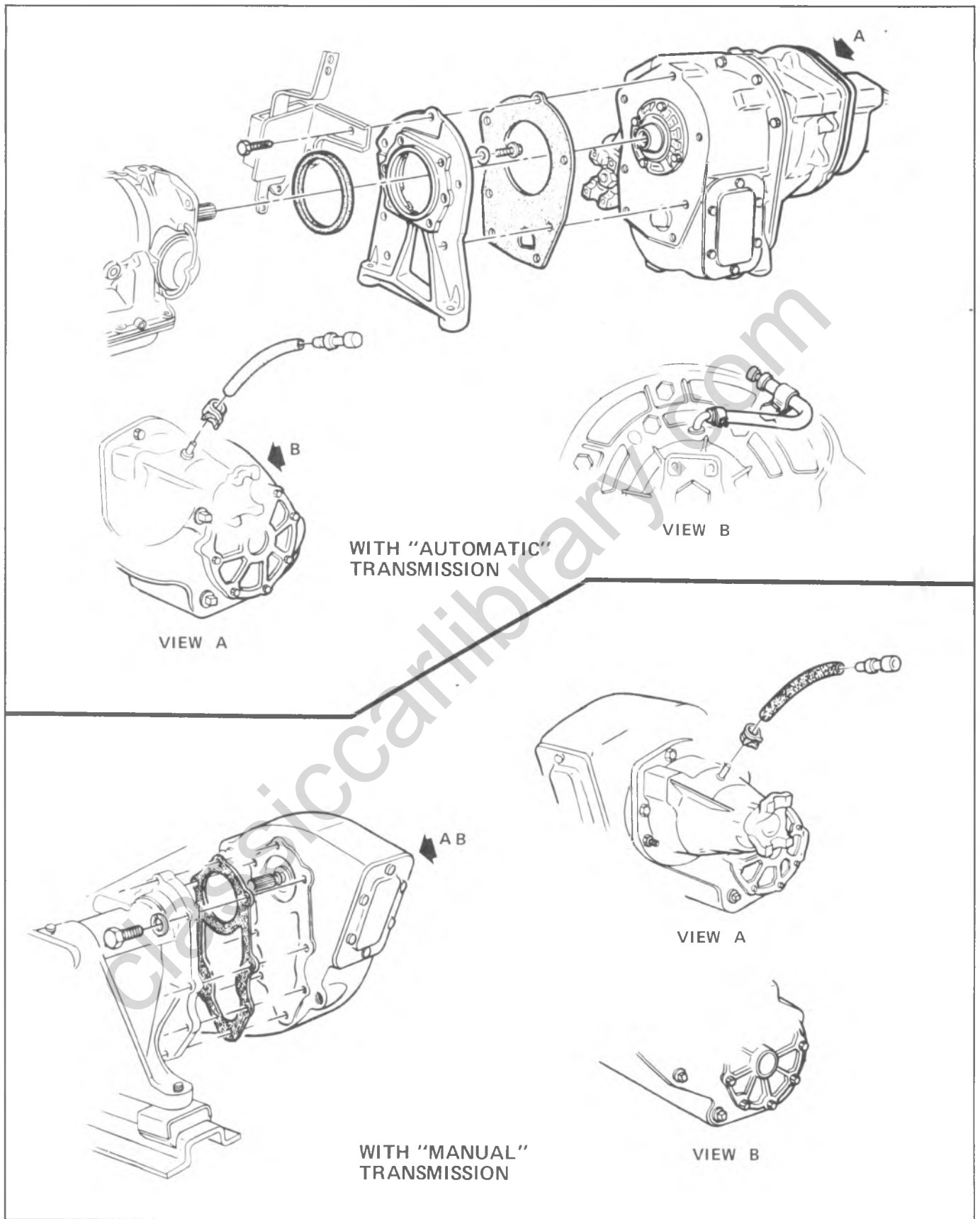
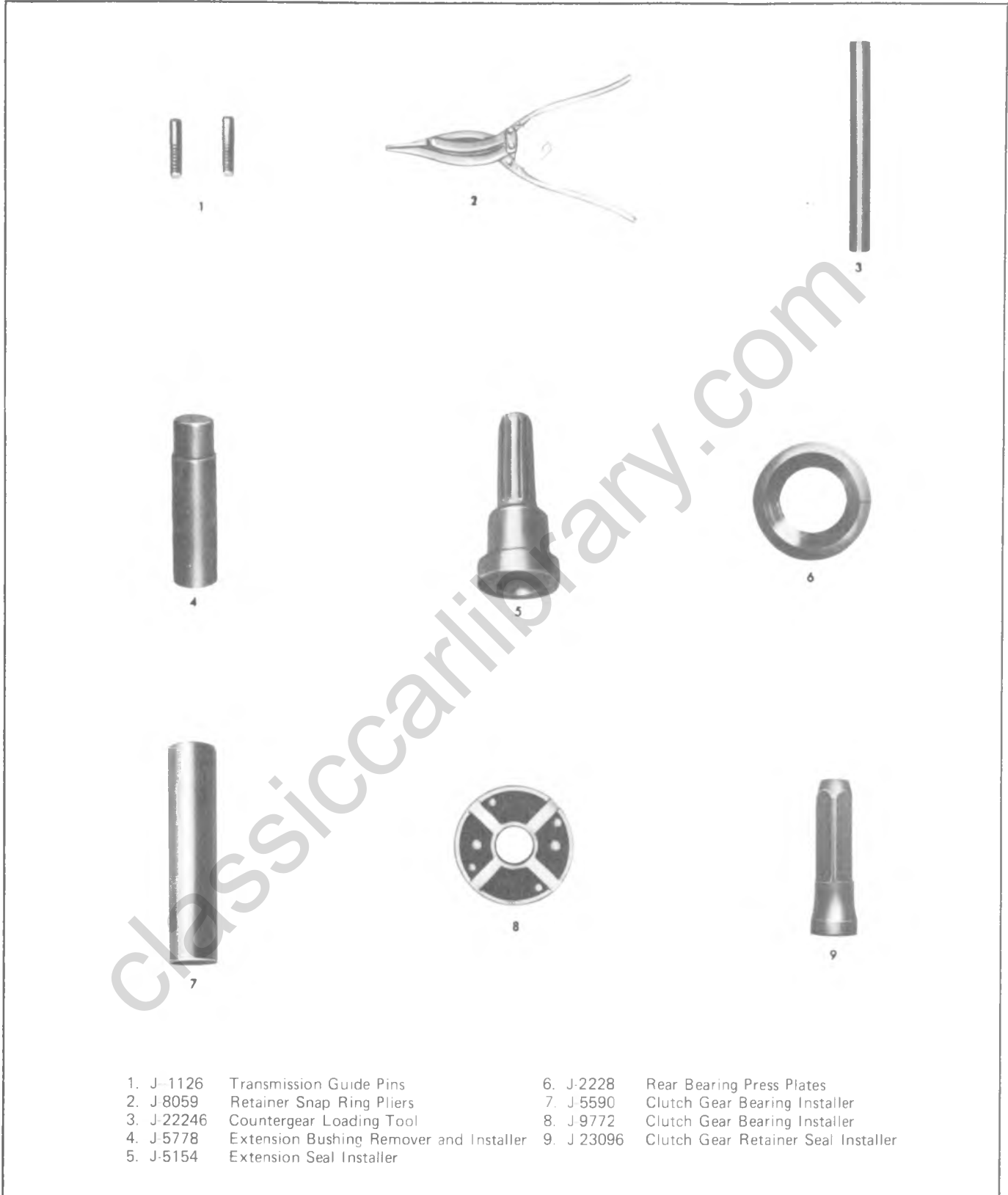


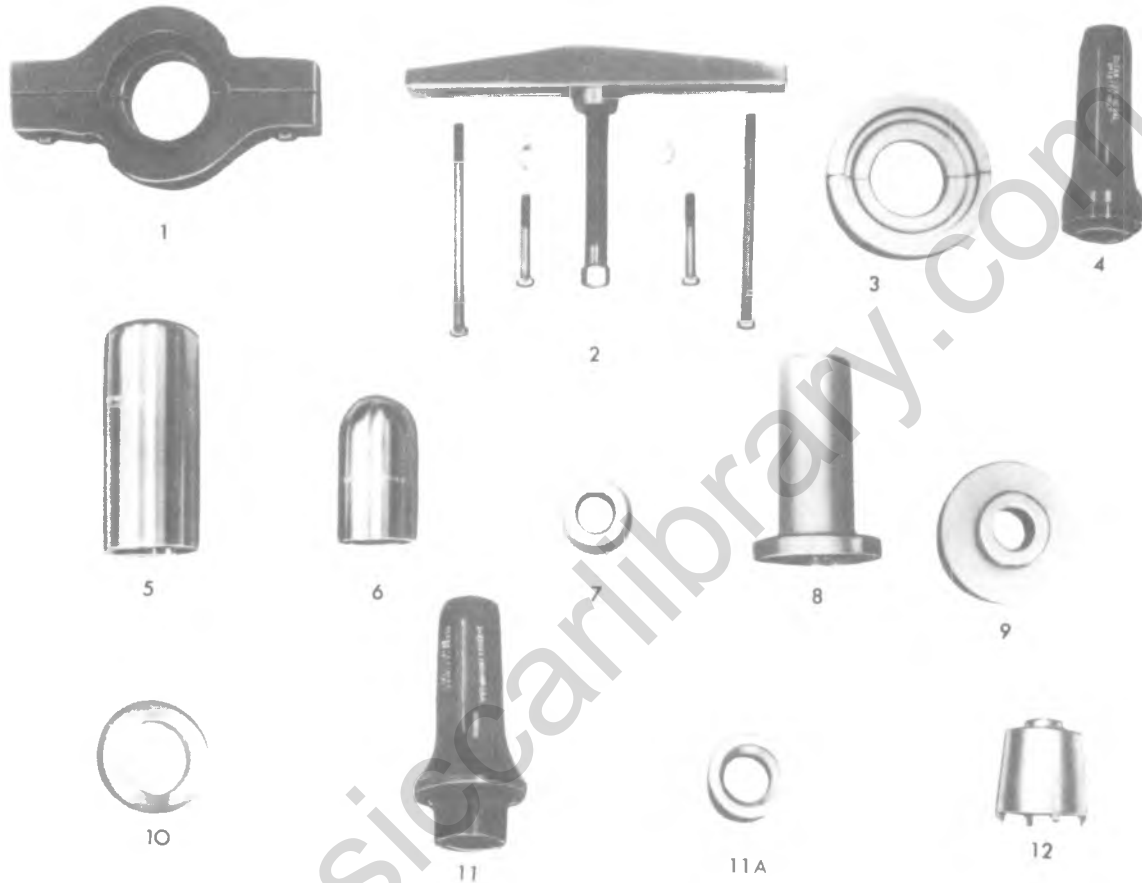
Fig. 7B-21--Transfer Case Mounting

SPECIAL TOOLS



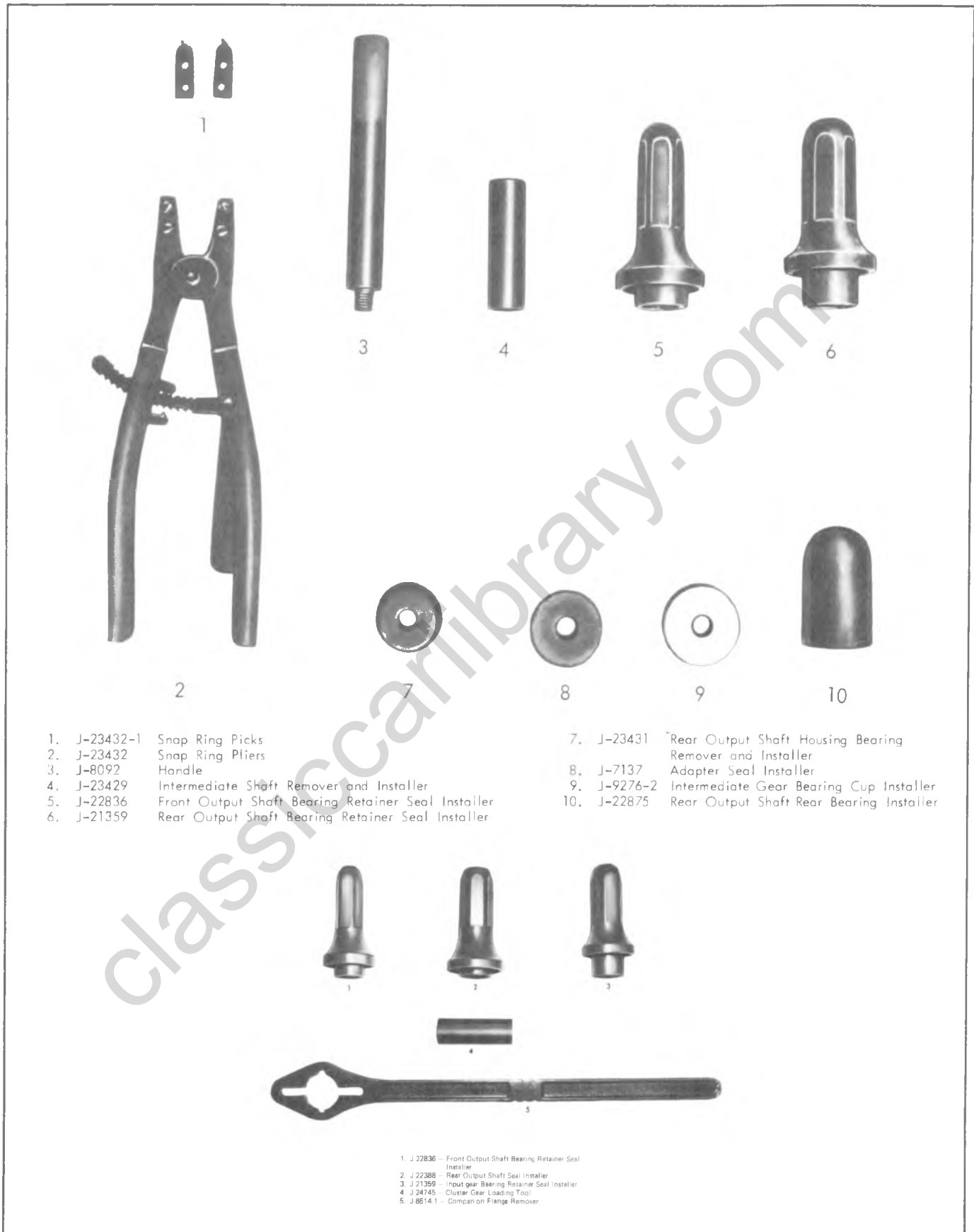
- | | | | |
|------------|---|------------|-------------------------------------|
| 1. J-1126 | Transmission Guide Pins | 6. J-2228 | Rear Bearing Press Plates |
| 2. J-8059 | Retainer Snap Ring Pliers | 7. J-5590 | Clutch Gear Bearing Installer |
| 3. J-22246 | Countergear Loading Tool | 8. J-9772 | Clutch Gear Bearing Installer |
| 4. J-5778 | Extension Bushing Remover and Installer | 9. J-23096 | Clutch Gear Retainer Seal Installer |
| 5. J-5154 | Extension Seal Installer | | |

Fig. 7B 1ST-3-Speed Special Tools



- | | | | | | |
|---|----------|---|-----|-----------|---|
| 1 | J-22832 | Countergear Rear Bearing Remover | 8 | J 22874 1 | Bearing Installer |
| 2 | J-8433-1 | Bearing Puller | 9 | J 22874 5 | Mainshaft Support Tool |
| 3 | J-22872 | Clutch Gear Bearing Remover and Installer | 10 | J 22874 2 | Countershaft Support Tool |
| 4 | J-22833 | Front Bearing Retainer Seal Installer | 11 | J 22834 2 | Rear Bearing Retainer Seal Installer |
| 5 | J-22873 | 2nd Speed Bushing Installer | 11a | J 22834 1 | Adapter |
| 6 | J-22875 | 3rd Speed Bushing Installer | 12 | J 23070 | Mainshaft Rear Bearing Lock Nut Installer |
| 7 | J-22830 | Snap Ring Installer | | | |

Fig. 7B-2ST--4-Speed Special Tools



- 1. J-23432-1 Snap Ring Picks
- 2. J-23432 Snap Ring Pliers
- 3. J-8092 Handle
- 4. J-23429 Intermediate Shaft Remove and Installer
- 5. J-22836 Front Output Shaft Bearing Retainer Seal Installer
- 6. J-21359 Rear Output Shaft Bearing Retainer Seal Installer

- 7. J-23431 Rear Output Shaft Housing Bearing Remove and Installer
- 8. J-7137 Adapter Seal Installer
- 9. J-9276-2 Intermediate Gear Bearing Cup Installer
- 10. J-22875 Rear Output Shaft Rear Bearing Installer

- 1. J 22836 - Front Output Shaft Bearing Retainer Seal Installer
- 2. J 22388 - Rear Output Shaft Seal Installer
- 3. J 21359 - Input gear Bearing Retainer Seal Installer
- 4. J 24745 - Cluster Gear Loading Tool
- 5. J 8614.1 - Companion Flange Remover

Fig. 7B-3ST--Transfer Case Special Tools

classicalibrary.com

SECTION 7C

CLUTCH

INDEX

General Description.....	7C-1	Component Parts Replacement.....	7C-12
Clutch Systems.....	7C-1	Preliminary Inspection.....	7C-12
Diaphragm Type.....	7C-1	Clutch Disc and Pressure Plate.....	7C-12
Coil Spring Type.....	7C-2	Diaphragm Type.....	7C-12
Clutch Controls.....	7C-4	Coil Spring Type.....	7C-13
Maintenance and Adjustments.....	7C-9	Pedal.....	7C-13
Inspection.....	7C-9	Cross-Shaft.....	7C-14
Free Pedal Adjustment.....	7C-9	Special Tools.....	7C-16
Diagnosis.....	7C-11		

GENERAL DESCRIPTION

CLUTCH SYSTEMS

DIAPHRAGM SPRING CLUTCH

Principal Components

The principal parts of a diaphragm-type clutch system are: the driving members, attached to the engine and turning with it; the driven members attached to the transmission and turning with it; the operating members which include the spring or springs and the linkage required to apply and release the pressure which holds the driving and driven members in contact with each other. Figure 7C-1 shows a clutch cutaway so operating members can be seen.

Driving Members

The driving members of a clutch usually consist of two nodular iron plates or flat surfaces machined to a smooth finish. Nodular iron is desirable because it contains enough graphite to provide some lubrication when the driving member is slipping during engagement. One of these surfaces is usually the rear face of the engine flywheel, and the other is a comparatively heavy flat ring with one side machined. This part is known as the pressure plate. It is fitted into a steel cover, which also contains some of the operating members, and is bolted to the flywheel.

Driven Members

The driven member is the clutch disc with a splined hub which is free to slide lengthwise along the splines of the clutch shaft, but which drives the shaft through these same splines. Grooves on both sides of the clutch disc lining prevent sticking of the plate to the flywheel and pressure plate. Suitable frictional facings are attached to each side of the clutch disc by means of brass rivets. These facings must be heat resistant since friction

produces heat. The most commonly used facings are made of cotton and asbestos fibers woven or molded together and impregnated with resin or similar binding agents. Very often, copper wires are woven, or pressed into material to give it additional strength.

In order to make clutch engagement as smooth as possible and eliminate chatter, the steel segments attached to the splined hub are slightly waved, which causes the contact pressure on the facings to rise gradually as the waved springs flatten out.

The clutch disc is provided with a flexible center to absorb the torsional vibration of the crankshaft which would be transmitted to the power train unless it were eliminated. The flexible center takes the form of steel compression springs placed between the hub and the steel plate. The springs permit the disc to rotate slightly with relation to its hub until the springs are compressed and relative motion stops. Then the disc can rotate slightly backward as the springs decompress. This slight backward and forward rotation permitted by the springs allows the clutch shaft to rotate at a more uniform rate than the crankshaft, thereby eliminating some of the torsional vibration from the crankshaft and preventing the vibration from being carried back through the transmission.

Operating Members

The driving and driven members are held in contact by spring pressure. This pressure may be exerted by a one-piece conical or diaphragm spring. In the diaphragm design clutch, the throwout bearing moves forward against the spring fingers forcing the diaphragm spring to pivot around the pivot ring, dishing the fingers toward the flywheel. The outer circumference of the spring now lifts the pressure plate away from the driven disc, through a series of retracting springs placed around the outer circumference of the pressure plate.

NOTE: Two variations of the diaphragm spring design are the flat finger type and the bent finger

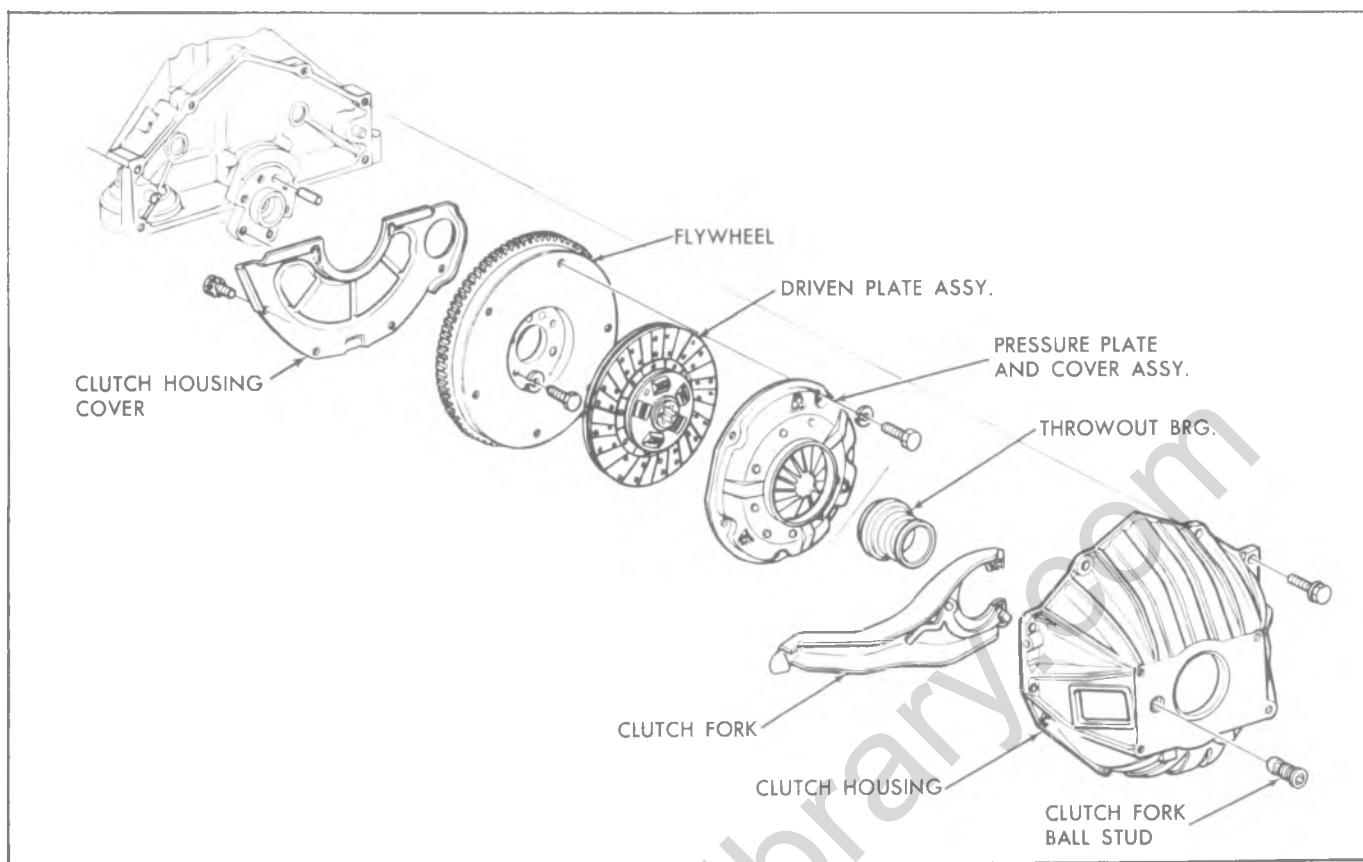


Fig. 7C-1-Clutch System Components

type (Fig. 7C-2). The integral release fingers in the bent finger design are bent back to gain a centrifugal boost to aid quick re-engagement at high engine speeds.

The throw-out (clutch release) bearing is a ball-thrust bearing contained in the clutch housing, mounted on a sleeve attached to the front of the transmission case. The throw-out bearing is moved by the clutch fork to contact the release levers and move the pressure plate to the rear, thus separating the clutch driving members from the driven member when the clutch pedal is depressed by the driver. A return spring preloads clutch linkage, removing looseness due to wear, keeping the bearing clear of the spring fingers. The clutch free pedal travel, therefore, will increase with linkage wear and decrease with driven disc wear. The free travel felt at the clutch pedal is throwout bearing lash.

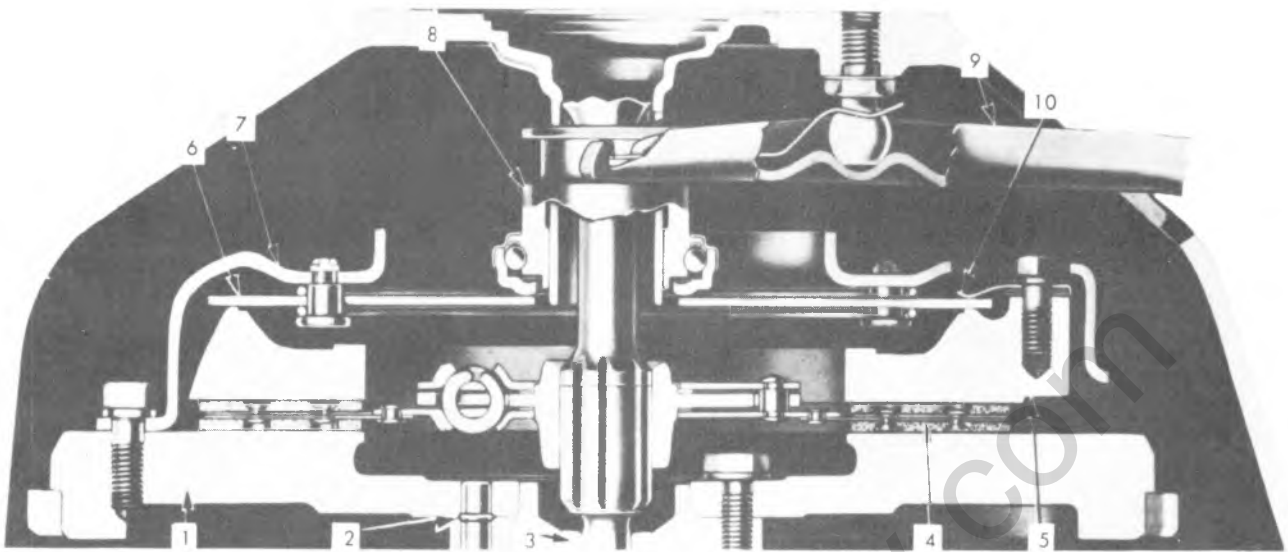
NOTE: The clutch release bearing used with the bent finger design is of shorter length than the release bearing used with the flat finger design clutch. Do not interchange the two bearings. The longer bearing, if used with the bent finger spring clutch, will cause inability to obtain proper free pedal travel resulting in slippage and rapid wear.

Clutch Spring Operation

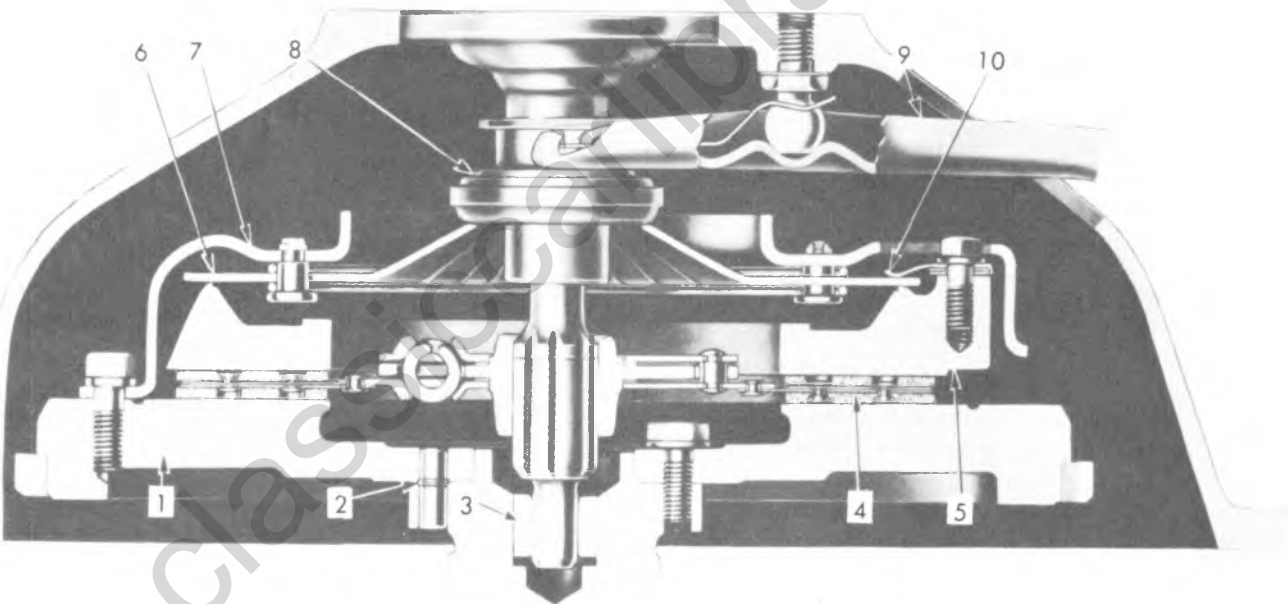
In diaphragm spring type clutches, a diaphragm spring is used instead of coil springs. It is a conical piece of spring steel punched to give it greater flexibility. The diaphragm is positioned between the cover and the pressure plate so that the diaphragm spring is nearly flat when the clutch is in the engaged position. The action of this type of spring is similar to that of the bottom of an ordinary oil can. The pressure of the outer rim of the spring on the pressure plate decreases as the flat position is passed. The outer rim of the diaphragm is secured to the pressure plate and is pivoted on rings approximately 1 inch in from the outer edge so that the application of the pressure at the inner section will cause the outer rim to move away from the flywheel and draw the pressure plate away from the clutch disc, releasing or disengaging the clutch. When the pressure is released from the inner section, the oil-can action of the diaphragm causes the inner section to move out, and the movement of the outer rim forces the pressure plate against the clutch disc, thus engaging the clutch.

COIL SPRING CLUTCH

The coil spring single plate clutch (Fig. 7C-4) is a dry disc type and no adjustment for wear is provided in the clutch itself. An individual adjustment is provided for locating each lever in manufacturing but the adjusting nut is locked in place and should never be



FLAT FINGER



BENT FINGER

- | | | | | |
|---------------|------------------|---------------------|---------------------|-----------------------|
| 1. Flywheel | 3. Pilot Bushing | 5. Pressure Plate | 7. Cover | 9. Fork |
| 2. Dowel-hole | 4. Driven Disc | 6. Diaphragm Spring | 8. Throwout Bearing | 10. Retracting Spring |

Fig. 7C-2--Cross-Section View of Diaphragm-Type

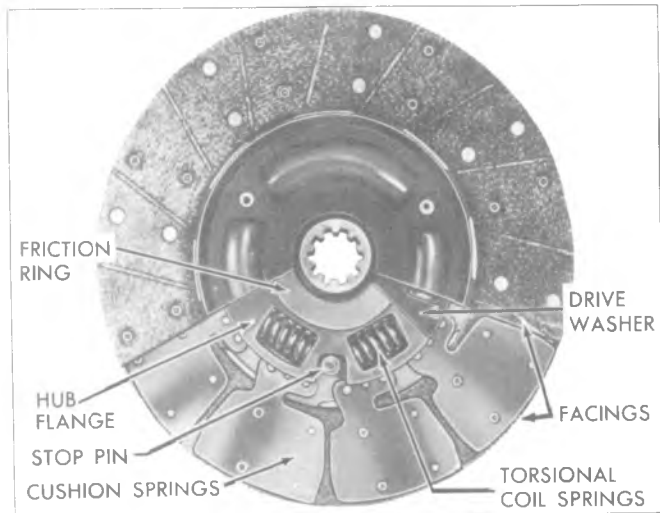


Fig. 7C-3-Clutch Disc

disturbed, unless the clutch assembly is dismantled for replacement of parts.

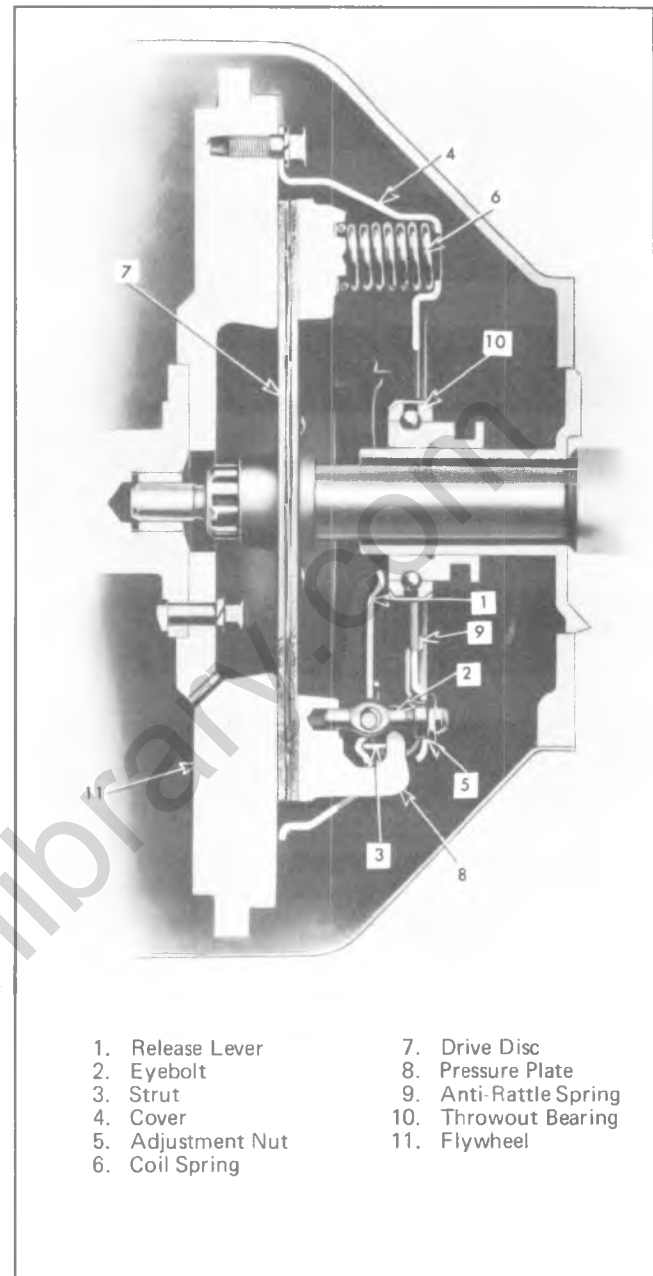
When the clutch pedal is depressed the throw-out bearing is moved toward the flywheel and contacts the inner ends of the release levers, (item 1 in Fig. 7C-5). Each release lever is pivoted on a floating pin which remains stationary in the lever and rolls across a short flat portion of the enlarged hole in the eyebolt (item 2). The outer end of each release lever engages the pressure plate lug by means of a strut (3), which provides knife-edge contact between the outer end of the lever and the lug. The outer ends of the eyebolts extend through holes in the stamped cover (4), and are fitted with adjusting nuts (5) to correctly position the levers.

When the clutch system is fully engaged, the clutch disc is firmly clamped between the flywheel and the pressure plate by the pressure of the springs. When the driver disengages the clutch by depressing the pedal, the release fork is moved on its pivot, and the pressure is applied to the throw-out bearing. The rotating race of the throw-out bearing presses against the clutch release levers and moves them on their pivot pins. The outer ends of the release levers, being fastened to the cover, move the pressure plate to the rear, compressing the clutch springs and allowing driving members to rotate independently of the driven member. The release fork moves only on its pivot, which contacts the clutch fork ball stud. All parts of the clutch system, except the throw-out bearing and collar, rotate with the flywheel when the clutch is engaged.

When the clutch is disengaged, the release bearing rotates with the flywheel, but the driven plate and the clutch shaft rotate as dictated by the transmission gear range and vehicle speed.

CLUTCH CONTROLS

The clutch operating controls for C-K trucks (Fig. 7C-6) are a mechanical type consisting of a pendant type pedal, return spring, pedal push rod, cross-shaft, fork



- | | |
|-------------------|-----------------------|
| 1. Release Lever | 7. Drive Disc |
| 2. Eyebolt | 8. Pressure Plate |
| 3. Strut | 9. Anti-Rattle Spring |
| 4. Cover | 10. Throwout Bearing |
| 5. Adjustment Nut | 11. Flywheel |
| 6. Coil Spring | |

Fig. 7C-4-Cross-Section View of Coil Spring Type

push rod, routed vertically, inside the cab, from the pedal lever down through two boots on the toe pan, to the cross-shaft lever. When the clutch pedal is depressed, the pedal push rod moves rotating the cross-shaft, pushing the fork push rod rearward, and pivoting the clutch fork to move the throwout bearing against the clutch release fingers and releasing the clutch.

The clutch operating controls for "G" and "P" models are a mechanical type similar to the C-K models. On "G" models (Fig. 7C-7) a pedal pull rod is routed vertically from the clutch pedal lever down through the toe-panel to the cross shaft. When the pedal is depressed, the pedal pull rod moves, rotating the cross shaft, pushing the clutch fork rod rearward and pivoting the

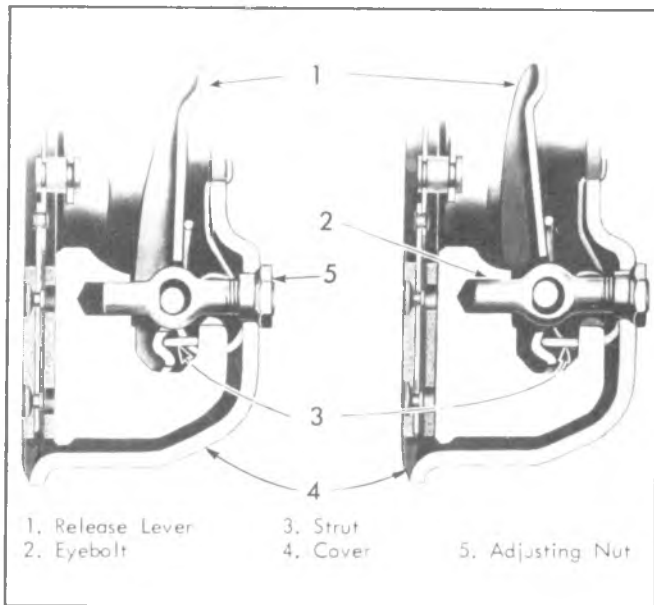


Fig. 7C-5--Release Lever, Coil Spring Type

clutch fork. This action moves the throwout bearing against the clutch release fingers, releasing the clutch.

"P" model controls (Fig. 7C-8) have an upper pull rod connected from the clutch pedal shaft to a bell crank and a lower pull rod from the bell crank to the cross shaft. When the pedal is depressed, the pull rods are moved rotating the cross shaft and pushing the clutch fork rearward, thus subsequently activating the clutch release mechanism.

classiccarlibrary.com

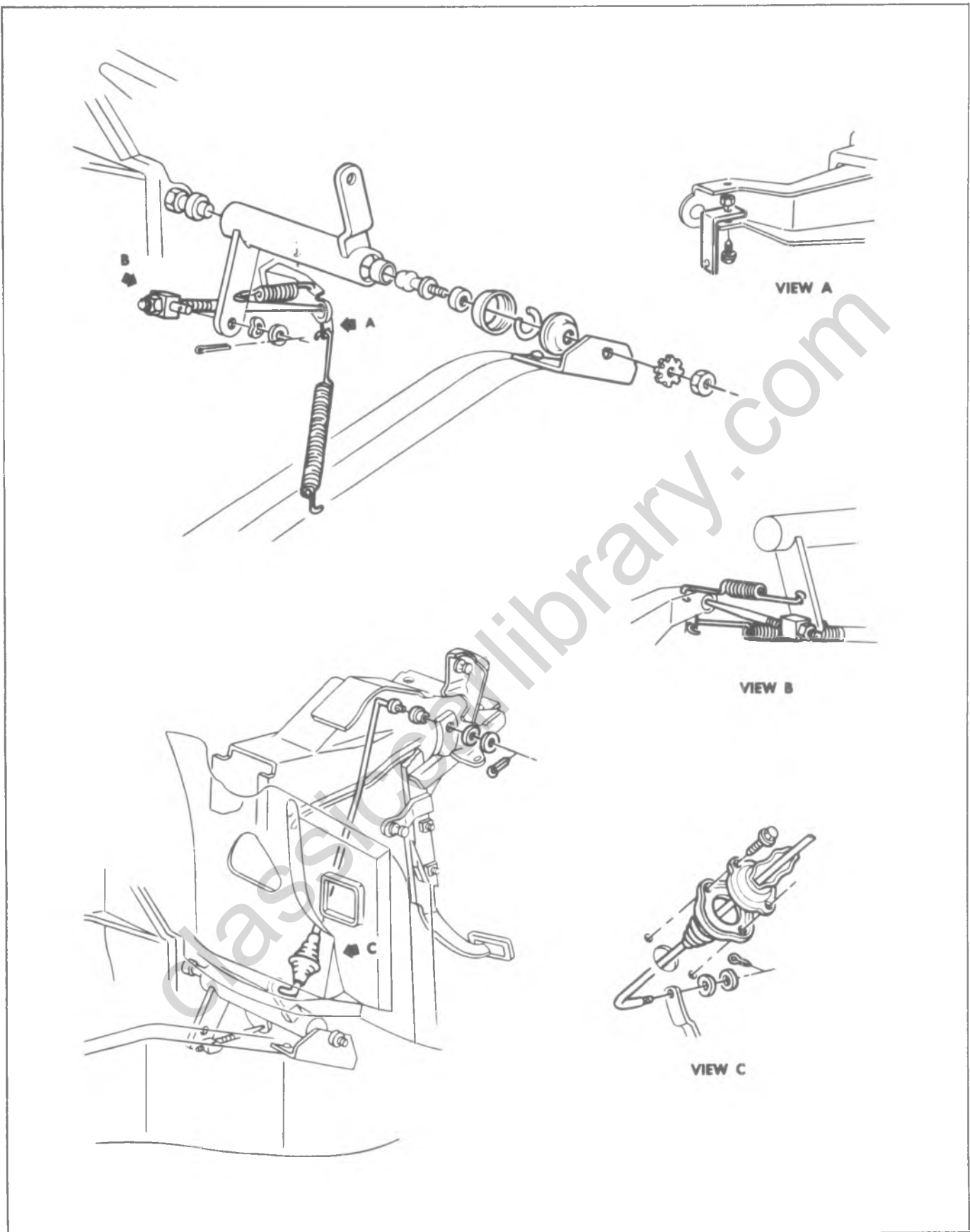


Fig. 7C-6-C-K Clutch Controls

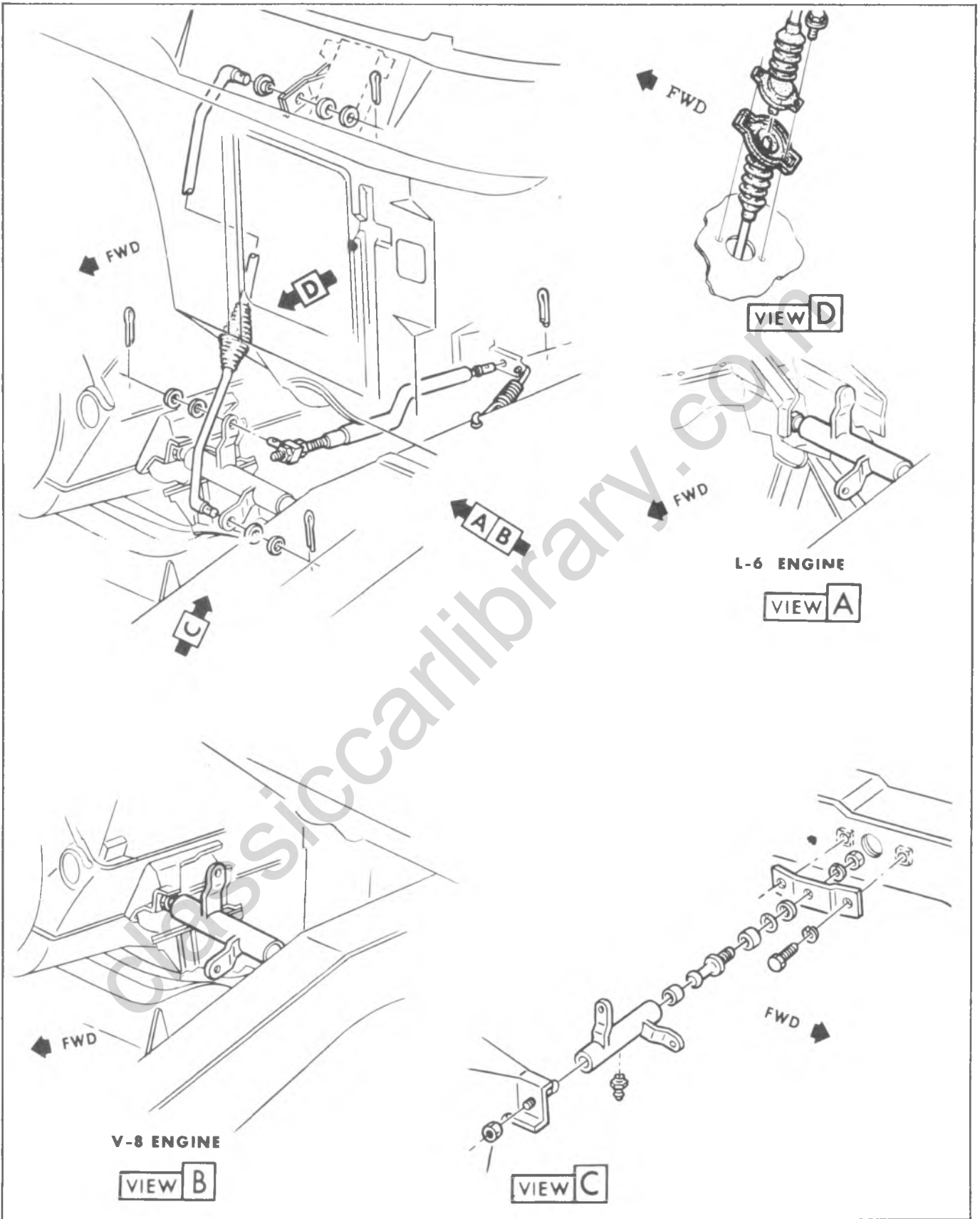


Fig. 7C-7-G-Truck Clutch Controls

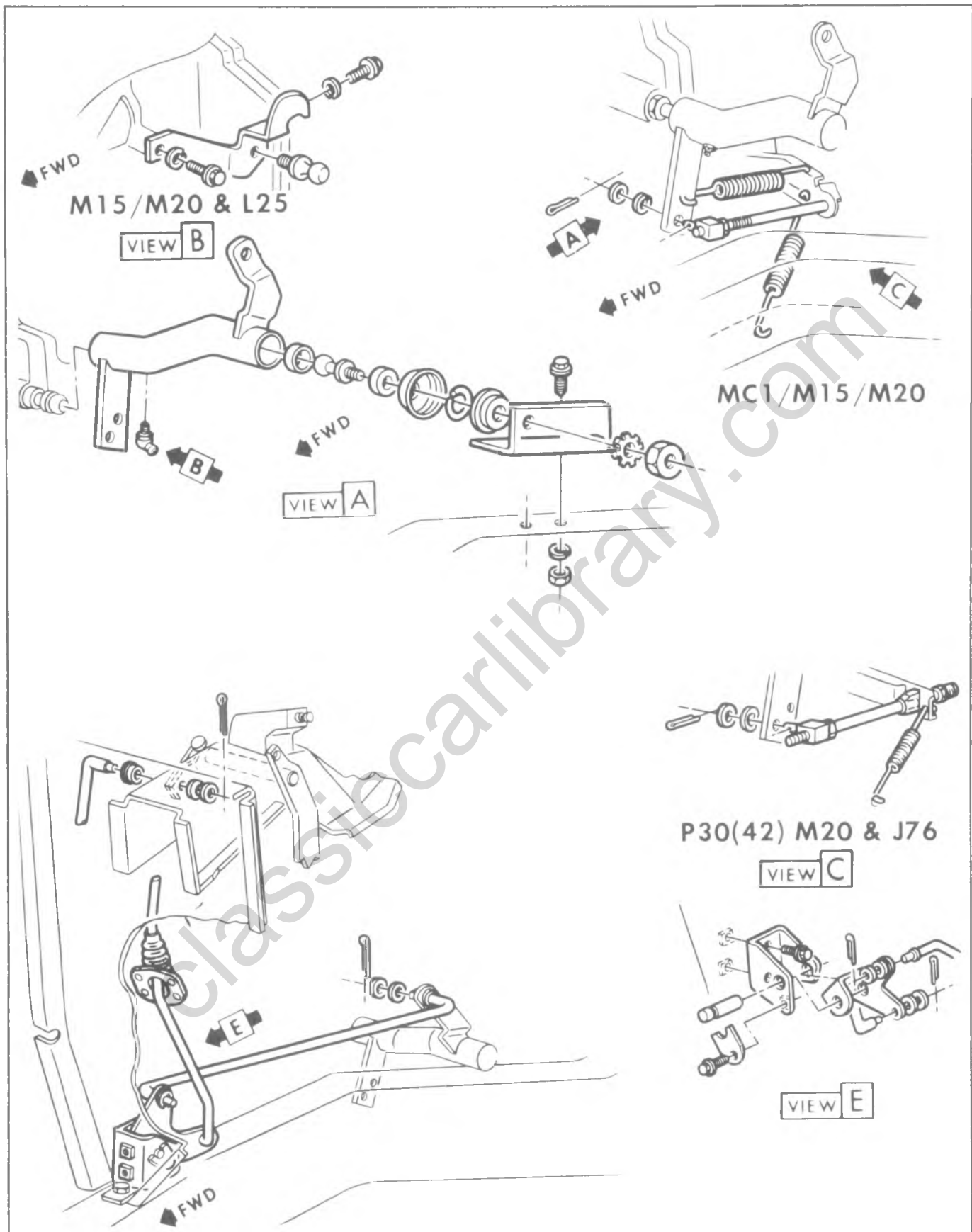


Fig. 7C-8--P-Truck Clutch Controls

MAINTENANCE AND ADJUSTMENTS

CLUTCH LINKAGE INSPECTION

There are several things which affect good clutch operations. Therefore, it is necessary, before performing any major clutch operations, to make preliminary inspections to determine whether trouble is actually in the clutch.

Check the clutch linkage to be sure the clutch releases fully as follows:

1. With engine running, hold the clutch pedal approximately 1/2" from floor mat and move shift lever between first and reverse several times. If this can be done smoothly, the clutch is fully releasing. If shift is not smooth, clutch is not fully releasing and adjustment is necessary.

2. Check clutch pedal bushings for sticking or excessive wear.

3. Check fork for proper installation on ball stud. Lack of lubrication on fork can cause fork to be pulled off the ball.

4. Check for bent, cracked or damaged cross shaft levers or support bracket.

5. Loose or damaged engine mounts may allow the engine to shift its position causing a bind on clutch linkage at the cross shaft. Check to be sure there is some clearance between cross shaft, both mount brackets, and ball studs.

6. Check throw out bearing end clearance between spring fingers and front bearing retainer on the transmission. If no clearance exists, fork may be improperly installed on ball stud or clutch disc may be worn out.

CLUTCH FREE PEDAL TRAVEL ADJUSTMENT

Only one adjustment is necessary to compensate for all normal clutch wear. The clutch pedal should have free travel (measured at clutch pedal pad) before the throwout bearing engages the clutch diaphragm spring or levers. Lash is required to prevent clutch slippage which would occur if the bearing was held against the fingers or to prevent the bearing from running continually. A clutch that has been slipping prior to free play adjustment may still slip right after the new adjustment due to previous heat damage.

C, K and P Models (Except P30 W/J76)

1. Disconnect return spring at clutch fork.
2. Rotate clutch lever and shaft assembly until clutch pedal is firmly against rubber bumper on brake pedal bracket.
3. Push outer end of clutch fork rearward until throwout bearing lightly contacts pressure plate fingers or levers.
4. Loosen lock nut and adjust rod length so that

swivel slips freely into gauge hole. Increase pushrod length until all lash is removed from system.

5. Remove swivel from gauge hole and insert into lower hole on lever. Install two washers and cotter pin. Tighten lock nut being careful not to change rod length.

6. Reinstall return spring and check pedal free travel. Pedal travel should be 1 3/8" to 1 5/8" on "C-K" models and 1 1/4" to 1 1/2" on "P" models.

P-30 Models W/J76 (Fig. 7C-10)

1. Disconnect clutch fork return spring.
2. Loosen nut "G" at swivel.
3. Move the clutch fork rod against fork to eliminate all clearance between throwout bearing and clutch fingers.
4. Rotate shaft lever until clutch pedal contacts the bumper mounted on the brake pedal bracket.
5. Rotate the fork rod until a clearance of approximately 1/4" to 5/16" (.29) is obtained between the shoulder on the fork rod and the adjustment nut.
6. Tighten nut "G" against swivel and install clutch return spring.
7. Check free pedal clearance at pedal. Pedal clearance should be 1 3/8" to 1 5/8". Readjust as required.

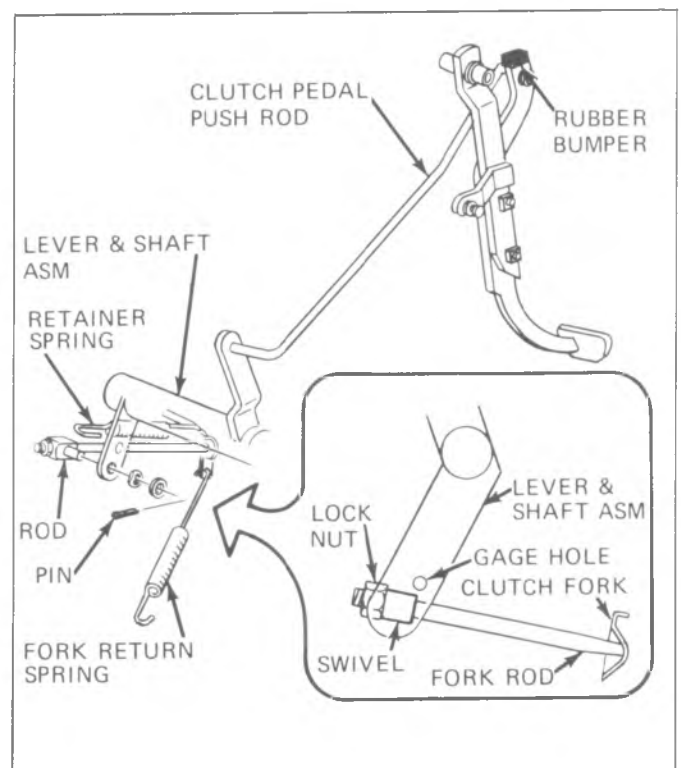


Fig. 7C-9--CK-Free Pedal Travel

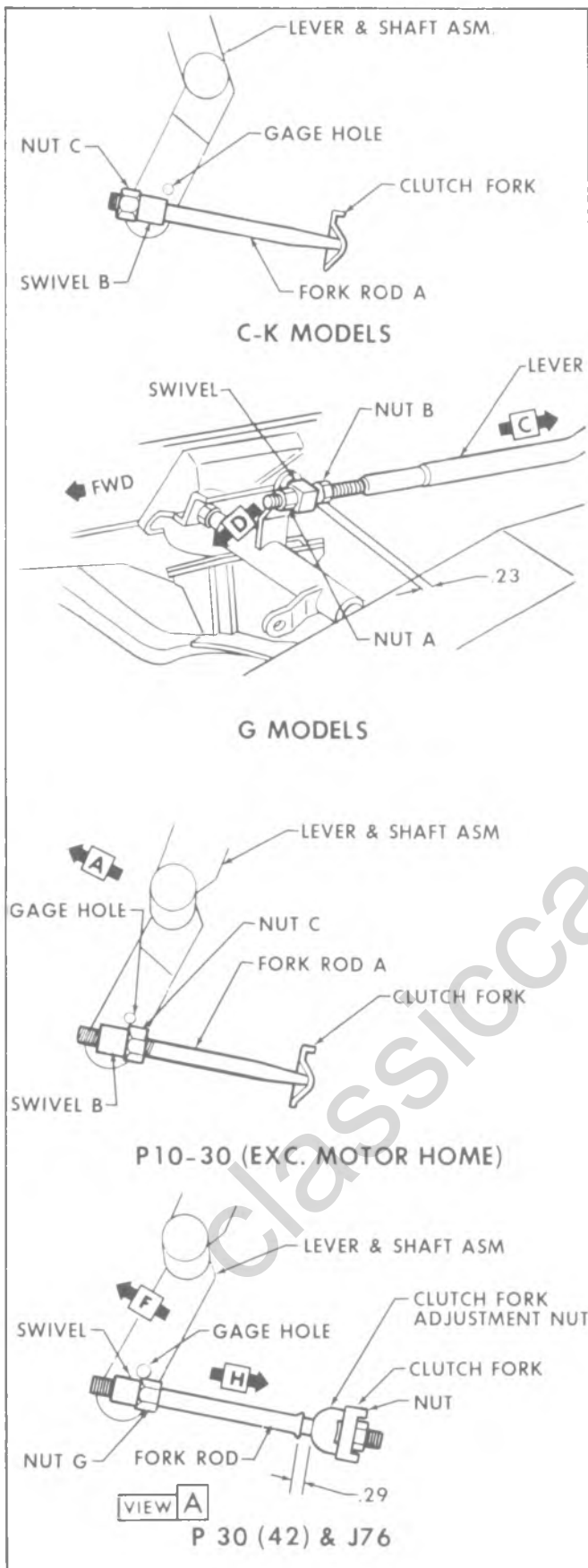


Fig. 7C-10-P-Truck Free Pedal Travel

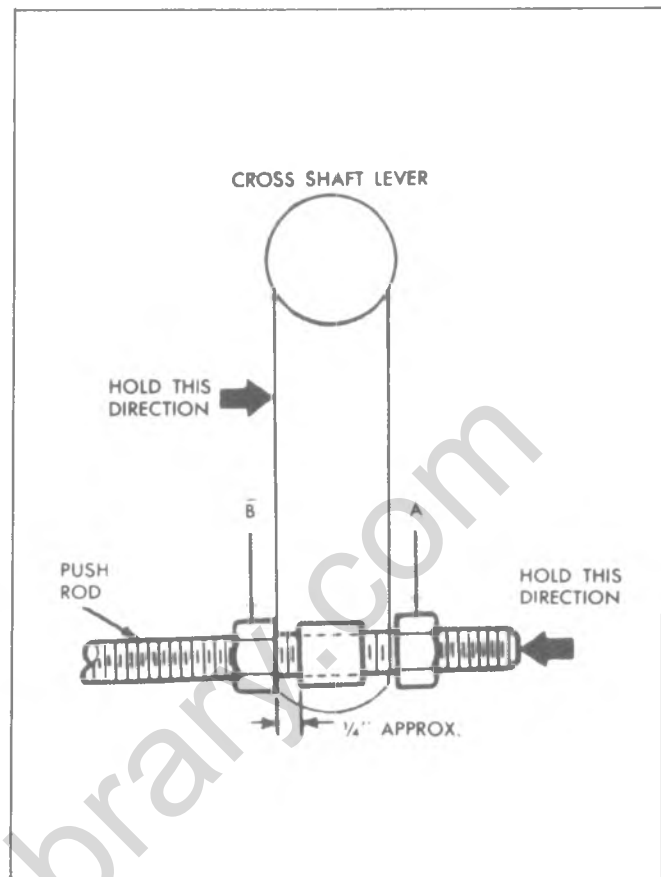


Fig. 7C-11-G-Truck Free Pedal Truck

G-Models (Fig. 7C-11)

1. Disconnect clutch fork return spring at fork.
2. Loosen nut "A" and back off from swivel approximately 1/2 inch.
3. Hold clutch fork push rod against fork to move throwout bearing against clutch fingers (push rod will slide through swivel at cross-shaft).
4. Adjust nut "B" to obtain approximately 1/4" clearance between nut "B" and swivel.
5. Release push rod, connect return spring and tighten nut "A" to lock swivel against nut "B".
6. Check free pedal clearance at pedal (1 1/4" to 1 1/2" is proper clearance). Readjust if necessary.

INSUFFICIENT CLUTCH RELEASE

Where complaints of first or reverse gear clash due to insufficient clutch release are encountered, the following may be helpful. Cut off the existing clutch pedal stop bumper to a height of 3/8". Since shortening the bumper increases the lash and not the usable stroke, the lash must be reduced to specifications in order to gain the additional stroke benefit.

DIAGNOSIS

CLUTCH TROUBLE DIAGNOSIS

CONDITION	PROBABLE CAUSE	CORRECTION
Fails to Release (Pedal pressed to floor-shift lever does not move freely in and out of reverse gear)	<ul style="list-style-type: none"> a. Improper linkage Adjustment b. Improper pedal travel c. Loose linkage d. Faulty pilot bearing e. Faulty driven disc f. Fork off ball stud g. Clutch disc hub binding on clutch gear spline h. Clutch disc warped or bent 	<ul style="list-style-type: none"> a. Adjust Linkage b. Trim bumper stop and adjust linkage c. Replace as necessary d. Replace bearing e. Replace disc f. Install properly and* lubricate fingers at throw-out bearing with wheel bearing grease. g. Repair or replace clutch gear and/or disc. h. Replace disc (run-out should not exceed .020"). <p>*Very lightly lubricate fingers</p>
Slipping	<ul style="list-style-type: none"> a. Improper Adjustment (no lash) b. Oil Soaked driven disc c. Worn facing or facing torn from disc. d. Warped pressure plate or flywheel e. Weak diaphragm spring f. Driven plate not seated in g. Driven plate overheated 	<ul style="list-style-type: none"> a. Adjust linkage to spec. b. Install new disc and correct leak at its source c. Replace disc d. Replace pressure plate or flywheel e. Replace pressure plate (Be sure lash is checked before replacing plate.) f. Make 30 to 40 normal starts CAUTION: Do Not Overheat g. Allow to cool – check lash
Grabbing (Chattering)	<ul style="list-style-type: none"> a. Oil on facing. Burned or glazed facings. b. Worn splines on clutch gear. c. Loose engine mountings. d. Warped pressure plate or flywheel. e. Burned or smeared resin on flywheel or pressure plate. 	<ul style="list-style-type: none"> a. Install new disc and correct leak. b. Replace transmission clutch gear. c. Tighten or replace mountings. d. Replace pressure plate or flywheel. e. Sand off if superficial, replace burned or heat checked parts.
Rattling-Transmission Click	<ul style="list-style-type: none"> a. Weak retracting springs. b. Throw-out fork loose on ball stud or in bearing groove. c. Oil in driven plate damper. d. Driven plate damper spring failure. 	<ul style="list-style-type: none"> a. Replace pressure plate. b. Check ball stud and retaining. c. Replace driven disc. d. Replace driven disc.
Throw-Out Bearing Noise with Clutch Fully Engaged	<ul style="list-style-type: none"> a. Improper adjustment. No Lash. b. Throw-out bearing binding on transmission bearing retainer. c. Insufficient tension between clutch fork spring and ball stud. d. Fork improperly installed. e. Weak linkage return spring. 	<ul style="list-style-type: none"> a. Adjust linkage. b. Clean, relubricate, check for burrs, nicks, etc. c. Replace fork. d. Install properly. e. Replace spring.
Noisy	<ul style="list-style-type: none"> a. Worn throw-out bearing. b. Fork off ball stud (heavy clicking). c. Pilot Bearing loose in crankshaft. 	<ul style="list-style-type: none"> a. Replace bearing. b. Install properly and lubricate fork fingers at bearing. c. See Section 6 for bearing fits.
Pedal Stays on Floor When Disengaged	<ul style="list-style-type: none"> a. Bind in linkage or release bearing. b. Springs weak in pressure plate. c. Springs being over traveled. 	<ul style="list-style-type: none"> a. Lubricate and free up linkage and release bearing. b. Replace pressure plate. c. Adjust linkage to get proper lash, be sure proper pedal stop (bumper) is installed.
Hard Pedal Effort	<ul style="list-style-type: none"> a. Bind in linkage. b. Driven plate worn. 	<ul style="list-style-type: none"> a. Lubricate and free up linkage. b. Replace driven plate.

Fig. 7C-12--Clutch Diagnosis Chart

COMPONENT PARTS REPLACEMENT

PRELIMINARY INSPECTION

There are many things which affect good clutch operation. Therefore, it is necessary, before performing any major clutch operations, to make a preliminary inspection to determine whether or not the trouble is actually in the clutch.

1. Check the clutch pedal and make sure that the pedal has proper free travel, as described in "Maintenance and Adjustments".
2. Check the clutch pedal bushing for wear and for sticking on the shaft or loose mountings.
3. Lubricate the pedal linkage.
4. Tighten all front and rear engine mounting bolts.

CLUTCH DISC AND PRESSURE PLATE

(DIAPHRAGM TYPE)

Removal from Vehicle

1. Remove transmission as outlined in Section 7B.
2. Disconnect clutch fork push rod and pull back spring.
3. Remove clutch and flywheel housing.
4. Remove clutch fork by pressing it away from its ball mounting with a screwdriver, until the fork snaps loose from the ball or remove ball stud from rear of clutch housing. Remove throwout bearing from clutch fork.

NOTE: The retainer may be removed from the fork by prying out with a small screwdriver.

5. Install Tool J-5824 or a used clutch drive gear to support the clutch assembly during removal.

NOTE: Before removing clutch from flywheel, mark the flywheel, clutch cover and one pressure plate lug, so that these parts may be assembled in their same relative positions, as they were balanced as an assembly.

6. Loosen the clutch attaching bolts one turn at a time to prevent distortion of clutch cover until diaphragm spring is released.
7. Remove clutch pilot tool and remove clutch assembly from vehicle.

NOTE: The flywheel should be inspected for cracks, heat checking, flatness and other defects.

Installation to Vehicle

1. Install the pressure plate in the cover assembly lining up the notch mark on pressure plate with notch mark on flange of cover.
2. Install pressure plate retracting springs, lock-washers and drive strap to pressure plate bolts. Tighten to 11 ft. lbs. torque. The clutch is now ready to be installed.
3. Hand crank the engine until "X" mark on flywheel is at the bottom.

4. Install clutch disc, pressure plate and cover assembly and support them with Tool J-5824 or a used clutch drive gear.

5. Turn clutch assembly until "X" mark or painted white letter on clutch cover flange lines up with "X" mark on flywheel.

6. Install attaching bolts and tighten each one a turn at a time to prevent distorting the cover as the spring pressure is taken up.

7. Remove clutch pilot tool.

8. Pack clutch fork ball seat with a small amount of high melting point grease. On "P" models with J76, install a new retainer in the groove of the clutch fork if the old retainer is worn or damaged.

NOTE: Install retainer with high side up, away from bottom of the ball socket and with open end of retainer on the horizontal.

CAUTION: Be careful not to use too much lubricant. Excessive lubricant may get on clutch fingers and cause slippage.

9. Replace clutch fork ball if removed from the clutch housing and snap clutch fork onto the ball.

10. Pack lubricant in the recess on the inside of the throwout bearing collar and coat the throwout fork groove with a small amount of graphite grease, as shown in Figure 7C-13.

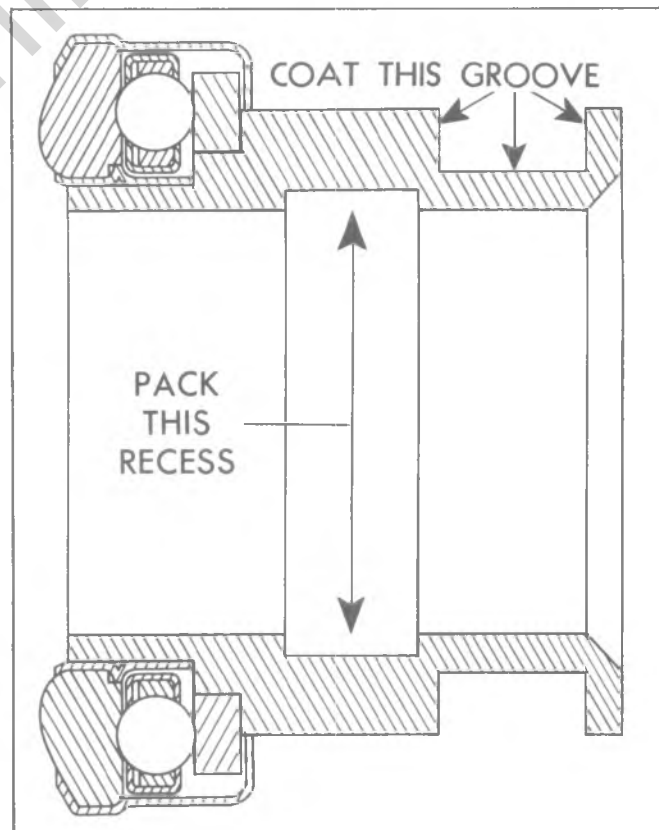


Fig. 7C-13--Lubrication Points on Clutch Throwout Bearing

11. Install throwout bearing assembly to the throwout fork. Install clutch and flywheel housing to engine.

12. Assemble transmission as outlined in Section 7B.

13. Align push rod to clutch fork and attach return spring to clutch fork.

14. Adjust clutch linkage as described in "Maintenance and Adjustments."

CLUTCH DISC AND PRESSURE PLATE

(COIL SPRING TYPE)

Removal From Vehicle

1. Remove transmission as outlined in Section 7B.
2. Disconnect clutch fork push rod and pull back spring.
3. Remove clutch and flywheel housing.
4. Remove clutch fork by pressing it away from its ball mounting with a screwdriver, until the fork snaps loose from the ball or remove ball stud from rear of clutch housing. Remove throwout bearing from clutch fork.

NOTE: The retainer may be removed from the fork by prying out with a small screwdriver.

5. Install Tool J-5824 or a used clutch drive gear to support the clutch assembly during removal.

NOTE: Before removing clutch from flywheel, mark the flywheel, clutch cover and one pressure plate lug, so that these parts may be assembled in their same relative positions, as they were balanced as an assembly.

6. Loosen the holding screws a turn or two at a time to avoid bending rim of cover. It is advantageous to place wood or metal spacers (approximately 3/8 thick) between the clutch levers and the cover to hold the levers down as the holding screws are removed or when clutch is removed from engine. When removing driven plate be sure to mark flywheel side.

7. Remove clutch pilot tool and remove clutch assembly from vehicle.

NOTE: Inspect flywheel for heat defects, cracks, flatness, or other defects.

Installation To Vehicle

1. Assemble driven plate and clutch cover assembly to flywheel in accordance with marking on driven plate for flywheel side. Use Tool J-5824 or a dummy shaft to support assembly.

2. Line up the clutch assembly with "X" mark or painted white letter with "X" mark on flywheel, before tightening cover holding screws.

3. Tighten holding screws, a turn at a time, before removing dummy shaft.

4. Remove clutch pilot tool.

5. Pack clutch fork ball seat with a small amount of high melting point grease and install a new retainer in the groove of the clutch fork if the old retainer is worn or damaged.

NOTE: Install retainer with high side up, away from bottom of the ball socket and with open end of retainer on the horizontal.

CAUTION: *Be careful not to use too much lubricant. Excessive lubricant may get on clutch fingers and cause slippage.*

6. Replace clutch fork ball if removed from the clutch housing and snap clutch fork onto the ball.

7. Pack lubricant in the recess on the inside of the throwout bearing collar and coat the throwout fork groove with a small amount of graphite grease, as shown in Figure 7C-13.

8. Install throwout bearing assembly to the throwout fork. Install clutch and flywheel housing to engine.

9. Assemble transmission as outlined in Section 7B.

10. Align push rod to clutch fork and attach return spring to clutch fork.

11. Adjust clutch linkage as described in "Maintenance and Adjustments."

CLUTCH PEDAL ARM, PUSH ROD OR BUSHING REPLACEMENT (Fig. 7C-14)

C-K Models

Removal

1. Disconnect battery negative ground cable at the battery terminal.
2. Disconnect clutch push rod at the cross shaft under the vehicle.
3. Remove steering column covers. Remove screws retaining push rod boots to bulkhead.
4. Remove air conditioning duct from lower left side of instrument cluster if so equipped. (Refer to Section 1A).

CAUTION: *Maintain pressure on lower arm. When lower attaching bolt is removed upper section will snap upward.*

5. Disconnect clutch neutral start switch from pedal arm.

6. Remove bolts attaching lower section of clutch pedal arm to the upper arm.

7. Remove lower arm and push rod from vehicle.

8. Remove pedal return spring.

9. Remove pedal pivot shaft retaining nut and pivot shaft. Insert a dummy shaft or rod through the support to hold the brake pedal components in place.

10. Remove the clutch pedal assembly from the support assembly.

11. Remove pedal bushings and spacer from pedal arm. Check pedal bumper for wear and replace as required.

Installation

1. Install new bushings and spacer in pedal arm. Components should be lubricated prior to assembly.
2. Position clutch pedal upper arm in support bracket and install pivot bolt through support and pedal arms.

NOTE: Bolt must be installed in direction shown in Figure 7C-14 in order to clear return spring.

3. Install pivot bolt retaining nut and torque to specifications.
4. Install pull back spring to support and pedal arm.

NOTE: If previously removed connect pedal push rod to clutch pedal arm.

5. Position lower pedal arm to upper arm and install upper attaching bolt. Push down on pedal and install lower bolt. Torque to specifications.
6. Install clutch neutral start switch.
7. Install air conditioning duct.
8. Install steering column covers. Install screws retaining push rod boots to bulk head.
9. Check operation of clutch assembly and adjust clutch as required.

G and P Models (Fig. 7C-14)**Removal**

1. Apply parking brake firmly. Disconnect neutral start switch from pedal arm.
2. Remove bolt at clutch pedal push rod lever, then remove lever from pedal shaft.
3. Hold pedal pad with one hand and slide clutch pedal and shaft assembly outboard enough to clear pedal stop. Insert a dummy shaft or rod through support and brake pedal assembly to hold components in place while removing clutch pedal shaft. Allow return spring (or center spring) to pull pedal up high enough to unhook spring from pedal arm.
4. Remove pedal and shaft assembly from support bracket.

Inspection

1. Check clutch pedal bushings for excessive wear and replace as necessary.
2. Check clutch pedal shaft for wear and alignment. Straighten or replace as necessary.

Installation

NOTE: Use new shaft bushing if needed. Lubricate with petrolatum.

1. Slide one pedal shaft bushing over shaft, install shaft in support enough to still clear pedal bumper stop, hook pedal return (or overcenter) spring to pedal, then rotate pedal forward of bumper stop; slide shaft into position in support and release pedal against bumper stop.
2. Install clutch pedal shaft bushing over pedal shaft end and into place in sleeve.
3. Assemble pedal push rod lever over pedal shaft and install bolts, washers, and nut.
4. Connect neutral start switch to pedal arm.
5. Adjust clutch pedal free travel as needed.

CLUTCH CROSS-SHAFT REPLACEMENT

(Figs. 7C-6, 7C-7, 7C-8)

1. Disconnect clutch fork return spring at fork.
2. Disconnect pedal push rod at cross-shaft lever and allow clutch fork push rod to hang free from lower lever.
3. On C-K models, remove ball stud retaining nut, at frame end and slide shaft toward engine. Then lift cross-shaft up to clear bracket and remove shaft from the engine ball stud. On G models, remove frame bracket retaining bolts, then remove shaft from engine ball stud.
4. REMOVE clutch fork push rod from cross-shaft lever.
5. Reverse removal procedure to install.

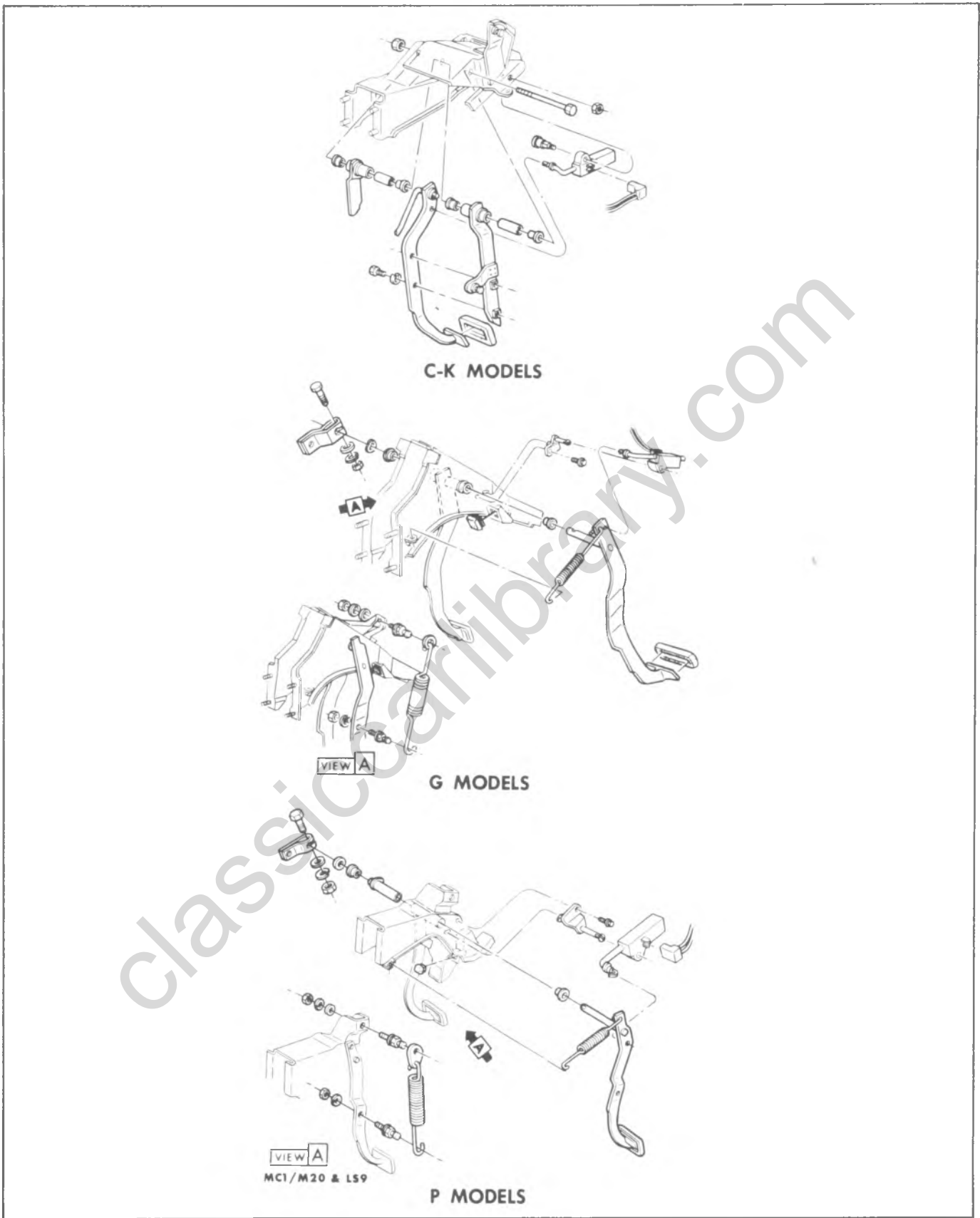


Fig. 7C-14--Clutch Pedal Mounting Attachment

SPECIAL TOOLS

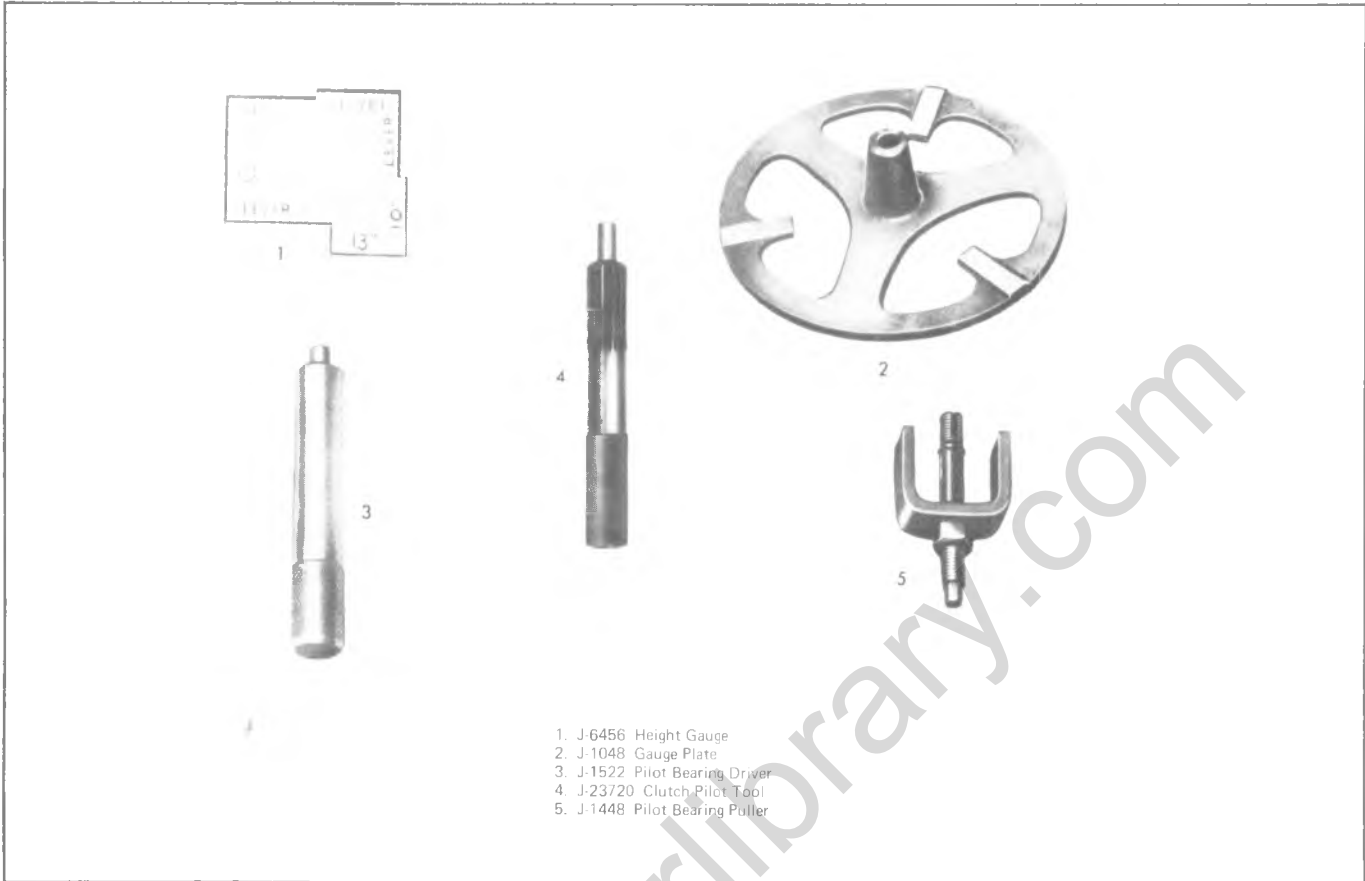


Fig. 7C-ST-Clutch Special Tools

SECTION 8

ELECTRICAL—BODY AND CHASSIS

CONTENTS

Lighting System.....	8-2	Oil Pressure Sending Unit.....	8-26
General Description.....	8-2	Voltmeter.....	8-26
Diagnosis.....	8-3	Directional Signal Switch.....	8-26
On-Vehicle Service.....	8-9	Windshield Wiper and Washer (C-K and G Models).....	8-26
Maintenance and Adjustments.....	8-9	General Description.....	8-26
Headlamp Adjustment.....	8-9	Electrical Circuits.....	8-27
Component Part Replacement.....	8-10	Diagnosis.....	8-30
Sealed Beam Unit.....	8-10	Wiper - On Vehicle.....	8-30
Parking Lamp Bulb.....	8-10	Wiper - Off Vehicle.....	8-30
Parking Lamp Housing.....	8-10	On Vehicle Service.....	8-39
Front Side Marker.....	8-10	Component Part Replacement.....	8-39
Rear Side Marker.....	8-10	Wiper Motor.....	8-39
Tail, Stop and Backup Lamps.....	8-11	Unit Repair.....	8-39
Directional Signal Lamps.....	8-11	Wiper/Washer Disassembly.....	8-39
Clearance, License Plate and Identification Lamps.....	8-11	Motor Disassembly.....	8-40
Light Switch.....	8-11	Motor Assembly.....	8-43
Headlamp Beam Selector Switch.....	8-11	Wiper Adjustments.....	8-43
Stoplamp Switch.....	8-11	Washer Pump.....	8-43
Instruments, Gauges and Controls.....	8-15	Windshield Wiper and Washer (P Models).....	8-45
General Description.....	8-15	General Description.....	8-45
Diagnosis.....	8-16	Diagnosis.....	8-47
On-Vehicle Service.....	8-20	Wiper - On Vehicle.....	8-47
Component Part Replacement.....	8-20	Unit Repair.....	8-52
Neutral Start Switch.....	8-20	Wiper Motor.....	8-52
Backing Lamp Switch.....	8-21	Windshield Washer.....	8-53
Windshield Wiper/Wiper/Washer Switch.....	8-21	Circuit Protection.....	8-56
Ignition Switch.....	8-22	General Description.....	8-56
Instrument Cluster.....	8-22	Circuit Breaker.....	8-56
Indicator and Illuminating Bulbs.....	8-22	Fuse.....	8-56
Laminated (Printed) Circuit.....	8-22	Fusible Link.....	8-57
Speedometer.....	8-24	Diagnosis.....	8-57
Speedometer Cable Core.....	8-25	On-Vehicle Service.....	8-58
Fuel Gauge.....	8-25	Component Part Replacement.....	8-58
Temperature Gauge.....	8-25	Headlamp Warning Buzzer.....	8-58
Temperature Sending Unit.....	8-25	Seat Belt Warning System.....	8-58
Oil Pressure Gauge.....	8-25	Specifications.....	8-61

LIGHTING SYSTEM

GENERAL DESCRIPTION

The lighting system includes the main light switch; stop light, dimmer and backing lamp switches; head and parking lamps; stop, tail, side marker, clearance and identification lamps; instrument illumination, directional signal and indicator lamps and the necessary wiring to complete the various circuits.

A bulkhead fuse panel (fig. 8-1) provides convenient power taps and fuse clips for the appropriate circuits. The engine wiring harness and forward lamp harness

connectors are bolted to the fuse panel.

All wiring systems not protected by a fuse or circuit breaker incorporate a fusible link which provides increased overload protection. The starting motor circuit is the exception.

Composite wiring diagrams are available in a separate manual. The standardized color code is common to all wiring harnesses. The wire covering color designates a particular circuit usage.

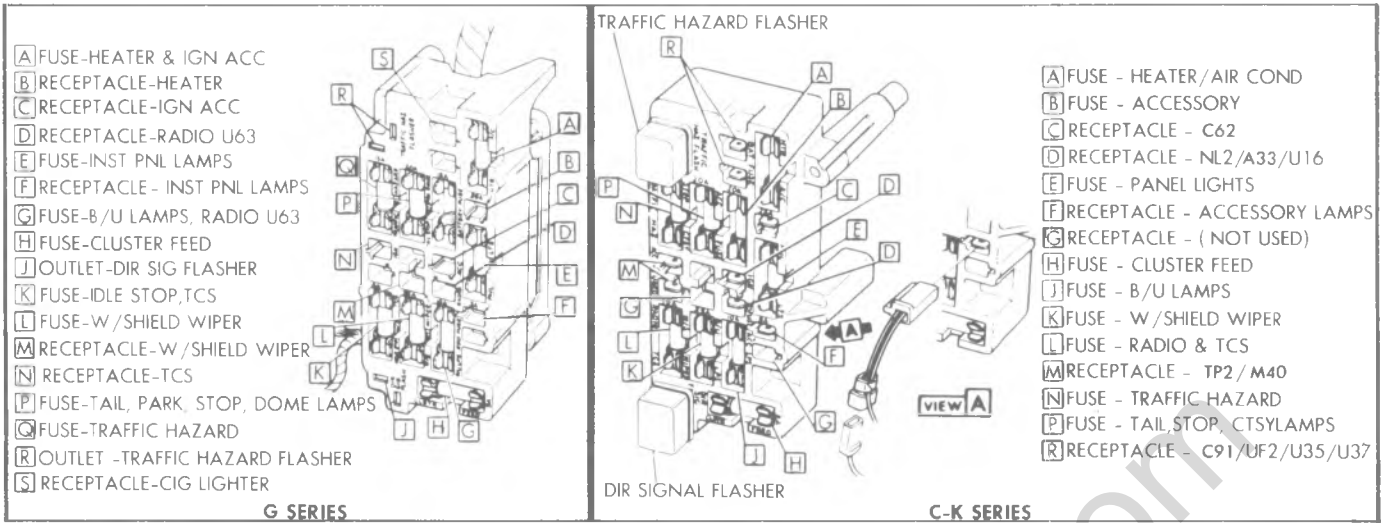


Fig. 8-1--Fuse Panel

Classiccarlibrary.com

DIAGNOSIS

HEADLAMP DIAGNOSIS

Condition	Possible Cause	Correction
One headlamp inoperative or intermittent	1. Loose connection	1. Secure connections to sealed beam including ground. (Black Wire)
	2. Defective Sealed Beam	2. Replace sealed beam
One or more headlights are dim.	1. Open ground connection at headlight	1. Repair black wire connection between sealed beam and body ground.
	2. Black ground wire mislocated in headlight connector (type 2 sealed beam)	2. Relocate black wire in connector
One or more headlights short life	1. Voltage regulator misadjusted	1. Readjust regulator to specifications.
All headlights inoperative or intermittent	1. Loose connection	1. Check and secure connections at dimmer switch and light switch.
	2. Defective dimmer switch	2. Check voltage at dimmer switch with test lamp. If test lamp bulb lights only at light blue wire terminal, replace dimmer switch.
	3. Open wiring - light switch to dimmer switch	3. Check light blue wire with test lamp. If bulb lights at light switch light blue wire terminal but not at dimmer switch, repair open wire.
	4. Open wiring - light switch to battery	4. Check red wire terminal at light switch with test lamp. If lamp does not light, repair open red wire circuit to battery. (possible open fusible link)
	5. Shorted ground circuit	5. If, after a few minutes operation, headlights flicker "ON" and "OFF" and or a thumping noise can be heard from the light switch (circuit breaker opening and closing), repair short to ground in circuit between light switch and headlights. After repairing short, check for headlight flickering after one minute operation. If flickering occurs, the circuit breaker has been damaged and light switch must be replaced.
	6. Defective light switch	6. Check red and white wire terminals at light switch with test lamp. If bulb lights at read wire terminal but not at light blue terminal, replace light switch.

Upper or lower beam will not light or intermittent	1. Open connection or defective dimmer switch	1. Check dimmer switch terminals with test lamp. If bulb lights at light blue or tan wire terminals, repair open wiring between dimmer switch and headlights. If bulb will not light at one of these terminals, replace dimmer switch.
	2. Short circuit to ground	2. Follow diagnosis above (All headlights inoperative or intermittent)

SIDE MARKER LAMP DIAGNOSIS

Condition	Possible Cause	Correction
One lamp inoperative	1. Turn signal bulb burnt out (Front lamp)	1. Switch turn signals on. If signal bulb does not light, replace bulb. (Bulb filament provides ground path for marker lamp bulb through the light blue or dark blue/white strip wires).
	2. Side marker bulb burnt out	2. Replace bulb.
	3. Loose connection or open in wiring	3. Using test lamp, check brown wire terminal at bulb socket. If test lamp lights, repair open ground circuit. If lamp does not light, repair open brown wire circuit.
Front or rear lamps inoperative	1. Loose connection or open ground connection	1. If associated tail or park lamps do not operate, secure all connectors in brown wire circuit. If park and turn lamps operate, repair open ground connections.
	2. Multiple bulbs burnt out	2. Replace burnt out bulbs.
All lamps inoperative	1. Blown fuse	1. If park and tail lamps do not operate, replace blown fuse. If new fuse blows, check for short to ground between fuse panel and lamps.
	2. Loose connection	2. Secure connector to light switch.
	3. Open in wiring	3. Check tail light fuse with test lamp. If test lamp lights, repair open wiring between fuse and light switch. If not, repair open wiring between fuse and battery. (Possible open fusible link).

- | | |
|---------------------------|--|
| 4. Defective light switch | 4. Check light switch with test lamp. If test lamp lights at terminal No. 5 but not at terminal No. 4, replace light switch. |
|---------------------------|--|

TAIL, PARK AND LICENSE LAMP DIAGNOSIS

Condition	Possible Cause	Correction
One side inoperative	1. Bulb burnt out	1. Replace bulb
	2. Open ground connection at bulb socket or ground wire terminal	2. Jumper bulb base socket connection to ground. If lamp lights, repair open ground circuit.
Both sides inoperative	1. Tail lamp fuse blown	1. Replace fuse. If new fuse blows, repair short to ground in brown wire circuit between fuse panel through light switch to lamps.
	2. Loose connection	2. Secure connector at light switch.
	3. Open wiring	3. Using test light, check circuit on both sides of fuse. If lamp does not light on either side, repair open circuit between fuse panel and battery. (possible open fusible link). If test lamp lights at light switch brown wire terminal, repair open wiring between light switch and lamps.
	4. Multiple bulb burnout	4. If test lamp lights at lamp socket brown wire terminal, replace bulbs.
	5. Defective light switch	5. If test lamp lights at light switch terminal No. 4 (Brown/white wire) but not at terminal No. 5 (Brown wire), replace defective light switch.

TURN SIGNAL AND HAZARD WARNING LAMP

Condition	Possible Cause	Correction
Turn signals inoperative one side	1. Bulb(s) burnt out (Flasher cannot be heard)	1. Turn hazard warning system on. If one or more bulbs are inoperative replace necessary bulbs.
	2. Open wiring or ground connection	2. Turn Hazard warning system on. If one or more bulbs are inoperative, use test lamp and check circuit at lamp socket. If test lamp lights, repair open ground connection. If not, repair open wiring between bulb socket and turn signal switch.
	3. Improper bulb or defective turn signal switch.	3. Turn hazard warning system on. If all front and rear lamps operate, check for improper bulb (1034 instead of 1157). If bulbs are OK, replace defective turn signal switch.
	4. Short to ground. (Flasher can be heard, no bulbs operate)	4. Locate and repair short to ground by disconnecting front and rear circuits separately.
Turn signals inoperative	1. Blown turn signal fuse	1. Turn hazard warning system on. If all lamps operate, replace blown fuse. If new fuse blows, repair short to ground between fuse and lamps.
	2. Defective flasher (Located behind instrument panel near steering column)	2. If turn signal fuse is OK and hazard warning system will operate lamps, replace defective turn signal flasher.
	3. Loose connection	3. Secure steering column connector. If necessary, check purple wire terminals in connector with test lamp. If test lamp lights only on one side of connector, clean or tighten connector contacts.

Hazard warning lamps inoperative	1. Blown stop-hazard fuse	1. Switch turn signals on. If lamps operate, replace stop-hazard fuse if blown. If new fuse blows, repair short to ground. (Could be in stop light circuit).
	2. Defective hazard warning flasher. (Located on fuse panel).	2. If stop-hazard fuse is OK, switch turn signals on. If lamps operate, replace defective hazard flasher.
	3. Open in wiring or defective turn signal switch.	3. Using test lamp, check brown wire in turn signal steering column connector. If lamp does not light on either side of connector, repair open circuit between flasher and connector. If lamp lights only on feed side of connector, clean connector contacts. If lamp lights on both sides of connector, replace defective turn signal switch assembly.

BACK-UP LAMP

Condition	Possible Cause	Correction
One lamp inoperative or intermittent	1. Loose or burnt out bulb	1. Secure or replace bulb.
	2. Loose connection	2. Tighten connectors.
	3. Open ground connections	3. Repair bulb ground circuit.
Both lamps inoperative or intermittent.	1. Neutral start switch misadjusted (Open when shift lever is in reverse position)	1. Readjust neutral start switch.
	2. Loose connection or open circuit	2. Secure all connectors. If OK, check continuity of circuit from fuse to lamps with test lamp. If lamp does not light on either side of fuse, correct open circuit from battery to fuse.
	3. Blown fuse	3. Replace fuse. If new fuse blows, repair short to ground in circuit from fuse through neutral start switch to back-up lamps.
	4. Defective neutral start switch	4. With ignition on, check switch terminals in back-up position with test lamp. If lamp lights at pink wire terminal but not at light green wire terminal, replace neutral start switch.
	5. Defective ignition switch	5. If test lamp lights at ignition switch battery terminal but not at output terminal, replace ignition switch.

Lamp will not turn off	1. Neutral start switch misadjusted (closed when shift lever is not in reverse position)	1. Readjust neutral start switch
STOP LIGHTS		
Condition	Possible Cause	Correction
One bulb inoperative	1. Bulb burnt out.	1. Replace bulb.
One side inoperative	1. Loose connection, open wiring or defective bulbs 2. Defective directional signal switch or cancelling cam	1. Turn on directional signal. If lamp does not operate, check bulbs. If bulbs are OK, secure all connections. If lamp still does not operate, use test lamp and check for open wiring. 2. If lamp will operate by turning directional signal on, the switch is not centering properly during cancelling operation. Replace defective cancelling cam or directional signal switch.
All inoperative	1. Stop-hazard fuse blown 2. Stop-switch misadjusted or defective	1. Replace fuse. If new fuse blows, repair short to ground in circuit between fuse and lamps. 2. With brake pedal depressed, check white wire terminal in steering column connector with test lamp. If lamp does not light, check stop switch for proper adjustment. If adjustment is OK, replace stop switch.
Will not turn off	1. Stop switch misadjusted or defective.	1. Readjust switch. If switch still malfunctions, replace.

ON-VEHICLE SERVICE

MAINTENANCE AND ADJUSTMENTS

Maintenance of the lighting units and wiring system consists of an occasional check to see that all wiring connections are tight and clean, that the lighting units are securely mounted to provide good ground and that the headlamps are properly adjusted. Loose or corroded connections may cause a discharged battery, difficult starting, dim lights, and possible damage to the generator. Wire harnesses must be replaced if insulation becomes burned, cracked, or deteriorated. Whenever it is necessary to splice a wire or repair one that is broken, always use solder to bond the splice. Always use rosin flux solder on electrical connections. Use insulating tape to cover all splices or bare wires.

When replacing wires, it is important that the correct size be used. Never replace a wire with one of a smaller size. Fusible links in the wiring are four gauge sizes smaller than the cable it is designed to protect. The links are marked on the insulation with wire gauge size because of the heavy insulation which makes the link appear a heavier gauge than it actually is.

Each harness and wire must be held securely in place by clips or other holding devices to prevent chafing or wearing away the insulation due to vibration.

By referring to the wiring diagram manual, circuits may be tested for continuous circuit or shorts with a conventional test lamp or low reading voltmeter.

HEADLAMP ADJUSTMENT (Fig. 8-2)

The headlamps must be properly aimed to obtain maximum road illumination. When using mechanical headlamp aimers, follow manufacturers instructions.

The headlamps must be checked for proper aim

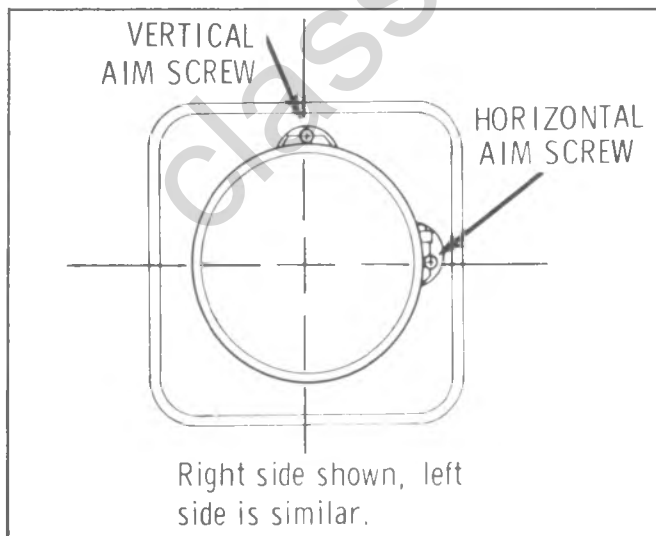


Fig. 8-2--Headlamp Adjustments (Typical)

whenever a sealed beam unit is replaced and after repairs of the front end sheet metal assembly.

Regardless of the method used for checking headlamp aim, the truck must be at normal weight, that is with gas, oil, water and spare tire. Tires must be inflated to specified pressures.

Some states have special requirements for headlamp aiming adjustment and these requirements must be known and followed.

Horizontal and vertical aiming of each sealed beam is provided by two adjusting screws visible through the bezel which move the mounting ring against the tension of the coil spring (fig. 8-2).

There is no adjustment for focus since the sealed beam unit is set for focus during manufacturing assembly.

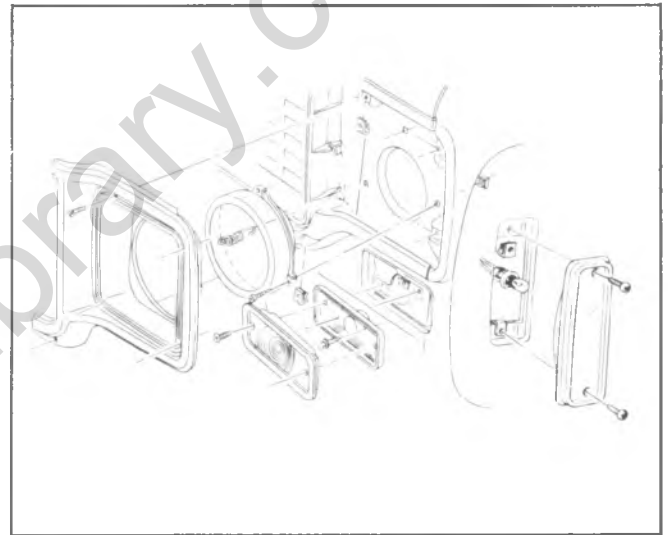


Fig. 8-3--Front Lighting (C-K Models)

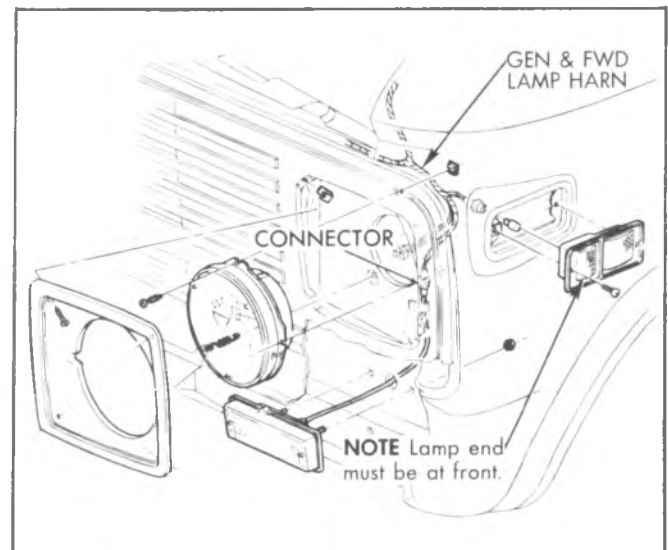


Fig. 8-4--Front Lighting (G Models)

COMPONENT PART REPLACEMENT

SEALED BEAM UNIT

Replacement (Figs. 8-3 and 8-4)

1. Remove bezel retaining screws and bezel.
2. Remove retaining ring.

NOTE: Do not disturb adjusting screw setting.

3. Disconnect wiring harness connector located at rear of unit in engine compartment and remove sealed beam unit.
4. Attach wiring harness connector to unit.
5. Position new sealed beam unit in mounting ring and install retaining ring.

NOTE: The number molded into lens face must be at top.

6. Install retaining ring then check operation of unit and install bezel.

PARKING LAMP BULB

Replacement (Figs. 8-3 and 8-4)

1. Remove lens retaining screws and remove lens from the housing.
2. Replace bulb and check lamp operation.
3. Install lens and retaining screws.

PARKING LAMP HOUSING

C-K Models

Replacement (Fig. 8-3)

1. Remove parking lamp lens screws and remove the lens.
2. Remove lamp housing retaining screws and pull housing forward.
3. Disconnect parking lamp wiring harness from housing by rotating bulb socket counterclockwise.
4. Connect wiring harness to new housing by inserting bulb socket into housing and rotating clockwise.
5. Install bulb if removed during disassembly. Install lens and retaining screws.

G Models

Replacement (Fig. 8-4)

Right Side

1. Remove both headlamp bezels.
2. Remove both parking lamp lens.
3. Remove grille.
4. Remove battery and battery box.
5. Disconnect wiring harness at connector.
6. Remove housing stud nuts and remove housing with pigtail.

7. To install, reverse removal steps.

Left Side

1. Remove two screws and parking lamp lens.
2. Disconnect wiring harness at connector.
3. Remove housing stud nuts and remove housing with pigtail.
4. To install, reverse removal steps.

FRONT SIDE MARKER LAMP BULB AND/OR HOUSING

All Models

Replacement

NOTE: For housing replacement follow procedure for the right side bulb replacement below.

1. **Left Side** - Raise hood.
- Right Side** - Remove lamp assembly retaining screws and pull outward on assembly.
2. Twist wiring harness socket 90° counterclockwise and remove harness and bulb from housing.
3. Replace bulb and check lamp operation.
4. Insert bulb into housing, press in on harness socket and twist 90° clockwise. Check that socket is securely attached.
5. **Left Side** - Lower hood.
- Right Side** - Install housing in opening and install retaining screws.

REAR SIDE MARKER LAMP BULB AND/OR HOUSING

C-K 03 models with E62 and G Models

Replacement

Same as Right Front Side Marker Lamp Bulb and/or Housing Replacement - All Vehicles.

NOTE: Bulb on G Models without interior trim may be removed from inside the vehicle.

C-K 14, 03 and 63 with E63, and 06 Models

Replacement

1. Remove lens to housing four screws.
2. Replace bulb and check operation.
3. Position lens and install four attaching screws.

Platform and Stake Rack Models (E56)

Exploded view of the different rear lighting arrangements are shown in Figures 8-7 and 8-8. The bulbs may be replaced by removing the lamp lens attaching screws and lamp lens. The lamp housings may

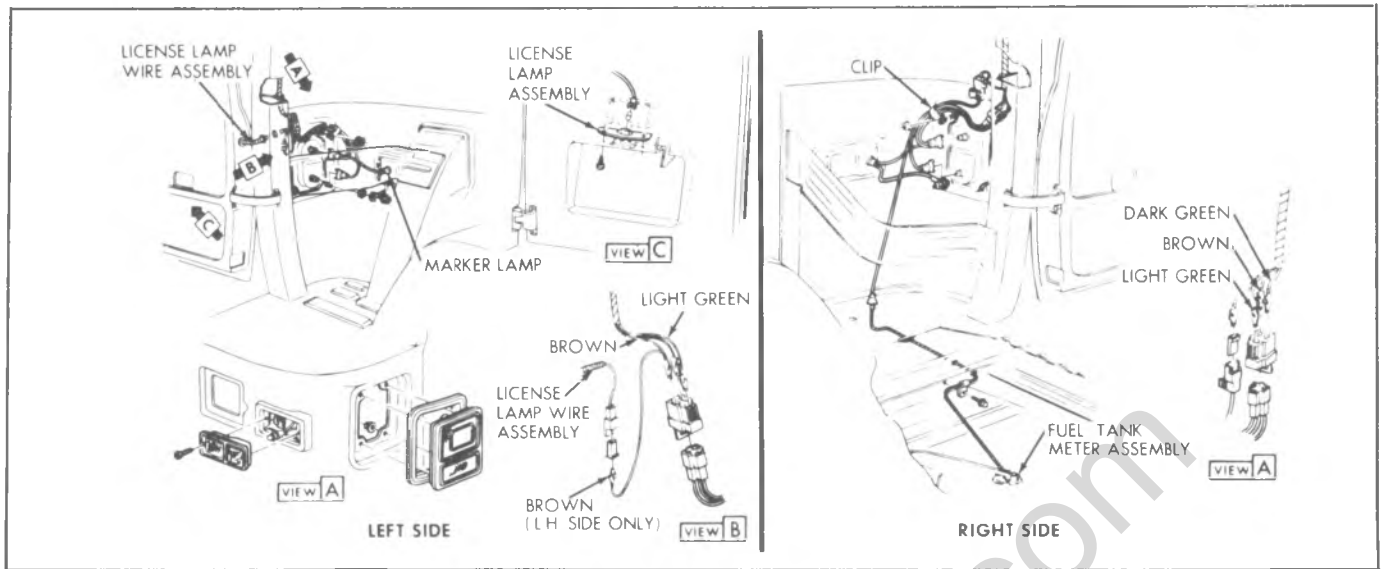


Fig. 8-5-Rear Lighting (G Models)

be replaced by removing housing attaching nuts or screws, or by removing nuts and bolts from bracket.

TAIL, STOP AND BACKUP LAMP BULBS

Replacement

1. Remove lens to housing attaching screws.
2. Replace bulb and check operation.
3. Position lens and install attaching screws.

TAIL, STOP AND BACKUP LAMP HOUSING

C-K 14, 03 and 63 w/E63 and 06 Models

All G Models

Replacement

1. Remove lens to housing attaching screws.
2. Remove bulbs from sockets.
3. Remove housing attaching screws (nuts on G Models).
4. Rotate wiring harness sockets counterclockwise and remove housing.
5. To install, reverse Steps 1-4 above.

DIRECTIONAL SIGNAL LAMPS

Directional signal lamps are an integral part of parking and tail lamp assemblies. Refer to the applicable lamp or bulb replacement procedures covered previously.

CLEARANCE, LICENSE PLATE AND IDENTIFICATION LAMPS

Refer to Figures 8-7 through 8-10 for clearance, license plate and identification lamp installations.

LIGHT SWITCH

C-K Models (Fig. 8-11)

Replacement

1. Disconnect battery ground cable.
2. Reaching up behind instrument cluster, depress shaft retaining button and remove switch knob and rod.
3. Remove instrument cluster bezel screws on left end. Pull out on bezel and hold switch nut with a wrench.
4. Disconnect multiple wiring connectors at switch terminals.
5. Remove switch by rotating while holding switch nut.
6. To install, reverse Steps 1-5 above.

G Models (Fig. 8-11)

Replacement

1. Disconnect battery ground cable.
2. Reaching up behind instrument panel, depress shaft retaining button and remove switch knob-shaft.
3. From front of instrument panel remove switch retaining nut.
4. Push switch from panel opening and remove multiple electrical connector at switch terminals.
5. To install, reverse Steps 1-4, making sure grounding ring is installed on switch.

HEADLAMP BEAM SELECTOR SWITCH

Replacement

1. Fold back upper left corner of the floor mat and remove two screws retaining switch to the floor pan.
2. Disconnect wiring connector from switch terminals.
3. Connect wiring to replacement switch and check operation.
4. Position switch to floor pan and install retaining screws.
5. Replace floor mat.

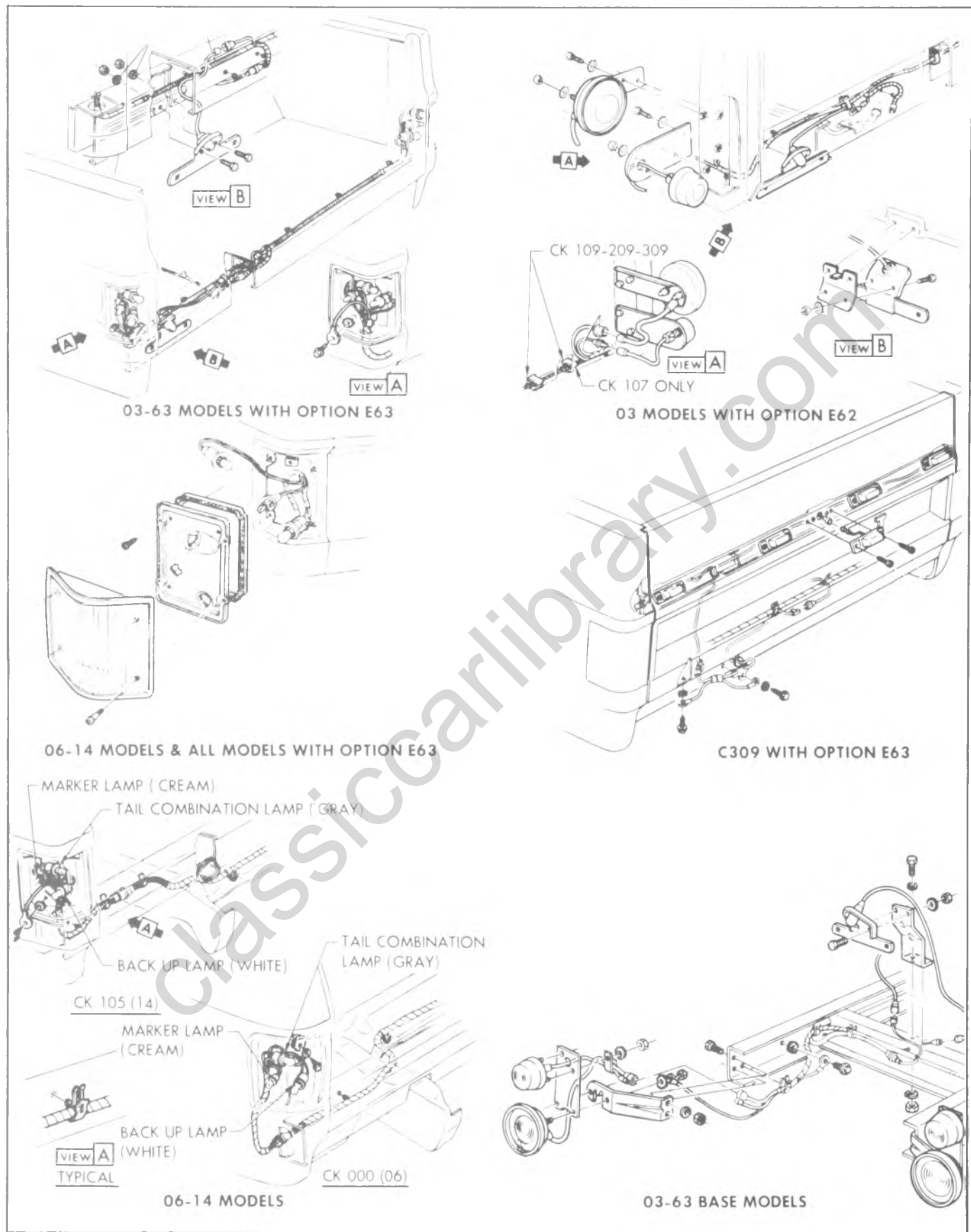


Fig. 8-6-Rear Lighting (C-K Models Except with E56 or E62)

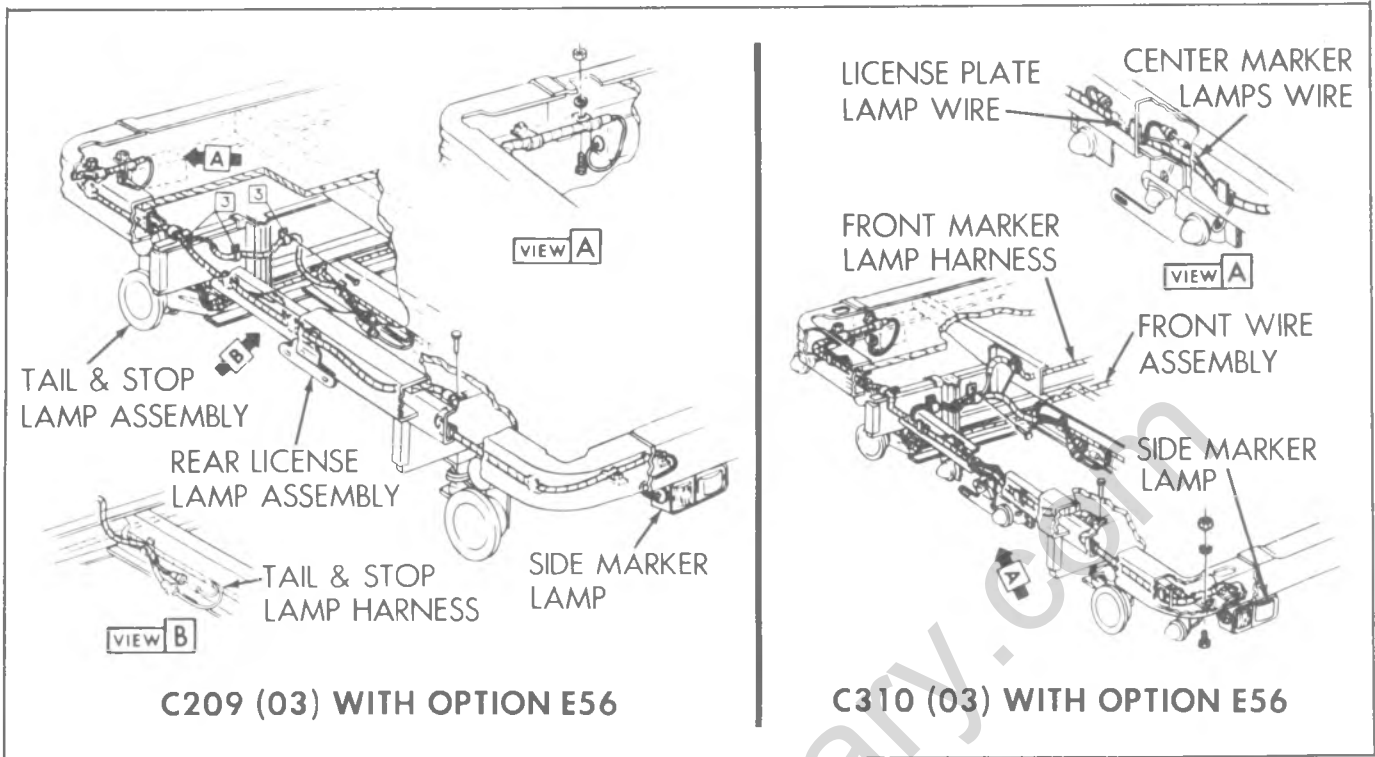


Fig. 8-7 -Rear Lighting (C-K Platform and Stake Rack Models)

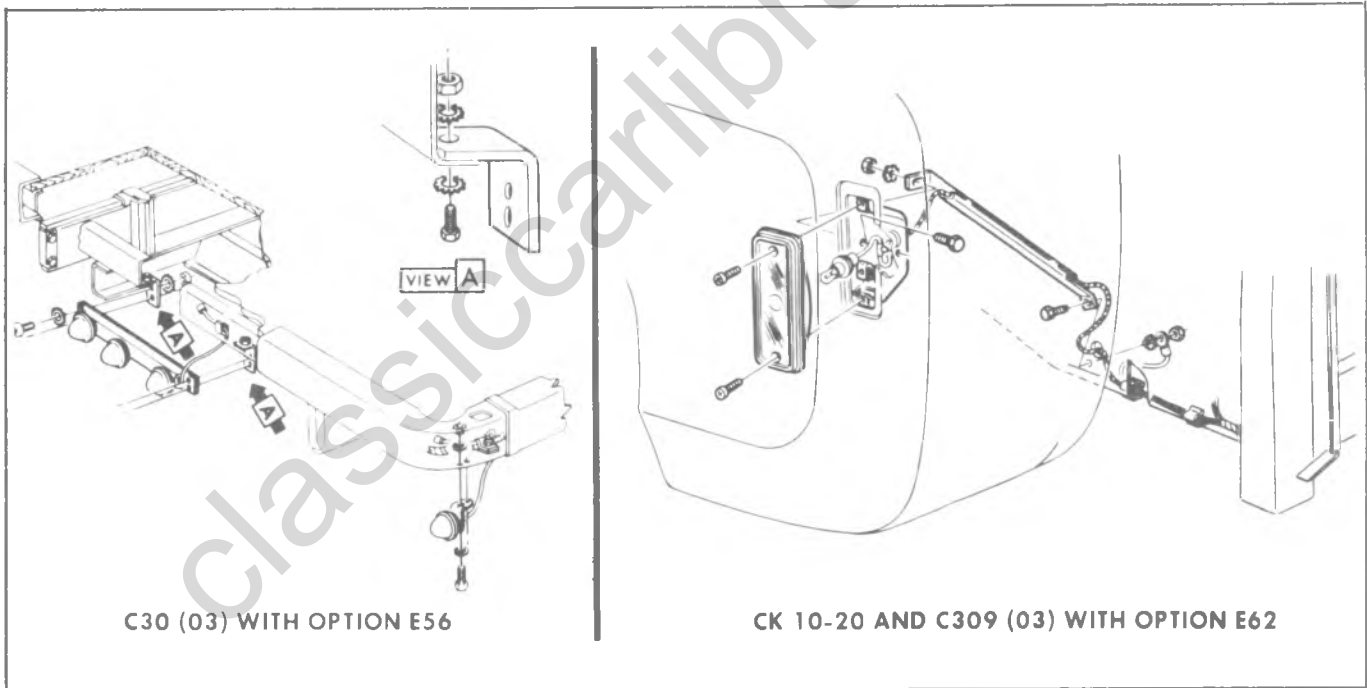


Fig. 8-8--Rear Lighting (C30 03 Models with E56 and C-K Models with E62)

STOPLAMP SWITCH

See Section 5 (Brakes) of this manual for adjustment and replacement procedures.

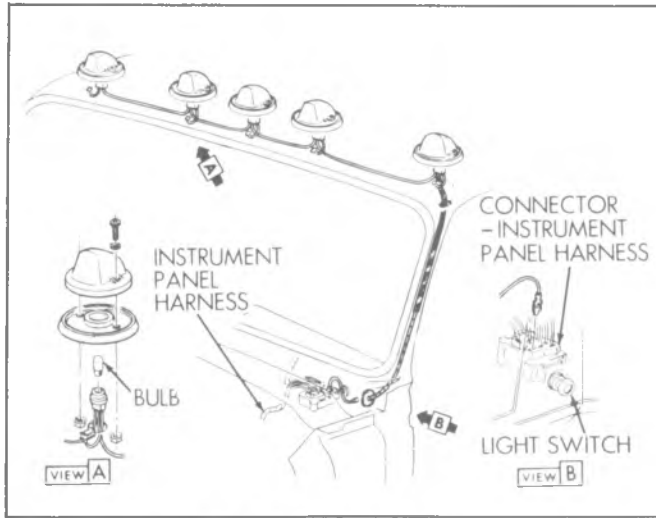


Fig. 8-9--Clearance Lamps

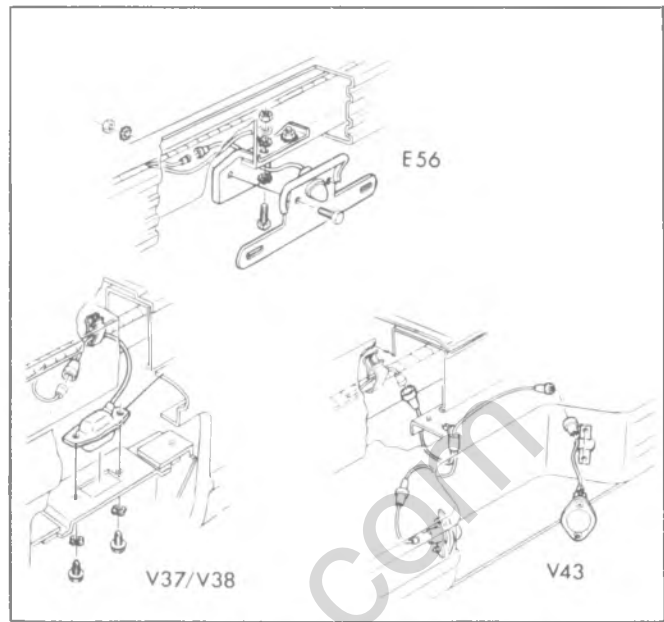


Fig. 8-10--License Plate Lamps (C-K Models)

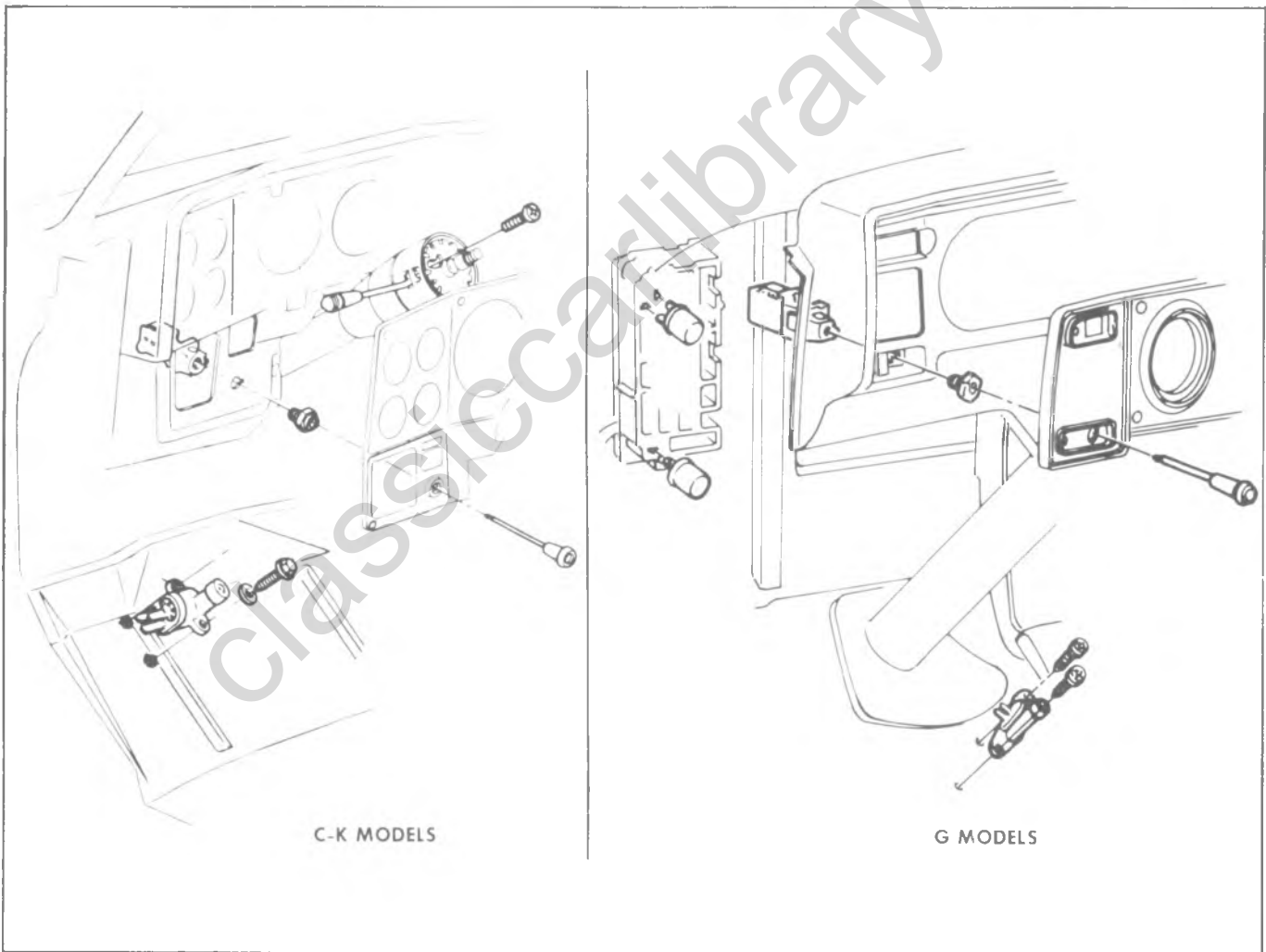


Fig. 8-11--Light and Headlamp Beam Selector Switches

INSTRUMENTS, GAUGES AND CONTROLS

GENERAL DESCRIPTION

All instruments and gauges are installed in the instrument cluster. Instruments and gauges can be serviced in the vehicle (C-K Models); however, the entire cluster must be removed from the vehicle for servicing of the instruments and gauges (G Models). Illuminating and indicator lamps may be replaced without removing

the cluster from the vehicle. Bulbs are installed in plastic holders which lock into the cluster housing.

Regular maintenance is not required on the instrument cluster or its components other than maintaining clean, tight electrical connections, replacing defective parts and keeping the speedometer cable properly lubricated.

classiccarlibrary.com

DIAGNOSIS

OIL PRESSURE INDICATOR

Condition	Possible Cause	Correction
Light not lit, ignition on and engine not running.	1. Bulb burned out.	1. Replace bulb.
	2. Open in light circuit.	2. Locate and correct open.
	3. Defective oil pressure switch.	3. Replace oil pressure switch.
Light on, engine running above idle speed.	1. Grounded wiring between light and switch.	1. Locate and repair ground.
	2. Defective oil pressure switch.	2. Replace oil pressure switch.
	3. Low oil pressure.	3. Locate cause of low oil pressure and correct.

COOLANT TEMPERATURE INDICATOR

Condition	Possible Cause	Correction
"HOT" indicator; light not lit when cranking engine.	1. Bulb burned out.	1. Replace bulb.
	2. Open in light circuit.	2. Locate and correct open.
	3. Defective ignition switch.	3. Replace ignition switch.
Light on, engine running.	1. Wiring grounded between light and switch.	1. Locate and correct grounded wiring.
	2. Defective temperature switch.	2. Replace temperature switch.
	3. Defective ignition switch.	3. Replace ignition switch.
	4. Coolant temperature above 258 degrees F.	4. Locate and correct cause of high coolant temperature.

HORNS WILL NOT OPERATE

Cause	Correction
Loose connections in circuit.	Check and tighten connections. Be sure to check ground straps.
Defective horn switch.	Replace defective parts.
Defective horn relay.	Replace relay.
Defects within horn.	Replace horn.

HORNS HAVE POOR TONE

Cause	Correction
Low available voltage at horn. Defects within horn.	Check battery and charging circuit. Although horn should blow at any voltage above 7.0 volts, a weak or poor tone may occur at operating voltages below 11.0 volts. If horn has weak or poor tone at operating voltage of 11.0 volts or higher, remove horn and replace.

HORNS OPERATE INTERMITTENTLY

Cause	Correction
Loose or intermittent connections in horn relay or horn circuit.	Check and tighten connections.
Defective horn switch.	Replace switch.
Defective relay.	Replace relay.
Defects within horn.	Replace horn.

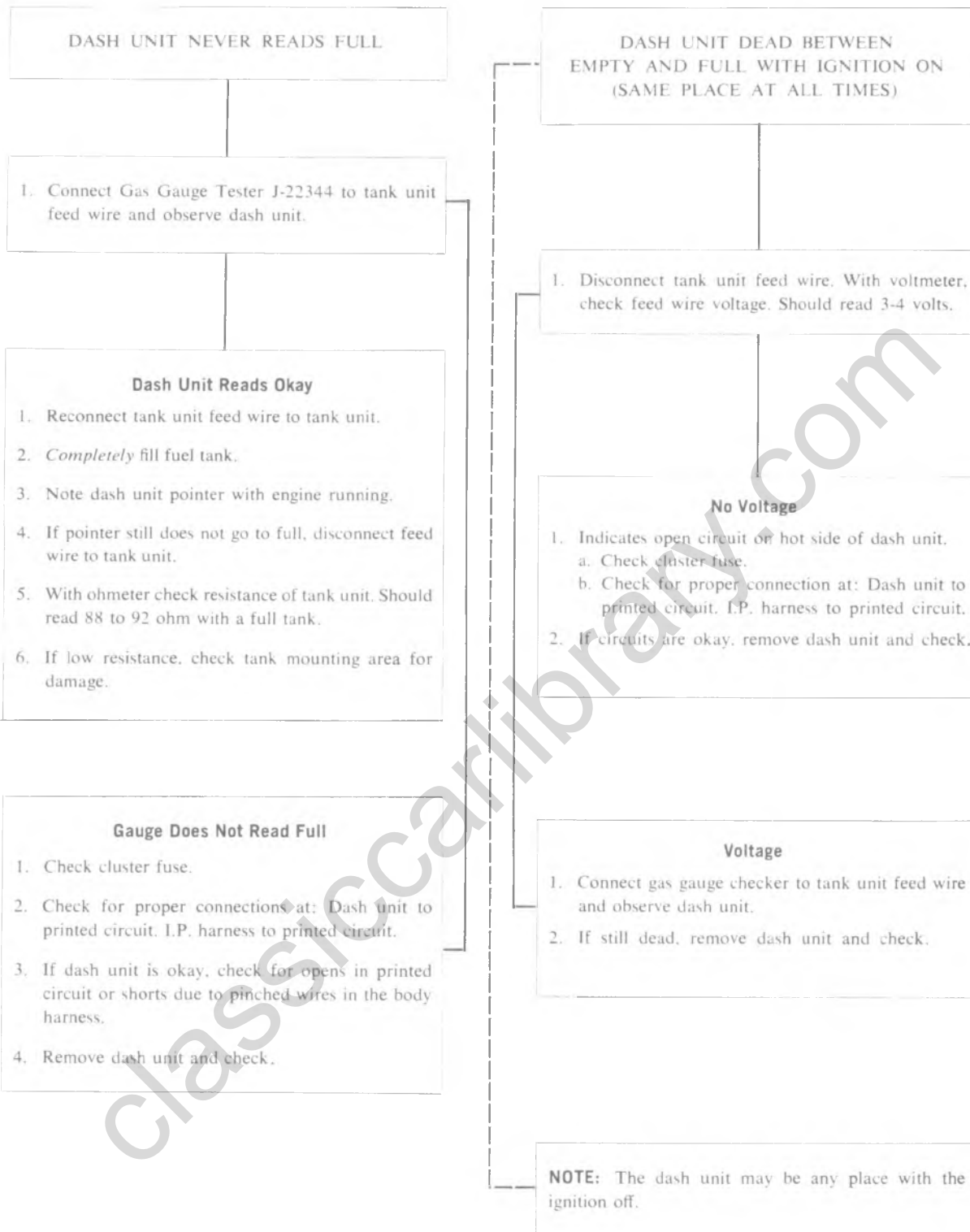
HORNS BLOW CONSTANTLY

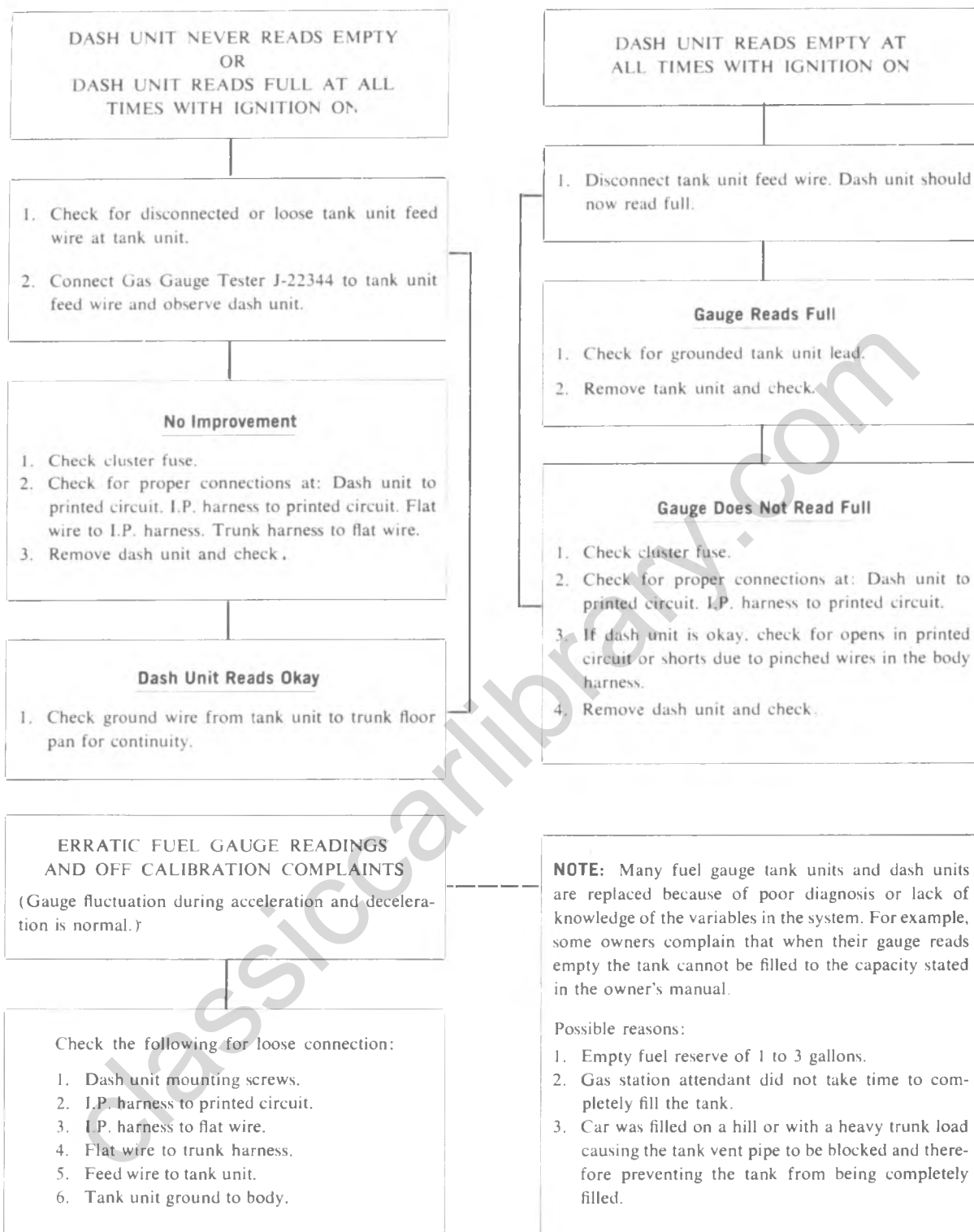
Cause	Correction
Sticking horn relay.	Replace relay.
Horn relay energized by grounded or shorted wiring.	Check and adjust wiring.
Horn button can be grounded by sticking closed.	Adjust or replace damaged parts.

SPEEDOMETER

Cause	Correction
Noisy speedometer cable.	1. Loosen over-tightened casing nuts and snap-on at speedometer head.
Pointer and odometer inoperative. Inaccurate reading.	2. Replace housing and core. Replace broken cable.
Kinked cable.	1. Check tire size.
Defective speedometer head.	2. Check for correct speedometer driven gear. Replace cable. Reroute casing so that bends have no less than 6" radius.
Casing connector loose on speedometer case.	Replace or have repaired at authorized service station. Tighten connector.

GAS GAUGE





CHARGING SYSTEM INDICATOR

Condition	Possible Cause	Correction
Light on, ignition off.	1. Shorted positive diode.	1. Locate and replace shorted diode.
Light not on, ignition on and engine not running.	1. Bulb burned out.	1. Replace bulb.
	2. Open in light circuit.	2. Locate and correct open.
	3. Open in field.	3. Replace rotor.
Light on, engine running above idle speed.	1. No generator output.	1. Check and correct cause of no output.
	2. Shorted negative diode.	2. Locate and replace shorted diode.
	3. Loose or broken generator belt.	3. Tighten or replace and tighten generator belt.

ON-VEHICLE SERVICE

COMPONENT PART
REPLACEMENT

NEUTRAL START SWITCH

C-K Models (Fig. 8-12)

Replacement and Adjustment

1. Disconnect battery ground cable.
2. Disconnect electrical harness at switch.
3. Remove switch mounting screws and remove switch.
4. Position shift lever in neutral gate notch.
5. Insert .096" gauge pin to depth of 3/8 inch into switch gauge hole. switch assembly is fixed in neutral position with internal plastic shear pin.
6. Assemble the switch to column by inserting the switch carrier tang in the shift tube slot and fasten in position by assembling mounting screws to retainers.

NOTE: If retainer strips out it must be replaced.

7. Remove .096" gauge pin.

8. Move shift lever out of neutral gate notch to park gate position to shear switch internal plastic pin.

9. Return shift lever to neutral gate notch.

10. Switch gauge hole will freely admit .080" gauge pin to a depth of 3/8 inch.

11. If pin will not freely enter gauge hole, switch must be reset as below.

12. Connect battery ground cable and electrical harness.

Reset Installation Procedure

1. Place shift lever in neutral gate notch.
2. Loosen attaching screws.
3. Rotate switch on column and insert .096" gauge pin to depth of 3/8 inch.
4. Tighten attaching screws.
5. Repeat installation procedure Steps 7 through 12 above.

G-P Models**Replacement (Fig. 8-12)**

1. Raise vehicle on a hoist.
2. Disconnect the switch harness from the switch.

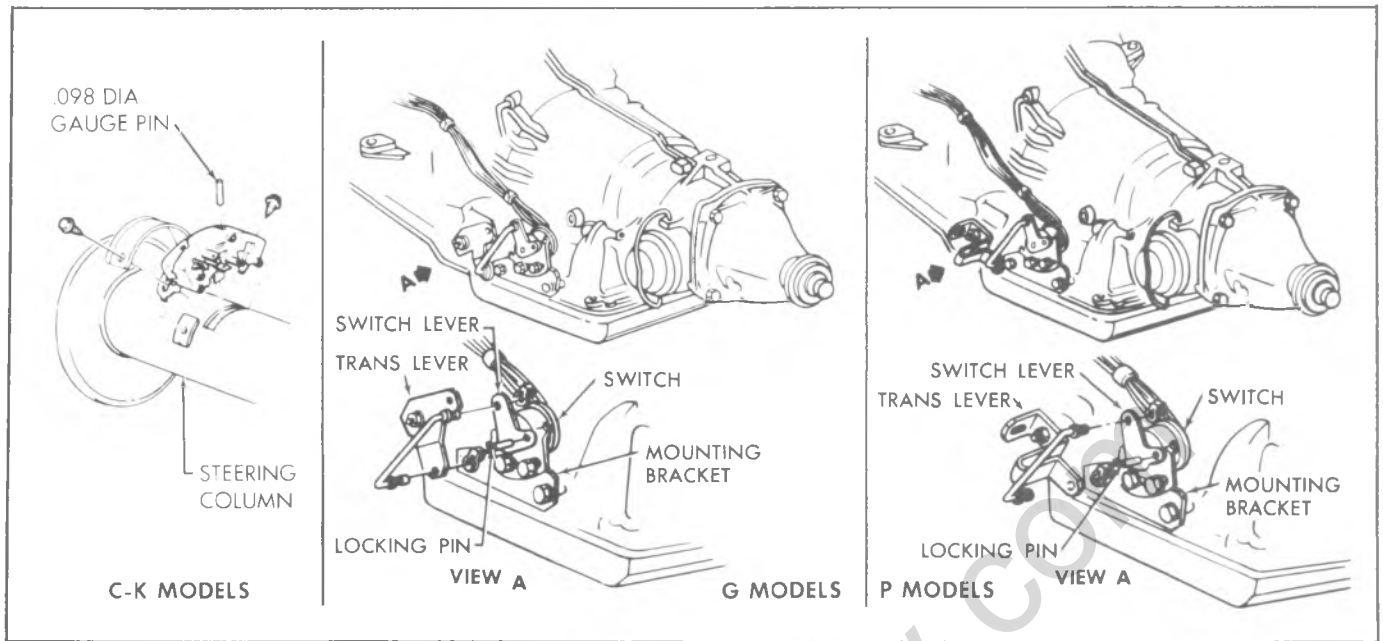


Fig. 8-12--Neutral Start Switch Replacement - Typical

3. Remove switch mounting bolts and remove switch.
4. Assemble new switch loosely to mounting bracket.
5. Align .093/.097" hole in Lever (B) with hole in Switch Assembly. Insert Pin (A) to hold in NEUTRAL position.
6. Set Transmission Lever (C) in NEUTRAL position by the following method.

NOTE: Obtain NEUTRAL by moving Transmission Lever counterclockwise to L1 detent, then clockwise three detents to the NEUTRAL detent position.

7. Install Rod into Transmission Lever and Switch Lever. Secure with clips.
8. Tighten switch attaching screws.
9. Lower vehicle from hoist and carefully check switch operation.

BACKING LAMP SWITCH

See "Neutral Start Switch" for automatic transmission models.

Column Mounted Switch (Manual Transmission)

Replacement

1. Disconnect battery ground cable.
2. Disconnect switch wiring harness.
3. Remove column mounting screws and remove switch.
4. Assemble the switch to the column. Fasten in position by installing mounting screws.
5. Install battery ground cable.

6. Check operation to make sure back-up lights come on in reverse gear only.

Transmission Mounted Switch

Replacement

1. Raise vehicle on a hoist.
2. Disconnect switch wiring harness.
3. Remove switch from transmission.
4. To install a new switch, reverse Steps 1-3 above.

WINDSHIELD WASHER/WIPER SWITCH

C-K Models

Replacement

1. Disconnect battery ground cable.
2. Remove instrument panel bezel screws and bezel.
3. Remove switch attaching screws.
4. Pull out on switch assembly and disconnect electrical harness - remove switch.
5. To install, reverse Steps 1-4 above. Check switch operation before reinstalling instrument panel bezel.

G Models

Replacement

1. Disconnect battery ground cable.
2. Reach up behind left side of instrument panel, and:
 - a. Remove plug connector from rear of switch.
 - b. Remove (3) mounting screws securing bezel and ground wires to switch.
3. Replace switch, installing ground wire and

connector. Check operation of switch, first observing washer solvent level.

IGNITION SWITCH

C-K Models

See Section 3B - Steering, for ignition switch replacement procedure.

G Models

Replacement (Fig. 8-13)

1. Disconnect battery ground cable.
2. Remove lock cylinder by positioning switch in "ACC" position and inserting stiff wire in small hole in cylinder face. Push in on wire to depress plunger and continue to turn key counterclockwise until lock cylinder can be removed.
3. Remove metallic ignition switch nut.
4. Pull ignition switch out from behind instrument panel and remove "theft resistant" connector. Use a screwdriver to unsnap locking tangs on connector from their position on switch.
5. Snap connector into place on new ignition switch.
6. Place switch into position from behind instrument panel, first adding grounding ring then install ignition switch nut.
7. Install lock cylinder, key inserted.
8. Install battery ground cable.

INSTRUMENT CLUSTER

C-K Models

Replacement (Fig. 8-14)

1. Disconnect battery ground cable.
2. Remove headlamp switch control knob.

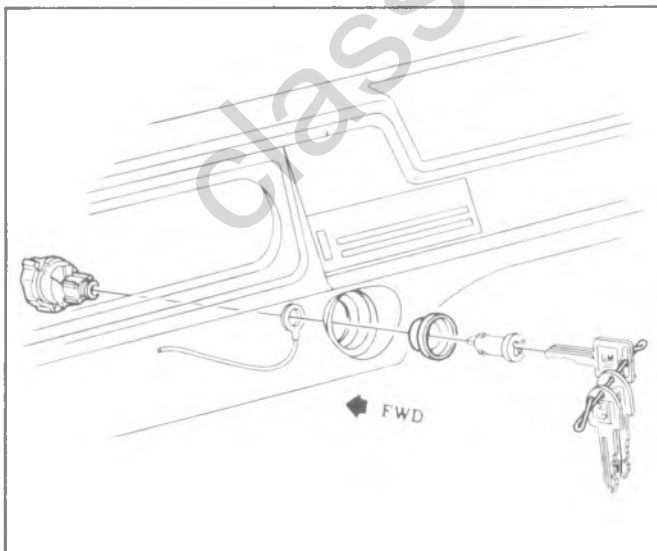


Fig. 8-13-Ignition Switch (G Models)

3. Remove radio control knobs.
4. Remove eight screws and remove instrument bezel.
5. Reach up under instrument cluster and disconnect speedometer by first depressing tang on rear of speedometer head, then pulling cable free from head as tang is depressed.
6. Disconnect oil pressure gauge line at fitting in engine compartment.
7. Pull instrument cluster out just far enough to disconnect line from oil pressure gauge.
8. Remove cluster to bench for further disassembly (laminated printed circuit, speedometer head, gauges).
9. Install cluster in reverse order of removal.

G Models

Replacement (Fig. 8-15)

1. Disconnect battery ground cable.
2. Reach up under instrument cluster and disconnect speedometer cable by first depressing tang on rear of speedometer head, then pulling cable free from head as tang is depressed.
3. Unplug instrument panel harness connector from printed circuit.
4. Disconnect oil pressure line from gauge if so equipped.
5. Remove two nuts attaching instrument cluster studs to lower opening in instrument panel.
6. Pull top of cluster away from instrument panel and lift out bottom of cluster.
7. Remove cluster to bench for further disassembly (laminated printed circuit, speedometer head, gauges).
8. Install cluster in reverse order of removal, noting that clips at top of cluster slip into instrument panel opening after bottom of cluster is installed.

INDICATOR AND ILLUMINATING BULBS

All Models

Replacement (Figs. 8-14 and 8-15)

1. Reach up under instrument panel and turn bulb holder counterclockwise to remove from cluster housing.
2. Pull bulb straight out to remove from holder.
3. Install replacement bulb in holder, press inward to lock in place.
4. Insert holder into housing, with lugs on holder entering notches in case, and turn clockwise to lock holder against printed circuit.

LAMINATED (PRINTED) CIRCUIT

All Models

Replacement

1. Remove instrument cluster assembly as previously described in this section.
2. Remove all instrument cluster lamp bulb assemblies.
3. Remove laminated circuit retaining screws.

NOTE: These screws serve as a ground for the

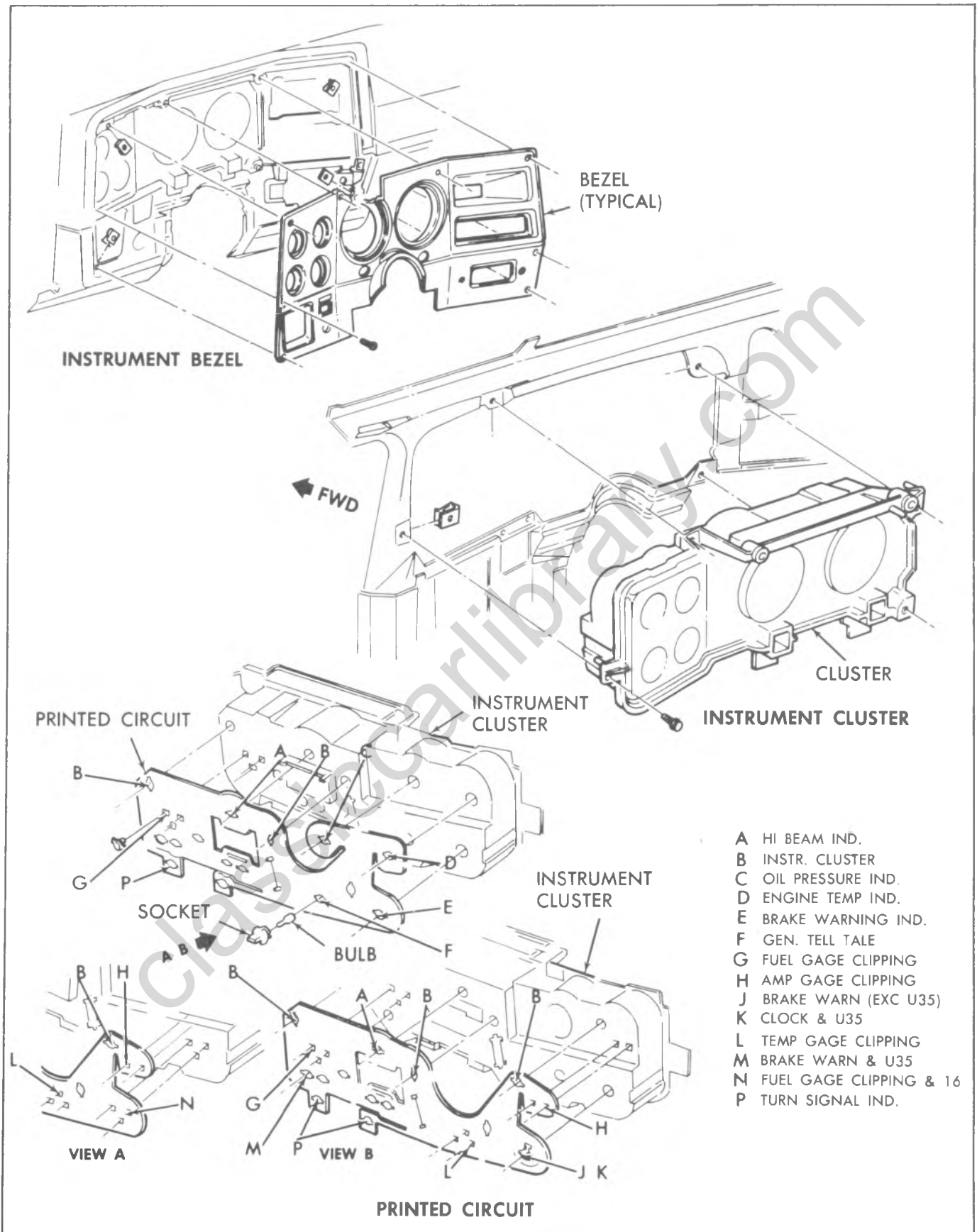


Fig. 8-14--Instrument Cluster Assembly (C-K Models)

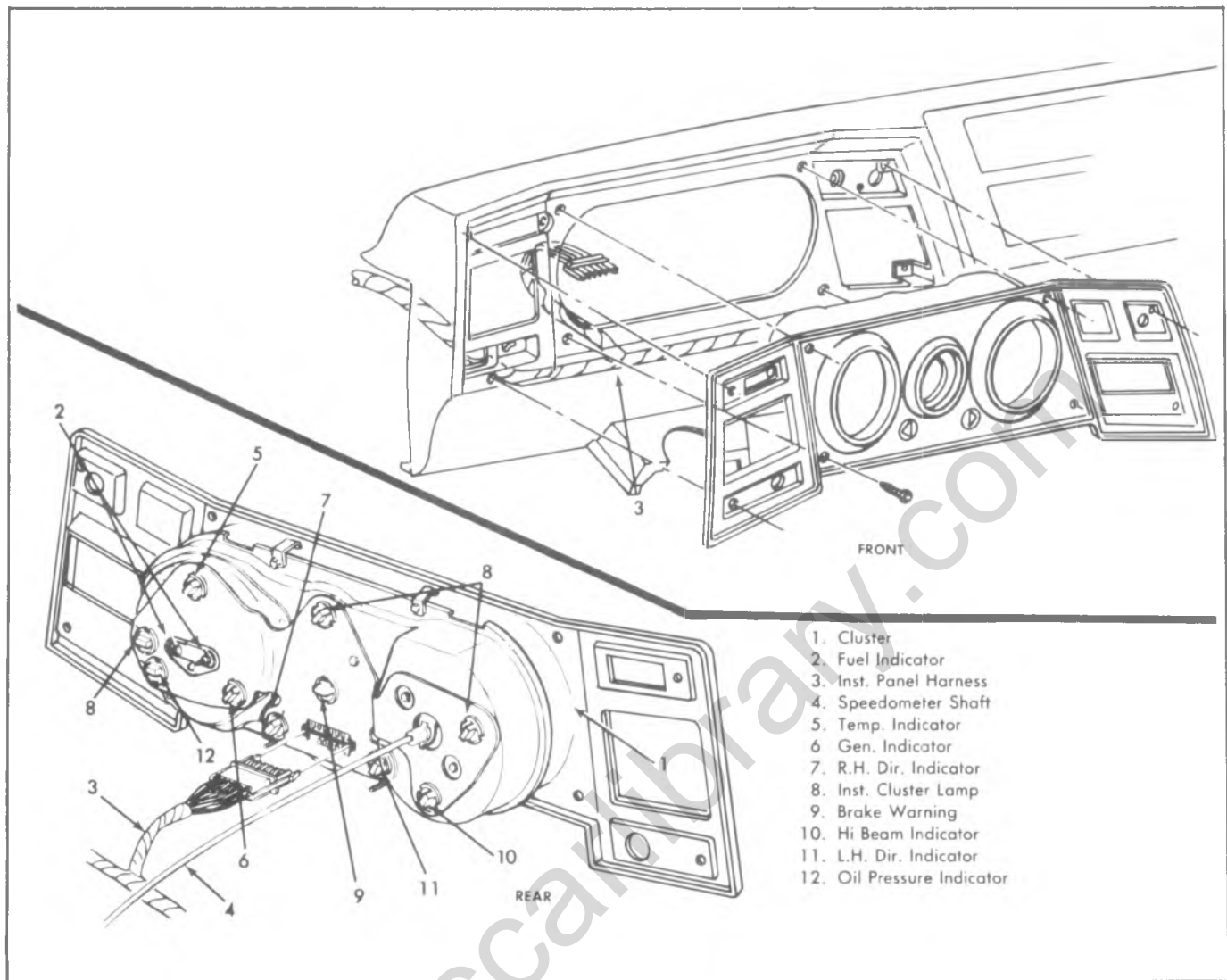


Fig. 8-15--Instrument Cluster Assembly (G Models)

circuit and must be reinstalled to provide the proper ground.

4. **G Models** - Remove fuel, temperature and ammeter terminal nuts retaining laminated circuit to rear of cluster.

5. Lift laminated circuit from cluster cover.

6. To install, reverse Steps 1-5 and check electrical operation of all affected components.

SPEEDOMETER

NOTE: Servicing of the speedometer assembly should only be performed by trained technicians having the proper test equipment.

C-K Models

Replacemnt

1. Disconnect battery ground cable.
2. Remove headlamp switch control knob.
3. Remove radio control knobs and clock adjuster stem.

4. Remove instrument cluster bezel and steering column cover.

5. Remove instrument cluster lens.

6. Remove transmission PRNDL indicator and case front cover.

7. Remove speedometer to cluster screws and speedometer assembly.

8. To install, reverse removal procedure. Check speedometer operation.

G Models

Replacement

1. Remove instrument cluster as previously described in this section.

2. Remove four screws retaining cluster rear cover containing speedometer.

3. Remove two hex head screws and rubber grommets securing speedometer assembly to cluster cover.

4. To install, reverse removal procedure and check operation of speedometer assembly.

CAUTION: Use care to prevent kinking the speedometer cable during removal and installation.

SPEEDOMETER CABLE CORE

All Vehicles

Replacement

1. Disconnect battery ground cable.
2. Disconnect speedometer cable from speedometer head by reaching up under instrument panel, depressing spring clip and pulling cable from head.
3. Remove old core by pulling it out at end of speedometer cable casing.

NOTE: If old cable core is broken it will be necessary to remove lower piece from transmission end of casing.

4. Lubricate entire length of cable core with speedometer cable lubricant.
5. To install, reverse Steps 1-3 above.

CAUTION: Use care to prevent kinking speedometer cable core during installation.

FUEL GAUGE

C-K Models

Replacement

1. Perform Steps 1-5 of "Instrument Cluster - Replacement".
2. Remove fuel gauge attaching screws and remove the gauge.
3. To install, reverse Steps 1-2 above. Check gauge operation.

G Models

Replacement

1. Remove instrument cluster assembly as previously described.
2. Remove instrument cluster bulb holders, ground screws, nuts and washers retaining laminated circuit to fuel gauge rear cover.
3. Remove three screws retaining fuel gauge rear cluster cover.
4. Lift gauge away from laminated circuit and rear cluster cover.
5. To install, reverse Steps 1-4 and check operation of fuel gauge.

NOTE: Mount insulator strip on fuel gauge studs first, then resistor, then a nut on each stud, next the laminated circuit, then a plain washer on each of two studs holding laminated circuit and finally a nut on back of the studs that have a washer and laminated circuit.

TEMPERATURE GAUGE

C-K Models

Replacement

1. Perform Steps 1-5 of "Instrument Cluster - Replacement".
2. Remove temperature gauge attaching screws and remove the gauge.
3. To install, reverse Steps 1 and 2 above and check gauge operation.

NOTE: Be sure gauge studs engage clips holding laminated circuit to back of cluster housing.

G Models

Replacement

1. Remove instrument cluster assembly as previously described in this section.
2. Remove terminal nuts retaining laminated circuit to gauge unit.
3. Remove attaching screws, cover and gauge assembly from cluster housing.
4. Remove terminal attaching nuts and gauge unit from cover plate.
5. To install, reverse removal procedure and check operation of gauge.

TEMPERATURE SENDING UNIT

Replacement

WARNING: Do not remove cap with engine hot, allow vehicle to cool off first.

1. Relieve cooling system pressure by loosening radiator cap to first stop. Tighten cap after pressure is relieved.
2. Disconnect sending unit wiring harness.
3. Remove sending unit from the engine.
4. Install new sending unit and connect electrical harness.
5. Check coolant level and unit operation.

NOTE: Coolant must have at least 0°F (-18°C) freeze protection for sending unit to function properly.

OIL PRESSURE GAUGE

C-K Models

Replacement

1. Perform Steps 1-5 of Instrument Cluster - Replacement" procedure.
2. Reach up under the instrument panel and place a cloth under the line to gauge connection. Remove line to gauge nut.
3. Remove gauge to cluster attaching screws and remove gauge.

4. To install, reverse Steps 1-3 above and check gauge operation.

G Models

Replacement

1. Remove instrument cluster as previously described in this section.

NOTE: Oil pressure line connection may leak oil when opened; wrap with cloth.

2. Remove bulb holders, grounding screws and lift laminated circuit aside as necessary.

3. Remove instrument cluster cover to separate oil pressure gauge from cluster.

4. Remove pipe fitting and retaining nut from gauge being replaced then remove gauge from cluster **DO NOT KINK PIPE.**

5. To install replacement oil pressure gauge, reverse Steps 1-4, then observe operation of gauge.

OIL PRESSURE SENDING UNIT

All Models

Replacement

1. Disconnect wiring harness connector from sending unit terminal located in block above starter on L-6 engines, at left front of distributor on V-8 (except 454 V-8) or rear left side of block (454 V-8) engines.

2. Remove sending unit using Tool J21757. Replace with new unit and check operation.

VOLTMETER

C-K Models

Replacement

1. Perform Steps 1-5 of "Instrument Cluster - Replacement" procedure.

2. Remove gauge to instrument panel screws and remove meter.

3. To install, reverse Steps 1 and 2 above and check meter operation.

NOTE: Be sure meter studs engage clips holding printed circuit to back of cluster housing.

G Models

Replacement

1. Remove instrument cluster assembly as previously described in this section.

2. Remove terminal nuts retaining laminated circuit to meter.

3. Lay back laminated circuit portion after removing grounding screws and bulb holders.

4. Remove attaching screws, cover and meter from cluster housing.

5. Remove terminal attaching nuts and meter from cover plate.

6. To install, reverse Steps 1-5 and check operation of meter.

DIRECTIONAL SIGNAL SWITCH

The directional signal switch is a self-contained unit which incorporates the hazard warning switch and the lane changing signal.

The hazard warning circuit is activated by a push-pull switch which is located on the right side of the steering column, opposite the directional signal lever. The switch knob must be pulled to cancel circuit.

The lane changing circuit is activated by holding the directional signal lever in the first detent position; there is no lock in or cancelling device in this position.

See Section 3B "Steering" for all servicing procedures.

WINDSHIELD WIPER AND WASHER

C-K-G MODELS

GENERAL DESCRIPTION

The wiper motor assembly consists of compound wound 12 volt D.C. motor, gear reduction mechanism and parking switch enclosed in a common die cast housing. The armature has a worm shaft which drives a gear and shaft assembly. A crank arm which is attached

externally to the gear shaft, operates the linkage which activates the blades.

The wiper motor is equipped with an internal circuit breaker mounted on the motor brush plate which protects the motor from overheating.

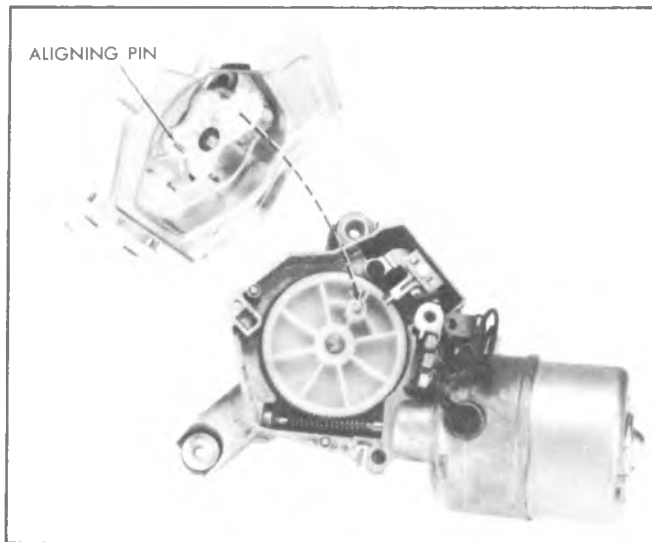


Fig. 8-16--Washer Mechanism Mounting on Wiper

Figure 8-16 shows the assembly of the washer pump to the wiper motor.

ELECTRICAL CIRCUITS

The following facts should be kept in mind throughout the following explanation.

1. The wiper dash switch is a grounding type switch, and therefore must be securely mounted.
2. When installed in a vehicle, the wiper motor is connected to the chassis through a ground strap. This in effect connects the wiper housing to the ground side of the battery.
3. The ignition switch opens and closes the feed wire circuit to the wiper. Therefore, it must be turned ON to operate wipers.

The wiper motor operation is controlled by two switches—a dash control switch and a parking switch located in the wiper motor gear box.

The parking switch contacts are normally closed and are opened by a cam on the gear when the wiper blades reach the park position. The park switch acts as a holding switch to maintain the motor circuits to ground during that period of operation between the time the operator turns the wiper off at the dash switch and the blades reach the park position. Figure 8-17 shows the park switch contact open.

"Lo" Speed Operation

When the operator turns the wiper dash switch to the "LO" speed position, the wiper motor circuits are completed to ground at the dash switch as follows: (Refer to Figure 8-18). Current flows from the battery through the ignition switch to the center terminal of the wiper terminal board. From the center terminal, current then passes through the black with pink stripe lead to the series field coils (Larger diameter wire) where it divides and flows as follows:

1. The shunt field coils to wiper terminal No. 3 through the wiring harness to the dash switch to ground.

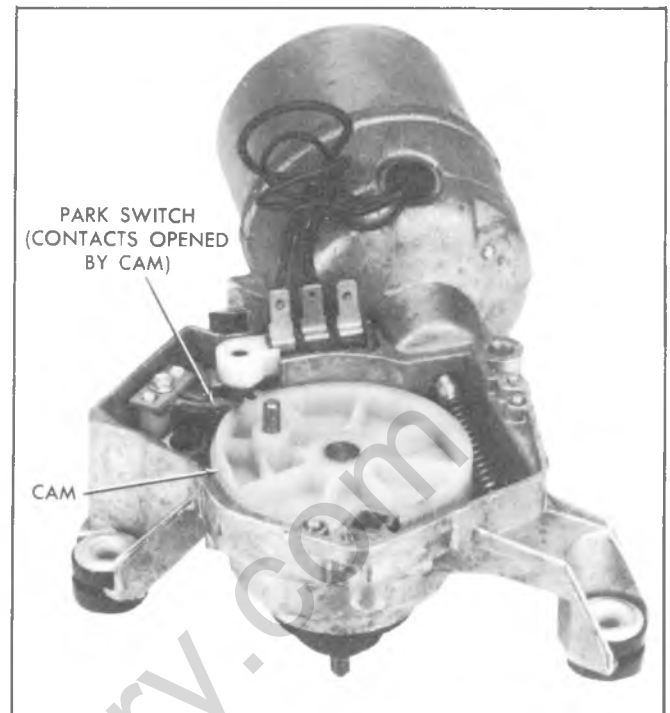


Fig. 8-17-Gear in PARK Position—Contacts Open

2. The series field-armature circuit is completed via wiper terminal No. 1 through the wiring harness to the dash switch to ground.

"HI" Speed Operation

Turning the wiper dash switch to the "HI" or fast speed position changes the shunt field coil circuit as follows: (Refer to Figure 8-19).

With the dash switch in the HI speed position, the shunt field coil current passes through a 20 ohm resistor on the back of the wiper terminal board to terminal No. 1 and then via the wiring harness to the dash switch to ground. The armature and series field circuit is also completed via the wiring harness from wiper terminal No. 1 to the dash switch to ground.

Turning the Wiper "OFF"

Turning the wiper dash switch to the OFF position opens the wiper circuits to ground at the dash switch. If, however, the wiper blades are in any position other than the normal park or off position, the wiper motor circuits are completed to ground by the wiper motor park switch as follows: (Refer to Figure 8-20).

1. The series field-armature circuit is completed to ground via the parking switch to the wiper housing to chassis of vehicle.
2. The shunt field coil circuit is completed to ground via wiper terminal No. 3 through the wiring harness to the dash wiring harness to wiper terminal No. 1, through the parking switch to ground.

IMPORTANT: Note that the shunt field circuit during the parking operation bypasses the resistor causing the wiper to operate in

LO Speed. Failure of the wiper to operate in LO Speed during parking results in the wiper failing to shut off.

With the wiper motor circuits completed to ground via the parking switch, the wiper motor continues to

operate until the wiper gear cam opens the park switch contact (Figure 8-17) stopping the wiper.

See Figure 8-21 for Wiper OFF Circuit.

Pulse type wipers use the same wiper motor as regular wipers but are controlled by an external mounted control unit.

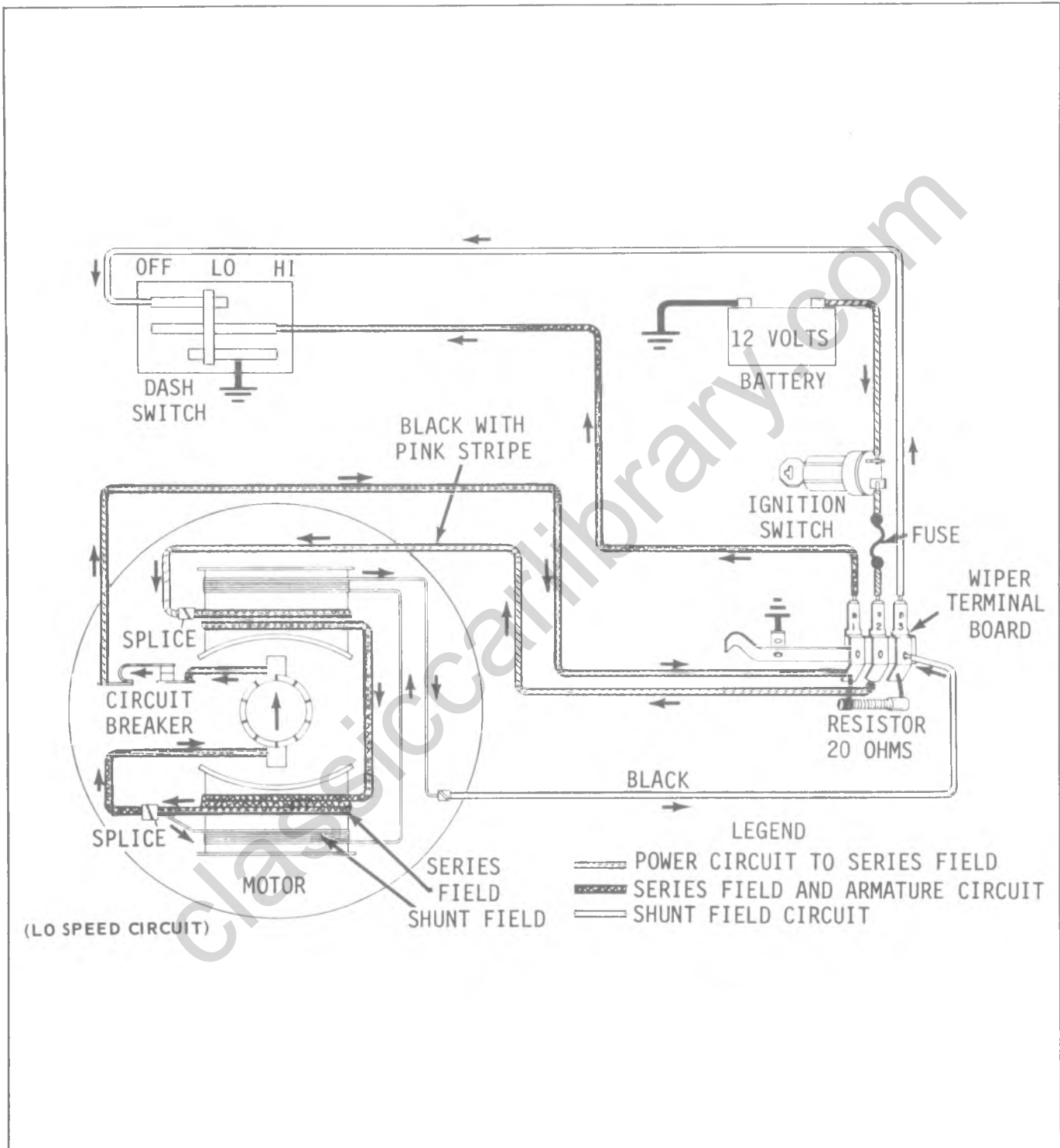


Fig. 8-18-LO Speed Circuit

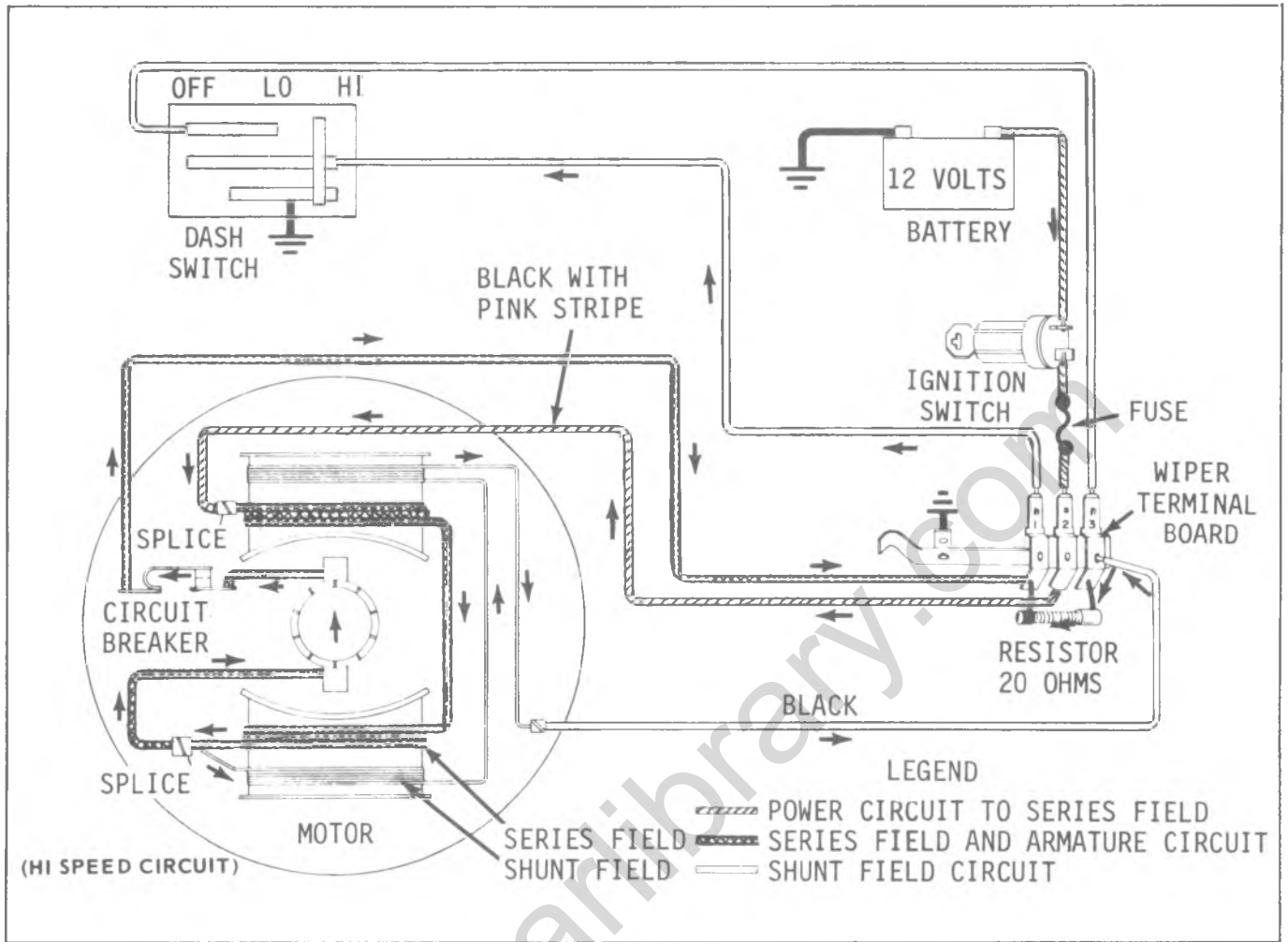


Fig. 8-19--HI Speed Circuit

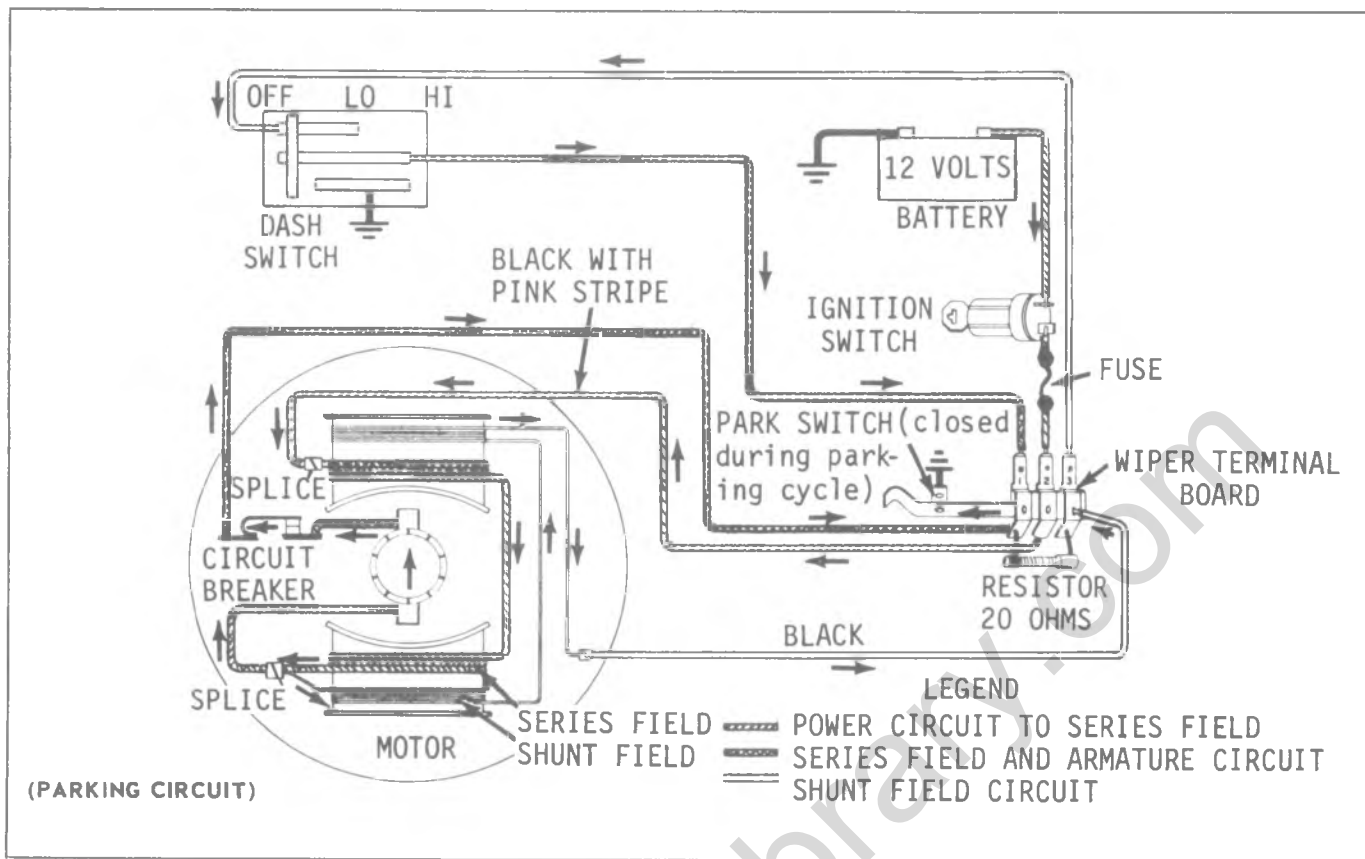


Fig. 8-20-PARKING Circuit

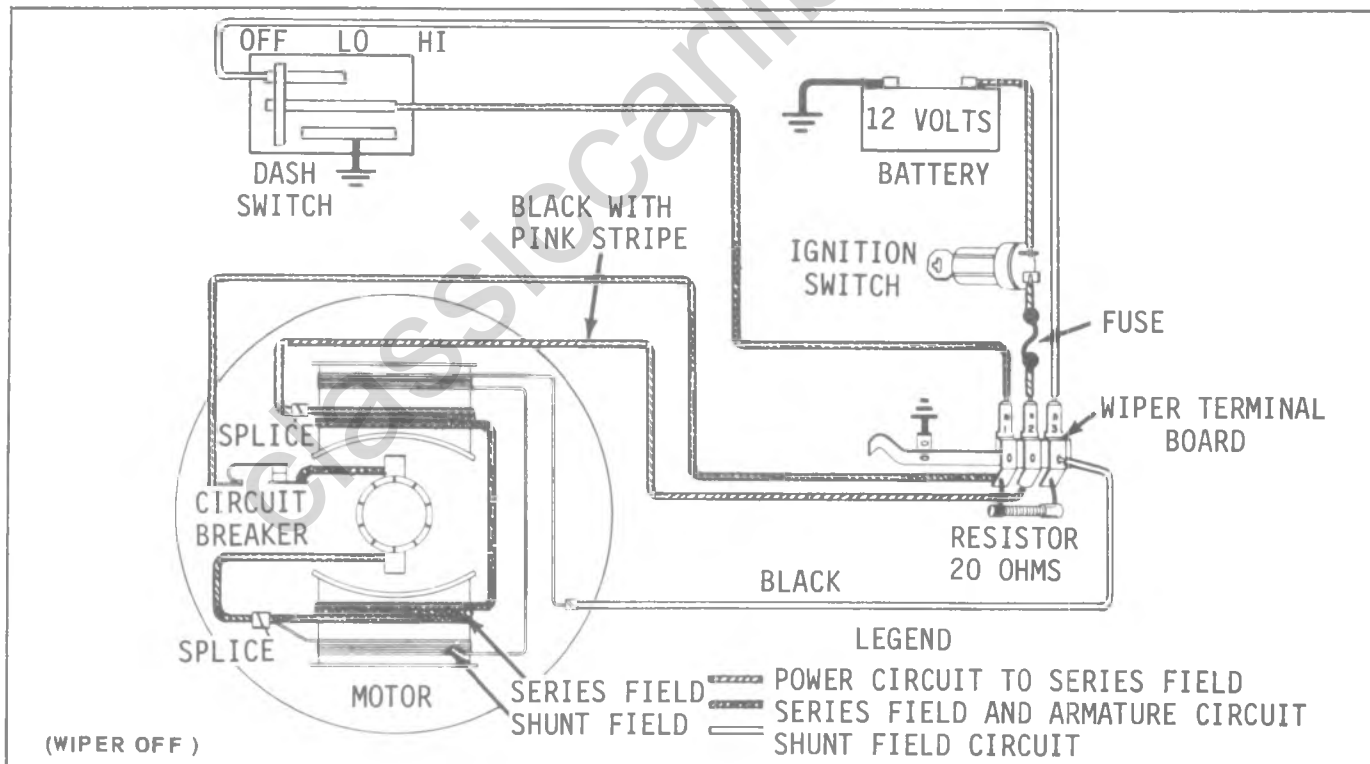


Fig. 8-21-OFF Circuit

DIAGNOSIS

WIPER - ON VEHICLE

Troubleshooting with wiper installed on the vehicle consists of two basic steps: (A) Preliminary inspection and (B) Operating wiper independent of vehicle wiring and dash switch.

Preliminary Inspection Procedure

A. Preliminary Inspection - Check the following items:

1. Body wiring securely connected to wiper unit and dash switch.
2. Wiper ground connection to vehicle chassis.
3. Dash switch is mounted securely.
4. Fuse.
5. With ignition switch "ON", there should be 12 volts at center terminal (No. 2) of wiper connector body. Refer to Figure 8-22 for #2 terminal location.

B. To determine if wiper is cause of trouble, disconnect existing harness from wiper and connect jumper leads to wiper terminals as shown in Figure 8-22. Try operating wiper in LO and HI speeds. Also check if wiper will shut off properly (blades in park position).

If wiper operates correctly, trouble must be in wiring harness or dash switch. Refer to TROUBLE CHART. If wiper fails to operate correctly, remove wiper and check it per instructions in TROUBLE CHART - WIPER DETACHED.

WIPER - OFF VEHICLE

Connect Ammeter (0-30 amps), Power Source and Jumper wires to wiper as shown in Figure 8-22. Observe current draw, determine type of trouble that exists and refer to the TROUBLE CHART - WIPER DETACHED.

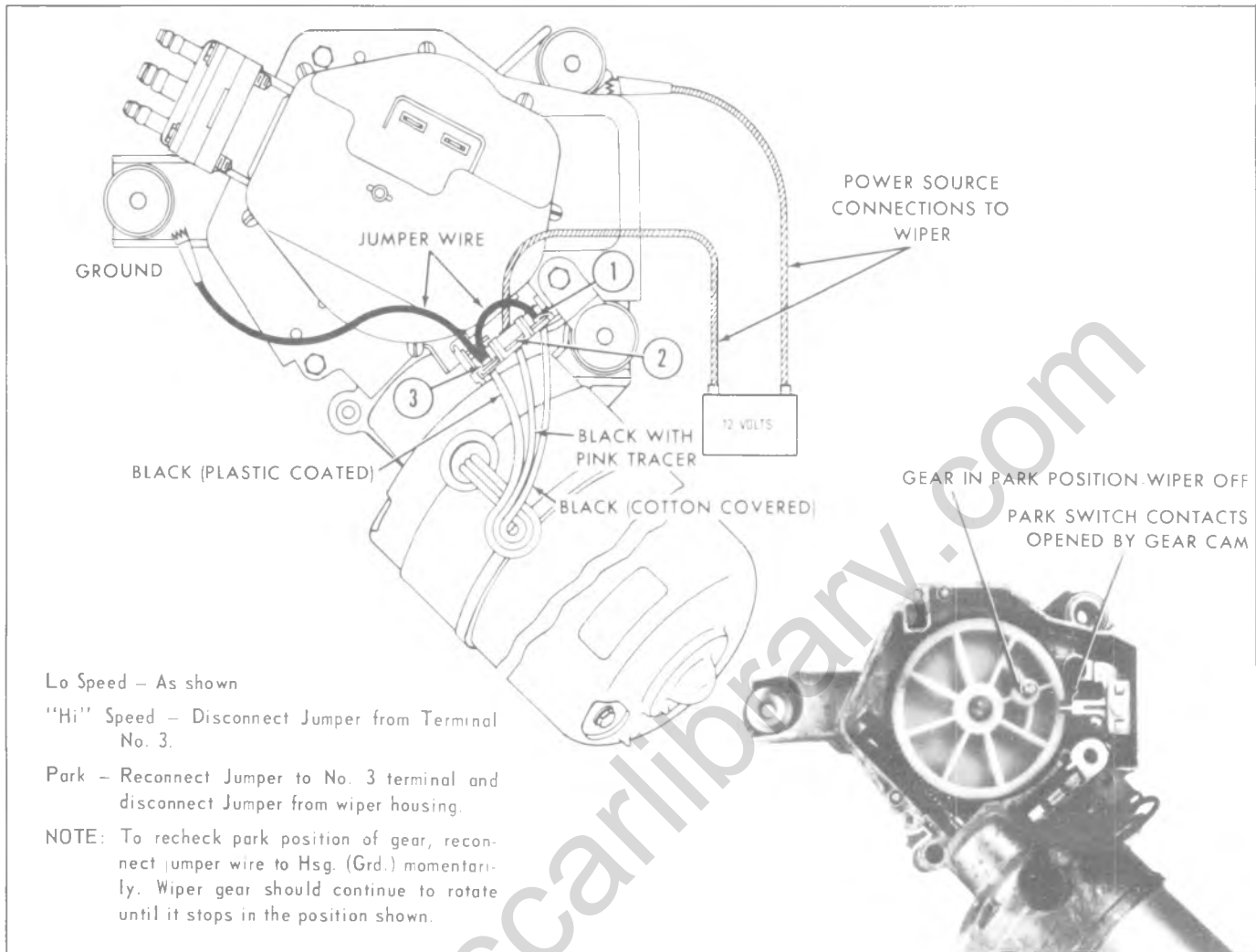
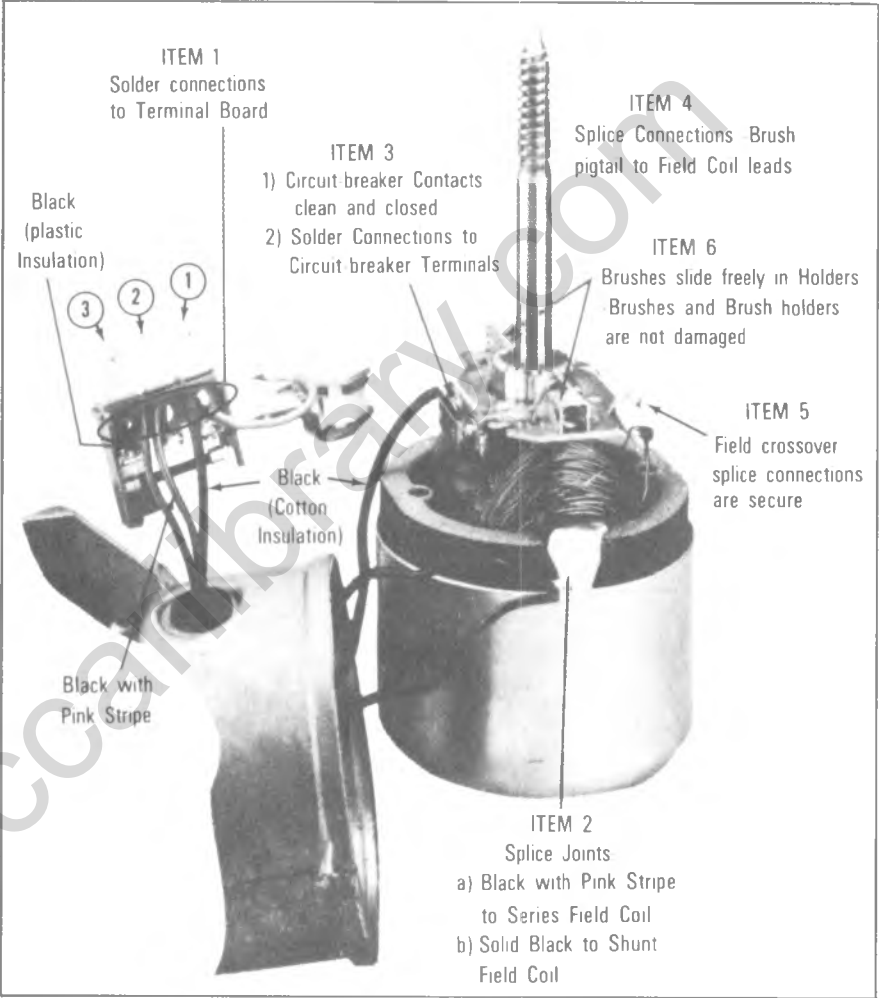


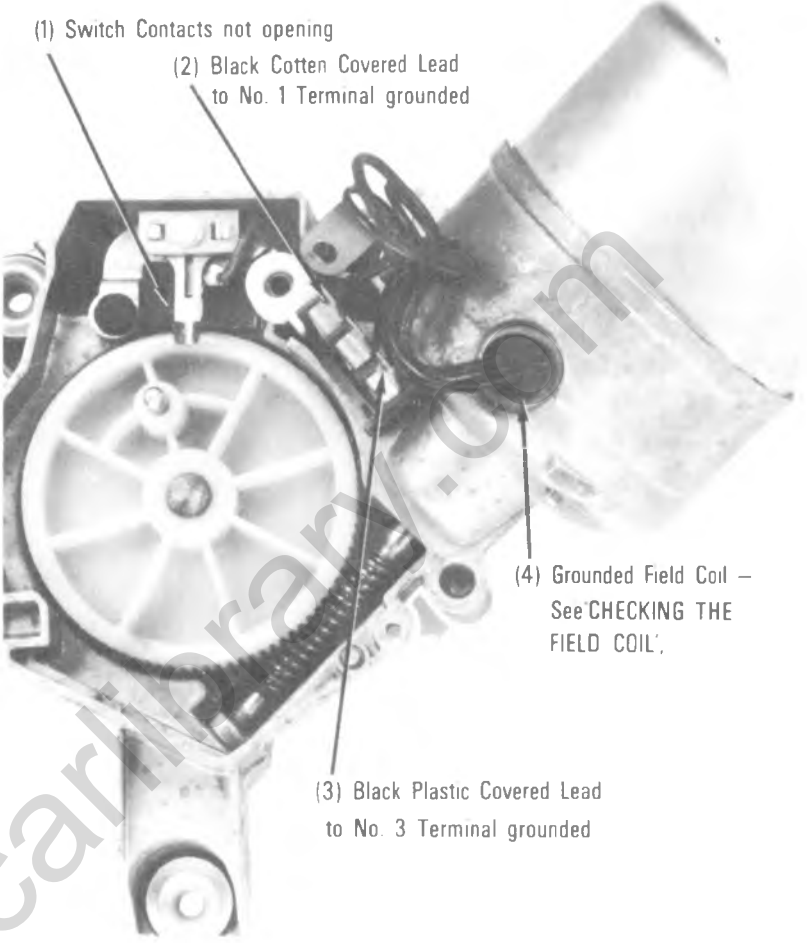
Fig. 8-22 Wiper Motor Diagnosis Diagram

TROUBLE CHART	
Wiper Performs Correctly in Step "B" But ORIGINAL TROUBLE Was	POSSIBLE CAUSE
1 — Wiper inoperative	<ul style="list-style-type: none"> — No voltage supply at wiper (Blown fuse or open in wire that connects to No. 2 wiper terminal.) — Defective Dash Switch — Wire from Wiper Terminal No. 1 to dash switch open.
2 — Wiper would not shut off but had: <ul style="list-style-type: none"> (a) Both LO and HI speeds (b) LO speed only (c) HI speed only 	<ul style="list-style-type: none"> (a) Wire from wiper terminal 1 to dash switch grounded. (b) Wire from wiper terminal No. 3 to dash switch grounded. (c) Wire from wiper terminal No. 3 to dash switch open.
3 — Wiper had "HI" speed only	See item 2 (c) above
4 — Wiper had "LO" speed only	See item 2 (b) above
5 — Intermittent Operation	Loose dash switch mounting. Defective dash switch.

TROUBLE CHART – WIPER DETACHED

Trouble Description	Check the items shown in the views opposite trouble description
<p>(1) <u>Wiper Inoperative</u> and</p> <p>(a) Ammeter Reading – 0 Amp. Check items: 1, 2(a), 4 and 5</p> <p>(b) Ammeter Reading – 2.0–3.0 Amps Check items: 1, 3, 4, 6</p> <p>(c) Ammeter Reading – 20 + Amps Check for condition that will stall wiper, such as broken gear or locked armature.</p>	 <p>ITEM 1 Solder connections to Terminal Board</p> <p>ITEM 2 Splice Joints a) Black with Pink Stripe to Series Field Coil b) Solid Black to Shunt Field Coil</p> <p>ITEM 3 1) Circuit-breaker Contacts clean and closed 2) Solder Connections to Circuit breaker Terminals</p> <p>ITEM 4 Splice Connections - Brush pigtail to Field Coil leads</p> <p>ITEM 5 Field crossover splice connections are secure</p> <p>ITEM 6 Brushes slide freely in Holders Brushes and Brush holders are not damaged</p> <p>Black (plastic Insulation)</p> <p>Black (Cotton Insulation)</p> <p>Black with Pink Stripe</p>

TROUBLE CHART – WIPER DETACHED (CONT.)

Trouble Description	Check Items shown in views opposite trouble description
<p>(2) <u>Wiper will not shut off and</u></p> <p>(a) Wiper has both LO and HI Speeds. Check Items (1) and (2).</p> <p>(b) Wiper has LO Speed Only. Check Items (3) and (4).</p> <p>(c) Wiper has HI Speed Only. (Shunt field circuit open) Refer to trouble condition "Wiper Inoperative" and check Items 1, 2 (b), 4 and 5.</p>	 <p>(1) Switch Contacts not opening</p> <p>(2) Black Cotton Covered Lead to No. 1 Terminal grounded</p> <p>(3) Black Plastic Covered Lead to No. 3 Terminal grounded</p> <p>(4) Grounded Field Coil – See 'CHECKING THE FIELD COIL'.</p>
<p>(3) <u>Wiper has "HI" Speed Only</u></p>	<p>Refer to view opposite trouble condition "Wiper Inoperative" and check Items 1, 2 (b), 4 and 5.</p>
<p>(4) <u>Wiper has "LO" Speed Only</u></p>	<p>See Trouble Description 2 (b).</p>
<p>(5) <u>Wiper Gear and/or crank arm does not park correctly. Wiper gear and/or crank arm stops rotating immediately when wiper motor is shut off.</u></p>	<p>Check for bent, damaged or dirty park switch contacts. See Item (1) in view opposite Trouble Description No. 2 "Wiper will not shut "Off".</p>
<p>(6) <u>Wiper Speed Excessive in Hi Speed Mode</u> (Crank arm or gear rotation exceeds 80 RPM)</p>	<p>Open resistor on back of wiper terminal board.</p>

TROUBLE CHART – WIPER DETACHED (CONT.)

Trouble Description	Check items shown in view opposite trouble description.
(7) Intermittent Operation:	
(a) Current Draw Normal (3.5 – 5.0 amps.)	(1) Check for loose splice joints and/or solder joints. Refer to view opposite trouble description (wiper Inop). If items check out, a defective circuit breaker is indicated.
(b) Current Draw – 6 – 8 amps. (Wiper runs slow and is noisy.)	(1) Check for shorted or grounded armature. (2) Check armature end play (.002" – .003" Normal) (3) Check gear shaft end play (.005" Max.)

CHECKING THE ARMATURE AND FIELD COIL ASSEMBLY

Field testing the armature and continuity of field coils consists of using a test light similar to that shown in Figure A.

Disassemble Motor as required to gain access to the field and armature assemblies.

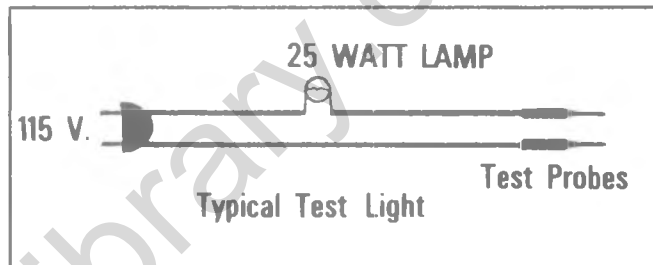


FIGURE A

Armature Checks:

Grounded—Touch test light probes to armature lamina and commutator. If armature is grounded, the lamp will light.

Open – A bar to bar check with the test light will indicate an open armature (Fig. B). If lamp does not light between any two adjacent commutator bars, an open armature is indicated.

Shorted – Test armature on growler for shorted condition.

Field Coil Checks:

IMPORTANT: Insulate brushes from armature commutator. A thin piece of paper will be adequate.

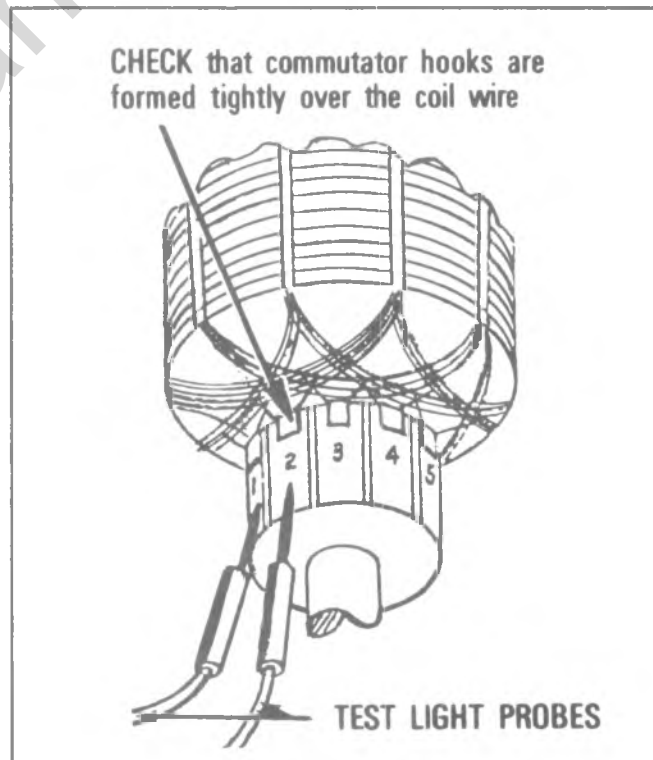


FIGURE B

CHECKING THE ARMATURE AND FIELD ASSEMBLY (CONT.)

- Open Check** Connect test light to following points. Refer to Figure C .
- Shunt Field:** Brush lead "A" and black wire terminal (No. 3) on wiper terminal board. If lamp fails to light, check splice joints — Items 2, 4 and 5 in Trouble Chart opposite wiper inoperative.
- Series Field:** Brush lead "A" and No. 2 terminal on wiper terminal board Figure C . If lamp fails to light, check splice joints — Items 2, 4 and 5 in Trouble Chart opposite wiper inoperative.
- Ground Check** Connect test light to field lamina and wiper terminal board, terminals 2 and 3. (Be sure End Cap and Field Lamina are not touching wiper gear casting.)

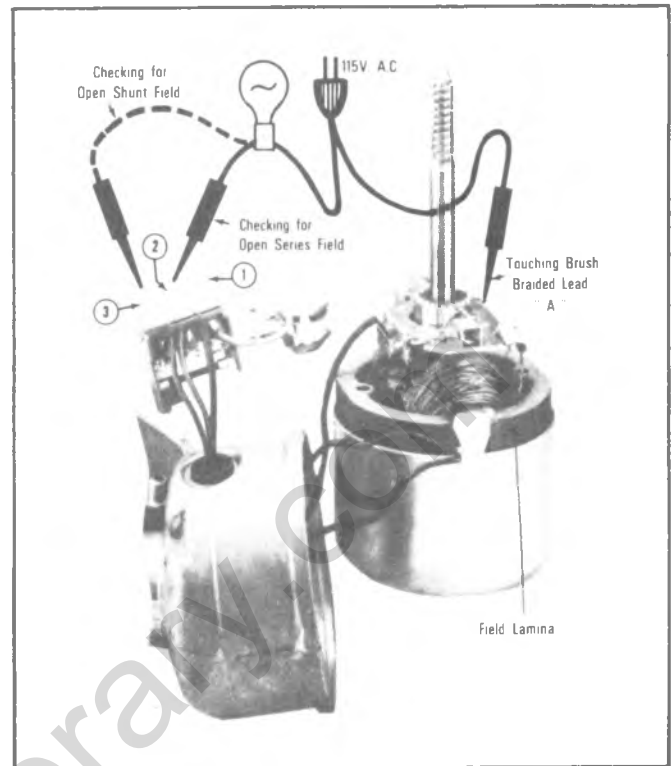


FIGURE C

DIAGNOSIS - WASHER SYSTEM

CONDITION	APPARENT CAUSE	CORRECTION
1. Washer inoperative	<p>A. Inadequate quantity of washer solution</p> <p>B. Hoses damaged or loose</p> <p>C. Plugged screen at end of jar cover hose</p> <p>D. Loose electrical connection to washer pump or wiper switch</p> <p>E. Open circuit in feed wire to pump solenoid coil</p> <p>F. Wiper switch defective</p> <p>G. Pump solenoid coil defective</p> <p>H. Washer nozzles plugged</p> <p>I. Ratchet wheel tooth missing</p> <p>J. Ratchet pawl spring missing</p> <p>K. Defective pump valve assembly</p>	<p>A. Add washer solution</p> <p>B. Cut short length to insure air tight connection or replace hose</p> <p>C. Clean screen</p> <p>D. Check electrical connection and repair if necessary</p> <p>E. Locate open circuit and repair</p> <p>F. Replace wiper switch</p> <p>G. Replace solenoid</p> <p>H. Clean washer nozzles</p> <p>I. Replace ratchet wheel</p> <p>J. Replace ratchet pawl spring</p> <p>K. Replace pump valve assembly</p>
2. Washer pumps continuously when wipers are operating	<p>A. Grounded wire from pump solenoid to switch</p> <p>B. Wiper Switch Defective</p> <p>C. Ratchet wheel tooth missing</p> <p>D. Ratchet wheel dog broken or not contacting ratchet wheel teeth</p> <p>E. Lock-out tang broken or bent on piston actuating plate</p>	<p>A. Locate grounded wire and repair</p> <p>B. Replace wiper switch</p> <p>C. Replace ratchet wheel</p> <p>D. Replace or repair ratchet wheel dog</p> <p>E. Replace piston actuating plate</p>

ON-VEHICLE SERVICE

COMPONENT PART REPLACEMENT

WIPER MOTOR

C-K Models

Replacement (Fig. 8-23)

1. Make sure wiper motor is in Park position.
2. Open hood and disconnect ground cable from battery.
3. Disconnect electrical harness at wiper motor and hoses at washer pump.
4. Reach down through access hole in plenum and loosen wiper drive rod attaching screws. Remove drive rod from wiper motor crank arm.
5. Remove wiper motor to dash panel attaching screws and remove the motor assembly.
6. To install, reverse Steps 1-5 above.

NOTE: Lubricate wiper motor crank arm pivot prior to reinstallation.

G Models

Replacement (Fig. 8-24)

1. Make sure wiper motor is in Park position.
2. Open hood and disconnect battery ground cable.
3. Remove wiper arms from wiper transmission linkage.
4. Remove remaining screws securing cowl panel cover and lift off.
5. Loosen nuts holding transmission linkage to wiper motor crank arm and lift linkage off arm.

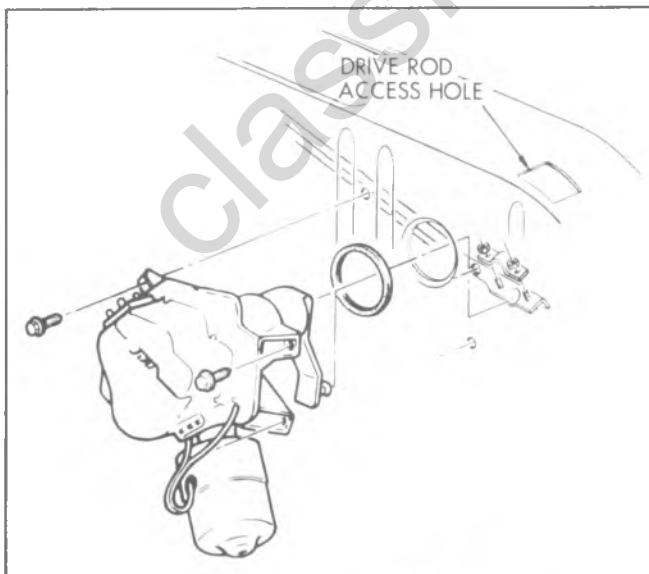


Fig. 8-23-Wiper Motor (C-K Models)

6. Disconnect power feed to wiper motor at multiple connector.

7. Remove left dash defroster outlet from flex hose and push hose aside for access to wiper motor screws.

8. Remove one screw securing left hand heater duct to engine cover shroud and slip heater duct down and out.

9. Protect carpet, then remove windshield washer hoses from washer pump.

10. Remove three screws securing wiper motor to cowl and lift wiper motor out from under dash for further disassembly on bench.

11. To install, reverse Steps 1-10 above.

NOTE: Install wiper in the PARK position. Lube wiper motor crank arm pivot prior to installation.

UNIT REPAIR

WIPER/WASHER DISASSEMBLY

Park Switch (Fig. 8-25)

1. Remove washer pump (fig. 8-16).
2. Remove screw retaining park switch.
3. Remove spacer.
4. Unsolder lead.

Terminal Board (Fig. 8-25)

1. Remove washer pump.
2. Remove spacer.
3. Unsolder leads.

Gear Assembly

1. Remove washer pump.
2. Remove park switch (See park switch removal). Unsolder lead only if required.
3. Clamp crank arm in vise and loosen crank arm retaining nut. Remove nut and crank arm (fig. 8-26).
4. Remove seal cap and using No. 22 External Snap Ring Pliers, remove the "C" retaining ring (fig. 8-27). Next, remove washer, end play washers, and outer spacer (fig. 8-28).
5. Slide the gear assembly out of the housing and remove the inner spacer washer (fig. 8-29).
6. To reassemble the gear box, reverse the disassembly procedure.

Crank Arm Assembly

1. Operate wiper gear to park position (fig. 8-26).
2. Position crank arm on gear shift flats according to position shown in Figure 8-26.
3. Install crank arm retaining nut finger tight, then

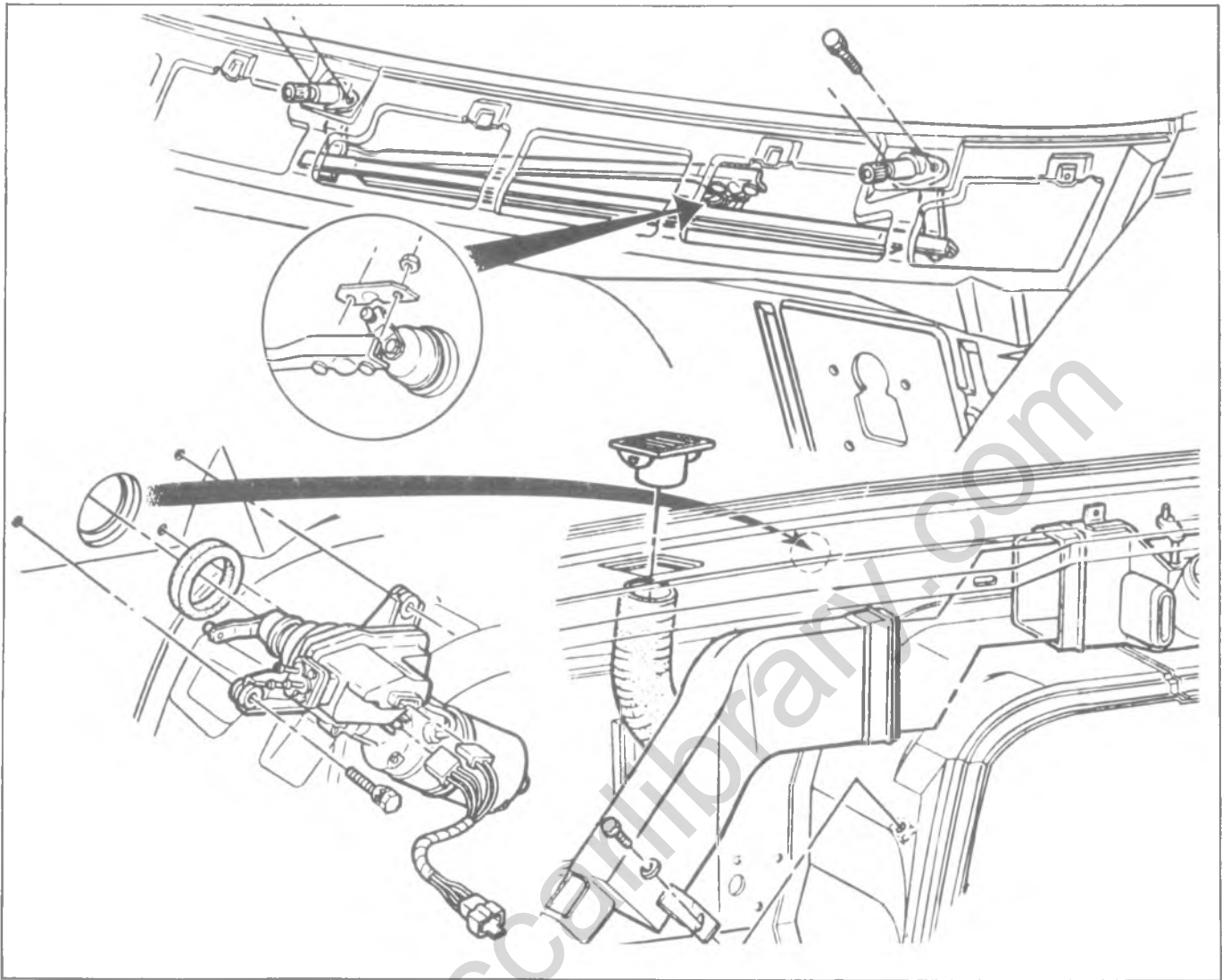


Fig. 8-24 - Wiper Motor (G Models)

clamp crank arm in vise and tighten retaining nut securely.

MOTOR DISASSEMBLY

NOTE: Motor section may be disassembled independently of the gear box.

Brush Plate and Circuit Breaker

Removal

1. Scribe a reference line along the side of the casting and end cap to insure proper reassembly.
2. Remove two motor through bolts.
3. Feed exposed excess length of motor leads through the casting grommet and carefully back the case and field assembly plus the armature away from the casting (fig. 8-30).

NOTE: It may be necessary to remove the armature end play adjusting screw and insert a rod

through the opening in order to apply pressure against the end of the armature.

4. Unsolder black cotton-covered lead from circuit breaker (fig. 8-31).
5. Straighten out the four tabs that secure brush plate to field coil retainers (fig. 8-31).

CAUTION: Be careful not to break any of the retainer tabs.

6. Install "U" shaped brush retainer clip over brush holder that has brush lead attached to circuit breaker (fig. 8-31).
7. Holding the opposite brush from that retained in Step 6, carefully lift brush holder off mounting tabs far enough to clear armature commutator (fig. 8-32).
8. Allow the brush, held in Step 7, to move out of its holder. Remove brush spring and lift brush holder off armature shaft.

Armature

Removal

1. Follow Steps 1 thru 8 under brush plate and circuit breaker removal.
2. Lift armature out of case and field assembly.
3. If armature is being replaced, remove thrust ball from end of defective armature shaft and install it in new armature.

NOTE: Thrust ball may be easily removed with a magnet.

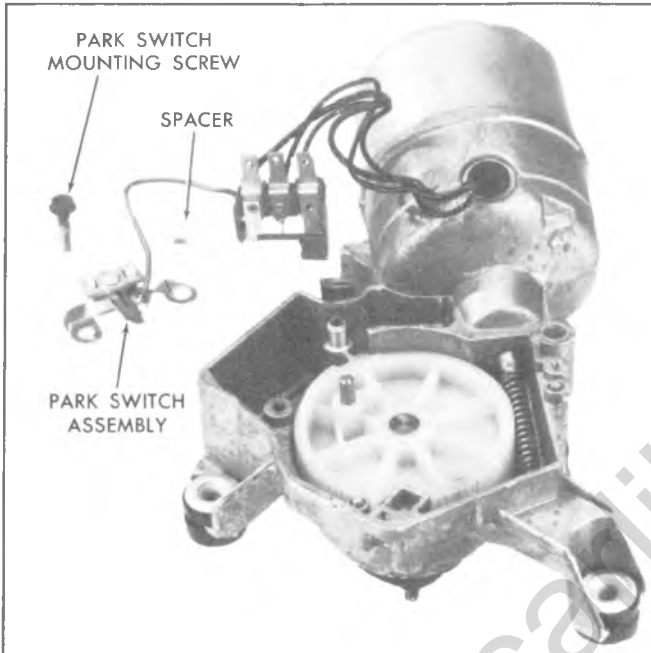


Fig. 8-25--Park Switch Removal

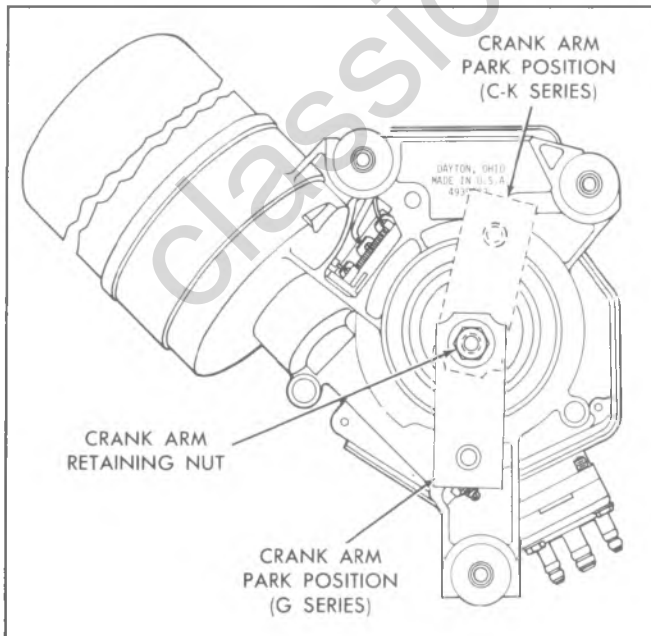


Fig. 8-26--Crank Arm in PARK Position

Case and Field Assembly

Removal

1. Remove brush plate and armature.
2. The end case and field assembly is serviced as a unit. To free the field and case assembly, cut the solid black plastic insulation and black with pink stripe leads in a location convenient for splicing—preferably near the wiper terminal board. Refer to Figure 8-31 for splicing location.

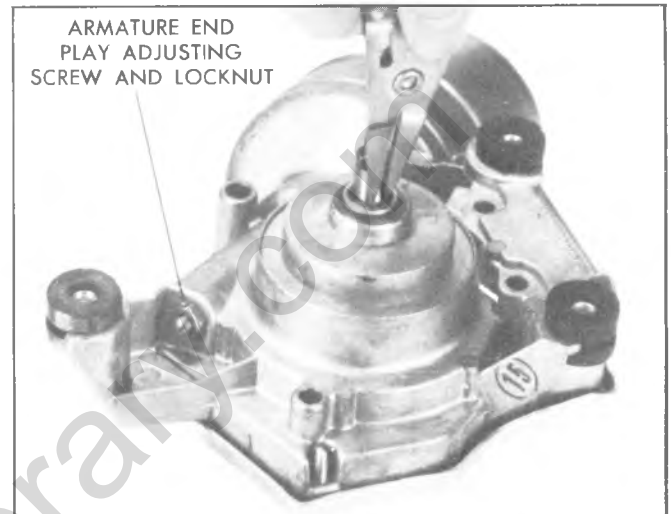


Fig. 8-27--"C" Ring Removal

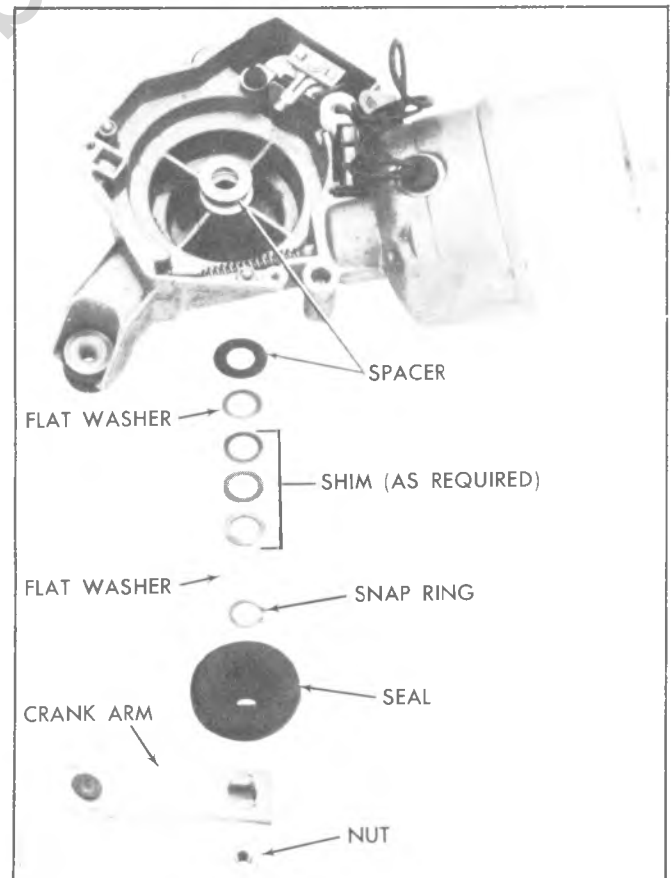


Fig. 8-28--Assembly Above Drive Gear

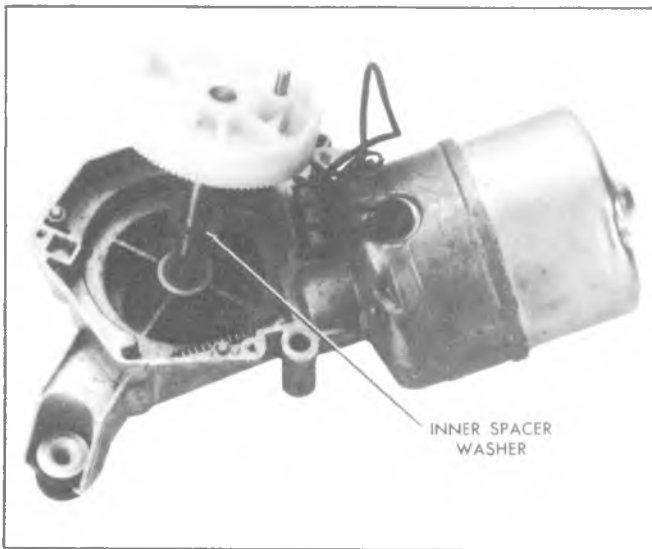


Fig. 8-29 - Drive Gear Removal

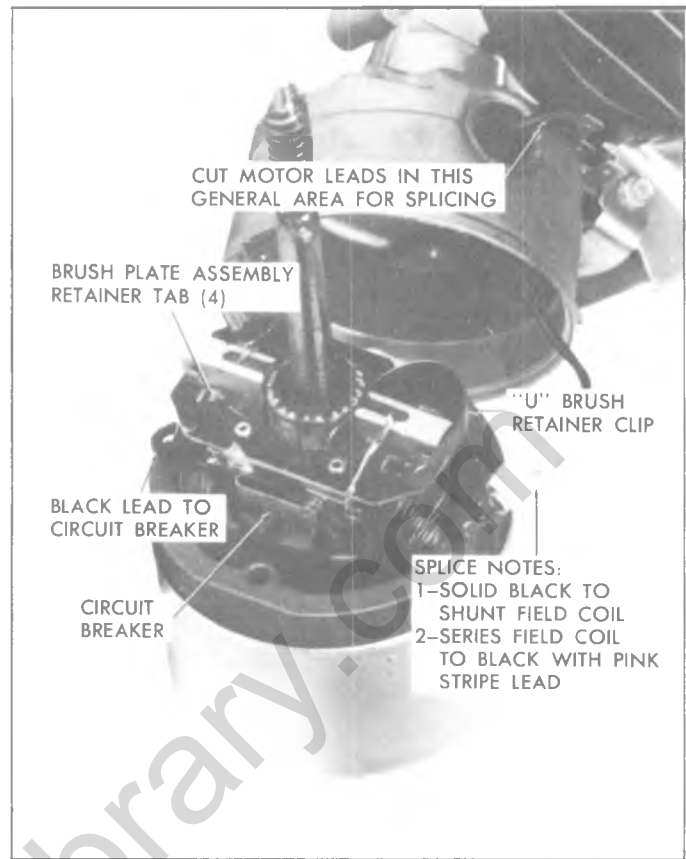


Fig. 8-31 - Circuit Breaker

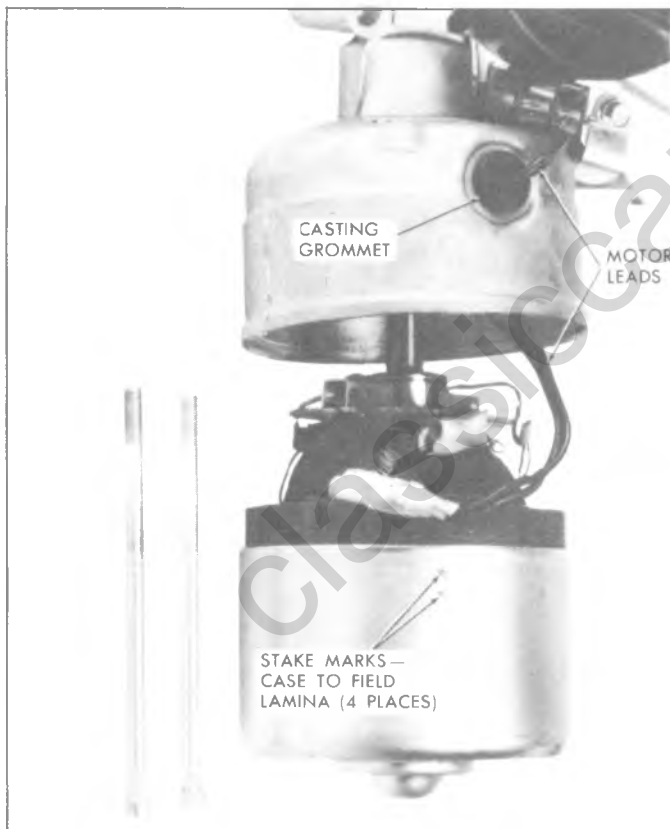


Fig. 8-30 - Wiper Motor Separation

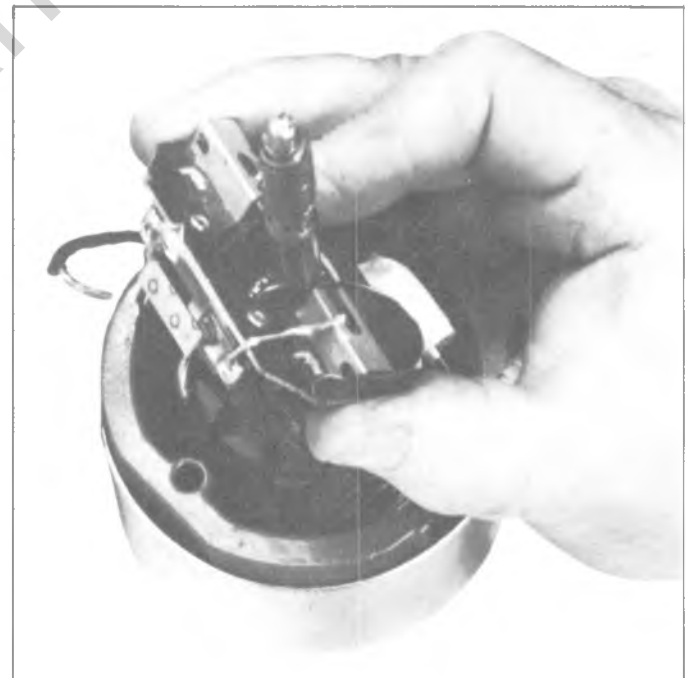


Fig. 8-32 - Removing Brush Holder

3. Remove steel thrust plate and rubber disc from case bearing as required.

MOTOR ASSEMBLY

1. If new field and case assembly is being installed, splice the black and black with pink stripe leads of the new field with the corresponding leads of the wiper terminal board.

2. Install rubber thrust disc, steel thrust disc and felt lubricating washer in case assembly bearing in order indicated.

3. Lubricate end of armature shaft that fits in case bearing. Next, install thrust ball in end of shaft.

4. Assemble armature in case and field assembly (fig. 8-33).

5. Position partially assembled brush plate (fig. 8-34) over armature shaft far enough to allow assembly of remaining brush in its brush holder, then position brush plate on mounting tabs in position shown in Figure 8-31.

NOTE: Circuit breaker should be opposite field cross over splice connections (Figure 8-32).

6. Center brush plate mounting holes over mounting tabs and bend tabs toward brush holders as required to secure brush plate in position.

CAUTION: Be sure tabs are centered in brush plate mounting holes.

7. Remove brush retainer clips and resolder black cotton covered lead to circuit breaker (fig. 8-31).

8. If new case and field assembly is used, scribe a line on it in the same location as the one scribed on the old case. This will insure proper alignment of the new

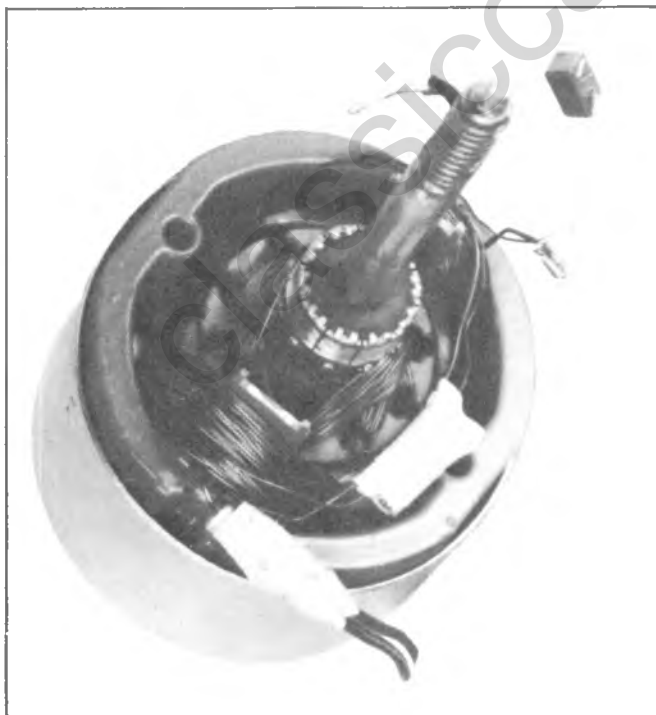


Fig. 8-33-Armature Installation

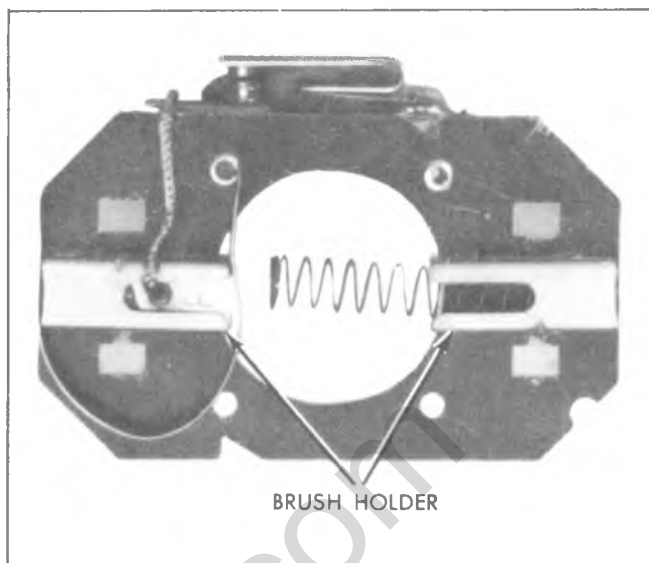


Fig. 8-34-Brush Plate Assembly

case with the scribed line made on the housing (Step 1 under Brush Plate Removal).

9. Position armature worm shaft inside housing and, using scribed reference marks, line up as near as possible the case and filed assembly with the housing.

10. Maintaining the armature in its assembled position in the case, start the armature worm shaft through the field and housing bearing until it starts to mesh with the worm gear. At the same time, carefully pull the excess black and black and pink stripe leads through the housing grommet.

CAUTION: It may be necessary at this point to rotate armature slightly before the armature worm will engage with worm gear teeth.

11. Rotate the case as required to align the bolt holes in the case with those in the housing.

12. Secure the case to the housing with the two tie bolts.

13. Adjust armature end-play as described under "Wiper Adjustments".

WIPER ADJUSTMENTS

Armature End-Play

Loosen adjusting screw locknut (Figure 8-27) and tighten the adjusting screw until finger tight, tighten locknut.

Gear Assembly End-Play

Add end-play washers as required to obtain .005" minimum end-play (Figure 8-27).

WASHER PUMP

The washer pump and/or valve assembly may be removed from the wiper assembly as a unit; therefore, it is not necessary to remove the wiper assembly from the vehicle if only the washer pump and/or valve assembly requires service.

When the pump is removed from the wiper

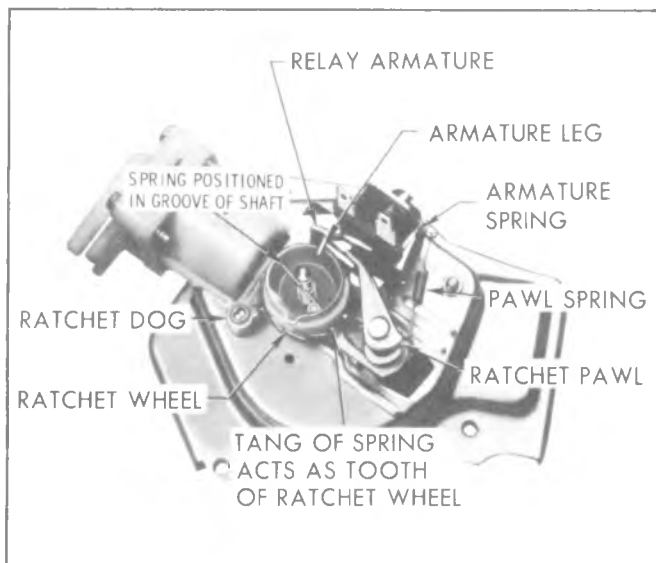


Fig. 8-35-Washer Pump Assembly

assembly, all working parts are readily accessible and may easily be serviced as necessary (fig. 8-35). A cross-section of the washer pump valve assembly is shown in Figure 8-36.

Replacement

1. Raise vehicle hood and disconnect ground cable from battery.
2. **G Models** - Remove left heater duct attached to engine shroud, for access.
3. Disconnect washer hoses and electrical connections from assembly.
4. Remove three screws securing washer pump and cover to wiper assembly. Remove pump from wiper gear box.
5. To install, reverse Step 1-4 above.

Pump Valve

Replacement

1. **G Models** - Remove the washer pump as outlined above.
C-K Models - Raise hood. Disconnect washer hoses and electrical connections from assembly.
2. Remove the four screws that attach the valve assembly to the pump housing.

CAUTION: During re-assembly be sure gasket between housing and valve plate is properly positioned in the housing and valve plate grooves. Also be sure triple "O" ring is properly installed between valve and pipe assembly.

3. To install, reverse removal procedure.

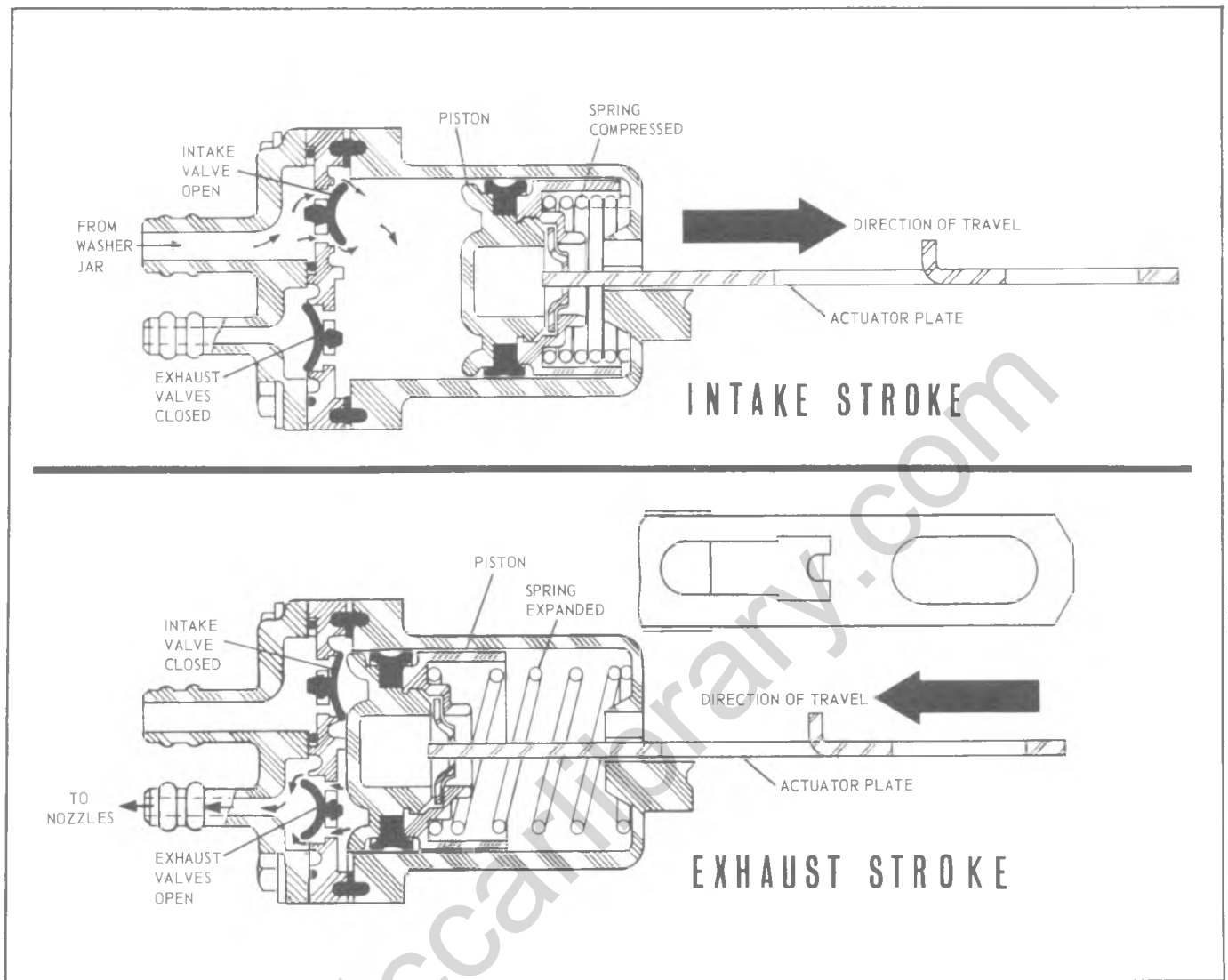


Fig. 8-36 - Cross Section of Windshield Washer Pump Valve Assembly

WINDSHIELD WIPER AND WASHER

P MODELS

GENERAL DESCRIPTION

The system consists of a compound wound rectangular-shaped motor attached to a gear box containing a parking switch in addition to the gear train. The gear train consists of a motor armature helical gearshaft which drives an intermediate gear and pinion assembly. The pinion gear of the intermediate gear and pinion drives an output gear and shaft assembly.

Turning the wiper switch to the LO speed position completes the circuits from the wiper terminals 1 and 3 to ground. Current then flows from the battery via wiper

terminal No. 2 through the series field and divides; (1) part passes through the armature to ground via wiper terminal No. 1 to the wiper switch and (2) the second part passes through the shunt field to ground through wiper terminal No. 3 to the wiper switch (fig. 8-37).

NOTE: The wiper switch must be securely grounded to body metal.

Moving the wiper switch to the HI speed position opens the shunt field circuit to ground at the switch. However, the shunt field is connected to a 20 ohm

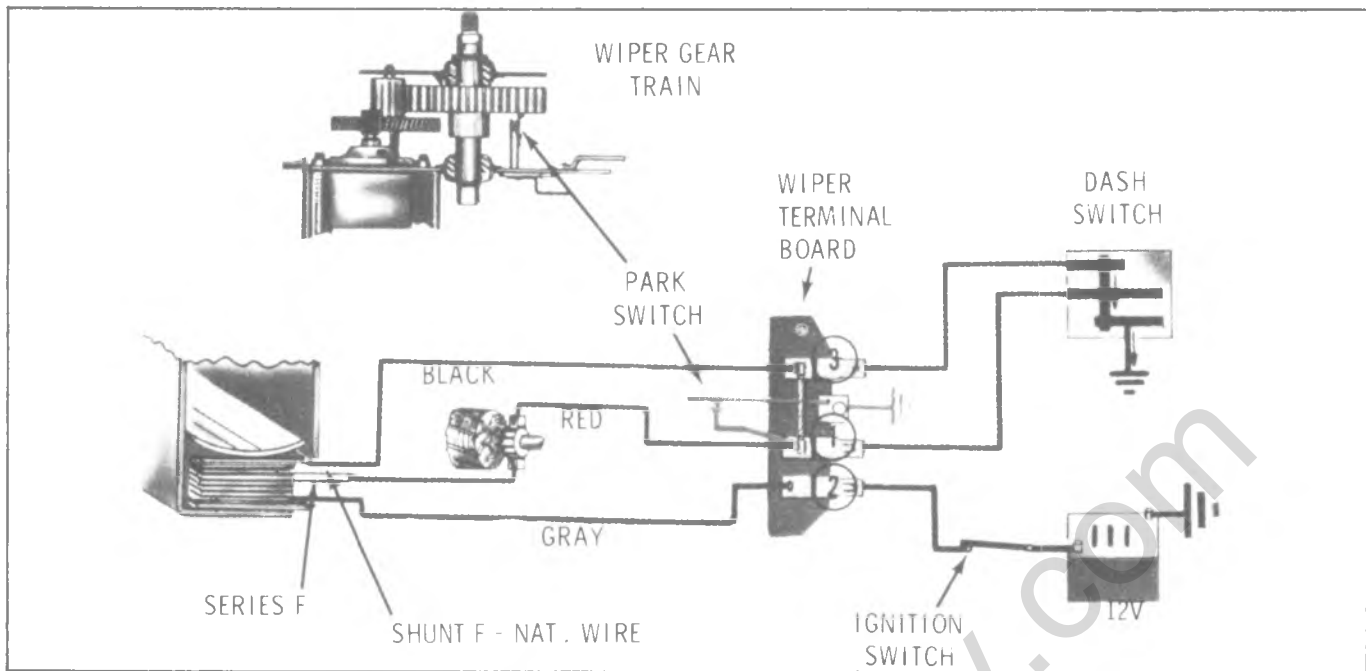


Fig. 8-37--LO Speed Circuit

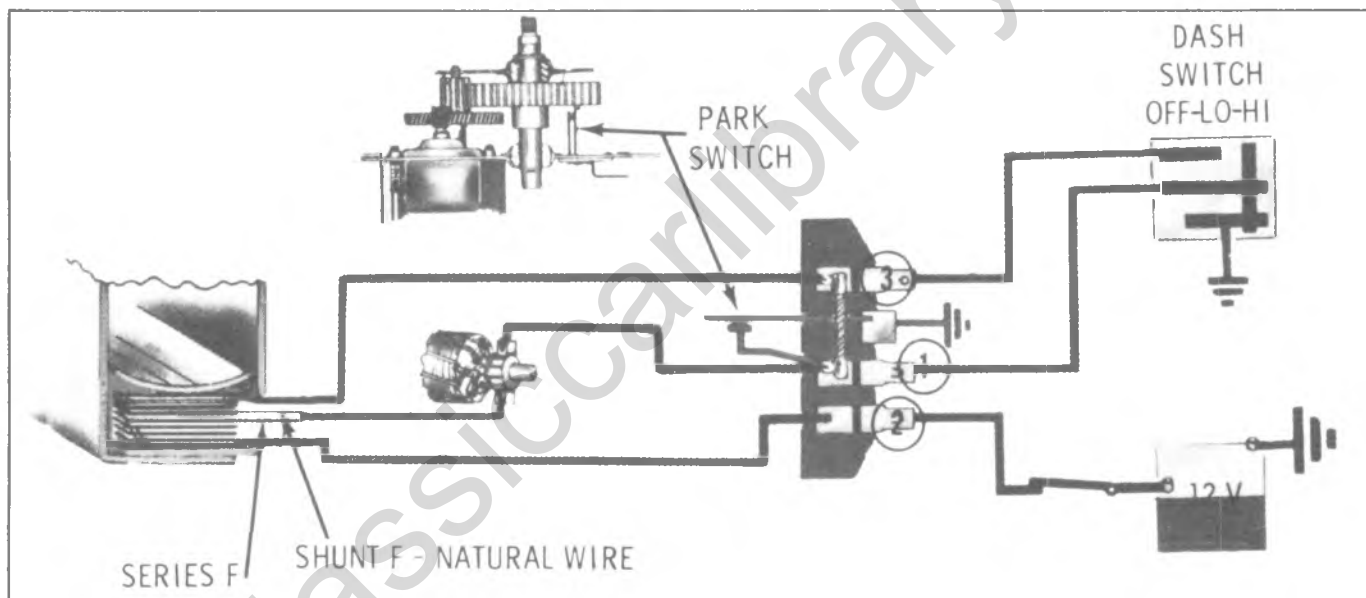


Fig. 8-38--HI Speed Circuit

resistor which is connected across wiper terminals 1 and 3. The shunt field current then flows via terminal No. 3 through the resistor to terminal No. 1 to the switch, to ground (fig. 8-38).

The parking circuit covers that portion of wiper operation when the wiper switch is turned "off" and the wiper blades have not reached the park position.

When the wiper blades are not in the normal park position, the parking switch contacts are still closed. The wiper will continue to operate until the wiper output gear is turned to a position where its cam opens the park switch. Referring to Figure 8-39, it can be seen that the wiper motor circuits are completed to ground through the parking switch.

NOTE: The wiper motor must be securely grounded to body metal.

The shunt field circuit is completed from terminal No. 3 via the switch to terminal No. 1 through the parking switch to ground. The series field and armature circuit is also completed from terminal No. 1 through the parking switch to ground.

NOTE: The shunt field is connected direct to ground, by-passing the resistor. This results in LO speed operation during the parking operation.

When the output gear cam opens the park switch contacts, the wiper is OFF.

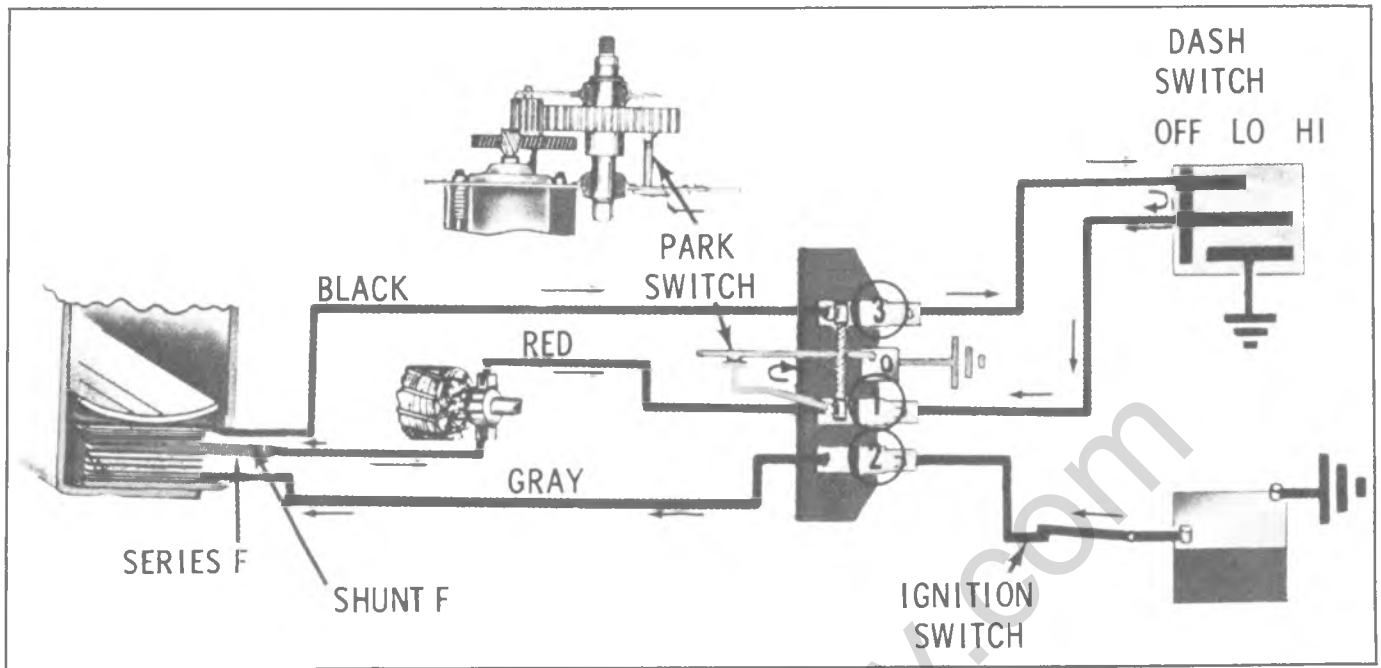


Fig. 8-39 - PARKING Circuit

DIAGNOSIS

WIPER - ON VEHICLE

1. Inspect for the following items:
 - a. Wiring harness is securely connected to wiper and switch.
 - b. Wiper motor is securely grounded to body.
 - c. Wiper switch is securely mounted and grounded.
 - d. Check fuse.
2. If items in Step 1 check out, try operating wiper in both "LO" and "HI" speeds, then turn wiper off (blades should return to park position). If wiper fails to operate correctly, proceed to Step 3.
3. Disconnect wiring harness from wiper and try operating wiper as shown in Figure 8-40.
 - a. If wiper operates correctly independently of switch and vehicle wiring, refer to the DIAGNOSIS CHART - WIPER ON VEHICLE.
 - b. If wiper still fails to operate correctly in Step 3, disconnect wiper linkage from motor crankarm and try operating wiper again. If wiper operates correctly independently of linkage, check linkage for cause of wiper malfunction.
 - c. If wiper fails to operate correctly independently of linkage, remove wiper motor from vehicle and refer to DIAGNOSIS CHART-WIPER OFF VEHICLE.

DIAGNOSIS - WIPER ON VEHICLE

NOTE: Ignition switch must be "on" for all electrical tests.

CONDITION	APPARENT CAUSE	CORRECTION
1. Wiper Inoperative or intermittent	<p>A. Blown fuse</p> <p>B. Open circuit in feed wire (No. 2 terminal on wiper motor)</p> <p>C. Loose mounting of wiper switch</p> <p>D. Defective wiper switch</p> <p>E. Open circuit in wire to wiper switch (No. 1 terminal on wiper motor)</p>	<p>A. Locate short circuit and repair. Replace fuse.</p> <p>B. Locate broken wire and repair</p> <p>C. Tighten switch mounting</p> <p>D. Replace switch</p> <p>E. Locate broken wire and repair</p>
<p>2. Wiper will not shut off:</p> <p>A. Wiper has both "Lo" and "Hi" speeds</p> <p>B. Wiper has "Lo" speed only</p> <p>C. Wiper has "Hi" speed only</p>	<p>A. Grounded Wire (No. 1 terminal on wiper motor) to wiper switch</p> <p>A. Defective wiper switch</p> <p>B. Grounded wire (No. 3 terminal on wiper motor) to wiper switch</p> <p>A. Defective wiper switch</p> <p>B. Open circuit in wire (No. 3 terminal on wiper motor) to wiper switch</p>	<p>A. Locate short circuit and repair</p> <p>A. Replace wiper switch</p> <p>B. Locate and repair short circuit</p> <p>A. Replace wiper switch</p> <p>B. Locate and repair broken wire</p>
3. Wiper has "Hi" speed only	A. Open circuit in wire (No. 3 terminal on wiper motor) to wiper switch	A. Locate broken wire and repair
4. Wiper has "Lo" speed only	<p>A. Grounded wire (No. 3 terminal on wiper motor) to wiper switch</p> <p>B. Defective wiper switch</p>	<p>A. Locate short circuit and repair</p> <p>B. Replace wiper switch</p>
5. Blades do not return to full park position	A. Loose wiper ground strap connection	A. Tighten strap connection

DIAGNOSIS - WIPER OFF VEHICLE

CONDITION	APPARENT CAUSE	CORRECTION
1. Wiper Inoperative or Intermittent	<p>A. Broken or damaged gear train (only if inoperative)</p> <p>B. Poor solder connections at terminal board</p> <p>C. Loose splice joints at brush plate</p> <p>D. Brushes binding in brush holder</p> <p>E. Open circuit in armature</p>	<p>A. Replace gears as required</p> <p>B. Resolder wires at terminals</p> <p>C. Recrimp or solder splice joints</p> <p>D. Clean holder or replace brush, spring or brush plate assembly.</p> <p>E. Replace armature</p>
<p>2. Wiper will not shut-off:</p> <p>A. Wiper has normal "Hi" and "Lo" speed</p> <p>B. Wiper has "Lo" speed only</p> <p>C. Wiper has "Hi" speed only</p>	<p>A. Defective park switch</p> <p>B. Grounded red lead wire</p> <p>A. Grounded shunt field coil</p> <p>B. Grounded black wire</p> <p>A. Open circuit in shunt field coil</p> <p>B. Open circuit in black wire</p>	<p>A. Replace terminal board assembly</p> <p>B. Repair short circuit in red wire</p> <p>A. Replace frame and field assembly</p> <p>B. Repair short circuit in black wire</p> <p>A. Replace frame and field assembly</p> <p>B. Repair broken wire or poor solder connection</p>
3. Wiper shuts off - but not in park position	A. Park switch defective or contacts dirty	A. Replace terminal board assembly or clean contacts
4. "Hi" speed too fast	A. Resistor defective	A. Replace terminal board assembly

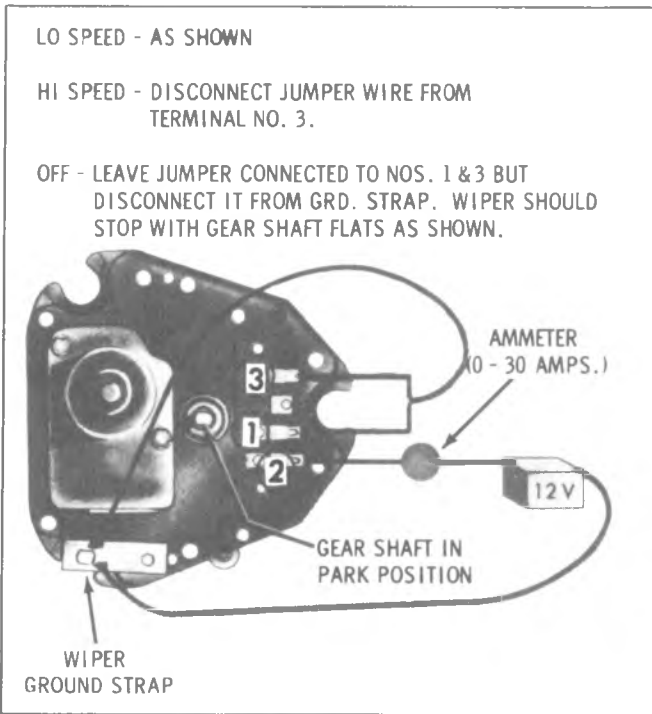


Fig. 8-40-Jumper Wire Connections

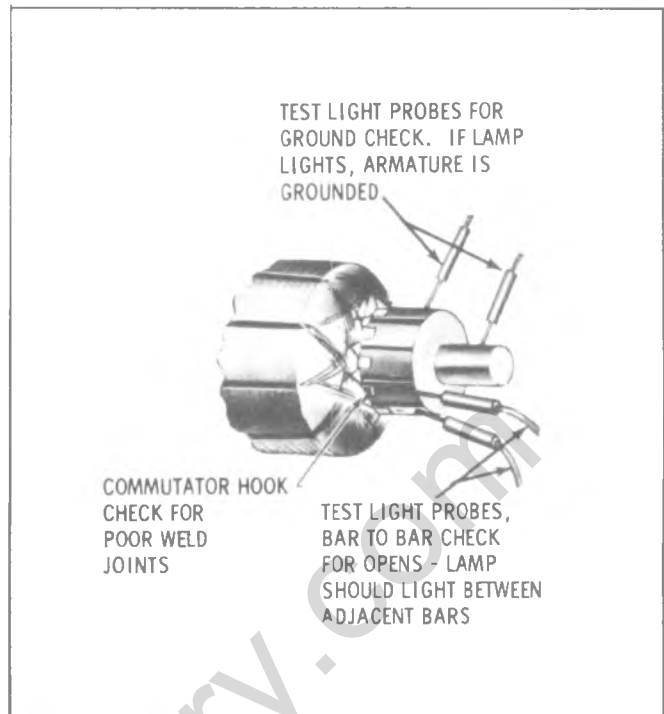


Fig. 8-41-Checking Armature

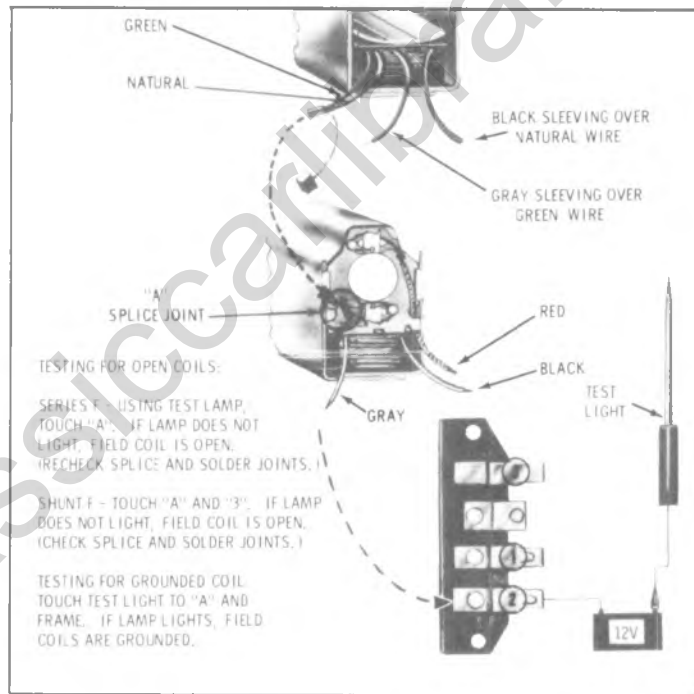


Fig. 8-42-Testing Field Coils

DIAGNOSIS - WASHER SYSTEM

CONDITION	APPARENT CAUSE	CORRECTION
1. Washers inoperative	<p>A. Inadequate quantity of washer solution</p> <p>B. Hoses damaged or loose</p> <p>C. Plugged screen at end of jar cover hose</p> <p>D. Loose electrical connection to washer pump or wiper switch</p> <p>E. Open circuit in feed wire to ratchet relay coil</p> <p>F. Wiper switch defective</p> <p>G. Ratchet relay coil defective</p> <p>H. Washer nozzles plugged</p> <p>I. Ratchet wheel tooth missing</p> <p>J. Ratchet pawl spring missing</p> <p>K. Defective pump valve assembly</p>	<p>A. Add washer solution</p> <p>B. Cut short length off end of hose to insure air tight connection or replace hose</p> <p>C. Clean screen</p> <p>D. Check electrical connections and repair if necessary</p> <p>E. Locate open circuit and repair</p> <p>F. Replace wiper switch</p> <p>G. Replace ratchet relay</p> <p>H. Clean washer nozzles</p> <p>I. Replace ratchet wheel</p> <p>J. Replace ratchet pawl spring</p> <p>K. Replace pump valve assembly</p>
2. Washer pumps continuously when wipers are operating	<p>A. Grounded wire from ratchet relay to switch</p> <p>B. Wiper switch defective</p> <p>C. Ratchet wheel tooth missing</p> <p>D. Ratchet wheel dog broken or not contacting ratchet wheel teeth</p> <p>E. Lock-out tang broken or bent on piston actuating plate</p>	<p>A. Locate grounded wire and repair</p> <p>B. Replace wiper switch</p> <p>C. Replace ratchet wheel</p> <p>D. Replace or repair ratchet wheel dog</p> <p>E. Replace piston actuating plate</p>

ON-VEHICLE SERVICE

WIPER MOTOR

Wiper motor replacement procedures are not

included here since installation is performed by the individual body manufacturers; however, disassembly of the unit will be covered.

UNIT REPAIR

WIPER MOTOR

Disassembly (Fig. 8-43)

Gear Box

1. Remove the two washer pump mounting screws and lift pump off washer.

2. Remove washer pump drive cam as required (figs. 8-46 and 8-47). The cam is pressed on the shaft but can be wedged off by using two screwdrivers between cam and plate.

3. Clamp crank arm in a vise and remove crank arm retaining nut.

CAUTION: Failure to clamp crank arm may result in stripping of wiper gears.

4. Remove crank arm, seal cap, retaining ring, and end-play washers.

NOTE: Seal cap should be cleaned and repacked with a waterproof grease before reassembly.

5. Drill out gear box cover retaining rivets, remove cover from gear train.

NOTE: Screws, nuts and lockwashers for reassembling cover to wiper are contained in the service repair package.

6. Remove output gear and shaft assembly, then slide intermediate gear and pinion assembly off shaft.

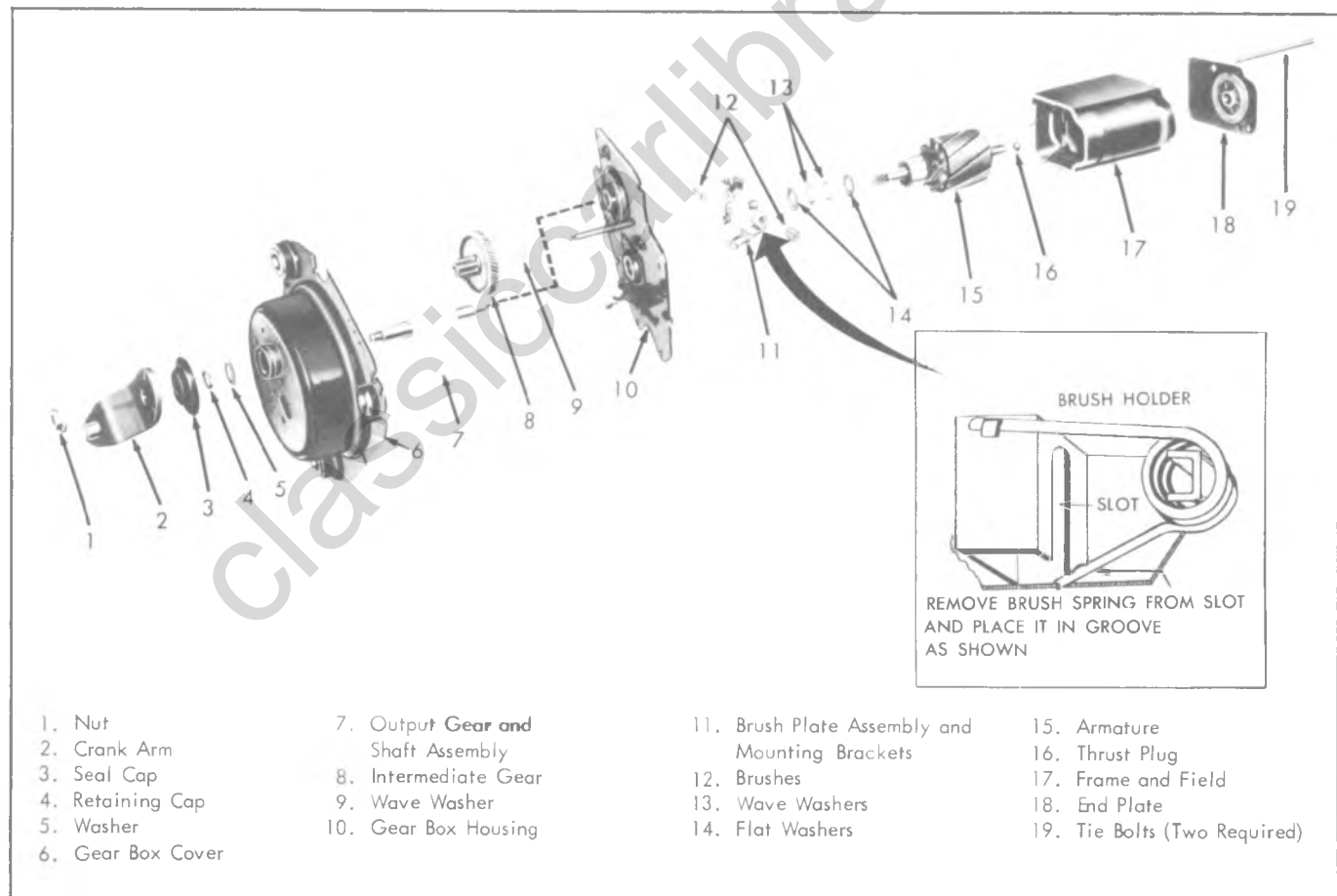


Fig. 8-43-Wiper Motor and Gear Box Assembly

7. If necessary, remove terminal board and park switch assembly as follows:

- a. Unsolder motor leads from terminals. Code motor leads.
- b. Drill out rivets securing terminal board and park switch ground strap to mounting plate.

NOTE: Screws, nuts and washers for attaching a replacement terminal board park switch assembly are included with the replacement assembly.

Motor

1. Follow Steps 1 through 7b under gear box disassembly.
2. Remove motor through bolts, tap motor frame lightly, and remove motor from mounting plate.
3. Remove brush spring tension (fig. 8-43), slide armature and end plate from motor frame. Pull end plate from armature.

NOTE: Thrust plug located between armature shaft and end plate.

4. Remove end play adjusting washers from armature, noting arrangement for proper reinstallation.

Inspection

Check and inspect all parts for wear; replace as necessary. All parts can be replaced individually except motor frame and field, which is serviced as an assembly. Service kits also provide screws, nuts and washers to replace gear cover and terminal board rivets.

Assembly

Refer to Figure 8-43 for exploded view of motor and gear train.

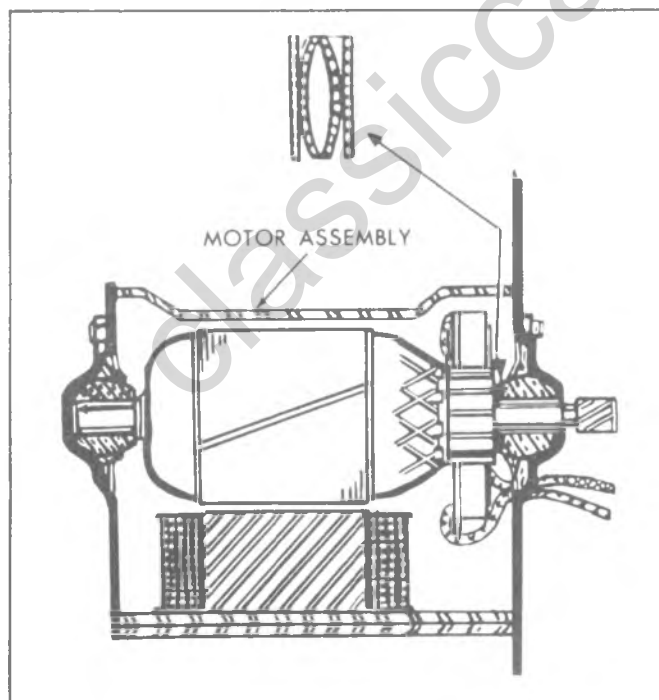


Fig. 8-44--End play Wave Washer Installation

Motor

Reassemble motor using reverse of disassembly procedure.

NOTE: Armature end play is controlled by end play washers. See Figure 8-44 for proper assembly of end play washers. Lubricate armature shaft bushings with light machine oil.

Gear Box

1. Assemble gear box using reverse of disassembly procedure.

NOTE: Lubricate gear teeth with Delco Cam and Ball Bearing lubricant (or equivalent). Be sure cover is properly located over dowel pins and be sure to reinstall ground strap.

2. Place wiper in park position and install crank arm on output shaft, rotate crank so alignment marks line up with those on cover (fig. 8-45).
3. Replace retaining nut, place crank arm in vise, tighten retaining nut.

WINDSHIELD WASHER

The positive displacement washer pump used on the two-speed non-depressed park wipers (fig. 8-46) use a pump mechanism consisting of a piston, piston spring and valve arrangement driven by a (4) lobe cam, and follower assembly (fig. 8-48). The cam is attached to one shaft of the wiper motor output gear (fig. 8-47). Programming is accomplished electrically and mechanically by a relay assembly and ratchet wheel arrangement.

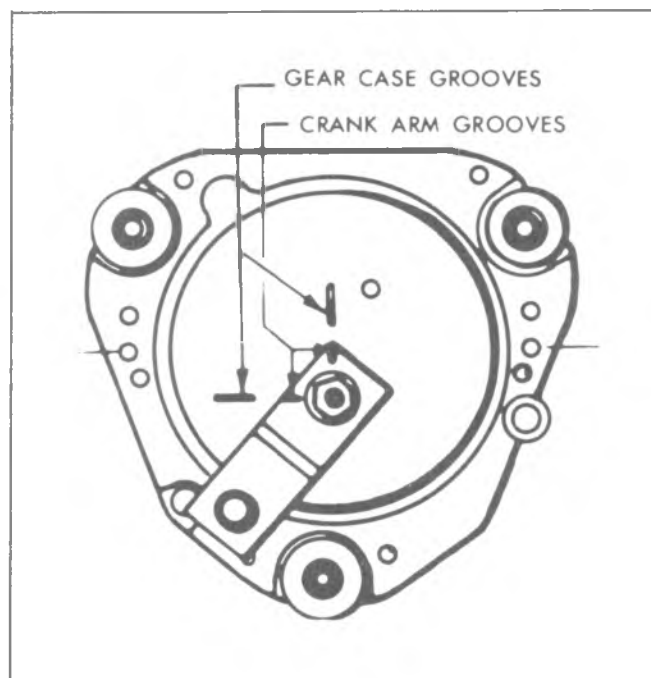


Fig. 8-45--Wiper Motor Crank Arm in Park Position

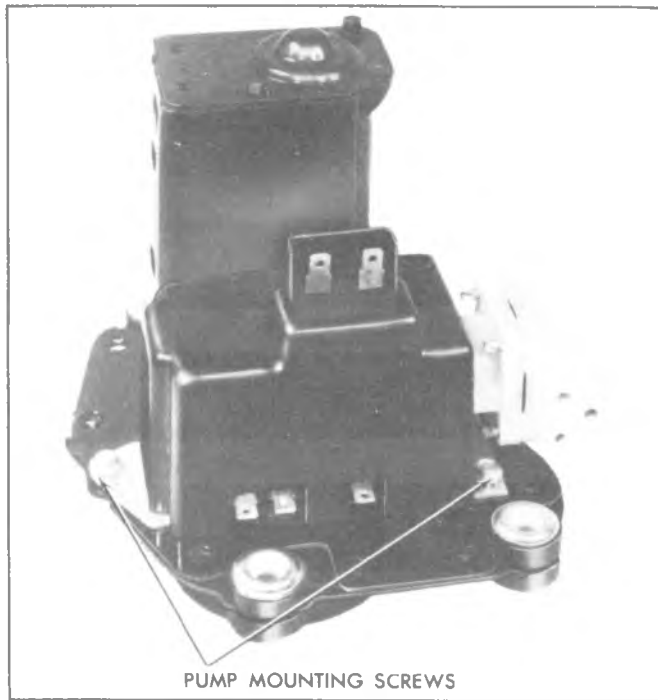


Fig. 8-46 Washer Pump Attaching Screws

Replacement

1. Disconnect battery ground cable.
2. Remove two pump mounting bolts.
3. Remove washer pump assembly.
4. To install reverse Steps 1-3 above.

CAUTION: Install washer multiplug harness connector with battery lead on terminal with no tang (fig. 8-46). Incorrect installation of

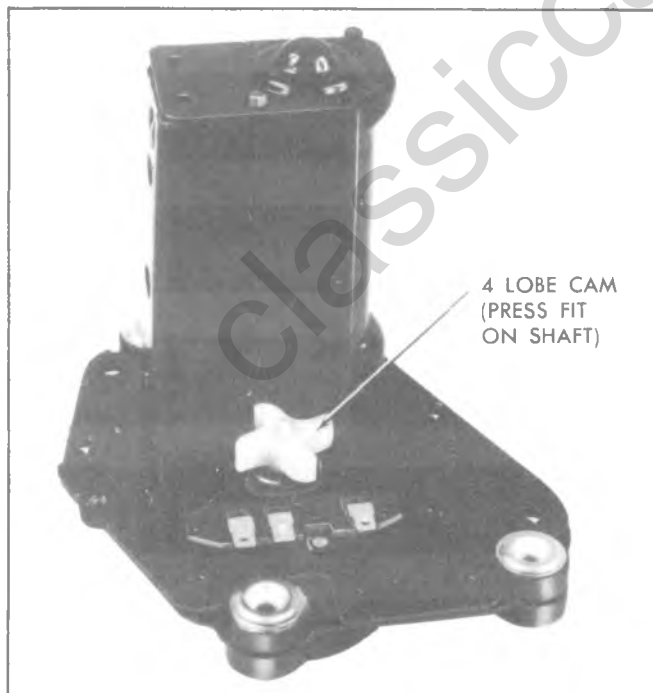


Fig. 8-47 Washer Pump Drive Cam

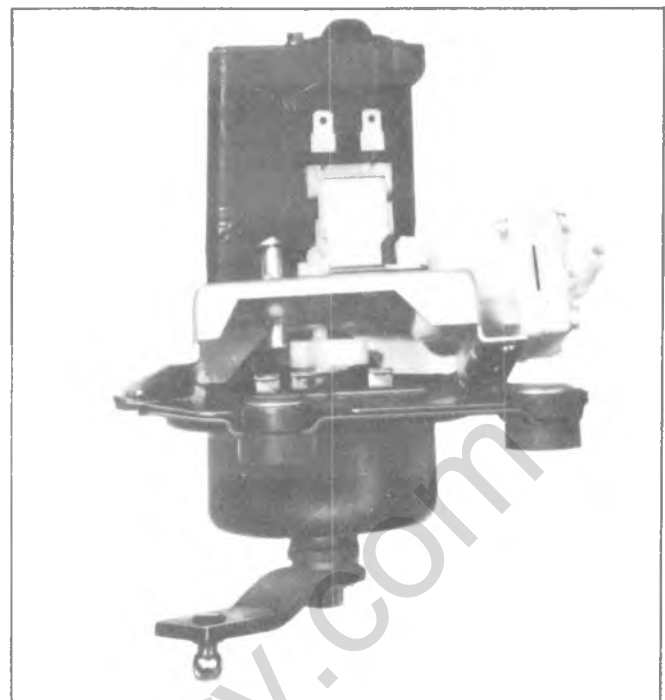


Fig. 8-48 Washer Pump Drive Cam and Actuator

connector will result in direct ground and destroy wiper motor fuse.

Disassembly-Assembly

(Figures 8-49-8-52)

1. Remove washer pump cover by squeezing.
2. Solenoid assembly - ratchet dog.
 - a. Remove ratchet dog retaining screw. Hold spring loaded solenoid plunger in position and carefully lift solenoid assembly and ratchet dog off frame of pump.
 - b. Separate ratchet dog from solenoid mounting plate as required.

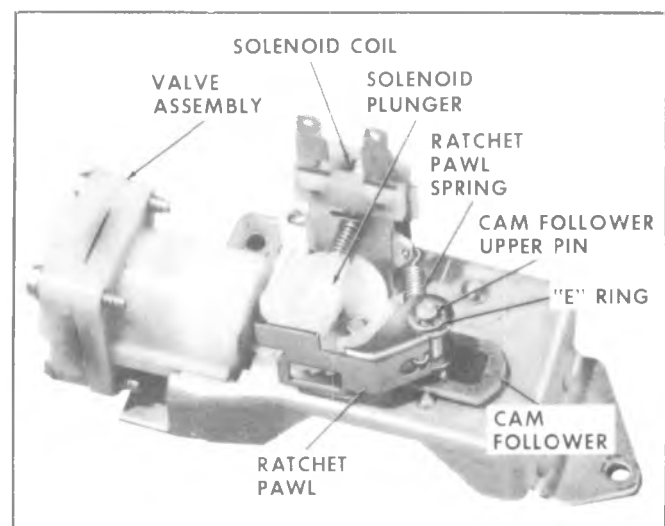


Fig. 8-49 Washer Pump Mechanism

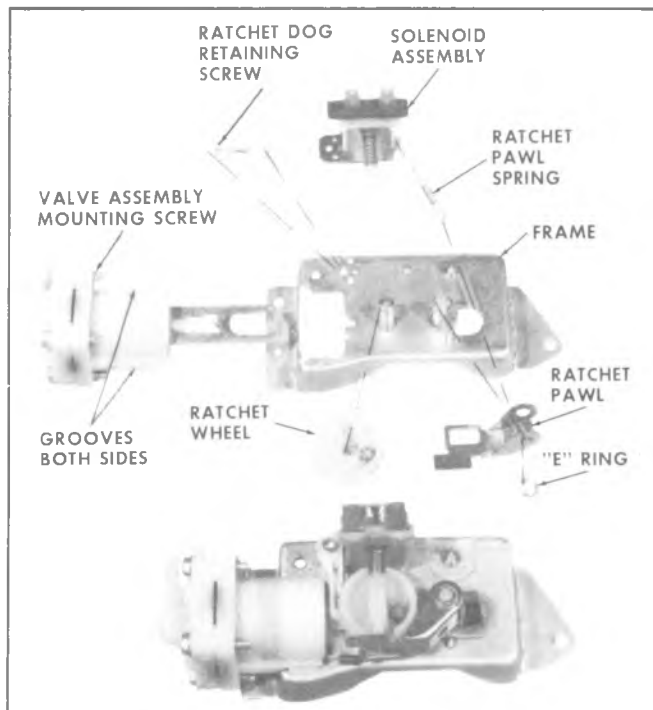


Fig. 8-50--Washer Pump-Exploded View

3. Ratchet pawl.
 - a. Disconnect ratchet pawl spring.
 - b. Remove ratchet pawl retaining ring and slide ratchet pawl off cam follower shaft.
4. Ratchet wheel.
 - a. Follow Step 1 under solenoid - ratchet dog disassembly.
 - b. Move ratchet wheel spring out of shaft groove and slide ratchet wheel off its shaft.
5. Pump and actuator plate assembly.
 - a. Remove solenoid assembly - ratchet pawl and ratchet wheel as outlined in their respective procedures.

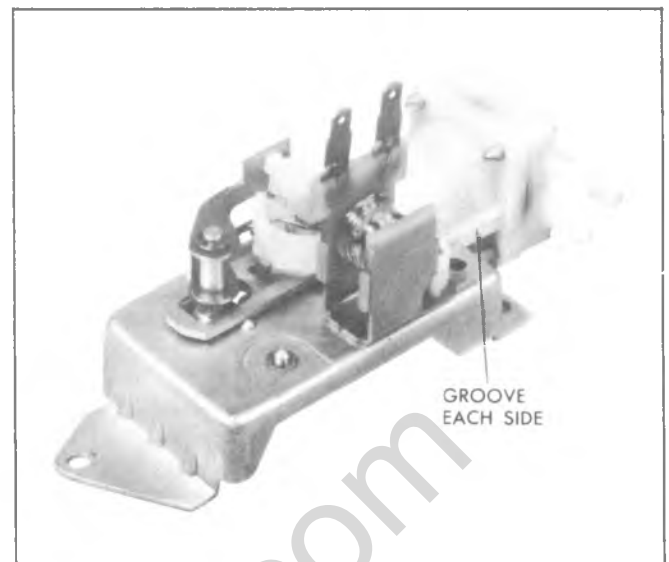


Fig. 8-51--Releasing Pump From Lockout Position

- b. To separate pump and pump actuator plate from frame, pull pump housing in direction of the arrow until grooves in housing clear the frame. Then remove actuator plate from ratchet wheel and cam follower shafts.
6. Valve assembly.
 - a. Remove four screws that attach the valve assembly to pump housing.

CAUTION: During assembly, be sure gasket between housing and valve plate is properly positioned in housing and valve plate grooves. Also be sure triple "O" ring is properly installed between valve body and pipe assembly.

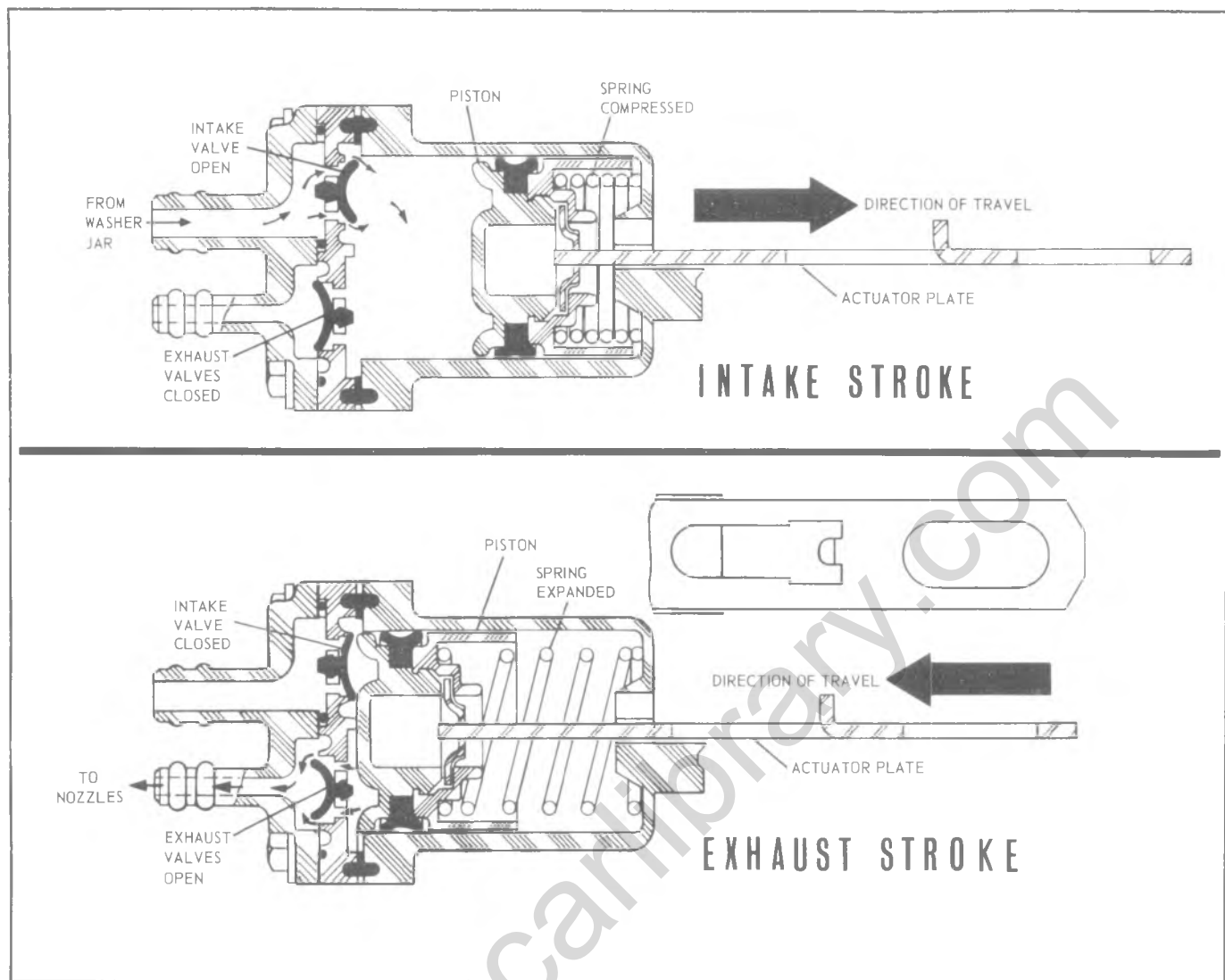


Fig. 8-52 Cross Section of Windshield Washer Pump Valve

CIRCUIT PROTECTION

GENERAL DESCRIPTION

All electrical circuits are protected against excessive loads which might occur due to shorts or overloads in the wiring system. Such protection is provided by either a circuit breaker, fuse or fusible link. Each of these protective devices are explained below.

CIRCUIT BREAKER (Fig. 8-53)

A circuit breaker is a protective device designed to open the circuit when a current load is in excess of rated breaker capacity. If there is a short or other type of overload condition in the circuit, the excess current will open the circuit breaker and cause it to cycle if it automatically resets, thus, indicating there is something

wrong in the system. The circuit breaker will continue to cycle until the trouble is found and corrected. Excessive cycling of the breaker will eventually damage the breaker contacts to the point that replacement of the breaker is necessary.

FUSE (Fig. 8-53)

A common method of protection is to use a fuse in the circuit. Whenever there is an excessive current through the circuit, the fusible element will melt and open the circuit. The disadvantage of using a fuse

ON-VEHICLE SERVICE

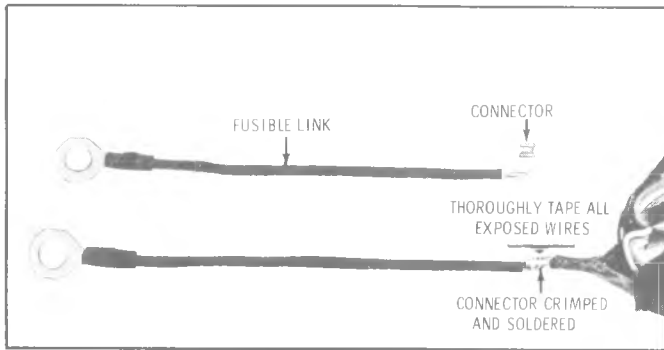


Fig. 8-55--Fusible Link Replacement

COMPONENT PART REPLACEMENT

Fusible Link Replacement (Fig. 8-55)

A new fusible link can be installed, after the short circuit is located and repaired, as follows:

1. Disconnect battery ground cable.
2. Disconnect fusible link from junction block or starter solenoid.
3. Cut harness directly behind connector to remove damaged fusible link (fig. 8-54).
4. Strip harness wire approximately 1/2".
5. Position clip around new fusible link and harness wire, crimp so that all wires are securely fastened.
6. Solder connection using rosin core solder. Use sufficient heat to obtain a good solder joint.
7. Tape all exposed wires with plastic electrical tape to prevent corrosion and shorting.
8. Connect fusible link to junction block or starter solenoid.
9. Connect battery ground cable.

HEADLAMPS WARNING BUZZER

Replacement (Fig. 8-56)

1. Disconnect electrical connector from LPS (Lamps) socket of fuse panel.
2. Disconnect electrical connector from IGN (Ignition) socket of fuse panel.

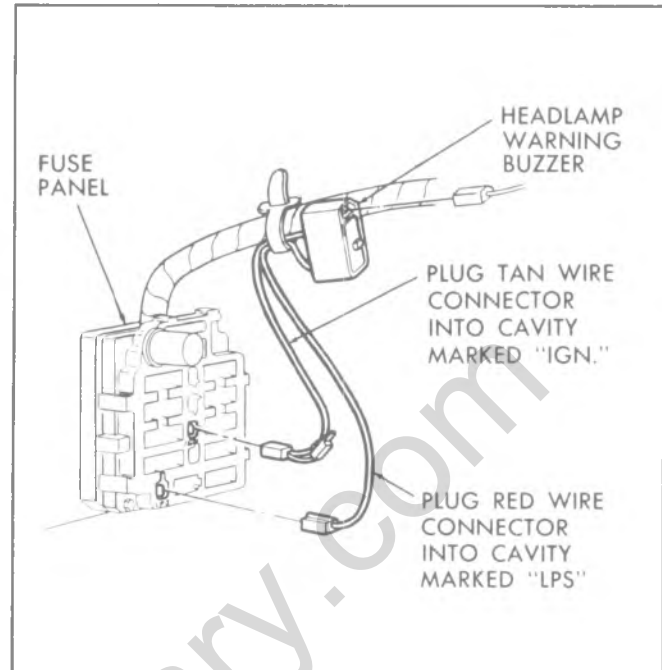


Fig. 8-56--Headlamp Warning Buzzer

3. Disconnect electrical connector to instrument panel harness.
4. Remove strap securing buzzer to instrument panel harness.
5. Install replacement headlamp warning buzzer in reverse sequence of removal.

SEAT BELT WARNING SYSTEM

All C-K type light duty trucks have a non-sequential timer controlled seat belt warning system. This system has an instrument panel warning light that will illuminate every time the ignition switch is turned on, whether or not the driver's seat belt is buckled, but will automatically go off after 4-8 seconds. The buzzer is also controlled by the 4-8 second timer, but will operate only if the driver has not buckled-up prior to turning on the ignition. If no attempt is made to buckle-up after turning on the ignition, the buzzer will also shut-off automatically after 4-8 seconds.

A trouble shooting diagnostic chart and wiring schematic are shown in Figures 8-57 and 8-58.

SEAT BELT REMINDER LIGHT/BUZZER DIAGNOSIS

NOTE: WHEN DIAGNOSING A WARNING SYSTEM FAILURE AND THE SYSTEM AUTOMATICALLY SHUTS OFF BECAUSE OF THE 4-8 SECOND TIMER, A MINIMUM OF 3 MINUTES MUST BE ALLOWED BETWEEN THE DIAGNOSTIC STEPS TO ALLOW THE TIMER TO RESET (KEY IN OFF POSITION DURING THIS PERIOD).

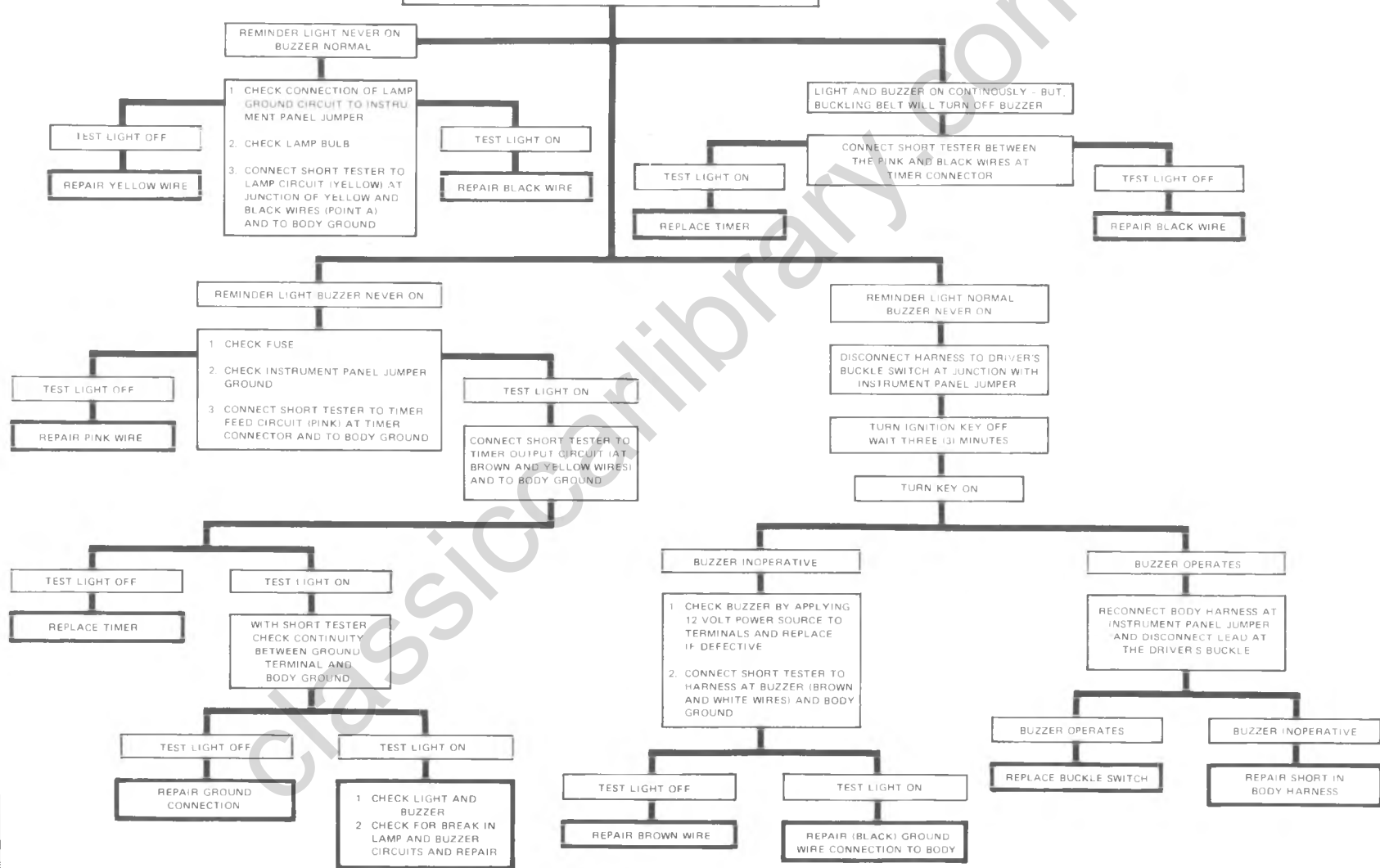


Fig. 8-57: Seat Belt Reminder System Diagnosis

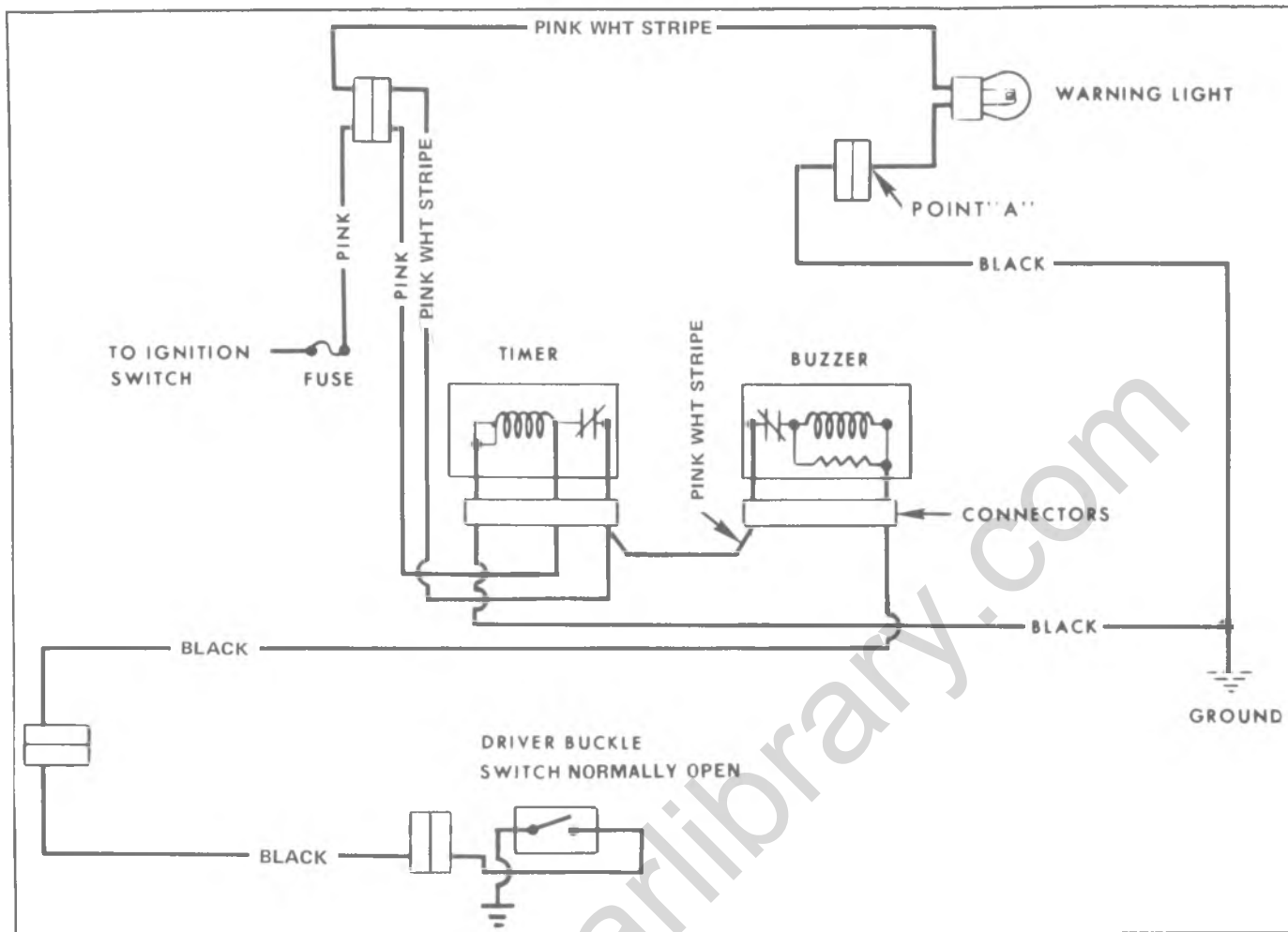


Fig. 8-58--Seat Belt Reminder System Schematic

SPECIFICATIONS

FUSES — CIRCUIT BREAKERS

The wiring circuits are protected from short circuits by a combination of fuses, circuit breakers, and fusible thermal links in the wiring itself. This greatly reduces the hazard of electrically caused fires in the vehicles.

The headlamp circuits are protected by a circuit breaker in the light switch. An electrical overload on the breaker will cause the lamps to go on and off, or in some cases to remain off.

In addition to a fuse, the windshield wiper motor is also protected by a circuit breaker. If the motor overheats, due to overloading caused by heavy snow, etc., the wipers will remain stopped until the motor cools.

Fuses located in the Junction Block beneath the dash on the drivers side are:

C-K TRUCK

Heater, Front A/C, Generator Warning Lamp	20 Amp
Idle Stop Solenoid, Aux. Battery, Radio, Time Delay Relay, Emission Control Solenoid, Transmission Downshift (M40)	15 Amp
Cigarette Lighter, Clock, Dome Lamp, Cargo Lamp	20 Amp
Fuel Gauge, Brake Warning Lamp, Temperature Warning Lamp, Oil Pressure Warning Lamp	4 Amp
Courtesy Lamp, Roof Marker Lamp, License Plate Lamp, Parking Lamp, Side Marker Lamp, Tail Lamp, Clearance Lamp	20 Amp
Directional Signal Indicator Lamp, Stop Lamp, Traffic Hazard	15 Amp
Instrument Cluster Lamp, Heater Dial Lamp, Radio Dial Lamp, Cruise Control Lamp, Windshield Wiper Switch Lamp	4 Amp
Windshield Wiper/Washer	25 Amp
Cruise Control, Rear Window Aux., Fuel Tank, Tachometer, Back-up Lamp, Directional Signal Indicator Lamp, Directional Signal Lamp, Headlamp Buzzer	15 Amp

P TRUCK

Heater†, Air Conditioning†	25 Amp
Instrument Cluster Lamp, Windshield Wiper Switch Lamp	3 Amp
Directional Signal Indicator Lamp, Stop Lamp, Traffic Hazard	15 Amp
Fuel Gauge, Brake Warning Lamp	3 Amp
License Plate Lamp, Parking Lamp, Side Marker Lamp, Tail Lamp, Clearance Lamp, Identification Lamp	15 Amp
Windshield Washer/Wiper	25 Amp
Cigarette Lighter†, Clock†, Courtesy†, Dome Lamp†	15 Amp
Auxiliary Battery†, Back-up Lamp, Radio	15 Amp

Idle Stop Solenoid, Cruise Control†, Directional Signal Lamp, Time Delay Relay, Emission Control Solenoid, Transmission Downshift (M40)	10 Amp
---	--------

In-line fuses are located in the auxiliary heater circuits (C-K-P models) and underhood lamp, front and rear A/C circuits (C-K models)

†When incorporated by body builder

Do not use fuses of higher amperage than those recommended above

The following wiring harnesses are protected by a "fusible link" which is a special wire incorporated in the circuit headlamp hi-beam indicator, horn, air conditioning high blower, ignition circuits (C-K-P models) starter solenoid (pull-in and hold) circuit (C-K models). Should an electrical overload occur, this wire will fail and prevent damage to the major harness.

G TRUCK

Heater, A/C	25 Amp
Idle Stop Solenoid, Cruise Control, Directional Signal Lamp, Directional Signal Indicator Lamp, Transmission Downshift (M-40)	10 Amp
Cigarette Lighter, Dome Lamp, Spot Lamp ...	15 Amp
Fuel Gauge, Brake Warning Lamp, Temperature Warning Lamp, Generator Warning Lamp, Oil Pressure Warning Lamp	3 Amp
Stop Lamp, Traffic Hazard	15 Amp
Auxiliary Battery, Backing Lamp, Radio Dial Lamp, Radio	15 Amp
Instrument Cluster Lamp, Heater Dial Lamp, Transmission Control Lamp with Tilt Wheel, Cruise Control Lamp, W/S Wiper Switch Lamp, Headlamp Buzzer	3 Amp
License Lamp, Parking Lamp, Side Marker Lamp, Tail Lamp	15 Amp
Windshield Wiper	25 Amp

An in-line fuse is located in the Ammeter and the auxiliary heater circuits.

Do not use fuses of higher amperage rating than those recommended above

The following wiring harnesses are protected by a "fusible link" which is a special wire incorporated in the circuit, ignition, horn and headlamp hi-beam indicator circuits, air conditioning high blower. Should an electrical overload occur, this wire will fail and prevent damage to the major harness.

CIRCUIT BREAKERS

DEVICE OR CIRCUIT PROTECTED	MODELS	AMPERES	LOCATION
Headlamp and parking lamp circuit	C-K-P-G	15	Light switch
Tailgate window motor	C-K	30	Dash (forward side)
Rear A/C (C69 overhead)	G	35	Dash (forward side)

LAMP BULB DATA C-K-P TRUCK

USED IN	QUANTITY	TRADE#	POWER
Dome Lamps:			
Cab	1	1004	15 CP
Utility & Suburban	1	211-2	12 CP
Oil Pressure indicator lamp ¹	1	168	3 CP
Generator indicator lamp ¹	1	168	3 CP
Instrument cluster lamps ²	5	168	3 CP
Headlamp beam indicator lamp	1	168	3 CP
Lamp assembly — tail & stop lamp	2	1157	3-32 CP
License Lamp ⁴	1	67	4 CP
Directional signal (front park lamps) ⁶	2	1157	3-32 CP
Head Lamps	2	6014	50-60 W
Temperature indicator lamp	1	168	3 CP
Directional signal indicator lamp	2	168	3 CP
Clearance and marker lamps	4	168	3 CP
Roof marker lamps ⁵	5	194	2 CP
Brake warning indicator	1	168	3 CP
Transmission control (auto)	1	1445	0.7 CP
Backing lamp (exc. motor home)	2	1156	32 CP
Backing lamp (motor home)	2	1295	50 CP
Heater or A/C	1	161	1 CP
Corner marker lamps (platform)	7	67	4 CP
Cargo lamp (C-K cab)	1	1142	21 CP
Radio dial lamp — AM	1	1816	3 CP
—AM/FM	1	216	1 CP
Cruise control lamp	1	53	1 CP
Courtesy lamp	1	1003	15 CP
Windshield wiper switch	1	161	1 CP
Clock	1	168	3 CP
Rear identification ⁷	10	1895	2 CP
Underhood lamp	1	93	15 CP
Seat belt warning	1	168	3 CP
Cargo/dome lamp	2	211-2	12 CP
Four wheel drive indicator	1	168	3 CP

¹ On CA, KA 10-35 instrument clusters only.

² 3 lamps used on instrument cluster on P models or C-K w/o gauges.

³ Double filament sealed beam 60W high beam, 50W low beam.

⁴ 2 lamps used with step bumper and P models.

⁵ 4 required on P models.

⁶ 1157 NA, 2.2-24 CP on C-K models.

⁷ Wideside Pickup.

LAMP BULB DATA G TRUCK

USED IN	QUANTITY	TRADE#	POWER
Dome lamps	2	211-2	12 CP
Oil pressure indicator lamp	1	168	3 CP
Generator indicator lamp	1	168	3 CP
Instrument cluster lamps	3	168	3 CP
Headlamp beam indicator lamp	1	168	3 CP
Park, directional signal lamps	2	1157	3-32 CP
Tail, stop lamps	2	1157	3-32 CP
License lamp	1	67	4 CP
Head lamps ¹	2	6014	50-60 W
Temperature indicator lamp	1	168	3 CP
Directional signal indicator lamp	2	168	3 CP
Marker lamps	4	168	3 CP
Brake warning indicator lamp	1	168	3 CP
Back-up lamp	2	1156	32 CP
Radio dial lamp	1	1893	2 CP
Heater or A/C control	1	194	2 CP
Transmission control w/tilt wheel	1	1445	0.7 CP
Cruise control	1	53	1 CP
W/S wiper switch lamp	1	161	1 CP

¹ Double filament sealed beam 60W high beam, 50W low beam.

SECTION 9

ACCESSORIES

CONTENTS

Cruise Master.....	9-1	General Description	9-10
General Description	9-1	Diagnosis.....	9-10
Diagnosis.....	9-3	Radio Dead.....	9-10
Electrical System	9-3	Radio Cuts on and off.....	9-10
Servo and Vacuum System	9-3	Radio Stations Mix Together.....	9-10
On-Vehicle Service.....	9-7	Radio Noisy.....	9-10
Maintenance and Adjustments	9-7	Distorted Tone.....	9-11
Regulator.....	9-7	Testing Windshield Antenna	9-11
Servo Unit.....	9-7	On-Vehicle Service	9-11
Brake Release Switches.....	9-7	Maintenance and Adjustments	9-11
Column Mounted Engagement Switch.....	9-7	Radio Installation Precautions.....	9-11
Component Part Replacement.....	9-7	Trimming Radio.....	9-11
Regulator.....	9-7	Component Part Replacement.....	9-12
Servo	9-8	Radio.....	9-12
Column Mounted Engagement Switch.....	9-8	Speaker.....	9-12
Specifications	9-10	Antenna.....	9-13
Radio.....	9-10	Special Tools	9-15

CRUISE MASTER

GENERAL DESCRIPTION

The Cruise Master is a speed control system which employs engine manifold vacuum to power the throttle servo unit. The servo moves the throttle, when speed adjustment is necessary, by receiving a varying amount of controlled vacuum from the regulator unit. The speedometer cable (from the transmission) drives the regulator, and a cable (from the regulator) drives the instrument panel speedometer. The engagement of the regulator unit is controlled by an engagement switch located at the end of the turn signal lever. Two brake release switches are provided: an electric switch disengages the regulator unit and a vacuum valve decreases the vacuum in the servo unit to quickly return the throttle to idle position.

The purpose of the Cruise Master system is to allow the driver to maintain a constant highway speed without the necessity of continually applying foot pressure to the accelerator pedal. Speed changes are easily made and override features allow the vehicle to be stopped, slowed or accelerated as desired.

Engaging the Cruise System

The driver accelerates to the desired cruise speed and partially depresses and releases the cruise control engagement switch button located at the end of the directional signal lever. The cruise system takes over speed control, and within engine limitation, maintains this speed regardless of changes in terrain.

The Engagement Switch button performs these functions:

1. Above 30 mph, when partially depressed and released, it engages the cruise system.
2. When depressed fully and held there, it disengages the system.
3. When released slowly from the fully depressed position, it will engage the system at the existing speed and cruise at that speed (above 30 mph).

NOTE: See Fig. 9-1C "Engage Switch Operation".

Speed Changes

Override-The accelerator pedal may be depressed at any time to override the cruise system. Release of the accelerator pedal will return the vehicle to the previous cruise speed.

To Cruise At A Higher Speed-Depress the accelerator pedal to reach the new desired speed. Then, fully depress and slowly release the cruise control engagement switch button. The system re-engages at the higher speed when the button is slowly released.

To Cruise At A Lower Speed-Disengage the system by depressing the engagement switch button fully and holding it there until the vehicle has decelerated to the new desired speed; then release the button slowly. The

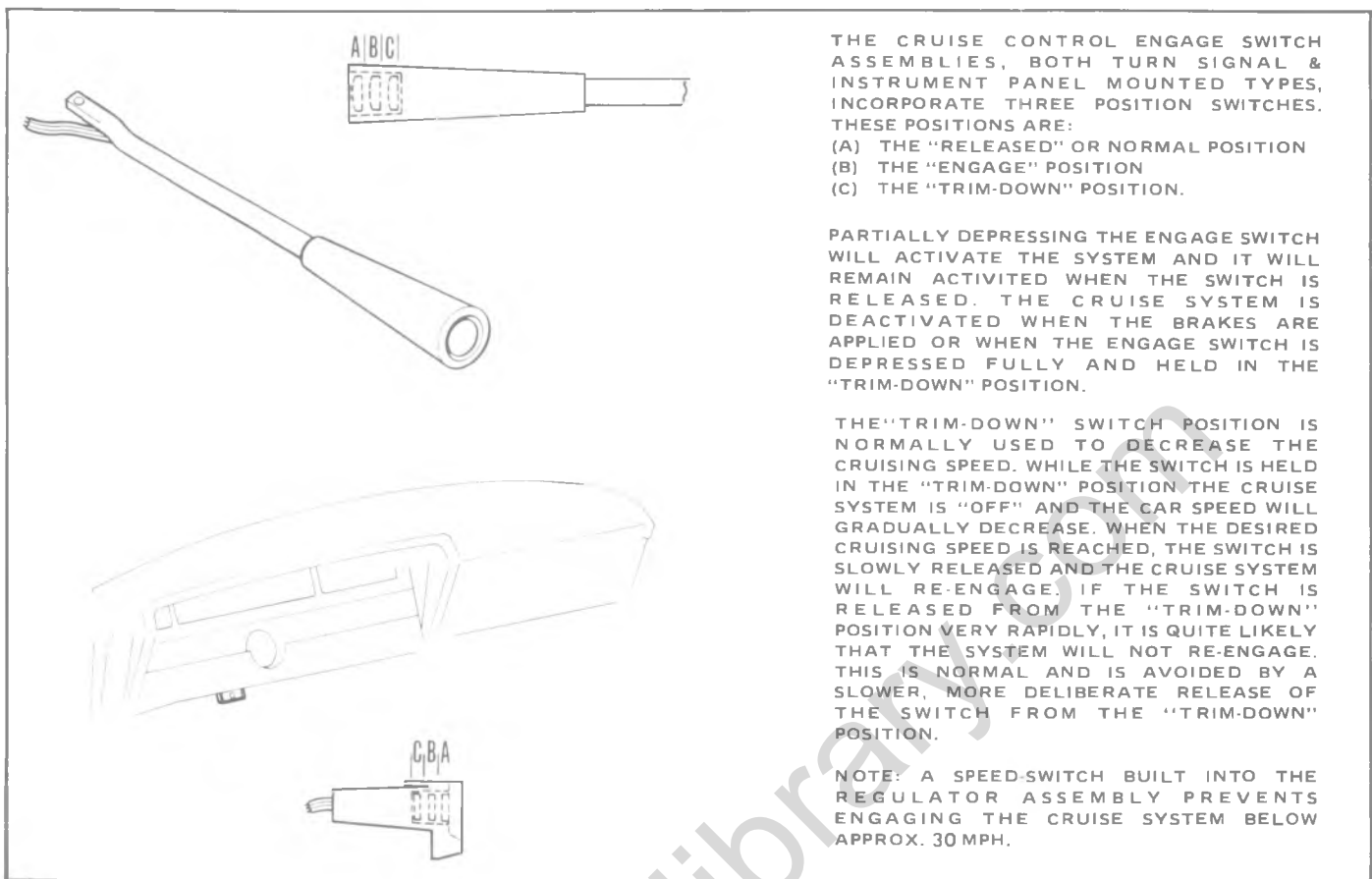


Fig. 9-1C-Cruise Master Engagement Switches

system re-engages at the lower speed when the button is slowly released.

Cruise Master Units

1. The Engagement Switch, which is located at the end of the directional signal lever, is used to control the system and for upward and downward speed adjustments.

2. The Regulator (fig. 9-2C) is mounted in the speedometer cable line. It is a combination speed sensing device and control unit. When engaged, it senses vehicle speed and positions the Servo Unit to maintain the selected speed.

3. The Servo Unit is mounted on the left front inner fender and is connected by a cable to the throttle linkage. It opens or closes the throttle as dictated by the Regulator.

4. The Cruise Brake Release Switch, which is mounted on the brake pedal bracket, disengages the system electrically when the brake pedal is depressed.

5. The Cruise Brake Release Valve, which is mounted on the brake pedal bracket, disengages the system pneumatically when the brake pedal is depressed.

6. The Cable and Casing Assemblies drive the regulator and speedometer.

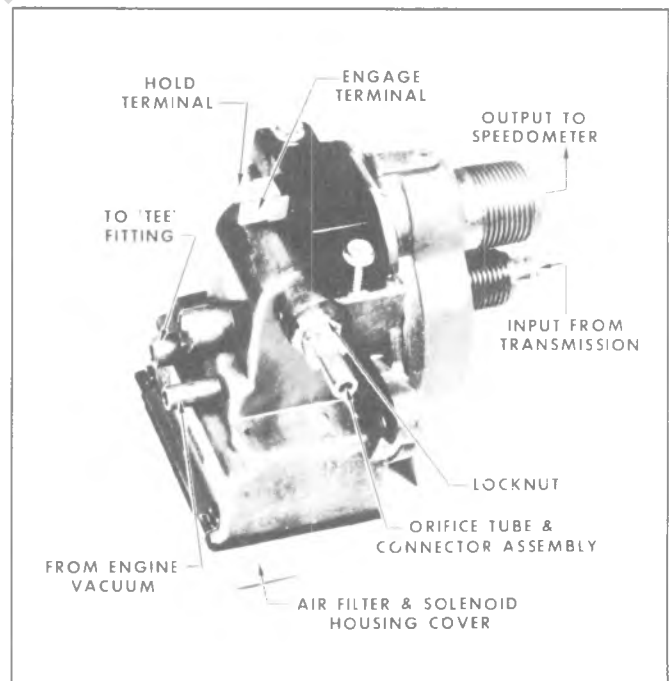


Fig. 9-2C-Regulator Unit

DIAGNOSIS

ELECTRICAL SYSTEM TROUBLESHOOTING

1. Check fuse and connector.
2. Check electric brake switch as follows:
 - a. Unplug connector at switch.
 - b. Connect ohmmeter across cruise master contacts on brake switch. The ohmmeter must indicate no continuity when the pedal is depressed and continuity when pedal is released. The cruise release brake switch (electric) is adjusted as is the standard stop light brake switch.
 - c. Replace electric brake switch if needed.
3. Check clutch release switch (manual transmission only) same as electric release switch above.

Engagement Switch Test

Check engagement switch and connecting wiring as follows: Unplug engagement switch connector (brown, blue, black) at electrical wiring harness connector then perform the following tests (fig. 9-3C).

Test #1—Connect ohmmeter between terminal #1 (brown wire) and terminal #2 (blue wire). Continuity shall be maintained until switch is depressed all the way in.

Test #2—Connect ohmmeter between terminal #1 (brown wire) and terminal #3 (black wire). No continuity shall be shown; however, when the button is partially depressed, continuity shall be indicated. When the button is pressed all the way down, no continuity shall be shown.

Test #3—Connect ohmmeter between terminal #2 (blue wire) and terminal #3 (black wire). Button released, no continuity; however, when the button is depressed partially and fully, continuity shall be shown.

Harness Test (Fig. 9-3C)

1. Disconnect engage switch wire harness connector from the main harness connector (red, brown/white, and white wires).
2. Connect ohmmeter between point C (brown/white stripe wire in main wire harness) and ground. Make sure the Regulator is well grounded to the chassis. The ohmmeter should read between 42 and 49 ohms. If a resistance either above or below the value indicated is

shown, then disconnect the connector from the Regulator and measure the resistance of the brown/white stripe wire from point C to D. It should measure 40 ohms \pm 2 ohms.

3. If a resistance either above or below the value indicated is shown, the main wiring harness should be replaced.

NOTE: When disconnecting or reconnecting the main wiring harness connector from the Regulator, care should be exercised so as not to damage the blade connectors or the wiring harness. The disconnect may be facilitated by prying carefully on the plastic connector with a small screwdriver.

4. Measuring the solenoid coil circuit resistance between point E (Hold Terminal) and ground, the ideal resistance should be between 5 and 6 ohms. A reading of less than 4 ohms indicates shorting in the coil circuit. A reading of more than 7 ohms indicates excessive resistance in the coil circuit. Either extremity indicates replacement of the Regulator assembly. The main harness wiring from point F to G (white wire) should also be checked for continuity.

SERVO AND VACUUM SYSTEM TEST

To determine the condition of the diaphragm, remove hose from the Servo Unit and apply 14 inches of vacuum to the tube opening and hold in for one minute. The vacuum shall not leak down more than 5 inches of vacuum in one minute. If leakage is detected, replace the Servo. To utilize engine as a vacuum source, proceed as follows:

1. Disconnect Servo cable at carburetor and vacuum hose from the Servo, then connect engine vacuum directly to the Servo fitting.
2. Note position of Servo diaphragm.
3. Start engine--the diaphragm should pull in.
4. Clamp off engine vacuum supply line and check for leakage.

The cruise release brake valve (vacuum) and connecting hoses can likewise be checked using a vacuum pump.

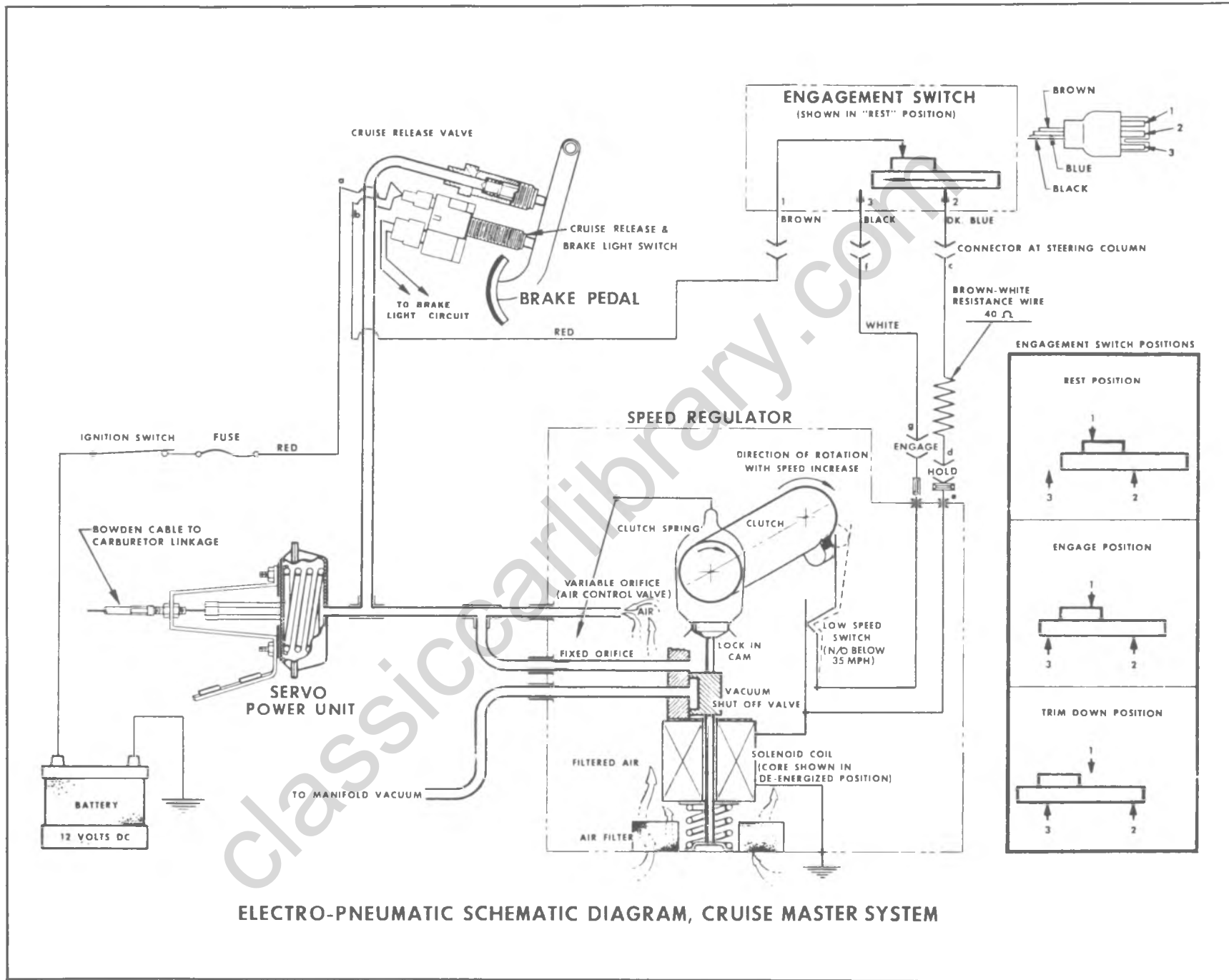
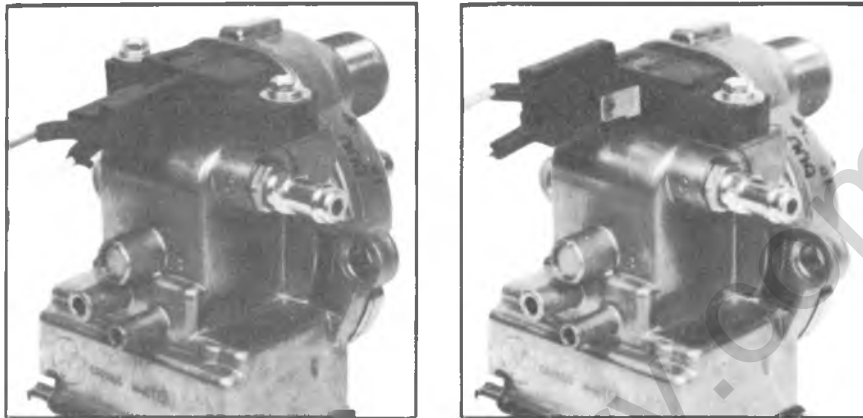


Fig. 9-3C--Electro-Pneumatic Schematic

CRUISE MASTER TROUBLESHOOTING

CHECK I FOR SYSTEMS WITH ERRATIC CRUISE PERFORMANCE

CHECK II FOR INOPERATIVE SYSTEMS MAKE ALL TESTS WITH TRANSMISSION SELECTOR IN "PARK" & PARKING BRAKE ON EXCEPT WHERE INDICATED OTHERWISE. RECONNECT ANY DISCONNECTED HOSES AND/OR ELECTRICAL CONNECTORS IN PROPER MANNER AT THE COMPLETION OF TEST.



CHECK I

1. CHECK SERVO CABLE ADJUSTMENT - MUST HAVE MINIMUM AMOUNT OF LOST MOTION SEE SERVICE ADJUSTMENT PROCEDURE
2. CHECK FOR PINCHED, KINKED, PLUGGED, OR DAMAGED VACUUM HOSES. ALSO CHECK VACUUM FITTINGS.
3. CHECK SPEEDOMETER CABLE ROUTING. IT MUST NOT BE KINKED OR HAVE TOO SHARP A TURNING RADIUS (NOT LESS THAN 6" RADIUS). CHECK DRIVE CABLE FOR DISTORTED OR BENT TIPS. FERRULES MUST BE SNUG.
4. CHECK FOR A BINDING THROTTLE LINKAGE CONDITION.
5. CHECK ADJUSTMENT OF BRAKE RELEASE SWITCH & VACUUM RELEASE VALVE. (SEE SERVICE & ADJUSTMENTS)
6. CHECK FOR PROPER OPERATING PROCEDURE OF THE ENGAGE SWITCH.
7. IF STEPS 1 THROUGH 6 DO NOT SOLVE THE PROBLEM PROCEED WITH CHECK II.

SPECIAL NOTE PERTAINING TO ENGAGEMENT-CRUISE SPEED ZEROING.

IF THE CAR CRUISES BELOW ENGAGEMENT SPEED, SCREW THE ORIFICE TUBE OUTWARD. IF THE CAR CRUISES ABOVE THE ENGAGEMENT SPEED, SCREW THE ORIFICE TUBE INWARD. EACH 1/4 TURN WILL CHANGE THE CAR SPEED APPROXIMATELY ONE MPH. ENGAGEMENT ACCURACY TESTING TO BE DONE AT 60 MPH. SNUG UP LOCK NUT AFTER EACH ADJUSTMENT.

CAUTION: DO NOT REMOVE ORIFICE TUBE FROM CASTING.

Fig. 9-4C-System Diagnosis Chart No. 1

CHECK II

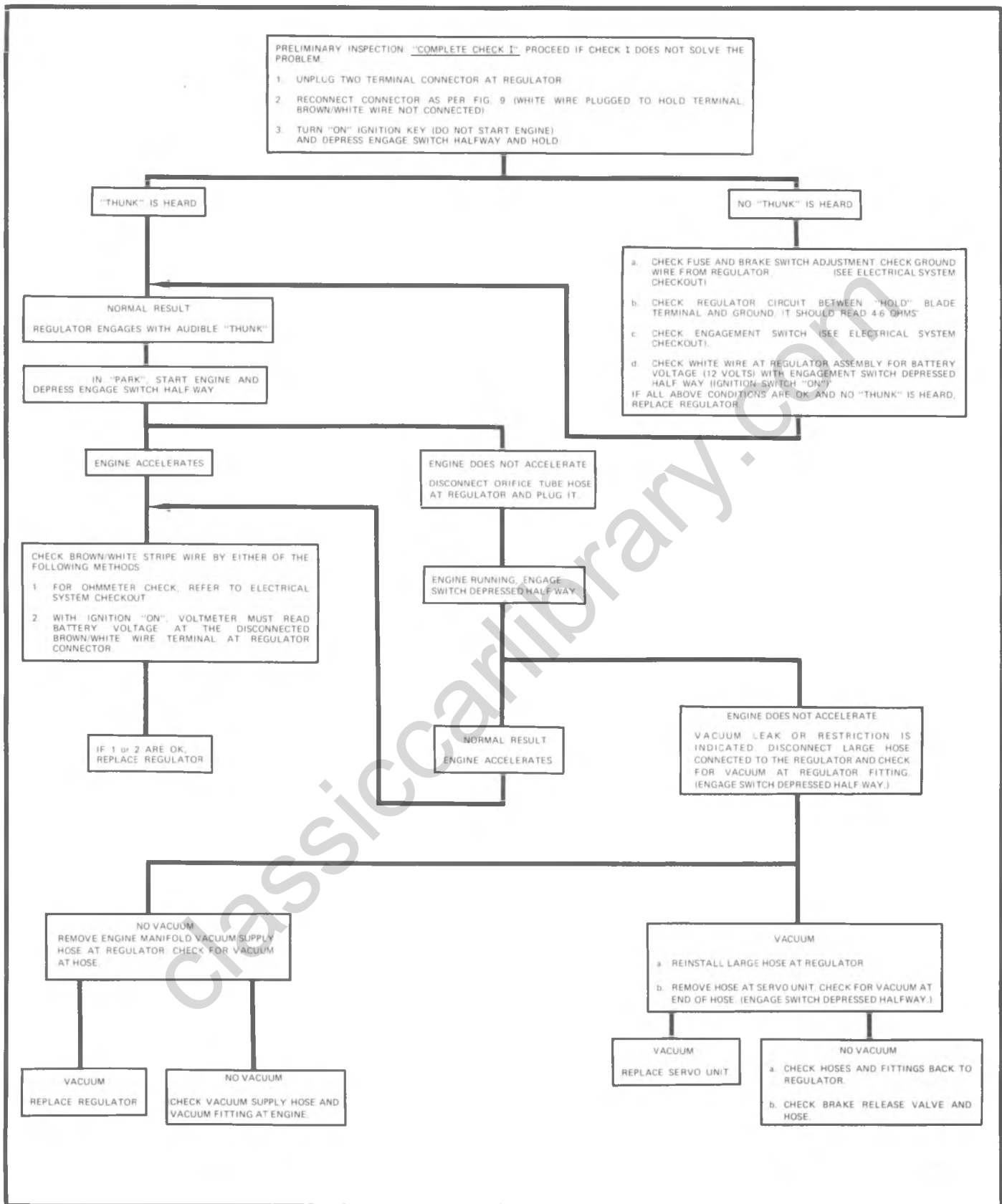


Fig. 9-5C--System Diagnosis Chart No.2

ON-VEHICLE SERVICE

MAINTENANCE AND ADJUSTMENTS

The components of the Cruise-Master System are designed to be replaced should they become inoperative. The Regulator is calibrated in such a manner during manufacturing that overhaul operations are impractical. However, one adjustment may be made to the Regulator to correct speed drop or increase at the time of engagement.

REGULATOR (FIG. 9-6C)

One regulator adjustment is possible - Engagement Cruising Speed Zeroing (to remove any difference between engagement and cruising speed). No regulator adjustment should be made, however, until the Servo Cable adjustment has been checked and vacuum hoses are checked for leaks, kinks, or other restrictions.

If the vehicle cruises at a speed a few mph above or below the engagement speed, this error can be corrected with a simple adjustment of the orifice tube in the regulator (fig. 9-2C).

CAUTION: Never remove orifice tube from casting. It cannot be reinstalled once it has been removed.

1. To check cruise speed error, engage Cruise-Master at 55 mph.
2. If vehicle cruises **below** engagement speed, screw orifice tube **outward**
3. If vehicle cruises **above** engagement speed, screw orifice tube **inward**

NOTE: Each 1/4 turn of the orifice tube will change cruise speed approximately one mph. Snug-up lock nut after each adjustment.

If a Regulator is found to be defective and not

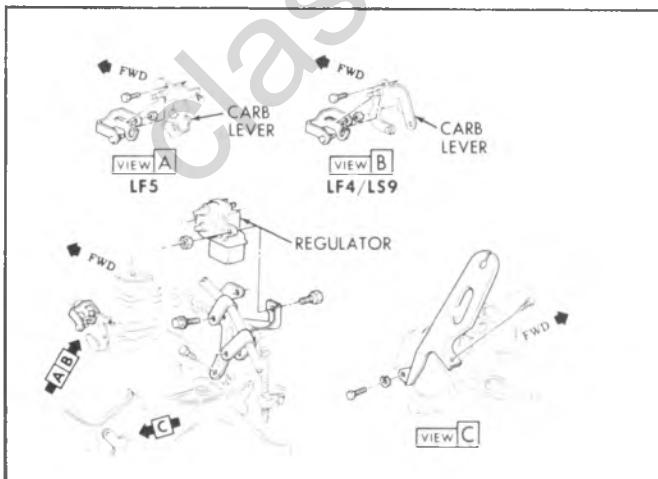


Fig. 9-6C-Regulator and Brackets (G Truck)

simply out-of-adjustment, it must be replaced. During replacement, check the hoses which connect to the Regulator and replace any which are cracked or deteriorated.

SERVO UNIT (FIG. 9-7C)

Before adjusting the Servo Cable, make sure the carburetor is set at its lowest idle throttle position by manually setting the fast idle cam at its lowest step with the ignition switch "OFF". Adjust the cable so there is as little lost motion at the Servo as possible (Fig. 9-7C).

If the Servo Unit is found to be defective, replacement is required. Note the condition of the hoses and replace any which are cracked or deteriorated.

BRAKE RELEASE SWITCHES (Fig. 9-8C)

Electric

The Cruise Master brake release switch electrical contacts must be switched open when the brake pedal is depressed .38" to .64", measured at the brake pedal.

An inoperative switch must be replaced. Switch replacement procedure is similar to standard brake lamp switch replacement.

Vacuum

The vacuum valve plunger must clear the pedal arm when the arm is moved 5/16 inch, measured at the switch (fig. 9-9C).

An inoperative (sticking, plugged, or leaking) vacuum valve must be replaced. Vacuum valve replacement is similar to brake lamp switch replacement. Be certain that the hose to the valve is connected firmly and is not cracked or deteriorated.

COLUMN MOUNTED ENGAGEMENT SWITCH

The engagement switch is serviced only by replacement of the turn signal lever assembly.

COMPONENT PART REPLACEMENT

REGULATOR

Replacement

1. Disconnect battery ground cable.
2. Disconnect speedometer cables at regulator.
3. Disconnect vacuum and wiring harness at regulator body.
4. Remove regulator to bracket screws and remove regulator.
5. To install, reverse Steps 1-4 above.

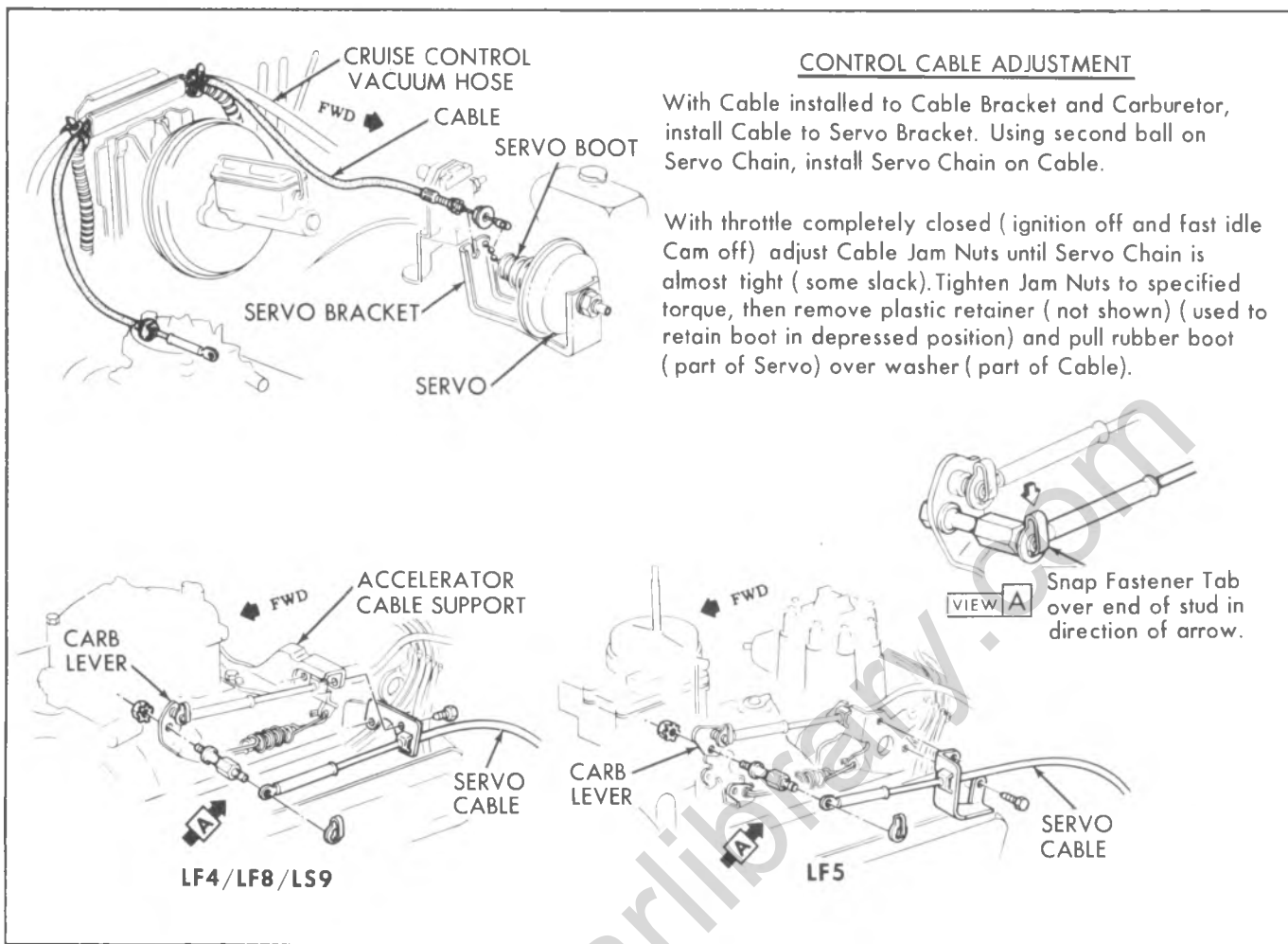


Fig. 9-7C-Servo Composite (C-K Trucks)

SERVO

Replacement

1. Disconnect battery ground cable.
2. Disconnect vacuum line at servo can.
3. Remove servo cover. Disconnect ball chain from cable retainer.
4. Remove servo to bracket screw(s) and remove servo.
5. To install, reverse Steps 1-4 above.
6. Adjust the servo cable as outlined in Figure 9-7C.

COLUMN MOUNTED ENGAGEMENT SWITCH

Removal

1. Disconnect the battery ground cable.
2. Disconnect cruise master engagement switch wiring harness plug on steering column.
3. Remove plastic protector from cruise master

wiring harness on column.

4. Remove turn signal lever (see Section 3B of this Manual).
5. Connect a 15" piece of piano wire to cruise master wiring harness plug for installation before easing turn signal lever assembly up and out of the column.

Installation

1. Attach new engagement switch harness plug to piano wire routed through column.
2. Pull connector and wire gently down column to prevent scraping wire insulation.
3. Install turn signal lever (see Section 3B of this Manual).
4. Slide plastic wiring protector over harness and up column.
5. Connect cruise master wiring harness on column.
6. Connect battery ground cable.

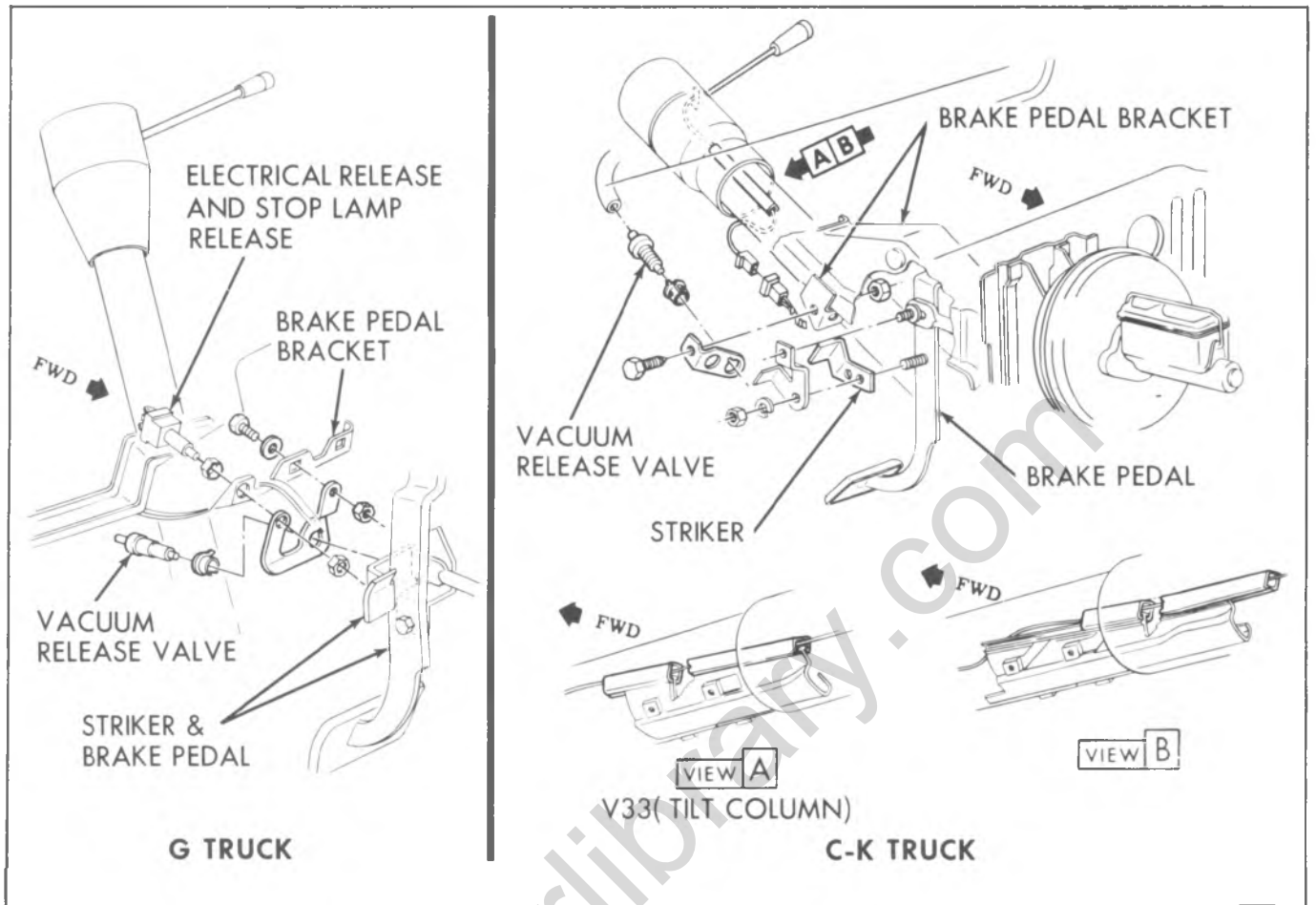


Fig. 9-8C--Release Switches, Valve and Brackets

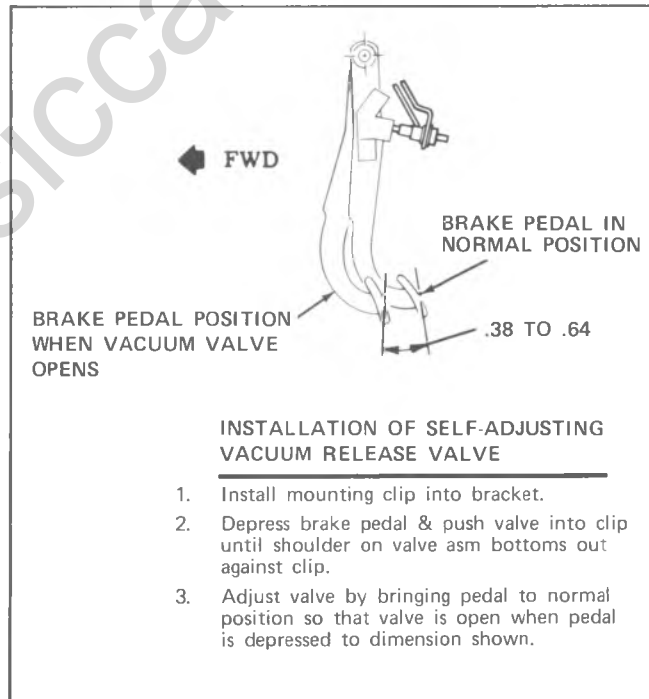


Fig. 9-9C--Vacuum Valve

SPECIFICATIONS

CRUISE-MASTER

Solenoid Resistance	5 ohms \pm 1/4 ohm
Solenoid Wire Resistance	40 ohms
Maximum allowable Vacuum Leakage rate for Servo unit	5 inches of Vacuum Per Minute
	Not Greater than 1 inch of Vacuum per 10 seconds
Operational Test Speed	55 MPH

RADIO

GENERAL DESCRIPTION

AM and AM/FM radios only are available on light duty trucks.

Rear speakers are available for certain series of C-K and G Trucks.

C-K model trucks incorporate a windshield antenna. The antenna lead snaps onto the center of the windshield, inside the vehicle. G model antennas are mounted externally on the right front fender.

DIAGNOSIS

The radio trouble diagnosis guide is intended as an aid in locating minor faults which can be corrected without a specialized knowledge of radio and without special radio test equipment. If the suggestions given here do not affect a correction, further testing should be done only by a trained radio technician having proper test equipment.

lead-in cable-Substitute and trim a known good radio.

Good radio plays-Defective radio.

Good radio still won't play-Defective antenna. Change windshield or antenna.

RADIO DEAD

Turn on radio.

No Thump Heard

Check fuse.

Fuse blown-Check receiver and speaker connectors.

Connectors loose or defective-Correct as required.

Connectors okay-Check speaker by substituting a known good speaker.

Radio does not play even with a known good substitute speaker-Defective receiver. Remove for servicing.

Radio plays with substitute speaker-Replace speaker.

Thump Heard

Check antenna connection at back of radio and at base of windshield or antenna.

Connections defective-Substitute a known good lead-in cable.

Radio plays-Defective cable.

Radio still won't play, even with a known good

RADIO CUTS ON AND OFF

Check for defective or loose receiver or antenna connectors at rear of radio or base of windshield or antenna.

Defective or loose connectors-Repair as necessary.

Connectors okay-Substitute a known good lead-in cable.

Radio plays okay-Defective cable.

Radio still cuts out with a known good lead-in cable-Check speaker by substituting a known good speaker.

Radio plays okay-Replace speaker.

Radio still plays intermittently, even with a known good speaker-Defective receiver.

RADIO STATIONS MIX TOGETHER

Trim radio as described earlier in this section. However, if two or more signals are picked up at the same time, there is no known way to separate them.

RADIO NOISY

Static-Start engine, rev up engine several times, and listen for speaker static.



Fig. 9-1R--Testing Windshield Antenna (Typical)

Static Heard—Trim radio - check for spark plug wire breakdown, loose or improperly seated wire, or loose or missing engine ground strap.

Check suppressors on voltage regulator, alternator, and resistor on timing control solenoid.

Static Still Present—Defective receiver.

WEAK RADIO SIGNAL

Test windshield antenna as described under "Antenna Testing" in this section.

DISTORTED TONE

Turn on radio, adjust for high volume and maximum bass. Check speaker by substituting a good speaker.

No Distortion—Replace speaker.

Distortion—Defective receiver—remove for servicing.

TESTING WINDSHIELD ANTENNA (FIG. 9-1R)

All C-K model trucks with factory installed radios

are equipped with windshield antennas. To positively identify antenna failure and eliminate the possibility of unnecessary windshield replacement, Windshield Antenna Tester J-23520 should be used to determine continuity of the thin antenna wire.

When antenna failure is suspected, the following checks should be made before replacing the windshield.

1. Check Tester J-23520 for operation on any vehicle radio antenna that is operating normally to test for a weak or dead battery.

2. Check all antenna connectings to insure that antenna is electrically coupled to the radio.

3. Turn ignition switch to accessory position, turn radio "ON", select AM band if receiver is AM/FM and tune radio to an off station position.

4. Hold tester to antenna beginning at the upper corner of antenna:

CAUTION: *The plastic Shield must be on tester at all times to avoid scratching windshield.*

a. If a shrill sound is emitted through the speaker when both antenna wires are tested, antenna is operational.

b. If no sound is emitted through one or both antenna wires, move tester along the wire toward center of windshield and down toward radio.

c. If a shrill sound is picked up, find exact location where the noise begins, this is the area of the defect. Replace windshield.

d. If no noise is heard over entire length of antenna, unplug antenna lead at radio and touch tester to antenna socket in radio.

e. If radio now makes a shrill sound, check connectors and antenna lead for possible defect before replacing windshield.

f. If no noise is emitted, radio, speaker, or fuse is defective.

NOTE: Make sure that antenna tester is turned off after completing antenna test.

ON-VEHICLE SERVICE

MAINTENANCE AND ADJUSTMENTS

RADIO INSTALLATION PRECAUTIONS

Listed below are common causes of inoperative radio receivers or poor reception on the AM scale upon reinstallation after repair.

- Radio speakers not connected--this could cause the output transistor to burn out in the receiver.
- Antenna lead not plugged into the receiver or windshield.
- Antenna trimmer not peaked.

TRIMMING RADIO

If diagnosis indicates the radio receiver must be

trimmed, perform the following procedure:

1. **G Models**—Set antenna mast at maximum height.
2. Remove tuner control knob and bezel (right hand knob).
3. Place ignition key in the "ACC" position.
4. Turn volume control to maximum volume.
5. Tune radio to a weak station (near 1400 KC) on the AM scale.
6. Adjust antenna trimmer screw ($\pm 2^\circ$ screw rotation) until maximum volume is received (fig. 9-2R).
7. Turn radio volume off.
8. Replace tuner control bezel and knob.
9. Turn ignition to "lock".

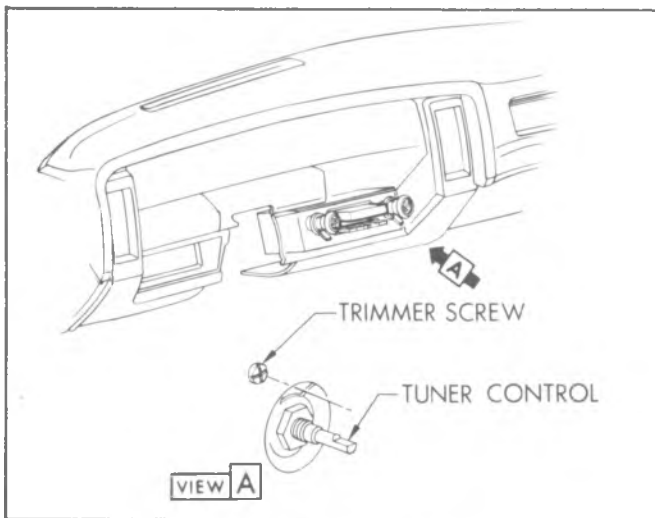


Fig. 9-2R--Trimming Radio

COMPONENT PART REPLACEMENT

RADIO RECEIVER

C-K Models

Replacement (Fig. 9-3R)

1. Disconnect battery ground cable.
2. Pull off radio control knobs and remove knob bezels. Remove nuts and washers from control shafts using a deep well socket.
3. **AM Radio**—Remove the radio support bracket stud nut and lockwasher.
3. **AM/FM Radio**—Remove radio support bracket to instrument panel screws.
4. Lift up on the rear edge of radio. Then push radio forward until control shafts clear instrument panel. Lower control far enough to disconnect electrical harness.
5. Disconnect power feed, speaker and antenna lead wires and remove radio.
6. To install, reverse Steps 1-5 above.

G Models

Replacement (Fig. 9-4R)

1. Disconnect battery ground cable.
2. Remove engine cover.
3. Remove air cleaner on carburetor.
4. Remove stud in carburetor throat for mounting air cleaner.
5. Cover carburetor throat with clean plastic to prevent dirt or radio attachments from falling into carburetor.
6. Remove knobs, washers and nuts from control shafts on front of radio.
7. Remove bracket to radio receiver screw.
8. Now guide radio forward and then down

through engine access area. Lower radio far enough to disconnect electrical connectors and antenna lead. Remove radio.

9. Reverse Steps 1-8 for installation of radio.

FRONT SPEAKER

C-K Models

Replacement (Fig. 9-5R)

1. Disconnect battery ground cable.
2. Remove instrument cluster bezel upper four screws.
3. Remove instrument panel pad screws and remove pad.
4. Remove speaker to dash panel screws.
5. Lift up on speaker, disconnect speaker wiring harness and then remove speaker.
6. To install, reverse Steps 1-5 above.

G Models

Replacement (Fig. 9-4R)

1. Follow radio removal Steps 1 through 8.
2. Remove left heater duct (attached to engine cover extension by one screw).
3. Remove speaker to mounting bracket screw and lower speaker out engine cover opening.
4. Reverse Steps 1-3 above for speaker replacement.

REAR SPEAKER

C-K Models

Replacement (Fig. 9-6R)

1. Remove four screws securing speaker grille to trim panel and remove grille.
2. Disconnect electrical connector from speaker.
3. Remove two screws securing speaker to trim panel and remove speaker.

NOTE: On 109 and 209 (06) models, there is a gasket between speaker and trim panel.

4. Install replacement speaker in reverse order of removal.

G Models

Replacement (Figs. 9-7R and 9-8R)

1. Remove the four most forward lower screws securing right rear trim panel. Pull trim panel outward slightly for access to speaker.
2. Disconnect electrical connector from speaker.
3. Remove four nuts securing speaker to grille studs and remove speaker.

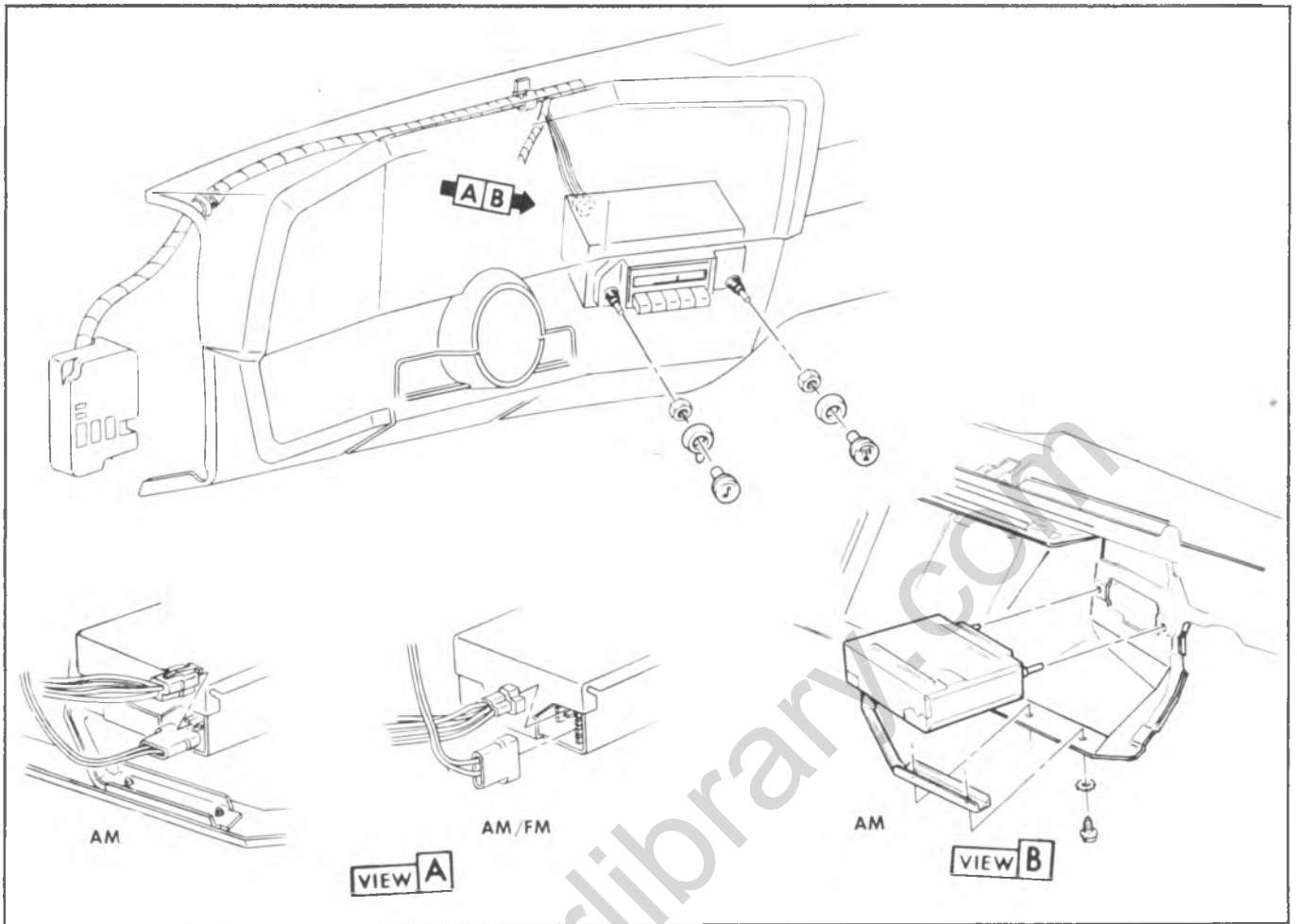


Fig. 9-3R--Radio Receiver (C-K Models)

4. Install replacement speaker in reverse order of removal.

ANTENNA

C-K Models (Fig. 9-9R)

Antenna Replacement

Refer to Section 2 of this manual "Windshield Replacement" procedure.

Cable Replacement

1. Disconnect battery ground cable.
2. Unsnap antenna cable from windshield.
3. Remove bracket to dash panel screws.
4. Disconnect cable at rear of radio receiver and remove cable assembly.

G Models (Fig. 9-10R)

Antenna Replacement

1. Unscrew mast nut. Prevent the cable assembly from turning by using two separate wrenches. Remove

rod and mast assembly.

2. To install, insert rod and mast assembly into cable assembly and tighten mast nut. Prevent cable assembly from turning by using a second wrench.

Cable Assembly Replacement

1. Disconnect battery ground cable.
2. Remove antenna assembly as described above.
3. Remove cable body nut and then remove seal, bezel, gasket and ring ground.
4. Perform Steps 2-8 of "Radio Receiver Removal".
5. Disconnect cable at rear of receiver.
6. Insert new cable through the dash panel (from the forward side).
7. Reverse Steps 1-5 above to complete installation.

NOTE: Be sure cable grommet is properly positioned in dash panel.

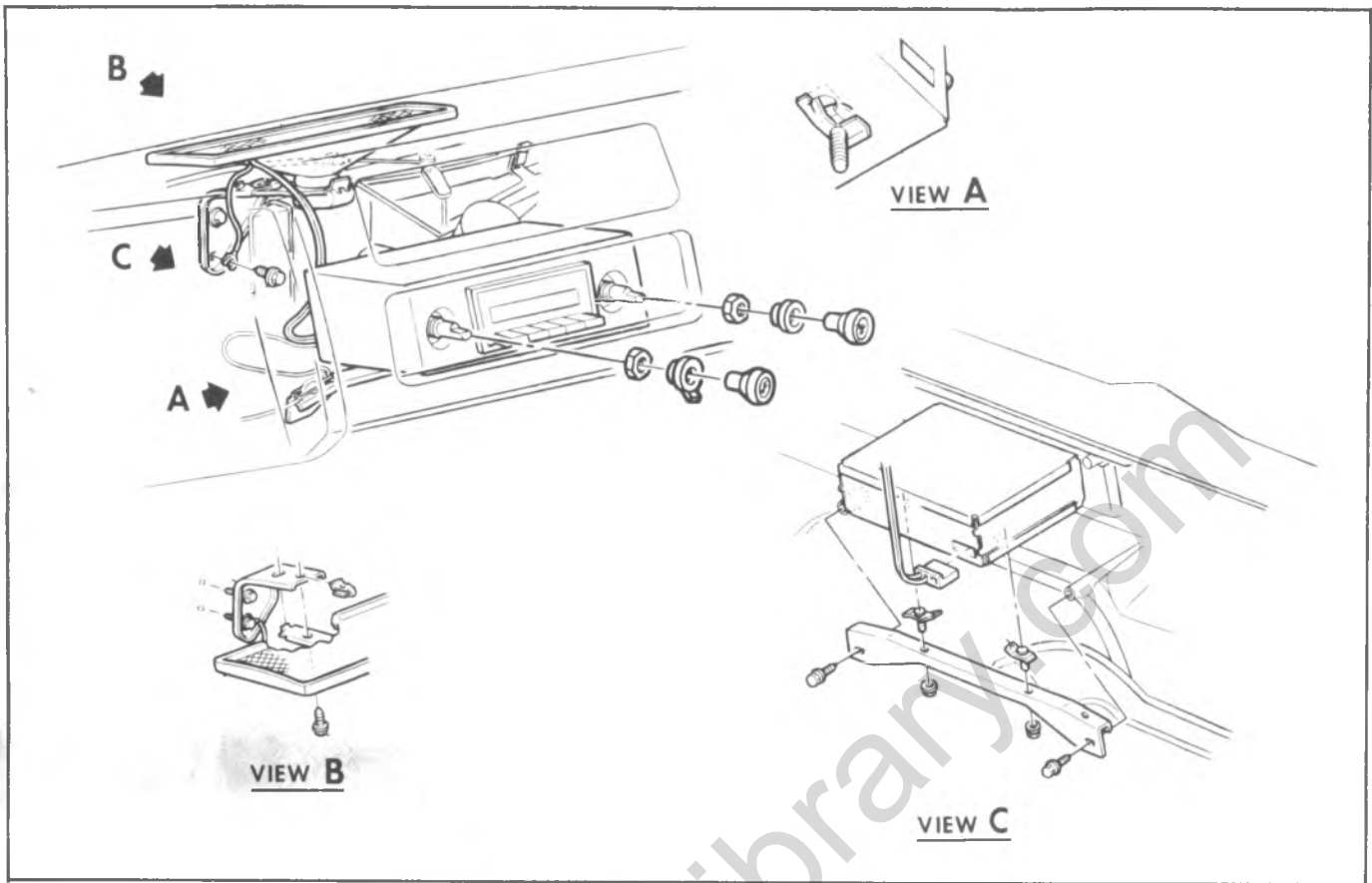


Fig. 9-4R--Radio Receiver and Front Speaker (G Models)

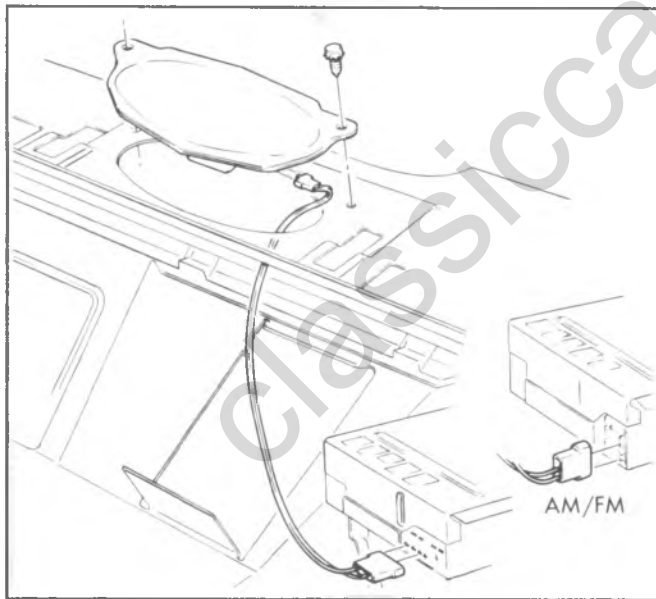


Fig. 9-5R--Radio Front Speaker (C-K Models)

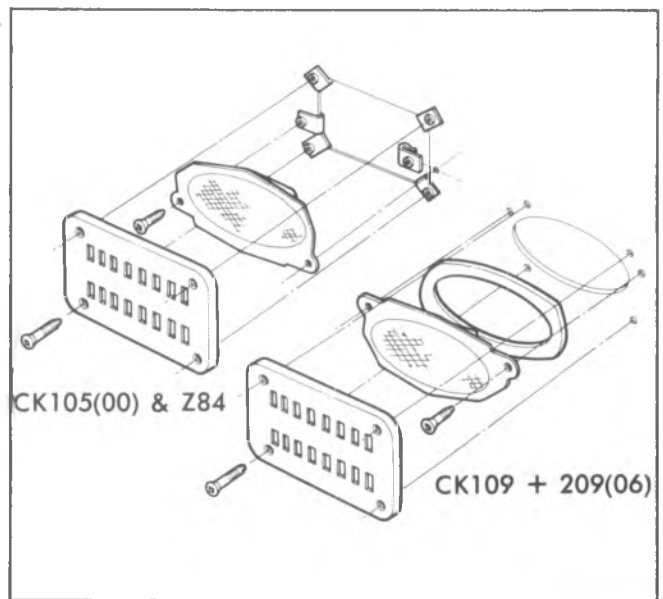


Fig. 9-6R--Rear Speaker (C-K Truck)

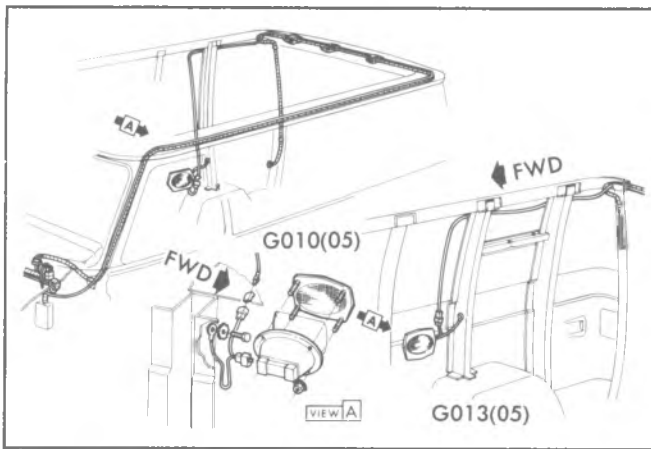


Fig. 9-7R--Rear Speaker (G (05) Truck)

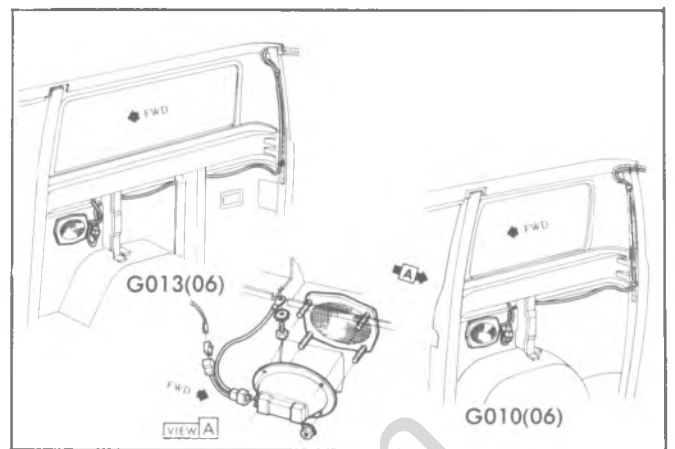


Fig. 9-8R--Rear Speaker (G (06) Truck)

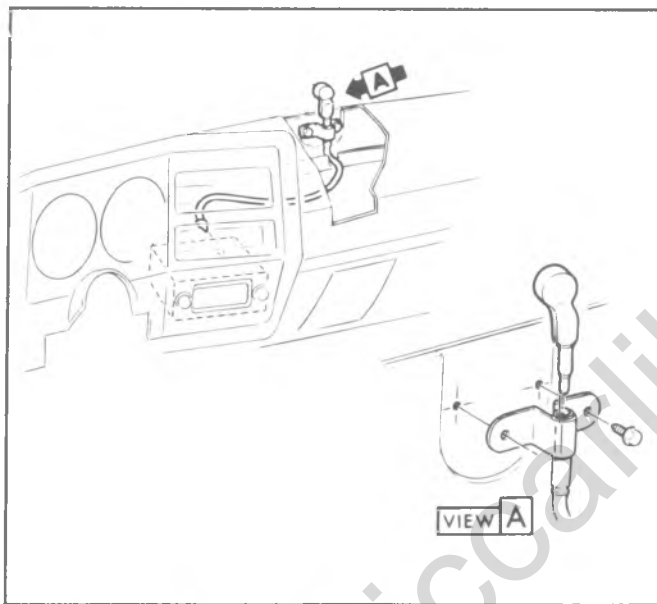


Fig. 9-9R--Antenna Lead (C-K Models)

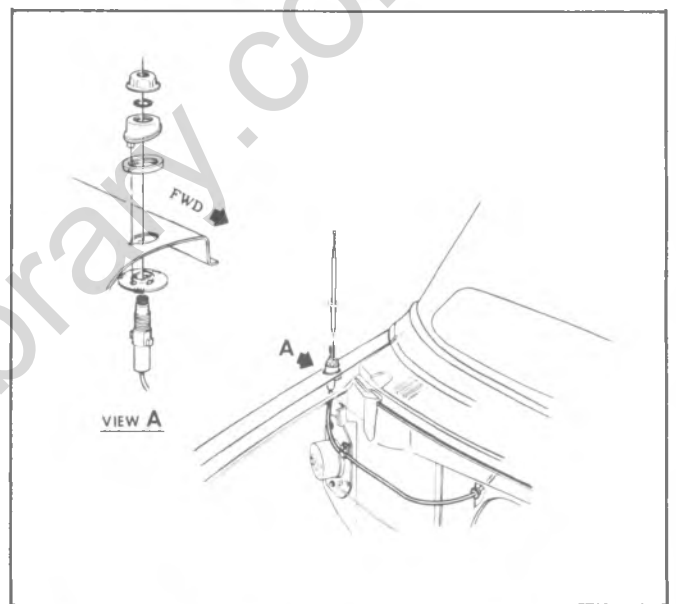


Fig. 9-10R--Antenna Installation (G Models)

SPECIAL TOOLS

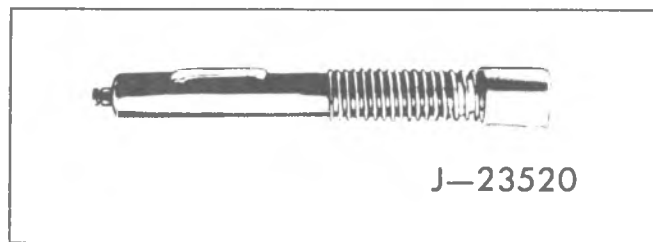


Fig. 9-11R--Windshield Antenna Tester (J-23520)

GM TABLE OF FREQUENTLY USED UNITS (U.S.) GM

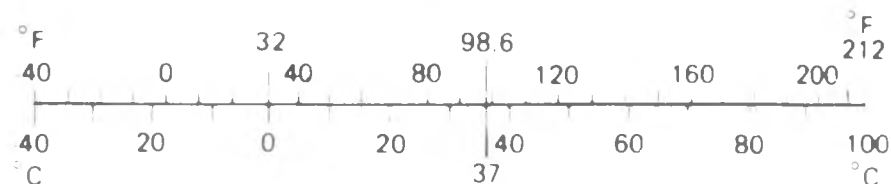
SI (SYSTEME INTERNATIONAL D'UNITES)

Multiply	by	to get equivalent number of:
LENGTH		
Inch	25.4	millimetres (mm)
Foot	0.304 8	metres (m)
Yard	0.914 4	metres
Mile	1.609	kilometres (km)
AREA		
Inch ²	645.2	millimetres ² (mm ²)
	6.45	centimetres ² (cm ²)
Foot ²	0.092 9	metres ² (m ²)
Yard ²	0.836 1	metres ²
VOLUME		
Inch ³	16 387.	mm ³
	16.387	cm ³
	0.016 4	litres (l)
Quart	0.946 4	litres
Gallon	3.785 4	litres
Yard ³	0.764 6	metres ³ (m ³)
MASS		
Pound	0.453 6	kilograms (kg)
Ton	907.18	kilogram
Ton	0.907	tonne (t)
FORCE		
Kilogram (force)	9.807	newtons (N)
Ounce	0.278 0	newtons
Pound	4.448	newtons

Multiply	by	to get equivalent number of:
ACCELERATION		
Foot/sec ²	0.304 8	metre/sec ² (m/s ²)
Inch/sec ²	0.025 4	metre/sec ²
TORQUE		
Pound-inch	0.112 98	newton-metres (N·m)
Pound-foot	1.355 8	newton-metres
POWER		
Horsepower	0.746	kilowatts (kW)
PRESSURE OR STRESS		
Inches of mercury	3.38	kilopascals (kPa)
Pounds/sq. in.	6.895	kilopascals
ENERGY OR WORK		
BTU	1 055.	joules (J)
Foot-pound	1.355 8	joules
Kilowatt-hour	3 600 000	joules (J = W·s)
	or 3.6x10 ⁶	
LIGHT		
Footcandle	10.764	lumens/metre ² (lm/m ²)
FUEL PERFORMANCE		
Miles/gal	0.425 1	kilometres/litre (km/l)
Gal/mile	2.352 7	litres/kilometre (l/km)
VELOCITY		
Miles/hour	1.609 3	kilometres/hr. (km/h)

TEMPERATURE

Degree Fahrenheit (°F-32) ÷ 1.8 = degree Celsius (°C)



HOW TO USE CONVERSION CHARTS

Left Column is units of 10, (0, 10, 20, 30 etc.);
Top Row is in units of one (0, 1, 2, 3, etc).

EXAMPLE: Feet to Inches Conversion Chart

feet	0	1	2	3	4	5	6	7	8	9	feet
	inches	inches	inches	inches	inches	inches	inches	inches	inches	inches	
--		12	24	36	48	60	72	84	96	108	--
10	120	132	144	156	168	180	192	204	216	228	10
20	240	252	264	276	288	300	312	324	336	348	20
30	360	372	384	396	408	420	432	444	456	468	30
40	480	492	504	516	528	540	552	564	576	588	40
50	600	612	624	636	648	660	672	684	696	708	50

12 feet equals 144 inches. Read across from 10 and down from 2.
6 feet equals 72 inches. Read down from 6.

FEET TO METRES

ft	0	1	2	3	4	5	6	7	8	9	ft
	m	m	m	m	m	m	m	m	m	m	
--		0.305	0.610	0.914	1.219	1.524	1.829	2.134	2.438	2.743	--
10	3.048	3.353	3.658	3.962	4.267	4.572	4.877	5.182	5.486	5.791	10
20	6.096	6.401	6.706	7.010	7.315	7.620	7.925	8.230	8.534	8.839	20
30	9.144	9.449	9.754	10.058	10.363	10.668	10.973	11.278	11.582	11.887	30
40	12.192	12.497	12.802	13.106	13.411	13.716	14.021	14.326	14.630	14.935	40
50	15.240	15.545	15.850	16.154	16.459	16.764	17.069	17.374	17.678	17.983	50
60	18.288	18.593	18.898	19.202	19.507	19.812	20.117	20.422	20.726	21.031	60
70	21.336	21.641	21.946	22.250	22.555	22.860	23.165	23.470	23.774	24.079	70
80	24.384	24.689	24.994	25.298	25.603	25.908	26.213	26.518	26.822	27.127	80
90	27.432	27.737	28.042	28.346	28.651	28.956	29.261	29.566	29.870	30.175	90
100	30.480	30.785	31.090	31.394	31.699	32.004	32.309	32.614	32.918	33.223	100

METRES TO FEET

m	0	1	2	3	4	5	6	7	8	9	m
	ft	ft	ft	ft	ft	ft	ft	ft	ft	ft	
--		3.2808	6.5617	9.8425	13.1234	16.4042	19.6850	22.9659	26.2467	29.5276	--
10	32.8084	36.0892	39.3701	42.6509	45.9318	49.2126	52.4934	55.7743	59.0551	62.3360	10
20	65.6168	68.8976	72.1785	75.4593	78.7402	82.0210	85.3018	88.5827	91.8635	95.1444	20
30	98.4252	101.7060	104.9869	108.2677	111.5486	114.8294	118.1102	121.3911	124.6719	127.9528	30
40	131.2336	134.5144	137.7953	141.0761	144.3570	147.6378	150.9186	154.1995	157.4803	160.7612	40
50	164.0420	167.3228	170.6037	173.8845	177.1654	180.4462	183.7270	187.0079	190.2887	193.5696	50
60	196.8504	200.1312	203.4121	206.6929	209.9738	213.2546	216.5354	219.8163	223.0971	226.3780	60
70	229.6588	232.9396	236.2205	239.5013	242.7822	246.0630	249.3438	252.6247	255.9055	259.1864	70
80	262.4672	265.7480	269.0289	272.3097	275.5906	278.8714	282.1522	285.4331	288.7139	291.9948	80
90	295.2756	298.5564	301.8373	305.1181	308.3990	311.6798	314.9606	318.2415	321.5223	324.8032	90
100	328.0840	331.3648	334.6457	337.9265	341.2074	344.4882	347.7690	351.0499	354.3307	357.6116	100

MILES TO KILOMETRES

mile	0	1	2	3	4	5	6	7	8	9	mile
	km	km	km	km	km	km	km	km	km	km	
--		1.609	3.219	4.828	6.437	8.047	9.656	11.265	12.875	14.484	--
10	16.093	17.703	19.312	20.921	22.531	24.140	25.750	27.359	28.968	30.578	10
20	32.187	33.796	35.406	37.015	38.624	40.234	41.843	43.452	45.062	46.671	20
30	48.280	49.890	51.499	53.108	54.718	56.327	57.936	59.546	61.155	62.764	30
40	64.374	65.983	67.593	69.202	70.811	72.421	74.030	75.639	77.249	78.858	40
50	80.467	82.077	83.686	85.295	86.905	88.514	90.123	91.733	93.342	94.951	50
60	96.561	98.170	99.779	101.39	103.00	104.61	106.22	107.83	109.44	111.04	60
70	112.65	114.26	115.87	117.48	119.09	120.70	122.31	123.92	125.53	127.14	70
80	128.75	130.36	131.97	133.58	135.19	136.79	138.40	140.01	141.62	143.23	80
90	144.84	146.45	148.06	149.67	151.28	152.89	154.50	156.11	157.72	159.33	90
100	160.93	162.54	164.15	165.76	167.37	168.98	170.59	172.20	173.81	175.42	100

KILOMETRES TO MILES

km	0	1	2	3	4	5	6	7	8	9	km
	mil	mil	mil	mil	mil	mil	mil	mil	mil	mil	
--		0.621	1.243	1.864	2.486	3.107	3.728	4.350	4.971	5.592	--
10	6.214	6.835	7.457	8.078	8.699	9.321	9.942	10.562	11.185	11.805	10
20	12.427	13.049	13.670	14.292	14.913	15.534	16.156	16.776	17.399	18.019	20
30	18.641	19.263	19.884	20.506	21.127	21.748	22.370	22.990	23.613	24.233	30
40	24.855	25.477	26.098	26.720	27.341	27.962	28.584	29.204	29.827	30.447	40
50	31.069	31.690	32.311	32.933	33.554	34.175	34.797	35.417	36.040	36.660	50
60	37.282	37.904	38.525	39.147	39.768	40.389	41.011	41.631	42.254	42.874	60
70	43.497	44.118	44.739	45.361	45.982	46.603	47.225	47.845	48.468	49.088	70
80	49.711	50.332	50.953	51.575	52.196	52.817	53.439	54.059	54.682	55.302	80
90	55.924	56.545	57.166	57.788	58.409	59.030	59.652	60.272	60.895	61.515	90
100	62.138	62.759	63.380	64.002	64.623	65.244	65.866	66.486	67.109	67.729	100

GALLONS (U.S.) TO LITRES

U.S. gal	0	1	2	3	4	5	6	7	8	9	U.S. gal
	L	L	L	L	L	L	L	L	L	L	
--		3.7854	7.5709	11.3563	15.1417	18.9271	22.7126	26.4980	30.2834	34.0638	--
10	37.8543	41.6397	45.4251	49.2105	52.9960	56.7814	60.5668	64.3523	68.1377	71.9231	10
20	75.7085	79.4940	83.2794	87.0648	90.8502	94.6357	98.4211	102.2065	105.9920	109.7774	20
30	113.5528	117.3482	121.1337	124.9191	128.7045	132.4899	136.2754	140.0608	143.8462	147.6316	30
40	151.4171	155.2025	158.9879	162.7734	166.5588	170.3442	174.1296	177.9151	181.7005	185.4859	40
50	189.2713	193.0568	196.8422	200.6276	204.4131	208.1985	211.9839	215.7693	219.5548	223.3402	50
60	227.1256	230.9110	234.6965	238.4819	242.2673	246.0527	249.8382	253.6236	257.4090	261.1945	60
70	264.9799	268.7653	272.5507	276.3362	280.1216	283.9070	287.6924	291.4779	295.2633	299.0487	70
80	302.8342	306.6196	310.4050	314.1904	317.9759	321.7613	325.5467	329.3321	333.1176	336.9030	80
90	340.6884	344.4738	348.2593	352.0447	355.8301	359.6156	363.4010	367.1864	370.9718	374.7573	90
100	378.5427	382.3281	386.1135	389.8990	393.6844	397.4698	401.2553	405.0407	408.8261	412.6115	100

LITRES TO GALLONS (U.S.)

L	0	1	2	3	4	5	6	7	8	9	L
	gal	gal	gal	gal	gal	gal	gal	gal	gal	gal	
--		0.2642	0.5283	0.7925	1.0567	1.3209	1.5850	1.8492	2.1134	2.3775	--
10	2.6417	2.9059	3.1701	3.4342	3.6984	3.9626	4.2267	4.4909	4.7551	5.0192	10
20	5.2834	5.5476	5.8118	6.0759	6.3401	6.6043	6.8684	7.1326	7.3968	7.6610	20
30	7.9251	8.1893	8.4535	8.7176	8.9818	9.2460	9.5102	9.7743	10.0385	10.3027	30
40	10.5668	10.8310	11.0952	11.3594	11.6235	11.8877	12.1519	12.4160	12.6802	12.9444	40
50	13.2086	13.4727	13.7369	14.0011	14.2652	14.5294	14.7936	15.0577	15.3219	15.5861	50
60	15.8503	16.1144	16.3786	16.6428	16.9069	17.1711	17.4353	17.6995	17.9636	18.2278	60
70	18.4920	18.7561	19.0203	19.2845	19.5487	19.8128	20.0770	20.3412	20.6053	20.8695	70
80	21.1337	21.3979	21.6620	21.9262	22.1904	22.4545	22.7187	22.9829	23.2470	23.5112	80
90	23.7754	24.0396	24.3037	24.5679	24.8321	25.0962	25.3604	25.6246	25.8888	26.1529	90
100	26.4171	26.6813	26.9454	27.2096	27.4738	27.7380	28.0021	28.2663	28.5305	28.7946	100

GALLONS (IMP.) TO LITRES

IMP gal	0	1	2	3	4	5	6	7	8	9	IMP gal
	L	L	L	L	L	L	L	L	L	L	
--		4.5460	9.0919	13.6379	18.1838	22.7298	27.2758	31.8217	36.3677	40.9136	--
10	45.4596	50.0056	54.5515	59.0975	63.6434	68.1894	72.7354	77.2813	81.8275	86.3732	10
20	90.9192	95.4652	100.0111	104.5571	109.1030	113.6490	118.1950	122.7409	127.2869	131.8328	20
30	136.3788	140.9248	145.4707	150.0167	154.5626	159.1086	163.6546	168.0005	172.7465	177.2924	30
40	181.8384	186.3844	190.9303	195.4763	200.0222	204.5682	209.1142	213.6601	218.2061	222.7520	40
50	227.2980	231.8440	236.3899	240.9359	245.4818	250.0278	254.5738	259.1197	263.6657	268.2116	50
60	272.7576	277.3036	281.8495	286.3955	290.9414	295.4874	300.0334	304.5793	309.1253	313.6712	60
70	318.2172	322.7632	327.3091	331.8551	336.4010	340.9470	345.4930	350.0389	354.5849	359.1308	70
80	363.6768	368.2223	372.7687	377.3147	381.8606	386.4066	390.9526	395.4985	400.0445	404.5904	80
90	409.1364	413.6824	418.2283	422.7743	427.3202	431.8662	436.4122	440.9581	445.9041	450.0500	90
100	454.5960	459.1420	463.6879	468.2339	472.7798	477.3258	481.8718	486.4177	490.9637	495.5096	100

LITRES TO GALLONS (IMP.)

L	0	1	2	3	4	5	6	7	8	9	L
	gal	gal	gal	gal	gal	gal	gal	gal	gal	gal	
--		0.2200	0.4400	0.6599	0.8799	1.0999	1.3199	1.5398	1.7598	1.9798	--
10	2.1998	2.4197	2.6397	2.8597	3.0797	3.2996	3.5196	3.7396	3.9596	4.1795	10
20	4.3995	4.6195	4.8395	5.0594	5.2794	5.4994	5.7194	5.9394	6.1593	6.3793	20
30	6.5993	6.8193	7.0392	7.2592	7.4792	7.6992	7.9191	8.1391	8.3591	8.5791	30
40	8.7990	9.0190	9.2390	9.4590	9.6789	9.8989	10.9189	10.3389	10.5588	10.7788	40
50	10.9988	11.2188	11.4388	11.6587	11.8787	12.0987	12.3187	12.5386	12.7586	12.9786	50
60	13.1986	13.4185	13.6385	13.8585	14.0785	14.2984	14.5184	14.7384	14.9584	15.1783	60
70	15.3983	15.6183	15.8383	16.0582	16.2782	16.4982	16.7182	16.9382	17.1581	17.3781	70
80	17.5981	17.8181	18.0380	18.2580	18.4780	18.6980	18.9179	19.1379	19.3579	19.5779	80
90	19.7978	20.0178	20.2378	20.4578	20.6777	20.8977	21.1177	21.3377	21.5576	21.7776	90
100	21.9976	22.2176	22.4376	22.6575	22.8775	23.0975	23.3175	23.5374	23.7574	23.9774	100

POUNDS TO KILOGRAMS

lb	0	.1	2	3	4	5	6	7	8	9	lb
	kg	kg	kg	kg	kg	kg	kg	kg	kg	kg	
--		0.454	0.907	1.361	1.814	2.268	2.722	3.175	3.629	4.082	--
10	4.536	4.990	5.443	5.897	6.350	6.804	7.257	7.711	8.165	8.618	10
20	9.072	9.525	9.979	10.433	10.886	11.340	11.793	12.247	12.701	13.154	20
30	13.608	14.061	14.515	14.969	15.422	15.876	16.329	16.783	17.237	17.690	30
40	18.144	18.597	19.051	19.504	19.958	20.412	20.865	21.319	21.772	22.226	40
50	22.680	23.133	23.587	24.040	24.494	24.948	25.401	25.855	26.308	26.762	50
60	27.216	27.669	28.123	28.576	29.030	29.484	29.937	30.391	30.844	31.298	60
70	31.751	32.205	32.659	33.112	33.566	34.019	34.473	34.927	35.380	35.834	70
80	36.287	36.741	37.195	37.648	38.102	38.555	39.009	39.463	39.916	40.370	80
90	40.823	41.277	41.730	42.184	42.638	43.092	43.545	43.998	44.453	44.906	90
100	45.359	45.813	46.266	46.720	47.174	47.627	48.081	48.534	48.988	49.442	100

KILOGRAMS TO POUNDS

kg	0	1	2	3	4	5	6	7	8	9	kg
	lb	lb	lb	lb	lb	lb	lb	lb	lb	lb	
--		2.205	4.409	6.614	8.818	11.023	13.228	15.432	17.637	19.842	--
10	22.046	24.251	26.455	28.660	30.865	33.069	35.274	37.479	39.683	41.888	10
20	44.092	46.297	48.502	50.706	52.911	55.116	57.320	59.525	61.729	63.934	20
30	66.139	68.343	70.548	72.752	74.957	77.162	79.366	81.571	83.776	85.980	30
40	88.185	90.389	92.594	94.799	97.003	99.208	101.41	103.62	105.82	108.03	40
50	110.23	112.44	114.64	116.84	119.05	121.25	123.46	125.66	127.87	130.07	50
60	132.28	134.48	136.69	138.89	141.10	143.30	145.51	147.71	149.91	152.12	60
70	154.32	156.53	158.73	160.94	163.14	165.35	167.55	169.76	171.96	174.17	70
80	176.37	178.57	180.78	182.98	185.19	187.39	189.60	191.80	194.01	196.21	80
90	198.42	200.62	202.83	205.03	207.23	209.44	211.64	213.85	216.05	218.26	90
100	220.46	222.67	224.87	227.08	229.28	231.49	233.69	235.89	238.10	240.30	100

POUNDS PER SQUARE INCHES TO KILOPASCALS

lb/in ²	0	1	2	3	4	5	6	7	8	9	lb/in ²
	kPa	kPa	kPa	kPa	kPa	kPa	kPa	kPa	kPa	kPa	
--	0.0000	6.8948	13.7895	20.6843	27.5790	34.4738	41.3685	48.2663	55.1581	62.0528	--
10	68.9476	75.8423	82.7371	89.6318	96.5266	103.4214	110.3161	117.2109	124.1056	131.0004	10
20	137.8951	144.7899	151.6847	158.5794	165.4742	172.3689	179.2637	186.1584	193.0532	199.9480	20
30	206.8427	213.7375	220.6322	227.5270	234.4217	241.3165	248.2113	255.1060	262.0008	268.8955	30
40	275.7903	282.6850	289.5798	296.4746	303.3693	310.2641	317.1588	324.0536	330.9483	337.8431	40
50	344.7379	351.6326	358.5274	365.4221	372.3169	379.2116	386.1064	393.0012	399.8959	406.7907	50
60	413.6854	420.5802	427.4749	434.3697	441.2645	448.1592	455.0540	461.9487	468.8435	475.7382	60
70	482.6330	489.5278	496.4225	503.3173	510.2120	517.1068	524.0015	530.8963	537.7911	544.6858	70
80	551.5806	558.4753	565.3701	572.2648	579.1596	586.0544	592.9491	599.8439	606.7386	613.6334	80
90	620.5281	627.4229	634.3177	641.2124	648.1072	655.0019	661.8967	668.7914	675.6862	682.5810	90
100	689.4757	696.3705	703.2653	710.1601	717.0549	723.9497	730.8445	737.7393	744.6341	751.5289	100

KILOPASCALS TO POUNDS PER SQUARE INCHES

kPa	0	1	2	3	4	5	6	7	8	9	kPa
	lb/in ²	lb/in ²	lb/in ²	lb/in ²	lb/in ²	lb/in ²	lb/in ²	lb/in ²	lb/in ²	lb/in ²	
--		.1450	.2901	.4351	.5801	.7252	.8702	1.0153	1.1603	1.3053	--
10	1.4504	1.5954	1.7404	1.8855	2.0305	2.1556	2.3206	2.4656	2.6107	2.7557	10
20	2.9007	3.0458	3.1908	3.3359	3.4809	3.6259	3.7710	3.9160	4.0610	4.2061	20
30	4.3511	4.4961	4.6412	4.7862	4.9313	5.0763	5.2213	5.3664	5.5114	5.6564	30
40	5.8015	5.9465	6.0916	6.2366	6.3816	6.5267	6.6717	6.8167	6.9618	7.1068	40
50	7.2518	7.3969	7.5419	7.6870	7.8320	7.9770	8.1221	8.2671	8.4121	8.5572	50
60	8.7022	8.8473	8.9923	9.1373	9.1824	9.4274	9.5724	9.7175	9.8625	10.0076	60
70	10.1526	10.2976	10.4427	10.5877	10.7327	10.8778	11.0228	11.1678	11.3129	11.4579	70
80	11.6030	11.7480	11.8930	12.0381	12.1831	12.3281	12.4732	12.6182	12.7633	12.9083	80
90	13.0533	13.1984	13.3434	13.4884	13.6335	13.7785	13.9236	14.0686	14.2136	14.3587	90
100	14.5037	14.6487	14.7938	14.9388	15.0838	15.2289	15.3739	15.5190	15.6640	15.8090	100

POUND FEET TO NEWTON-METRES

ft-lb	0	1	2	3	4	5	6	7	8	9	ft-lb
	N·m	N·m	N·m	N·m	N·m	N·m	N·m	N·m	N·m	N·m	
--		1.3558	2.7116	4.0675	5.4233	6.7791	8.1349	9.4907	10.8465	12.2024	--
10	13.5582	14.9140	16.2698	17.6256	18.9815	20.3373	21.6931	23.0489	24.4047	25.7605	10
20	27.1164	28.4722	29.8280	31.1838	32.5396	33.8954	35.2513	36.6071	37.9629	39.3187	20
30	40.6745	42.0304	43.3862	44.7420	46.0978	47.4536	48.8094	50.1653	51.5211	52.8769	30
40	54.2327	55.5885	56.9444	58.3002	59.6560	61.0118	62.3676	63.7234	65.0793	66.4351	40
50	67.7909	69.1467	70.5025	71.8584	73.2142	74.5700	75.9258	77.2816	78.6374	79.9933	50
60	81.3491	82.7049	84.0607	85.4165	86.7724	88.1282	89.4840	90.8398	92.1956	93.5514	60
70	94.9073	96.2631	97.6189	98.9747	100.3305	101.6863	103.0422	104.3980	105.7538	107.1096	70
80	108.4654	109.8213	111.1771	112.5329	113.8887	115.2445	116.6003	117.9562	119.3120	120.6678	80
90	122.0236	123.3794	124.7353	126.0911	127.4469	128.8027	130.1585	131.5143	132.8702	134.2260	90
100	135.5818	136.9376	138.2934	139.6493	141.0051	142.3609	143.7167	145.0725	146.4283	147.7842	100

NEWTON-METRES TO POUND FEET

N·m	0	1	2	3	4	5	6	7	8	9	N·m
	ft-lb	ft-lb	ft-lb	ft-lb	ft-lb	ft-lb	ft-lb	ft-lb	ft-lb	ft-lb	
--		.7376	1.4751	2.2127	2.9502	3.6878	4.4254	5.1692	5.9005	6.6381	--
10	7.3756	8.1132	8.8507	9.5883	10.3258	11.0634	11.8010	12.5385	13.2761	14.0136	10
20	14.7512	15.4888	16.2264	16.9639	17.7015	18.4390	19.1766	19.9142	20.6517	21.3893	20
30	22.1269	22.8644	23.6020	24.3395	25.0771	25.8147	26.5522	27.2898	28.0274	28.7649	30
40	29.5025	30.2400	30.9776	31.7152	32.4527	33.1903	33.9279	34.6654	35.4030	36.1405	40
50	36.8781	37.6157	38.3532	39.0908	39.8283	40.5659	41.3035	42.0410	42.7786	43.5162	50
60	44.2537	44.9913	45.7288	46.4664	47.2040	47.9415	48.6791	49.4167	50.1542	50.8918	60
70	51.6293	52.3669	53.1045	53.8420	54.5796	55.3171	56.0547	56.7923	57.5298	58.2674	70
80	59.0050	59.7425	60.4801	61.2176	61.9552	62.6928	63.4303	64.1679	64.9055	65.6430	80
90	66.3806	67.1181	67.8557	68.5933	69.3308	70.0684	70.8060	71.5435	72.2811	73.0186	90
100	73.7562	74.4938	75.2313	75.9689	76.7064	77.4440	78.1816	78.9191	79.6567	80.3943	100

DECIMAL AND METRIC EQUIVALENTS

Fractions	Decimal In.	Metric MM.	Fractions	Decimal In.	Metric MM.
1/64	.015625	.39688	33/64	.515625	13.09687
1/32	.03125	.79375	17/32	.53125	13.49375
3/64	.046875	1.19062	35/64	.546875	13.89062
1/16	.0625	1.58750	9/16	.5625	14.28750
5/64	.078125	1.98437	37/64	.578125	14.68437
3/32	.09375	2.38125	19/32	.59375	15.08125
7/64	.109375	2.77812	39/64	.609375	15.47812
1/8	.125	3.1750	5/8	.625	15.87500
9/64	.140625	3.57187	41/64	.640625	16.27187
5/32	.15625	3.96875	21/32	.65625	16.66875
11/64	.171875	4.36562	43/64	.671875	17.06562
3/16	.1875	4.76250	11/16	.6875	17.46250
13/64	.203125	5.15937	45/64	.703125	17.85937
7/32	.21875	5.55625	23/32	.71875	18.25625
15/64	.234375	5.95312	47/64	.734375	18.65312
1/4	.250	6.35000	3/4	.750	19.05000
17/64	.265625	6.74687	49/64	.765625	19.44687
9/32	.28125	7.14375	25/32	.78125	19.84375
19/64	.296875	7.54062	51/64	.796875	20.24062
5/16	.3125	7.93750	13/16	.8125	20.63750
21/64	.328125	8.33437	53/64	.828125	21.03437
11/32	.34375	8.73125	27/32	.84375	21.43125
23/64	.359375	9.12812	55/64	.859375	21.82812
3/8	.375	9.52500	7/8	.875	22.22500
25/64	.390625	9.92187	57/64	.890625	22.62187
13/32	.40625	10.31875	29/32	.90625	23.01875
27/64	.421875	10.71562	59/64	.921875	23.41562
7/16	.4375	11.11250	15/16	.9375	23.81250
29/64	.453125	11.50937	61/64	.953125	24.20937
15/32	.46875	11.90625	31/32	.96875	24.60625
31/64	.484375	12.30312	63/64	.984375	25.00312
1/2	.500	12.70000	1	1.00	25.40000



CHEVROLET

SERVICE